



LSC TRANSPORTATION CONSULTANTS, INC.  
2504 East Pikes Peak Avenue, Suite 304  
Colorado Springs, CO 80909  
(719) 633-2868  
FAX (719) 633-5430  
E-mail: [lsc@lsctrans.com](mailto:lsc@lsctrans.com)  
Website: <http://www.lsctrans.com>

ACCEPTED for FILE  
Engineering Review

11/02/2021 11:17:46 AM

*dsdnijkamp*

EPC Planning & Community  
Development Department

Bent Grass East Commercial  
Filing No. 3  
Updated Traffic Impact Analysis  
PCD File No. SP2010  
(LSC #204660)  
October 20, 2021

Traffic Engineer's Statement

This traffic report and supporting information were prepared under my responsible charge and they comport with the standard of care. So far as is consistent with the standard of care, said report was prepared in general conformance with the criteria established by the County for traffic reports.

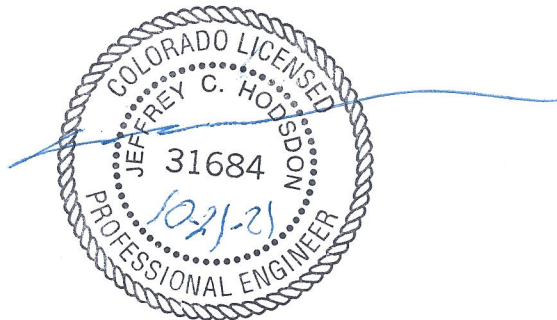

Developer's Statement

I, the Developer, have read and will comply with all commitments made on my behalf within this report.

*Ronald W. [Signature]*

10/20/21  
Date

# **Bent Grass East Commercial Filing No. 3 Updated Traffic Impact Analysis**

Prepared for:  
Land First, Inc.  
1378 Promontory Bluff View  
Colorado Springs, CO 80921

**OCTOBER 20, 2021**

---

LSC Transportation Consultants, Inc.  
Contacts: Kirstin D. Ferrin, P.E. & Jeffrey C. Hodsdon, P.E.

LSC #204660  
PCD File No. SP2010



CONTENTS

REPORT CONTENTS ..... 1

LAND USE AND ACCESS ..... 2

    Land Use..... 2

    Access Locations ..... 3

    Access Sight Distance ..... 3

        Bent Grass Meadows Drive Access..... 3

        Meridian Park Drive Access ..... 3

PEDESTRIAN & BICYCLE FACILITIES..... 4

EXISTING ROADWAY AND TRAFFIC CONDITIONS ..... 4

    Area Roadways..... 4

    Existing Traffic Conditions ..... 5

    Existing Levels of Service ..... 5

BACKGROUND TRAFFIC..... 7

TRIP GENERATION..... 8

TRIP DISTRIBUTION AND ASSIGNMENT..... 8

TOTAL TRAFFIC..... 9

PROJECTED LEVELS OF SERVICE ..... 9

    Meridian/Bent Grass Meadows ..... 9

    Bent Grass Meadows/Meridian Park ..... 9

    Bent Grass Meadows/Private Road (Bent Grass Market View) ..... 10

    Meridian Park Drive/Private Road (Bent Grass Market View) ..... 10

    Woodmen/Golden Sage ..... 10

    Woodmen North Frontage Road/Golden Sage ..... 10

        Possible Alternative to a Traffic Signal: A Modern Roundabout Intersection..... 11

    Woodmen Frontage Road/Bent Grass Meadows ..... 11

QUEUING ANALYSIS ..... 11

ROADWAY CLASSIFICATIONS & CROSS SECTIONS ..... 12

    Bent Grass Market View..... 12

    Meridian Park Drive ..... 12

AUXILIARY TURN LANE ANALYSIS..... 13

    Bent Grass Market View..... 13

TRUCK ACCOMMODATION ..... 13

APPROVED CORRIDOR STUDIES .....	13
DEVIATIONS .....	14
CONCLUSIONS AND RECOMMENDATIONS .....	14
Trip Generation.....	14
Level of Service .....	14
Roadway Improvements .....	15
Transportation Impact Fees .....	17
Enclosures:.....	17
Tables 2-5	
Figures 1-11	
Appendix Tables 1 and 2	
Appendix Figure 1	
MTCP Maps	
Traffic Count Reports	
Level of Service Reports	
Queueing Reports	
Truck Turning Exhibit	



LSC TRANSPORTATION CONSULTANTS, INC.  
2504 East Pikes Peak Avenue, Suite 304  
Colorado Springs, CO 80909  
(719) 633-2868  
FAX (719) 633-5430  
E-mail: [lsc@lsctrans.com](mailto:lsc@lsctrans.com)  
Website: <http://www.lsctrans.com>

October 20, 2021

Land First, Inc.  
C/O Mr. Ron Waldthausen  
1378 Promontory Bluff View  
Colorado Springs, CO 80921-3945

RE: Bent Grass East  
Commercial Filing No. 3  
El Paso County, Colorado  
Updated Traffic Impact Analysis  
PCD File No. SP2010  
LSC #204660

Dear Ron:

LSC Transportation Consultants, Inc. has prepared this updated traffic impact analysis for the Bent Grass East Commercial Filing No. 3 development. The site is located southwest of the intersection of Meridian Park Drive and Bent Grass Meadows Drive in El Paso County, Colorado. Figure 1 shows the site location.

A mix of commercial uses is envisioned and access to the site will be from Bent Grass Meadows Drive and Meridian Park Drive.

## REPORT CONTENTS

The report contains the following:

- The existing roadway and traffic conditions in the site's vicinity, including the roadway widths, surface conditions, lane geometries, traffic controls, and posted speed limits, etc.;
- The existing traffic volumes on the study-area roadways;
- The projected average weekday and peak-hour vehicle trips to be generated by the site at buildout;
- The assignment of the projected site-generated traffic volumes to the study-area roadways and intersections;
- The projected short-term and long-term total traffic volumes on the study-area roadway network;
- The projected levels of service at the intersections of Meridian Road/Bent Grass Meadows Boulevard, Meridian Park Drive/Bent Grass Meadows Drive and at the site access points.

For consistency with other traffic reports completed within Bent Grass, the following offsite intersections have also been analyzed:

- Woodmen frontage road/Bent Grass Meadows Drive
- Woodmen Road/Golden Sage Drive
- Recommendations for roadway improvements and phasing of these improvements

LSC has completed the following studies for this site:

- *Bent Grass Subdivision PUD Traffic Impact Analysis* -- October 6, 2006
- *Bent Grass East Commercial – Preliminary Plan* -- January 25, 2013
- *Bent Grass East Commercial – Report Supplement #2* -- March 14, 2013
- *Bent Grass East Commercial Filing No. 2 Updated Traffic Impact Analysis* -- July 17, 2014

Other studies completed in the vicinity include:

- *Bent Grass Subdivision Filing 1 Updated Traffic Impact Analysis* -- July 14, 2014
- *Falcon Dental East Commercial Filing No. 2A* -- March 7, 2016
- *Bent Grass Meadows Drive/Meridian Road Traffic Signal Warrant Analysis* -- October 2, 2017
- *Falcon Marketplace Traffic Impact Analysis* -- October 23, 2017 (September 5, 2018 Revision)
- *Bent Grass Residential Filing No. 2 Traffic Impact Analysis* -- April 17, 2020
- *Bent Grass Meadows Drive & Meridian Road Updated Transportation Memorandum* -- September 4, 2020
- *Falcon Meadows at Bent Grass Updated Traffic Impact Analysis* -- December 11, 2020
- *Golden Sage and Woodmen Road Transportation Memorandum* -- December 30, 2020

## **LAND USE AND ACCESS**

### **Land Use**

The Bent Grass East Commercial development is located west of Meridian Road and south of Bent Grass Meadows Drive. It is partially developed with a veterinary clinic, a gas station with convenience store, and a dental clinic. There are currently two vacant parcels within the Bent Grass East Commercial development. The 5.05-acre Bent Grass East Commercial Filing No. 2B Tract BB and the 1.46-acre Lot 1A Bent Grass East Commercial Fil No 2A.

The currently-proposed Bent Grass East Commercial Filing 3 preliminary plan and plat will subdivide Tract BB into six lots and a tract for a roadway. The site is planned to be developed with about 5,000 square feet of floor space for fast-food restaurants, 18,000 square feet of general retail floor space, and 10,800 square feet of floor space that will be used for a mix of office and warehouse uses.

This TIA assumes the 1.46-acre Lot 1A Bent Grass East Commercial Fil No 2A will be developed with about 15,000 square feet of retail floor space in the future.

## Access Locations

Bent Grass East Filing 3 is proposed to have one full-movement access point to Bent Grass Meadows Drive (an Urban Non-Residential Collector) about 525 feet west of Meridian Park Drive (an Urban Local). This access would be 505 feet east of Avena Road (an Urban Local). The proposed spacing exceeds the minimum intersection spacing of 330' for an Urban Non-Residential Collector when intersecting local roadways. An additional full-movement access point is proposed to Meridian Park Drive about 240 feet south of Bent Grass Meadows Drive aligning with the existing south 7-Eleven access. This exceeds the minimum intersection spacing of 175 feet for an Urban Local. As indicated in the sight distance section, given the site-specific conditions, there is sufficient sight distance for the proposed spacing.

## Access Sight Distance

### Bent Grass Meadows Drive Access

Figure 3 shows a sight distance analysis at the proposed access point to Bent Grass Meadows Drive. Based on a design speed of 40 miles per hour (mph) on Bent Grass Meadows Drive and the criteria contained in Table 2-21 of the *Engineering Criteria Manual (ECM)*, the required intersection sight distance at the proposed site access points is 455 feet. The required stopping sight distance from *ECM* Table 2-17 is also shown in the figure. The *ECM*-prescribed intersection sight distance and stopping sight distance can be met at the proposed intersection.

### Meridian Park Drive Access

Figure 4 shows the sight-distance analysis at the proposed access point to Meridian Park Drive. As shown in Figure 4, the sight distance to the south to the terminus of Meridian Park Drive is unrestricted.

The *ECM*-standard intersection sight distance for an intersection on an Urban Local street is 280 feet (based on the criteria contained in Table 2-21 of the *ECM*). However, Meridian Park Drive ends just to the north at Bent Grass Meadows Drive. Therefore, site specific conditions are such that vehicles turning onto Meridian Park Drive from Bent Grass Meadows Drive will not be traveling at the *ECM*-standard speed of 25 mph at the point they turn onto the street in the southbound direction.

The proposed access is located 240 feet south of Bent Grass Meadows Drive (centerline to centerline). Figure 4 shows the available sight distance of 208 feet from the proposed access point to the north. As mentioned above, vehicles turning from Bent Grass Meadows onto southbound Meridian Park Drive (approaching the site access) will be traveling at a speed less than the *ECM* standard posted speed of 25 miles per hour for Urban Local streets. Should a future access be constructed north of Bent Grass Meadows Drive, those vehicles continuing on Meridian Park Drive will be travelling from a stop condition.

The required stopping sight distance from *ECM* Table 2-17 is also shown in the figure. The *ECM*-prescribed intersection sight distance and stopping sight distance can be met at the proposed intersection.

Based on the criteria contained in Table 2-17 of the *ECM*, the required stopping sight distance approaching the Meridian Park site access is 155 feet. This requirement is met in both directions.

## **PEDESTRIAN & BICYCLE FACILITIES**

- Woodmen & Meridian are shown as proposed bike routes on the MTCP Non-Motorized Plan. Also shown is a proposed secondary regional trail west of the site.
- Generally, Bent Grass Meadows Drive is sufficiently wide for bicycles with the paved shoulder.
- Developing pedestrian connections along the north side of the Woodmen North Frontage Road, Bent Grass Meadows Drive, and Meridian Park Drive. Other area sections of sidewalk/trail connections are being added as development occurs.
- Sidewalks will be added along Bent Grass Meadows Drive with the connection south to the north terminus of the existing section adjacent to the School District 49 headquarters.
- This commercial subdivision will provide the required sidewalks to connect to the sidewalk along Bent Grass Meadows Drive.

## **EXISTING ROADWAY AND TRAFFIC CONDITIONS**

### **Area Roadways**

The roadways in the study area are identified below, followed by a brief description of each. Figure 1 shows the roadway system. Copies of the *2016 El Paso County Major Transportation Corridors Plan (MTCP)*, *2040 Roadway Plan*, and *2016 MTCP 2060 Corridor Preservation Plan* with the site location identified on each of them have been attached to this report.

**Meridian Road** is shown on the *El Paso County 2040 Major Transportation Corridors Plan* and the *Preserved Corridor Network Plan* as a four-lane Principal Arterial. Meridian Road was recently expanded from two lanes to four lanes between Woodmen Road and Rolling Thunder and may soon be connected to US Highway 24 (US Hwy 24). The posted speed limit is 55 miles per hour (mph).

**Bent Grass Meadows Drive** is a Non-Residential Collector that currently extends north from the Woodmen North frontage road for about 2,000 feet and west from Meridian Road for about one-half mile. Bent Grass Meadows Drive will be extended further west and then curve south to connect to the existing section north of the Woodmen frontage road, as part of the approved Bent Grass Residential Filing No. 2 development. The Bent Grass Meadows Drive/Meridian Road intersection is planned to be signalized in the short-term future once warrants for signalization are satisfied. This is anticipated to occur with development of that filing.



**Woodmen Road** is shown on the *El Paso County 2040 Major Transportation Corridors Plan* and the *Preserved Corridor Network Plan* as a four-lane Expressway in the vicinity of the site. The posted speed limit on Woodmen Road in the vicinity of Golden Sage Road is 55 mph.

**Woodmen Frontage Road** is a paved two-lane frontage road along the north side of Woodmen Road. The Woodmen frontage road extends from just west of Meridian Road to its current terminus west of Golden Sage Road. The posted speed limit on the Woodmen frontage road is 30 mph.

**Meridian Park Drive** is an Urban Local street which extends south from Bent Grass Meadows Drive about 575 feet. Meridian Park Drive could potentially be extended south if the Falcon Ranchettes subdivision is redeveloped and/or the intersection of Meridian Road and Owl Place is restricted to right-in/right-out. Although the speed limit is not posted, the assumed speed limit is 25 mph.

### **Existing Traffic Conditions**

Figure 5 shows the existing morning and afternoon peak-hour traffic volumes at the key area intersections. The traffic volumes shown for the intersections of Woodmen/Golden Sage and the Woodmen frontage road/Golden Sage are from traffic counts conducted in January 2020 and December 2020. Note that the January 2020 counts were conducted prior to the completion of Bent Grass Meadows Drive between the Woodmen frontage road and Meridian Road, but before effects of the COVID-19 pandemic. The December 2020 counts were conducted following the completion of Bent Grass Meadows Drive between the Woodmen frontage road and Meridian Road, but during the COVID-19 pandemic.

The traffic volumes shown for the intersection of the Woodmen frontage road/Bent Grass Meadow are from traffic counts conducted in May 2019. The traffic volumes at the intersection of Meridian Road/Bent Grass Meadows Drive, the 7-Eleven access to Bent Grass Meadows Drive (which has since been closed) and the intersection of Meridian Park Drive/Bent Grass Meadows Drive were counted in September and October 2018 and again in October 2020. Note that all of these counts were conducted prior to the completion of Bent Grass Meadows Drive between the Woodmen frontage road and Meridian Road. The more recent October 2020 counts are slightly lower than the volumes counted two years previously. Figure 5 shows both the October 2018 counts and the October 2020 counts, as the more current counts were likely impacted by the COVID-19 pandemic. The traffic count reports are attached.

### **Existing Levels of Service**

Level of service (LOS) is a quantitative measure of the level of congestion or delay at an intersection. Level of service is indicated on a scale from "A" to "F." LOS A represents control delay of less than 10 seconds for unsignalized and signalized intersections. LOS F represents

control delay of more than 50 seconds for unsignalized intersections and more than 80 seconds for signalized intersections. Table 1 shows the level of service delay ranges.

**Table 1: Intersection Levels of Service Delay Ranges**

Level of Service	Signalized Intersections	Unsignalized Intersections
	Average Control Delay (seconds per vehicle)	Average Control Delay (seconds per vehicle) <sup>(1)</sup>
A	10.0 sec or less	10.0 sec or less
B	10.1-20.0 sec	10.1-15.0 sec
C	20.1-35.0 sec	15.1-25.0 sec
D	35.1-55.0 sec	25.1-35.0 sec
E	55.1-80.0 sec	35.1-50.0 sec
F	80.1 sec or more	50.1 sec or more

(1) For unsignalized intersections, if V/C ratio is greater than 1.0 the level of service is LOS F, regardless of the projected average control delay per vehicle.

The intersections of Meridian Road/Bent Grass Meadows Drive, Meridian Park Drive/Bent Grass Meadows Drive, and Woodmen frontage road/Bent Grass Meadows Drive were analyzed to determine the existing levels of service based on the unsignalized method of analysis procedures found in the *Highway Capacity Manual, 6<sup>th</sup> Edition* by the Transportation Research Board. The intersection of Woodmen Road/Golden Sage Drive was analyzed using Synchro. Figure 5 shows the level of service analysis results. The level of service reports are attached.

The eastbound left-turn movement at the stop-sign-controlled intersection of Meridian/Bent Grass Meadows is currently operating at LOS F during the morning peak hour and LOS E during the afternoon peak hour. The eastbound right-turn movement is currently operating at LOS D during the morning peak hour and LOS B during the afternoon peak hour. This intersection will soon be signalized and other improvements will be completed. The construction documents have been approved and construction is expected to begin in the spring of 2021. All movements at this intersection are projected to operate at LOS D or better following the construction.

All movements at the intersections of Bent Grass Meadows/Meridian Park, the Woodmen frontage road/Bent Grass Meadows Drive, and the Woodmen frontage road/Golden Sage Road are currently operating at LOS B or better during the peak hours.

All movements at the signal-controlled intersection of Woodmen/Golden Sage are currently operating at LOS D or better during the peak hours. However, County staff has recently raised a requirement for separate eastbound left-turn phasing at this intersection as part of the Bent Grass Residential Filing No. 2 application. LSC is currently working on construction documents for this improvement as part of that subdivision application.

## BACKGROUND TRAFFIC

Background traffic is the traffic estimated to be on the roadways without the Bent Grass West traffic. The short-term (Year 2021) background traffic volumes are shown in Figure 6. The background traffic volumes are based on the existing traffic volumes shown in Figure 5, with a portion of the volumes assumed to be rerouted as the counts were conducted prior to the completion of Bent Grass Meadows Drive (between the sections located north of the Woodmen frontage road and west of Meridian Road) and the closure of the 7-Eleven access to Bent Grass Meadows Drive. All 7-Eleven traffic was assumed to use the south access to Meridian Park Drive that will align with the proposed access for Bent Grass East Commercial Filing No. 3.

The short-term background traffic volumes also include additional traffic projected to be generated by buildout of Bent Grass Residential Filing No. 2, buildout of Falcon Meadows at Bent Grass, buildout of the initial phase of Banning Lewis Ranch North, and **buildout of Falcon Marketplace** located northwest of the intersection of Woodmen Road/Meridian Road. As buildout of these projects has been assumed, these short-term volumes may be conservative if commercial buildout takes several years to occur. The short-term background traffic volumes also assume a right-in-only access to Woodmen Road just west of Meridian Road. Through traffic on Meridian Road was assumed to have a 2 percent growth rate per year.

Figure 7 shows the projected 2040 background traffic volumes. These volumes were estimated by LSC, based on previous work completed in the area by LSC, including other Bent Grass Meadows developments, the Falcon Marketplace, and *the Banning Lewis Ranch North - Traffic Impact Study* prepared by SM Rocha, LLC, dated August 2019. The 2040 background traffic volumes assume buildout of the area north of Woodmen Road and west of Meridian Road. Appendix Table 1 shows the trip generation estimates for all existing and future land uses assumed to be built out in this area by 2040. Appendix Figure 1 shows the location of each traffic analysis zone (TAZ) referenced in the appendix tables. The land uses assumed for TAZ 3 and TAZ 4 were revised with this updated TIS, based on an Early Assistance submittal to El Paso County for the parcels located north of Meridian Road and west of Bent Grass Meadows Drive. TAZ 2 and TAZ 3 were previously assumed to be developed with a mix of commercial, office, and residential land uses. They are now both assumed to be developed for residential uses only.

A significant portion of the background traffic shown on Meridian Park Drive is due to Owl Lane redevelopment trip estimates from 10-15 years ago. Commercial development of the size and configuration that was common at that time likely no longer applies today for the Owl Lane area, and any commercial development would likely be significantly smaller and generate significantly fewer trips.

## **TRIP GENERATION**

Estimates of the vehicle trips generated by Bent Grass East Commercial Filing No. 3 have been made using the nationally published trip generation rates found in *Trip Generation, 10th Edition* by the Institute of Transportation Engineers (ITE). The results of the trip generation estimate are shown in Table 2.

The total number of vehicle trips generated by the land uses has been reduced to account for the internal vehicle trips made within the site between land uses, without use of the external streets surrounding the site. As shown in Table 2, about five percent of the total trips were assumed to be internal to the site.

The total number of vehicle trips generated has been reduced to take into account the “pass by” phenomena. A pass-by trip is made by a motorist who would already be on the adjacent roadways regardless of the proposed development, but who stops in at the site while passing by. The motorist would then continue on his or her way to a final destination in the original direction. The pass-by percentages shown on Table 2 are from the *Trip Generation Handbook - An ITE Proposed Recommended Practice, 3rd Edition, 2017* by ITE.

Bent Grass East Commercial Filing No. 3 can be expected to generate about 2,873 vehicle trips on the average weekday, with about half entering and half exiting in a 24-hour period. During the morning peak hour, which generally occurs for one hour between 6:30 and 8:30 a.m., about 163 vehicles would enter, and 129 vehicles would exit the site. During the afternoon peak hour, which generally occurs for one hour between 4:15 and 6:15 p.m., about 145 vehicles would enter, and 154 vehicles would exit the site.

## **TRIP DISTRIBUTION AND ASSIGNMENT**

The estimated directional distribution of the site-generated traffic volumes on the adjacent roadways is an important factor in determining the site’s traffic impacts. Figure 8 shows the directional distribution estimates for the site-generated traffic. The estimates have been based on the following factors: the land use proposed for the site and its location, the existing and planned street and roadway system in the vicinity, and the existing/projected traffic volumes.

The pass-by trips from Meridian Road were assigned based, in large part, on the magnitude and direction of the existing traffic volumes.

Trips with destination and/or origins within the area bound by Woodmen Road on the south and Meridian Road on the east have been assigned separately. In the short term, a portion of the trips generated by Bent Grass East Commercial development are estimated to travel to and from residential areas within the study area. Appendix Tables 1 and 2 show the internal trip assumptions and calculations.

When the external trip distribution percentages (from Figure 8) are applied to the trip-generation estimates (from Table 2), the resulting site-generated traffic volumes can be determined. Figure 9 shows the site-generated traffic-volume estimates.

### **TOTAL TRAFFIC**

Figure 10 shows the projected short-term total traffic volumes at the site access points and key area intersections. The short-term-total traffic volumes are the sum of the short-term background traffic volumes from Figure 6 plus the site-generated traffic volumes from Figure 9.

Figure 11 shows the projected 2040 total traffic volumes at the site access points and key area intersections. The 2040 total traffic volumes are the sum of the 2040 background traffic volumes from Figure 7 plus the site-generated traffic volumes from Figure 9.

### **PROJECTED LEVELS OF SERVICE**

The site access points, and key area intersections were analyzed to determine the projected levels of service, based on the unsignalized method of analysis procedures found in the *Highway Capacity Manual, 6th Edition* (HCM) by the Transportation Research Board or using Synchro. Figures 6, 7, 10, and 11 show the level of service analysis results. The level of service technical reports are attached.

#### **Meridian/Bent Grass Meadows**

The intersection of Meridian/Bent Grass Meadows is currently two-way, stop-sign-controlled. It is our understanding that this intersection will be converted to traffic-signal control in the short-term future (See File Number CDR194). As a signal-controlled intersection, all movements are projected to operate at LOS D or better during the peak hours, based on both short-term and 2040 total traffic volumes.

#### **Bent Grass Meadows/Meridian Park**

The intersection of Bent Grass Meadows Drive/Meridian Park Drive is projected to operate at LOS B or better for all movements as a stop-sign-controlled intersection, based on the short-term total traffic volumes.

By 2040, it was assumed that the parcels north of Bent Grass Meadows would be developed with residential uses and would have an access that forms the north leg of the intersection. The 2040 total traffic volumes also assume Meridian Park Drive would be extended south to serve redevelopment of parcels currently served by Owl Lane. Based on the projected 2040 total traffic volumes and using the *HCM* unsignalized method of analysis procedures, the southbound approach is projected to operate at LOS F during the morning and afternoon peak hours. The upstream signal at Meridian/Bent Grass Meadows will create gaps in westbound traffic. The *HCM* unsignalized method of analysis allows for the effect of an upstream signal. However, the

southbound delay calculated by the *HCM* procedures at Meridian Park may be conservative. A SimTraffic simulation was run to better analyze the operational effects of the adjacent signal-controlled intersection. The projected 2040 peak-hour volumes were entered into the model and the model was run five times. The results were then averaged. The average projected delay for the southbound left-turn movement at the intersection of Meridian Park/Bent Grass Meadows was about 18.1 seconds per vehicle during the morning peak hour and 17.8 seconds per vehicle during the afternoon peak hour. Based the SimTraffic simulation results and on the Level of Service delay ranges shown in Table 1, this movement would be considered to operate at LOS C during the peak hours.

#### **Bent Grass Meadows/Private Road (Bent Grass Market View)**

The full-movement site private road connection to Bent Grass Meadows Drive is projected to operate at LOS B or better for all movements as a stop-sign-controlled intersection, based on the short-term and 2040 total traffic volumes.

#### **Meridian Park Drive/Private Road (Bent Grass Market View)**

The full-movement site private road connection to Meridian Park Drive is projected to operate at LOS D or better for all movements as a stop-sign-controlled intersection, based on the short-term and 2040 total traffic volumes.

#### **Woodmen/Golden Sage**

The shared southbound right-turn and through lane at the intersection of Woodmen/Golden Sage is projected to operate at LOS E during the afternoon peak hour, based on the projected short-term total traffic volumes. These movements are projected to operate at LOS D or better once a separate southbound right-turn lane is constructed. All other movements at this intersection are projected to operate at LOS D or better during the peak hours, based on the projected short-term total and 2040 total traffic volumes. The analysis assumes the addition of protected/permitted phasing for the eastbound and westbound left-turn movements in the short-term.

#### **Woodmen North Frontage Road/Golden Sage**

The intersection of the Woodmen North Frontage Road/Golden Sage is currently stop-sign-controlled. All movements at this intersection are projected to operate at LOS D or better during the peak hours, based on the projected short-term total traffic volumes. By 2040, the westbound approach is projected to operate at LOS F during the afternoon peak hour. All movements are projected to operate at LOS C or better, if this intersection is converted to either traffic-signal control or reconstructed as a modern roundabout. Due to right-of-way and spacing constraints, the signal is most likely the primary future option. Table 3 shows a comparison of the level of service for each of the options. Due to the short spacing between the frontage road and Woodmen Road and the high volume of northbound right-turning vehicles at this intersection,

LSC recommends a dual northbound right-turn to allow for better utilization of the dual eastbound left-turn lanes at the intersection of Woodmen/Golden Sage.

### Possible Alternative to a Traffic Signal: A Modern Roundabout Intersection

#### *Advantages*

- The delay for all movements is projected to be lower with a modern roundabout than with traffic-signal control.
- Generally, modern roundabouts have safety advantages over signal-controlled intersections. This is because crashes tend to be lower speed, there are fewer conflict points, and the types (angle) of crashes tend to be those which generally result in less severe accidents. Granted, conventional T-intersections have significantly fewer conflict points than four-leg conventional intersections.
- A roundabout may be more aesthetically appealing than a traditional signal-controlled intersection and may have generally lower traffic-noise levels.
- Long-term operation and maintenance cost is likely to be lower with a roundabout than a traffic signal.

#### *Disadvantages*

- A roundabout could potentially require additional right-of-way and construction costs than a traffic signal. The required right-of-way may not be available.
- Due to the proximity to Woodmen Road, southbound queues extending from the signal at Woodmen Road have the potential to back into the circulating lanes of a roundabout.

### **Woodmen Frontage Road/Bent Grass Meadows**

All movements at the stop-sign-controlled intersection of the Woodmen frontage road/Bent Grass Meadows are projected to operate at LOS C or better during the peak hours, based on the projected short-term and 2040 total traffic volumes.

### **QUEUING ANALYSIS**

A queuing analysis was performed using Synchro/SimTraffic for Bent Grass Meadows Drive between Meridian Park Drive and the site access (Bent Grass Market View). The 2040 total morning and afternoon peak-hour traffic volumes were entered into the Synchro model. The simulation was run five times.

The maximum eastbound left-turn queue on Bent Grass Meadows Drive approaching Meridian Park Drive is about 24 feet and the maximum westbound left-turn queue approaching the site access (Bent Grass Market View) is about 36 feet.

The maximum westbound left-turn queue on Bent Grass Meadows Drive approaching Meridian Park Drive is 164 feet.

## **ROADWAY CLASSIFICATIONS & CROSS SECTIONS**

### **Bent Grass Market View**

The private road, Bent Grass Market View should be classified as “Urban Local.” The proposed roadway cross section is 34-foot wide (flowline to flowline) with 30 feet of asphalt pavement width.

Each individual lot will be required to provide circulation such that vehicles will not back onto the street.

This street is intended only to serve the adjacent commercial lots and not through traffic. Each lot will be required to provide sufficient on-site parking as on-street parking will not be allowed. With no on-street parking, two-way traffic will be maintained.

As this will be a relatively short street serving a minimal number of commercial lots, a center two-way left-turn lane would not be necessary to separate left-turning traffic from through traffic at each of the internal lot driveway access points.

The site development plan for each individual lot will address lot access design and site circulation to accommodate the anticipated design vehicle – either single unit or multi-unit trucks.

### **Meridian Park Drive**

Meridian Park Dr is classified as an Urban Local street and is not identified on the *2016 El Paso County Major Transportation Corridors Plan (MTCP)*. This roadway was approved and constructed with the development of the Bent Grass Commercial PUD. The land use currently proposed is consistent with the land use shown at the time the PUD was approved. A southbound right-turn lane is required on Meridian Park Drive approaching the site access, as the projected turning volume would exceed *ECM* thresholds requiring a turn lane. This lane will be 12-foot wide and 100-foot long, plus a 45-foot taper. The adjacent southbound through lane will be 14-foot wide and there will be an 18-foot-wide northbound through lane and no northbound or southbound left-turn lanes.

Meridian Park Drive ADT shown in the TIS report includes previously estimated potential commercial development associated with the Owl Place area. Meridian Park Drive was required by EPC to extend to the south property line to allow for possible future access to the Owl Lane area and potentially a connection between [now] Falcon Marketplace and the south end of Meridian Park Drive. This was required to ensure access management on Meridian Road, as no full movement would be allowed between Eastonville and Bent Grass Meadows Drive. This



connection was basically intended as a commercial “local frontage road” for the relatively short distance between Eastonville and Bent Grass Meadows Drive.

A significant portion of the projected future background traffic ADT reflects Owl Lane redevelopment trip estimates from 10-15 years ago. Commercial development of the size and configuration that was common at that time likely no longer applies today for the Owl Lane area, and any commercial development would likely be significantly smaller and generate significantly fewer trips.

### **AUXILIARY TURN LANE ANALYSIS**

#### **Bent Grass Market View**

The currently-proposed Bent Grass Market View is planned to incorporate a dedicated left-turn lane and a shared through and right-turn lane approaching Meridian Park Drive. The proposed turn lane would be designated with a 50-foot-long white turn-lane stripe (8-in white). The standard *ECM* turn-lane length for a 25-mph design speed is 115 feet plus an 80-foot bay taper plus storage per *ECM* Table 2-30. This lane will be on a private street with a classification of Urban Local approaching a Stop condition. Therefore, deceleration distance is not necessary – all vehicles will be decelerating. The existing single-lane approach for 7-Eleven access on the west side of Meridian Park Drive should be signed for “NO straight through” due to the offset between the east and west legs.

The currently-proposed Bent Grass Market View is planned to incorporate separate left- and right-turn lanes approaching Bent Grass Meadows Drive. The proposed turn lane would be designated with a 50-foot-long white turn-lane stripe (8-in white). The standard *ECM* turn-lane length for a 25-mph design speed is 115 feet plus an 80-foot bay taper plus storage per *ECM* Table 2-30. This lane will be on a private street with a classification of Urban Local approaching a Stop condition. Therefore, deceleration distance is not necessary – all vehicles will be decelerating. When a north leg is constructed, the left-turn lane should be restriped for a shared through and left-turn movement.

### **TRUCK ACCOMMODATION**

Please refer to the attached Autoturn exhibit prepared by Classic Consulting for truck turns into/out of the private road and passage through the site on the private road. The site development plan for each individual lot will address lot access design and site circulation to accommodate the anticipated design vehicle – either single unit or multi-unit trucks.

### **APPROVED CORRIDOR STUDIES**

The *El Paso County 2016 Major Transportation Corridors Plan Update* does not identify any 2040 roadway improvements projects in the vicinity of the site and there are no other known approved corridor studies in the area.

## **DEVIATIONS**

A deviation for the internal-street cross section of the private roadway through the site is being included with this resubmittal.

## **CONCLUSIONS AND RECOMMENDATIONS**

### **Trip Generation**

- Bent Grass East Commercial Filing No. 3 can be expected to generate about 2,873 vehicle trips on the average weekday, with about half entering and half exiting in a 24-hour period. During the morning peak hour about 163 vehicles would enter, and 129 vehicles would exit the site. During the afternoon peak hour, about 145 vehicles would enter and 154 vehicles would exit the site.

### **Level of Service**

- The eastbound left-turn movement at the stop-sign-controlled intersection of Meridian/Bent Grass Meadows is currently operating at LOS F during the morning peak hour and LOS E during the afternoon peak hour. However, a traffic signal is currently under construction at this intersection. Once the signal becomes operational, all movements are projected to operate at LOS D or better during the peak hours, based on the projected short-term and 2040 total traffic volumes.
- The intersection of Bent Grass Meadows/Meridian Park is projected to operate at an acceptable LOS as a stop-sign-controlled intersection, based on the projected short-term total traffic volumes. By 2040, it was assumed that the parcels north of Bent Grass Meadows would be developed with residential uses and would have an access that forms the north leg of the intersection. The 2040 total traffic volumes also assume Meridian Park Drive would be extended south to serve potential future redevelopment of parcels currently served by Owl Lane (LSC is not aware of any current plans). Based on the projected 2040 total traffic volumes, the northbound and southbound approaches are projected to operate at LOS D or better, based on projected delay from a traffic simulation analysis.
- The site access points (private road connections) to Bent Grass Meadows and Meridian Park are projected to operate at LOS D or better for all movements during the peak hours as stop-sign-controlled intersections, based on the projected short-term and 2040 total traffic volumes.
- Off Site Intersections
  - The intersection of the Woodmen frontage road/Bent Grass is projected to operate at LOS C or better for all movements during the peak hours as a stop

sign-controlled intersection, based on the projected short-term and 2040 total traffic volumes.

- All movements at the stop-sign-controlled intersection of the Woodmen frontage road/Golden Sage are projected to operate at LOS D or better during the peak hours, based on the projected short-term total traffic volumes. By 2040, alternate intersection control, such as a traffic signal or a modern roundabout, will likely be needed to maintain an acceptable level of service for this intersection. **Note:** this information was originally provided when this intersection was under El Paso County jurisdiction. The intersection is now subject to review (and associated requirements) by the City of Colorado Springs.
- The shared southbound right-turn and through lane at the intersection of Woodmen/Golden Sage is projected to operate at LOS E during the afternoon peak hour, based on the projected short-term total traffic volumes. These movements are projected to operate at LOS D or better, once a separate southbound right-turn lane is constructed. This analysis has been included, although the traffic impact from this project is less than five percent during the morning peak hour, as this and other TIS reports for projects in this Bent Grass/Latigo/Falcon Marketplace “sub area” have called out cost sharing for these improvements. All other movements at this intersection are projected to operate at LOS D or better during the peak hours, based on the projected short-term and 2040 total traffic volumes. **Note:** this information was originally provided when this intersection was under El Paso County jurisdiction. The intersection is now subject to review (and associated requirements) by the City of Colorado Springs.

### Roadway Improvements

- Auxiliary Turn Lanes
  - The existing section of Bent Grass Meadows Drive between Meridian Road and Meridian Park Drive has recently been widened to allow for a three-lane eastbound approach at Meridian/Bent Grass Meadows. As part of this improvement, Bent Grass Meadows has been restriped to remove the existing westbound left-turn lane for the 7-Eleven access, which has been closed, and lengthen the existing westbound left-turn bay approaching Meridian Park Drive. The restriped lane will be about 195 feet long plus an 85-foot taper. Based on the queueing analysis discussed above, the proposed 195-foot lane will provide adequate storage for the projected queues.
  - A westbound left-turn lane already exists on Bent Grass Meadows Drive approaching the west site access. The roadway was originally striped with a 110-foot-long westbound left-turn lane approaching the access location (Bent Grass Market View) and a 150-foot-long eastbound left-turn lane approaching the

future access that will align with Meridian Park Drive. Based on the criteria contained in the *ECM* and a design speed of 40 miles per hour, the westbound left-turn lane approaching the west site access should be 215 feet long plus a 160-foot taper. Previous Bent Grass reports showed side-by-side left-turn lanes between Meridian Park and the west site access. However, it has been agreed upon through meetings with County staff, that ~~back-to-back~~ <sup>two-way</sup> left-turn lanes are the best solution given this existing section of Bent Grass Meadows Drive. The anticipated change in the projected land use for the parcels north of Bent Grass Meadows Drive to residential uses was a significant consideration. LSC's concept for restriping of the left-turn lanes is shown in Figure 12. Figure 12 depicts a dedicated eastbound left-turn lane at Meridian Park Drive/Bent Grass Meadows Drive and a striped, center, two-way left-turn lane west of that.

- An abbreviated southbound right-turn lane is recommended at the Meridian Park Drive/ Bent Grass Market View intersection. Please refer to the Auxiliary Turn Lanes section of the report for additional details/discussion.
- Private roadway (Bent Grass Market View):
  - The queuing analysis projects the maximum approach queues for 2040 for the minor street approaches on Bent Grass Market View to be 135 feet (about 5-6 vehicles) for the eastbound approach to Meridian Park Drive and 52 feet (about 2-3 vehicles) for the northbound approach to Bent Grass Meadows Drive. LSC recommends these queue lengths be considered when placing the individual lot access points to the private road. Queue length estimates may need to be updated with each site development plan as lot users become known and to verify projections of area traffic conditions.
  - The site development plan for each individual lot will address lot access design and site circulation to accommodate the anticipated design vehicle – either single-unit or multi-unit trucks.
- Table 4 identifies the future roadway improvements that may be needed in the vicinity of the site. Table 4 also gives a recommended trigger for when each improvement will be needed. This table has been updated with this report to note that requirements may change as this intersection is now subject to review (and associated requirements) by the City of Colorado Springs.
- Table 5 shows the percentage of the projected 2040 total traffic due to Bent Grass East Commercial Filing No. 3. These percentages could be used to determine the pro-rata share of the cost of intersection improvements. **Note:** this information was originally provided when this intersection was under El Paso County jurisdiction. The intersection is now subject to review (and associated requirements) by the City of Colorado Springs.

### Transportation Impact Fees

- Bent Grass East Commercial Filing No. 3 will not be required to participate in the Countywide Transportation Improvement Fee Program, as it is located within the Woodmen Road Metropolitan District. Woodmen Road district fees would apply.

\* \* \* \* \*

Please contact me if you have any questions regarding this report.

Respectfully Submitted,

LSC TRANSPORTATION CONSULTANTS, INC.

By: Jeffrey C. Hodsdon, P.E.  
Principal

JCH:KDF:jas

Enclosures: Tables 2-5  
Figures 1-11  
Appendix Tables 1 and 2  
Appendix Figure 1  
MTCP Maps  
Traffic Count Reports  
Level of Service Reports  
Queueing Reports  
Truck Turning Exhibit

# Tables

---



**Table 2  
Trip Generation Estimate  
Bent Grass East Commercial Filing No. 3**

Lot	Land Use Code	Land Use Description	Trip Generation Units	Trip Generation Rates <sup>(1)</sup>					Total Trips Generated					Internal Trips	Total External Trips Generated					Pass-By Trips <sup>(2)</sup>	New External Trips Generated Average Weekday Traffic
				Average Weekday Traffic	Morning Peak Hour In	Morning Peak Hour Out	Afternoon Peak Hour In	Afternoon Peak Hour Out	Average Weekday Traffic	Morning Peak Hour In	Morning Peak Hour Out	Afternoon Peak Hour In	Afternoon Peak Hour Out		Average Weekday Traffic	Morning Peak Hour In	Morning Peak Hour Out	Afternoon Peak Hour In	Afternoon Peak Hour Out		
1	934	Fast-Food Restaurant with Drive-Through Window	2.5 KSF <sup>(3)</sup>	470.95	20.50	19.69	16.99	15.68	1,177	51	49	42	39	5%	1,118	48	47	40	37	50%	559
2	934	Fast-Food Restaurant with Drive-Through Window	2.5 KSF	470.95	20.50	19.69	16.99	15.68	1,177	51	49	42	39	5%	1,118	48	47	40	37	50%	559
3	820	Shopping Center <sup>(4)</sup>	6.0 KSF	85.72	3.16	1.94	3.48	3.77	514	19	12	21	23	5%	488	18	11	20	22	34%	322
4	820	Shopping Center	6.0 KSF	85.72	3.16	1.94	3.48	3.77	514	19	12	21	23	5%	488	18	11	20	22	34%	322
5	820	Shopping Center	6.0 KSF	85.72	3.16	1.94	3.48	3.77	514	19	12	21	23	5%	488	18	11	20	22	34%	322
6	770	Business Park	10.8 KSF	76.88	1.29	0.23	0.48	1.36	830	14	2	5	15	5%	789	13	2	5	14	0%	789
					<b>4,726</b>	<b>173</b>	<b>136</b>	<b>152</b>	<b>162</b>						<b>4,490</b>	<b>163</b>	<b>129</b>	<b>145</b>	<b>154</b>		<b>2,873</b>

Notes:

(1) Source: "Trip Generation, 10th Edition, 2017" by the Institute of Transportation Engineers (ITE)

(2) Source: "Trip Generation Handbook - An ITE Proposed Recommended Practice, 3rd Edition, 2017" by ITE

(3) KSF = thousand square feet

(4) The "Shopping Center" trip generation rates were calculated using the fitted rate equations based on the total floor area of retail floor space within the Bent Grass East Commercial development (Includes 18 KSF within Fil No. 2 Tract BB and 15 KSF within Fil No. 2A Lot 1A)

Source: LSC Transportation Consultants, Inc.

**Table 3**  
**Level of Service Comparison**  
**Golden Sage Drive/Woodmen frontage road**  
**Bent Grass East Commercial Filing No. 3**

Scenario		2040 Total Traffic									
		AM Peak					PM Peak				
		Eastbound	Westbound	Northbound		Overall	Eastbound	Westbound	Northbound		Overall
Left	Right			Left	Right						
Stop-Sign Control	Delay	8.9	25.3	Free	Free	---	9.1	61.7	Free	Free	---
	LOS	A	D				A	F			
Modern Roundabout	Delay	5.7	6.4	3.2	Free	3.6	5.8	7.5	3.5	Free	3.8
	LOS	A	A	A		A	A	A	A		A
Traffic Signal Control With Single Northbound Right-Turn Lane	Delay	3.8	6.1	21.8	6.2	7.1	4.7	7.8	23.1	6.8	8.8
	LOS	A	A	C	A	A	A	A	C	A	A
Traffic Signal Control With Dual Northbound Right-Turn Lane <sup>(1)</sup>	Delay	3.9	6.8	13.4	6.3	7.9	5.4	11.3	20.3	6.9	12.1
	LOS	A	A	B	A	A	A	B	C	A	B

**Note:**

(1) Dual northbound right-turn lanes will allow for better utilization of the dual eastbound left-turn lanes at the intersection of Golden Sage/Woodmen



**Table 4  
Roadway System Improvements  
Bent Grass Commercial Filing No. 3**

Description		Trigger	Timing	Responsibility	Associated Project	
<b>Meridian Road/Bent Grass Meadows Road</b>						
A	Signalize Meridian/Bent Grass Meadows	Remove existing stop-sign and replace with traffic signal control.	When warrant(s) are met -- 2 of the 3 conditions of the "Crash Experience" warrant are currently met. The current number of reported crashes (susceptible to correction with a signal) exceeds the threshold as do the associated traffic volume thresholds.	Under Construction	Bent Grass Metro District/ Challenger Homes	Bent Grass Residential Filing No. 2
B	Right-turn acceleration lane on Meridian at Bent Grass Meadows	This improvement has been completed				
<b>Bent Grass Meadows Drive</b>						
C	Construct Bent Grass Meadows Drive between the existing sections located north of the Woodmen frontage road and west of Meridian Road	This improvement has been completed				
D	Restrict westbound left-turn at 7-Eleven access	This improvement has been completed				
E	Close 7-Eleven Access	This improvement has been completed				
F	Modify pavement markings to extend westbound left-turn lane approaching Meridian Park Drive	Restripe with a 195 foot long westbound left-turn lane plus an 85-foot taper	This improvement is part of an ongoing approved project		Bent Grass Metro District	Bent Grass Residential Filing No. 2
G	Modify the existing pavement markings to reconfigure the left-turn painted median on Bent Grass Meadows Drive between the site access and Meridian Park Drive	Restripe the section of Bent Grass Meadows Drive between Bent Grass Market View and Meridian Park Drive as shown in Figure 12	With Bent Grass East Commercial Filing No. 3	With Bent Grass East Commercial Filing No. 3	Applicant	Bent Grass East Commercial Filing No. 3
<b>Meridian Park Drive/Bent Grass Market View</b>						
H	Southbound Right Turn Lane on Meridian Park Drive approaching Bent Grass Market View	Restripe Meridian Park Drive to provide a 12-foot-wide 100 foot right-turn lane plus 45 foot taper.	SB RT > 50 vehicles per hour	With Bent Grass East Commercial Filing No. 3	Applicant	Bent Grass East Commercial Filing No. 3
<b>Woodmen frontage road/Bent Grass Meadows Drive Intersection (now subject to City of Colorado Springs review and requirements)</b>						
I	Eastbound left-turn lane on Woodmen frontage road approaching Bent Grass Meadows Dr.	ECM criteria indicates the left-turn lane would need to be 315 feet long (155 feet of deceleration length plus 160 feet of storage length) plus a 160-foot taper based on the design speed of 40 mph.	EB LT > 25 vehicles per hour	With the completion of Bent Grass Meadows Dr between the Woodmen frontage road and Meridian Road [The connection has been completed]	Challenger Homes	Falcon Meadows at Bent Grass
<b>Woodmen/Golden Sage</b>						
J	Add protected/permitted phasing for left-turn movements (now subject to City of Colorado Springs review and requirements)	Prepare a traffic signal modification plan and furnish/install new traffic signal heads for protected-permissive phasing and other necessary hardware, software needed to implement this phase; modify existing signal timing plan.	When Warrants are met	With Bent Grass Residential Fil No. 2	Bent Grass Metro District* - pro-rata share (based on total traffic volumes) of the cost of the improvement. <sup>(1)</sup> Note: Other potential responsibility for participation: In addition to the yet-to-be developed properties within the Bent Grass Metro District service area and the Falcon Marketplace development, other future developers of currently vacant lane within the "travel shed" of the north leg (and potentially the south leg) of the Golden Sage/Woodmen and Golden Sage/Woodmen N. Frontage Road intersection may also be assigned as responsible participants in future or completed (if a cost recovery agreement is put in place) traffic/roadway improvements.	Bent Grass Residential Filing No. 2
K	Lengthening of the current eastbound single left-turn deceleration lane on Woodmen approaching Golden Sage Road	Provide a 240-foot transition taper (20:1 taper ratio), 290 feet of deceleration distance plus sufficient vehicle stacking distance. CURRENT: 175-foot taper plus a 465-foot left-turn lane which translates to a 175-foot taper, 290-foot deceleration distance, and 175 feet of stacking distance. SHORT TERM: Adequate stacking is available in the current turn lane - calculated queue length 204 feet. LONG TERM: Lengthen single left-turn lane and/or future implementation of dual left-turn lanes (if capacity needs dictate). If a dual left is implemented in the future, consideration will need to be given to the configuration on Golden Sage and at the Golden Sage/Woodmen Frontage Road intersection to receive the dual left-turn movement.	The estimated "trigger" of 40 PM peak hour eastbound left turns above the estimated short term total volume (from Figure 16a of the TIS) approximately translates to and additional 589 directional ADT for residential trips making this turning movement (based on the ITE single family trip ratio). This estimated threshold may be reached with a combination of site-generated trips and background trips.	AS NEEDED TO MAINTAIN ADEQUATE LEVEL OF SERVICE AND VEHICLE STACKING DISTANCE. " This is estimated to be when the eastbound left turn turning volume reaches approximately 200 vehicles per hour during the PM peak. This translates to about 40 vehicles per hour over the estimated short term total volume from Figure 16a of the Falcon Marketplace TIS. Note: Short term total volumes assume the Meridian extension to Highway 24 to be open.	Challenger Homes <sup>(1)</sup> Note: Yet-to-be developed properties within the Bent Grass Metro District service area and the Falcon Marketplace development, other future developers of currently vacant lane within the "travel shed" of the north leg (and potentially the south leg) of the Golden Sage/Woodmen and Golden Sage/Woodmen N. Frontage Road intersection may also be assigned as responsible participants in future or completed (if a cost recovery agreement is put in place) traffic/roadway improvements.	Future
L	Southbound exclusive right-turn lane on Golden Sage Road approaching Woodmen Road	A continuous right-turn lane within the 150 feet between the Woodmen Frontage Road and Woodmen Road	The estimated "trigger" of 5-30 AM peak hour southbound right turns above the estimated short term total volume (from Figure 16a of the Falcon Marketplace TIS) approximately translates to an additional 85-510 directional ADT for residential trips making this turning movement (based on the ITE single family trip ratio). This estimated threshold may be reached with a combination of site-generated trips and background trips.	AS NEEDED TO MAINTAIN ADEQUATE LEVEL OF SERVICE AND VEHICLE STACKING DISTANCE. " A preliminary trigger could be a southbound right turn volume of about 150-175 vehicles per hour. This translates to about 5 to 30 vehicles per hour over the projected short term volume from Figure 16a of the Falcon Marketplace TIS. This may be conservative due to the westbound right turn acceleration lane on Woodmen Road. Additional study may indicate a higher threshold based on empirical data collection and analysis.	Bent Grass Metro District - pro-rata share (based on total traffic volumes) of the cost of the improvement. <sup>(1)</sup> Note: Other potential responsibility for participation: In addition to the yet-to-be developed properties within the Bent Grass Metro District service area and the Falcon Marketplace development, other future developers of currently vacant lane within the "travel shed" of the north leg (and potentially the south leg) of the Golden Sage/Woodmen and Golden Sage/Woodmen N. Frontage Road intersection may also be assigned as responsible participants in future or completed (if a cost recovery agreement is put in place) traffic/roadway improvements	Future
M	Signalization of Golden Sage Road/Woodmen Frontage Road or reconstruction as a modern roundabout; Future additional laneage may be necessary at this intersection to accommodate vehicle queues and for traffic operations.	Remove existing stop-signs and replace with traffic signal control or reconstruct as modern roundabout	If/when needed to maintain acceptable level of service/traffic operations and/or to control vehicle queues. Fair-share participation by the development or the district on behalf of the district members.	If/when needed to maintain acceptable level of service/traffic operations and/or to control vehicle queues.	Bent Grass Metro District* - pro-rata share (based on total traffic volumes) of the cost of the improvement. <sup>(1)</sup> Note: Other potential responsibility for participation: In addition to the yet-to-be developed properties within the Bent Grass Metro District service area and the Falcon Marketplace development, other future developers of currently vacant lane within the "travel shed" of the north leg (and potentially the south leg) of the Golden Sage/Woodmen and Golden Sage/Woodmen N. Frontage Road intersection may also be assigned as responsible participants in future or completed (if a cost recovery agreement is put in place) traffic/roadway improvements.	Future

\*Note: This improvement is now subject to City of Colorado Springs review and requirements

Notes: Previous Note: It is our understanding that the specifics of the district participation will need to be included in the SIA/ revised development agreement to be completed and finalized prior to the development of lots beyond the initial 49 lots. If for some reason the District is unable or unwilling to participate, or if determination by the district is delayed, the applicant would be responsible. In this case, an escrow agreement between the applicant and the County would be prepared and finalized. We understand that staff would like for that the applicant to understand the estimated/approximate costs associated with their fair share of future improvements at Golden Sage/Woodmen. LSC will provide preliminary fair share cost estimates utilizing available information from the Falcon Marketplace SIA. This will be provided by March 31st to the applicant and staff.

(1) See Table 5 for pro-rata percentage calculations

Source: LSC Transportation Consultants, Inc.

**Table 5**  
**Prorata Share Contribution Calculations<sup>(1)</sup>**  
**Bent Grass East Commercial Filing No. 3**

Item	Improvement Description and Estimated Cost		AM	PM	AM + PM	
J	Add protected/permitted phasing at Woodmen/Golden Sage		Site-Generated Traffic <sup>(2)</sup> (vehicles per hour)	5	4	9
			2040 Total Traffic <sup>(2)</sup> (vehicles per hour)	325	451	776
			%	1.54%	0.89%	1.16%
	Estimated Improvement Cost:	\$ 33,750	Estimated Fair-Share Portion for this project based on calculated AM + PM percentage:	\$ 391		
K	Lengthening of the current eastbound single left-turn deceleration lane on Woodmen approaching Golden Sage Road		Site-Generated Traffic <sup>(2)</sup> (vehicles per hour)	5	4	9
			2040 Total Traffic <sup>(2)</sup> (vehicles per hour)	325	451	776
			%	1.54%	0.89%	1.16%
	Estimated Improvement Cost:	\$ 200,000	Estimated Fair-Share Portion for this project based on calculated AM + PM percentage:	\$ 2,320		
L	Southbound exclusive right-turn lane on Golden Sage Road approaching Woodmen Road		Site-Generated Traffic <sup>(3)</sup> (vehicles per hour)	4	6	10
			2040 Total Traffic <sup>(3)</sup> (vehicles per hour)	411	397	808
			%	0.97%	1.51%	1.24%
	Estimated Improvement Cost:	\$ 100,000	Estimated Fair-Share Portion for this project based on calculated AM + PM percentage:	\$ 1,238		
M	Signalization of Golden Sage Road/Woodmen Frontage Road or reconstruction as a modern roundabout; Future additional laneage may be necessary at this intersection to accommodate vehicle queues and for traffic operations.		Site-Generated Traffic <sup>(4)</sup> (vehicles per hour)	13	14	27
			2040 Total Traffic <sup>(4)</sup> (vehicles per hour)	1004	1209	2213
			%	1.29%	1.16%	1.22%
	Estimated Improvement Cost:	\$ 350,000	Estimated Fair-Share Portion for this project based on calculated AM + PM percentage:	\$ 4,270		

Notes:

- (1) This information was originally provided when this intersection was under El Paso County jurisdiction. The intersection is now subject to review (and associated requirements) by the City of Colorado Springs.
- (2) Eastbound left-turn volume at the intersection of Woodmen/Golden Sage
- (3) Southbound right-turn volume at the intersection of Woodmen/Golden Sage
- (4) Sum of all traffic volumes at the intersection of Golden Sage/Woodmen frontage road

# Figures

---





Approximate Scale  
Scale: 1" = 1,200'



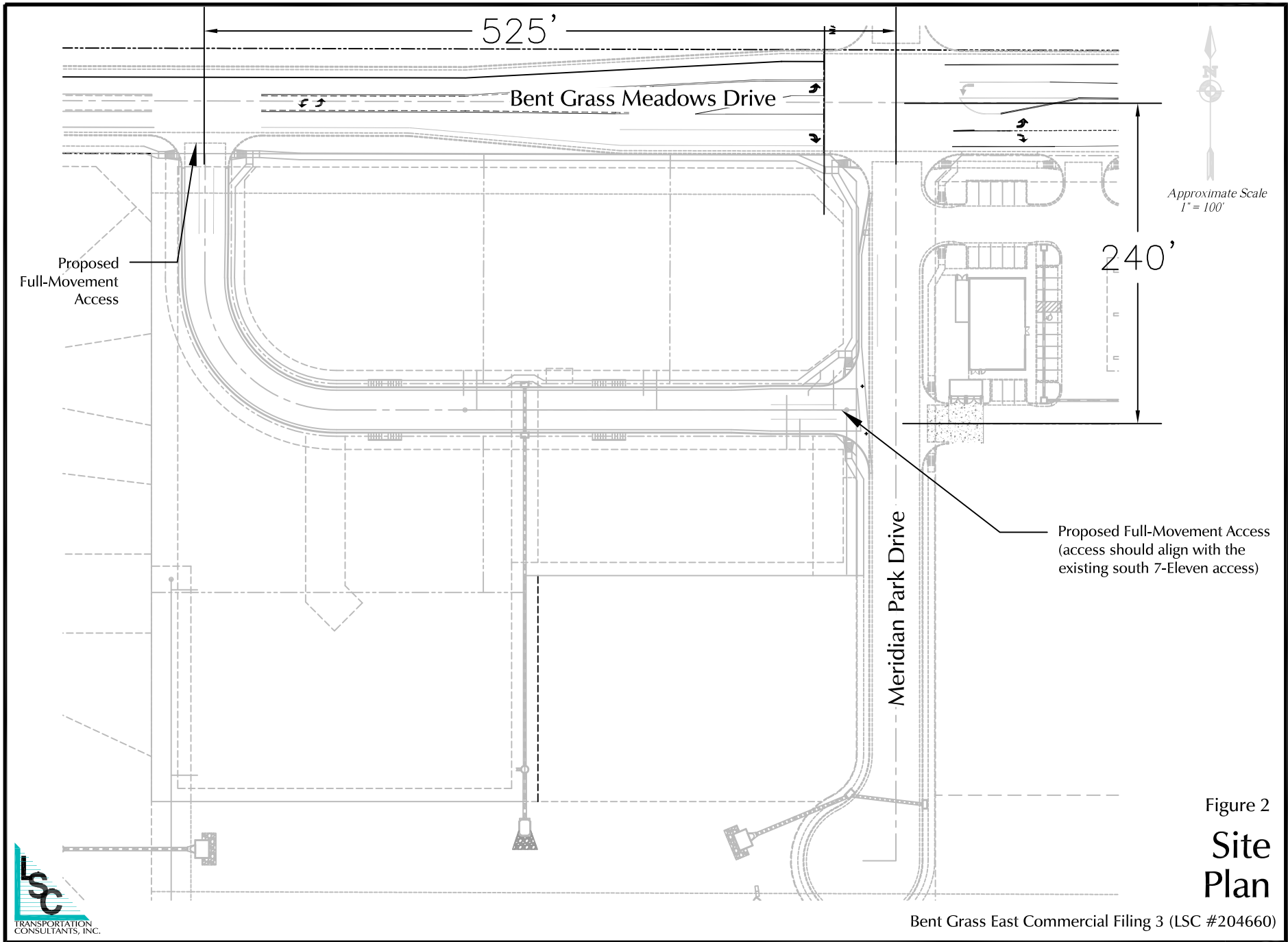

Figure 1  
**Vicinity Map**

Bent Grass East Commercial Filing 3 (LSC #204660)



LEGEND:

 ECM Required Intersection Sight Distance  
(445' from Table 2-21 based on a design speed limit of 40mph)

 ECM Required Stopping Sight Distance  
(305' from Table 2-17 based on a design speed limit of 40mph)



Approximate Scale  
Scale: NTS

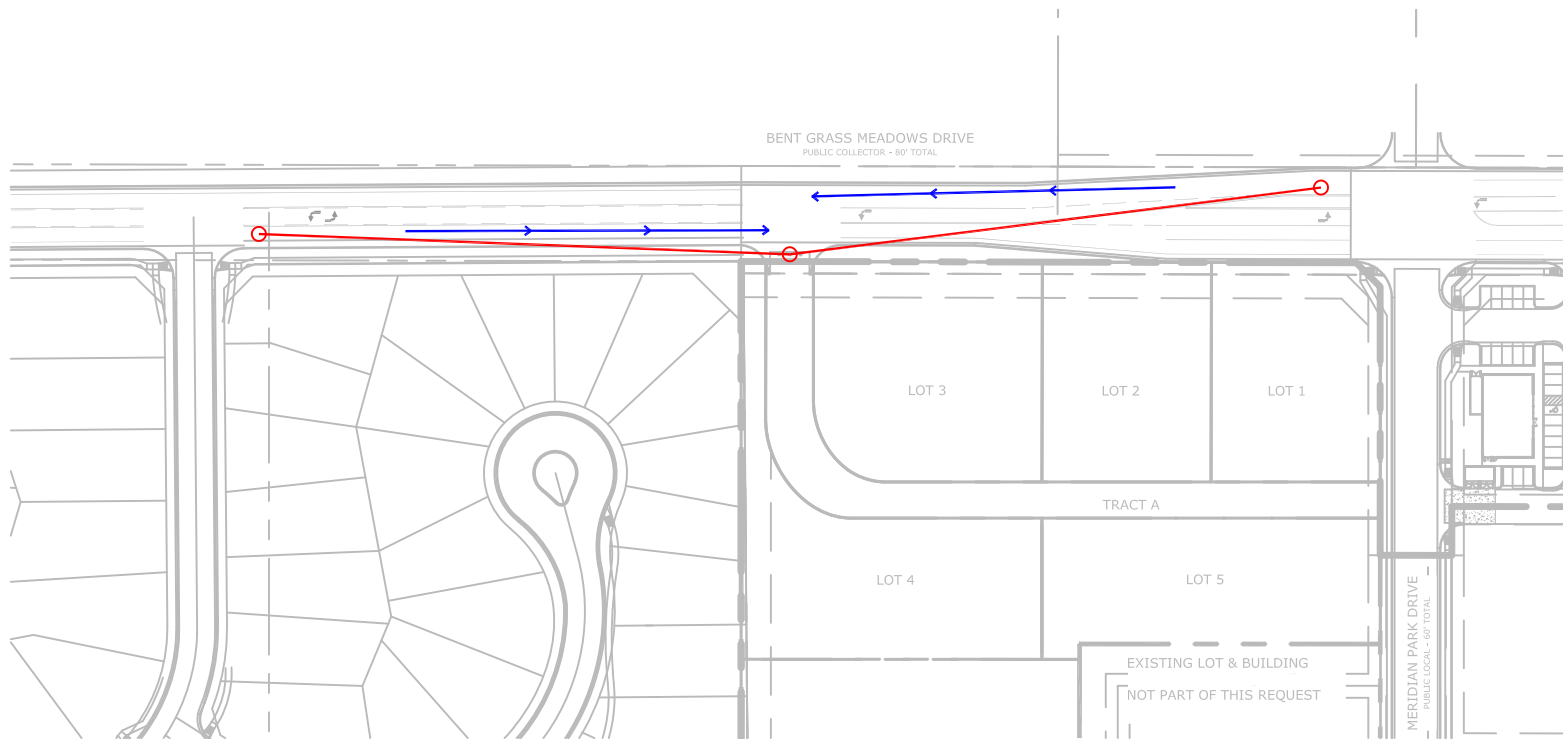



Figure 3

# Bent Grass Meadows Dr. Access Sight Distance Analysis

Bent Grass East Commercial Filing 3 (LSC #204660)

 ECM Required Intersection Sight Distance  
(280' from Table 2-21 based on a design speed of 25mph)

 ECM Required Stopping Sight Distance  
(155' from Table 2-17 based on a design speed of 25mph)

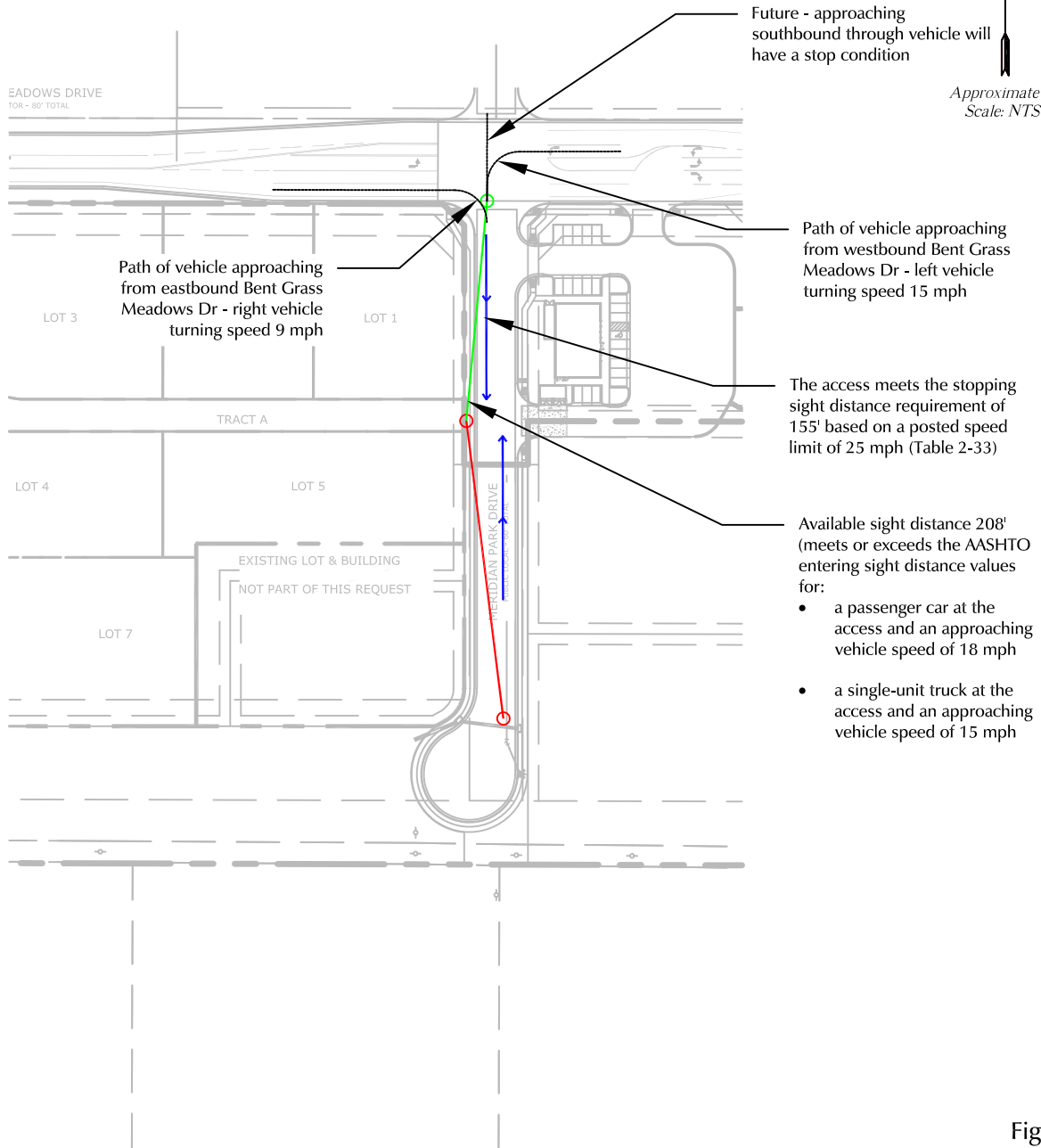
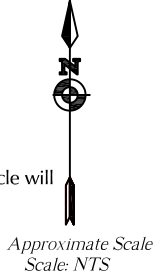
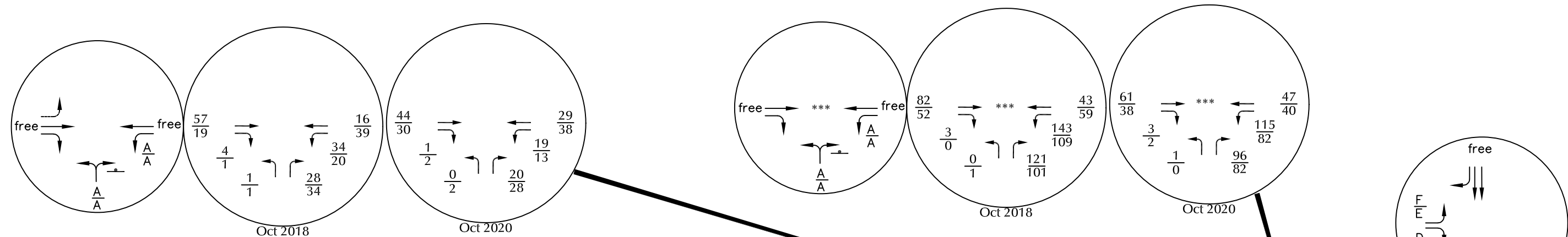

Figure 4

# Meridian Park Dr. Access Sight Distance Analysis

Bent Grass East Commercial Filing 3 (LSC #204660)



\*\*This traffic count was conducted following the completion of Bent Grass Meadows Drive between the Woodmen frontage road and Meridian Ranch. All other counts were conducted prior to this connection being made.  
 \*\*\*This access was closed after the traffic counts were conducted.

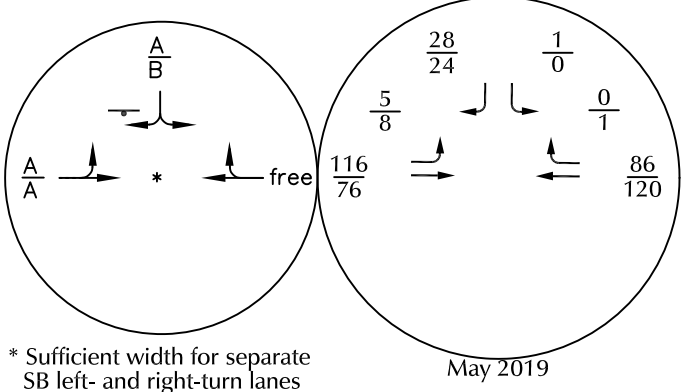
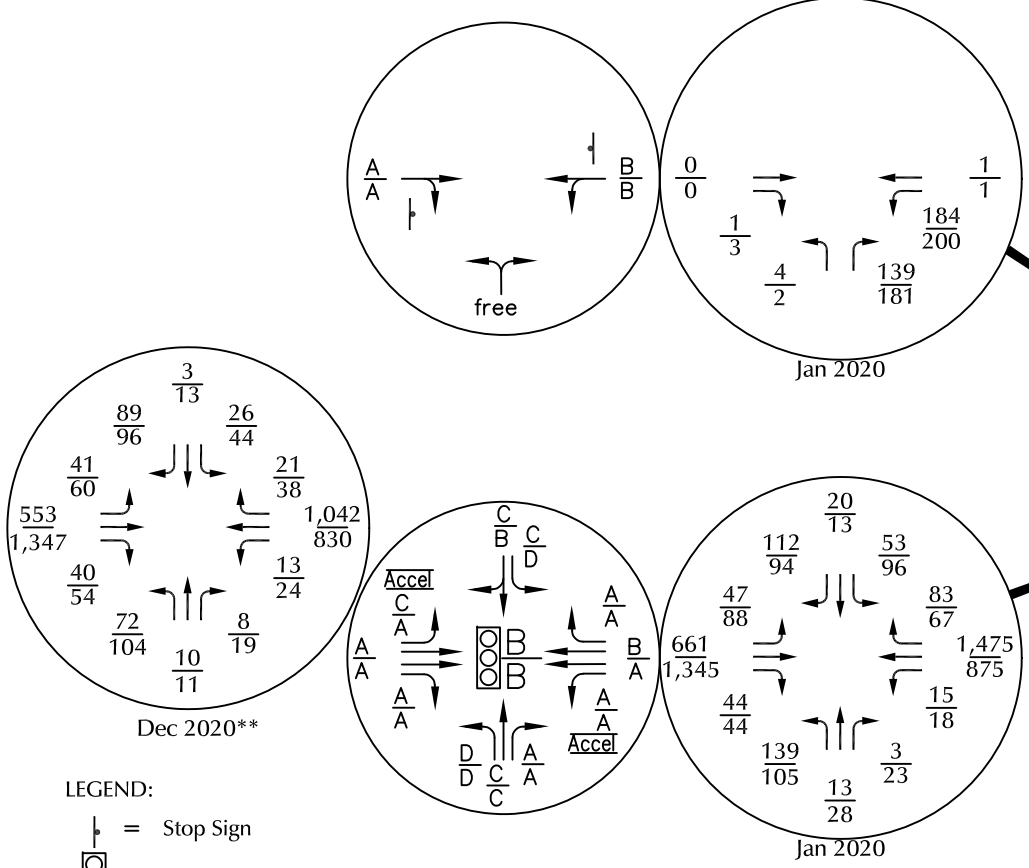
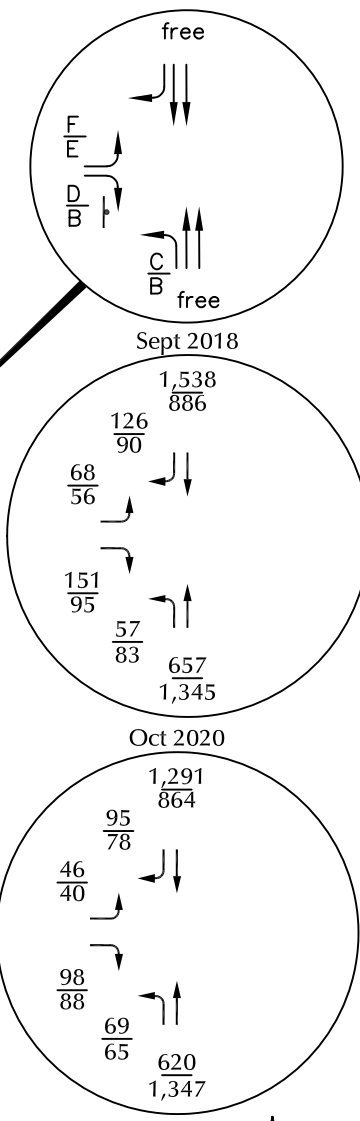

- LEGEND:
- ⊥ = Stop Sign
  - ⊞ = Traffic Signal
  - XX/XX = AM Weekday Peak-Hour Traffic (vehicles per hour)  
PM Weekday Peak-Hour Traffic (vehicles per hour)
  - A/B = AM Individual Movement Peak-Hour Level of Service  
PM Individual Movement Peak-Hour Level of Service
  - C = AM Entire Intersection Peak-Hour Level of Service  
C = PM Entire Intersection Peak-Hour Level of Service
  - X,XXX = Average Daily Traffic (vehicles per day)

\* Sufficient width for separate SB left- and right-turn lanes

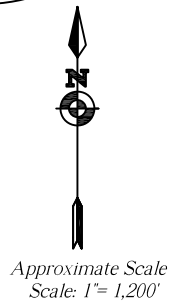

Figure 5  
**Existing Traffic, Lane Geometry, Traffic Control and Level of Service**  
 Bent Grass East Commercial Filing 3 (LSC #204660)







Approximate Scale  
Scale: 1" = 1,200'

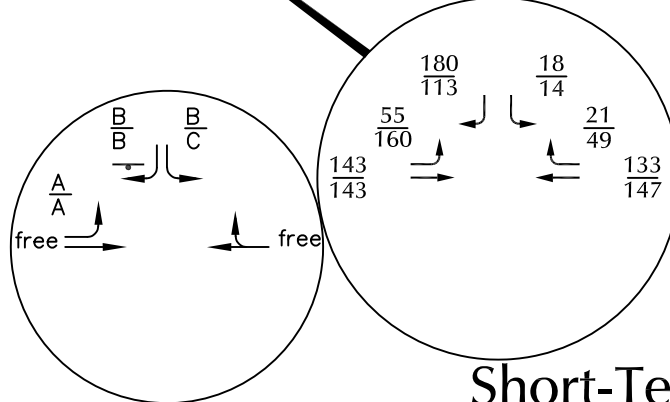
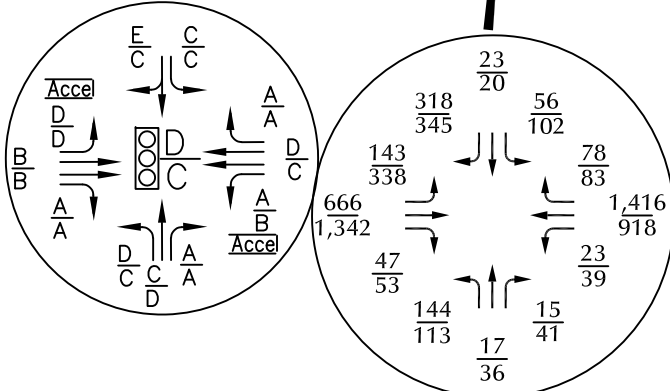
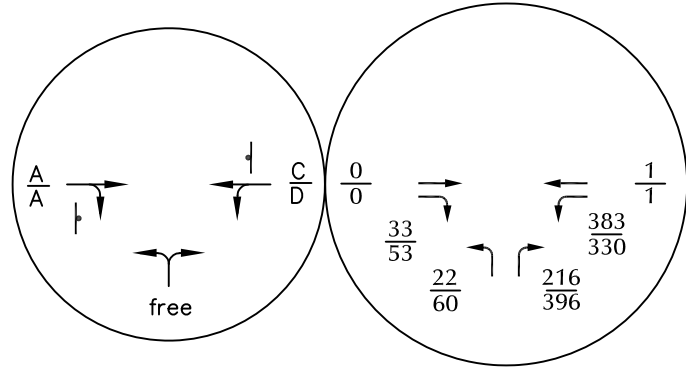
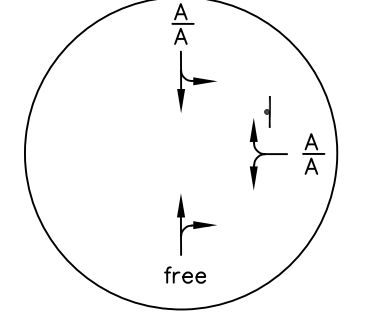
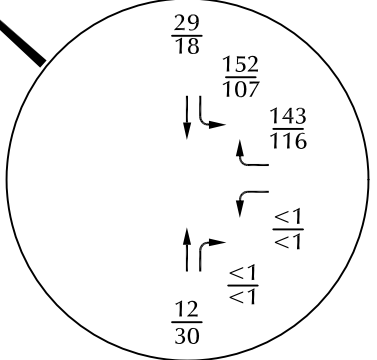
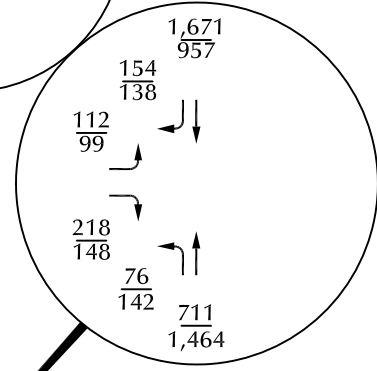
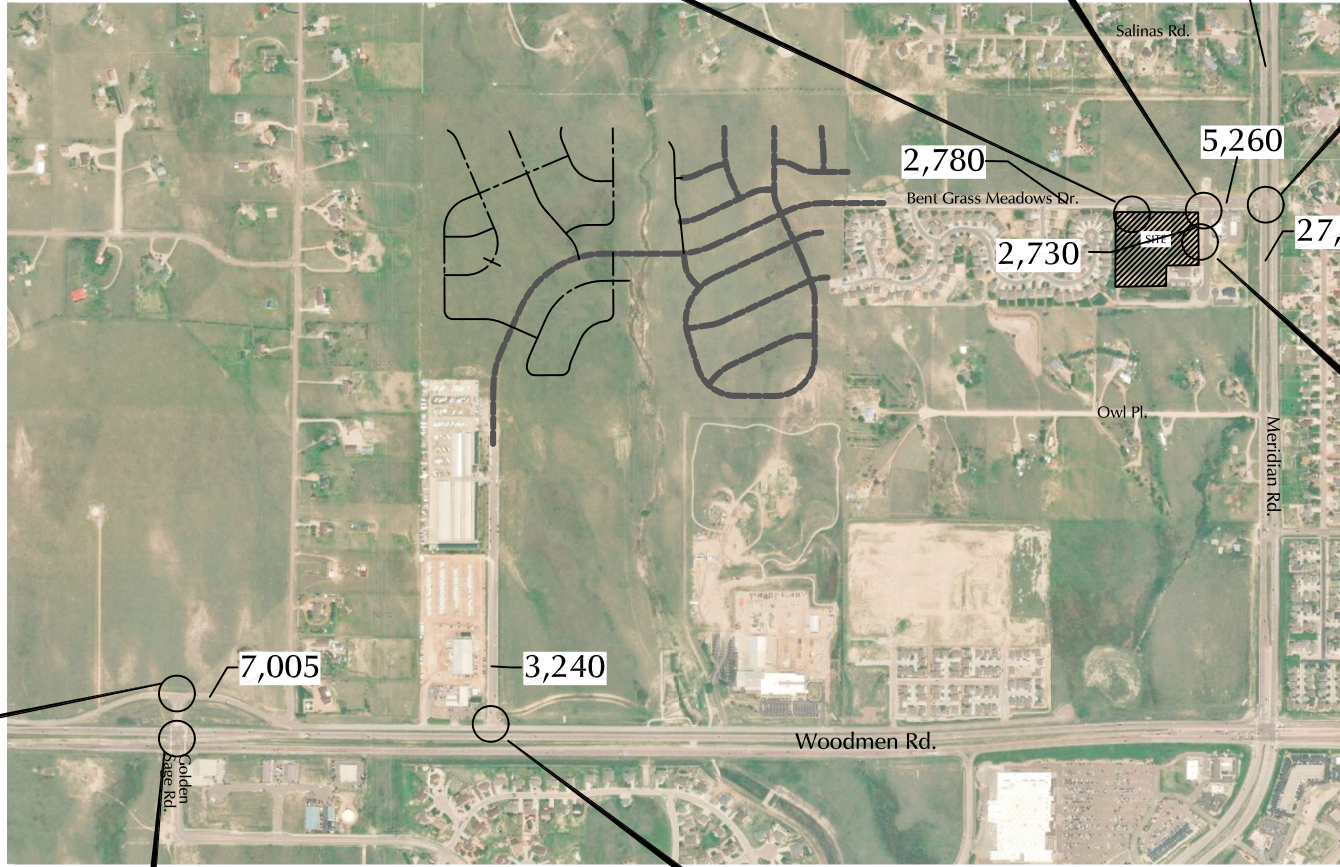
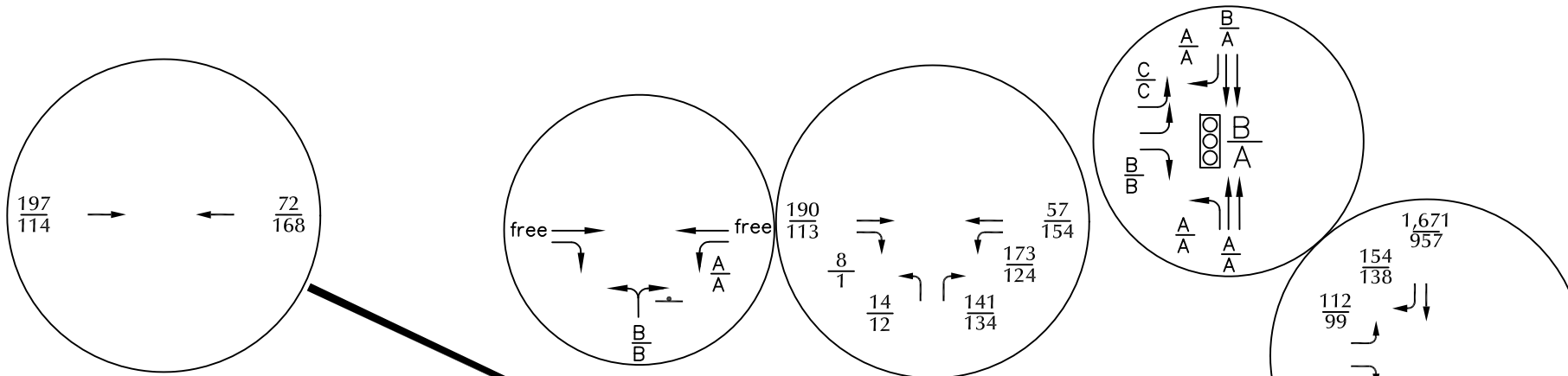

LEGEND:

- = Stop Sign
- = Traffic Signal
- $\frac{XX}{XX}$  = AM Weekday Peak-Hour Traffic (vehicles per hour)
- $\frac{XX}{XX}$  = PM Weekday Peak-Hour Traffic (vehicles per hour)
- $\frac{A}{B}$  = AM Individual Movement Peak-Hour Level of Service
- $\frac{A}{B}$  = PM Individual Movement Peak-Hour Level of Service
- $\frac{C}{C}$  = AM Entire Intersection Peak-Hour Level of Service
- $\frac{C}{C}$  = PM Entire Intersection Peak-Hour Level of Service
- X,XXX = Average Daily Traffic (vehicles per day)



# Short-Term Background Traffic, Lane Geometry, Traffic Control and Level of Service

Figure 6



Approximate Scale  
Scale: 1" = 1,200'

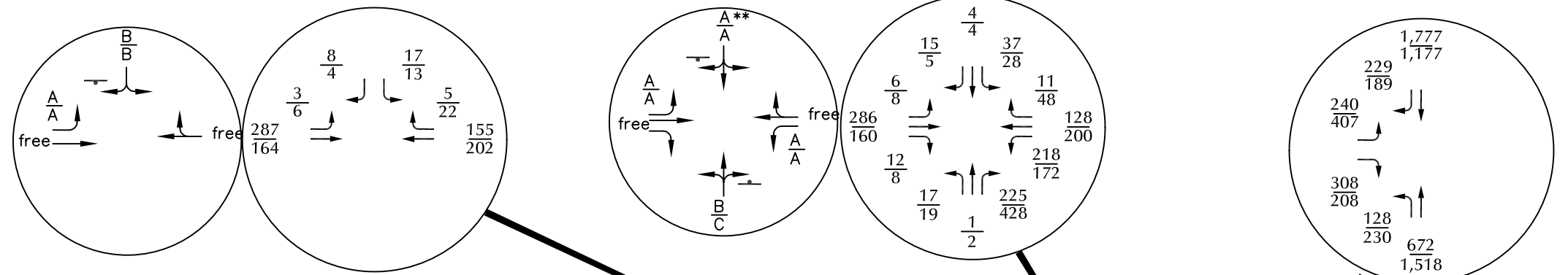

\*Note: The background traffic volumes on Meridian Park Drive south of Bent Grass East Commercial are based on the land uses shown in Appendix Table 1. These trip estimates are from 10-15 years ago. Commercial development of the size and configuration that was common at that time likely no longer applies today for the Owl Lane area, and any commercial development would likely be significantly smaller and generate significantly fewer trips.

\*\*Although the HCM unsignalized method of analysis results in a projected LOS F during the morning and afternoon peak hours based on simulation analysis, this movement is projected to operate at LOS A during the morning and afternoon peak hours. Please refer to the report narrative for details.

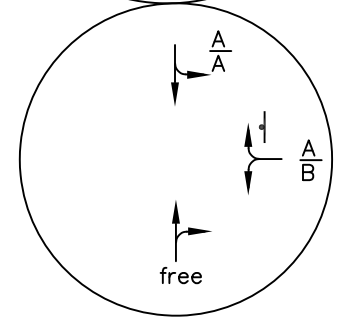
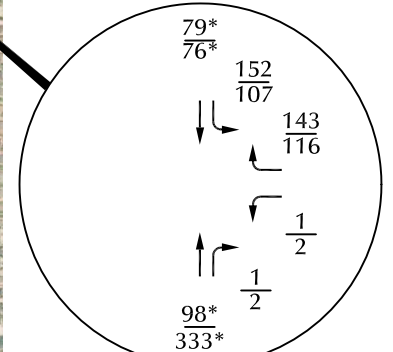
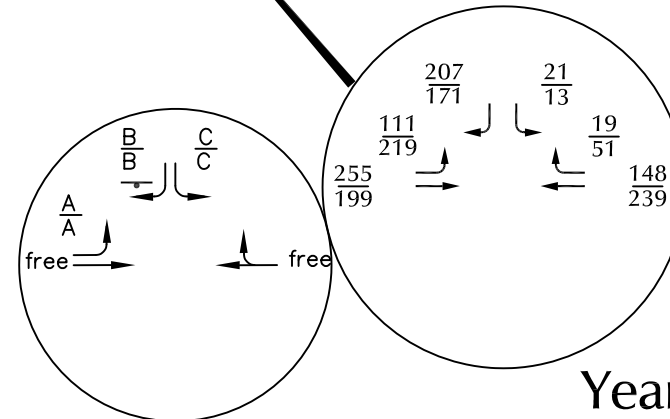
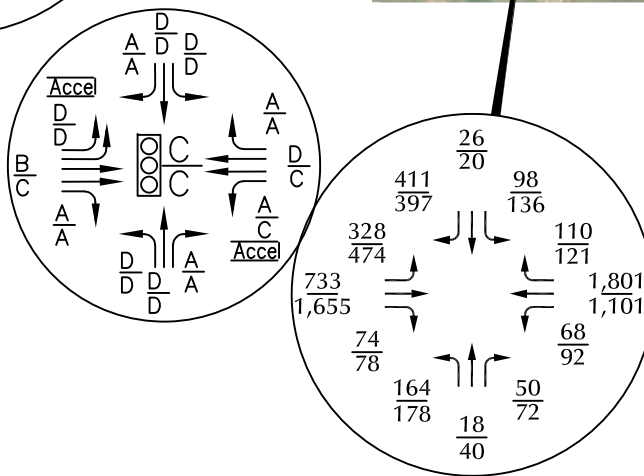
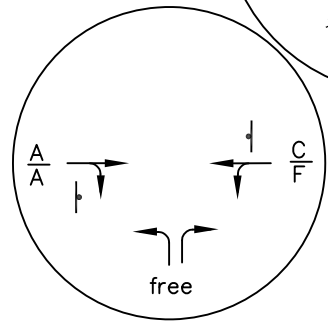
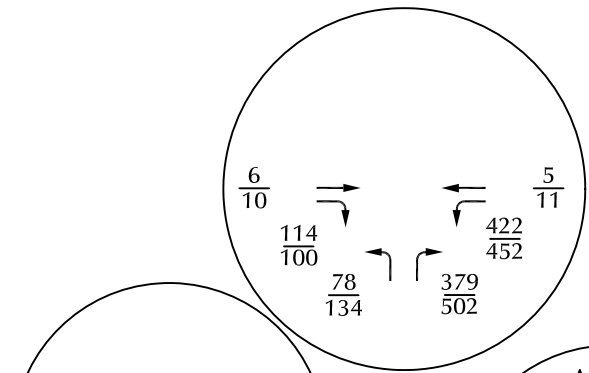
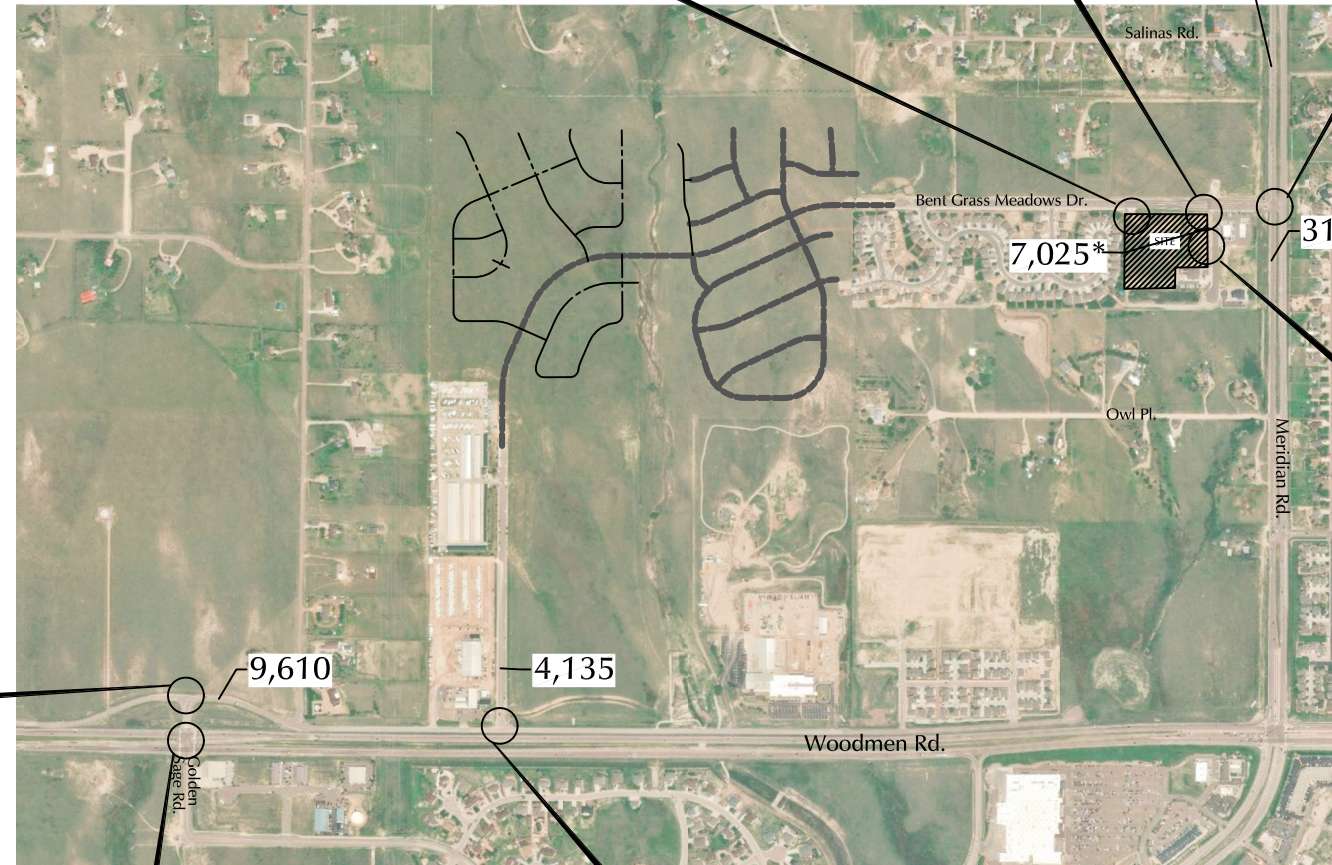

LEGEND:

- = Stop Sign
- = Traffic Signal
- = Modern Roundabout
- $\frac{XX}{XX}$  = AM Weekday Peak-Hour Traffic (vehicles per hour)
- $\frac{XX}{XX}$  = PM Weekday Peak-Hour Traffic (vehicles per hour)
- $\frac{A}{B}$  = AM Individual Movement Peak-Hour Level of Service
- $\frac{A}{B}$  = PM Individual Movement Peak-Hour Level of Service
- $\frac{C}{C}$  = AM Entire Intersection Peak-Hour Level of Service
- $\frac{C}{C}$  = PM Entire Intersection Peak-Hour Level of Service
- X,XXX = Average Daily Traffic (vehicles per day)



# Year 2040 Background Traffic, Lane Geometry, Traffic Control and Level of Service

Figure 7





  
 Approximate Scale  
 Scale: 1" = 1,200'

Figure 8

# Directional Distribution of Site-Generated Traffic

Bent Grass East Commercial Filing 3 (LSC #204660)

**LEGEND:**  
 XX% = Percent Directional Distribution of Primary External Traffic





Approximate Scale  
Scale: 1"= 1,200'

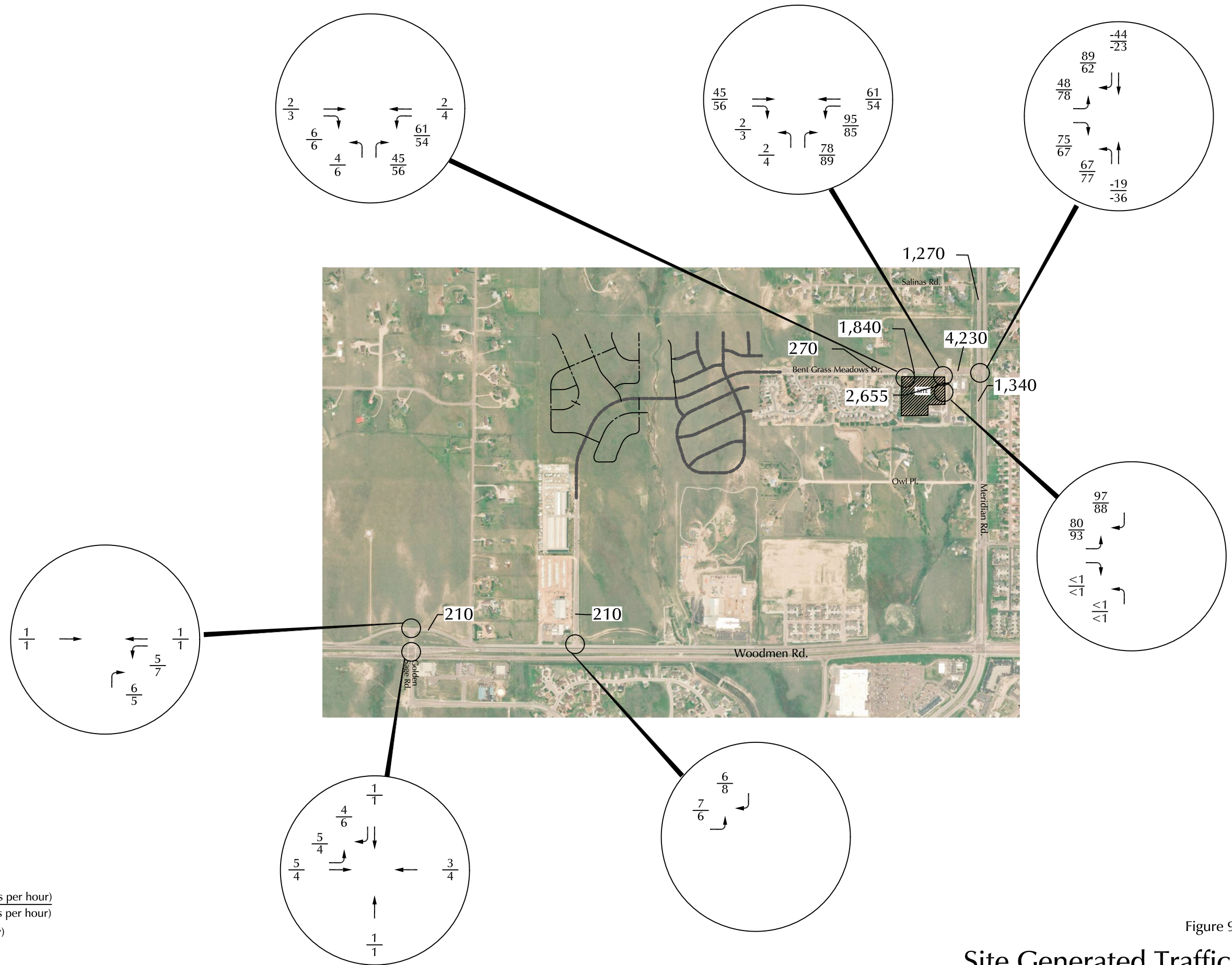

LEGEND:

- $\frac{XX}{XX}$  = AM Weekday Peak-Hour Traffic (vehicles per hour)
- $\frac{XX}{XX}$  = PM Weekday Peak-Hour Traffic (vehicles per hour)
- X,XXX= Average Daily Traffic (vehicles per day)



Figure 9

# Site Generated Traffic

Bent Grass East Commercial Filing 3 (LSC #204660)

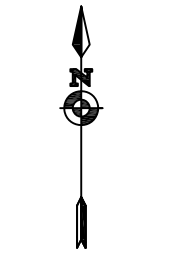

Approximate Scale  
Scale: 1" = 1,200'

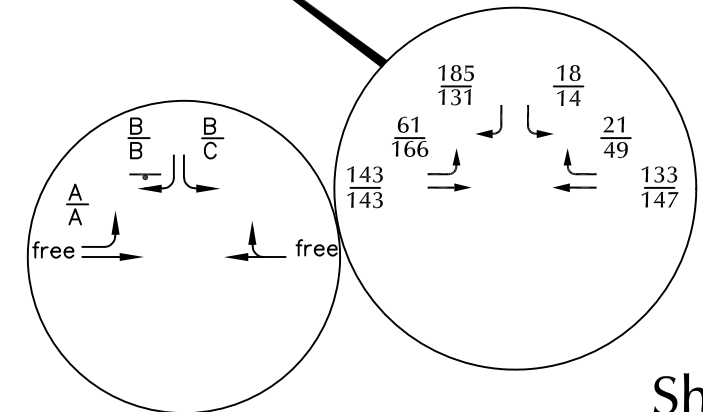
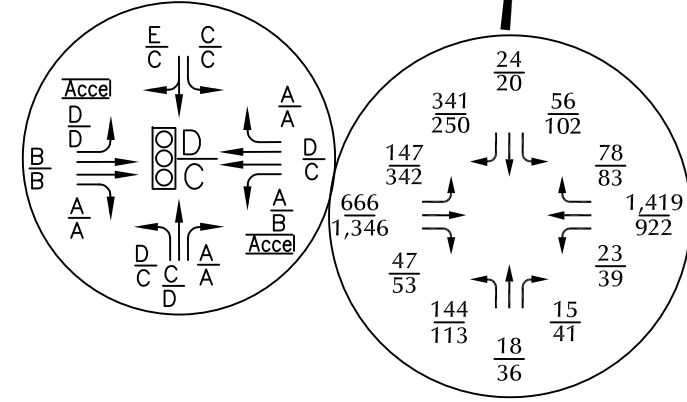
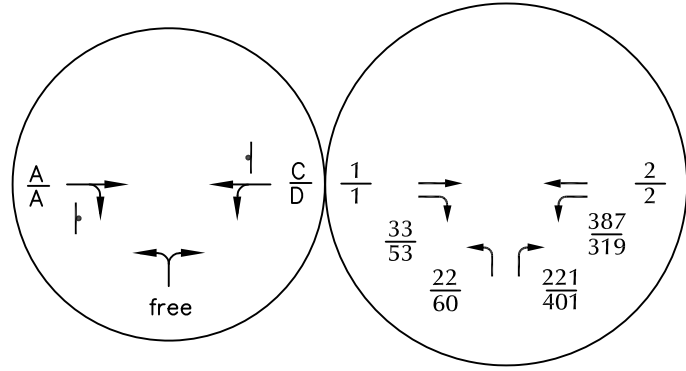
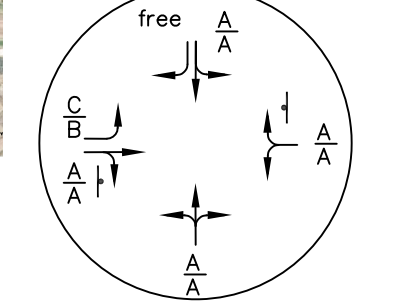
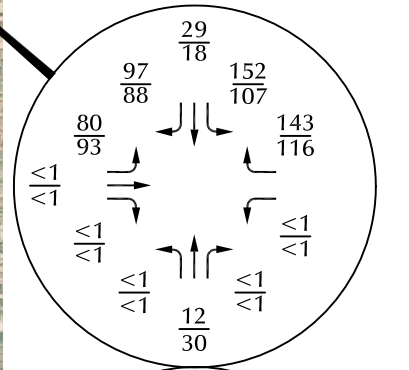
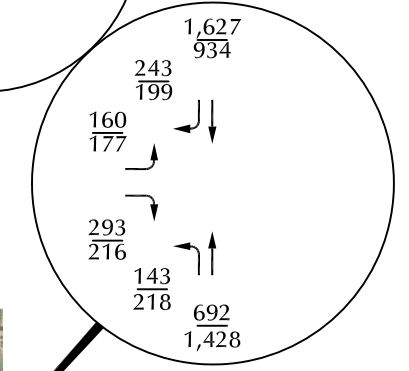
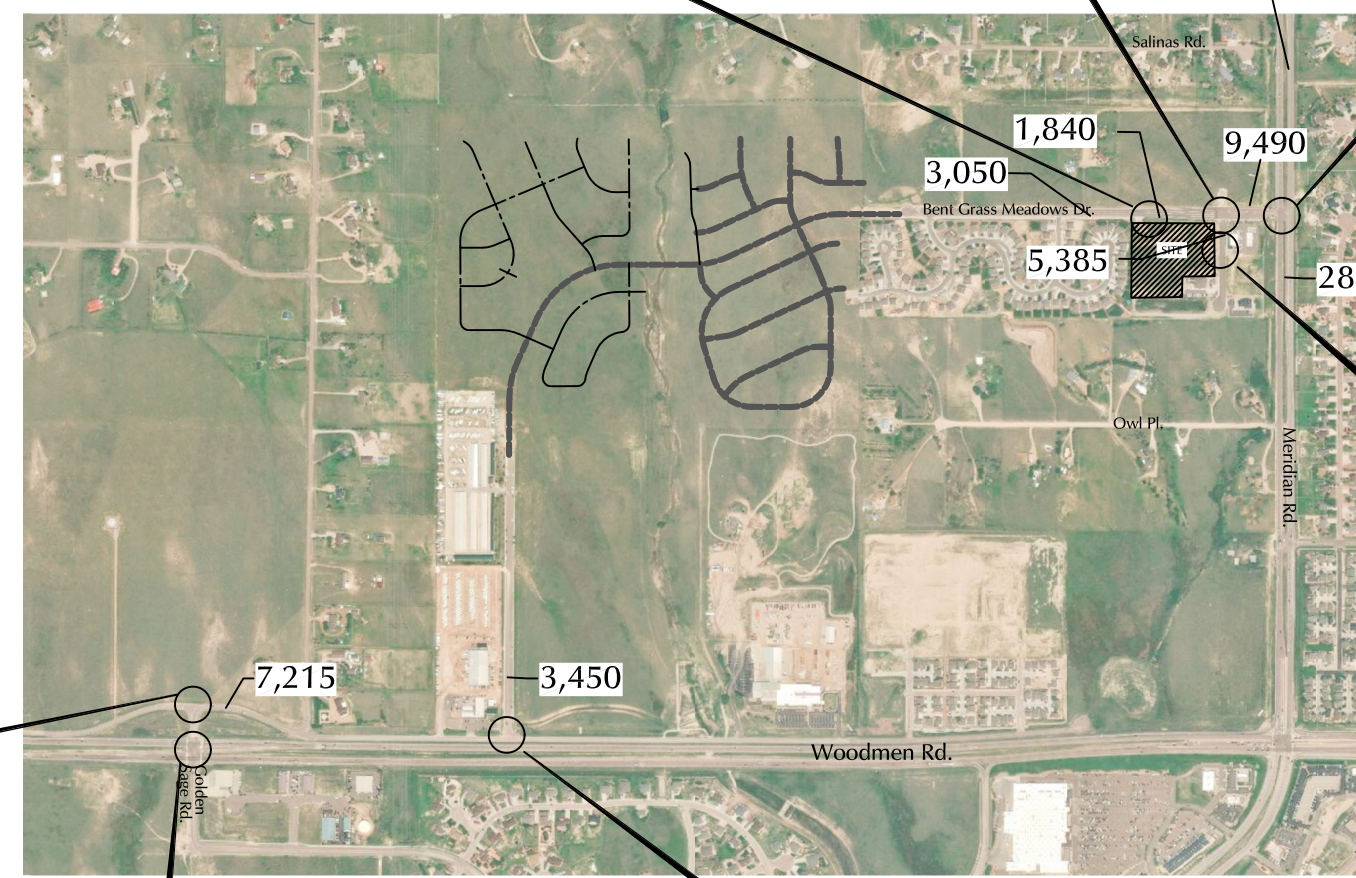
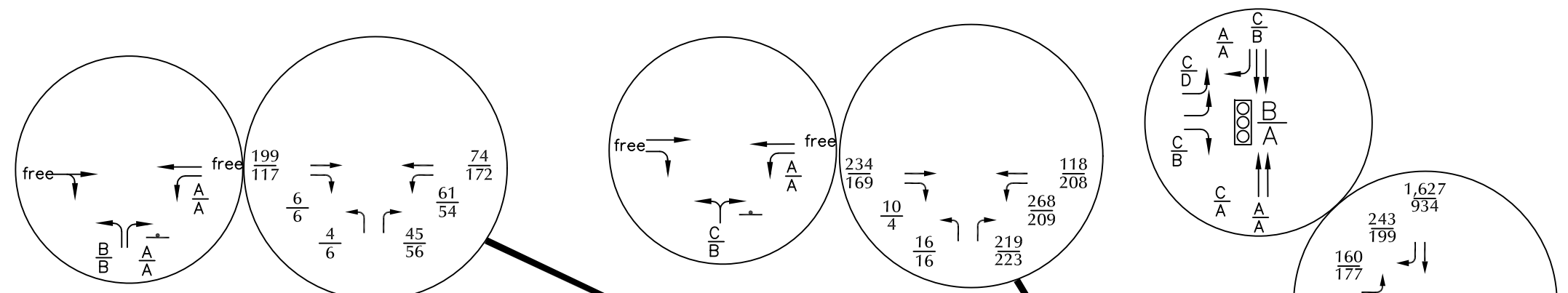

- LEGEND:
- = Stop Sign
  - = Traffic Signal
  - XX = AM Weekday Peak-Hour Traffic (vehicles per hour)
  - XX = PM Weekday Peak-Hour Traffic (vehicles per hour)
  - A = AM Individual Movement Peak-Hour Level of Service
  - B = PM Individual Movement Peak-Hour Level of Service
  - C = AM Entire Intersection Peak-Hour Level of Service
  - C = PM Entire Intersection Peak-Hour Level of Service
  - X,XXX = Average Daily Traffic (vehicles per day)

Figure 10

## Short-Term Total Traffic, Lane Geometry, Traffic Control and Level of Service





Approximate Scale  
Scale: 1" = 1,200'

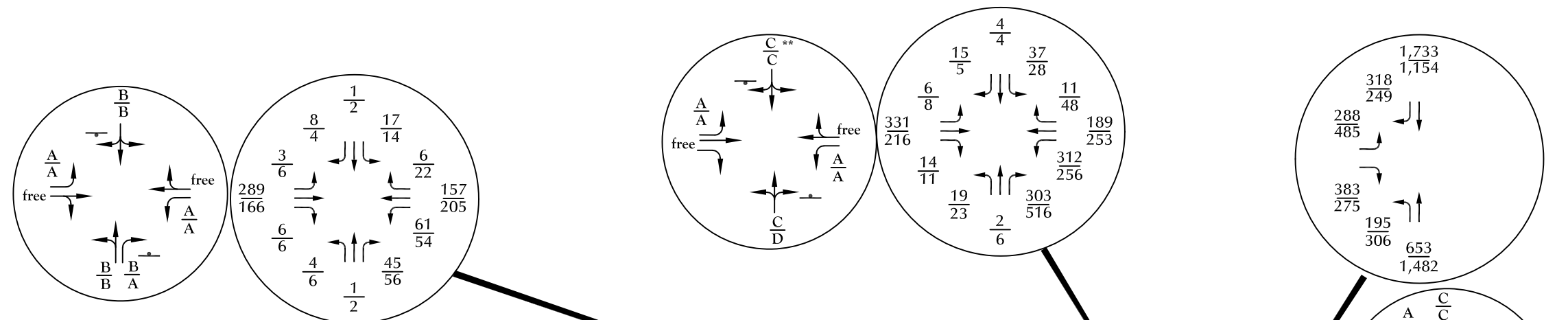

**Notes:**

\*The background traffic volumes on Meridian Park Drive south of Bent Grass East Commercial are based on the land uses shown in Appendix Table 1. These trip estimates are from 10-15 years ago. Commercial development of the size and configuration that was common at that time likely no longer applies today for the Owl Lane area, and any commercial development would likely be significantly smaller and generate significantly fewer trips.

\*\*Although the HCM unsignalized method of analysis results in a projected LOS F during the morning and afternoon peak hours based on simulation analysis, this movement is projected to operate at LOS C during the morning and afternoon peak hours. Please refer to the report narrative for details.

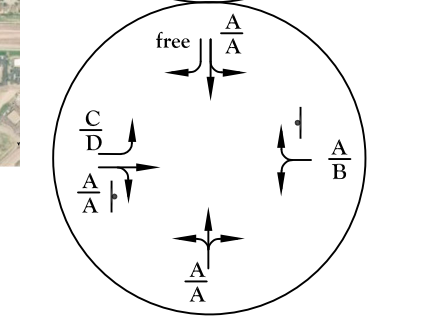
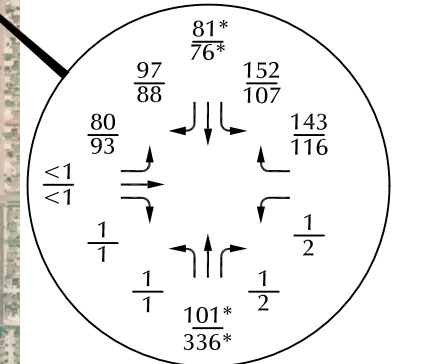
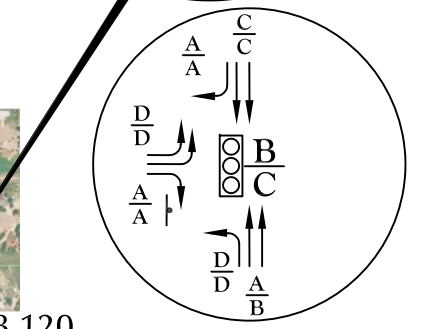
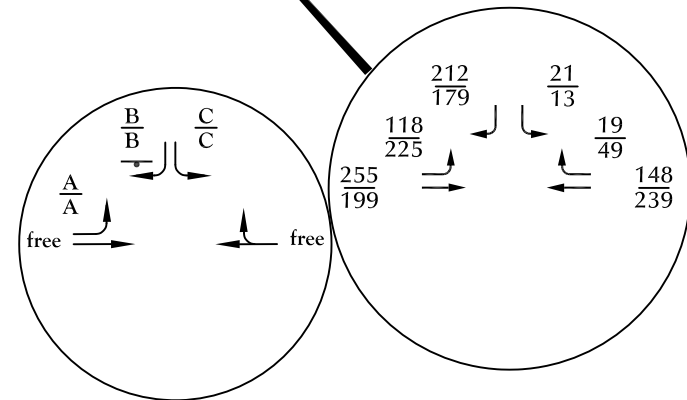
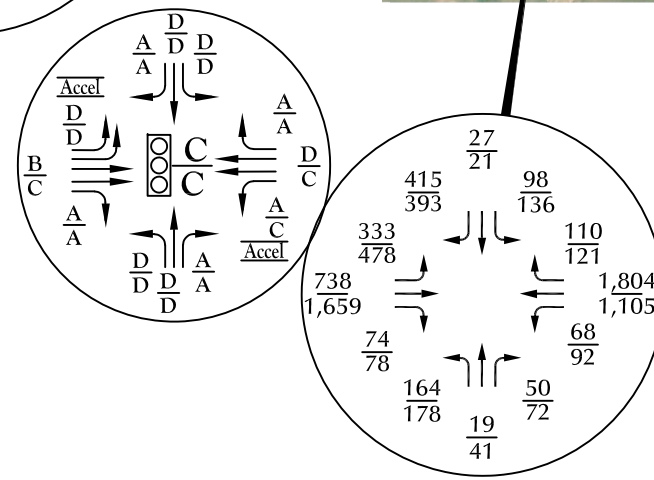
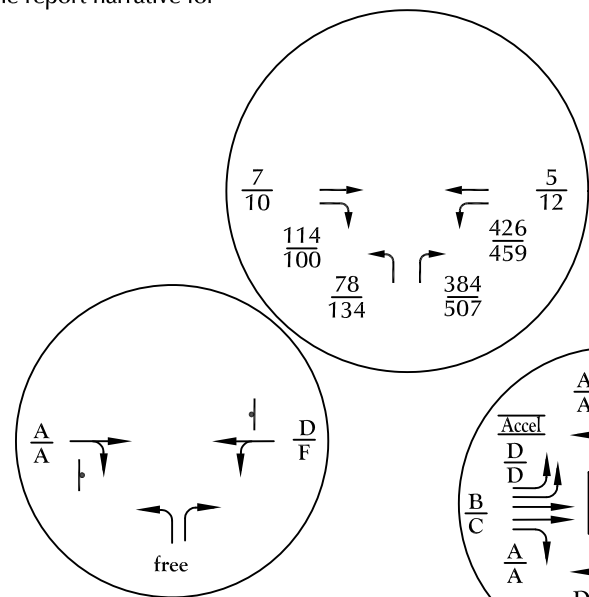
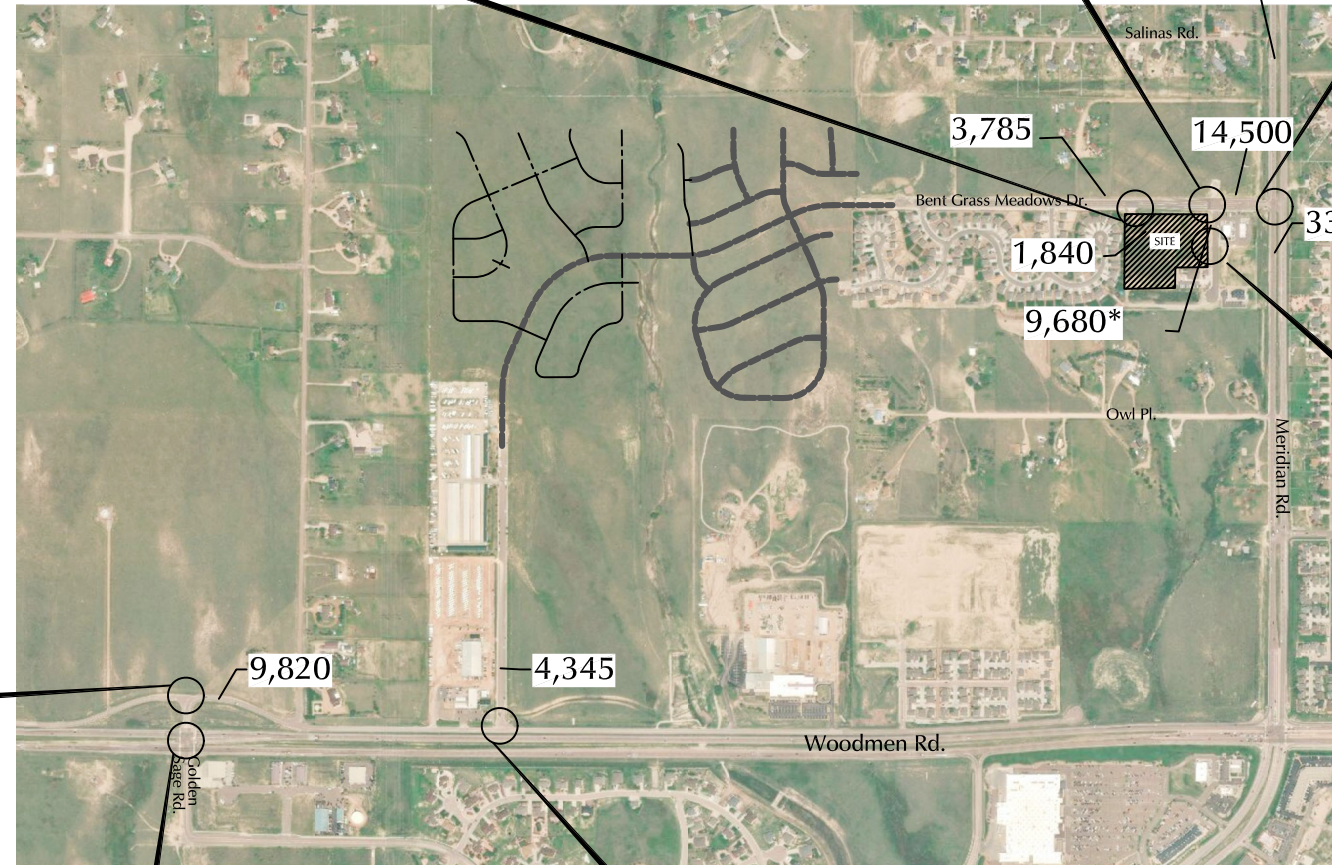

**LEGEND:**

- = Stop Sign
- = Traffic Signal
- = Modern Roundabout
- $\frac{XX}{XX}$  = AM Weekday Peak-Hour Traffic (vehicles per hour)
- $\frac{XX}{XX}$  = PM Weekday Peak-Hour Traffic (vehicles per hour)
- $\frac{A}{B}$  = AM Individual Movement Peak-Hour Level of Service
- $\frac{A}{B}$  = PM Individual Movement Peak-Hour Level of Service
- $\frac{C}{C}$  = AM Entire Intersection Peak-Hour Level of Service
- $\frac{C}{C}$  = PM Entire Intersection Peak-Hour Level of Service
- X,XXX = Average Daily Traffic (vehicles per day)



Figure 11  
**Year 2040 Total Traffic, Lane Geometry, Traffic Control and Level of Service**



Approximate Scale  
1" = 100'

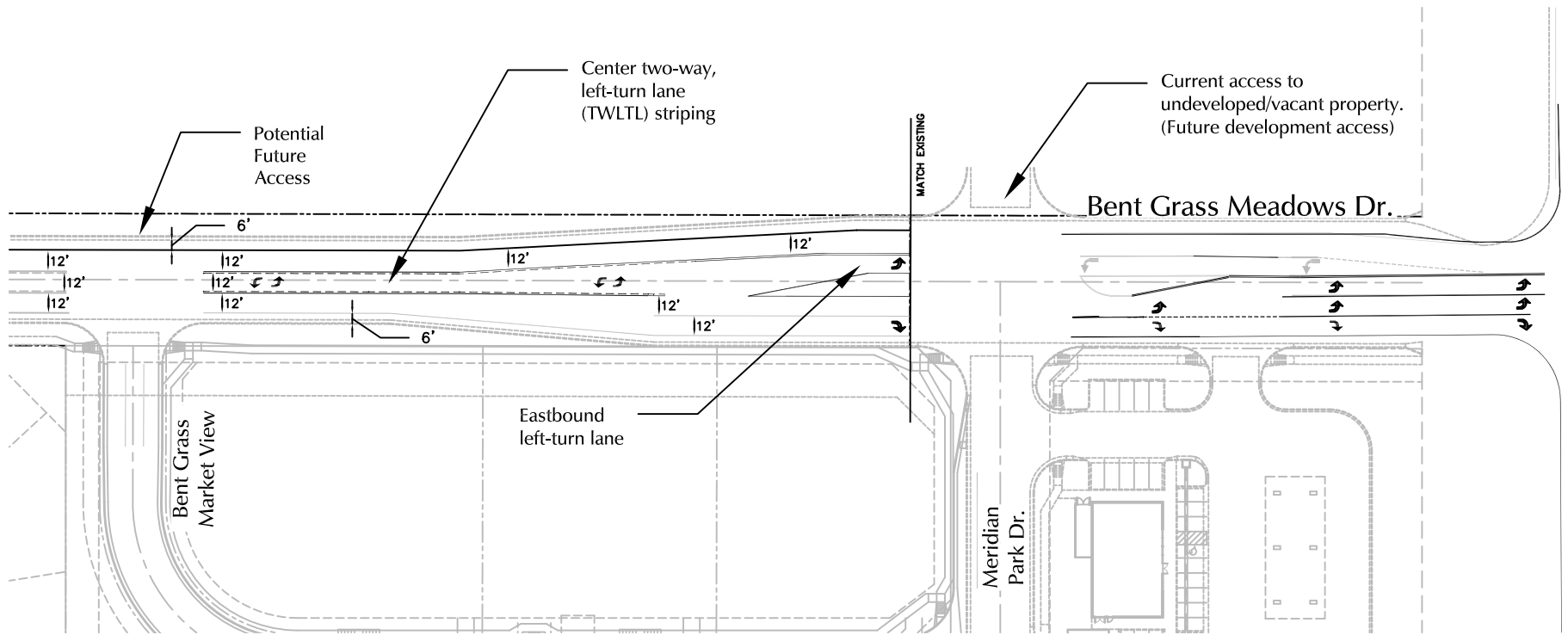

# Recommended Left Turn Lane Restriping - Bent Grass Meadows Dr.

Figure 12

Bent Grass East Commercial Filing 3 (LSC #204660)

# Appendix Tables 1-2





**Appendix Table 1**  
**Bent Grass East Commercial Filing No. 3**  
**Study Area Buildout Trip Generation Estimate**

TAZ Name	Land Use Code	Land Use Description	Future Trip Generation Units	Trip Generation Rates <sup>(1)</sup>					Total Future Trips Generated				TAZ Internal Trips	Total Future Trips Internal to the TAZ				Total Future Trips Internal to the Study Area				Pass-By Trips <sup>(7)</sup>	New External Trips Generated <sup>(8)</sup>	New Weekday Traffic				
				Average Weekday Traffic		Morning Peak Hour		Afternoon Peak Hour	Average Weekday Traffic	Morning Peak Hour		Afternoon Peak Hour		Average Weekday Traffic	Morning Peak Hour		Afternoon Peak Hour											
				Weekday	Peak Hour	In	Out	In	Out	Weekday	Peak Hour	In		Out	In	Out	Weekday	Peak Hour	In	Out	In				Out			
1	Bent Grass Residential Fil 2 South	210 Single-Family Detached Housing	121 DU <sup>(3)</sup>	9.44	0.19	0.56	0.62	0.37	1,142	22	67	75	44	0%	0	0	0	0	0	118	6	13	5	3	0%	1,024		
	Bent Grass Residential Fil 2 North	210 Single-Family Detached Housing	58 DU	9.44	0.19	0.56	0.62	0.37	548	11	32	36	21	0%	0	0	0	0	0	56	3	7	2	2	0%	492		
	Bent Grass West	210 Single-Family Detached Housing	16 DU	9.44	0.19	0.56	0.62	0.37	151	3	9	10	6	0%	0	0	0	0	0	16	1	2	0	0	0%	135		
	Bent Grass West	210 Single-Family Detached Housing	92 DU	9.44	0.19	0.56	0.62	0.37	868	17	51	57	34	0%	0	0	0	0	0	89	5	10	4	3	0%	779		
	Bent Grass West	210 Single-Family Detached Housing	93 DU	9.44	0.19	0.56	0.62	0.37	878	17	52	58	34	0%	0	0	0	0	0	91	5	11	4	3	0%	787		
2	Bent Grass School	520 Elementary School	500 Students	1.89	0.36	0.31	0.08	0.09	945	181	154	41	44	0%	0	0	0	0	0	473	91	39	10	22	0%	472		
	Parcel Number 5301000011	210 Single-Family Detached Housing	92 DU	9.44	0.19	0.56	0.62	0.37	868	17	51	57	34	0%	0	0	0	0	0	89	5	10	4	3	0%	779		
4	NW Bent Grass Meadows/Meridian	210 Single-Family Detached Housing	100 DU	9.44	0.19	0.56	0.62	0.37	944	19	56	62	37	0%	0	0	0	0	0	97	5	11	4	3	0%	847		
	Bent Grass Residential Filing 1	210 Single-Family Detached Housing	0 DU	9.44	0.19	0.56	0.62	0.37	0	0	0	0	0	0%	0	0	0	0	0	0	0	0	0	0	0%	0		
Bent Grass East Commercial Existing				---	---	---	---	---	0	0	0	0	0%	0	0	0	0	0	0	0	0	0	0	0%	50%	0		
6	Bent Grass East Commercial Fil No. 3	934 Fast-Food Restaurant with Drive-Through Window	2.5 KSF	470.95	20.50	19.69	16.99	15.68	1,177	51	49	42	39	5%	59	3	2	2	2	12	1	1	1	1	50%	547		
		934 Fast-Food Restaurant with Drive-Through Window	2.5 KSF	470.95	20.50	19.69	16.99	15.68	1,177	51	49	42	39	5%	59	3	2	2	2	12	0	0	1	1	50%	547		
		820 Shopping Center	6 KSF	85.72	3.16	1.94	3.48	3.77	514	19	12	21	23	5%	26	1	1	1	1	5	0	0	0	0	34%	317		
		820 Shopping Center	6 KSF	85.72	3.16	1.94	3.48	3.77	514	19	12	21	23	5%	26	1	1	1	1	5	0	0	0	0	34%	317		
		820 Shopping Center	6 KSF	85.72	3.16	1.94	3.48	3.77	514	19	12	21	23	5%	26	1	1	1	1	5	0	0	0	0	34%	317		
		770 Business Park	10.8 KSF	76.88	1.29	0.23	0.48	1.36	830	14	2	5	15	5%	42	1	0	0	1	8	0	0	0	0	0%	780		
Bent Grass East Commercial Fil. No. 2A Lot 1A				820 Shopping Center	15 KSF	85.72	3.16	1.94	3.48	3.77	1,286	47	29	52	57	5%	64	2	1	3	3	13	0	0	1	1	34%	794
7	Bent Grass Industrial (5301000017)	110 General Light Industrial	54 KSF	4.96	0.62	0.08	0.08	0.55	268	33	5	4	30	0%	0	0	0	0	0	0	0	0	0	0	0%	268		
8	Bent Grass West	210 Single-Family Detached Housing	82 DU	9.44	0.19	0.56	0.62	0.37	774	15	46	51	30	0%	0	0	0	0	0	80	5	9	4	3	0%	694		
9	Falcon Mini-Storage	151 Mini-Warehouse	3.74 Storage Units (100s)	---	---	---	---	---	0	0	0	0	0%	0	0	0	0	0	0	0	0	0	0	0	0%	0		
10	Man Cave at Bentgrass	--- RV/Vehicle Storage	0.65 Occupied Spaces (100s)	20.00	2.28	1.37	1.98	2.81	13	1	1	1	2	0%	0	0	0	0	0	0	0	0	0	0	0%	13		
		151 Mini-Warehouse	1.04 Storage Units (100s)	17.96	0.71	0.68	0.98	0.98	19	1	1	1	1	0%	0	0	0	0	0	0	0	0	0	0	0%	19		
11	Mountain View Electric	--- Mountain View Electric	---	---	---	---	---	---	0	0	0	0	0%	0	0	0	0	0	0	0	0	0	0	0	0%	0		
		110 General Light Industrial	218 KSF	4.96	0.62	0.08	0.08	0.55	1,081	134	18	18	119	0%	0	0	0	0	0	0	0	0	0	0	0	0%	1,081	
12	Owl Lane Redevelopment	820 Shopping Center	318 KSF	41.52	0.61	0.37	1.93	2.08	13,203	193	118	614	665	0%	0	0	0	0	0	132	3	2	6	6	20%	10,457		
		210 Single-Family Detached Housing	140 DU	9.44	0.19	0.56	0.62	0.37	1,322	26	78	87	51	0%	0	0	0	0	0	136	7	16	6	5	0%	1,186		
		220 Multifamily Housing Low-Rise	120 DU	7.32	0.11	0.35	0.35	0.21	878	13	43	42	25	0%	0	0	0	0	0	91	5	11	4	3	0%	787		
13	Falcon School District 49	--- Administration Office/Bus Barn	---	---	---	---	---	0	0	0	0	0	0%	0	0	0	0	0	0	0	0	0	0	0	0%	0		
14	Latigo (5301002007)	140 Manufacturing	29.34 Acres	33.92	3.95	0.44	1.95	2.59	995	116	13	57	76	0%	0	0	0	0	0	0	0	0	0	0	0%	995		
16	Courtyards at Woodmen Hills West	210 Single-Family Detached Housing	0 DU	9.44	0.19	0.56	0.62	0.37	0	0	0	0	0%	0	0	0	0	0	0	0	0	0	0	0	0%	0		
		866 Pet Supply Superstore <sup>(4)</sup>	15 KSF	39.24	0.53	0.33	1.69	1.69	574	8	5	25	25	0%	54	1	2	3	2	8	0	0	0	0	0%	463		
		850 Supermarket	123 KSF	78.26	2.11	1.29	3.76	3.62	9,626	259	159	463	445	0%	909	17	26	48	37	96	4	3	4	4	36%	5,517		
		944 Gasoline/Service Station	18 VFP <sup>(6)</sup>	168.56	6.20	5.96	6.94	6.94	3,034	112	107	125	125	0%	286	5	8	15	12	30	1	1	1	1	56%	1,196		
		934 Fast-Food Restaurant with Drive-Through Window <sup>(7)</sup>	2.5 KSF	496.12	0.42	0.39	16.98	15.67	1,240	1	1	42	39	0%	380	0	0	12	17	12	0	0	1	1	50%	424		
		820 Shopping Center	5 KSF	55.14	0.77	0.47	2.36	2.51	276	4	2	12	13	0%	26	1	0	1	1	3	0	0	0	0	34%	163		
		848 Tire Store	7.2 KSF	24.87	1.82	1.07	1.78	2.37	192	14	8	14	18	0%	18	0	1	1	1	2	0	0	0	0	28%	124		
		934 Fast-Food Restaurant with Drive-Through Window	3.5 KSF	496.12	23.16	22.26	16.98	15.67	1,736	81	78	59	55	0%	532	26	12	17	24	17	0	0	1	1	50%	593		
		934 Fast-Food Restaurant with Drive-Through Window <sup>(7)</sup>	2.5 KSF	496.12	0.42	0.39	16.98	15.67	1,240	1	1	42	39	0%	380	0	0	12	17	12	0	0	1	1	50%	424		
		610 Clinic	7.8 KSF	31.45	2.19	2.19	2.12	3.06	245	17	17	17	24	0%	40	3	16	10	5	2	0	0	0	0	0%	233		
820 Shopping Center	8 KSF	55.14	0.77	0.47	2.36	2.51	441	6	4	19	20	0%	42	1	1	2	2	4	0	0	0	0	34%	261				
937 Coffee/Donut Shop With Drive-Through Window	1.3 KSF	818.58	51.30	49.28	21.40	21.40	1,064	67	64	28	28	0%	326	21	10	9	12	11	0	0	0	0	89%	80				
<b>TOTAL</b>									<b>50,577</b>	<b>1,609</b>	<b>1,406</b>	<b>2,321</b>	<b>2,303</b>	<b>3,295</b>	<b>87</b>	<b>84</b>	<b>140</b>	<b>141</b>	<b>1,723</b>	<b>147</b>	<b>146</b>	<b>64</b>	<b>67</b>	<b>33,882</b>				

Notes:  
(1) Source: "Trip Generation, 10th Edition, 2017" by the Institute of Transportation Engineers (ITE)  
(2) Source: "Trip Generation Handbook - An ITE Proposed Recommended Practice, Third Edition" by ITE  
(3) DU = dwelling unit  
(4) KSF = thousand square feet  
(5) Daily and morning peak-hour trip generation rates for Pet Supply Superstore are estimates by LSC  
(6) VFP = vehicle fueling position  
(7) The AM peak-hour trip generation rates have been reduced by LSC as the proposed fast-food restaurant does not serve breakfast  
(8) Based on the NCHRP 684 Internal Trip Capture Estimate Tool  
Source: LSC Transportation Consultants, Inc.

**Appendix Table 2  
Bent Grass East Commercial Filing No. 3  
Buildout Internal Trip Estimate**

Land Use	Raw ITE Trip Generation (Individual Driveway Trips)					Percent Internal Trips					Total Internal Trips				
	Daily	AM Peak Hour		PM Peak Hour		Daily	AM Peak Hour		PM Peak Hour		Daily	AM Peak Hour		PM Peak Hour	
		In	Out	In	Out		In	Out	In	Out		In	Out		
Single-Family Detached Housing	7,495	147	442	493	291										
Multifamily Housing (Low-Rise)	878	13	43	42	25										
	<b>8,373</b>	<b>160</b>	<b>485</b>	<b>535</b>	<b>316</b>										
Elementary School	945	181	154	41	44	50%	50%	25%	25%	50%	473	91	39	10	22
Retail/Office	38,883	983	729	1,664	1,715	1%	1%	1%	1%	1%	389	10	7	17	17
Industrial/Manufacturing	2,376	285	38	81	228	0%	0%	0%	0%	0%	0	0	0	0	0
<b>TOTAL Non-Residential</b>	<b>42,204</b>	<b>1,449</b>	<b>921</b>	<b>1,786</b>	<b>1,987</b>						<b>862</b>	<b>101</b>	<b>46</b>	<b>27</b>	<b>39</b>
<b>TOTAL</b>	<b>50,577</b>	<b>1,609</b>	<b>1,406</b>	<b>2,321</b>	<b>2,303</b>						<b>1,724</b>	<b>147</b>	<b>147</b>	<b>66</b>	<b>66</b>

**School  
Other  
Total**

6%	24%	19%	4%	3%
5%	4%	2%	3%	5%
10%	29%	21%	7%	9%

473	39	91	22	10
389	7	10	17	17
<b>862</b>	<b>46</b>	<b>101</b>	<b>39</b>	<b>27</b>

# Appendix Figure 1



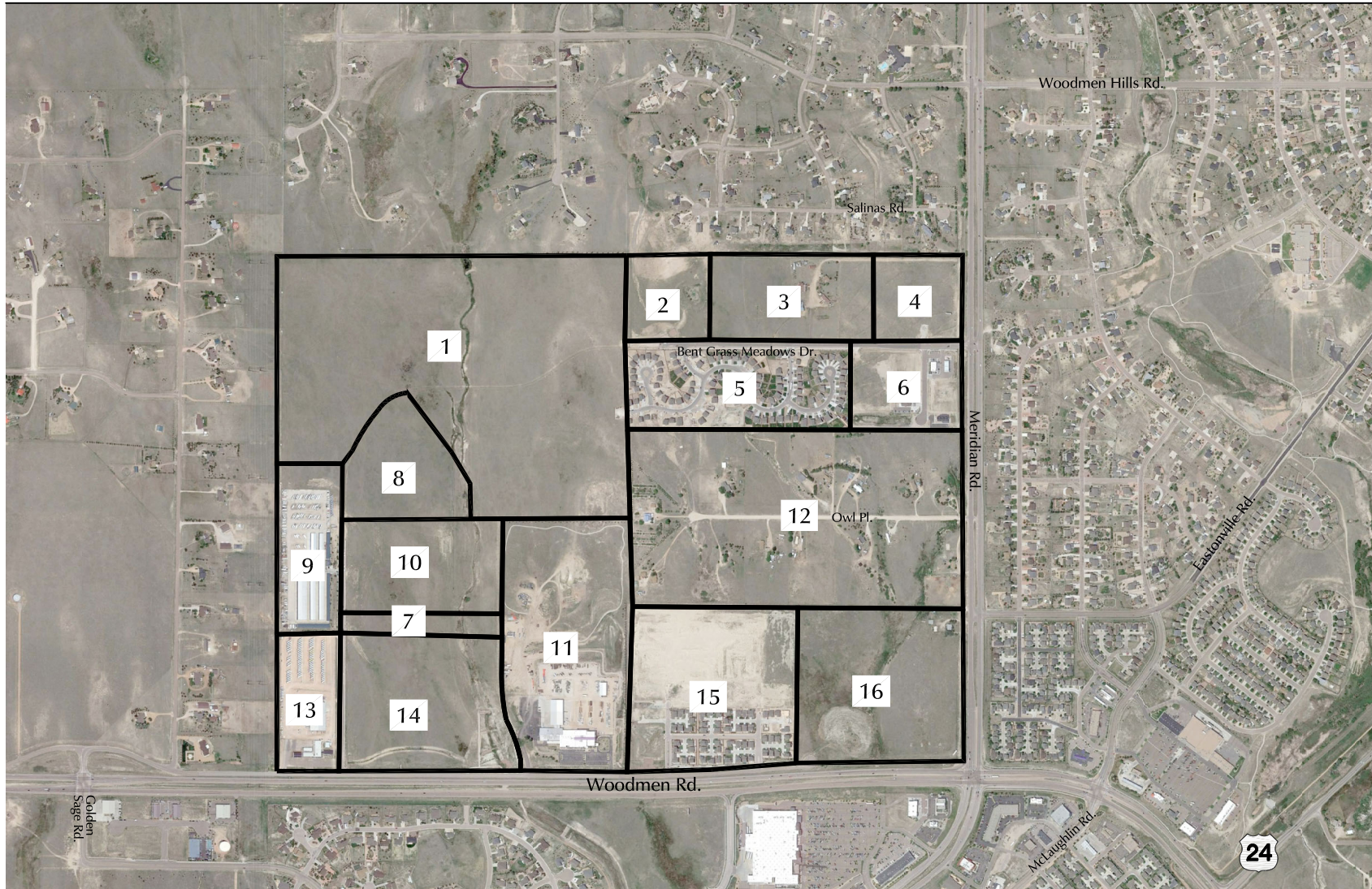

Approximate Scale  
Scale: 1" = 1,200'

# Appendix Figure 1 Traffic Analysis Zone Map

Bent Grass East Commercial Filing 3 (LSC #204660)



# MTCP Maps

---



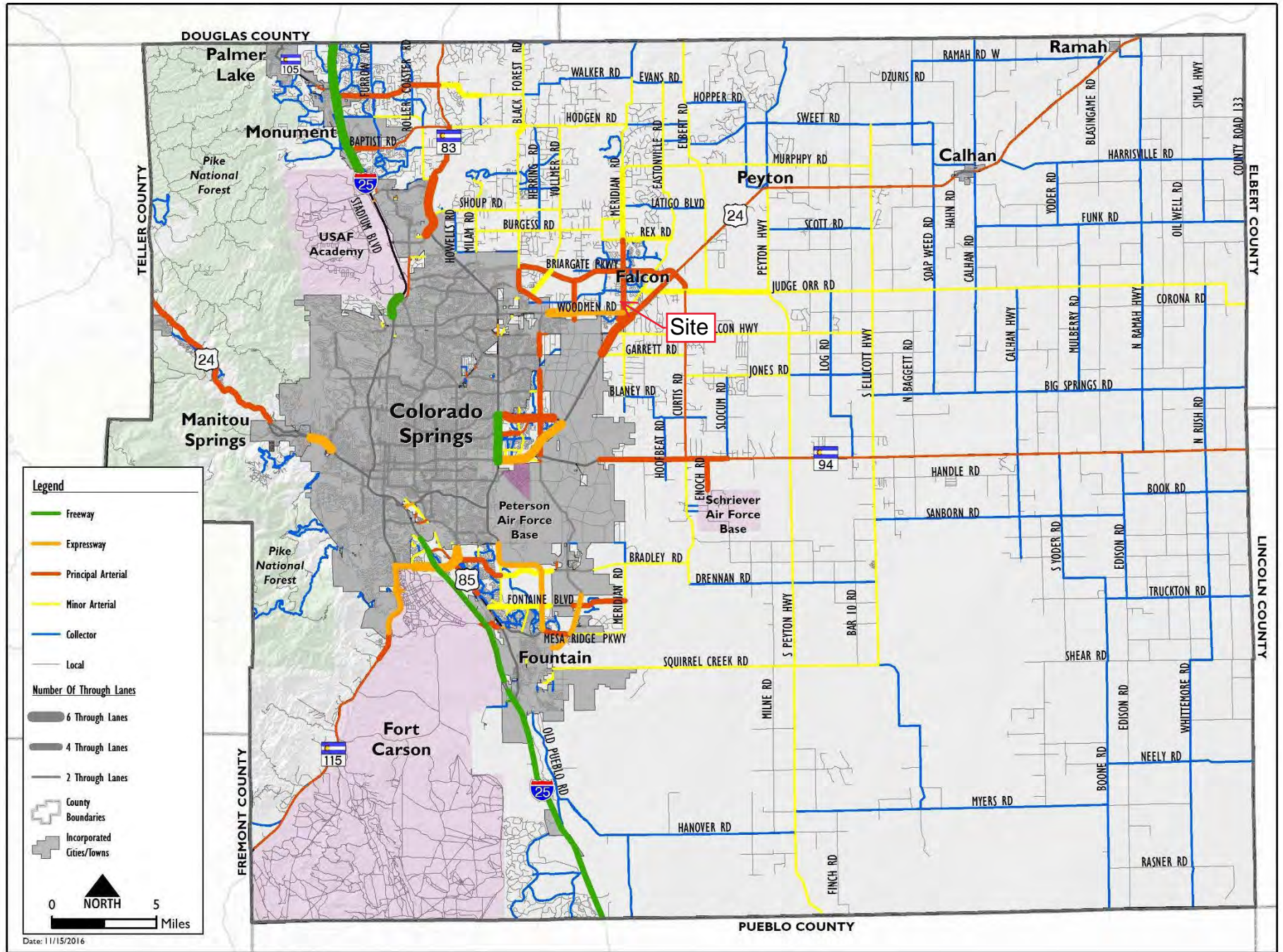

Map 14: 2040 Roadway Plan (Classification and Lanes)

# Map 17: 2060 Corridor Preservation

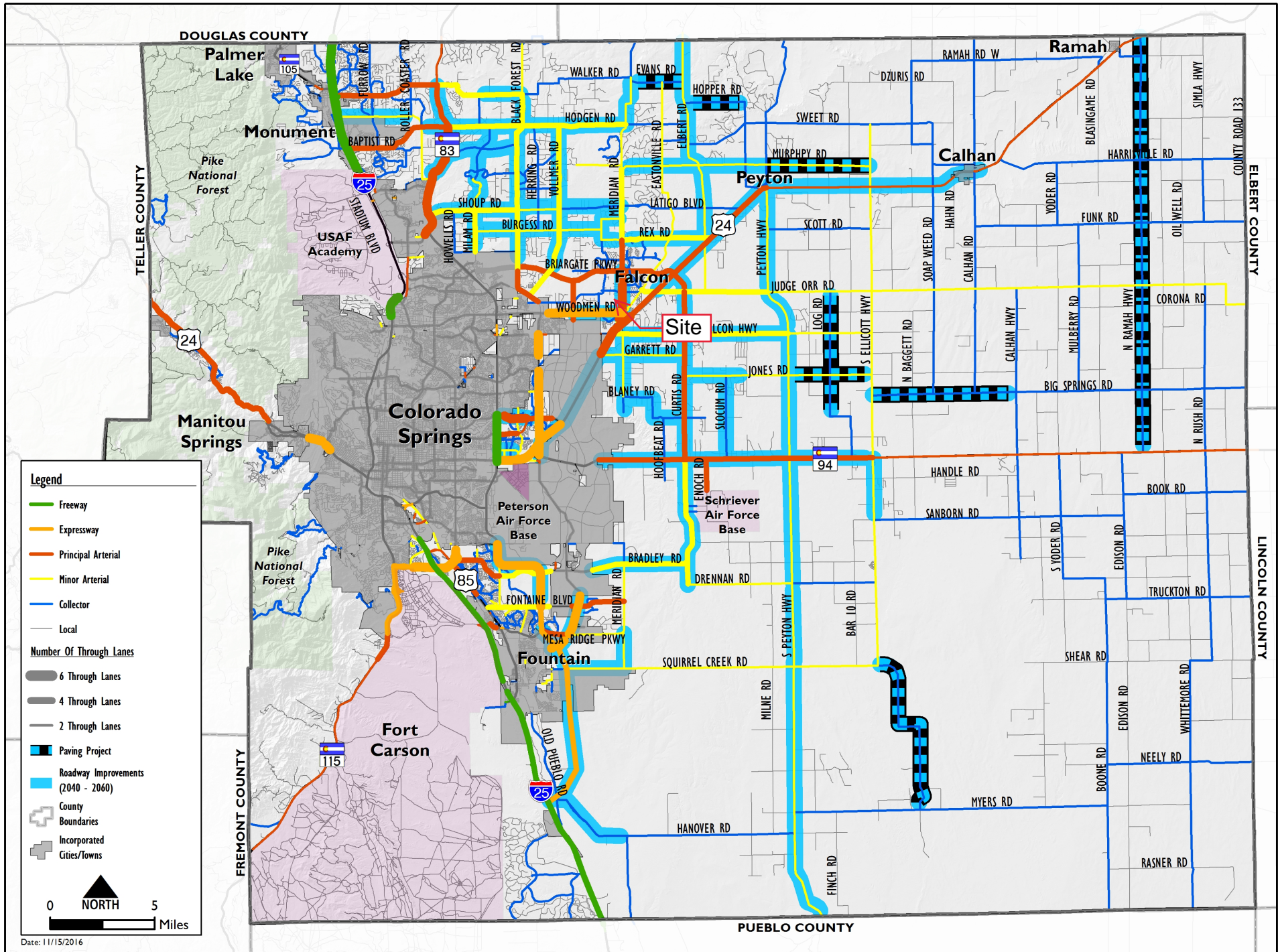

# Traffic Counts

---





**LSC Transportation Consultants, Inc.**  
 545 E Pikes Peak Ave, Suite 210  
 Colorado Springs, CO 80905  
 719-633-2868

File Name : Golden Sage Rd - Woodmen Rd AM  
 Site Code : 00194460  
 Start Date : 12/8/2020  
 Page No : 1

Groups Printed- Unshifted

Start Time	Golden Sage Rd Southbound					Woodmen Rd Westbound					Golden Sage Rd Northbound					Woodmen Rd Eastbound					
	L	T	R	U	App. Total	L	T	R	U	App. Total	L	T	R	U	App. Total	L	T	R	U	App. Total	Int. Total
07:00 AM	17	1	13	0	31	1	242	5	0	248	13	4	0	0	17	7	127	6	0	140	436
07:15 AM	8	0	20	0	28	4	289	7	0	300	20	2	1	0	23	7	138	4	0	149	500
07:30 AM	8	2	30	0	40	3	318	7	0	328	29	3	2	0	34	10	138	11	1	160	562
07:45 AM	7	0	21	0	28	4	211	3	0	218	11	2	2	0	15	8	133	17	0	158	419
Total	40	3	84	0	127	12	1060	22	0	1094	73	11	5	0	89	32	536	38	1	607	1917
08:00 AM	3	1	18	0	22	2	224	4	2	232	12	3	3	0	18	16	144	8	1	169	441
08:15 AM	10	2	23	0	35	3	210	6	0	219	14	2	3	0	19	18	165	4	0	187	460
08:30 AM	6	0	22	0	28	1	247	6	0	254	16	0	1	0	17	7	161	9	0	177	476
08:45 AM	10	3	12	0	25	3	170	8	0	181	19	2	0	0	21	12	142	14	0	168	395
Total	29	6	75	0	110	9	851	24	2	886	61	7	7	0	75	53	612	35	1	701	1772
Grand Total	69	9	159	0	237	21	1911	46	2	1980	134	18	12	0	164	85	1148	73	2	1308	3689
Apprch %	29.1	3.8	67.1	0		1.1	96.5	2.3	0.1		81.7	11	7.3	0		6.5	87.8	5.6	0.2		
Total %	1.9	0.2	4.3	0	6.4	0.6	51.8	1.2	0.1	53.7	3.6	0.5	0.3	0	4.4	2.3	31.1	2	0.1	35.5	

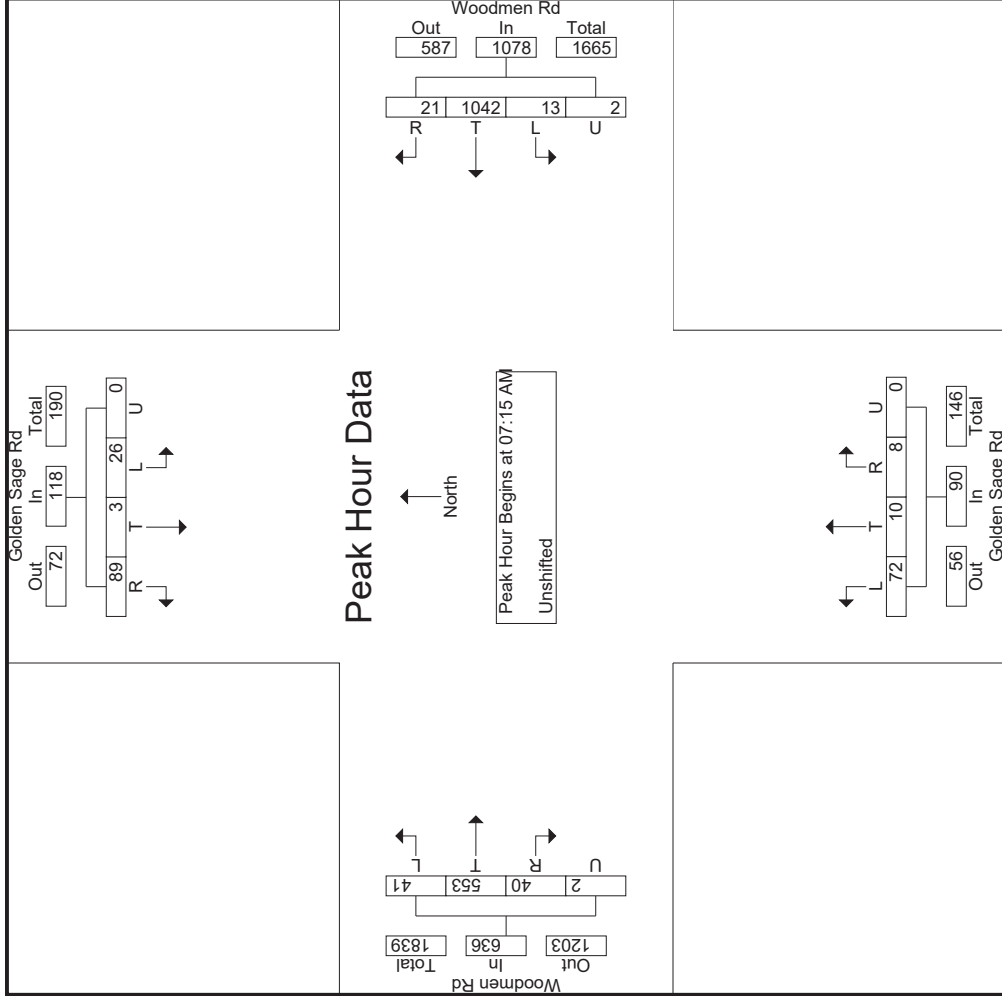

**LSC Transportation Consultants, Inc.**  
 545 E Pikes Peak Ave, Suite 210  
 Colorado Springs, CO 80905  
 719-633-2868

File Name : Golden Sage Rd - Woodmen Rd PM  
 Site Code : 00194460  
 Start Date : 12/3/2020  
 Page No : 1

Groups Printed- Unshifted

Start Time	Golden Sage Rd Southbound					Woodmen Rd Westbound					Golden Sage Rd Northbound					Woodmen Rd Eastbound				
	L	T	R	U	App. Total	L	T	R	U	App. Total	L	T	R	U	App. Total	L	T	R	U	App. Total
	04:00 PM	23	0	12	0	35	8	260	13	0	281	18	3	7	0	28	13	279	30	1
04:15 PM	13	1	15	0	29	4	220	8	0	232	16	2	4	0	22	16	332	19	0	367
04:30 PM	15	1	17	0	33	1	245	10	0	256	14	4	2	0	20	14	316	16	0	346
04:45 PM	11	0	13	0	24	2	223	12	2	239	21	2	3	0	26	10	335	8	1	354
Total	62	2	57	0	121	15	948	43	2	1008	69	11	16	0	96	53	1262	73	2	1390
05:00 PM	9	3	16	0	28	2	225	8	0	235	27	3	2	0	32	15	336	17	0	368
05:15 PM	7	4	12	0	23	5	190	13	2	210	32	4	11	0	47	18	325	19	0	362
05:30 PM	17	2	28	0	47	15	192	5	0	212	24	2	3	0	29	17	378	10	0	405
05:45 PM	10	2	5	0	17	3	145	9	1	158	12	4	2	0	18	15	278	16	1	310
Total	43	11	61	0	115	25	752	35	3	815	95	13	18	0	126	65	1317	62	1	1445
Grand Total	105	13	118	0	236	40	1700	78	5	1823	164	24	34	0	222	118	2579	135	3	2835
Appreh %	44.5	5.5	50	0	4.6	2.2	93.3	4.3	0.3	73.9	10.8	15.3	0	0	4.3	4.2	91	4.8	0.1	55.4
Total %	2.1	0.3	2.3	0	4.6	0.8	33.2	1.5	0.1	35.6	3.2	0.5	0.7	0	4.3	2.3	50.4	2.6	0.1	55.4

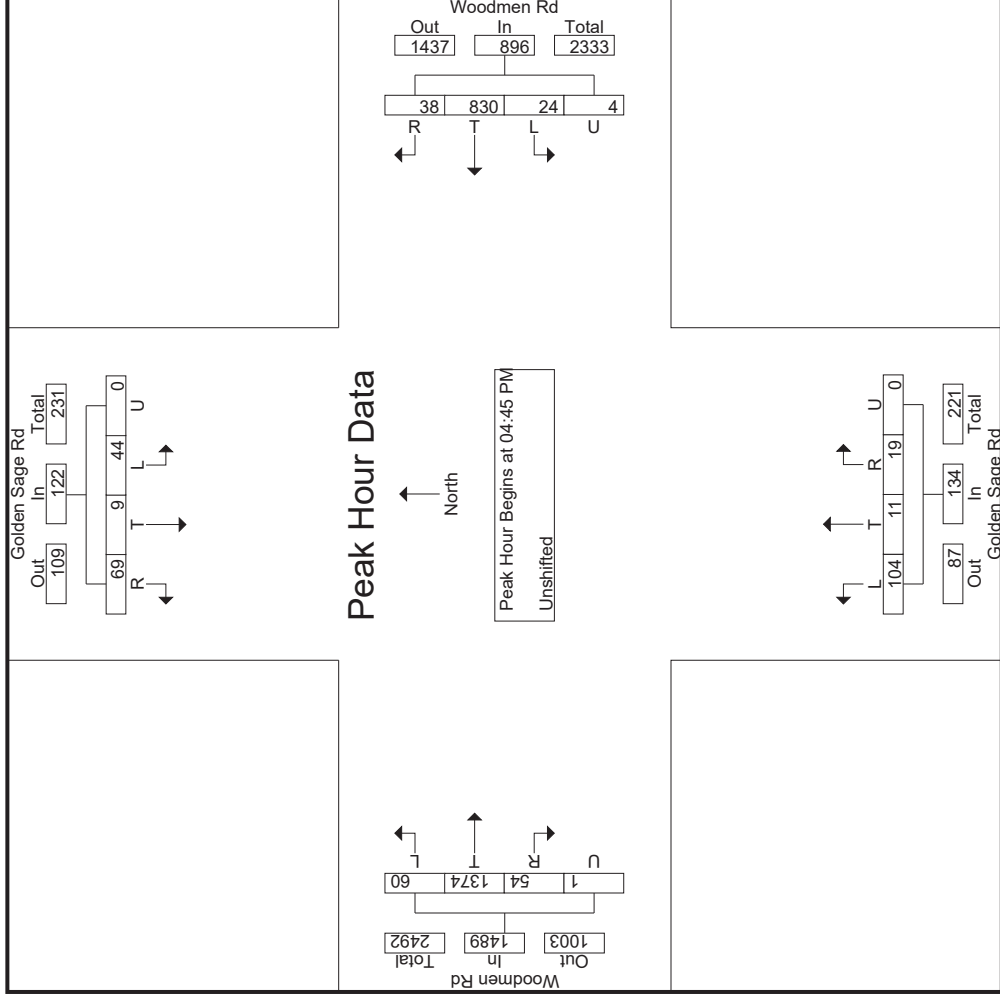

# LSC Transportation Consultants, Inc.

545 E Pikes Peak Ave, Suite 210

Colorado Springs, CO 80905

719-633-2868

File Name : Golden Sage Rd - Woodmen Rd AM 1-20

Site Code : 00194460

Start Date : 1/21/2020

Page No : 1

## Groups Printed- Unshifted

Start Time	Golden Sage Rd Southbound					Woodmen Rd Westbound					Golden Sage Rd Northbound					Woodmen Rd Eastbound					Int. Total
	Left	Through	Right	Peds	App. Total	Left	Through	Right	Peds	App. Total	Left	Through	Right	Peds	App. Total	Left	Through	Right	Peds	App. Total	
06:30 AM	5	1	25	0	31	0	195	48	1	244	20	2	0	0	22	10	107	0	0	117	414
06:45 AM	12	5	28	0	45	4	355	30	0	389	24	4	0	0	28	14	151	9	0	174	636
Total	17	6	53	0	76	4	550	78	1	633	44	6	0	0	50	24	258	9	0	291	1050
07:00 AM	17	7	29	0	53	2	340	25	0	367	42	2	1	0	45	13	158	13	0	184	649
07:15 AM	8	4	30	0	42	3	424	16	0	443	44	3	1	0	48	12	171	11	0	194	727
07:30 AM	16	4	25	1	46	6	356	12	0	374	29	4	1	0	34	8	181	11	0	200	654
07:45 AM	7	1	7	0	15	2	293	17	0	312	13	5	0	0	18	16	209	20	0	245	590
Total	48	16	91	1	156	13	1413	70	0	1496	128	14	3	0	145	49	719	55	0	823	2620
08:00 AM	9	1	14	0	24	3	239	12	1	255	18	0	0	0	18	16	165	13	1	195	492
08:15 AM	13	2	12	0	27	2	267	19	1	289	18	3	2	0	23	28	142	6	1	177	516
Grand Total	87	25	170	1	283	22	2469	179	3	2673	208	23	5	0	236	117	1284	83	2	1486	4678
Apprch %	30.7	8.8	60.1	0.4		0.8	92.4	6.7	0.1		88.1	9.7	2.1	0		7.9	86.4	5.6	0.1		
Total %	1.9	0.5	3.6	0	6	0.5	52.8	3.8	0.1	57.1	4.4	0.5	0.1	0	5	2.5	27.4	1.8	0	31.8	

# LSC Transportation Consultants, Inc.

545 E Pikes Peak Ave, Suite 210  
 Colorado Springs, CO 80905  
 719-633-2868

File Name : Golden Sage Rd - Woodmen Rd AM 1-20  
 Site Code : 00194460  
 Start Date : 1/21/2020  
 Page No : 2

Start Time	Golden Sage Rd Southbound					Woodmen Rd Westbound					Golden Sage Rd Northbound					Woodmen Rd Eastbound					Int. Total
	Left	Through	Right	Peds	App. Total	Left	Through	Right	Peds	App. Total	Left	Through	Right	Peds	App. Total	Left	Through	Right	Peds	App. Total	
<b>Peak Hour Analysis From 6:30:00 AM to 8:15:00 AM - Peak 1 of 1</b>																					
Peak Hour for Entire Intersection Begins at 6:45:00 AM																					
6:45:00 AM	12	5	28	0	45	4	355	30	0	389	24	4	0	0	28	14	151	9	0	174	636
7:00:00 AM	17	7	29	0	53	2	340	25	0	367	42	2	1	0	45	13	158	13	0	184	649
7:15:00 AM	8	4	30	0	42	3	424	16	0	443	44	3	1	0	48	12	171	11	0	194	727
7:30:00 AM	16	4	25	1	46	6	356	12	0	374	29	4	1	0	34	8	181	11	0	200	654
Total Volume	53	20	112	1	186	15	1475	83	0	1573	139	13	3	0	155	47	661	44	0	752	2666
% App. Total	28.5	10.8	60.2	0.5		1	93.8	5.3	0		89.7	8.4	1.9	0		6.2	87.9	5.9	0		
PHF	.779	.714	.933	.250	.877	.625	.870	.692	.000	.888	.790	.813	.750	.000	.807	.839	.913	.846	.000	.940	.917

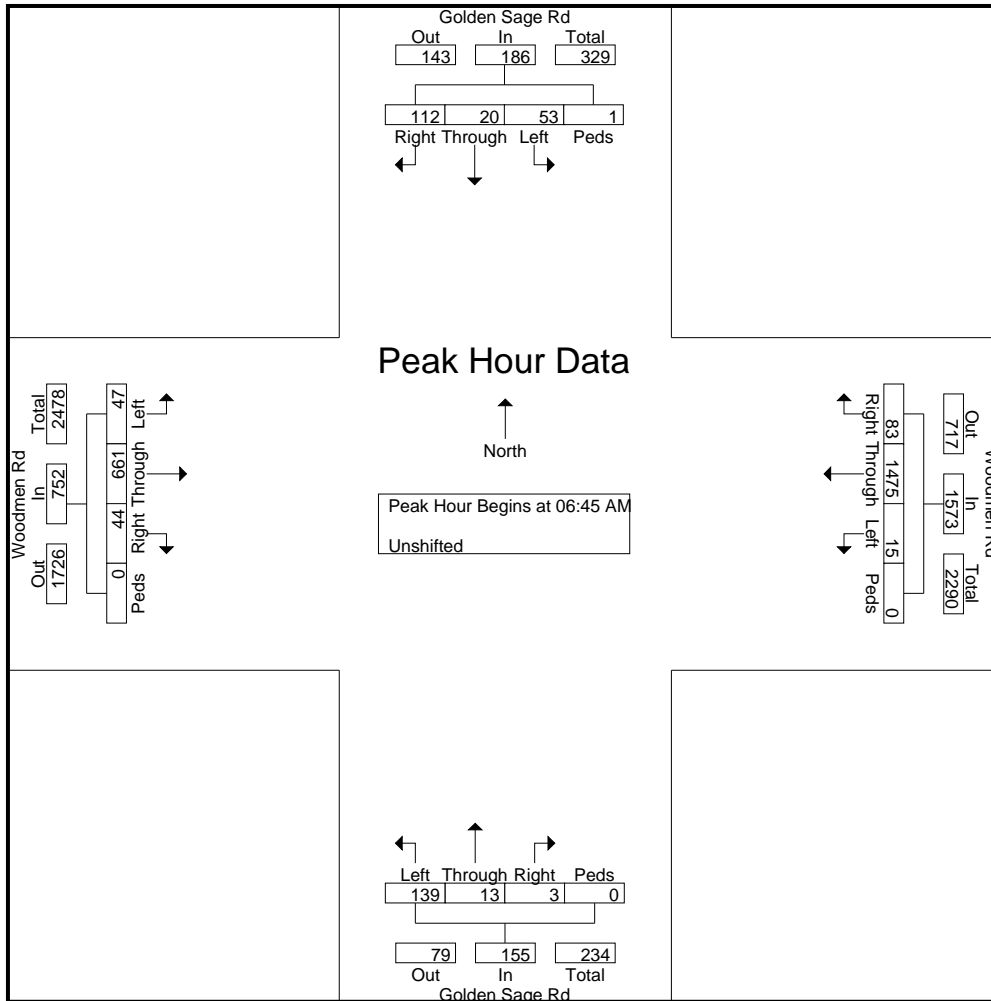

# LSC Transportation Consultants, Inc.

545 E Pikes Peak Ave, Suite 210  
 Colorado Springs, CO 80905  
 719-633-2868

File Name : Golden Sage Rd - Woodmen Rd AM 1-20  
 Site Code : 00194460  
 Start Date : 1/21/2020  
 Page No : 3

Start Time	Golden Sage Rd Southbound					Woodmen Rd Westbound					Golden Sage Rd Northbound					Woodmen Rd Eastbound					Int. Total
	Left	Through	Right	Peds	App. Total	Left	Through	Right	Peds	App. Total	Left	Through	Right	Peds	App. Total	Left	Through	Right	Peds	App. Total	
<b>Peak Hour Analysis From 6:30:00 AM to 8:15:00 AM - Peak 1 of 1</b>																					
Peak Hour for Each Approach Begins at:																					
	6:45:00 AM					6:45:00 AM					6:45:00 AM					7:15:00 AM					
+0 mins.	12	5	28	0	45	4	355	30	0	389	24	4	0	0	28	12	171	11	0	194	
+5 mins.	17	7	29	0	53	2	340	25	0	367	42	2	1	0	45	8	181	11	0	200	
+10 mins.	8	4	30	0	42	3	424	16	0	443	44	3	1	0	48	16	209	20	0	245	
+15 mins.	16	4	25	1	46	6	356	12	0	374	29	4	1	0	34	16	165	13	1	195	
Total Volume	53	20	112	1	186	15	1475	83	0	1573	139	13	3	0	155	52	726	55	1	834	
% App. Total	28.5	10.8	60.2	0.5		1	93.8	5.3	0		89.7	8.4	1.9	0		6.2	87.1	6.6	0.1		
PHF	.779	.714	.933	.250	.877	.625	.870	.692	.000	.888	.790	.813	.750	.000	.807	.813	.868	.688	.250	.851	

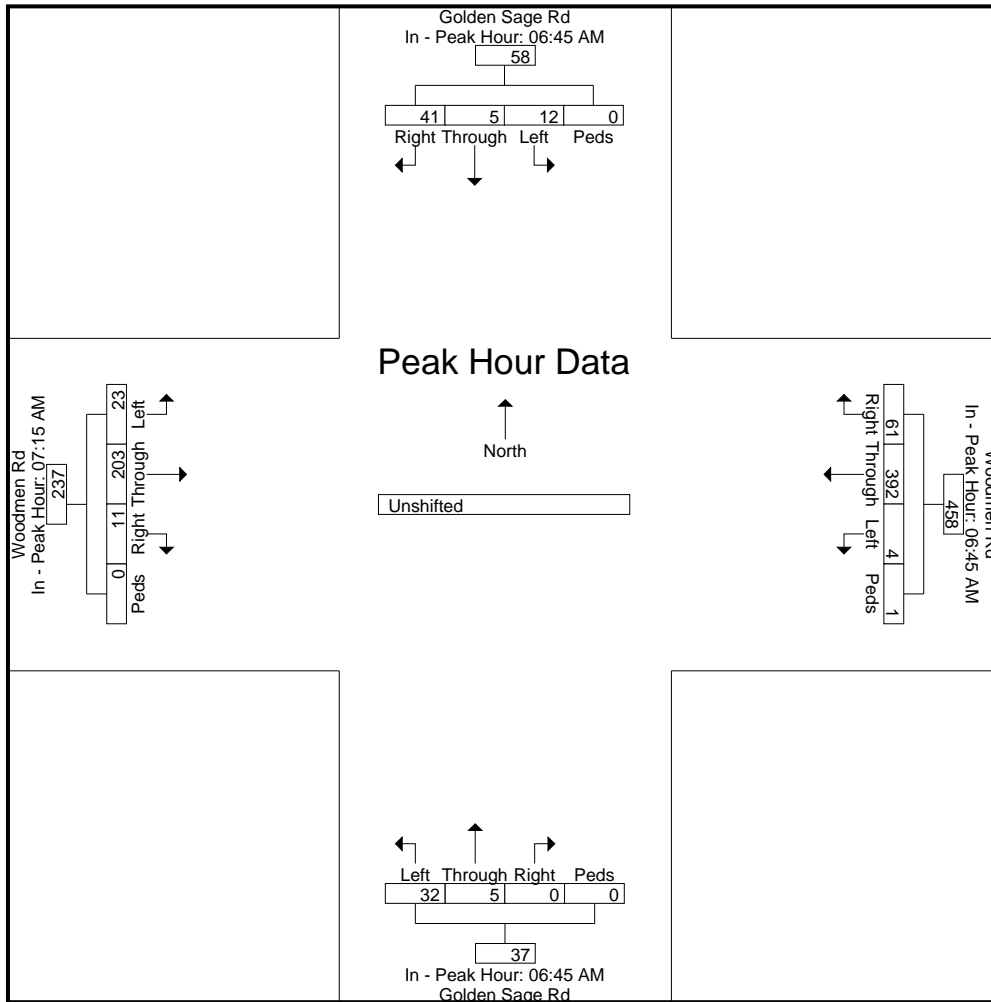

# LSC Transportation Consultants, Inc.

545 E Pikes Peak Ave, Suite 210

Colorado Springs, CO 80905

719-633-2868

File Name : Golden Sage Rd - Woodmen Rd PM 1-20

Site Code : 00194460

Start Date : 1/21/2020

Page No : 1

## Groups Printed- Unshifted

Start Time	Golden Sage Rd Southbound					Woodmen Rd Westbound					Golden Sage Rd Northbound					Woodmen Rd Eastbound					Int. Total
	Left	Through	Right	Peds	App. Total	Left	Through	Right	Peds	App. Total	Left	Through	Right	Peds	App. Total	Left	Through	Right	Peds	App. Total	
04:00 PM	17	2	26	0	45	7	205	16	0	228	23	9	5	0	37	21	272	23	2	318	628
04:15 PM	7	1	22	0	30	5	241	26	0	272	26	5	6	0	37	28	325	12	1	366	705
04:30 PM	21	4	24	0	49	1	241	20	1	263	26	8	4	0	38	24	313	3	1	341	691
04:45 PM	29	3	19	2	53	1	202	24	0	227	16	4	0	0	20	18	341	10	1	370	670
Total	74	10	91	2	177	14	889	86	1	990	91	26	15	0	132	91	1251	48	5	1395	2694
05:00 PM	18	1	27	0	46	2	254	11	2	269	27	7	1	0	35	19	328	11	0	358	708
05:15 PM	7	2	6	0	15	8	192	9	1	210	32	10	12	0	54	23	340	17	0	380	659
05:30 PM	42	7	42	1	92	7	227	23	0	257	30	7	10	0	47	28	336	6	0	370	766
05:45 PM	21	1	18	0	40	1	180	12	1	194	19	5	5	0	29	18	326	9	0	353	616
Total	88	11	93	1	193	18	853	55	4	930	108	29	28	0	165	88	1330	43	0	1461	2749
Grand Total	162	21	184	3	370	32	1742	141	5	1920	199	55	43	0	297	179	2581	91	5	2856	5443
Apprch %	43.8	5.7	49.7	0.8		1.7	90.7	7.3	0.3		67	18.5	14.5	0		6.3	90.4	3.2	0.2		
Total %	3	0.4	3.4	0.1	6.8	0.6	32	2.6	0.1	35.3	3.7	1	0.8	0	5.5	3.3	47.4	1.7	0.1	52.5	



# LSC Transportation Consultants, Inc.

545 E Pikes Peak Ave, Suite 210  
 Colorado Springs, CO 80905  
 719-633-2868

File Name : Golden Sage Rd - Woodmen Rd PM 1-20  
 Site Code : 00194460  
 Start Date : 1/21/2020  
 Page No : 2

Start Time	Golden Sage Rd Southbound					Woodmen Rd Westbound					Golden Sage Rd Northbound					Woodmen Rd Eastbound					Int. Total
	Left	Through	Right	Peds	App. Total	Left	Through	Right	Peds	App. Total	Left	Through	Right	Peds	App. Total	Left	Through	Right	Peds	App. Total	
<b>Peak Hour Analysis From 4:00:00 PM to 5:45:00 PM - Peak 1 of 1</b>																					
Peak Hour for Entire Intersection Begins at 4:45:00 PM																					
4:45:00 PM	29	3	19	2	53	1	202	24	0	227	16	4	0	0	20	18	341	10	1	370	670
5:00:00 PM	18	1	27	0	46	2	254	11	2	269	27	7	1	0	35	19	328	11	0	358	708
5:15:00 PM	7	2	6	0	15	8	192	9	1	210	32	10	12	0	54	23	340	17	0	380	659
5:30:00 PM	42	7	42	1	92	7	227	23	0	257	30	7	10	0	47	28	336	6	0	370	766
Total Volume	96	13	94	3	206	18	875	67	3	963	105	28	23	0	156	88	1345	44	1	1478	2803
% App. Total	46.6	6.3	45.6	1.5		1.9	90.9	7	0.3		67.3	17.9	14.7	0		6	91	3	0.1		
PHF	.571	.464	.560	.375	.560	.563	.861	.698	.375	.895	.820	.700	.479	.000	.722	.786	.986	.647	.250	.972	.915

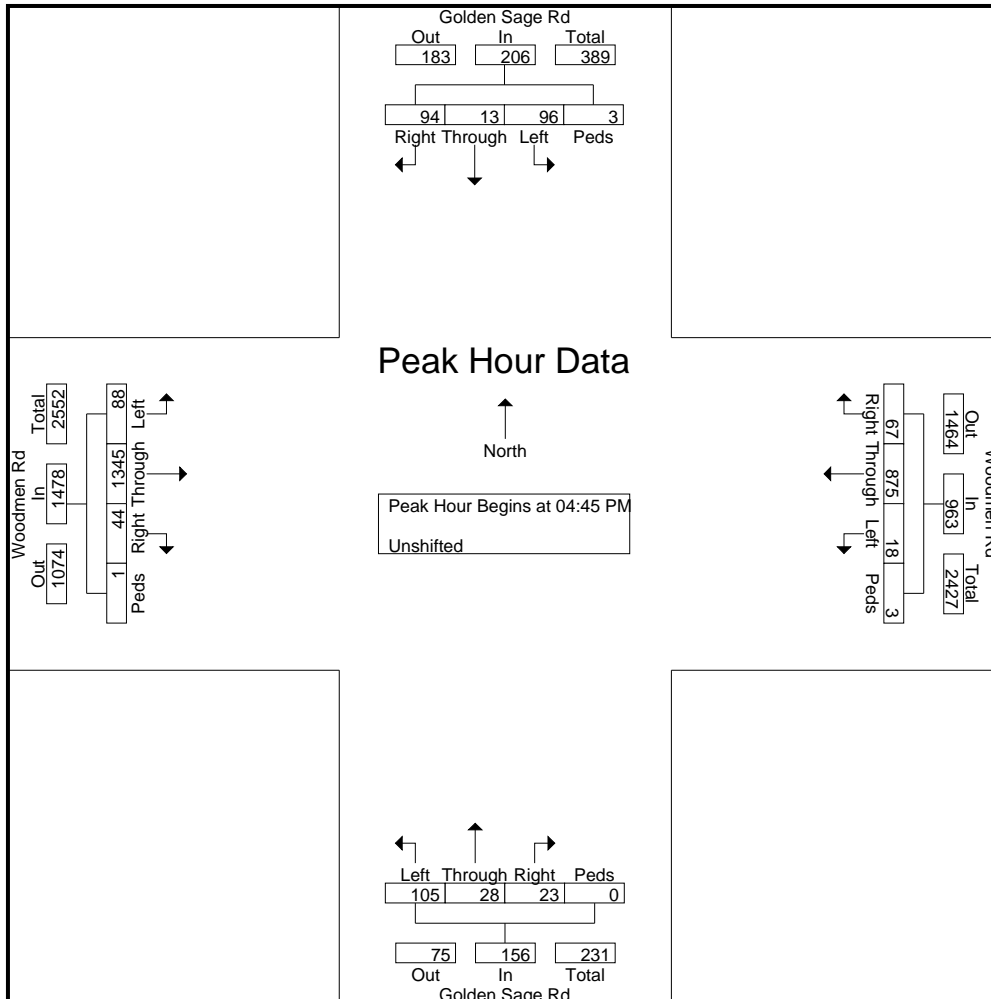

# LSC Transportation Consultants, Inc.

545 E Pikes Peak Ave, Suite 210  
 Colorado Springs, CO 80905  
 719-633-2868

File Name : Golden Sage Rd - Woodmen Rd PM 1-20  
 Site Code : 00194460  
 Start Date : 1/21/2020  
 Page No : 3

Start Time	Golden Sage Rd Southbound					Woodmen Rd Westbound					Golden Sage Rd Northbound					Woodmen Rd Eastbound					Int. Total
	Left	Through	Right	Peds	App. Total	Left	Through	Right	Peds	App. Total	Left	Through	Right	Peds	App. Total	Left	Through	Right	Peds	App. Total	
<b>Peak Hour Analysis From 4:00:00 PM to 5:45:00 PM - Peak 1 of 1</b>																					
Peak Hour for Each Approach Begins at:																					
	4:45:00 PM					4:15:00 PM					5:00:00 PM					4:45:00 PM					
+0 mins.	29	3	19	2	53	5	241	26	0	272	27	7	1	0	35	18	341	10	1	370	
+5 mins.	18	1	27	0	46	1	241	20	1	263	32	10	12	0	54	19	328	11	0	358	
+10 mins.	7	2	6	0	15	1	202	24	0	227	30	7	10	0	47	23	340	17	0	380	
+15 mins.	42	7	42	1	92	2	254	11	2	269	19	5	5	0	29	28	336	6	0	370	
Total Volume	96	13	94	3	206	9	938	81	3	1031	108	29	28	0	165	88	1345	44	1	1478	
% App. Total	46.6	6.3	45.6	1.5		0.9	91	7.9	0.3		65.5	17.6	17	0		6	91	3	0.1		
PHF	.571	.464	.560	.375	.560	.450	.923	.779	.375	.948	.844	.725	.583	.000	.764	.786	.986	.647	.250	.972	

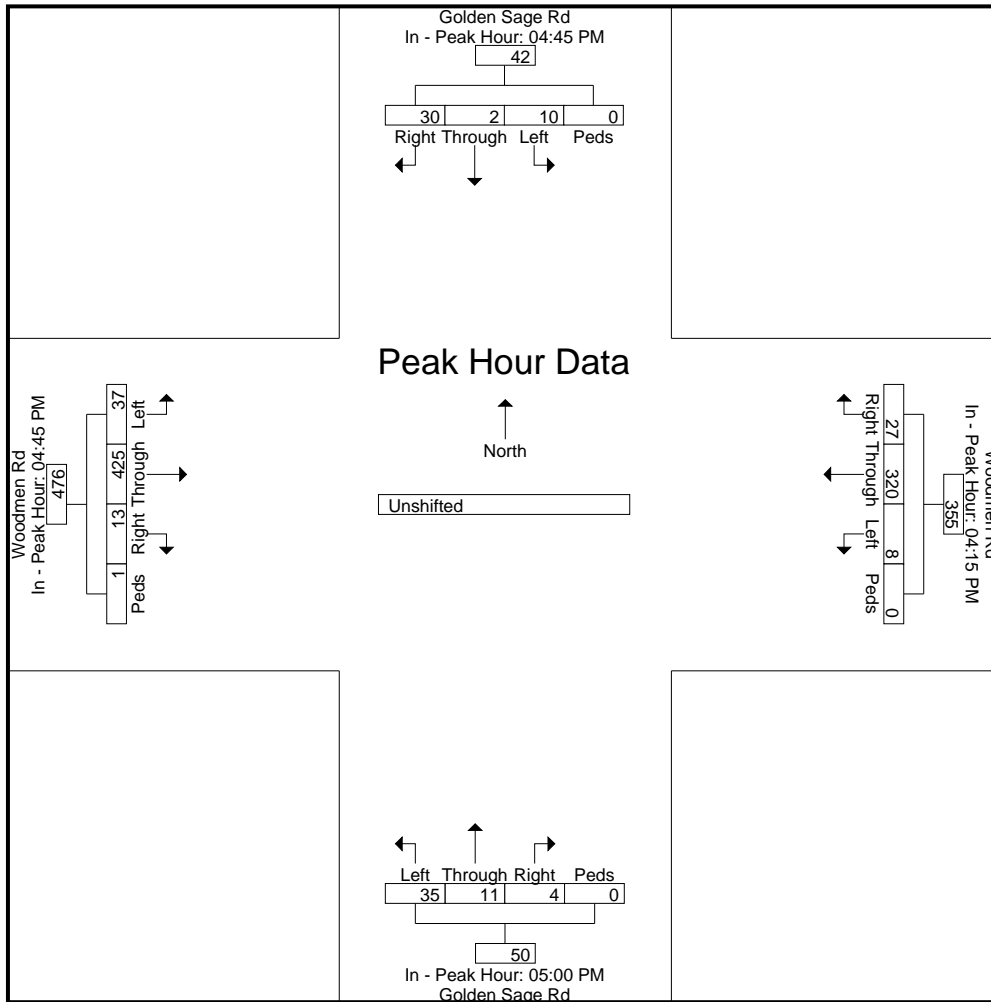

# LSC Transportation Consultants, Inc.

545 E Pikes Peak Ave, Suite 210  
 Colorado Springs, CO 80905  
 719-633-2868

File Name : Golden Sage Rd - Woodmen Frontage Rd AM 1-20  
 Site Code : 00194460  
 Start Date : 1/21/2020  
 Page No : 1

### Groups Printed- Bank 1

Start Time	Southbound					Woodmen Frontage Rd Westbound					Golden Sage Rd Northbound					Woodmen Frontage Rd Eastbound					Int. Total
	Left	Through	Right	Peds	App. Total	Left	Through	Right	Peds	App. Total	Left	Through	Right	Peds	App. Total	Left	Through	Right	Peds	App. Total	
06:30 AM	0	0	0	0	0	19	0	0	0	19	0	0	21	0	21	1	0	0	0	1	41
06:45 AM	0	0	2	0	2	41	0	1	0	42	4	0	47	0	51	0	0	0	0	0	95
Total	0	0	2	0	2	60	0	1	0	61	4	0	68	0	72	1	0	0	0	1	136
07:00 AM	0	0	0	0	0	49	1	0	0	50	0	0	19	0	19	0	0	0	0	0	69
07:15 AM	0	0	0	0	0	34	0	0	0	34	0	0	31	0	31	0	0	0	0	0	65
07:30 AM	0	0	0	0	0	45	0	0	0	45	0	0	22	0	22	0	0	1	0	1	68
07:45 AM	0	0	0	0	0	19	0	0	0	19	0	0	36	0	36	0	0	0	0	0	55
Total	0	0	0	0	0	147	1	0	0	148	0	0	108	0	108	0	0	1	0	1	257
08:00 AM	0	0	0	0	0	27	0	0	0	27	0	0	24	0	24	0	0	0	0	0	51
08:15 AM	0	0	0	0	0	26	0	0	0	26	0	0	48	1	49	0	0	1	0	1	76
Grand Total	0	0	2	0	2	260	1	1	0	262	4	0	248	1	253	1	0	2	0	3	520
Apprch %	0	0	100	0		99.2	0.4	0.4	0		1.6	0	98	0.4		33.3	0	66.7	0		
Total %	0	0	0.4	0	0.4	50	0.2	0.2	0	50.4	0.8	0	47.7	0.2	48.7	0.2	0	0.4	0	0.6	

# LSC Transportation Consultants, Inc.

545 E Pikes Peak Ave, Suite 210  
 Colorado Springs, CO 80905  
 719-633-2868

File Name : Golden Sage Rd - Woodmen Frontage Rd AM 1-20  
 Site Code : 00194460  
 Start Date : 1/21/2020  
 Page No : 2

Start Time	Southbound					Woodmen Frontage Rd Westbound					Golden Sage Rd Northbound					Woodmen Frontage Rd Eastbound					Int. Total	
	Left	Through	Right	Peds	App. Total	Left	Through	Right	Peds	App. Total	Left	Through	Right	Peds	App. Total	Left	Through	Right	Peds	App. Total		
<b>Peak Hour Analysis From 6:30:00 AM to 8:15:00 AM - Peak 1 of 1</b>																						
Peak Hour for Entire Intersection Begins at 6:45:00 AM																						
6:45:00 AM	0	0	2	0	2	41	0	1	0	42	4	0	47	0	51	0	0	0	0	0	0	95
7:00:00 AM	0	0	0	0	0	49	1	0	0	50	0	0	19	0	19	0	0	0	0	0	0	69
7:15:00 AM	0	0	0	0	0	34	0	0	0	34	0	0	31	0	31	0	0	0	0	0	0	65
7:30:00 AM	0	0	0	0	0	45	0	0	0	45	0	0	22	0	22	0	0	1	0	0	1	68
Total Volume	0	0	2	0	2	169	1	1	0	171	4	0	119	0	123	0	0	1	0	1	1	297
% App. Total	0	0	100	0		98.8	0.6	0.6	0		3.3	0	96.7	0		0	0	100	0			
PHF	.000	.000	.250	.000	.250	.862	.250	.250	.000	.855	.250	.000	.633	.000	.603	.000	.000	.250	.000	.250		.782

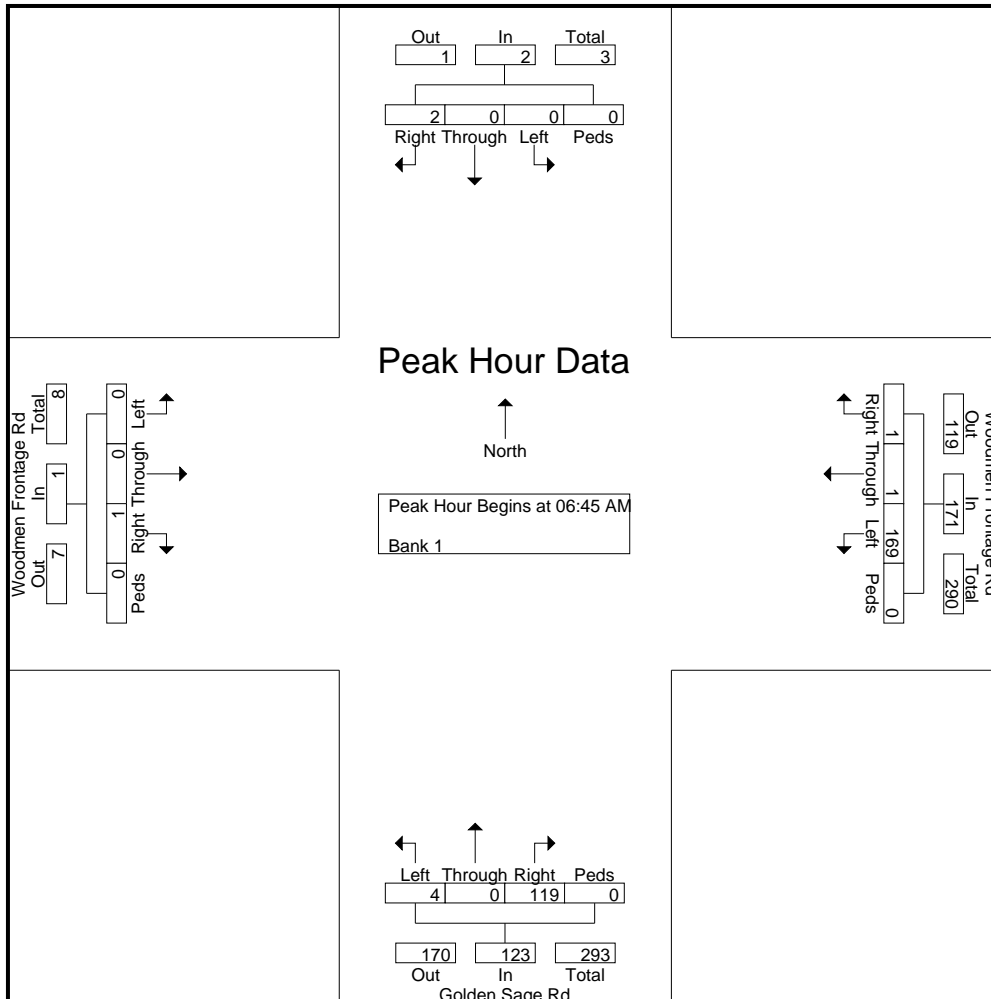

# LSC Transportation Consultants, Inc.

545 E Pikes Peak Ave, Suite 210  
 Colorado Springs, CO 80905  
 719-633-2868

File Name : Golden Sage Rd - Woodmen Frontage Rd AM 1-20  
 Site Code : 00194460  
 Start Date : 1/21/2020  
 Page No : 3

Start Time	Southbound					Woodmen Frontage Rd Westbound					Golden Sage Rd Northbound					Woodmen Frontage Rd Eastbound					Int. Total
	Left	Through	Right	Peds	App. Total	Left	Through	Right	Peds	App. Total	Left	Through	Right	Peds	App. Total	Left	Through	Right	Peds	App. Total	
<b>Peak Hour Analysis From 6:30:00 AM to 8:15:00 AM - Peak 1 of 1</b>																					
Peak Hour for Each Approach Begins at:																					
	6:30:00 AM					6:45:00 AM					7:30:00 AM					7:30:00 AM					
+0 mins.	0	0	0	0	0	41	0	1	0	42	0	0	22	0	22	0	0	1	0	1	
+5 mins.	0	0	2	0	2	49	1	0	0	50	0	0	36	0	36	0	0	0	0	0	
+10 mins.	0	0	0	0	0	34	0	0	0	34	0	0	24	0	24	0	0	0	0	0	
+15 mins.	0	0	0	0	0	45	0	0	0	45	0	0	48	1	49	0	0	1	0	1	
Total Volume	0	0	2	0	2	169	1	1	0	171	0	0	130	1	131	0	0	2	0	2	
% App. Total	0	0	100	0		98.8	0.6	0.6	0		0	0	99.2	0.8		0	0	100	0		
PHF	.000	.000	.250	.000	.250	.862	.250	.250	.000	.855	.000	.000	.677	.250	.668	.000	.000	.500	.000	.500	

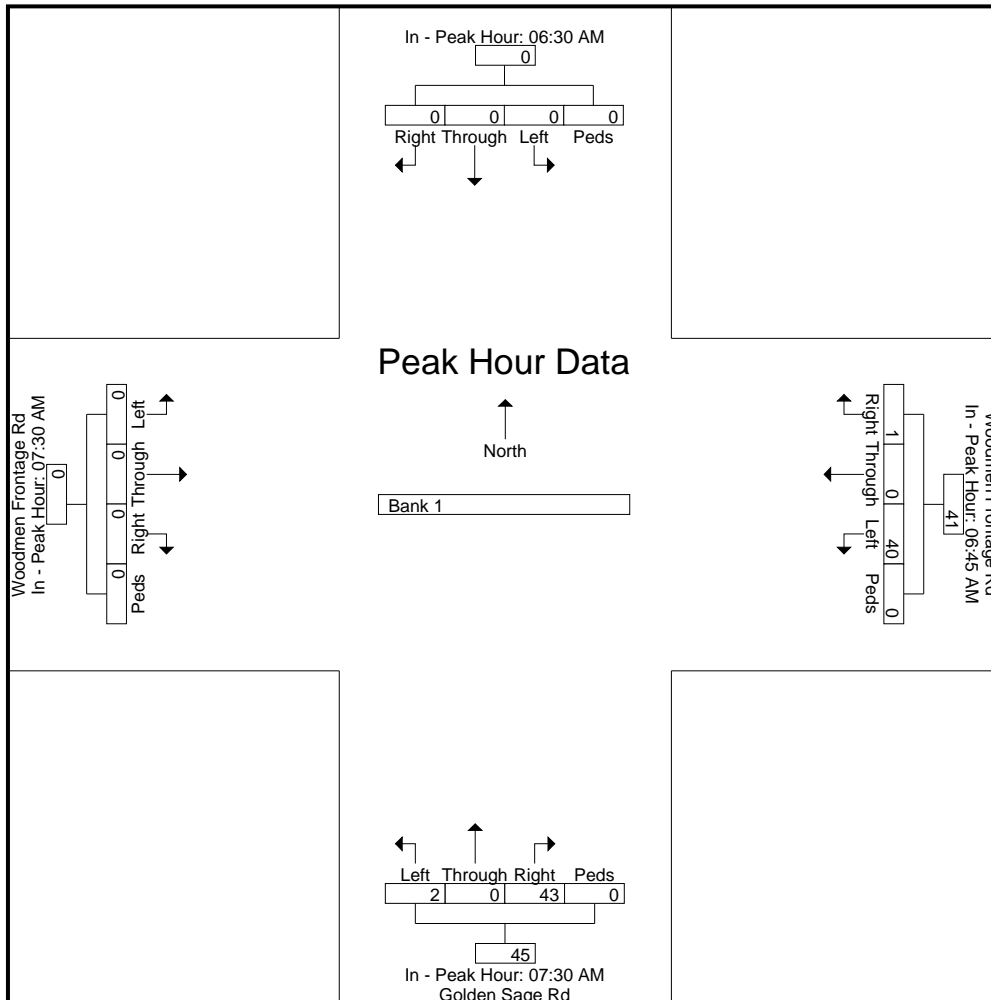

# LSC Transportation Consultants, Inc.

545 E Pikes Peak Ave, Suite 210

Colorado Springs, CO 80905

719-633-2868

File Name : Golden Sage Rd - Woodmen Frontage Rd PM 1-20

Site Code : 00194460

Start Date : 1/21/2020

Page No : 1

### Groups Printed- Bank 1

Start Time	Southbound					Woodmen Frontage Rd Westbound					Golden Sage Rd Northbound					Woodmen Frontage Rd Eastbound					Int. Total
	Left	Through	Right	Peds	App. Total	Left	Through	Right	Peds	App. Total	Left	Through	Right	Peds	App. Total	Left	Through	Right	Peds	App. Total	
04:00 PM	0	0	0	0	0	43	1	0	0	44	0	0	45	0	45	0	0	0	0	0	89
04:15 PM	0	0	0	0	0	33	0	0	0	33	0	0	52	0	52	0	1	0	0	1	86
04:30 PM	0	0	0	0	0	44	0	0	0	44	0	0	52	0	52	0	0	0	0	0	96
04:45 PM	0	0	0	0	0	60	0	0	0	60	0	0	44	0	44	0	0	0	0	0	104
Total	0	0	0	0	0	180	1	0	0	181	0	0	193	0	193	0	1	0	0	1	375
05:00 PM	0	0	0	0	0	45	0	0	0	45	0	0	33	0	33	0	0	2	0	2	80
05:15 PM	0	0	0	0	0	13	0	0	0	13	2	0	41	1	44	0	0	1	0	1	58
05:30 PM	0	0	0	0	0	89	0	1	0	90	0	0	35	0	35	0	0	0	0	0	125
05:45 PM	0	0	0	0	0	43	0	1	0	44	0	0	31	0	31	0	0	0	0	0	75
Total	0	0	0	0	0	190	0	2	0	192	2	0	140	1	143	0	0	3	0	3	338
Grand Total	0	0	0	0	0	370	1	2	0	373	2	0	333	1	336	0	1	3	0	4	713
Apprch %	0	0	0	0		99.2	0.3	0.5	0		0.6	0	99.1	0.3		0	25	75	0		
Total %	0	0	0	0	0	51.9	0.1	0.3	0	52.3	0.3	0	46.7	0.1	47.1	0	0.1	0.4	0	0.6	

# LSC Transportation Consultants, Inc.

545 E Pikes Peak Ave, Suite 210  
 Colorado Springs, CO 80905  
 719-633-2868

File Name : Golden Sage Rd - Woodmen Frontage Rd PM 1-20  
 Site Code : 00194460  
 Start Date : 1/21/2020  
 Page No : 2

Start Time	Southbound					Woodmen Frontage Rd Westbound					Golden Sage Rd Northbound					Woodmen Frontage Rd Eastbound					Int. Total	
	Left	Through	Right	Peds	App. Total	Left	Through	Right	Peds	App. Total	Left	Through	Right	Peds	App. Total	Left	Through	Right	Peds	App. Total		
<b>Peak Hour Analysis From 4:00:00 PM to 5:45:00 PM - Peak 1 of 1</b>																						
Peak Hour for Entire Intersection Begins at 4:00:00 PM																						
4:00:00 PM	0	0	0	0	0	43	1	0	0	44	0	0	45	0	45	0	0	0	0	0	0	89
4:15:00 PM	0	0	0	0	0	33	0	0	0	33	0	0	52	0	52	0	1	0	0	1	1	86
4:30:00 PM	0	0	0	0	0	44	0	0	0	44	0	0	52	0	52	0	0	0	0	0	0	96
4:45:00 PM	0	0	0	0	0	60	0	0	0	60	0	0	44	0	44	0	0	0	0	0	0	104
Total Volume	0	0	0	0	0	180	1	0	0	181	0	0	193	0	193	0	1	0	0	1	1	375
% App. Total	0	0	0	0	0	99.4	0.6	0	0		0	0	100	0		0	100	0	0			
PHF	.000	.000	.000	.000	.000	.750	.250	.000	.000	.754	.000	.000	.928	.000	.928	.000	.250	.000	.000	.250	.901	

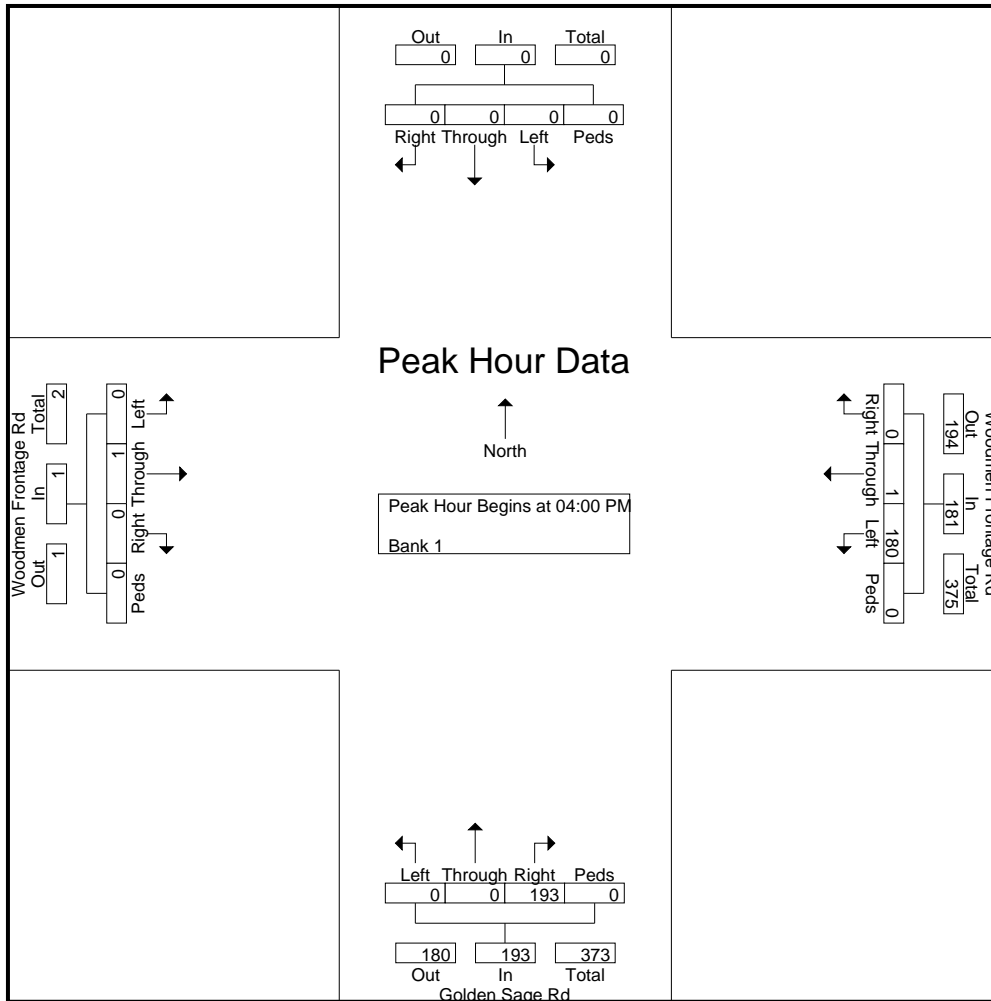

# LSC Transportation Consultants, Inc.

545 E Pikes Peak Ave, Suite 210  
 Colorado Springs, CO 80905  
 719-633-2868

File Name : Golden Sage Rd - Woodmen Frontage Rd PM 1-20  
 Site Code : 00194460  
 Start Date : 1/21/2020  
 Page No : 3

Start Time	Southbound					Woodmen Frontage Rd Westbound					Golden Sage Rd Northbound					Woodmen Frontage Rd Eastbound					Int. Total
	Left	Through	Right	Peds	App. Total	Left	Through	Right	Peds	App. Total	Left	Through	Right	Peds	App. Total	Left	Through	Right	Peds	App. Total	
<b>Peak Hour Analysis From 4:00:00 PM to 5:45:00 PM - Peak 1 of 1</b>																					
Peak Hour for Each Approach Begins at:																					
	4:00:00 PM					4:45:00 PM					4:00:00 PM					4:15:00 PM					
+0 mins.	0	0	0	0	0	60	0	0	0	60	0	0	45	0	45	0	1	0	0	1	
+5 mins.	0	0	0	0	0	45	0	0	0	45	0	0	52	0	52	0	0	0	0	0	
+10 mins.	0	0	0	0	0	13	0	0	0	13	0	0	52	0	52	0	0	0	0	0	
+15 mins.	0	0	0	0	0	89	0	1	0	90	0	0	44	0	44	0	0	2	0	2	
Total Volume	0	0	0	0	0	207	0	1	0	208	0	0	193	0	193	0	1	2	0	3	
% App. Total	0	0	0	0	0	99.5	0	0.5	0		0	0	100	0		0	33.3	66.7	0		
PHF	.000	.000	.000	.000	.000	.581	.000	.250	.000	.578	.000	.000	.928	.000	.928	.000	.250	.250	.000	.375	

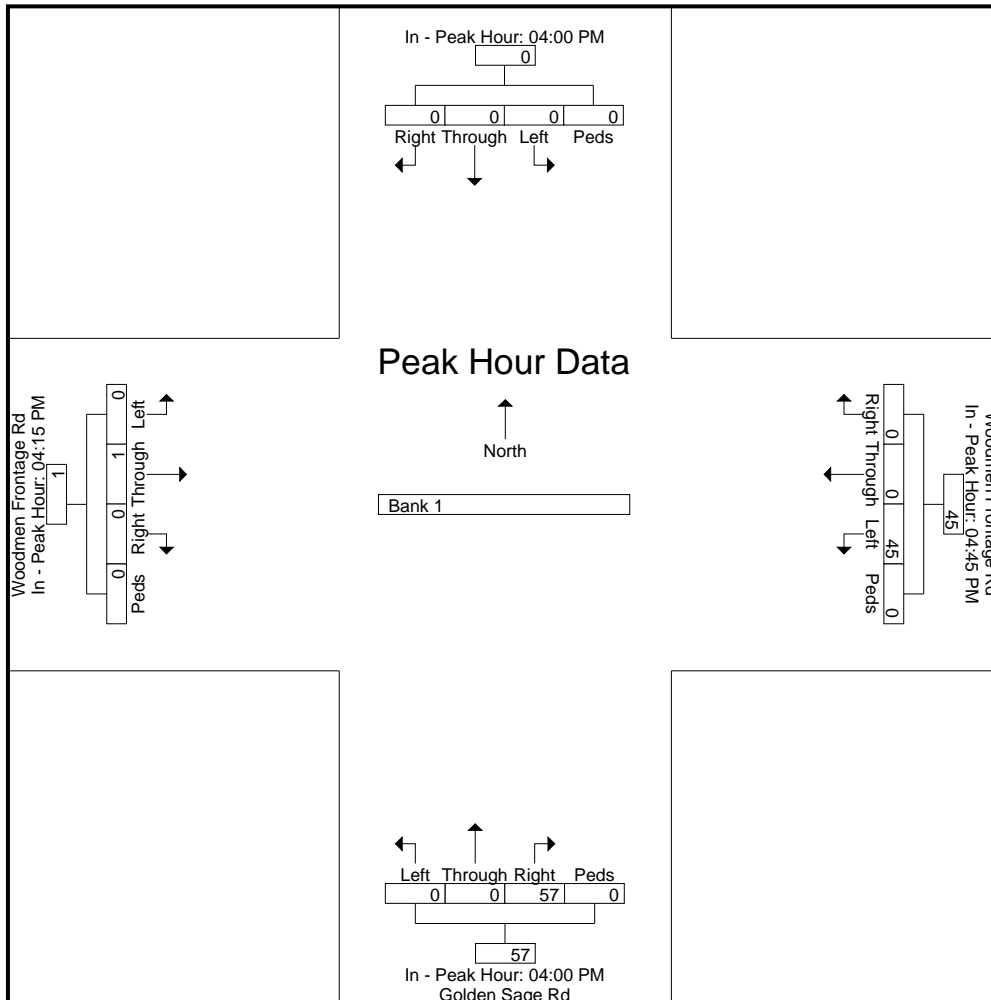





# LSC Transportation Consultants, Inc.

545 E Pikes Peak Ave, Suite 210

Colorado Springs, CO 80905

719-633-2868

File Name

Site Code

Start Date

Page #

### Groups Printed- Unshifted

Start Time	Bent Grass Meadows Southbound					Woodmen Frontage Rd Westbound					Northbound					Woodmen Frontage Rd Eastbound					Int. Total
	Left	Through	Right	Peds	App. Total	Left	Through	Right	Peds	App. Total	Left	Through	Right	Peds	App. Total	Left	Through	Right	Peds	App. Total	
06:30 AM	1	0	20	0	21	0	14	0	0	14	0	0	0	0	0	0	37	0	0	37	72
06:45 AM	0	0	6	0	6	0	15	0	0	15	0	0	0	0	0	1	49	0	0	50	71
Total	1	0	26	0	27	0	29	0	0	29	0	0	0	0	0	1	86	0	0	87	143
07:00 AM	0	0	0	0	0	0	24	0	0	24	0	0	0	0	0	0	14	0	0	14	38
07:15 AM	0	0	2	0	2	0	33	0	0	33	0	0	0	0	0	4	16	0	0	20	55
07:30 AM	0	0	3	0	3	0	24	0	0	24	0	0	0	0	0	2	6	0	0	8	35
07:45 AM	0	0	2	0	2	0	23	0	0	23	0	0	0	0	0	0	8	0	0	8	33
Total	0	0	7	0	7	0	104	0	0	104	0	0	0	0	0	6	44	0	0	50	161
08:00 AM	0	0	1	0	1	0	12	0	0	12	0	0	0	0	0	2	9	0	0	11	24
08:15 AM	0	0	13	0	13	0	14	0	0	14	0	0	0	0	0	0	11	0	0	11	38



# LSC Transportation Consultants, Inc.

545 E Pikes Peak Ave, Suite 210

Colorado Springs, CO 80905

719-633-2868

File Name

Site Code

Start Date

Page #

## Groups Printed- Unshifted

Start Time	Bent Grass Meadows Southbound					Woodmen Frontage Rd Westbound					Northbound					Woodmen Frontage Rd Eastbound					Int. Total
	Left	Through	Right	Peds	App. Total	Left	Through	Right	Peds	App. Total	Left	Through	Right	Peds	App. Total	Left	Through	Right	Peds	App. Total	
04:00 PM	0	0	2	0	2	0	13	0	0	13	0	0	0	0	0	3	14	0	0	17	32
04:15 PM	0	0	4	0	4	0	11	0	0	11	0	0	0	0	0	1	21	0	0	22	37
04:30 PM	0	0	20	0	20	0	10	0	0	10	0	0	0	0	0	3	16	0	0	19	49
04:45 PM	0	0	12	0	12	0	10	1	0	11	0	0	0	0	0	2	24	0	0	26	49
Total	0	0	38	0	38	0	44	1	0	45	0	0	0	0	0	9	75	0	0	84	167
05:00 PM	0	0	7	0	7	0	10	0	0	10	0	0	0	0	0	0	18	0	0	18	35
05:15 PM	0	0	3	0	3	0	17	0	0	17	0	0	0	0	0	3	17	0	0	20	40
05:30 PM	0	0	2	0	2	0	83	1	0	84	0	0	0	0	0	3	17	0	0	20	106
05:45 PM	0	0	3	0	3	0	25	0	0	25	0	0	0	0	0	1	16	0	0	17	45
Total	0	0	15	0	15	0	135	1	0	136	0	0	0	0	0	7	68	0	0	75	226

# Levels of Service

---



HCM 6th TWSC  
 3: Meridian Rd & Bent Grass Meadows Dr

Existing Traffic  
 AM Peak Hour

Intersection						
Int Delay, s/veh	5.7					
Movement	EBL	EBR	NBL	NBT	SBT	SBR
Lane Configurations	↘	↗	↘	↑↑	↑↑	↗
Traffic Vol, veh/h	68	151	57	657	1538	126
Future Vol, veh/h	68	151	57	657	1538	126
Conflicting Peds, #/hr	0	0	0	0	0	0
Sign Control	Stop	Stop	Free	Free	Free	Free
RT Channelized	-	None	-	None	-	None
Storage Length	0	0	700	-	-	330
Veh in Median Storage, #	1	-	-	0	0	-
Grade, %	0	-	-	0	0	-
Peak Hour Factor	96	96	86	86	88	88
Heavy Vehicles, %	2	2	2	2	2	2
Mvmt Flow	71	157	66	764	1748	143

Major/Minor	Minor2	Major1	Major2			
Conflicting Flow All	2262	874	1891	0	-	0
Stage 1	1748	-	-	-	-	-
Stage 2	514	-	-	-	-	-
Critical Hdwy	6.84	6.94	4.14	-	-	-
Critical Hdwy Stg 1	5.84	-	-	-	-	-
Critical Hdwy Stg 2	5.84	-	-	-	-	-
Follow-up Hdwy	3.52	3.32	2.22	-	-	-
Pot Cap-1 Maneuver	~ 35	293	312	-	-	-
Stage 1	125	-	-	-	-	-
Stage 2	565	-	-	-	-	-
Platoon blocked, %				-	-	-
Mov Cap-1 Maneuver	~ 28	293	312	-	-	-
Mov Cap-2 Maneuver	82	-	-	-	-	-
Stage 1	99	-	-	-	-	-
Stage 2	565	-	-	-	-	-

Approach	EB	NB	SB
HCM Control Delay, s	68.5	1.6	0
HCM LOS	F		

Minor Lane/Major Mvmt	NBL	NBT	EBLn1	EBLn2	SBT	SBR
Capacity (veh/h)	312	-	82	293	-	-
HCM Lane V/C Ratio	0.212	-	0.864	0.537	-	-
HCM Control Delay (s)	19.6	-	152.4	30.7	-	-
HCM Lane LOS	C	-	F	D	-	-
HCM 95th %tile Q(veh)	0.8	-	4.5	3	-	-

Notes  
 ~: Volume exceeds capacity    \$: Delay exceeds 300s    +: Computation Not Defined    \*: All major volume in platoon



HCM 6th TWSC  
 26: Golden Sage Rd & Woodmen Frontage Rd

Existing Traffic  
 AM Peak Hour

Intersection												
Int Delay, s/veh	5.5											
Movement	EBL	EBT	EBR	WBL	WBT	WBR	NBL	NBT	NBR	SBL	SBT	SBR
Lane Configurations		↗			↖			↕			↕	
Traffic Vol, veh/h	0	0	1	184	1	0	4	0	139	0	0	0
Future Vol, veh/h	0	0	1	184	1	0	4	0	139	0	0	0
Conflicting Peds, #/hr	0	0	0	0	0	0	0	0	0	0	0	0
Sign Control	Stop	Stop	Stop	Stop	Stop	Stop	Free	Free	Free	Free	Free	Free
RT Channelized	-	-	None	-	-	None	-	-	None	-	-	None
Storage Length	-	-	-	-	-	-	-	-	-	-	-	-
Veh in Median Storage, #	-	0	-	-	0	-	-	0	-	-	0	-
Grade, %	-	0	-	-	0	-	-	0	-	-	0	-
Peak Hour Factor	78	78	78	83	83	83	65	65	65	92	92	92
Heavy Vehicles, %	2	2	2	2	2	2	2	2	2	2	2	2
Mvmt Flow	0	0	1	222	1	0	6	0	214	0	0	0

Major/Minor	Minor2		Minor1		Major1		Major2					
Conflicting Flow All	-	227	1	121	120	-	1	0	0	214	0	0
Stage 1	-	1	-	119	119	-	-	-	-	-	-	-
Stage 2	-	226	-	2	1	-	-	-	-	-	-	-
Critical Hdwy	-	6.52	6.22	7.12	6.52	-	4.12	-	-	4.12	-	-
Critical Hdwy Stg 1	-	5.52	-	6.12	5.52	-	-	-	-	-	-	-
Critical Hdwy Stg 2	-	5.52	-	6.12	5.52	-	-	-	-	-	-	-
Follow-up Hdwy	-	4.018	3.318	3.518	4.018	-	2.218	-	-	2.218	-	-
Pot Cap-1 Maneuver	0	672	1084	854	770	0	1622	-	-	1356	-	-
Stage 1	0	895	-	885	797	0	-	-	-	-	-	-
Stage 2	0	717	-	1021	895	0	-	-	-	-	-	-
Platoon blocked, %								-	-	-	-	-
Mov Cap-1 Maneuver	-	669	1084	851	767	-	1622	-	-	1356	-	-
Mov Cap-2 Maneuver	-	669	-	851	767	-	-	-	-	-	-	-
Stage 1	-	895	-	881	794	-	-	-	-	-	-	-
Stage 2	-	714	-	1020	895	-	-	-	-	-	-	-

Approach	EB		WB		NB		SB			
HCM Control Delay, s	8.3		10.7		0.2		0			
HCM LOS	A		B							

Minor Lane/Major Mvmt	NBL	NBT	NBR	EBLn1	WBLn1	SBL	SBT	SBR
Capacity (veh/h)	1622	-	-	1084	850	1356	-	-
HCM Lane V/C Ratio	0.004	-	-	0.001	0.262	-	-	-
HCM Control Delay (s)	7.2	0	-	8.3	10.7	0	-	-
HCM Lane LOS	A	A	-	A	B	A	-	-
HCM 95th %tile Q(veh)	0	-	-	0	1.1	0	-	-

**Intersection**

Int Delay, s/veh 2.4

**Movement** EBL EBT WBT WBR SBL SBR

Lane Configurations	↘	↑	↗		↘	
Traffic Vol, veh/h	5	116	86	0	1	28
Future Vol, veh/h	5	116	86	0	1	28
Conflicting Peds, #/hr	0	0	0	0	0	0
Sign Control	Free	Free	Free	Free	Stop	Stop
RT Channelized	-	None	-	None	-	None
Storage Length	155	-	-	-	-	-
Veh in Median Storage, #	-	0	0	-	0	-
Grade, %	-	0	0	-	0	-
Peak Hour Factor	82	82	83	83	35	35
Heavy Vehicles, %	2	2	2	2	2	2
Mvmt Flow	6	141	104	0	3	80

**Major/Minor** Major1 Major2 Minor2

Conflicting Flow All	104	0	-	0	257	104
Stage 1	-	-	-	-	104	-
Stage 2	-	-	-	-	153	-
Critical Hdwy	4.12	-	-	-	6.42	6.22
Critical Hdwy Stg 1	-	-	-	-	5.42	-
Critical Hdwy Stg 2	-	-	-	-	5.42	-
Follow-up Hdwy	2.218	-	-	-	3.518	3.318
Pot Cap-1 Maneuver	1488	-	-	-	732	951
Stage 1	-	-	-	-	920	-
Stage 2	-	-	-	-	875	-
Platoon blocked, %		-	-	-		
Mov Cap-1 Maneuver	1488	-	-	-	729	951
Mov Cap-2 Maneuver	-	-	-	-	729	-
Stage 1	-	-	-	-	916	-
Stage 2	-	-	-	-	875	-

**Approach** EB WB SB

HCM Control Delay, s	0.3	0	9.2
HCM LOS			A

**Minor Lane/Major Mvmt** EBL EBT WBT WBR SBLn1

Capacity (veh/h)	1488	-	-	-	941
HCM Lane V/C Ratio	0.004	-	-	-	0.088
HCM Control Delay (s)	7.4	-	-	-	9.2
HCM Lane LOS	A	-	-	-	A
HCM 95th %tile Q(veh)	0	-	-	-	0.3

HCM 6th TWSC  
 3: Meridian Rd & Bent Grass Meadows Dr

Existing Traffic  
 PM Peak Hour

Intersection						
Int Delay, s/veh	1.9					
Movement	EBL	EBR	NBL	NBT	SBT	SBR
Lane Configurations	↙	↗	↙	↑↑	↑↑	↗
Traffic Vol, veh/h	56	95	83	1345	886	90
Future Vol, veh/h	56	95	83	1345	886	90
Conflicting Peds, #/hr	0	0	0	0	0	0
Sign Control	Stop	Stop	Free	Free	Free	Free
RT Channelized	-	None	-	None	-	None
Storage Length	0	0	700	-	-	330
Veh in Median Storage, #	1	-	-	0	0	-
Grade, %	0	-	-	0	0	-
Peak Hour Factor	86	86	96	96	100	100
Heavy Vehicles, %	2	2	2	2	2	2
Mvmt Flow	65	110	86	1401	886	90

Major/Minor	Minor2	Major1	Major2			
Conflicting Flow All	1759	443	976	0	-	0
Stage 1	886	-	-	-	-	-
Stage 2	873	-	-	-	-	-
Critical Hdwy	6.84	6.94	4.14	-	-	-
Critical Hdwy Stg 1	5.84	-	-	-	-	-
Critical Hdwy Stg 2	5.84	-	-	-	-	-
Follow-up Hdwy	3.52	3.32	2.22	-	-	-
Pot Cap-1 Maneuver	76	562	703	-	-	-
Stage 1	363	-	-	-	-	-
Stage 2	369	-	-	-	-	-
Platoon blocked, %				-	-	-
Mov Cap-1 Maneuver	67	562	703	-	-	-
Mov Cap-2 Maneuver	167	-	-	-	-	-
Stage 1	319	-	-	-	-	-
Stage 2	369	-	-	-	-	-

Approach	EB	NB	SB
HCM Control Delay, s	22.9	0.6	0
HCM LOS	C		

Minor Lane/Major Mvmt	NBL	NBT	EBLn1	EBLn2	SBT	SBR
Capacity (veh/h)	703	-	167	562	-	-
HCM Lane V/C Ratio	0.123	-	0.39	0.197	-	-
HCM Control Delay (s)	10.8	-	39.7	13	-	-
HCM Lane LOS	B	-	E	B	-	-
HCM 95th %tile Q(veh)	0.4	-	1.7	0.7	-	-



Timings  
25: Golden Sage & Woodmen

Existing Traffic  
PM Peak Hour

Lane Group	EBL	EBT	EBR	WBL	WBT	WBR	NBL	NBT	NBR	SBL	SBT
Lane Configurations											
Traffic Volume (vph)	88	1345	44	18	875	67	105	28	23	96	13
Future Volume (vph)	88	1345	44	18	875	67	105	28	23	96	13
Turn Type	Perm	NA	Perm	Perm	NA	Perm	Perm	NA	Perm	Perm	NA
Protected Phases		2			6			8			4
Permitted Phases	2		2	6		6	8		8	4	
Detector Phase	2	2	2	6	6	6	8	8	8	4	4
Switch Phase											
Minimum Initial (s)	4.0	4.0	4.0	4.0	4.0	4.0	4.0	4.0	4.0	4.0	4.0
Minimum Split (s)	11.0	11.0	11.0	11.0	11.0	11.0	21.5	21.5	21.5	21.5	21.5
Total Split (s)	65.0	65.0	65.0	65.0	65.0	65.0	25.0	25.0	25.0	25.0	25.0
Total Split (%)	72.2%	72.2%	72.2%	72.2%	72.2%	72.2%	27.8%	27.8%	27.8%	27.8%	27.8%
Yellow Time (s)	5.0	5.0	5.0	5.0	5.0	5.0	3.5	3.5	3.5	3.5	3.5
All-Red Time (s)	2.0	2.0	2.0	2.0	2.0	2.0	2.0	2.0	2.0	2.0	2.0
Lost Time Adjust (s)	0.0	-3.0	-3.0	-1.0	-3.0	-3.0	-1.0	0.0	0.0	0.0	0.0
Total Lost Time (s)	7.0	4.0	4.0	6.0	4.0	4.0	4.5	5.5	5.5	5.5	5.5
Lead/Lag											
Lead-Lag Optimize?											
Recall Mode	Max	Max	Max	Max	Max	Max	None	None	None	None	None
Act Effct Green (s)	58.1	61.1	61.1	59.1	61.1	61.1	16.2	15.2	15.2	15.2	15.2
Actuated g/C Ratio	0.68	0.71	0.71	0.69	0.71	0.71	0.19	0.18	0.18	0.18	0.18
v/c Ratio	0.25	0.58	0.04	0.11	0.37	0.06	0.69	0.10	0.09	0.71	0.45
Control Delay	8.5	7.7	1.6	7.3	5.8	1.4	52.4	29.6	4.7	49.6	10.6
Queue Delay	0.0	0.0	0.0	0.0	0.0	0.0	0.0	0.0	0.0	0.0	0.0
Total Delay	8.5	7.7	1.6	7.3	5.8	1.4	52.4	29.6	4.7	49.6	10.6
LOS	A	A	A	A	A	A	D	C	A	D	B
Approach Delay		7.6			5.5			41.2			29.0
Approach LOS		A			A			D			C

Intersection Summary

Cycle Length: 90  
 Actuated Cycle Length: 85.8  
 Natural Cycle: 55  
 Control Type: Semi Act-Uncoord  
 Maximum v/c Ratio: 0.71  
 Intersection Signal Delay: 11.3  
 Intersection Capacity Utilization 65.9%  
 Analysis Period (min) 15  
 Intersection LOS: B  
 ICU Level of Service C

Splits and Phases: 25: Golden Sage & Woodmen



Intersection												
Int Delay, s/veh	7.4											
Movement	EBL	EBT	EBR	WBL	WBT	WBR	NBL	NBT	NBR	SBL	SBT	SBR
Lane Configurations		↔			↔			↔			↔	
Traffic Vol, veh/h	0	0	3	200	1	0	2	0	181	0	0	0
Future Vol, veh/h	0	0	3	200	1	0	2	0	181	0	0	0
Conflicting Peds, #/hr	0	0	0	0	0	0	0	0	0	0	0	0
Sign Control	Stop	Stop	Stop	Stop	Stop	Stop	Free	Free	Free	Free	Free	Free
RT Channelized	-	-	None	-	-	None	-	-	None	-	-	None
Storage Length	-	-	-	-	-	-	-	-	-	-	-	-
Veh in Median Storage, #	-	0	-	-	0	-	-	0	-	-	0	-
Grade, %	-	0	-	-	0	-	-	0	-	-	0	-
Peak Hour Factor	78	78	78	58	58	58	83	83	83	92	92	92
Heavy Vehicles, %	2	2	2	2	2	2	2	2	2	2	2	2
Mvmt Flow	0	0	4	345	2	0	2	0	218	0	0	0

Major/Minor	Minor2		Minor1		Major1		Major2					
Conflicting Flow All	-	223	1	116	114	-	1	0	0	218	0	0
Stage 1	-	1	-	113	113	-	-	-	-	-	-	-
Stage 2	-	222	-	3	1	-	-	-	-	-	-	-
Critical Hdwy	-	6.52	6.22	7.12	6.52	-	4.12	-	-	4.12	-	-
Critical Hdwy Stg 1	-	5.52	-	6.12	5.52	-	-	-	-	-	-	-
Critical Hdwy Stg 2	-	5.52	-	6.12	5.52	-	-	-	-	-	-	-
Follow-up Hdwy	-	4.018	3.318	3.518	4.018	-	2.218	-	-	2.218	-	-
Pot Cap-1 Maneuver	0	676	1084	861	776	0	1622	-	-	1352	-	-
Stage 1	0	895	-	892	802	0	-	-	-	-	-	-
Stage 2	0	720	-	1020	895	0	-	-	-	-	-	-
Platoon blocked, %								-	-	-	-	-
Mov Cap-1 Maneuver	-	675	1084	858	775	-	1622	-	-	1352	-	-
Mov Cap-2 Maneuver	-	675	-	858	775	-	-	-	-	-	-	-
Stage 1	-	895	-	891	801	-	-	-	-	-	-	-
Stage 2	-	719	-	1016	895	-	-	-	-	-	-	-

Approach	EB		WB		NB		SB	
HCM Control Delay, s	8.3		12		0.1		0	
HCM LOS	A		B					

Minor Lane/Major Mvmt	NBL	NBT	NBR	EBLn1	WBLn1	SBL	SBT	SBR
Capacity (veh/h)	1622	-	-	1084	858	1352	-	-
HCM Lane V/C Ratio	0.001	-	-	0.004	0.404	-	-	-
HCM Control Delay (s)	7.2	0	-	8.3	12	0	-	-
HCM Lane LOS	A	A	-	A	B	A	-	-
HCM 95th %tile Q(veh)	0	-	-	0	2	0	-	-

Intersection						
Int Delay, s/veh	0.8					
Movement	EBL	EBT	WBT	WBR	SBL	SBR
Lane Configurations						
Traffic Vol, veh/h	8	76	120	1	0	24
Future Vol, veh/h	8	76	120	1	0	24
Conflicting Peds, #/hr	0	0	0	0	0	0
Sign Control	Free	Free	Free	Free	Stop	Stop
RT Channelized	-	None	-	None	-	None
Storage Length	155	-	-	-	-	-
Veh in Median Storage, #	-	0	0	-	0	-
Grade, %	-	0	0	-	0	-
Peak Hour Factor	78	78	36	36	78	78
Heavy Vehicles, %	2	2	2	2	2	2
Mvmt Flow	10	97	333	3	0	31

Major/Minor	Major1	Major2	Minor2		
Conflicting Flow All	336	0	-	0	452 335
Stage 1	-	-	-	-	335 -
Stage 2	-	-	-	-	117 -
Critical Hdwy	4.12	-	-	-	6.42 6.22
Critical Hdwy Stg 1	-	-	-	-	5.42 -
Critical Hdwy Stg 2	-	-	-	-	5.42 -
Follow-up Hdwy	2.218	-	-	-	3.518 3.318
Pot Cap-1 Maneuver	1223	-	-	-	565 707
Stage 1	-	-	-	-	725 -
Stage 2	-	-	-	-	908 -
Platoon blocked, %		-	-	-	
Mov Cap-1 Maneuver	1223	-	-	-	560 707
Mov Cap-2 Maneuver	-	-	-	-	560 -
Stage 1	-	-	-	-	719 -
Stage 2	-	-	-	-	908 -

Approach	EB	WB	SB
HCM Control Delay, s	0.8	0	10.3
HCM LOS			B

Minor Lane/Major Mvmt	EBL	EBT	WBT	WBR	SBLn1
Capacity (veh/h)	1223	-	-	-	707
HCM Lane V/C Ratio	0.008	-	-	-	0.044
HCM Control Delay (s)	8	-	-	-	10.3
HCM Lane LOS	A	-	-	-	B
HCM 95th %tile Q(veh)	0	-	-	-	0.1

Volume  
3: Meridian Rd & Bent Grass Meadows Dr

Short-Term Background Traffic  
AM Peak Hour



Lane Group	EBL	EBR	NBL	NBT	SBT	SBR
Traffic Volume (vph)	112	218	76	711	1671	154
Future Volume (vph)	112	218	76	711	1671	154
Confl. Peds. (#/hr)						
Confl. Bikes (#/hr)						
Peak Hour Factor	0.96	0.96	0.86	0.86	0.88	0.88
Growth Factor	100%	100%	100%	100%	100%	100%
Heavy Vehicles (%)	2%	2%	2%	2%	2%	2%
Bus Blockages (#/hr)	0	0	0	0	0	0
Parking (#/hr)						
Mid-Block Traffic (%)	0%			0%	0%	
Adj. Flow (vph)	117	227	88	827	1899	175
Shared Lane Traffic (%)						
Lane Group Flow (vph)	117	227	88	827	1899	175
<b>Intersection Summary</b>						

Timings  
3: Meridian Rd & Bent Grass Meadows Dr

Short-Term Background Traffic  
AM Peak Hour



Lane Group	EBL	EBR	NBL	NBT	SBT	SBR	Ø4
Lane Configurations	↖↗	↗	↖	↑↑	↑↑	↗	
Traffic Volume (vph)	112	218	76	711	1671	154	
Future Volume (vph)	112	218	76	711	1671	154	
Turn Type	pm+pt	Perm	pm+pt	NA	NA	Perm	
Protected Phases	7		5	2	6		4
Permitted Phases	4	7	2			6	
Detector Phase	7	7	5	2	6	6	
Switch Phase							
Minimum Initial (s)	5.0	5.0	5.0	5.0	5.0	5.0	5.0
Minimum Split (s)	23.0	23.0	10.0	23.0	23.0	23.0	23.0
Total Split (s)	25.0	25.0	15.0	65.0	50.0	50.0	25.0
Total Split (%)	27.8%	27.8%	16.7%	72.2%	55.6%	55.6%	28%
Yellow Time (s)	3.0	3.0	3.0	3.0	3.0	3.0	3.0
All-Red Time (s)	2.0	2.0	2.0	2.0	2.0	2.0	2.0
Lost Time Adjust (s)	0.0	0.0	0.0	0.0	0.0	0.0	
Total Lost Time (s)	5.0	5.0	5.0	5.0	5.0	5.0	
Lead/Lag			Lead		Lag	Lag	
Lead-Lag Optimize?			Yes		Yes	Yes	
Recall Mode	None	None	None	Max	Max	Max	None
Act Effct Green (s)	8.9	8.9	61.1	61.1	51.5	51.5	
Actuated g/C Ratio	0.11	0.11	0.76	0.76	0.64	0.64	
v/c Ratio	0.31	0.64	0.37	0.31	0.83	0.16	
Control Delay	34.1	15.6	9.9	3.5	17.5	1.8	
Queue Delay	0.0	0.0	0.0	0.0	0.0	0.0	
Total Delay	34.1	15.6	9.9	3.5	17.5	1.8	
LOS	C	B	A	A	B	A	
Approach Delay	21.9			4.1	16.1		
Approach LOS	C			A	B		

Intersection Summary





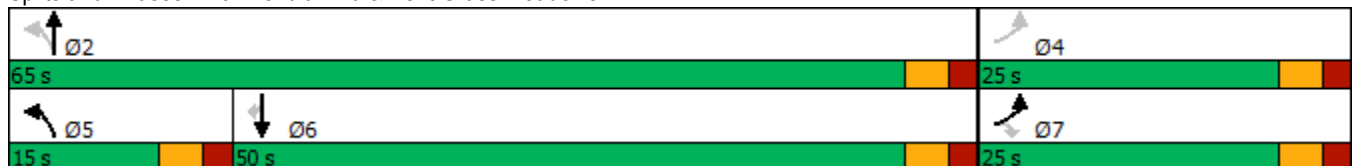







Cycle Length: 90  
 Actuated Cycle Length: 80  
 Natural Cycle: 80  
 Control Type: Semi Act-Uncoord  
 Maximum v/c Ratio: 0.83  
 Intersection Signal Delay: 13.4  
 Intersection LOS: B  
 Intersection Capacity Utilization 68.0%  
 ICU Level of Service C  
 Analysis Period (min) 15

Splits and Phases: 3: Meridian Rd & Bent Grass Meadows Dr



Volume  
25: Golden Sage & Woodmen

Short-Term Background Traffic  
AM Peak Hour

												
Lane Group	EBL	EBT	EBR	WBL	WBT	WBR	NBL	NBT	NBR	SBL	SBT	SBR
Traffic Volume (vph)	143	666	47	23	1416	78	144	17	15	56	23	338
Future Volume (vph)	143	666	47	23	1416	78	144	17	15	56	23	338
Confl. Peds. (#/hr)												
Confl. Bikes (#/hr)												
Peak Hour Factor	0.92	0.92	0.92	0.89	0.89	0.89	0.81	0.81	0.81	0.87	0.87	0.87
Growth Factor	100%	100%	100%	100%	100%	100%	100%	100%	100%	100%	100%	100%
Heavy Vehicles (%)	2%	2%	2%	2%	2%	2%	2%	2%	2%	2%	2%	2%
Bus Blockages (#/hr)	0	0	0	0	0	0	0	0	0	0	0	0
Parking (#/hr)												
Mid-Block Traffic (%)		0%			0%			0%			0%	
Adj. Flow (vph)	155	724	51	26	1591	88	178	21	19	64	26	389
Shared Lane Traffic (%)												
Lane Group Flow (vph)	155	724	51	26	1591	88	178	21	19	64	415	0
Intersection Summary												

Timings  
25: Golden Sage & Woodmen

Short-Term Background Traffic  
AM Peak Hour

Lane Group	EBL	EBT	EBR	WBL	WBT	WBR	NBL	NBT	NBR	SBL	SBT
Lane Configurations											
Traffic Volume (vph)	143	666	47	23	1416	78	144	17	15	56	23
Future Volume (vph)	143	666	47	23	1416	78	144	17	15	56	23
Turn Type	pm+pt	NA	Perm	pm+pt	NA	Perm	pm+pt	NA	Perm	pm+pt	NA
Protected Phases	5	2		1	6		3	8		7	4
Permitted Phases	2		2	6		6	8		8	4	
Detector Phase	5	2	2	1	6	6	3	8	8	7	4
Switch Phase											
Minimum Initial (s)	5.0	4.0	4.0	5.0	4.0	4.0	5.0	4.0	4.0	5.0	4.0
Minimum Split (s)	10.0	11.0	11.0	10.0	11.0	11.0	10.0	21.0	21.0	10.0	21.0
Total Split (s)	13.0	52.0	52.0	10.0	49.0	49.0	13.0	28.0	28.0	10.0	25.0
Total Split (%)	13.0%	52.0%	52.0%	10.0%	49.0%	49.0%	13.0%	28.0%	28.0%	10.0%	25.0%
Yellow Time (s)	3.0	5.0	5.0	3.0	5.0	5.0	3.0	3.0	3.0	3.0	3.0
All-Red Time (s)	2.0	2.0	2.0	2.0	2.0	2.0	2.0	2.0	2.0	2.0	2.0
Lost Time Adjust (s)	0.0	-3.0	-3.0	-1.0	-3.0	-3.0	-1.0	0.0	0.0	0.0	0.0
Total Lost Time (s)	5.0	4.0	4.0	4.0	4.0	4.0	4.0	5.0	5.0	5.0	5.0
Lead/Lag	Lead	Lag	Lag	Lead	Lag	Lag	Lead	Lag	Lag	Lead	Lag
Lead-Lag Optimize?	Yes	Yes	Yes	Yes	Yes	Yes	Yes	Yes	Yes	Yes	Yes
Recall Mode	None	Max	Max	None	Max	Max	None	None	None	None	None
Act Effct Green (s)	56.1	53.9	53.9	51.0	45.0	45.0	28.4	21.6	21.6	26.6	20.0
Actuated g/C Ratio	0.56	0.54	0.54	0.51	0.45	0.45	0.28	0.22	0.22	0.27	0.20
v/c Ratio	0.73	0.38	0.06	0.07	1.00	0.11	0.79	0.05	0.04	0.16	0.98
Control Delay	38.7	14.8	0.1	9.7	50.5	1.3	53.1	31.4	0.2	24.9	67.3
Queue Delay	0.0	0.0	0.0	0.0	0.0	0.0	0.0	0.0	0.0	0.0	0.0
Total Delay	38.7	14.8	0.1	9.7	50.5	1.3	53.1	31.4	0.2	24.9	67.3
LOS	D	B	A	A	D	A	D	C	A	C	E
Approach Delay		18.0			47.4			46.4			61.7
Approach LOS		B			D			D			E

Intersection Summary

Cycle Length: 100	
Actuated Cycle Length: 99.9	
Natural Cycle: 90	
Control Type: Semi Act-Uncoord	
Maximum v/c Ratio: 1.00	
Intersection Signal Delay: 41.2	Intersection LOS: D
Intersection Capacity Utilization 92.1%	ICU Level of Service F
Analysis Period (min) 15	

Splits and Phases: 25: Golden Sage & Woodmen

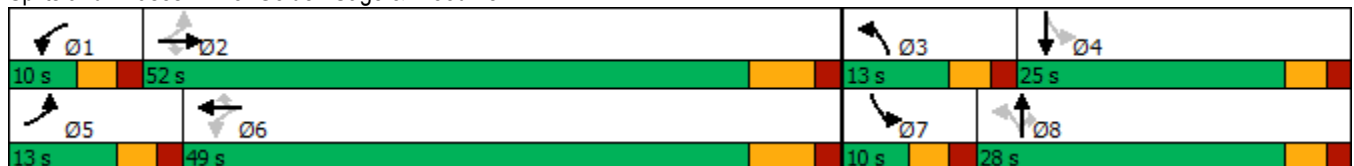

**Intersection**

Int Delay, s/veh 5.5

**Movement** EBT EBR WBL WBT NBL NBR

Lane Configurations	↑	↗	↘	↑	↘	
Traffic Vol, veh/h	190	8	173	57	14	141
Future Vol, veh/h	190	8	173	57	14	141
Conflicting Peds, #/hr	0	0	0	0	0	0
Sign Control	Free	Free	Free	Free	Stop	Stop
RT Channelized	-	None	-	None	-	None
Storage Length	-	150	120	-	0	-
Veh in Median Storage, #	0	-	-	0	0	-
Grade, %	0	-	-	0	0	-
Peak Hour Factor	85	85	85	85	85	85
Heavy Vehicles, %	2	2	2	2	2	2
Mvmt Flow	224	9	204	67	16	166

**Major/Minor** Major1 Major2 Minor1

Conflicting Flow All	0	0	233	0	699	224
Stage 1	-	-	-	-	224	-
Stage 2	-	-	-	-	475	-
Critical Hdwy	-	-	4.12	-	6.42	6.22
Critical Hdwy Stg 1	-	-	-	-	5.42	-
Critical Hdwy Stg 2	-	-	-	-	5.42	-
Follow-up Hdwy	-	-	2.218	-	3.518	3.318
Pot Cap-1 Maneuver	-	-	1335	-	406	815
Stage 1	-	-	-	-	813	-
Stage 2	-	-	-	-	626	-
Platoon blocked, %	-	-	-	-	-	-
Mov Cap-1 Maneuver	-	-	1335	-	344	815
Mov Cap-2 Maneuver	-	-	-	-	344	-
Stage 1	-	-	-	-	813	-
Stage 2	-	-	-	-	530	-

**Approach** EB WB NB

HCM Control Delay, s	0	6.2	11.6
HCM LOS			B

**Minor Lane/Major Mvmt** NBLn1 EBT EBR WBL WBT

Capacity (veh/h)	725	-	-	1335	-
HCM Lane V/C Ratio	0.252	-	-	0.152	-
HCM Control Delay (s)	11.6	-	-	8.2	-
HCM Lane LOS	B	-	-	A	-
HCM 95th %tile Q(veh)	1	-	-	0.5	-



Intersection												
Int Delay, s/veh	10.9											
Movement	EBL	EBT	EBR	WBL	WBT	WBR	NBL	NBT	NBR	SBL	SBT	SBR
Lane Configurations		↗			↖			↕			↕	
Traffic Vol, veh/h	0	0	33	383	1	0	22	0	216	0	0	0
Future Vol, veh/h	0	0	33	383	1	0	22	0	216	0	0	0
Conflicting Peds, #/hr	0	0	0	0	0	0	0	0	0	0	0	0
Sign Control	Stop	Stop	Stop	Stop	Stop	Stop	Free	Free	Free	Free	Free	Free
RT Channelized	-	-	None	-	-	None	-	-	None	-	-	None
Storage Length	-	-	-	-	-	-	-	-	-	-	-	-
Veh in Median Storage, #	-	0	-	-	0	-	-	0	-	-	0	-
Grade, %	-	0	-	-	0	-	-	0	-	-	0	-
Peak Hour Factor	78	78	78	87	87	87	87	87	87	92	92	92
Heavy Vehicles, %	2	2	2	2	2	2	2	2	2	2	2	2
Mvmt Flow	0	0	42	440	1	0	25	0	248	0	0	0

Major/Minor	Minor2		Minor1		Major1		Major2					
Conflicting Flow All	-	299	1	196	175	-	1	0	0	248	0	0
Stage 1	-	1	-	174	174	-	-	-	-	-	-	-
Stage 2	-	298	-	22	1	-	-	-	-	-	-	-
Critical Hdwy	-	6.52	6.22	7.12	6.52	-	4.12	-	-	4.12	-	-
Critical Hdwy Stg 1	-	5.52	-	6.12	5.52	-	-	-	-	-	-	-
Critical Hdwy Stg 2	-	5.52	-	6.12	5.52	-	-	-	-	-	-	-
Follow-up Hdwy	-	4.018	3.318	3.518	4.018	-	2.218	-	-	2.218	-	-
Pot Cap-1 Maneuver	0	613	1084	763	718	0	1622	-	-	1318	-	-
Stage 1	0	895	-	828	755	0	-	-	-	-	-	-
Stage 2	0	667	-	996	895	0	-	-	-	-	-	-
Platoon blocked, %								-	-	-	-	-
Mov Cap-1 Maneuver	-	602	1084	723	705	-	1622	-	-	1318	-	-
Mov Cap-2 Maneuver	-	602	-	723	705	-	-	-	-	-	-	-
Stage 1	-	895	-	813	741	-	-	-	-	-	-	-
Stage 2	-	655	-	957	895	-	-	-	-	-	-	-

Approach	EB		WB		NB		SB	
HCM Control Delay, s	8.5		17.5		0.7		0	
HCM LOS	A		C					

Minor Lane/Major Mvmt	NBL	NBT	NBR	EBLn1	WBLn1	SBL	SBT	SBR
Capacity (veh/h)	1622	-	-	1084	723	1318	-	-
HCM Lane V/C Ratio	0.016	-	-	0.039	0.61	-	-	-
HCM Control Delay (s)	7.3	0	-	8.5	17.5	0	-	-
HCM Lane LOS	A	A	-	A	C	A	-	-
HCM 95th %tile Q(veh)	0	-	-	0.1	4.2	0	-	-

**Intersection**

Int Delay, s/veh 7.2

**Movement** WBL WBR NBT NBR SBL SBT

Lane Configurations	W					
Traffic Vol, veh/h	0	143	12	0	152	29
Future Vol, veh/h	0	143	12	0	152	29
Conflicting Peds, #/hr	0	0	0	0	0	0
Sign Control	Stop	Stop	Free	Free	Free	Free
RT Channelized	-	None	-	None	-	None
Storage Length	0	-	-	-	-	-
Veh in Median Storage, #	0	-	0	-	-	0
Grade, %	0	-	0	-	-	0
Peak Hour Factor	85	85	85	85	85	85
Heavy Vehicles, %	2	2	2	2	2	2
Mvmt Flow	0	168	14	0	179	34

**Major/Minor** Minor1 Major1 Major2

Conflicting Flow All	406	14	0	0	14	0
Stage 1	14	-	-	-	-	-
Stage 2	392	-	-	-	-	-
Critical Hdwy	6.42	6.22	-	-	4.12	-
Critical Hdwy Stg 1	5.42	-	-	-	-	-
Critical Hdwy Stg 2	5.42	-	-	-	-	-
Follow-up Hdwy	3.518	3.318	-	-	2.218	-
Pot Cap-1 Maneuver	601	1066	-	-	1604	-
Stage 1	1009	-	-	-	-	-
Stage 2	683	-	-	-	-	-
Platoon blocked, %			-	-		
Mov Cap-1 Maneuver	532	1066	-	-	1604	-
Mov Cap-2 Maneuver	532	-	-	-	-	-
Stage 1	1009	-	-	-	-	-
Stage 2	605	-	-	-	-	-

**Approach** WB NB SB

HCM Control Delay, s	9	0	6.3
HCM LOS	A		

**Minor Lane/Major Mvmt** NBT NBRWBLn1 SBL SBT

Capacity (veh/h)	-	-	1066	1604	-
HCM Lane V/C Ratio	-	-	0.158	0.111	-
HCM Control Delay (s)	-	-	9	7.5	0
HCM Lane LOS	-	-	A	A	A
HCM 95th %tile Q(veh)	-	-	0.6	0.4	-

Intersection						
Int Delay, s/veh	4.6					
Movement	EBL	EBT	WBT	WBR	SBL	SBR
Lane Configurations	↙	↑	↘		↙	↘
Traffic Vol, veh/h	55	143	133	21	18	180
Future Vol, veh/h	55	143	133	21	18	180
Conflicting Peds, #/hr	0	0	0	0	0	0
Sign Control	Free	Free	Free	Free	Stop	Stop
RT Channelized	-	None	-	None	-	None
Storage Length	155	-	-	-	155	0
Veh in Median Storage, #	-	0	0	-	0	-
Grade, %	-	0	0	-	0	-
Peak Hour Factor	82	82	83	83	83	83
Heavy Vehicles, %	2	2	2	2	2	2
Mvmt Flow	67	174	160	25	22	217

Major/Minor	Major1	Major2	Minor2		
Conflicting Flow All	185	0	-	0	481 173
Stage 1	-	-	-	-	173 -
Stage 2	-	-	-	-	308 -
Critical Hdwy	4.12	-	-	-	6.42 6.22
Critical Hdwy Stg 1	-	-	-	-	5.42 -
Critical Hdwy Stg 2	-	-	-	-	5.42 -
Follow-up Hdwy	2.218	-	-	-	3.518 3.318
Pot Cap-1 Maneuver	1390	-	-	-	544 871
Stage 1	-	-	-	-	857 -
Stage 2	-	-	-	-	745 -
Platoon blocked, %		-	-	-	
Mov Cap-1 Maneuver	1390	-	-	-	518 871
Mov Cap-2 Maneuver	-	-	-	-	518 -
Stage 1	-	-	-	-	816 -
Stage 2	-	-	-	-	745 -

Approach	EB	WB	SB
HCM Control Delay, s	2.1	0	10.7
HCM LOS			B

Minor Lane/Major Mvmt	EBL	EBT	WBT	WBR	SBLn1	SBLn2
Capacity (veh/h)	1390	-	-	-	518	871
HCM Lane V/C Ratio	0.048	-	-	-	0.042	0.249
HCM Control Delay (s)	7.7	-	-	-	12.3	10.5
HCM Lane LOS	A	-	-	-	B	B
HCM 95th %tile Q(veh)	0.2	-	-	-	0.1	1

Volume  
3: Meridian Rd & Bent Grass Meadows Dr

Short-Term Background Traffic  
PM Peak Hour



Lane Group	EBL	EBR	NBL	NBT	SBT	SBR
Traffic Volume (vph)	99	148	142	1464	957	138
Future Volume (vph)	99	148	142	1464	957	138
Confl. Peds. (#/hr)						
Confl. Bikes (#/hr)						
Peak Hour Factor	0.86	0.86	0.96	0.96	1.00	1.00
Growth Factor	100%	100%	100%	100%	100%	100%
Heavy Vehicles (%)	2%	2%	2%	2%	2%	2%
Bus Blockages (#/hr)	0	0	0	0	0	0
Parking (#/hr)						
Mid-Block Traffic (%)	0%			0%	0%	
Adj. Flow (vph)	115	172	148	1525	957	138
Shared Lane Traffic (%)						
Lane Group Flow (vph)	115	172	148	1525	957	138
<b>Intersection Summary</b>						

Timings  
3: Meridian Rd & Bent Grass Meadows Dr

Short-Term Background Traffic  
PM Peak Hour



Lane Group	EBL	EBR	NBL	NBT	SBT	SBR
Lane Configurations	↖↗	↖	↖	↕↕	↕↕	↖
Traffic Volume (vph)	99	148	142	1464	957	138
Future Volume (vph)	99	148	142	1464	957	138
Turn Type	pm+pt	Perm	pm+pt	NA	NA	Perm
Protected Phases	7		5	2	6	
Permitted Phases	4	4	2			6
Detector Phase	7	4	5	2	6	6
Switch Phase						
Minimum Initial (s)	5.0	5.0	5.0	5.0	5.0	5.0
Minimum Split (s)	23.0	23.0	10.0	23.0	23.0	23.0
Total Split (s)	25.0	25.0	15.0	65.0	50.0	50.0
Total Split (%)	27.8%	27.8%	16.7%	72.2%	55.6%	55.6%
Yellow Time (s)	3.0	3.0	3.0	3.0	3.0	3.0
All-Red Time (s)	2.0	2.0	2.0	2.0	2.0	2.0
Lost Time Adjust (s)	0.0	0.0	0.0	0.0	0.0	0.0
Total Lost Time (s)	5.0	5.0	5.0	5.0	5.0	5.0
Lead/Lag			Lead		Lag	Lag
Lead-Lag Optimize?			Yes		Yes	Yes
Recall Mode	None	None	None	Max	Max	Max
Act Effct Green (s)	8.2	8.2	60.0	60.0	47.8	47.8
Actuated g/C Ratio	0.10	0.10	0.77	0.77	0.61	0.61
v/c Ratio	0.32	0.54	0.33	0.56	0.44	0.14
Control Delay	34.7	12.5	4.5	4.9	9.3	1.9
Queue Delay	0.0	0.0	0.0	0.0	0.0	0.0
Total Delay	34.7	12.5	4.5	4.9	9.3	1.9
LOS	C	B	A	A	A	A
Approach Delay	21.4			4.8	8.4	
Approach LOS	C			A	A	

Intersection Summary













Cycle Length: 90  
 Actuated Cycle Length: 78.2  
 Natural Cycle: 60  
 Control Type: Semi Act-Uncoord  
 Maximum v/c Ratio: 0.56  
 Intersection Signal Delay: 7.7  
 Intersection Capacity Utilization 53.0%  
 Analysis Period (min) 15  
 Intersection LOS: A  
 ICU Level of Service A

Splits and Phases: 3: Meridian Rd & Bent Grass Meadows Dr



Volume  
25: Golden Sage & Woodmen

Short-Term Background Traffic  
PM Peak Hour

												
Lane Group	EBL	EBT	EBR	WBL	WBT	WBR	NBL	NBT	NBR	SBL	SBT	SBR
Traffic Volume (vph)	338	1342	53	39	918	83	113	36	41	102	20	245
Future Volume (vph)	338	1342	53	39	918	83	113	36	41	102	20	245
Confl. Peds. (#/hr)												
Confl. Bikes (#/hr)												
Peak Hour Factor	0.92	0.92	0.92	0.93	0.93	0.93	0.83	0.83	0.83	0.87	0.87	0.87
Growth Factor	90%	100%	100%	100%	100%	100%	100%	100%	100%	100%	100%	100%
Heavy Vehicles (%)	2%	2%	2%	2%	2%	2%	2%	2%	2%	2%	2%	2%
Bus Blockages (#/hr)	0	0	0	0	0	0	0	0	0	0	0	0
Parking (#/hr)												
Mid-Block Traffic (%)		0%			0%			0%			0%	
Adj. Flow (vph)	331	1459	58	42	987	89	136	43	49	117	23	282
Shared Lane Traffic (%)												
Lane Group Flow (vph)	331	1459	58	42	987	89	136	43	49	117	305	0

Intersection Summary

Timings  
25: Golden Sage & Woodmen

Short-Term Background Traffic  
PM Peak Hour

Lane Group	EBL	EBT	EBR	WBL	WBT	WBR	NBL	NBT	NBR	SBL	SBT
Lane Configurations											
Traffic Volume (vph)	338	1342	53	39	918	83	113	36	41	102	20
Future Volume (vph)	338	1342	53	39	918	83	113	36	41	102	20
Turn Type	pm+pt	NA	Perm	pm+pt	NA	Perm	pm+pt	NA	Perm	pm+pt	NA
Protected Phases	5	2		1	6		3	8		7	4
Permitted Phases	2		2	6		6	8		8	4	
Detector Phase	5	2	2	1	6	6	3	8	8	7	4
Switch Phase											
Minimum Initial (s)	5.0	4.0	4.0	5.0	4.0	4.0	5.0	4.0	4.0	5.0	4.0
Minimum Split (s)	10.0	11.0	11.0	10.0	11.0	11.0	10.0	21.0	21.0	10.0	21.0
Total Split (s)	18.0	54.0	54.0	10.0	46.0	46.0	15.0	21.0	21.0	15.0	21.0
Total Split (%)	18.0%	54.0%	54.0%	10.0%	46.0%	46.0%	15.0%	21.0%	21.0%	15.0%	21.0%
Yellow Time (s)	3.0	5.0	5.0	3.0	5.0	5.0	3.0	3.0	3.0	3.0	3.0
All-Red Time (s)	2.0	2.0	2.0	2.0	2.0	2.0	2.0	2.0	2.0	2.0	2.0
Lost Time Adjust (s)	0.0	-3.0	-3.0	-1.0	-3.0	-3.0	-1.0	0.0	0.0	0.0	0.0
Total Lost Time (s)	5.0	4.0	4.0	4.0	4.0	4.0	4.0	5.0	5.0	5.0	5.0
Lead/Lag	Lead	Lag	Lag	Lead	Lag	Lag	Lead	Lag	Lag	Lead	Lag
Lead-Lag Optimize?	Yes	Yes	Yes	Yes	Yes	Yes	Yes	Yes	Yes	Yes	Yes
Recall Mode	None	Max	Max	None	Max	Max	None	None	None	None	None
Act Effct Green (s)	59.1	54.3	54.3	48.1	42.1	42.1	22.2	12.7	12.7	18.9	9.8
Actuated g/C Ratio	0.63	0.58	0.58	0.51	0.45	0.45	0.24	0.14	0.14	0.20	0.10
v/c Ratio	0.86	0.71	0.06	0.21	0.62	0.11	0.51	0.17	0.12	0.37	0.78
Control Delay	38.3	18.4	0.1	10.8	22.4	0.3	33.7	39.1	0.7	30.6	23.6
Queue Delay	0.0	0.0	0.0	0.0	0.0	0.0	0.0	0.0	0.0	0.0	0.0
Total Delay	38.3	18.4	0.1	10.8	22.4	0.3	33.7	39.1	0.7	30.6	23.6
LOS	D	B	A	B	C	A	C	D	A	C	C
Approach Delay		21.4			20.2			27.6			25.5
Approach LOS		C			C			C			C

Intersection Summary

Cycle Length: 100	
Actuated Cycle Length: 93.4	
Natural Cycle: 80	
Control Type: Semi Act-Uncoord	
Maximum v/c Ratio: 0.86	
Intersection Signal Delay: 21.9	Intersection LOS: C
Intersection Capacity Utilization 79.7%	ICU Level of Service D
Analysis Period (min) 15	

Splits and Phases: 25: Golden Sage & Woodmen



Intersection						
Int Delay, s/veh	4.6					
Movement	EBT	EBR	WBL	WBT	NBL	NBR
Lane Configurations	↑	↗	↘	↑	↘	↗
Traffic Vol, veh/h	113	1	124	154	12	134
Future Vol, veh/h	113	1	124	154	12	134
Conflicting Peds, #/hr	0	0	0	0	0	0
Sign Control	Free	Free	Free	Free	Stop	Stop
RT Channelized	-	None	-	None	-	None
Storage Length	-	150	120	-	0	-
Veh in Median Storage, #	0	-	-	0	0	-
Grade, %	0	-	-	0	0	-
Peak Hour Factor	85	85	85	85	85	85
Heavy Vehicles, %	2	2	2	2	2	2
Mvmt Flow	133	1	146	181	14	158

Major/Minor	Major1	Major2	Minor1		
Conflicting Flow All	0	0	134	0	606
Stage 1	-	-	-	-	133
Stage 2	-	-	-	-	473
Critical Hdwy	-	-	4.12	-	6.42
Critical Hdwy Stg 1	-	-	-	-	5.42
Critical Hdwy Stg 2	-	-	-	-	5.42
Follow-up Hdwy	-	-	2.218	-	3.518
Pot Cap-1 Maneuver	-	-	1451	-	460
Stage 1	-	-	-	-	893
Stage 2	-	-	-	-	627
Platoon blocked, %	-	-	-	-	-
Mov Cap-1 Maneuver	-	-	1451	-	414
Mov Cap-2 Maneuver	-	-	-	-	414
Stage 1	-	-	-	-	893
Stage 2	-	-	-	-	564

Approach	EB	WB	NB
HCM Control Delay, s	0	3.5	10.4
HCM LOS			B

Minor Lane/Major Mvmt	NBLn1	EBT	EBR	WBL	WBT
Capacity (veh/h)	833	-	-	1451	-
HCM Lane V/C Ratio	0.206	-	-	0.101	-
HCM Control Delay (s)	10.4	-	-	7.8	-
HCM Lane LOS	B	-	-	A	-
HCM 95th %tile Q(veh)	0.8	-	-	0.3	-



Intersection												
Int Delay, s/veh	11.9											
Movement	EBL	EBT	EBR	WBL	WBT	WBR	NBL	NBT	NBR	SBL	SBT	SBR
Lane Configurations		↗			↖			↔			↔	
Traffic Vol, veh/h	0	0	53	312	1	0	60	0	396	0	0	0
Future Vol, veh/h	0	0	53	312	1	0	60	0	396	0	0	0
Conflicting Peds, #/hr	0	0	0	0	0	0	0	0	0	0	0	0
Sign Control	Stop	Stop	Stop	Stop	Stop	Stop	Free	Free	Free	Free	Free	Free
RT Channelized	-	-	None	-	-	None	-	-	None	-	-	None
Storage Length	-	-	-	-	-	-	-	-	-	-	-	-
Veh in Median Storage, #	-	0	-	-	0	-	-	0	-	-	0	-
Grade, %	-	0	-	-	0	-	-	0	-	-	0	-
Peak Hour Factor	78	78	78	87	87	87	87	87	87	92	92	92
Heavy Vehicles, %	2	2	2	2	2	2	2	2	2	2	2	2
Mvmt Flow	0	0	68	359	1	0	69	0	455	0	0	0

Major/Minor	Minor2		Minor1		Major1		Major2					
Conflicting Flow All	-	594	1	401	367	-	1	0	0	455	0	0
Stage 1	-	1	-	366	366	-	-	-	-	-	-	-
Stage 2	-	593	-	35	1	-	-	-	-	-	-	-
Critical Hdwy	-	6.52	6.22	7.12	6.52	-	4.12	-	-	4.12	-	-
Critical Hdwy Stg 1	-	5.52	-	6.12	5.52	-	-	-	-	-	-	-
Critical Hdwy Stg 2	-	5.52	-	6.12	5.52	-	-	-	-	-	-	-
Follow-up Hdwy	-	4.018	3.318	3.518	4.018	-	2.218	-	-	2.218	-	-
Pot Cap-1 Maneuver	0	418	1084	560	562	0	1622	-	-	1106	-	-
Stage 1	0	895	-	653	623	0	-	-	-	-	-	-
Stage 2	0	493	-	981	895	0	-	-	-	-	-	-
Platoon blocked, %								-	-	-	-	-
Mov Cap-1 Maneuver	-	393	1084	501	528	-	1622	-	-	1106	-	-
Mov Cap-2 Maneuver	-	393	-	501	528	-	-	-	-	-	-	-
Stage 1	-	895	-	613	585	-	-	-	-	-	-	-
Stage 2	-	463	-	920	895	-	-	-	-	-	-	-

Approach	EB		WB		NB		SB	
HCM Control Delay, s	8.5		28.4		1		0	
HCM LOS	A		D					

Minor Lane/Major Mvmt	NBL	NBT	NBR	EBLn1	WBLn1	SBL	SBT	SBR
Capacity (veh/h)	1622	-	-	1084	501	1106	-	-
HCM Lane V/C Ratio	0.043	-	-	0.063	0.718	-	-	-
HCM Control Delay (s)	7.3	0	-	8.5	28.4	0	-	-
HCM Lane LOS	A	A	-	A	D	A	-	-
HCM 95th %tile Q(veh)	0.1	-	-	0.2	5.8	0	-	-

**Intersection**

Int Delay, s/veh 6.8

**Movement** WBL WBR NBT NBR SBL SBT

Lane Configurations	W					
Traffic Vol, veh/h	0	116	30	0	107	18
Future Vol, veh/h	0	116	30	0	107	18
Conflicting Peds, #/hr	0	0	0	0	0	0
Sign Control	Stop	Stop	Free	Free	Free	Free
RT Channelized	-	None	-	None	-	None
Storage Length	0	-	-	-	-	-
Veh in Median Storage, #	0	-	0	-	-	0
Grade, %	0	-	0	-	-	0
Peak Hour Factor	85	85	85	85	85	85
Heavy Vehicles, %	2	2	2	2	2	2
Mvmt Flow	0	136	35	0	126	21

**Major/Minor** Minor1 Major1 Major2

Conflicting Flow All	308	35	0	0	35	0
Stage 1	35	-	-	-	-	-
Stage 2	273	-	-	-	-	-
Critical Hdwy	6.42	6.22	-	-	4.12	-
Critical Hdwy Stg 1	5.42	-	-	-	-	-
Critical Hdwy Stg 2	5.42	-	-	-	-	-
Follow-up Hdwy	3.518	3.318	-	-	2.218	-
Pot Cap-1 Maneuver	684	1038	-	-	1576	-
Stage 1	987	-	-	-	-	-
Stage 2	773	-	-	-	-	-
Platoon blocked, %			-	-		-
Mov Cap-1 Maneuver	629	1038	-	-	1576	-
Mov Cap-2 Maneuver	629	-	-	-	-	-
Stage 1	987	-	-	-	-	-
Stage 2	710	-	-	-	-	-

**Approach** WB NB SB

HCM Control Delay, s	9	0	6.4
HCM LOS	A		

**Minor Lane/Major Mvmt** NBT NBRWBLn1 SBL SBT

Capacity (veh/h)	-	-	1038	1576	-
HCM Lane V/C Ratio	-	-	0.131	0.08	-
HCM Control Delay (s)	-	-	9	7.5	0
HCM Lane LOS	-	-	A	A	A
HCM 95th %tile Q(veh)	-	-	0.5	0.3	-

Intersection						
Int Delay, s/veh	4.4					
Movement	EBL	EBT	WBT	WBR	SBL	SBR
Lane Configurations	↘	↑	↗		↘	↗
Traffic Vol, veh/h	160	143	147	49	14	113
Future Vol, veh/h	160	143	147	49	14	113
Conflicting Peds, #/hr	0	0	0	0	0	0
Sign Control	Free	Free	Free	Free	Stop	Stop
RT Channelized	-	None	-	None	-	None
Storage Length	155	-	-	-	155	0
Veh in Median Storage, #	-	0	0	-	0	-
Grade, %	-	0	0	-	0	-
Peak Hour Factor	87	87	83	83	78	78
Heavy Vehicles, %	2	2	2	2	2	2
Mvmt Flow	184	164	177	59	18	145

Major/Minor	Major1	Major2	Minor2		
Conflicting Flow All	236	0	-	0	739 207
Stage 1	-	-	-	-	207 -
Stage 2	-	-	-	-	532 -
Critical Hdwy	4.12	-	-	-	6.42 6.22
Critical Hdwy Stg 1	-	-	-	-	5.42 -
Critical Hdwy Stg 2	-	-	-	-	5.42 -
Follow-up Hdwy	2.218	-	-	-	3.518 3.318
Pot Cap-1 Maneuver	1331	-	-	-	385 833
Stage 1	-	-	-	-	828 -
Stage 2	-	-	-	-	589 -
Platoon blocked, %		-	-	-	
Mov Cap-1 Maneuver	1331	-	-	-	332 833
Mov Cap-2 Maneuver	-	-	-	-	332 -
Stage 1	-	-	-	-	714 -
Stage 2	-	-	-	-	589 -

Approach	EB	WB	SB
HCM Control Delay, s	4.3	0	10.9
HCM LOS			B

Minor Lane/Major Mvmt	EBL	EBT	WBT	WBR	SBLn1	SBLn2
Capacity (veh/h)	1331	-	-	-	332	833
HCM Lane V/C Ratio	0.138	-	-	-	0.054	0.174
HCM Control Delay (s)	8.1	-	-	-	16.5	10.2
HCM Lane LOS	A	-	-	-	C	B
HCM 95th %tile Q(veh)	0.5	-	-	-	0.2	0.6

Volume  
3: Meridian Rd & Bent Grass Meadows Dr

Short-Term Total Traffic  
AM Peak Hour



Lane Group	EBL	EBR	NBL	NBT	SBT	SBR
Traffic Volume (vph)	160	293	143	692	1627	243
Future Volume (vph)	160	293	143	692	1627	243
Confl. Peds. (#/hr)						
Confl. Bikes (#/hr)						
Peak Hour Factor	0.96	0.96	0.86	0.86	0.88	0.88
Growth Factor	100%	100%	100%	100%	100%	100%
Heavy Vehicles (%)	2%	2%	2%	2%	2%	2%
Bus Blockages (#/hr)	0	0	0	0	0	0
Parking (#/hr)						
Mid-Block Traffic (%)	0%			0%	0%	
Adj. Flow (vph)	167	305	166	805	1849	276
Shared Lane Traffic (%)						
Lane Group Flow (vph)	167	305	166	805	1849	276
<b>Intersection Summary</b>						

Timings  
3: Meridian Rd & Bent Grass Meadows Dr

Short-Term Total Traffic  
AM Peak Hour



Lane Group	EBL	EBR	NBL	NBT	SBT	SBR	Ø4
Lane Configurations	↖↗	↗	↖	↑↑	↑↑	↗	
Traffic Volume (vph)	160	293	143	692	1627	243	
Future Volume (vph)	160	293	143	692	1627	243	
Turn Type	pm+pt	Perm	pm+pt	NA	NA	Perm	
Protected Phases	7		5	2	6		4
Permitted Phases	4	7	2			6	
Detector Phase	7	7	5	2	6	6	
Switch Phase							
Minimum Initial (s)	5.0	5.0	5.0	5.0	5.0	5.0	5.0
Minimum Split (s)	23.0	23.0	10.0	23.0	23.0	23.0	23.0
Total Split (s)	25.0	25.0	15.0	65.0	50.0	50.0	25.0
Total Split (%)	27.8%	27.8%	16.7%	72.2%	55.6%	55.6%	28%
Yellow Time (s)	3.0	3.0	3.0	3.0	3.0	3.0	3.0
All-Red Time (s)	2.0	2.0	2.0	2.0	2.0	2.0	2.0
Lost Time Adjust (s)	0.0	0.0	0.0	0.0	0.0	0.0	
Total Lost Time (s)	5.0	5.0	5.0	5.0	5.0	5.0	
Lead/Lag			Lead		Lag	Lag	
Lead-Lag Optimize?			Yes		Yes	Yes	
Recall Mode	None	None	None	Max	Max	Max	None
Act Effct Green (s)	12.0	12.0	60.2	60.2	47.0	47.0	
Actuated g/C Ratio	0.15	0.15	0.73	0.73	0.57	0.57	
v/c Ratio	0.33	0.75	0.62	0.31	0.91	0.27	
Control Delay	32.7	24.0	23.6	4.7	26.3	2.3	
Queue Delay	0.0	0.0	0.0	0.0	0.0	0.0	
Total Delay	32.7	24.0	23.6	4.7	26.3	2.3	
LOS	C	C	C	A	C	A	
Approach Delay	27.1			8.0	23.2		
Approach LOS	C			A	C		

Intersection Summary

Cycle Length: 90  
 Actuated Cycle Length: 82.2  
 Natural Cycle: 90  
 Control Type: Semi Act-Uncoord  
 Maximum v/c Ratio: 0.91  
 Intersection Signal Delay: 19.5  
 Intersection Capacity Utilization 71.5%  
 Analysis Period (min) 15  
 Intersection LOS: B  
 ICU Level of Service C

Splits and Phases: 3: Meridian Rd & Bent Grass Meadows Dr

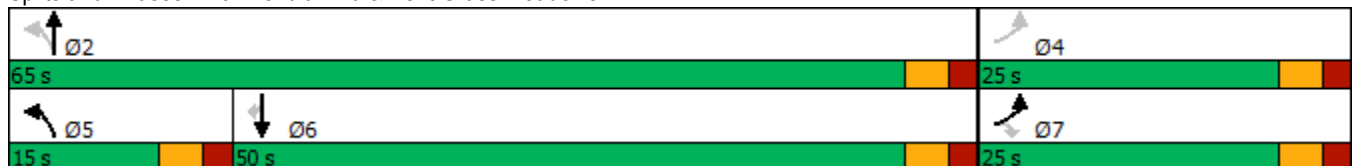

Intersection						
Int Delay, s/veh	2.5					
Movement	EBT	EBR	WBL	WBT	NBL	NBR
Lane Configurations						
Traffic Vol, veh/h	199	6	61	74	4	45
Future Vol, veh/h	199	6	61	74	4	45
Conflicting Peds, #/hr	0	0	0	0	0	0
Sign Control	Free	Free	Free	Free	Stop	Stop
RT Channelized	-	None	-	None	-	None
Storage Length	-	-	110	-	0	0
Veh in Median Storage, #	0	-	-	0	0	-
Grade, %	0	-	-	0	0	-
Peak Hour Factor	85	85	85	85	85	85
Heavy Vehicles, %	2	2	2	2	2	2
Mvmt Flow	234	7	72	87	5	53

Major/Minor	Major1	Major2	Minor1		
Conflicting Flow All	0	0	241	0	469 238
Stage 1	-	-	-	-	238 -
Stage 2	-	-	-	-	231 -
Critical Hdwy	-	-	4.12	-	6.42 6.22
Critical Hdwy Stg 1	-	-	-	-	5.42 -
Critical Hdwy Stg 2	-	-	-	-	5.42 -
Follow-up Hdwy	-	-	2.218	-	3.518 3.318
Pot Cap-1 Maneuver	-	-	1326	-	553 801
Stage 1	-	-	-	-	802 -
Stage 2	-	-	-	-	807 -
Platoon blocked, %	-	-	-	-	-
Mov Cap-1 Maneuver	-	-	1326	-	523 801
Mov Cap-2 Maneuver	-	-	-	-	595 -
Stage 1	-	-	-	-	802 -
Stage 2	-	-	-	-	763 -

Approach	EB	WB	NB
HCM Control Delay, s	0	3.6	9.9
HCM LOS			A

Minor Lane/Major Mvmt	NBLn1	NBLn2	EBT	EBR	WBL	WBT
Capacity (veh/h)	595	801	-	-	1326	-
HCM Lane V/C Ratio	0.008	0.066	-	-	0.054	-
HCM Control Delay (s)	11.1	9.8	-	-	7.9	-
HCM Lane LOS	B	A	-	-	A	-
HCM 95th %tile Q(veh)	0	0.2	-	-	0.2	-

**Intersection**

Int Delay, s/veh 6.8

**Movement** EBT EBR WBL WBT NBL NBR

Lane Configurations	↑	↗	↘	↑	↘	
Traffic Vol, veh/h	234	10	268	118	16	219
Future Vol, veh/h	234	10	268	118	16	219
Conflicting Peds, #/hr	0	0	0	0	0	0
Sign Control	Free	Free	Free	Free	Stop	Stop
RT Channelized	-	None	-	None	-	None
Storage Length	-	150	120	-	0	-
Veh in Median Storage, #	0	-	-	0	0	-
Grade, %	0	-	-	0	0	-
Peak Hour Factor	85	85	85	85	85	85
Heavy Vehicles, %	2	2	2	2	2	2
Mvmt Flow	275	12	315	139	19	258

**Major/Minor** Major1 Major2 Minor1

Conflicting Flow All	0	0	287	0	1044	275
Stage 1	-	-	-	-	275	-
Stage 2	-	-	-	-	769	-
Critical Hdwy	-	-	4.12	-	6.42	6.22
Critical Hdwy Stg 1	-	-	-	-	5.42	-
Critical Hdwy Stg 2	-	-	-	-	5.42	-
Follow-up Hdwy	-	-	2.218	-	3.518	3.318
Pot Cap-1 Maneuver	-	-	1275	-	254	764
Stage 1	-	-	-	-	771	-
Stage 2	-	-	-	-	457	-
Platoon blocked, %	-	-	-	-	-	-
Mov Cap-1 Maneuver	-	-	1275	-	191	764
Mov Cap-2 Maneuver	-	-	-	-	191	-
Stage 1	-	-	-	-	771	-
Stage 2	-	-	-	-	344	-

**Approach** EB WB NB













HCM Control Delay, s	0	6.1	15
HCM LOS			C

**Minor Lane/Major Mvmt** NBLn1 EBT EBR WBL WBT

Capacity (veh/h)	634	-	-	1275	-
HCM Lane V/C Ratio	0.436	-	-	0.247	-
HCM Control Delay (s)	15	-	-	8.7	-
HCM Lane LOS	C	-	-	A	-
HCM 95th %tile Q(veh)	2.2	-	-	1	-

Volume  
25: Golden Sage & Woodmen

Short-Term Total Traffic  
AM Peak Hour

												
Lane Group	EBL	EBT	EBR	WBL	WBT	WBR	NBL	NBT	NBR	SBL	SBT	SBR
Traffic Volume (vph)	147	671	47	23	1419	78	144	18	15	56	24	341
Future Volume (vph)	147	671	47	23	1419	78	144	18	15	56	24	341
Confl. Peds. (#/hr)												
Confl. Bikes (#/hr)												
Peak Hour Factor	0.92	0.92	0.92	0.89	0.89	0.89	0.81	0.81	0.81	0.87	0.87	0.87
Growth Factor	100%	100%	100%	100%	100%	100%	100%	100%	100%	100%	100%	100%
Heavy Vehicles (%)	2%	2%	2%	2%	2%	2%	2%	2%	2%	2%	2%	2%
Bus Blockages (#/hr)	0	0	0	0	0	0	0	0	0	0	0	0
Parking (#/hr)												
Mid-Block Traffic (%)		0%			0%			0%			0%	
Adj. Flow (vph)	160	729	51	26	1594	88	178	22	19	64	28	392
Shared Lane Traffic (%)												
Lane Group Flow (vph)	160	729	51	26	1594	88	178	22	19	64	420	0
Intersection Summary												



Timings  
25: Golden Sage & Woodmen

Short-Term Total Traffic  
AM Peak Hour

Lane Group	EBL	EBT	EBR	WBL	WBT	WBR	NBL	NBT	NBR	SBL	SBT
Lane Configurations											
Traffic Volume (vph)	147	671	47	23	1419	78	144	18	15	56	24
Future Volume (vph)	147	671	47	23	1419	78	144	18	15	56	24
Turn Type	pm+pt	NA	Perm	pm+pt	NA	Perm	pm+pt	NA	Perm	pm+pt	NA
Protected Phases	5	2		1	6		3	8		7	4
Permitted Phases	2		2	6		6	8		8	4	
Detector Phase	5	2	2	1	6	6	3	8	8	7	4
Switch Phase											
Minimum Initial (s)	5.0	4.0	4.0	5.0	4.0	4.0	5.0	4.0	4.0	5.0	4.0
Minimum Split (s)	10.0	11.0	11.0	10.0	11.0	11.0	10.0	21.0	21.0	10.0	21.0
Total Split (s)	13.0	52.0	52.0	10.0	49.0	49.0	13.0	28.0	28.0	10.0	25.0
Total Split (%)	13.0%	52.0%	52.0%	10.0%	49.0%	49.0%	13.0%	28.0%	28.0%	10.0%	25.0%
Yellow Time (s)	3.0	5.0	5.0	3.0	5.0	5.0	3.0	3.0	3.0	3.0	3.0
All-Red Time (s)	2.0	2.0	2.0	2.0	2.0	2.0	2.0	2.0	2.0	2.0	2.0
Lost Time Adjust (s)	0.0	-3.0	-3.0	-1.0	-3.0	-3.0	-1.0	0.0	0.0	0.0	0.0
Total Lost Time (s)	5.0	4.0	4.0	4.0	4.0	4.0	4.0	5.0	5.0	5.0	5.0
Lead/Lag	Lead	Lag	Lag	Lead	Lag	Lag	Lead	Lag	Lag	Lead	Lag
Lead-Lag Optimize?	Yes	Yes	Yes	Yes	Yes	Yes	Yes	Yes	Yes	Yes	Yes
Recall Mode	None	Max	Max	None	Max	Max	None	None	None	None	None
Act Effct Green (s)	56.2	54.0	54.0	51.0	45.0	45.0	28.4	21.6	21.6	26.6	20.0
Actuated g/C Ratio	0.56	0.54	0.54	0.51	0.45	0.45	0.28	0.22	0.22	0.27	0.20
v/c Ratio	0.75	0.38	0.06	0.07	1.00	0.11	0.79	0.05	0.04	0.16	0.99
Control Delay	41.0	14.8	0.1	9.7	51.1	1.3	53.2	31.4	0.2	24.9	69.8
Queue Delay	0.0	0.0	0.0	0.0	0.0	0.0	0.0	0.0	0.0	0.0	0.0
Total Delay	41.0	14.8	0.1	9.7	51.1	1.3	53.2	31.4	0.2	24.9	69.8
LOS	D	B	A	A	D	A	D	C	A	C	E
Approach Delay		18.5			47.9			46.4			63.9
Approach LOS		B			D			D			E

Intersection Summary

Cycle Length: 100	
Actuated Cycle Length: 100	
Natural Cycle: 90	
Control Type: Semi Act-Uncoord	
Maximum v/c Ratio: 1.00	
Intersection Signal Delay: 41.9	Intersection LOS: D
Intersection Capacity Utilization 92.7%	ICU Level of Service F
Analysis Period (min) 15	

Splits and Phases: 25: Golden Sage & Woodmen

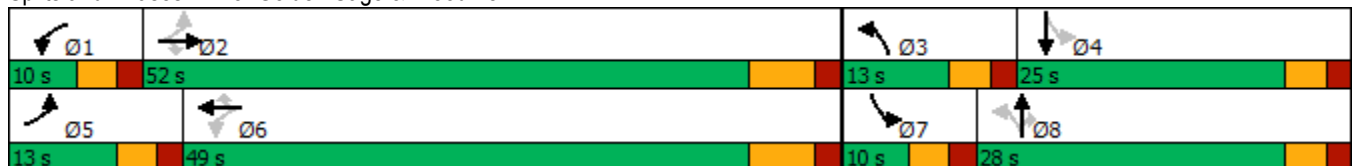

Intersection												
Int Delay, s/veh	11.2											
Movement	EBL	EBT	EBR	WBL	WBT	WBR	NBL	NBT	NBR	SBL	SBT	SBR
Lane Configurations		↗			↖			↔			↔	
Traffic Vol, veh/h	0	1	33	387	2	0	22	0	221	0	0	0
Future Vol, veh/h	0	1	33	387	2	0	22	0	221	0	0	0
Conflicting Peds, #/hr	0	0	0	0	0	0	0	0	0	0	0	0
Sign Control	Stop	Stop	Stop	Stop	Stop	Stop	Free	Free	Free	Free	Free	Free
RT Channelized	-	-	None	-	-	None	-	-	None	-	-	None
Storage Length	-	-	-	-	-	-	-	-	-	-	-	-
Veh in Median Storage, #	-	0	-	-	0	-	-	0	-	-	0	-
Grade, %	-	0	-	-	0	-	-	0	-	-	0	-
Peak Hour Factor	78	78	78	87	87	87	87	87	87	92	92	92
Heavy Vehicles, %	2	2	2	2	2	2	2	2	2	2	2	2
Mvmt Flow	0	1	42	445	2	0	25	0	254	0	0	0

Major/Minor	Minor2		Minor1		Major1		Major2					
Conflicting Flow All	-	305	1	200	178	-	1	0	0	254	0	0
Stage 1	-	1	-	177	177	-	-	-	-	-	-	-
Stage 2	-	304	-	23	1	-	-	-	-	-	-	-
Critical Hdwy	-	6.52	6.22	7.12	6.52	-	4.12	-	-	4.12	-	-
Critical Hdwy Stg 1	-	5.52	-	6.12	5.52	-	-	-	-	-	-	-
Critical Hdwy Stg 2	-	5.52	-	6.12	5.52	-	-	-	-	-	-	-
Follow-up Hdwy	-	4.018	3.318	3.518	4.018	-	2.218	-	-	2.218	-	-
Pot Cap-1 Maneuver	0	608	1084	759	716	0	1622	-	-	1311	-	-
Stage 1	0	895	-	825	753	0	-	-	-	-	-	-
Stage 2	0	663	-	995	895	0	-	-	-	-	-	-
Platoon blocked, %								-	-	-	-	-
Mov Cap-1 Maneuver	-	596	1084	717	702	-	1622	-	-	1311	-	-
Mov Cap-2 Maneuver	-	596	-	717	702	-	-	-	-	-	-	-
Stage 1	-	895	-	809	739	-	-	-	-	-	-	-
Stage 2	-	650	-	955	895	-	-	-	-	-	-	-

Approach	EB		WB		NB		SB	
HCM Control Delay, s	8.5		18		0.7		0	
HCM LOS	A		C					

Minor Lane/Major Mvmt	NBL	NBT	NBR	EBLn1	WBLn1	SBL	SBT	SBR
Capacity (veh/h)	1622	-	-	1059	717	1311	-	-
HCM Lane V/C Ratio	0.016	-	-	0.041	0.624	-	-	-
HCM Control Delay (s)	7.3	0	-	8.5	18	0	-	-
HCM Lane LOS	A	A	-	A	C	A	-	-
HCM 95th %tile Q(veh)	0	-	-	0.1	4.4	0	-	-

HCM 6th TWSC  
 29: Meridian Park Dr & Proposed Site Access/7-Eleven S Access

Short-Term Total Traffic  
 AM Peak Hour

Intersection												
Int Delay, s/veh	7.5											
Movement	EBL	EBT	EBR	WBL	WBT	WBR	NBL	NBT	NBR	SBL	SBT	SBR
Lane Configurations												
Traffic Vol, veh/h	80	0	0	0	0	143	0	12	0	152	29	97
Future Vol, veh/h	80	0	0	0	0	143	0	12	0	152	29	97
Conflicting Peds, #/hr	0	0	0	0	0	0	0	0	0	0	0	0
Sign Control	Stop	Stop	Stop	Stop	Stop	Stop	Free	Free	Free	Free	Free	Free
RT Channelized	-	-	None	-	-	None	-	-	None	-	-	None
Storage Length	0	-	-	-	-	-	-	-	-	-	-	-
Veh in Median Storage, #	-	0	-	-	0	-	-	0	-	-	0	-
Grade, %	-	0	-	-	0	-	-	0	-	-	0	-
Peak Hour Factor	85	85	85	85	85	85	85	85	85	85	85	85
Heavy Vehicles, %	2	2	2	2	2	2	2	2	2	2	2	2
Mvmt Flow	94	0	0	0	0	168	0	14	0	179	34	114

Major/Minor	Minor2		Minor1		Major1		Major2					
Conflicting Flow All	490	406	34	463	520	14	148	0	0	14	0	0
Stage 1	392	392	-	14	14	-	-	-	-	-	-	-
Stage 2	98	14	-	449	506	-	-	-	-	-	-	-
Critical Hdwy	7.12	6.52	6.22	7.12	6.52	6.22	4.12	-	-	4.12	-	-
Critical Hdwy Stg 1	6.12	5.52	-	6.12	5.52	-	-	-	-	-	-	-
Critical Hdwy Stg 2	6.12	5.52	-	6.12	5.52	-	-	-	-	-	-	-
Follow-up Hdwy	3.518	4.018	3.318	3.518	4.018	3.318	2.218	-	-	2.218	-	-
Pot Cap-1 Maneuver	489	534	1039	509	461	1066	1434	-	-	1604	-	-
Stage 1	633	606	-	1006	884	-	-	-	-	-	-	-
Stage 2	908	884	-	589	540	-	-	-	-	-	-	-
Platoon blocked, %								-	-	-	-	-
Mov Cap-1 Maneuver	373	468	1039	461	404	1066	1434	-	-	1604	-	-
Mov Cap-2 Maneuver	373	468	-	461	404	-	-	-	-	-	-	-
Stage 1	633	531	-	1006	884	-	-	-	-	-	-	-
Stage 2	765	884	-	517	474	-	-	-	-	-	-	-

Approach	EB	WB	NB	SB
HCM Control Delay, s	17.9	9	0	4.1
HCM LOS	C	A		

Minor Lane/Major Mvmt	NBL	NBT	NBR	EBLn1	EBLn2	WBLn1	SBL	SBT	SBR
Capacity (veh/h)	1434	-	-	373	-	1066	1604	-	-
HCM Lane V/C Ratio	-	-	-	0.252	-	0.158	0.111	-	-
HCM Control Delay (s)	0	-	-	17.9	0	9	7.5	0	-
HCM Lane LOS	A	-	-	C	A	A	A	A	-
HCM 95th %tile Q(veh)	0	-	-	1	-	0.6	0.4	-	-

Intersection						
Int Delay, s/veh	4.7					
Movement	EBL	EBT	WBT	WBR	SBL	SBR
Lane Configurations	↖	↑	↗		↖	↗
Traffic Vol, veh/h	61	143	133	21	18	185
Future Vol, veh/h	61	143	133	21	18	185
Conflicting Peds, #/hr	0	0	0	0	0	0
Sign Control	Free	Free	Free	Free	Stop	Stop
RT Channelized	-	None	-	None	-	None
Storage Length	155	-	-	-	155	0
Veh in Median Storage, #	-	0	0	-	0	-
Grade, %	-	0	0	-	0	-
Peak Hour Factor	82	82	83	83	83	83
Heavy Vehicles, %	2	2	2	2	2	2
Mvmt Flow	74	174	160	25	22	223

Major/Minor	Major1	Major2	Minor2		
Conflicting Flow All	185	0	-	0	495 173
Stage 1	-	-	-	-	173 -
Stage 2	-	-	-	-	322 -
Critical Hdwy	4.12	-	-	-	6.42 6.22
Critical Hdwy Stg 1	-	-	-	-	5.42 -
Critical Hdwy Stg 2	-	-	-	-	5.42 -
Follow-up Hdwy	2.218	-	-	-	3.518 3.318
Pot Cap-1 Maneuver	1390	-	-	-	534 871
Stage 1	-	-	-	-	857 -
Stage 2	-	-	-	-	735 -
Platoon blocked, %		-	-	-	
Mov Cap-1 Maneuver	1390	-	-	-	506 871
Mov Cap-2 Maneuver	-	-	-	-	506 -
Stage 1	-	-	-	-	812 -
Stage 2	-	-	-	-	735 -

Approach	EB	WB	SB
HCM Control Delay, s	2.3	0	10.7
HCM LOS			B

Minor Lane/Major Mvmt	EBL	EBT	WBT	WBR	SBLn1	SBLn2
Capacity (veh/h)	1390	-	-	-	506	871
HCM Lane V/C Ratio	0.054	-	-	-	0.043	0.256
HCM Control Delay (s)	7.7	-	-	-	12.4	10.5
HCM Lane LOS	A	-	-	-	B	B
HCM 95th %tile Q(veh)	0.2	-	-	-	0.1	1

Volume  
3: Meridian Rd & Bent Grass Meadows Dr

Short-Term Total Traffic  
PM Peak Hour



Lane Group	EBL	EBR	NBL	NBT	SBT	SBR
Traffic Volume (vph)	177	216	218	1428	934	199
Future Volume (vph)	177	216	218	1428	934	199
Confl. Peds. (#/hr)						
Confl. Bikes (#/hr)						
Peak Hour Factor	0.86	0.86	0.96	0.96	1.00	1.00
Growth Factor	100%	100%	100%	100%	100%	100%
Heavy Vehicles (%)	2%	2%	2%	2%	2%	2%
Bus Blockages (#/hr)	0	0	0	0	0	0
Parking (#/hr)						
Mid-Block Traffic (%)	0%			0%	0%	
Adj. Flow (vph)	206	251	227	1488	934	199
Shared Lane Traffic (%)						
Lane Group Flow (vph)	206	251	227	1488	934	199
<b>Intersection Summary</b>						

Timings  
3: Meridian Rd & Bent Grass Meadows Dr

Short-Term Total Traffic  
PM Peak Hour



Lane Group	EBL	EBR	NBL	NBT	SBT	SBR
Lane Configurations	↖↗	↖	↖	↑↑	↑↑	↖
Traffic Volume (vph)	177	216	218	1428	934	199
Future Volume (vph)	177	216	218	1428	934	199
Turn Type	pm+pt	Perm	pm+pt	NA	NA	Perm
Protected Phases	7		5	2	6	
Permitted Phases	4	4	2			6
Detector Phase	7	4	5	2	6	6
Switch Phase						
Minimum Initial (s)	5.0	5.0	5.0	5.0	5.0	5.0
Minimum Split (s)	23.0	23.0	10.0	23.0	23.0	23.0
Total Split (s)	25.0	25.0	15.0	65.0	50.0	50.0
Total Split (%)	27.8%	27.8%	16.7%	72.2%	55.6%	55.6%
Yellow Time (s)	3.0	3.0	3.0	3.0	3.0	3.0
All-Red Time (s)	2.0	2.0	2.0	2.0	2.0	2.0
Lost Time Adjust (s)	0.0	0.0	0.0	0.0	0.0	0.0
Total Lost Time (s)	5.0	5.0	5.0	5.0	5.0	5.0
Lead/Lag			Lead		Lag	Lag
Lead-Lag Optimize?			Yes		Yes	Yes
Recall Mode	None	None	None	Max	Max	Max
Act Effct Green (s)	10.1	10.1	60.1	60.1	46.7	46.7
Actuated g/C Ratio	0.13	0.13	0.75	0.75	0.58	0.58
v/c Ratio	0.48	0.60	0.49	0.56	0.45	0.20
Control Delay	36.2	11.1	6.9	5.6	10.9	2.0
Queue Delay	0.0	0.0	0.0	0.0	0.0	0.0
Total Delay	36.2	11.1	6.9	5.6	10.9	2.0
LOS	D	B	A	A	B	A
Approach Delay	22.4			5.8	9.3	
Approach LOS	C			A	A	

Intersection Summary

Cycle Length: 90  
 Actuated Cycle Length: 80.2  
 Natural Cycle: 60  
 Control Type: Semi Act-Uncoord  
 Maximum v/c Ratio: 0.60  
 Intersection Signal Delay: 9.3  
 Intersection Capacity Utilization 55.4%  
 Analysis Period (min) 15  
 Intersection LOS: A  
 ICU Level of Service B

Splits and Phases: 3: Meridian Rd & Bent Grass Meadows Dr



Intersection						
Int Delay, s/veh	2.4					
Movement	EBT	EBR	WBL	WBT	NBL	NBR
Lane Configurations	↔		↔	↑	↔	↔
Traffic Vol, veh/h	117	6	54	172	6	56
Future Vol, veh/h	117	6	54	172	6	56
Conflicting Peds, #/hr	0	0	0	0	0	0
Sign Control	Free	Free	Free	Free	Stop	Stop
RT Channelized	-	None	-	None	-	None
Storage Length	-	-	110	-	0	0
Veh in Median Storage, #	0	-	-	0	0	-
Grade, %	0	-	-	0	0	-
Peak Hour Factor	85	85	85	85	85	85
Heavy Vehicles, %	2	2	2	2	2	2
Mvmt Flow	138	7	64	202	7	66

Major/Minor	Major1	Major2	Minor1		
Conflicting Flow All	0	0	145	0	472 142
Stage 1	-	-	-	-	142 -
Stage 2	-	-	-	-	330 -
Critical Hdwy	-	-	4.12	-	6.42 6.22
Critical Hdwy Stg 1	-	-	-	-	5.42 -
Critical Hdwy Stg 2	-	-	-	-	5.42 -
Follow-up Hdwy	-	-	2.218	-	3.518 3.318
Pot Cap-1 Maneuver	-	-	1437	-	551 906
Stage 1	-	-	-	-	885 -
Stage 2	-	-	-	-	728 -
Platoon blocked, %	-	-	-	-	-
Mov Cap-1 Maneuver	-	-	1437	-	526 906
Mov Cap-2 Maneuver	-	-	-	-	585 -
Stage 1	-	-	-	-	885 -
Stage 2	-	-	-	-	695 -

Approach	EB	WB	NB
HCM Control Delay, s	0	1.8	9.5
HCM LOS			A

Minor Lane/Major Mvmt	NBLn1	NBLn2	EBT	EBR	WBL	WBT
Capacity (veh/h)	585	906	-	-	1437	-
HCM Lane V/C Ratio	0.012	0.073	-	-	0.044	-
HCM Control Delay (s)	11.2	9.3	-	-	7.6	-
HCM Lane LOS	B	A	-	-	A	-
HCM 95th %tile Q(veh)	0	0.2	-	-	0.1	-

**Intersection**

Int Delay, s/veh 5.8

Movement	EBT	EBR	WBL	WBT	NBL	NBR
Lane Configurations	↑	↗	↘	↑	↘	↗
Traffic Vol, veh/h	169	4	209	208	16	223
Future Vol, veh/h	169	4	209	208	16	223
Conflicting Peds, #/hr	0	0	0	0	0	0
Sign Control	Free	Free	Free	Free	Stop	Stop
RT Channelized	-	None	-	None	-	None
Storage Length	-	150	120	-	0	-
Veh in Median Storage, #	0	-	-	0	0	-
Grade, %	0	-	-	0	0	-
Peak Hour Factor	85	85	85	85	85	85
Heavy Vehicles, %	2	2	2	2	2	2
Mvmt Flow	199	5	246	245	19	262

**Major/Minor**

	Major1	Major2	Minor1		
Conflicting Flow All	0	0	204	0	936
Stage 1	-	-	-	-	199
Stage 2	-	-	-	-	737
Critical Hdwy	-	-	4.12	-	6.42
Critical Hdwy Stg 1	-	-	-	-	5.42
Critical Hdwy Stg 2	-	-	-	-	5.42
Follow-up Hdwy	-	-	2.218	-	3.518
Pot Cap-1 Maneuver	-	-	1368	-	294
Stage 1	-	-	-	-	835
Stage 2	-	-	-	-	473
Platoon blocked, %	-	-	-	-	-
Mov Cap-1 Maneuver	-	-	1368	-	241
Mov Cap-2 Maneuver	-	-	-	-	241
Stage 1	-	-	-	-	835
Stage 2	-	-	-	-	388

**Approach**

	EB	WB	NB
HCM Control Delay, s	0	4.1	13.1
HCM LOS			B













**Minor Lane/Major Mvmt**

	NBLn1	EBT	EBR	WBL	WBT
Capacity (veh/h)	722	-	-	1368	-
HCM Lane V/C Ratio	0.389	-	-	0.18	-
HCM Control Delay (s)	13.1	-	-	8.2	-
HCM Lane LOS	B	-	-	A	-
HCM 95th %tile Q(veh)	1.9	-	-	0.7	-



Volume  
25: Golden Sage & Woodmen

Short-Term Total Traffic  
PM Peak Hour

												
Lane Group	EBL	EBT	EBR	WBL	WBT	WBR	NBL	NBT	NBR	SBL	SBT	SBR
Traffic Volume (vph)	342	1346	53	39	922	83	113	36	41	102	20	250
Future Volume (vph)	342	1346	53	39	922	83	113	36	41	102	20	250
Confl. Peds. (#/hr)												
Confl. Bikes (#/hr)												
Peak Hour Factor	0.92	0.92	0.92	0.93	0.93	0.93	0.83	0.83	0.83	0.87	0.87	0.87
Growth Factor	90%	100%	100%	100%	100%	100%	100%	100%	100%	100%	100%	100%
Heavy Vehicles (%)	2%	2%	2%	2%	2%	2%	2%	2%	2%	2%	2%	2%
Bus Blockages (#/hr)	0	0	0	0	0	0	0	0	0	0	0	0
Parking (#/hr)												
Mid-Block Traffic (%)		0%			0%			0%			0%	
Adj. Flow (vph)	335	1463	58	42	991	89	136	43	49	117	23	287
Shared Lane Traffic (%)												
Lane Group Flow (vph)	335	1463	58	42	991	89	136	43	49	117	310	0
Intersection Summary												

Timings  
25: Golden Sage & Woodmen

Short-Term Total Traffic  
PM Peak Hour

Lane Group	EBL	EBT	EBR	WBL	WBT	WBR	NBL	NBT	NBR	SBL	SBT
Lane Configurations											
Traffic Volume (vph)	342	1346	53	39	922	83	113	36	41	102	20
Future Volume (vph)	342	1346	53	39	922	83	113	36	41	102	20
Turn Type	pm+pt	NA	Perm	pm+pt	NA	Perm	pm+pt	NA	Perm	pm+pt	NA
Protected Phases	5	2		1	6		3	8		7	4
Permitted Phases	2		2	6		6	8		8	4	
Detector Phase	5	2	2	1	6	6	3	8	8	7	4
Switch Phase											
Minimum Initial (s)	5.0	4.0	4.0	5.0	4.0	4.0	5.0	4.0	4.0	5.0	4.0
Minimum Split (s)	10.0	11.0	11.0	10.0	11.0	11.0	10.0	21.0	21.0	10.0	21.0
Total Split (s)	18.0	54.0	54.0	10.0	46.0	46.0	15.0	21.0	21.0	15.0	21.0
Total Split (%)	18.0%	54.0%	54.0%	10.0%	46.0%	46.0%	15.0%	21.0%	21.0%	15.0%	21.0%
Yellow Time (s)	3.0	5.0	5.0	3.0	5.0	5.0	3.0	3.0	3.0	3.0	3.0
All-Red Time (s)	2.0	2.0	2.0	2.0	2.0	2.0	2.0	2.0	2.0	2.0	2.0
Lost Time Adjust (s)	0.0	-3.0	-3.0	-1.0	-3.0	-3.0	-1.0	0.0	0.0	0.0	0.0
Total Lost Time (s)	5.0	4.0	4.0	4.0	4.0	4.0	4.0	5.0	5.0	5.0	5.0
Lead/Lag	Lead	Lag	Lag	Lead	Lag	Lag	Lead	Lag	Lag	Lead	Lag
Lead-Lag Optimize?	Yes	Yes	Yes	Yes	Yes	Yes	Yes	Yes	Yes	Yes	Yes
Recall Mode	None	Max	Max	None	Max	Max	None	None	None	None	None
Act Effct Green (s)	59.1	54.4	54.4	48.1	42.1	42.1	22.5	13.0	13.0	19.2	10.1
Actuated g/C Ratio	0.63	0.58	0.58	0.51	0.45	0.45	0.24	0.14	0.14	0.20	0.11
v/c Ratio	0.88	0.71	0.06	0.21	0.62	0.11	0.51	0.17	0.12	0.37	0.78
Control Delay	40.9	18.7	0.1	10.9	22.6	0.3	33.6	39.0	0.6	30.4	24.4
Queue Delay	0.0	0.0	0.0	0.0	0.0	0.0	0.0	0.0	0.0	0.0	0.0
Total Delay	40.9	18.7	0.1	10.9	22.6	0.3	33.6	39.0	0.6	30.4	24.4
LOS	D	B	A	B	C	A	C	D	A	C	C
Approach Delay		22.1			20.4			27.5			26.0
Approach LOS		C			C			C			C

Intersection Summary

Cycle Length: 100	
Actuated Cycle Length: 93.7	
Natural Cycle: 80	
Control Type: Semi Act-Uncoord	
Maximum v/c Ratio: 0.88	
Intersection Signal Delay: 22.4	Intersection LOS: C
Intersection Capacity Utilization 80.3%	ICU Level of Service D
Analysis Period (min) 15	

Splits and Phases: 25: Golden Sage & Woodmen



Intersection												
Int Delay, s/veh	12.8											
Movement	EBL	EBT	EBR	WBL	WBT	WBR	NBL	NBT	NBR	SBL	SBT	SBR
Lane Configurations		↗			↖			↔			↔	
Traffic Vol, veh/h	0	1	53	319	2	0	60	0	401	0	0	0
Future Vol, veh/h	0	1	53	319	2	0	60	0	401	0	0	0
Conflicting Peds, #/hr	0	0	0	0	0	0	0	0	0	0	0	0
Sign Control	Stop	Stop	Stop	Stop	Stop	Stop	Free	Free	Free	Free	Free	Free
RT Channelized	-	-	None	-	-	None	-	-	None	-	-	None
Storage Length	-	-	-	-	-	-	-	-	-	-	-	-
Veh in Median Storage, #	-	0	-	-	0	-	-	0	-	-	0	-
Grade, %	-	0	-	-	0	-	-	0	-	-	0	-
Peak Hour Factor	78	78	78	87	87	87	87	87	87	92	92	92
Heavy Vehicles, %	2	2	2	2	2	2	2	2	2	2	2	2
Mvmt Flow	0	1	68	367	2	0	69	0	461	0	0	0

Major/Minor	Minor2		Minor1		Major1		Major2					
Conflicting Flow All	-	600	1	405	370	-	1	0	0	461	0	0
Stage 1	-	1	-	369	369	-	-	-	-	-	-	-
Stage 2	-	599	-	36	1	-	-	-	-	-	-	-
Critical Hdwy	-	6.52	6.22	7.12	6.52	-	4.12	-	-	4.12	-	-
Critical Hdwy Stg 1	-	5.52	-	6.12	5.52	-	-	-	-	-	-	-
Critical Hdwy Stg 2	-	5.52	-	6.12	5.52	-	-	-	-	-	-	-
Follow-up Hdwy	-	4.018	3.318	3.518	4.018	-	2.218	-	-	2.218	-	-
Pot Cap-1 Maneuver	0	415	1084	556	560	0	1622	-	-	1100	-	-
Stage 1	0	895	-	651	621	0	-	-	-	-	-	-
Stage 2	0	490	-	980	895	0	-	-	-	-	-	-
Platoon blocked, %								-	-	-	-	-
Mov Cap-1 Maneuver	-	390	1084	495	526	-	1622	-	-	1100	-	-
Mov Cap-2 Maneuver	-	390	-	495	526	-	-	-	-	-	-	-
Stage 1	-	895	-	611	583	-	-	-	-	-	-	-
Stage 2	-	460	-	917	895	-	-	-	-	-	-	-

Approach	EB		WB		NB		SB	
HCM Control Delay, s	8.7		30.6		1		0	
HCM LOS	A		D					

Minor Lane/Major Mvmt	NBL	NBT	NBR	EBLn1	WBLn1	SBL	SBT	SBR
Capacity (veh/h)	1622	-	-	1049	495	1100	-	-
HCM Lane V/C Ratio	0.043	-	-	0.066	0.745	-	-	-
HCM Control Delay (s)	7.3	0	-	8.7	30.6	0	-	-
HCM Lane LOS	A	A	-	A	D	A	-	-
HCM 95th %tile Q(veh)	0.1	-	-	0.2	6.3	0	-	-

HCM 6th TWSC  
 29: Meridian Park Dr & Proposed Site Access/7-Eleven S Access

Short-Term Total Traffic  
 PM Peak Hour

Intersection												
Int Delay, s/veh	7.2											
Movement	EBL	EBT	EBR	WBL	WBT	WBR	NBL	NBT	NBR	SBL	SBT	SBR
Lane Configurations												
Traffic Vol, veh/h	93	0	0	0	0	116	0	30	0	107	18	88
Future Vol, veh/h	93	0	0	0	0	116	0	30	0	107	18	88
Conflicting Peds, #/hr	0	0	0	0	0	0	0	0	0	0	0	0
Sign Control	Stop	Stop	Stop	Stop	Stop	Stop	Free	Free	Free	Free	Free	Free
RT Channelized	-	-	None	-	-	None	-	-	None	-	-	None
Storage Length	0	-	-	-	-	-	-	-	-	-	-	-
Veh in Median Storage, #	-	0	-	-	0	-	-	0	-	-	0	-
Grade, %	-	0	-	-	0	-	-	0	-	-	0	-
Peak Hour Factor	85	85	85	85	85	85	85	85	85	85	85	85
Heavy Vehicles, %	2	2	2	2	2	2	2	2	2	2	2	2
Mvmt Flow	109	0	0	0	0	136	0	35	0	126	21	104

Major/Minor	Minor2		Minor1		Major1		Major2					
Conflicting Flow All	376	308	21	360	412	35	125	0	0	35	0	0
Stage 1	273	273	-	35	35	-	-	-	-	-	-	-
Stage 2	103	35	-	325	377	-	-	-	-	-	-	-
Critical Hdwy	7.12	6.52	6.22	7.12	6.52	6.22	4.12	-	-	4.12	-	-
Critical Hdwy Stg 1	6.12	5.52	-	6.12	5.52	-	-	-	-	-	-	-
Critical Hdwy Stg 2	6.12	5.52	-	6.12	5.52	-	-	-	-	-	-	-
Follow-up Hdwy	3.518	4.018	3.318	3.518	4.018	3.318	2.218	-	-	2.218	-	-
Pot Cap-1 Maneuver	581	606	1056	596	530	1038	1462	-	-	1576	-	-
Stage 1	733	684	-	981	866	-	-	-	-	-	-	-
Stage 2	903	866	-	687	616	-	-	-	-	-	-	-
Platoon blocked, %								-	-	-	-	-
Mov Cap-1 Maneuver	471	553	1056	556	484	1038	1462	-	-	1576	-	-
Mov Cap-2 Maneuver	471	553	-	556	484	-	-	-	-	-	-	-
Stage 1	733	624	-	981	866	-	-	-	-	-	-	-
Stage 2	784	866	-	627	562	-	-	-	-	-	-	-

Approach	EB	WB	NB	SB
HCM Control Delay, s	14.9	9	0	3.8
HCM LOS	B	A		

Minor Lane/Major Mvmt	NBL	NBT	NBR	EBLn1	EBLn2	WBLn1	SBL	SBT	SBR
Capacity (veh/h)	1462	-	-	471	-	1038	1576	-	-
HCM Lane V/C Ratio	-	-	-	0.232	-	0.131	0.08	-	-
HCM Control Delay (s)	0	-	-	14.9	0	9	7.5	0	-
HCM Lane LOS	A	-	-	B	A	A	A	A	-
HCM 95th %tile Q(veh)	0	-	-	0.9	-	0.5	0.3	-	-

Intersection						
Int Delay, s/veh	4.5					
Movement	EBL	EBT	WBT	WBR	SBL	SBR
Lane Configurations	↙	↑	↗		↙	↗
Traffic Vol, veh/h	166	143	147	49	14	120
Future Vol, veh/h	166	143	147	49	14	120
Conflicting Peds, #/hr	0	0	0	0	0	0
Sign Control	Free	Free	Free	Free	Stop	Stop
RT Channelized	-	None	-	None	-	None
Storage Length	155	-	-	-	155	0
Veh in Median Storage, #	-	0	0	-	0	-
Grade, %	-	0	0	-	0	-
Peak Hour Factor	87	87	83	83	78	78
Heavy Vehicles, %	2	2	2	2	2	2
Mvmt Flow	191	164	177	59	18	154

Major/Minor	Major1	Major2	Minor2		
Conflicting Flow All	236	0	-	0	753 207
Stage 1	-	-	-	-	207 -
Stage 2	-	-	-	-	546 -
Critical Hdwy	4.12	-	-	-	6.42 6.22
Critical Hdwy Stg 1	-	-	-	-	5.42 -
Critical Hdwy Stg 2	-	-	-	-	5.42 -
Follow-up Hdwy	2.218	-	-	-	3.518 3.318
Pot Cap-1 Maneuver	1331	-	-	-	377 833
Stage 1	-	-	-	-	828 -
Stage 2	-	-	-	-	580 -
Platoon blocked, %		-	-	-	
Mov Cap-1 Maneuver	1331	-	-	-	323 833
Mov Cap-2 Maneuver	-	-	-	-	323 -
Stage 1	-	-	-	-	709 -
Stage 2	-	-	-	-	580 -

Approach	EB	WB	SB
HCM Control Delay, s	4.4	0	11
HCM LOS			B

Minor Lane/Major Mvmt	EBL	EBT	WBT	WBR	SBLn1	SBLn2
Capacity (veh/h)	1331	-	-	-	323	833
HCM Lane V/C Ratio	0.143	-	-	-	0.056	0.185
HCM Control Delay (s)	8.2	-	-	-	16.8	10.3
HCM Lane LOS	A	-	-	-	C	B
HCM 95th %tile Q(veh)	0.5	-	-	-	0.2	0.7

Timings  
3: Meridian Rd & Bent Grass Meadows Dr

2040 Background Traffic  
AM Peak Hour



Lane Group	EBL	EBR	NBL	NBT	SBT	SBR
Lane Configurations	↖↗	↗	↖	↑↑	↑↑	↗
Traffic Volume (vph)	240	308	128	672	1777	229
Future Volume (vph)	240	308	128	672	1777	229
Turn Type	Prot	Free	pm+pt	NA	NA	Perm
Protected Phases	4		5	2	6	
Permitted Phases		Free	2			6
Detector Phase	4		5	2	6	6
Switch Phase						
Minimum Initial (s)	5.0		5.0	5.0	5.0	5.0
Minimum Split (s)	10.0		10.0	10.0	10.0	10.0
Total Split (s)	26.0		28.0	94.0	66.0	66.0
Total Split (%)	21.7%		23.3%	78.3%	55.0%	55.0%
Yellow Time (s)	3.0		3.0	3.0	3.0	3.0
All-Red Time (s)	2.0		2.0	2.0	2.0	2.0
Lost Time Adjust (s)	0.0		0.0	0.0	0.0	0.0
Total Lost Time (s)	5.0		5.0	5.0	5.0	5.0
Lead/Lag			Lead		Lag	Lag
Lead-Lag Optimize?			Yes		Yes	Yes
Recall Mode	None		None	Max	Max	Max
Act Effct Green (s)	13.5	112.6	89.1	89.1	74.8	74.8
Actuated g/C Ratio	0.12	1.00	0.79	0.79	0.66	0.66
v/c Ratio	0.61	0.20	0.64	0.25	0.80	0.21
Control Delay	53.7	0.3	33.5	3.5	18.0	2.3
Queue Delay	0.0	0.0	0.0	0.0	0.0	0.0
Total Delay	53.7	0.3	33.5	3.5	18.0	2.3
LOS	D	A	C	A	B	A
Approach Delay	23.7			8.3	16.2	
Approach LOS	C			A	B	

Intersection Summary

Cycle Length: 120  
 Actuated Cycle Length: 112.6  
 Natural Cycle: 60  
 Control Type: Semi Act-Uncoord  
 Maximum v/c Ratio: 0.80  
 Intersection Signal Delay: 15.5  
 Intersection Capacity Utilization 75.6%  
 Analysis Period (min) 15  
 Intersection LOS: B  
 ICU Level of Service D

Splits and Phases: 3: Meridian Rd & Bent Grass Meadows Dr



Intersection						
Int Delay, s/veh	0.6					
Movement	EBL	EBT	WBT	WBR	SBL	SBR
Lane Configurations						
Traffic Vol, veh/h	3	287	155	5	17	8
Future Vol, veh/h	3	287	155	5	17	8
Conflicting Peds, #/hr	0	0	0	0	0	0
Sign Control	Free	Free	Free	Free	Stop	Stop
RT Channelized	-	None	-	None	-	None
Storage Length	155	-	-	-	0	-
Veh in Median Storage, #	-	0	0	-	0	-
Grade, %	-	0	0	-	0	-
Peak Hour Factor	95	95	95	95	95	95
Heavy Vehicles, %	2	2	2	2	2	2
Mvmt Flow	3	302	163	5	18	8

Major/Minor	Major1	Major2	Minor2		
Conflicting Flow All	168	0	-	0	474 166
Stage 1	-	-	-	-	166 -
Stage 2	-	-	-	-	308 -
Critical Hdwy	4.12	-	-	-	6.42 6.22
Critical Hdwy Stg 1	-	-	-	-	5.42 -
Critical Hdwy Stg 2	-	-	-	-	5.42 -
Follow-up Hdwy	2.218	-	-	-	3.518 3.318
Pot Cap-1 Maneuver	1410	-	-	-	549 878
Stage 1	-	-	-	-	863 -
Stage 2	-	-	-	-	745 -
Platoon blocked, %		-	-	-	
Mov Cap-1 Maneuver	1410	-	-	-	548 878
Mov Cap-2 Maneuver	-	-	-	-	548 -
Stage 1	-	-	-	-	861 -
Stage 2	-	-	-	-	745 -

Approach	EB	WB	SB
HCM Control Delay, s	0.1	0	11
HCM LOS			B

Minor Lane/Major Mvmt	EBL	EBT	WBT	WBR	SBLn1
Capacity (veh/h)	1410	-	-	-	623
HCM Lane V/C Ratio	0.002	-	-	-	0.042
HCM Control Delay (s)	7.6	-	-	-	11
HCM Lane LOS	A	-	-	-	B
HCM 95th %tile Q(veh)	0	-	-	-	0.1

Intersection												
Int Delay, s/veh	7.2											
Movement	EBL	EBT	EBR	WBL	WBT	WBR	NBL	NBT	NBR	SBL	SBT	SBR
Lane Configurations	↙	↑	↗	↙	↗			↕			↕	
Traffic Vol, veh/h	6	286	12	218	128	11	17	2	225	37	4	15
Future Vol, veh/h	6	286	12	218	128	11	17	2	225	37	4	15
Conflicting Peds, #/hr	0	0	0	0	0	0	0	0	0	0	0	0
Sign Control	Free	Free	Free	Free	Free	Free	Stop	Stop	Stop	Stop	Stop	Stop
RT Channelized	-	-	None	-	-	None	-	-	None	-	-	None
Storage Length	-	-	150	0	-	-	-	-	-	-	-	-
Veh in Median Storage, #	-	0	-	-	0	-	-	1	-	-	1	-
Grade, %	-	0	-	-	0	-	-	0	-	-	0	-
Peak Hour Factor	95	95	95	95	95	95	95	95	95	95	95	95
Heavy Vehicles, %	2	2	2	2	2	2	2	2	2	2	2	2
Mvmt Flow	6	301	13	229	135	12	18	2	237	39	4	16

Major/Minor	Major1			Major2			Minor1			Minor2		
Conflicting Flow All	147	0	0	314	0	0	922	918	301	1038	925	141
Stage 1	-	-	-	-	-	-	313	313	-	599	599	-
Stage 2	-	-	-	-	-	-	609	605	-	439	326	-
Critical Hdwy	4.12	-	-	4.12	-	-	7.12	6.52	6.22	7.12	6.52	6.22
Critical Hdwy Stg 1	-	-	-	-	-	-	6.12	5.52	-	6.12	5.52	-
Critical Hdwy Stg 2	-	-	-	-	-	-	6.12	5.52	-	6.12	5.52	-
Follow-up Hdwy	2.218	-	-	2.218	-	-	3.518	4.018	3.318	3.518	4.018	3.318
Pot Cap-1 Maneuver	1435	-	-	1246	-	-	251	272	739	209	269	907
Stage 1	-	-	-	-	-	-	698	657	-	488	490	-
Stage 2	-	-	-	-	-	-	482	487	-	597	648	-
Platoon blocked, %	-	-	-	-	-	-	-	-	-	-	-	-
Mov Cap-1 Maneuver	1435	-	-	1246	-	-	209	221	739	121	219	907
Mov Cap-2 Maneuver	-	-	-	-	-	-	304	313	-	153	286	-
Stage 1	-	-	-	-	-	-	695	654	-	486	400	-
Stage 2	-	-	-	-	-	-	382	397	-	403	645	-

Approach	EB			WB			NB			SB		
HCM Control Delay, s	0.1			5.2			13.8			29.3		
HCM LOS							B			D		

Minor Lane/Major Mvmt	NBLn1	EBL	EBT	EBR	WBL	WBT	WBR	SBLn1
Capacity (veh/h)	665	1435	-	-	1246	-	-	206
HCM Lane V/C Ratio	0.386	0.004	-	-	0.184	-	-	0.286
HCM Control Delay (s)	13.8	7.5	-	-	8.5	-	-	29.3
HCM Lane LOS	B	A	-	-	A	-	-	D
HCM 95th %tile Q(veh)	1.8	0	-	-	0.7	-	-	1.1



## SimTraffic Performance Report

## 20: Meridian Park Dr &amp; Bent Grass Meadows Dr Performance by lane Interval #1 7:00

Lane	EB	EB	EB	WB	WB	NB	SB	All
Movements Served	L	T	R	L	TR	LTR	LTR	
Stop Del/Veh (s)	0.0	0.0	0.0	1.7	0.4	4.8	8.6	2.2

## 20: Meridian Park Dr &amp; Bent Grass Meadows Dr Performance by lane Interval #2 7:15

Lane	EB	EB	EB	WB	WB	NB	SB	All
Movements Served	L	T	R	L	TR	LTR	LTR	
Stop Del/Veh (s)	0.0	0.0	0.0	2.1	0.5	9.2	9.9	3.6

## 20: Meridian Park Dr &amp; Bent Grass Meadows Dr Performance by lane Interval #3 7:30

Lane	EB	EB	EB	WB	WB	NB	SB	All
Movements Served	L	T	R	L	TR	LTR	LTR	
Stop Del/Veh (s)	0.0	0.0	0.0	1.4	0.4	4.5	8.0	1.9

## 20: Meridian Park Dr &amp; Bent Grass Meadows Dr Performance by lane Interval #4 7:45

Lane	EB	EB	EB	WB	WB	NB	SB	All
Movements Served	L	T	R	L	TR	LTR	LTR	
Stop Del/Veh (s)	0.0	0.0	0.0	1.6	0.3	5.1	8.3	2.1

## 20: Meridian Park Dr &amp; Bent Grass Meadows Dr Performance by lane Entire Run

Lane	EB	EB	EB	WB	WB	NB	SB	All
Movements Served	L	T	R	L	TR	LTR	LTR	
Stop Del/Veh (s)	0.0	0.0	0.0	1.7	0.4	6.1	8.9	2.5

Timings  
25: Golden Sage Rd & Woodmen Rd

2040 Background Traffic  
AM Peak Hour

Lane Group	EBL	EBT	EBR	WBL	WBT	WBR	NBL	NBT	NBR	SBL	SBT	SBR
Lane Configurations												
Traffic Volume (vph)	328	733	74	68	1801	110	164	18	50	98	26	411
Future Volume (vph)	328	733	74	68	1801	110	164	18	50	98	26	411
Turn Type	Prot	NA	Perm	pm+pt	NA	Perm	pm+pt	NA	Perm	pm+pt	NA	Free
Protected Phases	5	2		1	6		3	8		7	4	
Permitted Phases			2	6		6	8		8	4		Free
Detector Phase	5	2	2	1	6	6	3	8	8	7	4	
Switch Phase												
Minimum Initial (s)	5.0	5.0	5.0	5.0	5.0	5.0	5.0	5.0	5.0	5.0	5.0	5.0
Minimum Split (s)	10.0	12.0	12.0	10.0	12.0	12.0	10.0	10.0	10.0	10.0	10.0	10.0
Total Split (s)	22.0	75.0	75.0	10.0	63.0	63.0	20.0	15.0	15.0	20.0	15.0	
Total Split (%)	18.3%	62.5%	62.5%	8.3%	52.5%	52.5%	16.7%	12.5%	12.5%	16.7%	12.5%	
Yellow Time (s)	3.0	5.0	5.0	3.0	5.0	5.0	3.0	3.0	3.0	3.0	3.0	3.0
All-Red Time (s)	2.0	2.0	2.0	2.0	2.0	2.0	2.0	2.0	2.0	2.0	2.0	2.0
Lost Time Adjust (s)	-1.0	-1.0	-1.0	-1.0	-1.0	-1.0	-1.0	-1.0	-1.0	-1.0	-1.0	-1.0
Total Lost Time (s)	4.0	6.0	6.0	4.0	6.0	6.0	4.0	4.0	4.0	4.0	4.0	4.0
Lead/Lag	Lead	Lag	Lag	Lead	Lag	Lag	Lead	Lag	Lag	Lead	Lag	Lag
Lead-Lag Optimize?	Yes	Yes	Yes	Yes	Yes	Yes	Yes	Yes	Yes	Yes	Yes	Yes
Recall Mode	None	Min	Min	None	Min	Min	None	None	None	None	None	None
Act Effct Green (s)	16.2	69.9	69.9	65.5	57.4	57.4	22.4	9.3	9.3	17.8	8.2	111.2
Actuated g/C Ratio	0.15	0.63	0.63	0.59	0.52	0.52	0.20	0.08	0.08	0.16	0.07	1.00
v/c Ratio	0.69	0.34	0.08	0.16	1.01	0.13	0.57	0.12	0.18	0.39	0.20	0.27
Control Delay	54.0	11.7	1.0	7.9	51.1	1.4	45.7	51.2	1.4	42.1	54.4	0.4
Queue Delay	0.0	0.0	0.0	0.0	0.0	0.0	0.0	0.0	0.0	0.0	0.0	0.0
Total Delay	54.0	11.7	1.0	7.9	51.1	1.4	45.7	51.2	1.4	42.1	54.4	0.4
LOS	D	B	A	A	D	A	D	D	A	D	D	A
Approach Delay		23.5			46.7			36.6			10.6	
Approach LOS		C			D			D			B	

Intersection Summary

Cycle Length: 120  
 Actuated Cycle Length: 111.2  
 Natural Cycle: 90  
 Control Type: Semi Act-Uncoord  
 Maximum v/c Ratio: 1.01  
 Intersection Signal Delay: 34.2  
 Intersection Capacity Utilization 86.6%  
 Analysis Period (min) 15

Intersection LOS: C  
 ICU Level of Service E

Splits and Phases: 25: Golden Sage Rd & Woodmen Rd



Intersection												
Int Delay, s/veh	19.5											
Movement	EBL	EBT	EBR	WBL	WBT	WBR	NBL	NBT	NBR	SBL	SBT	SBR
Lane Configurations		↔			↔			↔	↔		↔	
Traffic Vol, veh/h	0	6	114	422	5	0	78	0	379	0	0	0
Future Vol, veh/h	0	6	114	422	5	0	78	0	379	0	0	0
Conflicting Peds, #/hr	0	0	0	0	0	0	0	0	0	0	0	0
Sign Control	Stop	Stop	Stop	Stop	Stop	Stop	Free	Free	Free	Free	Free	Free
RT Channelized	-	-	None	-	-	None	-	-	Free	-	-	None
Storage Length	-	-	-	-	-	-	-	-	0	-	-	-
Veh in Median Storage, #	-	0	-	-	0	-	-	0	-	-	0	-
Grade, %	-	0	-	-	0	-	-	0	-	-	0	-
Peak Hour Factor	92	95	95	95	95	92	95	92	95	92	92	92
Heavy Vehicles, %	2	2	2	2	2	2	2	2	2	2	2	2
Mvmt Flow	0	6	120	444	5	0	82	0	399	0	0	0

Major/Minor	Minor2		Minor1		Major1		Major2					
Conflicting Flow All	-	165	1	228	165	-	1	0	-	0	0	0
Stage 1	-	1	-	164	164	-	-	-	-	-	-	-
Stage 2	-	164	-	64	1	-	-	-	-	-	-	-
Critical Hdwy	-	6.52	6.22	7.12	6.52	-	4.12	-	-	4.12	-	-
Critical Hdwy Stg 1	-	5.52	-	6.12	5.52	-	-	-	-	-	-	-
Critical Hdwy Stg 2	-	5.52	-	6.12	5.52	-	-	-	-	-	-	-
Follow-up Hdwy	-	4.018	3.318	3.518	4.018	-	2.218	-	-	2.218	-	-
Pot Cap-1 Maneuver	0	728	1084	727	728	0	1622	-	0	-	-	-
Stage 1	0	895	-	838	762	0	-	-	0	-	-	-
Stage 2	0	762	-	947	895	0	-	-	0	-	-	-
Platoon blocked, %								-			-	-
Mov Cap-1 Maneuver	-	691	1084	617	691	-	1622	-	-	-	-	-
Mov Cap-2 Maneuver	-	691	-	617	691	-	-	-	-	-	-	-
Stage 1	-	895	-	795	723	-	-	-	-	-	-	-
Stage 2	-	723	-	836	895	-	-	-	-	-	-	-

Approach	EB		WB		NB		SB	
HCM Control Delay, s	8.9		24.8		7.3		0	
HCM LOS	A		C					

Minor Lane/Major Mvmt	NBL	NBT	EBLn1	WBLn1	SBL	SBT	SBR
Capacity (veh/h)	1622	-	1054	618	-	-	-
HCM Lane V/C Ratio	0.051	-	0.12	0.727	-	-	-
HCM Control Delay (s)	7.3	0	8.9	24.8	0	-	-
HCM Lane LOS	A	A	A	C	A	-	-
HCM 95th %tile Q(veh)	0.2	-	0.4	6.2	-	-	-

Intersection						
Int Delay, s/veh	5.3					
Movement	WBL	WBR	NBT	NBR	SBL	SBT
Lane Configurations	T		T		T	
Traffic Vol, veh/h	1	143	101	1	152	81
Future Vol, veh/h	1	143	101	1	152	81
Conflicting Peds, #/hr	0	0	0	0	0	0
Sign Control	Stop	Stop	Free	Free	Free	Free
RT Channelized	-	None	-	None	-	None
Storage Length	0	-	-	-	-	-
Veh in Median Storage, #	0	-	0	-	-	0
Grade, %	0	-	0	-	-	0
Peak Hour Factor	95	95	95	95	95	95
Heavy Vehicles, %	2	2	2	2	2	2
Mvmt Flow	1	151	106	1	160	85

Major/Minor	Minor1	Major1	Major2			
Conflicting Flow All	512	107	0	0	107	0
Stage 1	107	-	-	-	-	-
Stage 2	405	-	-	-	-	-
Critical Hdwy	6.42	6.22	-	-	4.12	-
Critical Hdwy Stg 1	5.42	-	-	-	-	-
Critical Hdwy Stg 2	5.42	-	-	-	-	-
Follow-up Hdwy	3.518	3.318	-	-	2.218	-
Pot Cap-1 Maneuver	522	947	-	-	1484	-
Stage 1	917	-	-	-	-	-
Stage 2	673	-	-	-	-	-
Platoon blocked, %			-	-	-	-
Mov Cap-1 Maneuver	463	947	-	-	1484	-
Mov Cap-2 Maneuver	463	-	-	-	-	-
Stage 1	917	-	-	-	-	-
Stage 2	597	-	-	-	-	-

Approach	WB	NB	SB
HCM Control Delay, s	9.6	0	5
HCM LOS	A		

Minor Lane/Major Mvmt	NBT	NBRWBLn1	SBL	SBT
Capacity (veh/h)	-	-	940	1484
HCM Lane V/C Ratio	-	-	0.161	0.108
HCM Control Delay (s)	-	-	9.6	7.7
HCM Lane LOS	-	-	A	A
HCM 95th %tile Q(veh)	-	-	0.6	0.4

Intersection						
Int Delay, s/veh	4.4					
Movement	EBL	EBT	WBT	WBR	SBL	SBR
Lane Configurations	↘	↑	↗		↘	↗
Traffic Vol, veh/h	111	255	148	19	21	207
Future Vol, veh/h	111	255	148	19	21	207
Conflicting Peds, #/hr	0	0	0	0	0	0
Sign Control	Free	Free	Free	Free	Stop	Stop
RT Channelized	-	None	-	None	-	None
Storage Length	155	-	-	-	155	0
Veh in Median Storage, #	-	0	0	-	0	-
Grade, %	-	0	0	-	0	-
Peak Hour Factor	92	92	92	92	92	92
Heavy Vehicles, %	2	2	2	2	2	2
Mvmt Flow	121	277	161	21	23	225

Major/Minor	Major1	Major2	Minor2		
Conflicting Flow All	182	0	-	0	691
Stage 1	-	-	-	-	172
Stage 2	-	-	-	-	519
Critical Hdwy	4.12	-	-	-	6.42
Critical Hdwy Stg 1	-	-	-	-	5.42
Critical Hdwy Stg 2	-	-	-	-	5.42
Follow-up Hdwy	2.218	-	-	-	3.518
Pot Cap-1 Maneuver	1393	-	-	-	410
Stage 1	-	-	-	-	858
Stage 2	-	-	-	-	597
Platoon blocked, %		-	-	-	
Mov Cap-1 Maneuver	1393	-	-	-	374
Mov Cap-2 Maneuver	-	-	-	-	374
Stage 1	-	-	-	-	783
Stage 2	-	-	-	-	597

Approach	EB	WB	SB
HCM Control Delay, s	2.4	0	11
HCM LOS			B

Minor Lane/Major Mvmt	EBL	EBT	WBT	WBR	SBLn1	SBLn2
Capacity (veh/h)	1393	-	-	-	374	872
HCM Lane V/C Ratio	0.087	-	-	-	0.061	0.258
HCM Control Delay (s)	7.8	-	-	-	15.3	10.6
HCM Lane LOS	A	-	-	-	C	B
HCM 95th %tile Q(veh)	0.3	-	-	-	0.2	1

Timings  
3: Meridian Rd & Bent Grass Meadows Dr

2040 Background Traffic  
PM Peak Hour



Lane Group	EBL	EBR	NBL	NBT	SBT	SBR
Lane Configurations	↖↗	↖	↖	↑↑	↑↑	↖
Traffic Volume (vph)	407	208	230	1518	1177	189
Future Volume (vph)	407	208	230	1518	1177	189
Turn Type	Prot	Perm	pm+pt	NA	NA	Perm
Protected Phases	4		5	2	6	
Permitted Phases		4	2			6
Detector Phase	4	4	5	2	6	6
Switch Phase						
Minimum Initial (s)	5.0	5.0	5.0	5.0	5.0	5.0
Minimum Split (s)	10.0	10.0	10.0	10.0	10.0	10.0
Total Split (s)	32.0	32.0	37.0	88.0	51.0	51.0
Total Split (%)	26.7%	26.7%	30.8%	73.3%	42.5%	42.5%
Yellow Time (s)	3.0	3.0	3.0	3.0	3.0	3.0
All-Red Time (s)	2.0	2.0	2.0	2.0	2.0	2.0
Lost Time Adjust (s)	0.0	0.0	0.0	0.0	0.0	0.0
Total Lost Time (s)	5.0	5.0	5.0	5.0	5.0	5.0
Lead/Lag			Lead		Lag	Lag
Lead-Lag Optimize?			Yes		Yes	Yes
Recall Mode	None	None	None	Max	Max	Max
Act Effect Green (s)	19.5	19.5	83.1	83.1	63.3	63.3
Actuated g/C Ratio	0.17	0.17	0.74	0.74	0.56	0.56
v/c Ratio	0.72	0.48	0.63	0.61	0.62	0.20
Control Delay	51.3	9.0	17.4	8.8	20.2	2.9
Queue Delay	0.0	0.0	0.0	0.0	0.0	0.0
Total Delay	51.3	9.0	17.4	8.8	20.2	2.9
LOS	D	A	B	A	C	A
Approach Delay	37.0			9.9	17.8	
Approach LOS	D			A	B	

Intersection Summary

Cycle Length: 120  
 Actuated Cycle Length: 112.6  
 Natural Cycle: 55  
 Control Type: Semi Act-Uncoord  
 Maximum v/c Ratio: 0.72  
 Intersection Signal Delay: 17.3  
 Intersection Capacity Utilization 69.4%  
 Analysis Period (min) 15  
 Intersection LOS: B  
 ICU Level of Service C

Splits and Phases: 3: Meridian Rd & Bent Grass Meadows Dr



Intersection						
Int Delay, s/veh	0.6					
Movement	EBL	EBT	WBT	WBR	SBL	SBR
Lane Configurations						
Traffic Vol, veh/h	6	164	202	22	13	4
Future Vol, veh/h	6	164	202	22	13	4
Conflicting Peds, #/hr	0	0	0	0	0	0
Sign Control	Free	Free	Free	Free	Stop	Stop
RT Channelized	-	None	-	None	-	None
Storage Length	155	-	-	-	0	-
Veh in Median Storage, #	-	0	0	-	0	-
Grade, %	-	0	0	-	0	-
Peak Hour Factor	95	95	95	95	95	95
Heavy Vehicles, %	2	2	2	2	2	2
Mvmt Flow	6	173	213	23	14	4

Major/Minor	Major1	Major2	Minor2		
Conflicting Flow All	236	0	-	0	410 225
Stage 1	-	-	-	-	225 -
Stage 2	-	-	-	-	185 -
Critical Hdwy	4.12	-	-	-	6.42 6.22
Critical Hdwy Stg 1	-	-	-	-	5.42 -
Critical Hdwy Stg 2	-	-	-	-	5.42 -
Follow-up Hdwy	2.218	-	-	-	3.518 3.318
Pot Cap-1 Maneuver	1331	-	-	-	598 814
Stage 1	-	-	-	-	812 -
Stage 2	-	-	-	-	847 -
Platoon blocked, %		-	-	-	
Mov Cap-1 Maneuver	1331	-	-	-	595 814
Mov Cap-2 Maneuver	-	-	-	-	595 -
Stage 1	-	-	-	-	808 -
Stage 2	-	-	-	-	847 -

Approach	EB	WB	SB
HCM Control Delay, s	0.3	0	10.8
HCM LOS			B

Minor Lane/Major Mvmt	EBL	EBT	WBT	WBR	SBLn1
Capacity (veh/h)	1331	-	-	-	635
HCM Lane V/C Ratio	0.005	-	-	-	0.028
HCM Control Delay (s)	7.7	-	-	-	10.8
HCM Lane LOS	A	-	-	-	B
HCM 95th %tile Q(veh)	0	-	-	-	0.1

Intersection												
Int Delay, s/veh	9.6											
Movement	EBL	EBT	EBR	WBL	WBT	WBR	NBL	NBT	NBR	SBL	SBT	SBR
Lane Configurations	↙	↑	↗	↙	↗			↕			↕	
Traffic Vol, veh/h	8	160	8	172	200	48	19	6	428	28	4	5
Future Vol, veh/h	8	160	8	172	200	48	19	6	428	28	4	5
Conflicting Peds, #/hr	0	0	0	0	0	0	0	0	0	0	0	0
Sign Control	Free	Free	Free	Free	Free	Free	Stop	Stop	Stop	Stop	Stop	Stop
RT Channelized	-	-	None	-	-	None	-	-	None	-	-	None
Storage Length	150	-	150	0	-	-	-	-	-	-	-	-
Veh in Median Storage, #	-	0	-	-	0	-	-	1	-	-	0	-
Grade, %	-	0	-	-	0	-	-	0	-	-	0	-
Peak Hour Factor	95	95	95	95	95	95	95	95	95	95	95	95
Heavy Vehicles, %	2	2	2	2	2	2	2	2	2	2	2	2
Mvmt Flow	8	168	8	181	211	51	20	6	451	29	4	5

Major/Minor	Major1			Major2			Minor1			Minor2		
Conflicting Flow All	262	0	0	176	0	0	787	808	168	1016	791	237
Stage 1	-	-	-	-	-	-	184	184	-	599	599	-
Stage 2	-	-	-	-	-	-	603	624	-	417	192	-
Critical Hdwy	4.12	-	-	4.12	-	-	7.12	6.52	6.22	7.12	6.52	6.22
Critical Hdwy Stg 1	-	-	-	-	-	-	6.12	5.52	-	6.12	5.52	-
Critical Hdwy Stg 2	-	-	-	-	-	-	6.12	5.52	-	6.12	5.52	-
Follow-up Hdwy	2.218	-	-	2.218	-	-	3.518	4.018	3.318	3.518	4.018	3.318
Pot Cap-1 Maneuver	1302	-	-	1400	-	-	309	315	876	216	322	802
Stage 1	-	-	-	-	-	-	818	747	-	488	490	-
Stage 2	-	-	-	-	-	-	486	478	-	613	742	-
Platoon blocked, %	-	-	-	-	-	-	-	-	-	-	-	-
Mov Cap-1 Maneuver	1302	-	-	1400	-	-	272	273	876	93	279	802
Mov Cap-2 Maneuver	-	-	-	-	-	-	347	345	-	93	279	-
Stage 1	-	-	-	-	-	-	813	743	-	485	427	-
Stage 2	-	-	-	-	-	-	416	416	-	293	738	-

Approach	EB			WB			NB			SB		
HCM Control Delay, s	0.4			3.3			15.7			51.6		
HCM LOS							C			F		

Minor Lane/Major Mvmt	NBLn1	EBL	EBT	EBR	WBL	WBT	WBR	SBLn1
Capacity (veh/h)	808	1302	-	-	1400	-	-	115
HCM Lane V/C Ratio	0.59	0.006	-	-	0.129	-	-	0.339
HCM Control Delay (s)	15.7	7.8	-	-	8	-	-	51.6
HCM Lane LOS	C	A	-	-	A	-	-	F
HCM 95th %tile Q(veh)	3.9	0	-	-	0.4	-	-	1.3



## SimTraffic Performance Report

## 20: Meridian Park Dr &amp; Bent Grass Meadows Dr Performance by lane Interval #1 5:00

Lane	EB	EB	EB	WB	WB	NB	SB	All
Movements Served	L	T	R	L	TR	LTR	LTR	
Stop Del/Veh (s)	0.8	0.0	0.0	0.9	0.3	4.9	7.9	2.6

## 20: Meridian Park Dr &amp; Bent Grass Meadows Dr Performance by lane Interval #2 5:15

Lane	EB	EB	EB	WB	WB	NB	SB	All
Movements Served	L	T	R	L	TR	LTR	LTR	
Stop Del/Veh (s)	1.6	0.0	0.0	1.2	0.3	6.5	7.7	3.2

## 20: Meridian Park Dr &amp; Bent Grass Meadows Dr Performance by lane Interval #3 5:30

Lane	EB	EB	EB	WB	WB	NB	SB	All
Movements Served	L	T	R	L	TR	LTR	LTR	
Stop Del/Veh (s)	0.3	0.0	0.0	1.1	0.4	5.4	6.9	2.7

## 20: Meridian Park Dr &amp; Bent Grass Meadows Dr Performance by lane Interval #4 5:45

Lane	EB	EB	EB	WB	WB	NB	SB	All
Movements Served	L	T	R	L	TR	LTR	LTR	
Stop Del/Veh (s)	0.3	0.1	0.1	1.1	0.3	6.4	8.9	3.2

## 20: Meridian Park Dr &amp; Bent Grass Meadows Dr Performance by lane Entire Run

Lane	EB	EB	EB	WB	WB	NB	SB	All
Movements Served	L	T	R	L	TR	LTR	LTR	
Stop Del/Veh (s)	0.6	0.0	0.0	1.1	0.3	5.9	8.3	3.0

Timings  
25: Golden Sage Rd & Woodmen Rd

2040 Background Traffic  
PM Peak Hour

Lane Group	EBL	EBT	EBR	WBL	WBT	WBR	NBL	NBT	NBR	SBL	SBT	SBR
Lane Configurations												
Traffic Volume (vph)	474	1655	78	92	1101	121	178	40	72	136	20	397
Future Volume (vph)	474	1655	78	92	1101	121	178	40	72	136	20	397
Turn Type	Prot	NA	Perm	pm+pt	NA	Perm	pm+pt	NA	Perm	pm+pt	NA	Free
Protected Phases	5	2		1	6		3	8		7	4	
Permitted Phases			2	6		6	8		8	4		Free
Detector Phase	5	2	2	1	6	6	3	8	8	7	4	
Switch Phase												
Minimum Initial (s)	5.0	5.0	5.0	5.0	5.0	5.0	5.0	5.0	5.0	5.0	5.0	5.0
Minimum Split (s)	10.0	12.0	12.0	10.0	12.0	12.0	10.0	10.0	10.0	10.0	10.0	10.0
Total Split (s)	23.0	64.0	64.0	10.0	51.0	51.0	31.0	15.0	15.0	31.0	15.0	
Total Split (%)	19.2%	53.3%	53.3%	8.3%	42.5%	42.5%	25.8%	12.5%	12.5%	25.8%	12.5%	
Yellow Time (s)	3.0	5.0	5.0	3.0	5.0	5.0	3.0	3.0	3.0	3.0	3.0	3.0
All-Red Time (s)	2.0	2.0	2.0	2.0	2.0	2.0	2.0	2.0	2.0	2.0	2.0	2.0
Lost Time Adjust (s)	-1.0	-1.0	-1.0	-1.0	-1.0	-1.0	-1.0	-1.0	-1.0	-1.0	-1.0	-1.0
Total Lost Time (s)	4.0	6.0	6.0	4.0	6.0	6.0	4.0	4.0	4.0	4.0	4.0	4.0
Lead/Lag	Lead	Lag	Lag	Lead	Lag	Lag	Lead	Lag	Lag	Lead	Lag	Lag
Lead-Lag Optimize?	Yes	Yes	Yes	Yes	Yes	Yes	Yes	Yes	Yes	Yes	Yes	Yes
Recall Mode	None	Min	Min	None	Min	Min	None	None	None	None	None	None
Act Effct Green (s)	18.6	56.2	56.2	51.8	43.7	43.7	24.5	9.3	9.3	17.5	7.8	101.4
Actuated g/C Ratio	0.18	0.55	0.55	0.51	0.43	0.43	0.24	0.09	0.09	0.17	0.08	1.00
v/c Ratio	0.79	0.86	0.09	0.53	0.74	0.16	0.48	0.25	0.25	0.46	0.15	0.26
Control Delay	51.6	26.5	1.5	25.7	29.0	2.5	36.2	49.0	2.0	40.0	49.5	0.4
Queue Delay	0.0	0.0	0.0	0.0	0.0	0.0	0.0	0.0	0.0	0.0	0.0	0.0
Total Delay	51.6	26.5	1.5	25.7	29.0	2.5	36.2	49.0	2.0	40.0	49.5	0.4
LOS	D	C	A	C	C	A	D	D	A	D	D	A
Approach Delay		31.1			26.2			29.4			11.9	
Approach LOS		C			C			C			B	

Intersection Summary

Cycle Length: 120  
 Actuated Cycle Length: 101.4  
 Natural Cycle: 70  
 Control Type: Semi Act-Uncoord  
 Maximum v/c Ratio: 0.86  
 Intersection Signal Delay: 27.0  
 Intersection LOS: C  
 Intersection Capacity Utilization 79.0%  
 ICU Level of Service D  
 Analysis Period (min) 15

Splits and Phases: 25: Golden Sage Rd & Woodmen Rd

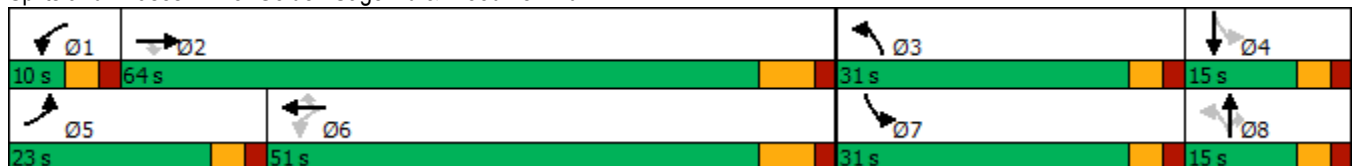

Intersection												
Int Delay, s/veh	40.8											
Movement	EBL	EBT	EBR	WBL	WBT	WBR	NBL	NBT	NBR	SBL	SBT	SBR
Lane Configurations		↔			↔			↔	↔		↔	
Traffic Vol, veh/h	0	10	100	452	11	0	134	0	502	0	0	0
Future Vol, veh/h	0	10	100	452	11	0	134	0	502	0	0	0
Conflicting Peds, #/hr	0	0	0	0	0	0	0	0	0	0	0	0
Sign Control	Stop	Stop	Stop	Stop	Stop	Stop	Free	Free	Free	Free	Free	Free
RT Channelized	-	-	None	-	-	None	-	-	Free	-	-	None
Storage Length	-	-	-	-	-	-	-	-	0	-	-	-
Veh in Median Storage, #	-	0	-	-	0	-	-	0	-	-	0	-
Grade, %	-	0	-	-	0	-	-	0	-	-	0	-
Peak Hour Factor	92	95	95	95	95	92	95	92	95	92	92	92
Heavy Vehicles, %	2	2	2	2	2	2	2	2	2	2	2	2
Mvmt Flow	0	11	105	476	12	0	141	0	528	0	0	0

Major/Minor	Minor2		Minor1		Major1		Major2					
Conflicting Flow All	-	283	1	341	283	-	1	0	-	0	0	0
Stage 1	-	1	-	282	282	-	-	-	-	-	-	-
Stage 2	-	282	-	59	1	-	-	-	-	-	-	-
Critical Hdwy	-	6.52	6.22	7.12	6.52	-	4.12	-	-	4.12	-	-
Critical Hdwy Stg 1	-	5.52	-	6.12	5.52	-	-	-	-	-	-	-
Critical Hdwy Stg 2	-	5.52	-	6.12	5.52	-	-	-	-	-	-	-
Follow-up Hdwy	-	4.018	3.318	3.518	4.018	-	2.218	-	-	2.218	-	-
Pot Cap-1 Maneuver	0	626	1084	613	626	0	1622	-	0	-	-	-
Stage 1	0	895	-	725	678	0	-	-	0	-	-	-
Stage 2	0	678	-	953	895	0	-	-	0	-	-	-
Platoon blocked, %								-			-	-
Mov Cap-1 Maneuver	-	572	1084	509	572	-	1622	-	-	-	-	-
Mov Cap-2 Maneuver	-	572	-	509	572	-	-	-	-	-	-	-
Stage 1	-	895	-	662	619	-	-	-	-	-	-	-
Stage 2	-	619	-	850	895	-	-	-	-	-	-	-

Approach	EB	WB	NB	SB
HCM Control Delay, s	9.1	58.1	7.4	0
HCM LOS	A	F		

Minor Lane/Major Mvmt	NBL	NBT	EBLn1	WBLn1	SBL	SBT	SBR
Capacity (veh/h)	1622	-	1002	510	-	-	-
HCM Lane V/C Ratio	0.087	-	0.116	0.956	-	-	-
HCM Control Delay (s)	7.4	0	9.1	58.1	0	-	-
HCM Lane LOS	A	A	A	F	A	-	-
HCM 95th %tile Q(veh)	0.3	-	0.4	12.2	-	-	-

Intersection						
Int Delay, s/veh	3.5					
Movement	WBL	WBR	NBT	NBR	SBL	SBT
Lane Configurations						
Traffic Vol, veh/h	2	116	336	2	107	76
Future Vol, veh/h	2	116	336	2	107	76
Conflicting Peds, #/hr	0	0	0	0	0	0
Sign Control	Stop	Stop	Free	Free	Free	Free
RT Channelized	-	None	-	None	-	None
Storage Length	0	-	-	-	-	-
Veh in Median Storage, #	0	-	0	-	-	0
Grade, %	0	-	0	-	-	0
Peak Hour Factor	95	95	95	95	95	95
Heavy Vehicles, %	2	2	2	2	2	2
Mvmt Flow	2	122	354	2	113	80

Major/Minor	Minor1	Major1	Major2		
Conflicting Flow All	661	355	0	0	356
Stage 1	355	-	-	-	-
Stage 2	306	-	-	-	-
Critical Hdwy	6.42	6.22	-	-	4.12
Critical Hdwy Stg 1	5.42	-	-	-	-
Critical Hdwy Stg 2	5.42	-	-	-	-
Follow-up Hdwy	3.518	3.318	-	-	2.218
Pot Cap-1 Maneuver	427	689	-	-	1203
Stage 1	710	-	-	-	-
Stage 2	747	-	-	-	-
Platoon blocked, %			-	-	-
Mov Cap-1 Maneuver	385	689	-	-	1203
Mov Cap-2 Maneuver	385	-	-	-	-
Stage 1	710	-	-	-	-
Stage 2	674	-	-	-	-

Approach	WB	NB	SB
HCM Control Delay, s	11.5	0	4.9
HCM LOS	B		

Minor Lane/Major Mvmt	NBT	NBRWBLn1	SBL	SBT
Capacity (veh/h)	-	-	680	1203
HCM Lane V/C Ratio	-	-	0.183	0.094
HCM Control Delay (s)	-	-	11.5	8.3
HCM Lane LOS	-	-	B	A
HCM 95th %tile Q(veh)	-	-	0.7	0.3

**Intersection**

Int Delay, s/veh 4.6

**Movement** EBL EBT WBT WBR SBL SBR

Lane Configurations	↘	↑	↗		↘	↗
Traffic Vol, veh/h	219	199	239	51	13	171
Future Vol, veh/h	219	199	239	51	13	171
Conflicting Peds, #/hr	0	0	0	0	0	0
Sign Control	Free	Free	Free	Free	Stop	Stop
RT Channelized	-	None	-	None	-	None
Storage Length	155	-	-	-	155	0
Veh in Median Storage, #	-	0	0	-	0	-
Grade, %	-	0	0	-	0	-
Peak Hour Factor	92	92	92	92	92	92
Heavy Vehicles, %	2	2	2	2	2	2
Mvmt Flow	238	216	260	55	14	186

**Major/Minor** Major1 Major2 Minor2

Conflicting Flow All	315	0	-	0	980	288
Stage 1	-	-	-	-	288	-
Stage 2	-	-	-	-	692	-
Critical Hdwy	4.12	-	-	-	6.42	6.22
Critical Hdwy Stg 1	-	-	-	-	5.42	-
Critical Hdwy Stg 2	-	-	-	-	5.42	-
Follow-up Hdwy	2.218	-	-	-	3.518	3.318
Pot Cap-1 Maneuver	1245	-	-	-	277	751
Stage 1	-	-	-	-	761	-
Stage 2	-	-	-	-	497	-
Platoon blocked, %		-	-	-		
Mov Cap-1 Maneuver	1245	-	-	-	224	751
Mov Cap-2 Maneuver	-	-	-	-	224	-
Stage 1	-	-	-	-	616	-
Stage 2	-	-	-	-	497	-

**Approach** EB WB SB

HCM Control Delay, s	4.5	0	12.2
HCM LOS			B

**Minor Lane/Major Mvmt** EBL EBT WBT WBR SBLn1 SBLn2

Capacity (veh/h)	1245	-	-	-	224	751
HCM Lane V/C Ratio	0.191	-	-	-	0.063	0.247
HCM Control Delay (s)	8.6	-	-	-	22.2	11.4
HCM Lane LOS	A	-	-	-	C	B
HCM 95th %tile Q(veh)	0.7	-	-	-	0.2	1

Timings  
3: Meridian Rd & Bent Grass Meadows Dr

2040 Total Traffic  
AM Peak Hour



Lane Group	EBL	EBR	NBL	NBT	SBT	SBR
Lane Configurations	↖↗	↗	↖	↑↑	↑↑	↗
Traffic Volume (vph)	288	383	195	653	1733	318
Future Volume (vph)	288	383	195	653	1733	318
Turn Type	Prot	Free	pm+pt	NA	NA	Perm
Protected Phases	4		5	2	6	
Permitted Phases		Free	2			6
Detector Phase	4		5	2	6	6
Switch Phase						
Minimum Initial (s)	5.0		5.0	5.0	5.0	5.0
Minimum Split (s)	10.0		10.0	10.0	10.0	10.0
Total Split (s)	26.0		28.0	94.0	66.0	66.0
Total Split (%)	21.7%		23.3%	78.3%	55.0%	55.0%
Yellow Time (s)	3.0		3.0	3.0	3.0	3.0
All-Red Time (s)	2.0		2.0	2.0	2.0	2.0
Lost Time Adjust (s)	0.0		0.0	0.0	0.0	0.0
Total Lost Time (s)	5.0		5.0	5.0	5.0	5.0
Lead/Lag			Lead		Lag	Lag
Lead-Lag Optimize?			Yes		Yes	Yes
Recall Mode	None		None	Max	Max	Max
Act Effct Green (s)	15.3	114.4	89.1	89.1	70.7	70.7
Actuated g/C Ratio	0.13	1.00	0.78	0.78	0.62	0.62
v/c Ratio	0.66	0.25	0.75	0.25	0.83	0.31
Control Delay	54.3	0.4	43.7	3.9	23.4	2.9
Queue Delay	0.0	0.0	0.0	0.0	0.0	0.0
Total Delay	54.3	0.4	43.7	3.9	23.4	2.9
LOS	D	A	D	A	C	A
Approach Delay	23.5			13.1	20.2	
Approach LOS	C			B	C	

Intersection Summary

Cycle Length: 120  
 Actuated Cycle Length: 114.4  
 Natural Cycle: 60  
 Control Type: Semi Act-Uncoord  
 Maximum v/c Ratio: 0.83  
 Intersection Signal Delay: 19.1  
 Intersection Capacity Utilization 79.4%  
 Analysis Period (min) 15  
 Intersection LOS: B  
 ICU Level of Service D

Splits and Phases: 3: Meridian Rd & Bent Grass Meadows Dr

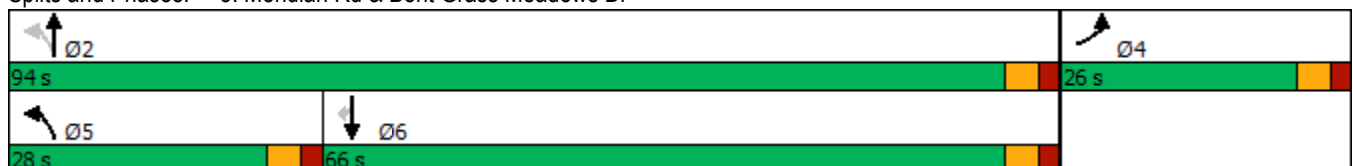

Intersection												
Int Delay, s/veh	2.4											
Movement	EBL	EBT	EBR	WBL	WBT	WBR	NBL	NBT	NBR	SBL	SBT	SBR
Lane Configurations	↖	↗		↖	↗			↖	↗		↔	
Traffic Vol, veh/h	3	289	6	61	157	6	4	1	45	17	1	8
Future Vol, veh/h	3	289	6	61	157	6	4	1	45	17	1	8
Conflicting Peds, #/hr	0	0	0	0	0	0	0	0	0	0	0	0
Sign Control	Free	Free	Free	Free	Free	Free	Stop	Stop	Stop	Stop	Stop	Stop
RT Channelized	-	-	None	-	-	None	-	-	None	-	-	None
Storage Length	155	-	-	110	-	-	-	-	0	-	-	-
Veh in Median Storage, #	-	0	-	-	0	-	-	0	-	-	0	-
Grade, %	-	0	-	-	0	-	-	0	-	-	0	-
Peak Hour Factor	95	95	95	95	95	95	95	95	95	95	95	95
Heavy Vehicles, %	2	2	2	2	2	2	2	2	2	2	2	2
Mvmt Flow	3	304	6	64	165	6	4	1	47	18	1	8

Major/Minor	Major1			Major2			Minor1			Minor2		
Conflicting Flow All	171	0	0	310	0	0	614	612	307	633	612	168
Stage 1	-	-	-	-	-	-	313	313	-	296	296	-
Stage 2	-	-	-	-	-	-	301	299	-	337	316	-
Critical Hdwy	4.12	-	-	4.12	-	-	7.12	6.52	6.22	7.12	6.52	6.22
Critical Hdwy Stg 1	-	-	-	-	-	-	6.12	5.52	-	6.12	5.52	-
Critical Hdwy Stg 2	-	-	-	-	-	-	6.12	5.52	-	6.12	5.52	-
Follow-up Hdwy	2.218	-	-	2.218	-	-	3.518	4.018	3.318	3.518	4.018	3.318
Pot Cap-1 Maneuver	1406	-	-	1250	-	-	404	408	733	392	408	876
Stage 1	-	-	-	-	-	-	698	657	-	712	668	-
Stage 2	-	-	-	-	-	-	708	666	-	677	655	-
Platoon blocked, %	-	-	-	-	-	-	-	-	-	-	-	-
Mov Cap-1 Maneuver	1406	-	-	1250	-	-	383	386	733	351	386	876
Mov Cap-2 Maneuver	-	-	-	-	-	-	383	386	-	351	386	-
Stage 1	-	-	-	-	-	-	697	656	-	711	634	-
Stage 2	-	-	-	-	-	-	664	632	-	631	654	-

Approach	EB			WB			NB			SB		
HCM Control Delay, s	0.1			2.2			10.7			13.9		
HCM LOS							B			B		

Minor Lane/Major Mvmt	NBLn1	NBLn2	EBL	EBT	EBR	WBL	WBT	WBR	SBLn1
Capacity (veh/h)	384	733	1406	-	-	1250	-	-	432
HCM Lane V/C Ratio	0.014	0.065	0.002	-	-	0.051	-	-	0.063
HCM Control Delay (s)	14.5	10.3	7.6	-	-	8	-	-	13.9
HCM Lane LOS	B	B	A	-	-	A	-	-	B
HCM 95th %tile Q(veh)	0	0.2	0	-	-	0.2	-	-	0.2

Intersection												
Int Delay, s/veh	7.2											
Movement	EBL	EBT	EBR	WBL	WBT	WBR	NBL	NBT	NBR	SBL	SBT	SBR
Lane Configurations	↙	↑	↗	↙	↗			↕			↕	
Traffic Vol, veh/h	6	331	14	312	189	11	19	2	303	37	4	15
Future Vol, veh/h	6	331	14	312	189	11	19	2	303	37	4	15
Conflicting Peds, #/hr	0	0	0	0	0	0	0	0	0	0	0	0
Sign Control	Free	Free	Free	Free	Free	Free	Stop	Stop	Stop	Stop	Stop	Stop
RT Channelized	-	-	None	-	-	None	-	-	None	-	-	None
Storage Length	150	-	150	0	-	-	-	-	-	-	-	-
Veh in Median Storage, #	-	0	-	-	0	-	-	1	-	-	1	-
Grade, %	-	0	-	-	0	-	-	0	-	-	0	-
Peak Hour Factor	95	95	95	95	95	95	95	95	95	95	95	95
Heavy Vehicles, %	2	2	2	2	2	2	2	2	2	2	2	2
Mvmt Flow	6	348	15	328	199	12	20	2	319	39	4	16

Major/Minor	Major1			Major2			Minor1			Minor2		
Conflicting Flow All	211	0	0	363	0	0	1231	1227	348	1389	1236	205
Stage 1	-	-	-	-	-	-	360	360	-	861	861	-
Stage 2	-	-	-	-	-	-	871	867	-	528	375	-
Critical Hdwy	4.12	-	-	4.12	-	-	7.12	6.52	6.22	7.12	6.52	6.22
Critical Hdwy Stg 1	-	-	-	-	-	-	6.12	5.52	-	6.12	5.52	-
Critical Hdwy Stg 2	-	-	-	-	-	-	6.12	5.52	-	6.12	5.52	-
Follow-up Hdwy	2.218	-	-	2.218	-	-	3.518	4.018	3.318	3.518	4.018	3.318
Pot Cap-1 Maneuver	1360	-	-	1196	-	-	154	178	695	120	176	836
Stage 1	-	-	-	-	-	-	658	626	-	350	372	-
Stage 2	-	-	-	-	-	-	346	370	-	534	617	-
Platoon blocked, %	-	-	-	-	-	-	-	-	-	-	-	-
Mov Cap-1 Maneuver	1360	-	-	1196	-	-	117	129	695	51	127	836
Mov Cap-2 Maneuver	-	-	-	-	-	-	196	214	-	~ -75	185	-
Stage 1	-	-	-	-	-	-	655	623	-	349	270	-
Stage 2	-	-	-	-	-	-	243	269	-	287	615	-

Approach	EB	WB	NB	SB
HCM Control Delay, s	0.1	5.6	18.7	
HCM LOS			C	-

Minor Lane/Major Mvmt	NBLn1	EBL	EBT	EBR	WBL	WBT	WBR	SBLn1
Capacity (veh/h)	598	1360	-	-	1196	-	-	+
HCM Lane V/C Ratio	0.57	0.005	-	-	0.275	-	-	-
HCM Control Delay (s)	18.7	7.7	-	-	9.1	-	-	-
HCM Lane LOS	C	A	-	-	A	-	-	-
HCM 95th %tile Q(veh)	3.6	0	-	-	1.1	-	-	-

Notes  
 ~: Volume exceeds capacity    \$: Delay exceeds 300s    +: Computation Not Defined    \*: All major volume in platoon



SimTraffic Performance Report

20: Meridian Park Dr & Bent Grass Meadows Dr Performance by lane Interval #1 7:00

Lane	EB	EB	EB	WB	WB	NB	SB	All
Movements Served	L	T	R	L	TR	LTR	LTR	
Stop Del/Veh (s)	0.0	0.1	0.1	2.3	0.4	11.3	15.6	4.4

20: Meridian Park Dr & Bent Grass Meadows Dr Performance by lane Interval #2 7:15

Lane	EB	EB	EB	WB	WB	NB	SB	All
Movements Served	L	T	R	L	TR	LTR	LTR	
Stop Del/Veh (s)	0.0	0.1	0.0	3.3	0.5	14.4	18.1	5.4

20: Meridian Park Dr & Bent Grass Meadows Dr Performance by lane Interval #3 7:30

Lane	EB	EB	EB	WB	WB	NB	SB	All
Movements Served	L	T	R	L	TR	LTR	LTR	
Stop Del/Veh (s)	0.4	0.1	0.0	3.0	0.4	10.8	15.8	4.5

20: Meridian Park Dr & Bent Grass Meadows Dr Performance by lane Interval #4 7:45

Lane	EB	EB	EB	WB	WB	NB	SB	All
Movements Served	L	T	R	L	TR	LTR	LTR	
Stop Del/Veh (s)	0.7	0.1	0.0	2.1	0.4	7.0	13.8	3.1

20: Meridian Park Dr & Bent Grass Meadows Dr Performance by lane Entire Run

Lane	EB	EB	EB	WB	WB	NB	SB	All
Movements Served	L	T	R	L	TR	LTR	LTR	
Stop Del/Veh (s)	0.4	0.1	0.0	2.7	0.5	11.1	16.2	4.4

Timings  
25: Golden Sage Rd & Woodmen Rd

2040 Total Traffic  
AM Peak Hour

Lane Group	EBL	EBT	EBR	WBL	WBT	WBR	NBL	NBT	NBR	SBL	SBT	SBR
Lane Configurations												
Traffic Volume (vph)	333	738	74	68	1804	110	164	19	50	98	27	415
Future Volume (vph)	333	738	74	68	1804	110	164	19	50	98	27	415
Turn Type	Prot	NA	Perm	pm+pt	NA	Perm	pm+pt	NA	Perm	pm+pt	NA	Free
Protected Phases	5	2		1	6		3	8		7	4	
Permitted Phases			2	6		6	8		8	4		Free
Detector Phase	5	2	2	1	6	6	3	8	8	7	4	
Switch Phase												
Minimum Initial (s)	5.0	5.0	5.0	5.0	5.0	5.0	5.0	5.0	5.0	5.0	5.0	5.0
Minimum Split (s)	10.0	12.0	12.0	10.0	12.0	12.0	10.0	10.0	10.0	10.0	10.0	10.0
Total Split (s)	22.0	75.0	75.0	10.0	63.0	63.0	20.0	15.0	15.0	20.0	15.0	
Total Split (%)	18.3%	62.5%	62.5%	8.3%	52.5%	52.5%	16.7%	12.5%	12.5%	16.7%	12.5%	
Yellow Time (s)	3.0	5.0	5.0	3.0	5.0	5.0	3.0	3.0	3.0	3.0	3.0	3.0
All-Red Time (s)	2.0	2.0	2.0	2.0	2.0	2.0	2.0	2.0	2.0	2.0	2.0	2.0
Lost Time Adjust (s)	-1.0	-1.0	-1.0	-1.0	-1.0	-1.0	-1.0	-1.0	-1.0	-1.0	-1.0	-1.0
Total Lost Time (s)	4.0	6.0	6.0	4.0	6.0	6.0	4.0	4.0	4.0	4.0	4.0	4.0
Lead/Lag	Lead	Lag	Lag	Lead	Lag	Lag	Lead	Lag	Lag	Lead	Lag	Lag
Lead-Lag Optimize?	Yes	Yes	Yes	Yes	Yes	Yes	Yes	Yes	Yes	Yes	Yes	Yes
Recall Mode	None	Min	Min	None	Min	Min	None	None	None	None	None	None
Act Effct Green (s)	16.3	70.1	70.1	65.5	57.5	57.5	22.5	9.4	9.4	17.8	8.3	111.4
Actuated g/C Ratio	0.15	0.63	0.63	0.59	0.52	0.52	0.20	0.08	0.08	0.16	0.07	1.00
v/c Ratio	0.70	0.34	0.08	0.16	1.01	0.13	0.57	0.13	0.18	0.39	0.20	0.28
Control Delay	54.3	11.8	1.0	7.9	51.9	1.4	45.7	51.3	1.4	42.1	54.5	0.4
Queue Delay	0.0	0.0	0.0	0.0	0.0	0.0	0.0	0.0	0.0	0.0	0.0	0.0
Total Delay	54.3	11.8	1.0	7.9	51.9	1.4	45.7	51.3	1.4	42.1	54.5	0.4
LOS	D	B	A	A	D	A	D	D	A	D	D	A
Approach Delay		23.7			47.4			36.6			10.7	
Approach LOS		C			D			D			B	

Intersection Summary

Cycle Length: 120  
 Actuated Cycle Length: 111.4  
 Natural Cycle: 90  
 Control Type: Semi Act-Uncoord  
 Maximum v/c Ratio: 1.01  
 Intersection Signal Delay: 34.6  
 Intersection Capacity Utilization 86.8%  
 Analysis Period (min) 15  
 Intersection LOS: C  
 ICU Level of Service E

Splits and Phases: 25: Golden Sage Rd & Woodmen Rd



HCM 6th TWSC  
 26: Golden Sage Rd & Woodmen Frontage Rd

2040 Total Traffic  
 AM Peak Hour

Intersection												
Int Delay, s/veh	19.9											
Movement	EBL	EBT	EBR	WBL	WBT	WBR	NBL	NBT	NBR	SBL	SBT	SBR
Lane Configurations		↻			↻			↻	↻		↻	
Traffic Vol, veh/h	0	7	114	426	5	0	78	0	384	0	0	0
Future Vol, veh/h	0	7	114	426	5	0	78	0	384	0	0	0
Conflicting Peds, #/hr	0	0	0	0	0	0	0	0	0	0	0	0
Sign Control	Stop	Stop	Stop	Stop	Stop	Stop	Free	Free	Free	Free	Free	Free
RT Channelized	-	-	None	-	-	None	-	-	Free	-	-	None
Storage Length	-	-	-	-	-	-	-	-	0	-	-	-
Veh in Median Storage, #	-	0	-	-	0	-	-	0	-	-	0	-
Grade, %	-	0	-	-	0	-	-	0	-	-	0	-
Peak Hour Factor	92	95	95	95	95	92	95	92	95	92	92	92
Heavy Vehicles, %	2	2	2	2	2	2	2	2	2	2	2	2
Mvmt Flow	0	7	120	448	5	0	82	0	404	0	0	0

Major/Minor	Minor2		Minor1		Major1		Major2					
Conflicting Flow All	-	165	1	229	165	-	1	0	-	0	0	0
Stage 1	-	1	-	164	164	-	-	-	-	-	-	-
Stage 2	-	164	-	65	1	-	-	-	-	-	-	-
Critical Hdwy	-	6.52	6.22	7.12	6.52	-	4.12	-	-	4.12	-	-
Critical Hdwy Stg 1	-	5.52	-	6.12	5.52	-	-	-	-	-	-	-
Critical Hdwy Stg 2	-	5.52	-	6.12	5.52	-	-	-	-	-	-	-
Follow-up Hdwy	-	4.018	3.318	3.518	4.018	-	2.218	-	-	2.218	-	-
Pot Cap-1 Maneuver	0	728	1084	726	728	0	1622	-	0	-	-	-
Stage 1	0	895	-	838	762	0	-	-	0	-	-	-
Stage 2	0	762	-	946	895	0	-	-	0	-	-	-
Platoon blocked, %								-			-	-
Mov Cap-1 Maneuver	-	691	1084	616	691	-	1622	-	-	-	-	-
Mov Cap-2 Maneuver	-	691	-	616	691	-	-	-	-	-	-	-
Stage 1	-	895	-	795	723	-	-	-	-	-	-	-
Stage 2	-	723	-	834	895	-	-	-	-	-	-	-

Approach	EB		WB		NB		SB	
HCM Control Delay, s	8.9		25.3		7.3		0	
HCM LOS	A		D					

Minor Lane/Major Mvmt	NBL	NBT	EBLn1	WBLn1	SBL	SBT	SBR
Capacity (veh/h)	1622	-	1049	617	-	-	-
HCM Lane V/C Ratio	0.051	-	0.121	0.735	-	-	-
HCM Control Delay (s)	7.3	0	8.9	25.3	0	-	-
HCM Lane LOS	A	A	A	D	A	-	-
HCM 95th %tile Q(veh)	0.2	-	0.4	6.4	-	-	-

HCM 6th TWSC  
 29: Meridian Park Dr & Proposed Site Access/7-Eleven S Access

2040 Total Traffic  
 AM Peak Hour

Intersection												
Int Delay, s/veh	6.4											
Movement	EBL	EBT	EBR	WBL	WBT	WBR	NBL	NBT	NBR	SBL	SBT	SBR
Lane Configurations												
Traffic Vol, veh/h	80	0	1	1	0	143	1	101	1	152	81	97
Future Vol, veh/h	80	0	1	1	0	143	1	101	1	152	81	97
Conflicting Peds, #/hr	0	0	0	0	0	0	0	0	0	0	0	0
Sign Control	Stop	Stop	Stop	Stop	Stop	Stop	Free	Free	Free	Free	Free	Free
RT Channelized	-	-	None	-	-	None	-	-	None	-	-	None
Storage Length	0	-	-	-	-	-	-	-	-	-	-	0
Veh in Median Storage, #	-	0	-	-	0	-	-	0	-	-	0	-
Grade, %	-	0	-	-	0	-	-	0	-	-	0	-
Peak Hour Factor	95	95	95	95	95	95	95	95	95	95	95	95
Heavy Vehicles, %	2	2	2	2	2	2	2	2	2	2	2	2
Mvmt Flow	84	0	1	1	0	151	1	106	1	160	85	102

Major/Minor	Minor2		Minor1		Major1		Major2					
Conflicting Flow All	589	514	85	566	616	107	187	0	0	107	0	0
Stage 1	405	405	-	109	109	-	-	-	-	-	-	-
Stage 2	184	109	-	457	507	-	-	-	-	-	-	-
Critical Hdwy	7.12	6.52	6.22	7.12	6.52	6.22	4.12	-	-	4.12	-	-
Critical Hdwy Stg 1	6.12	5.52	-	6.12	5.52	-	-	-	-	-	-	-
Critical Hdwy Stg 2	6.12	5.52	-	6.12	5.52	-	-	-	-	-	-	-
Follow-up Hdwy	3.518	4.018	3.318	3.518	4.018	3.318	2.218	-	-	2.218	-	-
Pot Cap-1 Maneuver	420	464	974	435	406	947	1387	-	-	1484	-	-
Stage 1	622	598	-	896	805	-	-	-	-	-	-	-
Stage 2	818	805	-	583	539	-	-	-	-	-	-	-
Platoon blocked, %								-	-	-	-	-
Mov Cap-1 Maneuver	320	407	974	394	356	947	1387	-	-	1484	-	-
Mov Cap-2 Maneuver	320	407	-	394	356	-	-	-	-	-	-	-
Stage 1	621	525	-	895	804	-	-	-	-	-	-	-
Stage 2	687	804	-	511	473	-	-	-	-	-	-	-

Approach	EB	WB	NB	SB
HCM Control Delay, s	20.1	9.6	0.1	3.6
HCM LOS	C	A		

Minor Lane/Major Mvmt	NBL	NBT	NBR	EBLn1	EBLn2	WBLn1	SBL	SBT	SBR
Capacity (veh/h)	1387	-	-	320	974	938	1484	-	-
HCM Lane V/C Ratio	0.001	-	-	0.263	0.001	0.162	0.108	-	-
HCM Control Delay (s)	7.6	0	-	20.2	8.7	9.6	7.7	0	-
HCM Lane LOS	A	A	-	C	A	A	A	A	-
HCM 95th %tile Q(veh)	0	-	-	1	0	0.6	0.4	-	-

Intersection						
Int Delay, s/veh	4.5					
Movement	EBL	EBT	WBT	WBR	SBL	SBR
Lane Configurations	↘	↑	↗		↘	↗
Traffic Vol, veh/h	118	255	148	19	21	212
Future Vol, veh/h	118	255	148	19	21	212
Conflicting Peds, #/hr	0	0	0	0	0	0
Sign Control	Free	Free	Free	Free	Stop	Stop
RT Channelized	-	None	-	None	-	None
Storage Length	155	-	-	-	155	0
Veh in Median Storage, #	-	0	0	-	0	-
Grade, %	-	0	0	-	0	-
Peak Hour Factor	92	92	92	92	92	92
Heavy Vehicles, %	2	2	2	2	2	2
Mvmt Flow	128	277	161	21	23	230

Major/Minor	Major1	Major2	Minor2		
Conflicting Flow All	182	0	-	0	705 172
Stage 1	-	-	-	-	172 -
Stage 2	-	-	-	-	533 -
Critical Hdwy	4.12	-	-	-	6.42 6.22
Critical Hdwy Stg 1	-	-	-	-	5.42 -
Critical Hdwy Stg 2	-	-	-	-	5.42 -
Follow-up Hdwy	2.218	-	-	-	3.518 3.318
Pot Cap-1 Maneuver	1393	-	-	-	403 872
Stage 1	-	-	-	-	858 -
Stage 2	-	-	-	-	588 -
Platoon blocked, %		-	-	-	
Mov Cap-1 Maneuver	1393	-	-	-	366 872
Mov Cap-2 Maneuver	-	-	-	-	366 -
Stage 1	-	-	-	-	779 -
Stage 2	-	-	-	-	588 -

Approach	EB	WB	SB
HCM Control Delay, s	2.5	0	11
HCM LOS			B

Minor Lane/Major Mvmt	EBL	EBT	WBT	WBR	SBLn1	SBLn2
Capacity (veh/h)	1393	-	-	-	366	872
HCM Lane V/C Ratio	0.092	-	-	-	0.062	0.264
HCM Control Delay (s)	7.8	-	-	-	15.5	10.6
HCM Lane LOS	A	-	-	-	C	B
HCM 95th %tile Q(veh)	0.3	-	-	-	0.2	1.1

Timings  
3: Meridian Rd & Bent Grass Meadows Dr

2040 Total Traffic  
PM Peak Hour



Lane Group	EBL	EBR	NBL	NBT	SBT	SBR
Lane Configurations	↖↗	↗	↖	↑↑	↑↑	↗
Traffic Volume (vph)	485	275	306	1482	1154	249
Future Volume (vph)	485	275	306	1482	1154	249
Turn Type	Prot	Perm	pm+pt	NA	NA	Perm
Protected Phases	4		5	2	6	
Permitted Phases		4	2			6
Detector Phase	4	4	5	2	6	6
Switch Phase						
Minimum Initial (s)	5.0	5.0	5.0	5.0	5.0	5.0
Minimum Split (s)	10.0	10.0	10.0	10.0	10.0	10.0
Total Split (s)	35.0	35.0	20.0	85.0	65.0	65.0
Total Split (%)	29.2%	29.2%	16.7%	70.8%	54.2%	54.2%
Yellow Time (s)	3.0	3.0	3.0	3.0	3.0	3.0
All-Red Time (s)	2.0	2.0	2.0	2.0	2.0	2.0
Lost Time Adjust (s)	0.0	0.0	0.0	0.0	0.0	0.0
Total Lost Time (s)	5.0	5.0	5.0	5.0	5.0	5.0
Lead/Lag			Lead		Lag	Lag
Lead-Lag Optimize?			Yes		Yes	Yes
Recall Mode	None	None	None	Max	Max	Max
Act Effct Green (s)	22.4	22.4	80.2	80.2	60.3	60.3
Actuated g/C Ratio	0.20	0.20	0.71	0.71	0.54	0.54
v/c Ratio	0.75	0.56	0.87	0.62	0.64	0.27
Control Delay	49.6	11.8	42.0	10.3	21.2	2.6
Queue Delay	0.0	0.0	0.0	0.0	0.0	0.0
Total Delay	49.6	11.8	42.0	10.3	21.2	2.6
LOS	D	B	D	B	C	A
Approach Delay	35.9			15.7	17.9	
Approach LOS	D			B	B	

Intersection Summary

Cycle Length: 120	
Actuated Cycle Length: 112.6	
Natural Cycle: 55	
Control Type: Semi Act-Uncoord	
Maximum v/c Ratio: 0.87	
Intersection Signal Delay: 20.4	Intersection LOS: C
Intersection Capacity Utilization 75.2%	ICU Level of Service D
Analysis Period (min) 15	

Splits and Phases: 3: Meridian Rd & Bent Grass Meadows Dr



Intersection												
Int Delay, s/veh	2.6											
Movement	EBL	EBT	EBR	WBL	WBT	WBR	NBL	NBT	NBR	SBL	SBT	SBR
Lane Configurations												
Traffic Vol, veh/h	6	166	6	54	205	22	6	2	56	14	2	4
Future Vol, veh/h	6	166	6	54	205	22	6	2	56	14	2	4
Conflicting Peds, #/hr	0	0	0	0	0	0	0	0	0	0	0	0
Sign Control	Free	Free	Free	Free	Free	Free	Stop	Stop	Stop	Stop	Stop	Stop
RT Channelized	-	-	None	-	-	None	-	-	None	-	-	None
Storage Length	155	-	-	110	-	-	-	-	0	-	-	-
Veh in Median Storage, #	-	0	-	-	0	-	-	0	-	-	0	-
Grade, %	-	0	-	-	0	-	-	0	-	-	0	-
Peak Hour Factor	95	95	95	95	95	95	95	95	95	95	95	95
Heavy Vehicles, %	2	2	2	2	2	2	2	2	2	2	2	2
Mvmt Flow	6	175	6	57	216	23	6	2	59	15	2	4

Major/Minor	Major1			Major2			Minor1			Minor2		
Conflicting Flow All	239	0	0	181	0	0	535	543	178	563	535	228
Stage 1	-	-	-	-	-	-	190	190	-	342	342	-
Stage 2	-	-	-	-	-	-	345	353	-	221	193	-
Critical Hdwy	4.12	-	-	4.12	-	-	7.12	6.52	6.22	7.12	6.52	6.22
Critical Hdwy Stg 1	-	-	-	-	-	-	6.12	5.52	-	6.12	5.52	-
Critical Hdwy Stg 2	-	-	-	-	-	-	6.12	5.52	-	6.12	5.52	-
Follow-up Hdwy	2.218	-	-	2.218	-	-	3.518	4.018	3.318	3.518	4.018	3.318
Pot Cap-1 Maneuver	1328	-	-	1394	-	-	456	447	865	437	452	811
Stage 1	-	-	-	-	-	-	812	743	-	673	638	-
Stage 2	-	-	-	-	-	-	671	631	-	781	741	-
Platoon blocked, %		-	-		-	-						
Mov Cap-1 Maneuver	1328	-	-	1394	-	-	436	426	865	392	431	811
Mov Cap-2 Maneuver	-	-	-	-	-	-	436	426	-	392	431	-
Stage 1	-	-	-	-	-	-	808	739	-	670	612	-
Stage 2	-	-	-	-	-	-	638	605	-	722	737	-

Approach	EB	WB	NB	SB
HCM Control Delay, s	0.3	1.5	10	13.6
HCM LOS			B	B

Minor Lane/Major Mvmt	NBLn1	NBLn2	EBL	EBT	EBR	WBL	WBT	WBR	SBLn1
Capacity (veh/h)	433	865	1328	-	-	1394	-	-	442
HCM Lane V/C Ratio	0.019	0.068	0.005	-	-	0.041	-	-	0.048
HCM Control Delay (s)	13.5	9.5	7.7	-	-	7.7	-	-	13.6
HCM Lane LOS	B	A	A	-	-	A	-	-	B
HCM 95th %tile Q(veh)	0.1	0.2	0	-	-	0.1	-	-	0.1

Intersection												
Int Delay, s/veh	18.5											
Movement	EBL	EBT	EBR	WBL	WBT	WBR	NBL	NBT	NBR	SBL	SBT	SBR
Lane Configurations	↖	↑	↗	↖	↗			↕			↕	
Traffic Vol, veh/h	8	216	11	256	252	48	23	6	516	28	4	5
Future Vol, veh/h	8	216	11	256	252	48	23	6	516	28	4	5
Conflicting Peds, #/hr	0	0	0	0	0	0	0	0	0	0	0	0
Sign Control	Free	Free	Free	Free	Free	Free	Stop	Stop	Stop	Stop	Stop	Stop
RT Channelized	-	-	None	-	-	None	-	-	None	-	-	None
Storage Length	150	-	150	0	-	-	-	-	-	-	-	-
Veh in Median Storage, #	-	0	-	-	0	-	-	1	-	-	0	-
Grade, %	-	0	-	-	0	-	-	0	-	-	0	-
Peak Hour Factor	95	95	95	95	95	95	95	95	95	95	95	95
Heavy Vehicles, %	2	2	2	2	2	2	2	2	2	2	2	2
Mvmt Flow	8	227	12	269	265	51	24	6	543	29	4	5

Major/Minor	Major1			Major2			Minor1			Minor2		
Conflicting Flow All	316	0	0	239	0	0	1076	1097	227	1353	1084	291
Stage 1	-	-	-	-	-	-	243	243	-	829	829	-
Stage 2	-	-	-	-	-	-	833	854	-	524	255	-
Critical Hdwy	4.12	-	-	4.12	-	-	7.12	6.52	6.22	7.12	6.52	6.22
Critical Hdwy Stg 1	-	-	-	-	-	-	6.12	5.52	-	6.12	5.52	-
Critical Hdwy Stg 2	-	-	-	-	-	-	6.12	5.52	-	6.12	5.52	-
Follow-up Hdwy	2.218	-	-	2.218	-	-	3.518	4.018	3.318	3.518	4.018	3.318
Pot Cap-1 Maneuver	1244	-	-	1328	-	-	197	213	812	127	217	748
Stage 1	-	-	-	-	-	-	761	705	-	365	385	-
Stage 2	-	-	-	-	-	-	363	375	-	537	696	-
Platoon blocked, %		-	-		-	-						
Mov Cap-1 Maneuver	1244	-	-	1328	-	-	161	169	812	35	172	748
Mov Cap-2 Maneuver	-	-	-	-	-	-	234	245	-	35	172	-
Stage 1	-	-	-	-	-	-	756	701	-	363	307	-
Stage 2	-	-	-	-	-	-	283	299	-	175	692	-

Approach	EB			WB			NB			SB		
HCM Control Delay, s	0.3			3.9			26.7			233.8		
HCM LOS							D			F		

Minor Lane/Major Mvmt	NBLn1	EBL	EBT	EBR	WBL	WBT	WBR	SBLn1
Capacity (veh/h)	719	1244	-	-	1328	-	-	45
HCM Lane V/C Ratio	0.798	0.007	-	-	0.203	-	-	0.865
HCM Control Delay (s)	26.7	7.9	-	-	8.4	-	-	233.8
HCM Lane LOS	D	A	-	-	A	-	-	F
HCM 95th %tile Q(veh)	8.2	0	-	-	0.8	-	-	3.5



SimTraffic Performance Report

20: Meridian Park Dr & Bent Grass Meadows Dr Performance by lane Interval #1 5:00

Lane	EB	EB	EB	WB	WB	NB	SB	All
Movements Served	L	T	R	L	TR	LTR	LTR	
Stop Del/Veh (s)	0.7	0.1	0.2	1.5	0.3	9.3	12.0	4.4

20: Meridian Park Dr & Bent Grass Meadows Dr Performance by lane Interval #2 5:15

Lane	EB	EB	EB	WB	WB	NB	SB	All
Movements Served	L	T	R	L	TR	LTR	LTR	
Stop Del/Veh (s)	1.3	0.2	0.0	1.6	0.3	11.2	11.8	5.2

20: Meridian Park Dr & Bent Grass Meadows Dr Performance by lane Interval #3 5:30

Lane	EB	EB	EB	WB	WB	NB	SB	All
Movements Served	L	T	R	L	TR	LTR	LTR	
Stop Del/Veh (s)	0.0	0.1	0.0	1.9	0.3	15.1	14.2	7.4

20: Meridian Park Dr & Bent Grass Meadows Dr Performance by lane Interval #4 5:45

Lane	EB	EB	EB	WB	WB	NB	SB	All
Movements Served	L	T	R	L	TR	LTR	LTR	
Stop Del/Veh (s)	1.4	0.1	0.0	1.7	0.3	15.4	17.8	7.1

20: Meridian Park Dr & Bent Grass Meadows Dr Performance by lane Entire Run

Lane	EB	EB	EB	WB	WB	NB	SB	All
Movements Served	L	T	R	L	TR	LTR	LTR	
Stop Del/Veh (s)	1.0	0.1	0.0	1.7	0.3	13.1	14.6	6.1

Timings  
25: Golden Sage Rd & Woodmen Rd

2040 Total Traffic  
PM Peak Hour

Lane Group	EBL	EBT	EBR	WBL	WBT	WBR	NBL	NBT	NBR	SBL	SBT	SBR
Lane Configurations												
Traffic Volume (vph)	478	1659	78	92	1105	121	178	41	72	136	21	403
Future Volume (vph)	478	1659	78	92	1105	121	178	41	72	136	21	403
Turn Type	Prot	NA	Perm	pm+pt	NA	Perm	pm+pt	NA	Perm	pm+pt	NA	Free
Protected Phases	5	2		1	6		3	8		7	4	
Permitted Phases			2	6		6	8		8	4		Free
Detector Phase	5	2	2	1	6	6	3	8	8	7	4	
Switch Phase												
Minimum Initial (s)	5.0	5.0	5.0	5.0	5.0	5.0	5.0	5.0	5.0	5.0	5.0	5.0
Minimum Split (s)	10.0	12.0	12.0	10.0	12.0	12.0	10.0	10.0	10.0	10.0	10.0	10.0
Total Split (s)	23.0	64.0	64.0	10.0	51.0	51.0	31.0	15.0	15.0	31.0	15.0	
Total Split (%)	19.2%	53.3%	53.3%	8.3%	42.5%	42.5%	25.8%	12.5%	12.5%	25.8%	12.5%	
Yellow Time (s)	3.0	5.0	5.0	3.0	5.0	5.0	3.0	3.0	3.0	3.0	3.0	3.0
All-Red Time (s)	2.0	2.0	2.0	2.0	2.0	2.0	2.0	2.0	2.0	2.0	2.0	2.0
Lost Time Adjust (s)	-1.0	-1.0	-1.0	-1.0	-1.0	-1.0	-1.0	-1.0	-1.0	-1.0	-1.0	-1.0
Total Lost Time (s)	4.0	6.0	6.0	4.0	6.0	6.0	4.0	4.0	4.0	4.0	4.0	4.0
Lead/Lag	Lead	Lag	Lag	Lead	Lag	Lag	Lead	Lag	Lag	Lead	Lag	Lag
Lead-Lag Optimize?	Yes	Yes	Yes	Yes	Yes	Yes	Yes	Yes	Yes	Yes	Yes	Yes
Recall Mode	None	Min	Min	None	Min	Min	None	None	None	None	None	None
Act Effct Green (s)	18.7	56.5	56.5	52.0	43.9	43.9	24.6	9.3	9.3	17.6	7.8	101.7
Actuated g/C Ratio	0.18	0.56	0.56	0.51	0.43	0.43	0.24	0.09	0.09	0.17	0.08	1.00
v/c Ratio	0.80	0.86	0.09	0.53	0.74	0.16	0.48	0.25	0.25	0.46	0.15	0.27
Control Delay	52.0	26.5	1.5	26.0	29.1	2.5	36.2	49.1	2.0	40.1	49.7	0.4
Queue Delay	0.0	0.0	0.0	0.0	0.0	0.0	0.0	0.0	0.0	0.0	0.0	0.0
Total Delay	52.0	26.5	1.5	26.0	29.1	2.5	36.2	49.1	2.0	40.1	49.7	0.4
LOS	D	C	A	C	C	A	D	D	A	D	D	A
Approach Delay		31.3			26.4			29.5			11.9	
Approach LOS		C			C			C			B	

Intersection Summary

Cycle Length: 120  
 Actuated Cycle Length: 101.7  
 Natural Cycle: 70  
 Control Type: Semi Act-Uncoord  
 Maximum v/c Ratio: 0.86  
 Intersection Signal Delay: 27.2  
 Intersection LOS: C  
 Intersection Capacity Utilization 79.2%  
 ICU Level of Service D  
 Analysis Period (min) 15

Splits and Phases: 25: Golden Sage Rd & Woodmen Rd

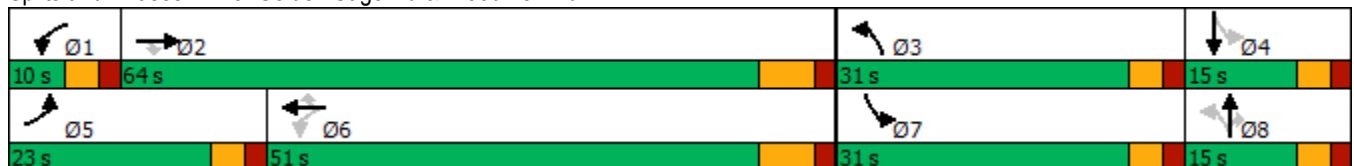

Intersection												
Int Delay, s/veh	43.4											
Movement	EBL	EBT	EBR	WBL	WBT	WBR	NBL	NBT	NBR	SBL	SBT	SBR
Lane Configurations		↻			↻			↻	↻		↻	
Traffic Vol, veh/h	0	10	100	459	12	0	134	0	507	0	0	0
Future Vol, veh/h	0	10	100	459	12	0	134	0	507	0	0	0
Conflicting Peds, #/hr	0	0	0	0	0	0	0	0	0	0	0	0
Sign Control	Stop	Stop	Stop	Stop	Stop	Stop	Free	Free	Free	Free	Free	Free
RT Channelized	-	-	None	-	-	None	-	-	Free	-	-	None
Storage Length	-	-	-	-	-	-	-	-	0	-	-	-
Veh in Median Storage, #	-	0	-	-	0	-	-	0	-	-	0	-
Grade, %	-	0	-	-	0	-	-	0	-	-	0	-
Peak Hour Factor	92	95	95	95	95	92	95	92	95	92	92	92
Heavy Vehicles, %	2	2	2	2	2	2	2	2	2	2	2	2
Mvmt Flow	0	11	105	483	13	0	141	0	534	0	0	0

Major/Minor	Minor2		Minor1		Major1		Major2					
Conflicting Flow All	-	283	1	341	283	-	1	0	-	0	0	0
Stage 1	-	1	-	282	282	-	-	-	-	-	-	-
Stage 2	-	282	-	59	1	-	-	-	-	-	-	-
Critical Hdwy	-	6.52	6.22	7.12	6.52	-	4.12	-	-	4.12	-	-
Critical Hdwy Stg 1	-	5.52	-	6.12	5.52	-	-	-	-	-	-	-
Critical Hdwy Stg 2	-	5.52	-	6.12	5.52	-	-	-	-	-	-	-
Follow-up Hdwy	-	4.018	3.318	3.518	4.018	-	2.218	-	-	2.218	-	-
Pot Cap-1 Maneuver	0	626	1084	613	626	0	1622	-	0	-	-	-
Stage 1	0	895	-	725	678	0	-	-	0	-	-	-
Stage 2	0	678	-	953	895	0	-	-	0	-	-	-
Platoon blocked, %								-			-	-
Mov Cap-1 Maneuver	-	572	1084	509	572	-	1622	-	-	-	-	-
Mov Cap-2 Maneuver	-	572	-	509	572	-	-	-	-	-	-	-
Stage 1	-	895	-	662	619	-	-	-	-	-	-	-
Stage 2	-	619	-	850	895	-	-	-	-	-	-	-

Approach	EB		WB		NB		SB	
HCM Control Delay, s	9.1		61.7		7.4		0	
HCM LOS	A		F					

Minor Lane/Major Mvmt	NBL	NBT	EBLn1	WBLn1	SBL	SBT	SBR
Capacity (veh/h)	1622	-	1002	510	-	-	-
HCM Lane V/C Ratio	0.087	-	0.116	0.972	-	-	-
HCM Control Delay (s)	7.4	0	9.1	61.7	0	-	-
HCM Lane LOS	A	A	A	F	A	-	-
HCM 95th %tile Q(veh)	0.3	-	0.4	12.8	-	-	-

Intersection												
Int Delay, s/veh	5.8											
Movement	EBL	EBT	EBR	WBL	WBT	WBR	NBL	NBT	NBR	SBL	SBT	SBR
Lane Configurations												
Traffic Vol, veh/h	93	0	1	2	0	116	1	336	2	107	76	88
Future Vol, veh/h	93	0	1	2	0	116	1	336	2	107	76	88
Conflicting Peds, #/hr	0	0	0	0	0	0	0	0	0	0	0	0
Sign Control	Stop	Stop	Stop	Stop	Stop	Stop	Free	Free	Free	Free	Free	Free
RT Channelized	-	-	None	-	-	None	-	-	None	-	-	None
Storage Length	0	-	-	-	-	-	-	-	-	-	-	0
Veh in Median Storage, #	-	0	-	-	0	-	-	0	-	-	0	-
Grade, %	-	0	-	-	0	-	-	0	-	-	0	-
Peak Hour Factor	95	95	95	95	95	95	95	95	95	95	95	95
Heavy Vehicles, %	2	2	2	2	2	2	2	2	2	2	2	2
Mvmt Flow	98	0	1	2	0	122	1	354	2	113	80	93

Major/Minor	Minor2		Minor1		Major1		Major2					
Conflicting Flow All	724	664	80	710	756	355	173	0	0	356	0	0
Stage 1	306	306	-	357	357	-	-	-	-	-	-	-
Stage 2	418	358	-	353	399	-	-	-	-	-	-	-
Critical Hdwy	7.12	6.52	6.22	7.12	6.52	6.22	4.12	-	-	4.12	-	-
Critical Hdwy Stg 1	6.12	5.52	-	6.12	5.52	-	-	-	-	-	-	-
Critical Hdwy Stg 2	6.12	5.52	-	6.12	5.52	-	-	-	-	-	-	-
Follow-up Hdwy	3.518	4.018	3.318	3.518	4.018	3.318	2.218	-	-	2.218	-	-
Pot Cap-1 Maneuver	341	381	980	348	337	689	1404	-	-	1203	-	-
Stage 1	704	662	-	661	628	-	-	-	-	-	-	-
Stage 2	612	628	-	664	602	-	-	-	-	-	-	-
Platoon blocked, %								-	-	-	-	-
Mov Cap-1 Maneuver	258	341	980	319	301	689	1404	-	-	1203	-	-
Mov Cap-2 Maneuver	258	341	-	319	301	-	-	-	-	-	-	-
Stage 1	703	592	-	660	627	-	-	-	-	-	-	-
Stage 2	503	627	-	594	539	-	-	-	-	-	-	-

Approach	EB		WB		NB		SB	
HCM Control Delay, s	27		11.5		0		3.3	
HCM LOS	D		B					

Minor Lane/Major Mvmt	NBL	NBT	NBR	EBLn1	EBLn2	WBLn1	SBL	SBT	SBR
Capacity (veh/h)	1404	-	-	258	980	676	1203	-	-
HCM Lane V/C Ratio	0.001	-	-	0.379	0.001	0.184	0.094	-	-
HCM Control Delay (s)	7.6	0	-	27.2	8.7	11.5	8.3	0	-
HCM Lane LOS	A	A	-	D	A	B	A	A	-
HCM 95th %tile Q(veh)	0	-	-	1.7	0	0.7	0.3	-	-

Intersection						
Int Delay, s/veh	4.8					
Movement	EBL	EBT	WBT	WBR	SBL	SBR
Lane Configurations	↙	↑	↘		↙	↘
Traffic Vol, veh/h	225	199	239	51	13	179
Future Vol, veh/h	225	199	239	51	13	179
Conflicting Peds, #/hr	0	0	0	0	0	0
Sign Control	Free	Free	Free	Free	Stop	Stop
RT Channelized	-	None	-	None	-	None
Storage Length	155	-	-	-	155	0
Veh in Median Storage, #	-	0	0	-	0	-
Grade, %	-	0	0	-	0	-
Peak Hour Factor	92	92	92	92	92	92
Heavy Vehicles, %	2	2	2	2	2	2
Mvmt Flow	245	216	260	55	14	195

Major/Minor	Major1	Major2	Minor2		
Conflicting Flow All	315	0	-	0	994 288
Stage 1	-	-	-	-	288 -
Stage 2	-	-	-	-	706 -
Critical Hdwy	4.12	-	-	-	6.42 6.22
Critical Hdwy Stg 1	-	-	-	-	5.42 -
Critical Hdwy Stg 2	-	-	-	-	5.42 -
Follow-up Hdwy	2.218	-	-	-	3.518 3.318
Pot Cap-1 Maneuver	1245	-	-	-	272 751
Stage 1	-	-	-	-	761 -
Stage 2	-	-	-	-	489 -
Platoon blocked, %		-	-	-	
Mov Cap-1 Maneuver	1245	-	-	-	218 751
Mov Cap-2 Maneuver	-	-	-	-	218 -
Stage 1	-	-	-	-	611 -
Stage 2	-	-	-	-	489 -

Approach	EB	WB	SB
HCM Control Delay, s	4.6	0	12.3
HCM LOS			B

Minor Lane/Major Mvmt	EBL	EBT	WBT	WBR	SBLn1	SBLn2
Capacity (veh/h)	1245	-	-	-	218	751
HCM Lane V/C Ratio	0.196	-	-	-	0.065	0.259
HCM Control Delay (s)	8.6	-	-	-	22.7	11.5
HCM Lane LOS	A	-	-	-	C	B
HCM 95th %tile Q(veh)	0.7	-	-	-	0.2	1

Timings  
26: Golden Sage Rd & Woodmen Frontage Rd

2040 Total Traffic (With 2 NB RT Lanes)  
AM Peak Hour



Lane Group	EBT	WBL	WBT	NBL	NBR
Lane Configurations	→		←	↔	↔
Traffic Volume (vph)	7	426	5	78	384
Future Volume (vph)	7	426	5	78	384
Turn Type	NA	pm+pt	NA	Prot	Over
Protected Phases	4	3	8	2	3
Permitted Phases		8			
Detector Phase	4	3	8	2	3
Switch Phase					
Minimum Initial (s)	5.0	5.0	5.0	5.0	5.0
Minimum Split (s)	10.0	10.0	10.0	10.0	10.0
Total Split (s)	10.0	30.0	40.0	80.0	30.0
Total Split (%)	8.3%	25.0%	33.3%	66.7%	25.0%
Yellow Time (s)	3.0	3.0	3.0	3.0	3.0
All-Red Time (s)	2.0	2.0	2.0	2.0	2.0
Lost Time Adjust (s)	-1.0		-1.0	-1.0	-1.0
Total Lost Time (s)	4.0		4.0	4.0	4.0
Lead/Lag	Lag	Lead			Lead
Lead-Lag Optimize?	Yes	Yes			Yes
Recall Mode	None	None	None	Min	None
Act Effct Green (s)	20.3		36.1	9.5	13.9
Actuated g/C Ratio	0.38		0.67	0.18	0.26
v/c Ratio	0.18		0.52	0.58	0.42
Control Delay	3.9		6.8	13.4	6.3
Queue Delay	0.0		0.0	0.0	0.0
Total Delay	3.9		6.8	13.4	6.3
LOS	A		A	B	A
Approach Delay	3.9		6.8	10.0	
Approach LOS	A		A	A	

Intersection Summary

Cycle Length: 120  
 Actuated Cycle Length: 53.6  
 Natural Cycle: 45  
 Control Type: Semi Act-Uncoord  
 Maximum v/c Ratio: 0.58  
 Intersection Signal Delay: 7.9  
 Intersection LOS: A  
 Intersection Capacity Utilization 53.5%  
 ICU Level of Service A  
 Analysis Period (min) 15

Splits and Phases: 26: Golden Sage Rd & Woodmen Frontage Rd

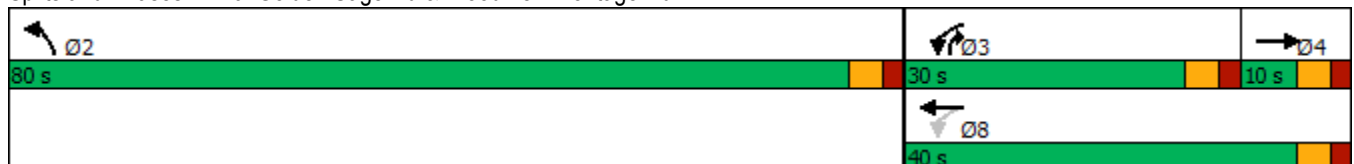

Timings  
26: Golden Sage Rd & Woodmen Frontage Rd

2040 Total Traffic  
AM Peak Hour

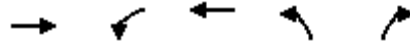

Lane Group	EBT	WBL	WBT	NBL	NBR
Lane Configurations	→		←	←	→
Traffic Volume (vph)	7	426	5	78	384
Future Volume (vph)	7	426	5	78	384
Turn Type	NA	pm+pt	NA	Prot	Over
Protected Phases	4	3	8	2	3
Permitted Phases		8			
Detector Phase	4	3	8	2	3
Switch Phase					
Minimum Initial (s)	5.0	5.0	5.0	5.0	5.0
Minimum Split (s)	10.0	10.0	10.0	10.0	10.0
Total Split (s)	10.0	30.0	40.0	80.0	30.0
Total Split (%)	8.3%	25.0%	33.3%	66.7%	25.0%
Yellow Time (s)	3.0	3.0	3.0	3.0	3.0
All-Red Time (s)	2.0	2.0	2.0	2.0	2.0
Lost Time Adjust (s)	-1.0		-1.0	-1.0	-1.0
Total Lost Time (s)	4.0		4.0	4.0	4.0
Lead/Lag	Lag	Lead			Lead
Lead-Lag Optimize?	Yes	Yes			Yes
Recall Mode	None	None	None	Min	None
Act Effct Green (s)	20.0		36.0	8.8	14.1
Actuated g/C Ratio	0.38		0.68	0.17	0.27
v/c Ratio	0.18		0.51	0.28	0.56
Control Delay	3.8		6.1	21.8	6.2
Queue Delay	0.0		0.0	0.0	0.0
Total Delay	3.8		6.1	21.8	6.2
LOS	A		A	C	A
Approach Delay	3.8		6.1	8.8	
Approach LOS	A		A	A	

Intersection Summary

Cycle Length: 120  
 Actuated Cycle Length: 52.8  
 Natural Cycle: 40  
 Control Type: Semi Act-Uncoord  
 Maximum v/c Ratio: 0.56  
 Intersection Signal Delay: 7.1  
 Intersection Capacity Utilization 45.6%  
 Analysis Period (min) 15  
 Intersection LOS: A  
 ICU Level of Service A

Splits and Phases: 26: Golden Sage Rd & Woodmen Frontage Rd

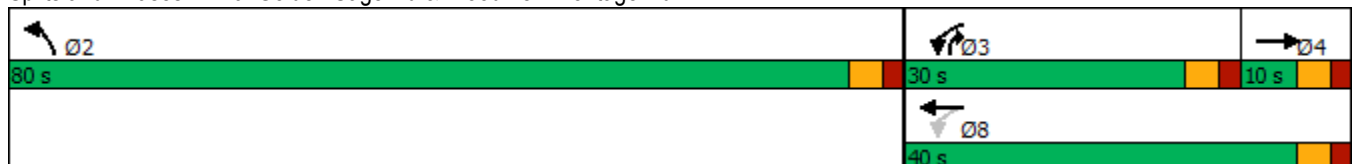

HCM 6th Roundabout  
 26: Golden Sage Rd & Woodmen Frontage Rd

2040 Total Traffic  
 AM Peak Hour

Intersection				
Intersection Delay, s/veh	3.6			
Intersection LOS	A			
Approach	EB	WB	NB	
Entry Lanes	1	1	1	
Conflicting Circle Lanes	1	1	1	
Adj Approach Flow, veh/h	127	453	486	
Demand Flow Rate, veh/h	129	462	496	
Vehicles Circulating, veh/h	457	84	7	
Vehicles Exiting, veh/h	89	7	579	
Ped Vol Crossing Leg, #/h	0	0	0	
Ped Cap Adj	1.000	1.000	1.000	
Approach Delay, s/veh	5.7	6.4	0.5	
Approach LOS	A	A	A	
Lane	Left	Left	Left	Bypass
Designated Moves	TR	LT	L	R
Assumed Moves	TR	LT	L	R
RT Channelized				Free
Lane Util	1.000	1.000	1.000	
Follow-Up Headway, s	2.609	2.609	2.609	
Critical Headway, s	4.976	4.976	4.976	412
Entry Flow, veh/h	129	462	84	1938
Cap Entry Lane, veh/h	866	1267	1370	0.980
Entry HV Adj Factor	0.983	0.980	0.976	404
Flow Entry, veh/h	127	453	82	1900
Cap Entry, veh/h	851	1242	1337	0.213
V/C Ratio	0.149	0.365	0.061	0.0
Control Delay, s/veh	5.7	6.4	3.2	A
LOS	A	A	A	1
95th %tile Queue, veh	1	2	0	



Timings  
26: Golden Sage Rd & Woodmen Frontage Rd

2040 Total Traffic (With 2 NB RT Lanes)  
PM Peak Hour



Lane Group	EBT	WBL	WBT	NBL	NBR
Lane Configurations	→		←	↔	↔
Traffic Volume (vph)	10	459	12	134	507
Future Volume (vph)	10	459	12	134	507
Turn Type	NA	pm+pt	NA	Prot	Over
Protected Phases	4	3	8	2	3
Permitted Phases		8			
Detector Phase	4	3	8	2	3
Switch Phase					
Minimum Initial (s)	5.0	5.0	5.0	5.0	5.0
Minimum Split (s)	10.0	10.0	10.0	10.0	10.0
Total Split (s)	10.0	30.0	40.0	80.0	30.0
Total Split (%)	8.3%	25.0%	33.3%	66.7%	25.0%
Yellow Time (s)	3.0	3.0	3.0	3.0	3.0
All-Red Time (s)	2.0	2.0	2.0	2.0	2.0
Lost Time Adjust (s)	-1.0		-1.0	-1.0	-1.0
Total Lost Time (s)	4.0		4.0	4.0	4.0
Lead/Lag	Lag	Lead			Lead
Lead-Lag Optimize?	Yes	Yes			Yes
Recall Mode	None	None	None	Min	None
Act Effct Green (s)	19.8		36.1	14.6	14.5
Actuated g/C Ratio	0.34		0.61	0.25	0.25
v/c Ratio	0.19		0.62	0.69	0.53
Control Delay	5.4		11.3	20.3	6.9
Queue Delay	0.0		0.0	0.0	0.0
Total Delay	5.4		11.3	20.3	6.9
LOS	A		B	C	A
Approach Delay	5.4		11.3	13.7	
Approach LOS	A		B	B	

Intersection Summary

Cycle Length: 120  
 Actuated Cycle Length: 58.8  
 Natural Cycle: 45  
 Control Type: Semi Act-Uncoord  
 Maximum v/c Ratio: 0.69  
 Intersection Signal Delay: 12.1  
 Intersection LOS: B  
 Intersection Capacity Utilization 57.2%  
 ICU Level of Service B  
 Analysis Period (min) 15

Splits and Phases: 26: Golden Sage Rd & Woodmen Frontage Rd

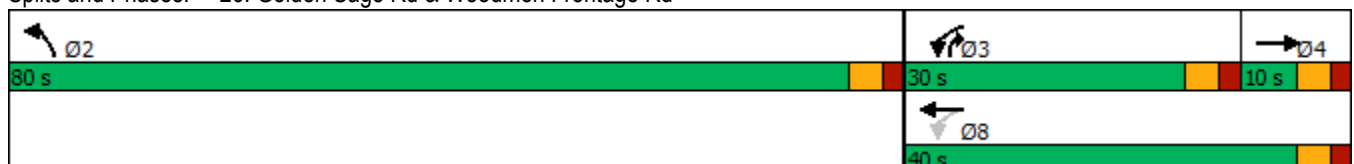

Timings  
26: Golden Sage Rd & Woodmen Frontage Rd

2040 Total Traffic  
PM Peak Hour

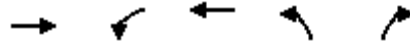

Lane Group	EBT	WBL	WBT	NBL	NBR
Lane Configurations	→		←	←	→
Traffic Volume (vph)	10	459	12	134	507
Future Volume (vph)	10	459	12	134	507
Turn Type	NA	pm+pt	NA	Prot	Over
Protected Phases	4	3	8	2	3
Permitted Phases		8			
Detector Phase	4	3	8	2	3
Switch Phase					
Minimum Initial (s)	5.0	5.0	5.0	5.0	5.0
Minimum Split (s)	10.0	10.0	10.0	10.0	10.0
Total Split (s)	10.0	30.0	40.0	80.0	30.0
Total Split (%)	8.3%	25.0%	33.3%	66.7%	25.0%
Yellow Time (s)	3.0	3.0	3.0	3.0	3.0
All-Red Time (s)	2.0	2.0	2.0	2.0	2.0
Lost Time Adjust (s)	-1.0		-1.0	-1.0	-1.0
Total Lost Time (s)	4.0		4.0	4.0	4.0
Lead/Lag	Lag	Lead			Lead
Lead-Lag Optimize?	Yes	Yes			Yes
Recall Mode	None	None	None	Min	None
Act Effct Green (s)	19.6		36.0	10.6	14.6
Actuated g/C Ratio	0.36		0.66	0.19	0.27
v/c Ratio	0.18		0.57	0.41	0.66
Control Delay	4.7		7.8	23.1	6.8
Queue Delay	0.0		0.0	0.0	0.0
Total Delay	4.7		7.8	23.1	6.8
LOS	A		A	C	A
Approach Delay	4.7		7.8	10.2	
Approach LOS	A		A	B	

Intersection Summary

Cycle Length: 120  
 Actuated Cycle Length: 54.6  
 Natural Cycle: 45  
 Control Type: Semi Act-Uncoord  
 Maximum v/c Ratio: 0.66  
 Intersection Signal Delay: 8.8  
 Intersection Capacity Utilization 46.8%  
 Analysis Period (min) 15  
 Intersection LOS: A  
 ICU Level of Service A

Splits and Phases: 26: Golden Sage Rd & Woodmen Frontage Rd

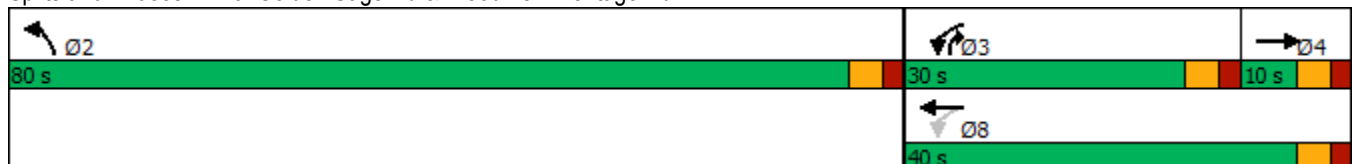

HCM 6th Roundabout  
 26: Golden Sage Rd & Woodmen Frontage Rd

2040 Total Traffic  
 PM Peak Hour

Intersection				
Intersection Delay, s/veh	3.8			
Intersection LOS	A			
Approach	EB	WB	NB	
Entry Lanes	1	1	1	
Conflicting Circle Lanes	1	1	1	
Adj Approach Flow, veh/h	116	496	675	
Demand Flow Rate, veh/h	118	506	689	
Vehicles Circulating, veh/h	493	144	11	
Vehicles Exiting, veh/h	157	11	600	
Ped Vol Crossing Leg, #/h	0	0	0	
Ped Cap Adj	1.000	1.000	1.000	
Approach Delay, s/veh	5.8	7.5	0.7	
Approach LOS	A	A	A	
Lane	Left	Left	Left	Bypass
Designated Moves	TR	LT	L	R
Assumed Moves	TR	LT	L	R
RT Channelized				Free
Lane Util	1.000	1.000	1.000	
Follow-Up Headway, s	2.609	2.609	2.609	
Critical Headway, s	4.976	4.976	4.976	545
Entry Flow, veh/h	118	506	144	1938
Cap Entry Lane, veh/h	835	1191	1364	0.980
Entry HV Adj Factor	0.981	0.980	0.979	534
Flow Entry, veh/h	116	496	141	1900
Cap Entry, veh/h	819	1167	1336	0.281
V/C Ratio	0.141	0.425	0.106	0.0
Control Delay, s/veh	5.8	7.5	3.5	A
LOS	A	A	A	1
95th %tile Queue, veh	0	2	0	

# Queuing Reports

---



## Queuing and Blocking Report

### Intersection: 19: West Site Access/Future Access & Bent Grass Meadows Dr

Movement	WB	NB	NB	SB
Directions Served	L	LT	R	LTR
Maximum Queue (ft)	36	30	52	38
Average Queue (ft)	9	4	24	15
95th Queue (ft)	30	20	48	40
Link Distance (ft)		267	267	287
Upstream Blk Time (%)				
Queuing Penalty (veh)				
Storage Bay Dist (ft)	110			
Storage Blk Time (%)				
Queuing Penalty (veh)				

### Intersection: 20: Meridian Park Dr & Bent Grass Meadows Dr

Movement	EB	EB	WB	NB	SB
Directions Served	L	T	L	LTR	LTR
Maximum Queue (ft)	15	9	164	162	79
Average Queue (ft)	1	0	59	86	30
95th Queue (ft)	8	7	120	149	62
Link Distance (ft)		314	352	155	260
Upstream Blk Time (%)				2	
Queuing Penalty (veh)				6	
Storage Bay Dist (ft)	150				
Storage Blk Time (%)					
Queuing Penalty (veh)					

### Intersection: 29: Meridian Park Dr & Proposed Site Access/7-Eleven S Access

Movement	EB	EB	WB	NB	SB
Directions Served	L	TR	LTR	LTR	LT
Maximum Queue (ft)	82	9	93	33	68
Average Queue (ft)	33	1	47	2	17
95th Queue (ft)	61	7	77	16	50
Link Distance (ft)	121	121	168	504	155
Upstream Blk Time (%)	0				
Queuing Penalty (veh)	0				
Storage Bay Dist (ft)					
Storage Blk Time (%)					
Queuing Penalty (veh)					

## Zone Summary

Zone wide Queuing Penalty: 6

## Queuing and Blocking Report

### Intersection: 19: West Site Access/Future Access & Bent Grass Meadows Dr

Movement	EB	WB	NB	NB	SB
Directions Served	L	L	LT	R	LTR
Maximum Queue (ft)	23	24	30	49	40
Average Queue (ft)	1	5	8	27	16
95th Queue (ft)	10	20	30	49	42
Link Distance (ft)			267	267	287
Upstream Blk Time (%)					
Queuing Penalty (veh)					
Storage Bay Dist (ft)	155	110			
Storage Blk Time (%)					
Queuing Penalty (veh)					

### Intersection: 20: Meridian Park Dr & Bent Grass Meadows Dr

Movement	EB	EB	WB	NB	SB
Directions Served	L	R	L	LTR	LTR
Maximum Queue (ft)	24	4	124	185	68
Average Queue (ft)	1	0	43	123	24
95th Queue (ft)	10	3	96	196	55
Link Distance (ft)			276	177	259
Upstream Blk Time (%)				3	
Queuing Penalty (veh)				18	
Storage Bay Dist (ft)	150	150			
Storage Blk Time (%)					
Queuing Penalty (veh)					

### Intersection: 29: Meridian Park Dr & Proposed Site Access/7-Eleven S Access

Movement	EB	EB	WB	NB	SB
Directions Served	L	TR	LTR	LTR	LT
Maximum Queue (ft)	135	17	133	107	83
Average Queue (ft)	45	1	53	13	30
95th Queue (ft)	103	7	106	75	71
Link Distance (ft)	203	203	125	180	177
Upstream Blk Time (%)	0		4	1	
Queuing Penalty (veh)	0		0	0	
Storage Bay Dist (ft)					
Storage Blk Time (%)					
Queuing Penalty (veh)					

## Zone Summary

Zone wide Queuing Penalty: 18

# Truck Turning Exhibit

---



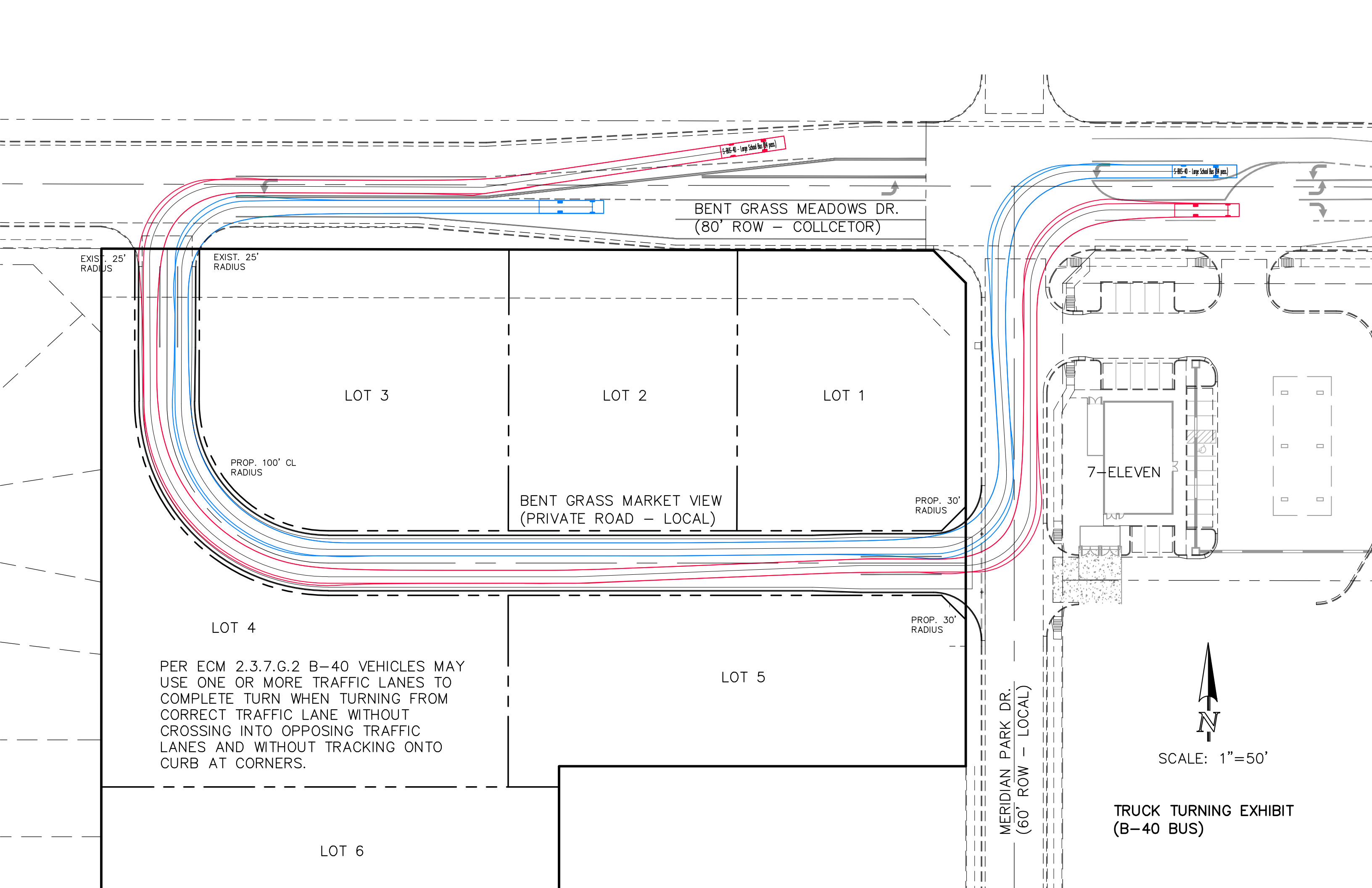

BENT GRASS MEADOWS DR.  
(80' ROW - COLLECTOR)

EXIST. 25'  
RADIUS

EXIST. 25'  
RADIUS

LOT 3

LOT 2

LOT 1

PROP. 100' CL  
RADIUS

BENT GRASS MARKET VIEW  
(PRIVATE ROAD - LOCAL)

PROP. 30'  
RADIUS

7-ELEVEN

LOT 4

LOT 5

PROP. 30'  
RADIUS

PER ECM 2.3.7.G.2 B-40 VEHICLES MAY  
USE ONE OR MORE TRAFFIC LANES TO  
COMPLETE TURN WHEN TURNING FROM  
CORRECT TRAFFIC LANE WITHOUT  
CROSSING INTO OPPOSING TRAFFIC  
LANES AND WITHOUT TRACKING ONTO  
CURB AT CORNERS.

LOT 6

MERIDIAN PARK DR.  
(60' ROW - LOCAL)



SCALE: 1"=50'

TRUCK TURNING EXHIBIT  
(B-40 BUS)