



See preliminary plan for comments.

LSC TRANSPORTATION CONSULTANTS, INC.
2504 East Pikes Peak Avenue, Suite 304
Colorado Springs, CO 80906
(719) 633-2868
FAX (719) 633-5430
E-mail: lsc@lsctrans.com
Website: <http://www.lsctrans.com>

6665 Walker Road Minor Subdivision Transportation Memorandum

(LSC #S214800)
January 11, 2022

Traffic Engineer's Statement

This traffic report and supporting information were prepared under my responsible charge and they comport with the standard of care. So far as is consistent with the standard of care, said report was prepared in general conformance with the criteria established by the County for traffic reports.

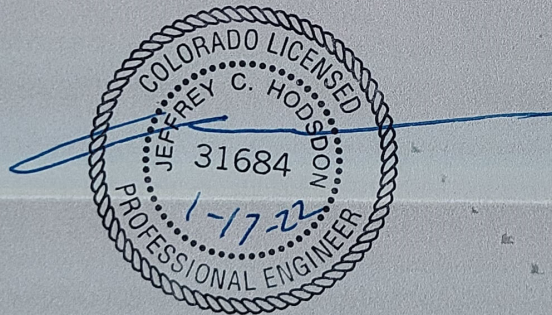

Developer's Statement

I, the Developer, have read and will comply with all commitments made on my behalf within this report.

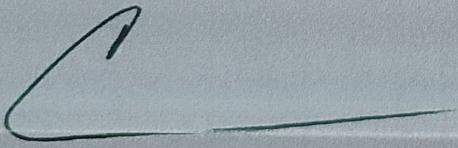

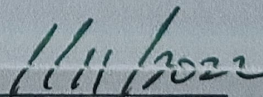

Date

6665 Walker Road

Transportation Memorandum

Prepared for:

Kurtis Brown
ERP Iron Works
6665 Walker Road
Colorado Springs, CO 80908

JANUARY 11, 2022

LSC Transportation Consultants
Prepared by: Jeffrey C. Hodsdon, P.E.

LSC #S214800



CONTENTS

REPORT CONTENTS 1

LAND USE AND ACCESS 2

 Proposed Land Use..... 2

 Proposed Site Access..... 3

ROAD AND TRAFFIC CONDITIONS 3

Existing and baseline TRAFFIC VOLUMES 3

 Existing Traffic Volumes 3

 Short-Term Baseline Traffic Volumes 3

SIGHT DISTANCE..... 4

 El Paso County Requirements 4

 Stopping Sight Distance at Grade 4

 Intersection Sight Distance 4

TRIP GENERATION..... 4

TRIP DISTRIBUTION AND ASSIGNMENT..... 5

 Trip Directional Distribution..... 5

 Site-Generated Traffic..... 5

 Short Term 5

 Short-Term Baseline-Plus-Site-Generated Traffic Volumes..... 5

 Estimated Future 2041 Background Traffic Volumes 6

 Future 2041 Total Traffic Volumes 6

LEVEL OF SERVICE ANALYSIS 6

 Walker Road/Proposed Site Access..... 7

AUXILIARY TURN-LANE ANALYSIS..... 7

 Walker Road/Proposed Site Access..... 7

 Left-Turn Deceleration Lanes 7

 Right-Turn Deceleration Lanes 7

AVERAGE DAILY TRAFFIC IMPACTS RELATIVE TO ROADWAY DESIGN ADT BY CLASSIFICATION 7

 Proposed Site Access..... 7

 Existing and Short Term 7

CONFORMANCE WITH THE MTCP 8

 Reimbursable Improvements..... 8

COUNTY ROAD IMPROVEMENT FEE PROGRAM..... 8
MULTI-MODAL TRANSPORTATION AND Transportation Demand Management (TDM)
OPPORTUNITIES 8
CONCLUSIONS..... 8
Enclosures: 9

Table 3

Figure 1 - Figure 9

Traffic Count Reports

Synchro LOS Reports

MTCP Maps



LSC TRANSPORTATION CONSULTANTS, INC.
2504 East Pikes Peak Avenue, Suite 304
Colorado Springs, CO 80909
(719) 633-2868
FAX (719) 633-5430
E-mail: lsc@lscctrans.com
Website: <http://www.lscctrans.com>

January 11, 2022

Kurtis Brown
ERP Iron Works
6665 Walker Road
Colorado Springs, CO 80908

RE: 6665 Walker Rd Minor Subdivision
Transportation Memorandum
El Paso County, CO
LSC # S214800

Dear Mr. Brown,

LSC Transportation Consultants, Inc. has prepared this transportation memorandum for the proposed single-family residential subdivision located at 6665 Walker Road in El Paso County, Colorado. The proposed four-lot, single-family residential minor subdivision site is located east of the intersection of Walker Road/Thompson Road (El Paso County parcel ID 5100000421).

One access point is proposed for the property, located approximately 2,008 feet east of the intersection of Walker Road/Thompson Road. This new public road connection would be stop-sign controlled on the northbound approach and would be a full-movement T-intersection with Walker Road. This report has been prepared for submittal to El Paso County.

REPORT CONTENTS

The preparation of this report included the following:

- Inventory of existing adjacent and nearby area road system. This included surface conditions, functional classifications, roadway widths, lane configurations, traffic control, posted speed limits, pavement markings, intersection and access spacing, roadway and intersection alignments, auxiliary left- and right-turn lanes, intersection sight distances, etc.;
- Peak-hour traffic counts on Walker Road adjacent to the site;
- Short-term baseline traffic-volume estimates, which account for remaining effects of the COVID-19 pandemic;

- Review of previously-completed traffic studies in the vicinity of this site for information and findings relative to this development. Other recent studies completed in the area and any applicable data/transferrable information/analysis etc. from previous LSC studies adjacent to the site were also utilized;
- Evaluation of intersection/access sight distance at the proposed access-point intersection on Walker Road, based on current criteria in El Paso County's *Engineering Criteria Manual (ECM)*;
- Estimates of average weekday and peak-hour trip generation for the proposed development;
- Estimation of directional distribution of site-generated vehicle trips on the area road system and at the proposed site-access point;
- Projections of site-generated turning-movement traffic volumes at the Walker Road/proposed site-access intersection;
- Estimates of long-term background traffic volumes;
- Total traffic (site traffic-plus-background traffic) projections at for the short and long term;
- Level of service (LOS) analysis at the site-access intersection;
- Evaluation of existing, short-term, and long-term projected intersection volumes to determine the potential need for any new auxiliary right-/left-turn lanes on Walker Road, based on the criteria in the County's *Engineering Criteria Manual*;
- Identification of the El Paso County Road Impact Fee Program fee amounts; and
- Summary of compiled data, analysis, findings, and recommendations.

LAND USE AND ACCESS

Proposed Land Use

Figure 1 shows the site location relative to the adjacent and nearby roads. The site is located east of the intersection of Walker Road/Thompson Road in El Paso County (EPC), Colorado (EPC parcel ID 5100000421). The proposed development is a four-lot, single-family residential minor subdivision A copy of the site plan is shown in Figure 2.

Proposed Site Access

One access point is proposed for the property, located approximately 2,008 feet east of the intersection of Walker Road/Thompson Road (355 feet west of the existing driveway east of this site). This public road connection would be stop-sign-controlled on the northbound approach and would be a full-movement T-intersection with Walker Road.

ROAD AND TRAFFIC CONDITIONS

Figure 1 shows the roads adjacent to and in the vicinity of the site. Adjacent roads serving the site are identified below followed by a brief description of each:

Walker Road is a paved, two-lane, “unimproved” rural roadway that extends east from State Highway (SH) 83. The *Major Transportation Corridors Plan (MTCP) 2040 Roadway Plan* shows Walker Road classified as a two-lane Minor Arterial east of Stepler Road and a 4-lane Minor Arterial roadway between Stepler Road and SH 83.

Thompson Road extends approximately 1.5 miles north-to-south between Hodgen Road and Walker Road. Thompson Road is identified in the *El Paso County Road System – 2016* report as a two-lane, gravel, Local roadway. The posted speed limit along Thompson Road is 30 miles per hour (mph). Right-of-way width on Thompson Road is 60 feet, while the roadway width is 24 feet.

Black Forest Road is a two-lane, paved, rural Minor Arterial with a posted speed limit of 45 mph at its two-way stop-sign-controlled (TWSC) intersection with Walker Road. No auxiliary turn lanes currently exist at Black Forest Road/Walker Road. Black Forest Road extends north from Woodmen Road to County Line Road.

EXISTING AND BASELINE TRAFFIC VOLUMES

Existing Traffic Volumes

Vehicular peak-period traffic counts were conducted on Walker Road in the vicinity of the site. Raw count data is attached. Figure 3 shows these volumes, as well as estimates of the daily traffic volumes on Walker Road adjacent to the site.

Short-Term Baseline Traffic Volumes

The COVID-19 pandemic may still be affecting the study-area traffic volumes. LSC incorporated recent traffic data and estimated “typical” current daily and design-hour volumes. Major-street through volumes on Walker Road were adjusted (increased) to align more closely with recently-recorded historical volumes from previously-conducted LSC traffic studies. Figure 4 shows estimated “short-term baseline” traffic volumes on the study-area streets and at the study-area intersections (short-term peak-hour turning-movement volumes).

SIGHT DISTANCE

El Paso County Requirements

The proposed access point (a planned public roadway intersection) must meet *Engineering Criteria Manual* standards for sight distance. The site-access point is anticipated to be a full-movement, stop-sign-controlled intersection with Walker Road. All sight-distance field measurements utilized a height of 3.5 feet for driver's eye height and for vehicles approaching from the east or west.

Stopping Sight Distance at Grade

Based on spot measurements taken during field observations, Walker Road features several consecutive hills approaching the site with grades of approximately 6 percent. The stopping distance at grade for the proposed site-access driveway would exceed the required 474 feet approaching the site access from both directions along Walker Road (per Table 2-18 of the County's *Engineering Criteria Manual*). Field measurements recorded 844 feet of sight distance looking to the east and 562 feet looking to the west from the proposed site-access location.

Intersection Sight Distance

With a 45-mph posted speed limit (assumed 50-mph design speed), the minimum required entering/intersection sight distance for both approaches at the proposed site access location is 555 feet for passenger vehicles (per Table 2-21 of the County's *Engineering Criteria Manual*). Sight distances for both approaches at the proposed site-access location to Walker Road meet the required 555-foot requirement. Field measurements recorded 844 feet of sight distance looking to the east and 562 feet looking to the west from the proposed site-access location.

TRIP GENERATION

Estimates of the existing and projected vehicle trips to be generated by the site have been made using nationally-published average trip-generation rates for land use code "210 – Single-Family (Detached) Housing" in *Trip Generation, 11th Edition, 2021* by the Institute of Transportation Engineers (ITE).

Table 1 below presents a summary of the estimated site trip generation. A detailed trip-generation estimate for the development, including ITE rates for the proposed land uses, is presented in Table 3 (attached).

Table 1: Estimated External Site Vehicle-Trip Generation

Analysis Period	Weekday		
	In	Out	Total
Morning Peak Hour	1	2	3
Evening Peak Hour	2	1	3
Daily/24-hour	19	19	38

Based on the ITE estimate for the proposed residential development, the site could generate about 38 external vehicle trips on the average weekday. During the weekday morning peak hour, approximately 1 vehicle would enter and 2 vehicles would exit the site. Approximately 2 entering vehicles and 1 exiting vehicle is projected for the weekday afternoon peak hour.

TRIP DISTRIBUTION AND ASSIGNMENT

Trip Directional Distribution

Estimating the directional distribution of site-generated vehicle trips to the study-area roads and intersections is a necessary component in determining the site's traffic impacts. Figure 5 shows the percentages of the site-generated vehicle trips projected to be oriented to and from the site's major approaches. Estimates have been based on the following factors: the proposed new land uses, the area street and road system serving the site, previously-conducted traffic studies for the site, and the site's geographic location relative to the City of Colorado Springs metro area, El Paso County, and the Pikes Peak region.

Site-Generated Traffic

Short Term

Figure 6 shows the projected short-term site-generated traffic volumes for the weekday morning and evening peak hours. Site-generated traffic volumes have been calculated by applying the directional-distribution percentages estimated by LSC (from Figure 5) to the trip-generation estimates (from Table 3).

Short-Term Baseline-Plus-Site-Generated Traffic Volumes

Figure 7 shows the sum of the short-term baseline traffic volumes (from Figure 4) and site-generated peak-hour traffic volumes (shown in Figure 6). These volumes represent the projected short-term total traffic.

Estimated Future 2041 Background Traffic Volumes

Figure 8 shows the projected 20-year background traffic volumes for the year 2041. Estimated 2041 background through traffic volumes on Walker Road account for projected background growth in the vicinity of the site. Projected 20-year background traffic volumes do **not** include projected traffic to be generated by this proposed residential development.

Future 2041 Total Traffic Volumes

Figure 9 shows the projected 2040 total traffic volumes, which are the sum of 2040 background traffic volumes (from Figure 8) plus the site-generated traffic volumes (from Figure 6).

LEVEL OF SERVICE ANALYSIS

The Walker Road/proposed site access intersection has been analyzed to determine the projected intersection levels of service for short- and long-term traffic scenarios for the morning and evening peak-hour time periods.

Level of service (LOS) is a quantitative measure of the level of congestion or delay at an intersection and is indicated on a scale from "A" to "F." LOS A is indicative of little congestion or delay. LOS F indicates a high level of congestion or delay. Table 2 shows the level of service delay ranges for signalized and unsignalized intersections.

Table 2: Intersection Levels of Service Delay Ranges

Level of Service	Signalized Intersections	Unsignalized Intersections
	Average Control Delay (seconds per vehicle)	Average Control Delay (seconds per vehicle) ⁽¹⁾
A	10.0 sec or less	10.0 sec or less
B	10.1-20.0 sec	10.1-15.0 sec
C	20.1-35.0 sec	15.1-25.0 sec
D	35.1-55.0 sec	25.1-35.0 sec
E	55.1-80.0 sec	35.1-50.0 sec
F	80.1 sec or more	50.1 sec or more

(1) For unsignalized intersections, if V/C ratio is greater than 1.0 the level of service is LOS F, regardless of the projected average control delay per vehicle.

Detailed Synchro reports are attached. A summary of LOS during the weekday morning and evening peak hours for the following unsignalized intersections is shown in the following figures:

- Figure 7: Short-Term Total Traffic, Lane Geometry, Traffic Control, and LOS
- Figure 9: 2041 Background + Site Traffic, Lane Geometry, Traffic Control, and LOS

Walker Road/Proposed Site Access

All individual turning movements at the proposed site-access intersection with Walker Road are projected to operate at LOS A during all short-term and long-term scenarios following the addition of site-generated traffic.

AUXILIARY TURN-LANE ANALYSIS

The *Engineering Criteria Manual* contains turning-volume thresholds which require auxiliary left- or right-turn lanes by roadway classifications.

- Walker Road – Minor Arterial

Walker Road/Proposed Site Access

Left-Turn Deceleration Lanes

Left-turn deceleration auxiliary turn lanes are required for a Minor Arterial access with a projected peak-hour left-ingress turning volume of 25 vph or greater. The westbound left-turn volume is **not** projected to exceed this 25-vph threshold during either peak hour following the completion of this residential development. As such, no modifications would be required to the westbound approach on Walker Road approaching the proposed site access.

Right-Turn Deceleration Lanes

Right-turn deceleration auxiliary turn lanes are required for a Minor Arterial access with a projected peak-hour right-ingress turning volume of 50 vph or greater. The eastbound right-turn volume is **not** projected to exceed this 50-vph threshold during either peak hour following the completion of this residential development. As such, no modifications would be required to the eastbound approach on Walker Road approaching the proposed site access.

AVERAGE DAILY TRAFFIC IMPACTS RELATIVE TO ROADWAY DESIGN ADT BY CLASSIFICATION

The projected buildout average daily traffic (ADT) impacts have been compared to the roadway design ADTs shown in Tables 2-4 and 2-5 of the *Engineering Criteria Manual (ECM)*. Actual current roadway capacities for specific roadway segments may differ from these *ECM*-identified “Design ADT” values for County-standard roadways by classification.

Proposed Site Access

Existing and Short Term

The site-access road is proposed as a two-lane, paved, Rural Local road. Additionally, the two existing driveways (located east of this proposed site access) would be removed.

CONFORMANCE WITH THE MTCP

Walker Road is identified as a two-lane Minor Arterial on the *MTCP*.

Reimbursable Improvements

The following roadway improvement projects have been identified as being needed by the year 2040, per Map 13 and Table 4 of El Paso County's 2016 *MTCP*:

- U13 – Walker Road from Stepler Road to Black Forest Road (\$6,783,000)
- Existing conditions – unimproved county road
- Future conditions – 2-lane Rural Principal Arterial

See the attached *MTCP* maps for reference.

COUNTY ROAD IMPROVEMENT FEE PROGRAM

The applicant will be required to participate in the County Road Improvement Fee Program. The applicant intends to opt out of the PID options. The current "full-fee" amount, payable at the building permit stage, identified on the County's Road Impact Fee Schedule is \$3,830 per single-family dwelling unit, for a total of \$15,420. The fees are subject to change.

MULTI-MODAL TRANSPORTATION AND TRANSPORTATION DEMAND MANAGEMENT (TDM) OPPORTUNITIES

The following roadway improvement projects have been identified as being needed by the year 2040 per Map 15 and Table 5 of El Paso County's 2016 *MTCP*:

- Proposed bicycle route on Walker Road (would begin at State Highway 105/Jackson Creek Parkway and extend east to Meridian Road, via Walker Road)

No sidewalks would be required, as the proposed subdivision roadway and study-area roadways are Rural.

CONCLUSIONS

- The site is projected to generate about 38 new driveway vehicle trips on the average weekday.
- During the weekday morning peak hour of adjacent street traffic, 1 vehicle would enter the site while 2 vehicles would exit.
- During the weekday evening peak hour of adjacent street traffic, 2 vehicles would enter the site while 1 vehicle would exit.

- All approaches are projected to operate at LOS A through the 20-year horizon at the site-access intersection on Walker Road. Please refer to the “Level of Service” section above for detailed LOS analysis results for more details.
- No auxiliary turn lanes would be required at the intersection of Walker Road/proposed site access, based on projected long-term total traffic volumes. Please refer to the “Auxiliary Turn-Lane Analysis” section more details.
- The proposed site-access point (a planned public roadway intersection with Walker Road) would meet the *Engineering Criteria Manual’s* standards for stopping sight distance at grade and intersection sight distance. Please refer to the “Sight Distance” section for details.
- The site-access road is proposed as a two-lane, paved, Rural Local road. Additionally, the two existing driveways (located east of this proposed site access) would be removed.
- Please refer to the El Paso County Road Improvement Fee Program amount above.

* * * * *

Please contact me if you have any questions regarding this report.

Respectfully Submitted,

LSC TRANSPORTATION CONSULTANTS, INC.

By: Jeffrey C. Hodsdon, P.E.
Principal

JCH/JAB:jas

Enclosures: Table 3
Figure 1 - Figure 9
Traffic Count Reports
Synchro LOS Reports
MTCP Maps

Table 3

The table area is currently blank.



Table 3: Detailed Trip Generation Estimate

ITE		Value	Units ¹	Trip Generation Rates ²				Total Trips Generated					
Code	Description			Average Weekday	A.M.		P.M.		Average Weekday	A.M.		P.M.	
				In	Out	In	Out		In	Out	In	Out	
210	Single-Family (Detached) Housing	4	DU	9.43	0.18	0.52	0.59	0.35	38	1	2	2	1

¹ DU = dwelling units

² Source: Trip Generation, 11th Edition, 2021, by the Institute of Transportation Engineers (ITE)

Figures 1-9





Not to scale

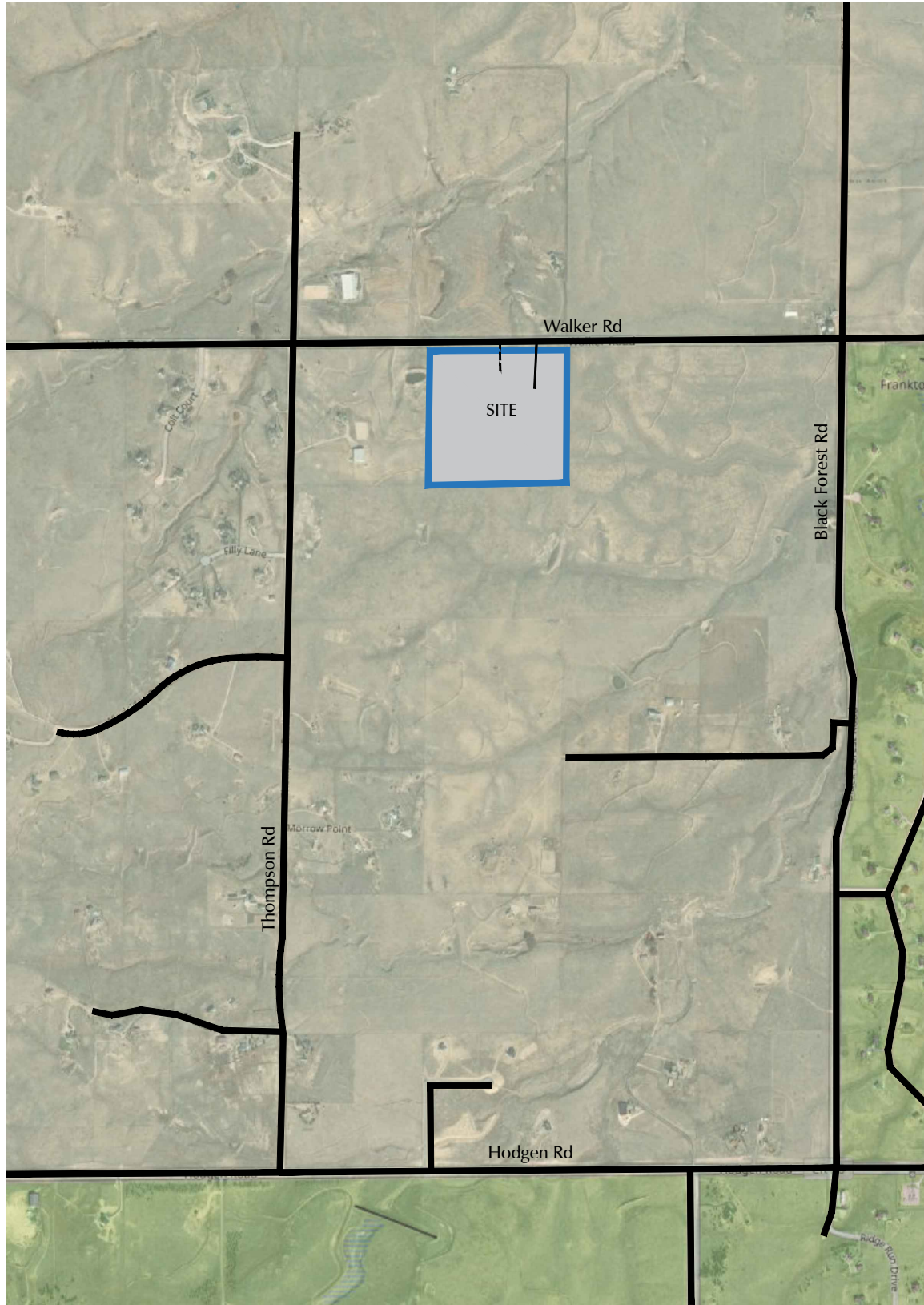

Figure 1

Vicinity Map

6665 Walker Rd (LSC #S214800)





Not to scale

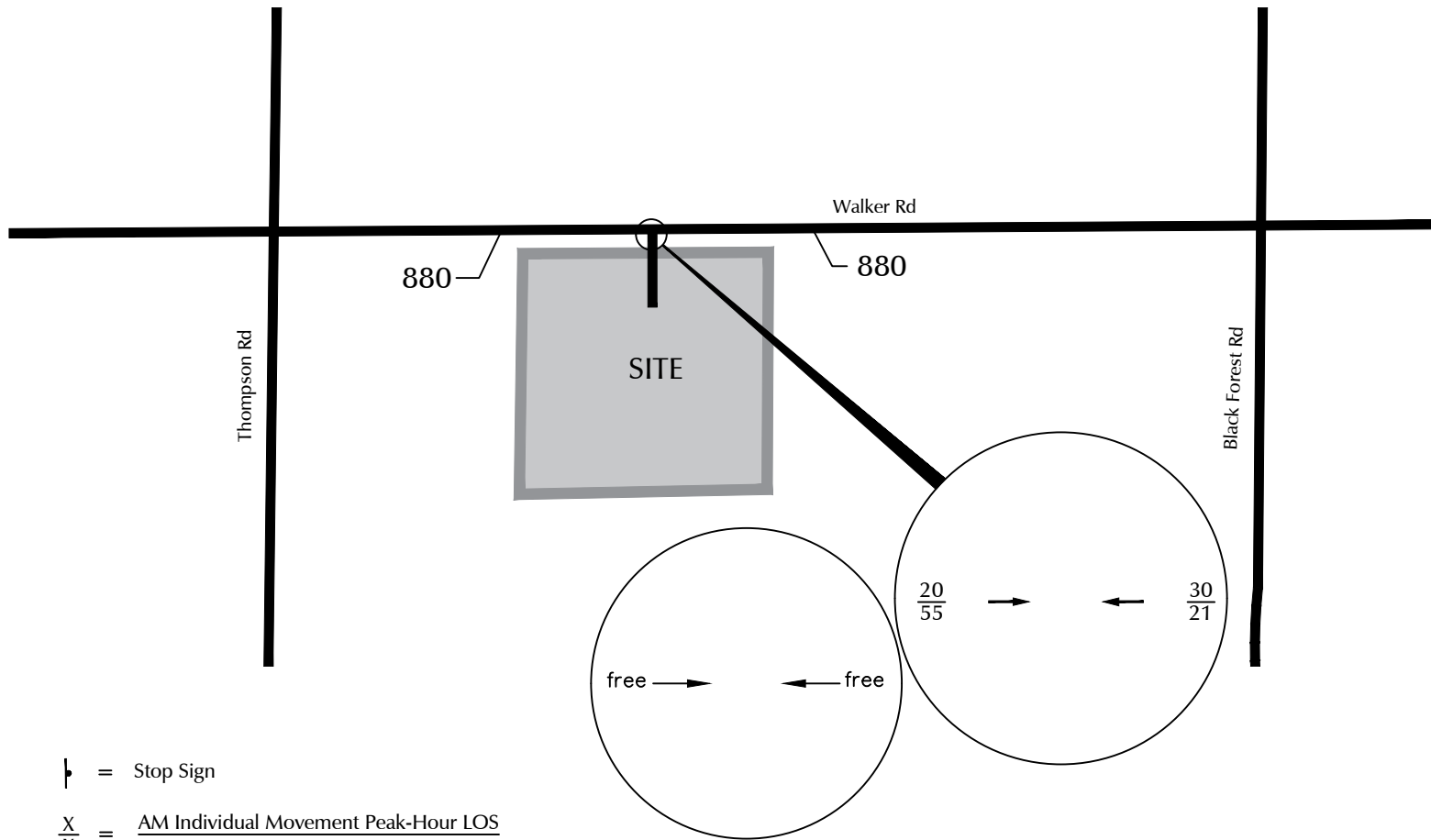

- ┆ = Stop Sign
 - $\frac{X}{X}$ = $\frac{\text{AM Individual Movement Peak-Hour LOS}}{\text{PM Individual Movement Peak-Hour LOS}}$
 - $\frac{XX}{XX}$ = $\frac{\text{AM Weekday Peak-Hour Traffic (Veh/Hour)}}{\text{PM Weekday Peak-Hour Traffic (Veh/Hour)}}$
 - X,XXX = Average Daily Traffic (Vehicles/Day), estimated by LSC
- Based on counts by LSC (September 2021)

Figure 3
Existing Traffic Conditions

6665 Walker Rd (LSC #S214800)



Short-term baseline (adjusted estimates for effects of Covid-19 pandemic)



Not to scale

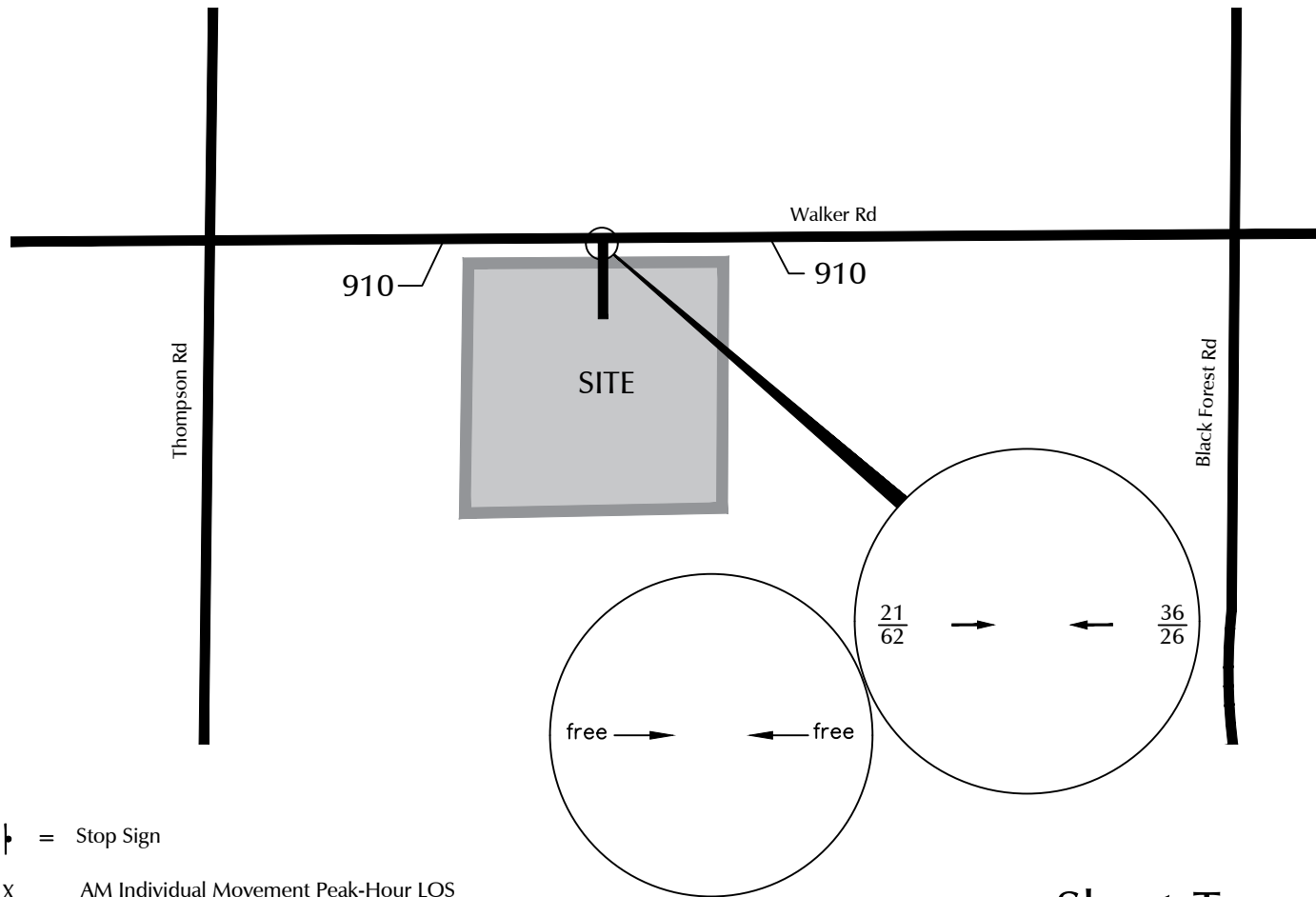

⊥ = Stop Sign

$\frac{X}{X}$ = AM Individual Movement Peak-Hour LOS
 $\frac{X}{X}$ = PM Individual Movement Peak-Hour LOS

$\frac{XX}{XX}$ = AM Weekday Peak-Hour Traffic (Veh/Hour)
 $\frac{XX}{XX}$ = PM Weekday Peak-Hour Traffic (Veh/Hour)

X,XXX = Average Daily Traffic (Vehicles/Day)

Figure 4
**Short-Term Baseline
 Traffic Conditions**

6665 Walker Rd (LSC #S214800)





Not to scale

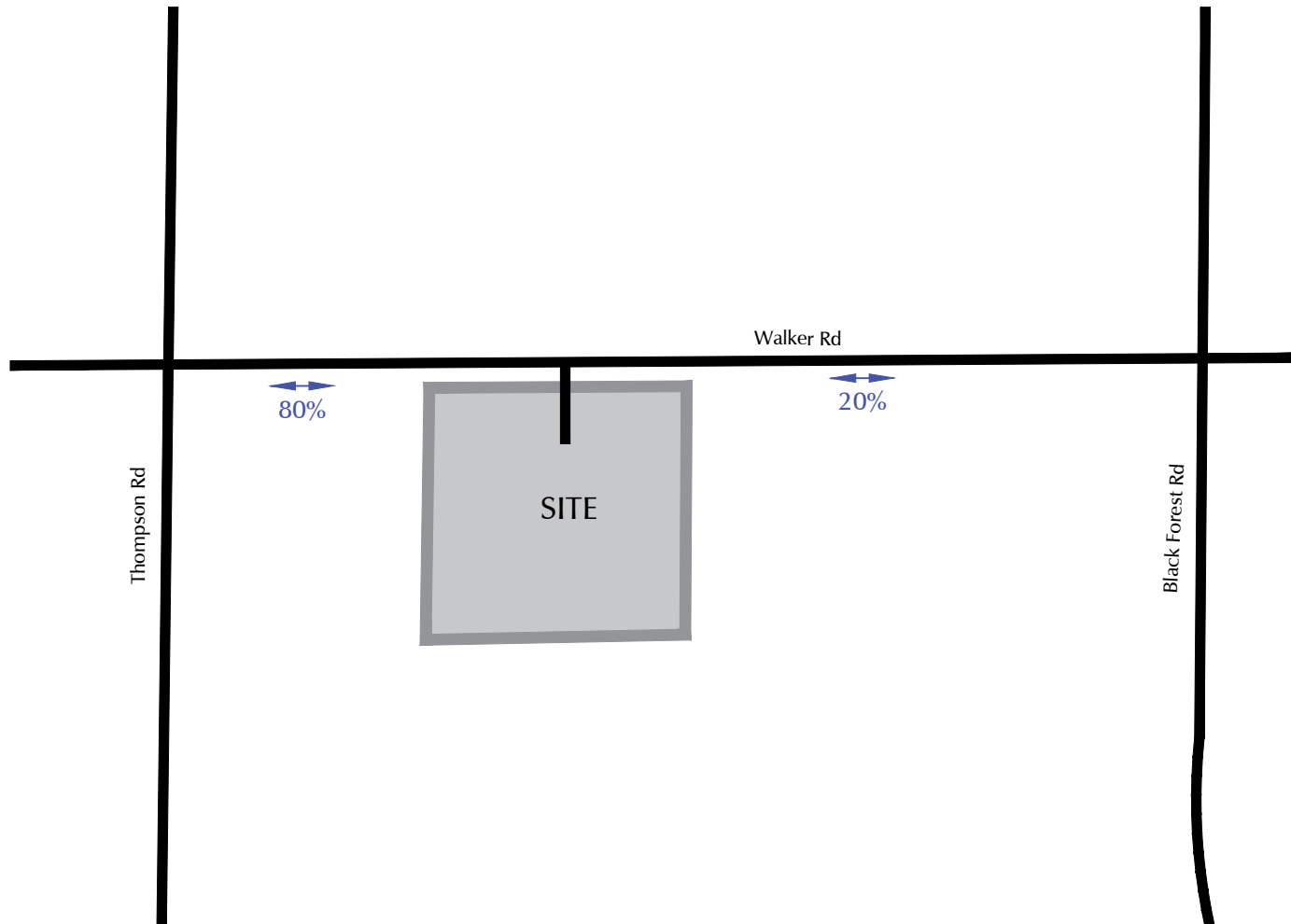



Figure 5
Directional Distribution

6665 Walker Rd (LSC #S214800)



 XX% = Directional Distribution Split



Not to scale

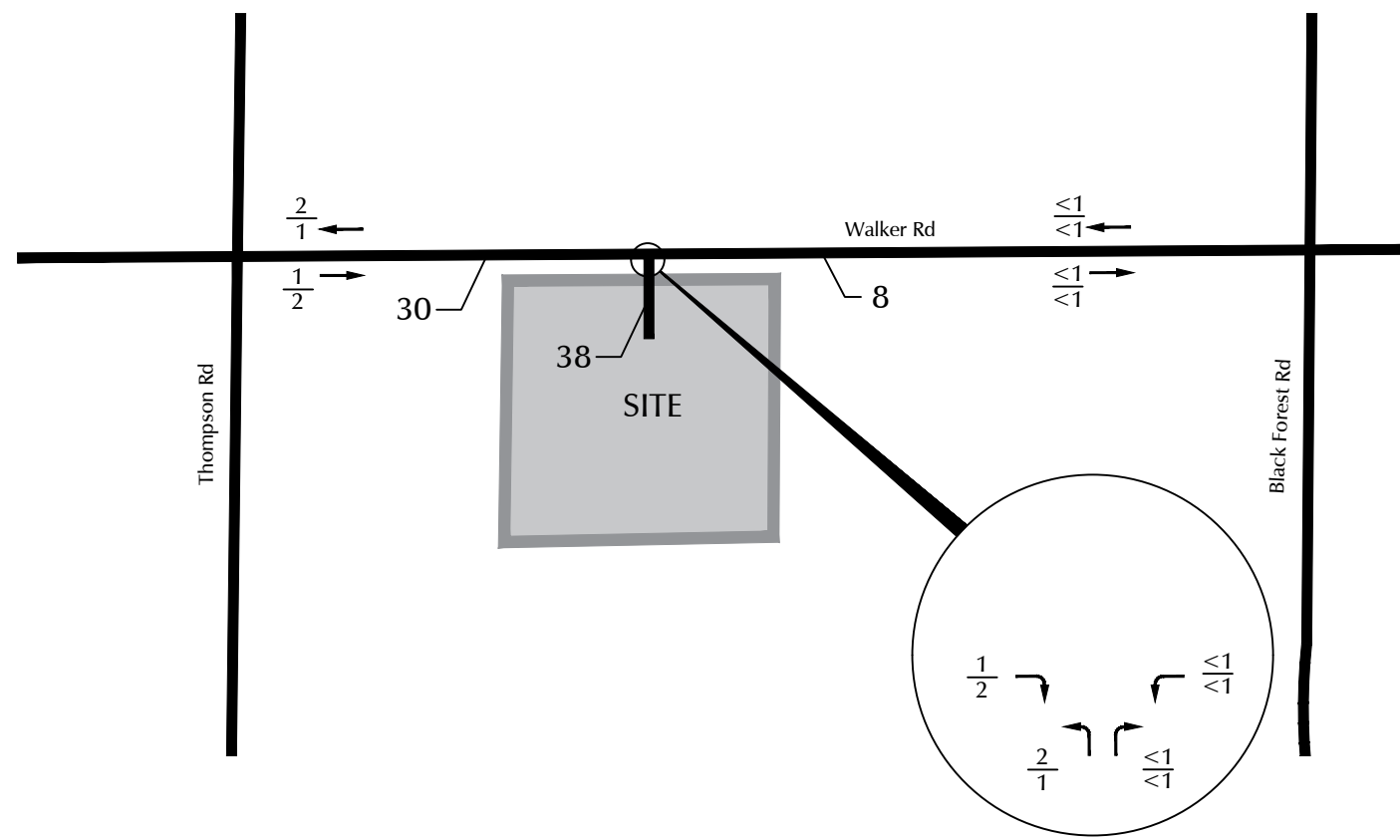

$\frac{XX}{XX}$ = AM Weekday Peak-Hour Traffic (Veh/Hour)
 $\frac{XX}{XX}$ = PM Weekday Peak-Hour Traffic (Veh/Hour)
X,XXX = Average Daily Traffic (Vehicles/Day)

Figure 6
Site-Generated Traffic
6665 Walker Rd (LSC #S214800)



Not to scale

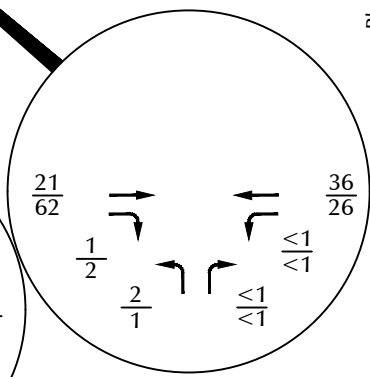
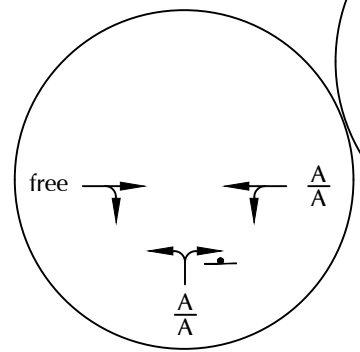
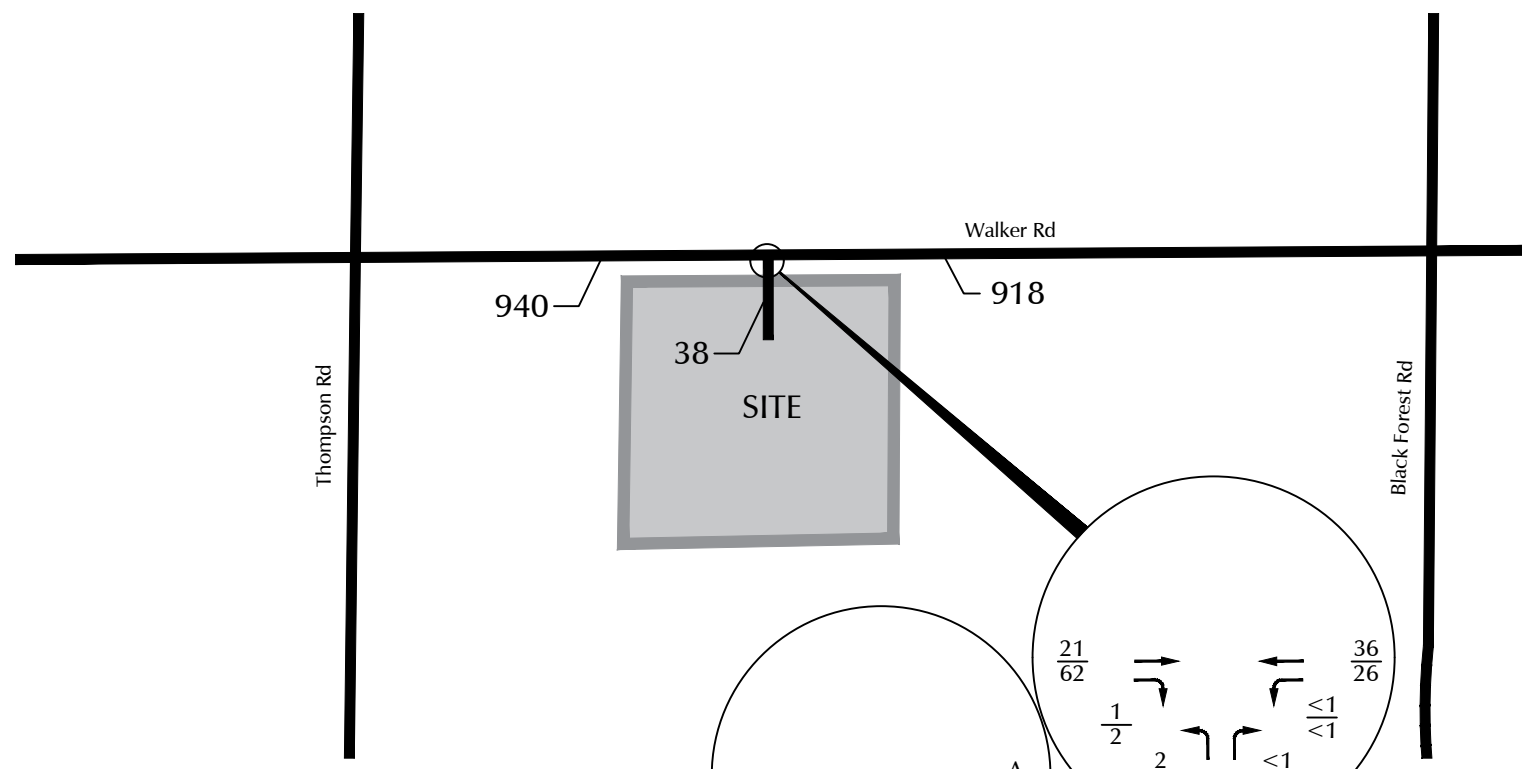

- ┆ = Stop Sign
- $\frac{X}{X}$ = $\frac{\text{AM Individual Movement Peak-Hour LOS}}{\text{PM Individual Movement Peak-Hour LOS}}$
- $\frac{XX}{XX}$ = $\frac{\text{AM Weekday Peak-Hour Traffic (Veh/Hour)}}{\text{PM Weekday Peak-Hour Traffic (Veh/Hour)}}$
- X,XXX = Average Daily Traffic (Vehicles/Day)

Figure 7
**Short-Term Baseline +
 Site-Generated Traffic Conditions**

6665 Walker Rd (LSC #S214800)





Not to scale

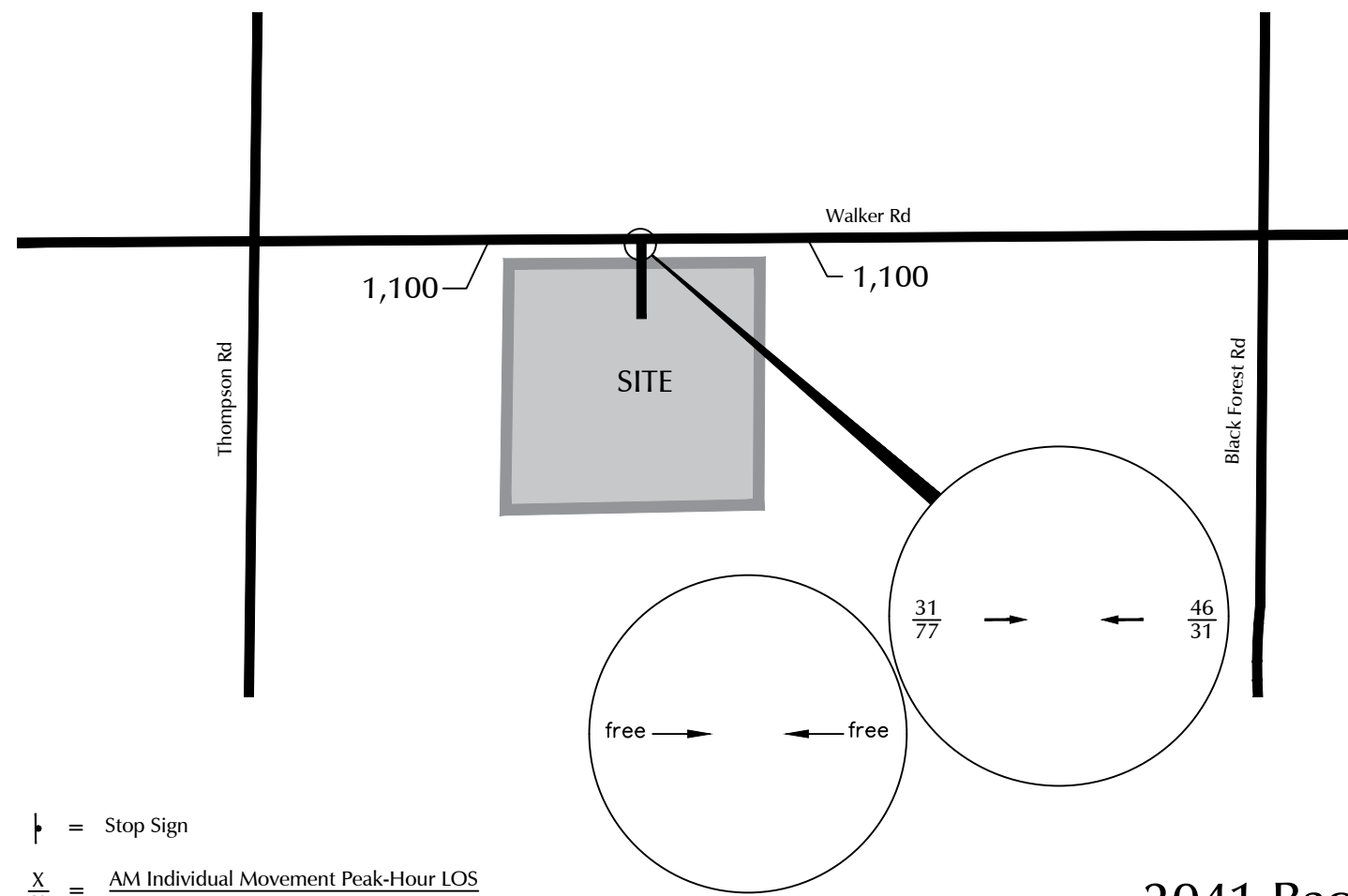

┆ = Stop Sign

$\frac{X}{X}$ = AM Individual Movement Peak-Hour LOS
PM Individual Movement Peak-Hour LOS

$\frac{XX}{XX}$ = AM Weekday Peak-Hour Traffic (Veh/Hour)
PM Weekday Peak-Hour Traffic (Veh/Hour)

X,XXX = Average Daily Traffic (Vehicles/Day)

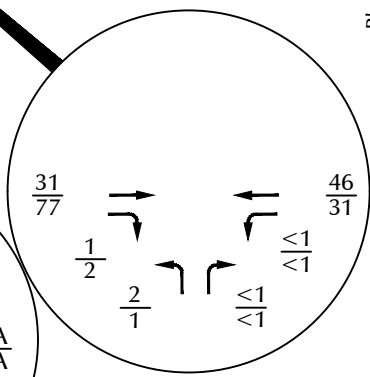
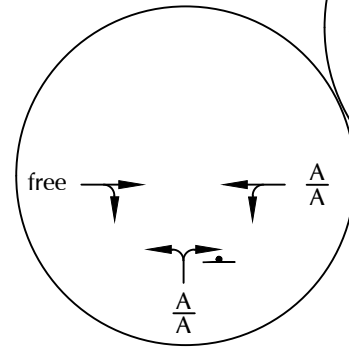
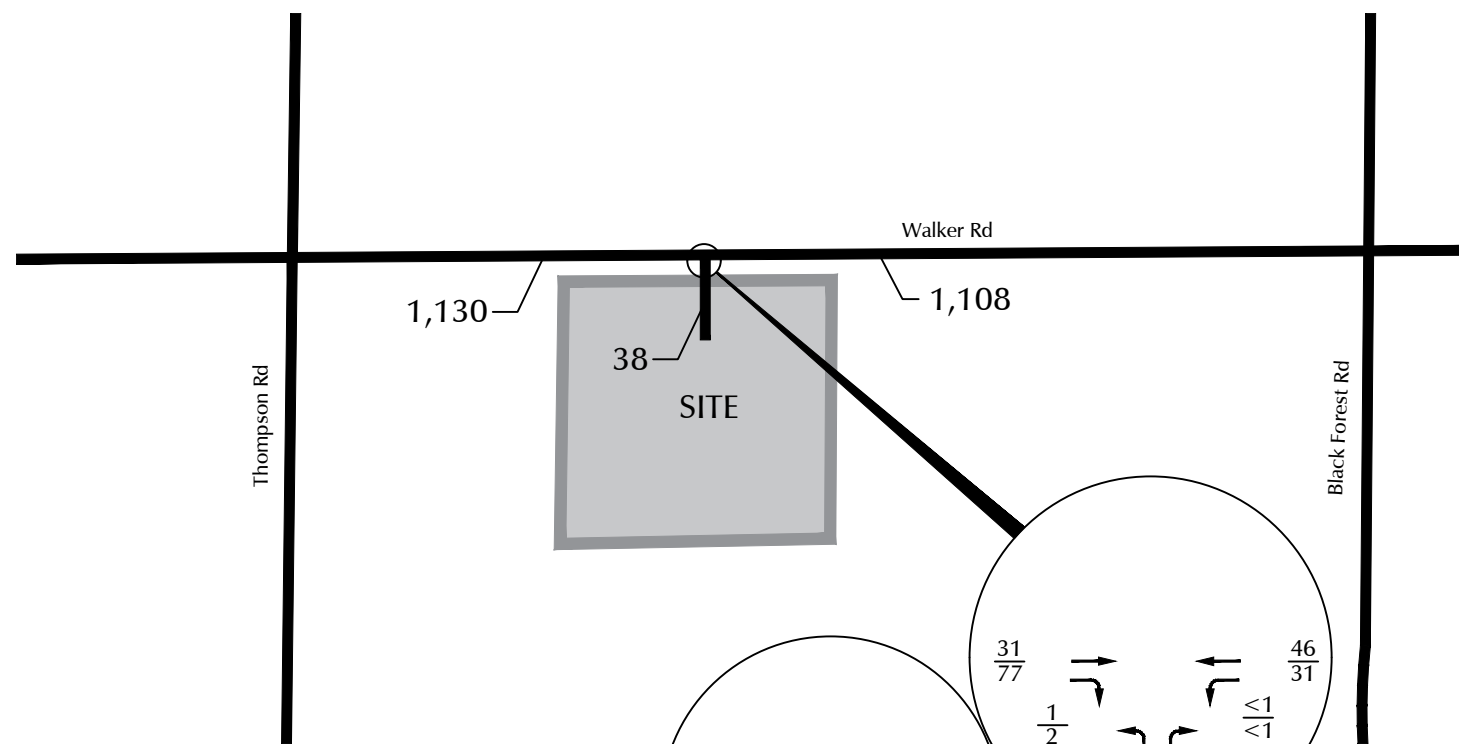

Figure 8
**2041 Background
Traffic Conditions**

6665 Walker Rd (LSC #S214800)



Not to scale



┆ = Stop Sign

$\frac{X}{X}$ = AM Individual Movement Peak-Hour LOS
PM Individual Movement Peak-Hour LOS

$\frac{XX}{XX}$ = AM Weekday Peak-Hour Traffic (Veh/Hour)

$\frac{XX}{XX}$ = PM Weekday Peak-Hour Traffic (Veh/Hour)

X,XXX = Average Daily Traffic (Vehicles/Day)

Figure 9
2041 Background + Site
Traffic Conditions

6665 Walker Rd (LSC #S214800)



Traffic Counts



LSC Transportation Consultants, Inc.

545 E Pikes Peak Ave, Suite 210
 Colorado Springs, CO 80905
 719-633-2868

File Name : Thompson Rd - Walker Rd AM
 Site Code : S214800
 Start Date : 9/9/2021
 Page No : 1

Groups Printed- Unshifted

Start Time	Southbound					Walker Rd Westbound					Thompson Rd Northbound					Walker Rd Eastbound					Int. Total
	L	T	R	U	App. Total	L	T	R	U	App. Total	L	T	R	U	App. Total	L	T	R	U	App. Total	
06:30 AM	0	0	0	0	0	0	2	0	0	2	0	0	0	0	0	0	2	0	0	2	4
06:35 AM	0	0	0	0	0	0	2	0	0	2	0	0	0	0	0	0	0	1	0	1	3
06:40 AM	0	0	0	0	0	0	6	0	0	6	0	0	0	0	0	0	2	0	0	2	8
06:45 AM	0	0	0	0	0	0	4	0	0	4	0	0	0	0	0	0	0	0	0	0	4
06:50 AM	0	0	0	0	0	0	5	0	0	5	0	0	0	0	0	0	1	0	0	1	6
06:55 AM	0	0	0	0	0	0	1	0	0	1	0	0	1	0	1	0	0	0	0	0	2
Total	0	0	0	0	0	0	20	0	0	20	0	0	1	0	1	0	5	1	0	6	27
07:00 AM	0	0	0	0	0	0	1	0	0	1	0	0	0	0	0	0	1	0	0	1	2
07:05 AM	0	0	0	0	0	0	2	0	0	2	1	0	0	0	1	0	0	0	0	0	3
07:10 AM	0	0	0	0	0	0	6	0	0	6	1	0	0	0	1	0	0	0	0	0	7
07:15 AM	0	0	0	0	0	1	0	0	0	1	0	0	0	0	0	0	1	0	0	1	2
07:20 AM	0	0	0	0	0	0	1	0	0	1	1	0	1	0	2	0	1	0	0	1	4
07:25 AM	0	0	0	0	0	0	2	0	0	2	1	0	0	0	1	0	3	0	0	3	6
07:30 AM	0	0	0	0	0	0	1	0	0	1	0	0	0	0	0	0	1	0	0	1	2
07:35 AM	0	0	0	0	0	0	4	0	0	4	0	0	0	0	0	0	5	0	0	5	9
07:40 AM	0	0	0	0	0	0	4	0	0	4	0	0	0	1	1	0	2	0	0	2	7
07:45 AM	0	0	0	0	0	0	2	0	0	2	0	0	0	0	0	0	2	0	0	2	4
07:50 AM	0	0	0	0	0	0	3	0	0	3	0	0	0	0	0	0	1	1	0	2	5
07:55 AM	0	0	0	0	0	0	2	0	0	2	0	0	0	0	0	0	0	0	0	0	2
Total	0	0	0	0	0	1	28	0	0	29	4	0	1	1	6	0	17	1	0	18	53
08:00 AM	0	0	0	0	0	0	2	0	0	2	0	0	0	0	0	0	3	0	0	3	5

LSC Transportation Consultants, Inc.

545 E Pikes Peak Ave, Suite 210
 Colorado Springs, CO 80905
 719-633-2868

File Name : Thompson Rd - Walker Rd AM
 Site Code : S214800
 Start Date : 9/9/2021
 Page No : 2

Groups Printed- Unshifted

Start Time	Southbound					Walker Rd Westbound					Thompson Rd Northbound					Walker Rd Eastbound					Int. Total
	L	T	R	U	App. Total	L	T	R	U	App. Total	L	T	R	U	App. Total	L	T	R	U	App. Total	
08:05 AM	0	0	0	0	0	0	1	0	0	1	0	0	0	0	0	0	2	0	0	2	3
08:10 AM	0	0	0	0	0	0	1	0	0	1	0	0	0	0	0	0	1	0	0	1	2
08:15 AM	0	0	0	0	0	0	3	0	0	3	0	0	0	0	0	0	0	0	0	0	3
08:20 AM	0	0	0	0	0	0	3	0	0	3	0	0	0	0	0	0	2	0	0	2	5
08:25 AM	0	0	0	0	0	0	2	0	0	2	0	0	0	1	1	0	0	0	0	0	3
Grand Total	0	0	0	0	0	1	60	0	0	61	4	0	2	2	8	0	30	2	0	32	101
Apprch %	0	0	0	0		1.6	98.4	0	0		50	0	25	25		0	93.8	6.2	0		
Total %	0	0	0	0	0	1	59.4	0	0	60.4	4	0	2	2	7.9	0	29.7	2	0	31.7	

LSC Transportation Consultants, Inc.

545 E Pikes Peak Ave, Suite 210
 Colorado Springs, CO 80905
 719-633-2868

File Name : Thompson Rd - Walker Rd AM
 Site Code : S214800
 Start Date : 9/9/2021
 Page No : 3

Start Time	Southbound					Walker Rd Westbound					Thompson Rd Northbound					Walker Rd Eastbound					Int. Total
	L	T	R	U	App. Total	L	T	R	U	App. Total	L	T	R	U	App. Total	L	T	R	U	App. Total	
Peak Hour Analysis From 06:30 AM to 08:25 AM - Peak 1 of 1																					
Peak Hour for Entire Intersection Begins at 07:05 AM																					
07:05 AM	0	0	0	0	0	0	2	0	0	2	1	0	0	0	1	0	0	0	0	0	3
07:10 AM	0	0	0	0	0	0	6	0	0	6	1	0	0	0	1	0	0	0	0	0	7
07:15 AM	0	0	0	0	0	1	0	0	0	1	0	0	0	0	0	0	1	0	0	1	2
07:20 AM	0	0	0	0	0	0	1	0	0	1	1	0	1	0	2	0	1	0	0	1	4
07:25 AM	0	0	0	0	0	0	2	0	0	2	1	0	0	0	1	0	3	0	0	3	6
07:30 AM	0	0	0	0	0	0	1	0	0	1	0	0	0	0	0	0	1	0	0	1	2
07:35 AM	0	0	0	0	0	0	4	0	0	4	0	0	0	0	0	0	5	0	0	5	9
07:40 AM	0	0	0	0	0	0	4	0	0	4	0	0	0	1	1	0	2	0	0	2	7
07:45 AM	0	0	0	0	0	0	2	0	0	2	0	0	0	0	0	0	2	0	0	2	4
07:50 AM	0	0	0	0	0	0	3	0	0	3	0	0	0	0	0	0	1	1	0	2	5
07:55 AM	0	0	0	0	0	0	2	0	0	2	0	0	0	0	0	0	0	0	0	0	2
08:00 AM	0	0	0	0	0	0	2	0	0	2	0	0	0	0	0	0	3	0	0	3	5
Total Volume	0	0	0	0	0	1	29	0	0	30	4	0	1	1	6	0	19	1	0	20	56
% App. Total	0	0	0	0	0	3.3	96.7	0	0		66.7	0	16.7	16.7		0	95	5	0		
PHF	.000	.000	.000	.000	.000	.083	.403	.000	.000	.417	.333	.000	.083	.083	.250	.000	.317	.083	.000	.333	.519

LSC Transportation Consultants, Inc.

545 E Pikes Peak Ave, Suite 210
 Colorado Springs, CO 80905
 719-633-2868

File Name : Thompson Rd - Walker Rd AM
 Site Code : S214800
 Start Date : 9/9/2021
 Page No : 4

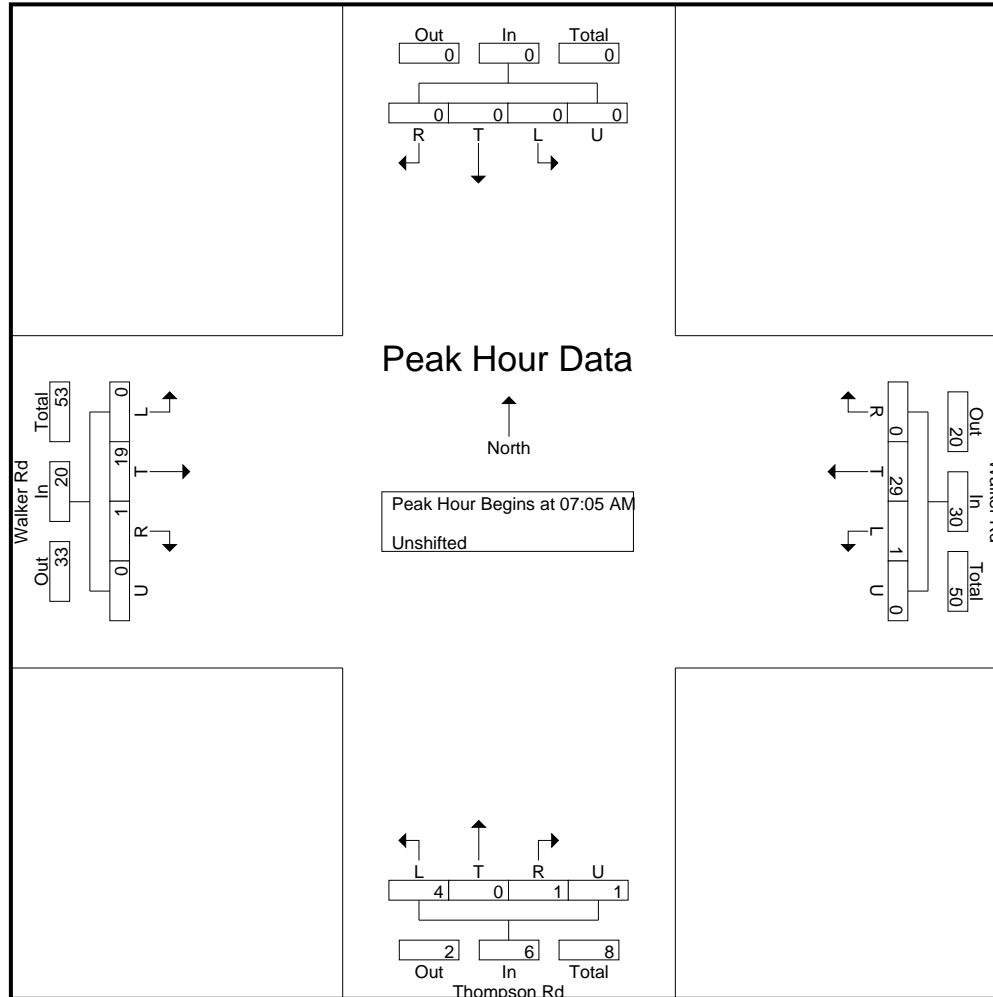

LSC Transportation Consultants, Inc.

545 E Pikes Peak Ave, Suite 210
 Colorado Springs, CO 80905
 719-633-2868

File Name : Thompson Rd - Walker Rd AM
 Site Code : S214800
 Start Date : 9/9/2021
 Page No : 5

Start Time	Southbound					Walker Rd Westbound					Thompson Rd Northbound					Walker Rd Eastbound					Int. Total
	L	T	R	U	App. Total	L	T	R	U	App. Total	L	T	R	U	App. Total	L	T	R	U	App. Total	

Peak Hour Analysis From 06:30 AM to 08:25 AM - Peak 1 of 1

Peak Hour for Each Approach Begins at:

	06:30 AM					06:40 AM					06:45 AM					07:15 AM				
+0 mins.	0	0	0	0	0	0	6	0	0	6	0	0	0	0	0	0	1	0	0	1
+5 mins.	0	0	0	0	0	0	4	0	0	4	0	0	0	0	0	0	1	0	0	1
+10 mins.	0	0	0	0	0	0	5	0	0	5	0	0	1	0	1	0	3	0	0	3
+15 mins.	0	0	0	0	0	0	1	0	0	1	0	0	0	0	0	0	1	0	0	1
+20 mins.	0	0	0	0	0	0	1	0	0	1	1	0	0	0	1	0	5	0	0	5
+25 mins.	0	0	0	0	0	0	2	0	0	2	1	0	0	0	1	0	2	0	0	2
+30 mins.	0	0	0	0	0	0	6	0	0	6	0	0	0	0	0	0	2	0	0	2
+35 mins.	0	0	0	0	0	1	0	0	0	1	1	0	1	0	2	0	1	1	0	2
+40 mins.	0	0	0	0	0	0	1	0	0	1	1	0	0	0	1	0	0	0	0	0
+45 mins.	0	0	0	0	0	0	2	0	0	2	0	0	0	0	0	0	3	0	0	3
+50 mins.	0	0	0	0	0	0	1	0	0	1	0	0	0	0	0	0	2	0	0	2
+55 mins.	0	0	0	0	0	0	4	0	0	4	0	0	0	1	1	0	1	0	0	1
Total Volume	0	0	0	0	0	1	33	0	0	34	4	0	2	1	7	0	22	1	0	23
% App. Total	0	0	0	0	0	2.9	97.1	0	0	0	57.1	0	28.6	14.3	0	0	95.7	4.3	0	0
PHF	.000	.000	.000	.000	.000	.083	.458	.000	.000	.472	.333	.000	.167	.083	.292	.000	.367	.083	.000	.383

LSC Transportation Consultants, Inc.

545 E Pikes Peak Ave, Suite 210
 Colorado Springs, CO 80905
 719-633-2868

File Name : Thompson Rd - Walker Rd AM
 Site Code : S214800
 Start Date : 9/9/2021
 Page No : 6

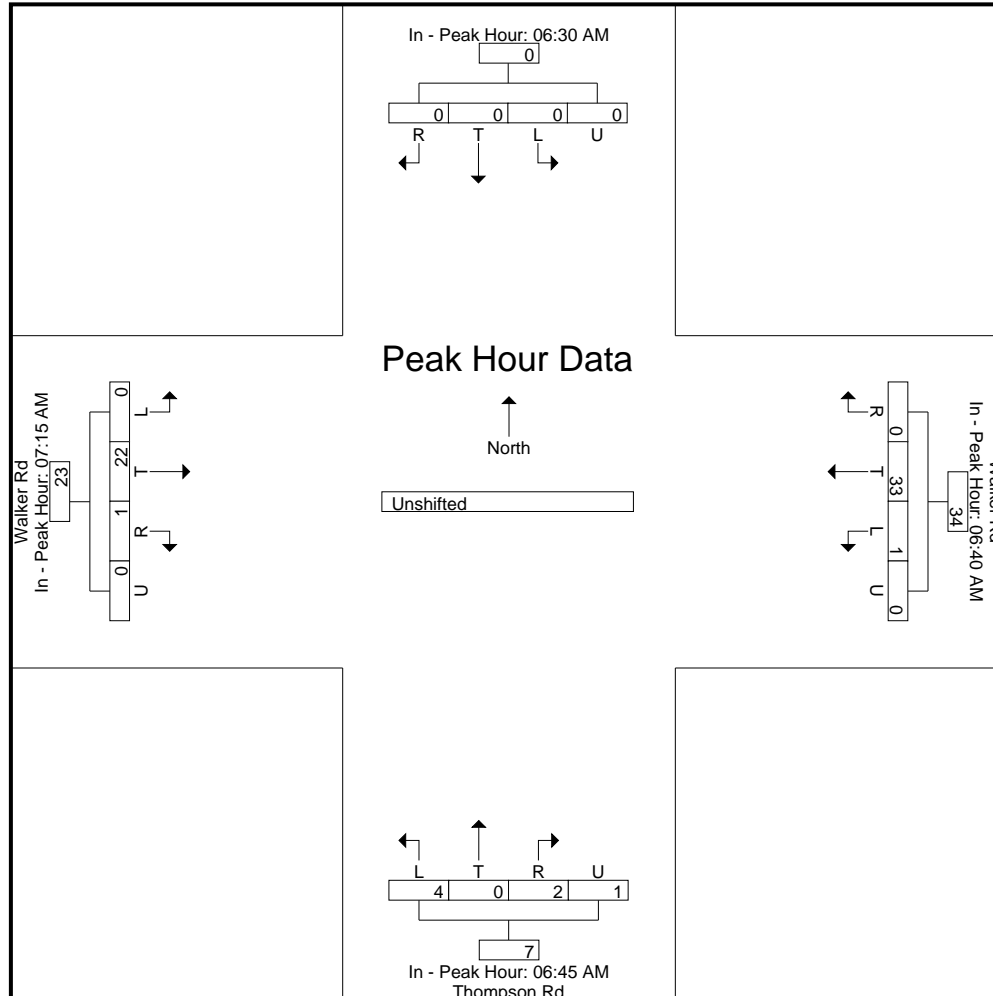

LSC Transportation Consultants, Inc.

545 E Pikes Peak Ave, Suite 210
 Colorado Springs, CO 80905
 719-633-2868

File Name : Thompson Rd - Walker Rd PM
 Site Code : S214800
 Start Date : 9/9/2021
 Page No : 1

Groups Printed- Unshifted

Start Time	Southbound					Walker Rd Westbound					Thompson Rd Northbound					Walker Rd Eastbound					Int. Total
	L	T	R	U	App. Total	L	T	R	U	App. Total	L	T	R	U	App. Total	L	T	R	U	App. Total	
04:00 PM	0	0	0	0	0	0	2	0	0	2	0	0	1	0	1	0	27	0	0	27	30
04:15 PM	0	0	0	0	0	0	5	0	0	5	0	0	1	0	1	0	9	0	0	9	15
04:30 PM	0	0	0	0	0	0	8	0	0	8	2	0	0	0	2	0	5	0	0	5	15
04:45 PM	0	0	0	0	0	1	5	0	0	6	0	0	0	0	0	0	12	0	0	12	18
Total	0	0	0	0	0	1	20	0	0	21	2	0	2	0	4	0	53	0	0	53	78
05:00 PM	0	0	0	0	0	1	4	0	0	5	0	0	0	0	0	0	10	1	0	11	16
05:15 PM	0	0	0	0	0	0	6	0	0	6	0	0	0	0	0	0	9	0	0	9	15
05:30 PM	0	0	0	0	0	2	6	0	0	8	0	0	0	0	0	0	12	0	0	12	20
05:45 PM	0	0	0	0	0	0	2	0	0	2	0	0	1	0	1	0	4	1	0	5	8
Total	0	0	0	0	0	3	18	0	0	21	0	0	1	0	1	0	35	2	0	37	59
Grand Total	0	0	0	0	0	4	38	0	0	42	2	0	3	0	5	0	88	2	0	90	137
Apprch %	0	0	0	0	0	9.5	90.5	0	0		40	0	60	0		0	97.8	2.2	0		
Total %	0	0	0	0	0	2.9	27.7	0	0	30.7	1.5	0	2.2	0	3.6	0	64.2	1.5	0	65.7	

LSC Transportation Consultants, Inc.

545 E Pikes Peak Ave, Suite 210
 Colorado Springs, CO 80905
 719-633-2868

File Name : Thompson Rd - Walker Rd PM
 Site Code : S214800
 Start Date : 9/9/2021
 Page No : 2

Start Time	Southbound					Walker Rd Westbound					Thompson Rd Northbound					Walker Rd Eastbound					Int. Total
	L	T	R	U	App. Total	L	T	R	U	App. Total	L	T	R	U	App. Total	L	T	R	U	App. Total	
Peak Hour Analysis From 4:00:00 PM to 5:45:00 PM - Peak 1 of 1																					
Peak Hour for Entire Intersection Begins at 4:00:00 PM																					
4:00:00 PM	0	0	0	0	0	0	2	0	0	2	0	0	1	0	1	0	27	0	0	27	30
4:15:00 PM	0	0	0	0	0	0	5	0	0	5	0	0	1	0	1	0	9	0	0	9	15
4:30:00 PM	0	0	0	0	0	0	8	0	0	8	2	0	0	0	2	0	5	0	0	5	15
4:45:00 PM	0	0	0	0	0	1	5	0	0	6	0	0	0	0	0	0	12	0	0	12	18
Total Volume	0	0	0	0	0	1	20	0	0	21	2	0	2	0	4	0	53	0	0	53	78
% App. Total	0	0	0	0	0	4.8	95.2	0	0		50	0	50	0		0	100	0	0		
PHF	.000	.000	.000	.000	.000	.250	.625	.000	.000	.656	.250	.000	.500	.000	.500	.000	.491	.000	.000	.491	.650

LSC Transportation Consultants, Inc.

545 E Pikes Peak Ave, Suite 210
 Colorado Springs, CO 80905
 719-633-2868

File Name : Thompson Rd - Walker Rd PM
 Site Code : S214800
 Start Date : 9/9/2021
 Page No : 3

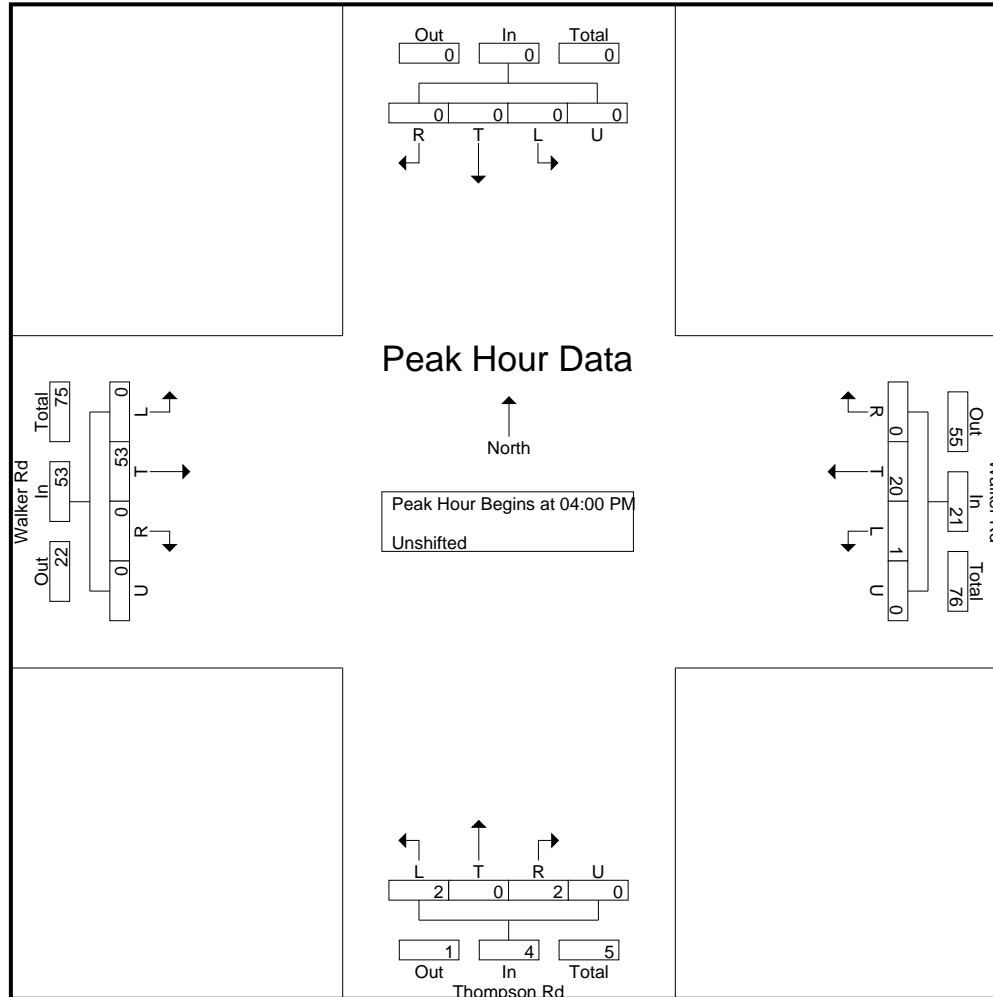

LSC Transportation Consultants, Inc.

545 E Pikes Peak Ave, Suite 210
 Colorado Springs, CO 80905
 719-633-2868

File Name : Thompson Rd - Walker Rd PM
 Site Code : S214800
 Start Date : 9/9/2021
 Page No : 4

Start Time	Southbound					Walker Rd Westbound					Thompson Rd Northbound					Walker Rd Eastbound					Int. Total
	L	T	R	U	App. Total	L	T	R	U	App. Total	L	T	R	U	App. Total	L	T	R	U	App. Total	

Peak Hour Analysis From 4:00:00 PM to 5:45:00 PM - Peak 1 of 1

Peak Hour for Each Approach Begins at:

	4:00:00 PM					4:30:00 PM					4:00:00 PM					4:00:00 PM				
+0 mins.	0	0	0	0	0	0	8	0	0	8	0	0	1	0	1	0	27	0	0	27
+5 mins.	0	0	0	0	0	1	5	0	0	6	0	0	1	0	1	0	9	0	0	9
+10 mins.	0	0	0	0	0	1	4	0	0	5	2	0	0	0	2	0	5	0	0	5
+15 mins.	0	0	0	0	0	0	6	0	0	6	0	0	0	0	0	0	12	0	0	12
Total Volume	0	0	0	0	0	2	23	0	0	25	2	0	2	0	4	0	53	0	0	53
% App. Total	0	0	0	0	0	8	92	0	0		50	0	50	0		0	100	0	0	
PHF	.000	.000	.000	.000	.000	.500	.719	.000	.000	.781	.250	.000	.500	.000	.500	.000	.491	.000	.000	.491

LSC Transportation Consultants, Inc.

545 E Pikes Peak Ave, Suite 210
 Colorado Springs, CO 80905
 719-633-2868

File Name : Thompson Rd - Walker Rd PM
 Site Code : S214800
 Start Date : 9/9/2021
 Page No : 5

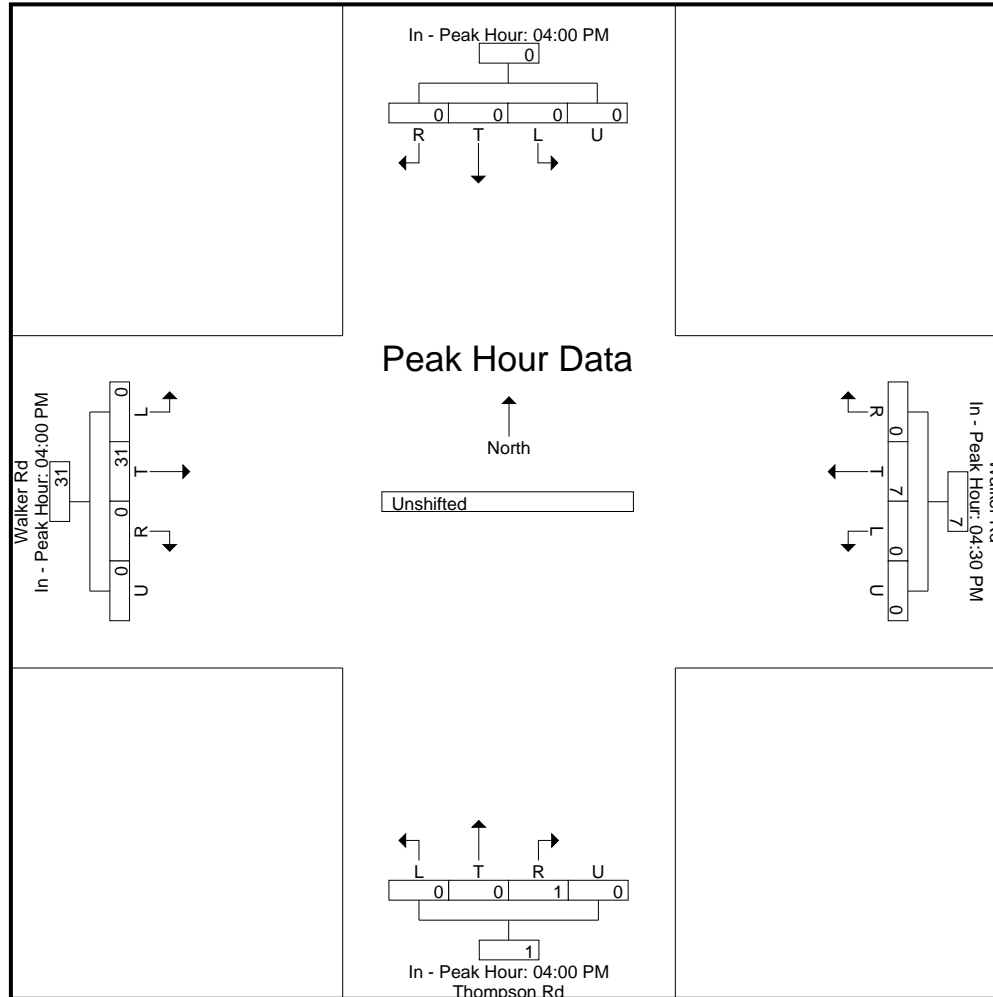

Levels of Service



Intersection						
Int Delay, s/veh	0.3					
Movement	EBT	EBR	WBL	WBT	NBL	NBR
Lane Configurations						
Traffic Vol, veh/h	21	1	0	36	2	0
Future Vol, veh/h	21	1	0	36	2	0
Conflicting Peds, #/hr	0	0	0	0	0	0
Sign Control	Free	Free	Free	Free	Stop	Stop
RT Channelized	-	None	-	None	-	None
Storage Length	-	-	-	-	0	-
Veh in Median Storage, #	0	-	-	0	0	-
Grade, %	0	-	-	0	0	-
Peak Hour Factor	78	78	78	78	78	78
Heavy Vehicles, %	2	2	2	2	2	2
Mvmt Flow	27	1	0	46	3	0

Major/Minor	Major1	Major2	Minor1	Minor2	Minor3
Conflicting Flow All	0	0	28	0	74
Stage 1	-	-	-	-	28
Stage 2	-	-	-	-	46
Critical Hdwy	-	-	4.12	-	6.42
Critical Hdwy Stg 1	-	-	-	-	5.42
Critical Hdwy Stg 2	-	-	-	-	5.42
Follow-up Hdwy	-	-	2.218	-	3.518
Pot Cap-1 Maneuver	-	-	1585	-	930
Stage 1	-	-	-	-	995
Stage 2	-	-	-	-	976
Platoon blocked, %	-	-	-	-	-
Mov Cap-1 Maneuver	-	-	1585	-	930
Mov Cap-2 Maneuver	-	-	-	-	930
Stage 1	-	-	-	-	995
Stage 2	-	-	-	-	976

Approach	EB	WB	NB
HCM Control Delay, s	0	0	8.9
HCM LOS			A

Minor Lane/Major Mvmt	NBLn1	EBT	EBR	WBL	WBT
Capacity (veh/h)	930	-	-	1585	-
HCM Lane V/C Ratio	0.003	-	-	-	-
HCM Control Delay (s)	8.9	-	-	0	-
HCM Lane LOS	A	-	-	A	-
HCM 95th %tile Q(veh)	0	-	-	0	-

Intersection						
Int Delay, s/veh	0.1					
Movement	EBT	EBR	WBL	WBT	NBL	NBR
Lane Configurations						
Traffic Vol, veh/h	62	2	0	26	1	0
Future Vol, veh/h	62	2	0	26	1	0
Conflicting Peds, #/hr	0	0	0	0	0	0
Sign Control	Free	Free	Free	Free	Stop	Stop
RT Channelized	-	None	-	None	-	None
Storage Length	-	-	-	-	0	-
Veh in Median Storage, #	0	-	-	0	0	-
Grade, %	0	-	-	0	0	-
Peak Hour Factor	83	83	78	78	78	78
Heavy Vehicles, %	2	2	2	2	2	2
Mvmt Flow	75	2	0	33	1	0

Major/Minor	Major1	Major2	Minor1		
Conflicting Flow All	0	0	77	0	109 76
Stage 1	-	-	-	-	76 -
Stage 2	-	-	-	-	33 -
Critical Hdwy	-	-	4.12	-	6.42 6.22
Critical Hdwy Stg 1	-	-	-	-	5.42 -
Critical Hdwy Stg 2	-	-	-	-	5.42 -
Follow-up Hdwy	-	-	2.218	-	3.518 3.318
Pot Cap-1 Maneuver	-	-	1522	-	888 985
Stage 1	-	-	-	-	947 -
Stage 2	-	-	-	-	989 -
Platoon blocked, %	-	-	-	-	-
Mov Cap-1 Maneuver	-	-	1522	-	888 985
Mov Cap-2 Maneuver	-	-	-	-	888 -
Stage 1	-	-	-	-	947 -
Stage 2	-	-	-	-	989 -

Approach	EB	WB	NB
HCM Control Delay, s	0	0	9.1
HCM LOS			A

Minor Lane/Major Mvmt	NBLn1	EBT	EBR	WBL	WBT
Capacity (veh/h)	888	-	-	1522	-
HCM Lane V/C Ratio	0.001	-	-	-	-
HCM Control Delay (s)	9.1	-	-	0	-
HCM Lane LOS	A	-	-	A	-
HCM 95th %tile Q(veh)	0	-	-	0	-

Intersection						
Int Delay, s/veh	0.2					
Movement	EBT	EBR	WBL	WBT	NBL	NBR
Lane Configurations						
Traffic Vol, veh/h	31	0	0	46	2	0
Future Vol, veh/h	31	0	0	46	2	0
Conflicting Peds, #/hr	0	0	0	0	0	0
Sign Control	Free	Free	Free	Free	Stop	Stop
RT Channelized	-	None	-	None	-	None
Storage Length	-	-	-	-	0	-
Veh in Median Storage, #	0	-	-	0	0	-
Grade, %	0	-	-	0	0	-
Peak Hour Factor	78	78	78	78	78	78
Heavy Vehicles, %	2	2	2	2	2	2
Mvmt Flow	40	0	0	59	3	0

Major/Minor	Major1	Major2	Minor1	Minor2	Minor3
Conflicting Flow All	0	0	40	0	99
Stage 1	-	-	-	-	40
Stage 2	-	-	-	-	59
Critical Hdwy	-	-	4.12	-	6.42
Critical Hdwy Stg 1	-	-	-	-	5.42
Critical Hdwy Stg 2	-	-	-	-	5.42
Follow-up Hdwy	-	-	2.218	-	3.518
Pot Cap-1 Maneuver	-	-	1570	-	900
Stage 1	-	-	-	-	982
Stage 2	-	-	-	-	964
Platoon blocked, %	-	-	-	-	-
Mov Cap-1 Maneuver	-	-	1570	-	900
Mov Cap-2 Maneuver	-	-	-	-	900
Stage 1	-	-	-	-	982
Stage 2	-	-	-	-	964

Approach	EB	WB	NB
HCM Control Delay, s	0	0	9
HCM LOS			A

Minor Lane/Major Mvmt	NBLn1	EBT	EBR	WBL	WBT
Capacity (veh/h)	900	-	-	1570	-
HCM Lane V/C Ratio	0.003	-	-	-	-
HCM Control Delay (s)	9	-	-	0	-
HCM Lane LOS	A	-	-	A	-
HCM 95th %tile Q(veh)	0	-	-	0	-

Intersection												
Int Delay, s/veh	0.4											
Movement	EBL	EBT	EBR	WBL	WBT	WBR	NBL	NBT	NBR	SBL	SBT	SBR
Lane Configurations		↕			↕			↕			↕	
Traffic Vol, veh/h	0	76	0	1	31	0	2	0	2	0	0	0
Future Vol, veh/h	0	76	0	1	31	0	2	0	2	0	0	0
Conflicting Peds, #/hr	0	0	0	0	0	0	0	0	0	0	0	0
Sign Control	Free	Free	Free	Free	Free	Free	Stop	Stop	Stop	Stop	Stop	Stop
RT Channelized	-	-	None	-	-	None	-	-	None	-	-	None
Storage Length	-	-	-	-	-	-	-	-	-	-	-	-
Veh in Median Storage, #	-	0	-	-	0	-	-	0	-	-	0	-
Grade, %	-	0	-	-	0	-	-	0	-	-	0	-
Peak Hour Factor	83	83	83	78	78	78	78	78	78	78	78	78
Heavy Vehicles, %	2	2	2	2	2	2	2	2	2	2	2	2
Mvmt Flow	0	92	0	1	40	0	3	0	3	0	0	0

Major/Minor	Major1			Major2			Minor1			Minor2		
Conflicting Flow All	40	0	0	92	0	0	134	134	92	136	134	40
Stage 1	-	-	-	-	-	-	92	92	-	42	42	-
Stage 2	-	-	-	-	-	-	42	42	-	94	92	-
Critical Hdwy	4.12	-	-	4.12	-	-	7.12	6.52	6.22	7.12	6.52	6.22
Critical Hdwy Stg 1	-	-	-	-	-	-	6.12	5.52	-	6.12	5.52	-
Critical Hdwy Stg 2	-	-	-	-	-	-	6.12	5.52	-	6.12	5.52	-
Follow-up Hdwy	2.218	-	-	2.218	-	-	3.518	4.018	3.318	3.518	4.018	3.318
Pot Cap-1 Maneuver	1570	-	-	1503	-	-	838	757	965	835	757	1031
Stage 1	-	-	-	-	-	-	915	819	-	972	860	-
Stage 2	-	-	-	-	-	-	972	860	-	913	819	-
Platoon blocked, %		-	-		-	-						
Mov Cap-1 Maneuver	1570	-	-	1503	-	-	837	756	965	832	756	1031
Mov Cap-2 Maneuver	-	-	-	-	-	-	837	756	-	832	756	-
Stage 1	-	-	-	-	-	-	915	819	-	972	859	-
Stage 2	-	-	-	-	-	-	971	859	-	911	819	-

Approach	EB			WB			NB			SB		
HCM Control Delay, s	0			0.2			9			0		
HCM LOS							A			A		

Minor Lane/Major Mvmt	NBLn1	EBL	EBT	EBR	WBL	WBT	WBR	SBLn1
Capacity (veh/h)	896	1570	-	-	1503	-	-	-
HCM Lane V/C Ratio	0.006	-	-	-	0.001	-	-	-
HCM Control Delay (s)	9	0	-	-	7.4	0	-	0
HCM Lane LOS	A	A	-	-	A	A	-	A
HCM 95th %tile Q(veh)	0	0	-	-	0	-	-	-

MTCP Maps



Map 13: Improvements Map

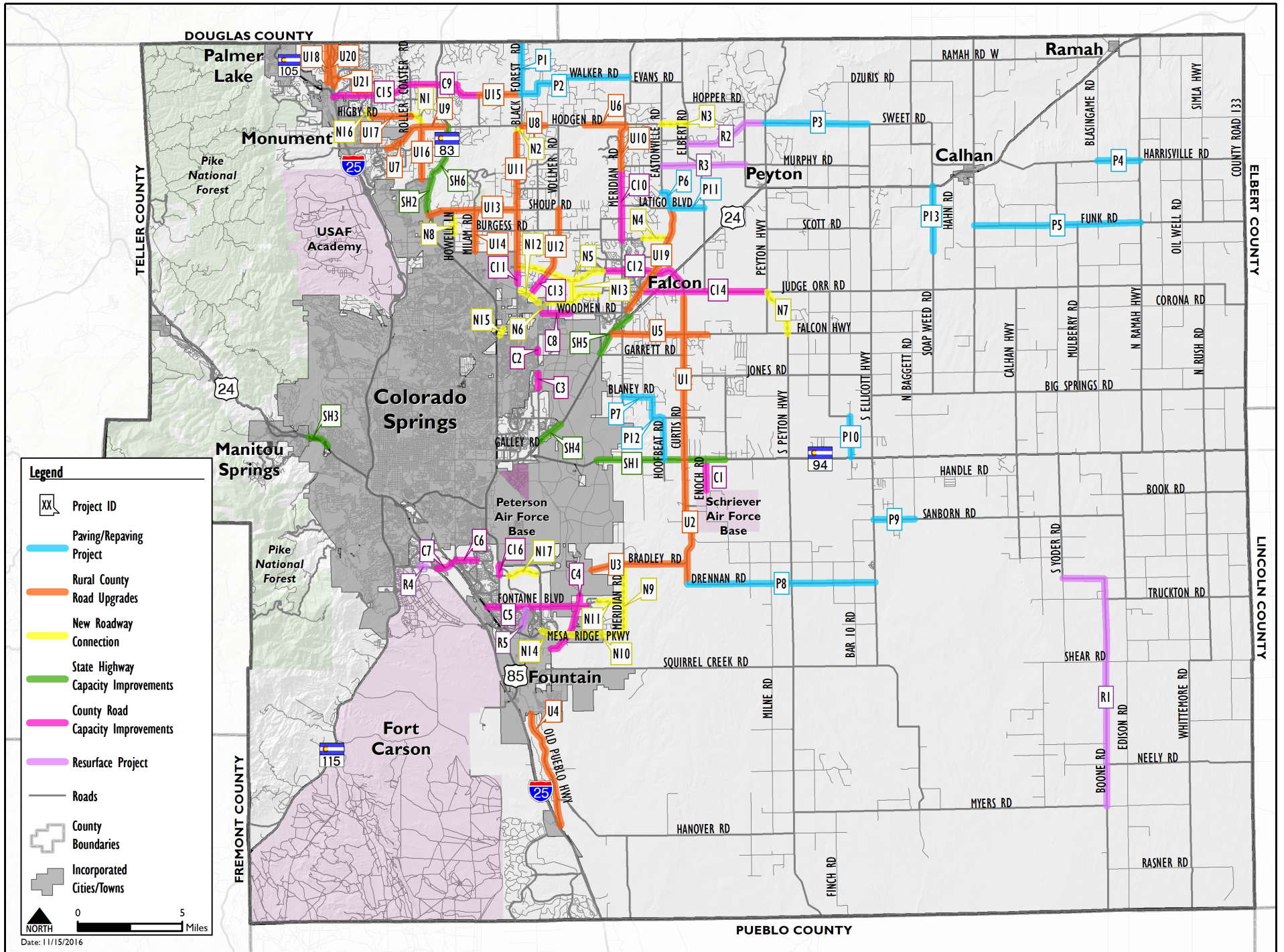

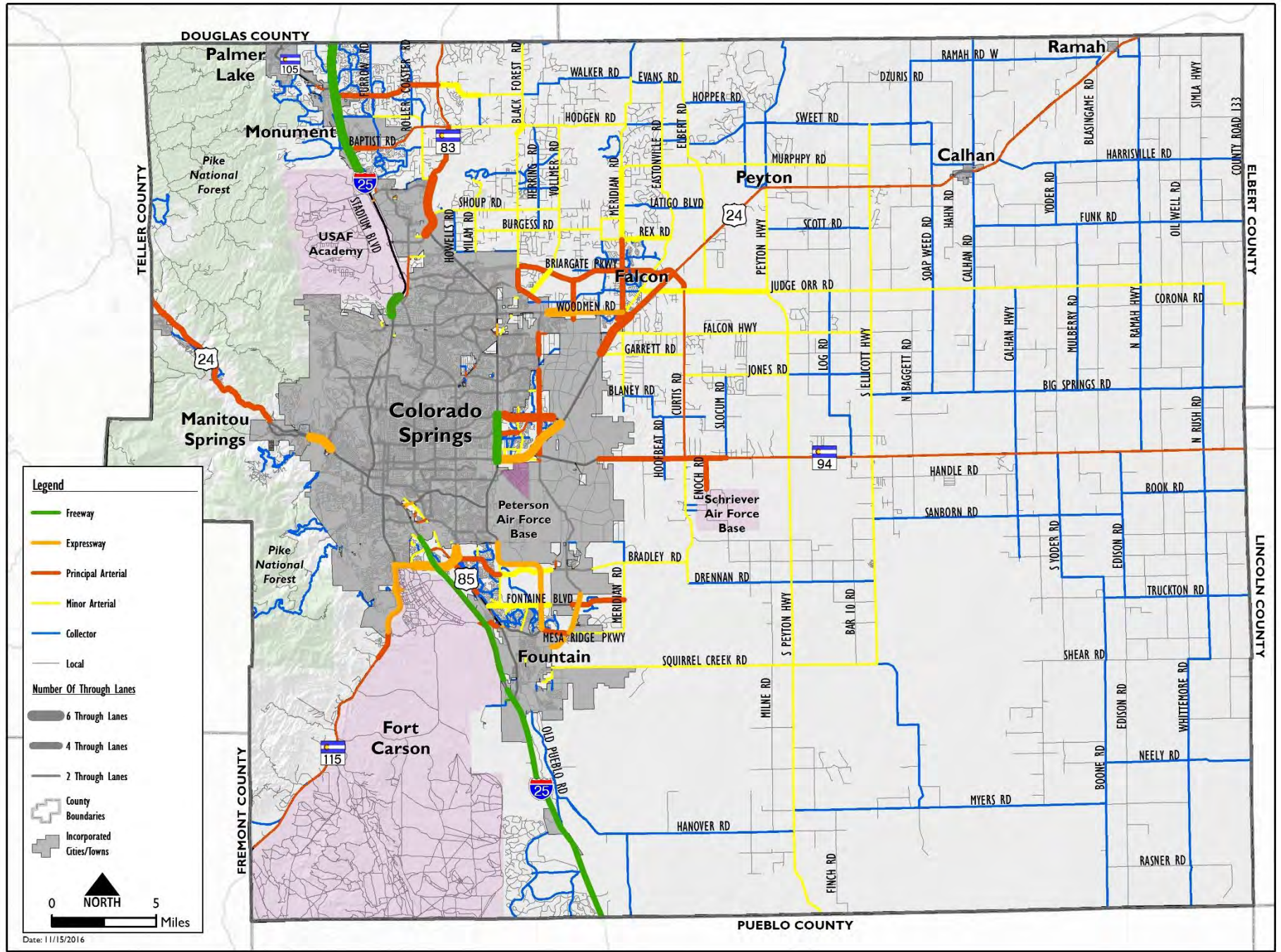

Map 14: 2040 Roadway Plan (Classification and Lanes)

Map 15: Multimodal Improvements

