



# CLEARWAY, LOT 5 (WIRENUT)

COUNTY OF EL PASO, STATE OF COLORADO

## DETAILED GRADING PLAN

### LEGEND

- LIMITS OF DISTURBANCE / CONSTRUCTION BOUNDARY
- CUT/FILL LINE
- (6920) EXISTING MAJOR CONTOUR
- (6918) EXISTING MINOR CONTOUR
- 6920 PROPOSED MAJOR CONTOUR
- 6918 PROPOSED MINOR CONTOUR
- EXISTING 100 YEAR FEMA FLOODPLAIN
- FILING BOUNDARY (PROPERTY LINE)
- PROPERTY LINE
- PROP SWALE
- EASEMENT LINE
- PROPOSED STORM SEWER PIPE
- PROPOSED INLET
- EXISTING FLOW DIRECTION ARROW
- EMERGENCY OVERFLOW DIRECTION
- FLOW DIRECTION & SLOPE
- FLARED END SECTION
- H.P. HIGH POINT
- L.P. LOW POINT
- TSB TEMPORARY SEDIMENT BASIN INITIAL/FINAL STAGES

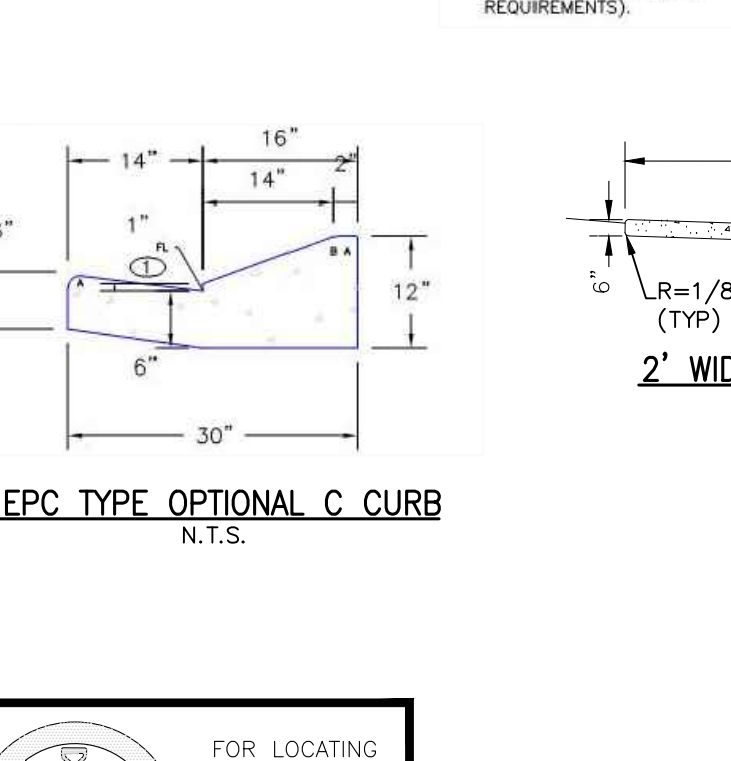
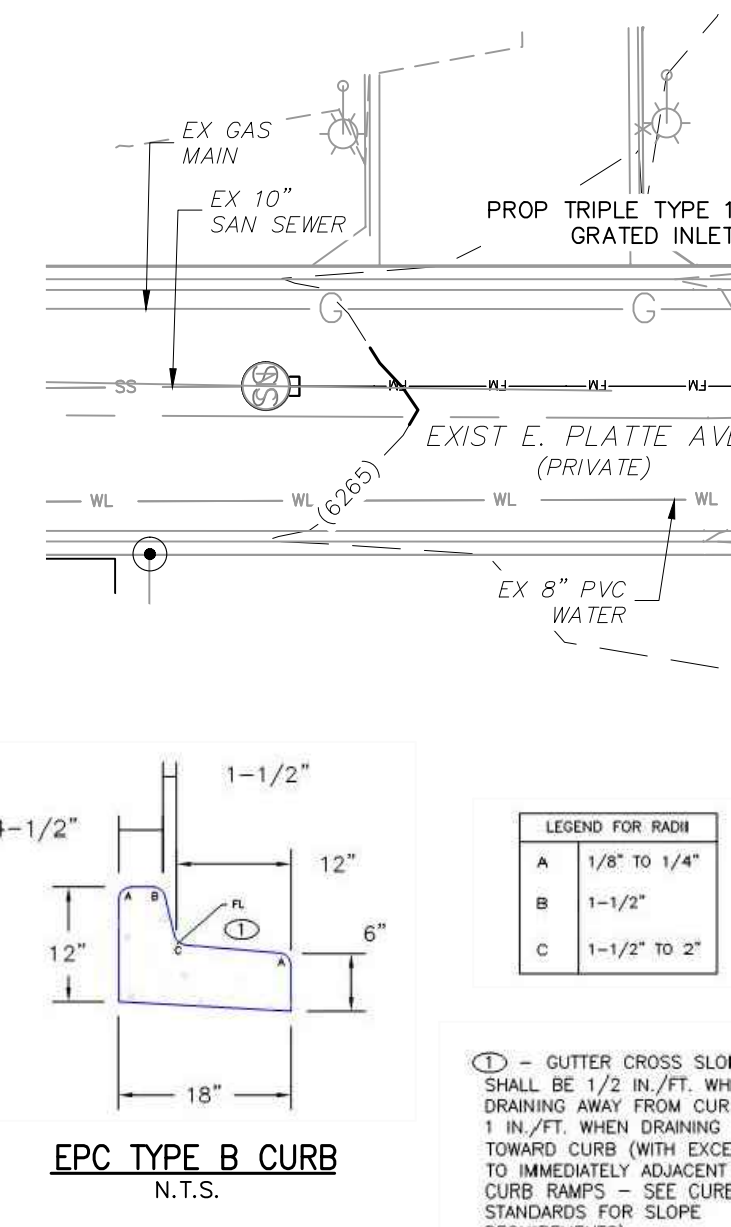

GRADING & EROSION CONTROL PLAN  
CLEARWAY, LOT 5  
JOB NO. 44-042  
DATE PREPARED: JUNE 1, 2023  
DATE REVISED:  
EL PASO COUNTY FILE NO. PPR-22-034

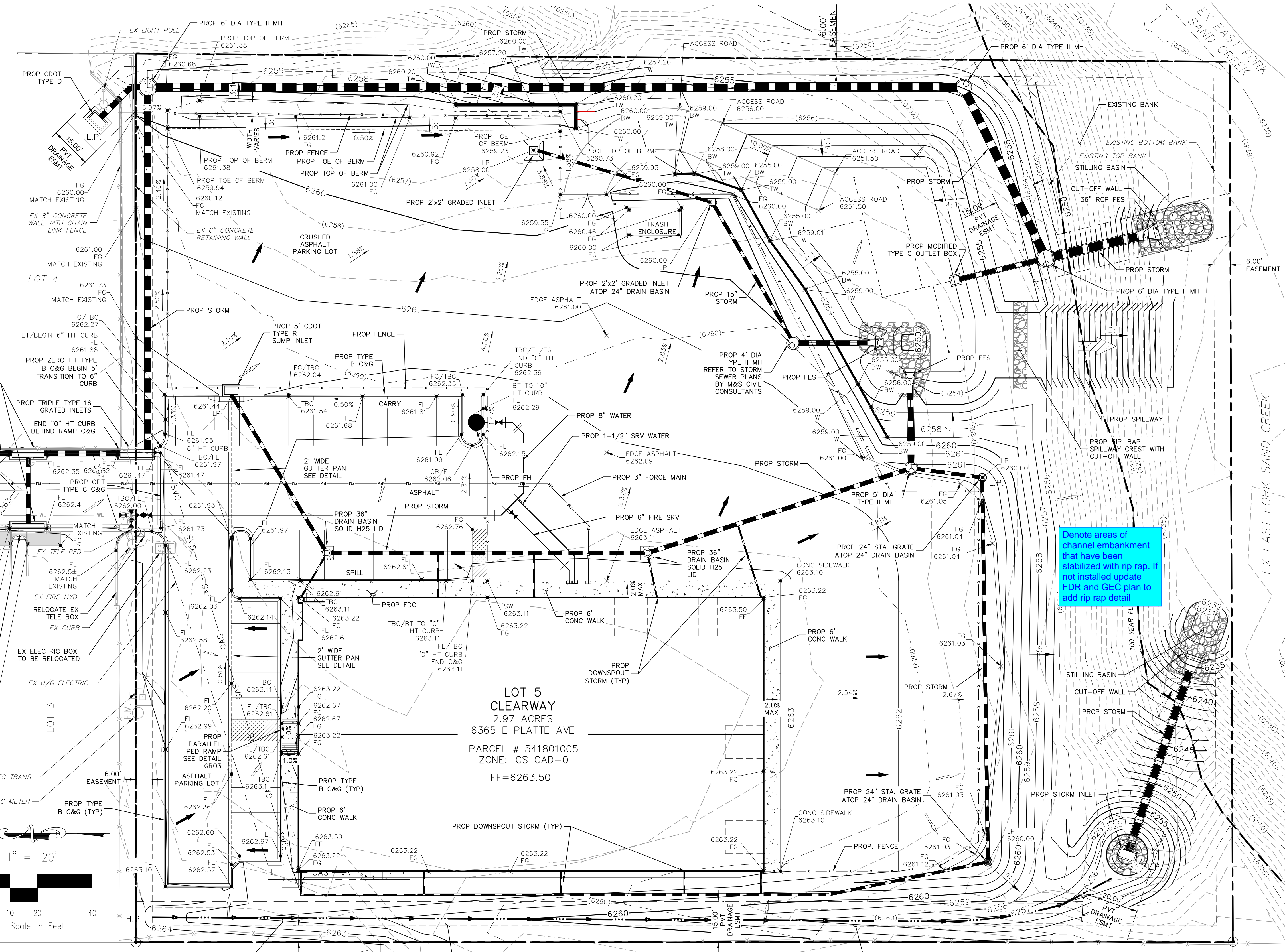

Denote areas of channel embankment that have been stabilized with rip rap. If not installed update FDR and GEC plan to add rip rap detail

File: 0:\44042A-Wire Nut\Hammers\Const Dwg\Grading\44042A-G802.dwg Plotstamp: 6/14/2023 1:19 PM



CLEARWAY, LOT 5		DATE: 06/13/2023	
DETAILED GRADING PLAN		SCALE: HORIZONTAL: 1"=20' VERTICAL: N/A	
PROJECT NO. 44-042A		DESIGNED BY: TAU	
212 N. WABATCH AVE., STE 305 COLORADO SPRINGS, CO 80903 PHONE: 719.955.5465		DRAWN BY: CLP	
FOR AND ON BEHALF OF M&S CIVIL CONSULTANTS, INC.		CHECKED BY: DLM	
VIRGIL A. SANCHEZ, COLORADO, P.E. NO. 371160		06/14/2023	
REVISIONS:	NO.	DATE:	DESCRIPTION:
THE ENGINEER PREPARING THESE PLANS WILL NOT BE RESPONSIBLE, OR LIABLE FOR, UNAUTHORIZED CHANGES TO OR USES OF THESE PLANS. ALL CHANGES TO THE PLANS MUST BE IN WRITING AND MUST BE APPROVED BY THE PREPARED OF THESE PLANS.			
CAUTION			

CLEARWAY, LOT 5		DATE: 06/13/2023	
DETAILED GRADING PLAN		SCALE: HORIZONTAL: 1"=20' VERTICAL: N/A	
PROJECT NO. 44-042A		DESIGNED BY: TAU	
212 N. WABATCH AVE., STE 305 COLORADO SPRINGS, CO 80903 PHONE: 719.955.5465		DRAWN BY: CLP	
FOR AND ON BEHALF OF M&S CIVIL CONSULTANTS, INC.		CHECKED BY: DLM	
VIRGIL A. SANCHEZ, COLORADO, P.E. NO. 371160		06/14/2023	
REVISIONS:	NO.	DATE:	DESCRIPTION:
THE ENGINEER PREPARING THESE PLANS WILL NOT BE RESPONSIBLE, OR LIABLE FOR, UNAUTHORIZED CHANGES TO OR USES OF THESE PLANS. ALL CHANGES TO THE PLANS MUST BE IN WRITING AND MUST BE APPROVED BY THE PREPARED OF THESE PLANS.			
CAUTION			

FOR AND ON BEHALF OF M&S CIVIL CONSULTANTS, INC.	06/14/2023		
VIRGIL A. SANCHEZ, COLORADO, P.E. NO. 371160			
REVISIONS:	NO.	DATE:	DESCRIPTION:
THE ENGINEER PREPARING THESE PLANS WILL NOT BE RESPONSIBLE, OR LIABLE FOR, UNAUTHORIZED CHANGES TO OR USES OF THESE PLANS. ALL CHANGES TO THE PLANS MUST BE IN WRITING AND MUST BE APPROVED BY THE PREPARED OF THESE PLANS.			
CAUTION			

FOR AND ON BEHALF OF M&S CIVIL CONSULTANTS, INC.	06/14/2023		
VIRGIL A. SANCHEZ, COLORADO, P.E. NO. 371160			
REVISIONS:	NO.	DATE:	DESCRIPTION:
THE ENGINEER PREPARING THESE PLANS WILL NOT BE RESPONSIBLE, OR LIABLE FOR, UNAUTHORIZED CHANGES TO OR USES OF THESE PLANS. ALL CHANGES TO THE PLANS MUST BE IN WRITING AND MUST BE APPROVED BY THE PREPARED OF THESE PLANS.			
CAUTION			

# CLEARWAY, LOT 5 (WIRENUT)

COUNTY OF EL PASO, STATE OF COLORADO  
 DETAILED GRADING DETAILS

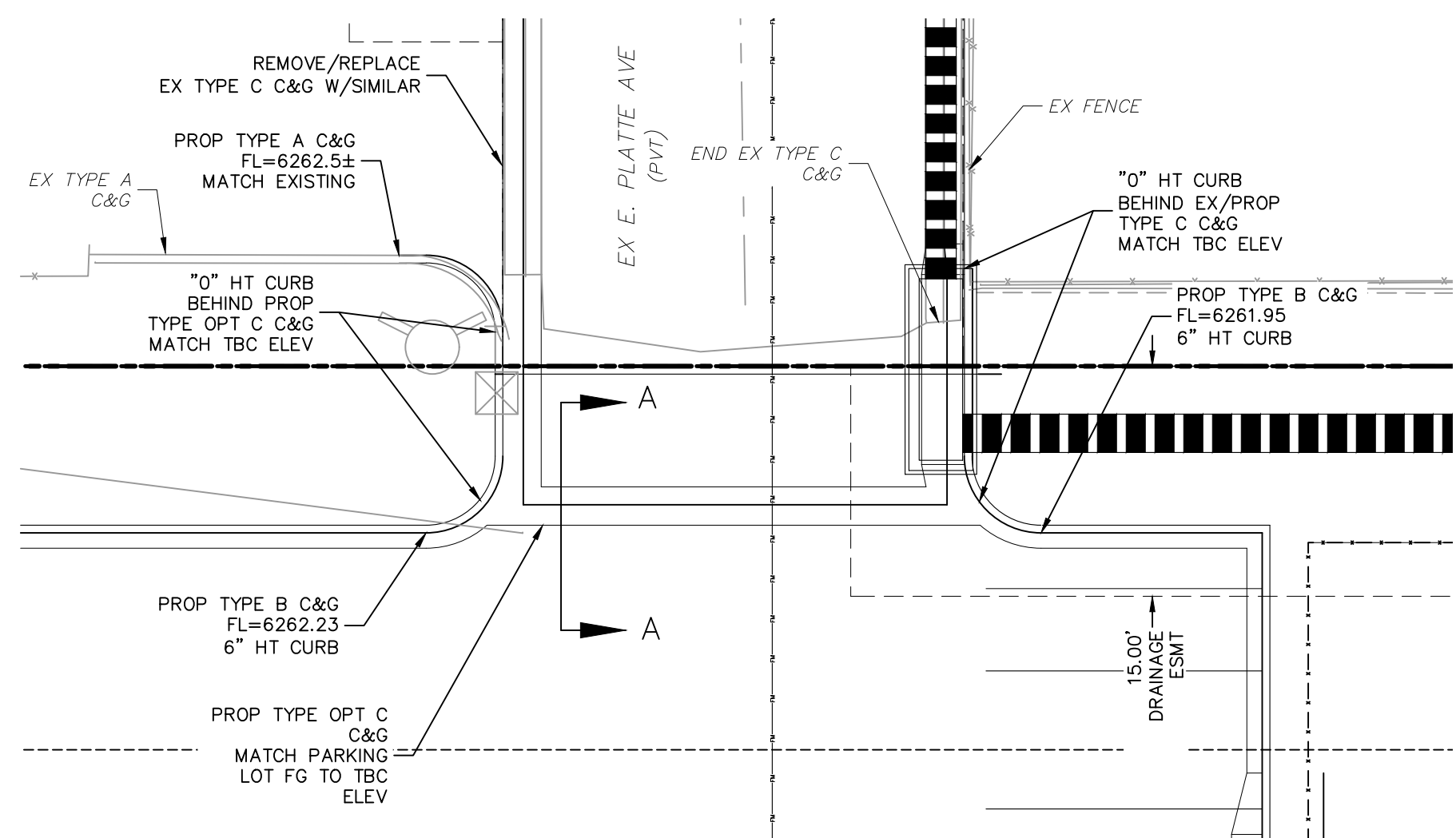

**SITE ENTRANCE**  
 SCALE: 1"=10'

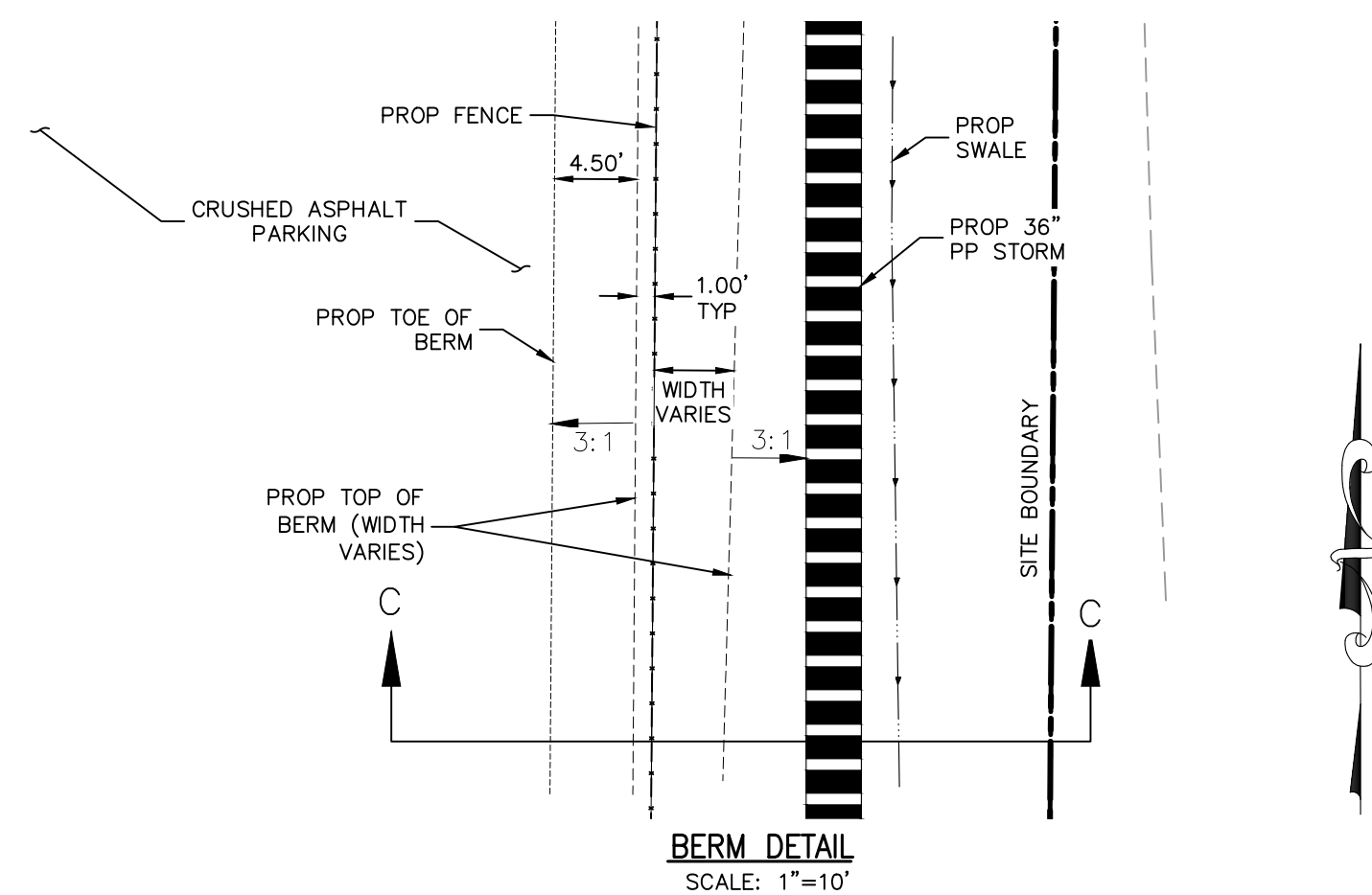
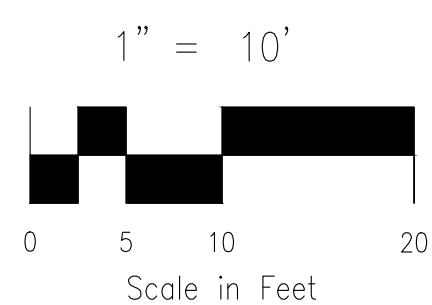

**BERM DETAIL**  
 SCALE: 1"=10'

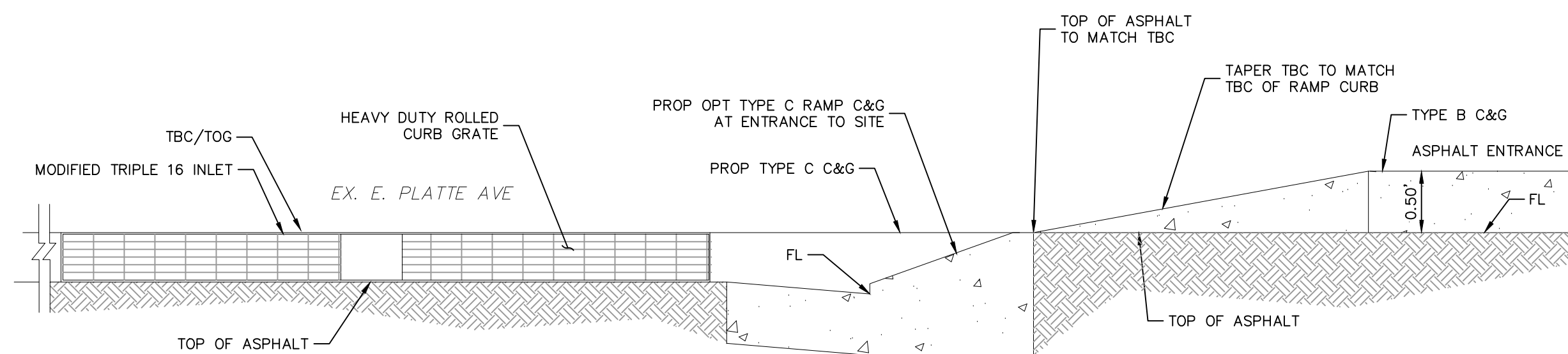

**SECTION A-A**  
 SCALE: NTS

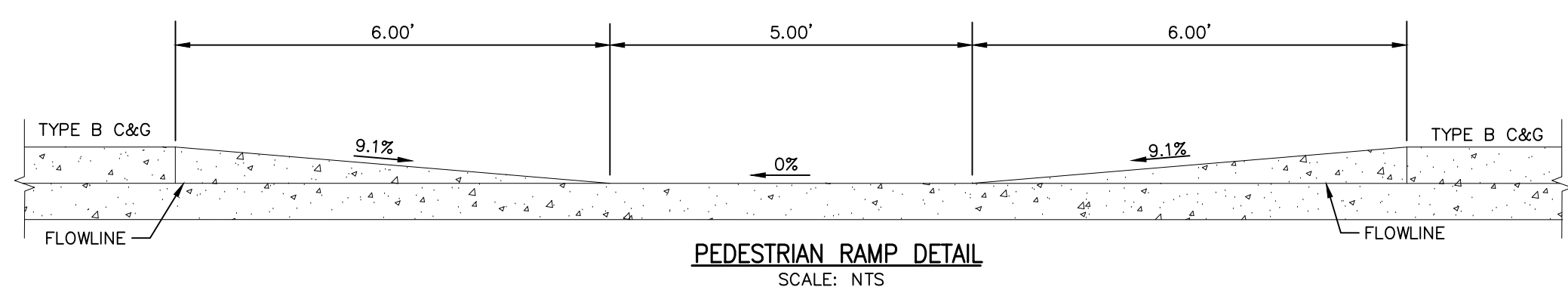

**PEDESTRIAN RAMP DETAIL**  
 SCALE: NTS

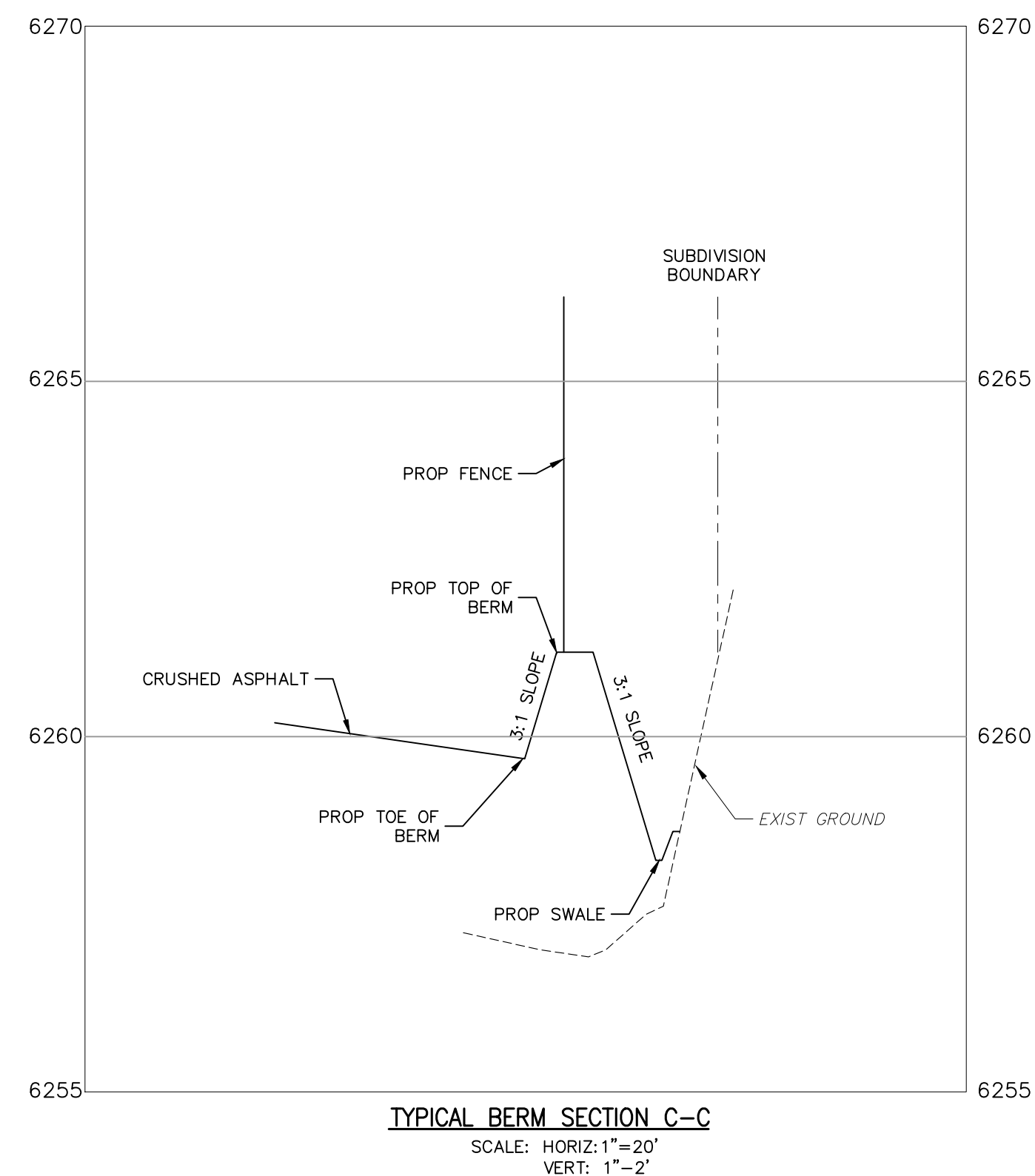

**TYPICAL BERM SECTION C-C**  
 SCALE: HORIZ: 1"=20'  
 VERT: 1"=2'

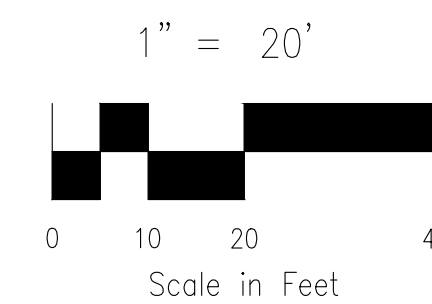

FOR LOCATING & MARKING GAS, ELECTRIC, WATER & TELEPHONE LINES  
 FOR BURIED UTILITY INFORMATION  
 48 HRS BEFORE YOU DIG  
 CALL 1-800-922-1987

GRADING DETAILS  
 CLEARWAY, LOT 5  
 JOB NO. 44-042  
 DATE PREPARED: JUNE 1, 2023  
 DATE REVISED:

EL PASO COUNTY FILE NO. PPR-22-034

CLEARWAY, LOT 5

DETAILED GRADING DETAILS

DATE: 06/13/2023

GR03

SHEET 3 OF 11

SCALE: HORIZONTAL: 1"=20' VERTICAL: N/A

PROJECT NO. 44-042A

DESIGNED BY: TAU CLP CHECKED BY: DLM

212 N. WASHATCH AVE., STE 305  
 COLORADO SPRINGS, CO 80903  
 PHONE: 719.555.5865

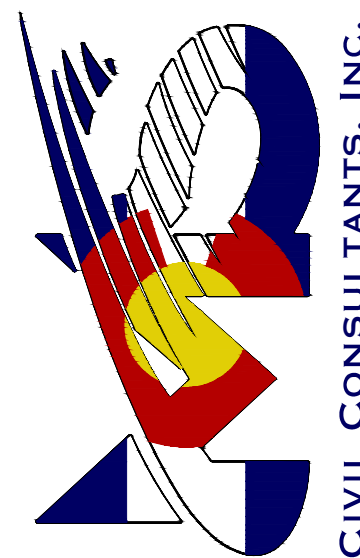

FOR AND ON BEHALF OF M&S CIVIL CONSULTANTS, INC.

VIRGIL A. SANCHEZ, COLORADO, P.E. NO. 37160



NO.	DATE	BY	DESCRIPTION

THE ENGINEER PREPARING THESE PLANS WILL NOT BE RESPONSIBLE, OR LIABLE FOR, UNAUTHORIZED CHANGES TO OR USES OF THESE PLANS. ALL CHANGES TO THE PLANS MUST BE IN WRITING AND MUST BE APPROVED BY THE PREPARED OF THESE PLANS.

CAUTION

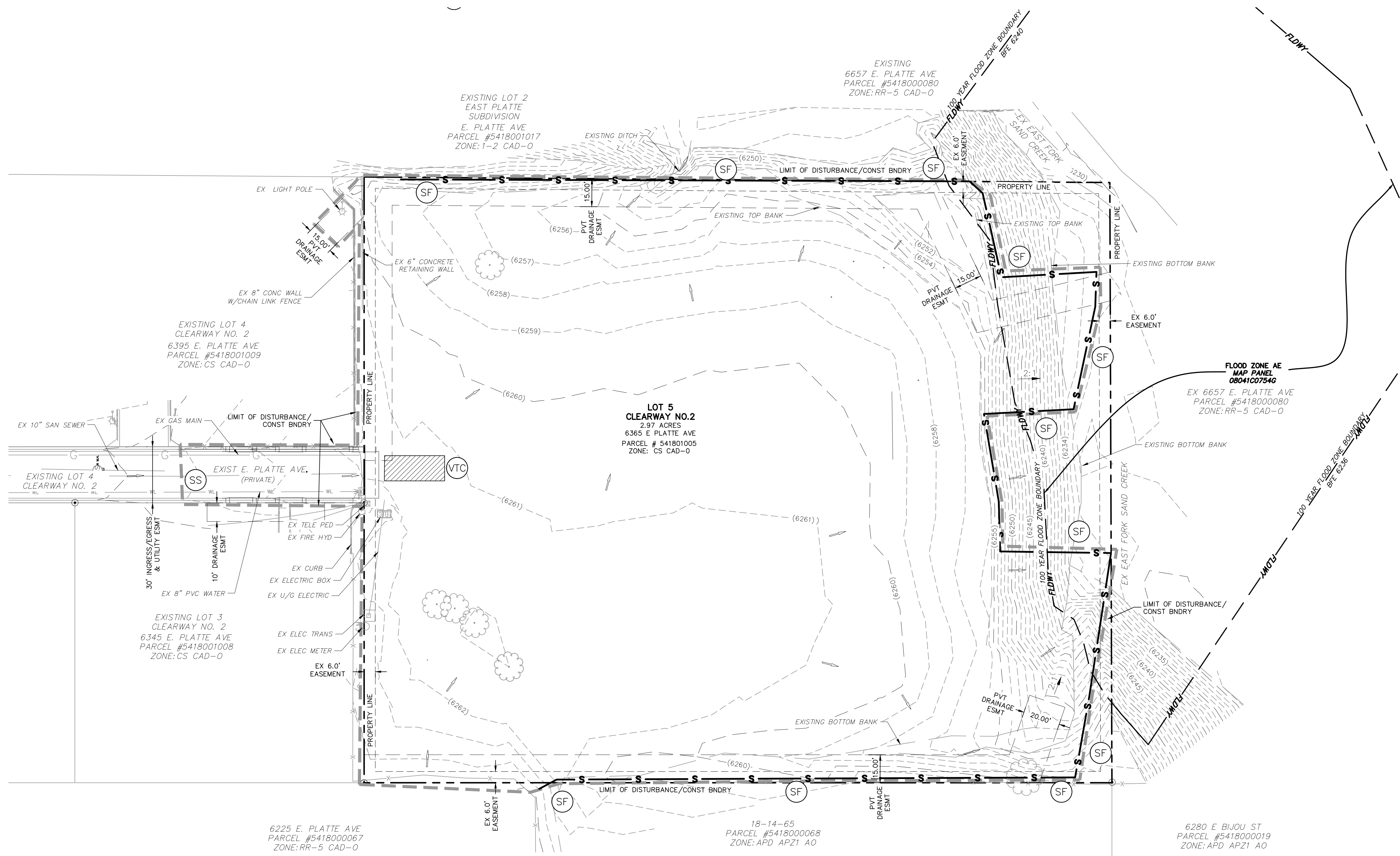

**LEGEND**

- 6920 --- EXISTING MAJOR CONTOUR
- 6918 --- EXISTING MINOR CONTOUR
- 6920 --- PROPOSED MAJOR CONTOUR
- 6918 --- PROPOSED MINOR CONTOUR
- - - - - FILING BOUNDARY LINE
- --- EXISTING PROPERTY LINE
- - - - - LIMIT OF DISTURBANCE/CONST FENCING /BOUNDARY
- (SF) --- S --- SILT FENCE
- L.P./H.P. --- LOW POINT/HIGH POINT
- 2:1 --- FLOW DIRECTION & SLOPE
- FLOW DIRECTION ARROW/ EMERGENCY OVERFLOW
- EXISTING FLOW DIRECTION ARROW
- (VTC) --- VEHICLE TRACKING CONTROL
- (SS) --- SWEEPING AT THIS LOCATION WHEN WORK IS BEING CONDUCTED

**NARRATIVE NOTES:**

1. LOCATION OF STOCKPILES SHALL BE DETERMINED BY CONTRACTOR. ALL STOCKPILES SHALL REMAIN WITHIN THE CONSTRUCTION BOUNDARIES AS INDICATED ON THE SITE MAP.
2. THE EXACT LOCATION FOR THE STABILIZED STAGING AREA, STORAGE EQUIPMENT AND TEMPORARY DISPOSAL AREAS SHALL BE DETERMINED IN THE FIELD BY THE CONTRACTOR. PLAN SHALL BE UPDATED BY CONTRACTOR UPON DETERMINATION OF EXACT LOCATION.
3. FINAL STABILIZATION SHALL BE COMPLETED AT THE END OF THE CONSTRUCTION ACTIVITIES. ALL AREAS DISTURBED WITHIN THE CONSTRUCTION BOUNDARY/LIMITS OF DISTURBANCE AREA SHALL BE RESEEDED WITH NATIVE SEEDING.
4. EROSION CONTROL BLANKET SHALL BE USED ON SLOPES GREATER THAN 4:1.
5. REFER TO WIRE NUT FILING NO. 1 CONSTRUCTION PLANS BY M&S CIVIL CONSULTANTS FOR ADDITIONAL DETAIL.

**ADDITIONAL NOTES:**

1. THE EROSION CONTROL DELINEATED ON THIS PLAN SHALL BE REGULARLY UPDATED BY THE CONTRACTOR.
2. OFFSITE GRADING ON PLATTE AVE AND LOT 4 DUE TO NON-EXISTING DRAINAGE INFRASTRUCTURE. TO BE APPROVED BY THE CITY OF COLORADO SPRINGS. (OR EPC.)
3. LOCATIONS OF ALL NON-STRUCTURAL CONTROL MEASURES. NON-STRUCTURAL CONTROLS (LIKE STREET SWEEPING) WITHOUT A SPECIFIC LOCATION MAY BE DESCRIBED USING NOTES.
4. PROPOSED SLOPES SHALL BE 4:1 OR GREATER.
5. THE CONTRACTOR SHALL OBTAIN A COPY OF THE GEOTECHNICAL ENGINEERING REPORT AND KEEP A COPY ONSITE DURING ALL EARTHWORK OPERATIONS.
6. TO REDUCED RUNOFF EROSION, THE CONTRACTOR SHALL IMPLEMENT SURFACING ROUGHING MEASURES OVER LARGER AREAS OF THE SITE. IF WEATHER DICTATES, THE CONTRACTOR SHOULD UTILIZE WATERING NON-STRUCTURAL MEASUREMENTS TO MINIMIZE WIND EROSION. THE SITE SHOULD BE MULCHED AFTER INTERIM GRADING WITHIN 21 DAYS, AND THE SITE SHALL BE SEEDDED IF CONSTRUCTION DOESN'T COMMENCE WITHIN 60 DAYS, PER EPC STANDARDS SPECIFICATIONS.
7. NO ASPHALT / CONCRETE BATCH PLANTS WILL BE UTILIZED ONSITE.

**VEGETATION:**

EXISTING VEGETATION: NATIVE PRAIRIE GRASSES AND SHRUBS.

**TEMPORARY NON-STRUCTURAL PRACTICES:**

TO REDUCED RUNOFF EROSION, THE CONTRACTOR SHALL IMPLEMENT SURFACING ROUGHING MEASURES OVER LARGER AREAS OF THE SITE. IF WEATHER DICTATES, THE CONTRACTOR SHOULD UTILIZE WATERING NON-STRUCTURAL MEASUREMENTS TO MINIMIZE WIND EROSION. THE SITE SHOULD BE MULCHED AFTER INTERIM GRADING WITHIN 21 DAYS, AND THE SITE SHALL BE SEEDDED IF CONSTRUCTION DOESN'T COMMENCE WITHIN 60 DAYS, PER EL PASO COUNTY (EPC) STANDARDS.

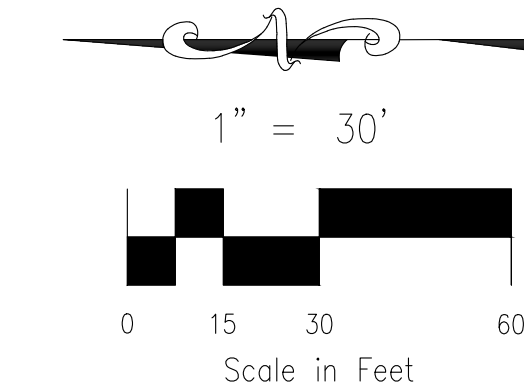

FOR LOCATING & MARKING GAS, ELECTRIC, WATER & TELEPHONE LINES

FOR BURIED UTILITY INFORMATION  
**48 HRS BEFORE YOU DIG**  
 CALL 1-800-922-1987

**CLEARWAY, LOT 5**

**INITIAL GRADING & EROSION CONTROL PLAN**

PROJECT NO. 44-042A DATE: 06/13/2023

SCALE: HORIZONTAL: 1"=30' VERTICAL: N/A

DESIGNED BY: TAU CLP CHECKED BY: TAU CLP

212 N. WASHCATCH AVE, STE 305  
 COLORADO SPRINGS, CO 80903  
 PHONE: 719.555.5465

**M&S CIVIL CONSULTANTS, INC.**

FOR AND ON BEHALF OF M&S CIVIL CONSULTANTS, INC.

VIRGIL A. SANCHEZ, COLORADO, P.E. NO. 371160

06/14/2023

REV. NO.	DATE	BY	DESCRIPTION

THE ENGINEER PREPARING THESE PLANS WILL NOT BE RESPONSIBLE, OR LIABLE FOR, UNAUTHORIZED CHANGES TO OR USES OF THESE PLANS. ALL CHANGES TO THE PLANS MUST BE IN WRITING AND MUST BE APPROVED BY THE PREPARE OF THESE PLANS.

**CAUTION**

EL PASO COUNTY FILE NO. PPR-22-034

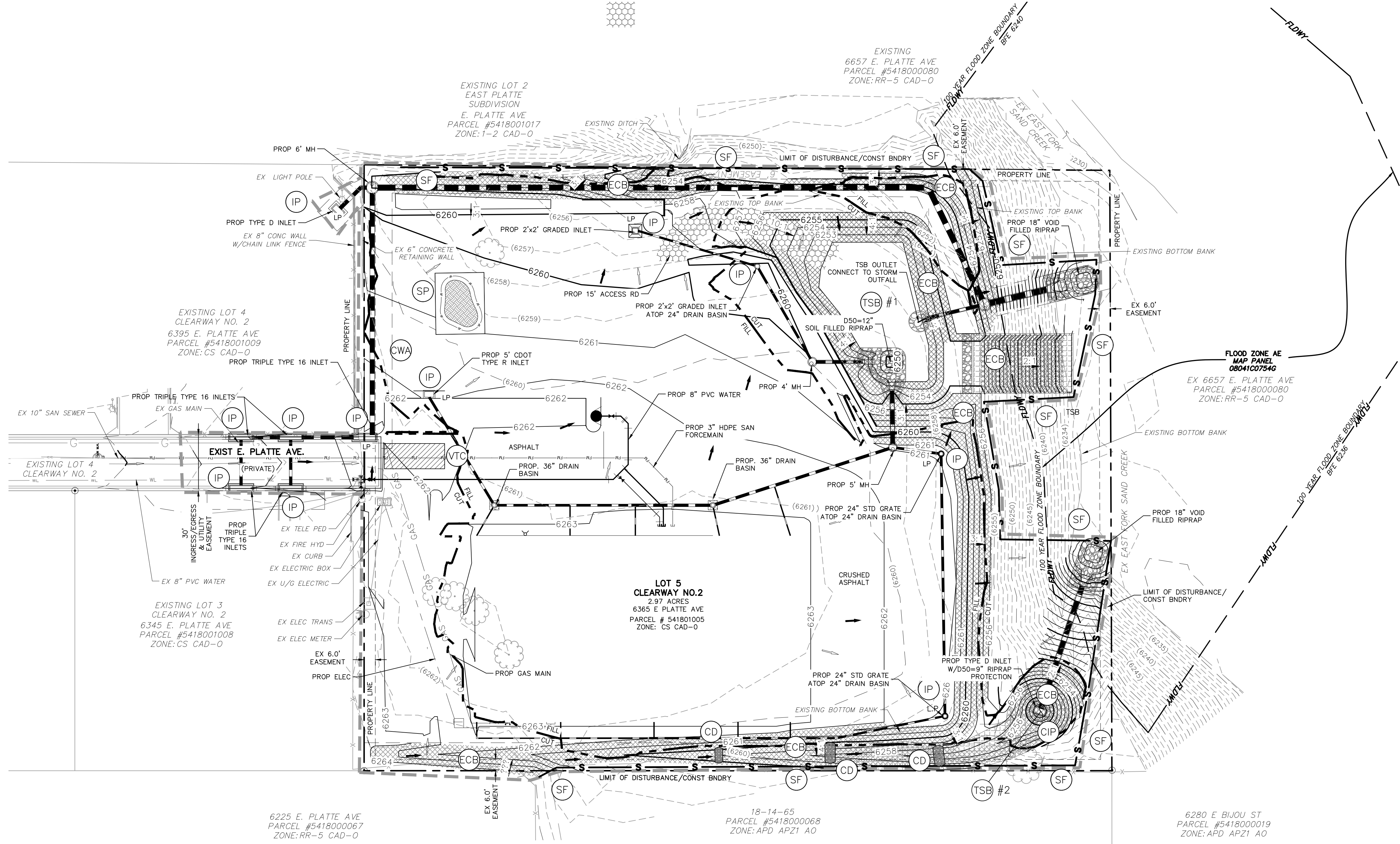

**LEGEND**

- 6920 --- EXISTING MAJOR CONTOUR
- 6918 --- EXISTING MINOR CONTOUR
- 6920 --- PROPOSED MAJOR CONTOUR
- 6918 --- PROPOSED MINOR CONTOUR
- - - - - FILING BOUNDARY LINE
- --- EXISTING PROPERTY LINE
- - - - - LIMIT OF DISTURBANCE/CONST BOUNDARY
- --- PROPOSED STORM SEWER
- (SF) --- S --- SILT FENCE
- L.P./H.P. --- LOW POINT/HIGH POINT
- 2:1 --- FLOW DIRECTION & SLOPE
- --- FLOW DIRECTION ARROW/ EMERGENCY OVERFLOW
- --- EXISTING FLOW DIRECTION ARROW
- (VTC) --- VEHICLE TRACKING CONTROL
- (CWA) --- CONCRETE WASH-OUT AREA
- (TSB) --- TEMPORARY SEDIMENT BASIN
- (IP) --- INLET PROTECTION
- (CIP) --- CULVERT INLET PROTECTION
- (CD) --- CHECK DAM
- (ECB) --- EROSION CONTROL BLANKET (INITIAL PHASE - TEMP EROSION CONTROL BLANKET SHALL REMAIN UNTIL FINAL STABILIZATION.)
- (SP) --- STOCK PILE MANAGEMENT

**NARRATIVE NOTES:**

1. LOCATION OF STOCKPILES SHALL BE DETERMINED BY CONTRACTOR. ALL STOCKPILES SHALL REMAIN WITHIN THE CONSTRUCTION BOUNDARIES AS INDICATED ON THE SITE MAP.
2. THE EXACT LOCATION FOR THE STABILIZED STAGING AREA, STORAGE EQUIPMENT AND TEMPORARY DISPOSAL AREAS SHALL BE DETERMINED IN THE FIELD BY THE CONTRACTOR. PLAN SHALL BE UPDATED BY CONTRACTOR UPON DETERMINATION OF EXACT LOCATION.
3. FINAL STABILIZATION SHALL BE COMPLETED AT THE END OF THE CONSTRUCTION ACTIVITIES. ALL AREAS DISTURBED WITHIN THE CONSTRUCTION BOUNDARY/LIMITS OF DISTURBANCE AREA SHALL BE RESEDED WITH NATIVE SEEDING.
4. EROSION CONTROL BLANKET SHALL BE USED ON SLOPES GREATER THAN 4:1.
5. REFER TO WIRE NUT FILING NO. 1 CONSTRUCTION PLANS BY M&S CIVIL CONSULTANTS FOR ADDITIONAL DETAIL.

**ADDITIONAL NOTES:**

1. THE EROSION CONTROL DELINEATED ON THIS PLAN SHALL BE REGULARLY UPDATED BY THE CONTRACTOR.
2. OFFSITE GRADING ON PLATTE AVE AND LOT 4 DUE TO NON-EXISTING DRAINAGE INFRASTRUCTURE. TO BE APPROVED BY THE CITY OF COLORADO SPRINGS. (OR EPC.)
3. LOCATIONS OF ALL NON-STRUCTURAL CONTROL MEASURES. NON-STRUCTURAL CONTROLS (LIKE STREET SWEEPING) WITHOUT A SPECIFIC LOCATION MAY BE DESCRIBED USING NOTES.
4. PROPOSED SLOPES SHALL BE 4:1 OR GREATER.
5. THE CONTRACTOR SHALL OBTAIN A COPY OF THE GEOTECHNICAL ENGINEERING REPORT AND KEEP A COPY ONSITE DURING ALL EARTHWORK OPERATIONS.
6. TO REDUCED RUNOFF EROSION, THE CONTRACTOR SHALL IMPLEMENT SURFACING ROUGHING MEASURES OVER LARGER AREAS OF THE SITE. IF WEATHER DICTATES, THE CONTRACTOR SHOULD UTILIZE WATERING NON-STRUCTURAL MEASUREMENTS TO MINIMIZE WIND EROSION. THE SITE SHOULD BE MULCHED AFTER INTERIM GRADING WITHIN 21 DAYS, AND THE SITE SHALL BE SEEDDED IF CONSTRUCTION DOESN'T COMMENCE WITHIN 60 DAYS, PER EPC STANDARDS SPECIFICATIONS.
7. NO ASPHALT / CONCRETE BATCH PLANTS WILL BE UTILIZED ONSITE.
8. REFER TO CLEARWAY, LOT 5 (WIRENUT) CONSTRUCTION PLANS FOR STORM SEWER INSTALLATION DETAILS.

**VEGETATION:**

EXISTING VEGETATION: NATIVE PRAIRIE GRASSES AND SHRUBS.

**TEMPORARY NON-STRUCTURAL PRACTICES:**

TO REDUCED RUNOFF EROSION, THE CONTRACTOR SHALL IMPLEMENT SURFACING ROUGHING MEASURES OVER LARGER AREAS OF THE SITE. IF WEATHER DICTATES, THE CONTRACTOR SHOULD UTILIZE WATERING NON-STRUCTURAL MEASUREMENTS TO MINIMIZE WIND EROSION. THE SITE SHOULD BE MULCHED AFTER INTERIM GRADING WITHIN 21 DAYS, AND THE SITE SHALL BE SEEDDED IF CONSTRUCTION DOESN'T COMMENCE WITHIN 60 DAYS, PER EL PASO COUNTY (EPC) STANDARDS.

**SEDIMENT BASIN TABLE**

SEDIMENT BASIN NO.	UPSTREAM DRAINAGE AREA AC.	BASEIN WIDTH FT.	BASEIN LENGTH FT.	ANTIC. MAX WATER HT FT.	REQ'D VOLUME C.F.	SPILLWAY LENGTH FT.	HOLE DIA. IN.	ROWS OF HOLES IN STANDPIPE
SB1	2	21	42	3	16,818	3	13/16	1
SB2	10	58	95	3	20,930	15	15/16	1

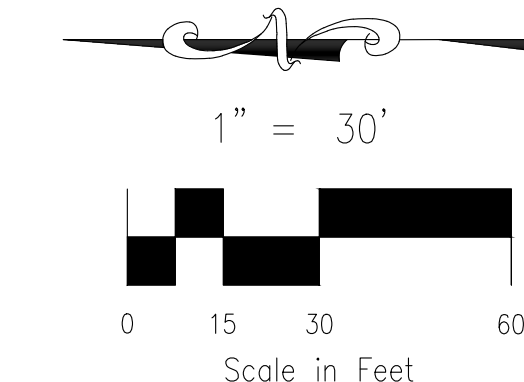

EL PASO COUNTY FILE NO. PPR-22-034

FOR LOCATING & MARKING GAS, ELECTRIC, WATER & TELEPHONE LINES

FOR BURIED UTILITY INFORMATION  
**48 HRS BEFORE YOU DIG**  
 CALL 1-800-922-1987

**CLEARWAY, LOT 5**

**INTERIM GRADING & EROSION CONTROL PLAN**

PROJECT NO. 44-042A DATE: 06/13/2023

SCALE: HORIZONTAL: 1"=30' VERTICAL: N/A

DESIGNED BY: TAU DRAWN BY: CLP CHECKED BY: DLM

212 N. WASHCATCH AVE, STE 305  
 COLORADO SPRINGS, CO 80903  
 PHONE: 719.555.5485

**CIVIL CONSULTANTS, INC.**

FOR AND ON BEHALF OF M&S CIVIL CONSULTANTS, INC.

06/14/2023

VIRGIL A. SANCHEZ, COLORADO, P.E. NO. 371160

REVISIONS:	NO.	DATE:	BY:	DESCRIPTION:

THE ENGINEER PREPARING THESE PLANS WILL NOT BE RESPONSIBLE, OR LIABLE FOR, UNAUTHORIZED CHANGES TO OR USES OF THESE PLANS. ALL CHANGES TO THE PLANS MUST BE IN WRITING AND MUST BE APPROVED BY THE PREPARE OF THESE PLANS.

**CAUTION**

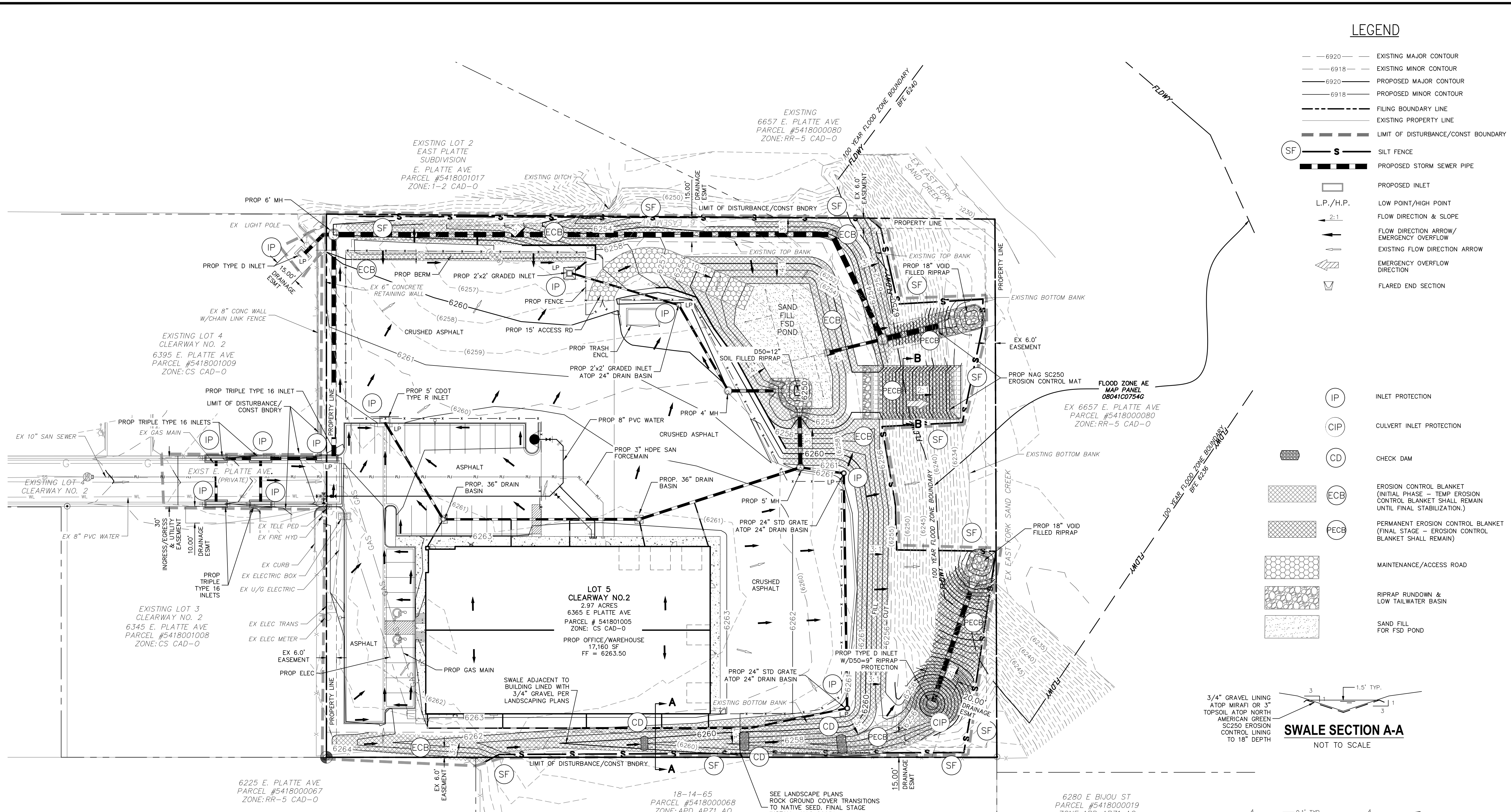

**LEGEND**

- 6920 --- EXISTING MAJOR CONTOUR
- 6918 --- EXISTING MINOR CONTOUR
- 6920 --- PROPOSED MAJOR CONTOUR
- 6918 --- PROPOSED MINOR CONTOUR
- - - - - FILING BOUNDARY LINE
- --- EXISTING PROPERTY LINE
- --- LIMIT OF DISTURBANCE/CONST BNDRY
- (SF) --- SILT FENCE
- s --- PROPOSED STORM SEWER PIPE
- [ ] --- PROPOSED INLET
- L.P./H.P. --- LOW POINT/HIGH POINT
- 2:1 --- FLOW DIRECTION & SLOPE
- > --- FLOW DIRECTION ARROW/ EMERGENCY OVERFLOW
- > --- EXISTING FLOW DIRECTION ARROW
- > --- EMERGENCY OVERFLOW DIRECTION
- > --- FLARED END SECTION
- (IP) --- INLET PROTECTION
- (CIP) --- CULVERT INLET PROTECTION
- (CD) --- CHECK DAM
- (ECB) --- EROSION CONTROL BLANKET (INITIAL PHASE - TEMP EROSION CONTROL BLANKET SHALL REMAIN UNTIL FINAL STABILIZATION.)
- (PECB) --- PERMANENT EROSION CONTROL BLANKET (FINAL STAGE - EROSION CONTROL BLANKET SHALL REMAIN)
- [ ] --- MAINTENANCE/ACCESS ROAD
- [ ] --- RIPRAP RUNDOWN & LOW TAILWATER BASIN
- [ ] --- SAND FILL FOR FSD POND

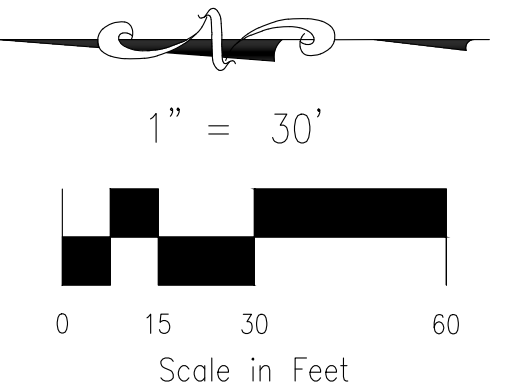
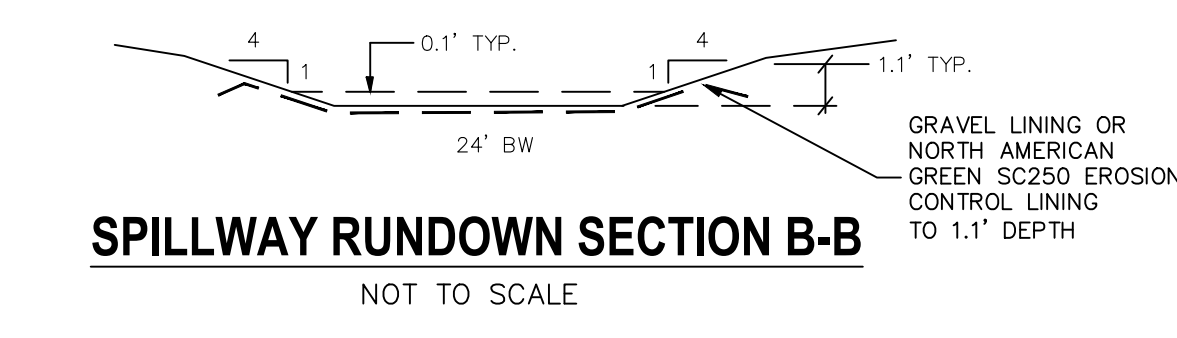
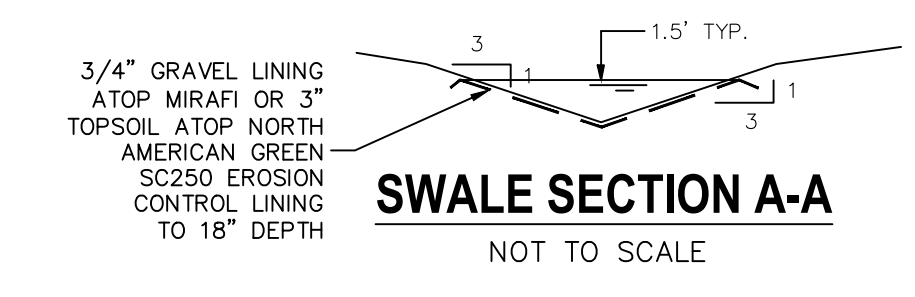

- NARRATIVE NOTES:**
1. LOCATION OF STOCKPILES SHALL BE DETERMINED BY CONTRACTOR. ALL STOCKPILES SHALL REMAIN WITHIN THE CONSTRUCTION BOUNDARIES AS INDICATED ON THE SITE MAP.
  2. THE EXACT LOCATION FOR THE STABILIZED STAGING AREA, STORAGE EQUIPMENT AND TEMPORARY DISPOSAL AREAS SHALL BE DETERMINED IN THE FIELD BY THE CONTRACTOR. PLAN SHALL BE UPDATED BY CONTRACTOR UPON DETERMINATION OF EXACT LOCATION.
  3. FINAL STABILIZATION SHALL BE COMPLETED AT THE END OF THE CONSTRUCTION ACTIVITIES. ALL AREAS DISTURBED WITHIN THE CONSTRUCTION BOUNDARY/LIMITS OF DISTURBANCE AREA SHALL BE RESEEDED WITH NATIVE SEEDING.
  4. EROSION CONTROL BLANKET SHALL BE USED ON SLOPES GREATER THAN 4:1.
  5. REFER TO WIRE NUT FILING NO. 1 CONSTRUCTION PLANS BY M&S CIVIL CONSULTANTS FOR ADDITIONAL DETAIL.

- ADDITIONAL NOTES:**
1. THE EROSION CONTROL DELINEATED ON THIS PLAN SHALL BE REGULARLY UPDATED BY THE CONTRACTOR.
  2. OFFSITE GRADING ON PLATTE AVE AND LOT 4 DUE TO NON-EXISTING DRAINAGE INFRASTRUCTURE. TO BE APPROVED BY THE CITY OF COLORADO SPRINGS. (OR EPC.)
  3. LOCATIONS OF ALL NON-STRUCTURAL CONTROL MEASURES. NONSTRUCTURAL CONTROLS (LIKE STREET SWEEPING) WITHOUT A SPECIFIC LOCATION MAY BE DESCRIBED USING NOTES.
  4. PROPOSED SLOPES SHALL BE 4:1 OR GREATER.
  5. THE CONTRACTOR SHALL OBTAIN A COPY OF THE GEOTECHNICAL ENGINEERING REPORT AND KEEP A COPY ONSITE DURING ALL EARTHWORK OPERATIONS.
  6. TO REDUCED RUNOFF EROSION, THE CONTRACTOR SHALL IMPLEMENT SURFACING ROUGHING MEASURES OVER LARGER AREAS OF THE SITE. IF WEATHER DICTATES, THE CONTRACTOR SHOULD UTILIZE WATERING NON-STRUCTURAL MEASUREMENTS TO MINIMIZE WIND EROSION. THE SITE SHOULD BE MULCHED AFTER INTERIM GRADING WITHIN 21 DAYS, AND THE SITE SHALL BE SEEDED IF CONSTRUCTION DOESN'T COMMENCE WITHIN 60 DAYS, PER EPC STANDARDS SPECIFICATIONS.
  7. NO ASPHALT / CONCRETE BATCH PLANTS WILL BE UTILIZED ONSITE.
  8. A FLOODPLAIN DEVELOPMENT PERMIT SHALL BE REQUIRED PRIOR TO GRADING WITHIN THE BOYR FLOODPLAIN
  9. LOT 4 AND LOT 5 ARE OWNED BY WIRENUT HOME SERVICES.

- VEGETATION:**  
EXISTING VEGETATION: NATIVE PRAIRIE GRASSES AND SHRUBS.  
PLEASE REFER TO FINAL LANDSCAPE PLANS BY HIGHER GROUND DESIGNS JOB NO. 1082-22
- TEMPORARY NON-STRUCTURAL PRACTICES:**  
TO REDUCED RUNOFF EROSION, THE CONTRACTOR SHALL IMPLEMENT SURFACING ROUGHING MEASURES OVER LARGER AREAS OF THE SITE. IF WEATHER DICTATES, THE CONTRACTOR SHOULD UTILIZE WATERING NON-STRUCTURAL MEASUREMENTS TO MINIMIZE WIND EROSION. THE SITE SHOULD BE MULCHED AFTER INTERIM GRADING WITHIN 21 DAYS, AND THE SITE SHALL BE SEEDED IF CONSTRUCTION DOESN'T COMMENCE WITHIN 60 DAYS, PER EL PASO COUNTY (EPC) STANDARDS.

FOR LOCATING & MARKING GAS, ELECTRIC, WATER & TELEPHONE LINES

FOR BURIED UTILITY INFORMATION 48 HRS BEFORE YOU DIG CALL 1-800-922-1987

**CLEARWAY, LOT 5**

**FINAL GRADING & EROSION CONTROL PLAN**

PROJECT NO. 44-042A DATE: 06/13/2023

SCALE: HORIZONTAL: 1"=30' VERTICAL: N/A

DESIGNED BY: TAU DRAWN BY: CLP CHECKED BY: DLM

212 N. WASHCATCH AVE, STE 305 COLORADO SPRINGS, CO 80903 PHONE: 719.955.5485

**CIVIL CONSULTANTS, INC.**

FOR AND ON BEHALF OF M&S CIVIL CONSULTANTS, INC.

VIRGIL A. SANCHEZ, COLORADO, P.E. NO. 371160

06/14/2023

REVISIONS: NO. DATE: BY: DESCRIPTION:

EL PASO COUNTY FILE NO. PPR-22-034

CAUTION

**Vehicle Tracking Control (VTC) SM-4**

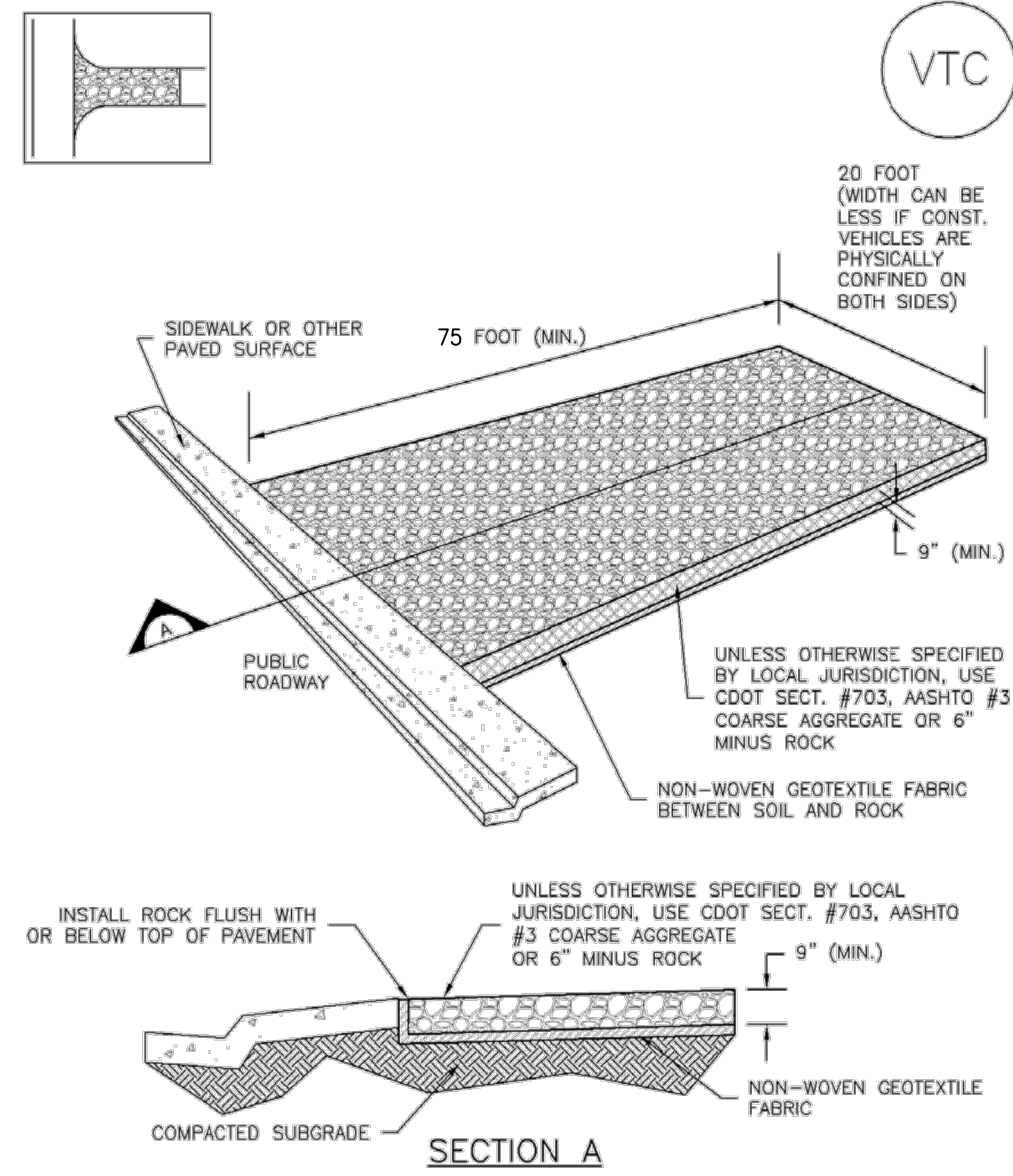

VTC-1. AGGREGATE VEHICLE TRACKING CONTROL

November 2010 Urban Drainage and Flood Control District Urban Storm Drainage Criteria Manual Volume 3 VTC-3

**SM-4 Vehicle Tracking Control (VTC)**

STABILIZED CONSTRUCTION ENTRANCE/EXIT INSTALLATION NOTES

- SEE PLAN VIEW FOR:
  - LOCATION OF CONSTRUCTION ENTRANCE(S)/EXIT(S).
  - TYPE OF CONSTRUCTION ENTRANCE(S)/EXIT(S) (WITH/WITHOUT WHEEL WASH, CONSTRUCTION MAT OR TRM).
- CONSTRUCTION MAT OR TRM STABILIZED CONSTRUCTION ENTRANCES ARE ONLY TO BE USED ON SHORT DURATION PROJECTS (TYPICALLY RANGING FROM A WEEK TO A MONTH) WHERE THERE WILL BE LIMITED VEHICULAR ACCESS.
- A STABILIZED CONSTRUCTION ENTRANCE/EXIT SHALL BE LOCATED AT ALL ACCESS POINTS WHERE VEHICLES ACCESS THE CONSTRUCTION SITE FROM PAVED RIGHT-OF-WAYS.
- STABILIZED CONSTRUCTION ENTRANCE/EXIT SHALL BE INSTALLED PRIOR TO ANY LAND DISTURBING ACTIVITIES.
- A NON-WOVEN GEOTEXTILE FABRIC SHALL BE PLACED UNDER THE STABILIZED CONSTRUCTION ENTRANCE/EXIT PRIOR TO THE PLACEMENT OF ROCK.
- UNLESS OTHERWISE SPECIFIED BY LOCAL JURISDICTION, ROCK SHALL CONSIST OF DOT SECT. #703, AASHTO #3 COARSE AGGREGATE OR 6" (MINUS) ROCK.

STABILIZED CONSTRUCTION ENTRANCE/EXIT MAINTENANCE NOTES

- INSPECT BMPs EACH WORKDAY, AND MAINTAIN THEM IN EFFECTIVE OPERATING CONDITION. MAINTENANCE OF BMPs SHOULD BE PROACTIVE, NOT REACTIVE. INSPECT BMPs AS SOON AS POSSIBLE (AND ALWAYS WITHIN 24 HOURS) FOLLOWING A STORM THAT CAUSES SURFACE EROSION, AND PERFORM NECESSARY MAINTENANCE.
- FREQUENT OBSERVATIONS AND MAINTENANCE ARE NECESSARY TO MAINTAIN BMPs IN EFFECTIVE OPERATING CONDITION. INSPECTIONS AND CORRECTIVE MEASURES SHOULD BE DOCUMENTED THOROUGHLY.
- WHERE BMPs HAVE FAILED, REPAIR OR REPLACEMENT SHOULD BE INITIATED UPON DISCOVERY OF THE FAILURE.
- ROCK SHALL BE REAPPLIED OR REGRADED AS NECESSARY TO THE STABILIZED ENTRANCE/EXIT TO MAINTAIN A CONSISTENT DEPTH.
- SEDIMENT TRACKED ONTO PAVED ROADS IS TO BE REMOVED THROUGHOUT THE DAY AND AT THE END OF THE DAY BY SHOVELING OR SWEEPING. SEDIMENT MAY NOT BE WASHED DOWN STORM SEWER DRAINS.

NOTE: MANY JURISDICTIONS HAVE BMP DETAILS THAT VARY FROM UDFCD STANDARD DETAILS. CONSULT WITH LOCAL JURISDICTIONS AS TO WHICH DETAIL SHOULD BE USED WHEN DIFFERENCES ARE NOTED.

(DETAILS ADAPTED FROM CITY OF BROOMFIELD, COLORADO, NOT AVAILABLE IN AUTOCAD)

VTC-6 Urban Drainage and Flood Control District Urban Storm Drainage Criteria Manual Volume 3 November 2010

**SC-3 Straw Bale Barrier (SBB)**

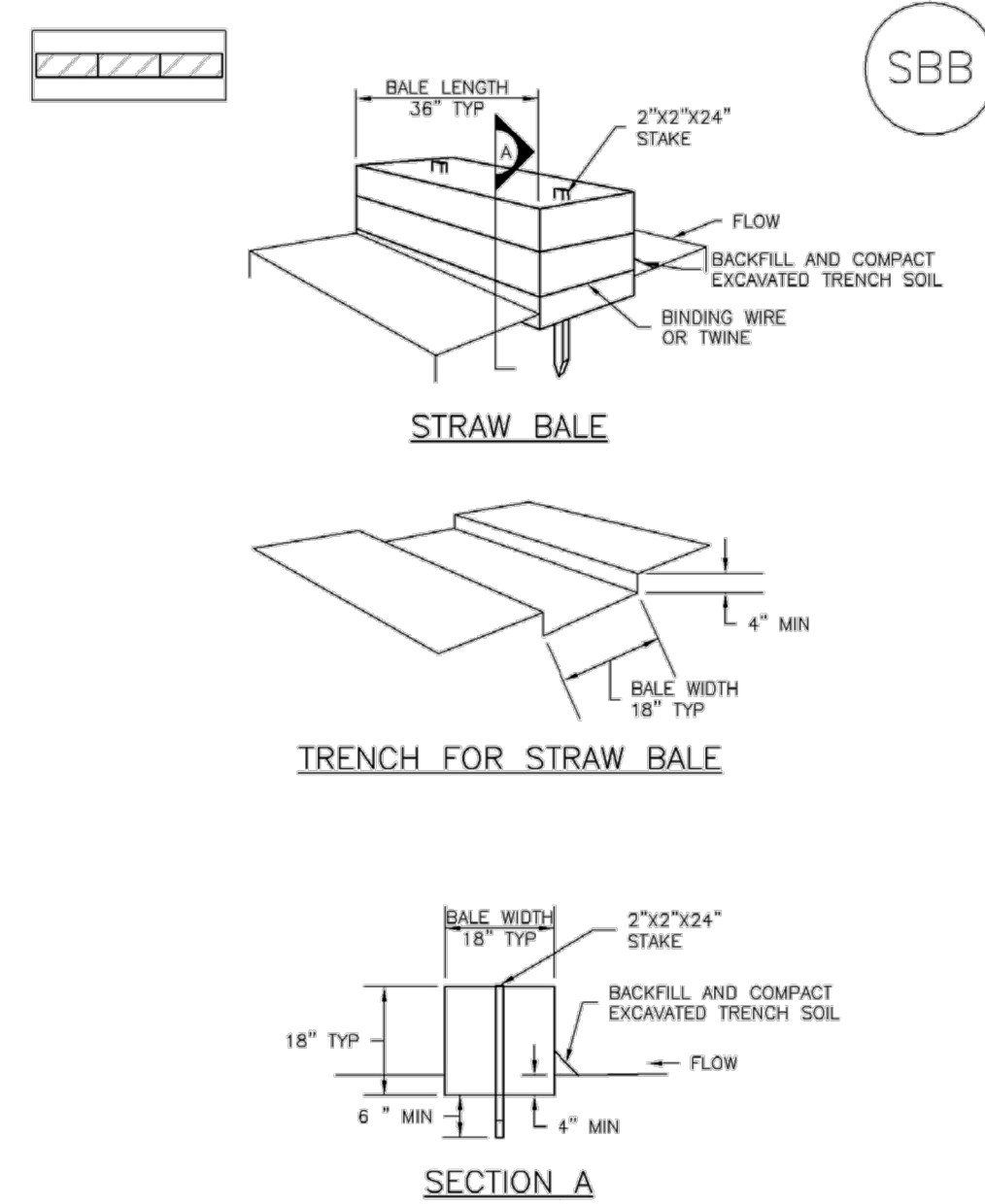

SBB-1. STRAW BALE

SBB-2 Urban Drainage and Flood Control District Urban Storm Drainage Criteria Manual Volume 3 November 2010

**Straw Bale Barrier (SBB) SC-3**

STRAW BALE INSTALLATION NOTES

- SEE PLAN VIEW FOR:
  - LOCATION(S) OF STRAW BALES.
- STRAW BALES SHALL CONSIST OF CERTIFIED WEED FREE STRAW OR HAY. LOCAL JURISDICTIONS MAY REQUIRE PROOF THAT BALES ARE WEED FREE.
- STRAW BALES SHALL CONSIST OF APPROXIMATELY 5 CUBIC FEET OF STRAW OR HAY AND WEIGH NOT LESS THAN 35 POUNDS.
- WHEN STRAW BALES ARE USED IN SERIES AS A BARRIER, THE END OF EACH BALE SHALL BE TIGHTLY ABUTTING ONE ANOTHER.
- STRAW BALE DIMENSIONS SHALL BE APPROXIMATELY 36"x18"x18".
- A UNIFORM ANCHOR TRENCH SHALL BE EXCAVATED TO A DEPTH OF 4". STRAW BALES SHALL BE PLACED SO THAT BINDING TWINE IS ENCOMPASSING THE VERTICAL SIDES OF THE BALE(S). ALL EXCAVATED SOIL SHALL BE PLACED ON THE UPHILL SIDE OF THE STRAW BALE(S) AND COMPACTED.
- TWO (2) WOODEN STAKES SHALL BE USED TO HOLD EACH BALE IN PLACE. WOODEN STAKES SHALL BE 2"x2"x24". WOODEN STAKES SHALL BE DRIVEN 6" INTO THE GROUND.

STRAW BALE MAINTENANCE NOTES

- INSPECT BMPs EACH WORKDAY, AND MAINTAIN THEM IN EFFECTIVE OPERATING CONDITION. MAINTENANCE OF BMPs SHOULD BE PROACTIVE, NOT REACTIVE. INSPECT BMPs AS SOON AS POSSIBLE (AND ALWAYS WITHIN 24 HOURS) FOLLOWING A STORM THAT CAUSES SURFACE EROSION, AND PERFORM NECESSARY MAINTENANCE.
- FREQUENT OBSERVATIONS AND MAINTENANCE ARE NECESSARY TO MAINTAIN BMPs IN EFFECTIVE OPERATING CONDITION. INSPECTIONS AND CORRECTIVE MEASURES SHOULD BE DOCUMENTED THOROUGHLY.
- WHERE BMPs HAVE FAILED, REPAIR OR REPLACEMENT SHOULD BE INITIATED UPON DISCOVERY OF THE FAILURE.
- STRAW BALES SHALL BE REPLACED IF THEY BECOME HEAVILY SOILED, ROTTEN, OR DAMAGED BEYOND REPAIR.
- SEDIMENT ACCUMULATED UPSTREAM OF STRAW BALE BARRIER SHALL BE REMOVED AS NEEDED TO MAINTAIN FUNCTIONALITY OF THE BMP. TYPICALLY WHEN DEPTH OF ACCUMULATED SEDIMENTS IS APPROXIMATELY 1/2 OF THE HEIGHT OF THE STRAW BALE BARRIER.
- STRAW BALES ARE TO REMAIN IN PLACE UNTIL THE UPSTREAM DISTURBED AREA IS STABILIZED AND APPROVED BY THE LOCAL JURISDICTION.
- WHEN STRAW BALES ARE REMOVED, ALL DISTURBED AREAS SHALL BE COVERED WITH TOPSOIL, SEEDED AND MULCHED OR OTHERWISE STABILIZED AS APPROVED BY LOCAL JURISDICTION.

(DETAILS ADAPTED FROM TOWN OF PARKER, COLORADO, NOT AVAILABLE IN AUTOCAD)

NOTE: MANY JURISDICTIONS HAVE BMP DETAILS THAT VARY FROM UDFCD STANDARD DETAILS. CONSULT WITH LOCAL JURISDICTIONS AS TO WHICH DETAIL SHOULD BE USED WHEN DIFFERENCES ARE NOTED.

November 2010 Urban Drainage and Flood Control District Urban Storm Drainage Criteria Manual Volume 3 SBB-3

**Stockpile Management (SP) MM-2**

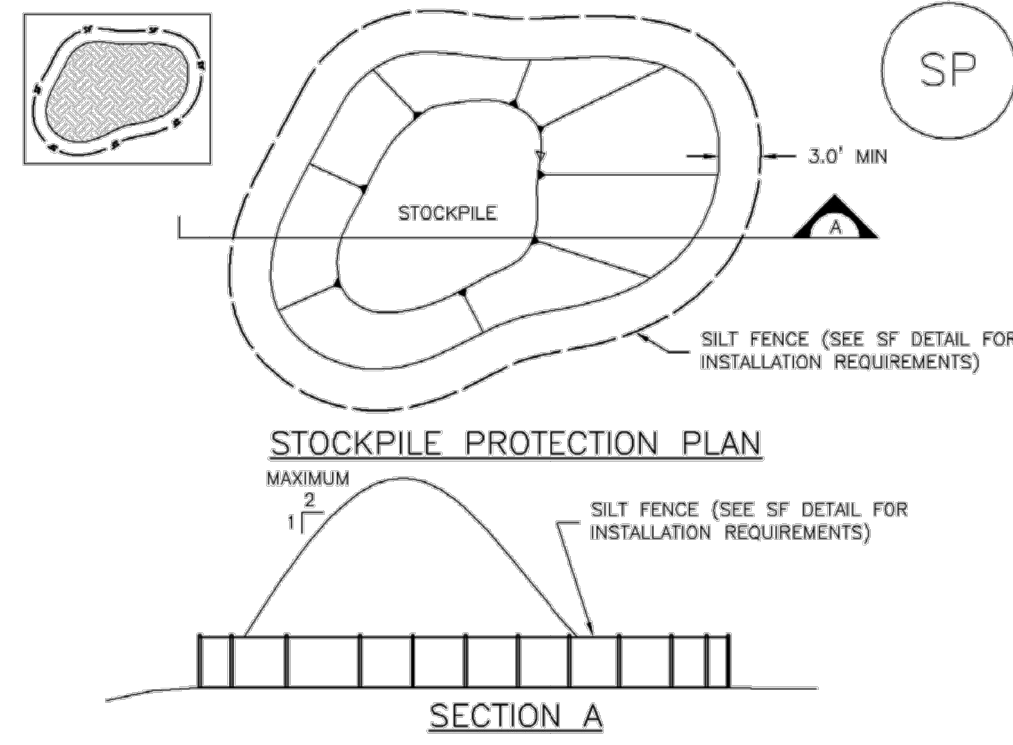

SP-1. STOCKPILE PROTECTION

STOCKPILE PROTECTION INSTALLATION NOTES

- SEE PLAN VIEW FOR:
  - LOCATION OF STOCKPILES
  - TYPE OF STOCKPILE PROTECTION.
- INSTALL PERIMETER CONTROLS IN ACCORDANCE WITH THEIR RESPECTIVE DESIGN DETAILS. SILT FENCE IS SHOWN IN THE STOCKPILE PROTECTION DETAILS; HOWEVER, OTHER TYPES OF PERIMETER CONTROLS INCLUDING SEDIMENT CONTROL LOGS OR ROCK SOCKS MAY BE SUITABLE IN SOME CIRCUMSTANCES. CONSIDERATIONS FOR DETERMINING THE APPROPRIATE TYPE OF PERIMETER CONTROL FOR A STOCKPILE INCLUDE WHETHER THE STOCKPILE IS LOCATED ON A PERVIOUS OR IMPERVIOUS SURFACE, THE RELATIVE HEIGHTS OF THE PERIMETER CONTROL AND STOCKPILE, THE ABILITY OF THE PERIMETER CONTROL TO CONTAIN THE STOCKPILE WITHOUT FAILING IN THE EVENT THAT MATERIAL FROM THE STOCKPILE SHIFTS OR SLUMPS AGAINST THE PERIMETER, AND OTHER FACTORS.
- STABILIZE THE STOCKPILE SURFACE WITH SURFACE ROUGHENING, TEMPORARY SEEDING AND MULCHING, EROSION CONTROL BLANKETS, OR SOIL BINDERS. SOILS STOCKPILED FOR AN EXTENDED PERIOD (TYPICALLY FOR MORE THAN 60 DAYS) SHOULD BE SEEDED AND MULCHED WITH A TEMPORARY GRASS COVER ONCE THE STOCKPILE IS PLACED (TYPICALLY WITHIN 14 DAYS). USE OF MULCH ONLY OR A SOIL BINDER IS ACCEPTABLE IF THE STOCKPILE WILL BE IN PLACE FOR A MORE LIMITED TIME PERIOD (TYPICALLY 30-60 DAYS).
- FOR TEMPORARY STOCKPILES ON THE INTERIOR PORTION OF A CONSTRUCTION SITE, WHERE OTHER DOWNGRADE CONTROLS, INCLUDING PERIMETER CONTROL, ARE IN PLACE, STOCKPILE PERIMETER CONTROLS MAY NOT BE REQUIRED.

November 2010 Urban Drainage and Flood Control District Urban Storm Drainage Criteria Manual Volume 3 SP-3

**Sediment Basin (SB) SC-7**

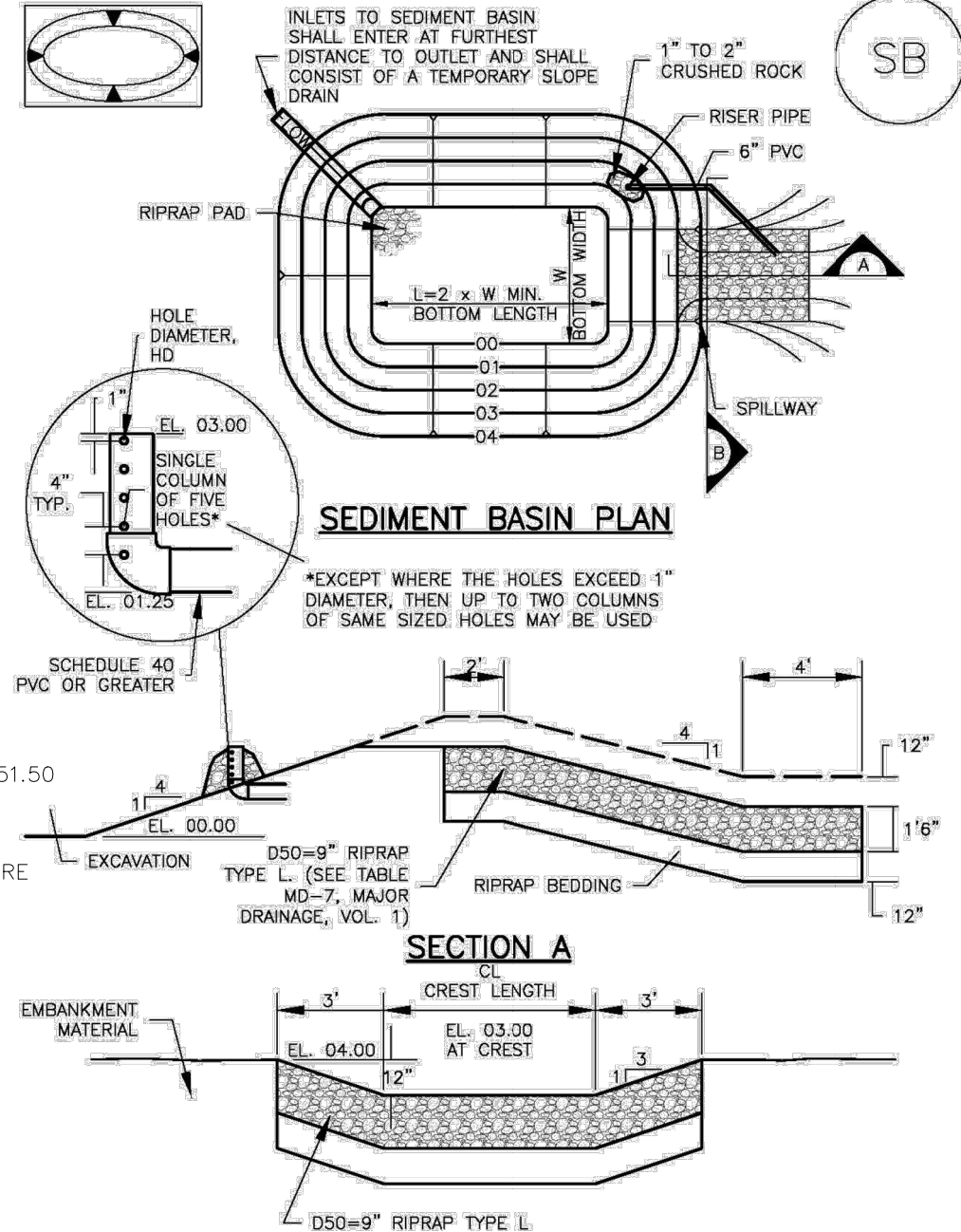

- NOTES:  
ELEV 0.00 = 6251.50  
TIE 6" PVC PIPE INTO OUTLET STRUCTURE 18" STORM SEWER OUTFALL PIPE REFER TO CONSTRUCTION DRAWINGS FOR STORM SEWER CONSTRUCTION DETAILS

Upstream Drainage Area (rounded to nearest acre), (ac)	Basin Bottom Width (W), (ft)	Spillway Crest Length (CL), (ft)	Hole Diameter (HD), (in)
1	12 1/2	2	3/8
2	21	3	1/2
3	28	5	5/8
4	33 1/2	6	3/4
5	38 1/2	8	7/8
6	43	9	1 1/8
7	47 1/2	11	1 1/4
8	51	12	1 1/2
9	55 1/2	13	1 3/8
10	58 1/2	15	1 5/8
11	61	16	1 3/4
12	64	18	1 7/8
13	67 1/2	19	1 7/8
14	70 1/2	21	1 7/8
15	73 1/2	22	1 7/8

SEDIMENT BASIN INSTALLATION NOTES

- SEE PLAN VIEW FOR:
  - LOCATION OF SEDIMENT BASIN.
  - TYPE OF BASIN (STANDARD BASIN OR NONSTANDARD BASIN).
  - FOR STANDARD BASIN, BOTTOM WIDTH W, CREST LENGTH CL, AND HOLE DIAMETER, HD.
  - FOR NONSTANDARD BASIN, SEE CONSTRUCTION DRAWINGS FOR DESIGN OF BASIN INCLUDING RISER HEIGHT H, NUMBER OF COLUMNS N, HOLE DIAMETER HD AND PIPE DIAMETER D.
- FOR STANDARD BASIN, BOTTOM DIMENSION MAY BE MODIFIED AS LONG AS BOTTOM AREA IS NOT REDUCED.
- SEDIMENT BASINS SHALL BE INSTALLED PRIOR TO ANY OTHER LAND-DISTURBING ACTIVITY THAT RELIES ON ON BASINS AS A STORMWATER CONTROL.
- EMBANKMENT MATERIAL SHALL CONSIST OF SOIL FREE OF DEBRIS, ORGANIC MATERIAL, AND ROCKS OR CONCRETE GREATER THAN 3 INCHES AND SHALL HAVE A MINIMUM OF 15 PERCENT BY WEIGHT PASSING THE NO. 200 SIEVE.
- EMBANKMENT MATERIAL SHALL BE COMPACTED TO AT LEAST 95 PERCENT OF MAXIMUM DENSITY IN ACCORDANCE WITH ASTM D698.
- PIPE SCH 40 OR GREATER SHALL BE USED.
- THE DETAILS SHOWN ON THESE SHEETS PERTAIN TO STANDARD SEDIMENT BASIN(S) FOR DRAINAGE AREAS LESS THAN 15 ACRES. SEE CONSTRUCTION DRAWINGS FOR EMBANKMENT, STORAGE VOLUME, SPILLWAY, OUTLET, AND OUTLET PROTECTION DETAILS FOR ANY SEDIMENT BASIN(S) THAT HAVE BEEN INDIVIDUALLY DESIGNED FOR DRAINAGE AREAS LARGER THAN 15 ACRES.

SB-6 Urban Drainage and Flood Control District Urban Storm Drainage Criteria Manual Volume 3 August 2013

**Sediment Basin (SB) SC-7**

SEDIMENT BASIN MAINTENANCE NOTES

- INSPECT BMPs EACH WORKDAY, AND MAINTAIN THEM IN EFFECTIVE OPERATING CONDITION. MAINTENANCE OF BMPs SHOULD BE PROACTIVE, NOT REACTIVE. INSPECT BMPs AS SOON AS POSSIBLE (AND ALWAYS WITHIN 24 HOURS) FOLLOWING A STORM THAT CAUSES SURFACE EROSION, AND PERFORM NECESSARY MAINTENANCE.
- FREQUENT OBSERVATIONS AND MAINTENANCE ARE NECESSARY TO MAINTAIN BMPs IN EFFECTIVE OPERATING CONDITION. INSPECTIONS AND CORRECTIVE MEASURES SHOULD BE DOCUMENTED THOROUGHLY.
- WHERE BMPs HAVE FAILED, REPAIR OR REPLACEMENT SHOULD BE INITIATED UPON DISCOVERY OF THE FAILURE.
- SEDIMENT ACCUMULATED IN BASIN SHALL BE REMOVED AS NEEDED TO MAINTAIN BMP EFFECTIVENESS. TYPICALLY WHEN SEDIMENT DEPTH REACHES ONE FOOT (I.E., TWO FEET BELOW THE SPILLWAY CREST).
- SEDIMENT BASINS ARE TO REMAIN IN PLACE UNTIL THE UPSTREAM DISTURBED AREA IS STABILIZED AND GRASS COVER IS ACCEPTED BY THE LOCAL JURISDICTION.
- WHEN SEDIMENT BASINS ARE REMOVED, ALL DISTURBED AREAS SHALL BE COVERED WITH TOPSOIL, SEEDED AND MULCHED OR OTHERWISE STABILIZED AS APPROVED BY LOCAL JURISDICTION.

(DETAILS ADAPTED FROM DOUGLAS COUNTY, COLORADO)

NOTE: MANY JURISDICTIONS HAVE BMP DETAILS THAT VARY FROM UDFCD STANDARD DETAILS. CONSULT WITH LOCAL JURISDICTIONS AS TO WHICH DETAIL SHOULD BE USED WHEN DIFFERENCES ARE NOTED.

August 2013 Urban Drainage and Flood Control District Urban Storm Drainage Criteria Manual Volume 3 SB-7

CLEARWAY, LOT 5

GRADING & EROSION CONTROL DETAILS

PROJECT NO. 44-042A  
SCALE: HORIZONTAL: N/A VERTICAL: 1"=5'  
DATE: 06/13/2023  
DESIGNED BY: TAU  
DRAWN BY: CLP  
CHECKED BY: DLM  
SHEET 7 OF 11  
GR07

212 N. WAHATCH AVE., STE 305  
COLORADO SPRINGS, CO 80903  
PHONE: 719.555.5465

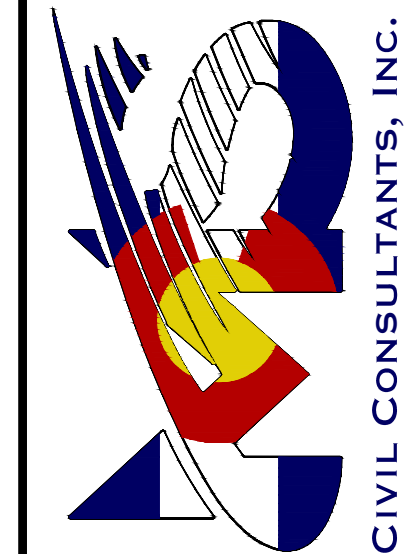

FOR AND ON BEHALF OF  
MKS CIVIL CONSULTANTS, INC.



REV. NO.	DATE	BY	DESCRIPTION	APPROVED BY	DATE

THE ENGINEER PREPARING THESE PLANS WILL NOT BE RESPONSIBLE, OR LIABLE FOR, UNAUTHORIZED CHANGES TO OR USES OF THESE PLANS. ALL CHANGES TO THE PLANS MUST BE IN WRITING AND MUST BE APPROVED BY THE PREPARED BY THESE PLANS.

CAUTION





**SC-6 Inlet Protection (IP)**

- IP-3. Rock Sock Inlet Protection for Sump/Area Inlet
- IP-4. Silt Fence Inlet Protection for Sump/Area Inlet
- IP-5. Over-excavation Inlet Protection
- IP-6. Straw Bale Inlet Protection for Sump/Area Inlet
- CIP-1. Culvert Inlet Protection

Proprietary inlet protection devices should be installed in accordance with manufacturer specifications. More information is provided below on selecting inlet protection for sump and on-grade locations.

**Inlets Located in a Sump**

When applying inlet protection in sump conditions, it is important that the inlet continue to function during larger runoff events. For curb inlets, the maximum height of the protective barrier should be lower than the top of the curb opening to allow overflow into the inlet during larger storms without excessive localized flooding. If the inlet protection height is greater than the curb elevation, particularly if the filter becomes clogged with sediment, runoff will not enter the inlet and may bypass it, possibly causing localized flooding, public safety issues, and downstream erosion and damage from bypassed flows.

Area inlets located in a sump setting can be protected through the use of silt fence, concrete block and rock socks (on paved surfaces), sediment control logs/straw wattles embedded in the adjacent soil and stacked around the area inlet (on pervious surfaces), over-excavation around the inlet, and proprietary products providing equivalent functions.

**Inlets Located on a Slope**

For curb and gutter inlets on paved sloping streets, block and rock sock inlet protection is recommended in conjunction with curb socks in the gutter leading to the inlet. For inlets located along unpaved roads, also see the Check Dam Fact Sheet.

**Maintenance and Removal**

- Inspect inlet protection frequently. Inspection and maintenance guidance includes:
  - Inspect for tears that can result in sediment directly entering the inlet, as well as result in the contents of the BMP (e.g., gravel) washing into the inlet.
  - Check for improper installation resulting in untreated flows bypassing the BMP and directly entering the inlet or bypassing to an unprotected downstream inlet. For example, silt fence that has not been properly trenched around the inlet can result in flows under the silt fence and directly into the inlet.
  - Look for displaced BMPs that are no longer protecting the inlet. Displacement may occur following larger storm events that wash away or reposition the inlet protection. Traffic or equipment may also crush or displace the BMP.
  - Monitor sediment accumulation upgradient of the inlet protection.

IP-2 Urban Drainage and Flood Control District Urban Storm Drainage Criteria Manual Volume 3 August 2013

**Inlet Protection (IP) SC-6**

- Remove sediment accumulation from the area upstream of the inlet protection, as needed to maintain BMP effectiveness, typically when it reaches no more than half the storage capacity of the inlet protection. For silt fence, remove sediment when it accumulates to a depth of no more than 6 inches. Remove sediment accumulation from the area upstream of the inlet protection as needed to maintain the functionality of the BMP.
- Proprietary inlet protection devices should be inspected and maintained in accordance with manufacturer specifications. If proprietary inlet insert devices are used, sediment should be removed in a timely manner to prevent devices from breaking and spilling sediment into the storm drain.

Inlet protection must be removed and properly disposed of when the drainage area for the inlet has reached final stabilization.

August 2013 Urban Drainage and Flood Control District Urban Storm Drainage Criteria Manual Volume 3 IP-3

**SC-6 Inlet Protection (IP)**

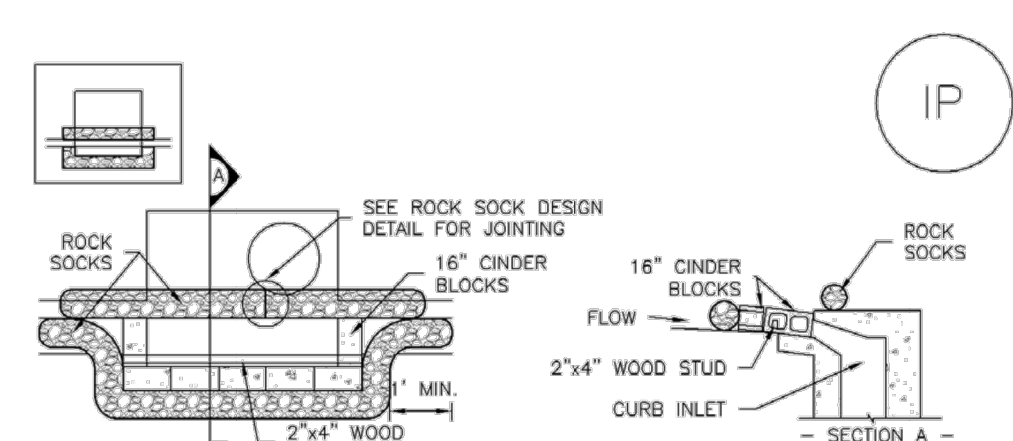

**IP-1. BLOCK AND ROCK SOCK SUMP OR ON GRADE INLET PROTECTION**

- BLOCK AND CURB SOCK INLET PROTECTION INSTALLATION NOTES**
- SEE ROCK SOCK DESIGN DETAIL FOR INSTALLATION REQUIREMENTS.
  - CONCRETE "CINDER" BLOCKS SHALL BE LAID ON THEIR SIDES AROUND THE INLET IN A SINGLE ROW, ABUTTING ONE ANOTHER WITH THE OPEN END FACING AWAY FROM THE CURB.
  - GRAVEL BAGS SHALL BE PLACED AROUND CONCRETE BLOCKS, CLOSELY ABUTTING ONE ANOTHER AND JOINED TOGETHER IN ACCORDANCE WITH ROCK SOCK DESIGN DETAIL.

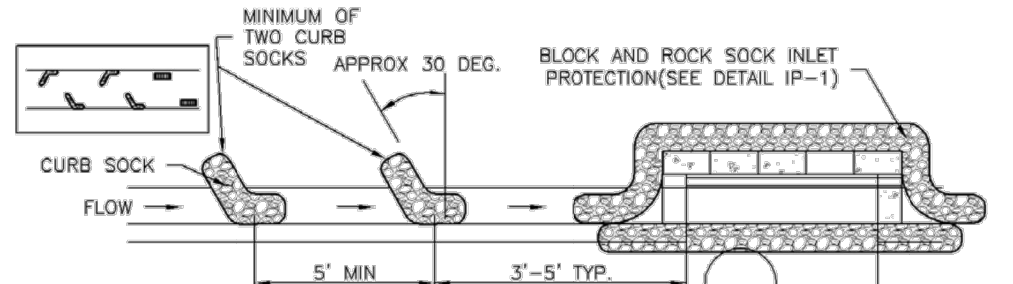

**IP-2. CURB ROCK SOCKS UPSTREAM OF INLET PROTECTION**

- CURB ROCK SOCK INLET PROTECTION INSTALLATION NOTES**
- SEE ROCK SOCK DESIGN DETAIL INSTALLATION REQUIREMENTS.
  - PLACEMENT OF THE SOCK SHALL BE APPROXIMATELY 30 DEGREES FROM PERPENDICULAR IN THE OPPOSITE DIRECTION OF FLOW.
  - SOCKS ARE TO BE FLUSH WITH THE CURB AND SPACED A MINIMUM OF 5 FEET APART.
  - AT LEAST TWO CURB SOCKS IN SERIES ARE REQUIRED UPSTREAM OF ON-GRADE INLETS.

IP-4 Urban Drainage and Flood Control District Urban Storm Drainage Criteria Manual Volume 3 August 2013

**SC-6 Inlet Protection (IP)**

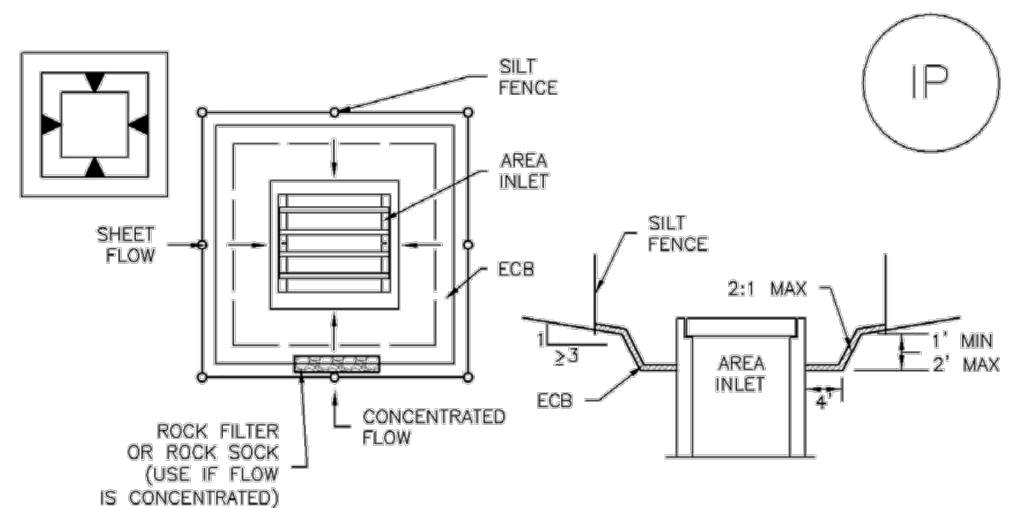

**IP-5. OVEREXCAVATION INLET PROTECTION**

- OVEREXCAVATION INLET PROTECTION INSTALLATION NOTES**
- THIS FORM OF INLET PROTECTION IS PRIMARILY APPLICABLE FOR SITES THAT HAVE NOT YET REACHED FINAL GRADE AND SHOULD BE USED ONLY FOR INLETS WITH A RELATIVELY SMALL CONTRIBUTING DRAINAGE AREA.
  - WHEN USING FOR CONCENTRATED FLOWS, SHAPE BASIN IN 2:1 RATIO WITH LENGTH ORIENTED TOWARDS DIRECTION OF FLOW.
  - SEDIMENT MUST BE PERIODICALLY REMOVED FROM THE OVEREXCAVATED AREA.

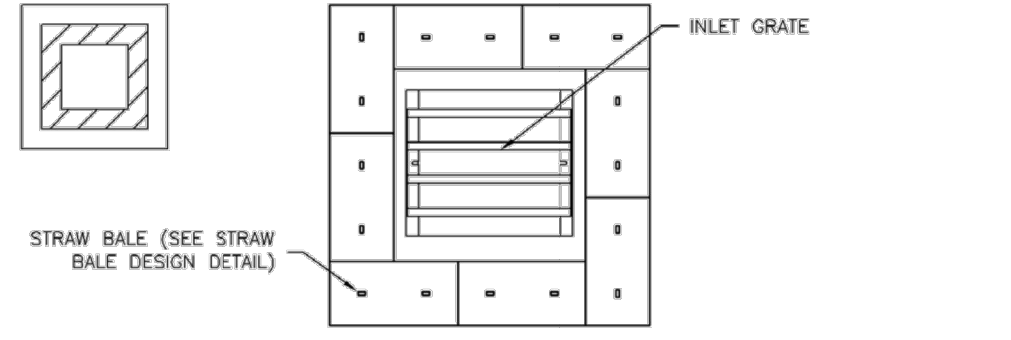

**IP-6. STRAW BALE FOR SUMP INLET PROTECTION**

- STRAW BALE BARRIER INLET PROTECTION INSTALLATION NOTES**
- SEE STRAW BALE DESIGN DETAIL FOR INSTALLATION REQUIREMENTS.
  - BALES SHALL BE PLACED IN A SINGLE ROW AROUND THE INLET WITH ENDS OF BALES TIGHTLY ABUTTING ONE ANOTHER.

IP-6 Urban Drainage and Flood Control District Urban Storm Drainage Criteria Manual Volume 3 August 2013

**Inlet Protection (IP) SC-6**

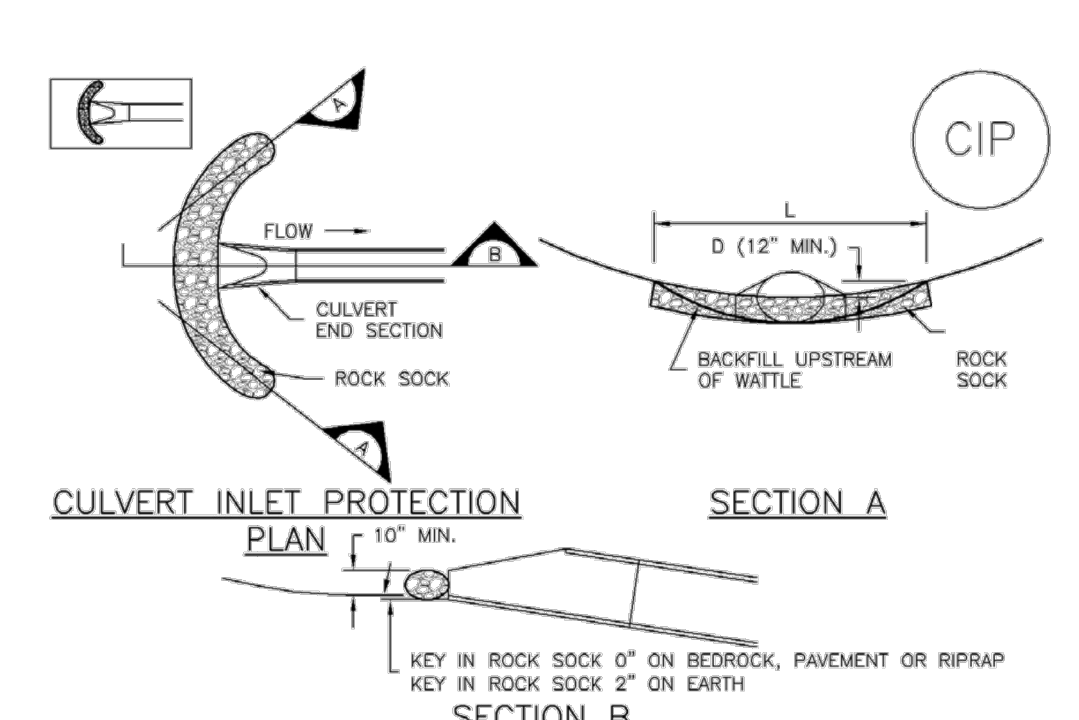

**CIP-1. CULVERT INLET PROTECTION**

- CULVERT INLET PROTECTION INSTALLATION NOTES**
- SEE PLAN VIEW FOR -LOCATION OF CULVERT INLET PROTECTION.
  - SEE ROCK SOCK DESIGN DETAIL FOR ROCK GRADATION REQUIREMENTS AND JOINTING DETAIL.

- CULVERT INLET PROTECTION MAINTENANCE NOTES**
- INSPECT BMPs EACH WORKDAY, AND MAINTAIN THEM IN EFFECTIVE OPERATING CONDITION. MAINTENANCE OF BMPs SHOULD BE PROACTIVE, NOT REACTIVE. INSPECT BMPs AS SOON AS POSSIBLE (AND ALWAYS WITHIN 24 HOURS) FOLLOWING A STORM THAT CAUSES SURFACE EROSION, AND PERFORM NECESSARY MAINTENANCE.
  - FREQUENT OBSERVATIONS AND MAINTENANCE ARE NECESSARY TO MAINTAIN BMPs IN EFFECTIVE OPERATING CONDITION. INSPECTIONS AND CORRECTIVE MEASURES SHOULD BE DOCUMENTED THOROUGHLY.
  - WHERE BMPs HAVE FAILED, REPAIR OR REPLACEMENT SHOULD BE INITIATED UPON DISCOVERY OF THE FAILURE.
  - SEDIMENT ACCUMULATED UPSTREAM OF THE CULVERT SHALL BE REMOVED WHEN THE SEDIMENT DEPTH IS 1/2 THE HEIGHT OF THE ROCK SOCK.
  - CULVERT INLET PROTECTION SHALL REMAIN IN PLACE UNTIL THE UPSTREAM DISTURBED AREA IS PERMANENTLY STABILIZED AND APPROVED BY THE LOCAL JURISDICTION.

(DETAILS ADAPTED FROM AURORA, COLORADO, NOT AVAILABLE IN AUTOCAD)  
NOTE: MANY JURISDICTIONS HAVE BMP DETAILS THAT VARY FROM UDFCD STANDARD DETAILS. CONSULT WITH LOCAL JURISDICTIONS AS TO WHICH DETAIL SHOULD BE USED WHEN DIFFERENCES ARE NOTED.

August 2013 Urban Drainage and Flood Control District Urban Storm Drainage Criteria Manual Volume 3 IP-7

**SC-6 Inlet Protection (IP)**

**GENERAL INLET PROTECTION INSTALLATION NOTES**

- SEE PLAN VIEW FOR:
  - LOCATION OF INLET PROTECTION.
  - TYPE OF INLET PROTECTION (IP.1, IP.2, IP.3, IP.4, IP.5, IP.6)
- INLET PROTECTION SHALL BE INSTALLED PROMPTLY AFTER INLET CONSTRUCTION OR PAVING IS COMPLETE (TYPICALLY WITHIN 48 HOURS). IF A RAINFALL/RUNOFF EVENT IS FORECAST, INSTALL INLET PROTECTION PRIOR TO ONSET OF EVENT.
- MANY JURISDICTIONS HAVE BMP DETAILS THAT VARY FROM UDFCD STANDARD DETAILS. CONSULT WITH LOCAL JURISDICTIONS AS TO WHICH DETAIL SHOULD BE USED WHEN DIFFERENCES ARE NOTED.

**INLET PROTECTION MAINTENANCE NOTES**

- INSPECT BMPs EACH WORKDAY, AND MAINTAIN THEM IN EFFECTIVE OPERATING CONDITION. MAINTENANCE OF BMPs SHOULD BE PROACTIVE, NOT REACTIVE. INSPECT BMPs AS SOON AS POSSIBLE (AND ALWAYS WITHIN 24 HOURS) FOLLOWING A STORM THAT CAUSES SURFACE EROSION, AND PERFORM NECESSARY MAINTENANCE.
- FREQUENT OBSERVATIONS AND MAINTENANCE ARE NECESSARY TO MAINTAIN BMPs IN EFFECTIVE OPERATING CONDITION. INSPECTIONS AND CORRECTIVE MEASURES SHOULD BE DOCUMENTED THOROUGHLY.
- WHERE BMPs HAVE FAILED, REPAIR OR REPLACEMENT SHOULD BE INITIATED UPON DISCOVERY OF THE FAILURE.
- SEDIMENT ACCUMULATED UPSTREAM OF INLET PROTECTION SHALL BE REMOVED AS NECESSARY TO MAINTAIN BMP EFFECTIVENESS, TYPICALLY WHEN STORAGE VOLUME REACHES 50% OF CAPACITY, A DEPTH OF 6" WHEN SILT FENCE IS USED, OR 1/4 OF THE HEIGHT FOR STRAW BALES.
- INLET PROTECTION IS TO REMAIN IN PLACE UNTIL THE UPSTREAM DISTURBED AREA IS PERMANENTLY STABILIZED, UNLESS THE LOCAL JURISDICTION APPROVES EARLIER REMOVAL OF INLET PROTECTION IN STREETS.
- WHEN INLET PROTECTION AT AREA INLETS IS REMOVED, THE DISTURBED AREA SHALL BE COVERED WITH TOP SOIL, SEEDED AND MULCHED, OR OTHERWISE STABILIZED IN A MANNER APPROVED BY THE LOCAL JURISDICTION.

(DETAIL ADAPTED FROM TOWN OF PARKER, COLORADO AND CITY OF AURORA, COLORADO, NOT AVAILABLE IN AUTOCAD)  
NOTE: MANY JURISDICTIONS HAVE BMP DETAILS THAT VARY FROM UDFCD STANDARD DETAILS. CONSULT WITH LOCAL JURISDICTIONS AS TO WHICH DETAIL SHOULD BE USED WHEN DIFFERENCES ARE NOTED.  
NOTE: THE DETAILS INCLUDED WITH THIS FACT SHEET SHOW COMMONLY USED, CONVENTIONAL METHODS OF INLET PROTECTION IN THE DENVER METROPOLITAN AREA. THERE ARE MANY PROPRIETARY INLET PROTECTION METHODS ON THE MARKET. UDFCD NEITHER ENDORSES NOR DISCOURAGES USE OF PROPRIETARY INLET PROTECTION; HOWEVER, IN THE EVENT PROPRIETARY METHODS ARE USED, THE APPROPRIATE DETAIL FROM THE MANUFACTURER MUST BE INCLUDED IN THE SWAMP AND THE BMP MUST BE INSTALLED AND MAINTAINED AS SHOWN IN THE MANUFACTURER'S DETAILS.  
NOTE: SOME MUNICIPALITIES DISCOURAGE OR PROHIBIT THE USE OF STRAW BALES FOR INLET PROTECTION. CHECK WITH LOCAL JURISDICTION TO DETERMINE IF STRAW BALE INLET PROTECTION IS ACCEPTABLE.

IP-8 Urban Drainage and Flood Control District Urban Storm Drainage Criteria Manual Volume 3 August 2013

**EROSION CONTROL CRITERIA:**

EROSION CONTROL MEASURES SHALL BE IMPLEMENTED IN A MANNER THAT WILL PROTECT PROPERTIES AND PUBLIC FACILITIES FROM THE ADVERSE EFFECTS OF EROSION AND SEDIMENTATION AS A RESULT OF CONSTRUCTION AND EARTHWORK ACTIVITIES WITHIN THE PROJECT SITE.

- PRIOR TO START OF GRADING OPERATIONS, LOCATE AND SET THE SILT FENCE AND VEHICLE TRACKING CONTROL AS SHOWN ON THE EROSION CONTROL PLAN.
- THE SILT FENCE SHALL BE KEPT IN PLACE AND MAINTAINED UNTIL EROSION AND SEDIMENTATION POTENTIAL IS MITIGATED. REMOVAL OF SILT AND SEDIMENT COLLECTED BY THE SILT FENCES IS REQUIRED ONCE IT REACHES HALF THE HEIGHT OF THE SILT FENCES.
- EROSION CONTROL DEVICES SHOULD BE CHECKED AFTER EVERY STORM OR NOT MORE THAN EVERY 14 DAYS. REPAIRS OR REPLACEMENT SHOULD BE MADE AS NECESSARY TO MAINTAIN PROPER PROTECTION.

SOIL EROSION CONTROL MEASURES FOR ALL SLOPES, CHANNELS, DITCHES, OR ANY DISTURBED LAND AREA SHALL BE COMPLETED WITHIN TWENTY-ONE (21) CALENDAR DAYS AFTER FINAL GRADING, OR FINAL EARTH DISTURBANCE HAS BEEN COMPLETED. DISTURBED AREAS AND STOCKPILES WHICH ARE NOT AT THE FINAL GRADE BUT WILL REMAIN DORMANT FOR LONGER THAN 30 DAYS SHALL ALSO BE MULCHED WITHIN 21 DAYS AFTER INTERIM GRADING. AN AREA THAT IS GOING TO REMAIN IN AN INTERIM STATE FOR MORE THAN 60 DAYS SHALL ALSO BE SEEDED. ALL TEMPORARY SOIL EROSION CONTROL MEASURES AND BMP'S SHALL BE MAINTAINED UNTIL PERMANENT SOIL EROSION CONTROL MEASURES ARE IMPLEMENTED.

**NOTE:**

SEE URBAN DRAINAGE CRITERIA MANUAL (VOL. 3) FOR INSTALLATION AND MAINTENANCE (TYP)

**CLEARWAY, LOT 5**

**GRADING & EROSION CONTROL DETAILS**

PROJECT NO. 44-042A      DATE: 06/13/2023

SCALE: HORIZONTAL: N/A      VERTICAL: 1"=5'

DESIGNED BY: TAU      CHECKED BY: CLP

DRAWN BY: CLP      DLM

SHEET 9 OF 11      **GR09**

212 N. WASHATCH AVE., STE 305  
COLORADO SPRINGS, CO 80903  
PHONE: 719.555.5485

FOR AND ON BEHALF OF  
MKS CIVIL CONSULTANTS, INC.

VIRGIL A. SANCHEZ, COLORADO, P.E. NO. 37160

06/14/2023

REV. NO.	DATE	BY	DESCRIPTION	APPROV. BY	DATE

THE ENGINEER PREPARING THESE PLANS WILL NOT BE RESPONSIBLE, OR LIABLE FOR, UNAUTHORIZED CHANGES TO OR USES OF THESE PLANS. ALL CHANGES TO THE PLANS MUST BE IN WRITING AND MUST BE APPROVED BY THE PREPARE OF THESE PLANS.

**CAUTION**

**EC-6 Rolled Erosion Control Products (RECP)**

- Turf Reinforcement Mat (TRM):** A rolled erosion control product composed of non-degradable synthetic fibers, filaments, nets, wire mesh, and/or other elements, processed into a permanent, three-dimensional matrix of sufficient thickness. TRMs, which may be supplemented with degradable components, are designed to impart immediate erosion protection, enhance vegetation establishment and provide long-term functionality by permanently reinforcing vegetation during and after maturation. Note: TRMs are typically used in hydraulic applications, such as high flow ditches and channels, steep slopes, stream banks, and shorelines, where erosive forces may exceed the limits of natural, unreinforced vegetation or in areas where limited vegetation establishment is anticipated.

Tables RECP-1 and RECP-2 provide guidelines for selecting rolled erosion control products appropriate to site conditions and desired longevity. Table RECP-1 is for conditions where natural vegetation alone will provide permanent erosion control, whereas Table RECP-2 is for conditions where vegetation alone will not be adequately stable to provide long-term erosion protection due to flow or other conditions.

RECP-2 Urban Drainage and Flood Control District Urban Storm Drainage Criteria Manual Volume 3 November 2010

**Table RECP-1. ECTC Standard Specification for Temporary Rolled Erosion Control Products**  
(Adapted from Erosion Control Technology Council 2005)

Product Description	Slope Applications*		Channel Applications*	Minimum Tensile Strength <sup>1</sup>	Expected Longevity
	Maximum Gradient	C Factor <sup>2,5</sup>			
Mulch Control Nets	5:1 (H:V)	≤0.10 @ 5:1	0.25 lbs/ft <sup>2</sup> (12 Pa)	5 lbs/ft (0.073 kN/m)	Up to 12 months
Netless Rolled Erosion Control Blankets	4:1 (H:V)	≤0.10 @ 4:1	0.5 lbs/ft <sup>2</sup> (24 Pa)	5 lbs/ft (0.073 kN/m)	
Single-net Erosion Control Blankets & Open Weave Textiles	3:1 (H:V)	≤0.15 @ 3:1	1.5 lbs/ft <sup>2</sup> (72 Pa)	50 lbs/ft (0.73 kN/m)	
Double-net Erosion Control Blankets	2:1 (H:V)	≤0.20 @ 2:1	1.75 lbs/ft <sup>2</sup> (84 Pa)	75 lbs/ft (1.09 kN/m)	
Mulch Control Nets	5:1 (H:V)	≤0.10 @ 5:1	0.25 lbs/ft <sup>2</sup> (12 Pa)	25 lbs/ft (0.36 kN/m)	24 months
Erosion Control Blankets & Open Weave Textiles (slowly degrading)	1.5:1 (H:V)	≤0.25 @ 1.5:1	2.00 lbs/ft <sup>2</sup> (96 Pa)	100 lbs/ft (1.45 kN/m)	24 months
Erosion Control Blankets & Open Weave Textiles	1:1 (H:V)	≤0.25 @ 1:1	2.25 lbs/ft <sup>2</sup> (108 Pa)	125 lbs/ft (1.82 kN/m)	36 months

\* C Factor and shear stress for mulch control nettings must be obtained with netting used in conjunction with pre-applied mulch material. (See Section 5.3 of Chapter 7 Construction BMPs for more information on the C Factor.)  
<sup>1</sup> Minimum Average Roll Values, Machine direction using ECTC Mod. ASTM D 5035.  
<sup>2</sup> C Factor calculated as ratio of soil loss from RECP protected slope (tested at specified or greater gradient, H:V) to ratio of soil loss from unprotected (control) plot in large-scale testing.  
<sup>3</sup> Required minimum shear stress RECP (unvegetated) can sustain without physical damage or excess erosion (> 12.7 mm (0.5 in.) soil loss) during a 30-minute flow event in large-scale testing.  
<sup>4</sup> The permissible shear stress levels established for each performance category are based on historical experience with products characterized by Manning's roughness coefficients in the range of 0.01 - 0.05.  
<sup>5</sup> Acceptable large-scale test methods may include ASTM D 6459, or other independent testing deemed acceptable by the engineer.  
<sup>6</sup> Per the engineer's discretion. Recommended acceptable large-scale testing protocol may include ASTM D 6460, or other independent testing deemed acceptable by the engineer.

RECP-3 Urban Drainage and Flood Control District Urban Storm Drainage Criteria Manual Volume 3 November 2010

**Table RECP-2. ECTC Standard Specification for Permanent Rolled Erosion Control Products**  
(Adapted from: Erosion Control Technology Council 2005)

Product Type	Slope Applications	Channel Applications	Minimum Tensile Strength <sup>1,3</sup>
	Maximum Gradient	Maximum Shear Stress <sup>4,5</sup>	
TRMs with a minimum thickness of 0.25 inches (6.35 mm) per ASTM D 6525 and UV stability of 80% per ASTM D 4355 (500 hours exposure).	0.5:1 (H:V)	6.0 lbs/ft <sup>2</sup> (288 Pa)	125 lbs/ft (1.82 kN/m)
	0.5:1 (H:V)	8.0 lbs/ft <sup>2</sup> (384 Pa)	150 lbs/ft (2.19 kN/m)
	0.5:1 (H:V)	10.0 lbs/ft <sup>2</sup> (480 Pa)	175 lbs/ft (2.55 kN/m)

<sup>1</sup> For TRMs containing degradable components, all property values must be obtained on the non-degradable portion of the matting alone.  
<sup>2</sup> Minimum Average Roll Values, machine direction only for tensile strength determination using ASTM D 6818 (Supersedes Mod. ASTM D 5035 for RECPs)  
<sup>3</sup> Field conditions with high loading and/or high survivability requirements may warrant the use of a TRM with a tensile strength of 44 kN/m (3,000 lb/ft) or greater.  
<sup>4</sup> Required minimum shear stress TRM (fully vegetated) can sustain without physical damage or excess erosion (> 12.7 mm (0.5 in.) soil loss) during a 30-minute flow event in large scale testing.  
<sup>5</sup> Acceptable large-scale testing protocols may include ASTM D 6460, or other independent testing deemed acceptable by the engineer.

**Design and Installation**  
 RECPs should be installed according to manufacturer's specifications and guidelines. Regardless of the type of product used, it is important to ensure no gaps or voids exist under the material and that all corners of the material are secured using stakes and trenching. Continuous contact between the product and the soil is necessary to avoid failure. Never use metal stakes to secure temporary erosion control products. Often wooden stakes are used to anchor RECPs; however, wood stakes may present installation and maintenance challenges and generally take a long time to biodegrade. Some local jurisdictions have had favorable experiences using biodegradable stakes.

- This BMP Fact Sheet provides design details for several commonly used ECB applications, including:
- ECB-1 Pipe Outlet to Drainageway
  - ECB-2 Small Ditch or Drainageway
  - ECB-3 Outside of Drainageway

RECP-4 Urban Drainage and Flood Control District Urban Storm Drainage Criteria Manual Volume 3 November 2010

**Staking patterns are also provided in the design details according to these factors:**

- ECB type
- Slope or channel type

For other types of RECPs including TRMs, these design details are intended to serve as general guidelines for design and installation; however, engineers should adhere to manufacturer's installation recommendations.

**Maintenance and Removal**

Inspection of erosion control blankets and other RECPs includes:

- Check for general signs of erosion, including voids beneath the mat. If voids are apparent, fill the void with suitable soil and replace the erosion control blanket, following the appropriate staking pattern.
- Check for damaged or loose stakes and secure loose portions of the blanket.

Erosion control blankets and other RECPs that are biodegradable typically do not need to be removed after construction. If they must be removed, then an alternate soil stabilization method should be installed promptly following removal.

Turf reinforcement mats, although generally resistant to biodegradation, are typically left in place as a dense vegetated cover grows in through the mat matrix. The turf reinforcement mat provides long-term stability and helps the established vegetation resist erosive forces.

RECP-5 Urban Drainage and Flood Control District Urban Storm Drainage Criteria Manual Volume 3 November 2010

**ECB-1. PIPE OUTLET TO DRAINAGEWAY**

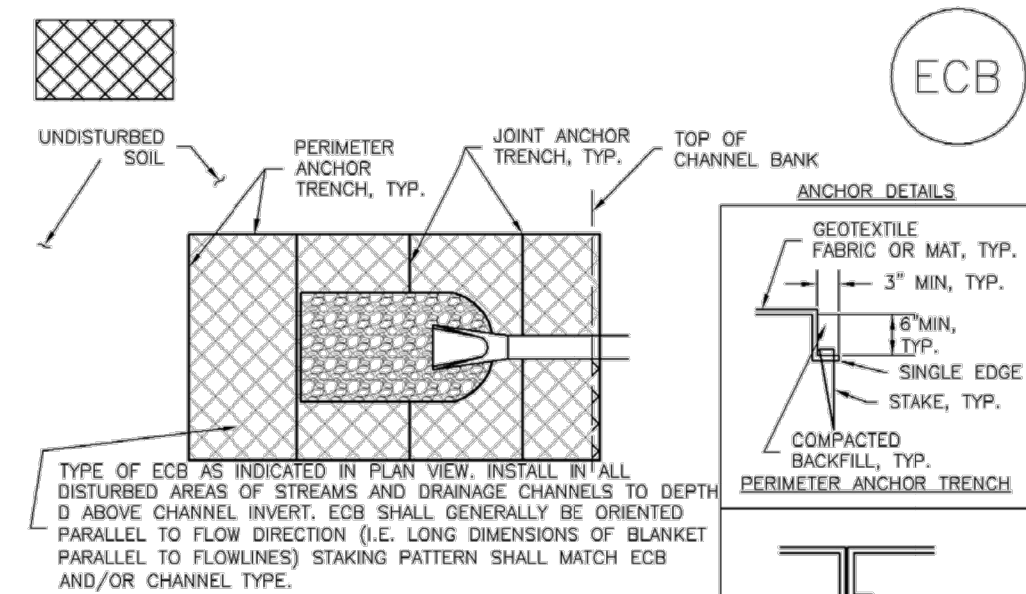

ECB-1. PIPE OUTLET TO DRAINAGEWAY

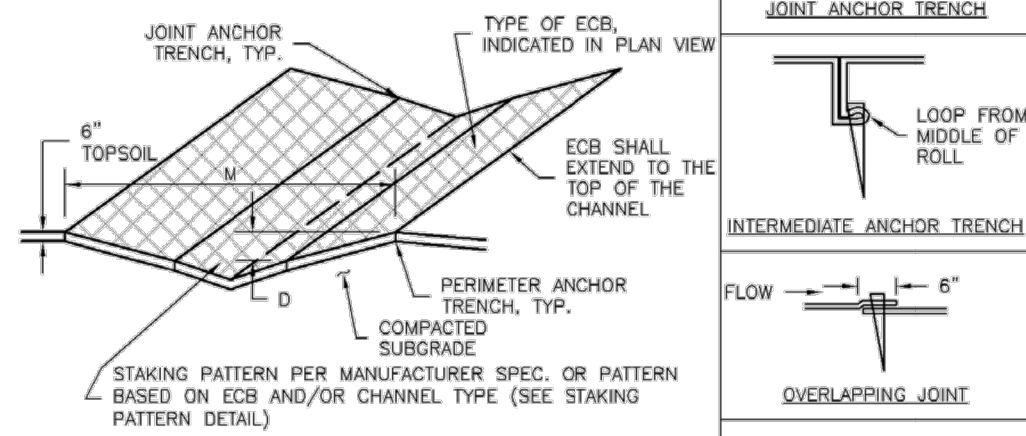

ECB-2. SMALL DITCH OR DRAINAGEWAY

RECP-6 Urban Drainage and Flood Control District Urban Storm Drainage Criteria Manual Volume 3 November 2010

**ECB-3. OUTSIDE OF DRAINAGEWAY**

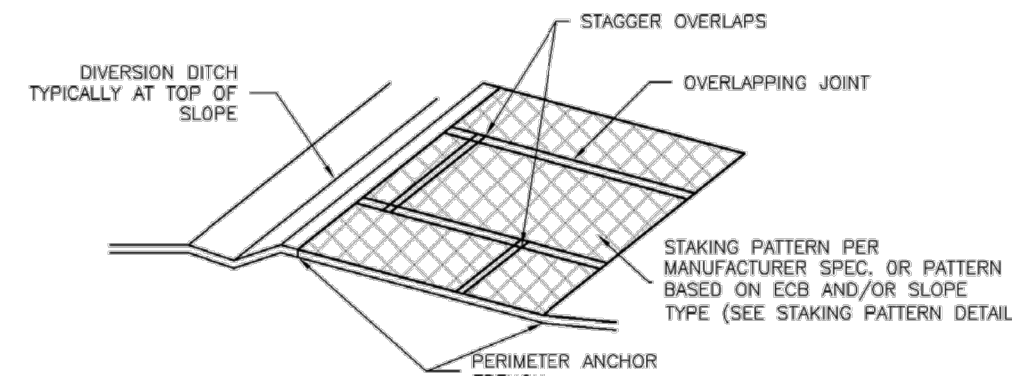

ECB-3. OUTSIDE OF DRAINAGEWAY

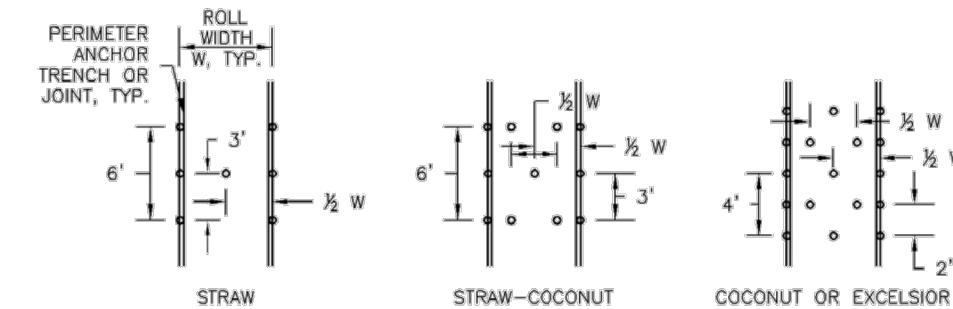

STAKING PATTERNS BY ECB TYPE

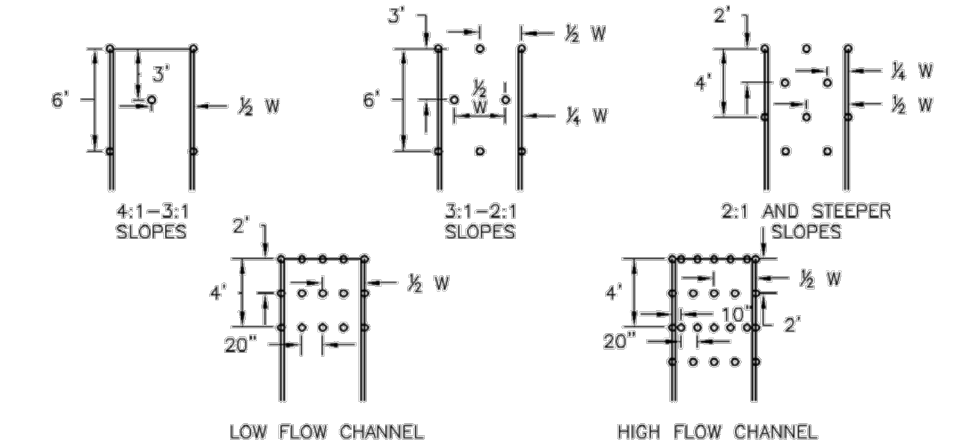

STAKING PATTERNS BY SLOPE OR CHANNEL TYPE

RECP-7 Urban Drainage and Flood Control District Urban Storm Drainage Criteria Manual Volume 3 November 2010

**EROSION CONTROL BLANKET INSTALLATION NOTES**

- SEE PLAN VIEW FOR:
  - LOCATION OF ECB.
  - TYPE OF ECB (STRAW, STRAW-COCONUT, COCONUT, OR EXCELSIOR).
  - AREA, A, IN SQUARE YARDS OF EACH TYPE OF ECB.
- 100% NATURAL AND BIODEGRADABLE MATERIALS ARE PREFERRED FOR RECPs, ALTHOUGH SOME JURISDICTIONS MAY ALLOW OTHER MATERIALS IN SOME APPLICATIONS.
- IN AREAS WHERE ECBs ARE SHOWN ON THE PLANS, THE PERMITEE SHALL PLACE TOPSOIL AND PERFORM FINAL GRADING, SURFACE PREPARATION, AND SEEDING AND MULCHING. SUBGRADE SHALL BE SMOOTH AND MOIST PRIOR TO ECB INSTALLATION AND THE ECB SHALL BE IN FULL CONTACT WITH SUBGRADE. NO GAPS OR VOIDS SHALL EXIST UNDER THE BLANKET.
- PERIMETER ANCHOR TRENCH SHALL BE USED ALONG THE OUTSIDE PERIMETER OF ALL BLANKET AREAS.
- JOINT ANCHOR TRENCH SHALL BE USED TO JOIN ROLLS OF ECBs TOGETHER (LONGITUDINALLY AND TRANSVERSELY) FOR ALL ECBs EXCEPT STRAW WHICH MAY USE AN OVERLAPPING JOINT.
- INTERMEDIATE ANCHOR TRENCH SHALL BE USED AT SPACING OF ONE-HALF ROLL LENGTH FOR COCONUT AND EXCELSIOR ECBs.
- OVERLAPPING JOINT DETAIL SHALL BE USED TO JOIN ROLLS OF ECBs TOGETHER FOR ECBs ON SLOPES.
- MATERIAL SPECIFICATIONS OF ECBs SHALL CONFORM TO TABLE ECB-1.
- ANY AREAS OF SEEDING AND MULCHING DISTURBED IN THE PROCESS OF INSTALLING ECBs SHALL BE RESEEDED AND MULCHED.
- DETAILS ON DESIGN PLANS FOR MAJOR DRAINAGEWAY STABILIZATION WILL GOVERN IF DIFFERENT FROM THOSE SHOWN HERE.

TYPE	COCONUT CONTENT	STRAW CONTENT	EXCELSIOR CONTENT	RECOMMENDED NETTING*
STRAW*	-	100%	-	DOUBLE/NATURAL
STRAW-COCONUT	30% MIN	70% MAX	-	DOUBLE/NATURAL
COCONUT	100%	-	-	DOUBLE/NATURAL
EXCELSIOR	-	-	100%	DOUBLE/NATURAL

\*STRAW ECBs MAY ONLY BE USED OUTSIDE OF STRAWS AND DRAINAGE CHANNELS.  
 \*\*ALTERNATE NETTING MAY BE ACCEPTABLE IN SOME JURISDICTIONS.

RECP-8 Urban Drainage and Flood Control District Urban Storm Drainage Criteria Manual Volume 3 November 2010

**EROSION CONTROL BLANKET MAINTENANCE NOTES**

- INSPECT BMPs EACH WORKDAY, AND MAINTAIN THEM IN EFFECTIVE OPERATING CONDITION. MAINTENANCE OF BMPs SHOULD BE PROACTIVE, NOT REACTIVE. INSPECT BMPs AS SOON AS POSSIBLE (AND ALWAYS WITHIN 24 HOURS) FOLLOWING A STORM THAT CAUSES SURFACE EROSION, AND PERFORM NECESSARY MAINTENANCE.
  - FREQUENT OBSERVATIONS AND MAINTENANCE ARE NECESSARY TO MAINTAIN BMPs IN EFFECTIVE OPERATING CONDITION. INSPECTIONS AND CORRECTIVE MEASURES SHOULD BE DOCUMENTED THOROUGHLY.
  - WHERE BMPs HAVE FAILED, REPAIR OR REPLACEMENT SHOULD BE INITIATED UPON DISCOVERY OF THE FAILURE.
  - ECBs SHALL BE LEFT IN PLACE TO EVENTUALLY BIODEGRADE, UNLESS REQUESTED TO BE REMOVED BY THE LOCAL JURISDICTION.
  - ANY ECB PULLED OUT, TORN, OR OTHERWISE DAMAGED SHALL BE REPAIRED OR REINSTALLED. ANY SUBGRADE AREAS BELOW THE GEOTEXTILE THAT HAVE ERODED TO CREATE A VOID UNDER THE BLANKET, OR THAT REMAIN DEVOID OF GRASS SHALL BE REPAIRED, RESEEDED AND MULCHED AND THE ECB REINSTALLED.
- NOTE: MANY JURISDICTIONS HAVE BMP DETAILS THAT VARY FROM UDFCD STANDARD DETAILS. CONSULT WITH LOCAL JURISDICTIONS AS TO WHICH DETAIL SHOULD BE USED WHEN DIFFERENCES ARE NOTED.
- (DETAILS ADAPTED FROM DOUGLAS COUNTY, COLORADO AND TOWN OF PARKER COLORADO, NOT AVAILABLE IN AUTOCAD)

RECP-9 Urban Drainage and Flood Control District Urban Storm Drainage Criteria Manual Volume 3 November 2010

CLEARWAY, LOT 5

GRADING & EROSION CONTROL DETAILS

PROJECT NO. 44-042A

DATE: 06/13/2023

SCALE: HORIZONTAL: N/A VERTICAL: 1"=5'

DESIGNED BY: TAU DRAWN BY: CUP CHECKED BY: DLM

212 N. WAHATCH AVE, STE 305 COLORADO SPRINGS, CO 80903 PHONE: 719.555.5465

CIVIL CONSULTANTS, INC.

FOR AND ON BEHALF OF MRS. CIVIL CONSULTANTS, INC.

VIRGIL A. SANCHEZ, COLORADO P.E. NO. 371160

06/14/2023

REVISIONS: NO. DATE: BY: DESCRIPTION: APPROV'D. BY: DATE:

THE ENGINEER PREPARING THESE PLANS WILL NOT BE RESPONSIBLE, OR LIABLE FOR, UNAUTHORIZED CHANGES TO OR USES OF THESE PLANS. ALL CHANGES TO THE PLANS MUST BE IN WRITING AND MUST BE APPROVED BY THE PREPARE OF THESE PLANS.

CAUTION

**Silt Fence (SF)**

**SC-1**

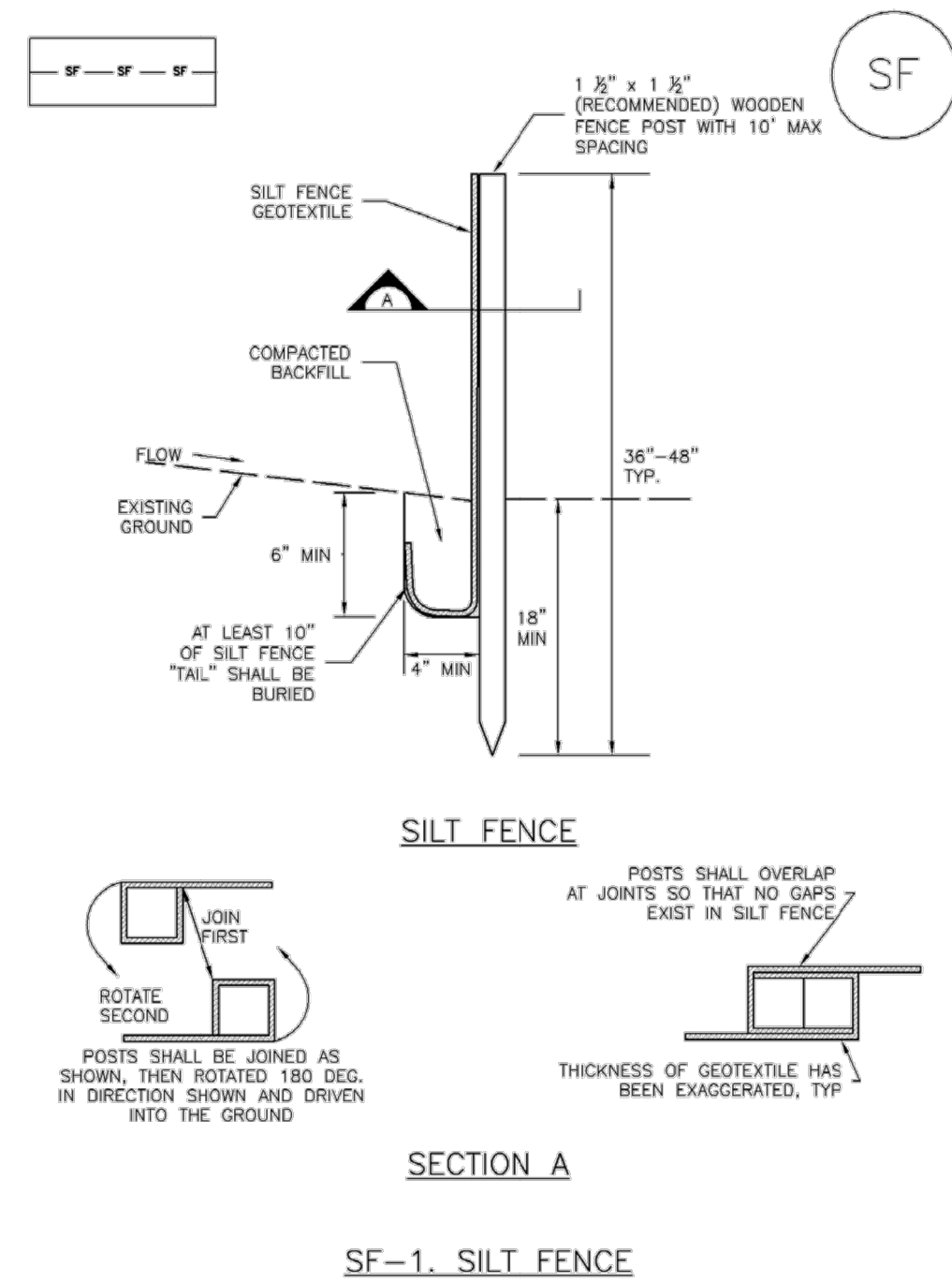

November 2010 Urban Drainage and Flood Control District Urban Storm Drainage Criteria Manual Volume 3 SF-3

**SC-1**

**Silt Fence (SF)**

**SILT FENCE INSTALLATION NOTES**

1. SILT FENCE MUST BE PLACED AWAY FROM THE TOE OF THE SLOPE TO ALLOW FOR WATER PONDING. SILT FENCE AT THE TOE OF A SLOPE SHOULD BE INSTALLED IN A FLAT LOCATION AT LEAST SEVERAL FEET (2-5 FT) FROM THE TOE OF THE SLOPE TO ALLOW ROOM FOR PONDING AND DEPOSITION.
2. A UNIFORM 6" X 4" ANCHOR TRENCH SHALL BE EXCAVATED USING TRENCHER OR SILT FENCE INSTALLATION DEVICE. NO ROAD GRADERS, BACKHOES, OR SIMILAR EQUIPMENT SHALL BE USED.
3. COMPACT ANCHOR TRENCH BY HAND WITH A "JUMPING JACK" OR BY WHEEL ROLLING. COMPACTOR SHALL BE SUCH THAT SILT FENCE RESISTS BEING PULLED OUT OF ANCHOR TRENCH BY HAND.
4. SILT FENCE SHALL BE PULLED TIGHT AS IT IS ANCHORED TO THE STAKES. THERE SHOULD BE NO NOTICEABLE SAG BETWEEN STAKES AFTER IT HAS BEEN ANCHORED TO THE STAKES.
5. SILT FENCE FABRIC SHALL BE ANCHORED TO THE STAKES USING 1" HEAVY DUTY STAPLES OR NAILS WITH 1" HEADS. STAPLES AND NAILS SHOULD BE PLACED 3" ALONG THE FABRIC DOWN THE STAKE.
6. AT THE END OF A RUN OF SILT FENCE ALONG A CONTOUR, THE SILT FENCE SHOULD BE TURNED PERPENDICULAR TO THE CONTOUR TO CREATE A "J-HOOK". THE "J-HOOK" EXTENDING PERPENDICULAR TO THE CONTOUR SHOULD BE OF SUFFICIENT LENGTH TO KEEP RUNOFF FROM FLOWING AROUND THE END OF THE SILT FENCE (TYPICALLY 10' - 20').
7. SILT FENCE SHALL BE INSTALLED PRIOR TO ANY LAND DISTURBING ACTIVITIES.

**SILT FENCE MAINTENANCE NOTES**

1. INSPECT BMPs EACH WORKDAY, AND MAINTAIN THEM IN EFFECTIVE OPERATING CONDITION. MAINTENANCE OF BMPs SHOULD BE PROACTIVE, NOT REACTIVE. INSPECT BMPs AS SOON AS POSSIBLE (AND ALWAYS WITHIN 24 HOURS) FOLLOWING A STORM THAT CAUSES SURFACE EROSION, AND PERFORM NECESSARY MAINTENANCE.
2. FREQUENT OBSERVATIONS AND MAINTENANCE ARE NECESSARY TO MAINTAIN BMPs IN EFFECTIVE OPERATING CONDITION. INSPECTIONS AND CORRECTIVE MEASURES SHOULD BE DOCUMENTED THOROUGHLY.
3. WHERE BMPs HAVE FAILED, REPAIR OR REPLACEMENT SHOULD BE INITIATED UPON DISCOVERY OF THE FAILURE.
4. SEDIMENT ACCUMULATED UPSTREAM OF THE SILT FENCE SHALL BE REMOVED AS NEEDED TO MAINTAIN THE FUNCTIONALITY OF THE BMP, TYPICALLY WHEN DEPTH OF ACCUMULATED SEDIMENTS IS APPROXIMATELY 6".
5. REPAIR OR REPLACE SILT FENCE WHEN THERE ARE SIGNS OF WEAR, SUCH AS SAGGING, TEARING, OR COLLAPSE.
6. SILT FENCE IS TO REMAIN IN PLACE UNTIL THE UPSTREAM DISTURBED AREA IS STABILIZED AND APPROVED BY THE LOCAL JURISDICTION, OR IS REPLACED BY AN EQUIVALENT PERIMETER SEDIMENT CONTROL BMP.
7. WHEN SILT FENCE IS REMOVED, ALL DISTURBED AREAS SHALL BE COVERED WITH TOPSOIL, SEEDED AND MULCHED OR OTHERWISE STABILIZED AS APPROVED BY LOCAL JURISDICTION.

(DETAIL ADAPTED FROM TOWN OF PARKER, COLORADO AND CITY OF AURORA, NOT AVAILABLE IN AUTOCAD)  
NOTE: MANY JURISDICTIONS HAVE BMP DETAILS THAT VARY FROM UDFCD STANDARD DETAILS. CONSULT WITH LOCAL JURISDICTIONS AS TO WHICH DETAIL SHOULD BE USED WHEN DIFFERENCES ARE NOTED.

SF-4 Urban Drainage and Flood Control District Urban Storm Drainage Criteria Manual Volume 3 November 2010

**Check Dams (CD)**

**EC-12**

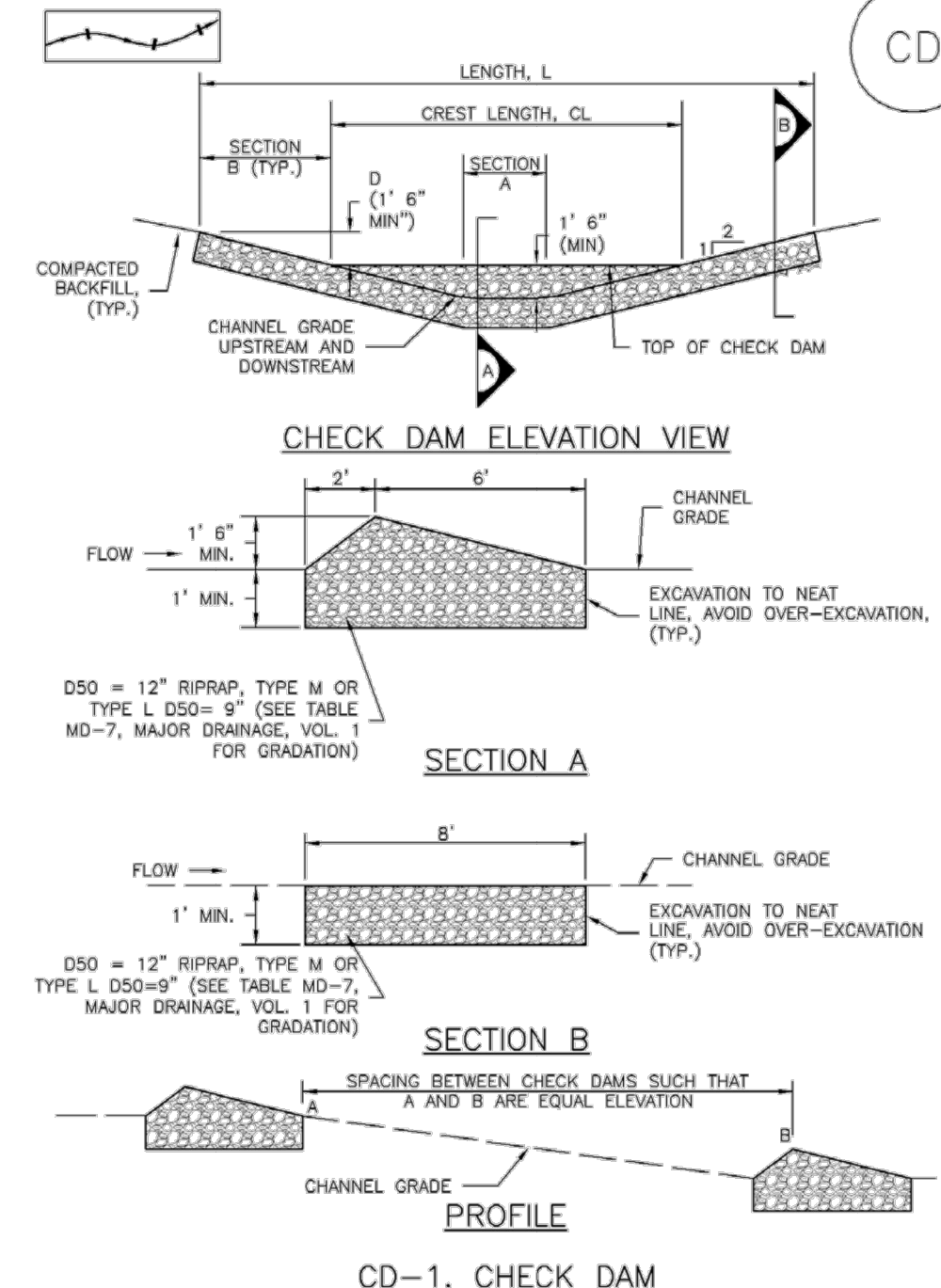

November 2010 Urban Drainage and Flood Control District Urban Storm Drainage Criteria Manual Volume 3 CD-3

**EC-12**

**Check Dams (CD)**

**CHECK DAM INSTALLATION NOTES**

1. SEE PLAN VIEW FOR:
  - LOCATION OF CHECK DAMS.
  - CHECK DAM TYPE (CHECK DAM OR REINFORCED CHECK DAM).
  - LENGTH (L), CREST LENGTH (CL), AND DEPTH (D).
2. CHECK DAMS INDICATED ON INITIAL SWMP SHALL BE INSTALLED AFTER CONSTRUCTION FENCE, BUT PRIOR TO ANY UPSTREAM LAND DISTURBING ACTIVITIES.
3. RIPRAP UTILIZED FOR CHECK DAMS SHOULD BE OF APPROPRIATE SIZE FOR THE APPLICATION. TYPICAL TYPES OF RIPRAP USED FOR CHECK DAMS ARE TYPE M (D50 12") OR TYPE L (D50 9").
4. RIPRAP PAD SHALL BE TRENCHED INTO THE GROUND A MINIMUM OF 1'.
5. THE ENDS OF THE CHECK DAM SHALL BE A MINIMUM OF 1' 6" HIGHER THAN THE CENTER OF THE CHECK DAM.

**CHECK DAM MAINTENANCE NOTES**

1. INSPECT BMPs EACH WORKDAY, AND MAINTAIN THEM IN EFFECTIVE OPERATING CONDITION. MAINTENANCE OF BMPs SHOULD BE PROACTIVE, NOT REACTIVE. INSPECT BMPs AS SOON AS POSSIBLE (AND ALWAYS WITHIN 24 HOURS) FOLLOWING A STORM THAT CAUSES SURFACE EROSION, AND PERFORM NECESSARY MAINTENANCE.
2. FREQUENT OBSERVATIONS AND MAINTENANCE ARE NECESSARY TO MAINTAIN BMPs IN EFFECTIVE OPERATING CONDITION. INSPECTIONS AND CORRECTIVE MEASURES SHOULD BE DOCUMENTED THOROUGHLY.
3. WHERE BMPs HAVE FAILED, REPAIR OR REPLACEMENT SHOULD BE INITIATED UPON DISCOVERY OF THE FAILURE.
4. SEDIMENT ACCUMULATED UPSTREAM OF THE CHECK DAMS SHALL BE REMOVED WHEN THE SEDIMENT DEPTH IS WITHIN 1/2 OF THE HEIGHT OF THE CREST.
5. CHECK DAMS ARE TO REMAIN IN PLACE UNTIL THE UPSTREAM DISTURBED AREA IS STABILIZED AND APPROVED BY THE LOCAL JURISDICTION.
6. WHEN CHECK DAMS ARE REMOVED, EXCAVATIONS SHALL BE FILLED WITH SUITABLE COMPACTED BACKFILL. DISTURBED AREA SHALL BE SEEDED AND MULCHED AND COVERED WITH GEOTEXTILE OR OTHERWISE STABILIZED IN A MANNER APPROVED BY THE LOCAL JURISDICTION.

(DETAILS ADAPTED FROM DOUGLAS COUNTY, COLORADO, NOT AVAILABLE IN AUTOCAD)  
NOTE: MANY JURISDICTIONS HAVE BMP DETAILS THAT VARY FROM UDFCD STANDARD DETAILS. CONSULT WITH LOCAL JURISDICTIONS AS TO WHICH DETAIL SHOULD BE USED WHEN DIFFERENCES ARE NOTED.

CD-4 Urban Drainage and Flood Control District Urban Storm Drainage Criteria Manual Volume 3 November 2010

**Street Sweeping and Vacuuming (SS)**

**SM-7**

**Description**

Street sweeping and vacuuming remove sediment that has been tracked onto roadways to reduce sediment transport into storm drain systems or a surface waterway.



**Photograph SS-1.** A street sweeper removes sediment and potential pollutants along the curb line at a construction site. Photo courtesy of Tom Gore.

**Appropriate Uses**

Use this practice at construction sites where vehicles may track sediment offsite onto paved roadways.

**Design and Installation**

Street sweeping or vacuuming should be conducted when there is noticeable sediment accumulation on roadways adjacent to the construction site. Typically, this will be concentrated at the entrance/exit to the construction site. Well-maintained stabilized construction entrances, vehicle tracking controls and tire wash facilities can help reduce the necessary frequency of street sweeping and vacuuming.

On smaller construction sites, street sweeping can be conducted manually using a shovel and broom. Never wash accumulated sediment on roadways into storm drains.

**Maintenance and Removal**

- Inspect paved roads around the perimeter of the construction site on a daily basis and more frequently, as needed. Remove accumulated sediment, as needed.
- Following street sweeping, check inlet protection that may have been displaced during street sweeping.
- Inspect area to be swept for materials that may be hazardous prior to beginning sweeping operations.

Street Sweeping/ Vacuuming	
<b>Functions</b>	
Erosion Control	No
Sediment Control	Yes
Site/Material Management	Yes

November 2010 Urban Drainage and Flood Control District Urban Storm Drainage Criteria Manual Volume 3 SS-1

**EROSION CONTROL CRITERIA:**

EROSION CONTROL MEASURES SHALL BE IMPLEMENTED IN A MANNER THAT WILL PROTECT PROPERTIES AND PUBLIC FACILITIES FROM THE ADVERSE EFFECTS OF EROSION AND SEDIMENTATION AS A RESULT OF CONSTRUCTION AND EARTHWORK ACTIVITIES WITHIN THE PROJECT SITE.

1. PRIOR TO START OF GRADING OPERATIONS, LOCATE AND SET THE SILT FENCE AND VEHICLE TRACKING CONTROL AS SHOWN ON THE EROSION CONTROL PLAN.
2. THE SILT FENCE SHALL BE KEPT IN PLACE AND MAINTAINED UNTIL EROSION AND SEDIMENTATION POTENTIAL IS MITIGATED. REMOVAL OF SILT AND SEDIMENT COLLECTED BY THE SILT FENCES IS REQUIRED ONCE IT REACHES HALF THE HEIGHT OF THE SILT FENCES.
3. EROSION CONTROL DEVICES SHOULD BE CHECKED AFTER EVERY STORM OR NOT MORE THAN EVERY 14 DAYS. REPAIRS OR REPLACEMENT SHOULD BE MADE AS NECESSARY TO MAINTAIN PROPER PROTECTION.

SOIL EROSION CONTROL MEASURES FOR ALL SLOPES, CHANNELS, DITCHES, OR ANY DISTURBED LAND AREA SHALL BE COMPLETED WITHIN TWENTY-ONE (21) CALENDAR DAYS AFTER FINAL GRADING, OR FINAL EARTH DISTURBANCE HAS BEEN COMPLETED. DISTURBED AREAS AND STOCKPILES WHICH ARE NOT AT THE FINAL GRADE BUT WILL REMAIN DORMANT FOR LONGER THAN 30 DAYS SHALL ALSO BE MULCHED WITHIN 21 DAYS AFTER INTERIM GRADING. AN AREA THAT IS GOING TO REMAIN IN AN INTERIM STATE FOR MORE THAN 60 DAYS SHALL ALSO BE SEEDED. ALL TEMPORARY SOIL EROSION CONTROL MEASURES AND BMPs SHALL BE MAINTAINED UNTIL PERMANENT SOIL EROSION CONTROL MEASURES ARE IMPLEMENTED.

**NOTE:**

SEE URBAN DRAINAGE CRITERIA MANUAL (VOL. 3) FOR INSTALLATION AND MAINTENANCE (TYP)

CLEARWAY, LOT 5

**GRADING & EROSION CONTROL DETAILS**

PROJECT NO. 44-042A DATE: 06/13/2023  
SCALE: HORIZONTAL: N/A VERTICAL: 1"=5'  
DESIGNED BY: TAU CLP CHECKED BY: DLM SHEET 11 OF 11  
GR11

2120 N. WASHCATCH AVE. STE 305  
COLORADO SPRINGS CO 80903  
PHONE: 719.955.5465

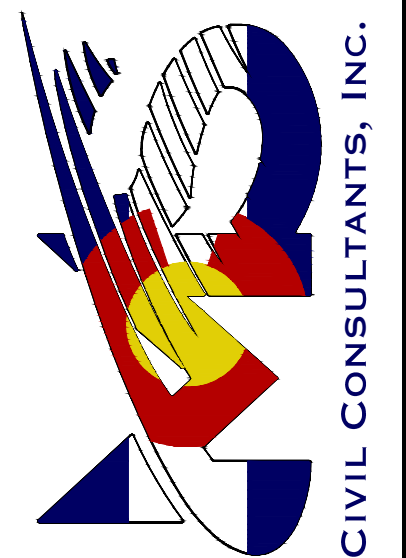

REV. NO.	DATE	BY	DESCRIPTION

THE ENGINEER PREPARING THESE PLANS WILL NOT BE RESPONSIBLE, OR LIABLE FOR, UNAUTHORIZED CHANGES TO OR USES OF THESE PLANS. ALL CHANGES TO THE PLANS MUST BE IN WRITING AND MUST BE APPROVED BY THE PREPARED BY THESE PLANS.

CAUTION