

**EL PASO COUNTY**  
**COLORADO**

**COMMISSIONERS:**  
**MARK WALLER (CHAIR)**  
**LONGINOS GONZALEZ, JR. (VICE-CHAIR)**

**HOLLY WILLIAMS**  
**STAN VANDERWERF**  
**CAMI BREMER**

PLANNING AND COMMUNITY DEVELOPMENT DEPARTMENT  
 CRAIG DOSSEY, EXECUTIVE DIRECTOR

**TO: El Paso County Planning Commission**  
**Brian Risley, Chair**

**FROM: Nina Ruiz, Planning Manager**  
**Gilbert LaForce, PE Engineer III**  
**Craig Dossey, Executive Director**

**RE: Project File #: PUDSP-16-004**  
**Project Name: Northbay at Lake Woodmoor**  
**Parcel Nos.: 71114-04-111 and 71114-00-007**

| <b>OWNER:</b>   | <b>REPRESENTATIVE:</b>  |
|---|---|
| Lake Woodmoor Holdings, LLC<br>1755 Telstar Drive Suite 211<br>Colorado Springs, CO 80920 | N.E.S., Inc.<br>619 N. Cascade Avenue<br>Colorado Springs, CO 80903 |

**Commissioner District: 1**

|  |           |
|--|-----------|
| Planning Commission Hearing Date:          | 5/19/2020 |
| Board of County Commissioners Hearing Date | 5/26/2020 |

**EXECUTIVE SUMMARY**

A request by Lake Woodmoor Holdings, LLC, for approval of a map amendment (rezoning) of 7.23 acres from R-4 (Obsolete) to PUD (Planned Unit Development) to develop 28 single-family attached residential lots, rights-of-way, and five (5) open space and floodplain tracts. The request also includes approval of the PUD development plan as a preliminary plan. The parcel is located approximately 450 feet east of the Deer Creek Road and Woodmoor Drive intersection and is within Section 11, Township 11 South, Range 67 West of the 6<sup>th</sup> P.M. The subject property is located within the boundaries of the Tri-Lakes Comprehensive Plan (2000). The applicant has made a concurrent request

2880 INTERNATIONAL CIRCLE, SUITE 110  
 PHONE: (719) 520-6300



COLORADO SPRINGS, CO 80910-3127  
 FAX: (719) 520-6695

for an administrative final plat of the 7.229 acre PUD area to create 28 single-family attached residential lots.

#### **A. REQUEST/MODIFICATIONS/AUTHORIZATION**

**Request:** Approval of a map amendment (rezoning) from R-4 (Planned Development) to PUD (Planned Unit Development) to develop 28 single-family attached dwelling lots within a 7.23 acre development area. In accordance with Section 4.2.6.E, a PUD Development Plan May be Approved as a Preliminary Plan, of the El Paso County Land Development Code (2019) the applicant is also requesting the PUD development plan be approved as a preliminary plan.

#### **Modification of Existing Land Development Code (LDC) or Engineering Criteria Manual (ECM) Standard:**

For approval of a modification of a general development standard in the LDC or standard of the ECM, the BoCC shall find that the proposal provides for the general health, safety, and welfare of the citizens and at least one of the following benefits:

- Preservation of natural features;
- Provision of a more livable environment, such as the installment of street furniture, decorative street lighting or decorative paving materials;
- Provision of a more efficient pedestrian system;
- Provision of additional open space;
- Provision of other public amenities not otherwise required by the Code; or
- The proposed modification is granted in exchange for the open space and/or amenity designs provided in the PUD development plan and/or development guide.

The applicant is requesting approval of the following modification(s) of the LDC:

1. The applicant is requesting a PUD modification to Sections 8.4.4.C. and 8.4.4.E.3 of the Code to allow for private roads that are proposed to not be built to public road standards.

Section 8.4.4.C, *Public Roads Required*, of the Code states:

“Divisions of land, lots and tracts shall be served by public roads.”

Section and 8.4.4.E.3, *Private Road Allowances*, of the Code states:

“Generally, private roads shall be constructed and maintained to ECM standards except as may be otherwise determined in the waiver. Private road waivers may include design standards for the following:

- Right-of-way width where suitable alternative provisions are made for pedestrian walkways and utilities;
- Design speed where it is unlikely the road will be needed for use by the general public;

- Standard section thickness minimums and pavement type where suitable and perpetual maintenance provisions are made;
- Maximum and minimum block lengths; and
- Maximum grade.

PCD Executive Director Recommendation:

The PCD Executive Director recommends approval of the requested PUD modification. Per the proposed PUD/Preliminary Plan, adequate lot accessibility can be provided via the proposed private roadway. The applicant has depicted a sidewalk design and layout that accommodates pedestrian movement throughout the proposed PUD/preliminary plan. As summarized in the applicant's letter of intent, reducing the requirement of constructing private roads to public road standards to a lesser standard is proposed to provide for a more efficient and livable environment and provision of more efficient pedestrian spaces.

ECM Administrator Recommendation:

The ECM Administrator recommends approval of the requested PUD modification.

The applicant is requesting the following modification(s) of the ECM:

1. The applicant requests a PUD modification of Section 2.2.4.B.7 to allow a narrower road cross-section with 21 feet 8 inches of pavement width where 24 feet for a typical urban local (low volume) cross-section is required.

ECM Administrator Recommendation:

The ECM Administrator recommends approval of the modification request due to the physical constraint of the site. The revised cross-section is a private road which will be owned and maintained by the homeowner's association.

2. The applicant requests a PUD modification of Section 2.2.3 to allow 40 feet center line radius on Red Bridge Point where 100 feet is required and a K-sag value of 8 where 17 is required for a vertical curve.

ECM Administrator Recommendation:

The ECM Administrator recommends approval of the modification request since the reduced centerline curve radius and vertical curve in conjunction with the narrow roadway design is expected to reduce the speed. The revised roadway is a private road which will be owned and maintained by the homeowner's association.

3. The applicant requests a PUD modification of Section 2.3.8 to allow for a roadway termination design as a hammerhead instead of a typical cul-de-sac bulb.

ECM Administrator Recommendation:

The ECM Administrator recommends approval of the modification request since this is a private road and the Tri-Lakes Monument Fire Protection District has approved the hammerhead turnaround for emergency access.

4. The applicant requests a PUD modification of Section 2.2.5.E for the proposed Shoreditch Heights access location which will result in intersection spacing of less than 330 feet. The proposed intersection will be located approximately 226 feet east of Burning Oak Way and approximately 236 feet west of Burnt Leaf Way.

ECM Administrator Recommendation:

The ECM Administrator recommends approval of the modification request. The first access point for the subdivision is located at the Burning Oak and Deer Creek Road intersection. Since Burnt Leaf Way and Deer Creek Road intersection is not located along the property frontage the proposed Shore Ditch Heights access is located midway between Burning Oak Way and Burnt Leaf Way to maximize the intersection spacing.

**Authorization to Sign:** PUD Development Plan and any other documents required to finalize the approval

**B. PLANNING COMMISSION SUMMARY**

**Request Heard:**

**Recommendation:**

**Waiver Recommendation:**

**Vote:**

**Vote Rationale:**

**Summary of Hearing:**

**Legal Notice:**

**C. APPROVAL CRITERIA**

The Planning Commission and BOCC shall determine that the following the criteria for approval outlined in Section 4.2.6, and Section 7.2.1 of the El Paso County Land Development Code (2019), have been met to approve a PUD zoning district:

- The proposed PUD district zoning advances the stated purposes set forth in this section.

- The application is in general conformity with the Master Plan;
- The proposed development is in compliance with the requirements of this Code and all applicable statutory provisions and will not otherwise be detrimental to the health, safety, or welfare of the present or future inhabitants of El Paso County;
- The subject property is suitable for the intended uses and the use is compatible with both the existing and allowed land uses on the neighboring properties, will be in harmony and responsive with the character of the surrounding area and natural environment, and will not have a negative impact upon the existing and future development of the surrounding area;
- The proposed development provides adequate consideration for any potentially detrimental use to use relationships (e.g. commercial use adjacent to single family use) and provides an appropriate transition or buffering between uses of differing intensities both on-site and off-site which may include innovative treatments of use to use relationships;
- The allowed uses, bulk requirements and landscaping and buffering are appropriate to and compatible with the type of development, the surrounding neighborhood or area and the community;
- Areas with unique or significant historical, cultural, recreational, aesthetic or natural features are preserved and incorporated into the design of the project;
- Open spaces and trails are integrated into the development plan to serve as amenities to residents and provide reasonable walking and biking opportunities;
- The proposed development will not overburden the capacities of existing or planned roads, utilities and other public facilities (e.g. fire protection, police protection, emergency services, and water and sanitation), and the required public services and facilities will be provided to support the development when needed;
- The proposed development would be a benefit through the provision of interconnected open space, conservation of environmental features, aesthetic features and harmonious design, and energy efficient site design;
- The proposed land use does not permit the use of any area containing a commercial mineral deposit in a manner which would unreasonably interfere with the present or future extraction of such deposit unless acknowledged by the mineral rights owner;
- Any proposed exception or deviation from the requirements if the zoning resolution or the subdivision regulation is warranted by virtue of the design and amenities incorporated in the development plan and development guide; and
- The owner has authorized the application.

The applicant has requested the proposed PUD also be reviewed and considered as a preliminary plan. Compliance with the requirements identified in Chapter 7 and Chapter 8 of the El Paso County Land Development Code (2019) for a preliminary plan requires the Planning Commission and the BoCC shall find that the additional criteria for a preliminary plan have also been met.:

- The proposed subdivision is in general conformance with the goals, objectives, and policies of the Master Plan;
- The subdivision is consistent with the purposes of this Code;
- The subdivision is in conformance with the subdivision design standards and any approved sketch plan;
- A sufficient water supply has been acquired in terms of quantity, quality, and dependability for the type of subdivision proposed, as determined in accordance with the standards set forth in the water supply standards [C.R.S. §30-28-133(6)(a)] and the requirements of Chapter 8 of this Code;
- A public sewage disposal system has been established and, if other methods of sewage disposal are proposed, the system complies with state and local laws and regulations, [C.R.S. §30-28-133(6) (b)] and the requirements of Chapter 8 of this Code;
- All areas of the proposed subdivision, which may involve soil or topographical conditions presenting hazards or requiring special precautions, have been identified and the proposed subdivision is compatible with such conditions. [C.R.S. §30-28-133(6)(c)];
- Adequate drainage improvements complying with State law [C.R.S. §30-28-133(3)(c)(VIII)] and the requirements of this Code and the ECM are provided by the design;
- The location and design of the public improvements proposed in connection with the subdivision are adequate to serve the needs and mitigate the effects of the development;
- Legal and physical access is or will be provided to all parcels by public rights-of-way or recorded easement, acceptable to the County in compliance with this Code and the ECM;
- The proposed subdivision has established an adequate level of compatibility by (1) incorporating natural physical features into the design and providing sufficient open spaces considering the type and intensity of the subdivision; (2) incorporating site planning techniques to foster the implementation of the County's plans, and encourage a land use pattern to support a balanced transportation system, including auto, bike and pedestrian traffic, public or mass transit if appropriate, and the cost effective delivery of other services consistent with adopted plans, policies and regulations of the County; (3) incorporating physical design features in the subdivision to provide a transition between the subdivision and adjacent land uses; (4) incorporating identified environmentally sensitive areas, including but not limited to, wetlands and wildlife corridors, into the design; and (5) incorporating public facilities or infrastructure, or provisions therefore, reasonably related to the proposed subdivision so the proposed subdivision will not negatively impact the levels of service of County services and facilities;
- Necessary services, including police and protection, recreation, utilities, open space and transportation system, are or will be available to serve the proposed subdivision;

- The subdivision provides evidence to show that the proposed methods for fire protection comply with Chapter 6 of this Code; and
- The proposed subdivision meets other applicable sections of Chapter 6 and 8 of this Code.

**D. LOCATION**

|                                   |               |
|-----------------------------------|---------------|
| North: RR-0.5 (Residential Rural) | Residential   |
| South: R-4 (Planned Development)  | Woodmoor Lake |
| East: R-4 (Planned Development)   | Residential   |
| West: R-4 (Planned Development)   | Residential   |

**E. BACKGROUND**

The property was zoned R-4 (Planned Development) in 1972. The R-4 zoning district allowed for 110 townhomes with an overall density of 9.6 dwelling units per acre. In 1974 the two (2) acres immediately west of the subject parcel were platted as The Cove at Woodmoor, which created 20 condominium units. Then in 1979 the westernmost four (4) acres of the overall R-4 development plan was platted as the Waterside Condominiums with 40 additional condominium units. The subject parcel is the remainder of the R-4 zoning district, which would allow for 50 additional dwelling units, for an overall density of 5.2 dwelling units per acre.

The applicant is proposing a map amendment of the 7.23 acre parcel from the R-4 zoning district to the PUD (Planned Unit Development) zoning district to allow for 28 single-family attached residential lots with an overall density of 3.87 dwelling units per acre.

**F. ANALYSIS**

**1. Land Development Code Analysis**

This application meets the preliminary plan submittal requirements, the standards for Divisions of Land in Chapter 7, and the standards for Subdivision in Chapter 8 as well as the Planned Unit Development (PUD) requirements outlined in Chapter 4 of the El Paso County Land Development Code (2019).

**2. Zoning Compliance**

The PUD Development Plan identifies allowed and permitted uses; use, density, and dimensional standards such as setbacks, maximum lot coverage, and maximum building height; and overall landscaping requirements. The PUD Development Plan is consistent with the proposed PUD development guidelines and with the submittal and processing requirements of the Land Development Code.

### 3. Policy Plan Analysis

The El Paso County Policy Plan (1998) has a dual purpose; it serves as a guiding document concerning broader land use planning issues, and provides a framework to tie together the more detailed sub-area elements of the County Master Plan. Relevant policies are as follows:

***Policy 6.1.3*** – Encourage new development which is continuous and compatible with previously developed areas in terms of factors such as density, land use, and access.

***Policy 6.1.11*** - Plan and implement land development so that it will be functionally and aesthetically integrated within the context of adjoining properties and uses.

***Policy 6.1.13*** - Encourage the use of carefully planned and implemented clustering concepts in order to promote efficient land use, conservation of open space and reduction of infrastructure costs.

***Policy 6.2.2*** – Promote the unique identity of neighborhoods through the use of focal points, parks, trails and open spaces, preservation of significant natural features, compatible location and design of mixed uses, and promotion of pedestrian and other non-motorized means of travel.

The property is encumbered by a significant natural feature which includes wetlands and floodplain. The applicant is proposing to utilize a clustered design to reserve approximately 4.3 acres (59 percent of the overall area) in open space tracts to preserve this natural feature. Please see the floodplain section below for additional background regarding the floodplain.

The parcels north of the proposed development are within the RR-0.5 zoning district and range in size from half of an acre to just over one acre in size. Lots in the Lake Woodmoor subdivision located adjacent to the east are zoned R-4 and range in lot size from 6,900 to 11,000 square feet. The condominium development located west of the subject parcel, which is known as The Cove at Woodmoor, has an overall density of 10 dwelling units per acre. The proposed lots in the North Bay PUD range in size from approximately 2,100 square feet to approximately 4,800 square feet.

The proposed North Bay PUD includes 28 dwelling units with an overall density of 3.78 dwelling units per acre, which represents a decrease in density from the previously approved 9.6 dwelling units per acre, pursuant to the current R-4 zoning(PCD File No. R4-72-006), which allows for the development of 50 dwelling units.



#### **4. Small Area Plan Analysis**

The property is located in the Woodmoor Subarea of the Tri-Lakes Comprehensive Plan (1999). The Woodmoor Subarea Land Use Scenario (page 118) recommends “new residential development should be consistent with, compatible with, or larger than existing lot sizes”. As discussed in the Policy Plan section above, the proposed North Bay PUD includes lot sizes that are comparable with adjacent residential developments.

#### **5. Water Master Plan Analysis**

The El Paso County Water Master Plan (2018) has three main purposes: better understand present conditions of water supply and demand; identify efficiencies that can be achieved; and encourage best practices for water demand management through the comprehensive planning and development review processes. Relevant policies are as follows:

**Goal 1.1** – Ensure an adequate water supply in terms of quantity, dependability, and quality for existing and future development.

**Goal 1.2** – Integrate water and land use planning.

**Policy 6.0.11** – Continue to limit urban level development to those areas served by centralized utilities.

The proposed development includes lots to be served by central water and wastewater systems with an overall density of 3.78 dwelling units per acre. Water sufficiency has been analyzed with the review of the proposed PUDSP. Please see the Water section below for a summary of the water findings and recommendations for the proposed development. The State Engineer and the County Attorney’s Office have recommended that the proposed development has an adequate water supply in terms of quantity and dependability.

#### **6. Other Master Plan Elements**

The El Paso County Wildlife Habitat Descriptors (1996) identifies the parcels as having a high wildlife impact potential. El Paso County Community Services Department, Environmental Division, and Colorado Parks and Wildlife were each sent a referral and have no outstanding comments.

The Master Plan for Mineral Extraction (1996) identifies potential upland deposits in the area of the subject parcels. A mineral rights certification was prepared by the applicant indicating that, upon researching the records of El Paso County, no severed mineral rights exist.

Please see the Parks Section below for information regarding conformance with The El Paso County Parks Master Plan (2013).

Please see the Transportation Section below for information regarding conformance with the 2016 Major Transportation Corridor Plan (MTCP).

## **G. PHYSICAL SITE CHARACTERISTICS**

### **1. Hazards**

The property is encumbered by floodplain. Please review the floodplain section below.

### **2. Wildlife**

The El Paso County Wildlife Habitat Descriptors (1996) identifies the parcels as having a high wildlife impact potential.

The property is not contain occupied Preble's Meadow Jumping Mouse habitat.

The property is encumbered by jurisdictional wetlands. The applicant has designated these areas as "No Build" and will not disturb the wetlands except for minor disturbances related to the creek improvements approved by the Federal Emergency Management Agency (FEMA). In preparation for these minor disturbances the applicant received verification on June 9, 2017, from the Army Corp of Engineers that the proposed work is authorized by the Nation-Wide Permit 29 Residential Development and that the proposed work will not require an additional permit or approval from the Army Corp of Engineers.

### **3. Floodplain**

FEMA Flood Insurance Rate Map (FIRM) No. 08041C0276G, which has an effective date of December 7, 2018, shows the 100-year floodplain (Zone AE) of Dirty Woman Creek-Lake Fork flowing through the property. On June 5, 2017, the applicant obtained an approved Conditional Letter of Map Revision (CLOMR), case number 17-08-0195R, for the proposed modification of the existing floodplain. The CLOMR does not result in a change to the FIRM but indicates that if creek improvements are built as proposed, then the proposed modification of the existing floodplain would be recognized by FEMA.

The applicant may not initiate the necessary improvements without approval of either early grading in association with a preliminary plan or grading with the final plat. The applicant has requested administrative approval of a concurrently reviewed final plat application. Following the approval of the final plat and an associated grading and erosion control plan the applicant may begin the necessary floodplain improvements.

Once creek improvements have been completed, the applicant must process an application with FEMA to obtain a Letter of Map Revision (LOMR) which formalizes the changes to the floodplain. The LOMR is required prior to recording of the final plat.

#### **4. Drainage and Erosion**

The site is in the Dirty Woman Creek (FOMO5200) drainage basin, which was studied in 1993. Drainage and bridge fees are required with the final plat.

The site generally drains to the south. Stormwater runoff will be collected by a storm sewer system and will be directed into two sand filter basins and a stormceptor system for water quality treatment. These facilities are private and will be maintained by the homeowners association. Flood control detention is provided off-site within Lake Woodmoor. Woodmoor Water and Sanitation District, which owns Lake Woodmoor, has provided a letter dated August 24, 2017, confirming they have no concerns with this subdivision utilizing the lake for flood control detention. The drainage basin planning study (DBPS) for Dirty Woman Creek identified three check structures which will be constructed as part of this development.

#### **5. Transportation**

The 2016 Major Transportation Corridors Plan Update (MTCP) does not call for any improvement projects in the immediate vicinity of the site. The site is located approximately 700 feet east of the Woodmoor Drive and Deer Creek Road intersection. The proposed residential development includes two access roads along Deer Creek Road. All interior roadways are planned to be privately owned and maintained by the homeowners association. The development will be subject to the County Road Impact Fee Program and these fees shall be paid at the time of building permit issuance.

### **H. SERVICES**

#### **1. Water**

The Woodmoor Water and Sanitation District provides water service and has committed to serve the property.

Sufficiency:

Quality: Sufficient

Quantity: Sufficient

Dependability: Sufficient

Attorney's summary: The State Engineer's Office has made a finding of adequacy and has stated water can be provided without causing injury to decreed water rights.

The County Attorney's Office has recommended a finding of sufficiency with regard to water quantity and dependability. El Paso County Public Health has made a favorable recommendation regarding water quality.

**2. Sanitation**

Wastewater service will be provided by Woodmoor Water and Sanitation District.

**3. Emergency Services**

The property is within the Tri-Lakes Monument Fire Protection District. The District was sent a referral and have no outstanding comments.

**4. Utilities**

Mountain View Electric Association (MVEA) will provide electrical service to the property. Black Hills Energy will provide natural gas services to the property.

**5. Metropolitan Districts**

The property is not within a metropolitan district.

**6. Parks/Trails**

Land dedication and fees in lieu of park land dedication are not required for a map amendment (rezoning) or preliminary plan application. Fees in lieu of park land dedication will be due at the time of recording the final plat. The El Paso County Parks Master Plan (2013) does not identify any trails or parks in the vicinity.

**7. Schools**

Land dedication and fees in lieu of school land dedication are not required for a map amendment (rezoning) or preliminary plan application. Fees in lieu of school land dedication will be due at the time of recording the final plat.

**I. APPLICABLE RESOLUTIONS**

See Attached Resolution

**J. STATUS OF MAJOR ISSUES**

There are no major outstanding issues.

**K. RECOMMENDED CONDITIONS AND NOTATIONS**

Should the Planning Commission and the Board of County Commissioners find that the request meets the criteria for approval outlined in Section 4.2.6, and Section 7.2.1 of the El Paso County Land Development Code (2019), staff recommends the following conditions and notations:

## **CONDITIONS**

1. Development of the property shall be in accordance with this PUD development plan. Minor changes in the PUD development plan, including a reduction in residential density, may be approved administratively by the Director of the Planning and Community Development Department consistent with the Land Development Code. Any substantial change will require submittal of a formal PUD development plan amendment application.
2. Approved land uses are those defined in the PUD development plan.
3. All owners of record must sign the PUD development plan.
4. The PUD development plan shall be recorded in the office of the El Paso County Clerk & Recorder prior to scheduling any final plats for hearing by the Planning Commission. The development guide shall be recorded in conjunction with the PUD development plan.
5. Developer shall comply with federal and state laws, regulations, ordinances, review and permit requirements, and other agency requirements, if any, of applicable agencies including, but not limited to, the Colorado Parks and Wildlife, Colorado Department of Transportation, U.S. Army Corps of Engineers and the U.S. Fish and Wildlife Service regarding the Endangered Species Act, particularly as it relates to the Preble's Meadow Jumping Mouse as a listed threatened species.
6. Applicable park, school, drainage, bridge, and traffic fee shall be paid to El Paso County Planning and Community Development at the time of final plat(s) recordation.

## **NOTATIONS**

1. Approval of the preliminary plan portion of this application authorizes future final plat filings to be approved administratively.
2. If a zone or rezone petition has been disapproved by the Board of County Commissioners, resubmittal of the previously denied petition will not be accepted for a period of one (1) year if it pertains to the same parcel of land and is a petition for a change to the same zone that was previously denied. However, if evidence is presented showing that there has been a substantial change in physical conditions or circumstances, the Planning Commission may reconsider said petition. The time limitation of one (1) year shall be computed from the date of final determination by the Board of County Commissioners or, in the event of court litigation, from the date of the entry of final judgment of any court of record.

3. Rezoning requests not forwarded to the Board of County Commissioners for consideration within 180 days of Planning Commission action will be deemed withdrawn and will have to be resubmitted in their entirety.
4. Preliminary plans not forwarded to the Board of County Commissioners within 12 months of Planning Commission action shall be deemed withdrawn and shall have to be resubmitted in their entirety.
5. Approval of the preliminary plan will expire after two (2) years unless a final plat has been approved and recorded or a time extension has been granted.

**L. PUBLIC COMMENT AND NOTICE**

The Planning and Community Development Department 24 adjoining property owners on April 30, 2020, for the Planning Commission meeting. Responses will be provided at the hearing.

**M. ATTACHMENTS**

Vicinity Map  
Letter of Intent  
Development Plan / Preliminary Plan  
State Engineer Letter  
County Attorney Letter  
El Paso County Health Department Letter

# El Paso County Parcel Information

File Name: PUDSP-16-004

| PARCEL     | NAME                       |
|------------|----------------------------|
| 7111404111 | LAKE WOODMOOR HOLDINGS LLC |
| 7111400007 | LAKE WOODMOOR HOLDINGS LLC |

Zone Map No. --

| ADDRESS                 | CITY             | STATE |
|-------------------------|------------------|-------|
| 1755 TELSTAR DR STE 211 | COLORADO SPRINGS | CO    |
| 1755 TELSTAR DR STE 211 | COLORADO SPRINGS | CO    |

| ZIP   | ZIPLUS |
|-------|--------|
| 80920 | 1018   |
| 80920 | 1018   |

Date: April 28, 2020



Please report any parcel discrepancies to:  
 El Paso County Assessor  
 1675 W. Garden of the Gods Rd.  
 Colorado Springs, CO 80907  
 15 520-6600



COPYRIGHT 2018 by the Board of County Commissioners, El Paso County, Colorado. All rights reserved. No part of this document or data contained hereon may be reproduced; used to prepare derivative products; or distributed without the specific written approval of the Board of County Commissioners, El Paso County, Colorado. This document was prepared from the best data available at the time of printing. El Paso County, Colorado, makes no claim as to the completeness or accuracy of the data contained hereon.

---

## NORTH BAY AT LAKE WOODMOOR

### LETTER OF INTENT

NOVEMBER 2016, REVISED FEBRUARY 2020

**OWNER/APPLICANT:**

Lake Woodmoor Holdings LLC  
1755 Telstar Drive, Suite 211  
Colorado Springs CO 80920

**CONSULTANT:**

N.E.S. Inc.  
619 North Cascade Avenue  
Colorado Springs, Colorado 80903

---

### LOCATION

North Bay at Lake Woodmoor is located southeast of the intersection of Woodmoor Drive and Deer Creek Road. Deer Creek Road forms the northern boundary of the property and Lake Woodmoor lies to the south. To the west is The Cove at Woodmoor condominium development and to the east is an open and forested common area owned by the Woodmoor Improvement Association (WIA), beyond which is Lake Woodmoor single-family residential neighborhood. The site comprises approximately 7.23 acres.

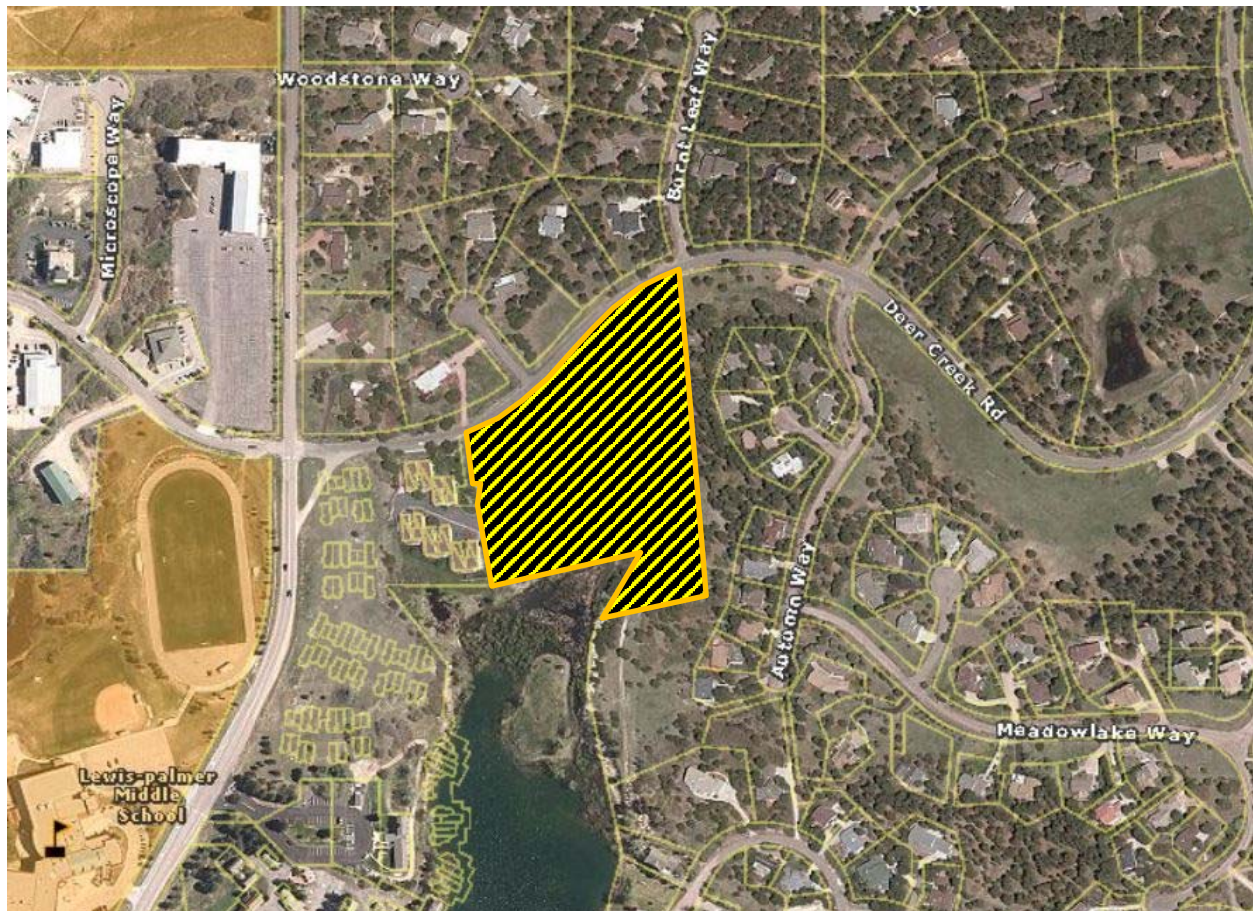



## REQUEST

Lake Woodmoor Holdings LLC requests approval of the following applications:

1. A Rezone from R-4 (Planned Development District – Obsolete) to PUD (Planned Unit Development District);
2. A PUD Development/Preliminary Plan for North Bay at Lake Woodmoor for a 28-unit townhome development on 7.23 acres, at a gross density of 3.87 dwelling units per acre and a maximum height of 30 feet, including PUD modifications; and
3. A Final Plat for North Bay at Woodmoor for 28 lots and 5 tracts on 7.23 acres.

## HISTORY

The property is part of a larger parcel for which a Development Plan was approved in 1972. The approved plan proposed 110 townhomes on 11.4 acres; a density of 9.6 dwelling units per acre. In 1974, two acres were platted for 20 Condominium units at The Cove at Woodmoor, which lies immediately west of the subject property (yellow). In 1979, four acres to the west of the Cove at Woodmoor were platted as the Waterside Condominiums (blue), which accounted for a further 40 units of the 110 units originally approved. The remaining 5.4 acres of the 1972 plan is part of the current PUD application site and would have accommodated the remaining 50 units approved by the 1972 Plan (red).

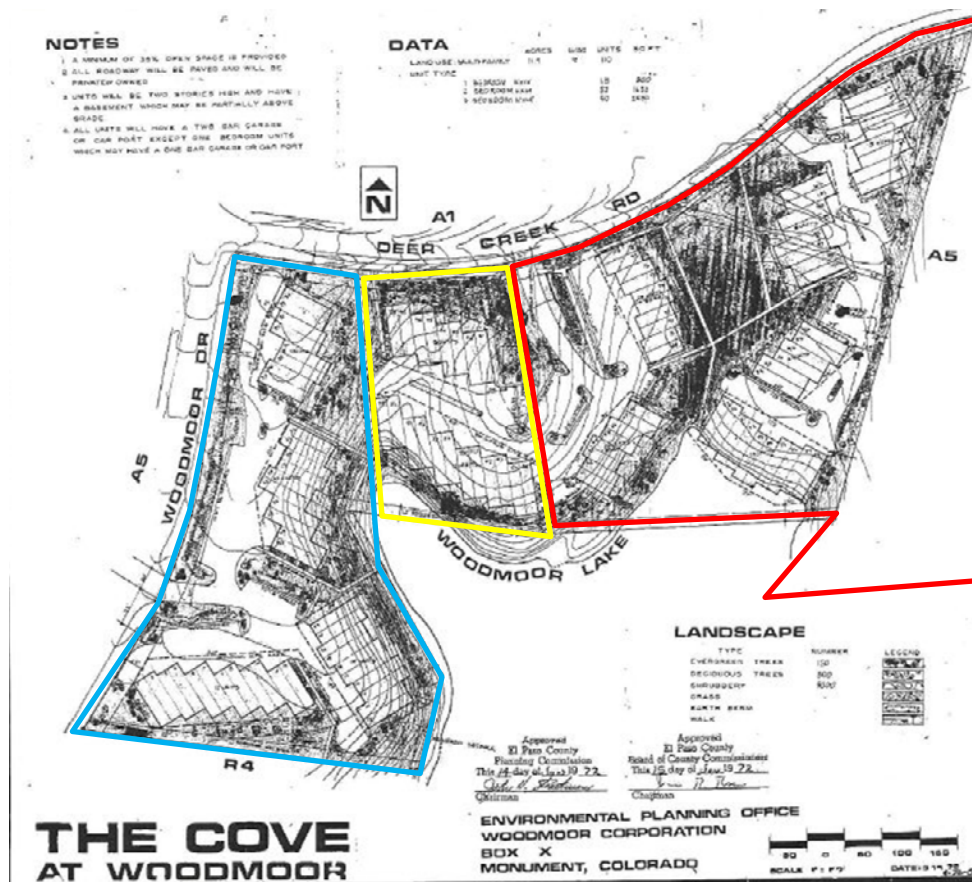

---

**SITE DESCRIPTION**

The site comprises undulating grassland with scattered trees and more substantial wooded areas along the eastern and southern boundaries.

The central part of the site is within the floodplain and there are wetland areas in the northeast corner of the property and adjacent to Lake Woodmoor.

A number of informal trails currently cross the site providing access to the lake.



There is an existing utility road off Deer Creek Road that provides access to the lift station in the southeast corner of the site.

The dense wooded tract along the eastern boundary of the site that is owned by the WIA provides a substantial buffer to the existing single-family residential neighborhood beyond.

Adjacent to the site's western boundary is The Cove at Woodmoor Condominium development. The western section of the site includes part of the access road and parking area for condominiums. The right to use this area for such purposes is provided by a non-exclusive access easement.



**PROJECT JUSTIFICATION**

The property and the wider area to the south, west, and east are zoned R-4, which is an obsolete zoning for Planned Development. Any new development proposal for the property requires a rezoning.

It is proposed to rezone the property to PUD as this is the current equivalent of the old R-4 zoning and is therefore compatible with the surrounding R-4 zoning. The PUD zoning also allows for flexibility in the dimensional and design standards needed to accommodate the proposed townhome product and enable the protection of the floodway and wetlands areas and other open space.

The PUD Development/Preliminary Plan proposes the construction of 28 townhomes in a combination of duplexes, triplexes and fourplexes at a gross density of 3.87 dwelling units per acre. This is significantly less dense than the approved 1972 plan. The maximum height of the buildings is 30 feet and each unit will have a two-car garage. An additional 27 parking spaces are provided within the development.

PUD Modifications are requested for the use of private roads and for the requirement that private roads be constructed and maintained to ECM standards. The requested PUD modifications meet the criteria in Chapter 4.2.6.F.2.h of the Land Development Code, as they will achieve the goal of preserving natural features and providing additional open space.

PUD Modifications and Deviations are requested as follows:

|   | <b>LDC/ECM Section</b>                                | <b>Category</b>  | <b>Standard</b>   | <b>Modification</b>  | <b>Justification</b>   |
|---|---|--|---|--|--|
| 1 | LDC Chapter 8.4.4(E)(2)                               | Private Roads Require Waiver                             | Use of private roads shall be limited.                              | Private roads proposed to serve only this subdivision.                         | Private roads provide more flexibility for the development to accommodate the physical constraints of the site and retain natural features. The private roads will be owned and maintained by the Home Owners Associations.  |
| 2 | LDC Chapter 8.4.4(E)(3)                               | Private Roads to meet County standards.                  | Private roads shall be constructed and maintained to ECM standards. | Road width, centerline radius and roadway terminations (see 3, 4, and 5 below) |  |
| 3 | ECM Section 2.2.4.B.7, Figure 2-17, and ECM Table 2-7 | Typical Urban Local (Low Volume) Cross Section           | 24' Paved Width, 12' Lane Width                                     | 21'-8" Paved Width, 10'-10" Lane Width   | A smaller road cross-section, compact road design, and the use of a hammerhead turnaround will achieve the goal of retaining natural features and open space. The Tri-Lakes Monument Fire Department has approved the hammerhead turnaround for emergency access. ECM standard does not take into account reduction in speed due to the T-intersection at SW end of Redbridge Point. Sight distance is |
| 4 | ECM Section 2.3, Table 2-7                            | Minimum centerline curve radius (urban local-low volume) | 100' CL Radius  | 40' CL Radius on Redbridge Point   |  |
| 5 | ECM Section 2.3.4.A.2, Table 2-14                     | Sag Vertical Curve                                       | K value = 26 for Design Speed = 25 MPH                              | K value = just over 8  |  |

|   |                     |   |   |  |   |
|---|---------------------|---|---|--|---|
| 6 | ECM Section 2.3.8   | Roadway Terminations                        | Urban Cul-de-Sac - Permanent hammerhead turnarounds not permitted | Permanent hammerhead turnaround proposed on Shoreditch Heights   | 62.8 feet with distance to T-intersection of approx. 50 ft.   |
| 7 | ECM Section 2.2.5.E | Intersection spacing on rural local roadway | 330' separation   | 226' between Redbridge Point and Shoreditch Heights and 236' between Shoreditch Heights and Burnt Leaf Way | The site is divided by a floodway and two points of access are required to serve the east and west sides of the development. The floodway and existing utilities limit the options for access locations to this property. |

Further justification for the proposed deviations from the ECM (#3-#7) are provided in **Appendix A**.

**PUD Zoning Approval Criteria**

Chapter 4.2.6.D of the LDC allows the combination of a preliminary plan with a PUD development plan, provided all review and approval standards for both the PUD development plan and preliminary plan are met.

The PUD Development/Preliminary Plan for North Bay at Lake Woodmoor is consistent with the PUD zoning approval criteria set forth in Chapter 4.2.6.D of the LDC as follows:

**1. The application is in general conformity with the Master Plan;**

The proposed residential subdivision satisfies the following policies of the County Policy Plan:

*Policy 6.1.3: Encourage new development which is contiguous and compatible with previously developed areas in terms of factors such as density, land use and access.*

*Policy 6.1.11: Plan and implement land development so that it will be functionally and aesthetically integrated within the context of adjoining properties and uses.*

The site lies within the Woodmoor Sub-Area of the Tri-Lakes Area Comprehensive Plan and almost the entirety of the sub-area is identified as medium density residential development on the Tri-Lakes Area Concept plan. This development is consistent with the intent of the Comprehensive Plan as it is lower in density than the adjacent townhome development to the west and the previously approved town home project on the property.

**2. The proposed development is in compliance with the requirements of this Code and all applicable statutory provisions and will not otherwise be detrimental to the health, safety, or welfare of the present or future inhabitants of El Paso County;**

The proposed development compiles with the requirements of the LDC and will not be detrimental to the health, safety, or welfare of the present or future inhabitants of El Paso County. The project proposes less density than was previously proposed for this property and, unlike the previous proposal, retains a substantial area of open space and provides trail connections to the lake and

adjacent neighborhoods. The project also offers alternative housing design to reduce environmental footprint by improving efficiencies and preserving more open space.

PUD Modifications are requested for the use of private roads and for the requirement that private roads be constructed and maintained to ECM standards. These modifications are described above.

- 3. The subject property is suitable for the intended uses and the use is compatible with both the existing and allowed land uses on the neighboring properties, will be in harmony and responsive with the character of the surrounding area and natural environment; and will not have a negative impact upon the existing and future development of the surrounding area;**

The proposed townhome development is consistent with the existing R-4 zoning and the previously approved Development Plan for the property and is therefore a suitable use for the property. The townhome development is harmonious with the existing and proposed uses surrounding the property, which comprise condominiums to the west and single-family residential to the east.

The central part of the site includes floodplain and wetlands. A Conditional Letter of Map Revision (CLOMR) has been approved by FEMA for the adjustment of the floodplain. The project avoids the jurisdictional wetlands on the property.

The Geotechnical Report prepared by CTL Thompson Inc. identifies existing geological conditions to include expansive or very hard, shallow bedrock, shallow groundwater, erosion potential and flood potential. These conditions can all be mitigated with engineering design and construction methods commonly used in the area, such as spread footing foundations and slab-on-grade floors, as well as minimizing irrigation of landscaping to reduce problems associated with expansive soils.

- 4. The proposed development provides adequate consideration for any potentially detrimental use to use relationships (e.g. commercial use adjacent to single family use) and provides an appropriate transition or buffering between uses of differing intensities both on-site and off-site which may include innovative treatments of use to use relationships;**

The proposed PUD zoning for a townhome development will provide an appropriate transition between the less dense single-family residential to the east, and the more dense townhome development to the west. There is a substantial existing tree buffer of approximately 70 to 130 feet wide between the site and the single-family residential to the east. Additional landscaping is to be provided with this plan to supplement this buffer and replace any trees that may be removed.

- 5. The allowed uses, bulk requirements and required landscaping and buffering are appropriate to and compatible with the type of development, the surrounding neighborhood or area and the community;**

The bulk of the proposed townhomes and the associated landscaping and buffering are compatible with the surrounding area.

- 6. Areas with unique or significant historical, cultural, recreational, aesthetic or natural features are preserved and incorporated into the design of the project;**

The natural features on the site have been preserved wherever possible and incorporated into the site design. The wetland areas have been preserved. A Conditional Letter of Map Revision (CLOMR) has been requested from FEMA for the realignment of the flood way.

**7. Open spaces and trails are integrated into the development plan to serve as amenities to residents and provide a reasonable walking and biking opportunities;**

The development includes a large central open space that accounts for approximately 59% of the total site area. Walking trails have been incorporated, which are intended for public use to access Lake Woodmoor.

**8. The proposed development will not overburden the capacities of existing or planned roads, utilities and other public facilities (e.g. fire protection, police protection, emergency services, and water and sanitation), and the required public services and facilities will be provided to support the development when needed;**

All necessary utility and fire protection commitments have been obtained. The traffic report demonstrates that the development is within the capacity of existing roads.

**9. The proposed development would be a benefit through the provision of interconnected open space, conservation of environmental features, aesthetic features and harmonious design, and energy efficient site design;**

The development conserves environmental features and provides interconnected open space and trails.

**10. The proposed land use does not permit the use of any area containing a commercial mineral deposit in a manner which would unreasonably interfere with the present or future extraction of such deposit unless acknowledged by the mineral rights owner;**

There are no mineral rights owners on this property.

**11. Any proposed exception or deviation from the requirements of the zoning resolution or the subdivision regulations is warranted by virtue of the design and amenities incorporated in the development plan and development guide; and**

No deviations are requested.

**12. The owner has authorized the application.**

Yes.

**Preliminary Plan Approval Criteria**

The PUD Development/Preliminary Plan for North Bay at Lake Woodmoor is also consistent with the Preliminary Plan approval criteria set forth in Chapter 7.2.1.D.2.e of the LDC as follows:

**1. The proposed subdivision is in general conformance with the goals, objectives, and policies of the Master Plan;**

The site lies within the Woodmoor Sub-Area of the Tri-Lakes Area Comprehensive Plan and almost the entirety of the sub-area is identified as medium density residential development on the Tri-Lakes Area Concept plan. This development is consistent with the intent of the Comprehensive Plan as it is lower in density than the adjacent townhome development to the west and the previously approved town home project on the property.

**2. The subdivision is consistent with the purposes of this Code;**

The stated purpose of the Code is to preserve and improve the public health, safety and general welfare of the citizens and businesses of El Paso County. This proposed townhome development will provide new and affordable housing opportunities that will benefit the citizens of El Paso County.

**3. The subdivision is in conformance with the subdivision design standards and any approved sketch plan;**

There is no approved sketch plan for this property. The subdivision design standards are met with the exception of the PUD modifications described above and as addressed by the submitted deviations for the project. Deviations are submitted for the modifications to the ECM identified in the PUD modifications table, as well as for the intersection spacing on Deer Creek Road and for providing an alternative BMP for stormwater quality treatment.

**4. A sufficient water supply has been acquired in terms of quantity, quality, and dependability for the type of subdivision proposed, as determined in accordance with the standards set forth in the water supply standards [C.R.S. §30-28-133(6)(a)] and the requirements of Chapter 8 of this Code;**

A sufficient water supply is available as demonstrated in the Water Resources and Wastewater Treatment Report prepared by Kiowa Engineering Corporation and through the water supply commitment from Woodmoor Water & Sanitation District.

**5. A public sewage disposal system has been established and, if other methods of sewage disposal are proposed, the system complies with state and local laws and regulations, [C.R.S. §30-28-133(6)(b)] and the requirements of Chapter 8 of this Code;**

Public sewage disposal is addressed in the Water Resources and Wastewater Treatment Report prepared by Kiowa Engineering Corporation.

**6. All areas of the proposed subdivision, which may involve soil or topographical conditions presenting hazards or requiring special precautions, have been identified and the proposed subdivision is compatible with such conditions. [C.R.S. §30-28-133(6)(c)];**

The central part of the site includes floodplain and wetlands. A Conditional Letter of Map Revision (CLOMR) has been approved by FEMA for the adjustment of the floodplain. The project avoids the jurisdictional wetlands on the property.

The Geotechnical Report prepared by CTL Thompson Inc. identifies existing geological conditions to include expansive or very hard, shallow bedrock, shallow groundwater, erosion potential and flood potential. These conditions can all be mitigated with engineering design and construction methods commonly used in the area, such as spread footing foundations and slab-on-grade floors, as well as minimizing irrigation of landscaping to reduce problems associated with expansive soils.

**7. Adequate drainage improvements complying with State law [C.R.S. §30-28-133(3)(c)(VIII)] and the requirements of this Code and the ECM are provided by the design;**

These matters are addressed in the Drainage Report, the grading and erosion control plan, and the construction drawings for stormwater facilities, all prepared by Kiowa Engineering Corporation

**8. Legal and physical access is or will be provided to all parcels by public rights-of-way or recorded easement, acceptable to the County in compliance with this Code and the ECM;**

The project is divided by the floodway into two halves that will be accessed via individual private streets off Deer Creek Road. The eastern section of the site will be served by a dead-end road that serves 14 units and continues to provide utility access to the lift station. The remaining 14 units in the western section of the development will be served via a loop road that utilizes the existing access road for the condominiums. As part of this development it is proposed to resurface and stripe the parking area which will provide a more efficient parking configuration.

**9. The proposed subdivision has established an adequate level of compatibility by**

**1) incorporating natural physical features into the design and providing sufficient open spaces considering the type and intensity of the subdivision;**

A substantial part of this project will remain as open space and serve as an amenity for residents. It is not proposed to provide public access to the floodway area but new trail connections are proposed that will continue the public access to the lake area.

**2) incorporating site planning techniques to foster the implementation of the County's plans, and encourage a land use pattern to support a balanced transportation system, including auto, bike and pedestrian traffic, public or mass transit if appropriate, and the cost effective delivery of other services consistent with adopted plans, policies and regulations of the County;**

Appropriate provision is made in this regard given the context of the site and surrounding area. The plan was designed to minimize cost of transportation and utility infrastructure improvements.

**3) incorporating physical design features in the subdivision to provide a transition between the subdivision and adjacent land uses;**

Landscaping is included to buffer the development from adjacent uses where appropriate.

**4) incorporating identified environmentally sensitive areas, including but not limited to, wetlands and wildlife corridors, into the design; and**

As part of this application, a revised flood way is proposed and the wetland areas will be protected from development impact. This contrasts with the 1972 approved development which proposed a more extensive development of the site. A detailed analysis of the natural features, wildlife and wetlands is provided in the accompanying ECOS environmental report.

**5) incorporating public facilities or infrastructure, or provisions therefore, reasonably related to the proposed subdivision so the proposed subdivision will not negatively impact the levels of service of County services and facilities;**



The Traffic Report by LSC Transportation Consultants Inc. demonstrates that the development will not materially impact existing levels of service on surrounding County Roads. The reports relating to water supply, wastewater treatment and drainage demonstrate that there will be no negative impact on the levels of service of County services and facilities

**10. Necessary services, including police and protection, recreation, utilities, open space and transportation system, are or will be available to serve the proposed subdivision;**

There are numerous utilities and utility easements that cross this site and a number of these are to be relocated to facilitate the development project, as depicted on the accompanying utility plans. Water and sanitary sewer service is to be provided by Woodmoor Water and Sanitation District and Mountain View Electric Association Inc. and Black Hills Energy will provide electric and natural gas services to the subdivision respectively. The required Will Serve letters are included with the submittal.

**11. The subdivision provides evidence to show that the proposed methods for fire protection comply with Chapter 6 of this Code; and**

The site lies within the Tri-Lakes Monument Fire Protection District. A will serve letter from the FPD and a Fire Protection Report are included with the submittal.

**12. The proposed subdivision meets other applicable sections of Chapter 6 and 8 of this Code.**

The proposed subdivision meets the applicable sections of these parts of the Code.

**Final Plat**

A Final Plat is submitted for 28 lots and 5 tracts, two of which are for private streets. The Final Plat accords with the approval criteria set forth in Section 7.2.1.D.3.f of the LDC, which are broadly the same as those for the Preliminary Plan referenced above. The additional criteria are that the Final Plat should be consistent with the Preliminary Plan, which it clearly is, and that any off-site impacts are addressed in a Subdivision Improvement Agreement (SIA). The SIA and CC&Rs will be submitted prior to the recording of the Final Plat.

**ACCOMPANYING REPORTS:**

The following Reports are submitted to support this application:

Geotechnical Report by CTL Thompson Inc.

Traffic Report by LSC Transportation Consultants Inc.

Final Drainage Report by Kiowa Engineering Corporation

Water Resources and Wastewater Treatment Report by Kiowa Engineering Corporation

Environmental Report by ECOS Ecosystems Services LLC

**APPENDIX A:**  
**NORTH BAY AT LAKE WOODMOOR: JUSTIFICATION FOR PROPOSED DEVIATIONS**

Chapter 4.2.6.F.2.g of the Land Development Code (LDC) allows for a PUD modification of a general development standard in the LDC or criteria of the Engineering Criteria Manual (ECM), provided at least one of the benefits identified in Chapter 4.2.6.F.2.h are met. Section 5.8 of the ECM establishes an additional mechanism whereby an engineering design standard can be modified provided the limits of consideration in ECM Section 5.8.6 are met and the modifications meets the criteria for approval in ECM Section 5.8.7.

The following deviations to the ECM are requested for the North Bay Development (numbers correspond to PUD modification table on the PUD cover sheet and in the Letter of Intent).

**#3 - Typical Urban Local (Low Volume) Cross-section**

**Nature of Request:**

Section of ECM from which Deviation Is Sought: 2.2.4.B.7

Specific Criteria from which a Deviation Is Sought: Figure 2-17, and ECM Table 2-7, Typical Urban Local (Low Volume) Cross-section.

Proposed Nature and Extent of Deviation: 21'-8" paved width with 10'10" lanes where 24' paved width with 12' lanes required.

**ECM Section 5.8.6: Limits of Consideration:**

The ECM Administrator may only consider a project-specific deviation to an existing standard when **one** of the following conditions is met:

- The ECM standard is inapplicable to a particular situation.  
The ECM standard is too restrictive to allow for reasonable development of the site.
- Topography, right-of-way, or other geographical conditions or impediments impose an undue economic hardship on the applicant, and an equivalent alternative that can accomplish the same design objective is available and does not compromise public safety or accessibility.  
Due to the site topographical constraints and goal of retaining natural features and open space for the project site.
- A change to a standard is required to address a specific design or construction problem, and if not modified, the standard will impose an undue hardship on the applicant with little or no material benefit to the public.  
A relaxation of the ECM requirement is needed in order to develop the site. The private roads act much like a private parking lot and the slightly reduced lane widths should not cause undue impact.

**ECM Section 5.8.7: Criteria for Approval**

No deviation shall be approved unless it is demonstrated that:

- The request for a deviation is not based exclusively on financial considerations;  
The request is to preserve natural features and open space on the site.
- The deviation will achieve the intended result with a comparable or superior design and quality of improvement;

The request will allow for a design that provides the intended result of preserving natural features and open space on the site.

- The deviation will not adversely affect safety or operations;  
The slight reduction in lane width will not adversely affect safety operations. The road narrowing and light through traffic will result in lower speeds, helping with pedestrian safety. Tri-Lakes Monument Fire Department is aware of the roadway widths and has approved the layout.
- The deviation will not adversely affect maintenance and its associated cost; and  
While private snow removal may be affected by the request, the overall maintenance costs should not be impacted. The proposed roads within the development are private and will not be maintained by the County the deviation for intersection spacing would not adversely affect maintenance as the proposed streets would be private and will not be maintained by the County.
- The deviation will not adversely affect aesthetic appearance.  
The narrower street cross-section will have a smaller footprint that will retain more natural features and open space for the development. As a result, the request will not adversely impact aesthetic appearance.

#### **#4 - Minimum Centerline Radius**

##### **Nature of Request:**

Section of ECM from which Deviation Is Sought: ECM Section 2.3, Table 2-7

Specific Criteria from which a Deviation Is Sought: Typical Urban Local (Low Volume) Centerline Curve Radius

Proposed Nature and Extent of Deviation: Allow 40' radius where 100' is required.

##### **ECM Section 5.8.6: Limits of Consideration:**

The ECM Administrator may only consider a project-specific deviation to an existing standard when **one** of the following conditions is met:

- The ECM standard is inapplicable to a particular situation.  
The ECM standard is too restrictive to allow for the site layout and provide adequate space for buildings and floodway.
- Topography, right-of-way, or other geographical conditions or impediments impose an undue economic hardship on the applicant, and an equivalent alternative that can accomplish the same design objective is available and does not compromise public safety or accessibility.  
Due to the existing site constraints, right-of-way of Deer Creek Road, drainage, and The Cove development a reduction in curve radius is necessary to develop the site.
- A change to a standard is required to address a specific design or construction problem, and if not modified, the standard will impose an undue hardship on the applicant with little or no material benefit to the public.  
A relaxation of the ECM requirement is needed in order to develop the site. The private roads act much like a private parking lot and the reduced curve radii will tend to reduce speeds on the roadway. Utilities are unaffected by the reduced curve radii.

### ECM Section 5.8.7: Criteria for Approval

No deviation shall be approved unless it is demonstrated that:

- The request for a deviation is not based exclusively on financial considerations;  
*The request is necessary to allow the buildings, roadways, utilities, and drainageway to be laid out in the site given the site constraints.*
- The deviation will achieve the intended result with a comparable or superior design and quality of improvement;  
*The deviation will allow for the design to provide a layout that accommodates the proposed buildings, utilities, and drainageway.*
- The deviation will not adversely affect safety or operations;  
*The deviation will not adversely affect safety or operations due to the location of the curves being close to both ends of the roadway where speeds tend to be lower.*
- The deviation will not adversely affect maintenance and its associated cost; and  
*Redbridge Point is a private road that will not be maintained by the County.*
- The deviation will not adversely affect aesthetic appearance.  
*The narrower street cross-section with tighter centerline radius will have a smaller footprint that will retain the natural features and open space for the development. As a result, the requested deviation will not adversely impact aesthetic appearance.*

### #5 - Vertical Curve

#### **Nature of Request:**

Section of ECM from which Deviation Is Sought: 2.3.4.A.2, Figure 2-31.

Specific Criteria from which a Deviation Is Sought: Sag and crest vertical curve requirements on Redbridge Point.

Proposed Nature and Extent of Deviation: Proposed use of sag curve k-value of just over 8 and crest curve k-value of just over 3 at the southwest end of Redbridge Point where it ties into The Cove's existing access and parking.

#### **ECM Section 5.8.6: Limits of Consideration:**

The ECM Administrator may only consider a project-specific deviation to an existing standard when **one** of the following conditions is met:

- The ECM standard is inapplicable to a particular situation.  
*The ECM Standard does not take into account reduction in speed due to the T-intersection.*
- Topography, right-of-way, or other geographical conditions or impediments impose an undue economic hardship on the applicant, and an equivalent alternative that can accomplish the same design objective is available and does not compromise public safety or accessibility.  
*The location of the proposed tie-in to The Cove's existing parking and access is a site constraint that will reduce speed and lessen the necessary sight distance.*
- A change to a standard is required to address a specific design or construction problem, and if not modified, the standard will impose an undue hardship on the applicant with little or no material benefit to the public.  
*A reduction of the required k-values for the vertical curves are appropriate for the physical layout of the roadway connection.*

### **ECM Section 5.8.7: Criteria for Approval**

No deviation shall be approved unless it is demonstrated that:

- The request for a deviation is not based exclusively on financial considerations;  
*The request is based upon the existing site conditions and the location of the proposed roadway connection.*
- The deviation will achieve the intended result with a comparable or superior design and quality of improvement;  
*The request will allow for adequate sight distance given the given the location of the vertical curve to the T-intersection of the roadway.*
- The deviation will not adversely affect safety or operations;  
*The request will not adversely impact safety as the roadway speeds are reduced due to the location of the T-intersection.*
- The deviation will not adversely affect maintenance and its associated cost; and  
*Redbridge Point is a private road that will not be maintained by the County.*
- The deviation will not adversely affect aesthetic appearance.  
*The overall appearance of the private road will be unchanged and the shorter vertical curve lengths a will not be noticeable enough to adversely impact aesthetic appearance. A longer street to meet criteria would increase the amount of pavement required, thereby retaining less natural features and open space for the development.*

### **#6 - Roadway Terminations**

#### **Nature of Request:**

Section of ECM from which Deviation Is Sought: 2.3.8

Specific Criteria from which a Deviation Is Sought: Roadway termination – urban cul-de-sac.

Proposed Nature and Extent of Deviation: Use of hammerhead as roadway termination.

#### **ECM Section 5.8.6: Limits of Consideration:**

The ECM Administrator may only consider a project-specific deviation to an existing standard when **one** of the following conditions is met:

- The ECM standard is inapplicable to a particular situation.  
*The ECM Standard will impact the natural features of the site if required to construct a cul-de-sac. A goal of the project is to retain natural features and open space.*
- Topography, right-of-way, or other geographical conditions or impediments impose an undue economic hardship on the applicant, and an equivalent alternative that can accomplish the same design objective is available and does not compromise public safety or accessibility.  
*Construction of a cul-de-sac at the end of Shoreditch Heights will impact the natural features on the site to the east.*
- A change to a standard is required to address a specific design or construction problem, and if not modified, the standard will impose an undue hardship on the applicant with little or no material benefit to the public.

Allowing a hammerhead turnaround in this location provides the proper emergency turnaround and doesn't impact the natural features of the site. Tri-Lakes Monument Fire Department has approved the hammerhead turnaround for emergency access

#### **ECM Section 5.8.7: Criteria for Approval**

No deviation shall be approved unless it is demonstrated that:

- The request for a deviation is not based exclusively on financial considerations;  
The request is to help preserve natural features east of Shoreditch Heights as the turnaround is formed naturally by the private roads allowing less impact to the site.
- The deviation will achieve the intended result with a comparable or superior design and quality of improvement;  
The hammerhead turnaround will provide a comparable roadway termination and has been approved by Tri-Lakes monument Fire Department.
- The deviation will not adversely affect safety or operations;  
The hammerhead turnaround has been approved by Tri-Lakes monument Fire Department for emergency access.
- The deviation will not adversely affect maintenance and its associated cost; and  
Shoreditch Heights is a private road that will not be maintained by the County.
- The deviation will not adversely affect aesthetic appearance.  
The narrower street cross-section and hammerhead turnaround layout will have a smaller footprint that will retain more features and open space for the development. As a result, the request will not adversely impact aesthetic appearance.

#### **#7 - Intersection Spacing**

##### **Nature of Request:**

Section of ECM from which Deviation Is Sought: 2.2.5.E

Specific Criteria from which a Deviation Is Sought: Intersection spacing along a Rural Local roadway.

Proposed Nature and Extent of Deviation: Allow access intersection spacing of 266 feet (east of the Burning Creek Way (proposed)/Redbridge Point intersection to Shoreditch Heights (proposed) along Deer Creek Road. Additionally, allow access intersection spacing of 236 feet between Shoreditch Heights (proposed) and Burnt Leaf Way along Deer Creek Road.

##### **ECM Section 5.8.6: Limits of Consideration:**

The ECM Administrator may only consider a project-specific deviation to an existing standard when **one** of the following conditions is met:

- The ECM standard is inapplicable to a particular situation.  
N/A
- Topography, right-of-way, or other geographical conditions or impediments impose an undue economic hardship on the applicant, and an equivalent alternative that can accomplish the same design objective is available and does not compromise public safety or accessibility.

The deviation is requested to provide access to the east portion of the site via Shoreditch Heights. The east section of the property lies within the 100-year FEMA floodplain and floodway, which constrains the access location.

- A change to a standard is required to address a specific design or construction problem, and if not modified, the standard will impose an undue hardship on the applicant with little or no material benefit to the public.

N/A

#### **ECM Section 5.8.7: Criteria for Approval**

No deviation shall be approved unless it is demonstrated that:

- The request for a deviation is not based exclusively on financial considerations;  
The request is based on the need to place the east site access (Shoreditch Heights) as far east as possible from the intersection of Redbridge Point at Deer Creek Road while avoiding the FEMA 100-year floodplain and floodway
- The deviation will achieve the intended result with a comparable or superior design and quality of improvement;  
The deviation would also allow for a second access to serve the eastern portion of the site. The possible location of this second access is constrained by the FEMA 100-year floodplain and floodway.
- The deviation will not adversely affect safety or operations;  
The proposed spacing will be sufficient and will not adversely affect safety or operations. The proposed spacing will not interfere with existing or proposed auxiliary turn lanes because there are currently none and none are proposed. Also, the stopping sight distance between the access point intersections meets ECM standards.
- The deviation will not adversely affect maintenance and its associated cost; and  
The deviation for intersection spacing would not adversely affect maintenance as the proposed streets would be private and will not be maintained by the County.
- The deviation will not adversely affect aesthetic appearance.  
The deviation would not adversely affect aesthetics. The spacing proposed is comparable to the Local street standard with respect to the overall roadway streetscape/appearance – IE the spacing is sufficient such that the roadway will not look “cluttered” with a series of very closely spaced driveways/access points.





**NORTH BAY AT LAKE WOODMOOR**  
PARCEL E  
DEER CREEK RD  
MONUMENT, CO 80132

LAKE WOODMOOR  
R-4  
SUBDIVISION DISTRICT

**PUD DEVELOPMENT PLAN**

| DATE     | BY  | DESCRIPTION                 |
|----------|-----|-----------------------------|
| 12-01-17 | KMM | PER COUNTY REVIEW COMMENTS  |
| 09-17-18 | KMM | PER COUNTY & UTILITY REVIEW |
| 11-21-19 | KMM | PER COUNTY & UTILITY REVIEW |
| 02-24-20 | KMM | PER COUNTY & UTILITY REVIEW |

**DEVELOPMENT PLAN**

**2**  
2 OF 14

PUD SP - 16 - 004

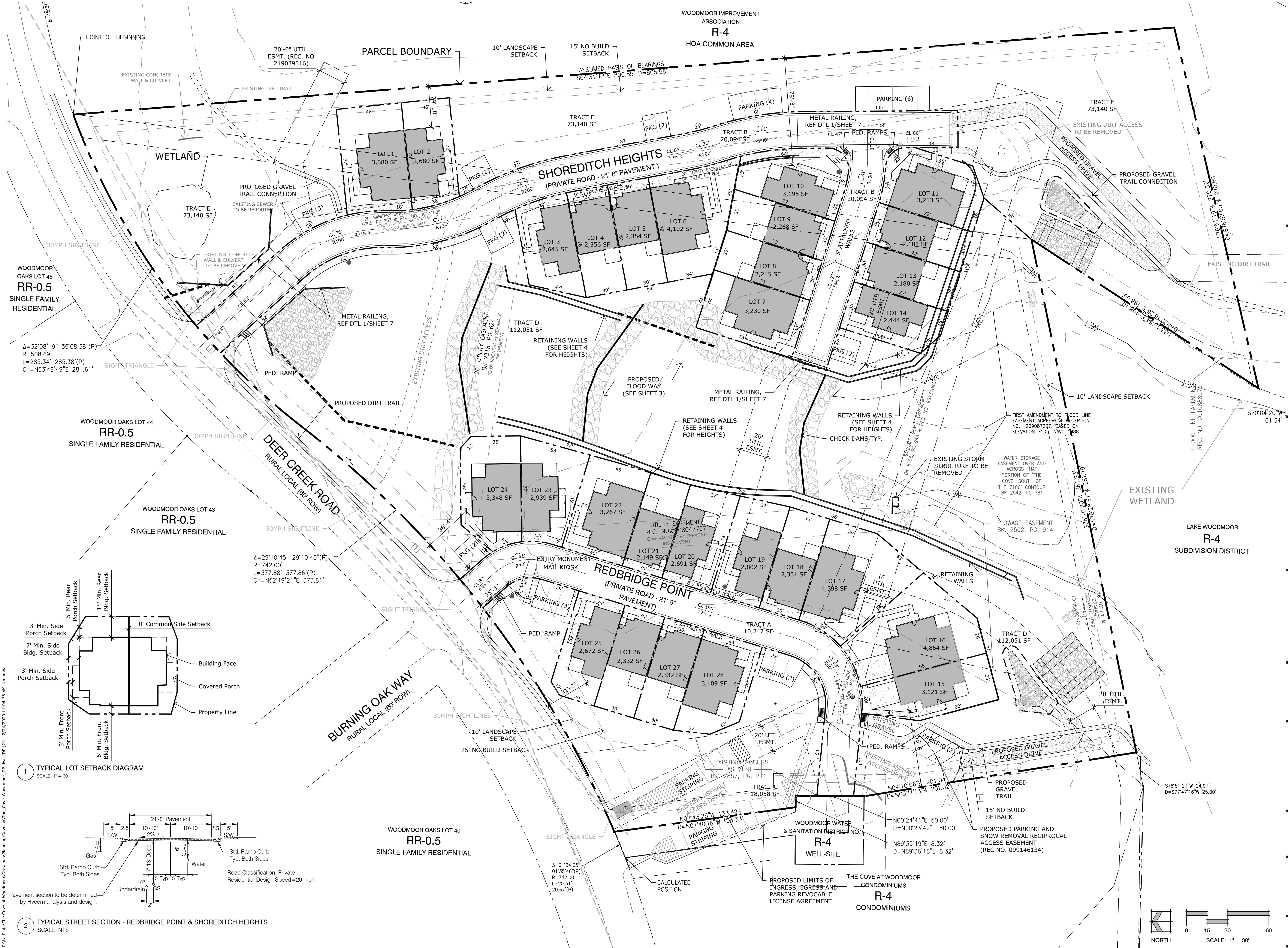

WOODMOOR OAKS LOT 45  
RR-0.5  
SINGLE FAMILY RESIDENTIAL  
Δ=32°08'19" 35°08'38"(P)  
R=508.69'  
L=285.34' 285.38'(P)  
Ch=N53°49'49"E 281.61'

WOODMOOR OAKS LOT 44  
RR-0.5  
SINGLE FAMILY RESIDENTIAL

WOODMOOR OAKS LOT 43  
RR-0.5  
SINGLE FAMILY RESIDENTIAL

Δ=29°10'45" 29°10'40"(P)  
R=742.00'  
L=377.88' 377.86'(P)  
Ch=N52°19'21"E 373.81'

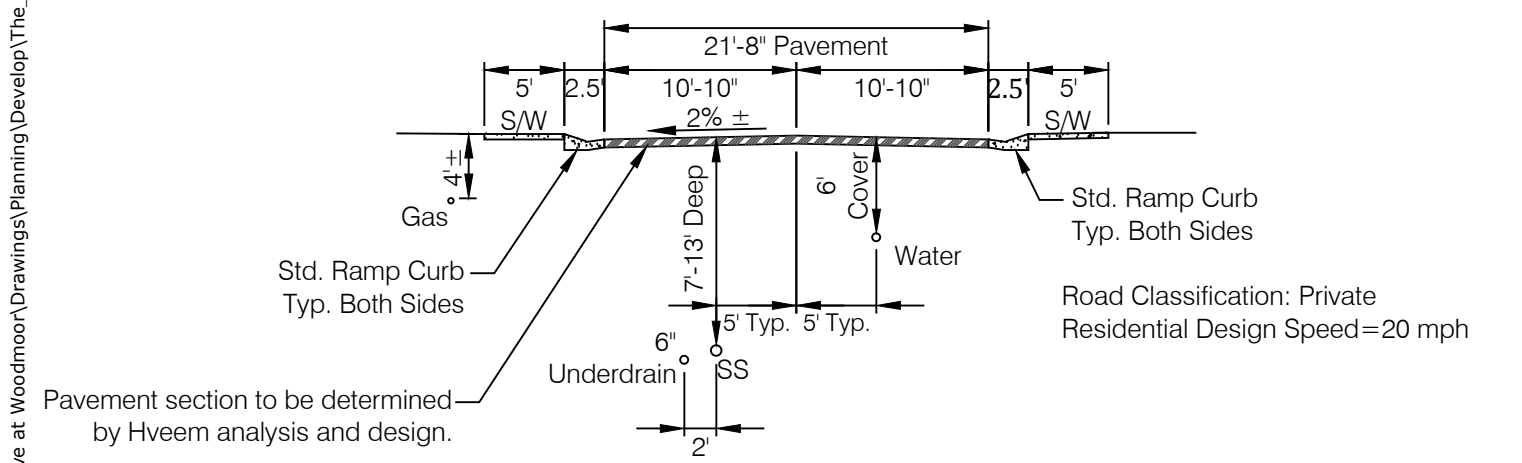
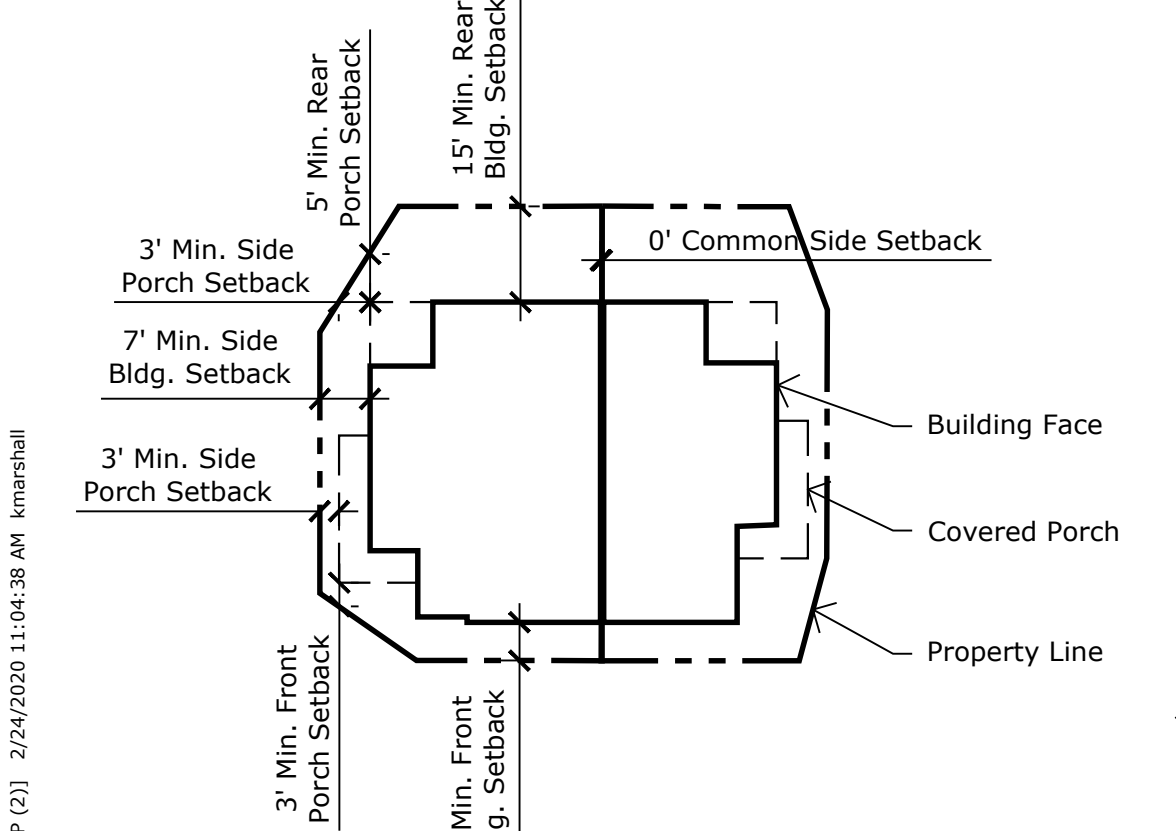

C:\Users\lph\OneDrive\Drawings\Planning\Development\The Cove\Woodmoor\_DP.dwg (DP) 2/24/2020 11:04:38 AM imarshall

**NORTH BAY  
AT LAKE  
WOODMOOR**  
PARCEL E  
DEER CREEK RD  
MONUMENT, CO 80132

DATE: 11-15-2016  
PROJECT MGR: A. BARLOW  
PREPARED BY: K. MARSHALL

**PUD  
DEVELOPMENT  
PLAN**



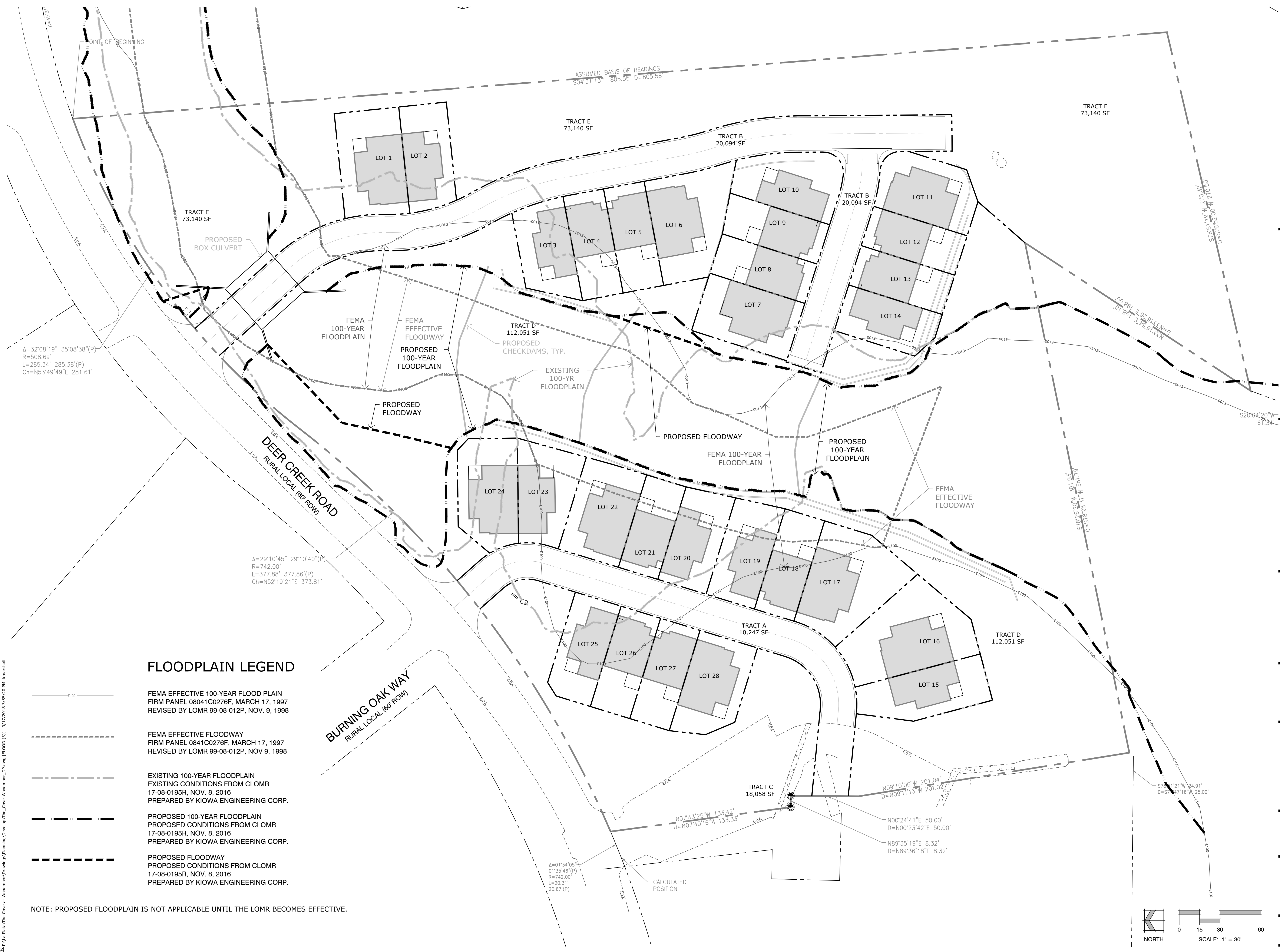

| DATE     | BY  | DESCRIPTION                 |
|----------|-----|-----------------------------|
| 12-01-17 | KMM | PER COUNTY REVIEW COMMENTS  |
| 09-17-18 | KMM | PER COUNTY & UTILITY REVIEW |

**FLOODPLAIN AND  
FLOODWAY  
EXHIBIT**

**3**  
3 OF 14  
PUD SP - 16 - 004



**FLOODPLAIN LEGEND**

-  FEMA EFFECTIVE 100-YEAR FLOOD PLAIN  
FIRM PANEL 08041C0276F, MARCH 17, 1997  
REVISED BY LOMR 99-08-012P, NOV. 9, 1998
-  FEMA EFFECTIVE FLOODWAY  
FIRM PANEL 0841C0276F, MARCH 17, 1997  
REVISED BY LOMR 99-08-012P, NOV 9, 1998
-  EXISTING 100-YEAR FLOODPLAIN  
EXISTING CONDITIONS FROM CLOMR  
17-08-0195R, NOV. 8, 2016  
PREPARED BY KIOWA ENGINEERING CORP.
-  PROPOSED 100-YEAR FLOODPLAIN  
PROPOSED CONDITIONS FROM CLOMR  
17-08-0195R, NOV. 8, 2016  
PREPARED BY KIOWA ENGINEERING CORP.
-  PROPOSED FLOODWAY  
PROPOSED CONDITIONS FROM CLOMR  
17-08-0195R, NOV. 8, 2016  
PREPARED BY KIOWA ENGINEERING CORP.

NOTE: PROPOSED FLOODPLAIN IS NOT APPLICABLE UNTIL THE LOMR BECOMES EFFECTIVE.

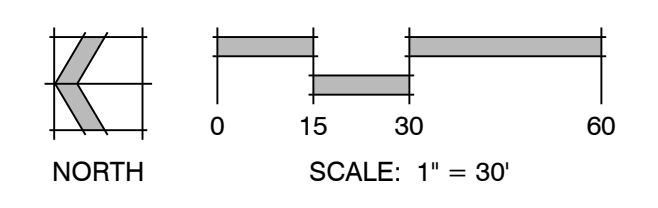

34 \\L:\Projects\The Cove at Woodmoor\Drawings\Planning\Development\The Cove-Woodmoor\_DP.dwg (PUCOD 03) 9/17/2018 3:52:20 PM kmarshall

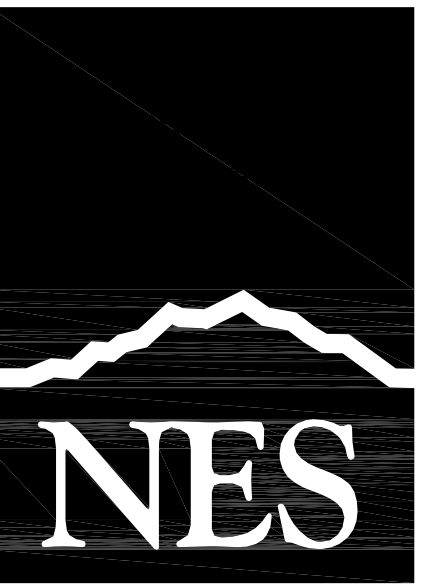

N.E.S. Inc.  
619 N. Cascade Avenue, Suite 200  
Colorado Springs, CO 80903

Tel. 719.471.0073  
Fax 719.471.0267

www.nescolorado.com

© 2012. All Rights Reserved.

**Kiowa**  
Engineering Corporation

1604 South 21st Street  
Colorado Springs, Colorado 80904  
(719) 630-7342

# NORTH BAY AT LAKE WOODMOOR

PARCEL E

DEER CREEK RD  
MONUMENT, CO 80132

LAKE WOODMOOR  
(PLAT BOOK K-2, PAGE 83)  
(WARRANTY DEED REC. NO. 201088802)  
OWNER: WOODMOOR WATER & SAN  
DISTRICT NO. 1

DATE: 11-09-2016  
PROJECT MGR: AWMC  
PREPARED BY: NRK

## PUD DEVELOPMENT PLAN

| DATE:    | BY: | DESCRIPTION:                |
|----------|-----|-----------------------------|
| 09-04-18 | CJC | PER UTILITY REVIEW          |
| 11-21-19 | CJC | PER COUNTY & UTILITY REVIEW |
| 02-21-20 | CJC | PER COUNTY & UTILITY REVIEW |

## PRELIMINARY GRADING PLAN

**4**  
4 OF 14

PUD SP - 16 - 004

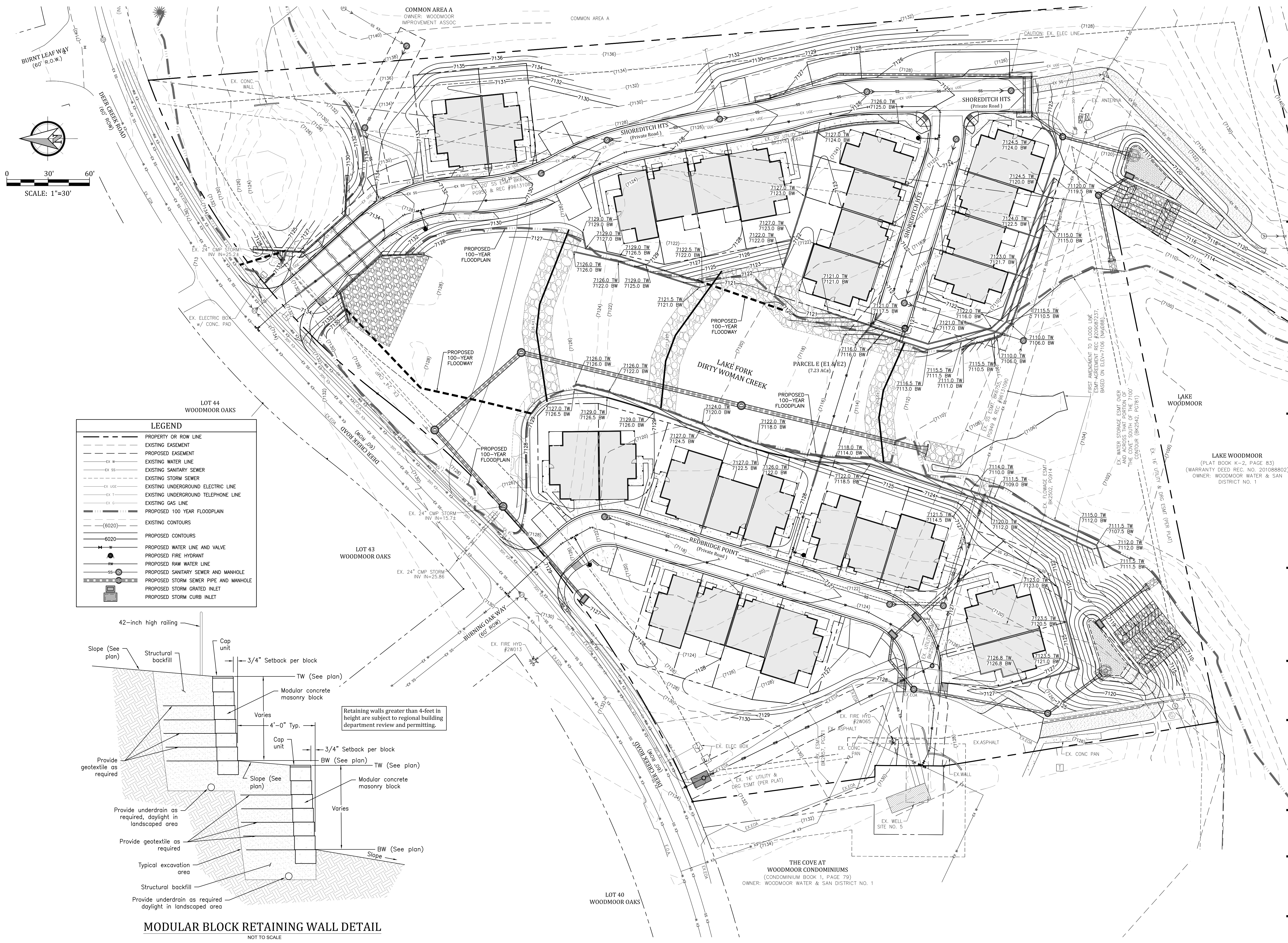

**LEGEND**

- PROPERTY OR ROW LINE
- - - EXISTING EASEMENT
- - - PROPOSED EASEMENT
- - - EXISTING WATER LINE
- - - EXISTING SANITARY SEWER
- - - EXISTING STORM SEWER
- - - EXISTING UNDERGROUND ELECTRIC LINE
- - - EXISTING UNDERGROUND TELEPHONE LINE
- - - EXISTING GAS LINE
- PROPOSED 100 YEAR FLOODPLAIN
- EXISTING CONTOURS
- PROPOSED CONTOURS
- PROPOSED WATER LINE AND VALVE
- PROPOSED FIRE HYDRANT
- PROPOSED RAW WATER LINE
- PROPOSED SANITARY SEWER AND MANHOLE
- PROPOSED STORM SEWER PIPE AND MANHOLE
- PROPOSED STORM GRATED INLET
- PROPOSED STORM CURB INLET

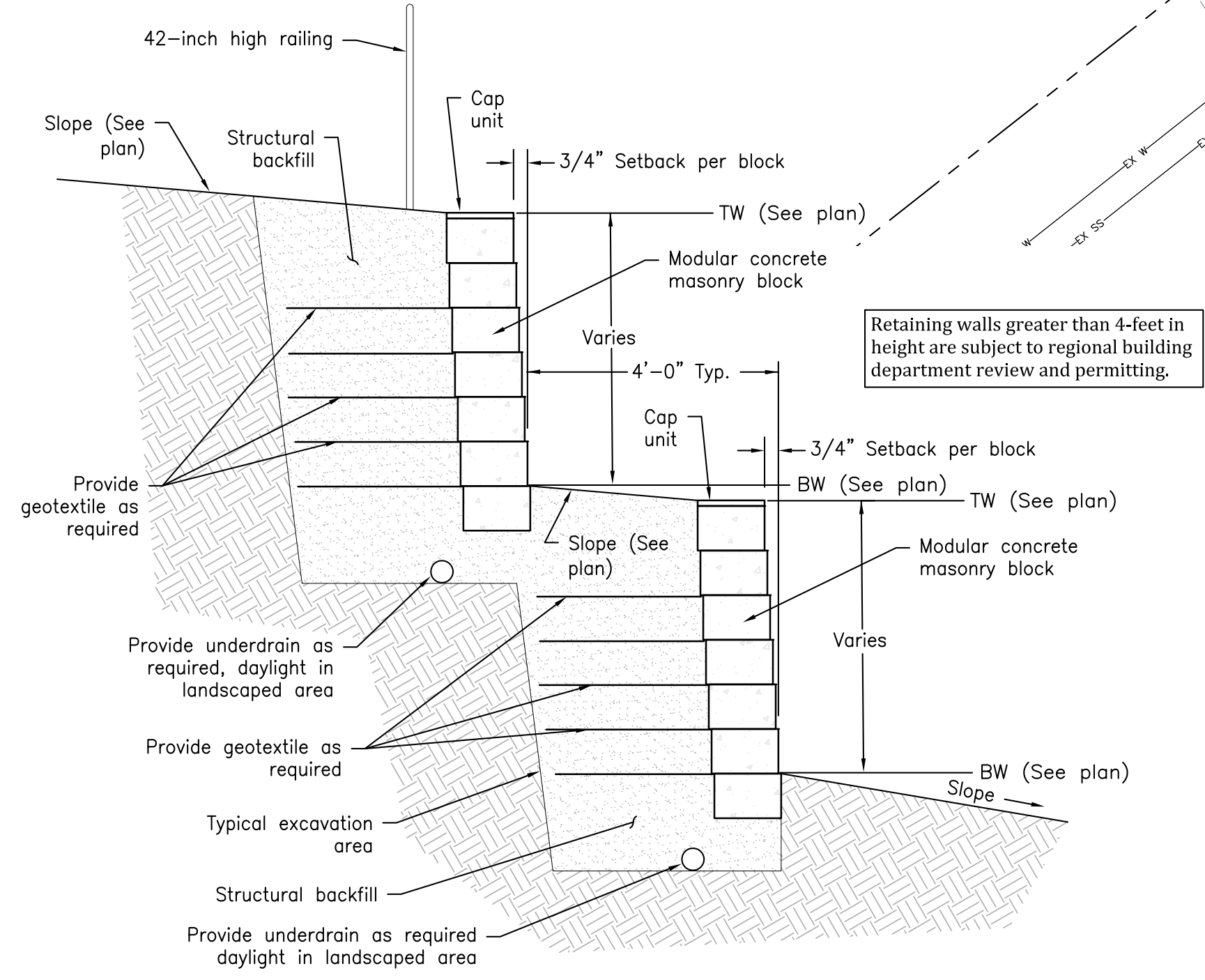

**MODULAR BLOCK RETAINING WALL DETAIL**  
NOT TO SCALE

V:\Projects\1604 South 21st Street\1604 South 21st Street.dwg [PUD] 4 - Grading [EC] 2/21/2020 11:12:39 AM ccsadell

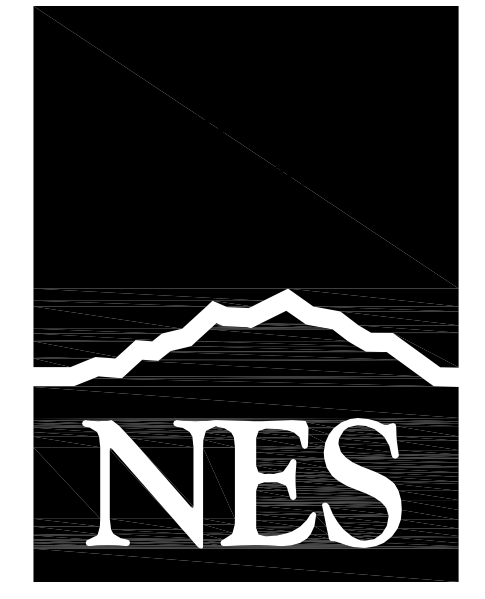
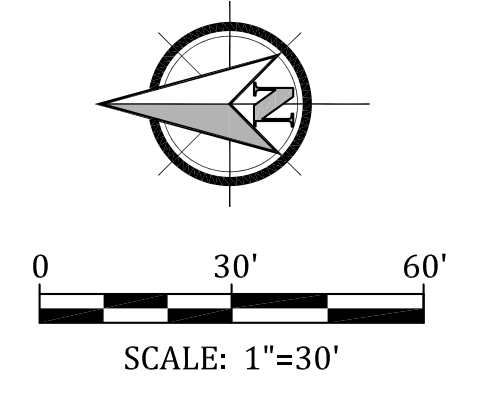

N.E.S. Inc.  
 619 N. Cascade Avenue, Suite 200  
 Colorado Springs, CO 80903  
 Tel. 719.471.0073  
 Fax 719.471.0267  
 www.nescolorado.com  
 © 2012. All Rights Reserved.



# NORTH BAY AT LAKE WOODMOOR

## PARCEL E

DEER CREEK RD  
 MONUMENT, CO 80132

DATE: 11-09-2016  
 PROJECT MGR: ANW  
 PREPARED BY: NRK

### PUD DEVELOPMENT PLAN

| DATE:    | BY: | DESCRIPTION:                |
|----------|-----|-----------------------------|
| 09-04-18 | CJC | PER UTILITY REVIEW          |
| 11-21-19 | CJC | PER COUNTY & UTILITY REVIEW |
| 02-21-20 | CJC | PER COUNTY & UTILITY REVIEW |

### MASTER FACILITIES PLAN

# 5

5 OF 14

PUD SP - 16 - 004

| LEGEND |   |
|--------|---|
|        | PROPOSED BUILDING                             |
|        | EXISTING FIRE HYDRANT                         |
|        | EXISTING WATER VALVE                          |
|        | EXISTING SANITARY SEWER MANHOLE               |
|        | EXISTING SANITARY SEWER CLEAN OUT             |
|        | EXISTING STORM SEWER MANHOLE                  |
|        | EXISTING WATER MANHOLE                        |
|        | EXISTING TELEPHONE PEDESTAL                   |
|        | EXISTING UTILITY POLE                         |
|        | EXISTING ELECTRIC BOX OR TRANSFORMER          |
|        | EXISTING OR PROPOSED PROPERTY LINE            |
|        | EXISTING EASEMENT                             |
|        | PROPOSED EASEMENT                             |
|        | EXISTING FENCE                                |
|        | EXISTING WATER LINE                           |
|        | EX. WATER LINE TO BE REMOVED OR ABANDONED     |
|        | EX. RAW WATER LINE                            |
|        | EX. RAW WATER LINE TO BE REMOVED OR ABANDONED |
|        | EX. SANITARY SEWER & FLOW DIRECTION           |
|        | EX. SANITARY SEWER TO BE REMOVED OR ABANDONED |
|        | EXISTING STORM SEWER                          |
|        | EX. STORM SEWER TO BE REMOVED OR ABANDONED    |
|        | EXISTING UNDERGROUND ELECTRIC LINE            |
|        | EXISTING OVERHEAD ELECTRIC LINE               |
|        | EXISTING UNDERGROUND TELEPHONE LINE           |
|        | EXISTING GAS LINE                             |
|        | PROPOSED WATER LINE AND VALVE                 |
|        | PROPOSED WATER LINE, THRUST BLOCK & MJ RSTNTS |
|        | PROPOSED FIRE HYDRANT                         |
|        | PROPOSED RAW WATER LINE                       |
|        | PROPOSED SANITARY SEWER AND MANHOLE           |
|        | PROPOSED STORM SEWER PIPE AND MANHOLE         |
|        | PROPOSED STORM GRATED INLET                   |
|        | PROPOSED STORM CURB INLET                     |

\\server\projects\_active\2015115073 North Bay at Lake Woodmoor\Drawings\15073 RD and Water Profiles\Sheets\6-12.dwg [PUD 5-Utility] 2/21/2020 3:57:39 PM mrobison

**NORTH BAY AT LAKE WOODMOOR**  
PARCEL E  
DEER CREEK RD MONUMENT, CO 80132

DATE: 11-09-2016  
PROJECT MGR: A. BARLOW  
PREPARED BY: K. MARSHALL

**PUD DEVELOPMENT PLAN**

| DATE     | BY  | DESCRIPTION                 |
|----------|-----|-----------------------------|
| 12-01-17 | KMM | PER COUNTY REVIEW COMMENTS  |
| 09-17-18 | KMM | PER COUNTY & UTILITY REVIEW |
| 11-21-19 | KMM | PER COUNTY & UTILITY REVIEW |
| 02-24-20 | KMM | PER COUNTY & UTILITY REVIEW |

**LANDSCAPE PLAN**

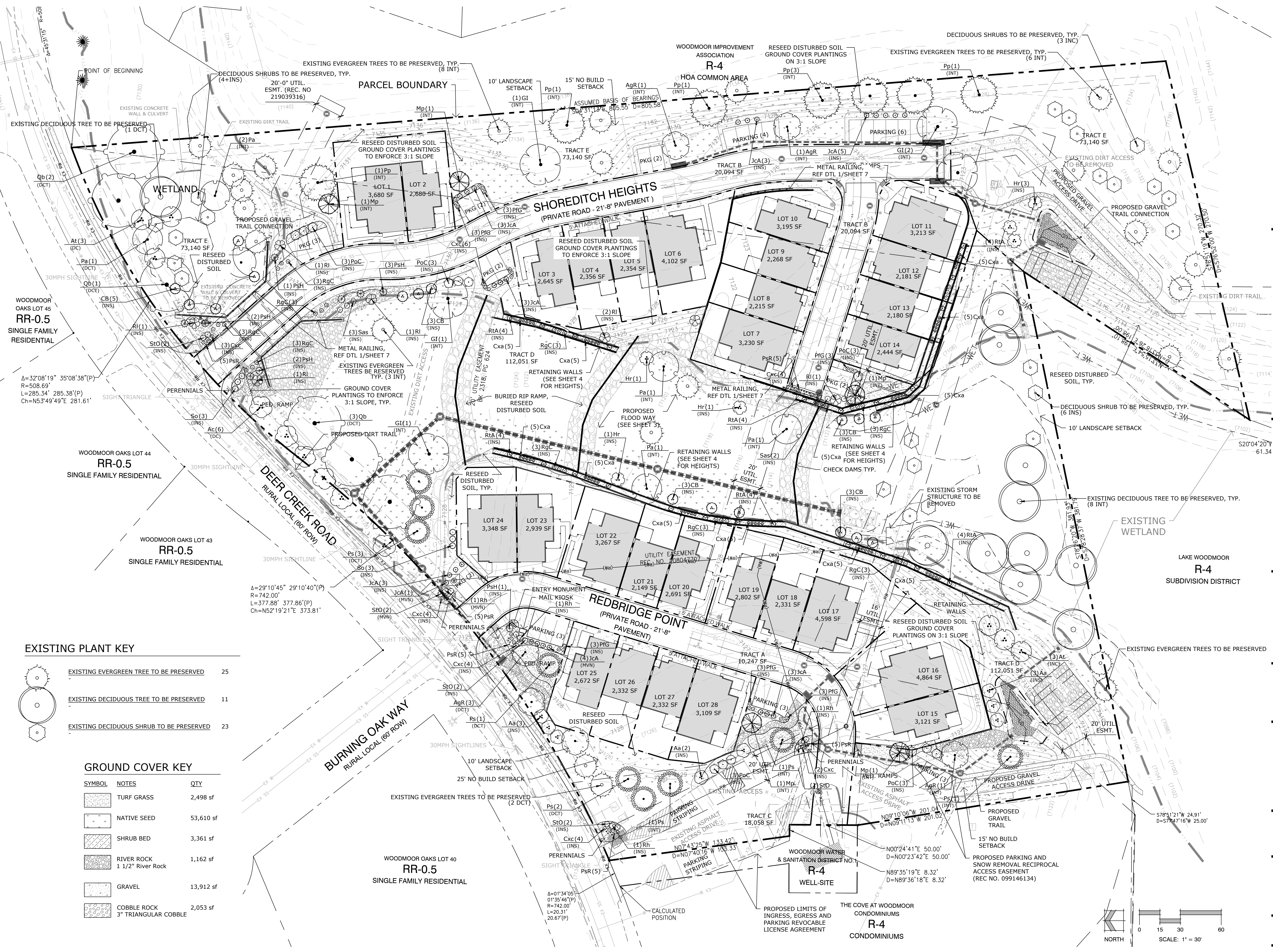

**EXISTING PLANT KEY**

|  |  |    |
|--|--|----|
|  | EXISTING EVERGREEN TREE TO BE PRESERVED  | 25 |
|  | EXISTING DECIDUOUS TREE TO BE PRESERVED  | 11 |
|  | EXISTING DECIDUOUS SHRUB TO BE PRESERVED | 23 |

**GROUND COVER KEY**

| SYMBOL | NOTES                               | QTY       |
|--------|-------------------------------------|-----------|
|        | TURF GRASS                          | 2,498 sf  |
|        | NATIVE SEED                         | 53,610 sf |
|        | SHRUB BED                           | 3,361 sf  |
|        | RIVER ROCK<br>1 1/2" River Rock     | 1,162 sf  |
|        | GRAVEL                              | 13,912 sf |
|        | COBBLE ROCK<br>3" TRIANGULAR COBBLE | 2,053 sf  |

C:\Users\kmarshall\OneDrive\Desktop\Woodmoor\Drawings\Planning\Final\land\The Cove-Woodmoor\_PUD.dwg [PUD] (6) 2/24/2020 11:05:01 AM kmarshall



NORTH BAY AT LAKE WOODMOOR  
 EL PASO COUNTY, COLORADO  
 PUD DEVELOPMENT PLAN



FRONT ELEVATION 'A'

SCALE: 1/4" = 1'-0"



FRONT ELEVATION 'B'

SCALE: 1/4" = 1'-0"

09.07.16



3-2 DUPLEX | FRONTS  
**BACKYARD VILLAS | JM WESTON**  
 COLORADO SPRINGS, COLORADO

NOTE: SQUARE FOOTAGE MAY VARY BASED ON CALCULATION METHODS

THESE DRAWINGS ARE INTENDED FOR DESIGN DEVELOPMENT AND PRELIMINARY STUDIES ONLY AND ARE NOT TO BE USED FOR ANY OTHER PURPOSE, SUCH AS FINAL FLOORING OR FINAL ENGINEERING. COPYRIGHT WOODLEY ARCHITECTURAL GROUP, INC. THESE DRAWINGS MAY NOT BE USED OR DUPLICATED WITHOUT THE EXPRESS WRITTEN PERMISSION OF WOODLEY ARCHITECTURAL GROUP, INC.

Sheet 8 of 14  
 PUD SP 16-004



colorado // 731 southpark dr. suite B  
 littleton, co 80120 / 303.683.7231  
 california // 2943 pullman st. suite A  
 santa ana, ca 92705 / 949.553.8919

NORTH BAY AT LAKE WOODMOOR  
EL PASO COUNTY, COLORADO  
PUD DEVELOPMENT PLAN



RIGHT ELEVATION 'B'

SCALE: 1/4" = 1'-0"



LEFT ELEVATION 'B'

SCALE: 1/4" = 1'-0"



REAR ELEVATION 'B'

SCALE: 1/4" = 1'-0"

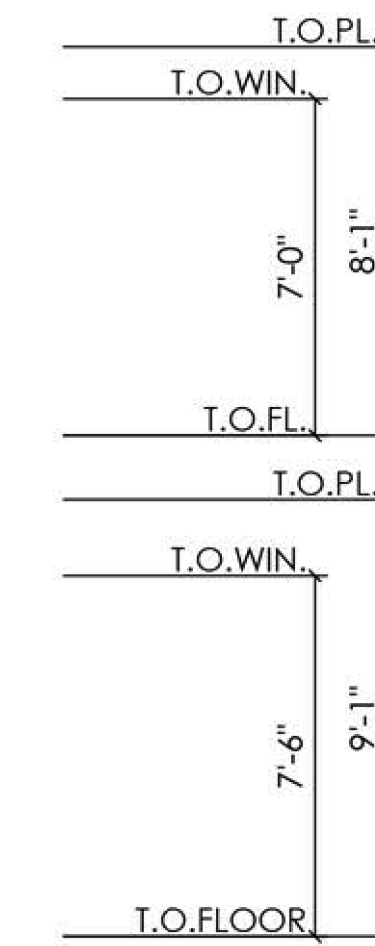

**MATERIAL NOTES**

- ASPHALT ROOF SHINGLES
- 8" CEMENTITIOUS HORIZONTAL SIDING
- 4" CEMENTITIOUS HORIZONTAL SIDING
- WOOD TRIM
- WOOD POSTS
- CULTURED STONE VENEER

09.07.16



3-2 DUPLEX | CONCEPT ELEVATIONS 'B'  
**BACKYARD VILLAS | JM WESTON**  
COLORADO SPRINGS, COLORADO

NOTE: SQUARE FOOTAGE MAY VARY BASED ON CALCULATION METHODS

THESE DRAWINGS ARE INTENDED FOR DESIGN DEVELOPMENT AND PRELIMINARY STUDIES ONLY AND ARE NOT TO BE USED FOR ANY OTHER PURPOSE, SUCH AS FINAL PLOTTING OR FINAL ENGINEERING. COPYRIGHT: WOODLEY ARCHITECTURAL GROUP, INC. THESE DRAWINGS MAY NOT BE USED OR DUPLICATED WITHOUT THE EXPRESS WRITTEN PERMISSION OF WOODLEY ARCHITECTURAL GROUP, INC.

Sheet 9 of 14  
PUD SP 16-004

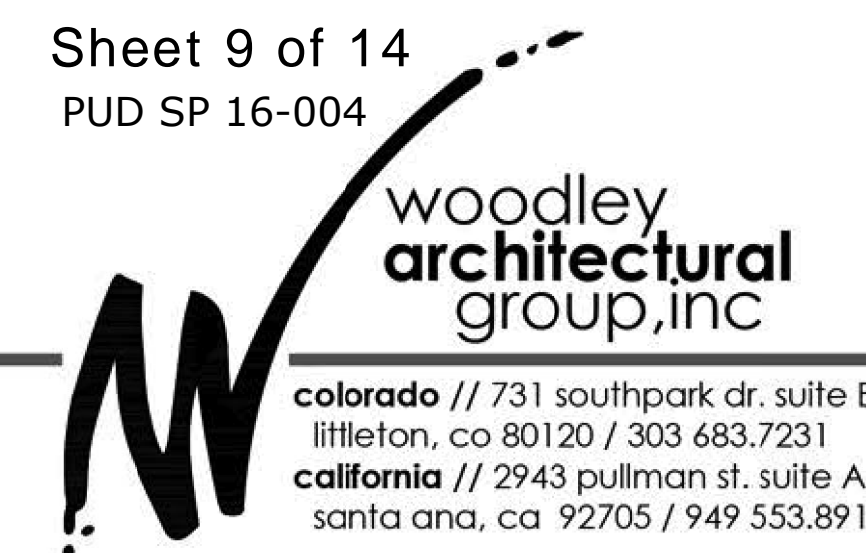

colorado // 731 southpark dr. suite B  
littleton, co 80120 / 303 683.7231  
california // 2943 pullman st. suite A  
santa ana, ca 92705 / 949 553.8919



NORTH BAY AT LAKE WOODMOOR  
EL PASO COUNTY, COLORADO  
PUD DEVELOPMENT PLAN



FRONT ELEVATION 'A'

SCALE: 1/4" = 1'-0"



FRONT ELEVATION 'B'

SCALE: 1/4" = 1'-0"

09.07.16



3-1-2 TRIPLEX | FRONTS  
**BACKYARD VILLAS | JM WESTON**  
COLORADO SPRINGS, COLORADO

NOTE: SQUARE FOOTAGE MAY VARY BASED ON CALCULATION METHODS

THESE DRAWINGS ARE INTENDED FOR DESIGN DEVELOPMENT AND PRELIMINARY STUDIES ONLY AND ARE NOT TO BE USED FOR ANY OTHER PURPOSE, SUCH AS FINAL FLOORING OR FINAL ENGINEERING. COPYRIGHT WOODLEY ARCHITECTURAL GROUP, INC. THESE DRAWINGS MAY NOT BE USED OR DUPLICATED WITHOUT THE EXPRESS WRITTEN PERMISSION OF WOODLEY ARCHITECTURAL GROUP, INC.

Sheet 10 of 14  
PUD SP 16-004

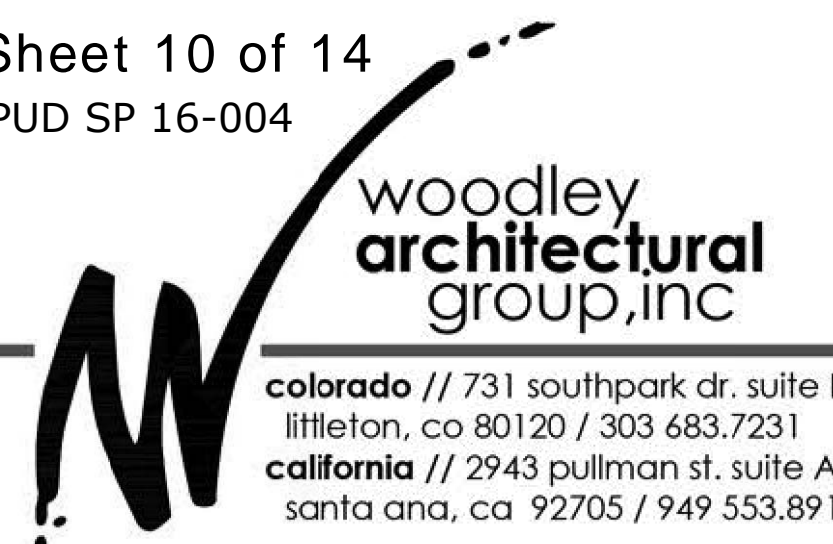

colorado // 731 southpark dr. suite B  
littleton, co 80120 / 303.683.7231  
california // 2943 pullman st. suite A  
santa ana, ca 92705 / 949.553.8919

NORTH BAY AT LAKE WOODMOOR  
 EL PASO COUNTY, COLORADO  
 PUD DEVELOPMENT PLAN



RIGHT ELEVATION 'B'

SCALE: 1/4" = 1'-0"



LEFT ELEVATION 'B'

SCALE: 1/4" = 1'-0"



REAR ELEVATION 'B'

SCALE: 1/4" = 1'-0"

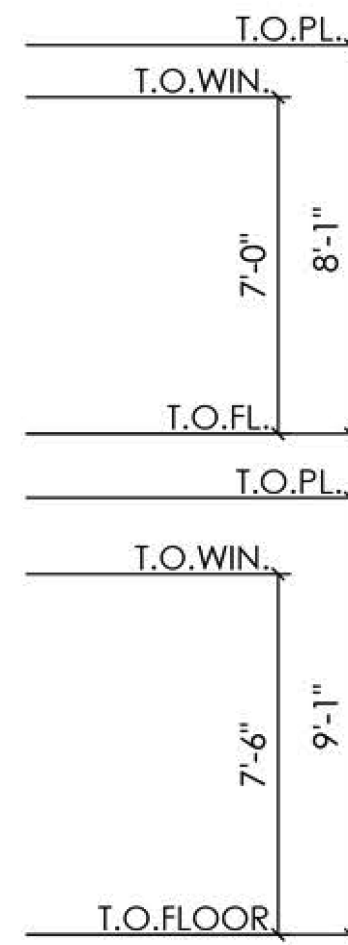

**MATERIAL NOTES**  
 -ASPHALT ROOF SHINGLES  
 -8" CEMENTITIOUS HORIZONTAL SIDING  
 -4" CEMENTITIOUS HORIZONTAL SIDING  
 -WOOD TRIM  
 -WOOD POSTS  
 -CULTURED STONE VENEER

Sheet 11 of 14  
 PUD SP 16-004

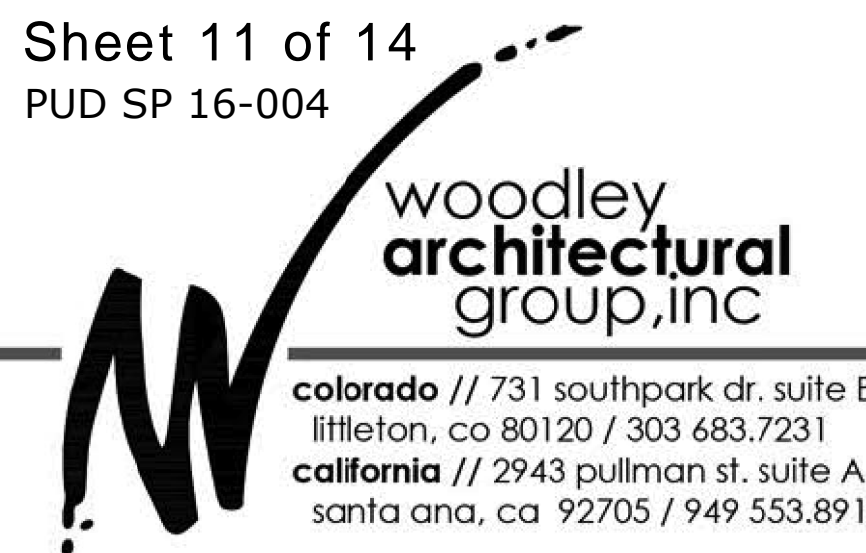

09.07.16



3-1-2 TRIPLEX | CONCEPT ELEVATIONS 'B'  
**BACKYARD VILLAS | JM WESTON**  
 COLORADO SPRINGS, COLORADO

NOTE: SQUARE FOOTAGE MAY VARY BASED ON CALCULATION METHODS  
 THESE DRAWINGS ARE INTENDED FOR DESIGN DEVELOPMENT AND PRELIMINARY STUDIES ONLY AND ARE NOT TO BE USED FOR ANY OTHER PURPOSE, SUCH AS FINAL PLOTTING OR FINAL ENGINEERING. COPYRIGHT WOODLEY ARCHITECTURAL GROUP, INC. THESE DRAWINGS MAY NOT BE USED OR DUPLICATED WITHOUT THE EXPRESS WRITTEN PERMISSION OF WOODLEY ARCHITECTURAL GROUP, INC.

NORTH BAY AT LAKE WOODMOOR  
EL PASO COUNTY, COLORADO  
PUD DEVELOPMENT PLAN



FRONT ELEVATION 'A'

SCALE: 1/4" = 1'-0"



FRONT ELEVATION 'B'

SCALE: 1/4" = 1'-0"

09.07.16



3-1-1-2 FOUR PLEX | FRONTS  
**BACKYARD VILLAS | JM WESTON**  
COLORADO SPRINGS, COLORADO

NOTE: SQUARE FOOTAGE MAY VARY BASED ON CALCULATION METHODS

THESE DRAWINGS ARE INTENDED FOR DESIGN DEVELOPMENT AND PRELIMINARY STUDIES ONLY AND ARE NOT TO BE USED FOR ANY OTHER PURPOSE, SUCH AS FINAL FLOORING OR FINAL ENGINEERING. COPYRIGHT WOODLEY ARCHITECTURAL GROUP, INC. THESE DRAWINGS MAY NOT BE USED OR DUPLICATED WITHOUT THE EXPRESS WRITTEN PERMISSION OF WOODLEY ARCHITECTURAL GROUP, INC.

Sheet 12 of 14  
PUD SP 16-004



woodley  
architectural  
group, inc

colorado // 731 southpark dr. suite B  
littleton, co 80120 / 303 683.7231  
california // 2943 pullman st. suite A  
santa ana, ca 92705 / 949 553.8919

NORTH BAY AT LAKE WOODMOOR  
 EL PASO COUNTY, COLORADO  
 PUD DEVELOPMENT PLAN



RIGHT ELEVATION 'B'

SCALE: 1/4" = 1'-0"



LEFT ELEVATION 'B'

SCALE: 1/4" = 1'-0"



REAR ELEVATION 'B'

SCALE: 1/4" = 1'-0"

**MATERIAL NOTES**

- ASPHALT ROOF SHINGLES
- 8" CEMENTITIOUS HORIZONTAL SIDING
- 4" CEMENTITIOUS HORIZONTAL SIDING
- WOOD TRIM
- WOOD POSTS
- CULTURED STONE VENEER

Sheet 13 of 14  
 PUD SP 16-004



09.07.16



3-1-1-2 FOUR PLEX | CONCEPT ELEVATIONS 'B'

**BACKYARD VILLAS | JM WESTON**  
 COLORADO SPRINGS, COLORADO

NOTE: SQUARE FOOTAGE MAY VARY BASED ON CALCULATION METHODS

THESE DRAWINGS ARE INTENDED FOR DESIGN DEVELOPMENT AND PRELIMINARY STUDIES ONLY AND ARE NOT TO BE USED FOR ANY OTHER PURPOSE, SUCH AS FINAL PLOTTING OR FINAL ENGINEERING. COPYRIGHT WOODLEY ARCHITECTURAL GROUP, INC. THESE DRAWINGS MAY NOT BE USED OR DUPLICATED WITHOUT THE EXPRESS WRITTEN PERMISSION OF WOODLEY ARCHITECTURAL GROUP, INC.

# NORTH BAY AT LAKE WOODMOOR

## EL PASO COUNTY, COLORADO

### PUD DEVELOPMENT PLAN

#### SITE DATA

**OWNER/APPLICANT:** Lake Woodmoor Holdings LLC  
1755 Telstar Drive, Suite 211  
Colorado Springs, CO 80920

**Tax ID Number:** 7111400007, 7111404111  
**Area:** 7.23 Acres, 314,889 S.F.

**Current Zoning:** R-4  
**Proposed Zoning:** PUD  
**Current Land Use:** Vacant  
**Proposed Land Use:** Townhomes; 81,242 S.F., 26%  
Private Roads, Circulation, & Parking; 46,885 S.F., 15%  
Open Space; 186,762 S.F., 59%

**Number of Units:** 28  
**Density:** 3.87 DU/AC  
**Building Height:** 30' Max.

**Building Setbacks:**  
Front: 6' Minimum,  
3' Minimum to Covered Porch  
Side: 7' Minimum,  
3' Minimum to Covered Porch  
(Exception: 0' at Property Line of Common Wall for Building and Covered Porch)  
Rear: 15' Minimum,  
5' Minimum to Covered Porch

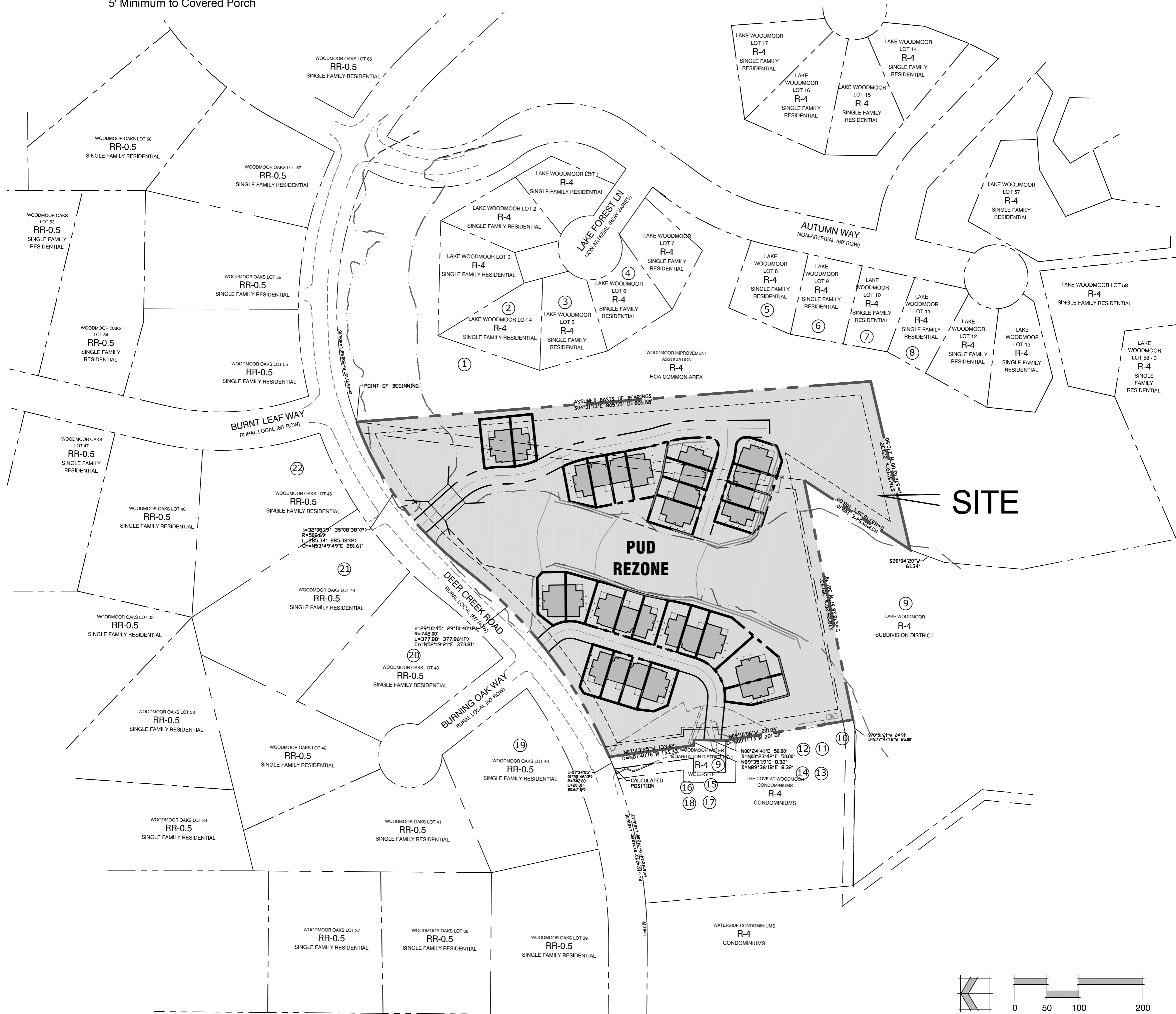

ADJACENT OWNERSHIP MAP

#### VICINITY MAP

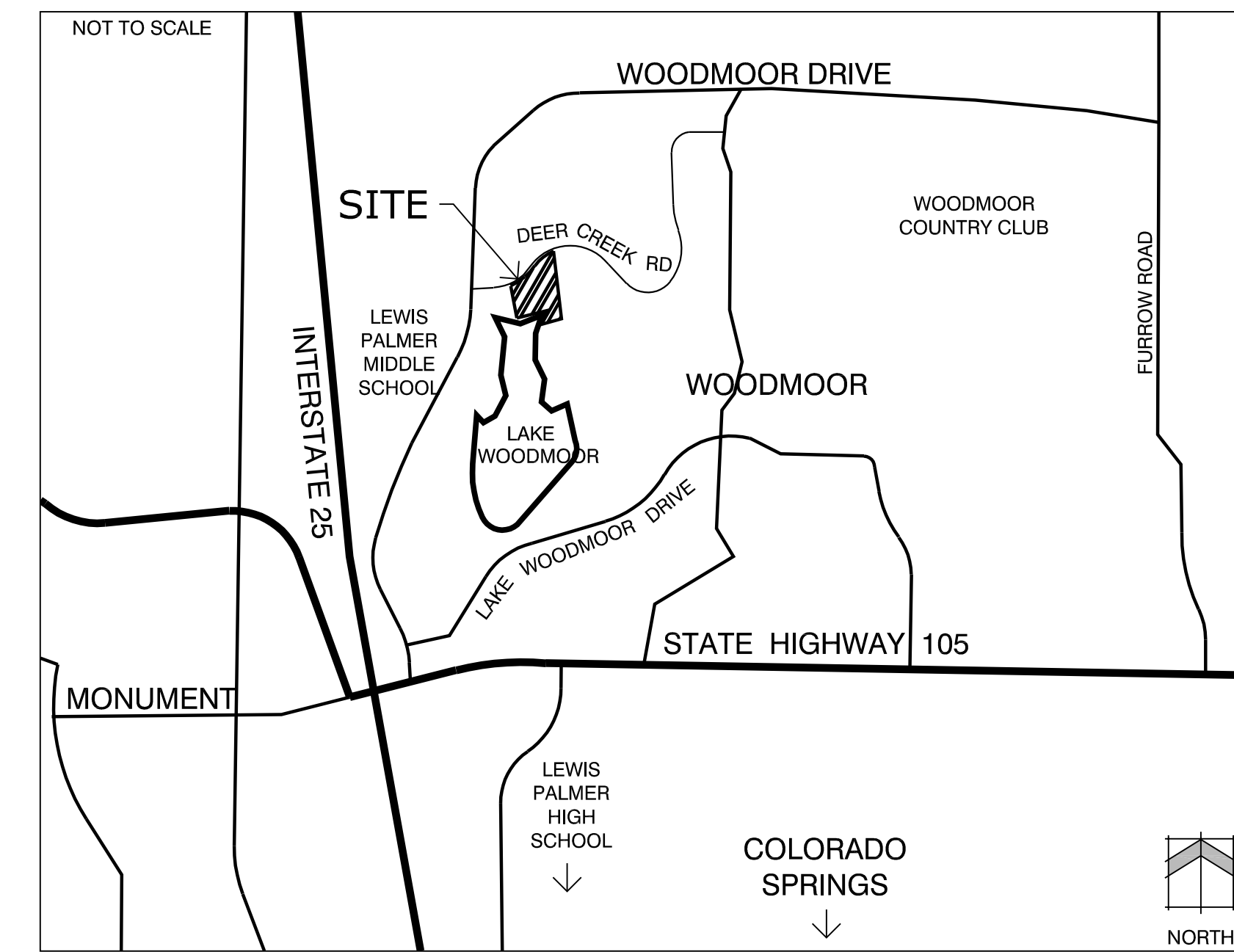

#### LEGAL DESCRIPTION

THOSE PORTIONS OF THE COVE AT WOODMOOR RECORDED JUNE 20, 1972 IN PLAT BOOK V2 AT PAGE 59 AND OF THE SOUTHEAST QUARTER OF SECTION 11, TOWNSHIP 11 SOUTH, RANGE 67 WEST OF THE 6TH PRINCIPAL MERIDIAN, EL PASO COUNTY COLORADO, DESCRIBED AS FOLLOWS:

**BASIS OF BEARINGS.** THE EAST LINE OF THE FOLLOWING DESCRIBED PROPERTY, MONUMENTED AT ITS NORTHERLY END WITH A REBAR & CAP, PLS 2682 AND AT ITS SOUTH END WITH A #4 REBAR. SAID LINE BEARS SOUTH 04 DEGREES 31 MINUTES 13 SECONDS EAST.

**BEGINNING** AT THE NORTHWEST CORNER OF LAKE WOODMOOR RECORDED NOVEMBER 22, 1968 IN PLAT BOOK K2 AT PAGE 83;  
THENCE SOUTH 04 DEGREES 31 MINUTES 13 SECONDS EAST ALONG THE WESTERLY LINE OF SAID SUBDIVISION 805.58 FEET TO AN ANGLE POINT IN SAID LINE;  
THENCE SOUTH 76 DEGREES 52 MINUTES 00 SECONDS WEST CONTINUING ALONG SAID LINE 270.50 FEET TO AN ANGLE POINT IN THE EASTERLY LINE OF THE PARCEL DESCRIBED IN WARRANTY DEED RECORDED JUNE 26, 2001 AT RECEPTION NO. 201088802;  
THENCE NORTH 33 DEGREES 16 MINUTES 26 SECONDS EAST ALONG SAID EASTERLY LINE 198.00 FEET TO THE SOUTHEAST CORNER OF SAID COVE AT WOODMOOR;  
THENCE SOUTH 78 DEGREES 28 MINUTES 37 SECONDS WEST ALONG THE SOUTH LINE OF SAID COVE AT WOODMOOR AND ALONG THE NORTHERLY LINE OF SAID PARCEL DESCRIBED IN WARRANTY DEED RECORDED JUNE 26, 2001 AT RECEPTION NO. 201088802 A DISTANCE OF 381.79 FEET TO THE SOUTHEAST CORNER OF THE COVE AT WOODMOOR CONDOMINIUMS RECORDED DECEMBER 19, 1974 IN PLAT BOOK 1 AT PAGE 79 (THE FOLLOWING FOUR COURSES ARE ALONG THE EASTERLY LINE OF SAID COVE AT WOODMOOR CONDOMINIUMS);

- 1) NORTH 09 DEGREES 11 MINUTES 13 SECONDS WEST, 201.02 FEET;
- 2) NORTH 00 DEGREES 23 MINUTES 42 SECONDS EAST, 50.00 FEET;
- 3) NORTH 89 DEGREES 36 MINUTES 18 SECONDS WEST, 8.32 FEET;
- 4) NORTH 07 DEGREES 40 MINUTES 16 SECONDS WEST, 133.33 FEET TO THE SOUTHERLY LINE OF DEER CREEK ROAD, THE SAME BEING THE NORTHERLY LINE OF SAID THE COVE AT WOODMOOR;

THENCE NORTHEASTERLY ALONG SAID NORTHERLY LINE, ALONG A NON-TANGENTIAL CURVE CONCAVE TO THE NORTHWEST, SAID CURVE HAVING A CENTRAL ANGLE OF 29 DEGREES 10 MINUTES 40 SECONDS, A RADIUS OF 742.00 FEET, FOR AN ARC LENGTH OF 377.86 FEET (THE CENTER OF SAID CURVE BEARS NORTH 23 DEGREES 04 MINUTES 14 SECONDS WEST) TO A POINT OF REVERSE CURVE;

THENCE NORTHEASTERLY ALONG A TANGENTIAL CURVE CONCAVE TO THE SOUTHEAST, SAID CURVE HAVING A CENTRAL ANGLE OF 35 DEGREES 08 MINUTES 38 SECONDS, A RADIUS OF 508.69 FEET, FOR AN ARC LENGTH OF 285.38 FEET TO THE POINT OF BEGINNING.

SAID PARCEL CONTAINS 7.23 ACRES OF LAND, MORE OR LESS.

#### ADJACENT OWNER LIST

- |  |  |  |
|--|--|--|
| 1. WOODMOOR IMPROVEMENT ASSN<br>1691 WOODMOOR DR<br>MONUMENT CO, 80132-9071  | 9. WOODMOOR WATER & SANITATION<br>DISTRICT NO 1<br>PO BOX 1407<br>MONUMENT CO, 80132-1407                        | 17. GILMOUR SASAKI FAMILY TRUST<br>C/O MIKE LANE<br>2015 BRAMBLEWOOD LN<br>COLORADO SPRINGS CO, 80920-1590 |
| 2. MCFADDEN ASHLEIGH C<br>18830 LAKE FOREST LN<br>MONUMENT CO, 80132-9013  | 10. LAKE WOODMOOR HOLDINGS LLC<br>1755 TELSTAR DR STE 211<br>COLORADO SPRINGS CO, 80920-1018                     | 18. ET INVESTMENTS GROUP LLC<br>106 N TEJON ST<br>COLORADO SPRINGS CO, 80903-1440                          |
| 3. HAMMER RONALD SCOTT II<br>HAMMER SARAH TOVA<br>18820 LAKE FOREST LN<br>MONUMENT CO, 80132-9013                  | 11. MOSBARGER BONNIE M<br>1655 DEER CREEK RD<br>MONUMENT CO, 80132-9004  | 19. MCHORTER CATHERINE M<br>1640 DEER CREEK RD<br>MONUMENT CO, 80132-9019                                  |
| 4. HICKS RICHARD A LIVING TRUST<br>HICKS REBECCA T LIVING TRUST<br>18810 LAKE FOREST LN<br>MONUMENT CO, 80132-9013 | 12. FORNOF JOHN C<br>545 3RD ST # 223<br>MONUMENT CO, 80132-4509   | 20. POUR MEHDI G<br>POUR MEREDITH A<br>1580 BURNING OAK WAY<br>MONUMENT CO, 80132-9015                     |
| 5. WEYER THOMAS C & PAMELA A<br>10115 CLEAR CREEK RD<br>COLORADO SPRINGS CO, 80920-1439                            | 13. JOHNSON JEFFREY JOSEPH<br>JOHNSON CRYSTAL DAWN<br>SEBASTIAN<br>1657 DEER CREEK RD<br>MONUMENT CO, 80132-9004 | 21. ELLIOTT JERE L & MARY L<br>1560 DEER CREEK RD<br>MONUMENT CO, 80132-9020                               |
| 6. FABER JAMES A<br>FABER SUZANNE<br>18760 AUTUMN WAY<br>MONUMENT CO, 80132-9014                                   | 14. DAVIS JACK<br>1658 DEER CREEK RD<br>MONUMENT CO, 80132-9004  | 22. DLB & YCB LIVING TRUST<br>18930 BURNT LEAF WAY<br>MONUMENT CO, 80132-9016                              |
| 7. HENDERLONG KEITH T<br>HENDERLONG DEBORAH G<br>104 AMBERGATE DR<br>MADISON AL, 35756-3487                        | 15. DEMATTEIS JUDY THOMAS LIVING<br>TRUST<br>5991 POMMEL CIR<br>WEST DES MOINES IA, 50266                        |  |
| 8. FUGGETTA CHARLES F JR<br>FUGGETTA BARBARA D<br>18720 AUTUMN WAY<br>MONUMENT CO, 80132-9014                      | 16. WILLIAMS KAREN E<br>1676 DEER CREEK RD<br>MONUMENT CO, 80132-9003  |  |

Land Planning  
Landscape  
Architecture  
Urban Design

N.E.S. Inc.  
619 N. Cascade Avenue, Suite 200  
Colorado Springs, CO 80903

Tel. 719.471.0073  
Fax 719.471.0267

www.nescolorado.com

© 2012. All Rights Reserved.

## NORTH BAY AT LAKE WOODMOOR

PARCEL E

DEER CREEK RD  
MONUMENT, CO 80132

DATE: 11-15-2016  
PROJECT MGR: A. BARLOW  
PREPARED BY: K. MARSHALL

### PUD DEVELOPMENT PLAN

| DATE:    | BY: | DESCRIPTION:                |
|----------|-----|-----------------------------|
| 12-01-17 | KMM | PER COUNTY REVIEW COMMENTS  |
| 09-17-18 | KMM | PER COUNTY & UTILITY REVIEW |
| 11-21-19 | KMM | PER COUNTY & UTILITY REVIEW |

### REZONING & ADJACENT OWNERS MAP

# 14

14 OF 14

PUD SP - 16 - 004

C:\Users\Phan\OneDrive\Drawings\Planning\Drawings\The Cove at Woodmoor\Drawings\Development\The Cove at Woodmoor\_PUD.dwg [ContMap.dwg] 11/22/2015 12:45:02 PM kmarshall



December 18, 2019

El Paso County Development Services Department  
2880 International Circle, Suite 110  
Colorado Springs, CO 80910-3127

RE: North Bay at Lake Woodmoor – Final Plat  
Sec. 11, Twp. 11S, Rng. 67W, 6<sup>th</sup> P.M.  
Water Division 2, Water District 10  
CDWR Assigned Subdivision No. 23991

To Whom It May Concern:

We have received additional information concerning the above-referenced proposal to subdivide a 7.23 +/- acre tract of land into 28 single-family dwelling lots and 5 tracts. The comments provided herein supersede those comments previously provided by letter dated December 28, 2016 and October 22, 2018. This office has no record of any existing wells located on the property. According to the submittal, the proposed source of water supply and wastewater disposal is to be served by the Woodmoor Water and Sanitation District (“District”).

### Water Supply Demand

The updated Water Supply Information Summary, Form No. GWS-76, provided with the submittal estimates a new demand of 0.342 acre-feet/year per household for a total of 28 household units. This equates to an anticipated annual water demand of 9.58 acre-feet/year for all combined units and uses. The proposal does not clearly define the amount of lawn and garden irrigation anticipated for each lot but does note that the water supply estimate accounts for some level of irrigation.

It should be noted that standard water use rates, as found in the *Guide to Colorado Well Permits, Water Rights, and Water Administration*, are 0.3 acre-foot per year for each ordinary household, 0.05 acre-foot per year for four large domestic animals, and 0.05 acre-foot per year for each 1,000 square feet of lawn and garden irrigation.

### Source of Water Supply

The proposed source of water for the development continues to be Woodmoor Water and Sanitation District and an updated letter of commitment from the District dated November 21, 2017 was included with the submittal. According to the letter, they have committed to supply 9.58 acre-feet/year to the proposed development. According to this office’s records, it appears that District has adequate water resources to serve 9.58 acre-feet/year for the proposed development.



### **Additional Comments**

Should the development include construction and/or modification of any storm water structure(s), the Applicant should be aware that, unless the storm water structure(s) can meet the requirements of a “storm water detention and infiltration facility” as defined in section 37-92-602(8), Colorado Revised Statutes, the structure may be subject to administration by this office. The applicant should review DWR’s *Administrative Statement Regarding the Management of Storm Water Detention Facilities and Post-Wildland Fire Facilities* in Colorado (<http://water.state.co.us/DWRIPub/Documents/DWR%20Storm%20Water%20Statement.pdf>) to ensure that the notice, construction and operation of the proposed structure meets statutory and administrative requirements.

### **State Engineer’s Office Opinion**

According to this office’s records, it appears the District has sufficient water resources to serve the proposed development. Based upon the above and pursuant to Section 30-28-136(1)(h)(II), C.R.S., it is the opinion of this office that the proposed water supply is adequate and can be provided without causing injury to decreed water rights. Should you have any further questions, please feel free to contact me directly.

Sincerely,



Ivan Franco, P.E.  
Water Resource Engineer

cc: Bill Tyner, Division 2 Engineer  
Doug Hollister, District 10 Water Commissioner

# EL PASO COUNTY



## OFFICE OF THE COUNTY ATTORNEY CIVIL DIVISION

**Diana K. May, County Attorney**

### Assistant County Attorneys

M. Cole Emmons  
Lori L. Seago  
Lisa A. Kirkman  
Steven A. Klaffky  
Peter A. Lichtman  
Mary Ritchie  
Bryan E. Schmid  
Nathan J. Whitney

February 19, 2020

North Bay at Lake Woodmoor  
PUD Preliminary Plan and Final Plat  
PUDSP-16-004 and SF-16-021

Reviewed by: M. Cole Emmons, Senior Assistant County Attorney  
Edi Anderson, Paralegal

### FINDINGS AND CONCLUSIONS:

1. This is a proposal by Lake Woodmoor Holdings, LLC ("Applicant"), for a PUD Preliminary Plan, and Final Plat to subdivide approximately 7.23 acres into 28 townhome units and 5 tracts (2 tracts allocated for private streets). The property is currently zoned R-4 (Planned Development District – Obsolete) and a concurrent rezoning request to a PUD ("Planned Unit Development") is under review.

2. The Applicant has provided that the source of water for the subdivision will derive from the Woodmoor Water and Sanitation District ("District"). The Applicant estimates its annual water needs at 9.58 acre-feet based on 0.342 acre-feet per townhome unit, as indicated on the Water Supply Information Summary included with the submittal. Based on these figures, the Applicant must be able to provide a supply of 2,874 acre-feet of water (9.58 acre-feet per year x 300 years) to meet the County's 300 year water supply requirement.

3. The District Manager of the Woodmoor Water & Sanitation District provided a letter regarding this proposal on November 21, 2017, committing to provide water and sewer services to the development.<sup>1</sup> Specifically, the District Manager stated that if the development of 28 multi-family units proceeds according to plan, "the North

<sup>1</sup> The Woodmoor Water and Sanitation District's Engineer provided an email to the County Attorney's Office on February 18, 2020, confirming that the November 21, 2017 commitment letter remained a valid commitment by the District.

200 S. CASCADE AVENUE  
OFFICE: (719) 520-6485



COLORADO SPRINGS, CO 80903  
FAX: (719) 520-6487



Bay water demands, as proposed by the Developer, are anticipated to total 9.4580 AF annually which the District is committed to serving.”

The District Manager detailed the water supply available to the District, and noted the agreement between the District and KAB-Pankey, LLC (“Agreement”). The District noted that the Agreement identifies the properties to be served by the Agreement, including, North Bay at Lake Woodmoor. The District letter states that the “North Bay property total 7.2 acres which the District is committed to providing water and sewer services in accordance with its standard policy allocation totaling 3.6 AF annually and additionally has committed to serving Agreement properties (collectively) with up to 86.21 of Supplemental Water Service. With the completion of the Dunes at Woodmoor and the Beach at Woodmoor, there will remain 64.182 AF/Yr of supplemental water service that can be allocated (wholly or partially) toward the remaining Agreement Properties, including North Bay.” The supplemental water service agreement is further detailed in the *Water Resources Report & Wastewater Treatment Report-North Bay at Lake Woodmoor* dated November 8, 2016, prepared by Kiowa Engineering Corporation.

4. In a letter dated December 18, 2019, the State Engineer’s Office reviewed the application based on the Water Supply Information Summary and information from the District, which estimated a demand of 9.58 acre-feet annually for 28 multi-family units (0.342 acre-feet per townhome). The Engineer noted that the proposal didn’t clearly define the amount of lawn and garden irrigation for each lot, but notes that the water supply estimate does account for some level of irrigation. The Engineer stated that based on the records available, the “District has adequate water resources to serve 9.58 acre-feet/year for the proposed development.” Further, the State Engineer stated that “pursuant to Section 30-28-136(1)(h)(II), C.R.S., it is the opinion of this office that the proposed water supply is adequate and can be provided without causing injury to decreed water rights.”

Note: The State Engineer’s Office also provided an advisory to the Applicant related to any possible storm water collection and/or conveyance facilities that may be included in the project. The Engineer advised the Applicant that “. . . unless the storm water structure(s) can meet the requirements of a ‘storm water detention and infiltration facility’ . . . the structure may be subject to administration by this office. The applicant should review the *DWR’s Administrative Statement Regarding the Management of Storm Water Detention Facilities and Post-Wildland Fire Facilities in Colorado* . . . to ensure that the notice, construction and operation of the proposed structure meets statutory and administrative requirements.”

5. Section 8.4.7(B)(10)(g), of the El Paso County Land Development Code allows for the presumption of acceptable water quality for projects such as this where

water is supplied by an existing Community Water Supply operating in conformance with Colorado Primary Drinking Water Regulations unless there is evidence to the contrary that may be provided by the El Paso County Health Department.

6. Analysis. The Woodmoor Water & Sanitation District has a total of 86.21 acre-feet of water supply available for the properties identified in the District's Agreement, including North Bay at Lake Woodmoor. Pursuant to the District's letter, the District has 64.182 acre-feet/year of water available to serve the North Bay development and other properties included in the Agreement. With a proposed annual demand of 9.58 acre-feet required for the North Bay at Lake Woodmoor development, and based on current commitments and available water supply of the District, it appears the proposed water supply will be sufficient.

7. Therefore, based on the above analysis and the requirements below, given the commitment to serve by the District, the commitments in the land purchase Agreement, and the finding of the State Engineer's Office that the proposed water supply can be provided without injury to existing water rights and is expected to be adequate, the County Attorney's Office recommends a finding that the proposed water supply is **sufficient** in terms of quantity and dependability. The El Paso County Health Department may wish to confirm that the District is in compliance with the water quality regulations.

#### REQUIREMENTS:

- A. Applicant, its successors and assigns, and all future owners of lots within this filing shall be advised of, and comply with, any conditions, rules, regulations, limitations, and specifications set by the District.
- B. It is Applicant's responsibility, and not the County's, to comply with the advisory by the State Engineer's Office regarding any storm water collection and/or conveyance facilities that may be included in the development to ensure that any such structures meet the requirements of a 'storm water detention and infiltration facility,' and that notice, construction, and operation of the proposed structure meets statutory and administrative requirements.

cc: Nina Ruiz, Project Manager, Planner III



Prevent • Promote • Protect

Environmental Health Division  
1675 W. Garden of the Gods Road  
Suite 2044  
Colorado Springs, CO 80907  
(719) 578-3199 *phone*  
(719) 578-3188 *fax*  
[www.elpasocountyhealth.org](http://www.elpasocountyhealth.org)

### **North Bay at Lake Woodmoor, PUDSP-16-004**

Please accept the following comments from El Paso County Public Health regarding the project referenced above:

- The proposed 28-unit townhome development will be provided water and wastewater services by Woodmoor Water and Sanitation District. A “Will Serve” letter dated 21Nov2017, has been provided for water service. There is a finding for sufficiency in terms of water quality for this Colorado Department of Public Health and Environment regulated public water system (PWSID# CO0121950).
- The wastewater treatment facility has adequate capacity for the proposed development based upon a “Will Serve” letter dated 21Nov2017, from the Woodmoor Water and Sanitation District.
- Radon resistant construction building techniques/practices are encouraged to be used in this area. The EPA has determined that Colorado, and the El Paso County area, have potentially higher radon levels than other areas of the country.
- El Paso County Public Health encourages increased “walkability” by design within the development. Walkability includes planned connection of sidewalks and trails to surrounding developments. Walkability provides a means for increased physical activity of the residents; which studies show lead to a decrease the incidence of cardiovascular diseases and obesity levels of the general public.
- Earthmoving activity between 1 and 25 acres will require a Construction Activity Permit from El Paso County Public Health. Information can be found at <https://www.elpasocountyhealth.org/service/air-quality/construction-activity-application>

Mike McCarthy  
El Paso County Public Health  
Environmental Health Division  
719-575-8602  
[mikemccarthy@elpasoco.com](mailto:mikemccarthy@elpasoco.com)  
08Feb2020