

**Preliminary and Final Drainage Report
North Bay at Lake Woodmoor
El Paso County, Colorado**

Prepared for:
Lake Woodmoor Holdings, LLC
1755 Telstar Drive, Suite 211
Colorado Springs, Colorado 80920



1604 South 21st Street
Colorado Springs, Colorado 80904
Ph: (719)630-7342

Kiowa Project No. 15073

September 4, 2018
Revised: February 21, 2020

February 21, 2020

Ms. Brandy R. Williams, P.E.
El Paso County Development Services
2880 International Circle
Colorado Springs, Colorado 80910

RE: North Bay at Lake Woodmoor
(Kiowa Project No. 15073)

Dear Brandy:

This report is titled *Preliminary and Final Drainage Report North Bay at Lake Woodmoor* and addresses the drainage issues for the property, including improvements to the Lake Fork Tributary of Dirty Woman Creek that flows through the property. The report was prepared according to current County drainage criteria and is being submitted for approval.

If there are any questions or if we may be of further assistance, please feel free to call at any time.

Sincerely,

Kiowa Engineering Corporation

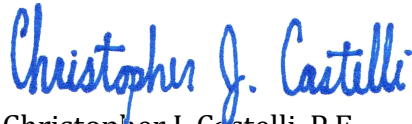

Christopher J. Castelli, P.E.
Senior Civil Engineer

TABLE OF CONTENTS

Table of Contents i
Statements and Approvals ii
I. General Location and Description 1
Major Drainage Basins and Subbasins 2
Drainage Design Criteria 3
II. Drainage Facility Design 3
 A. Stormwater Detention and Water Quality Design 8
 B. Cost of Proposed Private Drainage Facilities 11
 C. Drainage and Bridge Fees 11
III. Conclusions 11
IV. References 12
Appendix Table of Contents 13
Appendix Table of Contents (Continued) 14

List of Figures and Tables (Refer to the Appendix Table of Contents)

STATEMENTS AND APPROVALS

ENGINEER'S STATEMENT:

The attached drainage plan and report were prepared under my direction and supervision and are correct to the best of my knowledge and belief. Said drainage report has been prepared according to the criteria established by the County for drainage reports and said report is in conformity with the master plan of the drainage basin. I accept responsibility for any liability caused by any negligent acts, errors or omissions on my part in preparing this report.

Kiowa Engineering Corporation, 1604 South 21st Street, Colorado Springs, Colorado 80904



Christopher J. Castelli, P.E. (Lic# 38842)
For and on Behalf of Kiowa Engineering Corporation

5/18/2020

Date

DEVELOPER'S STATEMENT:

I, the Developer, have read and will comply with all of the requirements specified in this drainage report and plan.

By: 
Steve Rossoll, Director of Development Services
Lake Woodmoor Holdings, LLC

5/18/2020
Date

Print Name: Steve Rossoll
Address: Lake Woodmoor Holdings, LLC
1755 Telstar Drive, Suite 211
Colorado Springs, Colorado 80920

EL PASO COUNTY:

Filed in accordance with the requirements of the Drainage Criteria Manual, Volumes 1 & 2, El Paso County Engineering Criteria Manual, and Land Development Code, as amended.

Jennifer Irvine, P.E.
El Paso County Engineer/ECM Administrator

Date

I. GENERAL LOCATION AND DESCRIPTION

North Bay at Lake Woodmoor will be developed as a multi-family residential subdivision located in the Woodmoor area of El Paso County near Monument, Colorado. The subject property is located to the south of Deer Creek Road and approximately 400 feet east of Woodmoor Drive. The site is located in the southeast portion of Section 11, Township 11 South, Range 67 West of the 6th Principal Meridian, in El Paso County, Colorado. The site is bounded to the north by Deer Creek Road, to the west by the Cove at Woodmoor Condominiums, to the east by single family residences of the Woodmoor development and to the south by Lake Woodmoor. The property covers approximately 7.23 acres and is currently undeveloped. A vicinity map of the site is shown on Figure 1 included in the Appendix.

The existing vegetative cover within the property consists primarily of smooth brome (*Bromus inermis*), a non-native grass commonly used for re-vegetation in good condition throughout the site. There are a few coniferous trees scattered across the site, with a denser tree cover along the south and east property boundaries. There are riparian shrubs within the creek in the northeast corner of the property and deciduous trees and wetlands along the south property boundary at Lake Woodmoor. The existing ground slopes within the property range from approximately 2 to 38 percent. Soils within the west one third of the subject site are classified to be within Hydrologic Soil Group B (Pring coarse sandy loam #71), and soils within the east two thirds of the subject site are classified to be within Hydrologic Soil Group D (Alamosa loam #1) as shown in the El Paso County Custom Soil Resource Report. Excerpts from the report are included in the Appendix. Hydrologic Soil Groups B and D were used (where appropriate in accordance with the soil report) for the purposes of computing the existing and proposed hydrology for the site.

The Lake Fork Dirty Woman Creek (Lake Fork) enters the site in the northeast corner, and continues in a southerly direction through the middle of the site to Lake Woodmoor. Not only does the Lake Fork receive runoff from the entire site, but also from offsite basins to the north, west and east of the site. The Lake Fork conveys flow south to Lake Woodmoor, then continues south crossing Lake Woodmoor Drive to the Dirty Woman Creek main branch. Dirty Woman Creek is a tributary to Monument Creek.

There are no active irrigation ditches or facilities within or adjacent to the site.

Existing utilities adjacent to the site include three Woodmoor Water and Sanitation District (District) water lines (two potable water and one raw water), one District sanitary sewer line, an underground electric line and two telephone lines within the Deer Creek Road right-of-way. There is an existing District well (Well Site No. 5) just to the west of the property. There are several existing utilities within the site, including a water line that runs south from Deer Creek Road through the middle of the site, a water line that runs east from Deer Creek Road to a fire hydrant, sanitary sewer lines located near the south and east property boundaries that run to/from an existing lift station in the southeast corner of the site, and an underground electric line near the east property boundary from Deer Creek Road to the lift station. Near the northeast corner of the property, there is a concrete headwall and 24-inch CMP that diverts creek flow approximately 240 linear feet southwest along the north property boundary to a CMP manhole, where it combines with a 24-inch CMP culvert that crosses Deer Creek Road. The 24-inch CMP continues south approximately 340 linear feet to a concrete structure at the north end of Lake Woodmoor. There is also a 12-inch PVC raw water drainline that runs parallel to the north-south 24-inch CMP and daylights at the same concrete structure at Lake Woodmoor.

MAJOR DRAINAGE BASINS AND SUBBASINS

The site lies within the Dirty Woman Creek drainage basin. The site presently drains southwest and southeast by sheet flow to the Lake Fork, which drains southerly to Lake Woodmoor (Sub-basins EX-1 through EX-3). The existing drainage patterns for the site are shown on Sheet DP1 provided in a map pocket at the end of this report.

There is currently offsite runoff that enters the site from the east. Offsite Sub-basin OS-1 conveys runoff west by sheet flow from the Woodmoor residential development to the east property boundary (DP 1), where it sheet flows southwest across the east portion of the site to the Lake Fork tributary. Offsite Sub-basin OS-2 conveys runoff by sheet flow from the Woodmoor Oaks residential subdivision north of the site to a swale along the north side of Deer Creek Road. The swale terminates at a 24-inch CMP just east of Burning Oak Way that captures flow from Sub-basin OS-2 (DP 4) and conveys it south across Deer Creek Road to the north property boundary at a CMP manhole. Runoff from Sub-basin OS-2 is combined with diverted Lake Fork tributary flows at the CMP manhole (see existing utilities discussion in the General Location and Description section), and continues south in a 24-inch CMP to Lake Woodmoor. Offsite Sub-basin OS-3 conveys runoff southeast by sheet flow and gutter flow from a portion of the The Cove at Woodmoor Condominiums development to the west property boundary (DP 6). Sub-basin OS-3 runoff is then combined with runoff from Sub-basin EX-2 and is conveyed southeast by sheet flow to the Lake Fork tributary.

The reports and plans that were reviewed in the process of preparing this drainage report are included in the References section. The North Bay at Lake Woodmoor area was studied as a part of the *Dirty Woman and Crystal Creeks Drainage Basin Planning Study (DBPS)*. The portion of the Lake Fork tributary that is within the North Bay at Lake Woodmoor property (identified as "Reach LFDW-A-25" in the DBPS) is planned to be stabilized with a series of grade control (check) structures. The intent of the structures is to allow natural aggradation and degradation of the creek over time. The creek improvements will be constructed in conjunction with the North Bay at Lake Woodmoor improvements, so the development of the property will not adversely impact any improvements or drainageways downstream. Refer to the Drainage Facility Design section for additional discussion of the creek improvements.

The subject property limits are shown on Flood Insurance Rate Map (FIRM) 08041C0276 F (with an effective date of March 17, 1997). The FIRM was subsequently revised to reflect a Letter of Map Revision (LOMR) dated November 9, 1998. The FIRM showing the project site and the Letter of Map Change (LOMC) outlining the edits to the Lake Fork Dirty Woman Creek Base Flood Elevations per the approved LOMR are included in the Appendix and Appendix F. The middle approximately one third of the property is located within a FEMA regulated floodplain based on Flood Insurance Rate Map 08041C0276 F. The current FEMA floodplain and floodway limits (as shown on the effective FIRM) and the existing condition floodplain limits (based on detailed survey information for the site) are shown on Sheet DP1. Under proposed conditions, the property will be developed on both sides of the creek with grading limits outside of the existing 100-year floodway limits in all areas except for the transition grading required for the proposed culvert crossing at Shoreditch Heights. A Conditional Letter of Map Revision (CLOMR) that reflects the proposed design and a Letter of Map Revision (LOMR) that reflects the as-constructed conditions are therefore required for this project. The Conditional Letter of Map Revision (CLOMR) for this project has been submitted and approved by FEMA. A copy of the approval letter from FEMA is included in Appendix F. The current FEMA floodplain and floodway limits, existing condition floodplain limits, and proposed condition floodplain and floodway limits are all shown on Sheet DP2. Sheet DP2 also shows that finished floor elevations of all habitable/insurable structures will be located outside of the proposed 100-year floodplain.

DRAINAGE DESIGN CRITERIA

Hydrologic and hydraulic calculations for the site were performed using the methods outlined in the *El Paso County Drainage Criteria Manual (DCM)*. Topography for the site was compiled using a two-foot contour interval and is presented on the drainage plans. The hydrologic calculations were made for the existing and proposed site conditions. The drainage plans present the drainage patterns for the site, including the sub-basins. The peak flow rates for the sub-basins were estimated using the Rational Method. The 5-year (Minor Storm) and 100-year (Major Storm) recurrence intervals were determined. The one-hour rainfall depth was determined from Table 6-2 of the *Drainage Criteria Manual*. These depths are shown in the runoff calculations spreadsheet. The peak flow data generated using the rational method was used to verify street capacities and to size inlets and storm sewers within the development. The drainage basin area, time of concentration, and rainfall intensity were determined for each of the sub-basins within the property. As discussed in the General Location and Description section, Hydrologic Soil Groups B and D were used (where appropriate in accordance with the soil report) for the purposes of computing the existing and proposed hydrology for the site. For existing conditions, runoff coefficients for the on-site basins were determined using historic, packed gravel and pavement land uses. The land uses for the proposed development will be paved streets, roofs and lawns. Runoff coefficients for the offsite basins were determined using residential with a density of approximately 2 lots per acre for Sub-basin OS-1 and 1 lot per acre for Sub-basin OS-2. The land uses for offsite Sub-basin OS-3 were pavement and historic/lawns.

The sizing of the onsite hydraulic structures was made using the methods outlined in both the El Paso County and City of Colorado Springs Drainage Criteria Manuals. Colorado Department of Transportation (CDOT) Type R curb inlets, Type D grated inlets and a Stormceptor with a slotted grate will be used within the site. The hydraulic capacities of the Type R curb inlets and the Stormceptor grate were determined using the UDINLET spreadsheet developed by the Urban Drainage and Flood Control District (UDFCD), and Figure 8-10 (refer to Appendix B) was utilized for the Type D grated inlet capacities.

El Paso County Type C curbs will be used throughout the development, except between curb returns and at curb inlets, where a 6-inch vertical curb will be used. The UD-Inlet spreadsheet was used to determine the capacity of each street within the site, considering the County criteria for the Minor (5-year) and Major (100-year) Storms.

Storm sewer pipes were initially sized based on their full-flow capacity using the Manning's equation. The UDSewer program was then used to verify storm sewer pipe sizes and perform hydraulic grade line (HGL) and energy grade line (EGL) calculations for the 5-year and 100-year storm events. Hydraulic calculations are provided in Appendix B for the proposed street, inlet and pipe capacities.

The UD-Culvert spreadsheet was used to determine the extent and size of riprap erosion protection for pipe and box culvert outlets. These calculations are also included in Appendix B.

The on-site stormwater quality sand filter basins were sized using the UD-Detention spreadsheet created by the UDFCD. The supporting calculations associated with the sizing of the sand filter basins are included in Appendix D of this report. The proposed Stormceptor for the site was sized by Rinker Materials based on the drainage area and percent imperviousness of the drainage basins tributary to the Stormceptor. The design report prepared by Rinker is also included in Appendix D.

II. DRAINAGE FACILITY DESIGN

The drainage of the site will be accomplished through a combination of sheet flow, gutter flow and storm sewer flow. Curb inlets and grated inlets will be placed at low points (sump areas) throughout the site to accept the developed runoff and convey it directly to Lake Fork Dirty Woman Creek. One curb inlet on a continuous grade will be required along Shoreditch Heights to decrease the amount

of gutter flow for the minor and major storms. Riprap outlet protection will be placed at the end of each pipe outfall to reduce erosion.

Each stormwater quality sand filter basin will include a free-draining filter material underlain by a woven geotextile fabric, an underdrain system, a riprap presedimentation forebay at each proposed storm sewer outlet and a CDOT Type D grated inlet to serve as the outlet structure. In order to control the drain time of the sand filter basin to the required 12-hours, there will be an orifice plate at the downstream end of the underdrain system within the outlet structure. An emergency spillway and a maintenance access trail will also be provided.

The proposed sand filter basins and Stormceptor will be private facilities owned and maintained by the homeowner's association for the North Bay at Lake Woodmoor development.

The proposed drainage patterns for the site are shown on the Final Drainage Plan for the developed condition (Sheet DP2) provided in the map pocket at the end of this report. The hydrologic and hydraulic calculations are provided in Appendices A and B, refer to the Drainage Design Criteria section for additional information on the hydrologic and hydraulic calculations.

The evaluation related to the sizing of the onsite drainage improvements was carried out in accordance with the *El Paso County Drainage Criteria Manual*. The capacities of the proposed onsite facilities were calculated in accordance with the Criteria Manual.

The primary stormwater conveyance facilities will be storm sewer systems ranging in size from 18- to 36-inches conveying the on-site runoff to Lake Fork Dirty Woman Creek:

Storm Sewer System 'A1': Subbasin W2 drains to a Type D grated inlet in a sump condition, where an 18-inch RCP will convey the captured flow northeast beneath Redbridge Point to a new manhole with a grated cover in a low (sump) area within Sub-basin W7 (DP 10). This manhole will connect to an existing 24-inch CMP that crosses Deer Creek Road just east of Burning Oak Way. It was determined that the capacity of the existing 24-inch CMP that crosses Deer Creek Road is about 25 cfs, which is about 3 cfs less than the 100-year runoff of 28.3 cfs for Sub-basin OS-2. The remaining 3 cfs will sheet flow across Deer Creek Road in a 100-year event and be collected at the manhole with the grated cover. Flow that cannot be collected by the manhole will sheet flow overland southeast to the Lake Fork tributary. The system continues northeast to proposed manhole MH A1, where it combines with diverted creek flows.

Most of the existing 24-inch CMP that parallels Deer Creek Road will remain in place, with its upstream end connected to the proposed box culvert crossing of Shoreditch Heights through its northeast wingwall. Creek flows will be diverted and conveyed in the existing 24-inch CMP to a proposed manhole (MH A1), where the system will continue generally south in a 36-inch RCP along the westerly side of the Lake Fork tributary to a flared end section that daylights near the south end of the property (DP 13).

Storm Sewer System 'A2': This system begins at the low point in Redbridge Point, where a pair of Type D grated inlets will accept up to 100-year event flows from Sub-basins OS-3, W3, W4, W5 and W6 (DP's 11 and 12). The combined flow will be conveyed west then south in an 18-inch RCP to proposed Sand Filter Water Quality Basin 1.

Storm Sewer System 'A3': This system conveys up to 100-year event flows south in an 18-inch RCP from the proposed Sand Filter Water Quality Basin 1 outlet structure to the Lake Fork tributary (DP 12.1) as it enters Lake Woodmoor.

Storm Sewer System 'B1': The combined runoff from Sub-basins OS-1a and E2 will be conveyed to a 10' curb inlet on a continuous grade along the east side of Shoreditch Heights (DP 14). Captured runoff will be conveyed south in an 18-inch RCP to a 15' curb inlet in a sump condition at the south

end of Shoreditch Heights. The 15' curb inlet will capture up to 100-year event flows from Sub-basins OS-1b and E3 (DP 15) and carry-over flow from the inlet at DP 14, and convey it west to a 10' curb inlet in a sump condition at the south end of Shoreditch Heights. The 10' curb inlet will capture up to 100-year event runoff from Sub-basin E4, and the combined runoff from DP's 14 and 15 and Sub-basin E4. The captured flow will be conveyed south in an 18-inch RCP to proposed Sand Filter Water Quality Basin 2 (DP 16).

Storm Sewer System 'B2': This system conveys up to 100-year event flows west in an 18-inch RCP from the proposed Sand Filter Water Quality Basin 2 outlet structure to the Lake Fork tributary (DP 16.1) as it enters Lake Woodmoor.

Storm Sewer System 'C': A Stormceptor with a slotted grate in a sump condition at the west end of the dead-end street off Shoreditch Heights will capture runoff from Sub-basins E5 and E6, and convey it west in a 14-inch by 23-inch HERCP (18-inch circular equivalent) to the Lake Fork tributary (DP 17).

Following is a description of the on-site drainage sub-basins:

Sub-basin W1 is approximately 0.35 acres in area and is located at the northeast corner of the site. Runoff from this basin will gutter flow northerly from the high point in Shoreditch Heights to Deer Creek Road and sheet flow south from the Deer Creek Road crown to the Lake Fork tributary upstream (east) of the proposed triple (3) 12' wide by 4' high RCB's culvert crossing at Shoreditch Heights.

Sub-basin W2 is approximately 0.14 acres in area and is located along the north property boundary just west of proposed Redbridge Point (across from Burning Oak Way). Runoff from the majority of this basin will gutter flow northerly from the high point in Redbridge Point to Deer Creek Road and sheet flow south from the Deer Creek Road crown to a Type D grated inlet at a low point just west of Redbridge Point.

Sub-basin W3 is approximately 0.33 acres in area, is located south of Sub-basin W2, west of Sub-basin W4, and includes the west half of Redbridge Point between its high point and low point. Runoff from a portion of this basin will sheet flow southwest to a grass swale, where the flow will be conveyed south to a Type D grated inlet at the low point in Redbridge Point. The remaining portion of the basin will sheet flow southeast and gutter flow south to the Type D grated inlet (DP 11).

Sub-basin W4 is approximately 0.38 acres in area and is located west of Sub-basin W3. Runoff from this basin will combine with runoff from offsite Sub-basin OS-3 and sheet flow southeast to a grass swale, where the combined flow will be conveyed south to a Type D grated inlet at the low point in Redbridge Point. A small portion of runoff from this basin will gutter flow east to the low point in Redbridge Point (DP 11).

Sub-basin W5 is approximately 0.26 acres in area, is located east of Sub-basin W3, and includes the east half of Redbridge Point between its high point and low point. Runoff from this basin will sheet flow southwest and gutter flow south to a Type D grated inlet at the low point in Redbridge Point (DP 12).

Sub-basin W6 is approximately 0.13 acres in area, is located south of Sub-basin W4, and includes the south half of Redbridge Point that is west of its low point. Runoff from this basin will sheet flow northeast and gutter flow east to a Type D grated inlet at the low point in Redbridge Point (DP 12).

Sub-basin W7 is approximately 1.92 acres in area, is generally located east of Sub-basin W5 and south of Deer Creek Road, and includes all the area that drains directly to the Lake Fork tributary from the west. This basin accepts runoff from Sub-basins OS-2 and OS-3, and from Sub-basins W1 through W6 and W8. Runoff from this basin will sheet flow east and south to Lake Woodmoor (at DP 18).

Sub-basin W8 is approximately 0.26 acres in area, is located south of Redbridge Point and west of its low point. This basin represents the area that drains south by sheet flow directly to proposed Sand Filter Water Quality Basin 1.

Sub-basin E1 is approximately 0.20 acres in area and is located south of Sub-basin W1 at the northeast corner of the site. Runoff from this basin will sheet flow north to the Lake Fork tributary upstream (east) of the proposed triple (3) 12' wide by 4' high RCB's culvert crossing at Shoreditch Heights.

Sub-basin E2 is approximately 0.57 acres in area, is located south of Sub-basin E1 and west of Sub-basin OS-1, and includes the east half of Shoreditch Heights between its high point and DP 14. Runoff from this basin will combine with runoff from Sub-basin OS-1a, sheet flow east to Shoreditch Heights and gutter flow south along Shoreditch Heights to a 10' curb inlet on a continuous grade (DP 14).

Sub-basin E3 is approximately 0.26 acres in area, is located south of Sub-basin E2, and includes the east half of Shoreditch Heights between DP 14 and its low point at the south end of the street. Runoff from this basin will combine with runoff from Sub-basin OS-1b and sheet flow west to Shoreditch Heights, where it will combine with carry-over flow from the 10' curb inlet at DP 14 and gutter flow south to a 15' curb inlet at the low point at the south end of Shoreditch Heights (DP 15).

Sub-basin E4 is approximately 0.33 acres in area, is located west of Sub-basins E2 and E3, and includes the west half of Shoreditch Heights between its high point and its low point at the south end of the street. Runoff from this basin will sheet flow and gutter flow south to a 10' curb inlet in a sump condition at the south end of Shoreditch Heights.

Sub-basin E5 is approximately 0.14 acres in area, is located west of Sub-basin E4 near the south end of Shoreditch Heights, and includes the north half of the dead-end street off Shoreditch Heights. Runoff from this basin will sheet flow southwest to the dead-end street and gutter flow west to its west end, where the cross-slope pitches back to the south to direct runoff to a proposed Stormceptor with slotted grate in a sump condition within Sub-basin E6.

Sub-basin E6 is approximately 0.16 acres in area, is located south of Sub-basin E5, and includes the south half of the dead-end street off Shoreditch Heights. Runoff from this basin will sheet flow northwest to the dead-end street and gutter flow west to its west end at a Stormceptor with slotted grate in a sump condition, where it will combine with runoff from Sub-basin E5.

Sub-basin E7 is approximately 1.55 acres in area, is generally located west of Sub-basin E4, and includes areas that drain directly to the Lake Fork tributary from the east. This basin accepts runoff from Sub-basin OS-1, Sub-basins E1 through E6, and E8. Runoff from this basin will sheet flow southwest and south to Lake Woodmoor (at DP 18). DP 18 represents the total combined local runoff (all offsite and on-site drainage basins), and does not include the Lake Fork tributary flow of 1,100 cfs upstream of the site.

Sub-basin E8 is approximately 0.58 acres in area, and located in the southeast corner of the site. This basin represents the area that drains west by sheet flow directly to proposed Sand Filter Water Quality Basin 2.

Sub-basin E9 is approximately 0.33 acres in area, and located west of Sub-basin E8 at the south end of the site. This basin drains west by sheet flow directly to Lake Woodmoor.

The offsite drainage sub-basins are described in detail in the Major Drainage Basins and Subbasins section.

24-inch CMP Low Flow Creek Diversion

As previously discussed for Storm Sewer System 'A', creek flows will continue to be diverted and conveyed in the existing 24-inch CMP, combine with local runoff from Sub-basins OS-2 and W2, then

discharge back to the creek near the south property boundary. The design intent for the drainageway improvements is to preserve the existing conditions as much as possible and to disturb as little as possible. Preserving the creek diversion is in line with these concepts. Also, diverting the low flows will maintain a dry channel most of the time, which helps to minimize erosion and promotes safety for the private residences proposed adjacent to the creek.

Lake Fork Dirty Woman Creek Improvements

As discussed in the Major Drainage Basins and Subbasins section, creek improvements are proposed along the Lake Fork tributary within the North Bay at Lake Woodmoor property in accordance with the DBPS. As presented in the DBPS, three check structures are proposed within this reach of the creek. The DBPS states that the check structures are to be non-reimbursable improvements (refer to Plan and Profile Sheet LF2 and Table 14 from the DBPS, Reach LFDW-A-25, included in Appendix F). The structures are proposed to be vertical walls, completely buried, and constructed of reinforced concrete. The intent is for the structures to allow for natural aggradation and degradation of the creek over time, resulting in an even more stable longitudinal slope and slower velocities. The buried structures could create small vertical drops along the drainageway over time. If this occurs, flow velocities will increase immediately upstream and downstream of the vertical drops, where riprap is proposed to help prevent erosion in the channel bottom. The current average longitudinal slope of the creek through the site is approximately 4.4 percent, with an average flow depth of 2.2 feet.

The creek was analyzed using HEC-RAS hydraulic modeling software. Data for approximately 25 cross-sections were compiled and input into the model. The locations of the cross-sections are shown on Figure 2, "Proposed Conditions Floodplain Exhibit", included in Appendix E. Manning's roughness values were estimated using field observations in association with the City of Colorado Springs and El Paso County Storm Drainage Criteria Manual. A roughness value of 0.013 was used through the proposed culvert at Shoreditch Heights and at retaining walls (refer to cross-sections and culvert data input included in Appendix E). The hydraulic analysis was initialized using the 100-year water surface elevation of Lake Woodmoor (Elev. 7105.83, NAVD 88 vertical datum). Only the 100-year flood profile was modeled, and flow rates were used that range from 1,016 cfs to 1,107 cfs. Resulting flood depths range from 1.5 feet to 3.2 feet downstream of the proposed culvert. Resulting flow velocities range from 2 fps to 7.6 fps except at the culvert outlet where the flow velocity is 9.6 fps. Resulting shear stress values range from 0.9 lb/sf to 1.7 lb/sf, except at the culvert outlet where the shear stress is 2.95 lb/sf. Riprap outlet erosion protection will be placed in the channel bottom directly downstream of the culvert due to the higher velocities and shear stress. The resulting 100-year floodplain varies in width from 50 feet to 200 feet. The channel completely contains the 100-year flow.

The 40-foot-wide creek crossing at Shoreditch Heights will be a reinforced concrete structure consisting of three (3) 12' wide by 4' high precast concrete box culverts with cast-in-place concrete headwalls and wingwalls at each end to transition the structure to existing grades. Concrete toe walls and soil riprap will also be provided for scour protection and downstream erosion protection, respectively. The length of riprap outlet erosion protection was determined using the UD-Culvert spreadsheet and calculations are included in Appendix B. Results of the hydraulic analysis show a non-erosive channel velocity of 5.4 fps at Station 7+31, which is 10 feet upstream of the end of riprap protection.

The outside bend in the channel downstream of the proposed culvert (Station 6+50 to Station 7+58) was analyzed for stability and flow superelevation. The highest velocity along the channel bank through this reach is 6.2 fps, which is less than 7 fps and considered non-erosive for the native onsite soils. However, the portion of bank along the outside bend that is oriented laterally to the creek at approximately Station 6+40 will receive riprap bank lining with toe protection, to armor the bank from upstream channel flows. The flow superelevation calculations resulted in heights ranging from

0.3 feet to 0.6 feet, which still provides freeboard to Deer Creek Road. Refer to Appendix E for velocity distribution output at the cross sections along the outside bend and for the superelevation calculations. Riprap bank lining with toe protection will also be provided along the east side of the creek where there is a gap in the proposed retaining walls. The gap in the walls will cause a rapid expansion and contraction of the creek flows. The riprap will serve to protect the creek bank and adjacent lots from potential erosion.

As previously mentioned, proposed creek flows through the property have velocities ranging from 2 fps to 7.6 fps (except at the protected culvert outlet) over the existing clayey (less erosive) soils. The County's criteria (DCM, Table 10-4) is unclear regarding the maximum allowable channel velocity for native grasses. Table 10-4 presents maximum allowable velocities that range from 2.5 fps to 7 fps. Other reputable criteria were consulted, such as from the Urban Drainage and Flood Control District (USDCM Vol. 1, Table 8-1) and the City of Colorado Springs (DCM Vol. 1, Table 12-1) as a comparison, and both allow a maximum channel velocity of 7 fps in a 100-year event for vegetated, erosion resistant (cohesive) soils. Based on these criteria, experience and knowledge of the site conditions, 7 fps was selected as a reasonable maximum allowable design channel velocity for this project. Refer to Appendix F for excerpts from the County, City and UDFCD criteria manuals for open channel design. The few locations along the creek with proposed 100-year channel velocities slightly higher than 7 fps could result in minor channel erosion. If this situation occurs, the proposed buried check structures armored with riprap would be in place to control vertical movement of the creek bottom. The County's criteria also require a maximum Froude No. of 0.9 for a 100-year event. The proposed conditions Froude No.'s are between 0.8 and 1.0, which closely match the existing conditions Froude No. results. The velocity-depth relationship between existing and proposed conditions would therefore be unchanged, which is an indication that the currently stable and well-vegetated grass-lined channel would likely remain in this condition during proposed conditions.

An alternative analysis was performed (as a check) to evaluate the allowable shear stress for the native grass at the site. Several visits to the site have been conducted at different times of the year. The existing vegetative cover consistently appears to be in good condition, is mowed somewhat regularly with an average stem height of 12 inches, and there is no evidence of instability or surface erosion. The vegetation present at the site is estimated to be classified as long native grass. Typical permissible shear stress values range from 1.2 lb/sf to 1.7 lb/sf for long native grass. As stated above, the shear stress values calculated by the hydraulic model downstream of the protected culvert outlet range from 0.9 lb/sf to 1.7 lb/sf, which are at or less than the allowable values. Considering the wide, stable channel section with shallow flow depths, and a dry channel bottom during more frequent storm events due to the 24-inch low flow creek diversion, it is anticipated that only minor vertical movement of the creek bottom will occur over time as a result of the proposed development. If vertical movement does occur, the proposed check structures and associated riprap will stabilize the channel reach through the site.

A. STORMWATER DETENTION AND WATER QUALITY DESIGN

Stormwater Detention

Lake Woodmoor will provide 100-year detention storage for the developed runoff from the site. The DBPS assumed a land use of residential with 2 lots per acre for the area that encompasses the North Bay at Lake Woodmoor site (refer to Appendix F, Figure 3 from the DBPS). The assumed land use would have a 25 percent imperviousness resulting in a 0.53 ac-ft detention volume requirement. This volume includes 0.49 ac-ft. of 100-year detention volume plus one half of the water quality capture volume (0.04 ac-ft). The calculated composite percent imperviousness for the proposed site is 34.2 percent. This equates to a detention volume requirement of 0.62 ac-ft, which includes 0.57 ac-ft of 100-year detention volume plus one half of the water quality capture volume (0.05 ac-ft). The net increase in

detention volume to Lake Woodmoor from what was assumed in the DBPS is 0.09 ac-ft. Given the approximately 46-acre surface area of Lake Woodmoor (over 6 times larger than the proposed 7.23-acre site), the increase in detention volume would cause an increase of 0.0019 ft (0.02 in) in the lake's water surface elevation. Lake Woodmoor therefore has sufficient capacity to accept the additional runoff volume, and no improvements are recommended for the reservoir. Refer to Appendix C for detention volume calculations. The Woodmoor Water and Sanitation District (WWSD) has prepared a letter stating that they will allow the use of their facility (Lake Woodmoor) for this site's flood storage. Refer to Appendix F for a copy of the letter.

Stormwater Quality

Storm water quality measures are required as stated in the County's Drainage Criteria Manual. The selection of appropriate BMPs is based on the site's characteristics and potential pollutants. The County requires that a Four-Step Process be followed in the BMP selection process:

Step 1: Employ Runoff Reduction Practices

The natural drainage patterns were generally maintained for the site. The proposed site includes the construction of streets, driveways, sidewalks and parking areas to the minimum widths necessary in order to minimize imperviousness while still maintaining the functionality of the site as intended, providing for adequate parking, snow management, public safety and fire access. Site constraints limit the extent to which Low Impact Development (LID) techniques can be implemented. Runoff was therefore routed where possible (and practical) by sheet flow through grass areas to encourage infiltration.

Step 2: Stabilize Drainageways

As previously stated, the design intent for the drainageway improvements is to preserve the existing conditions as much as possible and to disturb as little as possible. In accordance with the DBPS, only selective channel improvements are proposed along the creek within the project limits. Three grade control check structures with riprap erosion protection will serve to help maintain a mild, stable slope for the channel and arrest any channel degradation that may occur (although only minor degradation is expected). Bank protection and culvert outlet erosion protection will also be provided in critical locations.

Step 3: Provide Water Quality Capture Volume (WQCV)

The letter received from the WWSD included in Appendix F also states that they will require the installation of permanent stormwater quality BMPs within the North Bay at Lake Woodmoor development. Also, the WWSD prefers sand filters over other forms of permanent stormwater quality BMPs.

Water Quality Basin 1. This basin is proposed to be a sand filter, that has a tributary drainage area of 1.37 acres. Storm Sewer System 'A2' conveys flow in an 18-inch RCP to the basin, where a low tailwater riprap basin will help capture sediment and dissipate the energy. The proposed outlet structure will be a CDOT Type D inlet with its grates set at the WQCV elevation of 7116.9. The outlet structure grates are sized to capture the 100-year storm event of 7.2 cfs (DP 12.1). There will be an underdrain system near the bottom of the filter media that connects to the outlet structure, where an orifice plate will control the release of the required 0.02 acre-ft WQCV in a 12-hour drain time. A proposed 18-inch RCP (Storm Sewer System 'A3') will convey runoff released from the basin south to the Lake Fork tributary. If

the outlet structure becomes plugged, a 16-foot wide emergency spillway will convey the runoff south to the Lake Fork tributary just upstream of Lake Woodmoor.

Water Quality Basin 2. This basin is proposed to be a sand filter, that has a tributary drainage area of 1.74 acres. Storm Sewer System 'B1' conveys flow in an 18-inch RCP to the basin, where a low tailwater riprap basin will help capture sediment and dissipate the energy. The proposed outlet structure will be a CDOT Type D inlet with its grates set at the WQCV elevation of 7118.0. The outlet structure grates are sized to capture the 100-year storm event of 11.3 cfs (DP 16.1). There will be an underdrain system near the bottom of the filter media that connects to the outlet structure, where an orifice plate will control the release of the required 0.02 acre-ft WQCV in a 12-hour drain time. A proposed 18-inch RCP (Storm Sewer System 'B2') will convey runoff released from the basin west to the Lake Fork tributary. If the outlet structure becomes plugged, a 24-foot wide emergency spillway will convey the runoff west to the Lake Fork tributary at Lake Woodmoor.

Stormceptor. Sub-basins E5 and E6 have an approximate total area of 0.30 acres that will drain to a low point at the west end of the proposed dead-end street off Shoreditch Heights. Due to space limitations and the concern of providing a permanent BMP that relies on stormwater infiltration in close proximity to foundations of the adjacent proposed buildings, a Stormceptor with a slotted grate is being proposed for this area. Also, the WWSD understands the site constraints and regards the Stormceptor as an acceptable alternative. The self-contained unit will provide stormwater quality treatment for the 0.007 acre-ft WQCV. Flows in excess of the WQCV and up to the 100-year storm event will bypass the Stormceptor insert and be conveyed in a 14-inch by 23-inch HERCP (18-inch circular equivalent) directly to the Lake Fork tributary (DP 17).

Step 4: Consider Need for Industrial and Commercial BMPs

The proposed development is not an industrial or commercial site, so no specialized BMPs were considered.

Stormwater Quality Exclusions

There are portions of the proposed site that qualify as applicable exclusion areas from the stormwater quality requirement. Based on the *El Paso County Engineering Criteria Manual* (ECM) that was recently updated by County Resolution 19-245, applicable development sites must be treated for water quality unless excluded from the requirement per *Appendix I - Stormwater Quality Policies and Procedures*, Sections I.7.1.B or I.7.1.C of the ECM. Refer to Figure WQ1 included in Appendix D.

Drainage Sub-basin E9 is approximately 0.33 acres in area and qualifies as "land disturbance to undeveloped land that will remain undeveloped" per Section I.7.1.B.7 of the ECM, since the sub-basin is currently undeveloped and will remain undeveloped with no human-made structures such as buildings or pavement.

Drainage Sub-basin E1 (0.20 acres) and the majority of Sub-basins W1 (0.27 acres), W7 (1.44 acres) and E7 (1.13 acres) qualify as "stream stabilization" per section I.7.1.B.8 of the ECM, since these areas will include construction activity that is solely for the purpose of stream stabilization improvements to the Lake Fork drainageway.

The remaining areas within Drainage Sub-basins W1 (0.02 acres), W7 (0.48 acres) and E7 (0.42 acres), and a small portion of Sub-basin W2 (0.05 acres) contain proposed development

that will drain directly to the Lake Fork. Runoff from these areas is not practicable to capture and drain towards a control measure. The total area is 0.97 acres, which is 13 percent of the total site area of 7.23 acres. The total area is less than 1.0 acres and is less than 20 percent of the total site, as allowed by the County. Therefore, these areas qualify for the “Water Quality Capture Volume (WQCV) Standard” exclusion per Section I.7.1.C.1 of the ECM.

B. COST OF PROPOSED PRIVATE DRAINAGE FACILITIES

Table 2 presents a cost estimate for the construction of private drainage improvements for the North Bay at Lake Woodmoor development.

C. DRAINAGE AND BRIDGE FEES

The site lies within the Dirty Woman Creek Drainage Basin. The current drainage basin fee associated with the Dirty Woman Creek Drainage Basin is \$15,720 per impervious acre. The current bridge fee associated with the Dirty Woman Creek Drainage Basin is \$860 per impervious acre. The North Bay at Lake Woodmoor development encompasses 7.23 acres. Table 1 details the fees due as part of this development.

III. CONCLUSIONS

North Bay at Lake Woodmoor will be a multi-family residential development covering approximately 7.23 acres. Onsite drainage will include the use of curb inlets, grated inlets and storm sewers to route runoff from the site to the Lake Fork Tributary of Dirty Woman Creek. The proposed on-site permanent BMPs are private and will be maintained by the North Bay at Lake Woodmoor Homeowners Association. In accordance with the Dirty Woman and Crystal Creeks Drainage Basin Planning Study, stabilization improvements will be provided for the Lake Fork Tributary of Dirty Woman Creek for the reach that passes through the North Bay at Lake Woodmoor property. With the site discharging its runoff to a major drainageway that is immediately upstream of Lake Woodmoor, the development of the North Bay at Lake Woodmoor property will not adversely impact or deteriorate improvements or natural drainageways downstream of the property.

IV. REFERENCES

- 1) Drainage Basin Planning Study, Dirty Woman Creek and Crystal Creek, El Paso County, Colorado, prepared by Kiowa Engineering Corporation, dated September 1993.
- 2) Flood Insurance Study, El Paso County, Colorado and Incorporated Areas, prepared by the Federal Emergency Management Agency, dated August 1999.
- 3) El Paso County Drainage Criteria Manual (Volumes 1 and 2) and Engineering Criteria Manual, current editions.
- 4) City of Colorado Springs Drainage Criteria Manual, Volumes 1 and 2, May 2014.
- 5) Flood Insurance Rate Map, Map Number 08041C0276F, by Federal Emergency Management Agency, dated March 17, 1997.
- 6) Letter of Map Change, Letter of Map Revision Case Number 99-08-012P, Community Number 080059, by Federal Emergency Management Agency, dated November 9, 1998.
- 7) Custom Soil Resource Report for El Paso County Area, Colorado, prepared by United States Department of Agriculture Natural Resources Conservation Service, dated August 24, 2016.

APPENDIX TABLE OF CONTENTS

APPENDIX

Figures and Exhibits

Figure 1: Vicinity Map

Excerpts from USDA NRCS Custom Soil Resource Report

FEMA Flood Insurance Rate Map (Panel 276)

Table 1: Impervious Area and Drainage Basin & Bridge Fee Calculations

Table 2: Opinion of Cost – Private Drainage Facilities

APPENDIX A

Existing and Developed Condition Hydrologic Calculations

Runoff Coefficient Calculations

Time of Concentration Calculations

Runoff Calculations

APPENDIX A.1

Supporting Hydrologic Tables and Figures

APPENDIX B

Hydraulic Calculations

Street Capacity Calculations

Inlet Capacity Calculations

Pipe Sizing Calculations

Storm Sewer System Layout Plan

UDSewer Input and Output Tables: 5-year and 100-year Storm Events

Pipe Outlet Erosion Protection Calculations

APPENDIX C

Detention Calculations

Detention Volume Calculations

APPENDIX D

Water Quality Basin Calculations

Volume Calculations

Outlet Structure Calculations

Emergency Spillway Calculations

Stormceptor Calculations

Water Quality Exclusion Areas (Figure WQ1)

APPENDIX E

Lake Fork Dirty Woman Creek Hydraulic Calculations

Figure 2: Floodplain Exhibit

Existing Condition HEC-RAS Model Cross Sections, Profile and Output

Proposed Condition HEC-RAS Model Cross Sections, Profile and Output

Shear Stress Calculations

Flow Superelevation Calculations

Velocity Distribution Output

Culvert Data Input

APPENDIX TABLE OF CONTENTS (CONTINUED)

APPENDIX F

Referenced Information

- Excerpts from Dirty Woman and Crystal Creeks Drainage Basin Planning Study
- FEMA Letter of Map Change for Lake Fork Dirty Woman Creek LOMR
- CLOMR Approval Letter from FEMA
- Woodmoor Water and Sanitation District Letter
- Open Channel Criteria

APPENDIX G

Existing and Proposed Drainage Plans

- Sheet DP1 - Drainage Plan Existing Condition
- Sheet DP2 - Final Drainage Plan Developed Condition

APPENDIX

Figures and Exhibits

Figure 1: Vicinity Map

Excerpts from USDA NRCS Custom Soil Resource Report

FEMA Flood Insurance Rate Map (Panel 276)

Table 1: Impervious Area and Drainage Basin & Bridge Fee Calculations

Table 2: Opinion of Cost – Private Drainage Facilities

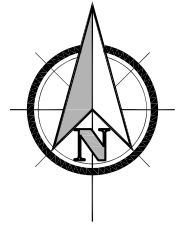

SCALE: NTS

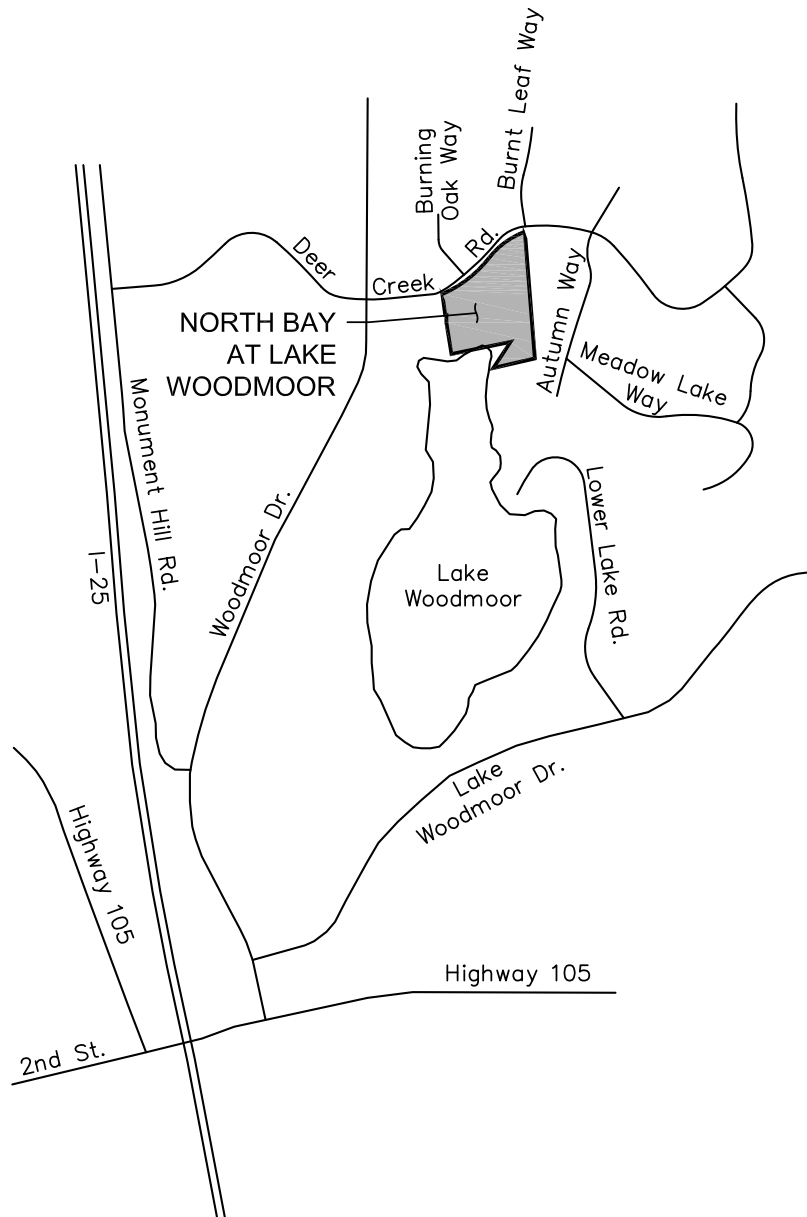

FIGURE 1

North Bay at Lake Woodmoor
Vicinity Map
El Paso County, Colorado

PROJECT NO. 15073

Kiowa
Engineering Corporation

1604 South 21st Street
Colorado Springs, Colorado 80904
(719) 630-7342



United States
Department of
Agriculture

NRCS

Natural
Resources
Conservation
Service

A product of the National
Cooperative Soil Survey,
a joint effort of the United
States Department of
Agriculture and other
Federal agencies, State
agencies including the
Agricultural Experiment
Stations, and local
participants

Custom Soil Resource Report for **El Paso County Area, Colorado**

North Bay at Lake Woodmoor



Custom Soil Resource Report Soil Map

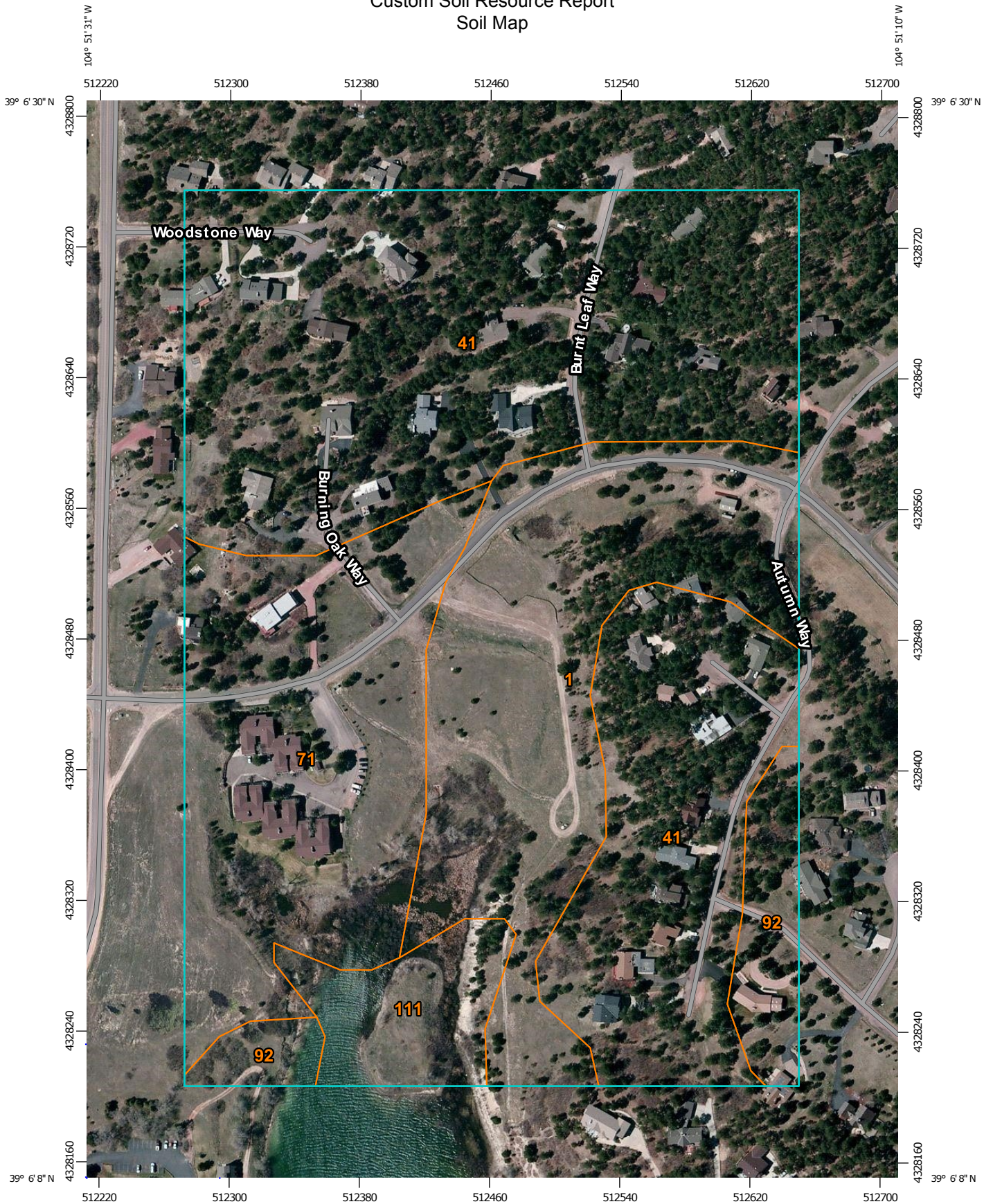

Map Scale: 1:3,210 if printed on A portrait (8.5" x 11") sheet.



MAP LEGEND

Area of Interest (AOI)

 Area of Interest (AOI)



















Soils





 Soil Map Unit Polygons

 Soil Map Unit Lines

 Soil Map Unit Points

Special Point Features





-  Blowout
-  Borrow Pit
-  Clay Spot
-  Closed Depression
-  Gravel Pit
-  Gravelly Spot
-  Landfill
-  Lava Flow
-  Marsh or swamp
-  Mine or Quarry
-  Miscellaneous Water
-  Perennial Water
-  Rock Outcrop
-  Saline Spot
-  Sandy Spot
-  Severely Eroded Spot
-  Sinkhole
-  Slide or Slip
-  Sodic Spot

-  Spoil Area
-  Stony Spot
-  Very Stony Spot
-  Wet Spot
-  Other
-  Special Line Features

Water Features

 Streams and Canals

Transportation

-  Rails
-  Interstate Highways
-  US Routes
-  Major Roads
-  Local Roads

Background

 Aerial Photography

MAP INFORMATION

The soil surveys that comprise your AOI were mapped at 1:24,000.

Warning: Soil Map may not be valid at this scale.

Enlargement of maps beyond the scale of mapping can cause misunderstanding of the detail of mapping and accuracy of soil line placement. The maps do not show the small areas of contrasting soils that could have been shown at a more detailed scale.

Please rely on the bar scale on each map sheet for map measurements.

Source of Map: Natural Resources Conservation Service
 Web Soil Survey URL: <http://websoilsurvey.nrcs.usda.gov>
 Coordinate System: Web Mercator (EPSG:3857)

Maps from the Web Soil Survey are based on the Web Mercator projection, which preserves direction and shape but distorts distance and area. A projection that preserves area, such as the Albers equal-area conic projection, should be used if more accurate calculations of distance or area are required.

This product is generated from the USDA-NRCS certified data as of the version date(s) listed below.

Soil Survey Area: El Paso County Area, Colorado
 Survey Area Data: Version 13, Sep 22, 2015

Soil map units are labeled (as space allows) for map scales 1:50,000 or larger.

Date(s) aerial images were photographed: Apr 15, 2011—Sep 22, 2011

The orthophoto or other base map on which the soil lines were compiled and digitized probably differs from the background imagery displayed on these maps. As a result, some minor shifting of map unit boundaries may be evident.

Map Unit Legend

El Paso County Area, Colorado (CO625)			
Map Unit Symbol	Map Unit Name	Acres in AOI	Percent of AOI
1	Alamosa loam, 1 to 3 percent slopes	11.0	21.3%
41	Kettle gravelly loamy sand, 8 to 40 percent slopes	25.1	48.9%
71	Pring coarse sandy loam, 3 to 8 percent slopes	10.4	20.3%
92	Tomah-Crowfoot loamy sands, 3 to 8 percent slopes	2.4	4.7%
111	Water	2.4	4.8%
Totals for Area of Interest		51.4	100.0%

Map Unit Descriptions

The map units delineated on the detailed soil maps in a soil survey represent the soils or miscellaneous areas in the survey area. The map unit descriptions, along with the maps, can be used to determine the composition and properties of a unit.

A map unit delineation on a soil map represents an area dominated by one or more major kinds of soil or miscellaneous areas. A map unit is identified and named according to the taxonomic classification of the dominant soils. Within a taxonomic class there are precisely defined limits for the properties of the soils. On the landscape, however, the soils are natural phenomena, and they have the characteristic variability of all natural phenomena. Thus, the range of some observed properties may extend beyond the limits defined for a taxonomic class. Areas of soils of a single taxonomic class rarely, if ever, can be mapped without including areas of other taxonomic classes. Consequently, every map unit is made up of the soils or miscellaneous areas for which it is named and some minor components that belong to taxonomic classes other than those of the major soils.

Most minor soils have properties similar to those of the dominant soil or soils in the map unit, and thus they do not affect use and management. These are called noncontrasting, or similar, components. They may or may not be mentioned in a particular map unit description. Other minor components, however, have properties and behavioral characteristics divergent enough to affect use or to require different management. These are called contrasting, or dissimilar, components. They generally are in small areas and could not be mapped separately because of the scale used. Some small areas of strongly contrasting soils or miscellaneous areas are identified by a special symbol on the maps. If included in the database for a given area, the contrasting minor components are identified in the map unit descriptions along with some characteristics of each. A few areas of minor components may not have been observed, and consequently they are not mentioned in the descriptions, especially where the pattern was so complex that it was impractical to make enough observations to identify all the soils and miscellaneous areas on the landscape.

El Paso County Area, Colorado

1—Alamosa loam, 1 to 3 percent slopes

Map Unit Setting

National map unit symbol: 3670

Elevation: 7,200 to 7,700 feet

Farmland classification: Prime farmland if irrigated and reclaimed of excess salts and sodium

Map Unit Composition

Alamosa and similar soils: 85 percent

Estimates are based on observations, descriptions, and transects of the mapunit.

Description of Alamosa

Setting

Landform: Flood plains, fans

Down-slope shape: Linear

Across-slope shape: Linear

Parent material: Alluvium

Typical profile

A - 0 to 6 inches: loam

Bt - 6 to 14 inches: clay loam

Btk - 14 to 33 inches: clay loam

Cg1 - 33 to 53 inches: sandy clay loam

Cg2 - 53 to 60 inches: sandy loam

Properties and qualities

Slope: 1 to 3 percent

Depth to restrictive feature: More than 80 inches

Natural drainage class: Poorly drained

Runoff class: Very high

Capacity of the most limiting layer to transmit water (Ksat): Moderately high (0.20 to 0.60 in/hr)

Depth to water table: About 12 to 18 inches

Frequency of flooding: Frequent

Frequency of ponding: None

Calcium carbonate, maximum in profile: 5 percent

Salinity, maximum in profile: Very slightly saline to strongly saline (2.0 to 16.0 mmhos/cm)

Available water storage in profile: High (about 10.2 inches)

Interpretive groups

Land capability classification (irrigated): None specified

Land capability classification (nonirrigated): 5w

***Hydrologic Soil Group:* D**

Ecological site: Mountain Meadow (R048AY241CO)

Hydric soil rating: Yes

Minor Components

Other soils

Percent of map unit:

Hydric soil rating: No

41—Kettle gravelly loamy sand, 8 to 40 percent slopes

Map Unit Setting

National map unit symbol: 368h
Elevation: 7,000 to 7,700 feet
Farmland classification: Not prime farmland

Map Unit Composition

Kettle and similar soils: 85 percent
Estimates are based on observations, descriptions, and transects of the mapunit.

Description of Kettle

Setting

Landform: Hills
Landform position (three-dimensional): Side slope
Down-slope shape: Linear
Across-slope shape: Linear
Parent material: Sandy alluvium derived from arkose

Typical profile

E - 0 to 16 inches: gravelly loamy sand
Bt - 16 to 40 inches: gravelly sandy loam
C - 40 to 60 inches: extremely gravelly loamy sand

Properties and qualities

Slope: 8 to 40 percent
Depth to restrictive feature: More than 80 inches
Natural drainage class: Somewhat excessively drained
Runoff class: Medium
Capacity of the most limiting layer to transmit water (Ksat): High (2.00 to 6.00 in/hr)
Depth to water table: More than 80 inches
Frequency of flooding: None
Frequency of ponding: None
Available water storage in profile: Low (about 3.4 inches)

Interpretive groups

Land capability classification (irrigated): None specified
Land capability classification (nonirrigated): 7e
***Hydrologic Soil Group:* B**
Hydric soil rating: No

Minor Components

Other soils

Percent of map unit:
Hydric soil rating: No

Pleasant

Percent of map unit:
Landform: Depressions

Hydric soil rating: Yes

71—Pring coarse sandy loam, 3 to 8 percent slopes

Map Unit Setting

National map unit symbol: 369k
Elevation: 6,800 to 7,600 feet
Farmland classification: Not prime farmland

Map Unit Composition

Pring and similar soils: 85 percent
Estimates are based on observations, descriptions, and transects of the mapunit.

Description of Pring

Setting

Landform: Hills
Landform position (three-dimensional): Side slope
Down-slope shape: Linear
Across-slope shape: Linear
Parent material: Arkosic alluvium derived from sedimentary rock

Typical profile

A - 0 to 14 inches: coarse sandy loam
C - 14 to 60 inches: gravelly sandy loam

Properties and qualities

Slope: 3 to 8 percent
Depth to restrictive feature: More than 80 inches
Natural drainage class: Well drained
Runoff class: Low
Capacity of the most limiting layer to transmit water (Ksat): High (2.00 to 6.00 in/hr)
Depth to water table: More than 80 inches
Frequency of flooding: None
Frequency of ponding: None
Available water storage in profile: Low (about 6.0 inches)

Interpretive groups

Land capability classification (irrigated): None specified
Land capability classification (nonirrigated): 3e
Hydrologic Soil Group: B
Ecological site: Loamy Park (R048AY222CO)
Hydric soil rating: No

Minor Components

Other soils

Percent of map unit:
Hydric soil rating: No

Pleasant

Percent of map unit:

Custom Soil Resource Report

Landform: Depressions
Hydric soil rating: Yes

92—Tomah-Crowfoot loamy sands, 3 to 8 percent slopes

Map Unit Setting

National map unit symbol: 36b9
Elevation: 7,300 to 7,600 feet
Farmland classification: Not prime farmland

Map Unit Composition

Tomah and similar soils: 50 percent
Crowfoot and similar soils: 30 percent
Estimates are based on observations, descriptions, and transects of the mapunit.

Description of Tomah

Setting

Landform: Alluvial fans, hills
Landform position (three-dimensional): Side slope, crest
Down-slope shape: Linear
Across-slope shape: Linear
Parent material: Alluvium derived from arkose and/or residuum weathered from arkose

Typical profile

A - 0 to 10 inches: loamy sand
E - 10 to 22 inches: coarse sand
C - 48 to 60 inches: coarse sand

Properties and qualities

Slope: 3 to 8 percent
Depth to restrictive feature: More than 80 inches
Natural drainage class: Well drained
Runoff class: Medium
Capacity of the most limiting layer to transmit water (Ksat): Moderately high to high
(0.60 to 2.00 in/hr)
Depth to water table: More than 80 inches
Frequency of flooding: None
Frequency of ponding: None
Available water storage in profile: Very low (about 2.0 inches)

Interpretive groups

Land capability classification (irrigated): None specified
Land capability classification (nonirrigated): 4e
***Hydrologic Soil Group:* B**
Ecological site: Sandy Divide (R049BY216CO)
Hydric soil rating: No

Description of Crowfoot

Setting

Landform: Alluvial fans, hills

Landform position (three-dimensional): Side slope, crest

Down-slope shape: Linear

Across-slope shape: Linear

Parent material: Alluvium

Typical profile

A - 0 to 12 inches: loamy sand

E - 12 to 23 inches: sand

Bt - 23 to 36 inches: sandy clay loam

C - 36 to 60 inches: coarse sand

Properties and qualities

Slope: 3 to 8 percent

Depth to restrictive feature: More than 80 inches

Natural drainage class: Well drained

Runoff class: Medium

Capacity of the most limiting layer to transmit water (Ksat): Moderately high to high
(0.60 to 2.00 in/hr)

Depth to water table: More than 80 inches

Frequency of flooding: None

Frequency of ponding: None

Available water storage in profile: Low (about 4.7 inches)

Interpretive groups

Land capability classification (irrigated): None specified

Land capability classification (nonirrigated): 4e

Hydrologic Soil Group: B

Ecological site: Sandy Divide (R049BY216CO)

Hydric soil rating: No

Minor Components

Other soils

Percent of map unit:

Hydric soil rating: No

Pleasant

Percent of map unit:

Landform: Depressions

Hydric soil rating: Yes

111—Water

Map Unit Composition

Water: 100 percent

Estimates are based on observations, descriptions, and transects of the mapunit.

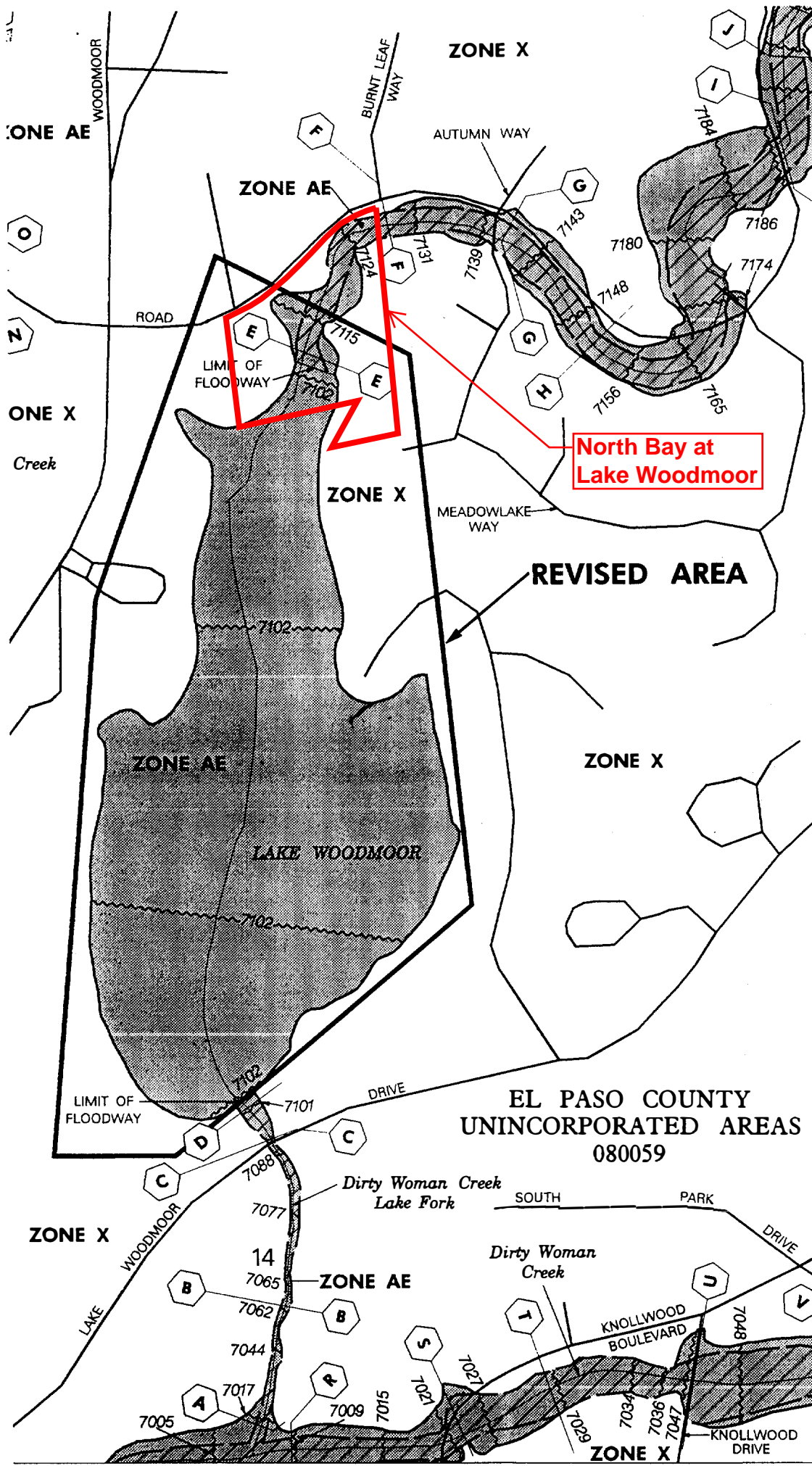

APPROXIMATE SCALE IN FEET

500 0 500

NATIONAL FLOOD INSURANCE PROGRAM

FIRM

FLOOD INSURANCE RATE MAP

EL PASO COUNTY,
COLORADO AND
INCORPORATED AREAS

PANEL 276 OF 1300
(SEE MAP INDEX FOR PANELS NOT PRINTED)

CONTAINS:
COMMUNITY NUMBER DATE SUFFIX
EL PASO COUNTY UNINCORPORATED AREAS 080059 080059 0276
MOUNTAIN TOWN OF 080059 080059 0276
NUMBER CASE TOWNSHIP 080059 080059 0276

REVISIO TO REFLECT LOMR

DATED NOV 09 1998

MAP NUMBER
08041C0276 F

EFFECTIVE DATE:
MARCH 17, 1997



Federal Emergency Management Agency

**North Bay at Lake Woodmoor
Drainage Basin and Bridge Fees**

Table 1: Impervious Area and Drainage Basin & Bridge Fee Calculation

Dirty Woman Creek Drainage Basin

	Acreage	% Impervious	Impervious Area
Pavement/Drives/Walks	1.541 ac	100%	1.541 ac
Roofs	0.928 ac	90%	0.835 ac
Lawns/Historic	4.760 ac	2%	0.095 ac
	<u>7.229 ac</u>		<u>2.471 ac</u>

Weighted % Impervious = 34.2 %

Drainage Basin Fee and Bridge Fee Calculations			
Drainage Basin Fee =	\$15,720 / ac	Drainage Basin Fee =	\$ 38,849.57
Bridge Fee =	\$860 / ac	Bridge Fee =	\$ 2,125.36

Impervious Area = Acreage x (% Impervious)

Drainage Basin Fee = Impervious Area x (Drainage Basin Fee per Acre)

Bridge Fee = Impervious Area x (Bridge Fee per Acre)

**North Bay at Lake Woodmoor
Opinion of Cost**

Table 2: Opinion of Cost - Private Drainage Facilities

Item	Quantity	Unit	Unit Cost	Item Total
Drainage Improvements				
24" Corrugated Metal Pipe (CMP) 45° Bend	1	EA	\$ 800.00	\$ 800.00
18" Reinforced Concrete Pipe (RCP) 18.5° Prefabricated Bend	1	EA	\$ 1,000.00	\$ 1,000.00
18" Reinforced Concrete Pipe (RCP) 48° Prefabricated Bend	1	EA	\$ 1,000.00	\$ 1,000.00
18" Reinforced Concrete Pipe (RCP)	669	LF	\$ 71.00	\$ 47,499.00
14"x23" Horizontal Elliptical Reinforced Concrete Pipe (HERCP)	11	LF	\$ 79.00	\$ 869.00
30" Reinforced Concrete Pipe (RCP)	74	LF	\$ 94.00	\$ 6,956.00
36" Reinforced Concrete Pipe (RCP)	379	LF	\$ 124.00	\$ 46,996.00
Flared End Section (FES) RCP 36"	1	EA	\$ 1,200.00	\$ 1,200.00
Flared End Section (FES) RCP 18"	4	EA	\$ 800.00	\$ 3,200.00
Curb Inlet (Type R) L=10', Depth < 5 feet	1	EA	\$ 5,528.00	\$ 5,528.00
Curb Inlet (Type R) L=10', 5'-10' Depth	1	EA	\$ 6,694.00	\$ 6,694.00
Curb Inlet (Type R) L=15', Depth < 5 feet	1	EA	\$ 7,923.00	\$ 7,923.00
Grated Inlet (Type D), Depth < 5 feet	3	EA	\$ 3,908.00	\$ 11,724.00
4' Dia. Storm Sewer Manhole, Slab Base, Depth < 5 feet	1	EA	\$ 4,000.00	\$ 4,000.00
4' Dia. Storm Sewer Manhole, Slab Base, 5'-10' Depth	3	EA	\$ 4,600.00	\$ 13,800.00
5' Dia. Storm Sewer Manhole, Slab Base, 5'-10' Depth	1	EA	\$ 5,600.00	\$ 5,600.00
5' Dia. Storm Sewer Manhole, Slab Base, 10'-15' Depth	3	EA	\$ 6,600.00	\$ 19,800.00
Riprap, d50 9" and 12"	1,070	CY	\$ 98.00	\$ 104,860.00
Riprap, d50 18"	100	CY	\$ 120.00	\$ 12,000.00
Concrete Cutoff Wall (18" RCP pipe outfall)	4	EA	\$ 800.00	\$ 3,200.00
Concrete Cutoff Wall (36" RCP pipe outfall)	1	EA	\$ 1,200.00	\$ 1,200.00
Concrete Collar (24" CMP)	1	EA	\$ 500.00	\$ 500.00
Triple (3) 12' W x 4' H RCB Crossing (incl. headwalls and wingwalls)	1	LS	\$ 140,000.00	\$ 140,000.00
Check Structures (LFDW Creek)	3	EA	\$ 11,000.00	\$ 33,000.00
Water Quality Basin Outlet Structure	2	EA	\$ 5,000.00	\$ 10,000.00
Stormceptor	1	EA	\$ 14,000.00	\$ 14,000.00
Sand Filter Basin w/ Underdrain System	2	EA	\$ 7,000.00	\$ 14,000.00
Gravel Maintenance Access Trail	445	SY	\$ 20.00	\$ 8,900.00
Seeding and Mulch	2.8	AC	\$ 520.00	\$ 1,435.20
Estimated Storm Drainage Facilities Cost				\$ 527,684.20
Engineering 10%				\$ 52,768.42
Contingency 5%				\$ 26,384.21
Total Estimated Cost				\$ 606,836.83

APPENDIX A
Existing and Developed Condition Hydrologic Calculations
Runoff Coefficient Calculations
Time of Concentration Calculations
Runoff Calculations

North Bay at Lake Woodmoor
Existing Condition
Runoff Coefficient and Percent Impervious Calculation

Basin / DP	Basin or DP Area (DP contributing basins)	Soil Type	PV				GR				HI				US1				US2				Basin % Imperv	Basin Runoff Coefficient	
			% Imperv	Land Use Area	% Area	Comp Land Use % Imp	% Imperv	Land Use Area	% Area	Comp Land Use % Imp	% Imperv	Land Use Area	% Area	Comp Land Use % Imp	% Imperv	Land Use Area	% Area	Comp Land Use % Imp	% Imperv	Land Use Area	% Area	Comp Land Use % Imp		C ₅	C ₁₀₀
OS-1	96,767 sf 2.22ac	B	100%		0%	0%	40%		0%	0%	2%		0%	0%	25%	2.22ac	100%	25%	20%		0%	0%	25.0%	0.22	0.46
OS-2	611,666 sf 14.04ac	B	100%		0%	0%	40%		0%	0%	2%		0%	0%	25%		0%	0%	20%	14.04ac	100%	20%	20.0%	0.20	0.44
OS-3	21,166 sf 0.49ac	B	100%	0.18ac	36%	36%	40%		0%	0%	2%	0.31ac	64%	1%	25%		0%	0%	20%		0%	0%	37.5%	0.28	0.49
EX-1	81,827 sf 1.88ac	D	100%	0.09ac	5%	5%	40%	0.05ac	3%	1%	2%	1.74ac	92%	2%	25%		0%	0%	20%		0%	0%	7.8%	0.20	0.53
EX-2	115,677 sf 2.66ac	D	100%	0.27ac	10%	10%	40%	0.06ac	2%	1%	2%	2.33ac	88%	2%	25%		0%	0%	20%		0%	0%	12.6%	0.22	0.54
EX-3	146,648 sf 3.37ac	D	100%	0.07ac	2%	2%	40%	0.12ac	4%	1%	2%	3.17ac	94%	2%	25%		0%	0%	20%		0%	0%	5.5%	0.18	0.52
DP 1	OS-1 2.22ac	B	100%		0%	0%	40%		0%	0%	2%		0%	0%	25%	2.22ac	100%	25%	20%		0%	0%	25.0%	0.22	0.46
DP 2	EX-1 1.88ac	D	100%	0.09ac	5%	5%	40%	0.05ac	3%	1%	2%	1.74ac	92%	2%	25%		0%	0%	20%		0%	0%	7.8%	0.20	0.53
DP 3	OS-1, EX-1 4.10ac	D	100%	0.09ac	2%	2%	40%	0.05ac	1%	1%	2%	1.74ac	42%	1%	25%	2.22ac	54%	14%	20%		0%	0%	17.1%	0.25	0.55
DP 4	OS-2 14.04ac	B	100%		0%	0%	40%		0%	0%	2%		0%	0%	25%		0%	0%	20%	14.04ac	100%	20%	20.0%	0.20	0.44
DP 5	OS-1, EX-1, EX-2 6.76ac	D	100%	0.36ac	5%	5%	40%	0.11ac	2%	1%	2%	4.07ac	60%	1%	25%	2.22ac	33%	8%	20%		0%	0%	15.3%	0.24	0.54
DP 6	OS-3 0.49ac	B	100%	0.18ac	36%	36%	40%		0%	0%	2%	0.31ac	64%	1%	25%		0%	0%	20%		0%	0%	37.5%	0.28	0.49
DP 6.1	OS-3 0.49ac	B	100%	0.18ac	36%	36%	40%		0%	0%	2%	0.31ac	64%	1%	25%		0%	0%	20%		0%	0%	37.5%	0.28	0.49
DP 7	OS-1, OS-2, OS-3, EX-1, EX-2 21.28ac	B	100%	0.53ac	3%	3%	40%	0.11ac	1%	0%	2%	4.38ac	21%	0%	25%	2.22ac	10%	3%	20%	14.04ac	66%	13%	18.9%	0.19	0.44
DP 8	EX-3 3.37ac	D	100%	0.07ac	2%	2%	40%	0.12ac	4%	1%	2%	3.17ac	94%	2%	25%		0%	0%	20%		0%	0%	5.5%	0.14	0.48
DP 9	OS-1, OS-2, OS-3, EX-1, EX-2, EX-3 24.65ac	B	100%	0.60ac	2%	2%	40%	0.23ac	1%	0%	2%	7.55ac	31%	1%	25%	2.22ac	9%	2%	20%	14.04ac	57%	11%	17.1%	0.18	0.43

Basin Runoff Coefficient is based on UDFCD % Imperviousness Calculation									
Runoff Coefficients and Percents Impervious									
Hydrologic Soil Type:	B	Runoff Coef Calc Method							%Imp
Land Use	Abb	%	C ₂	C ₅	C ₁₀	C ₂₅	C ₅₀	C ₁₀₀	Weighted %Imp
Commercial Area	CO	95%	0.79	0.81	0.83	0.85	0.87	0.88	A
Drives and Walks	DR	90%	0.71	0.73	0.75	0.78	0.80	0.81	A
Streets - Gravel (Packed)	GR	40%	0.23	0.30	0.36	0.42	0.46	0.50	B
Historic Flow Analysis	HI	2%	0.03	0.08	0.17	0.26	0.31	0.36	C
Lawns	LA	0%	0.02	0.08	0.15	0.25	0.30	0.35	D
Off-site flow-Undeveloped	OF	45%	0.26	0.32	0.38	0.44	0.48	0.51	
Park	PA	7%	0.05	0.12	0.20	0.29	0.34	0.39	
Playground	PL	13%	0.07	0.16	0.24	0.32	0.37	0.42	
Streets - Paved	PV	100%	0.89	0.90	0.92	0.94	0.95	0.96	
Roofs	RO	90%	0.71	0.73	0.75	0.78	0.80	0.81	
User Input 1 (2 lots/acre)	US1	25%	0.15	0.22	0.30	0.37	0.42	0.46	
User Input 2 (1 lot/acre)	US2	20%	0.12	0.20	0.27	0.35	0.40	0.44	

Equations (% Impervious Calculation):

$C_A = K_A + (1.31 i^3 - 1.44 i^2 + 1.135 i - 0.12)$ [Eqn RO-6]
 $C_{CD} = K_{CD} + (0.858 i^3 - 0.786 i^2 + 0.774 i + 0.04)$ [Eqn RO-7]
 $C_B = (C_A + C_{CD}) / 2$
 I = % imperviousness/100 as a decimal (See Table RO-3)
 C_A = Runoff coefficient for NRCS Type A Soils
 C_B = Runoff coefficient for NRCS Type B Soils
 C_{CD} = Runoff coefficient for NRCS Type C and D Soils

Correction Factors - Table RO-4

K_A = For Type A Soils
 $K_A (2\text{-yr}) = 0$
 $K_A (5\text{-yr}) = -0.08i + 0.09$
 $K_A (10\text{-yr}) = -0.14i + 0.17$
 $K_A (25\text{-yr}) = -0.19i + 0.24$
 $K_A (50\text{-yr}) = -0.22i + 0.28$
 $K_A (100\text{-yr}) = -0.25i + 0.32$
 K_{CD} = For Type C & D Soils
 $K_{CD} (2\text{-yr}) = 0$
 $K_{CD} (5\text{-yr}) = -0.10i + 0.11$
 $K_{CD} (10\text{-yr}) = -0.18i + 0.21$
 $K_{CD} (25\text{-yr}) = -0.28i + 0.33$
 $K_{CD} (50\text{-yr}) = -0.33i + 0.40$
 $K_{CD} (100\text{-yr}) = -0.39i + 0.46$

North Bay at Lake Woodmoor
Existing Condition
Time of Concentration Calculation

Sub-Basin Data				Time of Concentration Estimate										Final t_c
Basin / Design Point	Contributing Basins	Area	C_5	Initial/Overland Time (t_i)			Travel Time (t_t)						Comp.	
				Length	Slope	t_i	Length	Slope	Land Type	C_v	Velocity	t_t	t_c	
OS-1		2.22ac	0.22	100lf	2.0%	12.7 min.	110lf	13.3%	NBG	10	3.7 ft/sec	0.5 min.	13.2 min.	13.2 min.
OS-2		14.04ac	0.20	300lf	3.0%	19.9 min.	1120lf	4.7%	GW	15	3.3 ft/sec	5.7 min.	25.6 min.	25.6 min.
OS-3		0.49ac	0.28	50lf	2.0%	8.4 min.	180lf	2.0%	GW	15	2.1 ft/sec	1.4 min.	9.8 min.	9.8 min.
EX-1		1.88ac	0.20			0.0 min.	450lf	0.8%	GW	15	1.3 ft/sec	5.6 min.	5.6 min.	5.6 min.
EX-2		2.66ac	0.22	20lf	2.0%	5.7 min.	390lf	6.2%	GW	15	3.7 ft/sec	1.7 min.	7.4 min.	7.4 min.
EX-3		3.37ac	0.18	80lf	13.0%	6.4 min.	380lf	5.8%	GW	15	3.6 ft/sec	1.8 min.	8.1 min.	8.1 min.
DP 1	OS-1	2.22ac	0.22	100lf	2.0%	12.7 min.	110lf	13.3%	NBG	10	3.6 ft/sec	0.5 min.	13.2 min.	13.2 min.
DP 2	EX-1	1.88ac	0.20			0.0 min.	450lf	0.8%	GW	15	1.3 ft/sec	5.6 min.	5.6 min.	5.6 min.
DP 3	OS-1, EX-1	4.10ac	0.25	100lf	2.0%	12.4 min.	405lf	7.4%	GW	15	4.1 ft/sec	1.7 min.	14.1 min.	14.1 min.
DP 4	OS-2	14.04ac	0.20	300lf	3.0%	19.9 min.	1120lf	4.7%	GW	15	3.3 ft/sec	5.7 min.	25.6 min.	25.6 min.
DP 5	OS-1, EX-1, EX-2	6.76ac	0.24	100lf	2.0%	12.5 min.	340lf	9.2%	GW	15	4.5 ft/sec	1.2 min.	13.8 min.	13.8 min.
DP 6	OS-3	0.49ac	0.28	50lf	2.0%	8.4 min.	180lf	2.0%	GW	15	2.1 ft/sec	1.4 min.	9.8 min.	9.8 min.
DP 6.1	OS-3	0.49ac	0.28	50lf	2.0%	8.4 min.	420lf	6.8%	GW	15	3.9 ft/sec	1.8 min.	10.2 min.	10.2 min.
DP 7	OS-1, OS-2, OS-3, EX-1, EX-2	21.28ac	0.19	300lf	3.0%	20.0 min.	1120lf	4.7%	GW	15	3.3 ft/sec	5.7 min.	25.7 min.	25.7 min.
DP 8	EX-3	3.37ac	0.14	80lf	13.0%	6.7 min.	380lf	5.8%	GW	15	3.6 ft/sec	1.8 min.	8.4 min.	8.4 min.
DP 9	OS-1, OS-2, OS-3, EX-1, EX-2, EX-3	24.65ac	0.18	300lf	3.0%	20.2 min.	1260lf	4.5%	GW	15	3.2 ft/sec	6.6 min.	26.8 min.	26.8 min.

Equations:

$$t_i (\text{Overland}) = 0.395(1.1 - C_5)L^{0.5} S^{-0.333}$$

C_5 = Runoff coefficient for 5-year

L = Length of overland flow (ft)

S = Slope of flow path (ft/ft)

t_c Check = $(L/180) + 10$ (Developed Cond. Only)

L = Overall Length

$$\text{Velocity (Travel Time)} = C_v S^{0.5}$$

C_v = Conveyance Coef (see Table)

S = Watercourse slope (ft/ft)

Table RO-2

Land Surface Type	Land Type	C_v
Grassed Waterway	GW	15
Heavy Meadow	HM	2.5
Nearly Bare Ground	NBG	10
Paved Area	PV	20
Riprap (Not Buried)	RR	6.5
Short Pasture/Lawns	SP	7
Tillage/Fields	TF	5

**North Bay at Lake Woodmoor
Existing Condition
Runoff Calculation**

Basin / Design Point	Contributing Basins	Drainage Area	C ₅	C ₁₀₀	Time of Concentration	Rainfall Intensity		Runoff		Basin / DP
						i ₅	i ₁₀₀	Q ₅	Q ₁₀₀	
OS-1		2.22 ac	0.22	0.46	13.2 min.	3.7 in/hr	6.2 in/hr	1.8 cfs	6.3 cfs	OS-1
OS-2		14.04 ac	0.20	0.44	25.6 min.	2.7 in/hr	4.6 in/hr	7.5 cfs	28.3 cfs	OS-2
OS-3		0.49 ac	0.28	0.49	9.8 min.	4.2 in/hr	7.0 in/hr	0.6 cfs	1.7 cfs	OS-3
EX-1		1.88 ac	0.20	0.53	5.6 min.	5.0 in/hr	8.4 in/hr	1.9 cfs	8.3 cfs	EX-1
EX-2		2.66 ac	0.22	0.54	7.4 min.	4.6 in/hr	7.7 in/hr	2.7 cfs	11.0 cfs	EX-2
EX-3		3.37 ac	0.18	0.52	8.1 min.	4.4 in/hr	7.5 in/hr	2.8 cfs	13.0 cfs	EX-3
DP 1	OS-1	2.22 ac	0.22	0.46	13.2 min.	3.7 in/hr	6.2 in/hr	1.8 cfs	6.3 cfs	DP 1
DP 2	EX-1	1.88 ac	0.20	0.53	5.6 min.	5.0 in/hr	8.4 in/hr	1.9 cfs	8.3 cfs	DP 2
DP 3	OS-1, EX-1	4.10 ac	0.25	0.55	14.1 min.	3.6 in/hr	6.1 in/hr	3.7 cfs	13.6 cfs	DP 3
DP 4	OS-2	14.04 ac	0.20	0.44	25.6 min.	2.7 in/hr	4.6 in/hr	7.5 cfs	28.3 cfs	DP 4
DP 5	OS-1, EX-1, EX-2	6.76 ac	0.24	0.54	13.8 min.	3.6 in/hr	6.1 in/hr	5.9 cfs	22.5 cfs	DP 5
DP 6	OS-3	0.49 ac	0.28	0.49	9.8 min.	4.2 in/hr	7.0 in/hr	0.6 cfs	1.7 cfs	DP 6
DP 6.1	OS-3	0.49 ac	0.28	0.49	10.2 min.	4.1 in/hr	6.9 in/hr	0.6 cfs	1.6 cfs	DP 6.1
DP 7	OS-1, OS-2, OS-3, EX-1, EX-2	21.28 ac	0.19	0.44	25.7 min.	2.7 in/hr	4.6 in/hr	11.0 cfs	42.4 cfs	DP 7
DP 8	EX-3	3.37 ac	0.14	0.48	8.4 min.	4.4 in/hr	7.4 in/hr	2.1 cfs	11.9 cfs	DP 8
DP 9	OS-1, OS-2, OS-3, EX-1, EX-2, EX-3	24.65 ac	0.18	0.43	26.8 min.	2.6 in/hr	4.4 in/hr	11.8 cfs	47.3 cfs	DP 9

Equations (taken from Fig 6-5, City of Colorado Springs DCM):

$$i_2 = -1.19 \ln(T_c) + 6.035$$

$$i_5 = -1.50 \ln(T_c) + 7.583$$

$$i_{10} = -1.75 \ln(T_c) + 8.847$$

$$i_{25} = -2.00 \ln(T_c) + 10.111$$

$$i_{50} = -2.25 \ln(T_c) + 11.375$$

$$i_{100} = -2.52 \ln(T_c) + 12.735$$

$$Q = CiA$$

Q = Peak Runoff Rate (cubic feet/second)

C = Runoff coef representing a ratio of peak runoff rate to ave rainfall intensity for a duration equal to the runoff time of concentration.

i = average rainfall intensity in inches per hour

A = Drainage area in acres

P1	Inches
WQCV	0.60 in
2 yr	1.19 in
5 yr	1.50 in
10 yr	1.75 in
25 yr	2.00 in
50 yr	2.25 in
100 yr	2.52 in

**North Bay at Lake Woodmoor
Developed Condition
Time of Concentration Calculation**

Sub-Basin Data				Time of Concentration Estimate										Min. Tc in Urban		Final t_c
Basin / Design Point	Contributing Basins	Area	C_5	Initial/Overland Time (t_i)			Travel Time (t_t)					Comp.	Tc Check (urban)			
				Length	Slope	t_i	Length	Slope	Land Type	Cv	Velocity	t_t	t_c	Total Length	t_c Check	
OS-1a		1.21ac	0.22	100lf	2.0%	12.7 min.	110lf	13.3%	NBG	10	3.6 ft/sec	0.5 min.	13.2 min.			13.2 min.
OS-1b		1.02ac	0.22	100lf	2.0%	12.7 min.	110lf	13.3%	NBG	10	3.6 ft/sec	0.5 min.	13.2 min.			13.2 min.
OS-2		14.04ac	0.20	300lf	3.0%	19.9 min.	1120lf	4.7%	GW	15	3.3 ft/sec	5.7 min.	25.6 min.			25.6 min.
OS-3		0.49ac	0.28	50lf	2.0%	8.4 min.	180lf	2.0%	GW	15	2.1 ft/sec	1.4 min.	9.8 min.			9.8 min.
W1		0.35ac	0.61	80lf	11.0%	3.6 min.	120lf	1.0%	GW	15	1.5 ft/sec	1.3 min.	5.0 min.	200lf	11.1 min.	5.0 min.
W2		0.14ac	0.30	50lf	9.0%	5.0 min.	80lf	2.5%	GW	15	2.4 ft/sec	0.6 min.	5.5 min.	130lf	10.7 min.	5.5 min.
W3		0.33ac	0.51	25lf	2.4%	4.1 min.	200lf	1.7%	PV	20	2.6 ft/sec	1.3 min.	5.3 min.	225lf	11.3 min.	5.3 min.
W4		0.38ac	0.42	50lf	9.0%	4.2 min.	185lf	1.6%	GW	15	1.9 ft/sec	1.6 min.	5.9 min.	235lf	11.3 min.	5.9 min.
W5		0.26ac	0.62	25lf	2.5%	3.2 min.	245lf	1.7%	PV	20	2.6 ft/sec	1.6 min.	5.0 min.	270lf	11.5 min.	5.0 min.
W6		0.13ac	0.69	50lf	6.0%	2.9 min.	62lf	5.8%	PV	20	4.8 ft/sec	0.2 min.	5.0 min.	112lf	10.6 min.	5.0 min.
W7		1.92ac	0.26			0.0 min.	610lf	0.5%	GW	15	1.1 ft/sec	9.6 min.	9.6 min.	610lf	13.4 min.	9.6 min.
W8		0.26ac	0.27	60lf	2.0%	9.3 min.	60lf	2.5%	GW	15	2.4 ft/sec	0.4 min.	9.7 min.	120lf	10.7 min.	9.7 min.
E1		0.20ac	0.25	60lf	18.0%	4.6 min.	120lf	1.0%	GW	15	1.5 ft/sec	1.3 min.	6.0 min.	180lf	11.0 min.	6.0 min.
E2		0.57ac	0.34	20lf	2.0%	4.9 min.	360lf	2.4%	PV	20	3.1 ft/sec	1.9 min.	6.8 min.	380lf	12.1 min.	6.8 min.
E3		0.26ac	0.33	45lf	14.4%	3.9 min.	190lf	1.8%	PV	20	2.6 ft/sec	1.2 min.	5.1 min.	235lf	11.3 min.	5.1 min.
E4		0.33ac	0.85	20lf	2.0%	1.6 min.	550lf	2.4%	PV	20	3.1 ft/sec	3.0 min.	5.0 min.	570lf	13.2 min.	5.0 min.
E5		0.14ac	0.75	30lf	5.0%	2.1 min.	145lf	3.9%	PV	20	3.9 ft/sec	0.6 min.	5.0 min.	175lf	11.0 min.	5.0 min.
E6		0.16ac	0.63	20lf	5.0%	2.2 min.	145lf	3.9%	PV	20	3.9 ft/sec	0.6 min.	5.0 min.	165lf	10.9 min.	5.0 min.
E7		1.55ac	0.26			0.0 min.	610lf	0.5%	GW	15	1.1 ft/sec	9.6 min.	9.6 min.	610lf	13.4 min.	9.6 min.
E8		0.58ac	0.18	30lf	26.7%	3.1 min.	190lf	9.5%	GW	15	4.6 ft/sec	0.7 min.	5.0 min.	220lf	11.2 min.	5.0 min.
E9		0.33ac	0.19			0.0 min.	140lf	22.8%	GW	15	7.2 ft/sec	0.3 min.	5.0 min.	140lf	10.8 min.	5.0 min.
DP 10	W2, OS-2	14.18ac	0.20	300lf	3.0%	19.8 min.	1120lf	4.7%	GW	15	3.3 ft/sec	5.7 min.	25.6 min.			25.8 min.
DP 11	W3, W4, OS-3	1.20ac	0.37	50lf	2.0%	7.5 min.	275lf	3.3%	PV	20	3.6 ft/sec	1.3 min.	8.7 min.	325lf	11.8 min.	8.7 min.
DP 12	W5, W6	0.39ac	0.64	25lf	2.5%	3.1 min.	245lf	1.7%	PV	20	2.6 ft/sec	1.6 min.	5.0 min.	270lf	11.5 min.	5.0 min.
DP 12.1	W3-W6, W8, OS-3	1.85ac	0.40	50lf	2.0%	7.2 min.	445lf	2.4%	PV	20	3.1 ft/sec	2.4 min.	9.6 min.	495lf	12.8 min.	9.6 min.
DP 13	OS-2, W2	14.18ac	0.20	300lf	3.0%	19.8 min.	1120lf	4.7%	GW	15	3.3 ft/sec	5.7 min.	25.6 min.			26.4 min.
DP 14	OS-1a, E2	1.78ac	0.25	100lf	2.0%	12.4 min.	330lf	7.0%	PV	20	5.3 ft/sec	1.0 min.	13.4 min.			13.4 min.
DP 15	OS-1b, E3	1.28ac	0.24	100lf	2.0%	12.6 min.	345lf	7.0%	PV	20	5.3 ft/sec	1.1 min.	13.6 min.			13.6 min.
DP 15.1	OS-1a, OS-1b, E2, E3	3.05ac	0.24	100lf	2.0%	12.5 min.	508lf	5.1%	PV	20	4.5 ft/sec	1.9 min.	14.3 min.			13.8 min.
DP 16	OS-1a, OS-1b, E2, E3, E4	3.38ac	0.27	100lf	2.0%	12.0 min.	508lf	5.1%	PV	20	4.5 ft/sec	1.9 min.	13.9 min.			14.1 min.
DP 16.1	OS-1a, OS-1b, E2, E3, E4, E8	3.96ac	0.25	100lf	2.0%	12.3 min.	508lf	5.1%	PV	20	4.5 ft/sec	1.9 min.	14.2 min.			14.1 min.
DP 17	E5, E6	0.30ac	0.68	30lf	5.0%	2.4 min.	145lf	3.9%	PV	20	3.9 ft/sec	0.6 min.	5.0 min.	175lf	11.0 min.	5.0 min.
DP 18	OS-1 to OS-3, W1 to W8, E1 to E9	24.65ac	0.22	300lf	3.0%	19.3 min.	1120lf	4.7%	GW	15	3.3 ft/sec	5.7 min.	25.0 min.			27.0 min.

Equations:

$$t_i (\text{Overland}) = 0.395(1.1 - C_5)L^{0.5} S^{-0.333}$$

C_5 = Runoff coefficient for 5-year

L = Length of overland flow (ft)

S = Slope of flow path (ft/ft)

t_c Check = (L/180)+10 (Developed Cond. Only)

L = Overall Length

$$\text{Velocity (Travel Time)} = C_v S^{0.5}$$

C_v = Conveyance Coef (see Table)

S = Watercourse slope (ft/ft)

Table RO-2

Land Surface Type	Land Type	Cv
Grassed Waterway	GW	15
Heavy Meadow	HM	2.5
Nearly Bare Ground	NBG	10
Paved Area	PV	20
Riprap (Not Buried)	RR	6.5
Short Pasture/Lawns	SP	7
Tillage/Fields	TF	5

**North Bay at Lake Woodmoor
Developed Condition
Runoff Calculation**

Basin / Design Point	Contributing Basins	Drainage Area	C		Time of Concentration	Rainfall Intensity		Runoff		Basin / DP
			C ₅	C ₁₀₀		i ₅	i ₁₀₀	Q ₅	Q ₁₀₀	
OS-1a		1.21 ac	0.22	0.46	13.2 min.	3.7 in/hr	6.2 in/hr	1.0 cfs	3.4 cfs	OS-1a
OS-1b		1.02 ac	0.22	0.46	13.2 min.	3.7 in/hr	6.2 in/hr	0.8 cfs	2.9 cfs	OS-1b
OS-2		14.04 ac	0.20	0.44	25.6 min.	2.7 in/hr	4.6 in/hr	7.5 cfs	28.3 cfs	OS-2
OS-3		0.49 ac	0.28	0.49	9.8 min.	4.2 in/hr	7.0 in/hr	0.6 cfs	1.7 cfs	OS-3
W1		0.35 ac	0.61	0.74	5.0 min.	5.2 in/hr	8.7 in/hr	1.1 cfs	2.2 cfs	W1
W2		0.14 ac	0.30	0.50	5.5 min.	5.0 in/hr	8.4 in/hr	0.2 cfs	0.6 cfs	W2
W3		0.33 ac	0.51	0.63	5.3 min.	5.1 in/hr	8.5 in/hr	0.8 cfs	1.8 cfs	W3
W4		0.38 ac	0.42	0.57	5.9 min.	4.9 in/hr	8.3 in/hr	0.8 cfs	1.8 cfs	W4
W5		0.26 ac	0.62	0.72	5.0 min.	5.2 in/hr	8.7 in/hr	0.8 cfs	1.7 cfs	W5
W6		0.13 ac	0.69	0.78	5.0 min.	5.2 in/hr	8.7 in/hr	0.4 cfs	0.9 cfs	W6
W7		1.92 ac	0.26	0.55	9.6 min.	4.2 in/hr	7.0 in/hr	2.1 cfs	7.5 cfs	W7
W8		0.26 ac	0.27	0.48	9.7 min.	4.2 in/hr	7.0 in/hr	0.3 cfs	0.9 cfs	W8
E1		0.20 ac	0.25	0.55	6.0 min.	4.9 in/hr	8.2 in/hr	0.2 cfs	0.9 cfs	E1
E2		0.57 ac	0.34	0.58	6.8 min.	4.7 in/hr	7.9 in/hr	0.9 cfs	2.6 cfs	E2
E3		0.26 ac	0.33	0.58	5.1 min.	5.1 in/hr	8.6 in/hr	0.5 cfs	1.3 cfs	E3
E4		0.33 ac	0.85	0.92	5.0 min.	5.2 in/hr	8.7 in/hr	1.4 cfs	2.6 cfs	E4
E5		0.14 ac	0.75	0.84	5.0 min.	5.2 in/hr	8.7 in/hr	0.6 cfs	1.0 cfs	E5
E6		0.16 ac	0.63	0.75	5.0 min.	5.2 in/hr	8.7 in/hr	0.5 cfs	1.0 cfs	E6
E7		1.55 ac	0.26	0.55	9.6 min.	4.2 in/hr	7.0 in/hr	1.7 cfs	6.0 cfs	E7
E8		0.58 ac	0.18	0.52	5.0 min.	5.2 in/hr	8.7 in/hr	0.5 cfs	2.6 cfs	E8
E9		0.33 ac	0.19	0.52	5.0 min.	5.2 in/hr	8.7 in/hr	0.3 cfs	1.5 cfs	E9
DP 10	W2, OS-2	14.18 ac	0.20	0.44	25.8 min.	2.7 in/hr	4.5 in/hr	7.6 cfs	28.5 cfs	DP 10
DP 11	W3, W4, OS-3	1.20 ac	0.37	0.54	8.7 min.	4.3 in/hr	7.3 in/hr	1.9 cfs	4.7 cfs	DP 11
DP 12	W5, W6	0.39 ac	0.64	0.74	5.0 min.	5.2 in/hr	8.7 in/hr	1.3 cfs	2.5 cfs	DP 12
DP 12.1	W3-W6, W8, OS-3	1.85 ac	0.40	0.55	9.6 min.	4.2 in/hr	7.0 in/hr	3.1 cfs	7.2 cfs	DP 12.1
DP 13	OS-2, W2	14.18 ac	0.20	0.44	26.4 min.	2.7 in/hr	4.5 in/hr	7.5 cfs	28.1 cfs	DP 13
DP 14	OS-1a, E2	1.78 ac	0.25	0.47	13.4 min.	3.7 in/hr	6.2 in/hr	1.6 cfs	5.2 cfs	DP 14
DP 15	OS-1b, E3	1.28 ac	0.24	0.46	13.6 min.	3.7 in/hr	6.2 in/hr	1.1 cfs	3.6 cfs	DP 15
DP 15.1	OS-1a, OS-1b, E2, E3	3.05 ac	0.24	0.47	13.8 min.	3.6 in/hr	6.1 in/hr	2.7 cfs	8.7 cfs	DP 15.1
DP 16	OS-1a, OS-1b, E2, E3, E4	3.38 ac	0.27	0.48	14.1 min.	3.6 in/hr	6.1 in/hr	3.4 cfs	9.9 cfs	DP 16
DP 16.1	OS-1a, OS-1b, E2, E3, E4, E8	3.96 ac	0.25	0.47	14.1 min.	3.6 in/hr	6.1 in/hr	3.6 cfs	11.3 cfs	DP 16.1
DP 17	E5, E6	0.30 ac	0.68	0.79	5.0 min.	5.2 in/hr	8.7 in/hr	1.1 cfs	2.1 cfs	DP 17
DP 18	OS-1 to OS-3, W1 to W8, E1 to E9	24.65 ac	0.22	0.46	27.0 min.	2.6 in/hr	4.4 in/hr	14.6 cfs	49.9 cfs	DP 18

Equations (taken from Fig 6-5, City of Colorado Springs DCM):

$$i_2 = -1.19 \ln(T_c) + 6.035$$

$$i_5 = -1.50 \ln(T_c) + 7.583$$

$$i_{10} = -1.75 \ln(T_c) + 8.847$$

$$i_{25} = -2.00 \ln(T_c) + 10.111$$

$$i_{50} = -2.25 \ln(T_c) + 11.375$$

$$i_{100} = -2.52 \ln(T_c) + 12.735$$

$$Q = CiA$$

Q = Peak Runoff Rate (cubic feet/second)

C = Runoff coef representing a ratio of peak runoff rate to ave rainfall intensity for a duration equal to the runoff time of concentration.

i = average rainfall intensity in inches per hour

A = Drainage area in acres

P1	Inches
WQCV	0.60 in
2 yr	1.19 in
5 yr	1.50 in
10 yr	1.75 in
25 yr	2.00 in
50 yr	2.25 in
100 yr	2.52 in

APPENDIX A.1
Supporting Hydrologic Tables and Figures

Table 6-6. Runoff Coefficients for Rational Method
(Source: UDFCD 2001)

Land Use or Surface Characteristics	Percent Impervious	Runoff Coefficients											
		2-year		5-year		10-year		25-year		50-year		100-year	
		HSG A&B	HSG C&D	HSG A&B	HSG C&D	HSG A&B	HSG C&D	HSG A&B	HSG C&D	HSG A&B	HSG C&D	HSG A&B	HSG C&D
Business													
Commercial Areas	95	0.79	0.80	0.81	0.82	0.83	0.84	0.85	0.87	0.87	0.88	0.88	0.89
Neighborhood Areas	70	0.45	0.49	0.49	0.53	0.53	0.57	0.58	0.62	0.60	0.65	0.62	0.68
Residential													
1/8 Acre or less	65	0.41	0.45	0.45	0.49	0.49	0.54	0.54	0.59	0.57	0.62	0.59	0.65
1/4 Acre	40	0.23	0.28	0.30	0.35	0.36	0.42	0.42	0.50	0.46	0.54	0.50	0.58
1/3 Acre	30	0.18	0.22	0.25	0.30	0.32	0.38	0.39	0.47	0.43	0.52	0.47	0.57
1/2 Acre	25	0.15	0.20	0.22	0.28	0.30	0.36	0.37	0.46	0.41	0.51	0.46	0.56
1 Acre	20	0.12	0.17	0.20	0.26	0.27	0.34	0.35	0.44	0.40	0.50	0.44	0.55
Industrial													
Light Areas	80	0.57	0.60	0.59	0.63	0.63	0.66	0.66	0.70	0.68	0.72	0.70	0.74
Heavy Areas	90	0.71	0.73	0.73	0.75	0.75	0.77	0.78	0.80	0.80	0.82	0.81	0.83
Parks and Cemeteries	7	0.05	0.09	0.12	0.19	0.20	0.29	0.30	0.40	0.34	0.46	0.39	0.52
Playgrounds	13	0.07	0.13	0.16	0.23	0.24	0.31	0.32	0.42	0.37	0.48	0.41	0.54
Railroad Yard Areas	40	0.23	0.28	0.30	0.35	0.36	0.42	0.42	0.50	0.46	0.54	0.50	0.58
Undeveloped Areas													
Historic Flow Analysis-- Greenbelts, Agriculture	2	0.03	0.05	0.09	0.16	0.17	0.26	0.26	0.38	0.31	0.45	0.36	0.51
Pasture/Meadow	0	0.02	0.04	0.08	0.15	0.15	0.25	0.25	0.37	0.30	0.44	0.35	0.50
Forest	0	0.02	0.04	0.08	0.15	0.15	0.25	0.25	0.37	0.30	0.44	0.35	0.50
Exposed Rock	100	0.89	0.89	0.90	0.90	0.92	0.92	0.94	0.94	0.95	0.95	0.96	0.96
Offsite Flow Analysis (when landuse is undefined)	45	0.26	0.31	0.32	0.37	0.38	0.44	0.44	0.51	0.48	0.55	0.51	0.59
Streets													
Paved	100	0.89	0.89	0.90	0.90	0.92	0.92	0.94	0.94	0.95	0.95	0.96	0.96
Gravel	80	0.57	0.60	0.59	0.63	0.63	0.66	0.66	0.70	0.68	0.72	0.70	0.74
Drive and Walks	100	0.89	0.89	0.90	0.90	0.92	0.92	0.94	0.94	0.95	0.95	0.96	0.96
Roofs	90	0.71	0.73	0.73	0.75	0.75	0.77	0.78	0.80	0.80	0.82	0.81	0.83
Lawns	0	0.02	0.04	0.08	0.15	0.15	0.25	0.25	0.37	0.30	0.44	0.35	0.50

3.2 Time of Concentration

One of the basic assumptions underlying the Rational Method is that runoff is a function of the average rainfall rate during the time required for water to flow from the hydraulically most remote part of the drainage area under consideration to the design point. However, in practice, the time of concentration can be an empirical value that results in reasonable and acceptable peak flow calculations.

For urban areas, the time of concentration (t_c) consists of an initial time or overland flow time (t_i) plus the travel time (t_t) in the storm sewer, paved gutter, roadside drainage ditch, or drainage channel. For non-urban areas, the time of concentration consists of an overland flow time (t_i) plus the time of travel in a concentrated form, such as a swale or drainageway. The travel portion (t_t) of the time of concentration can be estimated from the hydraulic properties of the storm sewer, gutter, swale, ditch, or drainageway. Initial time, on the other hand, will vary with surface slope, depression storage, surface cover, antecedent rainfall, and infiltration capacity of the soil, as well as distance of surface flow. The time of concentration is represented by Equation 6-7 for both urban and non-urban areas.

Table 6-7. Conveyance Coefficient, C_v

Type of Land Surface	C_v
Heavy meadow	2.5
Tillage/field	5
Riprap (not buried)*	6.5
Short pasture and lawns	7
Nearly bare ground	10
Grassed waterway	15
Paved areas and shallow paved swales	20

* For buried riprap, select C_v value based on type of vegetative cover.

The travel time is calculated by dividing the flow distance (in feet) by the velocity calculated using Equation 6-9 and converting units to minutes.

The time of concentration (t_c) is then the sum of the overland flow time (t_i) and the travel time (t_r) per Equation 6-7.

3.2.3 First Design Point Time of Concentration in Urban Catchments

Using this procedure, the time of concentration at the first design point (typically the first inlet in the system) in an urbanized catchment should not exceed the time of concentration calculated using Equation 6-10. The first design point is defined as the point where runoff first enters the storm sewer system.

$$t_c = \frac{L}{180} + 10 \quad (\text{Eq. 6-10})$$

Where:

t_c = maximum time of concentration at the first design point in an urban watershed (min)

L = waterway length (ft)

Equation 6-10 was developed using the rainfall-runoff data collected in the Denver region and, in essence, represents regional “calibration” of the Rational Method. Normally, Equation 6-10 will result in a lesser time of concentration at the first design point and will govern in an urbanized watershed. For subsequent design points, the time of concentration is calculated by accumulating the travel times in downstream drainageway reaches.

3.2.4 Minimum Time of Concentration

If the calculations result in a t_c of less than 10 minutes for undeveloped conditions, it is recommended that a minimum value of 10 minutes be used. The minimum t_c for urbanized areas is 5 minutes.

3.2.5 Post-Development Time of Concentration

As Equation 6-8 indicates, the time of concentration is a function of the 5-year runoff coefficient for a drainage basin. Typically, higher levels of imperviousness (higher 5-year runoff coefficients) correspond to shorter times of concentration, and lower levels of imperviousness correspond to longer times of

For Colorado Springs and much of the Fountain Creek watershed, the 1-hour depths are fairly uniform and are summarized in Table 6-2. Depending on the location of the project, rainfall depths may be calculated using the described method and the NOAA Atlas maps shown in Figures 6-6 through 6-17.

Table 6-2. Rainfall Depths for Colorado Springs

Return Period	1-Hour Depth	6-Hour Depth	24-Hour Depth
2	1.19	1.70	2.10
5	1.50	2.10	2.70
10	1.75	2.40	3.20
25	2.00	2.90	3.60
50	2.25	3.20	4.20
100	2.52	3.50	4.60

Where $Z = 6,840 \text{ ft}/100$

These depths can be applied to the design storms or converted to intensities (inches/hour) for the Rational Method as described below. However, as the basin area increases, it is unlikely that the reported point rainfalls will occur uniformly over the entire basin. To account for this characteristic of rain storms an adjustment factor, the Depth Area Reduction Factor (DARF) is applied. This adjustment to rainfall depth and its effect on design storms is also described below. The UDFCD UD-Rain spreadsheet, available on UDFCD's website, also provides tools to calculate point rainfall depths and Intensity-Duration-Frequency curves² and should produce similar depth calculation results.

2.2 Design Storms

Design storms are used as input into rainfall/runoff models and provide a representation of the typical temporal distribution of rainfall events when the creation or routing of runoff hydrographs is required. It has long been observed that rainstorms in the Front Range of Colorado tend to occur as either short-duration, high-intensity, localized, convective thunderstorms (cloud bursts) or longer-duration, lower-intensity, broader, frontal (general) storms. The significance of these two types of events is primarily determined by the size of the drainage basin being studied. Thunderstorms can create high rates of runoff within a relatively small area, quickly, but their influence may not be significant very far downstream. Frontal storms may not create high rates of runoff within smaller drainage basins due to their lower intensity, but tend to produce larger flood flows that can be hazardous over a broader area and extend further downstream.

- Thunderstorms:** Based on the extensive evaluation of rain storms completed in the Carlton study (Carlton 2011), it was determined that typical thunderstorms have a duration of about 2 hours. The study evaluated over 300,000 storm cells using gage-adjusted NEXRAD data, collected over a 14-year period (1994 to 2008). Storms lasting longer than 3 hours were rarely found. Therefore, the results of the Carlton study have been used to define the shorter duration design storms.

To determine the temporal distribution of thunderstorms, 22 gage-adjusted NEXRAD storm cells were studied in detail. Through a process described in a technical memorandum prepared by the City of Colorado Springs (City of Colorado Springs 2012), the results of this analysis were interpreted and normalized to the 1-hour rainfall depth to create the distribution shown in Table 6-3 with a 5 minute time interval for drainage basins up to 1 square mile in size. This distribution represents the rainfall

APPENDIX B

Hydraulic Calculations

Street Capacity Calculations

Inlet Capacity Calculations

Pipe Sizing Calculations

Storm Sewer System Layout Plan

UDSewer Input and Output Tables: 5-year and 100-year Storm Events

Pipe Outlet Erosion Protection Calculations

ALLOWABLE CAPACITY FOR ONE-HALF OF STREET (Minor & Major Storm)

(Based on Regulated Criteria for Maximum Allowable Flow Depth and Spread)

Project: North Bay at Lake Woodmoor
 Inlet ID: DP 11

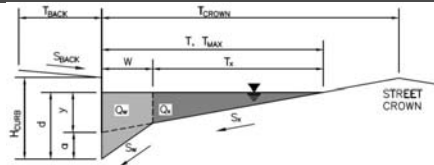

Gutter Geometry (Enter data in the blue cells)

Maximum Allowable Width for Spread Behind Curb $T_{BACK} =$ ft

Side Slope Behind Curb (leave blank for no conveyance credit behind curb) $S_{BACK} =$ ft/ft

Manning's Roughness Behind Curb (typically between 0.012 and 0.020) $n_{BACK} =$

Height of Curb at Gutter Flow Line $H_{CURB} =$ inches

Distance from Curb Face to Street Crown $T_{CROWN} =$ ft

Gutter Width $W =$ ft

Street Transverse Slope $S_X =$ ft/ft

Gutter Cross Slope (typically 2 inches over 24 inches or 0.083 ft/ft) $S_W =$ ft/ft

Street Longitudinal Slope - Enter 0 for sump condition $S_O =$ ft/ft

Manning's Roughness for Street Section (typically between 0.012 and 0.020) $n_{STREET} =$

	Minor Storm	Major Storm	
Max. Allowable Spread for Minor & Major Storm	$T_{MAX} = 12.0$	12.0	ft
Max. Allowable Depth at Gutter Flowline for Minor & Major Storm	$d_{MAX} = 6.0$	6.0	inches
Allow Flow Depth at Street Crown (leave blank for no)	<input type="checkbox"/>	<input type="checkbox"/>	check = yes

Maximum Capacity for 1/2 Street based On Allowable Spread

	Minor Storm	Major Storm	
Water Depth without Gutter Depression (Eq. ST-2)	$y = 2.88$	2.88	inches
Vertical Depth between Gutter Lip and Gutter Flowline (usually 2")	$d_C = 2.0$	2.0	inches
Gutter Depression ($d_C - (W * S_X * 12)$)	$a = 1.73$	1.73	inches
Water Depth at Gutter Flowline	$d = 4.61$	4.61	inches
Allowable Spread for Discharge outside the Gutter Section W (T - W)	$T_X = 10.8$	10.8	ft
Gutter Flow to Design Flow Ratio by FHWA HEC-22 method (Eq. ST-7)	$E_O = 0.335$	0.335	
Discharge outside the Gutter Section W, carried in Section T_X	$Q_X = 3.9$	3.9	cfs
Discharge within the Gutter Section W ($Q_G - Q_X$)	$Q_W = 1.9$	1.9	cfs
Discharge Behind the Curb (e.g., sidewalk, driveways, & lawns)	$Q_{BACK} = 0.0$	0.0	cfs
Maximum Flow Based On Allowable Spread	$Q_T = 5.8$	5.8	cfs
Flow Velocity within the Gutter Section	$V = 1.9$	1.9	fps
$V*d$ Product: Flow Velocity times Gutter Flowline Depth	$V*d = 0.7$	0.7	

Maximum Capacity for 1/2 Street based on Allowable Depth

	Minor Storm	Major Storm	
Theoretical Water Spread	$T_{TH} = 17.8$	17.8	ft
Theoretical Spread for Discharge outside the Gutter Section W (T - W)	$T_{XTH} = 16.6$	16.6	ft
Gutter Flow to Design Flow Ratio by FHWA HEC-22 method (Eq. ST-7)	$E_O = 0.215$	0.215	
Theoretical Discharge outside the Gutter Section W, carried in Section T_{XTH}	$Q_{XTH} = 12.1$	12.1	cfs
Actual Discharge outside the Gutter Section W, (limited by distance T_{CROWN})	$Q_X = 11.4$	11.4	cfs
Discharge within the Gutter Section W ($Q_G - Q_X$)	$Q_W = 3.3$	3.3	cfs
Discharge Behind the Curb (e.g., sidewalk, driveways, & lawns)	$Q_{BACK} = 0.0$	0.0	cfs
Total Discharge for Major & Minor Storm (Pre-Safety Factor)	$Q = 14.7$	14.7	cfs
Average Flow Velocity Within the Gutter Section	$V = 2.3$	2.3	fps
$V*d$ Product: Flow Velocity Times Gutter Flowline Depth	$V*d = 1.2$	1.2	
Slope-Based Depth Safety Reduction Factor for Major & Minor ($d \geq 6"$) Storm	$R = 1.00$	1.00	
Max Flow Based on Allowable Depth (Safety Factor Applied)	$Q_d = 14.7$	14.7	cfs
Resultant Flow Depth at Gutter Flowline (Safety Factor Applied)	$d = 6.00$	6.00	inches
Resultant Flow Depth at Street Crown (Safety Factor Applied)	$d_{CROWN} = 1.40$	1.40	inches

MINOR STORM Allowable Capacity is based on Spread Criterion

MAJOR STORM Allowable Capacity is based on Spread Criterion

	Minor Storm	Major Storm	
Minor storm max. allowable capacity GOOD - greater than the design flow given on sheet 'Inlet Management'	$Q_{ALLOW} = 5.8$	5.8	cfs
Major storm max. allowable capacity GOOD - greater than the design flow given on sheet 'Inlet Management'			

ALLOWABLE CAPACITY FOR ONE-HALF OF STREET (Minor & Major Storm)

(Based on Regulated Criteria for Maximum Allowable Flow Depth and Spread)

Project: North Bay at Lake Woodmoor
 Inlet ID: DP 12

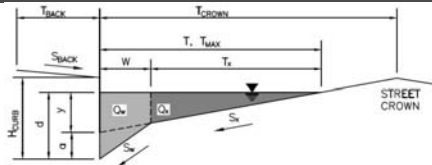

Gutter Geometry (Enter data in the blue cells)							
Maximum Allowable Width for Spread Behind Curb	$T_{BACK} =$ <input type="text"/> ft						
Side Slope Behind Curb (leave blank for no conveyance credit behind curb)	$S_{BACK} =$ <input type="text"/> ft/ft						
Manning's Roughness Behind Curb (typically between 0.012 and 0.020)	$n_{BACK} =$ <input type="text"/>						
Height of Curb at Gutter Flow Line	$H_{CURB} =$ <input type="text" value="6.00"/> inches						
Distance from Curb Face to Street Crown	$T_{CROWN} =$ <input type="text" value="12.0"/> ft						
Gutter Width	$W =$ <input type="text" value="1.17"/> ft						
Street Transverse Slope	$S_x =$ <input type="text" value="0.020"/> ft/ft						
Gutter Cross Slope (typically 2 inches over 24 inches or 0.083 ft/ft)	$S_w =$ <input type="text" value="0.143"/> ft/ft						
Street Longitudinal Slope - Enter 0 for sump condition	$S_o =$ <input type="text" value="0.017"/> ft/ft						
Manning's Roughness for Street Section (typically between 0.012 and 0.020)	$n_{STREET} =$ <input type="text" value="0.016"/>						
Max. Allowable Spread for Minor & Major Storm	<table border="1" style="width: 100%; text-align: center;"> <tr> <th>Minor Storm</th> <th>Major Storm</th> <th></th> </tr> <tr> <td>$T_{MAX} =$ <input type="text" value="12.0"/></td> <td><input type="text" value="12.0"/></td> <td>ft</td> </tr> </table>	Minor Storm	Major Storm		$T_{MAX} =$ <input type="text" value="12.0"/>	<input type="text" value="12.0"/>	ft
Minor Storm	Major Storm						
$T_{MAX} =$ <input type="text" value="12.0"/>	<input type="text" value="12.0"/>	ft					
Max. Allowable Depth at Gutter Flowline for Minor & Major Storm	<table border="1" style="width: 100%; text-align: center;"> <tr> <th>Minor Storm</th> <th>Major Storm</th> <th></th> </tr> <tr> <td>$d_{MAX} =$ <input type="text" value="6.0"/></td> <td><input type="text" value="6.0"/></td> <td>inches</td> </tr> </table>	Minor Storm	Major Storm		$d_{MAX} =$ <input type="text" value="6.0"/>	<input type="text" value="6.0"/>	inches
Minor Storm	Major Storm						
$d_{MAX} =$ <input type="text" value="6.0"/>	<input type="text" value="6.0"/>	inches					
Allow Flow Depth at Street Crown (leave blank for no)	<table border="1" style="width: 100%; text-align: center;"> <tr> <td><input type="checkbox"/></td> <td><input type="checkbox"/></td> <td>check = yes</td> </tr> </table>	<input type="checkbox"/>	<input type="checkbox"/>	check = yes			
<input type="checkbox"/>	<input type="checkbox"/>	check = yes					
Maximum Capacity for 1/2 Street based On Allowable Spread							
Water Depth without Gutter Depression (Eq. ST-2)	<table border="1" style="width: 100%; text-align: center;"> <tr> <th>Minor Storm</th> <th>Major Storm</th> <th></th> </tr> <tr> <td>$y =$ <input type="text" value="2.88"/></td> <td><input type="text" value="2.88"/></td> <td>inches</td> </tr> </table>	Minor Storm	Major Storm		$y =$ <input type="text" value="2.88"/>	<input type="text" value="2.88"/>	inches
Minor Storm	Major Storm						
$y =$ <input type="text" value="2.88"/>	<input type="text" value="2.88"/>	inches					
Vertical Depth between Gutter Lip and Gutter Flowline (usually 2")	$d_c =$ <input type="text" value="2.0"/> inches						
Gutter Depression ($d_c - (W * S_x * 12)$)	$a =$ <input type="text" value="1.73"/> inches						
Water Depth at Gutter Flowline	$d =$ <input type="text" value="4.61"/> inches						
Allowable Spread for Discharge outside the Gutter Section W ($T - W$)	$T_x =$ <input type="text" value="10.8"/> ft						
Gutter Flow to Design Flow Ratio by FHWA HEC-22 method (Eq. ST-7)	$E_o =$ <input type="text" value="0.335"/>						
Discharge outside the Gutter Section W , carried in Section T_x	$Q_x =$ <input type="text" value="3.9"/> cfs						
Discharge within the Gutter Section W ($Q_t - Q_x$)	$Q_w =$ <input type="text" value="1.9"/> cfs						
Discharge Behind the Curb (e.g., sidewalk, driveways, & lawns)	$Q_{BACK} =$ <input type="text" value="0.0"/> cfs						
Maximum Flow Based On Allowable Spread	$Q_T =$ <input type="text" value="5.8"/> cfs						
Flow Velocity within the Gutter Section	$V =$ <input type="text" value="1.9"/> fps						
$V*d$ Product: Flow Velocity times Gutter Flowline Depth	$V*d =$ <input type="text" value="0.7"/>						
Maximum Capacity for 1/2 Street based on Allowable Depth							
Theoretical Water Spread	<table border="1" style="width: 100%; text-align: center;"> <tr> <th>Minor Storm</th> <th>Major Storm</th> <th></th> </tr> <tr> <td>$T_{TH} =$ <input type="text" value="17.8"/></td> <td><input type="text" value="17.8"/></td> <td>ft</td> </tr> </table>	Minor Storm	Major Storm		$T_{TH} =$ <input type="text" value="17.8"/>	<input type="text" value="17.8"/>	ft
Minor Storm	Major Storm						
$T_{TH} =$ <input type="text" value="17.8"/>	<input type="text" value="17.8"/>	ft					
Theoretical Spread for Discharge outside the Gutter Section W ($T - W$)	$T_{XTH} =$ <input type="text" value="16.6"/> ft						
Gutter Flow to Design Flow Ratio by FHWA HEC-22 method (Eq. ST-7)	$E_o =$ <input type="text" value="0.215"/>						
Theoretical Discharge outside the Gutter Section W , carried in Section T_{XTH}	$Q_{XTH} =$ <input type="text" value="12.1"/> cfs						
Actual Discharge outside the Gutter Section W , (limited by distance T_{CROWN})	$Q_x =$ <input type="text" value="11.4"/> cfs						
Discharge within the Gutter Section W ($Q_d - Q_x$)	$Q_w =$ <input type="text" value="3.3"/> cfs						
Discharge Behind the Curb (e.g., sidewalk, driveways, & lawns)	$Q_{BACK} =$ <input type="text" value="0.0"/> cfs						
Total Discharge for Major & Minor Storm (Pre-Safety Factor)	$Q =$ <input type="text" value="14.7"/> cfs						
Average Flow Velocity Within the Gutter Section	$V =$ <input type="text" value="2.3"/> fps						
$V*d$ Product: Flow Velocity Times Gutter Flowline Depth	$V*d =$ <input type="text" value="1.2"/>						
Slope-Based Depth Safety Reduction Factor for Major & Minor ($d \geq 6"$) Storm	$R =$ <input type="text" value="1.00"/>						
Max Flow Based on Allowable Depth (Safety Factor Applied)	$Q_d =$ <input type="text" value="14.7"/> cfs						
Resultant Flow Depth at Gutter Flowline (Safety Factor Applied)	$d =$ <input type="text" value="6.00"/> inches						
Resultant Flow Depth at Street Crown (Safety Factor Applied)	$d_{CROWN} =$ <input type="text" value="1.40"/> inches						
MINOR STORM Allowable Capacity is based on Spread Criterion							
MAJOR STORM Allowable Capacity is based on Spread Criterion	<table border="1" style="width: 100%; text-align: center;"> <tr> <th>Minor Storm</th> <th>Major Storm</th> <th></th> </tr> <tr> <td>$Q_{ALLOW} =$ <input type="text" value="5.8"/></td> <td><input type="text" value="5.8"/></td> <td>cfs</td> </tr> </table>	Minor Storm	Major Storm		$Q_{ALLOW} =$ <input type="text" value="5.8"/>	<input type="text" value="5.8"/>	cfs
Minor Storm	Major Storm						
$Q_{ALLOW} =$ <input type="text" value="5.8"/>	<input type="text" value="5.8"/>	cfs					
Minor storm max. allowable capacity GOOD - greater than the design flow given on sheet 'Inlet Management'							
Major storm max. allowable capacity GOOD - greater than the design flow given on sheet 'Inlet Management'							

ALLOWABLE CAPACITY FOR ONE-HALF OF STREET (Minor & Major Storm)

(Based on Regulated Criteria for Maximum Allowable Flow Depth and Spread)

Project: North Bay at Lake Woodmoor
 Inlet ID: Inlet No. 4, DP 14

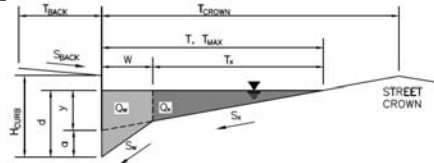

Gutter Geometry (Enter data in the blue cells)							
Maximum Allowable Width for Spread Behind Curb	$T_{BACK} =$ <input style="width: 50px;" type="text"/> ft						
Side Slope Behind Curb (leave blank for no conveyance credit behind curb)	$S_{BACK} =$ <input style="width: 50px;" type="text"/> ft/ft						
Manning's Roughness Behind Curb (typically between 0.012 and 0.020)	$n_{BACK} =$ <input style="width: 50px;" type="text"/>						
Height of Curb at Gutter Flow Line	$H_{CURB} =$ <input style="width: 50px;" type="text"/> inches						
Distance from Curb Face to Street Crown	$T_{CROWN} =$ <input style="width: 50px;" type="text"/> ft						
Gutter Width	$W =$ <input style="width: 50px;" type="text"/> ft						
Street Transverse Slope	$S_X =$ <input style="width: 50px;" type="text"/> ft/ft						
Gutter Cross Slope (typically 2 inches over 24 inches or 0.083 ft/ft)	$S_W =$ <input style="width: 50px;" type="text"/> ft/ft						
Street Longitudinal Slope - Enter 0 for sump condition	$S_O =$ <input style="width: 50px;" type="text"/> ft/ft						
Manning's Roughness for Street Section (typically between 0.012 and 0.020)	$n_{STREET} =$ <input style="width: 50px;" type="text"/>						
Max. Allowable Spread for Minor & Major Storm	<table border="1" style="width: 100%; text-align: center;"> <tr> <th style="width: 50%;">Minor Storm</th> <th style="width: 50%;">Major Storm</th> <th style="width: 10%;"></th> </tr> <tr> <td>$T_{MAX} =$ <input style="width: 40px;" type="text"/></td> <td><input style="width: 40px;" type="text"/></td> <td>ft</td> </tr> </table>	Minor Storm	Major Storm		$T_{MAX} =$ <input style="width: 40px;" type="text"/>	<input style="width: 40px;" type="text"/>	ft
Minor Storm	Major Storm						
$T_{MAX} =$ <input style="width: 40px;" type="text"/>	<input style="width: 40px;" type="text"/>	ft					
Max. Allowable Depth at Gutter Flowline for Minor & Major Storm	<table border="1" style="width: 100%; text-align: center;"> <tr> <th style="width: 50%;">Minor Storm</th> <th style="width: 50%;">Major Storm</th> <th style="width: 10%;"></th> </tr> <tr> <td>$d_{MAX} =$ <input style="width: 40px;" type="text"/></td> <td><input style="width: 40px;" type="text"/></td> <td>inches</td> </tr> </table>	Minor Storm	Major Storm		$d_{MAX} =$ <input style="width: 40px;" type="text"/>	<input style="width: 40px;" type="text"/>	inches
Minor Storm	Major Storm						
$d_{MAX} =$ <input style="width: 40px;" type="text"/>	<input style="width: 40px;" type="text"/>	inches					
Allow Flow Depth at Street Crown (leave blank for no)	<table style="width: 100%;"> <tr> <td style="text-align: center;"><input type="checkbox"/></td> <td style="text-align: center;"><input type="checkbox"/></td> <td>check = yes</td> </tr> </table>	<input type="checkbox"/>	<input type="checkbox"/>	check = yes			
<input type="checkbox"/>	<input type="checkbox"/>	check = yes					
Maximum Capacity for 1/2 Street based On Allowable Spread							
Water Depth without Gutter Depression (Eq. ST-2)	<table border="1" style="width: 100%; text-align: center;"> <tr> <th style="width: 50%;">Minor Storm</th> <th style="width: 50%;">Major Storm</th> <th style="width: 10%;"></th> </tr> <tr> <td>$y =$ <input style="width: 40px;" type="text"/></td> <td><input style="width: 40px;" type="text"/></td> <td>inches</td> </tr> </table>	Minor Storm	Major Storm		$y =$ <input style="width: 40px;" type="text"/>	<input style="width: 40px;" type="text"/>	inches
Minor Storm	Major Storm						
$y =$ <input style="width: 40px;" type="text"/>	<input style="width: 40px;" type="text"/>	inches					
Vertical Depth between Gutter Lip and Gutter Flowline (usually 2")	<table border="1" style="width: 100%; text-align: center;"> <tr> <th style="width: 50%;">Minor Storm</th> <th style="width: 50%;">Major Storm</th> <th style="width: 10%;"></th> </tr> <tr> <td>$d_c =$ <input style="width: 40px;" type="text"/></td> <td><input style="width: 40px;" type="text"/></td> <td>inches</td> </tr> </table>	Minor Storm	Major Storm		$d_c =$ <input style="width: 40px;" type="text"/>	<input style="width: 40px;" type="text"/>	inches
Minor Storm	Major Storm						
$d_c =$ <input style="width: 40px;" type="text"/>	<input style="width: 40px;" type="text"/>	inches					
Gutter Depression ($d_c - (W * S_x * 12)$)	<table border="1" style="width: 100%; text-align: center;"> <tr> <th style="width: 50%;">Minor Storm</th> <th style="width: 50%;">Major Storm</th> <th style="width: 10%;"></th> </tr> <tr> <td>$a =$ <input style="width: 40px;" type="text"/></td> <td><input style="width: 40px;" type="text"/></td> <td>inches</td> </tr> </table>	Minor Storm	Major Storm		$a =$ <input style="width: 40px;" type="text"/>	<input style="width: 40px;" type="text"/>	inches
Minor Storm	Major Storm						
$a =$ <input style="width: 40px;" type="text"/>	<input style="width: 40px;" type="text"/>	inches					
Water Depth at Gutter Flowline	<table border="1" style="width: 100%; text-align: center;"> <tr> <th style="width: 50%;">Minor Storm</th> <th style="width: 50%;">Major Storm</th> <th style="width: 10%;"></th> </tr> <tr> <td>$d =$ <input style="width: 40px;" type="text"/></td> <td><input style="width: 40px;" type="text"/></td> <td>inches</td> </tr> </table>	Minor Storm	Major Storm		$d =$ <input style="width: 40px;" type="text"/>	<input style="width: 40px;" type="text"/>	inches
Minor Storm	Major Storm						
$d =$ <input style="width: 40px;" type="text"/>	<input style="width: 40px;" type="text"/>	inches					
Allowable Spread for Discharge outside the Gutter Section W (T - W)	<table border="1" style="width: 100%; text-align: center;"> <tr> <th style="width: 50%;">Minor Storm</th> <th style="width: 50%;">Major Storm</th> <th style="width: 10%;"></th> </tr> <tr> <td>$T_X =$ <input style="width: 40px;" type="text"/></td> <td><input style="width: 40px;" type="text"/></td> <td>ft</td> </tr> </table>	Minor Storm	Major Storm		$T_X =$ <input style="width: 40px;" type="text"/>	<input style="width: 40px;" type="text"/>	ft
Minor Storm	Major Storm						
$T_X =$ <input style="width: 40px;" type="text"/>	<input style="width: 40px;" type="text"/>	ft					
Gutter Flow to Design Flow Ratio by FHWA HEC-22 method (Eq. ST-7)	<table border="1" style="width: 100%; text-align: center;"> <tr> <th style="width: 50%;">Minor Storm</th> <th style="width: 50%;">Major Storm</th> <th style="width: 10%;"></th> </tr> <tr> <td>$E_O =$ <input style="width: 40px;" type="text"/></td> <td><input style="width: 40px;" type="text"/></td> <td></td> </tr> </table>	Minor Storm	Major Storm		$E_O =$ <input style="width: 40px;" type="text"/>	<input style="width: 40px;" type="text"/>	
Minor Storm	Major Storm						
$E_O =$ <input style="width: 40px;" type="text"/>	<input style="width: 40px;" type="text"/>						
Discharge outside the Gutter Section W, carried in Section T_X	<table border="1" style="width: 100%; text-align: center;"> <tr> <th style="width: 50%;">Minor Storm</th> <th style="width: 50%;">Major Storm</th> <th style="width: 10%;"></th> </tr> <tr> <td>$Q_X =$ <input style="width: 40px;" type="text"/></td> <td><input style="width: 40px;" type="text"/></td> <td>cfs</td> </tr> </table>	Minor Storm	Major Storm		$Q_X =$ <input style="width: 40px;" type="text"/>	<input style="width: 40px;" type="text"/>	cfs
Minor Storm	Major Storm						
$Q_X =$ <input style="width: 40px;" type="text"/>	<input style="width: 40px;" type="text"/>	cfs					
Discharge within the Gutter Section W ($Q_g - Q_X$)	<table border="1" style="width: 100%; text-align: center;"> <tr> <th style="width: 50%;">Minor Storm</th> <th style="width: 50%;">Major Storm</th> <th style="width: 10%;"></th> </tr> <tr> <td>$Q_W =$ <input style="width: 40px;" type="text"/></td> <td><input style="width: 40px;" type="text"/></td> <td>cfs</td> </tr> </table>	Minor Storm	Major Storm		$Q_W =$ <input style="width: 40px;" type="text"/>	<input style="width: 40px;" type="text"/>	cfs
Minor Storm	Major Storm						
$Q_W =$ <input style="width: 40px;" type="text"/>	<input style="width: 40px;" type="text"/>	cfs					
Discharge Behind the Curb (e.g., sidewalk, driveways, & lawns)	<table border="1" style="width: 100%; text-align: center;"> <tr> <th style="width: 50%;">Minor Storm</th> <th style="width: 50%;">Major Storm</th> <th style="width: 10%;"></th> </tr> <tr> <td>$Q_{BACK} =$ <input style="width: 40px;" type="text"/></td> <td><input style="width: 40px;" type="text"/></td> <td>cfs</td> </tr> </table>	Minor Storm	Major Storm		$Q_{BACK} =$ <input style="width: 40px;" type="text"/>	<input style="width: 40px;" type="text"/>	cfs
Minor Storm	Major Storm						
$Q_{BACK} =$ <input style="width: 40px;" type="text"/>	<input style="width: 40px;" type="text"/>	cfs					
Maximum Flow Based On Allowable Spread	<table border="1" style="width: 100%; text-align: center;"> <tr> <th style="width: 50%;">Minor Storm</th> <th style="width: 50%;">Major Storm</th> <th style="width: 10%;"></th> </tr> <tr> <td>$Q_T =$ <input style="width: 40px;" type="text"/></td> <td><input style="width: 40px;" type="text"/></td> <td>cfs</td> </tr> </table>	Minor Storm	Major Storm		$Q_T =$ <input style="width: 40px;" type="text"/>	<input style="width: 40px;" type="text"/>	cfs
Minor Storm	Major Storm						
$Q_T =$ <input style="width: 40px;" type="text"/>	<input style="width: 40px;" type="text"/>	cfs					
Flow Velocity within the Gutter Section	<table border="1" style="width: 100%; text-align: center;"> <tr> <th style="width: 50%;">Minor Storm</th> <th style="width: 50%;">Major Storm</th> <th style="width: 10%;"></th> </tr> <tr> <td>$V =$ <input style="width: 40px;" type="text"/></td> <td><input style="width: 40px;" type="text"/></td> <td>fps</td> </tr> </table>	Minor Storm	Major Storm		$V =$ <input style="width: 40px;" type="text"/>	<input style="width: 40px;" type="text"/>	fps
Minor Storm	Major Storm						
$V =$ <input style="width: 40px;" type="text"/>	<input style="width: 40px;" type="text"/>	fps					
$V*d$ Product: Flow Velocity times Gutter Flowline Depth	<table border="1" style="width: 100%; text-align: center;"> <tr> <th style="width: 50%;">Minor Storm</th> <th style="width: 50%;">Major Storm</th> <th style="width: 10%;"></th> </tr> <tr> <td>$V*d =$ <input style="width: 40px;" type="text"/></td> <td><input style="width: 40px;" type="text"/></td> <td></td> </tr> </table>	Minor Storm	Major Storm		$V*d =$ <input style="width: 40px;" type="text"/>	<input style="width: 40px;" type="text"/>	
Minor Storm	Major Storm						
$V*d =$ <input style="width: 40px;" type="text"/>	<input style="width: 40px;" type="text"/>						
Maximum Capacity for 1/2 Street based on Allowable Depth							
Theoretical Water Spread	<table border="1" style="width: 100%; text-align: center;"> <tr> <th style="width: 50%;">Minor Storm</th> <th style="width: 50%;">Major Storm</th> <th style="width: 10%;"></th> </tr> <tr> <td>$T_{TH} =$ <input style="width: 40px;" type="text"/></td> <td><input style="width: 40px;" type="text"/></td> <td>ft</td> </tr> </table>	Minor Storm	Major Storm		$T_{TH} =$ <input style="width: 40px;" type="text"/>	<input style="width: 40px;" type="text"/>	ft
Minor Storm	Major Storm						
$T_{TH} =$ <input style="width: 40px;" type="text"/>	<input style="width: 40px;" type="text"/>	ft					
Theoretical Spread for Discharge outside the Gutter Section W (T - W)	<table border="1" style="width: 100%; text-align: center;"> <tr> <th style="width: 50%;">Minor Storm</th> <th style="width: 50%;">Major Storm</th> <th style="width: 10%;"></th> </tr> <tr> <td>$T_{XTH} =$ <input style="width: 40px;" type="text"/></td> <td><input style="width: 40px;" type="text"/></td> <td>ft</td> </tr> </table>	Minor Storm	Major Storm		$T_{XTH} =$ <input style="width: 40px;" type="text"/>	<input style="width: 40px;" type="text"/>	ft
Minor Storm	Major Storm						
$T_{XTH} =$ <input style="width: 40px;" type="text"/>	<input style="width: 40px;" type="text"/>	ft					
Gutter Flow to Design Flow Ratio by FHWA HEC-22 method (Eq. ST-7)	<table border="1" style="width: 100%; text-align: center;"> <tr> <th style="width: 50%;">Minor Storm</th> <th style="width: 50%;">Major Storm</th> <th style="width: 10%;"></th> </tr> <tr> <td>$E_O =$ <input style="width: 40px;" type="text"/></td> <td><input style="width: 40px;" type="text"/></td> <td></td> </tr> </table>	Minor Storm	Major Storm		$E_O =$ <input style="width: 40px;" type="text"/>	<input style="width: 40px;" type="text"/>	
Minor Storm	Major Storm						
$E_O =$ <input style="width: 40px;" type="text"/>	<input style="width: 40px;" type="text"/>						
Theoretical Discharge outside the Gutter Section W, carried in Section T_{XTH}	<table border="1" style="width: 100%; text-align: center;"> <tr> <th style="width: 50%;">Minor Storm</th> <th style="width: 50%;">Major Storm</th> <th style="width: 10%;"></th> </tr> <tr> <td>$Q_{XTH} =$ <input style="width: 40px;" type="text"/></td> <td><input style="width: 40px;" type="text"/></td> <td>cfs</td> </tr> </table>	Minor Storm	Major Storm		$Q_{XTH} =$ <input style="width: 40px;" type="text"/>	<input style="width: 40px;" type="text"/>	cfs
Minor Storm	Major Storm						
$Q_{XTH} =$ <input style="width: 40px;" type="text"/>	<input style="width: 40px;" type="text"/>	cfs					
Actual Discharge outside the Gutter Section W, (limited by distance T_{CROWN})	<table border="1" style="width: 100%; text-align: center;"> <tr> <th style="width: 50%;">Minor Storm</th> <th style="width: 50%;">Major Storm</th> <th style="width: 10%;"></th> </tr> <tr> <td>$Q_X =$ <input style="width: 40px;" type="text"/></td> <td><input style="width: 40px;" type="text"/></td> <td>cfs</td> </tr> </table>	Minor Storm	Major Storm		$Q_X =$ <input style="width: 40px;" type="text"/>	<input style="width: 40px;" type="text"/>	cfs
Minor Storm	Major Storm						
$Q_X =$ <input style="width: 40px;" type="text"/>	<input style="width: 40px;" type="text"/>	cfs					
Discharge within the Gutter Section W ($Q_g - Q_X$)	<table border="1" style="width: 100%; text-align: center;"> <tr> <th style="width: 50%;">Minor Storm</th> <th style="width: 50%;">Major Storm</th> <th style="width: 10%;"></th> </tr> <tr> <td>$Q_W =$ <input style="width: 40px;" type="text"/></td> <td><input style="width: 40px;" type="text"/></td> <td>cfs</td> </tr> </table>	Minor Storm	Major Storm		$Q_W =$ <input style="width: 40px;" type="text"/>	<input style="width: 40px;" type="text"/>	cfs
Minor Storm	Major Storm						
$Q_W =$ <input style="width: 40px;" type="text"/>	<input style="width: 40px;" type="text"/>	cfs					
Discharge Behind the Curb (e.g., sidewalk, driveways, & lawns)	<table border="1" style="width: 100%; text-align: center;"> <tr> <th style="width: 50%;">Minor Storm</th> <th style="width: 50%;">Major Storm</th> <th style="width: 10%;"></th> </tr> <tr> <td>$Q_{BACK} =$ <input style="width: 40px;" type="text"/></td> <td><input style="width: 40px;" type="text"/></td> <td>cfs</td> </tr> </table>	Minor Storm	Major Storm		$Q_{BACK} =$ <input style="width: 40px;" type="text"/>	<input style="width: 40px;" type="text"/>	cfs
Minor Storm	Major Storm						
$Q_{BACK} =$ <input style="width: 40px;" type="text"/>	<input style="width: 40px;" type="text"/>	cfs					
Total Discharge for Major & Minor Storm (Pre-Safety Factor)	<table border="1" style="width: 100%; text-align: center;"> <tr> <th style="width: 50%;">Minor Storm</th> <th style="width: 50%;">Major Storm</th> <th style="width: 10%;"></th> </tr> <tr> <td>$Q =$ <input style="width: 40px;" type="text"/></td> <td><input style="width: 40px;" type="text"/></td> <td>cfs</td> </tr> </table>	Minor Storm	Major Storm		$Q =$ <input style="width: 40px;" type="text"/>	<input style="width: 40px;" type="text"/>	cfs
Minor Storm	Major Storm						
$Q =$ <input style="width: 40px;" type="text"/>	<input style="width: 40px;" type="text"/>	cfs					
Average Flow Velocity Within the Gutter Section	<table border="1" style="width: 100%; text-align: center;"> <tr> <th style="width: 50%;">Minor Storm</th> <th style="width: 50%;">Major Storm</th> <th style="width: 10%;"></th> </tr> <tr> <td>$V =$ <input style="width: 40px;" type="text"/></td> <td><input style="width: 40px;" type="text"/></td> <td>fps</td> </tr> </table>	Minor Storm	Major Storm		$V =$ <input style="width: 40px;" type="text"/>	<input style="width: 40px;" type="text"/>	fps
Minor Storm	Major Storm						
$V =$ <input style="width: 40px;" type="text"/>	<input style="width: 40px;" type="text"/>	fps					
$V*d$ Product: Flow Velocity Times Gutter Flowline Depth	<table border="1" style="width: 100%; text-align: center;"> <tr> <th style="width: 50%;">Minor Storm</th> <th style="width: 50%;">Major Storm</th> <th style="width: 10%;"></th> </tr> <tr> <td>$V*d =$ <input style="width: 40px;" type="text"/></td> <td><input style="width: 40px;" type="text"/></td> <td></td> </tr> </table>	Minor Storm	Major Storm		$V*d =$ <input style="width: 40px;" type="text"/>	<input style="width: 40px;" type="text"/>	
Minor Storm	Major Storm						
$V*d =$ <input style="width: 40px;" type="text"/>	<input style="width: 40px;" type="text"/>						
Slope-Based Depth Safety Reduction Factor for Major & Minor ($d \geq 6"$) Storm	<table border="1" style="width: 100%; text-align: center;"> <tr> <th style="width: 50%;">Minor Storm</th> <th style="width: 50%;">Major Storm</th> <th style="width: 10%;"></th> </tr> <tr> <td>$R =$ <input style="width: 40px;" type="text"/></td> <td><input style="width: 40px;" type="text"/></td> <td></td> </tr> </table>	Minor Storm	Major Storm		$R =$ <input style="width: 40px;" type="text"/>	<input style="width: 40px;" type="text"/>	
Minor Storm	Major Storm						
$R =$ <input style="width: 40px;" type="text"/>	<input style="width: 40px;" type="text"/>						
Max Flow Based on Allowable Depth (Safety Factor Applied)	<table border="1" style="width: 100%; text-align: center;"> <tr> <th style="width: 50%;">Minor Storm</th> <th style="width: 50%;">Major Storm</th> <th style="width: 10%;"></th> </tr> <tr> <td>$Q_d =$ <input style="width: 40px;" type="text"/></td> <td><input style="width: 40px;" type="text"/></td> <td>cfs</td> </tr> </table>	Minor Storm	Major Storm		$Q_d =$ <input style="width: 40px;" type="text"/>	<input style="width: 40px;" type="text"/>	cfs
Minor Storm	Major Storm						
$Q_d =$ <input style="width: 40px;" type="text"/>	<input style="width: 40px;" type="text"/>	cfs					
Resultant Flow Depth at Gutter Flowline (Safety Factor Applied)	<table border="1" style="width: 100%; text-align: center;"> <tr> <th style="width: 50%;">Minor Storm</th> <th style="width: 50%;">Major Storm</th> <th style="width: 10%;"></th> </tr> <tr> <td>$d =$ <input style="width: 40px;" type="text"/></td> <td><input style="width: 40px;" type="text"/></td> <td>inches</td> </tr> </table>	Minor Storm	Major Storm		$d =$ <input style="width: 40px;" type="text"/>	<input style="width: 40px;" type="text"/>	inches
Minor Storm	Major Storm						
$d =$ <input style="width: 40px;" type="text"/>	<input style="width: 40px;" type="text"/>	inches					
Resultant Flow Depth at Street Crown (Safety Factor Applied)	<table border="1" style="width: 100%; text-align: center;"> <tr> <th style="width: 50%;">Minor Storm</th> <th style="width: 50%;">Major Storm</th> <th style="width: 10%;"></th> </tr> <tr> <td>$d_{CROWN} =$ <input style="width: 40px;" type="text"/></td> <td><input style="width: 40px;" type="text"/></td> <td>inches</td> </tr> </table>	Minor Storm	Major Storm		$d_{CROWN} =$ <input style="width: 40px;" type="text"/>	<input style="width: 40px;" type="text"/>	inches
Minor Storm	Major Storm						
$d_{CROWN} =$ <input style="width: 40px;" type="text"/>	<input style="width: 40px;" type="text"/>	inches					
MINOR STORM Allowable Capacity is based on Spread Criterion	<table border="1" style="width: 100%; text-align: center;"> <tr> <th style="width: 50%;">Minor Storm</th> <th style="width: 50%;">Major Storm</th> <th style="width: 10%;"></th> </tr> <tr> <td>$Q_{ALLOW} =$ <input style="width: 40px;" type="text"/></td> <td><input style="width: 40px;" type="text"/></td> <td>cfs</td> </tr> </table>	Minor Storm	Major Storm		$Q_{ALLOW} =$ <input style="width: 40px;" type="text"/>	<input style="width: 40px;" type="text"/>	cfs
Minor Storm	Major Storm						
$Q_{ALLOW} =$ <input style="width: 40px;" type="text"/>	<input style="width: 40px;" type="text"/>	cfs					
MAJOR STORM Allowable Capacity is based on Spread Criterion	<table border="1" style="width: 100%; text-align: center;"> <tr> <th style="width: 50%;">Minor Storm</th> <th style="width: 50%;">Major Storm</th> <th style="width: 10%;"></th> </tr> <tr> <td>$Q_{ALLOW} =$ <input style="width: 40px;" type="text"/></td> <td><input style="width: 40px;" type="text"/></td> <td>cfs</td> </tr> </table>	Minor Storm	Major Storm		$Q_{ALLOW} =$ <input style="width: 40px;" type="text"/>	<input style="width: 40px;" type="text"/>	cfs
Minor Storm	Major Storm						
$Q_{ALLOW} =$ <input style="width: 40px;" type="text"/>	<input style="width: 40px;" type="text"/>	cfs					
Minor storm max. allowable capacity GOOD - greater than the design flow given on sheet 'Inlet Management'							
Major storm max. allowable capacity GOOD - greater than the design flow given on sheet 'Inlet Management'							

ALLOWABLE CAPACITY FOR ONE-HALF OF STREET (Minor & Major Storm)

(Based on Regulated Criteria for Maximum Allowable Flow Depth and Spread)

Project: North Bay at Lake Woodmoor
 Inlet ID: Inlet No. 5, DP 15

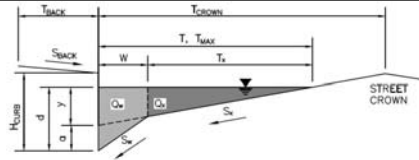

Gutter Geometry (Enter data in the blue cells)					
Maximum Allowable Width for Spread Behind Curb	T _{BACK} = <input type="text"/> ft				
Side Slope Behind Curb (leave blank for no conveyance credit behind curb)	S _{BACK} = <input type="text"/> ft/ft				
Manning's Roughness Behind Curb (typically between 0.012 and 0.020)	n _{BACK} = <input type="text"/>				
Height of Curb at Gutter Flow Line	H _{CURB} = <input type="text"/> 6.00 inches				
Distance from Curb Face to Street Crown	T _{CROWN} = <input type="text"/> 12.0 ft				
Gutter Width	W = <input type="text"/> 1.17 ft				
Street Transverse Slope	S _X = <input type="text"/> 0.020 ft/ft				
Gutter Cross Slope (typically 2 inches over 24 inches or 0.083 ft/ft)	S _W = <input type="text"/> 0.143 ft/ft				
Street Longitudinal Slope - Enter 0 for sump condition	S ₀ = <input type="text"/> 0.000 ft/ft				
Manning's Roughness for Street Section (typically between 0.012 and 0.020)	n _{STREET} = <input type="text"/> 0.016				
Max. Allowable Spread for Minor & Major Storm	T _{MAX} = <table border="1"><tr><td>Minor Storm</td><td>Major Storm</td></tr><tr><td><input type="text"/> 12.0</td><td><input type="text"/> 12.0</td></tr></table> ft	Minor Storm	Major Storm	<input type="text"/> 12.0	<input type="text"/> 12.0
Minor Storm	Major Storm				
<input type="text"/> 12.0	<input type="text"/> 12.0				
Max. Allowable Depth at Gutter Flowline for Minor & Major Storm	d _{MAX} = <table border="1"><tr><td>Minor Storm</td><td>Major Storm</td></tr><tr><td><input type="text"/> 6.0</td><td><input type="text"/> 6.0</td></tr></table> inches	Minor Storm	Major Storm	<input type="text"/> 6.0	<input type="text"/> 6.0
Minor Storm	Major Storm				
<input type="text"/> 6.0	<input type="text"/> 6.0				
Allow Flow Depth at Street Crown (leave blank for no)	<input type="checkbox"/> <input type="checkbox"/> check = yes				
Maximum Capacity for 1/2 Street based On Allowable Spread					
Water Depth without Gutter Depression (Eq. ST-2)	y = <table border="1"><tr><td>Minor Storm</td><td>Major Storm</td></tr><tr><td><input type="text"/> 2.88</td><td><input type="text"/> 2.88</td></tr></table> inches	Minor Storm	Major Storm	<input type="text"/> 2.88	<input type="text"/> 2.88
Minor Storm	Major Storm				
<input type="text"/> 2.88	<input type="text"/> 2.88				
Vertical Depth between Gutter Lip and Gutter Flowline (usually 2")	d _C = <table border="1"><tr><td>Minor Storm</td><td>Major Storm</td></tr><tr><td><input type="text"/> 2.0</td><td><input type="text"/> 2.0</td></tr></table> inches	Minor Storm	Major Storm	<input type="text"/> 2.0	<input type="text"/> 2.0
Minor Storm	Major Storm				
<input type="text"/> 2.0	<input type="text"/> 2.0				
Gutter Depression (d _C - (W * S _X * 12))	a = <table border="1"><tr><td>Minor Storm</td><td>Major Storm</td></tr><tr><td><input type="text"/> 1.72</td><td><input type="text"/> 1.72</td></tr></table> inches	Minor Storm	Major Storm	<input type="text"/> 1.72	<input type="text"/> 1.72
Minor Storm	Major Storm				
<input type="text"/> 1.72	<input type="text"/> 1.72				
Water Depth at Gutter Flowline	d = <table border="1"><tr><td>Minor Storm</td><td>Major Storm</td></tr><tr><td><input type="text"/> 4.60</td><td><input type="text"/> 4.60</td></tr></table> inches	Minor Storm	Major Storm	<input type="text"/> 4.60	<input type="text"/> 4.60
Minor Storm	Major Storm				
<input type="text"/> 4.60	<input type="text"/> 4.60				
Allowable Spread for Discharge outside the Gutter Section W (T - W)	T _X = <table border="1"><tr><td>Minor Storm</td><td>Major Storm</td></tr><tr><td><input type="text"/> 10.8</td><td><input type="text"/> 10.8</td></tr></table> ft	Minor Storm	Major Storm	<input type="text"/> 10.8	<input type="text"/> 10.8
Minor Storm	Major Storm				
<input type="text"/> 10.8	<input type="text"/> 10.8				
Gutter Flow to Design Flow Ratio by FHWA HEC-22 method (Eq. ST-7)	E _O = <table border="1"><tr><td>Minor Storm</td><td>Major Storm</td></tr><tr><td><input type="text"/> 0.334</td><td><input type="text"/> 0.334</td></tr></table>	Minor Storm	Major Storm	<input type="text"/> 0.334	<input type="text"/> 0.334
Minor Storm	Major Storm				
<input type="text"/> 0.334	<input type="text"/> 0.334				
Discharge outside the Gutter Section W, carried in Section T _X	Q _X = <table border="1"><tr><td>Minor Storm</td><td>Major Storm</td></tr><tr><td><input type="text"/> 0.0</td><td><input type="text"/> 0.0</td></tr></table> cfs	Minor Storm	Major Storm	<input type="text"/> 0.0	<input type="text"/> 0.0
Minor Storm	Major Storm				
<input type="text"/> 0.0	<input type="text"/> 0.0				
Discharge within the Gutter Section W (Q _T - Q _X)	Q _W = <table border="1"><tr><td>Minor Storm</td><td>Major Storm</td></tr><tr><td><input type="text"/> 0.0</td><td><input type="text"/> 0.0</td></tr></table> cfs	Minor Storm	Major Storm	<input type="text"/> 0.0	<input type="text"/> 0.0
Minor Storm	Major Storm				
<input type="text"/> 0.0	<input type="text"/> 0.0				
Discharge Behind the Curb (e.g., sidewalk, driveways, & lawns)	Q _{BACK} = <table border="1"><tr><td>Minor Storm</td><td>Major Storm</td></tr><tr><td><input type="text"/> 0.0</td><td><input type="text"/> 0.0</td></tr></table> cfs	Minor Storm	Major Storm	<input type="text"/> 0.0	<input type="text"/> 0.0
Minor Storm	Major Storm				
<input type="text"/> 0.0	<input type="text"/> 0.0				
Maximum Flow Based On Allowable Spread	Q _T = <table border="1"><tr><td>Minor Storm</td><td>Major Storm</td></tr><tr><td><input type="text"/> SUMP</td><td><input type="text"/> SUMP</td></tr></table> cfs	Minor Storm	Major Storm	<input type="text"/> SUMP	<input type="text"/> SUMP
Minor Storm	Major Storm				
<input type="text"/> SUMP	<input type="text"/> SUMP				
Flow Velocity within the Gutter Section	V = <table border="1"><tr><td>Minor Storm</td><td>Major Storm</td></tr><tr><td><input type="text"/> 0.0</td><td><input type="text"/> 0.0</td></tr></table> fps	Minor Storm	Major Storm	<input type="text"/> 0.0	<input type="text"/> 0.0
Minor Storm	Major Storm				
<input type="text"/> 0.0	<input type="text"/> 0.0				
V*d Product: Flow Velocity times Gutter Flowline Depth	V*d = <table border="1"><tr><td>Minor Storm</td><td>Major Storm</td></tr><tr><td><input type="text"/> 0.0</td><td><input type="text"/> 0.0</td></tr></table>	Minor Storm	Major Storm	<input type="text"/> 0.0	<input type="text"/> 0.0
Minor Storm	Major Storm				
<input type="text"/> 0.0	<input type="text"/> 0.0				
Maximum Capacity for 1/2 Street based on Allowable Depth					
Theoretical Water Spread	T _{TH} = <table border="1"><tr><td>Minor Storm</td><td>Major Storm</td></tr><tr><td><input type="text"/> 17.8</td><td><input type="text"/> 17.8</td></tr></table> ft	Minor Storm	Major Storm	<input type="text"/> 17.8	<input type="text"/> 17.8
Minor Storm	Major Storm				
<input type="text"/> 17.8	<input type="text"/> 17.8				
Theoretical Spread for Discharge outside the Gutter Section W (T - W)	T _{X TH} = <table border="1"><tr><td>Minor Storm</td><td>Major Storm</td></tr><tr><td><input type="text"/> 16.7</td><td><input type="text"/> 16.7</td></tr></table> ft	Minor Storm	Major Storm	<input type="text"/> 16.7	<input type="text"/> 16.7
Minor Storm	Major Storm				
<input type="text"/> 16.7	<input type="text"/> 16.7				
Gutter Flow to Design Flow Ratio by FHWA HEC-22 method (Eq. ST-7)	E _O = <table border="1"><tr><td>Minor Storm</td><td>Major Storm</td></tr><tr><td><input type="text"/> 0.214</td><td><input type="text"/> 0.214</td></tr></table>	Minor Storm	Major Storm	<input type="text"/> 0.214	<input type="text"/> 0.214
Minor Storm	Major Storm				
<input type="text"/> 0.214	<input type="text"/> 0.214				
Theoretical Discharge outside the Gutter Section W, carried in Section T _{X TH}	Q _{X TH} = <table border="1"><tr><td>Minor Storm</td><td>Major Storm</td></tr><tr><td><input type="text"/> 0.0</td><td><input type="text"/> 0.0</td></tr></table> cfs	Minor Storm	Major Storm	<input type="text"/> 0.0	<input type="text"/> 0.0
Minor Storm	Major Storm				
<input type="text"/> 0.0	<input type="text"/> 0.0				
Actual Discharge outside the Gutter Section W, (limited by distance T _{CROWN})	Q _X = <table border="1"><tr><td>Minor Storm</td><td>Major Storm</td></tr><tr><td><input type="text"/> 0.0</td><td><input type="text"/> 0.0</td></tr></table> cfs	Minor Storm	Major Storm	<input type="text"/> 0.0	<input type="text"/> 0.0
Minor Storm	Major Storm				
<input type="text"/> 0.0	<input type="text"/> 0.0				
Discharge within the Gutter Section W (Q _d - Q _X)	Q _W = <table border="1"><tr><td>Minor Storm</td><td>Major Storm</td></tr><tr><td><input type="text"/> 0.0</td><td><input type="text"/> 0.0</td></tr></table> cfs	Minor Storm	Major Storm	<input type="text"/> 0.0	<input type="text"/> 0.0
Minor Storm	Major Storm				
<input type="text"/> 0.0	<input type="text"/> 0.0				
Discharge Behind the Curb (e.g., sidewalk, driveways, & lawns)	Q _{BACK} = <table border="1"><tr><td>Minor Storm</td><td>Major Storm</td></tr><tr><td><input type="text"/> 0.0</td><td><input type="text"/> 0.0</td></tr></table> cfs	Minor Storm	Major Storm	<input type="text"/> 0.0	<input type="text"/> 0.0
Minor Storm	Major Storm				
<input type="text"/> 0.0	<input type="text"/> 0.0				
Total Discharge for Major & Minor Storm (Pre-Safety Factor)	Q = <table border="1"><tr><td>Minor Storm</td><td>Major Storm</td></tr><tr><td><input type="text"/> 0.0</td><td><input type="text"/> 0.0</td></tr></table> cfs	Minor Storm	Major Storm	<input type="text"/> 0.0	<input type="text"/> 0.0
Minor Storm	Major Storm				
<input type="text"/> 0.0	<input type="text"/> 0.0				
Average Flow Velocity Within the Gutter Section	V = <table border="1"><tr><td>Minor Storm</td><td>Major Storm</td></tr><tr><td><input type="text"/> 0.0</td><td><input type="text"/> 0.0</td></tr></table> fps	Minor Storm	Major Storm	<input type="text"/> 0.0	<input type="text"/> 0.0
Minor Storm	Major Storm				
<input type="text"/> 0.0	<input type="text"/> 0.0				
V*d Product: Flow Velocity Times Gutter Flowline Depth	V*d = <table border="1"><tr><td>Minor Storm</td><td>Major Storm</td></tr><tr><td><input type="text"/> 0.0</td><td><input type="text"/> 0.0</td></tr></table>	Minor Storm	Major Storm	<input type="text"/> 0.0	<input type="text"/> 0.0
Minor Storm	Major Storm				
<input type="text"/> 0.0	<input type="text"/> 0.0				
Slope-Based Depth Safety Reduction Factor for Major & Minor (d ≥ 6") Storm	R = <table border="1"><tr><td>Minor Storm</td><td>Major Storm</td></tr><tr><td><input type="text"/> SUMP</td><td><input type="text"/> SUMP</td></tr></table>	Minor Storm	Major Storm	<input type="text"/> SUMP	<input type="text"/> SUMP
Minor Storm	Major Storm				
<input type="text"/> SUMP	<input type="text"/> SUMP				
Max Flow Based on Allowable Depth (Safety Factor Applied)	Q _d = <table border="1"><tr><td>Minor Storm</td><td>Major Storm</td></tr><tr><td><input type="text"/> SUMP</td><td><input type="text"/> SUMP</td></tr></table> cfs	Minor Storm	Major Storm	<input type="text"/> SUMP	<input type="text"/> SUMP
Minor Storm	Major Storm				
<input type="text"/> SUMP	<input type="text"/> SUMP				
Resultant Flow Depth at Gutter Flowline (Safety Factor Applied)	d = <table border="1"><tr><td>Minor Storm</td><td>Major Storm</td></tr><tr><td><input type="text"/></td><td><input type="text"/></td></tr></table> inches	Minor Storm	Major Storm	<input type="text"/>	<input type="text"/>
Minor Storm	Major Storm				
<input type="text"/>	<input type="text"/>				
Resultant Flow Depth at Street Crown (Safety Factor Applied)	d _{CROWN} = <table border="1"><tr><td>Minor Storm</td><td>Major Storm</td></tr><tr><td><input type="text"/></td><td><input type="text"/></td></tr></table> inches	Minor Storm	Major Storm	<input type="text"/>	<input type="text"/>
Minor Storm	Major Storm				
<input type="text"/>	<input type="text"/>				
MINOR STORM Allowable Capacity is based on Depth Criterion					
MAJOR STORM Allowable Capacity is based on Depth Criterion					
	Q _{allow} = <table border="1"><tr><td>Minor Storm</td><td>Major Storm</td></tr><tr><td><input type="text"/> SUMP</td><td><input type="text"/> SUMP</td></tr></table> cfs	Minor Storm	Major Storm	<input type="text"/> SUMP	<input type="text"/> SUMP
Minor Storm	Major Storm				
<input type="text"/> SUMP	<input type="text"/> SUMP				

ALLOWABLE CAPACITY FOR ONE-HALF OF STREET (Minor & Major Storm)

(Based on Regulated Criteria for Maximum Allowable Flow Depth and Spread)

Project: North Bay at Lake Woodmoor
 Inlet ID: Inlet No. 6, Basin E-4

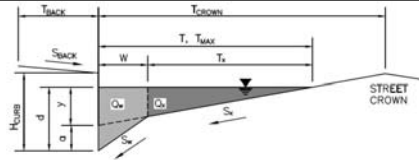

Gutter Geometry (Enter data in the blue cells)

Maximum Allowable Width for Spread Behind Curb
 Side Slope Behind Curb (leave blank for no conveyance credit behind curb)
 Manning's Roughness Behind Curb (typically between 0.012 and 0.020)

T _{BACK} =		ft
S _{BACK} =		ft/ft
n _{BACK} =		

Height of Curb at Gutter Flow Line
 Distance from Curb Face to Street Crown
 Gutter Width
 Street Transverse Slope
 Gutter Cross Slope (typically 2 inches over 24 inches or 0.083 ft/ft)
 Street Longitudinal Slope - Enter 0 for sump condition
 Manning's Roughness for Street Section (typically between 0.012 and 0.020)

H _{CURB} =	6.00	inches
T _{CROWN} =	12.0	ft
W =	1.17	ft
S _x =	0.020	ft/ft
S _w =	0.143	ft/ft
S _d =	0.000	ft/ft
n _{STREET} =	0.016	

Max. Allowable Spread for Minor & Major Storm
 Max. Allowable Depth at Gutter Flowline for Minor & Major Storm
 Allow Flow Depth at Street Crown (leave blank for no)

	Minor Storm	Major Storm	
T _{MAX} =	12.0	12.0	ft
d _{MAX} =	6.0	6.0	inches
	<input type="checkbox"/>	<input type="checkbox"/>	check = yes

Maximum Capacity for 1/2 Street based On Allowable Spread

Water Depth without Gutter Depression (Eq. ST-2)
 Vertical Depth between Gutter Lip and Gutter Flowline (usually 2")
 Gutter Depression (d_c - (W * S_x * 12))
 Water Depth at Gutter Flowline
 Allowable Spread for Discharge outside the Gutter Section W (T - W)
 Gutter Flow to Design Flow Ratio by FHWA HEC-22 method (Eq. ST-7)
 Discharge outside the Gutter Section W, carried in Section T_x
 Discharge within the Gutter Section W (Q_w - Q_x)
 Discharge Behind the Curb (e.g., sidewalk, driveways, & lawns)

	Minor Storm	Major Storm	
y =	2.88	2.88	inches
d _c =	2.0	2.0	inches
a =	1.72	1.72	inches
d =	4.60	4.60	inches
T _x =	10.8	10.8	ft
E ₀ =	0.334	0.334	
Q _x =	0.0	0.0	cfs
Q _w =	0.0	0.0	cfs
Q _{BACK} =	0.0	0.0	cfs
Q _T =	SUMP	SUMP	cfs
V =	0.0	0.0	fps
V*d =	0.0	0.0	

Maximum Flow Based On Allowable Spread

Flow Velocity within the Gutter Section
 V*d Product: Flow Velocity times Gutter Flowline Depth

Maximum Capacity for 1/2 Street based on Allowable Depth

Theoretical Water Spread
 Theoretical Spread for Discharge outside the Gutter Section W (T - W)
 Gutter Flow to Design Flow Ratio by FHWA HEC-22 method (Eq. ST-7)
 Theoretical Discharge outside the Gutter Section W, carried in Section T_{x,TH}
 Actual Discharge outside the Gutter Section W, (limited by distance T_{CROWN})
 Discharge within the Gutter Section W (Q_d - Q_x)
 Discharge Behind the Curb (e.g., sidewalk, driveways, & lawns)
 Total Discharge for Major & Minor Storm (Pre-Safety Factor)
 Average Flow Velocity Within the Gutter Section
 V*d Product: Flow Velocity Times Gutter Flowline Depth
 Slope-Based Depth Safety Reduction Factor for Major & Minor (d ≥ 6") Storm

	Minor Storm	Major Storm	
T _{TH} =	17.8	17.8	ft
T _{x,TH} =	16.7	16.7	ft
E ₀ =	0.214	0.214	
Q _{x,TH} =	0.0	0.0	cfs
Q _x =	0.0	0.0	cfs
Q _w =	0.0	0.0	cfs
Q _{BACK} =	0.0	0.0	cfs
Q =	0.0	0.0	cfs
V =	0.0	0.0	fps
V*d =	0.0	0.0	
R =	SUMP	SUMP	
Q _d =	SUMP	SUMP	cfs
d =			inches
d _{CROWN} =			inches

Max Flow Based on Allowable Depth (Safety Factor Applied)

Resultant Flow Depth at Gutter Flowline (Safety Factor Applied)
 Resultant Flow Depth at Street Crown (Safety Factor Applied)

MINOR STORM Allowable Capacity is based on Depth Criterion
 MAJOR STORM Allowable Capacity is based on Depth Criterion

	Minor Storm	Major Storm	
Q _{allow} =	SUMP	SUMP	cfs

ALLOWABLE CAPACITY FOR ONE-HALF OF STREET (Minor & Major Storm)

(Based on Regulated Criteria for Maximum Allowable Flow Depth and Spread)

Project: North Bay at Lake Woodmoor
 Inlet ID: Basins E5 or E6

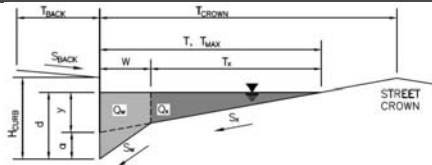

Gutter Geometry (Enter data in the blue cells)																																																													
Maximum Allowable Width for Spread Behind Curb	$T_{BACK} =$ <input style="width: 50px;" type="text"/> ft																																																												
Side Slope Behind Curb (leave blank for no conveyance credit behind curb)	$S_{BACK} =$ <input style="width: 50px;" type="text"/> ft/ft																																																												
Manning's Roughness Behind Curb (typically between 0.012 and 0.020)	$n_{BACK} =$ <input style="width: 50px;" type="text"/>																																																												
Height of Curb at Gutter Flow Line	$H_{CURB} =$ <input style="width: 50px;" type="text"/> inches																																																												
Distance from Curb Face to Street Crown	$T_{CROWN} =$ <input style="width: 50px;" type="text"/> ft																																																												
Gutter Width	$W =$ <input style="width: 50px;" type="text"/> ft																																																												
Street Transverse Slope	$S_X =$ <input style="width: 50px;" type="text"/> ft/ft																																																												
Gutter Cross Slope (typically 2 inches over 24 inches or 0.083 ft/ft)	$S_W =$ <input style="width: 50px;" type="text"/> ft/ft																																																												
Street Longitudinal Slope - Enter 0 for sump condition	$S_O =$ <input style="width: 50px;" type="text"/> ft/ft																																																												
Manning's Roughness for Street Section (typically between 0.012 and 0.020)	$n_{STREET} =$ <input style="width: 50px;" type="text"/>																																																												
Max. Allowable Spread for Minor & Major Storm	<table border="1" style="width: 100%; border-collapse: collapse;"> <thead> <tr> <th style="width: 50%;"></th> <th style="width: 25%; text-align: center;">Minor Storm</th> <th style="width: 25%; text-align: center;">Major Storm</th> <th style="width: 10%;"></th> </tr> </thead> <tbody> <tr> <td>$T_{MAX} =$</td> <td style="text-align: center;"><input style="width: 40px;" type="text"/></td> <td style="text-align: center;"><input style="width: 40px;" type="text"/></td> <td style="text-align: right;">ft</td> </tr> <tr> <td>$d_{MAX} =$</td> <td style="text-align: center;"><input style="width: 40px;" type="text"/></td> <td style="text-align: center;"><input style="width: 40px;" type="text"/></td> <td style="text-align: right;">inches</td> </tr> <tr> <td></td> <td style="text-align: center;"><input type="checkbox"/></td> <td style="text-align: center;"><input type="checkbox"/></td> <td style="text-align: right;">check = yes</td> </tr> </tbody> </table>		Minor Storm	Major Storm		$T_{MAX} =$	<input style="width: 40px;" type="text"/>	<input style="width: 40px;" type="text"/>	ft	$d_{MAX} =$	<input style="width: 40px;" type="text"/>	<input style="width: 40px;" type="text"/>	inches		<input type="checkbox"/>	<input type="checkbox"/>	check = yes																																												
	Minor Storm	Major Storm																																																											
$T_{MAX} =$	<input style="width: 40px;" type="text"/>	<input style="width: 40px;" type="text"/>	ft																																																										
$d_{MAX} =$	<input style="width: 40px;" type="text"/>	<input style="width: 40px;" type="text"/>	inches																																																										
	<input type="checkbox"/>	<input type="checkbox"/>	check = yes																																																										
Max. Allowable Depth at Gutter Flowline for Minor & Major Storm																																																													
Allow Flow Depth at Street Crown (leave blank for no)																																																													
Maximum Capacity for 1/2 Street based On Allowable Spread																																																													
Water Depth without Gutter Depression (Eq. ST-2)	<table border="1" style="width: 100%; border-collapse: collapse;"> <thead> <tr> <th style="width: 50%;"></th> <th style="width: 25%; text-align: center;">Minor Storm</th> <th style="width: 25%; text-align: center;">Major Storm</th> <th style="width: 10%;"></th> </tr> </thead> <tbody> <tr> <td>$y =$</td> <td style="text-align: center;"><input style="width: 40px;" type="text"/></td> <td style="text-align: center;"><input style="width: 40px;" type="text"/></td> <td style="text-align: right;">inches</td> </tr> <tr> <td>$d_C =$</td> <td style="text-align: center;"><input style="width: 40px;" type="text"/></td> <td style="text-align: center;"><input style="width: 40px;" type="text"/></td> <td style="text-align: right;">inches</td> </tr> <tr> <td>$a =$</td> <td style="text-align: center;"><input style="width: 40px;" type="text"/></td> <td style="text-align: center;"><input style="width: 40px;" type="text"/></td> <td style="text-align: right;">inches</td> </tr> <tr> <td>$d =$</td> <td style="text-align: center;"><input style="width: 40px;" type="text"/></td> <td style="text-align: center;"><input style="width: 40px;" type="text"/></td> <td style="text-align: right;">inches</td> </tr> <tr> <td>$T_X =$</td> <td style="text-align: center;"><input style="width: 40px;" type="text"/></td> <td style="text-align: center;"><input style="width: 40px;" type="text"/></td> <td style="text-align: right;">ft</td> </tr> <tr> <td>$E_O =$</td> <td style="text-align: center;"><input style="width: 40px;" type="text"/></td> <td style="text-align: center;"><input style="width: 40px;" type="text"/></td> <td></td> </tr> <tr> <td>$Q_X =$</td> <td style="text-align: center;"><input style="width: 40px;" type="text"/></td> <td style="text-align: center;"><input style="width: 40px;" type="text"/></td> <td style="text-align: right;">cfs</td> </tr> <tr> <td>$Q_W =$</td> <td style="text-align: center;"><input style="width: 40px;" type="text"/></td> <td style="text-align: center;"><input style="width: 40px;" type="text"/></td> <td style="text-align: right;">cfs</td> </tr> <tr> <td>$Q_{BACK} =$</td> <td style="text-align: center;"><input style="width: 40px;" type="text"/></td> <td style="text-align: center;"><input style="width: 40px;" type="text"/></td> <td style="text-align: right;">cfs</td> </tr> <tr> <td>$Q_T =$</td> <td style="text-align: center;"><input style="width: 40px;" type="text"/></td> <td style="text-align: center;"><input style="width: 40px;" type="text"/></td> <td style="text-align: right;">cfs</td> </tr> <tr> <td>$V =$</td> <td style="text-align: center;"><input style="width: 40px;" type="text"/></td> <td style="text-align: center;"><input style="width: 40px;" type="text"/></td> <td style="text-align: right;">fps</td> </tr> <tr> <td>$V*d =$</td> <td style="text-align: center;"><input style="width: 40px;" type="text"/></td> <td style="text-align: center;"><input style="width: 40px;" type="text"/></td> <td></td> </tr> </tbody> </table>		Minor Storm	Major Storm		$y =$	<input style="width: 40px;" type="text"/>	<input style="width: 40px;" type="text"/>	inches	$d_C =$	<input style="width: 40px;" type="text"/>	<input style="width: 40px;" type="text"/>	inches	$a =$	<input style="width: 40px;" type="text"/>	<input style="width: 40px;" type="text"/>	inches	$d =$	<input style="width: 40px;" type="text"/>	<input style="width: 40px;" type="text"/>	inches	$T_X =$	<input style="width: 40px;" type="text"/>	<input style="width: 40px;" type="text"/>	ft	$E_O =$	<input style="width: 40px;" type="text"/>	<input style="width: 40px;" type="text"/>		$Q_X =$	<input style="width: 40px;" type="text"/>	<input style="width: 40px;" type="text"/>	cfs	$Q_W =$	<input style="width: 40px;" type="text"/>	<input style="width: 40px;" type="text"/>	cfs	$Q_{BACK} =$	<input style="width: 40px;" type="text"/>	<input style="width: 40px;" type="text"/>	cfs	$Q_T =$	<input style="width: 40px;" type="text"/>	<input style="width: 40px;" type="text"/>	cfs	$V =$	<input style="width: 40px;" type="text"/>	<input style="width: 40px;" type="text"/>	fps	$V*d =$	<input style="width: 40px;" type="text"/>	<input style="width: 40px;" type="text"/>									
	Minor Storm	Major Storm																																																											
$y =$	<input style="width: 40px;" type="text"/>	<input style="width: 40px;" type="text"/>	inches																																																										
$d_C =$	<input style="width: 40px;" type="text"/>	<input style="width: 40px;" type="text"/>	inches																																																										
$a =$	<input style="width: 40px;" type="text"/>	<input style="width: 40px;" type="text"/>	inches																																																										
$d =$	<input style="width: 40px;" type="text"/>	<input style="width: 40px;" type="text"/>	inches																																																										
$T_X =$	<input style="width: 40px;" type="text"/>	<input style="width: 40px;" type="text"/>	ft																																																										
$E_O =$	<input style="width: 40px;" type="text"/>	<input style="width: 40px;" type="text"/>																																																											
$Q_X =$	<input style="width: 40px;" type="text"/>	<input style="width: 40px;" type="text"/>	cfs																																																										
$Q_W =$	<input style="width: 40px;" type="text"/>	<input style="width: 40px;" type="text"/>	cfs																																																										
$Q_{BACK} =$	<input style="width: 40px;" type="text"/>	<input style="width: 40px;" type="text"/>	cfs																																																										
$Q_T =$	<input style="width: 40px;" type="text"/>	<input style="width: 40px;" type="text"/>	cfs																																																										
$V =$	<input style="width: 40px;" type="text"/>	<input style="width: 40px;" type="text"/>	fps																																																										
$V*d =$	<input style="width: 40px;" type="text"/>	<input style="width: 40px;" type="text"/>																																																											
Vertical Depth between Gutter Lip and Gutter Flowline (usually 2")																																																													
Gutter Depression ($d_c - (W * S_x * 12)$)																																																													
Water Depth at Gutter Flowline																																																													
Allowable Spread for Discharge outside the Gutter Section W (T - W)																																																													
Gutter Flow to Design Flow Ratio by FHWA HEC-22 method (Eq. ST-7)																																																													
Discharge outside the Gutter Section W, carried in Section T_X																																																													
Discharge within the Gutter Section W ($Q_T - Q_X$)																																																													
Discharge Behind the Curb (e.g., sidewalk, driveways, & lawns)																																																													
Maximum Flow Based On Allowable Spread																																																													
Flow Velocity within the Gutter Section																																																													
$V*d$ Product: Flow Velocity times Gutter Flowline Depth																																																													
Maximum Capacity for 1/2 Street based on Allowable Depth																																																													
Theoretical Water Spread	<table border="1" style="width: 100%; border-collapse: collapse;"> <thead> <tr> <th style="width: 50%;"></th> <th style="width: 25%; text-align: center;">Minor Storm</th> <th style="width: 25%; text-align: center;">Major Storm</th> <th style="width: 10%;"></th> </tr> </thead> <tbody> <tr> <td>$T_{TH} =$</td> <td style="text-align: center;"><input style="width: 40px;" type="text"/></td> <td style="text-align: center;"><input style="width: 40px;" type="text"/></td> <td style="text-align: right;">ft</td> </tr> <tr> <td>$T_{XTH} =$</td> <td style="text-align: center;"><input style="width: 40px;" type="text"/></td> <td style="text-align: center;"><input style="width: 40px;" type="text"/></td> <td style="text-align: right;">ft</td> </tr> <tr> <td>$E_O =$</td> <td style="text-align: center;"><input style="width: 40px;" type="text"/></td> <td style="text-align: center;"><input style="width: 40px;" type="text"/></td> <td></td> </tr> <tr> <td>$Q_{XTH} =$</td> <td style="text-align: center;"><input style="width: 40px;" type="text"/></td> <td style="text-align: center;"><input style="width: 40px;" type="text"/></td> <td style="text-align: right;">cfs</td> </tr> <tr> <td>$Q_X =$</td> <td style="text-align: center;"><input style="width: 40px;" type="text"/></td> <td style="text-align: center;"><input style="width: 40px;" type="text"/></td> <td style="text-align: right;">cfs</td> </tr> <tr> <td>$Q_W =$</td> <td style="text-align: center;"><input style="width: 40px;" type="text"/></td> <td style="text-align: center;"><input style="width: 40px;" type="text"/></td> <td style="text-align: right;">cfs</td> </tr> <tr> <td>$Q_{BACK} =$</td> <td style="text-align: center;"><input style="width: 40px;" type="text"/></td> <td style="text-align: center;"><input style="width: 40px;" type="text"/></td> <td style="text-align: right;">cfs</td> </tr> <tr> <td>$Q =$</td> <td style="text-align: center;"><input style="width: 40px;" type="text"/></td> <td style="text-align: center;"><input style="width: 40px;" type="text"/></td> <td style="text-align: right;">cfs</td> </tr> <tr> <td>$V =$</td> <td style="text-align: center;"><input style="width: 40px;" type="text"/></td> <td style="text-align: center;"><input style="width: 40px;" type="text"/></td> <td style="text-align: right;">fps</td> </tr> <tr> <td>$V*d =$</td> <td style="text-align: center;"><input style="width: 40px;" type="text"/></td> <td style="text-align: center;"><input style="width: 40px;" type="text"/></td> <td></td> </tr> <tr> <td>$R =$</td> <td style="text-align: center;"><input style="width: 40px;" type="text"/></td> <td style="text-align: center;"><input style="width: 40px;" type="text"/></td> <td></td> </tr> <tr> <td>$Q_d =$</td> <td style="text-align: center;"><input style="width: 40px;" type="text"/></td> <td style="text-align: center;"><input style="width: 40px;" type="text"/></td> <td style="text-align: right;">cfs</td> </tr> <tr> <td>$d =$</td> <td style="text-align: center;"><input style="width: 40px;" type="text"/></td> <td style="text-align: center;"><input style="width: 40px;" type="text"/></td> <td style="text-align: right;">inches</td> </tr> <tr> <td>$d_{CROWN} =$</td> <td style="text-align: center;"><input style="width: 40px;" type="text"/></td> <td style="text-align: center;"><input style="width: 40px;" type="text"/></td> <td style="text-align: right;">inches</td> </tr> </tbody> </table>		Minor Storm	Major Storm		$T_{TH} =$	<input style="width: 40px;" type="text"/>	<input style="width: 40px;" type="text"/>	ft	$T_{XTH} =$	<input style="width: 40px;" type="text"/>	<input style="width: 40px;" type="text"/>	ft	$E_O =$	<input style="width: 40px;" type="text"/>	<input style="width: 40px;" type="text"/>		$Q_{XTH} =$	<input style="width: 40px;" type="text"/>	<input style="width: 40px;" type="text"/>	cfs	$Q_X =$	<input style="width: 40px;" type="text"/>	<input style="width: 40px;" type="text"/>	cfs	$Q_W =$	<input style="width: 40px;" type="text"/>	<input style="width: 40px;" type="text"/>	cfs	$Q_{BACK} =$	<input style="width: 40px;" type="text"/>	<input style="width: 40px;" type="text"/>	cfs	$Q =$	<input style="width: 40px;" type="text"/>	<input style="width: 40px;" type="text"/>	cfs	$V =$	<input style="width: 40px;" type="text"/>	<input style="width: 40px;" type="text"/>	fps	$V*d =$	<input style="width: 40px;" type="text"/>	<input style="width: 40px;" type="text"/>		$R =$	<input style="width: 40px;" type="text"/>	<input style="width: 40px;" type="text"/>		$Q_d =$	<input style="width: 40px;" type="text"/>	<input style="width: 40px;" type="text"/>	cfs	$d =$	<input style="width: 40px;" type="text"/>	<input style="width: 40px;" type="text"/>	inches	$d_{CROWN} =$	<input style="width: 40px;" type="text"/>	<input style="width: 40px;" type="text"/>	inches
	Minor Storm	Major Storm																																																											
$T_{TH} =$	<input style="width: 40px;" type="text"/>	<input style="width: 40px;" type="text"/>	ft																																																										
$T_{XTH} =$	<input style="width: 40px;" type="text"/>	<input style="width: 40px;" type="text"/>	ft																																																										
$E_O =$	<input style="width: 40px;" type="text"/>	<input style="width: 40px;" type="text"/>																																																											
$Q_{XTH} =$	<input style="width: 40px;" type="text"/>	<input style="width: 40px;" type="text"/>	cfs																																																										
$Q_X =$	<input style="width: 40px;" type="text"/>	<input style="width: 40px;" type="text"/>	cfs																																																										
$Q_W =$	<input style="width: 40px;" type="text"/>	<input style="width: 40px;" type="text"/>	cfs																																																										
$Q_{BACK} =$	<input style="width: 40px;" type="text"/>	<input style="width: 40px;" type="text"/>	cfs																																																										
$Q =$	<input style="width: 40px;" type="text"/>	<input style="width: 40px;" type="text"/>	cfs																																																										
$V =$	<input style="width: 40px;" type="text"/>	<input style="width: 40px;" type="text"/>	fps																																																										
$V*d =$	<input style="width: 40px;" type="text"/>	<input style="width: 40px;" type="text"/>																																																											
$R =$	<input style="width: 40px;" type="text"/>	<input style="width: 40px;" type="text"/>																																																											
$Q_d =$	<input style="width: 40px;" type="text"/>	<input style="width: 40px;" type="text"/>	cfs																																																										
$d =$	<input style="width: 40px;" type="text"/>	<input style="width: 40px;" type="text"/>	inches																																																										
$d_{CROWN} =$	<input style="width: 40px;" type="text"/>	<input style="width: 40px;" type="text"/>	inches																																																										
Theoretical Spread for Discharge outside the Gutter Section W (T - W)																																																													
Gutter Flow to Design Flow Ratio by FHWA HEC-22 method (Eq. ST-7)																																																													
Theoretical Discharge outside the Gutter Section W, carried in Section T_{XTH}																																																													
Actual Discharge outside the Gutter Section W, (limited by distance T_{CROWN})																																																													
Discharge within the Gutter Section W ($Q_d - Q_X$)																																																													
Discharge Behind the Curb (e.g., sidewalk, driveways, & lawns)																																																													
Total Discharge for Major & Minor Storm (Pre-Safety Factor)																																																													
Average Flow Velocity Within the Gutter Section																																																													
$V*d$ Product: Flow Velocity Times Gutter Flowline Depth																																																													
Slope-Based Depth Safety Reduction Factor for Major & Minor ($d \geq 6"$) Storm																																																													
Max Flow Based on Allowable Depth (Safety Factor Applied)																																																													
Resultant Flow Depth at Gutter Flowline (Safety Factor Applied)																																																													
Resultant Flow Depth at Street Crown (Safety Factor Applied)																																																													
MINOR STORM Allowable Capacity is based on Spread Criterion																																																													
MAJOR STORM Allowable Capacity is based on Spread Criterion																																																													
Minor storm max. allowable capacity GOOD - greater than the design flow given on sheet 'Inlet Management'																																																													
Major storm max. allowable capacity GOOD - greater than the design flow given on sheet 'Inlet Management'																																																													
	<table border="1" style="width: 100%; border-collapse: collapse;"> <thead> <tr> <th style="width: 50%;"></th> <th style="width: 25%; text-align: center;">Minor Storm</th> <th style="width: 25%; text-align: center;">Major Storm</th> <th style="width: 10%;"></th> </tr> </thead> <tbody> <tr> <td>$Q_{ALLOW} =$</td> <td style="text-align: center;"><input style="width: 40px;" type="text"/></td> <td style="text-align: center;"><input style="width: 40px;" type="text"/></td> <td style="text-align: right;">cfs</td> </tr> </tbody> </table>		Minor Storm	Major Storm		$Q_{ALLOW} =$	<input style="width: 40px;" type="text"/>	<input style="width: 40px;" type="text"/>	cfs																																																				
	Minor Storm	Major Storm																																																											
$Q_{ALLOW} =$	<input style="width: 40px;" type="text"/>	<input style="width: 40px;" type="text"/>	cfs																																																										

Inlet Management

Worksheet Protected

INLET NAME	Inlet 5 DP 14	Inlet 7 Basin E-4	Inlet 6 DP 15
Site Type (Urban or Rural)	URBAN	URBAN	URBAN
Inlet Application (Street or Area)	STREET	STREET	STREET
Hydraulic Condition	On Grade	In Sump	In Sump
Inlet Type	CDOT Type R Curb Opening	CDOT Type R Curb Opening	CDOT Type R Curb Opening

USER-DEFINED INPUT

User-Defined Design Flows

Minor Q_{Known} (cfs)	1.6	1.4	1.1
Major Q_{Known} (cfs)	5.0	2.6	3.5

Bypass (Carry-Over) Flow from Upstream

Receive Bypass Flow from:	No Bypass Flow Received	No Bypass Flow Received	DP 14
Minor Bypass Flow Received, Q_b (cfs)	0.0	0.0	0.0
Major Bypass Flow Received, Q_b (cfs)	0.0	0.0	0.2

Watershed Characteristics

Subcatchment Area (acres)			
Percent Impervious			
NRCS Soil Type			

Watershed Profile

Overland Slope (ft/ft)			
Overland Length (ft)			
Channel Slope (ft/ft)			
Channel Length (ft)			

Minor Storm Rainfall Input

Design Storm Return Period, T_r (years)			
One-Hour Precipitation, P_1 (inches)			

Major Storm Rainfall Input

Design Storm Return Period, T_r (years)			
One-Hour Precipitation, P_1 (inches)			

CALCULATED OUTPUT

Minor Total Design Peak Flow, Q (cfs)	1.6	1.4	1.1
Major Total Design Peak Flow, Q (cfs)	5.0	2.6	3.7
Minor Flow Bypassed Downstream, Q_b (cfs)	0.0	N/A	N/A
Major Flow Bypassed Downstream, Q_b (cfs)	0.2	N/A	N/A

INLET ON A CONTINUOUS GRADE

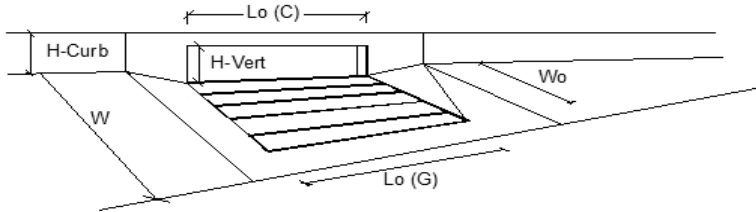

Inlet 5

Design Information (Input)	MINOR	MAJOR	
Type of Inlet	CDOT Type R Curb Opening		
Local Depression (additional to continuous gutter depression 'a')	3.0	3.0	inches
Total Number of Units in the Inlet (Grate or Curb Opening)	1	1	
Length of a Single Unit Inlet (Grate or Curb Opening)	10.00	10.00	ft
Width of a Unit Grate (cannot be greater than W, Gutter Width)	N/A	N/A	ft
Clogging Factor for a Single Unit Grate (typical min. value = 0.5)	N/A	N/A	
Clogging Factor for a Single Unit Curb Opening (typical min. value = 0.1)	0.10	0.10	
Street Hydraulics: OK - Q < Allowable Street Capacity			
Design Discharge for Half of Street (from Sheet Inlet Management)	MINOR	MAJOR	
Water Spread Width	1.6	5.0	cfs
Water Depth at Flowline (outside of local depression)	6.9	11.6	ft
Water Depth at Street Crown (or at T _{MAX})	3.4	4.5	inches
Ratio of Gutter Flow to Design Flow	0.0	0.0	inches
Discharge outside the Gutter Section W, carried in Section T _x	0.581	0.347	
Discharge within the Gutter Section W	0.7	3.3	cfs
Discharge Behind the Curb Face	0.9	1.7	cfs
Flow Area within the Gutter Section W	0.0	0.0	cfs
Velocity within the Gutter Section W	0.23	0.34	sq ft
Water Depth for Design Condition	4.0	5.1	fps
	6.4	7.5	inches
Grate Analysis (Calculated)			
Total Length of Inlet Grate Opening	MINOR	MAJOR	
Ratio of Grate Flow to Design Flow	N/A	N/A	ft
Under No-Clogging Condition			
Minimum Velocity Where Grate Splash-Over Begins	N/A	N/A	ft
Interception Rate of Frontal Flow	N/A	N/A	fps
Interception Rate of Side Flow	N/A	N/A	
Interception Capacity	N/A	N/A	cfs
Under Clogging Condition			
Clogging Coefficient for Multiple-unit Grate Inlet	N/A	N/A	
Clogging Factor for Multiple-unit Grate Inlet	N/A	N/A	
Effective (unclogged) Length of Multiple-unit Grate Inlet	N/A	N/A	ft
Minimum Velocity Where Grate Splash-Over Begins	N/A	N/A	fps
Interception Rate of Frontal Flow	N/A	N/A	
Interception Rate of Side Flow	N/A	N/A	
Actual Interception Capacity	N/A	N/A	cfs
Carry-Over Flow = Q_o - Q_a (to be applied to curb opening or next d/s inlet)	N/A	N/A	cfs
Curb or Slotted Inlet Opening Analysis (Calculated)			
Equivalent Slope S _e (based on grate carry-over)	MINOR	MAJOR	
Required Length L _T to Have 100% Interception	0.216	0.137	ft/ft
Under No-Clogging Condition	5.14	11.31	ft
Effective Length of Curb Opening or Slotted Inlet (minimum of L, L _T)	MINOR	MAJOR	
Interception Capacity	5.14	10.00	ft
Under Clogging Condition	1.6	4.9	cfs
Clogging Coefficient	MINOR	MAJOR	
Clogging Factor for Multiple-unit Curb Opening or Slotted Inlet	1.25	1.25	
Effective (Unclogged) Length	0.06	0.06	
Actual Interception Capacity	8.75	8.75	ft
Carry-Over Flow = Q_{b(GRATE)} - Q_a	1.6	4.8	cfs
	0.0	0.2	cfs
Summary			
Total Inlet Interception Capacity	MINOR	MAJOR	
Total Inlet Carry-Over Flow (flow bypassing inlet)	1.6	4.8	cfs
Capture Percentage = Q_a/Q_o	0.0	0.2	cfs
	100	96	%

INLET IN A SUMP OR SAG LOCATION

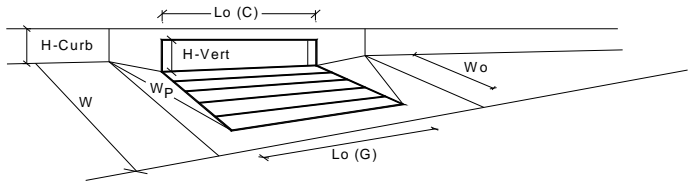

Inlet 6

Design Information (Input)		<table border="1"> <tr> <td>Type of Inlet</td> <td colspan="2">CDOT Type R Curb Opening</td> </tr> </table>		Type of Inlet	CDOT Type R Curb Opening	
Type of Inlet	CDOT Type R Curb Opening					
Local Depression (additional to continuous gutter depression 'a' from 'Q-Allow')	Type =		MINOR MAJOR			
Number of Unit Inlets (Grate or Curb Opening)	a _{local} =		CDOT Type R Curb Opening			
Water Depth at Flowline (outside of local depression)	No =		3.00 3.00 inches			
Grate Information	Ponding Depth =		1 1 inches			
Length of a Unit Grate	L _o (G) =		4.6 4.6 inches			
Width of a Unit Grate	W _o =		MINOR MAJOR <input type="checkbox"/> Override Depths			
Area Opening Ratio for a Grate (typical values 0.15-0.90)	A _{ratio} =		N/A N/A feet			
Clogging Factor for a Single Grate (typical value 0.50 - 0.70)	C ₁ (G) =		N/A N/A			
Grate Weir Coefficient (typical value 2.15 - 3.60)	C _w (G) =		N/A N/A			
Grate Orifice Coefficient (typical value 0.60 - 0.80)	C _o (G) =		N/A N/A			
Curb Opening Information	L _o (C) =		MINOR MAJOR			
Length of a Unit Curb Opening	H _{vert} =		15.00 15.00 feet			
Height of Vertical Curb Opening in Inches	H _{throat} =		6.00 6.00 inches			
Height of Curb Orifice Throat in Inches	Theta =		6.00 6.00 inches			
Angle of Throat (see USDCM Figure ST-5)	W _p =		63.40 63.40 degrees			
Side Width for Depression Pan (typically the gutter width of 2 feet)	C ₁ (C) =		1.17 1.17 feet			
Clogging Factor for a Single Curb Opening (typical value 0.10)	C _w (C) =		0.10 0.10			
Curb Opening Weir Coefficient (typical value 2.3-3.7)	C _o (C) =		3.60 3.60			
Curb Opening Orifice Coefficient (typical value 0.60 - 0.70)	C _o (C) =		0.67 0.67			
Grate Flow Analysis (Calculated)	Coef =		MINOR MAJOR			
Clogging Coefficient for Multiple Units	Clog =		N/A N/A			
Clogging Factor for Multiple Units	Q _{we} =		MINOR MAJOR			
Grate Capacity as a Weir (based on Modified HEC22 Method)	Q _{we} =		N/A N/A cfs			
Interception without Clogging	Q _{we} =		N/A N/A cfs			
Interception with Clogging	Q _{we} =		N/A N/A cfs			
Grate Capacity as an Orifice (based on Modified HEC22 Method)	Q _{or} =		MINOR MAJOR			
Interception without Clogging	Q _{or} =		N/A N/A cfs			
Interception with Clogging	Q _{or} =		N/A N/A cfs			
Grate Capacity as Mixed Flow	Q _{mi} =		MINOR MAJOR			
Interception without Clogging	Q _{mi} =		N/A N/A cfs			
Interception with Clogging	Q _{mi} =		N/A N/A cfs			
Resulting Grate Capacity (assumes clogged condition)	Q _{Grate} =		N/A N/A cfs			
Curb Opening Flow Analysis (Calculated)	Coef =		MINOR MAJOR			
Clogging Coefficient for Multiple Units	Clog =		1.31 1.31			
Clogging Factor for Multiple Units	Q _{we} =		0.04 0.04			
Curb Opening as a Weir (based on Modified HEC22 Method)	Q _{we} =		MINOR MAJOR			
Interception without Clogging	Q _{we} =		4.3 4.3 cfs			
Interception with Clogging	Q _{we} =		4.1 4.1 cfs			
Curb Opening as an Orifice (based on Modified HEC22 Method)	Q _{or} =		MINOR MAJOR			
Interception without Clogging	Q _{or} =		25.8 25.8 cfs			
Interception with Clogging	Q _{or} =		24.7 24.7 cfs			
Curb Opening Capacity as Mixed Flow	Q _{mi} =		MINOR MAJOR			
Interception without Clogging	Q _{mi} =		9.8 9.8 cfs			
Interception with Clogging	Q _{mi} =		9.3 9.3 cfs			
Resulting Curb Opening Capacity (assumes clogged condition)	Q _{Curb} =		4.1 4.1 cfs			
Resultant Street Conditions	L =		MINOR MAJOR			
Total Inlet Length	T =		15.00 15.00 feet			
Resultant Street Flow Spread (based on sheet Q-Allow geometry)	d _{CROWN} =		12.0 12.0 ft			
Resultant Flow Depth at Street Crown	d _{CROWN} =		0.0 0.0 inches			
Low Head Performance Reduction (Calculated)	d _{Grate} =		MINOR MAJOR			
Depth for Grate Midwidth	d _{Curb} =		N/A N/A ft			
Depth for Curb Opening Weir Equation	RF _{Combination} =		0.22 0.22 ft			
Combination Inlet Performance Reduction Factor for Long Inlets	RF _{Curb} =		0.43 0.43			
Curb Opening Performance Reduction Factor for Long Inlets	RF _{Grate} =		0.69 0.69			
Grated Inlet Performance Reduction Factor for Long Inlets	RF _{Grate} =		N/A N/A			
Total Inlet Interception Capacity (assumes clogged condition)	Q _s =		MINOR MAJOR			
Inlet Capacity IS GOOD for Minor and Major Storms(>Q PEAK)	Q _{PEAK REQUIRED} =		4.1 4.1 cfs			
	Q _{PEAK REQUIRED} =		1.1 3.7 cfs			

INLET IN A SUMP OR SAG LOCATION

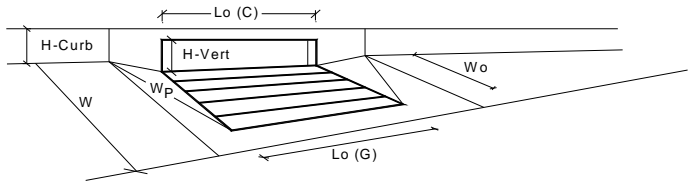

Inlet 7

Design Information (Input)		<table border="1"> <tr> <td>Type of Inlet</td> <td colspan="2">CDOT Type R Curb Opening</td> </tr> </table>		Type of Inlet	CDOT Type R Curb Opening																																
Type of Inlet	CDOT Type R Curb Opening																																				
Local Depression (additional to continuous gutter depression 'a' from 'Q-Allow')	<table border="1"> <tr> <td>MINOR</td> <td>MAJOR</td> </tr> <tr> <td>3.00</td> <td>3.00</td> </tr> </table> inches		MINOR	MAJOR	3.00	3.00																															
MINOR	MAJOR																																				
3.00	3.00																																				
Number of Unit Inlets (Grate or Curb Opening)	<table border="1"> <tr> <td>MINOR</td> <td>MAJOR</td> </tr> <tr> <td>1</td> <td>1</td> </tr> </table>		MINOR	MAJOR	1	1																															
MINOR	MAJOR																																				
1	1																																				
Water Depth at Flowline (outside of local depression)	<table border="1"> <tr> <td>MINOR</td> <td>MAJOR</td> </tr> <tr> <td>4.6</td> <td>4.6</td> </tr> </table> inches		MINOR	MAJOR	4.6	4.6																															
MINOR	MAJOR																																				
4.6	4.6																																				
Grate Information	<table border="1"> <tr> <td></td> <td>MINOR</td> <td>MAJOR</td> <td><input type="checkbox"/> Override Depths</td> </tr> <tr> <td>Length of a Unit Grate</td> <td>L_G (G) =</td> <td>N/A</td> <td>N/A</td> </tr> <tr> <td>Width of a Unit Grate</td> <td>W_G =</td> <td>N/A</td> <td>N/A</td> </tr> <tr> <td>Area Opening Ratio for a Grate (typical values 0.15-0.90)</td> <td>A_{ratio} =</td> <td>N/A</td> <td>N/A</td> </tr> <tr> <td>Clogging Factor for a Single Grate (typical value 0.50 - 0.70)</td> <td>C_r (G) =</td> <td>N/A</td> <td>N/A</td> </tr> <tr> <td>Grate Weir Coefficient (typical value 2.15 - 3.60)</td> <td>C_w (G) =</td> <td>N/A</td> <td>N/A</td> </tr> <tr> <td>Grate Orifice Coefficient (typical value 0.60 - 0.80)</td> <td>C_o (G) =</td> <td>N/A</td> <td>N/A</td> </tr> </table>			MINOR	MAJOR	<input type="checkbox"/> Override Depths	Length of a Unit Grate	L_G (G) =	N/A	N/A	Width of a Unit Grate	W_G =	N/A	N/A	Area Opening Ratio for a Grate (typical values 0.15-0.90)	A_{ratio} =	N/A	N/A	Clogging Factor for a Single Grate (typical value 0.50 - 0.70)	C_r (G) =	N/A	N/A	Grate Weir Coefficient (typical value 2.15 - 3.60)	C_w (G) =	N/A	N/A	Grate Orifice Coefficient (typical value 0.60 - 0.80)	C_o (G) =	N/A	N/A							
	MINOR	MAJOR	<input type="checkbox"/> Override Depths																																		
Length of a Unit Grate	L_G (G) =	N/A	N/A																																		
Width of a Unit Grate	W_G =	N/A	N/A																																		
Area Opening Ratio for a Grate (typical values 0.15-0.90)	A_{ratio} =	N/A	N/A																																		
Clogging Factor for a Single Grate (typical value 0.50 - 0.70)	C_r (G) =	N/A	N/A																																		
Grate Weir Coefficient (typical value 2.15 - 3.60)	C_w (G) =	N/A	N/A																																		
Grate Orifice Coefficient (typical value 0.60 - 0.80)	C_o (G) =	N/A	N/A																																		
Curb Opening Information	<table border="1"> <tr> <td></td> <td>MINOR</td> <td>MAJOR</td> </tr> <tr> <td>Length of a Unit Curb Opening</td> <td>L_C (C) =</td> <td>10.00</td> <td>10.00</td> </tr> <tr> <td>Height of Vertical Curb Opening in Inches</td> <td>H_{vert} =</td> <td>6.00</td> <td>6.00</td> </tr> <tr> <td>Height of Curb Orifice Throat in Inches</td> <td>H_{throat} =</td> <td>6.00</td> <td>6.00</td> </tr> <tr> <td>Angle of Throat (see USDCM Figure ST-5)</td> <td>Theta =</td> <td>63.40</td> <td>63.40</td> </tr> <tr> <td>Side Width for Depression Pan (typically the gutter width of 2 feet)</td> <td>W_p =</td> <td>1.17</td> <td>1.17</td> </tr> <tr> <td>Clogging Factor for a Single Curb Opening (typical value 0.10)</td> <td>C_r (C) =</td> <td>0.10</td> <td>0.10</td> </tr> <tr> <td>Curb Opening Weir Coefficient (typical value 2.3-3.7)</td> <td>C_w (C) =</td> <td>3.60</td> <td>3.60</td> </tr> <tr> <td>Curb Opening Orifice Coefficient (typical value 0.60 - 0.70)</td> <td>C_o (C) =</td> <td>0.67</td> <td>0.67</td> </tr> </table>			MINOR	MAJOR	Length of a Unit Curb Opening	L_C (C) =	10.00	10.00	Height of Vertical Curb Opening in Inches	H_{vert} =	6.00	6.00	Height of Curb Orifice Throat in Inches	H_{throat} =	6.00	6.00	Angle of Throat (see USDCM Figure ST-5)	Theta =	63.40	63.40	Side Width for Depression Pan (typically the gutter width of 2 feet)	W_p =	1.17	1.17	Clogging Factor for a Single Curb Opening (typical value 0.10)	C_r (C) =	0.10	0.10	Curb Opening Weir Coefficient (typical value 2.3-3.7)	C_w (C) =	3.60	3.60	Curb Opening Orifice Coefficient (typical value 0.60 - 0.70)	C_o (C) =	0.67	0.67
	MINOR	MAJOR																																			
Length of a Unit Curb Opening	L_C (C) =	10.00	10.00																																		
Height of Vertical Curb Opening in Inches	H_{vert} =	6.00	6.00																																		
Height of Curb Orifice Throat in Inches	H_{throat} =	6.00	6.00																																		
Angle of Throat (see USDCM Figure ST-5)	Theta =	63.40	63.40																																		
Side Width for Depression Pan (typically the gutter width of 2 feet)	W_p =	1.17	1.17																																		
Clogging Factor for a Single Curb Opening (typical value 0.10)	C_r (C) =	0.10	0.10																																		
Curb Opening Weir Coefficient (typical value 2.3-3.7)	C_w (C) =	3.60	3.60																																		
Curb Opening Orifice Coefficient (typical value 0.60 - 0.70)	C_o (C) =	0.67	0.67																																		
Grate Flow Analysis (Calculated)	<table border="1"> <tr> <td></td> <td>MINOR</td> <td>MAJOR</td> </tr> <tr> <td>Clogging Coefficient for Multiple Units</td> <td>Coef =</td> <td>N/A</td> <td>N/A</td> </tr> <tr> <td>Clogging Factor for Multiple Units</td> <td>Clog =</td> <td>N/A</td> <td>N/A</td> </tr> </table>			MINOR	MAJOR	Clogging Coefficient for Multiple Units	Coef =	N/A	N/A	Clogging Factor for Multiple Units	Clog =	N/A	N/A																								
	MINOR	MAJOR																																			
Clogging Coefficient for Multiple Units	Coef =	N/A	N/A																																		
Clogging Factor for Multiple Units	Clog =	N/A	N/A																																		
Grate Capacity as a Weir (based on Modified HEC22 Method)	<table border="1"> <tr> <td></td> <td>MINOR</td> <td>MAJOR</td> </tr> <tr> <td>Interception without Clogging</td> <td>Q_{wi} =</td> <td>N/A</td> <td>N/A</td> </tr> <tr> <td>Interception with Clogging</td> <td>Q_{ws} =</td> <td>N/A</td> <td>N/A</td> </tr> </table>			MINOR	MAJOR	Interception without Clogging	Q_{wi} =	N/A	N/A	Interception with Clogging	Q_{ws} =	N/A	N/A																								
	MINOR	MAJOR																																			
Interception without Clogging	Q_{wi} =	N/A	N/A																																		
Interception with Clogging	Q_{ws} =	N/A	N/A																																		
Grate Capacity as an Orifice (based on Modified HEC22 Method)	<table border="1"> <tr> <td></td> <td>MINOR</td> <td>MAJOR</td> </tr> <tr> <td>Interception without Clogging</td> <td>Q_{oi} =</td> <td>N/A</td> <td>N/A</td> </tr> <tr> <td>Interception with Clogging</td> <td>Q_{os} =</td> <td>N/A</td> <td>N/A</td> </tr> </table>			MINOR	MAJOR	Interception without Clogging	Q_{oi} =	N/A	N/A	Interception with Clogging	Q_{os} =	N/A	N/A																								
	MINOR	MAJOR																																			
Interception without Clogging	Q_{oi} =	N/A	N/A																																		
Interception with Clogging	Q_{os} =	N/A	N/A																																		
Grate Capacity as Mixed Flow	<table border="1"> <tr> <td></td> <td>MINOR</td> <td>MAJOR</td> </tr> <tr> <td>Interception without Clogging</td> <td>Q_{mi} =</td> <td>N/A</td> <td>N/A</td> </tr> <tr> <td>Interception with Clogging</td> <td>Q_{ms} =</td> <td>N/A</td> <td>N/A</td> </tr> </table>			MINOR	MAJOR	Interception without Clogging	Q_{mi} =	N/A	N/A	Interception with Clogging	Q_{ms} =	N/A	N/A																								
	MINOR	MAJOR																																			
Interception without Clogging	Q_{mi} =	N/A	N/A																																		
Interception with Clogging	Q_{ms} =	N/A	N/A																																		
Resulting Grate Capacity (assumes clogged condition)	<table border="1"> <tr> <td>Q_{Grate} =</td> <td>N/A</td> <td>N/A</td> <td>cfs</td> </tr> </table>		Q_{Grate} =	N/A	N/A	cfs																															
Q_{Grate} =	N/A	N/A	cfs																																		
Curb Opening Flow Analysis (Calculated)	<table border="1"> <tr> <td></td> <td>MINOR</td> <td>MAJOR</td> </tr> <tr> <td>Clogging Coefficient for Multiple Units</td> <td>Coef =</td> <td>1.25</td> <td>1.25</td> </tr> <tr> <td>Clogging Factor for Multiple Units</td> <td>Clog =</td> <td>0.06</td> <td>0.06</td> </tr> </table>			MINOR	MAJOR	Clogging Coefficient for Multiple Units	Coef =	1.25	1.25	Clogging Factor for Multiple Units	Clog =	0.06	0.06																								
	MINOR	MAJOR																																			
Clogging Coefficient for Multiple Units	Coef =	1.25	1.25																																		
Clogging Factor for Multiple Units	Clog =	0.06	0.06																																		
Curb Opening as a Weir (based on Modified HEC22 Method)	<table border="1"> <tr> <td></td> <td>MINOR</td> <td>MAJOR</td> </tr> <tr> <td>Interception without Clogging</td> <td>Q_{wi} =</td> <td>3.7</td> <td>3.7</td> </tr> <tr> <td>Interception with Clogging</td> <td>Q_{ws} =</td> <td>3.5</td> <td>3.5</td> </tr> </table>			MINOR	MAJOR	Interception without Clogging	Q_{wi} =	3.7	3.7	Interception with Clogging	Q_{ws} =	3.5	3.5																								
	MINOR	MAJOR																																			
Interception without Clogging	Q_{wi} =	3.7	3.7																																		
Interception with Clogging	Q_{ws} =	3.5	3.5																																		
Curb Opening as an Orifice (based on Modified HEC22 Method)	<table border="1"> <tr> <td></td> <td>MINOR</td> <td>MAJOR</td> </tr> <tr> <td>Interception without Clogging</td> <td>Q_{oi} =</td> <td>17.2</td> <td>17.2</td> </tr> <tr> <td>Interception with Clogging</td> <td>Q_{os} =</td> <td>16.1</td> <td>16.1</td> </tr> </table>			MINOR	MAJOR	Interception without Clogging	Q_{oi} =	17.2	17.2	Interception with Clogging	Q_{os} =	16.1	16.1																								
	MINOR	MAJOR																																			
Interception without Clogging	Q_{oi} =	17.2	17.2																																		
Interception with Clogging	Q_{os} =	16.1	16.1																																		
Curb Opening Capacity as Mixed Flow	<table border="1"> <tr> <td></td> <td>MINOR</td> <td>MAJOR</td> </tr> <tr> <td>Interception without Clogging</td> <td>Q_{mi} =</td> <td>7.4</td> <td>7.4</td> </tr> <tr> <td>Interception with Clogging</td> <td>Q_{ms} =</td> <td>6.9</td> <td>6.9</td> </tr> </table>			MINOR	MAJOR	Interception without Clogging	Q_{mi} =	7.4	7.4	Interception with Clogging	Q_{ms} =	6.9	6.9																								
	MINOR	MAJOR																																			
Interception without Clogging	Q_{mi} =	7.4	7.4																																		
Interception with Clogging	Q_{ms} =	6.9	6.9																																		
Resulting Curb Opening Capacity (assumes clogged condition)	<table border="1"> <tr> <td>Q_{Curb} =</td> <td>3.5</td> <td>3.5</td> <td>cfs</td> </tr> </table>		Q_{Curb} =	3.5	3.5	cfs																															
Q_{Curb} =	3.5	3.5	cfs																																		
Resultant Street Conditions	<table border="1"> <tr> <td></td> <td>MINOR</td> <td>MAJOR</td> </tr> <tr> <td>Total Inlet Length</td> <td>L =</td> <td>10.00</td> <td>10.00</td> </tr> <tr> <td>Resultant Street Flow Spread (based on sheet Q-Allow geometry)</td> <td>T =</td> <td>12.0</td> <td>12.0</td> </tr> <tr> <td>Resultant Flow Depth at Street Crown</td> <td>d_{crown} =</td> <td>0.0</td> <td>0.0</td> </tr> </table>			MINOR	MAJOR	Total Inlet Length	L =	10.00	10.00	Resultant Street Flow Spread (based on sheet Q-Allow geometry)	T =	12.0	12.0	Resultant Flow Depth at Street Crown	d_{crown} =	0.0	0.0																				
	MINOR	MAJOR																																			
Total Inlet Length	L =	10.00	10.00																																		
Resultant Street Flow Spread (based on sheet Q-Allow geometry)	T =	12.0	12.0																																		
Resultant Flow Depth at Street Crown	d_{crown} =	0.0	0.0																																		
Low Head Performance Reduction (Calculated)	<table border="1"> <tr> <td></td> <td>MINOR</td> <td>MAJOR</td> </tr> <tr> <td>Depth for Grate Midwidth</td> <td>d_{Grate} =</td> <td>N/A</td> <td>N/A</td> </tr> <tr> <td>Depth for Curb Opening Weir Equation</td> <td>d_{Curb} =</td> <td>0.22</td> <td>0.22</td> </tr> <tr> <td>Combination Inlet Performance Reduction Factor for Long Inlets</td> <td>$RF_{Combination}$ =</td> <td>0.43</td> <td>0.43</td> </tr> <tr> <td>Curb Opening Performance Reduction Factor for Long Inlets</td> <td>RF_{Curb} =</td> <td>0.84</td> <td>0.84</td> </tr> <tr> <td>Grated Inlet Performance Reduction Factor for Long Inlets</td> <td>RF_{Grate} =</td> <td>N/A</td> <td>N/A</td> </tr> </table>			MINOR	MAJOR	Depth for Grate Midwidth	d_{Grate} =	N/A	N/A	Depth for Curb Opening Weir Equation	d_{Curb} =	0.22	0.22	Combination Inlet Performance Reduction Factor for Long Inlets	$RF_{Combination}$ =	0.43	0.43	Curb Opening Performance Reduction Factor for Long Inlets	RF_{Curb} =	0.84	0.84	Grated Inlet Performance Reduction Factor for Long Inlets	RF_{Grate} =	N/A	N/A												
	MINOR	MAJOR																																			
Depth for Grate Midwidth	d_{Grate} =	N/A	N/A																																		
Depth for Curb Opening Weir Equation	d_{Curb} =	0.22	0.22																																		
Combination Inlet Performance Reduction Factor for Long Inlets	$RF_{Combination}$ =	0.43	0.43																																		
Curb Opening Performance Reduction Factor for Long Inlets	RF_{Curb} =	0.84	0.84																																		
Grated Inlet Performance Reduction Factor for Long Inlets	RF_{Grate} =	N/A	N/A																																		
Total Inlet Interception Capacity (assumes clogged condition)	<table border="1"> <tr> <td></td> <td>MINOR</td> <td>MAJOR</td> </tr> <tr> <td>Q_s =</td> <td>3.5</td> <td>3.5</td> <td>cfs</td> </tr> </table>			MINOR	MAJOR	Q_s =	3.5	3.5	cfs																												
	MINOR	MAJOR																																			
Q_s =	3.5	3.5	cfs																																		
Inlet Capacity IS GOOD for Minor and Major Storms(>Q PEAK)	<table border="1"> <tr> <td></td> <td>MINOR</td> <td>MAJOR</td> </tr> <tr> <td>$Q_{PEAK REQUIRED}$ =</td> <td>1.4</td> <td>2.6</td> <td>cfs</td> </tr> </table>			MINOR	MAJOR	$Q_{PEAK REQUIRED}$ =	1.4	2.6	cfs																												
	MINOR	MAJOR																																			
$Q_{PEAK REQUIRED}$ =	1.4	2.6	cfs																																		

TYPE D INLET CAPACITIES

USE CITY'S DCM VOL. 1, FIG. 8-10

INLETS 2 AND 3 : DP'S 11 AND 12 AT SUMP ALONG REDBRIDGE POINT

LANES ARE ONLY 12' WIDE W/ 2% CROSS SLOPE (0.24' OR 2.9" VERTICAL), SO ASSUME FLOW WILL OVERTOP CROWN AND REACH AN EQUILIBRIUM BTWN. DP'S 11 AND 12.

	5-YR.	100-YR.
DP 11	1.9 cfs	4.7 cfs
DP 12	1.3 cfs	2.5 cfs
TOTAL	3.2 cfs	7.2 cfs

ASSUME EACH INLET WILL NEED TO CAPTURE HALF OF EACH TOTAL FLOW =

5-YR. = $Q = 3.2 / 2 = 1.6$ cfs EACH

100-YR. = $Q = 7.2 / 2 = 3.6$ cfs EACH

FIG. 8-10 ALREADY INCLUDES A REDUCTION FACTOR, BUT WILL ALSO ASSUME 50% LESS CAPACITY FOR CLOGGING

AT $Q_5 = 1.6 \text{ cfs} \times 2 = 3.2 \text{ cfs}$, $Y \sim 2.5 \text{ in.}$ (AT EA. INLET)
 AT $Q_{100} = 3.6 \text{ cfs} \times 2 = 7.2 \text{ cfs}$, $Y \sim 4.3 \text{ in.}$ (AT EA. INLET)

CHECK FREEBOARD :

STREET & LOW POINT = 26.50
 $\bar{E} = 26.30$

LOWEST FIN. FLR. EL. = 27.2

5 YR F.B. = $27.2 - [26.30 + \frac{2.5}{12}] = 0.7 \text{ FT.}$

100 YR F.B. = $27.2 - [26.30 + \frac{4.3}{12}] = 0.5 \text{ FT.}$

2 GRATES, CLOSE MESH GRATES FOR EACH INLET

* THEREFORE, USE TWO CLOSE MESH GRATES, OR TYPE D INLET EACH FOR INLETS 2 AND 3.

TYPE D INLET CAPACITIES (CONT'D.) =

INLET 1 = BASIN WZ ($Q_5 = 0.2 \text{ cfs}$, $Q_{100} = 0.6 \text{ cfs}$)

FROM FIG. 8-10, ASSUMING 50% CLOGGING FACTOR,

AT $Q_5 = 0.2 \text{ cfs} \times 2 = 0.4 \text{ cfs}$, $Y \sim \frac{1.0 \text{ in.}}{\text{ONE GRATE}}, \frac{1.0 \text{ in.}}{\text{TWO GRATES}}$

AT $Q_{100} = 0.6 \text{ cfs} \times 2 = 1.2 \text{ cfs}$, $Y \sim \frac{1.7 \text{ in.}}{\text{ONE GRATE}}, \frac{1.3 \text{ in.}}{\text{TWO GRATES}}$

↑ ONE GRATE ↑ TWO GRATES

USE 2
CLOSE
MESH
GRATES

NOTE: DUE TO PIPE SIZES UPSTREAM AND DOWNSTREAM OF INLET 1 (36" DIA.), WILL USE A TYPE D INLET (2 GRATES) INSTEAD OF A TYPE C INLET (1 GRATE) - MAX. PIPE SIZE FOR A TYPE C INLET IS 30" DIA.

CHECK FREEBOARD = GRATE EL. AT INLET = 27.0

LOWEST ADJ. FFE = 28.2

5-YR. F.B. = $28.2 - [27.0 + \frac{1.0}{12}] = 1.1 \text{ FT.}$

100-YR. F.B. = $28.2 - [27.0 + \frac{1.3}{12}] = 1.0 \text{ FT.}$

INLET 4 = WQ BASIN 1 OUTLET STRUCTURE ($Q_{100} = 7.2 \text{ cfs}$) DP 12.1

FROM FIG. 8-10, ASSUMING 50% CLOGGING FACTOR,

AT $Q_{100} = 7.2 \text{ cfs} \times 2 = 14.4 \text{ cfs}$, $Y \sim 6.2 \text{ in. (0.52 ft.)}$

GRATE EL. = 16.9

SPILLWAY CREST = 17.7

100 YR. ELEV. = $16.9 + 0.52 = 17.42$

(0.28' FREEBOARD)

TYPE D INLET
W/ 2 STD.
GRATES

THEREFORE, OUTLET STRUCTURE IS SIZED FOR THE 100-YR. EVENT PRIOR TO THE SPILLWAY CREST BEING OVERTOPPED.

TYPE D INLET CAPACITIES (CONT'D.) :

INLET 8 = WQ BASIN 2 OUTLET STRUCTURE ($Q_{100} = 11.3$ cfs) DP 16.1

FROM FIG. 8-10, ASSUMING 50% CLOGGING FACTOR,

AT $Q_{100} = 11.3$ cfs $\times 2 = 22.6$ cfs, $Y \sim 8.3$ in. (0.7 ft.)

GRATE EL. = 18.0

SPILLWAY CREST = 18.7 FT.

100 YR. ELEV. = 18.0 + 0.7 FT. = 18.7 (0.0' FREEBOARD)

TYPE D INLET
W/ 2 STD. GRATES

THEREFORE, OUTLET STRUCTURE IS SIZED FOR THE
100 YR. EVENT PRIOR TO THE SPILLWAY CREST
BEING OVERTOPPED.

CHECK CAPACITY OF STORMCEPTOR GRATE :

INLET 9 = DP 17 ($Q_5 = 1.1$ cfs, $Q_{100} = 2.1$ cfs)

2' x 2' SLOTTED GRATE (D & L SUPPLY NO-I-9224-01 OR EQUAL)

OPEN AREA = 187 in.² / 144 = 1.3 SF

$Q_0 = CA (2gH)^{0.5}$ ORIFICE EQN.

$H = \frac{1}{2g} \left(\frac{Q_0}{CA} \right)^2$ $g = 32.2$ FT/SEC.²

$H_5 = \frac{1}{64.4} \left(\frac{2.2}{0.6(1.3)} \right)^2$ $C = 0.60$

= 0.12 FT., ASSUMES A 50% CLOGGING FACTOR

$H_{100} = \frac{1}{64.4} \left(\frac{4.2}{0.6(1.3)} \right)^2$

= 0.45 FT., ASSUMES A 50% CLOGGING FACTOR

CHECK FREEBOARD = GRATE EL. = 18.8

LOWEST ADJ. FFE = 21.0

5 YR. F.B. = 21.0 - [18.8 + 0.12] = 2.0 FT. ✓

100 YR. F.B. = 21.0 - [18.8 + 0.45] = 1.75 FT. ✓

Figure 8-10. Inlet Capacity Chart Sump Conditions, Area (Type C) Inlet

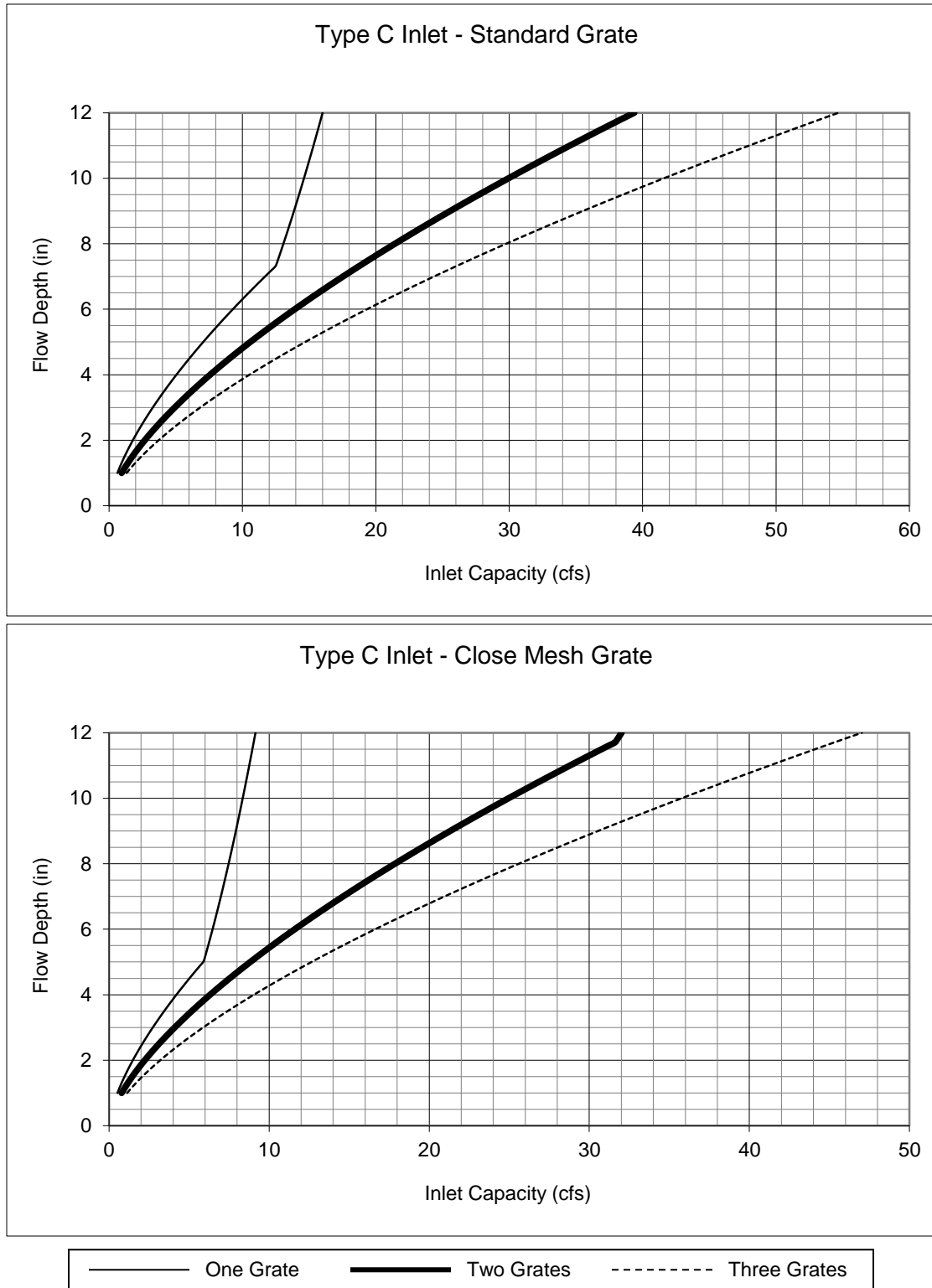

Notes:

1. The standard inlet parameters must apply to use these charts.

**North Bay at Lake Woodmoor
Pipe Diameter Calculations**

Pipe #	5yr Flow	100yr Flow	Design Flow ¹	Contributing Flows	Manning 'n'	Pipe Slope	Calculated Pipe Diameter	Pipe Diameter ²	Minimum Slope of Pipe	Full Pipe Flow Velocity	Head above Pipe Flowline	H	Pipe Inlet Control Capacity	Mannings Pipe Capacity	Capacity Check	Notes
Ex. 24" CMP (across Deer Crk Rd)	7.5 cfs	28.3 cfs	28.3 cfs	Basin OS-2	0.022	20.9%	18-inch	24-inch	4.47%	19.5 ft/sec	3.4 ft	2.4 ft	25.4 cfs	61.2 cfs	Pressure	2.9cfs will overtop Deer Crk Rd
S1: Ex. 24" CMP (creek diversion)	22.0 cfs	1100 cfs	22.0 cfs	LFDWC Low Flow	0.022	2.8%	24-inch	24-inch	2.71%	7.2 ft/sec	2.8 ft	1.8 ft	22.0 cfs	22.6 cfs	Pressure	HW=2.8ft = El. 28.0 - El. 25.2
S1: 24" CMP creek diversion (proposed condition)	22.0 cfs	1100 cfs	22.0 cfs	LFDWC Low Flow	0.022	2.8%	24-inch	24-inch	2.71%	7.2 ft/sec	2.8 ft	1.8 ft	22.0 cfs	22.6 cfs	Pressure	Matches ex. condition (HW=2.8ft = El. 28.4 - El. 25.6)
S1: 24" CMP creek diversion (proposed condition)	22.0 cfs	1100 cfs	41.5 cfs	LFDWC 100-yr Flow	0.022	2.8%	30-inch	24-inch	9.64%	7.2 ft/sec	7.4 ft	6.4 ft	41.5 cfs	22.6 cfs	Pressure	Pipe capacity with 100-yr flow in creek (HW=33.0)
S2-1	0.2 cfs	0.6 cfs	0.6 cfs	Basin W2 (Inlet 1)	0.013	2.93%	5-inch	18-inch	0.00%	10.2 ft/sec	4.0 ft	3.3 ft	16.6 cfs	18.0 cfs	OK	
S2-2	7.6 cfs	28.5 cfs	28.5 cfs	DP 10 (Inlet 1, Basin OS-2)	0.013	1.00%	26-inch	30-inch	0.48%	8.4 ft/sec	9.3 ft	8.1 ft	72.6 cfs	41.1 cfs	OK	
S3	29.6 cfs	70.0 cfs	70.0 cfs	Creek Diversion, DP 10	0.013	0.90%	37-inch	36-inch	1.10%	9.0 ft/sec	11.3 ft	9.8 ft	115.4 cfs	63.4 cfs	Pressure	
S4	1.3 cfs	2.5 cfs	2.5 cfs	Inlet 3	0.013	0.60%	12-inch	18-inch	0.06%	4.6 ft/sec	3.7 ft	3.0 ft	15.8 cfs	8.2 cfs	OK	
S5	3.1 cfs	7.2 cfs	7.2 cfs	Inlets 3 and 4	0.013	0.60%	17-inch	18-inch	0.47%	4.6 ft/sec	3.9 ft	3.2 ft	16.4 cfs	8.2 cfs	OK	
S6	3.1 cfs	7.2 cfs	7.2 cfs	DP 12.1	0.013	2.50%	13-inch	18-inch	0.47%	9.4 ft/sec	7.8 ft	7.1 ft	24.5 cfs	16.7 cfs	OK	
S7	1.6 cfs	5.2 cfs	5.2 cfs	Inlet 5	0.013	1.60%	13-inch	18-inch	0.25%	7.5 ft/sec	4.0 ft	3.3 ft	16.6 cfs	13.3 cfs	OK	
S8	2.7 cfs	8.7 cfs	8.7 cfs	Inlets 5 and 6	0.013	1.58%	15-inch	18-inch	0.69%	7.5 ft/sec	4.0 ft	3.3 ft	16.6 cfs	13.2 cfs	OK	
S9	3.4 cfs	9.9 cfs	9.9 cfs	Inlets 5, 6 and 7	0.013	1.00%	18-inch	18-inch	0.89%	6.0 ft/sec	3.3 ft	2.6 ft	14.7 cfs	10.5 cfs	OK	
S10	3.6 cfs	11.3 cfs	11.3 cfs	DP 16.1	0.013	1.00%	19-inch	18-inch	1.16%	6.0 ft/sec	7.5 ft	6.8 ft	23.9 cfs	10.5 cfs	Pressure	
S11	1.1 cfs	2.1 cfs	2.1 cfs	Inlet 9	0.013	0.94%	10-inch	18-inch	0.04%	5.8 ft/sec	4.4 ft	3.7 ft	17.6 cfs	10.2 cfs	OK	
12" Raw Water	--	--	--		0.011	4.77%		12-inch		11.7 ft/sec	10.8 ft	10.3 ft	13.1 cfs	9.2 cfs		

Equations:

$$\text{Pipe Dia} = ((2.16Qn)/(S^{0.5}))^{0.375}$$

Q = Discharge in cubic feet per second

n = Manning's roughness coefficient

RCP=0.013, CMP=0.024, HDPE (smooth)=0.012

S = Slope of the pipe

R_h = Hydraulic Radius

$$\text{Flow Velocity} = (1.49/n)R_h^{2/3} S^{1/2}$$

$$\text{Pipe Capacity} = (1.49/n)AR_h^{2/3} S^{1/2}$$

A = Cross-sectional area of pipe

$$A = p(D^2/4)$$

D = Inside Diameter of Pipe

$$R_h = A_w/W_p$$

$$A_w = p(d^2/4)$$

A_w = Water Cross Sectional Area

d = Water (Flow) Depth Within Pipe

W_p = pd (For Capacity Calculation)

W_p = Wetted Perimeter of Pipe

Orifice Equation:

$$Q = CA(2gH)^{0.5}$$

C = Orifice coefficient (dimensionless)

$$C = 0.65$$

A = Cross-sectional area of opening, in sf

g = Gravitational accel constant, 32.2 ft/sec²

H = Head above centerline of pipe, ft

Proposed Lake Fork Dirty Woman Creek diversion flow for 5-year and 100-year storm events.

¹ For Pipe #'s S1 and S3, design flow includes Lake Fork Dirty Woman Creek diversion flow of 41.5cfs in a 100-year event.

² 14" x 23" HERCP (18" circular equivalent) used for Pipe #S11.

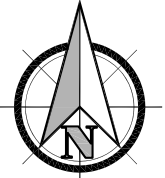

SCALE: NTS

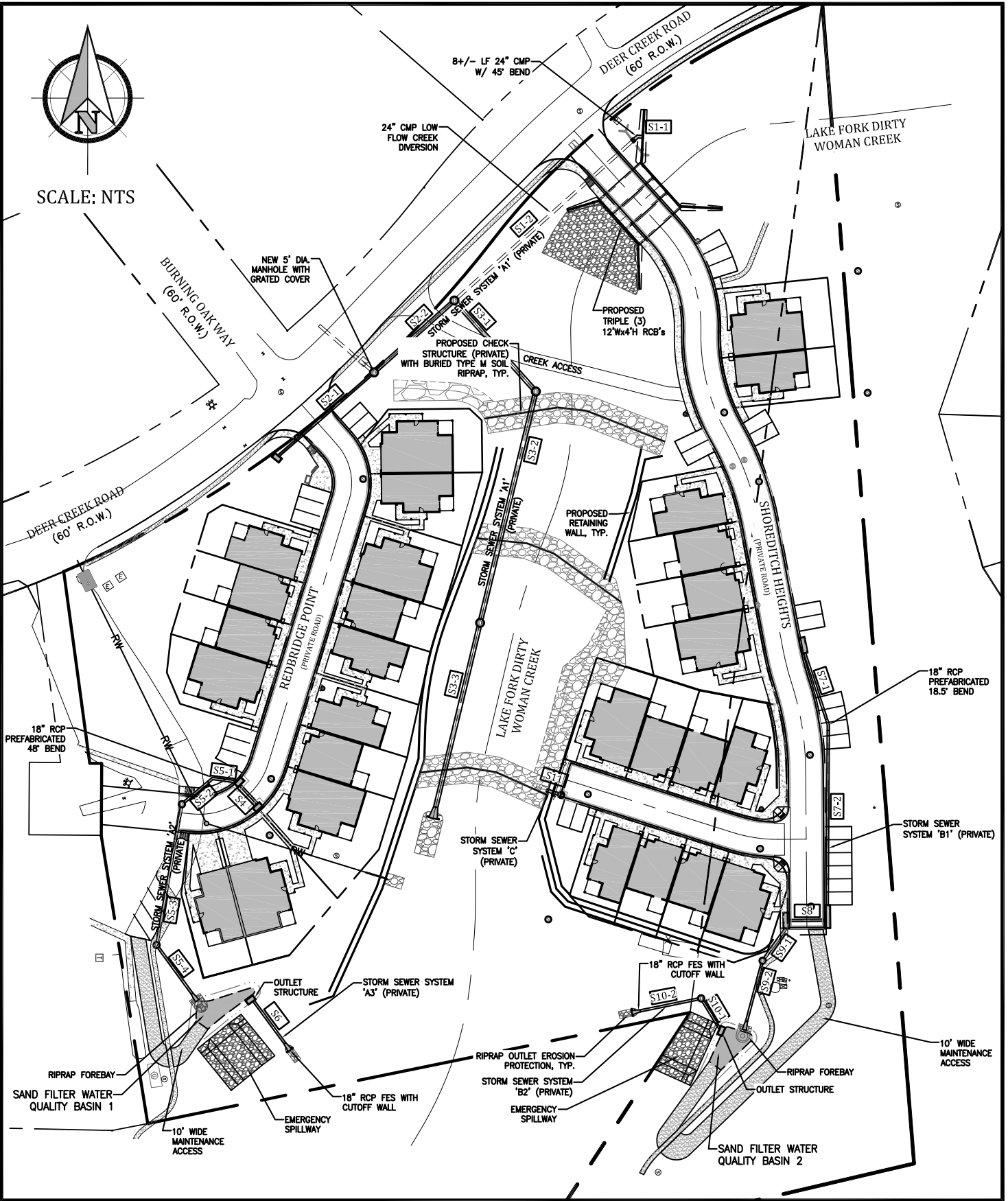

15073 Drainage Plan.dwg/Sep. 04, 2018

North Bay at Lake Woodmoor
 Storm Sewer System Layout
 El Paso County, Colorado

PROJECT NO. 15073



1604 South 21st Street
 Colorado Springs, Colorado 80904
 (719) 630-7342

System Input Summary

Rainfall Parameters

Rainfall Return Period: 5
Rainfall Calculation Method: Formula

One Hour Depth (in): 1.50
Rainfall Constant "A": 28.5
Rainfall Constant "B": 10
Rainfall Constant "C": 0.786

Rational Method Constraints

Minimum Urban Runoff Coeff.: 0.20
Maximum Rural Overland Len. (ft): 500
Maximum Urban Overland Len. (ft): 300
Used UDFCD Tc. Maximum: No

Sizer Constraints

Minimum Sewer Size (in): 18.00
Maximum Depth to Rise Ratio: 0.90
Maximum Flow Velocity (fps): 18.0
Minimum Flow Velocity (fps): 2.0

Backwater Calculations:

Tailwater Elevation (ft): 7110.60

North Bay at Lake Woodmoor
 UDSewer Input and Output Data
 Storm Sewer System A1 - 5yr

Manhole Input Summary:

Element Name	Ground Elevation (ft)	Given Flow		Sub Basin Information						
		Total Known Flow (cfs)	Local Contribution (cfs)	Drainage Area (Ac.)	Runoff Coefficient	Syr Coefficient	Overland Length (ft)	Overland Slope (%)	Gutter Length (ft)	Gutter Velocity (fps)
OUTFALL	7110.5	0	0	0	0	0	0	0	0	0
S3-3	7119.2	29.6	0	0	0	0	0	0	0	0
S3-2	7126.7	29.6	0	0	0	0	0	0	0	0
S3-1	7128	29.6	0	0	0	0	0	0	0	0
S1-2	7134.29	22	0	0	0	0	0	0	0	0
S1-1	7132.88	22	0	0	0	0	0	0	0	0
S2-2	7125	7.6	0	0	0	0	0	0	0	0
S2-1	7127	0.2	0	0	0	0	0	0	0	0

Manhole Output Summary:

Element Name	Local Contribution					Total Design Flow				Comment
	Overland Time (min)	Gutter Time (min)	Basin Tc (min)	Intensity (in/hr)	Local Contrib (cfs)	Coeff. Area	Intensity (in/hr)	Manhole Tc (min)	Peak Flow (cfs)	
OUTFALL	0	0	0	0	0	4.41	6.71	0.55	29.6	Surface Water Present (Upstream)
S3-3	0	0	0	0	0	0	0	0	29.6	Surface Water Present (Downstream)
S3-2	0	0	0	0	0	0	0	0	29.6	
S3-1	0	0	0	0	0	0	0	0	29.6	
S1-2	0	0	0	0	0	0	0	0	22	
S1-1	0	0	0	0	0	0	0	0	22	
S2-2	0	0	0	0	0	0	0	0	7.6	
S2-1	0	0	0	0	0	0	0	0	0.2	

Sewer Input Summary:

Element Name	Sewer Length (ft)	Elevation			Loss Coefficients			Given Dimensions		
		Downstream Invert (ft)	Slope (%)	Upstream Invert (ft)	Mannings n	Bend Loss	Lateral Loss	Cross Section	Rise (ft or in)	Span (ft or in)
S3-3	138.73	7107.07	0.9	7108.32	0.013	0	0	CIRCULAR	36.00 in	36.00 in
S3-2	164.18	7108.66	2.9	7113.42	0.013	0.05	1	CIRCULAR	36.00 in	36.00 in
S3-1	84.25	7113.52	1	7114.36	0.013	0.41	1	CIRCULAR	36.00 in	36.00 in
S1-2	155.5	7117.8	2.83	7122.2	0.019	1.01	0	CIRCULAR	24.00 in	24.00 in
S1-1	18.08	7122.2	18.8	7125.6	0.016	0.3	1	CIRCULAR	24.00 in	24.00 in
S2-2	74.38	7114.86	1	7115.6	0.013	1	0.25	CIRCULAR	30.00 in	30.00 in
S2-1	87.82	7120.72	2.93	7123.29	0.013	0.05	0.26	CIRCULAR	18.00 in	18.00 in

North Bay at Lake Woodmoor
 UDSewer Input and Output Data
 Storm Sewer System A1 - 5yr

Sewer Flow Summary:

Element Name	Full Flow Capacity		Critical Flow		Normal Flow				Flow (cfs)	Surcharged Length (ft)	Comment
	Flow (cfs)	Velocity (fps)	Depth (in)	Velocity (fps)	Depth (in)	Velocity (fps)	Froude Number	Flow Condition			
S3-3	63.45	8.98	21.14	6.86	17.29	8.82	1.47	Supercritical Jump	29.6	75.07	
S3-2	113.89	16.11	21.14	6.86	12.52	13.54	2.73	Supercritical	29.6	0	
S3-1	66.88	9.46	21.14	6.86	16.77	9.17	1.56	Supercritical	29.6	0	
S1-2	26.11	8.31	20.1	7.83	16.88	9.32	1.44	Supercritical	22	0	
S1-1	79.91	25.44	20.1	7.83	8.61	21.72	5.27	Supercritical	22	0	Velocity is Too High
S2-2	41.13	8.38	10.99	4.67	8.73	6.4	1.56	Supercritical	7.6	0	
S2-1	18.03	10.2	1.97	1.9	1.33	3.38	2.17	Supercritical	0.2	0	

A Froude number of 0 indicates that pressured flow occurs (adverse slope or undersized pipe).

If the sewer is not pressurized, full flow represents the maximum gravity flow in the sewer.

If the sewer is pressurized, full flow represents the pressurized flow conditions.

Sewer Sizing Summary:

Element Name	Peak Flow (cfs)	Cross Section	Existing		Calculated		Used			Comment
			Rise	Span	Rise	Span	Rise	Span	Area (ft^2)	
S3-3	29.6	CIRCULAR	36.00 in	36.00 in	30.00 in	30.00 in	36.00 in	36.00 in	7.07	
S3-2	29.6	CIRCULAR	36.00 in	36.00 in	24.00 in	24.00 in	36.00 in	36.00 in	7.07	
S3-1	29.6	CIRCULAR	36.00 in	36.00 in	27.00 in	27.00 in	36.00 in	36.00 in	7.07	
S1-2	22	CIRCULAR	24.00 in	24.00 in	24.00 in	24.00 in	24.00 in	24.00 in	3.14	
S1-1	22	CIRCULAR	24.00 in	24.00 in	18.00 in	18.00 in	24.00 in	24.00 in	3.14	
S2-2	7.6	CIRCULAR	30.00 in	30.00 in	18.00 in	18.00 in	30.00 in	30.00 in	4.91	
S2-1	0.2	CIRCULAR	18.00 in	18.00 in	18.00 in	18.00 in	18.00 in	18.00 in	1.77	

Calculated diameter was determined by sewer hydraulic capacity rounded up to the nearest commercially available size.

Sewer sizes should not decrease downstream.

All hydraulics were calculated using the 'Used' parameters.

Grade Line Summary:

Tailwater Elevation (ft): 7110.60

Element Name	Invert Elev.		Downstream Manhole Losses		HGL		EGL		
	Downstream (ft)	Upstream (ft)	Bend Loss (ft)	Lateral Loss (ft)	Downstream (ft)	Upstream (ft)	Downstream (ft)	Friction Loss (ft)	Upstream (ft)
S3-3	7107.07	7108.32	0	0	7110.6	7110.62	7110.87	0.15	7111.02
S3-2	7108.66	7113.42	0.01	0	7110.63	7115.18	7112.55	3.36	7115.91
S3-1	7113.52	7114.36	0.11	0	7115.29	7116.12	7116.22	0.63	7116.85
S1-2	7117.8	7122.2	0.77	0	7119.21	7123.87	7120.55	4.27	7124.83
S1-1	7122.2	7125.6	0.23	0	7124.1	7129.48	7130.24	0	7130.24
S2-2	7114.86	7115.6	0.04	0.26	7117.11	7117.11	7117.15	0.05	7117.2
S2-1	7120.72	7123.29	0	0.04	7120.83	7123.45	7121.01	2.51	7123.51

Bend and Lateral losses only apply when there is an outgoing sewer. The system outfall, sewer #0, is not considered a sewer.

Bend loss = Bend K * V_{fi} ^ 2 / (2 * g)

Lateral loss = V_{fo} ^ 2 / (2 * g) - Junction Loss K * V_{fi} ^ 2 / (2 * g).

Friction loss is always Upstream EGL - Downstream EGL.

Excavation Estimate:

The trench side slope is 1.0 ft/ft

The minimum trench width is 2.00 ft

Element Name	Length (ft)	Wall (in)	Bedding (in)	Bottom Width (ft)	Downstream			Upstream			Volume (cu. yd)	Comment
					Top Width (ft)	Trench Depth (ft)	Cover (ft)	Top Width (ft)	Trench Depth (ft)	Cover (ft)		
S3-3	138.73	4	6	6.67	0	4.26	0.1	19.76	11.71	7.55	382.09	Sewer Too Shallow
S3-2	164.18	4	6	6.67	19.08	11.37	7.21	24.56	14.11	9.95	877.15	
S3-1	84.25	4	6	6.67	24.37	14.02	9.85	25.28	14.47	10.31	553.63	
S1-2	155.5	3	4	5.5	19.4	10.78	7.95	23.18	12.67	9.84	735.67	
S1-1	18.08	3	4	5.5	23.18	12.67	9.84	13.56	7.86	5.03	69.41	
S2-2	74.38	3.5	6	6.08	24.79	13.94	10.35	17.3	10.19	6.61	365.96	
S2-1	87.82	2.5	4	4.92	8.07	4.82	2.57	6.92	4.25	2	78.24	

Total earth volume for sewer trenches = 3062 cubic yards.

The trench was estimated to have a bottom width equal to the outer pipe diameter plus 36 inches.

If the calculated width of the trench bottom is less than the minimum acceptable width, the minimum acceptable width was used.

The sewer wall thickness is equal to: (equivalent diameter in inches/12)+1 inches

The sewer bedding thickness is equal to:

Four inches for pipes less than 33 inches.

Six inches for pipes less than 60 inches.

Eight inches for all larger sizes.

Storm Sewer System A1 - 5yr

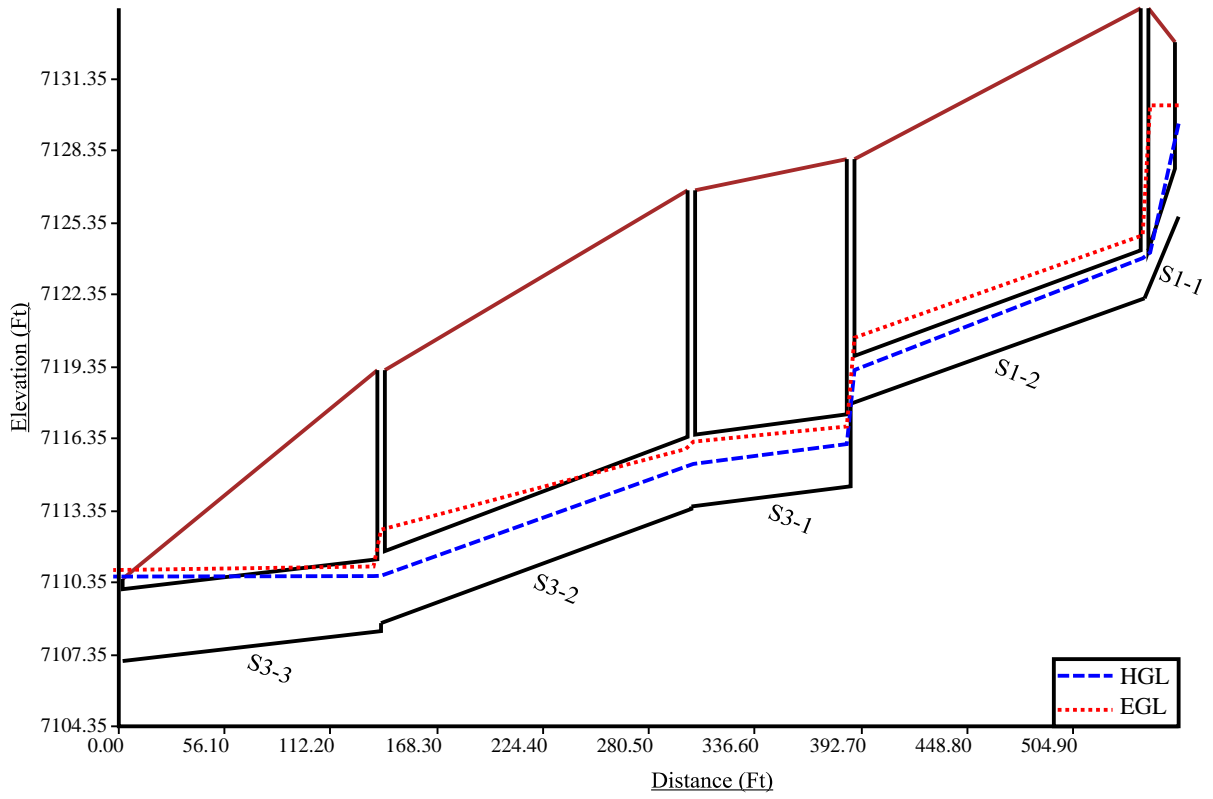

Storm Sewer System A1a - 5yr

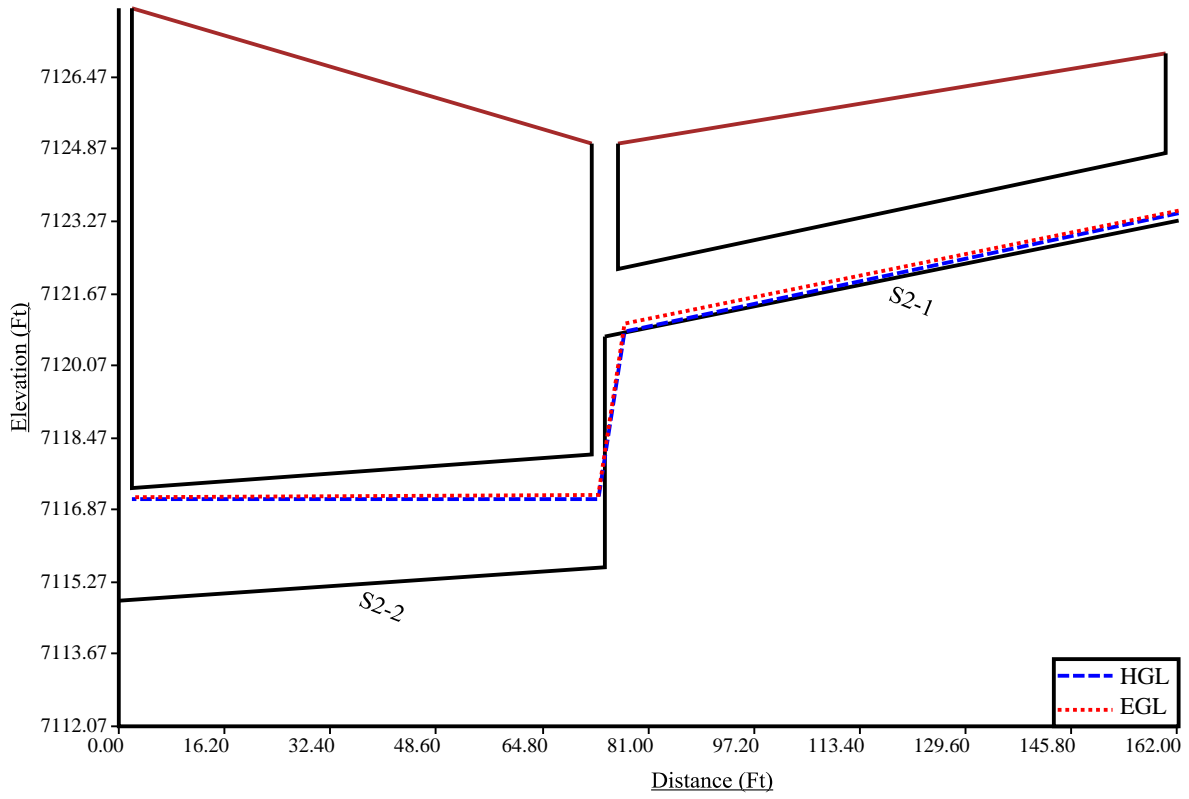

S3-1

System Input Summary

Rainfall Parameters

Rainfall Return Period: 5
Rainfall Calculation Method: Formula

One Hour Depth (in): 1.50
Rainfall Constant "A": 28.5
Rainfall Constant "B": 10
Rainfall Constant "C": 0.786

Rational Method Constraints

Minimum Urban Runoff Coeff.: 0.20
Maximum Rural Overland Len. (ft): 500
Maximum Urban Overland Len. (ft): 300
Used UDFCD Tc. Maximum: No

Sizer Constraints

Minimum Sewer Size (in): 18.00
Maximum Depth to Rise Ratio: 0.90
Maximum Flow Velocity (fps): 18.0
Minimum Flow Velocity (fps): 2.0

Backwater Calculations:

Tailwater Elevation (ft): 7116.70

North Bay at Lake Woodmoor
 UDSewer Input and Output Data
 Storm Sewer System A2 - 5yr

Manhole Input Summary:

Element Name	Ground Elevation (ft)	Given Flow		Sub Basin Information						
		Total Known Flow (cfs)	Local Contribution (cfs)	Drainage Area (Ac.)	Runoff Coefficient	Syr Coefficient	Overland Length (ft)	Overland Slope (%)	Gutter Length (ft)	Gutter Velocity (fps)
OUTFALL	7117.9	0	0	0	0	0	0	0	0	0
S5-4	7126.1	3.1	0	0	0	0	0	0	0	0
S5-3	7127.94	3.1	0	0	0	0	0	0	0	0
S5-2	7127	3.1	0	0	0	0	0	0	0	0
S5-1	7126.3	3.1	0	0	0	0	0	0	0	0
S4	7126.3	1.3	0	0	0	0	0	0	0	0

Manhole Output Summary:

Element Name	Local Contribution					Total Design Flow				Comment
	Overland Time (min)	Gutter Time (min)	Basin Tc (min)	Intensity (in/hr)	Local Contrib (cfs)	Coeff. Area	Intensity (in/hr)	Manhole Tc (min)	Peak Flow (cfs)	
OUTFALL	0	0	0	0	0	0.46	6.76	0.45	3.1	
S5-4	0	0	0	0	0	0	0	0	3.1	
S5-3	0	0	0	0	0	0	0	0	3.1	
S5-2	0	0	0	0	0	0	0	0	3.1	
S5-1	0	0	0	0	0	0	0	0	3.1	
S4	0	0	0	0	0	0	0	0	1.3	

Sewer Input Summary:

Element Name	Sewer Length (ft)	Elevation			Loss Coefficients			Given Dimensions		
		Downstream Invert (ft)	Slope (%)	Upstream Invert (ft)	Mannings n	Bend Loss	Lateral Loss	Cross Section	Rise (ft or in)	Span (ft or in)
S5-4	47.56	7116.1	1	7116.58	0.013	0	0	CIRCULAR	18.00 in	18.00 in
S5-3	98.69	7119.08	2.97	7122.01	0.013	0.39	1	CIRCULAR	18.00 in	18.00 in
S5-2	27.68	7122.11	0.61	7122.28	0.013	0.31	1	CIRCULAR	18.00 in	18.00 in
S5-1	16.81	7122.28	0.6	7122.38	0.013	0.43	1	CIRCULAR	18.00 in	18.00 in
S4	18.21	7122.48	0.6	7122.59	0.013	0.22	1	CIRCULAR	18.00 in	18.00 in

Sewer Flow Summary:

Element Name	Full Flow Capacity		Critical Flow		Normal Flow				Flow (cfs)	Surcharged Length (ft)	Comment
	Flow (cfs)	Velocity (fps)	Depth (in)	Velocity (fps)	Depth (in)	Velocity (fps)	Froude Number	Flow Condition			
S5-4	10.53	5.96	8.04	4.06	6.69	5.18	1.42	Supercritical	3.1	0	
S5-3	18.15	10.27	8.04	4.06	5.03	7.67	2.47	Supercritical	3.1	0	
S5-2	8.23	4.66	8.04	4.06	7.66	4.33	1.1	Supercritical	3.1	0	
S5-1	8.16	4.62	8.04	4.06	7.69	4.3	1.09	Supercritical	3.1	0	
S4	8.16	4.62	5.12	3.14	4.86	3.38	1.11	Supercritical	1.3	0	

A Froude number of 0 indicates that pressured flow occurs (adverse slope or undersized pipe).

If the sewer is not pressurized, full flow represents the maximum gravity flow in the sewer.

If the sewer is pressurized, full flow represents the pressurized flow conditions.

Sewer Sizing Summary:

Element Name	Peak Flow (cfs)	Cross Section	Existing		Calculated		Used		Area (ft ²)	Comment
			Rise	Span	Rise	Span	Rise	Span		
S5-4	3.1	CIRCULAR	18.00 in	18.00 in	18.00 in	18.00 in	18.00 in	18.00 in	1.77	
S5-3	3.1	CIRCULAR	18.00 in	18.00 in	18.00 in	18.00 in	18.00 in	18.00 in	1.77	
S5-2	3.1	CIRCULAR	18.00 in	18.00 in	18.00 in	18.00 in	18.00 in	18.00 in	1.77	
S5-1	3.1	CIRCULAR	18.00 in	18.00 in	18.00 in	18.00 in	18.00 in	18.00 in	1.77	
S4	1.3	CIRCULAR	18.00 in	18.00 in	18.00 in	18.00 in	18.00 in	18.00 in	1.77	

Calculated diameter was determined by sewer hydraulic capacity rounded up to the nearest commercially available size.

Sewer sizes should not decrease downstream.

All hydraulics were calculated using the 'Used' parameters.

Grade Line Summary:

Tailwater Elevation (ft): 7116.70

Element Name	Invert Elev.		Downstream Manhole Losses		HGL		EGL		
	Downstream (ft)	Upstream (ft)	Bend Loss (ft)	Lateral Loss (ft)	Downstream (ft)	Upstream (ft)	Downstream (ft)	Friction Loss (ft)	Upstream (ft)
S5-4	7116.1	7116.58	0	0	7116.7	7117.25	7117.08	0.43	7117.51
S5-3	7119.08	7122.01	0.02	0	7119.5	7122.68	7120.41	2.52	7122.94
S5-2	7122.11	7122.28	0.01	0	7122.75	7122.95	7123.04	0.17	7123.21
S5-1	7122.28	7122.38	0.02	0	7123.05	7123.05	7123.23	0.08	7123.31
S4	7122.48	7122.59	0	0.04	7123.32	7123.32	7123.35	0.01	7123.36

Bend and Lateral losses only apply when there is an outgoing sewer. The system outfall, sewer #0, is not considered a sewer.

Bend loss = Bend K * V_{fi} ^ 2 / (2 * g)

Lateral loss = V_{fo} ^ 2 / (2 * g) - Junction Loss K * V_{fi} ^ 2 / (2 * g).

Friction loss is always Upstream EGL - Downstream EGL.

Excavation Estimate:

The trench side slope is 1.0 ft/ft

The minimum trench width is 2.00 ft

Element Name	Length (ft)	Wall (in)	Bedding (in)	Bottom Width (ft)	Downstream			Upstream			Volume (cu. yd)	Comment
					Top Width (ft)	Trench Depth (ft)	Cover (ft)	Top Width (ft)	Trench Depth (ft)	Cover (ft)		
S5-4	47.56	2.5	4	4.92	0	2.34	0.09	18.54	10.06	7.81	94.18	Sewer Too Shallow
S5-3	98.69	2.5	4	4.92	13.54	7.56	5.31	11.36	6.47	4.22	179.07	
S5-2	27.68	2.5	4	4.92	11.16	6.37	4.12	8.94	5.26	3.01	36.38	
S5-1	16.81	2.5	4	4.92	8.94	5.26	3.01	7.34	4.46	2.21	16.6	
S4	18.21	2.5	4	4.92	7.14	4.36	2.11	6.92	4.25	2	15.03	

Total earth volume for sewer trenches = 341 cubic yards.

The trench was estimated to have a bottom width equal to the outer pipe diameter plus 36 inches.

If the calculated width of the trench bottom is less than the minimum acceptable width, the minimum acceptable width was used.

The sewer wall thickness is equal to: (equivalent diameter in inches/12)+1 inches

The sewer bedding thickness is equal to:

Four inches for pipes less than 33 inches.

Six inches for pipes less than 60 inches.

Eight inches for all larger sizes.

Storm Sewer A2 - 5yr

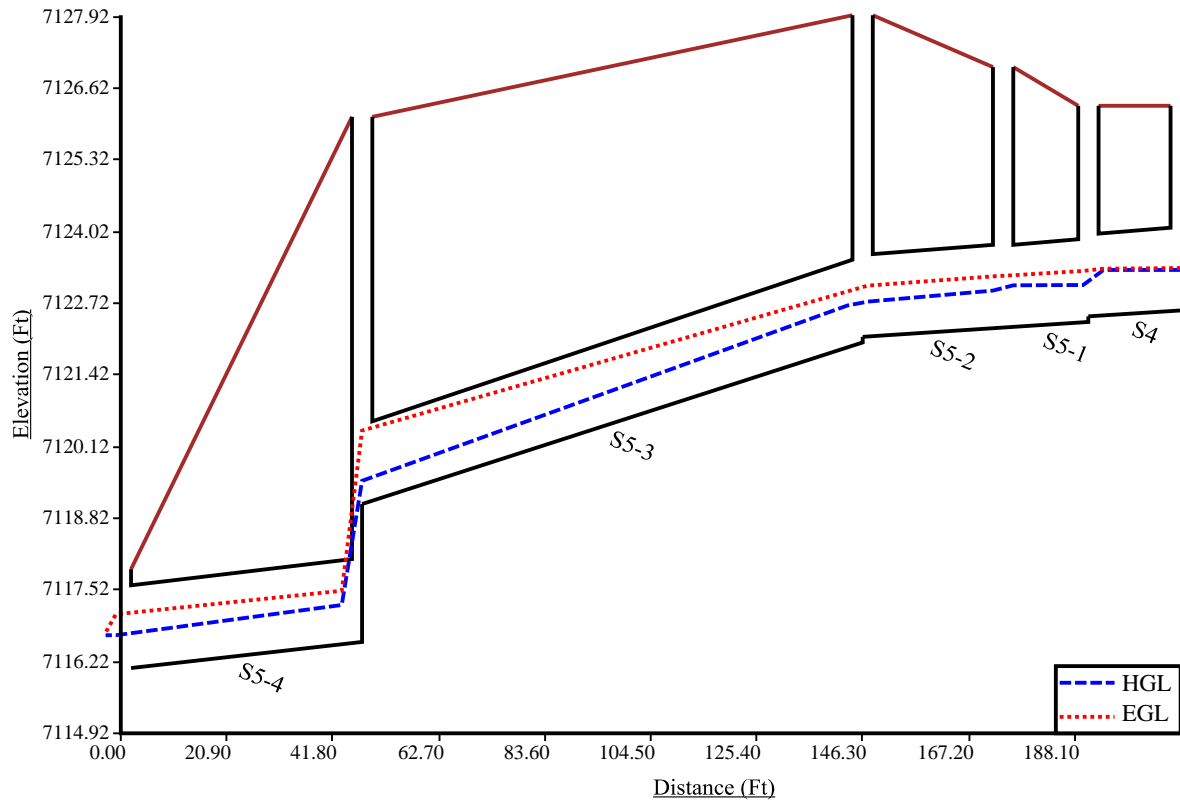

System Input Summary

Rainfall Parameters

Rainfall Return Period: 5
Rainfall Calculation Method: Formula

One Hour Depth (in): 1.50
Rainfall Constant "A": 28.5
Rainfall Constant "B": 10
Rainfall Constant "C": 0.786

Rational Method Constraints

Minimum Urban Runoff Coeff.: 0.20
Maximum Rural Overland Len. (ft): 500
Maximum Urban Overland Len. (ft): 300
Used UDFCD Tc. Maximum: No

Sizer Constraints

Minimum Sewer Size (in): 18.00
Maximum Depth to Rise Ratio: 0.90
Maximum Flow Velocity (fps): 18.0
Minimum Flow Velocity (fps): 2.0

Backwater Calculations:

Tailwater Elevation (ft): 7107.00

Manhole Input Summary:

Element Name	Ground Elevation (ft)	Given Flow		Sub Basin Information						
		Total Known Flow (cfs)	Local Contribution (cfs)	Drainage Area (Ac.)	Runoff Coefficient	Syr Coefficient	Overland Length (ft)	Overland Slope (%)	Gutter Length (ft)	Gutter Velocity (fps)
OUTFALL	7109.8	0	0	0	0	0	0	0	0	0
S6	7116.9	3.1	0	0	0	0	0	0	0	0

Manhole Output Summary:

Element Name	Local Contribution					Total Design Flow				Comment
	Overland Time (min)	Gutter Time (min)	Basin Tc (min)	Intensity (in/hr)	Local Contrib (cfs)	Coeff. Area	Intensity (in/hr)	Manhole Tc (min)	Peak Flow (cfs)	
OUTFALL	0	0	0	0	0	0.46	6.78	0.41	3.1	
S6	0	0	0	0	0	0	0	0	3.1	

Sewer Input Summary:

Element Name	Sewer Length (ft)	Elevation			Loss Coefficients			Given Dimensions		
		Downstream Invert (ft)	Slope (%)	Upstream Invert (ft)	Mannings n	Bend Loss	Lateral Loss	Cross Section	Rise (ft or in)	Span (ft or in)
S6	42.69	7108	2.5	7109.07	0.013	0	0	CIRCULAR	18.00 in	18.00 in

Sewer Flow Summary:

Element Name	Full Flow Capacity		Critical Flow		Normal Flow				Flow (cfs)	Surcharged Length (ft)	Comment
	Flow (cfs)	Velocity (fps)	Depth (in)	Velocity (fps)	Depth (in)	Velocity (fps)	Froude Number	Flow Condition			
S6	16.65	9.42	8.04	4.06	5.26	7.21	2.26	Supercritical	3.1	0	

A Froude number of 0 indicates that pressured flow occurs (adverse slope or undersized pipe).

If the sewer is not pressurized, full flow represents the maximum gravity flow in the sewer.

If the sewer is pressurized, full flow represents the pressurized flow conditions.

Sewer Sizing Summary:

Element Name	Peak Flow (cfs)	Cross Section	Existing		Calculated		Used			Comment
			Rise	Span	Rise	Span	Rise	Span	Area (ft ²)	
S6	3.1	CIRCULAR	18.00 in	18.00 in	18.00 in	18.00 in	18.00 in	18.00 in	1.77	

Calculated diameter was determined by sewer hydraulic capacity rounded up to the nearest commercially available size.

Sewer sizes should not decrease downstream.

All hydraulics were calculated using the 'Used' parameters.

Grade Line Summary:

Tailwater Elevation (ft): 7107.00

Element Name	Invert Elev.		Downstream Manhole Losses		HGL		EGL		
	Downstream (ft)	Upstream (ft)	Bend Loss (ft)	Lateral Loss (ft)	Downstream (ft)	Upstream (ft)	Downstream (ft)	Friction Loss (ft)	Upstream (ft)
S6	7108	7109.07	0	0	7108.44	7109.74	7109.25	0.75	7110

Bend and Lateral losses only apply when there is an outgoing sewer. The system outfall, sewer #0, is not considered a sewer.

Bend loss = Bend K * V_{fi}² / (2 * g)

Lateral loss = V_{fo}² / (2 * g) - Junction Loss K * V_{fi}² / (2 * g).

Friction loss is always Upstream EGL - Downstream EGL.

Excavation Estimate:

The trench side slope is 1.0 ft/ft

The minimum trench width is 2.00 ft

Element Name	Length (ft)	Wall (in)	Bedding (in)	Bottom Width (ft)	Downstream			Upstream			Volume (cu. yd)	Comment
					Top Width (ft)	Trench Depth (ft)	Cover (ft)	Top Width (ft)	Trench Depth (ft)	Cover (ft)		
S6	42.69	2.5	4	4.92	0	2.34	0.09	15.16	8.37	6.12	62.02	Sewer Too Shallow

Total earth volume for sewer trenches = 62 cubic yards.

The trench was estimated to have a bottom width equal to the outer pipe diameter plus 36 inches.

If the calculated width of the trench bottom is less than the minimum acceptable width, the minimum acceptable width was used.

The sewer wall thickness is equal to: (equivalent diameter in inches/12)+1 inches

The sewer bedding thickness is equal to:

Four inches for pipes less than 33 inches.

Six inches for pipes less than 60 inches.

Eight inches for all larger sizes.

Storm Sewer A3 - 5yr

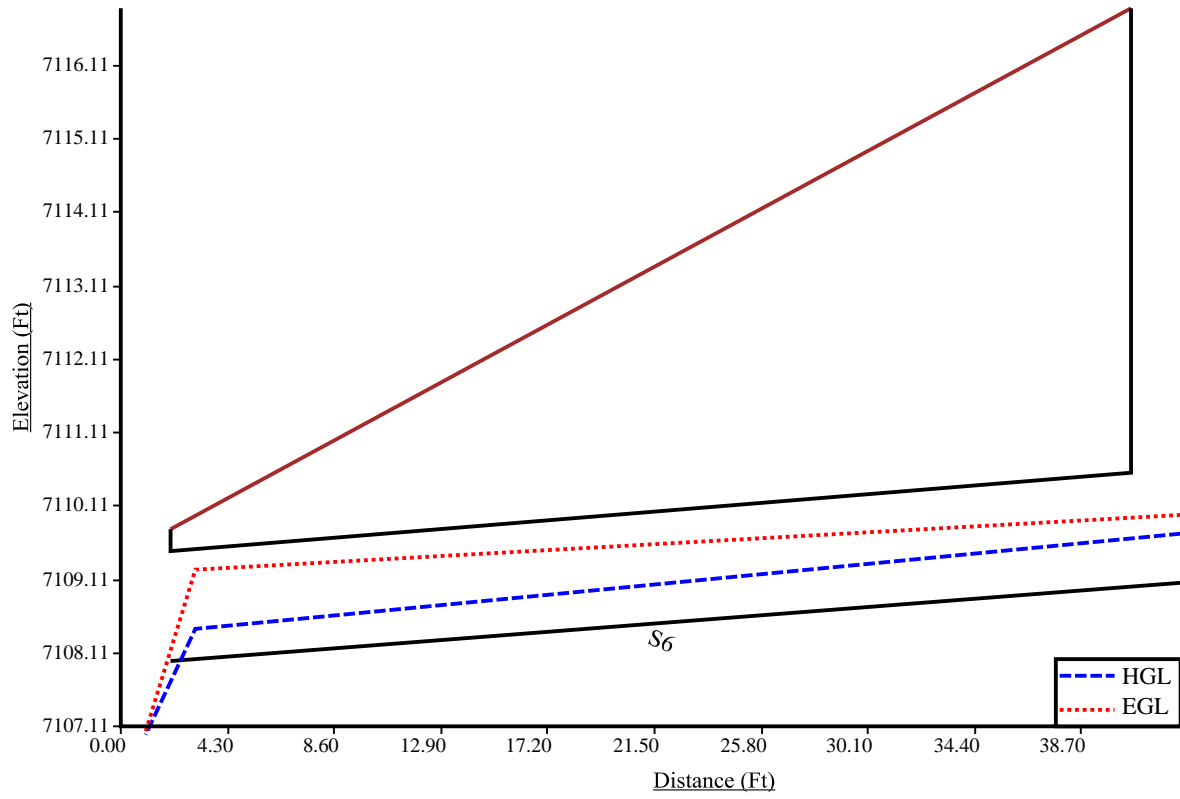

System Input Summary

Rainfall Parameters

Rainfall Return Period: 5
Rainfall Calculation Method: Formula

One Hour Depth (in): 1.50
Rainfall Constant "A": 28.5
Rainfall Constant "B": 10
Rainfall Constant "C": 0.786

Rational Method Constraints

Minimum Urban Runoff Coeff.: 0.20
Maximum Rural Overland Len. (ft): 500
Maximum Urban Overland Len. (ft): 300
Used UDFCD Tc. Maximum: No

Sizer Constraints

Minimum Sewer Size (in): 18.00
Maximum Depth to Rise Ratio: 0.90
Maximum Flow Velocity (fps): 18.0
Minimum Flow Velocity (fps): 2.0

Backwater Calculations:

Tailwater Elevation (ft): 7117.80

North Bay at Lake Woodmoor
 UDSewer Input and Output Data
 Storm Sewer System B1 - 5yr

Manhole Input Summary:

Element Name	Ground Elevation (ft)	Given Flow		Sub Basin Information						
		Total Known Flow (cfs)	Local Contribution (cfs)	Drainage Area (Ac.)	Runoff Coefficient	5yr Coefficient	Overland Length (ft)	Overland Slope (%)	Gutter Length (ft)	Gutter Velocity (fps)
OUTFALL	7119	0	0	0	0	0	0	0	0	0
S9-2	7121	3.4	0	0	0	0	0	0	0	0
S9-1	7123.47	3.4	0	0	0	0	0	0	0	0
S8	7123.47	2.7	0	0	0	0	0	0	0	0
S7-2	7126.5	1.6	0	0	0	0	0	0	0	0
S7-1	7127.23	1.6	0	0	0	0	0	0	0	0

Manhole Output Summary:

Element Name	Local Contribution				Total Design Flow					Comment
	Overland Time (min)	Gutter Time (min)	Basin Tc (min)	Intensity (in/hr)	Local Contrib (cfs)	Coeff. Area	Intensity (in/hr)	Manhole Tc (min)	Peak Flow (cfs)	
OUTFALL	0	0	0	0	0	0	0	0	3.4	
S9-2	0	0	0	0	0	0	0	0	3.4	
S9-1	0	0	0	0	0	0	0	0	3.4	
S8	0	0	0	0	0	0	0	0	2.7	
S7-2	0	0	0	0	0	0	0	0	1.6	
S7-1	0	0	0	0	0	0	0	0	1.6	

Sewer Input Summary:

Element Name	Sewer Length (ft)	Elevation			Loss Coefficients			Given Dimensions		
		Downstream Invert (ft)	Slope (%)	Upstream Invert (ft)	Mannings n	Bend Loss	Lateral Loss	Cross Section	Rise (ft or in)	Span (ft or in)
S9-2	49.19	7117.2	1	7117.69	0.013	0	0	CIRCULAR	18.00 in	18.00 in
S9-1	28.02	7117.79	1	7118.07	0.013	0.09	1	CIRCULAR	18.00 in	18.00 in
S8	25.34	7119.87	1.58	7120.27	0.013	0.53	1	CIRCULAR	18.00 in	18.00 in
S7-2	124.87	7120.37	1.62	7122.39	0.013	1.31	1	CIRCULAR	18.00 in	18.00 in
S7-1	52.44	7122.39	1.6	7123.23	0.013	0.09	1	CIRCULAR	18.00 in	18.00 in

North Bay at Lake Woodmoor
 UDSewer Input and Output Data
 Storm Sewer System B1 - 5yr

Sewer Flow Summary:

Element Name	Full Flow Capacity		Critical Flow		Normal Flow				Flow (cfs)	Surcharged Length (ft)	Comment
	Flow (cfs)	Velocity (fps)	Depth (in)	Velocity (fps)	Depth (in)	Velocity (fps)	Froude Number	Flow Condition			
S9-2	10.53	5.96	8.44	4.18	7.03	5.32	1.42	Supercritical	3.4	0	
S9-1	10.53	5.96	8.44	4.18	7.03	5.32	1.42	Supercritical	3.4	0	
S8	13.24	7.49	7.48	3.89	5.51	5.88	1.8	Supercritical	2.7	0	
S7-2	13.41	7.59	5.7	3.33	4.2	5.11	1.81	Supercritical	1.6	0	
S7-1	13.32	7.54	5.7	3.33	4.21	5.09	1.8	Supercritical	1.6	0	

A Froude number of 0 indicates that pressurized flow occurs (adverse slope or undersized pipe).
 If the sewer is not pressurized, full flow represents the maximum gravity flow in the sewer.
 If the sewer is pressurized, full flow represents the pressurized flow conditions.

Sewer Sizing Summary:

Element Name	Peak Flow (cfs)	Cross Section	Existing		Calculated		Used			Comment
			Rise	Span	Rise	Span	Rise	Span	Area (ft^2)	
S9-2	3.4	CIRCULAR	18.00 in	18.00 in	18.00 in	18.00 in	18.00 in	18.00 in	1.77	
S9-1	3.4	CIRCULAR	18.00 in	18.00 in	18.00 in	18.00 in	18.00 in	18.00 in	1.77	
S8	2.7	CIRCULAR	18.00 in	18.00 in	18.00 in	18.00 in	18.00 in	18.00 in	1.77	
S7-2	1.6	CIRCULAR	18.00 in	18.00 in	18.00 in	18.00 in	18.00 in	18.00 in	1.77	
S7-1	1.6	CIRCULAR	18.00 in	18.00 in	18.00 in	18.00 in	18.00 in	18.00 in	1.77	

Calculated diameter was determined by sewer hydraulic capacity rounded up to the nearest commercially available size.

Sewer sizes should not decrease downstream.
 All hydraulics were calculated using the 'Used' parameters.

Grade Line Summary:

Tailwater Elevation (ft): 7117.80

Element Name	Invert Elev.		Downstream Manhole Losses		HGL		EGL		
	Downstream (ft)	Upstream (ft)	Bend Loss (ft)	Lateral Loss (ft)	Downstream (ft)	Upstream (ft)	Downstream (ft)	Friction Loss (ft)	Upstream (ft)
S9-2	7117.2	7117.69	0	0	7117.8	7118.39	7118.22	0.44	7118.66
S9-1	7117.79	7118.07	0.01	0	7118.4	7118.77	7118.81	0.23	7119.04
S8	7119.87	7120.27	0.02	0.02	7120.33	7120.89	7120.87	0.26	7121.13
S7-2	7120.37	7122.39	0.02	0.02	7121.12	7122.87	7121.17	1.87	7123.04
S7-1	7122.39	7123.23	0	0	7122.87	7123.71	7123.14	0.73	7123.88

Bend and Lateral losses only apply when there is an outgoing sewer. The system outfall, sewer #0, is not considered a sewer.

Bend loss = Bend $K * V_{fi}^2 / (2 * g)$

Lateral loss = $V_{fo}^2 / (2 * g)$ - Junction Loss $K * V_{fi}^2 / (2 * g)$.

Friction loss is always Upstream EGL - Downstream EGL.

Excavation Estimate:

The trench side slope is 1.0 ft/ft

The minimum trench width is 2.00 ft

Element Name	Length (ft)	Wall (in)	Bedding (in)	Bottom Width (ft)	Downstream			Upstream			Volume (cu. yd)	Comment
					Top Width (ft)	Trench Depth (ft)	Cover (ft)	Top Width (ft)	Trench Depth (ft)	Cover (ft)		
S9-2	49.19	2.5	4	4.92	0	2.34	0.09	6.12	3.85	1.6	27.66	Sewer Too Shallow
S9-1	28.02	2.5	4	4.92	5.92	3.75	1.5	10.3	5.94	3.69	28.62	Sewer Too Shallow
S8	25.34	2.5	4	4.92	6.7	4.14	1.89	5.9	3.74	1.49	18.68	Sewer Too Shallow
S7-2	124.87	2.5	4	4.92	5.71	3.64	1.39	7.72	4.65	2.4	99.23	Sewer Too Shallow
S7-1	52.44	2.5	4	4.92	7.72	4.65	2.4	7.5	4.54	2.29	47.42	

Total earth volume for sewer trenches = 222 cubic yards.

The trench was estimated to have a bottom width equal to the outer pipe diameter plus 36 inches.

If the calculated width of the trench bottom is less than the minimum acceptable width, the minimum acceptable width was used.

The sewer wall thickness is equal to: (equivalent diameter in inches/12)+1 inches

The sewer bedding thickness is equal to:

Four inches for pipes less than 33 inches.

Six inches for pipes less than 60 inches.

Eight inches for all larger sizes.

Storm Sewer System B1 - 5yr

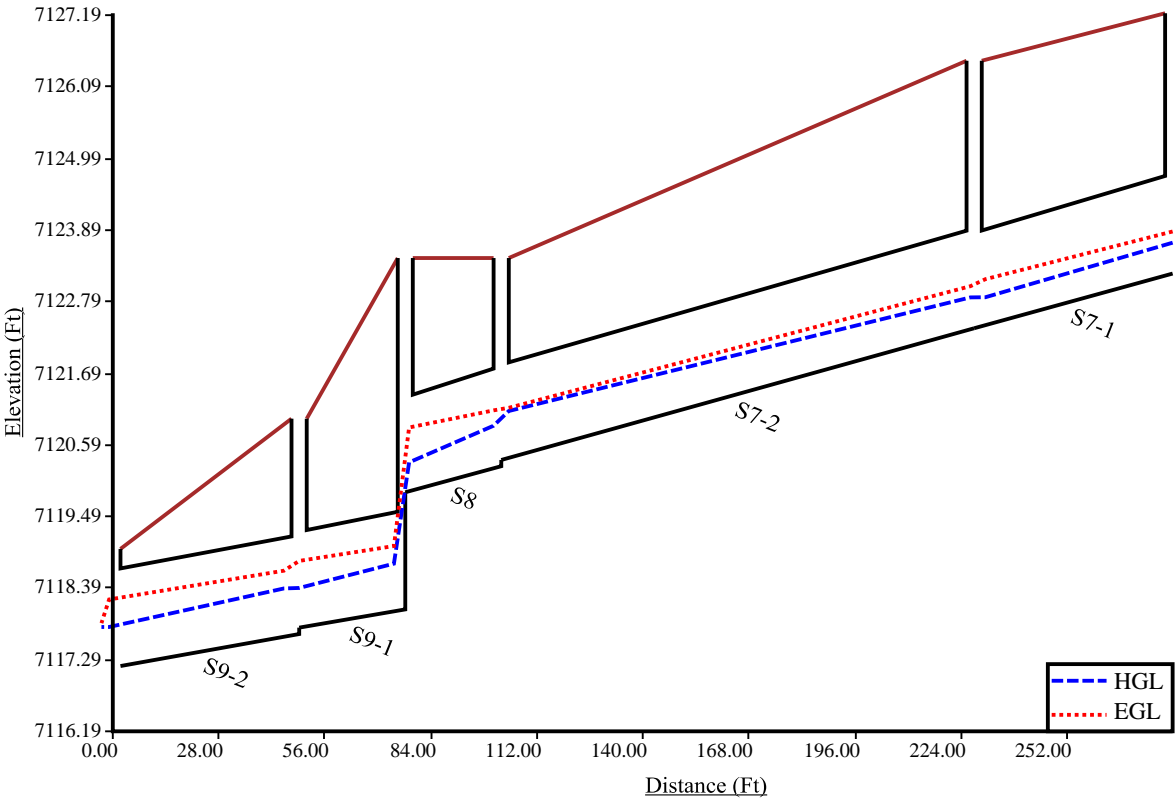

System Input Summary

Rainfall Parameters

Rainfall Return Period: 5
Rainfall Calculation Method: Formula

One Hour Depth (in): 1.50
Rainfall Constant "A": 28.5
Rainfall Constant "B": 10
Rainfall Constant "C": 0.786

Rational Method Constraints

Minimum Urban Runoff Coeff.: 0.20
Maximum Rural Overland Len. (ft): 500
Maximum Urban Overland Len. (ft): 300
Used UDFCD Tc. Maximum: No

Sizer Constraints

Minimum Sewer Size (in): 18.00
Maximum Depth to Rise Ratio: 0.90
Maximum Flow Velocity (fps): 18.0
Minimum Flow Velocity (fps): 2.0

Backwater Calculations:

Tailwater Elevation (ft): 7107.00

North Bay at Lake Woodmoor
 UD Sewer Input and Output Data
 Storm Sewer System B2 - 5yr

Manhole Input Summary:

Element Name	Ground Elevation (ft)	Given Flow		Sub Basin Information						
		Total Known Flow (cfs)	Local Contribution (cfs)	Drainage Area (Ac.)	Runoff Coefficient	5yr Coefficient	Overland Length (ft)	Overland Slope (%)	Gutter Length (ft)	Gutter Velocity (fps)
OUTFALL	7109.8	0	0	0	0	0	0	0	0	0
S10-2	7116	3.6	0	0	0	0	0	0	0	0
S10-1	7118	3.6	0	0	0	0	0	0	0	0

Manhole Output Summary:

Element Name	Local Contribution					Total Design Flow				Comment
	Overland Time (min)	Gutter Time (min)	Basin Tc (min)	Intensity (in/hr)	Local Contrib (cfs)	Coeff. Area	Intensity (in/hr)	Manhole Tc (min)	Peak Flow (cfs)	
OUTFALL	0	0	0	0	0	0.53	6.79	0.4	3.6	
S10-2	0	0	0	0	0	0	0	0	3.6	
S10-1	0	0	0	0	0	0	0	0	3.6	

Sewer Input Summary:

Element Name	Sewer Length (ft)	Elevation			Loss Coefficients			Given Dimensions		
		Downstream Invert (ft)	Slope (%)	Upstream Invert (ft)	Mannings n	Bend Loss	Lateral Loss	Cross Section	Rise (ft or in)	Span (ft or in)
S10-2	48.82	7108	1	7108.49	0.013	0	0	CIRCULAR	18.00 in	18.00 in
S10-1	24.73	7111	5.5	7112.36	0.013	0.63	1	CIRCULAR	18.00 in	18.00 in

Sewer Flow Summary:

Element Name	Full Flow Capacity		Critical Flow		Normal Flow				Flow (cfs)	Surcharged Length (ft)	Comment
	Flow (cfs)	Velocity (fps)	Depth (in)	Velocity (fps)	Depth (in)	Velocity (fps)	Froude Number	Flow Condition			
S10-2	10.53	5.96	8.69	4.26	7.26	5.4	1.41	Supercritical	3.6	0	
S10-1	24.7	13.98	8.69	4.26	4.64	9.97	3.35	Supercritical	3.6	0	

A Froude number of 0 indicates that pressurized flow occurs (adverse slope or undersized pipe).
 If the sewer is not pressurized, full flow represents the maximum gravity flow in the sewer.
 If the sewer is pressurized, full flow represents the pressurized flow conditions.

Sewer Sizing Summary:

Element Name	Peak Flow (cfs)	Cross Section	Existing		Calculated		Used		Area (ft^2)	Comment
			Rise	Span	Rise	Span	Rise	Span		
S10-2	3.6	CIRCULAR	18.00 in	18.00 in	18.00 in	18.00 in	18.00 in	18.00 in	1.77	
S10-1	3.6	CIRCULAR	18.00 in	18.00 in	18.00 in	18.00 in	18.00 in	18.00 in	1.77	

Calculated diameter was determined by sewer hydraulic capacity rounded up to the nearest commercially available size.
 Sewer sizes should not decrease downstream.
 All hydraulics were calculated using the 'Used' parameters.

Grade Line Summary:

Tailwater Elevation (ft): 7107.00

Element Name	Invert Elev.		Downstream Manhole Losses		HGL		EGL		
	Downstream (ft)	Upstream (ft)	Bend Loss (ft)	Lateral Loss (ft)	Downstream (ft)	Upstream (ft)	Downstream (ft)	Friction Loss (ft)	Upstream (ft)
S10-2	7108	7108.49	0	0	7108.61	7109.21	7109.06	0.44	7109.5
S10-1	7111	7112.36	0.04	0	7111.39	7113.08	7112.93	0.44	7113.37

Bend and Lateral losses only apply when there is an outgoing sewer. The system outfall, sewer #0, is not considered a sewer.

Bend loss = Bend K * V_{fi}² / (2 * g)

Lateral loss = V_{fo}² / (2 * g) - Junction Loss K * V_{fi}² / (2 * g).

Friction loss is always Upstream EGL - Downstream EGL.

Excavation Estimate:

The trench side slope is 1.0 ft/ft

The minimum trench width is 2.00 ft

Element Name	Length (ft)	Wall (in)	Bedding (in)	Bottom Width (ft)	Downstream			Upstream			Volume (cu. yd)	Comment
					Top Width (ft)	Trench Depth (ft)	Cover (ft)	Top Width (ft)	Trench Depth (ft)	Cover (ft)		
S10-2	48.82	2.5	4	4.92	0	2.34	0.09	14.52	8.05	5.8	66.64	Sewer Too Shallow
S10-1	24.73	2.5	4	4.92	9.5	5.54	3.29	10.78	6.18	3.93	32.74	

Total earth volume for sewer trenches = 99 cubic yards.

The trench was estimated to have a bottom width equal to the outer pipe diameter plus 36 inches.

If the calculated width of the trench bottom is less than the minimum acceptable width, the minimum acceptable width was used.

The sewer wall thickness is equal to: (equivalent diameter in inches/12)+1 inches

The sewer bedding thickness is equal to:

Four inches for pipes less than 33 inches.

Six inches for pipes less than 60 inches.

Eight inches for all larger sizes.

Storm Sewer System B2 - 5yr

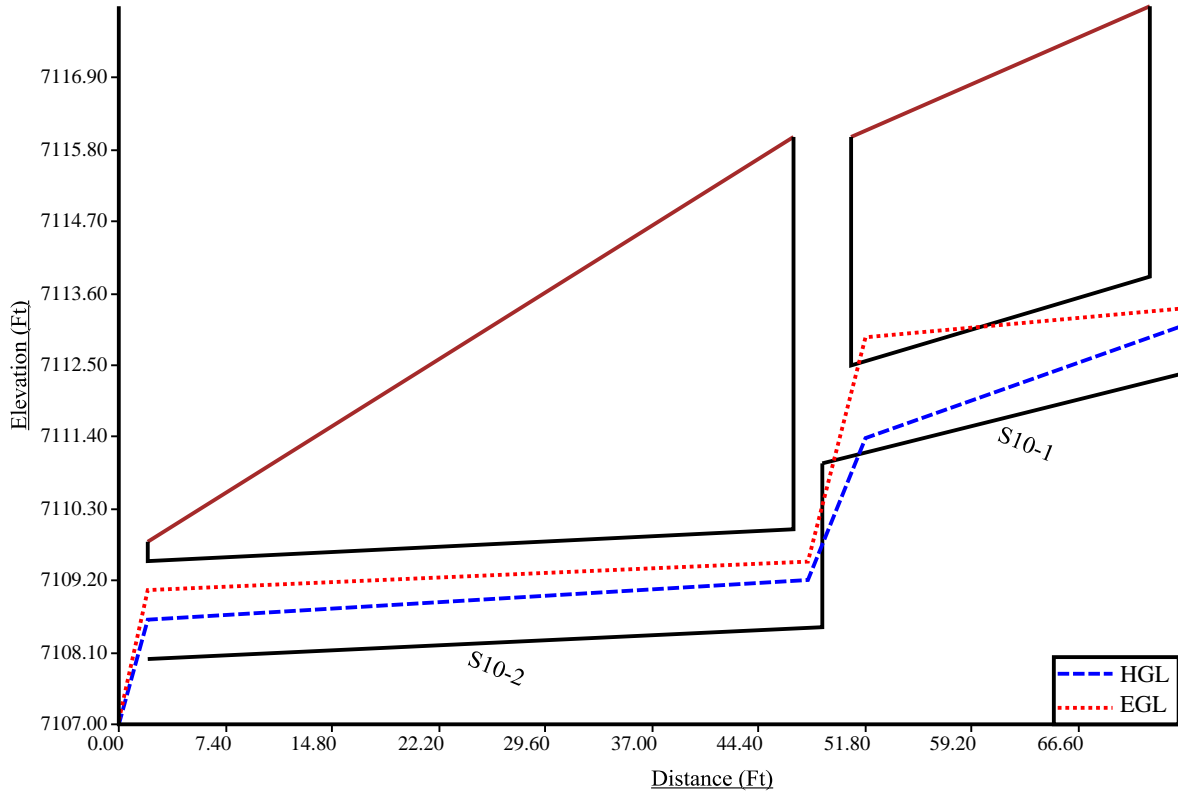

System Input Summary

Rainfall Parameters

Rainfall Return Period: 5
Rainfall Calculation Method: Formula

One Hour Depth (in): 1.50
Rainfall Constant "A": 28.5
Rainfall Constant "B": 10
Rainfall Constant "C": 0.786

Rational Method Constraints

Minimum Urban Runoff Coeff.: 0.20
Maximum Rural Overland Len. (ft): 500
Maximum Urban Overland Len. (ft): 300
Used UDFCD Tc. Maximum: No

Sizer Constraints

Minimum Sewer Size (in): 18.00
Maximum Depth to Rise Ratio: 0.90
Maximum Flow Velocity (fps): 18.0
Minimum Flow Velocity (fps): 2.0

Backwater Calculations:

Tailwater Elevation (ft): 7114.30

North Bay at Lake Woodmoor
 UDSewer Input and Output Data
 Storm Sewer System C - 5yr

Manhole Input Summary:

Element Name	Ground Elevation (ft)	Given Flow		Sub Basin Information						
		Total Known Flow (cfs)	Local Contribution (cfs)	Drainage Area (Ac.)	Runoff Coefficient	5yr Coefficient	Overland Length (ft)	Overland Slope (%)	Gutter Length (ft)	Gutter Velocity (fps)
OUTFALL	7116.2	0	0	0	0	0	0	0	0	0
S11	7118.8	1.1	0	0	0	0	0	0	0	0

Manhole Output Summary:

Element Name	Local Contribution				Total Design Flow				Comment	
	Overland Time (min)	Gutter Time (min)	Basin Tc (min)	Intensity (in/hr)	Local Contrib (cfs)	Coeff. Area	Intensity (in/hr)	Manhole Tc (min)		Peak Flow (cfs)
OUTFALL	0	0	0	0	0	0.16	6.87	0.25	1.1	
S11	0	0	0	0	0	0	0	0	1.1	

Sewer Input Summary:

Element Name	Sewer Length (ft)	Elevation			Loss Coefficients			Given Dimensions		
		Downstream Invert (ft)	Slope (%)	Upstream Invert (ft)	Mannings n	Bend Loss	Lateral Loss	Cross Section	Rise (ft or in)	Span (ft or in)
S11	10.67	7114.3	0.94	7114.4	0.013	0	0	ELLIPSE	14.00 in	23.00 in

Sewer Flow Summary:

Element Name	Full Flow Capacity		Critical Flow		Normal Flow				Flow (cfs)	Surcharged Length (ft)	Comment
	Flow (cfs)	Velocity (fps)	Depth (in)	Velocity (fps)	Depth (in)	Velocity (fps)	Froude Number	Flow Condition			
S11	10.12	6.68	4.66	2.98	3.95	3.76	1.38	Supercritical	1.1	0	

A Froude number of 0 indicates that pressurized flow occurs (adverse slope or undersized pipe).
 If the sewer is not pressurized, full flow represents the maximum gravity flow in the sewer.
 If the sewer is pressurized, full flow represents the pressurized flow conditions.

Sewer Sizing Summary:

Element Name	Peak Flow (cfs)	Cross Section	Existing		Calculated		Used		Area (ft ²)	Comment
			Rise	Span	Rise	Span	Rise	Span		
S11	1.1	ELLIPSE	14.00 in	23.00 in	18.00 in	18.00 in	14.00 in	23.00 in	1.52	Height is too small. Existing height is smaller than the suggested height.

Calculated diameter was determined by sewer hydraulic capacity rounded up to the nearest commercially available size.

Sewer sizes should not decrease downstream.

All hydraulics were calculated using the 'Used' parameters.

Grade Line Summary:

Tailwater Elevation (ft): 7114.30

Element Name	Invert Elev.		Downstream Manhole Losses		HGL		EGL		
	Downstream (ft)	Upstream (ft)	Bend Loss (ft)	Lateral Loss (ft)	Downstream (ft)	Upstream (ft)	Downstream (ft)	Friction Loss (ft)	Upstream (ft)
S11	7114.3	7114.4	0	0	7114.63	7114.79	7114.85	0.08	7114.93

Bend and Lateral losses only apply when there is an outgoing sewer. The system outfall, sewer #0, is not considered a sewer.

Bend loss = $Bend\ K * V_{fi}^2 / (2 * g)$

Lateral loss = $V_{fo}^2 / (2 * g) - Junction\ Loss\ K * V_{fi}^2 / (2 * g)$.

Friction loss is always Upstream EGL - Downstream EGL.

Excavation Estimate:

The trench side slope is 1.0 ft/ft

The minimum trench width is 2.00 ft

Element Name	Length (ft)	Wall (in)	Bedding (in)	Bottom Width (ft)	Downstream			Upstream			Volume (cu. yd)	Comment
					Top Width (ft)	Trench Depth (ft)	Cover (ft)	Top Width (ft)	Trench Depth (ft)	Cover (ft)		
S11	10.67	2.92	4	5.4	0	2.48	0.49	9.38	4.98	2.99	8.22	Sewer Too Shallow

Total earth volume for sewer trenches = 8 cubic yards.

The trench was estimated to have a bottom width equal to the outer pipe diameter plus 36 inches.

If the calculated width of the trench bottom is less than the minimum acceptable width, the minimum acceptable width was used.

The sewer wall thickness is equal to: (equivalent diameter in inches/12)+1 inches

The sewer bedding thickness is equal to:

Four inches for pipes less than 33 inches.

Six inches for pipes less than 60 inches.

Eight inches for all larger sizes.

Storm Sewer System C - 5yr

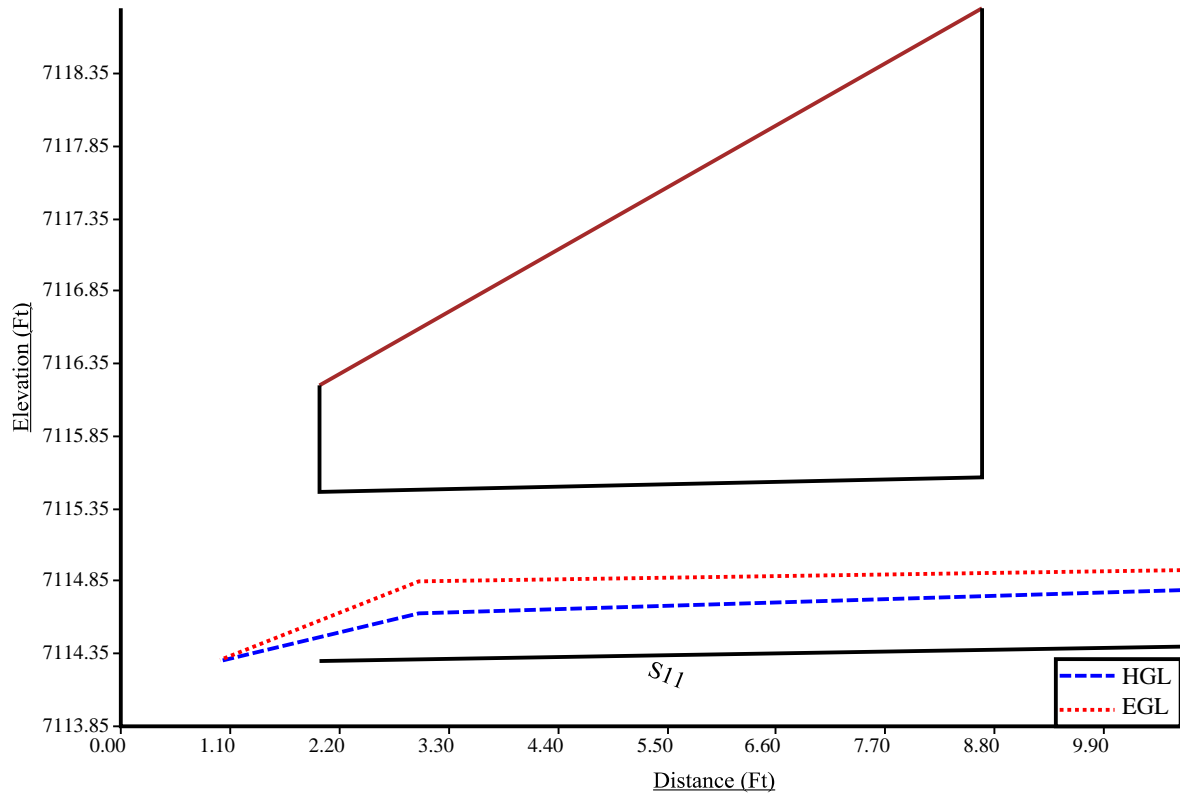

System Input Summary

Rainfall Parameters

Rainfall Return Period: 100
 Rainfall Calculation Method: Formula

One Hour Depth (in): 2.52
 Rainfall Constant "A": 28.5
 Rainfall Constant "B": 10
 Rainfall Constant "C": 0.786

Rational Method Constraints

Minimum Urban Runoff Coeff.: 0.20
 Maximum Rural Overland Len. (ft): 500
 Maximum Urban Overland Len. (ft): 300
 Used UDFCD Tc. Maximum: No

Sizer Constraints

Minimum Sewer Size (in): 18.00
 Maximum Depth to Rise Ratio: 0.90
 Maximum Flow Velocity (fps): 18.0
 Minimum Flow Velocity (fps): 2.0

Backwater Calculations:

Tailwater Elevation (ft): 7111.60

Manhole Input Summary:

Element Name	Ground Elevation (ft)	Given Flow		Sub Basin Information						
		Total Known Flow (cfs)	Local Contribution (cfs)	Drainage Area (Ac.)	Runoff Coefficient	5yr Coefficient	Overland Length (ft)	Overland Slope (%)	Gutter Length (ft)	Gutter Velocity (fps)
OUTFALL	7110.5	0	0	0	0	0	0	0	0	0
S3-3	7119.2	70	0	0	0	0	0	0	0	0
S3-2	7126.7	70	0	0	0	0	0	0	0	0
S3-1	7128	70	0	0	0	0	0	0	0	0
S1-2	7134.29	41.5	0	0	0	0	0	0	0	0
S1-1	7132.88	41.5	0	0	0	0	0	0	0	0
S2-2	7125	28.5	0	0	0	0	0	0	0	0
S2-1	7127	0.6	0	0	0	0	0	0	0	0

Manhole Output Summary:

Element Name	Local Contribution					Total Design Flow				Comment
	Overland Time (min)	Gutter Time (min)	Basin Tc (min)	Intensity (in/hr)	Local Contrib (cfs)	Coeff. Area	Intensity (in/hr)	Manhole Tc (min)	Peak Flow (cfs)	
OUTFALL	0	0	0	0	0	6.06	11.54	0.23	70	Surface Water Present (Upstream)
S3-3	0	0	0	0	0	0	0	0	70	Surface Water Present (Downstream)
S3-2	0	0	0	0	0	0	0	0	70	
S3-1	0	0	0	0	0	0	0	0	70	
S1-2	0	0	0	0	0	0	0	0	41.5	
S1-1	0	0	0	0	0	0	0	0	41.5	
S2-2	0	0	0	0	0	0	0	0	28.5	
S2-1	0	0	0	0	0	0	0	0	0.6	

Sewer Input Summary:

Element Name	Sewer Length (ft)	Elevation			Loss Coefficients			Given Dimensions		
		Downstream Invert (ft)	Slope (%)	Upstream Invert (ft)	Mannings n	Bend Loss	Lateral Loss	Cross Section	Rise (ft or in)	Span (ft or in)
S3-3	138.73	7107.07	0.9	7108.32	0.013	0	0	CIRCULAR	36.00 in	36.00 in
S3-2	164.18	7108.66	2.9	7113.42	0.013	0.05	1	CIRCULAR	36.00 in	36.00 in
S3-1	84.25	7113.52	1	7114.36	0.013	0.41	1	CIRCULAR	36.00 in	36.00 in
S1-2	155.5	7117.8	2.83	7122.2	0.019	1.01	0	CIRCULAR	24.00 in	24.00 in
S1-1	18.08	7122.2	18.8	7125.6	0.016	0.3	1	CIRCULAR	24.00 in	24.00 in
S2-2	74.38	7114.86	1	7115.6	0.013	1	0.25	CIRCULAR	30.00 in	30.00 in
S2-1	87.82	7120.72	2.93	7123.29	0.013	0.05	0.26	CIRCULAR	18.00 in	18.00 in

Sewer Flow Summary:

Element Name	Full Flow Capacity		Critical Flow		Normal Flow				Flow (cfs)	Surcharged Length (ft)	Comment
	Flow (cfs)	Velocity (fps)	Depth (in)	Velocity (fps)	Depth (in)	Velocity (fps)	Froude Number	Flow Condition			
S3-3	63.45	8.98	36	9.9	36	9.9	0	Pressurized	70	138.73	
S3-2	113.89	16.11	31.89	10.57	20.4	16.94	2.53	Supercritical Jump	70	85.2	
S3-1	66.88	9.46	36	9.9	36	9.9	0	Pressurized	70	84.25	
S1-2	26.11	8.31	24	13.21	24	13.21	0	Pressurized	41.5	155.5	
S1-1	79.91	25.44	23.5	13.28	12.27	25.68	5.03	Pressurized	41.5	18.08	Velocity is Too High
S2-2	41.13	8.38	21.84	7.44	18.37	9.05	1.4	Pressurized	28.5	74.38	
S2-1	18.03	10.2	3.45	2.54	2.25	4.71	2.32	Supercritical	0.6	0	

A Froude number of 0 indicates that pressured flow occurs (adverse slope or undersized pipe).
 If the sewer is not pressurized, full flow represents the maximum gravity flow in the sewer.
 If the sewer is pressurized, full flow represents the pressurized flow conditions.

Sewer Sizing Summary:

Element Name	Peak Flow (cfs)	Cross Section	Existing		Calculated		Used			Comment
			Rise	Span	Rise	Span	Rise	Span	Area (ft^2)	
S3-3	70	CIRCULAR	36.00 in	36.00 in	42.00 in	42.00 in	36.00 in	36.00 in	7.07	Existing height is smaller than the suggested height. Existing width is smaller than the suggested width. Exceeds max. Depth/Rise
S3-2	70	CIRCULAR	36.00 in	36.00 in	33.00 in	33.00 in	36.00 in	36.00 in	7.07	
S3-1	70	CIRCULAR	36.00 in	36.00 in	42.00 in	42.00 in	36.00 in	36.00 in	7.07	Existing height is smaller than the suggested height. Existing width is smaller than the suggested width. Exceeds max. Depth/Rise
S1-2	41.5	CIRCULAR	24.00 in	24.00 in	30.00 in	30.00 in	24.00 in	24.00 in	3.14	Existing height is smaller than the suggested height. Existing width is smaller than the suggested width. Exceeds max. Depth/Rise
S1-1	41.5	CIRCULAR	24.00 in	24.00 in	21.00 in	21.00 in	24.00 in	24.00 in	3.14	
S2-2	28.5	CIRCULAR	30.00 in	30.00 in	27.00 in	27.00 in	30.00 in	30.00 in	4.91	
S2-1	0.6	CIRCULAR	18.00 in	18.00 in	18.00 in	18.00 in	18.00 in	18.00 in	1.77	

Calculated diameter was determined by sewer hydraulic capacity rounded up to the nearest commercially available size.

Sewer sizes should not decrease downstream.

All hydraulics were calculated using the 'Used' parameters.

Grade Line Summary:

Tailwater Elevation (ft): 7111.60

Element Name	Invert Elev.		Downstream Manhole Losses		HGL		EGL		
	Downstream (ft)	Upstream (ft)	Bend Loss (ft)	Lateral Loss (ft)	Downstream (ft)	Upstream (ft)	Downstream (ft)	Friction Loss (ft)	Upstream (ft)
S3-3	7107.07	7108.32	0	0	7111.6	7113.12	7113.12	1.52	7114.64
S3-2	7108.66	7113.42	0.08	0	7113.2	7116.08	7114.72	3.09	7117.81
S3-1	7113.52	7114.36	0.62	0	7116.91	7117.84	7118.44	0.92	7119.36
S1-2	7117.8	7122.2	2.74	0	7120.57	7130.92	7122.51	11.12	7133.63
S1-1	7122.2	7125.6	0.81	0	7131.73	7132.65	7134.44	0.92	7135.36
S2-2	7114.86	7115.6	0.52	1.39	7120.75	7121.11	7121.28	0.36	7121.63
S2-1	7120.72	7123.29	0	0.52	7122.15	7123.58	7122.16	1.52	7123.68

Bend and Lateral losses only apply when there is an outgoing sewer. The system outfall, sewer #0, is not considered a sewer.

Bend loss = $Bend\ K * V_{fi}^2 / (2 * g)$

Lateral loss = $V_{fo}^2 / (2 * g) - Junction\ Loss\ K * V_{fi}^2 / (2 * g)$.

Friction loss is always Upstream EGL - Downstream EGL.

Excavation Estimate:

The trench side slope is 1.0 ft/ft

The minimum trench width is 2.00 ft

Element Name	Length (ft)	Wall (in)	Bedding (in)	Bottom Width (ft)	Downstream			Upstream			Volume (cu. yd)	Comment
					Top Width (ft)	Trench Depth (ft)	Cover (ft)	Top Width (ft)	Trench Depth (ft)	Cover (ft)		
S3-3	138.73	4	6	6.67	0	4.26	0.1	19.76	11.71	7.55	382.09	Sewer Too Shallow
S3-2	164.18	4	6	6.67	19.08	11.37	7.21	24.56	14.11	9.95	877.15	
S3-1	84.25	4	6	6.67	24.37	14.02	9.85	25.28	14.47	10.31	553.63	
S1-2	155.5	3	4	5.5	19.4	10.78	7.95	23.18	12.67	9.84	735.67	
S1-1	18.08	3	4	5.5	23.18	12.67	9.84	13.56	7.86	5.03	69.41	
S2-2	74.38	3.5	6	6.08	24.79	13.94	10.35	17.3	10.19	6.61	365.96	
S2-1	87.82	2.5	4	4.92	8.07	4.82	2.57	6.92	4.25	2	78.24	

Total earth volume for sewer trenches = 3062 cubic yards.

The trench was estimated to have a bottom width equal to the outer pipe diameter plus 36 inches.

If the calculated width of the trench bottom is less than the minimum acceptable width, the minimum acceptable width was used.

The sewer wall thickness is equal to: (equivalent diameter in inches/12)+1 inches

The sewer bedding thickness is equal to:

Four inches for pipes less than 33 inches.

Six inches for pipes less than 60 inches.

Eight inches for all larger sizes.

Storm Sewer A1 - 100yr

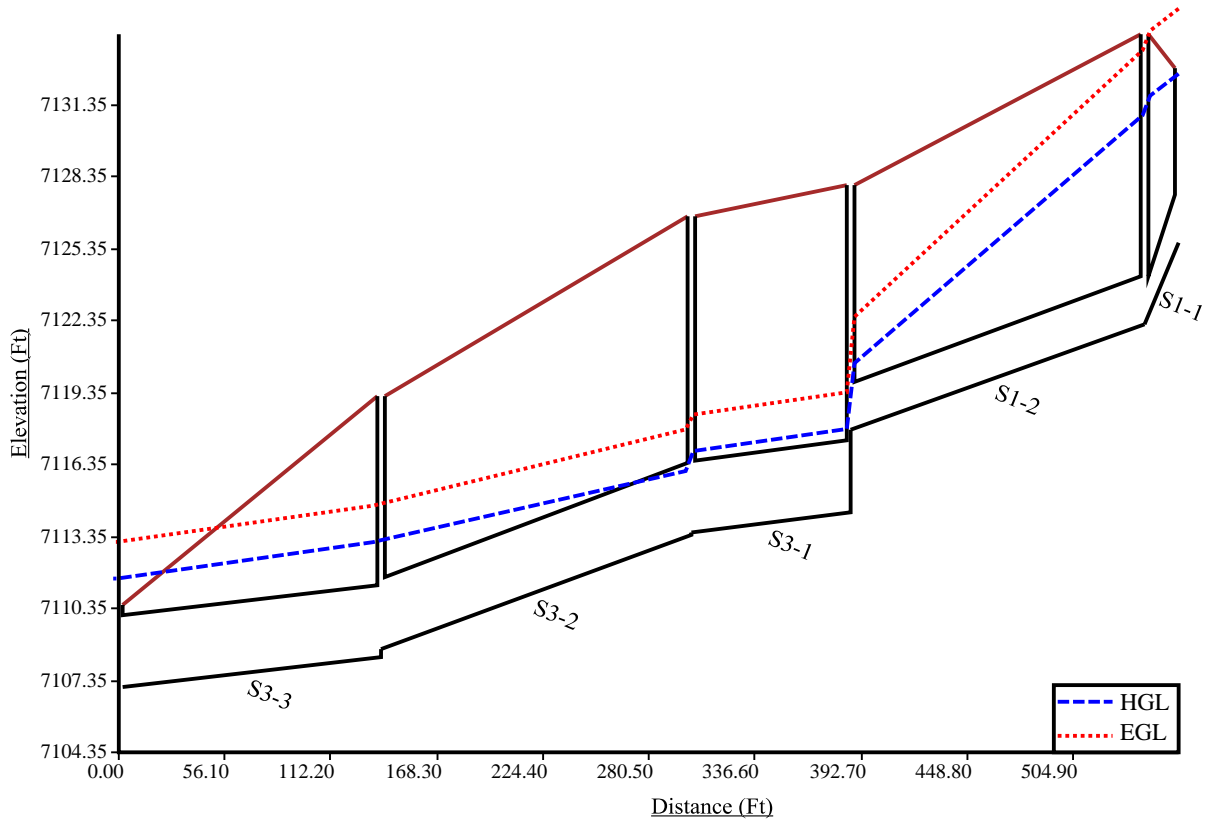

Storm Sewer A1a - 100yr

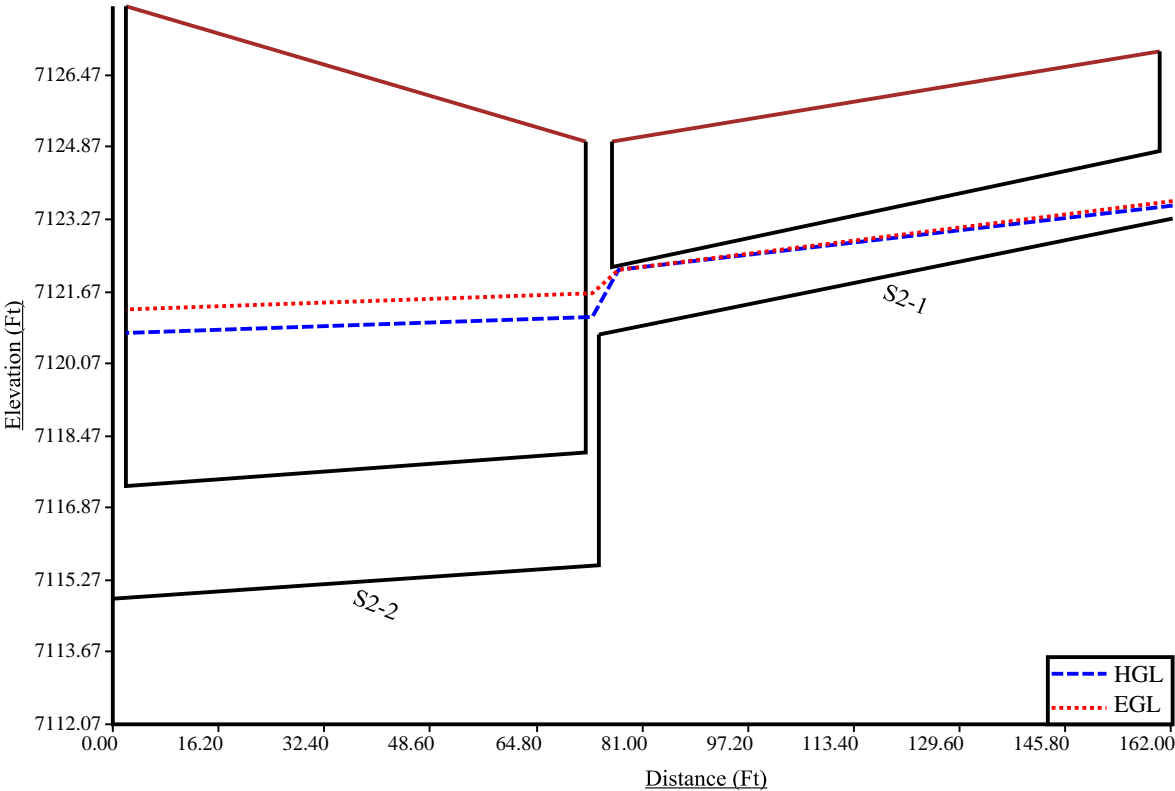

S3-1

System Input Summary

Rainfall Parameters

Rainfall Return Period: 100
Rainfall Calculation Method: Formula

One Hour Depth (in): 2.52
Rainfall Constant "A": 28.5
Rainfall Constant "B": 10
Rainfall Constant "C": 0.786

Rational Method Constraints

Minimum Urban Runoff Coeff.: 0.20
Maximum Rural Overland Len. (ft): 500
Maximum Urban Overland Len. (ft): 300
Used UDFCD Tc. Maximum: No

Sizer Constraints

Minimum Sewer Size (in): 18.00
Maximum Depth to Rise Ratio: 0.90
Maximum Flow Velocity (fps): 18.0
Minimum Flow Velocity (fps): 2.0

Backwater Calculations:

Tailwater Elevation (ft): 7116.90

Manhole Input Summary:

Element Name	Ground Elevation (ft)	Given Flow		Sub Basin Information						
		Total Known Flow (cfs)	Local Contribution (cfs)	Drainage Area (Ac.)	Runoff Coefficient	Syr Coefficient	Overland Length (ft)	Overland Slope (%)	Gutter Length (ft)	Gutter Velocity (fps)
OUTFALL	7117.9	0	0	0	0	0	0	0	0	0
S5-4	7126.1	7.2	0	0	0	0	0	0	0	0
S5-3	7127.94	7.2	0	0	0	0	0	0	0	0
S5-2	7127	7.2	0	0	0	0	0	0	0	0
S5-1	7126.3	7.2	0	0	0	0	0	0	0	0
S4	7126.3	2.5	0	0	0	0	0	0	0	0

Manhole Output Summary:

Element Name	Local Contribution					Total Design Flow				Comment
	Overland Time (min)	Gutter Time (min)	Basin Tc (min)	Intensity (in/hr)	Local Contrib (cfs)	Coeff. Area	Intensity (in/hr)	Manhole Tc (min)	Peak Flow (cfs)	
OUTFALL	0	0	0	0	0	0.62	11.58	0.19	7.2	
S5-4	0	0	0	0	0	0	0	0	7.2	
S5-3	0	0	0	0	0	0	0	0	7.2	
S5-2	0	0	0	0	0	0	0	0	7.2	
S5-1	0	0	0	0	0	0	0	0	7.2	
S4	0	0	0	0	0	0	0	0	2.5	

Sewer Input Summary:

Element Name	Sewer Length (ft)	Elevation			Loss Coefficients			Given Dimensions		
		Downstream Invert (ft)	Slope (%)	Upstream Invert (ft)	Mannings n	Bend Loss	Lateral Loss	Cross Section	Rise (ft or in)	Span (ft or in)
S5-4	47.56	7116.1	1	7116.58	0.013	0	0	CIRCULAR	18.00 in	18.00 in
S5-3	98.69	7119.08	2.97	7122.01	0.013	0.39	1	CIRCULAR	18.00 in	18.00 in
S5-2	27.68	7122.11	0.61	7122.28	0.013	0.31	1	CIRCULAR	18.00 in	18.00 in
S5-1	16.81	7122.28	0.6	7122.38	0.013	0.43	1	CIRCULAR	18.00 in	18.00 in
S4	18.21	7122.48	0.6	7122.59	0.013	0.22	1	CIRCULAR	18.00 in	18.00 in

Sewer Flow Summary:

Element Name	Full Flow Capacity		Critical Flow		Normal Flow				Flow (cfs)	Surcharged Length (ft)	Comment
	Flow (cfs)	Velocity (fps)	Depth (in)	Velocity (fps)	Depth (in)	Velocity (fps)	Froude Number	Flow Condition			
S5-4	10.53	5.96	12.47	5.51	10.92	6.42	1.29	Supercritical	7.2	0	
S5-3	18.15	10.27	12.47	5.51	7.88	9.68	2.41	Supercritical	7.2	0	
S5-2	8.23	4.66	12.47	5.51	13.05	5.25	0.91	Subcritical	7.2	0	
S5-1	8.16	4.62	12.47	5.51	13.13	5.21	0.9	Subcritical	7.2	0	
S4	8.16	4.62	7.18	3.8	6.84	4.06	1.1	Pressurized	2.5	18.21	

A Froude number of 0 indicates that pressured flow occurs (adverse slope or undersized pipe).
 If the sewer is not pressurized, full flow represents the maximum gravity flow in the sewer.

If the sewer is pressurized, full flow represents the pressurized flow conditions.

Sewer Sizing Summary:

Element Name	Peak Flow (cfs)	Cross Section	Existing		Calculated		Used			Comment
			Rise	Span	Rise	Span	Rise	Span	Area (ft ²)	
S5-4	7.2	CIRCULAR	18.00 in	18.00 in	18.00 in	18.00 in	18.00 in	18.00 in	1.77	
S5-3	7.2	CIRCULAR	18.00 in	18.00 in	18.00 in	18.00 in	18.00 in	18.00 in	1.77	
S5-2	7.2	CIRCULAR	18.00 in	18.00 in	18.00 in	18.00 in	18.00 in	18.00 in	1.77	
S5-1	7.2	CIRCULAR	18.00 in	18.00 in	18.00 in	18.00 in	18.00 in	18.00 in	1.77	
S4	2.5	CIRCULAR	18.00 in	18.00 in	18.00 in	18.00 in	18.00 in	18.00 in	1.77	

Calculated diameter was determined by sewer hydraulic capacity rounded up to the nearest commercially available size.

Sewer sizes should not decrease downstream.

All hydraulics were calculated using the 'Used' parameters.

Grade Line Summary:

Tailwater Elevation (ft): 7116.90

Element Name	Invert Elev.		Downstream Manhole Losses		HGL		EGL		
	Downstream (ft)	Upstream (ft)	Bend Loss (ft)	Lateral Loss (ft)	Downstream (ft)	Upstream (ft)	Downstream (ft)	Friction Loss (ft)	Upstream (ft)
S5-4	7116.1	7116.58	0	0	7117.01	7117.62	7117.65	0.44	7118.09
S5-3	7119.08	7122.01	0.1	0	7119.74	7123.05	7121.19	2.33	7123.52
S5-2	7122.11	7122.28	0.08	0	7123.15	7123.38	7123.62	0.18	7123.8
S5-1	7122.28	7122.38	0.11	0	7123.62	7123.67	7123.91	0.07	7123.98
S4	7122.48	7122.59	0.01	0.23	7124.18	7124.19	7124.21	0.01	7124.22

Bend and Lateral losses only apply when there is an outgoing sewer. The system outfall, sewer #0, is not considered a sewer.

Bend loss = $Bend\ K * V_{fi}^2 / (2 * g)$

Lateral loss = $V_{fo}^2 / (2 * g) - Junction\ Loss\ K * V_{fi}^2 / (2 * g)$.

Friction loss is always Upstream EGL - Downstream EGL.

Excavation Estimate:

The trench side slope is 1.0 ft/ft

The minimum trench width is 2.00 ft

Element Name	Length (ft)	Wall (in)	Bedding (in)	Bottom Width (ft)	Downstream			Upstream			Volume (cu. yd)	Comment
					Top Width (ft)	Trench Depth (ft)	Cover (ft)	Top Width (ft)	Trench Depth (ft)	Cover (ft)		
S5-4	47.56	2.5	4	4.92	0	2.34	0.09	18.54	10.06	7.81	94.18	Sewer Too Shallow
S5-3	98.69	2.5	4	4.92	13.54	7.56	5.31	11.36	6.47	4.22	179.07	
S5-2	27.68	2.5	4	4.92	11.16	6.37	4.12	8.94	5.26	3.01	36.38	
S5-1	16.81	2.5	4	4.92	8.94	5.26	3.01	7.34	4.46	2.21	16.6	
S4	18.21	2.5	4	4.92	7.14	4.36	2.11	6.92	4.25	2	15.03	

Total earth volume for sewer trenches = 341 cubic yards.

The trench was estimated to have a bottom width equal to the outer pipe diameter plus 36 inches.

If the calculated width of the trench bottom is less than the minimum acceptable width, the minimum acceptable width was used.

The sewer wall thickness is equal to: (equivalent diameter in inches/12)+1 inches

The sewer bedding thickness is equal to:

Four inches for pipes less than 33 inches.

Six inches for pipes less than 60 inches.

Eight inches for all larger sizes.

Storm Sewer A2 - 100yr

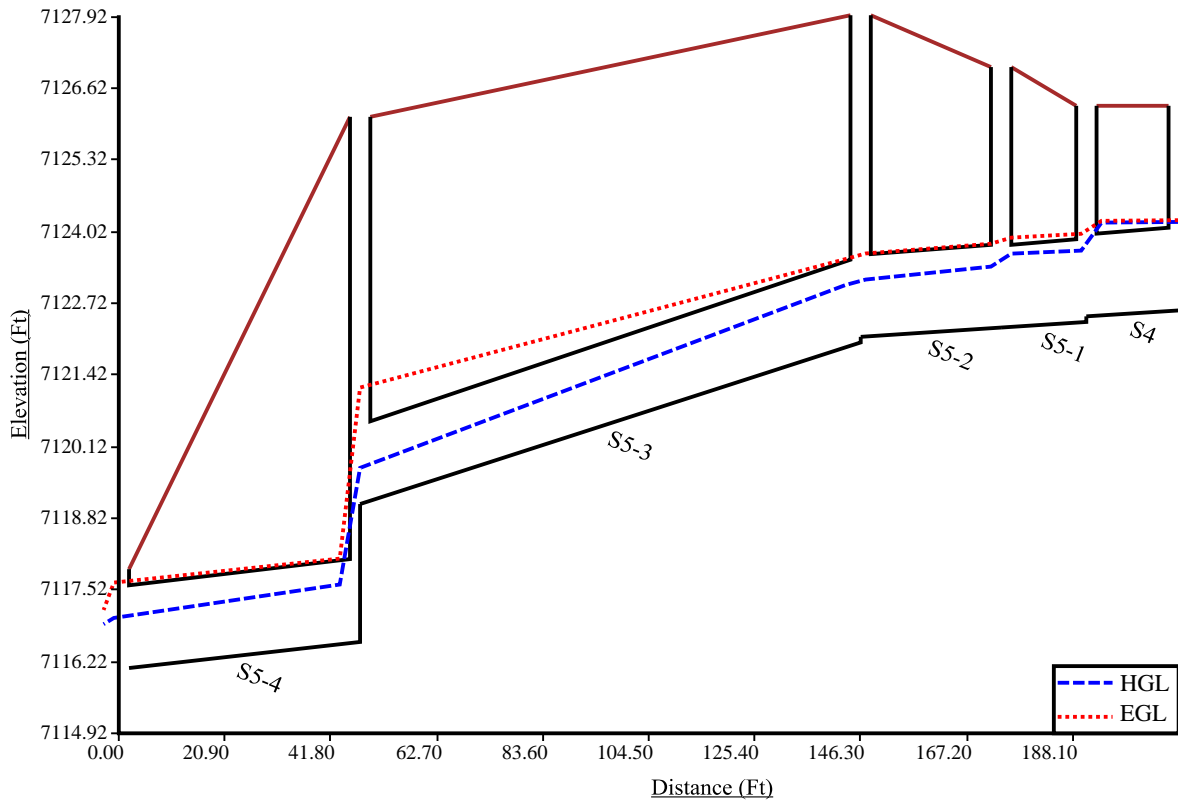

System Input Summary

Rainfall Parameters

Rainfall Return Period: 100
Rainfall Calculation Method: Formula

One Hour Depth (in): 2.52
Rainfall Constant "A": 28.5
Rainfall Constant "B": 10
Rainfall Constant "C": 0.786

Rational Method Constraints

Minimum Urban Runoff Coeff.: 0.20
Maximum Rural Overland Len. (ft): 500
Maximum Urban Overland Len. (ft): 300
Used UDFCD Tc. Maximum: No

Sizer Constraints

Minimum Sewer Size (in): 18.00
Maximum Depth to Rise Ratio: 0.90
Maximum Flow Velocity (fps): 18.0
Minimum Flow Velocity (fps): 2.0

Backwater Calculations:

Tailwater Elevation (ft): 7107.00

Manhole Input Summary:

Element Name	Ground Elevation (ft)	Given Flow		Sub Basin Information						
		Total Known Flow (cfs)	Local Contribution (cfs)	Drainage Area (Ac.)	Runoff Coefficient	Syr Coefficient	Overland Length (ft)	Overland Slope (%)	Gutter Length (ft)	Gutter Velocity (fps)
OUTFALL	7109.8	0	0	0	0	0	0	0	0	0
S6	7116.9	7.2	0	0	0	0	0	0	0	0

Manhole Output Summary:

Element Name	Local Contribution					Total Design Flow				Comment
	Overland Time (min)	Gutter Time (min)	Basin Tc (min)	Intensity (in/hr)	Local Contrib (cfs)	Coeff. Area	Intensity (in/hr)	Manhole Tc (min)	Peak Flow (cfs)	
OUTFALL	0	0	0	0	0	0.62	11.6	0.17	7.2	
S6	0	0	0	0	0	0	0	0	7.2	

Sewer Input Summary:

Element Name	Sewer Length (ft)	Elevation			Loss Coefficients			Given Dimensions		
		Downstream Invert (ft)	Slope (%)	Upstream Invert (ft)	Mannings n	Bend Loss	Lateral Loss	Cross Section	Rise (ft or in)	Span (ft or in)
S6	42.69	7108	2.5	7109.07	0.013	0	0	CIRCULAR	18.00 in	18.00 in

Sewer Flow Summary:

Element Name	Full Flow Capacity		Critical Flow		Normal Flow				Flow (cfs)	Surcharged Length (ft)	Comment
	Flow (cfs)	Velocity (fps)	Depth (in)	Velocity (fps)	Depth (in)	Velocity (fps)	Froude Number	Flow Condition			
S6	16.65	9.42	12.47	5.51	8.27	9.08	2.2	Supercritical	7.2	0	

A Froude number of 0 indicates that pressurized flow occurs (adverse slope or undersized pipe).
 If the sewer is not pressurized, full flow represents the maximum gravity flow in the sewer.
 If the sewer is pressurized, full flow represents the pressurized flow conditions.

Sewer Sizing Summary:

Element Name	Peak Flow (cfs)	Cross Section	Existing		Calculated		Used			Comment
			Rise	Span	Rise	Span	Rise	Span	Area (ft ²)	
S6	7.2	CIRCULAR	18.00 in	18.00 in	18.00 in	18.00 in	18.00 in	18.00 in	1.77	

Calculated diameter was determined by sewer hydraulic capacity rounded up to the nearest commercially available size.

Sewer sizes should not decrease downstream.

All hydraulics were calculated using the 'Used' parameters.

Grade Line Summary:

Tailwater Elevation (ft): 7107.00

Element Name	Invert Elev.		Downstream Manhole Losses		HGL		EGL		
	Downstream (ft)	Upstream (ft)	Bend Loss (ft)	Lateral Loss (ft)	Downstream (ft)	Upstream (ft)	Downstream (ft)	Friction Loss (ft)	Upstream (ft)
S6	7108	7109.07	0	0	7108.69	7110.11	7109.97	0.61	7110.58

Bend and Lateral losses only apply when there is an outgoing sewer. The system outfall, sewer #0, is not considered a sewer.

Bend loss = Bend K * V_{fi}² / (2 * g)

Lateral loss = V_{fo}² / (2 * g) - Junction Loss K * V_{fi}² / (2 * g).

Friction loss is always Upstream EGL - Downstream EGL.

Excavation Estimate:

The trench side slope is 1.0 ft/ft

The minimum trench width is 2.00 ft

Element Name	Length (ft)	Wall (in)	Bedding (in)	Bottom Width (ft)	Downstream			Upstream			Volume (cu. yd)	Comment
					Top Width (ft)	Trench Depth (ft)	Cover (ft)	Top Width (ft)	Trench Depth (ft)	Cover (ft)		
S6	42.69	2.5	4	4.92	0	2.34	0.09	15.16	8.37	6.12	62.02	Sewer Too Shallow

Total earth volume for sewer trenches = 62 cubic yards.

The trench was estimated to have a bottom width equal to the outer pipe diameter plus 36 inches.

If the calculated width of the trench bottom is less than the minimum acceptable width, the minimum acceptable width was used.

The sewer wall thickness is equal to: (equivalent diameter in inches/12)+1 inches

The sewer bedding thickness is equal to:

Four inches for pipes less than 33 inches.

Six inches for pipes less than 60 inches.

Eight inches for all larger sizes.

Storm Sewer A3 - 100yr

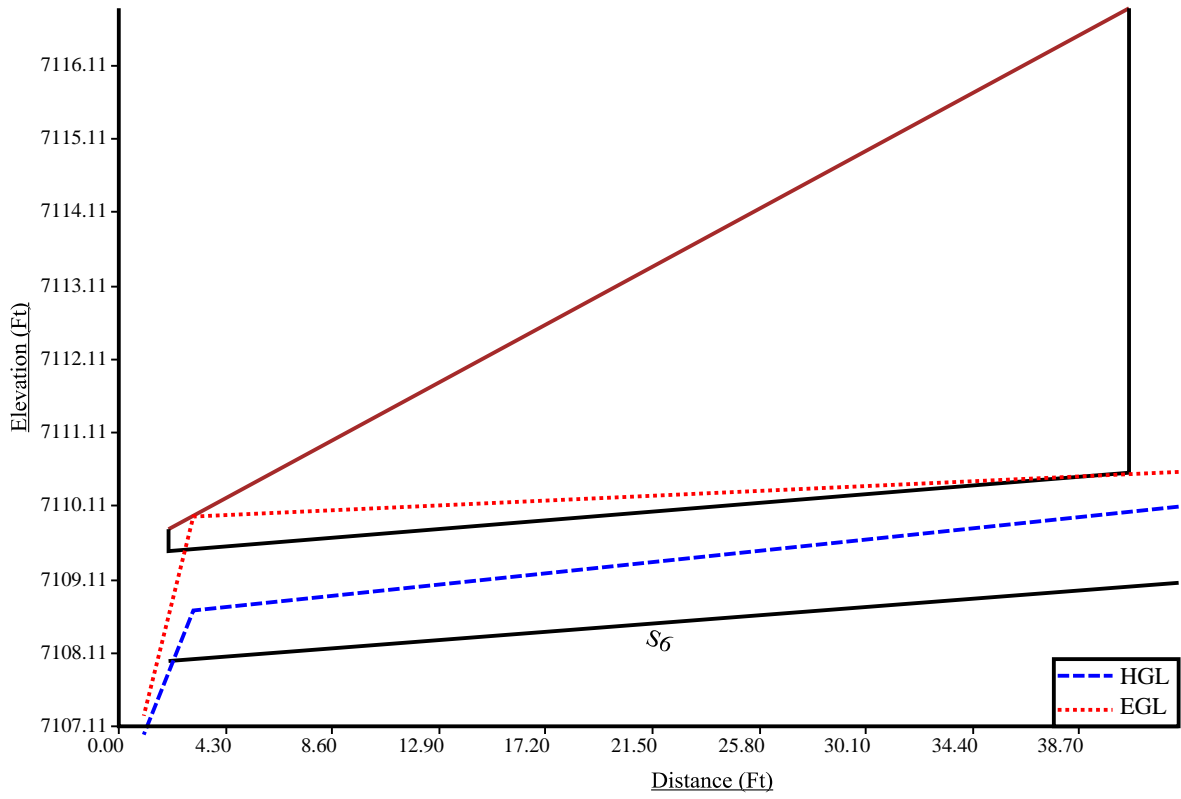

System Input Summary

Rainfall Parameters

Rainfall Return Period: 100
Rainfall Calculation Method: Formula

One Hour Depth (in): 2.52
Rainfall Constant "A": 28.5
Rainfall Constant "B": 10
Rainfall Constant "C": 0.786

Rational Method Constraints

Minimum Urban Runoff Coeff.: 0.20
Maximum Rural Overland Len. (ft): 500
Maximum Urban Overland Len. (ft): 300
Used UDFCD Tc. Maximum: No

Sizer Constraints

Minimum Sewer Size (in): 18.00
Maximum Depth to Rise Ratio: 0.90
Maximum Flow Velocity (fps): 18.0
Minimum Flow Velocity (fps): 2.0

Backwater Calculations:

Tailwater Elevation (ft): 7118.00

Manhole Input Summary:

Element Name	Ground Elevation (ft)	Given Flow		Sub Basin Information						
		Total Known Flow (cfs)	Local Contribution (cfs)	Drainage Area (Ac.)	Runoff Coefficient	Syr Coefficient	Overland Length (ft)	Overland Slope (%)	Gutter Length (ft)	Gutter Velocity (fps)
OUTFALL	7119	0	0	0	0	0	0	0	0	0
S9-2	7121	9.9	0	0	0	0	0	0	0	0
S9-1	7123.47	9.9	0	0	0	0	0	0	0	0
S8	7123.47	8.7	0	0	0	0	0	0	0	0
S7-2	7126.5	5.2	0	0	0	0	0	0	0	0
S7-1	7127.23	5.2	0	0	0	0	0	0	0	0

Manhole Output Summary:

Element Name	Local Contribution				Total Design Flow					Comment
	Overland Time (min)	Gutter Time (min)	Basin Tc (min)	Intensity (in/hr)	Local Contrib (cfs)	Coeff. Area	Intensity (in/hr)	Manhole Tc (min)	Peak Flow (cfs)	
OUTFALL	0	0	0	0	0	0.85	11.62	0.15	9.9	
S9-2	0	0	0	0	0	0	0	0	9.9	
S9-1	0	0	0	0	0	0	0	0	9.9	
S8	0	0	0	0	0	0	0	0	8.7	
S7-2	0	0	0	0	0	0	0	0	5.2	
S7-1	0	0	0	0	0	0	0	0	5.2	

Sewer Input Summary:

Element Name	Sewer Length (ft)	Elevation			Loss Coefficients			Given Dimensions		
		Downstream Invert (ft)	Slope (%)	Upstream Invert (ft)	Mannings n	Bend Loss	Lateral Loss	Cross Section	Rise (ft or in)	Span (ft or in)
S9-2	49.19	7117.2	1	7117.69	0.013	0	0	CIRCULAR	18.00 in	18.00 in
S9-1	28.02	7117.79	1	7118.07	0.013	0.09	1	CIRCULAR	18.00 in	18.00 in
S8	25.34	7119.87	1.58	7120.27	0.013	0.53	1	CIRCULAR	18.00 in	18.00 in
S7-2	124.87	7120.37	1.62	7122.39	0.013	1.31	1	CIRCULAR	18.00 in	18.00 in
S7-1	52.44	7122.39	1.6	7123.23	0.013	0.09	1	CIRCULAR	18.00 in	18.00 in

Sewer Flow Summary:

Element Name	Full Flow Capacity		Critical Flow		Normal Flow				Flow (cfs)	Surcharged Length (ft)	Comment
	Flow (cfs)	Velocity (fps)	Depth (in)	Velocity (fps)	Depth (in)	Velocity (fps)	Froude Number	Flow Condition			
S9-2	10.53	5.96	14.56	6.47	13.87	6.78	1.11	Supercritical	9.9	0	
S9-1	10.53	5.96	14.56	6.47	13.87	6.78	1.11	Supercritical	9.9	0	
S8	13.24	7.49	13.7	6.03	10.65	8	1.64	Supercritical	8.7	0	
S7-2	13.41	7.59	10.54	4.84	7.78	7.11	1.78	Supercritical Jump	5.2	28.52	
S7-1	13.32	7.54	10.54	4.84	7.81	7.07	1.77	Supercritical	5.2	0	

A Froude number of 0 indicates that pressurized flow occurs (adverse slope or undersized pipe).
 If the sewer is not pressurized, full flow represents the maximum gravity flow in the sewer.
 If the sewer is pressurized, full flow represents the pressurized flow conditions.

Sewer Sizing Summary:

Element Name	Peak Flow (cfs)	Cross Section	Existing		Calculated		Used		Area (ft ²)	Comment
			Rise	Span	Rise	Span	Rise	Span		
S9-2	9.9	CIRCULAR	18.00 in	18.00 in	18.00 in	18.00 in	18.00 in	18.00 in	1.77	
S9-1	9.9	CIRCULAR	18.00 in	18.00 in	18.00 in	18.00 in	18.00 in	18.00 in	1.77	
S8	8.7	CIRCULAR	18.00 in	18.00 in	18.00 in	18.00 in	18.00 in	18.00 in	1.77	
S7-2	5.2	CIRCULAR	18.00 in	18.00 in	18.00 in	18.00 in	18.00 in	18.00 in	1.77	
S7-1	5.2	CIRCULAR	18.00 in	18.00 in	18.00 in	18.00 in	18.00 in	18.00 in	1.77	

Calculated diameter was determined by sewer hydraulic capacity rounded up to the nearest commercially available size.
 Sewer sizes should not decrease downstream.
 All hydraulics were calculated using the 'Used' parameters.

Grade Line Summary:

Tailwater Elevation (ft): 7118.00

Element Name	Invert Elev.		Downstream Manhole Losses		HGL		EGL		
	Downstream (ft)	Upstream (ft)	Bend Loss (ft)	Lateral Loss (ft)	Downstream (ft)	Upstream (ft)	Downstream (ft)	Friction Loss (ft)	Upstream (ft)
S9-2	7117.2	7117.69	0	0	7118.35	7118.9	7119.07	0.49	7119.55
S9-1	7117.79	7118.07	0.04	0	7118.95	7119.28	7119.66	0.27	7119.93
S8	7119.87	7120.27	0.2	0.11	7120.76	7121.41	7121.75	0.23	7121.98
S7-2	7120.37	7122.39	0.18	0.24	7122.26	7123.27	7122.39	1.24	7123.63
S7-1	7122.39	7123.23	0.01	0	7123.28	7124.11	7123.82	0.65	7124.47

Bend and Lateral losses only apply when there is an outgoing sewer. The system outfall, sewer #0, is not considered a sewer.

Bend loss = Bend K * V_{fi} ^ 2 / (2 * g)

Lateral loss = V_{fo} ^ 2 / (2 * g) - Junction Loss K * V_{fi} ^ 2 / (2 * g).

Friction loss is always Upstream EGL - Downstream EGL.

Excavation Estimate:

The trench side slope is 1.0 ft/ft

The minimum trench width is 2.00 ft

Element Name	Length (ft)	Wall (in)	Bedding (in)	Bottom Width (ft)	Downstream			Upstream			Volume (cu. yd)	Comment
					Top Width (ft)	Trench Depth (ft)	Cover (ft)	Top Width (ft)	Trench Depth (ft)	Cover (ft)		
S9-2	49.19	2.5	4	4.92	0	2.34	0.09	6.12	3.85	1.6	27.66	Sewer Too Shallow
S9-1	28.02	2.5	4	4.92	5.92	3.75	1.5	10.3	5.94	3.69	28.62	Sewer Too Shallow
S8	25.34	2.5	4	4.92	6.7	4.14	1.89	5.9	3.74	1.49	18.68	Sewer Too Shallow
S7-2	124.87	2.5	4	4.92	5.71	3.64	1.39	7.72	4.65	2.4	99.23	Sewer Too Shallow
S7-1	52.44	2.5	4	4.92	7.72	4.65	2.4	7.5	4.54	2.29	47.42	

Total earth volume for sewer trenches = 222 cubic yards.

The trench was estimated to have a bottom width equal to the outer pipe diameter plus 36 inches.

If the calculated width of the trench bottom is less than the minimum acceptable width, the minimum acceptable width was used.

The sewer wall thickness is equal to: (equivalent diameter in inches/12)+1 inches

The sewer bedding thickness is equal to:

Four inches for pipes less than 33 inches.

Six inches for pipes less than 60 inches.

Eight inches for all larger sizes.

Storm Sewer System B1 - 100yr

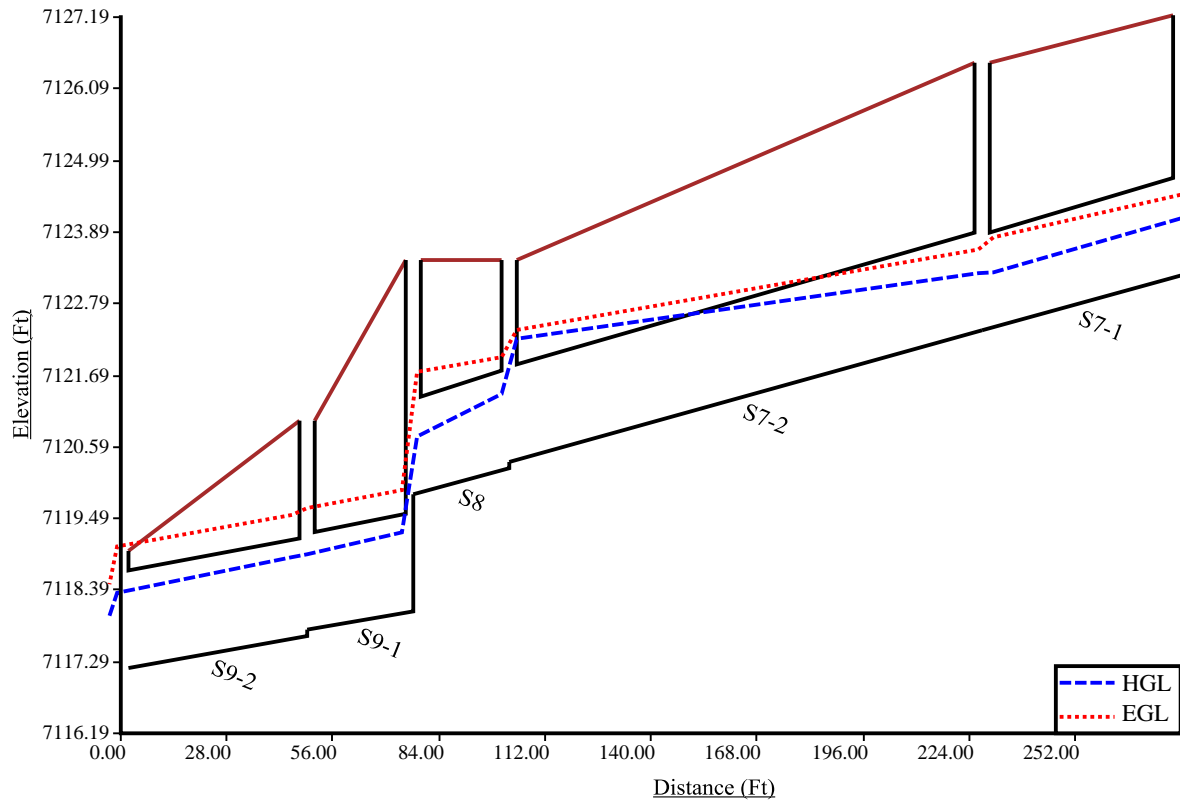

System Input Summary

Rainfall Parameters

Rainfall Return Period: 100
Rainfall Calculation Method: Formula

One Hour Depth (in): 2.52
Rainfall Constant "A": 28.5
Rainfall Constant "B": 10
Rainfall Constant "C": 0.786

Rational Method Constraints

Minimum Urban Runoff Coeff.: 0.20
Maximum Rural Overland Len. (ft): 500
Maximum Urban Overland Len. (ft): 300
Used UDFCD Tc. Maximum: No

Sizer Constraints

Minimum Sewer Size (in): 18.00
Maximum Depth to Rise Ratio: 0.90
Maximum Flow Velocity (fps): 18.0
Minimum Flow Velocity (fps): 2.0

Backwater Calculations:

Tailwater Elevation (ft): 7107.00

Manhole Input Summary:

Element Name	Ground Elevation (ft)	Given Flow		Sub Basin Information						
		Total Known Flow (cfs)	Local Contribution (cfs)	Drainage Area (Ac.)	Runoff Coefficient	Syr Coefficient	Overland Length (ft)	Overland Slope (%)	Gutter Length (ft)	Gutter Velocity (fps)
OUTFALL	7109.8	0	0	0	0	0	0	0	0	0
S10-2	7116	11.3	0	0	0	0	0	0	0	0
S10-1	7118	11.3	0	0	0	0	0	0	0	0

Manhole Output Summary:

Element Name	Local Contribution					Total Design Flow				Comment
	Overland Time (min)	Gutter Time (min)	Basin Tc (min)	Intensity (in/hr)	Local Contrib (cfs)	Coeff. Area	Intensity (in/hr)	Manhole Tc (min)	Peak Flow (cfs)	
OUTFALL	0	0	0	0	0	0.97	11.64	0.13	11.3	
S10-2	0	0	0	0	0	0	0	0	11.3	
S10-1	0	0	0	0	0	0	0	0	11.3	

Sewer Input Summary:

Element Name	Sewer Length (ft)	Elevation			Loss Coefficients			Given Dimensions		
		Downstream Invert (ft)	Slope (%)	Upstream Invert (ft)	Mannings n	Bend Loss	Lateral Loss	Cross Section	Rise (ft or in)	Span (ft or in)
S10-2	48.82	7108	1	7108.49	0.013	0	0	CIRCULAR	18.00 in	18.00 in
S10-1	24.73	7111	5.5	7112.36	0.013	0.63	1	CIRCULAR	18.00 in	18.00 in

Sewer Flow Summary:

Element Name	Full Flow Capacity		Critical Flow		Normal Flow				Flow (cfs)	Surcharged Length (ft)	Comment
	Flow (cfs)	Velocity (fps)	Depth (in)	Velocity (fps)	Depth (in)	Velocity (fps)	Froude Number	Flow Condition			
S10-2	10.53	5.96	18	6.39	18	6.39	0	Pressurized	11.3	48.82	
S10-1	24.7	13.98	15.41	7.02	8.55	13.67	3.24	Supercritical	11.3	0	

A Froude number of 0 indicates that pressured flow occurs (adverse slope or undersized pipe).
 If the sewer is not pressurized, full flow represents the maximum gravity flow in the sewer.
 If the sewer is pressurized, full flow represents the pressurized flow conditions.

Sewer Sizing Summary:

Element Name	Peak Flow (cfs)	Cross Section	Existing		Calculated		Used		Area (ft ²)	Comment
			Rise	Span	Rise	Span	Rise	Span		
S10-2	11.3	CIRCULAR	18.00 in	18.00 in	21.00 in	21.00 in	18.00 in	18.00 in	1.77	Existing height is smaller than the suggested height. Existing width is smaller than the suggested width. Exceeds max. Depth/Rise
S10-1	11.3	CIRCULAR	18.00 in	18.00 in	18.00 in	18.00 in	18.00 in	18.00 in	1.77	

Calculated diameter was determined by sewer hydraulic capacity rounded up to the nearest commercially available size.
 Sewer sizes should not decrease downstream.
 All hydraulics were calculated using the 'Used' parameters.

Grade Line Summary:

Tailwater Elevation (ft): 7107.00

Element Name	Invert Elev.		Downstream Manhole Losses		HGL		EGL		
	Downstream (ft)	Upstream (ft)	Bend Loss (ft)	Lateral Loss (ft)	Downstream (ft)	Upstream (ft)	Downstream (ft)	Friction Loss (ft)	Upstream (ft)
S10-2	7108	7108.49	0	0	7109.5	7110.06	7110.14	0.56	7110.7
S10-1	7111	7112.36	0.4	0	7111.71	7113.98	7114.61	0	7114.61

Bend and Lateral losses only apply when there is an outgoing sewer. The system outfall, sewer #0, is not considered a sewer.

Bend loss = Bend K * V_{fi} ^ 2 / (2 * g)

Lateral loss = V_{fo} ^ 2 / (2 * g) - Junction Loss K * V_{fi} ^ 2 / (2 * g).

Friction loss is always Upstream EGL - Downstream EGL.

Excavation Estimate:

The trench side slope is 1.0 ft/ft

The minimum trench width is 2.00 ft

Element Name	Length (ft)	Wall (in)	Bedding (in)	Bottom Width (ft)	Downstream			Upstream			Volume (cu. yd)	Comment
					Top Width (ft)	Trench Depth (ft)	Cover (ft)	Top Width (ft)	Trench Depth (ft)	Cover (ft)		
S10-2	48.82	2.5	4	4.92	0	2.34	0.09	14.52	8.05	5.8	66.64	Sewer Too Shallow
S10-1	24.73	2.5	4	4.92	9.5	5.54	3.29	10.78	6.18	3.93	32.74	

Total earth volume for sewer trenches = 99 cubic yards.

The trench was estimated to have a bottom width equal to the outer pipe diameter plus 36 inches.

If the calculated width of the trench bottom is less than the minimum acceptable width, the minimum acceptable width was used.

The sewer wall thickness is equal to: (equivalent diameter in inches / 12) + 1 inches

The sewer bedding thickness is equal to:

Four inches for pipes less than 33 inches.

Six inches for pipes less than 60 inches.

Eight inches for all larger sizes.

Storm Sewer System B2 - 100yr

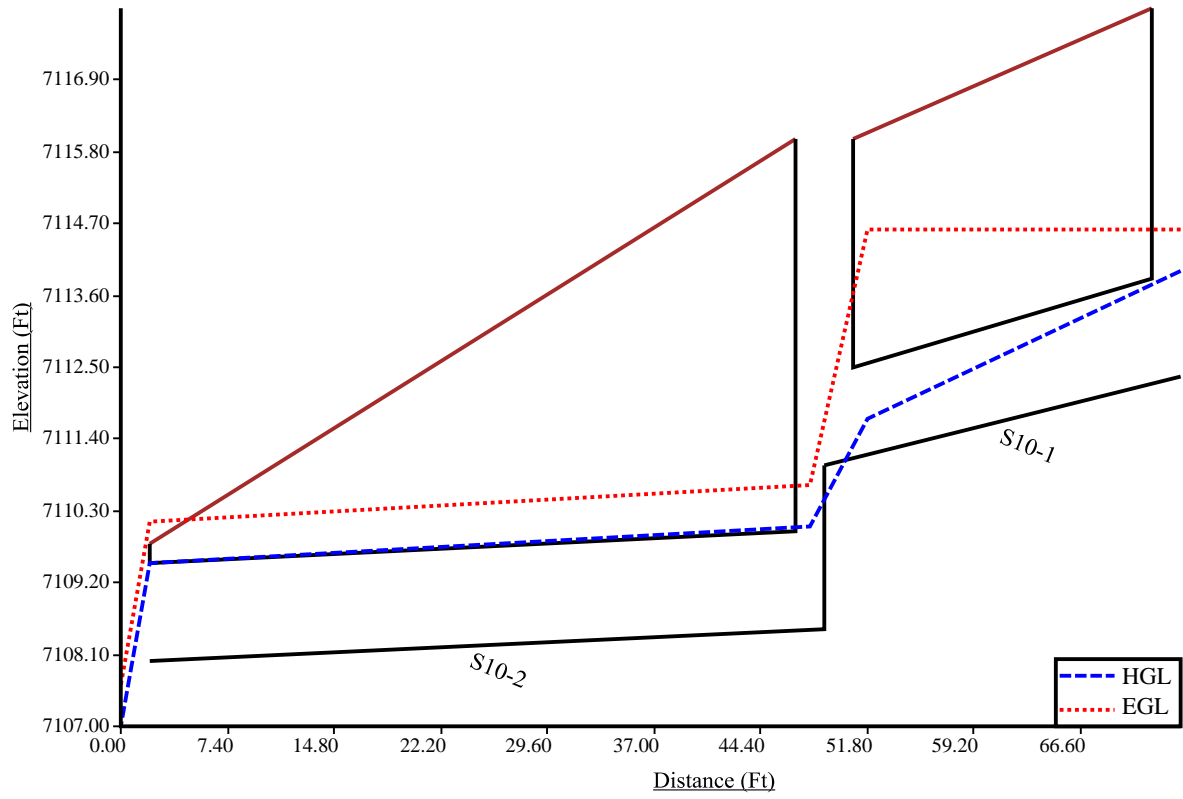

System Input Summary

Rainfall Parameters

Rainfall Return Period: 100
Rainfall Calculation Method: Formula

One Hour Depth (in): 2.52
Rainfall Constant "A": 28.5
Rainfall Constant "B": 10
Rainfall Constant "C": 0.786

Rational Method Constraints

Minimum Urban Runoff Coeff.: 0.20
Maximum Rural Overland Len. (ft): 500
Maximum Urban Overland Len. (ft): 300
Used UDFCD Tc. Maximum: No

Sizer Constraints

Minimum Sewer Size (in): 18.00
Maximum Depth to Rise Ratio: 0.90
Maximum Flow Velocity (fps): 18.0
Minimum Flow Velocity (fps): 2.0

Backwater Calculations:

Tailwater Elevation (ft): 7114.70

Manhole Input Summary:

Element Name	Ground Elevation (ft)	Given Flow		Sub Basin Information						
		Total Known Flow (cfs)	Local Contribution (cfs)	Drainage Area (Ac.)	Runoff Coefficient	Syr Coefficient	Overland Length (ft)	Overland Slope (%)	Gutter Length (ft)	Gutter Velocity (fps)
OUTFALL	7116.2	0	0	0	0	0	0	0	0	0
S11	7118.8	2.1	0	0	0	0	0	0	0	0

Manhole Output Summary:

Element Name	Local Contribution				Total Design Flow				Comment	
	Overland Time (min)	Gutter Time (min)	Basin Tc (min)	Intensity (in/hr)	Local Contrib (cfs)	Coeff. Area	Intensity (in/hr)	Manhole Tc (min)		Peak Flow (cfs)
OUTFALL	0	0	0	0	0	0.18	11.64	0.13	2.1	
S11	0	0	0	0	0	0	0	0	2.1	

Sewer Input Summary:

Element Name	Sewer Length (ft)	Elevation			Loss Coefficients			Given Dimensions		
		Downstream Invert (ft)	Slope (%)	Upstream Invert (ft)	Mannings n	Bend Loss	Lateral Loss	Cross Section	Rise (ft or in)	Span (ft or in)
S11	10.67	7114.3	0.94	7114.4	0.013	0	0	ELLIPSE	14.00 in	23.00 in

Sewer Flow Summary:

Element Name	Full Flow Capacity		Critical Flow		Normal Flow				Flow (cfs)	Surcharged Length (ft)	Comment
	Flow (cfs)	Velocity (fps)	Depth (in)	Velocity (fps)	Depth (in)	Velocity (fps)	Froude Number	Flow Condition			
S11	10.12	6.68	6.51	3.58	5.48	4.54	1.39	Supercritical	2.1	0	

A Froude number of 0 indicates that pressurized flow occurs (adverse slope or undersized pipe).

If the sewer is not pressurized, full flow represents the maximum gravity flow in the sewer.

If the sewer is pressurized, full flow represents the pressurized flow conditions.

Sewer Sizing Summary:

Element Name	Peak Flow (cfs)	Cross Section	Existing		Calculated		Used			Comment
			Rise	Span	Rise	Span	Rise	Span	Area (ft^2)	
S11	2.1	ELLIPSE	14.00 in	23.00 in	18.00 in	18.00 in	14.00 in	23.00 in	1.52	Height is too small. Existing height is smaller than the suggested height.

Calculated diameter was determined by sewer hydraulic capacity rounded up to the nearest commercially available size.

Sewer sizes should not decrease downstream.

All hydraulics were calculated using the 'Used' parameters.

Grade Line Summary:

Tailwater Elevation (ft): 7114.70

Element Name	Invert Elev.		Downstream Manhole Losses		HGL		EGL		
	Downstream (ft)	Upstream (ft)	Bend Loss (ft)	Lateral Loss (ft)	Downstream (ft)	Upstream (ft)	Downstream (ft)	Friction Loss (ft)	Upstream (ft)
S11	7114.3	7114.4	0	0	7114.76	7114.94	7115.08	0.07	7115.14

Bend and Lateral losses only apply when there is an outgoing sewer. The system outfall, sewer #0, is not considered a sewer.

Bend loss = $Bend\ K * V_{fi}^2 / (2 * g)$

Lateral loss = $V_{fo}^2 / (2 * g) - Junction\ Loss\ K * V_{fi}^2 / (2 * g)$.

Friction loss is always Upstream EGL - Downstream EGL.

Excavation Estimate:

The trench side slope is 1.0 ft/ft

The minimum trench width is 2.00 ft

Element Name	Length (ft)	Wall (in)	Bedding (in)	Bottom Width (ft)	Downstream			Upstream			Volume (cu. yd)	Comment
					Top Width (ft)	Trench Depth (ft)	Cover (ft)	Top Width (ft)	Trench Depth (ft)	Cover (ft)		
S11	10.67	2.92	4	5.4	0	2.48	0.49	9.38	4.98	2.99	8.22	Sewer Too Shallow

Total earth volume for sewer trenches = 8 cubic yards.

The trench was estimated to have a bottom width equal to the outer pipe diameter plus 36 inches.

If the calculated width of the trench bottom is less than the minimum acceptable width, the minimum acceptable width was used.

The sewer wall thickness is equal to: (equivalent diameter in inches/12)+1 inches

The sewer bedding thickness is equal to:

Four inches for pipes less than 33 inches.

Six inches for pipes less than 60 inches.

Eight inches for all larger sizes.

Storm Sewer System C - 100yr

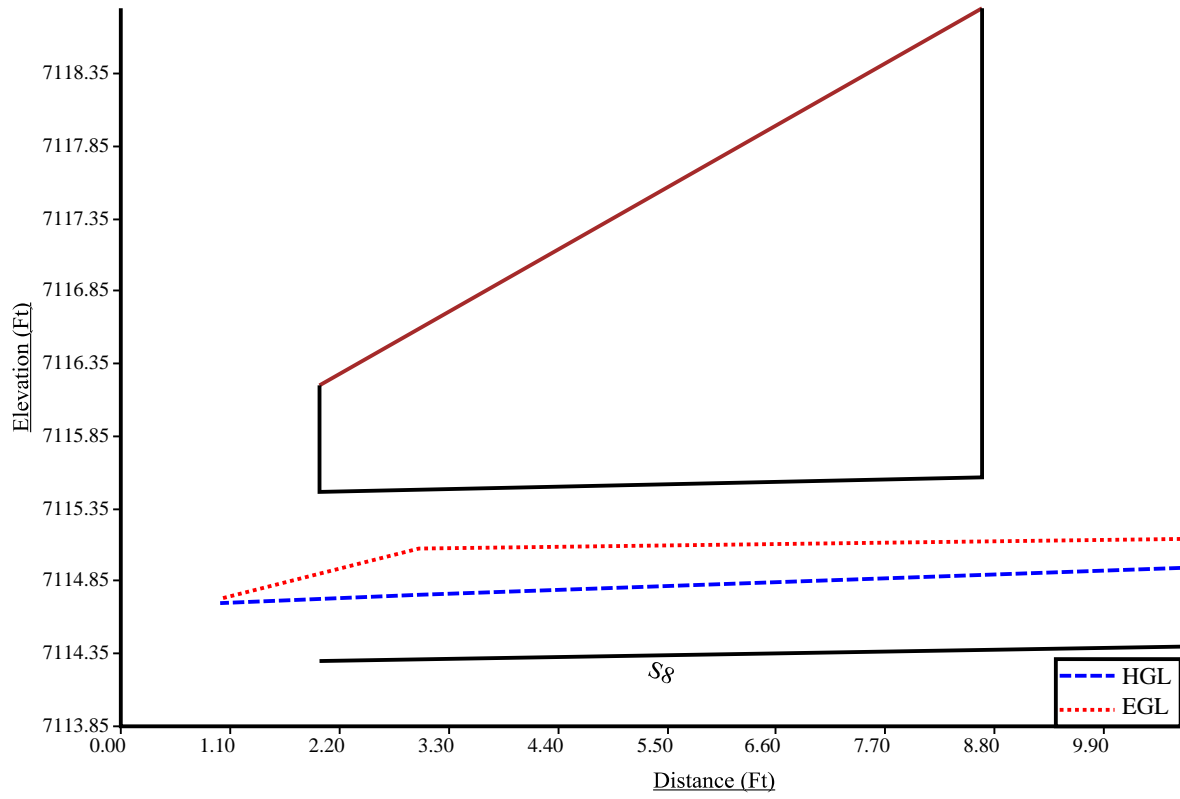

Determination of Culvert Headwater and Outlet Protection

Project: **North Bay at Lake Woodmoor**

Basin ID: **36" RCP, Pipe No. S3**

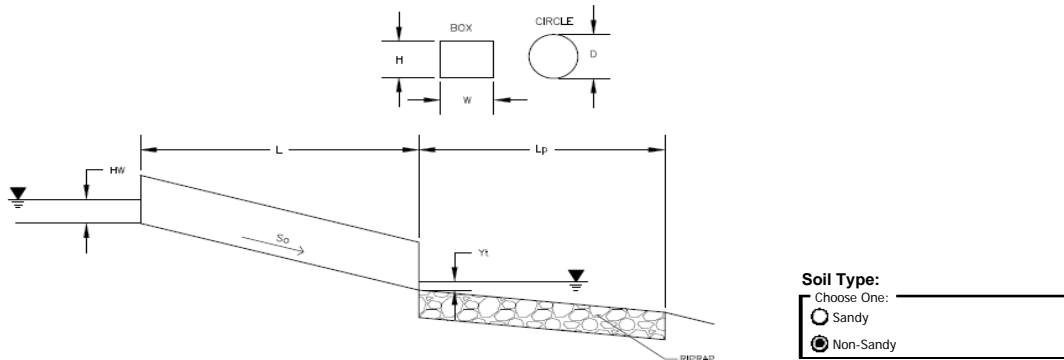

Soil Type:
 Choose One: Sandy Non-Sandy

Design Information (Input):

Design Discharge	Q = <input type="text" value="70"/> cfs
Circular Culvert:	
Barrel Diameter in Inches	D = <input type="text" value="36"/> inches
Inlet Edge Type (Choose from pull-down list)	Square End Projection <input type="text" value="Square End Projection"/>
Box Culvert:	
Barrel Height (Rise) in Feet	Height (Rise) = <input type="text" value=""/>
Barrel Width (Span) in Feet	Width (Span) = <input type="text" value=""/>
Inlet Edge Type (Choose from pull-down list)	<input type="text" value=""/>
Number of Barrels	No = <input type="text" value="1"/>
Inlet Elevation	Elev IN = <input type="text" value="7108.32"/> ft
Outlet Elevation OR Slope	Elev OUT = <input type="text" value="7107.07"/> ft
Culvert Length	L = <input type="text" value="138.73"/> ft
Manning's Roughness	n = <input type="text" value="0.013"/>
Bend Loss Coefficient	k_b = <input type="text" value="0"/>
Exit Loss Coefficient	k_x = <input type="text" value="1"/>
Tailwater Surface Elevation	Elev Y_t = <input type="text" value="7108.2"/> ft
Max Allowable Channel Velocity	V = <input type="text" value="5"/> ft/s

Required Protection (Output):

Tailwater Surface Height	Y_t = <input type="text" value="1.13"/> ft
Flow Area at Max Channel Velocity	A_f = <input type="text" value="14.00"/> ft ²
Culvert Cross Sectional Area Available	A = <input type="text" value="7.07"/> ft ²
Entrance Loss Coefficient	k_e = <input type="text" value="0.50"/>
Friction Loss Coefficient	k_f = <input type="text" value="1.00"/>
Sum of All Losses Coefficients	k_s = <input type="text" value="2.50"/> ft
Culvert Normal Depth	Y_n = <input type="text" value="2.27"/> ft
Culvert Critical Depth	Y_c = <input type="text" value="2.66"/> ft
Tailwater Depth for Design	d = <input type="text" value="2.83"/> ft
Adjusted Diameter OR Adjusted Rise	D_a = <input type="text" value="-"/> ft
Expansion Factor	$1/(2*\tan(\theta))$ = <input type="text" value="2.69"/>
Flow/Diameter ^{2.5} OR Flow/(Span * Rise ^{1.5})	Q/D ^{2.5} = <input type="text" value="4.49"/> ft ^{0.5} /s
Froude Number	Fr = <input type="text" value="-"/> Pressure flow!
Tailwater/Adjusted Diameter OR Tailwater/Adjusted Rise	Y_t/D = <input type="text" value="0.38"/>
Inlet Control Headwater	HW_i = <input type="text" value="5.94"/> ft
Outlet Control Headwater	HW_o = <input type="text" value="5.38"/> ft
Design Headwater Elevation	HW = <input type="text" value="7,114.26"/> ft
Headwater/Diameter OR Headwater/Rise Ratio	HW/D = <input type="text" value="1.98"/> HW/D > 1.5!
Minimum Theoretical Riprap Size	d_{50} = <input type="text" value="12"/> in
Nominal Riprap Size	d_{50} = <input type="text" value="12"/> in
UDFCD Riprap Type	Type = <input type="text" value="M"/>
Length of Protection	L_p = <input type="text" value="26"/> ft
Width of Protection	T = <input type="text" value="13"/> ft

Determination of Culvert Headwater and Outlet Protection

Project: **North Bay at Lake Woodmoor**

Basin ID: **18" RCP (Pipe No. S6)**

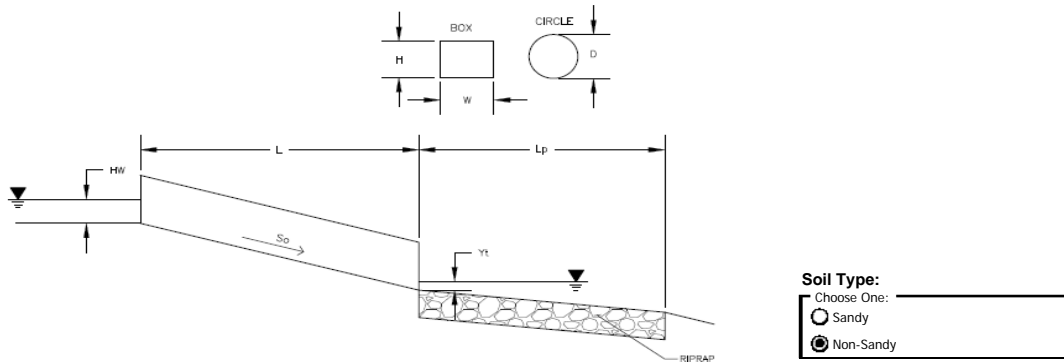

Soil Type:
 Choose One: Sandy Non-Sandy

Supercritical Flow! Using D_a to calculate protection type.

Design Information (Input):	
Design Discharge	Q = <input style="width: 50px;" type="text" value="7.2"/> cfs
Circular Culvert:	
Barrel Diameter in Inches	D = <input style="width: 50px;" type="text" value="18"/> inches
Inlet Edge Type (Choose from pull-down list)	Square End Projection <input type="button" value="v"/>
OR	
Box Culvert:	
Barrel Height (Rise) in Feet	Height (Rise) = <input style="width: 50px;" type="text"/>
Barrel Width (Span) in Feet	Width (Span) = <input style="width: 50px;" type="text"/>
Inlet Edge Type (Choose from pull-down list)	<input type="button" value="v"/>
Number of Barrels	No = <input style="width: 50px;" type="text" value="1"/>
Inlet Elevation	Elev IN = <input style="width: 50px;" type="text" value="7109.07"/> ft
Outlet Elevation OR Slope	Elev OUT = <input style="width: 50px;" type="text" value="7108"/> ft
Culvert Length	L = <input style="width: 50px;" type="text" value="42.69"/> ft
Manning's Roughness	n = <input style="width: 50px;" type="text" value="0.013"/>
Bend Loss Coefficient	k_b = <input style="width: 50px;" type="text" value="0"/>
Exit Loss Coefficient	k_x = <input style="width: 50px;" type="text" value="1"/>
Tailwater Surface Elevation	Elev Y_t = <input style="width: 50px;" type="text" value="7107"/> ft
Max Allowable Channel Velocity	V = <input style="width: 50px;" type="text" value="5"/> ft/s

Tailwater ELEVATION is less than outlet elevation, using $0.4 \times \text{RISE}$ as Y_t

Required Protection (Output):	
Tailwater Surface Height	Y_t = <input style="width: 50px;" type="text" value="0.60"/> ft
Flow Area at Max Channel Velocity	A_f = <input style="width: 50px;" type="text" value="1.44"/> ft ²
Culvert Cross Sectional Area Available	A = <input style="width: 50px;" type="text" value="1.77"/> ft ²
Entrance Loss Coefficient	k_e = <input style="width: 50px;" type="text" value="0.50"/>
Friction Loss Coefficient	k_f = <input style="width: 50px;" type="text" value="0.77"/>
Sum of All Losses Coefficients	k_s = <input style="width: 50px;" type="text" value="2.27"/> ft
Culvert Normal Depth	Y_n = <input style="width: 50px;" type="text" value="0.69"/> ft
Culvert Critical Depth	Y_c = <input style="width: 50px;" type="text" value="1.04"/> ft
Tailwater Depth for Design	d = <input style="width: 50px;" type="text" value="1.27"/> ft
Adjusted Diameter OR Adjusted Rise	D_a = <input style="width: 50px;" type="text" value="1.09"/> ft
Expansion Factor	$1/(2 \cdot \tan(\theta))$ = <input style="width: 50px;" type="text" value="6.47"/>
Flow/Diameter ^{2.5} OR Flow/(Span * Rise ^{1.5})	$Q/D^{2.5}$ = <input style="width: 50px;" type="text" value="2.61"/> ft ^{0.5} /s
Froude Number	Fr = <input style="width: 50px;" type="text" value="2.20"/> Supercritical!
Tailwater/Adjusted Diameter OR Tailwater/Adjusted Rise	Y_t/D = <input style="width: 50px;" type="text" value="0.55"/>
Inlet Control Headwater	HW_i = <input style="width: 50px;" type="text" value="1.67"/> ft
Outlet Control Headwater	HW_o = <input style="width: 50px;" type="text" value="0.79"/> ft
Design Headwater Elevation	HW = <input style="width: 50px;" type="text" value="7,110.74"/> ft
Headwater/Diameter OR Headwater/Rise Ratio	HW/D = <input style="width: 50px;" type="text" value="1.12"/>
Minimum Theoretical Riprap Size	d_{50} = <input style="width: 50px;" type="text" value="4"/> in
Nominal Riprap Size	d_{50} = <input style="width: 50px;" type="text" value="6"/> in
UDFCD Riprap Type	Type = <input style="width: 50px;" type="text" value="VL"/>
Length of Protection	L_p = <input style="width: 50px;" type="text" value="6"/> ft
Width of Protection	T = <input style="width: 50px;" type="text" value="3"/> ft

Determination of Culvert Headwater and Outlet Protection

Project: **North Bay at Lake Woodmoor**

Basin ID: **18" RCP (Pipe No. S10)**

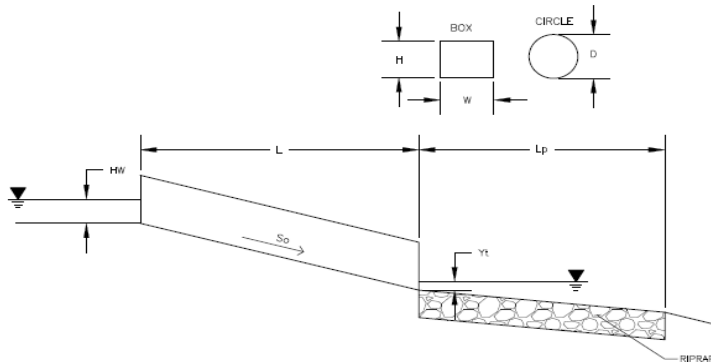

Soil Type:

Choose One:

Sandy

Non-Sandy

Design Information (Input):

Design Discharge	Q = <input type="text" value="11.3"/> cfs
Circular Culvert:	
Barrel Diameter in Inches	D = <input type="text" value="18"/> inches
Inlet Edge Type (Choose from pull-down list)	Square End Projection <input type="text" value="Square End Projection"/>
Box Culvert:	
Barrel Height (Rise) in Feet	Height (Rise) = <input type="text" value=""/> ft
Barrel Width (Span) in Feet	Width (Span) = <input type="text" value=""/> ft
Inlet Edge Type (Choose from pull-down list)	<input type="text" value=""/>
Number of Barrels	No = <input type="text" value="1"/>
Inlet Elevation	Elev IN = <input type="text" value="7108.49"/> ft
Outlet Elevation OR Slope	Elev OUT = <input type="text" value="7108"/> ft
Culvert Length	L = <input type="text" value="48.82"/> ft
Manning's Roughness	n = <input type="text" value="0.013"/>
Bend Loss Coefficient	k_b = <input type="text" value="0"/>
Exit Loss Coefficient	k_x = <input type="text" value="1"/>
Tailwater Surface Elevation	Elev Y_t = <input type="text" value="7107"/> ft
Max Allowable Channel Velocity	V = <input type="text" value="5"/> ft/s

Tailwater ELEVATION is less than outlet elevation, using 0.4 x RISE as Y_t

Required Protection (Output):

Tailwater Surface Height	Y_t = <input type="text" value="0.60"/> ft
Flow Area at Max Channel Velocity	A_f = <input type="text" value="2.26"/> ft ²
Culvert Cross Sectional Area Available	A = <input type="text" value="1.77"/> ft ²
Entrance Loss Coefficient	k_e = <input type="text" value="0.50"/>
Friction Loss Coefficient	k_f = <input type="text" value="0.88"/>
Sum of All Losses Coefficients	k_s = <input type="text" value="2.38"/> ft
Culvert Normal Depth	Y_n = <input type="text" value="1.37"/> ft
Culvert Critical Depth	Y_c = <input type="text" value="1.28"/> ft
Tailwater Depth for Design	d = <input type="text" value="1.39"/> ft
Adjusted Diameter OR Adjusted Rise	D_a = <input type="text" value=""/>
Expansion Factor	$1/(2*\tan(\theta))$ = <input type="text" value="3.40"/>
Flow/Diameter ^{2.5} OR Flow/(Span * Rise ^{1.5})	Q/D ^{2.5} = <input type="text" value="4.10"/> ft ^{0.5} /s
Froude Number	Fr = <input type="text" value="0.84"/>
Tailwater/Adjusted Diameter OR Tailwater/Adjusted Rise	Y_t/D = <input type="text" value="0.40"/>
Inlet Control Headwater	HW_i = <input type="text" value="2.65"/> ft
Outlet Control Headwater	HW_o = <input type="text" value="2.42"/>
Design Headwater Elevation	HW = <input type="text" value="7,111.14"/> ft
Headwater/Diameter OR Headwater/Rise Ratio	HW/D = <input type="text" value="1.76"/> HW/D > 1.5!
Minimum Theoretical Riprap Size	d_{50} = <input type="text" value="5"/> in
Nominal Riprap Size	d_{50} = <input type="text" value="6"/> in
UDFCD Riprap Type	Type = <input type="text" value="VL"/>
Length of Protection	L_p = <input type="text" value="8"/> ft
Width of Protection	T = <input type="text" value="4"/> ft

Determination of Culvert Headwater and Outlet Protection

Project: **North Bay at Lake Woodmoor**

Basin ID: **18" RCP (Pipe No. S11)**

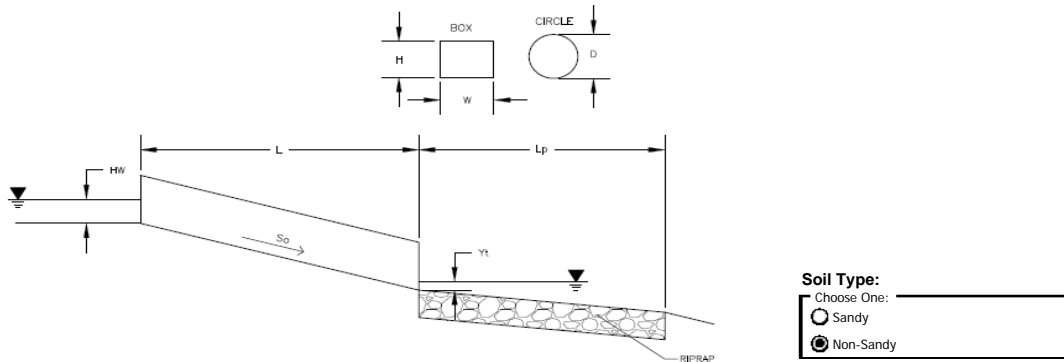

Soil Type:
 Choose One: Sandy
 Non-Sandy

Supercritical Flow! Using D_a to calculate protection type.

Design Information (Input):	
Design Discharge	Q = <input type="text" value="2.1"/> cfs
Circular Culvert:	
Barrel Diameter in Inches	D = <input type="text" value="18"/> inches
Inlet Edge Type (Choose from pull-down list)	Square End Projection <input type="text" value="Square End Projection"/>
OR	
Box Culvert:	
Barrel Height (Rise) in Feet	Height (Rise) = <input type="text" value=""/>
Barrel Width (Span) in Feet	Width (Span) = <input type="text" value=""/>
Inlet Edge Type (Choose from pull-down list)	<input type="text" value=""/>
Number of Barrels	No = <input type="text" value="1"/>
Inlet Elevation	Elev IN = <input type="text" value="7114.4"/> ft
Outlet Elevation OR Slope	Elev OUT = <input type="text" value="7114.3"/> ft
Culvert Length	L = <input type="text" value="10.7"/> ft
Manning's Roughness	n = <input type="text" value="0.013"/>
Bend Loss Coefficient	k_b = <input type="text" value="0"/>
Exit Loss Coefficient	k_x = <input type="text" value="1"/>
Tailwater Surface Elevation	Elev Y_t = <input type="text" value="7114.7"/> ft
Max Allowable Channel Velocity	V = <input type="text" value="5"/> ft/s

Required Protection (Output):	
Tailwater Surface Height	Y_t = <input type="text" value="0.40"/> ft
Flow Area at Max Channel Velocity	A_f = <input type="text" value="0.42"/> ft ²
Culvert Cross Sectional Area Available	A = <input type="text" value="1.77"/> ft ²
Entrance Loss Coefficient	k_e = <input type="text" value="0.50"/>
Friction Loss Coefficient	k_f = <input type="text" value="0.19"/>
Sum of All Losses Coefficients	k_s = <input type="text" value="1.69"/> ft
Culvert Normal Depth	Y_n = <input type="text" value="0.46"/> ft
Culvert Critical Depth	Y_c = <input type="text" value="0.55"/> ft
Tailwater Depth for Design	d = <input type="text" value="1.02"/> ft
Adjusted Diameter OR Adjusted Rise	D_a = <input type="text" value="0.98"/> ft
Expansion Factor	$1/(2*\tan(\theta))$ = <input type="text" value="6.70"/>
Flow/Diameter ^{2.5} OR Flow/(Span * Rise ^{1.5})	$Q/D^{2.5}$ = <input type="text" value="0.76"/> ft ^{0.5} /s
Froude Number	Fr = <input type="text" value="1.38"/> Supercritical!
Tailwater/Adjusted Diameter OR Tailwater/Adjusted Rise	Y_t/D = <input type="text" value="0.41"/>
Inlet Control Headwater	HW_i = <input type="text" value="0.77"/> ft
Outlet Control Headwater	HW_o = <input type="text" value="0.96"/> ft
Design Headwater Elevation	HW = <input type="text" value="7,115.36"/> ft
Headwater/Diameter OR Headwater/Rise Ratio	HW/D = <input type="text" value="0.64"/>
Minimum Theoretical Riprap Size	d_{50} = <input type="text" value="2"/> in
Nominal Riprap Size	d_{50} = <input type="text" value="6"/> in
UDFCD Riprap Type	Type = <input type="text" value="VL"/>
Length of Protection	L_p = <input type="text" value="5"/> ft
Width of Protection	T = <input type="text" value="3"/> ft

Determination of Culvert Headwater and Outlet Protection

Project: **North Bay at Lake Woodmoor**

Basin ID: **12" PVC, Raw Water Line**

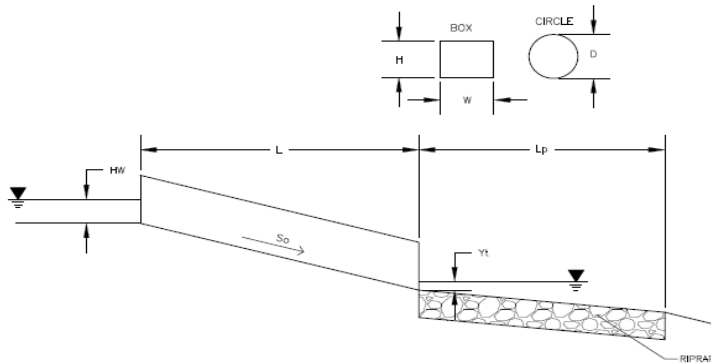

Soil Type:

Choose One:

Sandy

Non-Sandy

Design Information (Input):

Design Discharge

Q = cfs

Circular Culvert:

Barrel Diameter in Inches

D = inches

Inlet Edge Type (Choose from pull-down list)

Square End Projection

Box Culvert:

Barrel Height (Rise) in Feet

Height (Rise) = ft

Barrel Width (Span) in Feet

Width (Span) = ft

Inlet Edge Type (Choose from pull-down list)

Number of Barrels

No =

Inlet Elevation

Elev IN = ft

Outlet Elevation **OR** Slope

Elev OUT = ft

Culvert Length

L = ft

Manning's Roughness

n =

Bend Loss Coefficient

k_b =

Exit Loss Coefficient

k_x =

Tailwater Surface Elevation

Elev Y_t = ft

Max Allowable Channel Velocity

V = ft/s

Tailwater ELEVATION is less than outlet elevation, using 0.4 x RISE as Y_t

Required Protection (Output):

Tailwater Surface Height

Y_t = ft

Flow Area at Max Channel Velocity

A_f = ft²

Culvert Cross Sectional Area Available

A = ft²

Entrance Loss Coefficient

k_e =

Friction Loss Coefficient

k_f =

Sum of All Losses Coefficients

k_s = ft

Culvert Normal Depth

Y_n = ft

Culvert Critical Depth

Y_c = ft

Tailwater Depth for Design

d = ft

Adjusted Diameter **OR** Adjusted Rise

D_a = ft

Expansion Factor

$1/(2*\tan(\theta))$ =

Flow/Diameter^{2.5} **OR** Flow/(Span * Rise^{1.5})

Q/D^{2.5} = ft^{0.5}/s

Froude Number

Fr = **Pressure flow!**

Tailwater/Adjusted Diameter **OR** Tailwater/Adjusted Rise

Y_t/D =

Inlet Control Headwater

H_{w1} = ft

Outlet Control Headwater

H_{w0} =

Design Headwater Elevation

HW = ft

Headwater/Diameter **OR** Headwater/Rise Ratio

HW/D = **HW/D > 1.5!**

Minimum Theoretical Riprap Size

d_{50} = in

Nominal Riprap Size

d_{50} = in

UDFCD Riprap Type

Type =

Length of Protection

L_p = ft

Width of Protection

T = ft

Determination of Culvert Headwater and Outlet Protection

Project: **North Bay at Lake Woodmoor**

Basin ID: **Lake Fork Dirty Woman Creek - Shoreditch Heights Crossing**

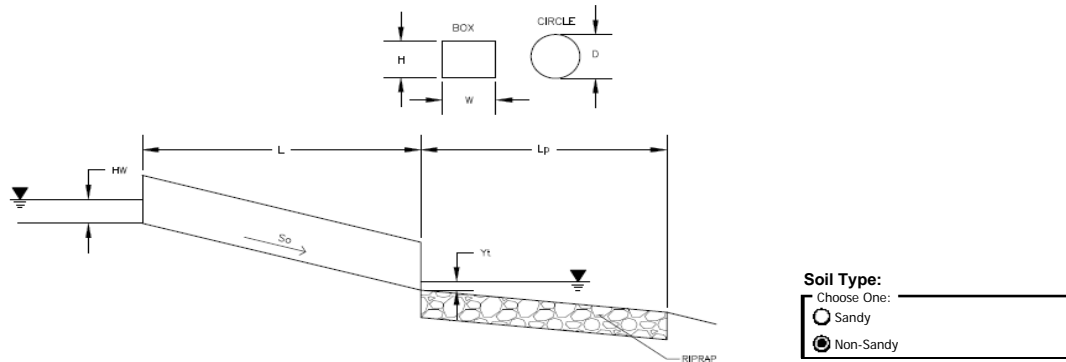

Supercritical Flow! Using Ha to calculate protection type.

Design Information (Input):	
Design Discharge	Q = <input type="text" value="1100"/> cfs
Circular Culvert:	
Barrel Diameter in Inches	D = <input type="text" value="48"/> inches
Inlet Edge Type (Choose from pull-down list)	<input type="text" value="Square Edge w/ 30-78 deg. Flared Wingwall"/>
OR	
Box Culvert:	
Barrel Height (Rise) in Feet	Height (Rise) = <input type="text" value="4"/> ft
Barrel Width (Span) in Feet	Width (Span) = <input type="text" value="12"/> ft
Inlet Edge Type (Choose from pull-down list)	<input type="text" value="Square Edge w/ 30-78 deg. Flared Wingwall"/>
Number of Barrels	No = <input type="text" value="3"/>
Inlet Elevation	Elev IN = <input type="text" value="7128.4"/> ft
Outlet Elevation OR Slope	Elev OUT = <input type="text" value="7128.2"/> ft
Culvert Length	L = <input type="text" value="40"/> ft
Manning's Roughness	n = <input type="text" value="0.013"/>
Bend Loss Coefficient	k _b = <input type="text" value="0"/>
Exit Loss Coefficient	k _x = <input type="text" value="1"/>
Tailwater Surface Elevation	Elev Y _t = <input type="text" value="7129.5"/> ft
Max Allowable Channel Velocity	V = <input type="text" value="5"/> ft/s
Required Protection (Output):	
Tailwater Surface Height	Y _t = <input type="text" value="1.30"/> ft
Flow Area at Max Channel Velocity	A _t = <input type="text" value="73.33"/> ft ²
Culvert Cross Sectional Area Available	A = <input type="text" value="48.00"/> ft ²
Entrance Loss Coefficient	k _e = <input type="text" value="0.40"/>
Friction Loss Coefficient	k _f = <input type="text" value="0.20"/>
Sum of All Losses Coefficients	k _s = <input type="text" value="1.60"/> ft
Culvert Normal Depth	Y _n = <input type="text" value="2.56"/> ft
Culvert Critical Depth	Y _c = <input type="text" value="3.07"/> ft
Tailwater Depth for Design	d = <input type="text" value="3.54"/> ft
Adjusted Diameter OR Adjusted Rise	H _a = <input type="text" value="3.28"/> ft
Expansion Factor	1/(2*tan(θ)) = <input type="text" value="2.59"/>
Flow/Diameter ^{2.5} OR Flow/(Span * Rise ^{1.5})	Q/WH ^{1.5} = <input type="text" value="3.82"/> ft ^{0.5} /s
Froude Number	Fr = <input type="text" value="1.32"/> Supercritical!
Tailwater/Adjusted Diameter OR Tailwater/Adjusted Rise	Y _t /H = <input type="text" value="0.40"/>
Inlet Control Headwater	HW _i = <input type="text" value="4.97"/> ft
Outlet Control Headwater	HW _o = <input type="text" value="4.78"/> ft
Design Headwater Elevation	HW = 7,133.37 ft
Headwater/Diameter OR Headwater/Rise Ratio	HW/H = 1.24
Minimum Theoretical Riprap Size	d ₅₀ = <input type="text" value="7"/> in
Nominal Riprap Size	d ₅₀ = <input type="text" value="9"/> in
UDFCD Riprap Type	Type = L
Length of Protection	L_p = 40 ft
Width of Protection	T = 28 ft

APPENDIX C
Detention Calculations
Detention Volume Calculations

North Bay at Lake Woodmoor Detention Calculations

UDFCD Detention Sizing

Detention Area	Total Acres	% Imperv.	Soil Group	100yr P ₁	WQCV					EURV		K ₁₀₀	V ₁₀₀	Required Detention Volume	
					a	Z	Depth	Factor	Volume	Depth	Volume			V _{100+1/2WQCV}	V _{100+1/2EURV}
Detention Req. for Site (as Designed)	7.23 ac	34.2%	D	2.52in	1.0	1.0	0.16in	0.014	0.099ac-ft 4,303 cf	0.38in	0.227ac-ft 9,884 cf	0.939	0.57ac-ft 24,651 cf	0.62 ac-ft	26,802 cf
Detention Req. for Site (DBPS Proposed Land Use)	7.23 ac	25.0%	D	2.52in	1.0	1.0	0.13in	0.011	0.081ac-ft 3,538 cf	0.27in	0.162ac-ft 7,046 cf	0.811	0.49ac-ft 21,285 cf	0.53 ac-ft	23,054 cf
													Difference	0.09 ac-ft	Additional 100-yr Volume to Lake Woodmoor
														3,748 cf	

WIR (Watershed Inches of Runoff) taken from Fig. EDB-2, Volume 3, Urban Storm Drainage Criteria Manual for the basin imperviousness shown.

$$\text{WIR} = \text{Depth} = a \cdot (0.91 \cdot I^3 - 1.19 \cdot I^2 + 0.78 \cdot I)$$

I = % Impervious

a = Drain Time

a (40hr) = 1.0
a (24hr) = 0.9
a (12hr) = 0.8

Extended Detention Basin

V ₁₀₀
V _{100+1/2WQCV}
V _{100+WQCV}
V _{100+1/2EURV}

EURV_k = Depth = Excess Urban Runoff Volume in watershed inches (K = A, B or CD)

$$\text{EURV}_A = 1.68 i^{1.28} \quad (\text{USDCM, Eqn 12-1})$$

$$\text{EURV}_B = 1.36 i^{1.08} \quad (\text{USDCM, Eqn 12-2})$$

$$\text{EURV}_{CD} = 1.20 i^{1.08} \quad (\text{USDCM, Eqn 12-3})$$

Required Detention Storage Volume (V_x) = K_x A (Equation SO-1)

$$K_2 = P_1 \cdot ((0.968i^{1.458})A\% + (0.964i^{1.183})B\% + (0.962i^{1.104})CD\%)$$

$$K_5 = P_1 \cdot ((0.973i^{1.368})A\% + (0.900i^{1.098} + 0.082i^{0.098})B\% + (0.795i^{1.226} + 0.159i^{0.226})CD\%)$$

$$K_{10} = P_1 \cdot ((0.988i^{1.237})A\% + (0.751i^{1.254} + 0.174i^{0.254})B\% + (0.630i^{1.371} + 0.248i^{0.371})CD\%)$$

$$K_{100} = P_1 \cdot ((0.728i^{1.258} + 0.150i^{0.258})A\% + (0.364i^{1.286} + 0.381i^{0.286})B\% + (0.306i^{1.286} + 0.402i^{0.286})CD\%)$$

$$K_x = (\text{in inches}) \cdot (\text{USDCM, Eqn 12-4 and UDFCD Runoff and Detention Storage Volumes Memo 2015-03-26})$$

Recommended Release Rate = 90% of Predevelopment Flow

WQCV Factor (Water Quality Capture Volume) = (WIR/12) x Z

Z = Volume Factor

Z (Extended Detention Basin) = 1.0

2015 USDCM

Approximate effect to Lake Woodmoor from additional volume generated from North Bay at Lake Woodmoor site:

Area of Lake: A = 2,010,670 sf = 46.16 ac

46.16 ac / 7.23 ac = 6.38 (Lake is over 6 times larger than site)

Additional Volume = 3,748 cf

Approximate Increase in Lake Level: 3,748 cf / 2,010,670 sf = **0.0019 ft = 0.02 in**

APPENDIX D

Water Quality Basin Calculations

Volume Calculations

Outlet Structure Calculations

Emergency Spillway Calculations

Stormceptor Calculations

Water Quality Exclusion Areas (Figure WQ1)

North Bay at Lake Woodmoor Water Quality Basin Calculations

Minimum Sand Filter Surface Area - Water Quality Basin 1

$$A_F = 0.0125AI = 0.0125 * 1.37ac * 43,560sf/ac * 0.650 = \underline{\underline{484.88 \text{ sf}}}$$

A_F = minimum surface area (flat surface area) (ft²)

A = tributary area to the sand filter (ft²)

I = imperviousness of area tributary to the sand filter (% expressed as a decimal)

Taken from Equation SF-2, Volume 3, Urban Storm Drainage Criteria Manual for sand filters.

Minimum Sand Filter Surface Area - Water Quality Basin 2

$$A_F = 0.0125AI = 0.0125 * 1.74ac * 43,560sf/ac * 0.384 = \underline{\underline{363.81 \text{ sf}}}$$

A_F = minimum surface area (flat surface area) (ft²)

A = tributary area to the sand filter (ft²)

I = imperviousness of area tributary to the sand filter (% expressed as a decimal)

Taken from Equation SF-2, Volume 3, Urban Storm Drainage Criteria Manual for sand filters.

DETENTION BASIN STAGE-STORAGE TABLE BUILDER

UD-Detention, Version 3.07 (February 2017)

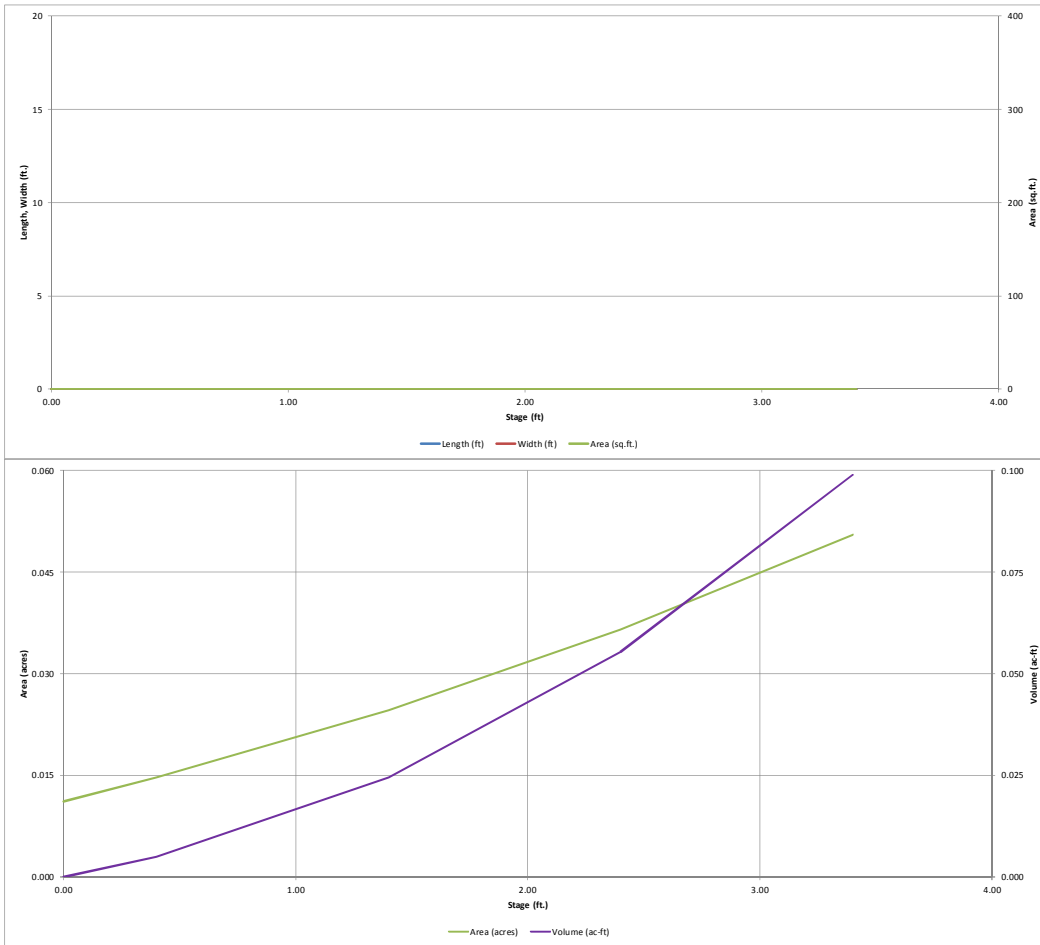

DETENTION BASIN STAGE-STORAGE TABLE BUILDER

UD-Detention, Version 3.07 (February 2017)

Project: North Bay at Lake Woodmoor
Basin ID: Water Quality Basin 2 (East)

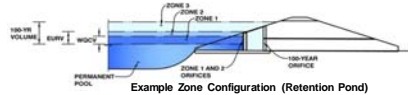

Example Zone Configuration (Retention Pond)

Required Volume Calculation

Table listing various volume calculations such as Watershed Area, Watershed Length, Watershed Slope, and various runoff volumes (2-yr, 5-yr, 10-yr, 25-yr, 50-yr, 100-yr, 500-yr). Includes a section for Stage-Storage Calculation with parameters like Zone 1 Volume, Zone 2 Volume, and Basin Length-to-Width Ratio.

Main stage-storage table with columns: Stage - Storage Description, Stage (ft), Optional Override Stage (ft), Length (ft), Width (ft), Area (ft^2), Optional Override Area (ft^2), Area (acre), Volume (ft^3), Volume (ac-ft). Includes rows for Media Surface and stages 7117 through 7120.

DETENTION BASIN STAGE-STORAGE TABLE BUILDER

UD-Detention, Version 3.07 (February 2017)

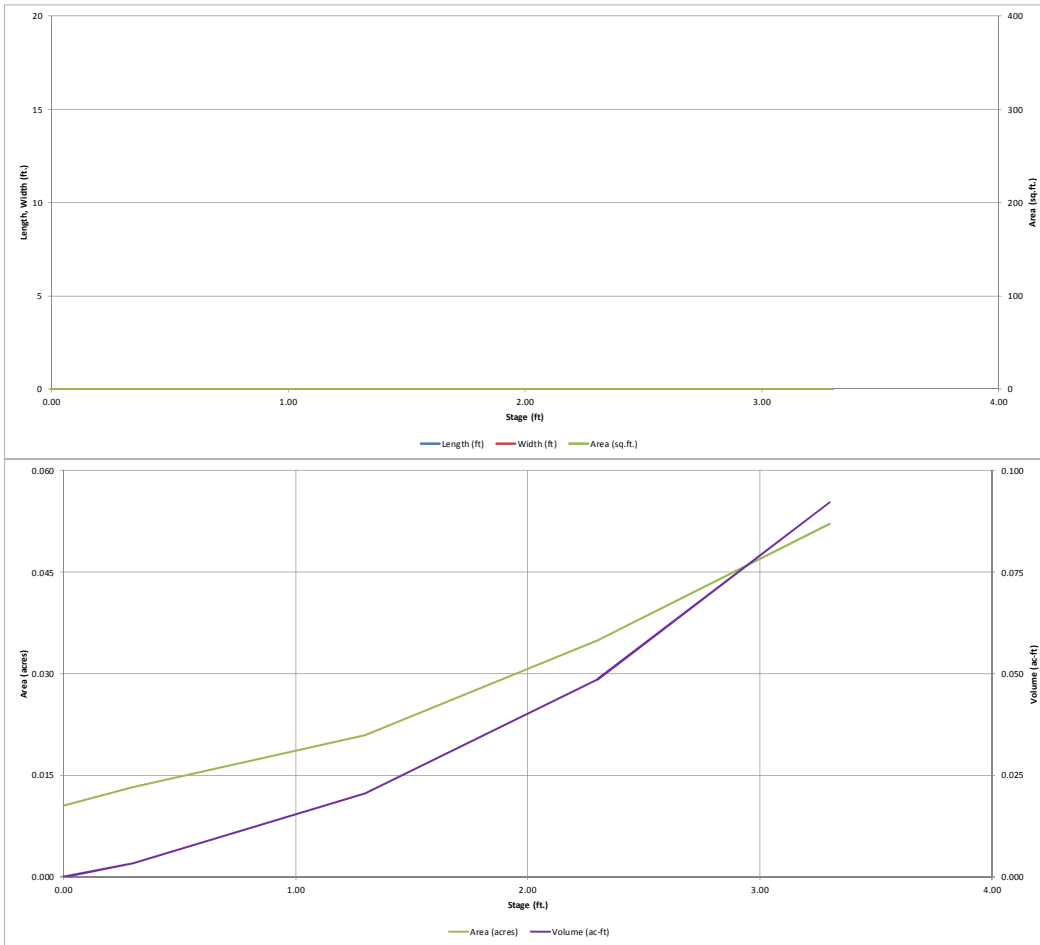

Detention Basin Outlet Structure Design

UD-Detention, Version 3.07 (February 2017)

Project: North Bay at Lake Woodmoor
Basin ID: Water Quality Basin 1 (West)

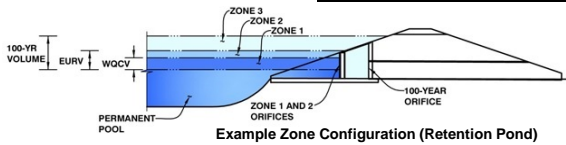

	Stage (ft)	Zone Volume (ac-ft)	Outlet Type
Zone 1 (WQCV)	1.34	0.023	Filtration Media
Zone 2 (100-year)		0.133	Weir&Pipe (Circular)
Zone 3			
		0.156	Total

User Input: Orifice at Underdrain Outlet (typically used to drain WQCV in a Filtration BMP)

Underdrain Orifice Invert Depth = 2.30 ft (distance below the filtration media surface)
Underdrain Orifice Diameter = 0.72 inches

Calculated Parameters for Underdrain

Underdrain Orifice Area = 0.0 ft²
Underdrain Orifice Centroid = 0.03 feet

User Input: Orifice Plate with one or more orifices or Elliptical Slot Weir (typically used to drain WQCV and/or EURV in a sedimentation BMP)

Invert of Lowest Orifice = N/A ft (relative to basin bottom at Stage = 0 ft)
Depth at top of Zone using Orifice Plate = N/A ft (relative to basin bottom at Stage = 0 ft)
Orifice Plate: Orifice Vertical Spacing = N/A inches
Orifice Plate: Orifice Area per Row = N/A inches

Calculated Parameters for Plate

WQ Orifice Area per Row = N/A ft²
Elliptical Half-Width = N/A feet
Elliptical Slot Centroid = N/A feet
Elliptical Slot Area = N/A ft²

User Input: Stage and Total Area of Each Orifice Row (numbered from lowest to highest)

	Row 1 (optional)	Row 2 (optional)	Row 3 (optional)	Row 4 (optional)	Row 5 (optional)	Row 6 (optional)	Row 7 (optional)	Row 8 (optional)
Stage of Orifice Centroid (ft)	N/A	N/A	N/A	N/A	N/A	N/A	N/A	N/A
Orifice Area (sq. inches)	N/A	N/A	N/A	N/A	N/A	N/A	N/A	N/A

	Row 9 (optional)	Row 10 (optional)	Row 11 (optional)	Row 12 (optional)	Row 13 (optional)	Row 14 (optional)	Row 15 (optional)	Row 16 (optional)
Stage of Orifice Centroid (ft)	N/A	N/A	N/A	N/A	N/A	N/A	N/A	N/A
Orifice Area (sq. inches)	N/A	N/A	N/A	N/A	N/A	N/A	N/A	N/A

User Input: Vertical Orifice (Circular or Rectangular)

	Not Selected	Not Selected	
Invert of Vertical Orifice =			ft (relative to basin bottom at Stage = 0 ft)
Depth at top of Zone using Vertical Orifice =			ft (relative to basin bottom at Stage = 0 ft)
Vertical Orifice Diameter =			inches

Calculated Parameters for Vertical Orifice

	Not Selected	Not Selected	
Vertical Orifice Area =			ft ²
Vertical Orifice Centroid =			feet

User Input: Overflow Weir (Dropbox) and Grate (Flat or Sloped)

	Zone 2 Weir	Not Selected	
Overflow Weir Front Edge Height, H _o =	1.34		ft (relative to basin bottom at Stage = 0 ft)
Overflow Weir Front Edge Length =	5.67		feet
Overflow Weir Slope =	0.00		H:V (enter zero for flat grate)
Horiz. Length of Weir Sides =	2.92		feet
Overflow Grate Open Area % =	70%		%, grate open area/total area
Debris Clogging % =	30%		%

Calculated Parameters for Overflow Weir

	Zone 2 Weir	Not Selected	
Height of Grate Upper Edge, H ₁ =	1.34		feet
Over Flow Weir Slope Length =	2.92		feet
Grate Open Area / 100-yr Orifice Area =			should be ≥ 4
Overflow Grate Open Area w/o Debris =	11.59		ft ²
Overflow Grate Open Area w/ Debris =	8.11		ft ²

User Input: Outlet Pipe w/ Flow Restriction Plate (Circular Orifice, Restrictor Plate, or Rectangular Orifice)

	Zone 2 Circular	Not Selected	
Depth to Invert of Outlet Pipe =			ft (distance below basin bottom at Stage = 0 ft)
Circular Orifice Diameter =			inches

Calculated Parameters for Outlet Pipe w/ Flow Restriction Plate

	Zone 2 Circular	Not Selected	
Outlet Orifice Area =			ft ²
Outlet Orifice Centroid =			feet
Half-Central Angle of Restrictor Plate on Pipe =	N/A	N/A	radians

User Input: Emergency Spillway (Rectangular or Trapezoidal)

Spillway Invert Stage =	2.10	ft (relative to basin bottom at Stage = 0 ft)
Spillway Crest Length =	16.00	feet
Spillway End Slopes =	4.00	H:V
Freeboard above Max Water Surface =	1.00	feet

Calculated Parameters for Spillway

Spillway Design Flow Depth =	0.16	feet
Stage at Top of Freeboard =	3.26	feet
Basin Area at Top of Freeboard =	0.05	acres

Routed Hydrograph Results

Design Storm Return Period =	WQCV
One-Hour Rainfall Depth (in) =	0.53
Calculated Runoff Volume (acre-ft) =	0.023
OPTIONAL Override Runoff Volume (acre-ft) =	
Inflow Hydrograph Volume (acre-ft) =	0.022
Predevelopment Unit Peak Flow, q (cfs/acre) =	0.00
Predevelopment Peak Q (cfs) =	0.0
Peak Inflow Q (cfs) =	0.3
Peak Outflow Q (cfs) =	0.0
Ratio Peak Outflow to Predevelopment Q =	N/A
Structure Controlling Flow =	Filtration Media
Max Velocity through Grate 1 (fps) =	N/A
Max Velocity through Grate 2 (fps) =	N/A
Time to Drain 97% of Inflow Volume (hours) =	12
Time to Drain 99% of Inflow Volume (hours) =	12
Maximum Ponding Depth (ft) =	1.09
Area at Maximum Ponding Depth (acres) =	0.02
Maximum Volume Stored (acre-ft) =	0.018

Detention Basin Outlet Structure Design

UD-Detention, Version 3.07 (February 2017)

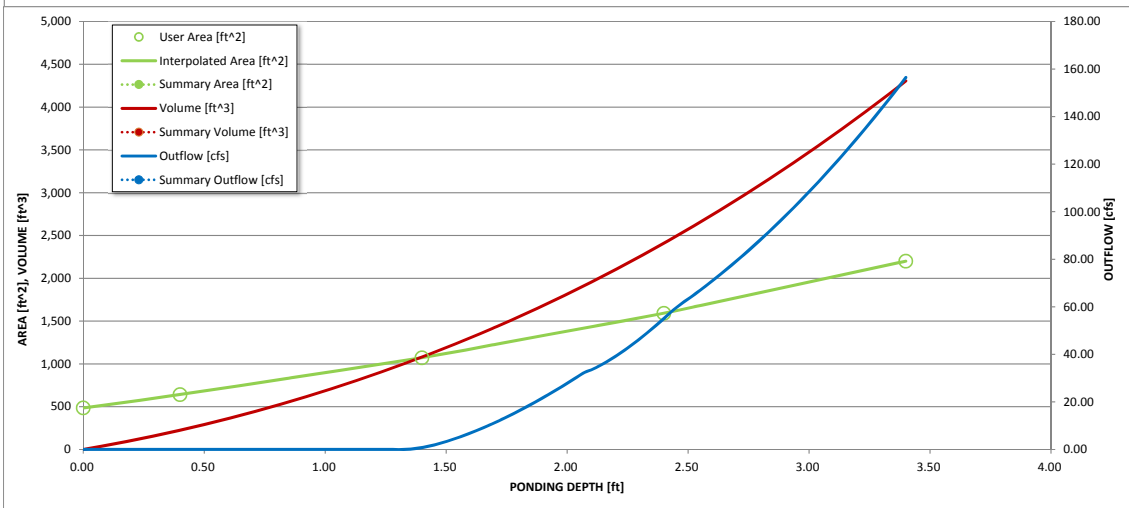
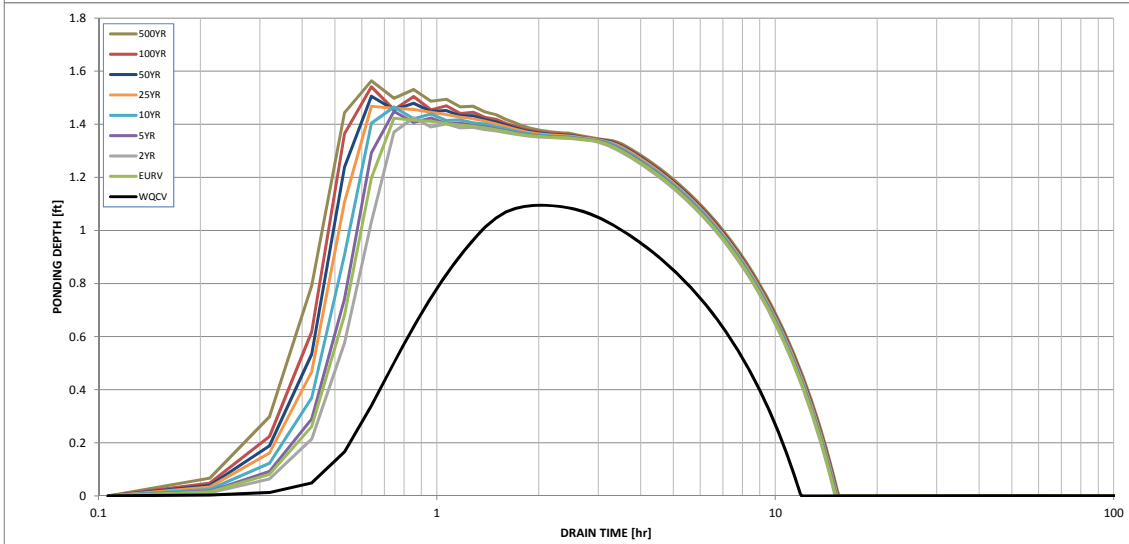
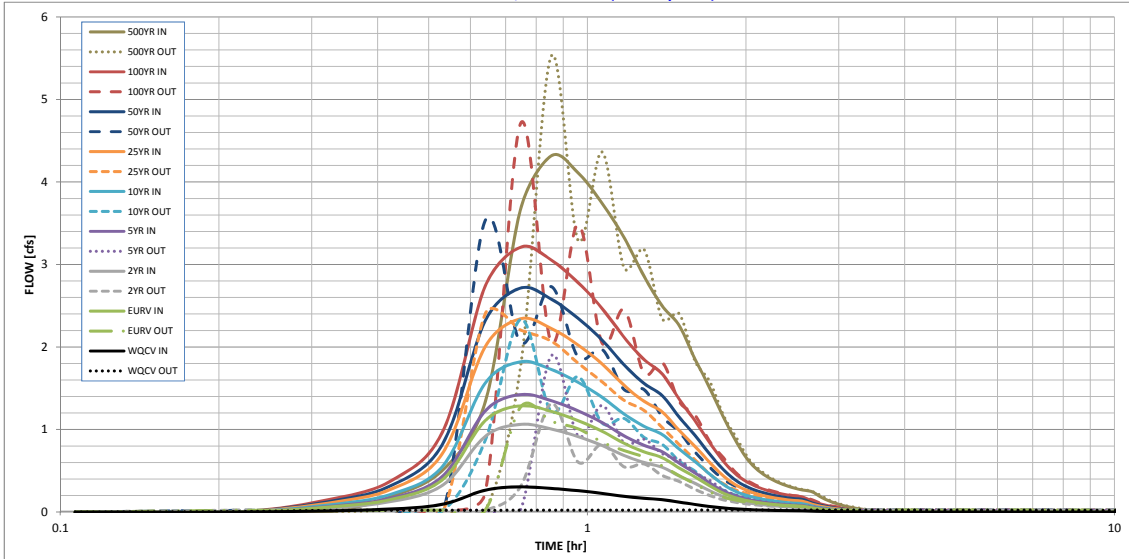

S-A-V-D Chart Axis Override

	X-axis	Left Y-Axis	Right Y-Axis
minimum bound			
maximum bound			

Detention Basin Outlet Structure Design

UD-Detention, Version 3.07 (February 2017)

Project: North Bay at Lake Woodmoor
Basin ID: Water Quality Basin 2 (East)

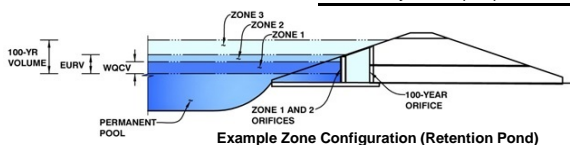

Example Zone Configuration (Retention Pond)

	Stage (ft)	Zone Volume (ac-ft)	Outlet Type
Zone 1 (WQCV)	1.29	0.020	Filtration Media
Zone 2 (100-year)		0.112	Weir&Pipe (Circular)
Zone 3		0.132	Total

User Input: Orifice at Underdrain Outlet (typically used to drain WQCV in a Filtration BMP)

Underdrain Orifice Invert Depth = 2.20 ft (distance below the filtration media surface)
Underdrain Orifice Diameter = 0.68 inches

Calculated Parameters for Underdrain

Underdrain Orifice Area = 0.0 ft²
Underdrain Orifice Centroid = 0.03 feet

User Input: Orifice Plate with one or more orifices or Elliptical Slot Weir (typically used to drain WQCV and/or EURV in a sedimentation BMP)

Invert of Lowest Orifice = N/A ft (relative to basin bottom at Stage = 0 ft)
Depth at top of Zone using Orifice Plate = N/A ft (relative to basin bottom at Stage = 0 ft)
Orifice Plate: Orifice Vertical Spacing = N/A inches
Orifice Plate: Orifice Area per Row = N/A inches

Calculated Parameters for Plate

WQ Orifice Area per Row = N/A ft²
Elliptical Half-Width = N/A feet
Elliptical Slot Centroid = N/A feet
Elliptical Slot Area = N/A ft²

User Input: Stage and Total Area of Each Orifice Row (numbered from lowest to highest)

	Row 1 (optional)	Row 2 (optional)	Row 3 (optional)	Row 4 (optional)	Row 5 (optional)	Row 6 (optional)	Row 7 (optional)	Row 8 (optional)
Stage of Orifice Centroid (ft)	N/A	N/A	N/A	N/A	N/A	N/A	N/A	N/A
Orifice Area (sq. inches)	N/A	N/A	N/A	N/A	N/A	N/A	N/A	N/A

	Row 9 (optional)	Row 10 (optional)	Row 11 (optional)	Row 12 (optional)	Row 13 (optional)	Row 14 (optional)	Row 15 (optional)	Row 16 (optional)
Stage of Orifice Centroid (ft)	N/A	N/A	N/A	N/A	N/A	N/A	N/A	N/A
Orifice Area (sq. inches)	N/A	N/A	N/A	N/A	N/A	N/A	N/A	N/A

User Input: Vertical Orifice (Circular or Rectangular)

Invert of Vertical Orifice = Not Selected ft (relative to basin bottom at Stage = 0 ft)
Depth at top of Zone using Vertical Orifice = Not Selected ft (relative to basin bottom at Stage = 0 ft)
Vertical Orifice Diameter = Not Selected inches

Calculated Parameters for Vertical Orifice

Vertical Orifice Area = Not Selected ft²
Vertical Orifice Centroid = Not Selected feet

User Input: Overflow Weir (Dropbox) and Grate (Flat or Sloped)

	Zone 2 Weir	Not Selected	
Overflow Weir Front Edge Height, H _o =	1.29		ft (relative to basin bottom at Stage = 0 ft)
Overflow Weir Front Edge Length =	5.67		feet
Overflow Weir Slope =	0.00		H:V (enter zero for flat grate)
Horiz. Length of Weir Sides =	2.92		feet
Overflow Grate Open Area % =	70%		%, grate open area/total area
Debris Clogging % =	30%		%

Calculated Parameters for Overflow Weir

	Zone 2 Weir	Not Selected	
Height of Grate Upper Edge, H ₁ =	1.29		feet
Over Flow Weir Slope Length =	2.92		feet
Grate Open Area / 100-yr Orifice Area =			should be ≥ 4
Overflow Grate Open Area w/o Debris =	11.59		ft ²
Overflow Grate Open Area w/ Debris =	8.11		ft ²

User Input: Outlet Pipe w/ Flow Restriction Plate (Circular Orifice, Restrictor Plate, or Rectangular Orifice)

	Zone 2 Circular	Not Selected	
Depth to Invert of Outlet Pipe =			ft (distance below basin bottom at Stage = 0 ft)
Circular Orifice Diameter =			inches

Calculated Parameters for Outlet Pipe w/ Flow Restriction Plate

	Zone 2 Circular	Not Selected	
Outlet Orifice Area =			ft ²
Outlet Orifice Centroid =			feet
Half-Central Angle of Restrictor Plate on Pipe =	N/A	N/A	radians

User Input: Emergency Spillway (Rectangular or Trapezoidal)

Spillway Invert Stage = 2.00 ft (relative to basin bottom at Stage = 0 ft)
Spillway Crest Length = 24.00 feet
Spillway End Slopes = 4.00 H:V
Freeboard above Max Water Surface = 1.00 feet

Calculated Parameters for Spillway

Spillway Design Flow Depth = 0.13 feet
Stage at Top of Freeboard = 3.13 feet
Basin Area at Top of Freeboard = 0.05 acres

Routed Hydrograph Results

Design Storm Return Period =	WQCV
One-Hour Rainfall Depth (in) =	0.53
Calculated Runoff Volume (acre-ft) =	0.020
OPTIONAL Override Runoff Volume (acre-ft) =	
Inflow Hydrograph Volume (acre-ft) =	0.019
Predevelopment Unit Peak Flow, q (cfs/acre) =	0.00
Predevelopment Peak Q (cfs) =	0.0
Peak Inflow Q (cfs) =	0.3
Peak Outflow Q (cfs) =	0.0
Ratio Peak Outflow to Predevelopment Q =	N/A
Structure Controlling Flow =	Filtration Media
Max Velocity through Grate 1 (fps) =	N/A
Max Velocity through Grate 2 (fps) =	N/A
Time to Drain 97% of Inflow Volume (hours) =	12
Time to Drain 99% of Inflow Volume (hours) =	12
Maximum Ponding Depth (ft) =	1.04
Area at Maximum Ponding Depth (acres) =	0.02
Maximum Volume Stored (acre-ft) =	0.016

Detention Basin Outlet Structure Design

UD-Detention, Version 3.07 (February 2017)

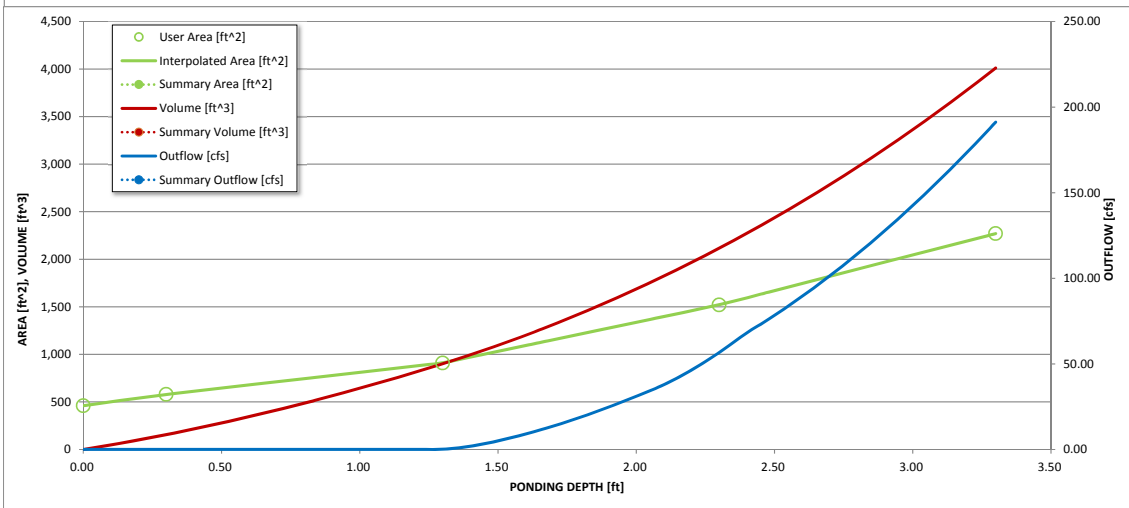
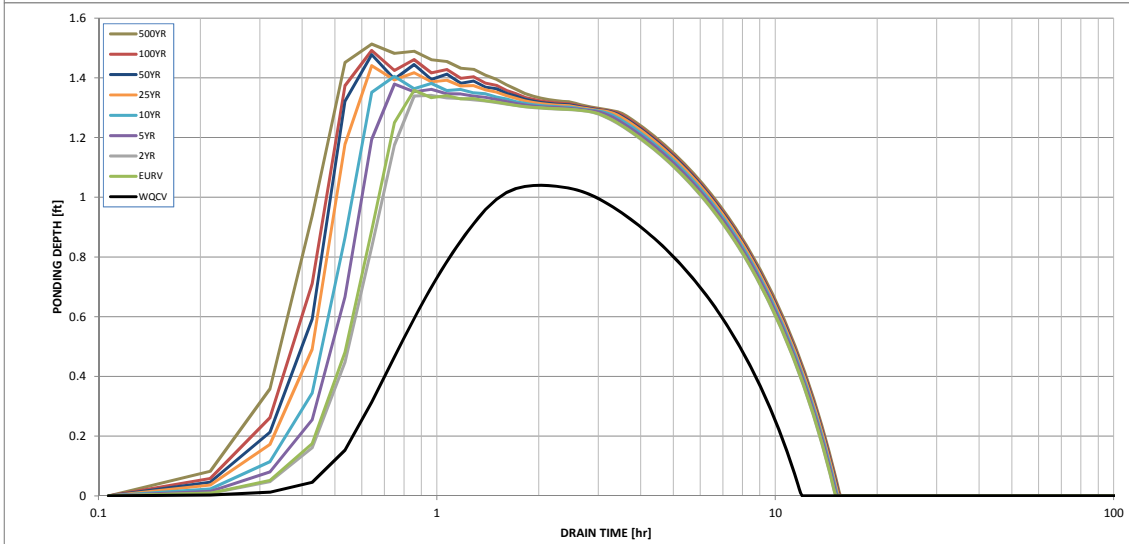
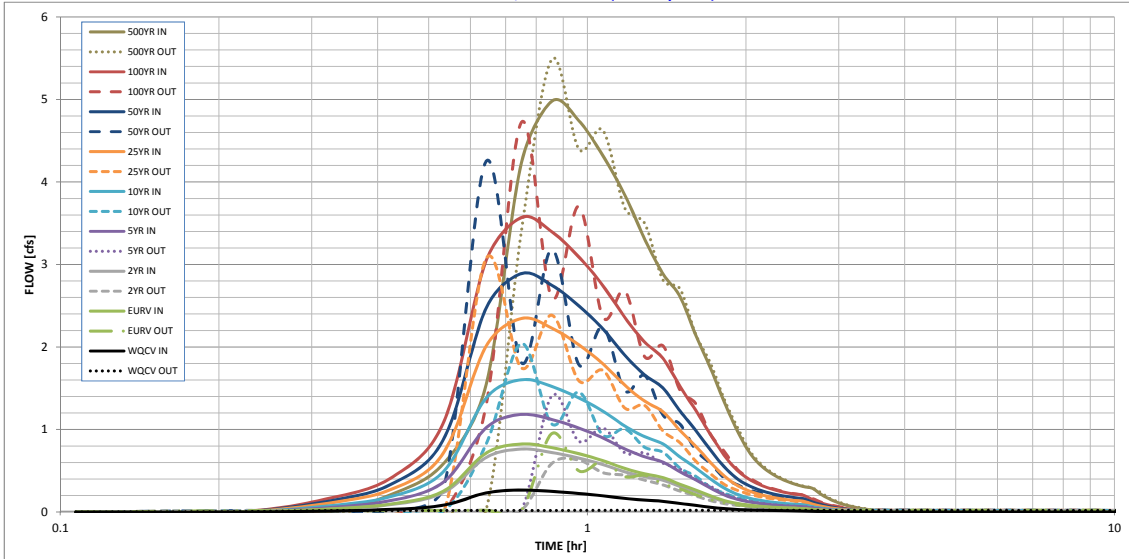

S-A-V-D Chart Axis Override

	X-axis	Left Y-Axis	Right Y-Axis
minimum bound			
maximum bound			

**North Bay at Lake Woodmoor
Water Quality Basin Calculations**

Emergency Spillway Calculation

Water Quality Area	100-yr Flow	Water Surf Elev	Crest Elev	Crest Length	Z	C	Flow Depth (H)	Calc'd Flow	Check
WQ1	7.2 cfs	7,118.0	7,117.7	16 ft	4:1	3.0	0.30 ft	8.4 cfs	OK
WQ2	11.3 cfs	7,119.0	7,118.7	24 ft	4:1	3.0	0.30 ft	12.3 cfs	OK

Broad Crested Weir Equation (USDCM Eqn 12-20 and 12-21):

$$Q = CLH^{1.5} + 2x((2/5)CZH^{5/2})$$

C = Weir coefficient, C = 3.0 (most cases)

L = Length of weir at Crest, in ft. Not including sideslopes.

H = Head above weir crest, in ft

Z = Side slope (horizontal:vertical)

Figure 13-12c. Emergency Spillway Protection

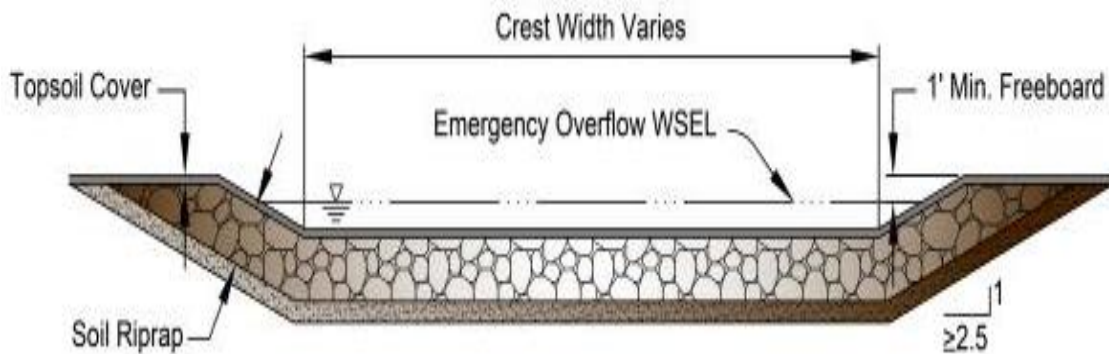
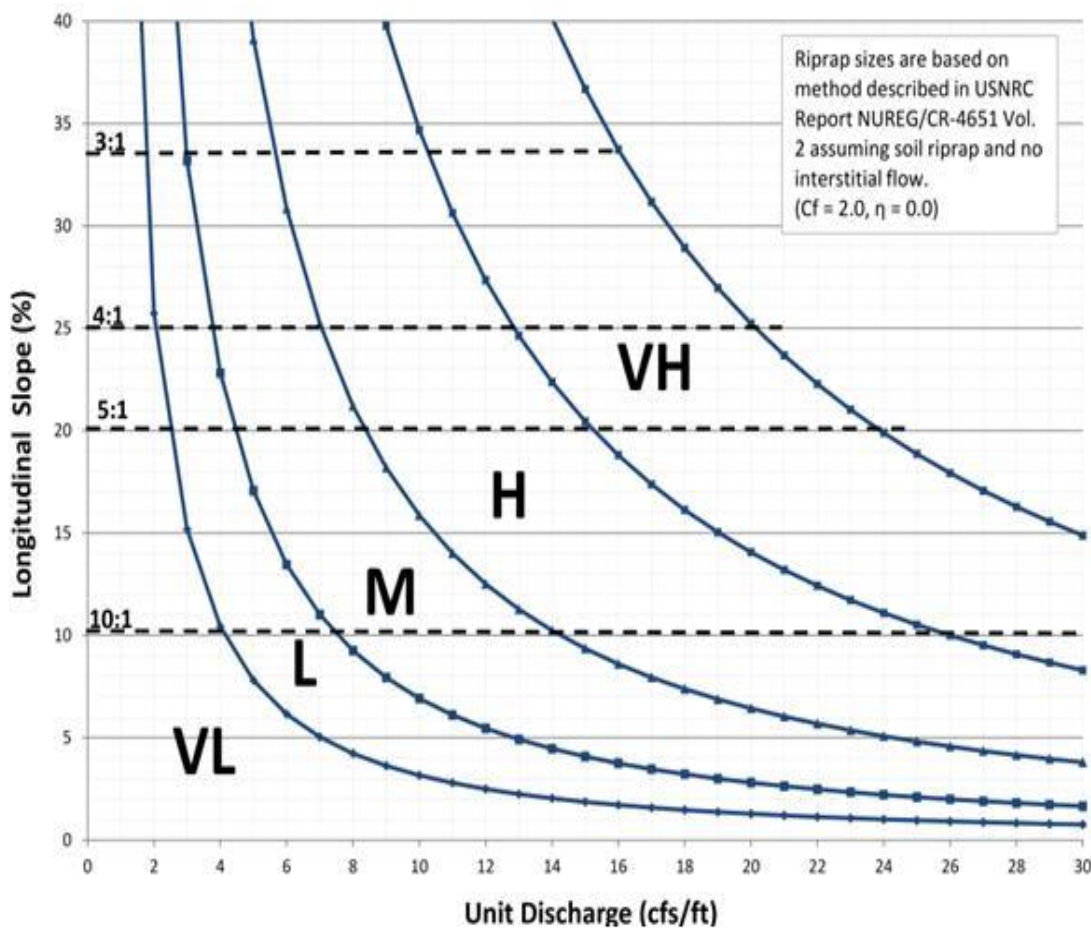

Figure 13-12d. Riprap Types for Emergency Spillway Protection



Detailed Stormceptor Sizing Report – North Bay at Lake Woodmoor

Project Information & Location			
Project Name	North Bay at Lake Woodmoor	Project Number	5256
City	Monument	State/ Province	Colorado
Country	United States of America	Date	11/20/2017
Designer Information		EOR Information (optional)	
Name	brian schram	Name	Chris Castelli
Company	rinker materials	Company	Kiowa
Phone #	303-918-1628	Phone #	720-330-2553
Email	briank.schram@rinkerpipe.com	Email	ccastelli@kiowaengineering.com

Stormwater Treatment Recommendation

The recommended Stormceptor Model(s) which achieve or exceed the user defined water quality objective for each site within the project are listed in the below Sizing Summary table.

Site Name	
Recommended Stormceptor Model	STC 450i
Target TSS Removal (%)	80.0
TSS Removal (%) Provided	91
PSD	Fine Distribution
Rainfall Station	GREENLAND 9 SE

The recommended Stormceptor model achieves the water quality objectives based on the selected inputs, historical rainfall records and selected particle size distribution.

Stormceptor Sizing Summary	
Stormceptor Model	% TSS Removal Provided
STC 450i	91
STC 900	95
STC 1200	95
STC 1800	95
STC 2400	96
STC 3600	97
STC 4800	98
STC 6000	98
STC 7200	98
STC 11000	99
STC 13000	99
STC 16000	99
StormceptorMAX	Custom

Stormceptor

The Stormceptor oil and sediment separator is sized to treat stormwater runoff by removing pollutants through gravity separation and flotation. Stormceptor’s patented design generates positive TSS removal for each rainfall event, including large storms. Significant levels of pollutants such as heavy metals, free oils and nutrients are prevented from entering natural water resources and the re-suspension of previously captured sediment (scour) does not occur.

Stormceptor provides a high level of TSS removal for small frequent storm events that represent the majority of annual rainfall volume and pollutant load. Positive treatment continues for large infrequent events, however, such events have little impact on the average annual TSS removal as they represent a small percentage of the total runoff volume and pollutant load.

Design Methodology

Stormceptor is sized using PCSWMM for Stormceptor, a continuous simulation model based on US EPA SWMM. The program calculates hydrology using local historical rainfall data and specified site parameters. With US EPA SWMM’s precision, every Stormceptor unit is designed to achieve a defined water quality objective. The TSS removal data presented follows US EPA guidelines to reduce the average annual TSS load. The Stormceptor’s unit process for TSS removal is settling. The settling model calculates TSS removal by analyzing:

- Site parameters
- Continuous historical rainfall data, including duration, distribution, peaks & inter-event dry periods
- Particle size distribution, and associated settling velocities (Stokes Law, corrected for drag)
- TSS load
- Detention time of the system

Hydrology Analysis	
PCSWMM for Stormceptor calculates annual hydrology with the US EPA SWMM and local continuous historical rainfall data. Performance calculations of Stormceptor are based on the average annual removal of TSS for the selected site parameters. The Stormceptor is engineered to capture sediment particles by treating the required average annual runoff volume, ensuring positive removal efficiency is maintained during each rainfall event, and preventing negative removal efficiency (scour). Smaller recurring storms account for the majority of rainfall events and average annual runoff volume, as observed in the historical rainfall data analyses presented in this section.	

Rainfall Station			
State/Province	Colorado	Total Number of Rainfall Events	6202
Rainfall Station Name	GREENLAND 9 SE	Total Rainfall (in)	909.4
Station ID #	3579	Average Annual Rainfall (in)	15.7
Coordinates	39°6'16"N, 104°43'43"W	Total Evaporation (in)	156.0
Elevation (ft)	7480	Total Infiltration (in)	132.8
Years of Rainfall Data	58	Total Rainfall that is Runoff (in)	620.6

Notes	
<ul style="list-style-type: none"> • Stormceptor performance estimates are based on simulations using PCSWMM for Stormceptor, which uses the EPA Rainfall and Runoff modules. • Design estimates listed are only representative of specific project requirements based on total suspended solids (TSS) removal defined by the selected PSD, and based on stable site conditions only, after construction is completed. • For submerged applications or sites specific to spill control, please contact your local Stormceptor representative for further design assistance. 	

Drainage Area	
Total Area (acres)	0.3
Imperviousness %	85.1

Up Stream Storage	
Storage (ac-ft)	Discharge (cfs)
0.000	0.000

Water Quality Objective	
TSS Removal (%)	80.0
Runoff Volume Capture (%)	
Oil Spill Capture Volume (Gal)	
Peak Conveyed Flow Rate (CFS)	
Water Quality Flow Rate (CFS)	

Up Stream Flow Diversion	
Max. Flow to Stormceptor (cfs)	0.00000

Design Details	
Stormceptor Inlet Invert Elev (ft)	
Stormceptor Outlet Invert Elev (ft)	
Stormceptor Rim Elev (ft)	
Normal Water Level Elevation (ft)	
Pipe Diameter (in)	
Pipe Material	
Multiple Inlets (Y/N)	No
Grate Inlet (Y/N)	No

Particle Size Distribution (PSD)		
Removing the smallest fraction of particulates from runoff ensures the majority of pollutants, such as metals, hydrocarbons and nutrients are captured. The table below identifies the Particle Size Distribution (PSD) that was selected to define TSS removal for the Stormceptor design.		
Fine Distribution		
Particle Diameter (microns)	Distribution %	Specific Gravity
20.0	20.0	1.30
60.0	20.0	1.80
150.0	20.0	2.20
400.0	20.0	2.65
2000.0	20.0	2.65

Site Name			
Site Details			
Drainage Area		Infiltration Parameters	
Total Area (acres)	0.3	Horton's equation is used to estimate infiltration	
Imperviousness %	85.1	Max. Infiltration Rate (in/hr)	2.44
Surface Characteristics		Min. Infiltration Rate (in/hr)	0.4
Width (ft)	229.00	Decay Rate (1/sec)	0.00055
Slope %	2	Regeneration Rate (1/sec)	0.01
Impervious Depression Storage (in)	0.05	Evaporation	
Pervious Depression Storage (in)	0.2	Daily Evaporation Rate (in/day)	0.1
Impervious Manning's n	0.015	Dry Weather Flow	
Pervious Manning's n	0.25	Dry Weather Flow (cfs)	0
Maintenance Frequency		Winter Months	
Maintenance Frequency (months) >	12	Winter Infiltration	0
TSS Loading Parameters			
TSS Loading Function		Build Up/ Wash-off	
Buildup/Wash-off Parameters		TSS Availability Parameters	
Target Event Mean Conc. (EMC) mg/L	125	Availability Constant A	0.05
Exponential Buildup Power	0.40	Availability Factor B	0.04
Exponential Washoff Exponent	0.20	Availability Exponent C	1.10
		Min. Particle Size Affected by Availability (micron)	400

Cumulative Runoff Volume by Runoff Rate			
Runoff Rate (cfs)	Runoff Volume (ft³)	Volume Over (ft³)	Cumulative Runoff Volume (%)
0.035	306669	396210	43.6
0.141	561978	140925	80.0
0.318	643567	59317	91.6
0.565	675726	27149	96.1
0.883	691412	11456	98.4
1.271	699280	3585	99.5
1.730	701571	1293	99.8
2.260	702613	251	100.0
2.860	702864	0	100.0
3.531	702864	0	100.0

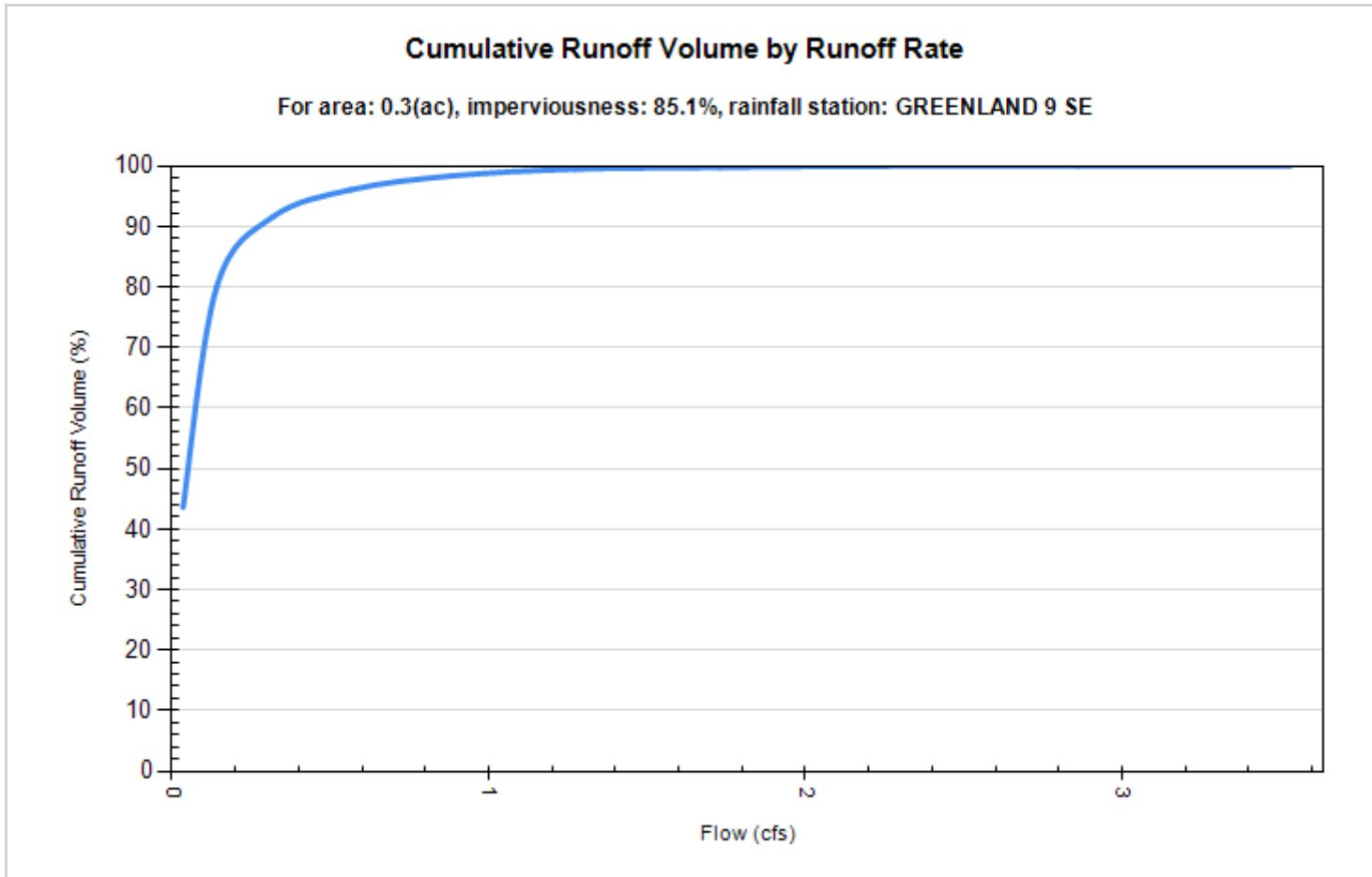

Rainfall Event Analysis				
Rainfall Depth (in)	No. of Events	Percentage of Total Events (%)	Total Volume (in)	Percentage of Annual Volume (%)
0.25	5398	87.0	459	50.5
0.50	529	8.5	193	21.2
0.75	141	2.3	88	9.7
1.00	55	0.9	48	5.3
1.25	34	0.5	38	4.2
1.50	18	0.3	24	2.7
1.75	7	0.1	11	1.2
2.00	7	0.1	13	1.4
2.25	4	0.1	9	0.9
2.50	1	0.0	2	0.3
2.75	4	0.1	11	1.2
3.00	2	0.0	6	0.6
3.25	2	0.0	6	0.7
3.50	0	0.0	0	0.0
3.75	0	0.0	0	0.0

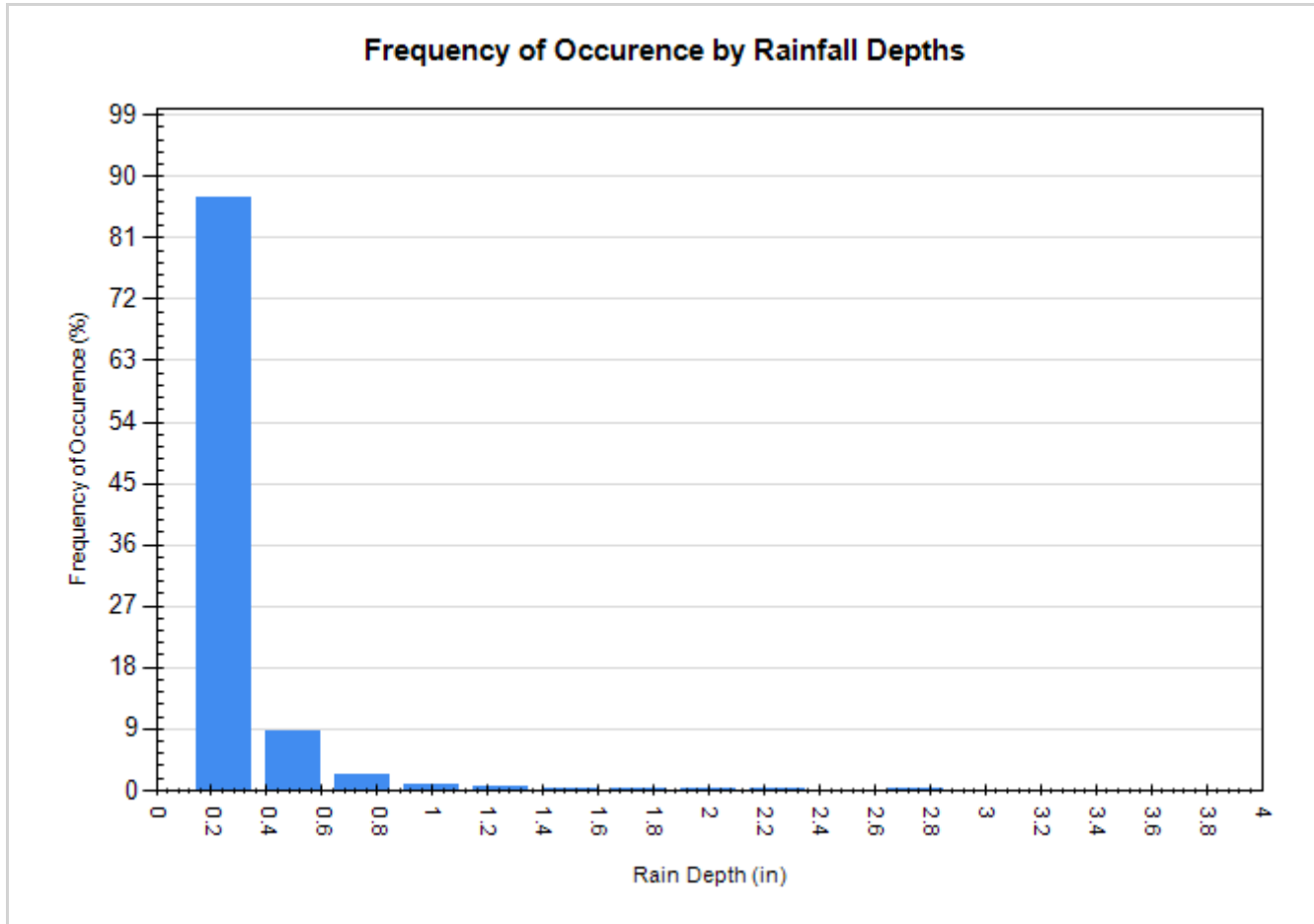

**For Stormceptor Specifications and Drawings Please Visit:
<http://www.imbriumsystems.com/technical-specifications>**

**STC 450i Precast Concrete Stormceptor®
(450 U.S. Gallon Capacity)**

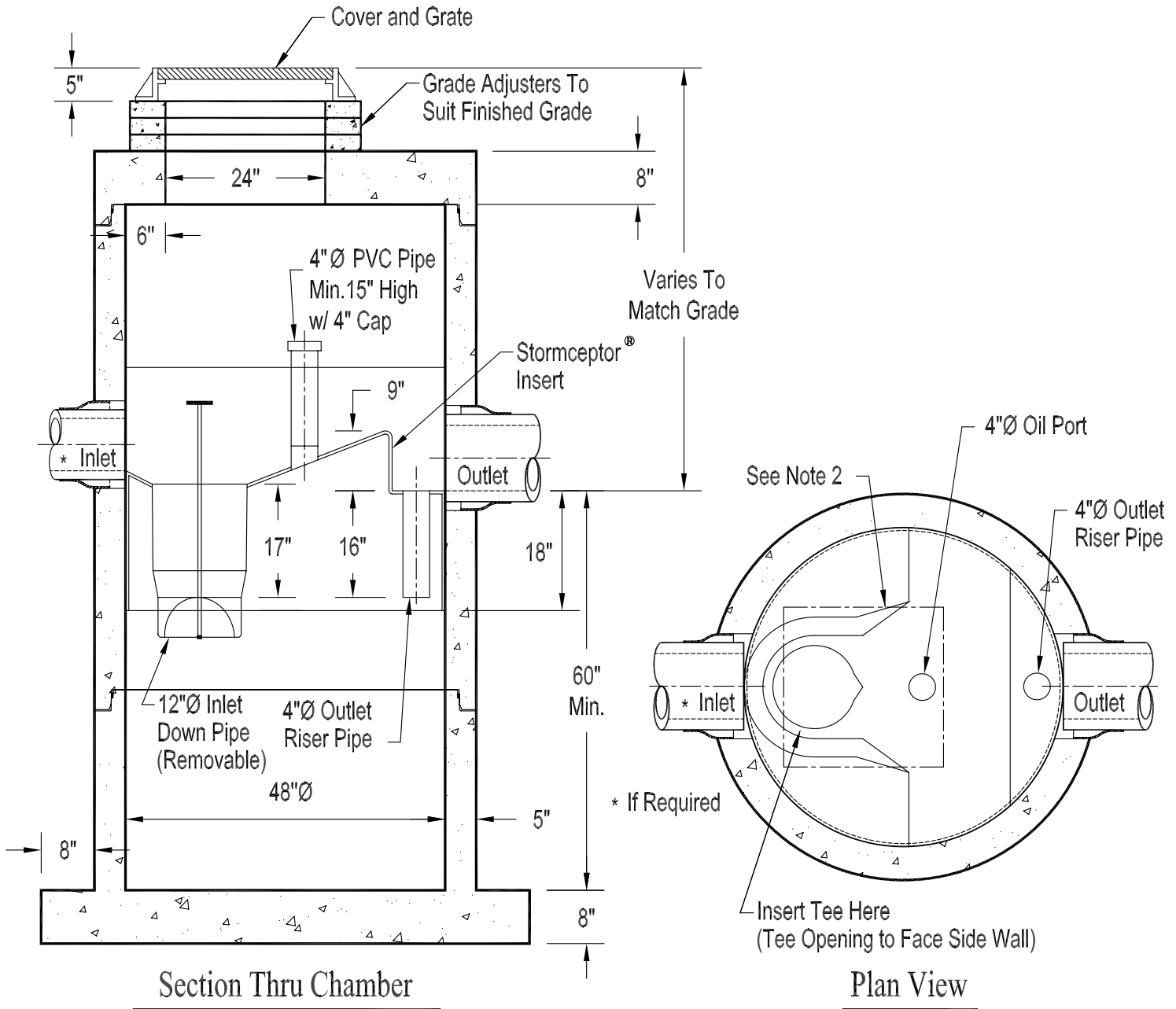

Notes:

1. The Use Of Flexible Connection is Recommended at The Inlet and Outlet Where Applicable.
2. The Cover Should be Positioned Over The Inlet Drop Pipe and The Oil Port.
3. The Stormceptor System is protected by one or more of the following U.S. Patents: #4985148, #5498331, #5725760, #5753115, #5849181, #6068765, #6371690.
4. Contact a Concrete Pipe Division representative for further details not listed on this drawing.

I-9224

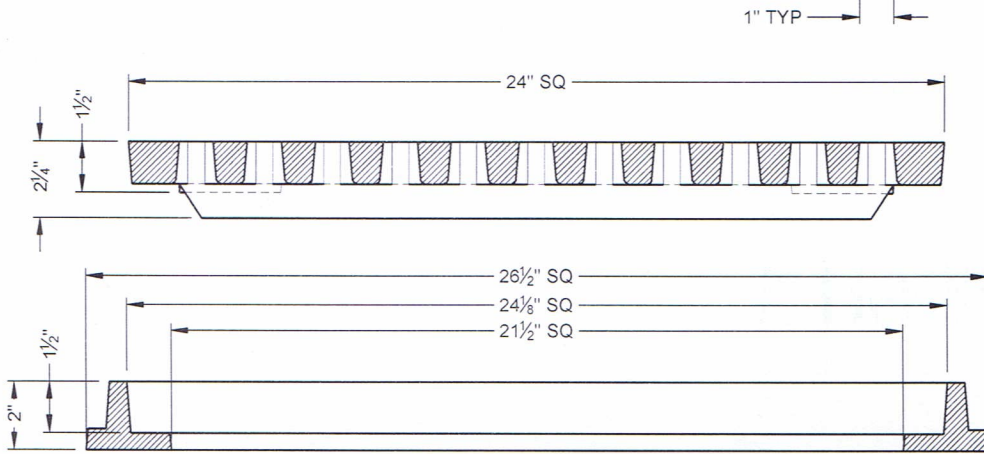
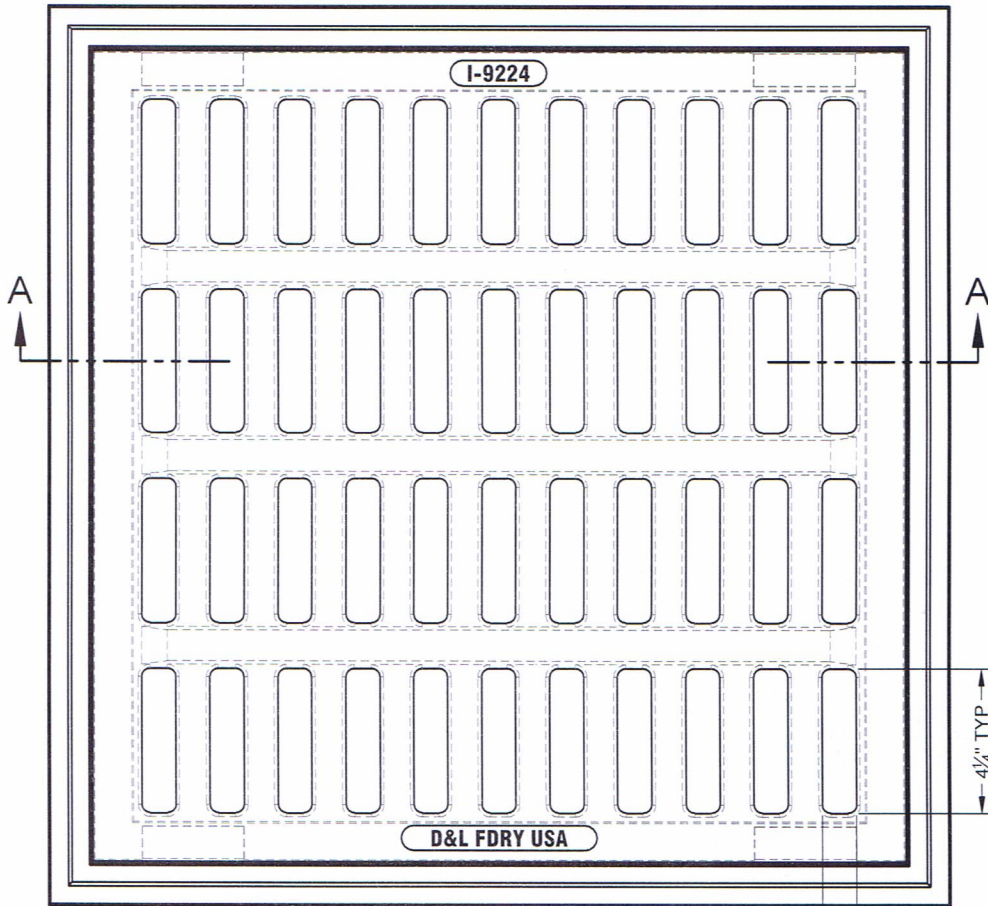

SECTION A-A

4 ROWS x 11 SLOTS
PER ROW

OPEN AREA =
 $44 \times (4.25 \times 1) = 187 \text{ sq in.}$

CONFIDENTIALITY STATEMENT

D&L Supply Co. (DLS) claims proprietary rights to the information disclosed in this document. The document is issued for information only and may not, in part or in whole, be reproduced or disclosed to anyone without the direct written consent of DLS. Dimensions are for reference ONLY. DLS reserves the right to change dimensions and or weights at its own discretion.

Washington Sales:
(509) 766-3131 Fax: (509) 765-8124
California Sales:
(707) 557-4525 Fax: (707) 557-4655
Utah Sales:
(801) 785-5015 Fax: (801) 785-0835



DRAWN BY: CDILLEY	DATE: 8/23/2016
PRODUCT NUMBER:	MATERIAL TYPE:
GRATE: I-9224-01	GRAY IRON: ASTM A-48 CL 35B
FRAME: I-9224-R1	GRAY IRON: ASTM A-48 CL 35B
MEETS:	H2O WHEEL LOADING
B:_DLS DRAWINGS\III-9224\I-9224-01_I-9224-R1.DWG	

√= INDICATES MACHINED SURFACE

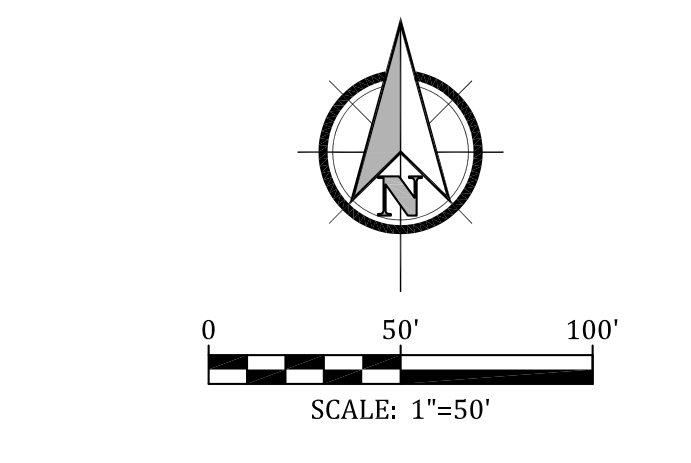
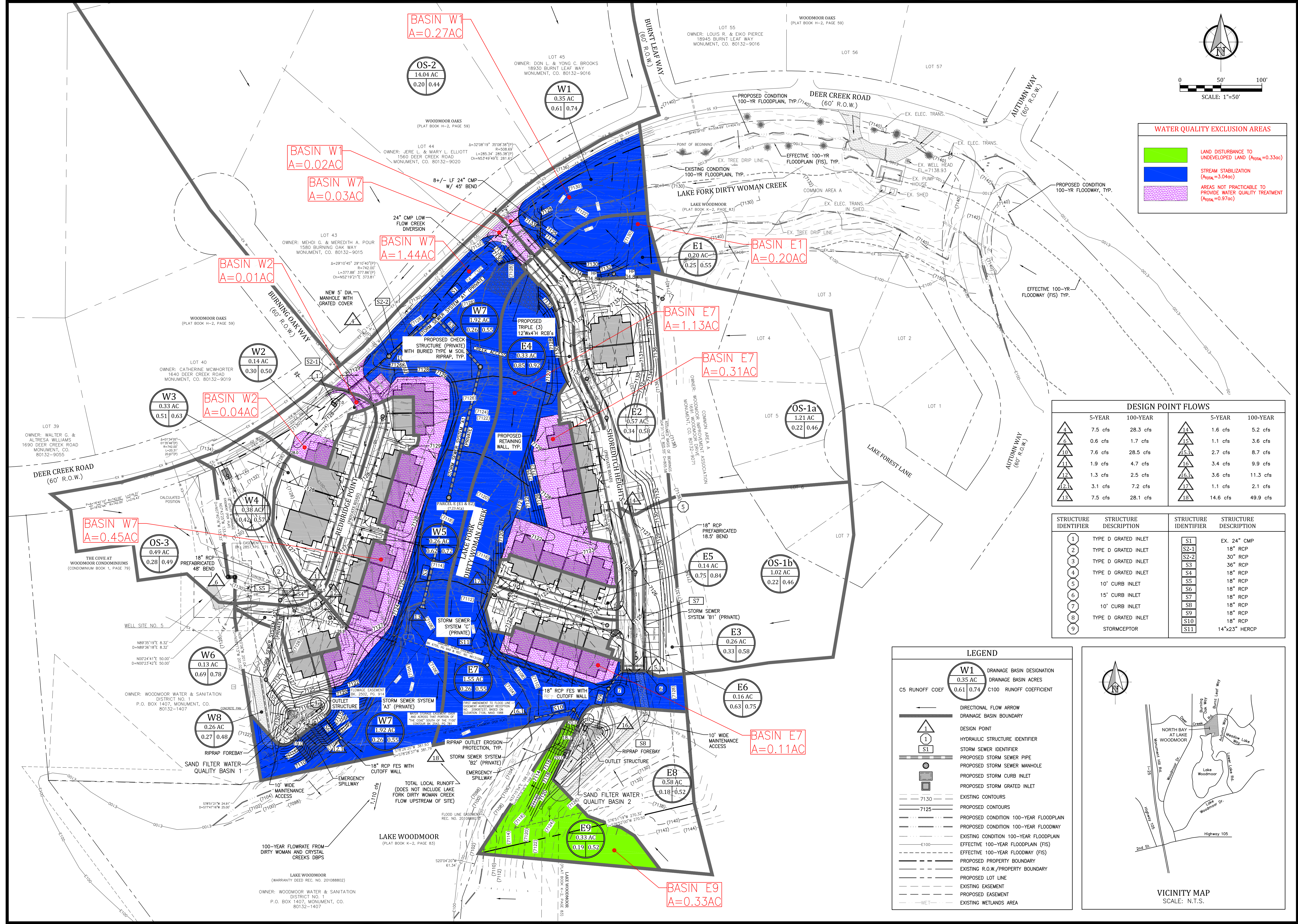

WATER QUALITY EXCLUSION AREAS

	LAND DISTURBANCE TO UNDEVELOPED LAND (A _{total} =0.33ac)
	STREAM STABILIZATION (A _{total} =3.04ac)
	AREAS NOT PRACTICABLE TO PROVIDE WATER QUALITY TREATMENT (A _{total} =0.97ac)

DESIGN POINT FLOWS

	5-YEAR	100-YEAR		5-YEAR	100-YEAR
▲ 4	7.5 cfs	28.3 cfs	▲ 14	1.6 cfs	5.2 cfs
▲ 6	0.6 cfs	1.7 cfs	▲ 15	1.1 cfs	3.6 cfs
▲ 10	7.6 cfs	28.5 cfs	▲ 15.1	2.7 cfs	8.7 cfs
▲ 11	1.9 cfs	4.7 cfs	▲ 16	3.4 cfs	9.9 cfs
▲ 12	1.3 cfs	2.5 cfs	▲ 16.1	3.6 cfs	11.3 cfs
▲ 12.1	3.1 cfs	7.2 cfs	▲ 17	1.1 cfs	2.1 cfs
▲ 13	7.5 cfs	28.1 cfs	▲ 18	14.6 cfs	49.9 cfs

STRUCTURE IDENTIFIER	STRUCTURE DESCRIPTION	STRUCTURE IDENTIFIER	STRUCTURE DESCRIPTION
1	TYPE D GRATED INLET	S1	EX. 24" CMP
2	TYPE D GRATED INLET	S2-1	18" RCP
3	TYPE D GRATED INLET	S2-2	30" RCP
4	TYPE D GRATED INLET	S3	36" RCP
5	10' CURB INLET	S4	18" RCP
6	15' CURB INLET	S5	18" RCP
7	10' CURB INLET	S6	18" RCP
8	TYPE D GRATED INLET	S7	18" RCP
9	STORMCEPTOR	S8	18" RCP
		S9	18" RCP
		S10	18" RCP
		S11	14"x23" HERCP

LEGEND

	W1 DRAINAGE BASIN DESIGNATION
	0.35 AC DRAINAGE BASIN ACRES
	0.61 0.74 C100 RUNOFF COEFFICIENT
	DIRECTIONAL FLOW ARROW
	DRAINAGE BASIN BOUNDARY
	DESIGN POINT
	HYDRAULIC STRUCTURE IDENTIFIER
	PROPOSED STORM SEWER PIPE
	PROPOSED STORM SEWER MANHOLE
	PROPOSED STORM CURB INLET
	PROPOSED STORM GRATED INLET
	EXISTING CONTOURS
	PROPOSED CONTOURS
	PROPOSED CONDITION 100-YEAR FLOODPLAIN
	PROPOSED CONDITION 100-YEAR FLOODWAY
	EXISTING CONDITION 100-YEAR FLOODPLAIN
	EFFECTIVE 100-YEAR FLOODPLAIN (FIS)
	PROPOSED PROPERTY BOUNDARY
	EXISTING R.O.W./PROPERTY BOUNDARY
	PROPOSED LOT LINE
	EXISTING EASEMENT
	PROPOSED EASEMENT
	EXISTING WETLANDS AREA

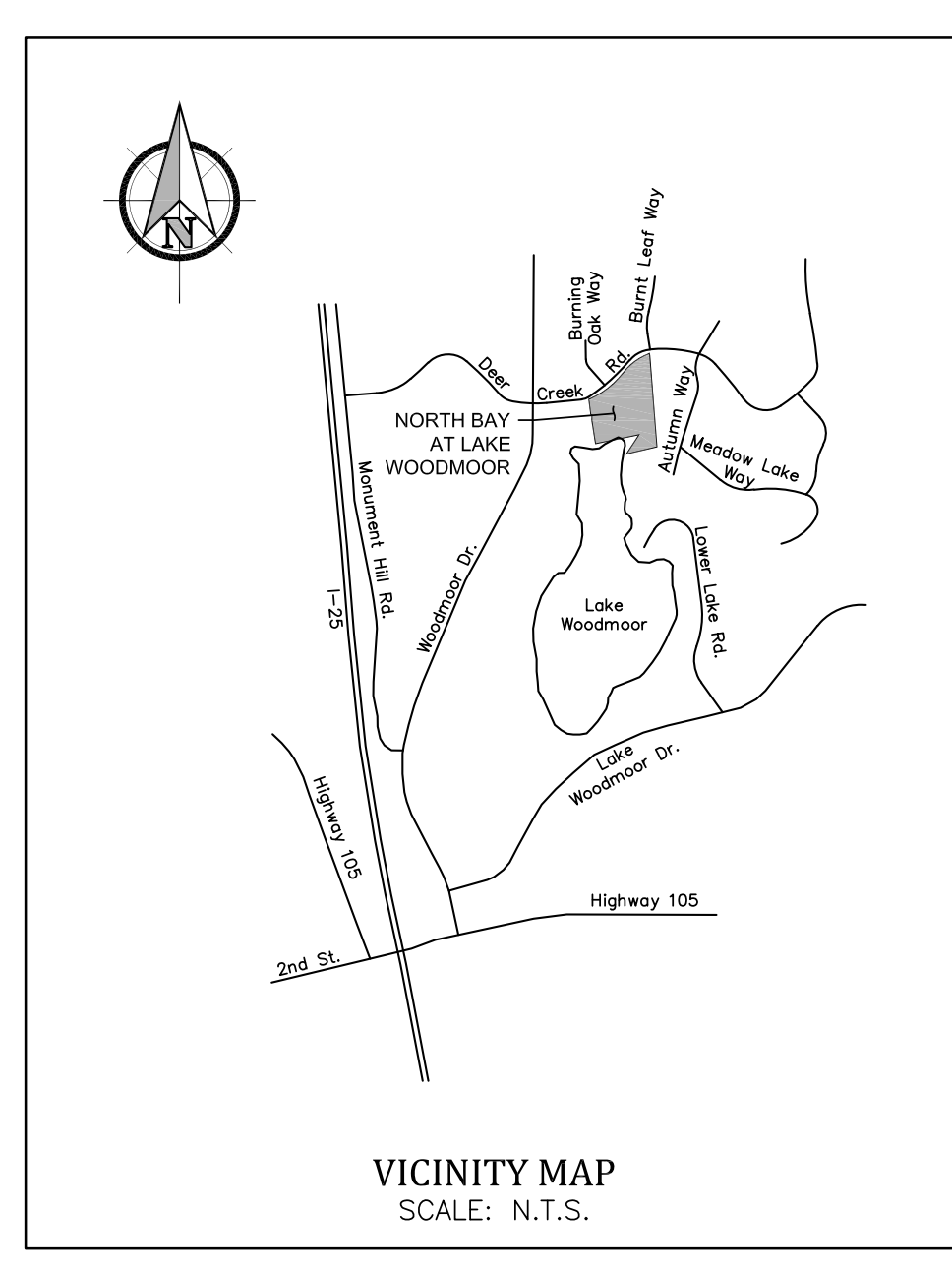

North Bay at Lake Woodmoor
Final Drainage Plan
Developed Condition
 El Paso County, Colorado

Project No.: 15073
 Date: February 18, 2020
 Design: CJC
 Drawn: CJC
 Check: AWMc
 Revisions:

FIGURE
WQ1

APPENDIX E

Lake Fork Dirty Woman Creek Hydraulic Calculations

Figure 2: Floodplain Exhibit
Existing Condition HEC-RAS Model Cross Sections, Profile and Output
Proposed Condition HEC-RAS Model Cross Sections, Profile and Output
Shear Stress Calculations
Flow Superelevation Calculations
Velocity Distribution Output
Culvert Data Input

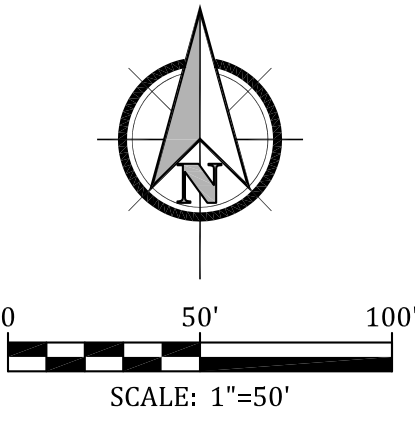

LEGEND	
	EXISTING CONTOURS
	PROPOSED CONTOURS
	PROPOSED 100-YEAR FLOODPLAIN
	PROPOSED FLOODWAY
	PROPOSED PROPERTY BOUNDARY
	EXISTING R.O.W./PROPERTY BOUNDARY
	HEC-RAS CROSS SECTION

TOPOGRAPHIC MAPPING IS BASED UPON COLORADO STATE PLANE COORDINATES 1983, AND NORTH AMERICAN VERTICAL DATUM OF 1988.

THE TOPOGRAPHY WAS COMPILED IN ACCORDANCE WITH NATIONAL MAPPING STANDARDS FOR 1"=200' & 2' CONTOUR INTERVAL DETAIL.

SITE BENCHMARK: NGS T 395

North Bay at Lake Woodmoor
Lake Fork Dirty Woman Creek
Proposed Conditions Floodplain Exhibit
El Paso County, Colorado

Project No.:	15073
Date:	September 4, 2018
Design:	ELS
Drawn:	ELS
Check:	CJC
Revisions:	

Lake Fork Dirty Woman Creek Plan: Existing 3/9/2017
 RS = 1380 209 FIRM Section G

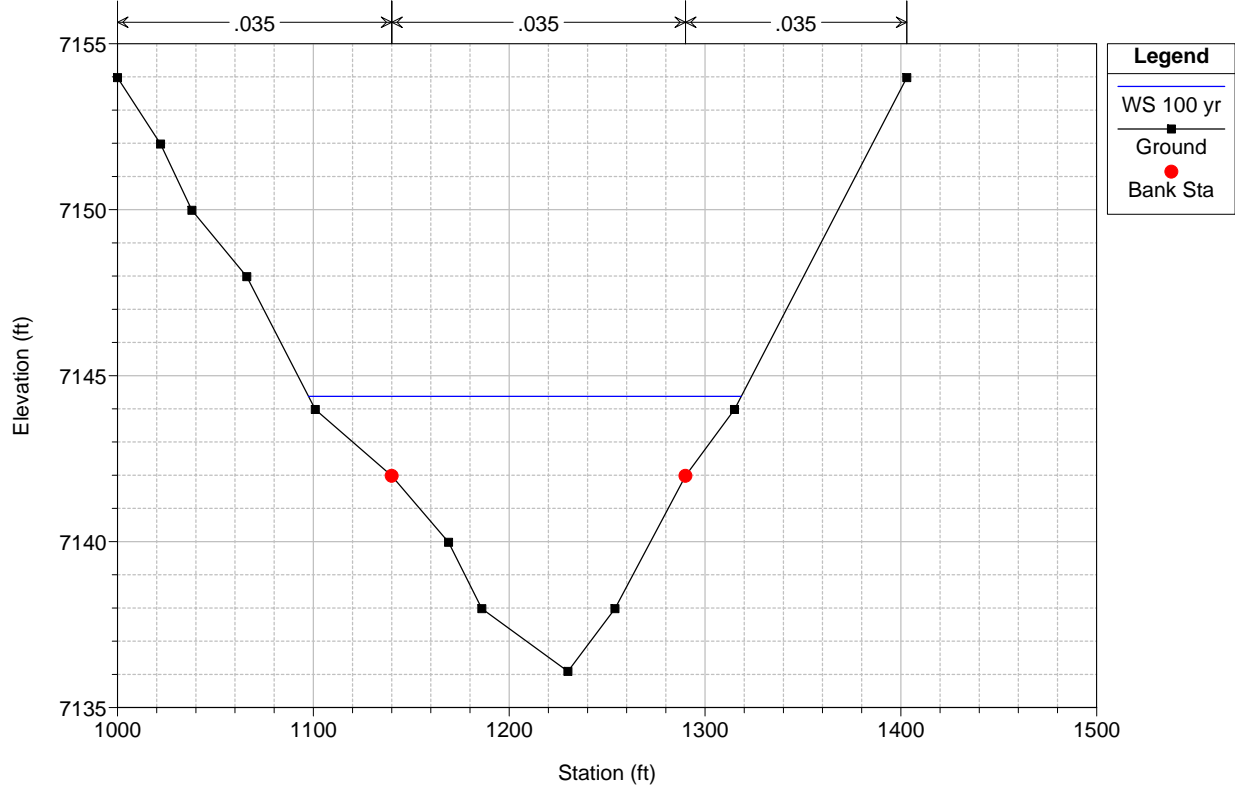

Lake Fork Dirty Woman Creek Plan: Existing 3/9/2017
 RS = 1337

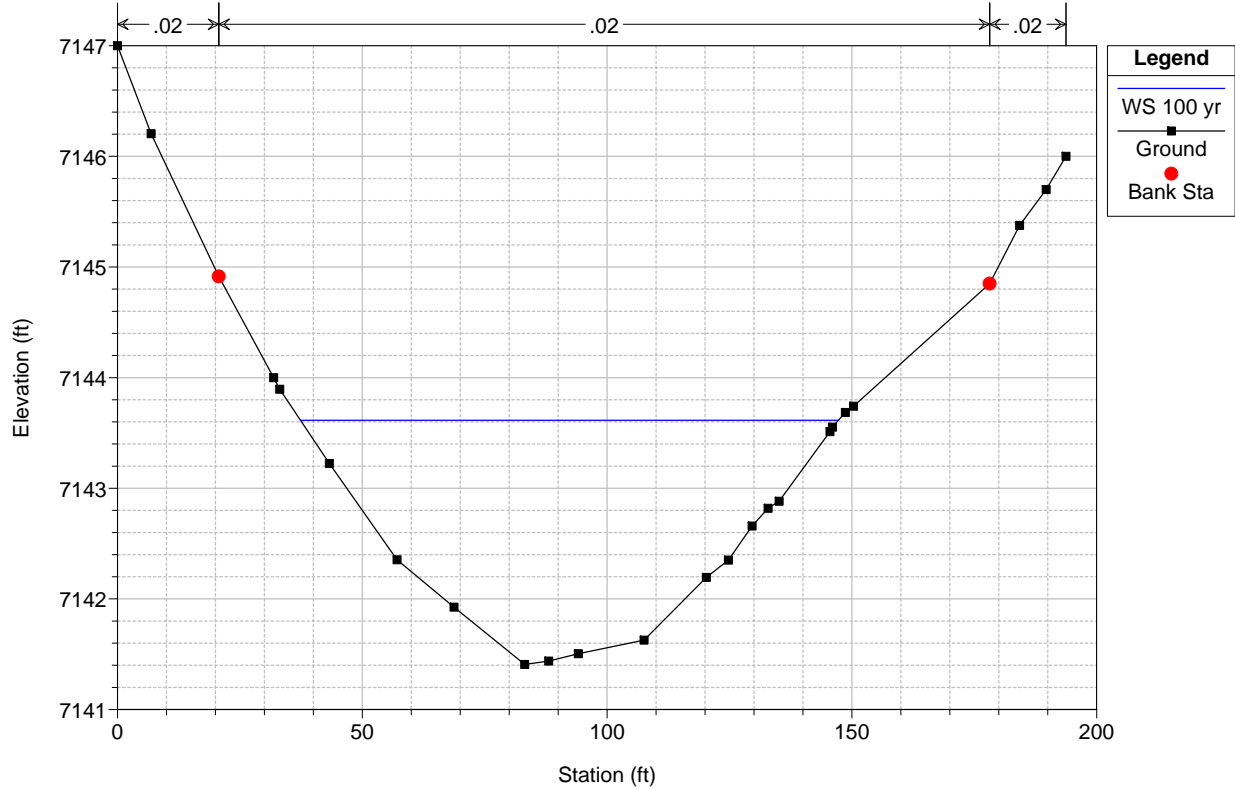

Lake Fork Dirty Woman Creek Plan: Existing 3/9/2017

RS = 1267

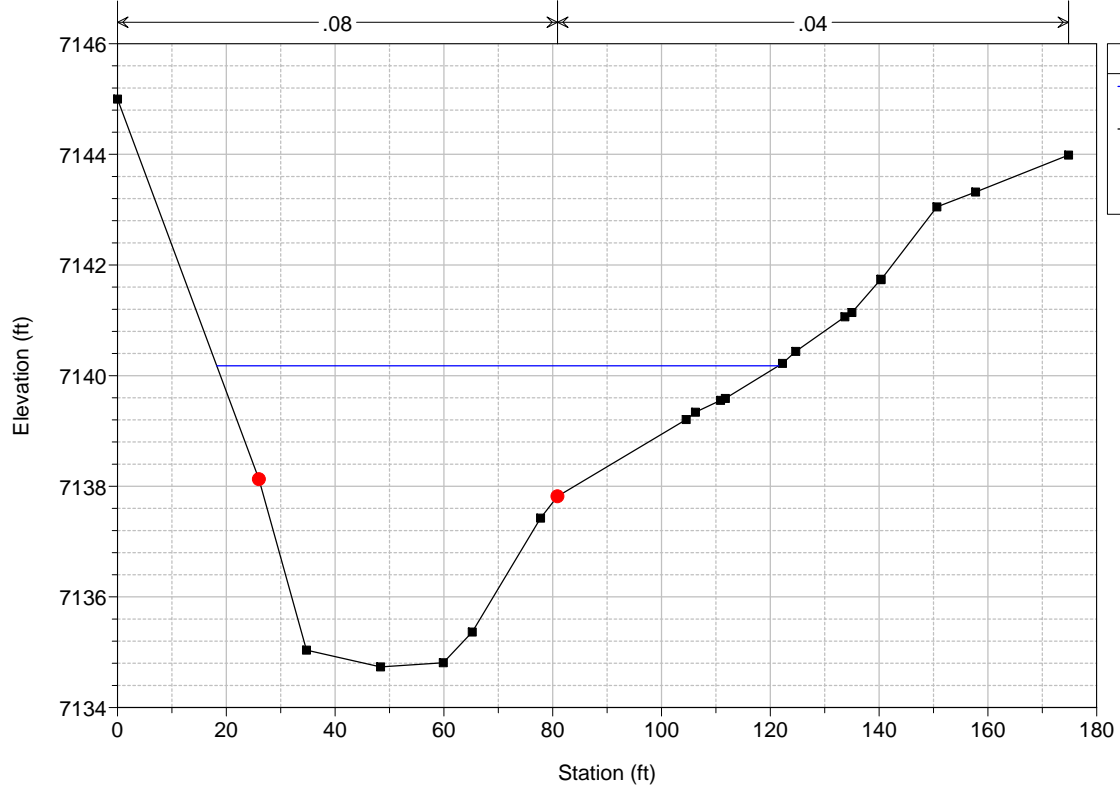

Legend

- WS 100 yr
- Ground
- Bank Sta

Lake Fork Dirty Woman Creek Plan: Existing 3/9/2017

RS = 1223

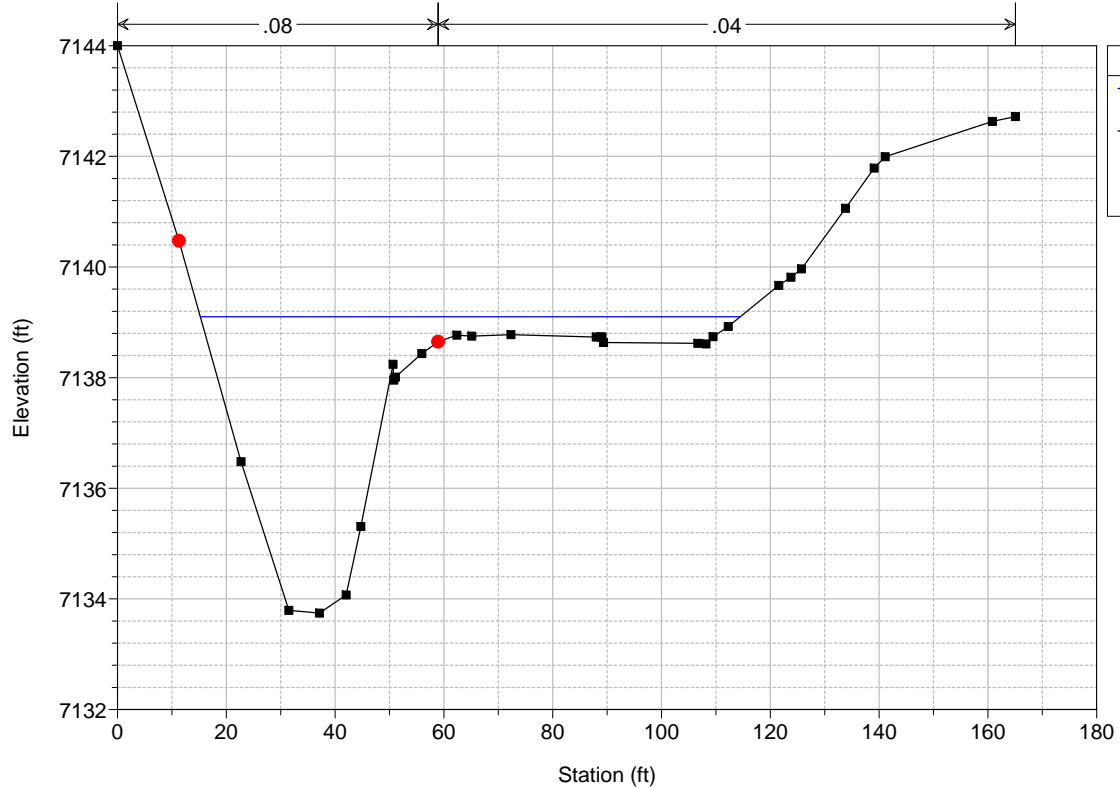

Legend

- WS 100 yr
- Ground
- Bank Sta

Lake Fork Dirty Woman Creek Plan: Existing 3/9/2017
RS = 1153

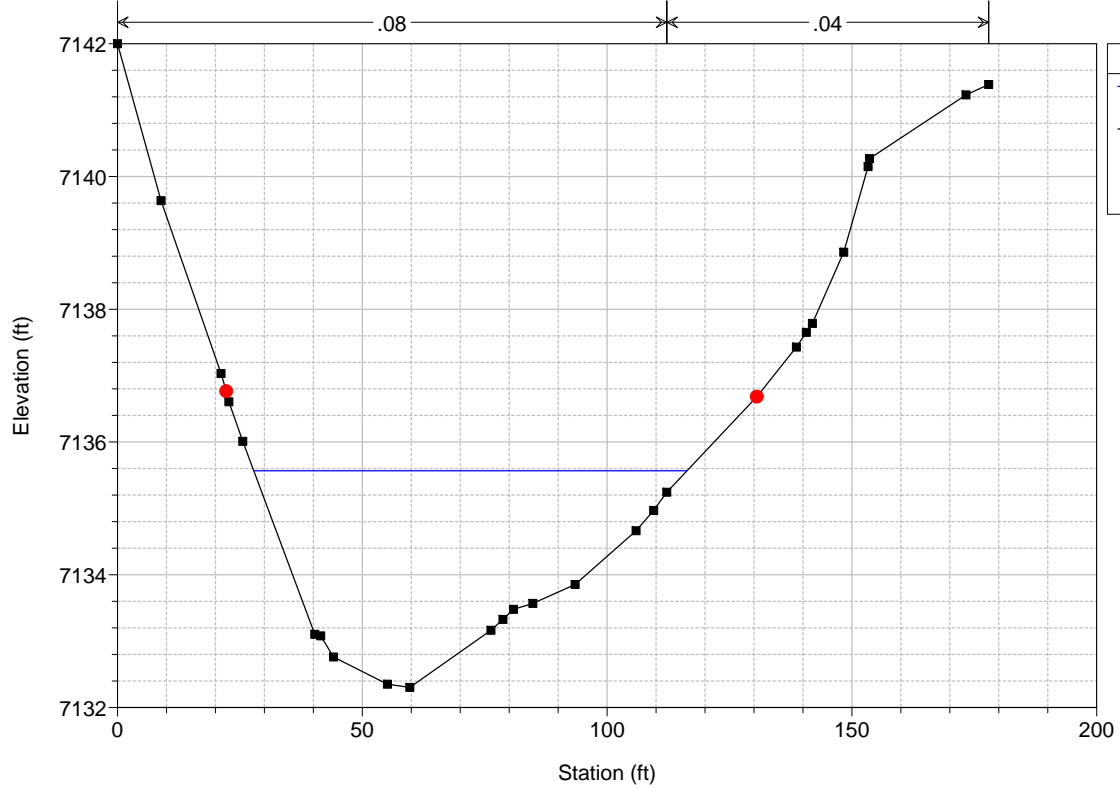

Legend

- WS 100 yr
- Ground
- Bank Sta

Lake Fork Dirty Woman Creek Plan: Existing 3/9/2017
RS = 1060

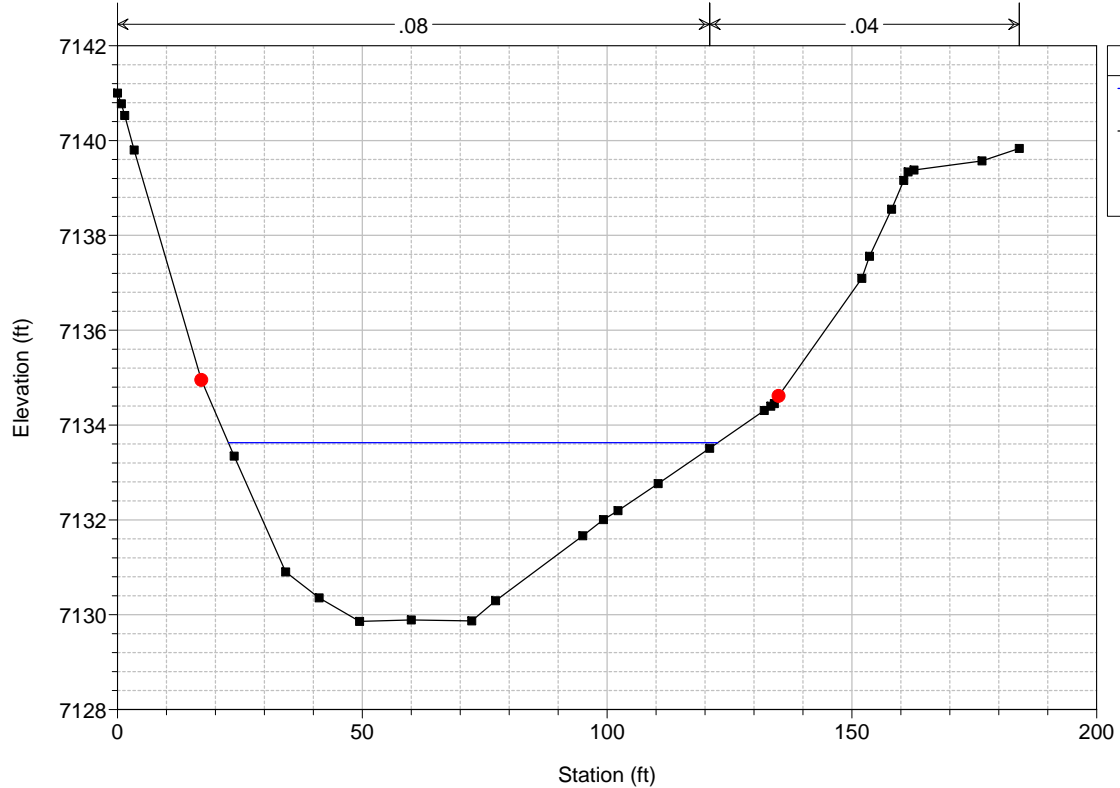

Legend

- WS 100 yr
- Ground
- Bank Sta

Lake Fork Dirty Woman Creek Plan: Existing 3/9/2017

RS = 958

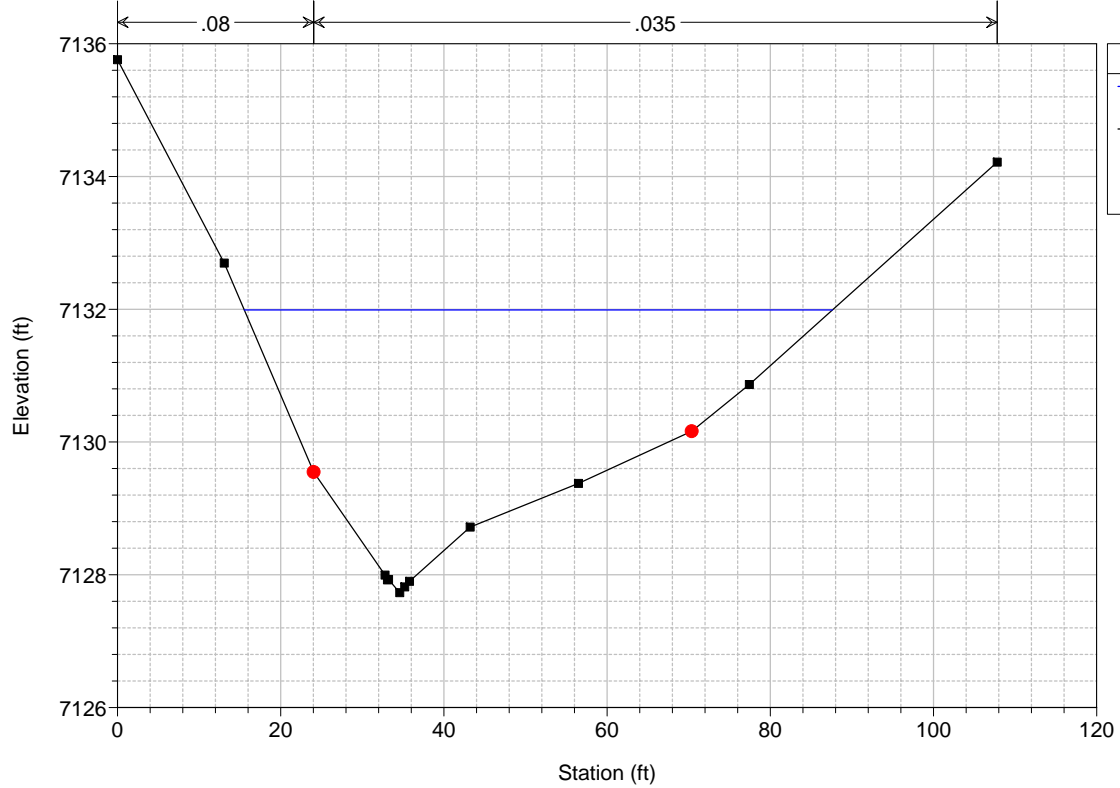

Legend

- WS 100 yr
- Ground
- Bank Sta

Lake Fork Dirty Woman Creek Plan: Existing 3/9/2017

RS = 911

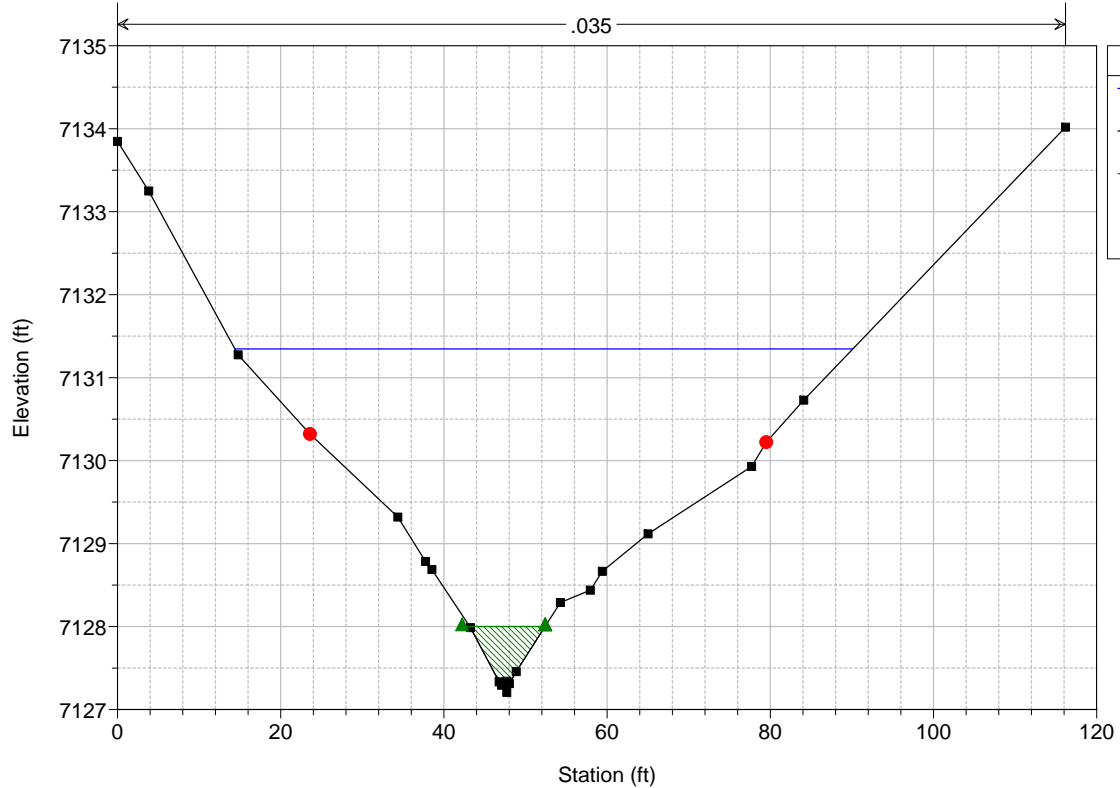

Legend

- WS 100 yr
- Ground
- Ineff
- Bank Sta

Lake Fork Dirty Woman Creek Plan: Existing 3/9/2017

RS = 860

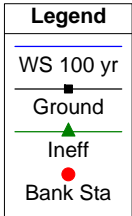
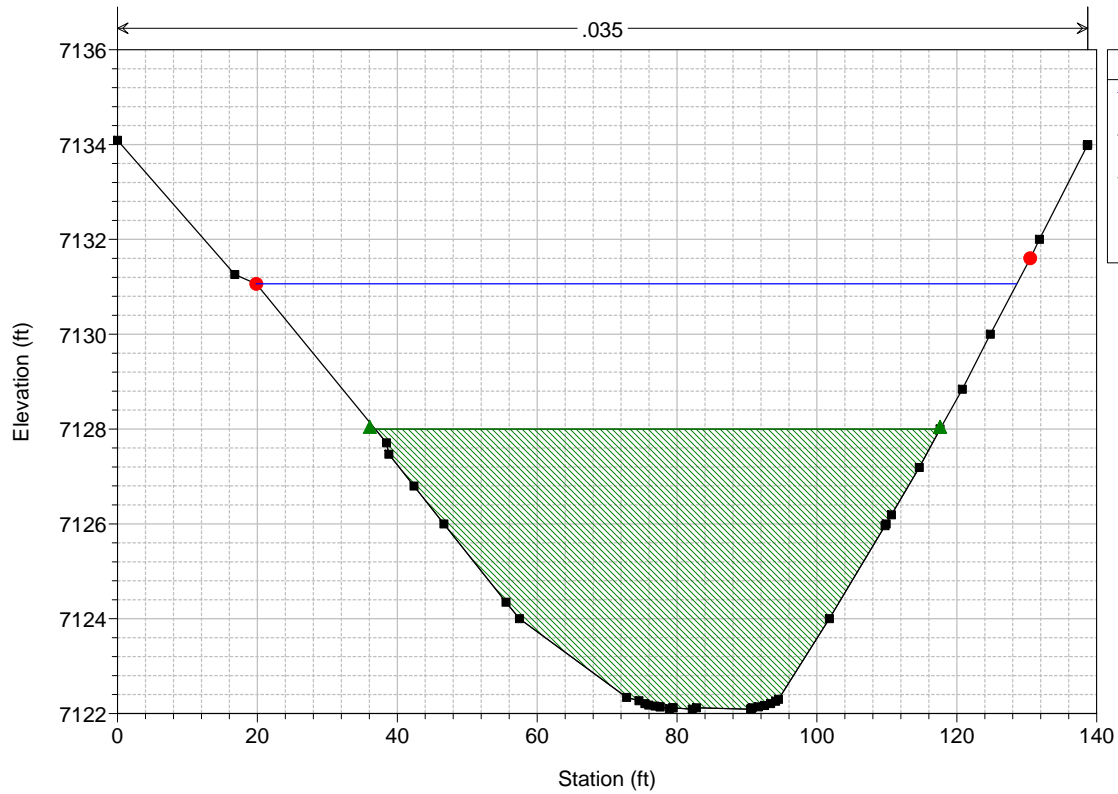

Lake Fork Dirty Woman Creek Plan: Existing 3/9/2017

RS = 828

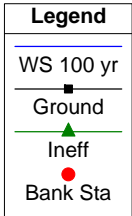
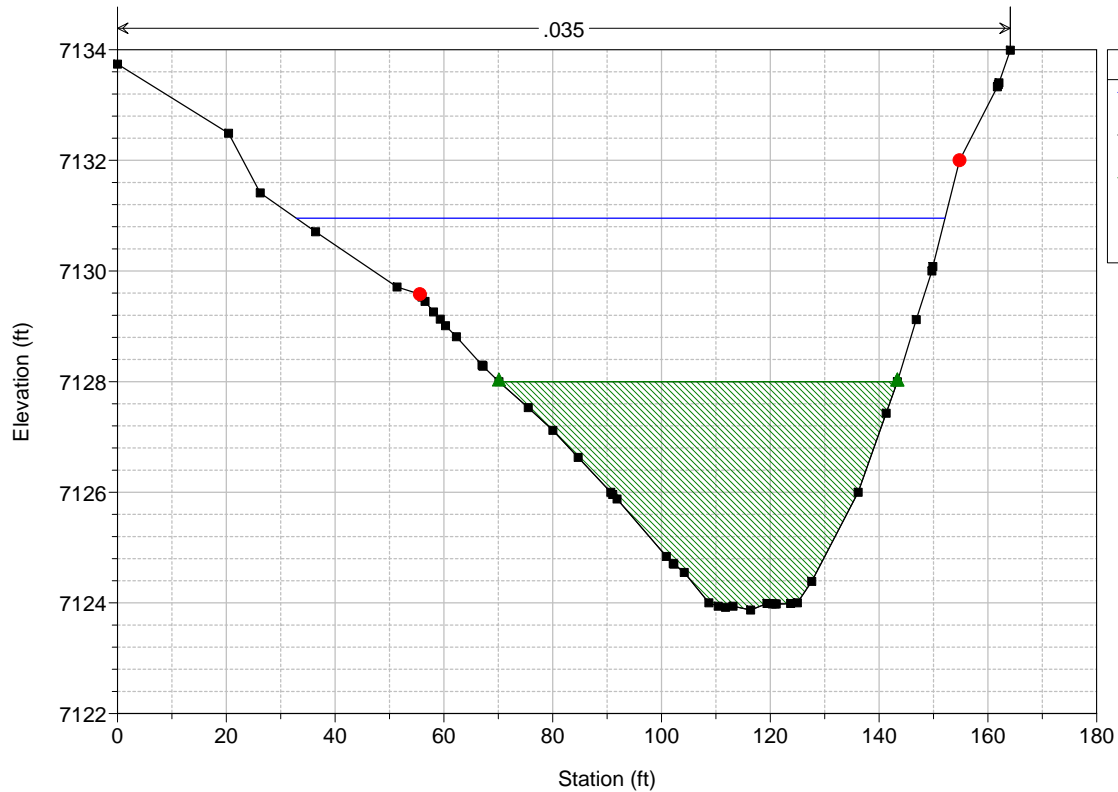

Lake Fork Dirty Woman Creek Plan: Existing 3/9/2017
RS = 808

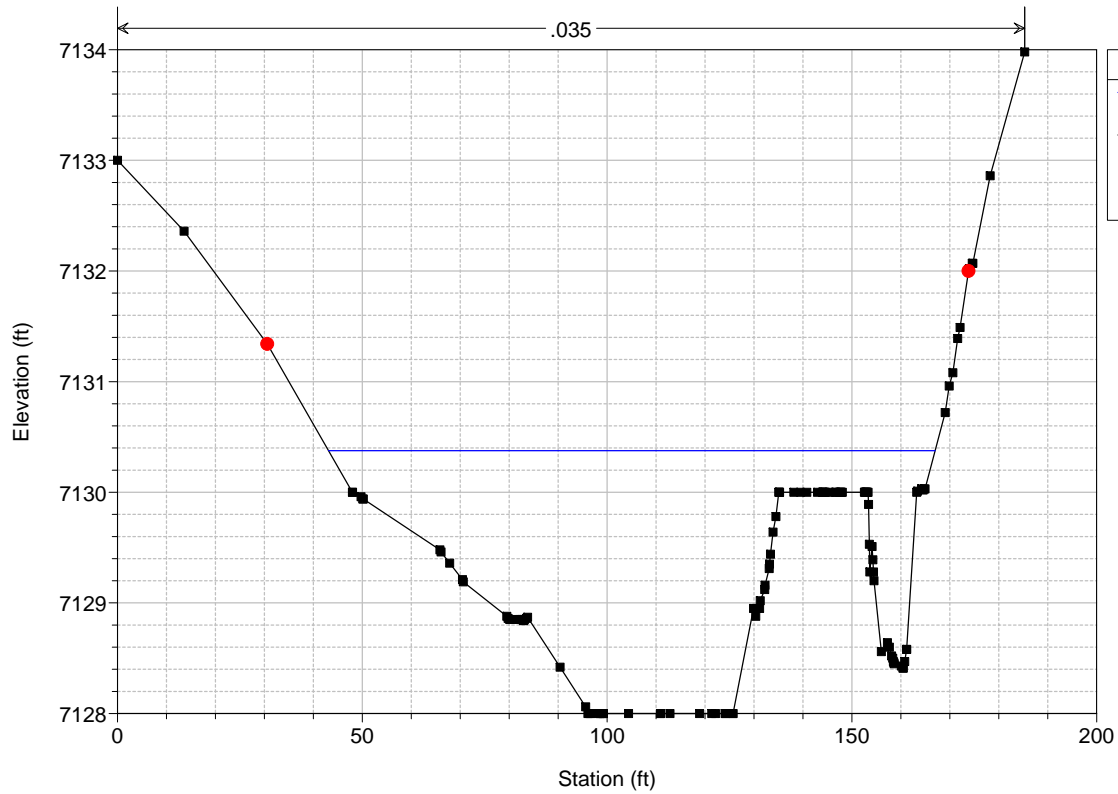

Lake Fork Dirty Woman Creek Plan: Existing 3/9/2017
RS = 731

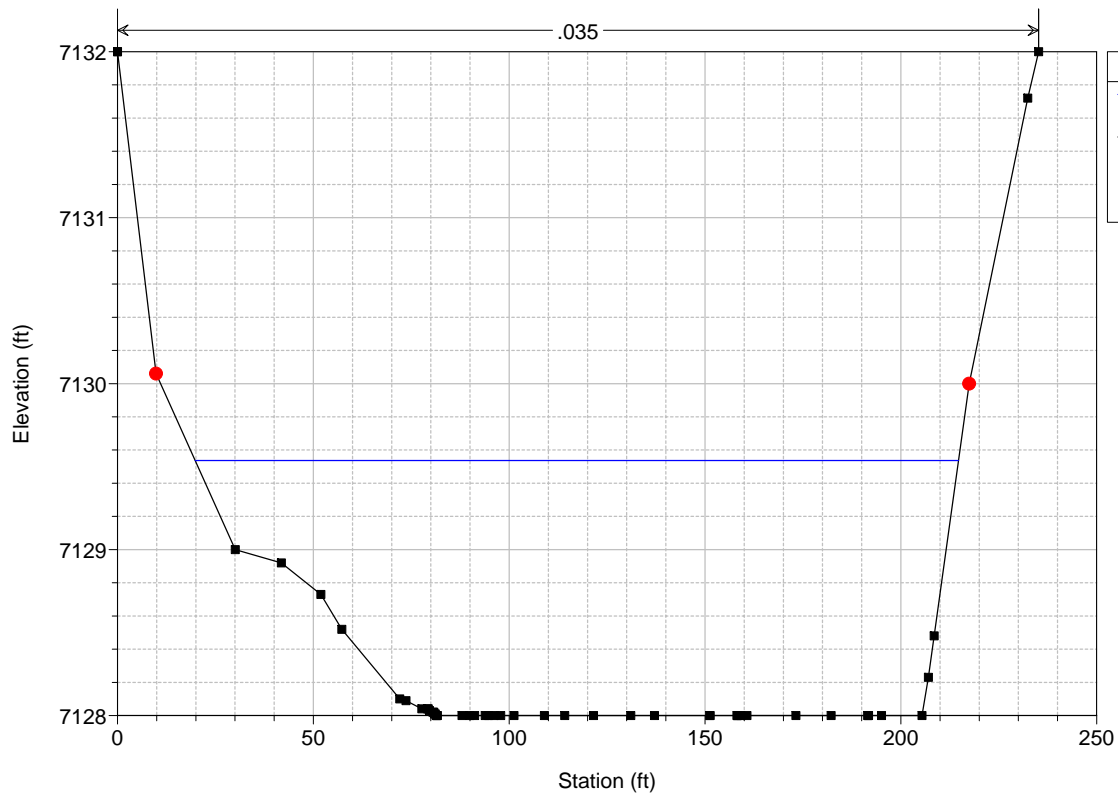

Lake Fork Dirty Woman Creek Plan: Existing 3/9/2017

RS = 700

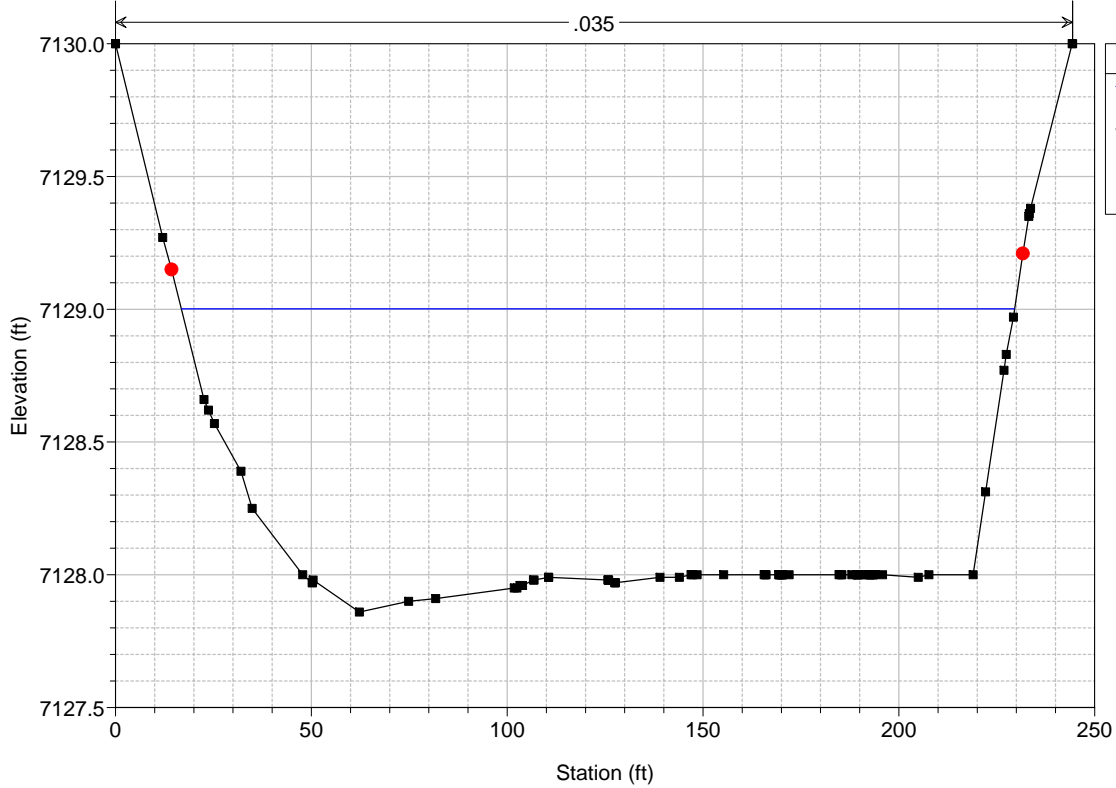

Lake Fork Dirty Woman Creek Plan: Existing 3/9/2017

RS = 650

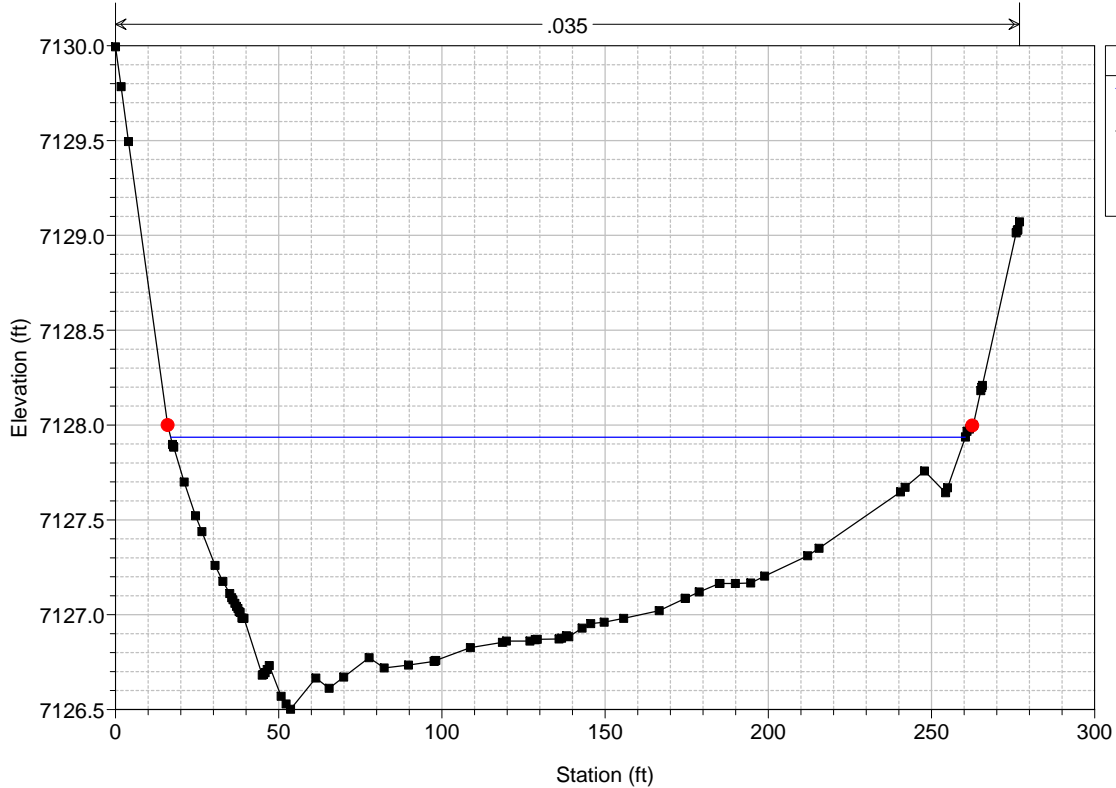

Lake Fork Dirty Woman Creek Plan: Existing 3/9/2017
RS = 605

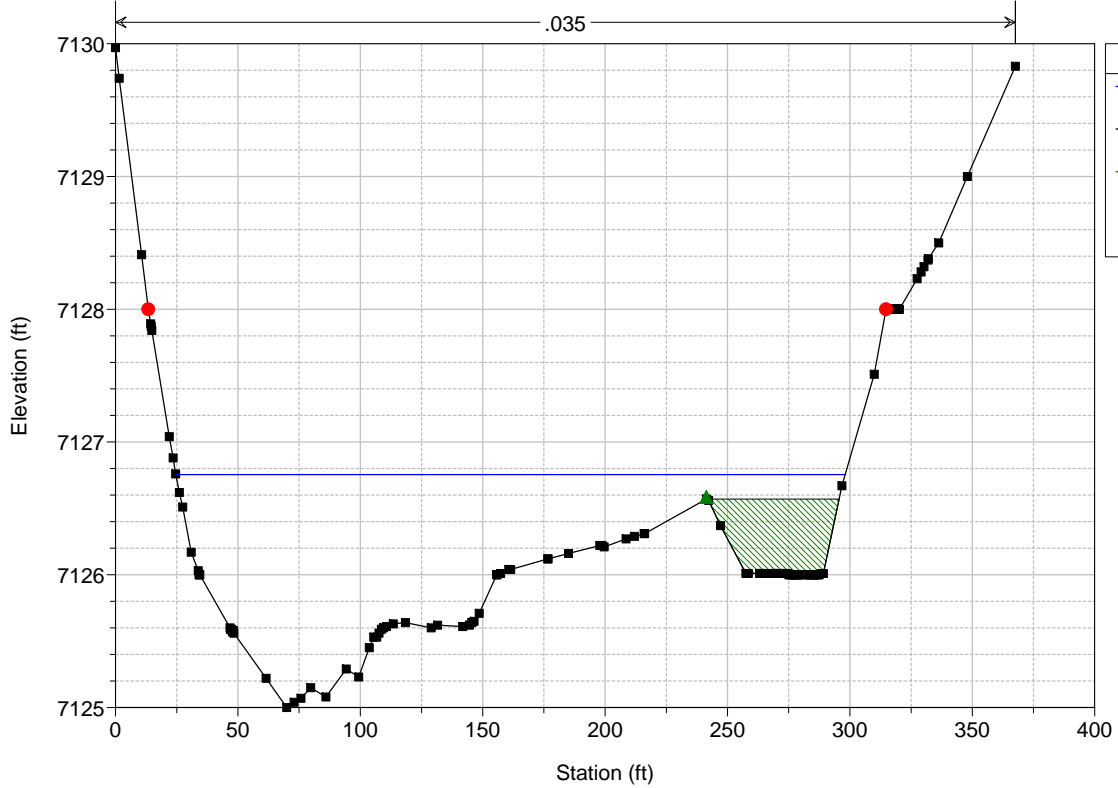

Lake Fork Dirty Woman Creek Plan: Existing 3/9/2017
RS = 574

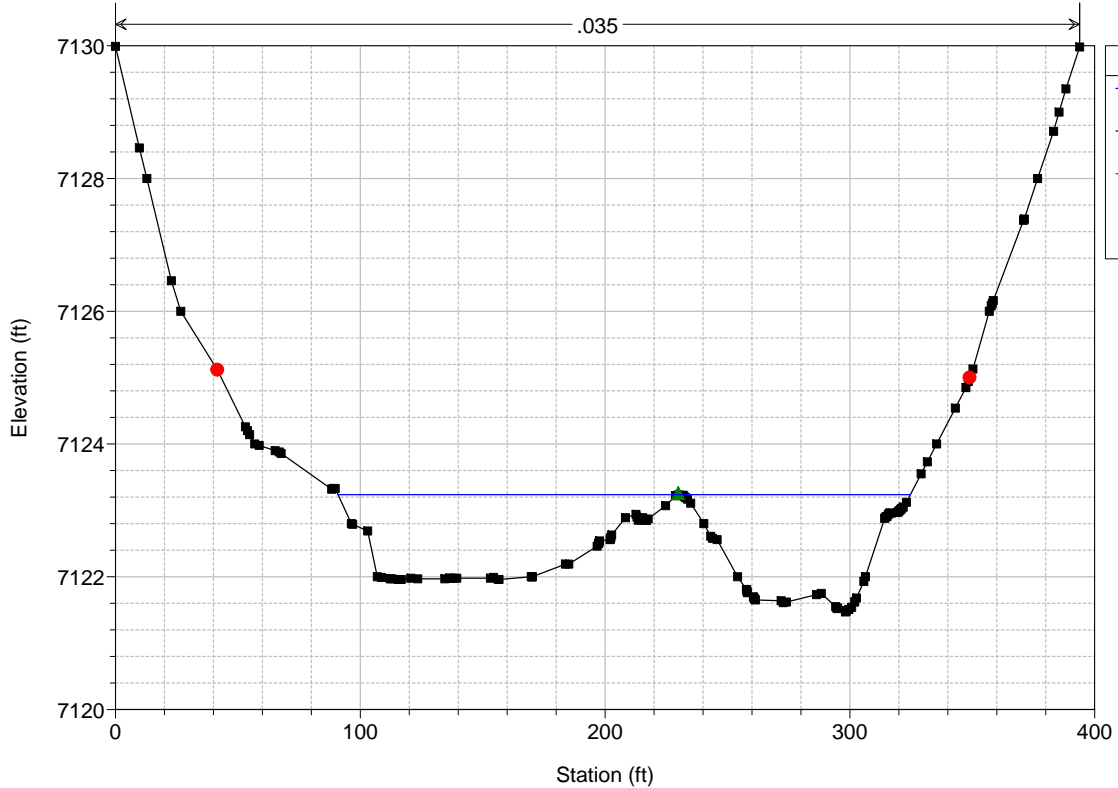

Lake Fork Dirty Woman Creek Plan: Existing 3/9/2017
RS = 479

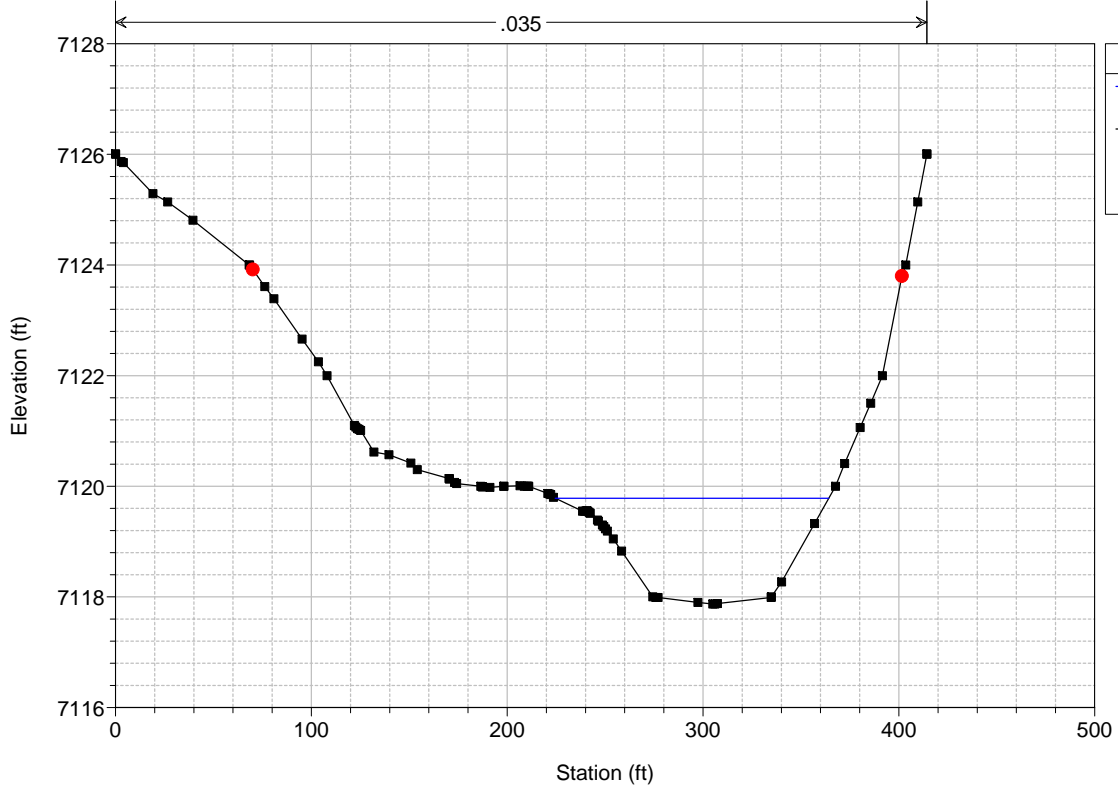

Lake Fork Dirty Woman Creek Plan: Existing 3/9/2017
RS = 451

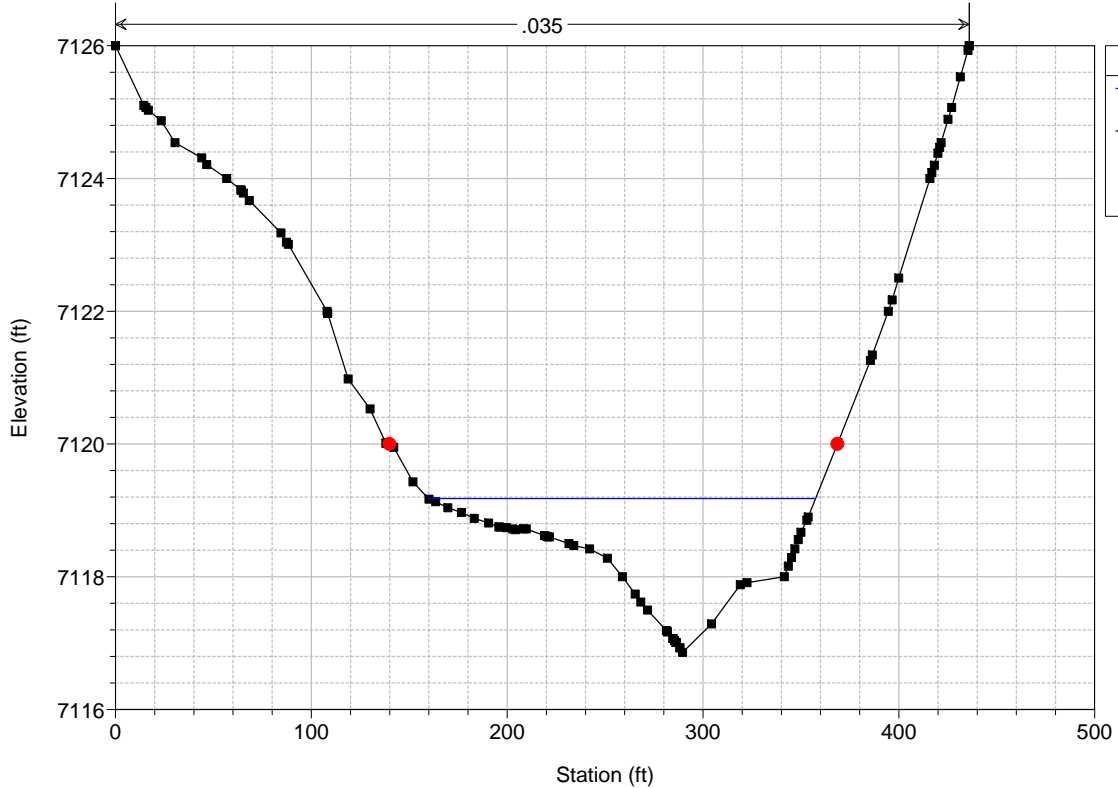

Lake Fork Dirty Woman Creek Plan: Existing 3/9/2017
RS = 367

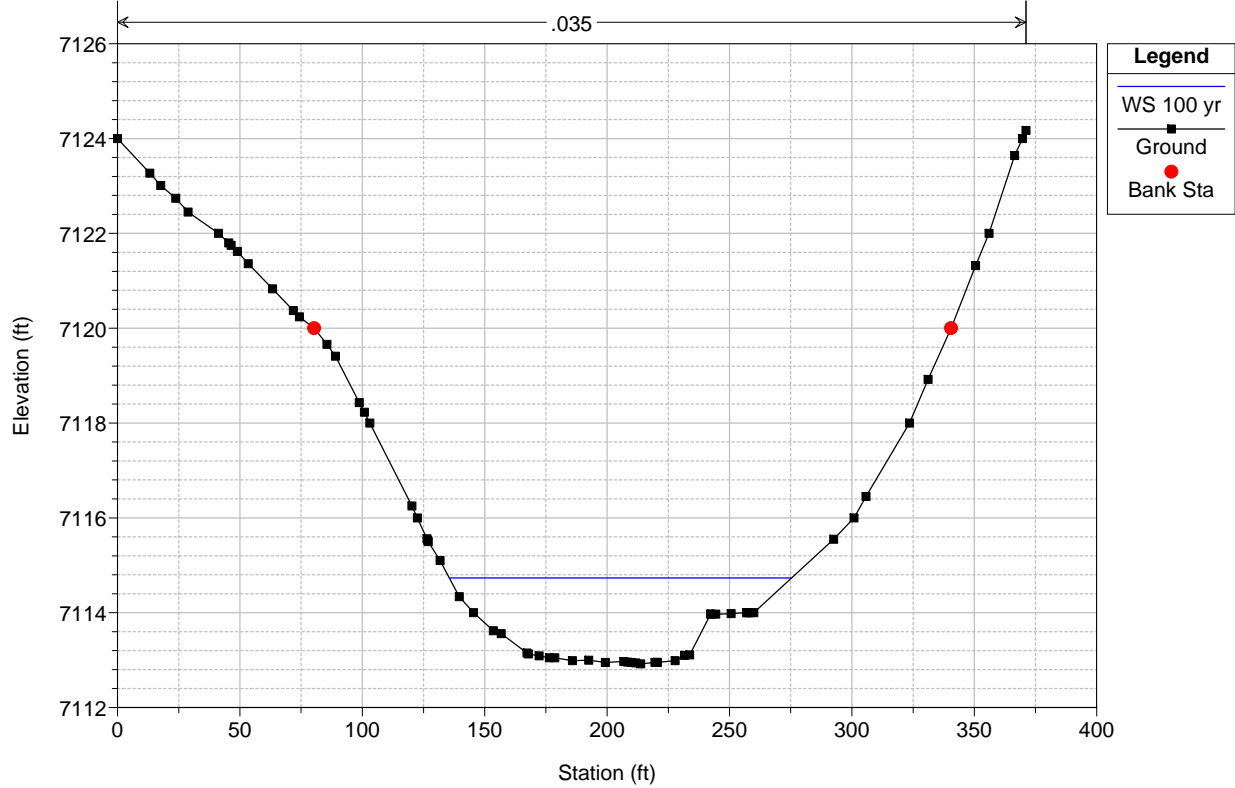

Lake Fork Dirty Woman Creek Plan: Existing 3/9/2017
RS = 300

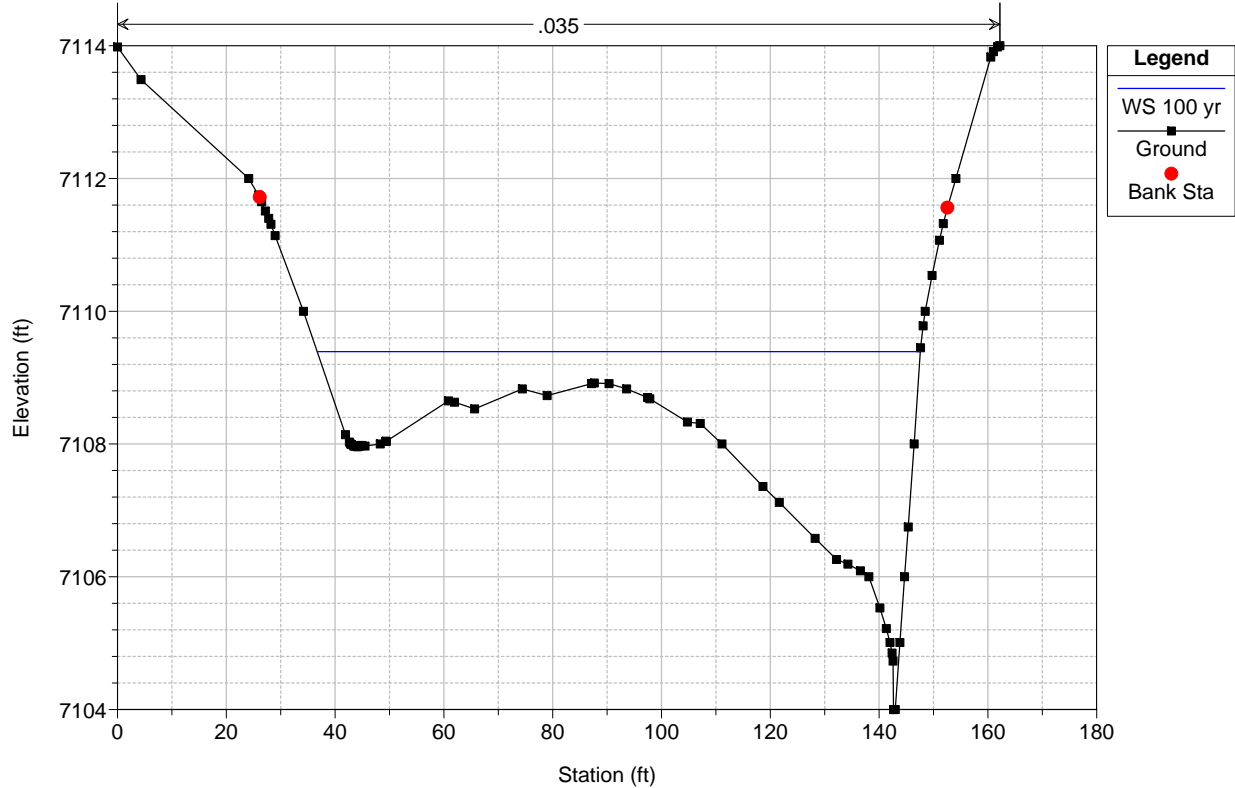

Lake Fork Dirty Woman Creek Plan: Existing 3/9/2017
RS = 269

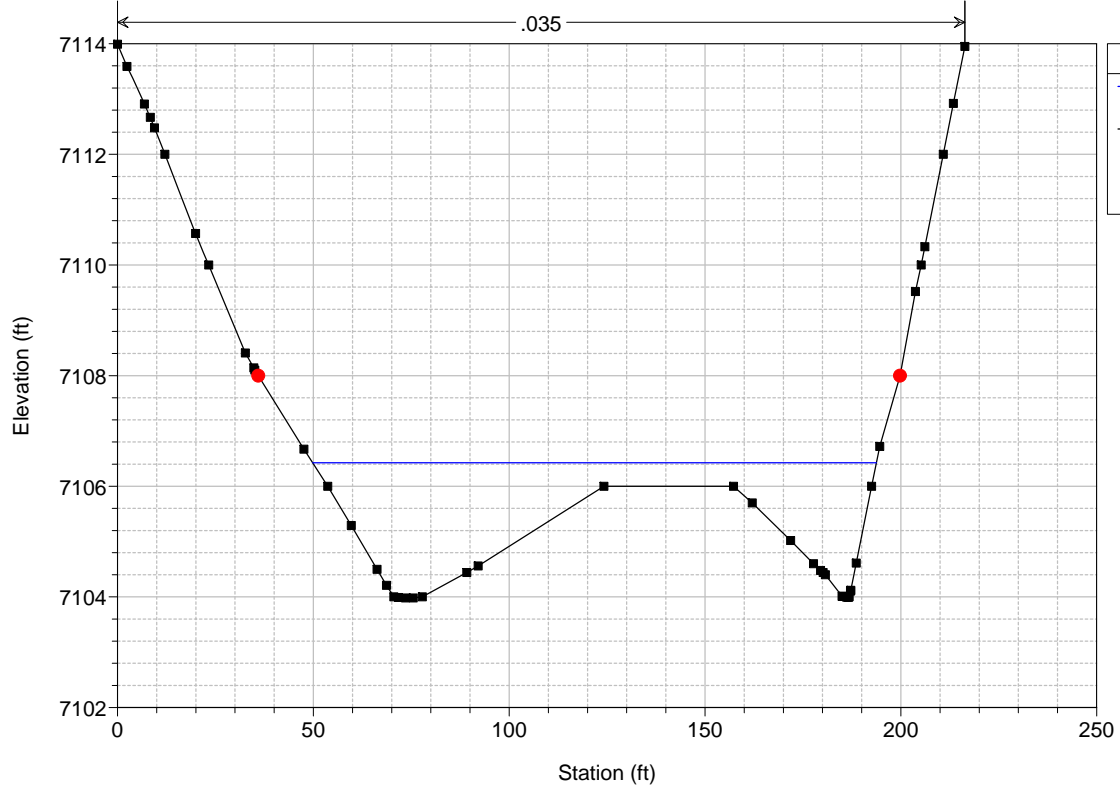

Legend

- WS 100 yr
- Ground
- Bank Sta

Lake Fork Dirty Woman Creek Plan: Existing 3/9/2017
RS = 200

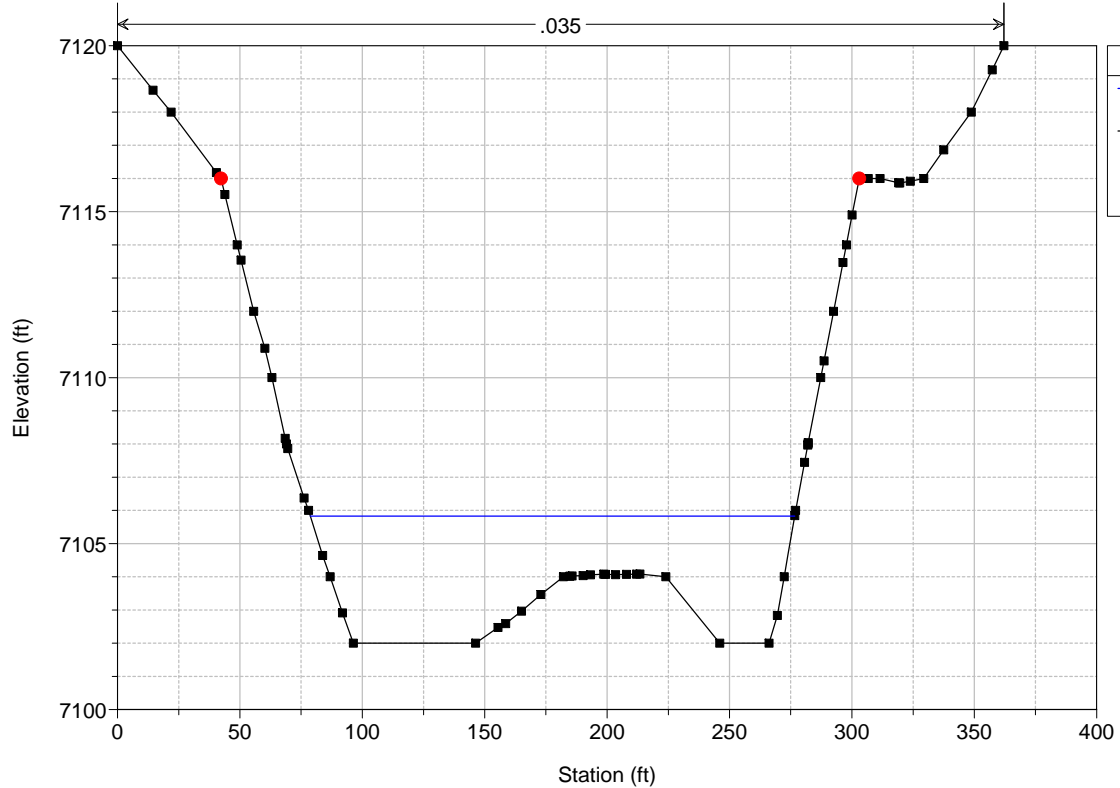

Legend

- WS 100 yr
- Ground
- Bank Sta

Lake Fork Dirty Woman Creek Plan: Existing 3/9/2017

Dirty Woman Cree Lake Fork

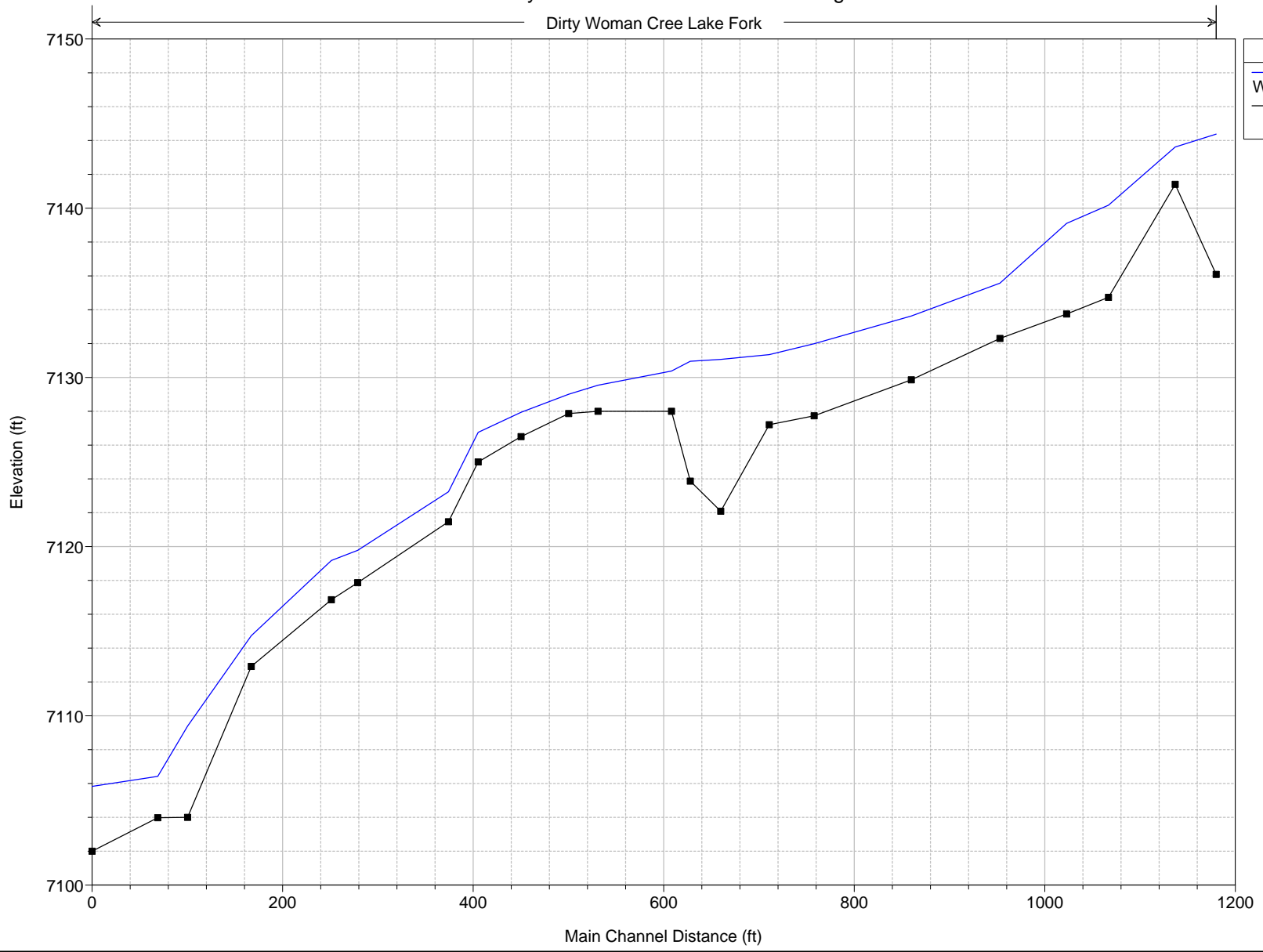

Legend

- WS 100 yr
- Ground

HEC-RAS Plan: Existing River: Dirty Woman Cree Reach: Lake Fork Profile: 100 yr

Reach	River Sta	Profile	Q Total (cfs)	Min Ch El (ft)	W.S. Elev (ft)	Crit W.S. (ft)	E.G. Elev (ft)	E.G. Slope (ft/ft)	Vel Chnl (ft/s)	Flow Area (sq ft)	Top Width (ft)	Froude # Chl
Lake Fork	1380	100 yr	1016.00	7136.09	7144.37	7138.96	7144.39	0.000074	1.15	937.95	220.92	0.09
Lake Fork	1337	100 yr	1016.00	7141.41	7143.62	7143.62	7144.32	0.005353	6.72	151.20	109.89	1.01
Lake Fork	1267	100 yr	1016.00	7134.73	7140.18	7137.82	7140.36	0.004820	3.50	304.18	103.31	0.29
Lake Fork	1223	100 yr	1016.00	7133.74	7139.10	7139.10	7139.84	0.035504	7.10	153.26	99.25	0.72
Lake Fork	1153	100 yr	1016.00	7132.30	7135.57	7135.10	7136.09	0.037171	5.79	175.48	88.48	0.72
Lake Fork	1060	100 yr	1016.00	7129.86	7133.63	7132.41	7133.90	0.015318	4.18	242.82	99.97	0.47
Lake Fork	958	100 yr	1107.00	7127.73	7131.99	7131.64	7132.81	0.007347	7.50	164.26	72.08	0.77
Lake Fork	911	100 yr	1107.00	7127.21	7131.35	7131.35	7132.36	0.012033	8.18	142.02	75.73	0.94
Lake Fork	860	100 yr	1107.00	7122.09	7131.06	7129.73	7131.29	0.002224	3.81	290.49	108.78	0.41
Lake Fork	828	100 yr	1107.00	7123.87	7130.95	7129.82	7131.21	0.002526	4.11	278.84	119.24	0.44
Lake Fork	808	100 yr	1107.00	7128.00	7130.38	7130.38	7131.06	0.016872	6.65	166.38	123.90	1.01
Lake Fork	731	100 yr	1107.00	7128.00	7129.54	7129.22	7129.84	0.007657	4.40	251.52	194.88	0.68
Lake Fork	700	100 yr	1107.00	7127.86	7129.00	7129.00	7129.47	0.018224	5.51	200.78	212.73	1.00
Lake Fork	650	100 yr	1107.00	7126.50	7127.94	7127.94	7128.37	0.019182	5.30	208.67	243.46	1.01
Lake Fork	605	100 yr	1107.00	7125.00	7126.76	7126.76	7127.17	0.020287	5.15	214.97	273.43	1.02
Lake Fork	574	100 yr	1107.00	7121.47	7123.24	7123.24	7123.59	0.012991	4.79	230.87	233.81	0.85
Lake Fork	479	100 yr	1107.00	7117.87	7119.78	7119.78	7120.42	0.017197	6.41	172.71	139.72	1.02
Lake Fork	451	100 yr	1107.00	7116.86	7119.18	7119.18	7119.68	0.018141	5.67	195.27	197.71	1.01
Lake Fork	367	100 yr	1107.00	7112.92	7114.74	7114.74	7115.36	0.016722	6.35	174.23	139.84	1.00
Lake Fork	300	100 yr	1107.00	7104.00	7109.39	7109.39	7110.12	0.016330	6.84	161.94	110.88	1.00
Lake Fork	269	100 yr	1107.00	7103.98	7106.43	7106.43	7107.05	0.017264	6.33	174.85	143.93	1.01
Lake Fork	200	100 yr	1107.00	7102.00	7105.83	7103.67	7105.89	0.000531	1.96	564.93	197.91	0.20

Lake Fork Dirty Woman Creek Plan: Proposed 3/9/2017
 RS = 1380 209 FIRM Section G

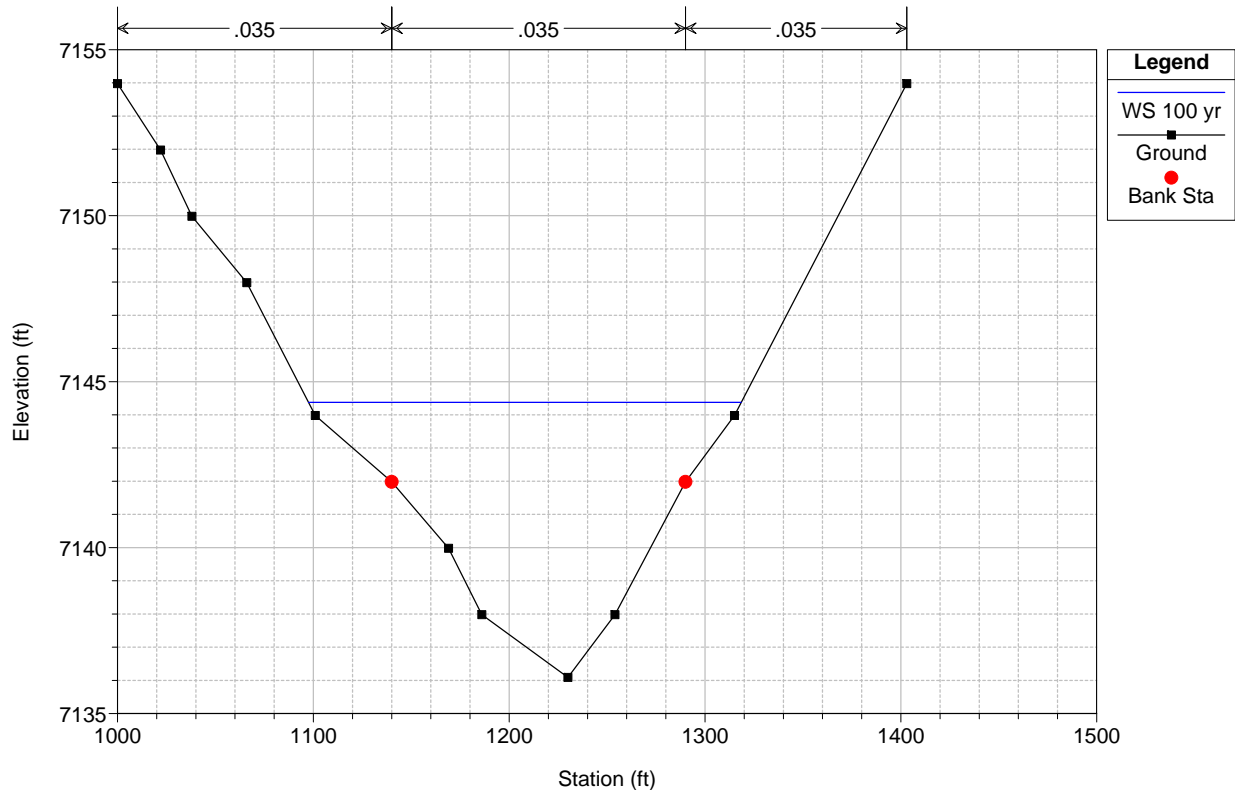

Lake Fork Dirty Woman Creek Plan: Proposed 3/9/2017
 RS = 1337

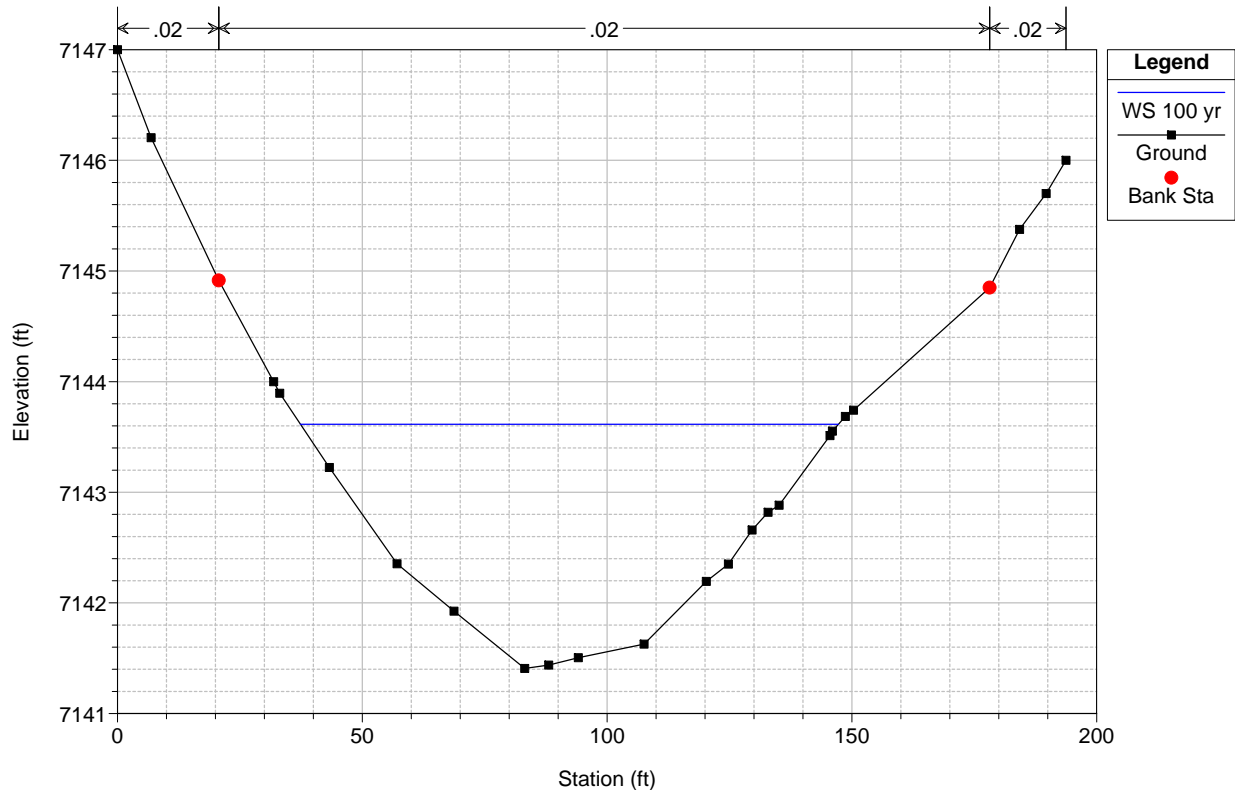

Lake Fork Dirty Woman Creek Plan: Proposed 3/9/2017

RS = 1267

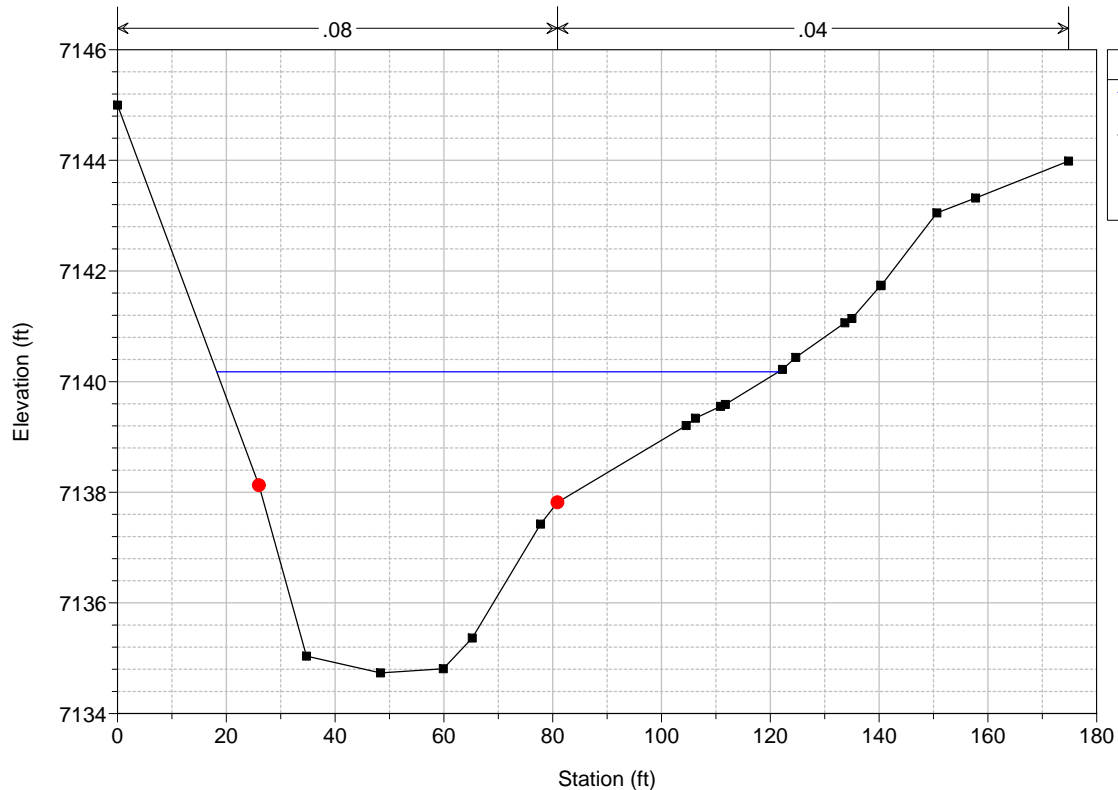

Legend

- WS 100 yr
- Ground
- Bank Sta

Lake Fork Dirty Woman Creek Plan: Proposed 3/9/2017

RS = 1223

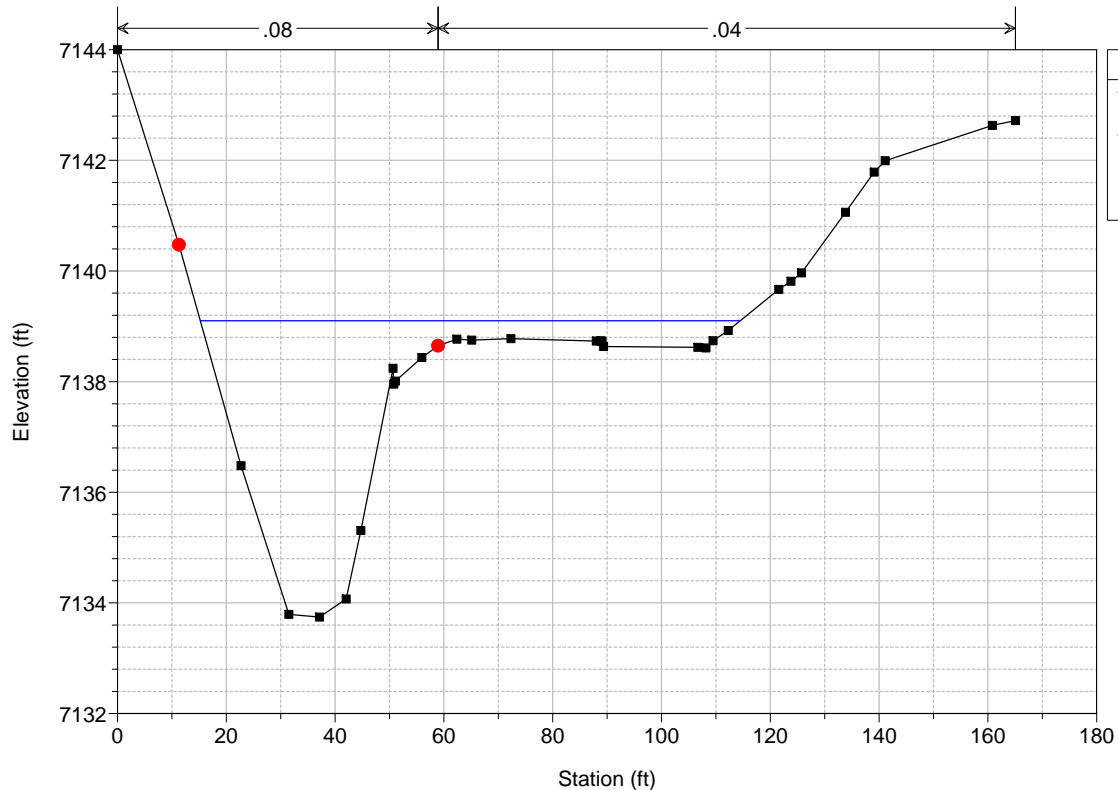

Legend

- WS 100 yr
- Ground
- Bank Sta

Lake Fork Dirty Woman Creek Plan: Proposed 3/9/2017
RS = 1153

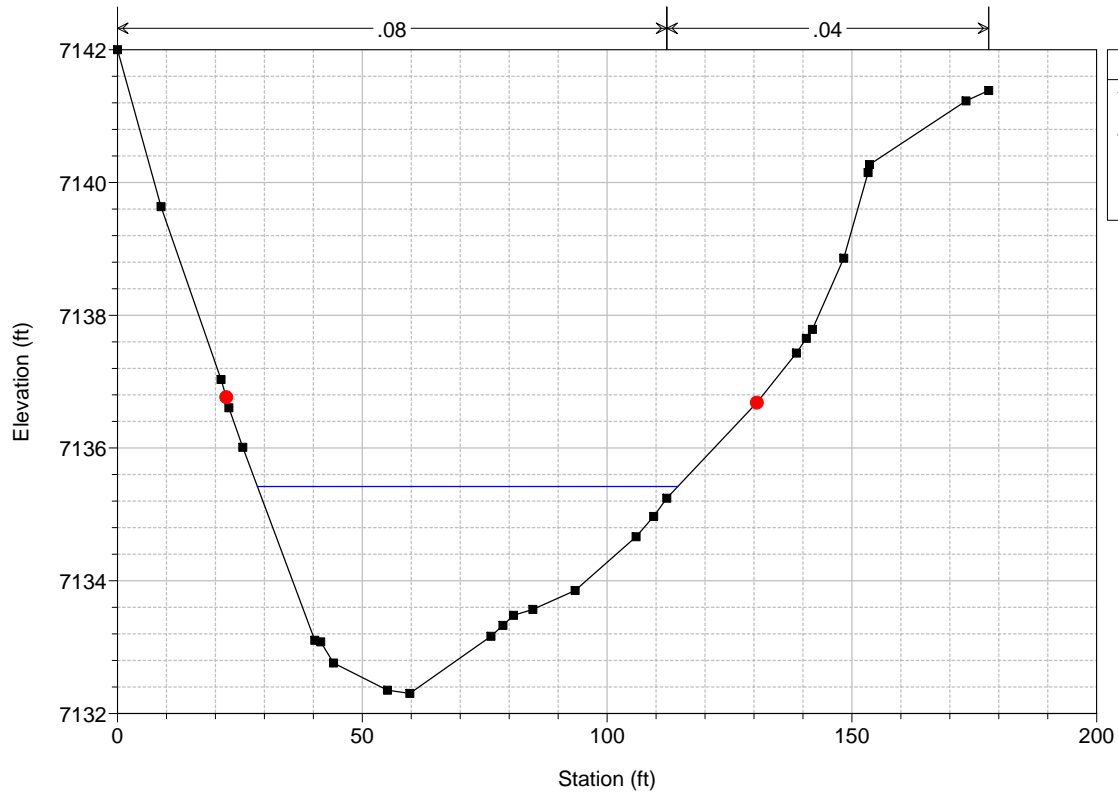

Legend	
WS 100 yr	— (Blue line)
Ground	— (Black line with squares)
Bank Sta	• (Red dot)

Lake Fork Dirty Woman Creek Plan: Proposed 3/9/2017
RS = 1060

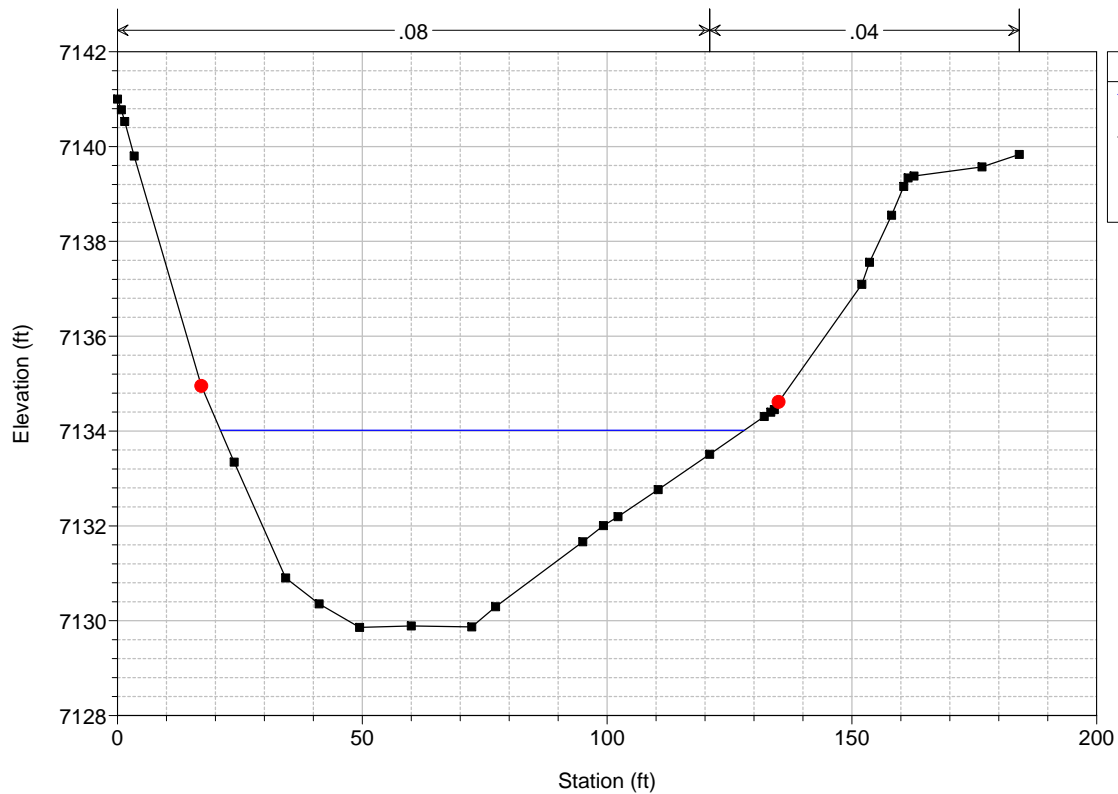

Legend	
WS 100 yr	— (Blue line)
Ground	— (Black line with squares)
Bank Sta	• (Red dot)

Lake Fork Dirty Woman Creek Plan: Proposed 3/9/2017

RS = 958

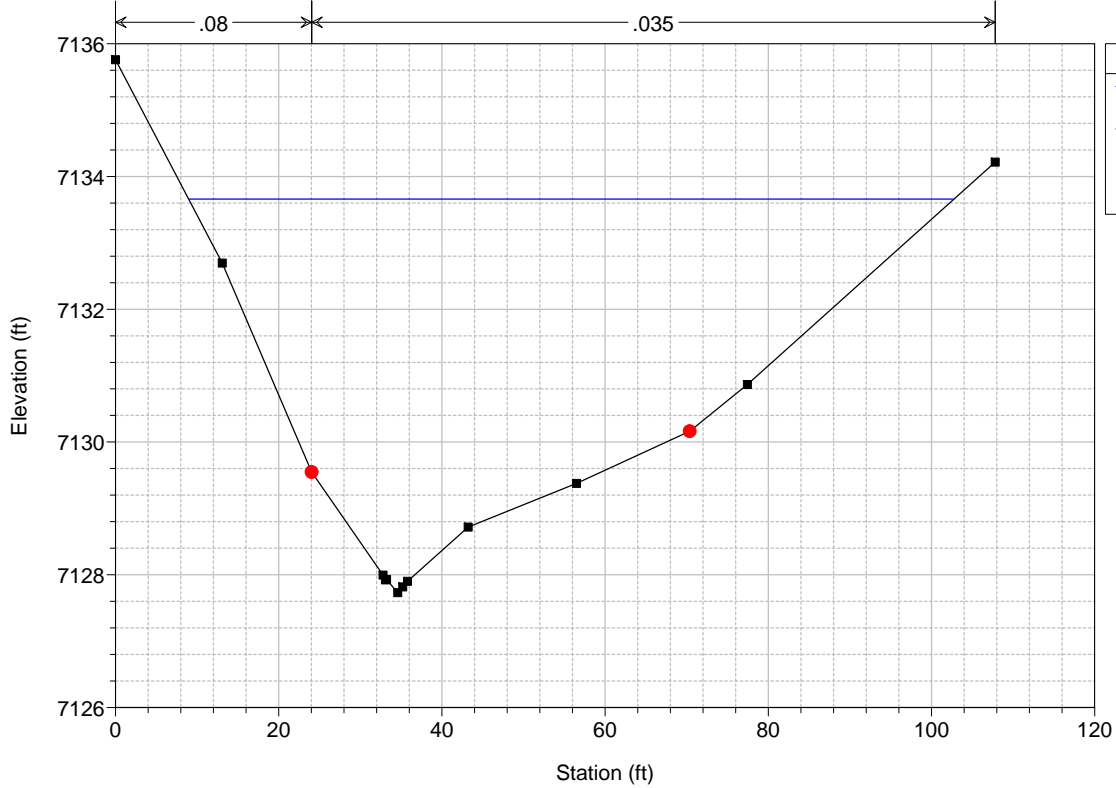

Legend	
WS 100 yr	— (Blue line)
Ground	■ (Black square)
Bank Sta	● (Red circle)

Lake Fork Dirty Woman Creek Plan: Proposed 3/9/2017

RS = 911

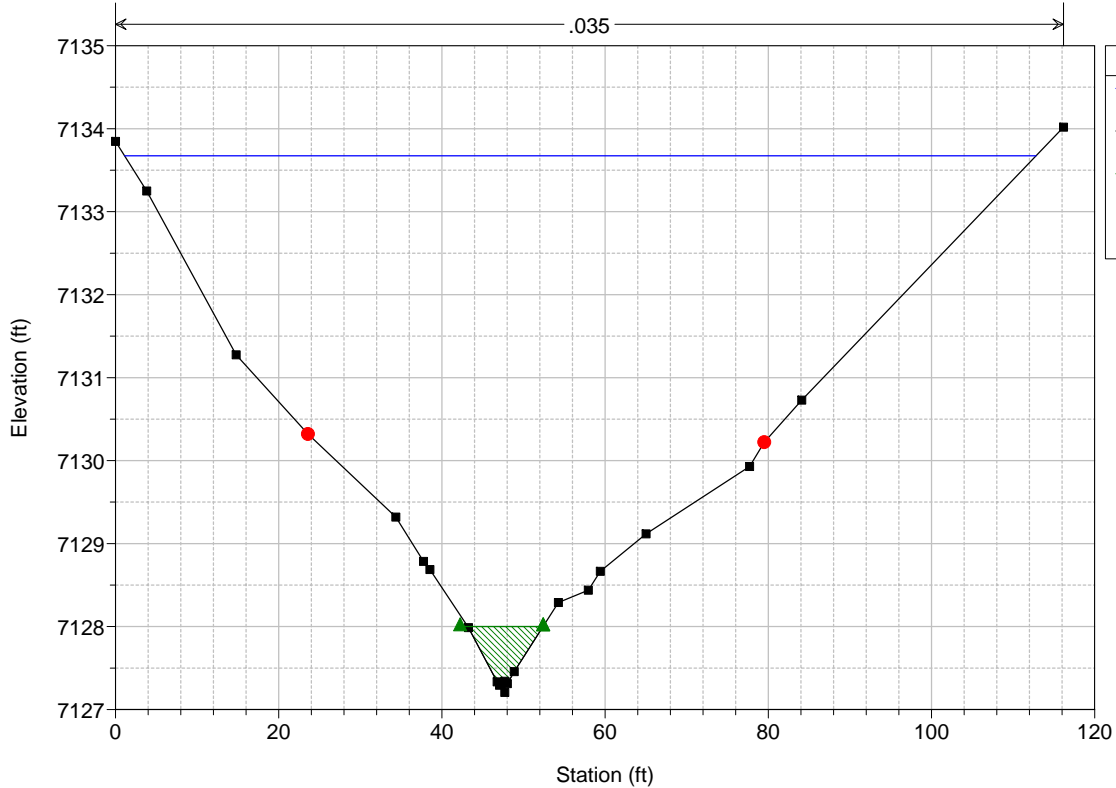

Legend	
WS 100 yr	— (Blue line)
Ground	■ (Black square)
Ineff	▲ (Green triangle)
Bank Sta	● (Red circle)

Lake Fork Dirty Woman Creek Plan: Proposed 3/9/2017

RS = 860

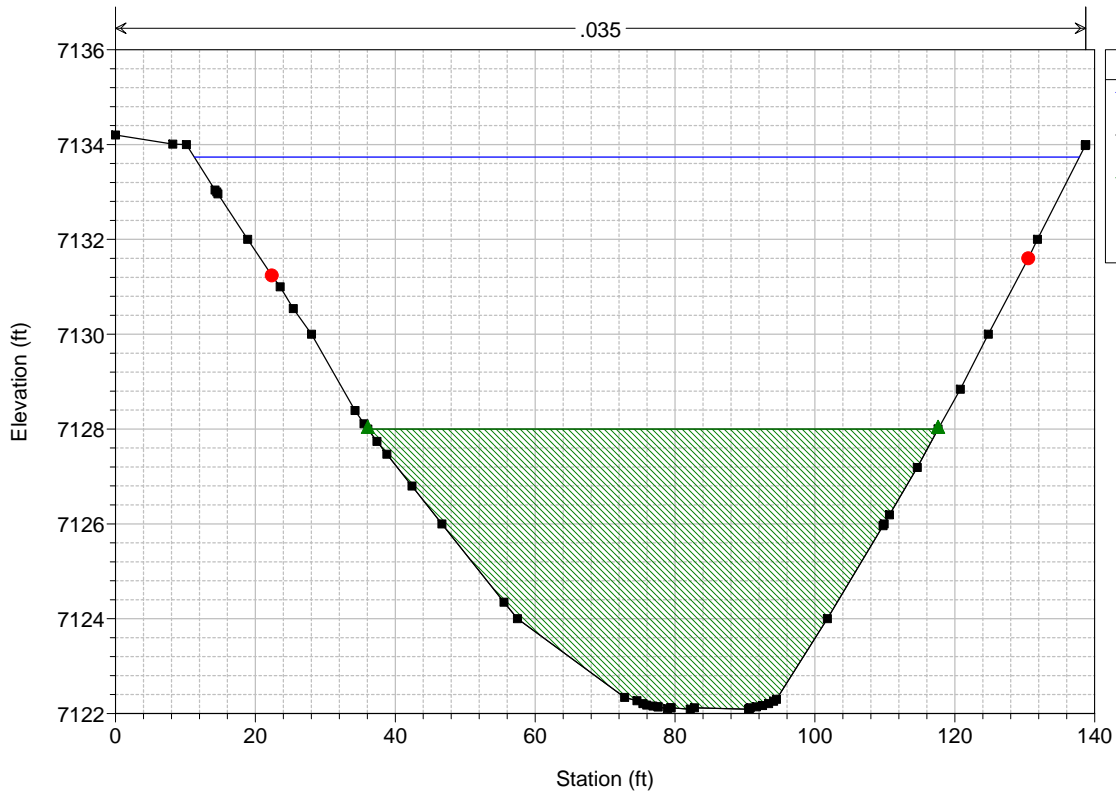

Legend	
WS 100 yr	— (Blue line)
Ground	— (Black line)
Ineff	— (Green shaded area)
Bank Sta	• (Red dot)

Lake Fork Dirty Woman Creek Plan: Proposed 3/9/2017

RS = 828

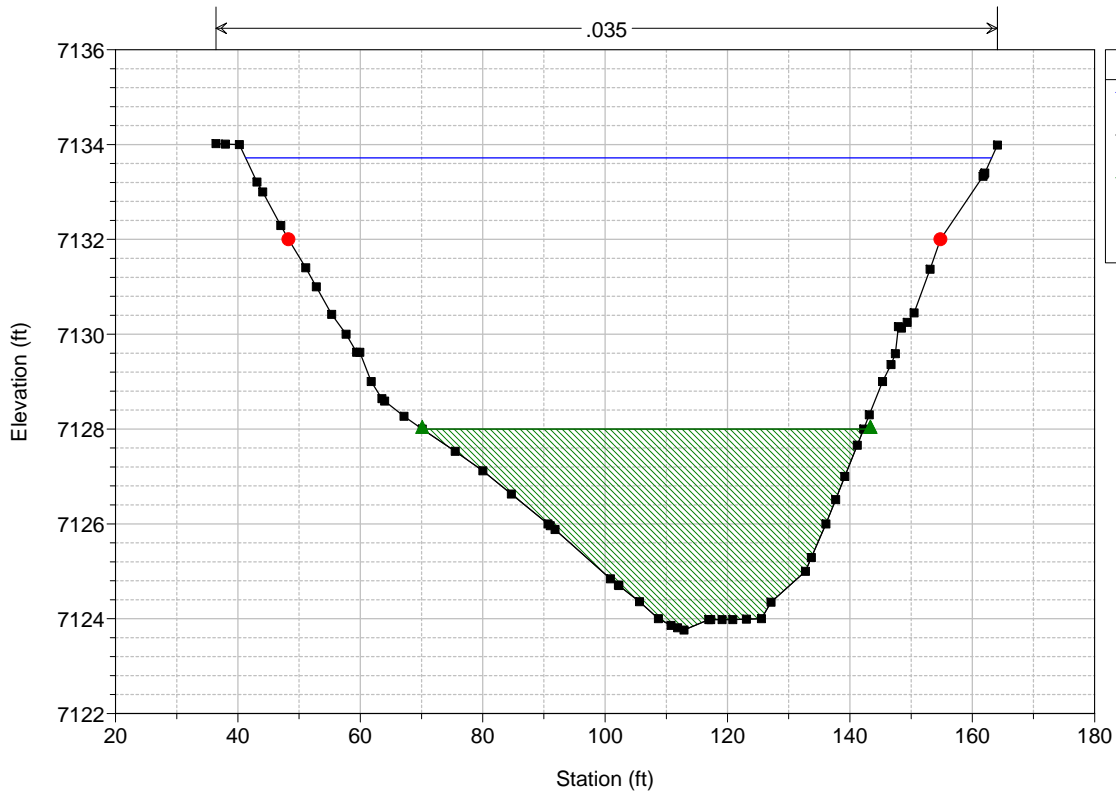

Legend	
WS 100 yr	— (Blue line)
Ground	— (Black line)
Ineff	— (Green shaded area)
Bank Sta	• (Red dot)

Lake Fork Dirty Woman Creek Plan: Proposed 3/9/2017
RS = 808

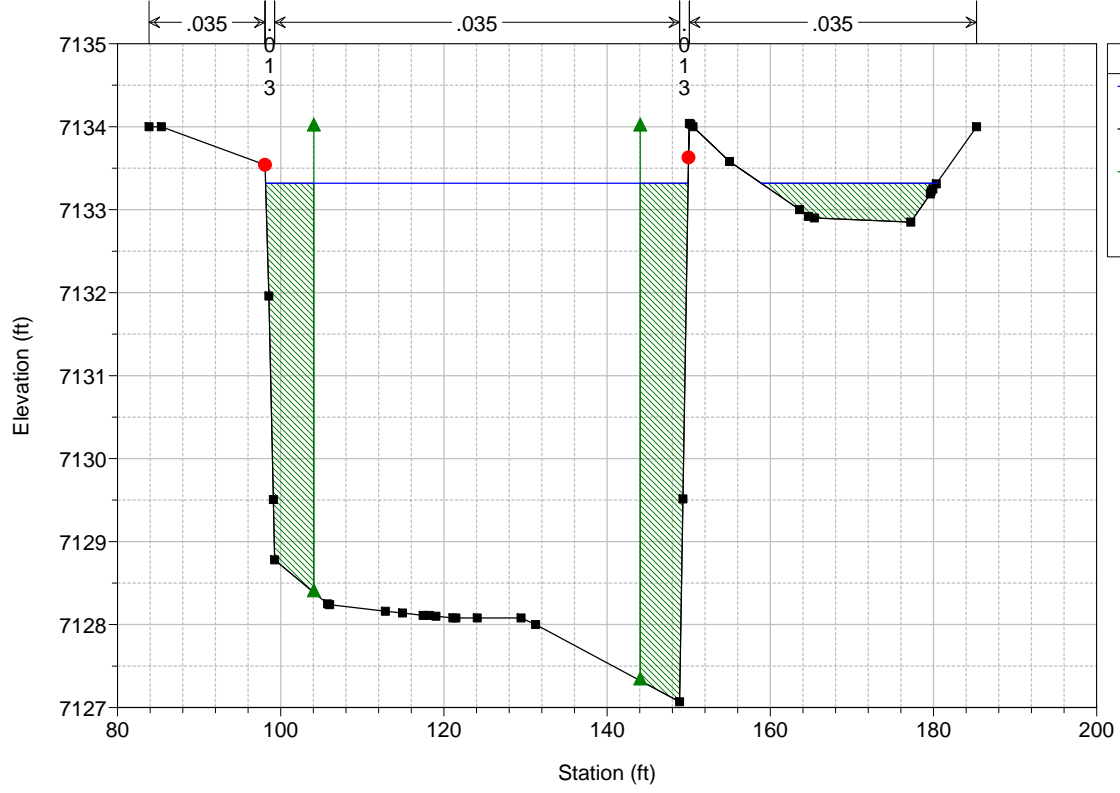

Legend

- WS 100 yr
- Ground
- Ineff
- Bank Sta

Lake Fork Dirty Woman Creek Plan: Proposed 3/9/2017
RS = 783 Culv

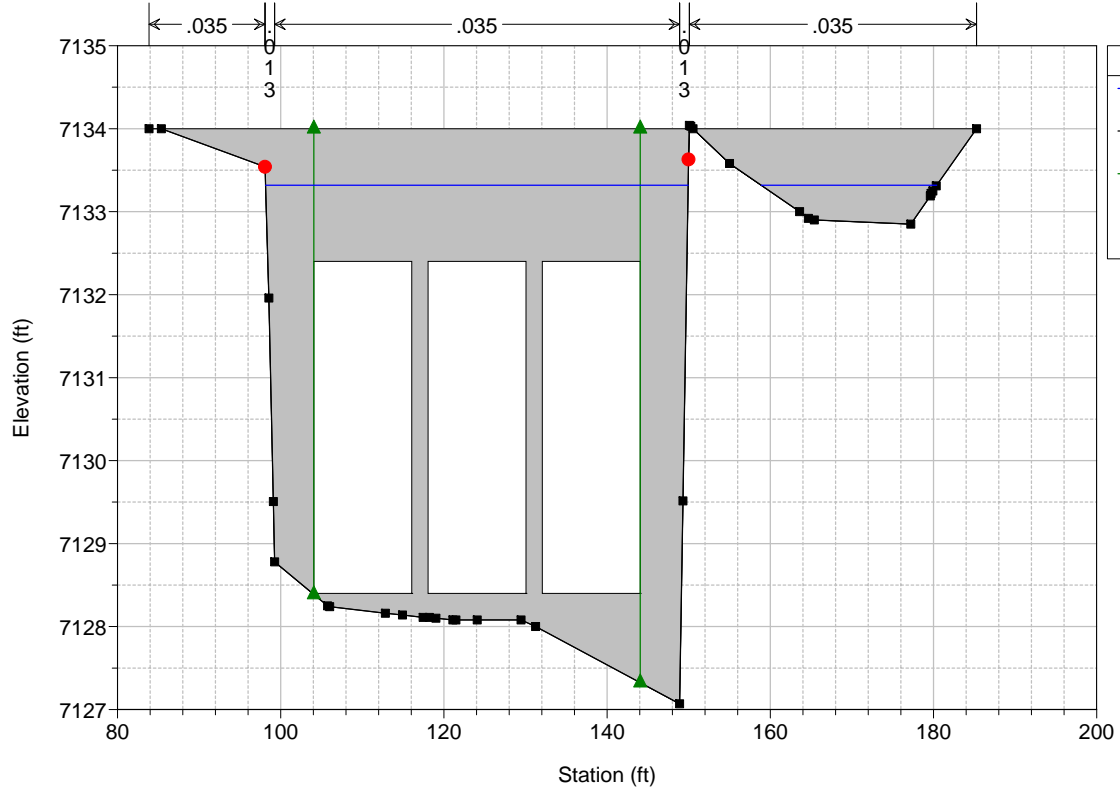

Legend

- WS 100 yr
- Ground
- Ineff
- Bank Sta

Lake Fork Dirty Woman Creek Plan: Proposed 3/9/2017
RS = 783 Culv

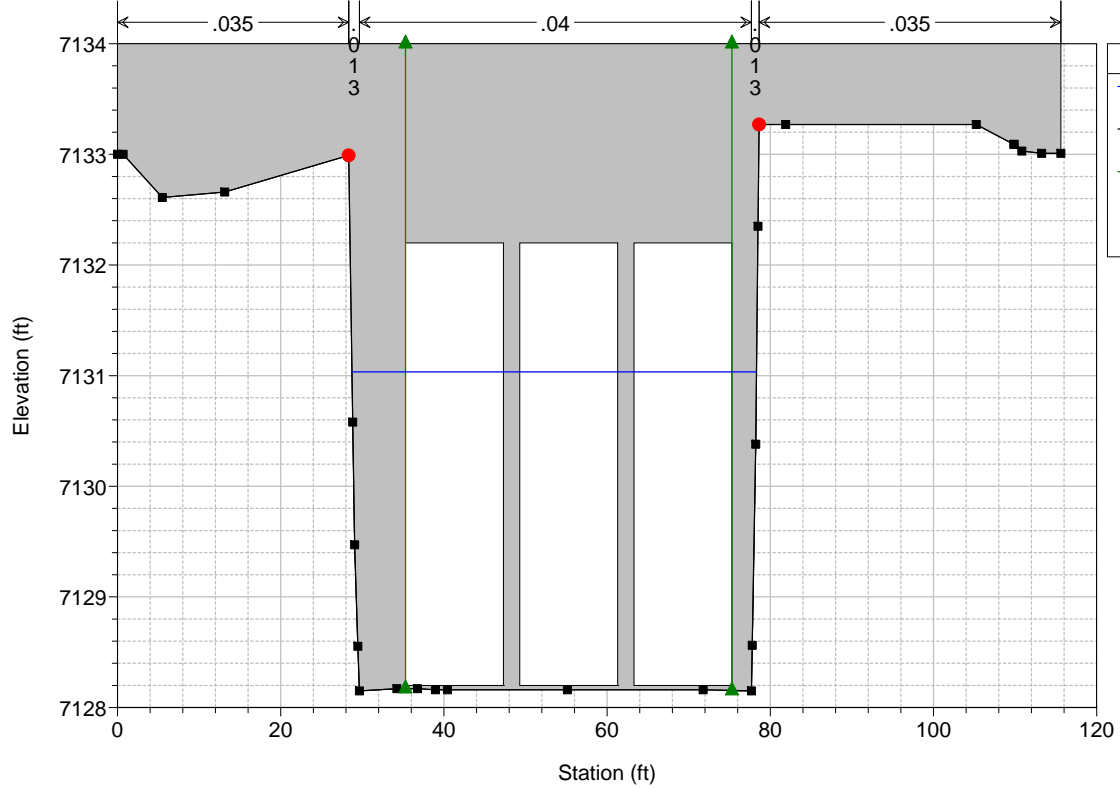

Lake Fork Dirty Woman Creek Plan: Proposed 3/9/2017
RS = 758

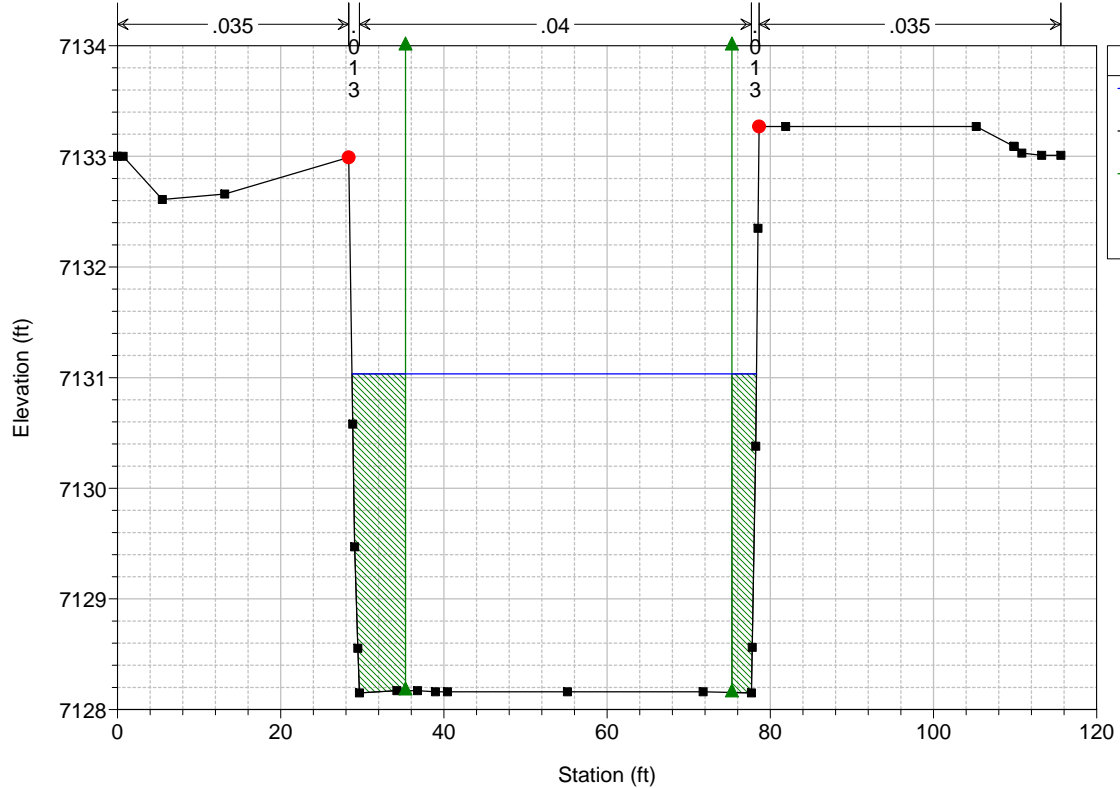

Lake Fork Dirty Woman Creek Plan: Proposed 3/9/2017
RS = 731

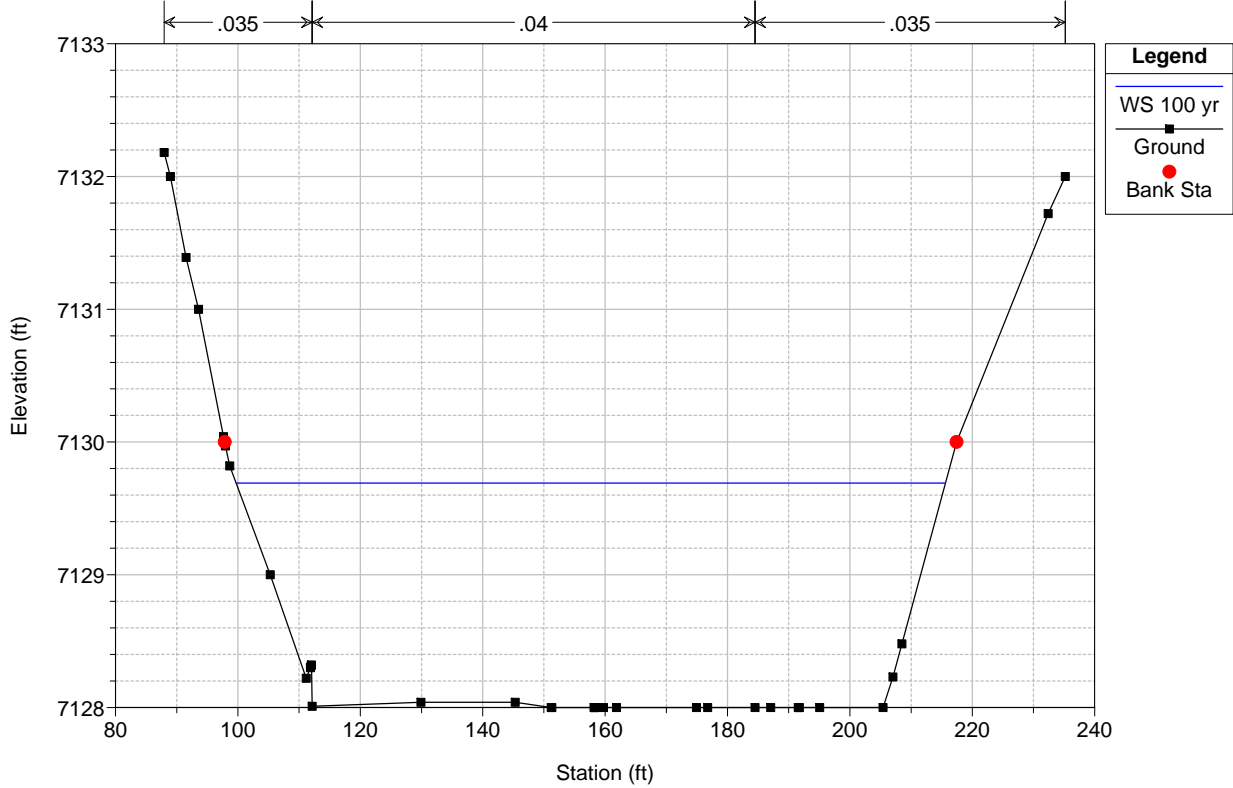

Lake Fork Dirty Woman Creek Plan: Proposed 3/9/2017
RS = 700

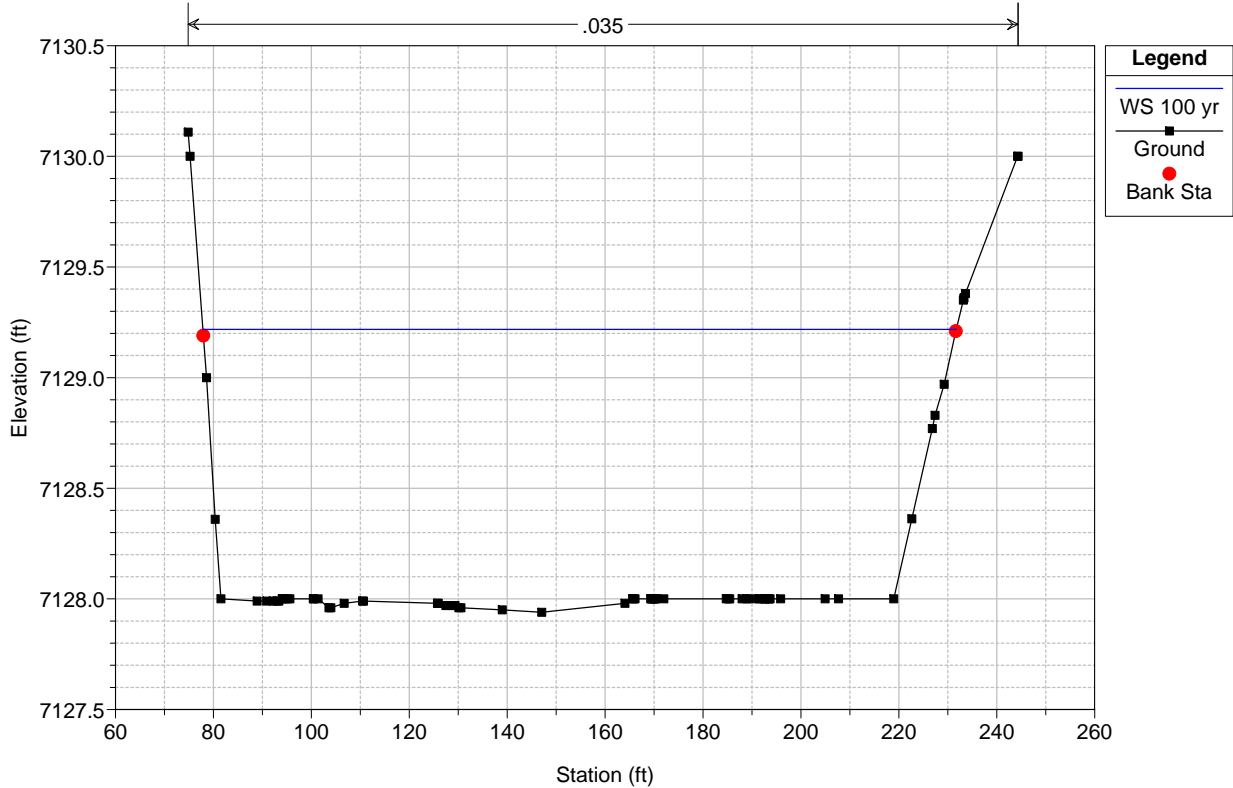

Lake Fork Dirty Woman Creek Plan: Proposed 3/9/2017

RS = 650

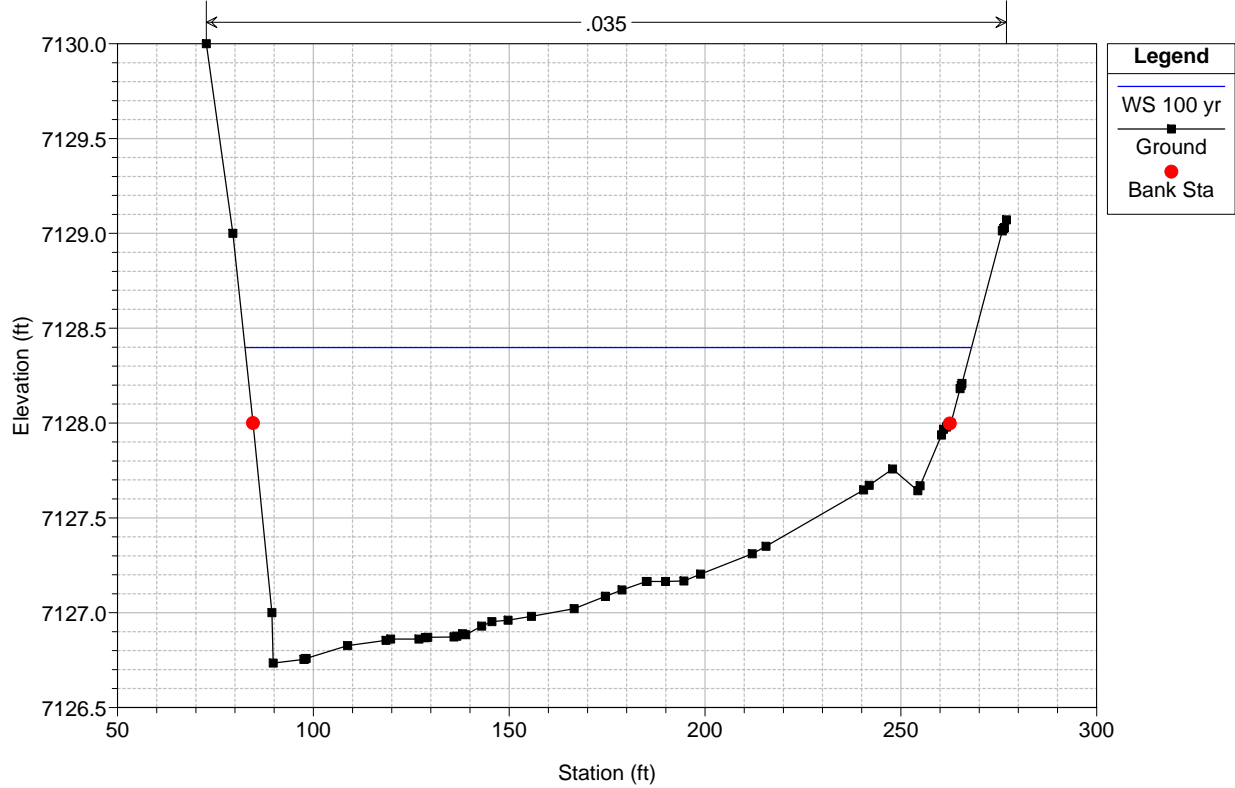

Lake Fork Dirty Woman Creek Plan: Proposed 3/9/2017

RS = 625

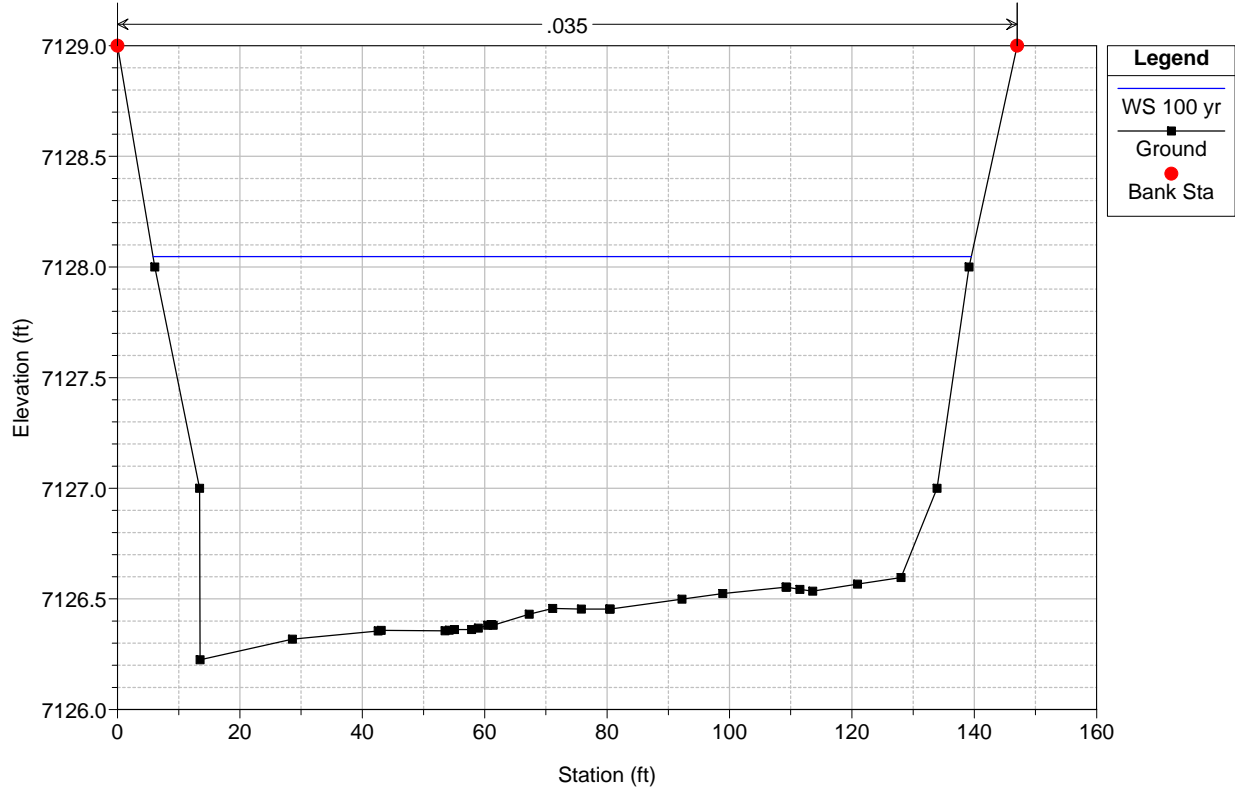

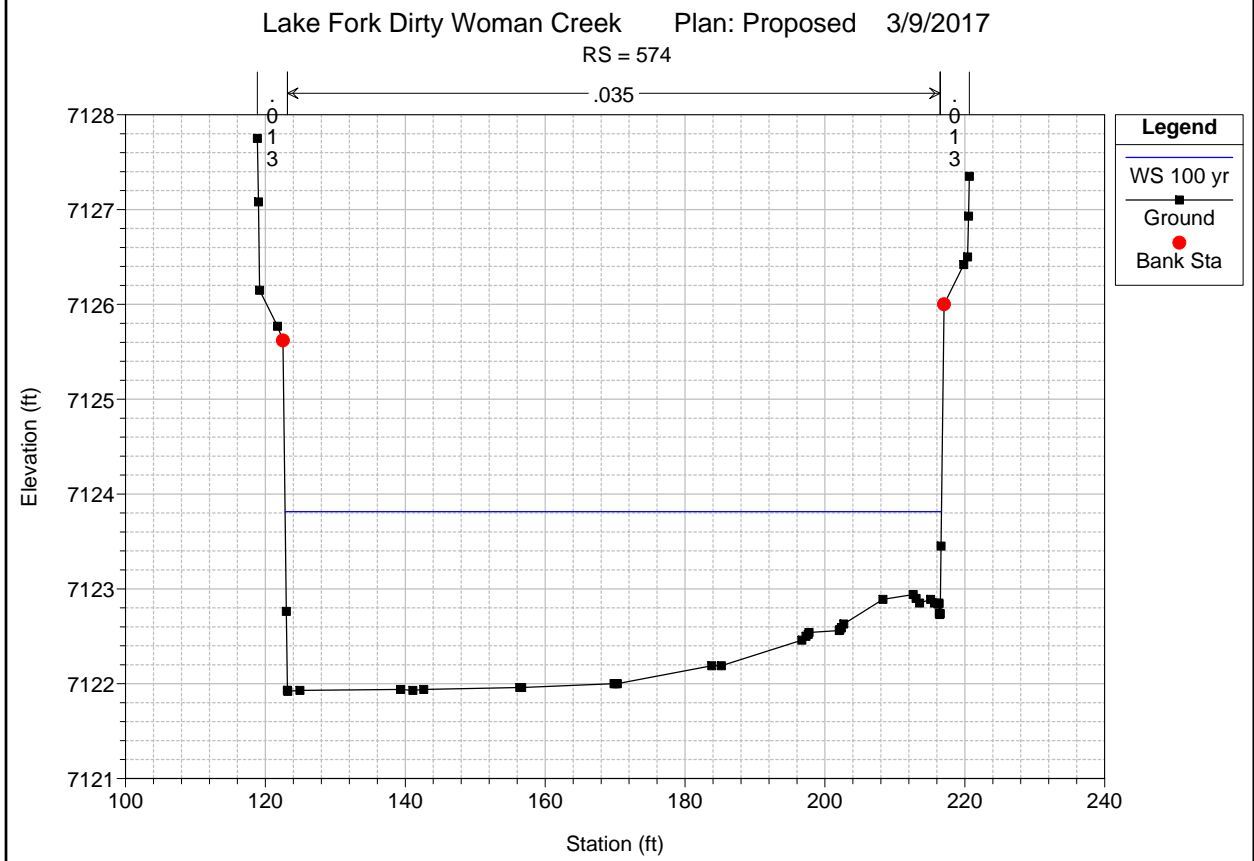
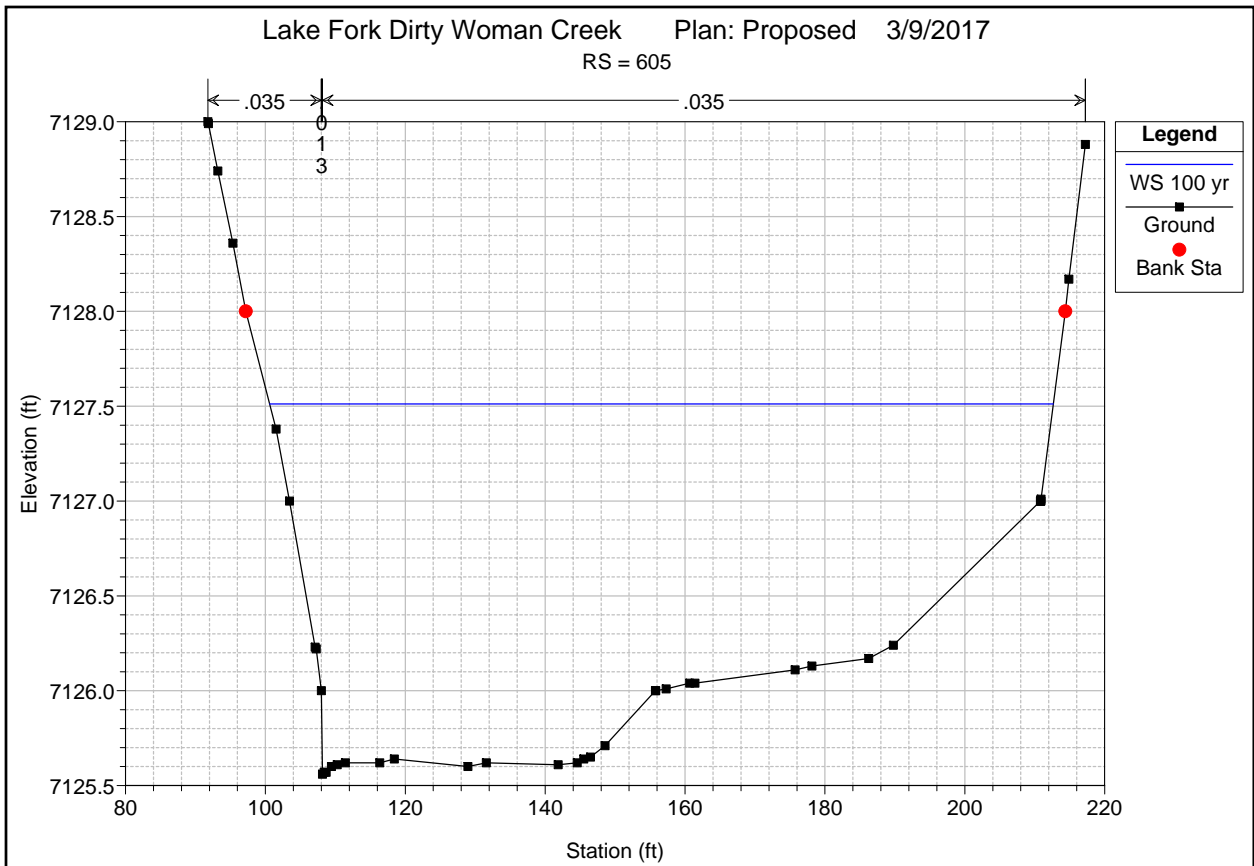

Lake Fork Dirty Woman Creek Plan: Proposed 3/9/2017

RS = 522

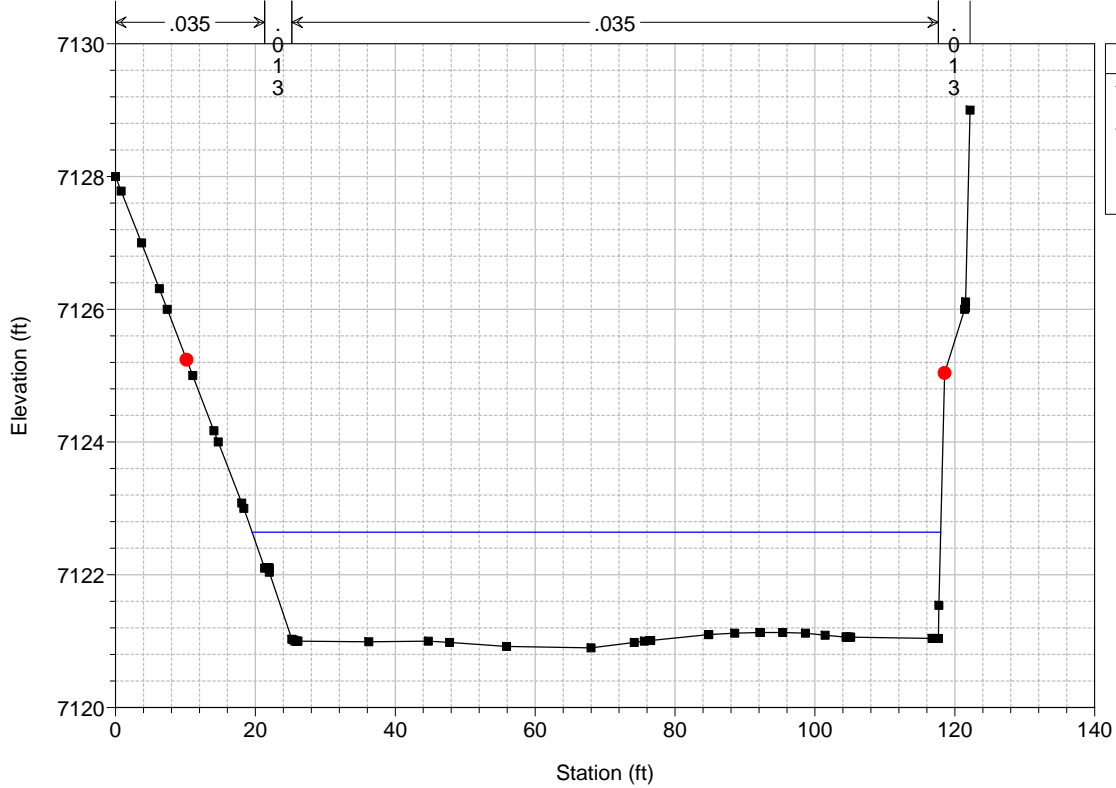

Legend	
—	WS 100 yr
■	Ground
●	Bank Sta

Lake Fork Dirty Woman Creek Plan: Proposed 3/9/2017

RS = 479

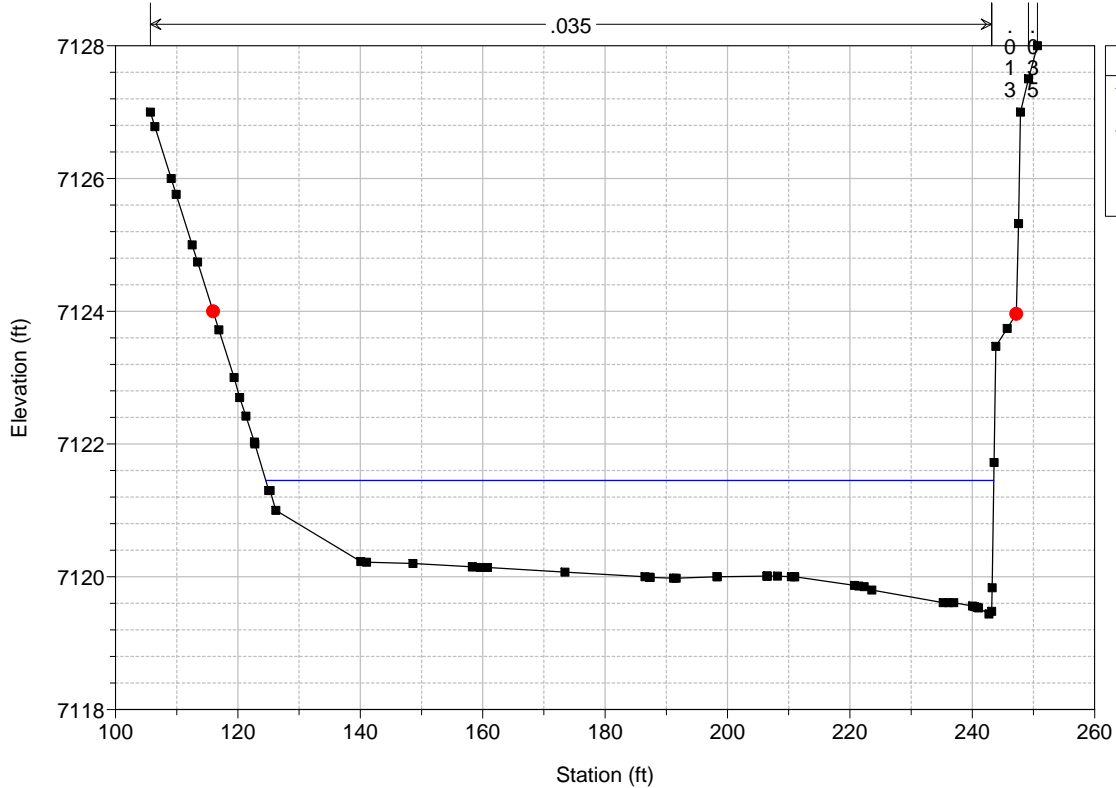

Legend	
—	WS 100 yr
■	Ground
●	Bank Sta

Lake Fork Dirty Woman Creek Plan: Proposed 3/9/2017

RS = 451

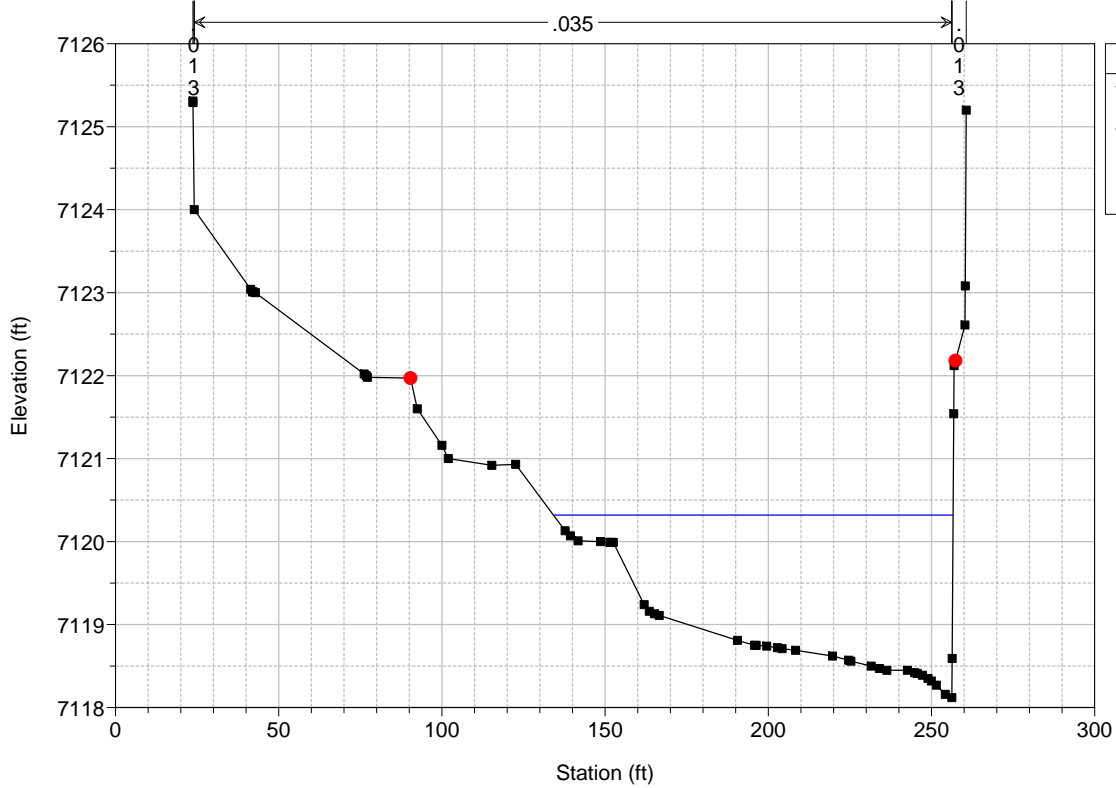

Lake Fork Dirty Woman Creek Plan: Proposed 3/9/2017

RS = 367

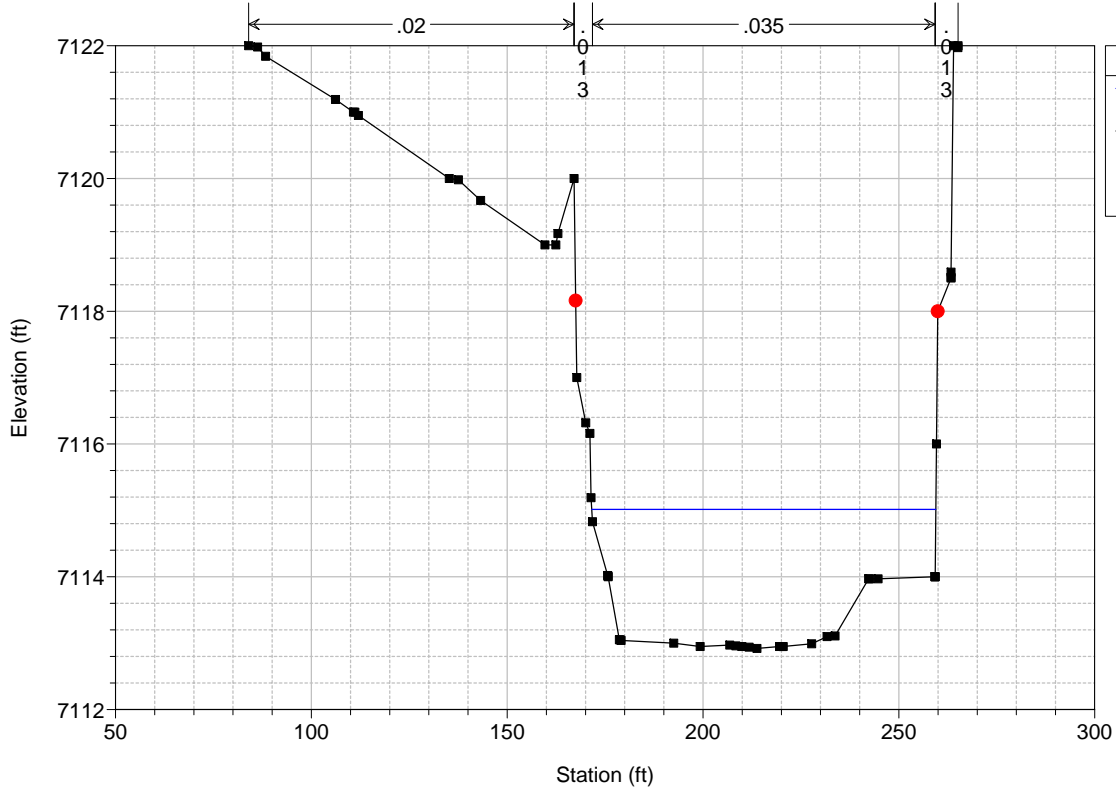

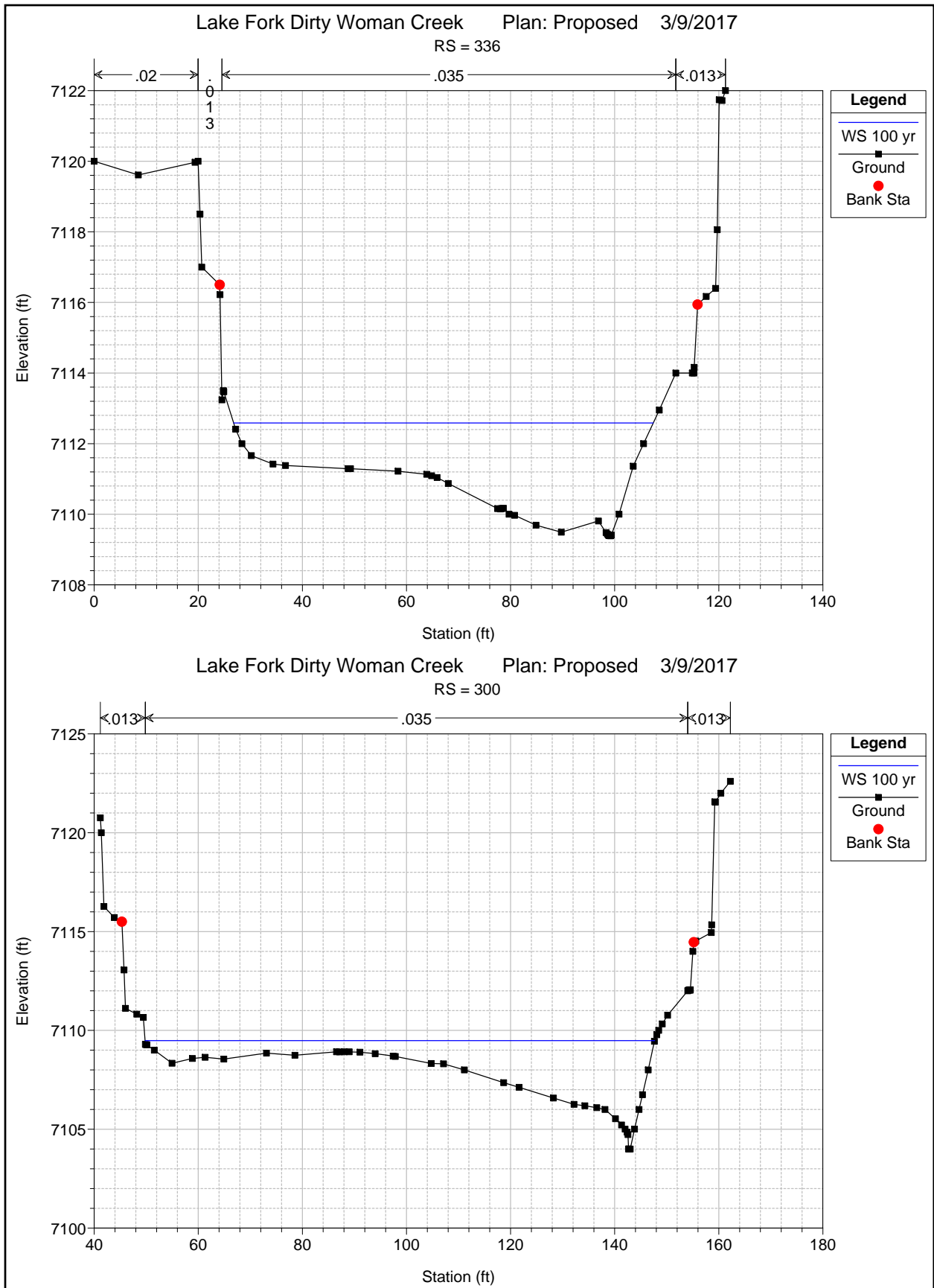

Lake Fork Dirty Woman Creek Plan: Proposed 3/9/2017
RS = 269

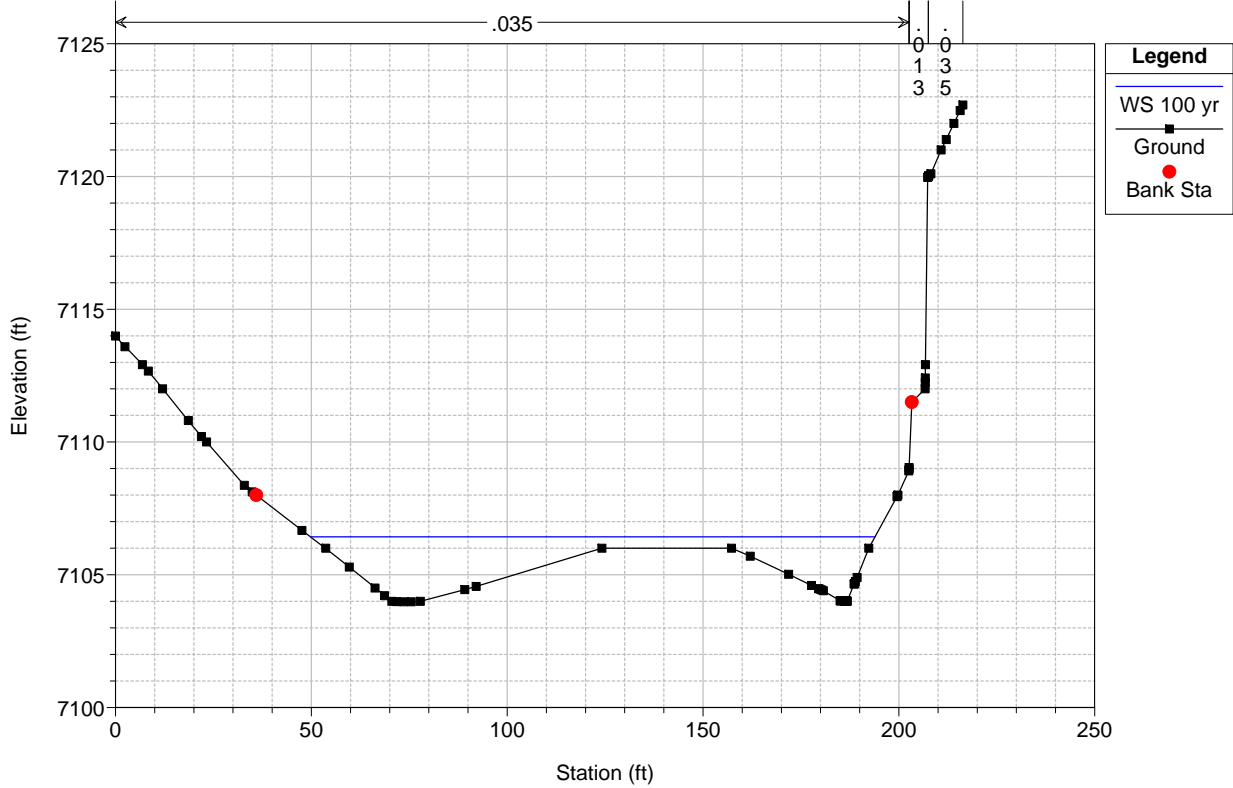

Lake Fork Dirty Woman Creek Plan: Proposed 3/9/2017
RS = 200

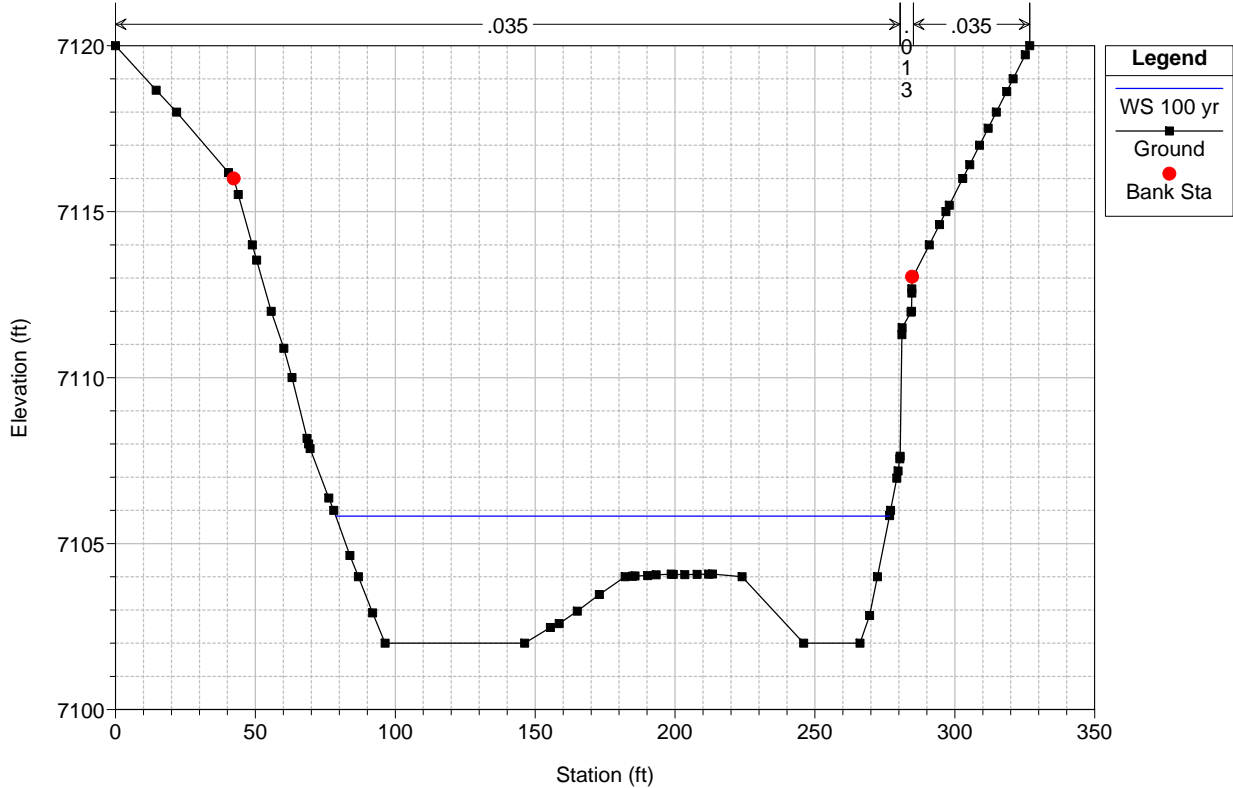

Lake Fork Dirty Woman Creek Plan: Proposed 3/9/2017

Dirty Woman Cree Lake Fork

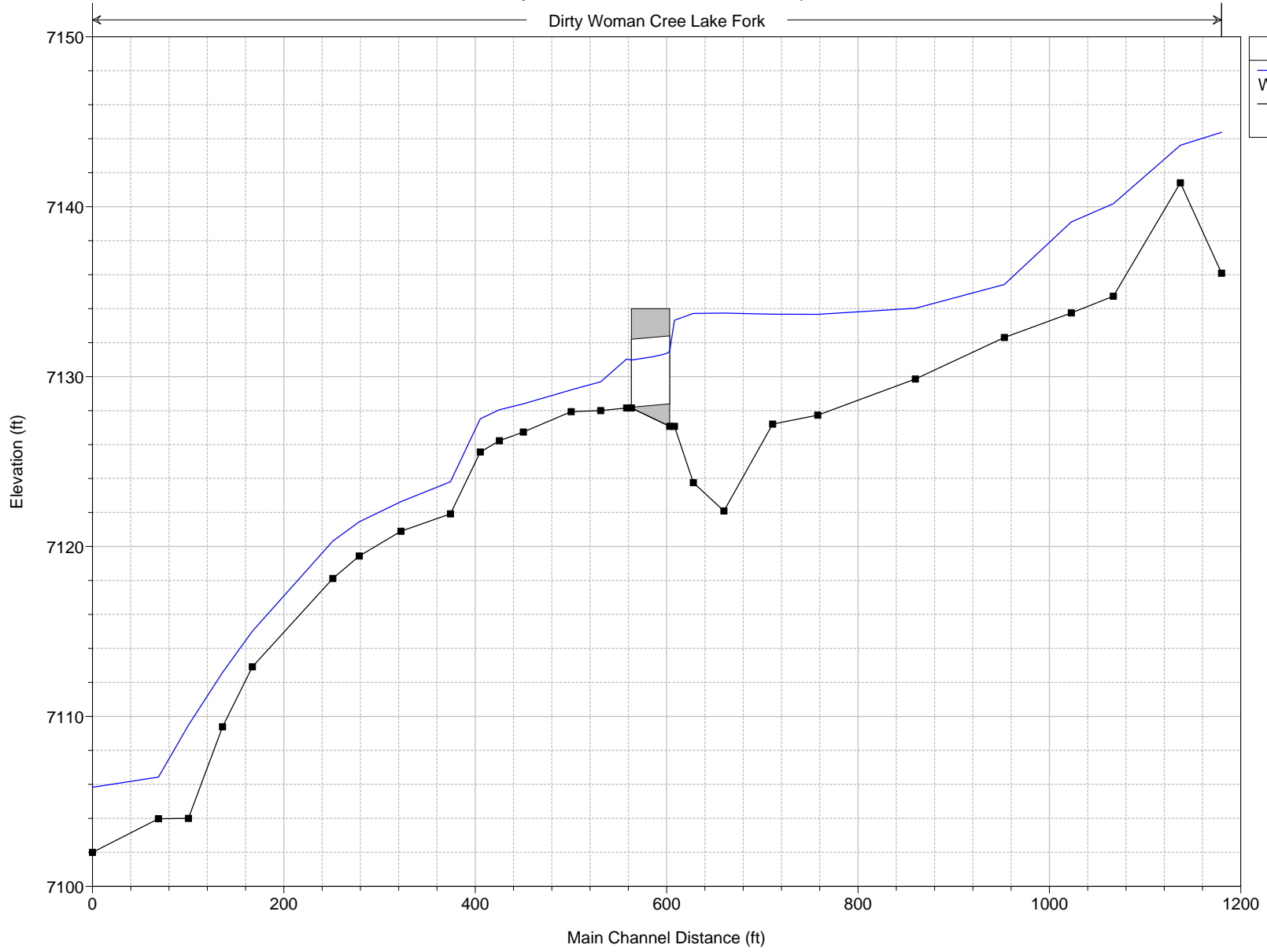

Legend

- WS 100 yr
- Ground

HEC-RAS Plan: Proposed River: Dirty Woman Cree Reach: Lake Fork Profile: 100 yr

Reach	River Sta	Profile	Q Total (cfs)	Min Ch El (ft)	W.S. Elev (ft)	Crit W.S. (ft)	E.G. Elev (ft)	E.G. Slope (ft/ft)	Vel Chnl (ft/s)	Flow Area (sq ft)	Top Width (ft)	Froude # Chl
Lake Fork	1380	100 yr	1016.00	7136.09	7144.37	7138.96	7144.39	0.000074	1.15	937.95	220.92	0.09
Lake Fork	1337	100 yr	1016.00	7141.41	7143.62	7143.62	7144.32	0.005353	6.72	151.20	109.89	1.01
Lake Fork	1267	100 yr	1016.00	7134.73	7140.18	7137.82	7140.36	0.004820	3.50	304.18	103.31	0.29
Lake Fork	1223	100 yr	1016.00	7133.74	7139.10	7139.10	7139.84	0.035504	7.10	153.26	99.25	0.72
Lake Fork	1153	100 yr	1016.00	7132.30	7135.42	7135.10	7136.03	0.046984	6.25	162.67	85.85	0.80
Lake Fork	1060	100 yr	1016.00	7129.86	7134.02	7132.41	7134.22	0.009537	3.59	283.04	107.03	0.39
Lake Fork	958	100 yr	1107.00	7127.73	7133.66	7131.64	7133.92	0.001382	4.38	302.72	93.83	0.36
Lake Fork	911	100 yr	1107.00	7127.21	7133.67	7131.35	7133.85	0.000899	3.54	359.80	111.70	0.29
Lake Fork	860	100 yr	1107.00	7122.09	7133.74	7129.73	7133.79	0.000222	1.90	596.31	126.53	0.15
Lake Fork	828	100 yr	1107.00	7123.76	7133.72	7129.83	7133.78	0.000259	2.01	560.52	121.90	0.16
Lake Fork	808	100 yr	1107.00	7127.07	7133.32	7130.85	7133.74	0.001604	5.19	213.35	73.32	0.40
Lake Fork	783		Culvert									
Lake Fork	758	100 yr	1107.00	7128.15	7131.03	7131.03	7132.47	0.016460	9.63	114.93	49.58	1.00
Lake Fork	731	100 yr	1107.00	7128.00	7129.69	7129.59	7130.31	0.014968	6.33	174.99	115.91	0.91
Lake Fork	700	100 yr	1107.00	7127.94	7129.22	7129.22	7129.81	0.017214	6.17	179.45	153.89	1.01
Lake Fork	650	100 yr	1107.00	7126.74	7128.40	7128.23	7128.80	0.010854	5.06	219.72	185.47	0.81
Lake Fork	625	100 yr	1107.00	7126.23	7128.05	7127.82	7128.52	0.010075	5.54	199.70	133.70	0.80
Lake Fork	605	100 yr	1107.00	7125.56	7127.51	7127.51	7128.25	0.016182	6.87	161.11	112.05	1.01
Lake Fork	574	100 yr	1107.00	7121.92	7123.81	7123.81	7124.64	0.015585	7.29	151.85	93.84	1.01
Lake Fork	522	100 yr	1107.00	7120.90	7122.64	7122.64	7123.43	0.014863	7.14	154.99	98.46	1.00
Lake Fork	479	100 yr	1107.00	7119.44	7121.45	7121.45	7122.16	0.016360	6.73	164.46	118.96	1.01
Lake Fork	451	100 yr	1107.00	7118.12	7120.32	7120.32	7121.01	0.016629	6.69	165.54	122.44	1.01
Lake Fork	367	100 yr	1107.00	7112.92	7115.02	7115.02	7115.88	0.015283	7.44	148.72	87.84	1.01
Lake Fork	336	100 yr	1107.00	7109.39	7112.59	7112.59	7113.49	0.014964	7.63	145.10	80.61	1.00
Lake Fork	300	100 yr	1107.00	7104.00	7109.48	7109.48	7110.30	0.016936	7.25	152.61	97.89	1.02
Lake Fork	269	100 yr	1107.00	7103.98	7106.43	7106.43	7107.05	0.017247	6.33	174.98	144.11	1.01
Lake Fork	200	100 yr	1107.00	7102.00	7105.83	7103.67	7105.89	0.000531	1.96	564.93	197.91	0.20

Lake Fork Dirty Woman Creek Plan: Proposed Floodway 3/9/2017
 RS = 1380 209 FIRM Section G

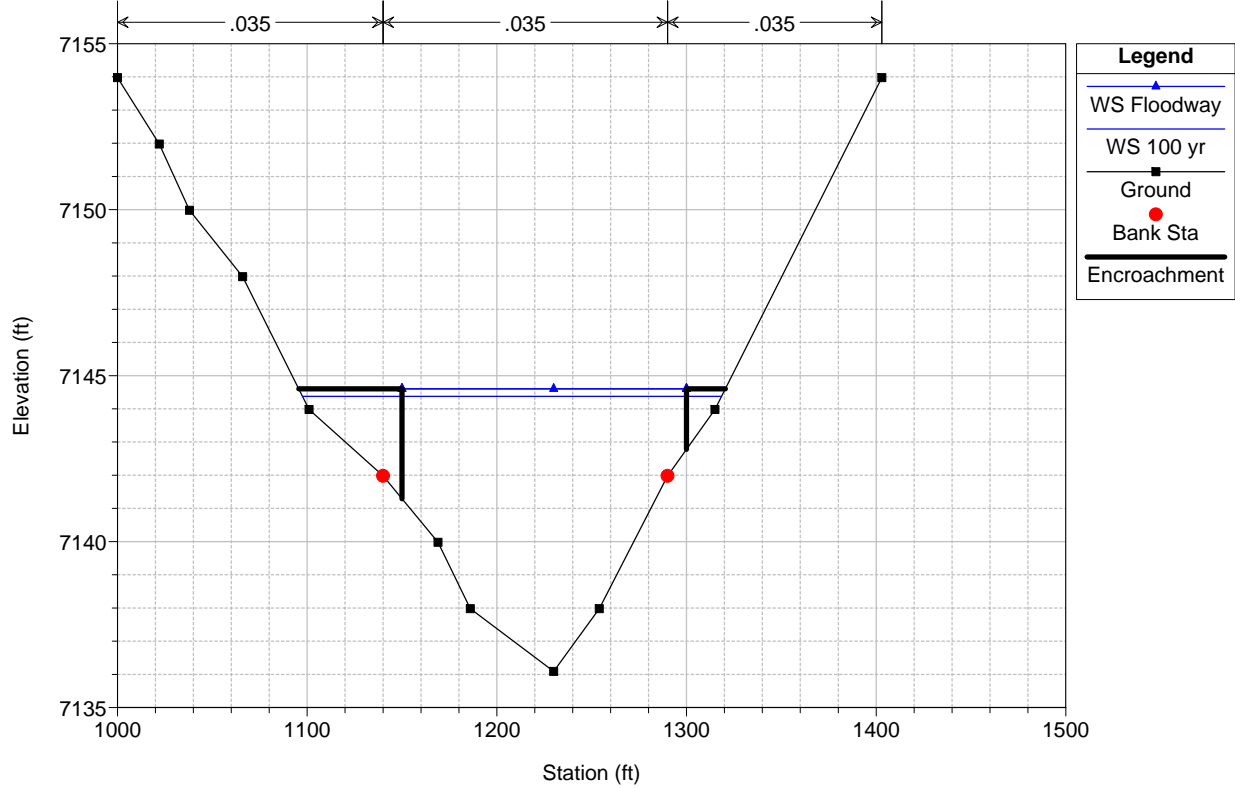

Lake Fork Dirty Woman Creek Plan: Proposed Floodway 3/9/2017
 RS = 1337

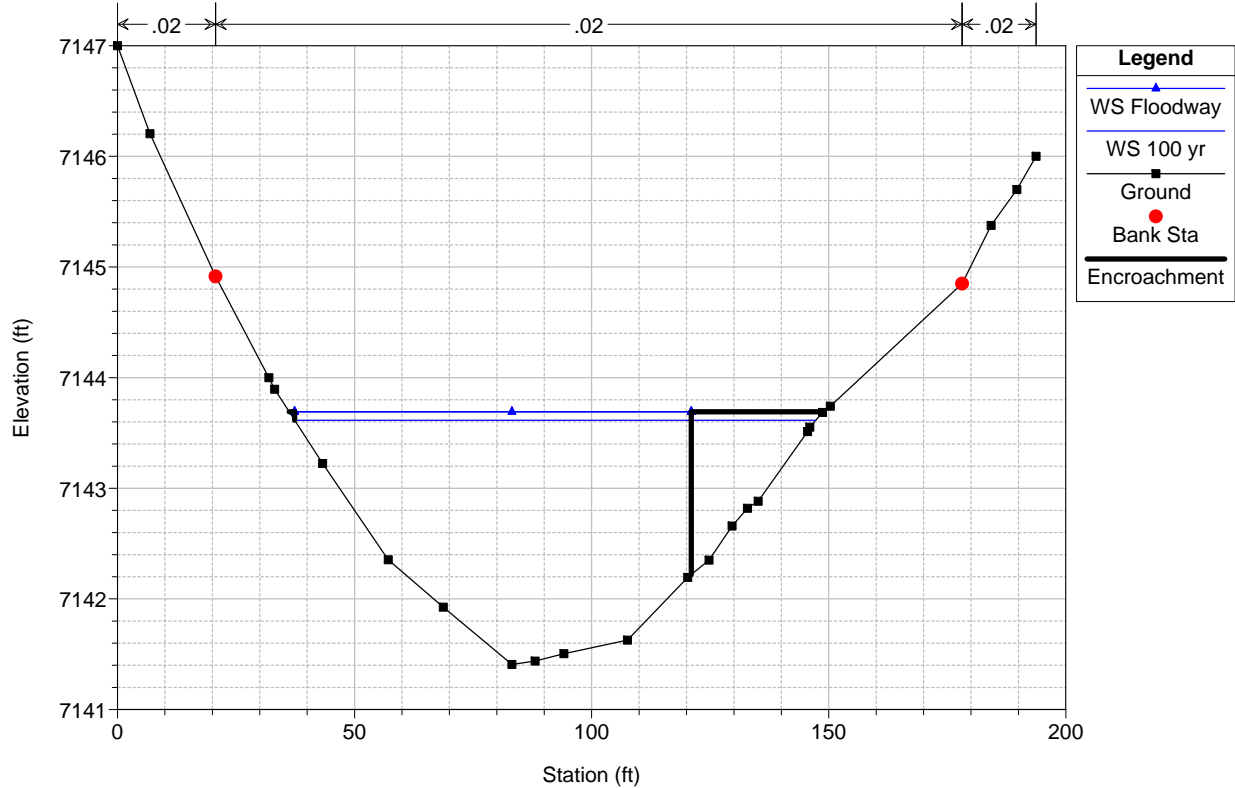

Lake Fork Dirty Woman Creek Plan: Proposed Floodway 3/9/2017
RS = 1267

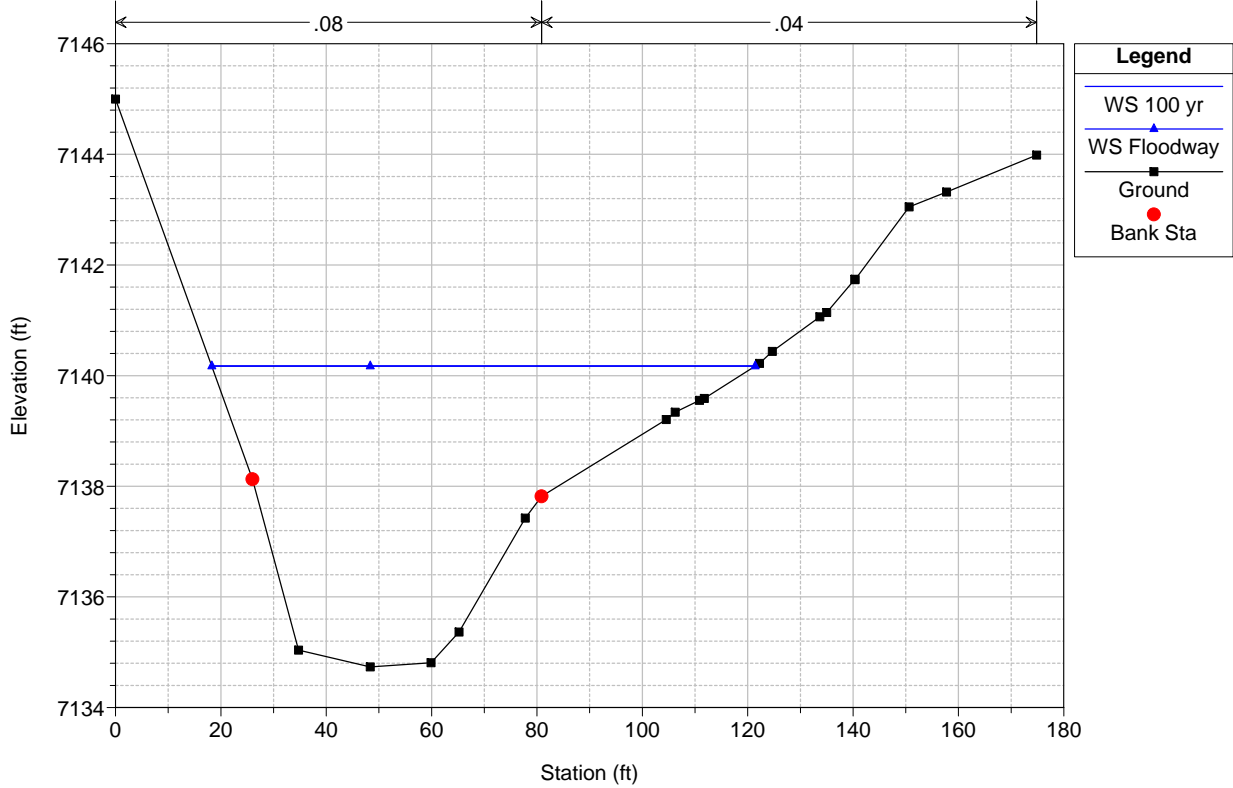

Lake Fork Dirty Woman Creek Plan: Proposed Floodway 3/9/2017
RS = 1223

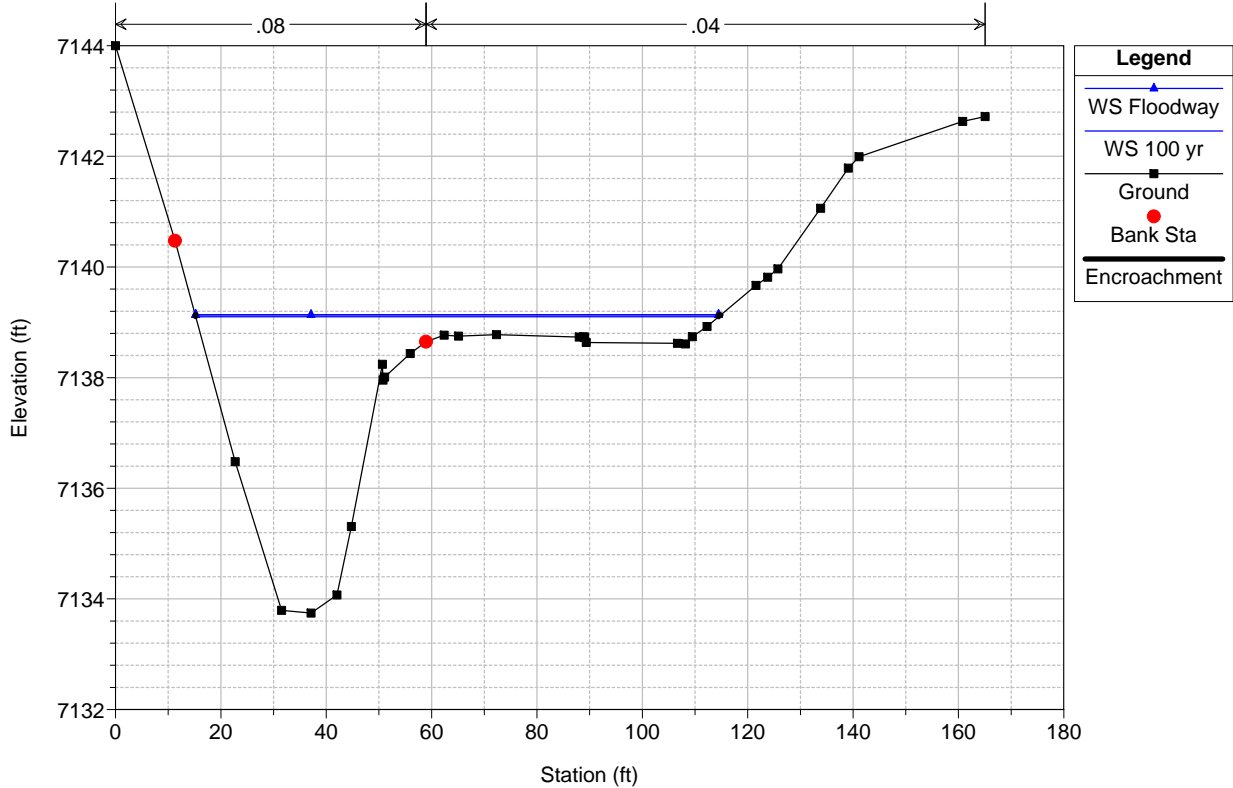

Lake Fork Dirty Woman Creek Plan: Proposed Floodway 3/9/2017

RS = 1153

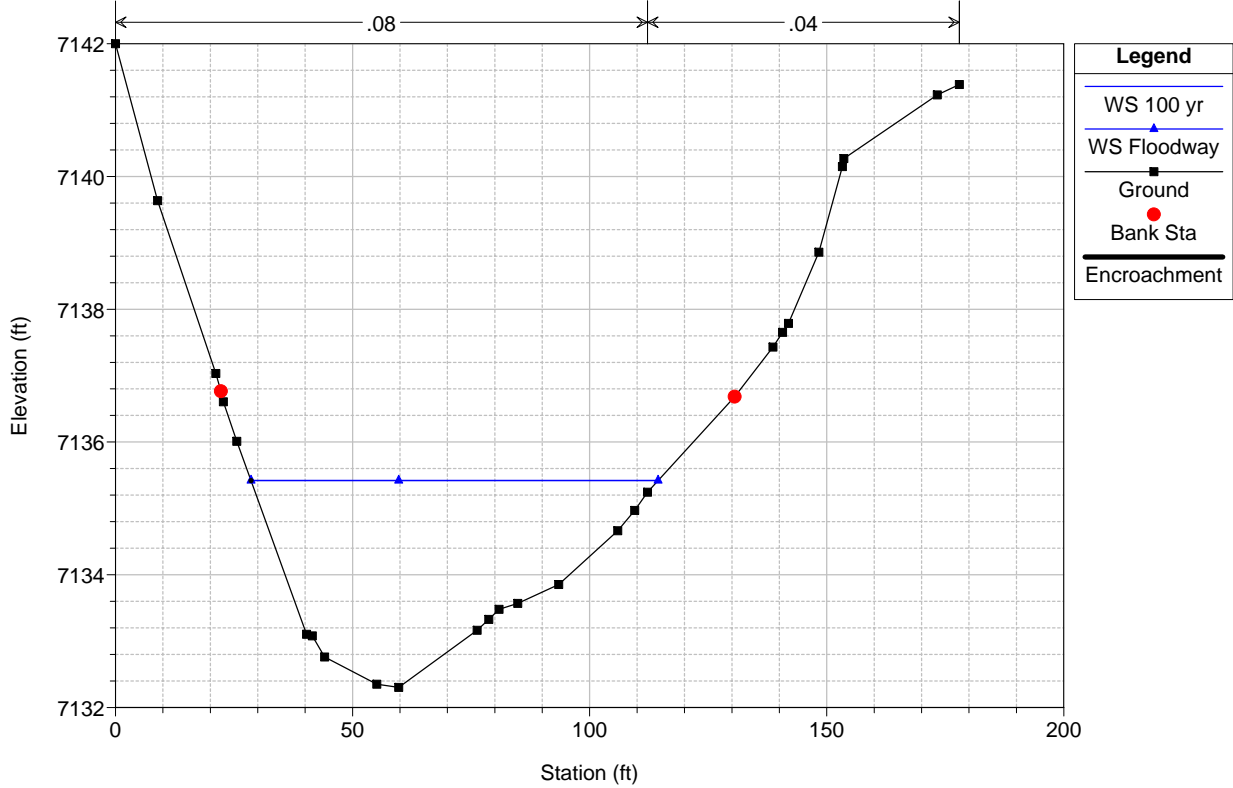

Lake Fork Dirty Woman Creek Plan: Proposed Floodway 3/9/2017

RS = 1060

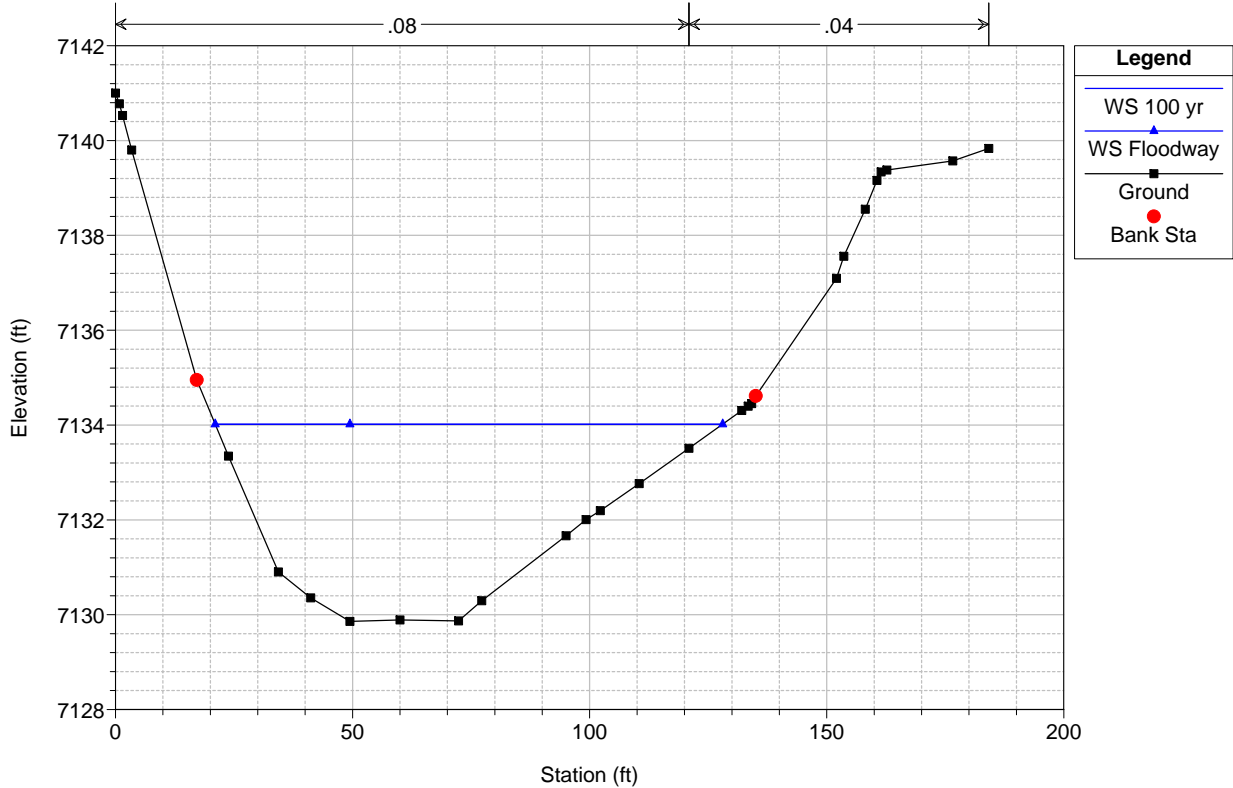

Lake Fork Dirty Woman Creek Plan: Proposed Floodway 3/9/2017
RS = 958

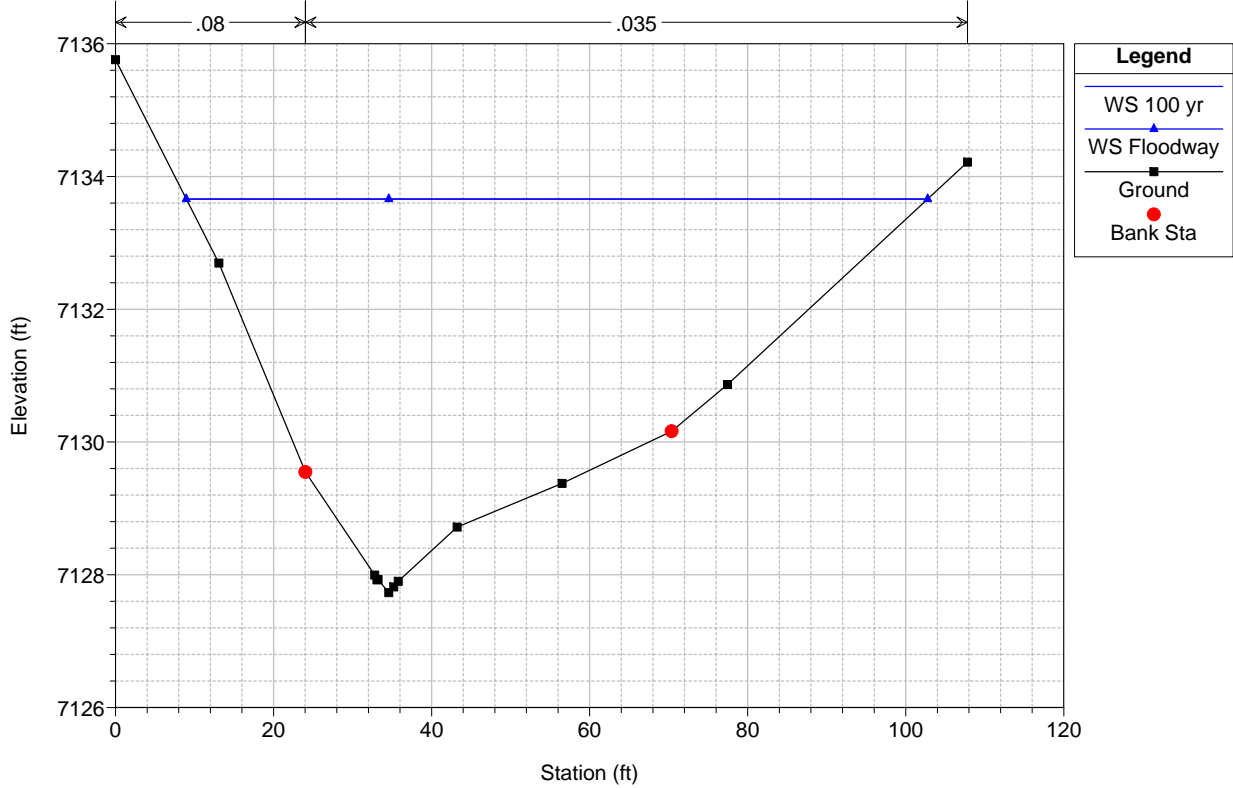

Lake Fork Dirty Woman Creek Plan: Proposed Floodway 3/9/2017
RS = 911

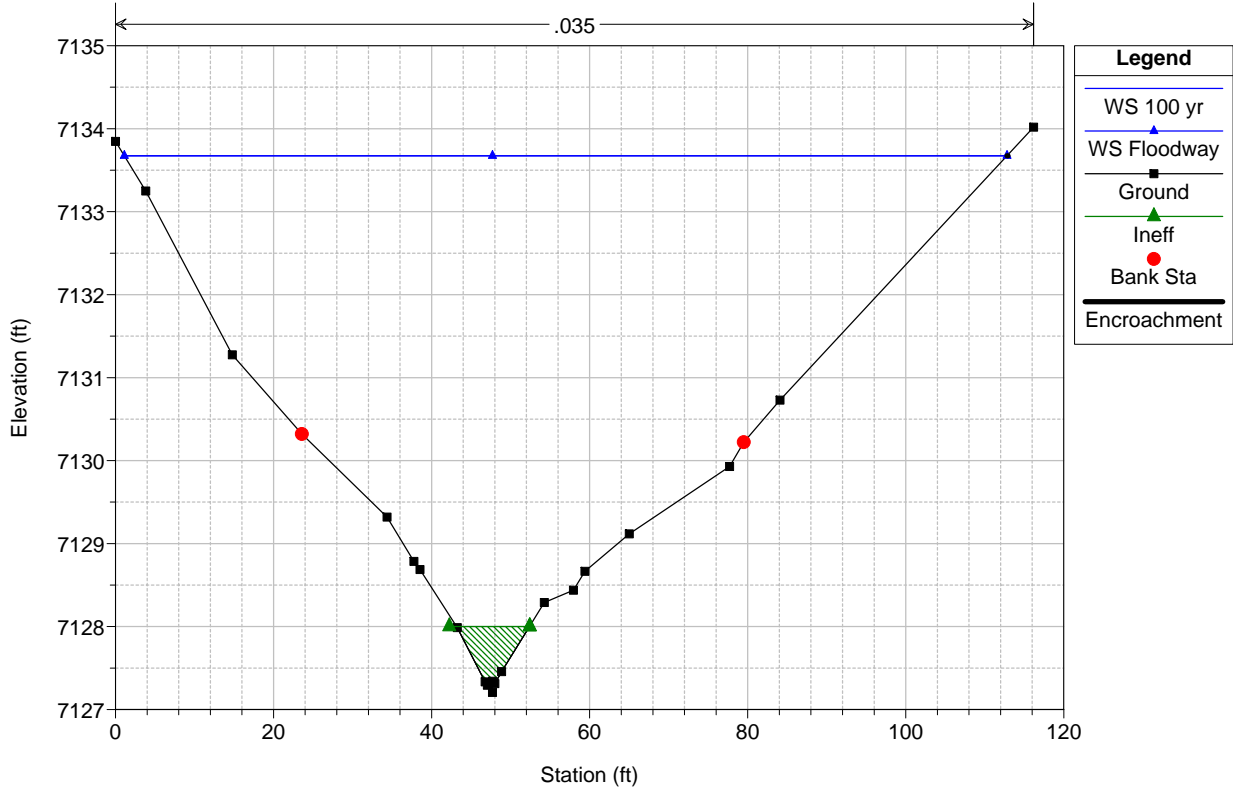

Lake Fork Dirty Woman Creek Plan: Proposed Floodway 3/9/2017

RS = 860

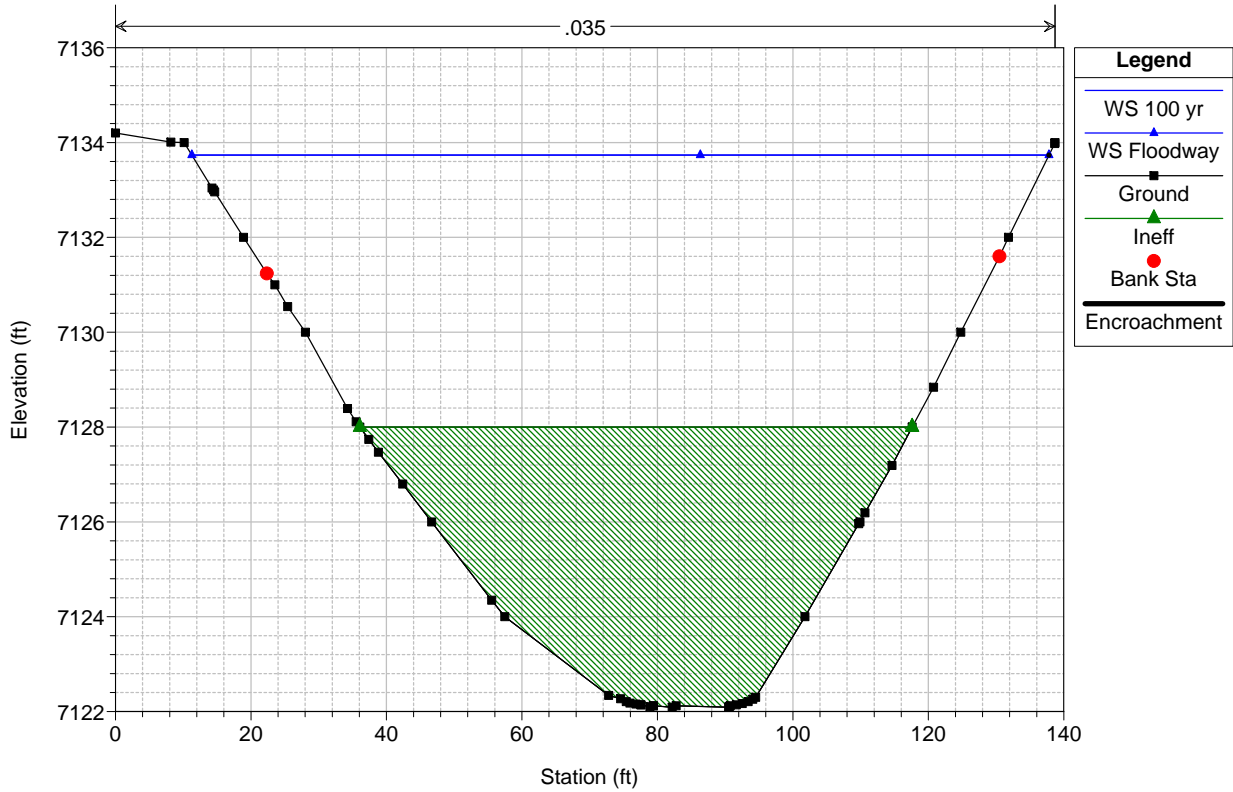

Lake Fork Dirty Woman Creek Plan: Proposed Floodway 3/9/2017

RS = 828

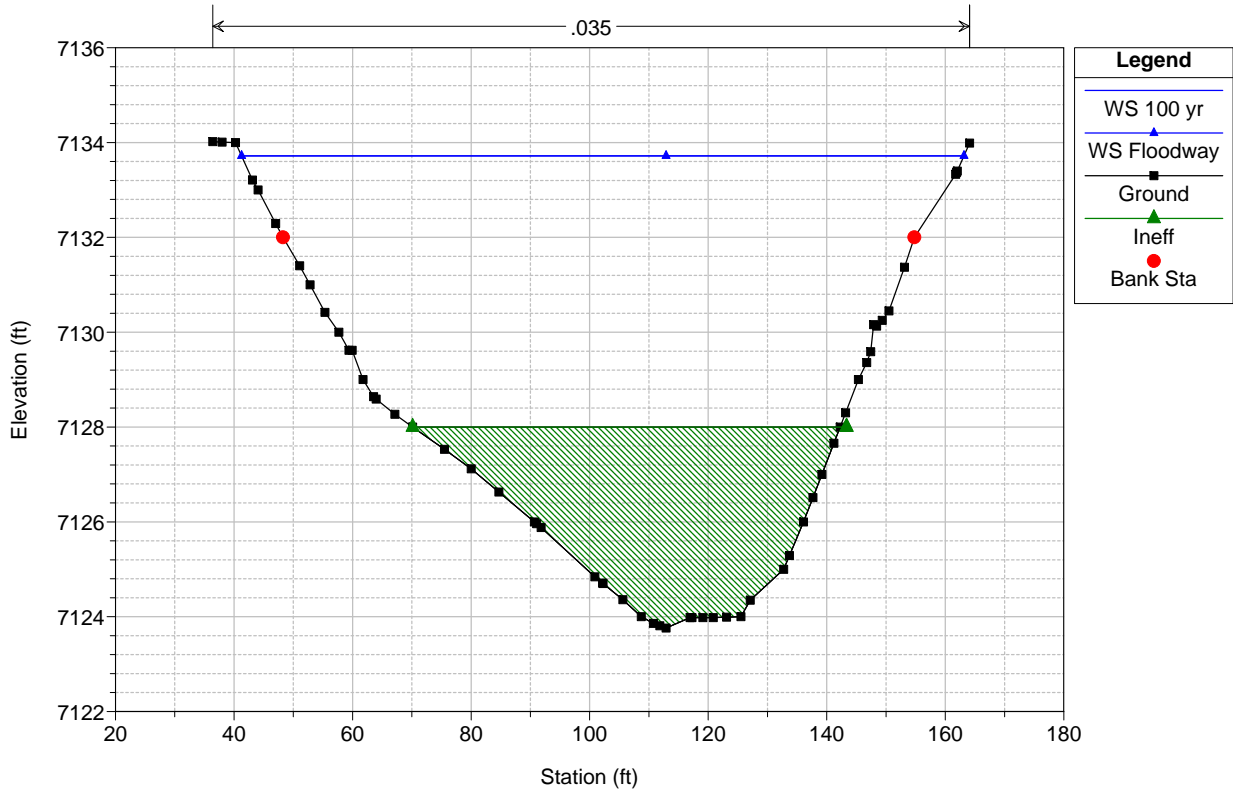

Lake Fork Dirty Woman Creek Plan: Proposed Floodway 3/9/2017

RS = 808

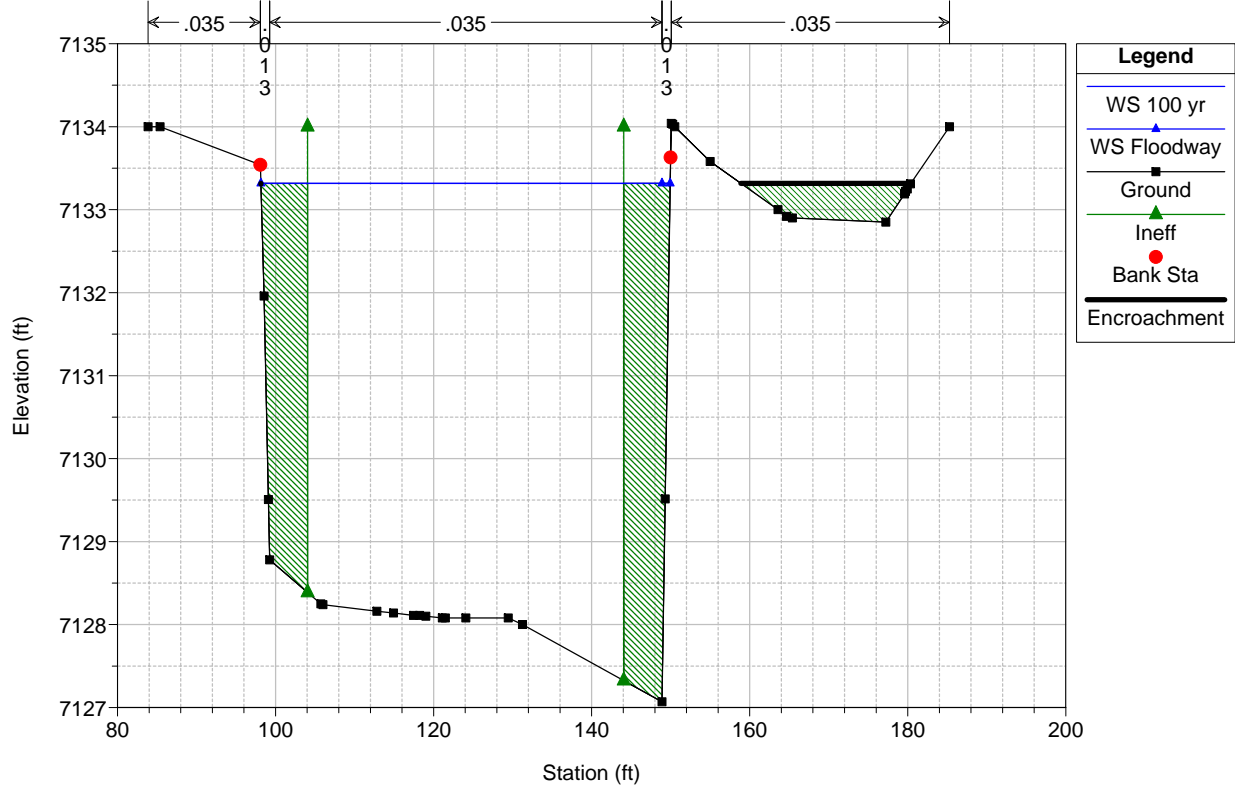

Lake Fork Dirty Woman Creek Plan: Proposed Floodway 3/9/2017

RS = 783 Culv

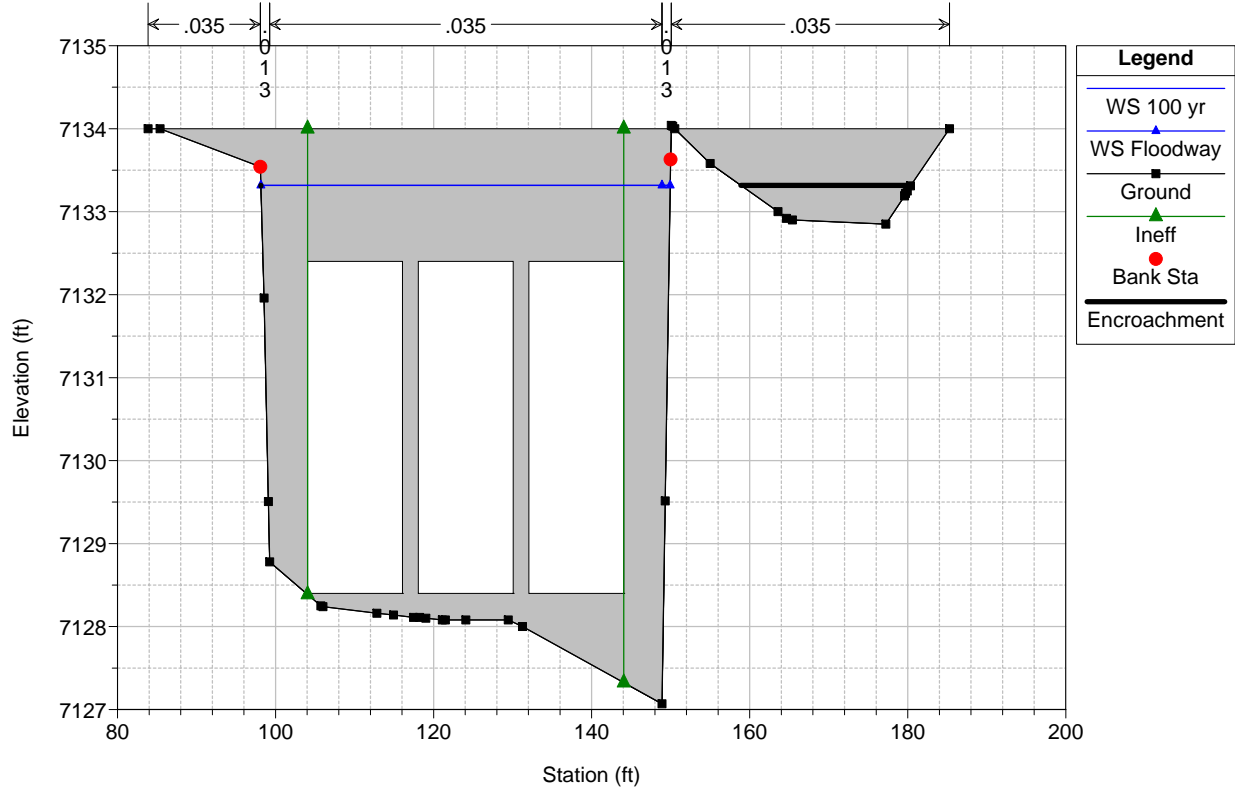

Lake Fork Dirty Woman Creek Plan: Proposed Floodway 3/9/2017

RS = 783 Culv

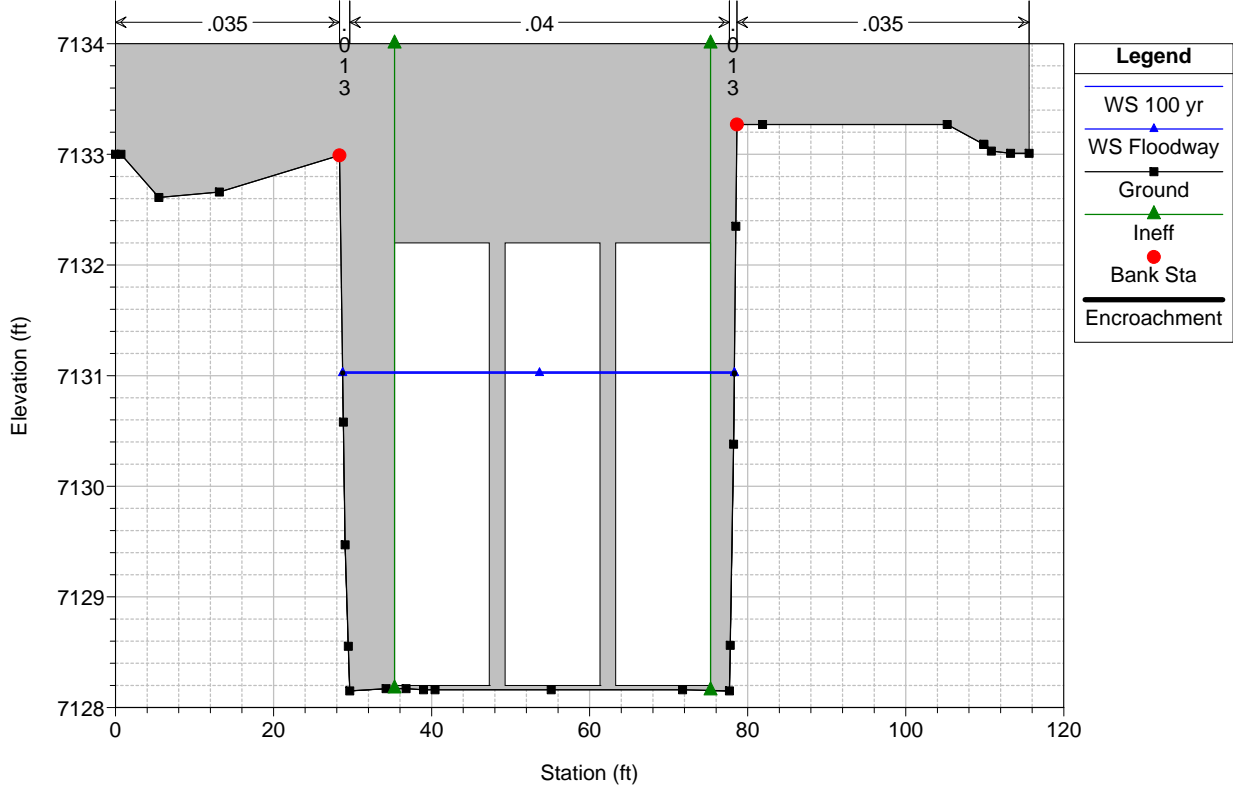

Lake Fork Dirty Woman Creek Plan: Proposed Floodway 3/9/2017

RS = 758

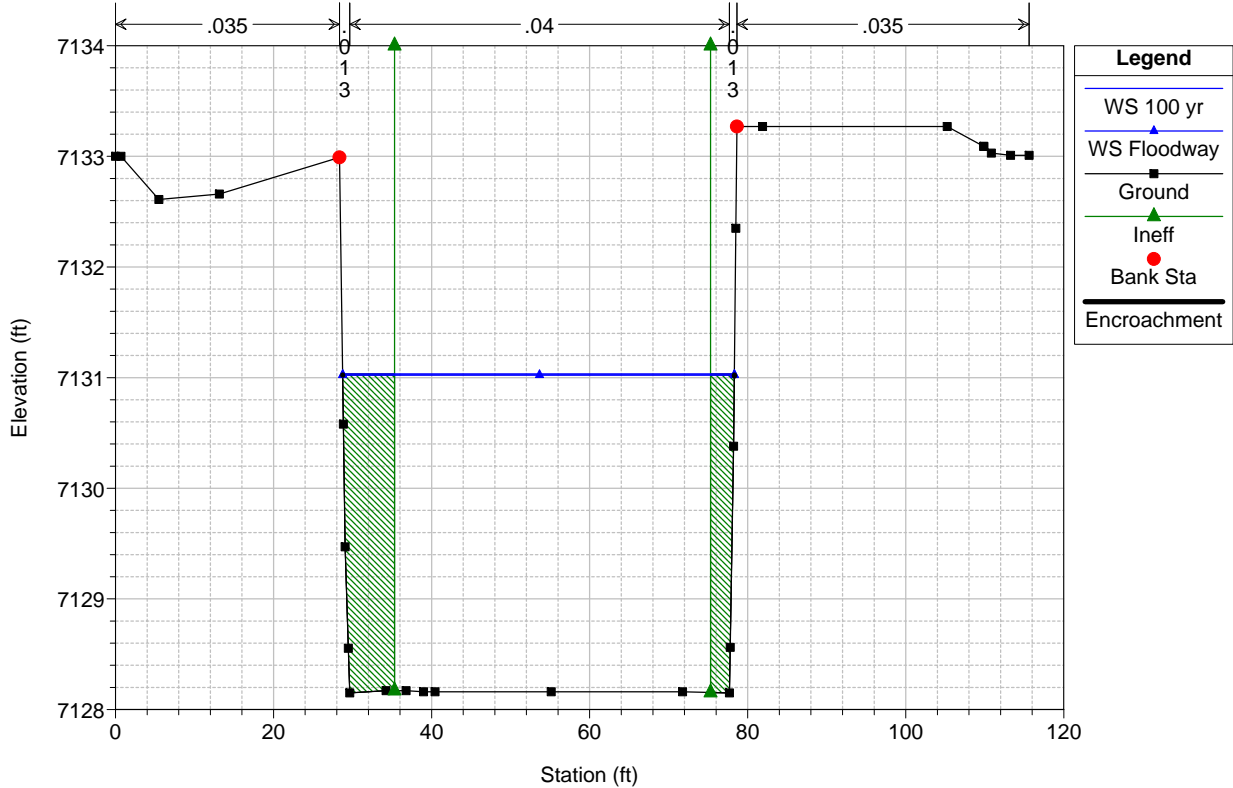

Lake Fork Dirty Woman Creek Plan: Proposed Floodway 3/9/2017
RS = 731

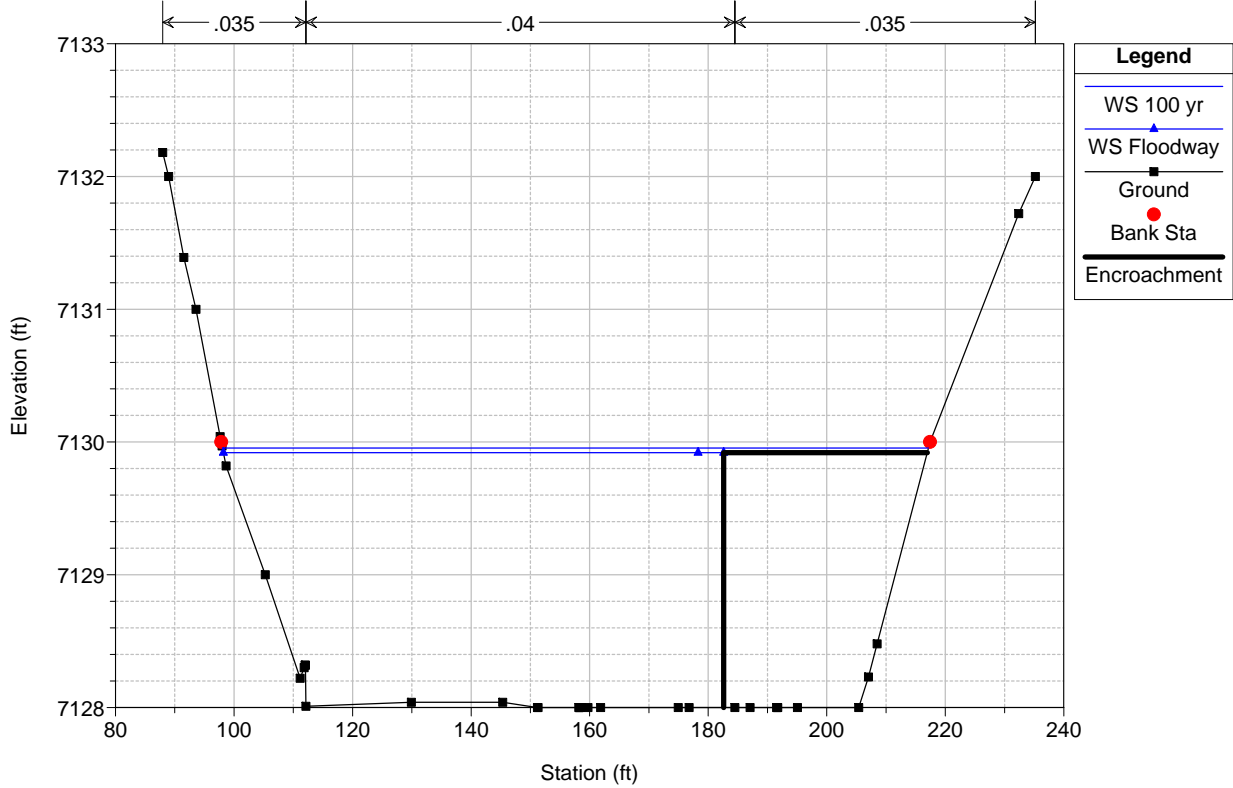

Lake Fork Dirty Woman Creek Plan: Proposed Floodway 3/9/2017
RS = 700

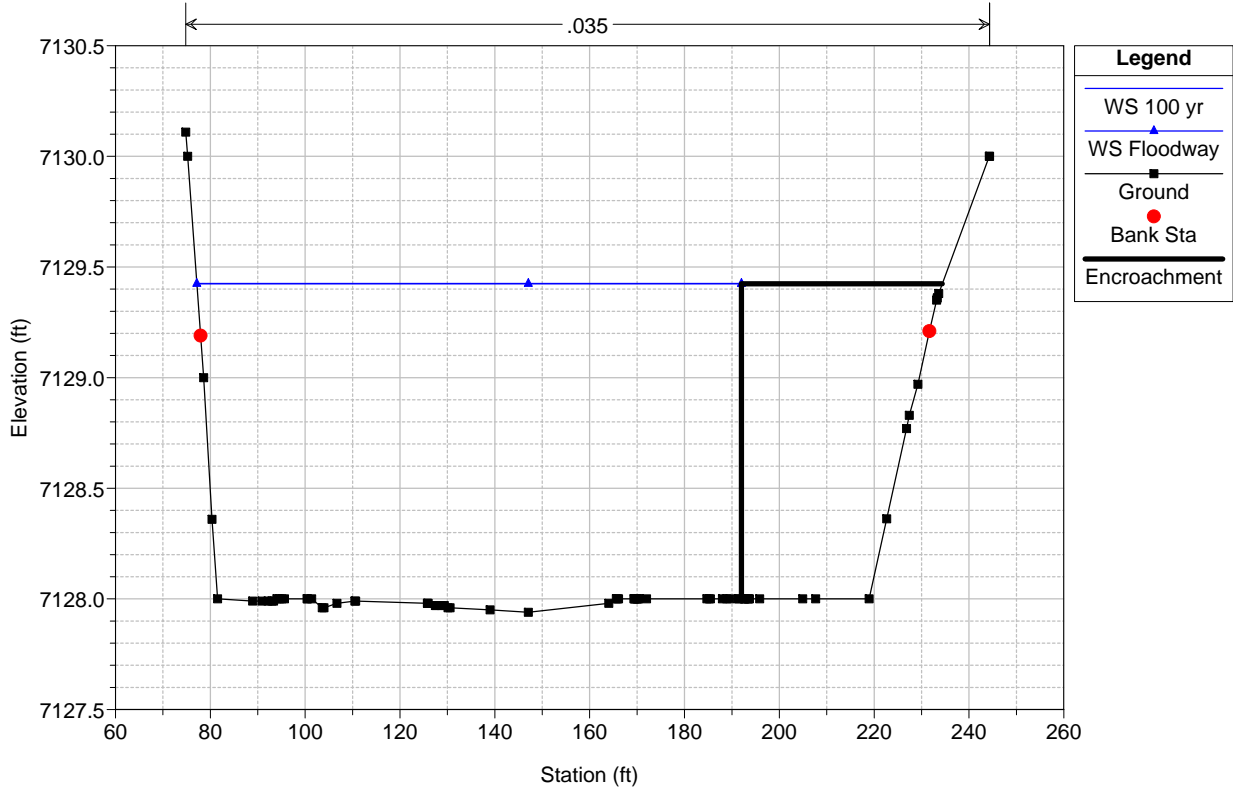

Lake Fork Dirty Woman Creek Plan: Proposed Floodway 3/9/2017

RS = 650

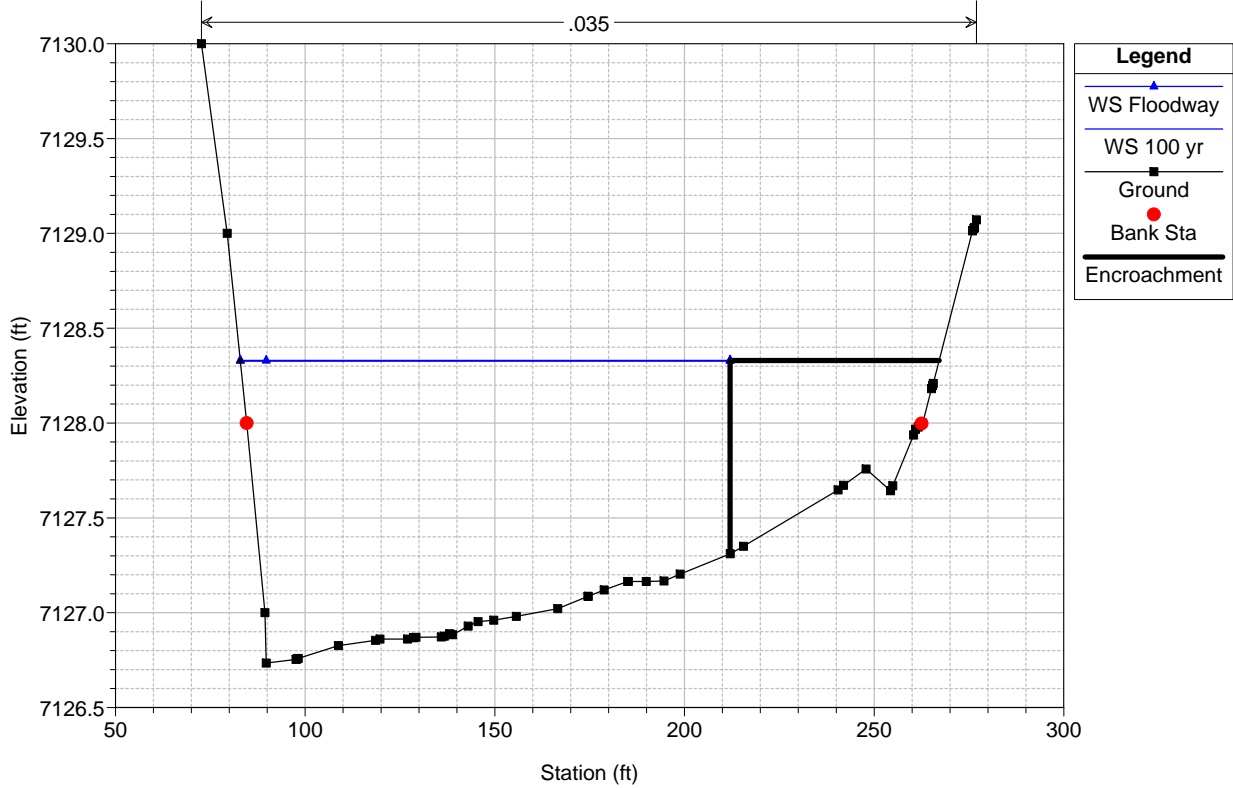

Lake Fork Dirty Woman Creek Plan: Proposed Floodway 3/9/2017

RS = 625

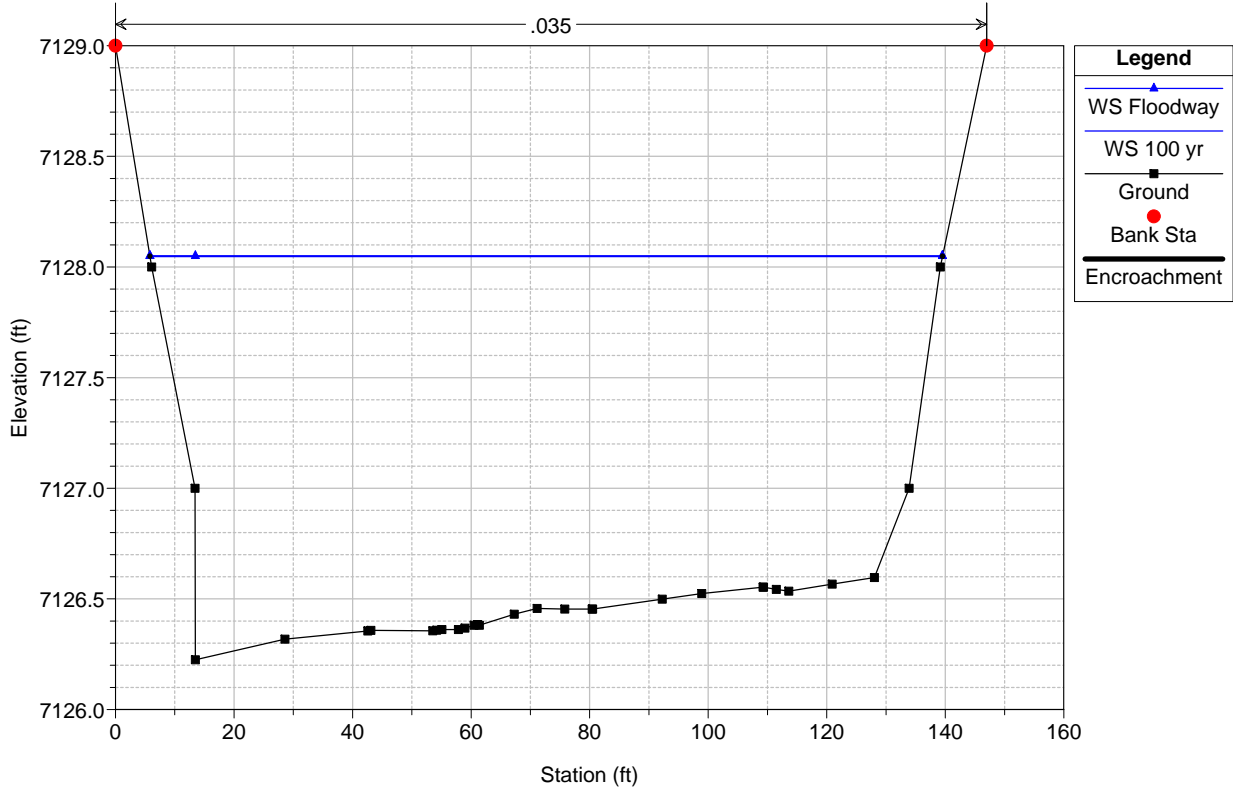

Lake Fork Dirty Woman Creek Plan: Proposed Floodway 3/9/2017
RS = 605

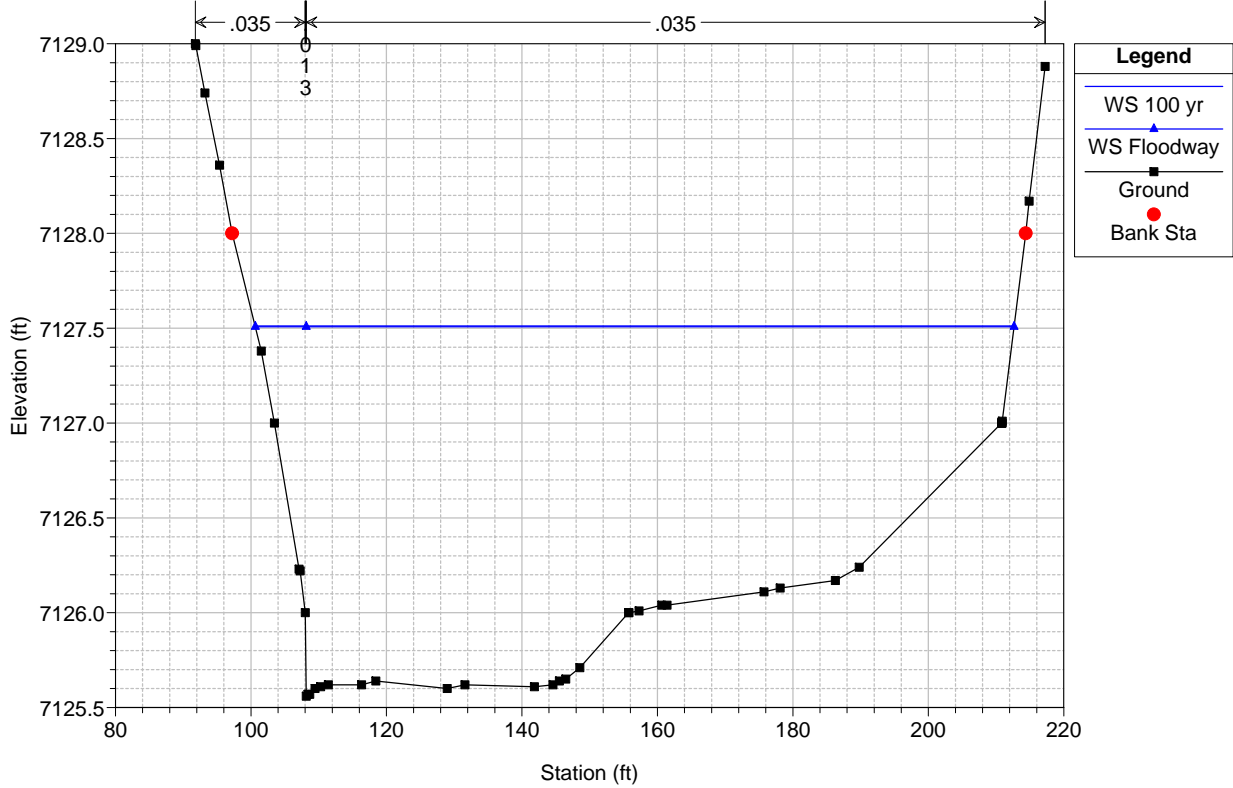

Lake Fork Dirty Woman Creek Plan: Proposed Floodway 3/9/2017
RS = 574

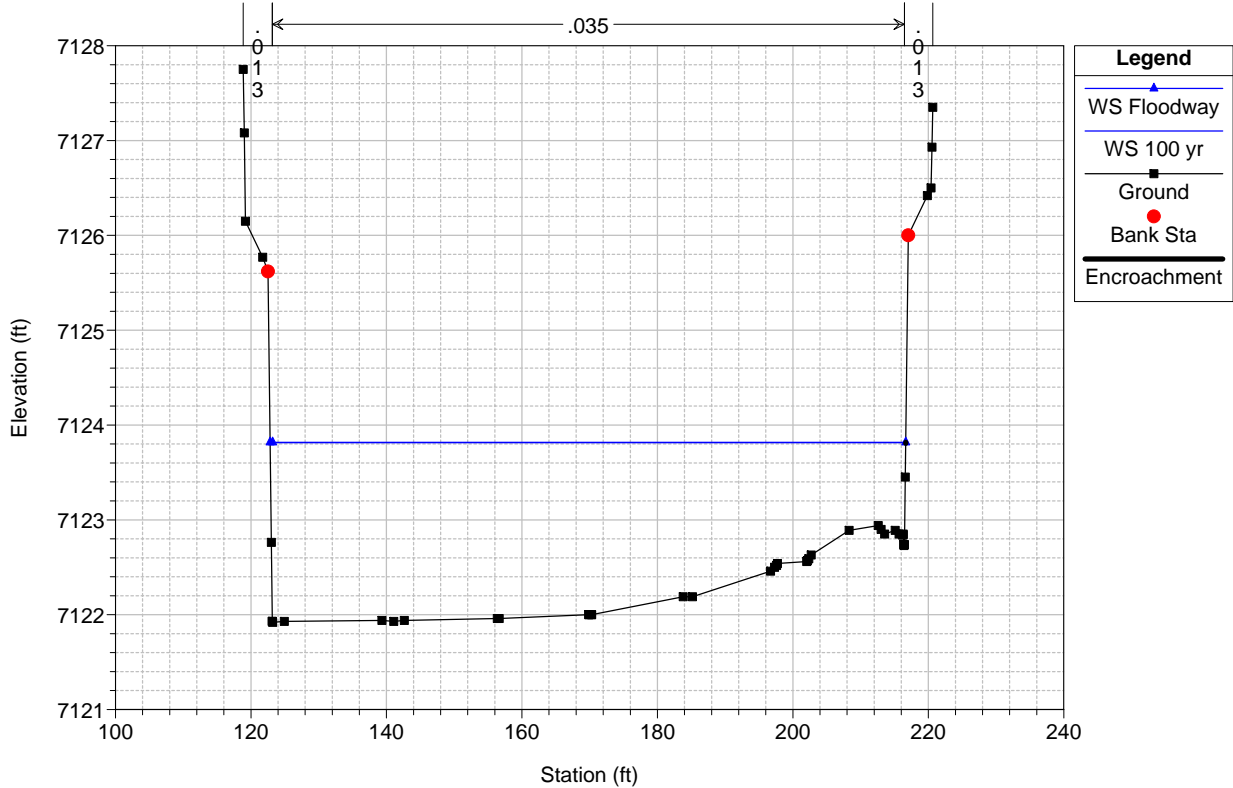

Lake Fork Dirty Woman Creek Plan: Proposed Floodway 3/9/2017

RS = 522

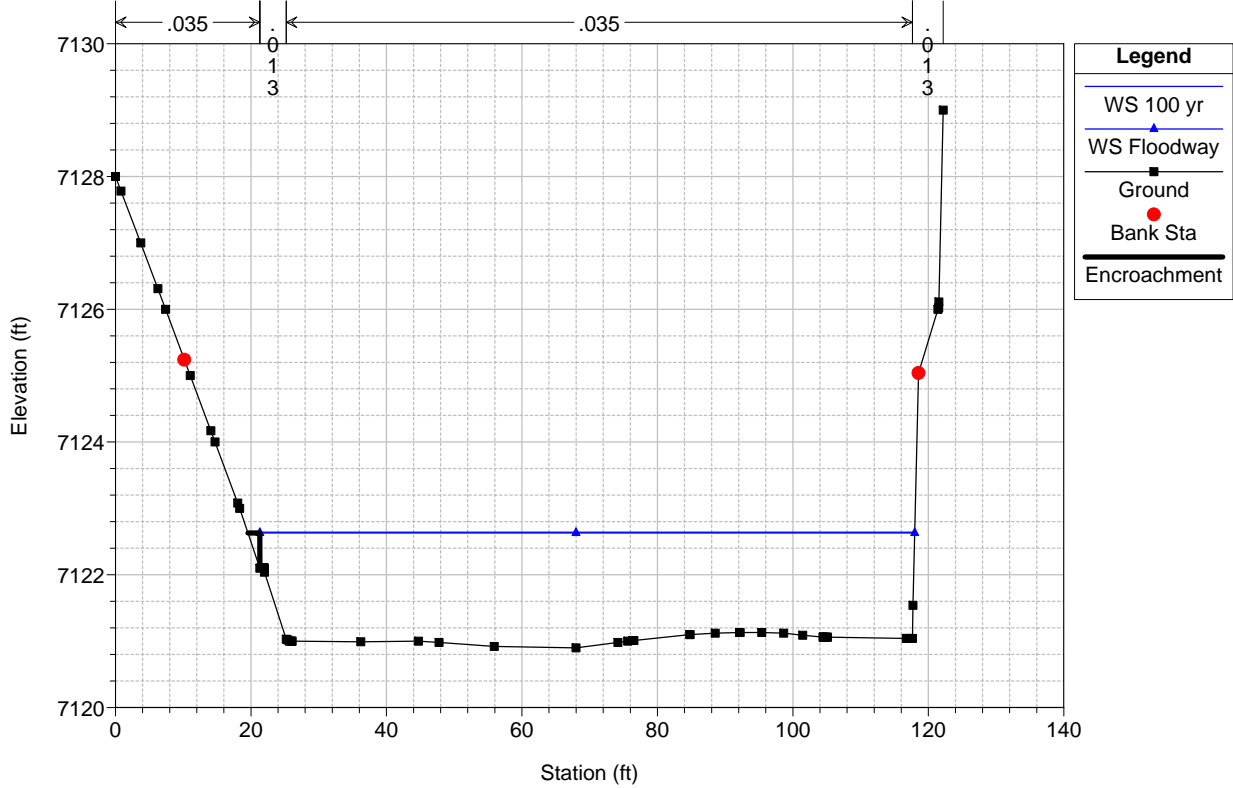

Lake Fork Dirty Woman Creek Plan: Proposed Floodway 3/9/2017

RS = 479

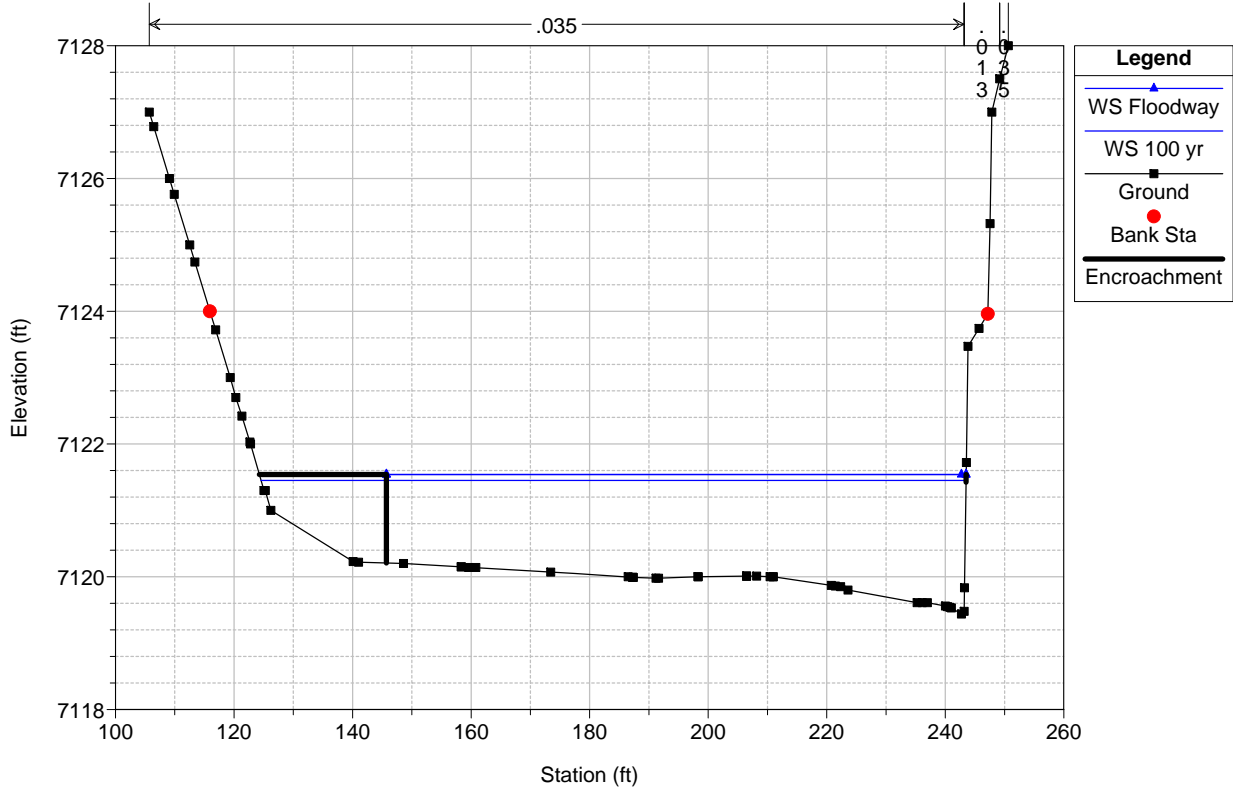

Lake Fork Dirty Woman Creek Plan: Proposed Floodway 3/9/2017
RS = 451

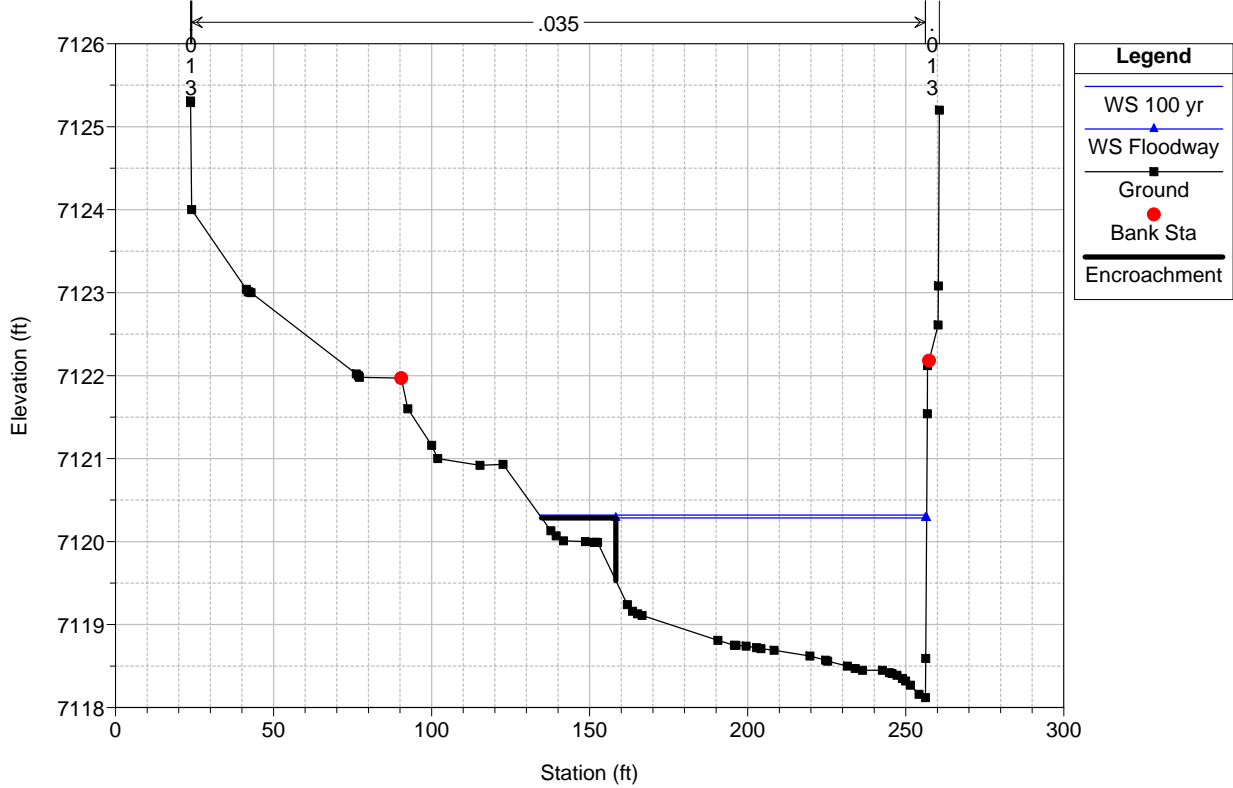

Lake Fork Dirty Woman Creek Plan: Proposed Floodway 3/9/2017
RS = 367

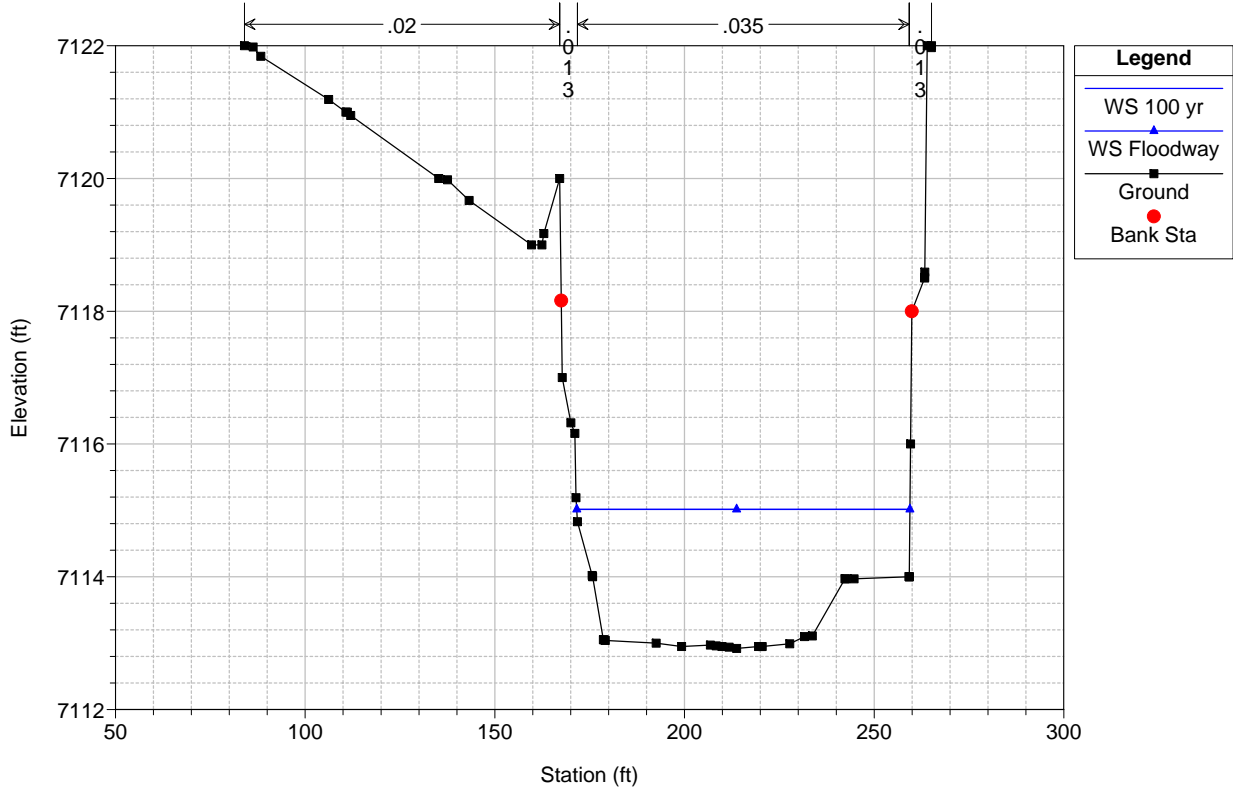

Lake Fork Dirty Woman Creek Plan: Proposed Floodway 3/9/2017
RS = 336

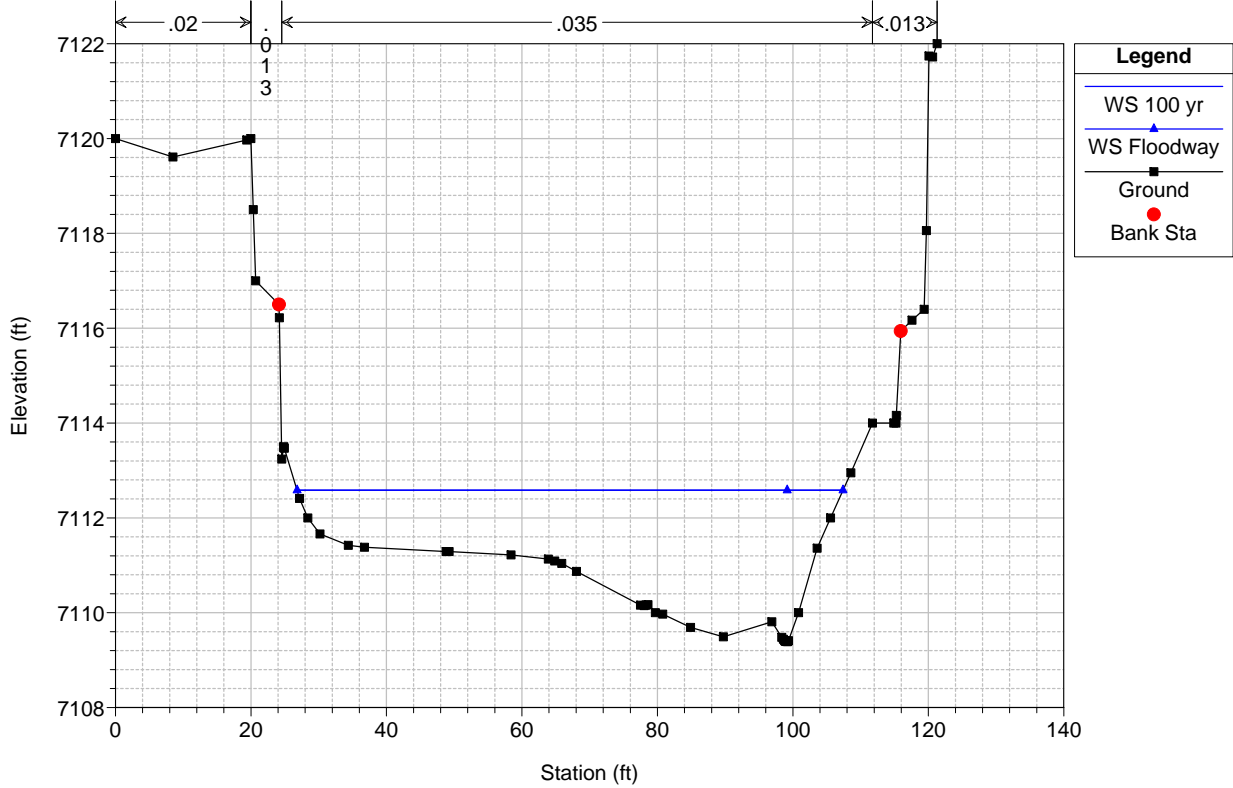

Lake Fork Dirty Woman Creek Plan: Proposed Floodway 3/9/2017
RS = 300

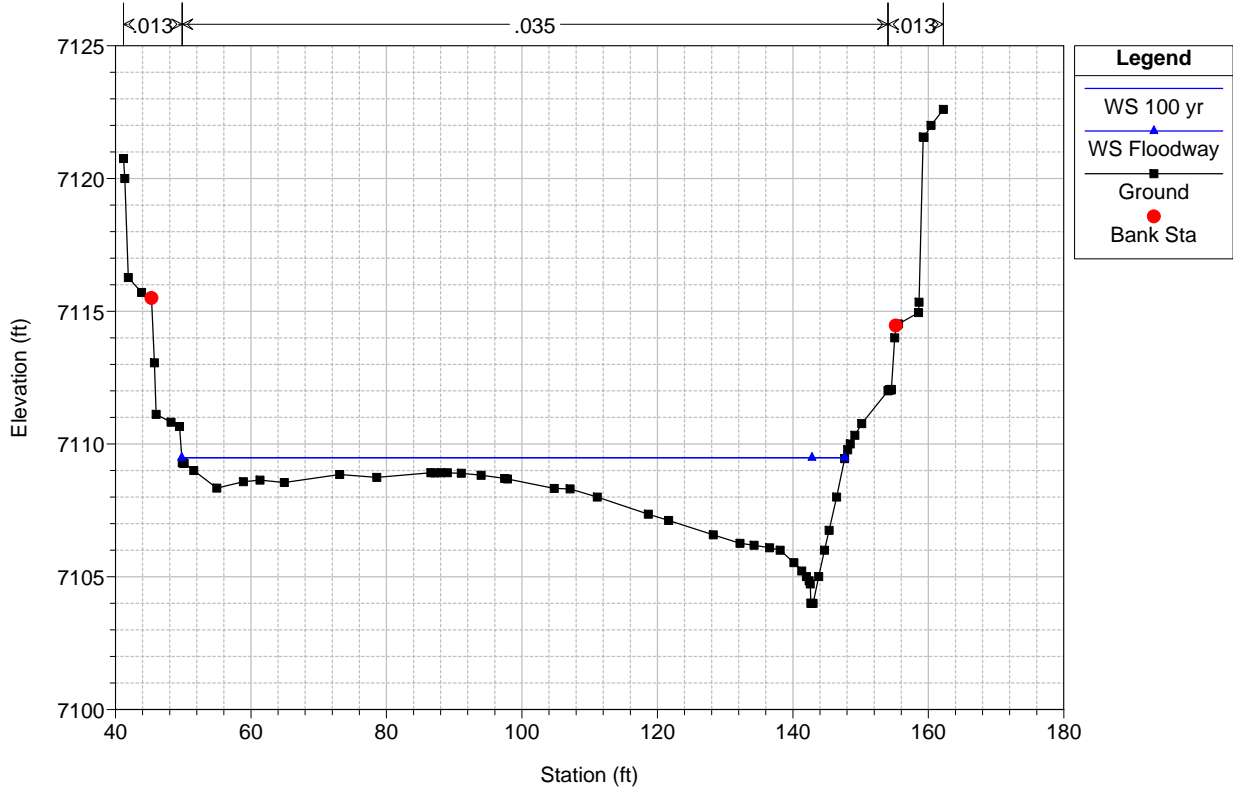

Lake Fork Dirty Woman Creek Plan: Proposed Floodway 3/9/2017
RS = 269

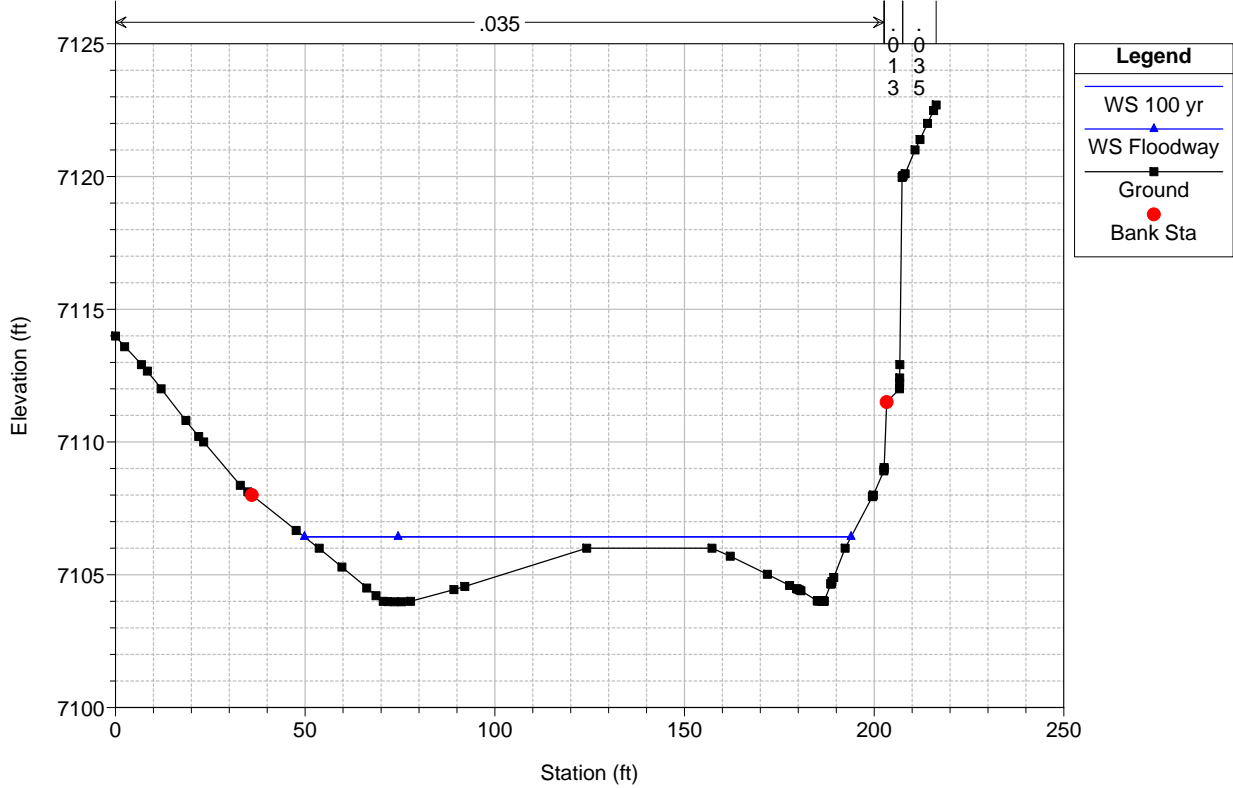

Lake Fork Dirty Woman Creek Plan: Proposed Floodway 3/9/2017
RS = 200

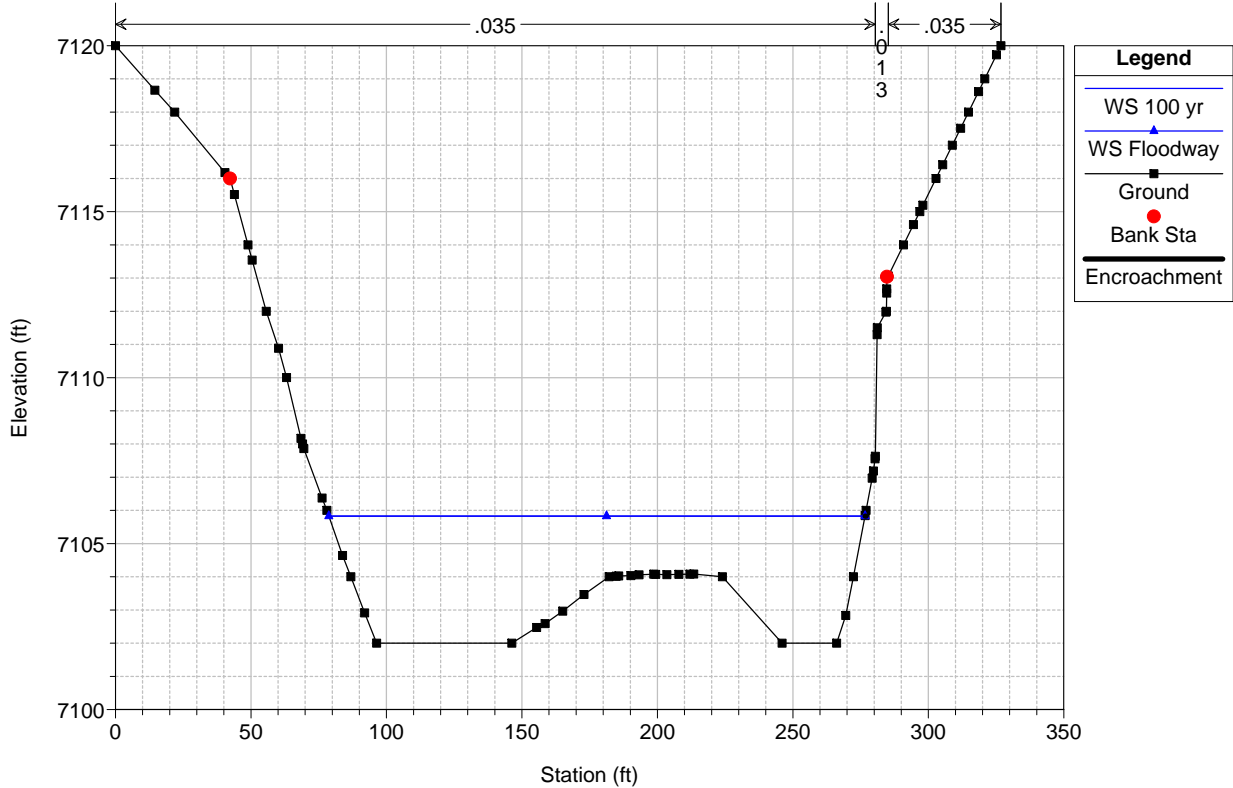

Lake Fork Dirty Woman Creek Plan: Proposed Floodway 3/9/2017

Dirty Woman Cree Lake Fork

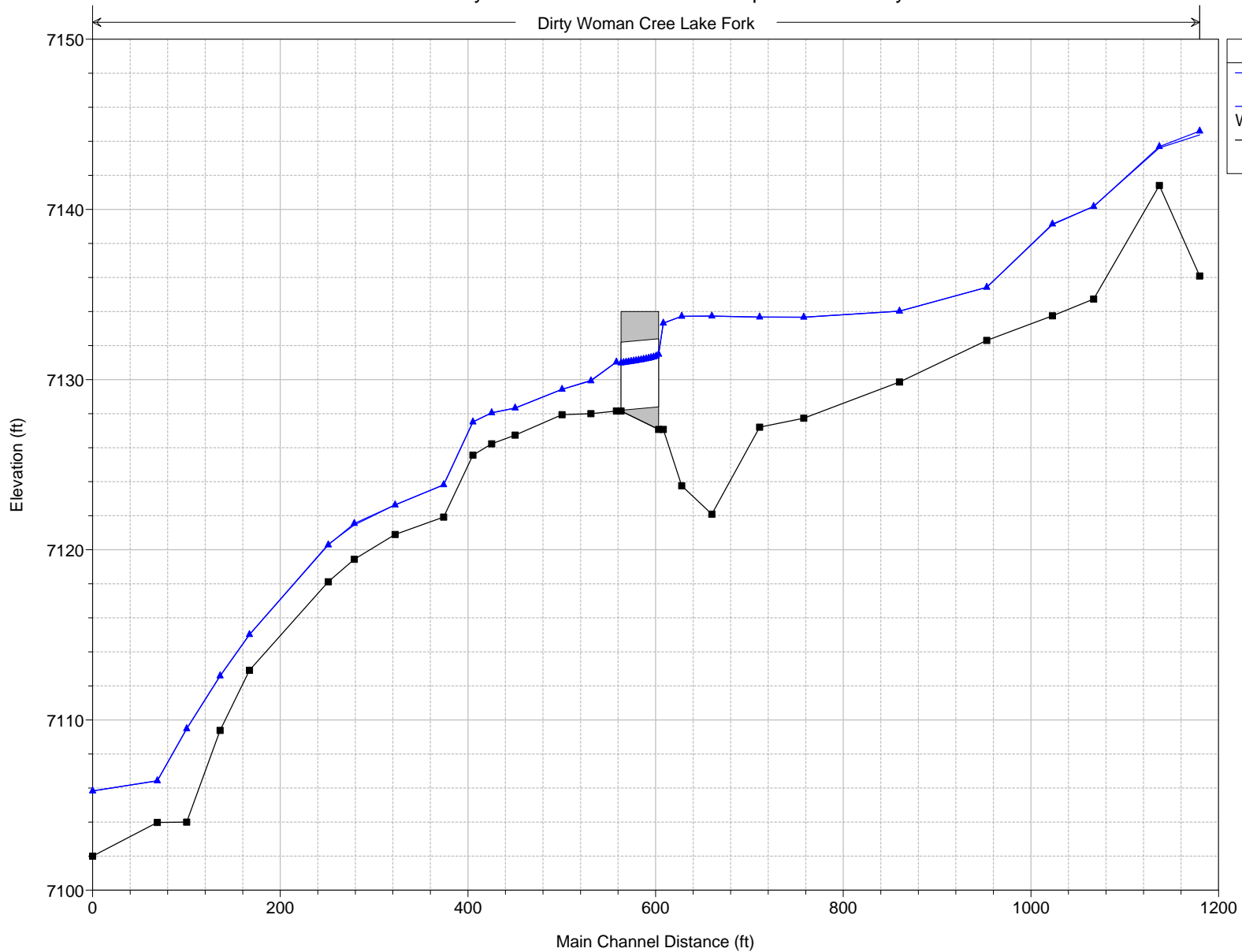

Legend

- WS 100 yr
- WS Floodway
- Ground

HEC-RAS Plan: Prop. Fldwy. River: Dirty Woman Cree Reach: Lake Fork

Reach	River Sta	Profile	Top Wdth Act (ft)	Area (sq ft)	Vel Total (ft/s)	W.S. Elev (ft)	Base WS (ft)	Prof Delta WS (ft)
Lake Fork	1380	100 yr	220.92	937.95	1.08	7144.37	7144.37	
Lake Fork	1380	Floodway	150.00	873.91	1.16	7144.60	7144.37	0.23
Lake Fork	1337	100 yr	109.89	151.20	6.72	7143.62	7143.62	
Lake Fork	1337	Floodway	83.63	138.23	7.35	7143.69	7143.62	0.08
Lake Fork	1267	100 yr	103.31	304.18	3.34	7140.18	7140.18	
Lake Fork	1267	Floodway	103.13	303.27	3.35	7140.17	7140.18	-0.01
Lake Fork	1223	100 yr	99.25	153.26	6.63	7139.10	7139.10	
Lake Fork	1223	Floodway	99.25	156.75	6.48	7139.14	7139.10	0.04
Lake Fork	1153	100 yr	85.85	162.67	6.25	7135.42	7135.42	
Lake Fork	1153	Floodway	85.85	162.67	6.25	7135.42	7135.42	0.00
Lake Fork	1060	100 yr	107.03	283.04	3.59	7134.02	7134.02	
Lake Fork	1060	Floodway	107.03	283.04	3.59	7134.02	7134.02	0.00
Lake Fork	958	100 yr	93.83	302.72	3.66	7133.66	7133.66	
Lake Fork	958	Floodway	93.83	302.72	3.66	7133.66	7133.66	0.00
Lake Fork	911	100 yr	111.70	363.36	3.08	7133.67	7133.67	
Lake Fork	911	Floodway	111.70	363.37	3.08	7133.67	7133.67	0.00
Lake Fork	860	100 yr	126.53	907.93	1.86	7133.73	7133.73	
Lake Fork	860	Floodway	126.53	907.93	1.86	7133.73	7133.73	0.00
Lake Fork	828	100 yr	121.89	742.10	1.98	7133.72	7133.72	
Lake Fork	828	Floodway	121.89	742.10	1.98	7133.72	7133.72	0.00
Lake Fork	808	100 yr	40.00	278.70	5.19	7133.32	7133.32	
Lake Fork	808	Floodway	40.00	271.28	5.19	7133.32	7133.32	0.00
Lake Fork	783		Culvert					
Lake Fork	758	100 yr	40.00	140.61	9.63	7131.03	7131.03	
Lake Fork	758	Floodway	40.00	140.10	9.67	7131.02	7131.03	-0.01
Lake Fork	731	100 yr	119.13	206.07	5.37	7129.96	7129.96	
Lake Fork	731	Floodway	84.40	146.84	7.54	7129.92	7129.96	-0.03
Lake Fork	700	100 yr	157.24	211.78	6.16	7129.43	7129.43	
Lake Fork	700	Floodway	114.84	162.59	6.81	7129.42	7129.43	0.00
Lake Fork	650	100 yr	129.08	206.45	6.56	7128.33	7128.33	
Lake Fork	650	Floodway	129.08	169.36	6.54	7128.33	7128.33	0.00
Lake Fork	625	100 yr	133.70	199.70	5.54	7128.05	7128.05	
Lake Fork	625	Floodway	133.71	200.10	5.53	7128.05	7128.05	0.00
Lake Fork	605	100 yr	112.05	161.11	6.87	7127.51	7127.51	
Lake Fork	605	Floodway	112.00	160.56	6.89	7127.51	7127.51	0.00
Lake Fork	574	100 yr	93.84	151.85	7.29	7123.81	7123.81	
Lake Fork	574	Floodway	93.84	152.21	7.27	7123.82	7123.81	0.00

HEC-RAS Plan: Prop. Fldwy. River: Dirty Woman Cree Reach: Lake Fork (Continued)

Reach	River Sta	Profile	Top Wdth Act (ft)	Area (sq ft)	Vel Total (ft/s)	W.S. Elev (ft)	Base WS (ft)	Prof Delta WS (ft)
Lake Fork	522	100 yr	98.46	154.99	7.14	7122.64	7122.64	
Lake Fork	522	Floodway	96.69	153.47	7.21	7122.63	7122.64	-0.01
Lake Fork	479	100 yr	118.96	164.46	6.73	7121.45	7121.45	
Lake Fork	479	Floodway	97.80	154.18	7.18	7121.54	7121.45	0.09
Lake Fork	451	100 yr	122.44	165.54	6.69	7120.32	7120.32	
Lake Fork	451	Floodway	98.29	154.16	7.18	7120.29	7120.32	-0.03
Lake Fork	367	100 yr	87.84	148.72	7.44	7115.02	7115.02	
Lake Fork	367	Floodway	87.84	148.72	7.44	7115.02	7115.02	0.00
Lake Fork	336	100 yr	80.61	145.10	7.63	7112.59	7112.59	
Lake Fork	336	Floodway	80.60	144.94	7.64	7112.58	7112.59	0.00
Lake Fork	300	100 yr	97.89	152.61	7.25	7109.48	7109.48	
Lake Fork	300	Floodway	97.89	152.61	7.25	7109.48	7109.48	0.00
Lake Fork	269	100 yr	144.11	174.98	6.33	7106.43	7106.43	
Lake Fork	269	Floodway	144.10	174.84	6.33	7106.43	7106.43	0.00
Lake Fork	200	100 yr	197.90	564.64	1.96	7105.83	7105.83	
Lake Fork	200	Floodway	197.90	564.54	1.96	7105.83	7105.83	0.00

HEC-RAS Plan: Proposed River: Dirty Woman Cree Reach: Lake Fork Profile: 100 yr

Reach	River Sta	Profile	Q Total (cfs)	Min Ch El (ft)	W.S. Elev (ft)	Crit W.S. (ft)	E.G. Elev (ft)	E.G. Slope (ft/ft)	Vel Chnl (ft/s)	Flow Area (sq ft)	Top Width (ft)	Froude # Chl	Shear Total (lb/sq ft)
Lake Fork	1380	100 yr	1016.00	7136.09	7144.37	7138.96	7144.39	0.000074	1.15	937.95	220.92	0.09	0.02
Lake Fork	1337	100 yr	1016.00	7141.41	7143.62	7143.62	7144.32	0.005353	6.72	151.20	109.89	1.01	0.46
Lake Fork	1267	100 yr	1016.00	7134.73	7140.18	7137.82	7140.36	0.004820	3.50	304.18	103.31	0.29	0.88
Lake Fork	1223	100 yr	1016.00	7133.74	7139.10	7139.10	7139.84	0.035504	7.10	153.26	99.25	0.72	3.35
Lake Fork	1153	100 yr	1016.00	7132.30	7135.42	7135.10	7136.03	0.046984	6.25	162.67	85.85	0.80	5.53
Lake Fork	1060	100 yr	1016.00	7129.86	7134.02	7132.41	7134.22	0.009537	3.59	283.04	107.03	0.39	1.57
Lake Fork	958	100 yr	1107.00	7127.73	7133.66	7131.64	7133.92	0.001382	4.38	302.72	93.83	0.36	0.28
Lake Fork	911	100 yr	1107.00	7127.21	7133.67	7131.35	7133.85	0.000899	3.54	359.80	111.70	0.29	0.18
Lake Fork	860	100 yr	1107.00	7122.09	7133.73	7129.73	7133.79	0.000222	1.90	596.25	126.53	0.15	0.06
Lake Fork	828	100 yr	1107.00	7123.76	7133.72	7129.82	7133.78	0.000259	2.01	560.46	121.89	0.16	0.07
Lake Fork	808	100 yr	1107.00	7127.07	7133.32	7130.85	7133.74	0.001605	5.19	213.33	73.31	0.40	0.53
Lake Fork	783		Culvert										
Lake Fork	758	100 yr	1107.00	7128.15	7131.03	7131.03	7132.47	0.016450	9.63	114.95	49.58	1.00	2.95
Lake Fork	731	100 yr	1107.00	7128.00	7129.96	7129.59	7130.40	0.008974	5.37	206.07	119.13	0.72	0.96
Lake Fork	700	100 yr	1107.00	7127.94	7129.43	7129.43	7130.02	0.017239	6.17	179.68	157.24	1.01	1.23
Lake Fork	650	100 yr	1107.00	7126.74	7128.33	7128.33	7129.00	0.016489	6.56	168.85	184.18	1.01	1.34
Lake Fork	625	100 yr	1107.00	7126.23	7128.05	7127.82	7128.52	0.010075	5.54	199.70	133.70	0.80	0.93
Lake Fork	605	100 yr	1107.00	7125.56	7127.51	7127.51	7128.25	0.016182	6.87	161.11	112.05	1.01	1.45
Lake Fork	574	100 yr	1107.00	7121.92	7123.81	7123.81	7124.64	0.015585	7.29	151.85	93.84	1.01	1.53
Lake Fork	522	100 yr	1107.00	7120.90	7122.64	7122.64	7123.43	0.014863	7.14	154.99	98.46	1.00	1.44
Lake Fork	479	100 yr	1107.00	7119.44	7121.45	7121.45	7122.16	0.016360	6.73	164.46	118.96	1.01	1.39
Lake Fork	451	100 yr	1107.00	7118.12	7120.32	7120.32	7121.01	0.016629	6.69	165.54	122.44	1.01	1.38
Lake Fork	367	100 yr	1107.00	7112.92	7115.02	7115.02	7115.88	0.015283	7.44	148.72	87.84	1.01	1.59
Lake Fork	336	100 yr	1107.00	7109.39	7112.59	7112.59	7113.49	0.014964	7.63	145.10	80.61	1.00	1.66
Lake Fork	300	100 yr	1107.00	7104.00	7109.48	7109.48	7110.30	0.016936	7.25	152.61	97.89	1.02	1.59
Lake Fork	269	100 yr	1107.00	7103.98	7106.43	7106.43	7107.05	0.017247	6.33	174.98	144.11	1.01	1.30
Lake Fork	200	100 yr	1107.00	7102.00	7105.83	7103.67	7105.89	0.000531	1.96	564.93	197.91	0.20	0.09

**North Bay at Lake Woodmoor
Superelevation Calculation**

Station	Description	Straight or Curved Section	Flow Velocity	For Curved Sections		Superelevation (dY)	100yr W.S. Elev.	100yr W.S. Elev. +dY	Deer Creek Rd. EOA Elev.	Freeboard
				rc	T					
7+31	Lake Fork Dirty Woman Creek	Curve	5.4ft/sec	200ft	119ft	0.27ft	7129.96	7130.23	7131.4	1.17 ft
7+00	Lake Fork Dirty Woman Creek	Curve	6.2ft/sec	200ft	157ft	0.46ft	7129.43	7129.89	7130.1	0.21 ft
6+50	Lake Fork Dirty Woman Creek	Curve	6.6ft/sec	200ft	184ft	0.61ft	7128.33	7128.94	7129.9	0.96 ft

OK
OK
OK

Superelevation (dY) = $V^2T/2gr_c$ (Eqn UDFCD MD-9)

V = Mean channel flow velocity

T = Top Width of the channel under design flow conditions (Q100=1,107 cfs)

g = Gravitational constant = 32.2 ft/sec²

r_c = channel centerline radius

Lake Fork Dirty Woman Creek Plan: Proposed 3/9/2017

RS = 731

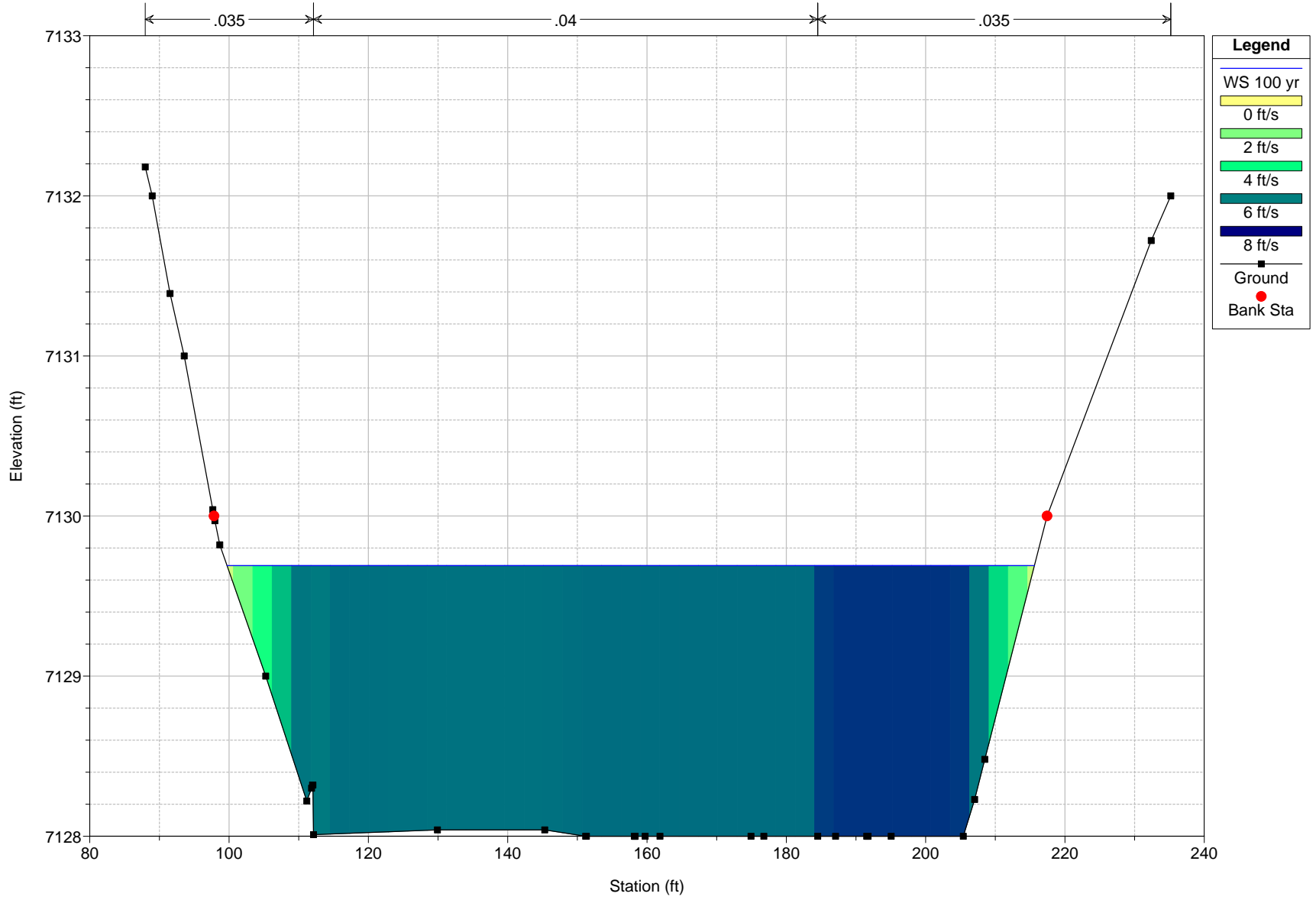

Lake Fork Dirty Woman Creek Plan: Proposed 3/9/2017

RS = 700

.035

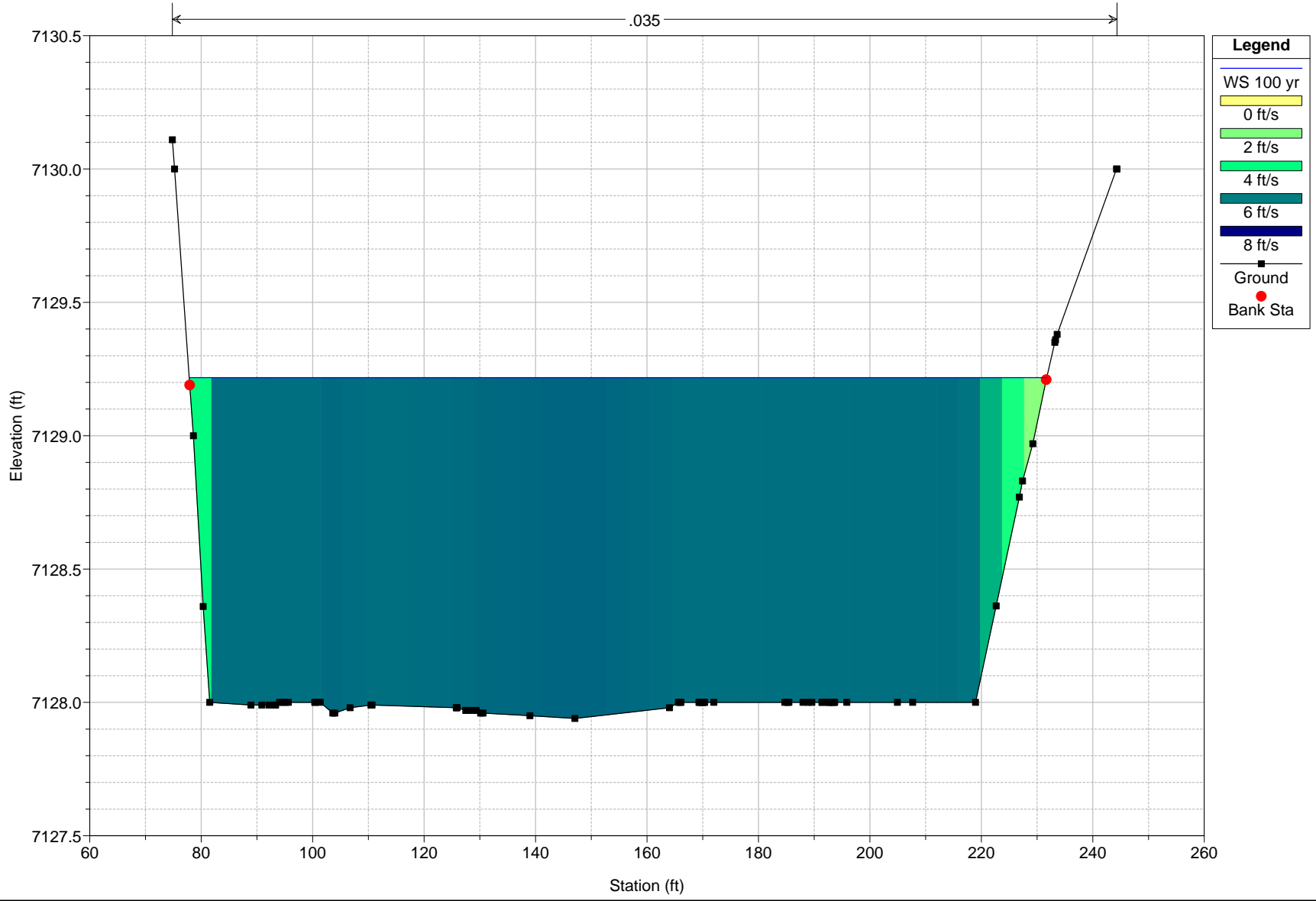

Lake Fork Dirty Woman Creek Plan: Proposed 3/9/2017

RS = 650

.035

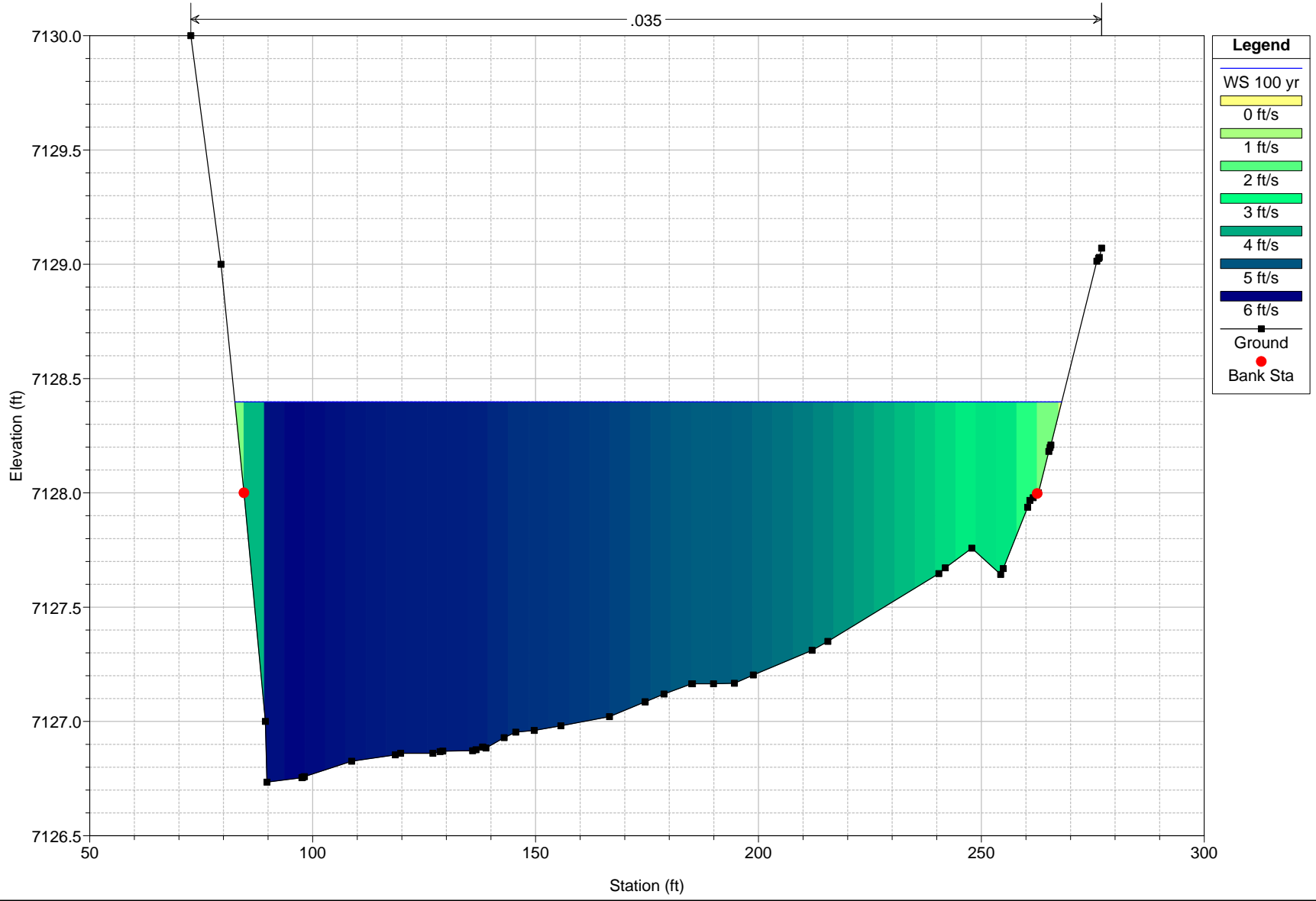

Apply Data + [icon]
[dropdown] [down] [up]
[dropdown] [down] [up] [dots]
een: 50.01 (ft)

Culvert Data Editor

Add ... Copy Delete ... Culvert ID: Culvert #1

Solution Criteria: Highest U.S. EG Rename ... [down] [up]

Shape: Box Span: 12 Rise: 4

Chart #: 8 - flared wingwalls

Scale #: 1 - Wingwall flared 30 to 75 deg.

Distance to Upstrm XS: 5 Upstream Invert Elev: 7128.4

Culvert Length: 40 Downstream Invert Elev: 7128.2

Entrance Loss Coeff: 0.4 [?] # identical barrels: 3

Exit Loss Coeff: 1

Manning's n for Top: 0.013 [?]

Manning's n for Bottom: 0.013

Depth to use Bottom n: 0

Depth Blocked: 0

Centerline Stations		
	Upstream	Downstream
1	110.06	41.3
2	124.06	55.3
3	138.06	69.3
4		

OK Cancel Help

Select culvert to edit

RS=783 Upstream (Culvert)

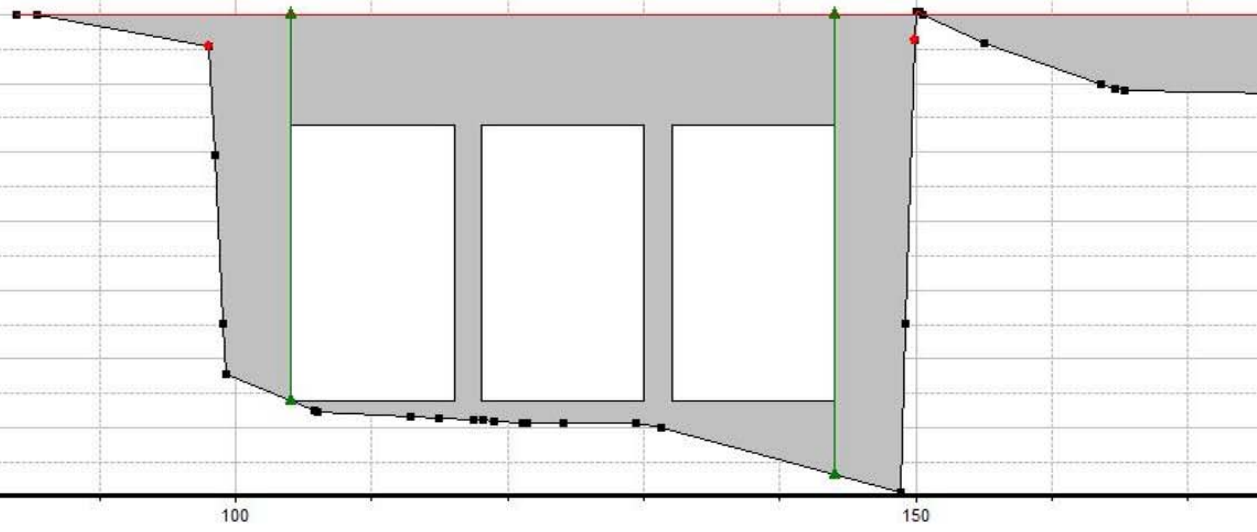

RS=783 Downstream (Culvert)



APPENDIX F

Referenced Information

Excerpts from Dirty Woman and Crystal Creeks Drainage Basin Planning Study
FEMA Letter of Map Change for Lake Fork Dirty Woman Creek LOMR
CLOMR Approval Letter from FEMA
Woodmoor Water and Sanitation District Letter
Open Channel Criteria

THIS DRAWING IS A MASTER PLANNING SHEET REPRESENTING PRELIMINARY AND CONCEPTUAL DESIGN ENGINEERING. ALL DRAINAGE FACILITIES SHOWN ARE FOR PLANNING PURPOSES ONLY AND SHOULD NOT BE USED AS THE FINAL DESIGN OR FOR CONSTRUCTION.

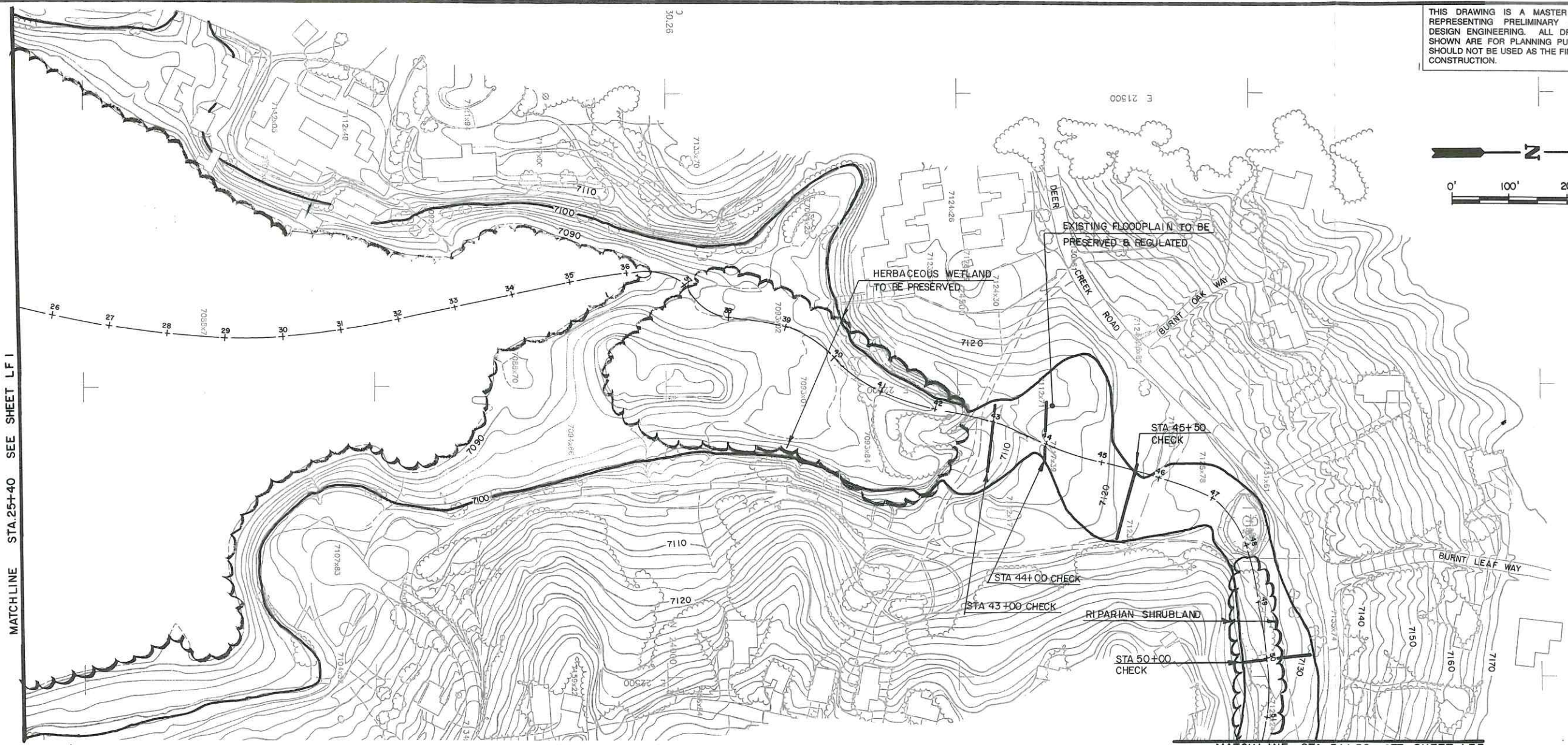
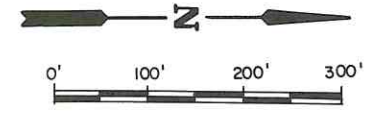

MATCHLINE STA. 25+40 SEE SHEET LF 1

MATCHLINE STA. 51+50 SEE SHEET LF 3

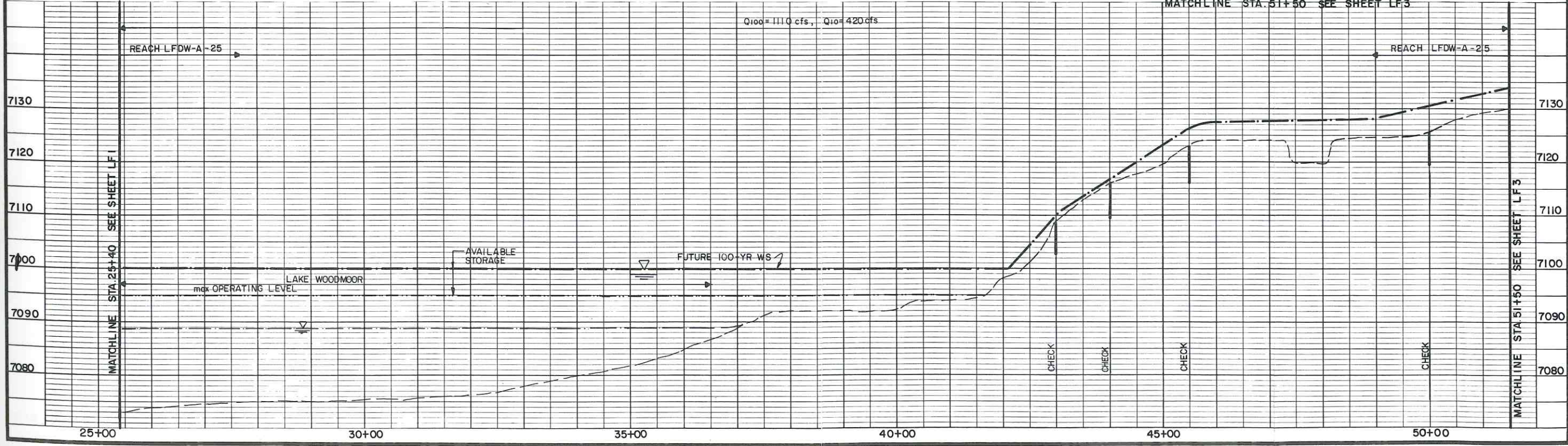







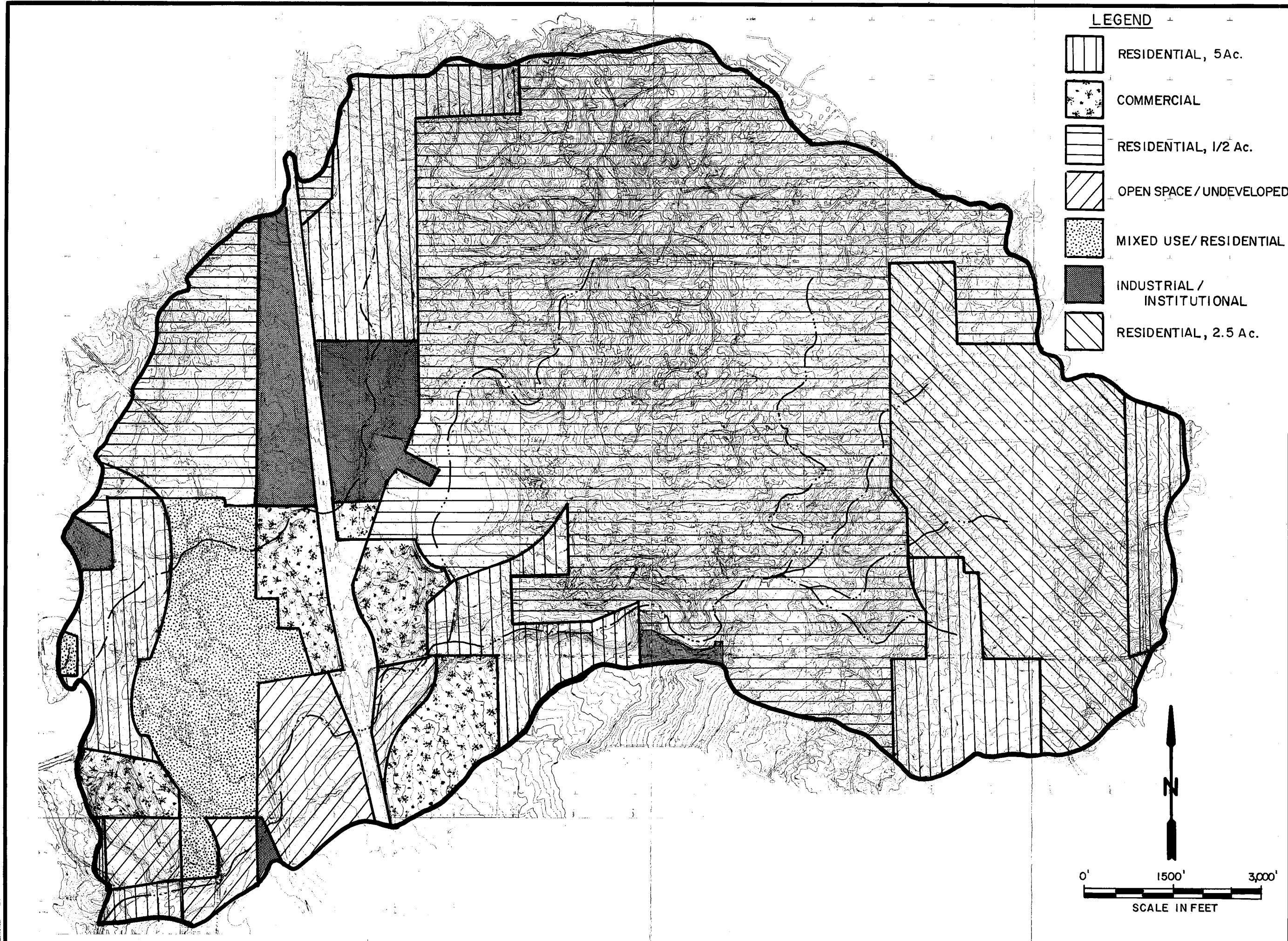

Kiowa Engineering Corporation
 419 West Bijou Street
 Colorado Springs, Colorado
 80905-1308

**Dirty Woman and Crystal Creeks
 Drainage Basin Planning Study**
 PRELIMINARY DESIGN
 Lake Fork Dirty Woman Creek
 Sta. 25+40 to Sta. 51+50
 El Paso County Department of Public Works Stormwater Management Division

Project No. 91-07-17
Date: 1/93
Design: AWMc
Drawn: EAK
Check: RNW
Revisions:

LF2



- LEGEND**
-  RESIDENTIAL, 5 Ac.
 -  COMMERCIAL
 -  RESIDENTIAL, 1/2 Ac.
 -  OPEN SPACE / UNDEVELOPED
 -  MIXED USE / RESIDENTIAL
 -  INDUSTRIAL / INSTITUTIONAL
 -  RESIDENTIAL, 2.5 Ac.

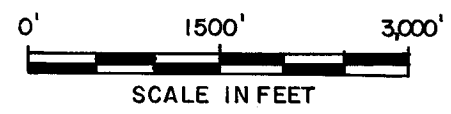

Kiowa Engineering Corporation
 419 W. Bijou Street
 Colorado Springs, Colorado
 80905-1308

DIRTY WOMAN CREEK & CRYSTAL CREEK
 DRAINAGE BASIN PLANNING STUDY
 PROPOSED LAND USE MAP

Project No. 91-07-17
Date: 12/91
Design: AW Mc
Drawn: EAK
Check: RNW
Revisions:

FIG 3

TABLE 12: DIRTY WOMAN & CRYSTAL CREEKS DRAINAGE BASIN PLANNING STUDY
 COST ESTIMATE -- SELECTIVE DRAINAGEWAY IMPROVEMENTS
 SELECTED ALTERNATIVE

REACH NUMBER	REACH LENGTH (FT)	NUMBER CHECK STRUCTURES	CHECK LENGTH (FT)	NUMBER DROP STRUCTURES	DROP LENGTH (FT)	LENGTH BANK SLOPE PROTECT (FT)	LENGTH OF 100 YR CHANNEL (FT)	LENGTH OF 10 YR CHANNEL (FT)	LENGTH OF CHNL STAB. & REPAIR (FT)	LENGTH OF OUTLET PROTECT (FT)	LENGTH OF SPILLWAY PROTECT (FT)	LENGTH OF BERM PROTECT (FT)	MITIGATION (AC)	LAND ACQUISITION (AC)	TOTAL COST
DW-A-01	1,093	3	243	1	85	300	130			95			0.70		\$144,182
DW-A-02	625			1	60	300		125					0.38		\$45,672
DW-A-03	1,333	1	60	3	290	1330				80					\$158,690
DW-A-04	120														\$0
DW-A-05	2,870	3	220	3	290	1020				100			0.61		\$190,316
DW-A-06	1,820	6	785	1	65	700							0.71		\$236,752
DW-B-07	2,150	2	185	1	120	370				90	100		0.94		\$129,645
DW-B-08	3,455	5	610	1	120			100		50			0.46		\$211,935
DW-B-09	520			1	120	200				50			0.22	0.742	\$62,391
DW-B-10	585	1	120	1	160					110			0.25	1.265	\$114,250
DW-B-11	490			1	80						50	240	0.16		\$48,512
UFDW-A-12	2,800	6	480	1	40	400				50			0.52		\$148,924
UFDW-A-13	2,335	1	75												\$11,600
SFDW-A-14	1,010	1	95							60			0.11		\$29,290
SFDW-A-15	1,540	1	160							90			0.06		\$47,857
SFDW-A-16	1,905	1	40	3	100					65					\$50,140
MFDW-A-17	1,375	1	100			400				60			0.30		\$40,874
MFDW-A-18	1,855	1	100	1	90	200				60			0.11		\$66,389
MFDW-A-19	375	1	120	1	40	170				70			0.23		\$54,727
MFDW-A-20	1,105	2	80	3	130	520				50			0.23		\$82,488
NFDW-A-21	560	2	190	1	130					70			0.23		\$99,039
NFDW-B-22	5,275	2	140	1	50	200				70	80		0.14		\$80,921
NFDW-B-23	850	2	95	2	80					40			0.07		\$54,955
NFDW-U-46	1,060														\$0
LFDW-A-24	1,265	3	160	6	280					70					\$192,440
LFDW-A-25	1,170	4	490							60	100		0.18		\$149,333
LFDW-B-26	1,035	2	220	1	80					60			0.24		\$88,404
LFDW-B-27	845	1	200	1	110					80	50		0.18		\$106,225
LFDW-B-28	1,460	2	240	1	150					90			0.07		\$119,465
LFDW-B-29	505			3	140			410		90		150			\$115,370
LFDW-B-30	200			1	100										\$34,500
LFDW-U-44	1,560							1250							\$162,500
LFDW-U-45	1,450														\$0
TOTAL DIRTY WOMAN CREEK															\$3,034,789
CC-A-31	565	2	160					450		60			0.92		\$107,129
CC-A-32	1,880														\$0
CC-B-33	290						290								\$79,750
CC-B-34	250						250								\$68,750
CC-B-35	235								230				0.40		\$59,084
CC-B-36	780	1	140							70			0.14		\$41,439
CC-B-37	1,045														\$0
CC-C-38	45														\$0
CC-C-39	2,445	4	330	1	80					90	75		0.22		\$134,605
CC-C-40	550	1	80							60					\$25,120
CC-U-41	4,050	3	300												\$74,400
CC-U-42	3,325														\$0
CC-U-43	3,375	3	300												\$74,400
TOTAL CRYSTAL CREEK															\$664,696

**TABLE 14: DIRTY WOMAN & CRYSTAL CREEKS DRAINAGE BASIN PLANNING STUDY
OVERALL COST ESTIMATE
SELECTED ALTERNATIVE**

REACH NUMBER	DRAINAGEWAY SUBTOTAL COSTS	CULVERT SUBTOTAL COSTS	OVERALL REACH COSTS	SUGGESTED NON-REIMBURSIBLE COST ALLOCATION			REIMBURSIBLE COSTS
				TOWN OF MONUMENT	CDOT	EL PASO COUNTY	
DW-A-01	\$144,182	\$105,800	\$249,982	\$105,800			\$144,182
DW-A-02	\$45,672	\$0	\$45,672	\$45,672			\$0
DW-A-03	\$158,690	\$123,750	\$282,440			\$123,750 (1)	\$158,690
DW-A-04	\$0	\$0	\$0				\$0
DW-A-05	\$190,316	\$136,250	\$326,566	\$73,490	\$136,250 (2)		\$116,826
DW-A-06	\$236,752	\$0	\$236,752	\$236,752			\$0
DW-B-07	\$129,645	\$86,000	\$215,645			\$135,320	\$80,325
DW-B-08	\$211,935	\$61,250	\$273,185			\$107,050	\$166,135
DW-B-09	\$62,391	\$136,875	\$199,266			\$199,266	\$0
DW-B-10	\$114,250	\$0	\$114,250			\$114,250	\$0
DW-B-11	\$48,512	\$71,600	\$120,112			\$120,112	\$0
UFDW-A-12	\$148,924	\$6,960	\$155,884			\$155,884	\$0
UFDW-A-13	\$18,600	\$0	\$18,600			\$18,600	\$0
SFDW-A-14	\$29,290	\$0	\$29,290			\$29,290	\$0
SFDW-A-15	\$47,857	\$72,500	\$120,357			\$120,357	\$0
SFDW-A-16	\$50,140	\$17,480	\$67,620			\$67,620	\$0
MFDW-A-17	\$40,874	\$24,200	\$65,074			\$65,074	\$0
MFDW-A-18	\$66,389	\$8,000	\$74,389			\$74,389	\$0
MFDW-A-19	\$54,727	\$16,250	\$70,977			\$70,977	\$0
MFDW-A-20	\$82,488	\$11,200	\$93,688			\$93,688	\$0
NFDW-A-21	\$99,039	\$15,800	\$114,839			\$114,839	\$0
NFDW-B-22	\$80,921	\$0	\$80,921			\$80,921	\$0
NFDW-B-23	\$54,955	\$27,900	\$82,855			\$82,855	\$0
NFDW-U-46	\$0	\$9,000	\$9,000			\$9,000	\$0
LFDW-A-24	\$142,440	\$81,000	\$223,440				\$223,440
LFDW-A-25	\$149,335	\$28,800	\$178,135			\$178,135	\$0
LFDW-B-26	\$88,404	\$95,200	\$183,604			\$183,604	\$0
LFDW-B-27	\$106,225	\$33,800	\$140,025			\$140,025	\$0
LFDW-B-28	\$119,465	\$35,000	\$154,465			\$154,465	\$0
LFDW-B-29	\$115,370	\$27,000	\$142,370			\$142,370	\$0
LFDW-B-30	\$34,500	\$0	\$34,500			\$34,500	\$0
LFDW-U-44	\$162,500	\$16,800	\$179,300			\$179,300	\$0
LFDW-U-45	\$0	\$0	\$0				\$0
TOTAL DIRTY WOMAN CREEK			\$4,283,203	\$461,714	\$136,250	\$2,795,641	\$889,598
CC-A-31	\$107,129	\$16,000	\$123,129	\$123,129			\$0
CC-A-32	\$0	\$0	\$0				\$0
CC-B-33	\$79,750	\$0	\$79,750	\$79,750			\$0
CC-B-34	\$68,750	\$0	\$68,750	\$68,750			\$0
CC-B-35	\$59,084	\$0	\$59,084	\$59,084			\$0
CC-B-36	\$41,459	\$76,400	\$117,859	\$117,859			\$0
CC-B-37	\$0	\$0	\$0				\$0
CC-C-38	\$0	\$125,000	\$125,000		\$125,000		\$0
CC-C-39	\$134,605	\$53,300	\$187,905				\$187,905
CC-C-40	\$25,120	\$14,400	\$39,520				\$39,520
CC-U-41	\$74,400	\$80,120	\$154,520	\$107,800			\$46,720
CC-U-42	\$0	\$49,000	\$49,000	\$49,000			\$0
CC-U-43	\$74,400	\$0	\$74,400				\$74,400
TOTAL CRYSTAL CREEK			\$1,078,917	\$605,372	\$125,000	\$0	\$348,545

(1) A portion of this amount is reimbursible under County Bridge Fee
(2) Considered a bridge by El Paso County



Federal Emergency Management Agency

Washington, D.C. 20472

CERTIFIED MAIL
RETURN RECEIPT REQUESTED

IN REPLY REFER TO:

Case No.: 99-08-012P

The Honorable Charles C. Brown
Chairman, El Paso County Board
of Commissioners
27 East Vermijo Avenue, Third Floor
Colorado Springs, Colorado 80903-2208

Community: El Paso County, Colorado
Community No.: 080059
Panel Affected: 08041C0276 F
Effective Date of **NOV 09 1998**
This Revision:

102-D-A

Dear Mr. Brown:

This responds to a request that the Federal Emergency Management Agency (FEMA) revise the effective Flood Insurance Rate Map (FIRM) and Flood Insurance Study (FIS) report for El Paso County, Colorado and Incorporated Areas (the effective FIRM and FIS report for your community), in accordance with Part 65 of the National Flood Insurance Program (NFIP) regulations. Mr. John Liou, Hydrologist, FEMA Region VIII, requested that FEMA revise the FIRM and FIS report to show the effects of a revised hydraulic analysis to correct the effective study along Dirty Woman Creek-Lake Fork and Lake Woodmoor.

Because this Letter of Map Revision (LOMR) is being issued to correct a mapping or study analysis error, fees were not assessed for the review.

We have completed our review of the submitted data and the flood data shown on the effective FIRM and FIS report. We have revised the FIRM and FIS report to modify the elevations of the flood having a 1-percent chance of being equaled or exceeded in any given year (base flood) along Dirty Woman Creek-Lake Fork from approximately 1,370 feet upstream to approximately 4,790 feet upstream of the confluence with Dirty Woman Creek. As a result of the modifications, the base flood elevations (BFEs) for Dirty Woman Creek-Lake Fork decreased. On the effective FIRM, the BFEs are shown as increasing throughout Lake Woodmoor. However, our review of the data used to create the effective FIRM revealed an error. The BFEs are at a constant elevation and have been corrected. This letter revises the BFEs for Lake Woodmoor and a reach of Dirty Woman Creek-Lake Fork from just upstream to approximately 700 feet upstream of Lake Woodmoor. The modifications are shown on the enclosed annotated copies of FIRM Panel(s) 08041C0276 F, Profile Panel(s) 314P and 315P, and affected portions of the Floodway Data Table. This LOMR hereby revises the above-referenced panel(s) of the effective FIRM and the affected portions of the FIS report, both dated March 17, 1997.

The modifications are effective as of the date shown above. The map panel(s) as listed above and as modified by this letter will be used for all flood insurance policies and renewals issued for your community.

The following table is a partial listing of existing and modified BFEs:

Location	Existing BFE (feet)*	Modified BFE (feet)*
Approximately 1,370 feet upstream of confluence with Dirty Woman Creek	7,102	7,102
Approximately 4,100 feet upstream of confluence with Dirty Woman Creek	7,110	7,102
Approximately 4,380 feet upstream of confluence with Dirty Woman Creek	7,116	7,115
Approximately 4,790 feet upstream of confluence with Dirty Woman Creek	7,128	7,128

*Referenced to the National Geodetic Vertical Datum, rounded to the nearest whole foot

Public notification of the modified BFEs will be given in *The Tribune* on or about December 10 and December 17, 1998. A copy of this notification is enclosed. In addition, a notice of changes will be published in the *Federal Register*. Within 90 days of the second publication in *The Tribune*, a citizen may request that FEMA reconsider the determination made by this LOMR. Any request for reconsideration must be based on scientific or technical data. All interested parties are on notice that, until the 90-day period elapses, the determination to modify the BFEs presented in this LOMR may itself be modified.

Because this LOMR will not be printed and distributed to primary users, such as local insurance agents and mortgage lenders, your community will serve as a repository for these new data. We encourage you to disseminate the information reflected by this LOMR throughout the community, so that interested persons, such as property owners, local insurance agents, and mortgage lenders, may benefit from the information. We also encourage you to prepare a related article for publication in your community's local newspaper. This article should describe the assistance that officials of your community will give to interested persons by providing these data and interpreting the NFIP maps.

We will not physically revise and republish the FIRM and FIS report for your community to reflect the modifications made by this LOMR at this time. When changes to the previously cited FIRM panel(s) and FIS report warrant physical revision and republication in the future, we will incorporate the modifications made by this LOMR at that time.

This LOMR is based on minimum floodplain management criteria established under the NFIP. Your community is responsible for approving all floodplain development, and for ensuring all necessary permits required by Federal or State law have been received. State, county, and community officials, based on knowledge of local conditions and in the interest of safety, may set higher standards for construction in the Special Flood Hazard Area. If the State, county, or community has adopted more restrictive or comprehensive floodplain management criteria, these criteria take precedence over the minimum NFIP criteria.

This determination has been made pursuant to Section 206 of the Flood Disaster Protection Act of 1973 (Public Law 93-234) and is in accordance with the National Flood Insurance Act of 1968, as amended (Title XIII of the Housing and Urban Development Act of 1968, Public Law 90-448), 42 U.S.C. 4001-4128, and 44 CFR Part 65. Pursuant to Section 1361 of the National Flood Insurance Act of 1968, as amended, communities participating in the NFIP are required to adopt and enforce floodplain

management regulations that meet or exceed NFIP criteria. These criteria are the minimum requirements and do not supersede any State or local requirements of a more stringent nature. This includes adoption of the effective FIRM and FIS report to which the regulations apply and the modifications described in this LOMR.

FEMA makes flood insurance available in participating communities; in addition, we encourage communities to develop their own loss reduction and prevention programs. Our Project Impact initiative, developed by FEMA Director James Lee Witt, seeks to focus the energy of businesses, citizens, and communities in the United States on the importance of reducing their susceptibility to the impact of all natural disasters, including floods, hurricanes, severe storms, earthquakes, and wildfires. Natural hazard mitigation is most effective when it is planned for and implemented at the local level, by the entities who are most knowledgeable of local conditions and whose economic stability and safety are at stake. For your information, we are enclosing a Project Impact Fact Sheet. For additional information on Project Impact, please visit our Web site at www.fema.gov.

If you have any questions regarding floodplain management regulations for your community or the NFIP in general, please contact the Consultation Coordination Officer (CCO) for your community. Information on the CCO for your community may be obtained by contacting the Director, Mitigation Division of FEMA in Denver, Colorado, at (303) 235-4830. If you have any technical questions regarding this LOMR, please contact Ms. Sally P. Magee of our staff in Washington, DC, either by telephone at (202) 646-8242 or by facsimile at (202) 646-4596.

Sincerely,



Sally P. Magee, Project Engineer
Hazards Study Branch
Mitigation Directorate

For: Matthew B. Miller, P.E., Chief
Hazards Study Branch
Mitigation Directorate

Enclosure(s)

cc: Mr. Dan Bunting
Regional Floodplain Administrator
Pikes Peaks Regional Building Department

CHANGES ARE MADE IN DETERMINATIONS OF BASE FLOOD ELEVATIONS FOR THE UNINCORPORATED AREAS OF EL PASO COUNTY, COLORADO, UNDER THE NATIONAL FLOOD INSURANCE PROGRAM

On March 17, 1997, the Federal Emergency Management Agency identified Special Flood Hazard Areas (SFHAs) in the unincorporated areas of El Paso County, Colorado, through issuance of a Flood Insurance Rate Map (FIRM). The Mitigation Directorate has determined that modification of the elevations of the flood having a 1-percent chance of being equaled or exceeded in any given year (base flood) for certain locations in this community is appropriate. The modified base flood elevations (BFEs) revise the FIRM for the community.

The changes are being made pursuant to Section 206 of the Flood Disaster Protection Act of 1973 (Public Law 93-234) and are in accordance with the National Flood Insurance Act of 1968, as amended (Title XIII of the Housing and Urban Development Act of 1968, Public Law 90-448), 42 U.S.C. 4001-4128, and 44 CFR Part 65.

A revised hydraulic analysis was performed to correct an error in the effective Flood Insurance Study and has resulted in decreased BFEs for Dirty Woman Creek-Lake Fork and Lake Woodmoor. The table below indicates existing and modified BFEs for selected locations along the affected lengths of the flooding source(s) cited above.

Location	Existing BFE (feet)*	Modified BFE (feet)*
Approximately 1,370 feet upstream of confluence with Dirty Woman Creek	7,102	7,102
Approximately 4,100 feet upstream of confluence with Dirty Woman Creek	7,110	7,102
Approximately 4,380 feet upstream of confluence with Dirty Woman Creek	7,116	7,115
Approximately 4,790 feet upstream of confluence with Dirty Woman Creek	7,128	7,128

*National Geodetic Vertical Datum, rounded to nearest whole foot

Under the above-mentioned Acts of 1968 and 1973, the Mitigation Directorate must develop criteria for floodplain management. To participate in the National Flood Insurance Program (NFIP), the community must use the modified BFEs to administer the floodplain management measures of the NFIP. These modified BFEs will also be used to calculate the appropriate flood insurance premium rates for new buildings and their contents and for the second layer of insurance on existing buildings and contents.

Upon the second publication of notice of these changes in this newspaper, any person has 90 days in which he or she can request, through the Chief Executive Officer of the community, that the Mitigation Directorate reconsider the determination. Any request for reconsideration must be based on knowledge of changed conditions or new scientific or technical data. All interested parties are on notice that until the 90-day period elapses, the Mitigation Directorate's determination to modify the BFEs may itself be changed.

Any person having knowledge or wishing to comment on these changes should immediately notify:

The Honorable Charles C. Brown
Chairman, El Paso County Board of Commissioners
27 East Vermijo Avenue, Third Floor
Colorado Springs, Colorado 80903-2208

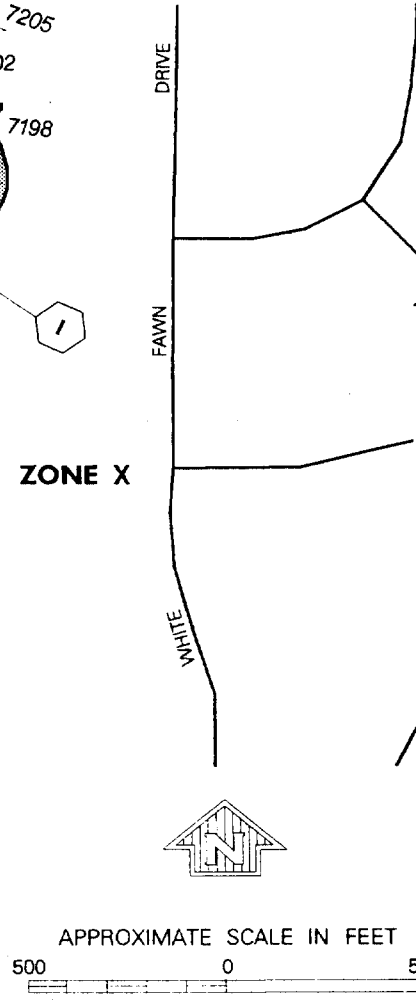
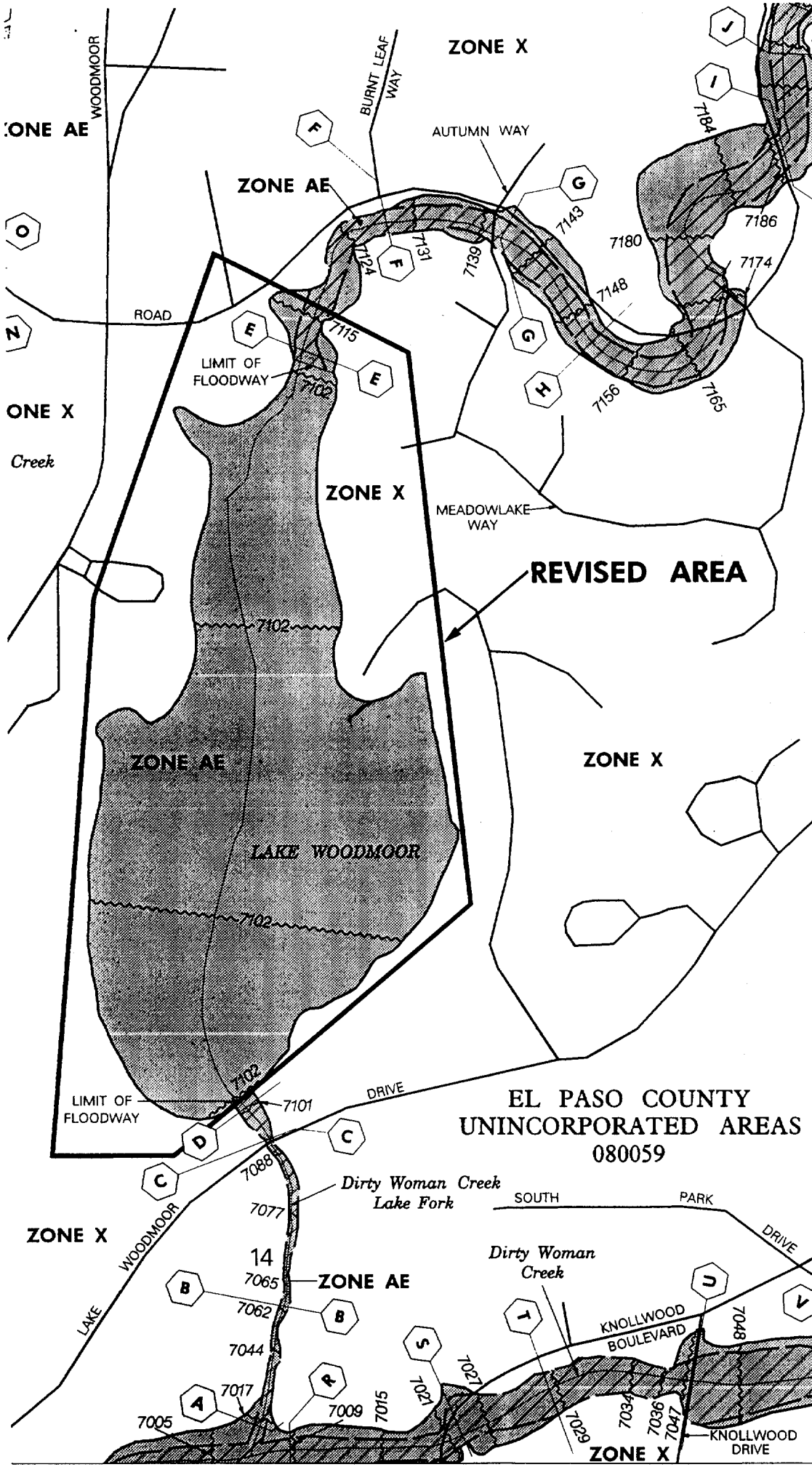

NATIONAL FLOOD INSURANCE PROGRAM

FIRM
FLOOD INSURANCE RATE MAP

EL PASO COUNTY,
 COLORADO AND
 INCORPORATED AREAS

PANEL 276 OF 1300
 (SEE MAP INDEX FOR PANELS NOT PRINTED)

CONTAINS:
 COMMUNITY NUMBER 080059
 UNINCORPORATED AREAS 080059
 MOUNTAIN TOWN OF 080059
 NUMBER ONE TOWN OF 080059

REVISED TO REFLECT LOMR

DATED NOV 09 1998

MAP NUMBER
 08041C0276 F

EFFECTIVE DATE:
 MARCH 17, 1997



Federal Emergency Management Agency

FLOODING SOURCE		FLOODWAY				BASE FLOOD WATER SURFACE ELEVATION			
CROSS SECTION	DISTANCE ¹	WIDTH (FEET)	SECTION AREA (SQUARE FEET)	MEAN VELOCITY (FEET PER SECOND)	REGULATORY	WITHOUT FLOODWAY	WITH FLOODWAY	INCREASE	
(FEET NGVD)									
Dirty Woman Creek-Lake Fork	A	130	79	6.1	7,014.5	7,014.5	7,014.5	0.0	
	B	580	57	8.5	7,061.8	7,061.8	7,061.8	0.0	
	C	1,203	67	7.1	7,091.2	7,091.2	7,091.2	0.0	
	D	1,358	77	6.3	7,101.9	7,101.9	7,101.9	0.0	
	E	4,198	71	8.0	7,108.9	7,108.9	7,109.4	0.5	
	F	4,788	68	8.1	7,128.1	7,128.1	7,128.1	0.0	
	G	5,216	150	1.2	7,140.5	7,140.5	7,140.7	0.2	
	H	5,720	80	7.5	7,150.4	7,150.4	7,150.5	0.1	
	I	7,168	130	6.4	7,188.8	7,188.8	7,188.9	0.1	
	J	7,508	110	6.4	7,201.3	7,201.3	7,201.4	0.1	
	K	7,691	130	5.7	7,204.8	7,204.8	7,204.8	0.0	
	L	8,356	70	7.5	7,220.9	7,220.9	7,221.1	0.2	
	M	8,731	75	6.9	7,233.8	7,233.8	7,234.0	0.2	
	N	9,309	130	1.2	7,252.0	7,252.0	7,252.2	0.2	
	O	9,669	70	6.5	7,269.5	7,269.5	7,269.7	0.2	

REVISED DATA

REVISED TO REFLECT LOMR DATED NOV 09 1998

¹Feet Above Dirty Woman Creek

FEDERAL EMERGENCY MANAGEMENT AGENCY
EL PASO COUNTY, CO
 AND INCORPORATED AREAS

FLOODWAY DATA
 DIRTY WOMAN CREEK-LAKE FORK

ELEVATION IN FEET (NGVD)

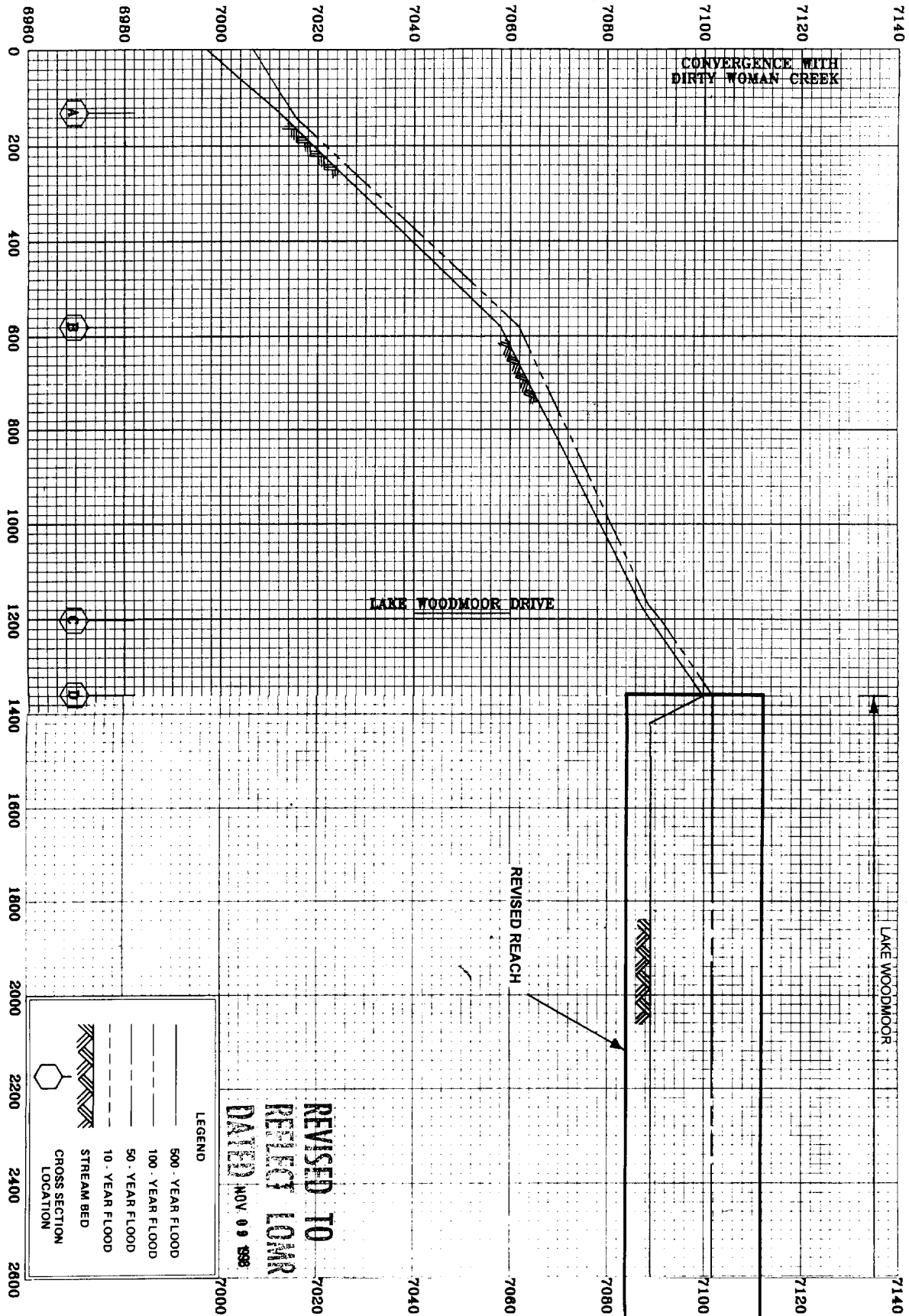

STREAM DISTANCE IN FEET ABOVE CONFLUENCE WITH DIRTY WOMAN CREEK

LEGEND	
— (solid line)	500 - YEAR FLOOD
- - - (dashed line)	100 - YEAR FLOOD
· · · (dotted line)	50 - YEAR FLOOD
- - - (long dashed line)	10 - YEAR FLOOD
▨ (hatched area)	STREAM BED
○ (circle with letter)	CROSS SECTION LOCATION

REVISED TO
REPLY LMR
DATED NOV 09 1998

314P

FEDERAL EMERGENCY MANAGEMENT AGENCY
EL PASO COUNTY, CO
AND INCORPORATED AREAS

FLOOD PROFILES
DIRTY WOMAN CREEK - LAKE FORK

ELEVATION IN FEET (NGVD)

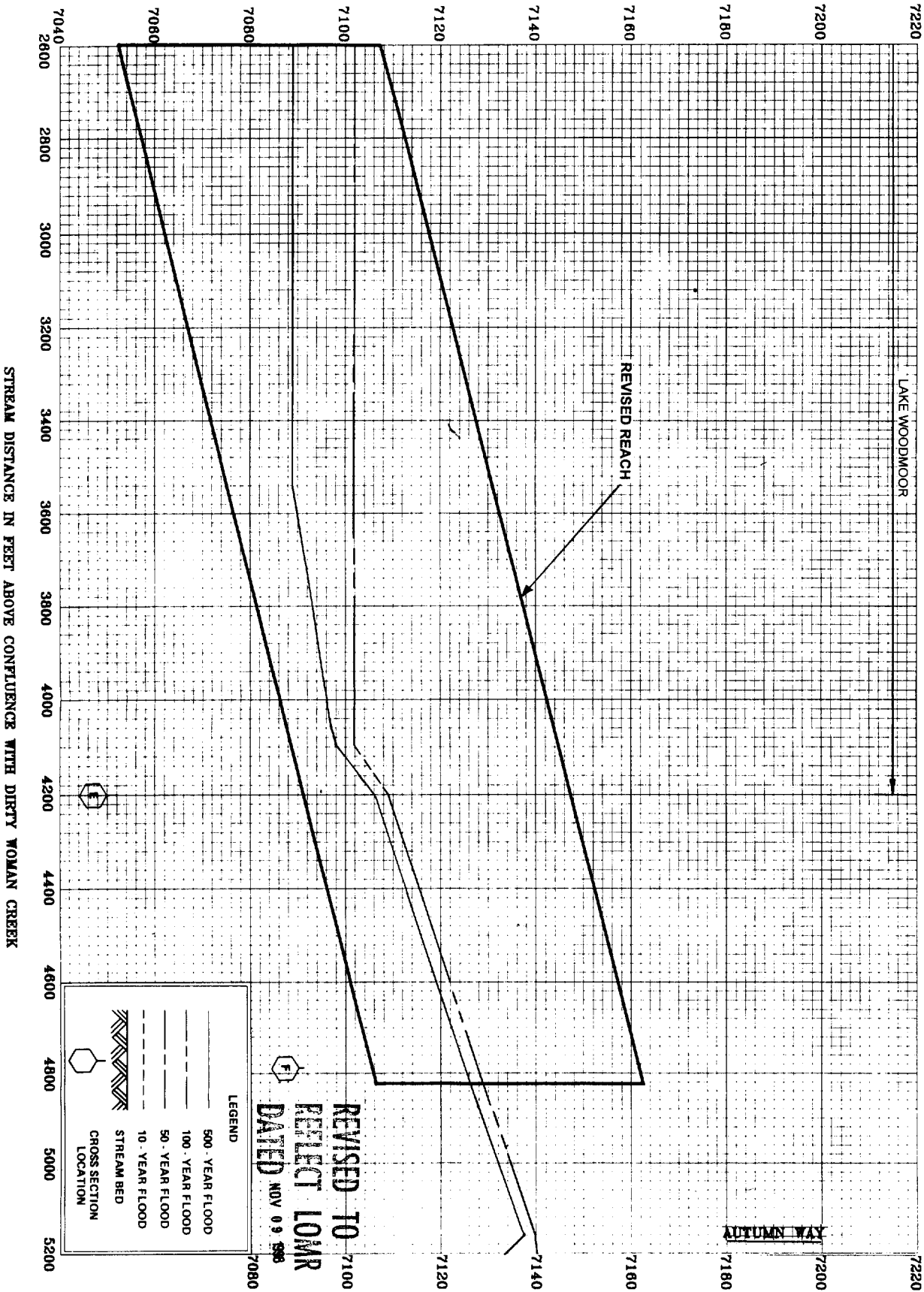

FEDERAL EMERGENCY MANAGEMENT AGENCY
 EL PASO COUNTY, CO
 AND INCORPORATED AREAS

FLOOD PROFILES

DIRTY WOMAN CREEK - LAKE FORK

315P



Federal Emergency Management Agency

Washington, D.C. 20472

June 5, 2017

CERTIFIED MAIL
RETURN RECEIPT REQUESTED

The Honorable Darryl Glenn
Chairman, El Paso County Board of Commissioners
200 South Cascade Avenue, Suite 100
Colorado Springs, CO 80903

IN REPLY REFER TO:

Case No.: 17-08-0195R
Community Name: El Paso County, CO
Community No.: 080059

104

Dear Mr. Glenn:

We are providing our comments with the enclosed Conditional Letter of Map Revision (CLOMR) on a proposed project within your community that, if constructed as proposed, could revise the effective Flood Insurance Study report and Flood Insurance Rate Map for your community.

If you have any questions regarding the floodplain management regulations for your community, the National Flood Insurance Program (NFIP) in general, or technical questions regarding this CLOMR, please contact the Director, Mitigation Division of the Federal Emergency Management Agency (FEMA) Regional Office in Denver, Colorado, at (303) 235-4830, or the FEMA Map Information eXchange (FMIX) toll free at 1-877-336-2627 (1-877-FEMA MAP). Additional information about the NFIP is available on our website at <http://www.fema.gov/national-flood-insurance-program>.

Sincerely,

Patrick "Rick" F. Sacbibit, P.E., Branch Chief
Engineering Services Branch
Federal Insurance and Mitigation Administration

List of Enclosures:

Conditional Letter of Map Revision Comment Document

cc: Mr. Keith Curtis, P.E., CFM
Floodplain Administrator
El Paso County

Mr. Christopher J. Castelli, P.E.
Project Engineer
Kiowa Engineering Corporation



Federal Emergency Management Agency

Washington, D.C. 20472

CONDITIONAL LETTER OF MAP REVISION COMMENT DOCUMENT

COMMUNITY INFORMATION		PROPOSED PROJECT DESCRIPTION	BASIS OF CONDITIONAL REQUEST
COMMUNITY	El Paso County Colorado (Unincorporated Areas)	FILL	HYDRAULIC ANALYSIS UPDATED TOPOGRAPHIC DATA FLOODWAY
	COMMUNITY NO.: 080059		
IDENTIFIER	North Bay at Lake Woodmoor CLOMR	APPROXIMATE LATITUDE & LONGITUDE: 39.105, -104.856 SOURCE: USGS QUADRANGLE DATUM: NAD 83	
AFFECTED MAP PANELS			
TYPE: FIRM*	NO.: 08041C0276F	DATE: March 17, 1997	* FIRM - Flood Insurance Rate Map

FLOODING SOURCE(S) AND REACH DESCRIPTION

Dirty Woman Creek- Lake Fork from approximately 1,280 feet downstream to approximately 40 feet upstream Autumn Way.

PROPOSED PROJECT DESCRIPTION

Flooding Source	Proposed Project	Location of Proposed Project
Dirty Woman Creek-Lake Fork	Fill Placement	From approximately 1,280 feet downstream to approximately 40 feet upstream of Autumn Way.

SUMMARY OF IMPACTS TO FLOOD HAZARD DATA

Flooding Source	Effective Flooding	Proposed Flooding	Increases	Decreases
Dirty Woman Creek-Lake Fork	Floodway	Floodway	Yes	Yes
	BFEs*	BFEs	Yes	Yes
	Zone AE	Zone AE	Yes	Yes

* BFEs - Base (1-percent-annual-chance) Flood Elevations

COMMENT

This document provides the Federal Emergency Management Agency's (FEMA's) comment regarding a request for a CLOMR for the project described above. This document is not a final determination; it only provides our comment on the proposed project in relation to the flood hazard information shown on the effective National Flood Insurance Program (NFIP) map. We reviewed the submitted data and the data used to prepare the effective flood hazard information for your community and determined that the proposed project meets the minimum floodplain management criteria of the NFIP. Your community is responsible for approving all floodplain development and for ensuring that all permits required by Federal or State/Commonwealth law have been received. State/Commonwealth, county, and community officials, based on their knowledge of local conditions and in the interest of safety, may set higher standards for construction in the Special Flood Hazard Area (SFHA), the area subject to inundation by the base flood). If the State/Commonwealth, county, or community has adopted more restrictive or comprehensive floodplain management criteria, these criteria take precedence over the minimum NFIP criteria.

This comment is based on the flood data presently available. If you have any questions about this document, please contact the FEMA Map Information eXchange (FMIX) toll free at 1-877-336-2627 (1-877-FEMA MAP) or by letter addressed to the LOMC Clearinghouse, 3601 Eisenhower Avenue, Suite 500, Alexandria, VA 22304-6426. Additional information about the NFIP is available on the FEMA website at <http://www.fema.gov/national-flood-insurance-program>.

Patrick "Rick" F. Sacbibit, P.E., Branch Chief
Engineering Services Branch
Federal Insurance and Mitigation Administration



Federal Emergency Management Agency
Washington, D.C. 20472

**CONDITIONAL LETTER OF MAP REVISION
COMMENT DOCUMENT (CONTINUED)**

COMMUNITY INFORMATION

To determine the changes in flood hazards that will be caused by the proposed project, we compared the hydraulic modeling reflecting the proposed project (referred to as the proposed conditions model) to the hydraulic modeling used to prepare the Flood Insurance Study (FIS) (referred to as the effective model). If the effective model does not provide enough detail to evaluate the effects of the proposed project, an existing conditions model must be developed to provide this detail. This existing conditions model is then compared to the effective model and the proposed conditions model to differentiate the increases or decreases in flood hazards caused by more detailed modeling from the increases or decreases in flood hazards that will be caused by the proposed project.

The table below shows the changes in the BFEs:

BFE Comparison Table

Flooding Source: Dirty Woman Creek-Lake Fork		BFE Change (feet)	Location of maximum change
Existing vs. Effective	Maximum increase	6.4	Approximately 780 feet downstream of Autumn Way
	Maximum decrease	0.3	At Autumn Way
Proposed vs. Existing	Maximum increase	2.9	Approximately 570 feet downstream of Autumn Way
	Maximum decrease	0.01	Approximately 1,070 feet downstream of Autumn Way
Proposed vs. Effective	Maximum increase	7.2	Approximately 780 feet downstream of Autumn Way
	Maximum decrease	0.3	At Autumn Way

Increases due to the proposed project that exceed those permitted under Paragraphs (c)(10) or (d)(3) of Section 60.3 of the NFIP regulations must adhere to Section 65.12 of the NFIP regulations. With this request, your community has complied with all requirements of Paragraph 65.12(a) of the NFIP regulations. Compliance with Paragraph 65.12(b) also is necessary before FEMA can issue a Letter of Map Revision when a community proposes to permit encroachments into the effective regulatory floodway that will cause BFE increases in excess of those permitted under Paragraph 60.3(d)(3).

This comment is based on the flood data presently available. If you have any questions about this document, please contact the FEMA Map Information eXchange (FMIX) toll free at 1-877-336-2627 (1-877-FEMA MAP) or by letter addressed to the LOMC Clearinghouse, 3601 Eisenhower Avenue, Suite 500, Alexandria, VA 22304-6426. Additional information about the NFIP is available on the FEMA website at <http://www.fema.gov/national-flood-insurance-program>.

Patrick "Rick" F. Sacbibit, P.E., Branch Chief
Engineering Services Branch
Federal Insurance and Mitigation Administration



Federal Emergency Management Agency

Washington, D.C. 20472

CONDITIONAL LETTER OF MAP REVISION COMMENT DOCUMENT (CONTINUED)

COMMUNITY INFORMATION (CONTINUED)

DATA REQUIRED FOR FOLLOW-UP LOMR

Upon completion of the project, your community must submit the data listed below and request that we make a final determination on revising the effective FIRM. If the project is built as proposed and the data below are received, a revision to the FIRM would be warranted.

- Detailed application and certification forms must be used for requesting final revisions to the maps. Therefore, when the map revision request for the area covered by this letter is submitted, Form 1, entitled "Overview and Concurrence Form," must be included. A copy of this form may be accessed at http://www.fema.gov/plan/prevent/fhm/dl_mt-2.shtm.
- The detailed application and certification forms listed below may be required if as-built conditions differ from the proposed plans. If required, please submit new forms, which may be accessed at http://www.fema.gov/plan/prevent/fhm/dl_mt-2.shtm, or annotated copies of the previously submitted forms showing the revised information.

Form 2, entitled "Riverine Hydrology and Hydraulics Form." Hydraulic analyses for as-built conditions of the base flood must be submitted with Form 2.

Form 3, entitled "Riverine Structures Form."

- A certified topographic work map showing the revised and effective base floodplain boundaries. Please ensure that the revised information ties-in with the current effective information at the downstream and upstream ends of the revised reach.
- An annotated copy of the FIRM; at the scale of the effective FIRM, that shows the revised base floodplain boundary delineations shown on the submitted work map and how they tie-in to the base floodplain boundary delineations shown on the current effective FIRM at the downstream and upstream ends of the revised reach.
- As-built plans, certified by a registered Professional Engineer, of all proposed project elements.
- A copy of the public notice distributed by your community stating its intent to revise the regulatory floodway, or a signed statement by your community that it has notified all affected property owners and affected adjacent jurisdictions.
- Documentation of the individual legal notices sent to property owners who will be affected by any widening or shifting of the base floodplain and/or any BFE increases along the Dirty Woman Creek-Lake Fork.

This comment is based on the flood data presently available. If you have any questions about this document, please contact the FEMA Map Information eXchange (FMIX) toll free at 1-877-336-2627 (1-877-FEMA MAP) or by letter addressed to the LOMC Clearinghouse, 3601 Eisenhower Avenue, Suite 500, Alexandria, VA 22304-6426. Additional information about the NFIP is available on the FEMA website at <http://www.fema.gov/national-flood-insurance-program>.

Patrick "Rick" F. Sacbbit, P.E., Branch Chief
Engineering Services Branch
Federal Insurance and Mitigation Administration



Federal Emergency Management Agency

Washington, D.C. 20472

CONDITIONAL LETTER OF MAP REVISION COMMENT DOCUMENT (CONTINUED)

COMMUNITY INFORMATION (CONTINUED)

DATA REQUIRED FOR FOLLOW-UP LOMR (continued)

• FEMA's fee schedule for reviewing and processing requests for conditional and final modifications to published flood information and maps may be accessed at <https://www.fema.gov/forms-documents-and-software/flood-map-related-fees>. The fee at the time of the map revision submittal must be received before we can begin processing the request. Payment of this fee can be made through a check or money order, made payable in U.S. funds to the National Flood Insurance Program, or by credit card (Visa or MasterCard only). Please either forward the payment, along with the revision application, to the following address:

LOMC Clearinghouse
Attention: LOMR Manager
3601 Eisenhower Avenue, Suite 500
Alexandria, Virginia 22304-6426

or submit the LOMR using the Online LOMC portal at: <https://hazards.fema.gov/femaportal/onlinelomc/signin>

After receiving appropriate documentation to show that the project has been completed, FEMA will initiate a revision to the FIRM. Because the flood hazard information (i.e., base flood elevations, base flood depths, SFHAs, zone designations, and/or regulatory floodways) will change as a result of the project, a 90-day appeal period will be initiated for the revision, during which community officials and interested persons may appeal the revised flood hazard information based on scientific or technical data.

This comment is based on the flood data presently available. If you have any questions about this document, please contact the FEMA Map Information eXchange (FMIX) toll free at 1-877-336-2627 (1-877-FEMA MAP) or by letter addressed to the LOMC Clearinghouse, 3601 Eisenhower Avenue, Suite 500, Alexandria, VA 22304-6426. Additional information about the NFIP is available on the FEMA website at <http://www.fema.gov/national-flood-insurance-program>.

A handwritten signature in black ink, appearing to read "Rick Sacbibit".

Patrick "Rick" F. Sacbibit, P.E., Branch Chief
Engineering Services Branch
Federal Insurance and Mitigation Administration



Federal Emergency Management Agency
Washington, D.C. 20472

**CONDITIONAL LETTER OF MAP REVISION
COMMENT DOCUMENT (CONTINUED)**

COMMUNITY INFORMATION (CONTINUED)

COMMUNITY REMINDERS

We have designated a Consultation Coordination Officer (CCO) to assist your community. The CCO will be the primary liaison between your community and FEMA. For information regarding your CCO, please contact:

Ms. Jeanine P. Petterson
Director, Mitigation Division
Federal Emergency Management Agency, Region VIII
Denver Federal Center, Building 710
P.O. Box 25267
Denver, CO 80225-0267
(303) 235-4830

WHEN PRELIMINARY STUDY HAS BEEN SUBMITTED TO COMMUNITY FOR REVIEW

A preliminary study is being conducted for El Paso County. Preliminary copies of the revised FIRM and FIS report were submitted to your community for review on July 29, 2015, and may become effective before the revision request following this CLOMR is submitted. Please ensure that the data submitted for the revision ties into the data effective at the time of the submittal.

This comment is based on the flood data presently available. If you have any questions about this document, please contact the FEMA Map Information eXchange (FMIX) toll free at 1-877-336-2627 (1-877-FEMA MAP) or by letter addressed to the LOMC Clearinghouse, 3601 Eisenhower Avenue, Suite 500, Alexandria, VA 22304-6426. Additional Information about the NFIP is available on the FEMA website at <http://www.fema.gov/national-flood-insurance-program>.

Patrick "Rick" F. Sacbibit, P.E., Branch Chief
Engineering Services Branch
Federal Insurance and Mitigation Administration



WOODMOOR

Water & Sanitation District No. 1

P. O. Box 1407 • Monument, Colorado 80132
Phone (719) 488-2525 • Fax (719) 488-2530

August 24, 2017

La Plata Communities, Inc.
1755 Telstar Dr., Suite 211
Colorado Springs, CO 80920

Subject: Proposed Stormwater Drainage - North Bay at Woodmoor

Dear Mr. Humphrey:

Woodmoor Water & Sanitation District (the "District") has reviewed the "Final Drainage Report for North Bay at Woodmoor" as prepared by Kiowa Engineering dated September 23, 2016. The report proposes to utilize Lake Woodmoor for meeting both water quality and water quantity stormwater detention pursuant to current El Paso county drainage criteria by allowing storm water runoff from the development to flow directly into Lake Woodmoor without any onsite permanent storm water controls. It is our understanding that current drainage criteria typically requires both storm water quantity as well as storm water quality detention facilities. The quantity of storm water entering Lake Woodmoor from the proposed development does not cause the District concern, however Lake Woodmoor is a primary drinking water supply for Woodmoor residents and therefore storm water quality is of concern. The District requests that permanent storm water quality BMP's be installed within the development that channels all developed flows through the BMP's in accordance with the current El Paso County Drainage Criteria. In addition, the District requests the usage of sand filters to other forms of permanent storm water quality BMP's.

Respectfully,

Joseph Seed
District Engineer
Woodmoor Water & Sanitation District
Phone: 719-488-2525 ext 13
E-mail: JoeyS@woodmoorwater.com

TABLE 10-4

MAXIMUM PERMISSIBLE VELOCITIES FOR EARTH CHANNELS WITH
VARIED GRASS LININGS AND SLOPES

<u>Channel Slope</u>	<u>Lining</u>	<u>Permissible Mean Channel Velocity *</u> (ft/sec)
0 - 5%	Sodded grass	7
	Bermudagrass	6
	Reed canarygrass	5
	Tall fescue	5
	Kentucky bluegrass	5
	Grass-legume mixture	4
	Red fescue	2.5
	Redtop	2.5
	Sericea lespedeza	2.5
	Annual lespedeza	2.5
	Small grains (temporary)	2.5
	5 - 10%	Sodded grass
Bermudagrass		5
Reed canarygrass		4
Tall fescue		4
Kentucky bluegrass		4
Grass-legume mixture		3
Greater than 10%	Sodded grass	5
	Bermudagrass	4
	Reed canarygrass	3
	Tall fescue	3
	Kentucky bluegrass	3

* For highly erodible soils, decrease permissible velocities by 25%.

* Grass lined channels are dependent upon assurances of continuous growth and maintenance of grass.

By measuring “bankfull” characteristics within the Jimmy Camp Creek drainage basin, a 67 square-mile tributary to Fountain Creek, and applying regression methods, a relationship between drainage area and channel dimensions has been developed. Bankfull channel dimensions can be useful to determine the configuration of the “low-flow channel” within the main channel. This is the portion of the channel that is most active and most affected by changes in hydrology due to development. Even with effective detention facilities upstream of “natural” channel reaches, it is anticipated that increases in flow volumes and frequency will cause channels to become unstable. By stabilizing the low-flow portion of the channels, it is anticipated that more significant channel stabilization projects can be avoided, reducing the overall cost of drainage facilities.

Allowable velocities for unlined low-flow channels are shown in Table 12-3. Criteria for lined channels are provided in the Major Drainage Chapter of Volume 1 of the UDFCD Manual.

Table 12-3. Hydraulic Design Criteria for Natural Unlined Channels

Design Parameter	Erosive Soils or Poor Vegetation	Erosion Resistant Soils and Vegetation
Maximum Low-flow Velocity (ft/sec)	3.5 ft/sec	5.0 ft/sec
Maximum 100-year Velocity (ft/sec)	5.0 ft/sec	7.0 ft/sec
Froude No., Low-flow	0.5	0.7
Froude No., 100-year	0.6	0.8
Maximum Tractive Force, 100-year	0.60 lb/sf	1.0 lb/sf

¹ Velocities, Froude numbers and tractive force values listed are average values for the cross section.

² “Erosion resistant” soils are those with 30% or greater clay content. Soils with less than 30% clay content shall be considered “erosive soils.”

Normally, a low-flow channel exhibits some meandering and sinuosity in natural channels. Stabilized channels should feature a meander pattern typical of natural channels. Side slopes for low-flow channel banks shall be no steeper than 4H:1V without adequate bank stabilization. Flatter slopes are encouraged and may provide improved vegetative cover, bank stability and access.

3.1.1.1 Low-Flow Channel Dimensions

Based on the Jimmy Camp Creek drainage basin channel analyses, the bankfull regression equation for design low-flow cross-sectional area is provided as Equation 12-1 below.

$$A_{low-flow} = 21.3 DA^{0.34} \quad \text{Equation 12-1}$$

Where:

$A_{low-flow}$ = design low-flow cross-sectional area (ft²)

DA = tributary drainage basin area (mi²)

From the design low-flow cross-sectional area, the design low-flow width for any drainage basin is calculated by Equation 12-2a below.

$$W_{low-flow} = [(W_{bankfull}/D_{bankfull})_{reference} * A_{low-flow}]^{0.5} \quad \text{Equation 12-2a}$$

Where:

possible for as much of the reach as possible to the maximum prudent values for the hydraulic parameters in the 100 year event. The designer should determine the return period where these parameters would be achieved and, with the owner and local jurisdiction, determine if the associated risks are acceptable.

On the other hand, if the recommendation to avoid floodplain filling is not followed and fill is proposed, this should only happen in floodplains where the maximum prudent values for the hydraulic parameters shown in Table 8-1 are not exceeded in the 100-year event.

Table 8-1. Maximum prudent values for natural channel hydraulic parameters

Design Parameter	Non-Cohesive Soils or Poor Vegetation	Cohesive Soils and Vegetation
Maximum flow velocity (average of section)	5 ft/s	7 ft/s
Maximum Froude number	0.6	0.8
Maximum tractive force (average of section)	0.60 lb/sf	1.0 lb/sf
Maximum depth outside bankfull channel	5 ft	5 ft

Stream Restoration Principle 8: Evaluate Hydraulics of Streams over a Range of Flows

Representative Design Tasks and Deliverables

1. Document hydraulic analyses of the project reach following the guidance of Section 7.0.
2. Describe how hydraulic performance of the project reach compares to maximum prudent values for the hydraulic parameters shown in Table 8-1 for several return periods (including 2-, 10-, and 100-year events at a minimum). Describe any locations in the reach where these parameters are exceeded and discuss efforts made to improve hydraulics.
3. Confirm that hydraulic parameters of Table 8-1 are satisfied in for the 100-year event in all locations where fill is proposed in the floodplain.

APPENDIX G

Existing and Proposed Drainage Plans

Sheet DP1 - Drainage Plan Existing Condition
Sheet DP2 - Final Drainage Plan Developed Condition

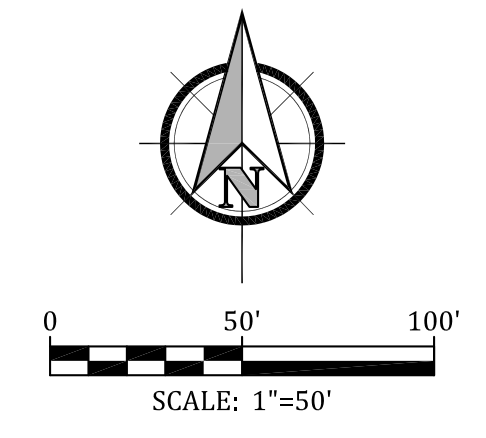
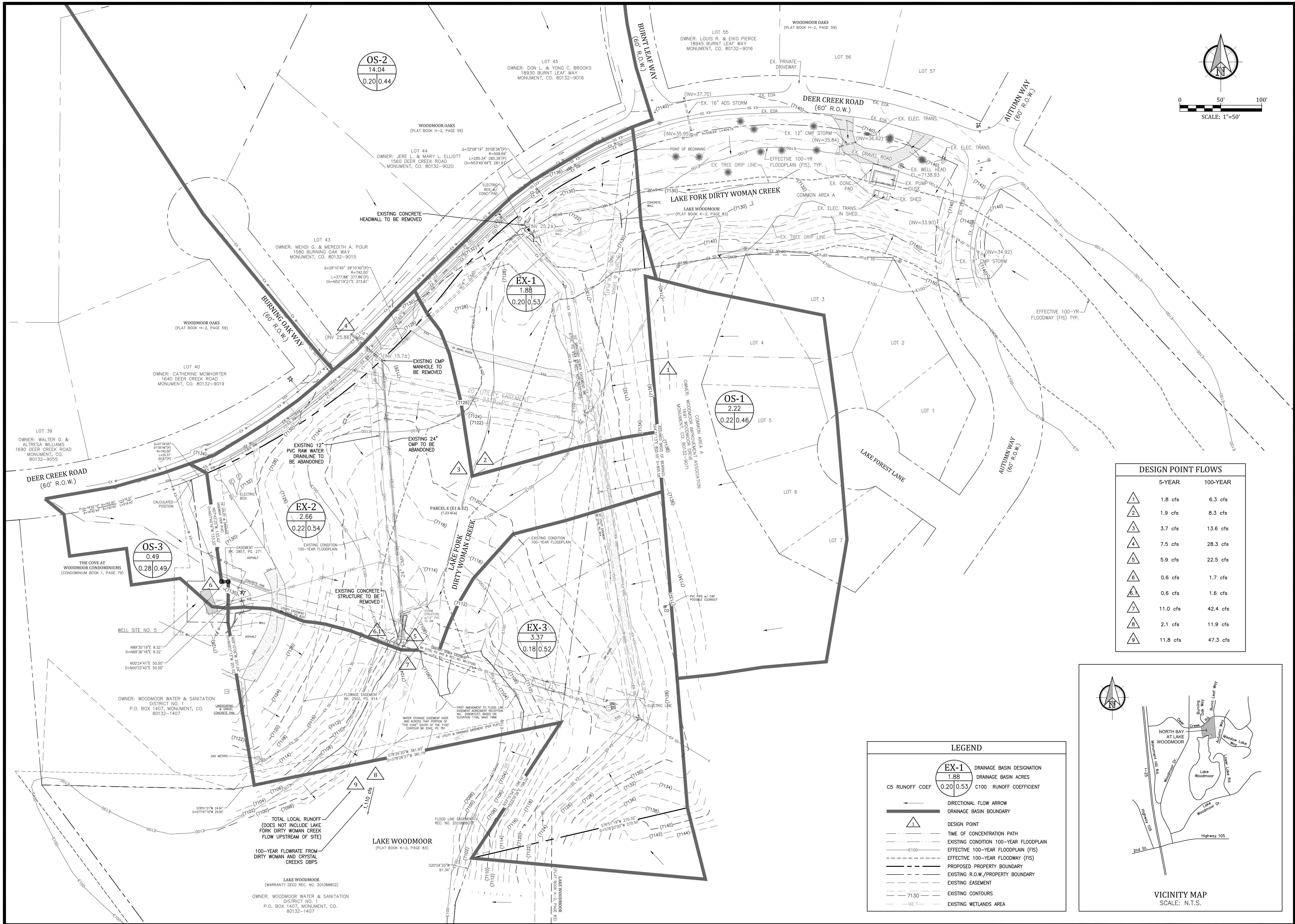

DESIGN POINT FLOWS		
	5-YEAR	100-YEAR
1	1.8 cfs	6.3 cfs
2	1.9 cfs	8.3 cfs
3	3.7 cfs	13.6 cfs
4	7.5 cfs	28.3 cfs
5	5.9 cfs	22.5 cfs
6	0.6 cfs	1.7 cfs
6.1	0.6 cfs	1.6 cfs
7	11.0 cfs	42.4 cfs
8	2.1 cfs	11.9 cfs
9	11.8 cfs	47.3 cfs

LEGEND	
	EX-1 DRAINAGE BASIN DESIGNATION 1.88 DRAINAGE BASIN ACRES 0.20 0.53 C100 RUNOFF COEFFICIENT
	DIRECTIONAL FLOW ARROW
	DRAINAGE BASIN BOUNDARY
	DESIGN POINT
	TIME OF CONCENTRATION PATH
	EXISTING CONDITION 100-YEAR FLOODPLAIN
	EFFECTIVE 100-YEAR FLOODPLAIN (FIS)
	EFFECTIVE 100-YEAR FLOODWAY (FIS)
	PROPOSED PROPERTY BOUNDARY
	EXISTING R.O.W./PROPERTY BOUNDARY
	EXISTING EASEMENT
	EXISTING CONTOURS
	EXISTING WETLANDS AREA

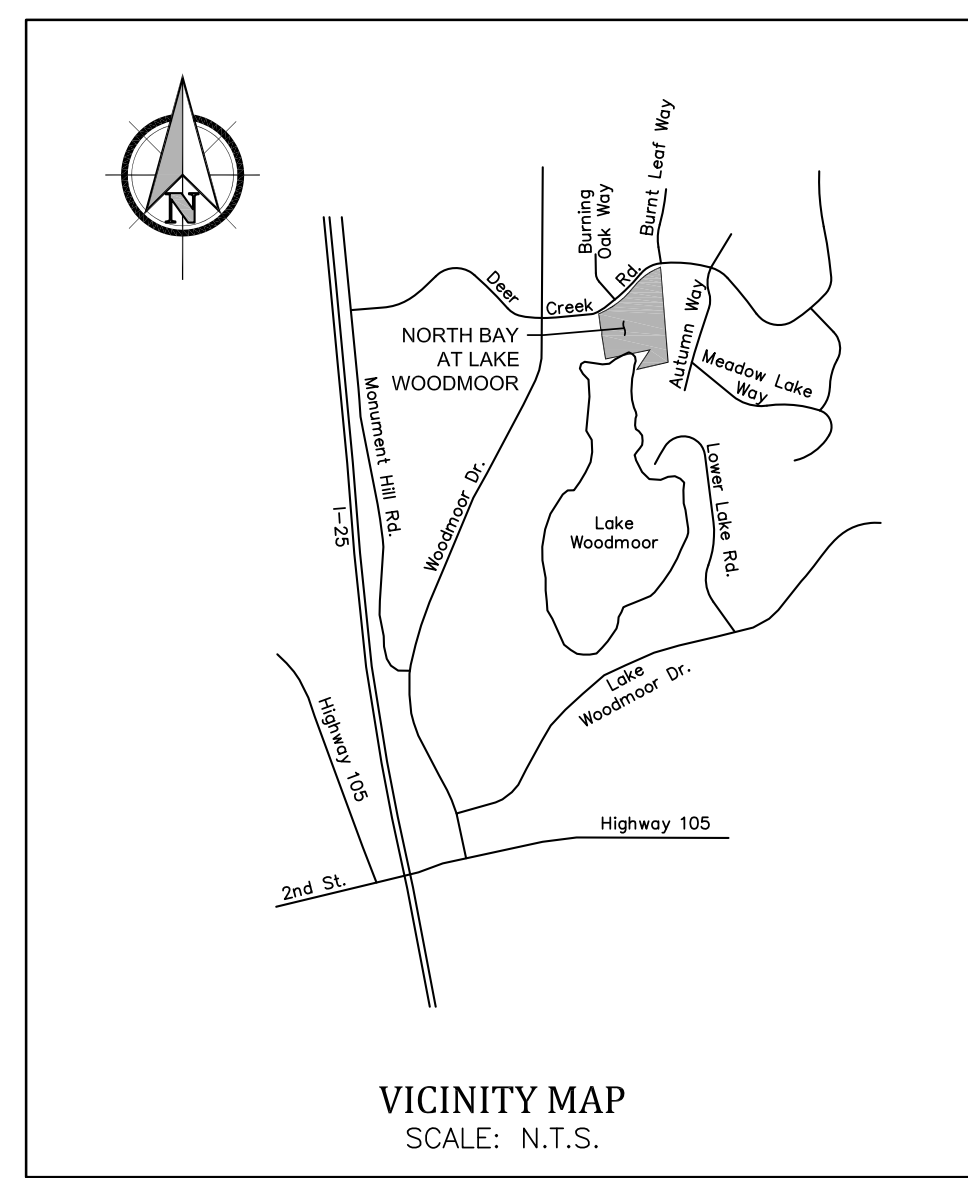

North Bay at Lake Woodmoor Drainage Plan Existing Condition

El Paso County, Colorado

Project No.:	15073
Date:	September 4, 2018
Design:	CJC
Drawn:	CJC
Check:	AWMc
Revisions:	

SHEET
DP1

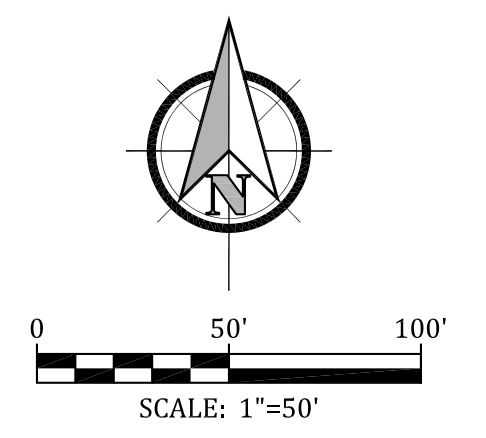
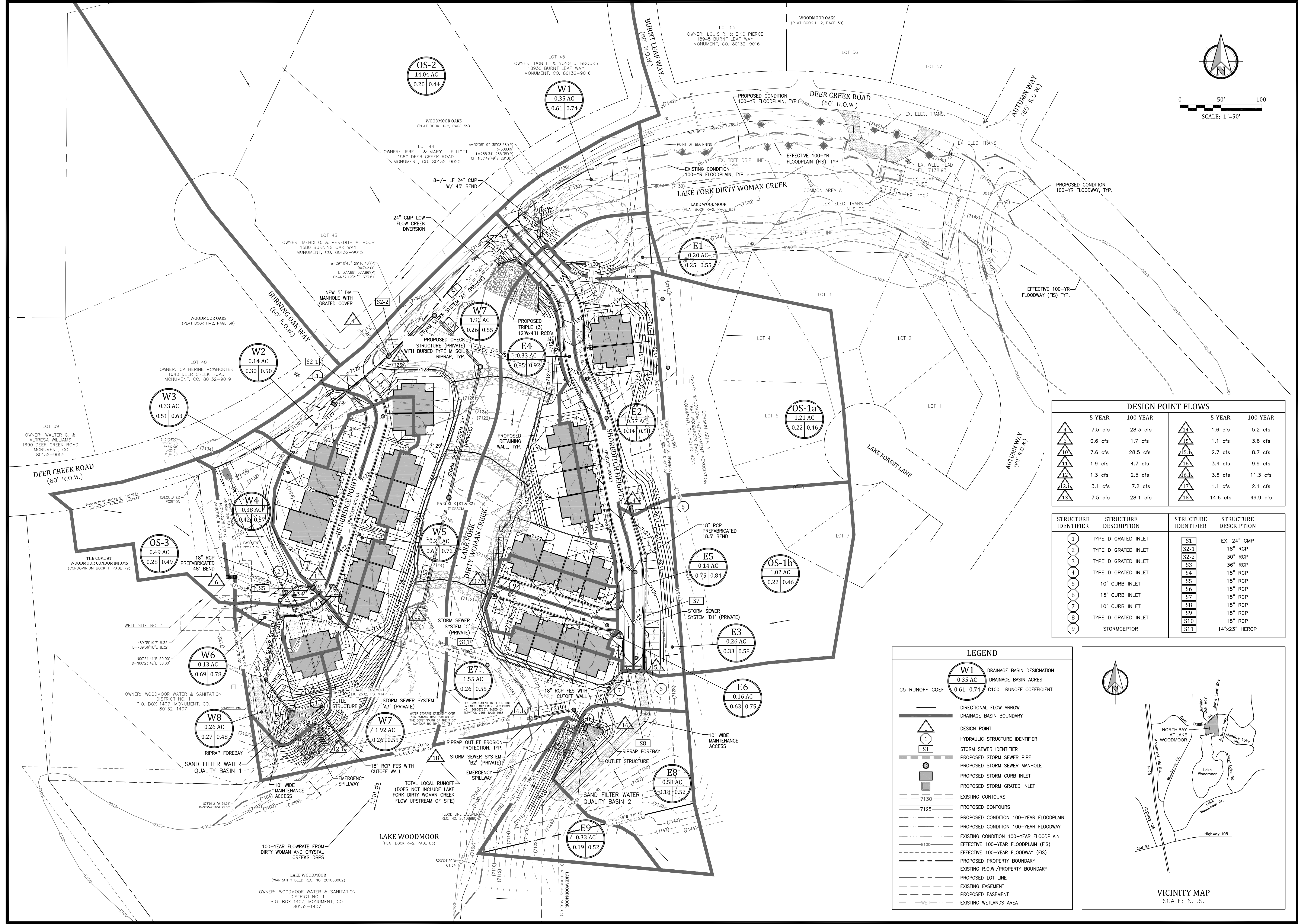

DESIGN POINT FLOWS					
	5-YEAR	100-YEAR		5-YEAR	100-YEAR
▲ 8	7.5 cfs	28.3 cfs	▲ 14	1.6 cfs	5.2 cfs
▲ 9	0.6 cfs	1.7 cfs	▲ 15	1.1 cfs	3.6 cfs
▲ 10	7.6 cfs	28.5 cfs	▲ 16	2.7 cfs	8.7 cfs
▲ 11	1.9 cfs	4.7 cfs	▲ 17	3.4 cfs	9.9 cfs
▲ 12	1.3 cfs	2.5 cfs	▲ 18	3.6 cfs	11.3 cfs
▲ 13	3.1 cfs	7.2 cfs		1.1 cfs	2.1 cfs
	7.5 cfs	28.1 cfs		14.6 cfs	49.9 cfs

STRUCTURE IDENTIFIER	STRUCTURE DESCRIPTION	STRUCTURE IDENTIFIER	STRUCTURE DESCRIPTION
1	TYPE D GRATED INLET	S1	EX. 24" CMP
2	TYPE D GRATED INLET	S2-1	18" RCP
3	TYPE D GRATED INLET	S2-2	30" RCP
4	TYPE D GRATED INLET	S3	36" RCP
5	10' CURB INLET	S4	18" RCP
6	15' CURB INLET	S5	18" RCP
7	10' CURB INLET	S6	18" RCP
8	TYPE D GRATED INLET	S7	18" RCP
9	STORMCEPTOR	S8	18" RCP
		S9	18" RCP
		S10	18" RCP
		S11	14"x23" HERCP

LEGEND	
W1	W1 DRAINAGE BASIN DESIGNATION 0.35 AC DRAINAGE BASIN ACRES
C5	C5 RUNOFF COEFF
0.61 0.74	0.61 0.74 C100 RUNOFF COEFFICIENT
→	DIRECTIONAL FLOW ARROW
—	DRAINAGE BASIN BOUNDARY
▲	DESIGN POINT
▲	HYDRAULIC STRUCTURE IDENTIFIER
○	STORM SEWER IDENTIFIER
○	PROPOSED STORM SEWER PIPE
○	PROPOSED STORM SEWER MANHOLE
○	PROPOSED STORM CURB INLET
○	PROPOSED STORM GRATED INLET
—	EXISTING CONTOURS
—	PROPOSED CONTOURS
—	PROPOSED CONDITION 100-YEAR FLOODPLAIN
—	PROPOSED CONDITION 100-YEAR FLOODWAY
—	EXISTING CONDITION 100-YEAR FLOODPLAIN
—	EFFECTIVE 100-YEAR FLOODWAY (FIS)
—	EFFECTIVE 100-YEAR FLOODWAY (FIS)
—	PROPOSED PROPERTY BOUNDARY
—	EXISTING R.O.W./PROPERTY BOUNDARY
—	PROPOSED LOT LINE
—	EXISTING EASEMENT
—	PROPOSED EASEMENT
—	EXISTING WETLANDS AREA

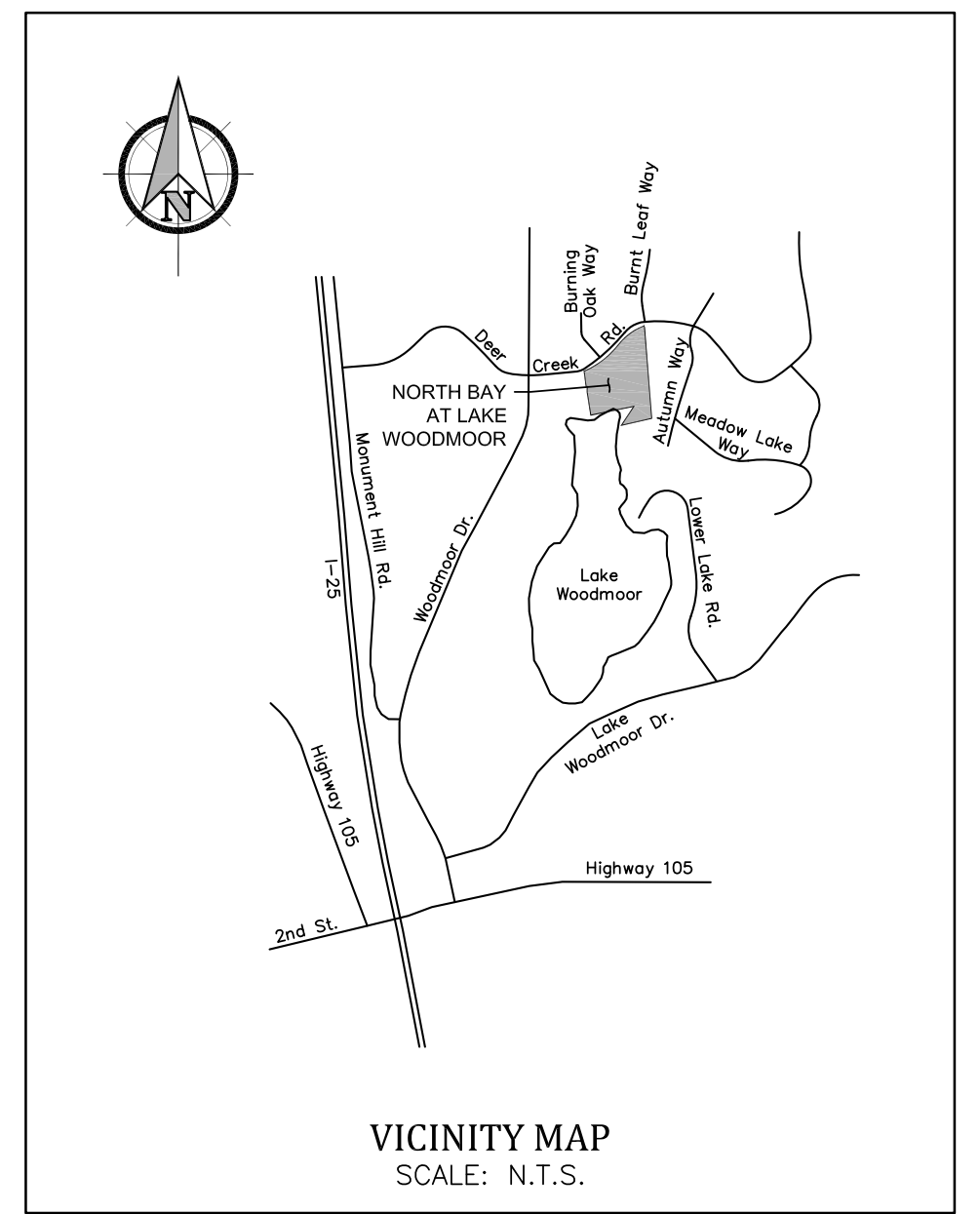

North Bay at Lake Woodmoor
Final Drainage Plan
Developed Condition
 El Paso County, Colorado

Project No.:	15073
Date:	September 4, 2018
Design:	CJC
Drawn:	CJC
Check:	AWMc
Revisions:	

SHEET
DP2