



**ENTECH**  
ENGINEERING, INC.

505 ELKTON DRIVE  
COLORADO SPRINGS, CO 80907  
PHONE (719) 531-5599

**PAVEMENT DESIGN REPORT  
RETREAT AT PRAIRIE RIDGE, FILING NO. 2  
BRIARGATE BOULEVARD  
EL PASO COUNTY, COLORADO**

**PCD File No. SF259**

Prepared for:  
**Classic SRJ**  
**2138 Flying Horse Club Drive**  
**Colorado Springs, CO 80921**

Attn: Austin Lenz

April 14, 2026

Respectfully Submitted,

ENTECH ENGINEERING, INC.

Lucas Morrison  
Geotechnical Engineering Staff

Reviewed by:

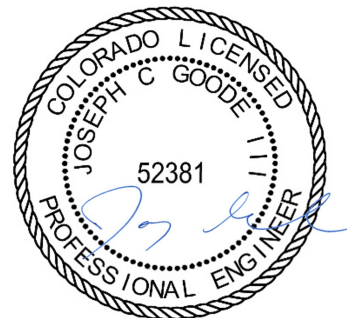

Joseph C. Goode III, P.E.  
Sr. Engineer

LJM:JCG/ed

Entech Job No. 241932

**Table of Contents**

**1 Introduction ..... 1**

**2 Project Description ..... 1**

**3 Subsurface Explorations and Laboratory Testing ..... 1**

    3.1 Subsurface Exploration Program ..... 1

    3.2 Geotechnical Index and Engineering Property Testing ..... 2

**4 Subgrade Conditions ..... 2**

    4.1 Subsurface Conditions ..... 3

    4.2 Groundwater ..... 3

**5 Pavement Design Recommendations ..... 3**

    5.1 Subgrade Conditions ..... 3

    5.2 Cement-Treated Subgrade Design ..... 4

    5.3 Swell Mitigation ..... 4

    5.4 Traffic Loading ..... 5

    5.5 Pavement Design ..... 5

**6 Construction Recommendations ..... 6**

    6.1 Earthwork Recommendations for Pavement Subgrade ..... 6

        6.1.1 Subgrade Preparation – Unbound Base Alternatives ..... 6

        6.1.2 Subgrade Preparation – Cement-Treated Base ..... 7

        6.1.3 Fill Placement and Compaction ..... 8

        6.1.4 Aggregate Base Course and Recycled Concrete Base ..... 8

    6.2 Concrete Degradation Due to Sulfate Attack ..... 8

    6.3 Construction Observation ..... 8

**7 Closure ..... 9**

**Figures**

Figure 1: Vicinity Map

Figure 2: Site and Exploration Plan

**List of Appendices**

Appendix A: Test Boring Logs

Appendix B: Laboratory Test Results

Appendix C: Pavement Design Calculations

## 1 Introduction

Entech Engineering, Inc. (Entech) completed this pavement design report for the Briargate Parkway and Dines Boulevard roadways within the Retreat at Prairie Ridge, Filing No. 2. This report describes the subsurface exploration program and laboratory testing program conducted for the proposed roadway improvements and provides pavement section alternatives and construction recommendations. Entech participated in this project as a subconsultant to Classic SRJ. The contents of this report, including the pavement design recommendations, are subject to the limitations and assumptions presented in Section 7.

## 2 Project Description

The site is located northeast of the intersection of Vollmer Road and Briargate Parkway within the Retreat at Prairie Ridge, Filing No. 2, in El Paso County, Colorado (Figure 1). The proposed improvements include paving portions of Briargate Parkway and the round-about connections to Dines Boulevard within the Retreat at Prairie Ridge, Filing No. 2. The extent of our investigation is shown in Figure 2.

At the time of our subsurface exploration program, the existing roadway was rough-graded, and utilities had been installed. Surrounding properties comprise vacant land, land being developed for future residential lots, and an existing subdivision. Based on the development plans, Briargate Parkway is designated as an urban principal 4-lane arterial roadway, and Dines Boulevard is designated as an urban residential collector roadway.

## 3 Subsurface Explorations and Laboratory Testing

### 3.1 Subsurface Exploration Program

Subsurface conditions within the project site were explored by nine test borings, designated TB-1 through TB-9, drilled on March 4, 2026. The locations of the test borings are shown on the Site and Exploration Plan (Figure 2). The borings were drilled to depths of 5 to 10 feet below the existing ground surface (bgs). The drilling was performed using a truck-mounted, continuous flight auger drill rig supplied and operated by Entech. Descriptive boring logs providing the lithologies of the subsurface conditions encountered during drilling are presented in Appendix A. Groundwater levels were measured in each of the open boreholes at the conclusion of drilling.

Soil samples were obtained from the borings utilizing the Standard Penetration Test (ASTM D1586) using a 2-inch outside diameter split spoon or a 2½-inch modified California sampler. Results of the Standard Penetration Test (SPT) are included on the boring logs in terms of N-values expressed in blows per foot (bpf). Soil samples recovered from the borings were visually classified and recorded on the boring logs. The soil classifications were later verified utilizing laboratory testing and grouped by soil type. The soil type numbers are included on the boring logs. It should be understood that the soil descriptions shown on the boring logs may vary between boring locations and sample depths. It should also be noted that the lines of stratigraphic separation shown on the boring logs represent approximate boundaries between soil types, and the actual stratigraphic transitions may be more gradual or variable with location.

### **3.2 Geotechnical Index and Engineering Property Testing**

Water content testing (ASTM D2216) was performed on the samples recovered from the borings, and the results are shown on the boring logs. Grain-size analysis (ASTM D422) and Atterberg limits testing (ASTM D4318) were performed on selected samples to assist in classifying the materials encountered in the borings.

For pavement design, a Modified Proctor (ASTM D1557) and a California Bearing Ratio (CBR) test (ASTM D1883) were completed. Soluble sulfate testing was performed on select soil samples to evaluate the potential for below-grade degradation of concrete due to sulfate attack. The laboratory testing results are presented in Appendix B and summarized in Table B-1.

Compressive strength testing of cement-treated soil was conducted on a representative soil sample collected from boring TB-3 and is presented in Section 5.2. A summary of the testing results is attached in Appendix B, Table B-2.

## **4 Subgrade Conditions**

Three primary soil types and one bedrock type were encountered in the test borings drilled for the subsurface investigation. Each soil type was classified in accordance with the Unified Soil Classification System (USCS) and the American Association of State Highway and Transportation Officials (AASHTO) soil classification system using the laboratory testing results and the observations made during drilling.

#### **4.1 Subsurface Conditions**

Subsurface conditions along the proposed roadways generally consisted of medium dense to dense silty sand fill (Soil Type 1, AASHTO A-1-b, A-2-4, A-2-6). Native hard sandy clay (Soil Type 2, AASHTO A-4) was encountered underlying Soil Type 1 in boring TB-4 at 4 feet bgs and extended to the termination depth of the boring. Native medium dense silty sand (Soil Type 3, AASHTO A-1-b, A-2-6) was encountered underlying Soil Type 1 in borings TB-8 and TB-9 at depths of 4 feet and 2 feet bgs, respectively. Sandstone bedrock, or very dense silty sand when classified as a soil (Soil Type 3, AASHTO A-2-4, A-4), was encountered underlying Soil Type 1 in borings TB-1 and TB-2 at a depth of 1 foot bgs and extended to the termination depth of both borings.

Laboratory test results are presented in Appendix B and are summarized in Table B-1.

#### **4.2 Groundwater**

Groundwater was not encountered in the test borings. Groundwater fluctuations are possible and will depend on seasonal variations, local precipitation, runoff, and other factors; however, we do not anticipate that groundwater will affect the proposed roadway construction.

### **5 Pavement Design Recommendations**

Pavement design recommendations were made in accordance with the *El Paso County Engineering Criteria Manual (ECM)*.

#### **5.1 Subgrade Conditions**

California Bearing Ratio (CBR) testing was performed on a representative sample of the Soil Type 1 silty sand fill from TB-3 to determine the support characteristics of the subgrade soils. The results of the CBR testing are presented in Appendix B and summarized in Exhibit 1.

**Exhibit 1: Subsurface Laboratory Testing Summary**

Design Parameter	Value
Soil Type	1 – Silty Sand
CBR at 95%	35.3
Design CBR	10
Liquid Limit	NV
Plasticity Index	NP
Percent Passing 200	21.9
AASHTO Classification	A-2-4
Unified Soils Classification	SM

**5.2 Cement-Treated Subgrade Design**

Strength testing for the site subgrade soils was performed on a set of soil-cement samples from boring TB-3 (Soil Type 1). Testing was performed on soil-cement samples prepared with 2% and 4% Portland Cement Type 1L. A compressive strength of 160 pounds per square inch (psi) is recommended for cement-stabilized subgrade. The results of the strength testing and Modified Proctor (ASTM D1557) maximum dry density are presented in Appendix B and summarized in Exhibit 2. A **2% mix is recommended** for Soil Type 1 based on the laboratory test results.

**Exhibit 2: Subsurface Laboratory Testing Summary**

Design Parameter	Value
Soil Type	1 – Clayey Sand Fill
Design CBR	10
Average Compressive Strength for 2% Mix (psi)	430 <sup>1</sup>
Average Compressive Strength for 4% Mix (psi)	430 <sup>1</sup>
Optimum Moisture Content (%)	8.1
Maximum Dry Density (pcf)	129.4

Note:

1. A low-capacity break machine was utilized for strength testing; however, the samples exceeded the machine’s maximum capacity.

The amount of cement applied shall be a minimum of 2% (by weight) of the subgrade’s maximum dry density as determined by the Modified Proctor (ASTM D1557) for granular soils.

**5.3 Swell Mitigation**

El Paso County requires swell mitigation for soils with swell testing results greater than 2% under a surcharge of 150 pounds per square foot (psf). Based on the swell testing and classification of the subgrade soils, mitigation for expansive soils is not required on this site.

#### 5.4 Traffic Loading

Traffic data is not available for the proposed roadways within the Retreat at Prairie Ridge, Filing No. 2; however, Briargate Parkway is designated as an urban principal 4-lane arterial roadway, and Dines Boulevard is designated as an urban residential collector roadway based on current development plans. The *El Paso County Engineering Criteria Manual* provides default 18-kip equivalent single axle loadings (ESAL) based on the street classification. For design, a default ESAL value of 5,256,000 was used for the urban principal 4-lane arterial roadway designation, and a default ESAL value of 821,000 was used for the urban residential collector roadway designation.

#### 5.5 Pavement Design

The pavement sections were determined utilizing the *El Paso County Engineering Criteria Manual*, the CBR testing, and the default ESAL. Design parameters used in the pavement analysis are presented in Exhibit 3.

**Exhibit 3: Pavement Design Parameters**

Design Parameter	Value
Reliability	
Principal 4-Lane Arterial	90%
Residential Collector	85%
Standard Deviation	0.45
Serviceability Loss ( $\Delta$ psi)	2.0
Design CBR	10
Resilient Modulus	15,000 psi
Structural Coefficients	
Hot Bituminous Pavement	0.44
Aggregate Base Course	0.11
Recycled Concrete Base	0.11
Cement-Treated Soil	0.11

Pavement section alternatives recommended for the proposed roadways are summarized in Exhibit 4. The pavement design calculations are presented in Appendix C.

**Exhibit 4: Recommended Pavement Sections**

Pavement Area	Roadway Designation	Design ESAL	Alternative <sup>1</sup>
Briargate Parkway	Principal Arterial 4-Lane	5,256,000	1. 5.0 inches HMA over 12.0 inches ABC/RCB
			2. 5.0 inches HMA over 12.0 inches CTS <sup>2</sup>
Dines Boulevard	Residential Collector	821,000	1. 4.0 inches HMA over 8.0 inches ABC/RCB
			2. 4.0 inches HMA over 8.0 inches CTS <sup>2</sup>

ABC = Aggregate Base Course; CTS = Cement-Treated Soil; ESAL = Equivalent Single Axle Loads; HMA = Hot Mix Asphalt; RCB = Recycled Concrete Base

Notes:

1. All pavement alternatives meet the minimum sections required per the *El Paso County Engineering Criteria Manual*.
2. The use of CTS will require a deviation request approval.

**6 Construction Recommendations**

Pavement design recommendations provided herein are contingent on good construction practices, and poor construction techniques may result in poor performance. Our analyses assumed that this project would be constructed according to the *El Paso County Engineering Criteria Manual* and the *Pikes Peak Region Asphalt Paving Specifications*.

**6.1 Earthwork Recommendations for Pavement Subgrade**

Proper subgrade preparation is required for adequate pavement performance. Paving areas should be cleared of all deleterious materials, including but not limited to existing pavements, utility poles, and fence poles. Surface vegetation, if any, should be removed by stripping, with the depth to be field-determined.

**6.1.1 Subgrade Preparation – Unbound Base Alternatives**

If pavement section alternatives are selected utilizing aggregate base course (ABC) or recycled concrete base (RCB), the final subgrade surface should be scarified to a depth of 8 inches, moisture conditioned within +/- 2% of the optimum water content, and recompacted to 95% of the Modified Proctor (ASTM D1557) maximum dry density.

The compacted surface below pavements should be proof rolled with a fully loaded, tandem-axle, 10-yard dump truck or equivalent. Any areas that are delineated to be soft, loose, or yielding during proof rolling should be removed and reconditioned, or replaced.

### 6.1.2 Subgrade Preparation – Cement-Treated Base

If pavement section alternatives are selected utilizing cement-treated soil (CTS), a preliminary proof roll should be completed with a fully loaded, tandem-axle, 10-yard dump truck or equivalent prior to placement of cement stabilization. Any areas that are delineated to be soft, loose, or yielding during proof rolling should be removed and reconditioned, or replaced.

Following the preliminary proof roll, the subgrade shall be stabilized by the addition of cement. The amount of cement applied shall be a minimum of 2% (by weight) of the subgrade's maximum dry density as determined by the Modified Proctor (ASTM D1557) for granular soils or by the Standard Proctor (ASTM D698) for cohesive soils. The cement should be spread evenly on the subgrade surface and thoroughly mixed into the subgrade such that a uniform blend of soil and cement is achieved to the CTS design depth. Densification of the cement-stabilized subgrade should be completed to obtain a compaction of at least 95% of the subgrade's maximum dry density as determined by the Modified Proctor (ASTM D1557) or by the Standard Proctor (ASTM D698). Satisfactory compaction of the subgrade shall occur within 90 minutes from the time of mixing the cement into the subgrade.

The following conditions shall be followed as part of the subgrade stabilization:

- Type 1L cement as supplied; a local supplier shall be used. All cement used for stabilization should come from the same source. If cement sources are changed, a new laboratory mix design should be completed.
- Moisture conditioning of the subgrade and/or mixing of the cement into the subgrade shall not occur when soil temperatures are below 40 degrees F. Cement-treated subgrades should be maintained at a temperature of 40 degrees F or greater until the subgrade has been compacted as required.
- Cement placement, cement mixing, and compaction of the cement-treated subgrade should be observed by Entech Engineering. Testing should include in-situ compaction tests and representative compacted specimens of the treated subgrade material for subsequent laboratory quality assurance testing. Testing reports will be provided to El Paso County as construction progresses.
- A minimum 7-day CTS compressive strength of 125 psi must be achieved.
- Soil strengths in excess of 275 psi will require microfracturing. Microfracturing will be completed using the Standard Method as defined by the *City of Colorado Springs Draft Standard Specification*, Section 305 – Chemically-Treated Subgrade. Microfracturing will be

performed with the same (or equivalent tonnage) steel drum vibratory roller used for compaction of the CTS. A minimum 12-ton roller shall be used. Three full passes with the roller operating at maximum amplitude and traveling at 2- 3 mph shall be applied. If the treated material breaks up excessively at the surface, the vibration amplitude shall be decreased or eliminated.

### **6.1.3 Fill Placement and Compaction**

Granular fill placed as part of the pavement subgrade shall consist of nonexpansive, granular soil, free of organic matter, unsuitable materials, debris, and cobbles greater than 3 inches in diameter. Additionally, any granular fill placed as part of the roadway subgrade should have a minimum CBR of 10. All granular fill placed within the pavement subgrade should be compacted to a minimum of 95% of the Modified Proctor (ASTM D1557) maximum dry density at +/-2% of optimum moisture content. Fill material should be placed in horizontal lifts such that each finished lift has a compacted thickness of 6 inches or less. Entech should approve any imported fill to be used within the pavement subgrade area prior to delivery to the site.

### **6.1.4 Aggregate Base Course and Recycled Concrete Base**

ABC or RCB materials shall conform to the *El Paso County Standard Specifications Manual*, Appendix D, Table D-6. ABC or RCB materials should be compacted to a minimum of 95% of the Modified Proctor (ASTM D1557) maximum dry density within +/-2% of optimum moisture content.

## **6.2 Concrete Degradation Due to Sulfate Attack**

Sulfate solubility testing was conducted on several samples recovered from the test borings to evaluate the potential for sulfate attack on concrete. The test results indicated less than 0.01% soluble sulfate (by weight). The test results indicate the sulfate component of the in-place soils presents a negligible to severe exposure threat to concrete placed below the site grade.

As presented in the *Evaluation of Selected Pavement Specifications and Responses to Questions Relevant to Design and Construction of Cement-Treated Soil and Aggregate Layers in El Paso County, Colorado* report from Spencer Gutherie and Robert Stevens dated March 13, 2024, soils with less than 3,000 ppm (0.3%) do not require special construction practices.

## **6.3 Construction Observation**

Subgrade preparation for pavement structures should be observed by Entech in order to verify that (1) no anomalies are present, (2) materials similar to those described in this report have been encountered or placed, and (3) no soft spots, expansive or organic soil, or debris are present in

the pavement subgrade prior to paving. Construction observation requirements, as presented in the Use of CTS for Paving Season Memorandum, should be followed.

## **7 Closure**

The subsurface investigation, geotechnical evaluation, and recommendations presented in this report are intended for use by Classic SRJ with application to the paving of Briargate Parkway and Dines Boulevard within the Retreat at Prairie Ridge, Filing No. 2, in El Paso County, Colorado. In conducting the subsurface investigation, laboratory testing, engineering evaluation, and reporting, Entech Engineering, Inc. endeavored to work in accordance with generally accepted professional geotechnical and geologic practices and principles consistent with the level of care and skill ordinarily exercised by members of the geotechnical profession currently practicing in the same locality and under similar conditions. No other warranty, expressed or implied, is made. During final design and/or construction, if conditions are encountered that appear different from those described in this report, Entech Engineering, Inc. requests to be notified so that the evaluation and recommendations presented herein can be reviewed and modified as appropriate.

If there are any questions regarding the information provided herein, or if Entech Engineering, Inc. can be of further assistance, please do not hesitate to contact us.





**VICINITY MAP**  
RETREAT AT PRAIRIE RIDGE, FILING NO. 2  
CLASSIC SRJ

JOB NO.  
241932

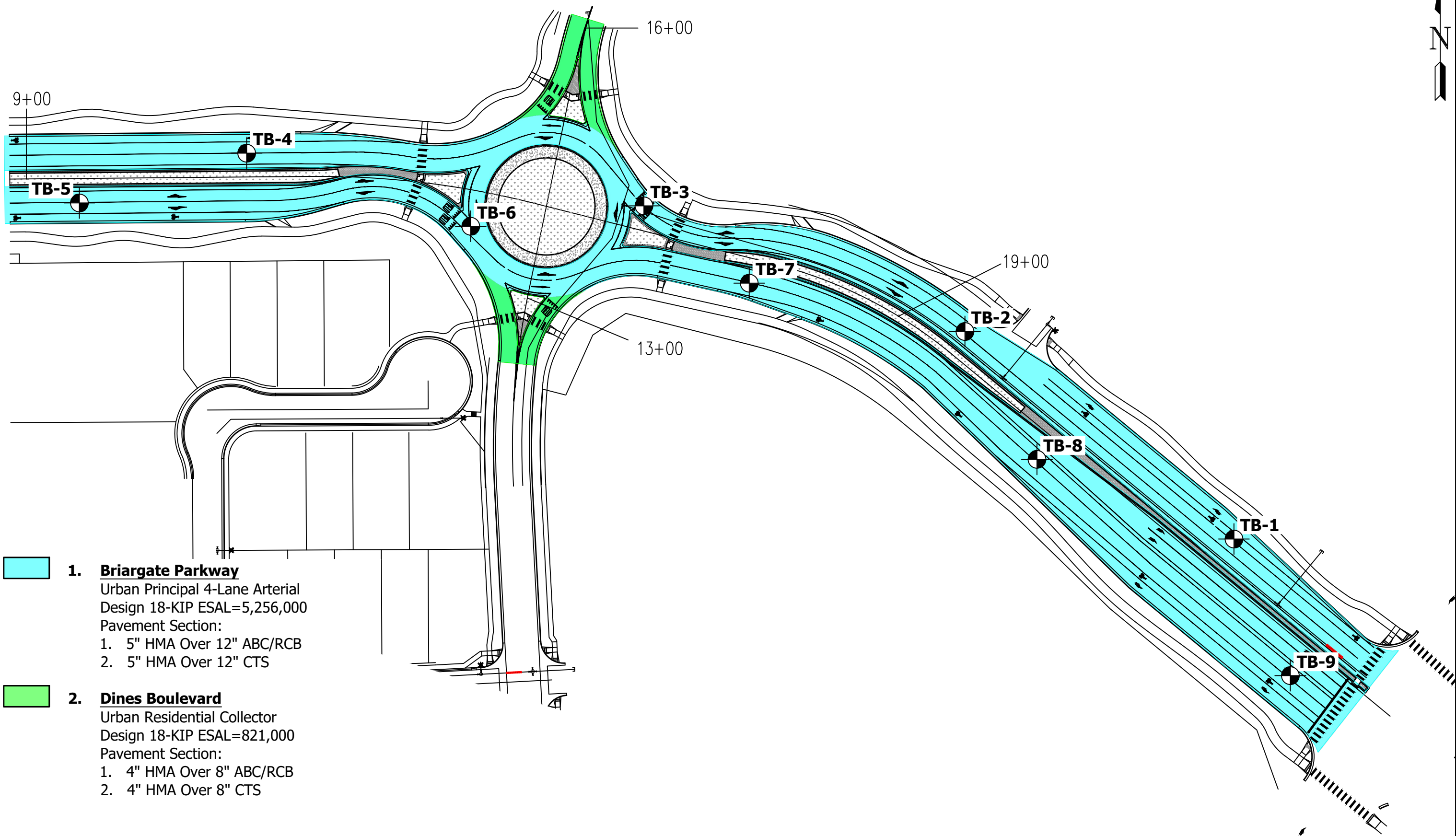
**FIG. 1**



-  **1. Briargate Parkway**  
Urban Principal 4-Lane Arterial  
Design 18-KIP ESAL=5,256,000  
Pavement Section:
  1. 5" HMA Over 12" ABC/RCB
  2. 5" HMA Over 12" CTS
  
-  **2. Dines Boulevard**  
Urban Residential Collector  
Design 18-KIP ESAL=821,000  
Pavement Section:
  1. 4" HMA Over 8" ABC/RCB
  2. 4" HMA Over 8" CTS

 **TB- APPROXIMATE TEST BORING LOCATION AND NUMBER**

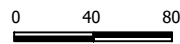
SCALE: 



**SITE AND EXPLORATION PLAN**  
RETREAT AT PRAIRIE RIDGE, FILING NO. 2  
CLASSIC SRJ

JOB NO.  
241932  
**FIG. 2**



## **APPENDIX A: Test Boring Logs**

TEST BORING 1  
 DATE DRILLED 3/4/2026

TEST BORING 2  
 DATE DRILLED 3/4/2026

REMARKS

REMARKS

DRY TO 5', 3/4/26

FILL, SAND, SILTY, BROWN  
 SANDSTONE, VERY WEAK, GRAY  
 to TAN, HIGHLY WEATHERED  
 (SAND, SILTY, VERY DENSE,  
 MOIST)

Depth (ft)	Symbol	Samples	Blows per foot	Watercontent %	Soil Type
0					1
0			50	10.7	2
5			50	13.7	2
5			7"		
10					
15					
20					

DRY TO 10', 3/4/26

FILL, SAND, SILTY, BROWN  
 SANDSTONE, VERY WEAK, GRAY  
 to TAN, HIGHLY WEATHERED  
 (SAND, SILTY, VERY DENSE,  
 MOIST)

Depth (ft)	Symbol	Samples	Blows per foot	Watercontent %	Soil Type
0					1
0			50	4.1	2
5			50	3.6	2
5			10"		
10			50	11.9	2
10			8"		
15					
20					



**TEST BORING LOGS**  
 RETREAT AT PRAIRIE RIDGE, FILING NO. 2  
 CLASSIC SRJ

JOB NO.  
 241932  
**FIG. A-1**

TEST BORING 3  
 DATE DRILLED 3/4/2026

TEST BORING 4  
 DATE DRILLED 3/4/2026

REMARKS

REMARKS

DRY TO 5', 3/4/26

FILL 0-5', SAND, SILTY, TAN to BROWN, MEDIUM DENSE, MOIST

Depth (ft)	Symbol	Samples	Blows per foot	Watercontent %	Soil Type
0-5	(Symbol: dots)		16	7.8	1
5-5.5	(Symbol: dots)		19	9.5	1

DRY TO 5', 3/4/26

FILL 0-5', SAND, SILTY, TAN to GRAY, MEDIUM DENSE, MOIST

FILL, CLAY, SANDY, GRAY, HARD, MOIST

Depth (ft)	Symbol	Samples	Blows per foot	Watercontent %	Soil Type
0-5	(Symbol: dots)		25	10.6	1
5-5.5	(Symbol: dots)		30	13.4	2



**TEST BORING LOGS**  
 RETREAT AT PRAIRIE RIDGE, FILING NO. 2  
 CLASSIC SRJ

JOB NO.  
 241932

**FIG. A-2**

TEST BORING 5  
 DATE DRILLED 3/4/2026

TEST BORING 6  
 DATE DRILLED 3/4/2026

REMARKS

REMARKS

DRY TO 5', 3/4/26

FILL 0-5', SAND, SILTY, TAN to BROWN, MEDIUM DENSE, MOIST

Depth (ft)	Symbol	Samples	Blows per foot	Watercontent %	Soil Type
5			21	10.8	1
5			20	10.7	1
10					
15					
20					

DRY TO 5', 3/4/26

FILL 0-10', SAND, SILTY, BROWN to TAN, MEDIUM DENSE, MOIST

Depth (ft)	Symbol	Samples	Blows per foot	Watercontent %	Soil Type
5			26	6.6	1
5			20	9.2	1
10			20	9.1	1
15					
20					



**TEST BORING LOGS**  
 RETREAT AT PRAIRIE RIDGE, FILING NO. 2  
 CLASSIC SRJ

JOB NO.  
 241932

**FIG. A-3**

TEST BORING 7  
 DATE DRILLED 3/4/2026

TEST BORING 8  
 DATE DRILLED 3/4/2026

REMARKS

REMARKS

DRY TO 5', 3/4/26

FILL 0-5', SAND, SILTY,  
 BROWN, MEDIUM DENSE,  
 MOIST

Depth (ft)	Symbol	Samples	Blows per foot	Watercontent %	Soil Type
0-5	(Symbol)		17	9.3	1
5	(Symbol)		23	9.9	1
10	(Symbol)				
15	(Symbol)				
20	(Symbol)				

DRY TO 5', 3/4/26

FILL 0-4', SAND, SILTY, BROWN,  
 MEDIUM DENSE, MOIST  
  
 SAND, SILTY, BROWN, MEDIUM  
 DENSE, MOIST

Depth (ft)	Symbol	Samples	Blows per foot	Watercontent %	Soil Type
0-4	(Symbol)		29	5.9	1
4-5	(Symbol)		16	7.2	3
10	(Symbol)				
15	(Symbol)				
20	(Symbol)				



**TEST BORING LOGS**  
 RETREAT AT PRAIRIE RIDGE, FILING NO. 2  
 CLASSIC SRJ

JOB NO.  
 241932  
**FIG. A-4**

TEST BORING 9  
 DATE DRILLED 3/4/2026

REMARKS

DRY TO 5', 3/4/26

FILL 0-2', SAND, SILTY, BROWN,  
 DENSE, MOIST  
 SAND, SILTY, BROWN, MEDIUM  
 DENSE, MOIST

Depth (ft)	Symbol	Samples	Blows per foot	Watercontent %	Soil Type
0-2	(Symbol: dots and dashes)	(Symbol: solid black)	32	7.8	1
2-5	(Symbol: dots and dashes)	(Symbol: solid black)	27	8.3	3
5-20	(Symbol: vertical line)	(Symbol: vertical line)			



**TEST BORING LOGS**  
 RETREAT AT PRAIRIE RIDGE, FILING NO. 2  
 CLASSIC SRJ

JOB NO.  
 241932

**FIG. A-5**



## **APPENDIX B: Laboratory Test Results**

**TABLE B-1  
SUMMARY OF LABORATORY TEST RESULTS**



SOIL TYPE	TEST BORING NO.	DEPTH (FT)	WATER (%)	DRY DENSITY (PCF)	PASSING NO. 200 SIEVE (%)	LIQUID LIMIT	PLASTIC LIMIT	PLASTIC INDEX	SULFATE (WT %)	SWELL/ COLLAPSE (%)	AASHTO CLASS. (GROUP INDEX)	USCS	SOIL DESCRIPTION
1, CBR	3	0-3	9.8		21.9	NV	NP	NP			A-2-4 (0)	SM	FILL, SAND, SILTY
1	3	1-2	7.8		13.3	NV	NP	NP	0.00		A-1-b (0)	SM	FILL, SAND, SILTY
1	4	1-2	10.5		23.7	33	25	8			A-1-b (0)	SM	FILL, SAND, SILTY
1	5	1-2	10.5		15.7	36	25	11			A-2-6 (0)	SM	FILL, SAND, SILTY
1	6	1-2	6.6		28.6	NV	NP	NP			A-2-4 (0)	SM	FILL, SAND, SILTY
1	7	1-2	8.7		22.9	NV	NP	NP			A-1-b (0)	SM	FILL, SAND, SILTY
1	8	1-2	5.9		19.8	NV	NP	NP			A-1-b (0)	SM	FILL, SAND, SILTY
1	9	1-2	8.0		21.1	NV	NP	NP			A-1-b (0)	SM	FILL, SAND, SILTY
1	7	0-3	7.4		20.9							SM	FILL, SAND, SILTY
2	4	5	12.0	117.2	65.9	33	23	10	0.00	0.3	A-4 (5)	CL	FILL, CLAY, SANDY
3	8	5	6.9		23.0	NV	NP	NP	<0.01		A-1-b (0)	SM	SAND, SILTY
3	9	5	8.1		11.0	40	27	13			A-2-6 (0)	SM	SAND, SILTY
4	1	1-3	9.7		41.9	NV	NP	NP			A-4 (0)	SM	SANDSTONE (SAND, SILTY)
4	1	1-2	22.2		47.2	NV	NP	NP	<0.01		A-4 (0)	SM	SANDSTONE (SAND, SILTY)
4	2	1-2	4.4		19.2	NV	NP	NP			A-2-4 (0)	SM	SANDSTONE (SAND, SILTY)

**TABLE B-2  
SUMMARY OF CTS TEST RESULTS**

<i>FIELD SAMPLE ID</i>	<i>SOIL ADDITIVE</i>	<i>ADDITIVE PERCENTAGE (%)</i>	<i>WATER CONTENT (%)</i>	<i>DENSITY (dry)</i>	<i>AGE (days)</i>	<i>STRENGTH (psi)</i>
TB-3 @ 0-3'	TYPE IL CEMENT	2	8.1	122.4	7	430*
				122.2		430*
				122.3		430*
AVERAGE:						<b>430*</b>
TB-3 @ 0-3'	TYPE IL CEMENT	4	8.1	122.4	7	430*
				122.7		430*
				122.3		430*
AVERAGE:						<b>430*</b>

Notes:

1. CURING METHOD: Ambient Temperature Oven

\* - Low-capacity break machine was utilized for strength testing; however, the samples exceeded the machine's maximum capacity.

TEST BORING 3  
 DEPTH (FT) 0-3

SOIL DESCRIPTION FILL, SAND, SILTY  
 SOIL TYPE 1, CBR

**Sieve Analysis  
 Grain Size Distribution**

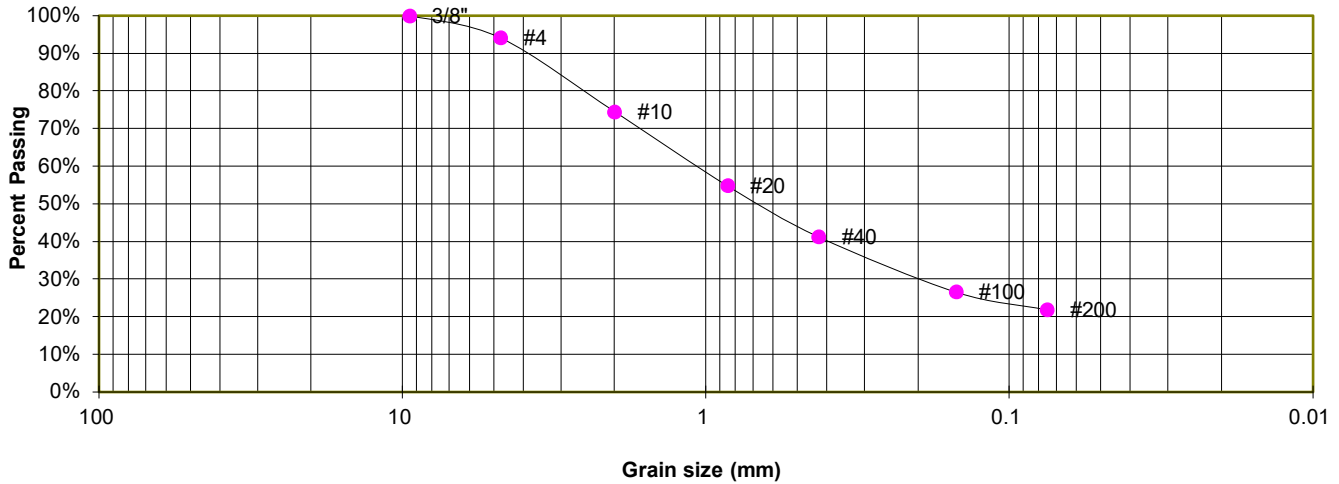

**GRAIN SIZE ANALYSIS**

U.S. Sieve #	Percent Finer
3"	
1 1/2"	
3/4"	
1/2"	
3/8"	100.0%
4	94.2%
10	74.5%
20	54.9%
40	41.3%
100	26.6%
200	21.9%

**ATTERBERG LIMITS**

Plastic Limit	NP
Liquid Limit	NV
Plastic Index	NP

**SOIL CLASSIFICATION**

USCS CLASSIFICATION: SM  
 AASHTO CLASSIFICATION: A-2-4  
 AASHTO GROUP INDEX: 0



**LABORATORY TEST RESULTS**

RETREAT AT PRAIRIE RIDGE, FILING NO. 2  
 CLASSIC SRJ

JOB NO.  
 241932

**FIG. B-1**

TEST BORING 3  
 DEPTH (FT) 1-2

SOIL DESCRIPTION FILL, SAND, SILTY  
 SOIL TYPE 1

**Sieve Analysis  
 Grain Size Distribution**

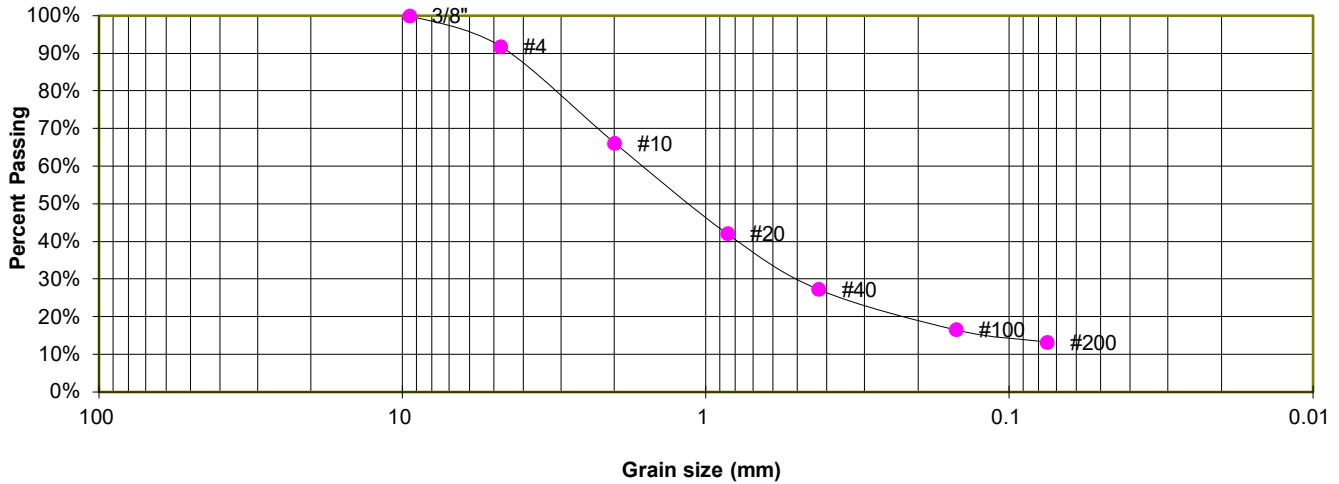

**GRAIN SIZE ANALYSIS**

U.S. Sieve #	Percent Finer
3"	
1 1/2"	
3/4"	
1/2"	
3/8"	100.0%
4	91.8%
10	66.2%
20	42.1%
40	27.3%
100	16.6%
200	13.3%

**ATTERBERG LIMITS**

Plastic Limit	NP
Liquid Limit	NV
Plastic Index	NP

**SOIL CLASSIFICATION**

USCS CLASSIFICATION: SM  
 AASHTO CLASSIFICATION: A-1-b  
 AASHTO GROUP INDEX: 0



**LABORATORY TEST RESULTS**  
 RETREAT AT PRAIRIE RIDGE, FILING NO. 2  
 CLASSIC SRJ

JOB NO.  
 241932  
**FIG. B-2**

TEST BORING 4  
 DEPTH (FT) 1-2

SOIL DESCRIPTION FILL, SAND, SILTY  
 SOIL TYPE 1

**Sieve Analysis  
 Grain Size Distribution**

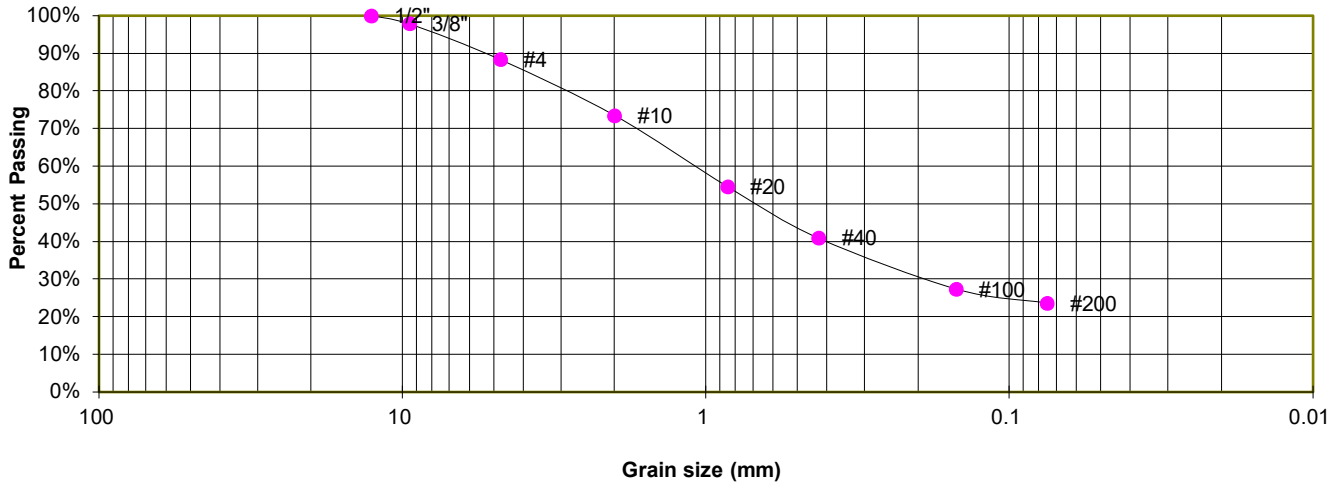

**GRAIN SIZE ANALYSIS**

U.S. Sieve #	Percent Finer
3"	
1 1/2"	
3/4"	
1/2"	100.0%
3/8"	97.9%
4	88.4%
10	73.5%
20	54.6%
40	40.9%
100	27.4%
200	23.7%

**ATTERBERG LIMITS**

Plastic Limit	25
Liquid Limit	33
Plastic Index	8

**SOIL CLASSIFICATION**

USCS CLASSIFICATION: SM  
 AASHTO CLASSIFICATION: A-1-b  
 AASHTO GROUP INDEX: 0



**LABORATORY TEST RESULTS**  
 RETREAT AT PRAIRIE RIDGE, FILING NO. 2  
 CLASSIC SRJ

JOB NO.  
 241932  
**FIG. B-3**

TEST BORING 5  
 DEPTH (FT) 1-2

SOIL DESCRIPTION FILL, SAND, SILTY  
 SOIL TYPE 1

**Sieve Analysis  
 Grain Size Distribution**

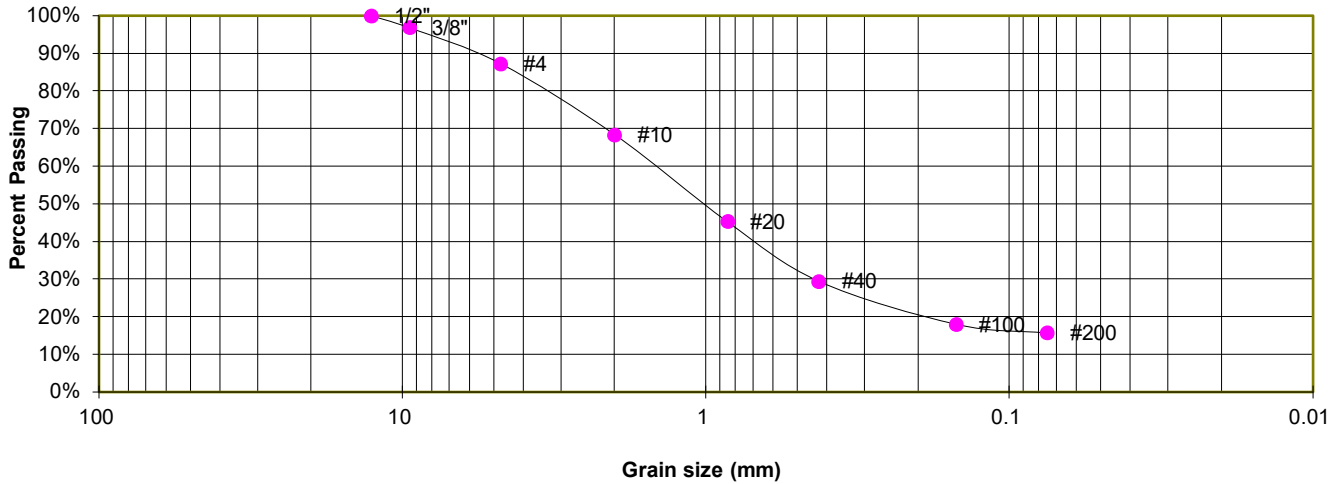

**GRAIN SIZE ANALYSIS**

U.S. Sieve #	Percent Finer
3"	
1 1/2"	
3/4"	
1/2"	100.0%
3/8"	96.9%
4	87.3%
10	68.4%
20	45.3%
40	29.5%
100	18.0%
200	15.7%

**ATTERBERG LIMITS**

Plastic Limit	25
Liquid Limit	36
Plastic Index	11

**SOIL CLASSIFICATION**

USCS CLASSIFICATION: SM  
 AASHTO CLASSIFICATION: A-2-6  
 AASHTO GROUP INDEX: 0



**LABORATORY TEST RESULTS**  
 RETREAT AT PRAIRIE RIDGE, FILING NO. 2  
 CLASSIC SRJ

JOB NO.  
 241932

**FIG. B-4**

TEST BORING 6  
 DEPTH (FT) 1-2

SOIL DESCRIPTION FILL, SAND, SILTY  
 SOIL TYPE 1

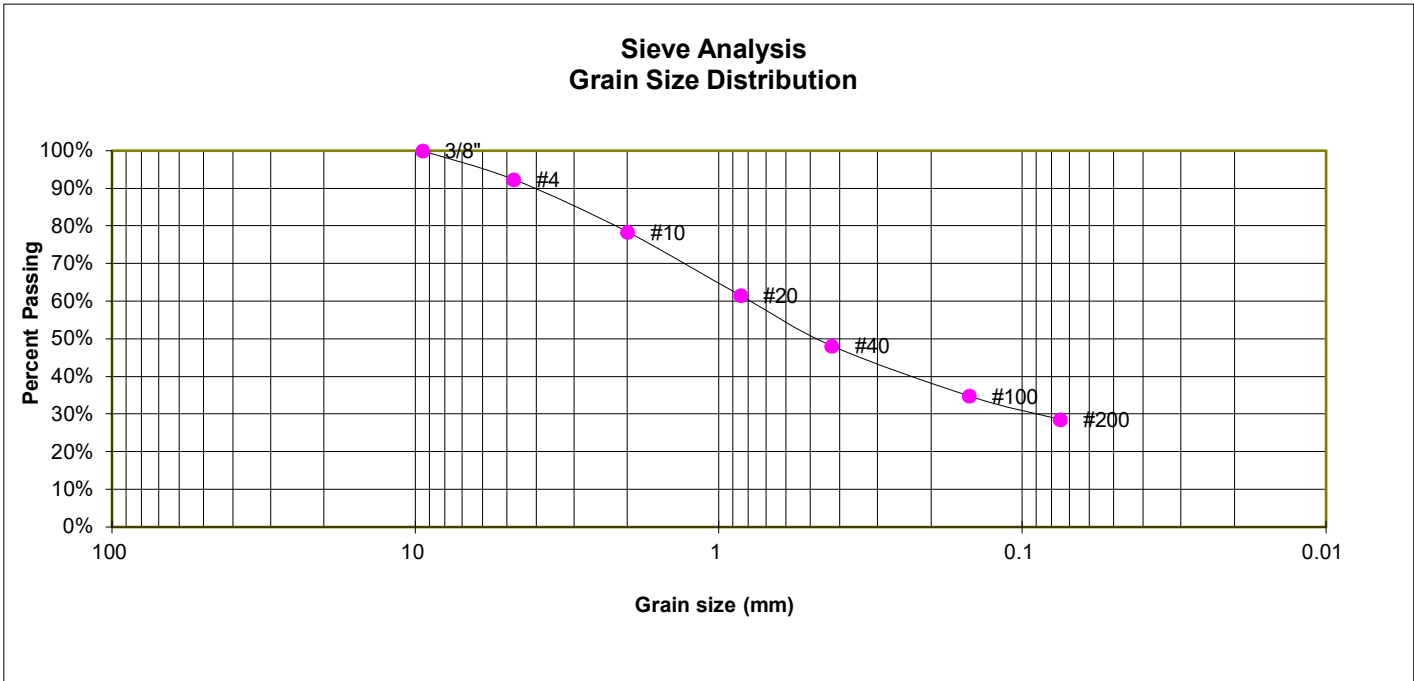

**GRAIN SIZE ANALYSIS**

U.S. Sieve #	Percent Finer
3"	
1 1/2"	
3/4"	
1/2"	
3/8"	100.0%
4	92.4%
10	78.4%
20	61.5%
40	48.2%
100	34.8%
200	28.6%

**ATTERBERG LIMITS**

Plastic Limit	NP
Liquid Limit	NV
Plastic Index	NP

**SOIL CLASSIFICATION**

USCS CLASSIFICATION: SM  
 AASHTO CLASSIFICATION: A-2-4  
 AASHTO GROUP INDEX: 0



**LABORATORY TEST RESULTS**  
 RETREAT AT PRAIRIE RIDGE, FILING NO. 2  
 CLASSIC SRJ

JOB NO.  
 241932  
**FIG. B-5**

TEST BORING 7  
 DEPTH (FT) 1-2

SOIL DESCRIPTION FILL, SAND, SILTY  
 SOIL TYPE 1

**Sieve Analysis  
 Grain Size Distribution**

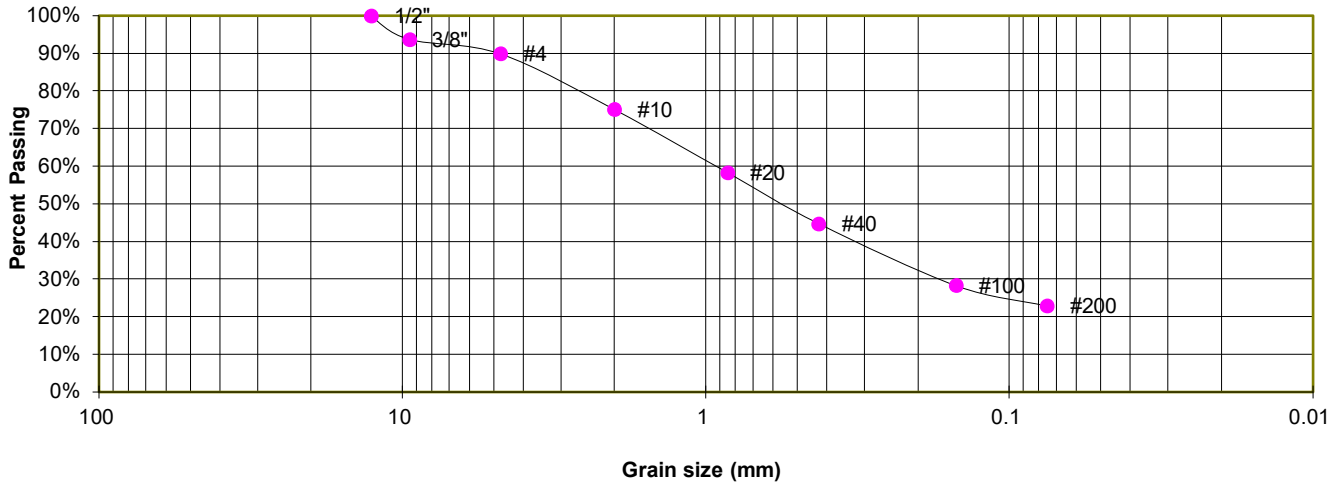

**GRAIN SIZE ANALYSIS**

U.S. Sieve #	Percent Finer
3"	
1 1/2"	
3/4"	
1/2"	100.0%
3/8"	93.7%
4	89.9%
10	75.1%
20	58.3%
40	44.7%
100	28.3%
200	22.9%

**ATTERBERG LIMITS**

Plastic Limit	NP
Liquid Limit	NV
Plastic Index	NP

**SOIL CLASSIFICATION**

USCS CLASSIFICATION: SM  
 AASHTO CLASSIFICATION: A-1-b  
 AASHTO GROUP INDEX: 0



**LABORATORY TEST RESULTS**

RETREAT AT PRAIRIE RIDGE, FILING NO. 2  
 CLASSIC SRJ

JOB NO.  
 241932

**FIG. B-6**

TEST BORING 8  
 DEPTH (FT) 1-2

SOIL DESCRIPTION FILL, SAND, SILTY  
 SOIL TYPE 1

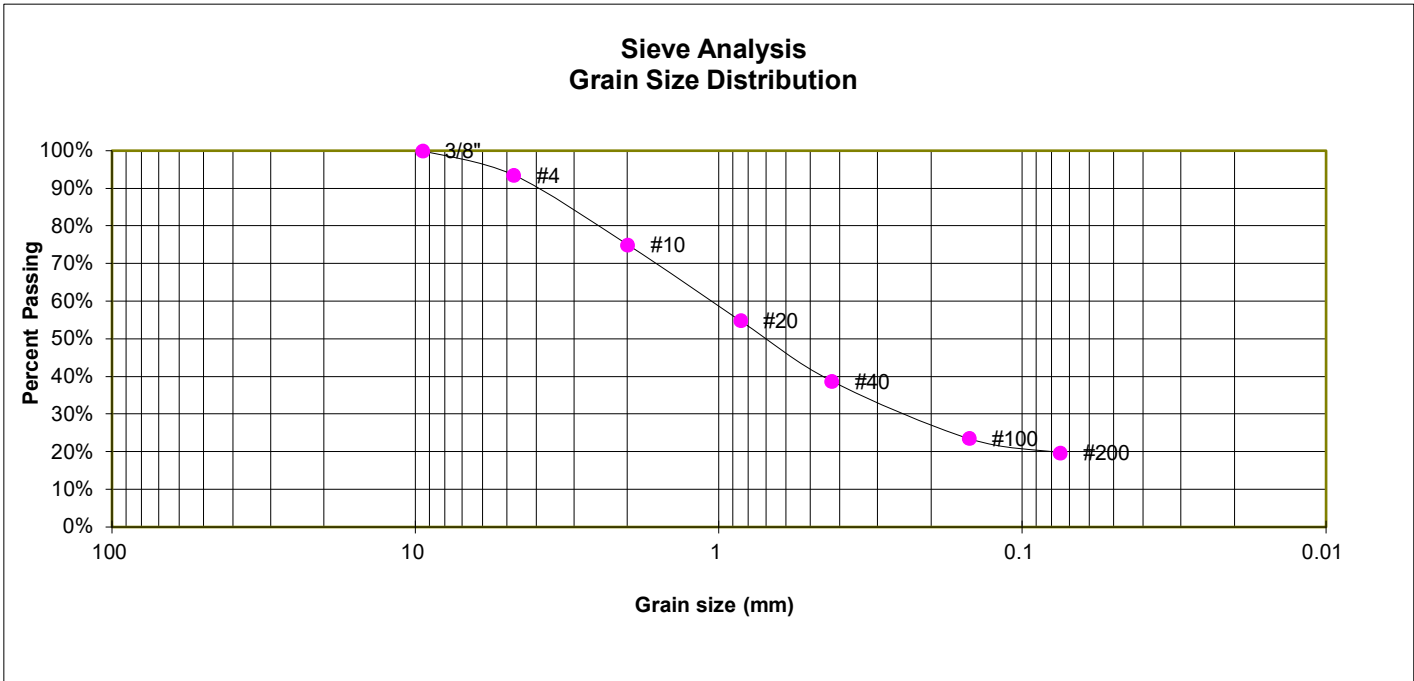

**GRAIN SIZE ANALYSIS**

U.S. Sieve #	Percent Finer
3"	
1 1/2"	
3/4"	
1/2"	
3/8"	100.0%
4	93.5%
10	75.0%
20	54.9%
40	38.7%
100	23.6%
200	19.8%

**ATTERBERG LIMITS**

Plastic Limit	NP
Liquid Limit	NV
Plastic Index	NP

**SOIL CLASSIFICATION**

USCS CLASSIFICATION: SM  
 AASHTO CLASSIFICATION: A-11-b  
 AASHTO GROUP INDEX: 0



**LABORATORY TEST RESULTS**  
 RETREAT AT PRAIRIE RIDGE, FILING NO. 2  
 CLASSIC SRJ

JOB NO.  
241932

**FIG. B-7**

TEST BORING 9  
 DEPTH (FT) 1-2

SOIL DESCRIPTION FILL, SAND, SILTY  
 SOIL TYPE 1

**Sieve Analysis  
 Grain Size Distribution**

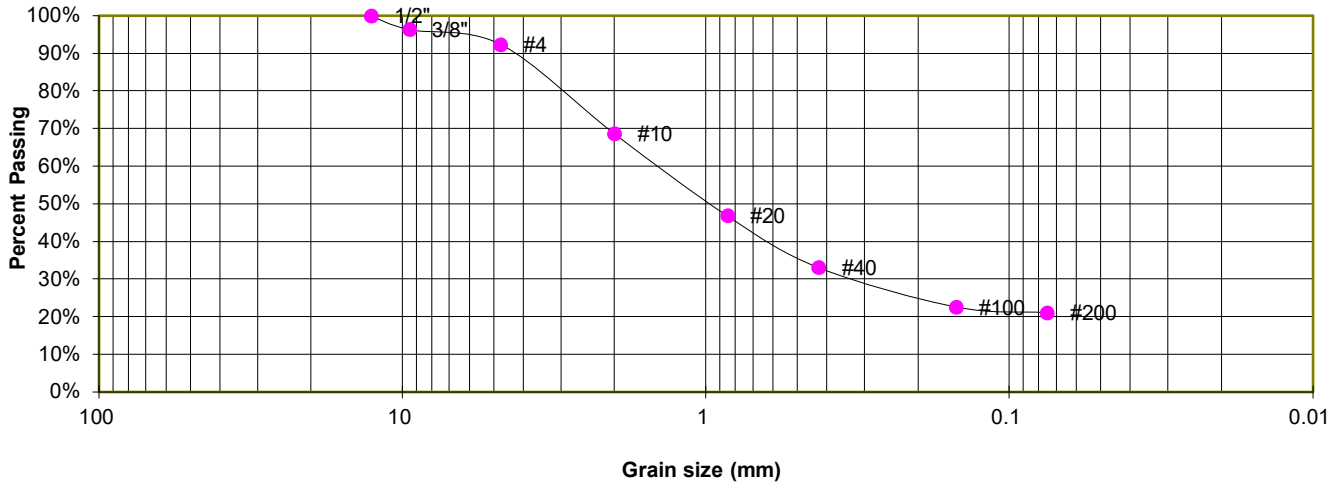

**GRAIN SIZE ANALYSIS**

U.S. Sieve #	Percent Finer
3"	
1 1/2"	
3/4"	
1/2"	100.0%
3/8"	96.3%
4	92.4%
10	68.6%
20	46.8%
40	33.1%
100	22.6%
200	21.1%

**ATTERBERG LIMITS**

Plastic Limit	NP
Liquid Limit	NV
Plastic Index	NP

**SOIL CLASSIFICATION**

USCS CLASSIFICATION: SM  
 AASHTO CLASSIFICATION: A-1-b  
 AASHTO GROUP INDEX: 0



**LABORATORY TEST RESULTS**  
 RETREAT AT PRAIRIE RIDGE, FILING NO. 2  
 CLASSIC SRJ

JOB NO.  
 241932  
**FIG. B-8**

TEST BORING 7  
 DEPTH (FT) 0-3

SOIL DESCRIPTION FILL, SAND, SILTY  
 SOIL TYPE 1

**Sieve Analysis  
 Grain Size Distribution**

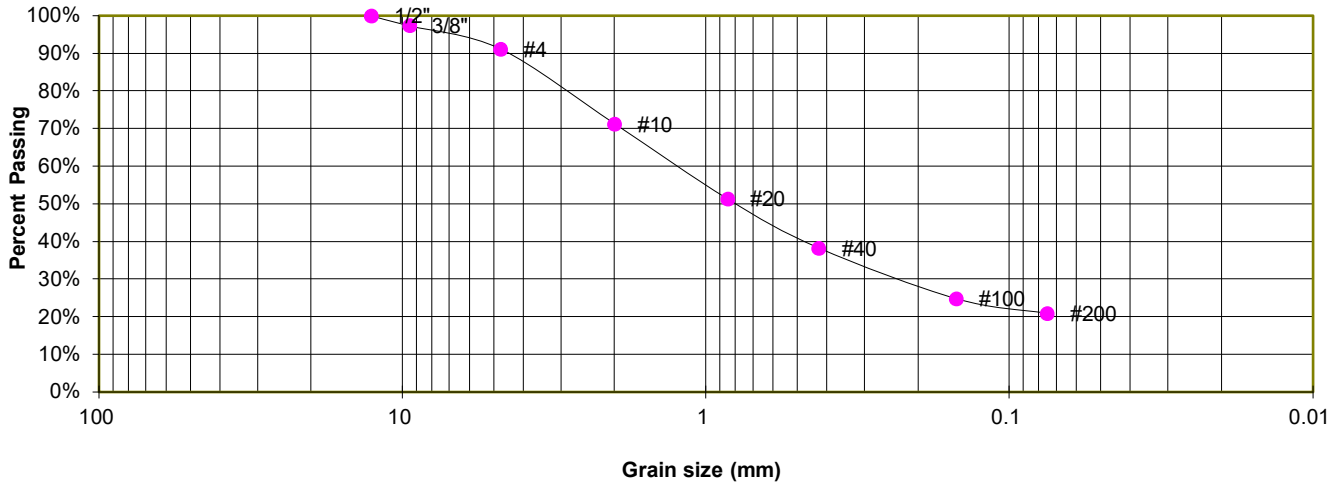

**GRAIN SIZE ANALYSIS**

U.S. Sieve #	Percent Finer
3"	
1 1/2"	
3/4"	
1/2"	100.0%
3/8"	97.4%
4	91.2%
10	71.3%
20	51.3%
40	38.2%
100	24.9%
200	20.9%

**SOIL CLASSIFICATION**

USCS CLASSIFICATION: SM  
 AASHTO CLASSIFICATION:  
 AASHTO GROUP INDEX:



**LABORATORY TEST RESULTS**  
 RETREAT AT PRAIRIE RIDGE, FILING NO. 2  
 CLASSIC SRJ

JOB NO.  
 241932  
**FIG. B-9**

TEST BORING 4  
 DEPTH (FT) 5

SOIL DESCRIPTION FILL, CLAY, SANDY  
 SOIL TYPE 2

**Sieve Analysis  
 Grain Size Distribution**

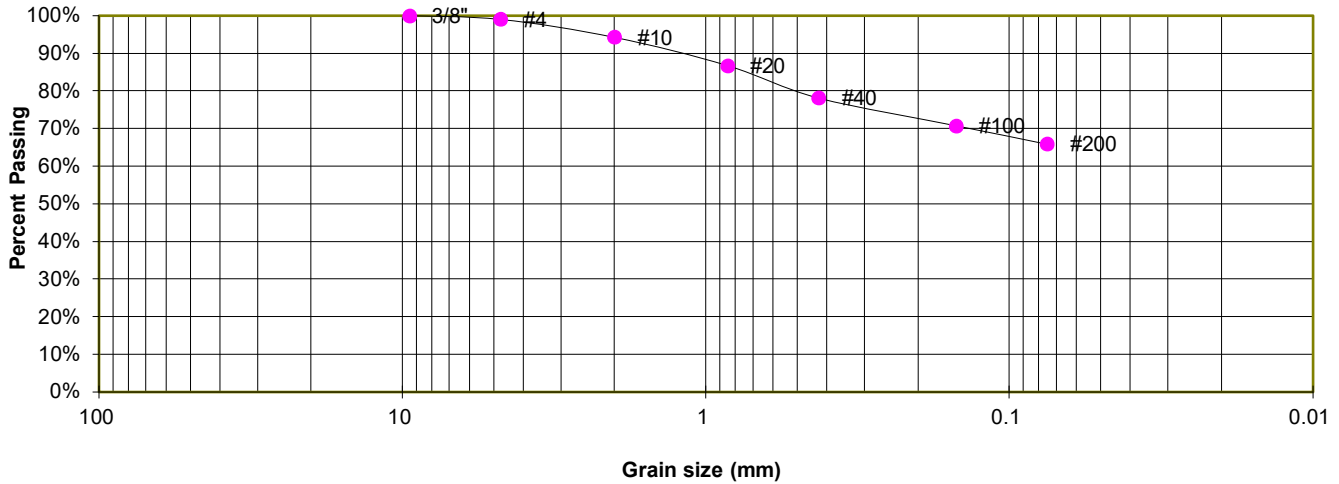

**GRAIN SIZE ANALYSIS**

U.S. Sieve #	Percent Finer
3"	
1 1/2"	
3/4"	
1/2"	
3/8"	100.0%
4	99.1%
10	94.3%
20	86.8%
40	78.2%
100	70.8%
200	65.9%

**ATTERBERG LIMITS**

Plastic Limit	23
Liquid Limit	33
Plastic Index	10

**SOIL CLASSIFICATION**

USCS CLASSIFICATION:	CL
AASHTO CLASSIFICATION:	A-4
AASHTO GROUP INDEX:	5



**LABORATORY TEST RESULTS**

RETREAT AT PRAIRIE RIDGE, FILING NO. 2  
 CLASSIC SRJ

JOB NO.  
 241932

**FIG. B-10**

TEST BORING 8  
 DEPTH (FT) 5

SOIL DESCRIPTION SAND, SILTY  
 SOIL TYPE 3

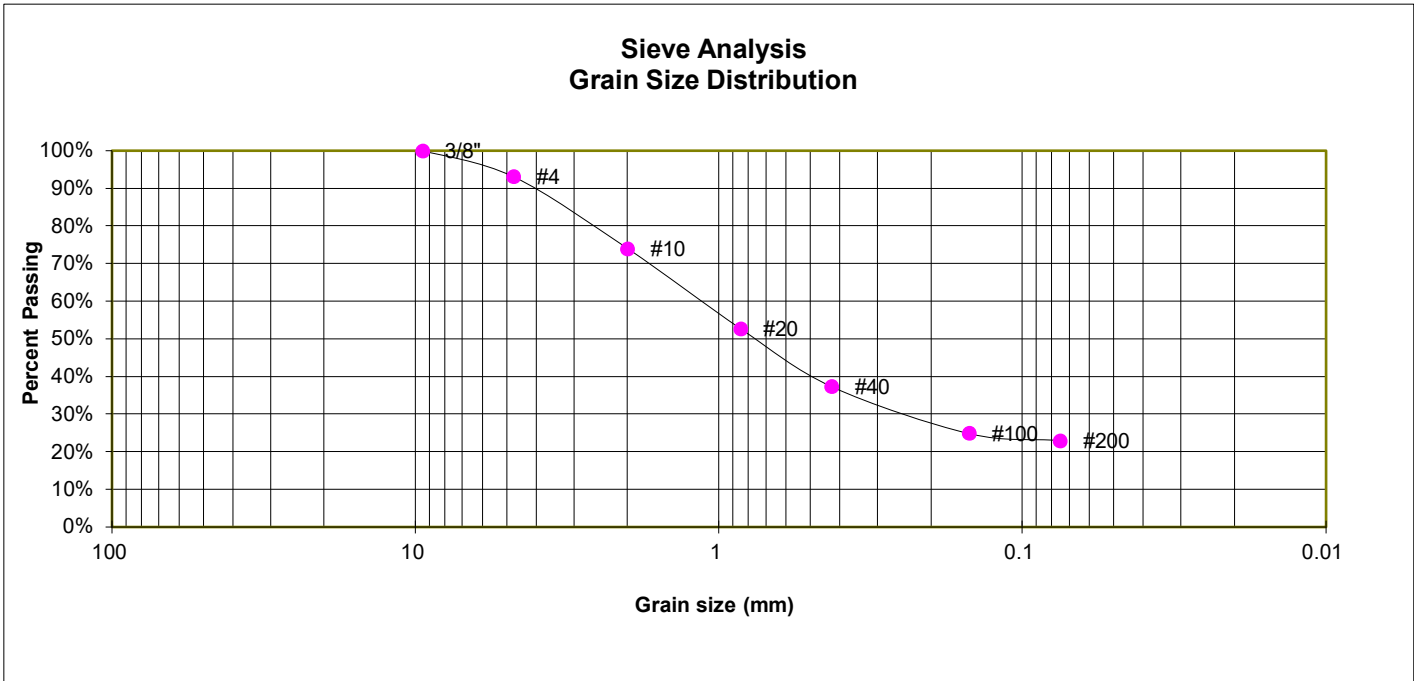

**GRAIN SIZE ANALYSIS**

U.S. Sieve #	Percent Finer
3"	
1 1/2"	
3/4"	
1/2"	
3/8"	100.0%
4	93.1%
10	74.0%
20	52.8%
40	37.3%
100	24.9%
200	23.0%

**ATTERBERG LIMITS**

Plastic Limit	NP
Liquid Limit	NV
Plastic Index	NP

**SOIL CLASSIFICATION**

USCS CLASSIFICATION: SM  
 AASHTO CLASSIFICATION: A-1-b  
 AASHTO GROUP INDEX: 0



**LABORATORY TEST RESULTS**  
 RETREAT AT PRAIRIE RIDGE, FILING NO. 2  
 CLASSIC SRJ

JOB NO.  
 241932  
**FIG. B-11**

TEST BORING 9  
 DEPTH (FT) 5

SOIL DESCRIPTION SAND, WITH SILT  
 SOIL TYPE 3

**Sieve Analysis  
 Grain Size Distribution**

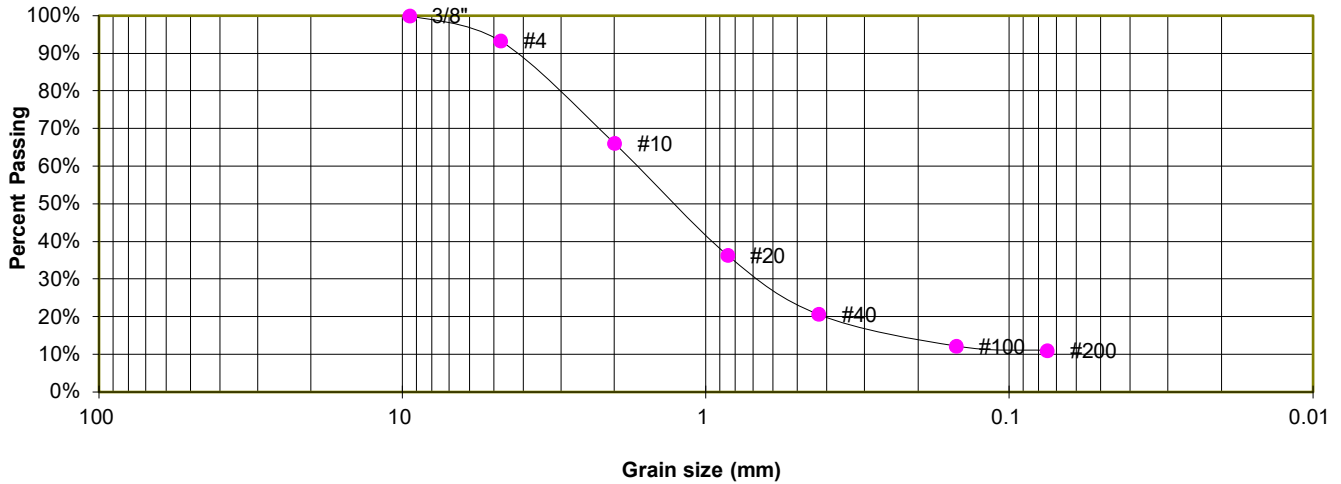

**GRAIN SIZE ANALYSIS**

U.S. Sieve #	Percent Finer
3"	
1 1/2"	
3/4"	
1/2"	
3/8"	100.0%
4	93.3%
10	66.1%
20	36.4%
40	20.6%
100	12.2%
200	11.0%

**ATTERBERG LIMITS**

Plastic Limit	27
Liquid Limit	40
Plastic Index	13

**SOIL CLASSIFICATION**

USCS CLASSIFICATION: SM  
 AASHTO CLASSIFICATION: A-2-6  
 AASHTO GROUP INDEX: 0



**LABORATORY TEST RESULTS**

RETREAT AT PRAIRIE RIDGE, FILING NO. 2  
 CLASSIC SRJ

JOB NO.  
 241932

**FIG. B-12**

TEST BORING 1  
 DEPTH (FT) 1-3

SOIL DESCRIPTION SANDSTONE (SAND, SILTY)  
 SOIL TYPE 4

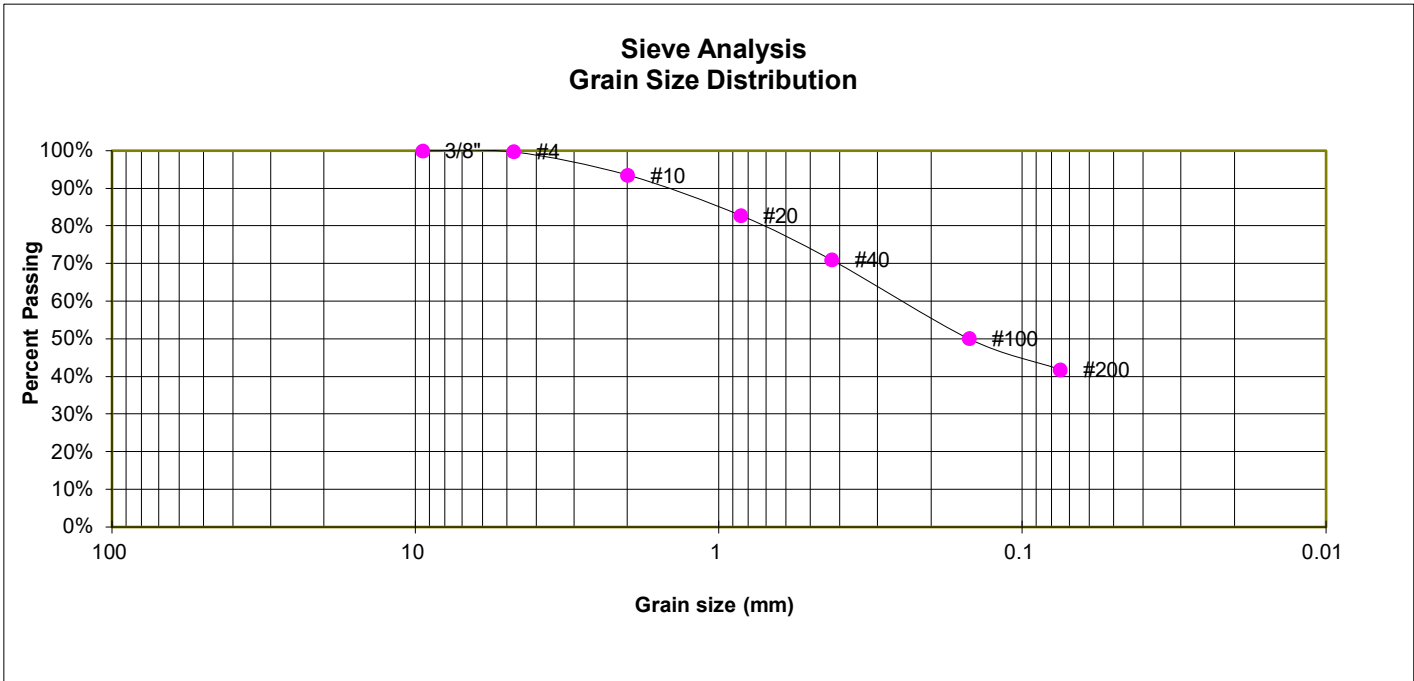

**GRAIN SIZE ANALYSIS**

U.S. Sieve #	Percent Finer
3"	
1 1/2"	
3/4"	
1/2"	
3/8"	100.0%
4	99.7%
10	93.6%
20	82.8%
40	71.0%
100	50.1%
200	41.9%

**ATTERBERG LIMITS**

Plastic Limit	NP
Liquid Limit	NV
Plastic Index	NP

**SOIL CLASSIFICATION**

USCS CLASSIFICATION:	SM
AASHTO CLASSIFICATION:	A-4
AASHTO GROUP INDEX:	0



**LABORATORY TEST RESULTS**

RETREAT AT PRAIRIE RIDGE, FILING NO. 2  
 CLASSIC SRJ

JOB NO.  
 241932

**FIG. B-13**

TEST BORING 1  
 DEPTH (FT) 1-2

SOIL DESCRIPTION SANDSTONE (SAND, SILTY)  
 SOIL TYPE 4

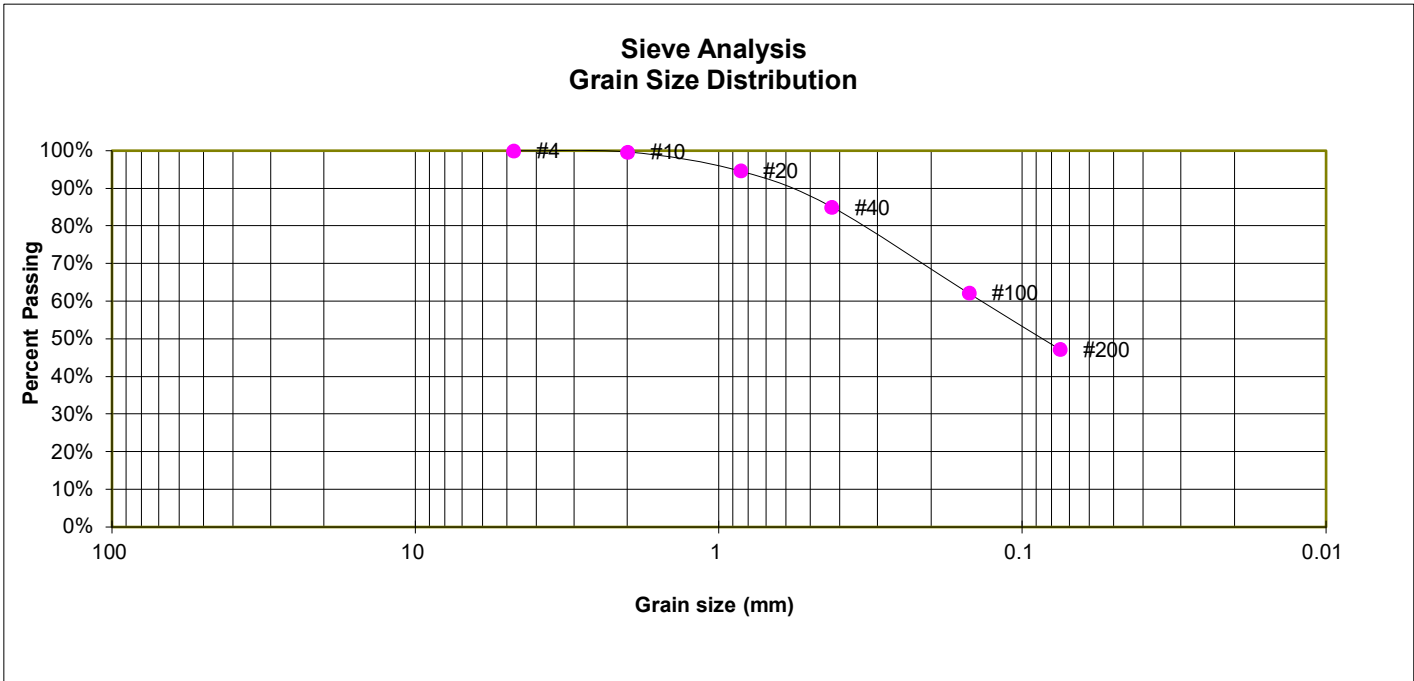

**GRAIN SIZE ANALYSIS**

U.S. Sieve #	Percent Finer
3"	
1 1/2"	
3/4"	
1/2"	
3/8"	
4	100.0%
10	99.7%
20	94.6%
40	85.1%
100	62.1%
200	47.2%

**ATTERBERG LIMITS**

Plastic Limit	NP
Liquid Limit	NV
Plastic Index	NP

**SOIL CLASSIFICATION**

USCS CLASSIFICATION:	SM
AASHTO CLASSIFICATION:	A-4
AASHTO GROUP INDEX:	0



**LABORATORY TEST RESULTS**  
 RETREAT AT PRAIRIE RIDGE, FILING NO. 2  
 CLASSIC SRJ

JOB NO.  
 241932  
**FIG. B-14**

TEST BORING 2  
 DEPTH (FT) 1-2

SOIL DESCRIPTION SANDSTONE (SAND, SILTY)  
 SOIL TYPE 4

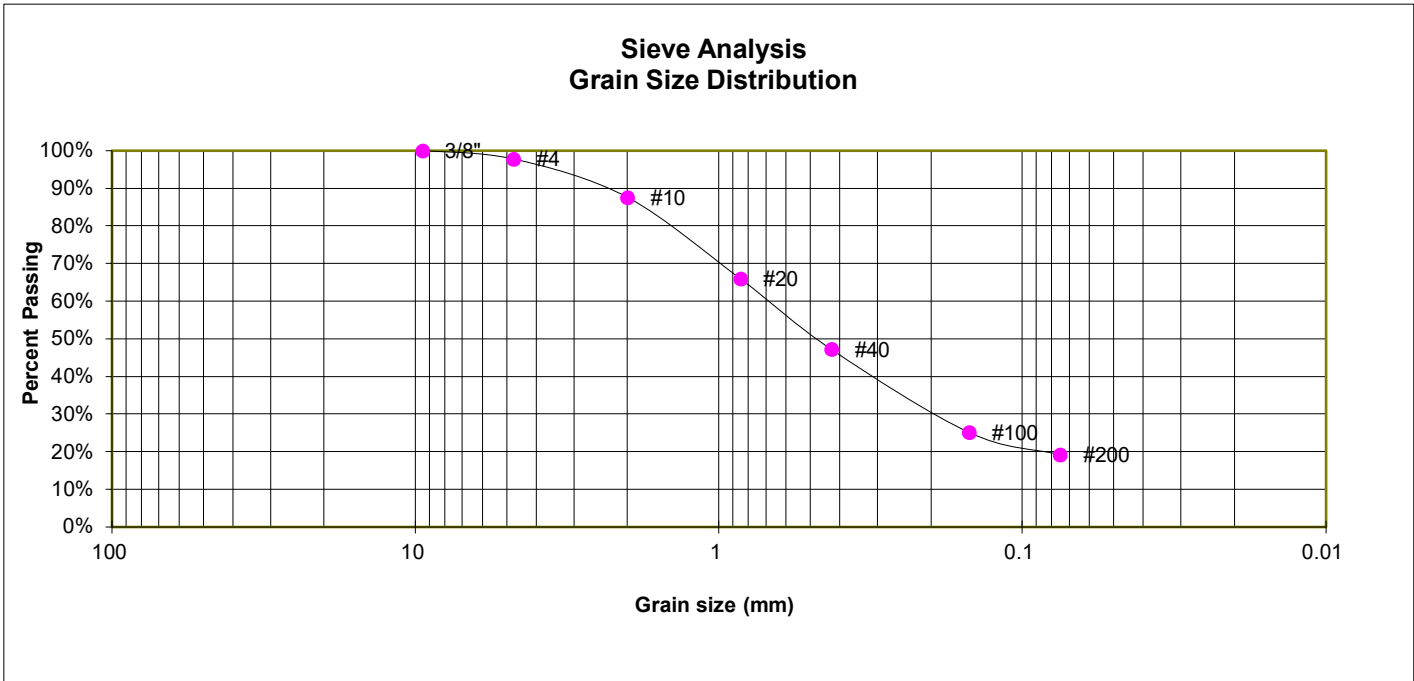

**GRAIN SIZE ANALYSIS**

U.S. Sieve #	Percent Finer
3"	
1 1/2"	
3/4"	
1/2"	
3/8"	100.0%
4	97.8%
10	87.6%
20	66.0%
40	47.2%
100	25.2%
200	19.2%

**ATTERBERG LIMITS**

Plastic Limit	NP
Liquid Limit	NV
Plastic Index	NP

**SOIL CLASSIFICATION**

USCS CLASSIFICATION: SM  
 AASHTO CLASSIFICATION: A-2-4  
 AASHTO GROUP INDEX: 0



**LABORATORY TEST RESULTS**  
 RETREAT AT PRAIRIE RIDGE, FILING NO. 2  
 CLASSIC SRJ

JOB NO.  
 241932  
**FIG. B-15**

TEST BORING 4  
DEPTH (FT) 5

SOIL DESCRIPTION FILL, CLAY, SANDY  
SOIL TYPE 2



**SWELL/COLLAPSE TEST RESULTS**

NATURAL UNIT DRY WEIGHT (PCF): 117  
NATURAL MOISTURE CONTENT: 12.0%  
SWELL/COLLAPSE (%): 0.3%



**SWELL TEST RESULTS**

RETREAT AT PRAIRIE RIDGE, FILING NO. 2  
CLASSIC SRJ

JOB NO.  
241932

**FIG. B-16**

SAMPLE LOCATION TB-3 @ 0-3'

SOIL DESCRIPTION FILL, SAND, SILTY, TAN  
SOIL TYPE 1

**PROCTOR DATA**

IDENTIFICATION: SM  
PROCTOR TEST #: 1  
TEST BY: DK  
TEST DESIGNATION: ASTM-1557-A  
MAXIMUM DRY DENSITY (PCF): 129.4  
OPTIMUM MOISTURE: 8.1

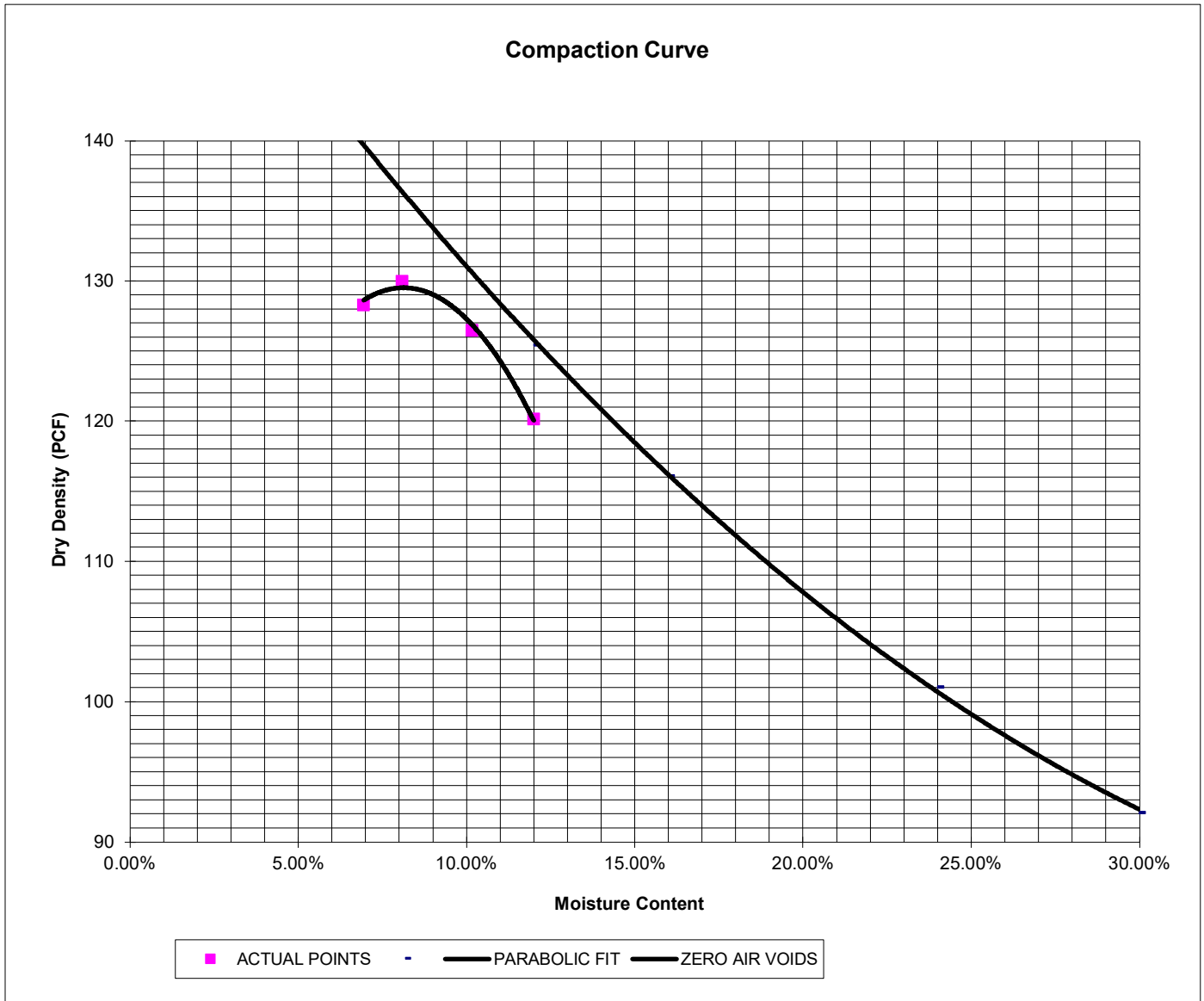

**LABORATORY TEST RESULTS**  
RETREAT AT PRAIRIE RIDGE, FILING NO. 2  
CLASSIC SRJ

JOB NO.  
241932

**FIG. B-17**

SAMPLE LOCATION TB-3 @ 0-3'

SOIL DESCRIPTION FILL, SAND, SILTY, TAN  
SOIL TYPE 1

**CBR TEST LOAD DATA**

Piston Diameter (cm): 4.958

Piston Area (in<sup>2</sup>): 2.993

Penetration Depth (inches)	10 BLOWS Mold # 1		25 BLOWS Mold # 2		56 BLOWS Mold # 3	
	Load (lbs)	Stress (psi)	Load (lbs)	Stress (psi)	Load (lbs)	Stress (psi)
0.000	0	0.00	0	0.00	0	0.00
0.025	233	77.86	699	233.58	1072	358.23
0.050	286	95.57	971	324.48	1685	563.07
0.075	308	102.92	1131	377.94	2160	721.80
0.100	328	109.61	1323	442.10	2568	858.14
0.125	380	126.98	1509	504.26	2885	964.07
0.150	409	136.67	1629	544.36	3060	1022.55
0.175	439	146.70	1739	581.12	3236	1081.37
0.200	462	154.39	1897	633.92	3513	1173.93
0.300	544	181.79	2390	798.66	4686	1565.91
0.400	660	220.55	2780	928.99	5541	1851.62
0.500	755	252.30	3227	1078.36	6000	2005.01

**MOISTURE AND DENSITY DATA**

	Mold # 1	Mold # 2	Mold # 3
Can #	506	507	508
Wt. Can	8.33	8.34	8.49
Wt. Can+Wet	276.4	259.58	203.83
Wt. Can+Dry	245.86	233.63	185.86
Wt. H2O	30.54	25.95	17.97
Wt. Dry Soil	237.53	225.29	177.37
Moisture Content	12.86%	11.52%	10.13%
Wet Density (PCF)	126.6	135.2	139.6
Dry Density (PCF)	117.1	125.1	129.1
% Compaction	91%	97%	100%
CBR	10.96	44.21	85.81

**PROCTOR DATA**

Maximum Dry Density (pcf)	129.4
Optimum Moisture	8.1
90% of Max. Dry Density (pcf)	116.5
95% of Max. Dry Density (pcf)	122.9

CBR at 90% of Max. Density = 8.1 ~ R VALUE 22  
CBR at 95% of Max. Density = 35.3 ~ R VALUE 74



**LABORATORY TEST RESULTS**  
RETREAT AT PRAIRIE RIDGE, FILING NO. 2  
CLASSIC SRJ

JOB NO.  
241932

**FIG. B-18**

SAMPLE LOCATION TB-3 @ 0-3'

SOIL DESCRIPTION FILL, SAND, SILTY, TAN  
SOIL TYPE 1

Stress VS Penetration

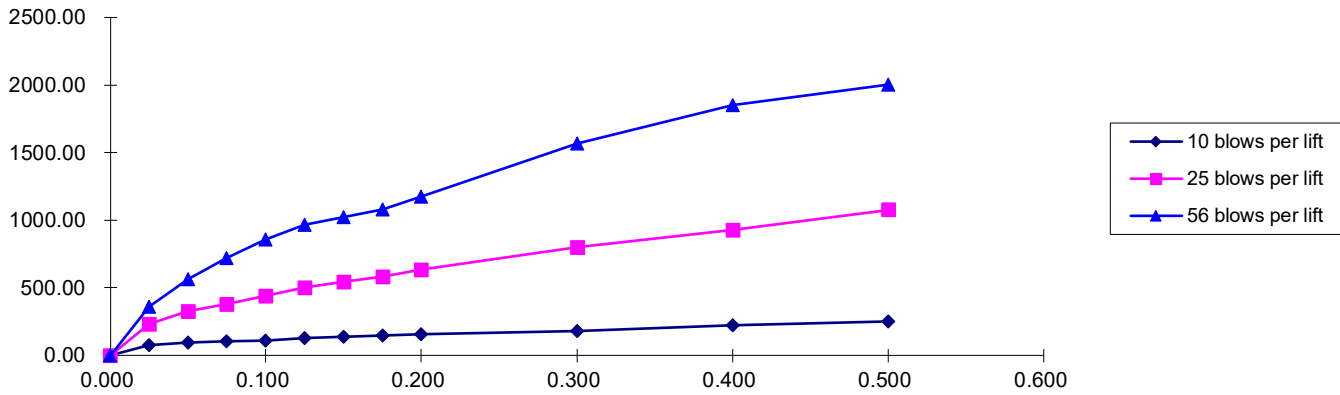

Bearing Ratio VS Dry Density

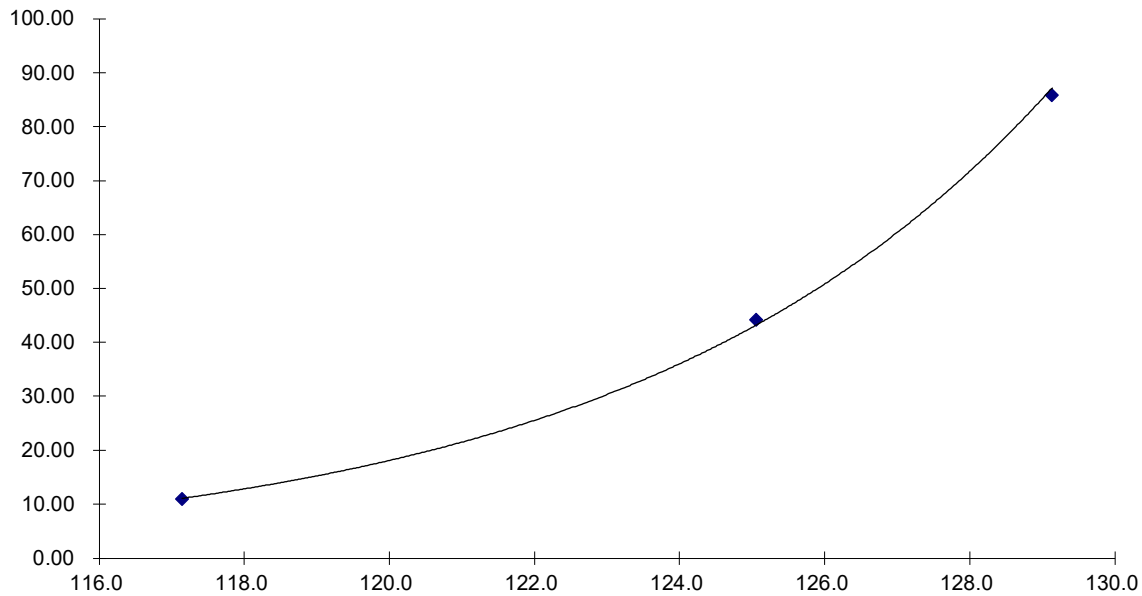

LABORATORY TEST RESULTS  
RETREAT AT PRAIRIE RIDGE, FILING NO. 2  
CLASSIC SRJ

JOB NO.  
241932

FIG. B-19



## **APPENDIX C: Pavement Design Calculations**

## FLEXIBLE PAVEMENT DESIGN

### PROJECT DATA

Project Location: Retreat at Prairie Ridge, Filing No. 2

Job Number: 241932

### DESIGN DATA

Equivalent (18-kip) Single Axle Load Applications (ESAL):	ESAL ( $W_{18}$ ) =	5,256,000
Design CBR	CBR =	10
Standard Deviation	$S_o$ =	0.45
Loss in Serviceability	$\Delta\psi$ =	2.0
Reliability	Reliability =	90
Reliability (z-statistic)	$Z_R$ =	-1.28
Soil Resilient Modulus	$M_R$ =	15,000 psi

Required Structural Number (SN): ➔ SN = 3.40

### DESIGN EQUATIONS

#### Resilient Modulus

If using CBR:

$$M_R = (\text{CBR}) \times 1,500$$

If using R-Value:

$$M_R = 10^{[(S_1 + 18.72) / 6.24]} \text{ where: } S_1 = [(R\text{-value} - 5) / 11.29] + 3$$

#### Required Structural Number

$$\log_{10} W_{18} = Z_R \cdot S_o + 9.36 \cdot \log_{10} (\text{SN} + 1) - 0.20 + \frac{\log_{10} \left[ \frac{\Delta \text{PSI}}{4.2 - 1.5} \right]}{0.40 + \frac{1094}{(\text{SN} + 1)^{5.19}}} + 2.32 \cdot \log_{10} M_R - 8.07$$

#### Pavement Section Thickness

$\text{SN}^* = C_1 D_1 + C_2 D_2$       where:       $C_1$  = Strength Coefficient - HMA  
 $C_2$  = Strength Coefficient - ABC/RCB  
 $D_1$  = Depth of HMA (inches)  
 $D_2$  = Depth of ABC/RCB (inches)

### RECOMMENDED THICKNESSES

Layer	Material	Structural Layer	Thickness ( $D_i^*$ )	$\text{SN}_i^*$	SN
1	HMA	$C_1 = 0.44$	5.0 inches	2.200	-
2	ABC/RCB	$C_2 = 0.11$	12.0 inches	1.320	
				$\text{SN}^* = 3.520$	3.40

Pavement SN > Required SN, Design is Acceptable

FIG. C-1

## FLEXIBLE PAVEMENT DESIGN

### PROJECT DATA

Project Location: Retreat at Prairie Ridge, Filing No. 2

Job Number: 241932

### DESIGN DATA

Equivalent (18-kip) Single Axle Load Applications (ESAL):	ESAL ( $W_{18}$ ) =	5,256,000
Design CBR	CBR =	10
Standard Deviation	$S_o$ =	0.45
Loss in Serviceability	$\Delta\psi$ =	2.0
Reliability	Reliability =	90
Reliability (z-statistic)	$Z_R$ =	-1.28
Soil Resilient Modulus	$M_R$ =	15,000 psi

Required Structural Number (SN): ➔ SN = 3.40

### DESIGN EQUATIONS

#### Resilient Modulus

If using CBR:

$$M_R = (\text{CBR}) \times 1,500$$

If using R-Value:

$$M_R = 10^{[(S_1 + 18.72) / 6.24]} \text{ where: } S_1 = [(R\text{-value} - 5) / 11.29] + 3$$

#### Required Structural Number

$$\log_{10} W_{18} = Z_R \cdot S_o + 9.36 \cdot \log_{10} (\text{SN} + 1) - 0.20 + \frac{\log_{10} \left[ \frac{\Delta \text{PSI}}{4.2 - 1.5} \right]}{0.40 + \frac{1094}{(\text{SN} + 1)^{5.19}}} + 2.32 \cdot \log_{10} M_R - 8.07$$

#### Pavement Section Thickness

$\text{SN}^* = C_1 D_1 + C_2 D_2$       where:       $C_1$  = Strength Coefficient - HMA  
 $C_2$  = Strength Coefficient - CTS  
 $D_1$  = Depth of HMA (inches)  
 $D_2$  = Depth of CTS (inches)

### RECOMMENDED THICKNESSES

Layer	Material	Structural Layer	Thickness ( $D_i^*$ )	$\text{SN}_i^*$	SN
1	HMA	$C_1 = 0.44$	5.0 inches	2.200	-
2	CTS	$C_2 = 0.11$	12.0 inches	1.320	
				$\text{SN}^* = 3.520$	3.40

Pavement SN > Required SN, Design is Acceptable

## FLEXIBLE PAVEMENT DESIGN

### PROJECT DATA

Project Location: Retreat at Prairie Ridge, Filing No. 2

Job Number: 241932

### DESIGN DATA

Equivalent (18-kip) Single Axle Load Applications (ESAL):	ESAL ( $W_{18}$ ) =	821,000
Design CBR	CBR =	10
Standard Deviation	$S_o$ =	0.45
Loss in Serviceability	$\Delta\psi$ =	2.0
Reliability	Reliability =	85
Reliability (z-statistic)	$Z_R$ =	-1.04
Soil Resilient Modulus	$M_R$ =	15,000 psi

Required Structural Number (SN): ➔ SN = 2.44

### DESIGN EQUATIONS

#### Resilient Modulus

If using CBR:

$$M_R = (\text{CBR}) \times 1,500$$

If using R-Value:

$$M_R = 10^{[(S_1 + 18.72) / 6.24]} \text{ where: } S_1 = [(R\text{-value} - 5) / 11.29] + 3$$

#### Required Structural Number

$$\log_{10} W_{18} = Z_R \cdot S_o + 9.36 \cdot \log_{10} (\text{SN} + 1) - 0.20 + \frac{\log_{10} \left[ \frac{\Delta \text{PSI}}{4.2 - 1.5} \right]}{0.40 + \frac{1094}{(\text{SN} + 1)^{5.19}}} + 2.32 \cdot \log_{10} M_R - 8.07$$

#### Pavement Section Thickness

$\text{SN}^* = C_1 D_1 + C_2 D_2$       where:       $C_1$  = Strength Coefficient - HMA  
 $C_2$  = Strength Coefficient - ABC/RCB  
 $D_1$  = Depth of HMA (inches)  
 $D_2$  = Depth of ABC/RCB (inches)

### RECOMMENDED THICKNESSES

Layer	Material	Structural Layer	Thickness ( $D_i^*$ )	$\text{SN}_i^*$	SN
1	HMA	$C_1 = 0.44$	4.0 inches	1.760	-
2	ABC/RCB	$C_2 = 0.11$	8.0 inches	0.880	
				$\text{SN}^* = 2.640$	2.44

Pavement SN > Required SN, Design is Acceptable

FIG. C-3

## FLEXIBLE PAVEMENT DESIGN

### PROJECT DATA

Project Location: Retreat at Prairie Ridge, Filing No. 2

Job Number: 241932

### DESIGN DATA

Equivalent (18-kip) Single Axle Load Applications (ESAL):	ESAL ( $W_{18}$ ) =	821,000
Design CBR	CBR =	10
Standard Deviation	$S_o$ =	0.45
Loss in Serviceability	$\Delta\psi$ =	2.0
Reliability	Reliability =	85
Reliability (z-statistic)	$Z_R$ =	-1.04
Soil Resilient Modulus	$M_R$ =	15,000 psi

Required Structural Number (SN): ➔ SN = 2.44

### DESIGN EQUATIONS

#### Resilient Modulus

If using CBR:

$$M_R = (\text{CBR}) \times 1,500$$

If using R-Value:

$$M_R = 10^{[(S_1 + 18.72) / 6.24]} \text{ where: } S_1 = [(R\text{-value} - 5) / 11.29] + 3$$

#### Required Structural Number

$$\log_{10} W_{18} = Z_R \cdot S_o + 9.36 \cdot \log_{10} (\text{SN} + 1) - 0.20 + \frac{\log_{10} \left[ \frac{\Delta \text{PSI}}{4.2 - 1.5} \right]}{0.40 + \frac{1094}{(\text{SN} + 1)^{5.19}}} + 2.32 \cdot \log_{10} M_R - 8.07$$

#### Pavement Section Thickness

$\text{SN}^* = C_1 D_1 + C_2 D_2$       where:

- $C_1$  = Strength Coefficient - HMA
- $C_2$  = Strength Coefficient - CTS
- $D_1$  = Depth of HMA (inches)
- $D_2$  = Depth of CTS (inches)

### RECOMMENDED THICKNESSES

Layer	Material	Structural Layer	Thickness ( $D_i^*$ )	$\text{SN}_i^*$	SN
1	HMA	$C_1 = 0.44$	4.0 inches	1.760	-
2	CTS	$C_2 = 0.11$	8.0 inches	0.880	
				$\text{SN}^* = 2.640$	2.44

Pavement SN > Required SN, Design is Acceptable