



INNOVATIVE DESIGN. **CLASSIC RESULTS.**

**FINAL DRAINAGE REPORT
FOR
RETREAT AT TIMBERRIDGE
FILING NO. 1**

Also see comment letter.

Prepared for:
TIMBERRIDGE DEVELOPMENT GROUP, LLC
6385 CORPORATE DR., SUITE 200
COLORADO SPRINGS CO 80919
(719) 592-9333

Prepared by:
CLASSIC CONSULTING
619 N. CASCADE AVE SUITE 200
COLORADO SPRINGS CO 80903
(719) 785-0790

Engineering Review
11/12/2019 2:42:46 PM
dsdrice
JeffRice@elpasoco.com
(719) 520-7877
**EPC Planning & Community
Development Department**

Job No. 1185.00

PCD Project No. SF-19-009



FINAL DRAINAGE REPORT FOR RETREAT AT TIMBERRIDGE FILING No. 1

ENGINEER'S STATEMENT:

The attached drainage plan and report were prepared under my direction and supervision and are correct to the best of my knowledge and belief. Said drainage report has been prepared according to the criteria established by the County for drainage reports and said report is in conformity with the applicable master plan of the drainage basin. I accept responsibility for any liability caused by any negligent acts, errors, or omissions on my part in preparing this report.

Marc A. Whorton Colorado P.E. #37155

Date

OWNER'S/DEVELOPER'S STATEMENT:

I, the owner/developer, have read and will comply with all of the requirements specified in this drainage report and plan.

Business Name: TIMBERRIDGE DEVELOPMENT GROUP, LLC

By: _____

Title: _____

Address: 6385 Corporate Dr., Suite 200

Colorado Springs, CO 80919

EL PASO COUNTY:

Filed in accordance with the requirements of the Drainage Criteria Manual, Volumes 1 and 2, El Paso County Engineering Criteria Manual and Land Development Code as amended.

Jennifer Irvine, P.E.
County Engineer, / ECM Administrator

Date

Conditions:

FINAL DRAINAGE REPORT FOR RETREAT AT TIMBERRIDGE FILING No. 1

TABLE OF CONTENTS:

PURPOSE	Page 4
GENERAL DESCRIPTION	Page 4
EXISTING DRAINAGE CONDITIONS	Page 4
PROPOSED DRAINAGE CONDITIONS	Page 8
DETENTION/SWQ FACILITIES	Page 18
SAND CREEK CHANNEL IMPROVEMENTS	Page 18
DRAINAGE CRITERIA	Page 23
FLOODPLAIN STATEMENT	Page 25
DRAINAGE AND BRIDGE FEES	Page 26
SUMMARY	Page 28
REFERENCES	Page 29

APPENDICES

VICINITY MAP
SOILS MAP (WEB SOIL SURVEY)
F.E.M.A. MAP / LOMR (08-08-0541P)
RECOMMENDATIONS PER SAND CREEK DBPS
HYDROLOGIC / HYDRAULIC CALCULATIONS
STORMWATER QUALITY / DETENTION POND CALCULATIONS
HEC-RAS CALCULATIONS
DRAINAGE MAPS
SECTION 404 PERMITTING / WETLAND IMPACT MAP (CORE Consultants)



PURPOSE

The purpose of this Final Drainage Report is to address on-site and off-site drainage patterns and identify specific drainage improvements and facilities required to minimize impacts to the adjacent properties.

GENERAL DESCRIPTION

The Retreat at TimberRidge Filing No. 1 is 68.14-acre site located in portions sections 27 and 28, township 12 south, range 65 west of the sixth principal meridian. The site is bounded on the north and east by future development phases within the TimberRidge property, to the south by Sterling Ranch property (zoned for future urban development) and to the west by Vollmer Road. The site is in the upper portion of the Sand Creek Drainage Basin. Both large lot rural single family residential and urban single family residential are proposed in this Filing.

The average soil condition reflects Hydrologic Group "B" (Pring coarse sandy loam and Kettle gravelly loamy sand) as determined by the "Web Soil Survey of El Paso County Area," prepared by the Natural Resources Conservation Service (see map in Appendix).

EXISTING DRAINAGE CONDITIONS

The Retreat at TimberRidge Filing No. 1 property is located in the upper portion of the Sand Creek drainage basin on the south edge of Black Forest. Nearly the entire site, other than the Sand Creek corridor, is mainly covered with native grasses with few or no pine trees. The Sand Creek channel bisects the site in a north-south direction. A wetlands delineation was prepared by CORE Consultants, Inc. and submitted along with the Preliminary Plan. (See Appendix) This document reflects some wetlands throughout the Sand Creek channel. Any effect on these wetlands within jurisdictional waters will be described later in this report along with the appropriate permitting.

Portions of this site have been previously studied in the "Sand Creek Drainage Basin Planning Study" (DBPS) prepared by Kiowa Engineering Corporation, March 1996. The portion of Sand Creek that traverses the site is defined as Reach SC-9 in the DBPS. 1000+ acres north of this property is tributary to this reach of the channel. (See Off-site Drainage Map in Appendix)

According to the DBPS, this reach of Sand Creek all contained within the channel has the following flow characteristics: $Q_{10} = 630$ cfs $Q_{100} = 2170$ cfs. However, the 100 yr. flow recognized by FEMA in the LOMR 08-08-0541P with effective date of July 23, 2009, equals nearly $Q_{100} = 2600$ cfs. Also, Sterling Ranch has recently finalized their MDDP which includes modeling of this property as well as the large acreage north up to the top of the Sand Creek Basin. The MDDP proposes developed flows within Sand Creek that are significantly lower than both the DBPS and FEMA currently show. These flows are as follows: At Arroya Lane crossing $Q_{10} = 430$ cfs $Q_{100} = 1487$ cfs and TimberRidge south property line $Q_{10} = 452$ cfs $Q_{100} = 1523$ cfs. Even with the County approval of the MDDP and these adjusted flows, a CLOMR/LOMR will be required to be prepared, submitted and approved by FEMA prior to utilizing these flows in any Final Drainage Reports within this development. Based on the anticipated 12-18 month timing of the CLOMR/LOMR process, this development has decided to continue to utilize the much larger FEMA recognized flows for all proposed channel improvements through this property. However, given the County's approval of the Sterling Ranch MDDP, and as such the acknowledgment of these reasonable lower flow quantities through this Reach, a deviation has been submitted for relief from the allowable clearance of the proposed major drainageway crossing as found in the DCM Vol. 1 6.4.2. The 2600 cfs FEMA recognized flows will be utilized in the structure calculations but relief from the 2 feet freeboard within the structure is being requested in the aforementioned deviation request.

← Is this necessary?

The majority of these off-site flows enter the property at the north end of the site conveying flows from the northwest (Black Forest area) and the off-site stock ponds to the north (both tributary to hundreds of acres of property in Black Forest). There are multiple existing culvert crossings of Vollmer Rd. just north of Arroya Lane to facilitate these historic flow patterns. The following are the few key culverts that directly feed the Sand Creek channel north of Arroya Lane: Approximately 1,000 feet north of Arroya Lane, an existing 36" CMP crosses Vollmer Road (Basin SC-1 on Off-site Drainage Map). A small basin and natural ravine just west of Vollmer feeds this facility. From a recent field visit, this small facility seems to be in good working condition,



however, not labeled in the DBPS. Another 700 feet+ north along Vollmer a much larger basin exists west of the roadway. This off-site basin is approximately 350+ acres northwest of Vollmer Road (Basin SC-2 on Off-site Drainage Map). As shown within the DBPS, this existing crossing is a 60" CMP with some very dense and tall vegetation at both the entrance and exit of this facility. But, based on a recent field visit this facility seems to be in good working condition. The DBPS depicts this facility and recommends an additional 60" CMP at this location. However, there are no signs of erosion or over topping the road at this location at this time based on the current development within the tributary area to this facility. Based on the existing surrounding topography and roadway configuration, the 100 yr. historic flows at this location would appear to spill over the roadway and continue in their historic drainage pattern downstream within the upper reach of Sand Creek.

The following descriptions represent the pre-development flow design points for the property excluding the major off-site flows within Sand Creek just described:

EX DP-1 ($Q_2 = 4.2$ cfs $Q_5 = 28.5$ cfs, $Q_{100} = 219.2$ cfs) This does not include the major off-site channel flows but reflects only the on-site and off-site flows that travel across the property and have a direct effect on the development. This total represents the allowed developed release off-site at this location. This total pre-development flow includes the flowing basins: EX-1, EX-4, EX-5, EX-6 and EX-7. Basins EX-1 ($Q_2 = 0.5$ cfs $Q_5 = 3.9$ cfs, $Q_{100} = 30.0$ cfs) and EX-6 ($Q_2 = 0.7$ cfs $Q_5 = 5.8$ cfs, $Q_{100} = 44.8$ cfs) consist of a good portion of the Filing 1 development and a significant future development area both on and off-site. These basins sheet flow in a southwesterly direction and eventually travel within various natural ravines created within the site. These ravines then route the predevelopment flows directly into Sand Creek in multiple locations. Upon development, over 90% of this historic tributary area will be routed directly into a proposed on-site facility and treated prior to entering Sand Creek. Basin EX-5 ($Q_2 = 2.0$ cfs $Q_5 = 13.5$ cfs, $Q_{100} = 107.2$ cfs) consists of the majority of the future TimberRidge development area along with an



off-site future Sterling Ranch development area. This basin also sheet flows in a southerly direction within natural ravines that route the predevelopment flows directly into Sand Creek in multiple locations. Upon development, over 65% of this historic on-site tributary area will also be routed directly into a proposed on-site facility and treated prior to entering Sand Creek. Basin EX-7 ($Q_2 = 1.0$ cfs $Q_5 = 5.2$ cfs, $Q_{100} = 32.1$ cfs) consists of an off-site basin west of Vollmer Road (not a part of this development) that drains under Vollmer into the TimberRidge property via an existing 48" CMP culvert and then within a natural ravine that routes the off-site flow directly into Sand Creek. This condition will remain with the development of Filing 1. Upon future TimberRidge development in this area, these off-site flows will be routed directly towards Sand Creek via an extension of the 48" storm within Arroya Lane.

EX DP-2 ($Q_2 = 0.03$ cfs $Q_5 = 0.3$ cfs, $Q_{100} = 2.3$ cfs) consists of a minimal portion of Filing 1 development area that currently sheet flows in a southwesterly direction. These pre-development flows travel off-site directly onto Sterling Ranch property prior to eventually entering the Sand Creek channel.

EX DP-3 ($Q_2 = 0.4$ cfs $Q_5 = 3.4$ cfs, $Q_{100} = 26.8$ cfs) consists of flows from on-site Basin EX-3 that travel off-site directly onto Sterling Ranch property prior to eventually entering the Sand Creek channel. Upon development, over nearly 100% of this historic tributary area will be routed directly into a proposed on-site facility and treated prior to entering Sand Creek.

EX DP-4 ($Q_2 = 0.2$ cfs $Q_5 = 1.4$ cfs, $Q_{100} = 10.5$ cfs) consists of on-site flows from Basin EX-4 that travel in a southeasterly direction directly towards Sand Creek. Upon development, nearly 60% of this historic tributary area will be routed directly into the proposed on-site facility and treated prior to entering Sand Creek.



PROPOSED DRAINAGE CONDITIONS

Proposed development within the Retreat at TimberRidge Filing No. 1 will consist of a variety of different residential lot sizes ranging from 1.0 – 2.5 acre large rural lots to 12,000 SF min. urban lots. The rural lots will have paved streets and roadside ditches while the urban lots paved streets with County standard curb, gutter and sidewalk. Development of the urban lots proposed will consist of overlot grading for the planned roadways and lots. Development of rural lots proposed within the site will be limited to roadways, building pads and 4'-6' high natural berm along Vollmer Road, conserving the natural feature areas. Individual home sites on these lots are to be left generally in their natural condition with minimal disturbance to existing conditions per individual lot construction. Per the El Paso County ECM, Section I.7.1.B, rural lots of 2.5 ac. and larger are not required to provide Water Quality Capture Volume (WQCV). However, based on the current County/Urban Drainage stormwater quality standards, a WQCV component is automatically built into the UD Detention spreadsheet utilized in the detention basin design. Thus, the proposed facilities within both the rural and urban portions of this development will provide WQCV along with an Excess Urban Runoff Volume (EURV) in the lower portion of the facility storage volume with an outlet control device. Frequent and infrequent inflows are released at rates approximating undeveloped conditions. This concept provides some mitigation of increased runoff volume by releasing a portion of the increased runoff at a low rate over an extended period of time, up to 72 hours. This means that frequent storms, smaller than the 2 year event, will be reduced to very low flows near or below the sediment carrying threshold value for downstream drainage ways. Also, by incorporating an outlet structure that limits the 100-year runoff to the undeveloped condition rate, the discharge hydrograph for storms between the 2 year and the 100 year event will approximate the hydrograph for the undeveloped conditions and will help effectively mitigate the effects of development. To the greatest extent possible, WQCV will be provided for all new roads and urban lots. The following describes how this development proposes to handle both the off-site and on-site drainage conditions:



As mentioned previously, the majority of the off-site flows are already within the Sand Creek channel prior to entering the property. However the few off-site basins that must travel through the proposed site development areas prior to entering Sand Creek have been accounted for.

The following represent the basins west of Sand Creek:

Basin OS-1 ($Q_2 = 2$ cfs $Q_5 = 2$ cfs, $Q_{100} = 5$ cfs) represents off-site flows from the east half of Vollmer Road. These existing flows will continue to travel in a southerly direction within the current roadside ditch along the east side of Vollmer road to the intersection with Poco Road. At this location, these existing flows will then be routed in an easterly direction via a proposed graded swale along the north side of Poco Road. **Basin C ($Q_2 = 1$ cfs $Q_5 = 2$ cfs, $Q_{100} = 12$ cfs)** will combine with these flows and travel via the swale towards Design Point 1. **Basin A ($Q_2 = 2$ cfs $Q_5 = 5$ cfs, $Q_{100} = 22$ cfs)** represents the majority of the proposed 2.5 ac. rural lots adjacent to Vollmer Road. Developed flows from this basin will continue to sheet flow in a southeasterly direction towards the west side of Aspen Valley Road. These ditch flows travel to **Design Point 1 ($Q_5 = 9$ cfs, $Q_{100} = 36$ cfs)** where proposed dual 24" RCP culverts will convey the flows under the road towards Pond 1. The sideroad ditch along the west side of Aspen Valley Road will be lined with a turf reinforcement matting (TRM) adjacent to Lots 1-5 and erosion control matting adjacent to Lots 6-7, in order to adequately convey the developed flows without exceeding the allowable velocity and shear stress limits. (See Appendix for ditch calculations)

Basin B ($Q_2 = 1$ cfs $Q_5 = 3$ cfs, $Q_{100} = 14$ cfs) represents a portion of the proposed 2.5 ac. rural lots adjacent to Sand Creek. Developed flows from this basin will continue to sheet flow in a southeasterly direction towards Pond 1. The sideroad ditch along the north side of Poco Road east of Aspen Valley Road (within a 50' public drainage esmt.) will be lined with TRM to adequately convey the developed flows directly into Pond 1 without exceeding the allowable velocity and shear stress limits. (See Appendix for ditch calculations)



Design Point 2 ($Q_5 = 11$ cfs, $Q_{100} = 47$ cfs) represents the total developed flows entering **Pond 1**. A proposed full-spectrum EDB is proposed at this location to release less than the pre-development flows currently seen. The following describes the design of this facility. (See Appendix for UD Detention pond design sheets):

Detention Pond 1 (Full Spectrum EDB – see multiple storm release data below)

0.214 Ac.-ft. WQCV required

0.177 Ac.-ft. EURV required with 4:1 max. slopes

0.877 Ac.-ft. 100-yr. Storage

1.268 Ac.-ft. Total

Total In-flow:	$Q_2 = 3.8$ cfs,	$Q_5 = 5.8$ cfs,	$Q_{100} = 47.0$ cfs
Pond Design Release:	$Q_2 = 0.1$ cfs,	$Q_5 = 0.17$ cfs,	$Q_{100} = 24.0$ cfs
Pre-development Release:	$Q_2 = 0.3$ cfs,	$Q_5 = 0.48$ cfs,	$Q_{100} = 29.2$ cfs

(Ownership and maintenance by the Retreat at TimberRidge Metro District)

Basin E ($Q_2 = 0.4$ cfs $Q_5 = 1$ cfs, $Q_{100} = 6$ cfs) represents a portion of the rural 2.5 ac. lots west of Sand Creek outside the proposed roadway improvements. Only lot 8 and possibly lot 9 is anticipated to have any building structure constructed within this basin. Per the ECM Section I.7.1.B, WQCV is not required for these lots given their size (2.5 Ac.). However, sediment control will be provided for this basin in the form of a permanent sediment basin at the northeast corner of lot 10 within a public drainage easement. (See Grading and Erosion Control Plan for design calculations and exact location) Basins OS-2 ($Q_2 = 0.0$ cfs $Q_5 = 0.2$ cfs, $Q_{100} = 1.6$ cfs) and F ($Q_2 = 0.1$ cfs $Q_5 = 0.4$ cfs, $Q_{100} = 1.9$ cfs) represent minor portions (both under 1.0 Ac.) of 2.5 Ac. lots that are not planned to have any building structure or roadway constructed within these basins. Thus, per ECM Section I.7.1.B, WQCV is not required and sediment control will be handled by silt fence and straw bale barriers as a part of the Grading and erosion Control Plan. Basin G ($Q_2 = 0.2$ cfs $Q_5 = 0.8$ cfs, $Q_{100} = 6$ cfs) represents a portion of Sand Creek that will



be platted with this Filing. No residential development is proposed within this basin other than the gravel trail along the west side of the creek and the proposed channel improvements as recommended in the DBPS.

Basins D1 ($Q_2 = 2$ cfs $Q_5 = 3$ cfs, $Q_{100} = 5$ cfs) and D2 ($Q_2 = 3$ cfs $Q_5 = 4$ cfs, $Q_{100} = 9$ cfs) represent flows from the development of Poco Road. Both of these basins develop flows that end up as curb and gutter flow in an easterly direction towards Design Points 4 and 7. **Design Point 4 ($Q_5 = 3$ cfs, $Q_{100} = 5$ cfs)** represents the developed flow from Basin D where a proposed 5' Type R Sump Inlet will be installed to completely intercept both the 5 yr. and 100 yr. developed flows. The emergency overflow will be 12" and then around the corner of the intersection of Poco Road and Antelope Ravine Dr.

The following represent the basins east of Sand Creek:

Basin H ($Q_2 = 1$ cfs $Q_5 = 2$ cfs, $Q_{100} = 6$ cfs) represents the rear yards of lots and the open space adjacent to Sand Creek within Tract E. These flows will sheet flow and be directed towards Design Point 7. **Design Point 7 ($Q_5 = 4$ cfs, $Q_{100} = 11$ cfs)** represents the developed flow from Basins D2, H and a portion of the 100 yr. flow-by from Design Point 6, described later. At this location, a proposed 10' Type R Sump Inlet will be installed to completely intercept both the 5 yr. and 100 yr. developed flows. The emergency overflow will be 12" and then around the corner of the intersection of Poco Road and Antelope Ravine Dr.

Design Point 5 ($Q_5 = 5$ cfs, $Q_{100} = 17$ cfs) represents the developed flow from future Basin OS-4 and I. At this location, a proposed 15' Type R At-Grade Inlet will be installed to intercept 100% of the 5 yr. and 75% of the 100 yr. developed flows. The flow-by that will continue down the east side of the street equals $Q_5 = 0$ cfs, $Q_{100} = 4.3$ cfs. (See Appendix for calculations) This flow-by will combine with Basin L and continue to travel in a southerly direction towards Design Point 10.



Design Point 6 ($Q_5 = 2$ cfs, $Q_{100} = 8$ cfs) represents the developed flow from future Basin OS-3. At this location, a proposed 10' Type R At-Grade Inlet will be installed to intercept 100% of the 5 yr. and 79% of the 100 yr. developed flows. The flow-by that will continue down the west side of the street equals $Q_5 = 0$ cfs, $Q_{100} = 1.7$ cfs. (See Appendix for calculations) This flow-by will combine with Basins D2 and H and continue to travel in a southerly direction towards Design Point 7.

Design Point 8 ($Q_5 = 1$ cfs, $Q_{100} = 4$ cfs) represents the developed flow from Basin K. At this location, a proposed 5' Type R Sump Inlet will be installed to completely intercept both the 5 yr. and 100 yr. developed flows. The emergency overflow will be 12" and then around the corner of the intersection of Bison Valley Trail and Rabbit Tail Place.

Design Point 9 ($Q_5 = 5$ cfs, $Q_{100} = 15$ cfs) represents the developed flow from Basins J and future OS-7. At this location, a proposed 10' Type R Sump Inlet will be installed to completely intercept both the 5 yr. and 100 yr. developed flows. The emergency overflow will be 12" and then over the highpoint at the intersection of Bison Valley Trail and Rabbit Tail Place.

Design Point 10 ($Q_5 = 5$ cfs, $Q_{100} = 22$ cfs) represents the developed flow from Basin L and the flow-by from Design Point 5. At this location, a proposed 15' Type R At-Grade Inlet will be installed to intercept 100% of the 5 yr. and 66% of the 100 yr. developed flows. The flow-by that will continue down the east side of the street equals $Q_5 = 0$ cfs, $Q_{100} = 7.4$ cfs. (See Appendix for calculations) This flow-by will combine with Basin P and continue to travel in a southerly direction towards Design Point 11.

Design Point 11 ($Q_5 = 4$ cfs, $Q_{100} = 21$ cfs) represents the developed flow from Basins N, O, P and a portion of the 100 yr. flow-by from Design Point 10. At this location, a proposed 15' Type R Sump Inlet will be installed to completely intercept both the 5 yr. and 100 yr. developed flows. The emergency overflow will be ponding of 9" and then spill directly into Pond 2.



The following represent future basins and Design Points anticipated to be constructed with the future filings that will all be tributary to Pond 2:

Future Design Point 12 ($Q_5 = 9$ cfs, $Q_{100} = 33$ cfs) represents the future developed flow from Basin OS-5. At this location, a future 15' Type R Sump Inlet will be installed to completely intercept both the 5 yr. and 100 yr. developed flows. The emergency overflow will be 12" and then westerly over the highpoint Elk Antler Lane.

Future Design Point 13 ($Q_5 = 1$ cfs, $Q_{100} = 13$ cfs) represents the future developed flow from Basin OS-6. Again, this basin is mainly comprised of tributary area off-site within the Sterling Ranch Master Plan. At this location, a future 10' Type R Sump Inlet will be installed to completely intercept both the 5 yr. and 100 yr. developed flows. The emergency overflow will be 12" and then westerly over the highpoint Elk Antler Lane. These basins are mainly comprised of tributary area off-site within the Sterling Ranch Master Plan. It is planned with this report that with the future development of this portion of Sterling Ranch developed flows equal to pre-development quantities are accounted for downstream in the on-site Pond 2. These future flows quantities will be treated and detained within Pond 2. Any developed flows above these quantities will need to be routed further downstream within the Sterling Ranch development. With the development of the proposed Filing No. 1 only, these pre-development flows will continue to enter the Timber Ridge property and be handled in multiple temporary sediment basins on-site. (See Interim Developed Drainage Map)

Future Design Point 14 ($Q_5 = 1$ cfs, $Q_{100} = 3$ cfs) represents the future developed flow from Basin OS-8. At this location, a future 5' Type R Sump Inlet will be installed to completely intercept both the 5 yr. and 100 yr. developed flows. The emergency overflow will be 12" and then southerly over the highpoint.



Future Design Point 15 ($Q_5 = 3$ cfs, $Q_{100} = 12$ cfs) represents the future developed flow from Basin OS-9. This basin is comprised of a good portion of tributary area off-site within the Sterling Ranch Master Plan. At this location, a future 10' Type R Sump Inlet will be installed to completely intercept both the 5 yr. and 100 yr. developed flows. The emergency overflow will be 12" and then south over the highpoint and ultimately west towards Design Point 17. It is planned with this report that with the future development of this portion of Sterling Ranch developed flows equal to pre-development quantities are accounted for downstream in the on-site Pond 2. These future flows quantities will be treated and detained within Pond 2. Any developed flows above these quantities will need to be routed further downstream within the Sterling Ranch development. With the development of the proposed Filing No. 1 only, these pre-development flows will continue to enter the Timber Ridge property and be handled in multiple temporary sediment basins on-site. (See Interim Developed Drainage Map)

Future Design Point 16 ($Q_5 = 1$ cfs, $Q_{100} = 3$ cfs) represents the future developed flow from Basin OS-10. At this location, a future 5' Type R Sump Inlet will be installed to completely intercept both the 5 yr. and 100 yr. developed flows. The emergency overflow will be 12" and then southerly over the highpoint.

Future Design Point 17 ($Q_5 = 7$ cfs, $Q_{100} = 22$ cfs) represents the future developed flow from Basin OS-11. At this location, a future 10' Type R Sump Inlet will be installed to completely intercept both the 5 yr. and 100 yr. developed flows. The emergency overflow will be 12" and then southerly over the highpoint in Bison Valley Trail.

Future Design Point 18 ($Q_5 = 6$ cfs, $Q_{100} = 30$ cfs) represents flows from future development area both on and off-site. However, with the construction of the secondary gravel road connection up to Arroya Lane, the ultimate 30" RCP culvert is planned to be constructed with Filing No. 1 to collect these flows. In the interim it will act as just a culvert routing these pre-developed flows under the gravel road towards Sand Creek as currently taking place. Upon



future development in this area, this 30" RCP storm system will be extended further downstream within the future roadway and ultimately into Pond 2.

Future Design Point 19 ($Q_5 = 1$ cfs, $Q_{100} = 4$ cfs) represents the future developed flow from Basin OS-13. At this location, a future 5' Type R Sump Inlet will be installed to completely intercept both the 5 yr. and 100 yr. developed flows. The emergency overflow will be 12" and then southerly over the highpoint.

Future Design Point 20 ($Q_5 = 6$ cfs, $Q_{100} = 21$ cfs) represents the future developed flow from Basin OS-14. At this location, a future 10' Type R Sump Inlet will be installed to completely intercept both the 5 yr. and 100 yr. developed flows. The emergency overflow will be 12" and then southerly over the highpoint Antelope Ravine Drive. This basin is comprised of a portion of tributary area off-site within the Sterling Ranch Master Plan. It is planned with this report that with the future development of this portion of Sterling Ranch developed flows equal to pre-development quantities are accounted for downstream in the on-site Pond 2. These future flows quantities will be treated and detained within Pond 2. Any developed flows above these quantities will need to be routed further downstream within the Sterling Ranch development. With the development of the proposed Filing No. 1 only, these pre-development flows will continue to enter the Timber Ridge property and be handled in multiple temporary sediment basins on-site. (See Interim Developed Drainage Map)

Future Design Point 21 ($Q_5 = 5$ cfs, $Q_{100} = 35$ cfs) represents the pre-development flows from Basin OS-15. This basin is mostly comprised of tributary area off-site within the Sterling Ranch Master Plan. With the development of the proposed Filing No. 1 only, these pre-development flows will continue to enter the existing stock pond located on-site. (See Interim Developed Drainage Map) This facility will act as a temporary sediment pond and a formal outlet pipe will be constructed. Also constructed with Filing No. 1 will be a permanent 24" RCP storm system routing the release from this existing stock pond directly towards Sand Creek, as currently



taking place. Upon future TimberRidge development in this area, this storm system will be extended further east to the property line, the existing stock pond will be removed and another formal sediment pond will be constructed within the Sterling Ranch property. An appropriate drainage easement will be acquired for this construction. The Sterling Ranch development will be responsible for the required treatment and detention for future development in this basin, with formal outfall through the 24" RCP storm system.

Design Point 22 (Q₅ = 51 cfs, Q₁₀₀ = 191 cfs) represents the total developed flows entering **Pond 2**. These flows include Basin Q (Q₂ = 0.4 cfs Q₅ = 1 cfs, Q₁₀₀ = 6 cfs) which represents the developed flow within the actual detention basin. A proposed full-spectrum EDB is proposed at this location to release less than the pre-development flows currently seen. The following describes the design of this facility.

(See Appendix for UD Detention pond design sheets):

Detention Pond 2 (Full Spectrum EDB – see multiple storm release data below)

1.060 Ac.-ft. WQCV required

1.180 Ac.-ft. EURV required with 4:1 max. slopes

3.465 Ac.-ft. 100-yr. Storage

5.705 Ac.-ft. Total

Total In-flow: Q₂ = 24.7 cfs, Q₅ = 35.9 cfs, Q₁₀₀ = 190.6 cfs

Pond Design Release: Q₂ = 0.7 cfs, Q₅ = 0.87 cfs, Q₁₀₀ = 100.5 cfs

Pre-development Release: Q₂ = 1.1 cfs, Q₅ = 1.91 cfs, Q₁₀₀ = 115.2 cfs

(Ownership and maintenance by the Retreat at TimberRidge Metro District)

Basin M (Q₂ = 1 cfs Q₅ = 2 cfs, Q₁₀₀ = 8 cfs) represents the rear yards of lots 16-24 and the open space adjacent to Sand Creek within Tract C. These flows will sheet flow in a southwesterly direction and be directed towards a proposed Rain Garden via a private 24" wide concrete chase section and natural swale. This facility will treat the developed stormwater within this



DETENTION / STORMWATER QUALITY FACILITIES

As required, storm water quality measures will be utilized in order to reduce the amount of sediment, debris and pollutants that are allowed to enter Sand Creek. These features include but are not limited to the multiple Full Spectrum Detention Basins, Rain Gardens and permanent sediment basins. Site Planning and design techniques for the large lot, rural areas should help limit impervious area, minimize directly impervious area, lengthen time of travel and increase infiltration in order to decrease the rate and volume of stormwater runoff. Urban areas that require detention will provide a Water Quality Capture Volume (WQCV) and Excess Urban Runoff Volume (EURV) in the lower portion of the facility storage volume that will release the more frequent storms at a slower rate to help minimize the effects of development of the property. The proposed detention/SWQ facilities are to be private facilities with ownership and maintenance by the TimberRidge Metropolitan District. After completion of construction and upon the Board of County Commissioners acceptance, the Sand Creek channel will be owned and maintained by the El Paso County along with all drainage facilities within the public Right of Way.

SAND CREEK CHANNEL IMPROVEMENTS

As stated in the Sand Creek DBPS, this Reach SC-9 is recommended as a floodplain preservation design concept. Given the fact of the current requirements for detention/SWQ facilities planned for the property with designed release at or below pre-development flows, the existing Sand Creek drainageway is expected to remain stable. Existing FEMA FIS channel velocities as found in the LOMR 08-080541P seem to exceed recommended allowable velocities. Although, based on the findings from the CORE Consultants, Inc. Impact Identification Report, no significant erosion or channel degradation through this property currently exists at this time. Specifically located grade control structures (See Appendix) were specified in the DBPS through this reach in order to slow the channel velocity to the DBPS recommended 7 feet per second and to prevent localized and long-term stream degradation affecting channel linings and overbanks. The allowable velocity and shear stress will vary depending upon the existing riparian vegetation/wetlands found within the channel and overbank floodplain terrace areas. A HEC-



RAS hydraulic analysis for this portion of Reach SC-9 has been provided in order to determine the necessary channel improvements for the proposed Filing No. 1 development and future Filings. A separate wetland impact report along with the Section 404 permitting, prepared by CORE Consultants, has been developed based on these proposed channel improvements and submitted directly to the U.S. Army Corps of Engineers with necessary consult with U.S. Fish and Wildlife for their review and approval. This report and documentation can be found in the Appendix for El Paso County staff **cursory** review.

HEC-RAS MODELING

HEC-RAS ver. 5.0.6 was used to perform a one-dimensional, steady flow hydraulic model of a portion of Reach SC-9 from Arroya Lane to approximately 650 feet downstream of the TimberRidge south property line. HEC-RAS was used to define the stream centerline, overbanks, cross-sections and manning's n values. The stream centerline follows the channel thalweg to define the reach network. Cross-section topography data was obtained by using the generated surface from the 2-ft. flown contours utilized for all site design. This data was then exported from AutoCAD containing three-dimensional coordinates for the stream centerline, cross-sections, reach stations, overbank stations, reach lengths and imported into HEC-RAS. Two separate models defining the existing condition and proposed condition were prepared using the same centerline stationing. The proposed model included the introduction of the ineffective flow area for the culvert added for the Poco Road crossing. Different Manning's n values were applied across the various channel cross-sections to reflect the changes in vegetative cover within the channel and overbanks. The selected Manning's n values for the channel and overbanks were determined using Tables 10-1 and 10-2 from the DCM and Table 3 from the USGS Guide for selecting Manning's Roughness Coefficients based on numerous site visits in an effort to photograph and document each cross-section. (See Appendix) The following table summarizes the selected Manning's n values:



Table 1 Manning's n Values

Feature	Manning's n Value
Main Channel	0.04 – 0.10
Overbank Floodplain Terraces	0.12 – 0.16

Steady flow data was entered starting at Arroya Lane, channel station 55+32.95, with a flow change location at station 15+07.91 representing the Sand Creek DBPS segment change from 171 to 170. Steady flow data corresponding to recurrence intervals of 10 Yr. and 100 Yr. for the FEMA, DBPS and Sterling Ranch MDDP conditions was entered. The models were run in subcritical mode to evaluate hydraulic conditions. Boundary conditions for the entire reach were based on normal depth calculations for the upstream and downstream channel slopes. The following table summarizes the flows used in the models:

Table 2 Model Flow Values

Flood Event / Location	Flow Value (cfs)
Arroya Lane (Sta: 55+32.95)	
FEMA 100 Yr.	2600
DBPS 100 Yr.	2170
DBPS 10 Yr.	630
Sterling MDDP 100 Yr.	1487
Sterling MDDP 10 Yr.	430
DBPS Segment 170 (Sta: 15+07.91)	
FEMA 100 Yr.	2600
DBPS 100 Yr.	2260
DBPS 10 Yr.	670
Sterling MDDP 100 Yr.	1520
Sterling MDDP 10 Yr.	450



Per the approved DBPS, the anticipated developed flows just upstream of this project are $Q_{10} = 630$ cfs and $Q_{100} = 2170$ cfs as depicted within DBPS segment no. 171. The anticipated developed flows exiting this property are $Q_{10} = 670$ cfs and $Q_{100} = 2260$ cfs as depicted within DBPS segment no. 170. As discussed earlier, the FEMA FIS flows appear to be significantly higher than both those presented in the DBPS and the Sterling Ranch MDDP. Based on the approved Sterling Ranch MDDP and the anticipated future CLOMR/LOMR processing by Sterling Ranch, we have continued to utilize the significantly larger flows as determined by the FEMA FIS (2600 cfs) in the channel improvement designs but request relief from the allowable clearance of the proposed major drainageway crossing as found in the DCM Vol. 1 6.4.2. The 2600 cfs will be utilized in the structure calculations but relief from the 2 feet freeboard within the structure is being requested via formal deviation.

The proposed public roadway crossing of Sand Creek is planned for this site. (Extension of Poco Road) Upon development of Filing No. 1, the proposed crossing will consist of a two cell multi-plate steel single radius arch (26' x 8.7') with concrete headwalls to facilitate the conveyance of the 100 yr. flow. (See Appendix) This facility has an $Hw/D = 0.80$ utilizing the 2600 cfs FEMA flows and using flows of 2170 cfs as presented in the Sand Creek DBPS, it has an $Hw/D = 0.69$ and allows for 1.7' freeboard within the structure. The proposed structure is made from heavy gage corrugated steel plates with 3 oz. per square foot galvanized coating (both sides) capable of providing a service life of 75 years or longer. Soils testing will provide further design information related to wall thickness to account for corrosion and abrasion requirements per County standards.

verify

Based on recent site visits during May and July of this year, the entire Sand Creek drainage corridor through the Retreat at TimberRidge development was walked and photographed for documentation purposes and aide in the HEC-RAS modeling. (See Appendix) As discovered in the field and documented in the photos taken both up-stream and down-stream at each HES-RAS station, this reach of the Sand Creek channel appears very stable with no signs of erosion within



the main channel or channel overbanks. This is mainly due to the significant vegetal cover throughout the reach. The classification of the vegetal cover seems to have a range from Retardance Class A-C as defined by HEC-15 chart (See Appendix) This type of vegetation retardance significantly increases the allowable shear stress within the channel while reducing the velocity. The following table defines the retardance level based on the vegetation class:

Table 3
Vegetal Retardance Curve Index by SCS Retardance Class

SCS Retardance Class	Retardance Curve Index
A	10.0
B	7.64
C	5.60
D	4.44
E	2.88

Based on this information, the maximum allowable sheer stress is found by the flowing equation:

$$\tau = 0.75 \text{Curve Index}$$

Thus, the range of shear stress for this reach of Sand Creek equals 4.2 – 7.5 (lb/ft²).

Referencing the HES-RAS model calculations in the Appendix shows that only a few stations showed shear stress exceeding this limit. (Sta: 33+34.27, 20+83.66 and 18+79.67) The latter two stations are within the Filing 1 development area and with the proposed channel improvements and selective embankment lining, the shear stress at those two locations will be reduced to the allowable range. Station 33+34.27 will be addressed with proposed channel improvements in the future Filing.

This is next to the proposed Filing 1 lots. Bank stabilization at a minimum (along with potentially unstable slopes) should be addressed.



Provide existing and proposed channel slopes. Discuss other flow attributes including Froude #, calculated velocities at reaches that have issues. Provide a table showing criteria and proposed values at specified stations. Deviations may be required.

The proposed channel improvements within this Filing consist of four check structures located approximately 600 feet apart. One will be constructed north of the Poco Road crossing and three south of the road crossing. The DBPS only depicts one structure along this stretch of channel but three additional ones are being planned to further limit degradation and help control the elevation of the channel invert. These check structures are designed to be sheet piling with a concrete cap per Urban Drainage Vol. 2 Figures 9-27 thru 9-28.

The DBPS also recommended to provide selective rip-rap channel stabilization located at culvert crossings, pipe outlets and outside bends of the channel. Based on the mean channel slope and maximum allowable velocity of 7.0 fps, Type L Rip-Rap stabilization will be provided at select locations within Filing No. 1. (See Appendix) In conjunction with the installation of the rip-rap stabilization, the selected stretches of channel have also been widened 15'-20' to create and extend the floodplain terraces, better stabilize the steeper natural slopes outside the floodplain area and help reduce the shear stress. The proposed widening of the floodplain terraces takes place outside of the wetland delineations. (Reference the wetland mitigation plan prepared by CORE Consultants found in the Appendix)

DRAINAGE CRITERIA

Hydrologic calculations were performed using the City of Colorado Springs/El Paso County Drainage Criteria Manual, as revised in November 1991 and October 1994 with County adopted Chapter 6 and Section 3.2.1 of Chapter 13 of the City of Colorado Springs/El Paso County Drainage Criteria Manual as revised in May 2014. The overall pre-development design model was calculated using PondPack V8i with time of concentrations estimated using NRCS Unit Hydrograph procedures described in the DCM based upon the hydrologic soil type and runoff ARC II curve numbers (CN) chart (Table 6-10) with a 24 hour NRCS Type II distribution. Individual on-site developed basin design used for detention/SWQ basin sizing, inlet sizing and storm system routing was calculated using the Rational Method. Runoff Coefficients are based on the



imperviousness of the particular land use and the hydrologic soil type in accordance with Table 6-6. The average rainfall intensity, by recurrence interval found in the Intensity-Duration-Frequency (IDF) curves in Figure 6-5. (See Appendix)

The City of Colorado Springs/El Paso County DCM requires the Four Step Process for receiving water protection that focuses on reducing runoff volumes, treating the water quality capture volume (WQCV), stabilizing drainage ways, and implementing long-term source controls. The Four Step Process pertains to management of smaller, frequently occurring storm events, as opposed to larger storms for which drainage and flood control infrastructure are sized. Implementation of these four steps helps to achieve storm water permit requirements.

This site adheres to this **Four Step Process** as follows:

1. **Employ Runoff Reduction Practices:** Proposed rural lot impervious area (roof tops, patios, etc.) will sheet flow across lengthy landscape/natural areas within the large lots and proposed urban lot impervious areas (roof tops, patios, etc.) will sheet flow across landscaped yards and through open space areas to slow runoff and increase time of concentration prior to being conveyed to the proposed public streets or detention facilities. This will minimize directly connected impervious areas within the project site.
2. **Stabilize Drainageways:** After developed flows utilize the runoff reduction practices through the front and rear yards, developed flows will travel via roadside ditches in the large lot, rural portions of the development, curb and gutter within the public streets in the urban portions of the development and eventually public storm systems. These collected flows are then routed directly to multiple extended detention basins (full-spectrum facilities) and a Rain Garden. Where developed flows are not able to be routed to public streets (rear yards of lots 25-28 adjacent to Sand Creek – 0.90 ac.), sheet flows will travel across landscaped rear yards towards the Sand Creek channel within the open



space corridor. This channel corridor will then be protected with various channel improvements as recommended in the Sand Creek DBPS and proposed with this Filing in order to reduce velocities to erosive levels.

3. **Provide Water Quality Capture Volume (WQCV):** Runoff from this development will be treated through capture and slow release of the WQCV and excess urban runoff volume (EURV) in the proposed Full-Spectrum permanent Extended Detention Basins and a Rain Garden designed per current El Paso County drainage criteria.

4. **Consider need for Industrial and Commercial BMPs:** No industrial or commercial uses are proposed within this development. However, a site specific storm water quality and erosion control plan and narrative has been submitted along with the grading and erosion control plan. Details such as site specific sediment and erosion control construction BMP's as well as temporary and permanent BMP's were detailed in this plan and narrative to protect receiving waters. Multiple temporary BMP's are proposed based on specific phasing of the overall development. BMP's will be constructed and maintained as the development has been graded and erosion control methods employed.

FLOODPLAIN STATEMENT

Portions of this site are located within a floodplain as determined by the Flood Insurance Rate Maps (F.I.R.M.) Map Number 08041C 0535G with effective date of December 7, 2018 and the previously mentioned LOMR 08-08-0541P with an effective date of July 23, 2009. (See Appendix).



DRAINAGE AND BRIDGE FEES

This site lies entirely within the Sand Creek Drainage Basin boundaries.

The fees are calculated using the following impervious acreage method approved by El Paso County. The Retreat at TimberRidge Filing No. 1 has a total area of 68.14 acres with the following different land uses proposed:

6.94 Ac.	Sand Creek Drainage corridor (Tracts A & C)
3.66 Ac.	Detention Facilities & Park (Tracts B, D & E)
33.60 Ac.	2.5 Ac. lots (Rural Lots 1-11,& Tract F)
23.94 Ac.	1/3 Ac. lots (Urban Lots 12-70 with avg. size 14,347 SF)
68.14	Total

The percent imperviousness for this subdivision is calculated as follows:

Fees for Sand Creek Drainage Corridor

(Per El Paso County Percent Impervious Chart: 2%)

$$6.94 \text{ Ac.} \times 2\% = \mathbf{0.14 \text{ Impervious Ac.}}$$

Fees for Detention Facilities & Park

(Per El Paso County Percent Impervious Chart: 7%)

$$3.66 \text{ Ac.} \times 7\% = \mathbf{0.26 \text{ Impervious Ac.}}$$

Fees for 2.5 Ac. lots

(Per El Paso County Percent Impervious Chart: 11% with

25% fee reduction for 2.5 ac. lots planned) – *Reduction for Drainage Fees only*

$$33.60 \text{ Ac.} \times 11\% \times 75\% = \mathbf{2.77 \text{ Impervious Ac.}} \text{ (Drainage Fees)}$$

$$33.60 \text{ Ac.} \times 11\% = \mathbf{3.70 \text{ Impervious Ac.}} \text{ (Bridge Fees)}$$



Fees for 1/3 Ac. lots (Avg. lot size of 14,347 SF)

(Per El Paso County Percent Impervious Chart: 30%)

23.94 Ac. x 30% = **7.18 Impervious Ac.**

Total Impervious Acreage: **10.35 Imp. Ac.** (Drainage Fees)

Total Impervious Acreage: **11.28 Imp. Ac.** (Bridge Fees)

The following calculations are based on the 2019 Sand Creek drainage/bridge fees:

ESTIMATED FEE TOTALS:

Bridge Fees

\$ 5,559.00 x 11.28 Impervious Ac. = **\$ 62,705.52** ●

Drainage Fees

\$ 18,940.00 x 10.35 Impervious Ac. = **\$ 196,029.00** ●

Per the ECM 3.10.5.a, this development requests a reduction of drainage fees based on the on-site regional channel improvements for this stretch of Sand Creek Reach SC-9 as shown in the DBPS. The following facilities within the Sand Creek Drainage Basin seem to meet the criteria for this reduction:

Sand Creek Channel Improvements per DBPS = \$ 175,000.00

(Exact facility costs provided upon construction and acceptance by County. Any credits may be used for future Filings)



SUMMARY

The proposed Retreat at TimberRidge Filing No. 1 is within the Sand Creek Drainage Basin. Recommendations are made within this report concerning necessary improvements that will be required as a result of development of this property. The points of storm water release from the proposed site are required to be at or below the calculated historic flow quantities. The development of the proposed site does not significantly impact any downstream facility or property to an extent greater than that which currently exists in the 'historic' conditions. All drainage facilities within this report were sized according to the Drainage Criteria Manuals and the full-spectrum storm water quality requirements.

PREPARED BY:

Classic Consulting Engineers & Surveyors, LLC

Marc A. Whorton, P.E.



Project Manager

maw/118500/FDR.doc



REFERENCES

1. City of Colorado Springs/County of El Paso Drainage Criteria Manual as revised in November 1991 and October 1994 with County adopted Chapter 6 and Section 3.2.1 of Chapter 13 of the City of Colorado Springs/El Paso County Drainage Criteria Manual as revised in May 2014.
2. "Urban Storm Drainage Criteria Manual Volume 1, 2 & 3" Urban Drainage and Flood Control District, dated January 2016.
3. "Final Drainage Report for Forest Gate Subdivision" Law & Mariotti Consultants, Inc. dated October 2004.
4. "Sand Creek Drainage Basin Planning Study," Kiowa Engineering Corporation, dated March 1996.
5. "Master Development Drainage Plan for The Retreat at TimberRidge", Classic Consulting, approved March 2018.
6. "Preliminary Drainage Report for The Retreat at TimberRidge Preliminary Plan – South of Arroya Lane", Classic Consulting, approved October 2018.
7. "2018 Sterling Ranch MDDP", M&S Civil Consultants, Inc., June 2018



APPENDIX

VICINITY MAP

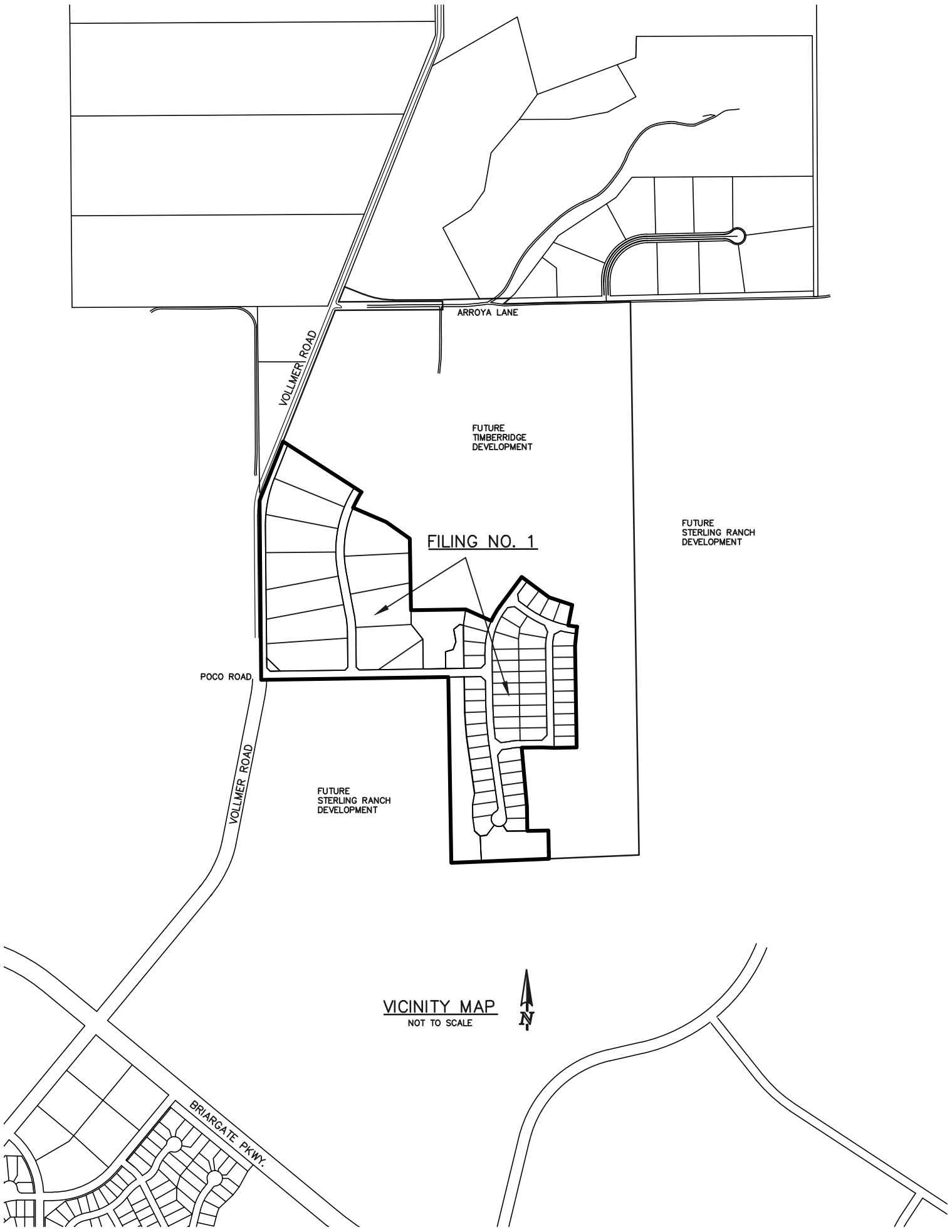

ARROYA LANE

VOLLMER ROAD

FUTURE
TIMBERRIDGE
DEVELOPMENT

FILING NO. 1

FUTURE
STERLING RANCH
DEVELOPMENT

POCO ROAD

VOLLMER ROAD

FUTURE
STERLING RANCH
DEVELOPMENT

VICINITY MAP
NOT TO SCALE



BRIARGATE PKWY.

SOILS MAP (S.C.S SURVEY)

Soil Map—El Paso County Area, Colorado

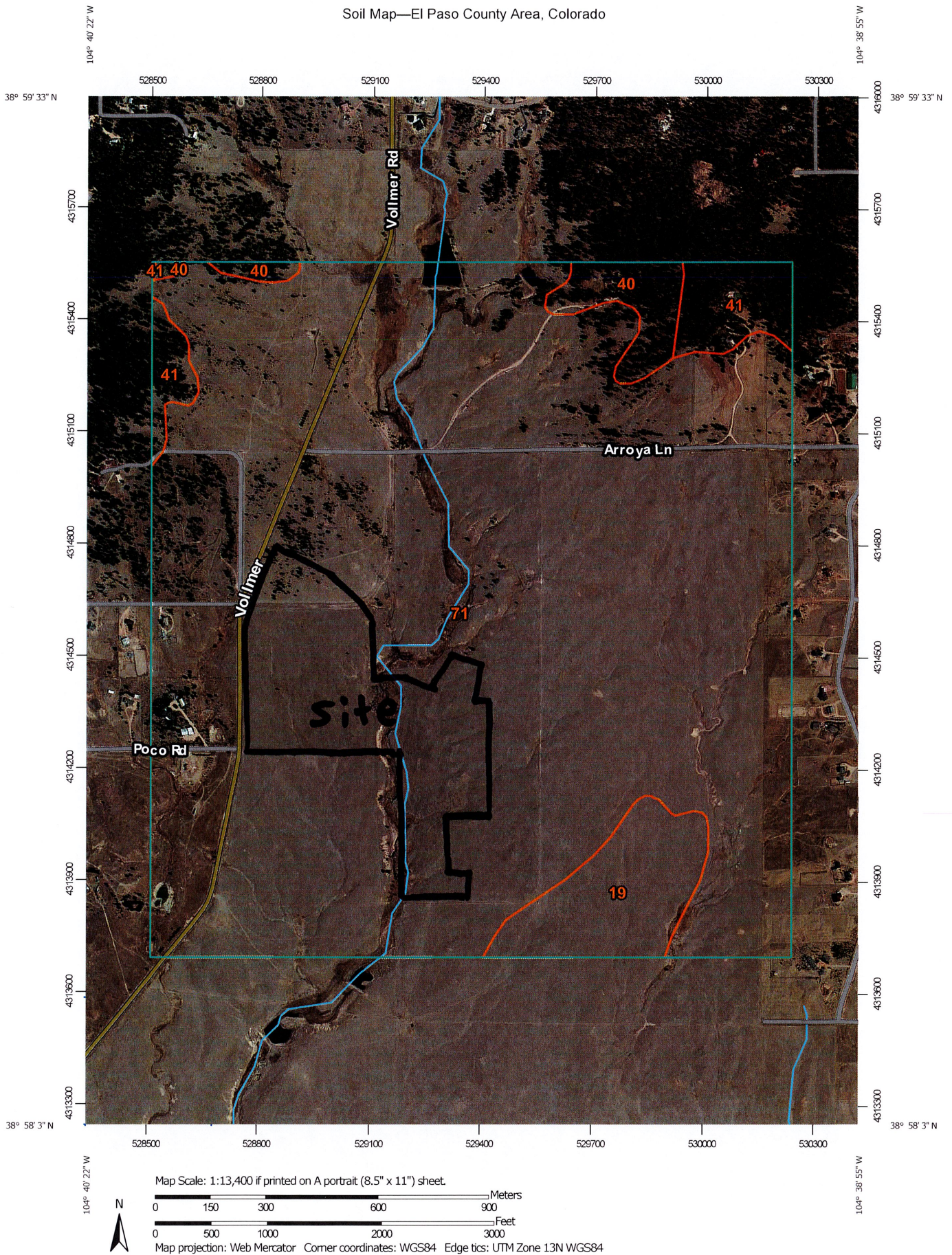

El Paso County Area, Colorado

71—Pring coarse sandy loam, 3 to 8 percent slopes

Map Unit Setting

National map unit symbol: 369k

Elevation: 6,800 to 7,600 feet

Farmland classification: Not prime farmland

Map Unit Composition

Pring and similar soils: 85 percent

Estimates are based on observations, descriptions, and transects of the mapunit.

Description of Pring

Setting

Landform: Hills

Landform position (three-dimensional): Side slope

Down-slope shape: Linear

Across-slope shape: Linear

Parent material: Arkosic alluvium derived from sedimentary rock

Typical profile

A - 0 to 14 inches: coarse sandy loam

C - 14 to 60 inches: gravelly sandy loam

Properties and qualities

Slope: 3 to 8 percent

Depth to restrictive feature: More than 80 inches

Natural drainage class: Well drained

Runoff class: Low

Capacity of the most limiting layer to transmit water (Ksat): High
(2.00 to 6.00 in/hr)

Depth to water table: More than 80 inches

Frequency of flooding: None

Frequency of ponding: None

Available water storage in profile: Low (about 6.0 inches)

Interpretive groups

Land capability classification (irrigated): None specified

Land capability classification (nonirrigated): 3e

Hydrologic Soil Group: B

Ecological site: Loamy Park (R048AY222CO)

Hydric soil rating: No

Minor Components

Pleasant

Percent of map unit:

Landform: Depressions

Hydric soil rating: Yes

Other soils

Percent of map unit:

Hydric soil rating: No

Data Source Information

Soil Survey Area: El Paso County Area, Colorado

Survey Area Data: Version 14, Sep 23, 2016

F.E.M.A. MAP / LOMR (08-08-0541P)



NOTES TO USERS

This map is for use in administering the National Flood Insurance Program. It does not necessarily identify all areas subject to flooding, particularly from local drainage sources of small size. The community map repository should be consulted for possible updated or additional flood hazard information.

To obtain more detailed information in areas where **Base Flood Elevations (BFEs)** and/or **floodways** have been determined, users are encouraged to consult the Flood Profiles and Floodway Data and/or Summary of Stillwater Elevations tables contained within the Flood Insurance Study (FIS) report that accompanies this FIRM. Users should be aware that BFEs shown on the FIRM represent rounded whole-foot elevations. These BFEs are intended for flood insurance rating purposes only and should not be used as the sole source of flood elevation information. Accordingly, flood elevation data presented in the FIS report should be utilized in conjunction with the FIRM for purposes of construction and/or floodplain management.

Coastal Base Flood Elevations shown on this map apply only landward of 0.0' North American Vertical Datum of 1988 (NAVD88). Users of this FIRM should be aware that coastal flood elevations are also provided in the Summary of Stillwater Elevations table in the Flood Insurance Study report for this jurisdiction. Elevations shown in the Summary of Stillwater Elevations table should be used for construction and/or floodplain management purposes when they are higher than the elevations shown on this FIRM.

Boundaries of the **floodways** were computed at cross sections and interpolated between cross sections. The floodways were based on hydraulic considerations with regard to requirements of the National Flood Insurance Program. Floodway widths and other pertinent floodway data are provided in the Flood Insurance Study report for this jurisdiction.

Certain areas not in Special Flood Hazard Areas may be protected by **flood control structures**. Refer to section 2.4 "Flood Protection Measures" of the Flood Insurance Study report for information on flood control structures for this jurisdiction.

The **projection** used in the preparation of this map was Universal Transverse Mercator (UTM) zone 13. The **horizontal datum** was NAD83, GRS80 spheroid. Differences in datum, spheroid, projection or UTM zones zones used in the production of FIRMs for adjacent jurisdictions may result in slight positional differences in map features across jurisdiction boundaries. These differences do not affect the accuracy of this FIRM.

Flood elevations on this map are referenced to the **North American Vertical Datum of 1988 (NAVD88)**. These flood elevations must be compared to structure and ground elevations referenced to the same vertical datum. For information regarding conversion between the National Geodetic Vertical Datum of 1929 and the North American Vertical Datum of 1988, visit the National Geodetic Survey website at <http://www.ngs.noaa.gov/> or contact the National Geodetic Survey at the following address:

NGS Information Services
NOAA, NIMS12
National Geodetic Survey
SSMC-3, #9202
1315 East-West Highway
Silver Spring, MD 20910-3282

To obtain current elevation, description, and/or location information for **bench marks** shown on this map, please contact the Information Services Branch of the National Geodetic Survey at (301) 713-3242 or visit its website at <http://www.ngs.noaa.gov/>.

Base Map information shown on this FIRM was provided in digital format by El Paso County, Colorado Springs Utilities, and Anderson Consulting Engineers, Inc. These data are current as of 2008.

This map reflects more detailed and up-to-date **stream channel configurations and floodplain delineations** than those shown on the previous FIRM for this jurisdiction. The floodplains and floodways that were transferred from the previous FIRM may have been adjusted to conform to these new stream channel configurations. As a result, the Flood Profiles and Floodway Data tables in the Flood Insurance Study Report (which contains authoritative hydraulic data) may reflect stream channel distances that differ from what is shown on this map. The profile baselines depicted on this map represent the hydraulic modeling baselines that match the flood profiles and Floodway Data Tables if applicable, in the FIS report. As a result, the profile baselines may deviate significantly from the new base map channel representation and may appear outside of the floodplain.

Corporate limits shown on this map are based on the best data available at the time of publication. Because changes due to annexations or de-annexations may have occurred after this map was published, map users should contact appropriate community officials to verify current corporate limit locations.

Please refer to the separately printed **Map Index** for an overview map of the county showing the layout of map panels; community map repository addresses; and a Listing of Communities table containing National Flood Insurance Program dates for each community as well as a listing of the panels on which each community is located.

Contact **FEMA Map Service Center (MSC)** via the FEMA Map Information eXchange (FIRM) 1-877-336-2627 for information on available products associated with this FIRM. Available products may include previously issued Letters of Map Change, a Flood Insurance Study Report, and/or digital versions of this map. The MSC may also be reached by Fax at 1-800-358-9620 and its website at <http://www.msc.fema.gov/>.

If you have **questions about this map** or questions concerning the National Flood Insurance Program in general, please call 1-877-FEMA MAP (1-877-336-2627) or visit the FEMA website at <http://www.fema.gov/business/nfp>.

El Paso County Vertical Datum Offset Table	
Flooding Source	Vertical Datum Offset (ft)

REFER TO SECTION 3.3 OF THE EL PASO COUNTY FLOOD INSURANCE STUDY FOR STREAM BY STREAM VERTICAL DATUM CONVERSION INFORMATION

Panel Location Map

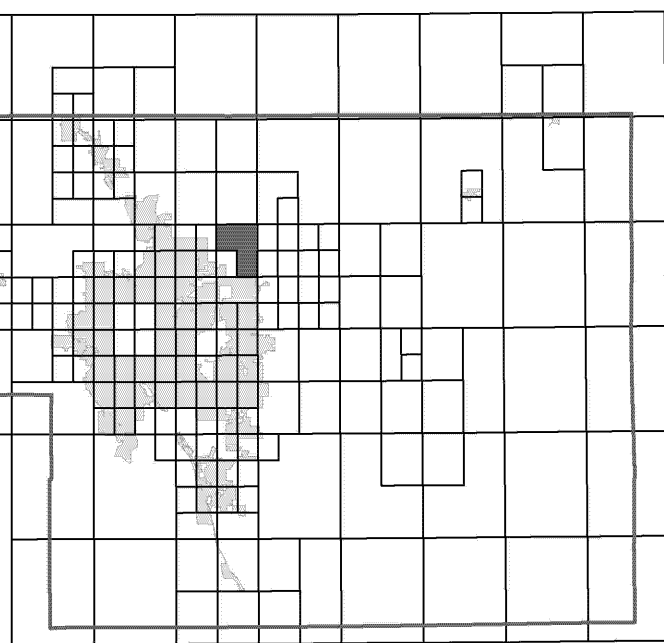

This Digital Flood Insurance Rate Map (DFIRM) was produced through a Cooperating Technical Partner (CTP) agreement between the State of Colorado Water Conservation Board (CWCB) and the Federal Emergency Management Agency (FEMA).



Additional Flood Hazard information and resources are available from local communities and the Colorado Water Conservation Board.

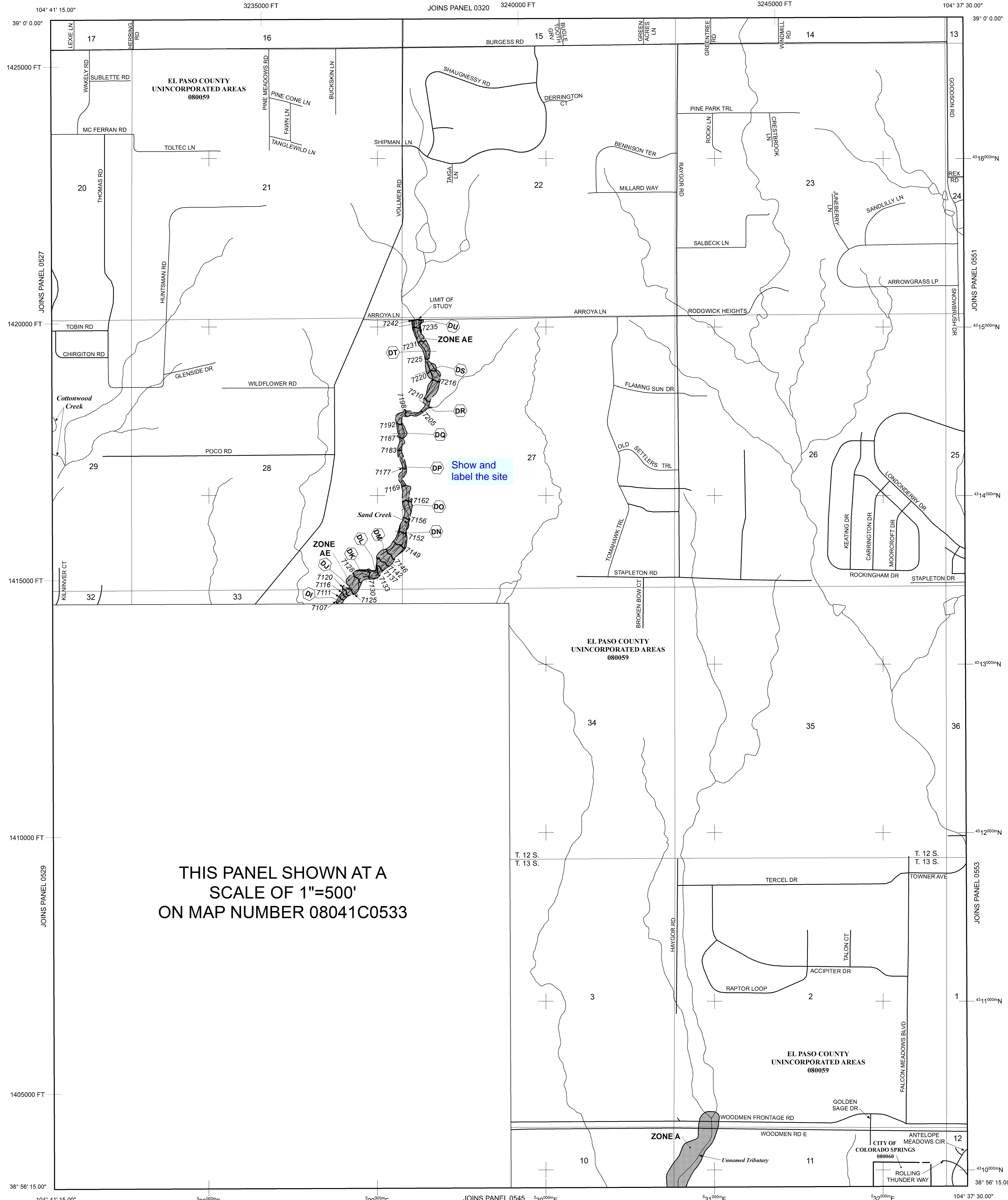

THIS PANEL SHOWN AT A SCALE OF 1"=500' ON MAP NUMBER 08041C0533

NOTE: MAP AREA SHOWN ON THIS PANEL IS LOCATED WITHIN TOWNSHIP 12 SOUTH, RANGE 65 WEST, AND TOWNSHIP 13 SOUTH, RANGE 65 WEST.

LEGEND

- SPECIAL FLOOD HAZARD AREAS (SFHAs) SUBJECT TO INUNDATION BY THE 1% ANNUAL CHANCE FLOOD
- The 1% annual chance flood (100-year flood), also known as the base flood, is the flood that has a 1% chance of being equalled or exceeded in any given year. The Special Flood Hazard Area is the area subject to flooding by the 1% annual chance flood. Areas of Special Flood Hazard include Zones A, AE, AH, AO, AR, A99, V, and VE. The Base Flood Elevation is the water-surface elevation of the 1% annual chance flood.
- ZONE A** No Base Flood Elevations determined.
- ZONE AE** Base Flood Elevations determined.
- ZONE AH** Flood depths of 1 to 3 feet (usually areas of ponding); Base Flood Elevations determined.
- ZONE AO** Flood depths of 1 to 3 feet (usually sheet flow on sloping terrain); average depths determined. For areas of alluvial fan flooding, velocities also determined.
- ZONE AR** Special Flood Hazard Area Formerly protected from the 1% annual chance flood by a flood control system that was subsequently decertified. Zone AR indicates that the former flood control system is being restored to provide protection from the 1% annual chance or greater flood.
- ZONE A99** Area to be protected from 1% annual chance flood by a Federal flood protection system under construction; no Base Flood Elevations determined.
- ZONE V** Coastal flood zone with velocity hazard (wave action); no Base Flood Elevations determined.
- ZONE VE** Coastal flood zone with velocity hazard (wave action); Base Flood Elevations determined.
- FLOODWAY AREAS IN ZONE AE
- The floodway is the channel of a stream plus any adjacent floodplain areas that must be kept free of encroachment so that the 1% annual chance flood can be carried without substantial increases in flood heights.
- OTHER FLOOD AREAS**
- ZONE X** Areas of 0.2% annual chance flood; areas of 1% annual chance flood with average depths of less than 1 foot, or with drainage areas less than 1 square mile; and areas protected by levees from 1% annual chance flood.
- OTHER AREAS**
- ZONE X** Areas determined to be outside the 0.2% annual chance floodplain.
- ZONE D** Areas in which flood hazards are undetermined, but possible.
- COASTAL BARRIER RESOURCES SYSTEM (CBRS) AREAS
- OTHERWISE PROTECTED AREAS (OPAs)
- CBRS areas and OPAs are normally located within or adjacent to Special Flood Hazard Areas.
- Floodplain boundary
- Floodway boundary
- Zone D boundary
- CBRS and OPA boundary
- Boundary dividing Special Flood Hazard Areas of different Base Flood Elevations, flood depths or flood velocities.
- Base Flood Elevation line and value; elevation in feet* (EL 987)
- Base Flood Elevation value where uniform within zone; elevation in feet*
- Cross section line
- Transsect line
- Geographic coordinates referenced to the North American Datum of 1983 (NAD-83)
- 1000-meter Universal Transverse Mercator grid ticks, zone 13
- 5000-foot grid ticks; Colorado State Plane coordinate system, central zone (FIPSZONE 0502), Lambert Conformal Conic Projection
- Bench mark (see explanation in Notes to Users section of this FIRM panel)
- River Mile
- MAP REPOSITORIES
Refer to Map Repositories list on Map Index
- EFFECTIVE DATE OF COUNTYWIDE FLOOD INSURANCE RATE MAP
MARCH 17, 1997
- EFFECTIVE DATE(S) OF REVISION(S) TO THIS PANEL
DECEMBER 7, 2018 - to update corporate limits, to change Base Flood Elevations and Special Flood Hazard Areas, to update map format, to add roads and road names, and to incorporate previously issued Letters of Map Revision
- For community map revision history prior to countywide mapping, refer to the Community Map History Table located in the Flood Insurance Study report for this jurisdiction.
- To determine if flood insurance is available in this community, contact your insurance agent or call the National Flood Insurance Program at 1-800-638-6620.

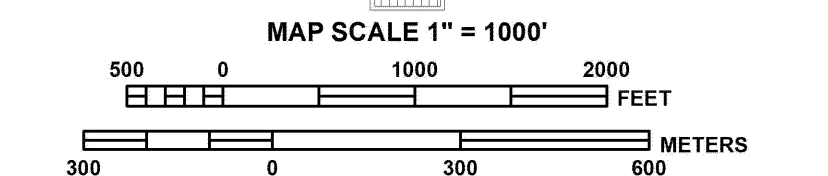

NFP PANEL 0535G

FIRM
FLOOD INSURANCE RATE MAP
EL PASO COUNTY,
COLORADO
AND INCORPORATED AREAS

PANEL 535 OF 1300
(SEE MAP INDEX FOR FIRM PANEL LAYOUT)

CONTAINS:

COMMUNITY	NUMBER	PANEL	SUFFIX
COLORADO SPRINGS, CITY OF	08060	0535	G
EL PASO COUNTY	08059	0535	G

Notice to User: The Map Number shown below should be used when placing map orders. The Community Number shown above should be used on insurance applications for the subject community.

MAP NUMBER
08041C0535G

MAP REVISED
DECEMBER 7, 2018

Federal Emergency Management Agency



Federal Emergency Management Agency

Washington, D.C. 20472

LETTER OF MAP REVISION DETERMINATION DOCUMENT

COMMUNITY AND REVISION INFORMATION		PROJECT DESCRIPTION	BASIS OF REQUEST
COMMUNITY	<p align="center">El Paso County Colorado (Unincorporated Areas)</p>	NO PROJECT	HYDRAULIC ANALYSIS NEW TOPOGRAPHIC DATA
	COMMUNITY NO.: 080059		
IDENTIFIER	Sand Creek Letter of Map Revision, Mustang Place to Arroya Lane	APPROXIMATE LATITUDE & LONGITUDE: 38.971, -104.668 SOURCE: USGS QUADRANGLE DATUM: NAD 27	
ANNOTATED MAPPING ENCLOSURES		ANNOTATED STUDY ENCLOSURES	
TYPE: FIRM* NO.: 08041C0535 F DATE: March 17, 1997		DATE OF EFFECTIVE FLOOD INSURANCE STUDY: August 23, 1999 PROFILE(S): 204P(a), 204P(b), 204P(c) AND 204P(d) FLOODWAY DATA TABLE: 5	

Enclosures reflect changes to flooding sources affected by this revision.

* FIRM - Flood Insurance Rate Map; ** FBFM - Flood Boundary and Floodway Map; *** FHBM - Flood Hazard Boundary Map

FLOODING SOURCE(S) & REVISED REACH(ES)

Sand Creek - from approximately 360 feet downstream of Mustang Place to just downstream of Arroya Lane

SUMMARY OF REVISIONS

Flooding Source	Effective Flooding	Revised Flooding	Increases	Decreases
Sand Creek	Zone A	Zone AE	YES	YES
	No BFEs*	BFEs	YES	NONE
	No Floodway	Floodway	YES	NONE

* BFEs - Base Flood Elevations

DETERMINATION

This document provides the determination from the Department of Homeland Security's Federal Emergency Management Agency (FEMA) regarding a request for a Letter of Map Revision (LOMR) for the area described above. Using the information submitted, we have determined that a revision to the flood hazards depicted in the Flood Insurance Study (FIS) report and/or National Flood Insurance Program (NFIP) map is warranted. This document revises the effective NFIP map, as indicated in the attached documentation. Please use the enclosed annotated map panels revised by this LOMR for floodplain management purposes and for all flood insurance policies and renewals in your community.

This determination is based on the flood data presently available. The enclosed documents provide additional information regarding this determination. If you have any questions about this document, please contact the FEMA Map Assistance Center toll free at 1-877-336-2627 (1-877-FEMA MAP) or by letter addressed to the LOMR Depot, 3601 Eisenhower Avenue, Alexandria, VA 22304. Additional Information about the NFIP is available on our website at <http://www.fema.gov/nfip>.

David N. Bascom, Program Specialist
Engineering Management Branch
Mitigation Directorate



Federal Emergency Management Agency

Washington, D.C. 20472

LETTER OF MAP REVISION DETERMINATION DOCUMENT (CONTINUED)

COMMUNITY INFORMATION

APPLICABLE NFIP REGULATIONS/COMMUNITY OBLIGATION

We have made this determination pursuant to Section 206 of the Flood Disaster Protection Act of 1973 (P.L. 93-234) and in accordance with the National Flood Insurance Act of 1968, as amended (Title XIII of the Housing and Urban Development Act of 1968, P.L. 90-448), 42 U.S.C. 4001-4128, and 44 CFR Part 65. Pursuant to Section 1361 of the National Flood Insurance Act of 1968, as amended, communities participating in the NFIP are required to adopt and enforce floodplain management regulations that meet or exceed NFIP criteria. These criteria, including adoption of the FIS report and FIRM, and the modifications made by this LOMR, are the minimum requirements for continued NFIP participation and do not supersede more stringent State/Commonwealth or local requirements to which the regulations apply.

We provide the floodway designation to your community as a tool to regulate floodplain development. Therefore, the floodway revision we have described in this letter, while acceptable to us, must also be acceptable to your community and adopted by appropriate community action, as specified in Paragraph 60.3(d) of the NFIP regulations.

COMMUNITY REMINDERS

We based this determination on the 1-percent-annual-chance flood discharges computed in the FIS for your community without considering subsequent changes in watershed characteristics that could increase flood discharges. Future development of projects upstream could cause increased flood discharges, which could cause increased flood hazards. A comprehensive restudy of your community's flood hazards would consider the cumulative effects of development on flood discharges subsequent to the publication of the FIS report for your community and could, therefore, establish greater flood hazards in this area.

Your community must regulate all proposed floodplain development and ensure that permits required by Federal and/or State/Commonwealth law have been obtained. State/Commonwealth or community officials, based on knowledge of local conditions and in the interest of safety, may set higher standards for construction or may limit development in floodplain areas. If your State/Commonwealth or community has adopted more restrictive or comprehensive floodplain management criteria, those criteria take precedence over the minimum NFIP requirements.

We will not print and distribute this LOMR to primary users, such as local insurance agents or mortgage lenders; instead, the community will serve as a repository for the new data. We encourage you to disseminate the information in this LOMR by preparing a news release for publication in your community's newspaper that describes the revision and explains how your community will provide the data and help interpret the NFIP maps. In that way, interested persons, such as property owners, insurance agents, and mortgage lenders, can benefit from the information.

This determination is based on the flood data presently available. The enclosed documents provide additional information regarding this determination. If you have any questions about this document, please contact the FEMA Map Assistance Center toll free at 1-877-336-2627 (1-877-FEMA MAP) or by letter addressed to the LOMR Depot, 3601 Eisenhower Avenue, Alexandria, VA 22304. Additional information about the NFIP is available on our website at <http://www.fema.gov/nfip>.

A handwritten signature in cursive script that reads "David N. Bascom".

David N. Bascom, Program Specialist
Engineering Management Branch
Mitigation Directorate



Federal Emergency Management Agency
Washington, D.C. 20472

**LETTER OF MAP REVISION
DETERMINATION DOCUMENT (CONTINUED)**

We have designated a Consultation Coordination Officer (CCO) to assist your community. The CCO will be the primary liaison between your community and FEMA. For information regarding your CCO, please contact:

Ms. Jeanine D. Petterson
Director, Mitigation Division
Federal Emergency Management Agency, Region VIII
Denver Federal Center, Building 710
P.O. Box 25267
Denver, CO 80225-0267
(303) 235-4830

STATUS OF THE COMMUNITY NFIP MAPS

We will not physically revise and republish the FIRM and FIS report for your community to reflect the modifications made by this LOMR at this time. When changes to the previously cited FIRM panel(s) and FIS report warrant physical revision and republication in the future, we will incorporate the modifications made by this LOMR at that time.

This determination is based on the flood data presently available. The enclosed documents provide additional information regarding this determination. If you have any questions about this document, please contact the FEMA Map Assistance Center toll free at 1-877-336-2627 (1-877-FEMA MAP) or by letter addressed to the LOMR Depot, 3601 Eisenhower Avenue, Alexandria, VA 22304. Additional Information about the NFIP is available on our website at <http://www.fema.gov/nfip>.

A handwritten signature in cursive script that reads "David N. Bascom".

David N. Bascom, Program Specialist
Engineering Management Branch
Mitigation Directorate



Federal Emergency Management Agency

Washington, D.C. 20472

LETTER OF MAP REVISION DETERMINATION DOCUMENT (CONTINUED)

PUBLIC NOTIFICATION OF REVISION

PUBLIC NOTIFICATION

FLOODING SOURCE	LOCATION OF REFERENCED ELEVATION	BFE (FEET NGVD 29)		MAP PANEL NUMBER(S)
		EFFECTIVE	REVISED	
Sand Creek	Just upstream of Mustang Place	None	6,984	08041C0535 F
	Just downstream of Arroya Lane	None	7,238	08041C0535 F

Within 90 days of the second publication in the local newspaper, a citizen may request that we reconsider this determination. Any request for reconsideration must be based on scientific or technical data. Therefore, this letter will be effective only after the 90-day appeal period has elapsed and we have resolved any appeals that we receive during this appeal period. Until this LOMR is effective, the revised BFEs presented in this LOMR may be changed.

A notice of changes will be published in the *Federal Register*. A short notice also will be published in your local newspaper on or about the dates listed below. Please refer to FEMA's website at https://www.floodmaps.fema.gov/fhm/Scripts/bfe_main.asp for a more detailed description of proposed BFE changes, which will be posted within a week of the date of this letter.

LOCAL NEWSPAPER

Name: *El Paso County News*
Dates: 03/18/09 03/25/09

This determination is based on the flood data presently available. The enclosed documents provide additional information regarding this determination. If you have any questions about this document, please contact the FEMA Map Assistance Center toll free at 1-877-336-2627 (1-877-FEMA MAP) or by letter addressed to the LOMR Depot, 3601 Eisenhower Avenue, Alexandria, VA 22304. Additional Information about the NFIP is available on our website at <http://www.fema.gov/nfip>.

David N. Bascom, Program Specialist
Engineering Management Branch
Mitigation Directorate

**EL PASO COUNTY
UNINCORPORATED AREAS
080059**

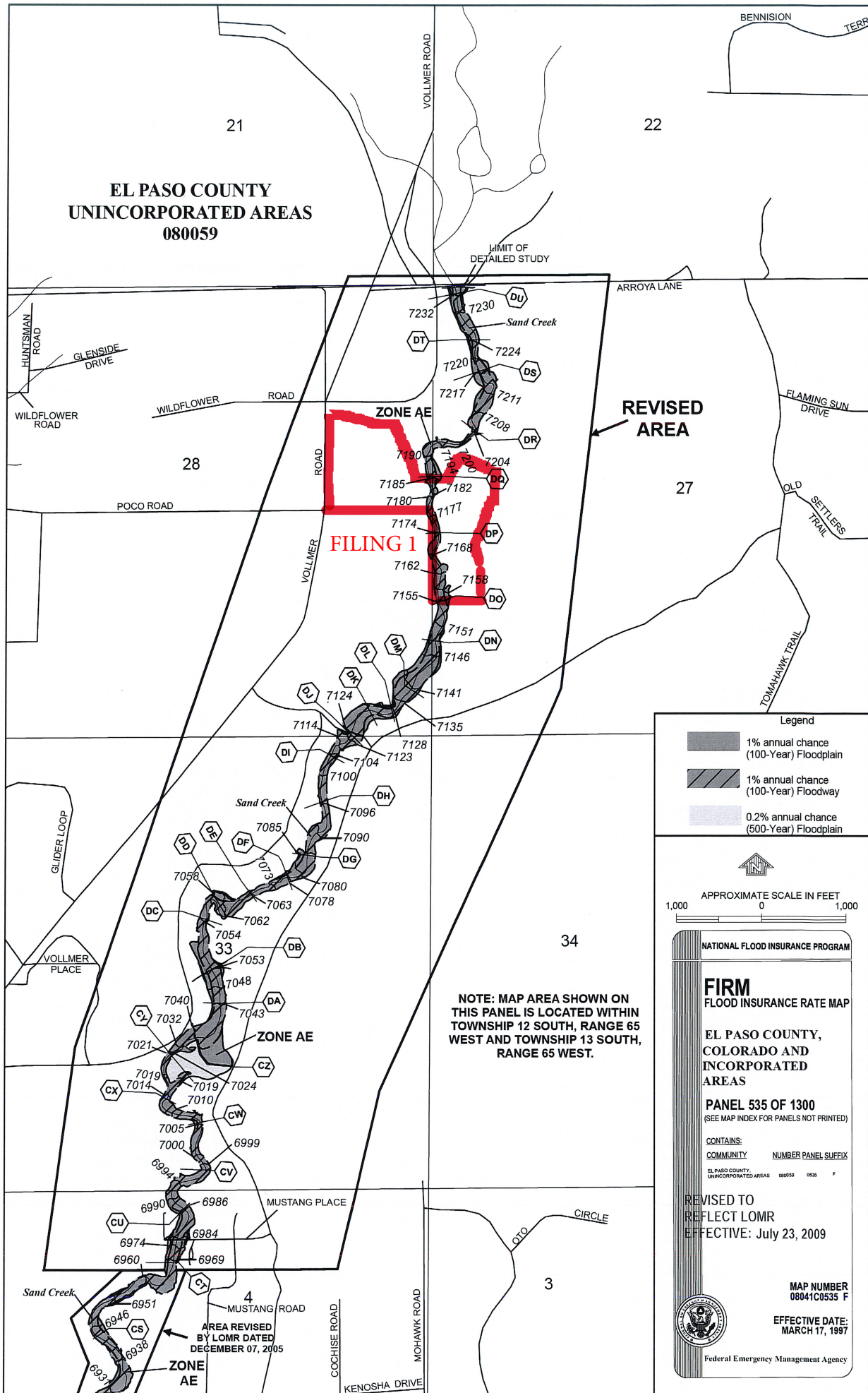



REVISED AREA

FILING 1

ZONE AE

Legend

-  1% annual chance (100-Year) Floodplain
-  1% annual chance (100-Year) Floodway
-  0.2% annual chance (500-Year) Floodplain



APPROXIMATE SCALE IN FEET
1,000 0 1,000

NATIONAL FLOOD INSURANCE PROGRAM

FIRM
FLOOD INSURANCE RATE MAP

EL PASO COUNTY,
COLORADO AND
INCORPORATED
AREAS

PANEL 535 OF 1300
(SEE MAP INDEX FOR PANELS NOT PRINTED)

CONTAINS:
COMMUNITY NUMBER PANEL SUFFIX
EL PASO COUNTY,
UNINCORPORATED AREAS 080059 0535 F

REVISED TO
REFLECT LOMR
EFFECTIVE: July 23, 2009

MAP NUMBER
08041C0535 F

EFFECTIVE DATE:
MARCH 17, 1997



Federal Emergency Management Agency

**NOTE: MAP AREA SHOWN ON
THIS PANEL IS LOCATED WITHIN
TOWNSHIP 12 SOUTH, RANGE 65
WEST AND TOWNSHIP 13 SOUTH,
RANGE 65 WEST.**

AREA REVISED
BY LOMR DATED
DECEMBER 07, 2005

FLOODING SOURCE		FLOODWAY			BASE FLOOD WATER SURFACE ELEVATION			
CROSS SECTION	DISTANCE ¹	WIDTH (FEET)	SECTION AREA (SQUARE FEET)	MEAN VELOCITY (FEET PER SECOND)	REGULATORY	WITHOUT FLOODWAY FEET (NGVD)	WITH FLOODWAY FEET (NGVD)	INCREASE
Sand Creek								
(cont'd)								
CA	65,292	164	427	6.1	6,748.7	6,748.7	6,749.4	0.7
CB	66,092	41	223	11.7	6,761.2	6,761.2	6,762.2	1.0
CC	66,247	90	270	9.6	6,773.6	6,773.6	6,773.7	0.1
CD	67,647	50	218	11.9	6,782.6	6,782.6	6,783.3	0.7
CE	68,297	65	284	8.8	6,793.9	6,793.9	6,794.4	0.5
CF	69,147	50	213	11.7	6,804.5	6,804.5	6,804.5	0.0
CG	70,157	50	213	11.7	6,815.1	6,815.1	6,815.3	0.2
CH	70,577	205	347	7.2	6,823.9	6,823.9	6,824.5	0.6
CI	70,627	180	267	9.4	6,826.7	6,826.7	6,827.7	1.0
CJ	70,727	210	340	7.3	6,831.1	6,831.1	6,831.1	0.0
CK	70,807	195	334	7.5	6,832.5	6,832.5	6,832.5	0.0
CL	71,162	90	255	9.8	6,838.0	6,838.0	6,839.0	1.0
CM	71,977	226	503	5.2	6,847.4	6,847.4	6,848.3	0.9
CN	73,052	174	328	7.9	6,861.1	6,861.1	6,861.2	0.1
CO	73,644	237	364	7.1	6,870.2	6,870.2	6,870.2	0.0
CP	75,142	172	324	8.0	6,888.5	6,888.5	6,888.7	0.2
CQ	76,161	109	283	9.2	6,903.5	6,903.5	6,903.7	0.2
CR	77,846	100	272	9.6	6,926.1	6,926.1	6,926.7	0.6
CS	79,187	117	287	9.1	6,944.1	6,944.1	6,944.1	0.0
CT	80,808	142	310	8.4	6,969.2	6,969.2	6,969.2	0.0
CU	81,501	120	342	7.6	6,986.1	6,986.1	6,986.5	0.4
CV	82,281	124	295	8.8	6,997.4	6,997.4	6,997.4	0.0
CW	82,897	64	237	11.0	7,005.3	7,005.3	7,006.1	0.8
CX	83,517	90	266	9.8	7,013.9	7,013.9	7,013.9	0.0
CY	84,087	70	244	10.7	7,024.3	7,024.3	7,024.3	0.0
CZ	84,473	160	322	8.1	7,040.2	7,040.2	7,040.2	0.0

REVISED TO REFLECT LOMR EFFECTIVE: July 23, 2009

¹ Feet Above Confluence With Fountain Creek

FLOODWAY DATA

FEDERAL EMERGENCY MANAGEMENT AGENCY
EL PASO COUNTY, CO
 AND INCORPORATED AREAS

SAND CREEK

TABLE 5

Revised Data From LOMR Dated Dec. 7, 2005

Revised Data

FLOODING SOURCE		FLOODWAY			BASE FLOOD WATER SURFACE ELEVATION			
CROSS SECTION	DISTANCE ¹	WIDTH (FEET)	SECTION AREA (SQUARE FEET)	MEAN VELOCITY (FEET PER SECOND)	REGULATORY	WITHOUT FLOODWAY FEET (NGVD)	WITH FLOODWAY FEET (NGVD)	INCREASE
Sand Creek (cont'd)								
DA	85,073	139	456	5.7	7,043.0	7,043.0	7,043.1	0.1
DB	85,483	170	328	7.9	7,053.4	7,053.4	7,053.5	0.1
DC	86,103	100	274	9.5	7,054.4	7,054.4	7,054.4	0.0
DD	86,673	197	434	6.0	7,061.7	7,061.7	7,062.0	0.3
DE	87,073	83	270	9.6	7,068.2	7,068.2	7,068.3	0.1
DF	87,573	98	325	8.0	7,077.7	7,077.7	7,077.9	0.2
DG	88,003	135	304	8.6	7,085.1	7,085.1	7,085.1	0.0
DH	88,738	89	263	9.9	7,096.9	7,096.9	7,096.9	0.0
DI	89,303	74	249	10.4	7,104.1	7,104.1	7,104.3	0.2
DJ	89,663	143	309	8.4	7,123.2	7,123.2	7,123.2	0.0
DK	90,058	140	426	6.1	7,125.1	7,125.1	7,125.2	0.1
DL	90,348	102	276	9.4	7,127.6	7,127.6	7,127.8	0.2
DM	90,698	300	398	6.5	7,141.0	7,141.0	7,141.0	0.0
DN	91,388	120	292	8.9	7,148.5	7,148.5	7,148.6	0.1
DO	91,868	105	313	8.3	7,155.2	7,155.2	7,155.9	0.7
DP	92,748	65	239	10.9	7,173.8	7,173.8	7,173.8	0.0
DQ	93,468	117	288	9.0	7,184.6	7,184.6	7,184.6	0.0
DR	94,448	81	260	10.0	7,204.5	7,204.5	7,204.6	0.1
DS	95,343	100	274	9.5	7,216.8	7,216.8	7,217.2	0.4
DT	95,723	77	252	10.3	7,224.2	7,224.2	7,224.3	0.1
DU	96,333	90	266	9.8	7,232.5	7,232.5	7,233.0	0.5

REVISED TO REFLECT LOMR

EFFECTIVE: July 23, 2009

¹ Feet Above Confluence With Fountain Creek

FEDERAL EMERGENCY MANAGEMENT AGENCY
EL PASO COUNTY, CO
 AND INCORPORATED AREAS

FLOODWAY DATA

SAND CREEK

TABLE 5

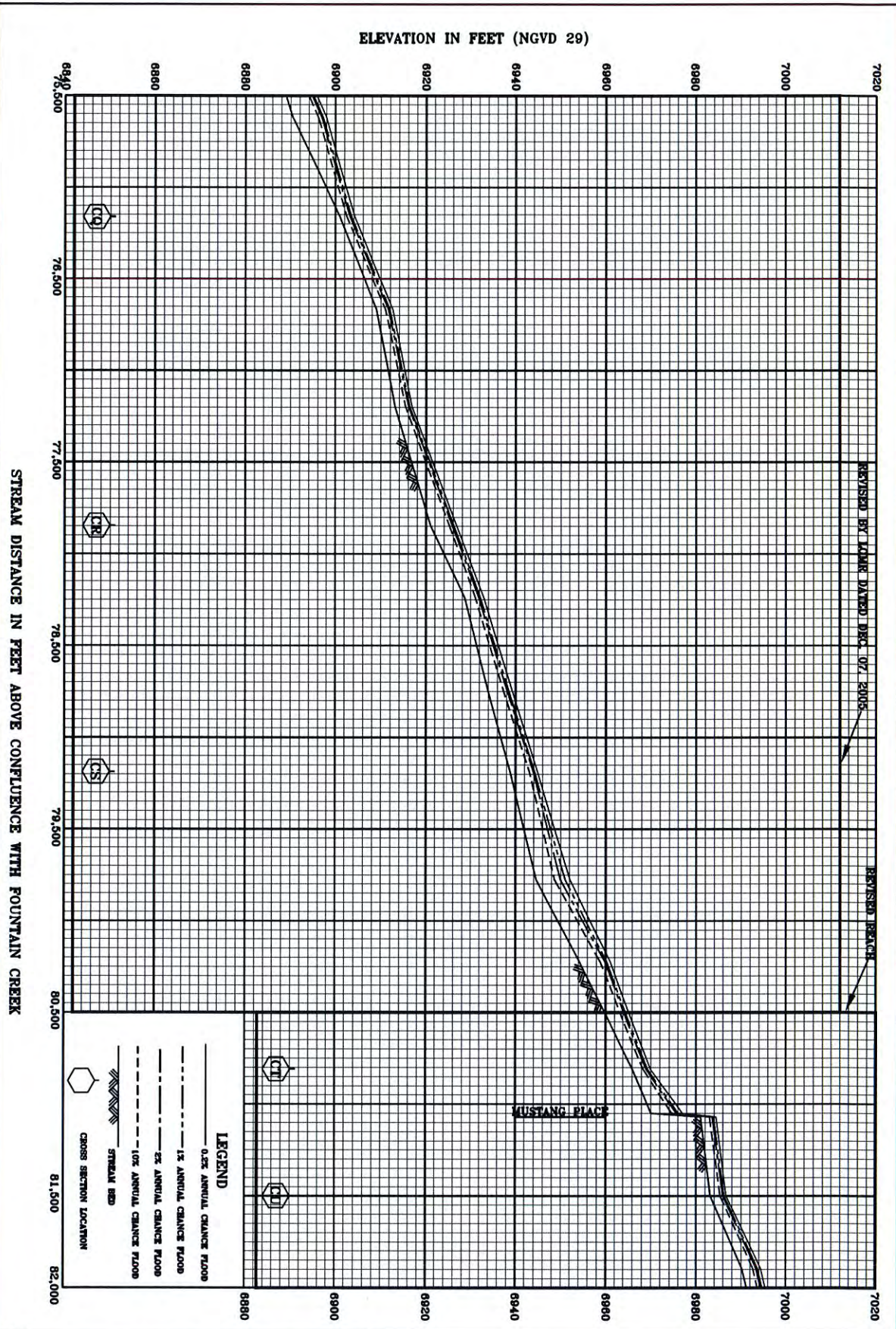

204P(a)

FEDERAL EMERGENCY MANAGEMENT AGENCY
 EL PASO COUNTY, CO
 AND INCORPORATED AREAS

REVISED TO
 REFLECT LOMR
 EFFECTIVE: July 23, 2009

FLOOD PROFILES
 SAND CREEK

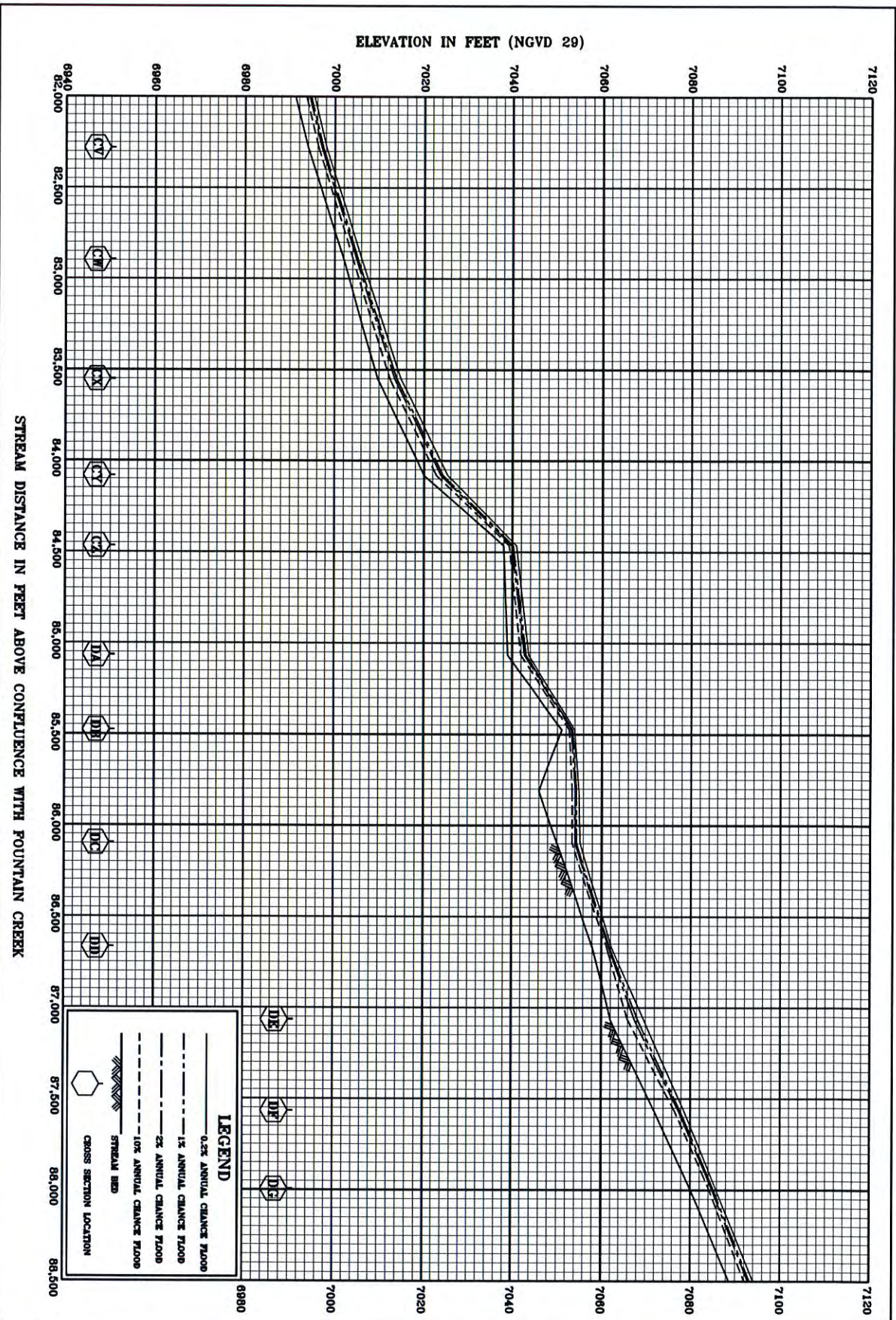

204P(b)

FEDERAL EMERGENCY MANAGEMENT AGENCY
 EL PASO COUNTY, CO
 AND INCORPORATED AREAS

FLOOD PROFILES

SAND CREEK

REVISED TO
 REFLECT LOMR
 EFFECTIVE: July 23, 2009

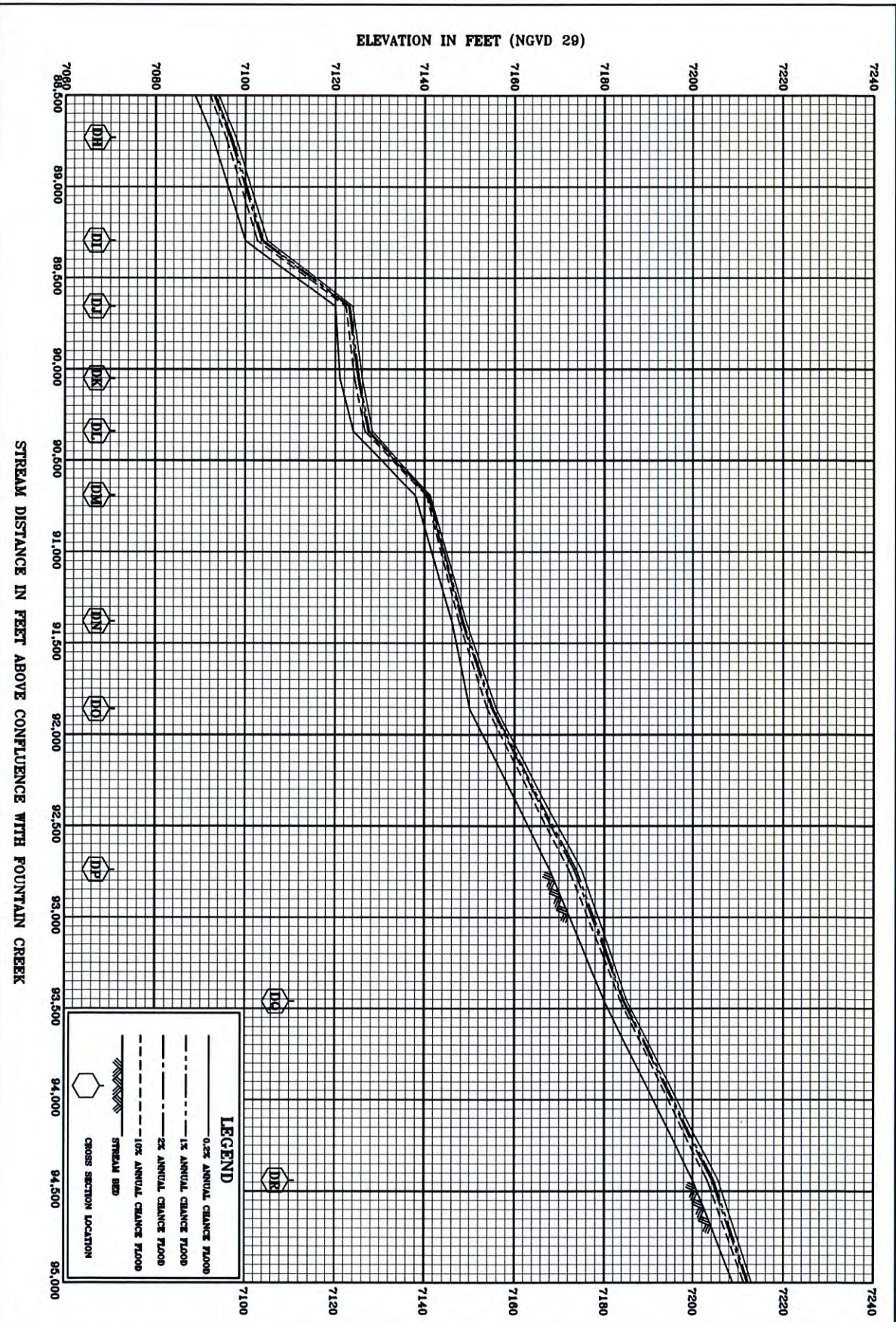

204P(c)

FEDERAL EMERGENCY MANAGEMENT AGENCY
 EL PASO COUNTY, CO
 AND INCORPORATED AREAS

REVISED TO
 REFLECT LOMR
 EFFECTIVE: July 23, 2009

FLOOD PROFILES
 SAND CREEK

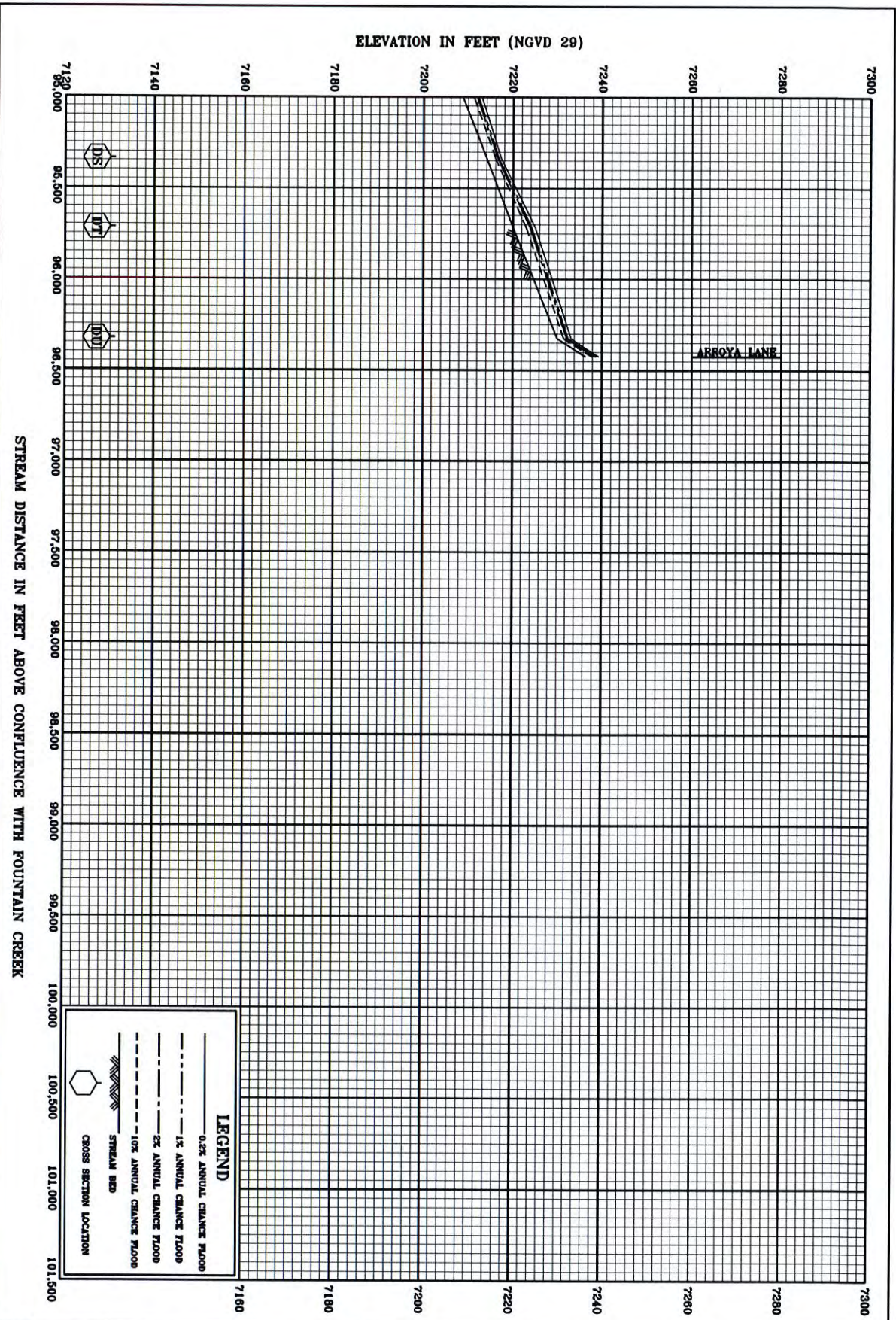

RECOMMENDATIONS PER SAND CREEK DBPS



Project No.	9034708
Date	9/92
Design	RNW
Drawn	EAK
Checked	RNW
Reviewed	

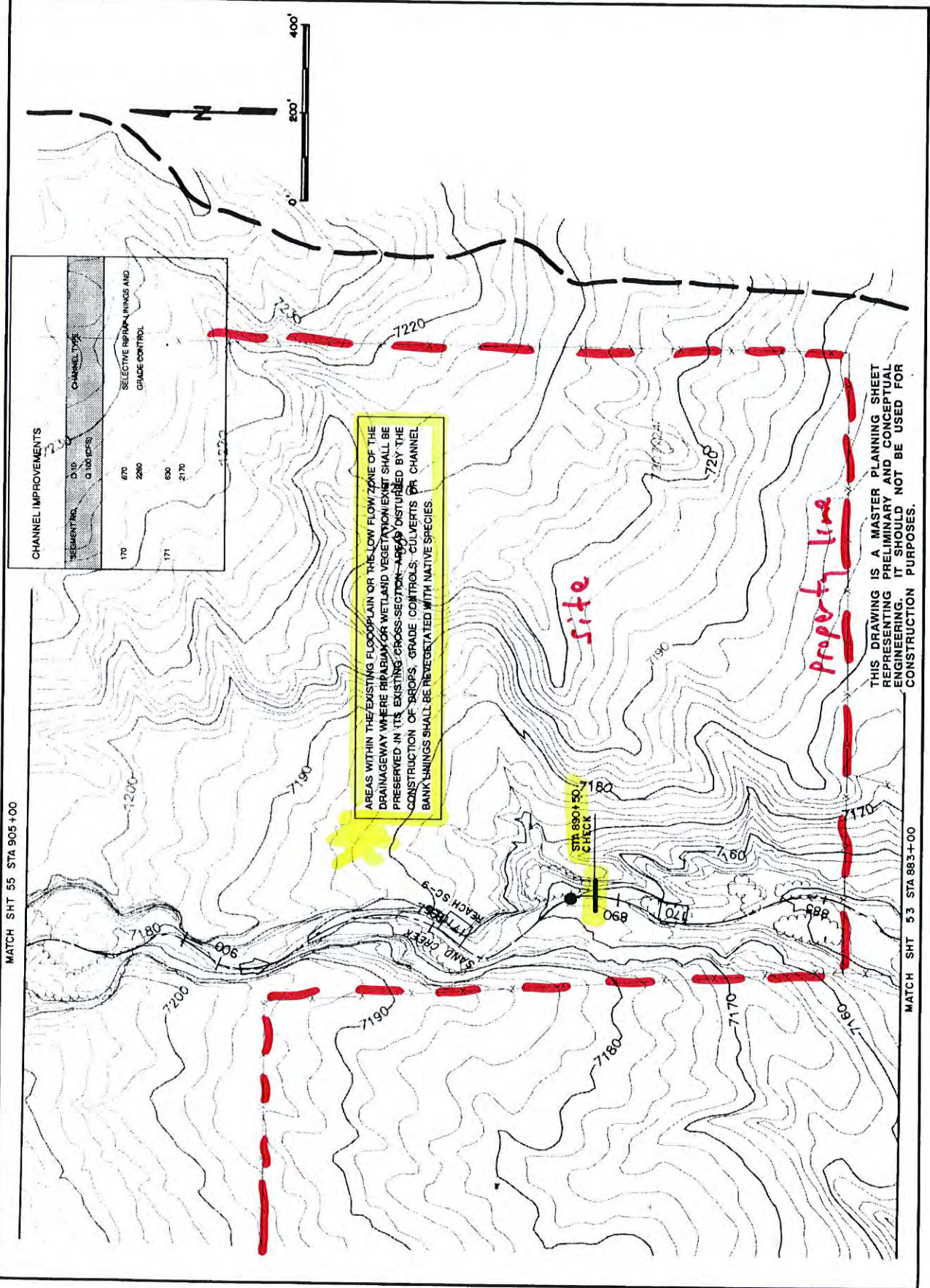

THIS DRAWING IS A MASTER PLANNING SHEET REPRESENTING PRELIMINARY AND CONCEPTUAL ENGINEERING. IT SHOULD NOT BE USED FOR CONSTRUCTION PURPOSES.

MATCH SHT 56 STA 933 + 80

Kiowa Engineering Corporation
 419 W. Bijou Street
 Colorado Springs, Colorado
 80905-1308

CHANNEL IMPROVEMENTS	CHANNEL TYPE	SELECTIVE RIPRAP LININGS AND GRADE CONTROL
171	6x6x6 CFS	6x6
2170		2170

SAND CREEK DRAINAGE BASIN PLANNING STUDY
 PRELIMINARY DESIGN PLANS

Project No.	80-04-09
Drawn	RAW
Check	EAK
Review	RAW

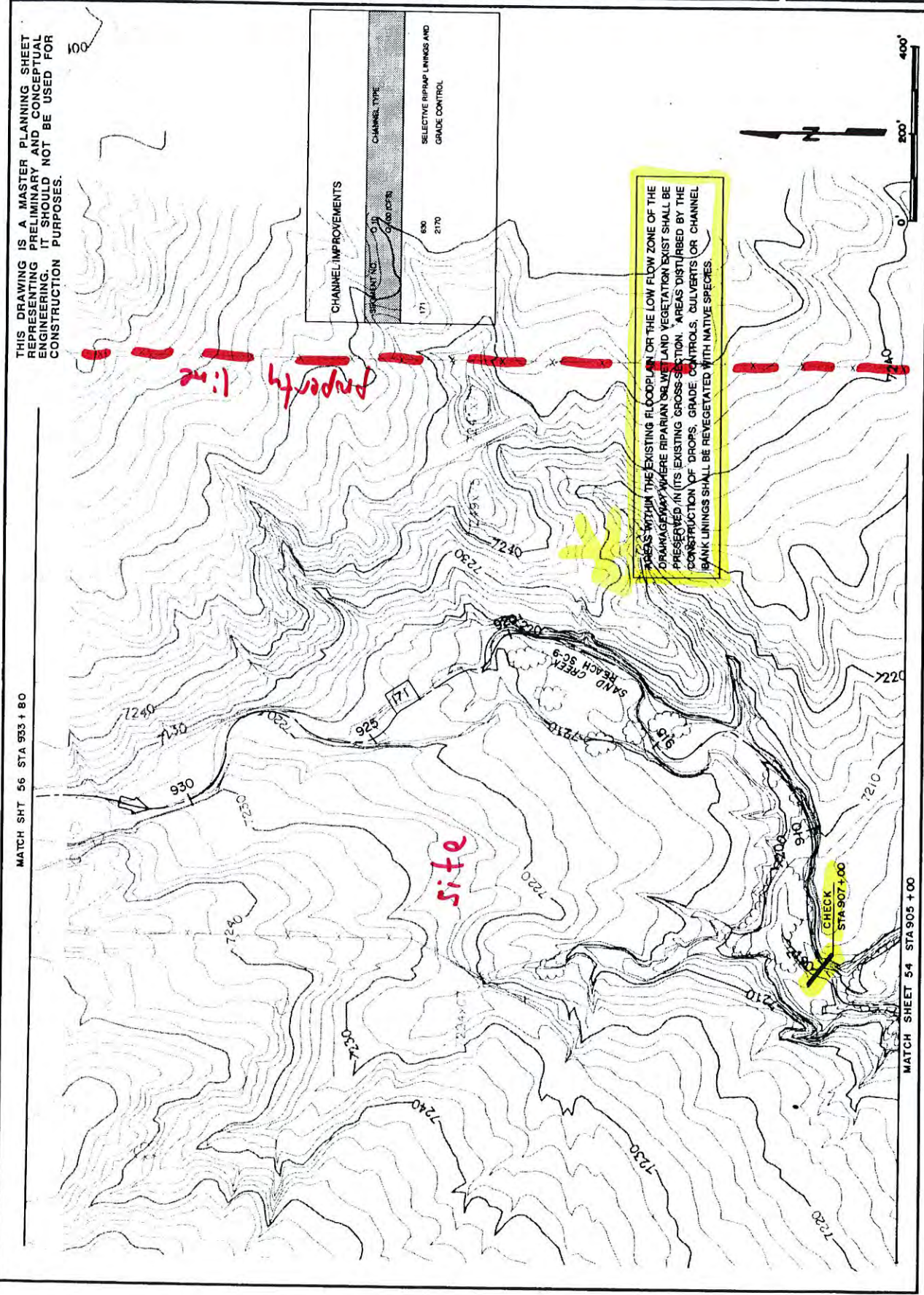

MATCH SHEET 54 STA 903 + 00

VI. DEVELOPMENT OF ALTERNATIVES AND RECOMMENDED PLAN

The concepts which are available for handling stormwater runoff within the Sand Creek basin have been presented and discussed in detail in the Sand Creek Drainage Basin Planning Study Development of Alternatives Report and the draft East Fork Sand Creek Drainage Basin Planning Study. The process of combining the various channel treatment options, detention schemes and roadway crossing structures into a contiguous plan for all of the reaches is presented in this chapter of the report. As a result of the evaluation of the flood control, environmental, open space, operations and maintenance, and implementation concerns within the Sand Creek basin, the following concepts were identified as having sufficient feasibility to warrant further evaluation and review:

Channel Concepts:	Floodplain Preservation Channelization, 10- or 100-year Selective Improvements
Detention:	Regional detention systems

Channel Concepts: The channel concepts listed above have been evaluated with respect to the parameters listed in the previous chapter. A concept's feasibility depends upon its impact, positive or negative, upon the evaluation parameters. *The floodplain preservation* concept has been considered to be the same as the "do-nothing" alternative. The floodplain preservation concept would involve the regulation of the floodplain limits, generally as depicted on the effective City of Colorado Springs and El Paso County Flood Insurance Rate Maps. Regulation of the floodplain so that future encroachments are minimized and the floodproofing of structures which are currently within the 100-year floodplain would presumably be the methods used to address the flood hazard concerns along Sand Creek. In the upper reaches of Sand Creek, the ownership or easements associated with the 100-year floodplain (or greater limits to allow for an erosion buffer zone) would be a primary issue in regards to implementation of such a concept. Detention in the upper reaches of the basin Sand Creek basin and in the East Fork Sand Creek basin will maintain the 100-year floodplain at existing limits within the lower reaches of Sand Creek. The "do-nothing" concept is feasible wherever

the existing drainageway improvements are of adequate capacity to convey flood flows. *Channelization* would involve the lining of the Creek into a more confined flow area, and could be done for either the 100-year or 10-year flood discharges. Several typical channel concepts have been presented. The primary bank lining material would probably be riprap. Grade control and/or drop structures would be required in a channelization concept so that the flood velocities could be controlled to a level requiring medium to heavy riprap. Soil cement offers an alternative to riprap and concrete for the construction of drops or grade control structures. *Revegetation* would occur wherever the native vegetation was disturbed by the channel construction. *Willows* at the toe of the riprap banks would be a minimum replacement. *Selective linings* would involve the construction of grade controls, drop structures, bank linings, storm sewer outlet control structures selectively sited to resist stream erosion or to reduce potential flooding damages. Areas of future concern such as at the outside bends of the creek, or at the outlets of bridges or culverts which will cross the drainageway would be subject to selective improvements.

Detention Concepts: The two general detention concepts evaluated were onsite versus regional detention. During the evaluation process, it was determined that the onsite detention concept has a low feasibility relative to a regional concept. This is because, (1) onsite detention has a unpredictable impact upon lowering peak discharges from urbanized areas to historic conditions (reference, Urbonas and Glidden, "Effect of Detention on Flows in Major Drainageways" ASCE Water Forum '81, 1981), (2) an onsite concept has little impact upon maintaining or enhancing water quality, (3) the number of onsite detention basins, their locations and size cannot be accurately determined in the undeveloped portions of the basin at this time, and (4) onsite detention would present a substantial maintenance responsibility to the jurisdictions involved. For these reasons the onsite detention concept was eliminated and regional detention basin concepts were developed. In the analysis of the channel concepts, regional detention facilities were assumed to be in place.

Channel Alternatives

Presented on Table VI-1 is a matrix of channel alternatives which were evaluated. All reaches of Sand Creek and the East Fork of Sand Creek had at least three alternatives analyzed. Presented on Tables VI-2 through VI-6 are comparative evaluations of the floodplain preservation (do-nothing), channelization and selective lining concepts, for the mainstem Sand Creek basin, by reach. The purpose of the evaluation process was to identify the relative advantages and disadvantages of each concept within each reach.

100-year peak discharge to levels. This will allow for the channel improvements to be constructed within the existing right-of-way.

Reaches SC-5 and SC-6: A selective channel improvement concept has been recommended for these reaches. Detention in Reach SC-8 of the basin will maintain flows to historic peak discharge levels, however the low flows will increase in frequency and volume. For this reason it has been recommended to provide riprap channel linings at selective locations to at least the 10-year water surface and install grade controls. This will prevent the long-term degradation of the invert. A residual 100-year floodplain will remain and will offer opportunities for habitat replacement and open space preservation. Land adjacent to the drainageway is currently undeveloped or unplatted at this time which makes the feasibility of implementing this concept greater in comparison to the urbanized reaches of the creek.

Reaches SC-7 and SC-8: A selective improvement concept involving the localized lining of channel banks and grade control construction has been recommended for these reaches. The feasibility of this concept stems from the fact that flows will be reduced because of detention. Numerous individual rural ownerships cross the drainageway, however no habitable structures lie within the 100-year floodplain. Because of this, the economic feasibility of channelization concepts is low. Non-structural measures can be used to limit encroachments into floodprone areas. Additionally, the City of Colorado Springs Comprehensive plan recommends that the floodplains be maintained as open space. Potential habitat disturbances can be avoided with a selective plan, or simply replaced as part of the particular construction activity which caused the disturbance.

Reach SC-9: A floodplain preservation concept has been recommended for this reach. Little increase in urbanization is anticipated in this reach, and for this reason the existing drainageway is expected to remain stable. Localized improvements may be necessary to limit erosion caused by flow concentrations at culverts or storm sewers. Private ownership of the drainageway is anticipated to continue which lower the feasibility of channel concepts which require permanent right-of-ways or easements for construction and maintenance.

Reaches WF-1 through WF-3: A 100-year channel concept has been recommended for these reaches primarily because of the potential for flooding damages. Several roadway crossings are in need of replacement because of the flood hazard the constrictions create. Some open space enhancement potential exists for this concept since these reaches have been degraded visually by debris accumulation, bank sloughing and sedimentation. Little opportunity exists for widening the drainageway because the

Development of the Recommended Plan

Presented on Table VI-7 is a matrix representing the recommended plan for each major drainageway reach. The selection of a recommended channel treatment scheme has been based upon the qualitative and quantitative information presented in the Sand Creek Drainage Basin Planning Study Development of Alternatives report and the draft East Fork Sand Creek Drainage Basin Planning Study. Contained within the Technical Addendum to the Sand Creek Drainage Basin Planning Study Development of Alternatives report, is the alternative hydrologic, hydraulic and conceptual cost data used in the evaluation and comparison of each of the alternatives within the mainstem Sand Creek basin.

Discussion of Recommended Plan

The recommendation of a particular channel treatment or detention scheme has been based upon the qualitative and quantitative data presented. For each reach the flood hazard, environmental, cost, operations and maintenance and open space aspects of the drainageway were weighed for each alternative concept.

Reach SC-1: For this reach a 10-year channel section was recommended for further evaluation. With the implementation of regional detention in the upper basin, the 100-year floodplain will generally be confined within the existing banks, excepting at roadway crossings lacking 100-year capacity. It is recommended that a 10-year low flow channel be constructed within the invert of the existing channel through the construction of benches and sand bars. As urbanization continues towards the full development scenario, the base flow and annual flows will increase in volume and frequency. For this reason, the low flow area must be stabilized to protect the existing channel banks from undermining and subsequent bank sloughing. The benched areas offer an opportunity for habitat replacement and enhancement. At some locations within this reach, a residual 100-year floodplain will remain which will have to be regulated. The residual 100-year floodplain offers some potential for open space preservation and enhancement. This is particularly true in the portion of the reach downstream of Hancock Expressway.

Reaches SC-2 through SC-4: A 100-year channel concept has been recommended primarily because of the potential for flooding damages which exists in these reaches. Habitat disturbed by the construction of channel linings and grade control structures could be replaced along the channel toes and on the overbanks. The replacement of the Waynoka Road crossing will reduce the potential for flood damages in areas adjacent to these roadways. The detention within the upper reaches will limit the

VII. PRELIMINARY DESIGN

The results of the preliminary design analysis are summarized in this section. The alternative improvements have been quantitatively and qualitatively evaluated, and presented to the City of Colorado Springs and other interested agencies and individuals. Field review of specific areas of concern have been conducted in order to refine the channel treatments suggested for use along Sand Creek, East Fork Sand Creek and their major tributaries. The preliminary plan for the recommended alternative is shown on the drawings contained at the rear of this report.

Criteria

The City of Colorado Springs, El Paso County Drainage Criteria Manual was used in the development of the typical sections and plans for the major drainageways within the Basin. The City/County manual was supplemented by various criteria manuals with more specific application. These were:

1. "Design Guidelines and Criteria for Channels and Hydraulic Structures on Sandy Soils," prepared by Simons, Li & Associates, Inc., 1981.
 2. Urban Storm Drainage Criteria Manual, Volumes I, II, and III, prepared by the Urban Drainage and Flood Control District.
- Various design plans for roadway and channel improvement projects, either proposed or already constructed were reviewed in order to prepare the preliminary design plans. Specifically, the project design plans for the Las Vegas Street and Galley Road bridge replacement projects were reviewed and the improvements incorporated in the preliminary design. The proposed Sand Creek Stabilization Project, AT&SF Railroad to Hancock Expressway and the proposed Sand Creek Stabilization Project at Fountain Boulevard design plans have been reviewed and incorporated into the preliminary design plan and profiles.

Hydrology

Presented on Table VII-1 is selected hydrologic data to be used for the sizing of major drainageway improvements within the Basin. **Peak flow rates for the 10- and 100-year frequency incorporating and the selected detention alternatives for the Sand Creek and East Fork Sand Creek Basin are summarized for key points along the major drainageways.**

Contained within the The technical addenda of this report contains a complete listing of peak discharges for all the sub-basins, stream segments and design points shown on Exhibit 1.

The sizing the drainageway improvements for the tributaries will need to be verified during the final design and layout of the proposed drainageway facilities. Land development activities may alter the location of design points along the tributaries, and therefore slight alteration in a sub-basin's length, slope and area may occur. The methods outlined in the City/County Drainage Criteria Manual should be applied during final design analysis. The rational method should be used to check the peak flow rates for all tributary drainageways and storm sewers draining areas less than 100 acres in size.

Channels

The recommended channel sections for each reach of drainageway has been outlined in Section VI of this report. In general, the banks of Sand Creek channel, from the confluence with Fountain Creek to the proposed Sand Creek Detention Basin No. 2 are to be lined, or in some cases relined, with riprap to either a 10-year or 100-year flow depth, as shown on the preliminary design plans. Above the Sand Creek Detention Basin No. 2, selectively located riprap bank protection such as at outside bends, at bridge or culvert outlets, and at confluences with side tributaries have been recommended. In conjunction with the selective improvement measures, and the 10-year low flow concept, the 100-year floodplain should be preserved and regulated. Wherever existing bank linings were judged to be adequate, no improvements have been recommended at this time.

For the West Fork Sand Creek, 100-year riprap bank linings have been recommended in order to address the 100-year flooding hazard which exists at numerous locations along the West Fork. The final design improvements shown in the Palmer Park Bridge Replacement project drawings have been incorporated into the preliminary design plans. In the uppermost reaches of the West Fork, a short segment of rectangular concrete channel has been recommended because of right-of-way constraints.

For the Center Tributary of Sand Creek, 100-year riprap lined channels have been recommended from the confluence with East Fork to Platte Avenue. Above Platte Avenue, the existing concrete channels have adequate capacity except where the drainageway channel has yet to be improved. The final design plans for the US 24 Bypass Project, Phase II have been incorporated into the plans. As part of the bypass construction, it is proposed to line the Center Tributary using riprap. The location of the proposed roadway, new crossings, drops and channel as shown on the Phase II Bypass plans have been reflected on the preliminary design drawings.

For the East Fork Sand Creek drainageway, riprap lined channel banks have been recommended for the majority of the reaches. This is mainly because of the high level of development predicted for the basin in the area known as the Banning-Lewis Ranch development. Open space to accommodate the 100-year floodplains should be allowed for as the East Fork Sand Creek drainageways develop. This is consistent with the Banning-Lewis Ranch master development plan which was approved at the time of annexation of this property. Above Woodmen Road, selective channel lining improvements and grade control structures have been recommended.

For the most part the side tributaries have been recommended to be lined with riprap, however there are some locations in the upper basin which have been proposed to be grasslined. The location of the side drainageways should be considered approximate and may very likely be modified in the future because of land development.

The primary criteria used when sizing the proposed channel sections has been velocity. For all riprap lined channels, the average design velocity should be no greater than 9 feet per second. This criteria allows for the use of Type H riprap within the main flow area of the drainageway. For the case of a 10-year channel with an overall floodplain section, limiting the main channel velocity to 9 feet per second will result in overbank velocities in the five feet per second range. At this level of overbank velocity, native vegetation will be able to withstand the erosive forces which might result in a 100-year flow event. Velocities approaching 10 feet per second could occur at constrictions such as at roadway crossings and at culvert outlets.

Drop Structures and Check Structures

Drop and check structures have been sited along Sand Creek in order to slow the channel velocity to the recommended 7 feet per second, and to prevent localized and long-term stream degradation from affecting channel linings and overbanks. In the reaches to be selectively lined, drops and check structures will protect the native vegetation from the detrimental effects of stream invert headcutting. Several types of structures could be considered for the Sand Creek Basin. For channel bottom widths in excess of fifty feet, soil cement or sheet piling drops/checks are feasible. For channels narrower than this, reinforced concrete structures are probably the best alternative. **A maximum drop height of three feet is recommended. The methodology recommended for use when designing vertical structures is contained with Volume II of the Urban Storm Drainage Criteria Manual.**

Detention

The recommended plan calls for the construction of six regional detention basins within the Sand Creek basin, and six regional basins within the East Fork Sand Creek basin. The

purpose of the Sand Creek detention basins is to limit peak discharges at Powers Boulevard to existing development condition levels. The detention basins in the upper portions of the Sand Creek basin will keep the majority of the existing channel sections and bridges below Powers Boulevard with adequate flow capacity in the future development condition. The detention basins within the East Fork Sand Creek basin have been sized to maintain the flow outfalling from the Banning-Lewis Ranch property at existing levels. This in turn will help to reduce flow to the mainstem of Sand Creek. The detention basins have been designed to accommodate the 100-year future condition volume without overtopping the overflow spillway. Sand Creek Basin Nos. 2 and 6, and East Fork Sand Creek Basin Nos. 1, 2, and 3 will be classified as jurisdictional structures, and their design and operation would be subject to State Engineer's office criteria. Sand Creek basins number 1 and 3 should be designed so as to take advantage of the adjacent roadway embankments, and therefore classifying as incidental storage and not subject State Engineer's regulations.

At Stetson Hills Boulevard, the roadway embankment has created a 2 acre open water wetland which was identified during the environmental review of the basin. It is recommended that this wetland be preserved. Accordingly, an outlet control structure will have to be constructed to pass the 100-year discharge to the downstream channel without overtopping the roadway. No floodwater storage or routing has been accounted for in the hydrology modelling at this roadway for the selected detention plan.

For the East Fork Sand Creek detention basin numbers 2, and 3, the existing embankment and outlet structure act to maintain a permanent pool at this time. It is recommended that the design of these detention basins be directed at maintaining the permanent pool when the flood control storage is to be added. The existence of a permanent pool may enhance the water quality aspects of these basins, and offer the opportunity of open space development conducive with open water.

Water Quality

Improvement of urban stormwater quality has become an important issue in drainage basin planning. Many pollutants are naturally associated with sediments that enter sensitive receiving waters. The pollutants are naturally occurring compounds that are carried to the drainageways in storm runoff. Other pollutants are the result of urbanization such as lawn chemicals, oil and grease, pet feces, lawn clippings and other items. Many pollutants can be limited by programs such as erosion control at construction sites, educational programs to inform the public as to the proper use of lawn chemicals, oil recycling programs and street sweeping programs. Even with these programs in place, erosion along the drainageways can generate large quantities of sediment that can settle out along the downstream channel bottoms.

TABLE VIII-2:

SAND CREEK DRAINAGE BASIN PLANNING STUDY
 DRAINAGEWAY CONVEYANCE COST ESTIMATE
 WITH SELECTED DETENTION ALTERNATIVES

SEGMENT NUMBER	REACH NUMBER	SEGMENT LENGTH (FT)	IMPROVEMENT TYPE	IMP. LENGTH (FT)	UNIT COST (\$/LF)	NUMBER OF GRADE CONTROLS	GRADE CONTROL LENGTH (FT)	TOTAL REIMBURSABL COSTS	TOTAL COST
148-2	"	2600	"	2150	127	5	620	\$384,650	\$384,650
151	SC-8	1700	10-YEAR RIPRAP	500	238	3	250	\$164,000	\$164,000
160	"	5100	SEL LININGS (1 SIDE) 10-YR RIPRAP	4400	127	6	720	\$688,400	\$688,400
"	"			600	238	0	0	\$142,800	\$142,800
163	"	6300	SEL LININGS (1 SIDE) 10-YR RIPRAP	2600	127	15	1200	\$546,200	\$546,200
"	"			350	238	0	0	\$83,300	\$83,300
187	"	1200	SEL LININGS (1 SIDE)	0	0	2	160	\$28,800	\$28,800
170	SC-9	3200	"	0	0	4	320	\$57,600	\$57,600
171	"	5000	"	0	0	2	170	\$30,600	\$30,600
172	"	3650	"	0	0	2	150	\$27,000	\$27,000
TOTAL SAND CREEK DRAINAGEWAY								\$15,560,220	\$18,279,420

TABLE VIII-3:

SAND CREEK DRAINAGE BASIN PLANNING STUDY
 TRIBUTARY DRAINAGEWAY CONVEYANCE COST ESTIMATE
 SAND CREEK, CENTER TRIBUTARY AND WEST FORK SAND CREEK

SEGMENT NUMBER	REACH NUMBER	IMPROVEMENT TYPE	IMP. LENGTH (FT)	UNIT COST (\$/LF)	NUMBER OF GRADE CONTROLS	LENGTH OF GRADE CONTROL (FT)	TOTAL REIMBURSABLE COSTS	TOTAL COST
147-2	"	"	1150	200	1	30	\$215,400	\$235,400
153-1	"	"	600	150	0	0	\$90,000	\$90,000
153-2	"	"	450	150	0	0	\$67,500	\$67,500
152-1	SC-7	100-YEAR GRASSLINED	1650	150	0	0	\$247,500	\$247,500
152-2	"	"	800	150	2	100	\$138,000	\$138,000
150-1	"	100-YEAR STORM SEWER 36" RCP	800	58	0	0	\$46,400	\$46,400
150-2	"	100-YEAR RIPRAP	2400	200	0	0	\$480,000	\$480,000
161-1	"	100-YEAR GRASSLINED	550	150	0	0	\$82,500	\$82,500
154	SC-8	"	2100	200	10	600	\$528,000	\$528,000
157	"	"	2400	200	13	520	\$573,600	\$573,600
155-1	"	100-YEAR GRASSLINED	550	175	4	140	\$121,450	\$121,450
159	"	100-YEAR RIPRAP	3450	200	14	840	\$841,200	\$841,200
164	"	"	1350	200	5	200	\$306,000	\$306,000
186	"	"	2250	200	5	200	\$486,000	\$486,000
169	"	"	650	175	1	40	\$120,950	\$120,950
173	SC-9	"	950	175	8	320	\$223,850	\$223,850
WEST FORK SAND CREEK								
154-1	WF-1	100-YEAR RIPRAP	1550	223	2	100	\$0	\$363,650
161	"	"	600	223	2	80	\$0	\$146,200
164-2	"	100-YEAR GRASSLINED	500	150	0	0	\$0	\$75,000
164-4	"	100-YEAR RIPRAP	2500	175	9	280	\$0	\$487,900
165-1	"	"	1350	175	0	0	\$0	\$296,250
TOTAL SAND CREEK TRIBUTARY DRAINAGEWAYS							\$7,420,650	\$12,543,750

Kiowa Engineering Corporation
 419 W. Blou Street
 Colorado Springs, Colorado
 80905-1308

**SAND CREEK DRAINAGE
 BASIN PLANNING STUDY**
 Typical Channel Sections

Project No.	
Date	
Scale	
Sheet	
Drawn	
Checked	
Reviewed	

CS-3

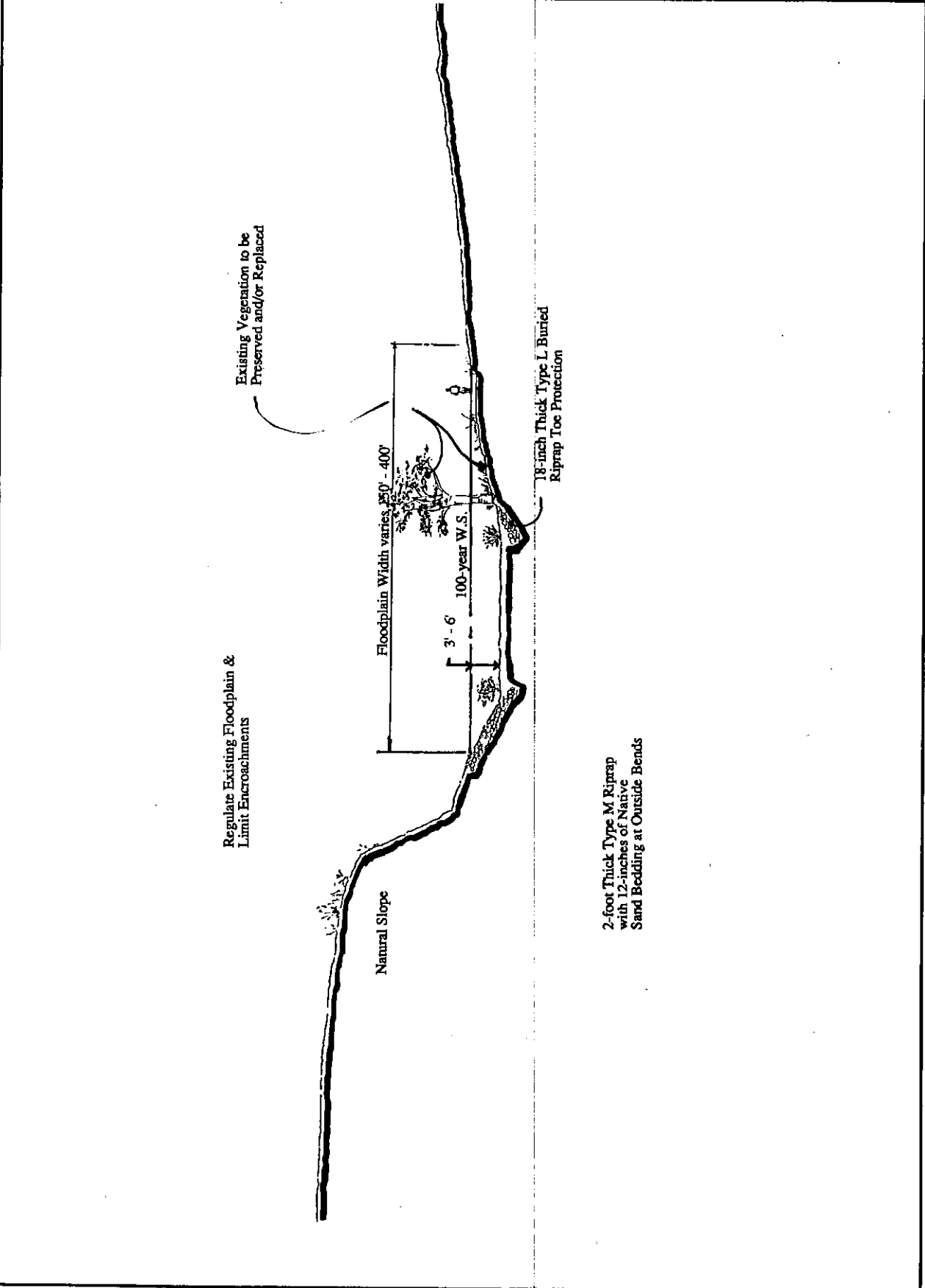

Prepared by	
Checked by	
Designed by	
Drawn by	
Reviewed by	

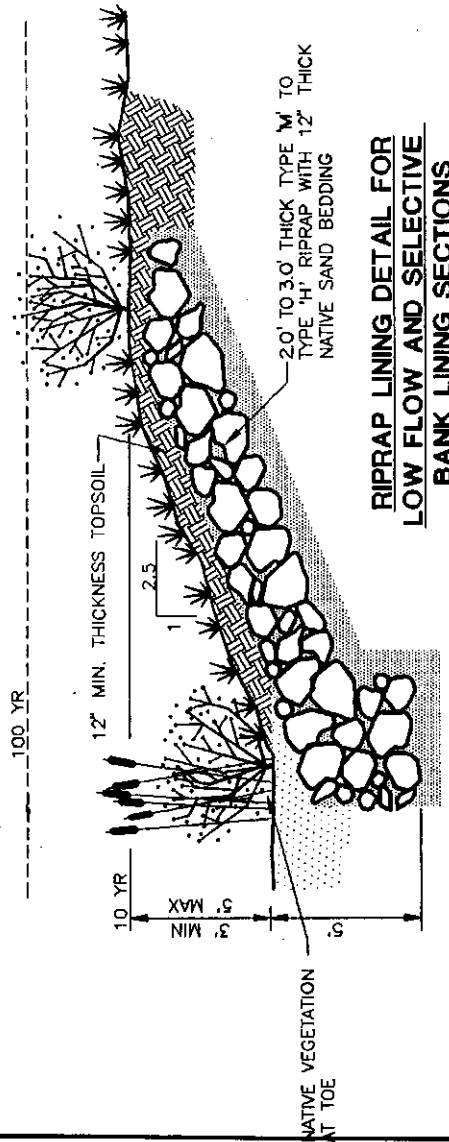

**RIPRAP LINING DETAIL FOR
 LOW FLOW AND SELECTIVE
 BANK LINING SECTIONS**
 NTS

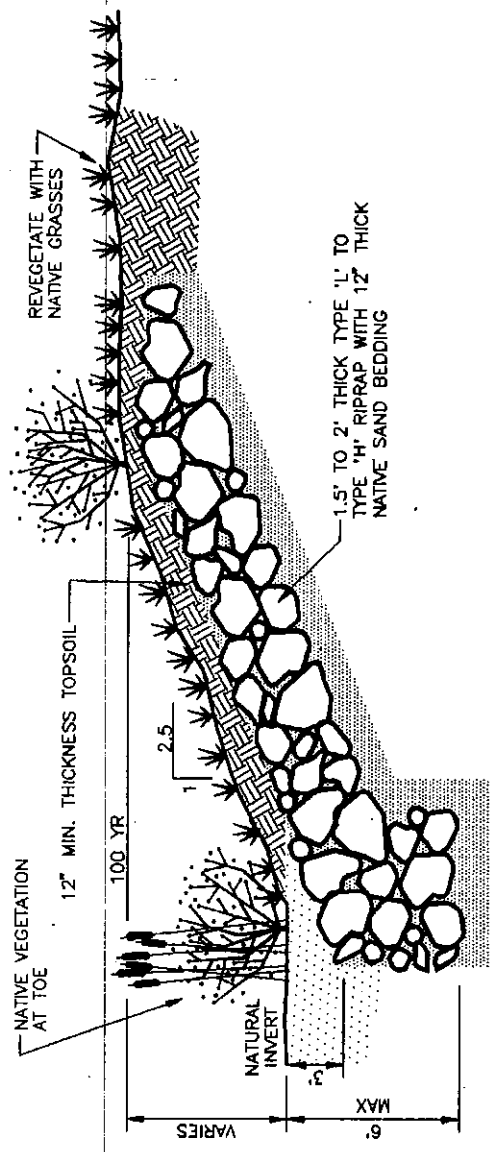

**RIPRAP LINING DETAIL FOR
 100 YR CHANNEL SECTIONS**
 NTS

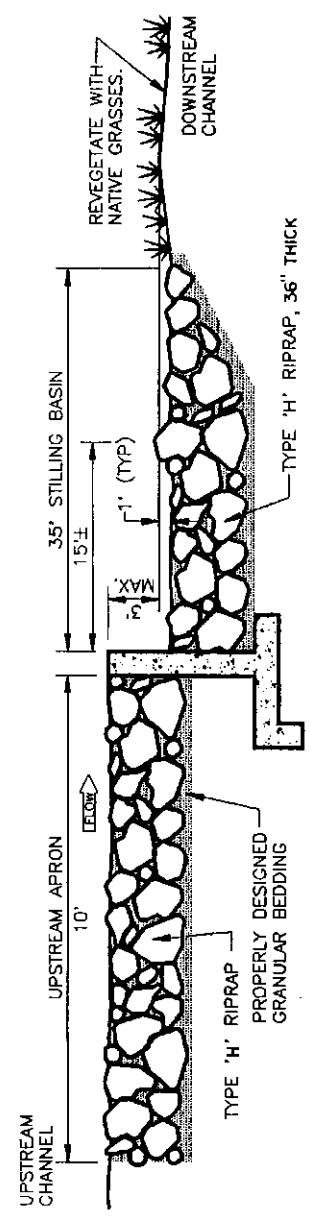

NOTE: DIMENSIONS OF APRON, STILLING BASIN, RIPRAP, AND CHECK STRUCTURE IS TO BE DETERMINED DURING FINAL DESIGN.

**TYPICAL DROP STRUCTURE
GENERALIZED PROFILE**

NTS

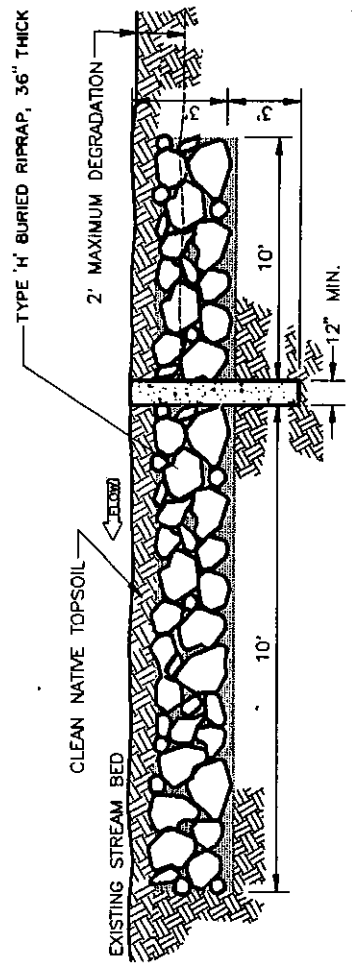

**TYPICAL EROSION CONTROL
CHECK PROFILE**

NTS

Project No.	
Date	
Author	
Checked	
Drawn	
Revised	

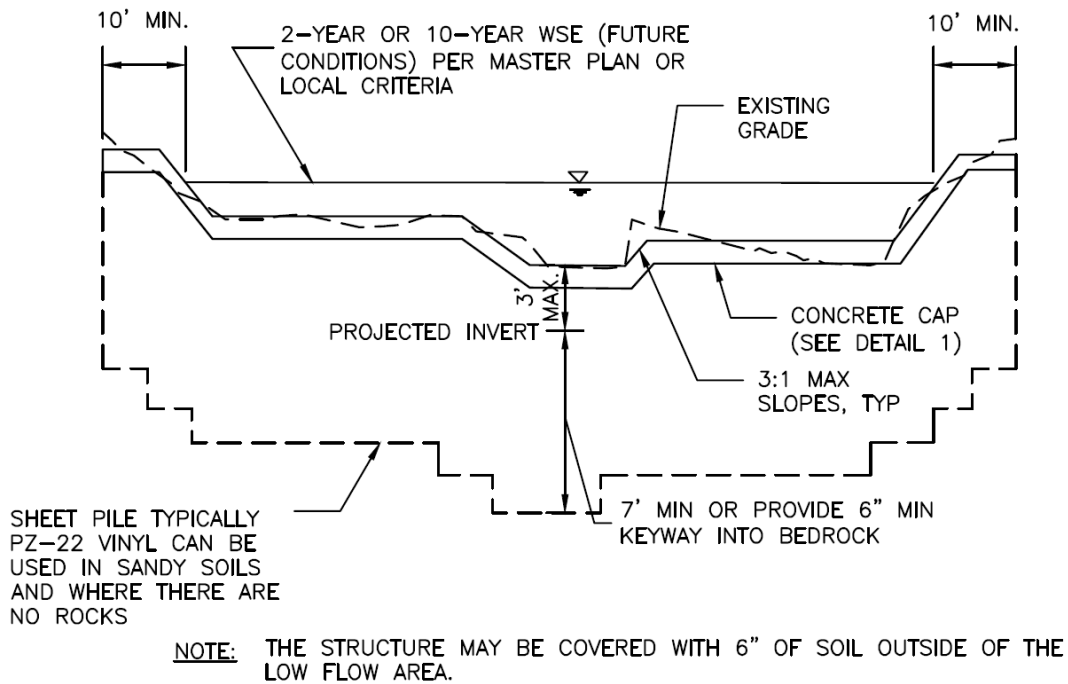

SECTION A1
SHEET PILE CHECK

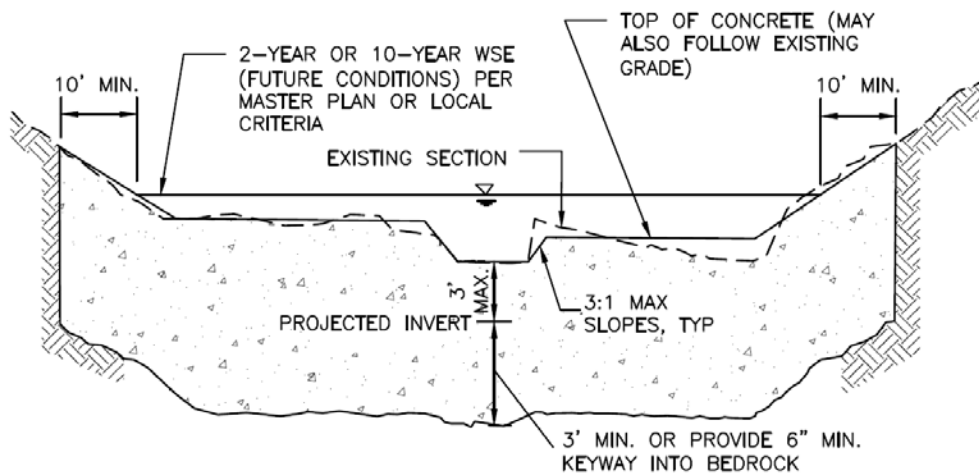

- NOTES:**
1. TRENCH IN UNDISTURBED SOIL. FORM TOP 6" OF CHECK. DO NOT OVER EXCAVATE TO FORM WALLS OR CONSTRUCT A FOOTING.
 2. THE STRUCTURE MAY BE COVERED WITH 6" OF SOIL OUTSIDE OF THE LOW FLOW AREA.
 3. VIBRATE CONCRETE INTO TRENCH.

SECTION A2
CONCRETE CHECK

Figure 9-27. Check structure details (Part 2 of 3)

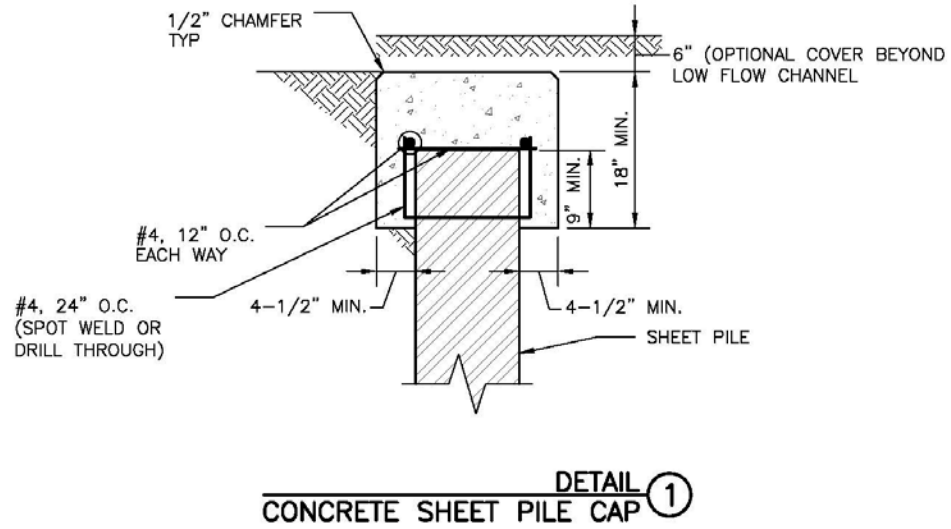
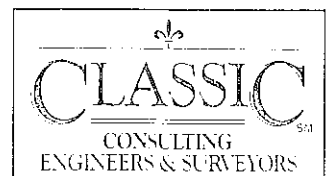

Figure 9-28. Check structure details (Part 3 of 3)

HYDROLOGIC CALCULATIONS



For Colorado Springs and much of the Fountain Creek watershed, the 1-hour depths are fairly uniform and are summarized in Table 6-2. Depending on the location of the project, rainfall depths may be calculated using the described method and the NOAA Atlas maps shown in Figures 6-6 through 6-17.

Table 6-2. Rainfall Depths for Colorado Springs

Return Period	1-Hour Depth	6-Hour Depth	24-Hour Depth
2	1.19	1.70	2.10
5	1.50	2.10	2.70
10	1.75	2.40	3.20
25	2.00	2.90	3.60
50	2.25	3.20	4.20
100	2.52	3.50	4.60

Where $Z = 6,840 \text{ ft}/100$

These depths can be applied to the design storms or converted to intensities (inches/hour) for the Rational Method as described below. However, as the basin area increases, it is unlikely that the reported point rainfalls will occur uniformly over the entire basin. To account for this characteristic of rain storms an adjustment factor, the Depth Area Reduction Factor (DARF) is applied. This adjustment to rainfall depth and its effect on design storms is also described below. The UDFCD UD-Rain spreadsheet, available on UDFCD's website, also provides tools to calculate point rainfall depths and Intensity-Duration-Frequency curves² and should produce similar depth calculation results.

2.2 Design Storms

Design storms are used as input into rainfall/runoff models and provide a representation of the typical temporal distribution of rainfall events when the creation or routing of runoff hydrographs is required. It has long been observed that rainstorms in the Front Range of Colorado tend to occur as either short-duration, high-intensity, localized, convective thunderstorms (cloud bursts) or longer-duration, lower-intensity, broader, frontal (general) storms. The significance of these two types of events is primarily determined by the size of the drainage basin being studied. Thunderstorms can create high rates of runoff within a relatively small area, quickly, but their influence may not be significant very far downstream. Frontal storms may not create high rates of runoff within smaller drainage basins due to their lower intensity, but tend to produce larger flood flows that can be hazardous over a broader area and extend further downstream.

- Thunderstorms:** Based on the extensive evaluation of rain storms completed in the Carlton study (Carlton 2011), it was determined that typical thunderstorms have a duration of about 2 hours. The study evaluated over 300,000 storm cells using gage-adjusted NEXRAD data, collected over a 14-year period (1994 to 2008). Storms lasting longer than 3 hours were rarely found. Therefore, the results of the Carlton study have been used to define the shorter duration design storms.

To determine the temporal distribution of thunderstorms, 22 gage-adjusted NEXRAD storm cells were studied in detail. Through a process described in a technical memorandum prepared by the City of Colorado Springs (City of Colorado Springs 2012), the results of this analysis were interpreted and normalized to the 1-hour rainfall depth to create the distribution shown in Table 6-3 with a 5 minute time interval for drainage basins up to 1 square mile in size. This distribution represents the rainfall

Table 6-6. Runoff Coefficients for Rational Method
(Source: UDFCD 2001)

Land Use or Surface Characteristics	Percent Impervious	Runoff Coefficients											
		2-year		5-year		10-year		25-year		50-year		100-year	
		HSG A&B	HSG C&D	HSG A&B	HSG C&D	HSG A&B	HSG C&D	HSG A&B	HSG C&D	HSG A&B	HSG C&D	HSG A&B	HSG C&D
Business													
Commercial Areas	95	0.79	0.80	0.81	0.82	0.83	0.84	0.85	0.87	0.87	0.88	0.88	0.89
Neighborhood Areas	70	0.45	0.49	0.49	0.53	0.53	0.57	0.58	0.62	0.60	0.65	0.62	0.68
Residential													
1/8 Acre or less	65	0.41	0.45	0.45	0.49	0.49	0.54	0.54	0.59	0.57	0.62	0.59	0.65
1/4 Acre	40	0.23	0.28	0.30	0.35	0.36	0.42	0.42	0.50	0.46	0.54	0.50	0.58
1/3 Acre	30	0.18	0.22	0.25	0.30	0.32	0.38	0.39	0.47	0.43	0.52	0.47	0.57
1/2 Acre	25	0.15	0.20	0.22	0.28	0.30	0.36	0.37	0.46	0.41	0.51	0.46	0.56
1 Acre	20	0.12	0.17	0.20	0.26	0.27	0.34	0.35	0.44	0.40	0.50	0.44	0.55
Industrial													
Light Areas	80	0.57	0.60	0.59	0.63	0.63	0.66	0.66	0.70	0.68	0.72	0.70	0.74
Heavy Areas	90	0.71	0.73	0.73	0.75	0.75	0.77	0.78	0.80	0.80	0.82	0.81	0.83
Parks and Cemeteries													
Parks and Cemeteries	7	0.05	0.09	0.12	0.19	0.20	0.29	0.30	0.40	0.34	0.46	0.39	0.52
Playgrounds	13	0.07	0.13	0.16	0.23	0.24	0.31	0.32	0.42	0.37	0.48	0.41	0.54
Railroad Yard Areas	40	0.23	0.28	0.30	0.35	0.36	0.42	0.42	0.50	0.46	0.54	0.50	0.58
Undeveloped Areas													
Historic Flow Analysis-- Greenbelts, Agriculture	2	0.03	0.05	0.09	0.16	0.17	0.26	0.26	0.38	0.31	0.45	0.36	0.51
Pasture/Meadow	0	0.02	0.04	0.08	0.15	0.15	0.25	0.25	0.37	0.30	0.44	0.35	0.50
Forest	0	0.02	0.04	0.08	0.15	0.15	0.25	0.25	0.37	0.30	0.44	0.35	0.50
Exposed Rock	100	0.89	0.89	0.90	0.90	0.92	0.92	0.94	0.94	0.95	0.95	0.96	0.96
Offsite Flow Analysis (when landuse is undefined)	45	0.26	0.31	0.32	0.37	0.38	0.44	0.44	0.51	0.48	0.55	0.51	0.59
Streets													
Paved	100	0.89	0.89	0.90	0.90	0.92	0.92	0.94	0.94	0.95	0.95	0.96	0.96
Gravel	80	0.57	0.60	0.59	0.63	0.63	0.66	0.66	0.70	0.68	0.72	0.70	0.74
Drive and Walks													
Drive and Walks	100	0.89	0.89	0.90	0.90	0.92	0.92	0.94	0.94	0.95	0.95	0.96	0.96
Roofs	90	0.71	0.73	0.73	0.75	0.75	0.77	0.78	0.80	0.80	0.82	0.81	0.83
Lawns	0	0.02	0.04	0.08	0.15	0.15	0.25	0.25	0.37	0.30	0.44	0.35	0.50

3.2 Time of Concentration

One of the basic assumptions underlying the Rational Method is that runoff is a function of the average rainfall rate during the time required for water to flow from the hydraulically most remote part of the drainage area under consideration to the design point. However, in practice, the time of concentration can be an empirical value that results in reasonable and acceptable peak flow calculations.

For urban areas, the time of concentration (t_c) consists of an initial time or overland flow time (t_i) plus the travel time (t_t) in the storm sewer, paved gutter, roadside drainage ditch, or drainage channel. For non-urban areas, the time of concentration consists of an overland flow time (t_i) plus the time of travel in a concentrated form, such as a swale or drainageway. The travel portion (t_t) of the time of concentration can be estimated from the hydraulic properties of the storm sewer, gutter, swale, ditch, or drainageway. Initial time, on the other hand, will vary with surface slope, depression storage, surface cover, antecedent rainfall, and infiltration capacity of the soil, as well as distance of surface flow. The time of concentration is represented by Equation 6-7 for both urban and non-urban areas.

Table 6-10. NRCS Curve Numbers for Frontal Storms & Thunderstorms for Developed Conditions (ARCII)

Fully Developed Urban Areas (vegetation established) ¹	Treatment	Hydrologic Condition	% I	Pre-Development CN			
				HSG A	HSG B	HSG C	HSG D
Open space (lawns, parks, golf courses, cemeteries, etc.):							
Poor condition (grass cover < 50%)	-----	-----	---	68	79	86	89
Fair condition (grass cover 50% to 75%)	-----	-----	---	49	69	79	84
Good condition (grass cover > 75%)	-----	-----	---	39	61	74	80
Impervious areas:							
Paved parking lots, roofs, driveways, etc. (excluding right-of-way)	-----	-----	---	98	98	98	98
Streets and roads:							
Paved; curbs and storm sewers (excluding right-of-way)	-----	-----	---	98	98	98	98
Paved; open ditches (including right-of-way)	-----	-----	---	83	89	92	93
Gravel (including right-of-way)	-----	-----	---	76	85	89	91
Dirt (including right-of-way)	-----	-----	---	72	82	87	89
Western desert urban areas:							
Natural desert landscaping (pervious areas only)	-----	-----	---	63	77	85	88
Artificial desert landscaping (impervious weed barrier, desert shrub with 1- to 2-inch sand or gravel mulch and basin borders)	-----	-----	---	96	96	96	96
Urban districts:							
Commercial and business	-----	-----	85	89	92	94	95
Industrial	-----	-----	72	81	88	91	93
Residential districts by average lot size:							
1/8 acre or less (town houses)	-----	-----	65	77	85	90	92
1/4 acre	-----	-----	38	61	75	83	87
1/3 acre	-----	-----	30	57	72	81	86
1/2 acre	-----	-----	25	54	70	80	85
1 acre	-----	-----	20	51	68	79	84
2 acres	-----	-----	12	46	65	77	82
Developing Urban Areas¹	Treatment²	Hydrologic Condition³	% I	HSG A	HSG B	HSG C	HSG D
Newly graded areas (pervious areas only, no vegetation)	-----	-----	---	77	86	91	94
Cultivated Agricultural Lands¹	Treatment	Hydrologic Condition	% I	HSG A	HSG B	HSG C	HSG D
Fallow	Bare soil	-----	---	77	86	91	94
	Crop residue cover (CR)	Poor	---	76	85	90	93
Row crops	Straight row (SR)	Good	---	74	83	88	90
		Poor	---	72	81	88	91
	SR + CR	Good	---	67	78	85	89
		Poor	---	71	80	87	90
	Contoured (C)	Good	---	64	75	82	85
		Poor	---	70	79	84	88
	C + CR	Good	---	65	75	82	86
		Poor	---	69	78	83	87
	Contoured & terraced (C&T)	Good	---	64	74	81	85
		Poor	---	66	74	80	82
	C&T+ CR	Good	---	62	71	78	81
		Poor	---	65	73	79	81
Small grain	SR	Good	---	61	70	77	80
		Poor	---	65	76	84	88
	SR + CR	Good	---	63	75	83	87
		Poor	---	64	75	83	86
	C	Good	---	60	72	80	84
		Poor	---	63	74	82	85
	C + CR Poor	Good	---	61	73	81	84
		Poor	---	62	73	81	84
	C&T	Good	---	60	72	80	83
		Poor	---	61	72	79	82
	C&T+ CR	Good	---	59	70	78	81
		Poor	---	60	71	78	81
		Good	---	58	69	77	80

Figure 6-5. Colorado Springs Rainfall Intensity Duration Frequency

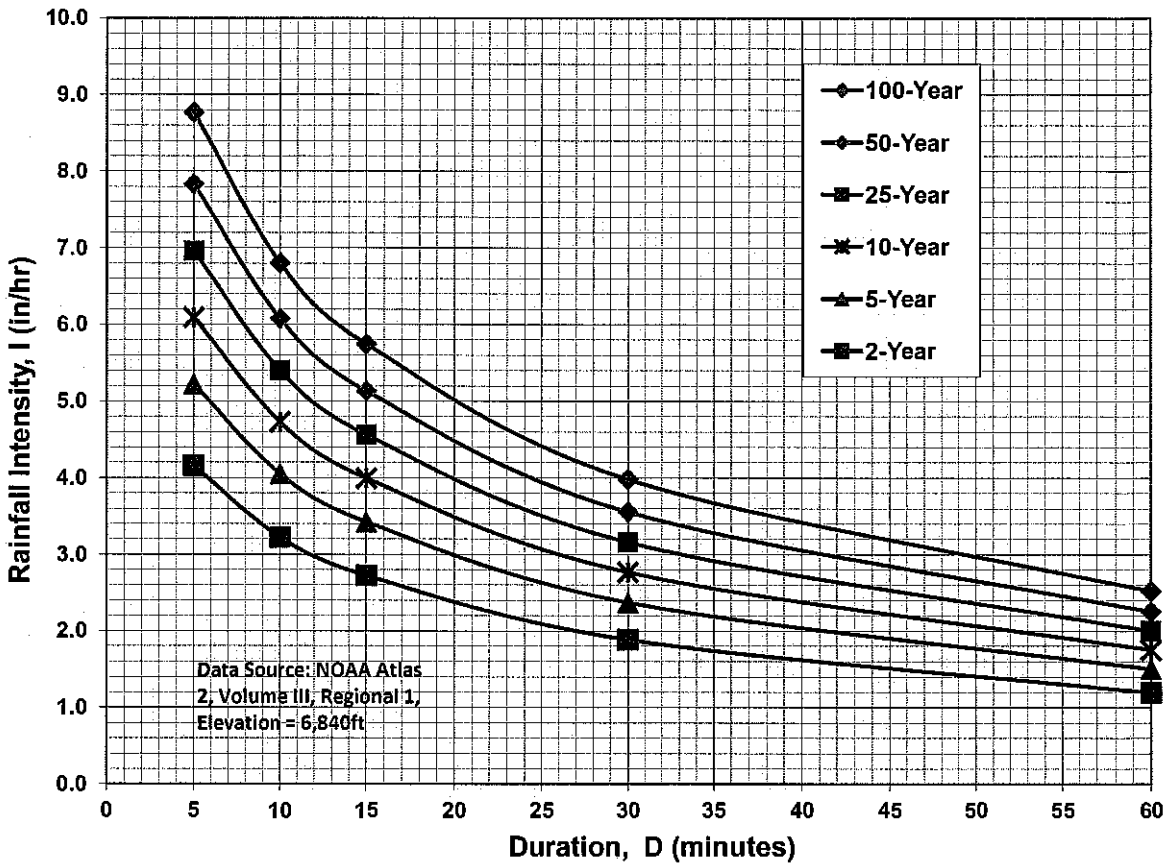

IDF Equations

$$I_{100} = -2.52 \ln(D) + 12.735$$

$$I_{50} = -2.25 \ln(D) + 11.375$$

$$I_{25} = -2.00 \ln(D) + 10.111$$

$$I_{10} = -1.75 \ln(D) + 8.847$$

$$I_5 = -1.50 \ln(D) + 7.583$$

$$I_2 = -1.19 \ln(D) + 6.035$$

Note: Values calculated by equations may not precisely duplicate values read from figure.

UNDEVELOPED LAND ASSUMED TO BE ONE OF THE FOLLOWING: PASTURE, GRASSLAND, RANGE - POOR
HERBACEOUS MIXTURE OF GRASS WEEDS AND LOW GROWING BRUSH WITH BRUSH MINOR ELEMMENT - POOR
WOODS - GRASS COMBINATION - POOR

C_N VALUES - EXISTING CONDITIONS

BASIN (label)	BASIN AREA (Ac)	SOIL TYPE B		WEIGHTED C _N
		CN	AREA (Ac.)	
EX-1	32.4	61	32.4	61
EX-2	1.7	61	1.7	61
EX-3	25.7	61	25.7	61
EX-4	9.6	61	9.6	61
EX-5	123.3	61	123.3	61
EX-6	41.8	61	41.8	61
EX-7	27.6	63	27.6	63
EX-8	9.5	61	9.5	61

TIME OF CONCENTRATION - EXISTING CONDITIONS

BASIN	Cn	C(5)	Length (ft)	OVERLAND Height (ft)	Tc (min)	STREET / CHANNEL FLOW				Tc TOTAL (min)	Tc LAG (min)	Tc LAG (hr)
						Length (ft)	Slope (%)	Velocity (fps)	Tc (min)			
EX-1	61.0	0.08	300	10	21.4	1500	1.8%	1.3	19.2	40.7	24.4	0.41
EX-2	61.0	0.08	300	10	21.4					21.4	12.9	0.21
EX-3	61.0	0.08	300	12	20.2	1500	4.0%	1.8	13.9	34.1	20.4	0.34
EX-4	61.0	0.08	300	10	21.4	1000	4.0%	1.8	9.3	30.7	18.4	0.31
EX-5	61.0	0.08	300	8	23.1	1800	2.0%	1.3	23.1	46.2	27.7	0.46
EX-6	61.0	0.08	300	10	21.4	800	3.0%	1.3	10.3	31.7	19.0	0.32
EX-7	63.0	0.08	300	10	21.4	1200	3.0%	1.4	14.3	35.7	21.4	0.36
EX-8	61.0	0.08	300	10	21.4	700	4.0%	1.3	9.0	30.4	18.2	0.30

BASIN SUMMARY - EXISTING CONDITIONS

BASIN (label)	TOTAL BASIN AREA (acres)	WEIGHTED CN	TOTAL LAG TIME (hours)	Q 2 Yr. (cfs)	Q 5 Yr. (cfs)	Q 100 Yr. (cfs)
EX-1	32.4	61	0.41	0.5	3.9	30.0
EX-2	1.7	61	0.21	0.03	0.3	2.3
EX-3	25.7	61	0.34	0.4	3.4	26.8
EX-4	9.6	61	0.31	0.2	1.4	10.5
EX-5	123.3	61	0.46	2.0	13.5	107.2
EX-6	41.8	61	0.32	0.7	5.8	44.8
EX-7	27.6	63	0.36	1.0	5.2	32.1
EX-8	9.5	61	0.30	0.2	1.4	10.7

DESIGN POINTS SURFACE ROUTING SUMMARY - EXISTING CONDITIONS

Design Point (label)	Contributing Basins	Q 2 Yr. Q (cfs)	Q 5 Yr. Q (cfs)	Q 100 Yr. Q (cfs)
EX DP-1	BASINS EX-1, EX-4, EX-5, EX-6, EX-7 (234.7 AC.)	4.2	28.5	219.2
EX DP-2	BASIN EX-2 (1.7 AC.)	0.03	0.3	2.3
EX DP-3	BASIN EX-3 (25.7 AC.)	0.4	3.4	26.8
EX-DP-4	BASIN EX-4 (9.6 AC.)	0.2	1.4	10.5
EX-DP-8	BASIN EX-8 (9.5 AC.)	0.2	1.4	10.7

JOB NAME: RETREAT AT TIMBERRIDGE FILING NO. 1
 JOB NUMBER: 1185.00
 DATE: 08/01/19
 CALCULATED BY: MAW

FINAL DRAINAGE REPORT ~ BASIN RUNOFF COEFFICIENT SUMMARY

BASIN	TOTAL AREA (AC)	IMPERVIOUS AREA / STREETS							LANDSCAPE/DEVELOPED AREAS							WEIGHTED			WEIGHTED CA		
		AREA (AC)	C(2)	C(5)	C(10)	C(25)	C(50)	C(100)	AREA (AC)	C(2)	C(5)	C(10)	C(25)	C(50)	C(100)	C(2)	C(5)	C(100)	CA(2)	CA(5)	CA(100)
OS-1	1.20	0.75	0.89	0.90	0.92	0.94	0.95	0.96	0.45	0.02	0.08	0.15	0.25	0.30	0.35	0.56	0.59	0.73	0.68	0.71	0.88
OS-2	0.90	0.00	0.89	0.90	0.92	0.94	0.95	0.96	0.90	0.02	0.08	0.15	0.25	0.30	0.35	0.02	0.08	0.35	0.02	0.07	0.32
OS-3	2.50	0.00	0.89	0.90	0.92	0.94	0.95	0.96	2.50	0.18	0.25	0.32	0.39	0.43	0.47	0.18	0.25	0.47	0.45	0.63	1.18
OS-4	3.10	0.00	0.89	0.90	0.92	0.94	0.95	0.96	3.10	0.15	0.22	0.30	0.37	0.41	0.46	0.15	0.22	0.46	0.47	0.68	1.43
OS-5	20.90	0.00	0.89	0.90	0.92	0.94	0.95	0.96	20.90	0.06	0.14	0.23	0.31	0.36	0.40	0.06	0.14	0.40	1.25	2.93	8.36
OS-6	1.20	0.00	0.89	0.90	0.92	0.94	0.95	0.96	1.20	0.07	0.16	0.24	0.32	0.37	0.41	0.07	0.16	0.41	0.08	0.19	0.49
OS-7	2.10	0.00	0.89	0.90	0.92	0.94	0.95	0.96	2.10	0.18	0.25	0.32	0.39	0.43	0.47	0.18	0.25	0.47	0.38	0.53	0.99
OS-8	1.00	0.00	0.89	0.90	0.92	0.94	0.95	0.96	1.00	0.18	0.25	0.32	0.39	0.43	0.47	0.18	0.25	0.47	0.18	0.25	0.47
OS-9	5.30	0.00	0.89	0.90	0.92	0.94	0.95	0.96	5.30	0.07	0.16	0.24	0.32	0.37	0.41	0.07	0.16	0.41	0.37	0.85	2.17
OS-10	1.00	0.00	0.89	0.90	0.92	0.94	0.95	0.96	1.00	0.18	0.25	0.32	0.39	0.43	0.47	0.18	0.25	0.47	0.18	0.25	0.47
OS-11	7.90	0.00	0.89	0.90	0.92	0.94	0.95	0.96	7.90	0.18	0.25	0.32	0.39	0.43	0.47	0.18	0.25	0.47	1.42	1.98	3.71
OS-12	15.00	0.00	0.89	0.90	0.92	0.94	0.95	0.96	15.00	0.06	0.14	0.23	0.31	0.36	0.40	0.06	0.14	0.40	0.90	2.10	6.00
OS-13	1.40	0.00	0.89	0.90	0.92	0.94	0.95	0.96	1.40	0.12	0.20	0.27	0.35	0.40	0.44	0.12	0.20	0.44	0.17	0.28	0.62
OS-14	9.10	0.00	0.89	0.90	0.92	0.94	0.95	0.96	9.10	0.12	0.20	0.27	0.35	0.40	0.44	0.12	0.20	0.44	1.09	1.82	4.00
OS-15	23.40	0.00	0.89	0.90	0.92	0.94	0.95	0.96	23.40	0.03	0.09	0.17	0.26	0.31	0.36	0.03	0.09	0.36	0.70	2.11	8.42
OS-16	7.70	0.00	0.89	0.90	0.92	0.94	0.95	0.96	7.70	0.03	0.09	0.17	0.26	0.31	0.36	0.03	0.09	0.36	0.23	0.69	2.77
OS-17	20.40	0.00	0.89	0.90	0.92	0.94	0.95	0.96	20.40	0.03	0.09	0.17	0.26	0.31	0.36	0.03	0.09	0.36	0.61	1.84	7.34
OS-18	10.90	0.00	0.89	0.90	0.92	0.94	0.95	0.96	10.90	0.03	0.09	0.17	0.26	0.31	0.36	0.03	0.09	0.36	0.33	0.98	3.92
OS-19	7.20	0.00	0.89	0.90	0.92	0.94	0.95	0.96	7.20	0.03	0.09	0.17	0.26	0.31	0.36	0.03	0.09	0.36	0.22	0.65	2.59
OS-20	25.10	0.00	0.89	0.90	0.92	0.94	0.95	0.96	25.10	0.03	0.09	0.17	0.26	0.31	0.36	0.03	0.09	0.36	0.75	2.26	9.04
A	13.80	0.00	0.89	0.90	0.92	0.94	0.95	0.96	13.80	0.06	0.14	0.23	0.31	0.36	0.40	0.06	0.14	0.40	0.83	1.93	5.52
B	7.70	0.00	0.89	0.90	0.92	0.94	0.95	0.96	7.70	0.06	0.14	0.23	0.31	0.36	0.40	0.06	0.14	0.40	0.46	1.08	3.08
C	6.70	0.00	0.89	0.90	0.92	0.94	0.95	0.96	6.70	0.06	0.14	0.23	0.31	0.36	0.40	0.06	0.14	0.40	0.40	0.94	2.68
D1	1.10	0.80	0.89	0.90	0.92	0.94	0.95	0.96	0.30	0.02	0.08	0.15	0.25	0.30	0.35	0.65	0.68	0.79	0.72	0.74	0.87
D2	2.20	0.80	0.89	0.90	0.92	0.94	0.95	0.96	1.40	0.18	0.25	0.32	0.39	0.43	0.47	0.44	0.49	0.65	0.96	1.07	1.43
E	3.20	0.00	0.89	0.90	0.92	0.94	0.95	0.96	3.20	0.06	0.14	0.23	0.31	0.36	0.40	0.06	0.14	0.40	0.19	0.45	1.28
F	0.90	0.00	0.89	0.90	0.92	0.94	0.95	0.96	0.90	0.06	0.14	0.23	0.31	0.36	0.40	0.06	0.14	0.40	0.05	0.13	0.36
G	2.40	0.00	0.89	0.90	0.92	0.94	0.95	0.96	2.40	0.02	0.08	0.15	0.25	0.30	0.35	0.02	0.08	0.35	0.05	0.19	0.84
H	2.00	0.00	0.89	0.90	0.92	0.94	0.95	0.96	2.00	0.15	0.22	0.30	0.37	0.41	0.46	0.15	0.22	0.46	0.30	0.44	0.92
I	3.70	0.00	0.89	0.90	0.92	0.94	0.95	0.96	3.70	0.18	0.25	0.32	0.39	0.43	0.47	0.18	0.25	0.47	0.67	0.93	1.74
J	3.60	0.00	0.89	0.90	0.92	0.94	0.95	0.96	3.60	0.18	0.25	0.32	0.39	0.43	0.47	0.18	0.25	0.47	0.65	0.90	1.69
K	1.50	0.00	0.89	0.90	0.92	0.94	0.95	0.96	1.50	0.18	0.25	0.32	0.39	0.43	0.47	0.18	0.25	0.47	0.27	0.38	0.71
L	7.30	0.00	0.89	0.90	0.92	0.94	0.95	0.96	7.30	0.18	0.25	0.32	0.39	0.43	0.47	0.18	0.25	0.47	1.31	1.83	3.43
M	2.70	0.00	0.89	0.90	0.92	0.94	0.95	0.96	2.70	0.15	0.22	0.30	0.37	0.41	0.46	0.15	0.22	0.46	0.41	0.59	1.24
N	2.10	0.00	0.89	0.90	0.92	0.94	0.95	0.96	2.10	0.18	0.25	0.32	0.39	0.43	0.47	0.18	0.25	0.47	0.38	0.53	0.99
O	1.50	0.00	0.89	0.90	0.92	0.94	0.95	0.96	1.50	0.18	0.25	0.32	0.39	0.43	0.47	0.18	0.25	0.47	0.27	0.38	0.71
P	2.70	0.00	0.89	0.90	0.92	0.94	0.95	0.96	2.70	0.18	0.25	0.32	0.39	0.43	0.47	0.18	0.25	0.47	0.49	0.68	1.27
Q	2.20	0.00	0.89	0.90	0.92	0.94	0.95	0.96	2.20	0.06	0.14	0.23	0.31	0.36	0.40	0.06	0.14	0.40	0.13	0.31	0.88
R	0.90	0.00	0.89	0.90	0.92	0.94	0.95	0.96	0.90	0.18	0.25	0.32	0.39	0.43	0.47	0.18	0.25	0.47	0.16	0.23	0.42
S	3.60	0.00	0.89	0.90	0.92	0.94	0.95	0.96	3.60	0.02	0.08	0.15	0.25	0.30	0.35	0.02	0.08	0.35	0.07	0.29	1.26

JOB NAME: RETREAT AT TIMBERRIDGE FILING NO. 1
 JOB NUMBER: 1185.00
 DATE: 08/01/19
 CALC'D BY: MAW

Table 6-7. Conveyance Coefficient, C_v

Type of Land Surface	C_v
Heavy meadow	2.5
Tillage/field	5
Riprap (not buried)* $t_c = \frac{L}{180} + 10$	6.5
Short pasture and lawns	7
Nearly bare ground	10
Grassed waterway	15
Paved areas and shallow paved swales	20

*For buried riprap, select C_v value based on type of vegetative cover.

$$t_i = \frac{0.395(1.1 - C_5)\sqrt{L}}{S^{0.33}} \quad V = C_v S_w^{0.5} \quad Tc = LV$$

FINAL DRAINAGE REPORT ~ BASIN RUNOFF SUMMARY

BASIN	WEIGHTED						OVERLAND				STREET / CHANNEL FLOW				Tc TOTAL (min)	INTENSITY						TOTAL FLOWS		
	CA(2)	CA(5)	CA(10)	CA(25)	CA(50)	CA(100)	C(5)	Length (ft)	Height (ft)	Tc (min)	Length (ft)	Slope (%)	Velocity (fps)	Tc (min)		I(2) (in/hr)	I(5) (in/hr)	I(10) (in/hr)	I(25) (in/hr)	I(50) (in/hr)	I(100) (in/hr)	Q(2) (cfs)	Q(5) (cfs)	Q(100) (cfs)
OS-1	0.68	0.71	0.76	0.82	0.85	0.88	0.08	10	0.2	4.6	1700	3.5%	1.9	15.1	19.8	2.48	3.11	3.62	4.14	4.66	5.21	2	2	5
OS-2	0.02	0.07	0.14	0.23	0.27	0.32	0.08	300	10.5	21.1					21.1	2.41	3.01	3.51	4.01	4.51	5.05	0.0	0.2	1.6
OS-3	0.45	0.63	0.80	0.98	1.08	1.18	0.25	55	1.1	9.1	600	3.0%	3.5	2.9	11.9	3.08	3.86	4.51	5.15	5.80	6.49	1	2	8
OS-4	0.47	0.68	0.93	1.15	1.27	1.43	0.22	200	6	15.6	400	3.0%	3.5	1.9	17.6	2.62	3.28	3.83	4.38	4.93	5.51	1	2	8
OS-5	1.25	2.93	4.81	6.48	7.52	8.36	0.14	200	8	15.5	750	2.0%	2.8	4.4	19.9	2.47	3.09	3.61	4.13	4.64	5.19	3	9	43
OS-6	0.08	0.19	0.29	0.38	0.44	0.49	0.16	55	1.1	10.0	500	3.0%	3.5	2.4	12.4	3.04	3.80	4.44	5.07	5.71	6.39	0.3	1	3
OS-7	0.38	0.53	0.67	0.82	0.90	0.99	0.25	100	10	7.2					7.2	3.69	4.63	5.40	6.17	6.94	7.77	1	2	8
OS-8	0.18	0.25	0.32	0.39	0.43	0.47	0.25	55	1.1	9.1	400	3.0%	3.5	1.9	11.0	3.18	3.99	4.65	5.32	5.98	6.70	1	1	3
OS-9	0.37	0.85	1.27	1.70	1.96	2.17	0.16	200	10	14.1	400	3.0%	3.5	1.9	16.0	2.73	3.42	3.99	4.56	5.13	5.74	1	3	12
OS-10	0.18	0.25	0.32	0.39	0.43	0.47	0.25	55	1.1	9.1	450	3.8%	3.9	1.9	11.0	3.18	3.99	4.65	5.32	5.98	6.69	1	1	3
OS-11	1.42	1.98	2.53	3.08	3.40	3.71	0.25	200	10	12.8	450	3.8%	3.9	1.9	14.7	2.84	3.55	4.14	4.74	5.33	5.96	4	7	22
OS-12	0.90	2.10	3.45	4.65	5.40	6.00	0.14	300	13	18.5	600	2.0%	2.8	3.5	22.0	2.35	2.94	3.43	3.93	4.42	4.94	2	6	30
OS-13	0.17	0.28	0.38	0.49	0.56	0.62	0.20	55	1.1	9.6	450	2.0%	2.8	2.7	12.2	3.05	3.83	4.46	5.10	5.74	6.42	0.5	1	4
OS-14	1.09	1.82	2.46	3.19	3.64	4.00	0.20	300	12	17.8	350	2.0%	2.8	2.1	19.9	2.48	3.10	3.62	4.13	4.65	5.20	3	6	21
OS-15	0.70	2.11	3.98	6.08	7.25	8.42	0.09	300	16	18.2	1300	3.5%	1.9	11.6	29.8	2.00	2.49	2.91	3.32	3.74	4.18	1	5	35

JOB NAME: RETREAT AT TIMBERRIDGE FILING NO. 1
 JOB NUMBER: 1185.00
 DATE: 08/01/19
 CALC'D BY: MAW

Table 6-7. Conveyance Coefficient, C_v

Type of Land Surface	C_v
Heavy meadow	2.5
Tillage/field	5
Riprap (not buried)* $t_c = \frac{L}{180} + 10$	6.5
Short pasture and lawns	7
Nearly bare ground	10
Grassed waterway	15
Paved areas and shallow paved swales	20

*For buried riprap, select C_v value based on type of vegetative cover.

$$t_i = \frac{0.395(1.1 - C_v)\sqrt{L}}{S^{0.33}} \quad V = C_v S_w^{0.5} \quad Tc = LV$$

FINAL DRAINAGE REPORT ~ BASIN RUNOFF SUMMARY

BASIN	WEIGHTED						OVERLAND				STREET / CHANNEL FLOW				Tc TOTAL (min)	INTENSITY						TOTAL FLOWS		
	CA(2)	CA(5)	CA(10)	CA(25)	CA(50)	CA(100)	C(5)	Length (ft)	Height (ft)	Tc (min)	Length (ft)	Slope (%)	Velocity (fps)	Tc (min)		I(2) (in/hr)	I(5) (in/hr)	I(10) (in/hr)	I(25) (in/hr)	I(50) (in/hr)	I(100) (in/hr)	Q(2) (cfs)	Q(5) (cfs)	Q(100) (cfs)
OS-16	0.23	0.69	1.31	2.00	2.39	2.77	0.09	300	10	21.2	600	3.5%	1.9	5.3	26.6	2.13	2.66	3.11	3.55	4.00	4.47	0.5	2	12
OS-17	0.61	1.84	3.47	5.30	6.32	7.34	0.09	300	9.5	21.6	650	3.5%	1.9	5.8	27.4	2.10	2.62	3.05	3.49	3.93	4.39	1.3	5	32
OS-18	0.33	0.98	1.85	2.83	3.38	3.92	0.09	300	10	21.2	700	3.5%	1.9	6.2	27.5	2.09	2.61	3.05	3.49	3.92	4.39	0.7	3	17
OS-19	0.22	0.65	1.22	1.87	2.23	2.59	0.09	300	10	21.2	400	3.5%	1.9	3.6	24.8	2.21	2.77	3.23	3.69	4.15	4.64	0.5	2	12
OS-20	0.75	2.26	4.27	6.53	7.78	9.04	0.09	300	16	18.2	1300	3.5%	1.9	11.6	29.8	2.00	2.49	2.91	3.32	3.74	4.18	2	6	38
A	0.83	1.93	3.17	4.28	4.97	5.52	0.14	300	10.5	19.9	1280	3.2%	1.8	11.9	31.8	1.92	2.39	2.79	3.19	3.59	4.02	2	5	22
B	0.46	1.08	1.77	2.39	2.77	3.08	0.14	300	10.5	19.9	400	2.0%	1.4	4.7	24.6	2.23	2.78	3.24	3.71	4.17	4.67	1	3	14
C	0.40	0.94	1.54	2.08	2.41	2.68	0.14	300	10.5	19.9	1100	1.5%	2.4	7.5	27.3	2.10	2.62	3.06	3.49	3.93	4.40	1	2	12
D1	0.72	0.74	0.78	0.83	0.85	0.87	0.08	15	0.3	5.7	1400	1.5%	2.4	9.5	15.2	2.80	3.50	4.08	4.67	5.25	5.88	2	3	5
D2	0.96	1.07	1.18	1.30	1.36	1.43	0.25	55	1.1	9.1	500	2.5%	3.2	2.6	11.7	3.11	3.89	4.54	5.19	5.84	6.54	3	4	9
E	0.19	0.45	0.74	0.99	1.15	1.28	0.14	300	10.5	19.9	300	2.0%	1.4	3.5	23.4	2.28	2.85	3.33	3.81	4.28	4.79	0.4	1	6
F	0.05	0.13	0.21	0.28	0.32	0.36	0.14	300	10.5	19.9					19.9	2.48	3.10	3.62	4.13	4.65	5.20	0.1	0.4	1.9
G	0.05	0.19	0.36	0.60	0.72	0.84	0.08	70	14	5.7	400	2.0%	1.4	4.7	10.4	3.24	4.06	4.74	5.42	6.10	6.82	0.2	0.8	6
H	0.30	0.44	0.60	0.74	0.82	0.92	0.22	100	4	10.1	300	3.0%	3.5	1.4	11.5	3.13	3.92	4.57	5.23	5.88	6.58	1	2	6
I	0.67	0.93	1.18	1.44	1.59	1.74	0.25	120	3	12.4	550	3.5%	3.7	2.4	14.9	2.82	3.53	4.12	4.71	5.30	5.93	2	3	10

JOB NAME: RETREAT AT TIMBERRIDGE FILING NO. 1
 JOB NUMBER: 1185.00
 DATE: 08/01/19
 CALC'D BY: MAW

Table 6-7. Conveyance Coefficient, C_v

Type of Land Surface	C_v
Heavy meadow	2.5
Tillage/field	5
Riprap (not buried)* $t_c = \frac{L}{180} + 10$	6.5
Short pasture and lawns	7
Nearly bare ground	10
Grassed waterway	15
Paved areas and shallow paved swales	20

*For buried riprap, select C_v value based on type of vegetative cover.

$$t_i = \frac{0.395(1.1 - C_s)\sqrt{L}}{S^{0.33}} \quad V = C_v S_w^{0.5} \quad Tc = LV$$

FINAL DRAINAGE REPORT ~ BASIN RUNOFF SUMMARY

BASIN	WEIGHTED						OVERLAND				STREET / CHANNEL FLOW				Tc TOTAL (min)	INTENSITY						TOTAL FLOWS		
	CA(2)	CA(5)	CA(10)	CA(25)	CA(50)	CA(100)	C(5)	Length (ft)	Height (ft)	Tc (min)	Length (ft)	Slope (%)	Velocity (fps)	Tc (min)		I(2) (in/hr)	I(5) (in/hr)	I(10) (in/hr)	I(25) (in/hr)	I(50) (in/hr)	I(100) (in/hr)	Q(2) (cfs)	Q(5) (cfs)	Q(100) (cfs)
J	0.65	0.90	1.15	1.40	1.55	1.69	0.25	120	3	12.4	600	2.0%	2.8	3.5	16.0	2.74	3.43	4.00	4.57	5.14	5.75	2	3	10
K	0.27	0.38	0.48	0.59	0.65	0.71	0.25	55	1.1	9.1	600	2.0%	2.8	3.5	12.6	3.02	3.78	4.41	5.05	5.68	6.35	0.8	1	4
L	1.31	1.83	2.34	2.85	3.14	3.43	0.25	150	4.5	13.1	850	2.5%	3.2	4.5	17.6	2.62	3.28	3.83	4.38	4.93	5.51	3	6	19
M	0.41	0.59	0.81	1.00	1.11	1.24	0.22	100	4	10.1	400	2.0%	2.8	2.4	12.4	3.04	3.80	4.44	5.07	5.71	6.39	1	2	8
N	0.38	0.53	0.67	0.82	0.90	0.99	0.25	55	1.1	9.1	1050	2.0%	2.8	6.2	15.2	2.79	3.50	4.08	4.66	5.25	5.87	1	2	6
O	0.27	0.38	0.48	0.59	0.65	0.71	0.25	80	5	7.5				7.5	3.64	4.56	5.32	6.08	6.84	7.66	1	2	5	
P	0.49	0.68	0.86	1.05	1.16	1.27	0.25	120	3	12.4	450	1.5%	2.4	3.1	15.5	2.77	3.47	4.05	4.63	5.21	5.83	1	2	7
Q	0.13	0.31	0.51	0.68	0.79	0.88	0.14	90	22	5.7	300	1.5%	1.2	4.1	9.8	3.32	4.16	4.85	5.54	6.24	6.98	0.4	1	6
R	0.16	0.23	0.29	0.35	0.39	0.42	0.25	90	6	7.8				7.8	3.59	4.50	5.26	6.01	6.76	7.56	1	1	3	
S	0.07	0.29	0.54	0.90	1.08	1.26	0.08	140	14	10.2	750	1.5%	2.4	5.1	15.3	2.79	3.49	4.07	4.66	5.24	5.86	0.2	1.0	7

JOB NAME: RETREAT AT TIMBERRIDGE FILING NO. 1
 JOB NUMBER: 1185.00
 DATE: 08/01/19
 CALCULATED BY: MAW

FINAL DRAINAGE REPORT ~ SURFACE ROUTING SUMMARY

Design Point(s)	Contributing Basins	Equivalent CA(5)	Equivalent CA(100)	Maximum Tc	Intensity		Flow		Inlet Size
					I(5)	I(100)	Q(5)	Q(100)	
1	A (13.8 Ac.), OS-1 (1.2 Ac.) and C (6.7 Ac.)	3.58	9.08	31.8	2.39	4.02	9	36	DUAL 24" RCP CULVERTS
2	TOTAL INFLOW INTO POND 1 A, B, C and OS-1 (29.4 Ac.)	4.66	12.16	33.8	2.30	3.86	11	47	POND 1
3	No longer used								
4	D1 (1.1 Ac.)	0.74	0.87	15.2	3.50	5.88	3	5	5' TYPE R SUMP INLET
5	OS-4 (3.1 Ac.), I (3.7 Ac.)	1.61	3.17	17.7	3.28	5.50	5	17	15' TYPE R AT-GRADE INLET
6	OS-3 (2.5 Ac.)	0.63	1.18	11.9	3.86	6.49	2	8	10' TYPE R AT-GRADE INLET
7	Basin D2, Basin H and 50% of 100 yr Flowby from DP-6 (5.5 Ac)	1.51	2.47	27.3	2.62	4.40	4	11	10' TYPE R SUMP INLET
8	K (1.5 Ac.)	0.38	0.71	12.6	3.78	6.35	1	4	5' TYPE R SUMP INLET
9	J and OS-7 (5.7 Ac.)	1.43	2.68	16.0	3.43	5.75	5	15	10' TYPE R SUMP INLET
10	Flowby from DP-5 and Basin L (7.3 Ac)	1.83	4.29	21.2	3.00	5.04	5	22	15' TYPE R AT-GRADE INLET
11	Basins N, O, P and 50% 100 Yr Flowby from DP 6 and portion of 100 Yr Flowby from DP 10 (13.6 Ac)	1.58	4.54	24.2	2.80	4.70	4	21	15' TYPE R SUMP INLET
12	OS-5 (20.9Ac.)	2.93	6.27	19.9	3.09	5.19	9	33	15' TYPE R SUMP INLET
13	OS-6 (1.2Ac.)	0.19	2.06	12.4	3.80	6.39	1	13	10' TYPE R SUMP INLET

JOB NAME: RETREAT AT TIMBERRIDGE FILING NO. 1
 JOB NUMBER: 1185.00
 DATE: 08/01/19
 CALCULATED BY: MAW

FINAL DRAINAGE REPORT ~ SURFACE ROUTING SUMMARY

Design Point(s)	Contributing Basins	Equivalent CA(5)	Equivalent CA(100)	Maximum Tc	Intensity		Flow		Inlet Size
					I(5)	I(100)	Q(5)	Q(100)	
14	OS-8 (1.0Ac.)	0.25	0.47	11.0	3.99	6.70	1	3	5' TYPE R SUMP INLET
15	OS-9 (5.3 Ac.)	0.85	2.17	16.0	3.42	5.74	3	12	10' TYPE R SUMP INLET
16	OS-10 (1.0 Ac.)	0.25	0.47	11.0	3.99	6.69	1	3	5' TYPE R SUMP INLET
17	OS-11 (7.9 Ac.)	1.98	3.71	14.7	3.55	5.96	7	22	10' TYPE R SUMP INLET
18	OS-12 (15.0 Ac.)	2.10	6.00	22.0	2.94	4.94	6	30	30" RCP CULVERT
19	OS-13 (1.4 Ac.)	0.28	0.62	12.2	3.83	6.42	1	4	5' TYPE R SUMP INLET
20	OS-14 (9.1 Ac.)	1.82	4.00	19.9	3.10	5.20	6	21	5' TYPE R SUMP INLET
21	TOTAL INFLOW INTO EXIST. STOCK POND (23.4 Ac.)	2.11	8.42	29.8	2.49	4.18	5	35	EXIST. STOCK POND WITH OUTLET
22	TOTAL INFLOW INTO POND 2 (104.8 Ac.)	20.50	45.77	30.0	2.48	4.16	51	191	POND 2

JOB NAME: RETREAT AT TIMBERRIDGE FILING NO. 1
 JOB NUMBER: 1185.00
 DATE: 08/01/19
 CALCULATED BY: MAW

* PIPES ARE LISTED AT MAXIMUM SIZE REQUIRED TO ACCOMMODATE Q100 FLOWS AT MINIMUM GRADE.
 REFER TO INDIVIDUAL PIPE SHEETS FOR HYDRAULIC INFORMATION.

FINAL DRAINAGE REPORT ~ PIPE ROUTING SUMMARY

Pipe Run	Contributing Basins	Equivalent CA(5)	Equivalent CA(100)	Maximum Tc	Intensity		Flow		Pipe Size*
					I(5)	I(100)	Q(5)	Q(100)	
1	DP-18	2.10	6.00	23.2	2.86	4.81	6	29	30" RCP
2	DP-19	0.28	0.62	12.2	3.83	6.42	1	4	18" RCP
3	DP-20	1.82	4.00	19.9	3.10	5.20	6	21	24" RCP
4	PR-1, PR-2, PR-3	4.20	10.62	23.9	2.82	4.73	12	50	36" RCP
5	Captured from DP-5	1.61	2.31	17.7	3.28	5.50	5	13	24" RCP
6	Captured from DP-6	0.63	0.93	11.9	3.86	6.49	2	6	18" RCP
7	PR-4, PR-5, PR-6	6.43	13.86	24.4	2.79	4.68	18	65	36" RCP
8	DP-4	0.74	0.87	15.2	3.50	5.88	3	5	18" RCP
9	DP-7	1.51	2.47	27.3	2.62	4.40	4	11	24" RCP
10	PR-8, PR-9	2.25	3.34	27.5	2.61	4.38	6	15	30" RCP
11	PR-7, PR-10	8.69	17.20	28.0	2.58	4.33	22	75	42" RCP
12	Captured from DP-10	1.83	2.83	21.2	3.00	5.04	5	14	24" RCP
13	PR-11, PR-12	10.51	20.03	28.1	2.58	4.33	27	87	42" RCP
14	DP-8	0.38	0.71	12.6	3.78	6.35	1	4	18" RCP
15	DP-9	1.43	2.68	16.0	3.43	5.75	5	15	24" RCP

JOB NAME: RETREAT AT TIMBERRIDGE FILING NO. 1
 JOB NUMBER: 1185.00
 DATE: 08/01/19
 CALCULATED BY: MAW

* PIPES ARE LISTED AT MAXIMUM SIZE REQUIRED TO ACCOMMODATE Q100 FLOWS AT MINIMUM GRADE.
 REFER TO INDIVIDUAL PIPE SHEETS FOR HYDRAULIC INFORMATION.

FINAL DRAINAGE REPORT ~ PIPE ROUTING SUMMARY

Pipe Run	Contributing Basins	Equivalent CA(5)	Equivalent CA(100)	Maximum Tc	Intensity		Flow		Pipe Size*
					I(5)	I(100)	Q(5)	Q(100)	
16	PR-14, PR-15	1.80	3.38	16.4	3.39	5.69	6	19	24" RCP
17	PR-13, PR-16	12.31	23.41	28.6	2.55	4.28	31	100	48" RCP
18	DP-11	1.58	4.54	24.2	2.80	4.70	4	21	30" RCP
19	PR-17, PR-18 W'LY FOREBAY OUTFALL	13.89	27.96	28.8	2.54	4.26	35	119	48" RCP
20	DP-12	2.93	6.27	19.9	3.09	5.19	9	33	30" RCP
21	DP-13	0.19	2.06	12.4	3.80	6.39	1	13	24" RCP
22	PR-20, PR-21	3.12	8.33	20.7	3.04	5.10	9	42	30" RCP
23	DP-14	0.25	0.47	11.0	3.99	6.70	1	3	18" RCP
24	DP-15	0.85	2.17	16.0	3.42	5.74	3	12	24" RCP
25	PR-22, PR-23, PR-24	4.22	10.97	22.0	2.94	4.94	12	54	36" RCP
26	DP-16	0.25	0.47	11.0	3.99	6.69	1	3	18" RCP
27	DP-17	1.98	3.71	14.7	3.55	5.96	7	22	30" RCP
28	PR-26, PR-27	2.23	4.18	14.9	3.53	5.93	8	25	30" RCP
29	PR-25, PR-28 E'LY FOREBAY OUTFALL	6.44	15.16	22.3	2.92	4.91	19	74	42" RCP



619 N. Cascade Avenue, Suite 200
Colorado Springs, CO 80903

Project: Timber Ridge Fil. 1
Date: 3/5/19
Contact: _____
Phone: _____
By: MAW

- NOTES
- Telephone Record
 - Note to the File
 - Job Information
 - Meeting Minutes
 - _____

Effective Imperviousness

Pond 1

Basin A ^{13.8} ~~16.3~~ Ac. @ 11% Imp.

Basin B 7.7 Ac. @ 11% Imp.

Basin C 6.7 Ac. @ 11% Imp.

Basin DS-1 1.2 Ac. @ 30% Imp.

Total trib. acreage = ~~24.0~~ Ac. @ ~~11%~~ Imp. ^{13.8}

29.4

Pond 2

Basin ^{DZ} E ~~6.4~~ ^{2.2} Ac. @ 1.1 Ac. 90% Imp.

= ~~27.6~~ Imp. ^{1.1} ~~0.9~~ Ac. 30% Imp.

60% ~~4.4~~ Ac. ~~11%~~

Basin ^{D1} H 1.1 Ac. @ 90% Imp.

- Basin I 2.0 Ac. @ 25% Imp.

Basin J ^{3.7} ~~4.0~~ Ac. @ 30% Imp.

- Basin K 3.6 Ac. @ 30% Imp.

- Basin L 1.5 Ac. @ 30% Imp.

- Basin M 7.3 Ac. @ 30% Imp.

- Basin N 2.1 Ac. @ 30% Imp.

✓ Basin O 1.5 Ac. @ 30% Imp.

✓ Basin P 2.7 Ac. @ 30% Imp.

✓ Basin Q 2.2 Ac. @ 10% Imp.



619 N. Cascade Avenue, Suite 200
Colorado Springs, CO 80903

Project: _____
Date: _____
Contact: _____
Phone: _____
By: _____

NOTES

- Telephone Record
- Note to the File
- Job Information
- Meeting Minutes
- _____

Effective Imperviousness (cont.)

Pond 2

		05-3	3.2 ^{2.5} Ac. @		30% Imp.
		05-4	6.2 ^{3.1} Ac. @		25% Imp.
		✓ 05-5	21.9 Ac. @		5.7 Ac. 30%
			= 10% Imp.		15.2 Ac. 2%
		✓ 05-6	1.2 Ac. @		0.6 Ac. 30%
			= 16% Imp.		6.6 Ac. 2%
		✓ 05-7	2.1 Ac. @		30% Imp.
		✓ 05-8	1.0 Ac. @		30% Imp.
		✓ 05-9	5.3 Ac. @		2.8 Ac. 30%
			= 17% Imp.		2.5 Ac. 2%
		✓ 05-10	1.0 Ac. @		30%
		✓ 05-11	7.9 Ac. @		30%
		✓ 05-12	15.0 Ac. @		10%
		05-13	6.8 ^{1.4} Ac. @		20%
		05-14	3.8 ^{2.1} Ac. @		20%
		Total trib. acreage = 104.8 ^{100.4} Ac.			
		Eff. Imp. = 21.4 ^{21.6} %			

ALLOWABLE CAPACITY FOR ONE-HALF OF STREET (Minor & Major Storm)

(Based on Regulated Criteria for Maximum Allowable Flow Depth and Spread)

Project:
Inlet ID:

RETREAT AT TIMBERRIDGE FILING NO. 1
DP-4

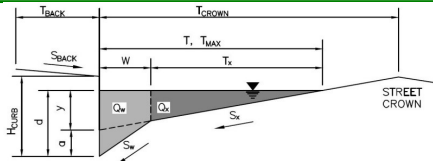

Gutter Geometry (Enter data in the blue cells)

Maximum Allowable Width for Spread Behind Curb
 Side Slope Behind Curb (leave blank for no conveyance credit behind curb)
 Manning's Roughness Behind Curb (typically between 0.012 and 0.020)
 Height of Curb at Gutter Flow Line
 Distance from Curb Face to Street Crown
 Gutter Width
 Street Transverse Slope
 Gutter Cross Slope (typically 2 inches over 24 inches or 0.083 ft/ft)
 Street Longitudinal Slope - Enter 0 for sump condition
 Manning's Roughness for Street Section (typically between 0.012 and 0.020)

$T_{BACK} = 12.5$ ft
 $S_{BACK} = 0.020$ ft/ft
 $n_{BACK} = 0.013$
 $H_{CURB} = 6.00$ inches
 $T_{CROWN} = 17.0$ ft
 $W = 2.00$ ft
 $S_x = 0.020$ ft/ft
 $S_w = 0.083$ ft/ft
 $S_o = 0.000$ ft/ft
 $n_{STREET} = 0.016$

Max. Allowable Spread for Minor & Major Storm
 Max. Allowable Depth at Gutter Flowline for Minor & Major Storm
 Check boxes are not applicable in SUMP conditions

	Minor Storm	Major Storm	
$T_{MAX} =$	17.0	17.0	ft
$d_{MAX} =$	6.0	12.0	inches
	<input type="checkbox"/>	<input type="checkbox"/>	

MINOR STORM Allowable Capacity is based on Depth Criterion
MAJOR STORM Allowable Capacity is based on Depth Criterion

$Q_{allow} =$

Minor Storm	Major Storm	
SUMP	SUMP	cfs

INLET IN A SUMP OR SAG LOCATION

Version 4.05 Released March 2017

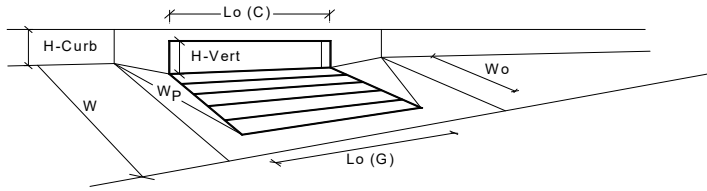

Design Information (Input)	MINOR	MAJOR	
Type of Inlet	CDOT Type R Curb Opening		
Local Depression (additional to continuous gutter depression 'a' from above)			
Number of Unit Inlets (Grate or Curb Opening)	1	1	
Water Depth at Flowline (outside of local depression)	6.0	12.0	inches
Grate Information	MINOR	MAJOR	<input checked="" type="checkbox"/> Override Depths
Length of a Unit Grate	N/A	N/A	feet
Width of a Unit Grate	N/A	N/A	feet
Area Opening Ratio for a Grate (typical values 0.15-0.90)	N/A	N/A	
Clogging Factor for a Single Grate (typical value 0.50 - 0.70)	N/A	N/A	
Grate Weir Coefficient (typical value 2.15 - 3.60)	N/A	N/A	
Grate Orifice Coefficient (typical value 0.60 - 0.80)	N/A	N/A	
Curb Opening Information	MINOR	MAJOR	
Length of a Unit Curb Opening	5.00	5.00	feet
Height of Vertical Curb Opening in Inches	6.00	6.00	inches
Height of Curb Orifice Throat in Inches	6.00	6.00	inches
Angle of Throat (see USDCM Figure ST-5)	63.40	63.40	degrees
Side Width for Depression Pan (typically the gutter width of 2 feet)	2.00	2.00	feet
Clogging Factor for a Single Curb Opening (typical value 0.10)	0.10	0.10	
Curb Opening Weir Coefficient (typical value 2.3-3.7)	3.60	3.60	
Curb Opening Orifice Coefficient (typical value 0.60 - 0.70)	0.67	0.67	
Low Head Performance Reduction (Calculated)	MINOR	MAJOR	
Depth for Grate Midwidth	N/A	N/A	ft
Depth for Curb Opening Weir Equation	0.33	0.83	ft
Combination Inlet Performance Reduction Factor for Long Inlets	0.77	1.00	
Curb Opening Performance Reduction Factor for Long Inlets	1.00	1.00	
Grated Inlet Performance Reduction Factor for Long Inlets	N/A	N/A	
Total Inlet Interception Capacity (assumes clogged condition)	MINOR	MAJOR	
Q_a	5.4	12.3	cfs
Q _{PEAK REQUIRED}	3.0	5.0	cfs

Inlet Capacity IS GOOD for Minor and Major Storms(>Q PEAK)

ALLOWABLE CAPACITY FOR ONE-HALF OF STREET (Minor & Major Storm)

(Based on Regulated Criteria for Maximum Allowable Flow Depth and Spread)

Project:
Inlet ID:

RETREAT AT TIMBERRIDGE FILING NO. 1
DP-5

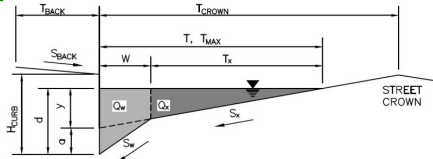

Gutter Geometry (Enter data in the blue cells)

Maximum Allowable Width for Spread Behind Curb
Side Slope Behind Curb (leave blank for no conveyance credit behind curb)
Manning's Roughness Behind Curb (typically between 0.012 and 0.020)

$T_{BACK} = 7.5$ ft
 $S_{BACK} = 0.020$ ft/ft
 $n_{BACK} = 0.013$

Height of Curb at Gutter Flow Line
Distance from Curb Face to Street Crown
Gutter Width
Street Transverse Slope
Gutter Cross Slope (typically 2 inches over 24 inches or 0.083 ft/ft)
Street Longitudinal Slope - Enter 0 for sump condition
Manning's Roughness for Street Section (typically between 0.012 and 0.020)

$H_{CURB} = 6.00$ inches
 $T_{CROWN} = 17.0$ ft
 $W = 2.00$ ft
 $S_x = 0.020$ ft/ft
 $S_w = 0.083$ ft/ft
 $S_o = 0.017$ ft/ft
 $n_{STREET} = 0.016$

Max. Allowable Spread for Minor & Major Storm
Max. Allowable Depth at Gutter Flowline for Minor & Major Storm
Allow Flow Depth at Street Crown (leave blank for no)

	Minor Storm	Major Storm	
$T_{MAX} =$	17.0	17.0	ft
$d_{MAX} =$	6.0	12.0	inches
	<input type="checkbox"/>	<input type="checkbox"/>	check = yes

MINOR STORM Allowable Capacity is based on Spread Criterion
MAJOR STORM Allowable Capacity is based on Spread Criterion

	Minor Storm	Major Storm	
$Q_{allow} =$	14.2	14.2	cfs

Minor storm max. allowable capacity GOOD - greater than the design flow given on sheet 'Inlet Management'
WARNING: MAJOR STORM max. allowable capacity is less than the design flow given on sheet 'Inlet Management'

INLET ON A CONTINUOUS GRADE

Version 4.05 Released March 2017

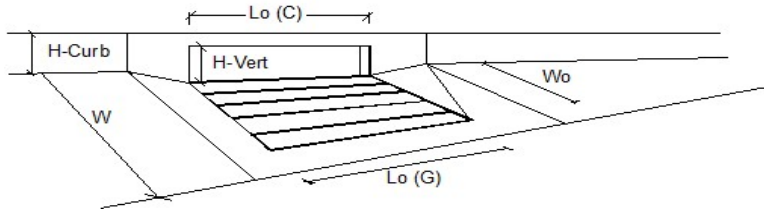

Design Information (Input)	MINOR	MAJOR	
Type of Inlet	CDOT Type R Curb Opening		
Local Depression (additional to continuous gutter depression 'a')	3.0	3.0	inches
Total Number of Units in the Inlet (Grate or Curb Opening)	1	1	
Length of a Single Unit Inlet (Grate or Curb Opening)	15.00	15.00	ft
Width of a Unit Grate (cannot be greater than W, Gutter Width)	N/A	N/A	ft
Clogging Factor for a Single Unit Grate (typical min. value = 0.5)	N/A	N/A	
Clogging Factor for a Single Unit Curb Opening (typical min. value = 0.1)	0.10	0.10	
Street Hydraulics: WARNING: Q > ALLOWABLE Q FOR MAJOR STORM			
Total Inlet Interception Capacity	5.0	12.7	cfs
Total Inlet Carry-Over Flow (flow bypassing inlet)	0.0	4.3	cfs
Capture Percentage = $Q_p/Q_o =$	100	75	%

ALLOWABLE CAPACITY FOR ONE-HALF OF STREET (Minor & Major Storm)

(Based on Regulated Criteria for Maximum Allowable Flow Depth and Spread)

Project:
Inlet ID:

RETREAT AT TIMBERRIDGE FILING NO. 1
DP-6

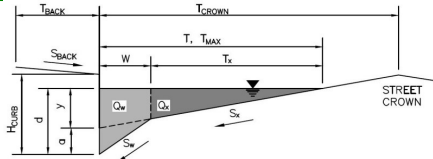

Gutter Geometry (Enter data in the blue cells)

Maximum Allowable Width for Spread Behind Curb
Side Slope Behind Curb (leave blank for no conveyance credit behind curb)
Manning's Roughness Behind Curb (typically between 0.012 and 0.020)

$T_{BACK} = 7.5$ ft
 $S_{BACK} = 0.020$ ft/ft
 $n_{BACK} = 0.013$

Height of Curb at Gutter Flow Line
Distance from Curb Face to Street Crown
Gutter Width
Street Transverse Slope
Gutter Cross Slope (typically 2 inches over 24 inches or 0.083 ft/ft)
Street Longitudinal Slope - Enter 0 for sump condition
Manning's Roughness for Street Section (typically between 0.012 and 0.020)

$H_{CURB} = 6.00$ inches
 $T_{CROWN} = 17.0$ ft
 $W = 2.00$ ft
 $S_X = 0.020$ ft/ft
 $S_W = 0.083$ ft/ft
 $S_D = 0.017$ ft/ft
 $n_{STREET} = 0.016$

Max. Allowable Spread for Minor & Major Storm
Max. Allowable Depth at Gutter Flowline for Minor & Major Storm
Allow Flow Depth at Street Crown (leave blank for no)

	Minor Storm	Major Storm	
$T_{MAX} =$	17.0	17.0	ft
$d_{MAX} =$	6.0	12.0	inches
	<input type="checkbox"/>	<input type="checkbox"/>	check = yes

MINOR STORM Allowable Capacity is based on Spread Criterion
MAJOR STORM Allowable Capacity is based on Spread Criterion

	Minor Storm	Major Storm	
$Q_{allow} =$	14.2	14.2	cfs

Minor storm max. allowable capacity GOOD - greater than the design flow given on sheet 'Inlet Management'
Major storm max. allowable capacity GOOD - greater than the design flow given on sheet 'Inlet Management'

INLET ON A CONTINUOUS GRADE

Version 4.05 Released March 2017

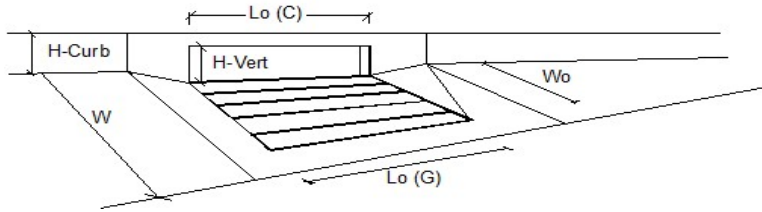

Design Information (Input)	MINOR	MAJOR	
Type of Inlet	CDOT Type R Curb Opening		
Local Depression (additional to continuous gutter depression 'a')	3.0	3.0	inches
Total Number of Units in the Inlet (Grate or Curb Opening)	1	1	
Length of a Single Unit Inlet (Grate or Curb Opening)	10.00	10.00	ft
Width of a Unit Grate (cannot be greater than W, Gutter Width)	N/A	N/A	ft
Clogging Factor for a Single Unit Grate (typical min. value = 0.5)	N/A	N/A	
Clogging Factor for a Single Unit Curb Opening (typical min. value = 0.1)	0.10	0.10	
Street Hydraulics: OK - Q < Allowable Street Capacity*			
Total Inlet Interception Capacity	2.0	6.3	cfs
Total Inlet Carry-Over Flow (flow bypassing inlet)	0.0	1.7	cfs
Capture Percentage = $Q_p/Q_o =$	100	79	%

ALLOWABLE CAPACITY FOR ONE-HALF OF STREET (Minor & Major Storm)

(Based on Regulated Criteria for Maximum Allowable Flow Depth and Spread)

Project:
Inlet ID:

RETREAT AT TIMBERRIDGE FILING NO. 1
DP-7

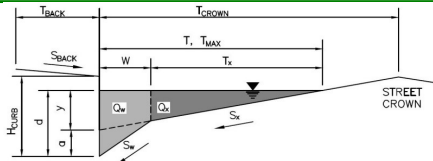

Gutter Geometry (Enter data in the blue cells)

Maximum Allowable Width for Spread Behind Curb
 Side Slope Behind Curb (leave blank for no conveyance credit behind curb)
 Manning's Roughness Behind Curb (typically between 0.012 and 0.020)
 Height of Curb at Gutter Flow Line
 Distance from Curb Face to Street Crown
 Gutter Width
 Street Transverse Slope
 Gutter Cross Slope (typically 2 inches over 24 inches or 0.083 ft/ft)
 Street Longitudinal Slope - Enter 0 for sump condition
 Manning's Roughness for Street Section (typically between 0.012 and 0.020)

T_{BACK} =	12.5	ft
S_{BACK} =	0.020	ft/ft
n_{BACK} =	0.013	
H_{CURB} =	6.00	inches
T_{CROWN} =	17.0	ft
W =	2.00	ft
S_X =	0.020	ft/ft
S_W =	0.083	ft/ft
S_D =	0.000	ft/ft
n_{STREET} =	0.016	
T_{MAX} =	17.0	ft
d_{MAX} =	6.0	inches

Max. Allowable Spread for Minor & Major Storm
 Max. Allowable Depth at Gutter Flowline for Minor & Major Storm
 Check boxes are not applicable in SUMP conditions

	Minor Storm	Major Storm	
T_{MAX} =	17.0	17.0	ft
d_{MAX} =	6.0	12.0	inches
	<input type="checkbox"/>	<input type="checkbox"/>	

MINOR STORM Allowable Capacity is based on Depth Criterion
MAJOR STORM Allowable Capacity is based on Depth Criterion

	Minor Storm	Major Storm	
Q_{allow} =	SUMP	SUMP	cfs

INLET IN A SUMP OR SAG LOCATION

Version 4.05 Released March 2017

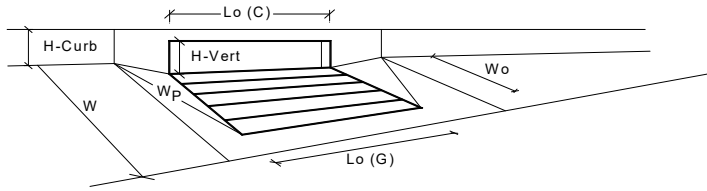

Design Information (Input)	MINOR	MAJOR	
Type of Inlet	CDOT Type R Curb Opening		
Local Depression (additional to continuous gutter depression 'a' from above)			
Number of Unit Inlets (Grate or Curb Opening)			
Water Depth at Flowline (outside of local depression)			
Grate Information	MINOR	MAJOR	
Length of a Unit Grate	L _g (G) =	N/A	feet
Width of a Unit Grate	W _g =	N/A	feet
Area Opening Ratio for a Grate (typical values 0.15-0.90)	A _{ratio} =	N/A	
Clogging Factor for a Single Grate (typical value 0.50 - 0.70)	C _f (G) =	N/A	
Grate Weir Coefficient (typical value 2.15 - 3.60)	C _w (G) =	N/A	
Grate Orifice Coefficient (typical value 0.60 - 0.80)	C _o (G) =	N/A	
Curb Opening Information	MINOR	MAJOR	
Length of a Unit Curb Opening	L _c (C) =	10.00	feet
Height of Vertical Curb Opening in Inches	H _{vert} =	6.00	inches
Height of Curb Orifice Throat in Inches	H _{throat} =	6.00	inches
Angle of Throat (see USDCM Figure ST-5)	Theta =	63.40	degrees
Side Width for Depression Pan (typically the gutter width of 2 feet)	W _p =	2.00	feet
Clogging Factor for a Single Curb Opening (typical value 0.10)	C _f (C) =	0.10	
Curb Opening Weir Coefficient (typical value 2.3-3.7)	C _w (C) =	3.60	
Curb Opening Orifice Coefficient (typical value 0.60 - 0.70)	C _o (C) =	0.67	
Low Head Performance Reduction (Calculated)	MINOR	MAJOR	
Depth for Grate Midwidth	d _{grate} =	N/A	ft
Depth for Curb Opening Weir Equation	d _{curb} =	0.33	ft
Combination Inlet Performance Reduction Factor for Long Inlets	RF _{Combination} =	0.57	
Curb Opening Performance Reduction Factor for Long Inlets	RF _{Curb} =	0.93	
Grated Inlet Performance Reduction Factor for Long Inlets	RF _{Grate} =	N/A	
Total Inlet Interception Capacity (assumes clogged condition)	MINOR	MAJOR	
Inlet Capacity IS GOOD for Minor and Major Storms(>Q PEAK)	Q _a =	8.3	cfs
	Q _{PEAK REQUIRED} =	4.0	cfs

ALLOWABLE CAPACITY FOR ONE-HALF OF STREET (Minor & Major Storm)

(Based on Regulated Criteria for Maximum Allowable Flow Depth and Spread)

Project:
Inlet ID:

RETREAT AT TIMBERRIDGE FILING NO. 1

DP-8

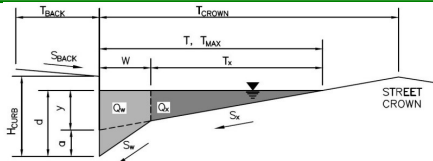

Gutter Geometry (Enter data in the blue cells)

Maximum Allowable Width for Spread Behind Curb
 Side Slope Behind Curb (leave blank for no conveyance credit behind curb)
 Manning's Roughness Behind Curb (typically between 0.012 and 0.020)
 Height of Curb at Gutter Flow Line
 Distance from Curb Face to Street Crown
 Gutter Width
 Street Transverse Slope
 Gutter Cross Slope (typically 2 inches over 24 inches or 0.083 ft/ft)
 Street Longitudinal Slope - Enter 0 for sump condition
 Manning's Roughness for Street Section (typically between 0.012 and 0.020)

$T_{BACK} = 7.5$ ft
 $S_{BACK} = 0.020$ ft/ft
 $n_{BACK} = 0.013$
 $H_{CURB} = 6.00$ inches
 $T_{CROWN} = 17.0$ ft
 $W = 2.00$ ft
 $S_x = 0.020$ ft/ft
 $S_w = 0.083$ ft/ft
 $S_D = 0.000$ ft/ft
 $n_{STREET} = 0.016$

Max. Allowable Spread for Minor & Major Storm
 Max. Allowable Depth at Gutter Flowline for Minor & Major Storm
 Check boxes are not applicable in SUMP conditions

	Minor Storm	Major Storm	
$T_{MAX} =$	17.0	17.0	ft
$d_{MAX} =$	6.0	12.0	inches
	<input type="checkbox"/>	<input type="checkbox"/>	

MINOR STORM Allowable Capacity is based on Depth Criterion
MAJOR STORM Allowable Capacity is based on Depth Criterion

	Minor Storm	Major Storm	
$Q_{allow} =$	SUMP	SUMP	cfs

INLET IN A SUMP OR SAG LOCATION

Version 4.05 Released March 2017

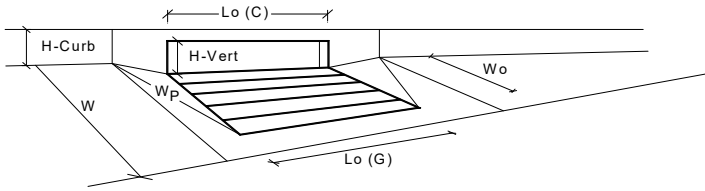

Design Information (Input)	MINOR	MAJOR	
Type of Inlet	CDOT Type R Curb Opening		
Local Depression (additional to continuous gutter depression 'a' from above)	3.00	3.00	inches
Number of Unit Inlets (Grate or Curb Opening)	1	1	
Water Depth at Flowline (outside of local depression)	6.0	12.0	inches
Grate Information	MINOR	MAJOR	<input checked="" type="checkbox"/> Override Depths
Length of a Unit Grate	N/A	N/A	feet
Width of a Unit Grate	N/A	N/A	feet
Area Opening Ratio for a Grate (typical values 0.15-0.90)	N/A	N/A	
Clogging Factor for a Single Grate (typical value 0.50 - 0.70)	N/A	N/A	
Grate Weir Coefficient (typical value 2.15 - 3.60)	N/A	N/A	
Grate Orifice Coefficient (typical value 0.60 - 0.80)	N/A	N/A	
Curb Opening Information	MINOR	MAJOR	
Length of a Unit Curb Opening	5.00	5.00	feet
Height of Vertical Curb Opening in Inches	6.00	6.00	inches
Height of Curb Orifice Throat in Inches	6.00	6.00	inches
Angle of Throat (see USDCM Figure ST-5)	63.40	63.40	degrees
Side Width for Depression Pan (typically the gutter width of 2 feet)	2.00	2.00	feet
Clogging Factor for a Single Curb Opening (typical value 0.10)	0.10	0.10	
Curb Opening Weir Coefficient (typical value 2.3-3.7)	3.60	3.60	
Curb Opening Orifice Coefficient (typical value 0.60 - 0.70)	0.67	0.67	
Low Head Performance Reduction (Calculated)	MINOR	MAJOR	
Depth for Grate Midwidth	N/A	N/A	ft
Depth for Curb Opening Weir Equation	0.33	0.83	ft
Combination Inlet Performance Reduction Factor for Long Inlets	0.77	1.00	
Curb Opening Performance Reduction Factor for Long Inlets	1.00	1.00	
Grated Inlet Performance Reduction Factor for Long Inlets	N/A	N/A	
Total Inlet Interception Capacity (assumes clogged condition)	MINOR	MAJOR	
Inlet Capacity IS GOOD for Minor and Major Storms(>Q PEAK)	5.4	12.3	cfs
Q PEAK REQUIRED =	1.0	4.0	cfs

ALLOWABLE CAPACITY FOR ONE-HALF OF STREET (Minor & Major Storm)

(Based on Regulated Criteria for Maximum Allowable Flow Depth and Spread)

Project:
Inlet ID:

RETREAT AT TIMBERRIDGE FILING NO. 1

DP-9

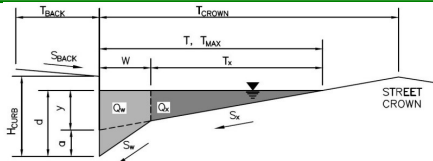

Gutter Geometry (Enter data in the blue cells)

Maximum Allowable Width for Spread Behind Curb
 Side Slope Behind Curb (leave blank for no conveyance credit behind curb)
 Manning's Roughness Behind Curb (typically between 0.012 and 0.020)
 Height of Curb at Gutter Flow Line
 Distance from Curb Face to Street Crown
 Gutter Width
 Street Transverse Slope
 Gutter Cross Slope (typically 2 inches over 24 inches or 0.083 ft/ft)
 Street Longitudinal Slope - Enter 0 for sump condition
 Manning's Roughness for Street Section (typically between 0.012 and 0.020)

$T_{BACK} = 7.5$ ft
 $S_{BACK} = 0.020$ ft/ft
 $n_{BACK} = 0.013$
 $H_{CURB} = 6.00$ inches
 $T_{CROWN} = 17.0$ ft
 $W = 2.00$ ft
 $S_X = 0.020$ ft/ft
 $S_W = 0.083$ ft/ft
 $S_D = 0.000$ ft/ft
 $n_{STREET} = 0.016$

Max. Allowable Spread for Minor & Major Storm
 Max. Allowable Depth at Gutter Flowline for Minor & Major Storm
 Check boxes are not applicable in SUMP conditions

	Minor Storm	Major Storm	
$T_{MAX} =$	17.0	17.0	ft
$d_{MAX} =$	6.0	12.0	inches
	<input type="checkbox"/>	<input type="checkbox"/>	

MINOR STORM Allowable Capacity is based on Depth Criterion
MAJOR STORM Allowable Capacity is based on Depth Criterion

$Q_{allow} =$

Minor Storm	Major Storm	
SUMP	SUMP	cfs

INLET IN A SUMP OR SAG LOCATION

Version 4.05 Released March 2017

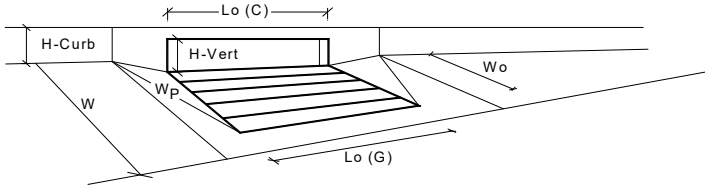

Design Information (Input)	MINOR	MAJOR	
Type of Inlet	CDOT Type R Curb Opening		
Local Depression (additional to continuous gutter depression 'a' from above)			
Number of Unit Inlets (Grate or Curb Opening)			
Water Depth at Flowline (outside of local depression)			
Grate Information	MINOR	MAJOR	
Length of a Unit Grate	L _g (G) =	N/A	feet
Width of a Unit Grate	W _g =	N/A	feet
Area Opening Ratio for a Grate (typical values 0.15-0.90)	A _{ratio} =	N/A	
Clogging Factor for a Single Grate (typical value 0.50 - 0.70)	C _f (G) =	N/A	
Grate Weir Coefficient (typical value 2.15 - 3.60)	C _w (G) =	N/A	
Grate Orifice Coefficient (typical value 0.60 - 0.80)	C _o (G) =	N/A	
Curb Opening Information	MINOR	MAJOR	
Length of a Unit Curb Opening	L _c (C) =	10.00	feet
Height of Vertical Curb Opening in Inches	H _{vert} =	6.00	inches
Height of Curb Orifice Throat in Inches	H _{throat} =	6.00	inches
Angle of Throat (see USDCM Figure ST-5)	Theta =	63.40	degrees
Side Width for Depression Pan (typically the gutter width of 2 feet)	W _p =	2.00	feet
Clogging Factor for a Single Curb Opening (typical value 0.10)	C _f (C) =	0.10	
Curb Opening Weir Coefficient (typical value 2.3-3.7)	C _w (C) =	3.60	
Curb Opening Orifice Coefficient (typical value 0.60 - 0.70)	C _o (C) =	0.67	
Low Head Performance Reduction (Calculated)	MINOR	MAJOR	
Depth for Grate Midwidth	d _{grate} =	N/A	ft
Depth for Curb Opening Weir Equation	d _{curb} =	0.33	ft
Combination Inlet Performance Reduction Factor for Long Inlets	RF _{Combination} =	0.57	
Curb Opening Performance Reduction Factor for Long Inlets	RF _{Curb} =	0.93	
Grated Inlet Performance Reduction Factor for Long Inlets	RF _{Grate} =	N/A	
Total Inlet Interception Capacity (assumes clogged condition)	MINOR	MAJOR	
Inlet Capacity IS GOOD for Minor and Major Storms(>Q PEAK)	Q _a =	8.3	cfs
	Q _{PEAK REQUIRED} =	5.0	cfs

ALLOWABLE CAPACITY FOR ONE-HALF OF STREET (Minor & Major Storm)

(Based on Regulated Criteria for Maximum Allowable Flow Depth and Spread)

Project:
Inlet ID:

RETREAT AT TIMBERRIDGE FILING NO. 1
DP-10

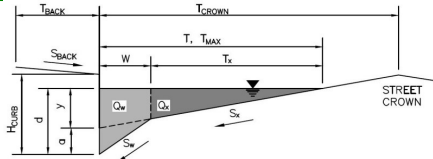

Gutter Geometry (Enter data in the blue cells)

Maximum Allowable Width for Spread Behind Curb
Side Slope Behind Curb (leave blank for no conveyance credit behind curb)
Manning's Roughness Behind Curb (typically between 0.012 and 0.020)

$T_{BACK} = 7.5$ ft
 $S_{BACK} = 0.020$ ft/ft
 $n_{BACK} = 0.013$

Height of Curb at Gutter Flow Line
Distance from Curb Face to Street Crown
Gutter Width
Street Transverse Slope
Gutter Cross Slope (typically 2 inches over 24 inches or 0.083 ft/ft)
Street Longitudinal Slope - Enter 0 for sump condition
Manning's Roughness for Street Section (typically between 0.012 and 0.020)

$H_{CURB} = 6.00$ inches
 $T_{CROWN} = 17.0$ ft
 $W = 2.00$ ft
 $S_x = 0.020$ ft/ft
 $S_w = 0.083$ ft/ft
 $S_o = 0.015$ ft/ft
 $n_{STREET} = 0.016$

Max. Allowable Spread for Minor & Major Storm
Max. Allowable Depth at Gutter Flowline for Minor & Major Storm
Allow Flow Depth at Street Crown (leave blank for no)

	Minor Storm	Major Storm	
$T_{MAX} =$	17.0	17.0	ft
$d_{MAX} =$	6.0	12.0	inches
	<input type="checkbox"/>	<input type="checkbox"/>	check = yes

MINOR STORM Allowable Capacity is based on Spread Criterion
MAJOR STORM Allowable Capacity is based on Spread Criterion

	Minor Storm	Major Storm	
$Q_{allow} =$	13.3	13.3	cfs

Minor storm max. allowable capacity GOOD - greater than the design flow given on sheet 'Inlet Management'
WARNING: MAJOR STORM max. allowable capacity is less than the design flow given on sheet 'Inlet Management'

INLET ON A CONTINUOUS GRADE

Version 4.05 Released March 2017

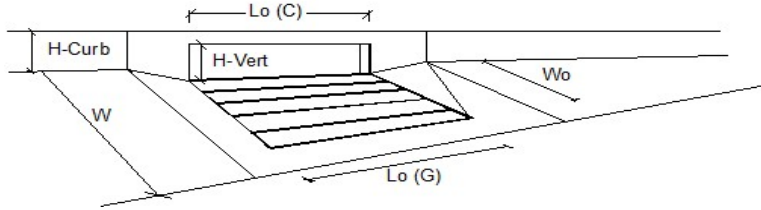

Design Information (Input)	MINOR	MAJOR	
Type of Inlet	CDOT Type R Curb Opening		
Local Depression (additional to continuous gutter depression 'a')	3.0	3.0	inches
Total Number of Units in the Inlet (Grate or Curb Opening)	1	1	
Length of a Single Unit Inlet (Grate or Curb Opening)	15.00	15.00	ft
Width of a Unit Grate (cannot be greater than W, Gutter Width)	N/A	N/A	ft
Clogging Factor for a Single Unit Grate (typical min. value = 0.5)	N/A	N/A	
Clogging Factor for a Single Unit Curb Opening (typical min. value = 0.1)	0.10	0.10	
Street Hydraulics: WARNING: Q > ALLOWABLE Q FOR MAJOR STORM			
Total Inlet Interception Capacity	5.0	14.6	cfs
Total Inlet Carry-Over Flow (flow bypassing inlet)	0.0	7.4	cfs
Capture Percentage = Q_p/Q_o =	100	66	%

ALLOWABLE CAPACITY FOR ONE-HALF OF STREET (Minor & Major Storm)

(Based on Regulated Criteria for Maximum Allowable Flow Depth and Spread)

Project:
Inlet ID:

RETREAT AT TIMBERRIDGE FILING NO. 1

DP-11

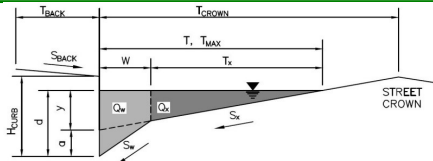

Gutter Geometry (Enter data in the blue cells)

Maximum Allowable Width for Spread Behind Curb
 Side Slope Behind Curb (leave blank for no conveyance credit behind curb)
 Manning's Roughness Behind Curb (typically between 0.012 and 0.020)
 Height of Curb at Gutter Flow Line
 Distance from Curb Face to Street Crown
 Gutter Width
 Street Transverse Slope
 Gutter Cross Slope (typically 2 inches over 24 inches or 0.083 ft/ft)
 Street Longitudinal Slope - Enter 0 for sump condition
 Manning's Roughness for Street Section (typically between 0.012 and 0.020)

$T_{BACK} = 8.0$ ft
 $S_{BACK} = 0.020$ ft/ft
 $n_{BACK} = 0.013$

$H_{CURB} = 6.00$ inches
 $T_{CROWN} = 17.0$ ft
 $W = 2.00$ ft
 $S_X = 0.020$ ft/ft
 $S_W = 0.083$ ft/ft
 $S_D = 0.000$ ft/ft
 $n_{STREET} = 0.016$

Max. Allowable Spread for Minor & Major Storm
 Max. Allowable Depth at Gutter Flowline for Minor & Major Storm
 Check boxes are not applicable in SUMP conditions

	Minor Storm	Major Storm	
$T_{MAX} =$	17.0	17.0	ft
$d_{MAX} =$	6.0	9.0	inches
	<input type="checkbox"/>	<input type="checkbox"/>	

MINOR STORM Allowable Capacity is based on Depth Criterion
MAJOR STORM Allowable Capacity is based on Depth Criterion

$Q_{allow} =$

Minor Storm	Major Storm	
SUMP	SUMP	cfs

INLET IN A SUMP OR SAG LOCATION

Version 4.05 Released March 2017

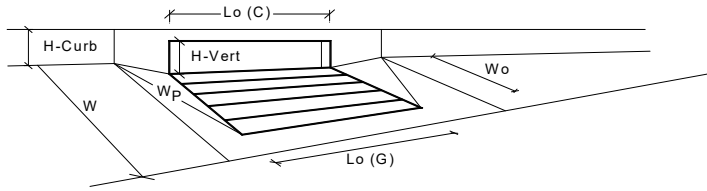

Design Information (Input)	MINOR	MAJOR	
Type of Inlet	CDOT Type R Curb Opening		
Local Depression (additional to continuous gutter depression 'a' from above)			
Number of Unit Inlets (Grate or Curb Opening)	1	1	
Water Depth at Flowline (outside of local depression)	6.0	9.0	inches
Grate Information	MINOR	MAJOR	<input checked="" type="checkbox"/> Override Depths
Length of a Unit Grate	N/A	N/A	feet
Width of a Unit Grate	N/A	N/A	feet
Area Opening Ratio for a Grate (typical values 0.15-0.90)	N/A	N/A	
Clogging Factor for a Single Grate (typical value 0.50 - 0.70)	N/A	N/A	
Grate Weir Coefficient (typical value 2.15 - 3.60)	N/A	N/A	
Grate Orifice Coefficient (typical value 0.60 - 0.80)	N/A	N/A	
Curb Opening Information	MINOR	MAJOR	
Length of a Unit Curb Opening	15.00	15.00	feet
Height of Vertical Curb Opening in Inches	6.00	6.00	inches
Height of Curb Orifice Throat in Inches	6.00	6.00	inches
Angle of Throat (see USDCM Figure ST-5)	63.40	63.40	degrees
Side Width for Depression Pan (typically the gutter width of 2 feet)	2.00	2.00	feet
Clogging Factor for a Single Curb Opening (typical value 0.10)	0.10	0.10	
Curb Opening Weir Coefficient (typical value 2.3-3.7)	3.60	3.60	
Curb Opening Orifice Coefficient (typical value 0.60 - 0.70)	0.67	0.67	
Low Head Performance Reduction (Calculated)	MINOR	MAJOR	
Depth for Grate Midwidth	N/A	N/A	ft
Depth for Curb Opening Weir Equation	0.33	0.58	ft
Combination Inlet Performance Reduction Factor for Long Inlets	0.57	0.85	
Curb Opening Performance Reduction Factor for Long Inlets	0.79	0.93	
Grated Inlet Performance Reduction Factor for Long Inlets	N/A	N/A	
Total Inlet Interception Capacity (assumes clogged condition)	MINOR	MAJOR	
Q_a	9.7	26.7	cfs
Q _{PEAK REQUIRED}	4.0	21.0	cfs

Inlet Capacity IS GOOD for Minor and Major Storms(>Q PEAK)

ALLOWABLE CAPACITY FOR ONE-HALF OF STREET (Minor & Major Storm)

(Based on Regulated Criteria for Maximum Allowable Flow Depth and Spread)

Project:
Inlet ID:

RETREAT AT TIMBERRIDGE FILING NO. 1
DP-12

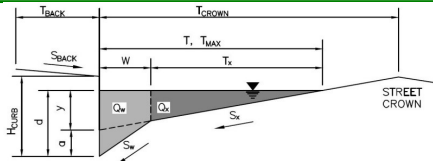

Gutter Geometry (Enter data in the blue cells)

Maximum Allowable Width for Spread Behind Curb
 Side Slope Behind Curb (leave blank for no conveyance credit behind curb)
 Manning's Roughness Behind Curb (typically between 0.012 and 0.020)
 Height of Curb at Gutter Flow Line
 Distance from Curb Face to Street Crown
 Gutter Width
 Street Transverse Slope
 Gutter Cross Slope (typically 2 inches over 24 inches or 0.083 ft/ft)
 Street Longitudinal Slope - Enter 0 for sump condition
 Manning's Roughness for Street Section (typically between 0.012 and 0.020)

$T_{BACK} = 7.5$ ft
 $S_{BACK} = 0.020$ ft/ft
 $n_{BACK} = 0.013$

$H_{CURB} = 6.00$ inches
 $T_{CROWN} = 17.0$ ft
 $W = 2.00$ ft
 $S_X = 0.020$ ft/ft
 $S_W = 0.083$ ft/ft
 $S_D = 0.000$ ft/ft
 $n_{STREET} = 0.016$

Max. Allowable Spread for Minor & Major Storm
 Max. Allowable Depth at Gutter Flowline for Minor & Major Storm
 Check boxes are not applicable in SUMP conditions

	Minor Storm	Major Storm	
$T_{MAX} =$	17.0	17.0	ft
$d_{MAX} =$	6.0	12.0	inches
	<input type="checkbox"/>	<input type="checkbox"/>	

MINOR STORM Allowable Capacity is based on Depth Criterion
MAJOR STORM Allowable Capacity is based on Depth Criterion

$Q_{allow} =$

Minor Storm	Major Storm	
SUMP	SUMP	cfs

INLET IN A SUMP OR SAG LOCATION

Version 4.05 Released March 2017

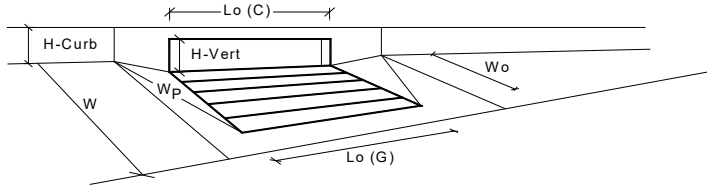

Design Information (Input)	MINOR	MAJOR	
Type of Inlet	CDOT Type R Curb Opening		
Local Depression (additional to continuous gutter depression 'a' from above)			
Number of Unit Inlets (Grate or Curb Opening)			
Water Depth at Flowline (outside of local depression)			
Grate Information	MINOR	MAJOR	
Length of a Unit Grate			
Width of a Unit Grate			
Area Opening Ratio for a Grate (typical values 0.15-0.90)			
Clogging Factor for a Single Grate (typical value 0.50 - 0.70)			
Grate Weir Coefficient (typical value 2.15 - 3.60)			
Grate Orifice Coefficient (typical value 0.60 - 0.80)			
Curb Opening Information	MINOR	MAJOR	
Length of a Unit Curb Opening			
Height of Vertical Curb Opening in Inches			
Height of Curb Orifice Throat in Inches			
Angle of Throat (see USDCM Figure ST-5)			
Side Width for Depression Pan (typically the gutter width of 2 feet)			
Clogging Factor for a Single Curb Opening (typical value 0.10)			
Curb Opening Weir Coefficient (typical value 2.3-3.7)			
Curb Opening Orifice Coefficient (typical value 0.60 - 0.70)			
Low Head Performance Reduction (Calculated)	MINOR	MAJOR	
Depth for Grate Midwidth			
Depth for Curb Opening Weir Equation			
Combination Inlet Performance Reduction Factor for Long Inlets			
Curb Opening Performance Reduction Factor for Long Inlets			
Grated Inlet Performance Reduction Factor for Long Inlets			
Total Inlet Interception Capacity (assumes clogged condition)	MINOR	MAJOR	
Inlet Capacity IS GOOD for Minor and Major Storms(>Q PEAK)			
Q _{PEAK REQUIRED}			

	MINOR	MAJOR	
Type =	CDOT Type R Curb Opening		
a _{local} =	3.00	3.00	inches
No =	1	1	
Ponding Depth =	6.0	12.0	inches
	MINOR	MAJOR	<input checked="" type="checkbox"/> Override Depths
L _s (G) =	N/A	N/A	feet
W _o =	N/A	N/A	feet
A _{ratio} =	N/A	N/A	
C _f (G) =	N/A	N/A	
C _w (G) =	N/A	N/A	
C _o (G) =	N/A	N/A	
	MINOR	MAJOR	
L _c (C) =	15.00	15.00	feet
H _{vert} =	6.00	6.00	inches
H _{throat} =	6.00	6.00	inches
Theta =	63.40	63.40	degrees
W _p =	2.00	2.00	feet
C _f (C) =	0.10	0.10	
C _w (C) =	3.60	3.60	
C _o (C) =	0.67	0.67	
	MINOR	MAJOR	
d _{grate} =	N/A	N/A	ft
d _{curb} =	0.33	0.83	ft
RF _{Combination} =	0.57	1.00	
RF _{Curb} =	0.79	1.00	
RF _{Grate} =	N/A	N/A	
	MINOR	MAJOR	
Q _a =	9.7	39.1	cfs
Q _{PEAK REQUIRED} =	9.0	33.0	cfs

ALLOWABLE CAPACITY FOR ONE-HALF OF STREET (Minor & Major Storm)

(Based on Regulated Criteria for Maximum Allowable Flow Depth and Spread)

Project:
Inlet ID:

RETREAT AT TIMBERRIDGE FILING NO. 1

DP-13

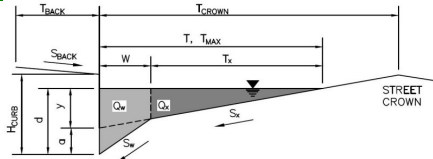

Gutter Geometry (Enter data in the blue cells)

Maximum Allowable Width for Spread Behind Curb
 Side Slope Behind Curb (leave blank for no conveyance credit behind curb)
 Manning's Roughness Behind Curb (typically between 0.012 and 0.020)
 Height of Curb at Gutter Flow Line
 Distance from Curb Face to Street Crown
 Gutter Width
 Street Transverse Slope
 Gutter Cross Slope (typically 2 inches over 24 inches or 0.083 ft/ft)
 Street Longitudinal Slope - Enter 0 for sump condition
 Manning's Roughness for Street Section (typically between 0.012 and 0.020)

$T_{BACK} = 7.5$ ft
 $S_{BACK} = 0.020$ ft/ft
 $n_{BACK} = 0.013$

$H_{CURB} = 6.00$ inches
 $T_{CROWN} = 17.0$ ft
 $W = 2.00$ ft
 $S_x = 0.020$ ft/ft
 $S_w = 0.083$ ft/ft
 $S_D = 0.000$ ft/ft
 $n_{STREET} = 0.016$

Max. Allowable Spread for Minor & Major Storm
 Max. Allowable Depth at Gutter Flowline for Minor & Major Storm
 Check boxes are not applicable in SUMP conditions

	Minor Storm	Major Storm	
$T_{MAX} =$	17.0	17.0	ft
$d_{MAX} =$	6.0	12.0	inches
	<input type="checkbox"/>	<input type="checkbox"/>	

MINOR STORM Allowable Capacity is based on Depth Criterion
MAJOR STORM Allowable Capacity is based on Depth Criterion

$Q_{allow} =$

Minor Storm	Major Storm	
SUMP	SUMP	cfs

INLET IN A SUMP OR SAG LOCATION

Version 4.05 Released March 2017

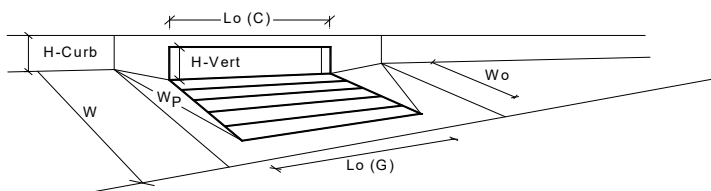

Design Information (Input)	MINOR	MAJOR	
Type of Inlet	CDOT Type R Curb Opening		
Local Depression (additional to continuous gutter depression 'a' from above)			
Number of Unit Inlets (Grate or Curb Opening)			
Water Depth at Flowline (outside of local depression)			
Grate Information	MINOR	MAJOR	
Length of a Unit Grate	L _o (G) =	N/A	feet
Width of a Unit Grate	W _o =	N/A	feet
Area Opening Ratio for a Grate (typical values 0.15-0.90)	A _{ratio} =	N/A	
Clogging Factor for a Single Grate (typical value 0.50 - 0.70)	C _f (G) =	N/A	
Grate Weir Coefficient (typical value 2.15 - 3.60)	C _w (G) =	N/A	
Grate Orifice Coefficient (typical value 0.60 - 0.80)	C _o (G) =	N/A	
Curb Opening Information	MINOR	MAJOR	
Length of a Unit Curb Opening	L _o (C) =	10.00	feet
Height of Vertical Curb Opening in Inches	H _{vert} =	6.00	inches
Height of Curb Orifice Throat in Inches	H _{throat} =	6.00	inches
Angle of Throat (see USDCM Figure ST-5)	Theta =	63.40	degrees
Side Width for Depression Pan (typically the gutter width of 2 feet)	W _p =	2.00	feet
Clogging Factor for a Single Curb Opening (typical value 0.10)	C _f (C) =	0.10	
Curb Opening Weir Coefficient (typical value 2.3-3.7)	C _w (C) =	3.60	
Curb Opening Orifice Coefficient (typical value 0.60 - 0.70)	C _o (C) =	0.67	
Low Head Performance Reduction (Calculated)	MINOR	MAJOR	
Depth for Grate Midwidth	d _{grate} =	N/A	ft
Depth for Curb Opening Weir Equation	d _{curb} =	0.33	ft
Combination Inlet Performance Reduction Factor for Long Inlets	RF _{Combination} =	0.57	
Curb Opening Performance Reduction Factor for Long Inlets	RF _{Curb} =	0.93	
Grated Inlet Performance Reduction Factor for Long Inlets	RF _{Grate} =	N/A	
Total Inlet Interception Capacity (assumes clogged condition)	MINOR	MAJOR	
Inlet Capacity IS GOOD for Minor and Major Storms(>Q PEAK)	Q _a =	8.3	cfs
	Q _{PEAK REQUIRED} =	1.0	cfs

ALLOWABLE CAPACITY FOR ONE-HALF OF STREET (Minor & Major Storm)

(Based on Regulated Criteria for Maximum Allowable Flow Depth and Spread)

Project:
Inlet ID:

RETREAT AT TIMBERRIDGE FILING NO. 1

DP-14

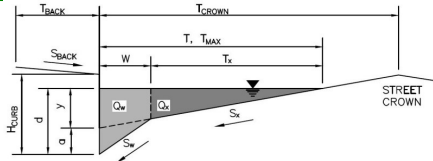

Gutter Geometry (Enter data in the blue cells)

Maximum Allowable Width for Spread Behind Curb
Side Slope Behind Curb (leave blank for no conveyance credit behind curb)
Manning's Roughness Behind Curb (typically between 0.012 and 0.020)

$T_{BACK} = 7.5$ ft
 $S_{BACK} = 0.020$ ft/ft
 $n_{BACK} = 0.013$

Height of Curb at Gutter Flow Line
Distance from Curb Face to Street Crown
Gutter Width
Street Transverse Slope
Gutter Cross Slope (typically 2 inches over 24 inches or 0.083 ft/ft)
Street Longitudinal Slope - Enter 0 for sump condition
Manning's Roughness for Street Section (typically between 0.012 and 0.020)

$H_{CURB} = 6.00$ inches
 $T_{CROWN} = 17.0$ ft
 $W = 2.00$ ft
 $S_x = 0.020$ ft/ft
 $S_w = 0.083$ ft/ft
 $S_D = 0.000$ ft/ft
 $n_{STREET} = 0.016$

Max. Allowable Spread for Minor & Major Storm
Max. Allowable Depth at Gutter Flowline for Minor & Major Storm
Check boxes are not applicable in SUMP conditions

	Minor Storm	Major Storm	
$T_{MAX} =$	17.0	17.0	ft
$d_{MAX} =$	6.0	12.0	inches
	<input type="checkbox"/>	<input type="checkbox"/>	

MINOR STORM Allowable Capacity is based on Depth Criterion
MAJOR STORM Allowable Capacity is based on Depth Criterion

$Q_{allow} =$

Minor Storm	Major Storm	
SUMP	SUMP	cfs

INLET IN A SUMP OR SAG LOCATION

Version 4.05 Released March 2017

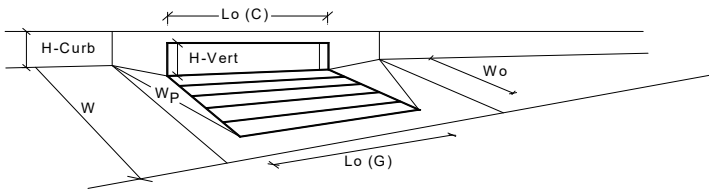

Design Information (Input)	CDOT Type R Curb Opening	
Type of Inlet	CDOT Type R Curb Opening	
Local Depression (additional to continuous gutter depression 'a' from above)		
Number of Unit Inlets (Grate or Curb Opening)		
Water Depth at Flowline (outside of local depression)		
Grate Information		
Length of a Unit Grate		
Width of a Unit Grate		
Area Opening Ratio for a Grate (typical values 0.15-0.90)		
Clogging Factor for a Single Grate (typical value 0.50 - 0.70)		
Grate Weir Coefficient (typical value 2.15 - 3.60)		
Grate Orifice Coefficient (typical value 0.60 - 0.80)		
Curb Opening Information		
Length of a Unit Curb Opening		
Height of Vertical Curb Opening in Inches		
Height of Curb Orifice Throat in Inches		
Angle of Throat (see USDCM Figure ST-5)		
Side Width for Depression Pan (typically the gutter width of 2 feet)		
Clogging Factor for a Single Curb Opening (typical value 0.10)		
Curb Opening Weir Coefficient (typical value 2.3-3.7)		
Curb Opening Orifice Coefficient (typical value 0.60 - 0.70)		
Low Head Performance Reduction (Calculated)		
Depth for Grate Midwidth		
Depth for Curb Opening Weir Equation		
Combination Inlet Performance Reduction Factor for Long Inlets		
Curb Opening Performance Reduction Factor for Long Inlets		
Grated Inlet Performance Reduction Factor for Long Inlets		
Total Inlet Interception Capacity (assumes clogged condition)		
Inlet Capacity IS GOOD for Minor and Major Storms(>Q PEAK)		

	MINOR	MAJOR	
Type =	CDOT Type R Curb Opening		
ϕ_{local} =	3.00	3.00	inches
No =	1	1	
Ponding Depth =	6.0	12.0	inches
<input checked="" type="checkbox"/> Override Depths			
	MINOR	MAJOR	
L_s (G) =	N/A	N/A	feet
W_o =	N/A	N/A	feet
A_{ratio} =	N/A	N/A	
C_r (G) =	N/A	N/A	
C_w (G) =	N/A	N/A	
C_o (G) =	N/A	N/A	
	MINOR	MAJOR	
L_s (C) =	5.00	5.00	feet
H_{vert} =	6.00	6.00	inches
H_{throat} =	6.00	6.00	inches
Theta =	63.40	63.40	degrees
W_p =	2.00	2.00	feet
C_r (C) =	0.10	0.10	
C_w (C) =	3.60	3.60	
C_o (C) =	0.67	0.67	
	MINOR	MAJOR	
d_{grate} =	N/A	N/A	ft
d_{curb} =	0.33	0.83	ft
$RF_{combination}$ =	0.77	1.00	
RF_{curb} =	1.00	1.00	
RF_{grate} =	N/A	N/A	
	MINOR	MAJOR	
Q_a =	5.4	12.3	cfs
$Q_{PEAK REQUIRED}$ =	1.0	3.0	cfs

ALLOWABLE CAPACITY FOR ONE-HALF OF STREET (Minor & Major Storm)

(Based on Regulated Criteria for Maximum Allowable Flow Depth and Spread)

Project:
Inlet ID:

RETREAT AT TIMBERRIDGE FILING NO. 1
DP-15

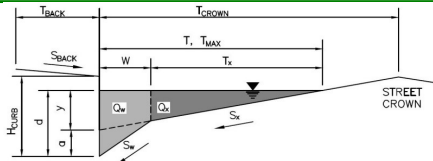

Gutter Geometry (Enter data in the blue cells)

Maximum Allowable Width for Spread Behind Curb
Side Slope Behind Curb (leave blank for no conveyance credit behind curb)
Manning's Roughness Behind Curb (typically between 0.012 and 0.020)

Height of Curb at Gutter Flow Line
Distance from Curb Face to Street Crown
Gutter Width
Street Transverse Slope
Gutter Cross Slope (typically 2 inches over 24 inches or 0.083 ft/ft)
Street Longitudinal Slope - Enter 0 for sump condition
Manning's Roughness for Street Section (typically between 0.012 and 0.020)

$T_{BACK} = 7.5$ ft
 $S_{BACK} = 0.020$ ft/ft
 $n_{BACK} = 0.013$

$H_{CURB} = 6.00$ inches
 $T_{CROWN} = 17.0$ ft
 $W = 2.00$ ft
 $S_X = 0.020$ ft/ft
 $S_W = 0.083$ ft/ft
 $S_D = 0.000$ ft/ft
 $n_{STREET} = 0.016$

Max. Allowable Spread for Minor & Major Storm
Max. Allowable Depth at Gutter Flowline for Minor & Major Storm
Check boxes are not applicable in SUMP conditions

	Minor Storm	Major Storm	
$T_{MAX} =$	17.0	17.0	ft
$d_{MAX} =$	6.0	12.0	inches
	<input type="checkbox"/>	<input type="checkbox"/>	

MINOR STORM Allowable Capacity is based on Depth Criterion
MAJOR STORM Allowable Capacity is based on Depth Criterion

$Q_{allow} =$

Minor Storm	Major Storm	
SUMP	SUMP	cfs

INLET IN A SUMP OR SAG LOCATION

Version 4.05 Released March 2017

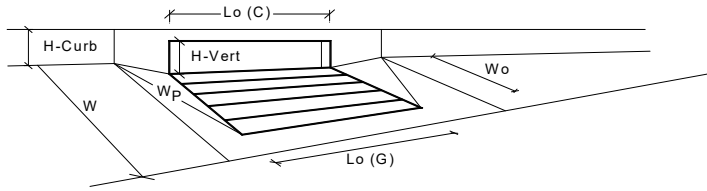

Design Information (Input)	MINOR	MAJOR	
Type of Inlet	CDOT Type R Curb Opening		
Local Depression (additional to continuous gutter depression 'a' from above)			
Number of Unit Inlets (Grate or Curb Opening)	1	1	
Water Depth at Flowline (outside of local depression)	6.0	12.0	inches
Grate Information	MINOR	MAJOR	<input checked="" type="checkbox"/> Override Depths
Length of a Unit Grate	N/A	N/A	feet
Width of a Unit Grate	N/A	N/A	feet
Area Opening Ratio for a Grate (typical values 0.15-0.90)	N/A	N/A	
Clogging Factor for a Single Grate (typical value 0.50 - 0.70)	N/A	N/A	
Grate Weir Coefficient (typical value 2.15 - 3.60)	N/A	N/A	
Grate Orifice Coefficient (typical value 0.60 - 0.80)	N/A	N/A	
Curb Opening Information	MINOR	MAJOR	
Length of a Unit Curb Opening	10.00	10.00	feet
Height of Vertical Curb Opening in Inches	6.00	6.00	inches
Height of Curb Orifice Throat in Inches	6.00	6.00	inches
Angle of Throat (see USDCM Figure ST-5)	63.40	63.40	degrees
Side Width for Depression Pan (typically the gutter width of 2 feet)	2.00	2.00	feet
Clogging Factor for a Single Curb Opening (typical value 0.10)	0.10	0.10	
Curb Opening Weir Coefficient (typical value 2.3-3.7)	3.60	3.60	
Curb Opening Orifice Coefficient (typical value 0.60 - 0.70)	0.67	0.67	
Low Head Performance Reduction (Calculated)	MINOR	MAJOR	
Depth for Grate Midwidth	N/A	N/A	ft
Depth for Curb Opening Weir Equation	0.33	0.83	ft
Combination Inlet Performance Reduction Factor for Long Inlets	0.57	1.00	
Curb Opening Performance Reduction Factor for Long Inlets	0.93	1.00	
Grated Inlet Performance Reduction Factor for Long Inlets	N/A	N/A	
Total Inlet Interception Capacity (assumes clogged condition)	MINOR	MAJOR	
Inlet Capacity IS GOOD for Minor and Major Storms(>Q PEAK)	8.3	25.5	cfs
Q _{PEAK REQUIRED}	3.0	12.0	cfs

ALLOWABLE CAPACITY FOR ONE-HALF OF STREET (Minor & Major Storm)

(Based on Regulated Criteria for Maximum Allowable Flow Depth and Spread)

Project:
Inlet ID:

RETREAT AT TIMBERRIDGE FILING NO. 1

DP-16

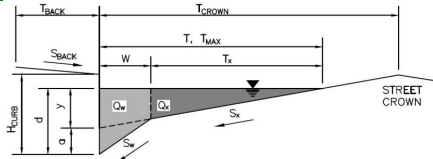

Gutter Geometry (Enter data in the blue cells)

Maximum Allowable Width for Spread Behind Curb
 Side Slope Behind Curb (leave blank for no conveyance credit behind curb)
 Manning's Roughness Behind Curb (typically between 0.012 and 0.020)
 Height of Curb at Gutter Flow Line
 Distance from Curb Face to Street Crown
 Gutter Width
 Street Transverse Slope
 Gutter Cross Slope (typically 2 inches over 24 inches or 0.083 ft/ft)
 Street Longitudinal Slope - Enter 0 for sump condition
 Manning's Roughness for Street Section (typically between 0.012 and 0.020)

$T_{BACK} = 7.5$ ft
 $S_{BACK} = 0.020$ ft/ft
 $n_{BACK} = 0.013$

$H_{CURB} = 6.00$ inches
 $T_{CROWN} = 17.0$ ft
 $W = 2.00$ ft
 $S_x = 0.020$ ft/ft
 $S_w = 0.083$ ft/ft
 $S_D = 0.000$ ft/ft
 $n_{STREET} = 0.016$

Max. Allowable Spread for Minor & Major Storm
 Max. Allowable Depth at Gutter Flowline for Minor & Major Storm
 Check boxes are not applicable in SUMP conditions

	Minor Storm	Major Storm	
$T_{MAX} =$	17.0	17.0	ft
$d_{MAX} =$	6.0	12.0	inches
	<input type="checkbox"/>	<input type="checkbox"/>	

MINOR STORM Allowable Capacity is based on Depth Criterion
MAJOR STORM Allowable Capacity is based on Depth Criterion

$Q_{allow} =$

Minor Storm	Major Storm	
SUMP	SUMP	cfs

INLET IN A SUMP OR SAG LOCATION

Version 4.05 Released March 2017

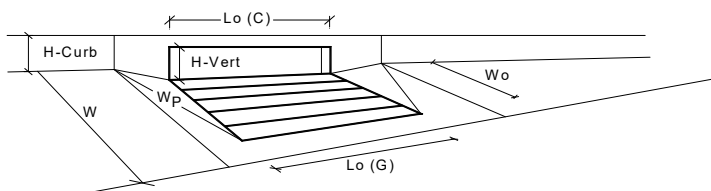

Design Information (Input)	MINOR	MAJOR	
Type of Inlet	CDOT Type R Curb Opening		
Local Depression (additional to continuous gutter depression 'a' from above)			
Number of Unit Inlets (Grate or Curb Opening)	1	1	
Water Depth at Flowline (outside of local depression)	6.0	12.0	inches
Grate Information	MINOR	MAJOR	<input checked="" type="checkbox"/> Override Depths
Length of a Unit Grate	N/A	N/A	feet
Width of a Unit Grate	N/A	N/A	feet
Area Opening Ratio for a Grate (typical values 0.15-0.90)	N/A	N/A	
Clogging Factor for a Single Grate (typical value 0.50 - 0.70)	N/A	N/A	
Grate Weir Coefficient (typical value 2.15 - 3.60)	N/A	N/A	
Grate Orifice Coefficient (typical value 0.60 - 0.80)	N/A	N/A	
Curb Opening Information	MINOR	MAJOR	
Length of a Unit Curb Opening	5.00	5.00	feet
Height of Vertical Curb Opening in Inches	6.00	6.00	inches
Height of Curb Orifice Throat in Inches	6.00	6.00	inches
Angle of Throat (see USDCM Figure ST-5)	63.40	63.40	degrees
Side Width for Depression Pan (typically the gutter width of 2 feet)	2.00	2.00	feet
Clogging Factor for a Single Curb Opening (typical value 0.10)	0.10	0.10	
Curb Opening Weir Coefficient (typical value 2.3-3.7)	3.60	3.60	
Curb Opening Orifice Coefficient (typical value 0.60 - 0.70)	0.67	0.67	
Low Head Performance Reduction (Calculated)	MINOR	MAJOR	
Depth for Grate Midwidth	N/A	N/A	ft
Depth for Curb Opening Weir Equation	0.33	0.83	ft
Combination Inlet Performance Reduction Factor for Long Inlets	0.77	1.00	
Curb Opening Performance Reduction Factor for Long Inlets	1.00	1.00	
Grated Inlet Performance Reduction Factor for Long Inlets	N/A	N/A	
Total Inlet Interception Capacity (assumes clogged condition)	MINOR	MAJOR	
Inlet Capacity IS GOOD for Minor and Major Storms(>Q PEAK)	5.4	12.3	cfs
Q PEAK REQUIRED =	1.0	3.0	cfs

ALLOWABLE CAPACITY FOR ONE-HALF OF STREET (Minor & Major Storm)

(Based on Regulated Criteria for Maximum Allowable Flow Depth and Spread)

Project:
Inlet ID:

RETREAT AT TIMBERRIDGE FILING NO. 1

DP-17

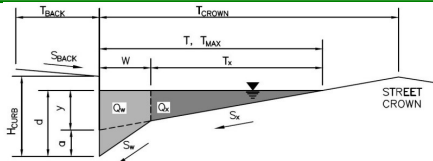

Gutter Geometry (Enter data in the blue cells)

Maximum Allowable Width for Spread Behind Curb
 Side Slope Behind Curb (leave blank for no conveyance credit behind curb)
 Manning's Roughness Behind Curb (typically between 0.012 and 0.020)
 Height of Curb at Gutter Flow Line
 Distance from Curb Face to Street Crown
 Gutter Width
 Street Transverse Slope
 Gutter Cross Slope (typically 2 inches over 24 inches or 0.083 ft/ft)
 Street Longitudinal Slope - Enter 0 for sump condition
 Manning's Roughness for Street Section (typically between 0.012 and 0.020)

$T_{BACK} = 7.5$ ft
 $S_{BACK} = 0.020$ ft/ft
 $n_{BACK} = 0.013$

$H_{CURB} = 6.00$ inches
 $T_{CROWN} = 17.0$ ft
 $W = 2.00$ ft
 $S_X = 0.020$ ft/ft
 $S_W = 0.083$ ft/ft
 $S_D = 0.000$ ft/ft
 $n_{STREET} = 0.016$

Max. Allowable Spread for Minor & Major Storm
 Max. Allowable Depth at Gutter Flowline for Minor & Major Storm
 Check boxes are not applicable in SUMP conditions

	Minor Storm	Major Storm	
$T_{MAX} =$	17.0	17.0	ft
$d_{MAX} =$	6.0	12.0	inches
	<input type="checkbox"/>	<input type="checkbox"/>	

MINOR STORM Allowable Capacity is based on Depth Criterion
MAJOR STORM Allowable Capacity is based on Depth Criterion

$Q_{allow} =$

Minor Storm	Major Storm	
SUMP	SUMP	cfs

INLET IN A SUMP OR SAG LOCATION

Version 4.05 Released March 2017

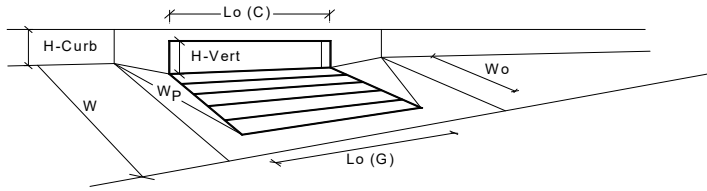

Design Information (Input)	MINOR	MAJOR	
Type of Inlet	CDOT Type R Curb Opening		
Local Depression (additional to continuous gutter depression 'a' from above)			
Number of Unit Inlets (Grate or Curb Opening)	1	1	
Water Depth at Flowline (outside of local depression)	6.0	12.0	inches
Grate Information	MINOR	MAJOR	<input checked="" type="checkbox"/> Override Depths
Length of a Unit Grate	N/A	N/A	feet
Width of a Unit Grate	N/A	N/A	feet
Area Opening Ratio for a Grate (typical values 0.15-0.90)	N/A	N/A	
Clogging Factor for a Single Grate (typical value 0.50 - 0.70)	N/A	N/A	
Grate Weir Coefficient (typical value 2.15 - 3.60)	N/A	N/A	
Grate Orifice Coefficient (typical value 0.60 - 0.80)	N/A	N/A	
Curb Opening Information	MINOR	MAJOR	
Length of a Unit Curb Opening	10.00	10.00	feet
Height of Vertical Curb Opening in Inches	6.00	6.00	inches
Height of Curb Orifice Throat in Inches	6.00	6.00	inches
Angle of Throat (see USDCM Figure ST-5)	63.40	63.40	degrees
Side Width for Depression Pan (typically the gutter width of 2 feet)	2.00	2.00	feet
Clogging Factor for a Single Curb Opening (typical value 0.10)	0.10	0.10	
Curb Opening Weir Coefficient (typical value 2.3-3.7)	3.60	3.60	
Curb Opening Orifice Coefficient (typical value 0.60 - 0.70)	0.67	0.67	
Low Head Performance Reduction (Calculated)	MINOR	MAJOR	
Depth for Grate Midwidth	N/A	N/A	ft
Depth for Curb Opening Weir Equation	0.33	0.83	ft
Combination Inlet Performance Reduction Factor for Long Inlets	0.57	1.00	
Curb Opening Performance Reduction Factor for Long Inlets	0.93	1.00	
Grated Inlet Performance Reduction Factor for Long Inlets	N/A	N/A	
Total Inlet Interception Capacity (assumes clogged condition)	MINOR	MAJOR	
Q_a	8.3	25.5	cfs
Q _{PEAK REQUIRED}	7.0	22.0	cfs

Inlet Capacity IS GOOD for Minor and Major Storms(>Q PEAK)

ALLOWABLE CAPACITY FOR ONE-HALF OF STREET (Minor & Major Storm)

(Based on Regulated Criteria for Maximum Allowable Flow Depth and Spread)

Project:
Inlet ID:

RETREAT AT TIMBERRIDGE FILING NO. 1
DP-19

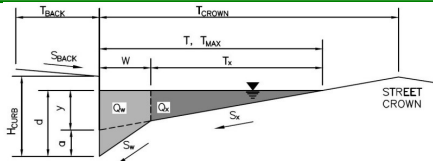

Gutter Geometry (Enter data in the blue cells)

Maximum Allowable Width for Spread Behind Curb
 Side Slope Behind Curb (leave blank for no conveyance credit behind curb)
 Manning's Roughness Behind Curb (typically between 0.012 and 0.020)
 Height of Curb at Gutter Flow Line
 Distance from Curb Face to Street Crown
 Gutter Width
 Street Transverse Slope
 Gutter Cross Slope (typically 2 inches over 24 inches or 0.083 ft/ft)
 Street Longitudinal Slope - Enter 0 for sump condition
 Manning's Roughness for Street Section (typically between 0.012 and 0.020)

$T_{BACK} = 7.5$ ft
 $S_{BACK} = 0.020$ ft/ft
 $n_{BACK} = 0.013$

$H_{CURB} = 6.00$ inches
 $T_{CROWN} = 17.0$ ft
 $W = 2.00$ ft
 $S_x = 0.020$ ft/ft
 $S_w = 0.083$ ft/ft
 $S_D = 0.000$ ft/ft
 $n_{STREET} = 0.016$

Max. Allowable Spread for Minor & Major Storm
 Max. Allowable Depth at Gutter Flowline for Minor & Major Storm
 Check boxes are not applicable in SUMP conditions

	Minor Storm	Major Storm	
$T_{MAX} =$	17.0	17.0	ft
$d_{MAX} =$	6.0	12.0	inches
	<input type="checkbox"/>	<input type="checkbox"/>	

MINOR STORM Allowable Capacity is based on Depth Criterion
MAJOR STORM Allowable Capacity is based on Depth Criterion

$Q_{allow} =$

Minor Storm	Major Storm	
SUMP	SUMP	cfs

INLET IN A SUMP OR SAG LOCATION

Version 4.05 Released March 2017

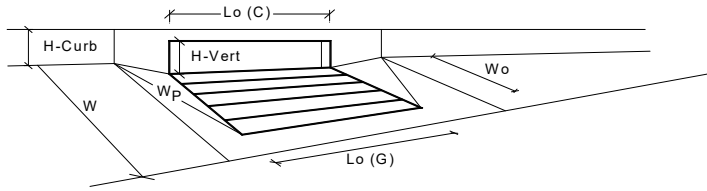

Design Information (Input)	MINOR	MAJOR	
Type of Inlet	CDOT Type R Curb Opening		
Local Depression (additional to continuous gutter depression 'a' from above)			
Number of Unit Inlets (Grate or Curb Opening)	1	1	
Water Depth at Flowline (outside of local depression)	6.0	12.0	inches
Grate Information	MINOR	MAJOR	<input checked="" type="checkbox"/> Override Depths
Length of a Unit Grate	N/A	N/A	feet
Width of a Unit Grate	N/A	N/A	feet
Area Opening Ratio for a Grate (typical values 0.15-0.90)	N/A	N/A	
Clogging Factor for a Single Grate (typical value 0.50 - 0.70)	N/A	N/A	
Grate Weir Coefficient (typical value 2.15 - 3.60)	N/A	N/A	
Grate Orifice Coefficient (typical value 0.60 - 0.80)	N/A	N/A	
Curb Opening Information	MINOR	MAJOR	
Length of a Unit Curb Opening	5.00	5.00	feet
Height of Vertical Curb Opening in Inches	6.00	6.00	inches
Height of Curb Orifice Throat in Inches	6.00	6.00	inches
Angle of Throat (see USDCM Figure ST-5)	63.40	63.40	degrees
Side Width for Depression Pan (typically the gutter width of 2 feet)	2.00	2.00	feet
Clogging Factor for a Single Curb Opening (typical value 0.10)	0.10	0.10	
Curb Opening Weir Coefficient (typical value 2.3-3.7)	3.60	3.60	
Curb Opening Orifice Coefficient (typical value 0.60 - 0.70)	0.67	0.67	
Low Head Performance Reduction (Calculated)	MINOR	MAJOR	
Depth for Grate Midwidth	N/A	N/A	ft
Depth for Curb Opening Weir Equation	0.33	0.83	ft
Combination Inlet Performance Reduction Factor for Long Inlets	0.77	1.00	
Curb Opening Performance Reduction Factor for Long Inlets	1.00	1.00	
Grated Inlet Performance Reduction Factor for Long Inlets	N/A	N/A	
Total Inlet Interception Capacity (assumes clogged condition)	MINOR	MAJOR	
Q_a	5.4	12.3	cfs
Q _{PEAK REQUIRED}	1.0	4.0	cfs

Inlet Capacity IS GOOD for Minor and Major Storms(>Q PEAK)

ALLOWABLE CAPACITY FOR ONE-HALF OF STREET (Minor & Major Storm)

(Based on Regulated Criteria for Maximum Allowable Flow Depth and Spread)

Project:
Inlet ID:

RETREAT AT TIMBERRIDGE FILING NO. 1
DP-20

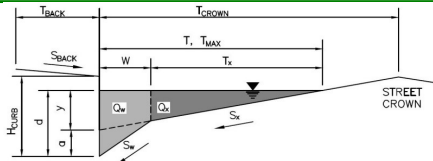

Gutter Geometry (Enter data in the blue cells)

Maximum Allowable Width for Spread Behind Curb
 Side Slope Behind Curb (leave blank for no conveyance credit behind curb)
 Manning's Roughness Behind Curb (typically between 0.012 and 0.020)
 Height of Curb at Gutter Flow Line
 Distance from Curb Face to Street Crown
 Gutter Width
 Street Transverse Slope
 Gutter Cross Slope (typically 2 inches over 24 inches or 0.083 ft/ft)
 Street Longitudinal Slope - Enter 0 for sump condition
 Manning's Roughness for Street Section (typically between 0.012 and 0.020)

$T_{BACK} = 7.5$ ft
 $S_{BACK} = 0.020$ ft/ft
 $n_{BACK} = 0.013$

$H_{CURB} = 6.00$ inches
 $T_{CROWN} = 17.0$ ft
 $W = 2.00$ ft
 $S_x = 0.020$ ft/ft
 $S_w = 0.083$ ft/ft
 $S_o = 0.000$ ft/ft
 $n_{STREET} = 0.016$

Max. Allowable Spread for Minor & Major Storm
 Max. Allowable Depth at Gutter Flowline for Minor & Major Storm
 Check boxes are not applicable in SUMP conditions

	Minor Storm	Major Storm	
$T_{MAX} =$	17.0	17.0	ft
$d_{MAX} =$	6.0	12.0	inches
	<input type="checkbox"/>	<input type="checkbox"/>	

MINOR STORM Allowable Capacity is based on Depth Criterion
MAJOR STORM Allowable Capacity is based on Depth Criterion

$Q_{allow} =$

Minor Storm	Major Storm	
SUMP	SUMP	cfs

INLET IN A SUMP OR SAG LOCATION

Version 4.05 Released March 2017

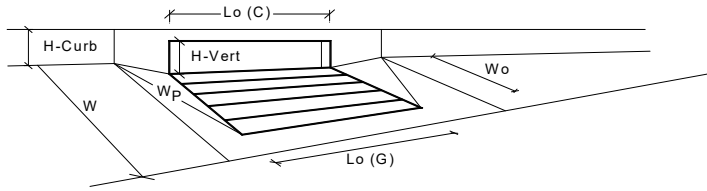

Design Information (Input)	MINOR	MAJOR	
Type of Inlet	CDOT Type R Curb Opening		
Local Depression (additional to continuous gutter depression 'a' from above)			
Number of Unit Inlets (Grate or Curb Opening)			
Water Depth at Flowline (outside of local depression)			
Grate Information	MINOR	MAJOR	
Length of a Unit Grate	L _o (G) =	N/A	feet
Width of a Unit Grate	W _o =	N/A	feet
Area Opening Ratio for a Grate (typical values 0.15-0.90)	A _{ratio} =	N/A	
Clogging Factor for a Single Grate (typical value 0.50 - 0.70)	C _f (G) =	N/A	
Grate Weir Coefficient (typical value 2.15 - 3.60)	C _w (G) =	N/A	
Grate Orifice Coefficient (typical value 0.60 - 0.80)	C _o (G) =	N/A	
Curb Opening Information	MINOR	MAJOR	
Length of a Unit Curb Opening	L _o (C) =	10.00	feet
Height of Vertical Curb Opening in Inches	H _{vert} =	6.00	inches
Height of Curb Orifice Throat in Inches	H _{throat} =	6.00	inches
Angle of Throat (see USDCM Figure ST-5)	Theta =	63.40	degrees
Side Width for Depression Pan (typically the gutter width of 2 feet)	W _p =	2.00	feet
Clogging Factor for a Single Curb Opening (typical value 0.10)	C _f (C) =	0.10	
Curb Opening Weir Coefficient (typical value 2.3-3.7)	C _w (C) =	3.60	
Curb Opening Orifice Coefficient (typical value 0.60 - 0.70)	C _o (C) =	0.67	
Low Head Performance Reduction (Calculated)	MINOR	MAJOR	
Depth for Grate Midwidth	d _{grate} =	N/A	ft
Depth for Curb Opening Weir Equation	d _{curb} =	0.33	ft
Combination Inlet Performance Reduction Factor for Long Inlets	RF _{Combination} =	0.57	
Curb Opening Performance Reduction Factor for Long Inlets	RF _{Curb} =	0.93	
Grated Inlet Performance Reduction Factor for Long Inlets	RF _{Grate} =	N/A	
Total Inlet Interception Capacity (assumes clogged condition)	MINOR	MAJOR	
Inlet Capacity IS GOOD for Minor and Major Storms(>Q PEAK)	Q _a =	8.3	cfs
	Q _{PEAK REQUIRED} =	6.0	cfs

Culvert Report

Two Cell Multi-plate Steel Single Arch Culverts (26'x8.6' equiv.) Flows FEMA Flows

Invert Elev Dn (ft) = 7172.00
Pipe Length (ft) = 130.00
Slope (%) = 3.08
Invert Elev Up (ft) = 7176.00
Rise (in) = 122.0
Shape = Arch
Span (in) = 244.0
No. Barrels = 2
n-Value = 0.024
Culvert Type = Arch **Corrugated Metal**
Culvert Entrance = 90D headwall (A)
Coeff. K,M,c,Y,k = 0.0083, 2, 0.0379, 0.69, 0.5

Embankment
Top Elevation (ft) = 7192.00
Top Width (ft) = 100.00
Crest Width (ft) = 140.00

Calculations
Qmin (cfs) = 2600.00
Qmax (cfs) = 2600.00
Tailwater Elev (ft) = (dc+D)/2

Highlighted
Qtotal (cfs) = 2600.00
Qpipe (cfs) = 2600.00
Qovertop (cfs) = 0.00
Veloc Dn (ft/s) = 9.37
Veloc Up (ft/s) = 13.22
HGL Dn (ft) = 7179.61
HGL Up (ft) = 7181.05
Hw Elev (ft) = 7184.15
Hw/D (ft) = 0.80
Flow Regime = Inlet Control

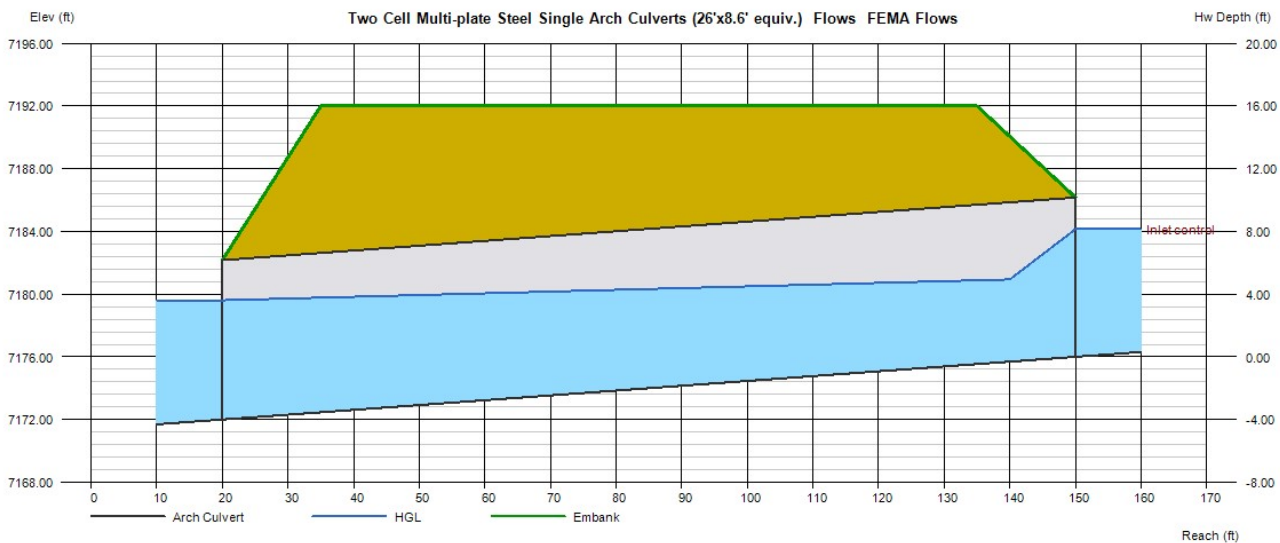

Culvert Report

Two Cell Multi-plate Steel Single Arch Culverts (26'x8.6' equiv.) DBPS Flows

Invert Elev Dn (ft)	= 7172.00
Pipe Length (ft)	= 130.00
Slope (%)	= 3.08
Invert Elev Up (ft)	= 7176.00
Rise (in)	= 122.0
Shape	= Arch
Span (in)	= 244.0
No. Barrels	= 2
n-Value	= 0.024
Culvert Type	= Arch Corrugated Metal
Culvert Entrance	= 90D headwall (A)
Coeff. K,M,c,Y,k	= 0.0083, 2, 0.0379, 0.69, 0.5

Embankment	
Top Elevation (ft)	= 7192.00
Top Width (ft)	= 100.00
Crest Width (ft)	= 140.00

Calculations	
Qmin (cfs)	= 2170.00
Qmax (cfs)	= 2170.00
Tailwater Elev (ft)	= (dc+D)/2

Highlighted	
Qtotal (cfs)	= 2170.00
Qpipe (cfs)	= 2170.00
Qovertop (cfs)	= 0.00
Veloc Dn (ft/s)	= 8.04
Veloc Up (ft/s)	= 12.24
HGL Dn (ft)	= 7179.34
HGL Up (ft)	= 7180.51
Hw Elev (ft)	= 7183.06
Hw/D (ft)	= 0.69
Flow Regime	= Inlet Control

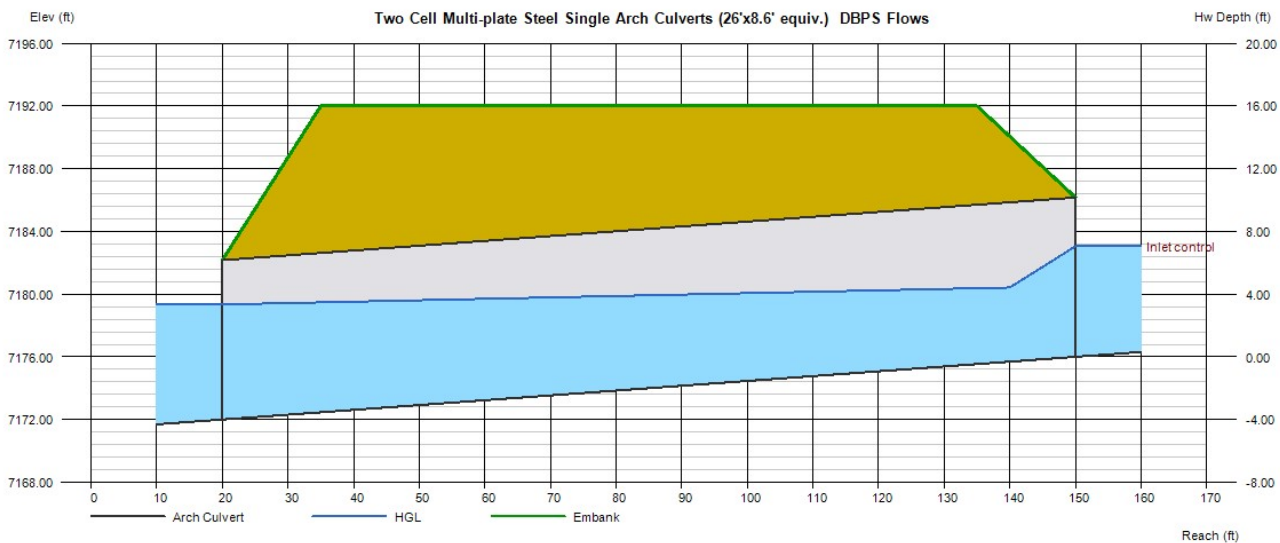

Culvert Report

DUAL 24 IN RCP CULVERTS AT DP-1

Invert Elev Dn (ft)	=	7196.35
Pipe Length (ft)	=	65.00
Slope (%)	=	1.00
Invert Elev Up (ft)	=	7197.00
Rise (in)	=	24.0
Shape	=	Circular
Span (in)	=	24.0
No. Barrels	=	2
n-Value	=	0.013
Culvert Type	=	Circular Concrete
Culvert Entrance	=	Groove end projecting (C)
Coeff. K,M,c,Y,k	=	0.0045, 2, 0.0317, 0.69, 0.2

Embankment	
Top Elevation (ft)	= 7200.00
Top Width (ft)	= 34.00
Crest Width (ft)	= 50.00

Calculations	
Qmin (cfs)	= 0.00
Qmax (cfs)	= 36.00
Tailwater Elev (ft)	= (dc+D)/2

Highlighted	
Qtotal (cfs)	= 36.00
Qpipe (cfs)	= 36.00
Qovertop (cfs)	= 0.00
Veloc Dn (ft/s)	= 6.14
Veloc Up (ft/s)	= 6.99
HGL Dn (ft)	= 7198.11
HGL Up (ft)	= 7198.53
Hw Elev (ft)	= 7199.43
Hw/D (ft)	= 1.21
Flow Regime	= Inlet Control

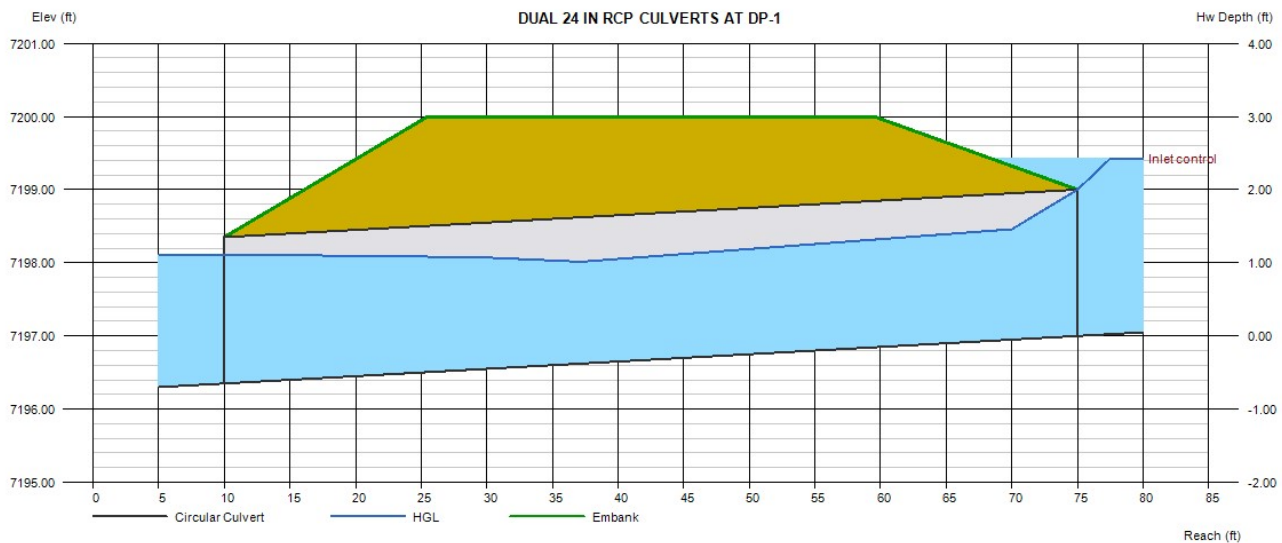

Channel Report

Grass Swale with TRM into Pond 1

Trapezoidal

Bottom Width (ft) = 3.00
Side Slopes (z:1) = 4.00, 4.00
Total Depth (ft) = 3.00
Invert Elev (ft) = 7194.00
Slope (%) = 1.50
N-Value = 0.030

Highlighted

Depth (ft) = 1.13
Q (cfs) = 40.00
Area (sqft) = 8.50
Velocity (ft/s) = 4.71
Wetted Perim (ft) = 12.32
Crit Depth, Yc (ft) = 1.13
Top Width (ft) = 12.04
EGL (ft) = 1.47

Calculations

Compute by: Known Q
Known Q (cfs) = 40.00

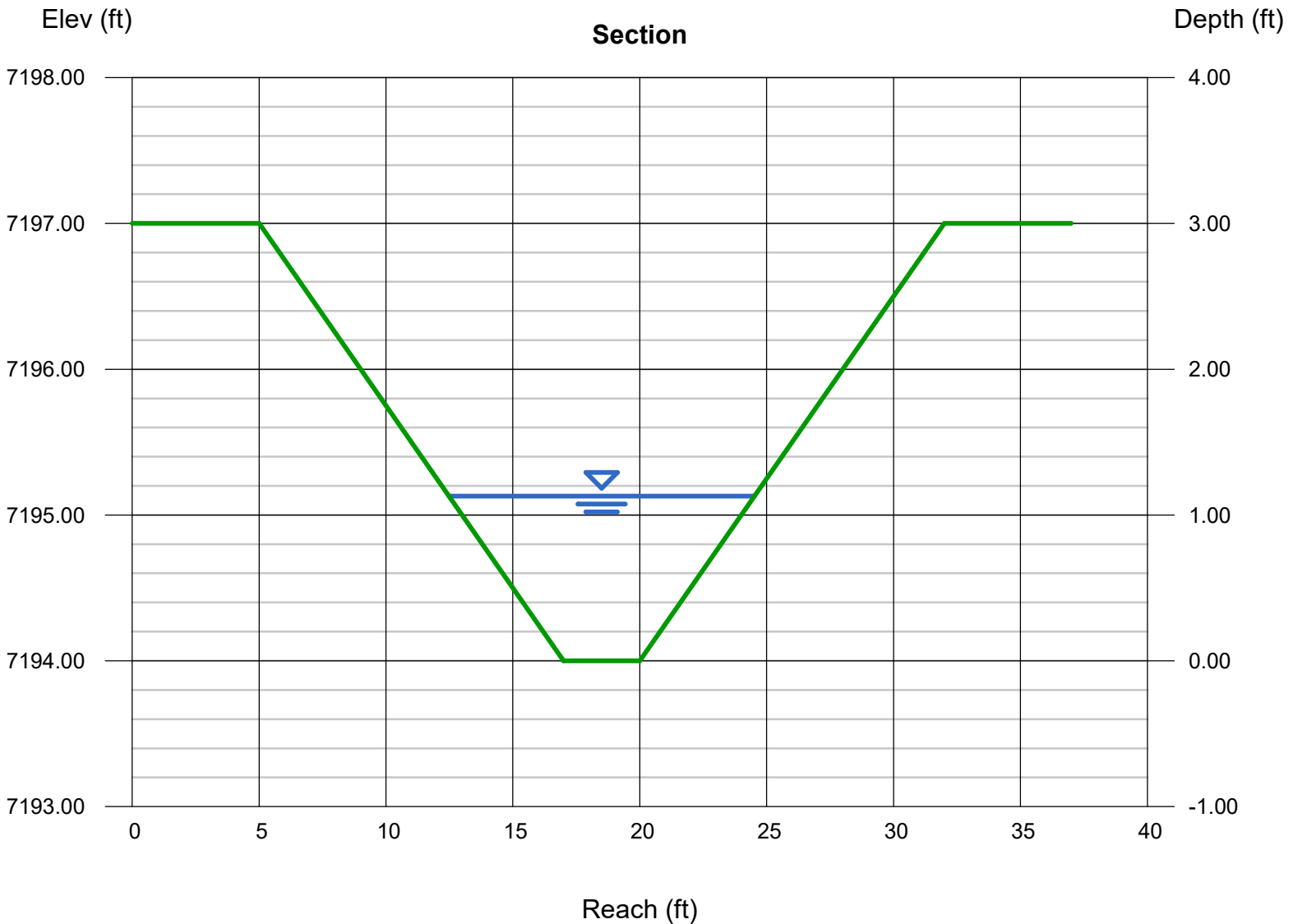

Culvert Report

30 IN. RCP CULVERT AT DP-18

Invert Elev Dn (ft)	= 7242.65
Pipe Length (ft)	= 35.00
Slope (%)	= 1.00
Invert Elev Up (ft)	= 7243.00
Rise (in)	= 30.0
Shape	= Circular
Span (in)	= 30.0
No. Barrels	= 1
n-Value	= 0.013
Culvert Type	= Circular Concrete
Culvert Entrance	= Square edge w/headwall (C)
Coeff. K,M,c,Y,k	= 0.0098, 2, 0.0398, 0.67, 0.5

Embankment	
Top Elevation (ft)	= 7248.20
Top Width (ft)	= 34.00
Crest Width (ft)	= 50.00

Calculations	
Qmin (cfs)	= 0.00
Qmax (cfs)	= 30.00
Tailwater Elev (ft)	= (dc+D)/2

Highlighted	
Qtotal (cfs)	= 30.00
Qpipe (cfs)	= 30.00
Qovertop (cfs)	= 0.00
Veloc Dn (ft/s)	= 6.60
Veloc Up (ft/s)	= 7.64
HGL Dn (ft)	= 7244.83
HGL Up (ft)	= 7244.87
Hw Elev (ft)	= 7246.15
Hw/D (ft)	= 1.26
Flow Regime	= Inlet Control

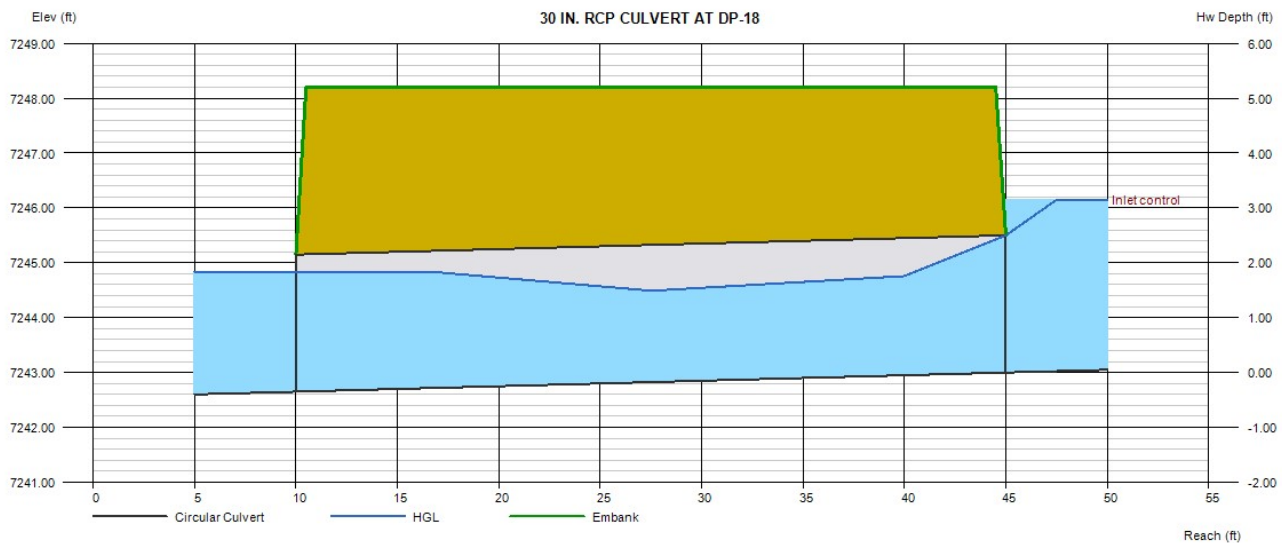

Channel Report

24 in. Wide Concrete Chase Section - Rear of lots 16-21

Rectangular

Bottom Width (ft) = 2.00
Total Depth (ft) = 0.50

Invert Elev (ft) = 7200.00
Slope (%) = 2.00
N-Value = 0.013

Calculations

Compute by: Known Q
Known Q (cfs) = 5.50

Highlighted

Depth (ft) = 0.40
Q (cfs) = 5.500
Area (sqft) = 0.80
Velocity (ft/s) = 6.88
Wetted Perim (ft) = 2.80
Crit Depth, Yc (ft) = 0.50
Top Width (ft) = 2.00
EGL (ft) = 1.13

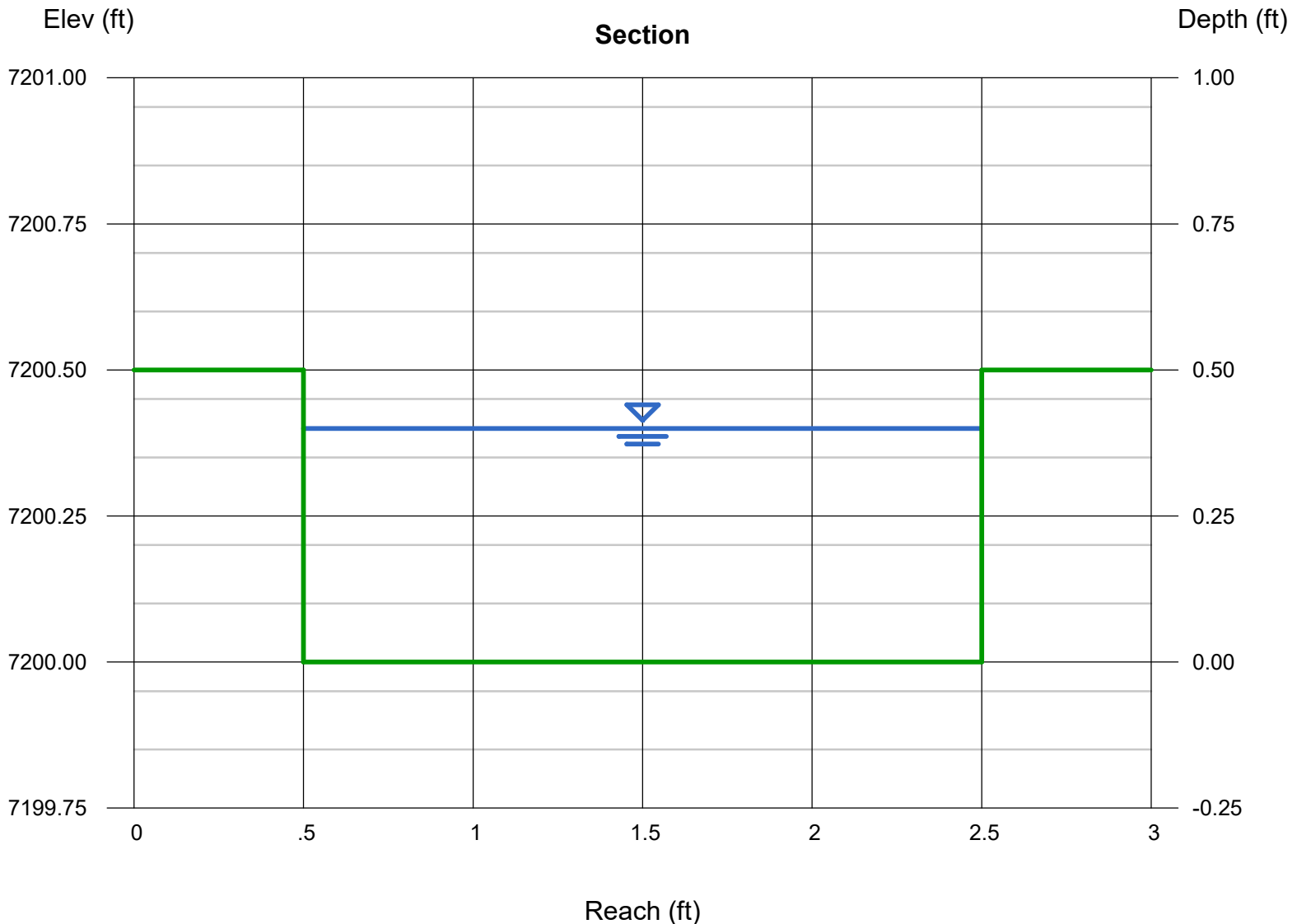

Culvert Report

18 IN. STORM OUTFALL INTO RG 1

Invert Elev Dn (ft)	= 7162.00
Pipe Length (ft)	= 60.00
Slope (%)	= 15.00
Invert Elev Up (ft)	= 7171.00
Rise (in)	= 18.0
Shape	= Circular
Span (in)	= 18.0
No. Barrels	= 1
n-Value	= 0.013
Culvert Type	= Circular Concrete
Culvert Entrance	= Square edge w/headwall (C)
Coeff. K,M,c,Y,k	= 0.0098, 2, 0.0398, 0.67, 0.5

Embankment	
Top Elevation (ft)	= 7174.00
Top Width (ft)	= 4.00
Crest Width (ft)	= 15.00

Calculations	
Qmin (cfs)	= 6.00
Qmax (cfs)	= 6.00
Tailwater Elev (ft)	= (dc+D)/2

Highlighted	
Qtotal (cfs)	= 6.00
Qpipe (cfs)	= 6.00
Qovertop (cfs)	= 0.00
Veloc Dn (ft/s)	= 3.89
Veloc Up (ft/s)	= 5.12
HGL Dn (ft)	= 7163.22
HGL Up (ft)	= 7171.95
Hw Elev (ft)	= 7172.35
Hw/D (ft)	= 0.90
Flow Regime	= Inlet Control

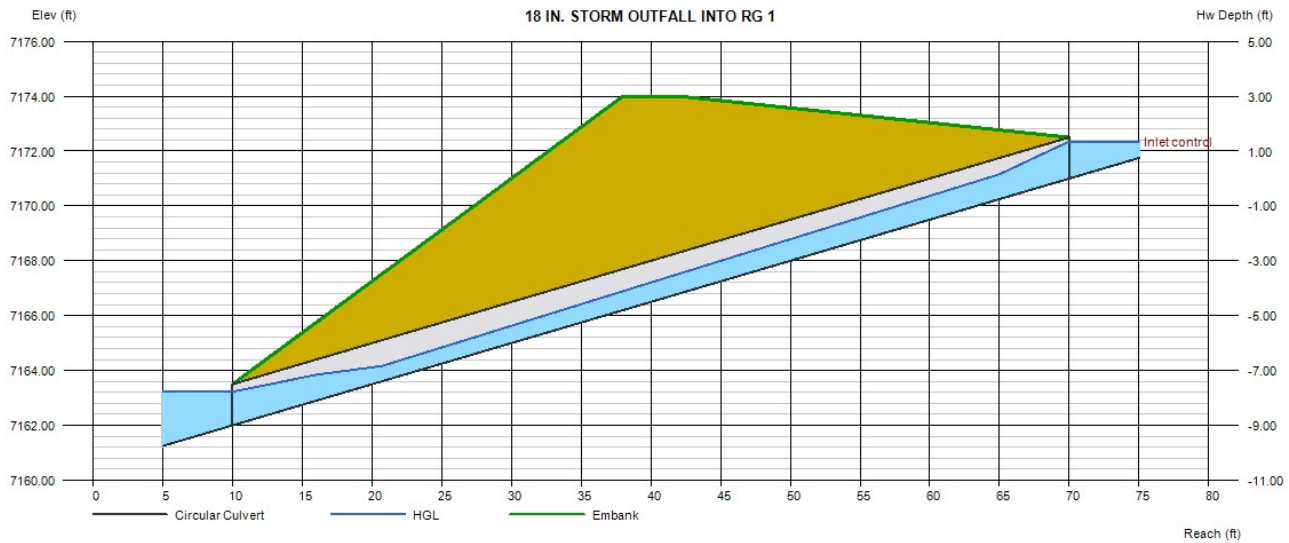

Culvert Report

DRIVEWAY CULVERT SIZING FOR LOT 1

Invert Elev Dn (ft)	=	7220.00
Pipe Length (ft)	=	20.00
Slope (%)	=	3.80
Invert Elev Up (ft)	=	7220.76
Rise (in)	=	24.0
Shape	=	Circular
Span (in)	=	24.0
No. Barrels	=	1
n-Value	=	0.013
Culvert Type	=	Circular Concrete
Culvert Entrance	=	Groove end projecting (C)
Coeff. K,M,c,Y,k	=	0.0045, 2, 0.0317, 0.69, 0.2

Embankment	
Top Elevation (ft)	= 7224.50
Top Width (ft)	= 16.00
Crest Width (ft)	= 20.00

Calculations	
Qmin (cfs)	= 15.00
Qmax (cfs)	= 15.00
Tailwater Elev (ft)	= (dc+D)/2

Highlighted	
Qtotal (cfs)	= 15.00
Qpipe (cfs)	= 15.00
Qovertop (cfs)	= 0.00
Veloc Dn (ft/s)	= 5.28
Veloc Up (ft/s)	= 6.41
HGL Dn (ft)	= 7221.70
HGL Up (ft)	= 7222.15
Hw Elev (ft)	= 7222.86
Hw/D (ft)	= 1.05
Flow Regime	= Inlet Control

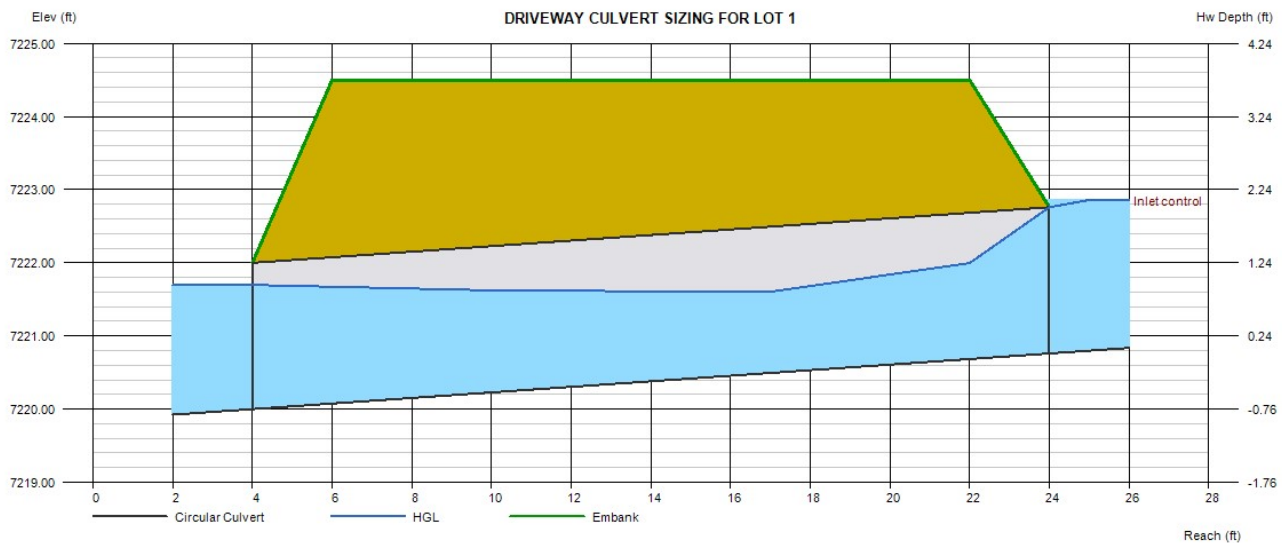

Culvert Report

DRIVEWAY CULVERT SIZING FOR LOTS 2-4

Invert Elev Dn (ft)	=	7220.00
Pipe Length (ft)	=	20.00
Slope (%)	=	3.80
Invert Elev Up (ft)	=	7220.76
Rise (in)	=	18.0
Shape	=	Circular
Span (in)	=	18.0
No. Barrels	=	1
n-Value	=	0.013
Culvert Type	=	Circular Concrete
Culvert Entrance	=	Groove end projecting (C)
Coeff. K,M,c,Y,k	=	0.0045, 2, 0.0317, 0.69, 0.2

Embankment	
Top Elevation (ft)	= 7224.00
Top Width (ft)	= 16.00
Crest Width (ft)	= 20.00

Calculations	
Qmin (cfs)	= 11.00
Qmax (cfs)	= 11.00
Tailwater Elev (ft)	= (dc+D)/2

Highlighted	
Qtotal (cfs)	= 11.00
Qpipe (cfs)	= 11.00
Qovertop (cfs)	= 0.00
Veloc Dn (ft/s)	= 6.45
Veloc Up (ft/s)	= 6.90
HGL Dn (ft)	= 7221.39
HGL Up (ft)	= 7222.03
Hw Elev (ft)	= 7223.00
Hw/D (ft)	= 1.49
Flow Regime	= Inlet Control

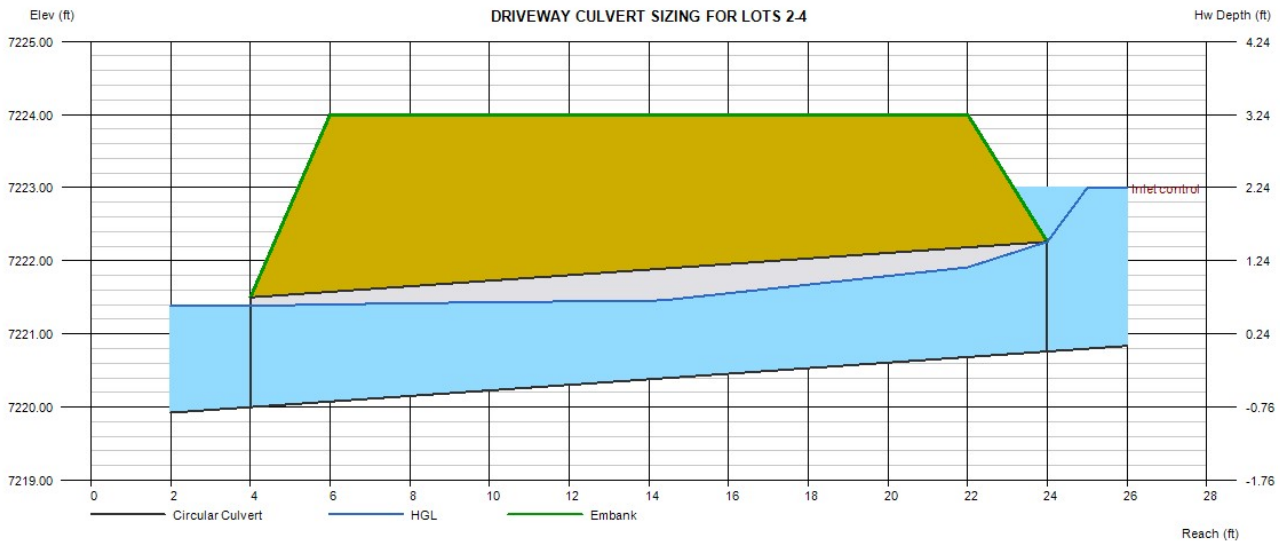

Culvert Report

DRIVEWAY CULVERT SIZING FOR LOTS 5-7

Invert Elev Dn (ft)	= 7220.00
Pipe Length (ft)	= 20.00
Slope (%)	= 2.50
Invert Elev Up (ft)	= 7220.50
Rise (in)	= 18.0
Shape	= Circular
Span (in)	= 18.0
No. Barrels	= 1
n-Value	= 0.013
Culvert Type	= Circular Concrete
Culvert Entrance	= Groove end projecting (C)
Coeff. K,M,c,Y,k	= 0.0045, 2, 0.0317, 0.69, 0.2

Embankment	
Top Elevation (ft)	= 7224.00
Top Width (ft)	= 16.00
Crest Width (ft)	= 20.00

Calculations	
Qmin (cfs)	= 6.00
Qmax (cfs)	= 6.00
Tailwater Elev (ft)	= (dc+D)/2

Highlighted	
Qtotal (cfs)	= 6.00
Qpipe (cfs)	= 6.00
Qovertop (cfs)	= 0.00
Veloc Dn (ft/s)	= 3.89
Veloc Up (ft/s)	= 5.12
HGL Dn (ft)	= 7221.22
HGL Up (ft)	= 7221.45
Hw Elev (ft)	= 7221.89
Hw/D (ft)	= 0.92
Flow Regime	= Inlet Control

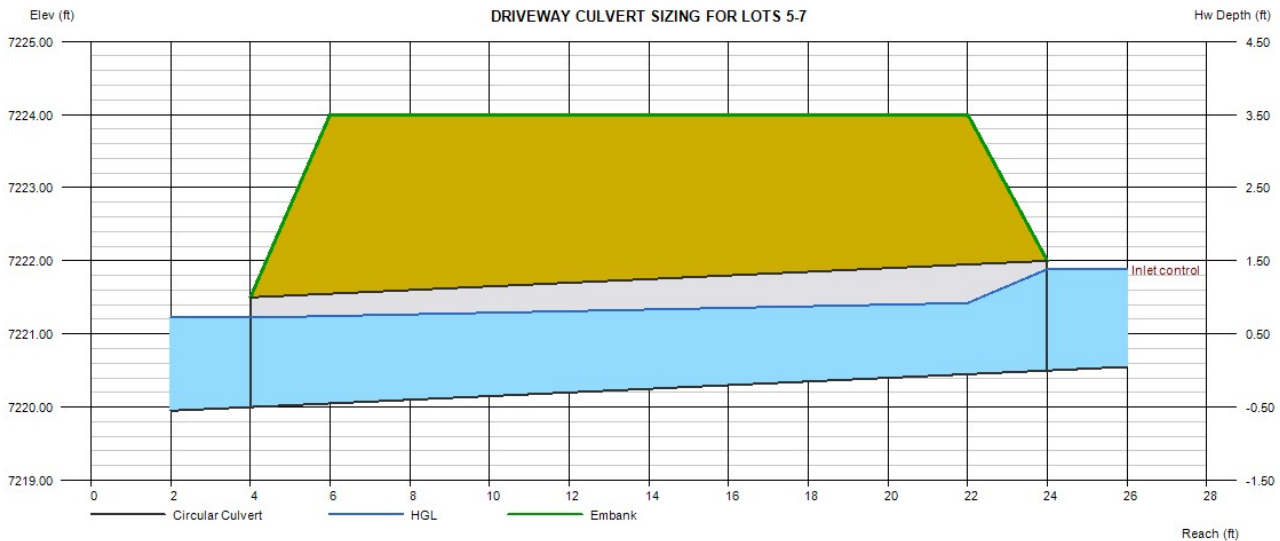

Culvert Report

DRIVEWAY CULVERT SIZING FOR LOT 11

Invert Elev Dn (ft)	= 7220.00
Pipe Length (ft)	= 20.00
Slope (%)	= 2.50
Invert Elev Up (ft)	= 7220.50
Rise (in)	= 18.0
Shape	= Circular
Span (in)	= 18.0
No. Barrels	= 1
n-Value	= 0.013
Culvert Type	= Circular Concrete
Culvert Entrance	= Groove end projecting (C)
Coeff. K,M,c,Y,k	= 0.0045, 2, 0.0317, 0.69, 0.2

Embankment	
Top Elevation (ft)	= 7224.00
Top Width (ft)	= 16.00
Crest Width (ft)	= 20.00

Calculations	
Qmin (cfs)	= 4.00
Qmax (cfs)	= 4.00
Tailwater Elev (ft)	= (dc+D)/2

Highlighted	
Qtotal (cfs)	= 4.00
Qpipe (cfs)	= 4.00
Qovertop (cfs)	= 0.00
Veloc Dn (ft/s)	= 2.79
Veloc Up (ft/s)	= 4.42
HGL Dn (ft)	= 7221.13
HGL Up (ft)	= 7221.27
Hw Elev (ft)	= 7221.57
Hw/D (ft)	= 0.71
Flow Regime	= Inlet Control

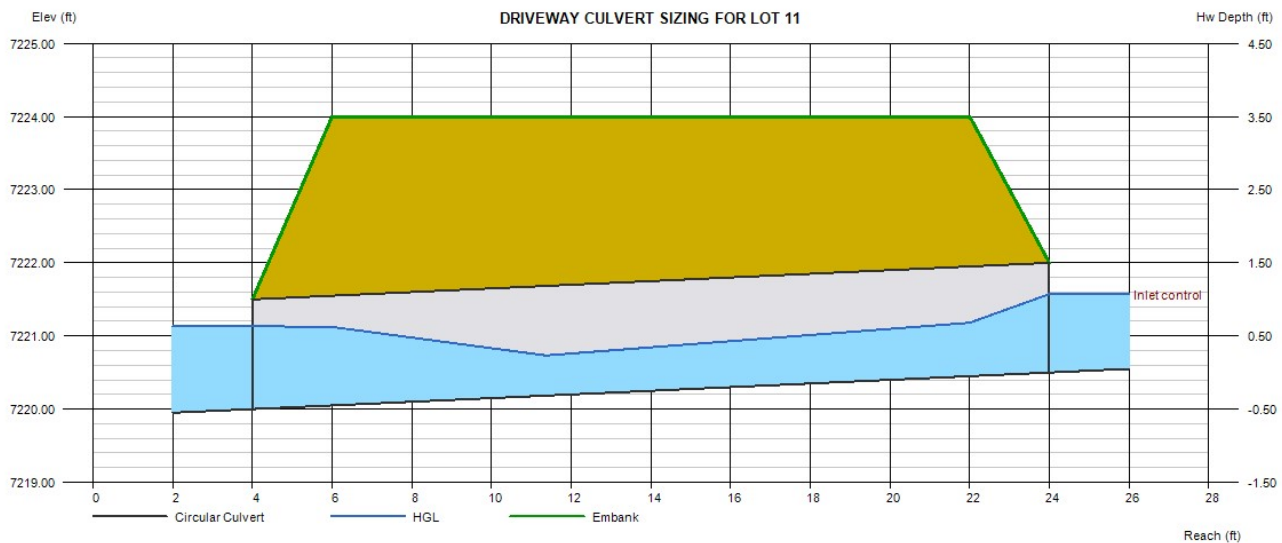

ROADSIDE DITCH CALCUALTIONS

Aspen Valley Road - West side of roadway (Sta. 1+50 to Sta. 11+50)

	Erosion Control Blanket (ECB)		Turf Reinforcement Mat (TRM)
	(North American Green - SC150)		(North American Green - P300)
Given:	(Temporary - 24 months)		(Permanent)
Design Flow (cfs)	22.0		22.0
Permissible Shear (lbs/ft. ²)	2.0		8.0
Permissible Velocity (ft./sec.)	8.0		16.0
Safety Factor	1		1
Ditch Slope (Max.)	3.8%		3.8%
Ditch Section (24 in. depth)	V-Ditch		V-Ditch
Flow Area (ft. ²)	2.89		9.00
Wetted Perimeter (ft.)	7.02		12.39
Hydraulic Radius	0.41		0.73
Mannings n	0.035		0.030
Depth of Flow (max.)	0.9		1.5
Calculations:			
Shear Stress (lbs/ft. ²)	2.0		3.6
Velocity (ft./sec.)	7.6		2.4
Allowed Flow (cfs)	13.3		70.4

ROADSIDE DITCH CALCUALTIONS

Aspen Valley Road - West side of roadway (Sta. 11+50 to Sta. 14+39)

	Erosion Control Blanket (ECB)		Turf Reinforcement Mat (TRM)	Revegetation - Grass lined
	(North American Green - SC150)		(North American Green - P300)	(Native Seed Mix)
Given:	(Temporary - 24 months)		(Permanent)	
Design Flow (cfs)	5.5		5.5	5.5
Permissible Shear (lbs/ft. ²)	2.0		8.0	0.1
Permissible Velocity (ft./sec.)	8.0		16.0	3.0
Safety Factor	1		1	1
Ditch Slope (Max.)	1.5%		1.5%	1.5%
Ditch Section (24 in. depth)	V-Ditch		V-Ditch	V-Ditch
Flow Area (ft. ²)	4.00		4.00	4.00
Wetted Perimeter (ft.)	8.26		8.26	8.26
Hydraulic Radius	0.48		0.48	0.48
Mannings n	0.035		0.030	0.030
Depth of Flow (max.)	1.0		1.0	1.0
Calculations:				
Shear Stress (lbs/ft. ²)	0.9		0.9	0.9
Velocity (ft./sec.)	1.4		1.4	1.4
Allowed Flow (cfs)	12.9		15.0	15.0

ROADSIDE DITCH CALCUALTIONS

Aspen Valley Road - East side of roadway (Sta. 1+50 to Sta. 4+50)

	Erosion Control Blanket (ECB)		Turf Reinforcement Mat (TRM)	Revegetation - Grass lined
	(North American Green - SC150)		(North American Green - P300)	(Native Seed Mix)
Given:	(Temporary - 24 months)		(Permanent)	
Design Flow (cfs)	3.0		3.0	3.0
Permissible Shear (lbs/ft. ²)	2.0		8.0	0.1
Permissible Velocity (ft./sec.)	8.0		16.0	3.0
Safety Factor	1		1	1
Ditch Slope (Max.)	3.8%		3.8%	0.5%
Ditch Section (24 in. depth)	V-Ditch		V-Ditch	V-Ditch
Flow Area (ft. ²)	1.00		1.00	1.00
Wetted Perimeter (ft.)	4.13		4.13	4.13
Hydraulic Radius	0.24		0.24	0.24
Mannings n	0.035		0.030	0.030
Depth of Flow (max.)	0.5		0.5	0.5
Calculations:				
Shear Stress (lbs/ft. ²)	1.2		1.2	0.2
Velocity (ft./sec.)	3.0		3.0	3.0
Allowed Flow (cfs)	3.2		3.8	1.4

ROADSIDE DITCH CALCUALTIONS

Poco Road - North side of roadway (Sta. 1+50 to Sta. 4+50)

	Erosion Control Blanket (ECB)		Turf Reinforcement Mat (TRM)
	(North American Green - SC150)		(North American Green - P300)
Given:	(Temporary - 24 months)		(Permanent)
Design Flow (cfs)	15.0		15.0
Permissible Shear (lbs/ft. ²)	2.0		8.0
Permissible Velocity (ft./sec.)	8.0		16.0
Safety Factor	1		1
Ditch Slope (Max.)	4.0%		4.0%
Ditch Section (24 in. depth)	V-Ditch		V-Ditch
Flow Area (ft. ²)	4.00		4.00
Wetted Perimeter (ft.)	8.26		8.26
Hydraulic Radius	0.48		0.48
Mannings n	0.035		0.030
Depth of Flow (max.)	1.0		1.0
Calculations:			
Shear Stress (lbs/ft. ²)	2.5		2.5
Velocity (ft./sec.)	3.8		3.8
Allowed Flow (cfs)	21.0		24.5

ROADSIDE DITCH CALCUALTIONS

Poco Road - Channel into pond north of roadway (Sta. 8+00 to Sta. 10+00)

	Erosion Control Blanket (ECB)		Turf Reinforcement Mat (TRM)	Revegetation - Grass lined
	(North American Green - SC150)		(North American Green - P300)	(Native Seed Mix)
Given:	(Temporary - 24 months)		(Permanent)	
Design Flow (cfs)	40.0		40.0	2.0
Permissible Shear (lbs/ft. ²)	2.0		8.0	0.1
Permissible Velocity (ft./sec.)	8.0		16.0	3.0
Safety Factor	1		1	1
Ditch Slope (Max.)	1.5%		1.5%	1.5%
Ditch Section (36 in. depth)	Trapezoidal-Ditch (3' wide)		Trapezoidal-Ditch (3' wide)	V-Ditch
Flow Area (ft. ²)	10.66		8.14	1.00
Wetted Perimeter (ft.)	13.74		9.09	4.13
Hydraulic Radius	0.78		0.90	0.24
Mannings n	0.035		0.030	0.030
Depth of Flow (max.)	1.3		1.1	0.5
Calculations:				
Shear Stress (lbs/ft. ²)	1.2		1.0	0.5
Velocity (ft./sec.)	3.8		4.9	2.0
Allowed Flow (cfs)	46.9		46.0	2.4

System Input Summary

Rainfall Parameters

Rainfall Return Period: 100

Rainfall Calculation Method: Table

Time	Intensity
5	8.68
10	6.93
20	5.19
30	4.16
40	3.44
60	2.42
120	0.67

Rational Method Constraints

Minimum Urban Runoff Coeff.: 0.20

Maximum Rural Overland Len. (ft): 500

Maximum Urban Overland Len. (ft): 300

Used UDFCD Tc. Maximum: Yes

Sizer Constraints

Minimum Sewer Size (in): 18.00

Maximum Depth to Rise Ratio: 0.90

Maximum Flow Velocity (fps): 18.0

Minimum Flow Velocity (fps): 2.0

Backwater Calculations:

Tailwater Elevation (ft): 7168.91

Sewer Flow Summary:

Element Name	Full Flow Capacity		Critical Flow		Normal Flow				Surcharged Length (ft)	Comment
	Flow (cfs)	Velocity (fps)	Depth (in)	Velocity (fps)	Velocity (fps)	Froude Number	Flow Condition	Flow (cfs)		
MH 1 SWR 1 - 1	142.67	14.83	32.32	9.31	14.96	2.22	Pressurized	74.00	28.00	
MH 2 SWR 2 - 1	352.36	36.62	32.32	9.31	28.99	5.76	Supercritical Jump	74.00	2.87	
MH 6 SWR 6 - 1	115.84	16.39	28.64	8.96	16.10	2.68	Supercritical	54.00	0.00	
MH 3 SWR 3 - 1	41.13	8.38	20.44	7.02	8.78	1.45	Pressurized	25.00	41.77	
MH 5 SWR 5 - 1	50.37	10.26	19.14	6.66	9.91	1.85	Supercritical Jump	22.00	4.65	
MH 4 SWR 4 - 1	22.34	12.64	7.90	4.02	8.81	3.03	Pressurized	3.00	6.86	

* outfall pipe into forebay) II RCP pipe
 Pond 2 (cast class spec.)

- A Froude number of 0 indicates that pressured flow occurs (adverse slope or undersized pipe).
- If the sewer is not pressurized, full flow represents the maximum gravity flow in the sewer.
- If the sewer is pressurized, full flow represents the pressurized flow conditions.

Grade Line Summary:

Tailwater Elevation (ft): 7168.91

Element Name	Invert Elev.		Downstream Manhole Losses			HGL		EGL	
	Downstream (ft)	Upstream (ft)	Bend Loss (ft)	Lateral Loss (ft)	Downstream (ft)	Upstream (ft)	Downstream (ft)	Friction Loss (ft)	Upstream (ft)
	MH 1 SWR 1 - 1	7164.75	7165.31	0.00	0.00	7168.91	7169.06	7169.83	0.15
MH 2 SWR 2 - 1	7165.30	7178.00	0.07	0.00	7169.13	7180.69	7170.05	11.99	7182.04
MH 6 SWR 6 - 1	7178.50	7179.40	0.07	0.01	7180.78	7183.06	7183.97	0.00	7183.97
MH 3 SWR 3 - 1	7179.00	7179.42	0.33	0.00	7181.97	7182.13	7182.37	0.15	7182.53
MH 5 SWR 5 - 1	7179.92	7180.31	0.26	0.00	7182.48	7182.48	7182.79	0.06	7182.84
MH 4 SWR 4 - 1	7180.42	7180.73	0.03	0.00	7182.51	7182.52	7182.56	0.01	7182.56

- Bend and Lateral losses only apply when there is an outgoing sewer. The system outfall, sewer #0, is not considered a sewer.
- Bend loss = Bend $K * V_{fi}^2 / (2 * g)$
- Lateral loss = $V_{fo}^2 / (2 * g)$ - Junction Loss $K * V_{fi}^2 / (2 * g)$.
- Friction loss is always Upstream EGL - Downstream EGL.

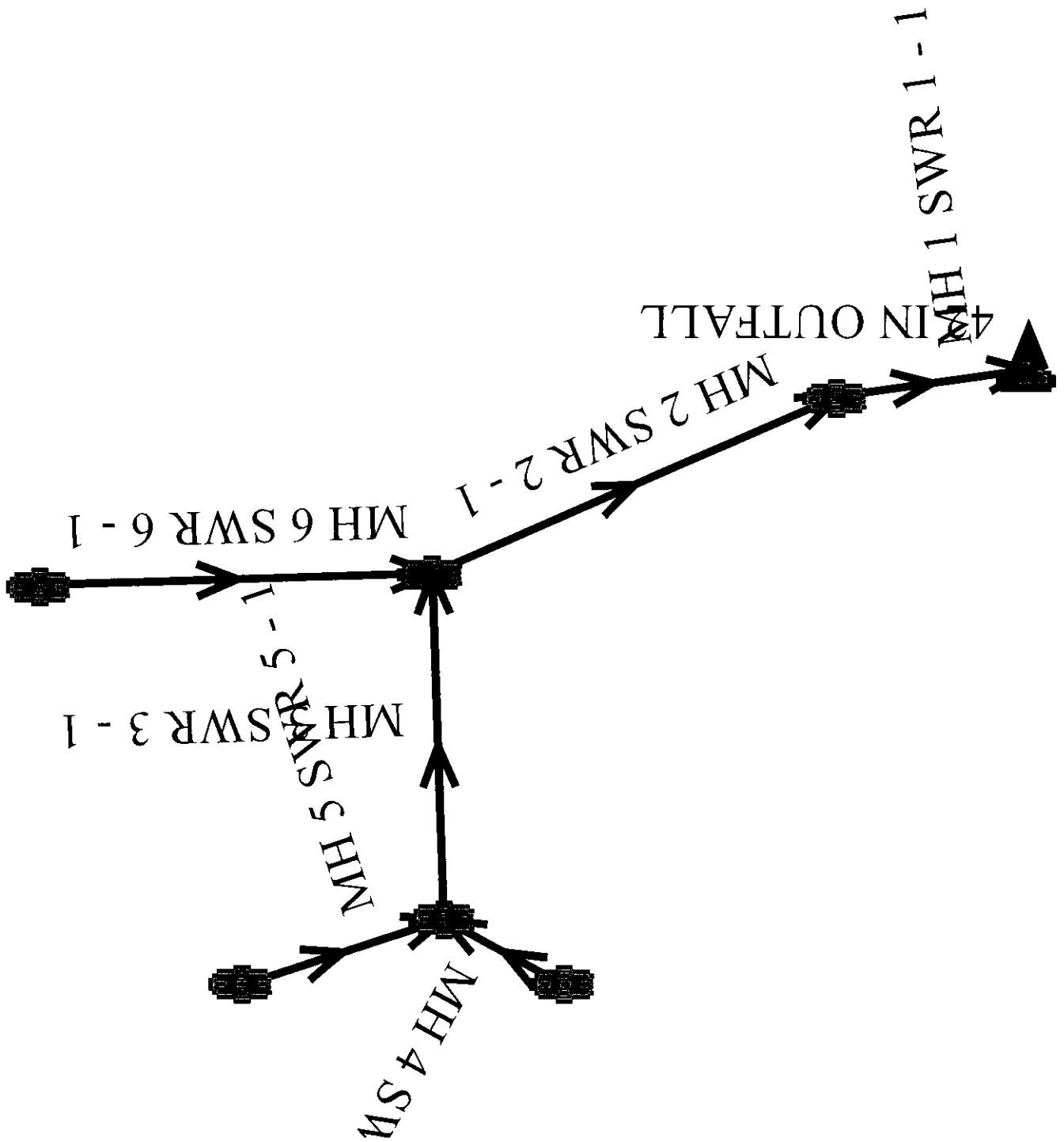

System Input Summary

Rainfall Parameters

Rainfall Return Period: 100

Rainfall Calculation Method: Table

Time	Intensity
5	8.68
10	6.93
20	5.19
30	4.16
40	3.44
60	2.42
120	0.67

Rational Method Constraints

Minimum Urban Runoff Coeff.: 0.20

Maximum Rural Overland Len. (ft): 500

Maximum Urban Overland Len. (ft): 300

Used UDFCD Tc. Maximum: Yes

Sizer Constraints

Minimum Sewer Size (in): 18.00

Maximum Depth to Rise Ratio: 0.90

Maximum Flow Velocity (fps): 18.0

Minimum Flow Velocity (fps): 2.0

Backwater Calculations:

Tailwater Elevation (ft): 7168.91

Sewer Flow Summary:

Element Name	Full Flow Capacity		Critical Flow		Normal Flow					Surcharged Length (ft)	Comment
	Flow (cfs)	Velocity (fps)	Depth (in)	Velocity (fps)	Depth (in)	Velocity (fps)	Froude Number	Flow Condition	Flow (cfs)		
MH 1 SWR 1 - 1	203.69	16.21	40.67	11.27	27.59	17.12	2.20	Pressurized	128.00	51.14	
MH 2 SWR 2 - 1	176.40	14.04	37.88	10.25	27.30	14.77	1.91	Supercritical Jump	109.00	74.57	
MH 3 SWR 3 - 1	100.88	10.49	36.11	10.80	32.41	11.92	1.28	Supercritical	95.00	0.00	
MH 14 SWR 14 - 1	44.22	14.07	16.17	6.22	9.28	12.49	2.90	Supercritical	14.00	0.00	
MH 4 SWR 4 - 1	123.55	12.84	34.09	9.92	25.20	13.77	1.83	Supercritical	83.00	0.00	
MH 12 SWR 12 - 1	41.13	8.38	19.58	6.78	16.04	8.61	1.47	Supercritical Jump	23.00	69.95	
MH 15 SWR 15 - 1	22.68	7.22	18.82	7.19	16.81	8.09	1.26	Supercritical	19.00	0.00	
MH 13 SWR 13 - 1	11.54	6.53	13.15	5.78	11.03	7.05	1.41	Supercritical	8.00	0.00	
MH 5 SWR 5 - 1	109.89	15.55	31.02	10.03	19.92	16.20	2.46	Supercritical	65.00	0.00	
MH 17 SWR 17 - 1	22.68	7.22	15.56	6.03	13.02	7.47	1.41	Supercritical	13.00	0.00	
MH 6 SWR 6 - 1	89.73	12.69	27.61	8.59	19.21	13.04	2.03	Supercritical	50.00	0.00	
MH 16 SWR 16 - 1	24.92	14.10	11.35	5.11	6.01	11.60	3.38	Supercritical	6.00	0.00	
MH 8 SWR 8 - 1	46.49	14.80	18.82	7.19	10.69	14.05	3.00	Supercritical Jump	19.00	42.39	
MH 9 SWR 9 - 1	22.68	7.22	18.82	7.19	16.81	8.09	1.26	Supercritical Jump	19.00	17.60	
MH 11 SWR 11 - 1	22.68	7.22	16.75	6.41	14.25	7.72	1.37	Supercritical	15.00	0.00	
MH 10 SWR 10 - 1	24.92	14.10	9.18	4.41	4.88	10.34	3.38	Supercritical	4.00	0.00	
MH 7 SWR 7 - 1	82.26	16.76	19.14	6.66	10.60	14.19	3.11	Supercritical	22.00	0.00	

- A Froude number of 0 indicates that pressurized flow occurs (adverse slope or undersized pipe).
- If the sewer is not pressurized, full flow represents the maximum gravity flow in the sewer.
- If the sewer is pressurized, full flow represents the pressurized flow conditions.

Grade Line Summary:

Tailwater Elevation (ft): 7168.91

Element Name	Invert Elev.		Downstream Manhole Losses			HGL		EGL	
	Downstream (ft)	Upstream (ft)	Bend Loss (ft)	Lateral Loss (ft)	Downstream (ft)	Upstream (ft)	Downstream (ft)	Friction Loss (ft)	Upstream (ft)
MH 1 SWR 1 - 1	7162.50	7163.52	0.00	0.00	7168.91	7169.31	7170.52	0.40	7170.92
MH 2 SWR 2 - 1	7165.57	7173.78	0.06	0.44	7170.26	7176.94	7171.43	7.14	7178.57
MH 3 SWR 3 - 1	7174.27	7174.73	0.08	0.00	7177.01	7177.74	7179.18	0.37	7179.55
MH 14 SWR 14 - 1	7176.73	7177.83	0.12	0.00	7177.86	7179.55	7179.92	0.00	7179.92
MH 4 SWR 4 - 1	7175.23	7182.57	0.06	0.36	7178.15	7185.41	7180.27	6.67	7186.94
MH 12 SWR 12 - 1	7184.07	7185.41	0.45	0.00	7187.05	7187.05	7187.39	0.37	7187.76
MH 15 SWR 15 - 1	7185.91	7186.14	0.22	0.00	7187.31	7187.71	7188.33	0.19	7188.51
MH 13 SWR 13 - 1	7186.41	7186.60	0.34	0.00	7187.39	7187.70	7188.10	0.11	7188.22
MH 5 SWR 5 - 1	7186.15	7199.87	0.07	0.00	7187.81	7202.46	7191.89	12.13	7204.02
MH 17 SWR 17 - 1	7202.13	7202.38	0.35	0.00	7203.26	7203.68	7204.04	0.20	7204.24
MH 6 SWR 6 - 1	7200.37	7204.60	0.04	0.54	7203.03	7206.90	7204.61	3.44	7208.05
MH 16 SWR 16 - 1	7202.38	7202.67	0.24	0.00	7202.88	7204.79	7204.97	0.00	7204.97
MH 8 SWR 8 - 1	7175.27	7192.15	0.75	0.00	7178.75	7193.72	7179.32	15.20	7194.52
MH 9 SWR 9 - 1	7192.65	7193.85	0.75	0.00	7194.70	7195.42	7195.27	0.95	7196.22
MH 11 SWR 11 - 1	7194.35	7194.60	0.47	0.00	7196.33	7196.33	7196.69	0.06	7196.75
MH 10 SWR 10 - 1	7194.85	7195.14	0.11	0.00	7195.52	7196.84	7196.92	0.00	7196.92
MH 7 SWR 7 - 1	7167.14	7167.47	0.20	0.00	7169.51	7170.84	7171.15	0.00	7171.15

- Bend and Lateral losses only apply when there is an outgoing sewer. The system outfall, sewer #0, is not considered a sewer.
- Bend loss = Bend $K * V_{fi}^2 / (2 * g)$
- Lateral loss = $V_{fo}^2 / (2 * g)$ - Junction Loss $K * V_{fi}^2 / (2 * g)$.
- Friction loss is always Upstream EGL - Downstream EGL.

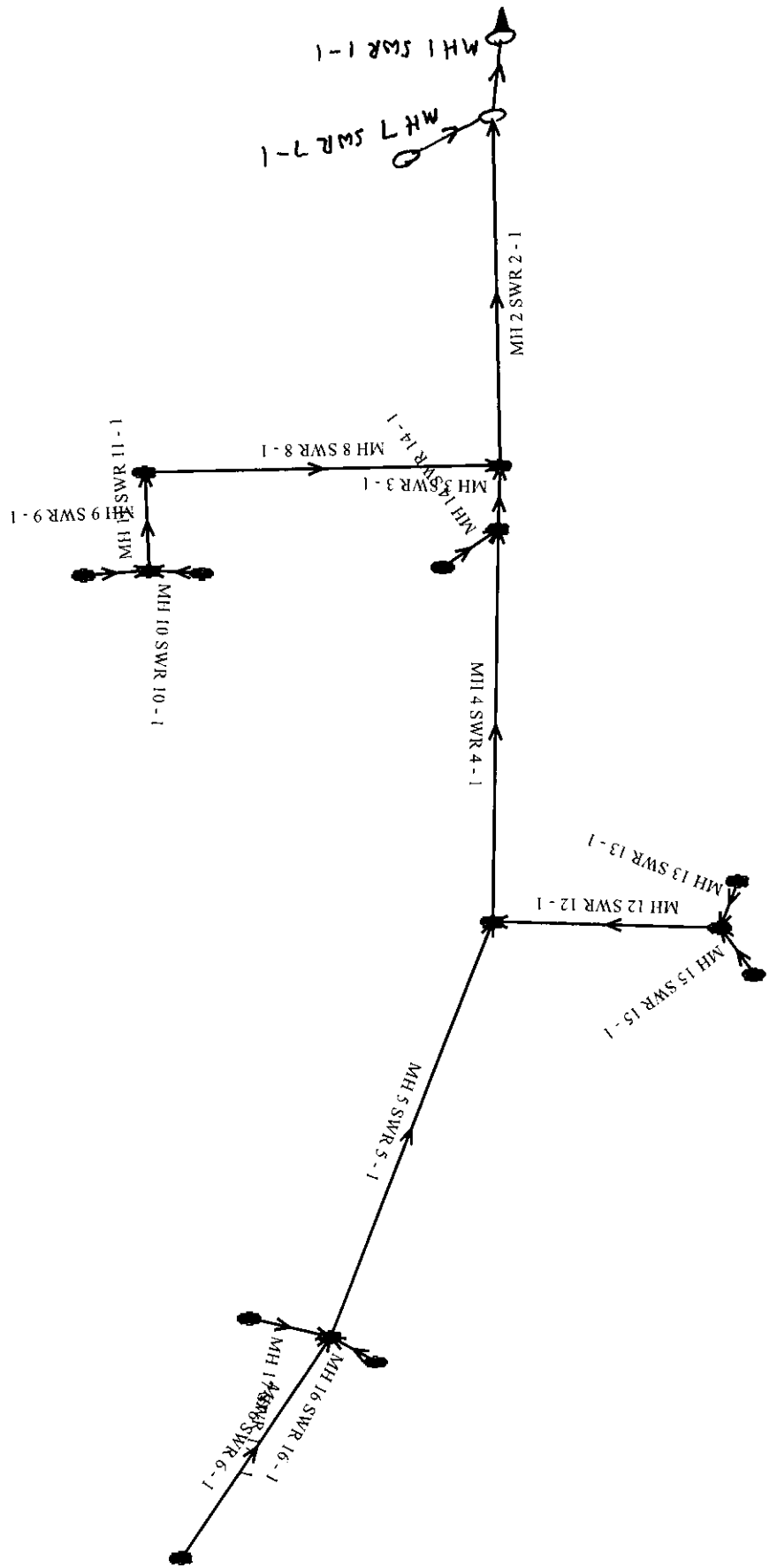

Description

A sediment basin is a temporary pond built on a construction site to capture eroded or disturbed soil transported in storm runoff prior to discharge from the site. Sediment basins are designed to capture site runoff and slowly release it to allow time for settling of sediment prior to discharge. Sediment basins are often constructed in locations that will later be modified to serve as post-construction stormwater basins.



Photograph SB-1. Sediment basin at the toe of a slope. Photo courtesy of WWE.

Appropriate Uses

Most large construction sites (typically greater than 2 acres) will require one or more sediment basins for effective management of construction site runoff. On linear construction projects, sediment basins may be impractical; instead, sediment traps or other combinations of BMPs may be more appropriate.

Sediment basins should not be used as stand-alone sediment controls. Erosion and other sediment controls should also be implemented upstream.

When feasible, the sediment basin should be installed in the same location where a permanent post-construction detention pond will be located.

Design and Installation

The design procedure for a sediment basin includes these steps:

- **Basin Storage Volume:** Provide a storage volume of at least 3,600 cubic feet per acre of drainage area. To the extent practical, undisturbed and/or off-site areas should be diverted around sediment basins to prevent “clean” runoff from mixing with runoff from disturbed areas. For undisturbed areas (both on-site and off-site) that cannot be diverted around the sediment basin, provide a minimum of 500 ft³/acre of storage for undeveloped (but stable) off-site areas in addition to the 3,600 ft³/acre for disturbed areas. For stable, developed areas that cannot be diverted around the sediment basin, storage volume requirements are summarized in Table SB-1.
- **Basin Geometry:** Design basin with a minimum length-to-width ratio of 2:1 (L:W). If this cannot be achieved because of site space constraints, baffling may be required to extend the effective distance between the inflow point(s) and the outlet to minimize short-circuiting.
- **Dam Embankment:** It is recommended that embankment slopes be 4:1 (H:V) or flatter and no steeper than 3:1 (H:V) in any location.

Sediment Basins	
Functions	
Erosion Control	No
Sediment Control	Yes
Site/Material Management	No

- **Inflow Structure:** For concentrated flow entering the basin, provide energy dissipation at the point of inflow.

Table SB-1. Additional Volume Requirements for Undisturbed and Developed Tributary Areas Draining through Sediment Basins

Imperviousness (%)	Additional Storage Volume (ft ³) Per Acre of Tributary Area
Undeveloped	500
10	800
20	1230
30	1600
40	2030
50	2470
60	2980
70	3560
80	4360
90	5300
100	6460

- **Outlet Works:** The outlet pipe shall extend through the embankment at a minimum slope of 0.5 percent. Outlet works can be designed using one of the following approaches:
 - **Riser Pipe (Simplified Detail):** Detail SB-1 provides a simplified design for basins treating no more than 15 acres.
 - **Orifice Plate or Riser Pipe:** Follow the design criteria for Full Spectrum Detention outlets in the EDB Fact Sheet provided in Chapter 4 of this manual for sizing of outlet perforations with an emptying time of approximately 72 hours. In lieu of the trash rack, pack uniformly sized 1½ - to 2-inch gravel in front of the plate or surrounding the riser pipe. This gravel will need to be cleaned out frequently during the construction period as sediment accumulates within it. The gravel pack will need to be removed and disposed of following construction to reclaim the basin for use as a permanent detention facility. If the basin will be used as a permanent extended detention basin for the site, a trash rack will need to be installed once contributing drainage areas have been stabilized and the gravel pack and accumulated sediment have been removed.
 - **Floating Skimmer:** If a floating skimmer is used, install it using manufacturer’s recommendations. Illustration SB-1 provides an illustration of a Faircloth Skimmer Floating Outlet™, one of the more commonly used floating skimmer outlets. A skimmer should be designed to release the design volume in no less than 48 hours. The use of a floating skimmer outlet can increase the sediment capture efficiency of a basin significantly. A floating outlet continually decants cleanest water off the surface of the pond and releases cleaner water than would discharge from a perforated riser pipe or plate.

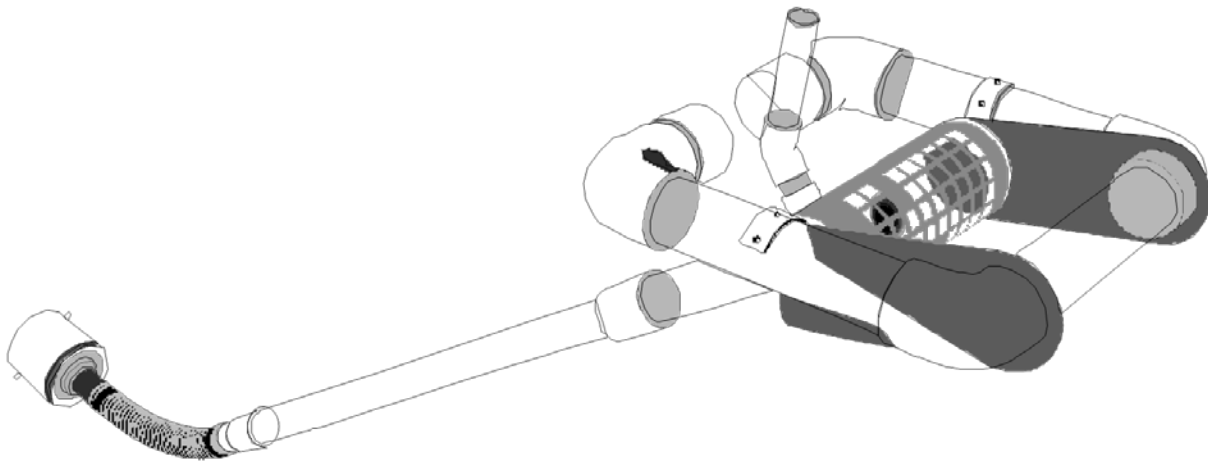

Illustration SB-1. Outlet structure for a temporary sediment basin - Faircloth Skimmer Floating Outlet. Illustration courtesy of J. W. Faircloth & Sons, Inc., FairclothSkimmer.com.

- **Outlet Protection and Spillway:** Consider all flow paths for runoff leaving the basin, including protection at the typical point of discharge as well as overtopping.
 - **Outlet Protection:** Outlet protection should be provided where the velocity of flow will exceed the maximum permissible velocity of the material of the waterway into which discharge occurs. This may require the use of a riprap apron at the outlet location and/or other measures to keep the waterway from eroding.
 - **Emergency Spillway:** Provide a stabilized emergency overflow spillway for rainstorms that exceed the capacity of the sediment basin volume and its outlet. Protect basin embankments from erosion and overtopping. If the sediment basin will be converted to a permanent detention basin, design and construct the emergency spillway(s) as required for the permanent facility. If the sediment basin will not become a permanent detention basin, it may be possible to substitute a heavy polyvinyl membrane or properly bedded rock cover to line the spillway and downstream embankment, depending on the height, slope, and width of the embankments.

Maintenance and Removal

Maintenance activities include the following:

- Dredge sediment from the basin, as needed to maintain BMP effectiveness, typically when the design storage volume is no more than one-third filled with sediment.
- Inspect the sediment basin embankments for stability and seepage.
- Inspect the inlet and outlet of the basin, repair damage, and remove debris. Remove, clean and replace the gravel around the outlet on a regular basis to remove the accumulated sediment within it and keep the outlet functioning.
- Be aware that removal of a sediment basin may require dewatering and associated permit requirements.
- Do not remove a sediment basin until the upstream area has been stabilized with vegetation.

Final disposition of the sediment basin depends on whether the basin will be converted to a permanent post-construction stormwater basin or whether the basin area will be returned to grade. For basins being converted to permanent detention basins, remove accumulated sediment and reconfigure the basin and outlet to meet the requirements of the final design for the detention facility. If the sediment basin is not to be used as a permanent detention facility, fill the excavated area with soil and stabilize with vegetation.

Include in I&M Plan

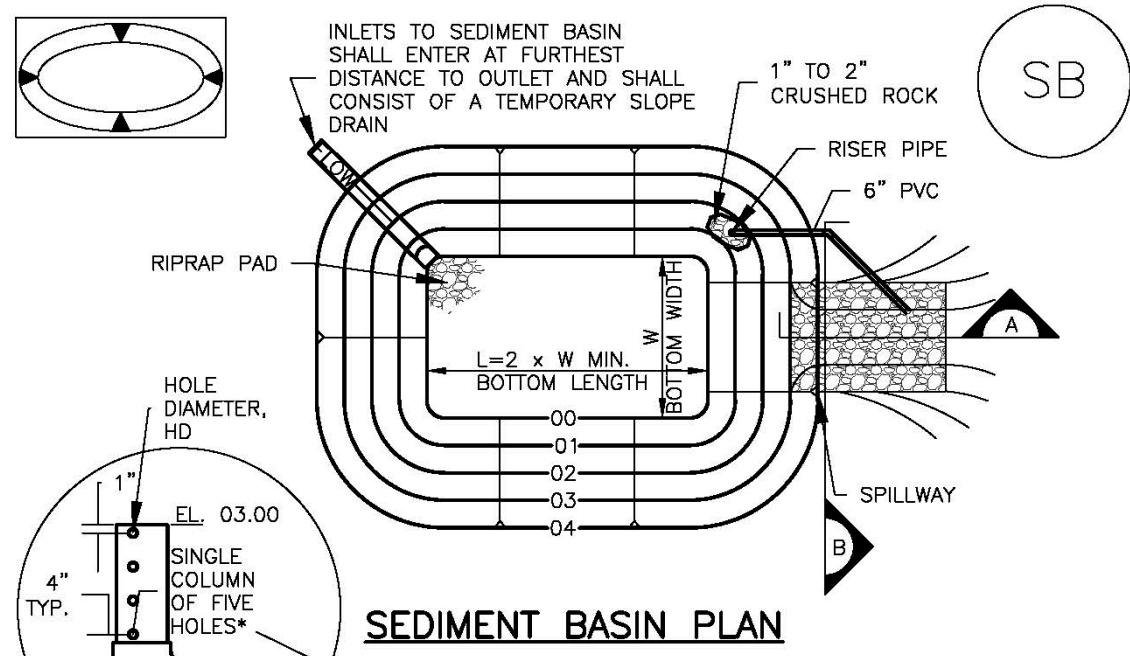

*EXCEPT WHERE THE HOLES EXCEED 1" DIAMETER, THEN UP TO TWO COLUMNS OF SAME SIZED HOLES MAY BE USED

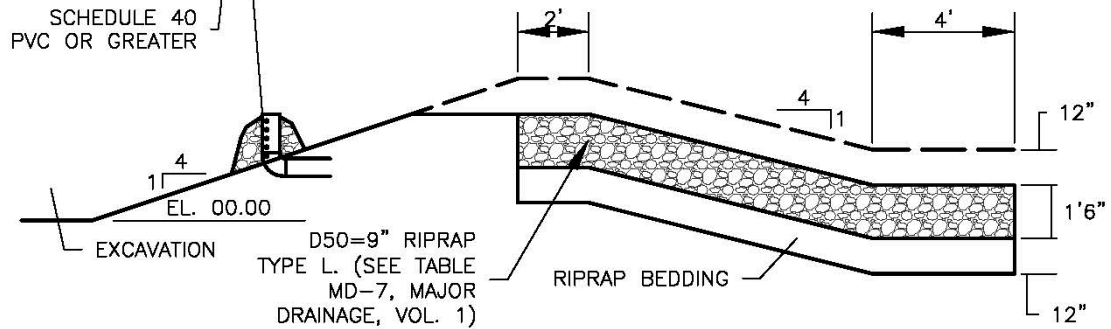

SECTION A

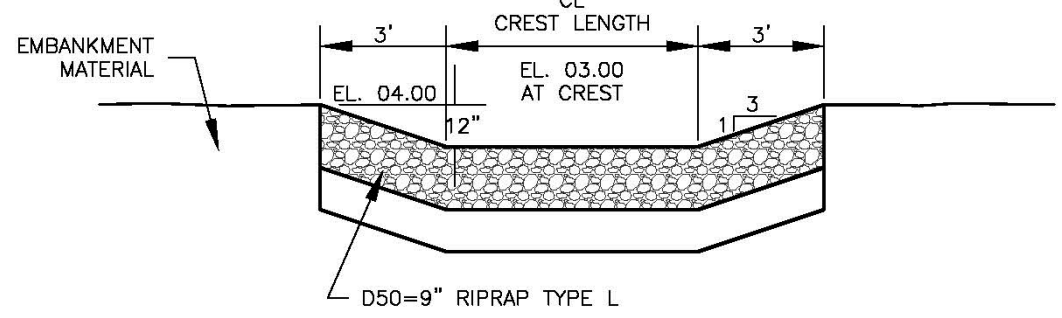

TABLE SB-1. SIZING INFORMATION FOR STANDARD SEDIMENT BASIN			
Upstream Drainage Area (rounded to nearest acre), (ac)	Basin Bottom Width (W), (ft)	Spillway Crest Length (CL), (ft)	Hole Diameter (HD), (in)
1	12 1/2	2	9/32
2	21	3	13/16
3	28	5	1/2
4	33 1/2	6	9/16
5	38 1/2	8	2 1/32
6	43	9	2 1/32
7	47 1/4	11	2 5/32
8	51	12	2 7/32
9	55	13	7/8
10	58 1/4	15	1 5/16
11	61	16	3 1/32
12	64	18	1
13	67 1/2	19	1 1/16
14	70 1/2	21	1 1/8
15	73 1/4	22	1 3/16

SEDIMENT BASIN INSTALLATION NOTES

1. SEE PLAN VIEW FOR:
 - LOCATION OF SEDIMENT BASIN.
 - TYPE OF BASIN (STANDARD BASIN OR NONSTANDARD BASIN).
 - FOR STANDARD BASIN, BOTTOM WIDTH W, CREST LENGTH CL, AND HOLE DIAMETER, HD.
 - FOR NONSTANDARD BASIN, SEE CONSTRUCTION DRAWINGS FOR DESIGN OF BASIN INCLUDING RISER HEIGHT H, NUMBER OF COLUMNS N, HOLE DIAMETER HD AND PIPE DIAMETER D.
2. FOR STANDARD BASIN, BOTTOM DIMENSION MAY BE MODIFIED AS LONG AS BOTTOM AREA IS NOT REDUCED.
3. SEDIMENT BASINS SHALL BE INSTALLED PRIOR TO ANY OTHER LAND-DISTURBING ACTIVITY THAT RELIES ON ON BASINS AS AS A STORMWATER CONTROL.
4. EMBANKMENT MATERIAL SHALL CONSIST OF SOIL FREE OF DEBRIS, ORGANIC MATERIAL, AND ROCKS OR CONCRETE GREATER THAN 3 INCHES AND SHALL HAVE A MINIMUM OF 15 PERCENT BY WEIGHT PASSING THE NO. 200 SIEVE.
5. EMBANKMENT MATERIAL SHALL BE COMPACTED TO AT LEAST 95 PERCENT OF MAXIMUM DENSITY IN ACCORDANCE WITH ASTM D698.
6. PIPE SCH 40 OR GREATER SHALL BE USED.
7. THE DETAILS SHOWN ON THESE SHEETS PERTAIN TO STANDARD SEDIMENT BASIN(S) FOR DRAINAGE AREAS LESS THAN 15 ACRES. SEE CONSTRUCTION DRAWINGS FOR EMBANKMENT, STORAGE VOLUME, SPILLWAY, OUTLET, AND OUTLET PROTECTION DETAILS FOR ANY SEDIMENT BASIN(S) THAT HAVE BEEN INDIVIDUALLY DESIGNED FOR DRAINAGE AREAS LARGER THAN 15 ACRES.

SEDIMENT BASIN MAINTENANCE NOTES

1. INSPECT BMPs EACH WORKDAY, AND MAINTAIN THEM IN EFFECTIVE OPERATING CONDITION. MAINTENANCE OF BMPs SHOULD BE PROACTIVE, NOT REACTIVE. INSPECT BMPs AS SOON AS POSSIBLE (AND ALWAYS WITHIN 24 HOURS) FOLLOWING A STORM THAT CAUSES SURFACE EROSION, AND PERFORM NECESSARY MAINTENANCE.
2. FREQUENT OBSERVATIONS AND MAINTENANCE ARE NECESSARY TO MAINTAIN BMPs IN EFFECTIVE OPERATING CONDITION. INSPECTIONS AND CORRECTIVE MEASURES SHOULD BE DOCUMENTED THOROUGHLY.
3. WHERE BMPs HAVE FAILED, REPAIR OR REPLACEMENT SHOULD BE INITIATED UPON DISCOVERY OF THE FAILURE.
4. SEDIMENT ACCUMULATED IN BASIN SHALL BE REMOVED AS NEEDED TO MAINTAIN BMP EFFECTIVENESS, TYPICALLY WHEN SEDIMENT DEPTH REACHES ONE FOOT (I.E., TWO FEET BELOW THE SPILLWAY CREST).
5. SEDIMENT BASINS ARE TO REMAIN IN PLACE UNTIL THE UPSTREAM DISTURBED AREA IS STABILIZED AND GRASS COVER IS ACCEPTED BY THE LOCAL JURISDICTION.
6. WHEN SEDIMENT BASINS ARE REMOVED, ALL DISTURBED AREAS SHALL BE COVERED WITH TOPSOIL, SEEDED AND MULCHED OR OTHERWISE STABILIZED AS APPROVED BY LOCAL JURISDICTION.

(DETAILS ADAPTED FROM DOUGLAS COUNTY, COLORADO)

NOTE: MANY JURISDICTIONS HAVE BMP DETAILS THAT VARY FROM UDFCD STANDARD DETAILS. CONSULT WITH LOCAL JURISDICTIONS AS TO WHICH DETAIL SHOULD BE USED WHEN DIFFERENCES ARE NOTED.

MULTI-PLATE®

Made to Perform, Built to Last.

Contech MULTI-PLATE structures provide designers of stormwater management systems underpasses and bridges with a versatile method of construction and a long history of strength, durability, and economy. A variety of shapes and sizes ensures that MULTI-PLATE structures fit most applications. Ease of design, construction, and proven reliability make them the frequent choice of experienced engineers.

MULTI-PLATE structures are made from sturdy, heavy gage, corrugated steel plates that are pre-formed to various shapes and sizes, then galvanized for long-term protection and performance. The plates are delivered to the job site and bolted together to form a MULTI-PLATE structure optimally suited for the project.

MULTI-PLATE is available in full round, arch, pipe-arch, horizontal and vertical ellipse, underpass, and long-span shapes—all in a wide range of sizes. Since 1931, MULTI-PLATE has been proven to offer:

Superior Durability

MULTI-PLATE's heavy gage steel uses an industry standard 3 oz. per square foot galvanized coating (both sides) capable of providing a service life of 75 years or longer. For additional information, see page 7.

When selecting the proper material for an application, designers need to evaluate the soil side of the structure along with the corrosive and abrasive action due to the flow at the invert of the structure. The use of structural plate gives designers more structure shape options to help minimize the impact of abrasion on the invert of the structure.

High Load-Carrying Capacity

As a steel-soil interaction system, MULTI-PLATE is designed to carry high combined live and dead loads. High traffic loads and deep cover applications are key benefits of specifying MULTI-PLATE.

A More Efficient Installation

Prefabricated plates are assembled in the field, translating into finished construction in days instead of weeks as with most concrete structures.

Versatility

MULTI-PLATE structures remove all of the shape, size and installation restrictions of precast or cast-in-place concrete.

Descriptions of Plates

MULTI-PLATE plates are field assembled into pipe, pipe-arches, ellipses, arches, and underpasses. Corrugations of 6-inch pitch and 2-inch depth are perpendicular to the length of each plate.

Thickness. Standard specified thickness of the galvanized plates vary from 0.111 to 0.380 inches.

Widths. Standard plates are fabricated in five net covering widths, 28.8 inches, 48.0 inches, 57.6 inches, 67.2 inches, and 76.8 inches. See Table 11.

The "Pi" ($\text{Pi} = 3.2$) nomenclature translated circumference directly into nominal diameter in inches. For example, four 15-Pi plates give a diameter of 60 inches; four 21-Pi plates provide an 84-inch diameter, etc. Various plate widths may be combined to obtain almost any diameter.

Lengths. MULTI-PLATE plates are furnished in either 10-foot or 12-foot nominal lengths. Actual length of the square-end structure is about four inches longer than its nominal length because a 2-inch lip protrudes beyond each end of every plate for lapping purposes.

Longitudinal bolt holes. The plates are punched with 7/8-inch holes on 3-inch centers to provide the standard four bolts per foot of longitudinal seam in two staggered rows on 2-inch centers. They may also be punched to provide either six or eight bolts per foot of longitudinal seam on 0.280 inch thickness material, if required. One-inch holes, punched 8 bolts per foot of long seam are used for 0.318-inch and 0.380-inch thick material.

The inside crests of the end (circumferential) corrugations are punched with 1-inch-diameter holes for circumferential seams on centers of 9.6 inches or $9^{19/32}$ inches (equals 3-Pi).



Single Radius Arch

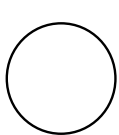

Round

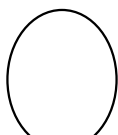

Vertical Ellipse

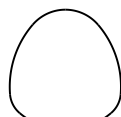

Underpass



Pipe-Arch



Horizontal Ellipse



Single Radius Arch

Standard Shapes

Standard Plate Detail

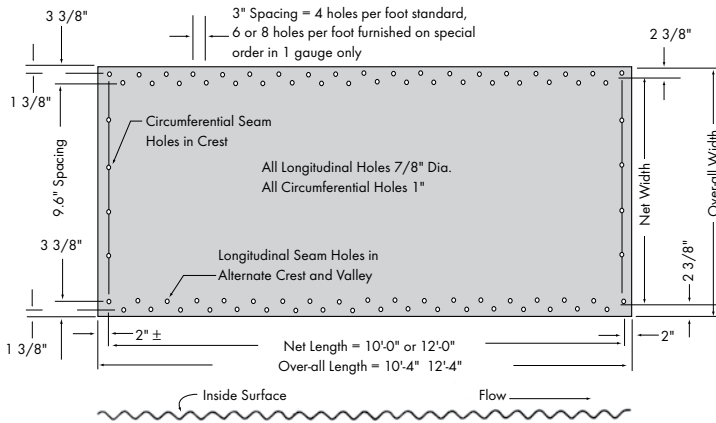

For square end structures on which headwalls are to be built, design should allow for a 2" lip at each end.

TABLE 11. DETAILS OF UNCURVED MULTI-PLATE® SECTIONS

Net Width, Inches	Overall Width (Inches)	Spaces (9.6 Inches)	Number of Circumferential Bolt Holes
9 Pi	28.8	28 13/16	3
15 Pi	48.0	48	5
18 Pi	57.6	57 5/8	6
21 Pi	67.2	67 3/16	7
24 Pi	76.8	76 13/16	8

For MULTI-PLATE, Pi = 3.2 inches

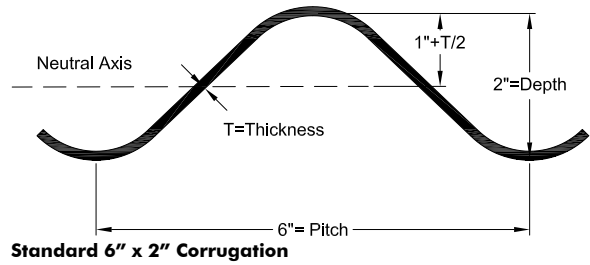

TABLE 12. APPROXIMATE WEIGHT OF MULTI-PLATE SECTIONS

Galvanized, in Pounds, without Fasteners

Pi	Net Length (Feet)	Specified Thickness, Inches								
		0.111 (12 Ga.)	0.140 (10 Ga.)	0.170 (8 Ga.)	0.188 (7 Ga.)	0.218 (5 Ga.)	0.249 (3 Ga.)	0.280 (1 Ga.)	0.318 (5/16 In.)	0.380 (3/8 In.)
9	10	161	205	250	272	316	361	405	460	545
9	12	193	246	299	325	379	432	485	551	653
15	10	253	323	393	428	498	568	638	725	859
15	12	303	386	470	511	595	678	762	865	1026
18	10	299	382	465	506	589	671	754	856	1015
18	12	357	456	555	604	703	801	900	1022	1212
21	10	345	441	536	583	679	774	869	987	1170
21	12	412	526	640	697	810	924	1038	1179	1398
24	10	396	504	613	667	775	886	995	N/A	N/A
24	12	473	603	732	797	927	1060	1190	N/A	N/A

Notes:

- Weights are based on a zinc coating of 3 oz./sq. ft., total both surfaces.
- All weights are subject to manufacturing tolerances.
- Specified thickness is a nominal galvanized thickness. Reference AASHTO M 167.
- Gages 12 thru 1 use 3/4" bolts. 5/16 and 3/8 use 7/8" bolts.

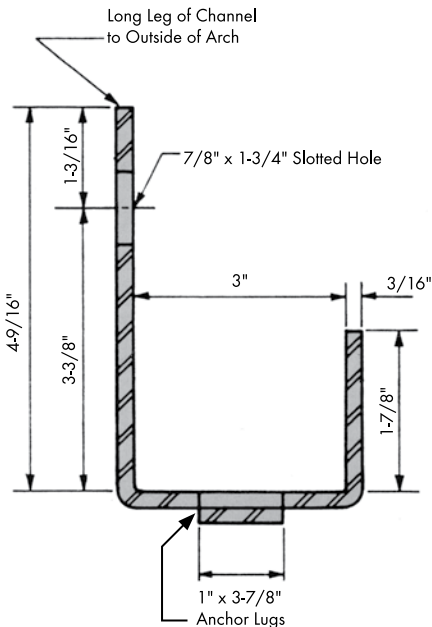

Unbalanced Channel Cross Section

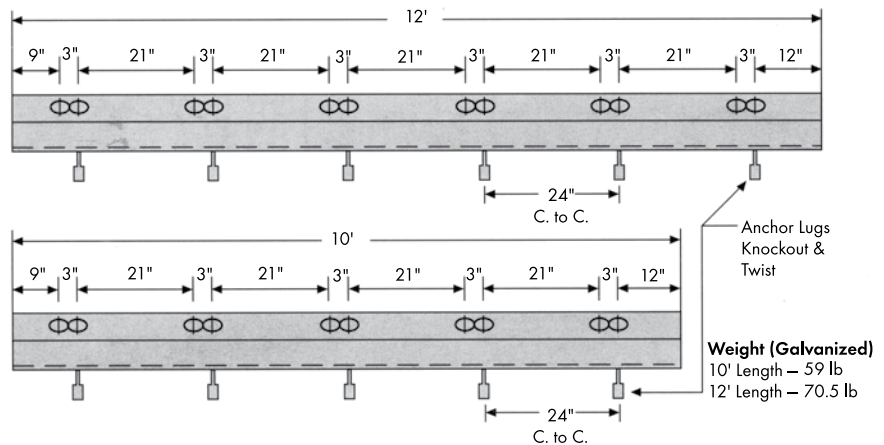

Unbalanced Channel for MULTI-PLATE® Arch

MULTI-PLATE® Bolts and Nuts

3/4" or 7/8" diameter hot-dipped galvanized steel (specially heat-treated) fasteners meeting ASTM A307/A449 specifications are used to assemble structural plate structures.

The underside of the bolt head is uniformly rounded and ribbed to prevent bolt head rotation while tightening. Unlike conventional bolts, once the nut is finger tight, final tightening can typically be accomplished by one worker with an air driven impact wrench to 100 – 300 ft. lbs. of torque.

In addition, one side of the nut is spherically formed to help align and center the fastener into the punched holes. The rounded side shall be placed against the metal side of the structure.

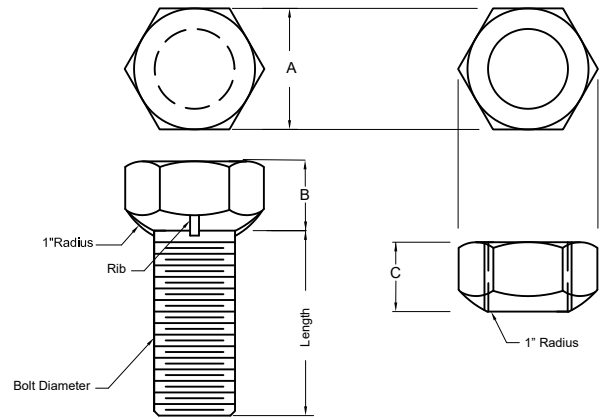

Typical Bolt and Nut

Diameter (Inches)	A (Inches)	B (Inches)	C (Inches)
3/4	1 1/4	5/8	13/16
7/8	1 7/16	3/4	7/8

Plate Gages	Bolt Lengths
12, 10 and 8	1 1/4" and 1 1/2"
7 and 5	1 1/2" and 1 3/4"
3 and 1	1 1/2" and 2"
5/16* and 3/8*	2" and 2 1/2"

* These are used with 7/8" diameter bolts.
Notes: The longer bolts are used in 3 plate lap seams.

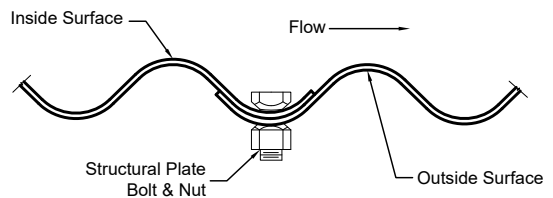

MULTI-PLATE® Round

TABLE 15. MULTI-PLATE ROUND PIPE					
Pipe Diameter		End Area (Sq. Ft.)	Pipe Diameter		End Area Sq. Ft.
(Feet)	(Inches)		(Feet)	(Inches)	
5.0	60	19.1	16.0	192	204.4
5.5	66	23.2	16.5	198	217.5
6.0	72	27.8	17.0	204	231.0
6.5	78	32.7	17.5	210	244.9
7.0	84	38.1	18.0	216	259.2
7.5	90	43.9	18.5	222	274.0
8.0	96	50.0	19.0	228	289.1
8.5	102	56.6	19.5	234	304.7
9.0	108	63.6	20.0	240	320.6
9.5	114	71.0	20.5	246	337.0
10.0	120	78.8	21.0	252	353.8
10.5	126	87.1	21.5	258	371.0
11.0	132	95.7	22.0	264	388.6
11.5	138	104.7	22.5	270	406.6
12.0	144	114.2	23.0	276	425.0
12.5	150	124.0	23.5	282	443.8
13.0	156	134.3	24.0	288	463.0
13.5	162	144.9	24.5	294	482.6
14.0	168	156.0	25.0	300	502.7
14.5	174	167.5	25.5	306	523.1
15.0	180	179.4	26.0	312	543.9
15.5	186	191.7			

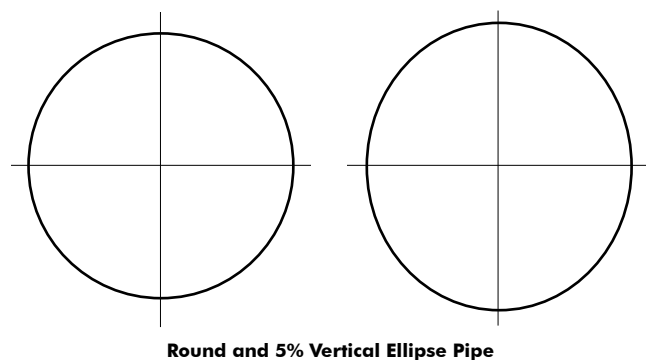

Round and 5% Vertical Ellipse Pipe

MULTI-PLATE® Height of Cover Tables

Height-of-Cover Tables 18, 21, 24, 26 and 29A are presented for the designer's convenience for use in routine applications. These tables are based on the outlined design procedures, using the following values for the soil and steel parameters:

- Unit weight of soil – 120 pcf.
- Relative density of compacted backfill – minimum 90% standard per AASHTO T 180
- Yield point of steel – 33,000 psi
- Heights of cover are based on 3/4" bolts (4 bolts/ft) except 5/16 and 3/8 which use 7/8" bolts (8 bolts/ft). 6 and 8 bolts/ft are available for 1 Ga. structures.

**TABLE 17. MULTI-PLATE® ROUND AND VERTICAL ELLIPSE PIPE 6" X 2"
AASHTO HEIGHT OF COVER LIMITS H-20, HS-20, H-25, HS-25 LIVE LOADS**

Span Diameter Ft.-In.	Minimum Cover (Inches)	Thickness In Inches (Gage) (Maximum Cover Height Shown In Feet)								
		0.111 (12 Ga.)	0.14 (10 Ga.)	0.17 (8 Ga.)	0.188 (7 Ga.)	0.218 (5 Ga.)	0.249 (3 Ga.)	0.28 (1 Ga.)	0.318 (5/16)	0.380 (3/8)
5-0	12	46	68	90	103	124	146	160	256	308
5-6	12	42	62	81	93	113	133	145	233	280
6-0	12	38	57	75	86	103	122	133	214	257
6-6	12	35	52	69	79	95	112	123	197	237
7-0	12	33	49	64	73	88	104	114	183	220
7-6	12	31	45	60	68	82	97	106	171	205
8-0	12	29	43	56	64	77	91	100	160	192
8-6	18	27	40	52	60	73	86	94	151	181
9-0	18	25	38	50	57	69	81	88	142	171
9-6	18	24	36	47	54	65	77	84	135	162
10-0	18	23	34	45	51	62	73	80	128	154
10-6	18	22	32	42	49	59	69	76	122	147
11-0	18	21	31	40	46	56	66	72	116	140
11-6	18	20	29	39	44	54	63	69	111	134
12-0	18	19	28	37	43	51	61	66	107	128
12-6	24	18	27	36	41	49	58	64	102	123
13-0	24	17	26	34	39	47	56	61	98	118
13-6	24	17	25	33	38	46	54	59	95	114
14-0	24	16	24	32	36	44	52	57	91	110
14-6	24	16	23	31	35	42	50	55	88	106
15-0	24	15	22	30	34	41	48	53	85	102
15-6	24	15	22	29	33	40	47	51	82	99
16-0	24		21	28	32	38	45	50	80	96
16-6	30		20	27	31	37	44	48	77	93
17-0	30		20	26	30	36	43	47	75	90
17-6	30		19	25	29	35	41	45	73	88
18-0	30			25	28	34	40	44	71	85
18-6	30			24	27	33	39	43	69	83
19-0	30			23	27	32	38	42	67	81
19-6	30			23	26	31	37	41	65	79
20-0	30				25	31	36	40	64	77
20-6	36				25	30	35	39	62	75
21-0	36				24	29	34	38	61	73
21-6	36					28	34	37	59	71
22-0	36					28	33	36	58	70
22-6	36					27	32	35	57	68
23-0	36						31	34	55	67
23-6	36						30	34	54	65
24-0	36							33	53	64
24-6	42							32	51	62
25-0	42								49	60
25-6	42								48	58
26-0	42								46	56

Notes:

1. Tables based upon AASHTO Sec. 12 Standard Specifications for Highway Bridges.
2. H-20, HS-20, H-25, HS-25 live loads
3. Minimum cover is defined as the vertical distance from the top of the corrugated structure to the bottom of flexible or top of rigid pavement.
4. Minimum cover for heavy off-road construction equipment loads must be checked.

**TABLE 18. PLATE ARRANGEMENT AND APPROXIMATE WEIGHT PER FOOT
FOR MULTI-PLATE® VERTICAL ELLIPSE SHAPES**

Nominal Pipe Diameter Pi	5% Vertical Ellipse		Number of Plates Per Ring					Approximate Weight Per Foot of Structures, Lbs. Specified Thickness, Inches							
	Horizontal (Inches)	Vertical (Inches)	Area Sq. Ft.	Pi				Total Plates	0.111 (12 Ga.)	0.140 (10 Ga.)	0.170 (8 Ga.)	0.188 (7 Ga.)	0.218 (5 Ga.)	0.249 (3 Ga.)	0.280 (1 Ga.)
				15	18	21	24								
60	56	62	19	4				4	110	138	166	180	208	236	264
66	62	68	23	2	2			4	119	150	180	196	227	257	287
72	68	75	28		4			4	129	162	195	212	245	277	310
78	73	81	32		2	2		4	138	174	209	227	263	298	333
84	79	88	38			4		4	147	185	223	243	281	318	356
90	85	94	44			2	2	4	157	198	239	260	300	341	382
96	91	101	50				4	4	168	211	254	276	320	364	407
102	97	107	56	2	4			6	184	231	278	302	349	395	442
108	103	114	63		6			6	193	242	292	317	367	416	465
114	109	120	71		4	2		6	202	254	306	333	385	436	488
120	115	127	79		2	4		6	212	266	321	349	403	457	512
126	120	133	87			6		6	221	278	335	364	421	478	535
132	126	139	95			4	2	6	231	291	350	381	440	500	560
138	132	146	104			2	4	6	241	304	366	398	460	523	585
144	138	152	114				6	6	251	316	381	415	479	546	611
150	142	157	124		6	2		8	267	335	404	439	507	575	644
156	148	163	134		4	4		8	276	347	418	454	525	596	667
162	154	170	144		2	6		8	285	359	432	470	543	616	690
168	159	176	155			8		8	295	371	447	485	561	637	713
174	165	183	167			6	2	8	305	384	462	502	581	660	738
180	171	189	179			4	4	8	315	396	478	519	600	682	764
186	177	195	191			2	6	8	325	409	493	536	620	705	789
192	182	202	204				8	8	335	422	508	553	639	728	814
198	189	209	217		4	6		10		440	530	576	666	755	845
204	195	215	230		2	8		10		452	544	591	684	776	868
210	201	222	244			10		10		464	559	607	701	796	891
216	206	228	258			8	2	10		476	574	624	721	819	917
222	212	235	273			6	4	10			589	640	741	841	942
228	218	241	288			4	6	10			605	657	760	864	967
234	224	247	303			2	8	10			620	674	780	887	993
240	229	253	319				10	10			635	691	799	909	1018
246	236	261	336		2	10		12				713	824	935	1046
252	242	267	352			12		12				728	842	955	1069
258	247	273	370			10	2	12					861	978	1095
264	253	280	387			8	4	12					881	1001	1120
270	259	286	405			6	6	12					900	1023	1145
276	264	291	423			4	8	12					920	1046	1171
282	271	299	442			2	10	12						1069	1196
288	276	305	461				12	12						1091	1222
294	283	312	481			14		14						1115	1248
300	289	319	501			12	2	14						1137	1273
306	294	325	521			10	4	14						1160	1298
312	300	332	542			8	6	14						1183	1324

Notes:

1. Dimensions are to inside crests of corrugations and are subject to manufacturing tolerances.
2. These plate arrangements will be furnished unless noted otherwise on assembly drawings.
3. Approximate weights include galvanized steel material, bolts, and nuts.
4. Specified thickness is a nominal galvanized thickness.
5. 24 pi plates are not available in 5/16 through 3/8. Inquire for number of plates per ring and structure weights.

MULTI-PLATE®

TABLE 22. MULTI-PLATE® ARCHES

Dimensions					Nominal Arc Length	
Span Ft.-In.	Rise Ft.-In.	Waterway Area Ft. ²	Rise/Span Ratio	Radius Inches	Pi	
6-0	1-10	7.9	0.30	41	27	
	2-4	10.0	0.38	37	30	
	3-2	15.0	0.53	36	36	
7-0	2-5	12.1	0.34	45	33	
	2-10	14.9	0.41	43	36	
	3-8	20.4	0.52	42	42	
8-0	2-11	17.0	0.36	51	39	
	3-4	20.3	0.42	49	42	
	4-2	26.6	0.52	48	48	
9-0	2-11	19.2	0.33	59	42	
	3-11	26.5	0.43	55	48	
	4-8	33.6	0.52	54	54	
10-0	3-6	25.4	0.35	64	48	
	4-5	33.5	0.44	61	54	
	5-3	41.4	0.52	60	60	
11-0	3-6	27.8	0.32	73	51	
	4-6	36.9	0.41	68	57	
	5-9	50.0	0.52	66	66	
12-0	4-1	35.3	0.34	78	57	
	5-0	45.2	0.42	73	63	
	6-3	59.4	0.52	72	72	
13-0	4-1	38.1	0.33	87	60	
	5-1	48.9	0.40	81	66	
	6-9	69.7	0.52	78	78	
14-0	4-8	47.0	0.31	91	66	
	5-7	58.5	0.38	86	72	
	7-3	80.7	0.44	84	84	
15-0	4-8	48.9	0.52	101	69	
	5-8	62.8	0.33	93	75	
	6-7	74.8	0.44	91	81	
	7-9	92.6	0.52	90	90	
16-0	5-3	60.1	0.31	105	75	
	7-1	86.2	0.42	97	87	
	8-4	105.3	0.52	96	96	
17-0	5-3	63.4	0.31	115	78	
	7-2	91.9	0.42	103	90	
	8-10	118.8	0.52	102	102	
18-0	5-9	74.8	0.32	119	84	
	7-8	104.6	0.43	109	96	
	8-11	126.0	0.50	108	105	
19-0	6-4	87.1	0.33	123	90	
	8-3	118.1	0.43	115	102	
	9-5	140.7	0.50	114	111	
20-0	6-4	91.0	0.32	133	93	
	8-3	124.4	0.42	122	105	
	10-0	156.3	0.50	120	117	
21-0	6-11	104.6	0.33	137	99	
	8-10	139.2	0.42	128	111	
	10-6	172.6	0.50	126	123	
22-0	6-11	109.3	0.32	146	102	
	8-11	145.9	0.40	135	114	
	11-0	189.8	0.50	132	129	
23-0	8-0	133.6	0.35	147	111	
	9-10	171.1	0.43	140	123	
	11-6	207.8	0.50	138	135	
24-0	8-6	149.4	0.36	152	117	
	10-4	188.3	0.43	146	129	
	12-0	226.6	0.50	144	141	
25-0	8-7	155.6	0.34	160	120	
	10-10	206.3	0.43	152	135	
	12-6	246.2	0.50	150	147	
26-0	8-7	161.4	0.33	169	123	
	11-0	214.9	0.42	158	138	
	13-1	266.7	0.50	156	153	

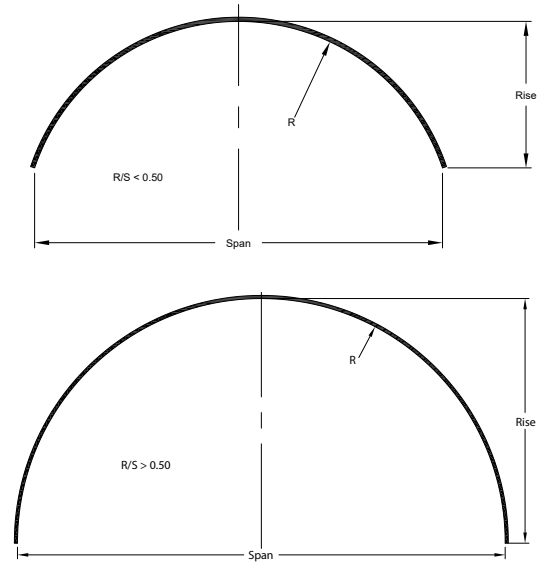

Single Radius Arch



MULTI-PLATE Arch Pedestrian Underpass

Notes:

1. Dimensions are to inside crests of corrugations and are subject to manufacturing tolerances.
2. To determine proper gage, use Table 24 and/or design information found on Pages 13-18.
3. For additional arch sizes, contact your Contech representative.

TABLE 23. PLATE ARRANGEMENT AND APPROXIMATE WEIGHT PER FOOT FOR SINGLE RADIUS MULTI-PLATE® ARCH

Arch Arc Length	Number of Plates Per Ring						Approximate Weight Per Foot of Structure, Pounds							
							Specified Thickness, Inches							
	Pi	9 Pi	15 Pi	18 Pi	21 Pi	24 Pi	Total Plates	0.111 (12 Ga.)	0.140 (10 Ga.)	0.170 (8 Ga.)	0.188 (7 Ga.)	0.218 (5 Ga.)	0.249 (3 Ga.)	0.280 (1 Ga.)
24						1	1	42	53	64	69	80	91	102
27	1			1			2	50	63	76	82	95	108	120
30		2					2	55	69	83	90	104	118	132
33		1	1				2	60	75	90	98	113	128	144
36		1			1		2	64	81	97	106	122	139	155
39				1	1		2	69	87	105	114	131	149	167
42				1		1	2	74	93	112	121	140	159	178
45					1	1	2	79	99	119	130	150	171	191
48						2	2	84	105	127	138	160	182	204
51		1	2				3	92	115	139	151	174	198	221
54			3				3	96	121	146	159	184	208	233
57			2	1			3	101	127	153	167	193	218	244
60			1	2			3	106	133	160	174	201	229	256
63				3			3	110	139	168	182	210	239	267
66				2	1		3	116	145	175	190	220	250	280
69				1	2		3	121	152	183	199	230	262	293
72					3		3	126	158	191	207	240	273	305
75			3	1			4	133	168	202	219	254	288	322
78			2	2			4	138	174	209	227	263	298	333
81			1	3			4	143	179	216	235	272	308	345
84			2			2	4	147	185	223	243	281	318	356
87				3	1		4	152	192	231	251	290	330	369
90				2	2		4	157	198	239	260	300	341	382
93				1	3		4	163	205	246	268	310	352	395
96			3	2			5	168	211	254	276	320	364	407
99			2	3			5	175	220	265	288	333	377	422
102			1	4			5	179	226	272	296	342	388	434
105				5			5	184	232	279	303	351	398	446
108				4	1		5		238	287	312	361	409	458
111				3	2		5		245	295	320	370	421	471
114				2	3		5		251	302	329	380	432	484
117				1	4		5		257	310	337	390	443	496
120					5		5		264	318	345	400	455	509
123			1	5			6			328	356	412	467	523
126			3			3	6			335	364	421	478	535
129				5	1		6			343	372	431	489	547
132				4	2		6				381	440	500	560
135				3	3		6				389	450	512	573
138				2	4		6				398	460	523	585
141				1	5		6				406	470	534	598
144			1	6			7					479	546	611
147				7			7					491	557	624
150				6	1		7					503	567	636
153				5	2		7					515	575	650

Notes:

1. Dimensions are to inside crests of corrugations and are subject to manufacturing tolerances.
2. These plate arrangements will be furnished unless noted otherwise on assembly drawings.
3. Approximate weights include galvanized steel material, bolts, and nuts.
4. 24 pi plates are not available in 5/16 through 3/8. Inquire for number of plates per ring and structure weights.

MULTI-PLATE®

**TABLE 24. MULTI-PLATE® ARCH 6" X 2"
AASHTO HEIGHT OF COVER LIMITS H-20, HS-20, H-25, HS-25 LIVE LOADS**

Span Ft.-In.	Rise Ft.-In.	Minimum Cover (Inches)	Thickness in Inches (Gage) (Maximum Cover Height Shown In Feet)								
			0.111	0.140	0.170	0.188	0.218	0.249	0.280	0.318	0.380
			(12 Ga.)	(10 Ga.)	(8 Ga.)	(7 Ga.)	(5 Ga.)	(3 Ga.)	(1 Ga.)	(5/16)	(3/8)
6-0	1-10	12	39	57	75	86	103	122	133	214	257
	2-4										
7-0	3-2	12	34	49	64	73	88	104	114	183	220
	2-5										
8-0	2-10	12	29	43	56	64	77	91	100	160	192
	3-8										
9-0	2-11	18	26	38	50	57	69	81	88	142	171
	3-4										
10-0	4-2	18	23	34	45	51	62	73	80	128	154
	2-11										
11-0	3-11	18	21	31	40	46	56	66	72	116	140
	4-8										
12-0	3-6	18	19	28	37	43	51	61	66	107	128
	4-5										
13-0	5-3	24	18	26	34	39	47	56	61	98	118
	3-6										
14-0	4-6	24	17	24	32	36	44	52	57	91	110
	5-9										
15-0	6-3	24	15	22	30	34	41	48	53	85	102
	4-1										
16-0	5-1	24	14	21	28	32	38	45	50	80	96
	6-9										
17-0	4-8	30	14	20	26	30	36	43	47	75	90
	5-7										
18-0	7-3	30	13	19	25	28	34	40	44	71	85
	8-10										
19-0	5-3	30	12	18	23	27	32	38	42	67	81
	7-8										
20-0	8-11	30	10	17	22	25	31	36	40	64	77
	6-4										
21-0	8-3	36	16	21	24	29	34	38	42	61	73
	10-0										
22-0	6-11	36	20	23	28	33	36	36	36	58	70
	8-10										
23-0	10-6	36	19	22	27	31	34	34	34	55	67
	6-11										
24-0	8-11	36	18	21	25	30	33	33	33	53	64
	11-0										
25-0	9-10	42	20	24	29	32	32	32	32	49	60
	11-6										
26-0	8-6	42	23	28	30	30	30	30	30	46	56
	10-4										
	12-0										
	8-7										
	10-10										
	12-6										
	8-7										
	11-0										
	13-1										

Notes:

1. Tables based upon AASHTO Sec. 12 Standard Specifications for Highway Bridges.
2. H-20, HS-20, H-25, HS-25 Live Loads.
3. Minimum cover is defined as the vertical distance from the top of the corrugated structure to the bottom of flexible or top of rigid pavement.
4. Minimum cover for heavy off-road construction equipment loads must be checked.
5. Footing reactions can be provided by supplier.

Galvanized Steel Structural Plate Specification

Scope: This specification covers the manufacture and installation of the galvanized steel structural plate structure detailed in the plans.

Material: The galvanized steel structural plate structure shall consist of plate and appurtenant items as shown on the plans and shall conform to the requirements of AASHTO M 167/ASTM A761. All manufacturing processes, including corrugating, punching, curving and galvanizing, shall be performed within the United States using raw materials made in the United States.

Assembly bolts and nuts shall be galvanized and meet the provisions of ASTM A449, Type 1 and ASTM A563, Grade C, respectively.

Assembly: The structure shall be assembled in accordance with the shop drawings provided by the manufacturer and per the manufacturer's recommendations. Bolts shall be tightened using an applied torque of between 100 and 300 ft.-lbs. When seam sealant tape is used, bolts shall be installed and retightened to these torque levels after 24 hours. Torque levels are for installation, not residual, in-service requirements.

Installation: The structure shall be installed in accordance with the plans and specifications, the manufacturer's recommendations, and the AASHTO Standard Specifications for Highway Bridges, Section 26 (Division II).

Backfill: The structure shall be backfilled using clean, well graded granular material that meets the requirements of AASHTO M 145 for soil classification A-1, A-2-4, A-2-5, or A-3. Backfill must be placed symmetrically on each side of the structure in 8-inch uncompacted lifts. Each lift shall be compacted to a minimum of 90 percent density per AASHTO T 180.

Notes: Construction loads that exceed highway load limits are not allowed on the structure without approval from the Engineer.



Hot-Dip Galvanizing Process

Galvanized Steel Key-Hole Slot Structural Plate Specification

Scope: This specification covers the manufacture and installation of the galvanized steel structural plate structure detailed in the plans.

Material: The galvanized steel structural plate structure shall consist of plates and appurtenant items as shown on the plans and shall conform to the requirements of AASHTO M 167/ASTM A761 except the longitudinal seam bolt holes shall be key-hole shaped as shown in the plans. All manufacturing processes including corrugating, punching, curving and galvanizing, shall be performed within the United States using raw materials made in the United States.

Assembly bolts and nuts shall be galvanized and meet the provisions of ASTM A449, Type 1 and ASTM A563, Grade C, respectively.

Assembly: The structure shall be assembled in accordance with the shop drawings provided by the manufacturer and per the manufacturer's recommendations. Bolts shall be tightened using an applied torque of between 100 and 300 ft.-lbs.

Installation: The structure shall be installed in accordance with the plans and specifications, the manufacturer's recommendations, and the AASHTO Standard Specifications for Highway Bridges, Section 26 (Construction).

Backfill: The structure shall be backfilled using clean, well graded granular material that meets the requirements of AASHTO M 145 for soil classifications A-1-a. Backfill must be placed symmetrically on each side of the structure in 8-inch uncompacted lifts. Each lift shall be compacted to a minimum of 90 percent density per AASHTO T 180. Backfill limits shall be in accordance with the details shown on the plans.

Notes: Construction loads that exceed highway load limits are not allowed on the structure without approval from the Project Engineer.

Installation

A successful installation is dependent on these five critical components being followed:

- Good foundation
- Use of structural backfill
- 8" lifts of backfill evenly placed on both sides of the structure
- Adequate compaction of backfill
- Adequate minimum cover over the structure

Required Elements

Satisfactory site preparation, trench excavation and bedding and backfill operations are essential to develop the strength of any flexible conduit. In order to obtain proper strength while preventing settlement, it is necessary that the soil envelope around the structure be of good granular material, properly placed, and carefully compacted.

Pipe-arch and underpass shapes pose special installation problems not found in other shapes. These two shapes generate high corner bearing pressures against the side fill and foundation. Therefore, special installation care must be implemented to achieve a composite soil structure.

A qualified Engineer should be engaged to design a proper foundation, adequate bedding, backfill, and erosion control.

Trench Excavation

If the adjacent embankment material is structurally adequate, the trench requires only a bottom clear width of the structure's span plus sufficient room for compaction equipment.

Bedding

Proper bedding preparation is critical to both structure performance and service life. The bedding should be constructed to a uniform line and grade to avoid distortions that may create undesirable stresses in the structure and/or rapid deterioration of the roadway. It should be free of rock formations, protruding stones, and frozen matter that may cause unequal settlement.

It is recommended that the bedding be a relatively loose granular material that is roughly shaped to fit the bottom of the structure, be a minimum of twice the corrugation depth in thickness and have a maximum particle size of one half the corrugation depth.

It should be noted that the bedding depth can vary based on the amount of cover and the shape of the structure's invert. The bedding should be shaped to match structures with flatter inverts.

Backfill

Satisfactory backfill material, proper placement and compaction are key factors in obtaining maximum strength and stability. Compaction needs to be achieved under the haunches by carefully tamping a granular or select material.

The backfill material should be free of rocks, frozen lumps, and foreign material that can cause hard spots or decompose to create voids. Backfill material should be well graded granular material that meets the requirements of AASHTO M 145 for soil classifications A-1, A-2-4, A-2-5, or A-3. Backfill must be placed symmetrically on each side of the structure in six-inch loose lifts. Each lift is to be compacted to a minimum of 90 percent density per AASHTO T 180.

A high percentage of silt or fine sand in the native soils suggests the need for a *well graded* granular backfill material to prevent soil migration.

During backfill, only small tracked vehicles (D4 or smaller) should be near the structure as fill progresses above the crown and to the finished grade. The Engineer and Contractor are cautioned that the minimum cover may need to be increased to handle temporary construction vehicle loads (larger than D4).

For more information, refer to ASTM A807 and AASHTO Standard Specifications for Highway Bridges Div. II – Construction Section 26.

Bolting

If the plates are well aligned, the torque applied with an air-powered wrench need not be excessive. Bolts should be torque initially to a minimum 100 foot pounds and a maximum 300 foot pounds. A good plate fit is far better than high torque.

Complete detailed assembly instructions and drawings are provided with each structure.

Erosion Control

During installation and prior to the construction of permanent erosion control and end treatment protection, special precautions may be necessary. The structure must be protected from unbalanced loads and from any structural loads or hydraulic forces that may bend or distort the unsupported ends of the structure. Erosion or washout of previously soils support must be prevented to ensure that the structure maintains its load capacity.

Design Procedure Form: Extended Detention Basin (EDB)

UD-BMP (Version 3.07, March 2018)

Sheet 1 of 3

Designer: Marc A. Whorton, P.E.
Company: Classic Consulting
Date: June 26, 2019
Project: Retreat at TimberRidge Filing No. 1
Location: Pond 1

<p>1. Basin Storage Volume</p> <p>A) Effective Imperviousness of Tributary Area, I_a</p> <p>B) Tributary Area's Imperviousness Ratio ($i = I_a / 100$)</p> <p>C) Contributing Watershed Area</p> <p>D) For Watersheds Outside of the Denver Region, Depth of Average Runoff Producing Storm</p> <p>E) Design Concept (Select EURV when also designing for flood control)</p> <p>F) Design Volume (WQCV) Based on 40-hour Drain Time ($V_{DESIGN} = (1.0 * (0.91 * i^3 - 1.19 * i^2 + 0.78 * i) / 12 * Area)$)</p> <p>G) For Watersheds Outside of the Denver Region, Water Quality Capture Volume (WQCV) Design Volume ($V_{WQCV\ OTHER} = (d_s * V_{DESIGN} / 0.43)$)</p> <p>H) User Input of Water Quality Capture Volume (WQCV) Design Volume (Only if a different WQCV Design Volume is desired)</p> <p>I) NRCS Hydrologic Soil Groups of Tributary Watershed i) Percentage of Watershed consisting of Type A Soils ii) Percentage of Watershed consisting of Type B Soils iii) Percentage of Watershed consisting of Type C/D Soils</p> <p>J) Excess Urban Runoff Volume (EURV) Design Volume For HSG A: $EURV_A = 1.68 * i^{1.28}$ For HSG B: $EURV_B = 1.36 * i^{1.08}$ For HSG C/D: $EURV_{C/D} = 1.20 * i^{1.08}$</p> <p>K) User Input of Excess Urban Runoff Volume (EURV) Design Volume (Only if a different EURV Design Volume is desired)</p>	<p>$I_a =$ <input type="text" value="13.8"/> %</p> <p>$i =$ <input type="text" value="0.138"/></p> <p>Area = <input type="text" value="29.400"/> ac</p> <p>$d_s =$ <input type="text" value="0.42"/> in</p> <p>Choose One <input type="radio"/> Water Quality Capture Volume (WQCV) <input checked="" type="radio"/> Excess Urban Runoff Volume (EURV)</p> <p>$V_{DESIGN} =$ <input type="text"/> ac-ft</p> <p>$V_{DESIGN\ OTHER} =$ <input type="text" value="0.209"/> ac-ft</p> <p>$V_{DESIGN\ USER} =$ <input type="text"/> ac-ft</p> <p>HSG _A = <input type="text" value="0"/> % HSG _B = <input type="text" value="100"/> % HSG _{C/D} = <input type="text" value="0"/> %</p> <p>$EURV_{DESIGN} =$ <input type="text" value="0.392"/> ac-ft</p> <p>$EURV_{DESIGN\ USER} =$ <input type="text"/> ac-ft</p>
<p>2. Basin Shape: Length to Width Ratio (A basin length to width ratio of at least 2:1 will improve TSS reduction.)</p>	<p>L : W = <input type="text" value="2.0"/> : 1</p>
<p>3. Basin Side Slopes</p> <p>A) Basin Maximum Side Slopes (Horizontal distance per unit vertical, 4:1 or flatter preferred)</p>	<p>Z = <input type="text" value="4.00"/> ft / ft</p>
<p>4. Inlet</p> <p>A) Describe means of providing energy dissipation at concentrated inflow locations:</p>	<p><u>Rip-Rap and Concrete Forebay into Concrete trickle channel</u></p> <hr/> <hr/> <hr/>
<p>5. Forebay</p> <p>A) Minimum Forebay Volume ($V_{FMIN} =$ <input type="text" value="2"/> % of the WQCV)</p> <p>B) Actual Forebay Volume</p> <p>C) Forebay Depth ($D_F =$ <input type="text" value="18"/> inch maximum)</p> <p>D) Forebay Discharge i) Undetained 100-year Peak Discharge ii) Forebay Discharge Design Flow ($Q_F = 0.02 * Q_{100}$)</p> <p>E) Forebay Discharge Design</p> <p>F) Discharge Pipe Size (minimum 8-inches)</p> <p>G) Rectangular Notch Width</p>	<p>$V_{FMIN} =$ <input type="text" value="0.004"/> ac-ft</p> <p>$V_F =$ <input type="text" value="0.004"/> ac-ft</p> <p>$D_F =$ <input type="text" value="8.0"/> in</p> <p>$Q_{100} =$ <input type="text" value="47.00"/> cfs</p> <p>$Q_F =$ <input type="text" value="0.94"/> cfs</p> <p>Choose One <input type="radio"/> Berm With Pipe <input checked="" type="radio"/> Wall with Rect. Notch <input type="radio"/> Wall with V-Notch Weir</p> <p align="right" style="color: blue;">Flow too small for berm w/ pipe</p> <p>Calculated $D_P =$ <input type="text"/> in</p> <p>Calculated $W_N =$ <input type="text" value="7.8"/> in</p>

Design Procedure Form: Extended Detention Basin (EDB)

Sheet 2 of 3

Designer: Marc A. Whorton, P.E.
Company: Classic Consulting
Date: June 26, 2019
Project: Retreat at TimberRidge Filing No. 1
Location: Pond 1

<p>6. Trickle Channel</p> <p>A) Type of Trickle Channel</p> <p>F) Slope of Trickle Channel</p>	<p>Choose One</p> <p><input checked="" type="radio"/> Concrete</p> <p><input type="radio"/> Soft Bottom</p> <p>S = <input type="text" value="0.0100"/> ft / ft</p>
<p>7. Micropool and Outlet Structure</p> <p>A) Depth of Micropool (2.5-foot minimum)</p> <p>B) Surface Area of Micropool (10 ft² minimum)</p> <p>C) Outlet Type</p> <p>D) Smallest Dimension of Orifice Opening Based on Hydrograph Routing (Use UD-Detention)</p> <p>E) Total Outlet Area</p>	<p>D_M = <input type="text" value="2.5"/> ft</p> <p>A_M = <input type="text" value="45"/> sq ft</p> <p>Choose One</p> <p><input checked="" type="radio"/> Orifice Plate</p> <p><input type="radio"/> Other (Describe):</p> <p>_____</p> <p>_____</p> <p>D_{orifice} = <input type="text" value="1.24"/> inches</p> <p>A_{orifice} = <input type="text" value="3.82"/> square inches</p>
<p>8. Initial Surcharge Volume</p> <p>A) Depth of Initial Surcharge Volume (Minimum recommended depth is 4 inches)</p> <p>B) Minimum Initial Surcharge Volume (Minimum volume of 0.3% of the WQCV)</p> <p>C) Initial Surcharge Provided Above Micropool</p>	<p>D_{IS} = <input type="text" value="6"/> in</p> <p>V_{IS} = <input type="text"/> cu ft</p> <p>V_s = <input type="text" value="22.5"/> cu ft</p>
<p>9. Trash Rack</p> <p>A) Water Quality Screen Open Area: $A_t = A_{ot} * 38.5 * (e^{-0.095D})$</p> <p>B) Type of Screen (If specifying an alternative to the materials recommended in the USDCM, indicate "other" and enter the ratio of the total open are to the total screen are for the material specified.)</p> <p>Other (Y/N): <input type="text" value="N"/></p> <p>C) Ratio of Total Open Area to Total Area (only for type 'Other')</p> <p>D) Total Water Quality Screen Area (based on screen type)</p> <p>E) Depth of Design Volume (EURV or WQCV) (Based on design concept chosen under 1E)</p> <p>F) Height of Water Quality Screen (H_{TR})</p> <p>G) Width of Water Quality Screen Opening (W_{opening}) (Minimum of 12 inches is recommended)</p>	<p>A_t = <input type="text" value="131"/> square inches</p> <p><input type="text" value="S.S. Well Screen with 60% Open Area"/></p> <p>_____</p> <p>_____</p> <p>User Ratio = <input type="text"/></p> <p>A_{total} = <input type="text" value="218"/> sq. in.</p> <p>H = <input type="text" value="3.5"/> feet</p> <p>H_{TR} = <input type="text" value="70"/> inches</p> <p>W_{opening} = <input type="text" value="12.0"/> inches VALUE LESS THAN RECOMMENDED MIN. WIDTH. WIDTH HAS BEEN SET TO 12 INCHES.</p>

Design Procedure Form: Extended Detention Basin (EDB)

Sheet 3 of 3

Designer: Marc A. Whorton, P.E.
Company: Classic Consulting
Date: June 26, 2019
Project: Retreat at TimberRidge Filing No. 1
Location: Pond 1

<p>10. Overflow Embankment</p> <p>A) Describe embankment protection for 100-year and greater overtopping:</p> <p>B) Slope of Overflow Embankment (Horizontal distance per unit vertical, 4:1 or flatter preferred)</p>	<p>Buried Rip-Rap</p> <hr/> <hr/> <p>Ze = <input type="text" value="10.00"/> ft / ft</p>
<p>11. Vegetation</p>	<p>Choose One</p> <p><input type="radio"/> Irrigated</p> <p><input checked="" type="radio"/> Not Irrigated</p>
<p>12. Access</p> <p>A) Describe Sediment Removal Procedures</p>	<p>Maintenace provided via access road</p> <hr/> <hr/> <hr/> <hr/>
<p>Notes: _____</p> <hr/> <hr/> <hr/>	

Design Procedure Form: Extended Detention Basin (EDB)

UD-BMP (Version 3.07, March 2018)

Sheet 1 of 3

Designer: MARC A. WHORTON, P.E.
Company: CLASSICCONSULTING
Date: August 1, 2019
Project: RETREAT AT TIMBERRIDGE FILING NO. 1
Location: POND 2

<p>1. Basin Storage Volume</p> <p>A) Effective Imperviousness of Tributary Area, I_a</p> <p>B) Tributary Area's Imperviousness Ratio ($i = I_a / 100$)</p> <p>C) Contributing Watershed Area</p> <p>D) For Watersheds Outside of the Denver Region, Depth of Average Runoff Producing Storm</p> <p>E) Design Concept (Select EURV when also designing for flood control)</p> <p>F) Design Volume (WQCV) Based on 40-hour Drain Time ($V_{DESIGN} = (1.0 * (0.91 * i^3 - 1.19 * i^2 + 0.78 * i) / 12 * Area)$)</p> <p>G) For Watersheds Outside of the Denver Region, Water Quality Capture Volume (WQCV) Design Volume ($V_{WQCV\ OTHER} = (d_s * V_{DESIGN} / 0.43)$)</p> <p>H) User Input of Water Quality Capture Volume (WQCV) Design Volume (Only if a different WQCV Design Volume is desired)</p> <p>I) NRCS Hydrologic Soil Groups of Tributary Watershed i) Percentage of Watershed consisting of Type A Soils ii) Percentage of Watershed consisting of Type B Soils iii) Percentage of Watershed consisting of Type C/D Soils</p> <p>J) Excess Urban Runoff Volume (EURV) Design Volume For HSG A: $EURV_A = 1.68 * i^{1.28}$ For HSG B: $EURV_B = 1.36 * i^{1.08}$ For HSG C/D: $EURV_{C/D} = 1.20 * i^{1.08}$</p> <p>K) User Input of Excess Urban Runoff Volume (EURV) Design Volume (Only if a different EURV Design Volume is desired)</p>	<p>$I_a =$ <input type="text" value="21.6"/> %</p> <p>$i =$ <input type="text" value="0.216"/></p> <p>Area = <input type="text" value="100.400"/> ac</p> <p>$d_s =$ <input type="text" value="0.42"/> in</p> <p>Choose One <input type="radio"/> Water Quality Capture Volume (WQCV) <input checked="" type="radio"/> Excess Urban Runoff Volume (EURV)</p> <p>$V_{DESIGN} =$ <input type="text"/> ac-ft</p> <p>$V_{DESIGN\ OTHER} =$ <input type="text" value="0.998"/> ac-ft</p> <p>$V_{DESIGN\ USER} =$ <input type="text"/> ac-ft</p> <p>HSG _A = <input type="text" value="0"/> % HSG _B = <input type="text" value="100"/> % HSG _{C/D} = <input type="text" value="0"/> %</p> <p>$EURV_{DESIGN} =$ <input type="text" value="2.174"/> ac-ft</p> <p>$EURV_{DESIGN\ USER} =$ <input type="text"/> ac-ft</p>
<p>2. Basin Shape: Length to Width Ratio (A basin length to width ratio of at least 2:1 will improve TSS reduction.)</p>	<p>L : W = <input type="text" value="2.0"/> : 1</p>
<p>3. Basin Side Slopes</p> <p>A) Basin Maximum Side Slopes (Horizontal distance per unit vertical, 4:1 or flatter preferred)</p>	<p>Z = <input type="text" value="4.00"/> ft / ft</p>
<p>4. Inlet</p> <p>A) Describe means of providing energy dissipation at concentrated inflow locations:</p>	<p>_____</p> <p>_____</p> <p>_____</p> <p>_____</p>
<p>5. Forebay</p> <p>A) Minimum Forebay Volume ($V_{MIN} =$ <input type="text" value="3%"/> of the WQCV)</p> <p>B) Actual Forebay Volume</p> <p>C) Forebay Depth ($D_F =$ <input type="text" value="30"/> inch maximum)</p> <p>D) Forebay Discharge i) Undetained 100-year Peak Discharge ii) Forebay Discharge Design Flow ($Q_F = 0.02 * Q_{100}$)</p> <p>E) Forebay Discharge Design</p> <p>F) Discharge Pipe Size (minimum 8-inches)</p> <p>G) Rectangular Notch Width</p>	<p>$V_{MIN} =$ <input type="text" value="0.030"/> ac-ft</p> <p>$V_F =$ <input type="text"/> ac-ft</p> <p>$D_F =$ <input type="text"/> in</p> <p>$Q_{100} =$ <input type="text"/> cfs</p> <p>$Q_F =$ <input type="text"/> cfs</p> <p>Choose One <input type="radio"/> Berm With Pipe <input type="radio"/> Wall with Rect. Notch <input type="radio"/> Wall with V-Notch Weir</p> <p>Calculated $D_P =$ <input type="text"/> in</p> <p>Calculated $W_N =$ <input type="text"/> in</p>

Design Procedure Form: Extended Detention Basin (EDB)

UD-BMP (Version 3.07, March 2018)

Sheet 1 of 3

Designer: MARC A. WHORTON, P.E.
Company: CLASSICCONSULTING
Date: March 26, 2019
Project: RETREAT AT TIMBERRIDGE FILING NO. 1
Location: POND 2 (EAST FOREBAY)

<p>1. Basin Storage Volume</p> <p>A) Effective Imperviousness of Tributary Area, I_a</p> <p>B) Tributary Area's Imperviousness Ratio ($i = I_a / 100$)</p> <p>C) Contributing Watershed Area</p> <p>D) For Watersheds Outside of the Denver Region, Depth of Average Runoff Producing Storm</p> <p>E) Design Concept (Select EURV when also designing for flood control)</p> <p>F) Design Volume (WQCV) Based on 40-hour Drain Time ($V_{DESIGN} = (1.0 * (0.91 * i^3 - 1.19 * i^2 + 0.78 * i) / 12 * Area)$)</p> <p>G) For Watersheds Outside of the Denver Region, Water Quality Capture Volume (WQCV) Design Volume ($V_{WQCV\ OTHER} = (d_s * V_{DESIGN} / 0.43)$)</p> <p>H) User Input of Water Quality Capture Volume (WQCV) Design Volume (Only if a different WQCV Design Volume is desired)</p> <p>I) NRCS Hydrologic Soil Groups of Tributary Watershed i) Percentage of Watershed consisting of Type A Soils ii) Percentage of Watershed consisting of Type B Soils iii) Percentage of Watershed consisting of Type C/D Soils</p> <p>J) Excess Urban Runoff Volume (EURV) Design Volume For HSG A: $EURV_A = 1.68 * i^{1.28}$ For HSG B: $EURV_B = 1.36 * i^{1.08}$ For HSG C/D: $EURV_{C/D} = 1.20 * i^{1.08}$</p> <p>K) User Input of Excess Urban Runoff Volume (EURV) Design Volume (Only if a different EURV Design Volume is desired)</p>	<p>$I_a =$ <input type="text" value="16.5"/> %</p> <p>$i =$ <input type="text" value="0.165"/></p> <p>Area = <input type="text" value="37.300"/> ac</p> <p>$d_s =$ <input type="text" value="0.42"/> in</p> <p>Choose One <input type="radio"/> Water Quality Capture Volume (WQCV) <input checked="" type="radio"/> Excess Urban Runoff Volume (EURV)</p> <p>$V_{DESIGN} =$ <input type="text"/> ac-ft</p> <p>$V_{DESIGN\ OTHER} =$ <input type="text" value="0.305"/> ac-ft</p> <p>$V_{DESIGN\ USER} =$ <input type="text"/> ac-ft</p> <p>HSG _A = <input type="text" value="0"/> % HSG _B = <input type="text" value="100"/> % HSG _{C/D} = <input type="text" value="0"/> %</p> <p>$EURV_{DESIGN} =$ <input type="text" value="0.604"/> ac-ft</p> <p>$EURV_{DESIGN\ USER} =$ <input type="text"/> ac-ft</p>
<p>2. Basin Shape: Length to Width Ratio (A basin length to width ratio of at least 2:1 will improve TSS reduction.)</p>	<p>L : W = <input type="text" value="2.0"/> : 1</p>
<p>3. Basin Side Slopes</p> <p>A) Basin Maximum Side Slopes (Horizontal distance per unit vertical, 4:1 or flatter preferred)</p>	<p>Z = <input type="text" value="4.00"/> ft / ft</p>
<p>4. Inlet</p> <p>A) Describe means of providing energy dissipation at concentrated inflow locations:</p>	<p>_____</p> <p>_____</p> <p>_____</p> <p>_____</p>
<p>5. Forebay</p> <p>A) Minimum Forebay Volume ($V_{FMIN} =$ <input type="text" value="3%"/> of the WQCV)</p> <p>B) Actual Forebay Volume</p> <p>C) Forebay Depth ($D_F =$ <input type="text" value="18"/> inch maximum)</p> <p>D) Forebay Discharge i) Undetained 100-year Peak Discharge ii) Forebay Discharge Design Flow ($Q_F = 0.02 * Q_{100}$)</p> <p>E) Forebay Discharge Design</p> <p>F) Discharge Pipe Size (minimum 8-inches)</p> <p>G) Rectangular Notch Width</p>	<p>$V_{FMIN} =$ <input type="text" value="0.009"/> ac-ft</p> <p>$V_F =$ <input type="text" value="0.009"/> ac-ft</p> <p>$D_F =$ <input type="text" value="18.0"/> in</p> <p>$Q_{100} =$ <input type="text" value="74.00"/> cfs</p> <p>$Q_F =$ <input type="text" value="1.48"/> cfs</p> <p>Choose One <input type="radio"/> Berm With Pipe <input checked="" type="radio"/> Wall with Rect. Notch <input type="radio"/> Wall with V-Notch Weir</p> <p align="right" style="color: blue;">Flow too small for berm w/ pipe</p> <p>Calculated $D_P =$ <input type="text"/> in</p> <p>Calculated $W_N =$ <input type="text" value="6.5"/> in</p>

Design Procedure Form: Extended Detention Basin (EDB)

Sheet 2 of 3

Designer: MARC A. WHORTON, P.E.
Company: CLASSICCONSULTING
Date: March 26, 2019
Project: RETREAT AT TIMBERRIDGE FILING NO. 1
Location: POND 2 (EAST FOREBAY)

<p>6. Trickle Channel</p> <p>A) Type of Trickle Channel</p> <p>F) Slope of Trickle Channel</p>	<p>Choose One</p> <p><input checked="" type="radio"/> Concrete</p> <p><input type="radio"/> Soft Bottom</p> <p>S = <input type="text" value="0.0100"/> ft / ft</p>
<p>7. Micropool and Outlet Structure</p> <p>A) Depth of Micropool (2.5-foot minimum)</p> <p>B) Surface Area of Micropool (10 ft² minimum)</p> <p>C) Outlet Type</p> <p>D) Smallest Dimension of Orifice Opening Based on Hydrograph Routing (Use UD-Detention)</p> <p>E) Total Outlet Area</p>	<p>D_M = <input type="text" value="2.5"/> ft</p> <p>A_M = <input type="text" value="200"/> sq ft</p> <p>Choose One</p> <p><input checked="" type="radio"/> Orifice Plate</p> <p><input type="radio"/> Other (Describe):</p> <p>_____</p> <p>_____</p> <p>D_{orifice} = <input type="text" value="2.25"/> inches</p> <p>A_{orifice} = <input type="text" value="13.43"/> square inches</p>
<p>8. Initial Surcharge Volume</p> <p>A) Depth of Initial Surcharge Volume (Minimum recommended depth is 4 inches)</p> <p>B) Minimum Initial Surcharge Volume (Minimum volume of 0.3% of the WQCV)</p> <p>C) Initial Surcharge Provided Above Micropool</p>	<p>D_{IS} = <input type="text" value="6"/> in</p> <p>V_{IS} = <input type="text" value="40"/> cu ft</p> <p>V_s = <input type="text" value="100.0"/> cu ft</p>
<p>9. Trash Rack</p> <p>A) Water Quality Screen Open Area: $A_t = A_{ot} * 38.5 * (e^{-0.095D})$</p> <p>B) Type of Screen (If specifying an alternative to the materials recommended in the USDCM, indicate "other" and enter the ratio of the total open area to the total screen area for the material specified.)</p> <p>Other (Y/N): <input type="text" value="N"/></p> <p>C) Ratio of Total Open Area to Total Area (only for type 'Other')</p> <p>D) Total Water Quality Screen Area (based on screen type)</p> <p>E) Depth of Design Volume (EURV or WQCV) (Based on design concept chosen under 1E)</p> <p>F) Height of Water Quality Screen (H_{TR})</p> <p>G) Width of Water Quality Screen Opening (W_{opening}) (Minimum of 12 inches is recommended)</p>	<p>A_t = <input type="text" value="418"/> square inches</p> <p><input o.c."="" type="text" value="Aluminum Amico-Klemp SR Series with Cross Rods 2"/></p> <p>_____</p> <p>_____</p> <p>User Ratio = <input type="text"/></p> <p>A_{total} = <input type="text" value="588"/> sq. in.</p> <p>H = <input type="text" value="5"/> feet</p> <p>H_{TR} = <input type="text" value="88"/> inches</p> <p>W_{opening} = <input type="text" value="12.0"/> inches VALUE LESS THAN RECOMMENDED MIN. WIDTH. WIDTH HAS BEEN SET TO 12 INCHES.</p>

Design Procedure Form: Extended Detention Basin (EDB)

Sheet 3 of 3

Designer: MARC A. WHORTON, P.E.
Company: CLASSICCONSULTING
Date: March 26, 2019
Project: RETREAT AT TIMBERRIDGE FILING NO. 1
Location: POND 2 (EAST FOREBAY)

<p>10. Overflow Embankment</p> <p>A) Describe embankment protection for 100-year and greater overtopping:</p> <p>B) Slope of Overflow Embankment (Horizontal distance per unit vertical, 4:1 or flatter preferred)</p>	<p>_____</p> <p>_____</p> <p>_____</p> <p>Ze = <input type="text" value=""/> ft / ft</p>
<p>11. Vegetation</p>	<p>Choose One</p> <p><input type="radio"/> Irrigated</p> <p><input type="radio"/> Not Irrigated</p>
<p>12. Access</p> <p>A) Describe Sediment Removal Procedures</p>	<p>_____</p> <p>_____</p> <p>_____</p> <p>_____</p> <p>_____</p>
<p>Notes: _____</p> <p>_____</p> <p>_____</p>	

Design Procedure Form: Extended Detention Basin (EDB)

UD-BMP (Version 3.07, March 2018)

Sheet 1 of 3

Designer: MARC A. WHORTON, P.E.
Company: CLASSICCONSULTING
Date: March 26, 2019
Project: RETREAT AT TIMBERRIDGE FILING NO. 1
Location: POND 2 (WEST FOREBAY)

<p>1. Basin Storage Volume</p> <p>A) Effective Imperviousness of Tributary Area, I_a</p> <p>B) Tributary Area's Imperviousness Ratio ($i = I_a / 100$)</p> <p>C) Contributing Watershed Area</p> <p>D) For Watersheds Outside of the Denver Region, Depth of Average Runoff Producing Storm</p> <p>E) Design Concept (Select EURV when also designing for flood control)</p> <p>F) Design Volume (WQCV) Based on 40-hour Drain Time ($V_{DESIGN} = (1.0 * (0.91 * i^3 - 1.19 * i^2 + 0.78 * i) / 12 * Area)$)</p> <p>G) For Watersheds Outside of the Denver Region, Water Quality Capture Volume (WQCV) Design Volume ($V_{WQCV\ OTHER} = (d_s * V_{DESIGN} / 0.43)$)</p> <p>H) User Input of Water Quality Capture Volume (WQCV) Design Volume (Only if a different WQCV Design Volume is desired)</p> <p>I) NRCS Hydrologic Soil Groups of Tributary Watershed i) Percentage of Watershed consisting of Type A Soils ii) Percentage of Watershed consisting of Type B Soils iii) Percentage of Watershed consisting of Type C/D Soils</p> <p>J) Excess Urban Runoff Volume (EURV) Design Volume For HSG A: $EURV_A = 1.68 * i^{1.28}$ For HSG B: $EURV_B = 1.36 * i^{1.08}$ For HSG C/D: $EURV_{C/D} = 1.20 * i^{1.08}$</p> <p>K) User Input of Excess Urban Runoff Volume (EURV) Design Volume (Only if a different EURV Design Volume is desired)</p>	<p>$I_a =$ <input type="text" value="25.0"/> %</p> <p>$i =$ <input type="text" value="0.250"/></p> <p>Area = <input type="text" value="65.300"/> ac</p> <p>$d_s =$ <input type="text" value="0.42"/> in</p> <p>Choose One <input type="radio"/> Water Quality Capture Volume (WQCV) <input checked="" type="radio"/> Excess Urban Runoff Volume (EURV)</p> <p>$V_{DESIGN} =$ <input type="text"/> ac-ft</p> <p>$V_{DESIGN\ OTHER} =$ <input type="text" value="0.717"/> ac-ft</p> <p>$V_{DESIGN\ USER} =$ <input type="text"/> ac-ft</p> <p>HSG _A = <input type="text" value="0"/> % HSG _B = <input type="text" value="100"/> % HSG _{C/D} = <input type="text" value="0"/> %</p> <p>$EURV_{DESIGN} =$ <input type="text" value="1.656"/> ac-ft</p> <p>$EURV_{DESIGN\ USER} =$ <input type="text"/> ac-ft</p>
<p>2. Basin Shape: Length to Width Ratio (A basin length to width ratio of at least 2:1 will improve TSS reduction.)</p>	<p>L : W = <input type="text" value="2.0"/> : 1</p>
<p>3. Basin Side Slopes</p> <p>A) Basin Maximum Side Slopes (Horizontal distance per unit vertical, 4:1 or flatter preferred)</p>	<p>Z = <input type="text" value="4.00"/> ft / ft</p>
<p>4. Inlet</p> <p>A) Describe means of providing energy dissipation at concentrated inflow locations:</p>	<p>_____</p> <p>_____</p> <p>_____</p> <p>_____</p>
<p>5. Forebay</p> <p>A) Minimum Forebay Volume ($V_{FMIN} =$ <input type="text" value="3%"/> of the WQCV)</p> <p>B) Actual Forebay Volume</p> <p>C) Forebay Depth ($D_F =$ <input type="text" value="18"/> inch maximum)</p> <p>D) Forebay Discharge</p> <p>i) Undetained 100-year Peak Discharge</p> <p>ii) Forebay Discharge Design Flow ($Q_F = 0.02 * Q_{100}$)</p> <p>E) Forebay Discharge Design</p> <p>F) Discharge Pipe Size (minimum 8-inches)</p> <p>G) Rectangular Notch Width</p>	<p>$V_{FMIN} =$ <input type="text" value="0.022"/> ac-ft</p> <p>$V_F =$ <input type="text" value="0.022"/> ac-ft</p> <p>$D_F =$ <input type="text" value="18.0"/> in</p> <p>$Q_{100} =$ <input type="text" value="128.00"/> cfs</p> <p>$Q_F =$ <input type="text" value="2.56"/> cfs</p> <p>Choose One <input type="radio"/> Berm With Pipe <input checked="" type="radio"/> Wall with Rect. Notch <input type="radio"/> Wall with V-Notch Weir</p> <p align="right" style="color: blue;">Flow too small for berm w/ pipe</p> <p>Calculated $D_P =$ <input type="text"/> in</p> <p>Calculated $W_N =$ <input type="text" value="8.6"/> in</p>

Design Procedure Form: Extended Detention Basin (EDB)

Designer: MARC A. WHORTON, P.E.
Company: CLASSICCONSULTING
Date: March 26, 2019
Project: RETREAT AT TIMBERRIDGE FILING NO. 1
Location: POND 2 (WEST FOREBAY)

<p>6. Trickle Channel</p> <p>A) Type of Trickle Channel</p> <p>F) Slope of Trickle Channel</p>	<p>Choose One</p> <p><input checked="" type="radio"/> Concrete</p> <p><input type="radio"/> Soft Bottom</p> <p>S = <input type="text" value="0.0100"/> ft / ft</p>
<p>7. Micropool and Outlet Structure</p> <p>A) Depth of Micropool (2.5-foot minimum)</p> <p>B) Surface Area of Micropool (10 ft² minimum)</p> <p>C) Outlet Type</p> <p>D) Smallest Dimension of Orifice Opening Based on Hydrograph Routing (Use UD-Detention)</p> <p>E) Total Outlet Area</p>	<p>D_M = <input type="text" value="2.5"/> ft</p> <p>A_M = <input type="text" value="200"/> sq ft</p> <p>Choose One</p> <p><input checked="" type="radio"/> Orifice Plate</p> <p><input type="radio"/> Other (Describe):</p> <p>_____</p> <p>_____</p> <p>D_{orifice} = <input type="text" value="2.25"/> inches</p> <p>A_{orifice} = <input type="text" value="13.43"/> square inches</p>
<p>8. Initial Surcharge Volume</p> <p>A) Depth of Initial Surcharge Volume (Minimum recommended depth is 4 inches)</p> <p>B) Minimum Initial Surcharge Volume (Minimum volume of 0.3% of the WQCV)</p> <p>C) Initial Surcharge Provided Above Micropool</p>	<p>D_{IS} = <input type="text" value="6"/> in</p> <p>V_{IS} = <input type="text" value="94"/> cu ft</p> <p>V_s = <input type="text" value="100.0"/> cu ft</p>
<p>9. Trash Rack</p> <p>A) Water Quality Screen Open Area: $A_t = A_{ot} * 38.5 * (e^{-0.095D})$</p> <p>B) Type of Screen (If specifying an alternative to the materials recommended in the USDCM, indicate "other" and enter the ratio of the total open are to the total screen are for the material specified.)</p> <p style="text-align: center;">Other (Y/N): <input type="text" value="N"/></p> <p>C) Ratio of Total Open Area to Total Area (only for type 'Other')</p> <p>D) Total Water Quality Screen Area (based on screen type)</p> <p>E) Depth of Design Volume (EURV or WQCV) (Based on design concept chosen under 1E)</p> <p>F) Height of Water Quality Screen (H_{TR})</p> <p>G) Width of Water Quality Screen Opening (W_{opening}) (Minimum of 12 inches is recommended)</p>	<p>A_t = <input type="text" value="418"/> square inches</p> <p><input o.c."="" type="text" value="Aluminum Amico-Klemp SR Series with Cross Rods 2"/></p> <p>_____</p> <p>_____</p> <p>User Ratio = <input type="text"/></p> <p>A_{total} = <input type="text" value="588"/> sq. in.</p> <p>H = <input type="text" value="5"/> feet</p> <p>H_{TR} = <input type="text" value="88"/> inches</p> <p>W_{opening} = <input type="text" value="12.0"/> inches VALUE LESS THAN RECOMMENDED MIN. WIDTH. WIDTH HAS BEEN SET TO 12 INCHES.</p>

Design Procedure Form: Extended Detention Basin (EDB)

Sheet 3 of 3

Designer: MARC A. WHORTON, P.E.
Company: CLASSICCONSULTING
Date: March 26, 2019
Project: RETREAT AT TIMBERRIDGE FILING NO. 1
Location: POND 2 (WEST FOREBAY)

<p>10. Overflow Embankment</p> <p>A) Describe embankment protection for 100-year and greater overtopping:</p> <p>B) Slope of Overflow Embankment (Horizontal distance per unit vertical, 4:1 or flatter preferred)</p>	<p>_____</p> <p>_____</p> <p>_____</p> <p>Ze = <input style="width: 50px;" type="text"/> ft / ft</p>
<p>11. Vegetation</p>	<p>Choose One</p> <p><input type="radio"/> Irrigated</p> <p><input type="radio"/> Not Irrigated</p>
<p>12. Access</p> <p>A) Describe Sediment Removal Procedures</p>	<p>_____</p> <p>_____</p> <p>_____</p> <p>_____</p> <p>_____</p>
<p>Notes: _____</p> <p>_____</p> <p>_____</p> <p>_____</p>	

Design Procedure Form: Rain Garden (RG)

UD-BMP (Version 3.07, March 2018)

Sheet 1 of 2

Designer: Marc A. Whorton, P.E.
Company: Classic Consulting
Date: July 19, 2019
Project: Retreat at TimberRidge Filing No. 1
Location: El Paso County RG-1

<p>1. Basin Storage Volume</p> <p>A) Effective Imperviousness of Tributary Area, I_a (100% if all paved and roofed areas upstream of rain garden)</p> <p>B) Tributary Area's Imperviousness Ratio ($i = I_a/100$)</p> <p>C) Water Quality Capture Volume (WQCV) for a 12-hour Drain Time ($WQCV = 0.8 * (0.91 * i^3 - 1.19 * i^2 + 0.78 * i)$)</p> <p>D) Contributing Watershed Area (including rain garden area)</p> <p>E) Water Quality Capture Volume (WQCV) Design Volume $Vol = (WQCV / 12) * Area$</p> <p>F) For Watersheds Outside of the Denver Region, Depth of Average Runoff Producing Storm</p> <p>G) For Watersheds Outside of the Denver Region, Water Quality Capture Volume (WQCV) Design Volume</p> <p>H) User Input of Water Quality Capture Volume (WQCV) Design Volume (Only if a different WQCV Design Volume is desired)</p>	<p>$I_a =$ <input style="width: 50px;" type="text" value="25.0"/> %</p> <p>$i =$ <input style="width: 50px;" type="text" value="0.250"/></p> <p>WQCV = <input style="width: 50px;" type="text" value="0.11"/> watershed inches</p> <p>Area = <input style="width: 50px;" type="text" value="117,600"/> sq ft</p> <p>$V_{WQCV} =$ <input style="width: 50px;" type="text" value=""/></p> <p>$d_6 =$ <input style="width: 50px;" type="text" value="0.42"/> in</p> <p>$V_{WQCV\ OTHER} =$ <input style="width: 50px;" type="text" value="1,033"/> cu ft</p> <p>$V_{WQCV\ USER} =$ <input style="width: 50px;" type="text" value=""/></p>
<p>2. Basin Geometry</p> <p>A) WQCV Depth (12-inch maximum)</p> <p>B) Rain Garden Side Slopes ($Z = 4$ min., horiz. dist per unit vertical) (Use "0" if rain garden has vertical walls)</p> <p>C) Minimum Flat Surface Area</p> <p>D) Actual Flat Surface Area</p> <p>E) Area at Design Depth (Top Surface Area)</p> <p>F) Rain Garden Total Volume ($V_T = ((A_{Top} + A_{Actual}) / 2) * Depth$)</p>	<p>$D_{WQCV} =$ <input style="width: 50px;" type="text" value="12"/> in</p> <p>$Z =$ <input style="width: 50px;" type="text" value="4.00"/> ft / ft</p> <p>$A_{Min} =$ <input style="width: 50px;" type="text" value="588"/> sq ft</p> <p>$A_{Actual} =$ <input style="width: 50px;" type="text" value="3125"/> sq ft</p> <p>$A_{Top} =$ <input style="width: 50px;" type="text" value="5350"/> sq ft</p> <p>$V_T =$ <input style="width: 50px;" type="text" value="4,238"/> cu ft</p>
<p>3. Growing Media</p>	<p>Choose One</p> <p><input checked="" type="radio"/> 18" Rain Garden Growing Media</p> <p><input type="radio"/> Other (Explain):</p> <p>_____</p> <p>_____</p>
<p>4. Underdrain System</p> <p>A) Are underdrains provided?</p> <p>B) Underdrain system orifice diameter for 12 hour drain time</p> <p style="margin-left: 20px;">i) Distance From Lowest Elevation of the Storage Volume to the Center of the Orifice</p> <p style="margin-left: 20px;">ii) Volume to Drain in 12 Hours</p> <p style="margin-left: 20px;">iii) Orifice Diameter, 3/8" Minimum</p>	<p>Choose One</p> <p><input checked="" type="radio"/> YES</p> <p><input type="radio"/> NO</p> <p>$y =$ <input style="width: 50px;" type="text" value="2.0"/> ft</p> <p>$Vol_{12} =$ <input style="width: 50px;" type="text" value="1,033"/> cu ft</p> <p>$D_O =$ <input style="width: 50px;" type="text" value="3/4"/> in</p>

Design Procedure Form: Rain Garden (RG)

Sheet 2 of 2

Designer: Marc A. Whorton, P.E.
Company: Classic Consulting
Date: July 19, 2019
Project: Retreat at TimberRidge Filing No. 1
Location: El Paso County RG-1

<p>5. Impermeable Geomembrane Liner and Geotextile Separator Fabric</p> <p>A) Is an impermeable liner provided due to proximity of structures or groundwater contamination?</p>	<p>Choose One _____ <input type="radio"/> YES <input checked="" type="radio"/> NO</p>
<p>6. Inlet / Outlet Control</p> <p>A) Inlet Control</p>	<p>Choose One _____ <input type="radio"/> Sheet Flow- No Energy Dissipation Required <input checked="" type="radio"/> Concentrated Flow- Energy Dissipation Provided</p>
<p>7. Vegetation</p>	<p>Choose One _____ <input checked="" type="radio"/> Seed (Plan for frequent weed control) <input type="radio"/> Plantings <input type="radio"/> Sand Grown or Other High Infiltration Sod</p>
<p>8. Irrigation</p> <p>A) Will the rain garden be irrigated?</p>	<p>Choose One _____ <input type="radio"/> YES <input type="radio"/> NO</p>
<p>Notes: _____ _____ _____</p>	

DETENTION BASIN STAGE-STORAGE TABLE BUILDER

UD-Detention, Version 3.07 (February 2017)

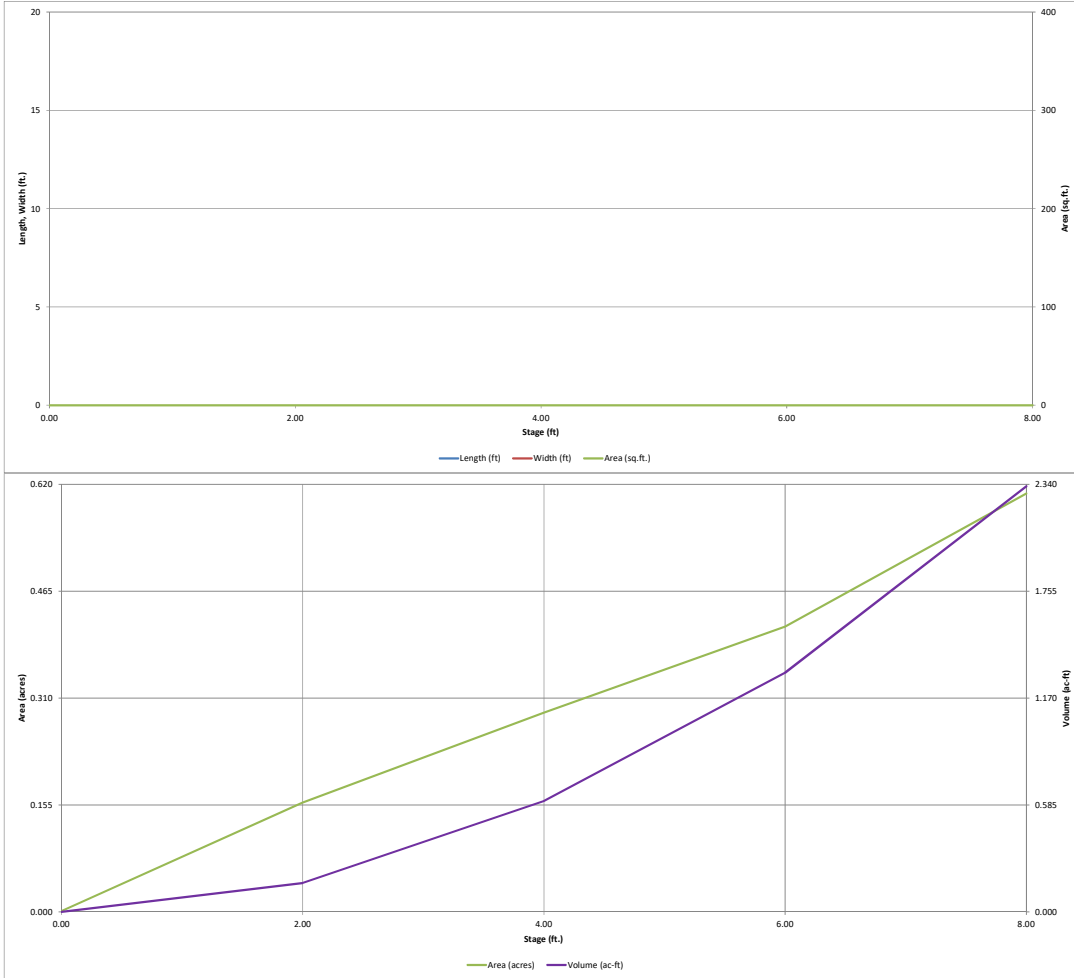

Detention Basin Outlet Structure Design

UD-Detention, Version 3.07 (February 2017)

Project: **RETREAT AT TIMBERRIDGE FILING NO. 1**
 Basin ID: **POND 1**

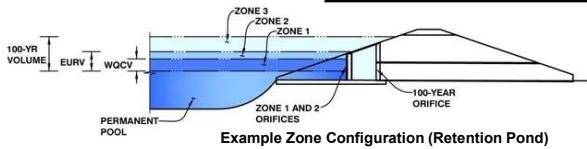

Example Zone Configuration (Retention Pond)

	Stage (ft)	Zone Volume (ac-ft)	Outlet Type
Zone 1 (WQCV)	2.33	0.214	Orifice Plate
Zone 2 (EURV)	3.18	0.177	Orifice Plate
Zone 3 (100-year)	5.91	0.877	Weir&Pipe (Restrict)
		1.268	Total

User Input: Orifice at Underdrain Outlet (typically used to drain WQCV in a Filtration BMP)

Underdrain Orifice Invert Depth =	N/A	ft (distance below the filtration media surface)
Underdrain Orifice Diameter =	N/A	inches

Calculated Parameters for Underdrain

Underdrain Orifice Area =	N/A	ft ²
Underdrain Orifice Centroid =	N/A	feet

User Input: Orifice Plate with one or more orifices or Elliptical Slot Weir (typically used to drain WQCV and/or EURV in a sedimentation BMP)

Invert of Lowest Orifice =	0.00	ft (relative to basin bottom at Stage = 0 ft)
Depth at top of Zone using Orifice Plate =	3.50	ft (relative to basin bottom at Stage = 0 ft)
Orifice Plate: Orifice Vertical Spacing =	14.00	inches
Orifice Plate: Orifice Area per Row =	N/A	inches

Calculated Parameters for Plate

WQ Orifice Area per Row =	N/A	ft ²
Elliptical Half-Width =	N/A	feet
Elliptical Slot Centroid =	N/A	feet
Elliptical Slot Area =	N/A	ft ²

User Input: Stage and Total Area of Each Orifice Row (numbered from lowest to highest)

	Row 1 (required)	Row 2 (optional)	Row 3 (optional)	Row 4 (optional)	Row 5 (optional)	Row 6 (optional)	Row 7 (optional)	Row 8 (optional)
Stage of Orifice Centroid (ft)	0.00	1.20	2.40					
Orifice Area (sq. inches)	1.20	1.31	1.31					
	Row 9 (optional)	Row 10 (optional)	Row 11 (optional)	Row 12 (optional)	Row 13 (optional)	Row 14 (optional)	Row 15 (optional)	Row 16 (optional)
Stage of Orifice Centroid (ft)								
Orifice Area (sq. inches)								

User Input: Vertical Orifice (Circular or Rectangular)

	Not Selected	Not Selected	
Invert of Vertical Orifice =	N/A	N/A	ft (relative to basin bottom at Stage = 0 ft)
Depth at top of Zone using Vertical Orifice =	N/A	N/A	ft (relative to basin bottom at Stage = 0 ft)
Vertical Orifice Diameter =	N/A	N/A	inches

Calculated Parameters for Vertical Orifice

	Not Selected	Not Selected	
Vertical Orifice Area =	N/A	N/A	ft ²
Vertical Orifice Centroid =	N/A	N/A	feet

User Input: Overflow Weir (Dropbox) and Grate (Flat or Sloped)

	Zone 3 Weir	Not Selected	
Overflow Weir Front Edge Height, Ho =	3.50	N/A	ft (relative to basin bottom at Stage = 0 ft)
Overflow Weir Front Edge Length =	4.00	N/A	feet
Overflow Weir Slope =	4.00	N/A	H:V (enter zero for flat grate)
Horiz. Length of Weir Sides =	4.00	N/A	feet
Overflow Grate Open Area % =	75%	N/A	%, grate open area/total area
Debris Clogging % =	50%	N/A	%

Calculated Parameters for Overflow Weir

	Zone 3 Weir	Not Selected	
Height of Grate Upper Edge, H _g =	4.50	N/A	feet
Overflow Weir Slope Length =	4.12	N/A	feet
Grate Open Area / 100-yr Orifice Area =	7.00	N/A	should be ≥ 4
Overflow Grate Open Area w/o Debris =	12.37	N/A	ft ²
Overflow Grate Open Area w/ Debris =	6.18	N/A	ft ²

User Input: Outlet Pipe w/ Flow Restriction Plate (Circular Orifice, Restrictor Plate, or Rectangular Orifice)

	Zone 3 Restrictor	Not Selected	
Depth to Invert of Outlet Pipe =	2.50	N/A	ft (distance below basin bottom at Stage = 0 ft)
Outlet Pipe Diameter =	18.00	N/A	inches
Restrictor Plate Height Above Pipe Invert =	18.00		inches

Calculated Parameters for Outlet Pipe w/ Flow Restriction Plate

	Zone 3 Restrictor	Not Selected	
Outlet Orifice Area =	1.77	N/A	ft ²
Outlet Orifice Centroid =	0.75	N/A	feet
Half-Central Angle of Restrictor Plate on Pipe =	3.14	N/A	radians

User Input: Emergency Spillway (Rectangular or Trapezoidal)

Spillway Invert Stage =	6.30	ft (relative to basin bottom at Stage = 0 ft)
Spillway Crest Length =	30.00	feet
Spillway End Slopes =	3.00	H:V
Freeboard above Max Water Surface =	1.00	feet

Calculated Parameters for Spillway

Spillway Design Flow Depth =	0.62	feet
Stage at Top of Freeboard =	7.92	feet
Basin Area at Top of Freeboard =	0.60	acres

Routed Hydrograph Results

	WQCV	EURV	2 Year	5 Year	10 Year	25 Year	50 Year	100 Year	500 Year
Design Storm Return Period =									
One-Hour Rainfall Depth (in) =	0.53	1.07	1.19	1.50	1.75	2.00	2.25	2.52	3.85
Calculated Runoff Volume (acre-ft) =	0.214	0.391	0.278	0.421	0.832	1.922	2.610	3.508	6.448
OPTIONAL Override Runoff Volume (acre-ft) =									
Inflow Hydrograph Volume (acre-ft) =	0.214	0.391	0.277	0.421	0.832	1.922	2.610	3.508	6.443
Predevelopment Unit Peak Flow, q (cfs/acre) =	0.00	0.00	0.01	0.02	0.15	0.53	0.73	0.99	1.81
Predevelopment Peak Q (cfs) =	0.0	0.0	0.3	0.479	4.5	15.5	21.5	29.2	53.1
Peak Inflow Q (cfs) =	3.0	5.4	3.8	5.8	11.3	26.0	35.1	47.0	85.1
Peak Outflow Q (cfs) =	0.1	0.2	0.1	0.172	3.8	17.5	22.3	24.0	75.6
Ratio Peak Outflow to Predevelopment Q =	N/A	N/A	N/A	0.4	0.8	1.1	1.0	0.8	1.4
Structure Controlling Flow =	Plate	Plate	Plate	Plate	Overflow Grate 1	Overflow Grate 1	Outlet Plate 1	Outlet Plate 1	Spillway
Max Velocity through Grate 1 (fps) =	N/A	N/A	N/A	N/A	0.3	1.4	1.8	1.9	2.0
Max Velocity through Grate 2 (fps) =	N/A	N/A	N/A	N/A	N/A	N/A	N/A	N/A	N/A
Time to Drain 97% of Inflow Volume (hours) =	41	53	46	55	57	48	44	39	28
Time to Drain 99% of Inflow Volume (hours) =	43	57	49	59	64	60	58	55	47
Maximum Ponding Depth (ft) =	2.22	3.05	2.54	3.18	4.00	4.67	5.11	6.22	6.96
Area at Maximum Ponding Depth (acres) =	0.17	0.23	0.19	0.23	0.29	0.33	0.36	0.43	0.51
Maximum Volume Stored (acre-ft) =	0.194	0.362	0.255	0.390	0.607	0.814	0.962	1.402	1.746

Detention Basin Outlet Structure Design

UD-Detention, Version 3.07 (February 2017)

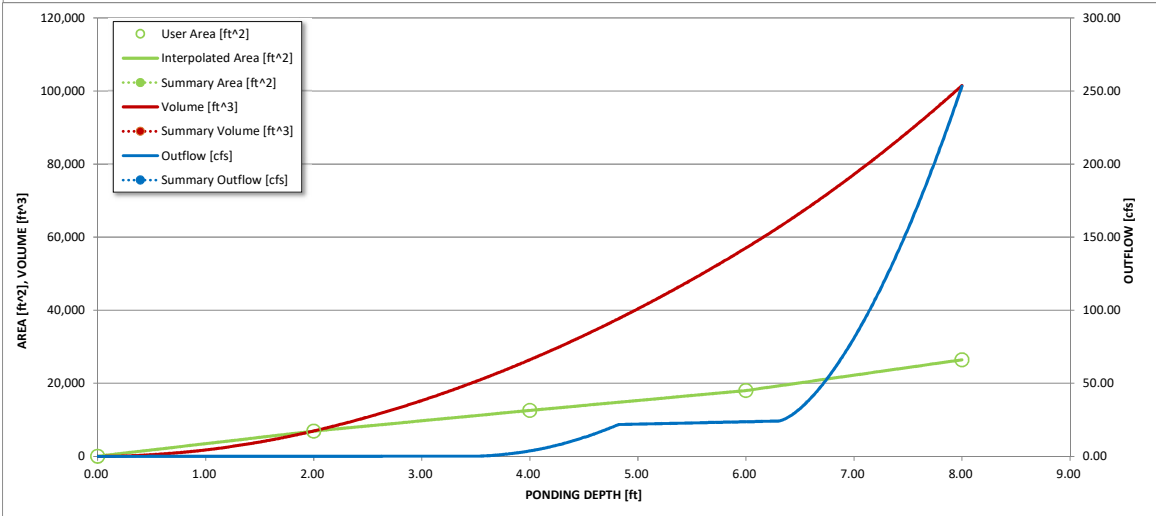
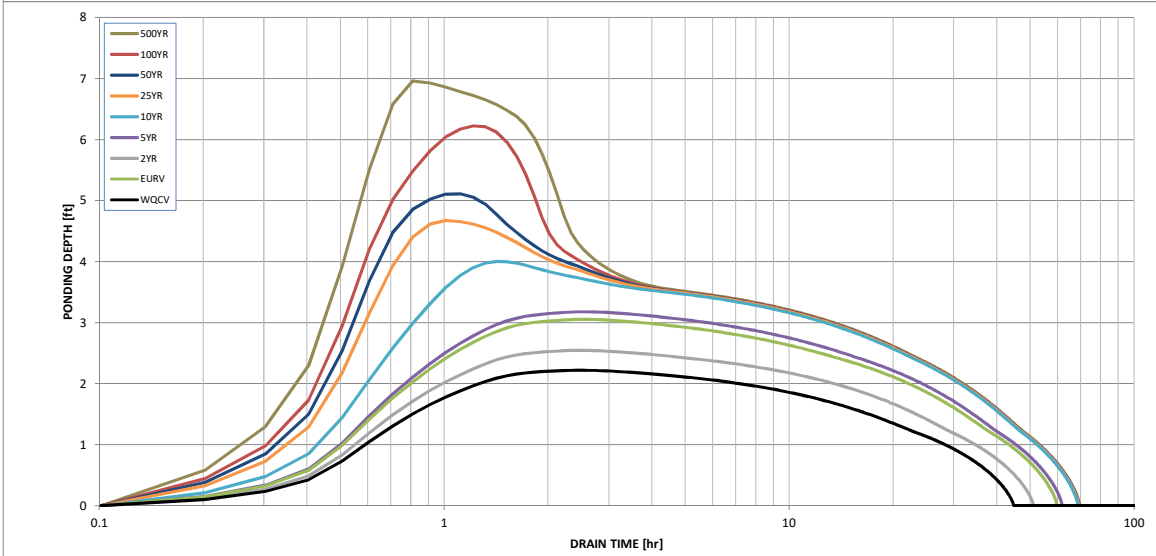
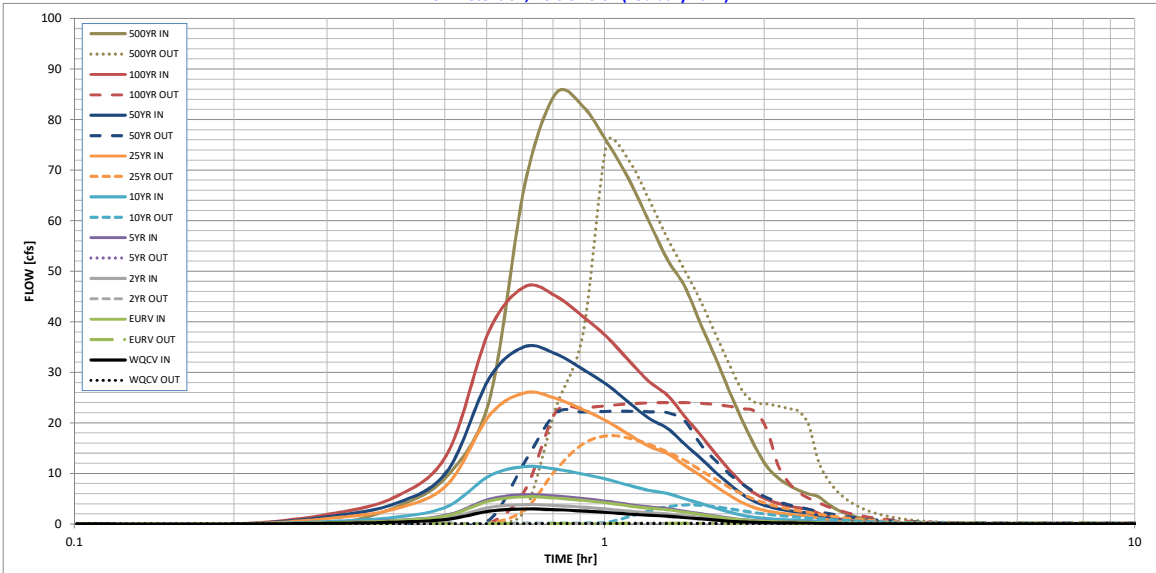

S-A-V-D Chart Axis Override

	X-axis	Left Y-Axis	Right Y-Axis
minimum bound			
maximum bound			

DETENTION BASIN STAGE-STORAGE TABLE BUILDER

UD-Detention, Version 3.07 (February 2017)

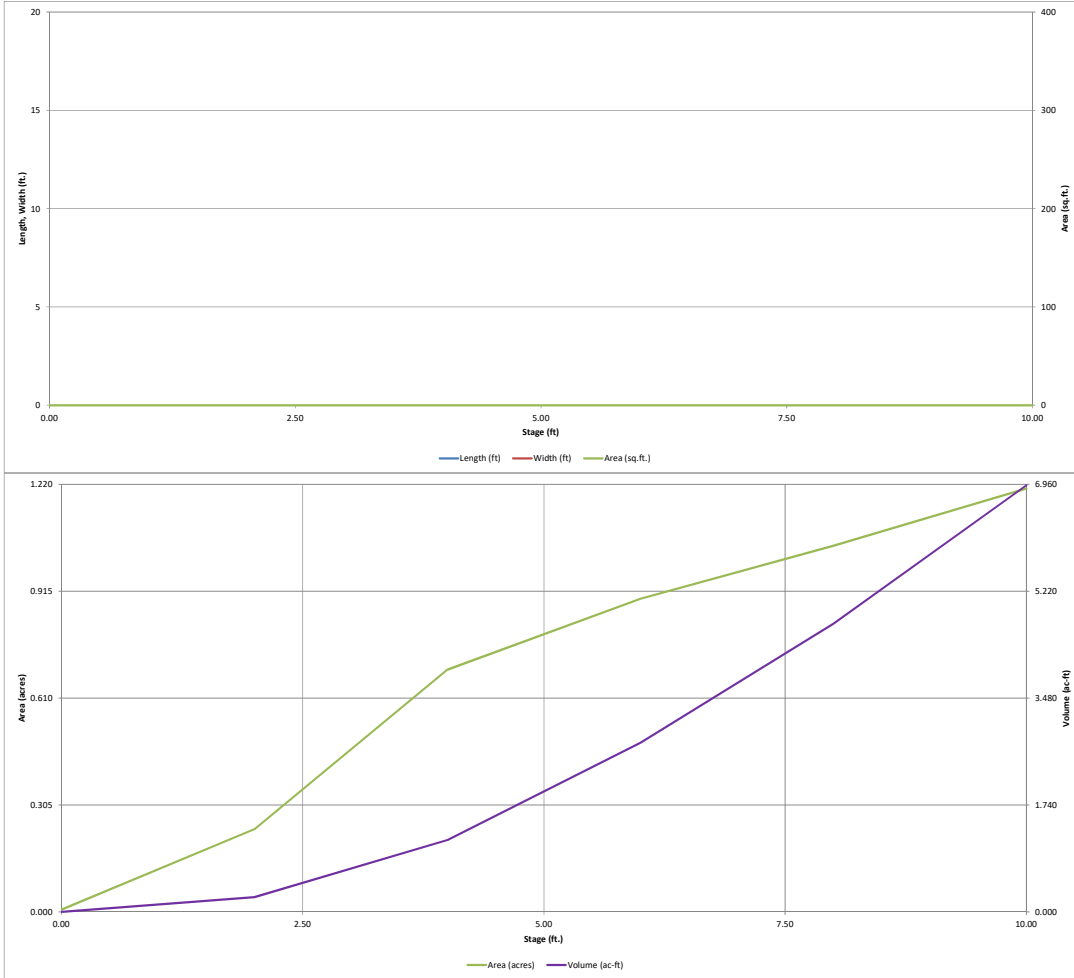

Detention Basin Outlet Structure Design

UD-Detention, Version 3.07 (February 2017)

Project: **RETREAT AT TIMBERRIDGE FILING NO. 1**

Basin ID: **POND 2**

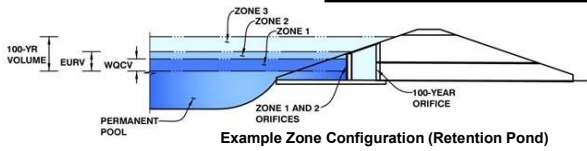

Example Zone Configuration (Retention Pond)

	Stage (ft)	Zone Volume (ac-ft)	Outlet Type
Zone 1 (WQCV)	3.78	1.022	Orifice Plate
Zone 2 (EURV)	5.32	1.146	Orifice Plate
Zone 3 (100-year)	8.75	3.327	Weir&Pipe (Restrict)
		5.494	Total

User Input: Orifice at Underdrain Outlet (typically used to drain WQCV in a Filtration BMP)

Underdrain Orifice Invert Depth =	N/A	ft (distance below the filtration media surface)
Underdrain Orifice Diameter =	N/A	inches

Calculated Parameters for Underdrain

Underdrain Orifice Area =	N/A	ft ²
Underdrain Orifice Centroid =	N/A	feet

User Input: Orifice Plate with one or more orifices or Elliptical Slot Weir (typically used to drain WQCV and/or EURV in a sedimentation BMP)

Invert of Lowest Orifice =	0.00	ft (relative to basin bottom at Stage = 0 ft)
Depth at top of Zone using Orifice Plate =	5.50	ft (relative to basin bottom at Stage = 0 ft)
Orifice Plate: Orifice Vertical Spacing =	16.50	inches
Orifice Plate: Orifice Area per Row =	N/A	inches

Calculated Parameters for Plate

WQ Orifice Area per Row =	N/A	ft ²
Elliptical Half-Width =	N/A	feet
Elliptical Slot Centroid =	N/A	feet
Elliptical Slot Area =	N/A	ft ²

User Input: Stage and Total Area of Each Orifice Row (numbered from lowest to highest)

	Row 1 (required)	Row 2 (optional)	Row 3 (optional)	Row 4 (optional)	Row 5 (optional)	Row 6 (optional)	Row 7 (optional)	Row 8 (optional)
Stage of Orifice Centroid (ft)	0.00	1.40	2.80	4.20				
Orifice Area (sq. inches)	3.00	4.00	4.00	4.00				

	Row 9 (optional)	Row 10 (optional)	Row 11 (optional)	Row 12 (optional)	Row 13 (optional)	Row 14 (optional)	Row 15 (optional)	Row 16 (optional)
Stage of Orifice Centroid (ft)								
Orifice Area (sq. inches)								

User Input: Vertical Orifice (Circular or Rectangular)

	Not Selected	Not Selected	
Invert of Vertical Orifice =	N/A	N/A	ft (relative to basin bottom at Stage = 0 ft)
Depth at top of Zone using Vertical Orifice =	N/A	N/A	ft (relative to basin bottom at Stage = 0 ft)
Vertical Orifice Diameter =	N/A	N/A	inches

Calculated Parameters for Vertical Orifice

	Not Selected	Not Selected	
Vertical Orifice Area =	N/A	N/A	ft ²
Vertical Orifice Centroid =	N/A	N/A	feet

User Input: Overflow Weir (Dropbox) and Grate (Flat or Sloped)

	Zone 3 Weir	Not Selected	
Overflow Weir Front Edge Height, Ho =	5.50	N/A	ft (relative to basin bottom at Stage = 0 ft)
Overflow Weir Front Edge Length =	12.00	N/A	feet
Overflow Weir Slope =	4.00	N/A	H:V (enter zero for flat grate)
Horiz. Length of Weir Sides =	4.00	N/A	feet
Overflow Grate Open Area % =	75%	N/A	%, grate open area/total area
Debris Clogging % =	50%	N/A	%

Calculated Parameters for Overflow Weir

	Zone 3 Weir	Not Selected	
Height of Grate Upper Edge, H _g =	6.50	N/A	feet
Overflow Weir Slope Length =	4.12	N/A	feet
Grate Open Area / 100-yr Orifice Area =	6.22	N/A	should be ≥ 4
Overflow Grate Open Area w/o Debris =	37.11	N/A	ft ²
Overflow Grate Open Area w/ Debris =	18.55	N/A	ft ²

User Input: Outlet Pipe w/ Flow Restriction Plate (Circular Orifice, Restrictor Plate, or Rectangular Orifice)

	Zone 3 Restrictor	Not Selected	
Depth to Invert of Outlet Pipe =	2.50	N/A	ft (distance below basin bottom at Stage = 0 ft)
Outlet Pipe Diameter =	42.00	N/A	inches
Restrictor Plate Height Above Pipe Invert =	25.00		inches

Calculated Parameters for Outlet Pipe w/ Flow Restriction Plate

	Zone 3 Restrictor	Not Selected	
Outlet Orifice Area =	5.97	N/A	ft ²
Outlet Orifice Centroid =	1.18	N/A	feet
Half-Central Angle of Restrictor Plate on Pipe =	1.76	N/A	radians

User Input: Emergency Spillway (Rectangular or Trapezoidal)

Spillway Invert Stage =	9.00	ft (relative to basin bottom at Stage = 0 ft)
Spillway Crest Length =	65.00	feet
Spillway End Slopes =	3.00	H:V
Freeboard above Max Water Surface =		feet

Calculated Parameters for Spillway

Spillway Design Flow Depth =	0.96	feet
Stage at Top of Freeboard =	9.96	feet
Basin Area at Top of Freeboard =	1.20	acres

Routed Hydrograph Results

	WQCV	EURV	2 Year	5 Year	10 Year	25 Year	50 Year	100 Year	500 Year
Design Storm Return Period =									
One-Hour Rainfall Depth (in) =	0.53	1.07	1.19	1.50	1.75	2.00	2.25	2.52	3.85
Calculated Runoff Volume (acre-ft) =	1.022	2.168	1.608	2.351	3.953	7.552	9.864	12.887	23.106
OPTIONAL Override Runoff Volume (acre-ft) =									
Inflow Hydrograph Volume (acre-ft) =	1.021	2.165	1.607	2.349	3.949	7.544	9.852	12.868	23.079
Predevelopment Unit Peak Flow, q (cfs/acre) =	0.00	0.00	0.01	0.02	0.17	0.58	0.80	1.08	1.97
Predevelopment Peak Q (cfs) =	0.0	0.0	1.0	1.800	17.0	58.0	80.3	108.7	197.5
Peak Inflow Q (cfs) =	15.1	31.7	23.6	34.3	57.3	107.8	139.7	180.8	316.4
Peak Outflow Q (cfs) =	0.5	0.8	0.7	0.858	17.1	62.2	85.9	91.9	96.7
Ratio Peak Outflow to Predevelopment Q =	N/A	N/A	N/A	0.5	1.0	1.1	1.1	0.8	0.5
Structure Controlling Flow =	Plate	Plate	Plate	Plate	Overflow Gate 1	Overflow Gate 1	Outlet Plate 1	Outlet Plate 1	N/A
Max Velocity through Gate 1 (fps) =	N/A	N/A	N/A	N/A	0.4	1.7	2.3	2.4	2.6
Max Velocity through Gate 2 (fps) =	N/A	N/A	N/A	N/A	N/A	N/A	N/A	N/A	N/A
Time to Drain 97% of Inflow Volume (hours) =	44	59	53	61	59	53	49	46	36
Time to Drain 99% of Inflow Volume (hours) =	47	65	58	68	68	64	62	59	53
Maximum Ponding Depth (ft) =	3.65	5.15	4.46	5.37	6.24	7.13	7.61	8.91	10.00
Area at Maximum Ponding Depth (acres) =	0.61	0.81	0.74	0.83	0.91	0.98	1.02	1.12	1.21
Maximum Volume Stored (acre-ft) =	0.935	2.031	1.498	2.203	2.961	3.802	4.290	5.676	6.944

Detention Basin Outlet Structure Design

UD-Detention, Version 3.07 (February 2017)

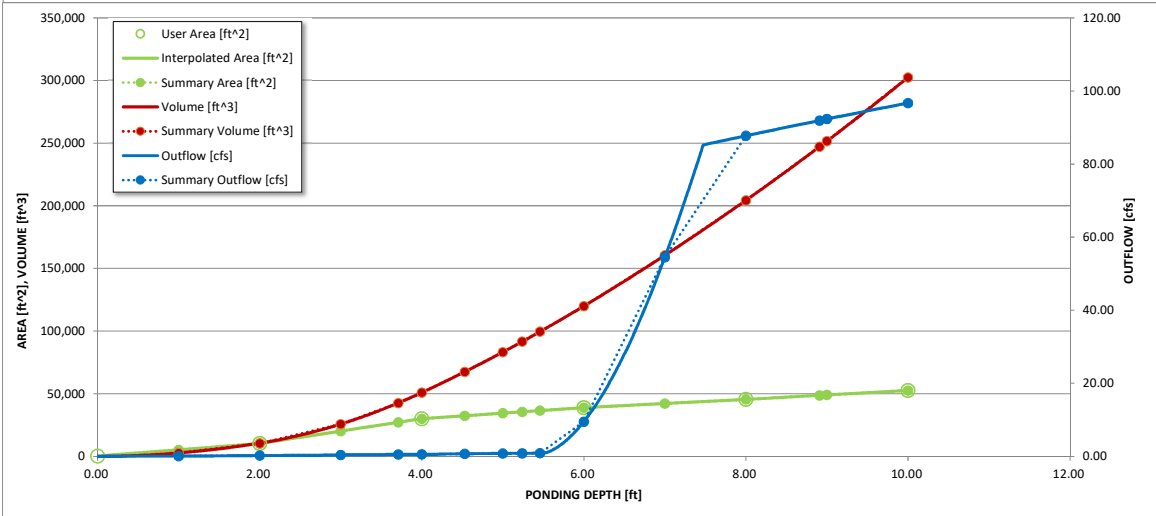
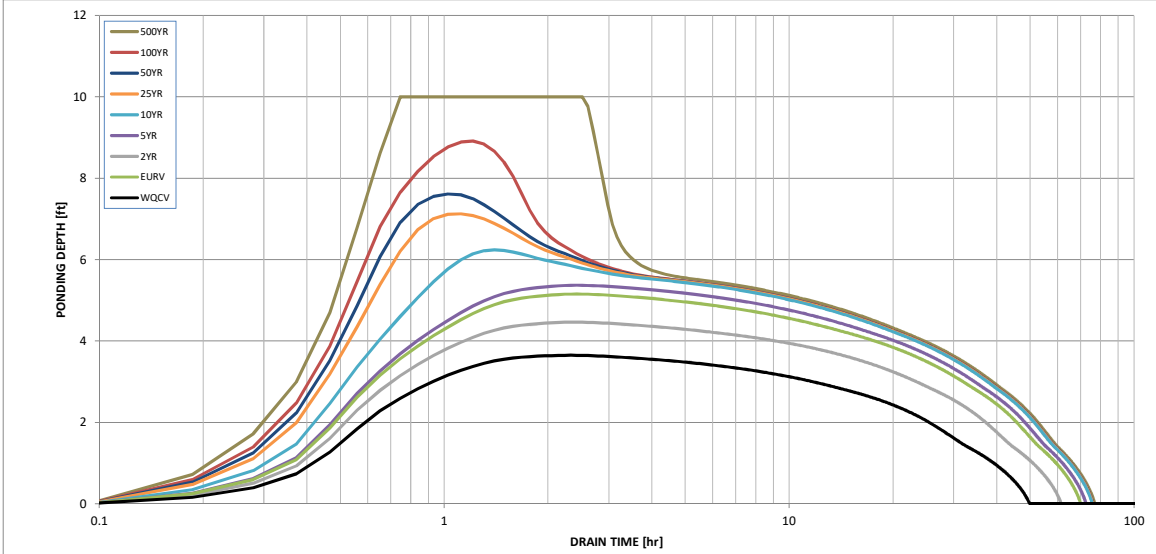
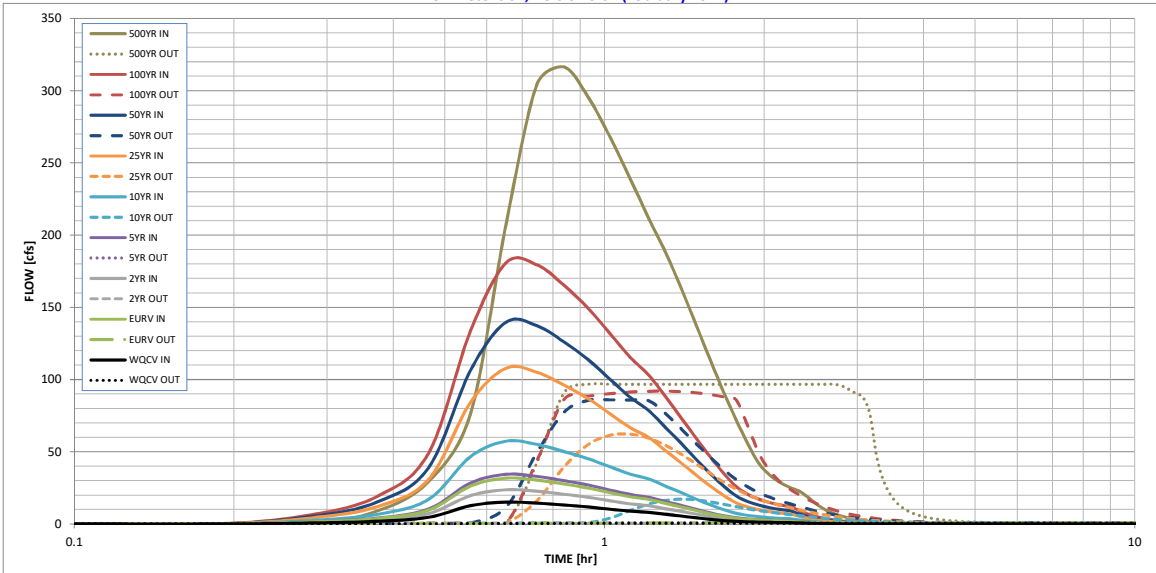

S-A-V-D Chart Axis Override

	X-axis	Left Y-Axis	Right Y-Axis
minimum bound			
maximum bound			

DETENTION BASIN STAGE-STORAGE TABLE BUILDER

UD-Detention, Version 3.07 (February 2017)

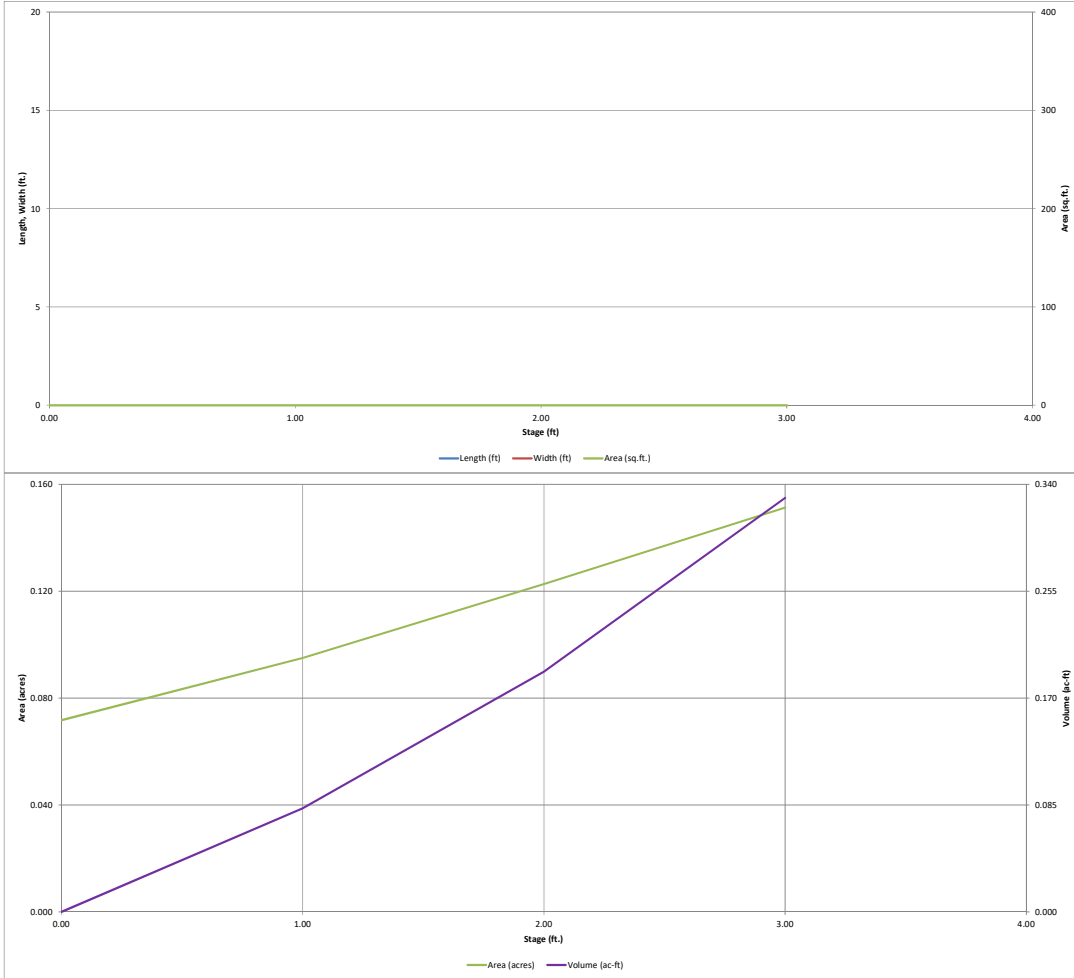

Detention Basin Outlet Structure Design

UD-Detention, Version 3.07 (February 2017)

Project: **RETREAT AT TIMBERRIDGE FILING NO. 1**

Basin ID: **Rain Garden 1**

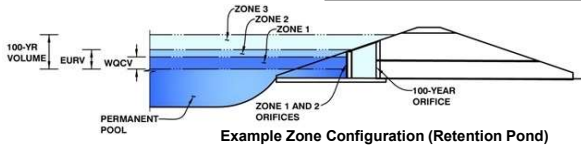

	Stage (ft)	Zone Volume (ac-ft)	Outlet Type
Zone 1 (WQCV)	0.33	0.024	Filtration Media
Zone 2 (100-year)	1.74	0.136	Weir&Pipe (Restrict)
Zone 3			
		0.161	Total

User Input: Orifice at Underdrain Outlet (typically used to drain WQCV in a Filtration BMP)

Underdrain Orifice Invert Depth =	2.00	ft (distance below the filtration media surface)
Underdrain Orifice Diameter =	0.81	inches

Calculated Parameters for Underdrain	
Underdrain Orifice Area =	0.0
Underdrain Orifice Centroid =	0.03

User Input: Orifice Plate with one or more orifices or Elliptical Slot Weir (typically used to drain WQCV and/or EURV in a sedimentation BMP)

Invert of Lowest Orifice =	N/A	ft (relative to basin bottom at Stage = 0 ft)
Depth at top of Zone using Orifice Plate =	N/A	ft (relative to basin bottom at Stage = 0 ft)
Orifice Plate: Orifice Vertical Spacing =	N/A	inches
Orifice Plate: Orifice Area per Row =	N/A	inches

Calculated Parameters for Plate	
WQ Orifice Area per Row =	N/A
Elliptical Half-Width =	N/A
Elliptical Slot Centroid =	N/A
Elliptical Slot Area =	N/A

User Input: Stage and Total Area of Each Orifice Row (numbered from lowest to highest)

	Row 1 (optional)	Row 2 (optional)	Row 3 (optional)	Row 4 (optional)	Row 5 (optional)	Row 6 (optional)	Row 7 (optional)	Row 8 (optional)
Stage of Orifice Centroid (ft)	N/A	N/A	N/A	N/A	N/A	N/A	N/A	N/A
Orifice Area (sq. inches)	N/A	N/A	N/A	N/A	N/A	N/A	N/A	N/A

	Row 9 (optional)	Row 10 (optional)	Row 11 (optional)	Row 12 (optional)	Row 13 (optional)	Row 14 (optional)	Row 15 (optional)	Row 16 (optional)
Stage of Orifice Centroid (ft)	N/A	N/A	N/A	N/A	N/A	N/A	N/A	N/A
Orifice Area (sq. inches)	N/A	N/A	N/A	N/A	N/A	N/A	N/A	N/A

User Input: Vertical Orifice (Circular or Rectangular)

	Not Selected	Not Selected	
Invert of Vertical Orifice =			ft (relative to basin bottom at Stage = 0 ft)
Depth at top of Zone using Vertical Orifice =			ft (relative to basin bottom at Stage = 0 ft)
Vertical Orifice Diameter =			inches

Calculated Parameters for Vertical Orifice	
Vertical Orifice Area =	Not Selected
Vertical Orifice Centroid =	Not Selected

User Input: Overflow Weir (Dropbox) and Grate (Flat or Sloped)

	Zone 2 Weir	Not Selected	
Overflow Weir Front Edge Height, H _o =	1.00		ft (relative to basin bottom at Stage = 0 ft)
Overflow Weir Front Edge Length =	2.90		feet
Overflow Weir Slope =	4.00		H:V (enter zero for flat grate)
Horiz. Length of Weir Sides =	2.90		feet
Overflow Grate Open Area % =	75%		% grate open area/total area
Debris Clogging % =	50%		%

Calculated Parameters for Overflow Weir		
Height of Grate Upper Edge, H _c =	1.73	feet
Over Flow Weir Slope Length =	2.99	feet
Grate Open Area / 100-yr Orifice Area =	16.56	should be ≥ 4
Overflow Grate Open Area w/o Debris =	6.50	ft ²
Overflow Grate Open Area w/ Debris =	3.25	ft ²

User Input: Outlet Pipe w/ Flow Restriction Plate (Circular Orifice, Restrictor Plate, or Rectangular Orifice)

	Zone 2 Restrictor	Not Selected	
Depth to Invert of Outlet Pipe =	2.50		ft (distance below basin bottom at Stage = 0 ft)
Outlet Pipe Diameter =	12.00		inches
Restrictor Plate Height Above Pipe Invert =	6.00		inches

Calculated Parameters for Outlet Pipe w/ Flow Restriction Plate		
Outlet Orifice Area =	0.39	ft ²
Outlet Orifice Centroid =	0.29	feet
Half-Central Angle of Restrictor Plate on Pipe =	1.57	N/A radians

User Input: Emergency Spillway (Rectangular or Trapezoidal)

Spillway Invert Stage =	2.00	ft (relative to basin bottom at Stage = 0 ft)
Spillway Crest Length =	10.00	feet
Spillway End Slopes =	3.00	H:V
Freeboard above Max Water Surface =		feet

Calculated Parameters for Spillway		
Spillway Design Flow Depth =	0.39	feet
Stage at Top of Freeboard =	2.39	feet
Basin Area at Top of Freeboard =	0.13	acres

Routed Hydrograph Results

	WQCV	EURV	2 Year	5 Year	10 Year	25 Year	50 Year	100 Year	500 Year
Design Storm Return Period =									
One-Hour Rainfall Depth (in) =	0.53	1.07	1.19	1.50	1.75	2.00	2.25	2.52	3.85
Calculated Runoff Volume (acre-ft) =	0.024	0.068	0.051	0.074	0.119	0.215	0.276	0.357	0.634
OPTIONAL Override Runoff Volume (acre-ft) =									
Inflow Hydrograph Volume (acre-ft) =	0.024	0.067	0.051	0.074	0.118	0.214	0.276	0.357	0.633
Predevelopment Unit Peak Flow, q (cfs/acre) =	0.00	0.00	0.02	0.03	0.29	0.92	1.27	1.68	3.03
Predevelopment Peak Q (cfs) =	0.0	0.0	0.0	0.079	0.8	2.5	3.4	4.5	8.2
Peak Inflow Q (cfs) =	0.6	1.6	1.2	1.7	2.7	4.9	6.2	8.0	14.2
Peak Outflow Q (cfs) =	0.0	0.0	0.0	0.029	0.4	2.3	3.5	3.8	4.3
Ratio Peak Outflow to Predevelopment Q =	N/A	N/A	N/A	0.4	0.6	0.9	1.0	0.8	0.5
Structure Controlling Flow =	Filtration Media	Filtration Media	Filtration Media	Filtration Media	Overflow Gate 1	Overflow Gate 1	Overflow Gate 1	Outlet Plate 1	N/A
Max Velocity through Gate 1 (fps) =	N/A	N/A	N/A	N/A	0.1	0.3	0.5	0.6	0.7
Max Velocity through Gate 2 (fps) =	N/A	N/A	N/A	N/A	N/A	N/A	N/A	N/A	N/A
Time to Drain 97% of Inflow Volume (hours) =	12	30	23	33	39	38	37	36	32
Time to Drain 99% of Inflow Volume (hours) =	12	31	24	33	40	40	40	39	38
Maximum Ponding Depth (ft) =	0.28	0.79	0.61	0.86	1.17	1.44	1.56	1.85	3.00
Area at Maximum Ponding Depth (acres) =	0.08	0.09	0.09	0.09	0.10	0.11	0.11	0.12	0.15
Maximum Volume Stored (acre-ft) =	0.021	0.063	0.047	0.069	0.099	0.128	0.141	0.173	0.329

Detention Basin Outlet Structure Design

UD-Detention, Version 3.07 (February 2017)

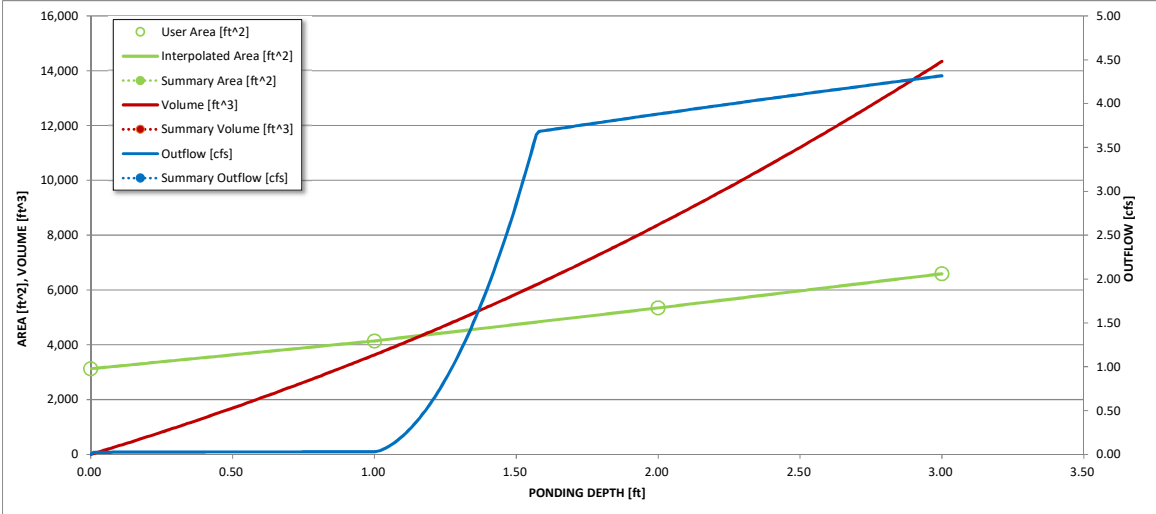
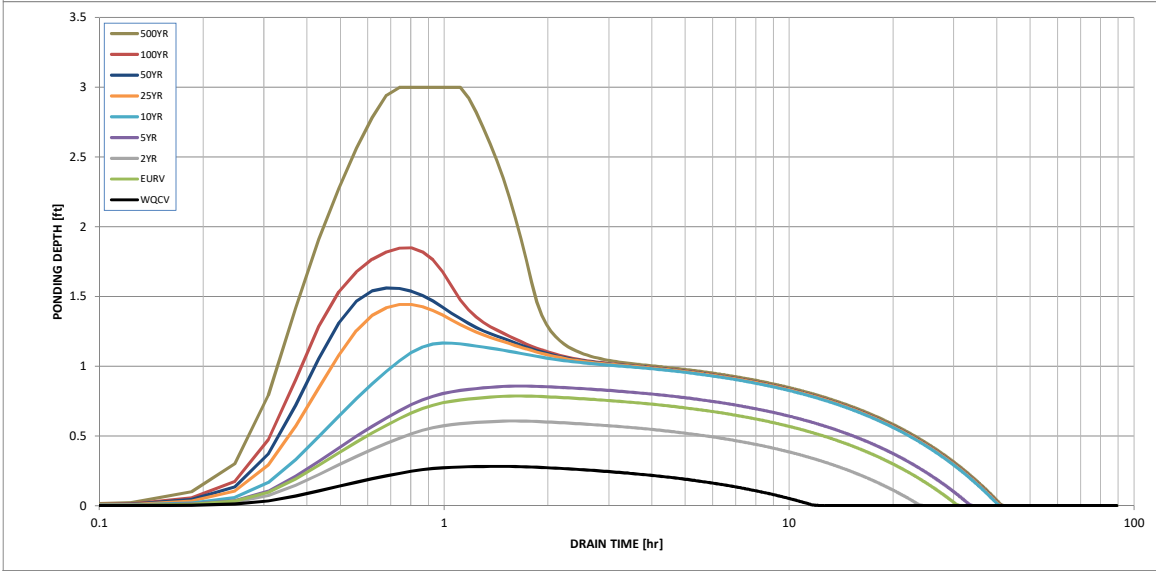
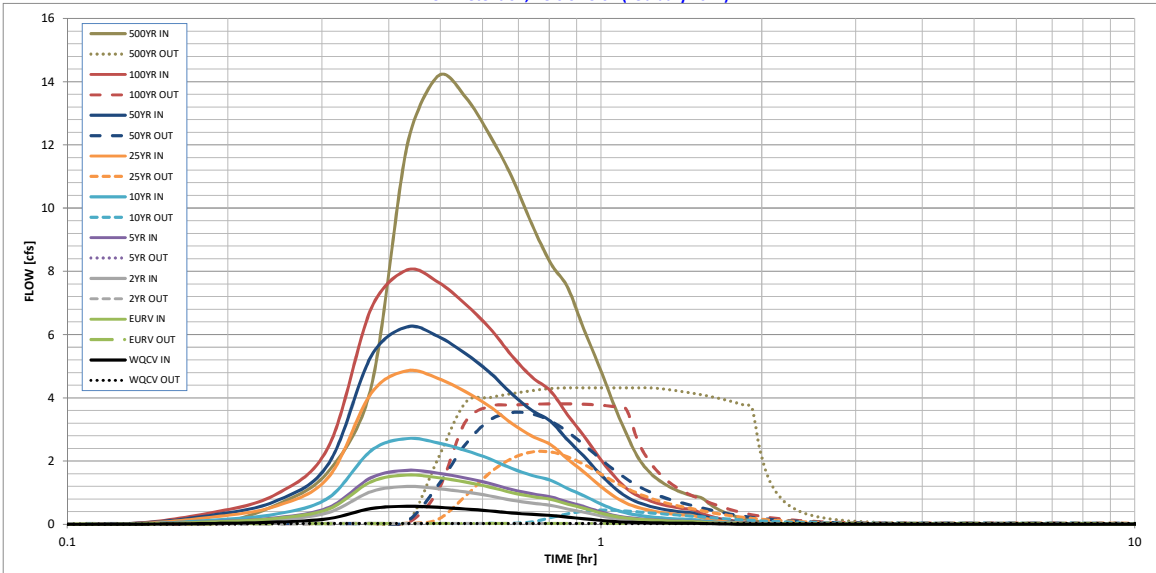

S-A-V-D Chart Axis Override

	X-axis	Left Y-Axis	Right Y-Axis
minimum bound			
maximum bound			

Pre-Dev 2 Year Routing

Project Summary

Title	Retreat at Timber Ridge Filing No. 1 Final Drainage Report
Engineer	MAW
Company	CCES
Date	6/26/2019

Notes	Pre-Dev 2 year SCS Model
-------	--------------------------

Table of Contents

	Master Network Summary	2
Colo Springs 2015	Time-Depth Curve, 2 years	3
EX DP-1		
	Addition Summary, 2 years	4
EX DP-2		
	Addition Summary, 2 years	5
EX DP-3		
	Addition Summary, 2 years	6
EX DP-4		
	Addition Summary, 2 years	7
EX DP-8		
	Addition Summary, 2 years	8

Pre-Dev 2 Year Routing

Subsection: Master Network Summary

Catchments Summary

Label	Scenario	Return Event (years)	Hydrograph Volume (ac-ft)	Time to Peak (hours)	Peak Flow (ft ³ /s)
EX-1	Pre-Development 2 YEAR	2	0.249	12.600	0.54
EX-2	Pre-Development 2 YEAR	2	0.013	12.300	0.03
EX-3	Pre-Development 2 YEAR	2	0.198	12.450	0.44
EX-4	Pre-Development 2 YEAR	2	0.074	12.400	0.17
EX-4	Pre-Development 2 YEAR	2	0.074	12.400	0.17
EX-5	Pre-Development 2 YEAR	2	0.945	12.750	2.04
EX-6	Pre-Development 2 YEAR	2	0.322	12.400	0.72
EX-7	Pre-Development 2 YEAR	2	0.287	12.300	0.97
EX-8	Pre-Development 2 YEAR	2	0.073	12.400	0.17

Node Summary

Label	Scenario	Return Event (years)	Hydrograph Volume (ac-ft)	Time to Peak (hours)	Peak Flow (ft ³ /s)
EX DP-1	Pre-Development 2 YEAR	2	1.876	12.500	4.21
EX DP-2	Pre-Development 2 YEAR	2	0.013	12.300	0.03
EX DP-3	Pre-Development 2 YEAR	2	0.198	12.450	0.44
EX DP-4	Pre-Development 2 YEAR	2	0.074	12.400	0.17
EX DP-8	Pre-Development 2 YEAR	2	0.073	12.400	0.17

Pre-Dev 2 Year Routing

Subsection: Time-Depth Curve
 Label: Colo Springs 2015

Return Event: 2 years
 Storm Event: TYPE II 24 HOUR

Time-Depth Curve: TYPE II 24 HOUR	
Label	TYPE II 24 HOUR
Start Time	0.000 hours
Increment	0.250 hours
End Time	24.000 hours
Return Event	2 years

CUMULATIVE RAINFALL (in)
Output Time Increment = 0.250 hours
Time on left represents time for first value in each row.

Time (hours)	Depth (in)	Depth (in)	Depth (in)	Depth (in)	Depth (in)
0.000	0.0	0.0	0.0	0.0	0.0
1.250	0.0	0.0	0.0	0.0	0.1
2.500	0.1	0.1	0.1	0.1	0.1
3.750	0.1	0.1	0.1	0.1	0.1
5.000	0.1	0.1	0.2	0.2	0.2
6.250	0.2	0.2	0.2	0.2	0.2
7.500	0.2	0.2	0.3	0.3	0.3
8.750	0.3	0.3	0.3	0.3	0.4
10.000	0.4	0.4	0.4	0.5	0.5
11.250	0.5	0.6	0.8	1.4	1.5
12.500	1.5	1.6	1.6	1.7	1.7
13.750	1.7	1.7	1.8	1.8	1.8
15.000	1.8	1.8	1.8	1.9	1.9
16.250	1.9	1.9	1.9	1.9	1.9
17.500	1.9	1.9	1.9	1.9	2.0
18.750	2.0	2.0	2.0	2.0	2.0
20.000	2.0	2.0	2.0	2.0	2.0
21.250	2.0	2.0	2.0	2.1	2.1
22.500	2.1	2.1	2.1	2.1	2.1
23.750	2.1	2.1	(N/A)	(N/A)	(N/A)

Pre-Dev 2 Year Routing

Subsection: Addition Summary

Label: EX DP-1

Return Event: 2 years
Storm Event: TYPE II 24 HOUR

Summary for Hydrograph Addition at 'EX DP-1'

Upstream Link	Upstream Node
<Catchment to Outflow Node>	EX-1
<Catchment to Outflow Node>	EX-5
<Catchment to Outflow Node>	EX-6
<Catchment to Outflow Node>	EX-7
<Catchment to Outflow Node>	EX-4

Node Inflows

Inflow Type	Element	Volume (ac-ft)	Time to Peak (hours)	Flow (Peak) (ft ³ /s)
Flow (From)	EX-1	0.249	12.600	0.54
Flow (From)	EX-5	0.945	12.750	2.04
Flow (From)	EX-6	0.322	12.400	0.72
Flow (From)	EX-7	0.287	12.300	0.97
Flow (From)	EX-4	0.074	12.400	0.17
Flow (In)	EX DP-1	1.876	12.500	4.21

Pre-Dev 2 Year Routing

Subsection: Addition Summary

Label: EX DP-2

Return Event: 2 years
Storm Event: TYPE II 24 HOUR

Summary for Hydrograph Addition at 'EX DP-2'

Upstream Link	Upstream Node
<Catchment to Outflow Node>	EX-2

Node Inflows

Inflow Type	Element	Volume (ac-ft)	Time to Peak (hours)	Flow (Peak) (ft ³ /s)
Flow (From)	EX-2	0.013	12.300	0.03
Flow (In)	EX DP-2	0.013	12.300	0.03

Pre-Dev 2 Year Routing

Subsection: Addition Summary
Label: EX DP-3

Return Event: 2 years
Storm Event: TYPE II 24 HOUR

Summary for Hydrograph Addition at 'EX DP-3'

Upstream Link	Upstream Node
<Catchment to Outflow Node>	EX-3

Node Inflows

Inflow Type	Element	Volume (ac-ft)	Time to Peak (hours)	Flow (Peak) (ft ³ /s)
Flow (From)	EX-3	0.198	12.450	0.44
Flow (In)	EX DP-3	0.198	12.450	0.44

Pre-Dev 2 Year Routing

Subsection: Addition Summary

Label: EX DP-4

Return Event: 2 years
Storm Event: TYPE II 24 HOUR

Summary for Hydrograph Addition at 'EX DP-4'

Upstream Link	Upstream Node
<Catchment to Outflow Node>	EX-4

Node Inflows

Inflow Type	Element	Volume (ac-ft)	Time to Peak (hours)	Flow (Peak) (ft ³ /s)
Flow (From)	EX-4	0.074	12.400	0.17
Flow (In)	EX DP-4	0.074	12.400	0.17

Pre-Dev 2 Year Routing

Subsection: Addition Summary

Label: EX DP-8

Return Event: 2 years
Storm Event: TYPE II 24 HOUR

Summary for Hydrograph Addition at 'EX DP-8'

Upstream Link	Upstream Node
<Catchment to Outflow Node>	EX-8

Node Inflows

Inflow Type	Element	Volume (ac-ft)	Time to Peak (hours)	Flow (Peak) (ft ³ /s)
Flow (From)	EX-8	0.073	12.400	0.17
Flow (In)	EX DP-8	0.073	12.400	0.17

Pre-Dev 2 Year Routing

Index

C

Colo Springs 2015 (Time-Depth Curve, 2 years)...3

E

EX DP-1 (Addition Summary, 2 years)...4

EX DP-2 (Addition Summary, 2 years)...5

EX DP-3 (Addition Summary, 2 years)...6

EX DP-4 (Addition Summary, 2 years)...7

EX DP-8 (Addition Summary, 2 years)...8

M

Master Network Summary...2

Pre-Dev 5 Year Routing

Project Summary

Title	Retreat at Timber Ridge Filing No. 1 Final Drainage Report
Engineer	MAW
Company	CCES
Date	6/26/2019

Notes	Pre-Dev 5 year SCS Model
-------	--------------------------

Table of Contents

	Master Network Summary	2
Colo Springs 2015	Time-Depth Curve, 5 years	3
EX DP-1		
	Addition Summary, 5 years	4
EX DP-2		
	Addition Summary, 5 years	5
EX DP-3		
	Addition Summary, 5 years	6
EX DP-4		
	Addition Summary, 5 years	7
EX DP-8		
	Addition Summary, 5 years	8

Pre-Dev 5 Year Routing

Subsection: Master Network Summary

Catchments Summary

Label	Scenario	Return Event (years)	Hydrograph Volume (ac-ft)	Time to Peak (hours)	Peak Flow (ft ³ /s)
EX-1	Pre-Development 5 YEAR	5	0.691	12.250	3.85
EX-2	Pre-Development 5 YEAR	5	0.036	12.100	0.31
EX-3	Pre-Development 5 YEAR	5	0.549	12.200	3.44
EX-4	Pre-Development 5 YEAR	5	0.205	12.150	1.38
EX-4	Pre-Development 5 YEAR	5	0.205	12.150	1.38
EX-5	Pre-Development 5 YEAR	5	2.624	12.300	13.49
EX-6	Pre-Development 5 YEAR	5	0.893	12.150	5.79
EX-7	Pre-Development 5 YEAR	5	0.717	12.200	5.15
EX-8	Pre-Development 5 YEAR	5	0.203	12.150	1.39

Node Summary

Label	Scenario	Return Event (years)	Hydrograph Volume (ac-ft)	Time to Peak (hours)	Peak Flow (ft ³ /s)
EX DP-1	Pre-Development 5 YEAR	5	5.131	12.200	28.49
EX DP-2	Pre-Development 5 YEAR	5	0.036	12.100	0.31
EX DP-3	Pre-Development 5 YEAR	5	0.549	12.200	3.44
EX DP-4	Pre-Development 5 YEAR	5	0.205	12.150	1.38
EX DP-8	Pre-Development 5 YEAR	5	0.203	12.150	1.39

Pre-Dev 5 Year Routing

Subsection: Time-Depth Curve
 Label: Colo Springs 2015

Return Event: 5 years
 Storm Event: TYPE II 24 HOUR

Time-Depth Curve: TYPE II 24 HOUR	
Label	TYPE II 24 HOUR
Start Time	0.000 hours
Increment	0.250 hours
End Time	24.000 hours
Return Event	5 years

CUMULATIVE RAINFALL (in)
Output Time Increment = 0.250 hours
Time on left represents time for first value in each row.

Time (hours)	Depth (in)	Depth (in)	Depth (in)	Depth (in)	Depth (in)
0.000	0.0	0.0	0.0	0.0	0.0
1.250	0.0	0.0	0.1	0.1	0.1
2.500	0.1	0.1	0.1	0.1	0.1
3.750	0.1	0.1	0.1	0.2	0.2
5.000	0.2	0.2	0.2	0.2	0.2
6.250	0.2	0.2	0.3	0.3	0.3
7.500	0.3	0.3	0.3	0.3	0.4
8.750	0.4	0.4	0.4	0.4	0.5
10.000	0.5	0.5	0.5	0.6	0.6
11.250	0.7	0.8	1.0	1.8	1.9
12.500	2.0	2.0	2.1	2.1	2.2
13.750	2.2	2.2	2.3	2.3	2.3
15.000	2.3	2.3	2.3	2.4	2.4
16.250	2.4	2.4	2.4	2.4	2.5
17.500	2.5	2.5	2.5	2.5	2.5
18.750	2.5	2.5	2.5	2.6	2.6
20.000	2.6	2.6	2.6	2.6	2.6
21.250	2.6	2.6	2.6	2.6	2.6
22.500	2.7	2.7	2.7	2.7	2.7
23.750	2.7	2.7	(N/A)	(N/A)	(N/A)

Pre-Dev 5 Year Routing

Subsection: Addition Summary

Label: EX DP-1

Return Event: 5 years
Storm Event: TYPE II 24 HOUR

Summary for Hydrograph Addition at 'EX DP-1'

Upstream Link	Upstream Node
<Catchment to Outflow Node>	EX-1
<Catchment to Outflow Node>	EX-5
<Catchment to Outflow Node>	EX-6
<Catchment to Outflow Node>	EX-7
<Catchment to Outflow Node>	EX-4

Node Inflows

Inflow Type	Element	Volume (ac-ft)	Time to Peak (hours)	Flow (Peak) (ft ³ /s)
Flow (From)	EX-1	0.691	12.250	3.85
Flow (From)	EX-5	2.624	12.300	13.49
Flow (From)	EX-6	0.893	12.150	5.79
Flow (From)	EX-7	0.717	12.200	5.15
Flow (From)	EX-4	0.205	12.150	1.38
Flow (In)	EX DP-1	5.131	12.200	28.49

Pre-Dev 5 Year Routing

Subsection: Addition Summary

Label: EX DP-2

Return Event: 5 years
Storm Event: TYPE II 24 HOUR

Summary for Hydrograph Addition at 'EX DP-2'

Upstream Link	Upstream Node
<Catchment to Outflow Node>	EX-2

Node Inflows

Inflow Type	Element	Volume (ac-ft)	Time to Peak (hours)	Flow (Peak) (ft ³ /s)
Flow (From)	EX-2	0.036	12.100	0.31
Flow (In)	EX DP-2	0.036	12.100	0.31

Pre-Dev 5 Year Routing

Subsection: Addition Summary
Label: EX DP-3

Return Event: 5 years
Storm Event: TYPE II 24 HOUR

Summary for Hydrograph Addition at 'EX DP-3'

Upstream Link	Upstream Node
<Catchment to Outflow Node>	EX-3

Node Inflows

Inflow Type	Element	Volume (ac-ft)	Time to Peak (hours)	Flow (Peak) (ft ³ /s)
Flow (From)	EX-3	0.549	12.200	3.44
Flow (In)	EX DP-3	0.549	12.200	3.44

Pre-Dev 5 Year Routing

Subsection: Addition Summary

Label: EX DP-4

Return Event: 5 years
Storm Event: TYPE II 24 HOUR

Summary for Hydrograph Addition at 'EX DP-4'

Upstream Link	Upstream Node
<Catchment to Outflow Node>	EX-4

Node Inflows

Inflow Type	Element	Volume (ac-ft)	Time to Peak (hours)	Flow (Peak) (ft ³ /s)
Flow (From)	EX-4	0.205	12.150	1.38
Flow (In)	EX DP-4	0.205	12.150	1.38

Pre-Dev 5 Year Routing

Subsection: Addition Summary

Label: EX DP-8

Return Event: 5 years
Storm Event: TYPE II 24 HOUR

Summary for Hydrograph Addition at 'EX DP-8'

Upstream Link	Upstream Node
<Catchment to Outflow Node>	EX-8

Node Inflows

Inflow Type	Element	Volume (ac-ft)	Time to Peak (hours)	Flow (Peak) (ft ³ /s)
Flow (From)	EX-8	0.203	12.150	1.39
Flow (In)	EX DP-8	0.203	12.150	1.39

Pre-Dev 5 Year Routing

Index

- C
 - Colo Springs 2015 (Time-Depth Curve, 5 years)...3
- E
 - EX DP-1 (Addition Summary, 5 years)...4
 - EX DP-2 (Addition Summary, 5 years)...5
 - EX DP-3 (Addition Summary, 5 years)...6
 - EX DP-4 (Addition Summary, 5 years)...7
 - EX DP-8 (Addition Summary, 5 years)...8
- M
 - Master Network Summary...2

Pre-Dev 100 Year Routing

Project Summary

Title	Retreat at TimberRidge Filing No. 1 Final Drainage Report
Engineer	MAW
Company	CCES
Date	6/26/2019

Notes	Pre-Dev 100 year SCS Model
-------	----------------------------

Table of Contents

	Master Network Summary	2
Colo Springs 2015	Time-Depth Curve, 100 years	3
EX DP-1		
	Addition Summary, 100 years	4
EX DP-2		
	Addition Summary, 100 years	5
EX DP-3		
	Addition Summary, 100 years	6
EX DP-4		
	Addition Summary, 100 years	7
EX DP-8		
	Addition Summary, 100 years	8

Pre-Dev 100 Year Routing

Subsection: Master Network Summary

Catchments Summary

Label	Scenario	Return Event (years)	Hydrograph Volume (ac-ft)	Time to Peak (hours)	Peak Flow (ft ³ /s)
EX-1	Pre-Development 100 YEAR	100	3.044	12.150	29.97
EX-2	Pre-Development 100 YEAR	100	0.160	12.050	2.25
EX-3	Pre-Development 100 YEAR	100	2.420	12.150	26.76
EX-4	Pre-Development 100 YEAR	100	0.904	12.100	10.53
EX-4	Pre-Development 100 YEAR	100	0.904	12.100	10.53
EX-5	Pre-Development 100 YEAR	100	11.571	12.200	107.20
EX-6	Pre-Development 100 YEAR	100	3.932	12.100	44.84
EX-7	Pre-Development 100 YEAR	100	2.887	12.150	32.06
EX-8	Pre-Development 100 YEAR	100	0.894	12.100	10.70

Node Summary

Label	Scenario	Return Event (years)	Hydrograph Volume (ac-ft)	Time to Peak (hours)	Peak Flow (ft ³ /s)
EX DP-1	Pre-Development 100 YEAR	100	22.338	12.150	219.24
EX DP-2	Pre-Development 100 YEAR	100	0.160	12.050	2.25
EX DP-3	Pre-Development 100 YEAR	100	2.420	12.150	26.76
EX DP-4	Pre-Development 100 YEAR	100	0.904	12.100	10.53
EX DP-8	Pre-Development 100 YEAR	100	0.894	12.100	10.70

Pre-Dev 100 Year Routing

Subsection: Time-Depth Curve
 Label: Colo Springs 2015

Return Event: 100 years
 Storm Event: TYPE II 24 HOUR

Time-Depth Curve: TYPE II 24 HOUR	
Label	TYPE II 24 HOUR
Start Time	0.000 hours
Increment	0.250 hours
End Time	24.000 hours
Return Event	100 years

CUMULATIVE RAINFALL (in)
Output Time Increment = 0.250 hours
Time on left represents time for first value in each row.

Time (hours)	Depth (in)	Depth (in)	Depth (in)	Depth (in)	Depth (in)
0.000	0.0	0.0	0.0	0.0	0.1
1.250	0.1	0.1	0.1	0.1	0.1
2.500	0.1	0.1	0.2	0.2	0.2
3.750	0.2	0.2	0.2	0.3	0.3
5.000	0.3	0.3	0.3	0.3	0.4
6.250	0.4	0.4	0.4	0.5	0.5
7.500	0.5	0.5	0.6	0.6	0.6
8.750	0.6	0.7	0.7	0.7	0.8
10.000	0.8	0.9	0.9	1.0	1.1
11.250	1.2	1.3	1.8	3.0	3.3
12.500	3.4	3.5	3.6	3.6	3.7
13.750	3.7	3.8	3.8	3.9	3.9
15.000	3.9	4.0	4.0	4.0	4.1
16.250	4.1	4.1	4.1	4.2	4.2
17.500	4.2	4.2	4.2	4.3	4.3
18.750	4.3	4.3	4.3	4.4	4.4
20.000	4.4	4.4	4.4	4.4	4.4
21.250	4.5	4.5	4.5	4.5	4.5
22.500	4.5	4.5	4.5	4.6	4.6
23.750	4.6	4.6	(N/A)	(N/A)	(N/A)

Pre-Dev 100 Year Routing

Subsection: Addition Summary

Label: EX DP-1

Return Event: 100 years
Storm Event: TYPE II 24 HOUR

Summary for Hydrograph Addition at 'EX DP-1'

Upstream Link	Upstream Node
<Catchment to Outflow Node>	EX-1
<Catchment to Outflow Node>	EX-5
<Catchment to Outflow Node>	EX-6
<Catchment to Outflow Node>	EX-7
<Catchment to Outflow Node>	EX-4

Node Inflows

Inflow Type	Element	Volume (ac-ft)	Time to Peak (hours)	Flow (Peak) (ft ³ /s)
Flow (From)	EX-1	3.044	12.150	29.97
Flow (From)	EX-5	11.571	12.200	107.20
Flow (From)	EX-6	3.932	12.100	44.84
Flow (From)	EX-7	2.887	12.150	32.06
Flow (From)	EX-4	0.904	12.100	10.53
Flow (In)	EX DP-1	22.338	12.150	219.24

Pre-Dev 100 Year Routing

Subsection: Addition Summary
Label: EX DP-2

Return Event: 100 years
Storm Event: TYPE II 24 HOUR

Summary for Hydrograph Addition at 'EX DP-2'

Upstream Link	Upstream Node
<Catchment to Outflow Node>	EX-2

Node Inflows

Inflow Type	Element	Volume (ac-ft)	Time to Peak (hours)	Flow (Peak) (ft ³ /s)
Flow (From)	EX-2	0.160	12.050	2.25
Flow (In)	EX DP-2	0.160	12.050	2.25

Pre-Dev 100 Year Routing

Subsection: Addition Summary

Label: EX DP-3

Return Event: 100 years
Storm Event: TYPE II 24 HOUR

Summary for Hydrograph Addition at 'EX DP-3'

Upstream Link	Upstream Node
<Catchment to Outflow Node>	EX-3

Node Inflows

Inflow Type	Element	Volume (ac-ft)	Time to Peak (hours)	Flow (Peak) (ft ³ /s)
Flow (From)	EX-3	2.420	12.150	26.76
Flow (In)	EX DP-3	2.420	12.150	26.76

Pre-Dev 100 Year Routing

Subsection: Addition Summary

Label: EX DP-4

Return Event: 100 years

Storm Event: TYPE II 24 HOUR

Summary for Hydrograph Addition at 'EX DP-4'

Upstream Link	Upstream Node
<Catchment to Outflow Node>	EX-4

Node Inflows

Inflow Type	Element	Volume (ac-ft)	Time to Peak (hours)	Flow (Peak) (ft ³ /s)
Flow (From)	EX-4	0.904	12.100	10.53
Flow (In)	EX DP-4	0.904	12.100	10.53

Pre-Dev 100 Year Routing

Subsection: Addition Summary

Label: EX DP-8

Return Event: 100 years
Storm Event: TYPE II 24 HOUR

Summary for Hydrograph Addition at 'EX DP-8'

Upstream Link	Upstream Node
<Catchment to Outflow Node>	EX-8

Node Inflows

Inflow Type	Element	Volume (ac-ft)	Time to Peak (hours)	Flow (Peak) (ft ³ /s)
Flow (From)	EX-8	0.894	12.100	10.70
Flow (In)	EX DP-8	0.894	12.100	10.70

Pre-Dev 100 Year Routing

Index

C

Colo Springs 2015 (Time-Depth Curve, 100 years)...3

E

EX DP-1 (Addition Summary, 100 years)...4

EX DP-2 (Addition Summary, 100 years)...5

EX DP-3 (Addition Summary, 100 years)...6

EX DP-4 (Addition Summary, 100 years)...7

EX DP-8 (Addition Summary, 100 years)...8

M

Master Network Summary...2

HEC-RAS CALCULATIONS

SEE RIGHT

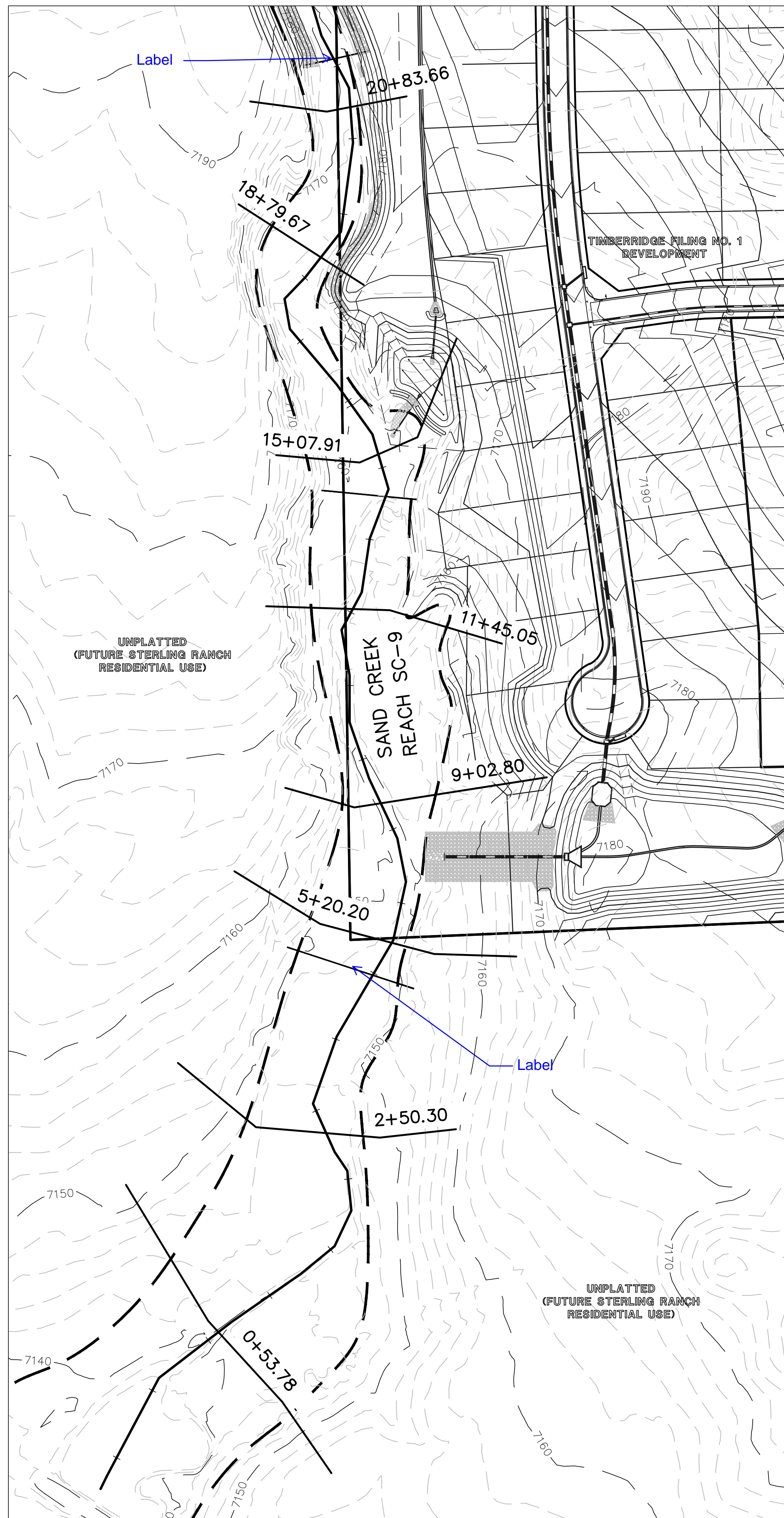

SEE RIGHT

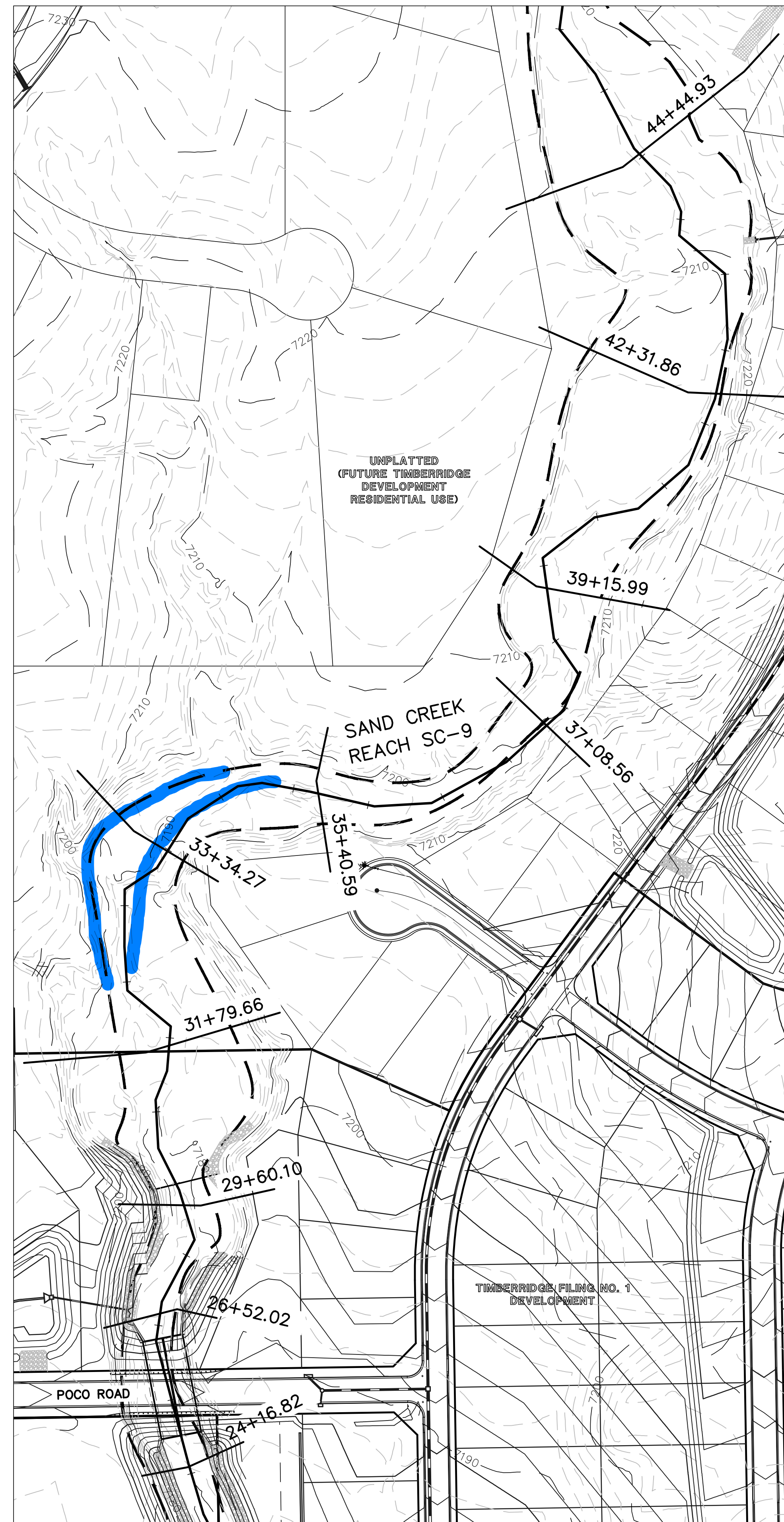

SEE LEFT

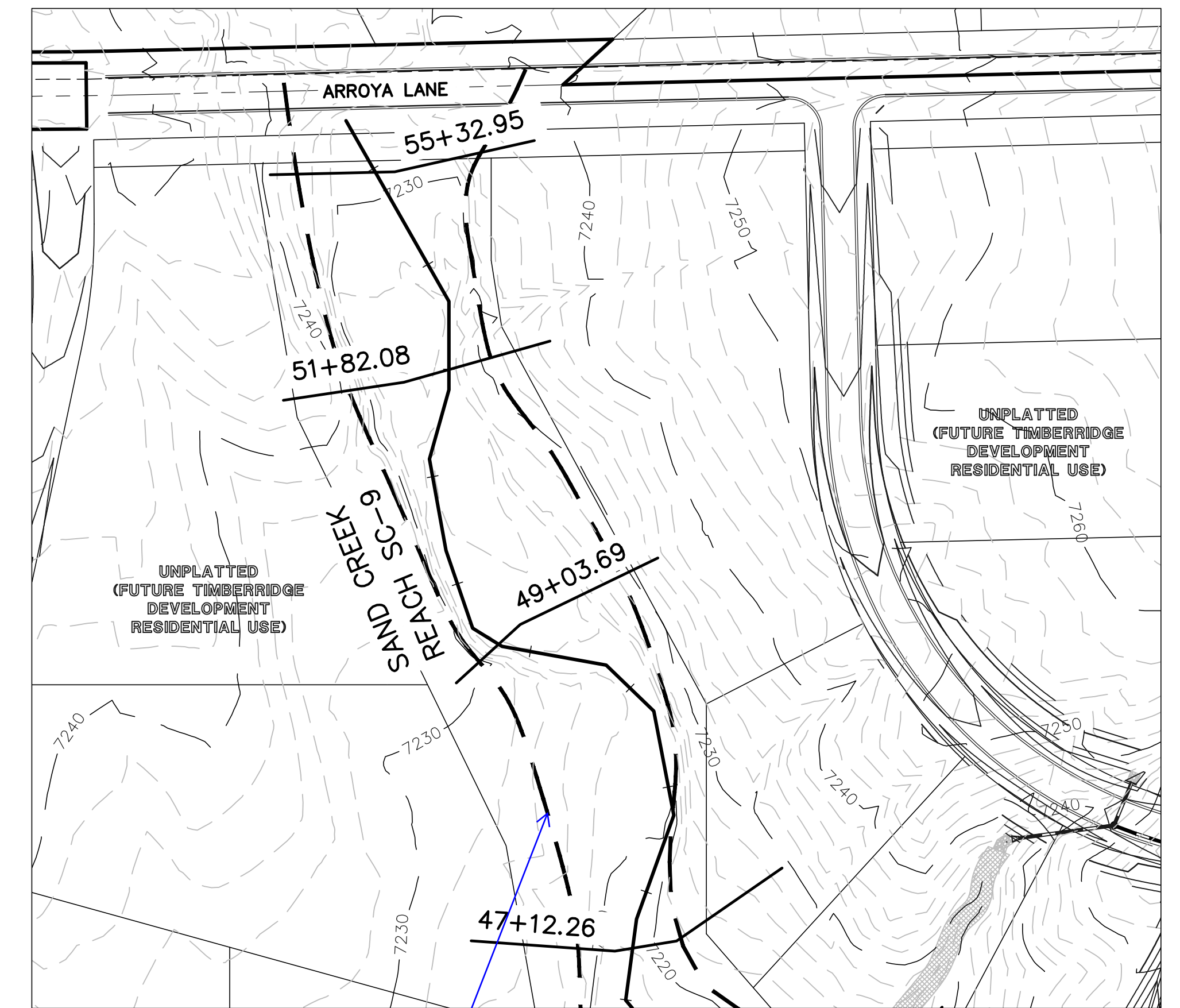

SEE LEFT

Label which floodplain line these are (FEMA 100-year flow?).

Provide complete channel plan and profile.

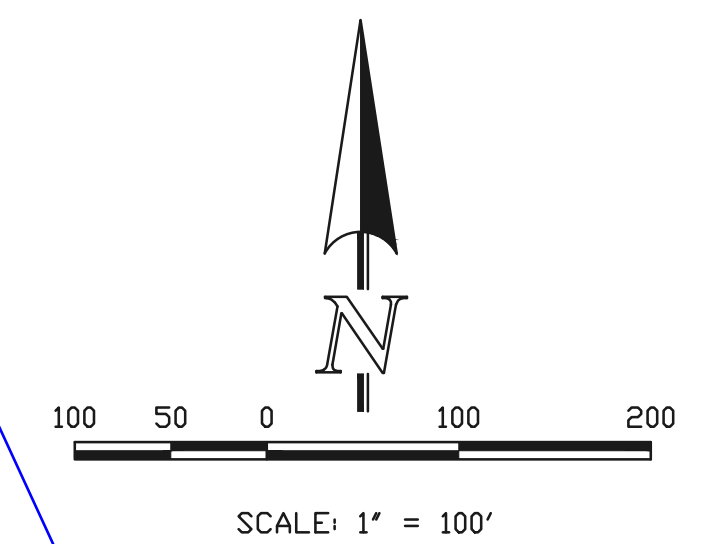

RETREAT AT TIMBERRIDGE FILING NO. 1
 CONSTRUCTION PLANS
 HEC-RAS ANALYSIS
 CHANNEL STATIONING EXHIBIT

DESIGNED BY	MAW	SCALE	DATE	7/22/19
DRAWN BY	MAW	(H) 1" = 100'	SHEET	1 OF 1
CHECKED BY		(V) 1" = N/A	JOB NO.	1185.00

619 N. Cascade Avenue, Suite 200 (719) 785-0790
 Colorado Springs, Colorado 80903 (719) 785-0799 (Fax)



N:\18500\DRAWINGS\SURFACES\VECTORS\VECTORS MODEL EXHIBIT.dwg, 6/7/2019 4:41:31 PM, 1:1

RETREAT AT TIMBERRIDGE FILING NO. 1



SAND CREEK REACH 9 - LOOKING DOWNSTREAM (HEC-RAS STA: 35+40.59)



SAND CREEK REACH 9 - LOOKING UPSTREAM (HEC-RAS STA: 35+40.59)

RETREAT AT TIMBERRIDGE FILING NO. 1



SAND CREEK REACH 9 - LOOKING DOWNSTREAM (HEC-RAS STA: 33+34.27)



SAND CREEK REACH 9 - LOOKING UPSTREAM (HEC-RAS STA: 33+34.27)

RETREAT AT TIMBERRIDGE FILING NO. 1



SAND CREEK REACH 9 - LOOKING DOWNSTREAM (HEC-RAS STA: 31+79.66)



SAND CREEK REACH 9 - LOOKING UPSTREAM (HEC-RAS STA: 31+79.66)

RETREAT AT TIMBERRIDGE FILING NO. 1



SAND CREEK REACH 9 - LOOKING DOWNSTREAM (HEC-RAS STA: 29+60.10)



SAND CREEK REACH 9 - LOOKING UPSTREAM (HEC-RAS STA: 29+60.10)

RETREAT AT TIMBERRIDGE FILING NO. 1



SAND CREEK REACH 9 - LOOKING DOWNSTREAM (HEC-RAS STA: 26+52.02)



SAND CREEK REACH 9 - LOOKING UPSTREAM (HEC-RAS STA: 26+52.02)

RETREAT AT TIMBERRIDGE FILING NO. 1



SAND CREEK REACH 9 - LOOKING DOWNSTREAM (HEC-RAS STA: 24+16.82)



SAND CREEK REACH 9 - LOOKING UPSTREAM (HEC-RAS STA: 24+16.82)

RETREAT AT TIMBERRIDGE FILING NO. 1



SAND CREEK REACH 9 - LOOKING DOWNSTREAM (HEC-RAS STA: 20+83.66)



SAND CREEK REACH 9 - LOOKING UPSTREAM (HEC-RAS STA: 20+83.66)

RETREAT AT TIMBERRIDGE FILING NO. 1



SAND CREEK REACH 9 - LOOKING DOWNSTREAM (HEC-RAS STA: 18+79.67)



SAND CREEK REACH 9 - LOOKING UPSTREAM (HEC-RAS STA: 18+79.67)

RETREAT AT TIMBERRIDGE FILING NO. 1



SAND CREEK REACH 9 - LOOKING DOWNSTREAM (HEC-RAS STA: 15+07.91)



SAND CREEK REACH 9 - LOOKING UPSTREAM (HEC-RAS STA: 15+07.91)

RETREAT AT TIMBERRIDGE FILING NO. 1



SAND CREEK REACH 9 - LOOKING DOWNSTREAM (HEC-RAS STA: 11+45.05)



SAND CREEK REACH 9 - LOOKING UPSTREAM (HEC-RAS STA: 11+45.05)

RETREAT AT TIMBERRIDGE FILING NO. 1



SAND CREEK REACH 9 - LOOKING DOWNSTREAM (HEC-RAS STA: 9+02.80)



SAND CREEK REACH 9 - LOOKING UPSTREAM (HEC-RAS STA: 9+02.80)

RETREAT AT TIMBERRIDGE FILING NO. 1



SAND CREEK REACH 9 - LOOKING DOWNSTREAM (HEC-RAS STA: 5+20.20)



SAND CREEK REACH 9 - LOOKING UPSTREAM (HEC-RAS STA: 5+20.20)

RETREAT AT TIMBERRIDGE FILING NO. 1



SAND CREEK REACH 9 - LOOKING UPSTREAM FROM HEC-RAS STA: 34+00



SAND CREEK REACH 9 - LOOKING UPSTREAM FROM HEC-RAS STA: 27+00

RETREAT AT TIMBERRIDGE FILING NO. 1



SAND CREEK REACH 9 - LOOKING DOWNSTREAM FROM HEC-RAS STA: 14+00

TABLE 10-1

COMPOSITE ROUGHNESS COEFFICIENTS FOR UNLINED OPEN CHANNELS
(Reference: Chow, Ven Te, 1959; Open-Channel Hydraulics)

$$n = (n_0 + n_1 + n_2 + n_3 + n_4)m \quad (10-2)$$

	<u>Channel Conditions</u>	<u>Value</u>
Material Type n_0	Earth	0.020
	Fine Gravel	0.024
	Coarse Gravel	0.028
Degree of Irregularity n_1	Smooth	0.000
	Minor	0.005
	Moderate	0.010
	Severe	0.020
Variation of Channel Cross Section n_2	Gradual	0.000
	Alternating Occasionally	0.005
	Alternating Frequently	0.010 - 0.015
Relative Effect of Obstructions n_3	Negligible	0.000
	Minor	0.010 - 0.015
	Appreciable	0.020 - 0.030
	Severe	0.040 - 0.060
Vegetation n_4	Low	0.005 - 0.010
	Medium	0.010 - 0.025
	High	0.025 - 0.050
	Very High	0.050 - 0.100
Degree of Meandering m	Minor	1.000 - 1.200
	Appreciable	1.200 - 1.500
	Severe	1.500

TABLE 10-2 (Continued)

TYPICAL ROUGHNESS COEFFICIENTS FOR OPEN CHANNELS

<u>Type of Channel and Description</u>	<u>Minimum</u>	<u>Normal</u>	<u>Maximum</u>
NATURAL STREAMS			
Minor streams (top width at flood stage 100 ft)			
a. Streams on plain			
1. Clean, straight, full stage, no rifts or deep pools	0.025	0.030	0.033
2. Same as above, but more stones and weeds	0.030	0.035	0.040
3. Clean, winding, some pools and shoals	0.033	0.040	0.045
4. Same as above, but some weeds and stones	0.035	0.045	0.050
5. Same as above, lower stages, more ineffective slopes and sections	0.040	0.048	0.055
6. Same as 4, but more stones	0.045	0.050	0.060
7. Sluggish reaches, weedy, deep pools	0.050	0.070	0.080
8. Very weedy reaches, deep pools, or floodways with heavy stand of timber and underbrush	0.075	0.100	0.150
LINED OR BUILT-UP CHANNELS			
a. Corrugated Metal	0.021	0.025	0.030
b. Concrete			
1. Trowel finish	0.011	0.013	0.015
2. Float finish	0.013	0.015	0.016
3. Finished, with gravel on bottom	0.015	0.017	0.020
4. Unfinished	0.014	0.017	0.020
5. Gunite, good section	0.016	0.019	0.023
6. Gunite, wavy section	0.018	0.022	0.025
7. On good excavated rock	0.017	0.020	
8. On irregular excavated rock	0.022	0.027	

Table 3. Adjustment values for factors that affect roughness of flood plains

[Modified from Aldridge and Garrett, 1973, table 2]

Flood-plain conditions	<i>n</i> value adjustment	Example	
Degree of irregularity (n_1)	Smooth	0.000	Compares to the smoothest, flattest flood plain attainable in a given bed material.
	Minor	0.001–0.005	Is a flood plain slightly irregular in shape. A few rises and dips or sloughs may be visible on the flood plain.
	Moderate	0.006–0.010	Has more rises and dips. Sloughs and hummocks may occur.
	Severe	0.011–0.020	Flood plain very irregular in shape. Many rises and dips or sloughs are visible. Irregular ground surfaces in pastureland and furrows perpendicular to the flow are also included.
Variation of flood-plain cross section (n_2)	0.0	Not applicable.	
Effect of obstructions (n_3)	Negligible	0.000–0.004	Few scattered obstructions, which include debris deposits, stumps, exposed roots, logs, or isolated boulders, occupy less than 5 percent of the cross-sectional area.
	Minor	0.005–0.019	Obstructions occupy less than 15 percent of the cross-sectional area.
	Appreciable	0.020–0.030	Obstructions occupy from 15 to 50 percent of the cross-sectional area.
Amount of vegetation (n_4)	Small	0.001–0.010	Dense growth of flexible turf grass, such as Bermuda, or weeds growing where the average depth of flow is at least two times the height of the vegetation, or supple tree seedlings such as willow, cottonwood, arrowweed, or saltcedar growing where the average depth of flow is at least three times the height of the vegetation.
	Medium	0.011–0.025	Turf grass growing where the average depth of flow is from one to two times the height of the vegetation, or moderately dense stemmy grass, weeds, or tree seedlings growing where the average depth of flow is from two to three times the height of the vegetation; brushy, moderately dense vegetation, similar to 1- to 2-year-old willow trees in the dormant season.
	Large	0.025–0.050	Turf grass growing where the average depth of flow is about equal to the height of the vegetation, or 8- to 10-year-old willow or cottonwood trees intergrown with some weeds and brush (none of the vegetation in foliage) where the hydraulic radius exceeds 2 ft, or mature row crops such as small vegetables, or mature field crops where depth of flow is at least twice the height of the vegetation.
	Very large	0.050–0.100	Turf grass growing where the average depth of flow is less than half the height of the vegetation, or moderate to dense brush, or heavy stand of timber with few down trees and little undergrowth where depth of flow is below branches, or mature field crops where depth of flow is less than the height of the vegetation.
	Extreme	0.100–0.200	Dense bushy willow, mesquite, and saltcedar (all vegetation in full foliage), or heavy stand of timber, few down trees, depth of flow reaching branches.
Degree of meander (m)	1.0	Not applicable.	

Chow (1959) presents a table showing minimum, normal, and maximum values of n for flood plains covered by pasture and crops. These values are helpful for comparing the roughness values of flood plains having similar vegetation.

Vegetation-Density Method

For a wooded flood plain, the vegetation-density method can be used as an alternative to the previous method for determining n values for flood plains. In a wooded flood plain, where the tree diameters can be measured, the vegetation density of the flood plain can be determined.

Determining the vegetation density is an effective way of relating plant height and density characteristics, as a function of depth of flow, to the flow resistance of vegetation. Application of the flow-resistance model presented below requires an estimate of the vegetation density as a function of depth of flow. The procedure requires a direct or indirect determination of vegetation density at a given depth. If the change in n value through a range in depth is required, then an estimation of vegetation density through that range is necessary.

Techniques for Determining Vegetation Density

Petryk and Bosmajian (1975) developed a method of analysis of the vegetation density to determine the rough-

Classification of Vegetal Covers

Retardance Class	Cover	Condition
A	Weeping lovegrass	Excellent stand, tall, average 30 in.
	Yellow bluestem <i>Ischaemum</i>	Excellent stand, tall, average 36 in.
B	Bermuda grass	Good stand, tall, average 12 in.
	Native grass mixture (little bluestem, bluestem, blue gamma, and other long and short Midwest grasses)	Good stand, unmowed
	Weeping lovegrass	Good stand, tall, average 24 in.
	Lespedeza serica	Good stand, not woody, tall, average 19 in.
	Alfalfa	Good stand uncut, average 11 in.
	Weeping lovegrass	Good stand, unmowed, average 13 in.
	Kudzu	Dense growth, uncut
C	Blue gamma	Good stand, uncut, average 13 in.
	Crabgrass	Fair stand, uncut, avg. 10 in.
	Bermuda grass	Good stand, mowed, average 6 in.
	Common lespedeza	Good stand, uncut, average 11 in.
	Grass-legume mixture - summer (orchard grass, redbow Italian ryegrass, and common lespedeza)	Good stand, uncut, average 6 to 8 in.
	Centipedegrass	Very dense cover, average 6 in.
	Kentucky Bluegrass	Good stand, headed, 6 to 12 in.
D	Bermuda grass	Good stand, cut to 2.5 in. height
	Common lespedeza	Excellent stand, uncut, average 4.5 in.
	Buffalo Grass	Good stand, uncut, 3 to 6 in.
	Grass-legume mixture - fall (orchard grass, redbow Italian ryegrass, and common lespedeza)	Good stand, uncut, 3 to 5 in.
E	Lespedeza serica	After cutting to 2 in. height, good stand before cutting
	Bermuda grass	Good stand, cut to average 1.5 in. height
	Bermuda grass	Burned stubble

Note: Covers classified have been tested in experimental channels. Covers were green and generally uniform.

Source: HEC-15



Coefficients for Roughness of Grass-Lined Channels

SCS Retardance Class	C _n
A	0.605
B	0.418
C	0.220
D	0.147
E	0.093

Source: HEC-15

Composite Roughness

Culverts using different materials for portions of the perimeter such as embedded culverts or culverts with an invert liner should use a composite Manning's n value. A weighted n value based on the materials can be derived using the following equation:

$$n_c = \left[\frac{\sum(p_i n_i^{1.5})}{p} \right]^{0.67}$$

Where:

- n_c = Composite/weighted Manning's n.
- p_i = Wetted perimeter for the material, ft.
- n_i = Manning's n value for the material.
- p = Total wetted perimeter, ft.

750.1.4.1.2 Hydraulic Radius

The hydraulic radius is a characteristic depth of flow and is defined as the cross-sectional area of flow divided by the wetted perimeter of the channel. The hydraulic radius is computed as follows:

$$R = \frac{A}{P}$$

where:

- R = hydraulic radius, ft
- A = cross-sectional area of flow, ft²
- P = wetted perimeter of the channel cross section, ft

750.1.4.1.3 Slope

Table 8-8 Characteristics of selected grass species for use in channels and waterways

Grass species	Height at maturity	
	(ft)	(m)
Cool-season grasses		
Creeping foxtail	3-4	0.9-1.2
Crested wheatgrass	2-3	0.6-0.9
Green needlegrass	3-4	0.9-1.2
Russian wild rye	3-4	0.9-1.2
Smooth brome grass	3-4	0.9-1.2
Tall fescue	3-4	0.9-1.2
Tall wheatgrass		1.2-1.5
Western wheatgrass	2-3	0.6-0.9
Warm-season grasses		
Bermudagrass	3/4-2	0.2-0.6
Big bluestem	4-6	1.2-1.8
Blue grama	1-2	0.3-0.6
Buffalograss	1/3-1	0.1-0.3
Green spangle top	3-4	0.9-1.2
Indiangrass	5-6	1.5-1.8
Klein grass	3-4	0.9-1.2
Little bluestem	3-4	0.9-1.2
Plains bristlegrass	1-2	0.3-0.6
Sand bluestem	5-6	1.5-1.8
Sideoats grama	2-3	0.6-0.9
Switchgrass	4-5	1.2-1.5
Vine mesquitegrass	1-2	0.3-0.6
Weeping lovegrass	3-4	0.9-1.2
Old World bluestems		
Caucasian bluestem	4-5	1.2-1.5
Ganada yellow bluestem	3-4	0.9-1.2

this table were obtained from a review of the available qualitative descriptions and stem counts reported by researchers studying channel resistance and stability.

Since cover conditions vary from year to year and season to season, it is recommended that an upper and lower bound be determined for C_F . The lower bound should be used in stability computations, and the upper bound should be used to determine channel capacity. Some practitioners find that the use of SCS retardance class (table 8-9) is a preferable approach.

The vegetal cover index, C_F , depends primarily on the density and uniformity of density in the immediate vicinity of the soil boundary. Because this parameter is associated with the prevention of local erosion damage which may lead to channel unraveling, the cover factor should represent the weakest area in a reach, rather than the average for the cover species. Recommended values for the cover factor are presented in table 8-10. Values in this table do not account for such considerations as maintenance practices or uniformity of soil fertility or moisture. Therefore, appropriate engineering judgment should be used in its application.

Table 8-10 Properties of grass channel linings values (apply to good uniform stands of each cover)

Cover factor (C_F)	Covers tested	Reference stem density (stems/ft ²)	Reference stem density (stems/m ²)
0.90	Bermudagrass	500	5,380
	Centipede grass	500	5,380
0.87	Buffalograss	400	4,300
	Kentucky bluegrass	350	3,770
	Blue grama	350	3,770
0.75	Grass mixture	200	2,150
0.50	Weeping lovegrass	350	3,770
	Yellow bluestem	250	2,690
0.50	Alfalfa	500	5,380
	Lespedeza sericea	300	3,280
0.50	Common lespedeza	150	1,610
	Sudangrass	50	538

Multiply the stem densities given by 1/3, 2/3, 1, 4/3, and 5/3 for poor, fair, good, very good, and excellent covers, respectively. Reduce the C_F by 20% for fair stands and 50% for poor stands.

Table 8-9 Retardance curve index by SCS retardance class

SCS retardance class	Retardance curve index
A	10.0
B	7.64
C	5.60
D	4.44
E	2.88



Two soil parameters are required for application of effective stress concepts to the stability design of lined or unlined channels having an erodible soil boundary: soil grain roughness, n_s , and allowable effective stress, τ_a . When the effective stress approach is used, the soil parameters are the same for both lined and unlined channels with negligible bed-material sediment transport.

Soil grain roughness is defined as the roughness associated with particles or aggregates of a size that can be independently moved by the flow at incipient channel failure. For noncohesive soils, the soil grain roughness and effective shear stress are both a function of the D_{75} grain size. When D_{75} is greater than 1.3 millimeter, the soil is considered coarse grained. When D_{75} is less than 1.3 millimeter, the soil is considered fine grained. Fine-grained roughness is considered to have a constant value of 0.0156. Fine-grained effective shear stress is taken to have a constant value of 0.02 pound per square foot. Coarse-grained shear stress and roughness are given in figures 8-21 and 8-22.

A soil grain roughness of 0.0156 is assigned to all cohesive soils. The allowable effective stresses are a function of the unified soil classification system soil type, the plasticity index, and the void ratio. The basic allowable shear stress, τ_{ab} , is determined from the plasticity index and soil classification, and then adjusted by the void ratio correction factor, C_e , using the following equation:

$$\tau_a = \tau_{ab} C_e^2 \quad (\text{eq. 8-29})$$

The basic allowable effective stress can be determined from figure 8-23 and the void ratio correction factor from figure 8-24. These two figures were developed directly from the allowable velocity curves in AH 667. Stress partitioning (slope partitioning) is essential to application of figures 8-21 to 8-24, with or without vegetation (Temple et al. 1987).

(e) General design procedure

Use the basic shear stress equation to determine effective shear stress on the soil beneath the vegetation. Use any consistent units of measurement.

$$\tau_e = \gamma d S (1 - C_p) \left(\frac{n_s}{n} \right)^2 \quad (\text{eq. 8-30})$$

where:

- τ_e = effective shear stress exerted on the soil beneath vegetation (lb/ft² or N/m²)
- γ = specific weight of water (lb/ft³ or N/m³)
- d = maximum depth of flow in the cross section (ft or m)
- S = energy slope, dimensionless
- C_p = vegetation cover factor (0 for unlined channel), dimensionless
- n_s = grain roughness of underlying soil, typically taken as dimensionless
- n = roughness coefficient of vegetation, typically taken as dimensionless

The flow depth is used instead of the hydraulic radius because this will result in the maximum local shear stress, rather than the average shear stress. The cover factor is a function of the grass and stem density. Roughness coefficients are standard Manning's roughness values; n_s can be determined from figure 8-22, n can be determined from the old SCS curves (fig. 8-20) or from the following equation.

$$n_r = \exp \left\{ C_1 \left[0.0133 (\ln R_v)^2 - 0.0954 \ln R_v + 0.297 \right] - 4.16 \right\} \quad (\text{eq. 8-31})$$

where:

- R_v = $(VR/v) \times 10^{-5}$ (this dimensionless term reduces to VR for practical application in English units)
- V = channel velocity (ft/s or m/s)
- R = hydraulic radius (ft or m)
- Limited to $0.0025 C_1^{2.5} < R_v < 36$

A reference value of Manning's resistance coefficient, n_r , is applicable to vegetation established on relatively smoothly graded fine-grained soil.

If vegetated channel liner mats are used, manufacturer-supplied roughness coefficients for particular mats may be used in the equation.



Maximum allowable shear stress, τ_{va} , in pound per square foot is determined as a function of the retardance curve index, C_r . Very little information is available for vegetal performance under very high stresses and this relation is believed to be conservative.

$$\tau_{va} = 0.75 C_r \quad (\text{eq. 8-32})$$

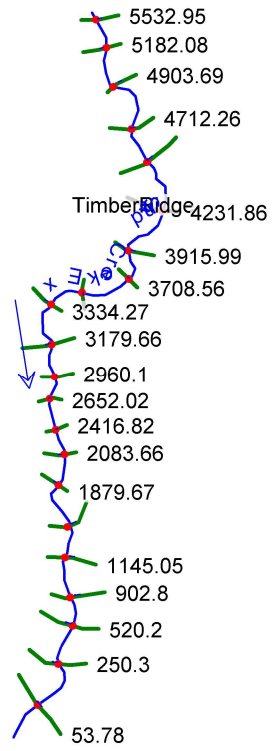

TIMBERRIDGE EXIST. Plan: SC EX 7/24/2019

Sand Creek Ex TimberRidge

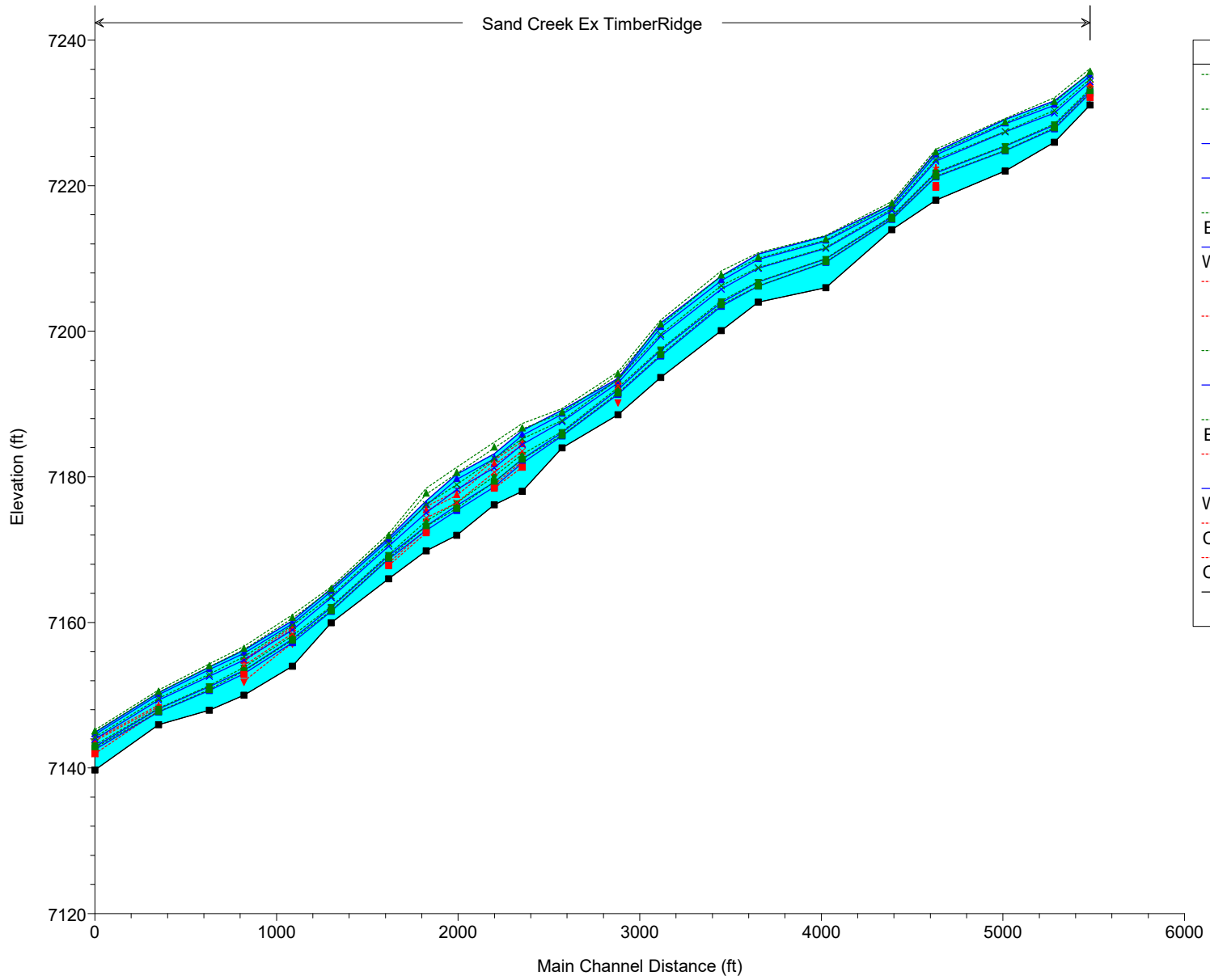

Legend	
EG FEMA 100 Yr.	(dotted green line with upward triangles)
EG DBPS 100 Yr.	(dotted green line with downward triangles)
WS FEMA 100 Yr.	(solid blue line with upward triangles)
WS DBPS 100 Yr.	(solid blue line with downward triangles)
EG Sterling MDDP 10	(dotted green line with 'x' markers)
WS Sterling MDDP 10	(solid blue line with 'x' markers)
Crit FEMA 100 Yr.	(dotted red line with upward triangles)
Crit DBPS 100 Yr.	(dotted red line with downward triangles)
EG DBPS 10 Yr.	(dotted green line with downward triangles)
WS DBPS 10 Yr.	(solid blue line with downward triangles)
EG Sterling MDDP 10	(dotted green line with square markers)
Crit DBPS 10 Yr.	(dotted red line with square markers)
WS Sterling MDDP 10	(solid blue line with square markers)
Crit Sterling MDDP 10	(dotted red line with square markers)
Crit Sterling MDDP 10	(dotted red line with 'x' markers)
Ground	(solid black line with square markers)

TIMBERRIDGE EXIST. Plan: SC EX 7/24/2019
 River = Sand Creek Ex Reach = TimberRidge RS = 5532.95

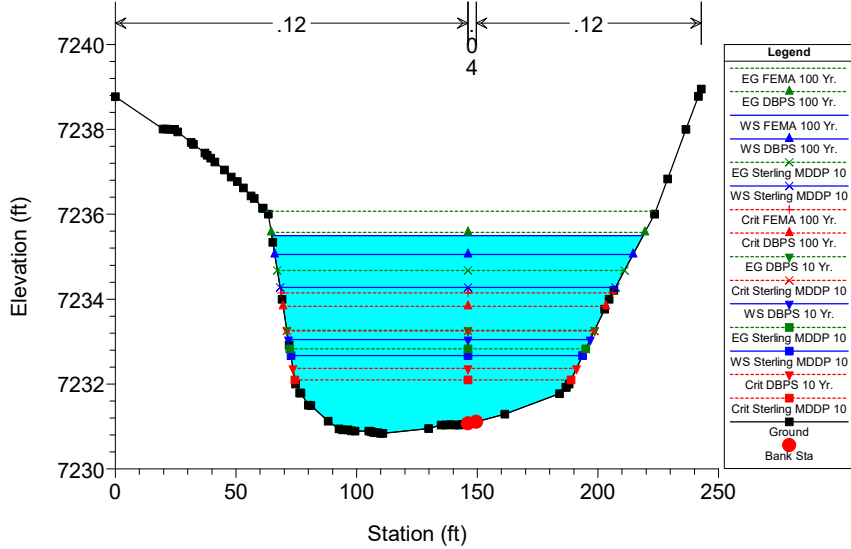

TIMBERRIDGE EXIST. Plan: SC EX 7/24/2019
 River = Sand Creek Ex Reach = TimberRidge RS = 5182.08

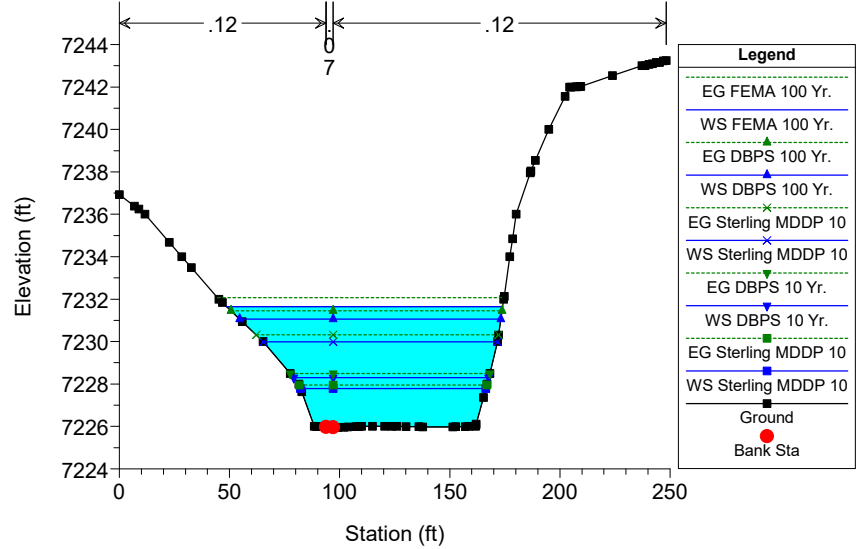

TIMBERRIDGE EXIST. Plan: SC EX 7/24/2019
 River = Sand Creek Ex Reach = TimberRidge RS = 4903.69

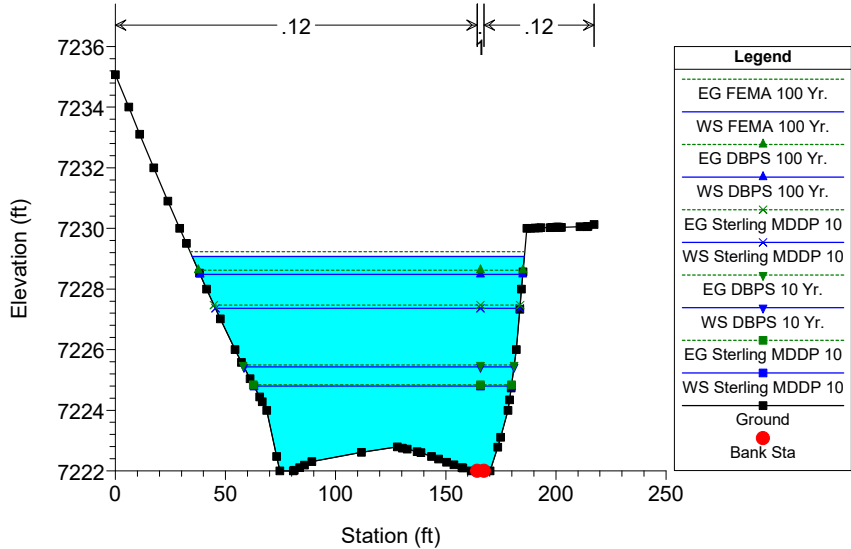

TIMBERRIDGE EXIST. Plan: SC EX 7/24/2019
 River = Sand Creek Ex Reach = TimberRidge RS = 4712.26

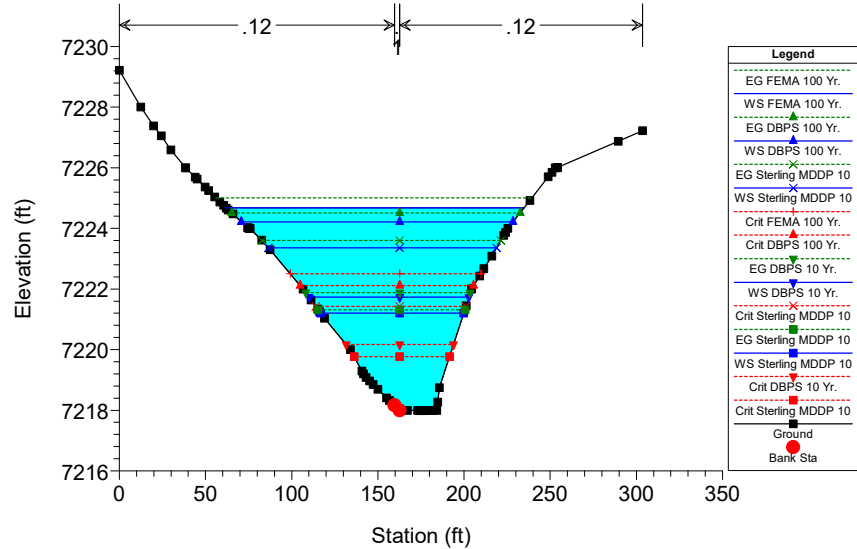

TIMBERRIDGE EXIST. Plan: SC EX 7/24/2019

River = Sand Creek Ex Reach = TimberRidge RS = 4444.93

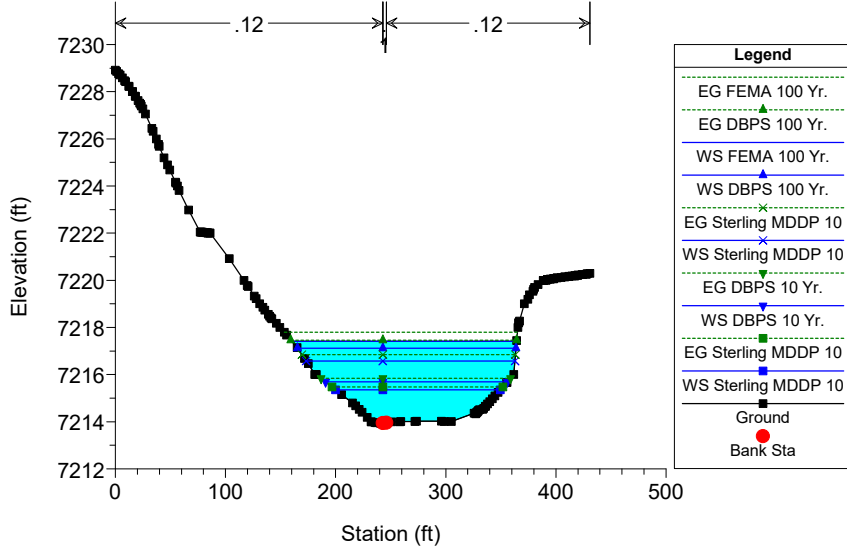

TIMBERRIDGE EXIST. Plan: SC EX 7/24/2019

River = Sand Creek Ex Reach = TimberRidge RS = 4231.86

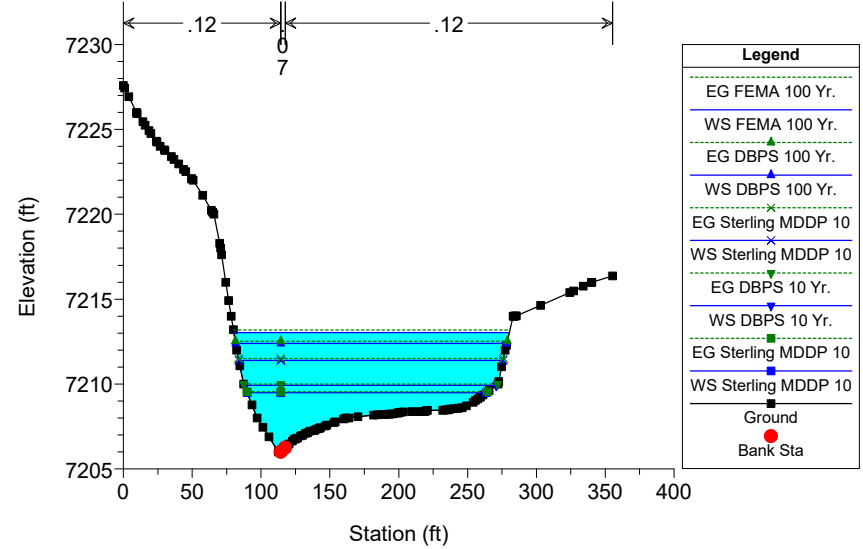

TIMBERRIDGE EXIST. Plan: SC EX 7/24/2019

River = Sand Creek Ex Reach = TimberRidge RS = 3915.99

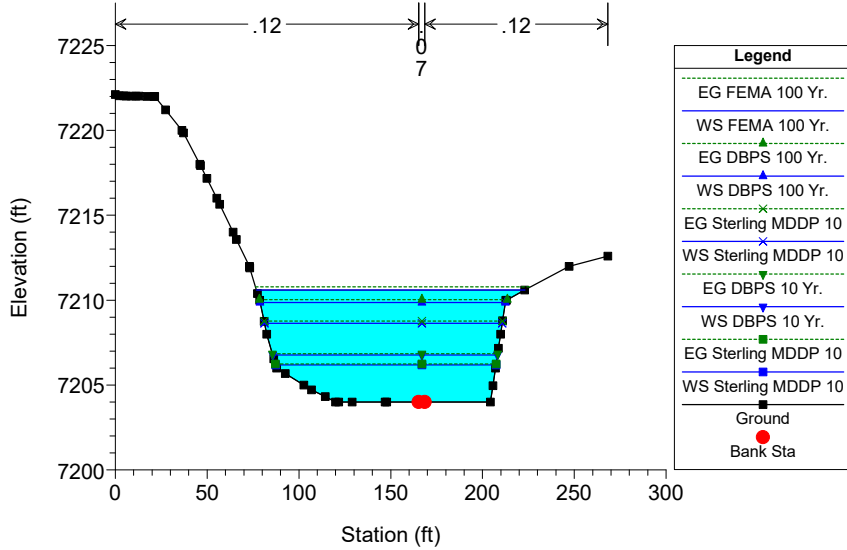

TIMBERRIDGE EXIST. Plan: SC EX 7/24/2019

River = Sand Creek Ex Reach = TimberRidge RS = 3708.56

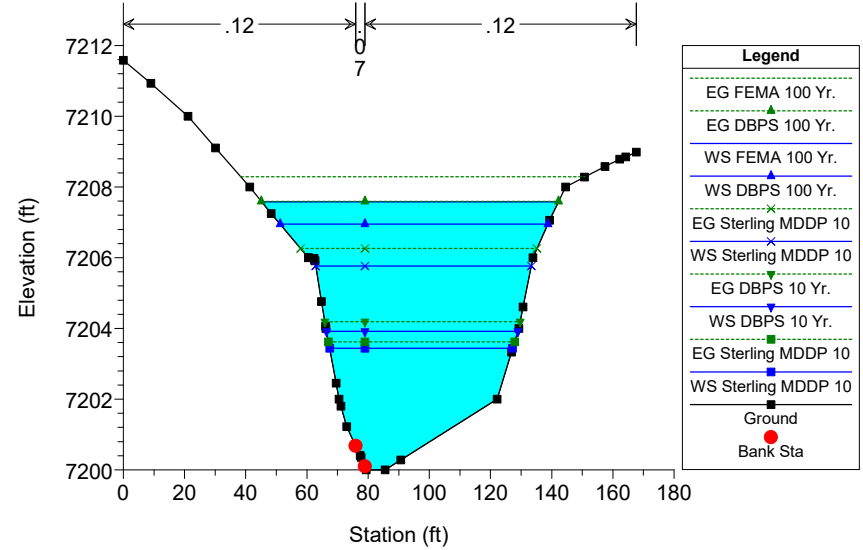

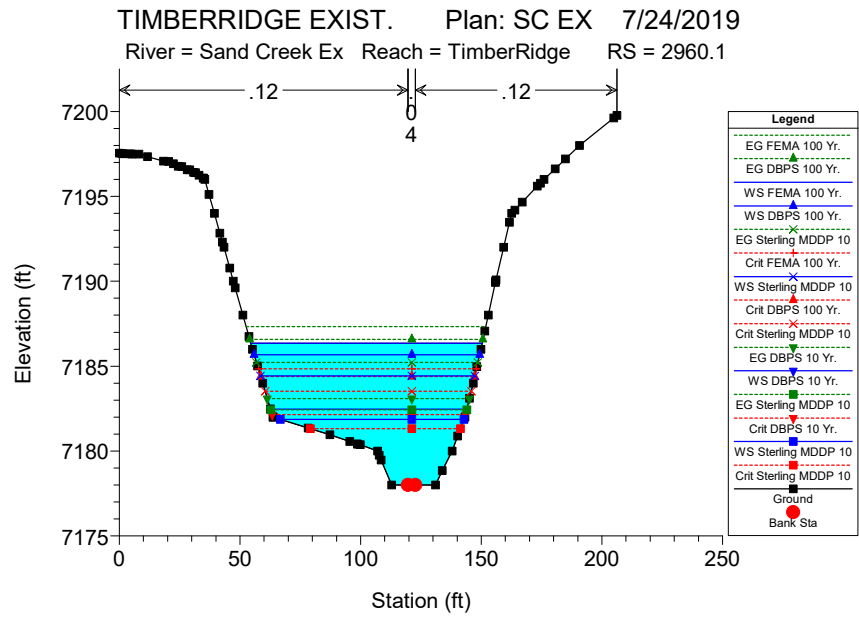
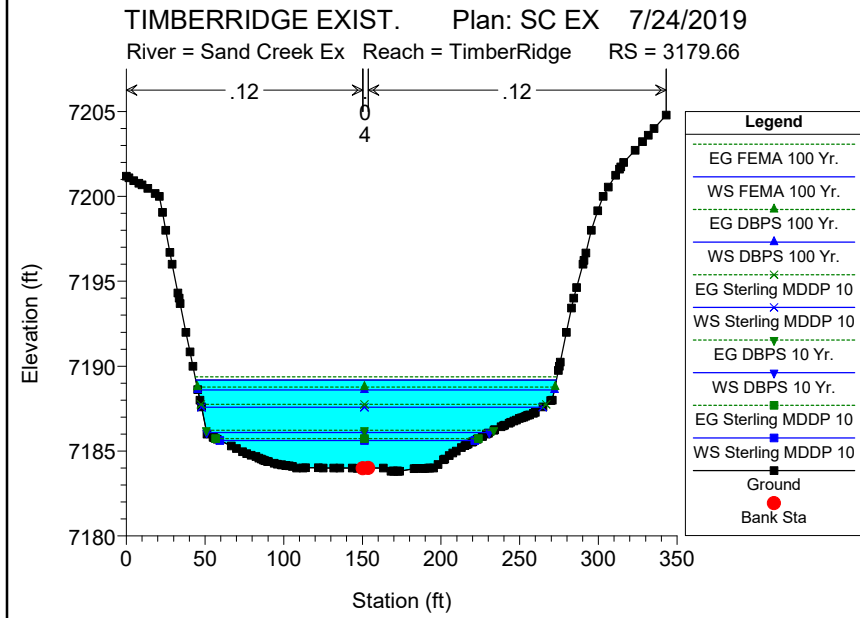
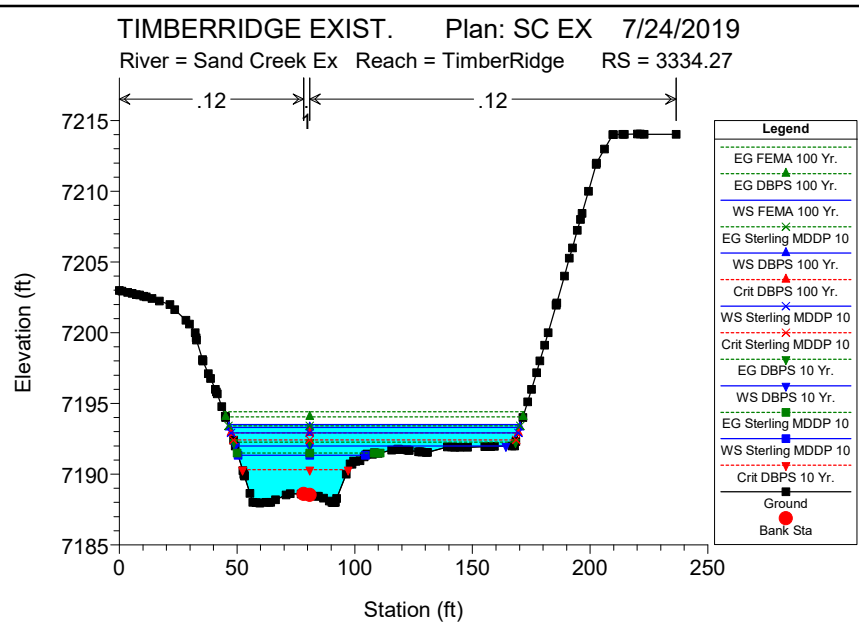
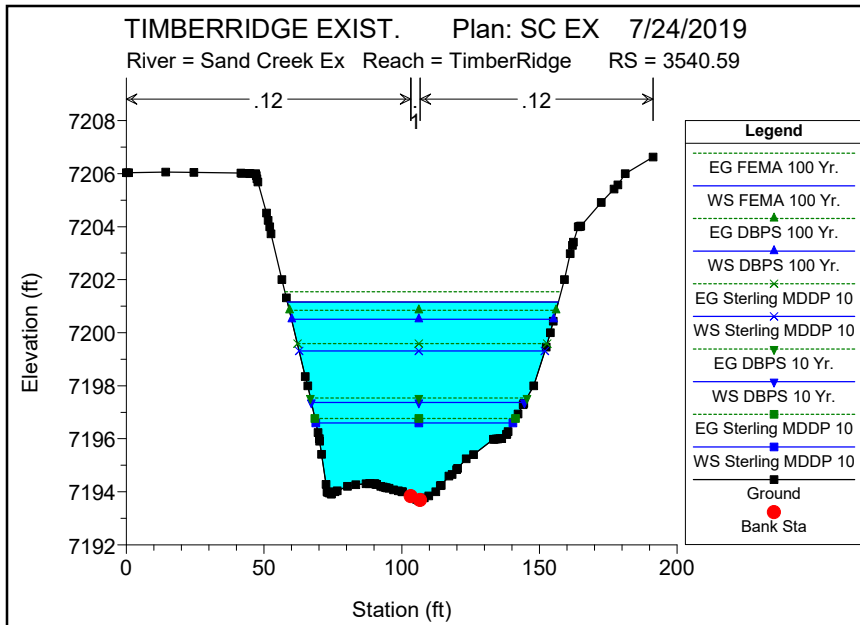

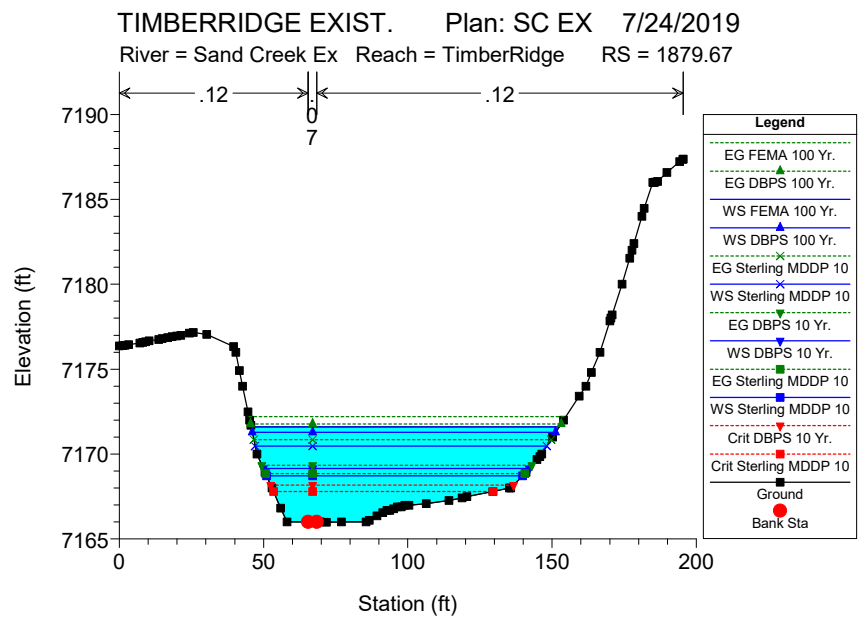
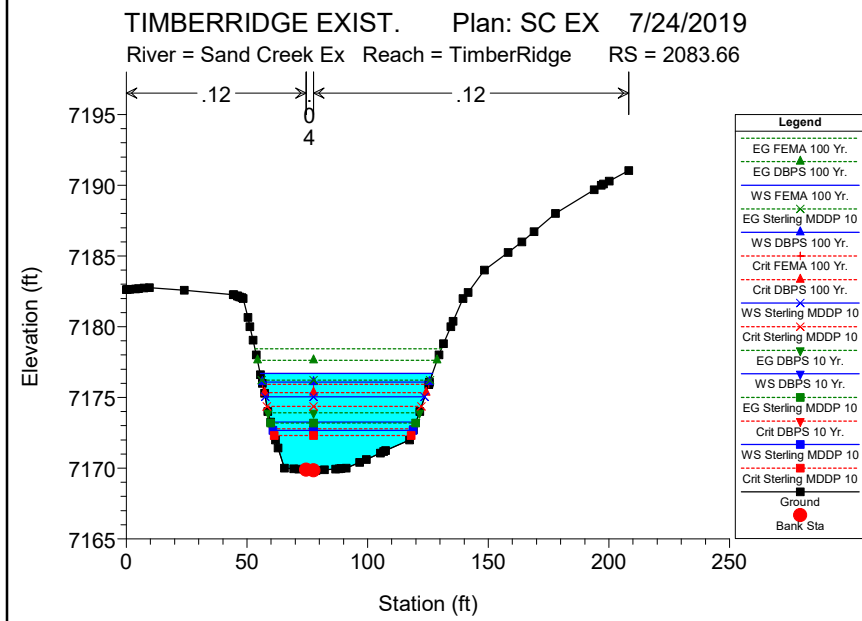
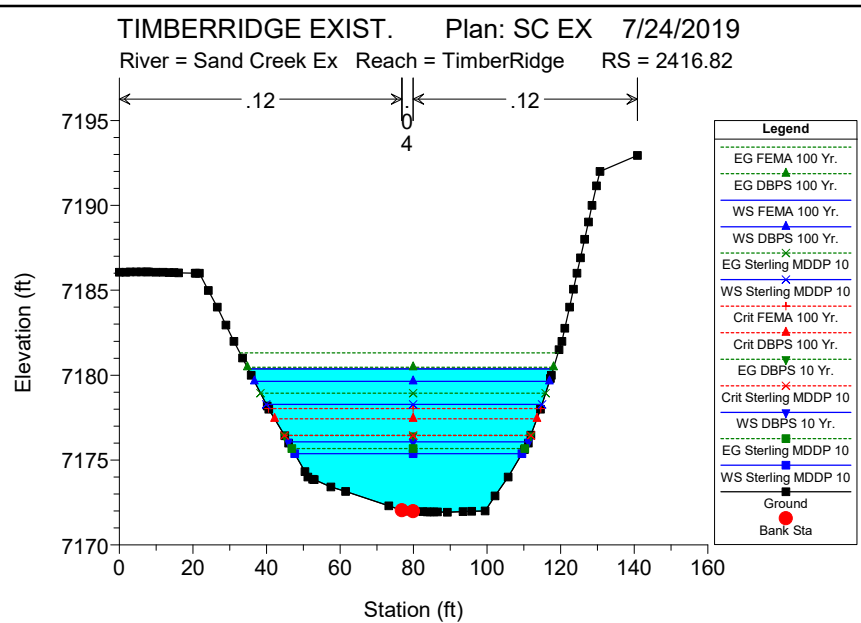
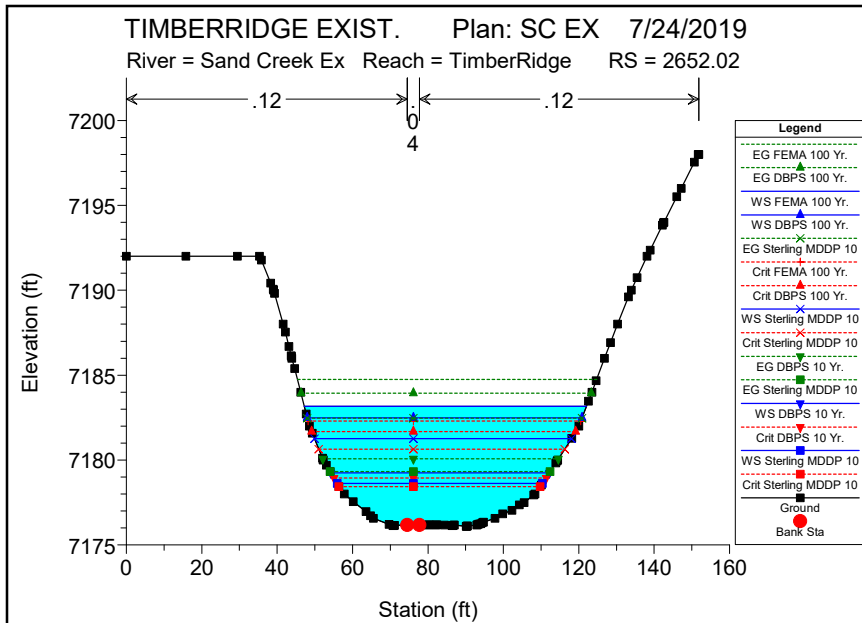

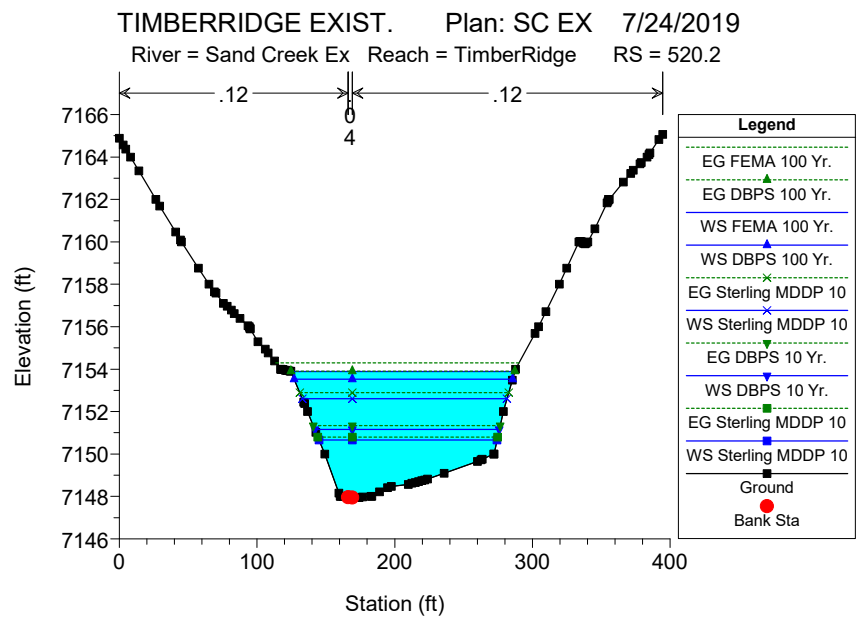
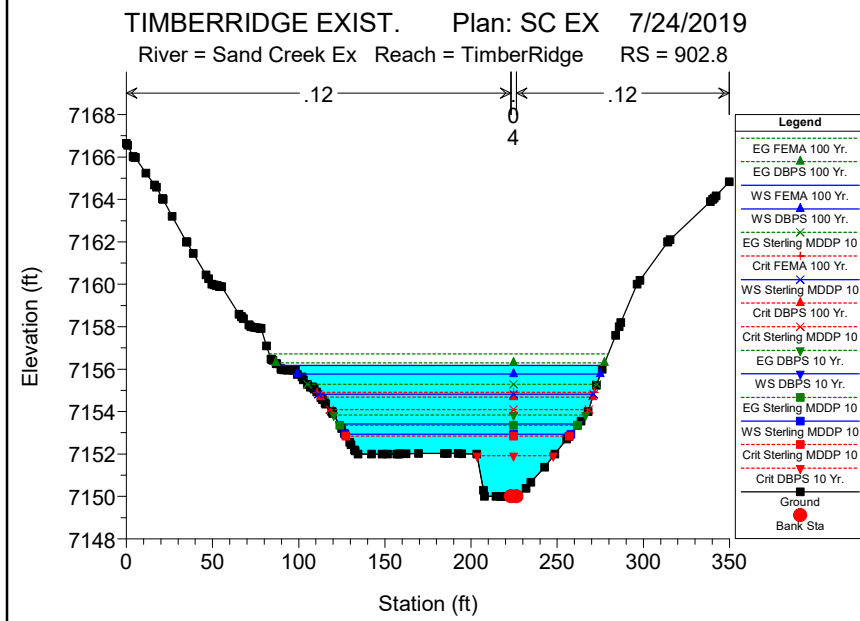
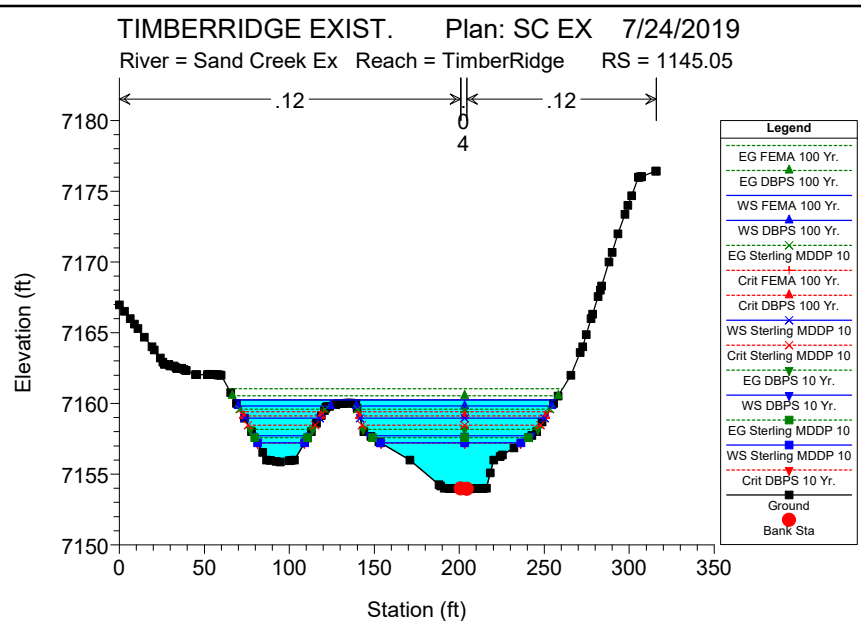
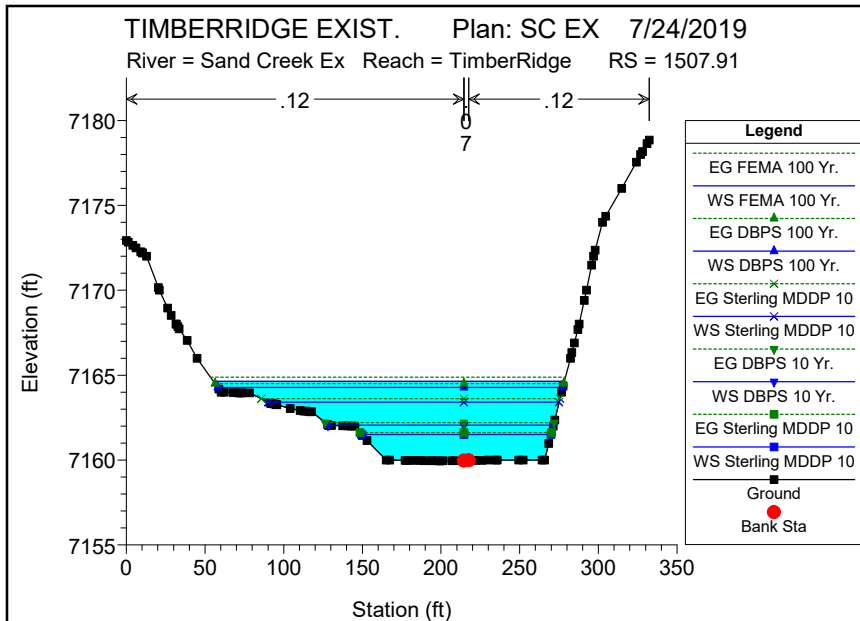

TIMBERRIDGE EXIST. Plan: SC EX 7/24/2019

River = Sand Creek Ex Reach = TimberRidge RS = 250.3

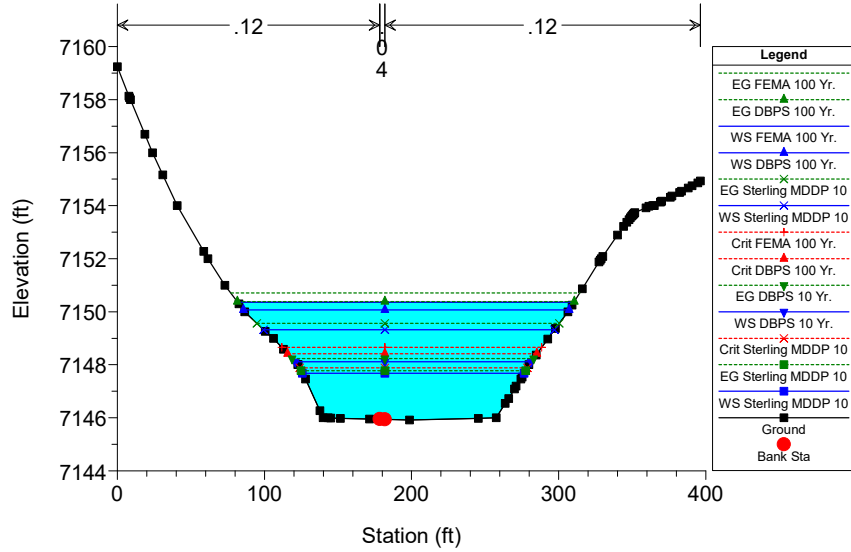

TIMBERRIDGE EXIST. Plan: SC EX 7/24/2019

River = Sand Creek Ex Reach = TimberRidge RS = 53.78

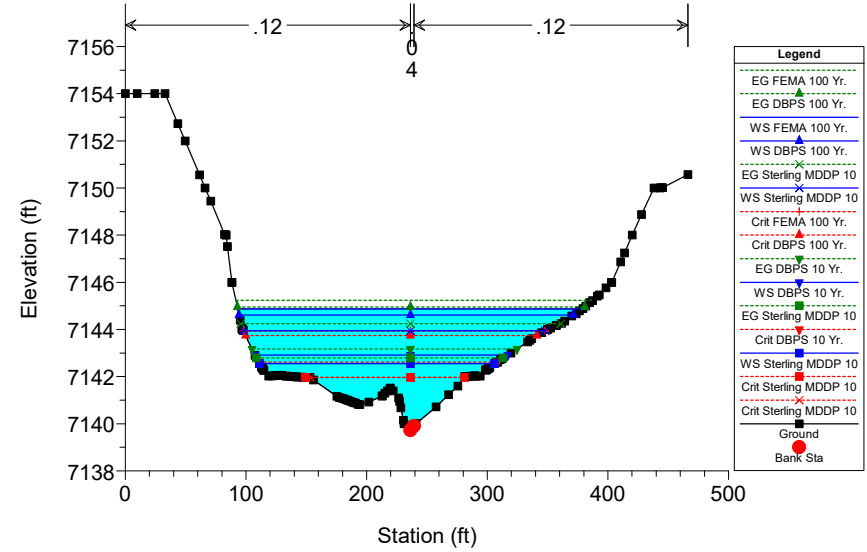

HEC-RAS Plan: SC EX River: Sand Creek Ex Reach: TimberRidge

Reach	River Sta	Profile	Q Total (cfs)	Min Ch El (ft)	W.S. Elev (ft)	Crit W.S. (ft)	Max Chl Dpth (ft)	Hydr Radius (ft)	E.G. Elev (ft)	E.G. Slope (ft/ft)	Vel Total (ft/s)	Shear Total (lb/sq ft)	Flow Area (sq ft)	Top Width (ft)	Froude # Chl
TimberRidge	5532.95	FEMA 100 Yr.	2600	7231.07	7235.50	7234.14	4.66	3.61	7236.07	0.022123	4.66	4.98	558.42	153.96	1.25
TimberRidge	5532.95	DBPS 100 Yr.	2170	7231.07	7235.06	7233.83	4.22	3.29	7235.57	0.022489	4.42	4.62	491.29	148.54	1.24
TimberRidge	5532.95	DBPS 10 Yr.	630	7231.07	7233.05	7232.37	2.21	1.73	7233.27	0.022690	2.45	2.94	216.94	125.08	1.10
TimberRidge	5532.95	Sterling MDDP 10	1487	7231.07	7234.28	7233.25	3.44	2.71	7234.68	0.022906	3.92	3.88	379.03	139.02	1.20
TimberRidge	5532.95	Sterling MDDP 10	430	7231.07	7232.67	7232.10	1.83	1.41	7232.83	0.022520	2.53	1.98	170.10	120.85	1.06
TimberRidge	5182.08	FEMA 100 Yr.	2600	7225.96	7231.65		5.70	4.27	7232.07	0.018672	4.79	4.97	542.26	125.30	0.68
TimberRidge	5182.08	DBPS 100 Yr.	2170	7225.96	7231.06		5.11	3.92	7231.45	0.019529	4.61	4.77	470.40	118.57	0.69
TimberRidge	5182.08	DBPS 10 Yr.	630	7225.96	7228.29		2.34	2.07	7228.49	0.026393	3.41	3.42	184.86	88.41	0.70
TimberRidge	5182.08	Sterling MDDP 10	1487	7225.96	7229.99		4.04	3.26	7230.32	0.021556	4.24	4.39	350.64	106.44	0.69
TimberRidge	5182.08	Sterling MDDP 10	430	7225.96	7227.79		1.84	1.68	7227.95	0.027954	3.03	2.93	142.00	84.12	0.69
TimberRidge	4903.69	FEMA 100 Yr.	2600	7222.00	7229.08		7.08	5.44	7229.23	0.006505	3.12	2.21	833.97	150.82	0.29
TimberRidge	4903.69	DBPS 100 Yr.	2170	7222.00	7228.48		6.48	5.01	7228.62	0.006320	2.91	1.98	745.57	146.46	0.28
TimberRidge	4903.69	DBPS 10 Yr.	630	7222.00	7225.44		3.43	2.70	7225.49	0.006018	1.88	1.02	334.41	122.62	0.25
TimberRidge	4903.69	Sterling MDDP 10	1487	7222.00	7227.37		5.37	4.19	7227.47	0.006081	2.53	1.59	586.70	138.16	0.27
TimberRidge	4903.69	Sterling MDDP 10	430	7222.00	7224.80		2.80	2.20	7224.84	0.006198	1.66	0.85	258.34	116.86	0.24
TimberRidge	4712.26	FEMA 100 Yr.	2600	7218.00	7224.68	7222.51	6.70	3.44	7225.00	0.022780	4.35	4.89	597.42	173.07	0.54
TimberRidge	4712.26	DBPS 100 Yr.	2170	7218.00	7224.22	7222.12	6.24	3.29	7224.51	0.022035	4.16	4.52	521.13	157.68	0.53
TimberRidge	4712.26	DBPS 10 Yr.	630	7218.00	7221.73	7220.17	3.75	2.31	7221.88	0.016908	2.92	2.44	215.45	92.67	0.42
TimberRidge	4712.26	Sterling MDDP 10	1487	7218.00	7223.36	7221.42	5.38	2.98	7223.60	0.020204	3.74	3.76	397.13	132.38	0.49
TimberRidge	4712.26	Sterling MDDP 10	430	7218.00	7221.20	7219.77	3.22	2.02	7221.31	0.015247	2.55	1.92	168.65	82.95	0.39
TimberRidge	4444.93	FEMA 100 Yr.	2600	7213.94	7217.42		3.49	2.61	7217.80	0.040856	4.86	6.67	535.42	204.29	0.65
TimberRidge	4444.93	DBPS 100 Yr.	2170	7213.94	7217.12		3.19	2.39	7217.46	0.040744	4.56	6.08	475.55	198.45	0.64
TimberRidge	4444.93	DBPS 10 Yr.	630	7213.94	7215.69		1.76	1.27	7215.84	0.041075	3.00	3.26	209.85	165.13	0.58
TimberRidge	4444.93	Sterling MDDP 10	1487	7213.94	7216.58		2.65	1.95	7216.84	0.041527	4.02	5.05	369.98	189.56	0.63
TimberRidge	4444.93	Sterling MDDP 10	430	7213.94	7215.36		1.43	1.05	7215.48	0.044062	2.73	2.89	157.29	149.73	0.58
TimberRidge	4231.86	FEMA 100 Yr.	2600	7206.00	7213.04		7.04	4.68	7213.17	0.006041	2.76	1.76	943.54	200.13	0.40
TimberRidge	4231.86	DBPS 100 Yr.	2170	7206.00	7212.40		6.40	4.11	7212.52	0.006650	2.66	1.71	816.05	196.98	0.41
TimberRidge	4231.86	DBPS 10 Yr.	630	7206.00	7209.92		3.92	1.87	7209.99	0.008563	1.84	1.00	343.25	182.92	0.43
TimberRidge	4231.86	Sterling MDDP 10	1487	7206.00	7211.39		5.39	3.22	7211.50	0.007420	2.40	1.49	620.71	191.95	0.42
TimberRidge	4231.86	Sterling MDDP 10	430	7206.00	7209.48		3.48	1.53	7209.55	0.008485	1.62	0.81	265.27	173.55	0.42
TimberRidge	3915.99	FEMA 100 Yr.	2600	7204.00	7210.59		6.60	5.34	7210.78	0.007054	3.26	2.35	797.06	146.22	0.43
TimberRidge	3915.99	DBPS 100 Yr.	2170	7204.00	7209.87		5.88	5.10	7210.03	0.006914	3.12	2.20	696.16	133.70	0.42
TimberRidge	3915.99	DBPS 10 Yr.	630	7204.00	7206.77		2.77	2.41	7206.84	0.008582	2.11	1.29	297.89	122.42	0.41
TimberRidge	3915.99	Sterling MDDP 10	1487	7204.00	7208.63		4.64	4.05	7208.76	0.007503	2.79	1.90	533.41	129.50	0.42
TimberRidge	3915.99	Sterling MDDP 10	430	7204.00	7206.18		2.19	1.88	7206.24	0.009565	1.89	1.12	226.98	120.03	0.42
TimberRidge	3708.56	FEMA 100 Yr.	2600	7200.10	7207.58		7.58	4.46	7208.29	0.025141	5.87	7.01	442.63	97.03	0.81
TimberRidge	3708.56	DBPS 100 Yr.	2170	7200.10	7206.95		6.95	4.29	7207.59	0.024814	5.65	6.64	384.34	87.56	0.80
TimberRidge	3708.56	DBPS 10 Yr.	630	7200.10	7203.92		3.92	2.65	7204.19	0.021965	3.74	3.63	168.25	62.60	0.68
TimberRidge	3708.56	Sterling MDDP 10	1487	7200.10	7205.77		5.77	4.03	7206.26	0.023482	5.11	5.91	291.25	70.41	0.75
TimberRidge	3708.56	Sterling MDDP 10	430	7200.10	7203.44		3.44	2.29	7203.62	0.018225	3.10	2.60	138.66	59.80	0.60
TimberRidge	3540.59	FEMA 100 Yr.	2600	7193.66	7201.16		7.50	5.28	7201.54	0.016276	4.88	5.37	533.27	98.38	0.47
TimberRidge	3540.59	DBPS 100 Yr.	2170	7193.66	7200.50		6.84	4.82	7200.85	0.016469	4.62	4.95	469.77	95.16	0.46
TimberRidge	3540.59	DBPS 10 Yr.	630	7193.66	7197.37		3.71	2.51	7197.54	0.018076	3.19	2.84	197.61	77.42	0.44
TimberRidge	3540.59	Sterling MDDP 10	1487	7193.66	7199.31		5.65	3.95	7199.59	0.017044	4.13	4.20	359.82	89.21	0.45
TimberRidge	3540.59	Sterling MDDP 10	430	7193.66	7196.60		2.94	1.93	7196.76	0.023454	3.07	2.82	139.94	71.61	0.48

HEC-RAS Plan: SC EX River: Sand Creek Ex Reach: TimberRidge (Continued)

Reach	River Sta	Profile	Q Total (cfs)	Min Ch El (ft)	W.S. Elev (ft)	Crit W.S. (ft)	Max Chl Dpth (ft)	Hydr Radius (ft)	E.G. Elev (ft)	E.G. Slope (ft/ft)	Vel Total (ft/s)	Shear Total (lb/sq ft)	Flow Area (sq ft)	Top Width (ft)	Froude # Chl
TimberRidge	3334.27	FEMA 100 Yr.	2600	7188.53	7193.50		5.54	2.87	7194.42	0.072171	7.14	12.95	364.29	124.33	0.92
TimberRidge	3334.27	DBPS 100 Yr.	2170	7188.53	7193.30	7192.93	5.34	2.70	7194.05	0.061480	6.38	10.37	340.20	123.58	0.84
TimberRidge	3334.27	DBPS 10 Yr.	630	7188.53	7191.99	7190.32	4.03	1.55	7192.25	0.028505	3.48	2.76	180.93	114.98	0.54
TimberRidge	3334.27	Sterling MDDP 10	1487	7188.53	7192.91	7192.43	4.95	2.35	7193.41	0.044673	5.08	6.57	292.52	122.08	0.71
TimberRidge	3334.27	Sterling MDDP 10	430	7188.53	7191.33		3.37	2.36	7191.50	0.021223	3.27	3.13	131.30	54.16	0.45
TimberRidge	3179.66	FEMA 100 Yr.	2600	7183.98	7189.18		5.38	4.11	7189.37	0.006788	2.75	1.74	947.01	229.24	0.71
TimberRidge	3179.66	DBPS 100 Yr.	2170	7183.98	7188.59		4.79	3.57	7188.77	0.007722	2.67	1.72	811.57	226.59	0.74
TimberRidge	3179.66	DBPS 10 Yr.	630	7183.98	7186.09		2.29	1.61	7186.22	0.014486	2.17	1.46	289.82	179.56	0.89
TimberRidge	3179.66	Sterling MDDP 10	1487	7183.98	7187.58		3.78	2.70	7187.75	0.009902	2.53	1.67	587.35	216.95	0.81
TimberRidge	3179.66	Sterling MDDP 10	430	7183.98	7185.63		1.83	1.30	7185.74	0.016961	2.04	1.37	210.63	162.16	0.93
TimberRidge	2960.1	FEMA 100 Yr.	2600	7178.00	7186.36	7184.83	8.36	5.46	7187.33	0.012243	4.81	4.17	540.94	95.93	1.03
TimberRidge	2960.1	DBPS 100 Yr.	2170	7178.00	7185.67	7184.39	7.67	4.94	7186.58	0.012402	4.56	3.83	475.88	93.43	1.02
TimberRidge	2960.1	DBPS 10 Yr.	630	7178.00	7182.47	7182.15	4.47	2.37	7183.10	0.013556	3.22	2.01	195.76	81.33	0.98
TimberRidge	2960.1	Sterling MDDP 10	1487	7178.00	7184.43	7183.52	6.43	3.99	7185.23	0.012823	4.09	3.19	363.22	88.84	1.01
TimberRidge	2960.1	Sterling MDDP 10	430	7178.00	7181.87	7181.32	3.87	1.92	7182.43	0.013212	2.91	1.58	147.93	76.11	0.94
TimberRidge	2652.02	FEMA 100 Yr.	2600	7176.17	7183.17	7182.29	7.08	5.21	7184.75	0.023099	6.44	7.52	403.64	74.87	1.38
TimberRidge	2652.02	DBPS 100 Yr.	2170	7176.17	7182.48	7181.67	6.39	4.70	7183.94	0.023997	6.15	7.05	352.70	72.89	1.38
TimberRidge	2652.02	DBPS 10 Yr.	630	7176.17	7179.25	7178.95	3.16	2.37	7180.06	0.030715	4.53	4.55	139.16	57.95	1.38
TimberRidge	2652.02	Sterling MDDP 10	1487	7176.17	7181.25	7180.64	5.16	3.82	7182.47	0.025731	5.59	6.14	265.99	68.14	1.38
TimberRidge	2652.02	Sterling MDDP 10	430	7176.17	7178.61	7178.44	2.52	1.88	7179.31	0.034607	4.16	4.07	103.34	54.38	1.41
TimberRidge	2416.82	FEMA 100 Yr.	2600	7171.98	7180.37	7178.04	8.45	6.07	7181.30	0.011437	4.97	4.33	523.22	82.99	1.00
TimberRidge	2416.82	DBPS 100 Yr.	2170	7171.98	7179.63	7177.43	7.71	5.57	7180.46	0.011363	4.69	3.95	462.43	80.16	0.98
TimberRidge	2416.82	DBPS 10 Yr.	630	7171.98	7176.06		4.14	3.04	7176.45	0.010686	3.11	2.03	202.28	65.37	0.86
TimberRidge	2416.82	Sterling MDDP 10	1487	7171.98	7178.27	7176.44	6.35	4.63	7178.93	0.011295	4.16	3.27	357.08	74.95	0.94
TimberRidge	2416.82	Sterling MDDP 10	430	7171.98	7175.37		3.45	2.53	7175.67	0.010159	2.71	1.60	158.43	61.76	0.81
TimberRidge	2083.66	FEMA 100 Yr.	2600	7169.85	7176.70	7175.92	6.86	5.13	7178.44	0.026213	6.79	8.39	382.97	71.41	1.46
TimberRidge	2083.66	DBPS 100 Yr.	2170	7169.85	7176.08	7175.34	6.24	4.70	7177.62	0.025996	6.39	7.63	339.53	69.34	1.43
TimberRidge	2083.66	DBPS 10 Yr.	630	7169.85	7173.26	7172.77	3.42	2.55	7173.92	0.022312	4.02	3.55	156.58	60.29	1.20
TimberRidge	2083.66	Sterling MDDP 10	1487	7169.85	7175.05	7174.36	5.21	3.95	7176.21	0.024078	5.50	5.94	270.14	66.11	1.34
TimberRidge	2083.66	Sterling MDDP 10	430	7169.85	7172.66	7172.31	2.82	2.05	7173.20	0.022657	3.55	2.90	120.98	58.07	1.17
TimberRidge	1879.67	FEMA 100 Yr.	2600	7165.99	7171.60		5.62	4.12	7172.21	0.031058	5.81	8.00	447.76	106.82	0.88
TimberRidge	1879.67	DBPS 100 Yr.	2170	7165.99	7171.28		5.30	3.87	7171.78	0.027596	5.25	6.67	413.29	105.18	0.82
TimberRidge	1879.67	DBPS 10 Yr.	630	7165.99	7169.14	7168.18	3.16	2.17	7169.33	0.020768	3.13	2.81	201.48	92.17	0.65
TimberRidge	1879.67	Sterling MDDP 10	1487	7165.99	7170.47		4.49	3.23	7170.85	0.025649	4.50	5.17	330.59	101.12	0.77
TimberRidge	1879.67	Sterling MDDP 10	430	7165.99	7168.71	7167.80	2.73	1.82	7168.85	0.018543	2.64	2.11	162.65	88.71	0.60
TimberRidge	1507.91	FEMA 100 Yr.	2600	7159.96	7164.64		4.70	3.16	7164.88	0.017631	3.68	3.47	706.87	222.98	0.64
TimberRidge	1507.91	DBPS 100 Yr.	2260	7159.96	7164.27		4.33	2.84	7164.51	0.019313	3.61	3.43	625.38	219.14	0.66
TimberRidge	1507.91	DBPS 10 Yr.	670	7159.96	7162.06		2.12	1.66	7162.20	0.024564	2.81	2.54	238.33	143.22	0.66
TimberRidge	1507.91	Sterling MDDP 10	1520	7159.96	7163.41		3.47	2.44	7163.61	0.020460	3.35	3.12	453.97	184.96	0.66
TimberRidge	1507.91	Sterling MDDP 10	450	7159.96	7161.50		1.56	1.39	7161.62	0.028802	2.68	2.50	168.19	120.55	0.68
TimberRidge	1145.05	FEMA 100 Yr.	2600	7153.97	7160.24	7159.41	6.27	3.32	7161.04	0.017900	4.11	3.71	633.15	188.76	1.19
TimberRidge	1145.05	DBPS 100 Yr.	2260	7153.97	7159.81	7159.12	5.84	3.24	7160.55	0.017502	4.07	3.54	555.70	169.49	1.16
TimberRidge	1145.05	DBPS 10 Yr.	670	7153.97	7157.71	7157.19	3.74	1.89	7158.17	0.014853	2.77	1.75	242.31	127.24	0.99
TimberRidge	1145.05	Sterling MDDP 10	1520	7153.97	7158.97	7158.47	5.00	2.72	7159.60	0.017048	3.61	2.90	420.67	152.99	1.12
TimberRidge	1145.05	Sterling MDDP 10	450	7153.97	7157.21		3.24	1.65	7157.58	0.013286	2.46	1.37	183.08	110.30	0.92

HEC-RAS Plan: SC EX River: Sand Creek Ex Reach: TimberRidge (Continued)

Reach	River Sta	Profile	Q Total (cfs)	Min Ch El (ft)	W.S. Elev (ft)	Crit W.S. (ft)	Max Chl Dpth (ft)	Hydr Radius (ft)	E.G. Elev (ft)	E.G. Slope (ft/ft)	Vel Total (ft/s)	Shear Total (lb/sq ft)	Flow Area (sq ft)	Top Width (ft)	Froude # Chl
TimberRidge	902.8	FEMA 100 Yr.	2600	7150.00	7156.17	7154.91	6.18	3.62	7156.72	0.014230	3.78	3.22	687.79	188.79	1.06
TimberRidge	902.8	DBPS 100 Yr.	2260	7150.00	7155.77	7154.68	5.78	3.47	7156.29	0.014183	3.68	3.07	614.75	175.97	1.04
TimberRidge	902.8	DBPS 10 Yr.	670	7150.00	7153.41	7151.92	3.42	1.75	7153.83	0.017658	2.74	1.93	244.24	139.03	1.07
TimberRidge	902.8	Sterling MDDP 10	1520	7150.00	7154.82	7154.10	4.83	2.83	7155.28	0.015037	3.34	2.66	454.59	159.67	1.04
TimberRidge	902.8	Sterling MDDP 10	450	7150.00	7152.93	7152.84	2.94	1.36	7153.36	0.019115	2.51	1.62	179.31	131.07	1.08
TimberRidge	520.2	FEMA 100 Yr.	2600	7147.95	7153.89		5.95	4.29	7154.30	0.011030	3.70	2.95	702.00	162.64	0.93
TimberRidge	520.2	DBPS 100 Yr.	2260	7147.95	7153.53		5.59	4.04	7153.90	0.010716	3.51	2.70	644.34	158.70	0.90
TimberRidge	520.2	DBPS 10 Yr.	670	7147.95	7151.16		3.22	2.22	7151.33	0.009585	2.25	1.33	297.98	134.04	0.78
TimberRidge	520.2	Sterling MDDP 10	1520	7147.95	7152.61		4.67	3.36	7152.89	0.010128	3.03	2.13	502.43	148.68	0.85
TimberRidge	520.2	Sterling MDDP 10	450	7147.95	7150.66		2.72	1.79	7150.80	0.009340	1.94	1.04	231.84	129.25	0.75
TimberRidge	250.3	FEMA 100 Yr.	2600	7145.94	7150.36	7148.66	4.44	3.22	7150.70	0.015253	3.53	3.06	736.72	228.67	1.04
TimberRidge	250.3	DBPS 100 Yr.	2260	7145.94	7150.07	7148.41	4.15	3.02	7150.38	0.015037	3.37	2.84	671.11	221.52	1.02
TimberRidge	250.3	DBPS 10 Yr.	670	7145.94	7148.11		2.19	1.85	7148.24	0.013044	2.26	1.51	296.94	160.35	0.85
TimberRidge	250.3	Sterling MDDP 10	1520	7145.94	7149.32	7147.88	3.40	2.59	7149.56	0.014286	2.96	2.31	513.32	197.91	0.96
TimberRidge	250.3	Sterling MDDP 10	450	7145.94	7147.68		1.76	1.52	7147.77	0.012686	1.96	1.21	230.01	150.74	0.81
TimberRidge	53.78	FEMA 100 Yr.	2600	7139.72	7144.87	7143.94	5.17	2.75	7145.23	0.016007	3.30	2.75	787.94	285.68	1.08
TimberRidge	53.78	DBPS 100 Yr.	2260	7139.72	7144.61	7143.74	4.91	2.58	7144.96	0.016004	3.16	2.57	714.84	277.12	1.07
TimberRidge	53.78	DBPS 10 Yr.	670	7139.72	7142.91	7142.61	3.21	1.44	7143.17	0.016016	2.21	1.44	303.06	209.76	1.00
TimberRidge	53.78	Sterling MDDP 10	1520	7139.72	7143.94	7141.96	4.24	2.15	7144.25	0.016012	2.82	2.15	539.52	250.13	1.05
TimberRidge	53.78	Sterling MDDP 10	450	7139.72	7142.55	7141.96	2.85	1.17	7142.79	0.015995	1.97	1.17	228.51	194.63	0.98

TIMBERRIDGE EXIST. Plan: SC EX 7/24/2019

Sand Creek Ex TimberRidge

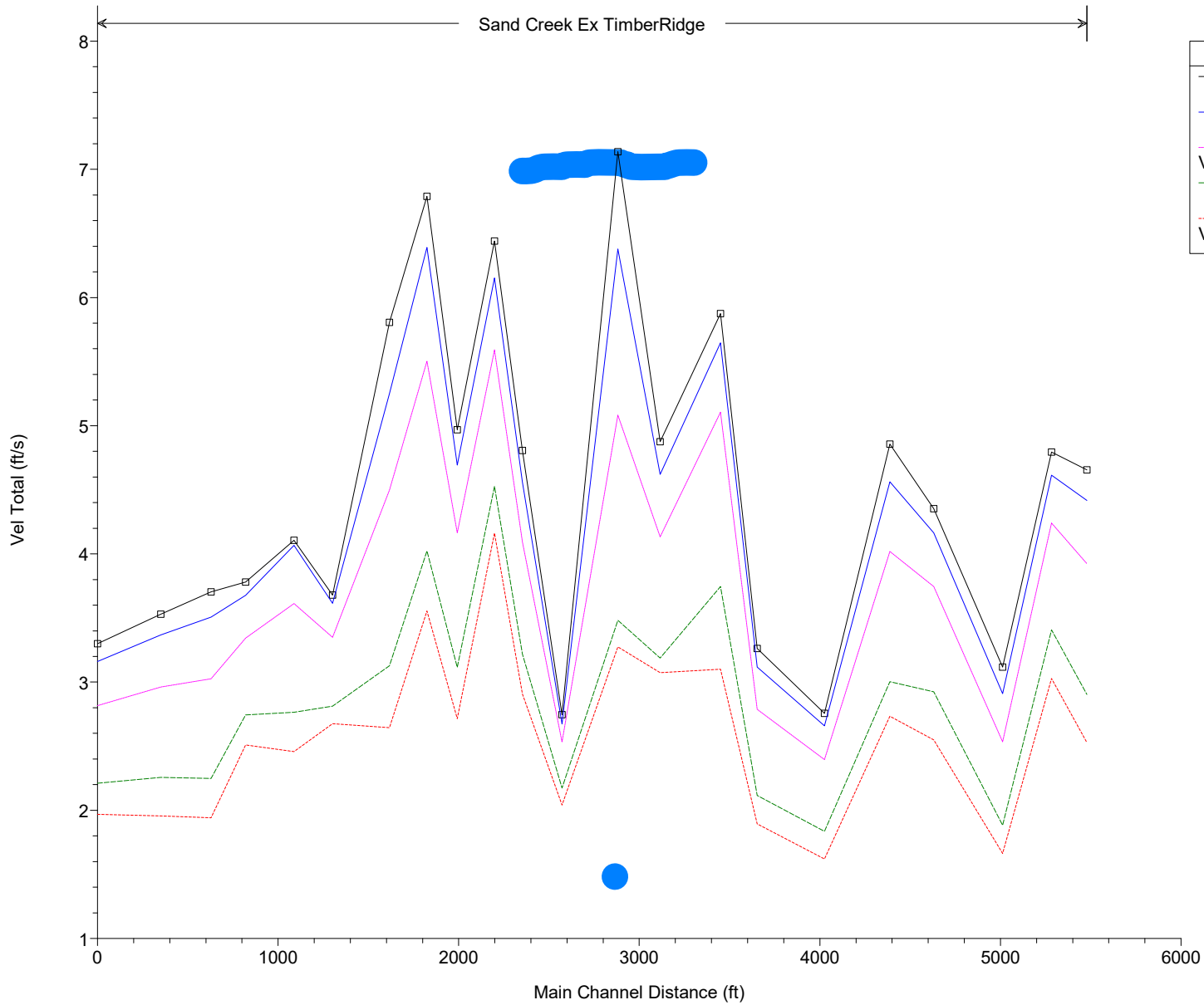

Legend	
□	Vel Total FEMA 100 Yr.
—	Vel Total DBPS 100 Yr.
—	Vel Total Sterling MDDP 10
—	Vel Total DBPS 10 Yr.
—	Vel Total Sterling MDDP 10

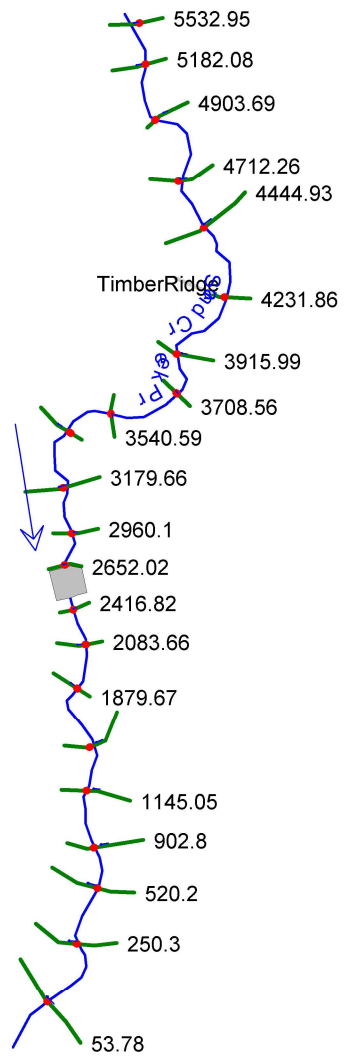

TIMBERRIDGE PR Plan: SC PR 7/24/2019

Sand Creek Pr TimberRidge

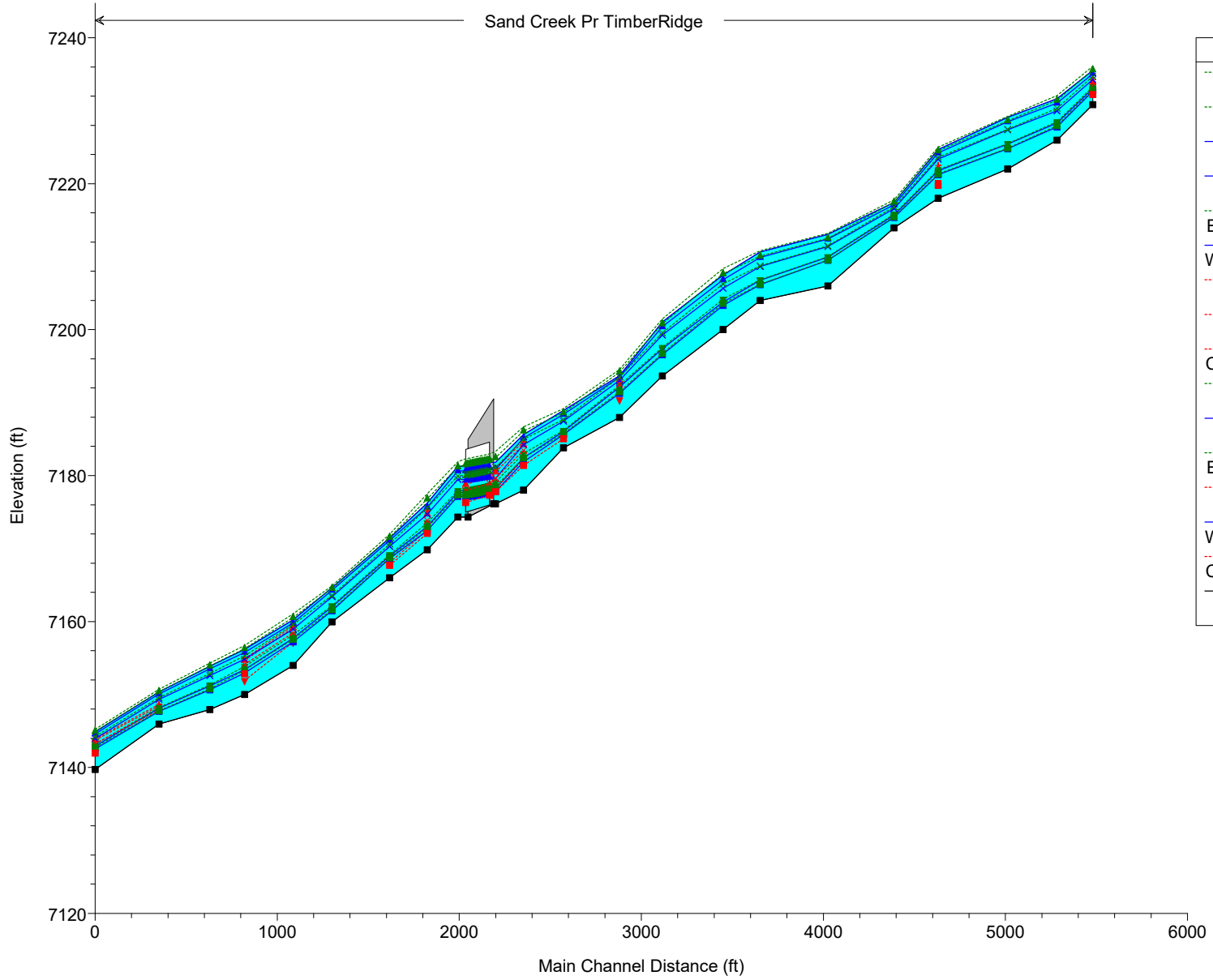

Legend	
EG FEMA 100 Yr.	▲
EG DBPS 100 Yr.	▲
WS FEMA 100 Yr.	▲
WS DBPS 100 Yr.	▲
EG Sterling MDDP 10	×
WS Sterling MDDP 10	×
Crit FEMA 100 Yr.	▲
Crit DBPS 100 Yr.	▲
Crit Sterling MDDP 10	×
EG DBPS 10 Yr.	▼
WS DBPS 10 Yr.	▼
EG Sterling MDDP 10	■
Crit DBPS 10 Yr.	■
WS Sterling MDDP 10	■
Crit Sterling MDDP 10	■
Ground	■

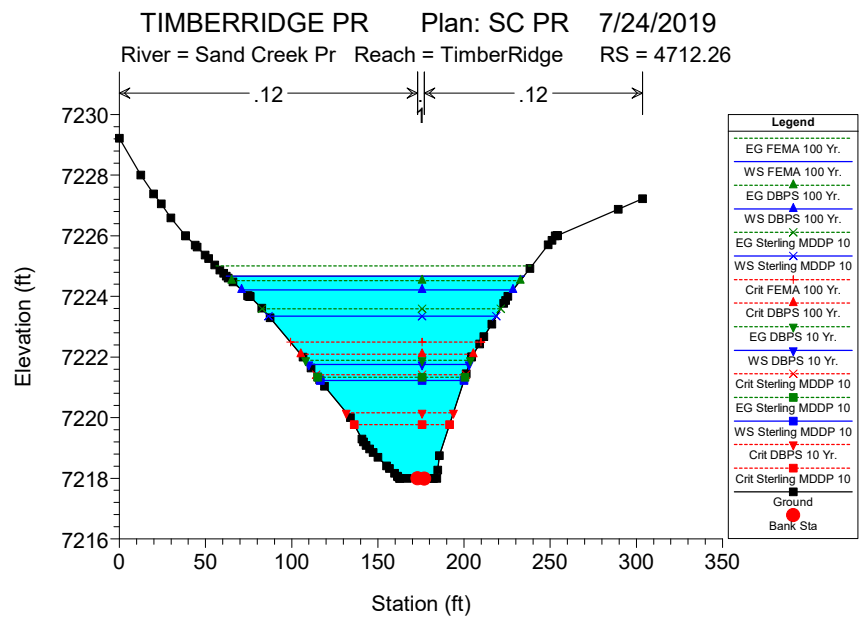
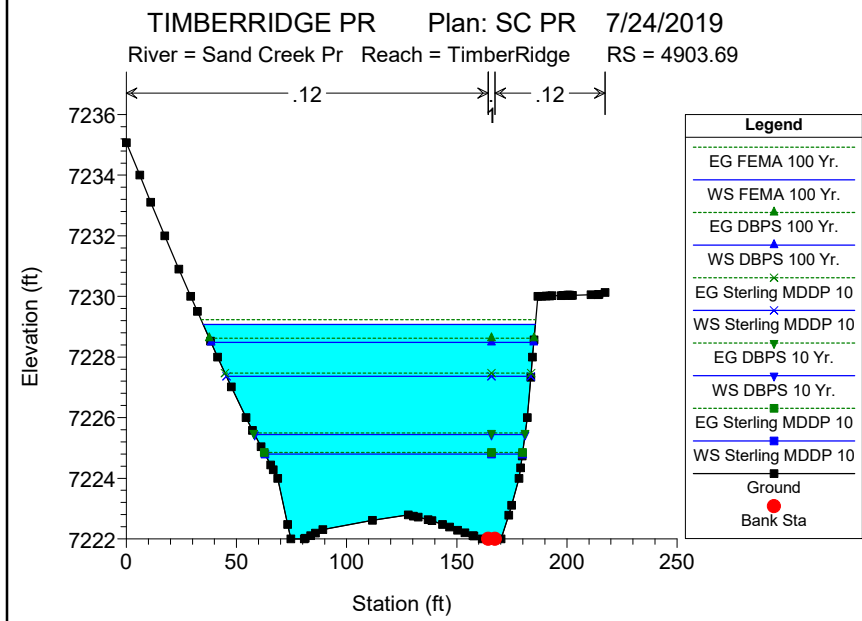
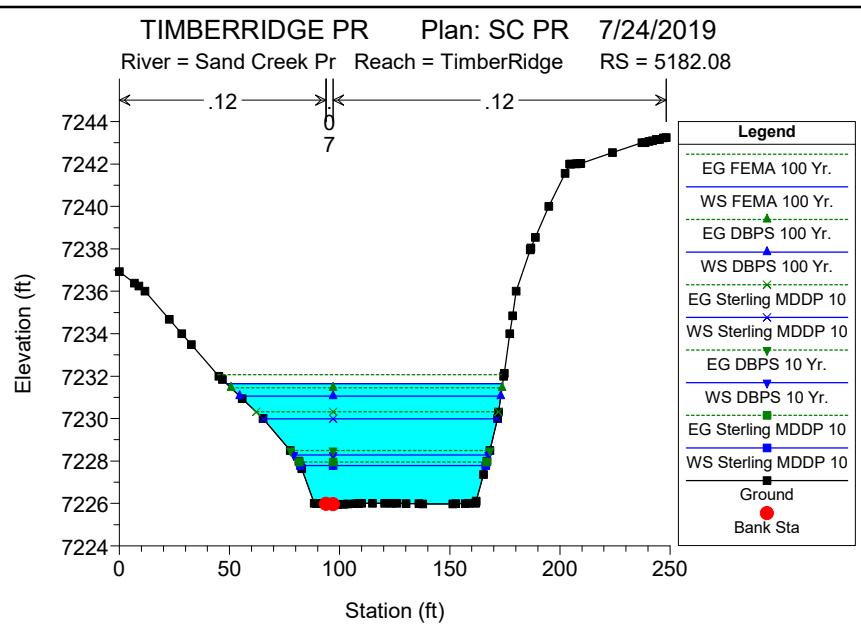
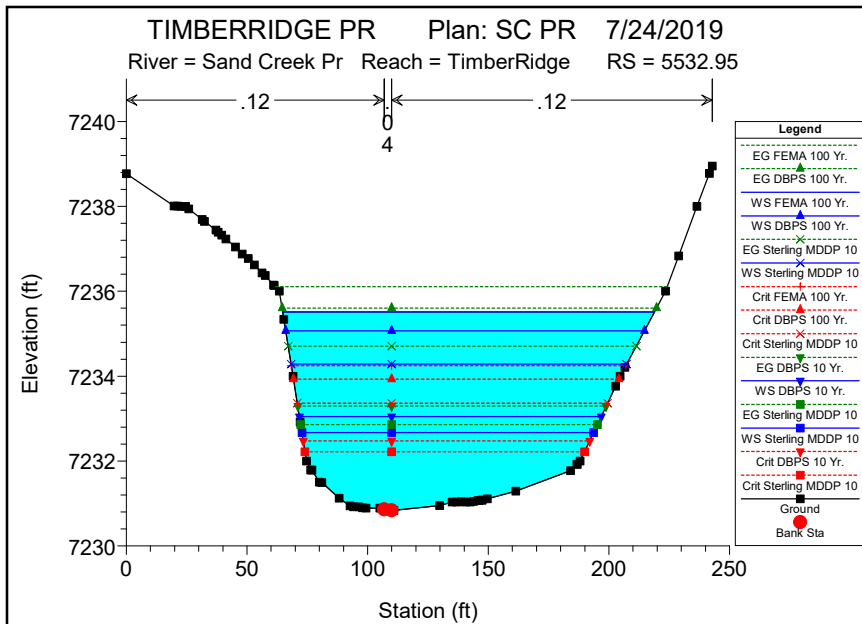

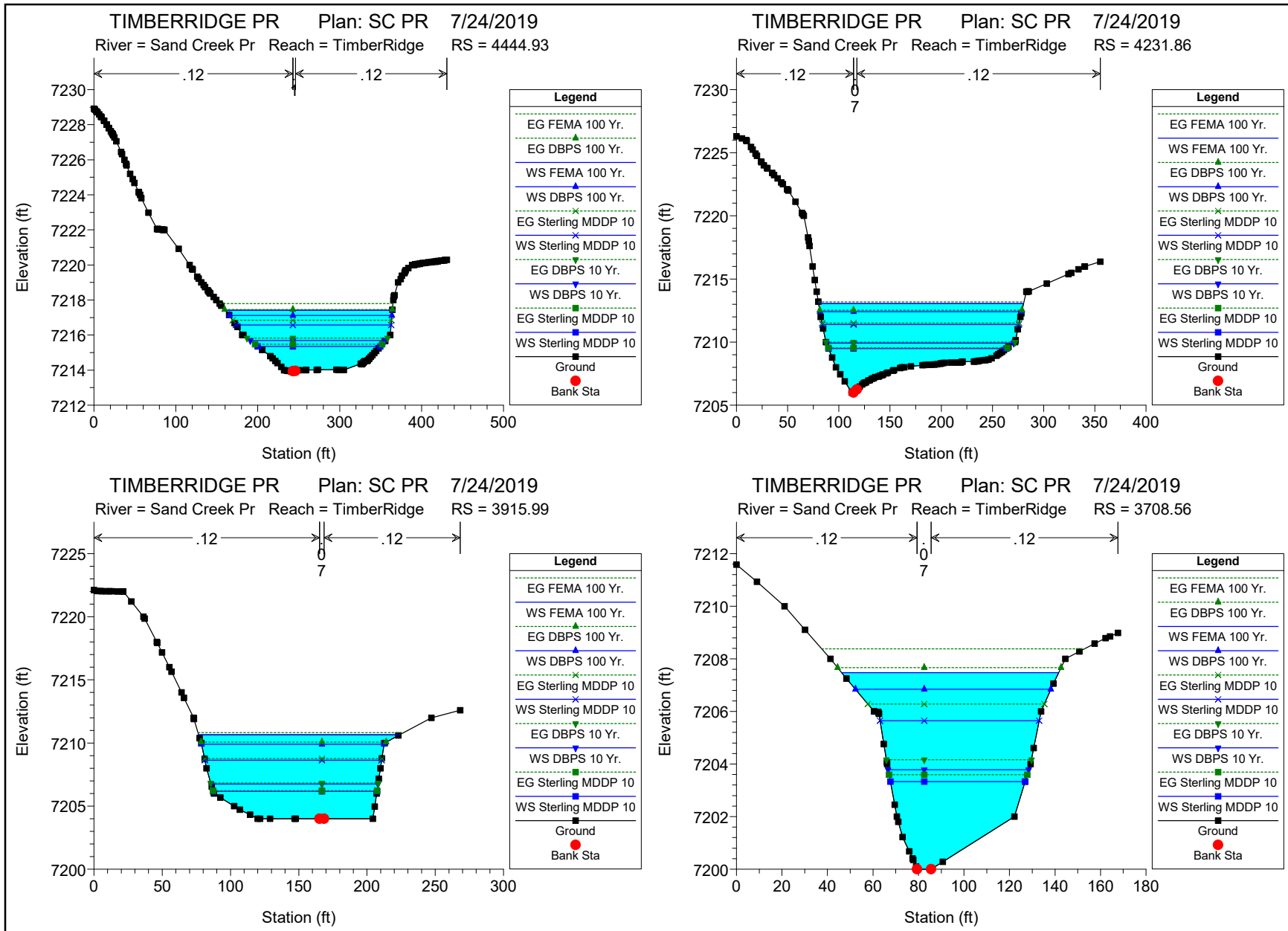

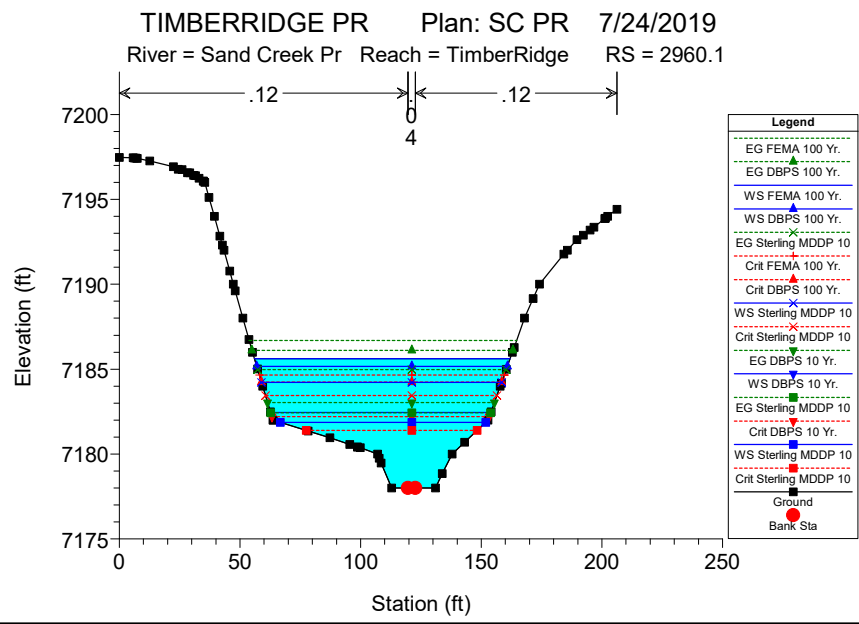
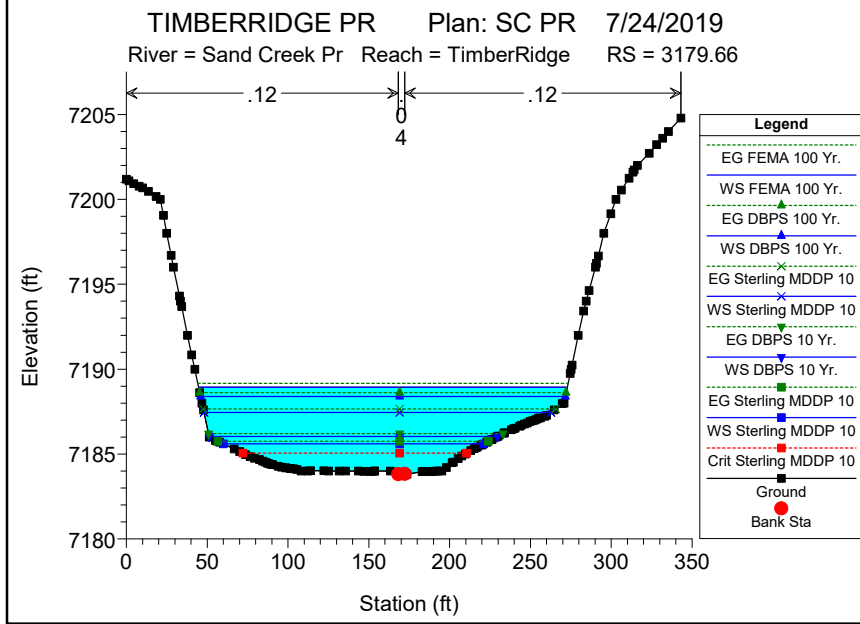
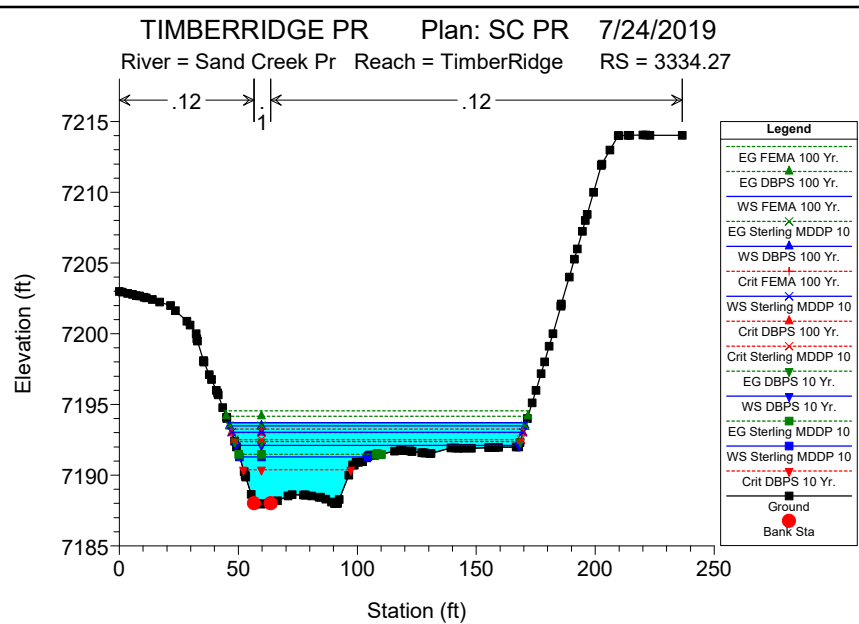
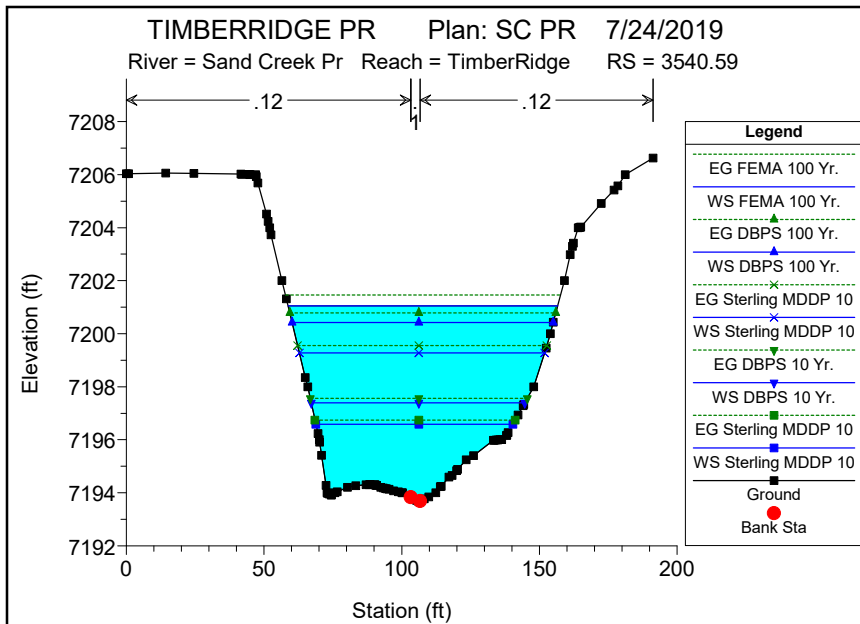

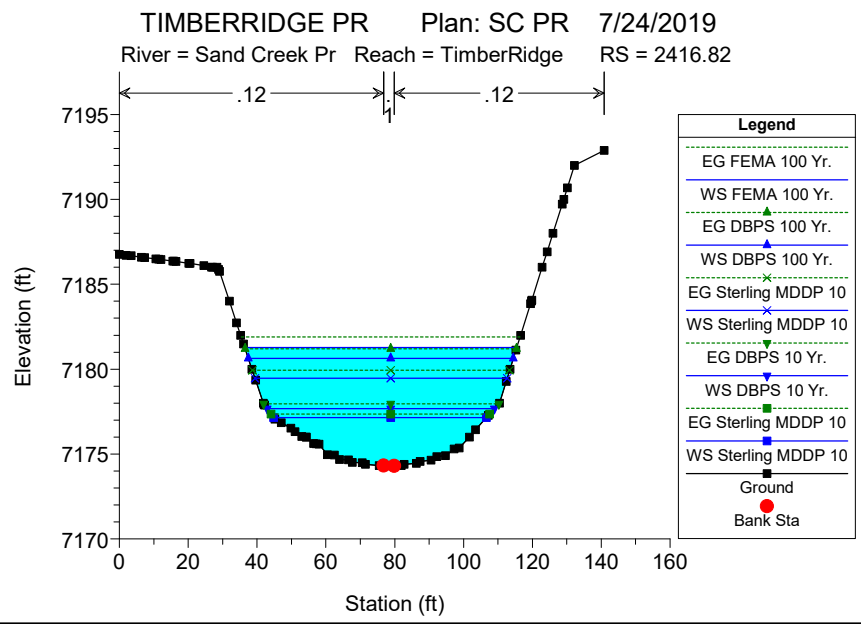
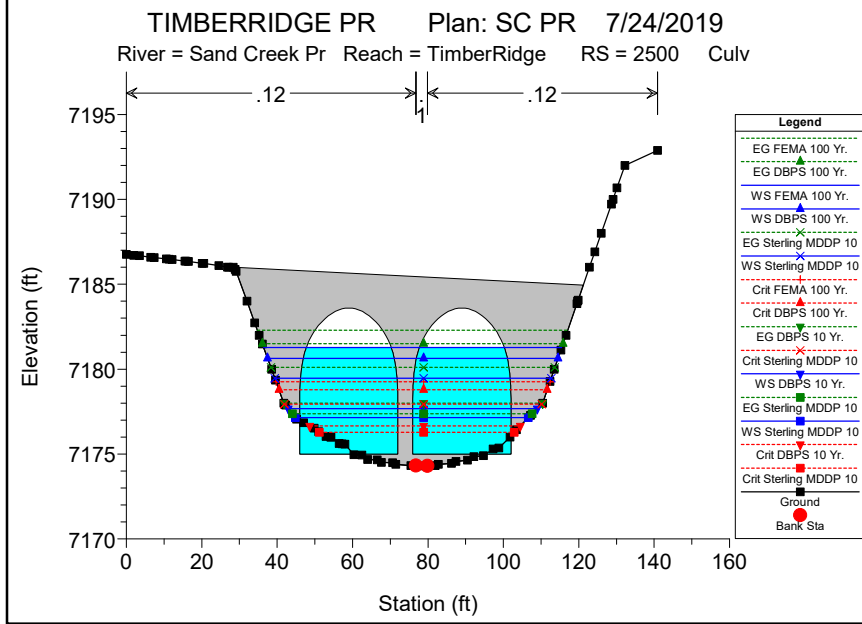
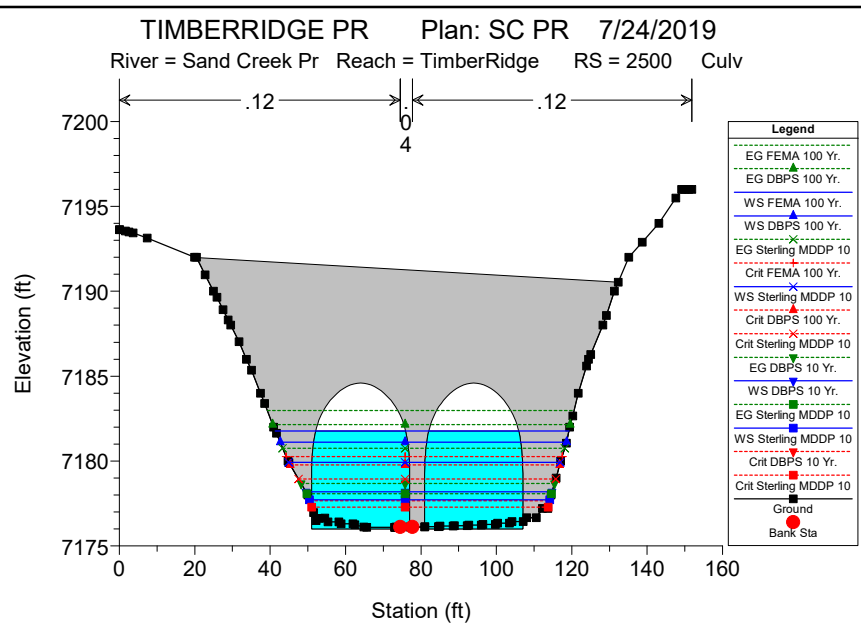
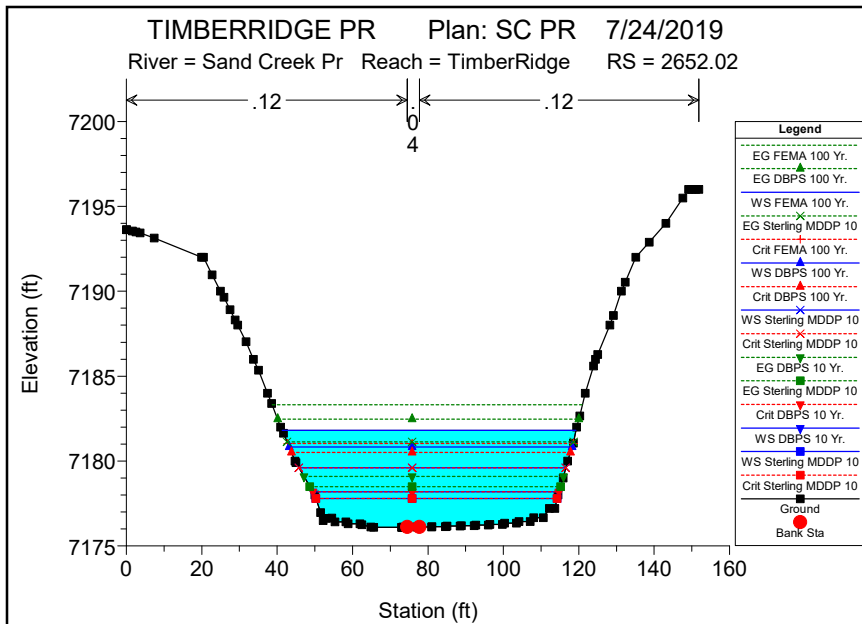

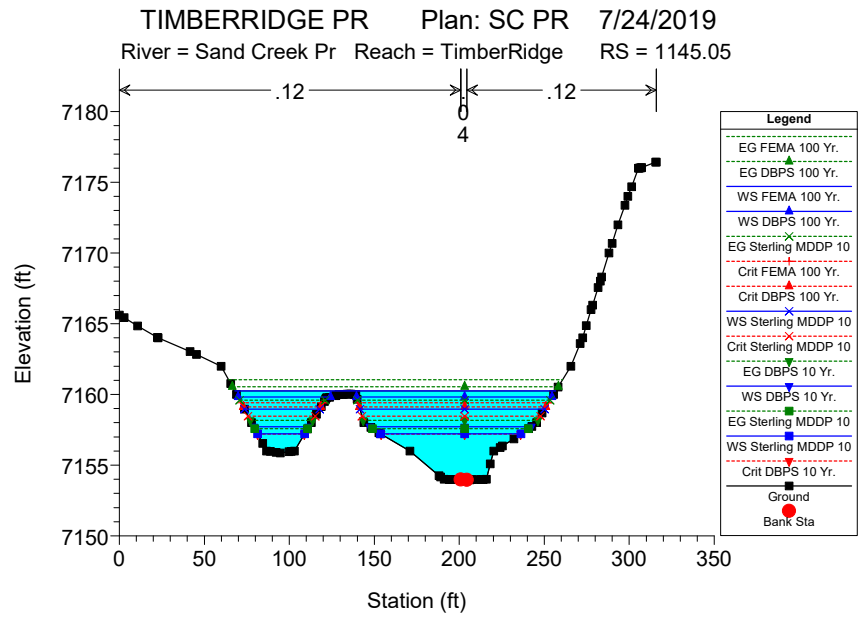
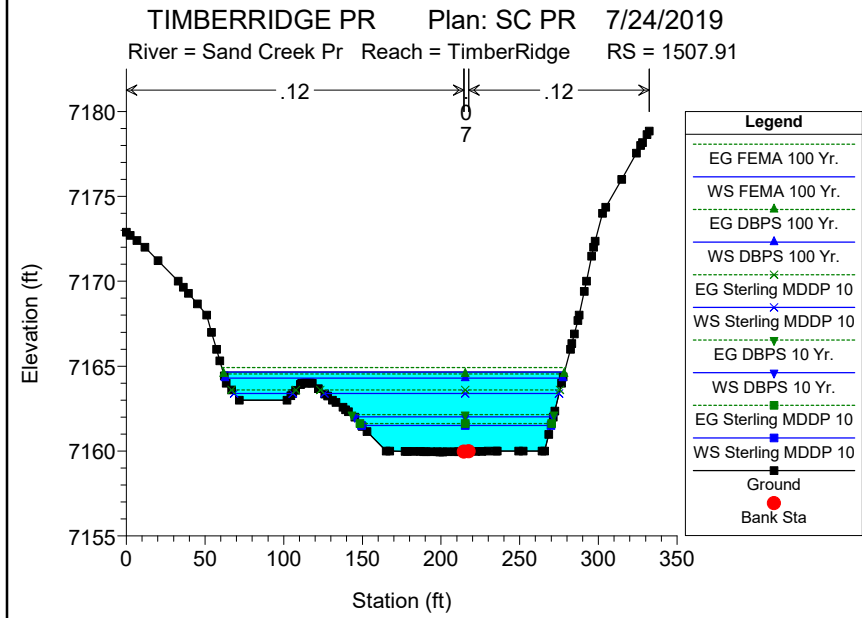
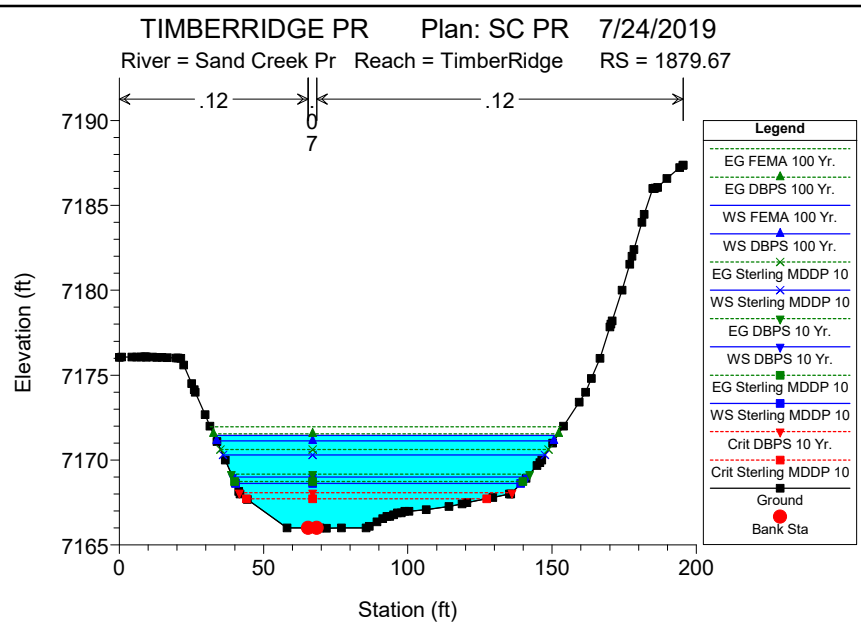
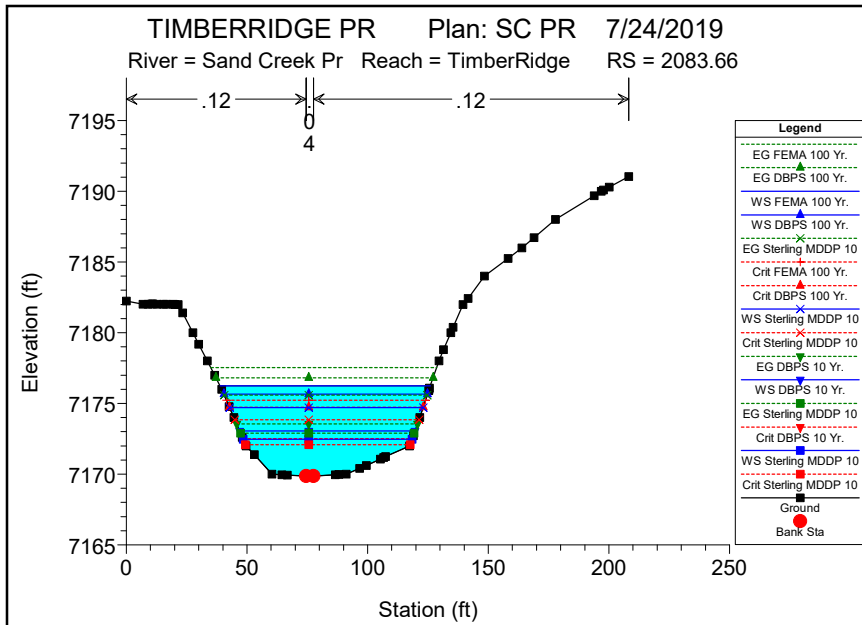

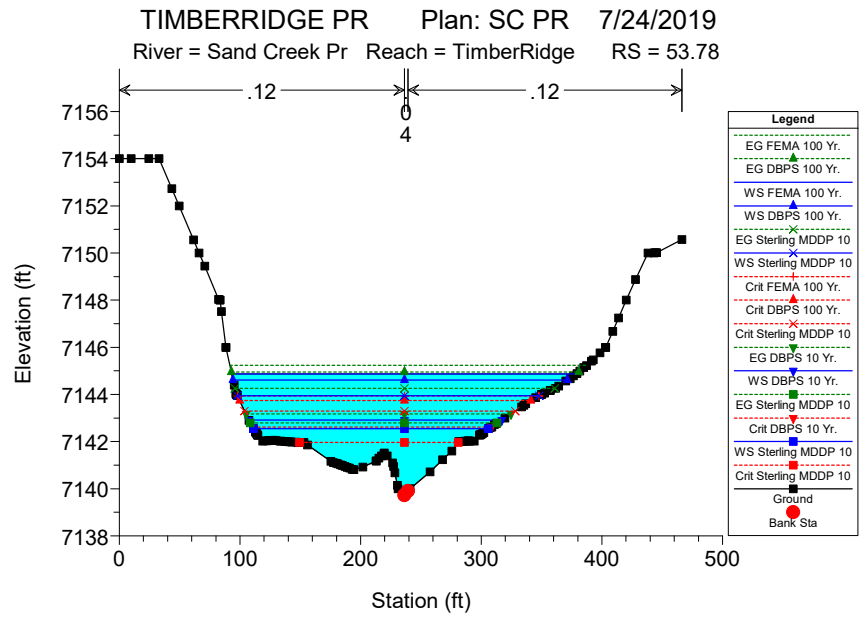
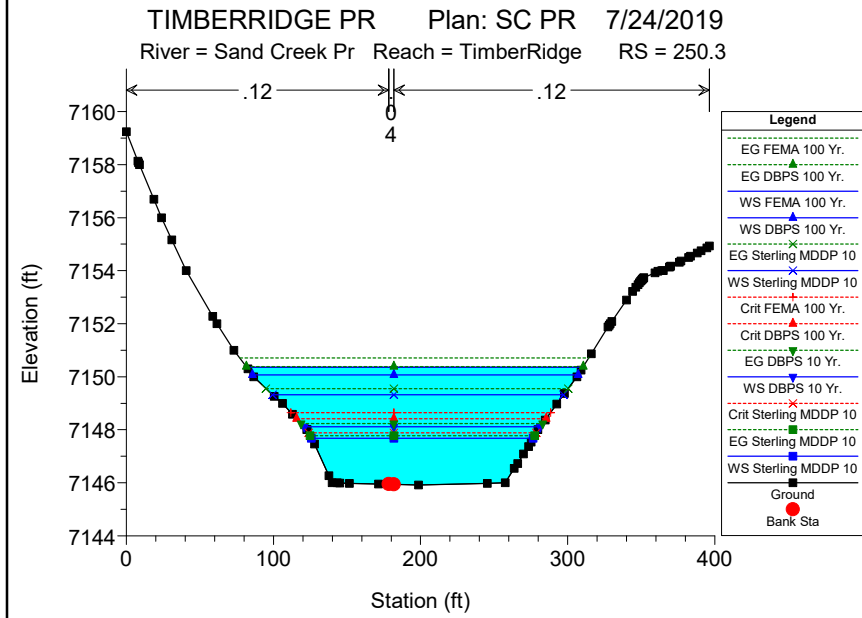
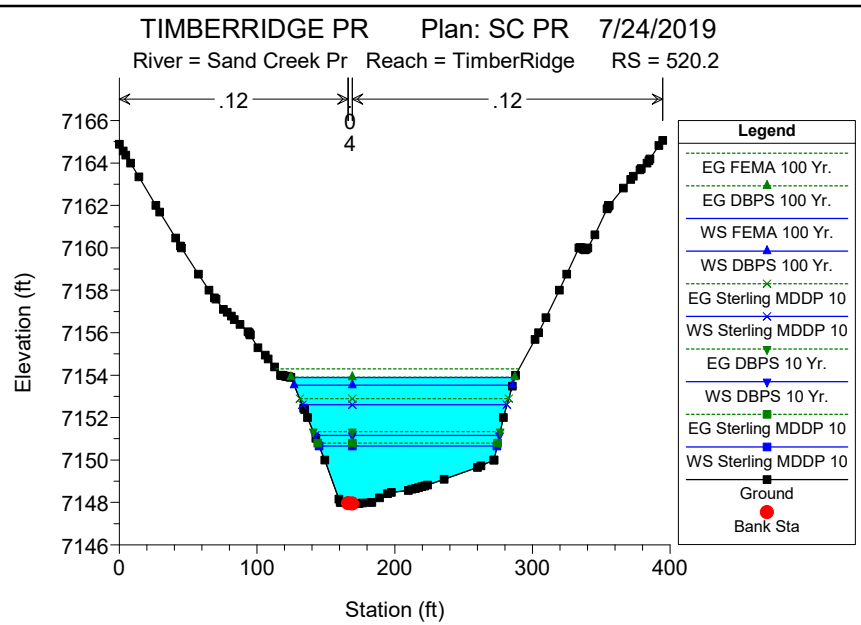
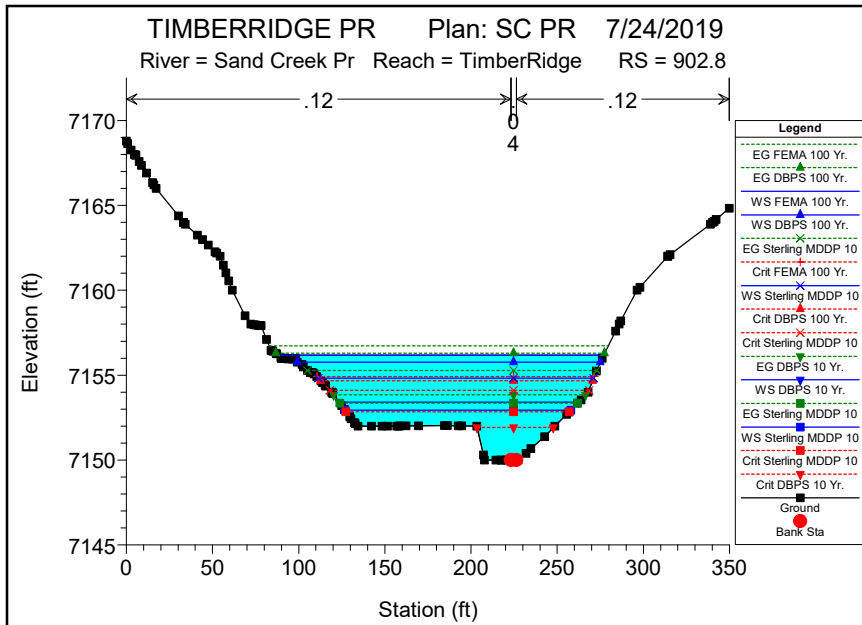

HEC-RAS Plan: SC PR River: Sand Creek Pr Reach: TimberRidge

Reach	River Sta	Profile	Q Total (cfs)	Min Ch El (ft)	W.S. Elev (ft)	Crit W.S. (ft)	Max Chl Dpth (ft)	Hydr Radius (ft)	E.G. Elev (ft)	E.G. Slope (ft/ft)	Vel Total (ft/s)	Shear Total (lb/sq ft)	Flow Area (sq ft)	Top Width (ft)	Froude # Chl
TimberRidge	5532.95	FEMA 100 Yr.	2600	7230.84	7235.51	7234.24	4.67	3.62	7236.11	0.022388	4.64	5.06	560.60	154.13	1.27
TimberRidge	5532.95	DBPS 100 Yr.	2170	7230.84	7235.07	7233.93	4.23	3.30	7235.60	0.022756	4.40	4.69	492.89	148.67	1.26
TimberRidge	5532.95	DBPS 10 Yr.	630	7230.84	7233.05	7232.48	2.21	1.73	7233.29	0.022796	2.90	2.47	217.30	125.12	1.13
TimberRidge	5532.95	Sterling MDDP 10	1487	7230.84	7234.28	7233.36	3.44	2.72	7234.71	0.023124	3.91	3.93	379.98	139.11	1.22
TimberRidge	5532.95	Sterling MDDP 10	430	7230.84	7232.67	7232.22	1.83	1.41	7232.86	0.022549	2.52	1.98	170.46	120.88	1.09
TimberRidge	5182.08	FEMA 100 Yr.	2600	7225.96	7231.65		5.70	4.27	7232.07	0.018672	4.79	4.97	542.26	125.30	0.68
TimberRidge	5182.08	DBPS 100 Yr.	2170	7225.96	7231.06		5.11	3.92	7231.45	0.019529	4.61	4.77	470.40	118.57	0.69
TimberRidge	5182.08	DBPS 10 Yr.	630	7225.96	7228.29		2.34	2.07	7228.49	0.026507	3.41	3.43	184.60	88.38	0.70
TimberRidge	5182.08	Sterling MDDP 10	1487	7225.96	7229.99		4.04	3.26	7230.32	0.021566	4.24	4.39	350.59	106.43	0.69
TimberRidge	5182.08	Sterling MDDP 10	430	7225.96	7227.79		1.84	1.67	7227.95	0.028109	3.03	2.94	141.75	84.10	0.69
TimberRidge	4903.69	FEMA 100 Yr.	2600	7222.00	7229.08		7.08	5.44	7229.23	0.006505	3.12	2.21	833.97	150.82	0.29
TimberRidge	4903.69	DBPS 100 Yr.	2170	7222.00	7228.48		6.48	5.01	7228.62	0.006319	2.91	1.98	745.64	146.46	0.28
TimberRidge	4903.69	DBPS 10 Yr.	630	7222.00	7225.44		3.44	2.71	7225.50	0.005985	1.88	1.01	335.00	122.67	0.25
TimberRidge	4903.69	Sterling MDDP 10	1487	7222.00	7227.37		5.37	4.19	7227.47	0.006075	2.53	1.59	586.90	138.17	0.27
TimberRidge	4903.69	Sterling MDDP 10	430	7222.00	7224.80		2.80	2.20	7224.85	0.006169	1.66	0.85	258.74	116.89	0.24
TimberRidge	4712.26	FEMA 100 Yr.	2600	7217.98	7224.67	7222.50	6.69	3.43	7225.00	0.022718	4.36	4.87	595.90	172.79	0.54
TimberRidge	4712.26	DBPS 100 Yr.	2170	7217.98	7224.21	7222.09	6.23	3.29	7224.52	0.022010	4.17	4.52	520.13	157.47	0.53
TimberRidge	4712.26	DBPS 10 Yr.	630	7217.98	7221.75	7220.16	3.77	2.32	7221.90	0.016909	2.90	2.45	217.13	93.01	0.42
TimberRidge	4712.26	Sterling MDDP 10	1487	7217.98	7223.35	7221.42	5.37	2.98	7223.60	0.020241	3.75	3.77	396.29	132.22	0.49
TimberRidge	4712.26	Sterling MDDP 10	430	7217.98	7221.22	7219.77	3.24	2.03	7221.33	0.015213	2.52	1.93	170.40	83.35	0.39
TimberRidge	4444.93	FEMA 100 Yr.	2600	7213.94	7217.41		3.48	2.61	7217.80	0.041202	4.87	6.71	533.92	204.14	0.65
TimberRidge	4444.93	DBPS 100 Yr.	2170	7213.94	7217.12		3.19	2.39	7217.46	0.040898	4.57	6.10	474.97	198.40	0.64
TimberRidge	4444.93	DBPS 10 Yr.	630	7213.94	7215.69		1.76	1.27	7215.83	0.041394	3.01	3.28	209.29	164.98	0.58
TimberRidge	4444.93	Sterling MDDP 10	1487	7213.94	7216.58		2.65	1.95	7216.84	0.041495	4.02	5.05	370.08	189.57	0.63
TimberRidge	4444.93	Sterling MDDP 10	430	7213.94	7215.35		1.42	1.05	7215.47	0.044849	2.75	2.93	156.35	149.44	0.59
TimberRidge	4231.86	FEMA 100 Yr.	2600	7206.00	7213.05		7.05	4.69	7213.19	0.005988	2.75	1.75	946.18	200.20	0.40
TimberRidge	4231.86	DBPS 100 Yr.	2170	7206.00	7212.40		6.40	4.12	7212.53	0.006633	2.66	1.71	816.72	197.00	0.41
TimberRidge	4231.86	DBPS 10 Yr.	630	7206.00	7209.92		3.92	1.88	7210.00	0.008511	1.83	1.00	343.96	183.01	0.43
TimberRidge	4231.86	Sterling MDDP 10	1487	7206.00	7211.39		5.39	3.22	7211.50	0.007423	2.40	1.49	620.62	191.95	0.42
TimberRidge	4231.86	Sterling MDDP 10	430	7206.00	7209.49		3.49	1.53	7209.55	0.008398	1.62	0.80	266.20	173.66	0.42
TimberRidge	3915.99	FEMA 100 Yr.	2600	7204.00	7210.65		6.66	5.36	7210.83	0.006878	3.23	2.30	805.23	147.33	0.43
TimberRidge	3915.99	DBPS 100 Yr.	2170	7204.00	7209.90		5.91	5.13	7210.06	0.006770	3.10	2.17	700.86	133.82	0.41
TimberRidge	3915.99	DBPS 10 Yr.	630	7204.00	7206.76		2.77	2.41	7206.83	0.008665	2.12	1.30	296.99	122.39	0.41
TimberRidge	3915.99	Sterling MDDP 10	1487	7204.00	7208.64		4.65	4.06	7208.77	0.007458	2.78	1.89	534.42	129.52	0.42
TimberRidge	3915.99	Sterling MDDP 10	430	7204.00	7206.17		2.18	1.87	7206.23	0.009791	1.91	1.14	225.34	119.98	0.42
TimberRidge	3708.56	FEMA 100 Yr.	2600	7200.00	7207.47		7.47	4.43	7208.38	0.024427	6.02	6.76	432.11	95.41	0.82
TimberRidge	3708.56	DBPS 100 Yr.	2170	7200.00	7206.84		6.84	4.26	7207.66	0.024066	5.79	6.40	374.77	85.91	0.80
TimberRidge	3708.56	DBPS 10 Yr.	630	7200.00	7203.78		3.78	2.55	7204.16	0.022012	3.94	3.50	159.80	61.81	0.69
TimberRidge	3708.56	Sterling MDDP 10	1487	7200.00	7205.65		5.65	3.95	7206.28	0.022798	5.25	5.62	283.10	69.93	0.75
TimberRidge	3708.56	Sterling MDDP 10	430	7200.00	7203.33		3.33	2.21	7203.60	0.017662	3.24	2.44	132.53	59.20	0.61
TimberRidge	3540.59	FEMA 100 Yr.	2600	7193.66	7201.05		7.39	5.21	7201.46	0.017227	4.97	5.60	523.07	97.87	0.48
TimberRidge	3540.59	DBPS 100 Yr.	2170	7193.66	7200.42		6.76	4.76	7200.78	0.017298	4.70	5.14	462.03	94.77	0.47
TimberRidge	3540.59	DBPS 10 Yr.	630	7193.66	7197.39		3.73	2.53	7197.56	0.017643	3.16	2.79	199.24	77.58	0.43
TimberRidge	3540.59	Sterling MDDP 10	1487	7193.66	7199.27		5.61	3.92	7199.56	0.017542	4.17	4.29	356.34	89.00	0.46
TimberRidge	3540.59	Sterling MDDP 10	430	7193.66	7196.58		2.92	1.91	7196.75	0.024094	3.10	2.88	138.68	71.48	0.48

protect bend, side slopes

HEC-RAS Plan: SC PR River: Sand Creek Pr Reach: TimberRidge (Continued)

Reach	River Sta	Profile	Q Total (cfs)	Min Ch El (ft)	W.S. Elev (ft)	Crit W.S. (ft)	Max Chl Dpth (ft)	Hydr Radius (ft)	E.G. Elev (ft)	E.G. Slope (ft/ft)	Vel Total (ft/s)	Shear Total (lb/sq ft)	Flow Area (sq ft)	Top Width (ft)	Froude # Chl
TimberRidge	3334.27	FEMA 100 Yr.	2600	7187.96	7193.70	7193.27	5.74	3.05	7194.55	0.058800	6.67	11.21	389.99	125.12	0.85
TimberRidge	3334.27	DBPS 100 Yr.	2170	7187.96	7193.47	7193.00	5.51	2.85	7194.17	0.051790	6.00	9.23	361.50	124.24	0.79
TimberRidge	3334.27	DBPS 10 Yr.	630	7187.96	7192.11	7190.39	4.15	1.62	7192.37	0.028019	3.23	2.83	195.35	119.05	0.56
TimberRidge	3334.27	Sterling MDDP 10	1487	7187.96	7193.03	7192.52	5.07	2.46	7193.51	0.040268	4.85	6.18	306.86	122.53	0.69
TimberRidge	3334.27	Sterling MDDP 10	430	7187.96	7191.28		3.32	2.33	7191.48	0.020678	3.34	3.01	128.80	53.80	0.46
TimberRidge	3179.66	FEMA 100 Yr.	2600	7183.81	7188.93		5.13	3.88	7189.16	0.008005	2.92	1.94	889.95	228.13	0.77
TimberRidge	3179.66	DBPS 100 Yr.	2170	7183.81	7188.39		4.59	3.39	7188.61	0.008901	2.83	1.88	766.96	225.71	0.80
TimberRidge	3179.66	DBPS 10 Yr.	630	7183.81	7186.04		2.24	1.57	7186.20	0.015243	2.24	1.50	280.82	178.46	0.92
TimberRidge	3179.66	Sterling MDDP 10	1487	7183.81	7187.45		3.65	2.60	7187.66	0.010976	2.66	1.78	559.01	214.63	0.85
TimberRidge	3179.66	Sterling MDDP 10	430	7183.81	7185.60	7185.05	1.80	1.28	7185.75	0.017110	2.08	1.37	206.44	161.13	0.94
TimberRidge	2960.1	FEMA 100 Yr.	2600	7178.00	7185.62	7184.65	7.62	4.81	7186.69	0.015671	4.99	4.71	521.50	106.03	1.15
TimberRidge	2960.1	DBPS 100 Yr.	2170	7178.00	7185.17	7184.23	7.17	4.47	7186.10	0.014460	4.58	4.03	473.67	103.92	1.09
TimberRidge	2960.1	DBPS 10 Yr.	630	7178.00	7182.44	7182.19	4.44	2.25	7183.04	0.013310	3.03	1.87	207.80	91.21	0.97
TimberRidge	2960.1	Sterling MDDP 10	1487	7178.00	7184.22	7183.45	6.22	3.73	7184.97	0.013220	3.94	3.08	377.18	99.49	1.02
TimberRidge	2960.1	Sterling MDDP 10	430	7178.00	7181.87	7181.40	3.87	1.82	7182.42	0.013199	2.75	1.50	156.55	85.16	0.94
TimberRidge	2652.02	FEMA 100 Yr.	2600	7176.11	7181.80	7181.03	5.71	4.68	7183.32	0.031766	6.86	9.27	379.13	77.95	1.56
TimberRidge	2652.02	DBPS 100 Yr.	2170	7176.11	7180.82	7180.50	4.73	3.92	7182.46	0.043312	7.14	10.60	304.13	75.07	1.76
TimberRidge	2652.02	DBPS 10 Yr.	630	7176.11	7178.19	7178.19	2.10	1.79	7179.10	0.066403	5.29	7.44	119.03	65.29	1.91
TimberRidge	2652.02	Sterling MDDP 10	1487	7176.11	7179.59	7179.59	3.50	2.96	7181.13	0.059183	6.93	10.92	214.58	70.79	1.96
TimberRidge	2652.02	Sterling MDDP 10	430	7176.11	7177.78	7177.78	1.69	1.43	7178.49	0.068075	4.63	6.09	92.83	63.99	1.86
TimberRidge	2500		Culvert												
TimberRidge	2416.82	FEMA 100 Yr.	2600	7174.30	7181.27		6.97	5.12	7181.90	0.027831	6.23	8.89	417.47	79.01	0.60
TimberRidge	2416.82	DBPS 100 Yr.	2170	7174.30	7180.64		6.34	4.65	7181.20	0.028273	5.89	8.20	368.30	77.00	0.60
TimberRidge	2416.82	DBPS 10 Yr.	630	7174.30	7177.67		3.37	2.31	7177.95	0.034137	4.09	4.92	153.99	66.03	0.59
TimberRidge	2416.82	Sterling MDDP 10	1487	7174.30	7179.47		5.17	3.75	7179.93	0.030410	5.30	7.11	280.54	73.31	0.60
TimberRidge	2416.82	Sterling MDDP 10	430	7174.30	7177.14		2.84	1.93	7177.36	0.033132	3.58	3.99	120.01	61.77	0.57
TimberRidge	2083.66	FEMA 100 Yr.	2600	7169.85	7176.23	7175.22	6.38	4.81	7177.52	0.023739	6.06	7.13	429.08	87.11	1.37
TimberRidge	2083.66	DBPS 100 Yr.	2170	7169.85	7175.66	7174.73	5.81	4.40	7176.81	0.023663	5.71	6.50	379.73	84.42	1.35
TimberRidge	2083.66	DBPS 10 Yr.	630	7169.85	7173.05	7172.51	3.19	2.38	7173.55	0.020599	3.61	3.06	174.34	72.62	1.14
TimberRidge	2083.66	Sterling MDDP 10	1487	7169.85	7174.71	7173.86	4.86	3.70	7175.58	0.021945	4.92	5.07	301.99	80.23	1.26
TimberRidge	2083.66	Sterling MDDP 10	430	7169.85	7172.47	7172.09	2.62	1.89	7172.89	0.021633	3.22	2.56	133.43	69.98	1.13
TimberRidge	1879.67	FEMA 100 Yr.	2600	7165.99	7171.45		5.46	4.01	7171.97	0.028093	5.40	7.03	481.66	119.04	0.83
TimberRidge	1879.67	DBPS 100 Yr.	2170	7165.99	7171.12		5.14	3.76	7171.55	0.025138	4.89	5.89	443.35	116.95	0.78
TimberRidge	1879.67	DBPS 10 Yr.	630	7165.99	7168.99	7168.08	3.01	2.05	7169.16	0.020865	3.00	2.66	209.66	102.03	0.65
TimberRidge	1879.67	Sterling MDDP 10	1487	7165.99	7170.29		4.31	3.10	7170.62	0.024512	4.26	4.75	348.67	111.56	0.75
TimberRidge	1879.67	Sterling MDDP 10	430	7165.99	7168.61	7167.72	2.63	1.73	7168.74	0.017958	2.50	1.94	171.72	98.94	0.59
TimberRidge	1507.91	FEMA 100 Yr.	2600	7159.96	7164.66		4.72	3.19	7164.91	0.017930	3.74	3.57	696.01	217.05	0.65
TimberRidge	1507.91	DBPS 100 Yr.	2260	7159.96	7164.29		4.35	2.86	7164.54	0.019670	3.66	3.51	616.82	214.88	0.67
TimberRidge	1507.91	DBPS 10 Yr.	670	7159.96	7162.01		2.06	1.82	7162.15	0.023724	2.91	2.70	230.61	126.17	0.65
TimberRidge	1507.91	Sterling MDDP 10	1520	7159.96	7163.38		3.44	2.31	7163.59	0.020300	3.51	2.93	432.96	186.33	0.65
TimberRidge	1507.91	Sterling MDDP 10	450	7159.96	7161.50		1.56	1.39	7161.62	0.028975	2.68	2.51	167.86	120.51	0.68
TimberRidge	1145.05	FEMA 100 Yr.	2600	7153.97	7160.24	7159.41	6.27	3.32	7161.04	0.017900	4.11	3.71	633.15	188.76	1.19
TimberRidge	1145.05	DBPS 100 Yr.	2260	7153.97	7159.81	7159.12	5.84	3.24	7160.55	0.017502	4.07	3.54	555.70	169.49	1.16
TimberRidge	1145.05	DBPS 10 Yr.	670	7153.97	7157.71	7157.19	3.74	1.89	7158.17	0.014853	2.77	1.75	242.31	127.24	0.99
TimberRidge	1145.05	Sterling MDDP 10	1520	7153.97	7158.97	7158.47	5.00	2.72	7159.60	0.017048	3.61	2.90	420.67	152.99	1.12

What are velocities and shear through the culvert?

HEC-RAS Plan: SC PR River: Sand Creek Pr Reach: TimberRidge (Continued)

Reach	River Sta	Profile	Q Total (cfs)	Min Ch El (ft)	W.S. Elev (ft)	Crit W.S. (ft)	Max Chl Dpth (ft)	Hydr Radius (ft)	E.G. Elev (ft)	E.G. Slope (ft/ft)	Vel Total (ft/s)	Shear Total (lb/sq ft)	Flow Area (sq ft)	Top Width (ft)	Froude # Chl
TimberRidge	1145.05	Sterling MDDP 10	450	7153.97	7157.21		3.24	1.65	7157.58	0.013286	2.46	1.37	183.08	110.30	0.92
TimberRidge	902.8	FEMA 100 Yr.	2600	7150.00	7156.17	7154.91	6.18	3.62	7156.72	0.014230	3.78	3.22	687.79	188.79	1.06
TimberRidge	902.8	DBPS 100 Yr.	2260	7150.00	7155.77	7154.68	5.78	3.47	7156.29	0.014183	3.68	3.07	614.75	175.97	1.04
TimberRidge	902.8	DBPS 10 Yr.	670	7150.00	7153.41	7151.92	3.42	1.75	7153.83	0.017672	2.74	1.93	244.17	139.02	1.07
TimberRidge	902.8	Sterling MDDP 10	1520	7150.00	7154.82	7154.11	4.83	2.83	7155.28	0.015037	3.34	2.66	454.59	159.67	1.04
TimberRidge	902.8	Sterling MDDP 10	450	7150.00	7152.93	7152.84	2.94	1.36	7153.36	0.019115	2.51	1.62	179.31	131.07	1.08
TimberRidge	520.2	FEMA 100 Yr.	2600	7147.95	7153.89		5.95	4.29	7154.30	0.011034	3.70	2.95	701.92	162.63	0.93
TimberRidge	520.2	DBPS 100 Yr.	2260	7147.95	7153.53		5.59	4.04	7153.90	0.010712	3.51	2.70	644.41	158.71	0.90
TimberRidge	520.2	DBPS 10 Yr.	670	7147.95	7151.16		3.22	2.22	7151.33	0.009579	2.25	1.32	298.04	134.05	0.78
TimberRidge	520.2	Sterling MDDP 10	1520	7147.95	7152.61		4.67	3.36	7152.89	0.010132	3.03	2.13	502.36	148.67	0.85
TimberRidge	520.2	Sterling MDDP 10	450	7147.95	7150.66		2.72	1.79	7150.80	0.009340	1.94	1.04	231.83	129.25	0.75
TimberRidge	250.3	FEMA 100 Yr.	2600	7145.94	7150.37	7148.65	4.44	3.22	7150.70	0.015242	3.53	3.06	736.88	228.68	1.04
TimberRidge	250.3	DBPS 100 Yr.	2260	7145.94	7150.07	7148.42	4.15	3.03	7150.38	0.015033	3.37	2.84	671.16	221.52	1.02
TimberRidge	250.3	DBPS 10 Yr.	670	7145.94	7148.11		2.19	1.85	7148.24	0.013036	2.26	1.51	297.00	160.35	0.85
TimberRidge	250.3	Sterling MDDP 10	1520	7145.94	7149.32	7147.88	3.40	2.59	7149.56	0.014296	2.96	2.31	513.19	197.88	0.96
TimberRidge	250.3	Sterling MDDP 10	450	7145.94	7147.68		1.76	1.52	7147.77	0.012714	1.96	1.21	229.84	150.71	0.81
TimberRidge	53.78	FEMA 100 Yr.	2600	7139.72	7144.87	7143.94	5.17	2.75	7145.23	0.016007	3.30	2.75	787.94	285.68	1.08
TimberRidge	53.78	DBPS 100 Yr.	2260	7139.72	7144.61	7143.74	4.91	2.58	7144.96	0.016004	3.16	2.57	714.84	277.12	1.07
TimberRidge	53.78	DBPS 10 Yr.	670	7139.72	7142.91	7142.61	3.21	1.44	7143.17	0.016016	2.21	1.44	303.06	209.76	1.00
TimberRidge	53.78	Sterling MDDP 10	1520	7139.72	7143.94	7143.29	4.24	2.15	7144.25	0.016002	2.82	2.15	539.65	250.15	1.05
TimberRidge	53.78	Sterling MDDP 10	450	7139.72	7142.55	7141.96	2.85	1.17	7142.79	0.015995	1.97	1.17	228.51	194.63	0.98

TIMBERRIDGE PR Plan: SC PR 7/24/2019

Sand Creek Pr TimberRidge

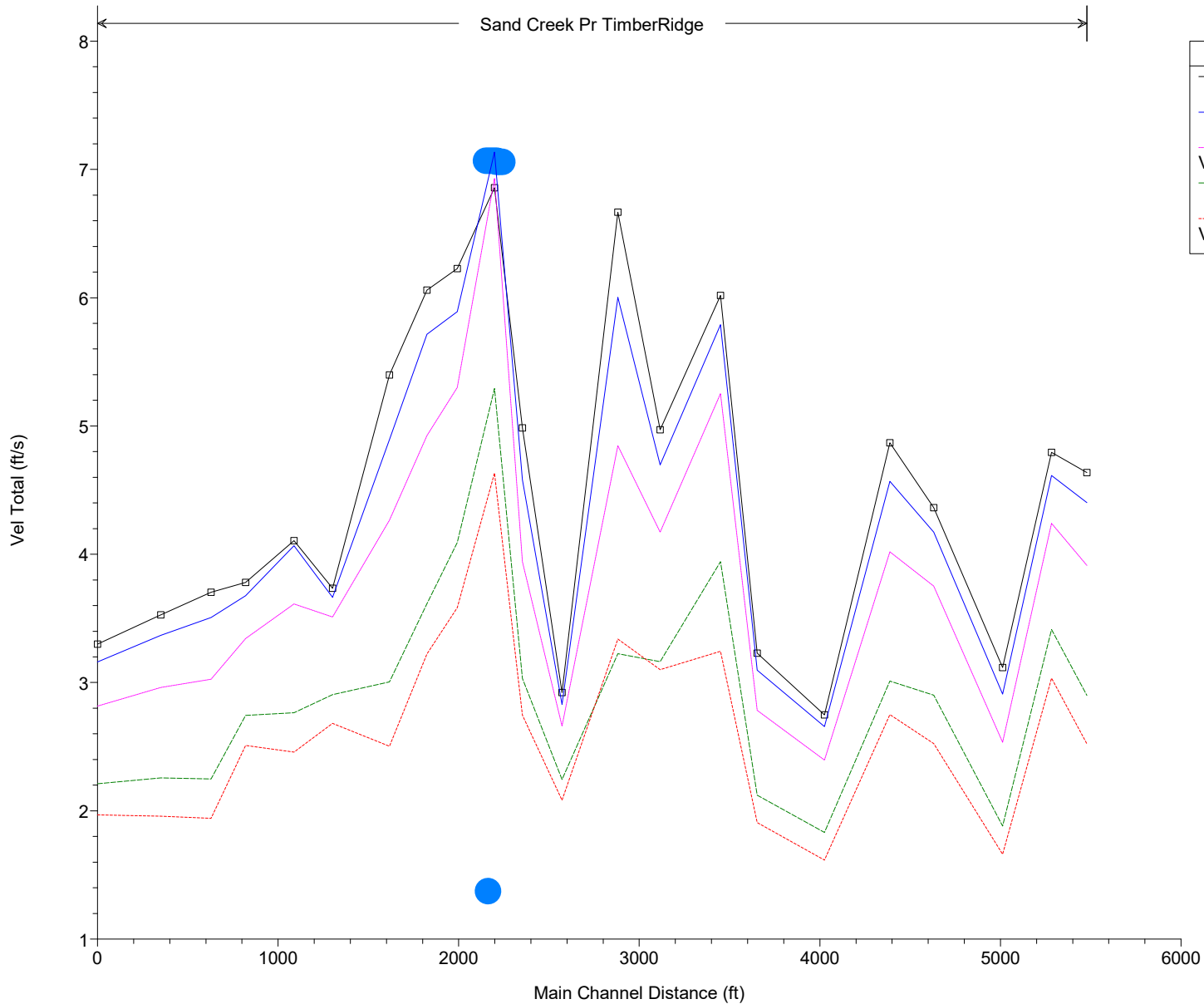

Legend	
□	Vel Total FEMA 100 Yr.
—	Vel Total DBPS 100 Yr.
—	Vel Total Sterling MDDP 10
—	Vel Total DBPS 10 Yr.
—	Vel Total Sterling MDDP 10

DRAINAGE MAPS

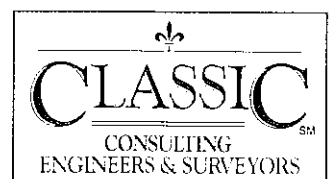

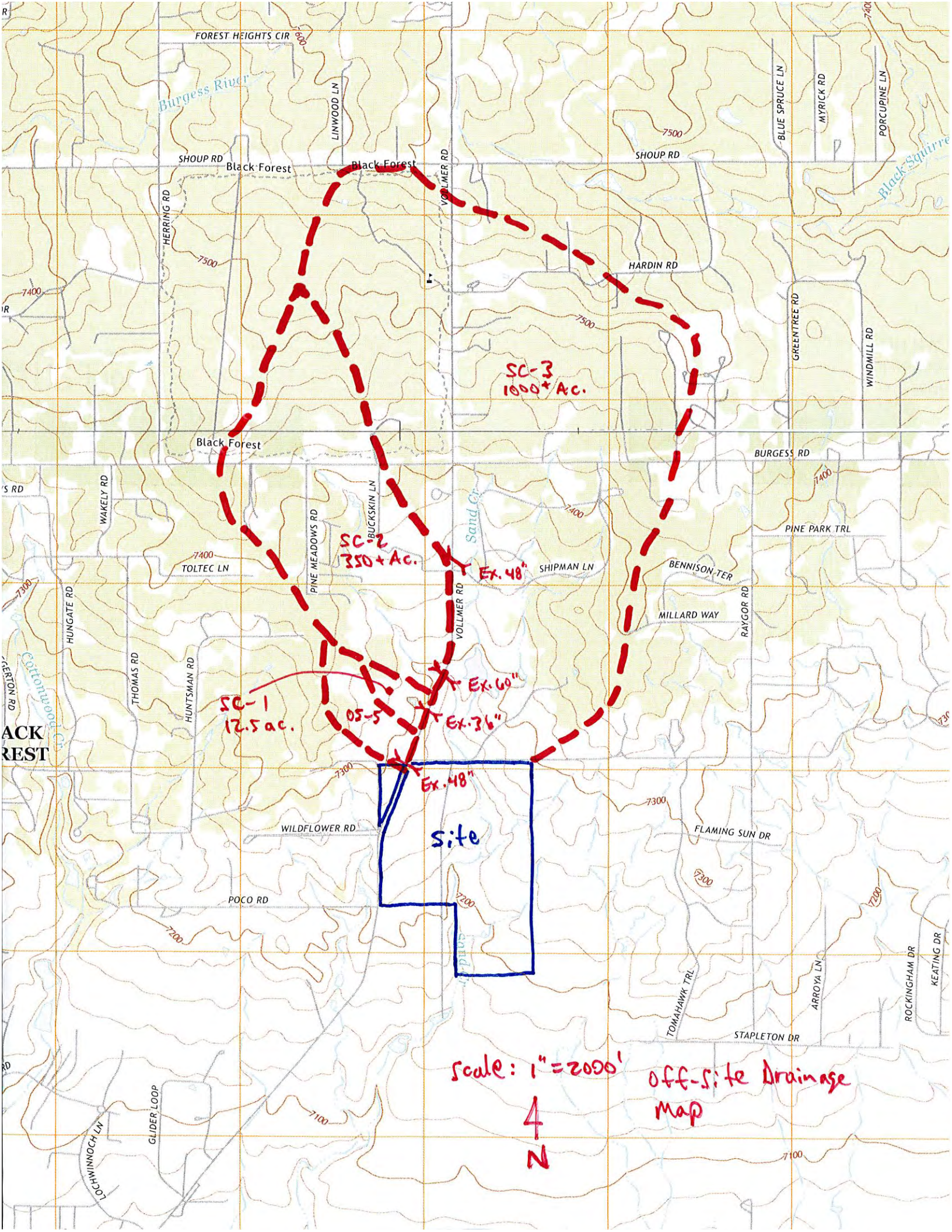

FOREST HEIGHTS CIR

Burgess River

LINWOOD LN

SHOUP RD

Black Forest

Black Forest

SHOUP RD

BLUE SPRUCE LN

MYRICK RD

PORCUPINE LN

HERRING RD

VOLLMER RD

HARDIN RD

GREENTREE RD

WINDMILL RD

SC-3
1000+ AC.

Black Forest

BURGESS RD

WAKELY RD

PINE MEADOWS RD

SC-2
350+ AC.

BUCKSKIN LN

EX. 48"

SHIPMAN LN

BENNISON TER

PINE PARK TRL

S RD

7300

TOLTEC LN

HUNGATE RD

THOMAS RD

HUNTSMAN RD

SC-1
12.5 ac.

OS-5

EX. 60"

EX. 36"

ACK
REST

EX. 48"

site

WILDFLOWER RD

FLAMING SUN DR

POCO RD

7200

7300

TOMAHAWK TRL

ARROYA LN

ROCKINGHAM DR

KEATING DR

STAPLETON DR

scale: 1"=2000' off-site Drainage Map

4
N

GLIDER LOOP

LOCHWINNOCH LN

7100

7100

CN VALUES - EXISTING CONDITIONS

BASIN (label)	BASIN AREA (Ac)	SOIL TYPE B		WEIGHTED C _w
		CN	AREA (Ac.)	
EX-1	32.4	61	32.4	61
EX-2	1.7	61	1.7	61
EX-3	25.7	61	25.7	61
EX-4	9.6	61	9.6	61
EX-5	123.3	61	123.3	61
EX-6	41.8	61	41.8	61
EX-7	27.6	63	27.6	63
EX-8	9.5	61	9.5	61

TIME OF CONCENTRATION - EXISTING CONDITIONS

BASIN	Cn	Q(5)	OVERLAND			STREET / CHANNEL FLOW			Tc (min)	Tc (min)	Tc (min)	Tc (min)
			Length (ft)	Height (ft)	Tc (min)	Length (ft)	Slope (%)	Velocity (ft/s)				
EX-1	61.0	0.08	300	10	21.4	1500	1.8%	1.3	19.2	40.7	24.4	0.41
EX-2	61.0	0.08	300	10	21.4	1500	1.8%	1.3	19.2	21.4	12.9	0.21
EX-3	61.0	0.08	300	12	20.2	1500	4.0%	1.8	13.9	34.1	20.4	0.34
EX-4	61.0	0.08	300	10	21.4	1000	4.0%	1.8	9.3	30.7	18.4	0.31
EX-5	61.0	0.08	300	8	23.1	1800	2.0%	1.3	23.1	46.2	27.7	0.46
EX-6	61.0	0.08	300	10	21.4	800	3.0%	1.3	10.3	31.7	19.0	0.32
EX-7	63.0	0.08	300	10	21.4	1200	3.0%	1.4	14.3	35.7	21.6	0.36
EX-8	61.0	0.08	300	10	21.4	700	4.0%	1.3	9.0	30.4	18.2	0.30

BASIN SUMMARY - EXISTING CONDITIONS

BASIN (label)	TOTAL BASIN AREA (acres)	WEIGHTED CN	TOTAL LAG TIME (hours)	Q 2 Yr. (cfs)	Q 5 Yr. (cfs)	Q 100 Yr. (cfs)
EX-1	32.4	61	0.41	0.5	3.9	30.0
EX-2	1.7	61	0.21	0.03	0.3	2.3
EX-3	25.7	61	0.34	0.4	3.4	26.8
EX-4	9.6	61	0.31	0.2	1.4	10.5
EX-5	123.3	61	0.46	2.0	13.3	107.2
EX-6	41.8	61	0.32	0.7	5.8	44.8
EX-7	27.6	63	0.36	1.0	5.2	32.1
EX-8	9.5	61	0.30	0.2	1.4	10.7

DESIGN POINTS SURFACE ROUTING SUMMARY - EXISTING CONDITIONS

Design Point (label)	Contributing Basins	Q 2 Yr. (cfs)	Q 5 Yr. (cfs)	Q 100 Yr. (cfs)
EX DP-1	BASINS EX-1, EX-4, EX-5, EX-6, EX-7 (234.7 AC.)	4.2	28.5	219.2
EX DP-2	BASIN EX-2 (1.7 AC.)	0.03	0.3	2.3
EX DP-3	BASIN EX-3 (25.7 AC.)	0.4	3.4	26.8
EX DP-4	BASIN EX-4 (9.6 AC.)	0.2	1.4	10.5
EX DP-8	BASIN EX-8 (9.5 AC.)	0.2	1.4	10.7

LEGEND

DESCRIPTION	SYMBOL
EXISTING GROUND CONTOUR	6910
PROPOSED FINISHED CONTOUR	6910
BASIN BOUNDARY	---
DESIGN POINT	*
BASIN IDENTIFIER	BB
AREA IN ACRES	100
EXISTING DIRECTION OF FLOW	→
EXISTING STORM SEWER	---
WETLAND DELINEATION	---

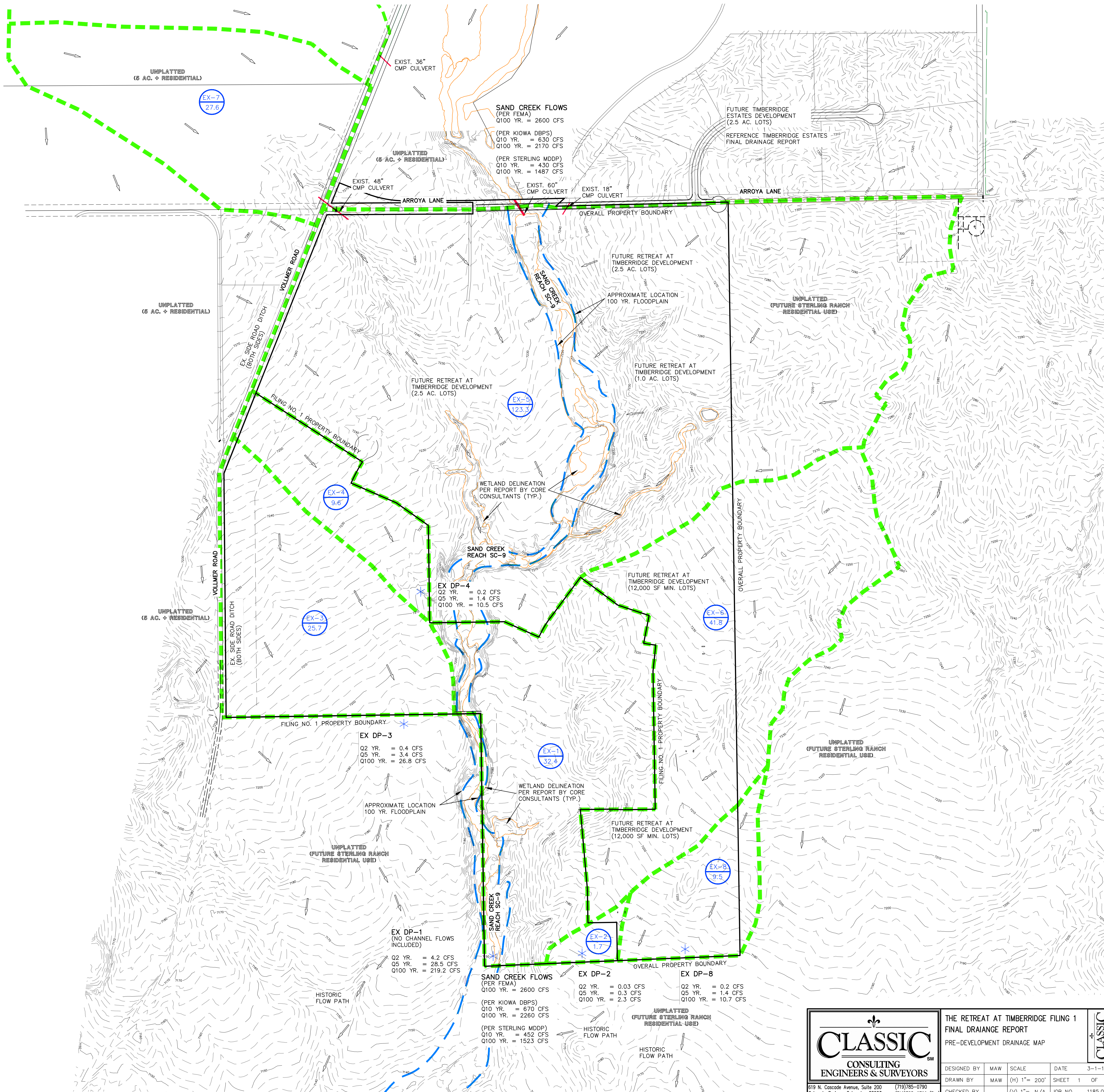
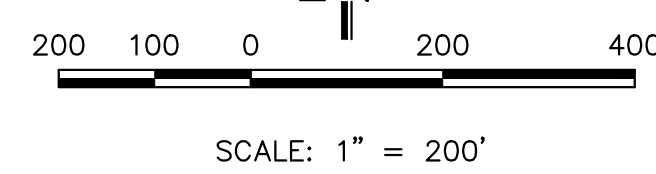

619 N. Cascade Avenue, Suite 200
Colorado Springs, Colorado 80903

**THE RETREAT AT TIMBERRIDGE FILING 1
FINAL DRAINAGE REPORT
PRE-DEVELOPMENT DRAINAGE MAP**

DESIGNED BY: MAW
DRAWN BY: MAW
CHECKED BY: (V)

SCALE: (H) 1" = 200'
N/A

DATE: 3-1-19
SHEET 1 OF 5
JOB NO. 1185.00

DESCRIPTION	SYMBOL
EXISTING GROUND CONTOUR	6910
PROPOSED FINISHED CONTOUR	6910
BASIN BOUNDARY	
BASIN IDENTIFIER AREA IN ACRES	OS-1 10.0
DESIGN POINT	
EXISTING DIRECTION OF FLOW	
PROPOSED DIRECTION OF FLOW	
PROPOSED DRAINAGE IMPROVEMENTS	
PIPE RUN	
WETLAND DELINEATION	

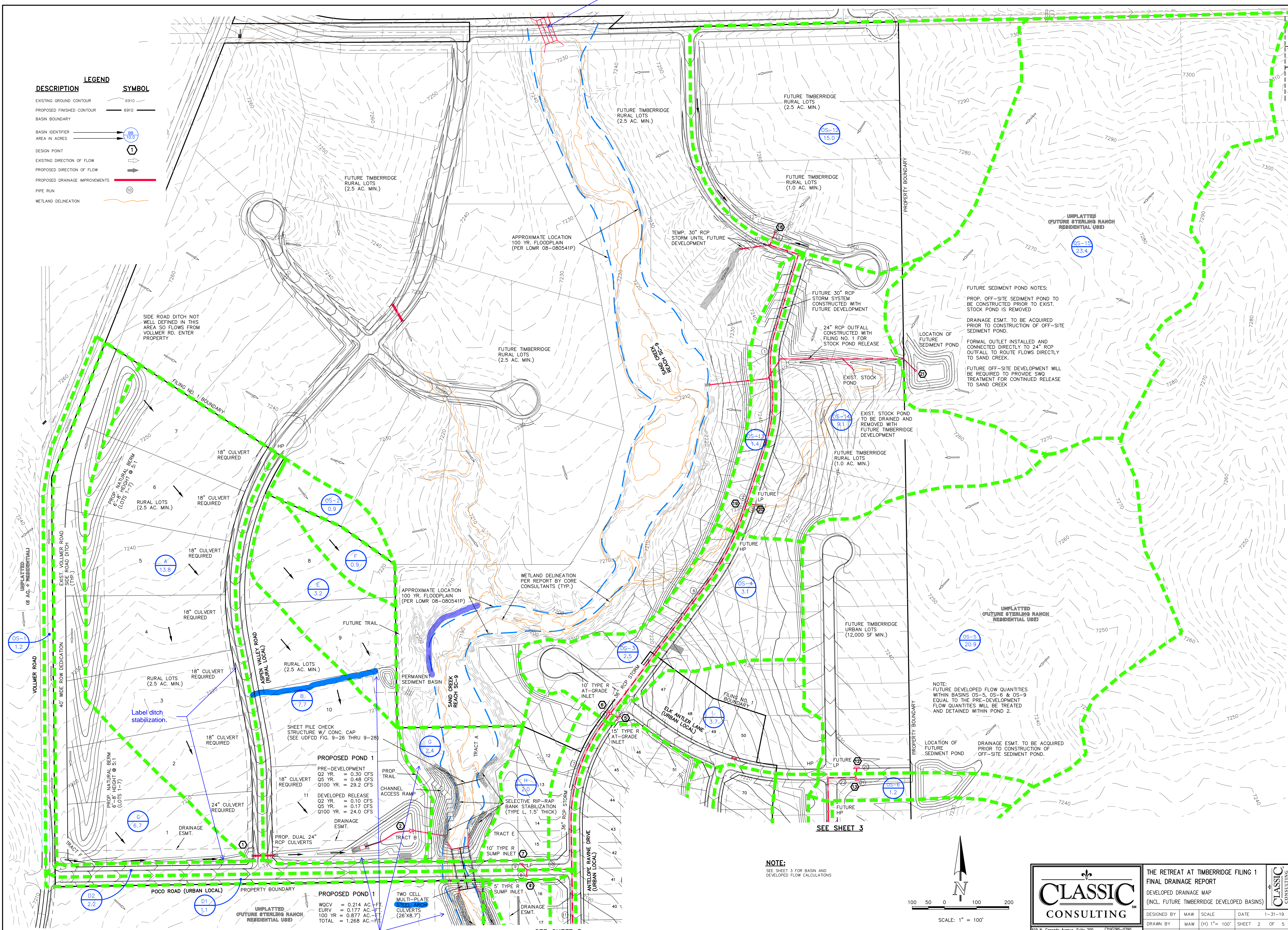

SIDE ROAD DITCH NOT WELL DEFINED IN THIS AREA SO FLOWS FROM VOLLMER RD. ENTER PROPERTY

Label ditch stabilization.

Show maintenance access roads

FUTURE SEDIMENT POND NOTES:
 PROP. OFF-SITE SEDIMENT POND TO BE CONSTRUCTED PRIOR TO EXIST. STOCK POND IS REMOVED.
 DRAINAGE ESMT. TO BE ACQUIRED PRIOR TO CONSTRUCTION OF OFF-SITE SEDIMENT POND.
 FORMAL OUTLET INSTALLED AND CONNECTED DIRECTLY TO 24" RCP OUTFALL TO ROUTE FLOWS DIRECTLY TO SAND CREEK.
 FUTURE OFF-SITE DEVELOPMENT WILL BE REQUIRED TO PROVIDE SWO TREATMENT FOR CONTINUED RELEASE TO SAND CREEK.

NOTE:
 FUTURE DEVELOPED FLOW QUANTITIES WITHIN BASINS OS-5, OS-6 & OS-9 EQUAL TO THE PRE-DEVELOPMENT FLOW QUANTITIES WILL BE TREATED AND DETAINED WITHIN POND 2.

PROPOSED POND 1

PRE-DEVELOPMENT	Q2 YR. = 0.30 CFS
Q5 YR. = 0.48 CFS	Q100 YR. = 29.2 CFS
DEVELOPED RELEASE	Q2 YR. = 0.10 CFS
Q5 YR. = 0.17 CFS	Q100 YR. = 24.0 CFS

PROPOSED POND 1

WOCV	= 0.214 AC.-FT.
EURV	= 0.177 AC.-FT.
100 YR.	= 0.877 AC.-FT.
TOTAL	= 1.268 AC.-FT.

NOTE:
 SEE SHEET 3 FOR BASIN AND DEVELOPED FLOW CALCULATIONS

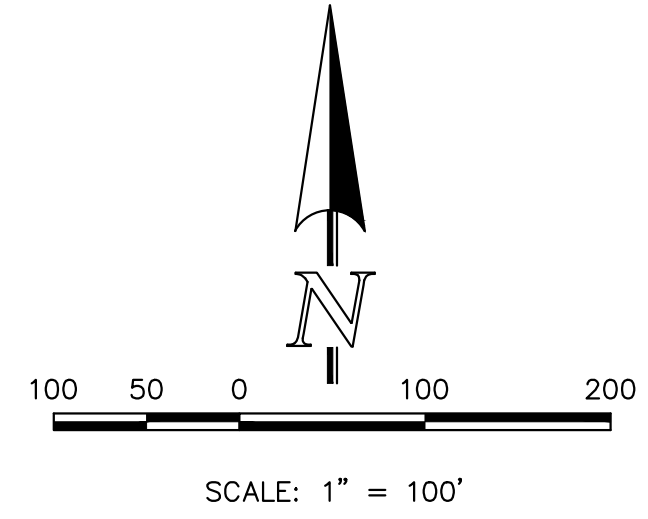

		THE RETREAT AT TIMBERIDGE FILING 1 FINAL DRAINAGE REPORT DEVELOPED DRAINAGE MAP (INCL. FUTURE TIMBERIDGE DEVELOPED BASINS)	
		DESIGNED BY	MAW
619 N. Cascade Avenue, Suite 200 Colorado Springs, Colorado 80903		(719)785-0790 (719)785-0799 (Fax)	1-31-19 SHEET 2 OF 5 JOB NO. 2520.00

N:\1185001\REPORTS\DRN\1980000_REV.dwg, 7/31/2019 8:26:08 AM, 11.03451

FINAL DRAINAGE REPORT - SURFACE ROUTING SUMMARY										
Design Point(s)	Contributing Basins	Equivalent CA(5)	Equivalent CA(100)	Maximum Tc	Intensity				Flow	Inlet Size
					I(5)	I(100)	Q(5)	Q(100)		
1	A(13.8Ac), OS-1(1.2Ac) and C(6.7Ac)	3.58	9.08	31.8	2.38	4.02	9	36	DUAL 24" RCP CULVERTS	
2	TOTAL INFLOW INTO POND 1 A, B, C and OS-1 (28.4 Ac.)	4.66	12.16	33.8	2.30	3.86	11	47	POND 1	
3	No longer used									
4	D1 (1.1 Ac.)	0.74	0.87	15.2	3.50	5.88	3	5	9" TYFER SUMP INLET	
5	OS-4 (3.1 Ac.) I (0.7 Ac.)	1.61	3.17	17.7	3.28	5.50	5	17	15" TYFER AT-GRADE INLET	
6	OS-3 (2.5 Ac.)	0.63	1.18	11.9	3.86	6.49	2	8	10" TYFER AT-GRADE INLET	
7	Basin D2, Basin H and 50% of 100 yr Flow from DP-6 (5.5 Ac.)	1.51	2.47	27.3	2.62	4.40	4	11	9" TYFER SUMP INLET	
8	K (1.5 Ac.)	0.38	0.71	12.6	3.78	6.35	1	4	9" TYFER SUMP INLET	
9	J and OS-7 (5.7 Ac.)	1.43	2.68	16.0	3.43	5.75	5	15	10" TYFER SUMP INLET	
10	Flow from DP-5 and Basin L (7.3 Ac.)	1.83	4.29	21.2	3.00	5.04	5	22	15" TYFER AT-GRADE INLET	
11	Basins N, O, P and 50% 100 Yr Flow from DP-6 and portion of 100 Yr Flow from DP-10 (13.8 Ac.)	1.58	4.54	24.2	2.80	4.70	4	21	15" TYFER SUMP INLET	
12	OS-5 (20.9 Ac.)	2.93	6.27	19.9	3.08	5.19	9	33	15" TYFER SUMP INLET	
13	OS-6 (1.2 Ac.)	0.19	2.06	12.4	3.80	6.30	1	13	10" TYFER SUMP INLET	
14	OS-8 (1.0 Ac.)	0.25	0.47	11.0	3.99	6.89	1	3	9" TYFER SUMP INLET	
15	OS-9 (5.3 Ac.)	0.85	2.17	16.0	3.42	5.74	3	12	10" TYFER SUMP INLET	
16	OS-10 (1.0 Ac.)	0.25	0.47	11.0	3.99	6.89	1	3	9" TYFER SUMP INLET	
17	OS-11 (7.9 Ac.)	1.98	3.71	14.7	3.55	5.96	7	22	10" TYFER SUMP INLET	
18	OS-12 (15.0 Ac.)	2.10	6.00	22.0	2.94	4.94	6	30	30" RCP CULVERT	
19	OS-13 (1.4 Ac.)	0.28	0.62	12.2	3.83	6.42	1	4	9" TYFER SUMP INLET	
20	OS-14 (9.1 Ac.)	1.82	4.00	19.9	3.10	5.20	6	21	15" TYFER SUMP INLET	
21	TOTAL INFLOW INTO EXIST. STOCK POND (23.4 Ac.)	2.11	8.42	28.8	2.49	4.18	5	35	EXIST. STOCK POND WITH OUTLET	
22	TOTAL INFLOW INTO POND 2 (104.6 Ac.)	20.50	45.77	30.0	2.48	4.16	51	191	POND 2	

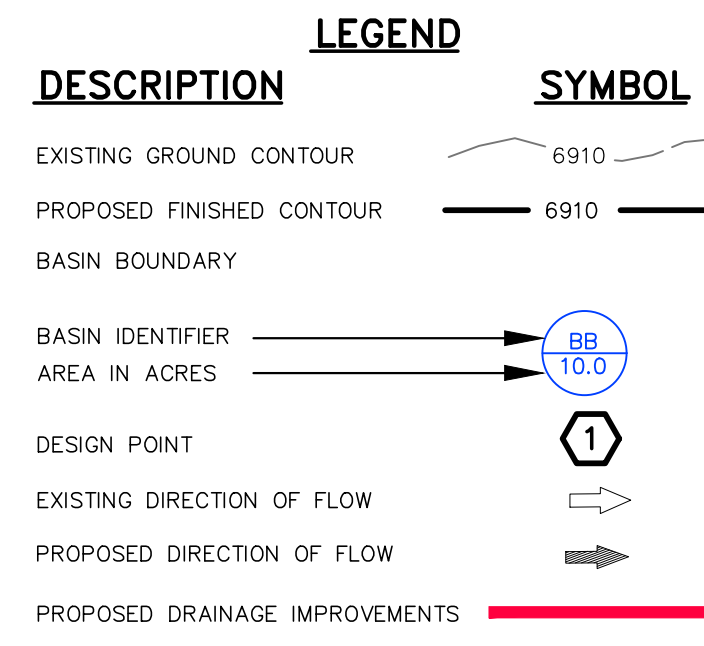

FINAL DRAINAGE REPORT - BASIN RUNOFF SUMMARY																		
BASIN	WEIGHTED						OVERLAND				STREET / CHANNEL FLOW				TOTAL FLOWS			
	CA(2)	CA(5)	CA(10)	CA(25)	CA(50)	CA(100)	Q(5)	Length (ft)	Height (ft)	Tc (min)	Length (ft)	Slope (%)	Velocity (ft/s)	Tc (min)	Q(2)	Q(5)	Q(100)	
OS-1	0.68	0.71	0.76	0.82	0.85	0.88	0.08	10	0.2	46	1700	3.5%	1.9	15.1	19.8	2.48	3.11	3.82
OS-2	0.02	0.07	0.14	0.23	0.27	0.32	0.00	300	10.5	21.1	211	2.4%	3.01	3.51	4.01	4.51	5.05	0.2
OS-3	4.45	0.63	0.80	0.96	1.08	1.18	0.25	55	1.1	9.1	600	3.0%	3.5	3.9	4.19	3.08	3.66	4.51
OS-4	0.47	0.68	0.93	1.15	1.27	1.43	0.22	200	6	156	400	3.0%	3.5	1.9	17.6	2.62	3.28	3.83
OS-5	1.25	2.93	4.81	6.46	7.52	8.36	0.14	200	8	15.5	750	2.0%	2.8	4.4	18.9	2.47	3.09	3.61
OS-6	0.08	0.19	0.29	0.38	0.44	0.49	0.16	55	1.1	10.0	500	3.0%	3.5	2.4	12.4	3.04	3.80	4.44
OS-7	0.38	0.53	0.67	0.82	0.90	0.99	0.25	100	10	7.2				7.2	3.69	4.63	5.40	
OS-8	0.18	0.25	0.32	0.39	0.43	0.47	0.25	55	1.1	9.1	400	3.0%	3.5	1.9	11.0	3.18	3.99	4.65
OS-9	0.37	0.85	1.27	1.70	1.96	2.17	0.94	200	10	14.1	400	3.0%	3.5	1.9	16.0	2.73	3.42	3.99
OS-10	0.18	0.25	0.32	0.39	0.43	0.47	0.25	55	1.1	9.1	450	3.0%	3.9	1.9	11.0	3.18	3.99	4.65
OS-11	1.42	1.98	2.53	3.08	3.40	3.71	0.25	200	10	12.8	450	3.0%	3.9	1.9	14.7	2.84	3.55	4.14
OS-12	0.90	2.10	3.45	4.65	5.40	6.00	0.14	300	13	18.5	600	2.0%	2.8	3.5	22.0	2.35	2.94	3.43
OS-13	0.17	0.28	0.38	0.49	0.56	0.62	0.20	55	1.1	9.6	450	2.0%	2.8	2.7	12.3	3.05	3.83	4.46
OS-14	1.08	1.82	2.46	3.19	3.64	4.00	0.20	300	12	17.8	350	2.0%	2.8	2.1	19.9	2.48	3.10	3.62
OS-15	0.70	2.11	3.98	6.08	7.25	8.42	0.09	300	16	18.2	1300	3.5%	1.9	11.6	28.8	2.49	3.02	3.74
OS-16	0.23	0.69	1.31	2.00	2.39	2.77	0.09	300	10	21.2	600	3.5%	1.9	5.3	26.8	2.13	2.66	3.11
OS-17	0.61	1.84	3.47	5.30	6.32	7.34	0.09	300	9.5	21.6	650	3.5%	1.9	5.8	27.4	2.10	2.62	3.05
OS-18	0.33	0.98	1.85	2.83	3.38	3.92	0.09	300	10	21.2	700	3.5%	1.9	6.2	27.5	2.05	2.61	3.05
OS-19	0.22	0.65	1.22	1.87	2.23	2.59	0.09	300	10	21.2	400	3.5%	1.9	3.6	24.8	2.21	2.77	3.23
OS-20	0.75	2.28	4.27	6.53	7.78	9.04	0.09	300	16	18.2	1300	3.5%	1.9	11.6	28.8	2.49	2.91	3.32
A	0.83	1.93	3.17	4.28	4.97	5.52	0.14	300	10.5	18.9	1200	3.2%	1.8	11.9	31.8	1.92	2.39	2.79
B	0.46	1.08	1.77	2.39	2.77	3.08	0.14	300	10.5	18.9	400	2.0%	1.4	4.7	24.6	2.23	2.78	3.24
C	0.40	0.94	1.54	2.08	2.41	2.68	0.14	300	10.5	18.9	1100	1.5%	2.4	7.5	27.3	2.10	2.62	3.06
D	0.72	0.74	0.78	0.83	0.85	0.87	0.08	15	0.3	5.7	1400	1.5%	2.4	9.5	15.2	2.80	3.50	4.07
D2	0.96	1.07	1.18	1.30	1.36	1.43	0.25	55	1.1	9.1	500	2.5%	3.2	2.6	11.7	3.11	3.89	4.54
E	0.19	0.45	0.74	0.99	1.15	1.28	0.14	300	10.5	18.9	300	2.0%	1.4	3.5	23.4	2.38	2.85	3.33
F	0.05	0.13	0.21	0.28	0.32	0.36	0.14	300	10.5	18.9				19.9	2.48	3.10	3.62	
G	0.05	0.19	0.36	0.60	0.72	0.84	0.08	70	14	5.7	400	2.0%	1.4	4.7	10.4	3.24	4.06	4.74
H	0.30	0.44	0.60	0.74	0.82	0.92	0.22	100	4	10.1	300	3.0%	3.5	1.4	11.5	3.13	3.92	4.57
I	0.67	0.93	1.18	1.44	1.59	1.74	0.25	120	3	12.4	550	3.5%	3.7	2.4	14.9	2.82	3.53	4.12
J	0.65	0.90	1.15	1.40	1.55	1.69	0.25	120	3	12.4	600	2.0%	2.8	3.5	16.0	2.74	3.43	4.00
K	0.27	0.38	0.48	0.59	0.65	0.71	0.25	55	1.1	9.1	600	2.0%	2.8	3.5	12.6	3.02	3.78	4.41
L	1.31	1.83	2.34	2.85	3.14	3.43	0.25	150	4.5	13.1	850	2.5%	3.2	4.5	17.6	2.62	3.28	3.83
M	0.41	0.59	0.81	1.00	1.11	1.24	0.22	100	4	10.1	400	2.0%	2.8	2.4	12.4	3.04	3.80	4.44
N	0.38	0.53	0.67	0.82	0.90	0.99	0.25	55	1.1	9.1	1000	2.0%	2.8	2.6	15.2	2.70	3.40	4.08
O	0.27	0.38	0.48	0.59	0.65	0.71	0.25	80	5	7.5				7.5	3.64	4.58	5.32	
P	0.49	0.68	0.86	1.05	1.16	1.27	0.25	120	3	12.4	400	1.5%	2.4	3.1	15.5	2.77	3.47	4.05
Q	0.13	0.31	0.51	0.68	0.79	0.88	0.14	90	3.2	5.7	300	1.5%	1.2	4.1	9.8	3.22	4.16	4.85
R	0.18	0.23	0.29	0.35	0.39	0.42	0.25	90	6	7.8				7.8	3.59	4.50	5.26	
S	0.07	0.29	0.54	0.90	1.08	1.28	0.09	140	14	10.2	750	1.5%	2.4	5.1	15.3	2.79	3.49	4.07

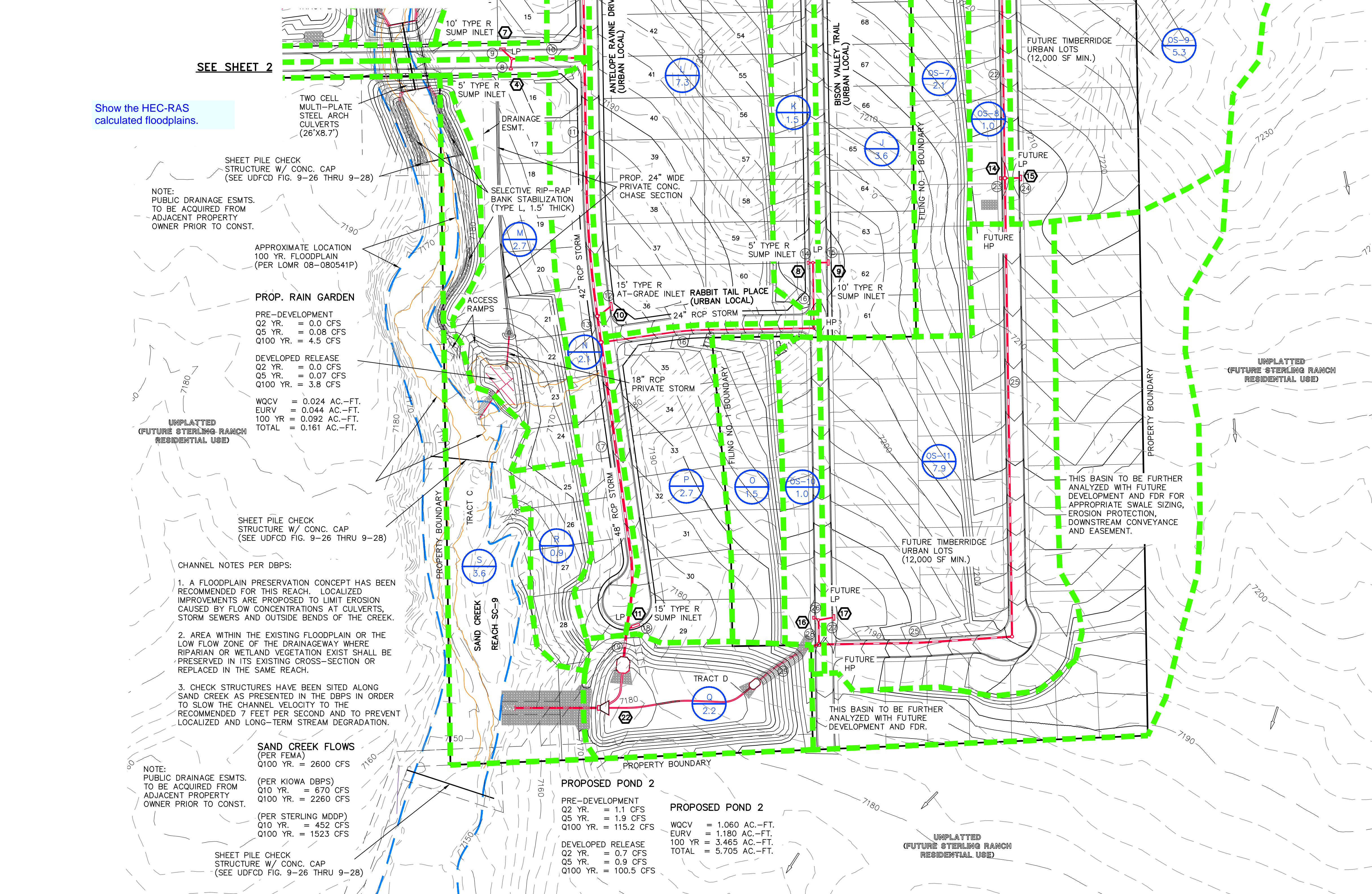

FINAL DRAINAGE REPORT - PIPE ROUTING SUMMARY										
Pipe Run	Contributing Basins	Equivalent CA(5)	Equivalent CA(100)	Maximum Tc	Intensity				Flow	Pipe Size
					I(5)	I(100)	Q(5)	Q(100)		
1	DP-18	2.10	6.00	23.2	2.86	4.81	6	29	30" RCP	
2	DP-19	0.28	0.62	12.2	3.83	6.42	1	4	18" RCP	
3	DP-20	1.82	4.00	19.9	3.10	5.20	6	21	24" RCP	
4	PR-1, PR-2, PR-3	4.20	10.62	23.9	2.82	4.73	12	50	36" RCP	
5	Captured from DP-5	1.61	2.31	17.7	3.28	5.50	5	13	24" RCP	
6	Captured from DP-6	0.63	0.93	11.9	3.86	6.49	2	6	18" RCP	
7	PR-4, PR-5, PR-6	6.43	13.86	24.4	2.79	4.68	18	65	36" RCP	
8	DP-4	0.74	0.87	15.2	3.50	5.86	3	5	18" RCP	
9	DP-7	1.51	2.47	27.3	2.62	4.40	4	11	24" RCP	
10	PR-8, PR-9	2.25	3.34	27.5	2.61	4.36	6	15	30" RCP	
11	PR-7, PR-10	8.69	17.20	28.0	2.58	4.33	22	75	42" RCP	
12	Captured from DP-10	1.83	2.83	21.2	3.00	5.04	5	14	24" RCP	
13	PR-11, PR-12	10.51	20.03	28.1	2.58	4.33	27	87	42" RCP	
14	DP-8	0.38	0.71	12.6	3.78	6.35	1	4	18" RCP	
15	DP-9	1.43	2.68	16.0	3.43	5.75	5	15	24" RCP	
16	PR-14, PR-15	1.80	3.38	16.4	3.39	5.69	6	19	24" RCP	
17	PR-13, PR-16	12.31	23.41	28.6	2.55	4.28	31	100	48" RCP	
18	DP-11	1.58	4.54	24.2	2.80	4.70	4	21	30" RCP	
19	PR-17, PR-18 WLY FOREBAY OUTFALL	13.89	27.96	28.8	2.54	4.26	35	119	48" RCP	
20	DP-12	2.93	6.27	19.9	3.09	5.19	9	33	30" RCP	
21	DP-13	0.19	2.06	12.4	3.80	6.30	1	13	24" RCP	
22	PR-20, PR-21	3.12	8.33	20.7	3.04	5.10	9	42	30" RCP	
23	DP-14	0.25	0.47	11.0	3.99	6.70	1	3	18" RCP	
24	DP-15	0.85	2.17	16.0	3.42	5.74	3	12	24" RCP	
25	PR-22, PR-23, PR-24	4.22								

DESCRIPTION	LEGEND	SYMBOL
EXISTING GROUND CONTOUR		6910
PROPOSED FINISHED CONTOUR		6910
BASIN BOUNDARY		
BASIN IDENTIFIER		BS
AREA IN ACRES		10.0
DESIGN POINT		
EXISTING DIRECTION OF FLOW		
PROPOSED DIRECTION OF FLOW		
PROPOSED DRAINAGE IMPROVEMENTS		
PIPE RUN		

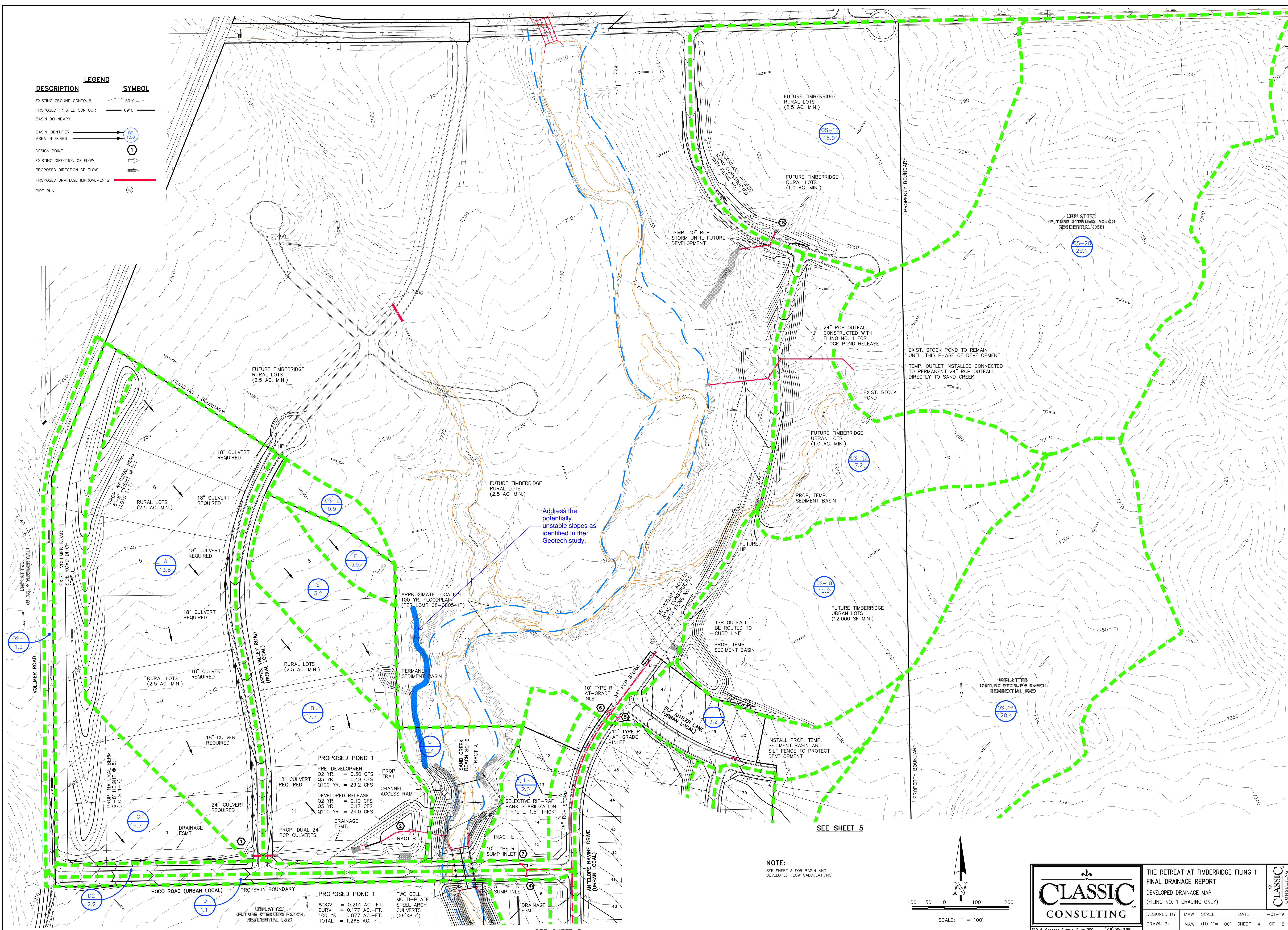

PROPOSED POND 1

PRE-DEVELOPMENT	
Q2 YR. = 0.30 CFS	
Q5 YR. = 0.48 CFS	
Q100 YR. = 29.2 CFS	
DEVELOPED RELEASE	
Q2 YR. = 0.10 CFS	
Q5 YR. = 0.17 CFS	
Q100 YR. = 24.0 CFS	

PROPOSED POND 1

WOCV = 0.214 AC.-FT.
EURV = 0.177 AC.-FT.
100 YR. = 0.977 AC.-FT.
TOTAL = 1.268 AC.-FT.

SEE SHEET 5

SEE SHEET 5

NOTE:
SEE SHEET 3 FOR BASIN AND DEVELOPED FLOW CALCULATIONS

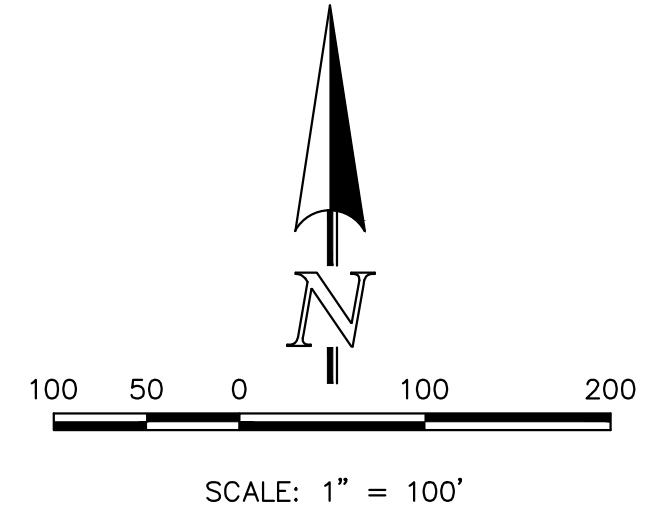

THE RETREAT AT TIMBERIDGE FILING 1
FINAL DRAINAGE REPORT
DEVELOPED DRAINAGE MAP
(FILING NO. 1 GRADING ONLY)

DESIGNED BY	MAW	SCALE	DATE	1-31-19
DRAWN BY	MAW	(H) 1" = 100'	SHEET	4 OF 5
CHECKED BY	(V) 1" = N/A	JOB NO.	1185.00	

619 N. Cascade Avenue, Suite 200 (719)785-0790
Colorado Springs, Colorado 80903 (719)785-0799 (Fax)

N:\1185001\6200RIS\DRN\198000\interior_REV.dwg, 7/31/2019, 8:24:40 AM, L1, 03451

FINAL DRAINAGE REPORT - SURFACE ROUTING SUMMARY										
Design Point(s)	Contributing Basins	Equivalent CA(5)	Equivalent CA(100)	Maximum Tc	Intensity I(5)	I(100)	Flow Q(5)	Q(100)	Flow	Inlet Size
1	A (13.8 Ac), OS-1 (1.2 Ac) and C (6.7 Ac)	3.58	9.08	31.8	2.39	4.02	9	36		DUAL 24" RCP CULVERTS
2	TOTAL INFLOW INTO POND 1 A, B, C and OS-1 (29.4 Ac)	4.66	12.16	33.8	2.30	3.86	11	47		POND 1
3	No longer used									
4	D1 (1.1 Ac)	0.74	0.87	15.2	3.50	5.88	3	5		6" TYFER SUMP INLET
5	OS-4 (3.1 Ac), J (3.7 Ac)	1.61	3.17	17.7	3.28	5.50	5	17		10" TYFER AT-GRADE INLET
6	OS-3 (2.5 Ac)	0.63	1.18	11.9	3.86	6.49	2	8		10" TYFER AT-GRADE INLET
7	Basin D2, Basin Hand 50% of 100 yr Flow from DP-6 (5.5 Ac)	1.51	2.47	27.3	2.62	4.40	4	11		10" TYFER SUMP INLET
8	K (1.5 Ac)	0.38	0.71	12.6	3.78	6.35	1	4		6" TYFER SUMP INLET
9	Hand OS-7 (5.7 Ac)	1.43	2.88	16.0	3.43	5.75	5	15		10" TYFER SUMP INLET
10	Flow from DP-5 and Basin L (7.3 Ac)	1.83	4.29	21.2	3.00	5.04	5	22		10" TYFER AT-GRADE INLET
11	Basin N, Q, P and 50% 100 Yr Flow from DP-6 and portion of 100 Yr Flow from DP-10 (13.8 Ac)	1.58	4.54	24.2	2.80	4.70	4	21		10" TYFER SUMP INLET
12	OS-5 (20.9 Ac)	2.93	6.27	19.9	3.08	5.19	9	33		10" TYFER SUMP INLET
13	OS-6 (1.2 Ac)	0.19	2.06	12.4	3.80	6.39	1	13		10" TYFER SUMP INLET
14	OS-8 (1.0 Ac)	0.25	0.47	11.0	3.99	6.70	1	3		6" TYFER SUMP INLET
15	OS-9 (5.3 Ac)	0.85	2.17	16.0	3.42	5.74	3	12		10" TYFER SUMP INLET
16	OS-10 (1.0 Ac)	0.25	0.47	11.0	3.99	6.69	1	3		6" TYFER SUMP INLET
17	OS-11 (7.9 Ac)	1.98	3.71	14.7	3.55	5.96	7	22		10" TYFER SUMP INLET
18	OS-12 (15.0 Ac)	2.10	6.00	22.0	2.94	4.94	6	30		10" TYFER SUMP INLET
19	OS-13 (1.4 Ac)	0.28	0.82	12.2	3.83	6.62	1	4		6" TYFER SUMP INLET
20	OS-14 (9.1 Ac)	1.82	4.00	19.9	3.10	5.20	6	21		10" TYFER SUMP INLET
21	TOTAL INFLOW INTO EXIST. STOCK POND (23.4 Ac)	2.11	8.42	29.8	2.49	4.18	5	35		EXIST. STOCK POND WITH OUTLET
22	TOTAL INFLOW INTO POND 2 (19.6 Ac)	20.50	45.77	30.0	2.48	4.16	51	191		POND 2

DESCRIPTION	LEGEND	SYMBOL
EXISTING GROUND CONTOUR		6910
PROPOSED FINISHED CONTOUR		6910
BASIN BOUNDARY		
BASIN IDENTIFIER		OS-1
AREA IN ACRES		10.0
DESIGN POINT		1
EXISTING DIRECTION OF FLOW		
PROPOSED DIRECTION OF FLOW		
PROPOSED DRAINAGE IMPROVEMENTS		

FINAL DRAINAGE REPORT - BASIN RUNOFF SUMMARY																									
BASIN	WEIGHTED						OVERLAND			STREET / CHANNEL FLOW			TOTAL FLOWS												
	CA(2)	CA(5)	CA(10)	CA(25)	CA(50)	CA(100)	Length (ft)	Height (ft)	Tc (min)	Length (ft)	Slope (%)	Velocity (ft/s)	Tc (min)	Q(2)	Q(5)	Q(100)									
OS-1	0.68	0.71	0.76	0.82	0.85	0.88	0.08	10	0.2	4.6	1700	3.5%	1.9	15.1	19.8	2.48	4.11	3.62	4.4	4.66	5.21	2	2	5	
OS-2	0.02	0.07	0.14	0.23	0.27	0.32	0.08	300	10.5	21.1	211	2.41	3.01	3.51	4.01	2.41	3.01	3.51	4.01	4.51	5.01	0.0	0.0	0.2	1.6
OS-3	0.45	0.63	0.80	0.96	1.08	1.18	0.25	55	1.1	9.1	600	3.0%	3.5	2.9	11.9	3.08	3.86	4.51	5.15	5.80	6.48	1	2	8	
OS-4	0.47	0.68	0.93	1.15	1.27	1.43	0.22	200	6	15.6	400	3.0%	3.5	1.9	17.8	2.62	3.28	3.83	4.38	4.93	5.51	1	2	8	
OS-5	1.25	2.93	4.81	6.48	7.52	8.36	0.14	200	8	15.5	750	2.0%	2.8	4.4	19.8	2.47	3.09	3.61	4.13	4.64	5.19	3	9	43	
OS-6	0.08	0.19	0.28	0.38	0.44	0.49	0.16	55	1.1	10.0	500	3.0%	3.5	2.4	12.4	3.04	3.80	4.44	5.07	5.71	6.38	0.3	1	3	
OS-7	0.38	0.53	0.67	0.82	0.90	0.99	0.25	100	10	7.2	72	3.69	4.63	5.40	6.17	6.94	7.77	8.61	9.44	10.27	1	2	8		
OS-8	0.18	0.25	0.32	0.39	0.43	0.47	0.25	55	1.1	9.1	400	3.0%	3.5	1.9	11.0	3.18	3.89	4.65	5.32	5.98	6.70	1	1	3	
OS-9	0.37	0.85	1.27	1.70	1.96	2.17	0.16	200	10	14.1	400	3.0%	3.5	1.9	16.0	2.73	3.42	3.99	4.56	5.13	5.74	1	3	12	
OS-10	0.18	0.25	0.32	0.39	0.43	0.47	0.25	55	1.1	9.1	450	3.8%	3.9	1.9	11.0	3.18	3.89	4.65	5.32	5.98	6.69	1	1	3	
OS-11	1.42	1.98	2.53	3.08	3.40	3.71	0.23	200	10	13.8	450	3.8%	3.9	1.9	14.7	2.94	3.59	4.14	4.74	5.33	5.96	4	7	29	
OS-12	0.90	2.10	3.45	4.65	5.40	6.00	0.14	300	13	18.5	600	2.0%	2.8	3.5	22.0	2.35	2.94	3.43	3.89	4.42	4.94	2	6	30	
OS-13	0.17	0.28	0.38	0.49	0.56	0.62	0.20	55	1.1	9.6	450	2.0%	2.8	2.7	12.2	3.05	3.83	4.46	5.10	5.74	6.42	0.5	1	4	
OS-14	1.09	1.82	2.46	3.19	3.66	4.00	0.20	300	12	17.8	350	2.0%	2.8	2.1	19.9	2.48	3.10	3.62	4.13	4.65	5.20	3	6	21	
OS-15	0.70	2.11	3.68	5.08	7.25	8.42	0.09	300	16	18.2	1300	3.5%	1.9	11.6	29.8	2.00	2.49	2.91	3.32	3.74	4.18	1	1	5	35
OS-16	0.23	0.69	1.31	2.00	2.39	2.77	0.09	300	10	21.2	600	3.5%	1.9	5.3	26.6	2.13	2.66	3.11	3.55	4.00	4.47	0.5	2	12	
OS-17	0.61	1.94	3.47	5.30	6.32	7.34	0.09	300	9.5	21.6	650	3.5%	1.9	5.8	27.4	2.10	2.62	3.05	3.49	3.93	4.39	1.3	5	32	
OS-18	0.33	0.98	1.65	2.63	3.38	3.92	0.09	300	10	21.2	700	3.5%	1.9	6.2	27.5	2.09	2.61	3.05	3.49	3.92	4.39	0.7	3	17	
OS-19	0.22	0.65	1.22	1.87	2.23	2.59	0.09	300	10	21.2	400	3.5%	1.9	3.6	26.8	2.21	2.77	3.23	3.69	4.15	4.64	0.5	2	12	
OS-20	0.75	2.26	4.27	6.53	7.78	9.04	0.09	300	16	18.2	1300	3.5%	1.9	11.6	29.8	2.00	2.49	2.91	3.32	3.74	4.18	2	6	38	
A	0.83	1.93	3.17	4.28	4.97	5.52	0.14	300	10.5	19.9	1280	3.2%	1.8	11.9	31.8	1.92	2.39	2.79	3.19	3.59	4.02	2	5	22	
B	0.46	1.08	1.77	2.39	2.77	3.08	0.14	300	10.5	19.9	400	2.0%	1.4	4.7	24.6	2.23	2.78	3.24	3.71	4.17	4.67	1	3	14	
C	0.40	0.94	1.54	2.08	2.41	2.68	0.14	300	10.5	19.9	1100	1.5%	2.4	7.5	27.3	2.10	2.62	3.08	3.49	3.93	4.40	1	2	12	
D	0.72	0.74	0.78	0.83	0.85	0.87	0.08	15	0.3	5.7	1400	1.5%	2.4	9.5	15.2	2.60	3.00	3.40	3.80	4.20	4.60	2	3	5	
E	0.96	1.07	1.18	1.30	1.36	1.43	0.25	55	1.1	9.1	500	2.5%	3.2	2.6	11.7	3.19	3.94	4.54	5.19	5.84	6.54	3	4	9	
F	0.19	0.45	0.74	0.99	1.15	1.28	0.14	300	10.5	19.9	300	2.0%	1.4	3.5	23.4	2.85	3.33	3.81	4.28	4.79	5.24	1	1	6	19
G	0.05	0.19	0.36	0.60	0.72	0.84	0.08	70	14	5.7	400	2.0%	1.4	4.7	10.4	3.24	4.06	4.74	5.42	6.10	6.82	0.2	0.8	6	19
H	0.30	0.44	0.60	0.74	0.82	0.92	0.22	100	4	10.1	300	3.0%	3.5	1.4	11.5	3.13	3.82	4.57	5.23	5.88	6.58	1	2	6	
I	0.67	0.93	1.19	1.44	1.59	1.74	0.25	120	3	12.4	550	3.5%	3.7	2.4	14.9	2.82	3.33	3.82	4.31	4.80	5.30	2	3	10	
J	0.65	0.90	1.15	1.40	1.55	1.69	0.25	120	3	12.4	600	2.0%	2.8	3.5	16.0	2.74	3.43	4.00	4.57	5.14	5.75	2	3	10	
K	0.27	0.38	0.48	0.59	0.65	0.71	0.25	55	1.1	9.1	600	2.0%	2.8	3.5	12.6	3.02	3.78	4.41	5.05	5.68	6.35	0.8	1	4	
L	1.31	1.83	2.34	2.85	3.14	3.43	0.25	150	4.5	13.1	850	2.5%	3.2	4.5	17.6	2.62	3.28	3.83	4.38	4.93	5.51	3	6	19	
M	0.41	0.99	0.81	1.00	1.11	1.24	0.22	100	4	10.1	400	2.0%	2.8	2.4	12.4	3.04	3.80	4.44	5.07	5.71	6.39	1	2	8	
N	0.38	0.53	0.67	0.82	0.90	0.99	0.25	55	1.1	9.1	1050	2.0%	2.8	6.2	15.2	2.79	3.50	4.08	4.66	5.25	5.87	1	2	6	
O	0.27	0.38	0.48	0.59	0.65	0.71	0.25	80	5	7.5	7.5	3.64	4.56	5.32	6.08	6.84	7.68	8.51	9.34	10.17	1	2	5		
P	0.49	0.68	0.86	1.05	1.16	1.27	0.25	120	3	12.4	450	1.5%	2.4	3.1	15.5	2.77	3.47	4.05	4.63	5.21	5.83	1	2	7	
Q	0.13	0.31	0.51	0.68	0.79	0.88	0.14	90	22	5.7	300	1.5%	1.2	4.1	6.8	3.32	4.16	4.85	5.54	6.24	6.98	0.4	1	6	
R	0.16	0.23	0.29	0.35	0.39	0.42	0.25	90	6	7.8	3.59	4.50	5.26	6.01	6.76	7.56	8.31	9.06	9.81	10.56	1	1	3	3	
S	0.07	0.29	0.54	0.90	1.08	1.26	0.08	140	14	10.2	750	1.5%	2.4	5.1	15.3	2.79	3.49	4.07	4.66	5.24	5.86	0.2	1.0	7	

FINAL DRAINAGE REPORT - PIPE ROUTING SUMMARY										
Pipe Run	Contributing Basins	Intensity				Flow		Pipe Size		
		Equivalent CA(5)	Equivalent CA(100)	Maximum Tc	I(5)	I(100)	Q(5)		Q(100)	
1	DP-18	2.10	6.00	23.2	2.86	4.81	6	29	30" RCP	
2	DP-19	0.28	0.62	12.2	3.63	6.42	1	4	18" RCP	
3	DP-20	1.82	4.00	19.9	3.10	5.20	6	21	24" RCP	
4	PR-1, PR-2, PR-3	4.20	10.62	23.9	2.62	4.73	12	50	36" RCP	
5	Captured from DP-5	1.61	2.31	17.7	3.38	5				

**SECTION 404 PERMITTING
WETLAND IMPACT MAP
(CORE CONSULTANTS REPORT)**





COMPENSATORY MITIGATION PLAN

The Retreat at Timber Ridge Residential Development – Filing No. 1 El Paso County, CO

PREPARED FOR:

Classic Communities
6385 Corporate Drive-Suite 101
Colorado Springs, CO 80919
Phone: 719-785-3270
Contact: Loren Moreland

PREPARED BY:

CORE Consultants, Inc.
1950 W. Littleton Boulevard, Suite 109
Littleton, CO 80120
Phone: 303-730-5979
Contact: Dan Maynard
CORE Project Number: 19-XXX

July 2019

TABLE OF CONTENTS

1.0 INTRODUCTION	2
2.0 SITE DESCRIPTION	3
3.0 COMPENSATORY MITIGATION PLAN	4
3.1 Objectives	4
3.2 Site Selection	4
3.3 Mitigation Area Protection	5
3.4 Baseline Information	5
3.5 Mitigation Work Plan	5
3.6 Mitigation Work Plan Schedule	5
3.7 Operation and Maintenance	6
3.8 Performance Standards and Monitoring Requirements	6
4.0 LONG TERM MANAGEMENT PLAN.....	10
4.1 Adaptive Management Strategy.....	10
5.0 CONCLUSIONS AND RECOMMENDATIONS	11
REFERENCES	12

TABLES

TABLE 3-1. IMPACTED WETLANDS LOCATIONS
TABLE 3-2. EL PASO COUNTY NOXIOUS WEEDS

APPENDICES

APPENDIX I: SITE LOCATION MAP
APPENDIX II: COMPENSATORY WETLAND MITIGATION PLAN MAP

I.0 INTRODUCTION

CORE Consultants, Inc. (CORE) was retained by Classic Communities (Applicant) to provide a compensatory mitigation plan for the proposed The Retreat at Timber Ridge Residential Development – Filing No. 1 (“Project”). The Project encompasses approximately 68 acres of largely undisturbed land zoned for a planned unit development (PUD), located southeast of the intersection of Vollmer Road and Arroya Lane on portions of Sections 27 and 28 in Township 12 South, Range 65 West, and can be found on the U.S. Geological Survey (USGS) Falcon Northwest 7.5-minute quadrangle (**Appendix I: Site Location Map**). Coordinates of the approximate center of the Project are latitude 38.980576° North and longitude -104.663569° West.

The Project would consist of 70 single family lots, open space and trails, permanent access roads, utilities, stormwater detention ponds, and channel improvements to prevent long-term stream degradation. Permanent impacts to potentially jurisdictional wetlands totaling 0.44 acre and 691 linear feet would result from the development of the Project. Construction of the southernmost access road and associated culvert construction would result in 0.11 acre and 211 linear feet of permanent impacts to Stream Channel Containing Wetlands (SCCW) 6. Construction of the southernmost detention pond would result in an additional 0.26 acre and 210 linear feet of permanent impacts to SCCW 6 (**Appendix II: Compensatory Wetland Mitigation Plan Map**). Construction of the northern access road would result in 0.07 acre and 270 linear feet of permanent impacts to SCCW 4 (**Appendix II**). Temporary impacts to potentially jurisdictional wetlands totaling 0.06 acre and 64 linear feet would result from the development of the four buried sheet pile check structures. This report presents the mitigation plan for the establishment and management of a wetland mitigation area on the Project site which would offset 0.44 acre of permanent loss to Waters of the U.S. (WOTUS) resulting from development of the Project.

2.0 SITE DESCRIPTION

CORE conducted a formal wetland delineation on May 15 and 16, 2017 in accordance with the U.S. Army Corps of Engineers' (USACE) 1987 USACE Wetland Delineation Manual (USACE 1987) and the Western Mountains, Valleys, and Coasts Regional Supplement (Version 2.0) (USACE 2010). The regulatory status of the wetlands and waters considered herein are assumed jurisdictional for the purpose of quantifying impacts to WOTUS.

The main channel of Sand Creek drains the Project in a southerly direction. Two eastern tributaries identified in NHD spatial data, and one unidentified western tributary are located in the proposed Project area (**Appendix II**). The majority of the main channel of Sand Creek and its associated tributaries were characterized as stream channels containing potentially jurisdictional persistent emergent (PEM) wetlands; short stretches of the main channel throughout the Project area were characterized as potentially jurisdictional stream channels lacking wetlands (**Appendix II**). Sand Creek and its tributaries flow to the Fountain Creek watershed approximately 20 miles downstream.

The Environmental Protection Agency (EPA) Section 303(d) list identifies stream segments that do not meet water quality standards. Selenium and *E. coli* are listed as causes for impairment of Sand Creek within the Fountain watershed (EPA 2016). As such, primary needs for the watershed headwaters include mechanisms to reduce waste runoff into watercourses, as well as mechanisms to capture and uptake excess nutrients and waste. The mitigation proposed is anticipated to encourage the removal of excess nutrients and prevent additional nutrient runoff through the creation of wetlands. Creation of wetlands would improve local habitats and water quality. Improved water quality would be expected as a result of locating the mitigation wetlands upslope and upstream of the majority of the areas of wetland impacts within the Project area.

3.0 COMPENSATORY MITIGATION PLAN

This compensatory mitigation plan was prepared to compensate for the loss of 0.44 acre of wetland habitat through the establishment of new emergent wetlands within the Project. Coordinates of the wetland areas to be impacted are shown in Table 3-1 below, and depicted in **Appendix II**.

TABLE 3-1: LOCATIONS OF IMPACTED WETLANDS

WOTUS ID ¹	LATITUDE	LONGITUDE	PERMANENT IMPACTS
SCCW 4	38.979822	-104.660451	0.07 acre; 270 linear feet
SCCW 6	38.976811	-104.663614	0.11 acre; 211 linear feet
SCCW 6	38.975046	-104.662760	0.26 acre; 210 linear feet

¹Only the USACE can determine jurisdictional status

3.1 Objectives

Mitigation for 0.44 acre of permanent wetland loss would be located adjacent to the main channel of Sand Creek within the Project. Specifically, mitigation would involve the following:

- Creation of 0.44 acre of emergent, palustrine wetland habitat adjacent to and between the main channel of Sand Creek identified as JD Channel A and Isolated Wetland I (Proposed Mitigation B; **Attachment II**).
- Creation of stable upland buffers through soil amendments (as necessary), seedbed preparation and decompaction (as necessary), and appropriate native plant selection based on surrounding and existing native vegetation. Noxious weed control and management would be implemented as needed.

A total of 0.44 acre of emergent wetlands would be established within the Project and would offset the 0.44 acre of permanent wetland loss resulting from the construction of the Project.

3.2 Site Selection

Completing the majority of mitigation near the site of impacts would ensure the mitigation directly offsets the on-site Project impacts. Moreover, on-site mitigation ensures that hydrologic and soil conditions are conducive to successful mitigation implementation. Hydrology for the mitigation area would be supplied in part by runoff from the proposed Project, and by contouring adjacent to the existing channel and upland within the proposed mitigation area to ensure sufficient saturation. The NRCS identifies Project area soils as hydric (NRCS 2014). Therefore, retention of on-site soils would further facilitate the establishment and longevity of the proposed mitigation area. Salvaged soils from impacted wetland areas on the Project site would be utilized to prepare the mitigation area.

The Proposed mitigation area would consist of one palustrine, persistent emergent, seasonally flooded wetland and upland buffer located between JD Channel A and Isolated Wetland I. The proposed location of the mitigation area would serve to connect the existing Isolated Wetland A with the main channel of Sand Creek (JD Channel A), thereby serving to increase filtration of additional stormwater runoff resulting from Project construction.

3.3 Mitigation Area Protection

The mitigation area will be owned by the Applicant and authorized access would require permission from the Applicant. According to the USACE's *Regional Compensatory Mitigation and Monitoring Guidelines for South Pacific Division* (2015), the mitigation area requires protection of the site in the form of a deed restriction, easement or similar legally-binding document. A deed restriction would be prepared to provide for long-term protection of the mitigation area.

3.4 Baseline Information

The Project would result in the permanent loss of 0.44 acre of wetland characterized as palustrine, emergent, persistent, and seasonally flooded (PEMIC). The proposed mitigation area would consist of 0.44 acre of wetland characterized as palustrine, emergent, persistent, and seasonally flooded (PEMIC) since the mitigation area would develop wetlands mirroring the surrounding wetland areas within and adjacent to Sand Creek (**Appendix II**). Wetland vegetation was dominant during the 2017 wetland delineation within the channel where impacts are proposed: vegetation consisted of Arctic rush (*Juncus arcticus* syn. *J. balticus*), Nebraska sedge (*Carex nebrascensis*), clustered field sedge (*Carex praegracilis*), and common spike rush (*Eleocharis palustris*).

3.5 Mitigation Work Plan

The mitigation area would be created immediately adjacent to the main channel of Sand Creek (JD Channel A; **Appendix II**). Contouring of both the upland area associated with the proposed mitigation area and the proposed mitigation area itself would ensure that drainage patterns would direct sufficient hydrology to the mitigation area. Soil preparation and amendments, seeding, and installation of wetland plugs would create 0.44 acre of emergent wetland adjacent to the main channel of Sand Creek (**Appendix II**). Establishment of the wetland would augment water filtration capacity of anticipated runoff resulting from the proposed Project, and would support the Sand Creek watershed priority to reduce selenium and *E. coli* within the watershed.

Native wetland plant communities would be established within the mitigation area through seeding and the installation of wetland plugs. Newly seeded areas and plugs would be protected by erosion control mats. A CORE biologist would determine, upon a site assessment of the mitigation area, if transplanting of neighboring wetland plants would expedite the establishment of the proposed wetland mitigation area. Potential wetland plant populations that would be utilized for transplant include Arctic rush, Nebraska sedge, and clustered field sedge.

3.6 Mitigation Work Plan Schedule

Mitigation work would begin immediately in conjunction with the commencement of construction activities and would be completed within three months of commencement. Project construction is anticipated to begin in fall of 2019. Construction is expected to be completed in summer or fall of 2020; restoration and mitigation installation measures would be completed by fall 2020. Primary mitigation measures and an estimated schedule of activities implementation are outlined below:

- Year I
 - Grading, clearing, and other site preparation as needed for construction of the wetland mitigation site;

- Documentation of baseline conditions and seeding of mitigation area and uplands; installation of wetland plugs.
- Year 2
 - Monitoring and management: set up monitoring locations and collect relevant data, control noxious weeds (if needed), and transplant wetland vegetation from existing on-site wetlands (if needed).
- Years 3, 4, and 5
 - Site monitoring to determine whether performance standards are met and request concurrence from USACE;
 - If standards are not met, continue monitoring and management until they are met.

3.7 Operation and Maintenance

The Applicant would be responsible for monitoring the proposed mitigation area throughout the life of the Project. The Applicant, or an authorized representative for the Applicant familiar with wetland ecology would monitor the condition of the mitigation site and would make adjustments on an as-needed basis in accordance with USACE mitigation requirements and permit conditions.

3.8 Performance Standards and Monitoring Requirements

Performance standards would be used to assess the success of mitigation measures implemented at the Project. Performance standards are required and must be met in order for mitigation activities to be approved by the USACE. However, performance standards may change based on the conditions included in the approved Section 404 permit to be issued for the Project. The mitigation area would be monitored for a period of five years, or until performance standards are met. If performance standards are met during the first year of monitoring, additional monitoring would not be required. Performance standards should be met by the end of the five-year monitoring period. If standards are not met within five years, additional monitoring and corrective action may be required at the request of the USACE.

The mitigation plan for The Retreat at Timber Ridge – Filing No. 1 would be determined successful and complete when the following standards of performance are met:

1. Wetland vegetation areas and buffers should have a vegetation cover of at least 85 percent, and the vegetation must be composed of at least 50 percent emergent wetland species (i.e., species rated facultative, facultative wetland, or obligate wetland plant species on the National Wetland Plant List (Lichvar et al. 2016) and at least 50 percent of dominant species shall be newly established. Mitigation areas (wetlands and buffers) will have no more than 20 percent non-native species coverage. Vegetation maintenance activities for locations not meeting these requirements may include transplanting the appropriate wetland species and eradication of non-native species if necessary.
2. Upland buffer establishment will be determined successful when ground cover of native species – species rated upland, facultative upland, or facultative plants on the National Wetland Plant List (Lichvar et al. 2016) – is equal to or greater than 85 percent, with less than 1-percent invasive species documented at each monitoring location. Vegetation maintenance activities for sample

locations not meeting ground cover requirements would include re-seeding or planting of the appropriate native species and eradication of invasive species if necessary.

3. Coverage of noxious weed species (**Table 3-2: El Paso County Noxious Weeds**) shall be 95 percent eradicated across all mitigation areas (wetlands and upland buffers) and maintained as such in perpetuity.
4. Documentation shall demonstrate consistent wetland hydrology during the growing season. Data shall indicate 14 or more consecutive days of flooding or ponding, or a water table 12 inches or less below the soil surface. Data must demonstrate the presence of wetland hydrology with 50% or higher probability. Documentation of recorded data will be presented with photographs, moisture probe data, and/or the collection of multiple soil pit samples during the growing season.
5. Soil documentation and morphologic description should demonstrate the development of redoximorphic features or other hydric soil indicators over time, and progression toward hydric soil conditions. Documentation would include pre-and post-construction, and during the 3rd, 5th, and final years of wetland establishment and would be collected according to the Western Mountains, Valleys, and Coasts Regional Supplement (Version 2.0) (USACE 2010) to the 1987 USACE Wetland Delineation Manual (USACE 1987).

TABLE 3-2: EI PASO COUNTY NOXIOUS WEEDS

COMMON NAME	SCIENTIFIC NAME
Bull Thistle	<i>Cirsium vulgare</i>
Canada Thistle	<i>Cirsium arvense</i>
Common Mullein	<i>Verbascum thapsus</i>
Common Tansy	<i>Tanacetum vulgare</i>
Common Teasel	<i>Dipsacus fullonum</i>
Cutleaf Teasel	<i>Dipsacus laciniatus</i>
Cypress Spurge	<i>Euphorbia cyparissias</i>
Dalmation Toadflax	<i>Linaria dalmatica</i>
Dalmation Toadflax	<i>Linaria genistifolia</i>
Diffuse Knapweed	<i>Centaurea diffusa</i>
Field Bindweed	<i>Convolvulus arvensis</i>
Hoary Cress	<i>Cardaria draba</i>
Houndstongue	<i>Cynoglossum officinale</i>
Leafy Spurge	<i>Euphorbia esula</i>
Mediterranean Sage	<i>Salvia aethiopis</i>
Musk Thistle	<i>Carduus nutans</i>
Myrtle Spurge	<i>Euphorbia myrcinites</i>
Orange Hawkweed	<i>Hieracium aurantiacum</i>
Perennial Pepperweed	<i>Lepidium latifolium</i>
Plumeless Thistle	<i>Carduus acanthoides</i>
Poison Hemlock	<i>Conium maculatum</i>
Puncturevine	<i>Tribulus terrestris</i>
Purple Loosestrife	<i>Lythrum salicaria</i>
Redstem Filaree	<i>Erodium cicutarium</i>
Russian Knapweed	<i>Acroptilon repens</i>
Russian Olive	<i>Elaeagnus angustifolia</i>
Salt Cedar	<i>Tamarix chinensis</i>
Salt Cedar	<i>Tamarix parviflora</i>
Salt Cedar	<i>Tamarix ramosissima</i>
Scotch Thistle	<i>Onopordum acanthium</i>
Spotted Knapweed	<i>Centaurea maculosa</i>
Sulfur Cinquefoil	<i>Potentilla recta</i>

Monitoring would be conducted during the growing season by qualified personnel experienced in wetland ecology and mitigation. Monitoring would occur for a minimum of five years post-construction, unless conditions are met in prior years. Results of monitoring visits would be used to assess and modify maintenance and operations plans as appropriate and implement adaptive management strategies as necessary. Monitoring would entail annual site visits to assess progress in meeting performance standards, and to evaluate establishment, development, and maintenance of the mitigation area. The mitigation area would be monitored to ensure the establishment of desirable wetland characteristics. Standardized plots would be established to confirm the dominance of emergent wetland species at the wetland establishment location. A report detailing the results of each monitoring survey would be submitted to the USACE within two months of any site visit. The site would also be monitored incidentally while walking between sampling points. During incidental observations, areas of concern would be noted, including areas of erosion, significant areas of bare ground, and areas where invasive species have become established. Incidental observations would be included in the annual report and would be considered for maintenance and adaptive management.

Photo monitoring points would be established prior to construction to determine baseline conditions. Each monitoring report would include photos depicting baseline conditions, construction, and current state to demonstrate progress toward wetland establishment. A map would document the locations of sampling transects and photo monitoring points.

4.0 LONG TERM MANAGEMENT PLAN

Funding for the management of the mitigation plan would be provided by the Applicant and the Applicant would be responsible for the monitoring and long-term management of the proposed mitigation area. Since the mitigation site would be located on the Applicant's property, access to the site could be controlled to protect the area. Periodic inspections would also be conducted by the Applicant or by the Applicant's authorized personnel to ensure that the desired site characteristics are maintained including maintaining proper hydrology through the mitigation area, controlling invasive plants (if any), and other maintenance as needed. If invasive species are detected during inspections, invasive species control measures would be implemented. Where invasive plants are limited, control methods would consist of removal by hand or mechanical methods. If invasive plants become established beyond a point of mechanical control, chemical control methods would be initiated. Appropriate herbicides would be selected based on target species and would be applied in accordance with manufacturer and invasive species control recommendations. Herbicide application would not occur when rain is forecasted, or during or immediately following precipitation events to prevent herbicides from running into sensitive water features. Invasive species control would be conducted in a manner that minimizes impacts to desirable species to the extent practicable. Where significant invasive species infestations have occurred, the area would be transplanted with local wetland plant sources, or re-seeded with desirable vegetation after control of invasives. Alternative methods of invasive species control would be utilized as appropriate based on target species. For example, prolonged flooding followed by heavy seeding has been documented to control Johnsongrass (*Sorghum halepense*). Wetland and transitional vegetation would be mowed on an as-needed basis. Signage may also be used along the boundaries of the proposed mitigation area identifying the area as such. If control of the development were to transfer from the Applicant to a different entity, that entity would become responsible for the maintenance and upkeep of the mitigation area.

The principal management concerns for the mitigation area are maintaining suitable hydrology to support wetland growth and the maintenance of vegetation, including the control of invasive and weedy species. Operation and maintenance activities would generally ensure compliance with the conditions of the USACE permit. Project area management needs would be assessed during monitoring sessions and on an as-needed basis. Operation and maintenance activities would be modified as appropriate in accordance with principles of adaptive management and based on observations during mitigation monitoring activities.

4.1 Adaptive Management Strategy

Management objectives and techniques may be modified in response to feedback such as monitoring results. Adaptive management is based on the idea that the collective general understanding of natural system is necessarily incomplete, and thus new information should be allowed to influence the potential re-evaluation of strategies for management.

Management techniques would be modified as appropriate to ensure performance standards are met, based on monitoring and incidental observations. Potential management modifications or corrective actions that may be taken to ensure standards are met include: alternative vegetation management, modification of hydrology, alternative control measures for invasive species, re-seeding or planting, stabilization of banks or other areas.

If the mitigation area should fail to meet performance standards, corrective action would be taken. If necessary, corrective action may be taken prior to the end of the five-year monitoring period.

5.0 CONCLUSIONS AND RECOMMENDATIONS

In summary, the proposed Project, consisting of 70 single family lots, open space and trails, permanent access roads, utilities, stormwater detention ponds, and channel improvements to prevent long-term stream degradation, would result in 0.44 acre and 91 linear feet of permanent impacts to the main channel of Sand Creek and its associated tributaries. On-site mitigation is planned that would offset 0.44 acre of wetland loss. Mitigation practices would comply with the 2008 Mitigation Rule (33 CFR 332-Compensatory Mitigation for losses of aquatic resources) as specified by the USACE Albuquerque District Southern Colorado Regulatory Office.

REFERENCES

- Chapman, S.S., Griffith, G.E., Omernik, J.M., Price, A.B., Freeouf, J., and Schrupp, D.L., 2006, ECOREgions of Colorado. Reston, Virginia, U.S. Geological Survey (map scale 1:1,200,000). ftp://ftp.epa.gov/wed/eCOREgions/co/co_front.pdf
- Environmental Protection Agency (EPA). 2016. *Watershed Assessment, Tracking, and Environmental Results System*. https://ofmpub.epa.gov/waters10/attains_watershed.control Accessed July 2019.
- Lichvar, R.W., M. Butterwick, N.C. Melvin, and W.N. Kirchner. 2016. The National Wetland Plant List: 2016 Update of Wetland Ratings. *Phytoneuron* 2016-30: 1-17.
- Natural Resources Conservation Service. 2014. List of Hydric Soils.
- U.S. Army Corps of Engineers (USACE). 1987. *Wetlands Delineation Manual*.
- _____. 2010. *Regional Supplement to the Corps of Engineers Wetland Delineation Manual: Western Mountains, Valleys, and Coast Region (Version 2)*.
- _____. 2015. *Final Regional Compensatory Mitigation and Monitoring Guidelines for South Pacific Division USACE*. Albuquerque District.



APPENDIX I

SITE LOCATION MAP

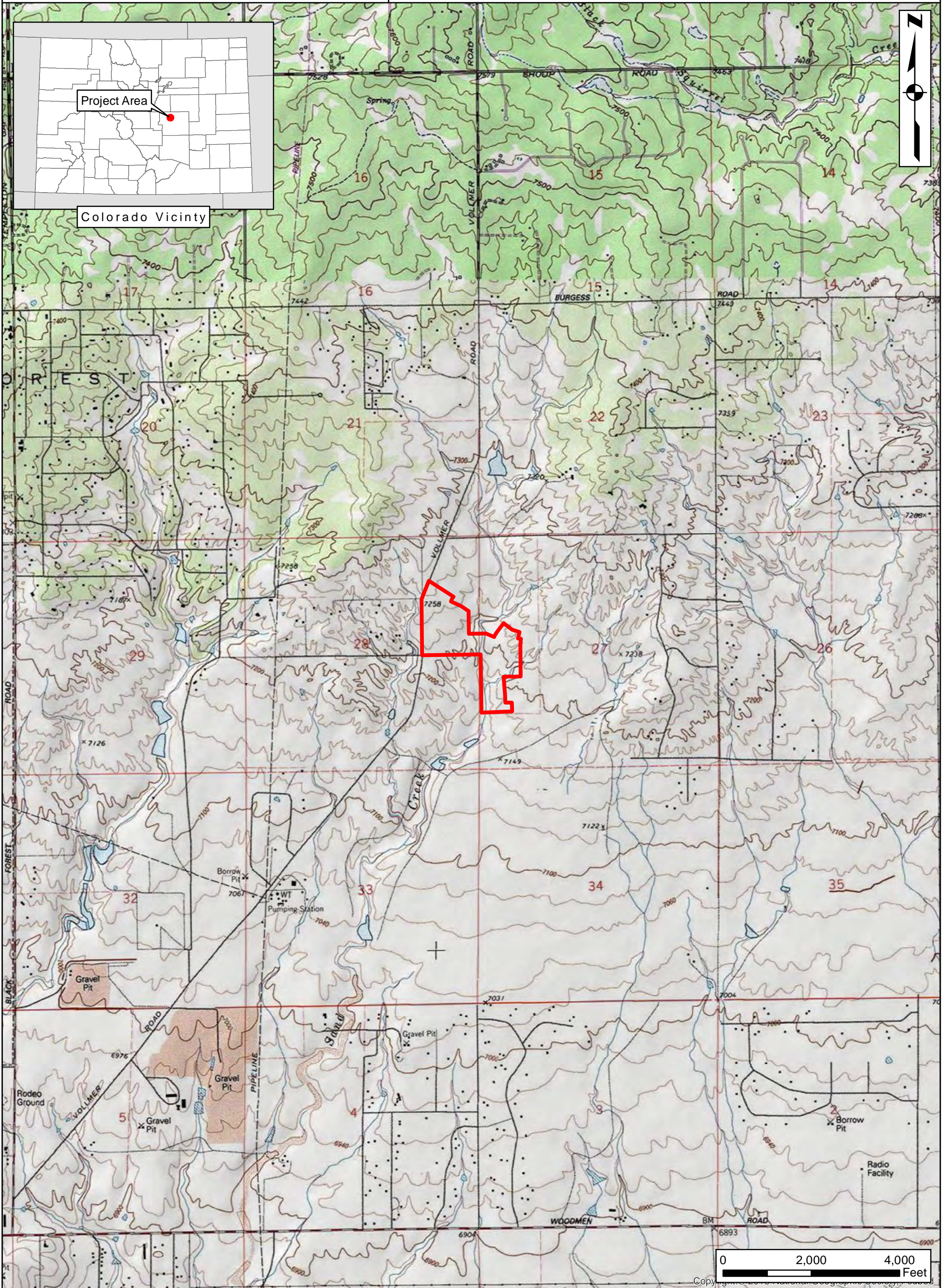

 Filing 1 Boundary



APPENDIX II

COMPENSATORY WETLAND MITIGATION PLAN MAP

Retreat at Timber Ridge

Compensatory Mitigation Map

El Paso County, Colorado

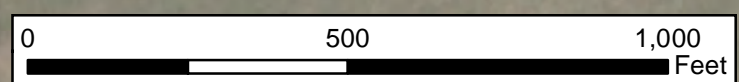
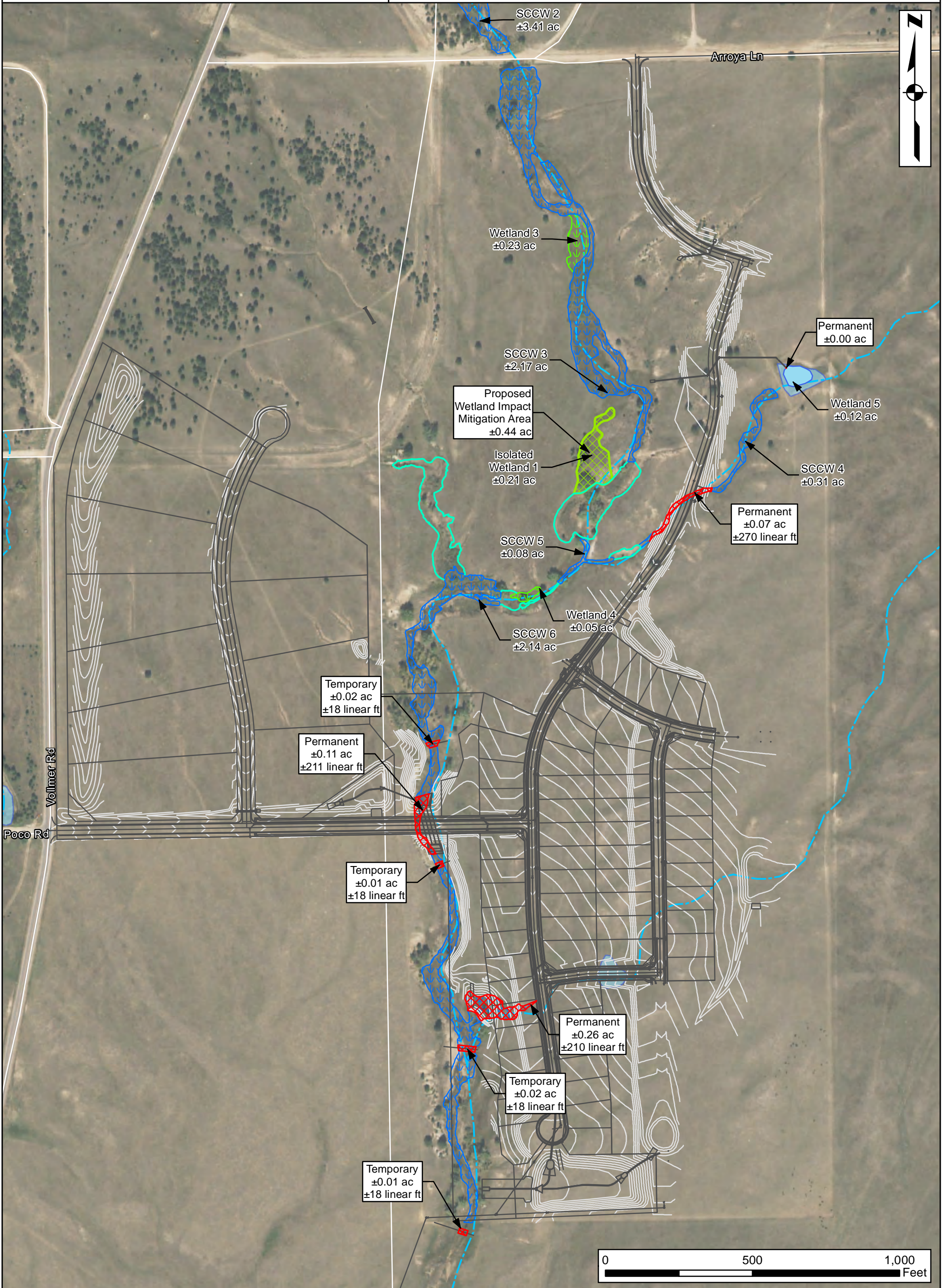

- | | | |
|-----------------------|--------------------------------------|---------------------|
| — Filing 1 Layout | — JD Channel (OHWM) | ▣ Proposed Impacts |
| - - - NHD Watercourse | ▣ Stream Channel Containing Wetlands | — Proposed Grading |
| ▣ NHD Waterbody | ▣ Wetland | ▣ Mitigated Wetland |
| ▣ Pond | ▣ Isolated Wetland | |