

RETREAT AT TIMBERRIDGE FILING NO. 1

COUNTY OF EL PASO, STATE OF COLORADO

CONSTRUCTION DRAWINGS

AUGUST 2019

GENERAL CONSTRUCTION NOTES:

1. THE LOCATION OF EXISTING UTILITIES ARE SHOWN IN AN APPROXIMATE WAY ONLY AND MAY NOT INCLUDE ALL UTILITIES. THE EXCAVATION CONTRACTOR SHALL DETERMINE THE EXACT LOCATION OF ALL EXISTING UTILITIES BEFORE COMMENCING WORK. THE CONTRACTOR AGREES TO BE FULLY RESPONSIBLE FOR ANY AND ALL DAMAGES WHICH MIGHT BE OCCASIONED BY HIS FAILURE TO EXACTLY LOCATE AND PRESERVE ANY AND ALL UTILITIES.
2. BEFORE COMMENCING ANY EXCAVATION, CALL 1-800-922-1987 FOR EXISTING UTILITY LOCATIONS.
3. THE CONTRACTOR WILL TAKE THE NECESSARY PRECAUTIONS TO PROTECT EXISTING UTILITIES FROM DAMAGE DUE TO THIS OPERATION. ANY DAMAGE TO THE UTILITIES WILL BE REPAIRED AT THE CONTRACTOR'S EXPENSE, AND ANY SERVICE DISRUPTION WILL BE SETTLED BY THE CONTRACTOR.
4. ALL BACKFILL, SUB-BASE AND/OR BASE COURSE (CLASS 6) MATERIAL SHALL BE COMPACTED TO THE SOILS ENGINEER'S RECOMMENDATIONS, AND APPROVED BY EL PASO COUNTY PLANNING AND COMMUNITY DEVELOPMENT (PCD).
5. ALL STATIONING IS CENTERLINE UNLESS OTHERWISE INDICATED. ALL ELEVATIONS ARE CENTERLINE UNLESS OTHERWISE INDICATED.
6. THE CONTRACTOR SHALL REVEGETATE ALL DISTURBED AREAS AS SOON AS POSSIBLE AND EROSION CONTROL SHALL BE INSTALLED AND MAINTAINED IN A FUNCTIONAL MANNER AT ALL TIMES. DEVELOPER RESPONSIBLE FOR MAINTAINING DISTURBED AREAS UNTIL REVEGETATION IS COMPLETE.
7. ALL DISTURBED EROSION EDGES SHALL BE CUT TO NEAT LINES. REPAIR SHALL CONFORM TO THE EPC ECM APPENDIX K - 1.2C.
8. ADDITIONAL EROSION CONTROL STRUCTURES MAY BE REQUIRED AT THE TIME OF CONSTRUCTION.
9. BUILDING CONTRACTORS WILL BE RESPONSIBLE FOR CONSTRUCTING POSITIVE DRAINAGE AWAY FROM ALL STRUCTURES.
10. ASPHALT THICKNESS AND BASE COURSE THICKNESS (COMPACTED) FOR ROADS SHALL BE PER DESIGN REVIEW BY OWNER'S GEOTECHNICAL ENGINEER. OWNER'S GEOTECHNICAL ENGINEER TO BE ON SITE AT TIME OF ROAD CONSTRUCTION TO EVALUATE SOIL CONDITIONS AND DETERMINE IF ADDITIONAL MEASURES ARE NECESSARY TO ASSURE STABILITY OF THE NEW ROADS. PAVEMENT DESIGN SHALL BE APPROVED BY PLANNING AND COMMUNITY DEVELOPMENT PRIOR TO CONSTRUCTION.
11. THE CONTRACTOR SHALL REVEGETATE ALL DISTURBED AREAS WITHIN 31 DAYS OF SUBSTANTIAL GRADING COMPLETION. EROSION CONTROL SHALL BE INSTALLED AND MAINTAINED IN A FUNCTIONAL MANNER AT ALL TIMES. DEVELOPER IS RESPONSIBLE FOR MAINTAINING DISTURBED AREAS UNTIL REVEGETATION IS COMPLETE.
12. TYPE M RIP-RAP WITH 4" OF TYPE II GRANULAR BEDDING AND WRAP 180N OR EQUAL MAY BE SUBSTITUTED WHERE TYPE L RIP-RAP WITH WRAP FW 700 OR EQUAL IS SPECIFIED.
13. ALL MATERIALS AND INSTALLATION PROCEDURES SHALL BE IN COMPLIANCE WITH ANY AND ALL APPLICABLE EL PASO COUNTY STANDARDS.

STANDARD NOTES FOR EL PASO COUNTY CONSTRUCTION PLANS:

1. ALL DRAINAGE AND ROADWAY CONSTRUCTION SHALL MEET THE STANDARDS AND SPECIFICATIONS OF THE CITY OF COLORADO SPRINGS/EL PASO COUNTY DRAINAGE CRITERIA MANUAL, VOLUMES 1 AND 2, AND THE EL PASO COUNTY ENGINEERING CRITERIA MANUAL.
2. CONTRACTOR SHALL BE RESPONSIBLE FOR THE NOTIFICATION AND FIELD NOTIFICATION OF ALL EXISTING UTILITIES, WHETHER SHOWN ON THE PLANS OR NOT, BEFORE BEGINNING CONSTRUCTION. LOCATION OF EXISTING UTILITIES SHALL BE VERIFIED BY THE CONTRACTOR PRIOR TO CONSTRUCTION. CALL 811 TO CONTACT THE UTILITY NOTIFICATION CENTER OF COLORADO (UNCC).
3. CONTRACTOR SHALL KEEP A COPY OF THESE APPROVED PLANS, THE GRADING AND EROSION CONTROL PLAN, THE STORMWATER MANAGEMENT PLAN (SWMP), THE SOILS AND GEOTECHNICAL REPORT, AND THE APPROPRIATE DESIGN AND CONSTRUCTION STANDARDS AND SPECIFICATIONS AT THE JOB SITE AT ALL TIMES, INCLUDING THE FOLLOWING:
 - a. EL PASO COUNTY ENGINEERING CRITERIA MANUAL (ECM)
 - b. CITY OF COLORADO SPRINGS/EL PASO COUNTY DRAINAGE CRITERIA MANUAL, VOLUMES 1 AND 2
 - c. COLORADO DEPARTMENT OF TRANSPORTATION (CDOT) STANDARD SPECIFICATIONS FOR ROAD AND BRIDGE CONSTRUCTION
 - d. CDOT M & S STANDARDS
4. NOTWITHSTANDING ANYTHING DEPICTED IN THESE PLANS IN WORDS OR GRAPHIC REPRESENTATION, ALL DESIGN AND CONSTRUCTION RELATED TO ROADS, STORM DRAINAGE AND EROSION CONTROL SHALL CONFORM TO THE STANDARDS AND REQUIREMENTS OF THE MOST RECENT VERSION OF THE RELEVANT ADOPTED EL PASO COUNTY STANDARDS INCLUDING THE LAND DEVELOPMENT CODE, THE ENGINEERING CRITERIA MANUAL, THE DRAINAGE CRITERIA MANUAL, AND THE DRAINAGE CRITERIA MANUAL VOLUME 2. ANY DEVIATIONS FROM REGULATIONS AND STANDARDS MUST BE REQUESTED, AND APPROVED, IN WRITING. ANY MODIFICATIONS NECESSARY TO MEET CRITERIA AFTER-THE-FACT WILL BE ENTIRELY THE DEVELOPER'S RESPONSIBILITY TO RECTIFY.
5. IT IS THE DESIGN ENGINEER'S RESPONSIBILITY TO ACCURATELY SHOW EXISTING CONDITIONS, BOTH ON-SITE AND OFF-SITE, ON THE CONSTRUCTION PLANS. ANY MODIFICATIONS NECESSARY DUE TO CONFLICTS, OMISSIONS, OR CHANGED CONDITIONS WILL BE ENTIRELY THE DEVELOPER'S RESPONSIBILITY TO RECTIFY.
6. CONTRACTOR SHALL SCHEDULE A PRE-CONSTRUCTION MEETING WITH EL PASO COUNTY PLANNING AND COMMUNITY DEVELOPMENT - INSPECTIONS, PRIOR TO STARTING CONSTRUCTION.
7. IT IS THE CONTRACTOR'S RESPONSIBILITY TO UNDERSTAND THE REQUIREMENTS OF ALL JURISDICTIONAL AGENCIES AND TO OBTAIN ALL REQUIRED PERMITS, INCLUDING BUT NOT LIMITED TO EL PASO COUNTY EROSION AND STORMWATER QUALITY CONTROL PERMIT (ESQCP), REGIONAL BUILDING FLOODPLAIN DEVELOPMENT PERMIT, U.S. ARMY CORPS OF ENGINEERS-ISSUED 401 AND/OR 404 PERMITS, AND COUNTY AND STATE FUGITIVE DUST PERMITS.
8. CONTRACTOR SHALL NOT DEVIATE FROM THE PLANS WITHOUT FIRST OBTAINING WRITTEN APPROVAL FROM THE DESIGN ENGINEER AND PCD. CONTRACTOR SHALL NOTIFY THE DESIGN ENGINEER IMMEDIATELY UPON DISCOVERY OF ANY ERRORS OR INCONSISTENCIES.
9. ALL STORM DRAIN PIPE SHALL BE CLASS III RCP UNLESS OTHERWISE NOTED AND APPROVED BY PCD.
10. CONTRACTOR SHALL COORDINATE GEOTECHNICAL TESTING PER ECM STANDARDS. PAVEMENT DESIGN SHALL BE APPROVED BY EL PASO COUNTY PCD PRIOR TO PLACEMENT OF CURB AND OUTER AND PAVEMENT.
11. ALL CONSTRUCTION TRAFFIC MUST ENTER/EXIT THE SITE AT APPROVED CONSTRUCTION ACCESS POINTS.
12. SHORT VISIBILITY TRIANGLES AS IDENTIFIED IN THE PLANS SHALL BE PROVIDED AT ALL INTERSECTIONS. OBSTRUCTIONS GREATER THAN 18 INCHES ABOVE FLOWLINE ARE NOT ALLOWED WITHIN SIGHT TRIANGLES.
13. SIGNING AND STRIPING SHALL COMPLY WITH EL PASO COUNTY DEPARTMENT OF PUBLIC WORKS AND MUTCD CRITERIA.
14. CONTRACTOR SHALL OBTAIN ANY PERMITS REQUIRED BY EL PASO COUNTY DEPARTMENT OF PUBLIC WORKS, INCLUDING WORK WITHIN THE RIGHT-OF-WAY AND SPECIAL TRANSPORT PERMITS.
15. THE LIMITS OF CONSTRUCTION SHALL REMAIN WITHIN THE PROPERTY LINE UNLESS OTHERWISE NOTED. THE OWNER/DEVELOPER SHALL OBTAIN WRITTEN PERMISSION AND EASEMENTS, WHERE REQUIRED, FROM ADJOINING PROPERTY OWNER(S) PRIOR TO ANY OFF-SITE DISTURBANCE, GRADING, OR CONSTRUCTION.

SIGNING AND STRIPING NOTES:

1. ALL SIGNS AND PAVEMENT MARKINGS SHALL BE IN COMPLIANCE WITH THE CURRENT MANUAL ON UNIFORM TRAFFIC CONTROL DEVICES (MUTCD).
2. REMOVAL OF EXISTING PAVEMENT MARKINGS SHALL BE ACCOMPLISHED BY A METHOD THAT DOES NOT MATERIALLY DAMAGE THE PAVEMENT. THE PAVEMENT MARKINGS SHALL BE REMOVED TO THE EXTENT THAT THEY WILL NOT BE VISIBLE UNDER DAY OR NIGHT CONDITIONS. AT NO TIME WILL IT BE ACCEPTABLE TO PAINT OVER EXISTING PAVEMENT MARKINGS.
3. ANY DEVIATION FROM THE STRIPING AND SIGNING PLAN SHALL BE APPROVED BY EL PASO COUNTY PLANNING AND COMMUNITY DEVELOPMENT.
4. ALL SIGNS SHOWN ON THE SIGNING AND STRIPING PLAN SHALL BE NEW SIGNS. EXISTING SIGNS MAY REMAIN OR BE REUSED IF THEY MEET CURRENT EL PASO COUNTY AND MUTCD STANDARDS.
5. STREET NAME AND REGULATORY STOP SIGNS SHALL BE ON THE SAME POST AT INTERSECTIONS.
6. ALL REMOVED SIGNS SHALL BE DISPOSED OF IN A PROPER MANNER BY THE CONTRACTOR.
7. ALL STREET NAME SIGNS SHALL HAVE "T" SERIES LETTERS, WITH LOCAL ROADWAY SIGNS BEING 4" UPPER-LOWER CASE LETTERING, ON 8" BLANK AND NON-LOCAL ROADWAY SIGNS BEING 6" LETTERING, UPPER-LOWER CASE ON 12" BLANK, WITH A WHITE BORDER THAT IS NOT RECESSED. MULTI-LANE ROADWAYS WITH SPEED LIMITS OF 40 MPH OR HIGHER SHALL HAVE 8" UPPER-LOWER CASE LETTERING ON 18" BLANK WITH A WHITE BORDER THAT IS NOT RECESSED. THE WIDTH OF THE NON-RECESSED WHITE BORDERS SHALL MATCH PAGE 255 OF THE 2012 MUTCD "STANDARD HIGHWAY SIGNS".
8. ALL TRAFFIC SIGNS SHALL HAVE A MINIMUM HIGH INTENSITY PRISMATIC GRADE SHEETING.
9. ALL LOCAL RESIDENTIAL STREET SIGNS SHALL BE MOUNTED ON A 1.75" X 1.75" SQUARE TUBE SIGN POST AND STUB POST BASE. FOR OTHER APPLICATIONS, REFER TO THE CDOT STANDARD S-514-B REGARDING USE OF THE P2 TUBULAR STEEL POST SLIPBASE DESIGN.
10. ALL SIGNS SHALL BE SINGLE SHEET ALUMINUM WITH 0.100" MINIMUM THICKNESS.
11. ALL LIMIT LINES/STOP LINES, CROSSWALK LINES, PAVEMENT LEGENDS, AND ARROWS SHALL BE A MINIMUM 125 MIL THICKNESS PREFORMED THERMOPLASTIC PAVEMENT MARKINGS WITH TAPERED LEADING EDGES PER CDOT STANDARD S-627-1. WORD AND SYMBOL MARKINGS SHALL BE THE NARROW TYPE. STOP BARS SHALL BE 24" IN WIDTH. CROSSWALKS LINES SHALL BE 12" WIDE AND 8" LONG PER CDOT S-627-1.
12. ALL LONGITUDINAL LINES SHALL BE A MINIMUM 15MIL THICKNESS EPOXY PAINT. ALL NON-LOCAL RESIDENTIAL ROADWAYS SHALL INCLUDE BOTH RIGHT AND LEFT EDGE LINE STRIPING AND ANY ADDITIONAL STRIPING AS REQUIRED BY CDOT S-627-1.
13. THE CONTRACTOR SHALL NOTIFY EL PASO COUNTY PLANNING AND COMMUNITY DEVELOPMENT (719) 520-6819 PRIOR TO AND UPON COMPLETION OF SIGNING AND STRIPING.
14. THE CONTRACTOR SHALL OBTAIN A WORK IN THE RIGHT OF WAY PERMIT FROM THE EL PASO COUNTY DEPARTMENT OF PUBLIC WORKS (DPW) PRIOR TO ANY SIGNAGE OR STRIPING WORK WITHIN AN EXISTING EL PASO COUNTY ROADWAY.

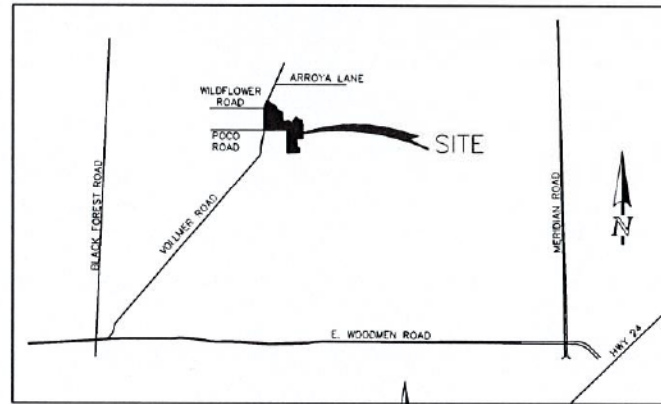

VICINITY MAP
N.T.S.

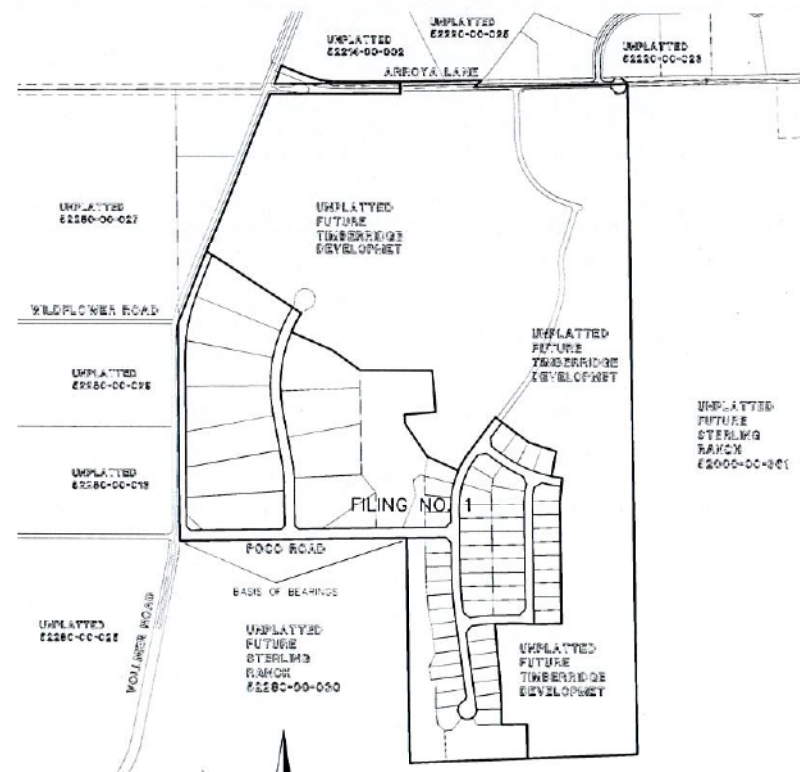

SITE MAP
SCALE: 1" = 500'

BASIS OF BEARINGS:

THE SOUTH LINE OF THE SOUTHWEST QUARTER OF THE NORTHEAST QUARTER OF SECTION 28, TOWNSHIP 12 SOUTH, RANGE 65 WEST OF THE SIXTH PRINCIPAL MERIDIAN, BEING MONUMENTED AT THE WEST END WHICH IS THE SOUTHWEST CORNER OF THE SOUTHWEST QUARTER OF THE NORTHEAST QUARTER OF SAID SECTION 28, BY A 3-1/4" ALUMINUM SURVEYORS CAP STAMPED "ES 10376, 2006" AND AT THE EAST END, WHICH IS A 30" WITNESS CORNER TO THE EAST OF THE EAST QUARTER CORNER OF SAID SECTION 28, BY A 3-1/4" ALUMINUM SURVEYORS CAP STAMPED "ES 10376, 2006", IS ASSUMED TO BEAR S89°02'28"W A DISTANCE OF 1326.68 FEET.

BENCHMARKS:

BENCHMARK #1: A 3.25 ALUMINUM SURVEYORS CAP STAMPED "WC 30 2006 PLS 10376" LOCATED 50 EAST OF THE EAST QUARTER CORNER OF SECTION 28, TOWNSHIP 12 SOUTH, RANGE 65 WEST OF THE 6TH PRINCIPAL MERIDIAN. ELEVATION = 7168.20

BENCH MARK #2: A 3.25 ALUMINUM SURVEYORS CAP STAMPED "2006 PLS 10376" LOCATED AT THE SOUTHWEST CORNER OF SECTION 28, TOWNSHIP 12 SOUTH, RANGE 65 WEST OF THE 6TH PRINCIPAL MERIDIAN. ELEVATION = 7141.36

AGENCIES:

- OWNER/DEVELOPER: TIMBERRIDGE DEVELOPMENT GROUP, LLC
5365 CORPORATE DRIVE, SUITE 200
COLORADO SPRINGS, CO 80919
MR. LOREN J. MORELAND, (719) 592-9333
- CIVIL ENGINEER: CLASSIC CONSULTING ENGINEERS & SURVEYORS
619 N. CASCADE AVENUE, SUITE 200
COLORADO SPRINGS, COLORADO 80903
MR. MARC A. WHORTON, P.E. (719) 785-2802
- COUNTY ENGINEERING: EL PASO COUNTY PLANNING AND COMMUNITY DEVELOPMENT
2880 INTERNATIONAL CIRCLE, SUITE 110
COLORADO SPRINGS, COLORADO 80910
MR. JEFF RICE (719) 520-7877
- GAS COMPANY: BLACKHILLS ENERGY
37 WIDEFIELD BOULEVARD
WIDEFIELD, COLORADO 80511
MR. GEORGE M. PETERSON, (719) 392-3491
- ELECTRIC COMPANY: MOUNTAIN VIEW ELECTRIC
P.O. BOX 1600
LIMON, COLORADO 80826
MR. LES ULFERS, (719) 495-2283
- FIRE DISTRICT: BLACK FOREST FIRE PROTECTION DISTRICT
11445 TEACOUT ROAD
COLORADO SPRINGS, CO 80908
CHIEF BRYAN JACK, (719) 495-4300
- TELEPHONE COMPANY: CENTURY LINK
(LOCATORS) 811
AT & T
(LOCATORS) 811

SHEET INDEX

SHEET 1 OF 35	TITLE SHEET
SHEET 2 OF 35	STREET SECTIONS / EROSION CONTROL NOTES
SHEET 3-9 OF 35	OVERLOT GRADING & EROSION CONTROL PLAN
SHEET 10 OF 35	FOCO ROAD PLAN AND PROFILE
SHEET 11 OF 35	ASPEN VALLEY ROAD PLAN AND PROFILE
SHEET 12-13 OF 35	ANTELOPE RAVINE DRIVE PLAN AND PROFILE
SHEET 14 OF 35	ANTELOPE RAVINE DR. & HAWK HILLS CT. PLAN AND PROFILE
SHEET 15 OF 35	ELK ANTLER LANE & RABBIT TAIL PLACE PLAN AND PROFILE
SHEET 16 OF 35	BISON VALLEY TRAIL PLAN AND PROFILE
SHEET 17 OF 35	EXISTING VOLLMER ROAD EAST SHOULDER WIDENING
SHEET 18-19 OF 35	PEDESTRIAN RAMPS & USPS CLUSTER BOX DETAILS
SHEET 20 OF 35	STREET LIGHT POLE LOCATION PLAN
SHEET 21-25 OF 35	STORM SEWER PLAN AND PROFILES
SHEET 26 OF 35	FOCO ROAD (2) MP STEEL ARCH CULVERTS CROSSING (ALSO REFERENCE CULVERT DESIGN PLANS BY CONTECH DATED 3/20/20 UNDER SEPARATE DOCUMENT)
SHEET 27-29 OF 35	CHANNEL CHECK STRUCTURES & BANK STABILIZATION PLAN
SHEET 30 OF 35	RAIN GARDEN
SHEET 31-32 OF 35	POND PLAN-1 AND DETAILS
SHEET 33-34 OF 35	POND PLAN-2 AND DETAILS
SHEET 35 OF 35	DETAIL SHEET

APPROVALS:

DESIGN ENGINEER'S STATEMENT:

THESE DETAILED PLANS AND SPECIFICATIONS WERE PREPARED UNDER MY DIRECTION AND SUPERVISION. SAID PLANS AND SPECIFICATIONS HAVE BEEN PREPARED ACCORDING TO THE CRITERIA ESTABLISHED BY THE COUNTY FOR DETAILED ROADWAY, DRAINAGE, GRADING AND EROSION CONTROL PLANS AND SPECIFICATIONS, AND SAID PLANS AND SPECIFICATIONS ARE IN CONFORMITY WITH APPLICABLE MASTER DRAINAGE PLANS AND MASTER TRANSPORTATION PLANS. SAID PLANS AND SPECIFICATIONS MEET THE PURPOSES FOR WHICH THE PARTICULAR ROADWAY AND DRAINAGE FACILITIES ARE DESIGNED AND ARE CORRECT TO THE BEST OF MY KNOWLEDGE AND BELIEF. I ACCEPT RESPONSIBILITY FOR ANY LIABILITY DIRECTLY CAUSED BY THE NEGLIGENCE, ACTS, ERRORS, OR OMISSIONS ON MY PART IN PREPARATION OF THESE DETAILED PLANS AND SPECIFICATIONS.

MARC A. WHORTON, COLORADO P.E. #37155
FOR AND ON THE BEHALF OF CLASSIC CONSULTING ENGINEERS & SURVEYORS

6/9/2020
DATE

OWNER/DEVELOPER'S STATEMENT:

I, THE OWNER/DEVELOPER HAVE READ AND WILL COMPLY WITH THE REQUIREMENTS OF THE EROSION CONTROL PLAN AND AS SPECIFIED IN THESE DETAILED PLANS AND SPECIFICATIONS.

LOREN J. MORELAND
DATE 6/9/2020

EL PASO COUNTY:

COUNTY PLAN REVIEW IS PROVIDED ONLY FOR GENERAL CONFORMANCE WITH COUNTY DESIGN CRITERIA. THE COUNTY IS NOT RESPONSIBLE FOR THE ACCURACY AND ADEQUACY OF THE DESIGN, DIMENSIONS, AND/OR ELEVATIONS WHICH SHALL BE CONFIRMED AT THE JOB SITE. THE COUNTY THROUGH THE APPROVAL OF THIS DOCUMENT ASSUMES NO RESPONSIBILITY FOR COMPLETENESS AND/OR ACCURACY OF THIS DOCUMENT.

FILED IN ACCORDANCE WITH THE REQUIREMENTS OF THE EL PASO COUNTY LAND DEVELOPMENT CODE, DRAINAGE CRITERIA MANUAL, VOLUMES 1 AND 2 AND ENGINEERING CRITERIA MANUAL AS AMENDED.

IN ACCORDANCE WITH WITH ECM SECTION 1.12, THESE CONSTRUCTION DOCUMENTS WILL BE VALID FOR CONSTRUCTION FOR A PERIOD OF 2 YEARS FROM THE DATE SIGNED BY THE EL PASO COUNTY ENGINEER. IF CONSTRUCTION HAS NOT STARTED WITHIN THOSE 2 YEARS, THE PLANS WILL NEED TO BE RESUBMITTED FOR APPROVAL, INCLUDING PAYMENT OF REVIEW FEES AT THE PLANNING AND COMMUNITY DEVELOPMENT DIRECTOR'S DISCRETION.

JENNIFER IRVINE, P.E.
COUNTY ENGINEER / ECM ADMINISTRATOR

DATE

PCD No. SF-19-009

48 HOURS BEFORE YOU DIG,
CALL UTILITY LOCATORS
811
UTILITY NOTIFICATION CENTER OF COLORADO
IT'S THE LAW

THE LOCATIONS OF EXISTING UNDERGROUND UTILITIES ARE SHOWN IN AN APPROXIMATE WAY ONLY. THE CONTRACTOR SHALL DETERMINE THE EXACT LOCATION OF ALL EXISTING UTILITIES BEFORE COMMENCING WORK. THE CONTRACTOR SHALL BE FULLY RESPONSIBLE FOR ANY AND ALL DAMAGES WHICH MIGHT BE CAUSED BY HIS FAILURE TO EXACTLY LOCATE AND PRESERVE ANY AND ALL UNDERGROUND UTILITIES.

NO.	REVISION	DATE	REVIEW:
1	REVISED PER COUNTY COMMENTS	08-13-19	
2	REVISED PER COUNTY COMMENTS	6-5-20	

PREPARED UNDER MY DIRECT SUPERVISION FOR AND ON BEHALF OF CLASSIC CONSULTING ENGINEERS & SURVEYORS, LLC

MARC A. WHORTON, COLORADO P.E. #37155

6/9/2020
DATE



RETREAT AT TIMBERRIDGE FILING NO. 1
CONSTRUCTION DRAWINGS
TITLE SHEET

DESIGNED BY	M&W	SCALE	DATE	04-05-19
DRAWN BY	M&W	(H) 1" = N/A	SHEET	1 OF 35
CHECKED BY	(V) 1" = N/A	JOB NO.	1165.00	

STANDARD NOTES FOR EL PASO COUNTY GRADING AND EROSION CONTROL PLANS:

- STORMWATER DISCHARGES FROM CONSTRUCTION SITES SHALL NOT CAUSE OR THREATEN TO CAUSE POLLUTION, CONTAMINATION, OR DEGRADATION OF STATE WATERS. ALL WORK AND EARTH DISTURBANCE SHALL BE DONE IN A MANNER THAT MINIMIZES POLLUTION OF ANY ON-SITE OR OFF-SITE WATERS, INCLUDING WETLANDS.
- NOTWITHSTANDING ANYTHING DEPICTED IN THESE PLANS IN WORDS OR GRAPHIC REPRESENTATION, ALL DESIGN AND CONSTRUCTION RELATED TO ROADS, STORM DRAINAGE AND EROSION CONTROL SHALL CONFORM TO THE STANDARDS AND REQUIREMENTS OF THE MOST RECENT VERSION OF THE RELEVANT ADOPTED EL PASO COUNTY STANDARDS, INCLUDING THE LAND DEVELOPMENT CODE, THE ENGINEERING CRITERIA MANUAL, THE DRAINAGE CRITERIA MANUAL, AND THE DRAINAGE CRITERIA MANUAL VOLUME 2. ANY DEVIATIONS TO REGULATIONS AND STANDARDS MUST BE REQUESTED, AND APPROVED, IN WRITING.
- A SEPARATE STORMWATER MANAGEMENT PLAN (SWMP) FOR THIS PROJECT SHALL BE COMPLETED AND AN EROSION AND STORMWATER QUALITY CONTROL PERMIT (ESQCP) ISSUED PRIOR TO COMMENCING CONSTRUCTION. DURING CONSTRUCTION THE SWMP IS THE RESPONSIBILITY OF THE DESIGNATED QUALIFIED STORMWATER MANAGER OR CERTIFIED EROSION CONTROL INSPECTOR AND SHALL BE LOCATED ON SITE AT ALL TIMES DURING CONSTRUCTION AND SHALL BE KEPT UP TO DATE WITH WORK PROGRESS AND CHANGES IN THE FIELD.
- ONCE THE ESQCP IS APPROVED AND A (NOTICE TO PROCEED) HAS BEEN ISSUED, THE CONTRACTOR MAY INSTALL THE INITIAL STAGE EROSION AND SEDIMENT CONTROL MEASURES AS INDICATED ON THE APPROVED G.C. A PRE-CONSTRUCTION MEETING BETWEEN THE CONTRACTOR, ENGINEER, AND EL PASO COUNTY WILL BE HELD PRIOR TO ANY CONSTRUCTION. IT IS THE RESPONSIBILITY OF THE APPLICANT TO COORDINATE THE MEETING TIME AND PLACE WITH COUNTY STAFF.
- CONTROL MEASURES MUST BE INSTALLED PRIOR TO COMMENCEMENT OF ACTIVITIES THAT MAY CONTRIBUTE POLLUTANTS TO STORMWATER. TEMPORARY SEDIMENT AND EROSION CONTROL MEASURES FOR ALL SLOPES, CHANNELS, DITCHES, OR ANY DISTURBED LAND AREA SHALL BE COMPLETED IMMEDIATELY UPON COMPLETION OF THE DISTURBANCE.
- ALL TEMPORARY SEDIMENT AND EROSION CONTROL MEASURES SHALL BE MAINTAINED AND REMAIN IN EFFECTIVE OPERATING CONDITION UNTIL PERMANENT SOIL EROSION CONTROL MEASURES ARE IMPLEMENTED AND FINAL STABILIZATION IS ESTABLISHED. ALL PERSONS ENGAGED IN LAND DISTURBANCE ACTIVITIES SHALL ASSESS THE ADEQUACY OF CONTROL MEASURES AT THE SITE AND IDENTIFY IF CHANGES TO THOSE CONTROL MEASURES IS NEEDED TO ENSURE THE CONTINUED EFFECTIVE PERFORMANCE OF THE CONTROL MEASURES. ALL CHANGES TO TEMPORARY SEDIMENT AND EROSION CONTROL MEASURES MUST BE INCORPORATED INTO THE STORMWATER MANAGEMENT PLAN.
- TEMPORARY STABILIZATION SHALL BE IMPLEMENTED ON DISTURBED AREAS AND STOCKPILES WHERE GROUND DISTURBING CONSTRUCTION ACTIVITY HAS PERMANENTLY CEASED OR TEMPORARILY CEASED FOR LONGER THAN 14 DAYS.
- FINAL STABILIZATION MUST BE IMPLEMENTED AT ALL APPLICABLE CONSTRUCTION SITES. FINAL STABILIZATION IS ACHIEVED WHEN ALL GROUND DISTURBING ACTIVITIES ARE COMPLETE AND ALL DISTURBED AREAS EITHER HAVE A UNIFORM VEGETATIVE COVER WITH INDIVIDUAL PLAN DENSITY OF 70 PERCENT OF PRE-DISTURBANCE LEVELS ESTABLISHED OR EQUIVALENT PERMANENT ALTERNATIVE STABILIZATION METHOD IS IMPLEMENTED. ALL TEMPORARY SEDIMENT AND EROSION CONTROL MEASURES SHALL BE REMOVED UPON FINAL STABILIZATION AND BEFORE PERMIT CLOSURE.
- ALL PERMANENT STORMWATER MANAGEMENT FACILITIES SHALL BE INSTALLED AS DEFINED IN THE APPROVED PLANS. ANY PROPOSED CHANGES THAT AFFECT THE HYDROLOGY OR HYDRAULICS OF A PERMANENT STORMWATER MANAGEMENT STRUCTURE MUST BE APPROVED BY THE EGM ADMINISTRATOR PRIOR TO IMPLEMENTATION.
- EARTH DISTURBANCES SHALL BE CONDUCTED IN SUCH A MANNER SO AS TO EFFECTIVELY MINIMIZE ACCELERATED SOIL EROSION AND RESULTING SEDIMENTATION. ALL DISTURBANCES SHALL BE DESIGNED, CONSTRUCTED, AND COMPLETED SO THAT THE EXPOSED AREA OF ANY DISTURBED LAND SHALL BE LIMITED TO THE SHORTEST PRACTICAL PERIOD OF TIME. PRE-EXISTING VEGETATION SHALL BE PROTECTED AND MAINTAINED WITHIN 50 HORIZONTAL FEET OF A WATERS OF THE STATE, UNLESS SHOWN TO BE INFEASIBLE AND SPECIFICALLY REQUESTED AND APPROVED.
- COMPACTION OF SOIL MUST BE PREVENTED IN AREAS DESIGNATED FOR INFILTRATION CONTROL MEASURES OR WHERE FINAL STABILIZATION WILL BE ACHIEVED BY VEGETATIVE COVER. AREAS DESIGNATED FOR INFILTRATION CONTROL MEASURES SHALL ALSO BE PROTECTED FROM SEDIMENTATION DURING CONSTRUCTION UNTIL FINAL STABILIZATION IS ACHIEVED. IF COMPACTION PREVENTION IS NOT FEASIBLE DUE TO SITE CONSTRAINTS, ALL AREAS DESIGNATED FOR INFILTRATION AND VEGETATION CONTROL MEASURES MUST BE LOOSENEED PRIOR TO INSTALLATION OF THE CONTROL MEASURE(S).
- ANY TEMPORARY OR PERMANENT FACILITY DESIGNED AND CONSTRUCTED FOR THE CONVEYANCE OF STORMWATER AROUND, THROUGH, OR FROM THE EARTH DISTURBANCE AREA SHALL BE A STABILIZED CONVEYANCE DESIGNED TO MINIMIZE EROSION AND THE DISCHARGE OF SEDIMENT OFF SITE.
- CONCRETE WASH WATER SHALL BE CONTAINED AND DISPOSED OF IN ACCORDANCE WITH THE SWMP. NO WASH WATER SHALL BE DISCHARGED TO OR ALLOWED TO RUNOFF TO STATE WATERS, INCLUDING ANY SURFACE OR SUBSURFACE STORM DRAINAGE SYSTEM OR FACILITIES. CONCRETE WASHOUTS SHALL NOT BE LOCATED IN AN AREA WHERE SHALLOW GROUNDWATER MAY BE PRESENT, OR WITHIN 50 FEET OF A SURFACE WATER BODY, CREEK OR STREAM.
- DURING DEWATERING OPERATIONS: UNCONTAMINATED GROUND WATER MAY BE DISCHARGED ON SITE, BUT SHALL NOT LEAVE THE SITE IN THE FORM OF SURFACE RUNOFF UNLESS AN APPROVED STATE DEWATERING PERMIT IS IN PLACE..
- EROSION CONTROL BLANKETING OR OTHER PROTECTIVE COVERING SHALL BE USED ON SLOPES STEEPER THAN 3:1.
- CONTRACTOR SHALL BE RESPONSIBLE FOR THE REMOVAL OF ALL WASTES FROM THE CONSTRUCTION SITE FOR DISPOSAL IN ACCORDANCE WITH LOCAL AND STATE REGULATORY REQUIREMENTS. NO CONSTRUCTION DEBRIS, TREE SLASH, BUILDING MATERIAL WASTES OR UNUSED BUILDING MATERIALS SHALL BE BURIED, DUMPED OR DISCHARGED AT THE SITE.
- WASTE MATERIALS SHALL NOT BE TEMPORARILY PLACED IN THE STREET, ALLEY OR OTHER PUBLIC WAY, UNLESS IN ACCORDANCE WITH AN APPROVED TRAFFIC CONTROL PLAN. CONTROL MEASURES MAY BE REQUIRED BY EL PASO COUNTY ENGINEERING IF DEEMED NECESSARY, BASED ON SPECIFIC CONDITIONS AND CIRCUMSTANCES.
- TRACKING OF SOILS AND CONSTRUCTION DEBRIS OFF-SITE SHALL BE MINIMIZED. MATERIALS TRACKED OFFSITE SHALL BE CLEANED UP AND PROPERLY DISPOSED OF IMMEDIATELY.
- THE OWNER/DEVELOPER SHALL BE RESPONSIBLE FOR THE REMOVAL OF ALL CONSTRUCTION DEBRIS, DIRT, TRASH, ROCK, SEDIMENT, SOIL AND SAND THAT MAY ACCUMULATE IN ROADS, STORM DRAINS AND OTHER DRAINAGE CONVEYANCE SYSTEMS AND STORMWATER APPURTENANCES AS A RESULT OF SITE DEVELOPMENT.
- THE QUANTITY OF MATERIALS STORED ON THE PROJECT SITE SHALL BE LIMITED, AS MUCH AS PRACTICAL, TO THAT QUANTITY REQUIRED TO PERFORM THE WORK IN AN ORDERLY SEQUENCE. ALL MATERIALS STORED ON-SITE SHALL BE STORED IN A NEAT, ORDERLY MANNER, IN THEIR ORIGINAL CONTAINERS, WITH ORIGINAL MANUFACTURER'S LABELS.
- NO CHEMICAL(S) HAVING THE POTENTIAL TO BE RELEASED IN STORMWATER ARE TO BE STORED OR USED ONSITE UNLESS PERMISSION FOR THE USE OF A SPECIFIC CHEMICAL(S) IS GRANTED IN WRITING BY THE EGM ADMINISTRATOR. IN GRANTING APPROVAL FOR THE USE OF SUCH CHEMICAL(S), SPECIAL CONDITIONS AND MONITORING MAY BE REQUIRED.
- BULK STORAGE OF ALLOWED PETROLEUM PRODUCTS OR OTHER LIQUID CHEMICALS IN ACCESS OF 55 GALLONS SHALL REQUIRE ADEQUATE SECONDARY CONTAINMENT PROTECTION TO CONTAIN ALL SPILLS ONSITE AND TO PREVENT ANY SPILLED MATERIALS FROM ENTERING STATE WATERS, ANY SURFACE OR SUBSURFACE STORM DRAINAGE SYSTEM OR FACILITIES.
- NO PERSON SHALL CAUSE THE IMPEDIMENT OF STORMWATER FLOW IN THE CURB AND GUTTER OR DITCH EXCEPT WITH APPROVED SEDIMENT CONTROL MEASURES.
- OWNER/DEVELOPER AND THEIR AGENTS SHALL COMPLY WITH THE COLORADO WATER QUALITY CONTROL ACT (TITLE 25, ARTICLE 8, CRS), AND THE CLEAN WATER ACT (33 USC 1344), IN ADDITION TO THE REQUIREMENTS OF THE LAND DEVELOPMENT CODE, DCM VOLUME II AND THE EGM APPENDIX I. ALL APPROPRIATE PERMITS MUST BE OBTAINED BY THE CONTRACTOR PRIOR TO CONSTRUCTION (1041, NPDES, FLOODPLAIN, 404, FUGITIVE DUST, ETC.). IN THE EVENT OF CONFLICTS BETWEEN THESE REQUIREMENTS AND LAWS, RULES, OR REGULATIONS OF OTHER FEDERAL, STATE, OR COUNTY AGENCIES, THE MORE RESTRICTIVE LAWS, RULES, OR REGULATIONS SHALL APPLY.
- ALL CONSTRUCTION TRAFFIC MUST ENTER/EXIT THE SITE AT APPROVED CONSTRUCTION ACCESS POINTS.
- PRIOR TO CONSTRUCTION THE PERMITEE SHALL VERIFY THE LOCATION OF EXISTING UTILITIES.
- A WATER SOURCE SHALL BE AVAILABLE ON SITE DURING EARTHWORK OPERATIONS AND UTILIZED AS REQUIRED TO MINIMIZE DUST FROM EARTHWORK EQUIPMENT AND WIND.
- THE SOILS REPORTS FOR THIS SITE HAVE BEEN PREPARED BY ENTECH ENGINEERING, INC. TITLED "SOIL GEOLOGY, GEOLOGIC HAZARD AND WASTEWATER STUDY - THE RETREAT AT TIMBER RIDGE VOLLMER ROAD AND ARROYA LANE," DATED APRIL 12, 2017, REVISED DECEMBER 1, 2017 AND "SUBSURFACE SOIL INVESTIGATION RETREAT AT TIMBERRIDGE, FILING NO. 1 POCO ROAD SAND CREEK CROSSING, DROP STRUCTURES AND DETENTION PONDS" DATED AUGUST 8, 2019. THESE REPORTS SHALL BE CONSIDERED A PART OF THESE PLANS.
- AT LEAST TEN (10) DAYS PRIOR TO THE ANTICIPATED START OF CONSTRUCTION, FOR PROJECTS THAT WILL DISTURB ONE (1) ACRE OR MORE, THE OWNER OR OPERATOR OF CONSTRUCTION ACTIVITY SHALL SUBMIT A PERMIT APPLICATION FOR STORMWATER DISCHARGE TO THE COLORADO DEPARTMENT OF PUBLIC HEALTH AND ENVIRONMENT, WATER QUALITY DIVISION. THE APPLICATION CONTAINS CERTIFICATION OF COMPLETION OF A STORMWATER MANAGEMENT PLAN (SWMP), OF WHICH THIS GRADING AND EROSION CONTROL PLAN MAY BE A PART. FOR INFORMATION OR APPLICATION MATERIALS CONTACT:
COLORADO DEPARTMENT OF PUBLIC HEALTH AND ENVIRONMENT
WATER QUALITY CONTROL DIVISION
WOOD - PERMITS
4300 CHERRY CREEK DRIVE SOUTH
DENVER, CO 80246-1530
ATTN: PERMITS UNIT

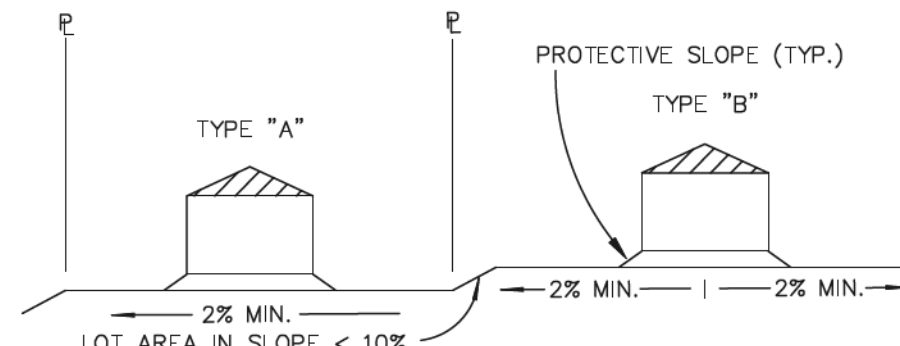

TYPICAL LOT SECTION DETAIL
N.T.S.

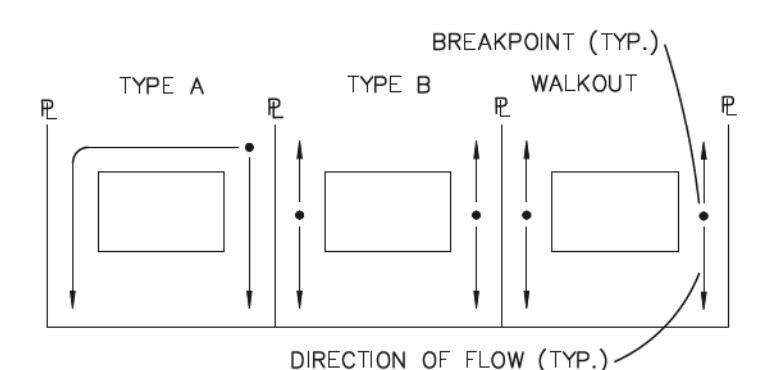

LOT DRAINAGE TYPES
N.T.S.



TYPICAL (A) LOT
N.T.S.

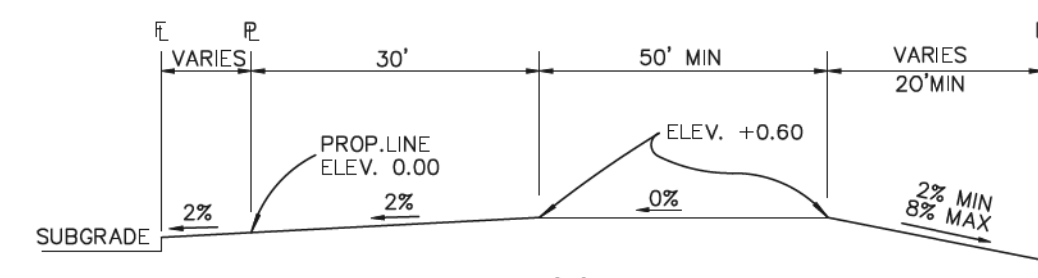

TYPICAL (B) LOT
N.T.S.

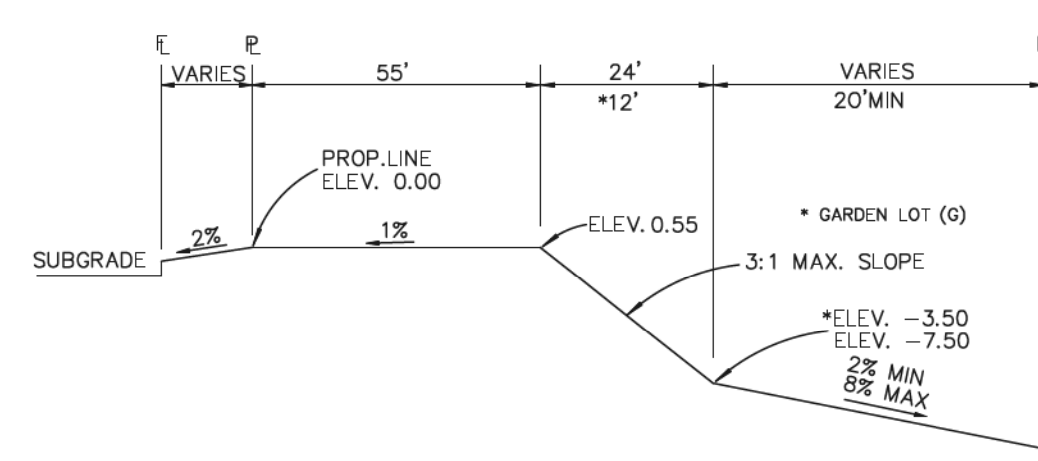

TYPICAL WALKOUT LOT (W/O) OR GARDEN (G)
N.T.S.

NOTES:

- BASED ON GREATER TYPICAL DEPTH OF PROPOSED LOTS, ALL LOT TEMPLATES ADJUSTED AND ADDITIONAL 5'.
- "T" LOTS OR "TRANSITION" LOTS OCCUR IN PLACES WHERE BOTH PROPERTY LINES CANNOT BE GRADED AS THE TYPICAL STANDARD LOT TEMPLATES SHOWN. THESE LOTS WILL STILL BE GRADED TO CREATE POSITIVE DRAINAGE AWAY FROM THE STRUCTURE.
- SIDE LOT SWALES ARE REQUIRED ON THE DOWNHILL LOTS, EITHER BY BUILDER OR GRADING CONTRACTOR.

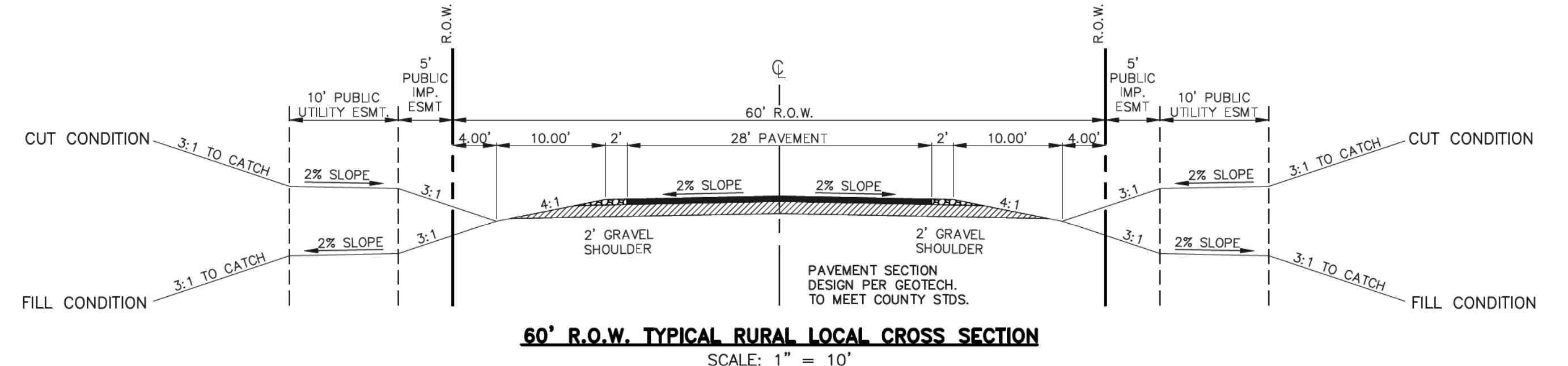

60' R.O.W. TYPICAL RURAL LOCAL CROSS SECTION
SCALE: 1" = 10'

SIGN PLACEMENT PER 2009 MUTCD
FIG. 2A-2 A AND LOCATED
8' BEHIND GRAVEL SHOULDER

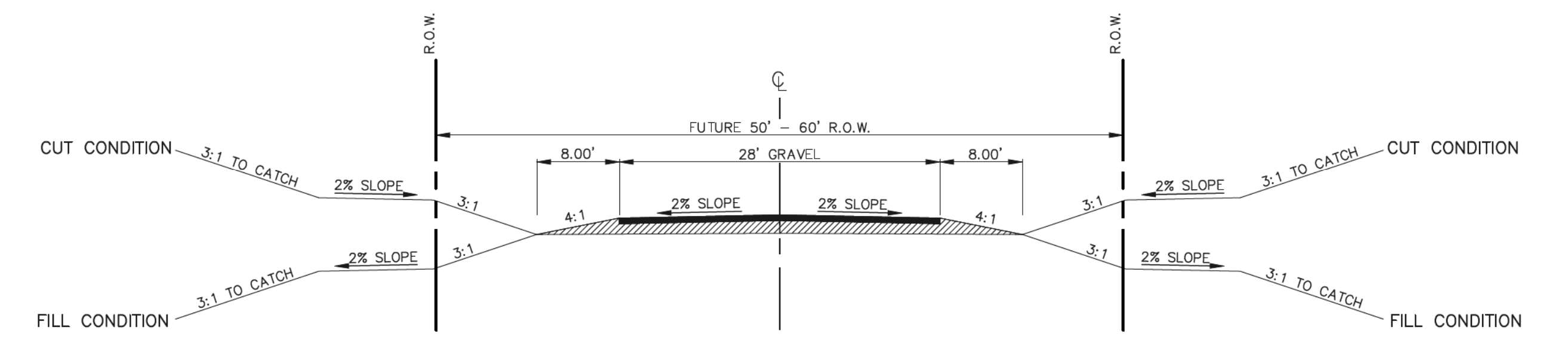

FUTURE R.O.W. TYPICAL SECONDARY ACCESS ROAD
SCALE: 1" = 10'

SECONDARY EMERGENCY ACCESS
UP TO ARROYA LANE

SIGN PLACEMENT PER 2009 MUTCD
FIG. 2A-2 A AND LOCATED
8' BEHIND GRAVEL SHOULDER

NO ADDITIONAL IMPROVEMENTS REQUIRED AT THIS TIME ON THE EXISTING ARROYA LANE AS IT CURRENTLY FUNCTIONS AS A VIABLE EMERGENCY ACCESS DRIVE PER BLACK FOREST FIRE DISTRICT.
FUTURE PLATTING ADJACENT TO ARROYA LANE WILL REQUIRE ADDITIONAL IMPROVEMENTS TO THIS ROADWAY.

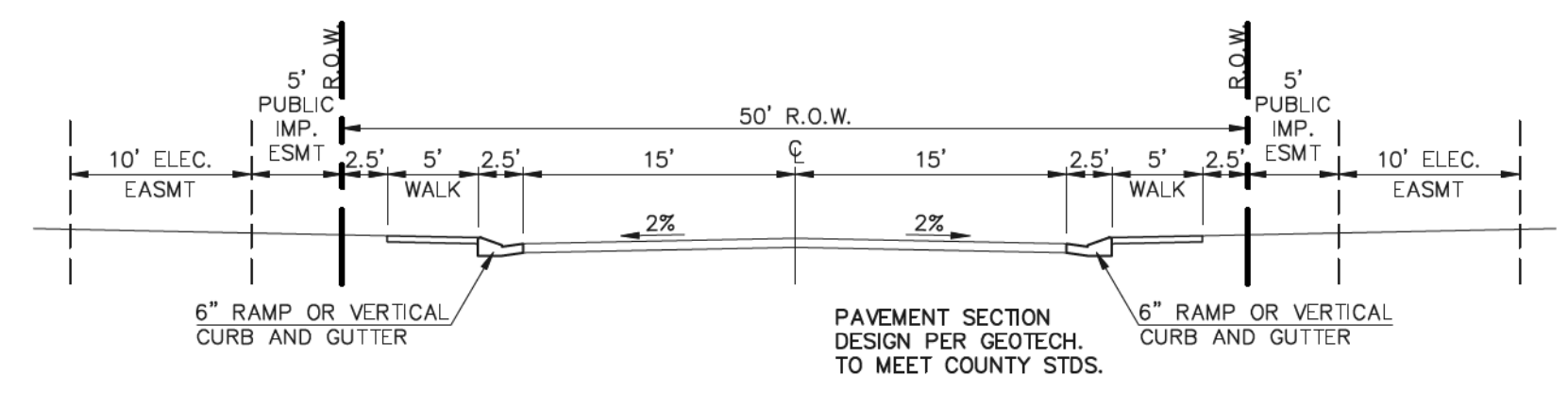

50' R.O.W. TYPICAL URBAN LOCAL CROSS SECTION
SCALE: 1" = 10'

ANTELOPE RAVINE DRIVE
RABBIT TAIL PLACE
ELK ANTLER LANE
BISON VALLEY TRAIL

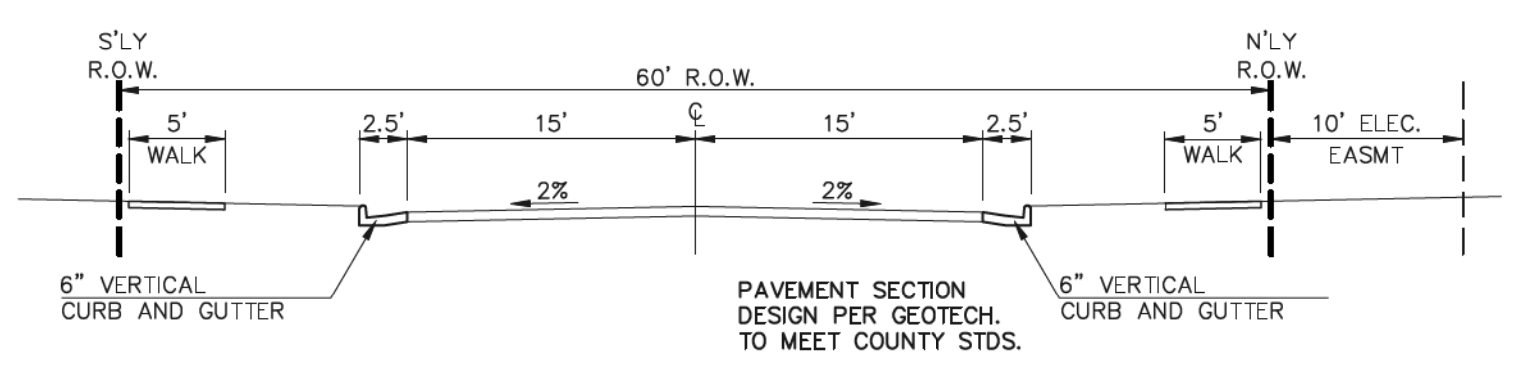

60' R.O.W. TYPICAL URBAN LOCAL CROSS SECTION
SCALE: 1" = 10'

POCO ROAD

<p>48 HOURS BEFORE YOU DIG, CALL UTILITY LOCATORS 811 UTILITY NOTIFICATION CENTER OF COLORADO IT'S THE LAW</p> <p>THE LOCATIONS OF EXISTING UNDERGROUND UTILITIES ARE SHOWN IN AN APPROXIMATE WAY ONLY. THE CONTRACTOR SHALL DETERMINE THE EXACT LOCATION OF ALL EXISTING UTILITIES BEFORE COMMENCING WORK. THE CONTRACTOR SHALL BE FULLY RESPONSIBLE FOR ANY AND ALL DAMAGES WHICH MIGHT BE CAUSED BY HIS FAILURE TO EXACTLY LOCATE AND PRESERVE ANY AND ALL UNDERGROUND UTILITIES.</p>	<p>NO. REVISION</p> <table border="1"> <tr> <td>1</td> <td>REVISED PER COUNTY COMMENTS</td> <td>06-10-19</td> </tr> <tr> <td>2</td> <td>REVISED PER COUNTY COMMENTS</td> <td>01-21-20</td> </tr> <tr> <td>3</td> <td>REVISED PER COUNTY COMMENTS</td> <td>6-5-20</td> </tr> </table>	1	REVISED PER COUNTY COMMENTS	06-10-19	2	REVISED PER COUNTY COMMENTS	01-21-20	3	REVISED PER COUNTY COMMENTS	6-5-20	<p>DATE</p> <p>06-10-19</p> <p>01-21-20</p> <p>6-5-20</p>	<p>REVIEW:</p> <p>PREPARED UNDER MY DIRECT SUPERVISION FOR AND ON BEHALF OF CLASSIC CONSULTING ENGINEERS AND SURVEYORS, LLC</p> <p>6/9/2020</p> <p>DATE</p>	<p>RETREAT AT TIMBERRIDGE FILING NO. 1 CONSTRUCTION DRAWINGS STREET SECTIONS / EROSION CONTROL NOTES</p> <p>DESIGNED BY PRA SCALE DATE 04-05-19</p> <p>DRAWN BY PRA (H) 1" = N/A SHEET 2 OF 35</p> <p>CHECKED BY (V) 1" = N/A JOB NO. 1185.00</p>	<p>CLASSIC CONSULTING</p> <p>619 N. Cascade Avenue, Suite 200 Colorado Springs, Colorado 80903 (719)785-0790 (719)785-0799(Fax)</p>
	1	REVISED PER COUNTY COMMENTS	06-10-19											
	2	REVISED PER COUNTY COMMENTS	01-21-20											
3	REVISED PER COUNTY COMMENTS	6-5-20												
<p>CLASSIC CONSULTING</p>		<p>MARC A. WHORTON, COLORADO P.E. #37155</p>												
<p>CLASSIC CONSULTING</p>		<p>DATE</p>												

LEGEND

- LIMIT OF GRADING
- CUT/FILL LINE
- PROPOSED CONTOUR-10
- PROPOSED CONTOUR-2
- EXISTING CONTOUR-10
- EXISTING CONTOUR-2
- SILT FENCE
- SILT FENCE
- SEEDING/MULCHING
- VEHICLE TRACKING CONTROL
- STRAW BALES
- INLET PROTECTION
- EROSION CONTROL BLANKET
- TEMPORARY SEDIMENT BASIN
- EXIST. DIRECTION OF FLOW
- DIRECTION OF FLOW
- HIGH POINT
- LOW POINT
- A LOT
- B LOT
- WALKOUT LOT
- NATURAL LOT
- TRANSITION LOT
- GARDEN LOT
- EROSION CONTROL BLANKET (NORTH AMERICAN GREEN - SC150 OR EQUIVALENT) TO BE INSTALLED ON ALL 3:1 SLOPES OR GREATER

SEEDING/MULCHING NOTE:
SEEDING AND MULCHING SHALL BE INSTALLED INSIDE THE ENTIRE LIMITS OF GRADING EXCLUDING ROADWAY SURFACES, SIDEWALK AREAS AND RIP-RAP AREAS.

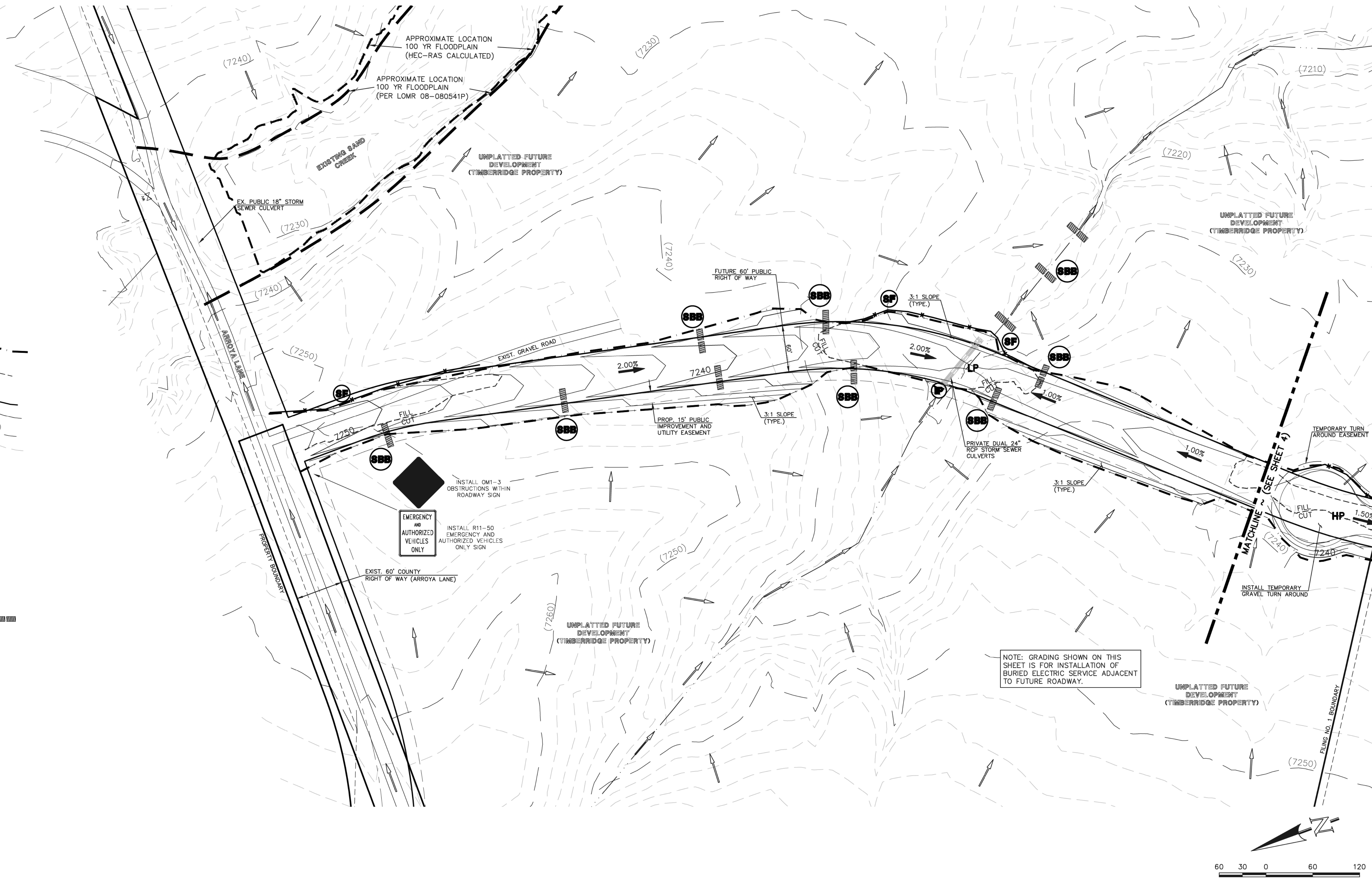

NOTE: GRADING SHOWN ON THIS SHEET IS FOR INSTALLATION OF BURIED ELECTRIC SERVICE ADJACENT TO FUTURE ROADWAY.

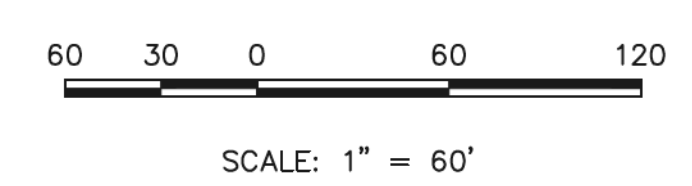

<p style="text-align: center;">48 HOURS BEFORE YOU DIG, CALL UTILITY LOCATORS 811</p> <p style="text-align: center;">UTILITY NOTIFICATION CENTER OF COLORADO IT'S THE LAW</p> <p style="font-size: small;">THE LOCATIONS OF EXISTING UNDERGROUND UTILITIES ARE SHOWN IN AN APPROXIMATE WAY ONLY. THE CONTRACTOR SHALL DETERMINE THE EXACT LOCATION OF ALL EXISTING UTILITIES BEFORE COMMENCING WORK. THE CONTRACTOR SHALL BE FULLY RESPONSIBLE FOR ANY AND ALL DAMAGES WHICH MIGHT BE CAUSED BY HIS FAILURE TO EXACTLY LOCATE AND PRESERVE ANY AND ALL UNDERGROUND UTILITIES.</p>	<table border="1" style="width: 100%; border-collapse: collapse;"> <thead> <tr> <th>NO.</th> <th>REVISION</th> <th>DATE</th> </tr> </thead> <tbody> <tr> <td>1</td> <td>REVISED PER COUNTY COMMENTS</td> <td>08-13-19</td> </tr> <tr> <td>2</td> <td>REVISED PER COUNTY COMMENTS</td> <td>1-21-20</td> </tr> </tbody> </table>	NO.	REVISION	DATE	1	REVISED PER COUNTY COMMENTS	08-13-19	2	REVISED PER COUNTY COMMENTS	1-21-20	<p>REVIEW:</p> <p style="font-size: x-small;">PREPARED UNDER MY DIRECT SUPERVISION FOR AND ON BEHALF OF CLASSIC CONSULTING ENGINEERS AND SURVEYORS, LLC</p> <div style="text-align: center;"> </div> <p>MARC A. WHORTON, COLORADO P.E. #37155 DATE: 6/9/2020</p>	<div style="text-align: center;"> </div> <p style="font-size: x-small;">619 N. Cascade Avenue, Suite 200 Colorado Springs, Colorado 80903 (719) 785-0790 (719) 785-0799 (Fax)</p>	<p>RETREAT AT TIMBERIDGE FILING NO. 1 CONSTRUCTION PLANS</p> <p>GRADING & EROSION CONTROL PLAN</p> <table border="1" style="width: 100%; border-collapse: collapse;"> <tr> <td>DESIGNED BY</td> <td>PRA</td> <td>SCALE</td> <td>DATE</td> <td>04-05-19</td> </tr> <tr> <td>DRAWN BY</td> <td>ESO</td> <td>(H) 1" = 60'</td> <td>SHEET</td> <td>3 OF 35</td> </tr> <tr> <td>CHECKED BY</td> <td>(V)</td> <td>1" = N/A</td> <td>JOB NO.</td> <td>1185.00</td> </tr> </table>	DESIGNED BY	PRA	SCALE	DATE	04-05-19	DRAWN BY	ESO	(H) 1" = 60'	SHEET	3 OF 35	CHECKED BY	(V)	1" = N/A	JOB NO.	1185.00
NO.	REVISION	DATE																										
1	REVISED PER COUNTY COMMENTS	08-13-19																										
2	REVISED PER COUNTY COMMENTS	1-21-20																										
DESIGNED BY	PRA	SCALE	DATE	04-05-19																								
DRAWN BY	ESO	(H) 1" = 60'	SHEET	3 OF 35																								
CHECKED BY	(V)	1" = N/A	JOB NO.	1185.00																								

LEGEND

- LIMIT OF GRADING
- CUT/FILL LINE
- PROPOSED CONTOUR-10
- PROPOSED CONTOUR-2
- EXISTING CONTOUR-10
- EXISTING CONTOUR-2
- SILT FENCE
- FEMA FLOODPLAIN
- SILT FENCE
- SEEDING/MULCHING
- ROCK CHECK DAM
- VEHICLE TRACKING CONTROL
- STRAW BALES

- INLET PROTECTION
- EROSION CONTROL BLANKET
- TURF REINFORCEMENT MAT (NORTH AMERICAN GREEN - ROLLMAX P300 OR EQUIV.)
- TEMPORARY SEDIMENT BASIN
- EXIST. DIRECTION OF FLOW
- DIRECTION OF FLOW
- HIGH POINT
- LOW POINT
- A LOT
- B LOT
- WALKOUT LOT
- NATURAL LOT
- TRANSITION LOT
- GARDEN LOT

- IP** EROSION CONTROL BLANKET (NORTH AMERICAN GREEN - SC150 OR EQUIVALENT) TO BE INSTALLED ON ALL 3:1 SLOPES OR GREATER
- ECB** SEEDING/MULCHING NOTE: SEEDING AND MULCHING SHALL BE INSTALLED INSIDE THE ENTIRE LIMITS OF GRADING EXCLUDING ROADWAY SURFACES, SIDEWALK AREAS AND RIP-RAP AREAS.
- TRM**
- TSB**
- SF**
- SM**
- CD**
- VTC**
- SBB**

PERMANENT SEDIMENT BASIN DESIGN INFO
 PERMANENT SEDIMENT BASIN
 (3.2 DISTURBED ACRES AT 800 C.F./AC.)
 TOTAL REQUIRED STORAGE 2,560 CF
 APPROX. DIMENSIONS WIDTH = 40', LENGTH = 65', DEPTH = 4.0'
 OUTLET = 6" PVC STANDPIPE W/ (1) COLUMN, (5) HOLES OF PERFORATIONS W/4" SPACING BETWEEN HOLES. 9/16" DIAMETER PERFORATIONS. 6' MIN. SPILLWAY WIDTH. (SEE DETAIL SHEET SC-7)

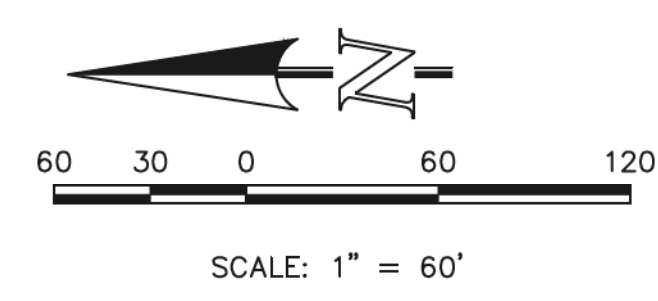
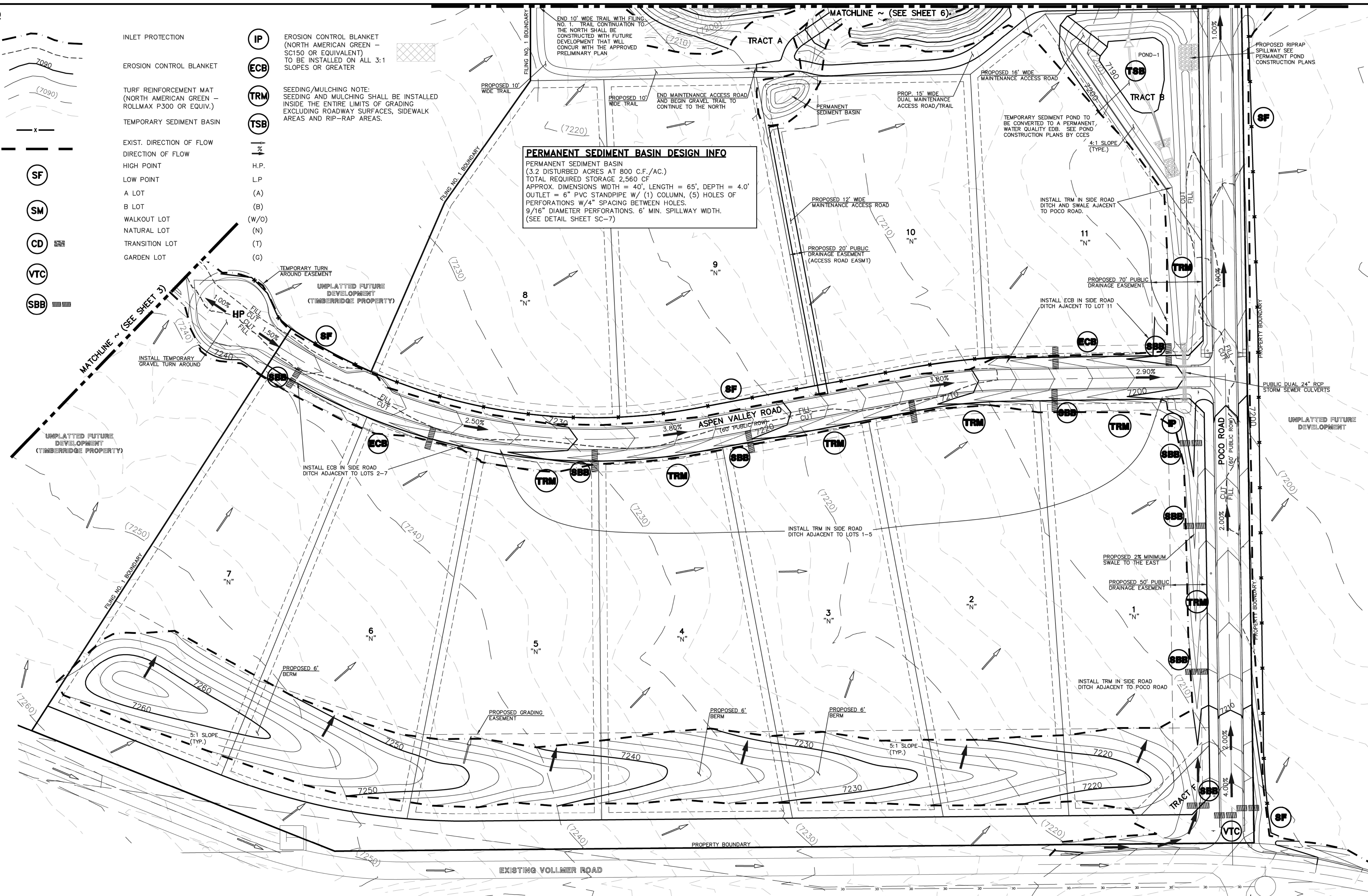

48 HOURS BEFORE YOU DIG,
 CALL UTILITY LOCATORS
811
 UTILITY NOTIFICATION CENTER OF COLORADO
 IT'S THE LAW

THE LOCATIONS OF EXISTING UNDERGROUND UTILITIES ARE SHOWN IN AN APPROXIMATE WAY ONLY. THE CONTRACTOR SHALL DETERMINE THE EXACT LOCATION OF ALL EXISTING UTILITIES BEFORE COMMENCING WORK. THE CONTRACTOR SHALL BE FULLY RESPONSIBLE FOR ANY AND ALL DAMAGES WHICH MIGHT BE CAUSED BY HIS FAILURE TO EXACTLY LOCATE AND PRESERVE ANY AND ALL UNDERGROUND UTILITIES.

NO.	REVISION	DATE
1	REVISED PER COUNTY COMMENTS	08-13-19
2	REVISED PER COUNTY COMMENTS	03-05-20

REVIEW:
 PREPARED UNDER MY DIRECT SUPERVISION FOR AND ON BEHALF OF
 CLASSIC CONSULTING ENGINEERS AND SURVEYORS, LLC

MARC A. WHORTON, COLORADO, P.E. #37155

DATE: 6/9/2020

CLASSIC CONSULTING

619 N. Cascade Avenue, Suite 200
 Colorado Springs, Colorado 80903

(719)785-0790
 (719)785-0799 (fax)

**RETREAT AT TIMBERIDGE FILING NO. 1
 CONSTRUCTION PLANS
 GRADING & EROSION CONTROL PLAN**

DESIGNED BY	PRA	SCALE	DATE	04-05-19
DRAWN BY	ESO	(H) 1" = 60'	SHEET	4 OF 35
CHECKED BY	(V) 1" = N/A	JOB NO.	1185.00	



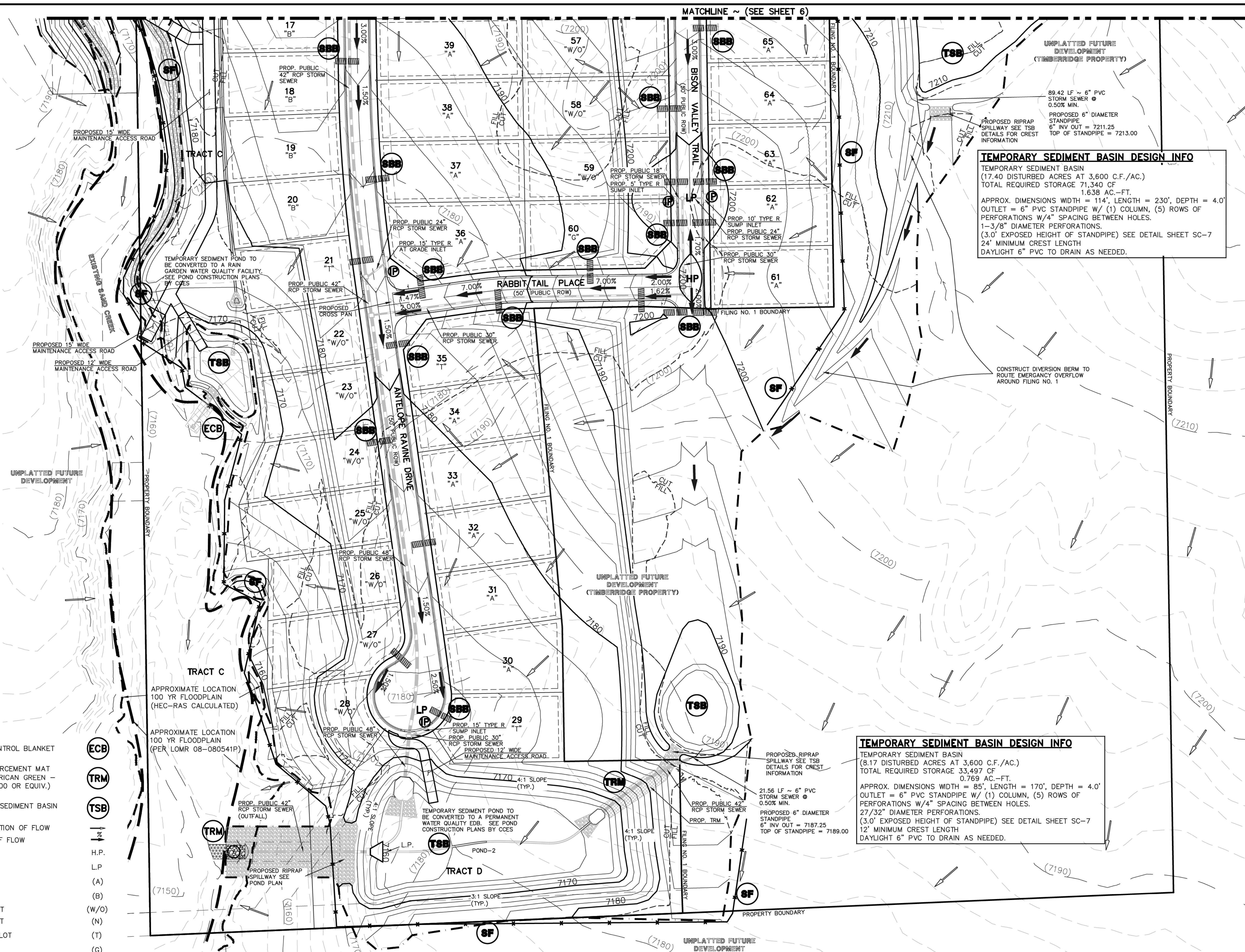
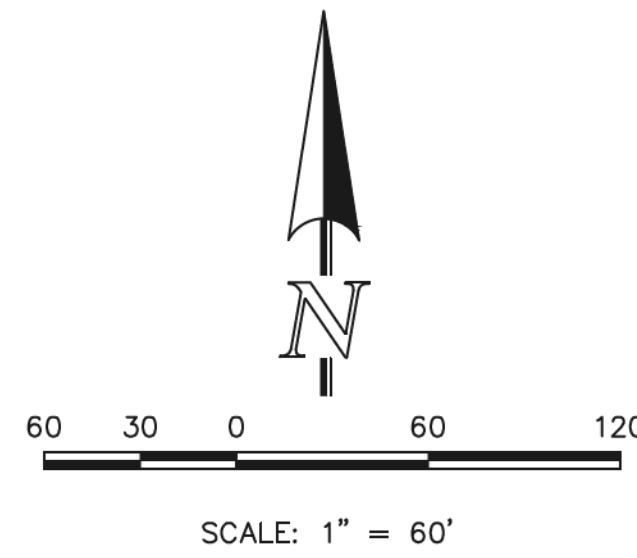

TEMPORARY SEDIMENT BASIN DESIGN INFO
 TEMPORARY SEDIMENT BASIN
 (17.40 DISTURBED ACRES AT 3,600 C.F./AC.)
 TOTAL REQUIRED STORAGE 71,340 CF
 1.638 AC.-FT.
 APPROX. DIMENSIONS WIDTH = 114', LENGTH = 230', DEPTH = 4.0'
 OUTLET = 6" PVC STANDPIPE W/ (1) COLUMN, (5) ROWS OF PERFORATIONS W/4" SPACING BETWEEN HOLES.
 1-3/8" DIAMETER PERFORATIONS.
 (3.0' EXPOSED HEIGHT OF STANDPIPE) SEE DETAIL SHEET SC-7
 24' MINIMUM CREST LENGTH
 DAYLIGHT 6" PVC TO DRAIN AS NEEDED.

TEMPORARY SEDIMENT BASIN DESIGN INFO
 TEMPORARY SEDIMENT BASIN
 (8.17 DISTURBED ACRES AT 3,600 C.F./AC.)
 TOTAL REQUIRED STORAGE 33,497 CF
 0.769 AC.-FT.
 APPROX. DIMENSIONS WIDTH = 85', LENGTH = 170', DEPTH = 4.0'
 OUTLET = 6" PVC STANDPIPE W/ (1) COLUMN, (5) ROWS OF PERFORATIONS W/4" SPACING BETWEEN HOLES.
 27/32" DIAMETER PERFORATIONS.
 (3.0' EXPOSED HEIGHT OF STANDPIPE) SEE DETAIL SHEET SC-7
 12' MINIMUM CREST LENGTH
 DAYLIGHT 6" PVC TO DRAIN AS NEEDED.

LEGEND

- LIMIT OF GRADING
- CUT/FILL LINE
- PROPOSED CONTOUR-10
- PROPOSED CONTOUR-2
- EXISTING CONTOUR-10
- EXISTING CONTOUR-2
- SILT FENCE
- FEMA FLOODPLAIN
- SILT FENCE
- SEEDING/MULCHING
- ROCK CHECK DAM
- VEHICLE TRACKING CONTROL
- STRAW BALES
- INLET PROTECTION
- EROSION CONTROL BLANKET
- TURF REINFORCEMENT MAT (NORTH AMERICAN GREEN - ROLLMAX P300 OR EQUIV.)
- TEMPORARY SEDIMENT BASIN
- EXIST. DIRECTION OF FLOW
- HIGH POINT
- LOW POINT
- A LOT
- B LOT
- WALKOUT LOT
- NATURAL LOT
- TRANSITION LOT
- GARDEN LOT
- EROSION CONTROL BLANKET (NORTH AMERICAN GREEN - SC150 OR EQUIVALENT) TO BE INSTALLED ON ALL 3:1 SLOPES OR GREATER

48 HOURS BEFORE YOU DIG,
 CALL UTILITY LOCATORS
811
 UTILITY NOTIFICATION CENTER OF COLORADO
 IT'S THE LAW

THE LOCATIONS OF EXISTING UNDERGROUND UTILITIES ARE SHOWN IN AN APPROXIMATE WAY ONLY. THE CONTRACTOR SHALL DETERMINE THE EXACT LOCATION OF ALL EXISTING UTILITIES BEFORE COMMENCING WORK. THE CONTRACTOR SHALL BE FULLY RESPONSIBLE FOR ANY AND ALL DAMAGES WHICH MIGHT BE CAUSED BY HIS FAILURE TO EXACTLY LOCATE AND PRESERVE ANY AND ALL UNDERGROUND UTILITIES.

NO.	REVISION	DATE
1	REVISED PER COUNTY COMMENTS	08-13-19
2	REVISED PER COUNTY COMMENTS	1-21-20

REVIEW:
 PREPARED UNDER MY DIRECT SUPERVISION FOR AND ON BEHALF OF CLASSIC CONSULTING ENGINEERS AND SURVEYORS, LLC

MARC A. WHORTON, COLORADO, P.E. #37155

6/9/2020

CLASSIC CONSULTING

619 N. Cascade Avenue, Suite 200
 Colorado Springs, Colorado 80903

(719)785-0790
 (719)785-0799(fax)

RETREAT AT TIMBERIDGE FILING NO. 1 CONSTRUCTION PLANS
 GRADING & EROSION CONTROL PLAN

DESIGNED BY	PRA	SCALE	DATE	04-05-19
DRAWN BY	ESO	(H) 1" = 60'	SHEET	5 OF 35
CHECKED BY	(V)	1" = N/A	JOB NO.	1185.00

MATCHLINE ~ (SEE SHEET 7)

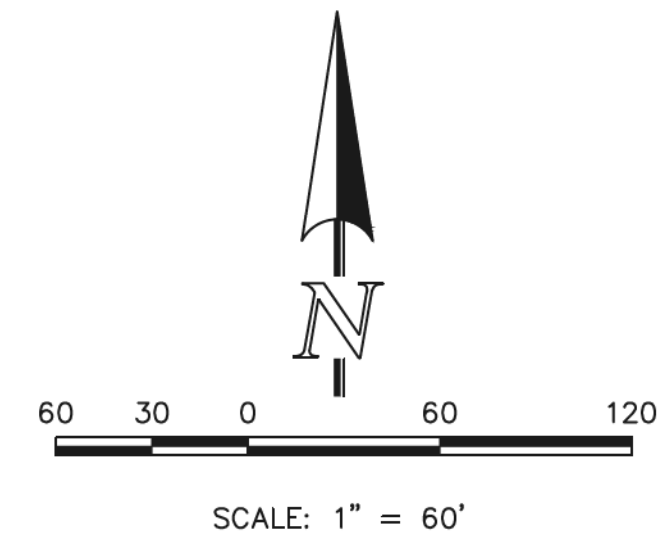

LEGEND

- LIMIT OF GRADING
- CUT/FILL LINE
- PROPOSED CONTOUR-10
- PROPOSED CONTOUR-2
- EXISTING CONTOUR-10
- EXISTING CONTOUR-2
- SILT FENCE
- FEMA FLOODPLAIN
- SILT FENCE
- SEEDING/MULCHING
- ROCK CHECK DAM
- VEHICLE TRACKING CONTROL
- STRAW BALES
- INLET PROTECTION
- EROSION CONTROL BLANKET
- TURF REINFORCEMENT MAT (NORTH AMERICAN GREEN - ROLLMAX P300 OR EQUIV.)
- TEMPORARY SEDIMENT BASIN
- EXIST. DIRECTION OF FLOW
- DIRECTION OF FLOW
- HIGH POINT
- LOW POINT
- A LOT
- B LOT
- WALKOUT LOT
- NATURAL LOT
- TRANSITION LOT
- GARDEN LOT
- EROSION CONTROL BLANKET (NORTH AMERICAN GREEN - SC150 OR EQUIVALENT) TO BE INSTALLED ON ALL 3:1 SLOPES OR GREATER

MATCHLINE ~ (SEE SHEET 4)

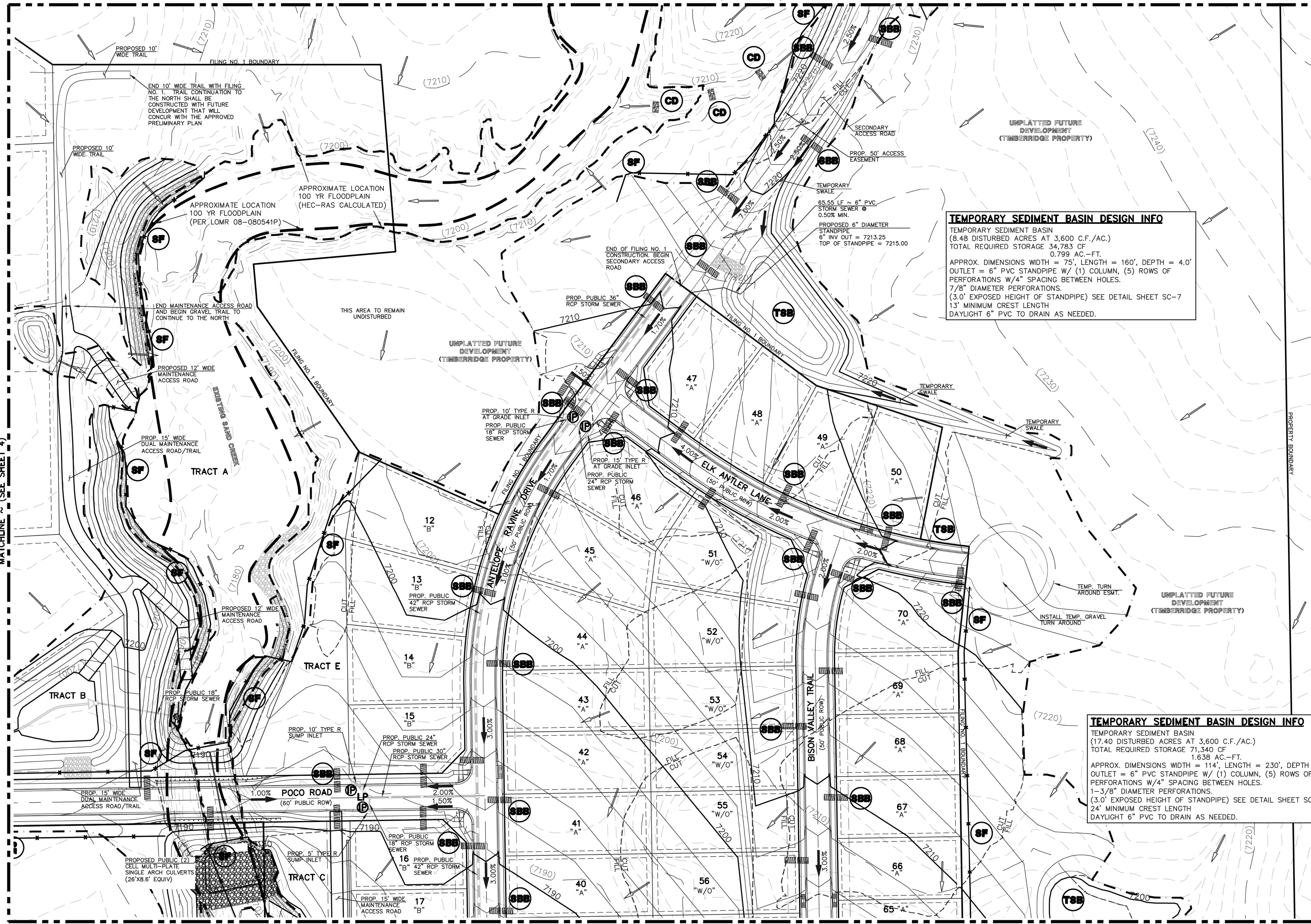

TEMPORARY SEDIMENT BASIN DESIGN INFO
 TEMPORARY SEDIMENT BASIN
 (8.48 DISTURBED ACRES AT 3,600 C.F./AC.)
 TOTAL REQUIRED STORAGE 34,783 CF
 0.799 AC.-FT.
 APPROX. DIMENSIONS WIDTH = 75', LENGTH = 160', DEPTH = 4.0'
 OUTLET = 6" PVC STANDPIPE W/ (1) COLUMN, (5) ROWS OF PERFORATIONS W/4" SPACING BETWEEN HOLES.
 7/8" DIAMETER PERFORATIONS.
 (3.0' EXPOSED HEIGHT OF STANDPIPE) SEE DETAIL SHEET SC-7
 13' MINIMUM CREST LENGTH
 DAYLIGHT 6" PVC TO DRAIN AS NEEDED.

TEMPORARY SEDIMENT BASIN DESIGN INFO
 TEMPORARY SEDIMENT BASIN
 (17.40 DISTURBED ACRES AT 3,600 C.F./AC.)
 TOTAL REQUIRED STORAGE 71,340 CF
 1.638 AC.-FT.
 APPROX. DIMENSIONS WIDTH = 114', LENGTH = 230', DEPTH = 4.0'
 OUTLET = 6" PVC STANDPIPE W/ (1) COLUMN, (5) ROWS OF PERFORATIONS W/4" SPACING BETWEEN HOLES.
 1-3/8" DIAMETER PERFORATIONS.
 (3.0' EXPOSED HEIGHT OF STANDPIPE) SEE DETAIL SHEET SC-7
 24' MINIMUM CREST LENGTH
 DAYLIGHT 6" PVC TO DRAIN AS NEEDED.

MATCHLINE ~ (SEE SHEET 5)

<p>48 HOURS BEFORE YOU DIG, CALL UTILITY LOCATORS 811 UTILITY NOTIFICATION CENTER OF COLORADO IT'S THE LAW</p> <p>THE LOCATIONS OF EXISTING UNDERGROUND UTILITIES ARE SHOWN IN AN APPROXIMATE WAY ONLY. THE CONTRACTOR SHALL DETERMINE THE EXACT LOCATION OF ALL EXISTING UTILITIES BEFORE COMMENCING WORK. THE CONTRACTOR SHALL BE FULLY RESPONSIBLE FOR ANY AND ALL DAMAGES WHICH MIGHT BE CAUSED BY HIS FAILURE TO EXACTLY LOCATE AND PRESERVE ANY AND ALL UNDERGROUND UTILITIES.</p>	<table border="1" style="width: 100%; border-collapse: collapse;"> <thead> <tr> <th>NO.</th> <th>REVISION</th> <th>DATE</th> </tr> </thead> <tbody> <tr> <td>1</td> <td>REVISED PER COUNTY COMMENTS</td> <td>08-12-19</td> </tr> <tr> <td>2</td> <td>REVISED PER COUNTY COMMENTS</td> <td>1-21-20</td> </tr> </tbody> </table>	NO.	REVISION	DATE	1	REVISED PER COUNTY COMMENTS	08-12-19	2	REVISED PER COUNTY COMMENTS	1-21-20	<p>REVIEW:</p> <p>PREPARED UNDER MY DIRECT SUPERVISION FOR AND ON BEHALF OF CLASSIC CONSULTING ENGINEERS AND SURVEYORS, LLC</p> <p>MARC. A. WORTON, CO. GRADUATE P.E. #37155</p> <p>DATE 6/9/2020</p>	<p>CLASSIC CONSULTING</p> <p>619 N. Cascade Avenue, Suite 200 Colorado Springs, Colorado 80903 (719)785-0790 (719)785-0799(Fax)</p>	<p>RETREAT AT TIMBERIDGE FILING NO. 1 CONSTRUCTION PLANS GRADING & EROSION CONTROL PLAN</p> <table border="1" style="width: 100%; border-collapse: collapse;"> <tr> <td>DESIGNED BY</td> <td>PRA</td> <td>SCALE</td> <td>DATE</td> <td>04-05-19</td> </tr> <tr> <td>DRAWN BY</td> <td>ESO</td> <td>(H) 1" = 60'</td> <td>SHEET</td> <td>6 OF 35</td> </tr> <tr> <td>CHECKED BY</td> <td>(V) 1" = N/A</td> <td>JOB NO.</td> <td colspan="2">1185.00</td> </tr> </table>	DESIGNED BY	PRA	SCALE	DATE	04-05-19	DRAWN BY	ESO	(H) 1" = 60'	SHEET	6 OF 35	CHECKED BY	(V) 1" = N/A	JOB NO.	1185.00	
NO.	REVISION	DATE																										
1	REVISED PER COUNTY COMMENTS	08-12-19																										
2	REVISED PER COUNTY COMMENTS	1-21-20																										
DESIGNED BY	PRA	SCALE	DATE	04-05-19																								
DRAWN BY	ESO	(H) 1" = 60'	SHEET	6 OF 35																								
CHECKED BY	(V) 1" = N/A	JOB NO.	1185.00																									

LEGEND

- LIMIT OF GRADING
- CUT/FILL LINE
- PROPOSED CONTOUR-10
- PROPOSED CONTOUR-2
- EXISTING CONTOUR-10
- EXISTING CONTOUR-2
- SILT FENCE
- FEMA FLOODPLAIN
- SILT FENCE
- SEEDING/MULCHING
- ROCK CHECK DAM
- VEHICLE TRACKING CONTROL
- STRAW BALES
- INLET PROTECTION
- EROSION CONTROL BLANKET
- TURF REINFORCEMENT MAT (NORTH AMERICAN GREEN - ROLLMAX P300 OR EQUIV.)
- TEMPORARY SEDIMENT BASIN
- EXIST. DIRECTION OF FLOW
- DIRECTION OF FLOW
- HIGH POINT
- LOW POINT
- A LOT
- B LOT
- WALKOUT LOT
- NATURAL LOT
- TRANSITION LOT
- GARDEN LOT
- EROSION CONTROL BLANKET (NORTH AMERICAN GREEN - SC150 OR EQUIVALENT) TO BE INSTALLED ON ALL 3:1 SLOPES OR GREATER

SEEDING/MULCHING NOTE:
SEEDING AND MULCHING SHALL BE INSTALLED INSIDE THE ENTIRE LIMITS OF GRADING EXCLUDING ROADWAY SURFACES, SIDEWALK AREAS AND RIP-RAP AREAS.

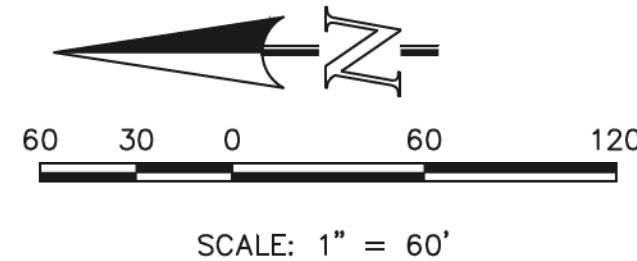

48 HOURS BEFORE YOU DIG,
CALL UTILITY LOCATORS

811

UTILITY NOTIFICATION CENTER OF COLORADO
IT'S THE LAW

THE LOCATIONS OF EXISTING UNDERGROUND UTILITIES ARE SHOWN IN AN APPROXIMATE WAY ONLY. THE CONTRACTOR SHALL DETERMINE THE EXACT LOCATION OF ALL EXISTING UTILITIES BEFORE COMMENCING WORK. THE CONTRACTOR SHALL BE FULLY RESPONSIBLE FOR ANY AND ALL DAMAGES WHICH MIGHT BE CAUSED BY HIS FAILURE TO EXACTLY LOCATE AND PRESERVE ANY AND ALL UNDERGROUND UTILITIES.

NO.	REVISION	DATE
1	REVISED PER COUNTY COMMENTS	08-13-19
2	REVISED PER COUNTY COMMENTS	2-21-20

REVIEW:

PREPARED UNDER MY DIRECT SUPERVISION FOR AND ON BEHALF OF CLASSIC CONSULTING ENGINEERS AND SURVEYORS, LLC

MARC A. WORTON, CO. BRABO, P.E. #37155
DATE 6/9/2020

CLASSIC CONSULTING
619 N. Cascade Avenue, Suite 200
Colorado Springs, Colorado 80903
(719) 785-0790
(719) 785-0799 (fax)

RETREAT AT TIMBERIDGE FILING NO. 1
CONSTRUCTION PLANS

GRADING & EROSION CONTROL PLAN

DESIGNED BY	PRA	SCALE	DATE	04-05-19
DRAWN BY	ESO	(H) 1" = 60'	SHEET	7 OF 35
CHECKED BY	(V)	1" = N/A	JOB NO.	1185.00

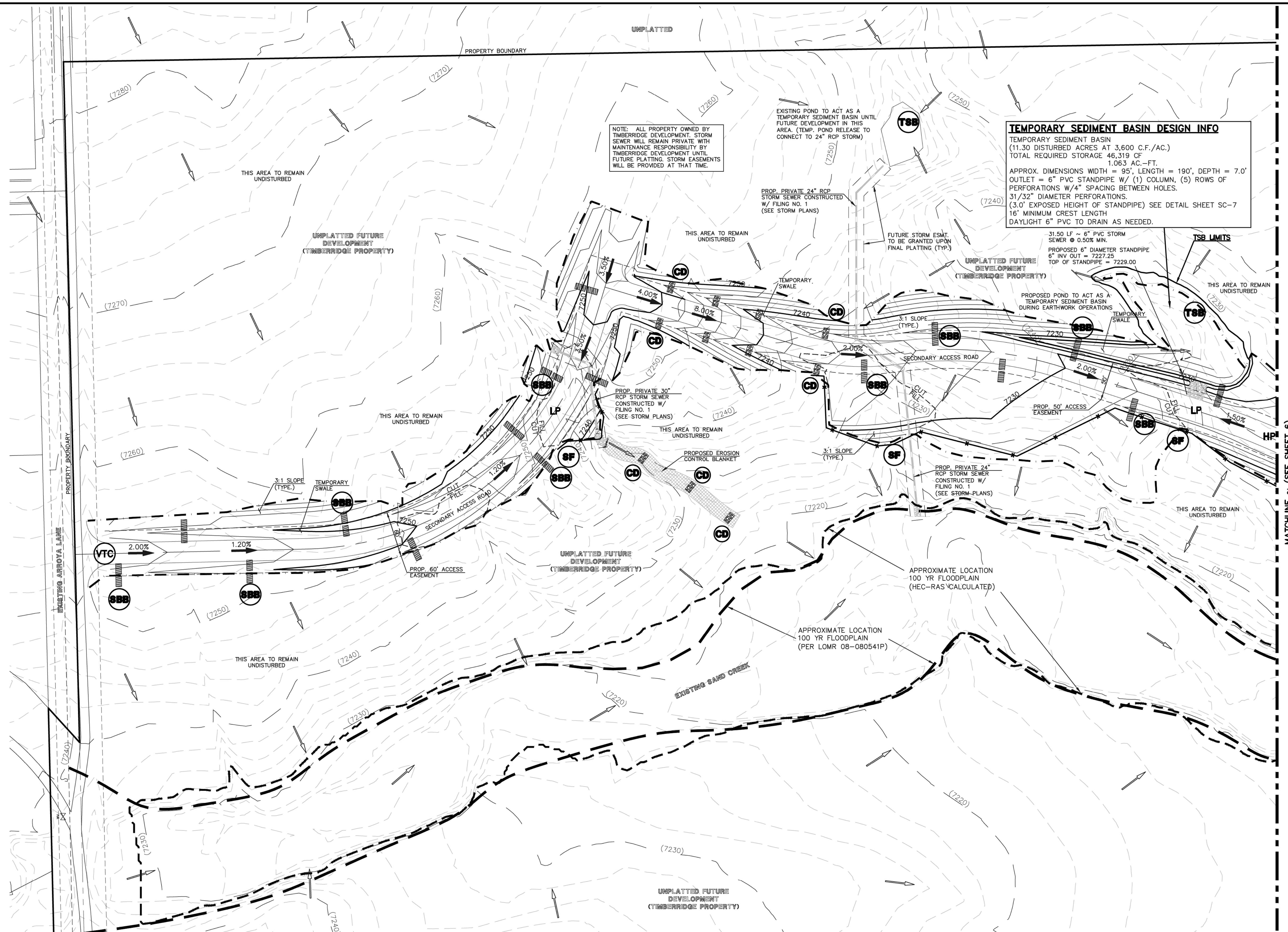

NOTE: ALL PROPERTY OWNED BY TIMBERIDGE DEVELOPMENT. STORM SEWER WILL REMAIN PRIVATE WITH MAINTENANCE RESPONSIBILITY BY TIMBERIDGE DEVELOPMENT UNTIL FUTURE PLATTING. STORM EASEMENTS WILL BE PROVIDED AT THAT TIME.

TEMPORARY SEDIMENT BASIN DESIGN INFO
TEMPORARY SEDIMENT BASIN
(11.30 DISTURBED ACRES AT 3,600 C.F./AC.)
TOTAL REQUIRED STORAGE 46,319 CF
1.063 AC.-FT.
APPROX. DIMENSIONS WIDTH = 95', LENGTH = 190', DEPTH = 7.0'
OUTLET = 6" PVC STANDPIPE W/ (1) COLUMN, (5) ROWS OF PERFORATIONS W/4" SPACING BETWEEN HOLES.
31/32" DIAMETER PERFORATIONS.
(3.0' EXPOSED HEIGHT OF STANDPIPE) SEE DETAIL SHEET SC-7
16' MINIMUM CREST LENGTH
DAYLIGHT 6" PVC TO DRAIN AS NEEDED.

MATCHLINE ~ (SEE SHEET 6)

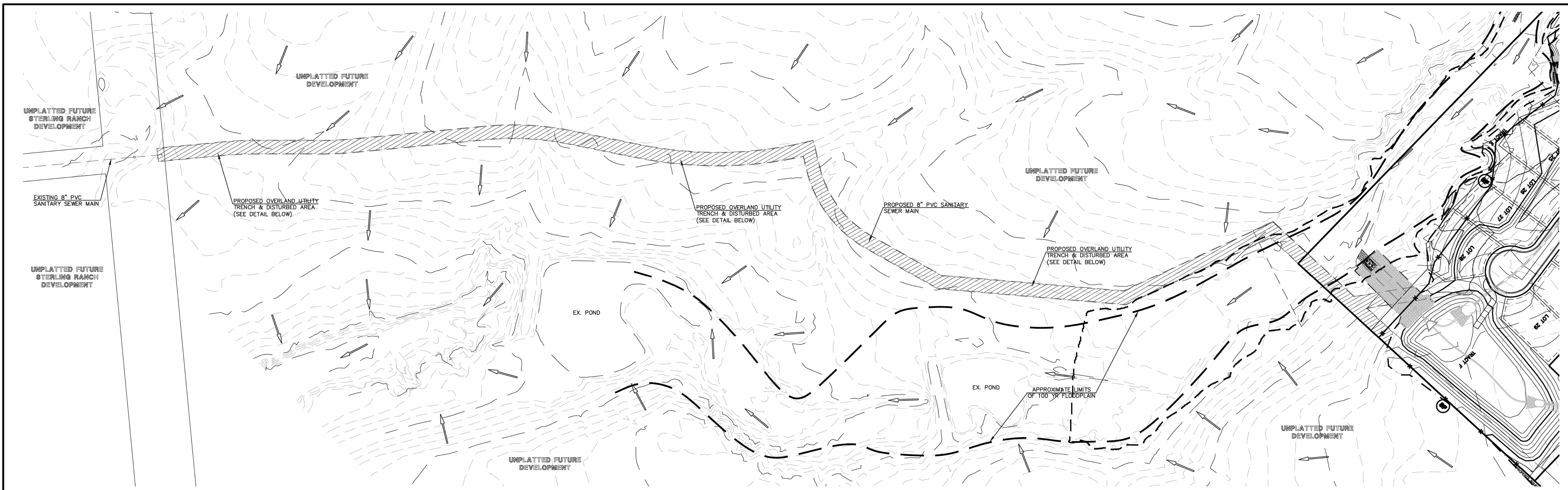

LEGEND

- LIMIT OF GRADING
- PROPOSED CONTOUR-10
- PROPOSED CONTOUR-2
- EXISTING CONTOUR-10
- EXISTING CONTOUR-2
- SILT FENCE
- SILT FENCE
- SEEDING/MULCHING
- ROCK CHECK DAM
- VEHICLE TRACKING CONTROL
- STRAW BALES
- INLET PROTECTION
- EROSION CONTROL BLANKET
- TURF REINFORCEMENT MAT
- TEMPORARY SEDIMENT BASIN
- EXIST. DIRECTION OF FLOW
- DIRECTION OF FLOW
- HIGH POINT
- LOW POINT
- EROSION CONTROL BLANKET (NORTH AMERICAN GREEN - SC150 OR EQUIVALENT) TO BE INSTALLED ON ALL 3:1 SLOPES OR GREATER

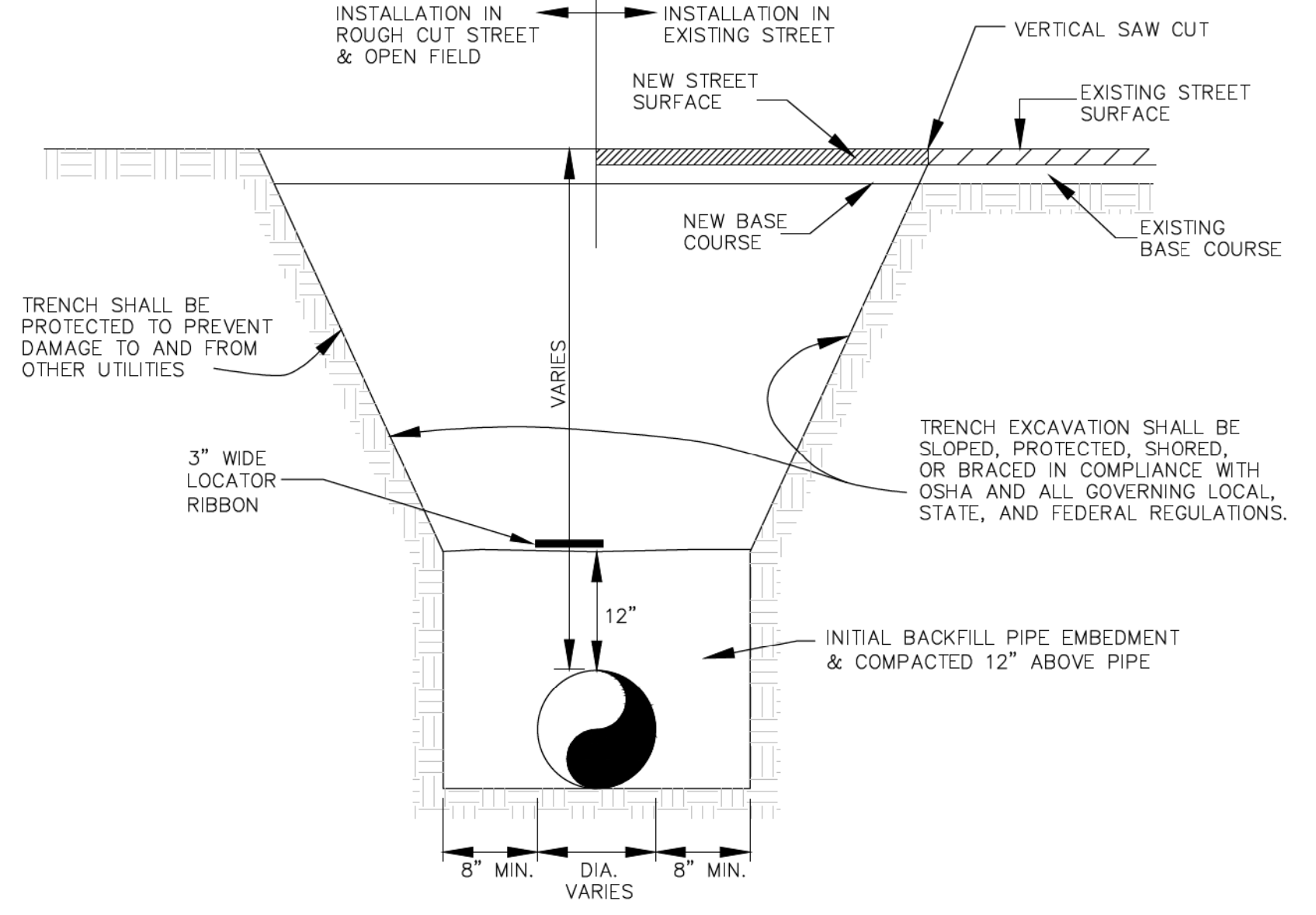

BOTTOM OF TRENCH WIDTH	
PIPE DIAMETER	MINIMUM WIDTH
6"	24"
12"	30"

AN OVER EXCAVATED TRENCH SHALL BE FILLED AND THOROUGHLY COMPACTED

UNDER NO CIRCUMSTANCES WILL PIPE BE LAID IN A PROPOSED FILL AREA PRIOR TO IT BEING COMPLETELY FILLED. THE FILL WILL BE PLACED AND COMPACTED TO PROPOSED GRADE OF THE PIPE.

TYPICAL TRENCH CROSS SECTION

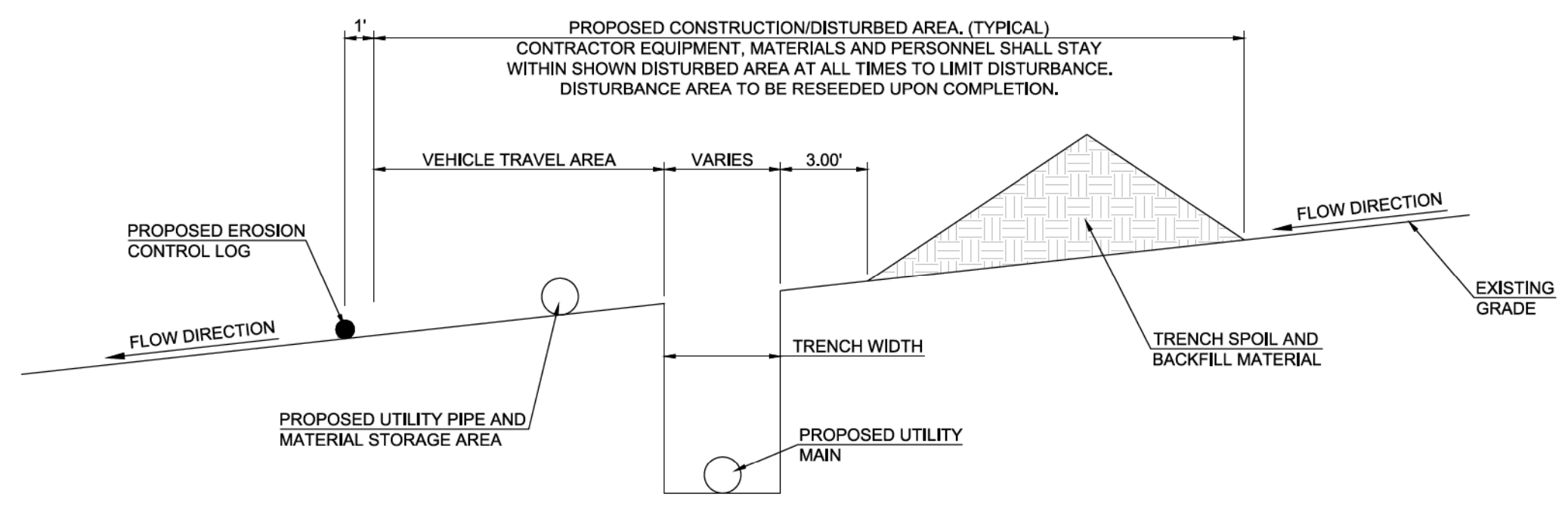

TYPICAL OVERLAND UTILITY TRENCH & DISTURBED AREA DETAIL

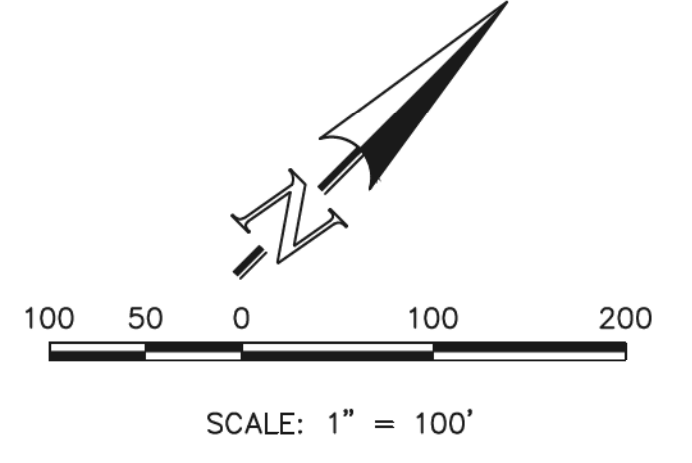

<p>48 HOURS BEFORE YOU DIG, CALL UTILITY LOCATORS 811</p> <p>UTILITY NOTIFICATION CENTER OF COLORADO IT'S THE LAW</p> <p>THE LOCATIONS OF EXISTING UNDERGROUND UTILITIES ARE SHOWN IN AN APPROXIMATE WAY ONLY. THE CONTRACTOR SHALL DETERMINE THE EXACT LOCATION OF ALL EXISTING UTILITIES BEFORE COMMENCING WORK. THE CONTRACTOR SHALL BE FULLY RESPONSIBLE FOR ANY AND ALL DAMAGES WHICH MIGHT BE CAUSED BY HIS FAILURE TO EXACTLY LOCATE AND PRESERVE ANY AND ALL UNDERGROUND UTILITIES.</p>	<table border="1" style="width: 100%; border-collapse: collapse;"> <thead> <tr> <th>NO.</th> <th>REVISION</th> <th>DATE</th> </tr> </thead> <tbody> <tr> <td>1</td> <td>REVISED PER COUNTY COMMENTS</td> <td>08-13-19</td> </tr> </tbody> </table>	NO.	REVISION	DATE	1	REVISED PER COUNTY COMMENTS	08-13-19	<p>REVIEW:</p> <p>PREPARED UNDER MY DIRECT SUPERVISION FOR AND ON BEHALF OF CLASSIC CONSULTING ENGINEERS AND SURVEYORS, LLC</p> <p style="text-align: center;"></p> <p>MARC A. WHORTON, COLORADO, P.E. #37155</p>	<p style="text-align: center;">CLASSIC CONSULTING</p> <p>619 N. Cascade Avenue, Suite 200 Colorado Springs, Colorado 80903</p> <p>(719)785-0790 (719)785-0799 (fax)</p>	<p>RETREAT AT TIMBERRIDGE FILING NO. 1</p> <p>CONSTRUCTION PLANS</p> <p>GRADING & EROSION CONTROL PLAN</p> <table border="1" style="width: 100%; border-collapse: collapse;"> <tr> <td>DESIGNED BY</td> <td>PRA</td> <td>SCALE</td> <td>DATE</td> </tr> <tr> <td>DRAWN BY</td> <td>ESO</td> <td>(H) 1" = 100'</td> <td>SHEET 8 OF 35</td> </tr> <tr> <td>CHECKED BY</td> <td>(V) 1" = N/A</td> <td>JOB NO.</td> <td>1185.00</td> </tr> </table>	DESIGNED BY	PRA	SCALE	DATE	DRAWN BY	ESO	(H) 1" = 100'	SHEET 8 OF 35	CHECKED BY	(V) 1" = N/A	JOB NO.	1185.00
NO.	REVISION	DATE																				
1	REVISED PER COUNTY COMMENTS	08-13-19																				
DESIGNED BY	PRA	SCALE	DATE																			
DRAWN BY	ESO	(H) 1" = 100'	SHEET 8 OF 35																			
CHECKED BY	(V) 1" = N/A	JOB NO.	1185.00																			

SEEDING/MULCHING NOTE: SEEDING AND MULCHING SHALL BE INSTALLED INSIDE THE ENTIRE LIMITS OF GRADING EXCLUDING ROADWAY SURFACES, SIDEWALK AREAS AND RIP-RAP AREAS.

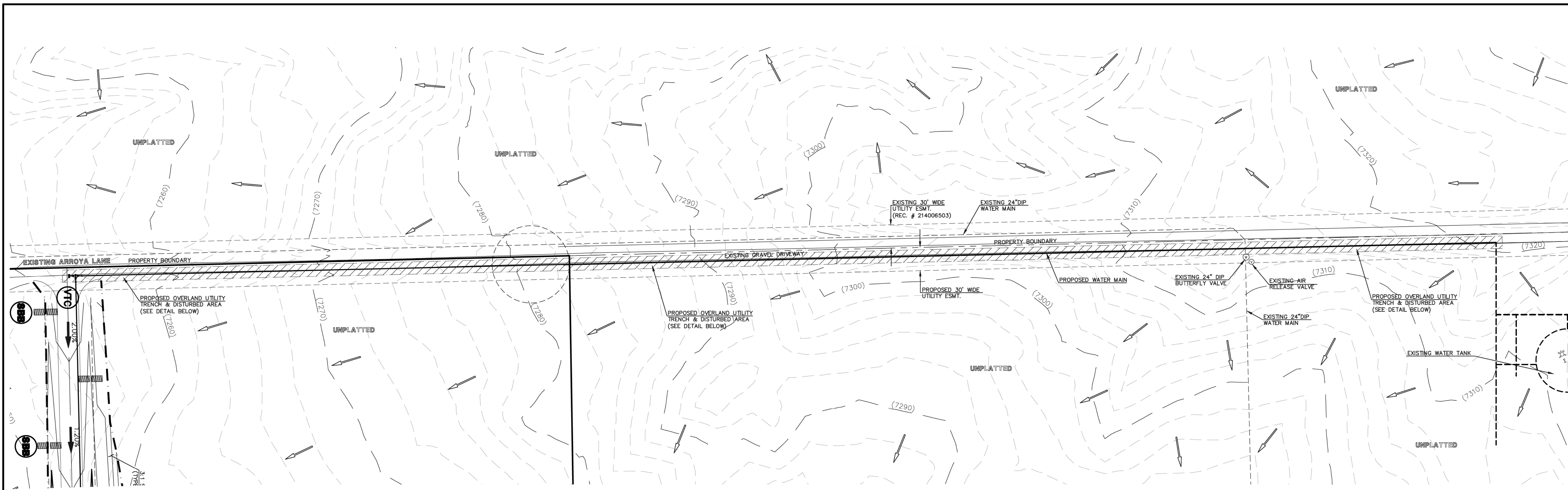

LEGEND

- LIMIT OF GRADING
- PROPOSED CONTOUR-10
- PROPOSED CONTOUR-2
- EXISTING CONTOUR-10
- EXISTING CONTOUR-2
- SILT FENCE
- SILT FENCE
- SEEDING/MULCHING
- ROCK CHECK DAM
- VEHICLE TRACKING CONTROL
- STRAW BALES
- INLET PROTECTION
- EROSION CONTROL BLANKET
- TURF REINFORCEMENT MAT
- TEMPORARY SEDIMENT BASIN
- EXIST. DIRECTION OF FLOW
- DIRECTION OF FLOW
- HIGH POINT
- LOW POINT
- EROSION CONTROL BLANKET (NORTH AMERICAN GREEN - SC150 OR EQUIVALENT) TO BE INSTALLED ON ALL 3:1 SLOPES OR GREATER
- SEEDING/MULCHING NOTE: SEEDING AND MULCHING SHALL BE INSTALLED INSIDE THE ENTIRE LIMITS OF GRADING EXCLUDING ROADWAY SURFACES, SIDEWALK AREAS AND RIP-RAP AREAS.

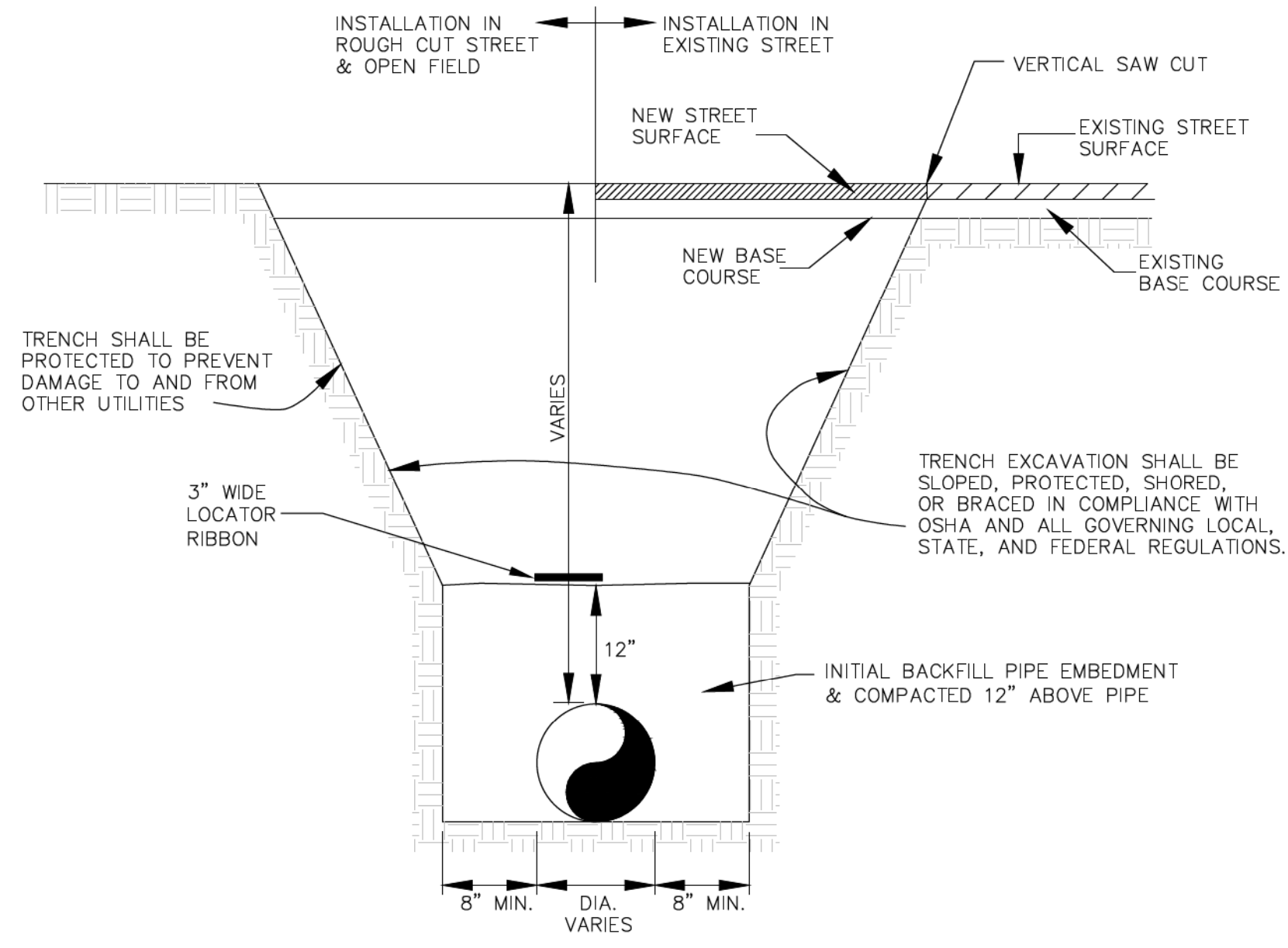

BOTTOM OF TRENCH WIDTH	
PIPE DIAMETER	MINIMUM WIDTH
6"	24"
12"	30"

AN OVER EXCAVATED TRENCH SHALL BE FILLED AND THOROUGHLY COMPACTED.

UNDER NO CIRCUMSTANCES WILL PIPE BE LAID IN A PROPOSED FILL AREA PRIOR TO IT BEING COMPLETELY FILLED. THE FILL WILL BE PLACED AND COMPACTED TO PROPOSED GRADE OF THE PIPE.

TYPICAL TRENCH CROSS SECTION

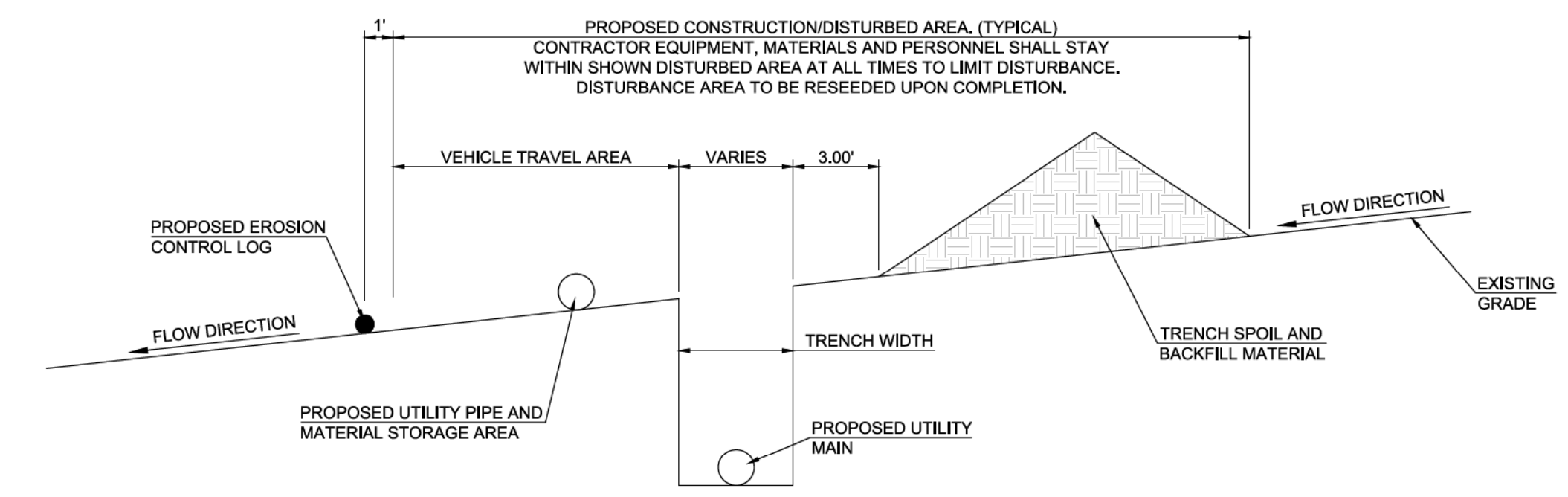

TYPICAL OVERLAND UTILITY TRENCH & DISTURBED AREA DETAIL

<p>48 HOURS BEFORE YOU DIG, CALL UTILITY LOCATORS 811</p> <p>UTILITY NOTIFICATION CENTER OF COLORADO IT'S THE LAW</p> <p>THE LOCATIONS OF EXISTING UNDERGROUND UTILITIES ARE SHOWN IN AN APPROXIMATE WAY ONLY. THE CONTRACTOR SHALL DETERMINE THE EXACT LOCATION OF ALL EXISTING UTILITIES BEFORE COMMENCING WORK. THE CONTRACTOR SHALL BE FULLY RESPONSIBLE FOR ANY AND ALL DAMAGES WHICH MIGHT BE CAUSED BY HIS FAILURE TO EXACTLY LOCATE AND PRESERVE ANY AND ALL UNDERGROUND UTILITIES.</p>	<table border="1" style="width: 100%; border-collapse: collapse;"> <thead> <tr> <th>NO.</th> <th>REVISION</th> <th>DATE</th> </tr> </thead> <tbody> <tr> <td>1</td> <td>REVISED PER COUNTY COMMENTS</td> <td>08-13-19</td> </tr> <tr> <td>2</td> <td>REVISED PER COUNTY COMMENTS</td> <td>6-8-20</td> </tr> </tbody> </table>	NO.	REVISION	DATE	1	REVISED PER COUNTY COMMENTS	08-13-19	2	REVISED PER COUNTY COMMENTS	6-8-20	<p>REVIEW:</p> <p>PREPARED UNDER MY DIRECT SUPERVISION FOR AND ON BEHALF OF CLASSIC CONSULTING ENGINEERS AND SURVEYORS, LLC</p> <p style="text-align: center;"></p> <p>MARC A. WHORTON, COLORADO P.E. #37155</p>	<p>6/9/2020</p> <p>DATE</p>	<p></p> <p>CLASSIC CONSULTING</p>	<p>RETREAT AT TIMBERIDGE FILING NO. 1</p> <p>CONSTRUCTION PLANS</p> <p>GRADING & EROSION CONTROL PLAN</p> <table border="1" style="width: 100%; border-collapse: collapse;"> <tr> <td>DESIGNED BY</td> <td>PRA</td> <td>SCALE</td> <td>DATE</td> <td>04-05-19</td> </tr> <tr> <td>DRAWN BY</td> <td>ESO</td> <td>(H) 1" = 60'</td> <td>SHEET</td> <td>9 OF 35</td> </tr> <tr> <td>CHECKED BY</td> <td>(V) 1" = N/A</td> <td>JOB NO.</td> <td colspan="2">1185.00</td> </tr> </table>	DESIGNED BY	PRA	SCALE	DATE	04-05-19	DRAWN BY	ESO	(H) 1" = 60'	SHEET	9 OF 35	CHECKED BY	(V) 1" = N/A	JOB NO.	1185.00	
NO.	REVISION	DATE																											
1	REVISED PER COUNTY COMMENTS	08-13-19																											
2	REVISED PER COUNTY COMMENTS	6-8-20																											
DESIGNED BY	PRA	SCALE	DATE	04-05-19																									
DRAWN BY	ESO	(H) 1" = 60'	SHEET	9 OF 35																									
CHECKED BY	(V) 1" = N/A	JOB NO.	1185.00																										

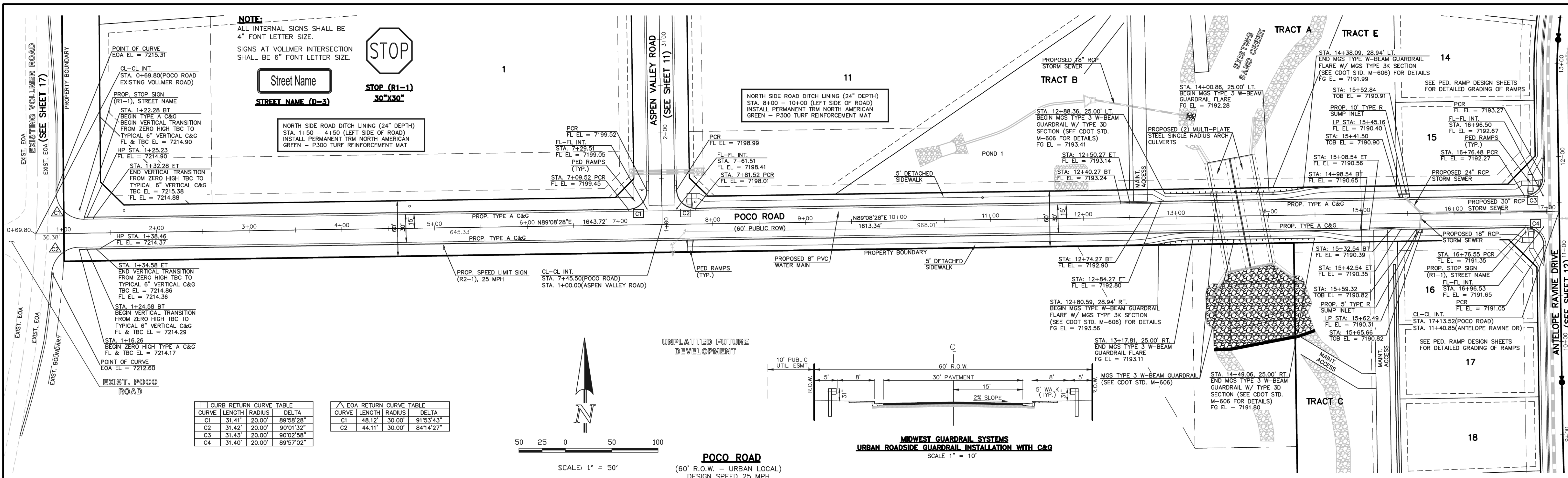

CURB RETURN CURVE TABLE			
CURVE	LENGTH	RADIUS	DELTA
C1	31.41'	20.00'	89°58'28"
C2	31.42'	20.00'	90°01'32"
C3	31.43'	20.00'	90°02'58"
C4	31.40'	20.00'	89°57'02"

EOA RETURN CURVE TABLE			
CURVE	LENGTH	RADIUS	DELTA
C1	48.12'	30.00'	91°53'43"
C2	44.11'	30.00'	84°14'27"

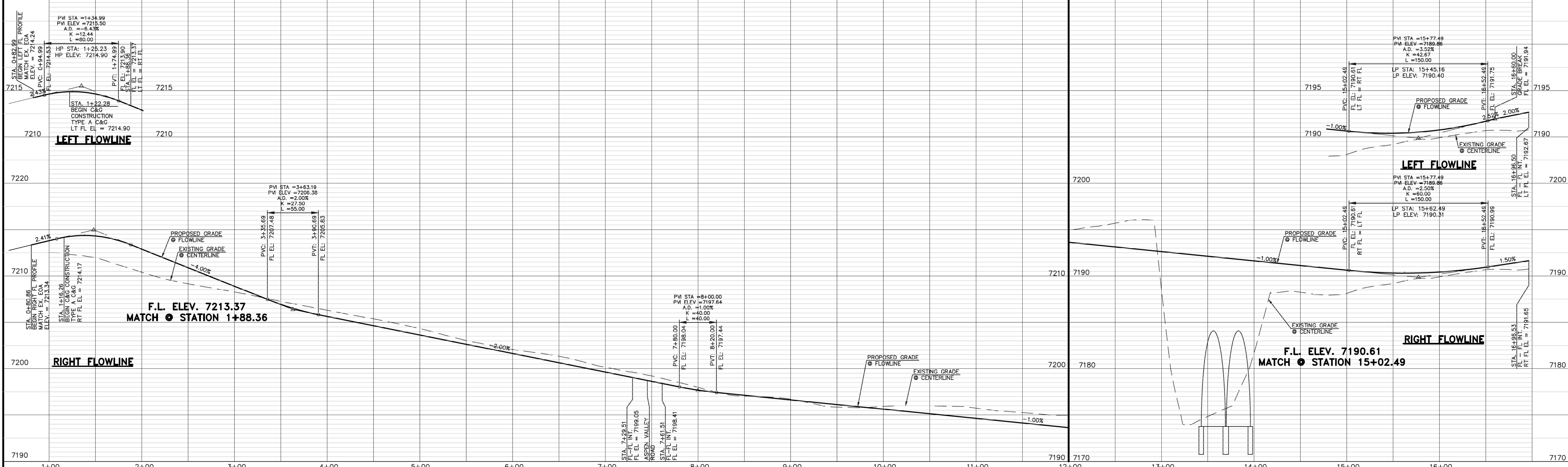
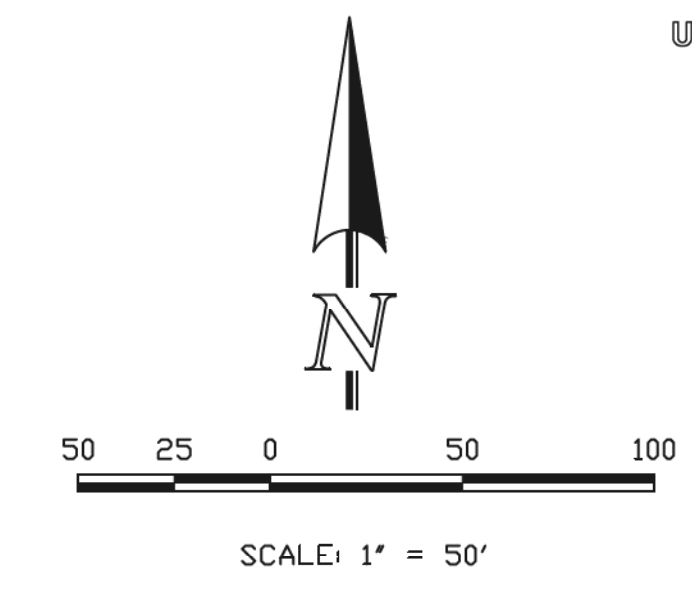

48 HOURS BEFORE YOU DIG,
CALL UTILITY LOCATORS
811
UTILITY NOTIFICATION CENTER OF COLORADO
IT'S THE LAW

THE LOCATIONS OF EXISTING UNDERGROUND UTILITIES ARE SHOWN IN AN APPROXIMATE WAY ONLY. THE CONTRACTOR SHALL DETERMINE THE EXACT LOCATION OF ALL EXISTING UTILITIES BEFORE COMMENCING WORK. THE CONTRACTOR SHALL BE FULLY RESPONSIBLE FOR ANY AND ALL DAMAGES WHICH MIGHT BE CAUSED BY HIS FAILURE TO EXACTLY LOCATE AND PRESERVE ANY AND ALL UNDERGROUND UTILITIES.

NO.	REVISION	DATE
1	REVISED PER COUNTY COMMENTS	08-13-19
2	REVISED PER COUNTY COMMENTS	3-13-20
3	REVISED PER COUNTY COMMENTS	6-8-20

REVIEW:

PREPARED UNDER MY DIRECT SUPERVISION FOR AND ON BEHALF OF
CLASSIC CONSULTING ENGINEERS AND SURVEYORS, LLC

MARC A. WHORTON, COLORADO #37155

6/9/2020



RETREAT AT TIMBERIDGE FILING NO. 1
CONSTRUCTION PLANS
STREET IMPROVEMENT PLANS
POCO ROAD

DESIGNED BY: MAW
DRAWN BY: ESO
CHECKED BY:

SCALE: (H) 1" = 50'
(V) 1" = 5'

DATE: 04-05-19
SHEET: 10 OF 35
JOB NO.: 1185.00

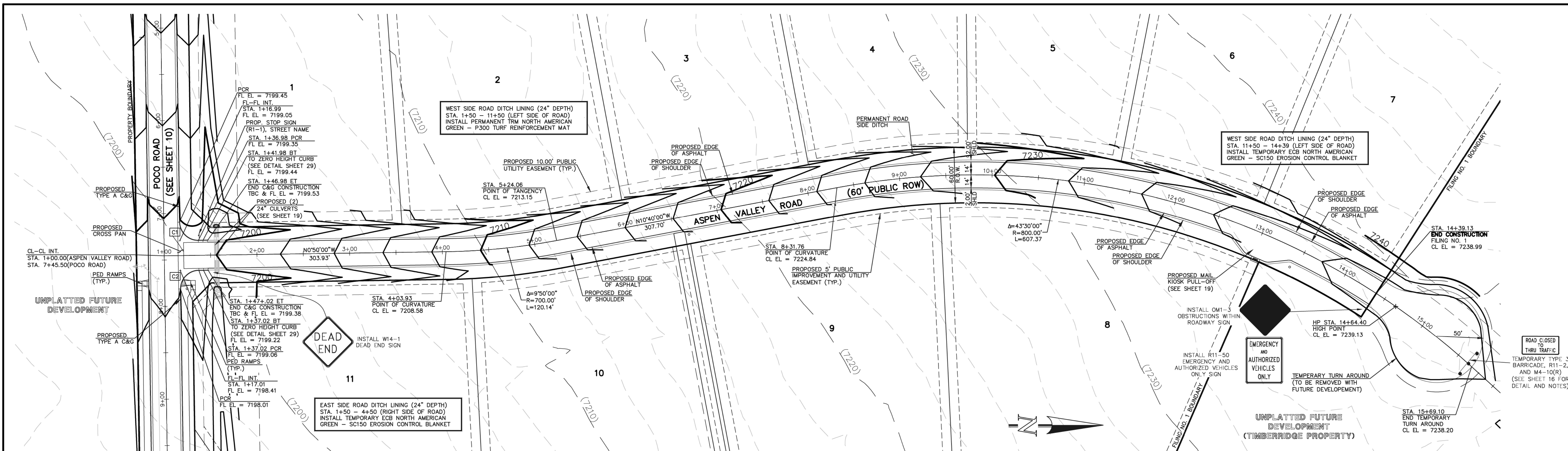

CURB RETURN CURVE TABLE

CURVE	LENGTH	RADIUS	DELTA
C1	31.41'	20.00'	89°58'28"
C2	31.42'	20.00'	90°01'32"

ASPEN VALLEY ROAD
 (60' R.O.W. - RURAL LOCAL)
 DESIGN SPEED 25 MPH

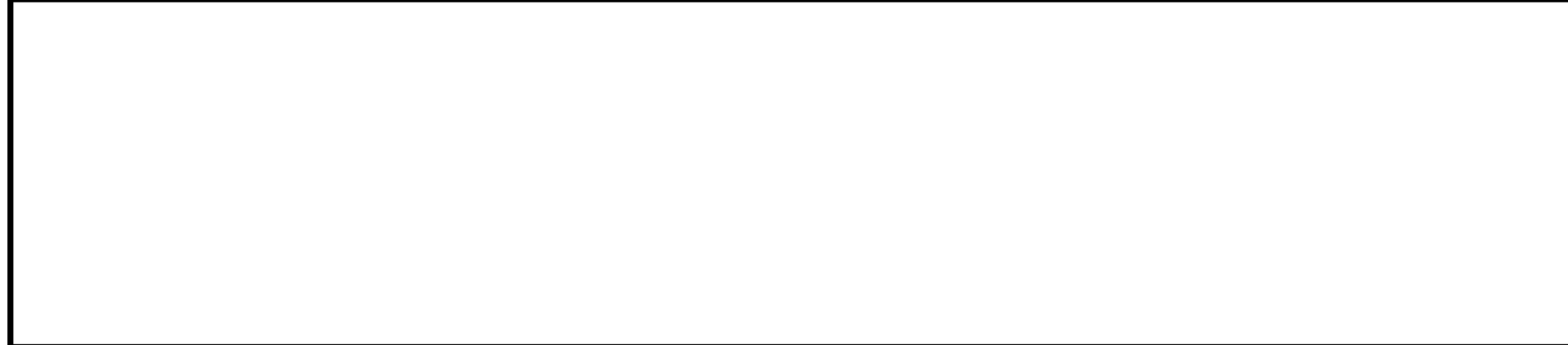
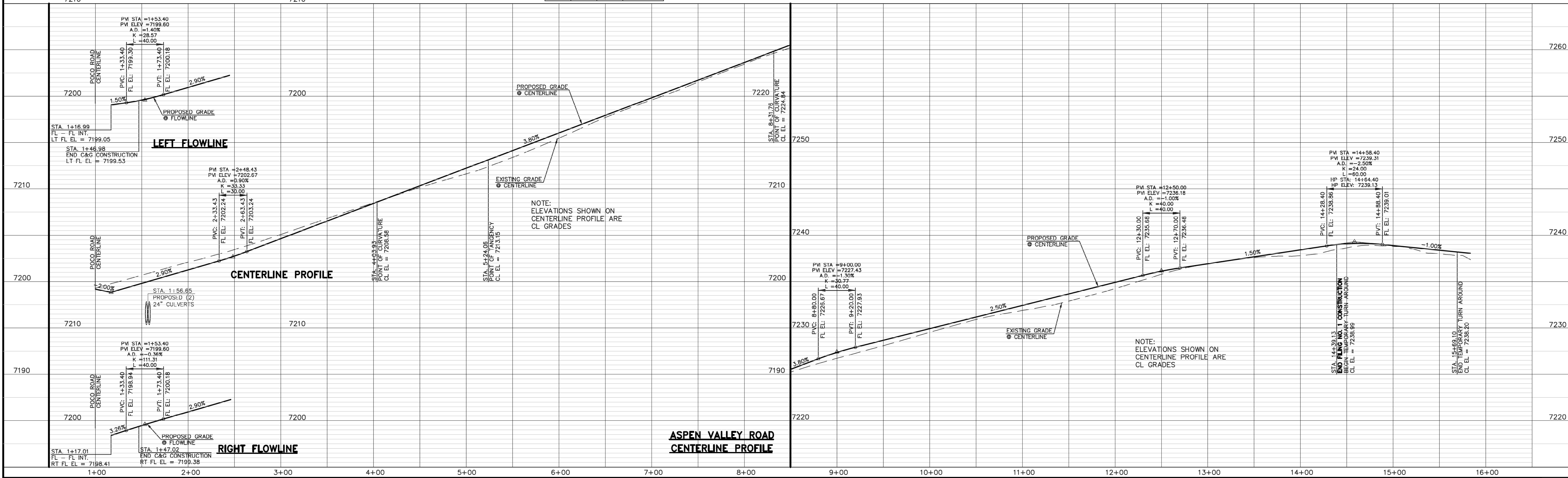
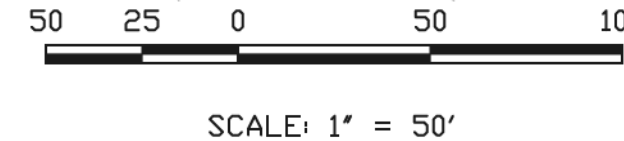

48 HOURS BEFORE YOU DIG,
 CALL UTILITY LOCATORS
811
 UTILITY NOTIFICATION CENTER OF COLORADO
 IT'S THE LAW

THE LOCATIONS OF EXISTING UNDERGROUND UTILITIES ARE SHOWN IN AN APPROXIMATE WAY ONLY. THE CONTRACTOR SHALL DETERMINE THE EXACT LOCATION OF ALL EXISTING UTILITIES BEFORE COMMENCING WORK. THE CONTRACTOR SHALL BE FULLY RESPONSIBLE FOR ANY AND ALL DAMAGES WHICH MIGHT BE CAUSED BY HIS FAILURE TO EXACTLY LOCATE AND PRESERVE ANY AND ALL UNDERGROUND UTILITIES.

NO.	REVISION	DATE
1	REVISED PER COUNTY COMMENTS	08-13-19
2	ADDED MAIL KIOSK PULL-OFF	2-12-20

REVIEW:

PREPARED UNDER MY DIRECT SUPERVISION FOR AND ON BEHALF OF
 CLASSIC CONSULTING ENGINEERS AND SURVEYORS, LLC

MARC A. WHORTON, COLORADO P.E. #37155

DATE: 6/9/2020



RETREAT AT TIMBERIDGE FILING NO. 1
CONSTRUCTION PLANS
 STREET IMPROVEMENT PLANS
 ASPEN VALLEY ROAD

DESIGNED BY: MAW
 DRAWN BY: ESO
 CHECKED BY:

SCALE: (H) 1" = 50'
 (V) 1" = 5'

DATE: 04-05-19
 SHEET: 11 OF 35
 JOB NO.: 1185.00

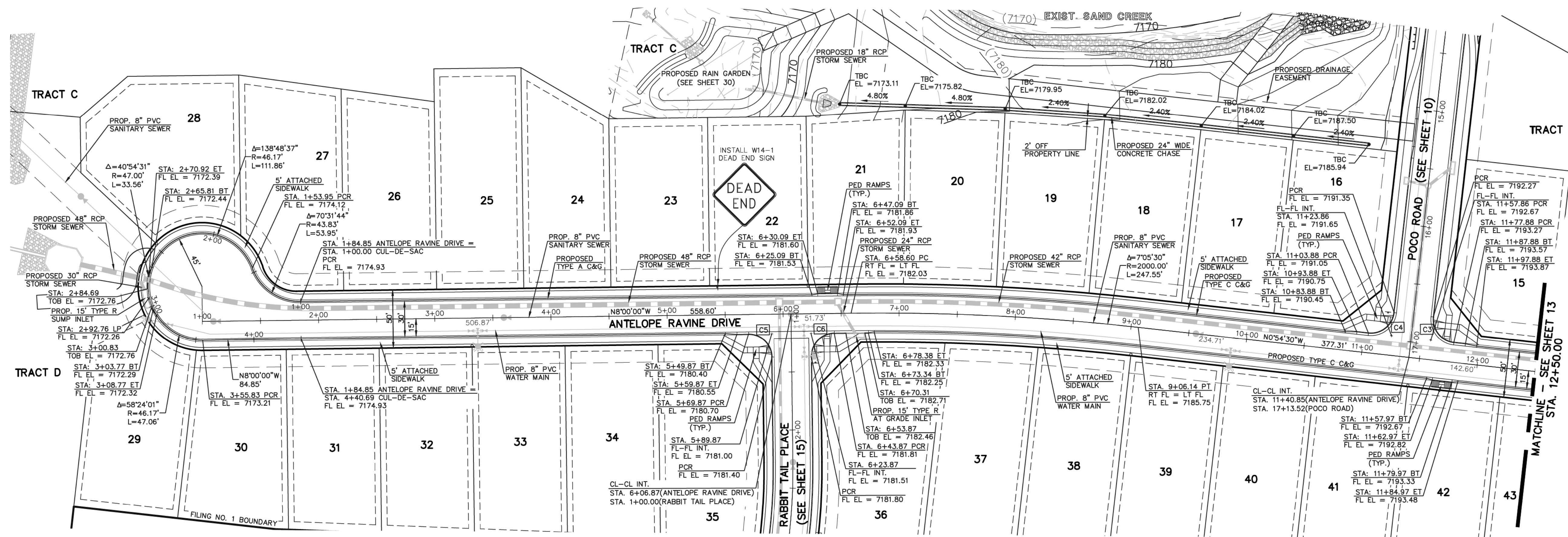

CURVE	LENGTH	RADIUS	DELTA
C3	31.43'	20.00'	90°02'58"
C4	31.40'	20.00'	89°57'02"
C5	31.42'	20.00'	90°00'00"
C6	31.42'	20.00'	90°00'00"

ANTELOPE RAVINE DRIVE
 (50' R.O.W. - URBAN LOCAL)
 DESIGN SPEED 25 MPH

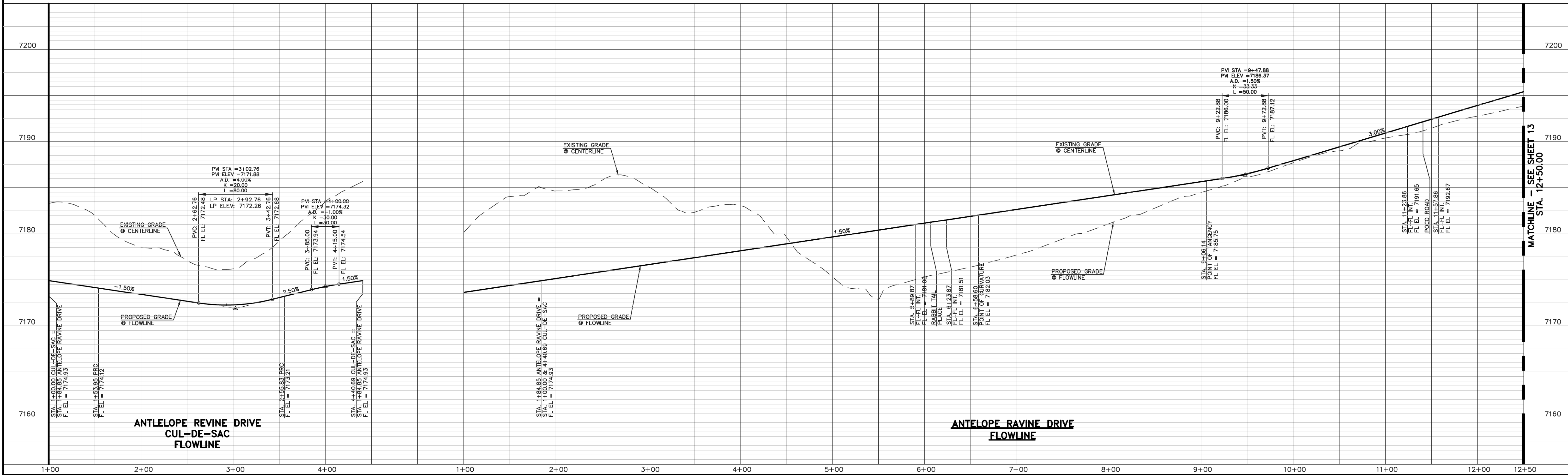
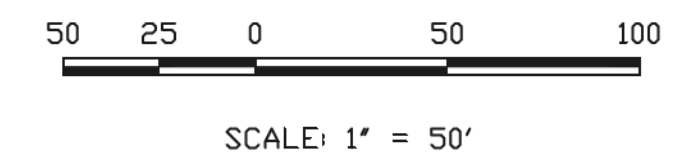

48 HOURS BEFORE YOU DIG,
 CALL UTILITY LOCATORS
811
 UTILITY NOTIFICATION CENTER OF COLORADO
 IT'S THE LAW

THE LOCATIONS OF EXISTING UNDERGROUND UTILITIES ARE SHOWN IN AN APPROXIMATE WAY ONLY. THE CONTRACTOR SHALL DETERMINE THE EXACT LOCATION OF ALL EXISTING UTILITIES BEFORE COMMENCING WORK. THE CONTRACTOR SHALL BE FULLY RESPONSIBLE FOR ANY AND ALL DAMAGES WHICH MIGHT BE CAUSED BY HIS FAILURE TO EXACTLY LOCATE AND PRESERVE ANY AND ALL UNDERGROUND UTILITIES.

NO.	REVISION	DATE
1	REVISED PER COUNTY COMMENTS	08-13-19

REVIEW:
 PREPARED UNDER MY DIRECT SUPERVISION FOR AND ON BEHALF OF
 CLASSIC CONSULTING ENGINEERS AND SURVEYORS, LLC

MARC A. WHORTON, COLORADO #37155

6/9/2020



RETREAT AT TIMBERIDGE FILING NO. 1
 CONSTRUCTION PLANS
 STREET IMPROVEMENT PLANS
 ANTELOPE RAVINE DRIVE & CUL-DE-SAC

DESIGNED BY: MAW
 DRAWN BY: ESO
 CHECKED BY:

SCALE: (H) 1" = 50'
 (V) 1" = 5'

DATE: 04-05-19
 SHEET 12 OF 35
 JOB NO. 1185.00

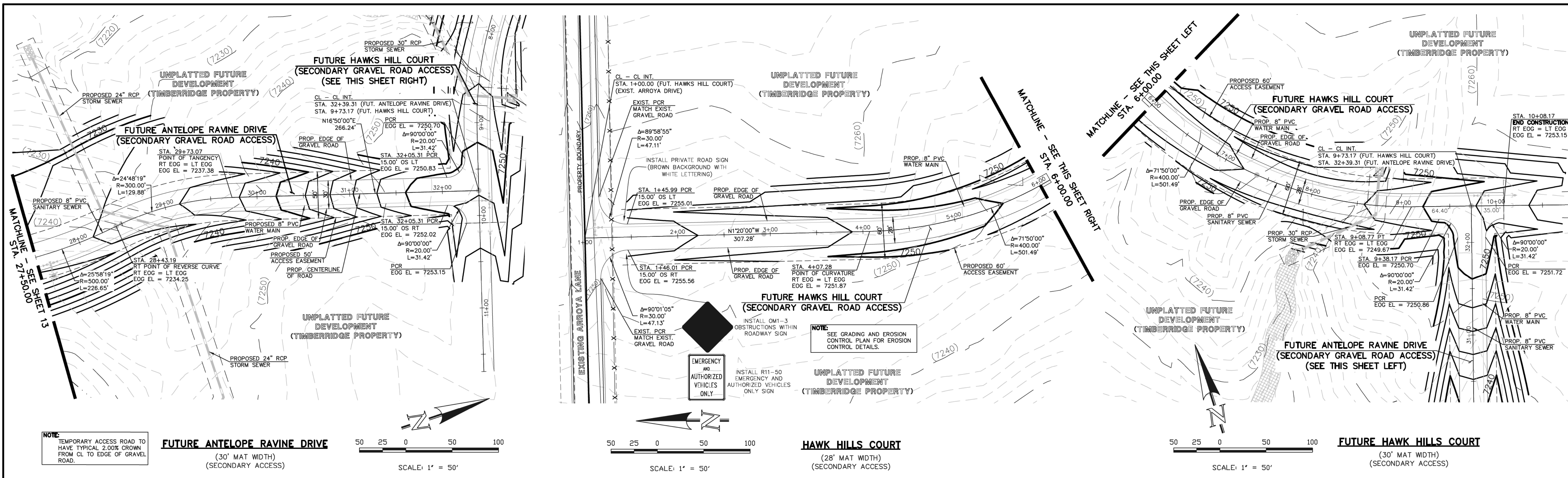

NOTE: TEMPORARY ACCESS ROAD TO HAVE TYPICAL 2.00% CROWN FROM CL TO EDGE OF GRAVEL ROAD.

FUTURE ANTELOPE RAVINE DRIVE
(30' MAT WIDTH)
(SECONDARY ACCESS)

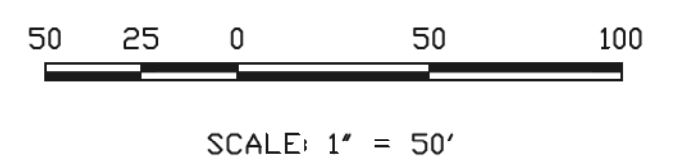
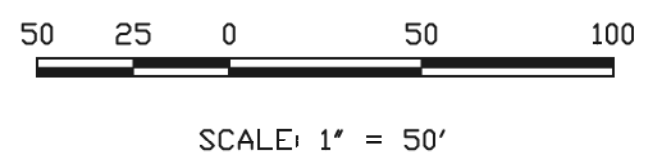

HAWK HILLS COURT
(28' MAT WIDTH)
(SECONDARY ACCESS)

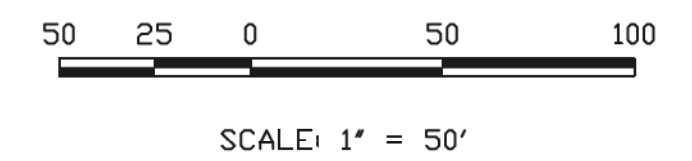

FUTURE HAWK HILLS COURT
(30' MAT WIDTH)
(SECONDARY ACCESS)

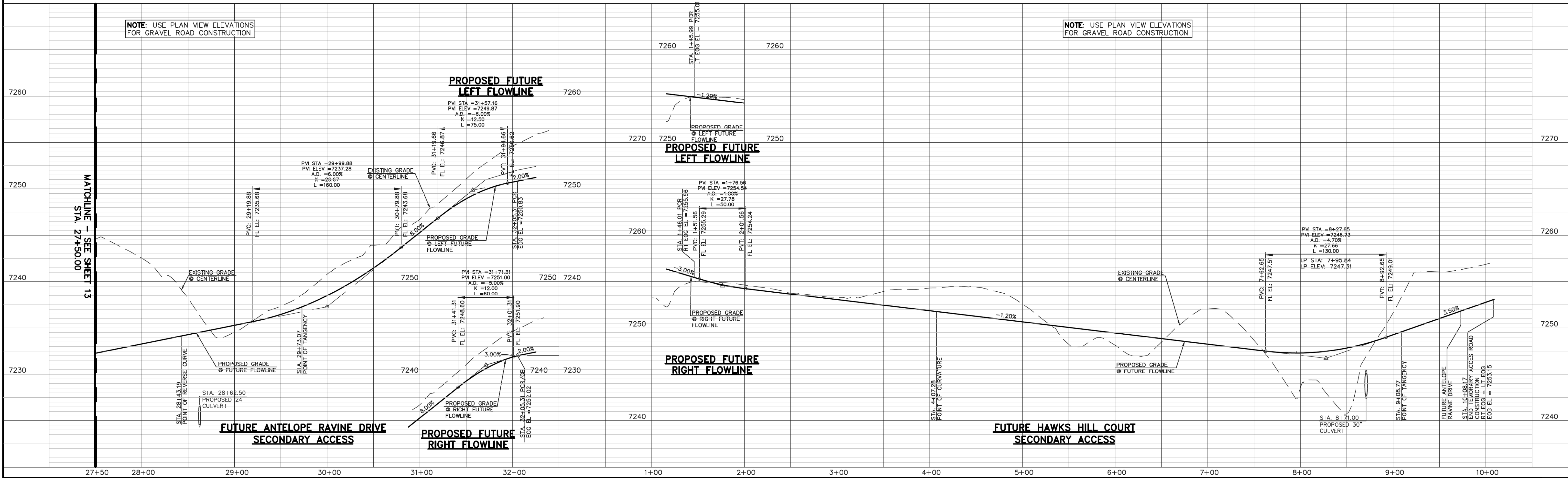

NOTE: USE PLAN VIEW ELEVATIONS FOR GRAVEL ROAD CONSTRUCTION

NOTE: USE PLAN VIEW ELEVATIONS FOR GRAVEL ROAD CONSTRUCTION

48 HOURS BEFORE YOU DIG,
CALL UTILITY LOCATORS
811
UTILITY NOTIFICATION CENTER OF COLORADO
IT'S THE LAW

THE LOCATIONS OF EXISTING UNDERGROUND UTILITIES ARE SHOWN IN AN APPROXIMATE WAY ONLY. THE CONTRACTOR SHALL DETERMINE THE EXACT LOCATION OF ALL EXISTING UTILITIES BEFORE COMMENCING WORK. THE CONTRACTOR SHALL BE FULLY RESPONSIBLE FOR ANY AND ALL DAMAGES WHICH MIGHT BE CAUSED BY HIS FAILURE TO EXACTLY LOCATE AND PRESERVE ANY AND ALL UNDERGROUND UTILITIES.

NO.	REVISION	DATE
1	REVISED PER COUNTY COMMENTS	08-13-19
2	REVISED PER COUNTY COMMENTS	6-9-20

REVIEW:
PREPARED UNDER MY DIRECT SUPERVISION FOR AND ON BEHALF OF CLASSIC CONSULTING ENGINEERS AND SURVEYORS, LLC

MARC A. WHORTON, COLORADO P.E. #37155

DATE: 6/10/2020

619 N. Cascade Avenue, Suite 200
Colorado Springs, Colorado 80903

(719) 785-0790
(719) 785-0799 (fax)

RETREAT AT TIMBERIDGE FILING NO. 1
CONSTRUCTION PLANS
STREET IMPROVEMENT PLANS
ANTELOPE RAVINE DR. & HAWK HILL CT.

DESIGNED BY: MAW
DRAWN BY: ESO
CHECKED BY:

SCALE: (H) 1" = 50'
(V) 1" = 5'

DATE: 04-05-19
SHEET 14 OF 35
JOB NO. 1185.00

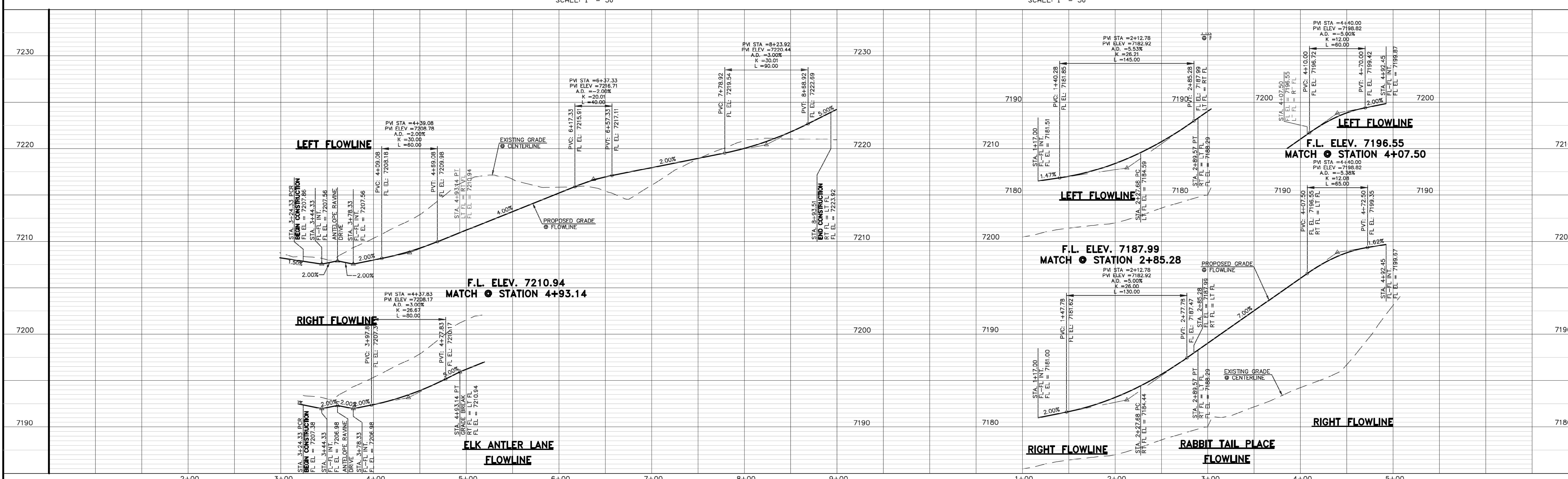
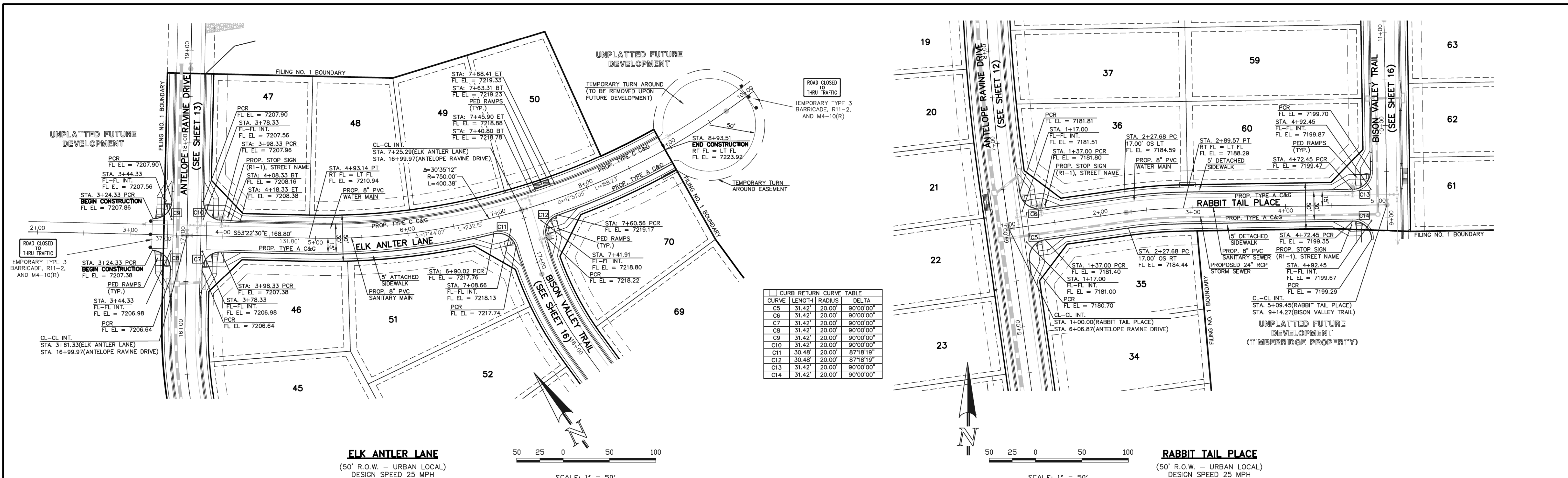

48 HOURS BEFORE YOU DIG,
CALL UTILITY LOCATORS
811
UTILITY NOTIFICATION CENTER OF COLORADO
IT'S THE LAW

THE LOCATIONS OF EXISTING UNDERGROUND UTILITIES ARE SHOWN IN AN APPROXIMATE WAY ONLY. THE CONTRACTOR SHALL DETERMINE THE EXACT LOCATION OF ALL EXISTING UTILITIES BEFORE COMMENCING WORK. THE CONTRACTOR SHALL BE FULLY RESPONSIBLE FOR ANY AND ALL DAMAGES WHICH MIGHT BE CAUSED BY HIS FAILURE TO EXACTLY LOCATE AND PRESERVE ANY AND ALL UNDERGROUND UTILITIES.

NO.	REVISION	DATE
1	REVISED PER COUNTY COMMENTS	08-13-19
2	REVISED PER COUNTY COMMENTS	6-9-20

REVIEW: PREPARED UNDER MY DIRECT SUPERVISION FOR AND ON BEHALF OF CLASSIC CONSULTING ENGINEERS AND SURVEYORS, LLC

MARC A. WHORTON, COLORADO P.E. #37155

6/10/2020

CLASSIC CONSULTING

619 N. Cascade Avenue, Suite 200
Colorado Springs, Colorado 80903
(719)785-0790
(719)785-0799(fax)

RETREAT AT TIMBERIDGE FILING NO. 1
CONSTRUCTION PLANS
STREET IMPROVEMENT PLANS
ELK ANTLER LANE & RABBIT TAIL PLACE

DESIGNED BY	MAW	SCALE	DATE	04-05-19
DRAWN BY	ESO	(H) 1" = 50'	SHEET	15 OF 35
CHECKED BY	(V) 1" = 5'	JOB NO.	1185.00	

RAIL LENGTH TABLE *

TYPE 3 BARRICADE		LENGTH
FIXED	MOVABLE	
F - A	M - A	8' - 14'
F - B	M - B	15' - 24'
F - C	M - C	25' - 35'
F - D	M - D	> 35'

- NOTES**
- TYPE 3 BARRICADES HAVE 3 REFLECTORIZED RAIL FACES IF FACING TRAFFIC IN ONE DIRECTION AND 6 IF FACING TRAFFIC IN TWO DIRECTIONS.
 - THE PORTION OF THE POST ABOVE THE GROUND LINE SHALL BE PAINTED IN ACCORDANCE WITH THE APPROPRIATE GENERAL NOTE.
 - DETACHABLE EXTENSION WING RAILS FOR BYPASSING OF CONSTRUCTION EQUIPMENT ARE PERMITTED, WHEN NECESSARY, ON FIXED OR MOVABLE TYPE 3 BARRICADES. THE LENGTH SHALL BE ADEQUATE TO CLOSE THE SHOULDER AS REQUIRED.

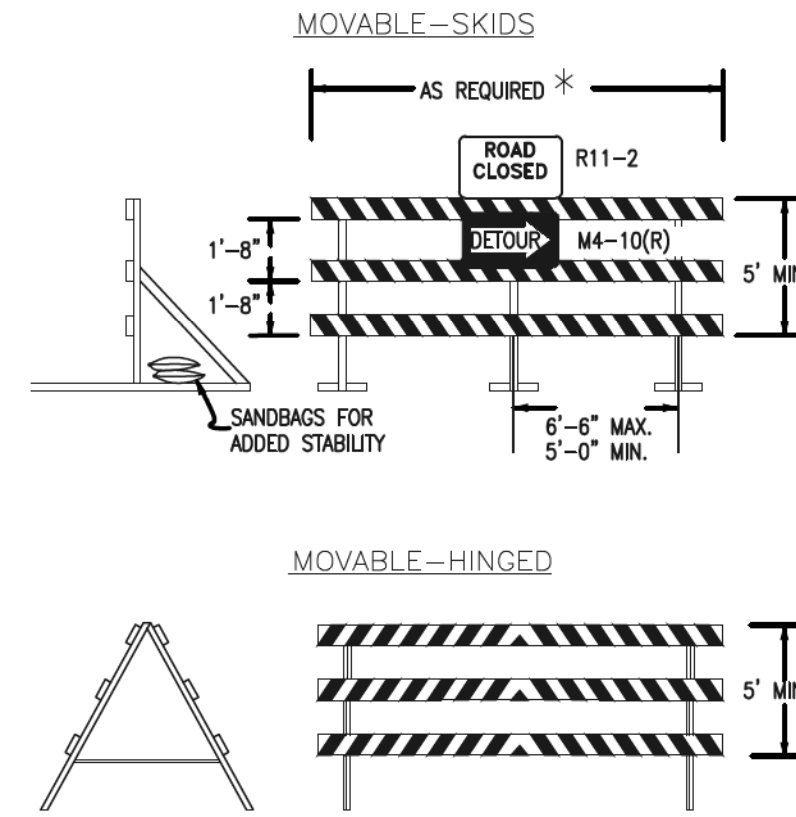

TYPICAL TYPE 3 BARRICADES



STOP (R1-1)
30"x30"



Street Name
STREET NAME (D-3)



SPEED LIMIT 25
SPEED LIMIT (R2-1)
24"x30"



NO OUTLET →
W14-2aR & W14-2aL

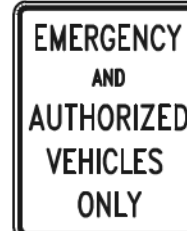

EMERGENCY AND AUTHORIZED VEHICLES ONLY
INSTALL R11-50 EMERGENCY AND AUTHORIZED VEHICLES ONLY SIGN



INSTALL OM1-3 OBSTRUCTIONS WITHIN ROADWAY SIGN

CURB RETURN CURVE TABLE			
CURVE	LENGTH	RADIUS	DELTA
C11	30.48'	20.00'	87°18'19"
C12	30.48'	20.00'	87°18'19"
C13	31.42'	20.00'	90°00'00"
C14	31.42'	20.00'	90°00'00"

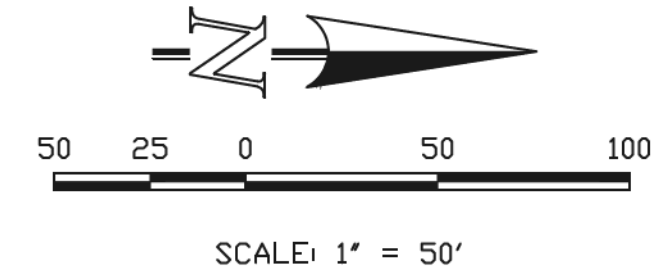
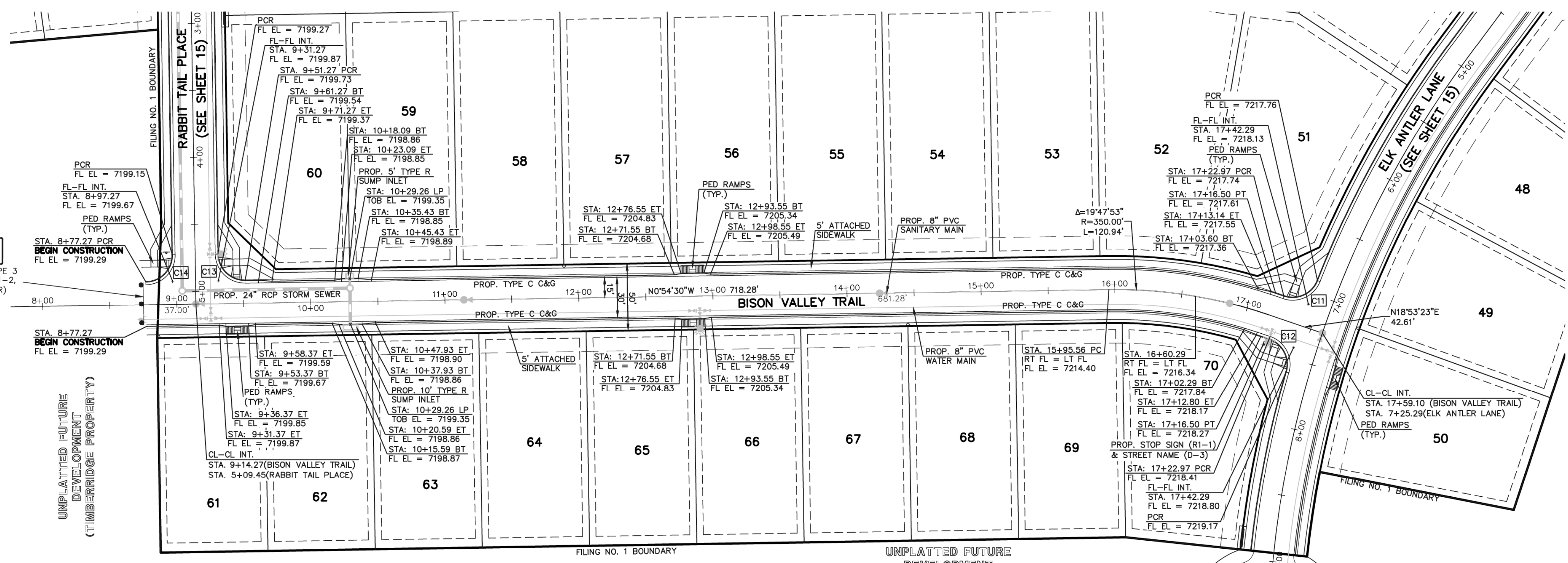

BISON VALLEY TRAIL
(50' R.O.W. - URBAN LOCAL)
DESIGN SPEED 25 MPH



48 HOURS BEFORE YOU DIG,
CALL UTILITY LOCATORS
811
UTILITY NOTIFICATION CENTER OF COLORADO
IT'S THE LAW

THE LOCATIONS OF EXISTING UNDERGROUND UTILITIES ARE SHOWN IN AN APPROXIMATE WAY ONLY. THE CONTRACTOR SHALL DETERMINE THE EXACT LOCATION OF ALL EXISTING UTILITIES BEFORE COMMENCING WORK. THE CONTRACTOR SHALL BE FULLY RESPONSIBLE FOR ANY AND ALL DAMAGES WHICH MIGHT BE CAUSED BY HIS FAILURE TO EXACTLY LOCATE AND PRESERVE ANY AND ALL UNDERGROUND UTILITIES.

NO.	REVISION	DATE
1	REVISED PER COUNTY COMMENTS	08-13-19
2	REVISED PER COUNTY COMMENTS	6-9-20

REVIEW:
PREPARED UNDER MY DIRECT SUPERVISION FOR AND ON BEHALF OF CLASSIC CONSULTING ENGINEERS AND SURVEYORS, LLC

MARC A. WHORTON, COLORADO P.E. #37155

6/10/2020



RETREAT AT TIMBRIDGE FILING NO. 1
CONSTRUCTION PLANS
STREET IMPROVEMENT PLANS
BISON VALLEY TRAIL

DESIGNED BY: MAW
DRAWN BY: ESO
CHECKED BY:

SCALE: (H) 1" = 50'
(V) 1" = 5'

DATE: 04-05-19
SHEET 16 OF 35
JOB NO. 1185.00

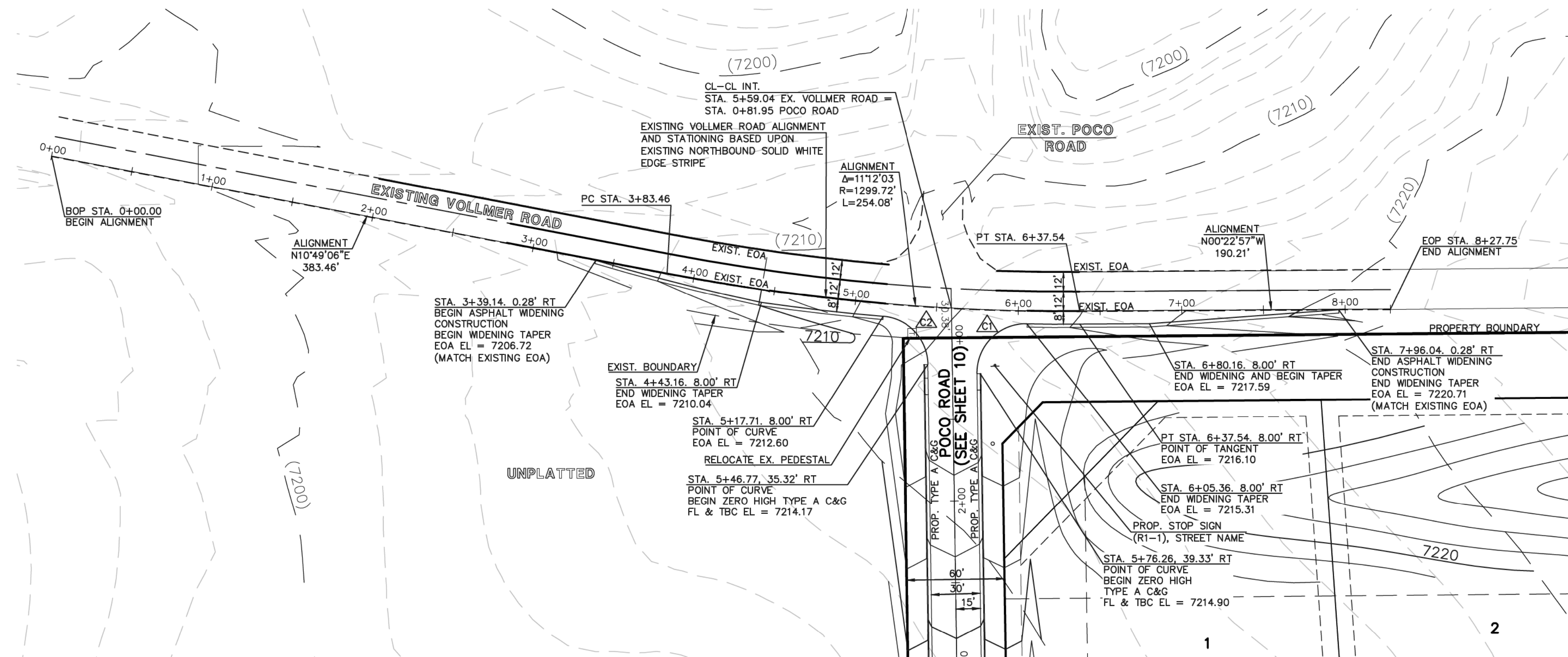

△	EOA RETURN	CURVE TABLE	
CURVE	LENGTH	RADIUS	DELTA
C1	48.12'	30.00'	91°53'43"
C2	44.11'	30.00'	84°14'27"

EXISTING VOLLMER ROAD
(R.O.W. VARIES- RURAL MINOR ARTERIAL)
POSTED SPEED 45 MPH

NOTE:
ALL INTERNAL SIGNS SHALL BE 4" FONT LETTER SIZE.
SIGNS AT VOLLMER INTERSECTION SHALL BE 6" FONT LETTER SIZE.

Street Name
STREET NAME (R-3)

STOP (R1-1)
30"x30"

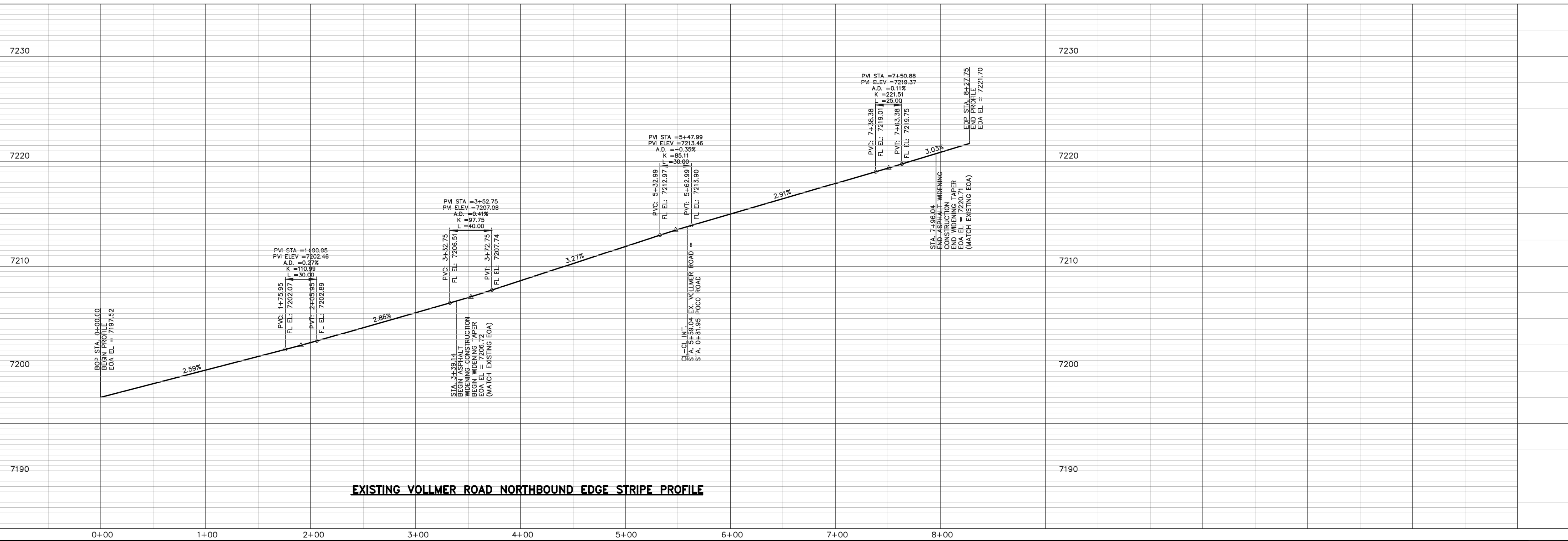
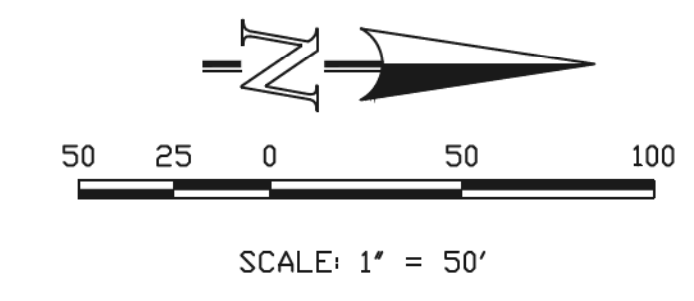
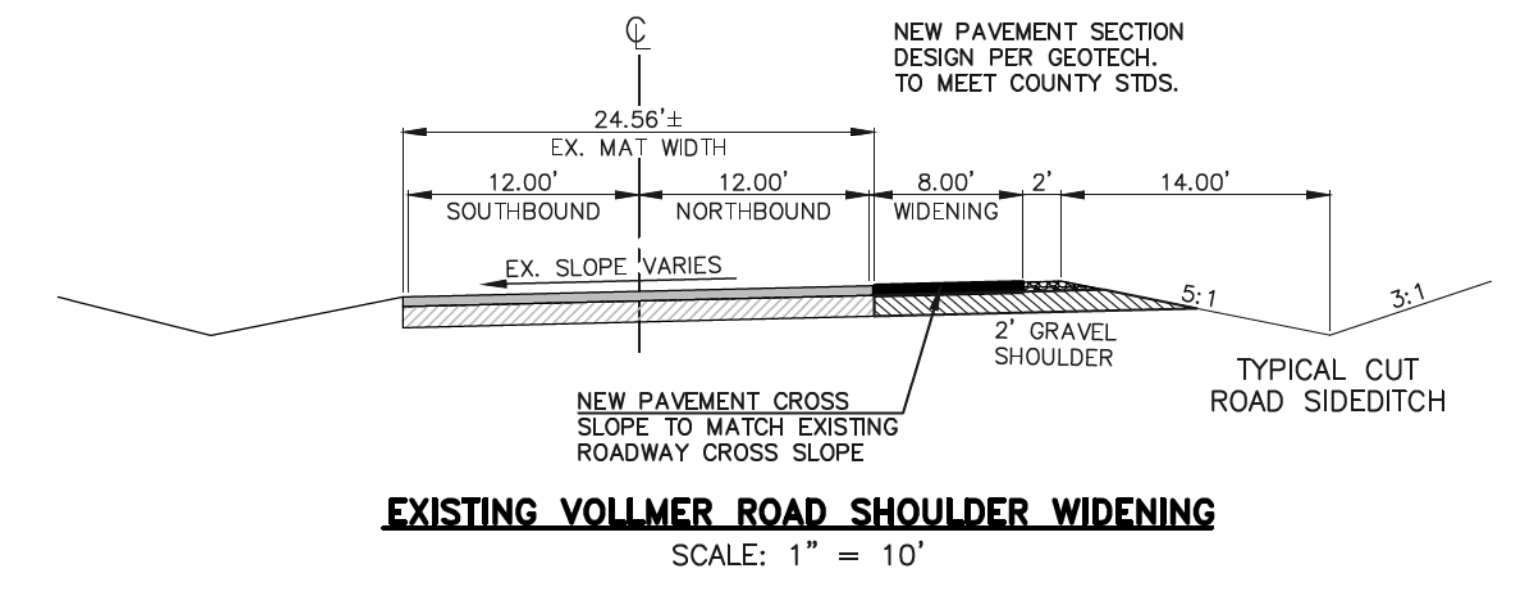

48 HOURS BEFORE YOU DIG,
CALL UTILITY LOCATORS
811
UTILITY NOTIFICATION CENTER OF COLORADO
IT'S THE LAW

THE LOCATIONS OF EXISTING UNDERGROUND UTILITIES ARE SHOWN IN AN APPROXIMATE WAY ONLY. THE CONTRACTOR SHALL DETERMINE THE EXACT LOCATION OF ALL EXISTING UTILITIES BEFORE COMMENCING WORK. THE CONTRACTOR SHALL BE FULLY RESPONSIBLE FOR ANY AND ALL DAMAGES WHICH MIGHT BE CAUSED BY HIS FAILURE TO EXACTLY LOCATE AND PRESERVE ANY AND ALL UNDERGROUND UTILITIES.

NO.	REVISION	DATE
1	REVISED PER COUNTY COMMENTS	08-13-19

REVIEW:
PREPARED UNDER MY DIRECT SUPERVISION FOR AND ON BEHALF OF CLASSIC CONSULTING ENGINEERS AND SURVEYORS, LLC

MARC A. WHORTON, COLORADO, P.E. #37155

DATE: 6/10/2020



RETREAT AT TIMBERRIDGE FILING NO. 1
CONSTRUCTION PLANS
STREET IMPROVEMENT PLANS
VOLLMER ROAD EAST SHOULDER WIDENING

DESIGNED BY	MAW	SCALE	DATE	04-05-19
DRAWN BY	ESO	(H) 1" = 50'	SHEET	17 OF 35
CHECKED BY	(V) 1" = 5'	JOB NO.	1185.00	

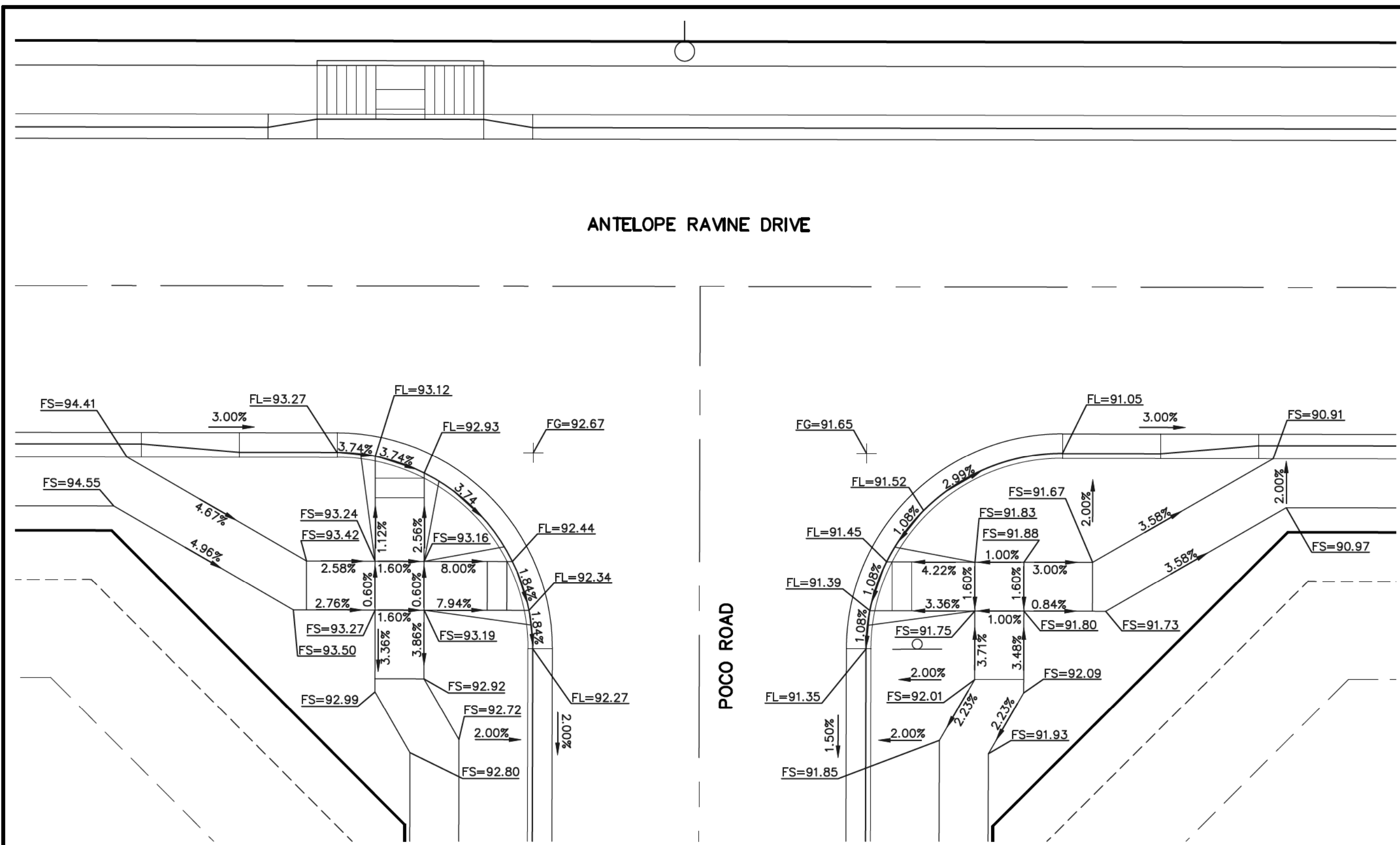

**INTERSECTION OF
POCO ROAD & ANTELOPE RAVINE DRIVE
'RAMP-01'**

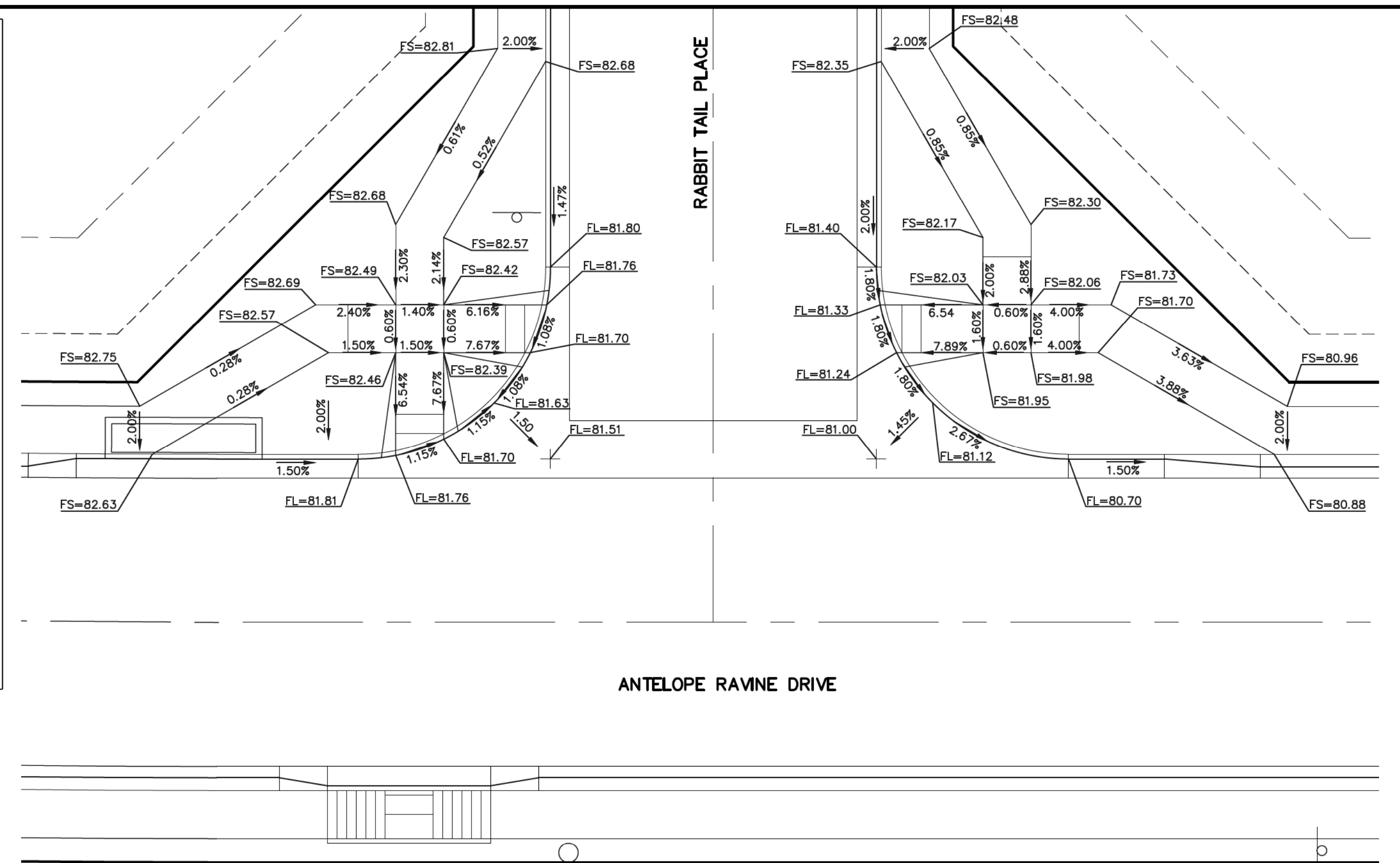
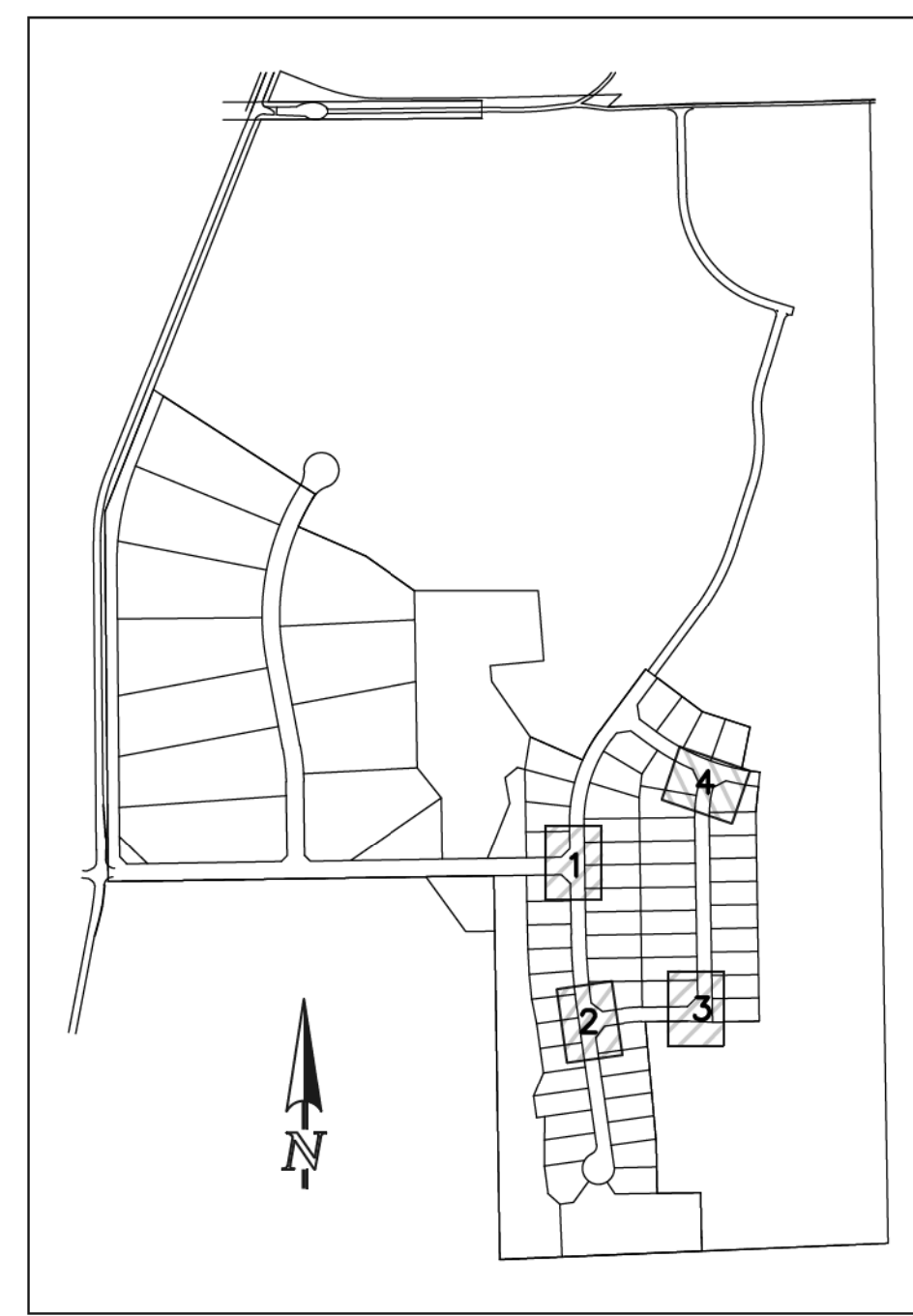
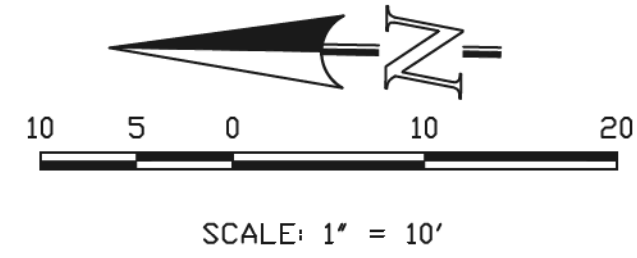

**INTERSECTION OF
ANTELOPE RAVINE DRIVE & RABBIT TAIL PLACE
'RAMP-02'**

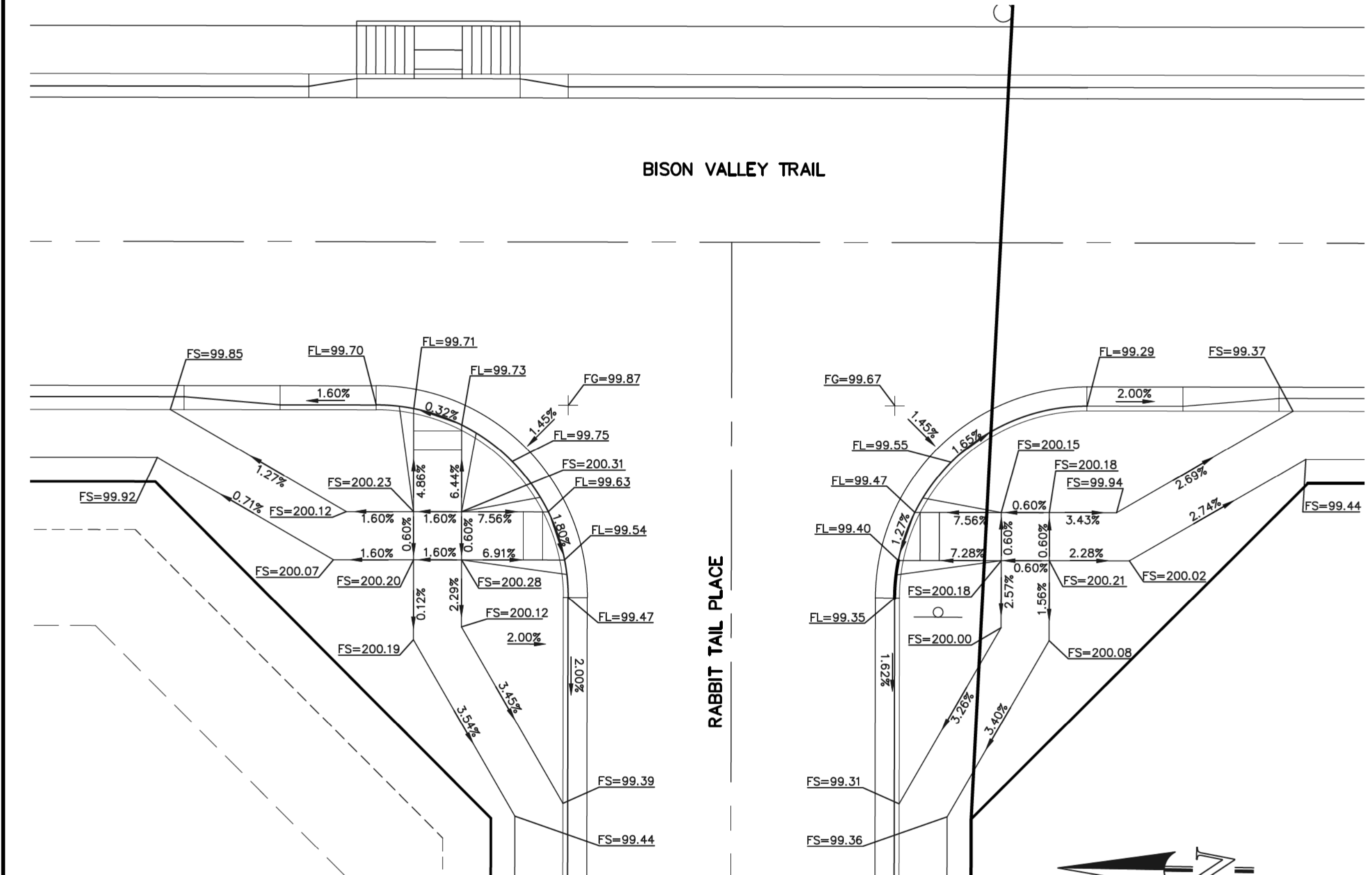
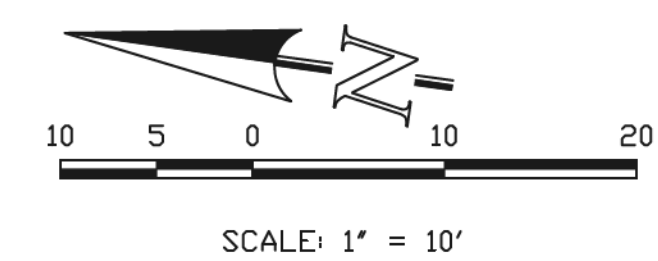

**INTERSECTION OF
BISON VALLEY TRAIL & RABBIT TAIL PLACE
'RAMP-03'**

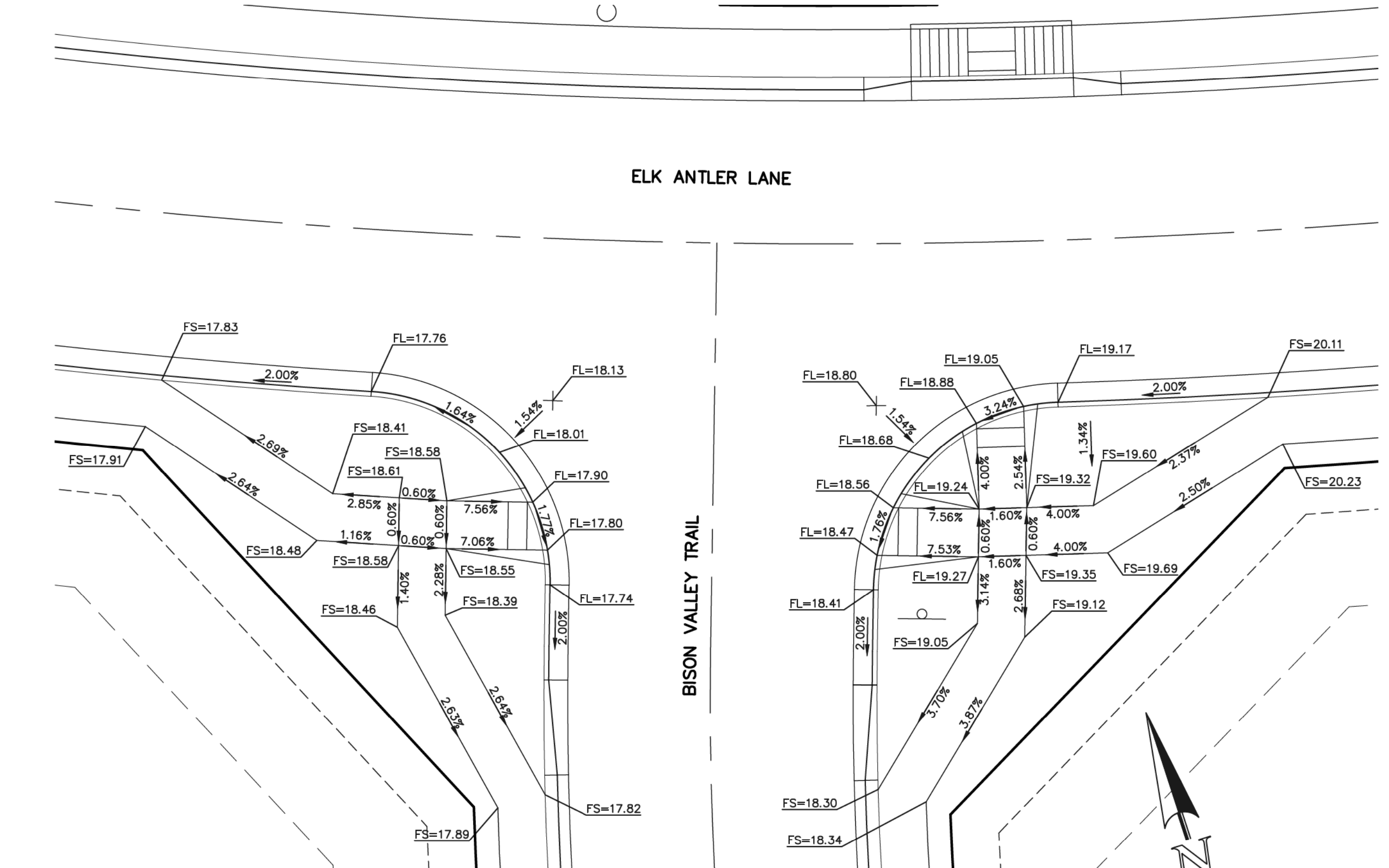
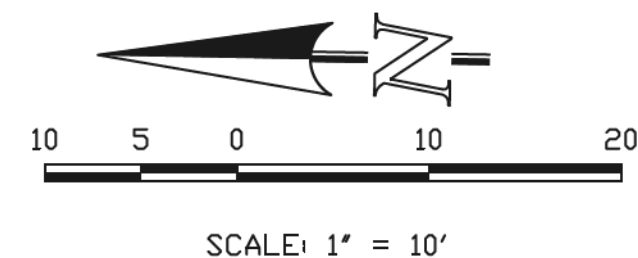

**INTERSECTION OF
ELK ANTLER LANE & BISON VALLEY TRAIL
'RAMP-04'**

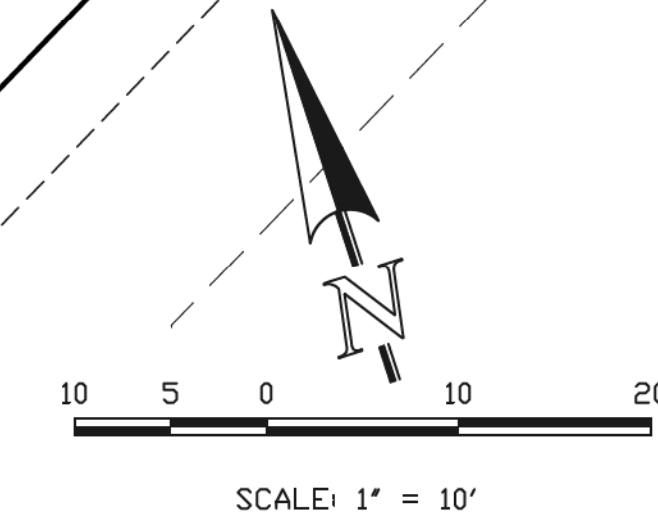

48 HOURS BEFORE YOU DIG,
CALL UTILITY LOCATORS
811

UTILITY NOTIFICATION CENTER OF COLORADO
IT'S THE LAW

THE LOCATIONS OF EXISTING UNDERGROUND UTILITIES ARE SHOWN IN AN APPROXIMATE WAY ONLY. THE CONTRACTOR SHALL DETERMINE THE EXACT LOCATION OF ALL EXISTING UTILITIES BEFORE COMMENCING WORK. THE CONTRACTOR SHALL BE FULLY RESPONSIBLE FOR ANY AND ALL DAMAGES WHICH MIGHT BE CAUSED BY HIS FAILURE TO EXACTLY LOCATE AND PRESERVE ANY AND ALL UNDERGROUND UTILITIES.

NO.	REVISION	DATE
1	REVISED PER COUNTY COMMENTS	2-12-20
2	REVISED PER COUNTY COMMENTS	06-10-20

REVIEW:
PREPARED UNDER MY DIRECT SUPERVISION FOR AND ON BEHALF OF
CLASSIC CONSULTING ENGINEERS AND SURVEYORS, LLC

MARC A. WHORTON, COLORADO P.E. #37155
DATE: 6/10/2020



619 N. Cascade Avenue, Suite 200
Colorado Springs, Colorado 80903
(719)785-0790
(719)785-0799(fax)

RETREAT AT TIMBERIDGE FILING NO. 1
CONSTRUCTION PLANS

STREET IMPROVEMENT PLANS
PEDESTRIAN RAMP DETAILS 1-4

DESIGNED BY	PRA	SCALE	DATE
DRAWN BY	PRA	(H) 1" = 10'	SHEET 18 OF 35
CHECKED BY	(V) 1" = N/A	JOB NO.	1185.00





American Revolution LED Series 247L

PRODUCT OVERVIEW



Features:

- Die-cast aluminum housing and hood for long-life performance
- Die-cast trigger latch (TL) and captive thumb screws option available for easy access to internal components
- Optical assembly designed for maximum performance, available in Type II, Type III and Type V
- Hinged hood and captive thumb screws provision afford quick, easy access to electrical and optical area for servicing
- Slipfitter with three set screws allows secure installation to pole sizes 2-3/8" or 3" O.D.
- Surge protection device (standard) exceeds ANSI C82.41 Category C1 criteria (surge tested at 10kV/50A)
- Complies with ANSI: C136.2, C136.10, C136.15
- CSA listed and suitable for up to 30°C ambient
- Rated L70, LED life greater than 100,000 hours at 25°C
- Replaces up to 150W HPS light source incumbent models
- LED electronic 0V-10V dimmable driver
- DesignLights Consortium® (DLC) qualified product. Not all versions of this product may be DLC qualified. Please check the DLC Qualified Products List at www.designlights.org/DPL to confirm which versions are qualified.

Applications:

- Streetscapes
- Walkways
- Pathways
- Parks

MVEA Spec # 247L 10LEDE10 MVOLT 4K RS AY PCLL

DIMENSIONS

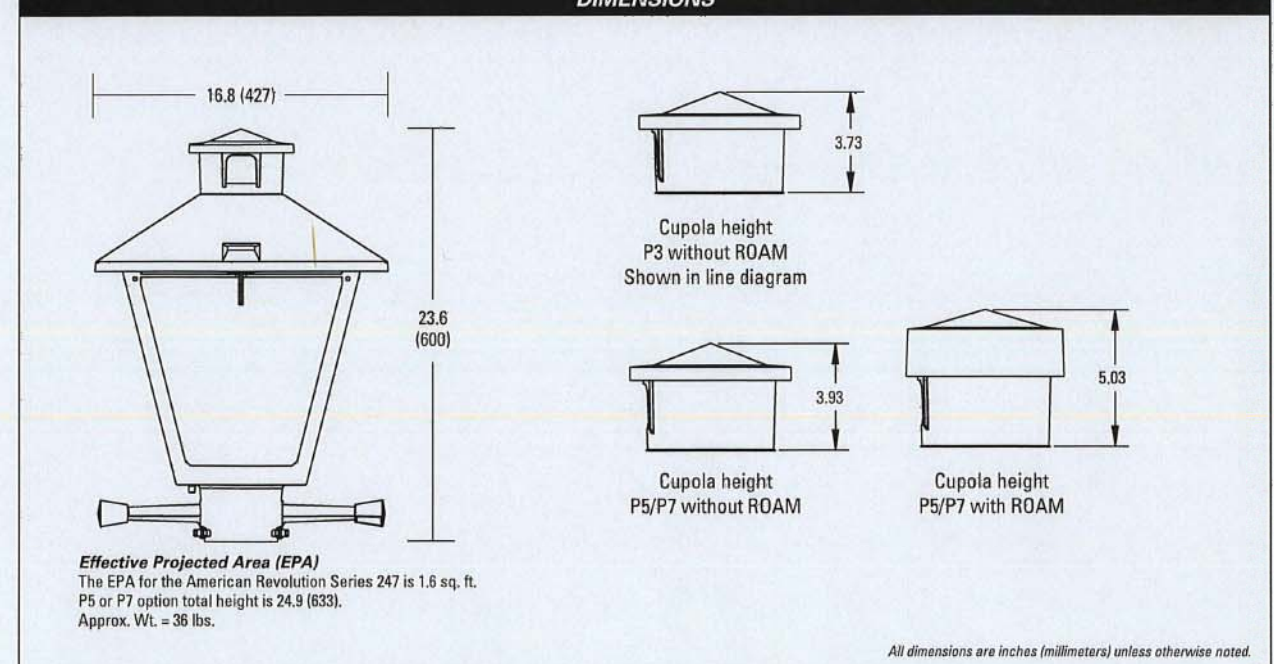

Note: Specifications subject to change without notice. American Revolution Series 247L LED



American Revolution LED Series 247L

ORDERING INFORMATION

Example: 247L 20LEDE70 MVOLT 4K RS AY

Series	Performance Package	Voltage	Color Temperature (CCT)
247L American Revolution LED	20LEDE10 20 Chips, 1050 mA Driver, 72 input watts 20LEDE70 20 Chips, 700 mA Driver, 40 input watts 10LEDE10 10 Chips, 1050 mA Driver, 38 input watts 10LEDE70 10 Chips, 700 mA Driver, 25 input watts 10LEDE35 10 Chips, 350 mA Driver, 13 input watts	MVOLT Multi-volt, 120-277V 247 247V 480 480V	3K 3000K 4K 4000K 5K 5000K

Distribution	Optics	Options	Miscellaneous
R2 Type II R3 Type III R5 Type V	AY Acrylic PY Polycarbonate	Paint (blank) Black (standard) GY Gray DBB Dark Bronze WH White BZ Bronze Photocentral (blank) 3 pin NEMA Photocentral Receptacle (standard) NR 1 No Photocentral Receptacle PS 1 5 pin NEMA Photocentral Receptacle (diminable driver included) P7 1 7 pin NEMA Photocentral Receptacle (diminable driver included) PCLL 15 Solid State Long Life Photocentral PCSS 15 Not CSA Listed Solid State Long Life Photocentral (120-277V)	SS Stainless steel hardware NL NEMA Label XL Not CSA Listed TL Tool-less Entry LDR Ladder Rest SH Shorting Cap SHX Not CSA Listed Shorting Cap HSB House Side Shield Black HSW House Side Shield White CR Enhanced Corrosion Resistant Finish RCC ROAM Dimming Node Cupola Cover Accessories RDC37 ROAM Dimming Node Cupola Cover

Cupola size based on type of control and receptacle

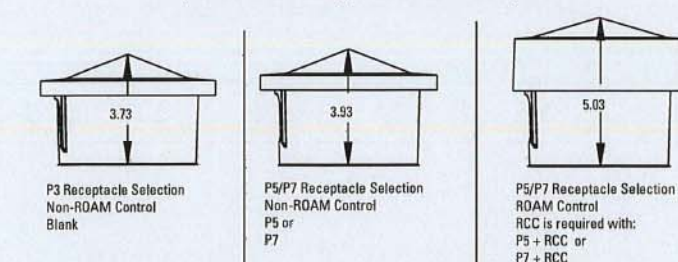

- Notes:
- Other colors available, please contact factory
 - PC and SH not available with NR option
 - Taller cupola cover (RCC) is required when used with ROAM or other similar wireless monitoring control systems
 - Standard failure mode="Fail On"
 - Photocenters supplied with ANSI Standard Turn-On levels
 - XL option is required
 - Ships with unit, field installed
 - Required when using ROAM or other similar wireless monitoring control systems



Warranty: Five-year limited warranty. Complete warranty terms located at www.ael.com
 Actual performance may differ as a result of end-user environment and application. All values are design or typical values, measured under laboratory conditions at 25°C. Specifications subject to change without notice.
 Please contact your sales representative for the latest product information.

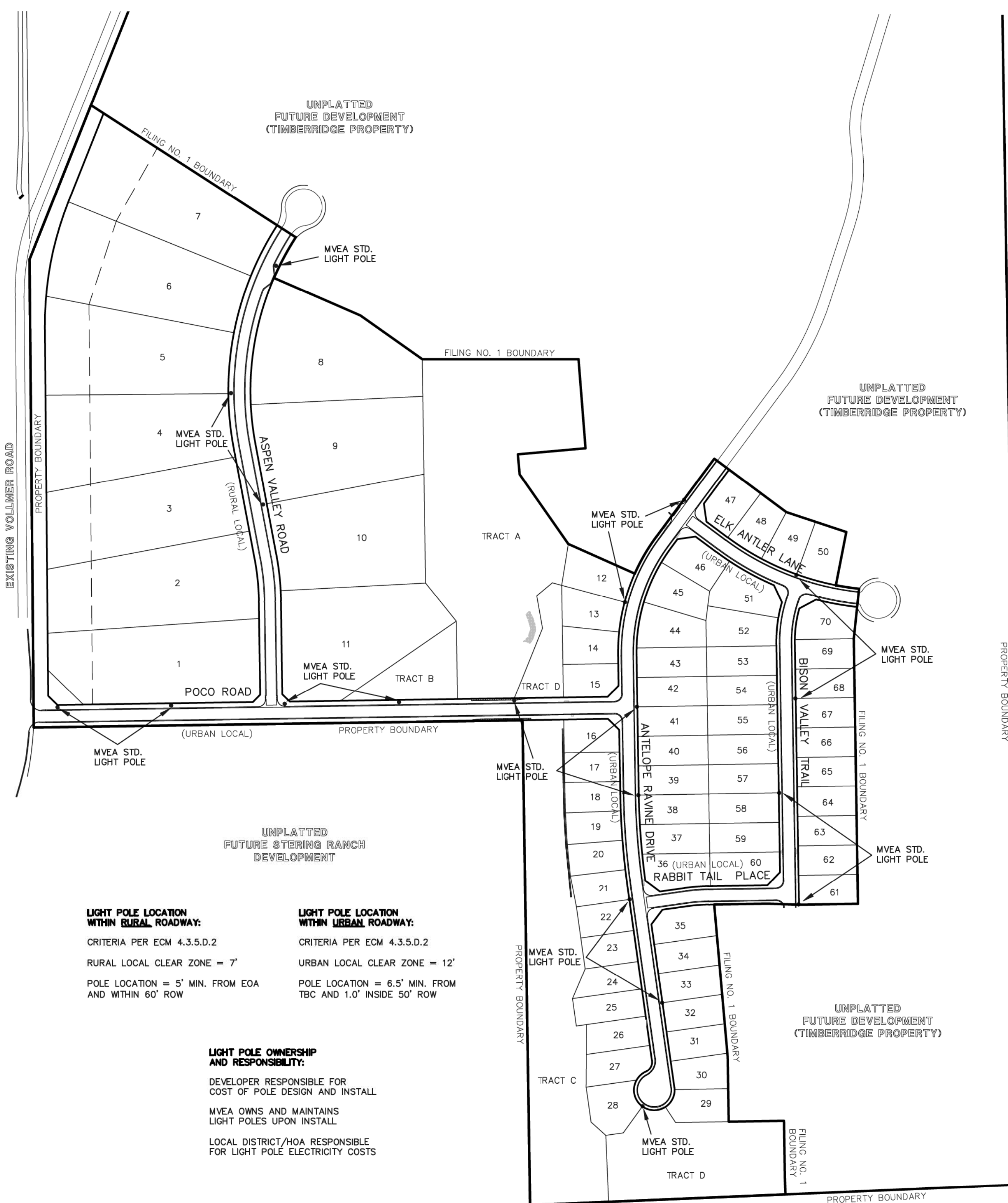

LIGHT POLE LOCATION WITHIN RURAL ROADWAY:
 CRITERIA PER ECM 4.3.5.D.2
 RURAL LOCAL CLEAR ZONE = 7'
 POLE LOCATION = 5' MIN. FROM EOA AND WITHIN 60' ROW

LIGHT POLE LOCATION WITHIN URBAN ROADWAY:
 CRITERIA PER ECM 4.3.5.D.2
 URBAN LOCAL CLEAR ZONE = 12'
 POLE LOCATION = 6.5' MIN. FROM TBC AND 1.0' INSIDE 50' ROW

LIGHT POLE OWNERSHIP AND RESPONSIBILITY:
 DEVELOPER RESPONSIBLE FOR COST OF POLE DESIGN AND INSTALL
 MVEA OWNS AND MAINTAINS LIGHT POLES UPON INSTALL
 LOCAL DISTRICT/HOA RESPONSIBLE FOR LIGHT POLE ELECTRICITY COSTS

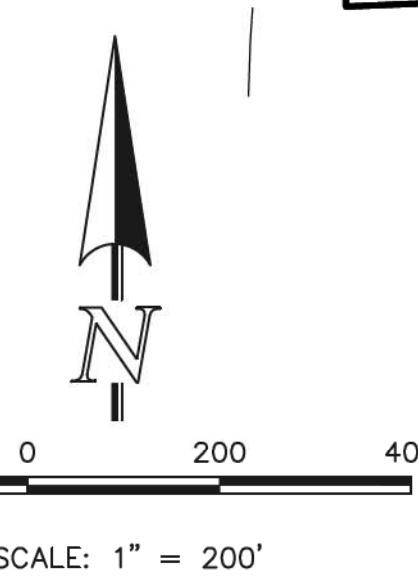

ORIENTATION VIEWED FROM TOP OF POLE

COLOR: BLACK

CMT		MOUNTAIN VIEW	
CMT 110 Wood Street Suffolk, VA 23198 804.644.4270 www.cmtpole.com		CAT. NO.: TB23-D-50-3-H-T238	
QUANTITY:	JOB NUMBER:	SPECS:	WIND VEL.: 100@1.3
PO. NUMBER:	APPD BY:	TOT. LENGTH: 23'-0"	LUM. WEIGHT: 50 lbs.
REV. DATE BY	REMARKS	EMBED DEPTH: 4'-0"	LUM. EPA: 3.50 sq.ft.
QUOTE:		TIP WIDTH: 4.41"	STATIC DEFL.:
		WEIGHT: 50 lbs.	TOTAL DEFL.:
		DRAWN BY: PLF	DATE: 01/16/2017

48 HOURS BEFORE YOU DIG,
CALL UTILITY LOCATORS
811
UTILITY NOTIFICATION CENTER OF COLORADO
IT'S THE LAW

THE LOCATIONS OF EXISTING UNDERGROUND UTILITIES ARE SHOWN IN AN APPROXIMATE WAY ONLY. THE CONTRACTOR SHALL DETERMINE THE EXACT LOCATION OF ALL EXISTING UTILITIES BEFORE COMMENCING WORK. THE CONTRACTOR SHALL BE FULLY RESPONSIBLE FOR ANY AND ALL DAMAGES WHICH MIGHT BE CAUSED BY HIS FAILURE TO EXACTLY LOCATE AND PRESERVE ANY AND ALL UNDERGROUND UTILITIES.

NO. REVISION	DATE

REVIEW:

PREPARED UNDER MY DIRECT SUPERVISION FOR AND ON BEHALF OF CLASSIC CONSULTING ENGINEERS AND SURVEYORS, LLC

MARC. A. WHORTON, COLORADO, P.E. #37155 DATE: 6/10/2020

RETREAT AT TIMBERRIDGE FILING NO. 1
CONSTRUCTION PLANS
STREET LIGHT POLE LOCATION PLAN

DESIGNED BY	MAW	SCALE	DATE	04-05-20
DRAWN BY	MAW	(H) 1" = 200'	SHEET	20 OF 35
CHECKED BY	(V) 1" = N/A	JOB NO.	1185.00	

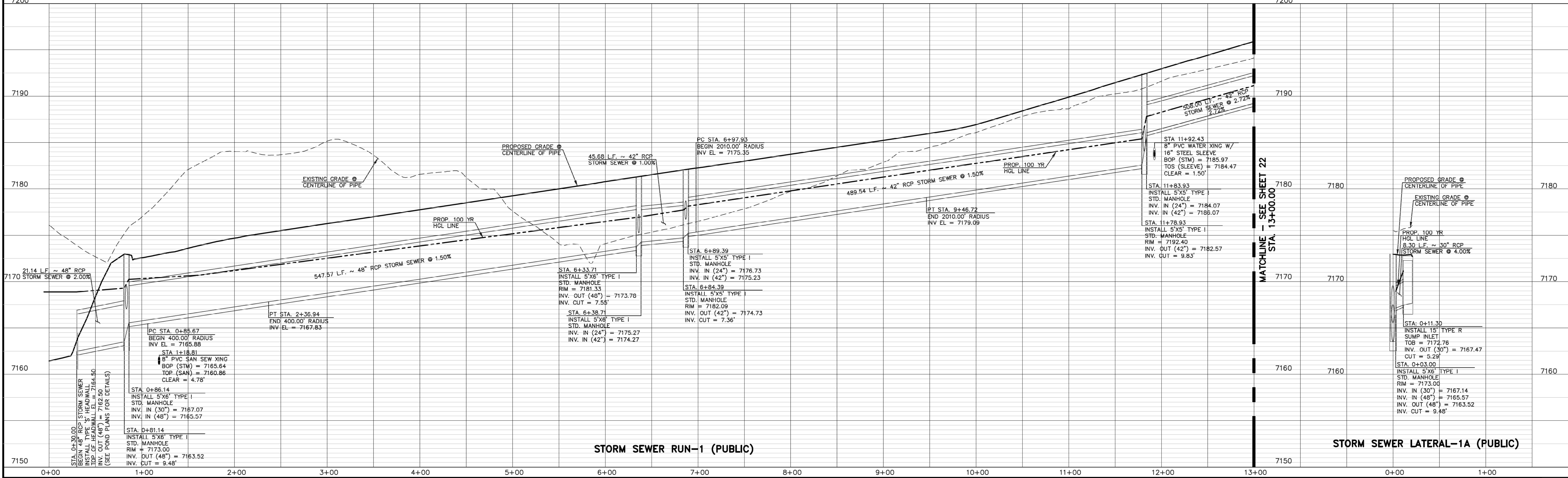
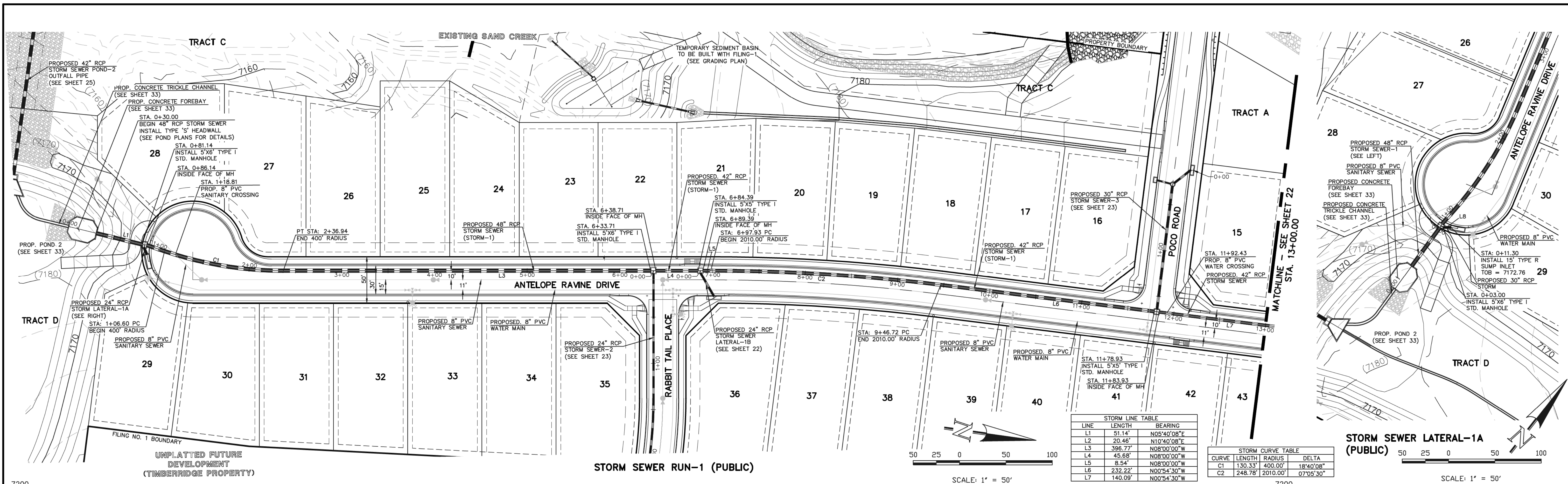

48 HOURS BEFORE YOU DIG,
CALL UTILITY LOCATORS
811
UTILITY NOTIFICATION CENTER OF COLORADO
IT'S THE LAW

THE LOCATIONS OF EXISTING UNDERGROUND UTILITIES ARE SHOWN IN AN APPROXIMATE WAY ONLY. THE CONTRACTOR SHALL DETERMINE THE EXACT LOCATION OF ALL EXISTING UTILITIES BEFORE COMMENCING WORK. THE CONTRACTOR SHALL BE FULLY RESPONSIBLE FOR ANY AND ALL DAMAGES WHICH MIGHT BE CAUSED BY HIS FAILURE TO EXACTLY LOCATE AND PRESERVE ANY AND ALL UNDERGROUND UTILITIES.

NO.	REVISION	DATE
1	REVISED PER COUNTY COMMENTS	08-13-19

REVIEW: PREPARED UNDER MY DIRECT SUPERVISION FOR AND ON BEHALF OF CLASSIC CONSULTING ENGINEERS AND SURVEYORS, LLC

MARC A. WHORTON, COLORADO P.E. #37155

6/10/2020

CLASSIC CONSULTING

619 N. Cascade Avenue, Suite 200
Colorado Springs, Colorado 80903

(719)785-0790
(719)785-0799(fax)

RETREAT AT TIMBERIDGE FILING NO. 1
CONSTRUCTION PLANS
STORM SEWER PLAN

DESIGNED BY: MAW
DRAWN BY: ESO
CHECKED BY:

SCALE: (H) 1" = 50'
(V) 1" = 5'

DATE: 04-05-19
SHEET 21 OF 35
JOB NO. 1185.00

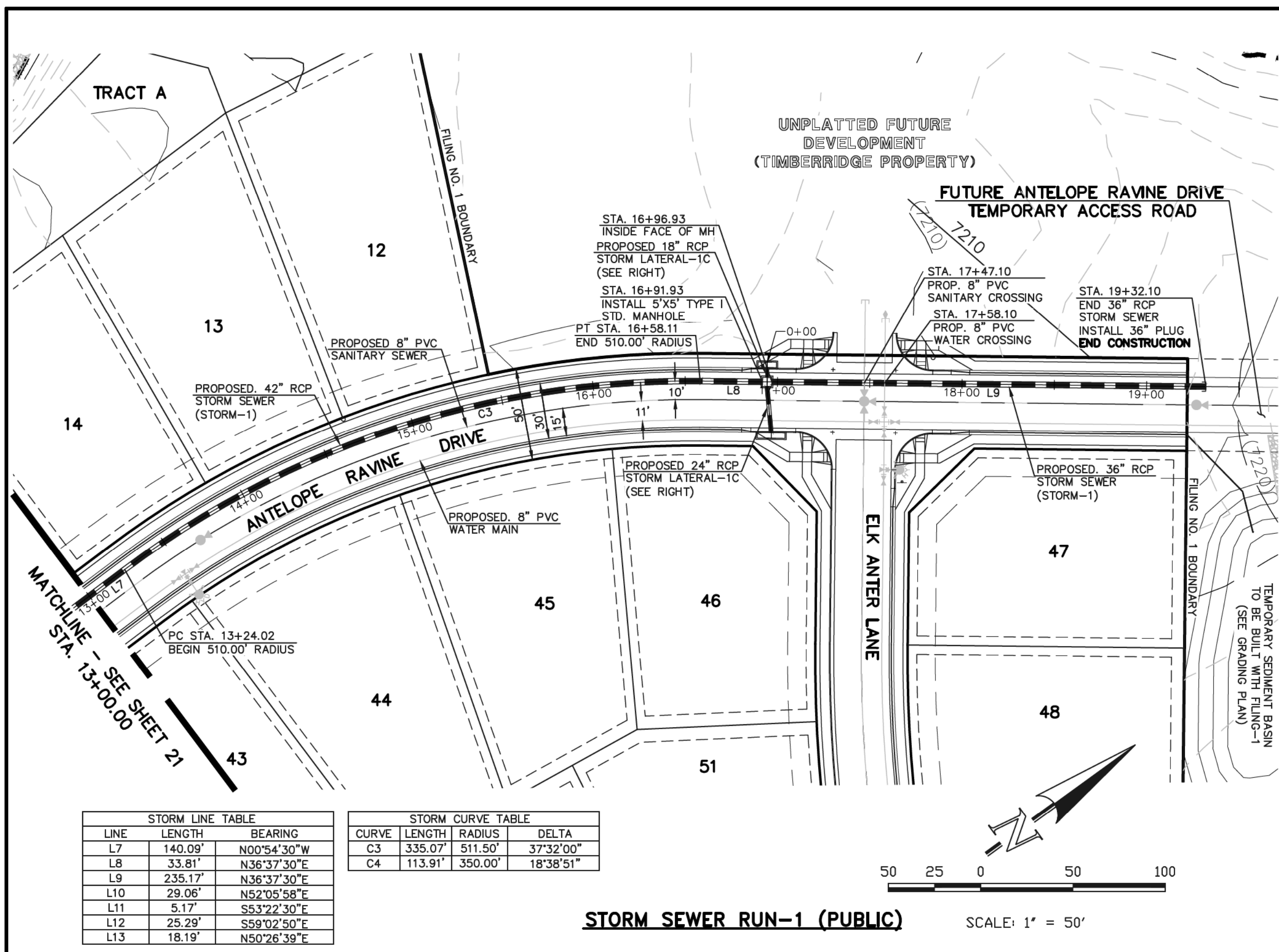

STORM LINE TABLE

LINE	LENGTH	BEARING
L7	140.09'	N00°54'30"W
L8	33.81'	N36°37'30"E
L9	235.17'	N36°37'30"E
L10	29.06'	N82°05'58"E
L11	5.17'	S83°22'30"E
L12	25.29'	S89°02'50"E
L13	18.19'	N50°26'39"E

STORM CURVE TABLE

CURVE	LENGTH	RADIUS	DELTA
C3	335.07'	511.50'	37°32'00"
C4	113.91'	350.00'	18°38'51"

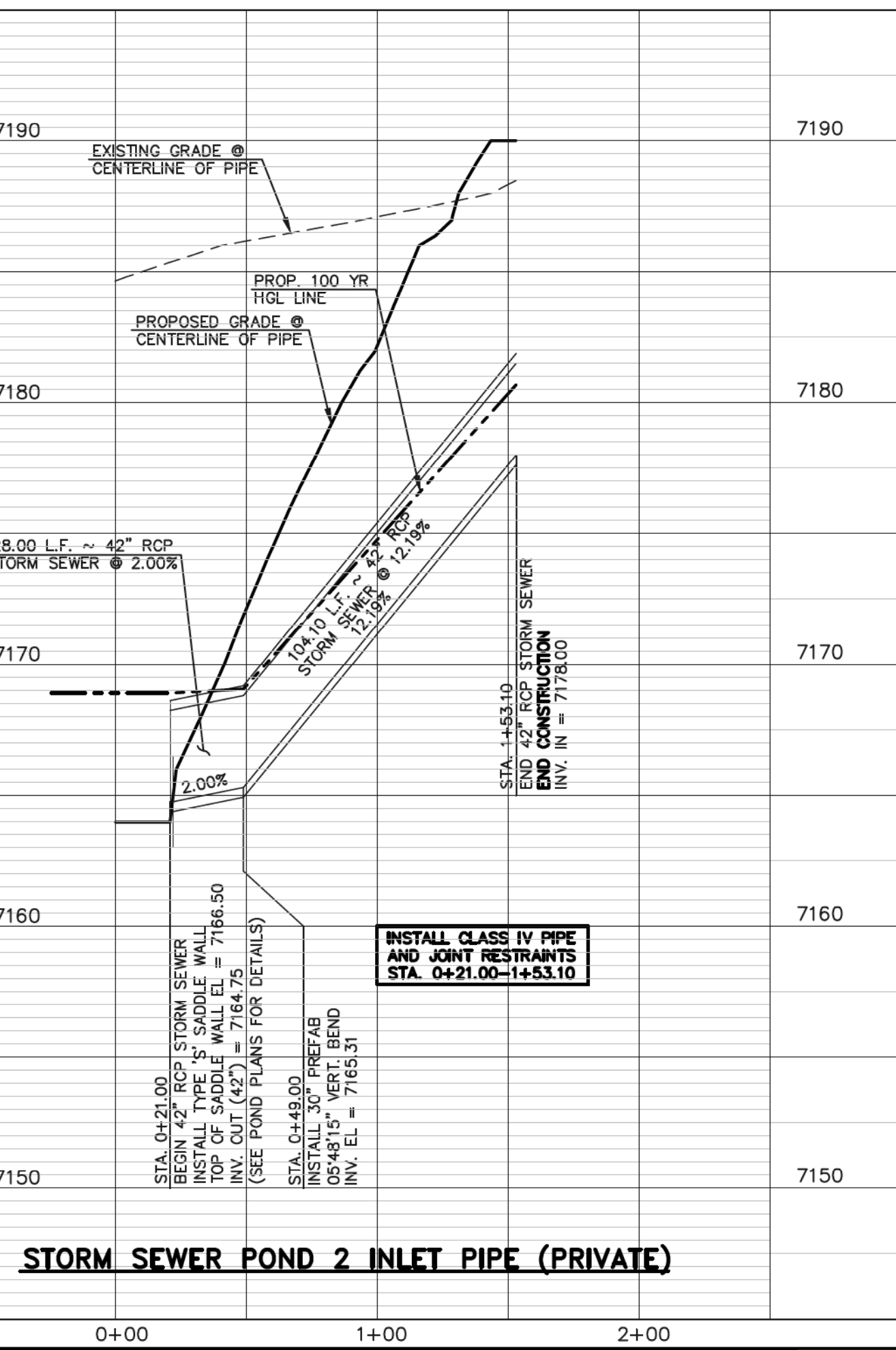
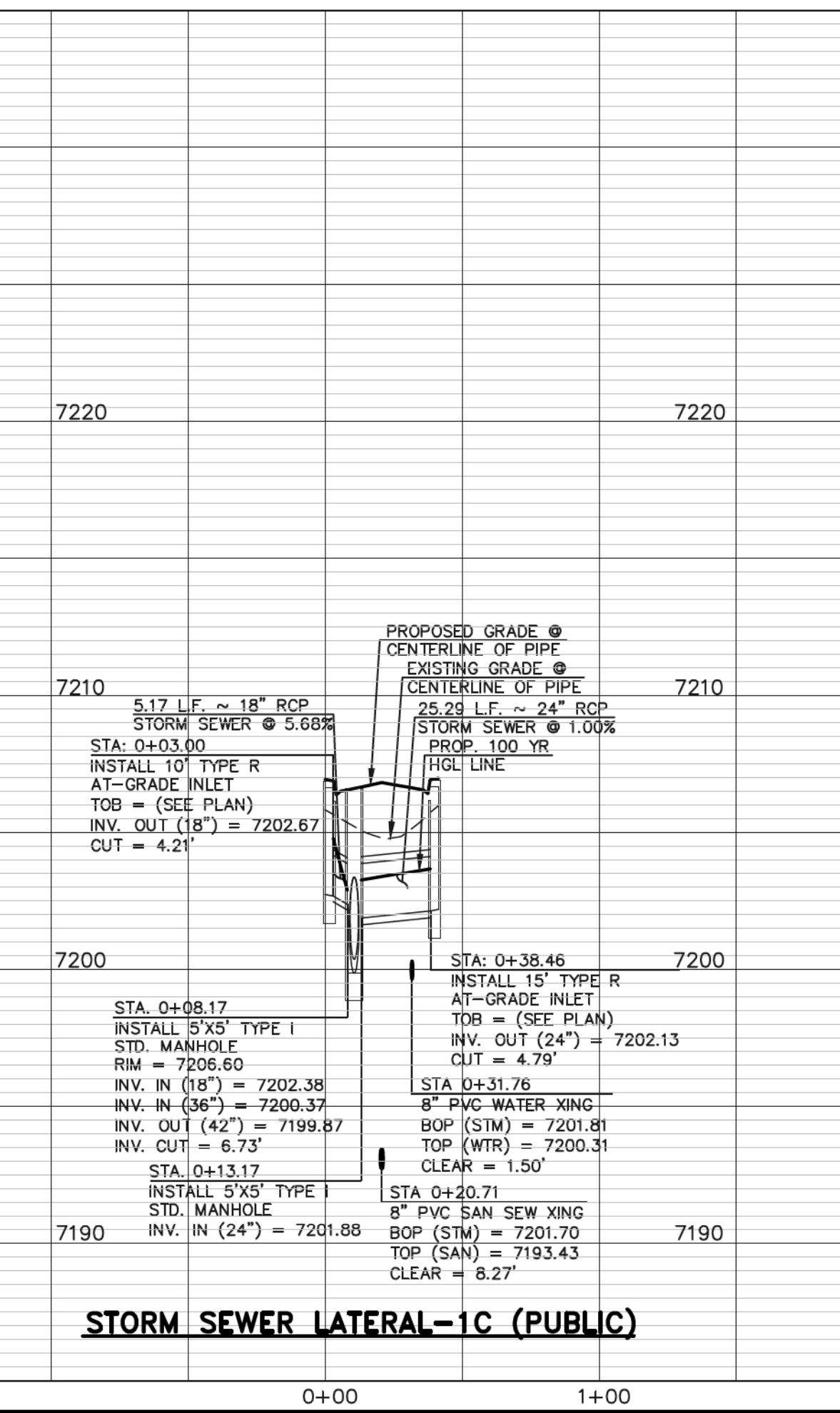
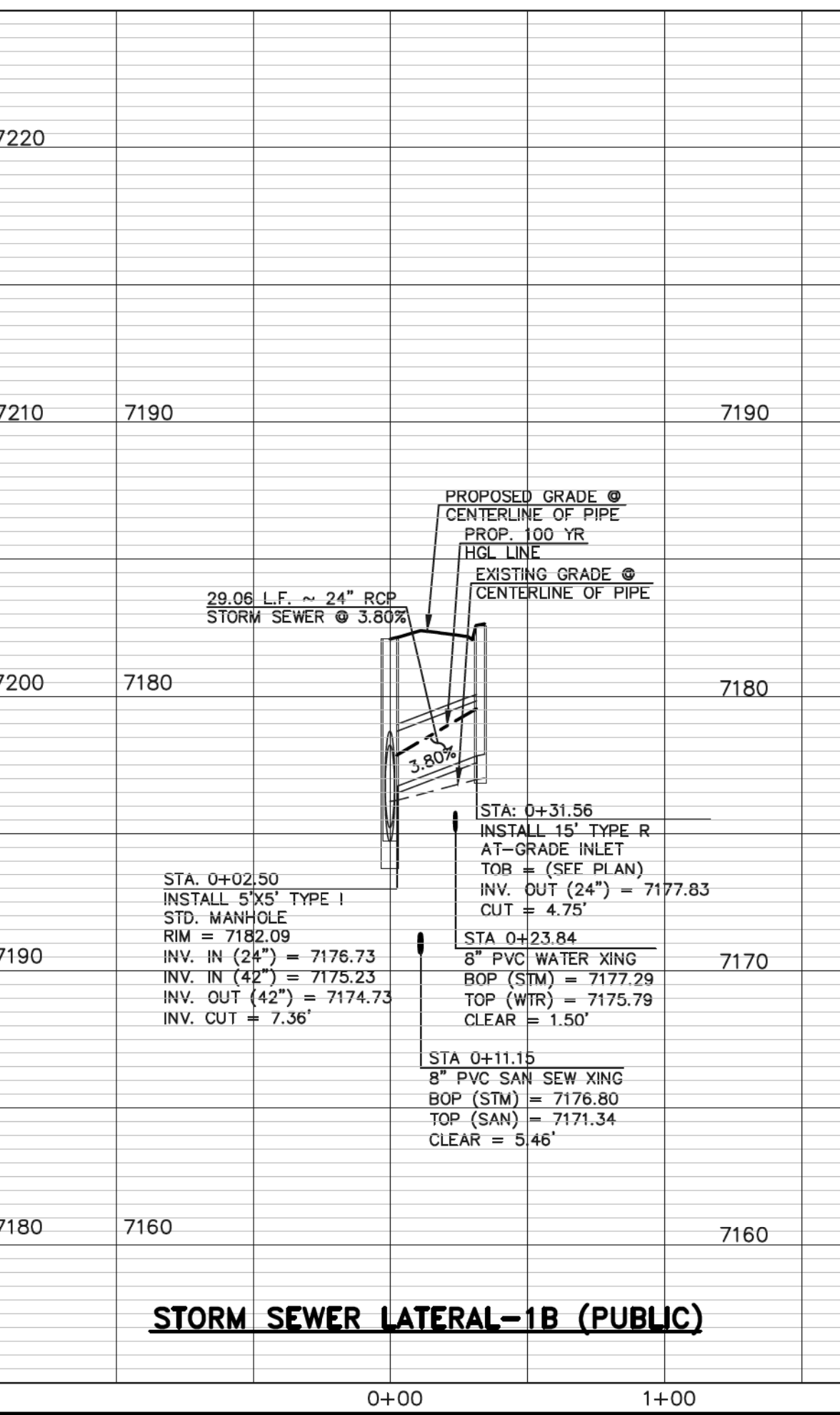
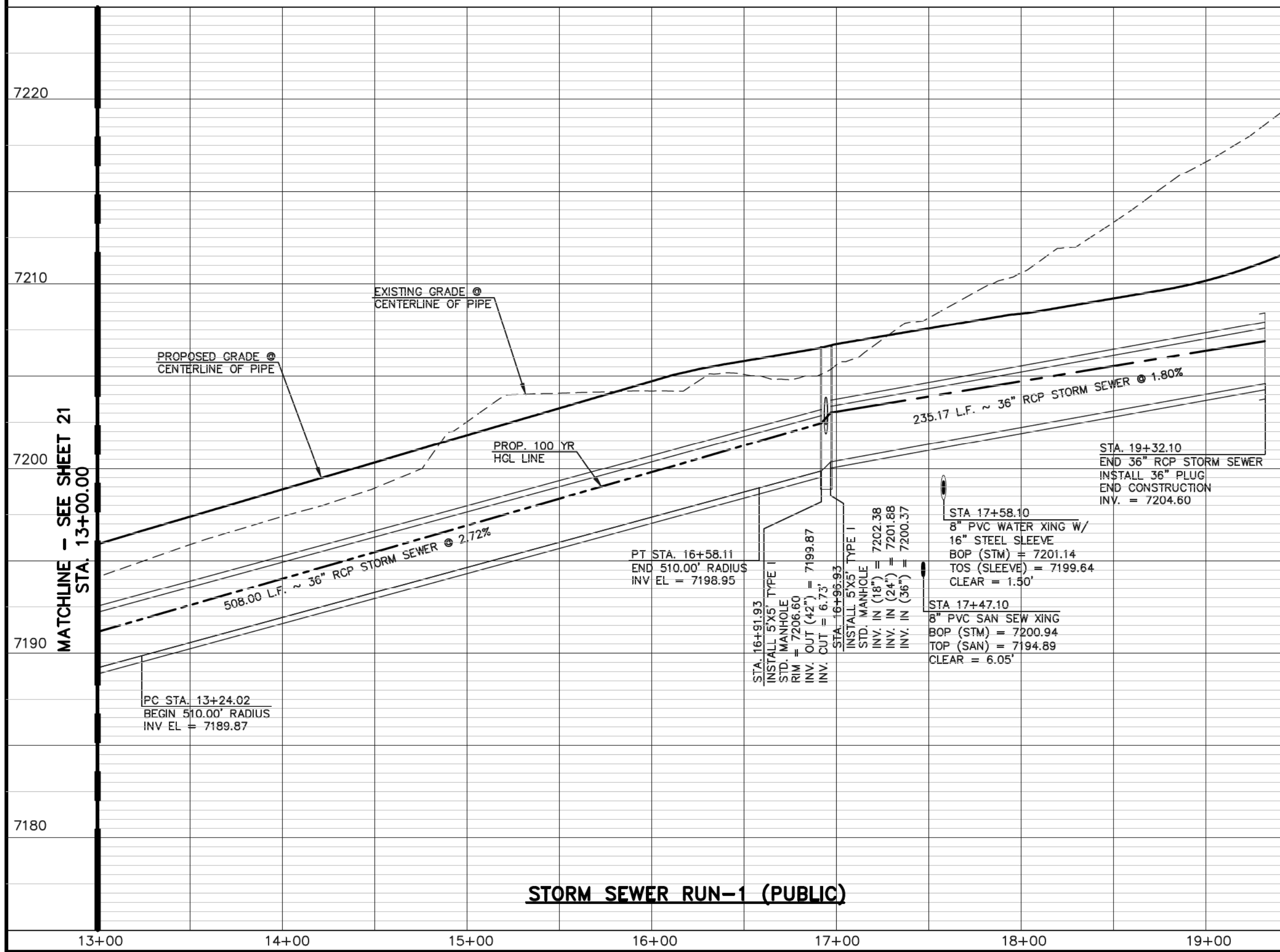
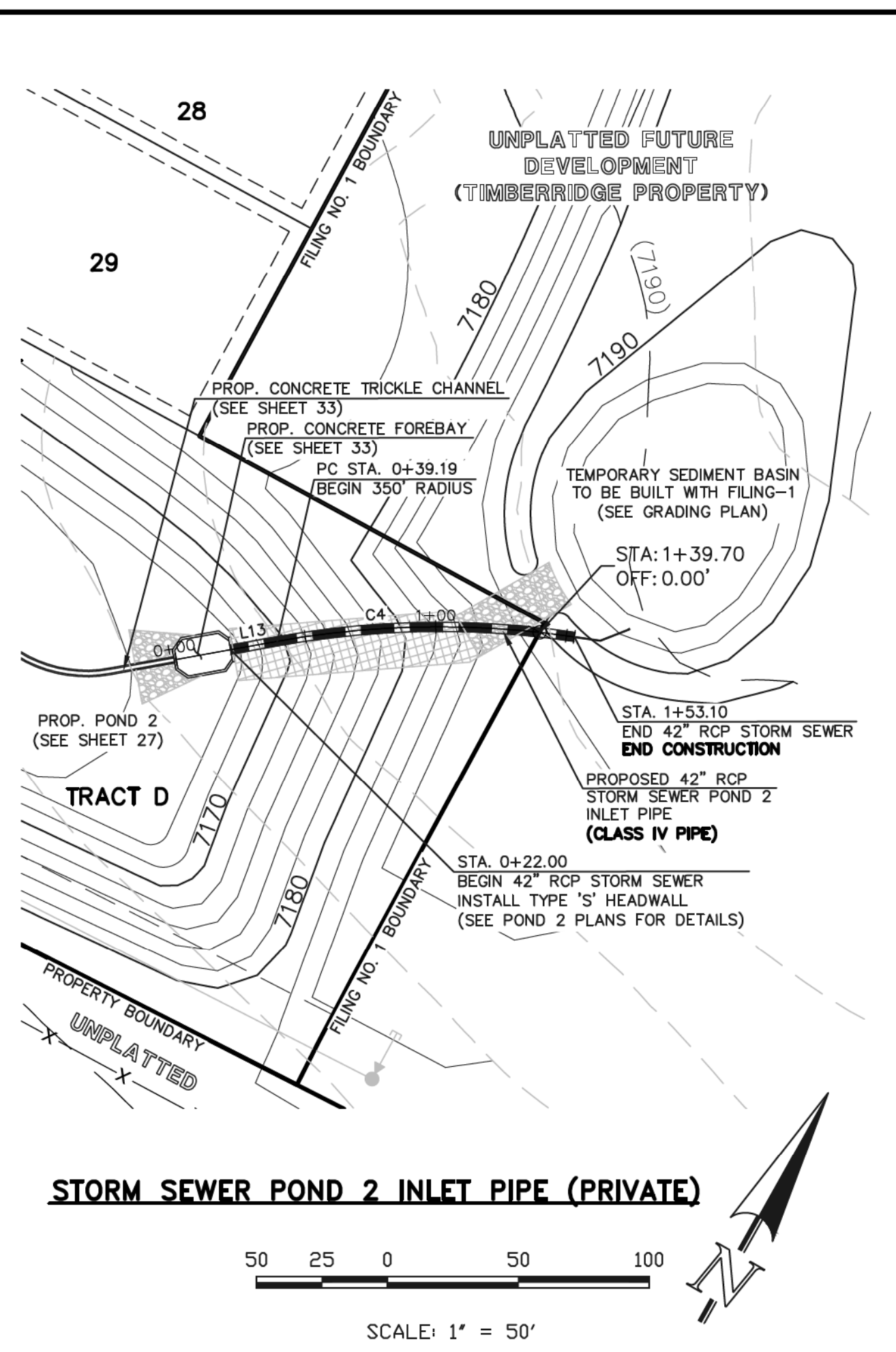
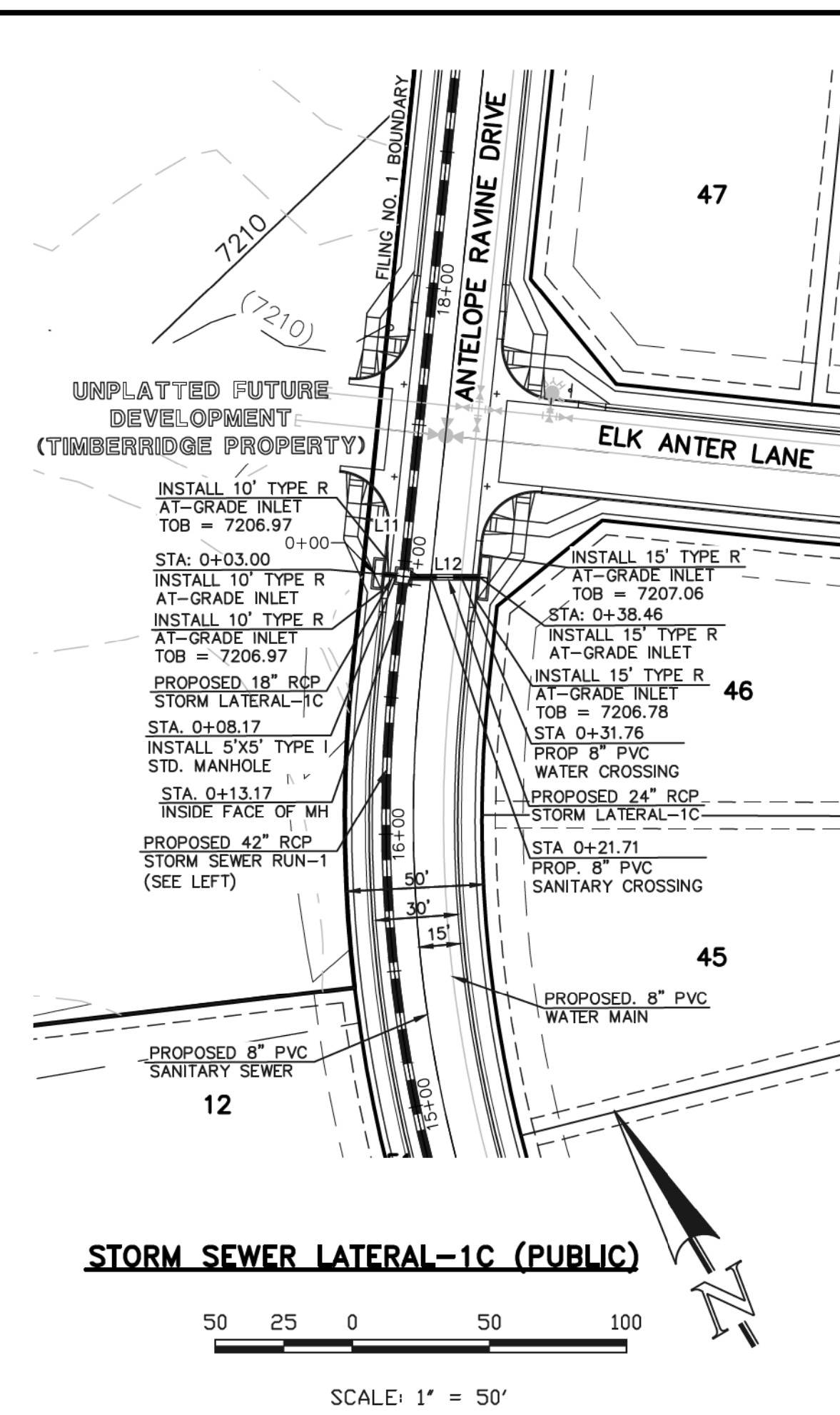
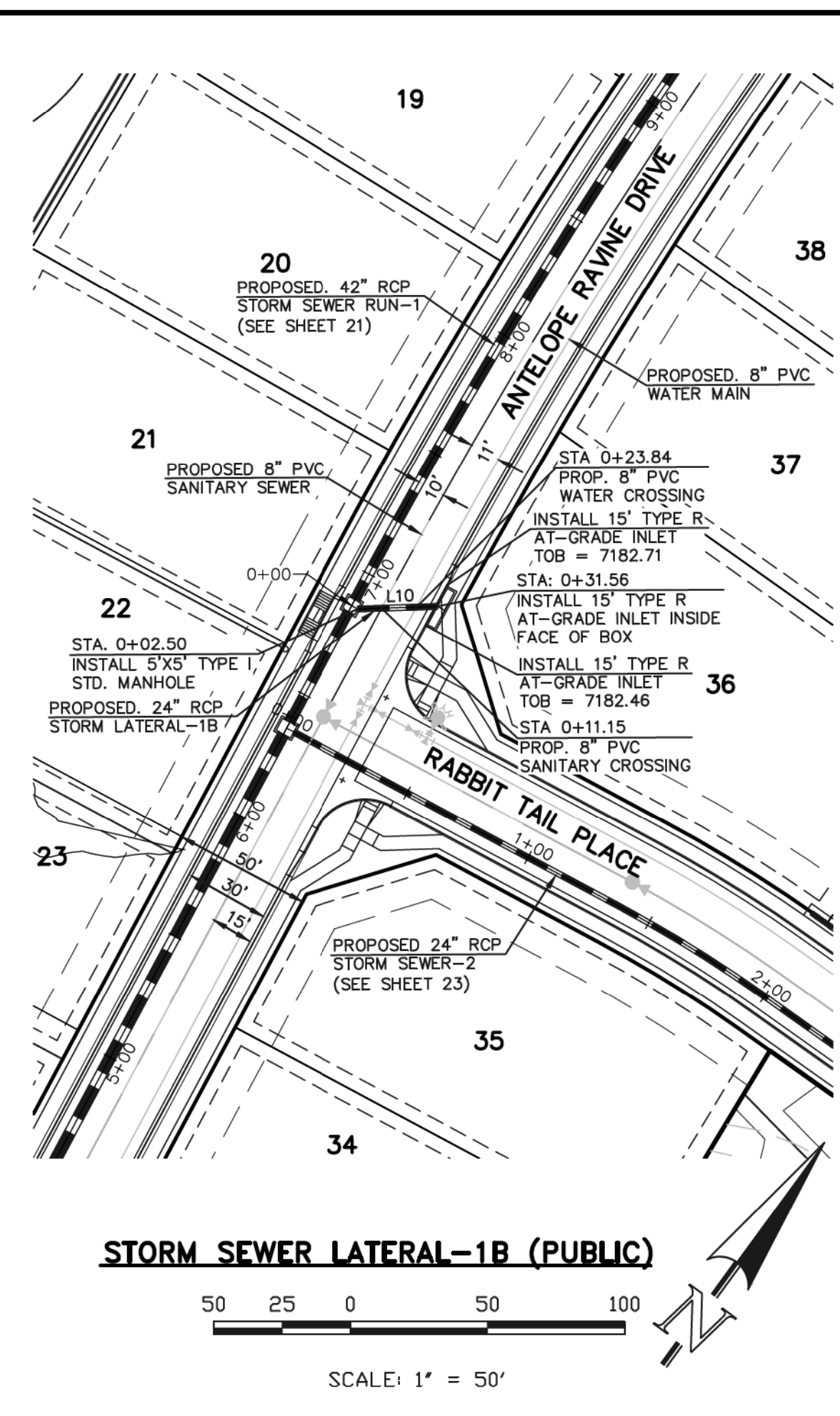

48 HOURS BEFORE YOU DIG,
CALL UTILITY LOCATORS
811
UTILITY NOTIFICATION CENTER OF COLORADO
IT'S THE LAW

THE LOCATIONS OF EXISTING UNDERGROUND UTILITIES ARE SHOWN IN AN APPROXIMATE WAY ONLY. THE CONTRACTOR SHALL DETERMINE THE EXACT LOCATION OF ALL EXISTING UTILITIES BEFORE COMMENCING WORK. THE CONTRACTOR SHALL BE FULLY RESPONSIBLE FOR ANY AND ALL DAMAGES WHICH MIGHT BE CAUSED BY HIS FAILURE TO EXACTLY LOCATE AND PRESERVE ANY AND ALL UNDERGROUND UTILITIES.

NO. REVISION DATE REVIEW:

1	REVISED PER COUNTY COMMENTS	08-13-19	
2	REVISED PER COUNTY COMMENTS	3-13-20	

PREPARED UNDER MY DIRECT SUPERVISION FOR AND ON BEHALF OF CLASSIC CONSULTING ENGINEERS AND SURVEYORS, LLC

MARC A. WHORTON, COLORADO P.E. #37155

DATE: 6/10/2020

RETRAIT AT TIMBERIDGE FILING NO. 1
CONSTRUCTION PLANS
STORM SEWER PLAN

DESIGNED BY: MAW
DRAWN BY: ESO
CHECKED BY: (V)

SCALE: (H) 1" = 50'
(V) 1" = 5'

DATE: 04-05-19
SHEET 22 OF 35
JOB NO. 1185.00

CLASSIC CONSULTING

619 N. Cascade Avenue, Suite 200
Colorado Springs, Colorado 80903

(719) 785-0790
(719) 785-0799 (fax)

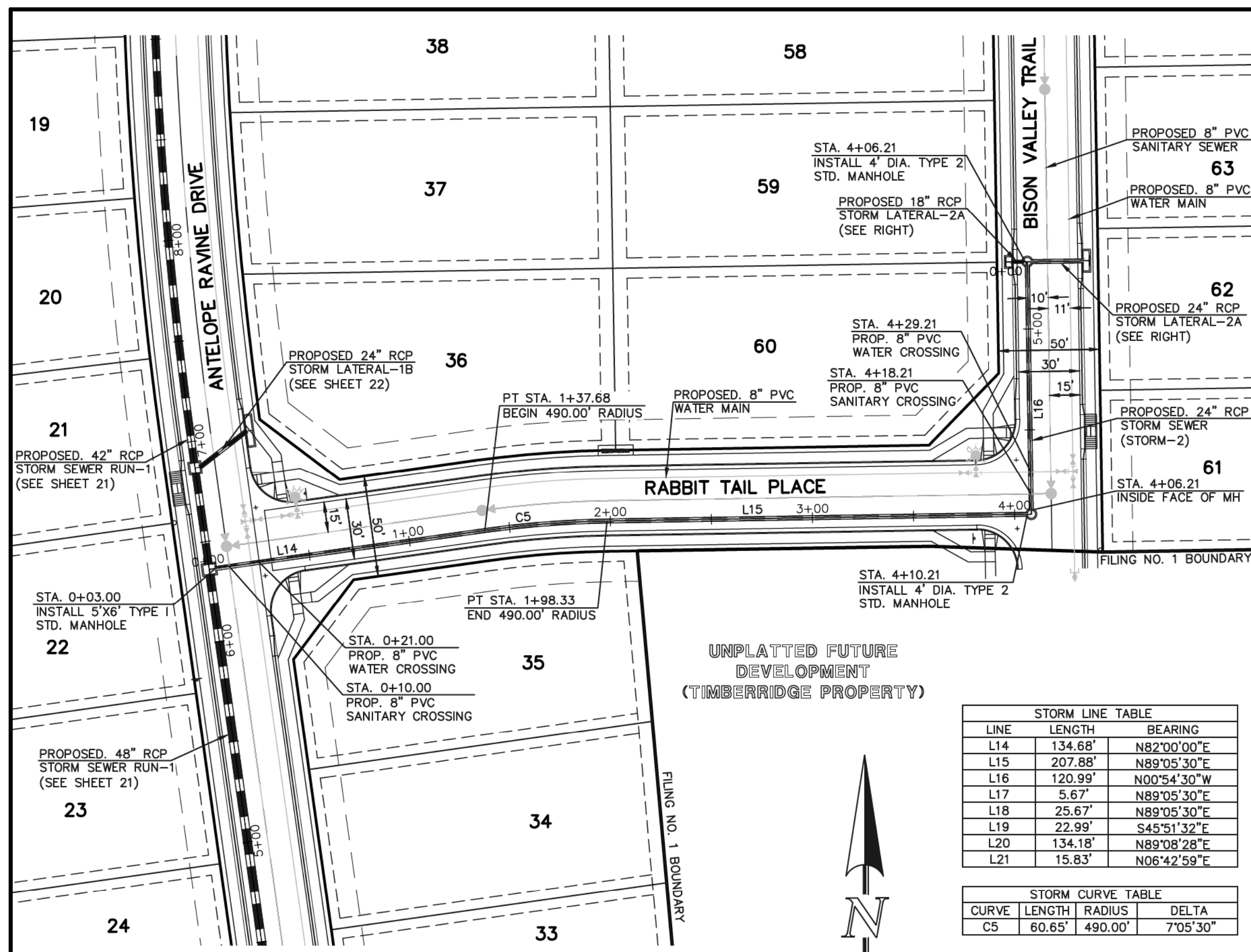

STORM SEWER RUN-2 (PUBLIC)

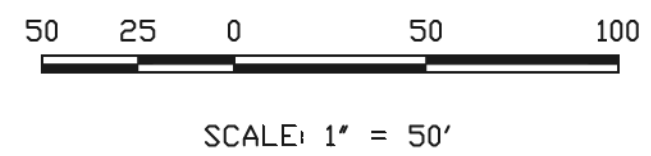

SCALE: 1" = 50'

STORM LINE TABLE		
LINE	LENGTH	BEARING
L14	134.68'	N82°00'00"E
L15	207.88'	N89°05'30"E
L16	120.99'	N00°54'30"W
L17	5.67'	N89°05'30"E
L18	25.67'	N89°05'30"E
L19	22.99'	S45°51'32"E
L20	134.18'	N89°08'28"E
L21	15.83'	N06°42'59"E

STORM CURVE TABLE			
CURVE	LENGTH	RADIUS	DELTA
C5	60.65'	490.00'	7°05'30"

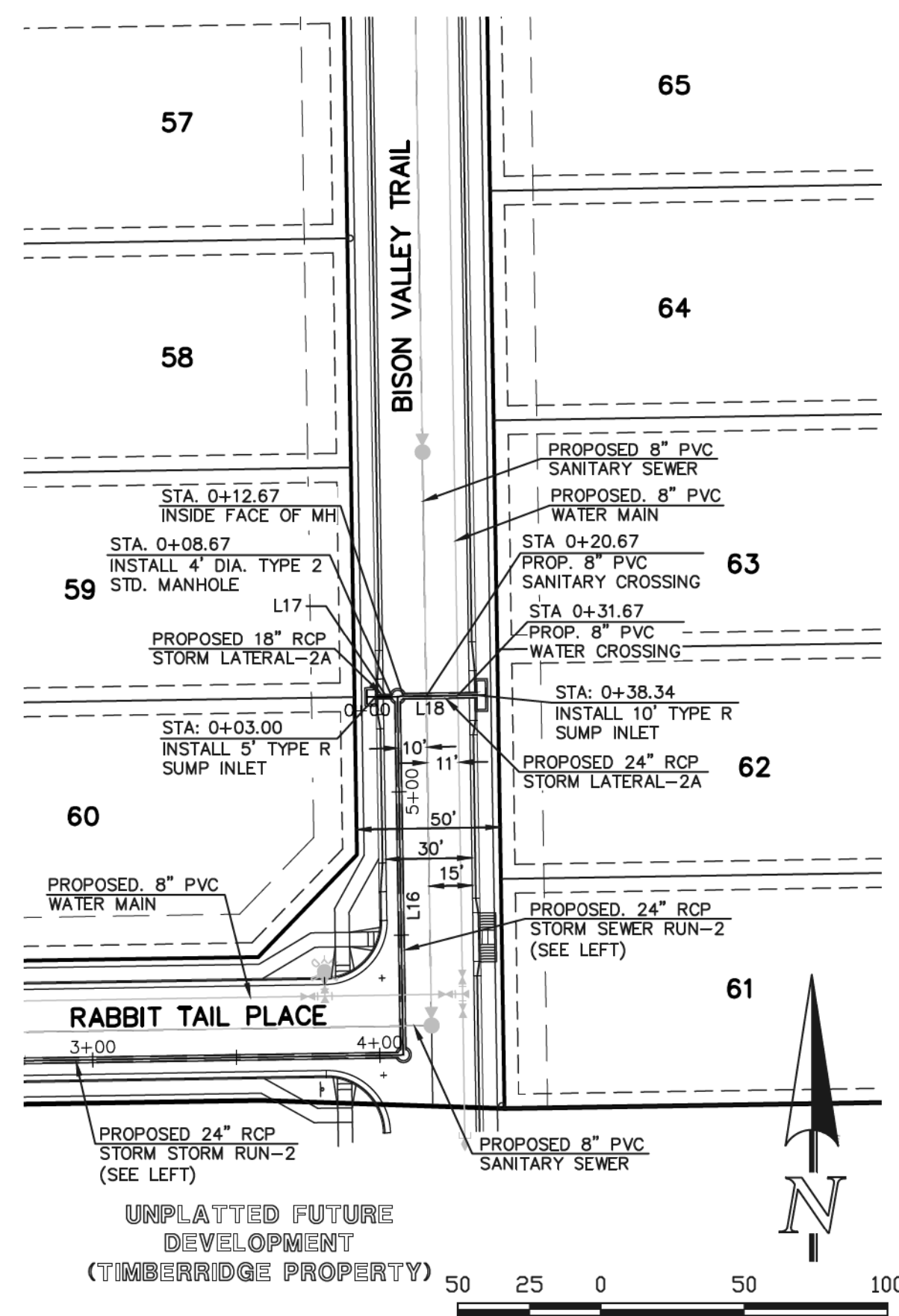

STORM SEWER LATERAL-2A (PUBLIC)

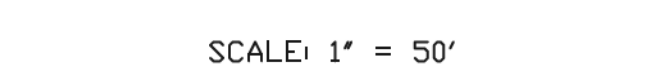

SCALE: 1" = 50'

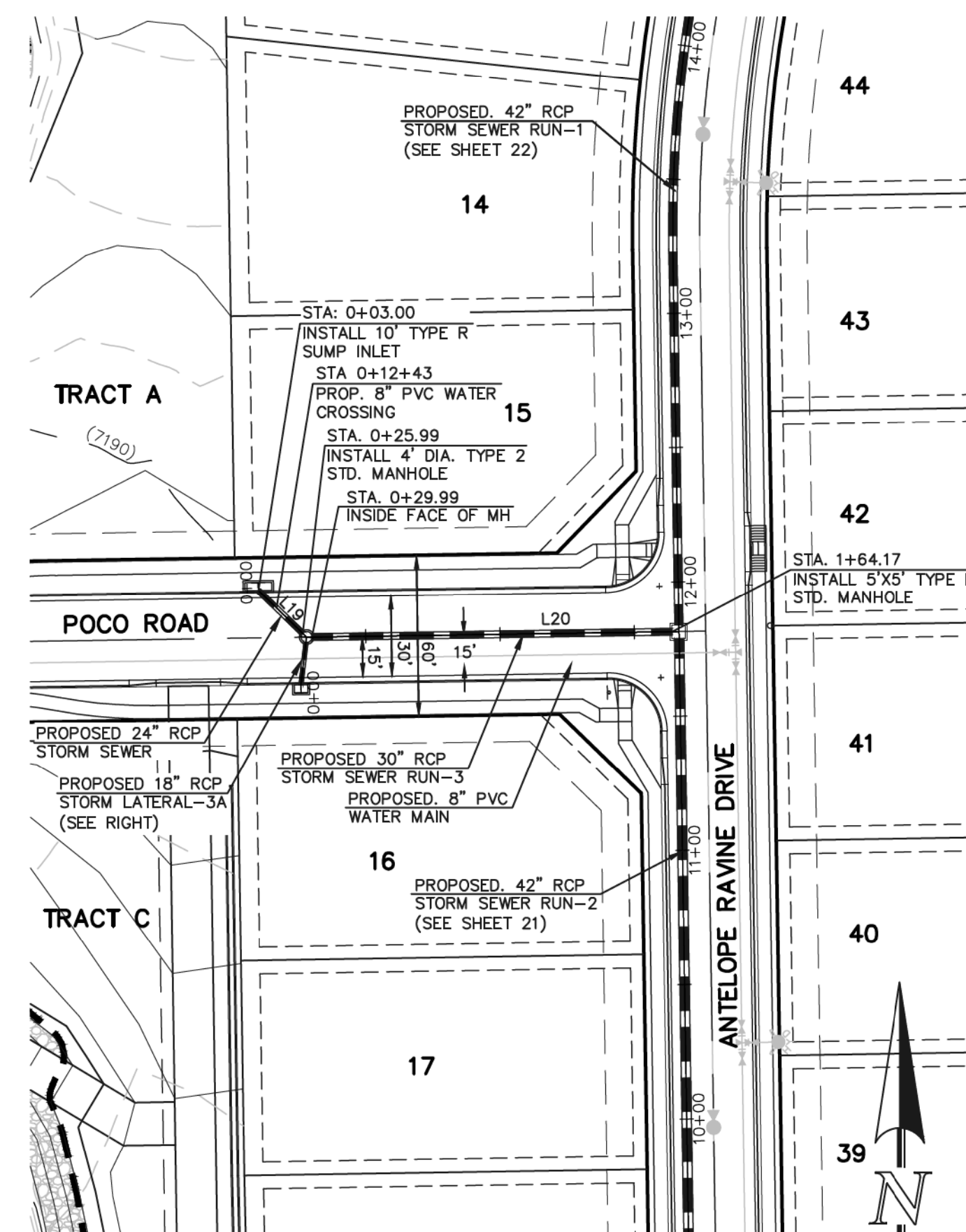

STORM SEWER RUN-3 (PUBLIC)



SCALE: 1" = 50'

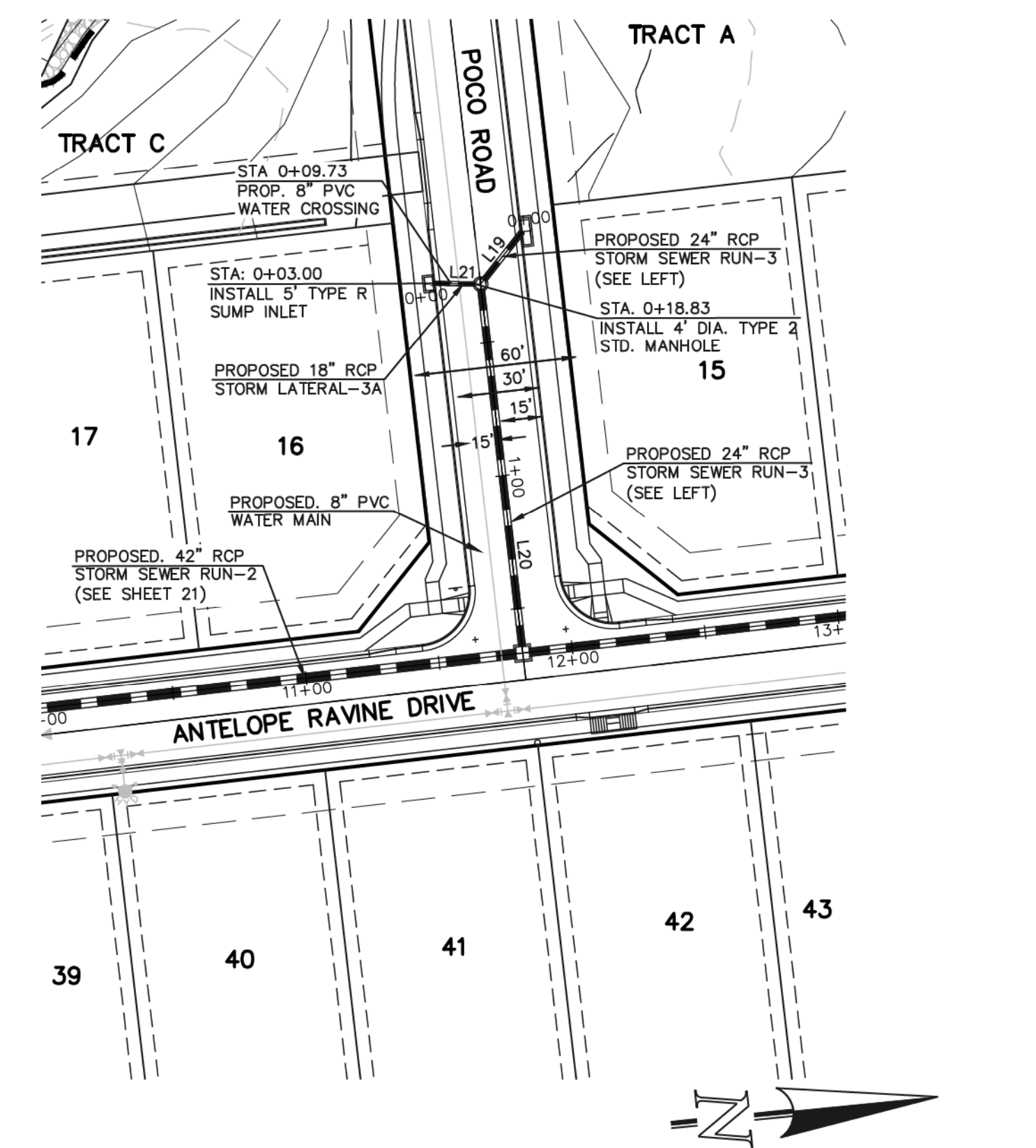

STORM SEWER LATERAL-3A (PUBLIC)



SCALE: 1" = 50'

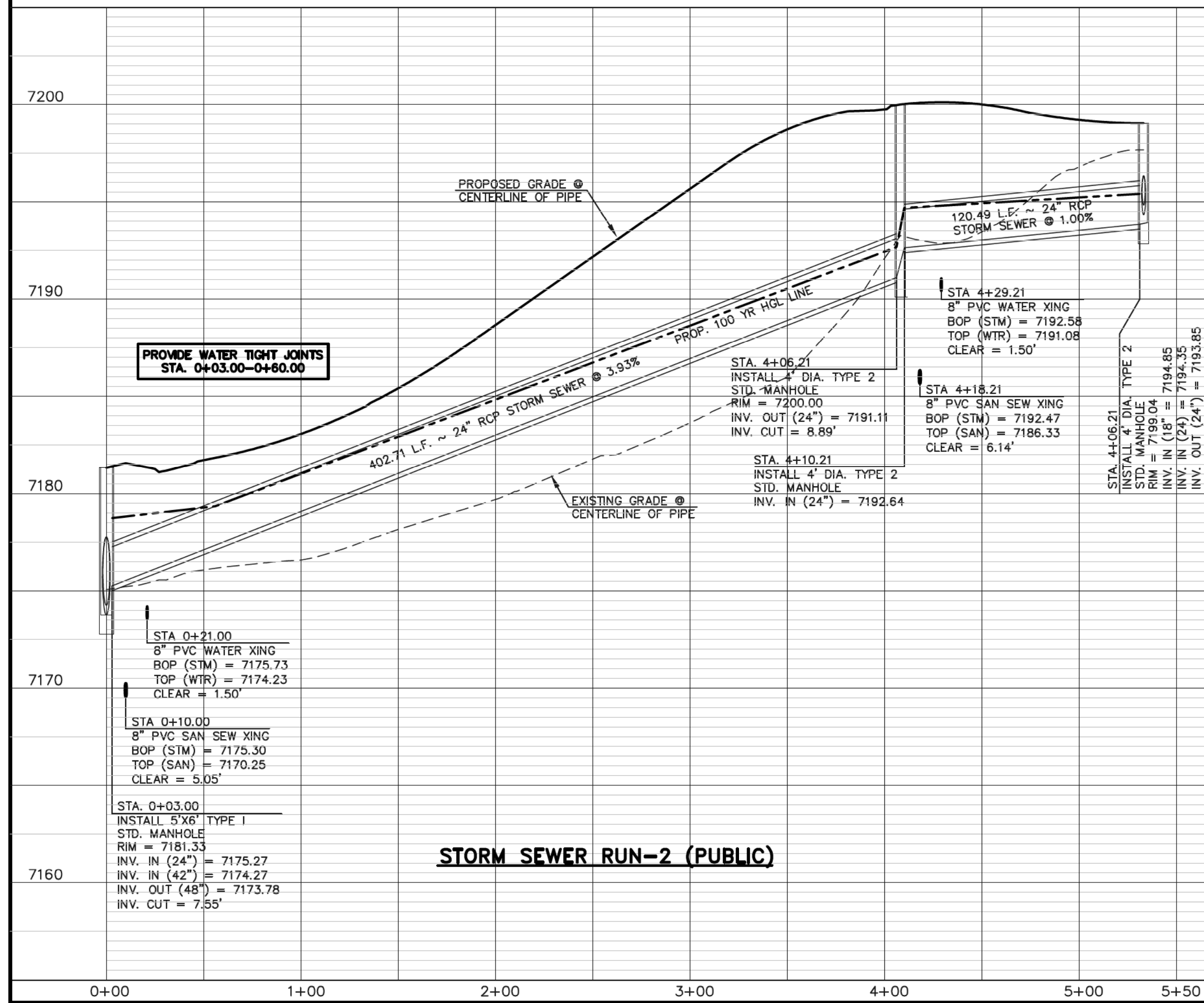

STORM SEWER RUN-2 (PUBLIC)

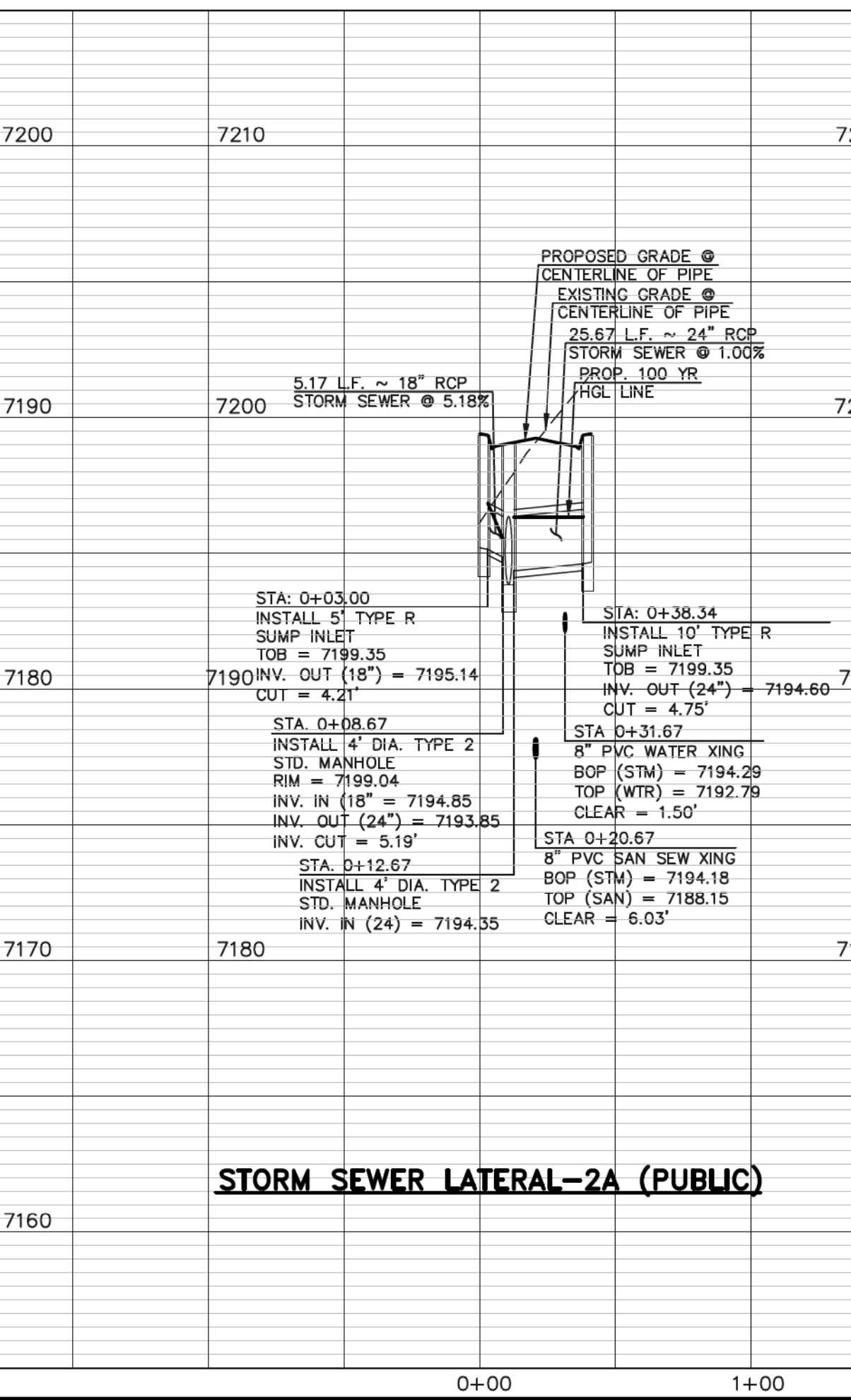

STORM SEWER LATERAL-2A (PUBLIC)

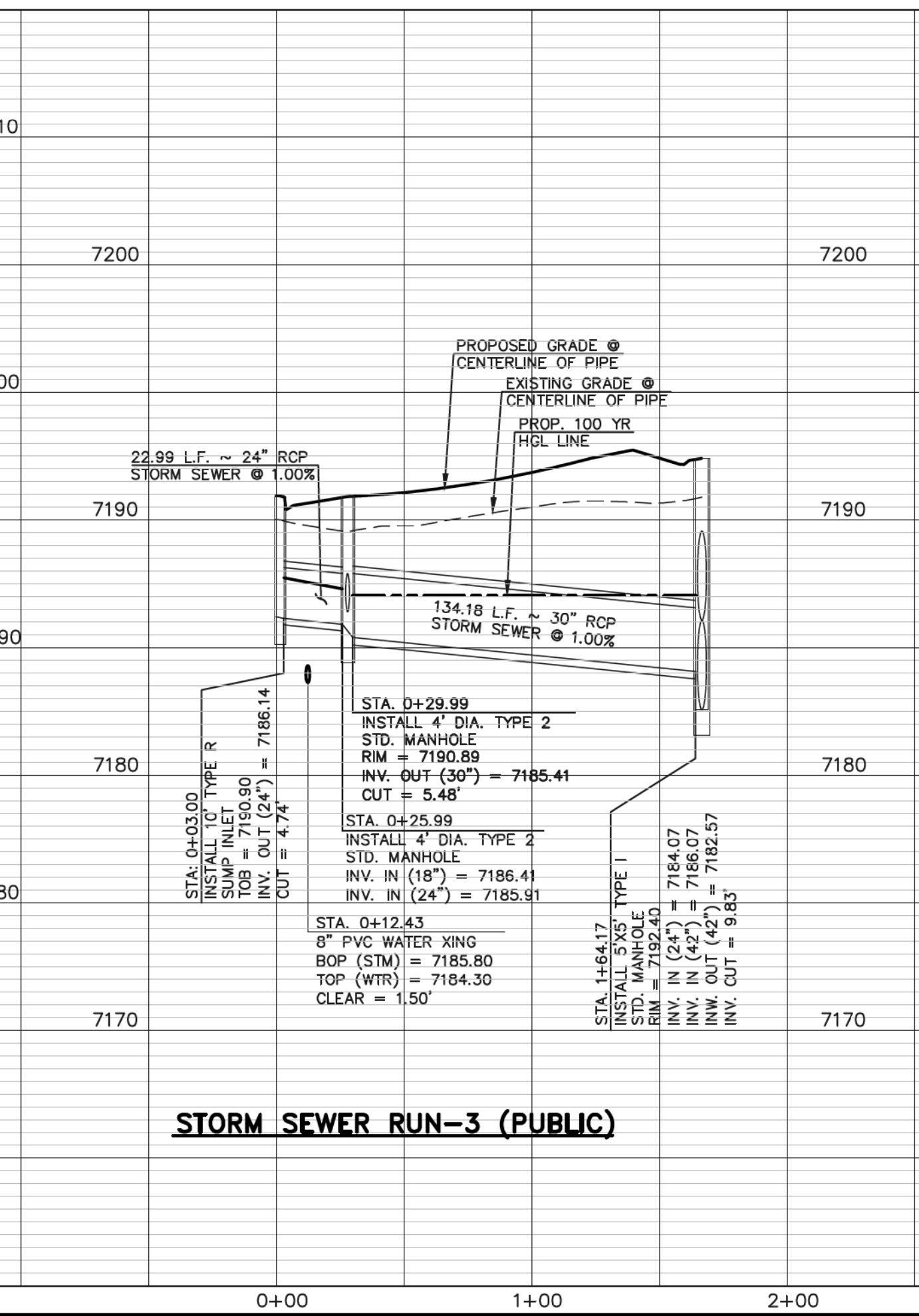

STORM SEWER RUN-3 (PUBLIC)

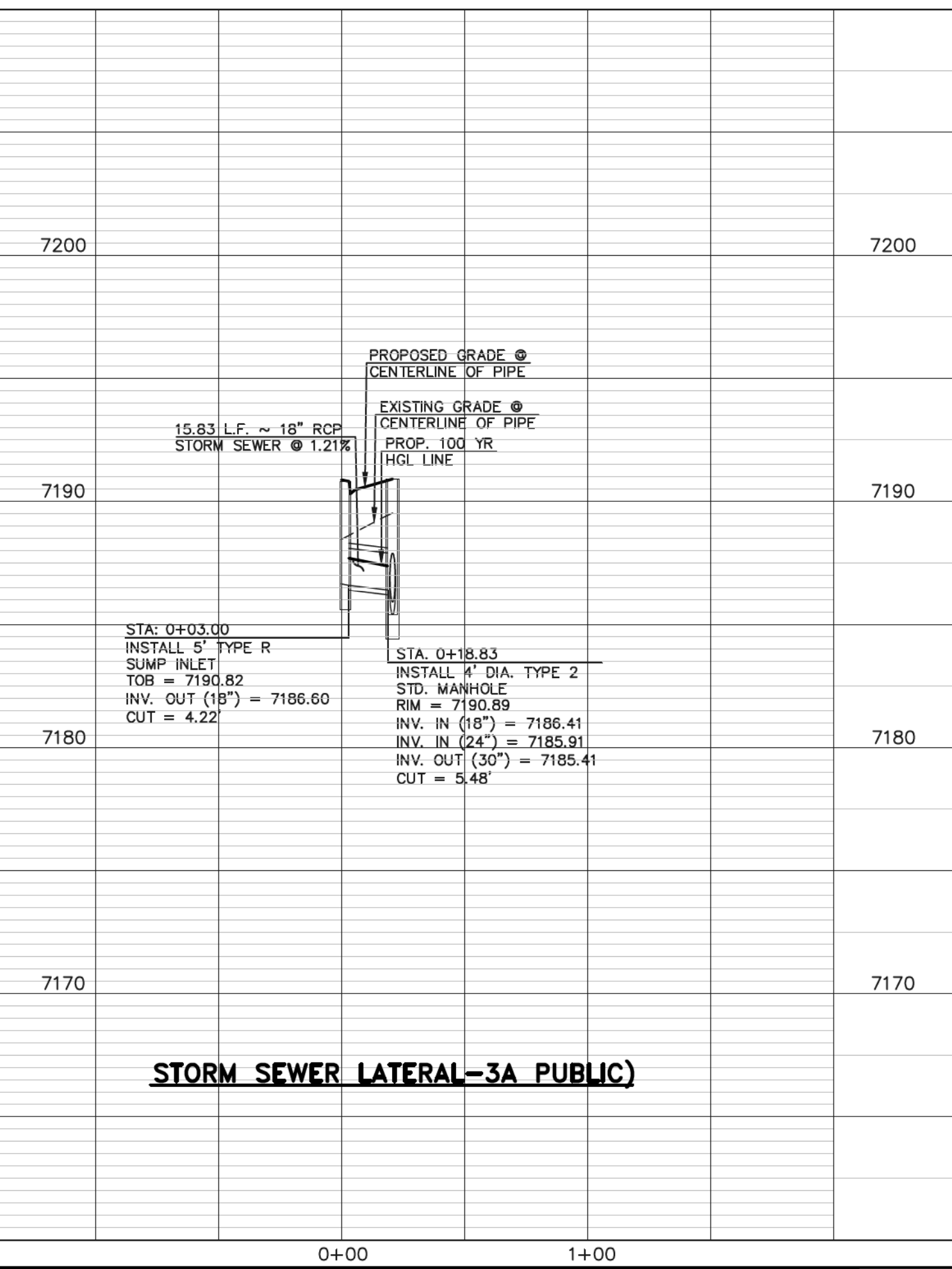

STORM SEWER LATERAL-3A (PUBLIC)

48 HOURS BEFORE YOU DIG,
CALL UTILITY LOCATORS
811
UTILITY NOTIFICATION CENTER OF COLORADO
IT'S THE LAW

THE LOCATIONS OF EXISTING UNDERGROUND UTILITIES ARE SHOWN IN AN APPROXIMATE WAY ONLY. THE CONTRACTOR SHALL DETERMINE THE EXACT LOCATION OF ALL EXISTING UTILITIES BEFORE COMMENCING WORK. THE CONTRACTOR SHALL BE FULLY RESPONSIBLE FOR ANY AND ALL DAMAGES WHICH MIGHT BE CAUSED BY HIS FAILURE TO EXACTLY LOCATE AND PRESERVE ANY AND ALL UNDERGROUND UTILITIES.

NO.	REVISION	DATE
1	REVISED PER COUNTY COMMENTS	08-13-19
2	REVISED PER COUNTY COMMENTS	3-13-20

REVIEW:
PREPARED UNDER MY DIRECT SUPERVISION FOR AND ON BEHALF OF
CLASSIC CONSULTING ENGINEERS AND SURVEYORS, LLC

MARC A. WHORTON, COLORADO P.E. #37155
DATE: 6/10/2020



RETREAT AT TIMBERRIDGE FILING NO. 1
CONSTRUCTION PLANS
STORM SEWER PLAN

DESIGNED BY	MAW	SCALE	DATE	04-05-19
DRAWN BY	ESO	(H) 1" = 50'	SHEET	23 OF 35
CHECKED BY	(V) 1" = 5'	JOB NO.	1185.00	

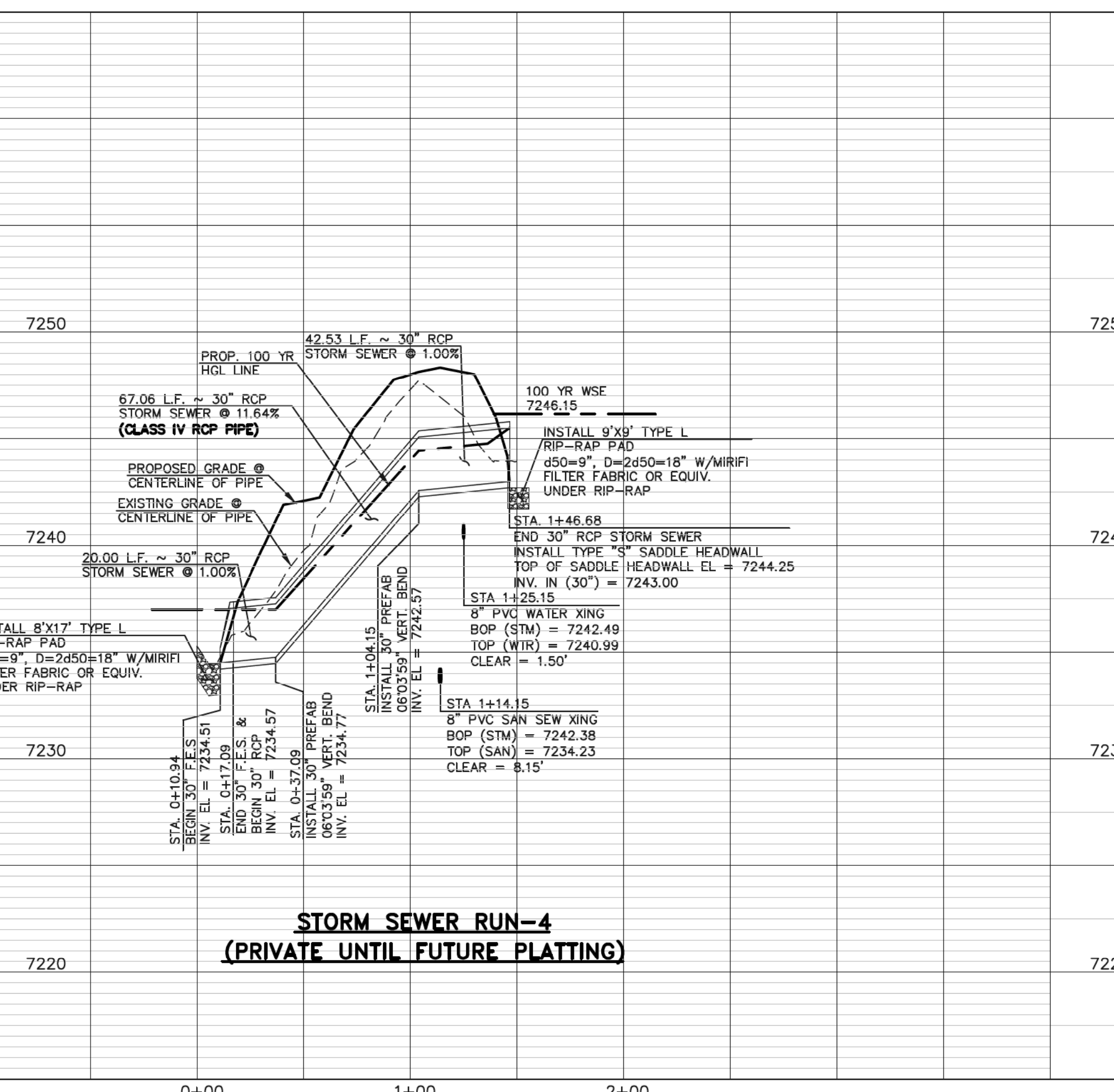
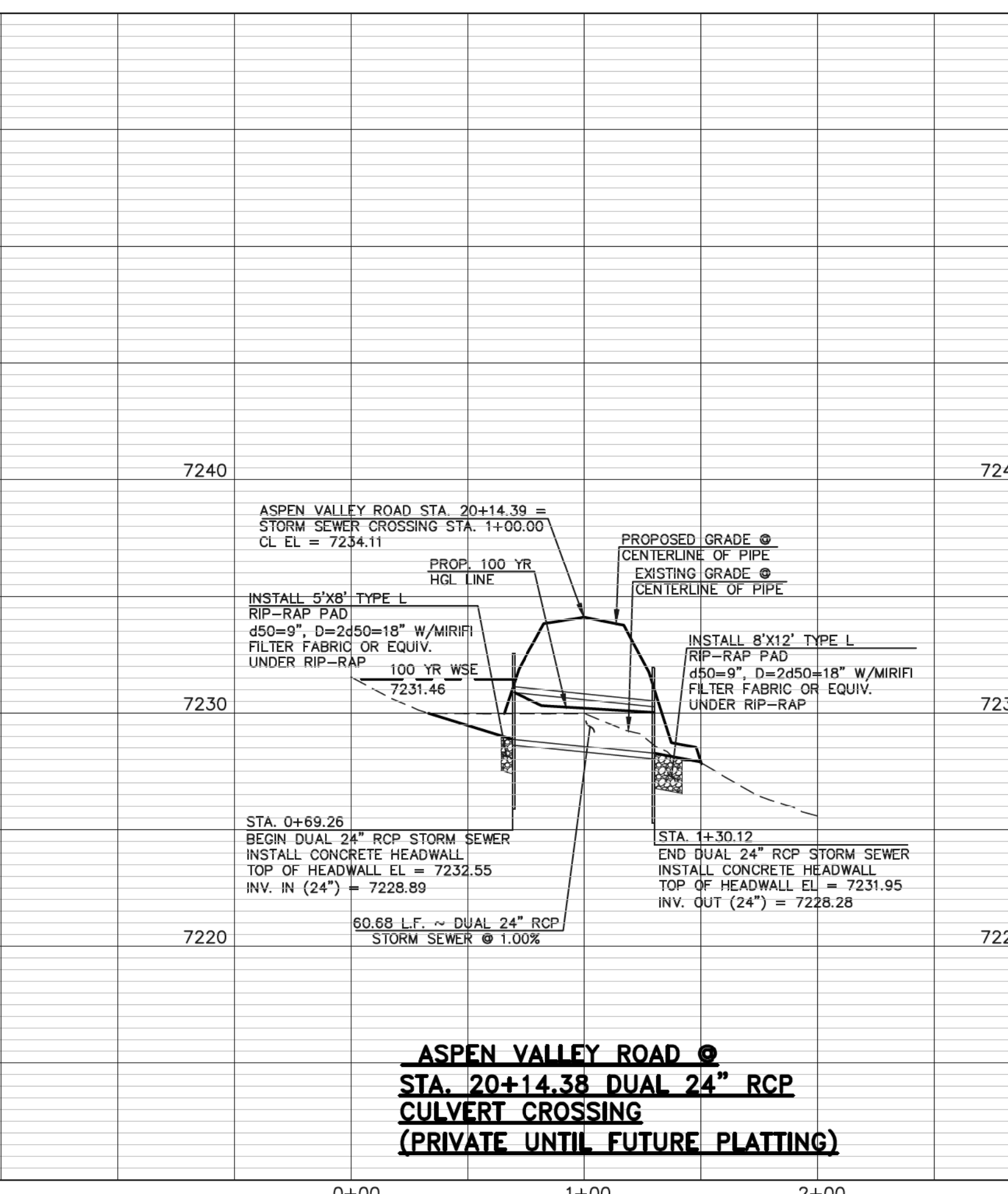
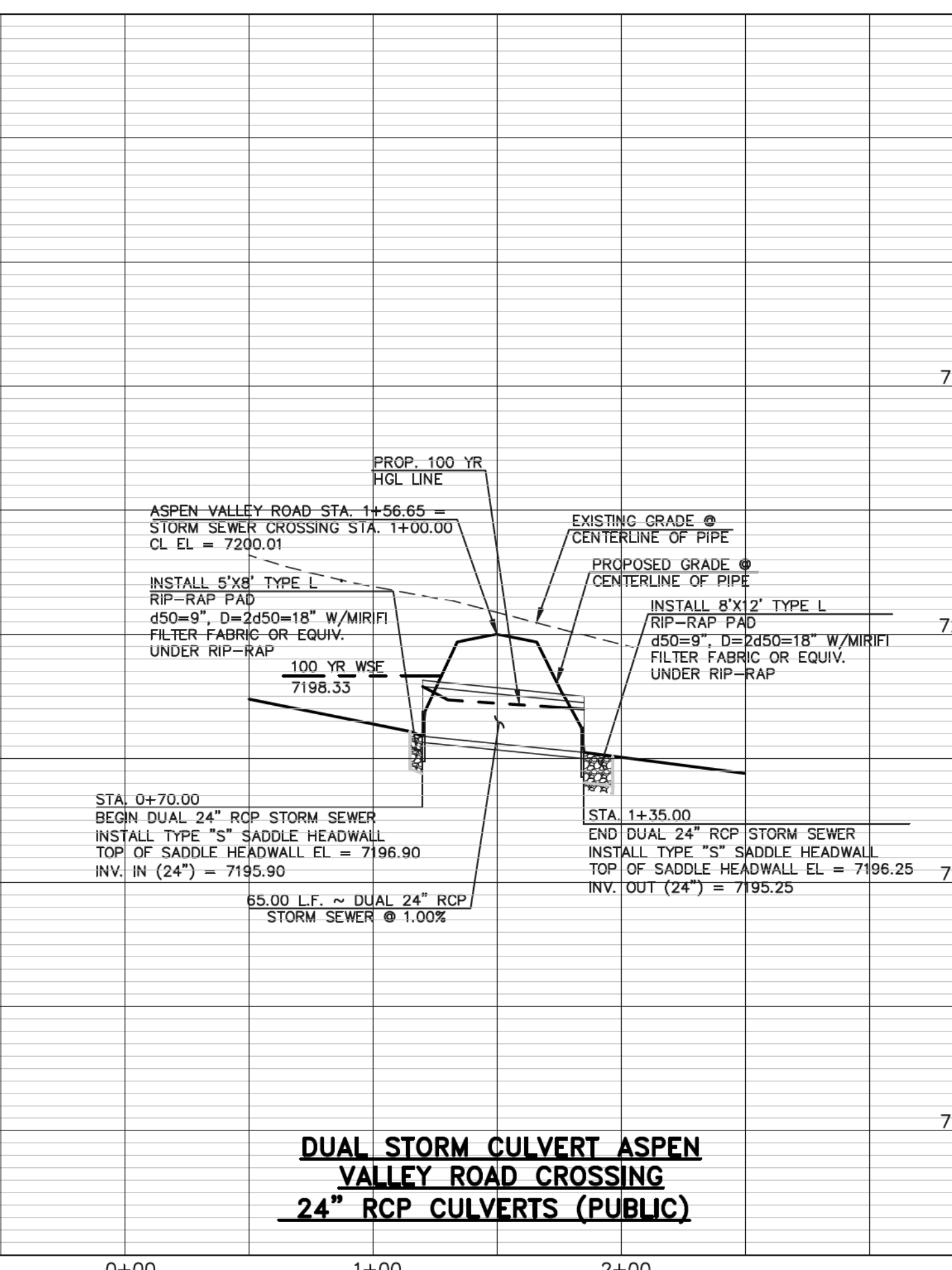
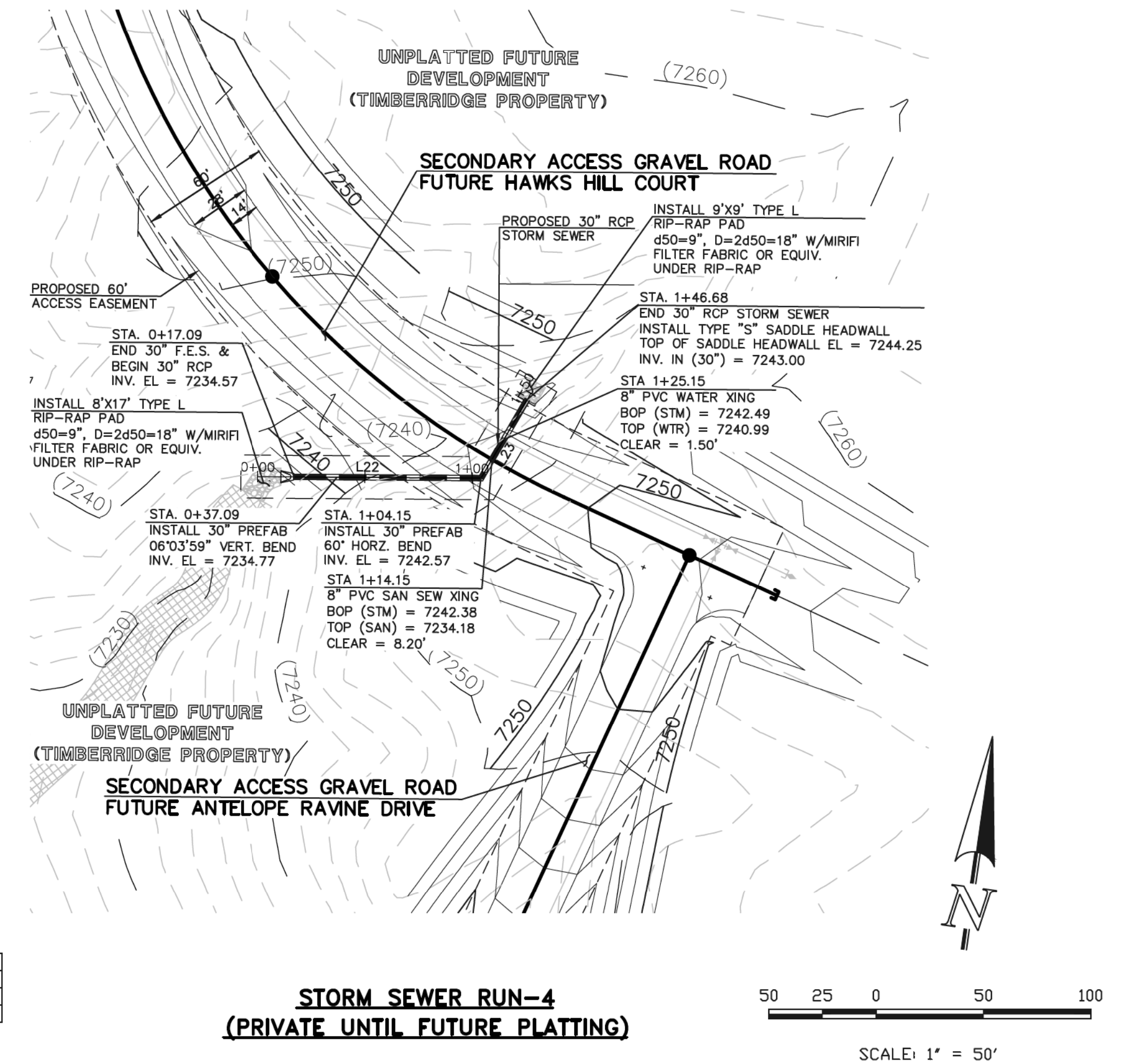
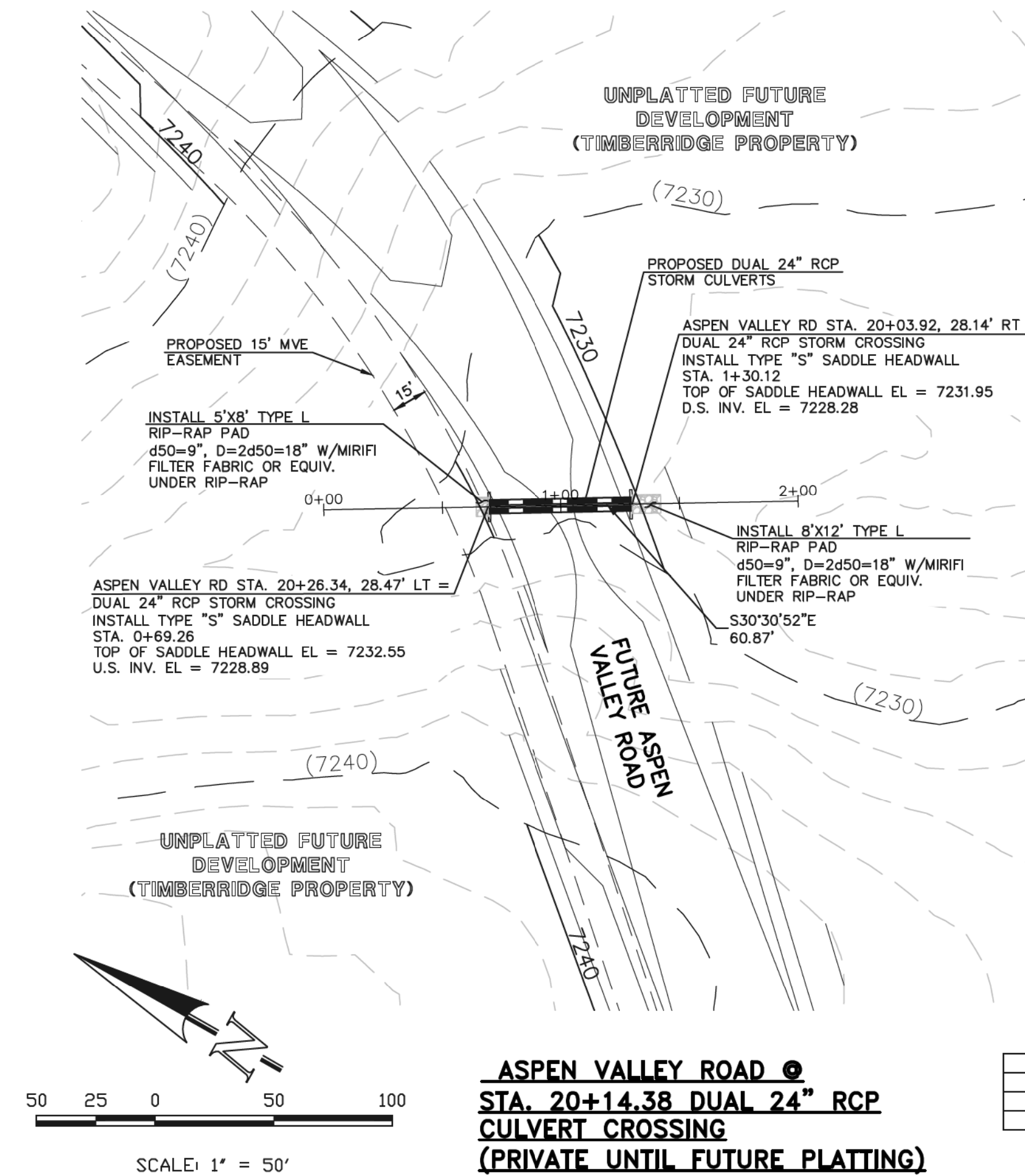
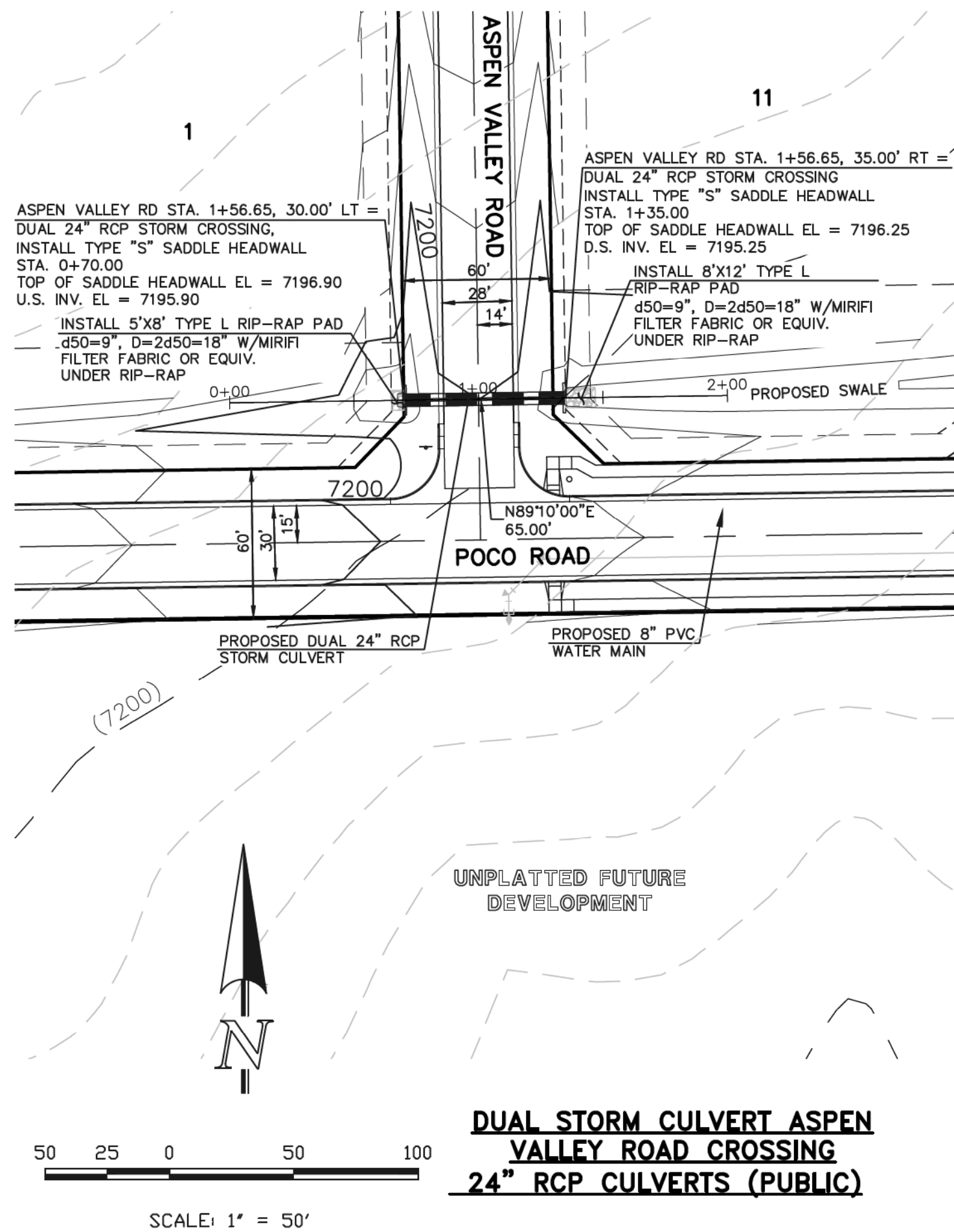

LINE	LENGTH	BEARING
L22	87.06'	N82°23'14\"/>
L23	42.53'	N22°23'14\"/>

48 HOURS BEFORE YOU DIG,
CALL UTILITY LOCATORS
811
UTILITY NOTIFICATION CENTER OF COLORADO
IT'S THE LAW

THE LOCATIONS OF EXISTING UNDERGROUND UTILITIES ARE SHOWN IN AN APPROXIMATE WAY ONLY. THE CONTRACTOR SHALL DETERMINE THE EXACT LOCATION OF ALL EXISTING UTILITIES BEFORE COMMENCING WORK. THE CONTRACTOR SHALL BE FULLY RESPONSIBLE FOR ANY AND ALL DAMAGES WHICH MIGHT BE CAUSED BY HIS FAILURE TO EXACTLY LOCATE AND PRESERVE ANY AND ALL UNDERGROUND UTILITIES.

NO.	REVISION	DATE
1	REVISED PER COUNTY COMMENTS	08-13-19
2	REVISED PER COUNTY COMMENTS	3-16-20

REVIEW:
PREPARED UNDER MY DIRECT SUPERVISION FOR AND ON BEHALF OF
CLASSIC CONSULTING ENGINEERS AND SURVEYORS, LLC

MARC A. WHORTON, COLORADO, P.E. #37155
DATE: 6/10/2020



RETREAT AT TIMBERIDGE FILING NO. 1
CONSTRUCTION PLANS
STORM SEWER PLAN

DESIGNED BY: MAW
DRAWN BY: ESO
CHECKED BY:

SCALE: (H) 1" = 50'
(V) 1" = 5'

DATE: 04-05-19
SHEET: 24 OF 35
JOB NO.: 1185.00

NOTE: ALL PROPERTY OWNED BY TIMBERRIDGE DEVELOPMENT. STORM SEWER WILL REMAIN PRIVATE WITH MAINTENANCE RESPONSIBILITY BY TIMBERRIDGE DEVELOPMENT AND SUCCESSORS AND ASSIGNS UNTIL FUTURE PLATTING. STORM EASEMENTS WILL BE PROVIDED AT THAT TIME.

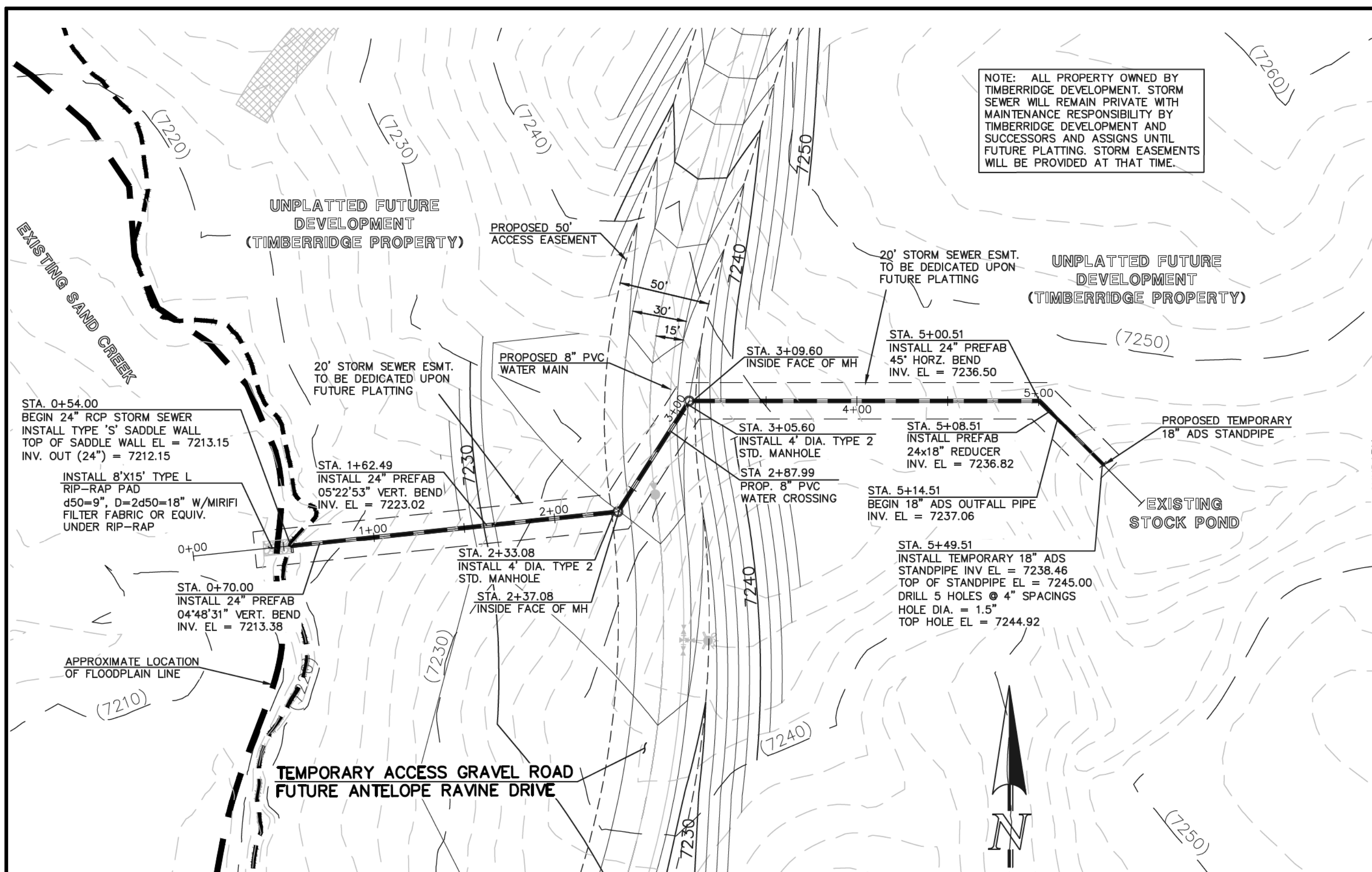

STORM SEWER RUN-5 (PRIVATE)
SCALE: 1" = 50'

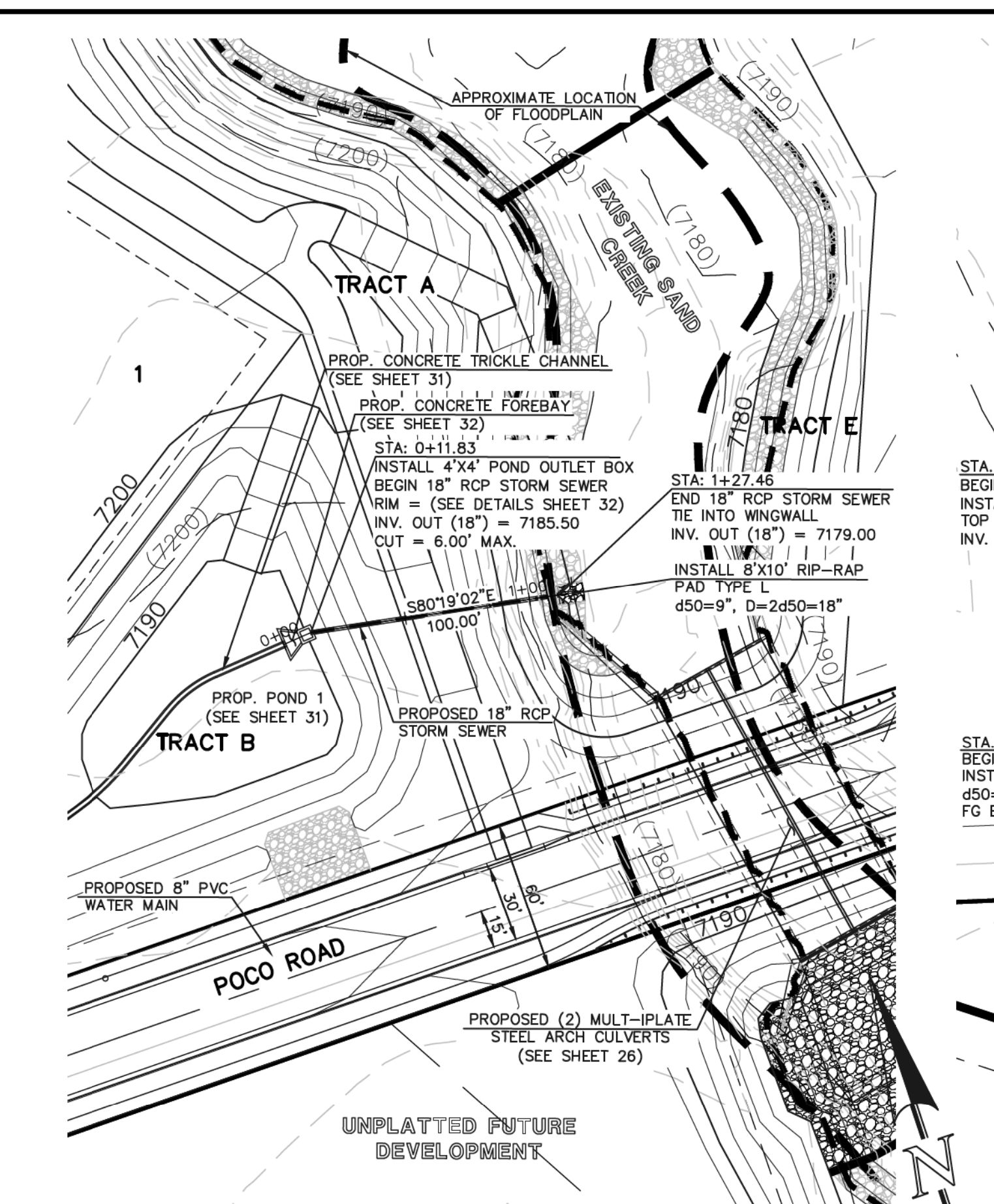

18\"/>

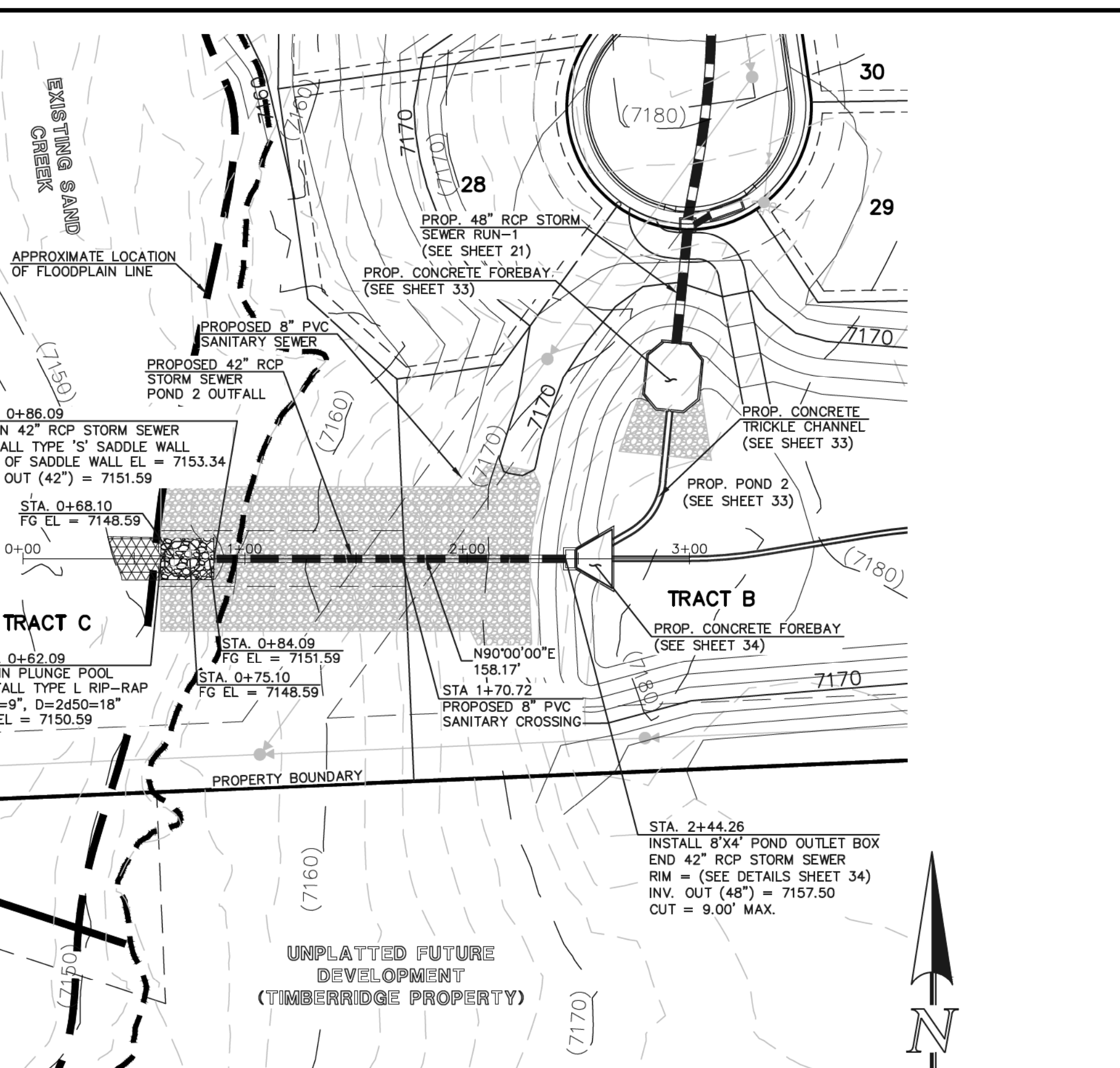

42\"/>

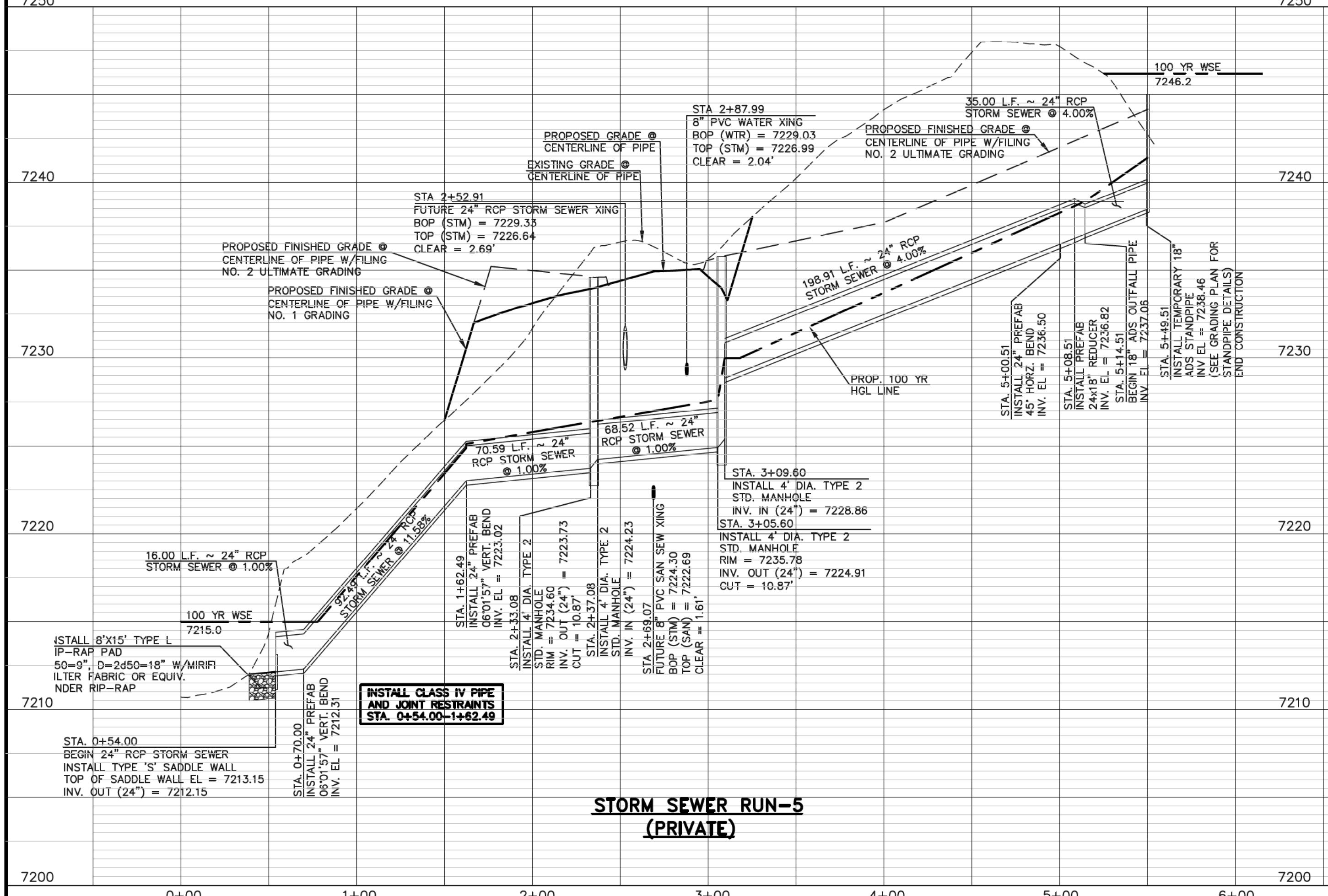

STORM SEWER RUN-5 (PRIVATE)

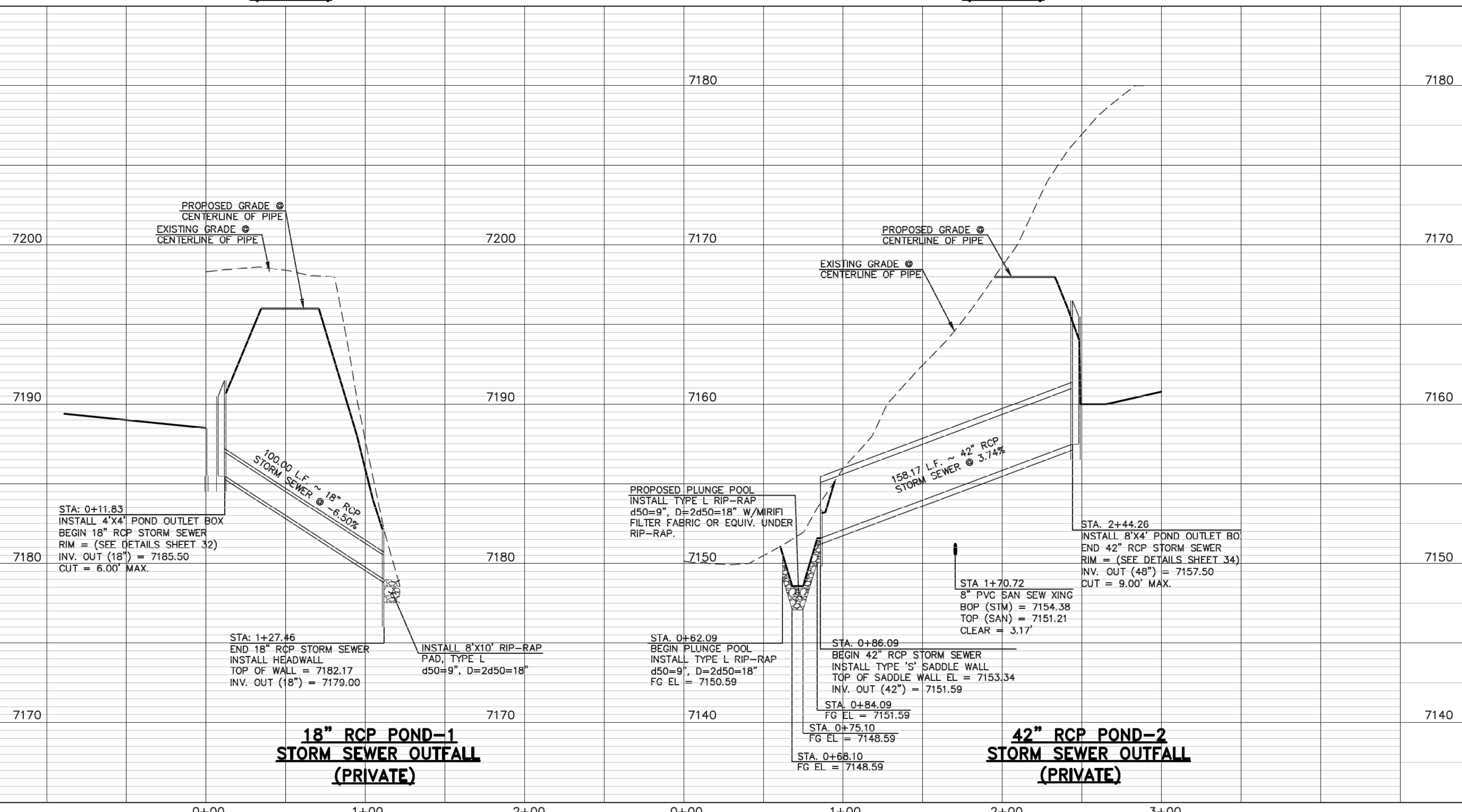

18\"/>

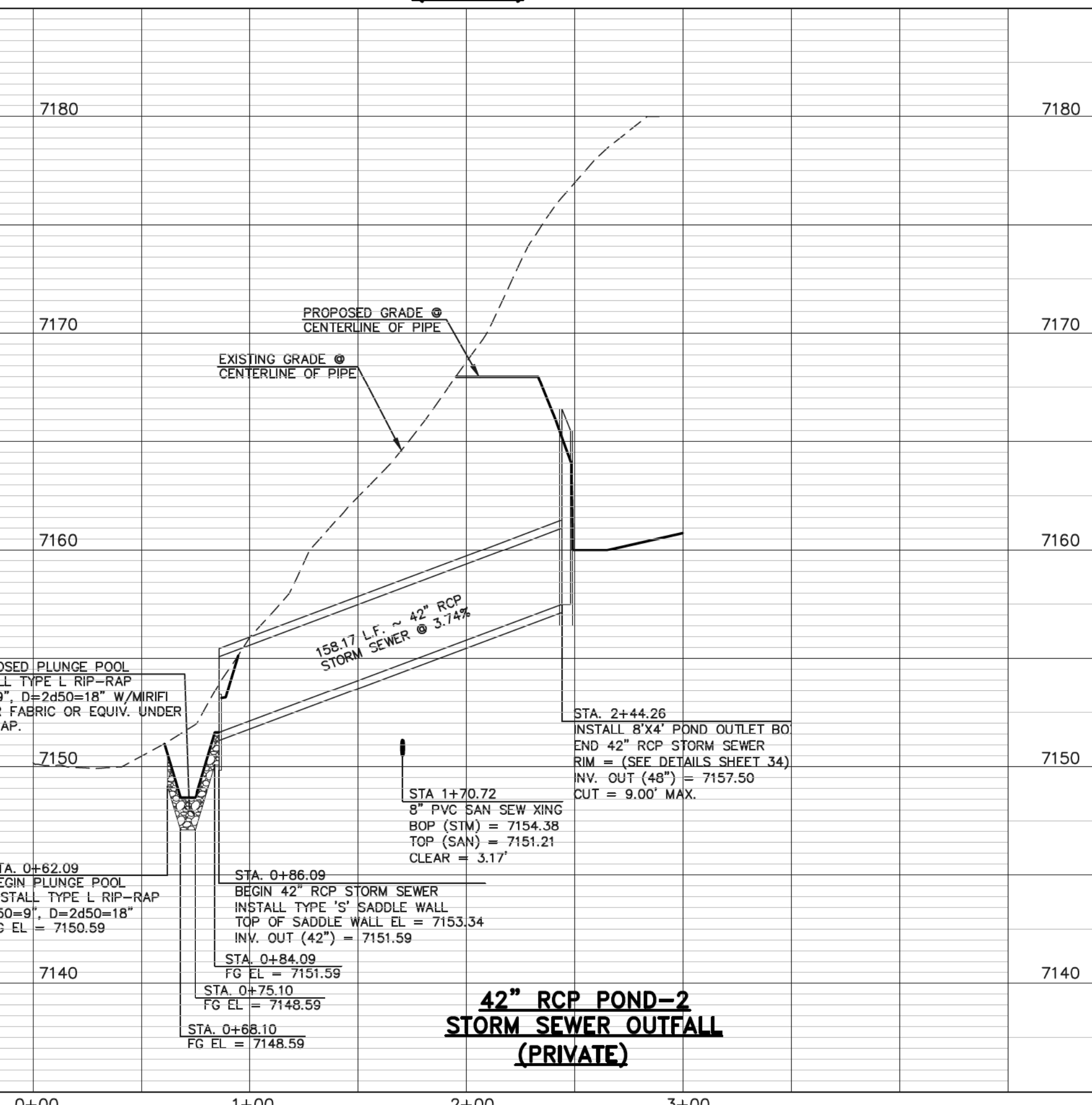

42\"/>

48 HOURS BEFORE YOU DIG,
CALL UTILITY LOCATORS
811
UTILITY NOTIFICATION CENTER OF COLORADO
IT'S THE LAW

THE LOCATIONS OF EXISTING UNDERGROUND UTILITIES ARE SHOWN IN AN APPROXIMATE WAY ONLY. THE CONTRACTOR SHALL DETERMINE THE EXACT LOCATION OF ALL EXISTING UTILITIES BEFORE COMMENCING WORK. THE CONTRACTOR SHALL BE FULLY RESPONSIBLE FOR ANY AND ALL DAMAGES WHICH MIGHT BE CAUSED BY HIS FAILURE TO EXACTLY LOCATE AND PRESERVE ANY AND ALL UNDERGROUND UTILITIES.

NO.	REVISION	DATE
1	REVISED PER COUNTY COMMENTS	08-13-19
2	REVISED PER COUNTY COMMENTS	3-16-20

REVIEW:
PREPARED UNDER MY DIRECT SUPERVISION FOR AND ON BEHALF OF
CLASSIC CONSULTING ENGINEERS AND SURVEYORS, LLC

MARC A. WHORTON, COLORADO P.E. #37155
DATE: 6/10/2020



RETREAT AT TIMBERRIDGE FILING NO. 1
CONSTRUCTION PLANS
STORM SEWER PLAN

DESIGNED BY: MAW
DRAWN BY: ESO
CHECKED BY:

SCALE: (H) 1" = 50'
(V) 1" = 5'

DATE: 04-05-19
SHEET 25 OF 35
JOB NO. 1185.00

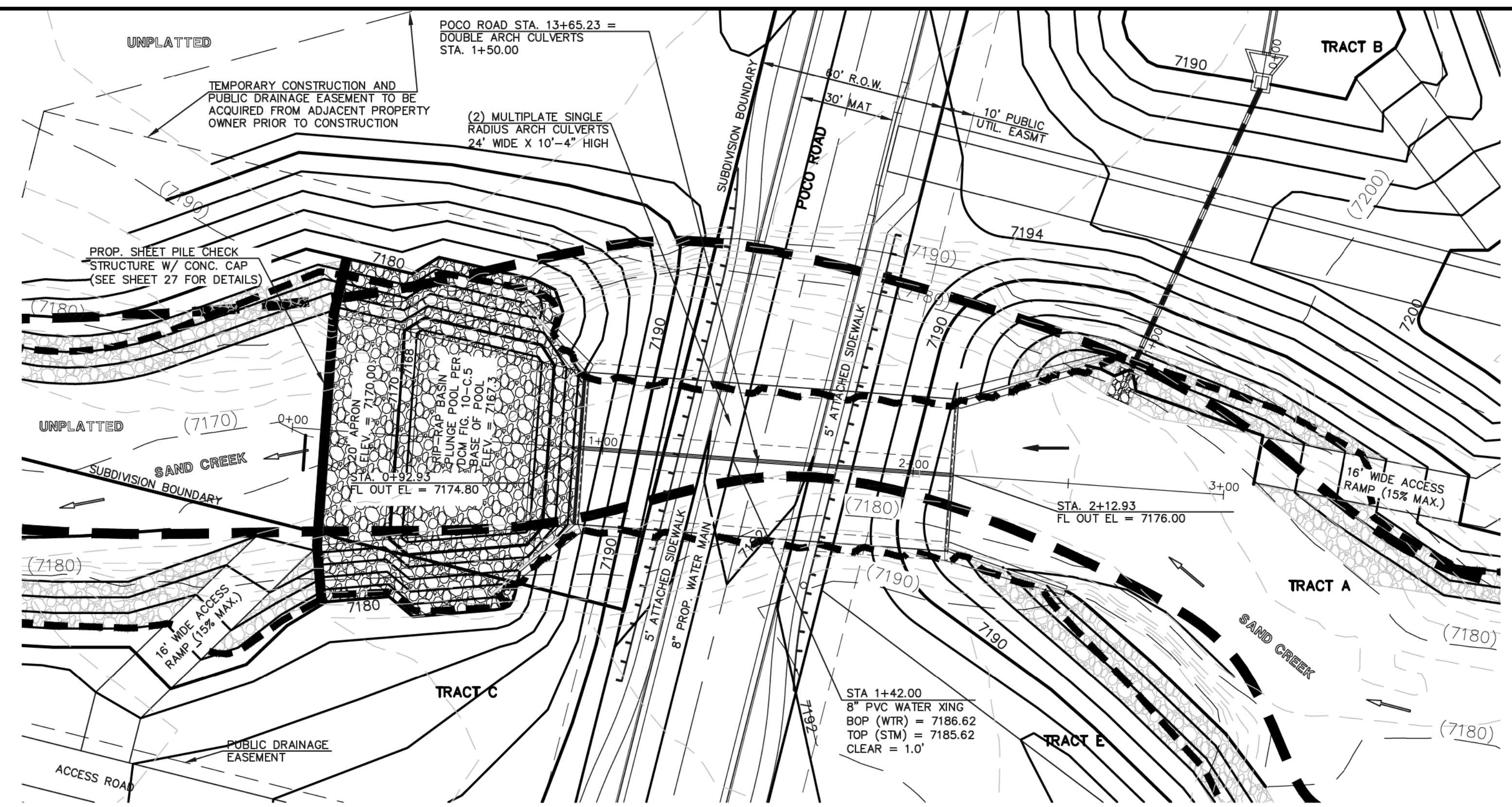

TWO MULTI-PLATE STEEL ARCH CULVERT CROSSING

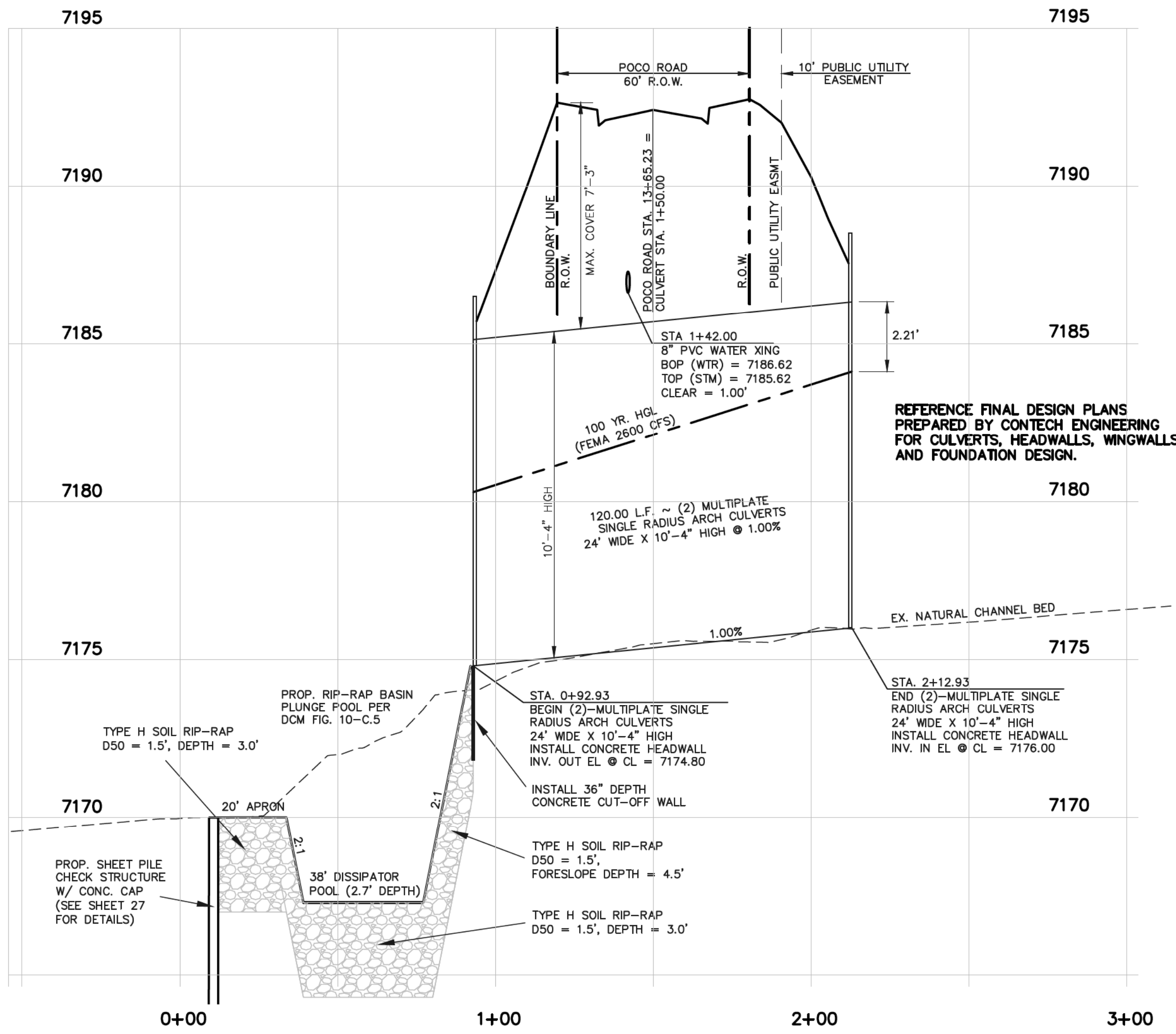
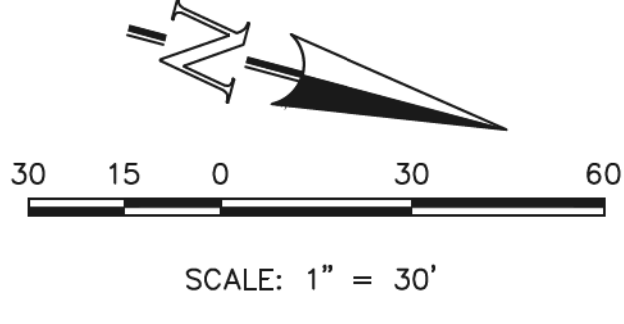

TWO MULTI-PLATE STEEL ARCH CULVERT CROSSING

HORIZONTAL SCALE: 1" = 30'
VERTICAL SCALE: 1" = 3'

REFERENCE FINAL DESIGN PLANS PREPARED BY CONTECH ENGINEERING FOR CULVERTS, HEADWALLS, WINGWALLS AND FOUNDATION DESIGN.

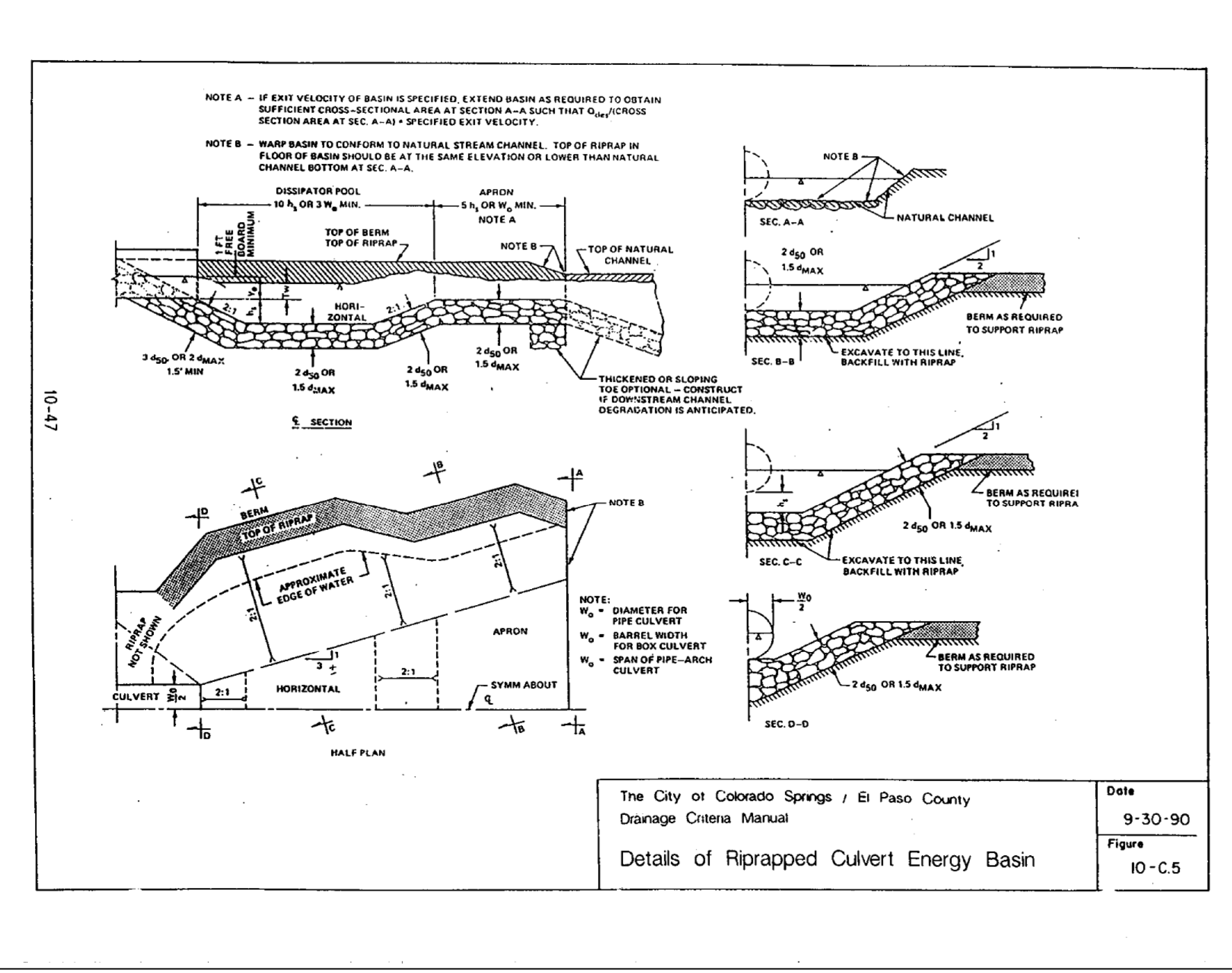

The City of Colorado Springs / El Paso County
Damage Criteria Manual
Details of Riprapped Culvert Energy Basin
Date: 9-30-90
Figure: 10-C.5

48 HOURS BEFORE YOU DIG,
CALL UTILITY LOCATORS
811
UTILITY NOTIFICATION CENTER OF COLORADO
IT'S THE LAW
THE LOCATIONS OF EXISTING UNDERGROUND UTILITIES ARE SHOWN IN AN APPROXIMATE WAY ONLY. THE CONTRACTOR SHALL DETERMINE THE EXACT LOCATION OF ALL EXISTING UTILITIES BEFORE COMMENCING WORK. THE CONTRACTOR SHALL BE FULLY RESPONSIBLE FOR ANY AND ALL DAMAGES WHICH MIGHT BE CAUSED BY HIS FAILURE TO EXACTLY LOCATE AND PRESERVE ANY AND ALL UNDERGROUND UTILITIES.

NO.	REVISION	DATE
1	REVISED PER COUNTY COMMENTS	08-13-19
2	REVISED PER COUNTY COMMENTS	03-20-20
3	REVISED PER COUNTY COMMENTS	6-9-20

REVIEW:
PREPARED UNDER MY DIRECT SUPERVISION FOR AND ON BEHALF OF CLASSIC CONSULTING ENGINEERS AND SURVEYORS, LLC
MARC A. WHORTON, COLORADO P.E. #37155
DATE: 6/10/2020



RETREAT AT TIMBERIDGE FILING NO. 1
CONSTRUCTION PLANS
POCO ROAD CULVERT CROSSING
DESIGNED BY: PRA
DRAWN BY: PRA
CHECKED BY: (V)
SCALE: (H) 1" = 30'
(V) 1" = 3'
DATE: 04-05-19
SHEET 26 OF 35
JOB NO. 1185.00

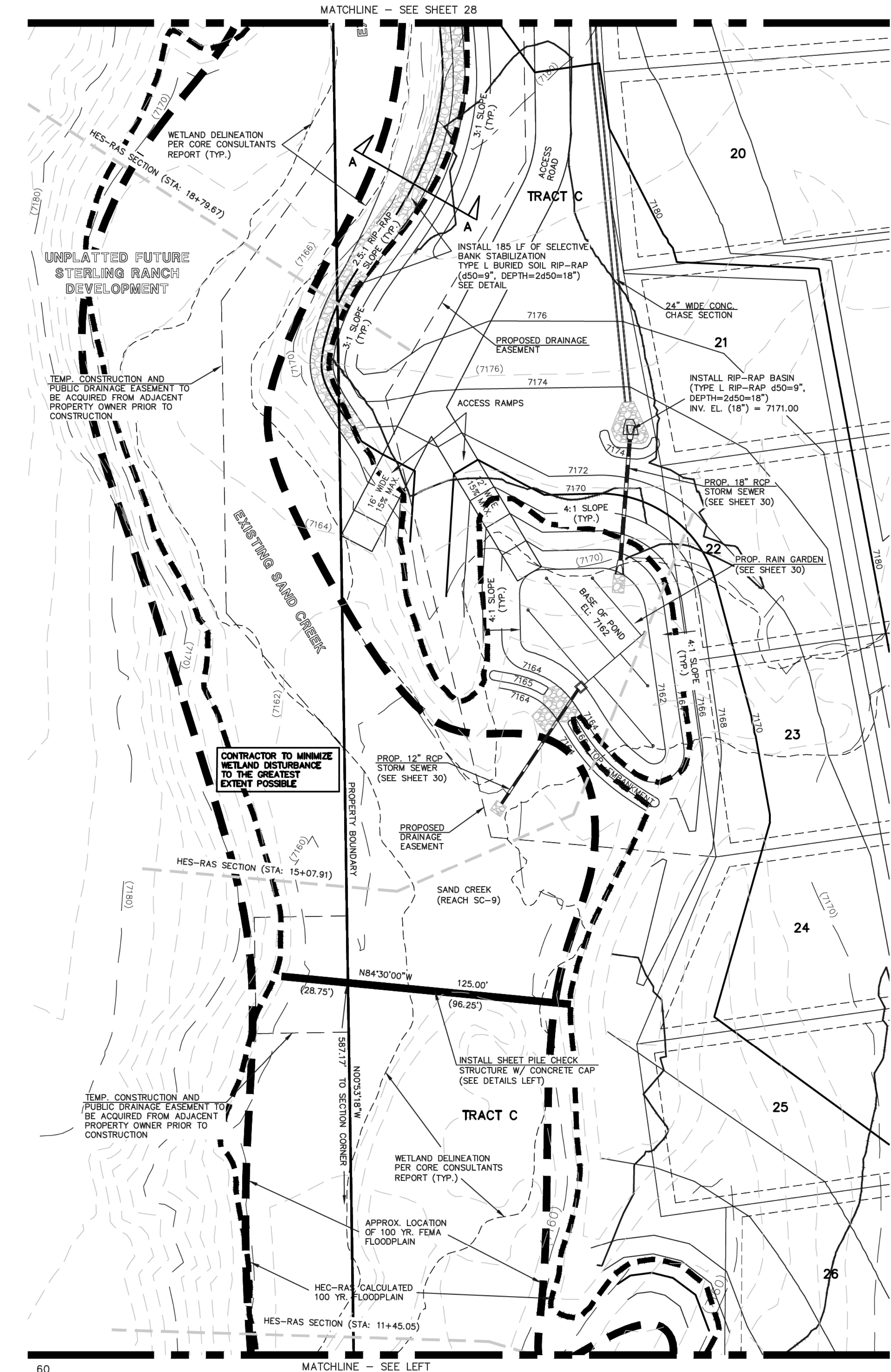
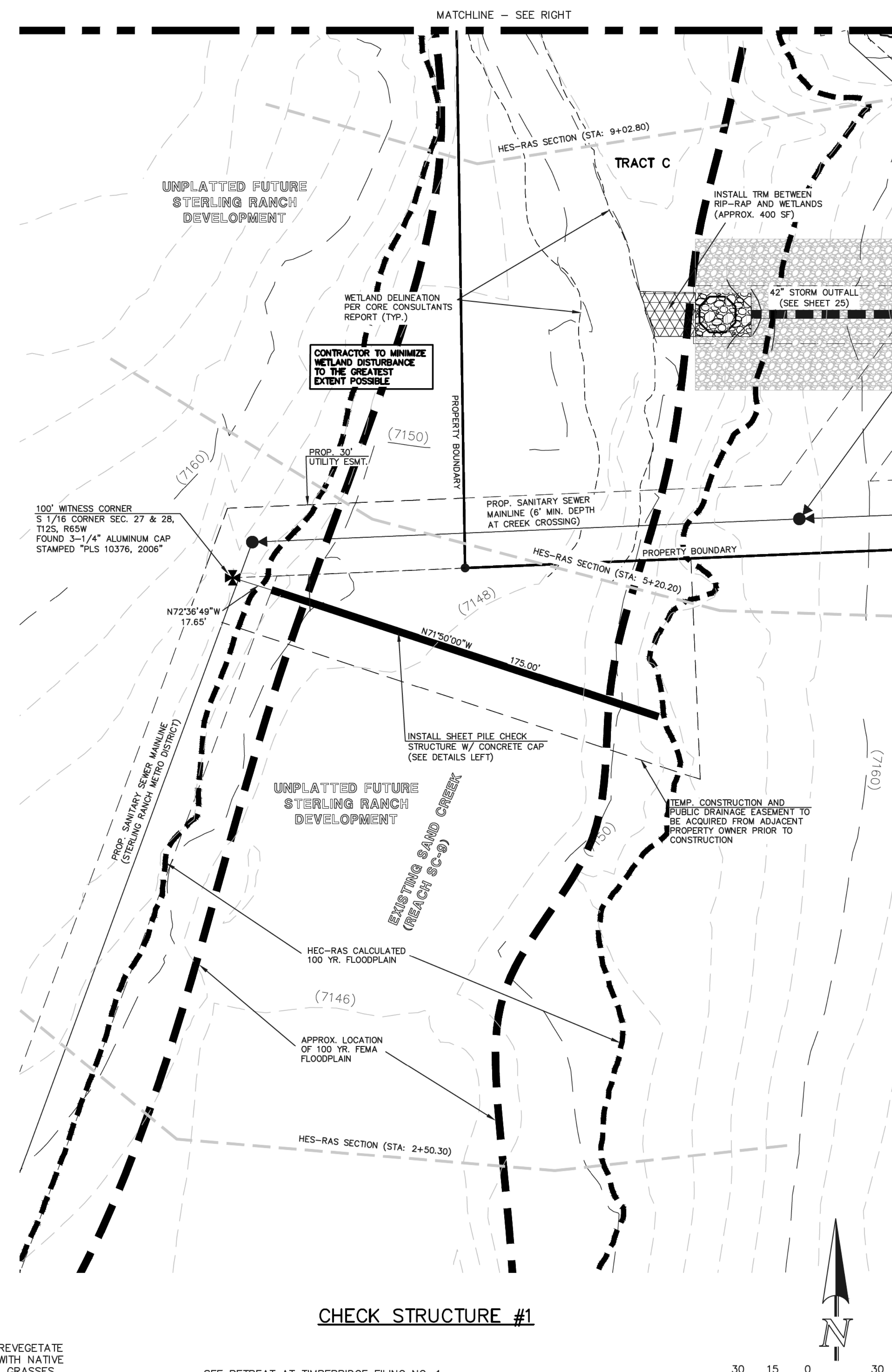
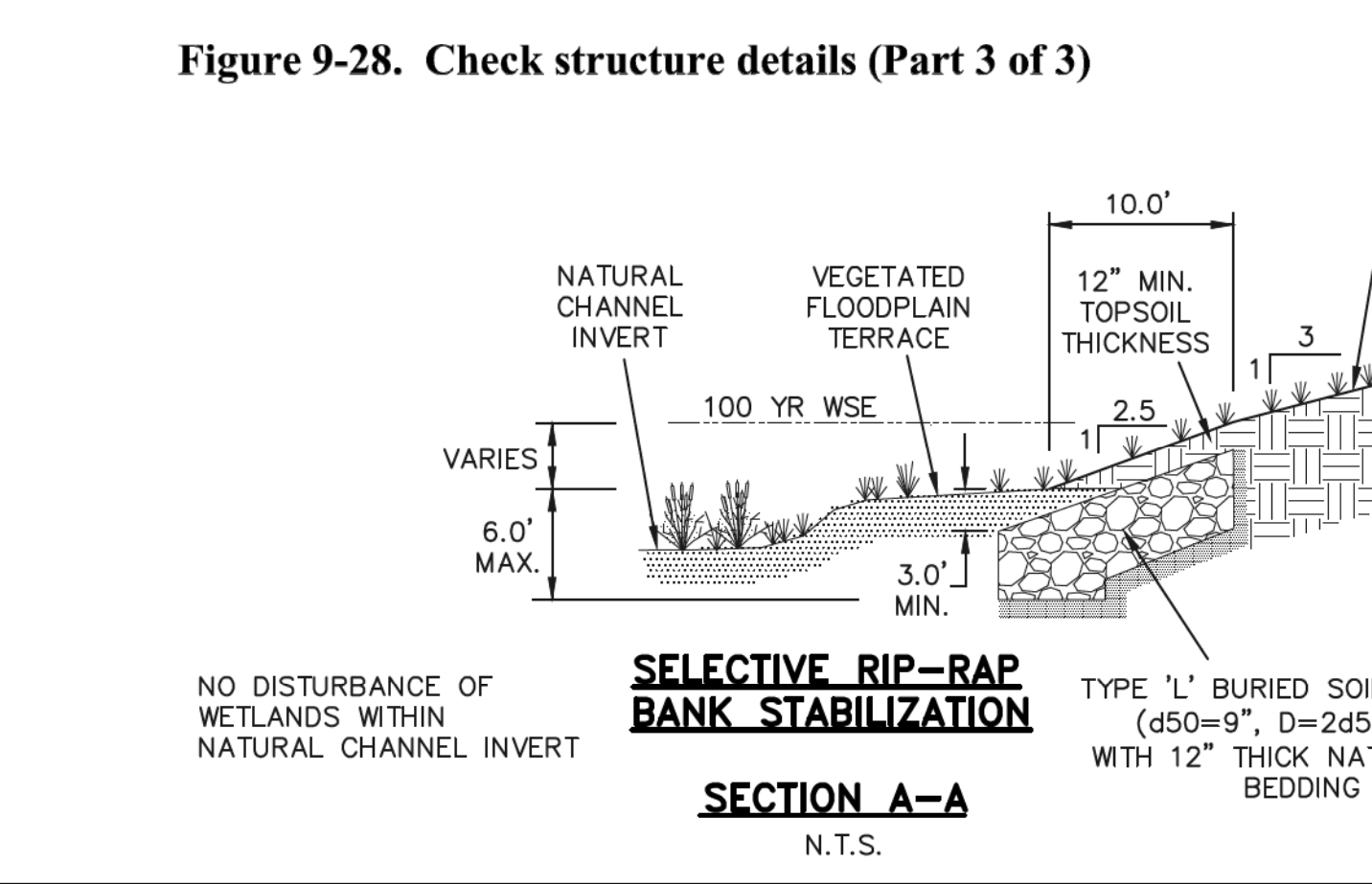
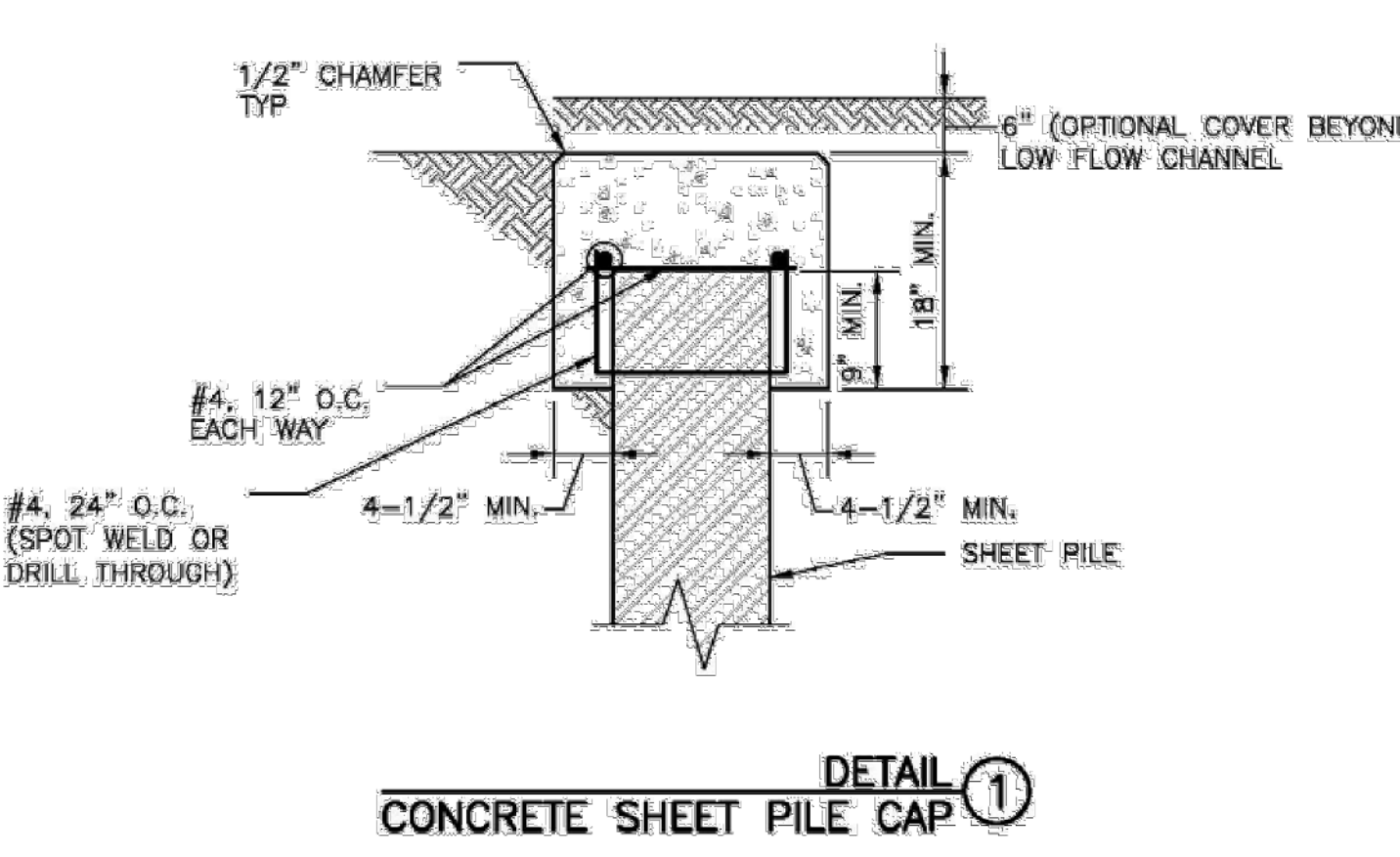
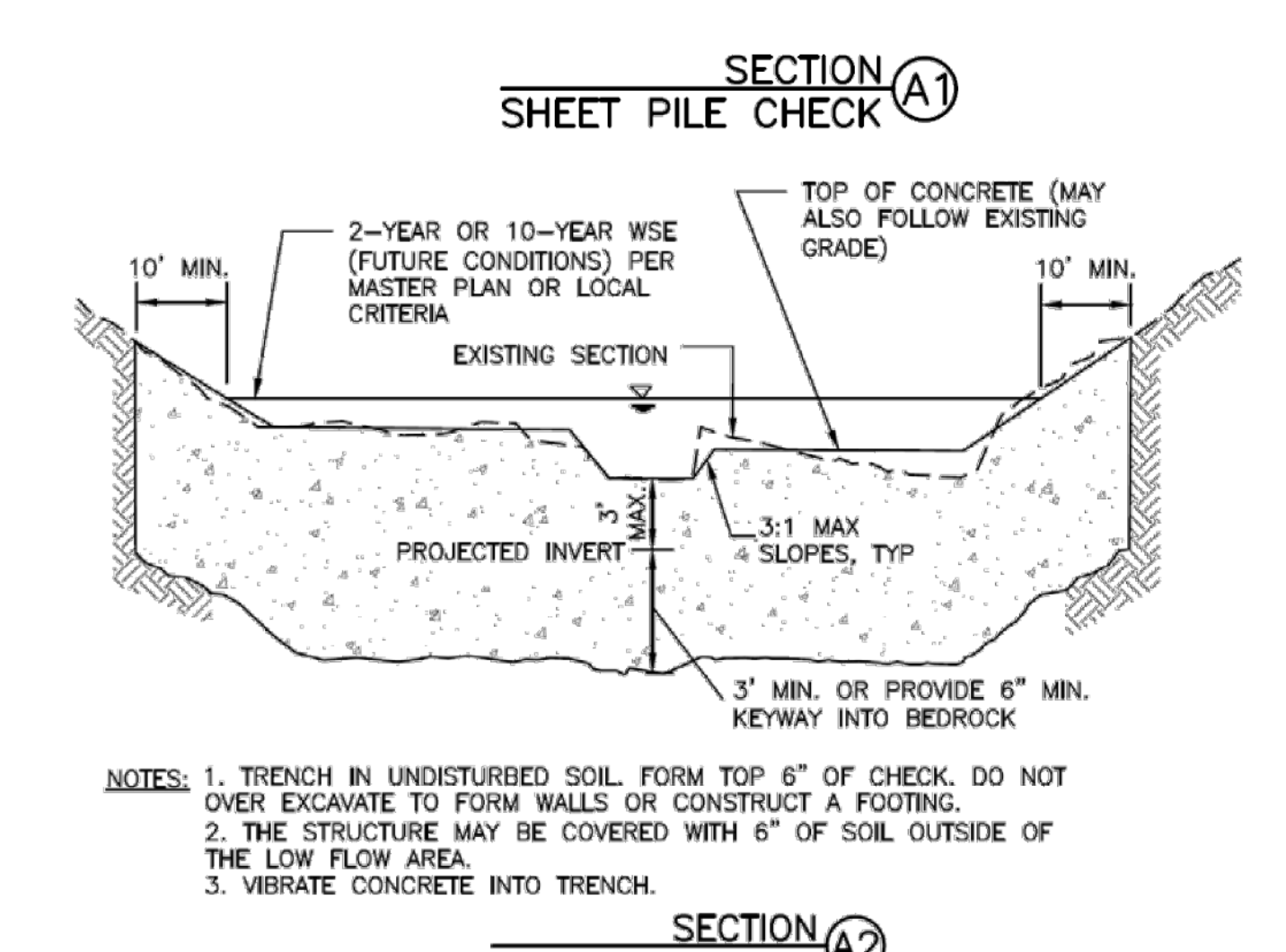
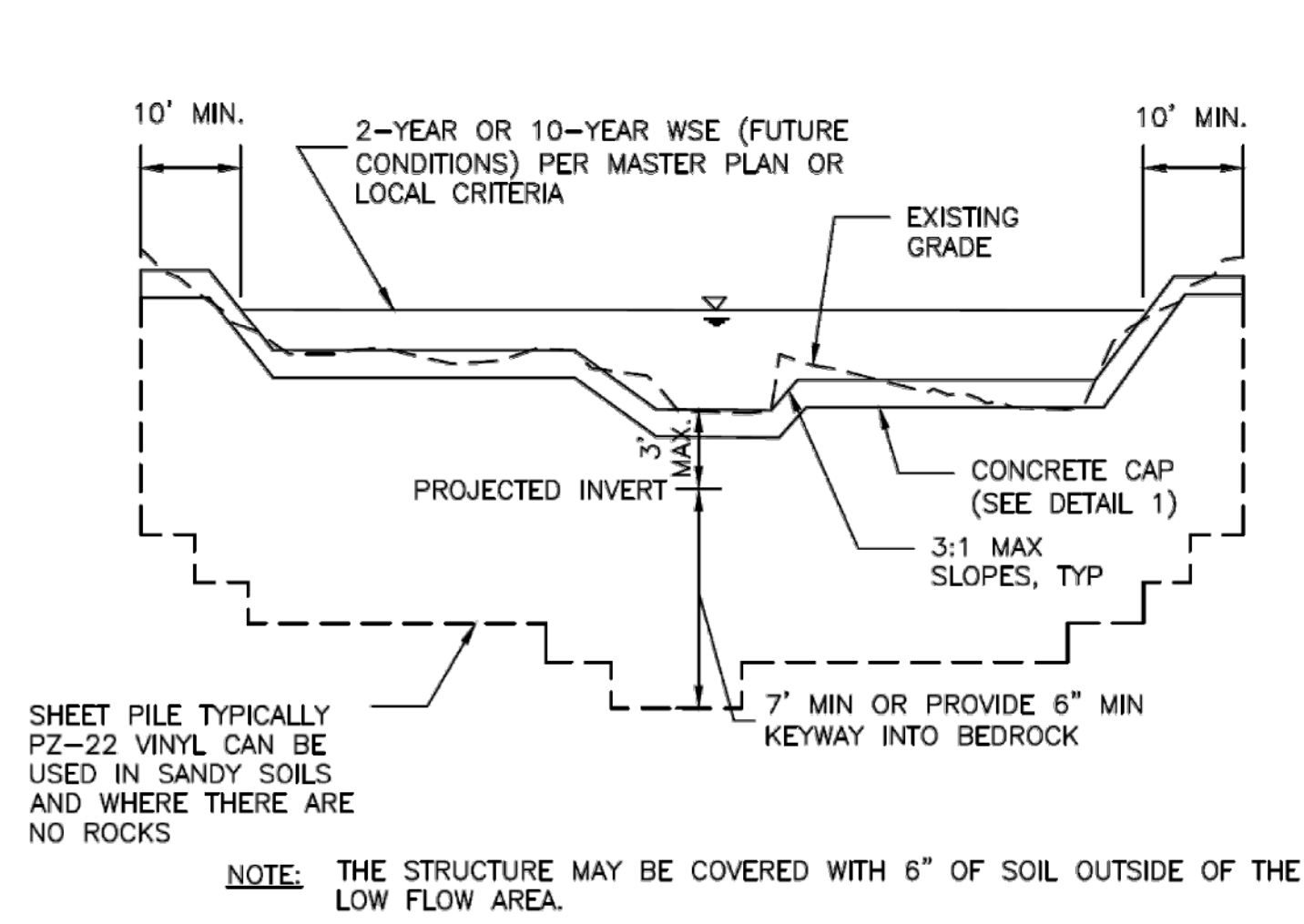

48 HOURS BEFORE YOU DIG,
CALL UTILITY LOCATORS
811
UTILITY NOTIFICATION CENTER OF COLORADO
IT'S THE LAW

THE LOCATIONS OF EXISTING UNDERGROUND UTILITIES ARE SHOWN IN AN APPROXIMATE WAY ONLY. THE CONTRACTOR SHALL DETERMINE THE EXACT LOCATION OF ALL EXISTING UTILITIES BEFORE COMMENCING WORK. THE CONTRACTOR SHALL BE FULLY RESPONSIBLE FOR ANY AND ALL DAMAGES WHICH MIGHT BE CAUSED BY HIS FAILURE TO EXACTLY LOCATE AND PRESERVE ANY AND ALL UNDERGROUND UTILITIES.

NO.	REVISION	DATE
1	REVISED PER COUNTY COMMENTS	08-13-19

REVIEW:
PREPARED UNDER MY DIRECT SUPERVISION FOR AND ON BEHALF OF
CLASSIC CONSULTING ENGINEERS AND SURVEYORS, LLC

MARC A. WHORTON, COLORADO, P.E. #37155

6/10/2020



RETREAT AT TIMBERIDGE FILING NO. 1
CONSTRUCTION PLANS
CHECK STRUCTURES AND
SELECTIVE BANK STABILIZATION

DESIGNED BY MAW SCALE DATE 04-05-19
DRAWN BY MAW (H) 1" = 30' SHEET 27 OF 35
CHECKED BY (V) 1" = N/A JOB NO. 1185.00

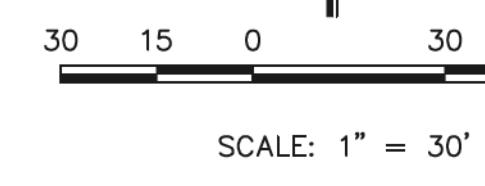
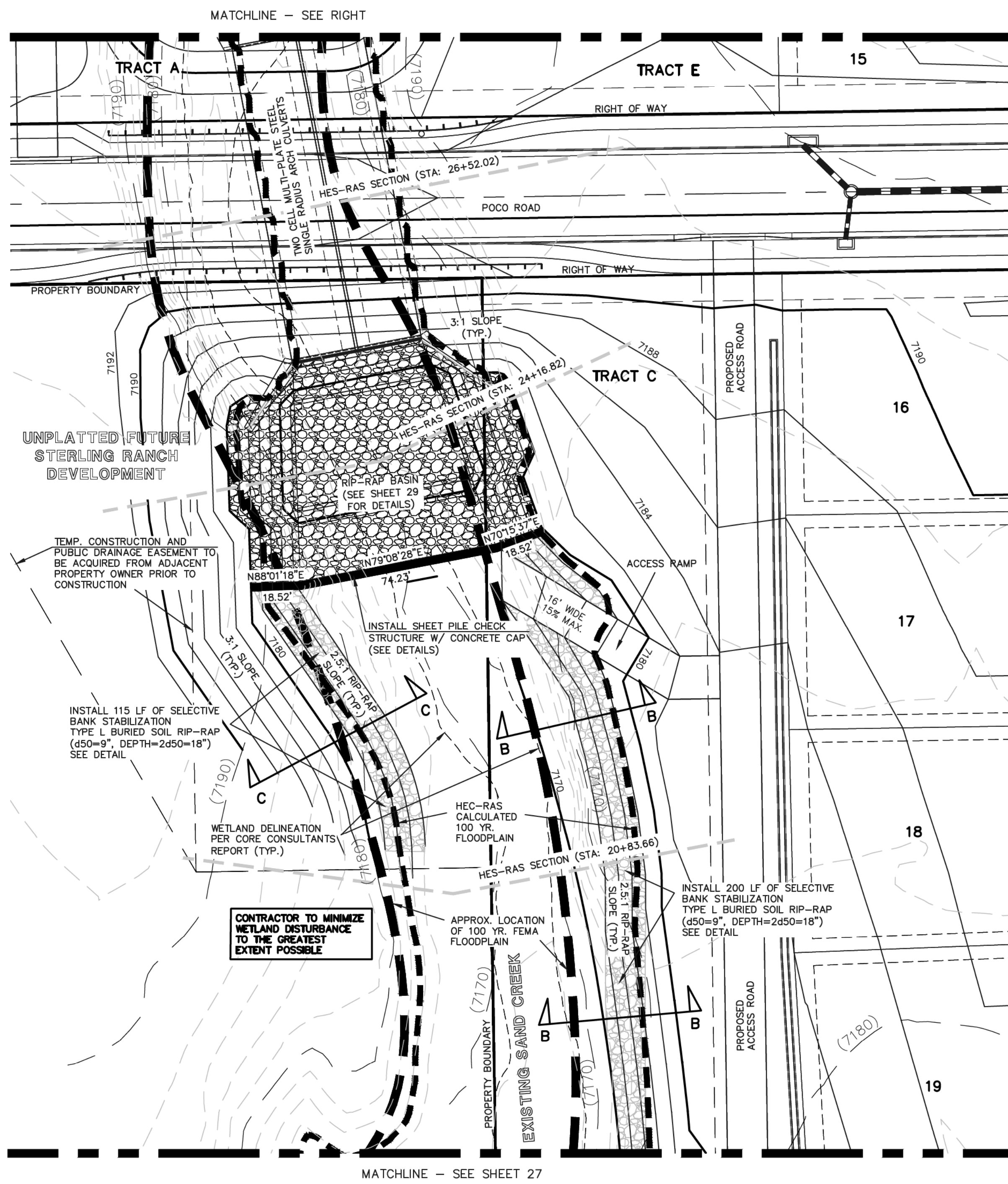
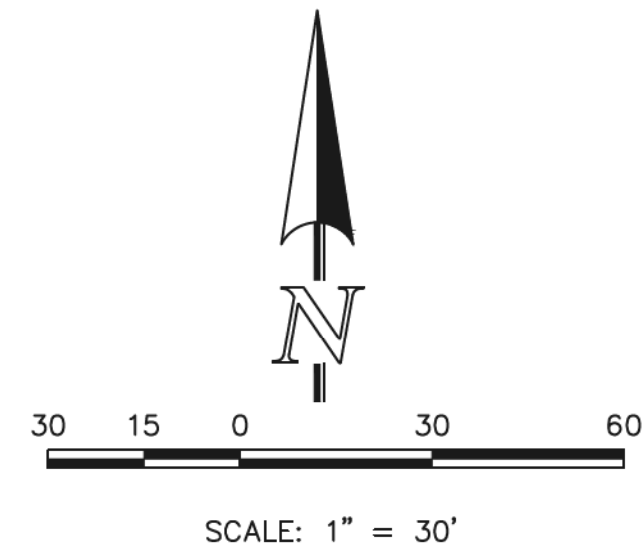

Figure 9-27. Check structure details (Part 2 of 3)

Figure 9-28. Check structure details (Part 3 of 3)



CHECK STRUCTURE #3 & SELECTIVE BANK STABILIZATION



SEE RETREAT AT TIMBERIDGE FILING NO. 1 GRADING AND EROSION CONTROL PLAN FOR EROSION CONTROL DETAILS.

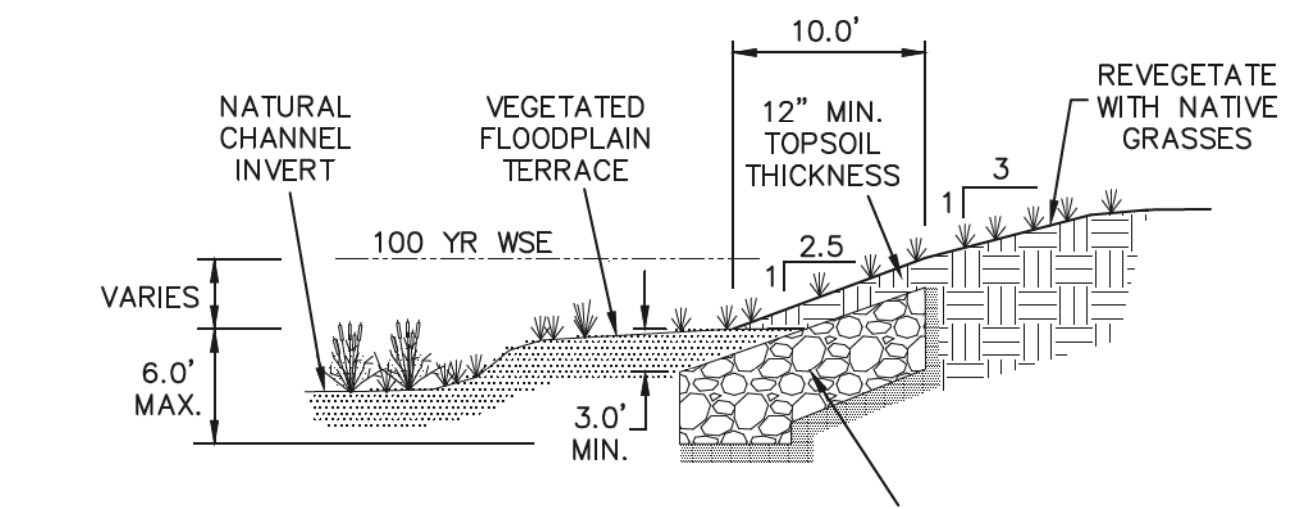

NO DISTURBANCE OF WETLANDS WITHIN NATURAL CHANNEL INVERT

SELECTIVE RIP-RAP BANK STABILIZATION
SECTION A-A
N.T.S.

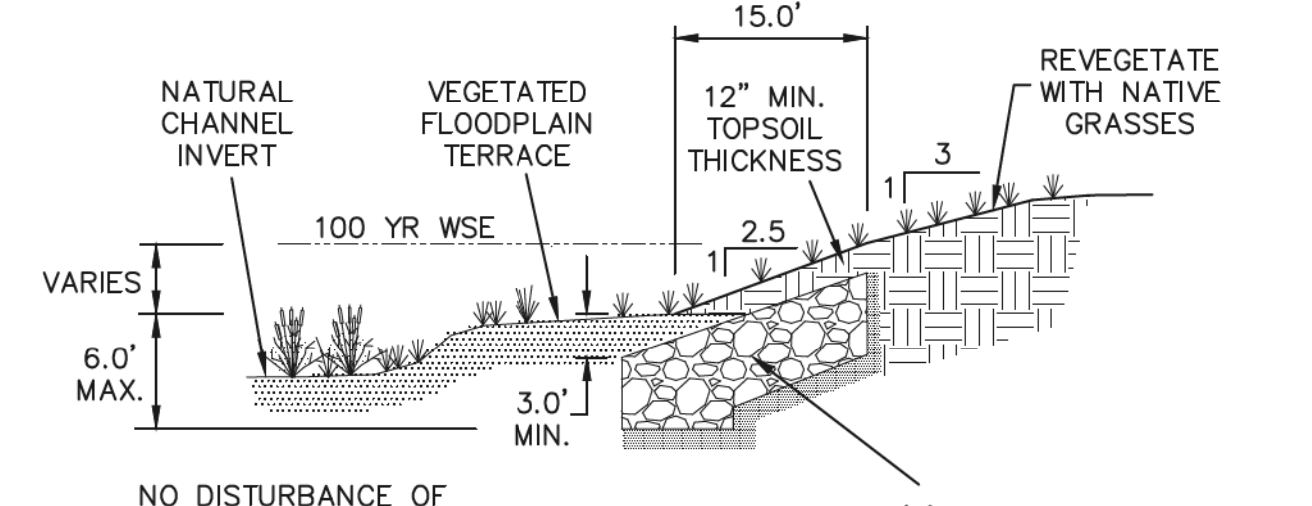

NO DISTURBANCE OF WETLANDS WITHIN NATURAL CHANNEL INVERT

SELECTIVE RIP-RAP BANK STABILIZATION
SECTION B-B
N.T.S.

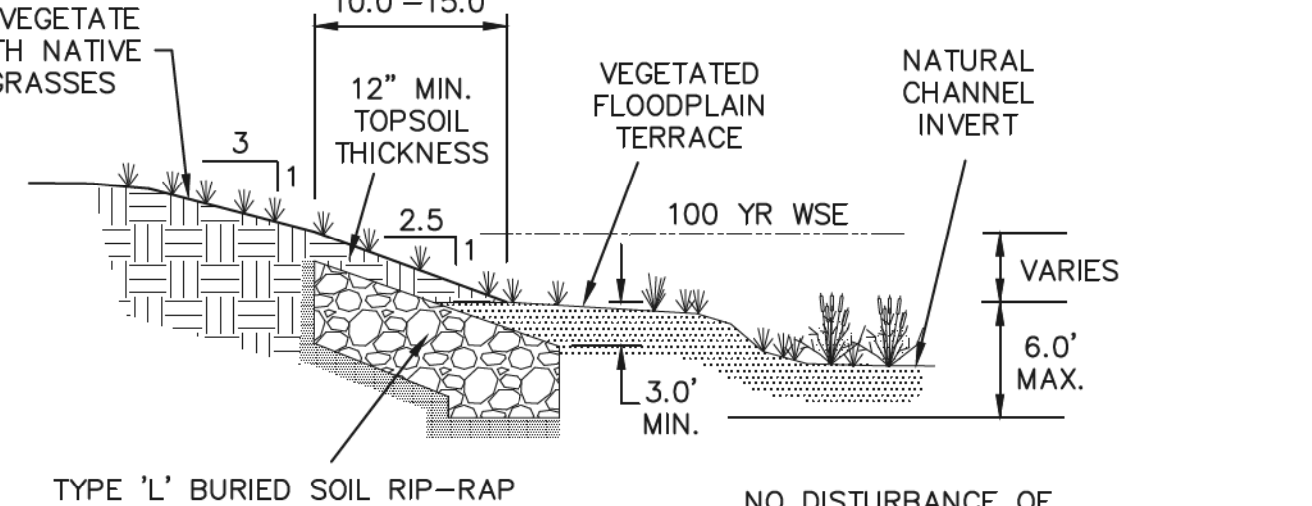

NO DISTURBANCE OF WETLANDS WITHIN NATURAL CHANNEL INVERT

SELECTIVE RIP-RAP BANK STABILIZATION
SECTION C-C
N.T.S.

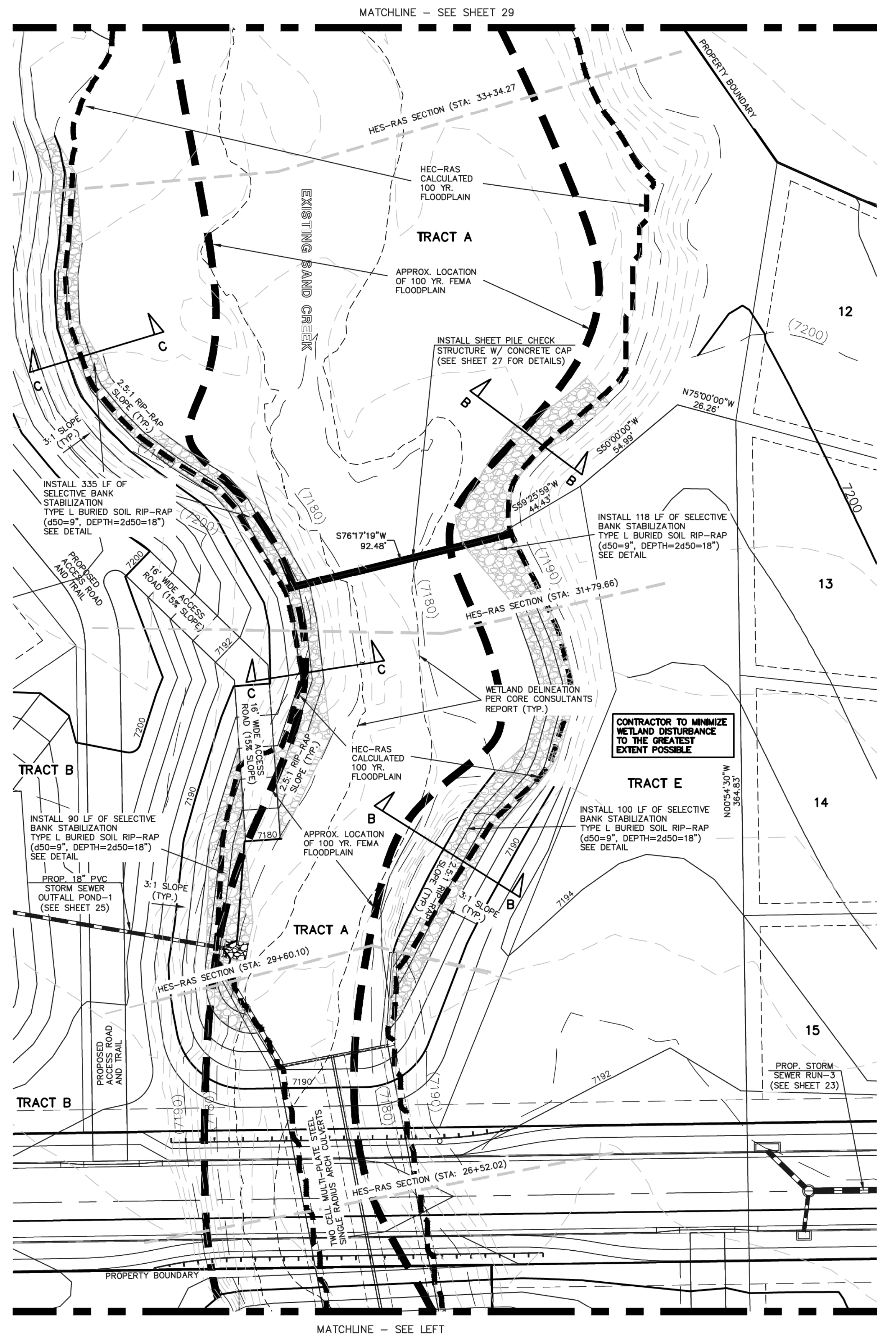

CHECK STRUCTURE #4 & SELECTIVE BANK STABILIZATION

<p>48 HOURS BEFORE YOU DIG, CALL UTILITY LOCATORS</p> <p>811</p> <p>UTILITY NOTIFICATION CENTER OF COLORADO IT'S THE LAW</p> <p>THE LOCATIONS OF EXISTING UNDERGROUND UTILITIES ARE SHOWN IN AN APPROXIMATE WAY ONLY. THE CONTRACTOR SHALL DETERMINE THE EXACT LOCATION OF ALL EXISTING UTILITIES BEFORE COMMENCING WORK. THE CONTRACTOR SHALL BE FULLY RESPONSIBLE FOR ANY AND ALL DAMAGES WHICH MIGHT BE CAUSED BY HIS FAILURE TO EXACTLY LOCATE AND PRESERVE ANY AND ALL UNDERGROUND UTILITIES.</p>	<p>NO. REVISION</p> <p>1 REVISED PER COUNTY COMMENTS 08-13-19</p> <p>2 REVISED PER COUNTY COMMENTS 6-9-20</p>	<p>DATE</p> <p>08-13-19</p> <p>6-9-20</p>	<p>REVIEW:</p> <p>PREPARED UNDER MY DIRECT SUPERVISION FOR AND ON BEHALF OF CLASSIC CONSULTING ENGINEERS AND SURVEYORS, LLC</p> <p>6/10/2020</p> <p>MARC A. WHORTON, COLORADO P.E. #37155</p>	<p>RETREAT AT TIMBERIDGE FILING NO. 1</p> <p>CONSTRUCTION PLANS</p> <p>CHECK STRUCTURES AND SELECTIVE BANK STABILIZATION</p> <p>DESIGNED BY MAW SCALE DATE 04-05-19</p> <p>DRAWN BY MAW (H) 1"= 30' SHEET 28 OF 35</p> <p>CHECKED BY (V) 1"= N/A JOB NO. 1185.00</p>
	<p>CLASSIC CONSULTING</p> <p>619 N. Cascade Avenue, Suite 200 (719)785-0790 Colorado Springs, Colorado 80903 (719)785-0799(Fax)</p>			<p>CLASSIC CONSULTING</p>

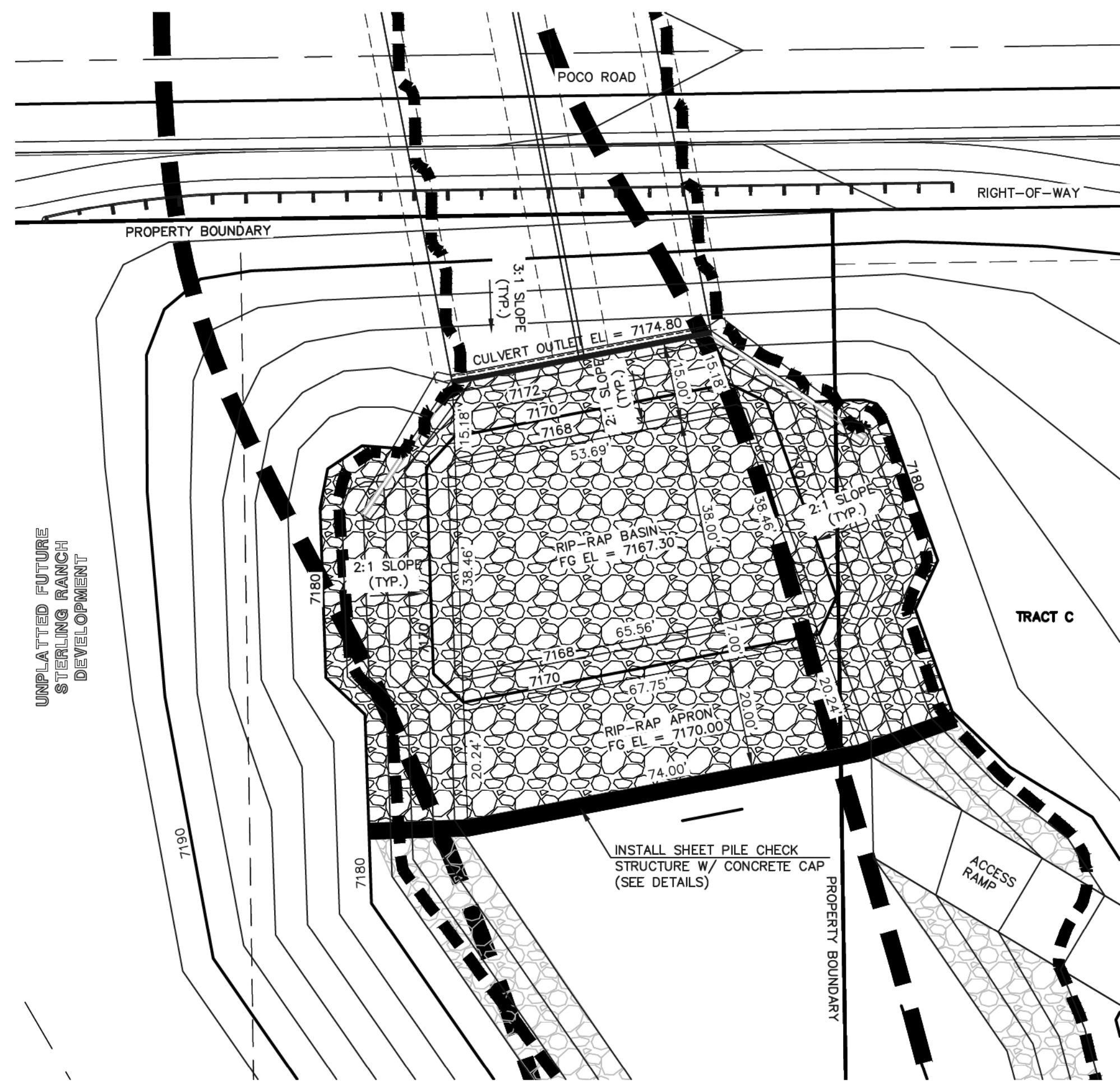

RIP-RAP BASIN PLUNGE POOL
(PER DCM FIG. 10-C.5)

TYPE H SOIL RIP-RAP
D50 = 1.5' DEPTH = 3.0'-4.5'

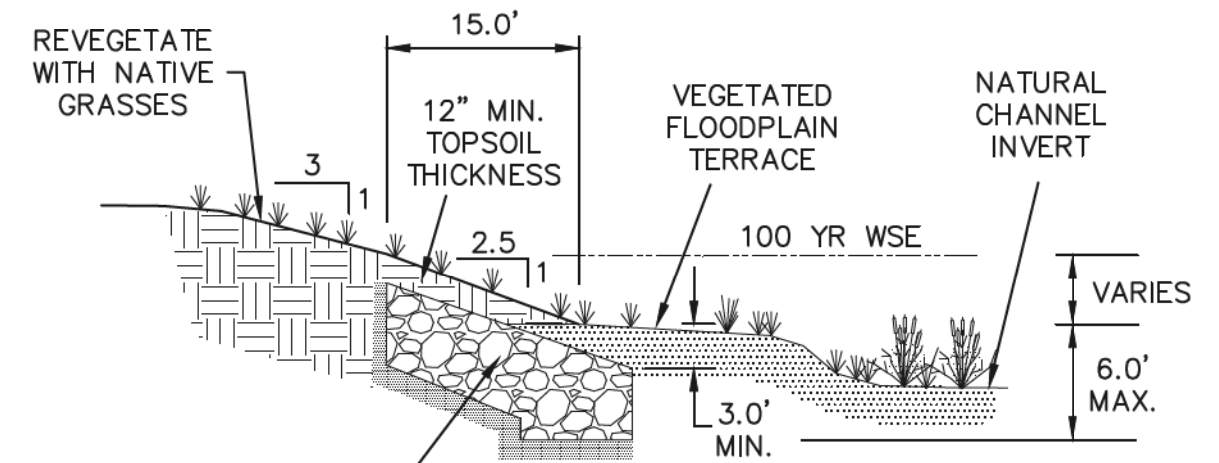
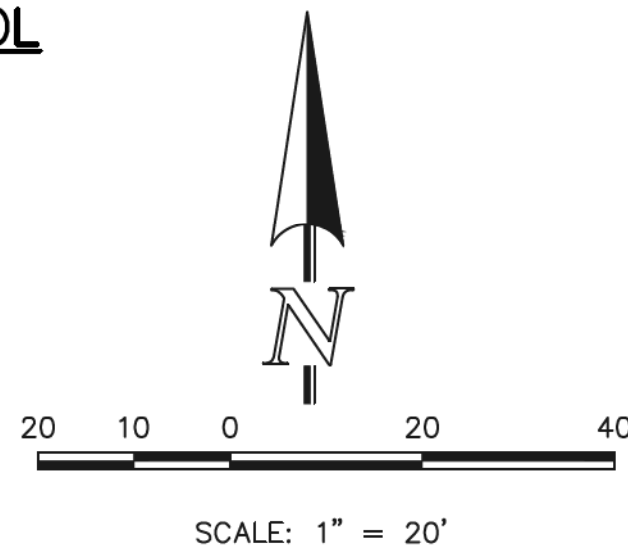

TYPE 'L' BURIED SOIL RIP-RAP
(d50=9", D=2d50=18")
WITH 12" THICK NATIVE SAND
BEDDING

NO DISTURBANCE OF
WETLANDS WITHIN
NATURAL CHANNEL INVERT

**SELECTIVE RIP-RAP
BANK STABILIZATION**

SECTION C-C
N.T.S.

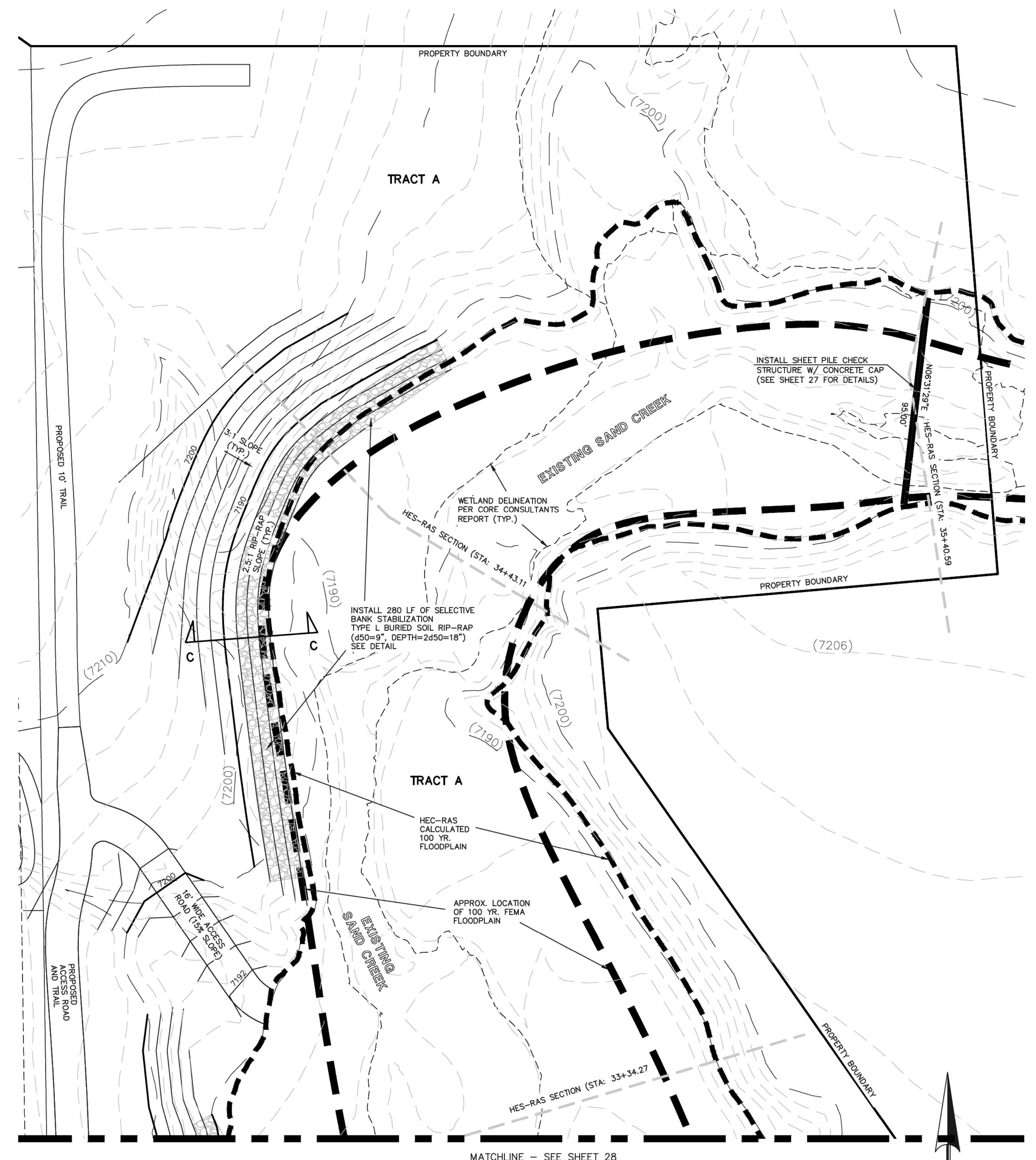

CHECK STRUCTURE #5 & SELECTIVE BANK STABILIZATION

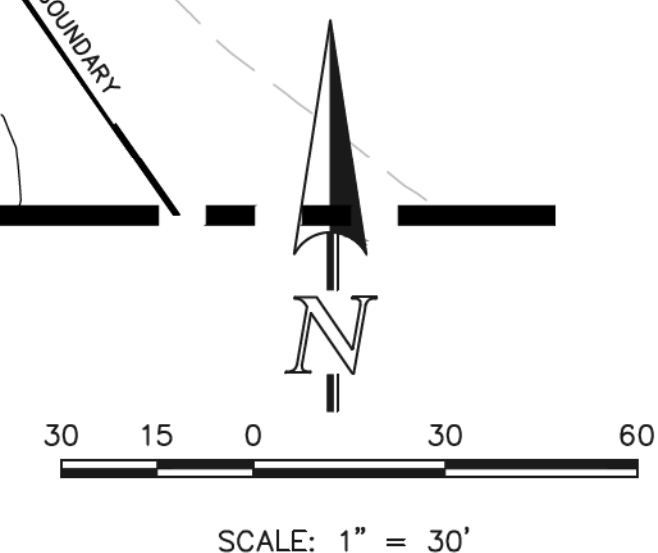

<p>48 HOURS BEFORE YOU DIG, CALL UTILITY LOCATORS</p> <p>811</p> <p>UTILITY NOTIFICATION CENTER OF COLORADO IT'S THE LAW</p> <p>THE LOCATIONS OF EXISTING UNDERGROUND UTILITIES ARE SHOWN IN AN APPROXIMATE WAY ONLY. THE CONTRACTOR SHALL DETERMINE THE EXACT LOCATION OF ALL EXISTING UTILITIES BEFORE COMMENCING WORK. THE CONTRACTOR SHALL BE FULLY RESPONSIBLE FOR ANY AND ALL DAMAGES WHICH MIGHT BE CAUSED BY HIS FAILURE TO EXACTLY LOCATE AND PRESERVE ANY AND ALL UNDERGROUND UTILITIES.</p>	<p>NO. REVISION</p> <p>1 REVISED PER COUNTY COMMENTS</p>	<p>DATE</p> <p>08-13-19</p>	<p>REVIEW:</p> <p>PREPARED UNDER MY DIRECT SUPERVISION FOR AND ON BEHALF OF CLASSIC CONSULTING ENGINEERS AND SURVEYORS, LLC</p> <p>MARC A. WHORTON, COLORADO P.E. #37155</p>	<p>6/10/2020</p> <p>DATE</p>	<p>RETREAT AT TIMBERRIDGE FILING NO. 1 CONSTRUCTION PLANS</p> <p>CHECK STRUCTURES AND SELECTIVE BANK STABILIZATION</p> <p>DESIGNED BY MAW SCALE DATE 04-05-19</p> <p>DRAWN BY MAW (H) 1" = 30' SHEET 29 OF 35</p> <p>CHECKED BY (V) 1" = N/A JOB NO. 1185.00</p>
	<p>SEE RETREAT AT TIMBERRIDGE FILING NO. 1 GRADING AND EROSION CONTROL PLAN FOR EROSION CONTROL DETAILS.</p>			<p>CLASSIC CONSULTING</p> <p>619 N. Cascade Avenue, Suite 200 Colorado Springs, Colorado 80903</p> <p>(719) 785-0790 (719) 785-0799 (fax)</p>	

Bioretention T-3

Table B-1. Material specification for bioretention/rain garden facilities

Material	Quantity	Notes
Gravel (1/2" - 3/4")	1000	USDA #200
Gravel (3/4" - 1 1/2")	1000	USDA #200
Gravel (1 1/2" - 2")	1000	USDA #200
Gravel (2" - 3")	1000	USDA #200
Gravel (3" - 4 1/2")	1000	USDA #200
Gravel (4 1/2" - 6")	1000	USDA #200
Gravel (6" - 12")	1000	USDA #200
Gravel (12" - 18")	1000	USDA #200
Gravel (18" - 24")	1000	USDA #200
Gravel (24" - 30")	1000	USDA #200
Gravel (30" - 36")	1000	USDA #200
Gravel (36" - 42")	1000	USDA #200
Gravel (42" - 48")	1000	USDA #200
Gravel (48" - 54")	1000	USDA #200
Gravel (54" - 60")	1000	USDA #200
Gravel (60" - 66")	1000	USDA #200
Gravel (66" - 72")	1000	USDA #200
Gravel (72" - 78")	1000	USDA #200
Gravel (78" - 84")	1000	USDA #200
Gravel (84" - 90")	1000	USDA #200
Gravel (90" - 96")	1000	USDA #200
Gravel (96" - 102")	1000	USDA #200
Gravel (102" - 108")	1000	USDA #200
Gravel (108" - 114")	1000	USDA #200
Gravel (114" - 120")	1000	USDA #200
Gravel (120" - 126")	1000	USDA #200
Gravel (126" - 132")	1000	USDA #200
Gravel (132" - 138")	1000	USDA #200
Gravel (138" - 144")	1000	USDA #200
Gravel (144" - 150")	1000	USDA #200
Gravel (150" - 156")	1000	USDA #200
Gravel (156" - 162")	1000	USDA #200
Gravel (162" - 168")	1000	USDA #200
Gravel (168" - 174")	1000	USDA #200
Gravel (174" - 180")	1000	USDA #200
Gravel (180" - 186")	1000	USDA #200
Gravel (186" - 192")	1000	USDA #200
Gravel (192" - 198")	1000	USDA #200
Gravel (198" - 204")	1000	USDA #200
Gravel (204" - 210")	1000	USDA #200
Gravel (210" - 216")	1000	USDA #200
Gravel (216" - 222")	1000	USDA #200
Gravel (222" - 228")	1000	USDA #200
Gravel (228" - 234")	1000	USDA #200
Gravel (234" - 240")	1000	USDA #200
Gravel (240" - 246")	1000	USDA #200
Gravel (246" - 252")	1000	USDA #200
Gravel (252" - 258")	1000	USDA #200
Gravel (258" - 264")	1000	USDA #200
Gravel (264" - 270")	1000	USDA #200
Gravel (270" - 276")	1000	USDA #200
Gravel (276" - 282")	1000	USDA #200
Gravel (282" - 288")	1000	USDA #200
Gravel (288" - 294")	1000	USDA #200
Gravel (294" - 300")	1000	USDA #200
Gravel (300" - 306")	1000	USDA #200
Gravel (306" - 312")	1000	USDA #200
Gravel (312" - 318")	1000	USDA #200
Gravel (318" - 324")	1000	USDA #200
Gravel (324" - 330")	1000	USDA #200
Gravel (330" - 336")	1000	USDA #200
Gravel (336" - 342")	1000	USDA #200
Gravel (342" - 348")	1000	USDA #200
Gravel (348" - 354")	1000	USDA #200
Gravel (354" - 360")	1000	USDA #200
Gravel (360" - 366")	1000	USDA #200
Gravel (366" - 372")	1000	USDA #200
Gravel (372" - 378")	1000	USDA #200
Gravel (378" - 384")	1000	USDA #200
Gravel (384" - 390")	1000	USDA #200
Gravel (390" - 396")	1000	USDA #200
Gravel (396" - 402")	1000	USDA #200
Gravel (402" - 408")	1000	USDA #200
Gravel (408" - 414")	1000	USDA #200
Gravel (414" - 420")	1000	USDA #200
Gravel (420" - 426")	1000	USDA #200
Gravel (426" - 432")	1000	USDA #200
Gravel (432" - 438")	1000	USDA #200
Gravel (438" - 444")	1000	USDA #200
Gravel (444" - 450")	1000	USDA #200
Gravel (450" - 456")	1000	USDA #200
Gravel (456" - 462")	1000	USDA #200
Gravel (462" - 468")	1000	USDA #200
Gravel (468" - 474")	1000	USDA #200
Gravel (474" - 480")	1000	USDA #200
Gravel (480" - 486")	1000	USDA #200
Gravel (486" - 492")	1000	USDA #200
Gravel (492" - 498")	1000	USDA #200
Gravel (498" - 504")	1000	USDA #200
Gravel (504" - 510")	1000	USDA #200
Gravel (510" - 516")	1000	USDA #200
Gravel (516" - 522")	1000	USDA #200
Gravel (522" - 528")	1000	USDA #200
Gravel (528" - 534")	1000	USDA #200
Gravel (534" - 540")	1000	USDA #200
Gravel (540" - 546")	1000	USDA #200
Gravel (546" - 552")	1000	USDA #200
Gravel (552" - 558")	1000	USDA #200
Gravel (558" - 564")	1000	USDA #200
Gravel (564" - 570")	1000	USDA #200
Gravel (570" - 576")	1000	USDA #200
Gravel (576" - 582")	1000	USDA #200
Gravel (582" - 588")	1000	USDA #200
Gravel (588" - 594")	1000	USDA #200
Gravel (594" - 600")	1000	USDA #200
Gravel (600" - 606")	1000	USDA #200
Gravel (606" - 612")	1000	USDA #200
Gravel (612" - 618")	1000	USDA #200
Gravel (618" - 624")	1000	USDA #200
Gravel (624" - 630")	1000	USDA #200
Gravel (630" - 636")	1000	USDA #200
Gravel (636" - 642")	1000	USDA #200
Gravel (642" - 648")	1000	USDA #200
Gravel (648" - 654")	1000	USDA #200
Gravel (654" - 660")	1000	USDA #200
Gravel (660" - 666")	1000	USDA #200
Gravel (666" - 672")	1000	USDA #200
Gravel (672" - 678")	1000	USDA #200
Gravel (678" - 684")	1000	USDA #200
Gravel (684" - 690")	1000	USDA #200
Gravel (690" - 696")	1000	USDA #200
Gravel (696" - 702")	1000	USDA #200
Gravel (702" - 708")	1000	USDA #200
Gravel (708" - 714")	1000	USDA #200
Gravel (714" - 720")	1000	USDA #200
Gravel (720" - 726")	1000	USDA #200
Gravel (726" - 732")	1000	USDA #200
Gravel (732" - 738")	1000	USDA #200
Gravel (738" - 744")	1000	USDA #200
Gravel (744" - 750")	1000	USDA #200
Gravel (750" - 756")	1000	USDA #200
Gravel (756" - 762")	1000	USDA #200
Gravel (762" - 768")	1000	USDA #200
Gravel (768" - 774")	1000	USDA #200
Gravel (774" - 780")	1000	USDA #200
Gravel (780" - 786")	1000	USDA #200
Gravel (786" - 792")	1000	USDA #200
Gravel (792" - 798")	1000	USDA #200
Gravel (798" - 804")	1000	USDA #200
Gravel (804" - 810")	1000	USDA #200
Gravel (810" - 816")	1000	USDA #200
Gravel (816" - 822")	1000	USDA #200
Gravel (822" - 828")	1000	USDA #200
Gravel (828" - 834")	1000	USDA #200
Gravel (834" - 840")	1000	USDA #200
Gravel (840" - 846")	1000	USDA #200
Gravel (846" - 852")	1000	USDA #200
Gravel (852" - 858")	1000	USDA #200
Gravel (858" - 864")	1000	USDA #200
Gravel (864" - 870")	1000	USDA #200
Gravel (870" - 876")	1000	USDA #200
Gravel (876" - 882")	1000	USDA #200
Gravel (882" - 888")	1000	USDA #200
Gravel (888" - 894")	1000	USDA #200
Gravel (894" - 900")	1000	USDA #200
Gravel (900" - 906")	1000	USDA #200
Gravel (906" - 912")	1000	USDA #200
Gravel (912" - 918")	1000	USDA #200
Gravel (918" - 924")	1000	USDA #200
Gravel (924" - 930")	1000	USDA #200
Gravel (930" - 936")	1000	USDA #200
Gravel (936" - 942")	1000	USDA #200
Gravel (942" - 948")	1000	USDA #200
Gravel (948" - 954")	1000	USDA #200
Gravel (954" - 960")	1000	USDA #200
Gravel (960" - 966")	1000	USDA #200
Gravel (966" - 972")	1000	USDA #200
Gravel (972" - 978")	1000	USDA #200
Gravel (978" - 984")	1000	USDA #200
Gravel (984" - 990")	1000	USDA #200
Gravel (990" - 996")	1000	USDA #200
Gravel (996" - 1002)	1000	USDA #200

November 2015 Urban Drainage and Flood Control District Urban Storm Drainage Criteria Manual Volume 3 B-7

T-3 Bioretention

Table B-3. Native seed mix for rain gardens

Common Name	Scientific Name	Variety	PLS ¹ lbs per Acre	Omnis per Acre	
Sand blanket	Andropogon hallii	Garden	3.5		
Sideoats grama	Bouteloua curtipendula	Butte	3		
Prairie sandreed	Calamovilfa longifolia	Goshen	3		
Indian ricegrass	Oryzopsis hymenoides	Paloma	3		
Switchgrass	Panicum virgatum	Blackwell	4		
Western wheatgrass	Panicopyrum smithii	Arriba	3		
Little bluestem	Schizachyrium scoparium	Patura	3		
Alkali sacaton	Sporobolus airoides		3		
Sand dropseed	Sporobolus cryptandrus		3		
Pasture sage	Artemisia frigida		2		
Blue aster	Aster laevis		4		
Blanket flower	Gaillardia aristata		8		
Prairie coneflower	Ratibida columnifera		4		
Purple prairieclover	Dalea (Pealostemum) purpurea		3		
Sub-Totals:				27.5	22
Total lbs per acre:				28.9	

¹ Wildflower seed (optional) for a more diverse and natural look.
² PLS = Pure Live Seed.

B-12 Urban Drainage and Flood Control District Urban Storm Drainage Criteria Manual Volume 3 November 2015

T-3 Bioretention

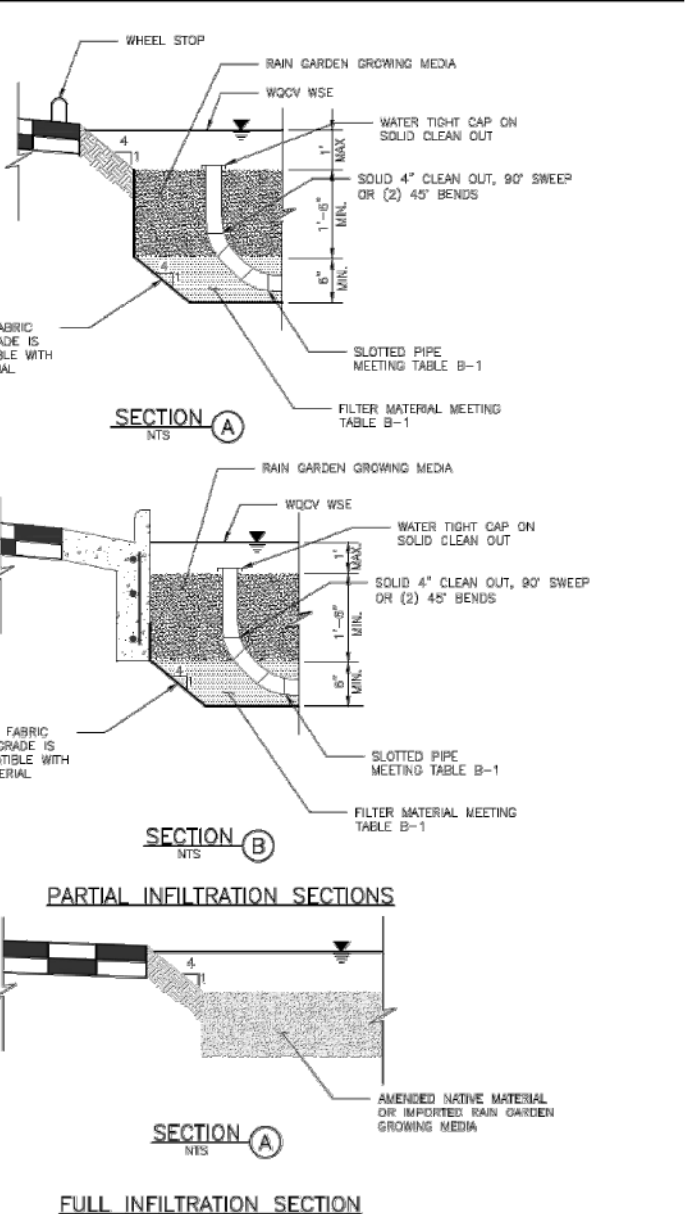

B-16 Urban Drainage and Flood Control District Urban Storm Drainage Criteria Manual Volume 3 November 2015

Bioretention T-3

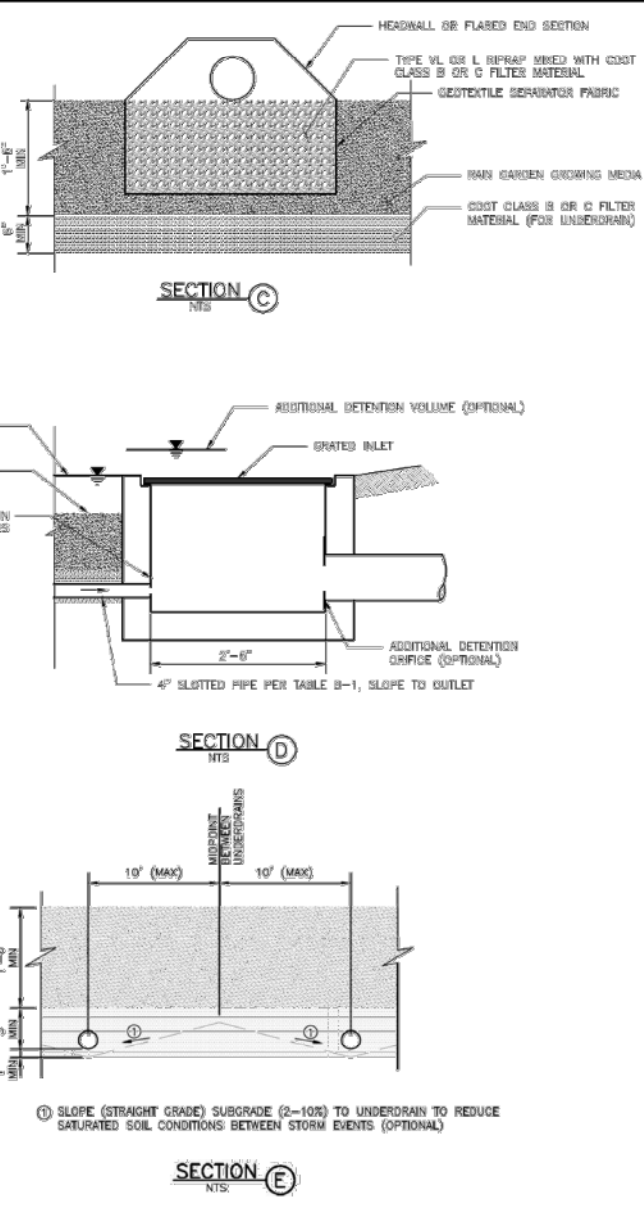

November 2015 Urban Drainage and Flood Control District Urban Storm Drainage Criteria Manual Volume 3 B-17

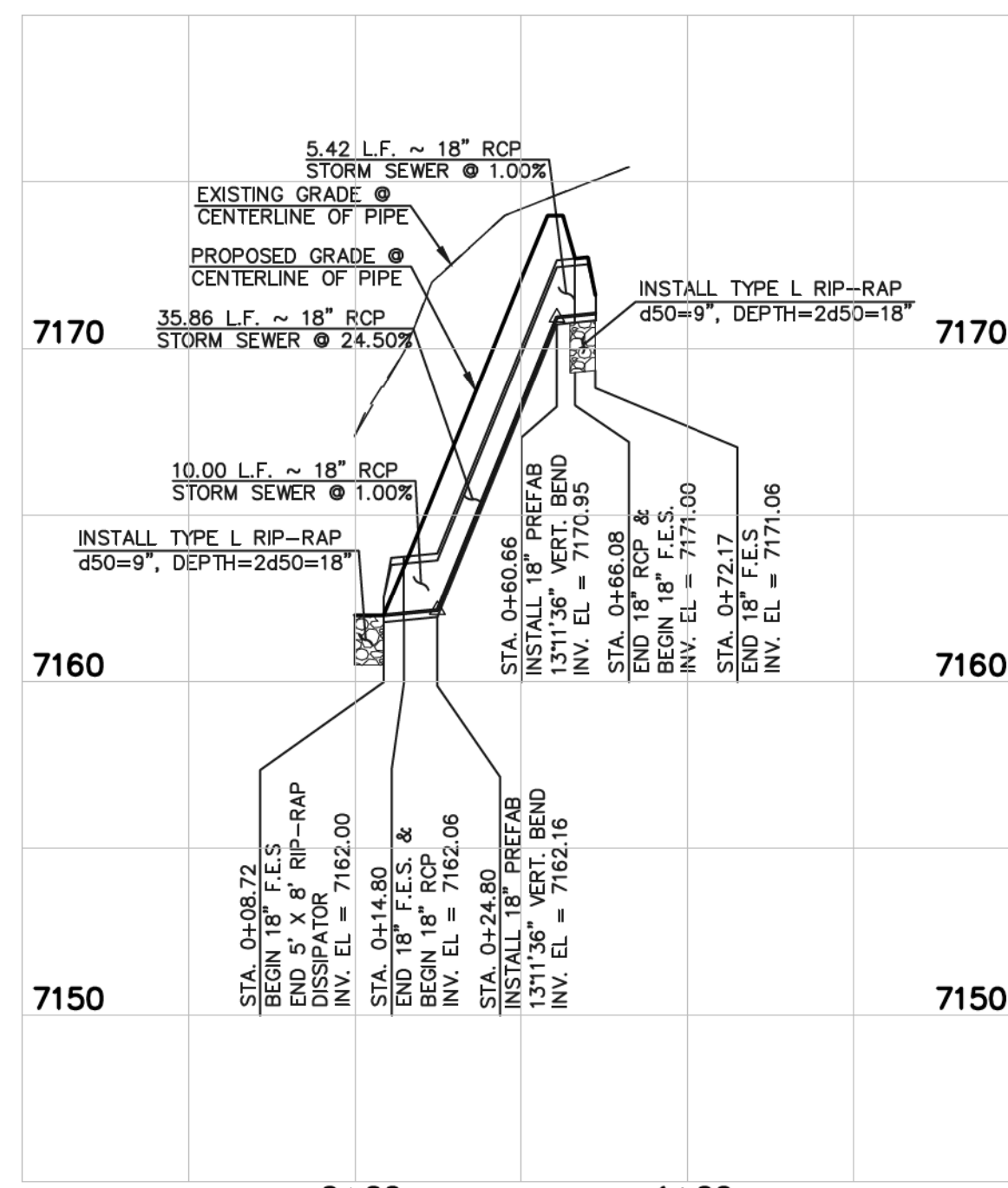

18" RCP INLET TO RAIN GARDEN SCALE 1" = 50' HORIZ. 1" = 5' VERT.

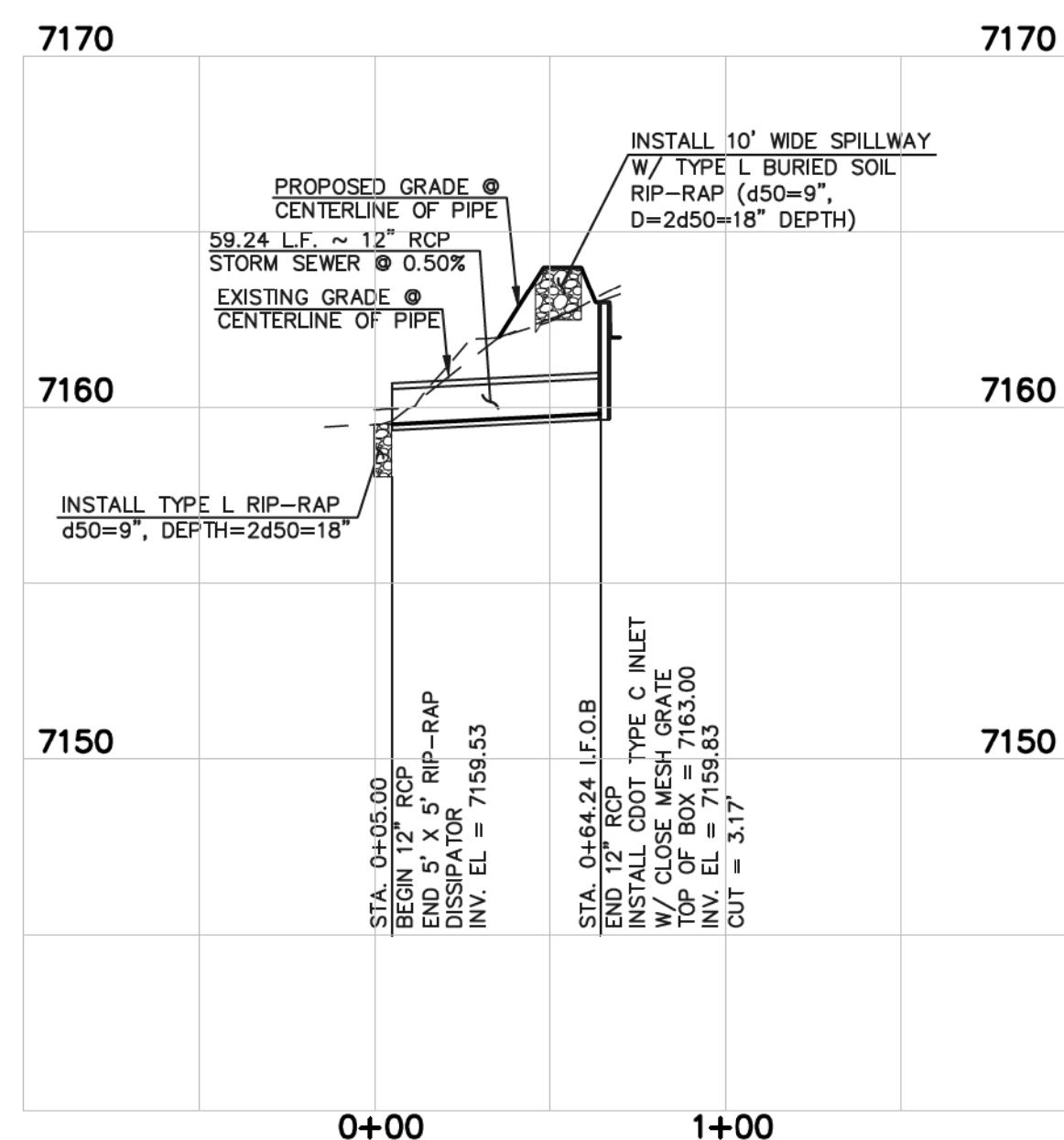

12" RCP STORM SEWER OUTLET FROM RAIN GARDEN SCALE 1" = 50' HORIZ. 1" = 5' VERT.

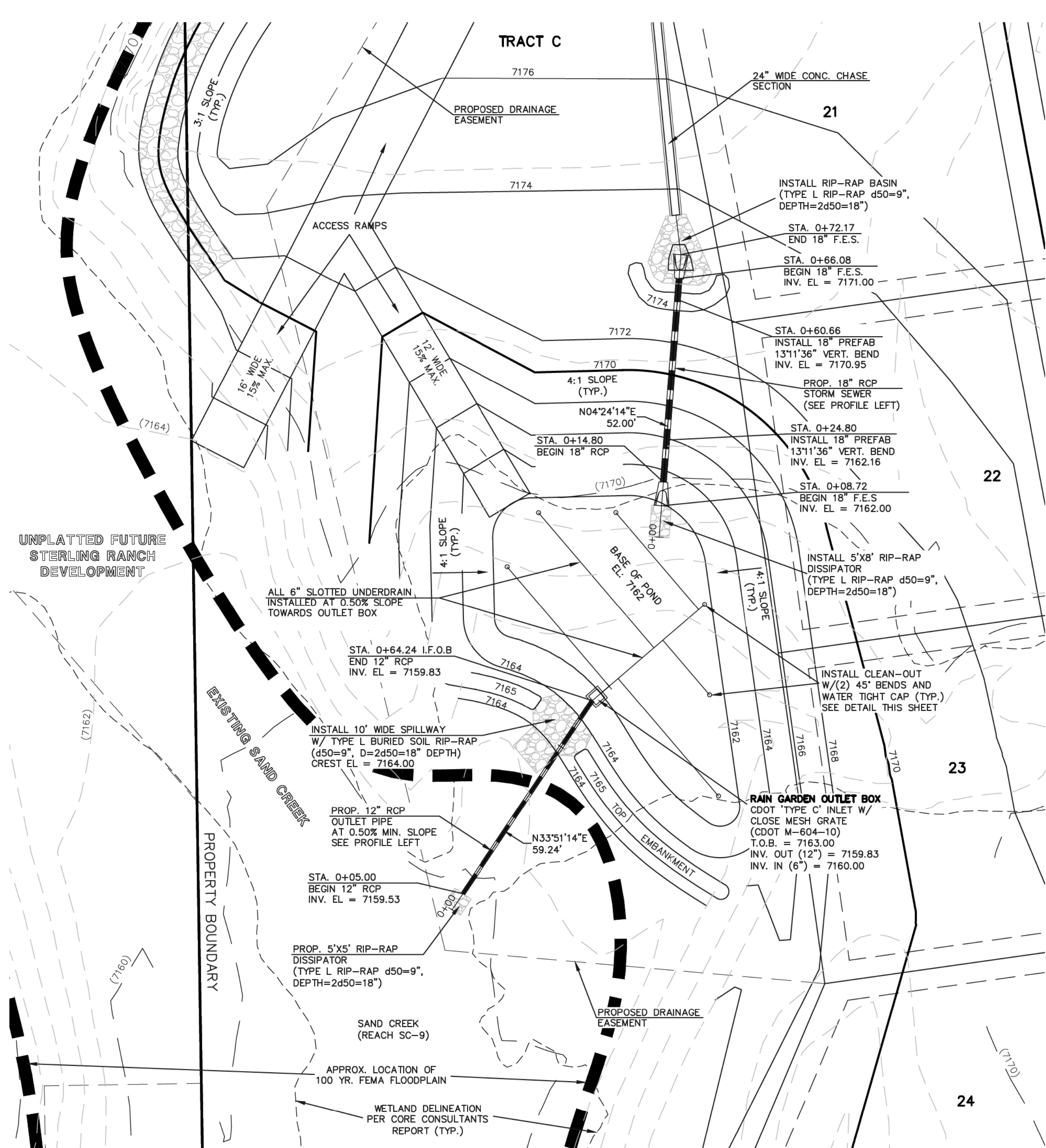

RAIN GARDEN
WQCV REQUIRED = 1,045 CF
WQCV PROVIDED = 3,572 CF
UNDERDRAIN ORIFICE DIA. = 13/16 IN.
6" SLOTTED UNDERDRAIN SPACED 15" O.C.

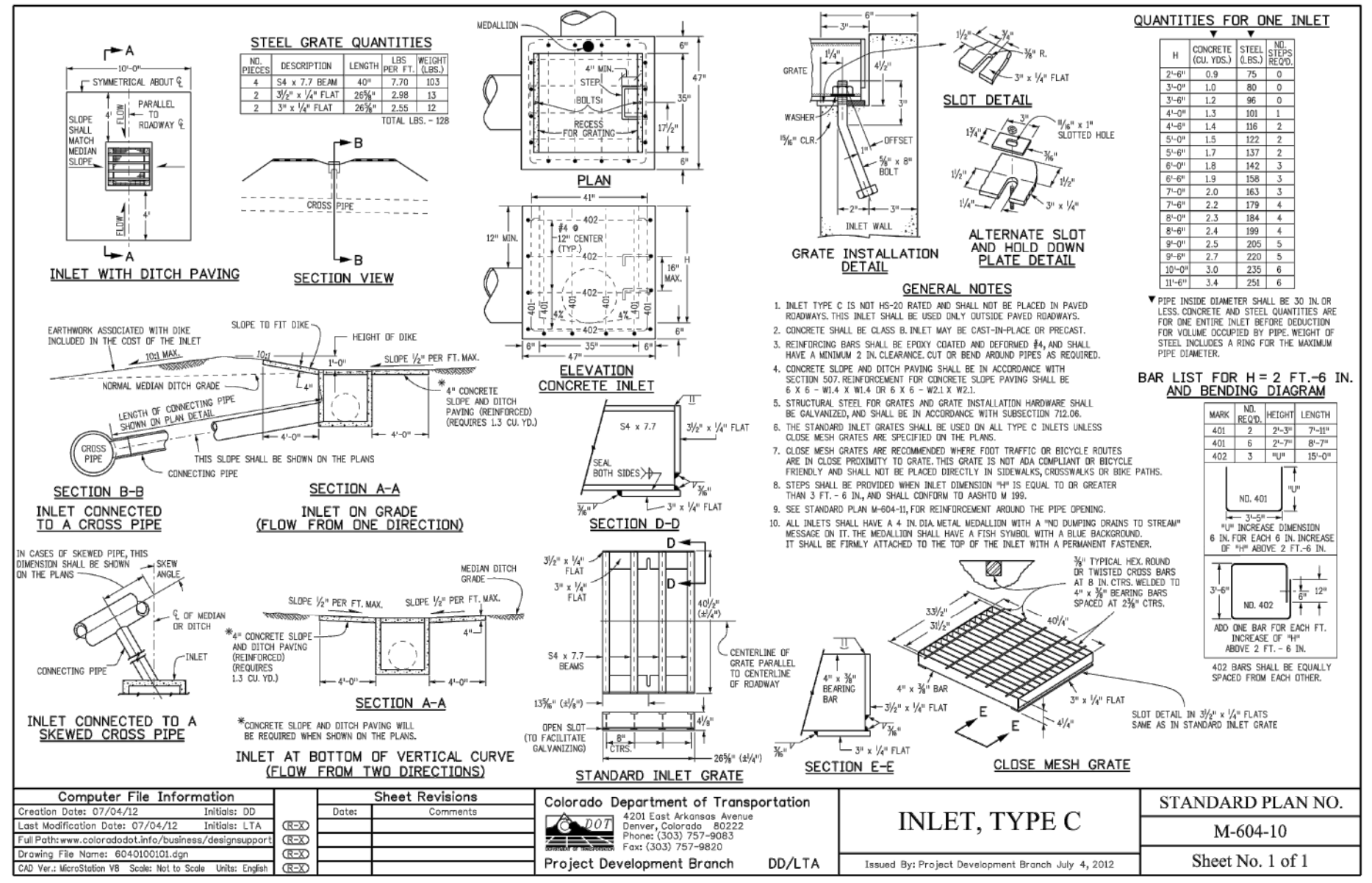
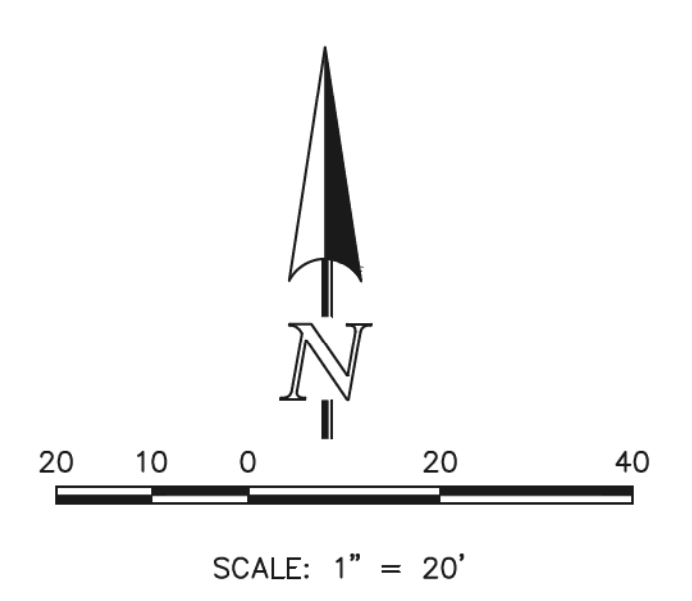

48 HOURS BEFORE YOU DIG, CALL UTILITY LOCATORS
811
UTILITY NOTIFICATION CENTER OF COLORADO
IT'S THE LAW

NO.	REVISION	DATE
1	REVISED PER COUNTY COMMENTS	08-13-19
2	REVISED PER COUNTY COMMENTS	04-16-20
3	REVISED PER COUNTY COMMENTS	6-9-20

REVIEW:
PREPARED UNDER MY DIRECT SUPERVISION FOR AND ON BEHALF OF
CLASSIC CONSULTING ENGINEERS AND SURVEYORS, LLC



RETREAT AT TIMBERIDGE FILING NO. 1
CONSTRUCTION PLANS
RAIN GARDEN AND DETAILS

DESIGNED BY MAW SCALE DATE 04-05-19
DRAWN BY MAW (H) 1" = 30' SHEET 30 OF 35
CHECKED BY (V) 1" = N/A JOB NO. 1185.00

MARC A. WHORTON, COLORADO P.E. #37155
DATE 6/10/2020

619 N. Cascade Avenue, Suite 200 (719)785-0790
Colorado Springs, Colorado 80903 (719)785-0799(fax)

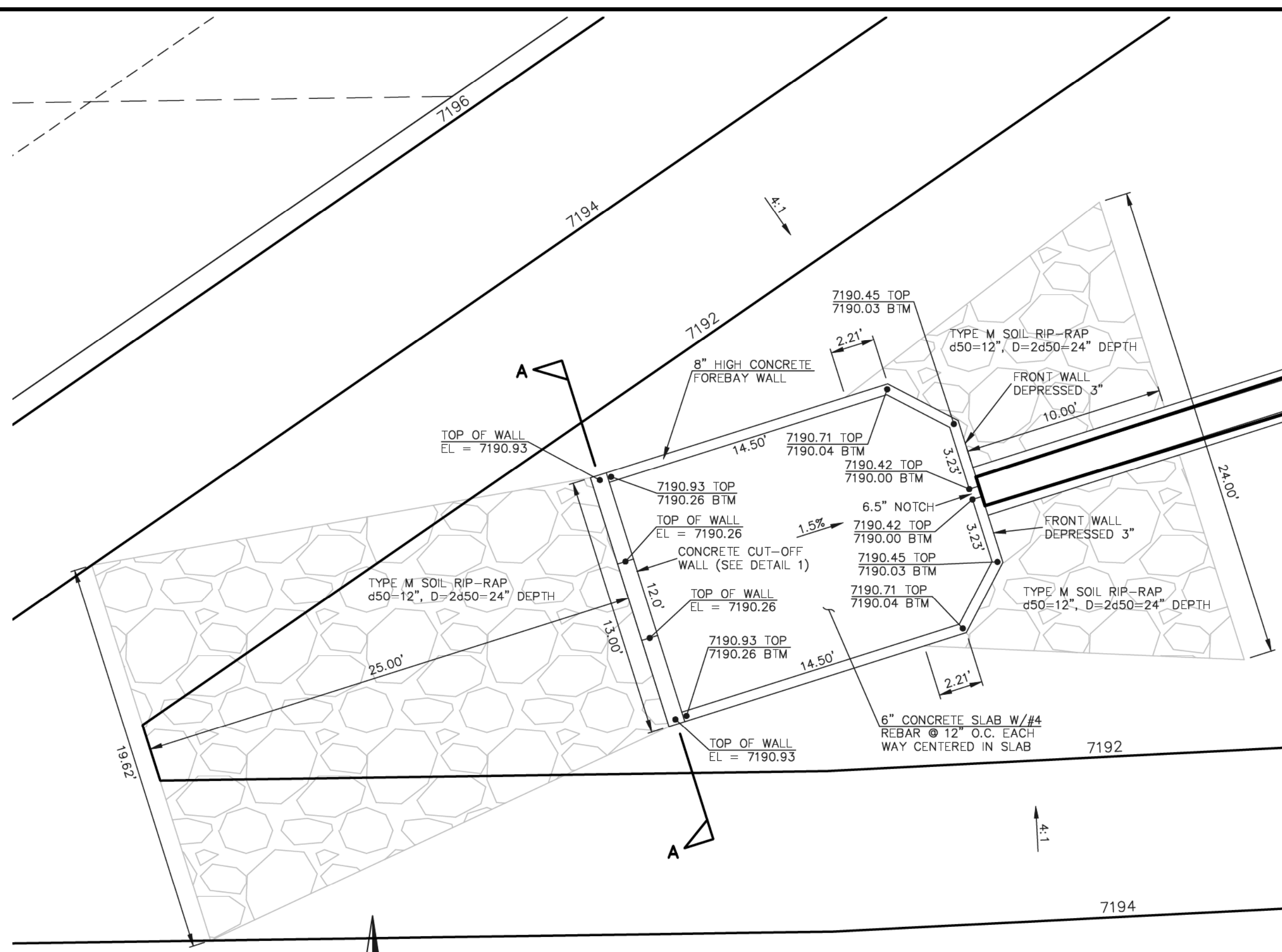

CONCRETE FOREBAY
SCALE: 1" = 5'

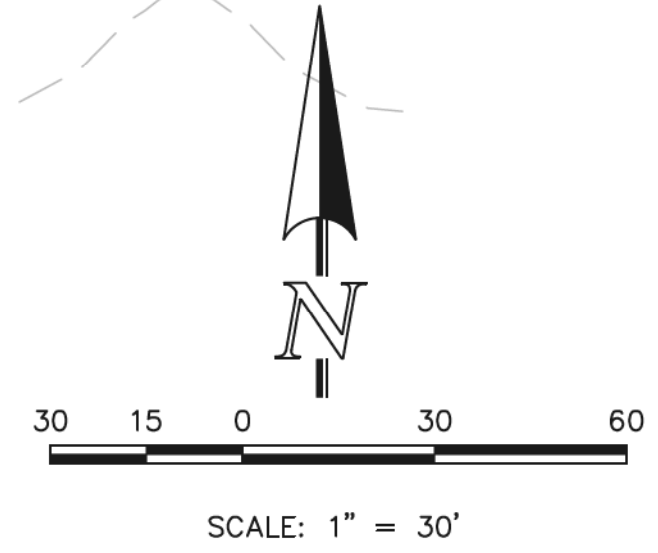
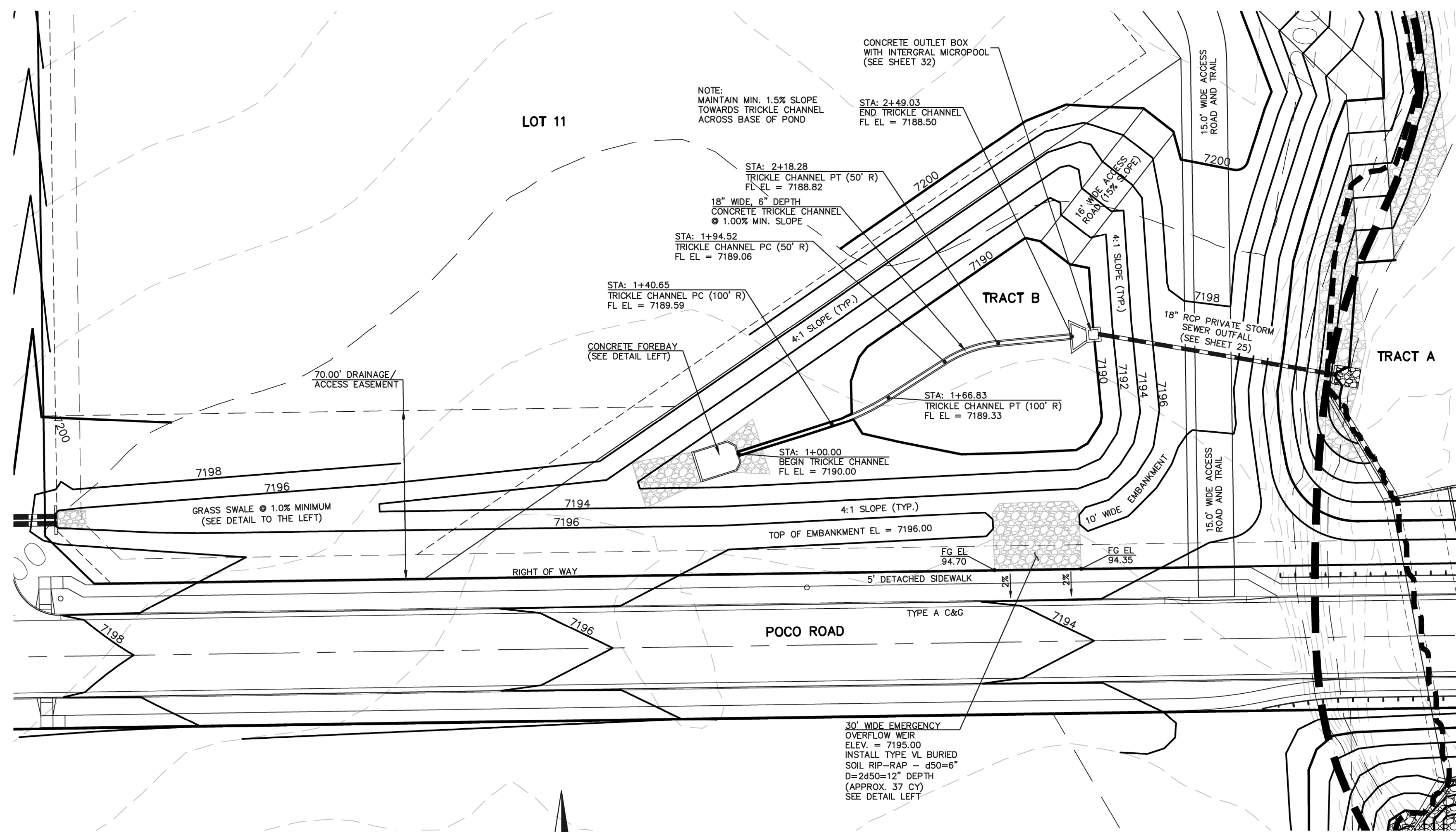
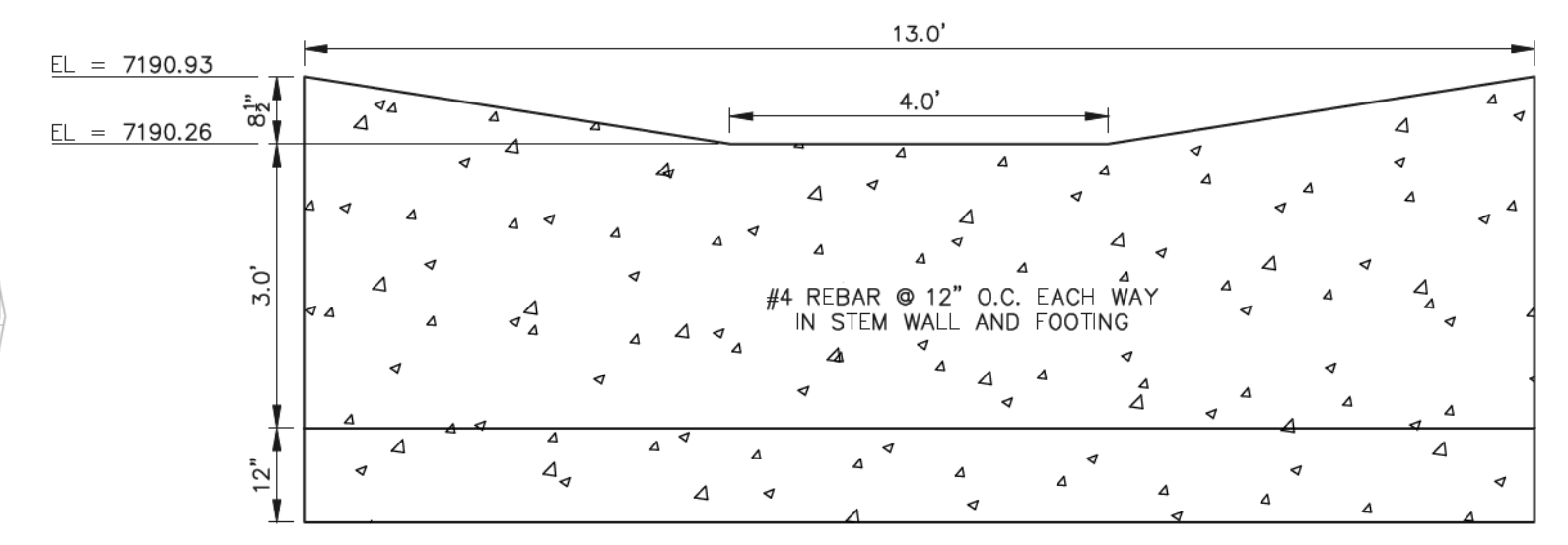
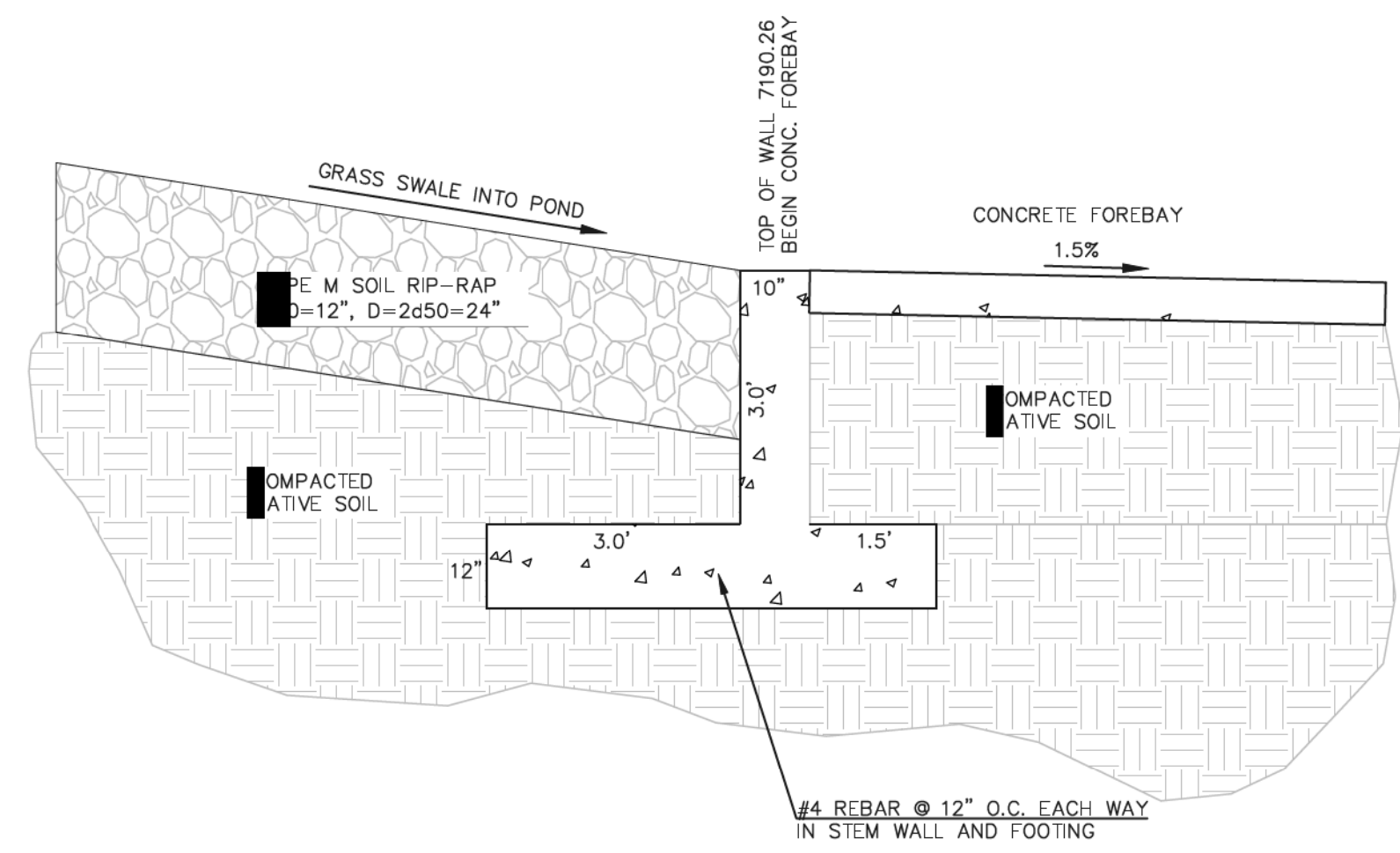
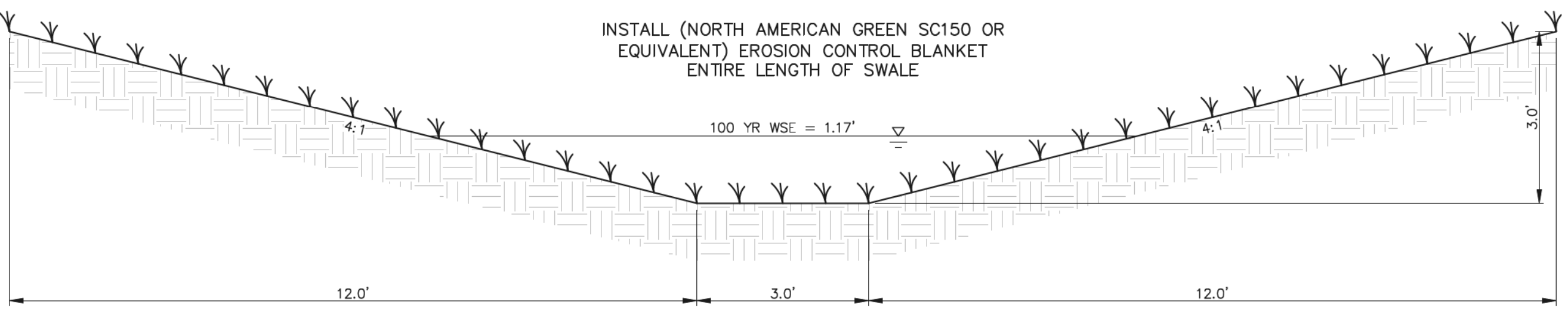
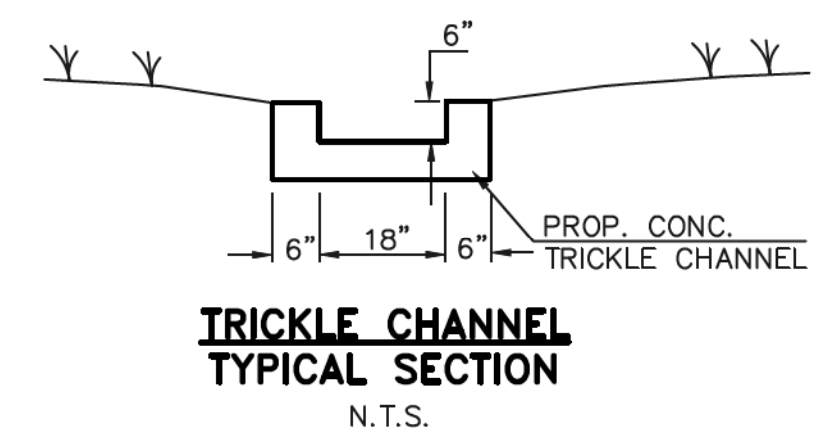
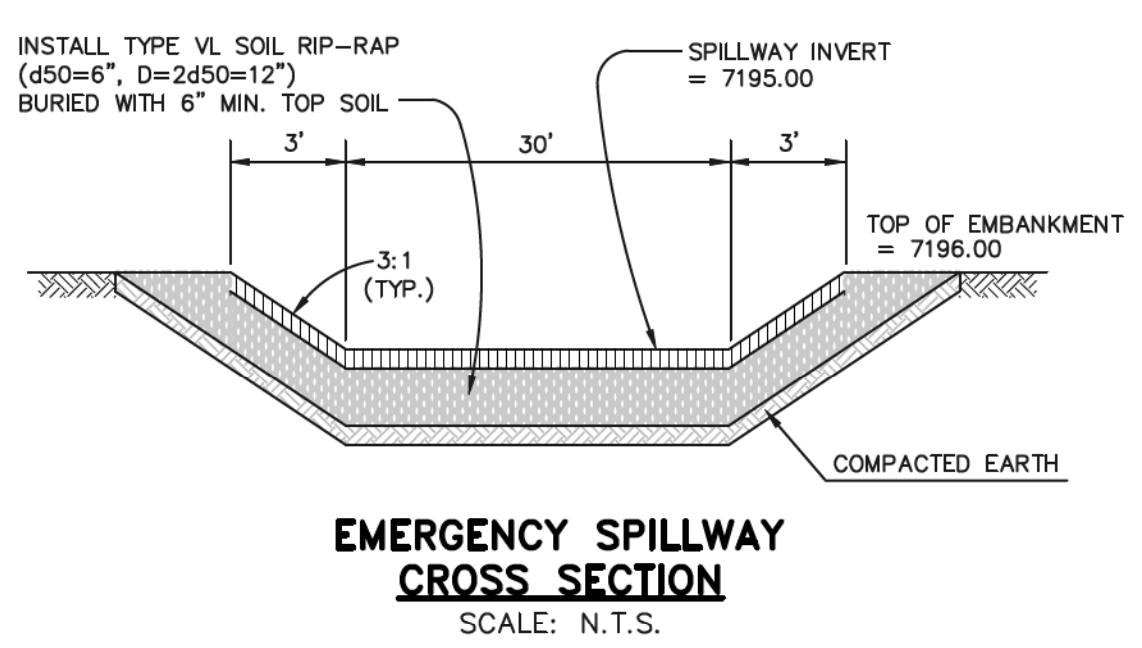

SEE RETREAT AT TIMBERRIDGE FILING NO. 1 GRADING AND EROSION CONTROL PLAN FOR EROSION CONTROL DETAILS.

<p>48 HOURS BEFORE YOU DIG, CALL UTILITY LOCATORS</p> <p>811</p> <p>UTILITY NOTIFICATION CENTER OF COLORADO IT'S THE LAW</p> <p>THE LOCATIONS OF EXISTING UNDERGROUND UTILITIES ARE SHOWN IN AN APPROXIMATE WAY ONLY. THE CONTRACTOR SHALL DETERMINE THE EXACT LOCATION OF ALL EXISTING UTILITIES BEFORE COMMENCING WORK. THE CONTRACTOR SHALL BE FULLY RESPONSIBLE FOR ANY AND ALL DAMAGES WHICH MIGHT BE CAUSED BY HIS FAILURE TO EXACTLY LOCATE AND PRESERVE ANY AND ALL UNDERGROUND UTILITIES.</p>	<p>NO. REVISION</p> <p>1 REVISED PER COUNTY COMMENTS</p> <p>2 REVISED PER COUNTY COMMENTS</p> <p>3 REVISED ACCESS RAMP LOCATION</p>	<p>DATE</p> <p>08-14-19</p> <p>04-16-20</p> <p>6-9-20</p>	<p>REVIEW:</p> <p>PREPARED UNDER MY DIRECT SUPERVISION FOR AND ON BEHALF OF CLASSIC CONSULTING ENGINEERS AND SURVEYORS, LLC</p> <p>MARC A. WHORTON, COLORADO, P.E. #37155</p>	<p>6/10/2020</p> <p>DATE</p>	<p>RETREAT AT TIMBERRIDGE FILING NO. 1 CONSTRUCTION PLANS DETENTION FACILITY POND 1 POND PLAN</p> <p>DESIGNED BY MAW SCALE DATE 04-05-19</p> <p>DRAWN BY MAW (H) 1" = 30' SHEET 31 OF 35</p> <p>CHECKED BY (V) 1" = N/A JOB NO. 1185.00</p>
	<p>CLASSIC CONSULTING</p>			<p>619 N. Cascade Avenue, Suite 200 Colorado Springs, Colorado 80903</p> <p>(719)785-0790 (719)785-0799(Fax)</p>	
	<p>SEE RETREAT AT TIMBERRIDGE FILING NO. 1 GRADING AND EROSION CONTROL PLAN FOR EROSION CONTROL DETAILS.</p>				

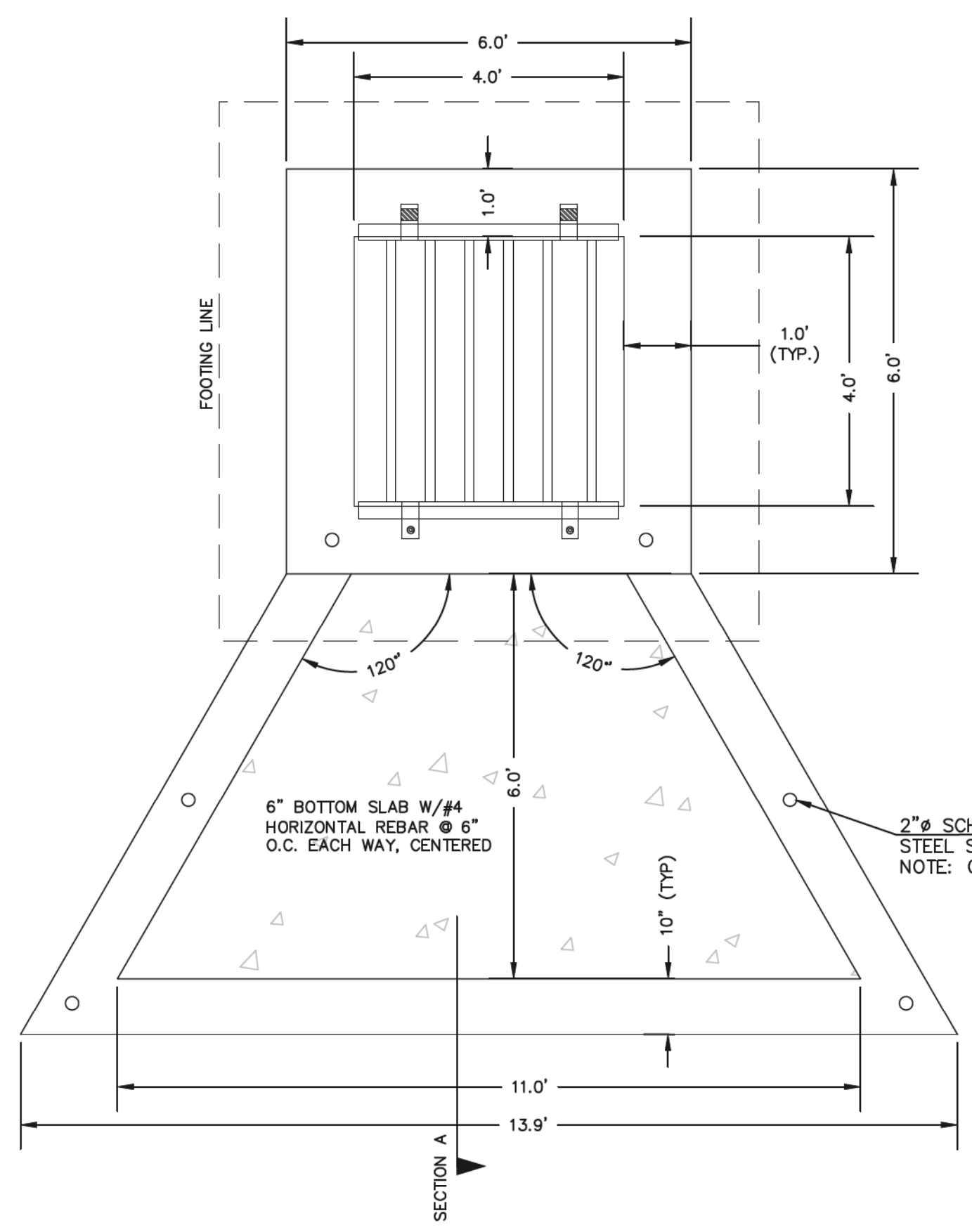

CONCRETE MICROPOOL
SCALE 1" = 2'

- NOTES:
1. WELD PLATES MAY BE SUBSTITUTED FOR PIPE EMBEDMENT.
 2. DESIGN CRITERIA SHALL BE IN ACCORDANCE WITH AASHTO STANDARDS.
 3. HANDRAIL DESIGN SHALL BE COMPATIBLE WITH THE DESIGN OF THE WINGWALLS AND HEADWALLS.
 4. RAILING POSTS SHALL BE SET TO NORMAL TO GRADE. RAILS SHALL RUN PARALLEL TO THE SLOPES OF TOPS OF THE WALLS.
 5. ALL RAILS SHALL HAVE EXPANSION JOINTS SPACED AT 40'-0" MAX. JOINT ENDS SHALL BE FREE OF ANY SHARP EDGES OR CORNERS.

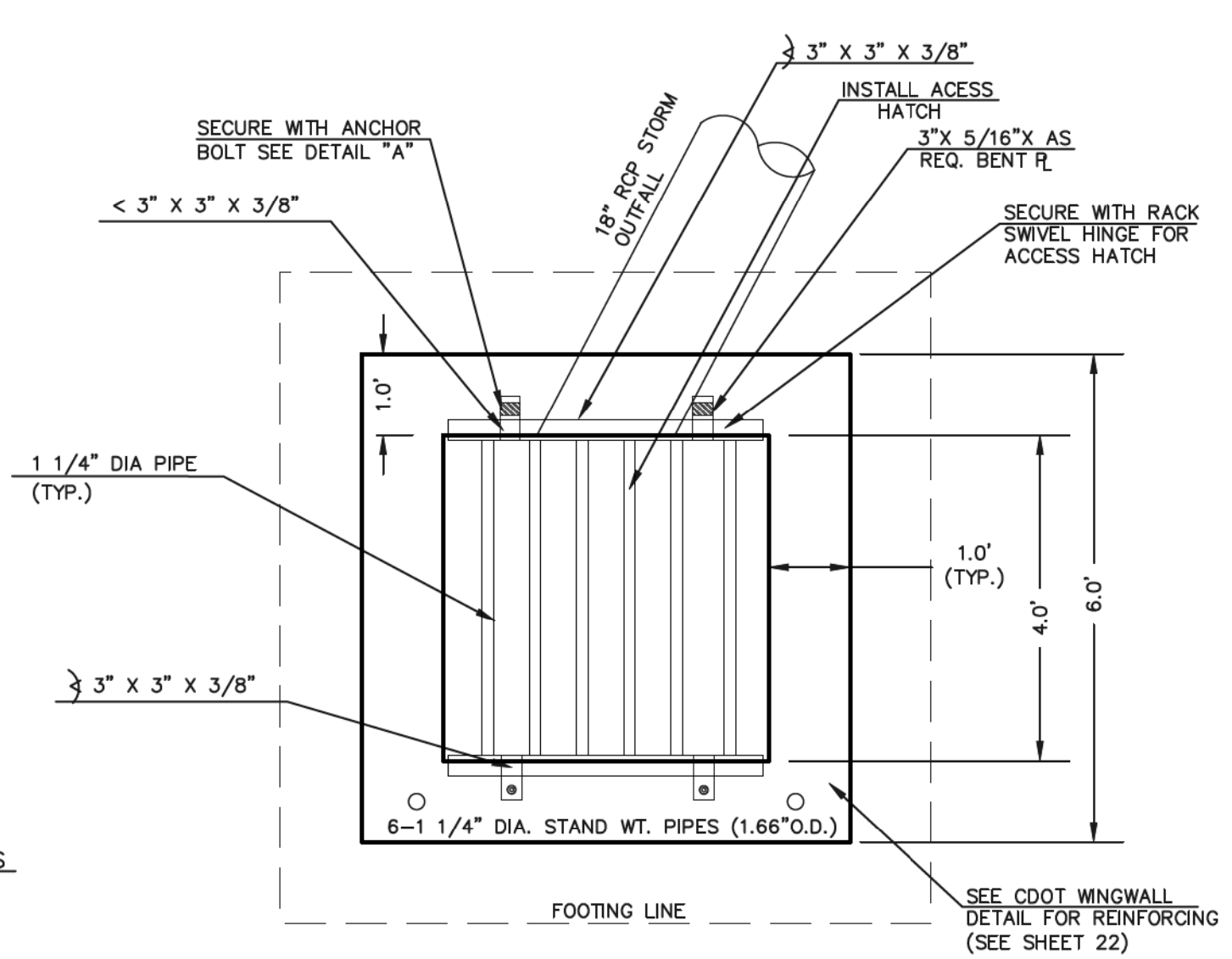

4'X4' OUTLET BOX OVERFLOW TRASH RACK
SCALE 1" = 2'

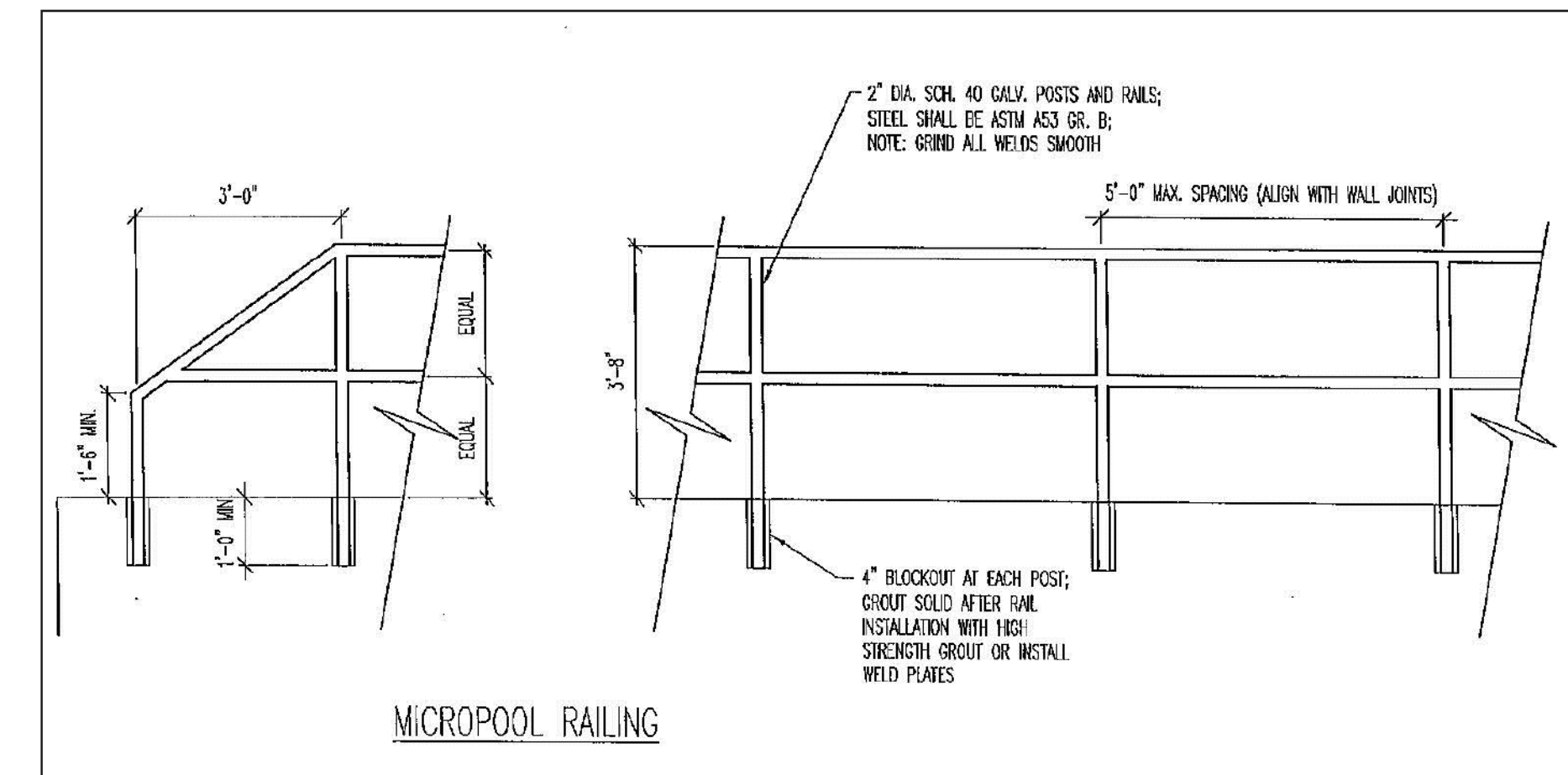
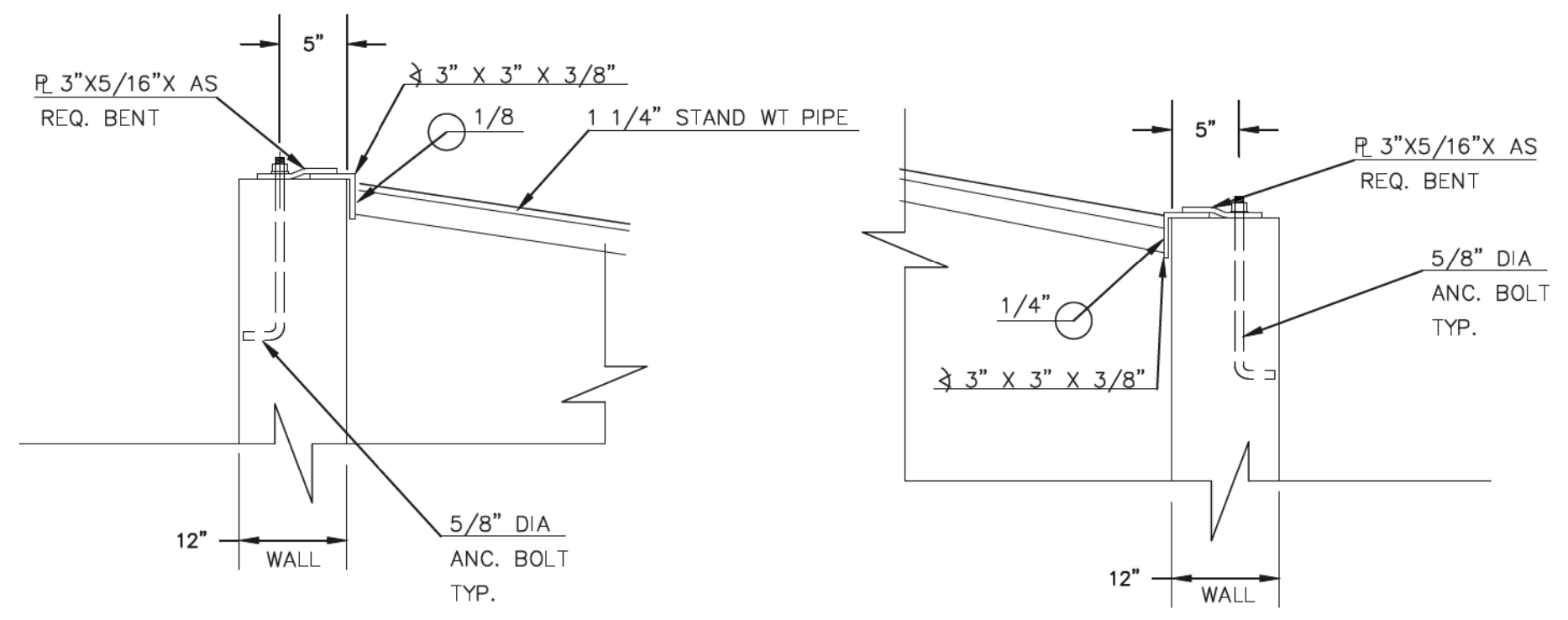

OUTLET BOX RAILING
N.T.S.

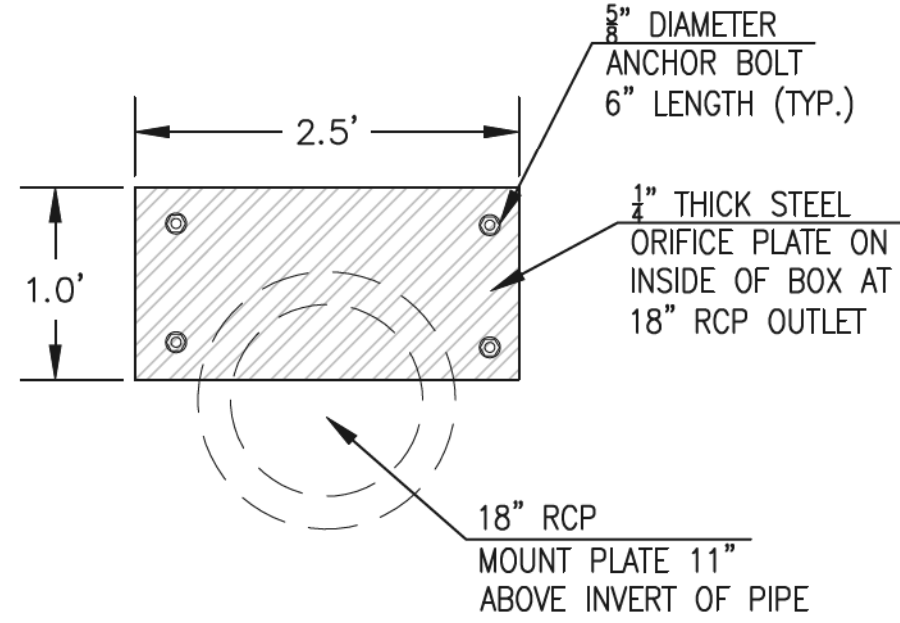

OUTLET BOX ORIFICE PLATE - 1/4" STEEL

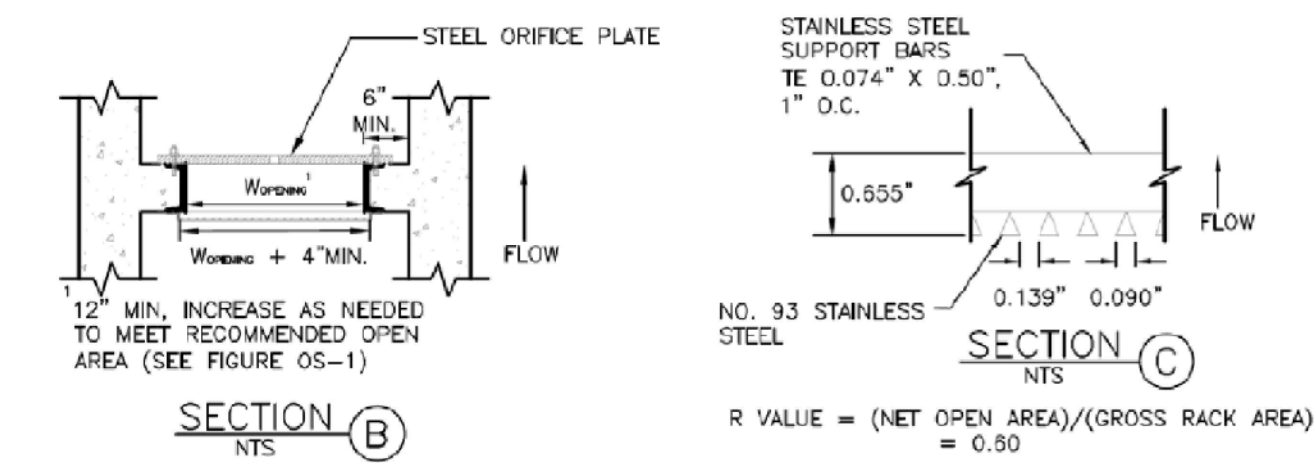

100-YR W.S.E. = 7193.87

EURV W.S.E. = 7190.40 / 5 YEAR W.S.E. = 7190.49
WQCV YR W.S.E. = 7189.81 / 2 YEAR W.S.E. = 7189.99

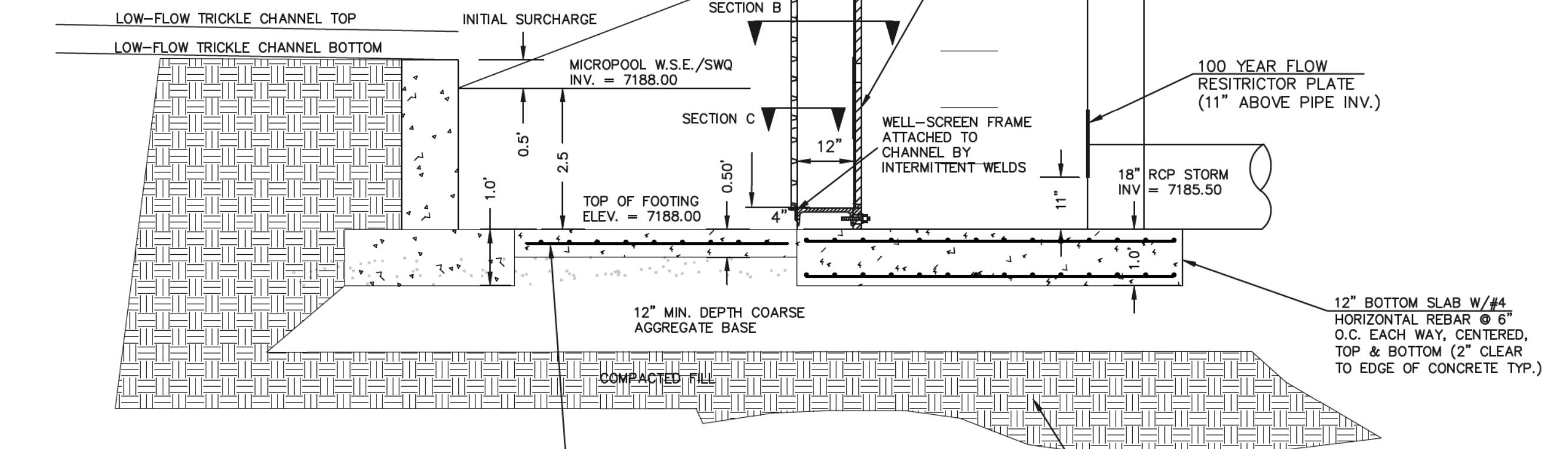

4'X4' OUTLET BOX MICRO POOL SECTION A
SCALE 1" = 2'

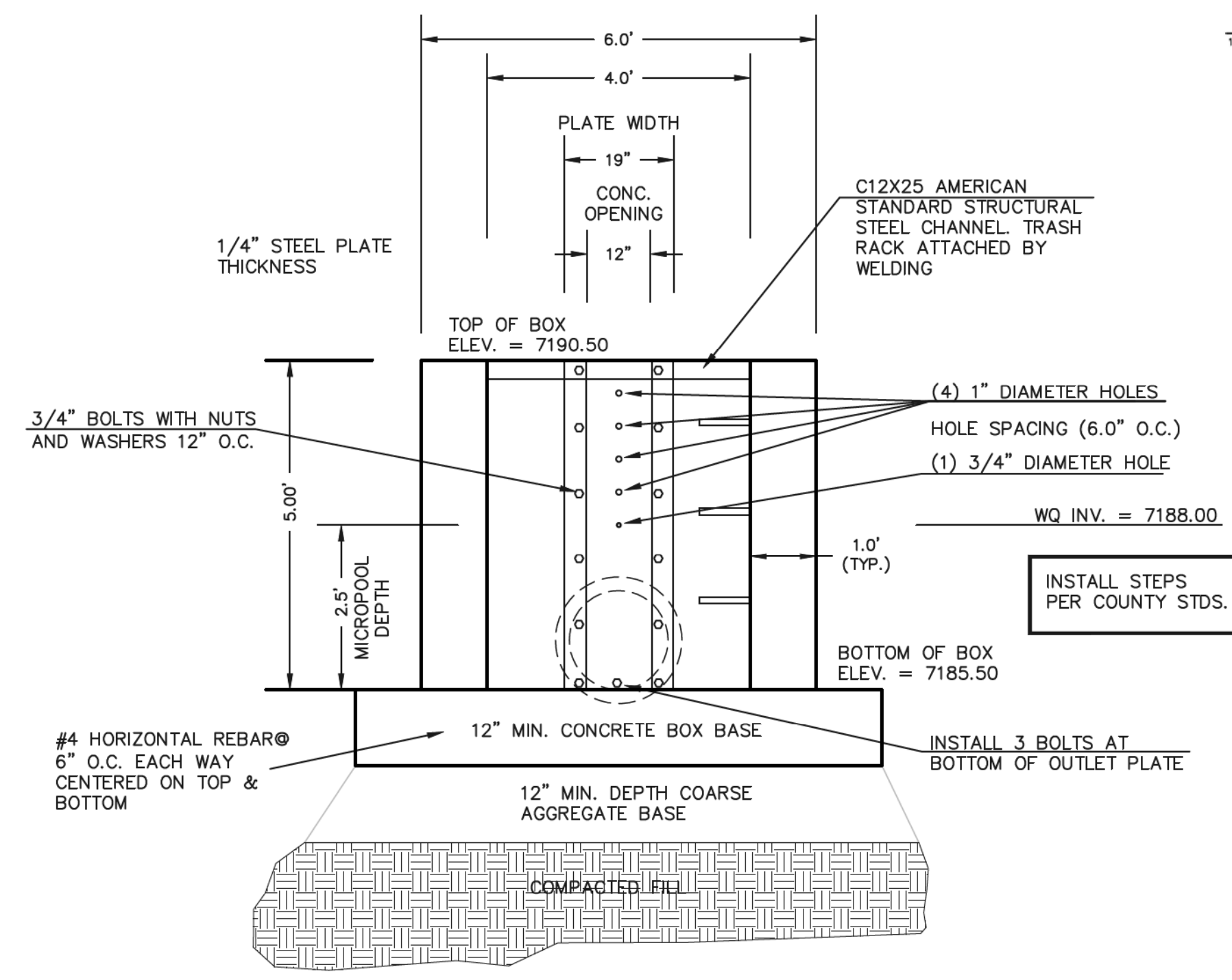

4'X4' OUTLET BOX ORIFICE PLATE
SCALE 1" = 2'

- (ALL MATERIALS PER EL PASO COUNTY SPECIFICATIONS)
- ORIFICE PLATE NOTES:
1. INSTALL HOLES AS SHOWN ON DETAIL TO LEFT.
 2. PROVIDE GASKET MATERIAL BETWEEN THE ORIFICE PLATE AND CONCRETE
- EURV AND WQCV TRASH RACKS:
3. WELL-SCREEN TRASH RACKS SHALL BE STAINLESS STEEL AND SHALL BE ATTACHED BY INTERMITTENT WELDS ALONG THE EDGE OF THE MOUNTING FRAME.
 4. BAR GRATE TRASH RACKS SHALL BE ALUMINUM AND SHALL BE BOLTED USING STAINLESS STEEL HARDWARE.
 5. STRUCTURAL DESIGN OF TRASH RACKS SHALL BE BASED ON FULL HYDROSTATIC HEAD WITH ZERO HEAD DOWNSTREAM OF RACK
- OVERFLOW TRASH RACKS:
1. ALL TRASH RACKS SHALL BE MOUNTED USING STAINLESS STEEL HARDWARE AND PROVIDED WITH HINGED AND LOCKABLE OR BOLTABLE ACCESS PANELS
 2. TRASH RACKS SHALL BE STAINLESS STEEL, ALUMINUM, OR STEEL. STEEL TRASH RACKS SHALL BE HOT DIP GALVANIZED AND MAY BE HOT POWDER COATED AFTER GALVANIZING.
 3. TRASH RACKS SHALL BE DESIGNED SUCH THAT THE DIAGONAL DIMENSION OF EACH OPENING IS SMALLER THAN THE DIAMETER OF THE OUTLET PIPE.
 4. STRUCTURAL DESIGN OF THE TRASH RACKS SHALL BE BASED ON FULL HYDROSTATIC HEAD WITH ZERO HEAD DOWNSTREAM OF THE RACK.

48 HOURS BEFORE YOU DIG,
CALL UTILITY LOCATORS
811
UTILITY NOTIFICATION CENTER OF COLORADO
IT'S THE LAW

THE LOCATIONS OF EXISTING UNDERGROUND UTILITIES ARE SHOWN IN AN APPROXIMATE WAY ONLY. THE CONTRACTOR SHALL DETERMINE THE EXACT LOCATION OF ALL EXISTING UTILITIES BEFORE COMMENCING WORK. THE CONTRACTOR SHALL BE FULLY RESPONSIBLE FOR ANY AND ALL DAMAGES WHICH MIGHT BE CAUSED BY HIS FAILURE TO EXACTLY LOCATE AND PRESERVE ANY AND ALL UNDERGROUND UTILITIES.

NO.	REVISION	DATE
1	REVISED PER COUNTY COMMENTS	08-13-19
2	REVISED PER COUNTY COMMENTS	04-16-20
3	REVISED PER COUNTY COMMENTS	6-9-20

REVIEW:

PREPARED UNDER MY DIRECT SUPERVISION FOR AND ON BEHALF OF CLASSIC CONSULTING ENGINEERS AND SURVEYORS, LLC

MARC A. WHORTON, COLORADO P.E. #37155

6/10/2020



RETREAT AT TIMBERDINGS FILING NO. 1
CONSTRUCTION DRAWINGS
DETENTION FACILITY 1
OUTLET BOX DETAILS

DESIGNED BY	MAW	SCALE	DATE	04-05-19
DRAWN BY	MAW	(H) 1" = N/A	SHEET	32 OF 35
CHECKED BY	(V) 1" = N/A	JOB NO.	1185.00	

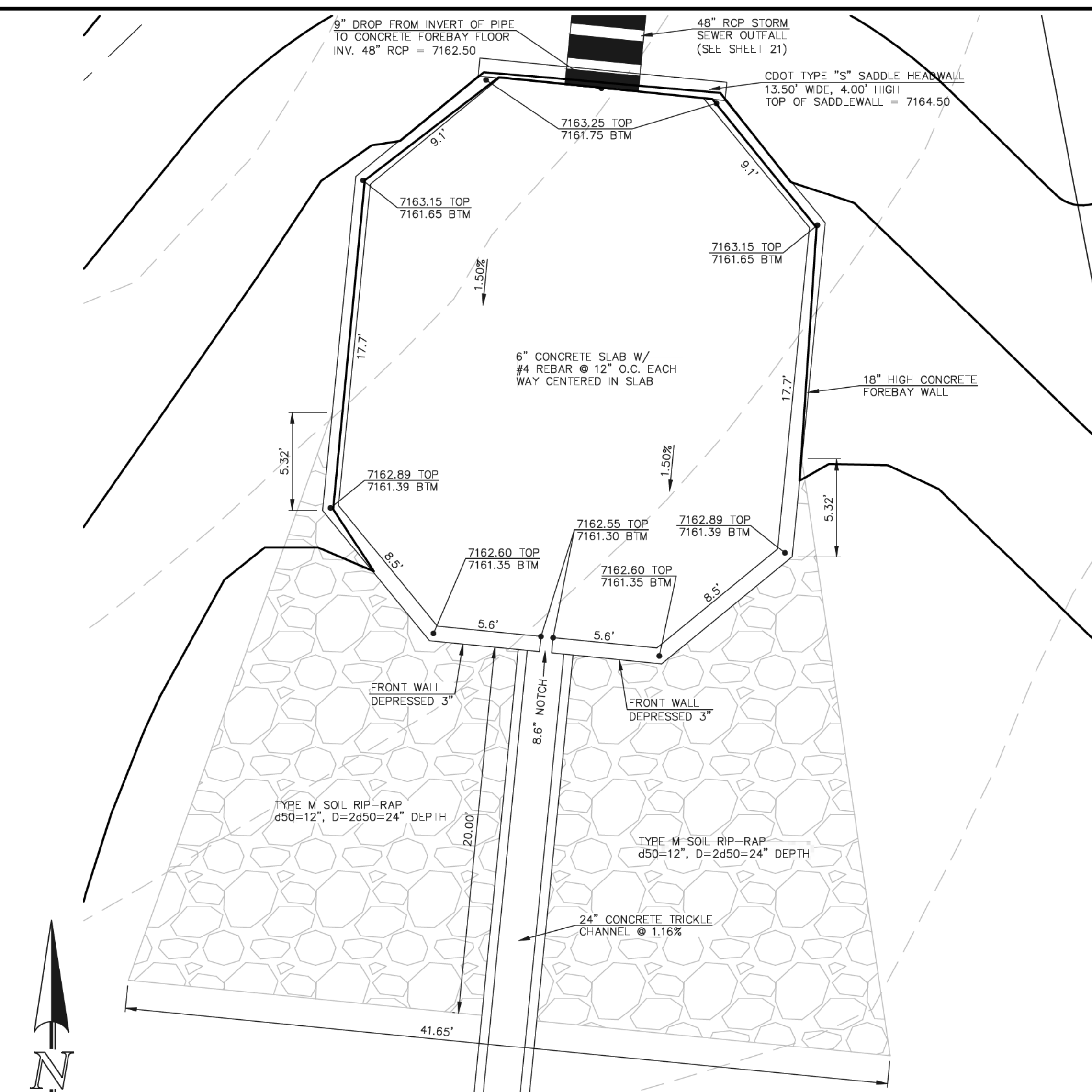

WESTERLY CONCRETE FOREBAY
SCALE: 1" = 5'

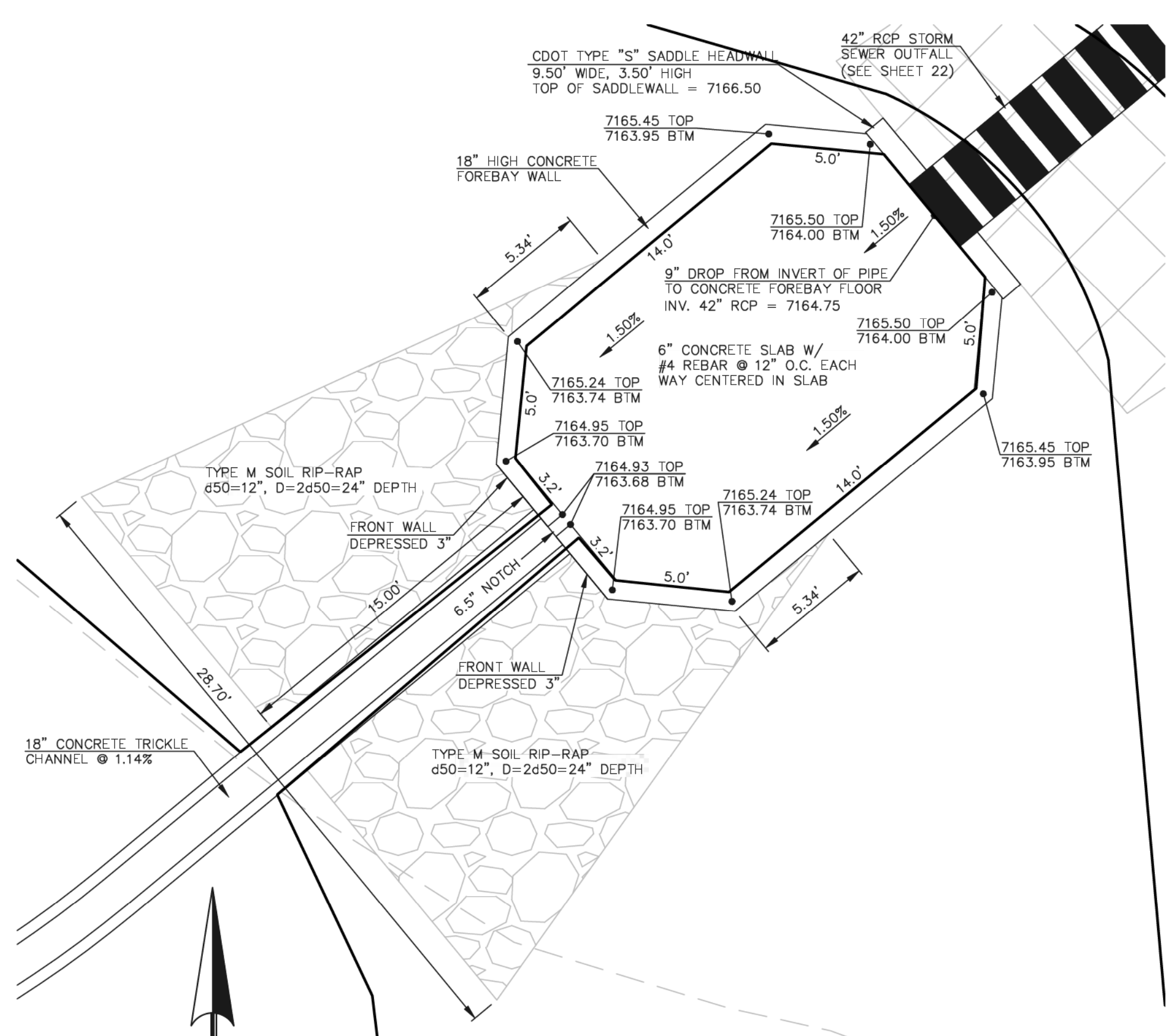

EASTERLY CONCRETE FOREBAY
SCALE: 1" = 5'

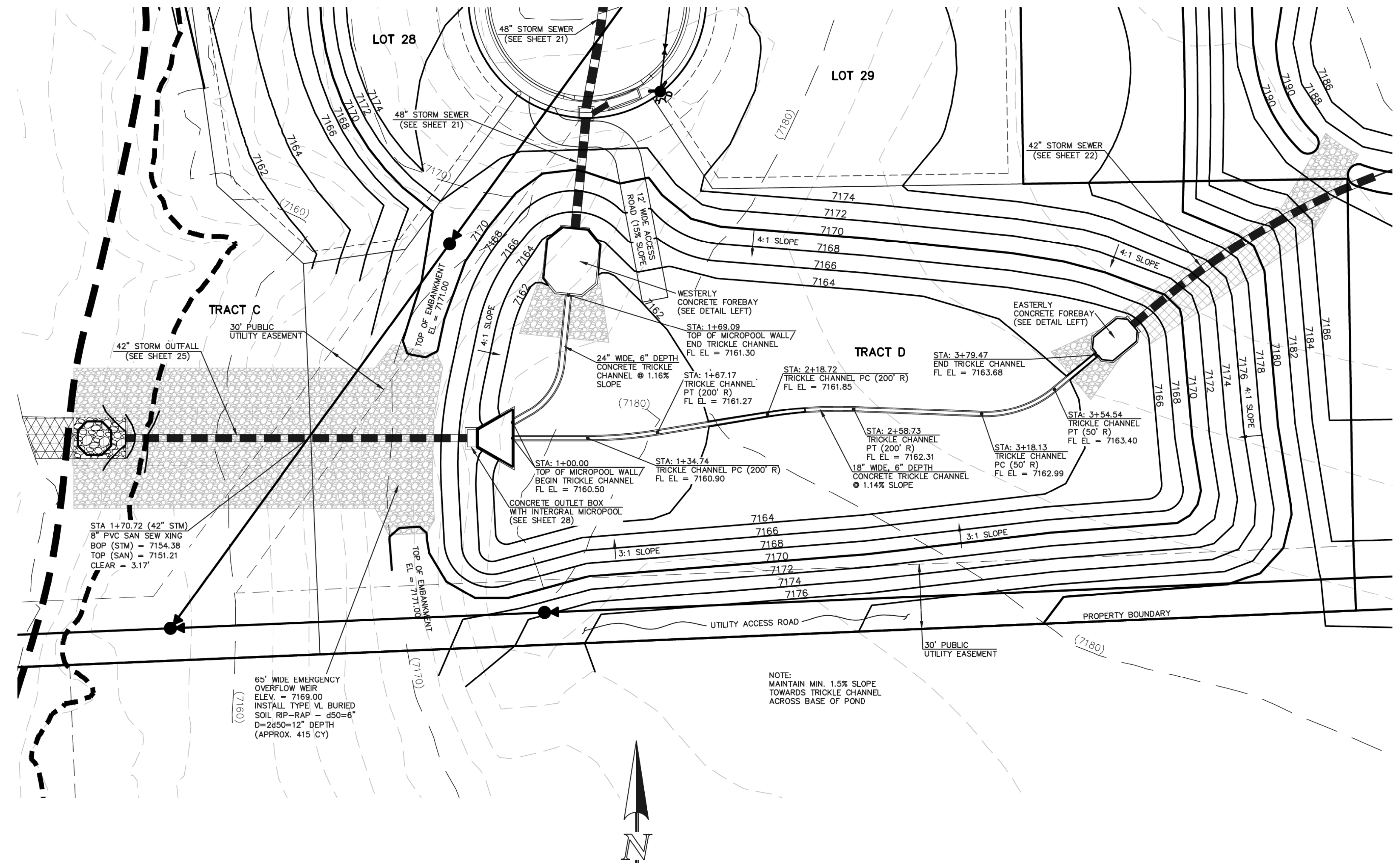
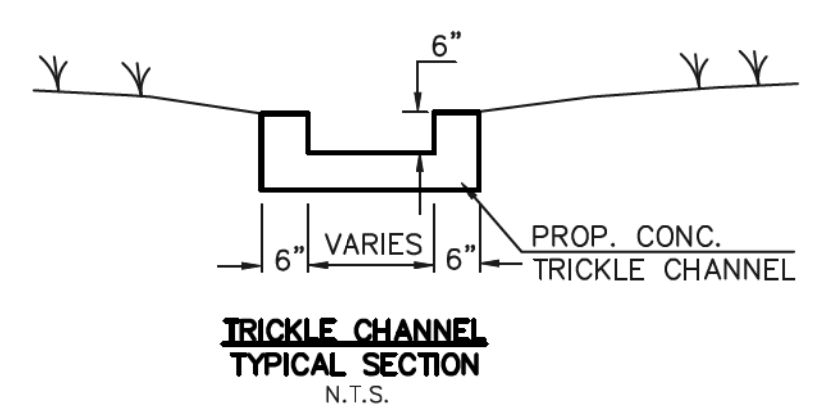

SCALE: 1" = 30'

DETENTION FACILITY POND 2

SEE RETREAT AT TIMBERBRIDGE FILING NO. 1 GRADING AND EROSION CONTROL PLAN FOR EROSION CONTROL DETAILS.

<p>48 HOURS BEFORE YOU DIG, CALL UTILITY LOCATORS 811</p> <p>UTILITY NOTIFICATION CENTER OF COLORADO IT'S THE LAW</p> <p>THE LOCATIONS OF EXISTING UNDERGROUND UTILITIES ARE SHOWN IN AN APPROXIMATE WAY ONLY. THE CONTRACTOR SHALL DETERMINE THE EXACT LOCATION OF ALL EXISTING UTILITIES BEFORE COMMENCING WORK. THE CONTRACTOR SHALL BE FULLY RESPONSIBLE FOR ANY AND ALL DAMAGES WHICH MIGHT BE CAUSED BY HIS FAILURE TO EXACTLY LOCATE AND PRESERVE ANY AND ALL UNDERGROUND UTILITIES.</p>	<p>NO. REVISION</p> <p>1 REVISED PER COUNTY COMMENTS</p>	<p>DATE</p> <p>08-13-19</p>	<p>REVIEW:</p> <p>PREPARED UNDER MY DIRECT SUPERVISION FOR AND ON BEHALF OF CLASSIC CONSULTING ENGINEERS AND SURVEYORS, LLC</p> <p>MARC A. WHORTON, COLORADO, P.E. #37155</p>	<p>DATE</p> <p>6/10/2020</p>	<p>CLASSIC CONSULTING</p> <p>619 N. Cascade Avenue, Suite 200 Colorado Springs, Colorado 80903</p> <p>(719)785-0790 (719)785-0799(Fax)</p>	<p>RETREAT AT TIMBERBRIDGE FILING NO. 1 CONSTRUCTION PLANS</p> <p>DETENTION FACILITY POND 2 POND PLAN</p>	<p>DESIGNED BY</p> <p>MAW</p>	<p>SCALE</p> <p>(H) 1" = 30' (V) 1" = N/A</p>	<p>DATE</p> <p>04-05-19</p>	<p>SHEET 33 OF 35</p>	<p>JOB NO.</p> <p>1185.00</p>
	<p>CLASSIC CONSULTING</p>	<p>CLASSIC CONSULTING</p>									

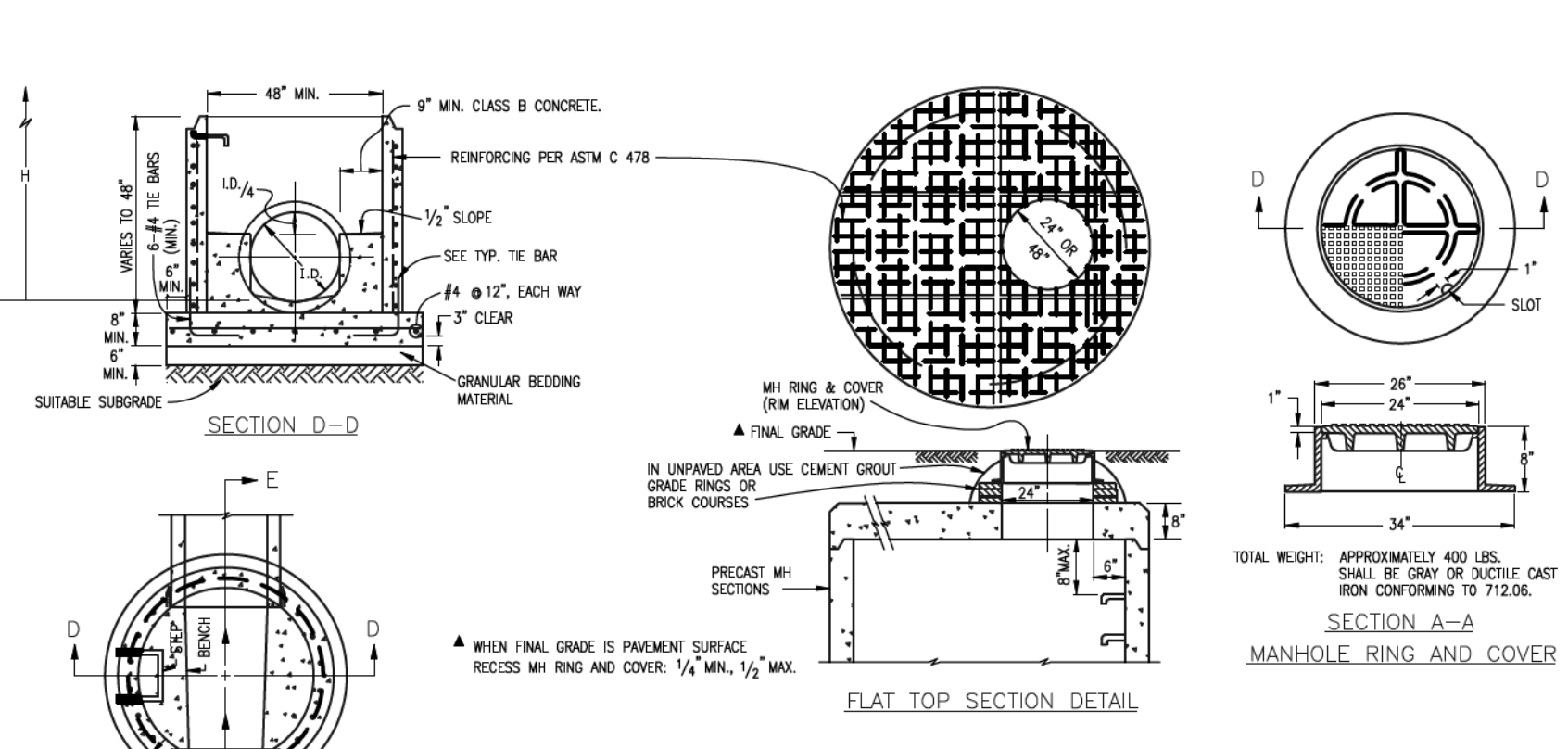
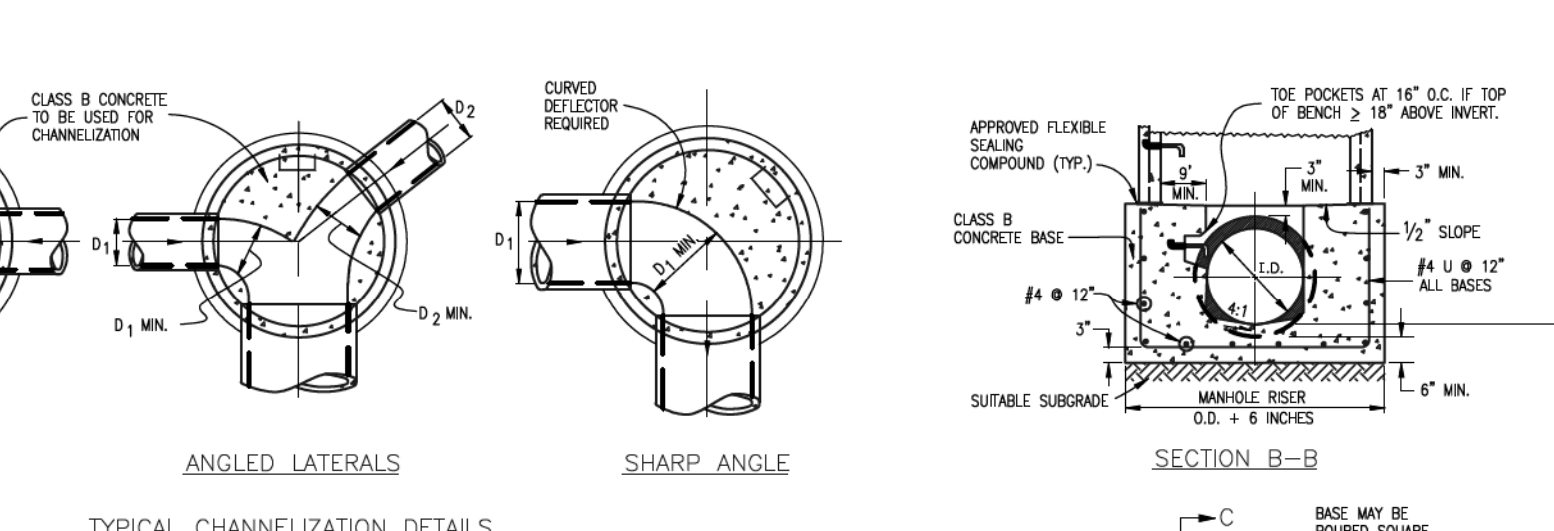
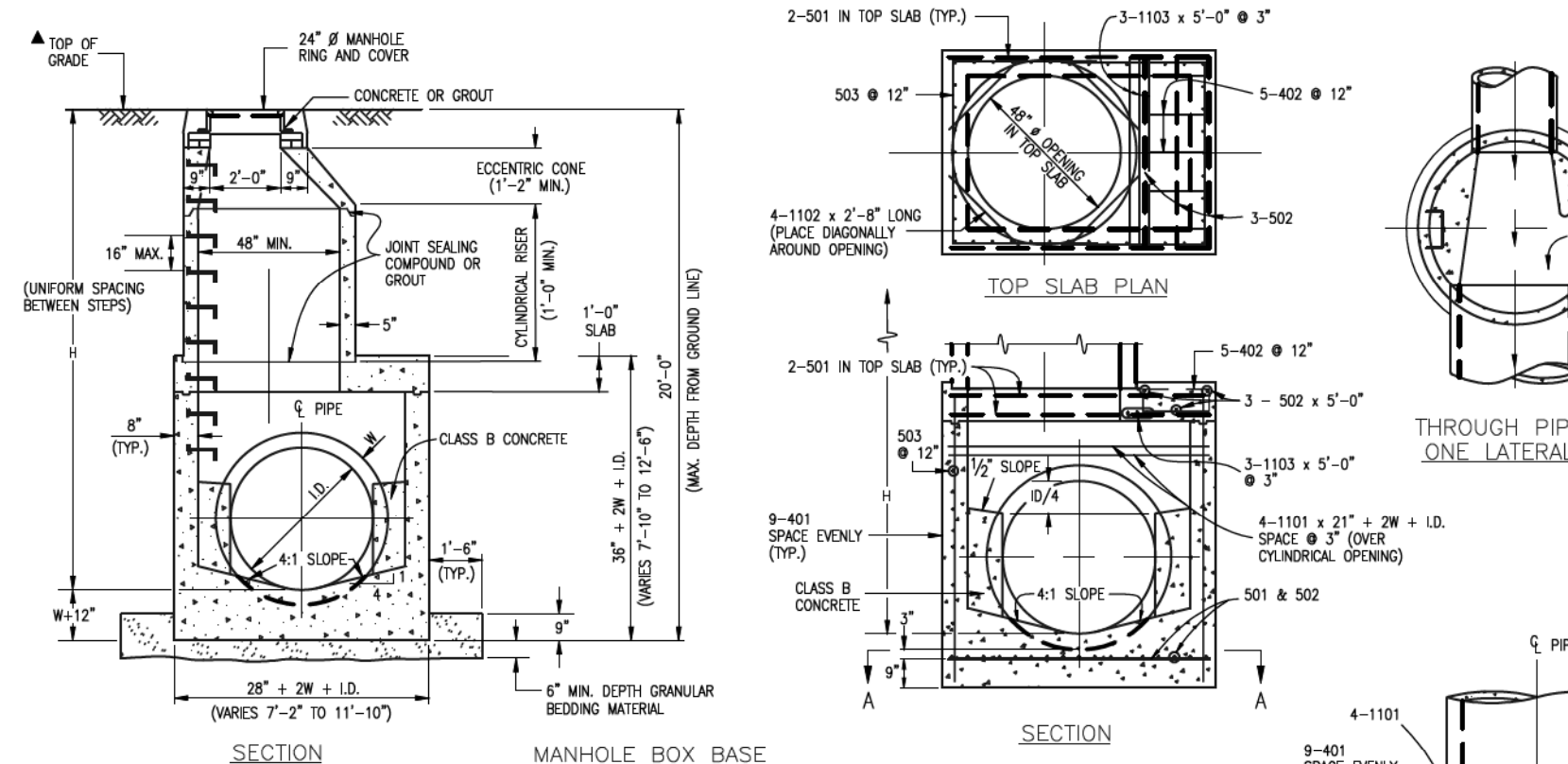
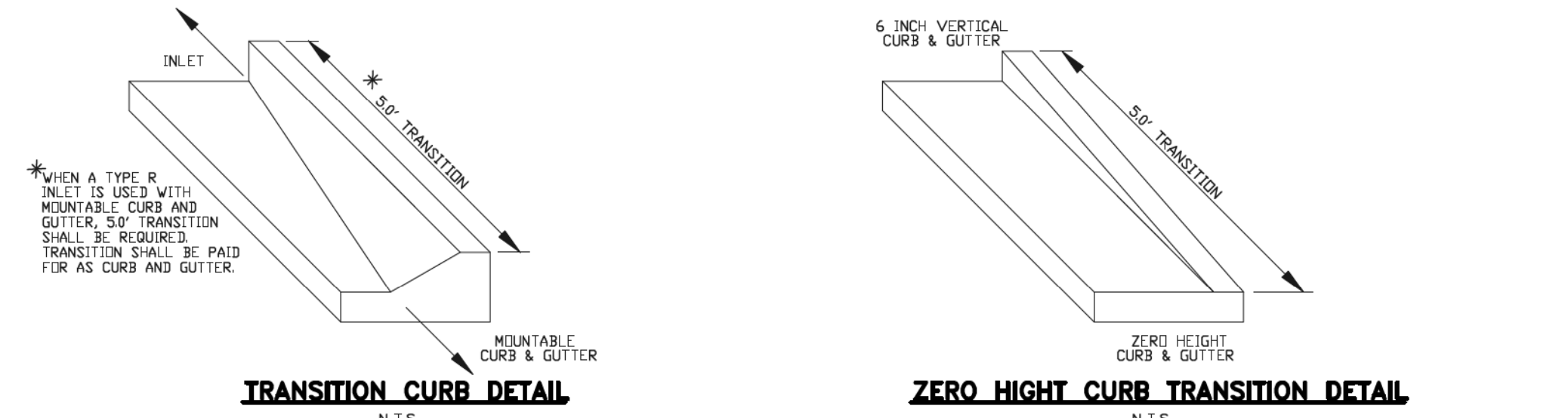
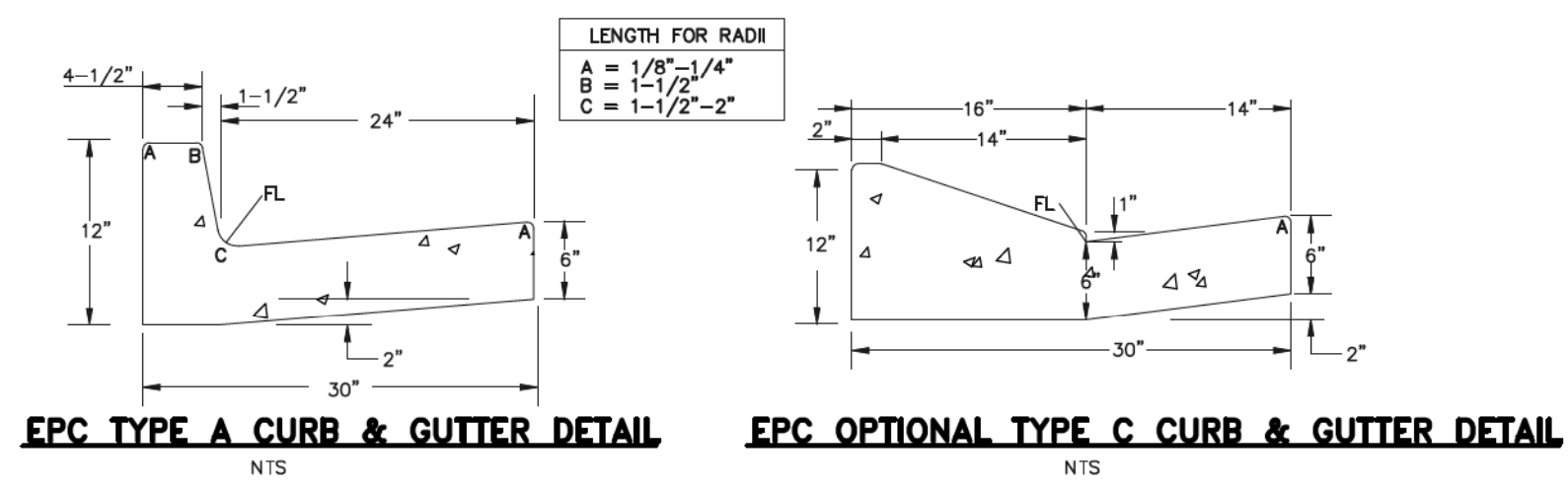

QUANTITIES FOR CONCRETE MANHOLE BOX BASE

MARK	SIZE	TYPE	WT. P.Y.	NO. REQ'D.	LENGTH	NO. REQ'D.	LENGTH	NO. REQ'D.	LENGTH	NO. REQ'D.	LENGTH	NO. REQ'D.	LENGTH	NO. REQ'D.	LENGTH	NO. REQ'D.	LENGTH	NO. REQ'D.	LENGTH	
401	4	I	0.668	18	18	18	18	18	18	18	18	18	18	18	18	18	18	18	18	18
402	4	II	0.668	5	5	5	5	5	5	5	5	5	5	5	5	5	5	5	5	5
501	5	I	1.043	17	17	17	17	17	17	17	17	17	17	17	17	17	17	17	17	17
502	5	II	1.043	22	22	22	22	22	22	22	22	22	22	22	22	22	22	22	22	22
503	5	III	1.043	12	12	12	12	12	12	12	12	12	12	12	12	12	12	12	12	12
504	5	IV	1.043	12	12	12	12	12	12	12	12	12	12	12	12	12	12	12	12	12
1101	11	I	5.313	4	4	4	4	4	4	4	4	4	4	4	4	4	4	4	4	4
1102	11	II	5.313	4	4	4	4	4	4	4	4	4	4	4	4	4	4	4	4	4
1103	11	III	5.313	3	3	3	3	3	3	3	3	3	3	3	3	3	3	3	3	3
1104	11	IV	5.313	3	3	3	3	3	3	3	3	3	3	3	3	3	3	3	3	3
REINFORCING STEEL TOTAL				865.6	1073.4	1073.4	1073.4	1073.4	1073.4	1073.4	1073.4	1073.4	1073.4	1073.4	1073.4	1073.4	1073.4	1073.4	1073.4	1073.4
CONCRETE - CURB VARS - TOTAL				6.0	6.6	7.3	8.0	8.5	11.1											

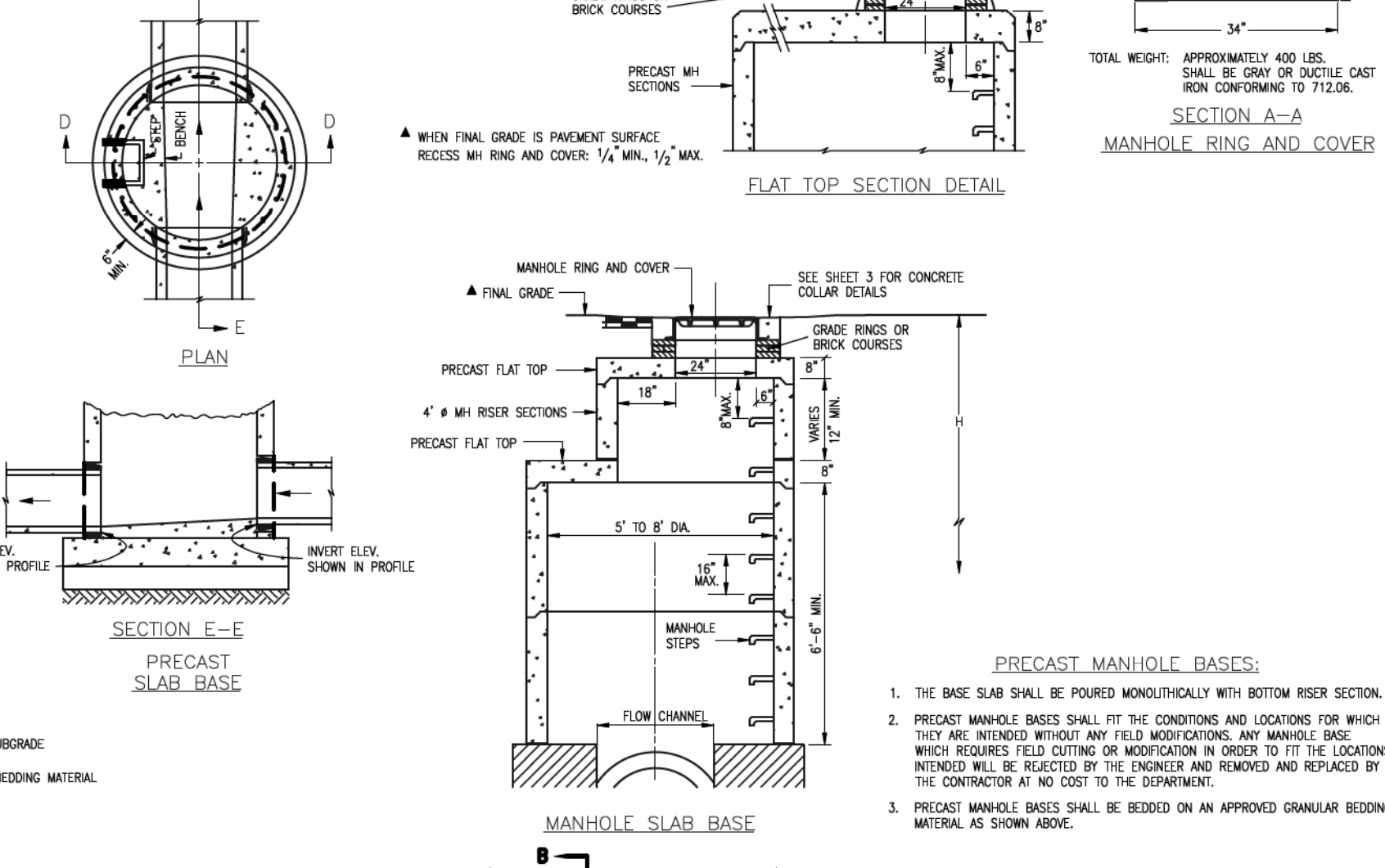
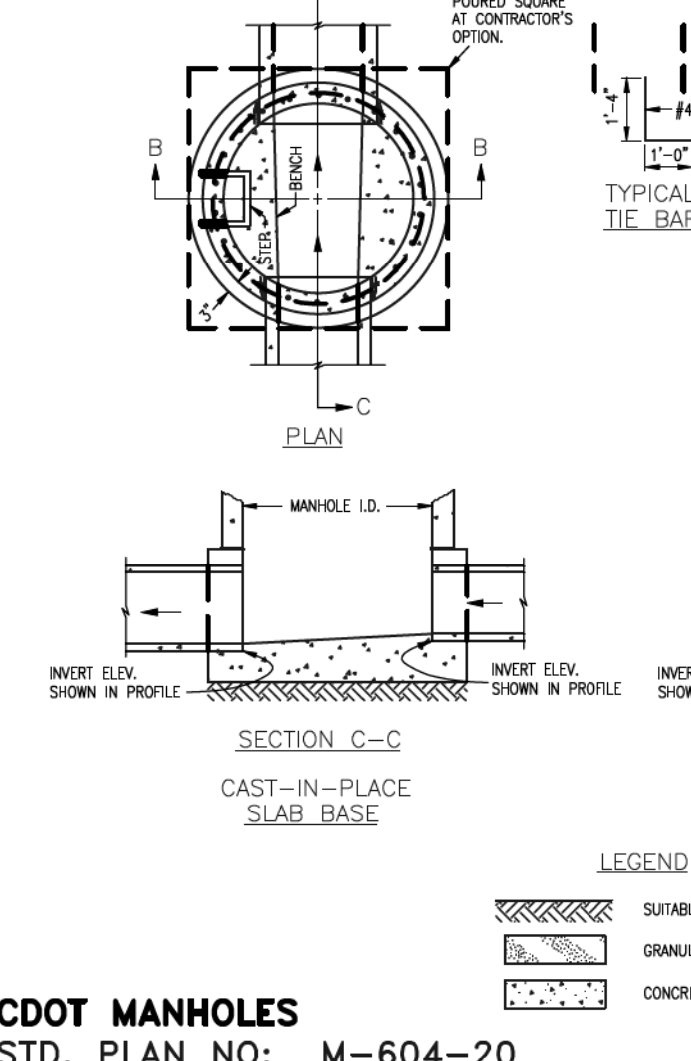
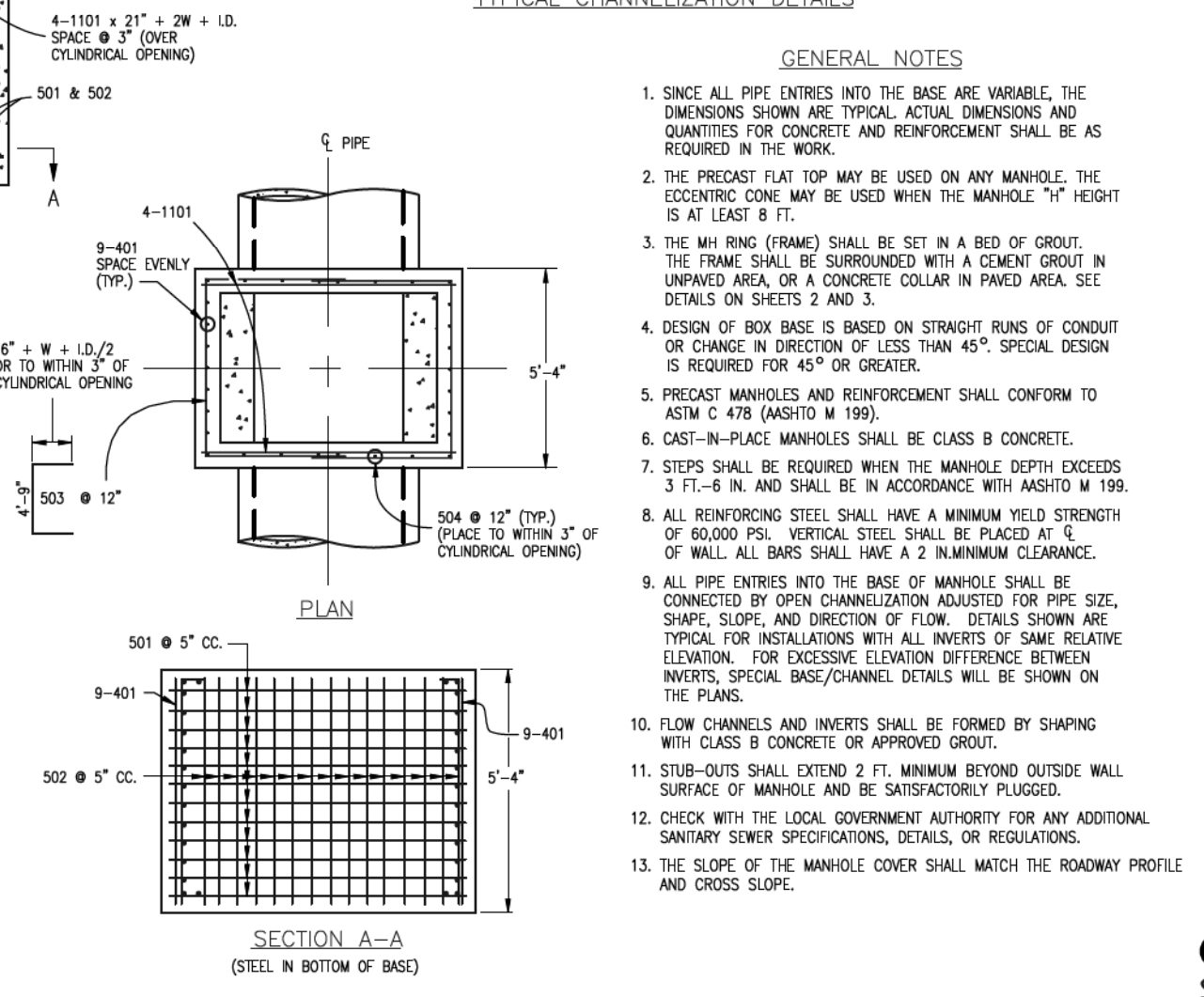

CDOT MANHOLES
STD. PLAN NO: M-604-20

TABLE ONE ~ BAR LIST FOR CURB INLETS, TYPE "R"

MARK	DIA. IN.	O.C. SPACING	TYPE	INLETS, H = 5'				INLETS, H = 5'				
				NO. REQ'D.	LENGTH	NO. REQ'D.	LENGTH	NO. REQ'D.	LENGTH	NO. REQ'D.	LENGTH	
401	11"	II	15	21	26	11	11					
402	11"	II	7	13	18	7	7					
403	9"	II	4	10	14	4	4					
405	6"	VI	11	8'-10"	21	8'-10"	31	8'-10"	11	8'-10"	11	8'-10"
406	6"	VIII	7	8'-10"	7	8'-10"	7	8'-10"	7	8'-10"	7	8'-10"
407	1 1/2"	II	3	5'-10"	3	10'-10"	3	5'-10"	3	5'-10"	3	5'-10"
408	12"	II	3	6'-0"	3	11'-0"	3	16'-0"	3	16'-0"	3	16'-0"
409	8"	II	6	5'-10"	6	10'-10"	6	10'-10"	6	15'-10"	6	15'-10"
410	11"	VII	3	3	3	3	3					
411	11"	II	3	5'-2"	3	10'-2"	3	5'-2"	3	10'-2"	3	10'-2"
412	11"	II	3	2'-9"	3	2'-9"	3	2'-9"	3	2'-9"	3	2'-9"
413	9"	II	7	10'-10"	7	15'-10"	7	15'-10"	7	15'-10"	7	15'-10"
501	5 1/2"	IV	11	3'-4"	22	3'-4"	33	3'-4"	22	3'-4"	33	3'-4"
502	5 1/2"	II	5	3'-6"	16	3'-6"	27	3'-6"	6	3'-6"	6	3'-6"
503	5 1/2"	IX	5	3'-6"	16	3'-6"	27	3'-6"	6	3'-6"	6	3'-6"
504	5 1/2"	IX	5	3'-6"	16	3'-6"	27	3'-6"	6	3'-6"	6	3'-6"
601	2 1/2"	V	2	8'-10"	2	8'-10"	2	8'-10"	2	8'-10"	4	8'-10"
801	8	1	1	5'-10"	1	10'-10"	1	15'-10"	1	10'-10"	1	15'-10"

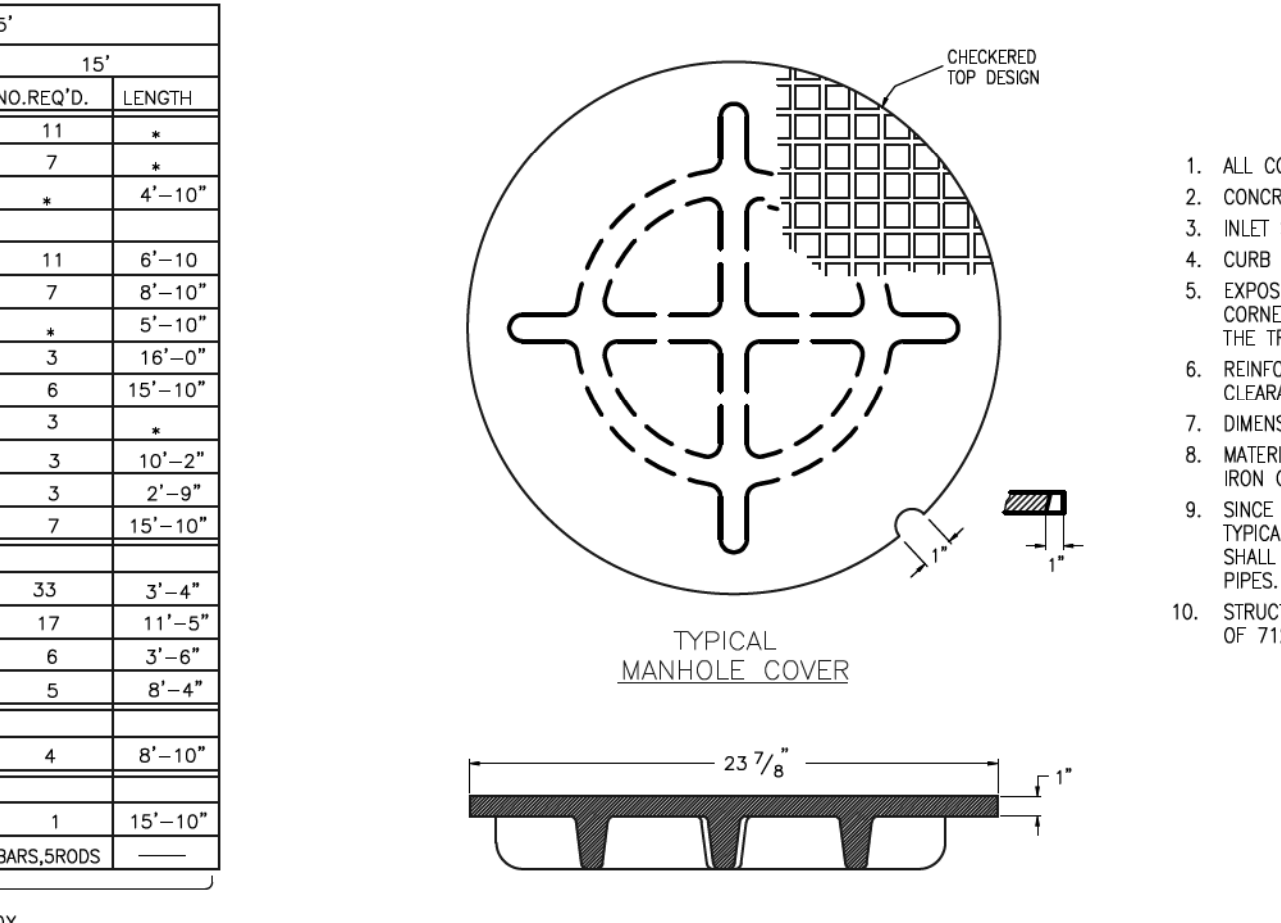

GENERAL NOTES

- ALL CONCRETE SHALL BE CLASS B.
- CONCRETE WALLS SHALL BE FORMED ON BOTH SIDES AND SHALL BE 8 IN. THICK.
- INLET STEPS SHALL BE IN ACCORDANCE WITH ASHOTO M 199.
- CURB FACE ASSEMBLY SHALL BE GALVANIZED AFTER WELDING.
- EXPOSED CONCRETE CORNERS SHALL BE CHAMFERED 3/4" IN. CURB AND GUTTER CORNERS SHALL BE FINISHED TO MATCH THE EXISTING CURB AND GUTTER BEYOND THE TRANSITION GUTTER.
- REINFORCING BARS SHALL BE DEFORMED AND SHALL HAVE A 2 IN. MINIMUM CLEARANCE; ALL REINFORCING BARS SHALL BE EPOXY COATED.
- DIMENSIONS AND WEIGHTS OF TYPICAL MANHOLE RING AND COVER ARE NOMINAL.
- MATERIAL FOR MANHOLE RINGS AND COVERS SHALL BE GRAY OR DUCTILE CAST IRON CONFORMING TO 712.06.
- SINCE PIPE ENTRIES INTO THE BASE ARE VARIABLE, THE DIMENSIONS SHOWN ARE TYPICAL ACTUAL DIMENSIONS AND QUANTITIES FOR CONCRETE AND REINFORCEMENT SHALL BE AS REQUIRED IN THE WORK. QUANTITIES INCLUDE VOLUMES OCCUPIED BY PIPES.
- STRUCTURAL STEEL SHALL BE GALVANIZED AND SHALL CONFORM TO THE REQUIREMENTS OF 712.06.

TABLE TWO ~ BARS AND QUANTITIES VARIABLE WITH "H"

H'	LENGTH	REGULAR INLETS				DROP BOX INLETS			
		NO. REQ'D.	LENGTH	NO. REQ'D.	LENGTH	NO. REQ'D.	LENGTH	NO. REQ'D.	LENGTH
3'-0"	2'-8"	10	7	3.4	305	5.3	528	7.9	747
3'-6"	3'-2"	10	7	3.4	305	5.7	528	7.9	747
4'-0"	3'-8"	12	9	3.7	326	6.0	559	8.4	786
4'-6"	4'-2"	12	9	3.9	334	6.4	571	8.8	803
5'-0"	4'-8"	14	11	4.1	354	6.7	602	9.3	844
5'-6"	5'-2"	16	13	4.4	375	6.0	607	7.4	850
6'-0"	5'-8"	16	13	4.6	382	6.2	616	7.6	860
6'-6"	6'-2"	18	15	4.8	402	6.4	637	7.8	880
7'-0"	6'-8"	20	17	5.0	423	6.6	654	8.0	897
7'-6"	7'-2"	20	17	5.3	430	6.9	664	8.3	907
8'-0"	7'-8"	22	19	5.5	451	7.1	684	8.5	927
8'-6"	8'-2"	24	21	5.7	471	7.3	702	8.7	944
9'-0"	8'-8"	24	21	6.0	479	7.6	711	9.0	954
9'-6"	9'-2"	26	23	6.2	499	7.8	732	9.2	974
10'-0"	9'-8"	28	25	6.4	520	8.0	749	9.4	992
10'-6"	10'-2"	28	25	6.7	527	8.3	759	9.7	1001
11'-0"	10'-8"	30	27	6.9	547	8.5	779	9.9	1022

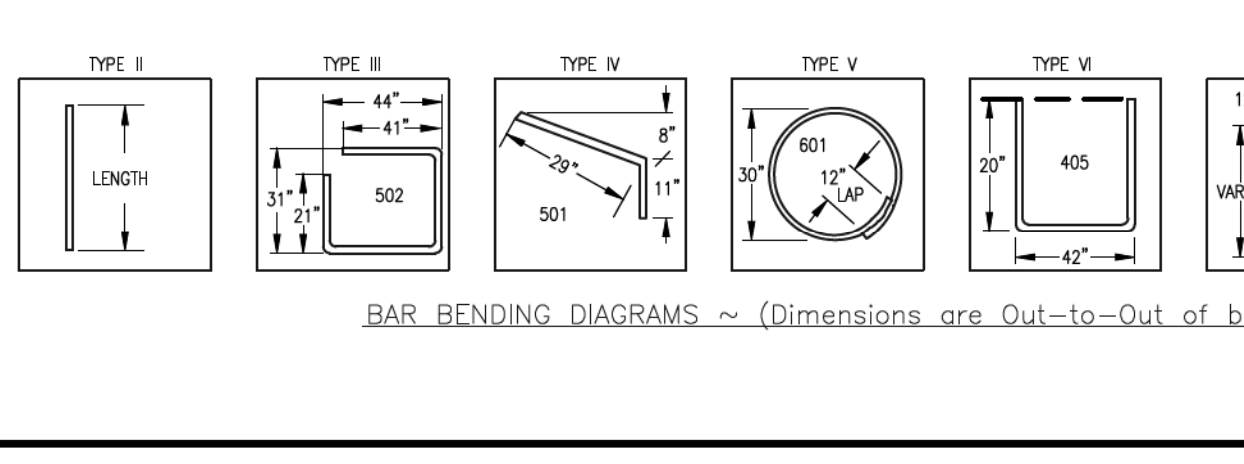
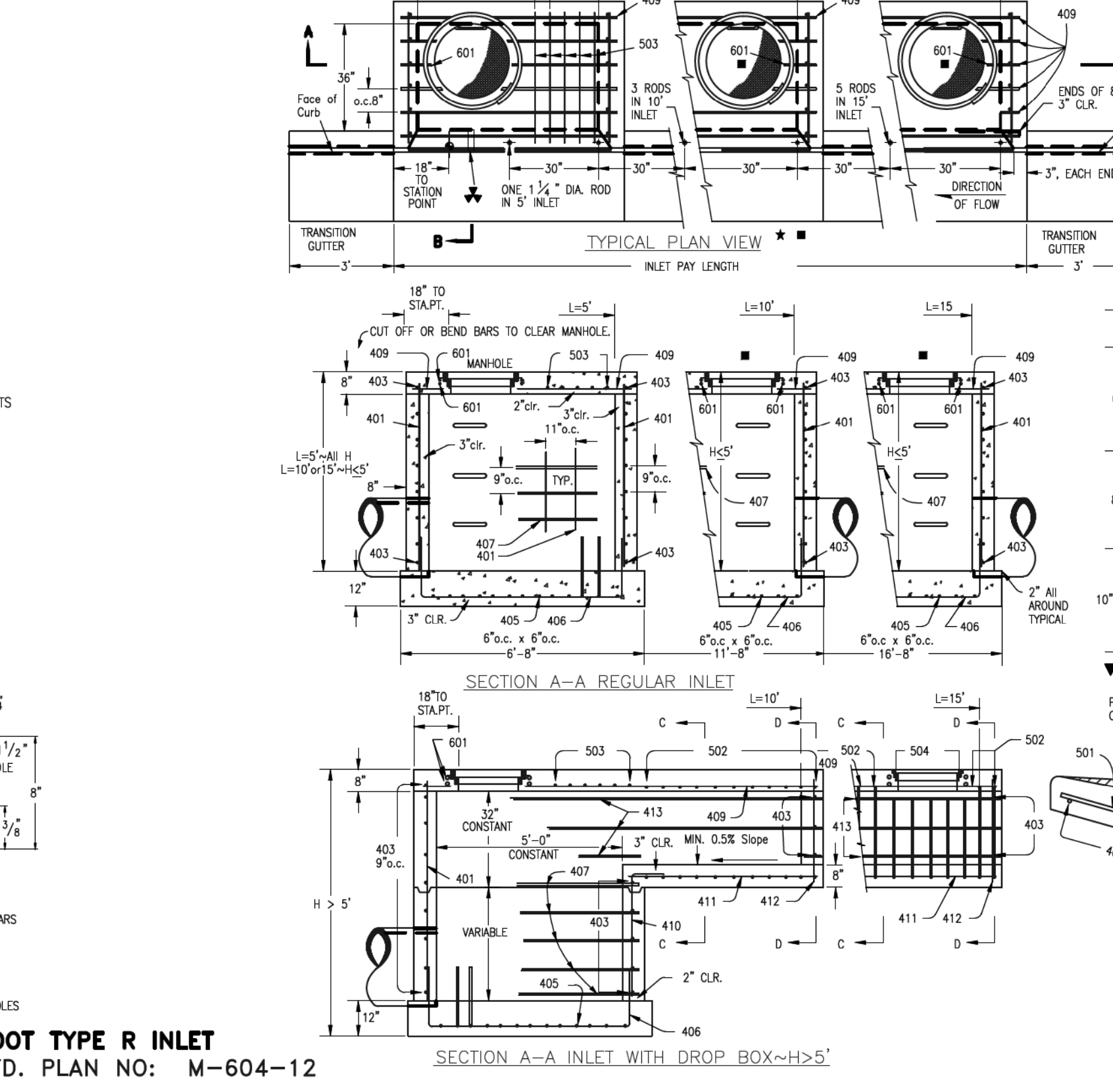
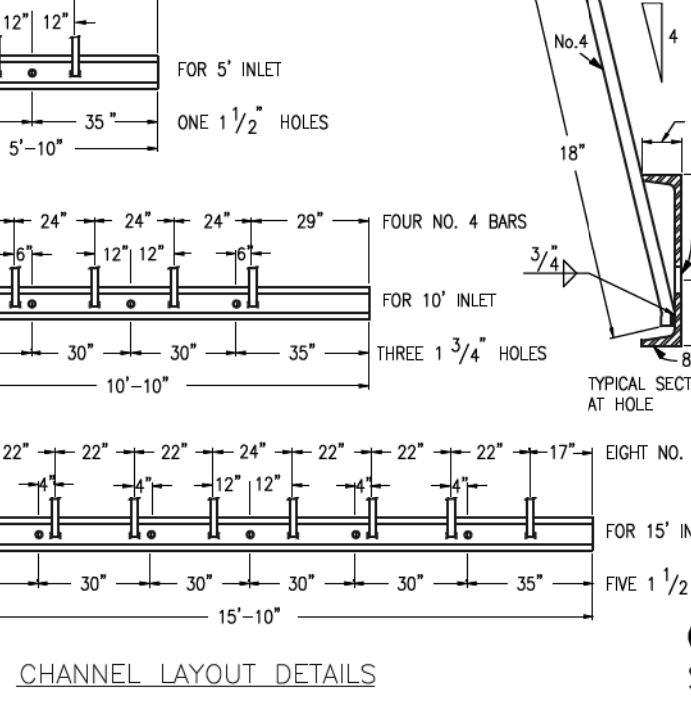
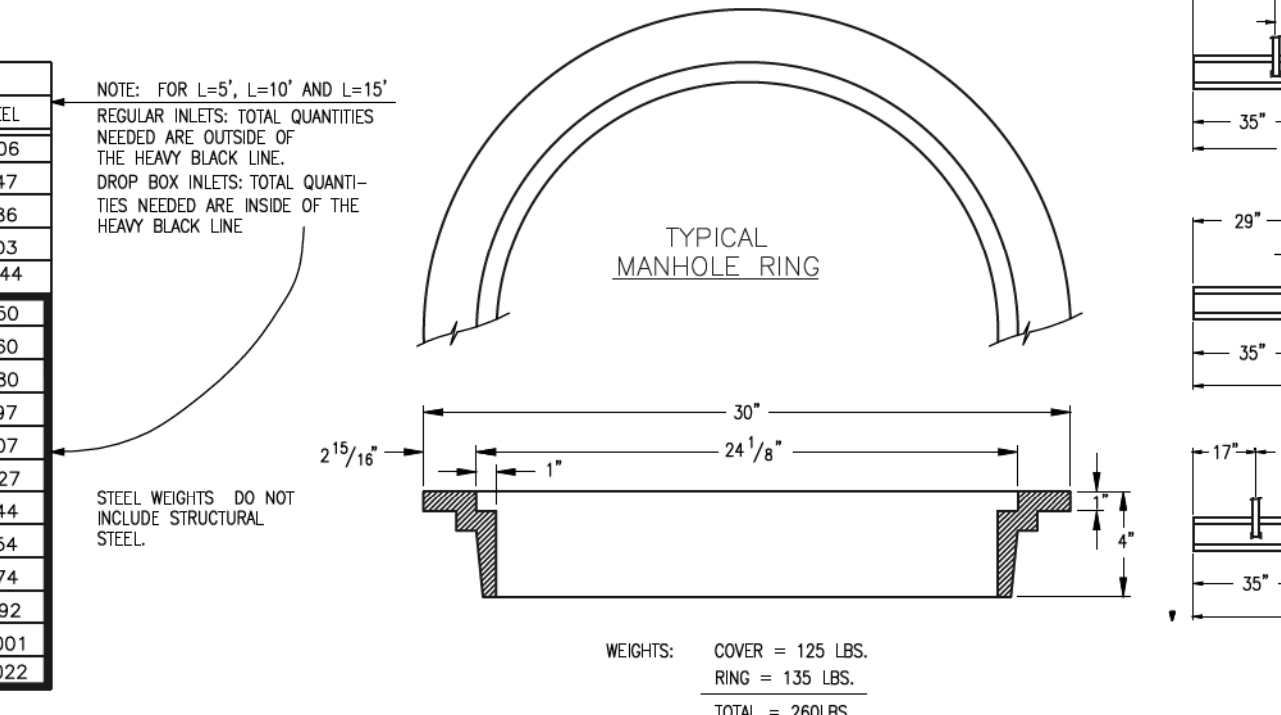

38 HOURS BEFORE YOU DIG, CALL UTILITY LOCATORS
811
UTILITY NOTIFICATION CENTER OF COLORADO
IT'S THE LAW

THE LOCATIONS OF EXISTING UNDERGROUND UTILITIES ARE SHOWN IN AN APPROXIMATE WAY ONLY. THE CONTRACTOR SHALL DETERMINE THE EXACT LOCATION OF ALL EXISTING UTILITIES BEFORE COMMENCING WORK. THE CONTRACTOR SHALL BE FULLY RESPONSIBLE FOR ANY AND ALL DAMAGES WHICH MIGHT BE CAUSED BY HIS FAILURE TO EXACTLY LOCATE AND PRESERVE ANY AND ALL UNDERGROUND UTILITIES.

NO. REVISION	DATE

REVIEW: PREPARED UNDER MY DIRECT SUPERVISION FOR AND ON BEHALF OF CLASSIC CONSULTING ENGINEERS AND SURVEYORS, LLC

MARC A. WHORTON, COLORADO P.E. #37155

6/10/2020

RETREAT AT TIMBERIDGE FILING NO. 1
CONSTRUCTION PLANS
DETAIL SHEET

DESIGNED BY MAW SCALE DATE 04-05-19
DRAWN BY MAW (H) 1"= NA SHEET 35 OF 35
CHECKED BY (V) 1"= NA JOB NO. 1185.00

CLASSIC CONSULTING

619 N. Cascade Avenue, Suite 200
Colorado Springs, Colorado 80903
(719)785-0790
(719)785-0799(fax)

CONTECH ENGINEERED SOLUTIONS, LLC DESIGN OF CONCRETE SPREAD FOOTINGS, CONCRETE HEADWALLS AND WINGWALLS FOR A TWIN 24'X10'-4" MULTI-PLATE ARCH STRUCTURE (617696); RETREAT AT TIMBER RIDGE, EL PASO, COLORADO

INDEX	
1.	TITLE SHEET/INDEX
2.	PLAN, PROFILE & FOOTINGS
3.	ELEVATION VIEWS AND WINGWALL SECTION
4.	DOWNSTREAM HEADWALL DETAILS
5.	DOWNSTREAM SECTIONS AND DETAILS
6.	UPSTREAM HEADWALL DETAILS
7.	UPSTREAM SECTIONS AND DETAILS
8.	SPECIFICATIONS



NOTE:
 1.) CONCRETE SHALL BE $f'_c = 3,500$ psi.
 2.) ALL REINFORCEMENT SHALL BE ASTM A-615, GRADE 60.
 3.) FOOTING IS DESIGNED FOR A 3,500 psf ALLOWABLE BEARING CAPACITY. THIS VALUE MUST BE FIELD VERIFIED PRIOR TO CONSTRUCTION.
 4.) SCOUR IS NOT ADDRESSED HEREIN AND IS THE RESPONSIBILITY OF OTHERS THAN CBC ENGINEERS.

CBC Engineers			
TITLE SHEET / INDEX			
<small>Drawn By</small>	JBE	<small>Date</small>	03/20/20
<small>Approved By</small>		<small>Date</small>	
CONTECH ENGINEERED SOLUTIONS, LLC DESIGN OF CONCRETE SPREAD FOOTINGS, CONCRETE HEADWALLS AND WINGWALLS FOR A TWIN 24'X10'-4" MULTI-PLATE ARCH STRUCTURE (617696); RETREAT AT TIMBER RIDGE, EL PASO, COLORADO			
<small>Scale</small>	GRAPHIC	<small>Project No.</small>	CBC-23088
		<small>Rev.</small>	-
		<small>Sheet</small>	1 OF 8

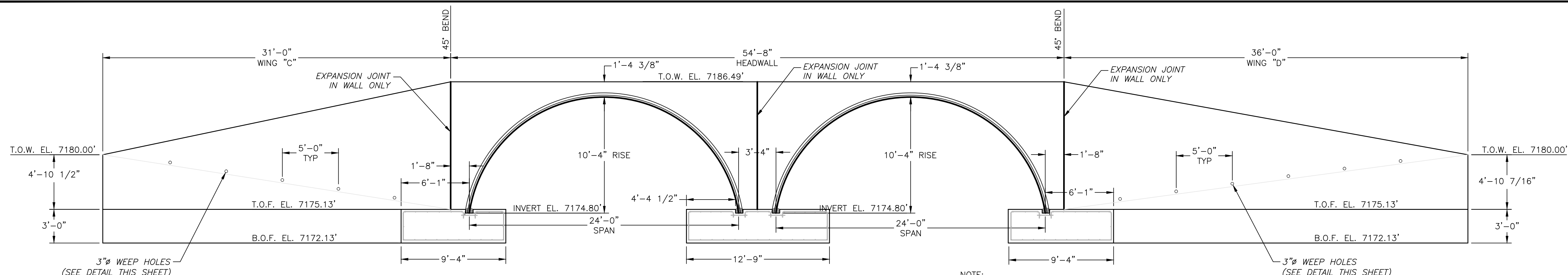

ELEVATION VIEW (DOWNSTREAM)

NOTE: WINGWALLS ARE ROTATED FOR CLARITY SEE PLAN VIEW FOR EXACT LOCATIONS

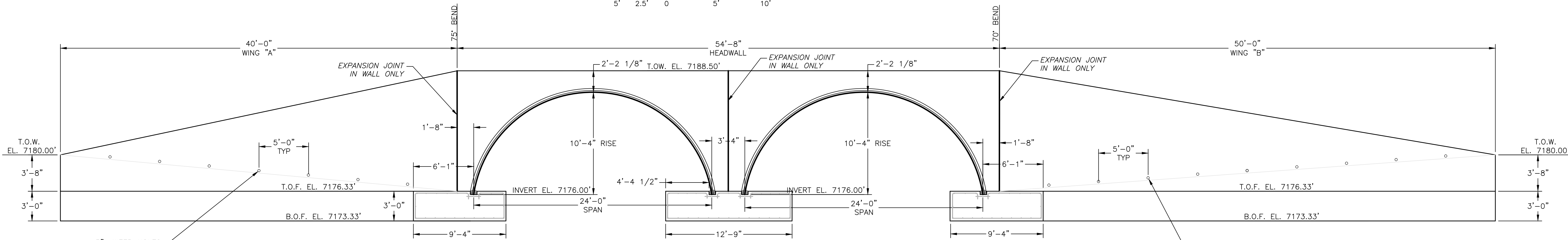

ELEVATION VIEW (UPSTREAM)

NOTE: WINGWALLS ARE ROTATED FOR CLARITY SEE PLAN VIEW FOR EXACT LOCATIONS

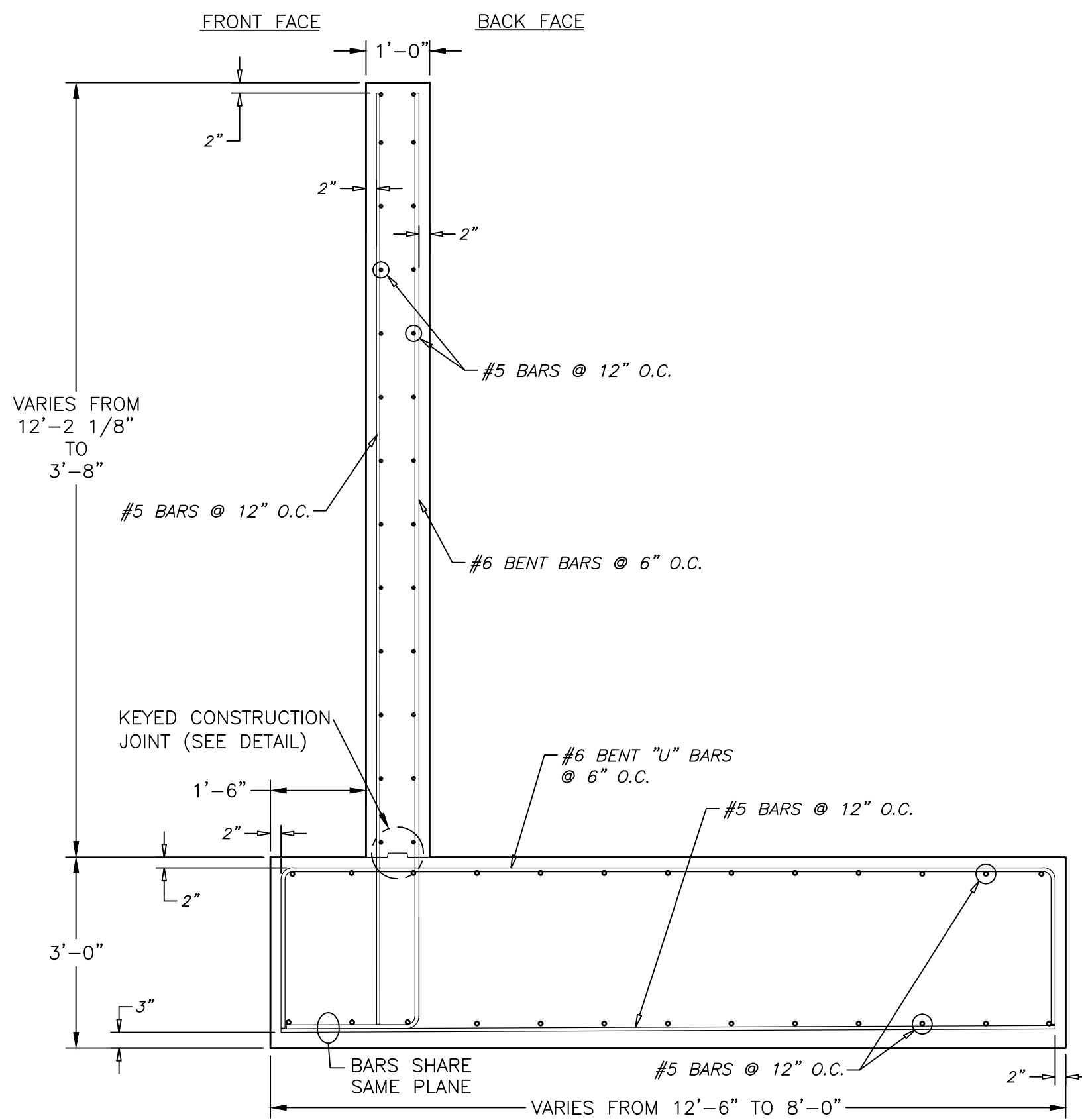

TYPICAL WINGWALL SECTION

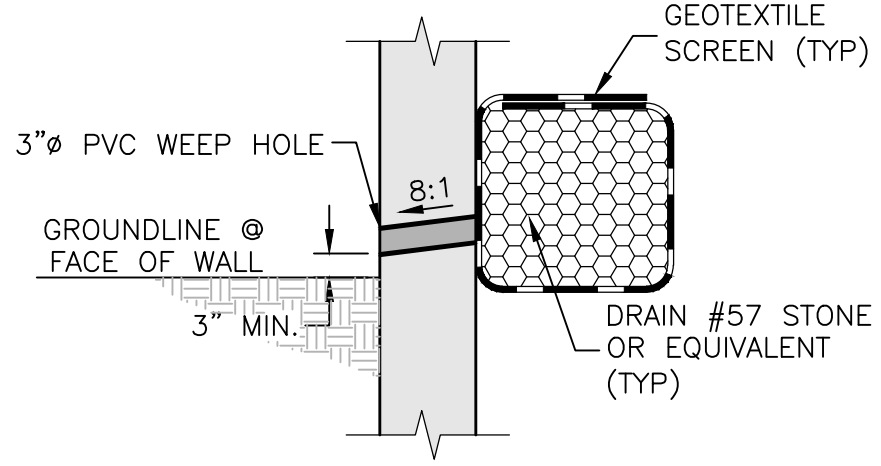

WEEP HOLE DETAIL
NOT TO SCALE

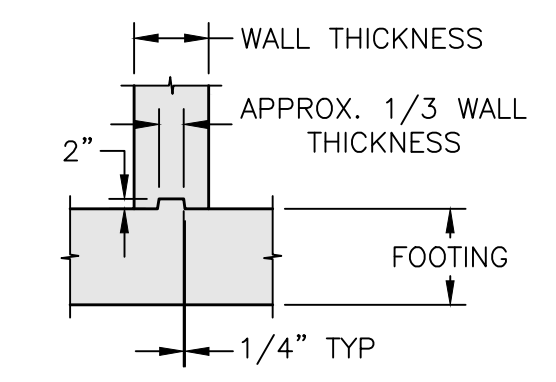

KEYED CONSTRUCTION JOINT DETAIL
NOT TO SCALE

- NOTE:
- 1.) CONCRETE SHALL BE $f'c = 3,500$ psi.
 - 2.) ALL REINFORCEMENT SHALL BE ASTM A-615, GRADE 60.
 - 3.) FOOTING IS DESIGNED FOR A 3,500 psf ALLOWABLE BEARING CAPACITY. THIS VALUE MUST BE FIELD VERIFIED PRIOR TO CONSTRUCTION.
 - 4.) SCOUR IS NOT ADDRESSED HEREIN AND IS THE RESPONSIBILITY OF OTHERS THAN CBC ENGINEERS.

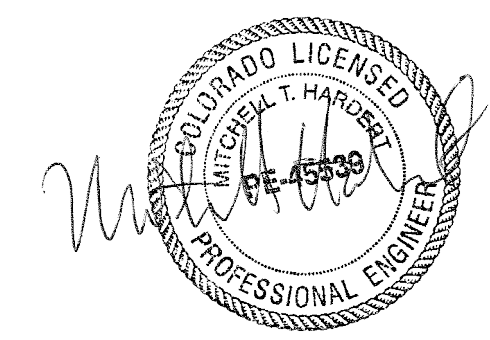

CBC Engineers			
ELEVATION VIEWS AND WINGWALL SECTION			
Drawn By JBE	Date 03/20/20	CONTECH ENGINEERED SOLUTIONS, LLC DESIGN OF CONCRETE SPREAD FOOTINGS, CONCRETE HEADWALLS AND WINGWALLS FOR A TWIN 24'x10'-4" MULTI-PLATE ARCH STRUCTURE (617696); RETREAT AT TIMBER RIDGE, EL PASO, COLORADO	
Approved By	Date	Project No. CBC-23088	Rev. Sheet - 3 OF 8
Scale GRAPHIC			

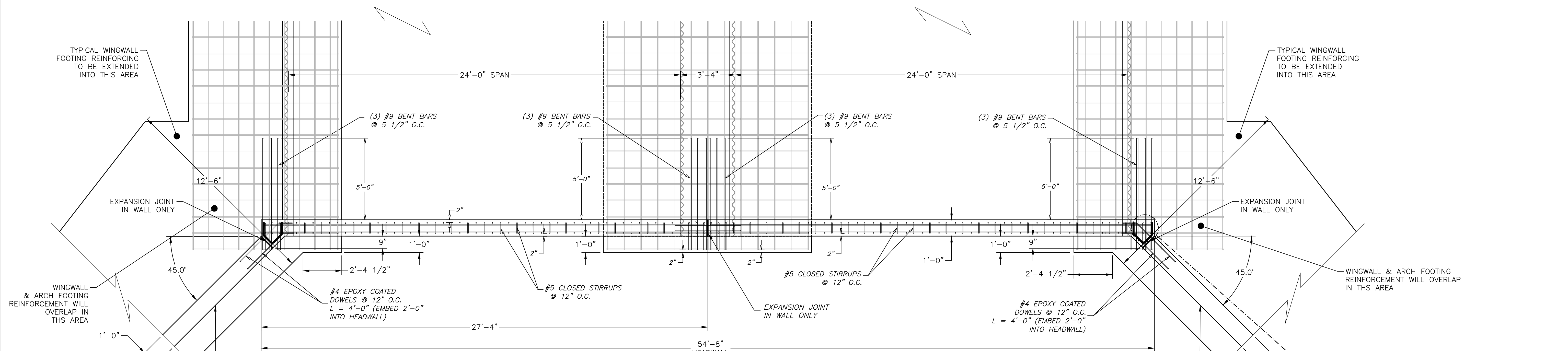

PLAN VIEW

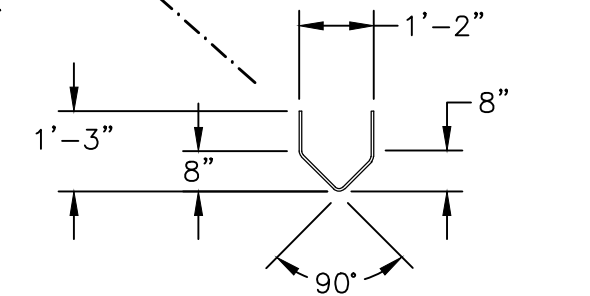

#4 STIRRUPS

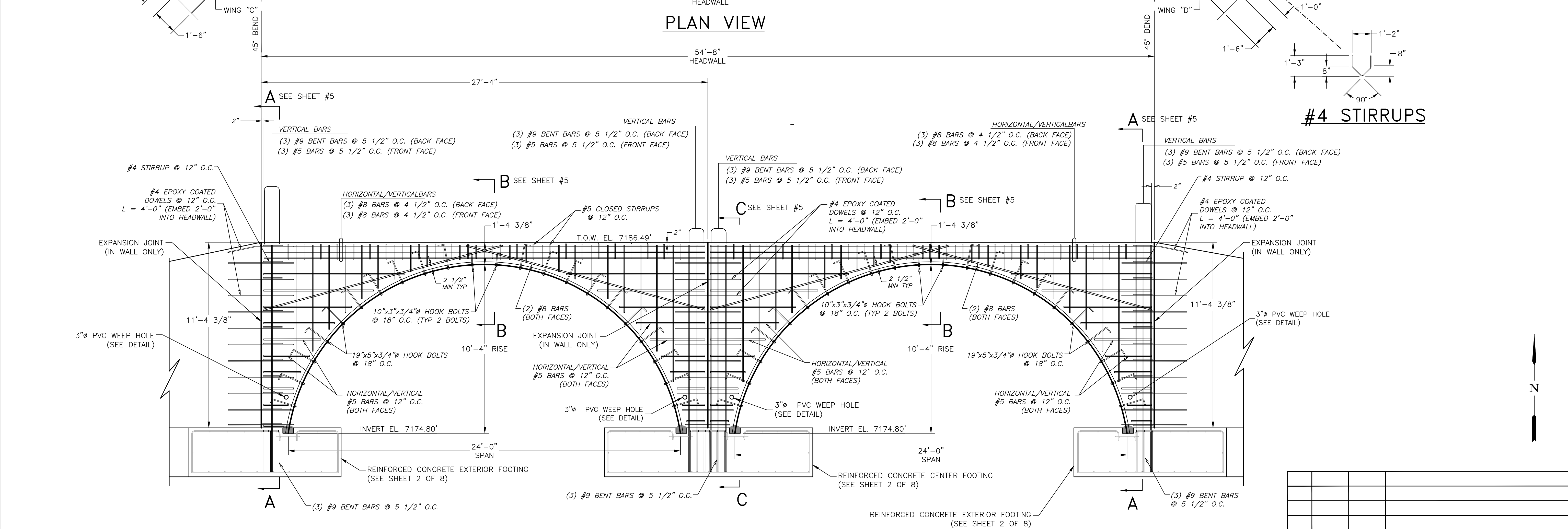

ELEVATION VIEW

DOWNSTREAM HEADWALL DETAILS



- NOTE:
- 1.) CONCRETE SHALL BE $f'_c = 3,500$ psi.
 - 2.) ALL REINFORCEMENT SHALL BE ASTM A-615, GRADE 60.
 - 3.) FOOTING IS DESIGNED FOR A 3,500 psf ALLOWABLE BEARING CAPACITY. THIS VALUE MUST BE FIELD VERIFIED PRIOR TO CONSTRUCTION.
 - 4.) SCOUR IS NOT ADDRESSED HEREIN AND IS THE RESPONSIBILITY OF OTHERS THAN CBC ENGINEERS.

		DOWNSTREAM HEADWALL DETAILS	
Drawn By JBE	Date 03/20/20	Project No. CBC-23088	Rev. -
Scale GRAPHIC	Sheet 4 OF 8		

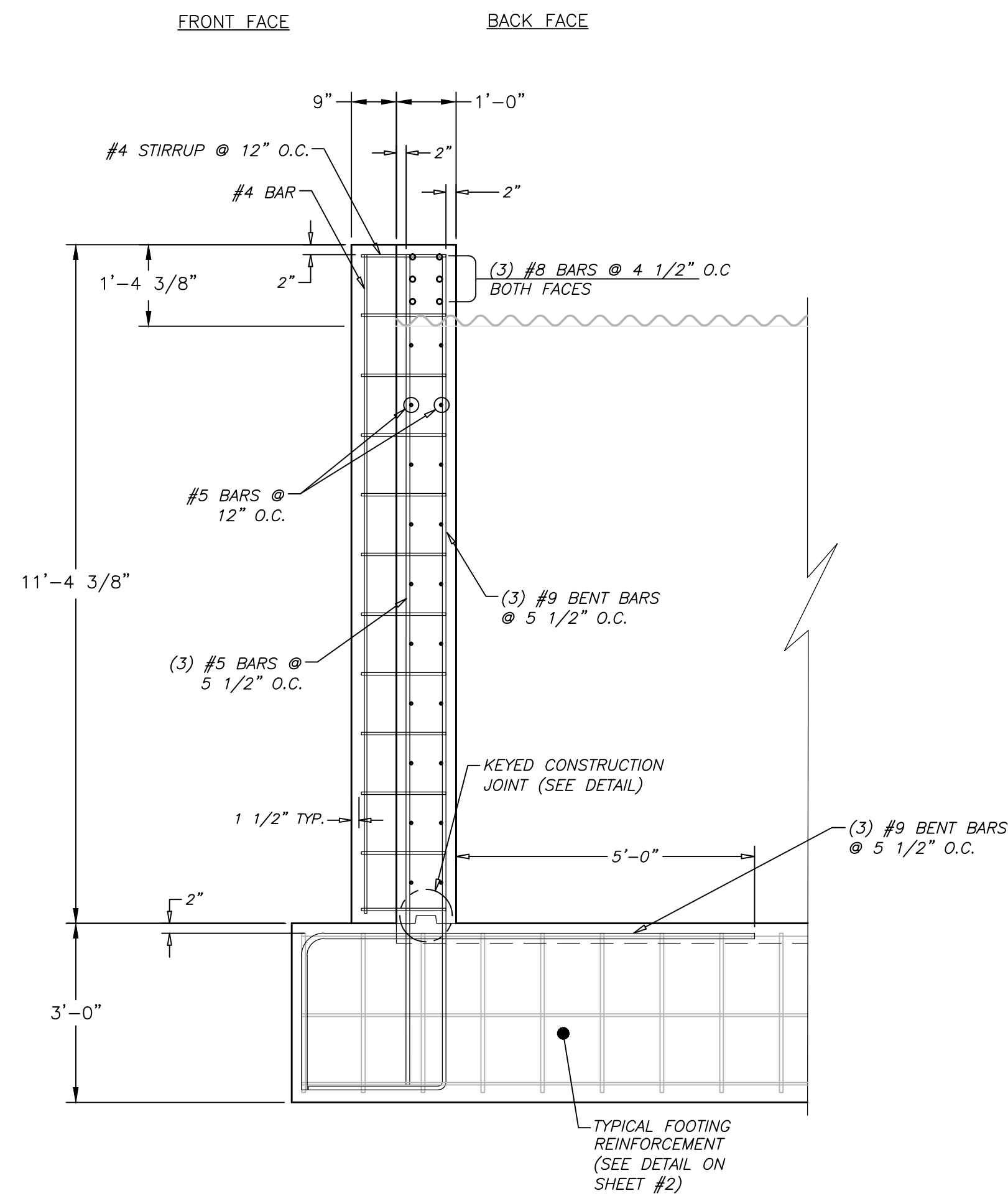

SECTION A-A

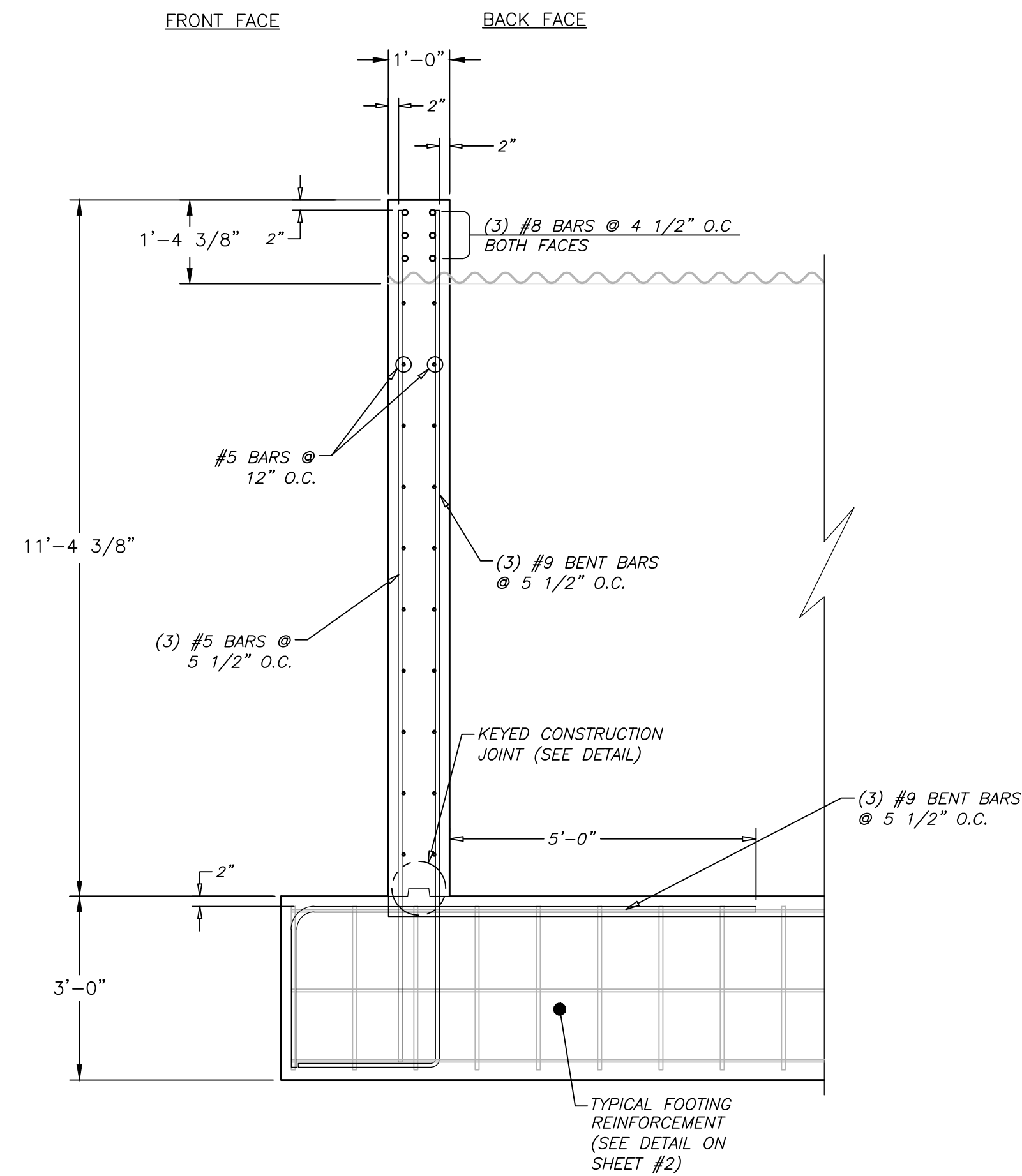

SECTION C-C

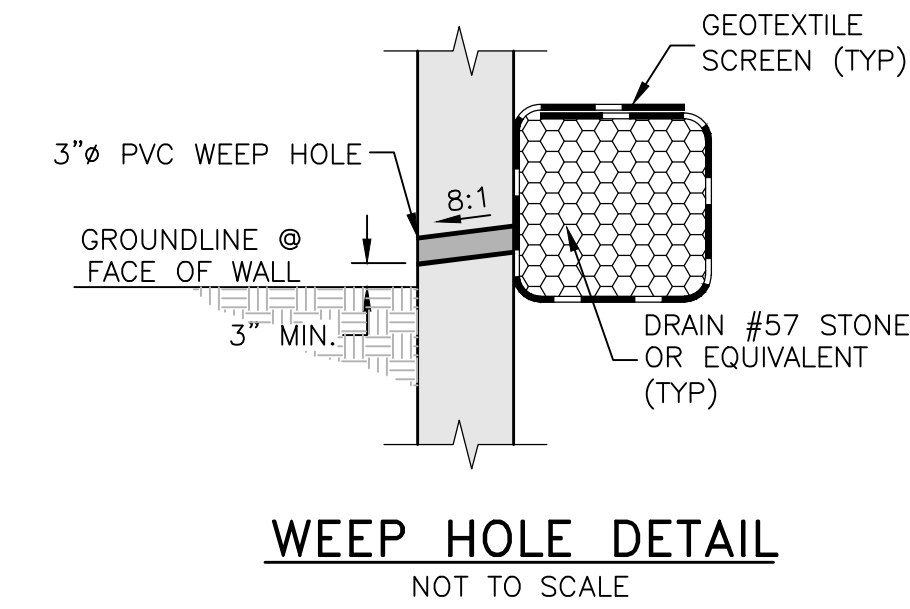

WEEP HOLE DETAIL
NOT TO SCALE

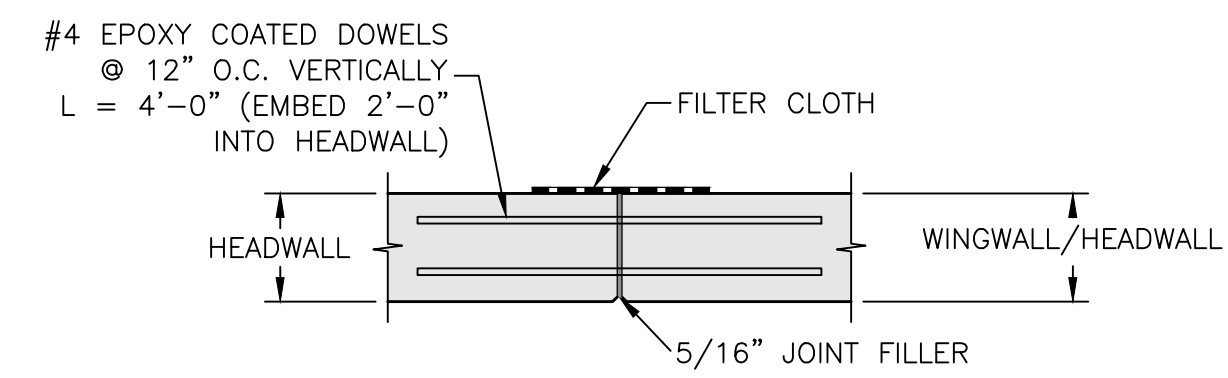

EXPANSION JOINT DETAIL
NOT TO SCALE

NOTES FOR EXPANSION JOINT:
A FILTER CLOTH THREE FEET IN WIDTH AND DOUBLE THICKNESS SHALL BE APPLIED TO ALL TRANSVERSE JOINTS IN THE FOOTING AND WALLS. THE MATERIAL SHALL BE CENTERED ON THE JOINT AND THE EDGES SEALED WITH A MASTIC OR WITH TWO SIDED TAPE. THE FILTER CLOTH SHALL BE A GEOTEXTILE MEETING THE APPROVAL OF THE ENGINEER.

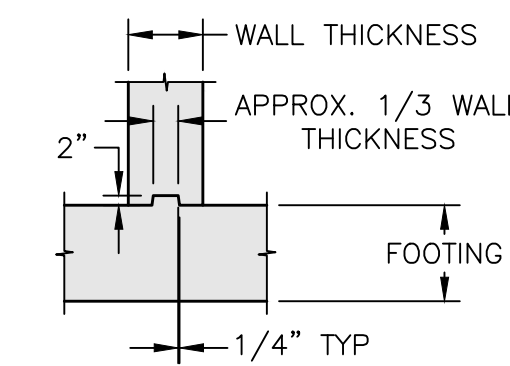

KEYED CONSTRUCTION
JOINT DETAIL
NOT TO SCALE

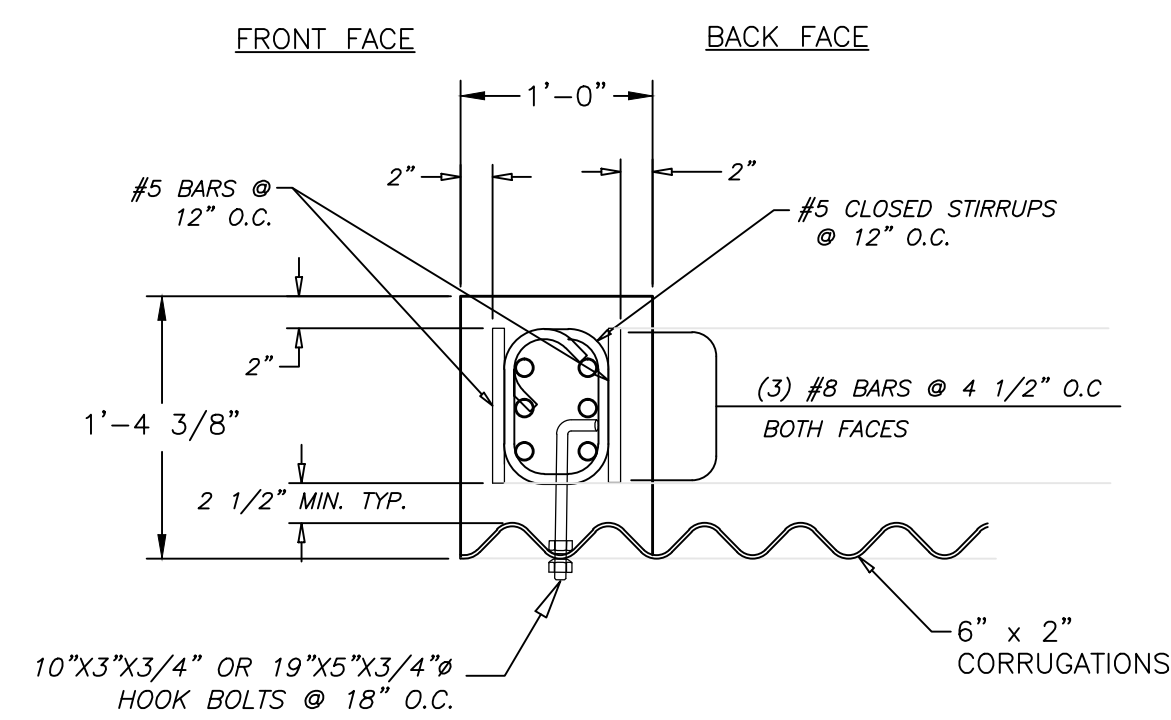

SECTION B-B

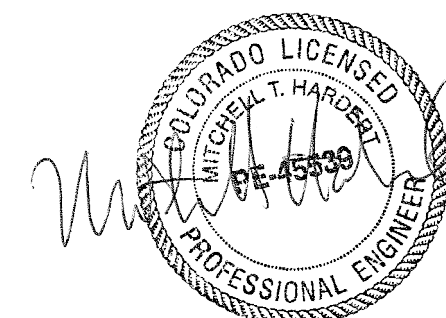

- NOTE:
- 1.) CONCRETE SHALL BE $f'c = 3,500$ psi.
 - 2.) ALL REINFORCEMENT SHALL BE ASTM A-615, GRADE 60.
 - 3.) FOOTING IS DESIGNED FOR A 4,000 psf LFRD FACTORED BEARING CAPACITY. THIS VALUE MUST BE FIELD VERIFIED PRIOR TO CONSTRUCTION.
 - 4.) SCOUR IS NOT ADDRESSED HEREIN AND IS THE RESPONSIBILITY OF OTHERS THAN CBC ENGINEERS.

DOWNSTREAM SECTIONS AND DETAILS			
Drawn By JBE	Date 03/20/20	CONTECH ENGINEERED SOLUTIONS, LLC DESIGN OF CONCRETE SPREAD FOOTINGS, CONCRETE HEADWALLS AND WINGWALLS FOR A TWIN 24'x10'-4" MULTI-PLATE ARCH STRUCTURE (617696); RETREAT AT TIMBER RIDGE, EL PASO, COLORADO	
Approved By	Date	Project No. CBC-23088	Rev. - Sheet 5 OF 8
Scale GRAPHIC			

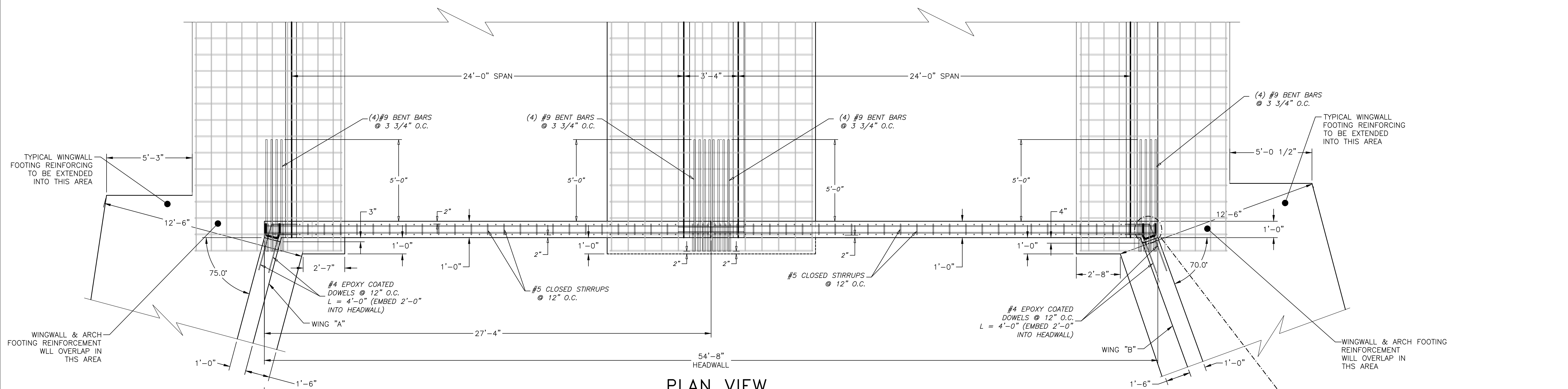

PLAN VIEW

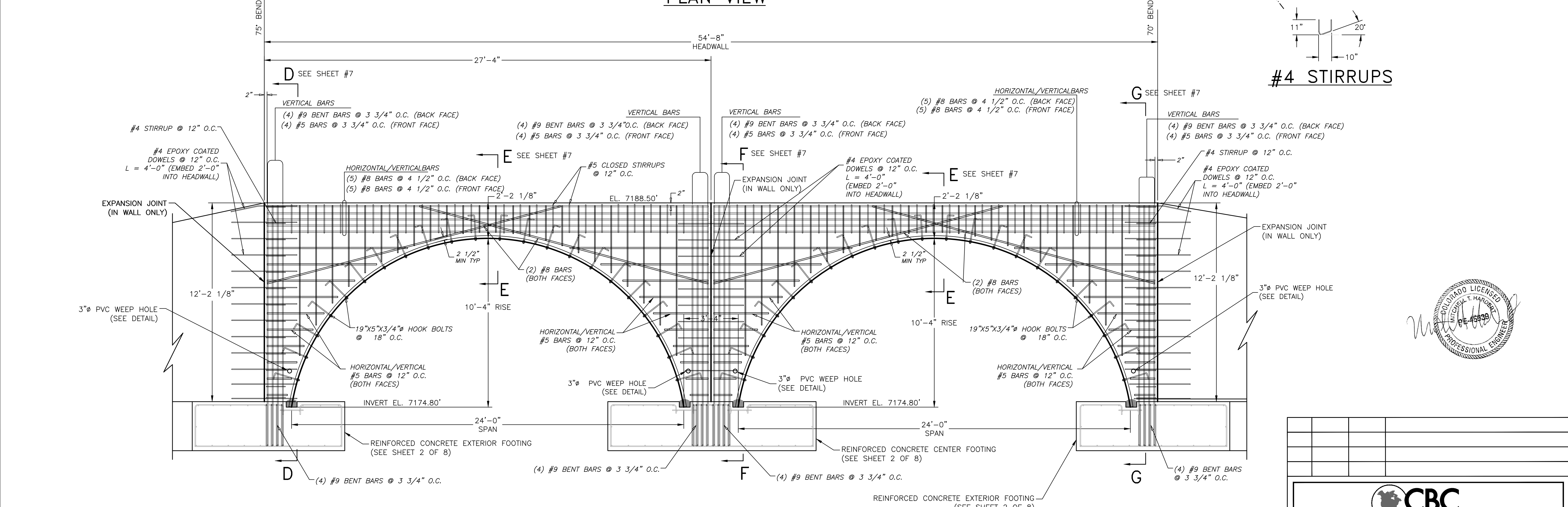

ELEVATION VIEW

DOWNSTREAM HEADWALL DETAILS



- NOTE:
- 1.) CONCRETE SHALL BE $f'c = 3,500$ psi.
 - 2.) ALL REINFORCEMENT SHALL BE ASTM A-615, GRADE 60.
 - 3.) FOOTING IS DESIGNED FOR A 4,000 psf LFRD FACTORED BEARING CAPACITY. THIS VALUE MUST BE FIELD VERIFIED PRIOR TO CONSTRUCTION.
 - 4.) SCOUR IS NOT ADDRESSED HEREIN AND IS THE RESPONSIBILITY OF OTHERS THAN CBC ENGINEERS.



CBC Engineers			
UPSTREAM HEADWALL DETAILS			
Drawn By JBE	Date 03/20/20	CONTECH ENGINEERED SOLUTIONS, LLC DESIGN OF CONCRETE SPREAD FOOTINGS, CONCRETE HEADWALLS AND WINGWALLS FOR A TWIN 24'x10'-4" MULTI-PLATE ARCH STRUCTURE (617696); RETREAT AT TIMBER RIDGE, EL PASO, COLORADO	
Approved By	Date	Project No. CBC-23088	Rev. Sheet 6 OF 8
Scale GRAPHIC			

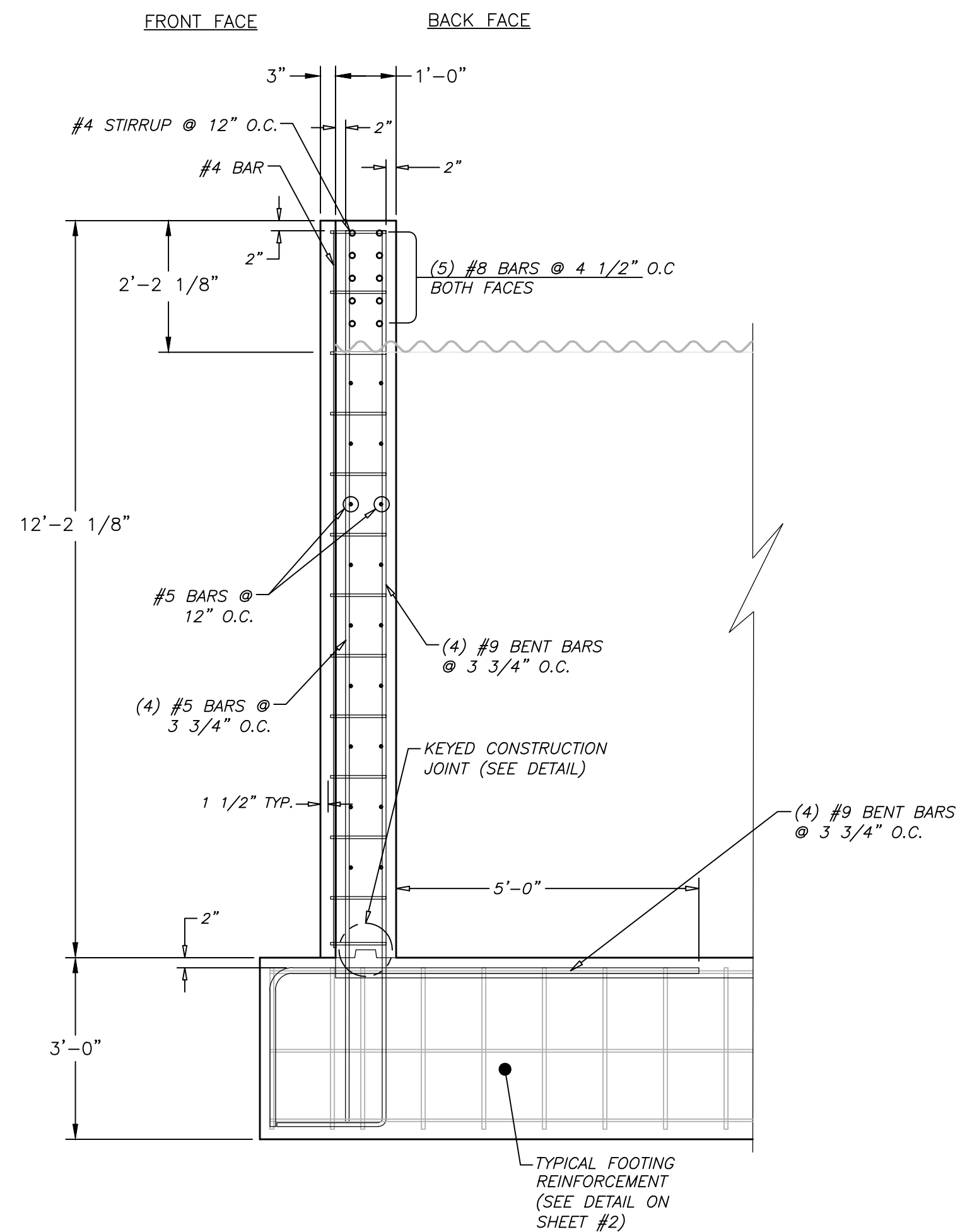

SECTION D-D

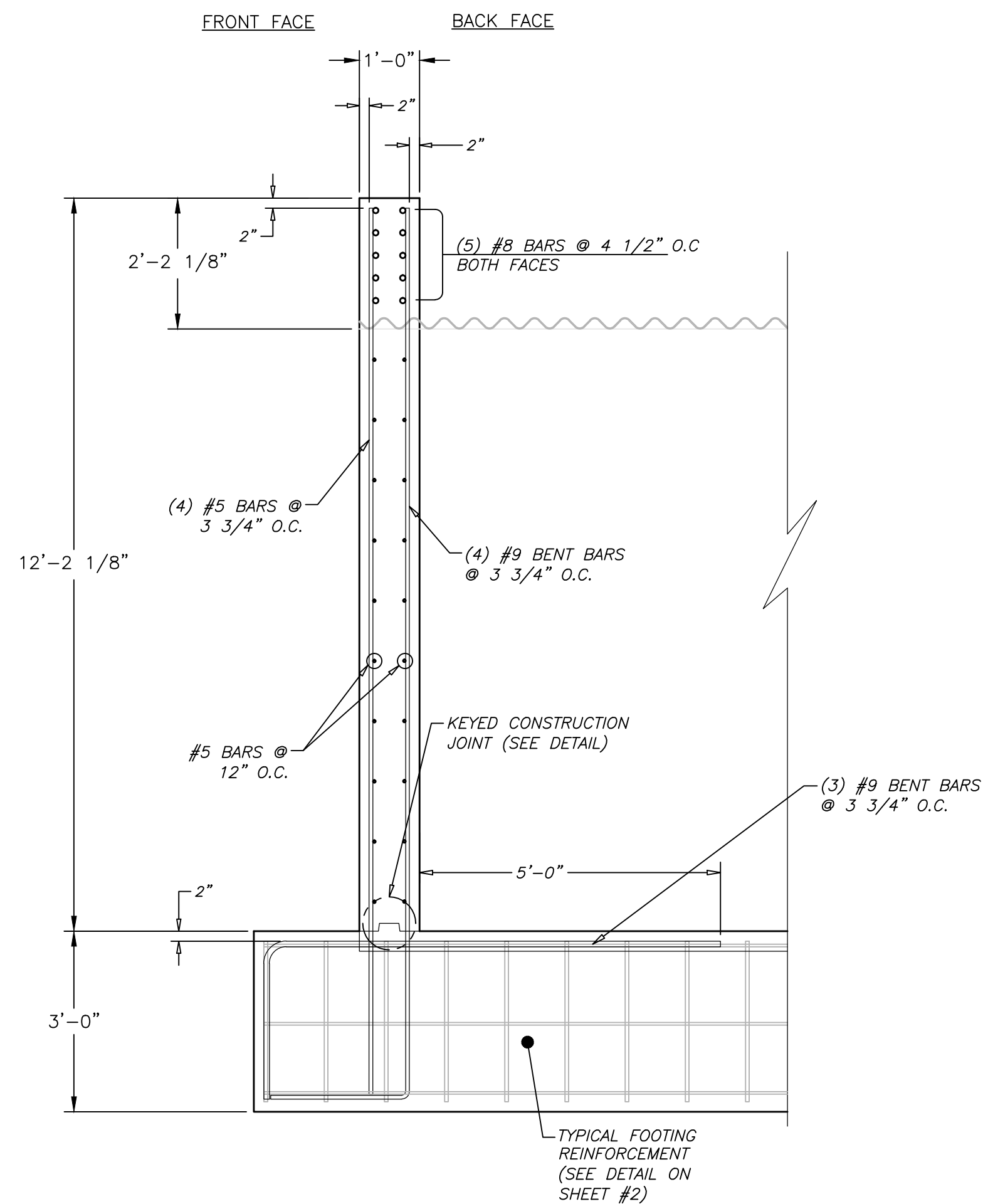

SECTION F-F

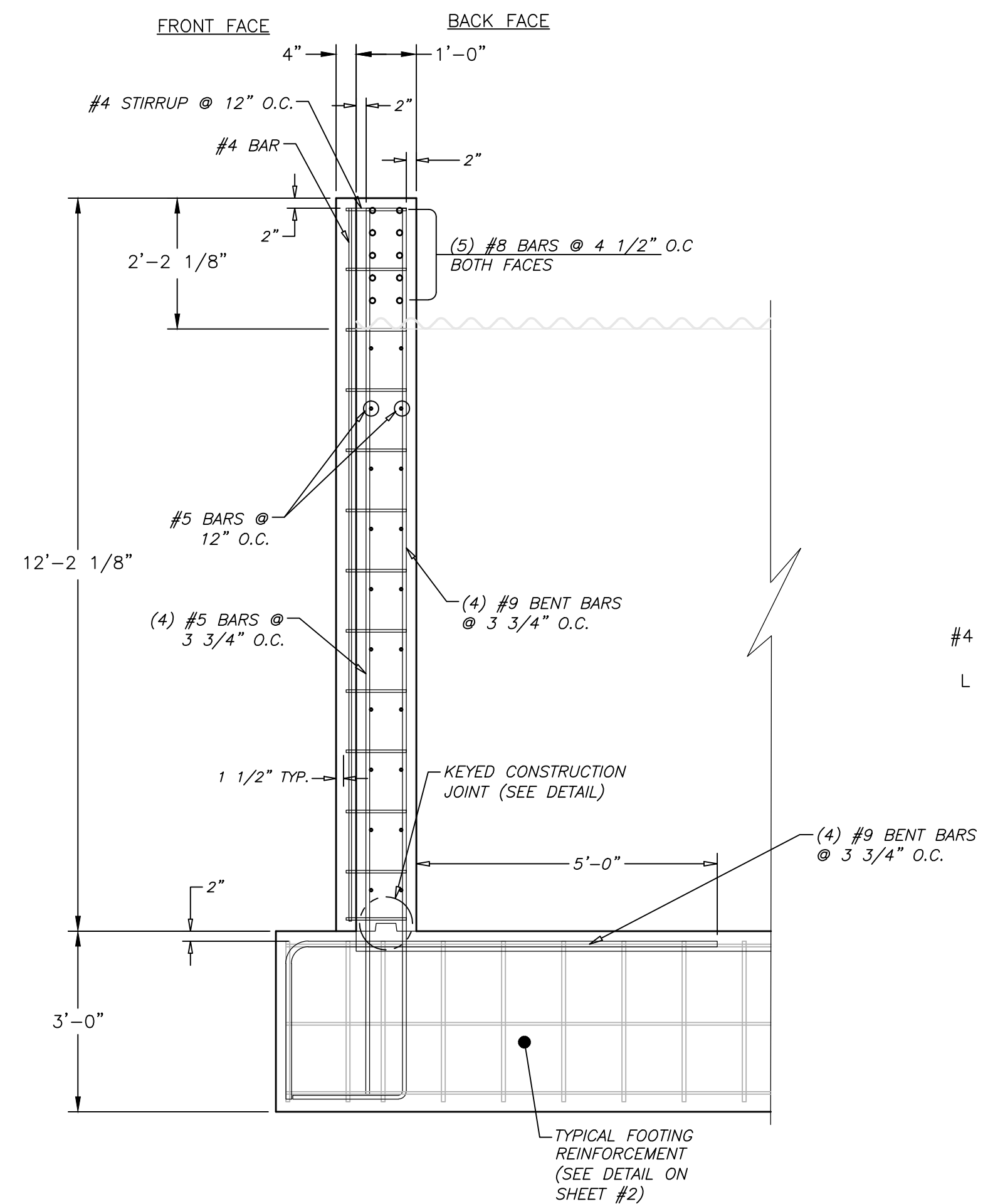

SECTION G-G

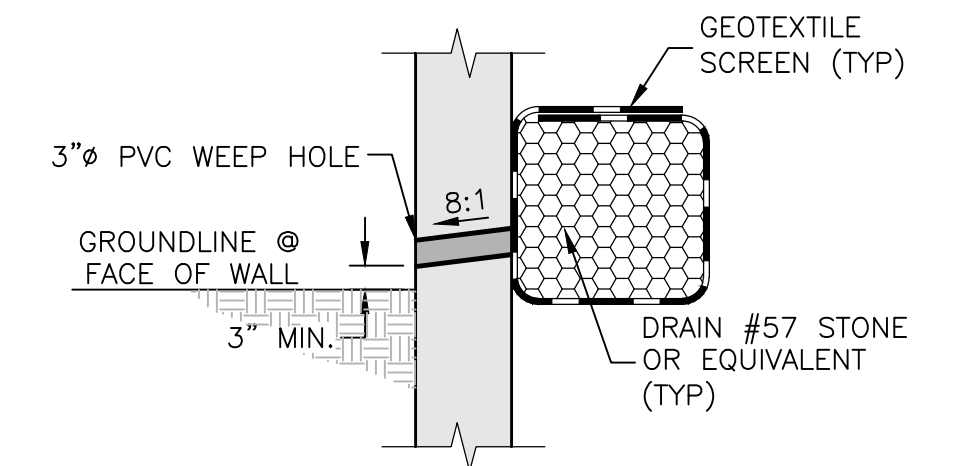
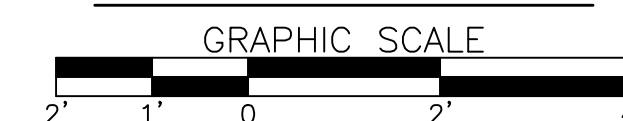

WEEP HOLE DETAIL
NOT TO SCALE

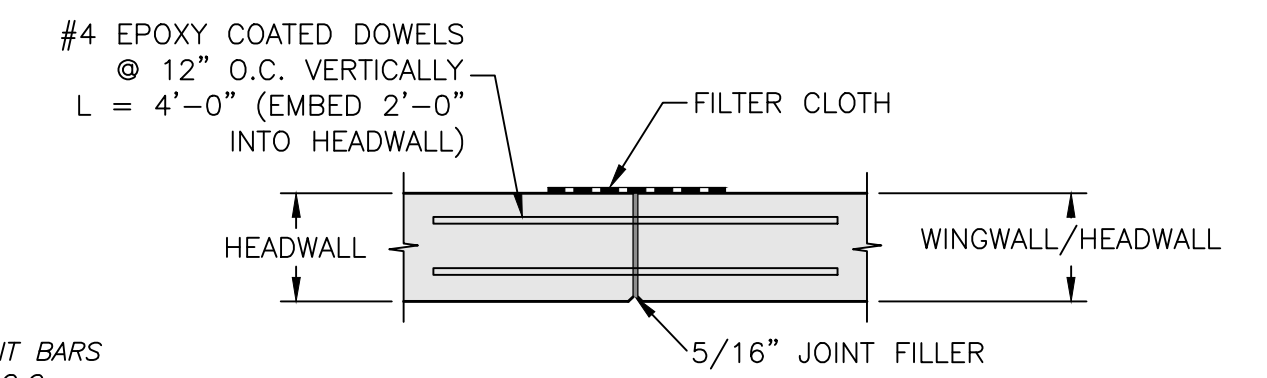

EXPANSION JOINT DETAIL
NOT TO SCALE

NOTES FOR EXPANSION JOINT:
A FILTER CLOTH THREE FEET IN WIDTH AND DOUBLE THICKNESS SHALL BE APPLIED TO ALL TRANSVERSE JOINTS IN THE FOOTING AND WALLS. THE MATERIAL SHALL BE CENTERED ON THE JOINT AND THE EDGES SEALED WITH A MASTIC OR WITH TWO SIDED TAPE. THE FILTER CLOTH SHALL BE A GEOTEXTILE MEETING THE APPROVAL OF THE ENGINEER.

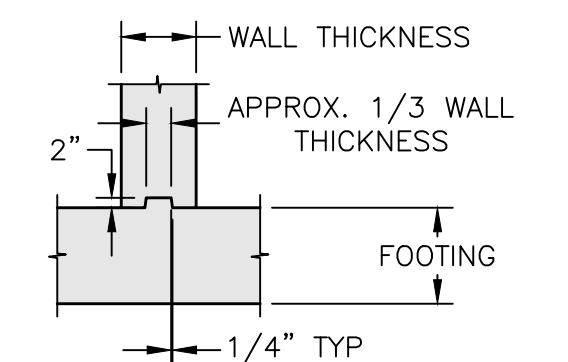

KEYED CONSTRUCTION JOINT DETAIL
NOT TO SCALE

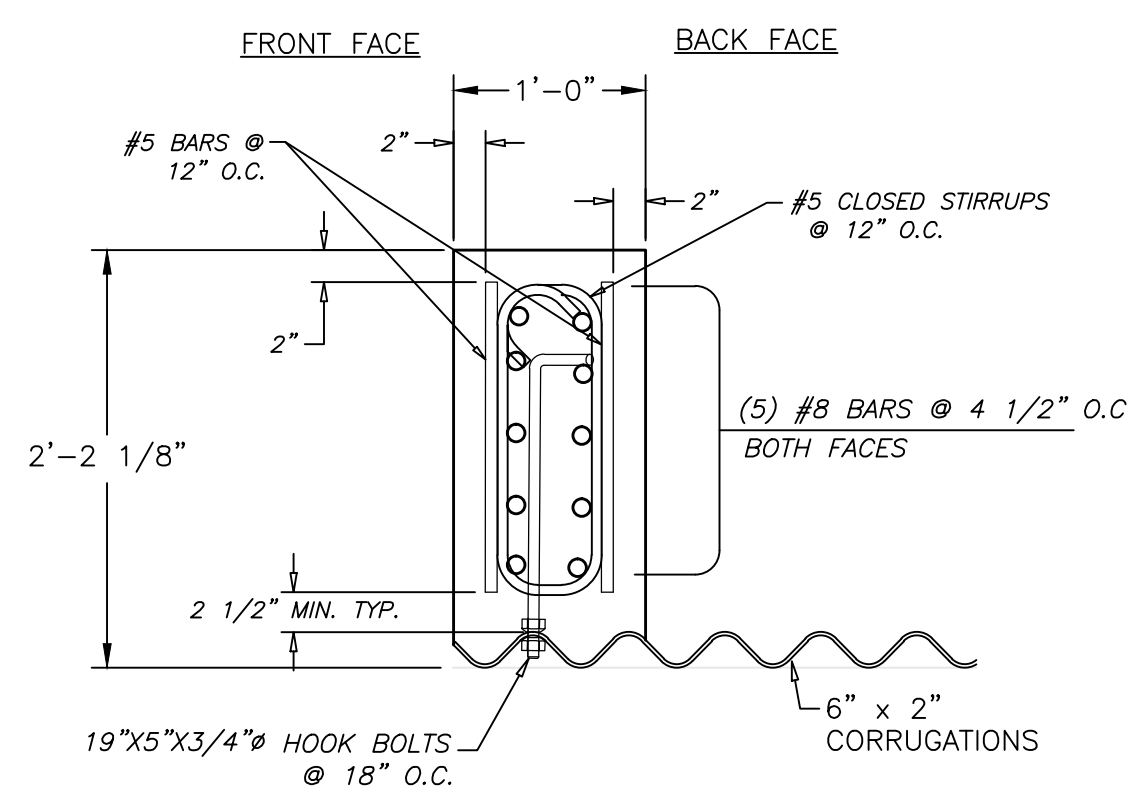

SECTION E-E

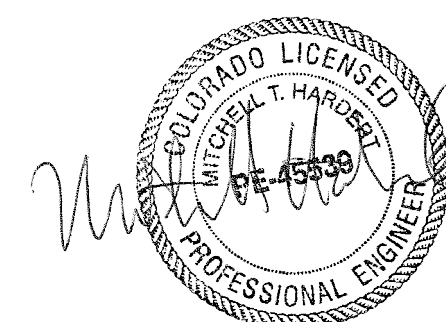

- NOTE:
- 1.) CONCRETE SHALL BE $f'c = 3,500$ psi.
 - 2.) ALL REINFORCEMENT SHALL BE ASTM A-615, GRADE 60.
 - 3.) FOOTING IS DESIGNED FOR A 4,000 psf LFRD FACTORED BEARING CAPACITY. THIS VALUE MUST BE FIELD VERIFIED PRIOR TO CONSTRUCTION.
 - 4.) SCOUR IS NOT ADDRESSED HEREIN AND IS THE RESPONSIBILITY OF OTHERS THAN CBC ENGINEERS.

CBC Engineers			
UPSTREAM SECTIONS AND DETAILS			
Drawn By	Date	CONTECH ENGINEERED SOLUTIONS, LLC DESIGN OF CONCRETE SPREAD FOOTINGS, CONCRETE HEADWALLS AND WINGWALLS FOR A TWIN 24'x10'-4" MULTI-PLATE ARCH STRUCTURE (617696); RETREAT AT TIMBER RIDGE, EL PASO, COLORADO	
JBE	03/20/20	Project No.	Rev.
Approved By	Date	CBC-23088	-
Scale	Project No.	Rev.	Sheet
GRAPHIC	CBC-23088	-	7 OF 8

I – GENERAL

1.0 STANDARDS AND DEFINITIONS

1.1 STANDARDS - All standards refer to latest edition unless otherwise noted.

- 1.1.1 ASTM D-698-70 (Method C) "Standard Test Methods for Moisture, Density Relations of Soils and Soil Aggregate Mixtures Using 5.5-lb (2.5 kg.) Rammer and 12-inch (305-mm) Drop".
- 1.1.2 ASTM D-2922 "Standard Test Method for Density of Soil and Soil Aggregate in Place by Nuclear methods (Shallow Depth)".
- 1.1.3 ASTM D-1556 "Standard Test Method for Density of Soil in place by the Sand-Cone Method".
- 1.1.4 ASTM D-1557 "Standard Test Method for Laboratory Compaction Characteristics of Soil Using Modified Effort."
- 1.1.5 All construction and materials shall be in accordance with the latest AASHTO LRFD Bridge Design Specifications.

1.2 DEFINITIONS

- 1.2.1 Owner - In these specifications the word "Owner" shall mean Elite Properties of America, LLC.
- 1.2.2 Engineer - In these specifications the word "Engineer" shall mean the Owner designated engineer.
- 1.2.3 Design Engineer - In these specifications the words "Design Engineer" shall mean CBC Engineers and Associates, Ltd.
- 1.2.4 Contractor - In these specifications the word "Contractor" shall mean the firm or corporation undertaking the execution of any work under the terms of these specifications.
- 1.2.5 Approved - In these specifications the word "approved" shall refer to the approval of the Engineer or his designated representative.
- 1.2.6 As Directed - In these specifications the words "as directed" shall refer to the directions to the Contractor from the Owner or his designated representative.

2.0 GENERAL CONDITIONS

2.1 The Contractor shall furnish all labor, material and equipment and perform all work and services except those set out and furnished by the Owner, necessary to complete in a satisfactory manner the site preparation, excavation, filling, compaction, grading, footing construction, headwall/wingwall construction as shown on the plans and as described therein.

This work shall consist of all mobilization clearing and grading, grubbing, stripping, removal of existing material unless otherwise stated, preparation of the land to be filled, filling of the land, spreading and compaction of the fill, and all subsidiary work necessary to complete the grading of the cut and fill areas to conform with the lines, grades, slopes, and specifications.

This work is to be accomplished under the observation of the Owner or his designated representative.

2.2 Prior to bidding the work, the Contractor shall examine, investigate and inspect the construction site as to the nature and location of the work, and the general and local conditions at the construction site, including, without limitation, the character of surface or subsurface conditions and obstacles to be encountered on and around the construction site; and shall make such additional investigation as he may deem necessary for the planning and proper execution of the work.

If conditions other than those indicated are discovered by the Contractor, the Owner should be notified immediately. The material which the Contractor believes to be a changed condition should not be disturbed so that the owner can investigate the condition.

2.3 The construction shall be performed under the direction of an experienced engineer who is familiar with the design plan.

II – FOOTINGS

1.0 EXCAVATION FOR FOOTINGS

- 1.1 Footing excavation shall consist of the removal of all material, of whatever nature, necessary for the construction of foundations.
- 1.2 It shall be the responsibility of the Contractor to identify and relocate all existing utilities which conflict with the proposed footing locations shown on the plan. The Contractor must call the appropriate utility company at least 48 hours before any excavation to request exact field location of utilities, and coordinate removal and installation of all utilities with the respective utility company.
- 1.3 The side of all excavations shall be cut to prevent sliding or caving of the material above the footings.
- 1.4 Excavated material shall be disposed in accordance with the plan established by the Engineer.
- 1.5 The footings for the MULTI-PLATE arch, and headwalls/wingwalls are designed for an allowable bearing capacity of the non-yielding foundation material of 3,500 psf and a friction factor of 0.45. These values shall be verified in the field before construction. The evaluation and design of any required foundation improvement to achieve the design allowable bearing capacity and friction factor, and to protect against frost and scour and settlement, is the responsibility of others than CBC.

2.0 CONCRETE FOOTING DIMENSIONS

The footings shall be reinforced in accordance with the construction drawings.

III – HEADWALLS/WINGWALLS

- 1.0 The headwalls/wingwalls shall consist of reinforced concrete conforming to Chapter IV of these specifications and to Division II, Section 8, of the AASHTO Standard Specifications for Highway Bridges having a minimum compression strength of 4,000 psi.
- 2.0 Reinforcing steel shall conform to ASTM A-615, Grade 60, having minimum yield strength of 60,000 psi.
- 3.0 The headwalls shall be anchored to the MULTI-PLATE arch in the manner shown on the plans and shall be formed and poured in accordance with the plan dimensions.
- 4.0 Round weep holes spaced not over 5 feet on center shall be placed in the walls above finished grade as shown on the construction drawings. A granular envelope, consisting of #57 stone (clean 3/4" aggregate) or equivalent, shall be placed behind each weep hole for a distance of approximately 1 foot from all edges of the weep hole. A free-draining geotextile screen shall be placed between the weep hole and the stone to prevent erosion of the stone.
- 5.0 The select backfill behind the headwalls must be a well-graded, angular, durable granular material conforming to the select backfill specifications for the MULTI-PLATE arch placed and compacted to achieve a minimum internal friction angle of 34 degrees and a maximum unit weight of 120 pcf. The material must be placed in strict conformance with the project specifications, the manufacturer's requirements, and industry standards. The select backfill behind the wingwalls extending to a minimum distance of 15.0 feet behind the back face of the walls must be a well-graded, angular, durable granular material placed and compacted to achieve a minimum internal friction angle of 34 degrees and a maximum unit weight of 120 pcf. These values must be field verified.
- 6.0 All Federal, State, and Local regulations shall be strictly adhered to relative to excavation side-slope geometry and any required excavation shoring.

IV – CONCRETE FOR FOOTINGS AND HEADWALLS/WINGWALLS

1.0 CODES AND STANDARDS

1.1 Reinforced concrete shall conform to the requirements of AASHTO Standard Specifications for Highway Bridges, Division II - Construction, Section 8, "Concrete Structures", for Class A concrete, having a minimum compressive strength of 4,000 psi.

2.0 STANDARDS FOR MATERIALS

- 2.1 Portland Cement - Conforming to ASTM Specification C-150, Type I or II.
- 2.2 Water - The water shall be drinkable, clean free from injurious amounts of oils, acids, alkalis, organic materials, or deleterious substances.
- 2.3 Aggregates - Fine and coarse aggregates shall conform to current ASTM Specification C-33 "Specification for Concrete Aggregates" except that local aggregates which have been shown by tests and by actual service to produce satisfactory qualities may be used when approved by the Engineer.
- 2.4 Submittals - Test data and/or certifications to the Owner shall be furnished upon request.

3.0 PROPORTIONING OF CONCRETE

3.1 COMPOSITION

- 3.1.1 The concrete shall be composed of cement, fine aggregate, coarse aggregate and water.
- 3.1.2 The concrete shall be homogeneous, readily placeable and uniformly workable and shall be proportioned in accordance with ACI-211.1.
- 3.1.3 Proportions shall be established on the basis of field experience with the materials to be employed. The amount of water used shall not exceed the maximum 0.45 water/cement ratio, and shall be reduced as necessary to produce concrete of the specified consistency at the time of placement.
- 3.1.4 An air-entraining admixture, conforming to the requirements of ASTM C260, shall be used in all concrete furnished under this contract. The quantity of admixture shall be such as to produce an air content in the freshly mixed concrete of 6 percent plus or minus 1 percent as determined in accordance with ASTM C231 or C173.

3.2 Qualities Required - As indicated in the table below:

TABLE IV-1
QUALITIES REQUIRED

ITEM	QUALITY REQUIRED
AASHTO Class	A
Type of Cement	I or II
Compressive Strength <i>f_c</i> @ 28 days	4,000 psi
Slump, inches	2 - 4 in.

- 3.3 Maximum Size of Coarse Aggregates - Maximum size of coarse aggregates shall not be larger than 19 mm (3/4 inches).
- 3.4 Rate of Hardening of Concrete - Concrete mix shall be adjusted to produce the required rate of hardening for varied climatic conditions:

Under 40°F Ambient Temperature - Accelerate calcium chloride at 2% is acceptable when used within the recommendations of ACI-306R "Cold Weather Concreting." Admixtures containing chloride ion in excess of 1% by weight of admixture shall not be used in reinforced concrete.

4.0 MIXING AND PLACING

- 4.1 Equipment - Ready Mix Concrete shall be used and shall conform to the "Specifications for Ready-Mix Concrete," ASTM C-94. Approval is required prior to using job mixed concrete.
- 4.2 Preparation - All work shall be in accordance with ACI-304, "Recommended Practice for Measuring, Mixing, Transporting and Placing Concrete." All construction debris and extraneous matter shall be removed from within the forms. Concrete shall be placed on clean surfaces, free from water. Concrete that has to be dropped four (4) feet or more shall be placed through a tremie.
- 4.3 All concrete shall be consolidated by internal mechanical vibration immediately after placement. Vibrators shall be of a size appropriate for the work, capable of transmitting vibration to concrete at frequencies of not less than 4,500 impulses per minute.

5.0 FORM WORK

- 5.1 Forms shall be of wood, steel or other approved material and shall be set and held true to the dimensions, lines and grades of the structure prior to and during the placement of concrete.
- 5.2 Forms shall not be removed until the concrete has sufficient strength to prevent concrete damage and/or drainage.

6.0 CURING

- 6.1 Fresh concrete shall be protected from rains, flowing water and mechanical injury for a period of four (4) days. Loads shall not be placed on the concrete until it has reached its design strength.

7.0 REINFORCING STEEL

7.1 MATERIAL

- 7.1.1 All reinforcing bars shall be deformed bars (ASTM-A615) Grade 60.

7.2 BENDING AND SPLICING

- 7.2.1 Bar reinforcement shall be cut and bent to the shapes shown on the plans. Fabrication tolerances shall be in accordance with ACI 315. All bars shall be bent cold, unless otherwise permitted.
- 7.2.2 All reinforcement shall be furnished in the full lengths indicated on the plans unless otherwise permitted. Except for splices shown on the plans and splices for No. 5 or smaller bars, splicing of bars will not be permitted without written approval. Splices shall be staggered as far as possible.
- 7.2.3 In lapped splices, the bars shall be placed and wired in such a manner as to maintain the minimum distance to the surface of the concrete shown on the plans.
- 7.2.4 Substitution of different size bars will be permitted only when authorized by the engineer. The substituted bars shall have an area equivalent to the design area, or larger.

7.3 PLACING AND FASTENING

- 7.3.1 Steel reinforcement shall be accurately placed as shown on the plans and firmly held in position during the placing and setting of concrete. Bars shall be tied at all intersections around the perimeter of each mat and at not less than 2 foot centers or at every intersection, whichever is greater, elsewhere. Welding of cross bars (tack welding) will not be permitted for assembly of reinforcement.
- 7.3.2 Reinforcing steel shall be supported in its proper position by use of mortar blocks, wire bar supports, supplementary bars or other approved devices. Such devices shall be of such height and placed at sufficiently frequent intervals so as to maintain the distance between the reinforcing and the formed surface or the top surface within 1/4 inch of that indicated on the plans.

V - FILTER FABRIC (GEOTEXTILE SCREEN)

- 1.0 Filter fabric shall be placed at all locations shown on the construction drawings, and as necessary between all dissimilar materials to prevent soil migration and to maintain a soil-tight system.
- 2.0 Filter fabric cloth shall conform to Contech specification for C60-NW or equivalent and shall meet the following ASTM tests:
 - 2.1 ASTM D4751 - Apparent opening size equal to #70 U.S. Standard Sieve Size.
 - 2.2 ASTM D4632 (Grab Tensile Test) - Minimum Strength = 160 pounds.
 - 2.3 ASTM D4632 (Grab Elongation) - 30-70%.
 - 2.4 ASTM D4533 (Trapezoidal Tear) - Minimum Strength = 60 pounds.
 - 2.5 ASTM D4355 (Stabilized for Heat and Ultra-Violet Degradation) - 70% strength retained.
- 3.0 The minimum fabric coefficient of permeability (ASTM D4491) shall be 0.24 cm/sec.
- 4.0 The fabric shall be non-woven with a minimum thickness (ASTM D5199) of 60 mils.
- 5.0 Fabric shall not be placed over sharp or angular rocks that could tear or puncture it.
- 6.0 Care should be exercised to prevent any puncturing or rupture of the filter fabric. Should such rupture occur the damaged area should be covered with a patch of filter fabric using an overlap minimum of one (1) foot.

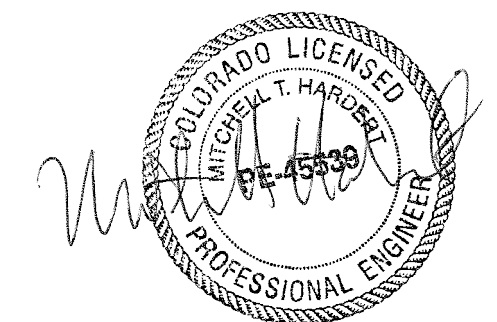

CBC Engineers			
SPECIFICATIONS			
Drawn By JBE	Date 03/20/20	CONTECH ENGINEERED SOLUTIONS, LLC DESIGN OF CONCRETE SPREAD FOOTINGS, CONCRETE HEADWALLS AND WINGWALLS FOR A TWIN 24'x10'-4" MULTI-PLATE ARCH STRUCTURE (617696); RETREAT AT TIMBER RIDGE, EL PASO, COLORADO	
Approved By	Date	Project No. CBC-23088	Rev. Sheet - 8 OF 8
Scale GRAPHIC			