

TO:

DATE: August 9, 2022

SUBJECT: Notification of Application for a Special Use Permit  
Solberg Gravel LLC

This letter is being sent to inform you that Solberg Gravel LLC is proposing a land use project in El Paso County at 5445 Curtis Road, Peyton, CO 80933. This information is being provided to you prior to submittal with the County. Please direct any questions on the proposal to Angela Bellantoni of Pioneer Landscaping Materials Inc., 630 Plaza Drive, Suite 150, Highlands Ranch, CO 80129; [angela.bellantoni@pioneerco.com](mailto:angela.bellantoni@pioneerco.com); (719) 429-8950. Prior to any public hearing on this proposal a notification of the time and place of the public hearing will be sent to the adjacent property owners by the El Paso County Planning and Community Development Department. At that time, you will be given the El Paso County contact information, the file number and an opportunity to respond either for, against, or expressing no opinion in writing at the public hearing for this proposal.

The Solberg Pit is located at the southwest corner of the intersection of Curtis Road and Garrett Road aka 5445 Curtis Road, Peyton, CO. The quarry is currently operating in 234 acres and is submitting application to expand to 313 acres by adding an additional 70 acres to the west. The subject parcels are zoned A-35 Agricultural.

Solberg Gravel LLC began producing construction aggregate in 1981. The initial 234 acres are considered a non-conforming land use since it commenced operating prior to land use zoning in El Paso County. This application is required in order to include into the permit area the adjoining 79 acres to the west. The operation will not change. The number of employees at the site will not change. The traffic generated by the operation will not change. All site structures are temporary and portable. Two wash plants operate with an addition portable plant available if market demands. Reclamation is occurring concurrently with mining as grading and slope contouring in preparation for final reclamation to rangeland. The CO DRMS mine permit is M-1981-044.

# EXHIBIT C MINE PLAN MAP - SOLBERG PIT

SECTION 21, TOWNSHIP 13 SOUTH, RANGE 64 WEST  
OF THE 6TH P.M.  
EL PASO COUNTY, COLORADO

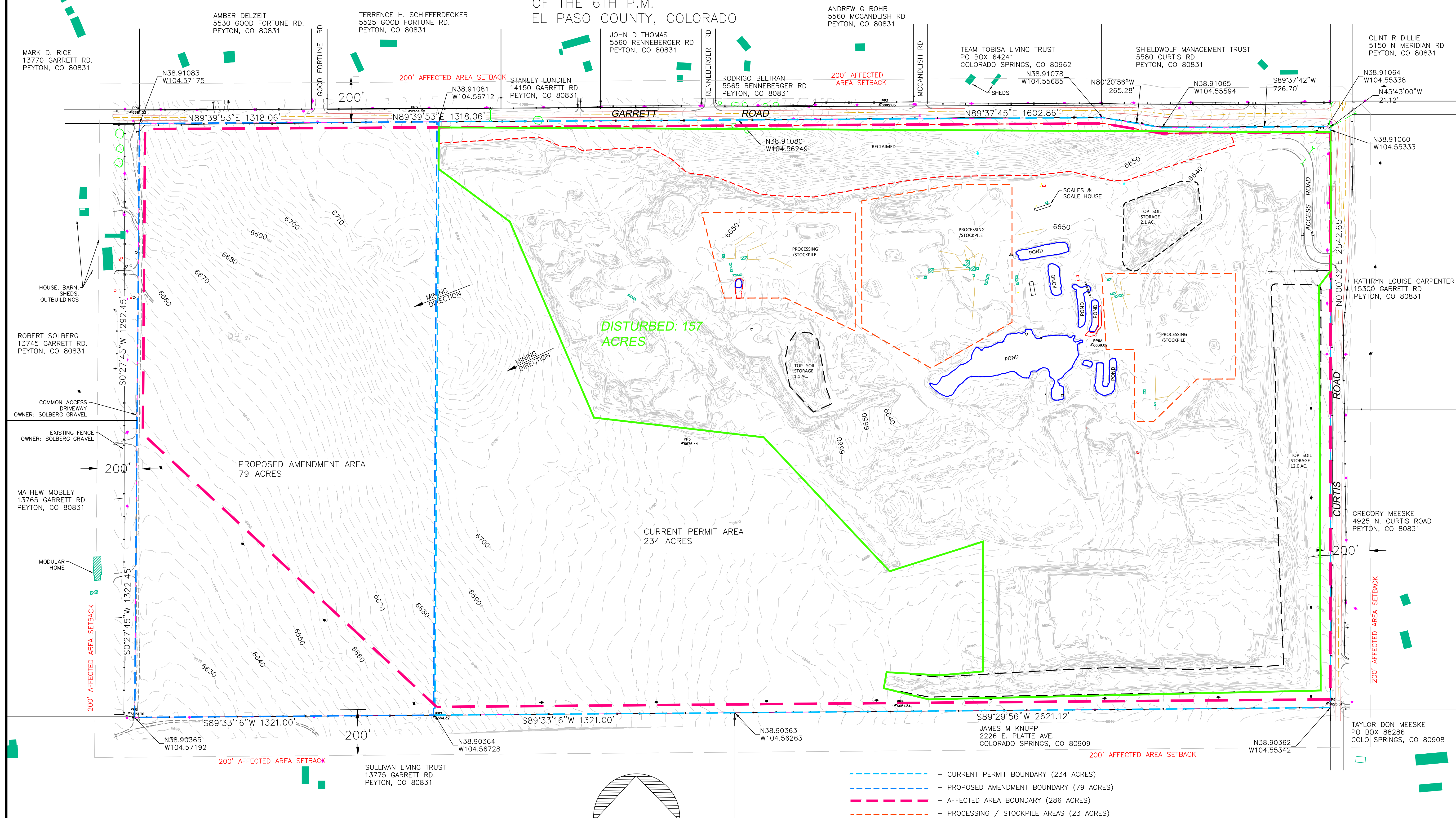

I, JOHN E. KRATZ, HEREBY CERTIFY THIS EXHIBIT WAS PREPARED UNDER MY DIRECT SUPERVISION AND CHECKING, AND TO THE BEST OF MY KNOWLEDGE AND BELIEF ACCURATELY DEPICTS THE MINE PERMIT AND AFFECTED AREA BOUNDARIES DEFINED HEREIN. THIS EXHIBIT IS NOT A LAND SURVEY PLAT. LAND USE INFORMATION SHOWN HEREIN IS FROM FIELD OBSERVATION (JULY 6, 2021), AERIAL TOPOGRAPHY AND REPORT BY OTHERS AND MAY NOT BE ACCURATE AFTER THIS DATE.

*John E. Kratz*

PROFESSIONAL LAND SURVEYOR  
20142  
07/25/2022

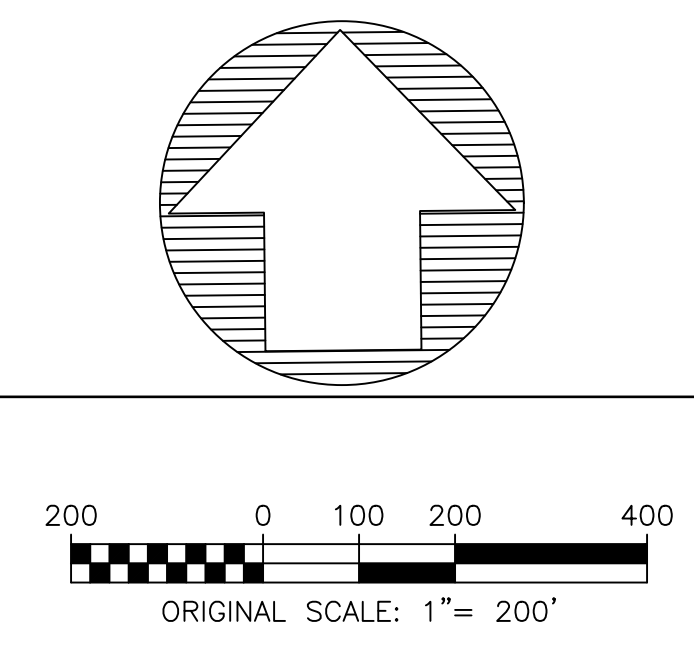

- - - - - CURRENT PERMIT BOUNDARY (234 ACRES)
- - - - - PROPOSED AMENDMENT BOUNDARY (79 ACRES)
- - - - - AFFECTED AREA BOUNDARY (286 ACRES)
- - - - - PROCESSING / STOCKPILE AREAS (23 ACRES)
- - - - - TOP SOIL STOCKPILE (15 ACRES)
- - - - - RECLAIMED AREA (16 ACRES)
- - - - - PONDS (3 ACRES APPROX.)
- - - - - EXISTING FENCE
- - - - - EXISTING BUILDINGS
- - - - - TRANSMISSION POLE (NEXTERA ENERGY)
- - - - - DISTRIBUTION POLE (MOUNTAIN VALLEY ELECTRIC)

1. TOPOGRAPHY BY LANDMARK MAPPING, INC. FROM AERIAL PHOTOGRAPHY 4/20/21.
2. CONTOUR INTERVAL 2 FEET.
3. BOUNDARY SURVEY INFORMATION FROM LSP 207900045, PLS 28658

REVISIONS		
NO.	DATE	BY
5	11/09/21	JEK
6	02/16/22	JEK
7	02/23/22	JEK
8	07/25/22	JEK
8	08/11/22	JEK

NO.	DATE	BY
5	11/09/21	JEK
6	02/16/22	JEK
7	02/23/22	JEK
8	07/25/22	JEK
8	08/11/22	JEK

SCALE VERIFICATION  
BAR IS 1" = 200' ON ORIGINAL DRAWING  
IF NOT ONE INCH ON THIS SHEET, ADJUST SCALES ACCORDINGLY.

REUSE OF DOCUMENT  
THIS EXHIBIT IS CERTIFIED ONLY TO THE PARTIES NAMED HERON AND REMAINS THE PROPERTY OF RED ROCK LAND SURVEYS, INC. CORRECT THIS PLAT SHOULD NEW OR UNDISCOVERED FACTS EMERGE. USE OF THIS PLAT BY OTHER THAN CERTIFICATE HOLDER IS AT YOUR OWN RISK.

△	FIRE
☆	LPOLE
○	MANHOLE
●	SIGN
◆	UPOLE
+	FENCE
•	MISC
⊙	TOWER
⊙	PILE
⊙	CULVERT
⊙	ROCK
⊙	IRRIGATION
⊙	MAILBOX
⊙	TREE
⊙	TRAFFIC
⊙	RIP-RAP
⊙	POLE-ANCHOR

PREPARED FOR: PIONEER LANDSCAPE MATERIALS

2021 MAP  
SOLBERG GRAVEL, LLC  
13745 GARRETT ROAD  
PEYTON, CO 80831

7020 2450 0002 1853 6078

U.S. Postal Service™  
CERTIFIED MAIL® RECEIPT  
Domestic Mail Only

For delivery information, visit our website at [www.usps.com](http://www.usps.com)®.

OFFICIAL USE

Certified Mail Fee

Extra Services & Fees (check box, add fee as appropriate)  
 Return Receipt (hardcopy) \$  
 Return Receipt (electronic) \$  
 Certified Mail Restricted Delivery \$  
 Adult Signature Required \$  
 Adult Signature Restricted Delivery \$

Postage

Total Postage and

Sent To

Street and Apt. No.

City, State, ZIP+4®

PS Form 3800, A

Gregory Meeske  
4925 N. Curtis Road  
Peyton, CO 80831



7020 2450 0002 1853 5972

U.S. Postal Service™  
CERTIFIED MAIL® RECEIPT  
Domestic Mail Only

For delivery information, visit our website at [www.usps.com](http://www.usps.com)®.

OFFICIAL

Certified Mail Fee

Extra Services & Fees (check box, add fee as appropriate)  
 Return Receipt (hardcopy) \$  
 Return Receipt (electronic) \$  
 Certified Mail Restricted Delivery \$  
 Adult Signature Required \$  
 Adult Signature Restricted Delivery \$

Postage

Total Postage and

Sent To

Street and Apt. No.

City, State, ZIP+4®

PS Form 3800, A

James Knupp  
2226 E. Platt Avenue  
Colorado Springs, CO 80909

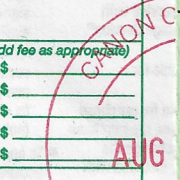

SENDER: COMPLETE THIS SECTION

- Complete items 1, 2, and 3.
- Print your name and address on the reverse so that we can return the card to you.
- Attach this card to the back of the mailpiece, or on the front if space permits.

1. Article Addressed to:

James Knupp  
2226 E. Platt Avenue  
Colorado Springs, CO 80909



9590 9402 7472 2055 3114 90

2. Article Number (Transfer from service label)

7020 2450 0002 1853 5972

PS Form 3811, July 2020 PSN 7530-02-000-9053

COMPLETE THIS SECTION ON DELIVERY

A. Signature

X *Josh Johnston*  Agent  Addressee

B. Received by (Printed Name)

Josh Johnston

C. Date of Delivery

8/13/22

D. Is delivery address different from item 1?  Yes  
If YES, enter delivery address below:  No

3. Service Type

- Adult Signature
- Adult Signature Restricted Delivery
- Certified Mail®
- Certified Mail Restricted Delivery
- Collect on Delivery
- Collect on Delivery Restricted Delivery
- Registered Mail™
- Registered Mail Restricted Delivery
- Signature Confirmation™
- Signature Confirmation Restricted Delivery
- Priority Mail Express®

(over \$500)

Domestic Return Receipt

7020 2450 0002 1853 6085

U.S. Postal Service™  
CERTIFIED MAIL® RECEIPT  
Domestic Mail Only

For delivery information, visit our website at [www.usps.com](http://www.usps.com)®.

OFFICIAL

Certified Mail Fee

Extra Services & Fees (check box, add fee as appropriate)  
 Return Receipt (hardcopy) \$  
 Return Receipt (electronic) \$  
 Certified Mail Restricted Delivery \$  
 Adult Signature Required \$  
 Adult Signature Restricted Delivery \$

Postage

Total Postage and

Sent To

Street and Apt. No.

City, State, ZIP+4®

PS Form 3800, A

Taylor Meeske  
PO Box 88286  
Colorado Springs, CO 80908

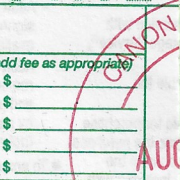

SENDER: COMPLETE THIS SECTION

- Complete items 1, 2, and 3.
- Print your name and address on the reverse so that we can return the card to you.
- Attach this card to the back of the mailpiece, or on the front if space permits.

1. Article Addressed to:

Taylor Meeske  
PO Box 88286  
Colorado Springs, CO 80908



9590 9402 7472 2055 3115 13

2. Article Number (Transfer from service label)

7020 2450 0002 1853 6085

PS Form 3811, July 2020 PSN 7530-02-000-9053

COMPLETE THIS SECTION ON DELIVERY

A. Signature

X *Taylor Meeske*  Agent  Addressee

B. Received by (Printed Name)

Taylor Meeske

C. Date of Delivery

8/28/22

D. Is delivery address different from item 1?  Yes  
If YES, enter delivery address below:  No

3. Service Type

- Adult Signature
- Adult Signature Restricted Delivery
- Certified Mail®
- Certified Mail Restricted Delivery
- Collect on Delivery
- Collect on Delivery Restricted Delivery
- Registered Mail™
- Registered Mail Restricted Delivery
- Signature Confirmation™
- Signature Confirmation Restricted Delivery
- Priority Mail Express®

Restricted Delivery

Domestic Return Receipt

7020 2450 0002 1853 6030

# U.S. Postal Service™ CERTIFIED MAIL® RECEIPT

Domestic Mail Only

For delivery information, visit our website at [www.usps.com](http://www.usps.com)

## OFFICIAL MAIL

Certified Mail Fee \$

Extra Services & Fees (check box, add fee as appropriate)

Return Receipt (hardcopy) \$

Return Receipt (electronic) \$

Certified Mail Restricted Delivery \$

Adult Signature Required \$

Adult Signature Restricted Delivery \$

Postage \$

Total Postage and Fees \$

Sent To Stanley Lundien  
14150 Garrett Road  
Peyton, CO 80831

Street and Apt. No.  
City, State, ZIP+4

PS Form 3800, July 2020 PSN 7530-02-000-9053

### SENDER: COMPLETE THIS SECTION

- Complete items 1, 2, and 3.
- Print your name and address on the reverse so that we can return the card to you.
- Attach this card to the back of the mailpiece, or on the front if space permits.

1. Article Addressed to:

Stanley Lundien  
14150 Garrett Road  
Peyton, CO 80831

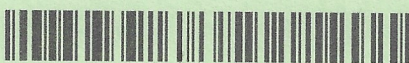

9590 9402 7472 2055 3114 45

2. Article Number (Transfer from service label)

7020 2450 0002 1853 6030

PS Form 3811, July 2020 PSN 7530-02-000-9053

### COMPLETE THIS SECTION ON DELIVERY

A. Signature  Agent  Addressee  
*Stanley Lundien*

B. Received by (Printed Name)  Agent  Addressee  
*Stanley Lundien*

C. Date of Delivery

D. Is delivery address different from item 1?  Yes  No  
If YES, enter delivery address below:

3. Service Type

Adult Signature  Priority Mail Express®

Adult Signature Restricted Delivery  Registered Mail™

Certified Mail®  Registered Mail Restricted Delivery

Certified Mail Restricted Delivery  Signature Confirmation™

Collect on Delivery  Signature Confirmation Restricted Delivery

Collect on Delivery Restricted Delivery  Signature Confirmation Restricted Delivery (over \$500)

Domestic Return Receipt

7020 2450 0002 1853 6047

# U.S. Postal Service™ CERTIFIED MAIL® RECEIPT

Domestic Mail Only

For delivery information, visit our website at [www.usps.com](http://www.usps.com)

## OFFICIAL MAIL

Certified Mail Fee \$

Extra Services & Fees (check box, add fee as appropriate)

Return Receipt (hardcopy) \$

Return Receipt (electronic) \$

Certified Mail Restricted Delivery \$

Adult Signature Required \$

Adult Signature Restricted Delivery \$

Postage \$

Total Postage and Fees \$

Sent To John Thomas  
5560 Renneberger Road  
Peyton, CO 80831

Street and Apt. No.  
City, State, ZIP+4

PS Form 3800, July 2020 PSN 7530-02-000-9053

### SENDER: COMPLETE THIS SECTION

- Complete items 1, 2, and 3.
- Print your name and address on the reverse so that we can return the card to you.
- Attach this card to the back of the mailpiece, or on the front if space permits.

1. Article Addressed to:

John Thomas  
5560 Renneberger Road  
Peyton, CO 80831



9590 9402 7472 2055 3114 52

2. Article Number (Transfer from service label)

7020 2450 0002 1853 6047

PS Form 3811, July 2020 PSN 7530-02-000-9053

### COMPLETE THIS SECTION ON DELIVERY

A. Signature  Agent  Addressee  
*John Thomas*

B. Received by (Printed Name)  Agent  Addressee  
*John Thomas*

C. Date of Delivery *8/3/28*

D. Is delivery address different from item 1?  Yes  No  
If YES, enter delivery address below:

3. Service Type

Adult Signature  Priority Mail Express®

Adult Signature Restricted Delivery  Registered Mail™

Certified Mail®  Registered Mail Restricted Delivery

Certified Mail Restricted Delivery  Signature Confirmation™

Collect on Delivery  Signature Confirmation Restricted Delivery

Collect on Delivery Restricted Delivery  Signature Confirmation Restricted Delivery (over \$500)

Domestic Return Receipt

7020 2450 0002 1853 6061

# U.S. Postal Service™ CERTIFIED MAIL® RECEIPT

Domestic Mail Only

For delivery information, visit our website at [www.usps.com](http://www.usps.com)

## OFFICIAL MAIL

Certified Mail Fee \$

Extra Services & Fees (check box, add fee as appropriate)

Return Receipt (hardcopy) \$

Return Receipt (electronic) \$

Certified Mail Restricted Delivery \$

Adult Signature Required \$

Adult Signature Restricted Delivery \$

Postage \$

Total Postage and Fees \$

Sent To Andrew Rohr  
5560 McCandlish Road  
Peyton, CO 80831

Street and Apt. No.  
City, State, ZIP+4

PS Form 3800, July 2020 PSN 7530-02-000-9053

### SENDER: COMPLETE THIS SECTION

- Complete items 1, 2, and 3.
- Print your name and address on the reverse so that we can return the card to you.
- Attach this card to the back of the mailpiece, or on the front if space permits.

1. Article Addressed to:

Andrew Rohr  
5560 McCandlish Road  
Peyton, CO 80831



9590 9402 7472 2055 3114 76

2. Article Number (Transfer from service label)

7020 2450 0002 1853 6061

PS Form 3811, July 2020 PSN 7530-02-000-9053

### COMPLETE THIS SECTION ON DELIVERY

A. Signature  Agent  Addressee  
*Danielle Rohr*

B. Received by (Printed Name)  Agent  Addressee  
*DANIELLE ROHR*

C. Date of Delivery *8-16-22*

D. Is delivery address different from item 1?  Yes  No  
If YES, enter delivery address below:

3. Service Type

Adult Signature  Priority Mail Express®

Adult Signature Restricted Delivery  Registered Mail™

Certified Mail®  Registered Mail Restricted Delivery

Certified Mail Restricted Delivery  Signature Confirmation™

Collect on Delivery  Signature Confirmation Restricted Delivery

Collect on Delivery Restricted Delivery  Signature Confirmation Restricted Delivery (over \$500)

Domestic Return Receipt

7020 2450 0002 1853 5927

U.S. Postal Service™  
CERTIFIED MAIL® RECEIPT

Domestic Mail Only

For delivery information, visit our website at [www.usps.com](http://www.usps.com)®.

OFFICIAL USE

Certified Mail Fee

Extra Services & Fees (check box, add fee as appropriate)

Return Receipt (hardcopy) \$

Return Receipt (electronic) \$

Certified Mail Restricted Delivery \$

Adult Signature Required \$

Adult Signature Restricted Delivery \$

Postage

Total Postage and

Sent To

Mathew Mobley  
13765 Garrett Road  
Peyton, CO 80831

PS Form 3800,

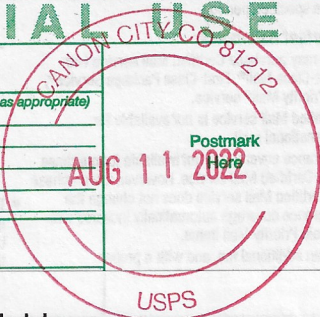

7020 2450 0002 1853 5941

U.S. Postal Service™  
CERTIFIED MAIL® RECEIPT

Domestic Mail Only

For delivery information, visit our website at [www.usps.com](http://www.usps.com)®.

OFFICIAL USE

Certified Mail Fee

Extra Services & Fees (check box, add fee as appropriate)

Return Receipt (hardcopy) \$

Return Receipt (electronic) \$

Certified Mail Restricted Delivery \$

Adult Signature Required \$

Adult Signature Restricted Delivery \$

Postage

Total Postage and

Sent To

Sullivan Living Trust  
13775 Garrett Road  
Peyton, CO 80831

PS Form 3800,

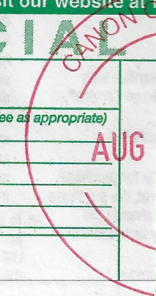

SENDER: COMPLETE THIS SECTION

- Complete items 1, 2, and 3.
- Print your name and address on the reverse so that we can return the card to you.
- Attach this card to the back of the mailpiece, or on the front if space permits.

1. Article Addressed to:

Sullivan Living Trust  
13775 Garrett Road  
Peyton, CO 80831

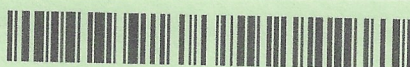

9590 9402 7472 2055 3113 53

2. Article Number (Transfer from service label)

7020 2450 0002 1853 5941

PS Form 3811, July 2020 PSN 7530-02-000-9053

COMPLETE THIS SECTION ON DELIVERY

A. Signature

X *Peggy Sullivan*

- Agent  
 Addressee

B. Received by (Printed Name)

C. Date of Delivery

8/15/2022

D. Is delivery address different from item 1?  Yes  
If YES, enter delivery address below:  No

3. Service Type

- Adult Signature  Priority Mail Express®
- Adult Signature Restricted Delivery  Registered Mail™
- Certified Mail®  Registered Mail Restricted Delivery
- Certified Mail Restricted Delivery  Signature Confirmation™
- Collect on Delivery  Signature Confirmation Restricted Delivery
- Collect on Delivery Restricted Delivery  Restricted Delivery

Domestic Return Receipt

7020 2450 0002 1853 5958

U.S. Postal Service™  
CERTIFIED MAIL® RECEIPT

Domestic Mail Only

For delivery information, visit our website at [www.usps.com](http://www.usps.com)®.

OFFICIAL USE

Certified Mail Fee

Extra Services & Fees (check box, add fee as appropriate)

Return Receipt (hardcopy) \$

Return Receipt (electronic) \$

Certified Mail Restricted Delivery \$

Adult Signature Required \$

Adult Signature Restricted Delivery \$

Postage

Total Postage and

Sent To

Sheldwolf Management Trust  
5580 Curtis Road  
Peyton, CO 80831

PS Form 3800,

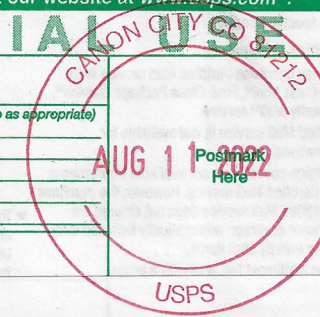

*Returned*

Pioneer Landscaping Materials Inc.  
630 Plaza Drive, Suite 150  
Colorado Springs, CO 80129

**CERTIFIED MAIL®**



7020 2450 0002 1853 5958

Sheldwolf Management Trust  
5580 Curtis Road  
Peyton, CO 80831



U.S. POSTAGE PAID  
FCM LETTER  
CANON CITY, CO  
81212  
AUG 11, 22  
AMOUNT  
**\$7.85**  
R2305K132786-11



1023

80831

8-13  
8-18  
8-28

NIXIE 808 DE 1 8009/03/22  
RETURN TO SENDER  
UNCLAIMED  
UNABLE TO FORWARD  
BC: 80129Z75025 1968-07112-05-27

9400921968245230

80831-758260  
80129>2750

7020 2450 0002 1853 6009

U.S. Postal Service™  
CERTIFIED MAIL® REC  
Domestic Mail Only

For delivery information, visit our website at [www.usps.com](http://www.usps.com)

OFFICIAL

Certified Mail Fee \$

Extra Services & Fees (check box, add fee as appropriate)

Return Receipt (hardcopy) \$

Return Receipt (electronic) \$

Certified Mail Restricted Delivery \$

Adult Signature Required \$

Adult Signature Restricted Delivery \$

Postage \$

Total Postage and Fees \$

Sent To **Mark Rice**  
 Street and Apt. No. **13770 Garrett Road**  
 City, State, ZIP+4 **Peyton, CO 80831**

PS Form 3800, July 2020

SENDER: COMPLETE THIS SECTION

- Complete items 1, 2, and 3.
- Print your name and address on the reverse so that we can return the card to you.
- Attach this card to the back of the mailpiece, or on the front if space permits.

1. Article Addressed to:

**Mark Rice**  
**13770 Garrett Road**  
**Peyton, CO 80831**



9590 9402 7472 2055 3113 15

2. Article Number (Transfer from service label)  
7020 2450 0002 1853 6009

PS Form 3811, July 2020 PSN 7530-02-000-9053

COMPLETE THIS SECTION ON DELIVERY

A. Signature  
 **Mark Rice**  Agent  Addressee

B. Received by (Printed Name) **MARK RICE** C. Date of Delivery **8/16/22**

D. Is delivery address different from item 1?  Yes  
 If YES, enter delivery address below:  No

3. Service Type

Adult Signature  Priority Mail Express®

Adult Signature Restricted Delivery  Registered Mail™

Certified Mail®  Registered Mail Restricted Delivery

Certified Mail Restricted Delivery  Signature Confirmation™

Collect on Delivery  Signature Confirmation Restricted Delivery

Collect on Delivery Restricted Delivery

7020 2450 0002 1853 6016

U.S. Postal Service™  
CERTIFIED MAIL® RECEIPT  
Domestic Mail Only

For delivery information, visit our website at [www.usps.com](http://www.usps.com)

OFFICIAL

Certified Mail Fee \$

Extra Services & Fees (check box, add fee as appropriate)

Return Receipt (hardcopy) \$

Return Receipt (electronic) \$

Certified Mail Restricted Delivery \$

Adult Signature Required \$

Adult Signature Restricted Delivery \$

Postage \$

Total Postage and Fees \$

Sent To **Amber Delzeit**  
 Street and Apt. No. **5530 Good Fortune Road**  
 City, State, ZIP+4 **Peyton, CO 80831**

PS Form 3800, July 2020

- Complete items 1, 2, and 3.
- Print your name and address on the reverse so that we can return the card to you.
- Attach this card to the back of the mailpiece, or on the front if space permits.

1. Article Addressed to:

**Amber Delzeit**  
**5530 Good Fortune Road**  
**Peyton, CO 80831**



9590 9402 7472 2055 3114 21

2. Article Number (Transfer from service label)  
7020 2450 0002 1853 6016

PS Form 3811, July 2020 PSN 7530-02-000-9053

A. Signature  
 **Amber Delzeit**  Agent  Addressee

B. Received by (Printed Name) C. Date of Delivery

D. Is delivery address different from item 1?  Yes  
 If YES, enter delivery address below:  No

3. Service Type

Adult Signature  Priority Mail Express®

Adult Signature Restricted Delivery  Registered Mail™

Certified Mail®  Registered Mail Restricted Delivery

Certified Mail Restricted Delivery  Signature Confirmation™

Collect on Delivery  Signature Confirmation Restricted Delivery

Collect on Delivery Restricted Delivery

7020 2450 0002 1853 6023

U.S. Postal Service™  
CERTIFIED MAIL® RECEIPT  
Domestic Mail Only

For delivery information, visit our website at [www.usps.com](http://www.usps.com)

OFFICIAL

Certified Mail Fee \$

Extra Services & Fees (check box, add fee as appropriate)

Return Receipt (hardcopy) \$

Return Receipt (electronic) \$

Certified Mail Restricted Delivery \$

Adult Signature Required \$

Adult Signature Restricted Delivery \$

Postage \$

Total Postage and Fees \$

Sent To **Terrence Schifferdecker**  
 Street and Apt. No. **5525 Good Fortune Road**  
 City, State, ZIP+4 **Peyton, CO 80831**

PS Form 3800, July 2020

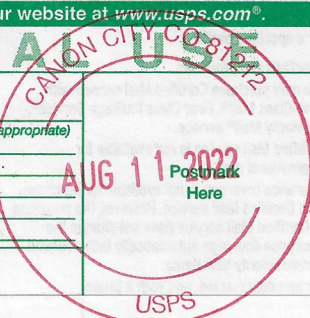

Returned

Pioneer Landscaping Materials Inc  
630 Plaza Drive, Suite 150  
Highlands Ranch, CO 80129

**CERTIFIED MAIL®**



7020 2450 0002 1853 6023



1023



80831

U.S. POSTAGE PAID  
FCM LETTER  
CANON CITY, CO  
81212  
AUG 11, 22  
AMOUNT

**\$7.85**

R2305K132786-11

Terrence Schifferdecker  
5525 Good Fortune Road  
Peyton, CO 80831

8-13  
3819

8-13  
8-18

0005/05/ZZ

BOB DE 1

NIXIE

RETURN TO SENDER  
UNCLAIMED  
UNABLE TO FORWARD

BC: 80129275025 \*1720-05473-11-44

80831-75025  
801292750

940092130824529012



Pioneer Landscaping Materials Inc  
630 Plaza Drive, Suite 150  
Highlands Ranch, CO 80129

*Sof  
8-13  
GreenCard*

**CERTIFIED MAIL**



7020 2450 0002 1853 6016

Amber Delzeit  
5530 Good Fortune Road  
Peyton, CO 80831

SEVER CO CO  
AUG 20 2008



1023



80831

U.S. POSTAGE PAID  
FORM LETTER  
CANON CITY, CO  
81212  
AUG 11, 22  
AMOUNT

**\$7.85**  
R2305K132786-11

NIXIE

006 DE 1

0006/23/22

RETURN TO SENDER  
UNCLAIMED  
UNABLE TO FORWARD

UNC

BC: 80129275025

\*1468-07077-23-32

80831253390

7020 2450 0002 1853 5965

U.S. Postal Service™  
CERTIFIED MAIL® RECEIPT  
Domestic Mail Only

For delivery information, visit our website at [www.usps.com](http://www.usps.com)

OFFICIAL USE

Certified Mail Fee \$

Extra Services & Fees (check box, add fee as appropriate)

Return Receipt (hardcopy) \$

Return Receipt (electronic) \$

Certified Mail Restricted Delivery \$

Adult Signature Required \$

Adult Signature Restricted Delivery \$

Postage \$

Total Postage and Fees \$

Sent To Kathryn Carpenter

Street and Apt. No. 15300 Garrett Road

City, State, ZIP+4 Peyton, CO 80831

PS Form 3800, July 2020 PSN 7530-02-000-9053

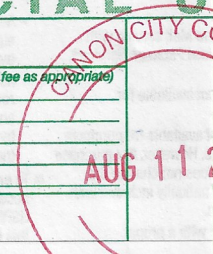

SENDER: COMPLETE THIS SECTION

- Complete items 1, 2, and 3.
- Print your name and address on the reverse so that we can return the card to you.
- Attach this card to the back of the mailpiece, or on the front if space permits.

1. Article Addressed to:

Kathryn Carpenter  
15300 Garrett Road  
Peyton, CO 80831



9590 9402 7472 2055 3115 06

2. Article Number (Transfer from service label)

7020 2450 0002 1853 5965

PS Form 3811, July 2020 PSN 7530-02-000-9053

COMPLETE THIS SECTION ON DELIVERY

A. Signature  
X *Kathryn Carpenter*  Agent  Addressee

B. Received by (Printed Name) Kathryn Carpenter

C. Date of Delivery 8/18/22

D. Is delivery address different from item 1?  Yes  No  
If YES, enter delivery address below:

3. Service Type

Adult Signature  Priority Mail Express®

Adult Signature Restricted Delivery  Registered Mail™

Certified Mail®  Registered Mail Restricted Delivery

Certified Mail Restricted Delivery  Signature Confirmation™

Collect on Delivery  Signature Confirmation Restricted Delivery

Collect on Delivery Restricted Delivery  all Restricted Delivery

Domestic Return Receipt

7020 2450 0002 1853 5996

U.S. Postal Service™  
CERTIFIED MAIL® RECEIPT  
Domestic Mail Only

For delivery information, visit our website at [www.usps.com](http://www.usps.com)

OFFICIAL USE

Certified Mail Fee \$

Extra Services & Fees (check box, add fee as appropriate)

Return Receipt (hardcopy) \$

Return Receipt (electronic) \$

Certified Mail Restricted Delivery \$

Adult Signature Required \$

Adult Signature Restricted Delivery \$

Postage \$

Total Postage and Fees \$

Sent To Team Tobisa Living Trust

Street and Apt. No. PO Box 64241

City, State, ZIP+4 Colorado Springs, CO 80962

PS Form 3800, July 2020 PSN 7530-02-000-9053

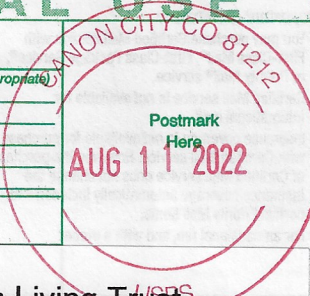

Returned

SENDER: COMPLETE THIS SECTION

- Complete items 1, 2, and 3.
- Print your name and address on the reverse so that we can return the card to you.
- Attach this card to the back of the mailpiece, or on the front if space permits.

1. Article Addressed to:

Robert Solberg  
13745 Garrett Road  
Peyton, CO 80831



9590 9402 7472 2055 3113 91

2. Article Number (Transfer from service label)

7020 2450 0002 1853 5934

PS Form 3811, July 2020 PSN 7530-02-000-9053

COMPLETE THIS SECTION ON DELIVERY

A. Signature  
X *Robert Solberg*  Agent  Addressee

B. Received by (Printed Name)

C. Date of Delivery

D. Is delivery address different from item 1?  Yes  No  
If YES, enter delivery address below:

3. Service Type

Adult Signature  Priority Mail Express®

Adult Signature Restricted Delivery  Registered Mail™

Certified Mail®  Registered Mail Restricted Delivery

Certified Mail Restricted Delivery  Signature Confirmation™

Collect on Delivery  Signature Confirmation Restricted Delivery

Collect on Delivery Restricted Delivery  all Restricted Delivery

Domestic Return Receipt

7020 2450 0002 1853 5934

U.S. Postal Service™  
CERTIFIED MAIL® RECEIPT  
Domestic Mail Only

For delivery information, visit our website at [www.usps.com](http://www.usps.com)

OFFICIAL USE

Certified Mail Fee \$

Extra Services & Fees (check box, add fee as appropriate)

Return Receipt (hardcopy) \$

Return Receipt (electronic) \$

Certified Mail Restricted Delivery \$

Adult Signature Required \$

Adult Signature Restricted Delivery \$

Postage \$

Total Postage and Fees \$

Sent To Robert Solberg

Street and Apt. No. 13745 Garrett Road

City, State, ZIP+4 Peyton, CO 80831

PS Form 3800, July 2020 PSN 7530-02-000-9053

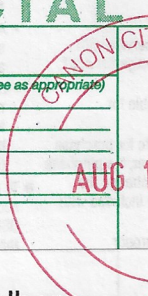

Pioneer Landscaping Materials Inc  
630 Plaza Drive, Suite 150  
Highlands Ranch, CO 80129

**CERTIFIED MAIL®**

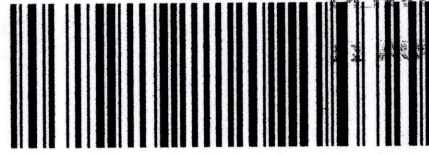

7020 2450 0002 1853 5996

Team Tobisa Living Trust  
PO Box 64241  
Colorado Springs, CO 80962



1023

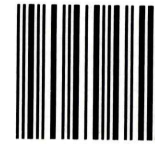

80962

U.S. POSTAGE PAID  
FCM LETTER  
CANON CITY, CO  
81212  
AUG 11, 22  
AMOUNT

**\$7.85**

R2305K132786-11

NIXIE 808 DE 1 0009/08/22

RETURN TO SENDER  
UNCLAIMED  
UNABLE TO FORWARD

UNC BC: 80129275025 \*2020-06176-11-44

80962-4241-4750

7020 2450 0002 1853 5989

U.S. Postal Service™  
CERTIFIED MAIL® RECEIPT  
Domestic Mail Only

For delivery information, visit our website at [www.usps.com](http://www.usps.com)

OFFICIAL USE

Certified Mail Fee \$

Extra Services & Fees (check box, add fee as appropriate)

Return Receipt (hardcopy) \$

Return Receipt (electronic) \$

Certified Mail Restricted Delivery \$

Adult Signature Required \$

Adult Signature Restricted Delivery \$

Postage \$

Total Postage and Fees \$

Sent To  
Clint Dillie  
5150 Meridian Road  
Peyton, CO 80831

PS Form 3800, July 2020

SENDER: COMPLETE THIS SECTION

- Complete items 1, 2, and 3.
- Print your name and address on the reverse so that we can return the card to you.
- Attach this card to the back of the mailpiece, or on the front if space permits.

1. Article Addressed to:

Clint Dillie  
5150 Meridian Road  
Peyton, CO 80831



9590 9402 7472 2055 3114 83

2. Article Number (Transfer from service label)

7020 2450 0002 1853 5989

PS Form 3811, July 2020 PSN 7530-02-000-9053

COMPLETE THIS SECTION ON DELIVERY

A. Signature

X

Agent

Addressee

B. Received by (Printed Name)

C. Date of Delivery

8/5/22

D. Is delivery address different from item 1?  Yes  
If YES, enter delivery address below:  No

3. Service Type

- Adult Signature
- Adult Signature Restricted Delivery
- Certified Mail®
- Certified Mail Restricted Delivery
- Collect on Delivery
- Collect on Delivery Restricted Delivery
- Priority Mail Express®
- Registered Mail™
- Registered Mail Restricted Delivery
- Signature Confirmation™
- Signature Confirmation Restricted Delivery

Restricted Delivery

Domestic Return Receipt

7020 2450 0002 1853 6054

U.S. Postal Service™  
CERTIFIED MAIL® RECEIPT  
Domestic Mail Only

For delivery information, visit our website at [www.usps.com](http://www.usps.com)

OFFICIAL USE

Certified Mail Fee \$

Extra Services & Fees (check box, add fee as appropriate)

Return Receipt (hardcopy) \$

Return Receipt (electronic) \$

Certified Mail Restricted Delivery \$

Adult Signature Required \$

Adult Signature Restricted Delivery \$

Postage \$

Total Postage and Fees \$

Sent To  
Rodrigo Beltran  
5565 Renneberger Road  
Peyton, CO 80831

PS Form 3800, July 2020

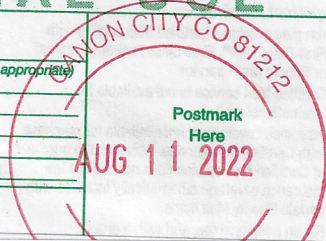

Returned

Pioneer Landscaping Materials Inc  
630 Plaza Drive, Suite 150  
Highlands Ranch, CO 80129

*Altern  
8/15  
Gate  
8/20  
8/30*

**CERTIFIED MAIL®**



7020 2450 0002 1853 6054

DENVER CO 802  
12 AUG 2022



1023

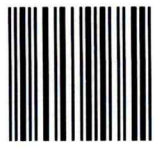

80831

**A4**

U.S. POSTAGE PAID  
FCM LETTER  
CANON CITY, CO  
81212  
AUG 12, 22  
AMOUNT

**\$4.60**

R2305K132786-11

Rodrigo Beltran  
5565 Renneberger Road  
Peyton, CO 80831



U.S. POSTAGE PAID  
FCM LETTER  
CANON CITY, CO  
81212  
AUG 12, 22  
AMOUNT

**\$2.25**

NIXIE 808 DE 1 0009/08/22

RETURN TO SENDER  
UNCLAIMED  
UNABLE TO FORWARD

BC: 80129275025 \*1820-08116-12-44

9 7 4 8 2 9 3 0 1 0 0 0 8 4 2 4 7 8 1 2

UNC  
801292750  
80831 7800005 0

