



PROVIDING VALUE FIRST

Solberg Pit - El Paso County Land Use Application Curtis Road & Garrett Road Traffic Impact Analysis

Peyton, CO

August 2023

PREPARED FOR:

Holcim WCR, Inc.

PREPARED BY:

Y2K Engineering, LLC.

Project No. 23-073

Contact: Rae Stephani PE, PTOE, RSP₁; rstephani@y2keng.com



1921 S. Alma School Rd, Ste 204, Mesa, AZ 85210



480.696.1701



info@y2keng.com

Table of Contents

EXECUTIVE SUMMARY	1
INTRODUCTION	2
STUDY OBJECTIVES.....	2
SCOPE OF STUDY	2
EXISTING CONDITIONS	3
SURROUNDING AREA.....	3
DESCRIPTION OF EXISTING TRANSPORTATION SYSTEM	4
ROADWAY CONDITION SURVEY.....	6
PROPOSED DEVELOPMENT	6
SITE LOCATION AND ACCESS	6
EXISTING TRAFFIC VOLUMES	6
DECELERATION AND TURN LANES	9
RECOMMENDED IMPROVEMENTS	10
PRINCIPAL FINDINGS	11
APPENDICES	12

List of Appendices

APPENDIX A:	REVIEW COMMENTS (RESERVED)
APPENDIX B:	ALL TRAFFIC DATA TRAFFIC VOLUMES
APPENDIX C:	EXISTING LEVEL OF SERVICE ANALYSIS
APPENDIX D:	SITE PLAN
APPENDIX E:	ROADWAY CONDITION SURVEY

List of Tables

Table 1: Level of Service Criteria.....	8
Table 2: 2023 Existing Level of Service Analysis	9
Table 3: El Paso County Engineering Criteria Manual - Table 2-30 - Required Storage Lengths for Stop Controlled Intersections	9
Table 4: Turn Lane Storage	10

List of Figures

Figure 1: Vicinity Map	2
Figure 2: Project Site Aerial.....	3
Figure 3: Existing Lane Configurations and Traffic Control	5
Figure 4: Site Plan.....	6
Figure 5: 2023 Existing Traffic Volumes.....	7
Figure 6: Site Driveway 24-Hour Volume Distribution	8

EXECUTIVE SUMMARY

Holcim WCR, Inc. is proposing a change in land use to a parcel of land immediately west of a sand quarry on the southwest corner of Garrett Road and Cutris Road in Peyton, Colorado. The proposed land use change will add an adjoining undeveloped parcel to the existing sand quarry. The material transported from the site will be sent north on Curtis Road and East on Garrett Road.

TRIP GENERATION

- The site currently generates 29 AM peak hour trips and 15 PM peak hour trips with 211 total daily trips.

SITE ACCESS

- The existing full access driveway on Curtis Road will be maintained and serve as the sole access point to the Solberg Pit.

LEVEL OF SERVICE ANALYSIS

- All approaches at the intersection of Curtis Road and Garrett Road are expected to operate at acceptable levels of service (LOS C or above) in both the AM and PM peak hour conditions. The intersection operates at LOS A in both the AM and PM peak hours.
- All approaches at the intersection of Curtis Road and Falcon Highway are expected to operate at acceptable levels of service (LOS C or above) in both the AM and PM peak hour conditions. The intersection operates at LOS A in both the AM and PM peak hours.

TURN LANE ANALYSIS

- Based on turn lane criteria storage criteria provided by AASHTO and El Paso County, the existing 340-foot right turn lane is expected to adequately serve southbound right turns into the site.
- The existing turn lanes on Curtis Road, Garrett Road, and Falcon Highway within the study corridor are expected to adequately serve turning movements.

RECOMMENDATIONS

- The existing roadway facilities are anticipated to accommodate existing traffic as well as future traffic conditions considering the expansion of Solberg Pit.

should this be west on Garrett?

Indicate the Haul vehicles destination from Garrett Rd. I assume that it is to Hwy 24 as opposed to another County Rd. Please state it in the report and clearly state that this is the intended Haul route

Also please indicate if all vehicles (haul vehicles & passenger car/truck) will utilize the same haul route.

INTRODUCTION

Holcim WCR, Inc. is proposing a change in land use to a parcel of land immediately west of a sand quarry on the southwest corner of Garrett Road and Cutris Road in Peyton, Colorado. The proposed land use change will add an adjoining undeveloped parcel to the existing sand quarry. The material transported from the site will be sent north on Curtis Road and **East** on Garrett Road.

STUDY OBJECTIVES

The objectives of the study include the following:

- Document existing conditions and perform an existing level of service analysis.
- Recommend roadway improvements, potentially including auxiliary lanes and a review of on-site circulation, to provide for a safe and efficient transportation system and to minimize impacts of the proposed development.

SCOPE OF STUDY

The Traffic Impact Analysis has been prepared in accordance with the El Paso County Engineering Criteria Manual (October 2020). The analysis year for the study is the opening year (assumed to be 2023).

Figure 1 provides the vicinity map and **Figure 2** includes an aerial of existing site.

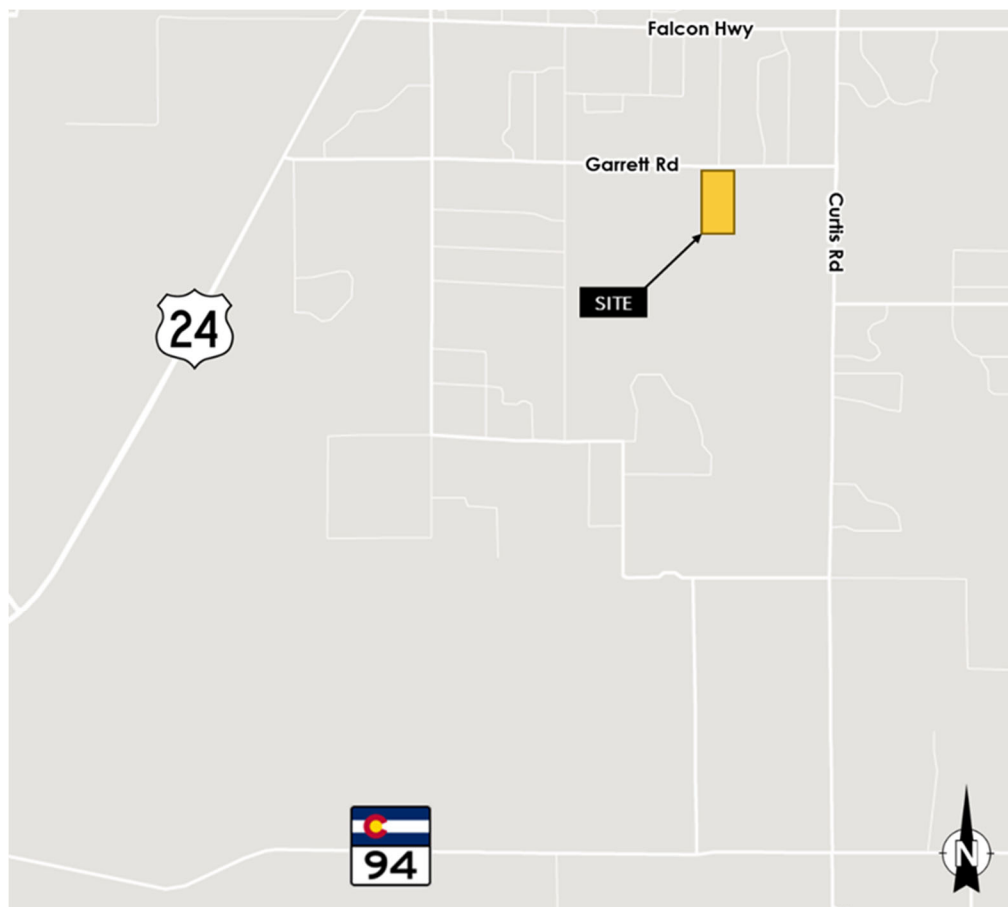

Figure 1: Vicinity Map

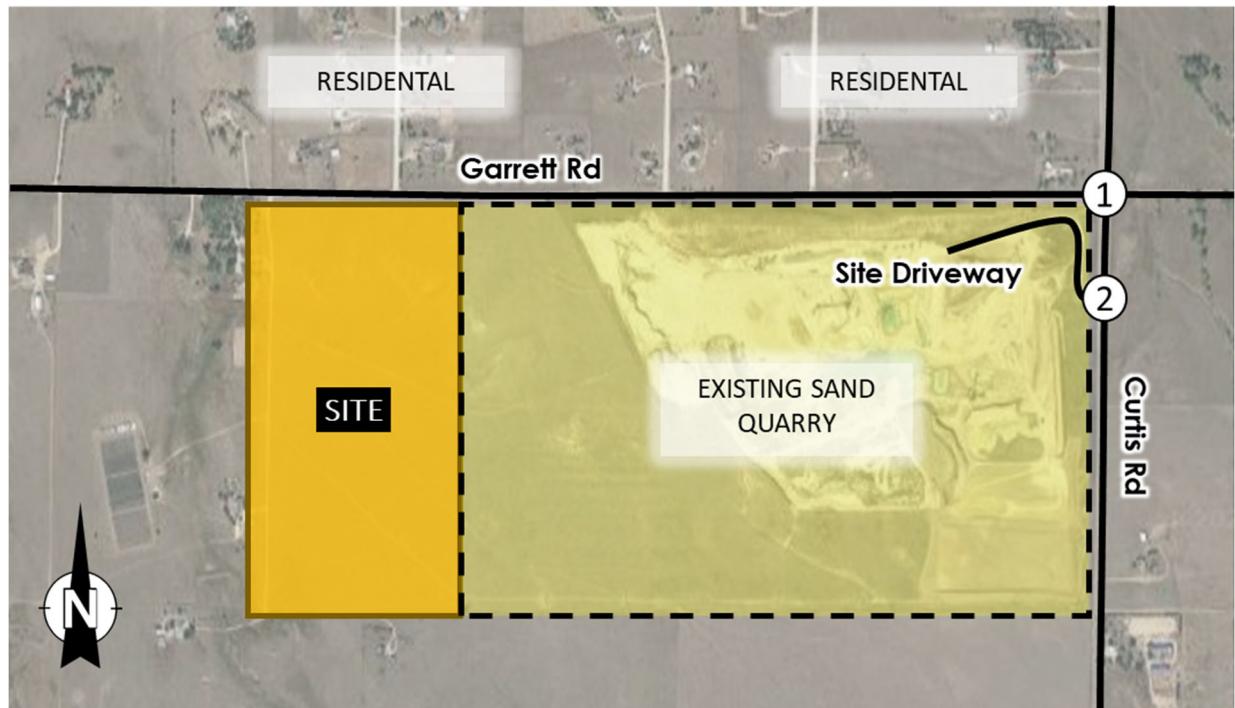

Figure 2: Project Site Aerial

STUDY AREA

The study area includes the following intersections:

- Curtis Road and Garrett Road
- Site Driveway and Curtis Road
- Falcon Highway and Curtis Road

ANALYSIS TIME PERIODS AND HORIZON YEARS

The weekday AM and PM peak hour periods were analyzed. The traffic analysis was conducted for the 2023 Opening Year.

EXISTING CONDITIONS

SURROUNDING AREA

The parcel is located approximately 4.5 miles north of Colorado State Highway 94 (SH-94) and three miles to the east of U.S. Route 24 (US 24). The parcel is currently undeveloped and borders an existing sand quarry with residential developments to the west and north. The existing lane configurations and intersections can be seen in **Figure 3**.

DESCRIPTION OF EXISTING TRANSPORTATION SYSTEM

GARRETT ROAD

Garrett Road is classified as a minor arterial per the El Paso County 2016 Major Transportation Corridors Plan Update and has an east-west orientation. The roadway features one lane in each direction. Garrett Road has a posted speed limit of 45 mph. Roadway facilities such as curbs, gutter, streetlights, sidewalks, and bike lanes are not present along Garrett Road. Overhead utilities run along the north side of the roadway. Garrett Road connects to U.S. Route 24 (US 24) approximately three miles west of the project site.

CURTIS ROAD

Curtis Road is a north-south roadway classified as a principal arterial by the El Paso County 2016 Major Transportation Corridors Plan Update. Within the vicinity of the project site, Curtis Road provides one lane in each direction. The posted speed limit is 45 mph. Facilities such as curbs, gutter, streetlights, sidewalks, and bike lanes are not provided on the roadway. Overhead utilities are available on both the east and west sides of Curtis Road. Approximately 4.5 miles to the south, Curtis Road connects directly to Colorado State Highway 94 (SH-94).

FALCON HIGHWAY

Falcon Highway is classified as a minor arterial per the El Paso County 2016 Major Transportation Corridors Plan Update and has an east-west orientation. The roadway features one lane in each direction. Falcon Highway has a posted speed limit of 45 mph. Roadway facilities such as curbs, gutter, streetlights, sidewalks, and bike lanes are not present along Falcon Highway. Falcon Highway connects to U.S. Route 24 (US 24) approximately three and a half miles west of Curtis Road.

INTERSECTION OF GARRETT ROAD AND CURTIS ROAD

The intersection of Garrett Road and Curtis Road is an unsignalized four-legged intersection that operates under two-way stop-control with the east and westbound direction stopping for through traffic on Curtis Road. The eastbound approach is served by a left-turn lane and a right-turn lane, both of which have a storage length of approximately 410 feet. The westbound approach is served by a shared left/right-turn lane. These two approaches are offset from each other by approximately 45 feet, measured from the centerline of each approach and both feature a STOP sign. A left-turn lane with a storage length of approximately 350 feet and a shared through/right-turn lane serve the northbound approach of the intersection. The southbound approach is served by a through lane and a right-turn lane with a storage length of approximately 280 feet. Pedestrian facilities such as crosswalks and ramps are not available on any leg of the intersection.

INTERSECTION OF SITE DRIVEWAY AND CURTIS ROAD

The existing sand quarry features a paved driveway that intersects with Curtis Road. The Site Driveway acts as the eastbound approach to the intersection. The intersection of the Site Driveway and Curtis Road is an unsignalized three-legged intersection that operates under minor-street stop-control. The eastbound approach is served by a shared left/right-turn lane. Eastbound traffic stops to northbound and southbound traffic. The northbound approach is served by one shared left/through lane and the southbound approach is served by a through lane and a right-turn lane with approximately 340 feet of queue storage. There are no pedestrian facilities available at the intersection.

INTERSECTION OF FALCON HIGHWAY AND CURTIS ROAD

The intersection of Falcon Highway and Curtis Road is an unsignaled four-legged intersection that operates under two-way stop-control with the north and southbound direction stopping for the east and westbound direction. A flashing beacon is present at the intersection to increase visibility and awareness of the traffic control condition. The eastbound approach is served by a through lane, a left-turn lane, and a right-turn lane. Both turn lanes have a storage length of approximately 315 feet. The westbound approach is served by a shared through/right-turn lane and a left turn lane with approximately 300 feet of storage. A left-turn lane with a storage length of approximately 430 feet and a shared through/right-turn lane serve the northbound approach of the intersection. A left-turn lane with a storage length of approximately 350 feet and a shared through/right-turn lane serve the southbound approach of the intersection. Pedestrian facilities such as crosswalks and ramps are not available on any leg of the intersection.

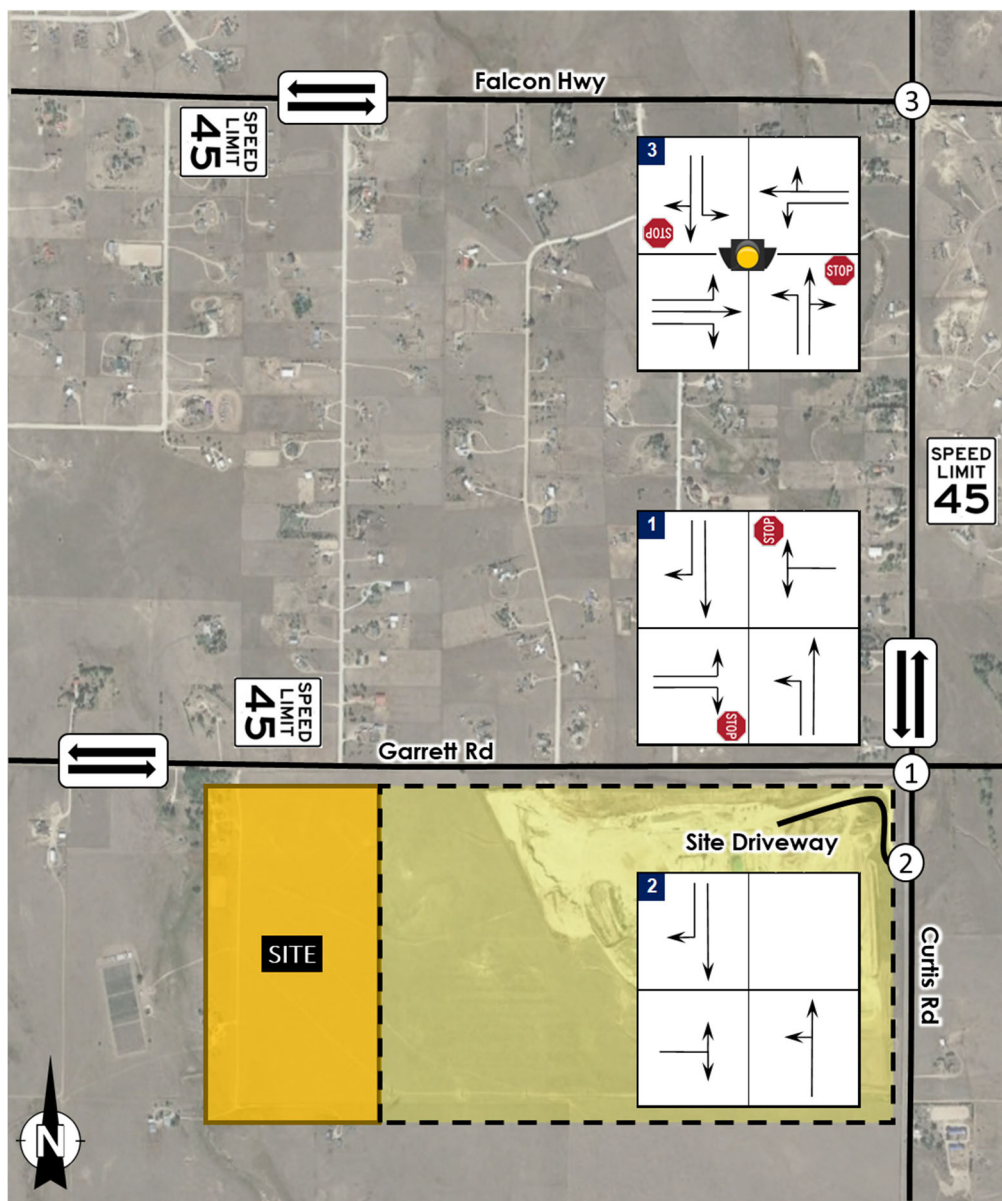

Figure 3: Existing Lane Configurations and Traffic Control

Please explain why it is not expected to change. Is the intent for operations in the existing quarry to shift to the new site and therefore traffic volume and patterns will stay the same? or will operations grow adding additional traffic which will need to be analyzed? please clearly address in the report and clearly state whether or not the expansion will change current traffic conditions.

ROADWAY CONDITION SURVEY

A field review was conducted at the site. During this review, photos of the roadway were taken of the roadway facing each direction (west and east on Garrett Road, north and south on Curtis Road). The roadway condition survey report is provided in **Appendix E**.

PROPOSED DEVELOPMENT

SITE LOCATION AND ACCESS

The project is located within an undeveloped parcel on the southwest corner of Garrett Road and Curtis Road in Peyton, Colorado. The parcel is located west of the existing sand quarry and will act as an extension of the facility. The proposed expansion is 79 acres. The site is accessed from an existing driveway, denoted as Site Driveway, on Curtis Road. The Site Driveway provides full access to the proposed site. While the addition of the west parcel will expand the area of the existing sand quarry, operational changes including frequency of traffic, number of employees, etc. is not expected to substantially change as a result of the added area. The site plan is shown in **Figure 4** and is provided in **Appendix D**.

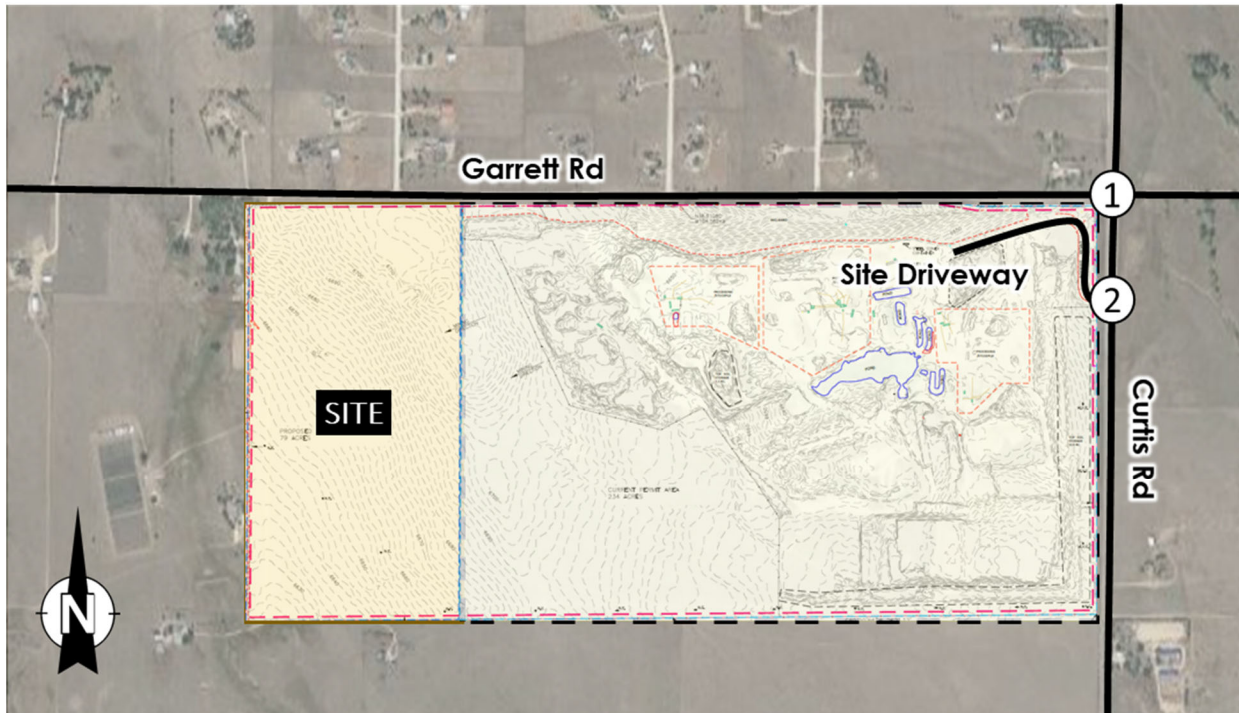

Figure 4: Site Plan

EXISTING TRAFFIC VOLUMES

TRAFFIC COUNTS

Peak hour turning movement traffic counts were collected on Thursday, July 13th, 2023 at the intersections of Curtis Road and Falcon Highway and Curtis Road and Garrett Road. Ingress and egress volumes were also collected at the site driveway on Curtis Road on the same day for a 24-hour period. Traffic volume data collected includes observed site traffic into and out of the Site Driveway and heavy vehicle volumes at the

two study intersections. Coordination with the Solberg Pit indicated that pit operations on July 13th were reflective of typical site conditions.

Traffic volumes at the two intersections were collected from 7:00-9:00 AM and 4:00-6:00 PM. Based on the existing traffic volumes, peak hours were identified as 7:00-8:00 AM and 4:00-5:00 PM. The peak hours for the driveway occurred between 7:00-8:00 AM, 10:30-11:30 AM, and 1:45-2:45 PM. No vehicles exited the site after 4:30 PM, and no vehicles entered the site after 5:15 PM. The 2023 traffic volumes are shown in **Figure 5**.

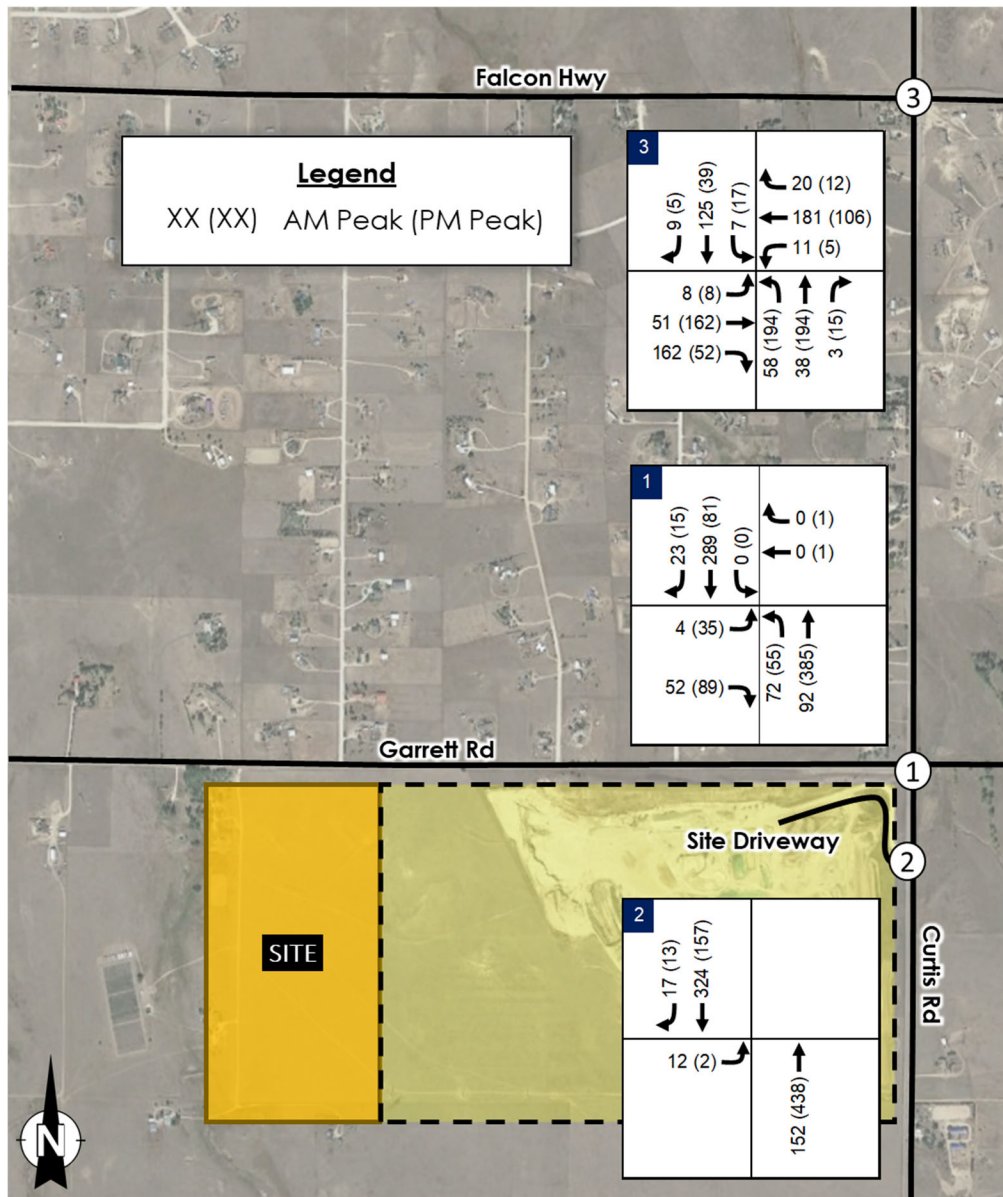

Figure 5: 2023 Existing Traffic Volumes

The total AM peak hour traffic at the site driveway was observed to be 29 vehicles, with 17 vehicles entering the site and 12 vehicles exiting the site. The observed PM peak hour recorded 15 total vehicles, with 13 vehicles entering and 2 vehicles exiting the site. At the site driveway, traffic volumes peak at 7:00 to 8:00

AM, slightly decrease in the late morning and early afternoon, then decline until all traffic stops by 5:15 PM. The total daily trips observed on July 13th, 2023, were 113 entering vehicles and 98 exiting vehicles, or 211 total daily trips. The 24-hour traffic distribution for the site driveway is shown in **Figure 6**.



Figure 6: Site Driveway 24-Hour Volume Distribution

LEVEL OF SERVICE ANALYSIS

The 2023 existing traffic volumes were analyzed to determine the level of service (LOS) during the weekday AM and PM peak hours at the existing intersections within the study area. As the inclusion of the west parcel is not expected to change the operations of the site, the existing analysis is expected to be reflective of the proposed condition. The LOS analysis was prepared using Synchro 11 software. The level of service criteria, as stated in the *Highway Capacity Manual, Sixth Edition*, is provided in **Table 1**. The analysis worksheets are included in **Appendix C**, and a summary of the existing level of service analysis is provided in **Table 2**.

Table 1: Level of Service Criteria

Level-of-Service	Average Delay (seconds per vehicle)	
	Unsignalized	Signalized
A	≤ 10	≤ 10
B	> 10 to 15	> 10 to 20
C	> 15 to 25	> 20 to 35
D	> 25 to 35	> 35 to 55
E	> 35 to 50	> 55 to 80
F	> 50	> 80

Table 2: 2023 Existing Level of Service Analysis

Intersection	Traffic Control	Movement/ Approach	Existing Conditions			
			AM Peak Hour		PM Peak Hour	
			Avg Delay (sec/veh)	LOS	Avg Delay (sec/veh)	LOS
1 Curtis Rd & Garrett Rd	Minor Street Stop Control	INTERSECTION	2.4	A	2.8	A
		EB Approach	11.1	B	11.3	B
		EB Left	14.6	B	16.5	C
		EB Thru/Right	10.6	B	9.2	A
		WB Approach	0.0	A	13.1	B
		NB Approach	3.7	A	1.0	A
		NB Left	8.5	A	7.6	A
2 Curtis Rd & Site Driveway	Minor Street Stop Control	INTERSECTION	0.5	A	0.1	A
		EB Approach	15.8	C	17.8	C
3 Curtis Rd & Falcon Hwy	Minor Street Stop Control	INTERSECTION	5.6	A	9.8	A
		EB Approach	0.3	A	0.3	A
		EB Left	7.9	A	7.6	A
		WB Approach	0.4	A	0.3	A
		WB Left	7.7	A	8.2	A
		NB Approach	14.9	B	17.1	C
		NB Left	16.6	C	17.5	C
		NB Thru/Right	12.5	B	16.8	C
		SB Approach	16.5	C	14.1	B
		SB Left	13.2	B	17.9	C
SB Thru/Right	16.7	C	12.6	B		

Under existing traffic conditions, all approaches operate at acceptable levels of service (LOS C or above).

DECELERATION AND TURN LANES

Turn lane storage length criteria is provided by El Paso County Engineering Criteria Manual and is shown in **Table 3**.

Table 3: El Paso County Engineering Criteria Manual - Table 2-30 - Required Storage Lengths for Stop Controlled Intersections

DHV (VPH)	<60	61—120	121—180	181—250	>250
Storage Length (feet)	50—75	100	150	200	250 or more

According to El Paso County, the primary factors that determine the required length of deceleration lanes involve the number of vehicles-per-hour and the intersection control type. The design speed for Curtis

Road, Garrett Road, and Falcon Highway was assumed to be 50 mph to conduct a conservative estimate for storage length.

AASHTO guidance recommends that turn lanes at unsignalized intersections accommodate the number of vehicles likely to arrive in a 2-minute period. In this methodology, a vehicle length of 50 feet was assumed for only the Site Driveway because of the high percentage of heavy vehicles that will use the driveway as opposed to a typical 25-foot length assumed for passenger vehicles. A vehicle length of 25 feet was assumed for both Curtis Road and Garrett Road and Curtis Road and Falcon Highway. The resulting storage lengths are rounded to the nearest 25 feet. The turn lane storage for the study intersections was calculated using the AASHTO methodology and the El Paso County guidelines. Results of that calculation are shown in **Table 4** below.

Table 4: Turn Lane Storage

Intersection	Traffic Control	Movement	AM/PM Volume (vph)	Queue Storage (ft)			
				AASHTO	Table 2-30	Existing	Recommended
1 Curtis Rd & Garrett Rd	Two Way Stop Sign	NB Left	72 / 55	75	100	350	350*
		EB Left	4 / 35	50	75	410	410*
		SB Right	23 / 15	25	75	280	280*
		EB Right	52 / 89	75	100	410	410*
2 Curtis Rd & Site Driveway	Two Way Stop Sign	SB Right	17 / 13	50	75	340	340*
3 Curtis Rd & Falcon Hwy	Two Way Stop Sign	NB Left	58 / 194	175	200	430	430*
		SB Left	7 / 17	25	75	350	350*
		EB Left	8 / 8	25	75	315	315*
		WB Left	11 / 5	25	75	300	300*
		EB Right	162 / 52	150	150	315	315*

*Existing storage length - no change recommended

Based on the AASHTO and El Paso County criteria, a storage length of 75 feet is recommended for the southbound right turn lane into the site. The existing 340-foot right-turn lane is expected to adequately serve southbound right turns into the site.

RECOMMENDED IMPROVEMENTS

Recommendations are based on the deceleration and turn lane analysis along with the existing traffic analysis. The existing roadway facilities are expected to accommodate all existing traffic, including turning vehicles into the existing Solberg Pit. As changes to the traffic conditions are not expected as a result of the inclusion of the additional parcel, the existing roadway facilities are expected to adequately accommodate future traffic.

PRINCIPAL FINDINGS

TRIP GENERATION

- The site currently generates 29 AM peak hour trips and 15 PM peak hour trips with 211 total daily trips.

SITE ACCESS

- The existing full access driveway on Curtis Road will be maintained and serve as the sole access point to the Solberg Pit.

LEVEL OF SERVICE ANALYSIS

- All approaches at the intersection of Curtis Road and Garrett Road are expected to operate at acceptable levels of service (LOS C or above) in both the AM and PM peak hour conditions. The intersection operates at LOS A in both the AM and PM peak hours.
- All approaches at the intersection of Curtis Road and the Site Driveway operate are expected to operate at acceptable levels of service (LOS C or above) in both the AM and PM peak hour conditions. The intersection operates at LOS A in both the AM and PM peak hours.
- All approaches at the intersection of Curtis Road and Falcon Highway are expected to operate at acceptable levels of service (LOS C or above) in both the AM and PM peak hour conditions. The intersection operates at LOS A in both the AM and PM peak hours.

TURN LANE ANALYSIS

- Based on turn lane criteria storage criteria provided by AASHTO and El Paso County, the existing 340-foot right turn lane is expected to adequately serve southbound right turns into the site.
- The existing turn lanes on Curtis Road, Garrett Road, and Falcon Highway within the study corridor are expected to adequately serve turning movements.

RECOMMENDATIONS

- The existing roadway facilities are anticipated to accommodate existing traffic as well as future traffic conditions considering the expansion of Solberg Pit.

APPENDICES

APPENDIX A: REVIEW COMMENTS (RESERVED)

APPENDIX B: ALL TRAFFIC DATA TRAFFIC VOLUMES

Location: 1 CURTIS RD & FALCON HWY AM

Date: Thursday, July 13, 2023

Peak Hour: 07:00 AM - 08:00 AM

Peak 15-Minutes: 07:15 AM - 07:30 AM

Peak Hour - Motorized Vehicles

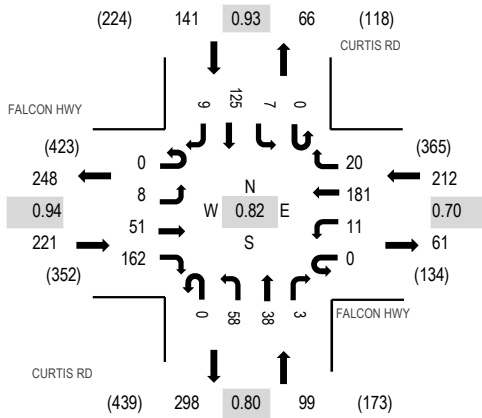

Peak Hour - Bicycles

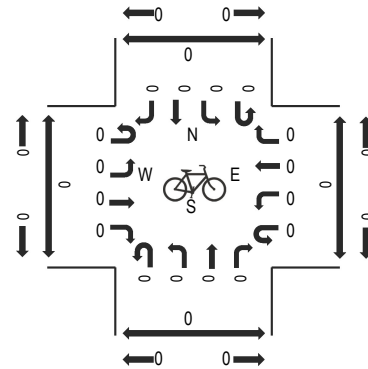

Peak Hour - Pedestrians

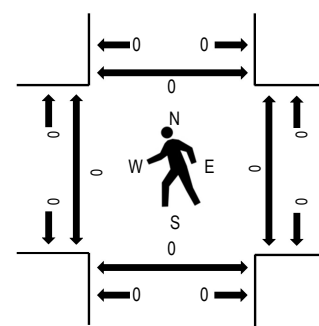

Note: Total study counts contained in parentheses.

Traffic Counts - Motorized Vehicles

Interval Start Time	FALCON HWY Eastbound				FALCON HWY Westbound				CURTIS RD Northbound				CURTIS RD Southbound				Total	Rolling Hour	Pedestrian Crossings			
	U-Turn	Left	Thru	Right	U-Turn	Left	Thru	Right	U-Turn	Left	Thru	Right	U-Turn	Left	Thru	Right			West	East	South	North
7:00 AM	0	2	9	45	0	4	43	5	0	16	4	0	0	4	30	1	163	673	0	0	0	0
7:15 AM	0	1	10	48	0	3	66	7	0	14	16	1	0	0	36	2	204	617	0	0	0	0
7:30 AM	0	3	11	44	0	3	43	4	0	14	11	2	0	2	29	4	170	520	0	0	0	0
7:45 AM	0	2	21	25	0	1	29	4	0	14	7	0	0	1	30	2	136	456	0	0	0	0
8:00 AM	0	4	9	21	0	2	29	0	0	11	5	2	0	2	21	1	107	441	0	0	0	0
8:15 AM	0	1	15	11	0	4	35	6	0	10	5	0	0	0	17	3	107		0	0	0	0
8:30 AM	0	0	12	17	0	4	32	6	0	7	7	2	0	3	13	3	106		0	0	0	0
8:45 AM	0	1	23	17	0	1	28	6	0	14	11	0	0	5	13	2	121		0	0	0	0
Count Total	0	14	110	228	0	22	305	38	0	100	66	7	0	17	189	18	1,114		0	0	0	0
Peak Hour	0	8	51	162	0	11	181	20	0	58	38	3	0	7	125	9	673		0	0	0	0

Peak Hour - Motorized Vehicles

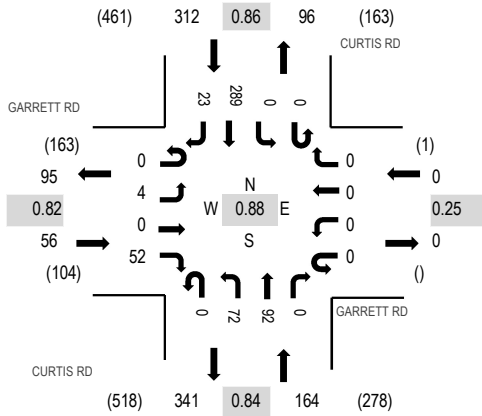

Peak Hour - Bicycles

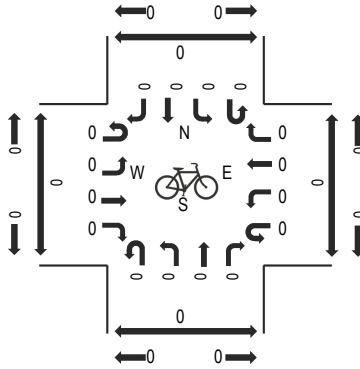

Peak Hour - Pedestrians

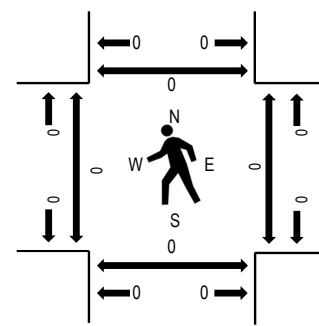

Note: Total study counts contained in parentheses.

Traffic Counts - Motorized Vehicles

Interval Start Time	GARRETT RD Eastbound				GARRETT RD Westbound				CURTIS RD Northbound				CURTIS RD Southbound				Total	Rolling Hour	Pedestrian Crossings				
	U-Turn	Left	Thru	Right	U-Turn	Left	Thru	Right	U-Turn	Left	Thru	Right	U-Turn	Left	Thru	Right			West	East	South	North	
7:00 AM	0	0	0	14	0	0	0	0	0	13	23	0	0	0	0	74	4	128	532	0	0	0	0
7:15 AM	0	1	0	16	0	0	0	0	0	19	29	0	0	0	0	79	7	151	488	0	0	0	0
7:30 AM	0	1	0	10	0	0	0	0	0	26	23	0	0	0	0	82	9	151	419	0	0	0	0
7:45 AM	0	2	0	12	0	0	0	0	0	14	17	0	0	0	0	54	3	102	340	0	0	0	0
8:00 AM	0	0	0	12	0	0	1	0	0	9	15	0	0	0	0	42	5	84	312	0	0	0	0
8:15 AM	0	0	0	16	0	0	0	0	0	14	16	0	0	0	0	31	5	82		0	0	0	0
8:30 AM	0	1	0	8	0	0	0	0	0	17	13	0	0	0	0	30	3	72		0	0	0	0
8:45 AM	0	2	0	9	0	0	0	0	0	10	20	0	0	0	0	29	4	74		0	0	0	0
Count Total	0	7	0	97	0	0	1	0	0	122	156	0	0	0	0	421	40	844		0	0	0	0
Peak Hour	0	4	0	52	0	0	0	0	0	72	92	0	0	0	0	289	23	532		0	0	0	0

Peak Hour - Motorized Vehicles

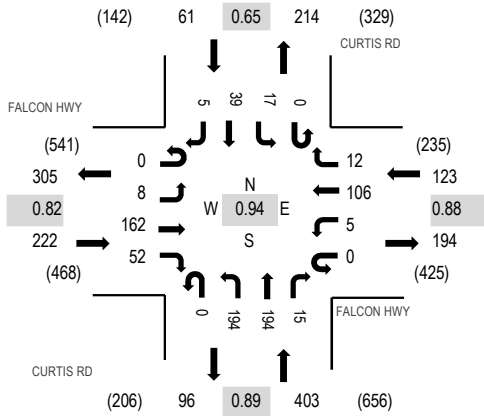

Peak Hour - Bicycles

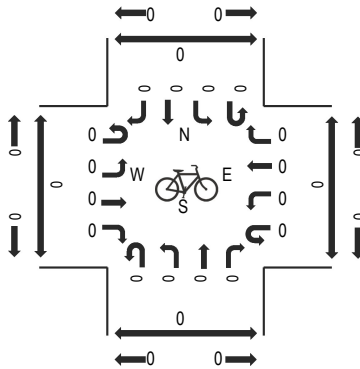

Peak Hour - Pedestrians

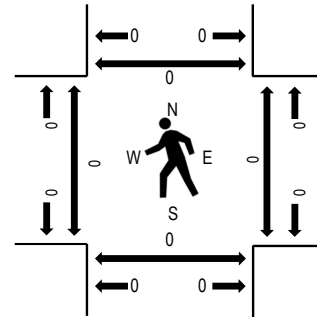

Note: Total study counts contained in parentheses.

Traffic Counts - Motorized Vehicles

Interval Start Time	FALCON HWY Eastbound				FALCON HWY Westbound				CURTIS RD Northbound				CURTIS RD Southbound				Total	Rolling Hour	Pedestrian Crossings			
	U-Turn	Left	Thru	Right	U-Turn	Left	Thru	Right	U-Turn	Left	Thru	Right	U-Turn	Left	Thru	Right			West	East	South	North
4:00 PM	0	2	50	10	0	3	31	1	0	34	42	1	0	4	12	0	190	809	0	0	0	0
4:15 PM	0	0	36	11	0	2	26	4	0	58	51	5	0	9	9	4	215	784	0	0	0	0
4:30 PM	0	2	41	22	0	0	29	3	0	53	43	6	0	4	9	1	213	767	0	0	0	0
4:45 PM	0	4	35	9	0	0	20	4	0	49	58	3	0	0	9	0	191	720	0	0	0	0
5:00 PM	0	4	28	9	0	0	23	3	0	40	32	8	0	3	13	2	165	692	0	0	0	0
5:15 PM	0	1	50	20	0	1	27	0	0	30	31	7	0	6	18	7	198		0	0	0	0
5:30 PM	0	0	43	16	0	1	24	3	0	29	22	8	0	6	13	1	166		0	0	0	0
5:45 PM	0	1	61	13	0	0	26	4	0	26	14	6	0	5	6	1	163		0	0	0	0
Count Total	0	14	344	110	0	7	206	22	0	319	293	44	0	37	89	16	1,501		0	0	0	0
Peak Hour	0	8	162	52	0	5	106	12	0	194	194	15	0	17	39	5	809		0	0	0	0

Peak Hour - Motorized Vehicles

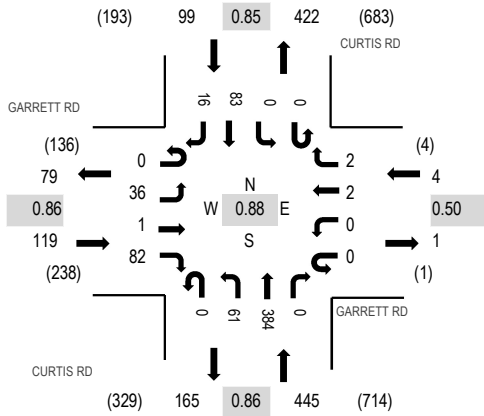

Peak Hour - Bicycles

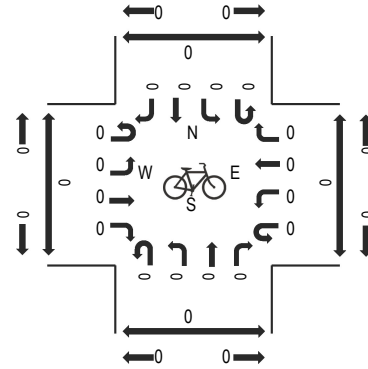

Peak Hour - Pedestrians

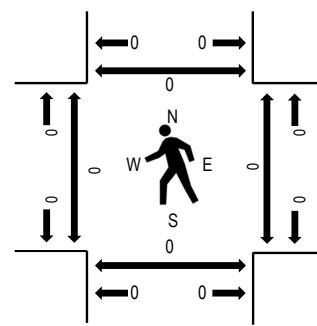

Note: Total study counts contained in parentheses.

Traffic Counts - Motorized Vehicles

Interval Start Time	GARRETT RD Eastbound				GARRETT RD Westbound				CURTIS RD Northbound				CURTIS RD Southbound				Total	Rolling Hour	Pedestrian Crossings			
	U-Turn	Left	Thru	Right	U-Turn	Left	Thru	Right	U-Turn	Left	Thru	Right	U-Turn	Left	Thru	Right			West	East	South	North
4:00 PM	0	7	0	23	0	0	0	0	0	13	72	0	0	0	21	1	137	662	0	0	0	0
4:15 PM	0	12	0	17	0	0	1	0	0	16	114	0	0	0	23	6	189	667	0	0	0	0
4:30 PM	0	8	0	28	0	0	0	1	0	17	102	0	0	0	23	3	182	610	0	0	0	0
4:45 PM	0	8	0	21	0	0	0	0	0	9	97	0	0	0	14	5	154	547	0	0	0	0
5:00 PM	0	8	1	16	0	0	1	1	0	19	71	0	0	0	23	2	142	487	0	0	0	0
5:15 PM	0	9	0	23	0	0	0	0	0	13	59	0	0	0	24	4	132		0	0	0	0
5:30 PM	2	11	0	14	0	0	0	0	0	8	57	0	0	0	24	3	119		0	0	0	0
5:45 PM	0	10	0	20	0	0	0	0	0	11	36	0	0	0	15	2	94		0	0	0	0
Count Total	2	73	1	162	0	0	2	2	0	106	608	0	0	0	167	26	1,149		0	0	0	0
Peak Hour	0	36	1	82	0	0	2	2	0	61	384	0	0	0	83	16	667		0	0	0	0

Vehicle Volume Report - Hourly

Site Description: DRIVEWAY W.O. CURTIS RD
 Site Number: 3
 Start Date: 7/13/2023
 End Date: 7/13/2023

Time	Monday			Tuesday			Wednesday			Thursday			Friday			Saturday			Sunday			3 Day Avg		5 Day Avg		7 Day Avg	
	7/17/23			7/18/23			7/19/23			7/20/23			7/21/23			7/22/23			7/23/23			Tue-Thu		Mon-Fri		Mon-Sun	
	EB	WB	Total	EB	WB	Total	EB	WB	Total	EB	WB	Total	EB	WB	Total	EB	WB	Total	EB	WB	Total	EB	WB	EB	WB	EB	WB
12:00 AM	-	-	-	-	-	-	-	-	-	0	0	0	-	-	-	-	-	-	-	-	-	-	-	-	-	-	
1:00 AM	-	-	-	-	-	-	-	-	-	0	0	0	-	-	-	-	-	-	-	-	-	-	-	-	-	-	
2:00 AM	-	-	-	-	-	-	-	-	-	0	0	0	-	-	-	-	-	-	-	-	-	-	-	-	-	-	
3:00 AM	-	-	-	-	-	-	-	-	-	0	0	0	-	-	-	-	-	-	-	-	-	-	-	-	-	-	
4:00 AM	-	-	-	-	-	-	-	-	-	0	0	0	-	-	-	-	-	-	-	-	-	-	-	-	-	-	
5:00 AM	-	-	-	-	-	-	-	-	-	3	0	3	-	-	-	-	-	-	-	-	-	-	-	-	-	-	
6:00 AM	-	-	-	-	-	-	-	-	-	12	1	13	-	-	-	-	-	-	-	-	-	-	-	-	-	-	
7:00 AM	-	-	-	-	-	-	-	-	-	12	17	29	-	-	-	-	-	-	-	-	-	-	-	-	-	-	
8:00 AM	-	-	-	-	-	-	-	-	-	7	9	16	-	-	-	-	-	-	-	-	-	-	-	-	-	-	
9:00 AM	-	-	-	-	-	-	-	-	-	11	9	20	-	-	-	-	-	-	-	-	-	-	-	-	-	-	
10:00 AM	-	-	-	-	-	-	-	-	-	12	12	24	-	-	-	-	-	-	-	-	-	-	-	-	-	-	
11:00 AM	-	-	-	-	-	-	-	-	-	7	8	15	-	-	-	-	-	-	-	-	-	-	-	-	-	-	
12:00 PM	-	-	-	-	-	-	-	-	-	9	12	21	-	-	-	-	-	-	-	-	-	-	-	-	-	-	
1:00 PM	-	-	-	-	-	-	-	-	-	7	7	14	-	-	-	-	-	-	-	-	-	-	-	-	-	-	
2:00 PM	-	-	-	-	-	-	-	-	-	7	14	21	-	-	-	-	-	-	-	-	-	-	-	-	-	-	
3:00 PM	-	-	-	-	-	-	-	-	-	9	6	15	-	-	-	-	-	-	-	-	-	-	-	-	-	-	
4:00 PM	-	-	-	-	-	-	-	-	-	2	13	15	-	-	-	-	-	-	-	-	-	-	-	-	-	-	
5:00 PM	-	-	-	-	-	-	-	-	-	0	5	5	-	-	-	-	-	-	-	-	-	-	-	-	-	-	
6:00 PM	-	-	-	-	-	-	-	-	-	0	0	0	-	-	-	-	-	-	-	-	-	-	-	-	-	-	
7:00 PM	-	-	-	-	-	-	-	-	-	0	0	0	-	-	-	-	-	-	-	-	-	-	-	-	-	-	
8:00 PM	-	-	-	-	-	-	-	-	-	0	0	0	-	-	-	-	-	-	-	-	-	-	-	-	-	-	
9:00 PM	-	-	-	-	-	-	-	-	-	0	0	0	-	-	-	-	-	-	-	-	-	-	-	-	-	-	
10:00 PM	-	-	-	-	-	-	-	-	-	0	0	0	-	-	-	-	-	-	-	-	-	-	-	-	-	-	
11:00 PM	-	-	-	-	-	-	-	-	-	0	0	0	-	-	-	-	-	-	-	-	-	-	-	-	-	-	
6:00 AM - 9:00 AM	-	-	-	-	-	-	-	-	-	31	27	58	-	-	-	-	-	-	-	-	-	-	-	-	-	-	
3:00 PM - 6:00 PM	-	-	-	-	-	-	-	-	-	11	24	35	-	-	-	-	-	-	-	-	-	-	-	-	-	-	
6:00 AM - 7:00 PM	-	-	-	-	-	-	-	-	-	95	113	208	-	-	-	-	-	-	-	-	-	-	-	-	-	-	
12:00 AM - 12:00 AM	-	-	-	-	-	-	-	-	-	98	113	211	-	-	-	-	-	-	-	-	-	-	-	-	-	-	
Percent	-	-	-	-	-	-	-	-	-	46.4%	53.6%	100.0%	-	-	-	-	-	-	-	-	-	-	-	-	-	-	
AM Peak	-	-	-	-	-	-	-	-	-	7:00 AM	8:00 AM	-	-	-	-	-	-	-	-	-	-	-	-	-	-	-	
PM Peak	-	-	-	-	-	-	-	-	-	12:00 PM	1:00 PM	-	-	-	-	-	-	-	-	-	-	-	-	-	-	-	

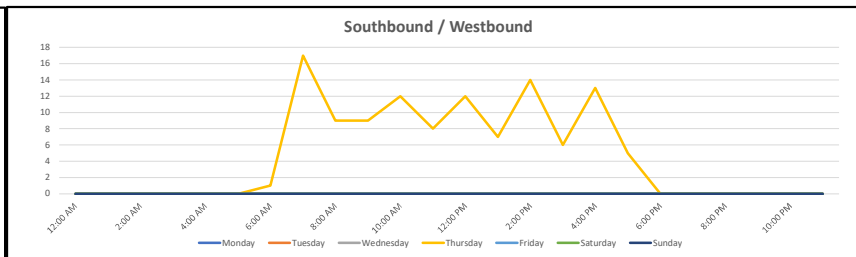
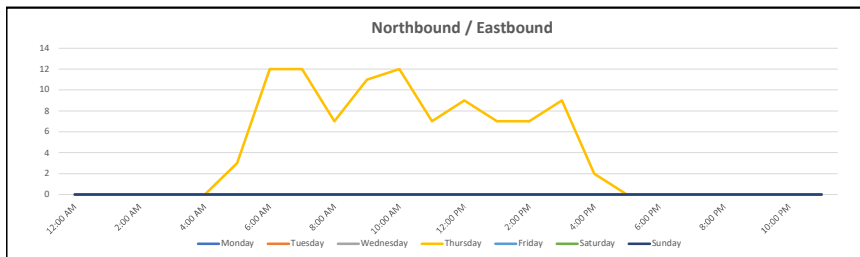

APPENDIX C: EXISTING LEVEL OF SERVICE ANALYSIS

1: Curtis Rd & Garrett Rd
AM Peak Hour

HCM 6th TWSC

Intersection												
Int Delay, s/veh	2.4											
Movement	EBL	EBT	EBR	WBL	WBT	WBR	NBL	NBT	NBR	SBL	SBT	SBR
Lane Configurations		↖	↗		↔		↖	↗			↖	↗
Traffic Vol, veh/h	4	0	52	0	0	0	72	92	0	0	289	23
Future Vol, veh/h	4	0	52	0	0	0	72	92	0	0	289	23
Conflicting Peds, #/hr	0	0	0	0	0	0	0	0	0	0	0	0
Sign Control	Stop	Stop	Stop	Stop	Stop	Stop	Free	Free	Free	Free	Free	Free
RT Channelized	-	-	None	-	-	None	-	-	None	-	-	None
Storage Length	-	-	410	-	-	-	350	-	-	-	-	280
Veh in Median Storage, #	-	0	-	-	0	-	-	0	-	-	0	-
Grade, %	-	0	-	-	0	-	-	0	-	-	0	-
Peak Hour Factor	82	82	82	25	25	25	84	84	84	86	86	86
Heavy Vehicles, %	0	0	11	0	0	0	15	10	0	0	1	0
Mvmt Flow	5	0	63	0	0	0	86	110	0	0	336	27

Major/Minor	Minor2		Minor1			Major1		Major2				
Conflicting Flow All	618	618	336	663	645	110	363	0	0	110	0	0
Stage 1	336	336	-	282	282	-	-	-	-	-	-	-
Stage 2	282	282	-	381	363	-	-	-	-	-	-	-
Critical Hdwy	7.1	6.5	6.31	7.1	6.5	6.2	4.25	-	-	4.1	-	-
Critical Hdwy Stg 1	6.1	5.5	-	6.1	5.5	-	-	-	-	-	-	-
Critical Hdwy Stg 2	6.1	5.5	-	6.1	5.5	-	-	-	-	-	-	-
Follow-up Hdwy	3.5	4	3.399	3.5	4	3.3	2.335	-	-	2.2	-	-
Pot Cap-1 Maneuver	404	408	686	377	393	949	1127	-	-	1493	-	-
Stage 1	682	645	-	729	681	-	-	-	-	-	-	-
Stage 2	729	681	-	645	628	-	-	-	-	-	-	-
Platoon blocked, %								-	-	-	-	-
Mov Cap-1 Maneuver	381	377	686	322	363	949	1127	-	-	1493	-	-
Mov Cap-2 Maneuver	381	377	-	322	363	-	-	-	-	-	-	-
Stage 1	630	645	-	674	629	-	-	-	-	-	-	-
Stage 2	673	629	-	585	628	-	-	-	-	-	-	-

Approach	EB		WB		NB		SB	
HCM Control Delay, s	11.1		0		3.7		0	
HCM LOS	B		A					

Minor Lane/Major Mvmt	NBL	NBT	NBR	EBLn1	EBLn2	WBLn1	SBL	SBT	SBR
Capacity (veh/h)	1127	-	-	381	686	-	1493	-	-
HCM Lane V/C Ratio	0.076	-	-	0.013	0.092	-	-	-	-
HCM Control Delay (s)	8.5	-	-	14.6	10.8	0	0	-	-
HCM Lane LOS	A	-	-	B	B	A	A	-	-
HCM 95th %tile Q(veh)	0.2	-	-	0	0.3	-	0	-	-

2: Curtis Rd & Site Driveway
AM Peak Hour

HCM 6th TWSC

Intersection						
Int Delay, s/veh	0.5					
Movement	EBL	EBR	NBL	NBT	SBT	SBR
Lane Configurations	↔			↔	↔	↔
Traffic Vol, veh/h	12	0	0	152	324	17
Future Vol, veh/h	12	0	0	152	324	17
Conflicting Peds, #/hr	0	0	0	0	0	0
Sign Control	Stop	Stop	Free	Free	Free	Free
RT Channelized	-	None	-	None	-	None
Storage Length	0	-	-	-	-	340
Veh in Median Storage, #	0	-	-	0	0	-
Grade, %	0	-	-	0	0	-
Peak Hour Factor	60	60	47	84	84	47
Heavy Vehicles, %	100	100	100	2	2	100
Mvmt Flow	20	0	0	181	386	36

Major/Minor	Minor2	Major1	Major2			
Conflicting Flow All	567	386	422	0	-	0
Stage 1	386	-	-	-	-	-
Stage 2	181	-	-	-	-	-
Critical Hdwy	7.4	7.2	5.1	-	-	-
Critical Hdwy Stg 1	6.4	-	-	-	-	-
Critical Hdwy Stg 2	6.4	-	-	-	-	-
Follow-up Hdwy	4.4	4.2	3.1	-	-	-
Pot Cap-1 Maneuver	354	492	762	-	-	-
Stage 1	517	-	-	-	-	-
Stage 2	661	-	-	-	-	-
Platoon blocked, %				-	-	-
Mov Cap-1 Maneuver	354	492	762	-	-	-
Mov Cap-2 Maneuver	354	-	-	-	-	-
Stage 1	517	-	-	-	-	-
Stage 2	661	-	-	-	-	-

Approach	EB	NB	SB
HCM Control Delay, s	15.8	0	0
HCM LOS	C		

Minor Lane/Major Mvmt	NBL	NBT	EBLn1	SBT	SBR
Capacity (veh/h)	762	-	354	-	-
HCM Lane V/C Ratio	-	-	0.056	-	-
HCM Control Delay (s)	0	-	15.8	-	-
HCM Lane LOS	A	-	C	-	-
HCM 95th %tile Q(veh)	0	-	0.2	-	-

3: Curtis Rd & Falcon Hwy
AM Peak Hour

HCM 6th TWSC

Intersection												
Int Delay, s/veh	5.6											
Movement	EBL	EBT	EBR	WBL	WBT	WBR	NBL	NBT	NBR	SBL	SBT	SBR
Lane Configurations	↙	↑	↗	↙	↑	↗	↙	↑	↗	↙	↑	↗
Traffic Vol, veh/h	8	51	162	11	181	20	58	38	3	7	125	9
Future Vol, veh/h	8	51	162	11	181	20	58	38	3	7	125	9
Conflicting Peds, #/hr	0	0	0	0	0	0	0	0	0	0	0	0
Sign Control	Free	Free	Free	Free	Free	Free	Stop	Stop	Stop	Stop	Stop	Stop
RT Channelized	-	-	None	-	-	None	-	-	None	-	-	None
Storage Length	315	-	315	300	-	-	430	-	-	350	-	-
Veh in Median Storage, #	-	0	-	-	0	-	-	0	-	-	0	-
Grade, %	-	0	-	-	0	-	-	0	-	-	0	-
Peak Hour Factor	94	94	94	70	70	70	80	80	80	93	93	93
Heavy Vehicles, %	3	3	3	2	2	2	5	18	10	0	0	0
Mvmt Flow	9	54	172	16	259	29	73	48	4	8	134	10

Major/Minor	Major1			Major2			Minor1			Minor2		
Conflicting Flow All	288	0	0	226	0	0	450	392	54	490	550	274
Stage 1	-	-	-	-	-	-	72	72	-	306	306	-
Stage 2	-	-	-	-	-	-	378	320	-	184	244	-
Critical Hdwy	4.13	-	-	4.12	-	-	7.15	6.68	6.3	7.1	6.5	6.2
Critical Hdwy Stg 1	-	-	-	-	-	-	6.15	5.68	-	6.1	5.5	-
Critical Hdwy Stg 2	-	-	-	-	-	-	6.15	5.68	-	6.1	5.5	-
Follow-up Hdwy	2.227	-	-	2.218	-	-	3.545	4.162	3.39	3.5	4	3.3
Pot Cap-1 Maneuver	1268	-	-	1342	-	-	514	520	991	492	446	770
Stage 1	-	-	-	-	-	-	930	805	-	708	665	-
Stage 2	-	-	-	-	-	-	638	625	-	822	708	-
Platoon blocked, %	-	-	-	-	-	-	-	-	-	-	-	-
Mov Cap-1 Maneuver	1268	-	-	1342	-	-	382	510	991	449	438	770
Mov Cap-2 Maneuver	-	-	-	-	-	-	382	510	-	449	438	-
Stage 1	-	-	-	-	-	-	923	799	-	703	657	-
Stage 2	-	-	-	-	-	-	495	618	-	765	703	-

Approach	EB			WB			NB			SB		
HCM Control Delay, s	0.3			0.4			14.9			16.5		
HCM LOS							B			C		

Minor Lane/Major Mvmt	NBLn1	NBLn2	EBL	EBT	EBR	WBL	WBT	WBR	SBLn1	SBLn2
Capacity (veh/h)	382	529	1268	-	-	1342	-	-	449	451
HCM Lane V/C Ratio	0.19	0.097	0.007	-	-	0.012	-	-	0.017	0.319
HCM Control Delay (s)	16.6	12.5	7.9	-	-	7.7	-	-	13.2	16.7
HCM Lane LOS	C	B	A	-	-	A	-	-	B	C
HCM 95th %tile Q(veh)	0.7	0.3	0	-	-	0	-	-	0.1	1.4

1: Curtis Rd & Garrett Rd
PM Peak Hour

HCM 6th TWSC

Intersection												
Int Delay, s/veh	2.8											
Movement	EBL	EBT	EBR	WBL	WBT	WBR	NBL	NBT	NBR	SBL	SBT	SBR
Lane Configurations		↖	↗		↔		↖	↗			↖	↗
Traffic Vol, veh/h	35	0	89	0	1	1	55	385	0	0	81	15
Future Vol, veh/h	35	0	89	0	1	1	55	385	0	0	81	15
Conflicting Peds, #/hr	0	0	0	0	0	0	0	0	0	0	0	0
Sign Control	Stop	Stop	Stop	Stop	Stop	Stop	Free	Free	Free	Free	Free	Free
RT Channelized	-	-	None	-	-	None	-	-	None	-	-	None
Storage Length	-	-	410	-	-	-	350	-	-	-	-	280
Veh in Median Storage, #	-	0	-	-	0	-	-	0	-	-	0	-
Grade, %	-	0	-	-	0	-	-	0	-	-	0	-
Peak Hour Factor	86	86	86	50	50	50	86	86	86	85	85	85
Heavy Vehicles, %	3	3	3	0	0	0	10	2	0	0	6	6
Mvmt Flow	41	0	103	0	2	2	64	448	0	0	95	18

Major/Minor	Minor2		Minor1		Major1			Major2				
Conflicting Flow All	673	671	95	732	689	448	113	0	0	448	0	0
Stage 1	95	95	-	576	576	-	-	-	-	-	-	-
Stage 2	578	576	-	156	113	-	-	-	-	-	-	-
Critical Hdwy	7.13	6.53	6.23	7.1	6.5	6.2	4.2	-	-	4.1	-	-
Critical Hdwy Stg 1	6.13	5.53	-	6.1	5.5	-	-	-	-	-	-	-
Critical Hdwy Stg 2	6.13	5.53	-	6.1	5.5	-	-	-	-	-	-	-
Follow-up Hdwy	3.527	4.027	3.327	3.5	4	3.3	2.29	-	-	2.2	-	-
Pot Cap-1 Maneuver	368	376	959	339	371	615	1428	-	-	1123	-	-
Stage 1	909	814	-	506	505	-	-	-	-	-	-	-
Stage 2	500	501	-	851	806	-	-	-	-	-	-	-
Platoon blocked, %								-	-	-	-	-
Mov Cap-1 Maneuver	353	359	959	292	354	615	1428	-	-	1123	-	-
Mov Cap-2 Maneuver	353	359	-	292	354	-	-	-	-	-	-	-
Stage 1	868	814	-	483	482	-	-	-	-	-	-	-
Stage 2	474	478	-	759	806	-	-	-	-	-	-	-

Approach	EB		WB		NB			SB		
HCM Control Delay, s	11.3		13.1		1			0		
HCM LOS	B		B							

Minor Lane/Major Mvmt	NBL	NBT	NBR	EBLn1	EBLn2	WBLn1	SBL	SBT	SBR
Capacity (veh/h)	1428	-	-	353	959	449	1123	-	-
HCM Lane V/C Ratio	0.045	-	-	0.115	0.108	0.009	-	-	-
HCM Control Delay (s)	7.6	-	-	16.5	9.2	13.1	0	-	-
HCM Lane LOS	A	-	-	C	A	B	A	-	-
HCM 95th %tile Q(veh)	0.1	-	-	0.4	0.4	0	0	-	-

2: Curtis Rd & Site Driveway
PM Peak Hour

HCM 6th TWSC

Intersection						
Int Delay, s/veh	0.1					
Movement	EBL	EBR	NBL	NBT	SBT	SBR
Lane Configurations	↔			↔	↑	↔
Traffic Vol, veh/h	2	0	0	438	157	13
Future Vol, veh/h	2	0	0	438	157	13
Conflicting Peds, #/hr	0	0	0	0	0	0
Sign Control	Stop	Stop	Free	Free	Free	Free
RT Channelized	-	None	-	None	-	None
Storage Length	0	-	-	-	-	340
Veh in Median Storage, #	0	-	-	0	0	-
Grade, %	0	-	-	0	0	-
Peak Hour Factor	50	50	47	84	84	40
Heavy Vehicles, %	100	100	100	2	2	100
Mvmt Flow	4	0	0	521	187	33

Major/Minor	Minor2	Major1	Major2			
Conflicting Flow All	708	187	220	0	-	0
Stage 1	187	-	-	-	-	-
Stage 2	521	-	-	-	-	-
Critical Hdwy	7.4	7.2	5.1	-	-	-
Critical Hdwy Stg 1	6.4	-	-	-	-	-
Critical Hdwy Stg 2	6.4	-	-	-	-	-
Follow-up Hdwy	4.4	4.2	3.1	-	-	-
Pot Cap-1 Maneuver	285	656	933	-	-	-
Stage 1	656	-	-	-	-	-
Stage 2	438	-	-	-	-	-
Platoon blocked, %				-	-	-
Mov Cap-1 Maneuver	285	656	933	-	-	-
Mov Cap-2 Maneuver	285	-	-	-	-	-
Stage 1	656	-	-	-	-	-
Stage 2	438	-	-	-	-	-

Approach	EB	NB	SB
HCM Control Delay, s	17.8	0	0
HCM LOS	C		

Minor Lane/Major Mvmt	NBL	NBT	EBLn1	SBT	SBR
Capacity (veh/h)	933	-	285	-	-
HCM Lane V/C Ratio	-	-	0.014	-	-
HCM Control Delay (s)	0	-	17.8	-	-
HCM Lane LOS	A	-	C	-	-
HCM 95th %tile Q(veh)	0	-	0	-	-

3: Curtis Rd & Falcon Hwy
PM Peak Hour

HCM 6th TWSC

Intersection												
Int Delay, s/veh	9.8											
Movement	EBL	EBT	EBR	WBL	WBT	WBR	NBL	NBT	NBR	SBL	SBT	SBR
Lane Configurations	↙	↑	↗	↙	↑	↗	↙	↑	↗	↙	↑	↗
Traffic Vol, veh/h	8	162	52	5	106	12	194	194	15	17	39	5
Future Vol, veh/h	8	162	52	5	106	12	194	194	15	17	39	5
Conflicting Peds, #/hr	0	0	0	0	0	0	0	0	0	0	0	0
Sign Control	Free	Free	Free	Free	Free	Free	Stop	Stop	Stop	Stop	Stop	Stop
RT Channelized	-	-	None	-	-	None	-	-	None	-	-	None
Storage Length	315	-	315	300	-	-	430	-	-	350	-	-
Veh in Median Storage, #	-	0	-	-	0	-	-	0	-	-	0	-
Grade, %	-	0	-	-	0	-	-	0	-	-	0	-
Peak Hour Factor	94	94	94	70	70	70	80	80	80	93	93	93
Heavy Vehicles, %	3	3	3	40	10	8	1	3	13	0	18	0
Mvmt Flow	9	172	55	7	151	17	243	243	19	18	42	5

Major/Minor	Major1			Major2			Minor1			Minor2		
Conflicting Flow All	168	0	0	227	0	0	387	372	172	523	419	160
Stage 1	-	-	-	-	-	-	190	190	-	174	174	-
Stage 2	-	-	-	-	-	-	197	182	-	349	245	-
Critical Hdwy	4.13	-	-	4.5	-	-	7.11	6.53	6.33	7.1	6.68	6.2
Critical Hdwy Stg 1	-	-	-	-	-	-	6.11	5.53	-	6.1	5.68	-
Critical Hdwy Stg 2	-	-	-	-	-	-	6.11	5.53	-	6.1	5.68	-
Follow-up Hdwy	2.227	-	-	2.56	-	-	3.509	4.027	3.417	3.5	4.162	3.3
Pot Cap-1 Maneuver	1404	-	-	1147	-	-	573	557	844	468	502	890
Stage 1	-	-	-	-	-	-	814	741	-	833	726	-
Stage 2	-	-	-	-	-	-	807	747	-	671	675	-
Platoon blocked, %	-	-	-	-	-	-	-	-	-	-	-	-
Mov Cap-1 Maneuver	1404	-	-	1147	-	-	528	550	844	297	496	890
Mov Cap-2 Maneuver	-	-	-	-	-	-	528	550	-	297	496	-
Stage 1	-	-	-	-	-	-	809	737	-	828	722	-
Stage 2	-	-	-	-	-	-	751	743	-	437	671	-

Approach	EB			WB			NB			SB		
HCM Control Delay, s	0.3			0.3			17.1			14.1		
HCM LOS							C			B		

Minor Lane/Major Mvmt	NBLn1	NBLn2	EBL	EBT	EBR	WBL	WBT	WBR	SBLn1	SBLn2
Capacity (veh/h)	528	564	1404	-	-	1147	-	-	297	522
HCM Lane V/C Ratio	0.459	0.463	0.006	-	-	0.006	-	-	0.062	0.091
HCM Control Delay (s)	17.5	16.8	7.6	-	-	8.2	-	-	17.9	12.6
HCM Lane LOS	C	C	A	-	-	A	-	-	C	B
HCM 95th %tile Q(veh)	2.4	2.4	0	-	-	0	-	-	0.2	0.3

APPENDIX D: SITE PLAN

SOLBERG PIT - SITE PLAN

SECTION 21, TOWNSHIP 13 SOUTH, RANGE 64 WEST
OF THE 6TH P.M., EL PASO COUNTY, COLORADO

LAND USE: QUARRY
 PARCEL SIZE: 306 ACRES
 ZONING: A-35
 OPEN SPACE: 100%
 DWELLING UNITS: 0
 REQUIRED PARKING: N/A

EXISTING EASEMENT NOTES:

- LAND TITLE GUARANTEE COMPANY TITLE COMMITMENT NO. SC55107533, DATED 8/23/2022 WAS RELIED UPON FOR INFORMATION REGARDING EASEMENTS OF RECORD AS SHOWN ON THIS EXHIBIT.
1. COLO. INTERSTATE GAS EASEMENT BK. 2450 P. 586 PROVIDES FOR AN EASEMENT IN THE COUNTY ROADS ONLY.
 2. MTN. VIEW ELECTRIC EASEMENT BK. 3673 P. 894 IS BLANKET IN NATURE AND CANNOT BE PLOTTED.
 3. THE LOCATION OF MTN. VIEW ELECTRIC EASEMENT (10' X 30') IN THE NW 1/4 OF SEC. 21 CANNOT BE DETERMINED

1. THERE ARE NO SIDEWALKS EXISTING OR PROPOSED ONSITE.
2. THERE ARE NO WALLS EXISTING OR PROPOSED ONSITE.
3. THERE ARE NO BERMS ONSITE, HOWEVER OVERBURDEN AND TOPSOIL STORAGE PILES ON THE EAST AND SOUTHEAST PERIMETER SERVE AS NOISE AND VISUAL BARRIER.
4. THERE ARE NO PROPOSED SIGNS, CURRENT SIGNAGE CONSISTS OF 1 ENTRY SIGN AND MINE BOUNDARY WARNING SIGNS AT INTERVALS ALONG PERIMETER
5. THERE ARE NO ADA PARKING SPACES, RAMPS, PATHWAYS OR SIGNS EXISTING OR PROPOSED ONSITE.
6. THERE IS NO OUTDOOR ILLUMINATION EXISTING OR PROPOSED ONSITE.
7. THERE IS NO WATER OR WASTEWATER INFRASTRUCTURE EXISTING OR PROPOSED ONSITE.
8. THERE ARE NO "NO-BUILD" AREAS, FLOODPLAINS OR DRAINAGE FACILITIES EXISTING OR PROPOSED ONSITE.
9. THERE ARE NO DUMPSTERS, DUMPSTER SCREENS OR LOADING DOCKS EXISTING OR PROPOSED ONSITE.
10. THERE ARE NO DESIGNATED (DELINEATED) PARKING SPACES ONSITE. EMPLOYEE PARKING IS ON NATURAL GROUND NEXT TO OFFICE.
11. THERE ARE NO PROPOSED UTILITY LINES OR INFRASTRUCTURE ONSITE.

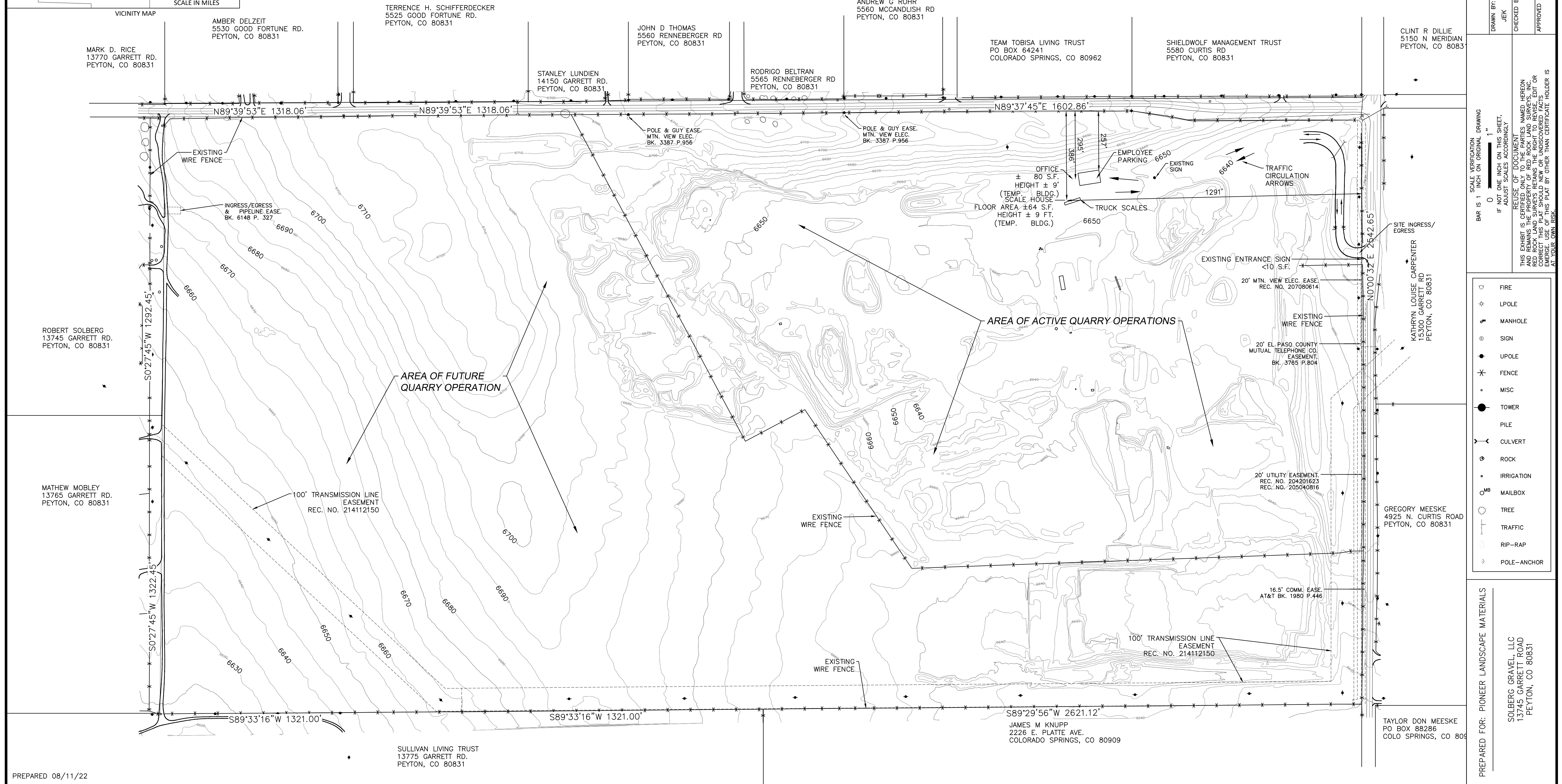
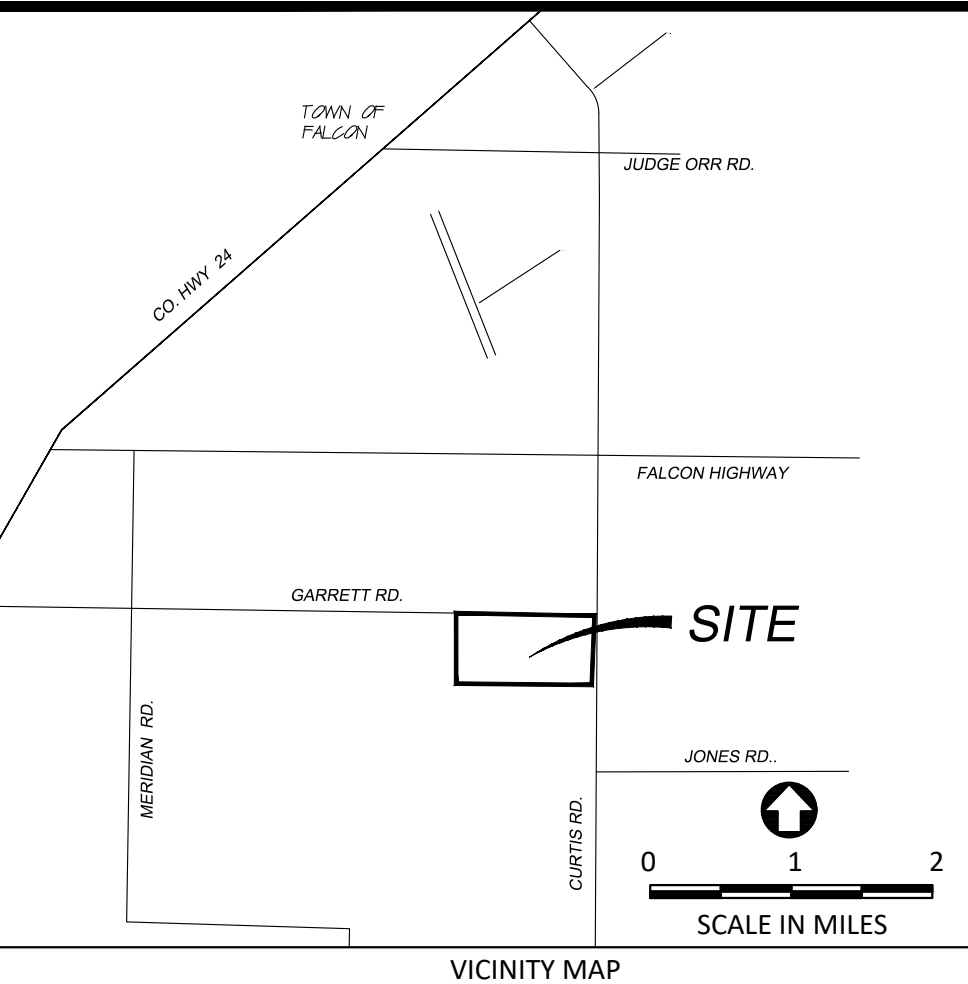
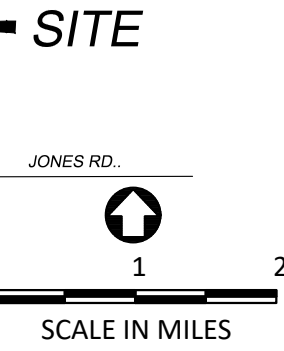
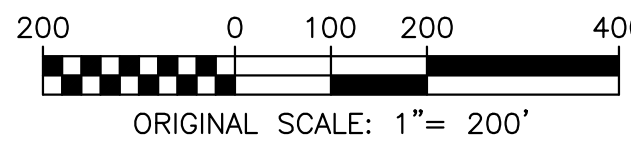
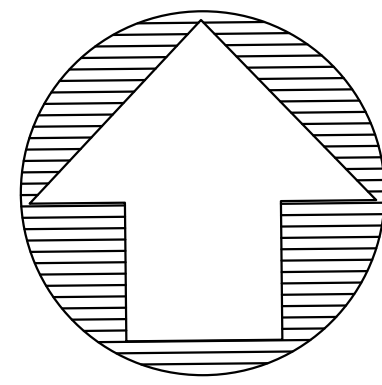

NO.	DATE	BY

SCALE VERIFICATION
 BAR IS 1" INCH ON ORIGINAL DRAWING
 IF NOT ONE INCH ON THIS SHEET,
 ADJUST SCALES ACCORDINGLY.
 REUSE OF DOCUMENT
 THIS EXHIBIT IS CERTIFIED ONLY TO THE PARTIES NAMED HEREON
 AND REMAINS THE PROPERTY OF RED ROCK LAND SURVEYS, INC.
 ANY REUSE OF THIS EXHIBIT FOR ANY OTHER PROJECT OR
 CORRECT THIS PLAN SHOULD NEW OR UNDISCOVERED FACTS
 EMERGE. USE OF THIS PLAN BY OTHER THAN CERTIFICATE HOLDER IS
 AT YOUR OWN RISK.

- FIRE
- ⊛ LPOLE
- ⊙ MANHOLE
- ⊙ SIGN
- ⊙ UPOLE
- ⊙ FENCE
- ⊙ MISC
- ⊙ TOWER
- ⊙ PILE
- ⊙ CULVERT
- ⊙ ROCK
- ⊙ IRRIGATION
- ⊙ MAILBOX
- ⊙ TREE
- ⊙ TRAFFIC
- ⊙ RIP-RAP
- ⊙ POLE-ANCHOR

PREPARED FOR: PIONEER LANDSCAPE MATERIALS
 SOLBERG GRAVEL, LLC
 13745 GARRETT ROAD
 PEYTON, CO 80831

APPENDIX E: ROADWAY CONDITIONS SURVEY REPORT



July 25, 2022

Angela Bellantoni, Ph.D.
Permits and Licenses Specialist
630 Plaza Drive, Suite 150
Highlands Ranch, CO 80129

Subject: Road Condition Survey for DRMS – Peyton, Colorado

Dear Dr. Bellantoni,

Y2K Engineering, LLC. (Y2K) has been retained to prepare a survey of the road conditions on Curtis Road and Garrett Road along site frontage of the existing Pioneer Sand Company in Peyton, Colorado. Pioneer Sand Company is planning to add an adjoining undeveloped parcel located to the west of the existing sand quarry, which is anticipated to add approximately 30 peak hour trips to the roadway network. **Figure 1** provides the vicinity map.

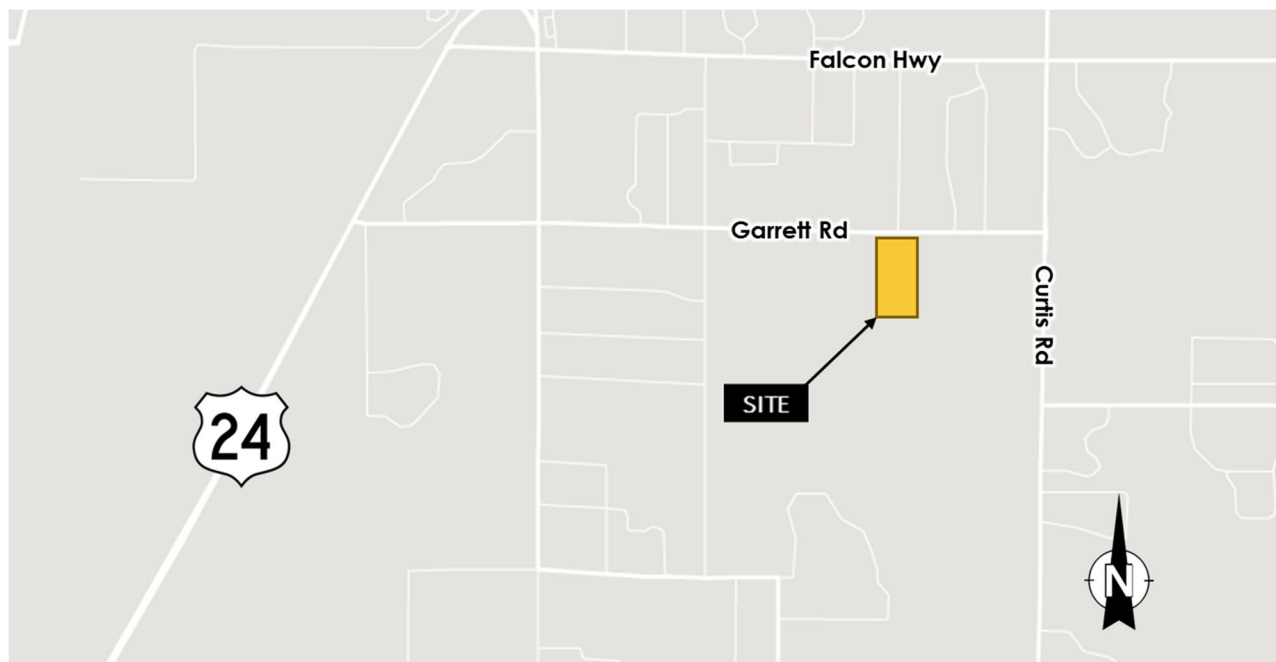

Figure 1: Vicinity Map

STUDY AREA

The study area of the survey of roadway conditions includes the following roadways:

GARRETT ROAD

Garrett road is classified as a minor arterial per the El Paso County 2016 Major Transportation Corridors Plan Update and has an east-west orientation. The roadway features one lane in each direction. Garrett Road has a posted speed limit of 45 mph. Roadway facilities such as curbs, gutter, streetlights, sidewalks, and bike lanes are not present along Garrett Road. Overhead utilities run along the north side of the roadway. Garrett Road connects to U.S. Route 24 (US 24) approximately three miles west of the project site.

CURTIS ROAD

Curtis Road is a north-south roadway classified as a principal arterial by the El Paso County 2016 Major Transportation Corridors Plan Update. Within the vicinity of the project site, Curtis Road provides one lane in each direction. The posted speed limit is 45 mph. Facilities such as curbs, gutter, streetlights, sidewalks, and bike lanes are not provided on the roadway. Overhead utilities are available on both the east and west sides of Curtis Road. Approximately 4.5 miles to the south, Curtis Road connects directly to Colorado State Highway 94 (SH-94).

ROADWAY CONDITION SURVEY

A field review was conducted at the site on Wednesday, June 22nd to observe roadway conditions. During this review, photos of the roadway were taken at approximate 300-foot intervals. At each interval, a photo of the roadway was taken facing each direction (west and east on Garrett Road, north and south on Curtis Road). Photos are provided in **Attachment A. Figure 2** shows the location of photos. Odd number photos are oriented west and north, while even number photos are oriented east and south.



Figure 2: Road Condition Locations

We appreciate the opportunity to prepare this study. Should you have any questions, please feel free to contact me by email at rstephani@y2keng.com or by phone at (720-735-5855).

Sincerely,

Y2K Engineering, LLC.

A handwritten signature in blue ink that reads 'Rae Stephani'.

Rae Stephani, PE, PTOE
Traffic Engineer

ATTACHMENT A
PHOTO LOG



PICTURE 1



PICTURE 2



PICTURE 3



PICTURE 4



PICTURE 5



PICTURE 6



PICTURE 7



PICTURE 8



PICTURE 9



PICTURE 10



PICTURE 11



PICTURE 12



PICTURE 13



PICTURE 14



PICTURE 15



PICTURE 16



PICTURE 17



PICTURE 18



PICTURE 19



PICTURE 20



PICTURE 21



PICTURE 22



PICTURE 23



PICTURE 24



PICTURE 25



PICTURE 26



PICTURE 27



PICTURE 28



PICTURE 29



PICTURE 30



PICTURE 31



PICTURE 32



PICTURE 33



PICTURE 34



PICTURE 35



PICTURE 36



PICTURE 37



PICTURE 38



PICTURE 39



PICTURE 40

V2_Traffic Impact Study.pdf Markup Summary 10-25-2023

Daniel Torres (3)



Author: Daniel Torres
Subject: Callout
Page Label: 3
Date: 10/25/2023 4:41:48 PM
Status:
Color: ■
Layer:
Space:

should this be west on Garrett?

Indicate the Haul vehicles destination from Garrett Rd. I assume that it is to Hwy 24 as opposed to another County Rd. Please state it in the report and clearly state that this is the intended Haul route

Also please indicate if all vehicles (haul vehicles& passenger car/truck) will utilize the same haul route.

parcel to the
and East on

Author: Daniel Torres
Subject: Highlight
Page Label: 4
Date: 10/25/2023 4:42:08 PM
Status:
Color: ■
Layer:
Space:

East

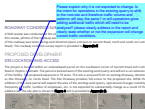

Author: Daniel Torres
Subject: Callout
Page Label: 8
Date: 10/25/2023 4:47:28 PM
Status:
Color: ■
Layer:
Space:

Please explain why it is not expected to change. Is the intent for operations in the existing quarry to shift to the new site and therefore traffic volume and patterns will stay the same? or will operations grow adding additional traffic which will need to be analyzed? please clearly address in the report and clearly state whether or not the expansion will change current traffic conditions.