



Final Drainage Report

Tract A, Wilsons Widefield
Addition No. 6
El Paso County, Colorado

Prepared for:
Widefield School District 3
445 Jersey Ln
Colorado Springs, CO 80911
Contact: Dave Gish

Prepared by:
Kimley-Horn and Associates, Inc.
2 North Nevada Avenue, Suite 300
Colorado Springs, Colorado 80903
(719) 453-0180
Contact: Eric Gunderson, P.E.

Project #: 096958001

Prepared: October 14, 2022

PCD File Number: PPR-22-009

Kimley»»Horn



CERTIFICATION

DESIGN ENGINEER'S STATEMENT

The attached drainage plan and report were prepared under my direction and supervision and are correct to the best of my knowledge and belief. Said drainage report has been prepared according to the criteria established by the County for drainage reports and said report is in conformity with the master plan of the drainage basin. I accept responsibility for any liability caused by any negligent acts, errors or omissions on my part in preparation of this report.

SIGNATURE (Affix Seal): *Eric Lundberg* 12/13/22
Colorado P.E. No. 49487 Date



OWNER/DEVELOPER'S STATEMENT

I, the developer, have read and will comply with all of the requirements specified in this Drainage Report and Plan.

Widefield School District 3
Name of Developer

David Gish 12/26/2022
Authorized Signature Date

David Gish
Printed Name

Chief Operations Officer
Title

1820 Main St. C/S, CO 80911
Address:

EL PASO COUNTY

Filed in accordance with the requirements of the Drainage Criteria Manual, Volumes 1 and 2, El Paso County Engineering Criteria Manual and Land Development Code as amended.

Josh Palmer, P.E.
County Engineer/ ECM Administrator

APPROVED
Engineering Department
01/18/2023 1:50:51 PM
dsdnijkamp
EPC Planning & Community
Development Department

Conditions:

TABLE OF CONTENTS

CERTIFICATION2

 DESIGN ENGINEER’S STATEMENT2

 OWNER/DEVELOPER’S STATEMENT2

 EL PASO COUNTY.....2

TABLE OF CONTENTS3

INTRODUCTION5

 PURPOSE AND SCOPE OF STUDY5

 LOCATION5

 DESCRIPTION OF PROPERTY5

DRAINAGE BASINS5

 MAJOR BASIN DESCRIPTIONS5

 EXISTING SUB-BASIN DESCRIPTIONS.....6

Sub-Basin Ex-1.....6

Sub-Basin EX-2.....6

 PROPOSED RATIONAL SUB-BASIN DESCRIPTIONS.....6

Sub-Basin A1.....6

Sub-Basin A2.....6

Sub-Basin A3.....7

Sub-Basin A4.....7

Sub-Basin A5.....7

Sub-Basin A6.....7

Sub-Basin A7.....8

Sub-Basin A8.....8

Sub-Basin A9.....8

Sub-Basin A10.....8

Sub-Basin A11.....8

Sub-Basin A12.....9

Sub-Basin R19

DRAINAGE DESIGN CRITERIA.....9

 DEVELOPMENT CRITERIA REFERENCE.....9

 HYDROLOGIC CRITERIA9

 HYDRAULIC CRITERIA.....10

THE FOUR STEP PROCESS10

DRAINAGE FACILITY DESIGN11

 GENERAL CONCEPT11

 SPECIFIC DETAILS11

 GEOTECHNICAL RECOMMENDATIONS.....12

 COMPLIANCE WITH PREVIOUS STUDIES12

SUMMARY13

REFERENCES14

APPENDIX15

APPENDIX A: FIGURES.....16
APPENDIX B: HYDROLOGY17
APPENDIX C: HYDRAULICS.....18
APPENDIX D: OPERATIONS AND MAINTENANCE MANUAL.....19
APPENDIX E: GEOTECHNICAL SUBSURFACE EXPLORATION.....20
APPENDIX F: MESA RIDGE SELF STORAGE DRAINAGE REPORT21
APPENDIX G: COST ESTIMATE.....22
APPENDIX H: DRAINAGE MAPS23

INTRODUCTION

PURPOSE AND SCOPE OF STUDY

The purpose of this Final Drainage Report (FDR) is to provide the hydrologic and hydraulic calculations and to document and finalize the drainage design methodology in support of the proposed Tract A of Wilsons Widefield Addition No. 6 (“the Project”) for Widefield School District 3. The Project is located within the jurisdictional limits of El Paso County (“the County”). Thus, the guidelines for the hydrologic and hydraulic design components were based on the criteria for the County and City of Colorado Springs, described below.

LOCATION

The 7.93-acre parcel (TSN: 55193-13-001) is located at the southeast corner of the Syracuse St. and Jersey Ln. intersection. A vicinity map has been provided in the **Appendix A** of this report.

DESCRIPTION OF PROPERTY

The Project is located on approximately 7.93 acres of land consisting of an existing elementary school with associated playground, parking lot, ballfield and hardscape. The Project consists of a building addition to the existing elementary school with associated sidewalk and hardscape extensions, new playground equipment, and a proposed onsite full spectrum extended detention basin (“EDB”). The Site does not currently provide water quality or detention for the Project area. The existing land use is for an elementary school.

The existing topography consists of slopes ranging from 1% to 25% and generally slopes from northeast to southwest.

NRCS soil data is available for this Site and it has been noted that soils onsite are generally USCS Type B/C. The NRCS soil data can be found in **Appendix A**. There are no major drainage ways or irrigation facilities within the Site.

Improvements will consist of mowing, clearing and grubbing, weed control, paved access road construction, building pad grading, one EDB, culverts, drainage swales, and native seeding.

An updated topographic field survey was completed for the Project by Drexel, Barrell & CO, dated July 26, 2021 and is the basis for design for the drainage improvements.

DRAINAGE BASINS

MAJOR BASIN DESCRIPTIONS

The Site improvements are located in Zone X, as determined by the Flood Insurance Rate Map (FIRM) number 08041C0952G effective date, December 7, 2018 (see **Appendix A**).

The Project is located within El Paso County’s East Big Johnson Drainage Basin.

EXISTING SUB-BASIN DESCRIPTIONS

Site runoff flows from north to south via sheet and concentrated flows over developed land to Syracuse St. Below is a description of the existing onsite sub-basins.

Sub-Basin Ex-1

Sub-Basin EX-1 consists of the majority of the school property. The northern section of this basin consists of roof drainage and surface flows which are collected via an existing grass lined swale on the east portion of the Site which conveys flows to the southwest corner of the Site at design point EX1. The southern section of this basin flows overland from northeast to southwest to the southwest corner at design point EX1. Runoff during the 5-year and 100-year events are 8.19 cfs and 21.73 cfs, respectively. Runoff from this basin is currently directed to design point EX1 where it drains into an existing ditch and 18-inch RCP culvert that runs parallel to Syracuse St. This sub-basin has an area of 6.89 acres. The impervious value for this basin is 34%. Refer to **Appendix F** for the Existing Conditions Drainage Map.

Sub-Basin EX-2

Sub-Basin EX-2 consists of a portion of the northwest corner of the Property. Drainage flows overland from east to west and conveys to the curb and gutter that runs north-south along the eastern side of Syracuse St. at design point EX2. Direct runoff during the 5-year and 100-year events are 3.38 cfs and 6.62 cfs, respectively. Runoff from this basin is currently directed to design point EX2 where it will drain into the existing Syracuse Street curb and gutter and run to the south, which collects in an existing 10-foot public Type R Inlet. This sub-basin has an area of 1.11 acres. The impervious value for this basin is 71%. Refer to **Appendix F** for the Existing Conditions Drainage Map.

PROPOSED RATIONAL SUB-BASIN DESCRIPTIONS

Sub-Basin A1

Sub-Basin A1 consists of a portion of the southwest portion of the Site, including the proposed EDB. Runoff from this basin will sheet flow to design point A1 where it will drain into the EDB, which will outfall through the proposed outlet structure and 18" PVC pipe to the existing 18" RCP culvert to the southwest of the Site. This sub-basin has an area of 1.13 acres. The impervious value for this basin is 11%. The basin will generate direct runoff of 0.42 cfs and 3.74 cfs in the minor and major storm event. The cumulative runoff will be 8.52 cfs and 27.84 cfs in the minor and major storm event.

Sub-Basin A2

Sub-Basin A2 consists of a portion of landscaping on the north side of the Site. Runoff from this basin will be directed to Design Point A2 which will outfall to the existing curb and gutter in Syracuse St. This sub-basin has an area of 0.54 acres. The impervious value for Sub-Basin A2 is 14%. The basin will generate direct runoff of 0.17 cfs and 1.29 cfs in the minor and major storm event.

Sub-Basin A3

Sub-Basin A3 consists of an existing portion of landscaping and a playground on the northeast side of the existing building. There is no disturbance proposed to Sub-Basin A3. The northern portion of this basin consists of an existing playground area where developed flows either infiltrate into the wood mulch play surface or a nominal amount flows overland to Jersey Lane.

The remaining area either flows overland to Sub-Basin A4 or flows into the area inlet at design point A3.

This sub-basin has an area of 0.26 acres. The impervious value for Sub-Basin A3 is 13%. The basin will generate direct runoff of 0.08 cfs and 0.69 cfs in the minor and major storm event. Flows from this Sub-Basin ultimately outfall into the proposed EDB.

A portion of the north wing of the existing building drains via a downspout on the west side of Sub-Basin A3. These flows will enter a proposed 12" area inlet at Design Point A3 and then conveyed via an existing 8" CMP culvert to the east where they outfall into an existing swale in Sub-Basin A4. Analysis of the existing 8" CMP culvert is included in **Appendix C**. Flows from Sub-Basin A3 entering the proposed 12" area inlet are negligible and are not included in the analysis of the existing culvert.

Sub-Basin A4

Sub-Basin A4 consists of an existing portion of landscaping, an asphalt drive-aisle, and a grass-lined swale in the northeast corner of the Site. There is no disturbance proposed to Sub-Basin A4. Sub-Basin A4 accepts flows from an existing 8" CMP culvert and a proposed 6" PVC roof drain which conveys runoff from the north and east wings of the existing building roof. Runoff from this basin will be conveyed to the south via a grass-lined swale to an existing 12" CMP culvert at Design Point A4. Analysis of the existing 12" CMP culvert is included in **Appendix C**. This sub-basin has an area of 0.67 acres. The impervious value for Sub-Basin A4 is 46%. The basin will generate direct runoff of 0.70 cfs and 2.42 cfs in the minor and major storm event. The cumulative runoff will be 0.78 cfs and 3.11 cfs in the minor and major storm event. Flows from this Sub-Basin ultimately outfall into the proposed EDB.

Sub-Basin A5

Sub-Basin A5 consists of proposed concrete sidewalk and asphalt on the west side of the building. Runoff from this basin will be conveyed to the west to a proposed 12" area inlet at Design Point A5. This sub-basin has an area of 0.09 acres. The impervious value for Sub-Basin A5 is 100%. The basin will generate direct runoff of 0.28 cfs and 0.63 cfs in the minor and major storm event. Flows from this Sub-Basin ultimately outfall into the proposed EDB.

Sub-Basin A6

Sub-Basin A6 consists of proposed concrete sidewalk and asphalt on the east side of the building. Runoff from this basin will be conveyed to the west to a proposed 12" area inlet at Design Point A6. This sub-basin has an area of 0.14 acres. The impervious value for Sub-Basin A6 is 100%. The basin will generate direct runoff of 0.44 cfs and 0.98 cfs in the minor and major storm event. Flows from this Sub-Basin ultimately outfall into the proposed EDB.

Sub-Basin A7

Sub-Basin A7 consists of proposed and existing landscaping, an existing concrete sidewalk and a grass-lined swale along the east portion of the Site. Sub-Basin A7 accepts flows from Sub-Basin A4 via an existing 12" CMP culvert. Runoff from this basin will be conveyed to the south via a proposed grass-lined swale to a proposed 12" wide, 8" deep trench-drain at Design Point A7 where it will cross a proposed sidewalk. Analysis of the proposed trench-drain and swale is included in **Appendix C**. This sub-basin has an area of 0.23 acres. The impervious value for Sub-Basin A7 is 20%. The basin will generate direct runoff of 0.12 cfs and 0.70 cfs in the minor and major storm event. The cumulative flows will be 0.90 cfs and 3.81 cfs in the minor and major storm. Flows from this Sub-Basin ultimately outfall into the proposed EDB. Cumulative flows represent flows routed from Sub-Basins 3 and 4 through Sub-Basin 7. The cumulative flows represent the total of these flows combined.

Sub-Basin A8

Sub-Basin A8 consists of a proposed concrete sidewalk and play area on the south side of the building. Runoff from this basin will be collected via a series of proposed 4" PVC perforated underdrains at Design Point A8. This sub-basin has an area of 0.23 acres. The impervious value for Sub-Basin A8 is 100%. The basin will generate direct runoff of 0.72 cfs and 1.61 cfs in the minor and major storm event. Flows from this Sub-Basin ultimately outfall into the proposed EDB.

Sub-Basin A9

Sub-Basin A9 consists of proposed and existing landscaping, a proposed concrete sidewalk, and a proposed grass-lined swale on the south side of the building. Runoff from this basin will be conveyed to the south via a proposed grass-lined swale where it will outfall directly into the proposed EDB at Design Point A9. Analysis of the proposed swale is included in **Appendix C**. This sub-basin has an area of 0.31 acres. The impervious value for Sub-Basin A9 is 3%. The basin will generate direct runoff of 0.04 cfs and 0.75 cfs in the minor and major storm event.

Sub-Basin A10

Sub-Basin A10 consists of a proposed concrete sidewalk and asphalt basketball courts and a play area at the southeast corner of the building. Runoff from this basin will be collected via a series of proposed 4" PVC perforated underdrains at Design Point A10. This sub-basin has an area of 0.36 acres. The impervious value for Sub-Basin A10 is 64%. The basin will generate direct runoff of 0.64 cfs and 1.82 cfs in the minor and major storm event. Flows from this Sub-Basin ultimately outfall into the proposed EDB.

Sub-Basin A11

Sub-Basin A11 consists of proposed and existing landscaping, proposed and existing concrete sidewalks, and a proposed grass-lined swale, and the existing building in the southeast corner of the Site. Runoff from this basin will be conveyed to the south and west via a proposed grass-lined swale where it will outfall directly into the proposed EDB at Design Point A11. Analysis of the proposed swale is included in **Appendix C**. This sub-basin has an area of 1.85 acres. The impervious value for Sub-Basin A11 is 38%. The basin will generate direct runoff of 1.62 cfs and 6.35 cfs in the minor and major storm event. The cumulative runoff will be 2.52 cfs and 10.16 cfs in the minor and major storm.

Sub-Basin A12

Sub-basin A12 consists of proposed parking, sidewalks, and landscaping along the western portion of the site. Runoff from this basin will be conveyed via curb and gutter west to Syracuse St where it will enter existing curb and gutter at Design Point A12. Flows from this sub-basin will follow historic drainage patterns. This sub-basin has an area of 0.95 acres. The impervious value for Sub-Basin A12 is 92%. The basin will generate direct runoff of 2.76 cfs and 6.40 cfs in the minor and major storm. This basin contains approx. 0.95 acres of disturbed impervious area, which qualifies under the WQ exclusion I.7.1.C.1.a Water Quality Capture Volume (WQCV) Standard as the disturbed area is under 20%, not exceeding 1 acre (please see Proposed Drainage Map for total area).

Sub-Basin R1

Sub-Basin R1 consists of the entire roof area of the existing building and the proposed addition. Runoff from this basin will be conveyed to existing and proposed roof drains and downspouts on all sides of the building. This sub-basin has an area of 1.22 acres. The impervious value for Sub-Basin R1 is 90%. The basin will generate direct runoff of 3.47 cfs and 8.15 cfs in the minor and major storm event. The approximate flows for each roof drain location are shown on the proposed drainage map. Flows for roof drains calculated from architectural roof exhibit. Flows for each drain represent percentage of roof area being captured by roof section.

DRAINAGE DESIGN CRITERIA

DEVELOPMENT CRITERIA REFERENCE

The proposed storm facilities are designed to be in compliance with the City of Colorado Springs and El Paso County “Drainage Criteria Manual (DCM)” dated October 2018 (“the MANUAL”), El Paso County “Engineering Criteria Manual” (“the Engineering Manual”), Chapter 6 and Section 3.2.1 of Chapter 13 of the City of Colorado Springs Drainage Criteria Manual dated May 2014 (“the Colorado Springs MANUAL”).

There are no known master plans or studies for the site.

HYDROLOGIC CRITERIA

The 5-year and 100-year design storm events were used in determining rainfall and runoff for the existing and proposed drainage analysis per the MANUAL. The rainfall depths for the Site were determined from equation 6-1 and equation 6-2 utilizing Figures 6-6, 6-11, 6-12, and 6 -17 from the DCM. Refer to **Table 1** below for the rainfall depths utilized for the Site and **Appendix B** for the hydrologic calculations for the site.

Table 1: Rainfall Depths

	Duration (HRS)
Storm Event	1 HR
5 Year	1.52
100 Year	2.55

Calculations for the runoff coefficients and percent imperviousness are included in the **Appendix B**. The rational method was used to determine the peak flows for the project. These flows were used to determine the size of the proposed inlets, culvert, storm drain system and on-site swales.

The proposed impervious values in Table 6-6 of the DCM were utilized in this report for the final design. Refer to **Appendix B** of this report for Table 6-6.

The Site is providing one full spectrum extended detention basin. The Site is maintaining the historic drainage patterns as much as possible.

There are no additional provisions selected or deviations from the criteria in both the MANUAL and Colorado Springs MANUAL.

HYDRAULIC CRITERIA

Applicable design methods were utilized to size the proposed EDB, which includes the use of the UD-Detention spreadsheet and rational calculations spreadsheet. Storm sewer sizing and hydraulic grade line calculations were computed using StormCAD implementing the standard step method. Bentley FlowMaster (Edition Update 3) was used for the sizing and analysis for proposed and existing culverts, swales, and a proposed trench-drain.

Proposed drainage features on-site have been analyzed and sized for the following storm events:

- Major Storm: 100-year Storm Event

One EDB is proposed to provide the required water quality capture volume, EURV volume and 100-year detention. The proposed EDB is located in the southwest corner of the Site with a proposed volume of 1.12 ac-ft and designed for the 100-year storm event. Developed flows from the Site will be released at controlled rates from the EDB and is ultimately tributary to Fountain Creek. EDB calculations are provided in the **Appendix C**. The EDB is designed to release the 100-year flow rates below the pre-development flow rate and at or below the anticipated 100-year flows from the final drainage report for the property immediately to the south. See the "Compliance with Previous Studies" section of this report for specific flow rates and compliance details.

Curb and gutter, area inlets, trench-drains, culverts, grass lined swales, and storm drain pipes are designed to carry flows to the EDB, calculations for the proposed improvements are provided in the **Appendix C** and the design points are provided in the Proposed Drainage Map located in **Appendix D**.

Emergency overflows will be routed over the southwest corner of the pond through the proposed emergency spillway. It will follow the historic drainage patterns and enter the existing roadside ditch that conveys drainage southward to the existing 18" RCP culvert south from the Property.

THE FOUR STEP PROCESS

The Project was designed in accordance with the four-step process to minimize adverse impacts of urbanization, as outlined in the County's "Four-Step Process" for selecting structural BMPs (ECM Section I.7.2 BMP Selection).

Step 1. Employ Runoff Reduction Practices- The project is proposing an expansion to an existing school building that will be designed to minimize the impact to the existing terrain. The Site's proposed paved roadways and building footprint will increase the Site's impervious area; however, drainage swales will be constructed to slow the runoff velocity and reduce runoff peaks. A full spectrum detention pond will be used to capture stormwater and maintain flows discharging off site at or below historic levels.

Step 2. Stabilize Drainageways- Stabilizing proposed drainage swales by designing them with slopes that control the flow rates. Placement of riprap upstream and downstream of culverts to help reduce erosion of the drainage swales. Rock chutes will be constructed to reduce the velocities of runoff entering the ponds at the channel locations. It is anticipated this will minimize erosion.

Step 3. Provide Water Quality Capture Volume (WQCV) –Permanent water quality measures and detention facilities will be provided with the Project. More specifically, this project proposes the construction of an EDB to provide the required water quality capture volume.

Step 4. Consider Need for Industrial and Commercial BMPs – The Project is proposing a school addition; therefore, covering of storage/handling areas and spill containment and control will not need to be provided.

DRAINAGE FACILITY DESIGN

GENERAL CONCEPT

The proposed drainage patterns will match the historic patterns. To maintain historic flows, a full spectrum EDB is being proposed and will capture and control the release of flows from the Site. Site drainage will be conveyed to the EDB via a series of swales, parking lot sheet flow, and a storm drain system.

Provided in the **Appendix B** are hydrologic calculations utilizing the Rational method for the existing and proposed conditions. Provided in **Appendix C** are the hydraulic calculations for the proposed conditions, including the proposed detention basin sizing. As previously mentioned, the existing drainage map and proposed drainage map can be found in **Appendix F**.

SPECIFIC DETAILS

The existing condition of the Site consists of flows draining from the northeast to the southwest corner and which outfall into the existing roadside ditch and existing 18" RCP culvert that conveys flows south underneath the adjacent property's drive access. Runoff conditions for the Site were developed utilizing the Rational Method described in the Hydrologic Criteria section of this report.

Sub-basins A1, A3-11 and R1 consist of a school expansion and EDB. Flows are conveyed from the northeast side of the Site to the southwest corner of the Site. On site flows enter the EDB which are released into the existing roadside ditch and 18" RCP culvert that conveys flows south underneath the adjacent property's drive access at a rate less than the planned rate from the Mesa Ridge Self Storage Preliminary/Final Drainage Report. Developed flows within this

were anticipated to be 2.9 and 6.87 cfs respectively for the 5-year and 100-year storm events. The EDB is designed to release the 5-year and 100-year flows at discharge rates of 0.3 and 6.7 cfs, respectively. These flow rates are less than the rates described in the Mesa Storage FDR. Therefore, impact to downstream infrastructure is not anticipated and the planned release rates are in compliance with the Mesa Storage FDR.

The South Pond will be privately owned and maintained by Widefield School District 3 as outlined in the Operations and Maintenance Manual for the Pond. Maintenance access to the proposed forebays and outlet structure will be provided via a 15' wide gravel access road extending to the bottom of the pond with longitudinal slopes less than 12%. The Operations and Maintenance Manual for the Pond is provided in **Appendix D** of this report for reference.

The hydrologic calculations, hydraulic calculations, and Drainage Maps are included in the **Appendix B, Appendix C, and Appendix F** of this report for reference.

The Site will disturb more than 1 acre and will require a Colorado Discharge Permit System (CDPS) General Permit for Stormwater Discharge Associated with Construction Activities from the Colorado Department of Public Health and Environment (CDPHE).

Since the Site was previously platted, there are no associated drainage and bridge fees due at this time.

A cost estimate for the proposed private storm drain improvements is included in **Appendix G** of this report for reference.

GEOTECHNICAL RECOMMENDATIONS

Per the Geotechnical Subsurface Exploration Program for Widefield Parks and Recreation Facility Expansion by Ground Engineering (dated 8/6/2021), on-site soils support slopes up to 10-feet in height to be constructed at a 3:1 (H:V) slope. The report also specifies that a low permeable liner is not needed if the pond is down-gradient from all proposed buildings, structures, and improvements. The proposed South Pond will be constructed with 3:1 side slopes in the southwest corner of the Site which is a natural low-point for property.

COMPLIANCE WITH PREVIOUS STUDIES

The Site area was previously included and studied as part of the Mesa Ridge Self Storage Preliminary/Final Drainage Report (herein the "Mesa Storage FDR"). The Site lies within sub-basins OS-1 and OS-2 from the Mesa Storage FDR. Calculations from the Mesa Storage FDR are provided in **Appendix H**.

Sub-basin OS-1 is 22.5 acres in size and consists of the northern portion of the Site (approximately 3.93 acres) and the residential neighborhood to the north. The runoff from this sub-basin is conveyed via curb and gutter within Syracuse St. to an existing 10-foot Type R curb inlet south of the Site, within Syracuse Street (Design Point 8 from the Mesa Storage FDR). The capacity of this inlet and drainage approach was analyzed and discussed in the Mesa Storage FDR.

In the Mesa Storage FDR, the flows from the 3.93-acre portion of OS-1 consisting of the Webster Elementary Site are not quantified specifically. Therefore, the following approach and discussion has been developed to describe the existing vs. proposed.

Per the existing condition section of this report, only sub-basin EX2 is tributary to Syracuse St. and consists of approximately 1.11 acres. This acreage is less than the estimated 3.93-acre portion of OS-1 from the Mesa Storage FDR.

Per the proposed condition section of this report, only sub-basin A2 is tributary to Syracuse St. and consists of approximately 1.49 acres. This acreage is less than the estimated 3.93-acre portion of OS-1 from the Mesa Storage FDR.

Additionally, based upon the imperviousness of A2, the developed flows in the proposed condition that are tributary to Syracuse St. are less than what is estimated in the existing condition. Therefore, the proposed condition is not negatively impacting the downstream infrastructure or adding additional flows to the existing Syracuse St. section and 10-foot Type R inlet.

Existing Condition (EX2)

5 year = 3.38 cfs
100 year = 6.62 cfs

Proposed Condition (A2)

5 year = 1.89 cfs
100 year = 5.37 cfs

Sub-basin OS-1 has 5-year and 100-year direct runoff values of 36.08 and 74.92 cfs, respectively and has 5-year and 100-year runoff coefficients of 0.60 and 0.70 cfs, respectively.

Utilizing the runoff coefficients for OS-1 and applying them to the 3.93 acre portion of the sub-basin, the estimated developed flow rates for the Webster Elementary School Site per the Mesa Storage FDR are approximately 6.32 and 13.13 cfs for the 5-year and 100-year storm events respectively. These values are greater than both existing and proposed condition estimates as described above.

Sub-basin OS-2 consists of the southern portion of the Site with a total area of 4.0 acres. Developed flows within this sub-basin were anticipated to be 2.9 and 6.87 cfs respectively for the 5-year and 100-year storm events at design point 9 from the Mesa Storage FDR. The runoff from this sub-basin is conveyed through an existing 18" RCP culvert at the southwest corner of the Site.

The proposed EDB will control release rates into the existing culvert (Design Point 9 from the Mesa Storage FDR), following historic patterns. The EDB is designed to release the 5-year and 100-year flows at discharge rates of 0.3 and 6.7 cfs, respectively. These flow rates are less than the rates of 2.9 and 6.87 cfs as described in the Mesa Storage FDR. Therefore, impact to downstream infrastructure is not anticipated and the planned release rates are in compliance with the Mesa Storage FDR.

SUMMARY

The proposed drainage design is to maintain the historic drainage patterns, the overall imperviousness and release rates for the Site. Runoff from the Site will flow through an existing storm drain system to an existing El Paso County drainage basin: The East Big Johnson Basin. The basin ultimately discharges to Fountain Creek. The drainage design presented within this report conforms to the criteria presented in both the MANUAL and the Colorado Springs MANUAL. Additionally, the Site runoff and storm drain facilities will not adversely affect the downstream and surrounding developments, including Fountain Creek.

REFERENCES

1. City of Colorado Springs “Drainage Criteria Manual (DCM) Volume 1”, dated May, 2014
2. El Paso County “Drainage Criteria Manual”, dated October 31, 2018
3. El Paso County “Engineering Criteria Manual” Revision 6, dated December 13, 2016
4. Chapter 6 and Section 3.2.1. of Chapter 13-City of Colorado Springs Drainage Criteria Manual, May 2014.
5. Urban Drainage and Flood Control District Drainage Criteria Manual (UDFCDCM), Vol. 1, prepared by Wright-McLaughlin Engineers, June 2001, with latest revisions.
6. Flood Insurance Rate Map, El Paso County, Colorado and Incorporated Areas, Map Number 08041C0756G, Effective Date December 7, 2018, prepared by the Federal Emergency Management Agency (FEMA).
7. “Mesa Ridge Self Storage Preliminary/Final Drainage Report” prepared by M&S Civil Consultants, Inc. (March 2014, Revised July 9, 2014, Revised September 20, 2014)
8. “Geotechnical Subsurface Exploration Program for Widefield Parks and Recreation Facility Expansion” prepared by Ground Engineering (August 6, 2021)

APPENDIX

APPENDIX A: FIGURES

Webster Elementary
Vicinity Map



National Flood Hazard Layer FIRMMette



104°43'9"W 38°43'45"N



Legend

SEE FIS REPORT FOR DETAILED LEGEND AND INDEX MAP FOR FIRM PANEL LAYOUT

- | | | |
|------------------------------------|--|--|
| SPECIAL FLOOD HAZARD AREAS | | Without Base Flood Elevation (BFE)
<i>Zone A, V, A99</i> |
| | | With BFE or Depth <i>Zone AE, AO, AH, VE, AR</i> |
| | | Regulatory Floodway |
| OTHER AREAS OF FLOOD HAZARD | | 0.2% Annual Chance Flood Hazard, Areas of 1% annual chance flood with average depth less than one foot or with drainage areas of less than one square mile <i>Zone X</i> |
| | | Future Conditions 1% Annual Chance Flood Hazard <i>Zone X</i> |
| | | Area with Reduced Flood Risk due to Levee. See Notes. <i>Zone X</i> |
| | | Area with Flood Risk due to Levee <i>Zone D</i> |
| OTHER AREAS | | NO SCREEN Area of Minimal Flood Hazard <i>Zone X</i> |
| | | Effective LOMRs |
| GENERAL STRUCTURES | | Area of Undetermined Flood Hazard <i>Zone D</i> |
| | | Channel, Culvert, or Storm Sewer |
| OTHER FEATURES | | Levee, Dike, or Floodwall |
| | | 20.2 Cross Sections with 1% Annual Chance Water Surface Elevation |
| OTHER FEATURES | | 17.5 Coastal Transect |
| | | Base Flood Elevation Line (BFE) |
| OTHER FEATURES | | Limit of Study |
| | | Jurisdiction Boundary |
| OTHER FEATURES | | Coastal Transect Baseline |
| | | Profile Baseline |
| MAP PANELS | | Digital Data Available |
| | | No Digital Data Available |
| MAP PANELS | | Unmapped |
| | | The pin displayed on the map is an approximate point selected by the user and does not represent an authoritative property location. |

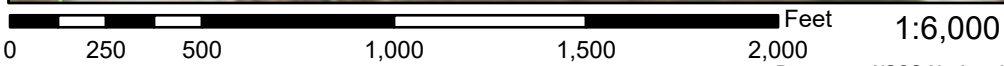

104°42'31"W 38°43'17"N

Basemap: USGS National Map: Orthoimagery: Data refreshed October, 2020

This map complies with FEMA's standards for the use of digital flood maps if it is not void as described below. The basemap shown complies with FEMA's basemap accuracy standards

The flood hazard information is derived directly from the authoritative NFHL web services provided by FEMA. This map was exported on **12/16/2021 at 9:46 AM** and does not reflect changes or amendments subsequent to this date and time. The NFHL and effective information may change or become superseded by new data over time.

This map image is void if the one or more of the following map elements do not appear: basemap imagery, flood zone labels, legend, scale bar, map creation date, community identifiers, FIRM panel number, and FIRM effective date. Map images for unmapped and unmodernized areas cannot be used for regulatory purposes.

Hydrologic Soil Group—El Paso County Area, Colorado

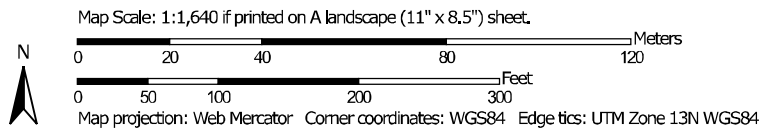
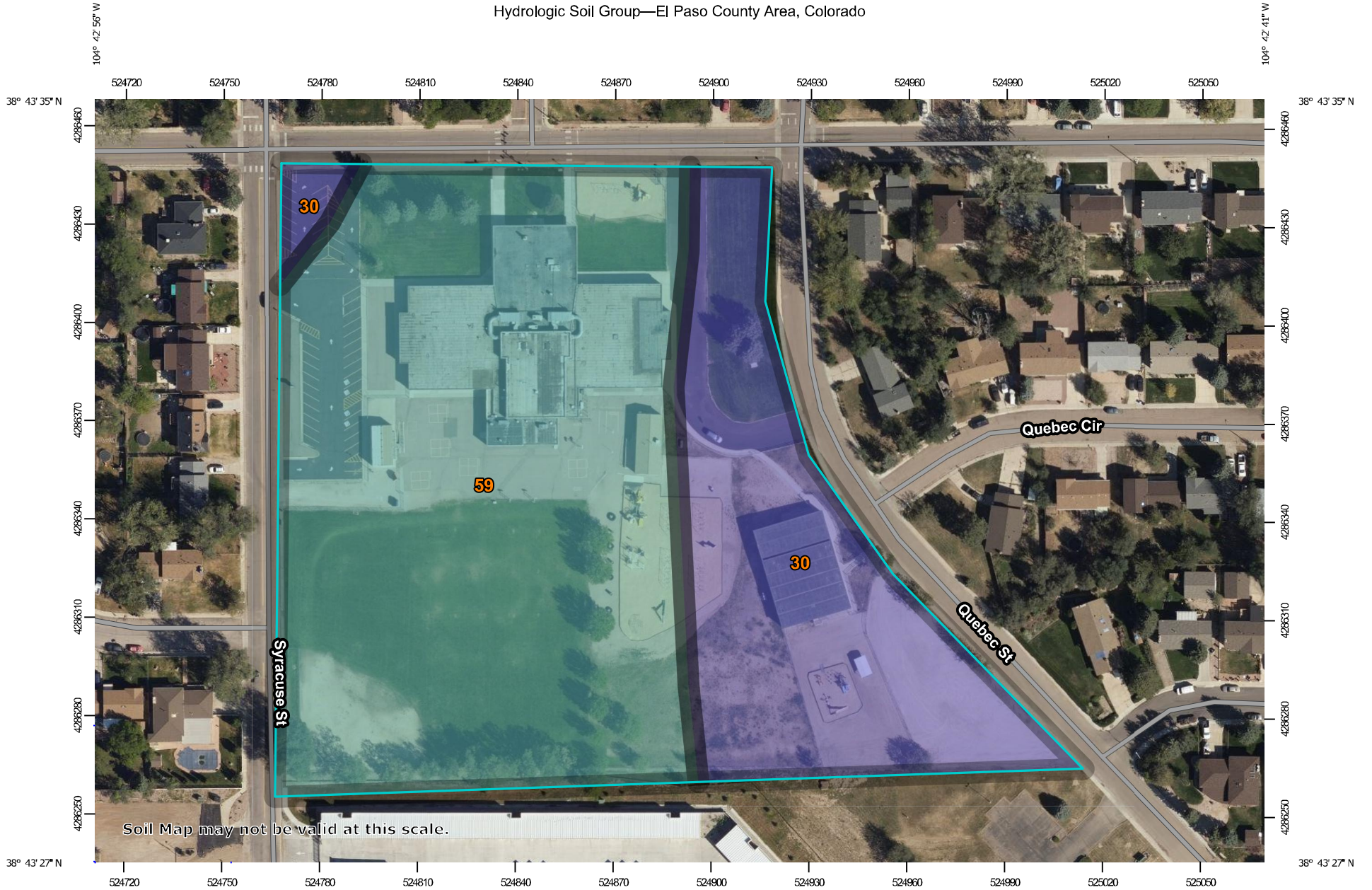

MAP LEGEND

Area of Interest (AOI)









 Area of Interest (AOI)

Soils

Soil Rating Polygons





-  A
-  A/D
-  B
-  B/D
-  C
-  C/D
-  D
-  Not rated or not available

Soil Rating Lines

-  A
-  A/D
-  B
-  B/D
-  C
-  C/D
-  D
-  Not rated or not available

Soil Rating Points

-  A
-  A/D
-  B
-  B/D

-  C
-  C/D
-  D
-  Not rated or not available

Water Features

 Streams and Canals

Transportation

-  Rails
-  Interstate Highways
-  US Routes
-  Major Roads
-  Local Roads

Background

 Aerial Photography

MAP INFORMATION

The soil surveys that comprise your AOI were mapped at 1:24,000.

Warning: Soil Map may not be valid at this scale.

Enlargement of maps beyond the scale of mapping can cause misunderstanding of the detail of mapping and accuracy of soil line placement. The maps do not show the small areas of contrasting soils that could have been shown at a more detailed scale.

Please rely on the bar scale on each map sheet for map measurements.

Source of Map: Natural Resources Conservation Service
 Web Soil Survey URL:
 Coordinate System: Web Mercator (EPSG:3857)

Maps from the Web Soil Survey are based on the Web Mercator projection, which preserves direction and shape but distorts distance and area. A projection that preserves area, such as the Albers equal-area conic projection, should be used if more accurate calculations of distance or area are required.

This product is generated from the USDA-NRCS certified data as of the version date(s) listed below.

Soil Survey Area: El Paso County Area, Colorado
 Survey Area Data: Version 18, Jun 5, 2020

Soil map units are labeled (as space allows) for map scales 1:50,000 or larger.

Date(s) aerial images were photographed: Aug 14, 2018—Sep 23, 2018

The orthophoto or other base map on which the soil lines were compiled and digitized probably differs from the background imagery displayed on these maps. As a result, some minor shifting of map unit boundaries may be evident.

Hydrologic Soil Group

Map unit symbol	Map unit name	Rating	Acres in AOI	Percent of AOI
30	Fort Collins loam, 0 to 3 percent slopes	B	2.7	31.5%
59	Nunn clay loam, 0 to 3 percent slopes	C	5.8	68.5%
Totals for Area of Interest			8.4	100.0%

Description

Hydrologic soil groups are based on estimates of runoff potential. Soils are assigned to one of four groups according to the rate of water infiltration when the soils are not protected by vegetation, are thoroughly wet, and receive precipitation from long-duration storms.

The soils in the United States are assigned to four groups (A, B, C, and D) and three dual classes (A/D, B/D, and C/D). The groups are defined as follows:

Group A. Soils having a high infiltration rate (low runoff potential) when thoroughly wet. These consist mainly of deep, well drained to excessively drained sands or gravelly sands. These soils have a high rate of water transmission.

Group B. Soils having a moderate infiltration rate when thoroughly wet. These consist chiefly of moderately deep or deep, moderately well drained or well drained soils that have moderately fine texture to moderately coarse texture. These soils have a moderate rate of water transmission.

Group C. Soils having a slow infiltration rate when thoroughly wet. These consist chiefly of soils having a layer that impedes the downward movement of water or soils of moderately fine texture or fine texture. These soils have a slow rate of water transmission.

Group D. Soils having a very slow infiltration rate (high runoff potential) when thoroughly wet. These consist chiefly of clays that have a high shrink-swell potential, soils that have a high water table, soils that have a claypan or clay layer at or near the surface, and soils that are shallow over nearly impervious material. These soils have a very slow rate of water transmission.

If a soil is assigned to a dual hydrologic group (A/D, B/D, or C/D), the first letter is for drained areas and the second is for undrained areas. Only the soils that in their natural condition are in group D are assigned to dual classes.

Rating Options

Aggregation Method: Dominant Condition

Component Percent Cutoff: None Specified

Tie-break Rule: Higher

APPENDIX B: HYDROLOGY

The methods described in this Manual require only that the 1-hour, 6-hour and 24-hours depths be used as input. The storm return periods required for the application of methods in this Manual are the 2-, 5-, 10-, 25-, 50- and 100-year events. The 6-hour and 24-hour depths for these return periods can be read directly from Figures 6-6 through 6-17 at the end of this chapter. The 1-hour depth for return periods can be calculated for all design return periods following this procedure:

Step 1: Calculate 2-year, 1-hour rainfall based on 2-year, 6-hour and 24-hour values.

$$Y_2 = 0.218 + 0.709 \cdot (X_1 \cdot X_1 / X_2) \quad (\text{Eq. 6-1})$$

Where:

Y_2 = 2-year, 1-hour rainfall (in)

X_1 = 2-year, 6-hour rainfall (in) from Figure 6-6

X_2 = 2-year, 24-hour rainfall (in) from Figure 6-12

Step 2: Calculate 100-year, 1-hour rainfall based on 2-year 6-hour and 24-hour values

$$Y_{100} = 1.897 + 0.439 \cdot (X_3 \cdot X_3 / X_4) - 0.008 Z \quad (\text{Eq. 6-2})$$

Where

Y_{100} = 100-year, 1-hour rainfall (in)

X_3 = 100-year, 6-hour rainfall (in) from Figure 6-11

X_4 = 100-year, 24-hour rainfall (in) from Figure 6-17

Z = Elevation in hundreds of feet above sea level

Step 3: Plot the 2-year and 100-year, 1-hour values on the diagram provided in Figure 6-18 and connect the points with a straight line. The 1-hour point rainfall values for other recurrence intervals can be read directly from the straight line drawn on Figure 6-18.

Example: Determine the 10-year, 1-hour rainfall depth for downtown Colorado Springs.

Step 1: Calculate 2-year, 1-hour rainfall (Y_2) based on 2-year, 6-hour and 24-hour values. From Figure 6-6, the 2-year, 6-hour rainfall depth for downtown Colorado Springs is approximately 1.7 inches (X_1), and from Figure 6-12, the 2-year 24-hour depth is approximately 2.1 inches (X_2). The 2-year, 1-hour rainfall is calculated as follows:

$$Y_2 = 0.218 + 0.709 \cdot (1.7 \cdot 1.7 / 2.1) = 1.19 \text{ in} \quad (\text{Eq. 6-3})$$

Step 2: Calculate 100-year, 1-hour rainfall (Y_{100}) based on 100-year, 6-hour and 24-hour values. From Figure 6-11, the 100-year, 6-hour rainfall depth for downtown Colorado Springs is approximately 3.5 inches (X_3), and from Figure 6-17, the 100-year 24-hour depth is approximately 4.5 inches (X_4). Assume an elevation of 6,840 feet for Colorado Springs. The 100-year, 1-hour rainfall is calculated as follows:

$$Y_{100} = 1.897 + 0.439 \cdot (3.5 \cdot 3.5 / 4.6) - 0.008 \cdot (6,840 / 100) = 2.52 \text{ in} \quad (\text{Eq. 6-4})$$

Step 3: Plot 2-year and 100-year, 1-hour rainfall depths on Figure 6-18 and read 10-year value from straight line. This example is illustrated on Figure 6-18, with a 1-hour, 10-year rainfall depth of approximately 1.75 inches. Figure 6-18a provides the example, and Figure 6-18b provides a blank chart.

Figure 6-6. 2-Year, 6-Hour Precipitation Tenths of an Inch (NOAA Atlas 2)

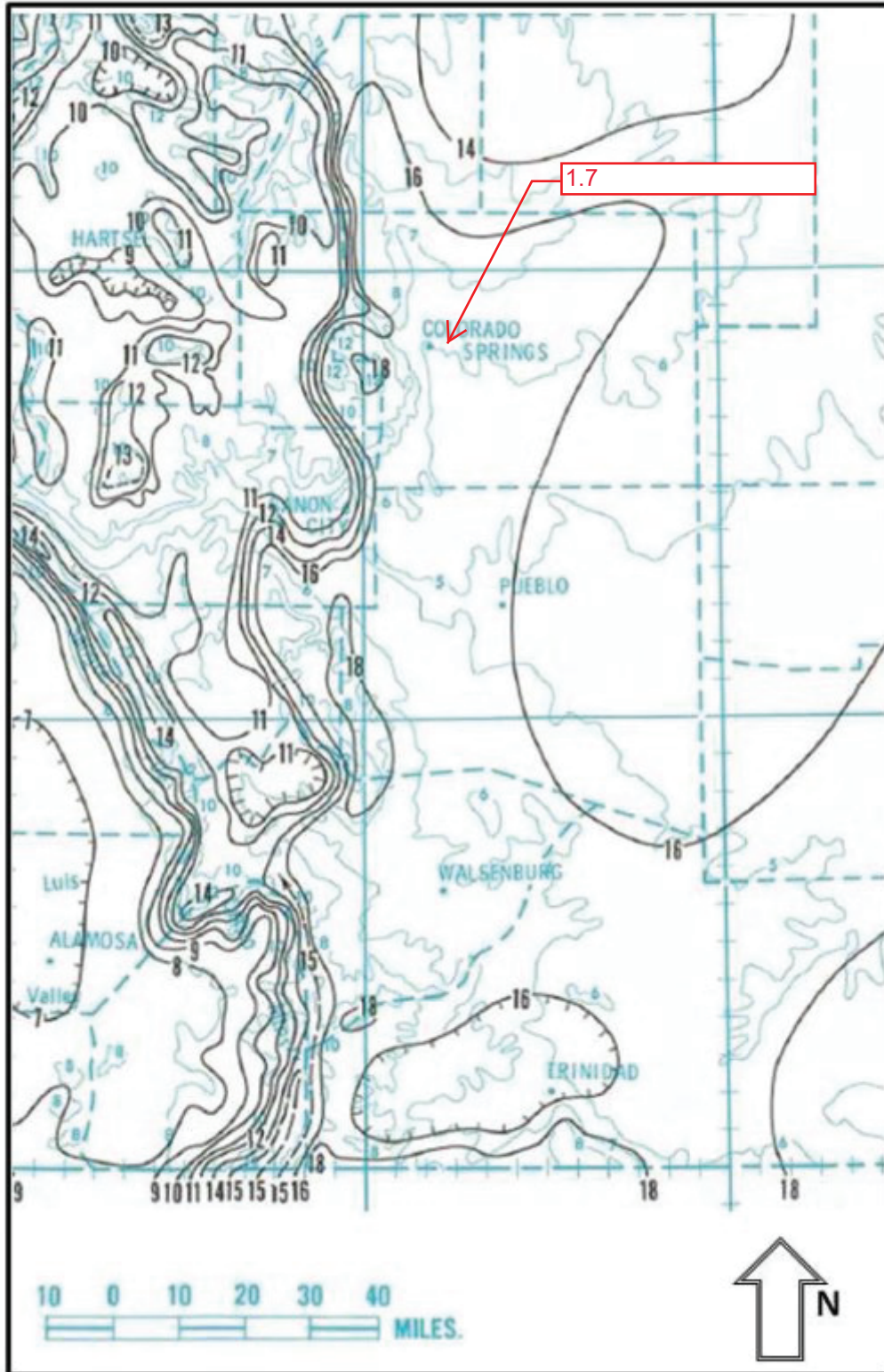

Figure 6-12. 2-Year, 24-Hour Precipitation Tenths of an Inch (NOAA Atlas 2)

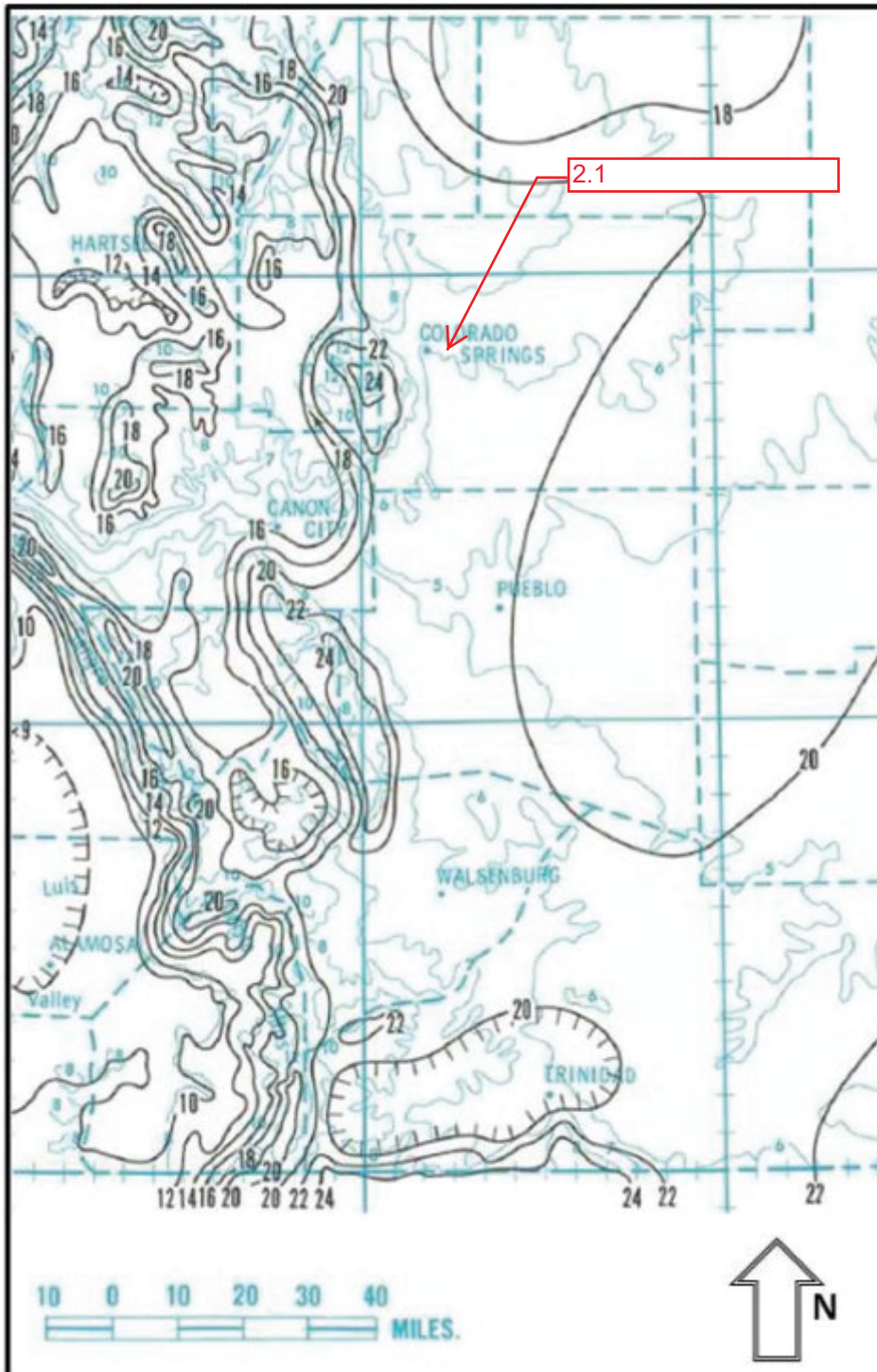

Figure 6-11. 100-Year, 6-Hour Precipitation Tenths of an Inch (NOAA Atlas 2)

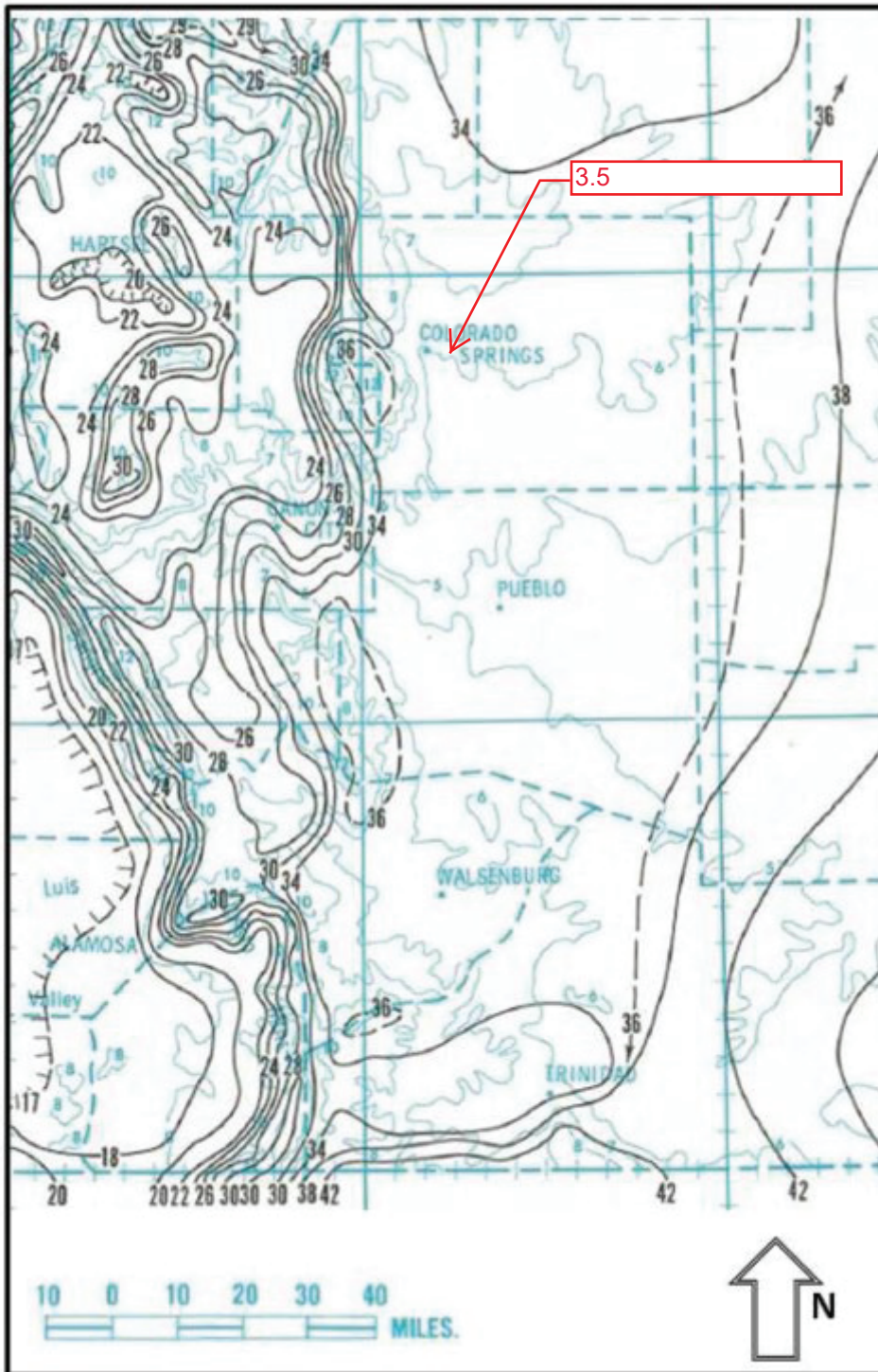
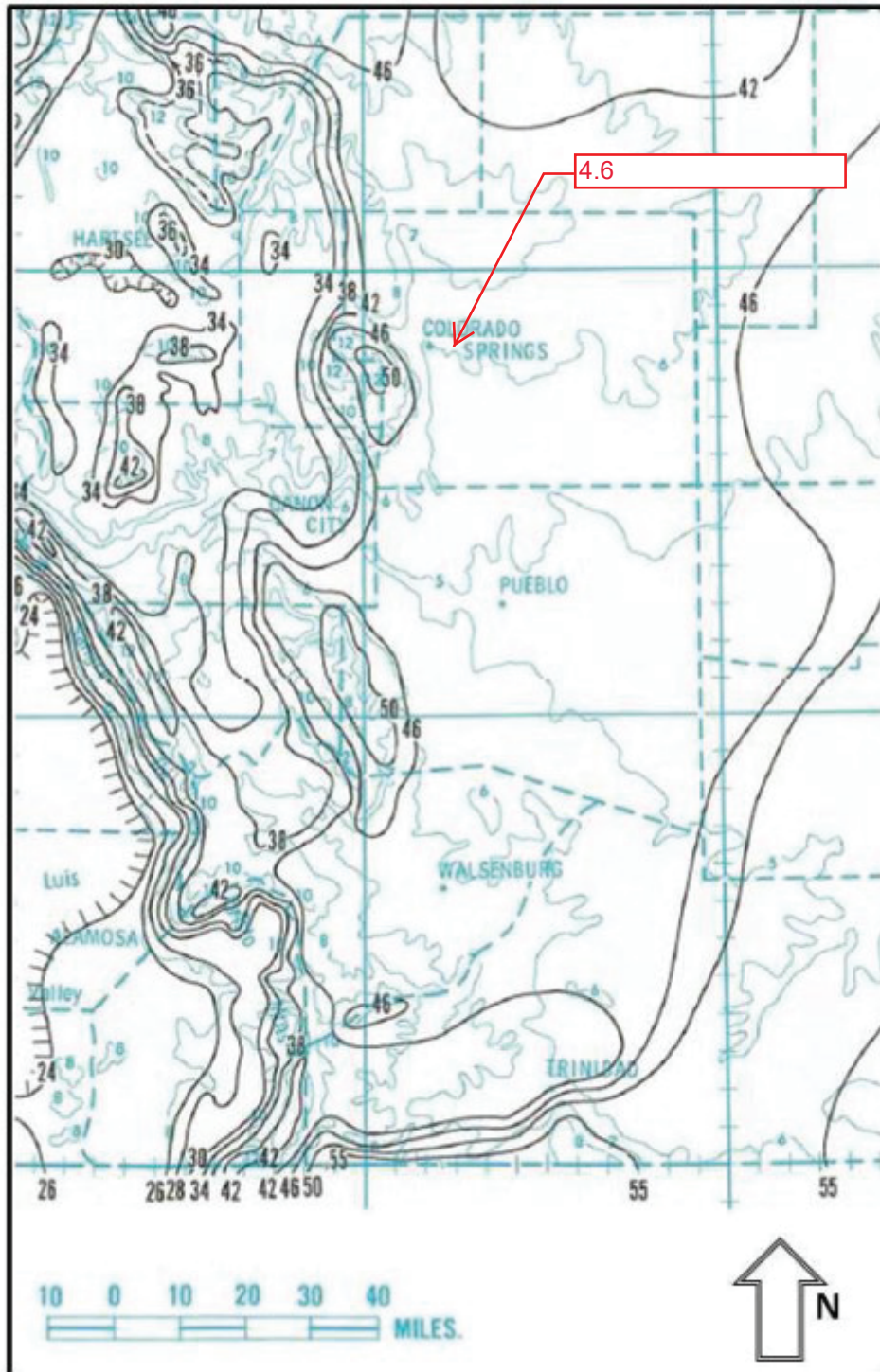
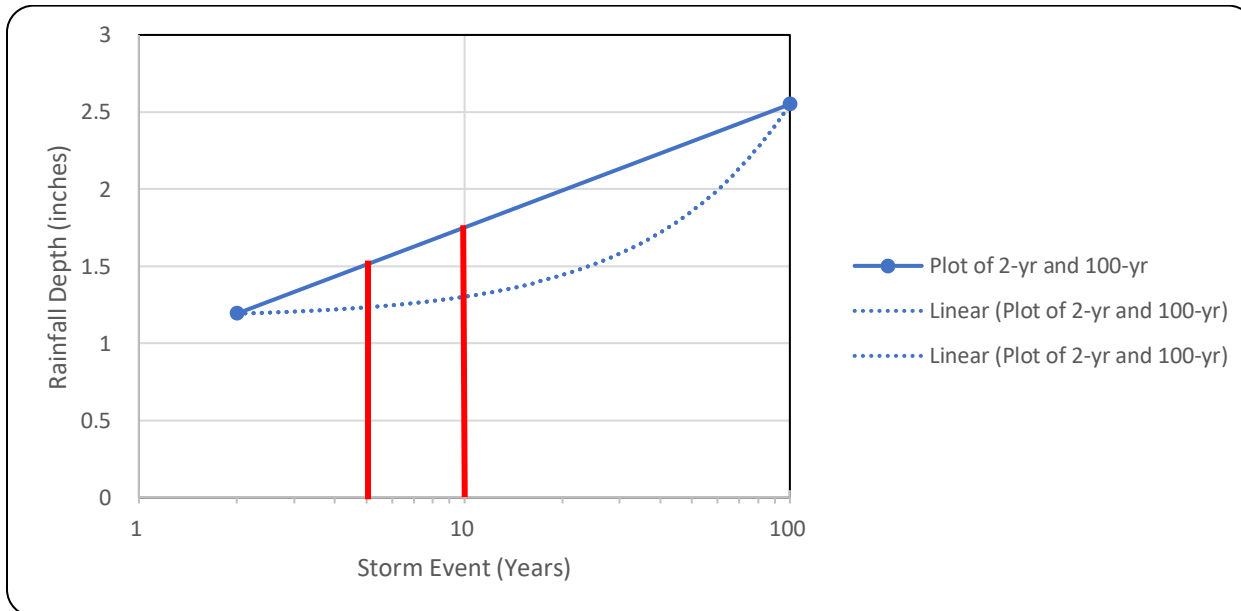

Figure 6-17. 100-Year, 24-Hour Precipitation Tenths of an Inch (NOAA Atlas 2)



Rainfall Depths			
			Notes
2 yr, 6 hr rainfall (in)	$X_1 =$	1.7	From Figure 6-6
2 yr, 24 hr rainfall (in)	$X_2 =$	2.1	From Figure 6-12
100 yr, 6 hr rainfall (in)	$X_3 =$	3.5	From Figure 6-11
100 yr, 24 hr rainfall (in)	$X_4 =$	4.6	From Figure 6-17
Elevation (hundreds of feet)]	$Z =$	64.5	
2 yr, 1 hr rainfall (in)	$Y_2 =$	1.193719	Equation 6-1
100 yr, 1 hr rainfall (in)	$Y_{100} =$	2.550076	Equation 6-2
Graph			
X-axis		Y-axis	
2	Y_2	1.193719	Calculated from Eq 6-1
100	Y_{100}	2.550076	Calculated from Eq 6-2
	Y_5	1.52	Determined From Graph below
	Y_{10}	1.75	Determined From Graph below



Tract A, Wilsons Widefield Addition No. 6
Drainage Report
El Paso County, CO

$$I = \frac{28.5 P_1}{(10 + T_D)^{0.786}}$$

Where:

I = rainfall intensity (inches per hour)

P₁ = one-hour rainfall depth (inches) from Table 6-2 One-hour Point Rainfall [City of Colorado Springs Drainage Design

T_c = storm duration (minutes)

	<u>2-yr</u>	<u>5-yr</u>	<u>10-yr</u>	<u>100-yr</u>
P ₁ =	1.19	1.52	1.75	2.55

Time Intensity Frequency Tabulation

TIME	2 YR	5 YR	10 YR	100 YR
5	4.05	5.16	5.94	8.65
10	3.23	4.11	4.73	6.90
15	2.71	3.45	3.97	5.79
30	1.87	2.38	2.75	4.00
60	1.21	1.54	1.77	2.58
120	0.74	0.94	1.09	1.58

Weighted Imperviousness Calculations

SUB-BASIN	AREA (SF)	AREA (Acres)	ROOF AREA	ROOF IMPERVIOUSNESS	ROOF				LANDSCAPE AREA	LANDSCAPE IMPERVIOUSNESS	LANDSCAPE				PAVEMENT AREA	PAVEMENT IMPERVIOUSNESS	PAVEMENT				WEIGHTED IMPERVIOUSNESS	WEIGHTED COEFFICIENTS			
					C2	C5	C10	C100			C2	C5	C10	C100			C2	C5	C10	C100		C2	C5	C10	C100
EX-1	300314	6.89	0.787	90%	0.71	0.73	0.75	0.81	4.557261	2%	0.03	0.09	0.17	0.36	1.55	100%	0.89	0.90	0.92	0.96	34%	0.30	0.35	0.40	0.55
EX-2	48423.57	1.11	0	90%	0.71	0.73	0.75	0.81	0.331652	2%	0.03	0.09	0.17	0.36	0.78	100%	0.89	0.90	0.92	0.96	71%	0.63	0.66	0.70	0.78
TOTAL	348,738	8.01	0.79	90%	0.71	0.73	0.75	0.81	4.89	2%	0.03	0.09	0.17	0.36	2.33	100%	0.89	0.90	0.92	0.96	39%	0.35	0.39	0.45	0.58

Tract A, Wilsons Widefield Addition No. 6
 Drainage Report
 El Paso County, CO

Webster Elementary - Drainage Report																				
Proposed Runoff Calculations																				
Time of Concentration																				
Watercourse Coefficient																				
					Forest & Meadow	2.50						Short Grass Pasture & Lawns	7.00						Grassed Waterway	15.00
					Fallow or Cultivation	5.00						Nearly Bare Ground	10.00						Paved Area & Shallow Gutter	20.00
DESIGN POINT	SUB-BASIN DATA				INITIAL / OVERLAND TIME			TRAVEL TIME T(t)					T(c) CHECK (URBANIZED BASINS)			FINAL T(c) min.				
	DRAIN BASIN	AREA sq. ft.	AREA ac.	C(5)	Length ft.	Slope %	T(i) min	Length ft.	Slope %	Coeff.	Velocity fps	T(t) min.	COMP. T(c)	TOTAL LENGTH	L/180+10					
1	EX-1	300,314	6.89	0.35	100	1.5%	12.1	820	1.5%	10.00	1.2	11.2	23.3	920	15.1	15.1				
2	EX-2	48,424	1.11	0.66	100	1.7%	6.8	180	1.7%	20.00	2.6	1.2	8.0	280	11.6	8.0				

Webster Elementary - Drainage Report Proposed Runoff Calculations Design Storm 5 Year (Rational Method Procedure)												
BASIN INFORMATION				DIRECT RUNOFF				CUMULATIVE RUNOFF				NOTES
DESIGN POINT	DRAIN BASIN	AREA ac.	RUNOFF COEFF	T(c) min	C x A	I in/hr	Q cfs	T(c) min	C x A	I in/hr	Q cfs	
1	EX-1	6.89	0.35	15.1	2.38	3.44	8.19				8.19	
2	EX-2	1.11	0.66	8.0	0.73	4.48	3.38				3.38	

Webster Elementary - Drainage Report Proposed Runoff Calculations (Rational Method Procedure)												
BASIN INFORMATION				DIRECT RUNOFF				CUMULATIVE RUNOFF				NOTES
DESIGN POINT	DRAIN BASIN	AREA ac.	RUNOFF COEFF	T(c) min	C x A	I in/hr	Q cfs	T(c) min	C x A	I in/hr	Q cfs	
1	EX-1	6.89	0.55	15.1	3.77	5.77	21.73				21.73	
2	EX-2	1.11	0.78	8.0	0.87	7.51	6.62				6.62	

SUMMARY - EXISTING RUNOFF TABLE						
DESIGN POINT	BASIN DESIGNATION	BASIN AREA (ACRES)	DIRECT 5-YR RUNOFF (CFS)	DIRECT 100-YR RUNOFF (CFS)	CUMULATIVE 5-YR RUNOFF (CFS)	CUMULATIVE 100-YR RUNOFF (CFS)
EX1	EX-1	6.89	8.19	21.73	8.19	21.73
EX2	EX-2	1.11	3.38	6.62	3.38	6.62

BASIN IMPERVIOUSNESS

Landuse	I	Runoff Coefficient		
		2-YR	5-YR	100-YR
Landscape	0%	0.02	0.08	0.35
Roof	90%	0.71	0.73	0.81
Drives&Walks	100%	0.89	0.90	0.96

Basin Designation	A _{TOTAL} (AC)	A _{TOTAL} (SF)	A _{LANDSCAPE} (SF)	A _{ROOF} (SF)	A _{DRIVES & WALKS} (SF)	I _{WEIGHTED}
A1	1.13	49,384	44,048	0	5,336	11%
A3	0.26	11,451	9,944	0	1,507	13%
A4	0.67	29,259	15,867	0	13,392	46%
A5	0.09	4,128	0	0	4,128	100%
A6	0.14	6,010	0	0	6,010	100%
A7	0.23	10,232	8,226	0	2,006	20%
A8	0.23	10,030	0	0	10,030	100%
A9	0.31	13,685	13,315	0	370	3%
A10	0.36	15,679	5,625	0	10,054	64%
A11	1.85	80,445	49,406	7,027	24,012	38%
R1	1.22	53,280	0	53,280	0	90%
Total On-Site	6.51	283583.00	146431.00	60307.00	76,845	46%
Basins that Flow Off-site						
A2	0.54	23,389	20,101	0	3,288	14%
A12	0.95	41,517	3,486	0	38,031	92%
Total Off Site	1.49	64906	23587	0	41319	64%
Total	8.00	348,489.00	170,018.00	60,307.00	118,164.00	49%

Tract A, Wilsons Widefield Addition No. 6
Drainage Report
El Paso County, CO

$$I = \frac{28.5 P_1}{(10 + T_D)^{0.786}}$$

Where:

I = rainfall intensity (inches per hour)

P₁ = one-hour rainfall depth (inches) from Table 6-2 One-hour Point Rainfall [City of Colorado Springs Drainage Design

T_c = storm duration (minutes)

	<u>2-yr</u>	<u>5-yr</u>	<u>10-yr</u>	<u>100-yr</u>
P ₁ =	1.19	1.52	1.75	2.55

Time Intensity Frequency Tabulation

TIME	2 YR	5 YR	10 YR	100 YR
5	4.05	5.16	5.94	8.65
10	3.23	4.11	4.73	6.90
15	2.71	3.45	3.97	5.79
30	1.87	2.38	2.75	4.00
60	1.21	1.54	1.77	2.58
120	0.74	0.94	1.09	1.58

SUMMARY - PROPOSED RUNOFF TABLE							
DESIGN POINT	BASIN DESIGNATION	BASIN AREA (ACRES)	DIRECT 5-YR RUNOFF (CFS)	DIRECT 100-YR RUNOFF (CFS)	CUMULATIVE 5-YR RUNOFF (CFS)	CUMULATIVE 100-YR RUNOFF (CFS)	FLOW ROUTING FOR CUMULATIVE FLOWS
A1	A1	1.13	0.42	3.74	8.53	27.84	INCLUDES: A1, A3-R1
A2	A2	0.54	0.17	1.29	0.17	1.29	
A3	A3	0.26	0.08	0.69	0.08	0.69	
A4	A4	0.67	0.70	2.42	0.78	3.11	INCLUDES: A3-A4
A5	A5	0.09	0.28	0.63	0.28	0.63	
A6	A6	0.14	0.44	0.98	0.44	0.98	
A7	A7	0.23	0.12	0.70	0.90	3.81	INCLUDES: A3-A4,A7
A8	A8	0.23	0.72	1.61	0.72	1.61	
A9	A9	0.31	0.04	0.75	0.04	0.75	
A10	A10	0.36	0.64	1.82	0.64	1.82	
A11	A11	1.85	1.62	6.35	2.52	10.16	INCLUDES: A3-A4,A7,A11
R1	R1	1.22	3.47	8.15	3.47	8.15	
A12	A12	0.95	2.76	6.40	2.76	6.40	

Calculation of Peak Runoff using Rational Method

Designer: Jared Roberts
 Company: Kimley-Horn
 Date: 6/14/2022
 Project: Webster Elementary School
 Location: Widefield, Colorado

Version 2.00 released May 2017

Cells of this color are for required user-input
 Cells of this color are for optional override values
 Cells of this color are for calculated results based on overrides

$$t_t = \frac{0.395(1.1 - C_s)\sqrt{L_t}}{S^{0.33}}$$

$$t_t = \frac{L_t}{60K\sqrt{S_t}} = \frac{L_t}{60V_t}$$

Computed $t_c = t_i + t_t$

$t_{\text{minimum}} = 5$ (urban)
 $t_{\text{minimum}} = 10$ (non-urban)

Regional $t_c = (26 - 17I) + \frac{L_t}{60(14I + 9)\sqrt{S_t}}$

Selected $t_c = \max(t_{\text{minimum}}, \min(\text{Computed } t_c, \text{Regional } t_c))$

Select UDFCD location for NOAA Atlas 14 Rainfall Depths from the pulldown list OR enter your own depths obtained from the NOAA website (click this link).

1-hour rainfall depth, P1 (in) =	2-yr	5-yr	10-yr	25-yr	50-yr	100-yr	500-yr
	0.83	1.09	1.33	1.69	1.99	2.31	3.14

Rainfall Intensity Equation Coefficients =

a	b	c
28.50	10.00	0.786

$$I(\text{in/hr}) = \frac{a + P_1}{(b + t_c)^c}$$

$Q(\text{cfs}) = CIA$

Subcatchment Name	Area (ac)	NRCS Hydrologic Soil Group	Percent Imperviousness	Runoff Coefficient, C							Overland (Initial) Flow Time				Channelized (Travel) Flow Time					Time of Concentration			Rainfall Intensity, I (in/hr)							Peak Flow, Q (cfs)									
				2-yr	5-yr	10-yr	25-yr	50-yr	100-yr	500-yr	Overland Flow Length L _t (ft)	U/S Elevation (ft) (Optional)	D/S Elevation (ft) (Optional)	Overland Flow Slope S _t (ft/ft)	Overland Flow Time t _t (min)	Channelized Flow Length L _t (ft)	U/S Elevation (ft) (Optional)	D/S Elevation (ft) (Optional)	Channelized Flow Slope S _t (ft/ft)	NRCS Conveyance Factor K	Channelized Flow Velocity V _t (ft/sec)	Channelized Flow Time t _t (min)	Computed t _c (min)	Regional t _c (min)	Selected t _c (min)	2-yr	5-yr	10-yr	25-yr	50-yr	100-yr	500-yr	2-yr	5-yr	10-yr	25-yr	50-yr	100-yr	500-yr
A1	1.13	C	11.0	0.07	0.12	0.21	0.38	0.45	0.53	0.62	77.00	5665.00	5655.00	0.130	6.63	188.00	5655.00	5654.00	0.005	20	1.46	2.15	8.78	28.21	10.00	2.23	2.95	3.60	4.57	5.38	6.25	8.50	0.18	0.42	0.87	1.97	2.72	3.74	5.98
A2	0.54	C	14.0	0.09	0.15	0.23	0.40	0.46	0.54	0.63	200.00	5665.00	5662.00	0.015	21.24	0.00	0.00	0.00	0.014	20	2.38	0.00	21.24	23.62	21.24	1.57	2.08	2.53	3.22	3.79	4.40	5.98	0.08	0.17	0.32	0.69	0.95	1.29	2.04
A3	0.26	C	13.0	0.08	0.14	0.23	0.39	0.46	0.54	0.63	110.00	5666.00	5664.70	0.012	17.19	NO CHANNELIZED FLOW - OVERLAND FLOW TIME USED FOR TOTAL TC							17.19	17.19	17.19	1.75	2.32	2.83	3.59	4.23	4.91	6.67	0.04	0.08	0.17	0.37	0.50	0.69	1.09
A4	0.67	C	46.0	0.35	0.41	0.47	0.58	0.62	0.67	0.73	92.00	5666.50	5664.00	0.027	8.59	157.00	5664.00	5663.85	0.001	15	0.46	5.64	14.24	23.66	14.24	1.92	2.54	3.09	3.93	4.63	5.37	7.30	0.45	0.70	0.97	1.52	1.92	2.42	3.59
A5	0.09	C	100.0	0.83	0.85	0.87	0.88	0.89	0.89	0.90	73.00	5665.21	5664.33	0.012	3.63	NO CHANNELIZED FLOW - T-MINIMUM (5 MINUTES) USED FOR TOTAL TC							5.00	5.00	5.00	2.80	3.70	4.51	5.73	6.75	7.84	10.65	0.21	0.28	0.35	0.45	0.54	0.63	0.87
A6	0.14	C	100.0	0.83	0.85	0.87	0.88	0.89	0.89	0.90	54.00	5665.27	5664.50	0.014	2.95	NO CHANNELIZED FLOW - T-MINIMUM (5 MINUTES) USED FOR TOTAL TC							5.00	5.00	5.00	2.80	3.70	4.51	5.73	6.75	7.84	10.65	0.33	0.44	0.55	0.71	0.84	0.98	1.35
A7	0.23	C	20.0	0.14	0.20	0.28	0.43	0.49	0.57	0.65	99.00	5665.12	5663.42	0.017	13.56	50.00	5663.42	5663.05	0.007	15	1.29	0.65	14.20	23.42	14.20	1.92	2.54	3.10	3.94	4.63	5.38	7.31	0.06	0.12	0.20	0.39	0.52	0.70	1.09
A8	0.23	C	100.0	0.83	0.85	0.87	0.88	0.89	0.89	0.90	61.00	5665.24	5663.76	0.024	2.63	NO CHANNELIZED FLOW - T-MINIMUM (5 MINUTES) USED FOR TOTAL TC							5.00	5.00	5.00	2.80	3.70	4.51	5.73	6.75	7.84	10.65	0.54	0.72	0.90	1.16	1.38	1.61	2.21
A9	0.31	C	3.0	0.02	0.06	0.15	0.34	0.41	0.50	0.60	127.00	5661.76	5659.16	0.020	16.71	80.00	5659.16	5658.16	0.013	15	1.68	0.80	17.51	26.76	17.51	1.74	2.30	2.80	3.56	4.19	4.86	6.61	0.01	0.04	0.13	0.37	0.53	0.75	1.22
A10	0.36	C	64.0	0.51	0.56	0.60	0.68	0.71	0.75	0.79	122.00	5665.00	5662.00	0.025	8.05		5662.00			20					8.05	2.42	3.20	3.90	4.96	5.84	6.77	9.21	0.44	0.64	0.85	1.21	1.49	1.82	2.62
A11	1.85	C	38.0	0.28	0.34	0.41	0.53	0.58	0.64	0.71	179.00	5666.00	5660.00	0.034	12.24	226.00	5660.00	5656.50	0.015	15	1.87	2.02	14.26	21.65	14.26	1.92	2.53	3.09	3.93	4.63	5.37	7.30	1.00	1.62	2.35	3.87	4.97	6.35	9.56
R1	1.22	C	90.0	T-MINIMUM (5 MINUTES) ASSUMED FOR ROOF SUB-BASIN															5.00	5.00	5.00	2.80	3.70	4.51	5.73	6.75	7.84	10.65	2.53	3.47	4.37	5.76	6.90	8.15	11.32				
A12	0.95	C	92.0	0.76	0.78	0.81	0.83	0.85	0.86	0.88	20.00	5663.00	5662.00	0.050	1.50	200.00	5662.00	5657.00	0.025	20	3.16	1.05	2.55	11.32	5.00	2.80	3.70	4.51	5.73	6.75	7.84	10.65	2.02	2.76	3.46	4.54	5.43	6.40	8.88

APPENDIX C: HYDRAULICS

DETENTION BASIN STAGE-STORAGE TABLE BUILDER

MHFD-Detention, Version 4.04 (February 2021)

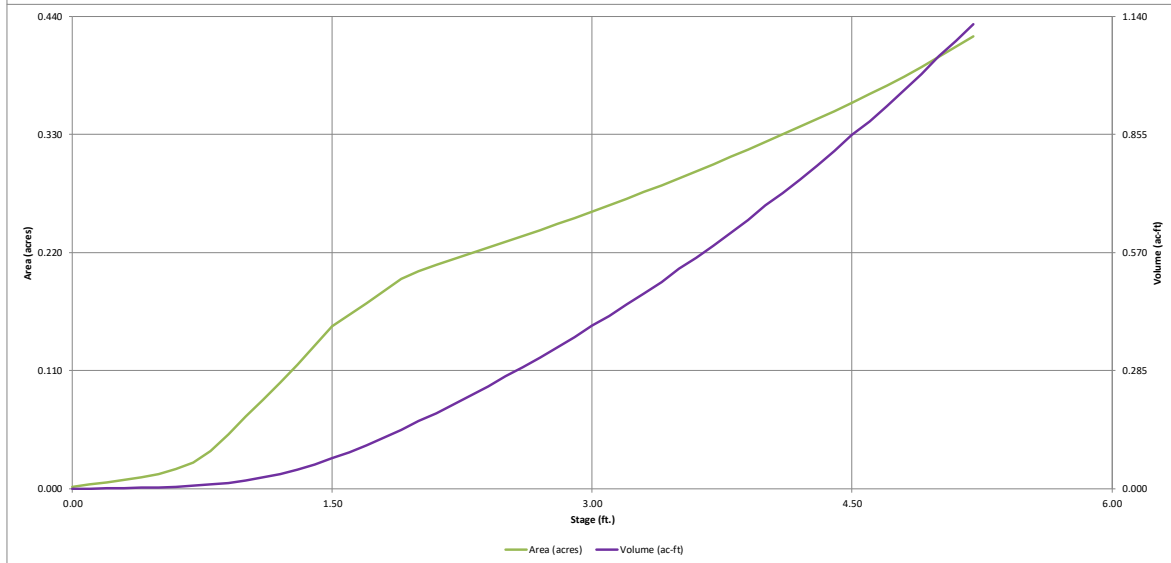
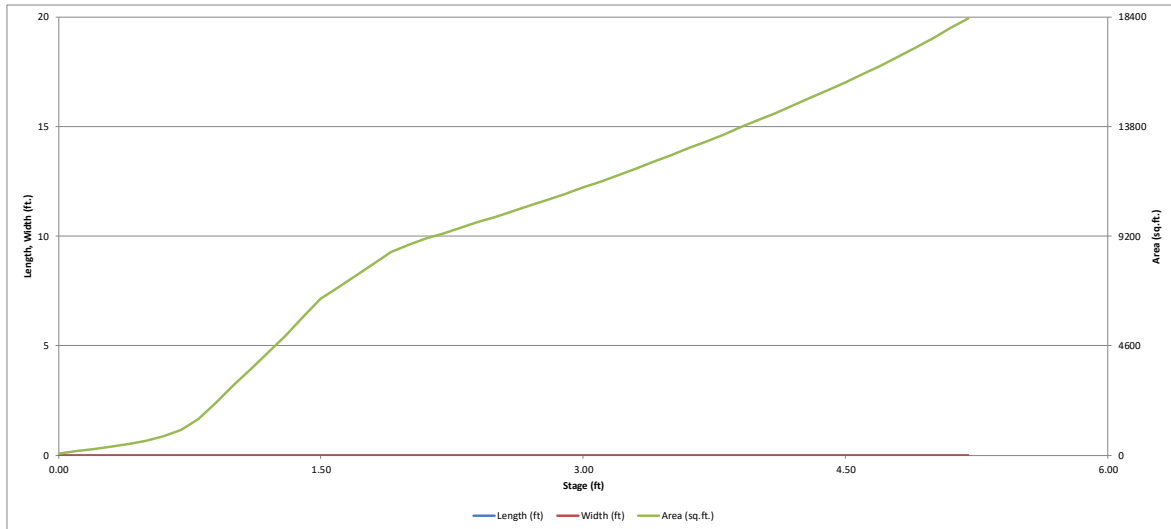

DETENTION BASIN OUTLET STRUCTURE DESIGN

MHFD-Detention, Version 4.04 (February 2021)

Project: Webster Elementary
Basin ID: South Pond

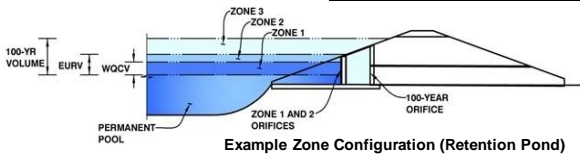

	Estimated Stage (ft)	Estimated Volume (ac-ft)	Outlet Type
Zone 1 (WQCV)	1.70	0.106	Orifice Plate
Zone 2 (EURV)	2.60	0.187	Circular Orifice
Zone 3 (100-year)	3.63	0.276	Weir&Pipe (Restrict)
Total (all zones)		0.569	

User Input: Orifice at Underdrain Outlet (typically used to drain WQCV in a Filtration BMP)

Underdrain Orifice Invert Depth =	N/A	ft (distance below the filtration media surface)
Underdrain Orifice Diameter =	N/A	inches

Calculated Parameters for Underdrain

Underdrain Orifice Area =	N/A	ft ²
Underdrain Orifice Centroid =	N/A	feet

User Input: Orifice Plate with one or more orifices or Elliptical Slot Weir (typically used to drain WQCV and/or EURV in a sedimentation BMP)

Calculated Parameters for Plate

Invert of Lowest Orifice =	0.00	ft (relative to basin bottom at Stage = 0 ft)
Depth at top of Zone using Orifice Plate =	3.63	ft (relative to basin bottom at Stage = 0 ft)
Orifice Plate: Orifice Vertical Spacing =	N/A	inches
Orifice Plate: Orifice Area per Row =	N/A	inches

WQ Orifice Area per Row =	N/A	ft ²
Elliptical Half-Width =	N/A	feet
Elliptical Slot Centroid =	N/A	feet
Elliptical Slot Area =	N/A	ft ²

User Input: Stage and Total Area of Each Orifice Row (numbered from lowest to highest)

	Row 1 (required)	Row 2 (optional)	Row 3 (optional)	Row 4 (optional)	Row 5 (optional)	Row 6 (optional)	Row 7 (optional)	Row 8 (optional)
Stage of Orifice Centroid (ft)	0.00	1.05	1.25	1.45				
Orifice Area (sq. inches)	0.44	0.44	1.23	0.60				

	Row 9 (optional)	Row 10 (optional)	Row 11 (optional)	Row 12 (optional)	Row 13 (optional)	Row 14 (optional)	Row 15 (optional)	Row 16 (optional)
Stage of Orifice Centroid (ft)								
Orifice Area (sq. inches)								

User Input: Vertical Orifice (Circular or Rectangular)

Calculated Parameters for Vertical Orifice

	Zone 2 Circular	Not Selected	
Invert of Vertical Orifice =	2.60	N/A	ft (relative to basin bottom at Stage = 0 ft)
Depth at top of Zone using Vertical Orifice =	3.63	N/A	ft (relative to basin bottom at Stage = 0 ft)
Vertical Orifice Diameter =	4.00	N/A	inches

	Zone 2 Circular	Not Selected	
Vertical Orifice Area =	0.09	N/A	ft ²
Vertical Orifice Centroid =	0.17	N/A	feet

User Input: Overflow Weir (Dropbox with Flat or Sloped Gate and Outlet Pipe OR Rectangular/Trapezoidal Weir (and No Outlet Pipe))

Calculated Parameters for Overflow Weir

	Zone 3 Weir	Not Selected	
Overflow Weir Front Edge Height, Ho =	3.63	N/A	ft (relative to basin bottom at Stage = 0 ft)
Overflow Weir Front Edge Length =	4.00	N/A	feet
Overflow Weir Gate Slope =	0.00	N/A	H:V
Horiz. Length of Weir Sides =	4.00	N/A	feet
Overflow Gate Type =	Type C Gate	N/A	
Debris Clogging % =	50%	N/A	%

	Zone 3 Weir	Not Selected	
Height of Gate Upper Edge, H ₁ =	3.63	N/A	feet
Overflow Weir Slope Length =	4.00	N/A	feet
Gate Open Area / 100-yr Orifice Area =	15.30	N/A	
Overflow Gate Open Area w/o Debris =	11.14	N/A	ft ²
Overflow Gate Open Area w/ Debris =	5.57	N/A	ft ²

User Input: Outlet Pipe w/ Flow Restriction Plate (Circular Orifice, Restrictor Plate, or Rectangular Orifice)

Calculated Parameters for Outlet Pipe w/ Flow Restriction Plate

	Zone 3 Restrictor	Not Selected	
Depth to Invert of Outlet Pipe =	0.50	N/A	ft (distance below basin bottom at Stage = 0 ft)
Outlet Pipe Diameter =	18.00	N/A	inches
Restrictor Plate Height Above Pipe Invert =	7.75		inches

	Zone 3 Restrictor	Not Selected	
Outlet Orifice Area =	0.73	N/A	ft ²
Outlet Orifice Centroid =	0.37	N/A	feet
Half-Central Angle of Restrictor Plate on Pipe =	1.43	N/A	radians

User Input: Emergency Spillway (Rectangular or Trapezoidal)

Calculated Parameters for Spillway

Spillway Invert Stage =	4.30	ft (relative to basin bottom at Stage = 0 ft)
Spillway Crest Length =	5.00	feet
Spillway End Slopes =	4.00	H:V
Freeboard above Max Water Surface =	1.00	feet

Spillway Design Flow Depth =	0.80	feet
Stage at Top of Freeboard =	6.10	feet
Basin Area at Top of Freeboard =	0.42	acres
Basin Volume at Top of Freeboard =	1.13	acre-ft

Routed Hydrograph Results

The user can override the default CUHP hydrographs and runoff volumes by entering new values in the Inflow Hydrographs table (Columns W through AF).

	WQCV	EURV	2 Year	5 Year	10 Year	25 Year	50 Year	100 Year	500 Year
Design Storm Return Period =	N/A	N/A	1.19	1.52	1.75	2.00	2.25	2.55	3.14
One-Hour Rainfall Depth (in)	N/A	N/A	1.19	1.52	1.75	2.00	2.25	2.55	3.14
CUHP Runoff Volume (acre-ft)	0.106	0.293	0.320	0.477	0.596	0.754	0.890	1.077	1.408
Inflow Hydrograph Volume (acre-ft)	N/A	N/A	0.320	0.477	0.596	0.754	0.890	1.077	1.408
CUHP Predevelopment Peak Q (cfs)	N/A	N/A	1.0	2.3	3.2	5.1	6.3	8.2	11.1
OPTIONAL Override Predevelopment Peak Q (cfs)	N/A	N/A							
Predevelopment Unit Peak Flow, q (cfs/acre)	N/A	N/A	0.16	0.35	0.48	0.79	0.97	1.26	1.71
Peak Inflow Q (cfs)	N/A	N/A	4.5	6.8	8.2	10.7	12.5	15.1	19.7
Peak Outflow Q (cfs)	0.1	0.1	0.1	0.4	0.5	2.2	4.2	7.1	8.3
Ratio Peak Outflow to Predevelopment Q	N/A	N/A	N/A	0.2	0.2	0.4	0.7	0.9	0.7
Structure Controlling Flow	Plate	Plate	Vertical Orifice 1	Vertical Orifice 1	Vertical Orifice 1	Overflow Weir 1	Overflow Weir 1	Outlet Plate 1	Spillway
Max Velocity through Gate 1 (fps)	N/A	N/A	N/A	N/A	N/A	0.1	0.3	0.6	0.6
Max Velocity through Gate 2 (fps)	N/A	N/A	N/A	N/A	N/A	N/A	N/A	N/A	N/A
Time to Drain 97% of Inflow Volume (hours)	46	65	68	71	71	68	65	61	56
Time to Drain 99% of Inflow Volume (hours)	49	71	75	80	81	81	80	78	75
Maximum Ponding Depth (ft)	1.70	2.60	2.62	3.14	3.51	3.79	3.90	4.03	4.44
Area at Maximum Ponding Depth (acres)	0.17	0.24	0.24	0.27	0.29	0.31	0.32	0.33	0.35
Maximum Volume Stored (acre-ft)	0.107	0.295	0.300	0.430	0.530	0.617	0.648	0.693	0.832

DETENTION BASIN OUTLET STRUCTURE DESIGN

MHFD-Detention, Version 4.04 (February 2021)

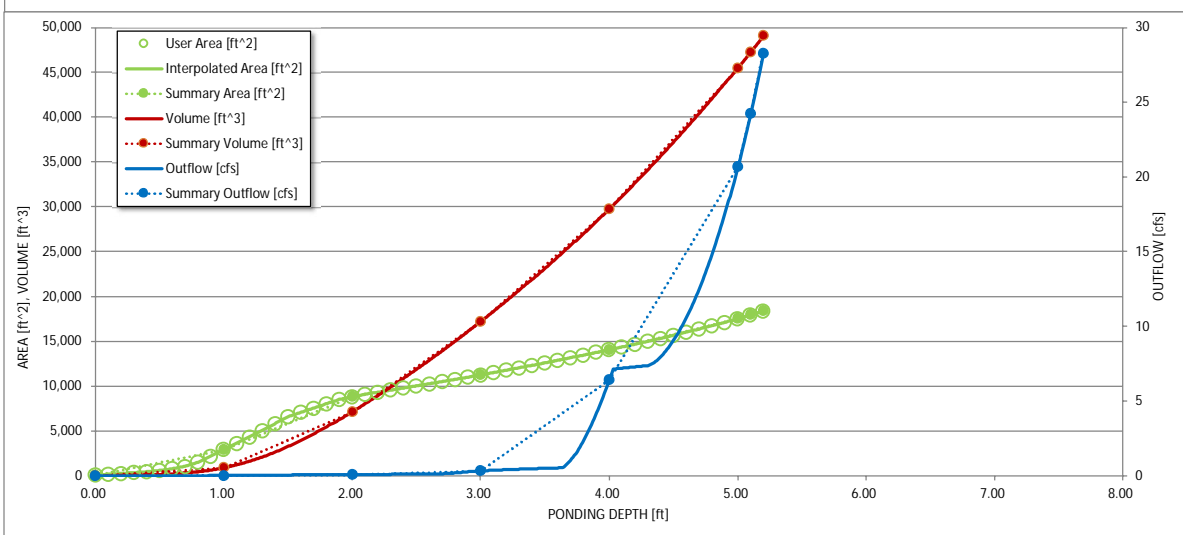
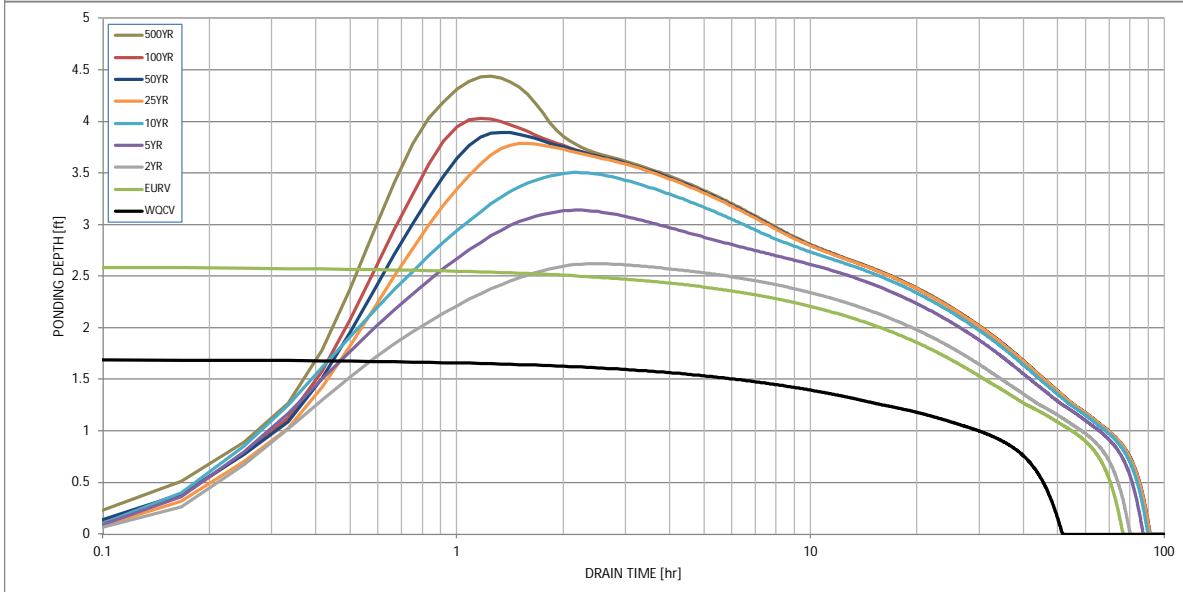
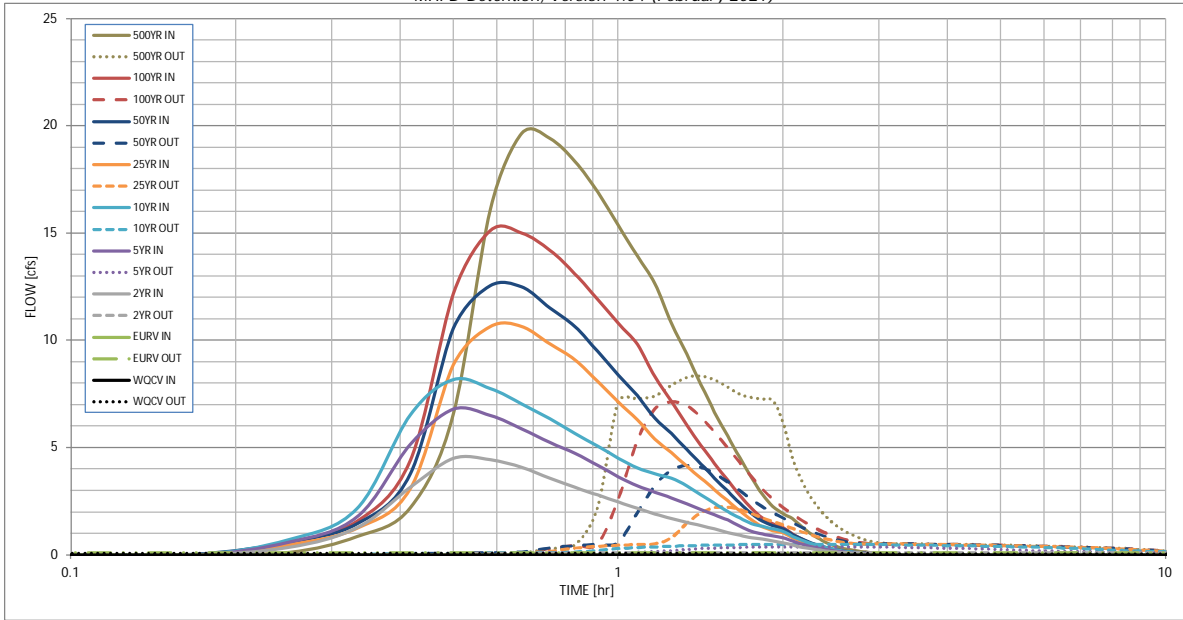

S-A-V-D Chart Axis Override	X-axis	Left Y-Axis	Right Y-Axis
minimum bound			
maximum bound			

DETENTION BASIN OUTLET STRUCTURE DESIGN

Outflow Hydrograph Workbook Filename: _____

Inflow Hydrographs

The user can override the calculated inflow hydrographs from this workbook with inflow hydrographs developed in a separate program.

Time Interval	SOURCE	CUHP	CUHP	CUHP	CUHP	CUHP	CUHP	CUHP	CUHP	CUHP
	TIME	WOCV [cfs]	EURV [cfs]	2 Year [cfs]	5 Year [cfs]	10 Year [cfs]	25 Year [cfs]	50 Year [cfs]	100 Year [cfs]	500 Year [cfs]
5.00 min	0:00:00	0.00	0.00	0.00	0.00	0.00	0.00	0.00	0.00	0.00
	0:05:00	0.00	0.00	0.00	0.00	0.00	0.00	0.00	0.00	0.00
	0:10:00	0.00	0.00	0.00	0.00	0.00	0.00	0.04	0.01	0.13
	0:15:00	0.00	0.00	0.36	0.60	0.72	0.49	0.61	0.60	0.85
	0:20:00	0.00	0.00	1.28	1.79	2.18	1.25	1.46	1.59	2.21
	0:25:00	0.00	0.00	3.15	5.17	6.55	3.10	3.79	4.42	6.58
	0:30:00	0.00	0.00	4.50	6.79	8.18	8.85	10.56	12.16	16.11
	0:35:00	0.00	0.00	4.43	6.49	7.75	10.65	12.55	15.13	19.66
	0:40:00	0.00	0.00	4.09	5.89	7.04	10.65	12.49	15.02	19.42
	0:45:00	0.00	0.00	3.58	5.24	6.35	9.83	11.52	14.21	18.34
	0:50:00	0.00	0.00	3.15	4.73	5.68	9.10	10.65	13.11	16.92
	0:55:00	0.00	0.00	2.79	4.17	5.07	8.08	9.48	11.90	15.36
	1:00:00	0.00	0.00	2.46	3.65	4.52	7.14	8.38	10.80	13.94
	1:05:00	0.00	0.00	2.19	3.22	4.07	6.31	7.42	9.81	12.66
	1:10:00	0.00	0.00	1.92	2.94	3.80	5.41	6.39	8.31	10.81
	1:15:00	0.00	0.00	1.71	2.67	3.59	4.77	5.66	7.17	9.37
	1:20:00	0.00	0.00	1.53	2.38	3.23	4.14	4.91	6.06	7.93
	1:25:00	0.00	0.00	1.37	2.12	2.80	3.59	4.25	5.10	6.66
	1:30:00	0.00	0.00	1.21	1.87	2.40	3.03	3.59	4.26	5.55
	1:35:00	0.00	0.00	1.06	1.63	2.04	2.52	2.98	3.49	4.54
	1:40:00	0.00	0.00	0.91	1.34	1.72	2.05	2.42	2.78	3.62
	1:45:00	0.00	0.00	0.80	1.11	1.47	1.64	1.93	2.17	2.83
	1:50:00	0.00	0.00	0.74	0.97	1.33	1.33	1.57	1.73	2.27
	1:55:00	0.00	0.00	0.65	0.89	1.22	1.15	1.36	1.46	1.93
	2:00:00	0.00	0.00	0.58	0.81	1.10	1.03	1.23	1.27	1.69
	2:05:00	0.00	0.00	0.47	0.65	0.88	0.81	0.96	0.98	1.30
	2:10:00	0.00	0.00	0.37	0.51	0.69	0.62	0.74	0.73	0.98
	2:15:00	0.00	0.00	0.29	0.40	0.54	0.48	0.57	0.55	0.73
	2:20:00	0.00	0.00	0.23	0.31	0.42	0.37	0.44	0.41	0.54
	2:25:00	0.00	0.00	0.18	0.24	0.32	0.28	0.33	0.31	0.41
	2:30:00	0.00	0.00	0.14	0.18	0.24	0.21	0.25	0.23	0.31
	2:35:00	0.00	0.00	0.11	0.14	0.18	0.16	0.19	0.18	0.23
	2:40:00	0.00	0.00	0.08	0.10	0.14	0.12	0.14	0.13	0.18
	2:45:00	0.00	0.00	0.06	0.08	0.10	0.09	0.11	0.10	0.14
	2:50:00	0.00	0.00	0.04	0.05	0.07	0.07	0.08	0.08	0.10
	2:55:00	0.00	0.00	0.03	0.04	0.05	0.05	0.06	0.05	0.07
	3:00:00	0.00	0.00	0.02	0.02	0.03	0.03	0.04	0.03	0.04
	3:05:00	0.00	0.00	0.01	0.01	0.02	0.02	0.02	0.02	0.02
	3:10:00	0.00	0.00	0.00	0.01	0.01	0.01	0.01	0.01	0.01
	3:15:00	0.00	0.00	0.00	0.00	0.00	0.00	0.00	0.00	0.00
	3:20:00	0.00	0.00	0.00	0.00	0.00	0.00	0.00	0.00	0.00
	3:25:00	0.00	0.00	0.00	0.00	0.00	0.00	0.00	0.00	0.00
	3:30:00	0.00	0.00	0.00	0.00	0.00	0.00	0.00	0.00	0.00
	3:35:00	0.00	0.00	0.00	0.00	0.00	0.00	0.00	0.00	0.00
	3:40:00	0.00	0.00	0.00	0.00	0.00	0.00	0.00	0.00	0.00
	3:45:00	0.00	0.00	0.00	0.00	0.00	0.00	0.00	0.00	0.00
	3:50:00	0.00	0.00	0.00	0.00	0.00	0.00	0.00	0.00	0.00
	3:55:00	0.00	0.00	0.00	0.00	0.00	0.00	0.00	0.00	0.00
	4:00:00	0.00	0.00	0.00	0.00	0.00	0.00	0.00	0.00	0.00
	4:05:00	0.00	0.00	0.00	0.00	0.00	0.00	0.00	0.00	0.00
	4:10:00	0.00	0.00	0.00	0.00	0.00	0.00	0.00	0.00	0.00
	4:15:00	0.00	0.00	0.00	0.00	0.00	0.00	0.00	0.00	0.00
	4:20:00	0.00	0.00	0.00	0.00	0.00	0.00	0.00	0.00	0.00
	4:25:00	0.00	0.00	0.00	0.00	0.00	0.00	0.00	0.00	0.00
	4:30:00	0.00	0.00	0.00	0.00	0.00	0.00	0.00	0.00	0.00
	4:35:00	0.00	0.00	0.00	0.00	0.00	0.00	0.00	0.00	0.00
	4:40:00	0.00	0.00	0.00	0.00	0.00	0.00	0.00	0.00	0.00
	4:45:00	0.00	0.00	0.00	0.00	0.00	0.00	0.00	0.00	0.00
	4:50:00	0.00	0.00	0.00	0.00	0.00	0.00	0.00	0.00	0.00
	4:55:00	0.00	0.00	0.00	0.00	0.00	0.00	0.00	0.00	0.00
	5:00:00	0.00	0.00	0.00	0.00	0.00	0.00	0.00	0.00	0.00
	5:05:00	0.00	0.00	0.00	0.00	0.00	0.00	0.00	0.00	0.00
	5:10:00	0.00	0.00	0.00	0.00	0.00	0.00	0.00	0.00	0.00
	5:15:00	0.00	0.00	0.00	0.00	0.00	0.00	0.00	0.00	0.00
	5:20:00	0.00	0.00	0.00	0.00	0.00	0.00	0.00	0.00	0.00
	5:25:00	0.00	0.00	0.00	0.00	0.00	0.00	0.00	0.00	0.00
	5:30:00	0.00	0.00	0.00	0.00	0.00	0.00	0.00	0.00	0.00
	5:35:00	0.00	0.00	0.00	0.00	0.00	0.00	0.00	0.00	0.00
	5:40:00	0.00	0.00	0.00	0.00	0.00	0.00	0.00	0.00	0.00
	5:45:00	0.00	0.00	0.00	0.00	0.00	0.00	0.00	0.00	0.00
	5:50:00	0.00	0.00	0.00	0.00	0.00	0.00	0.00	0.00	0.00
	5:55:00	0.00	0.00	0.00	0.00	0.00	0.00	0.00	0.00	0.00
	6:00:00	0.00	0.00	0.00	0.00	0.00	0.00	0.00	0.00	0.00



Nyloplast Inlet Capacity Table

DISCLAIMER: SAFETY FACTORS ARE NOT INCLUDED IN THESE CALCULATIONS. ACTUAL CALCULATIONS SHOULD BE CARRIED OUT AND VERIFIED BY THE DESIGN ENGINEER TAKING INTO ACCOUNT ALL LOCAL CONDITIONS. NYLOPLAST RECOMMENDS USING A MINIMUM SAFETY FACTOR OF 1.25 FOR PAVED AREAS AND 2.0 FOR TURF AREAS. ADS/NYLOPLAST IS NOT RESPONSIBLE FOR MISUSE OF THIS TOOL.

Input	
Type of Grate	12" Standard
Head (ft)	0.5
Properties	
Orifice Flow Area (in)	60.62
Orifice Flow Area (ft)	0.42
Weir Flow Perimeter (in)	43.75
Weir Flow Perimeter (ft)	3.65
Solution	
Capacity (cfs)	1.42
Capacity (gpm)	638.88

$$Q_{weir} = CLH^{3/2}$$

$C = 3.33$ Weir Discharge Coefficient

$L =$ Perimeter of Grate Opening (ft)

$H =$ Flow Height of Water Surface Above Weir (ft)

$$Q_{orifice} = CA\sqrt{2gh}$$

$C = 0.60$ Orifice Discharge Coefficient

$A =$ Area of the Orifice (ft²)

$g =$ Gravitational Constant $\left(32.2 \frac{ft}{s^2}\right)$

$H =$ Depth of Water Above Center of Orifice (ft)

REV 2.1.21

		Forebay D	
		Required	Release Rate
Forebay Release and Configuration	Release 2% of the undetained 100-year peak discharge by way of a wall/notch or berm/pipe configuration	Flow: $Q_{100} =$ (cfs)	
		5.54	0.06

		40hr drain time a = 1	Required (CF)	Provided (CF)
Minimum Forebay Volume Required	2% of the WQCV	I = 0.95 A = 0.83 AC	26.95	29.97

Maximum Forebay Depth	Required	Provided	
	18" Max	18"	Concrete Forebay Structure

Forebay Notch Calculations			
$Q = C_o A_o (2gH_o)^{0.5}$			
Q_a	0.06 cfs		2% of Peak 100 YR Discharge for contributing Sub-Basins
C_o	0.6		
H_o	0.5 ft		
g	32.2 ft/s ²		
A_a	0.02 ft ²		
L_a	0.01 ft		
	0.13 in		3" Minimum per Criteria

$WQCV = a(0.91I^3 - 1.19I^2 + 0.78I)$ Equation 3-1

Where:

- WQCV = Water Quality Capture Volume (watershed inches)
- a = Coefficient corresponding to WQCV drain time (Table 3-2)
- I = Imperviousness (%/100) (see Figures 3-3 through 3-5 [single family land use] and /or the Runoff chapter of Volume 1[other typical land uses])

Table 3-2. Drain Time Coefficients for WQCV Calculations

Drain Time (hrs)	Coefficient, a
12 hours	0.8
24 hours	0.9
40 hours	1.0

		Forebay D	
		Required	Release Rate
Forebay Release and Configuration	Release 2% of the undetained 100-year peak discharge by way of a wall/notch or berm/pipe configuration	Flow: $Q_{100} =$ (cfs)	
		6.70	0.07

		40hr drain time $a = 1$	Required (CF)	Provided (CF)
Minimum Forebay Volume Required	2% of the WQCV	$I = 0.95$ $A = 1.23$ AC	39.94	47.51

Maximum Forebay Depth	Required	Provided	
	18" Max	18"	Concrete Forebay Structure

Forebay Notch Calculations			
$Q = C_o A_o (2gH_o)^{0.5}$			
Q_a	0.07 cfs		2% of Peak 100 YR Discharge for contributing Sub-Basins
C_o	0.6		
H_o	0.5 ft		
g	32.2 ft/s ²		
A_a	0.02 ft ²		
L_a	0.01 ft		
	0.16 in		3" Minimum per Criteria

$WQCV = a(0.91I^3 - 1.19I^2 + 0.78I)$ Equation 3-1

Where:

- WQCV = Water Quality Capture Volume (watershed inches)
- a = Coefficient corresponding to WQCV drain time (Table 3-2)
- I = Imperviousness (%/100) (see Figures 3-3 through 3-5 [single family land use] and /or the *Runoff* chapter of Volume 1 [other typical land uses])

Table 3-2. Drain Time Coefficients for WQCV Calculations

Drain Time (hrs)	Coefficient, a
12 hours	0.8
24 hours	0.9
40 hours	1.0

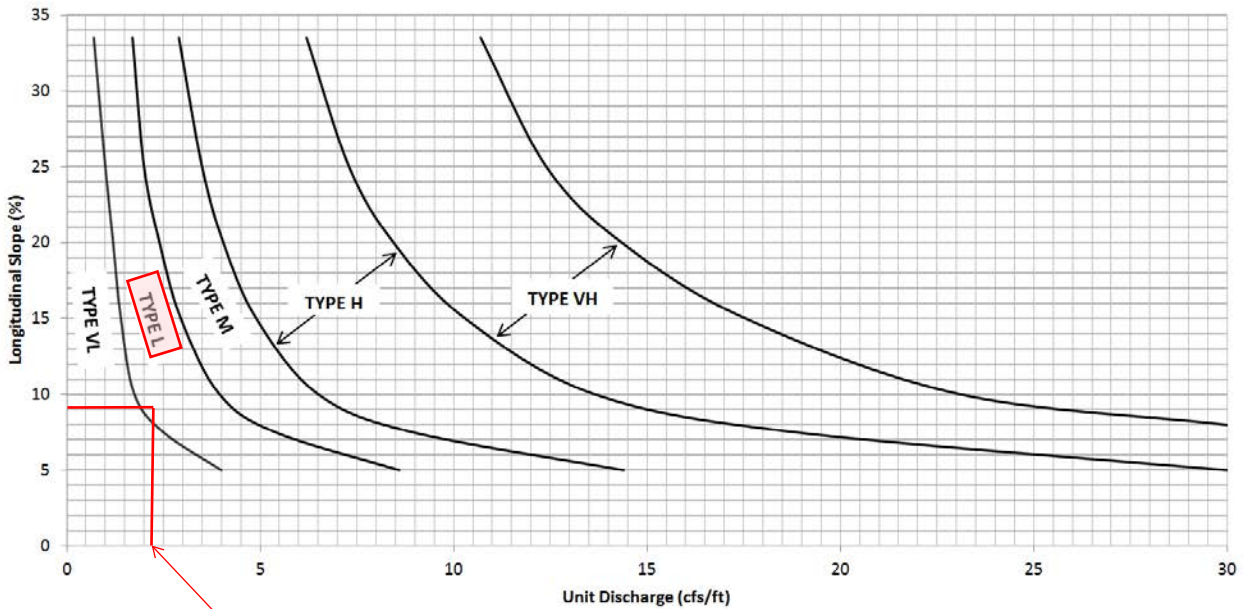
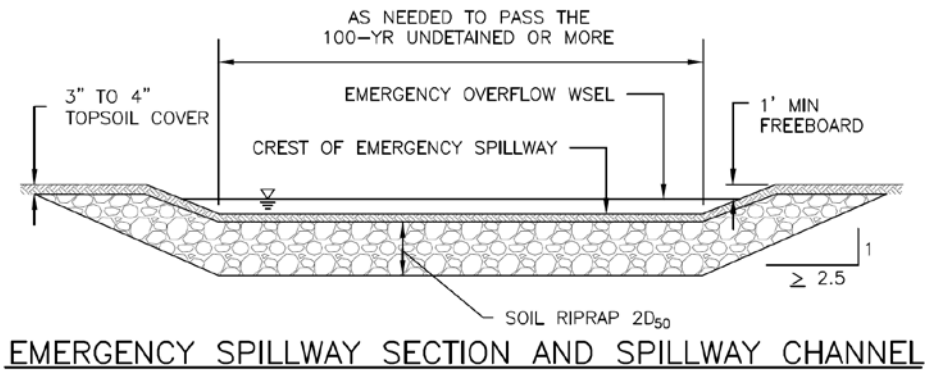
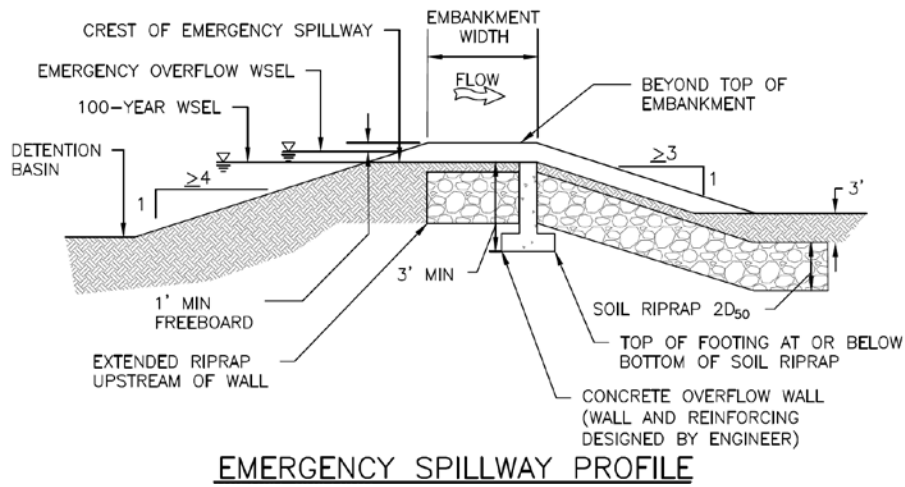

Figure 12-21. Embankment protection details and rock sizing chart (adapted from Arapahoe County)

100-yr undetained flow = 27.84 cfs

27.84 cfs / 13 ft = 2.14

Rip-Rap Calculation Pond Outlet

Applicable Equations:

$L_p = (1/2 \tan \theta)(A_v Y_1 D)$	Equation 9-11 per USDCM
$A_v = Q/V$	Equation 9-12 per USDCM
$\theta = \tan^{-1}(1/(2 \cdot \text{ExpansionFactor}))$	Equation 9-13 per USDCM
$W = 2(L_p \tan \theta) + D$	Equation 9-14 per USDCM
$T = 2D_{50}$	Equation 9-15 per USDCM

Assumptions

Maximum Major Event Velocity is 7fps for FES outletting into trickle channels

Input parameters:

Description	Variable	Input	Unit
Width of the conduit (use diameter for circular conduits),	D:	1.50	ft
Rectangular conduit	H:	0.00	
HGL Elevation		6445.47	ft
Invert Elevation		6444.88	ft
Tailwater depth (ft),	Y_1 :	0.59	ft
Expansion angle of the culvert flow	θ :	0.08	radians
Design discharge (cfs)*	Q:	5.60	cfs
Froude Number	F_r	0.73	Subcritical

Unitless Variables for Tables:

For Figure 9-35 $Q/D^{2.5}$	2.03
For Figure 9-36 $Q/WH^{3/2}$	#DIV/0!
For Figure 9-35 Y_1/D	0.39
For Figure 9-38 $Q/D^{1.5}$	3.05
For Figure 9-38 Y_1/D	0.39

Allowable non-eroding velocity in the downstream channel (ft/sec)	V:	5	ft/sec
Expansion Factor (Figure 9-35), $1/(2 \tan \theta)$		6.5	

Solve for:

Description	Variable	Output	Unit
1. Required area of flow at allowable velocity (ft ²)	A_v :	1.12	ft ²
2. Length of Protection	L_p :	2.59	ft
	$L_p < 3D$?	Yes	
	L_{pmin} :	4.50	ft
3. Width of downstream riprap protection	W:	2.00	ft
4. Rip Rap Type (Figure 9-38)	-	L	
5. Rip Rap Size (Figure 8-34)	D_{50} :	9	inches

Rip Rap Summary

Length	L_p	5.00	ft
Width	W	2.00	ft
Size	D_{50}	9	inches
Type	-	L	
Thickness	T	18	inches

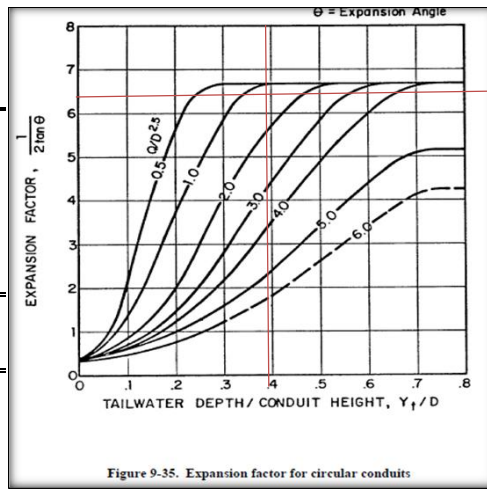

Figure 9-35. Expansion factor for circular conduits

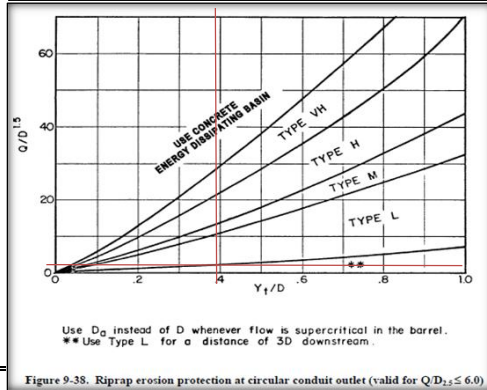

Figure 9-38. Riprap erosion protection at circular conduit outlet (valid for $Q/D^{2.5} \leq 6.0$)

RIPRAP DESIGNATION	% SMALLER THAN GIVEN SIZE BY WEIGHT	INTERMEDIATE ROCK DIMENSION (INCHES)	D_{50} * (INCHES)
TYPE VL	70 - 100	12	6
	50 - 70	9	
	35 - 50	6	
TYPE L	70 - 100	15	9
	50 - 70	12	
	35 - 50	9	
TYPE M	70 - 100	21	12
	50 - 70	18	
	35 - 50	12	
TYPE H	70 - 100	30	18
	50 - 70	24	
	35 - 50	18	
	2 - 10	6	

* D_{50} = MEAN ROCK SIZE

Figure 8-34. Riprap and soil riprap placement and gradation (part 1 of 3)

Rock Chute Design Data

(Version WI-Nov. 2017, Based on Design of Rock Chutes by Robinson, Rice, Kadavy, ASAE, 1998)

Project: Webster
Designer: AJL
Date: June 24, 2022

County: El Paso
Checked by: EJG
Date: _____

Input Geometry:

Upstream Channel	Chute	Downstream Channel
Bw = 8.0 ft.	Bw = 8.0 ft.	Bw = 4.0 ft.
Side slopes = 4.0 (m:1)	Factor of safety = 1.20 (F _s) 1.2 Min	Side slopes = 4.0 (m:1)
Velocity n-value = 0.030	Side slopes = 2.0 (m:1) → 2.0:1 max.	Velocity n-value = 0.013
Bed slope = 0.0200 ft./ft.	Bed slope (4:1) = 0.250 ft./ft → 3.0:1 max.	Bed slope = 0.0100 ft./ft.
<i>Note: n value = a) velocity n from waterway program or b) computed manning's n for channel</i>	Freeboard = 0.5 ft. →	Base flow = 0.0 cfs
	Outlet apron depth, d = 0.0 ft.	

Design Storm Data (Table 2, FOTG, WI-NRCS Grade Stabilization Structure No. 410):

Apron elev. --- Inlet = 5656.6 ft. ----- Outlet 5655.0 ft. --- (H _{drop} = 1.6 ft.)		Note: The total required capacity is routed through the chute (principal spillway) or in combination with an auxiliary spillway.
Q _{high} = Runoff from design storm capacity from Table 2, FOTG Standard 410	Input tailwater (Tw): 0.25 1.20	
Q ₅ = Runoff from a 5-year, 24-hour storm.		
Q _{high} = 10.2 cfs High flow storm through chute	→ Tw (ft.) = Program	
Q ₅ = 2.5 cfs Low flow storm through chute	→ Tw (ft.) = Program	

Profile and Cross Section (Output):

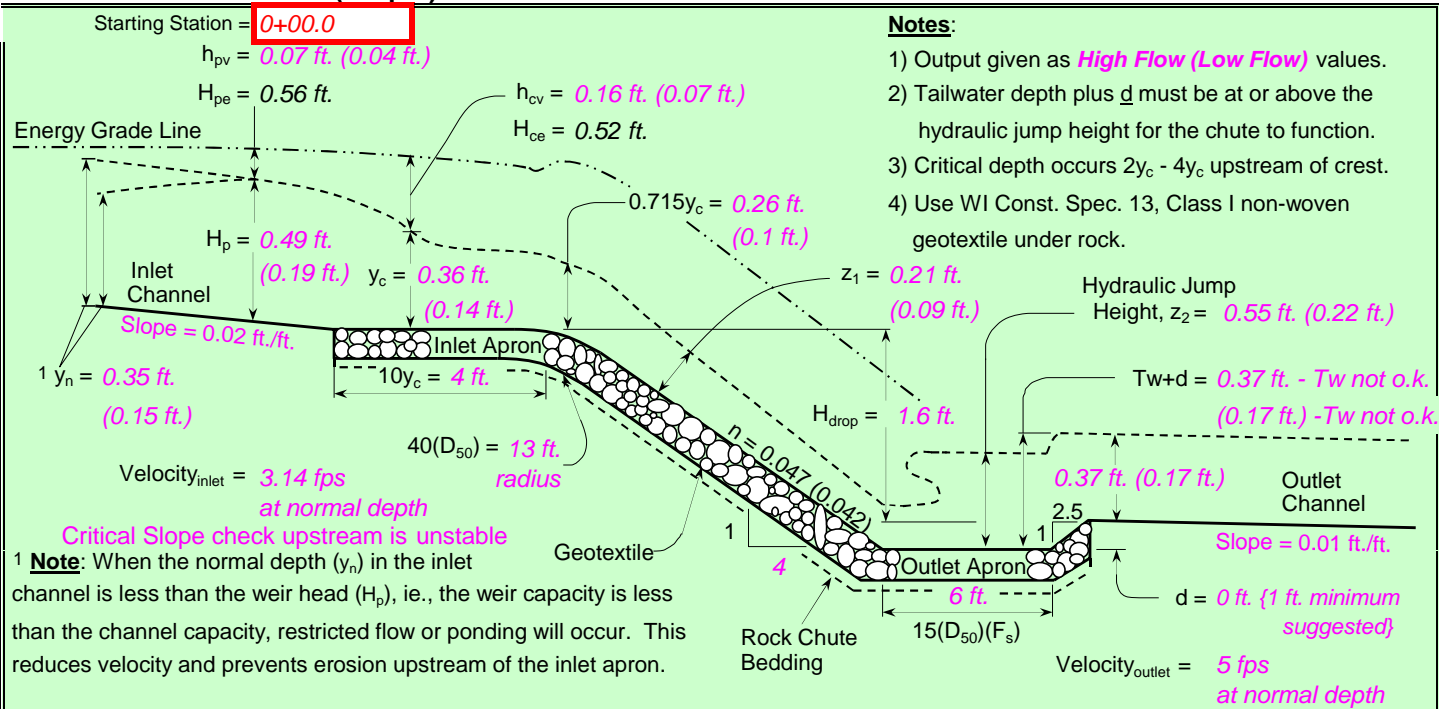

Profile Along Centerline of Chute

Typical Cross Section

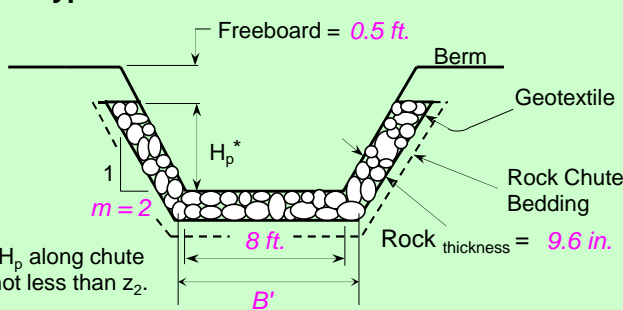

F _s =	1.20	Factor of safety (multiplier)
z ₁ =	0.21 ft.	Normal depth in chute
n-value =	0.047	Manning's roughness coefficient
D ₅₀ (F _s) =	4.8 in.	Minimum Design D50*
2(D ₅₀)(F _s) =	9.6 in.	Rock chute thickness
Tw + d =	0.37 ft.	Tailwater above outlet apron
z ₂ =	0.55 ft.	Hydraulic jump height
*** The outlet	will not	function adequately

High Flow Storm Information

Cross Section for 2' Grass-Lined Swale (DP 9)

Project Description	
Friction Method	Manning Formula
Solve For	Discharge

Input Data	
Roughness Coefficient	0.030
Channel Slope	0.100 ft/ft
Normal Depth	3.0 in
Left Side Slope	4.000 H:V
Right Side Slope	4.000 H:V
Discharge	0.96 cfs (Required Flow: 0.75 cfs)

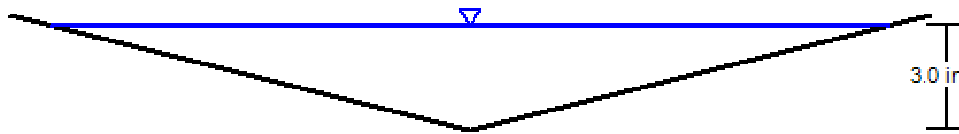

V: 1 
H: 1

Worksheet for 2' Grass-Lined Swale

Project Description	
Friction Method	Manning Formula
Solve For	Normal Depth
Input Data	
Roughness Coefficient	0.030
Channel Slope	0.015 ft/ft
Left Side Slope	4.000 H:V
Right Side Slope	4.000 H:V
Discharge	0.96 cfs
Results	
Normal Depth	4.3 in
Flow Area	0.5 ft ²
Wetted Perimeter	2.9 ft
Hydraulic Radius	2.1 in
Top Width	2.86 ft
Critical Depth	3.9 in
Critical Slope	0.025 ft/ft
Velocity	1.88 ft/s
Velocity Head	0.06 ft
Specific Energy	0.41 ft
Froude Number	0.786
Flow Type	Subcritical
GVF Input Data	
Downstream Depth	0.0 in
Length	0.0 ft
Number Of Steps	0
GVF Output Data	
Upstream Depth	0.0 in
Profile Description	N/A
Profile Headloss	0.00 ft
Downstream Velocity	Infinity ft/s
Upstream Velocity	Infinity ft/s
Normal Depth	4.3 in
Critical Depth	3.9 in
Channel Slope	0.015 ft/ft
Critical Slope	0.025 ft/ft

Cross Section for 8' Grass-Lined Swale (DP 11)

Project Description	
Friction Method	Manning Formula
Solve For	Discharge

Input Data	
Roughness Coefficient	0.030
Channel Slope	0.015 ft/ft
Normal Depth	12.0 in
Left Side Slope	4.000 H:V
Right Side Slope	4.000 H:V
Discharge	14.98 cfs (Required Flow: 10.16 cfs)

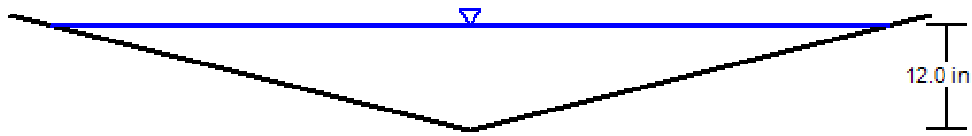

V: 1
H: 1

Worksheet for 8' Grass-Lined Swale

Project Description	
Friction Method	Manning Formula
Solve For	Normal Depth
Input Data	
Roughness Coefficient	0.030
Channel Slope	0.014 ft/ft
Left Side Slope	4.000 H:V
Right Side Slope	4.000 H:V
Discharge	10.68 cfs
Results	
Normal Depth	10.7 in
Flow Area	3.2 ft ²
Wetted Perimeter	7.4 ft
Hydraulic Radius	5.2 in
Top Width	7.14 ft
Critical Depth	10.2 in
Critical Slope	0.018 ft/ft
Velocity	3.35 ft/s
Velocity Head	0.17 ft
Specific Energy	1.07 ft
Froude Number	0.885
Flow Type	Subcritical
GVF Input Data	
Downstream Depth	0.0 in
Length	0.0 ft
Number Of Steps	0
GVF Output Data	
Upstream Depth	0.0 in
Profile Description	N/A
Profile Headloss	0.00 ft
Downstream Velocity	0.00 ft/s
Upstream Velocity	0.00 ft/s
Normal Depth	10.7 in
Critical Depth	10.2 in
Channel Slope	0.014 ft/ft
Critical Slope	0.018 ft/ft

Cross Section for 8" Trench Drain

Project Description	
Friction Method	Manning Formula
Solve For	Discharge

Input Data	
Roughness Coefficient	0.013
Channel Slope	0.018 ft/ft
Normal Depth	8.0 in
Bottom Width	1.00 ft
Discharge	4.43 cfs (Required Flow: 3.81 cfs)

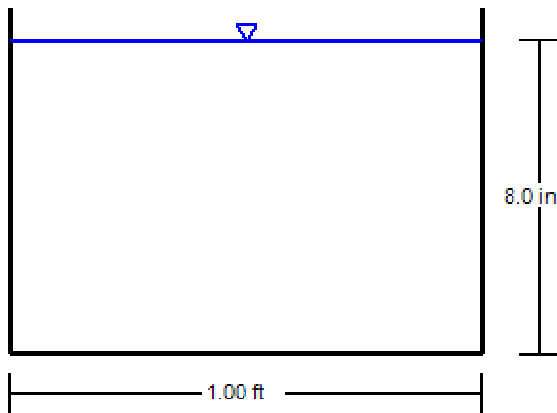

V: 1
H: 1

Worksheet for 8" Trench Drain

Project Description	
Friction Method	Manning Formula
Solve For	Discharge
Input Data	
Roughness Coefficient	0.013
Channel Slope	0.018 ft/ft
Normal Depth	8.0 in
Bottom Width	1.00 ft
Results	
Discharge	4.43 cfs
Flow Area	0.7 ft ²
Wetted Perimeter	2.3 ft
Hydraulic Radius	3.4 in
Top Width	1.00 ft
Critical Depth	10.2 in
Critical Slope	0.010 ft/ft
Velocity	6.65 ft/s
Velocity Head	0.69 ft
Specific Energy	1.35 ft
Froude Number	1.436
Flow Type	Supercritical
GVF Input Data	
Downstream Depth	0.0 in
Length	0.0 ft
Number Of Steps	0
GVF Output Data	
Upstream Depth	0.0 in
Profile Description	N/A
Profile Headloss	0.00 ft
Downstream Velocity	Infinity ft/s
Upstream Velocity	Infinity ft/s
Normal Depth	8.0 in
Critical Depth	10.2 in
Channel Slope	0.018 ft/ft
Critical Slope	0.010 ft/ft

Cross Section for Ex. Swale (NEC)

Project Description	
Friction Method	Manning Formula
Solve For	Discharge
Input Data	
Roughness Coefficient	0.030
Channel Slope	0.005 ft/ft
Normal Depth	8.5 in
Left Side Slope	20.000 H:V
Right Side Slope	8.000 H:V
Discharge	11.66 cfs (Required Flow: 3.11 cfs)

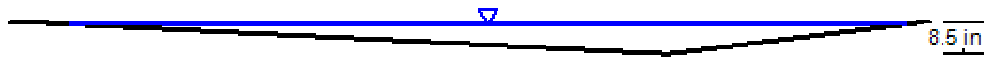

V: 1 H: 1

Worksheet for Ex. Swale (NEC)

Project Description	
Friction Method	Manning Formula
Solve For	Discharge
Input Data	
Roughness Coefficient	0.030
Channel Slope	0.005 ft/ft
Normal Depth	8.5 in
Left Side Slope	20.000 H:V
Right Side Slope	8.000 H:V
Results	
Discharge	11.66 cfs
Flow Area	7.0 ft ²
Wetted Perimeter	19.9 ft
Hydraulic Radius	4.2 in
Top Width	19.83 ft
Critical Depth	6.4 in
Critical Slope	0.020 ft/ft
Velocity	1.66 ft/s
Velocity Head	0.04 ft
Specific Energy	0.75 ft
Froude Number	0.492
Flow Type	Subcritical
GVF Input Data	
Downstream Depth	0.0 in
Length	0.0 ft
Number Of Steps	0
GVF Output Data	
Upstream Depth	0.0 in
Profile Description	N/A
Profile Headloss	0.00 ft
Downstream Velocity	0.00 ft/s
Upstream Velocity	0.00 ft/s
Normal Depth	8.5 in
Critical Depth	6.4 in
Channel Slope	0.005 ft/ft
Critical Slope	0.020 ft/ft

Cross Section for Ex. 12" CMP Culvert (East Entrance)

Project Description	
Friction Method	Manning Formula
Solve For	Discharge

Input Data	
Roughness Coefficient	0.024
Channel Slope	0.022 ft/ft
Normal Depth	12.0 in
Diameter	12.0 in
Discharge	2.86 cfs

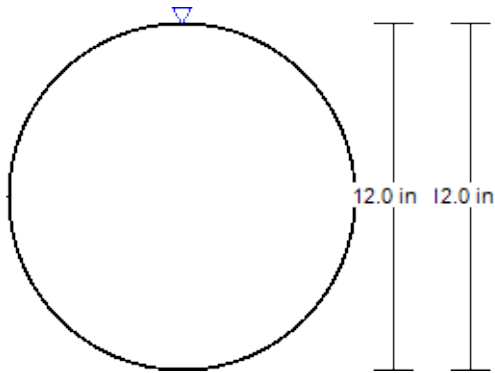

V: 1
H: 1

Rip-Rap Calculation
PR. 12" RCP Culvert (East Entrance) Outfall Protection

Applicable Equations:

$L_p = (1/2 \tan \theta)(A_i/Y_i D)$	Equation 9-11 per USDCM
$A_i = Q/V$	Equation 9-12 per USDCM
$\theta = \tan^{-1}(1/(2 \cdot \text{Expansion Factor}))$	Equation 9-13 per USDCM
$W = 2(L_p \tan \theta) + D$	Equation 9-14 per USDCM
$T = 2D_{50}$	Equation 9-15 per USDCM

Assumptions

Maximum Major Event Velocity is 7fps for FES outfalling into trickle channels

Input parameters:

Description	Variable	Input	Unit
Width of the conduit (use diameter for circular conduits),	D:	1.00	ft
Rectangular conduit	H:	0.00	
HGL Elevation		0.50	ft
Invert Elevation		0.00	ft
Tailwater depth (ft),	Y_i :	0.50	ft
Expansion angle of the culvert flow	θ :	0.09	radians
Design discharge (cfs)*	Q:	3.11	cfs
Froude Number	F_r	0.99	Subcritical

Unitless Variables for Tables:

For Figure 9-35 $Q/D^{2.5}$	3.11		
For Figure 9-36 $Q/WH^{3/2}$	#DIV/0!		
For Figure 9-35 Y_i/D	0.50		
For Figure 9-38 $Q/D^{1.5}$	3.11		
For Figure 9-38 Y_i/D	0.50		
Allowable non-eroding velocity in the downstream channel (ft/sec)	V:	5	ft/sec
Expansion Factor (Figure 9-35), $1/(2 \tan \theta)$		5.6	

Solve for:

Description	Variable	Output	Unit
1. Required area of flow at allowable velocity (ft^2)	A_i :	0.62	ft^2
2. Length of Protection	L_p :	1.37	ft
	$L_p < 3D?$	Yes	
	L_{pmin} :	3.00	ft
3. Width of downstream riprap protection	W:	2.00	ft
4. Rip Rap Type (Figure 9-38)	-	L	
5. Rip Rap Size (Figure 8-34)	D_{50} :	9	inches

Rip Rap Summary

Length	L_p	3.00	ft
Width	W	2.00	ft
Size	D_{50}	9	inches
Type	-	L	
Thickness	T	18	inches

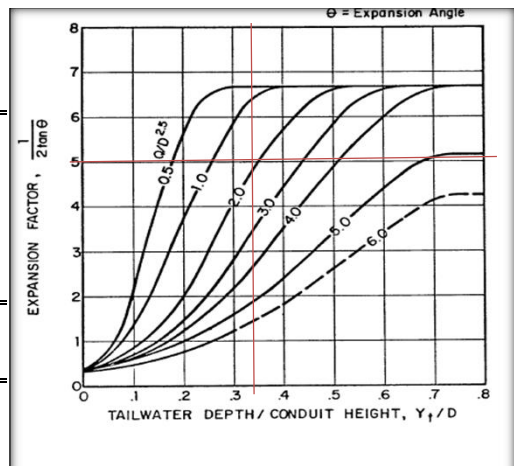

Figure 9-35. Expansion factor for circular conduits

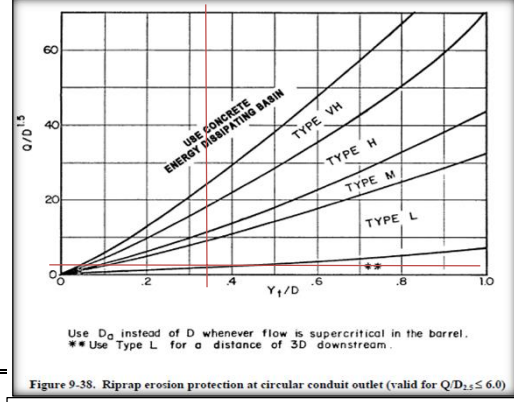

Figure 9-38. Riprap erosion protection at circular conduit outlet (valid for $Q/D_{2.5} \leq 6.0$)

RIPRAP DESIGNATION	% SMALLER THAN GIVEN SIZE BY WEIGHT	INTERMEDIATE ROCK DIMENSION (INCHES)	D_{50} * (INCHES)
TYPE VL	70 - 100	12	6
	50 - 70	9	
	35 - 50	6	
	2 - 10	2	
TYPE L	70 - 100	15	9
	50 - 70	12	
	35 - 50	9	
	2 - 10	3	
TYPE M	70 - 100	21	12
	50 - 70	18	
	35 - 50	12	
	2 - 10	4	
TYPE H	70 - 100	30	18
	50 - 70	24	
	35 - 50	18	
	2 - 10	6	

* D_{50} = MEAN ROCK SIZE

Figure 8-34. Riprap and soil riprap placement and gradation (part 1 of 3)

Worksheet for Pr. 12" RCP Culvert (East Entrance)

Project Description	
Friction Method	Manning Formula
Solve For	Discharge
Input Data	
Roughness Coefficient	0.013
Channel Slope	0.022 ft/ft
Normal Depth	12.0 in
Diameter	12.0 in
Results	
Discharge	5.28 cfs
Flow Area	0.8 ft ²
Wetted Perimeter	3.1 ft
Hydraulic Radius	3.0 in
Top Width	0.00 ft
Critical Depth	11.2 in
Percent Full	100.0 %
Critical Slope	0.019 ft/ft
Velocity	6.73 ft/s
Velocity Head	0.70 ft
Specific Energy	1.70 ft
Froude Number	(N/A)
Maximum Discharge	5.68 cfs
Discharge Full	5.28 cfs
Slope Full	0.022 ft/ft
Flow Type	Supercritical
GVF Input Data	
Downstream Depth	0.0 in
Length	0.0 ft
Number Of Steps	0
GVF Output Data	
Upstream Depth	0.0 in
Profile Description	N/A
Profile Headloss	0.00 ft
Average End Depth Over Rise	0.0 %
Normal Depth Over Rise	100.0 %
Downstream Velocity	Infinity ft/s
Upstream Velocity	Infinity ft/s
Normal Depth	12.0 in
Critical Depth	11.2 in
Channel Slope	0.022 ft/ft
Critical Slope	0.019 ft/ft

Cross Section for Trickle Channel

Project Description	
Friction Method	Manning Formula
Solve For	Normal Depth

Input Data	
Roughness Coefficient	0.013
Channel Slope	0.015 ft/ft
Normal Depth	4.4 in
Bottom Width	4.00 ft
Discharge	9.43 cfs

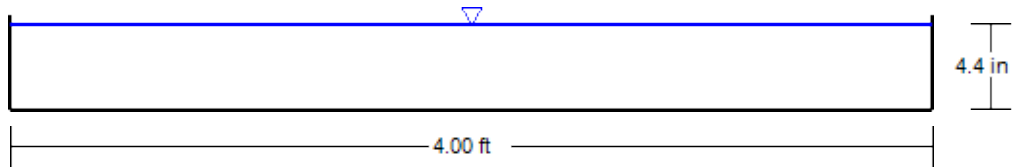

V: 1
H: 1

Worksheet for Trickle Channel

Project Description	
Friction Method	Manning Formula
Solve For	Normal Depth
Input Data	
Roughness Coefficient	0.013
Channel Slope	0.015 ft/ft
Bottom Width	4.00 ft
Discharge	9.43 cfs
Results	
Normal Depth	4.4 in
Flow Area	1.5 ft ²
Wetted Perimeter	4.7 ft
Hydraulic Radius	3.7 in
Top Width	4.00 ft
Critical Depth	6.7 in
Critical Slope	0.004 ft/ft
Velocity	6.42 ft/s
Velocity Head	0.64 ft
Specific Energy	1.01 ft
Froude Number	1.866
Flow Type	Supercritical
GVF Input Data	
Downstream Depth	0.0 in
Length	0.0 ft
Number Of Steps	0
GVF Output Data	
Upstream Depth	0.0 in
Profile Description	N/A
Profile Headloss	0.00 ft
Downstream Velocity	Infinity ft/s
Upstream Velocity	Infinity ft/s
Normal Depth	4.4 in
Critical Depth	6.7 in
Channel Slope	0.015 ft/ft
Critical Slope	0.004 ft/ft

OVERALL STORM LAYOUT



WEBSTER ELEMENTARY
Active Scenario: 5-YR
Profile Report
Engineering Profile - STRM A (StormCAD.stsw)

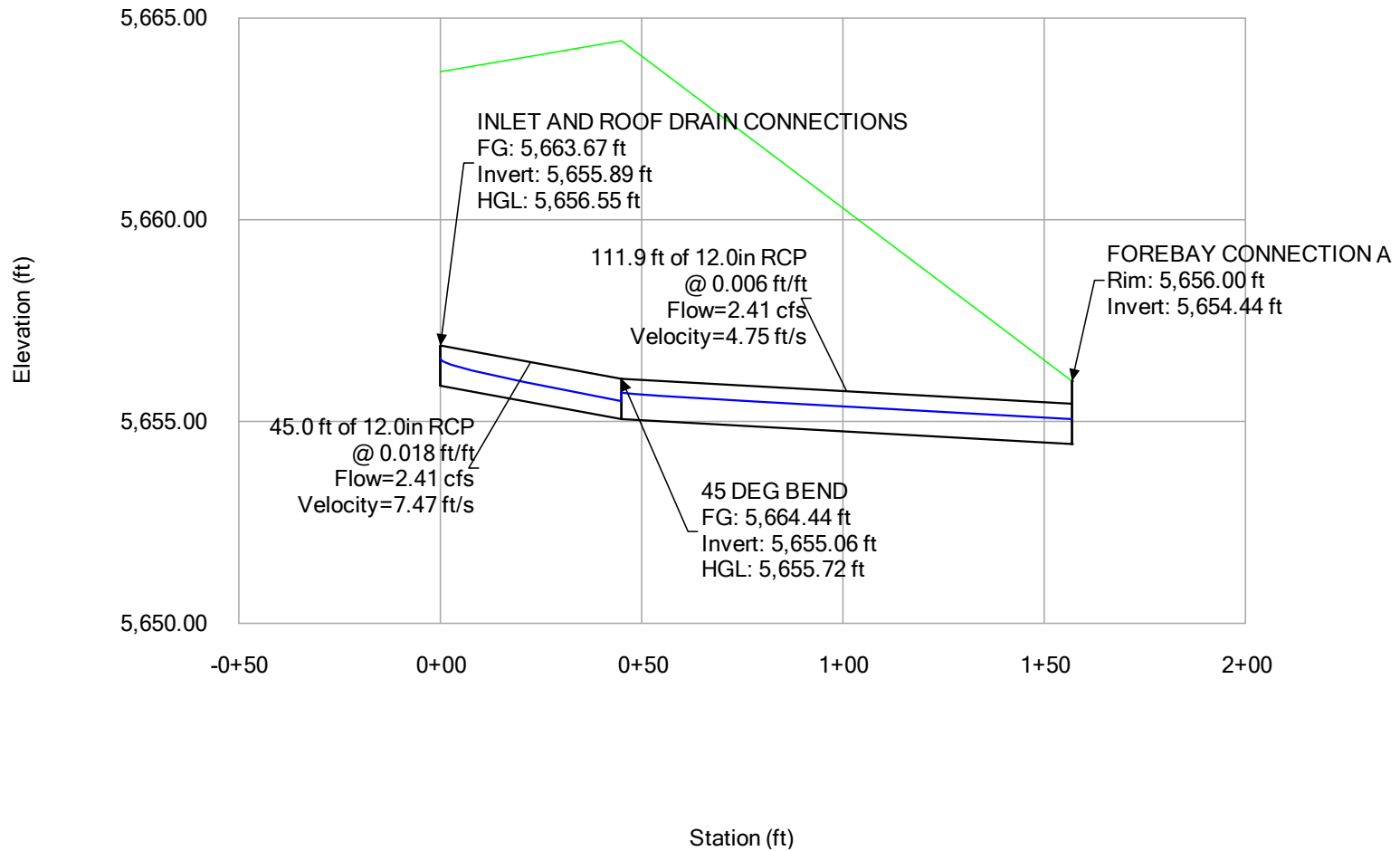

WEBSTER ELEMENTARY
Active Scenario: 100-YR
Profile Report
Engineering Profile - STRM A (StormCAD.stsw)

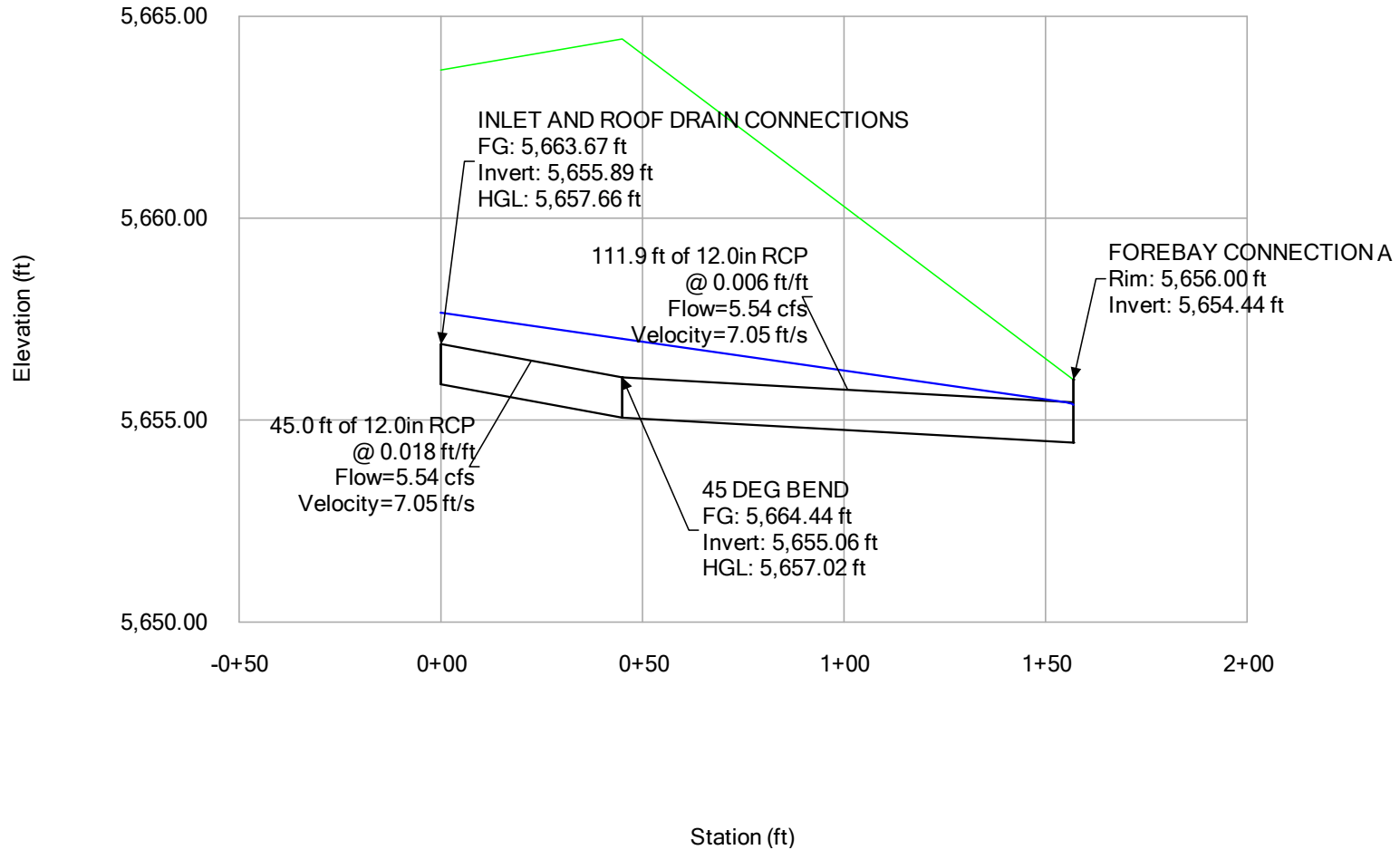

WEBSTER ELEMENTARY

Active Scenario: 5-YR

Profile Report

Engineering Profile - STRM B (StormCAD.stsw)

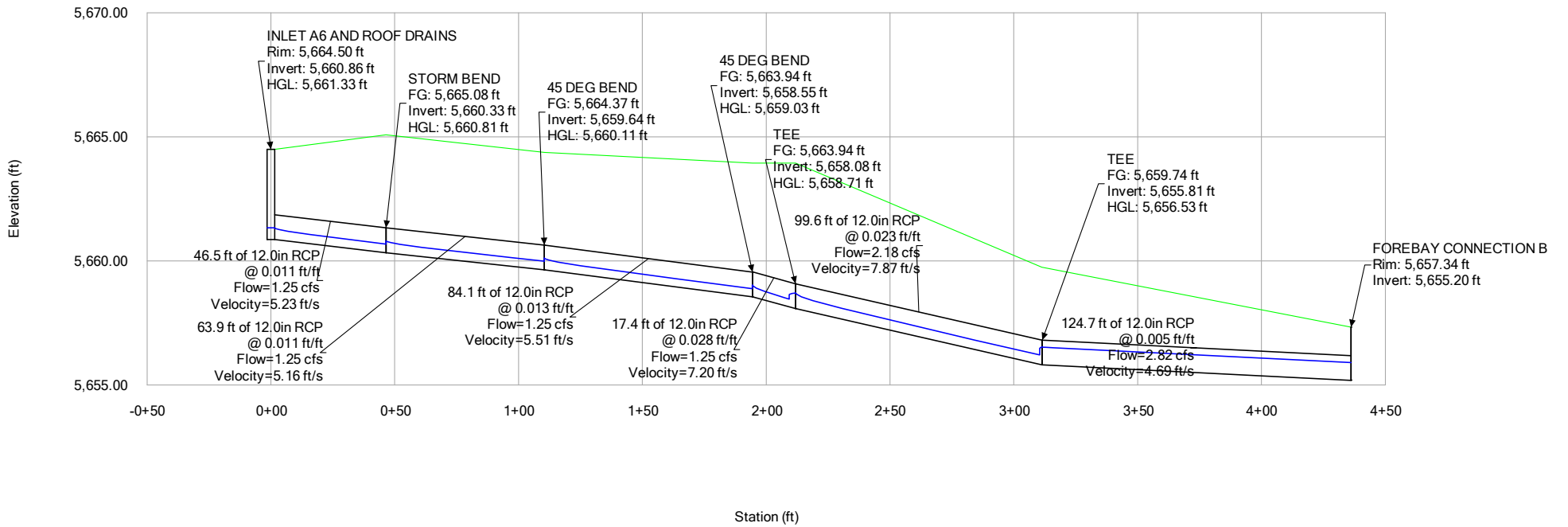

WEBSTER ELEMENTARY

Active Scenario: 100-YR

Profile Report

Engineering Profile - STRM B (StormCAD.stsw)

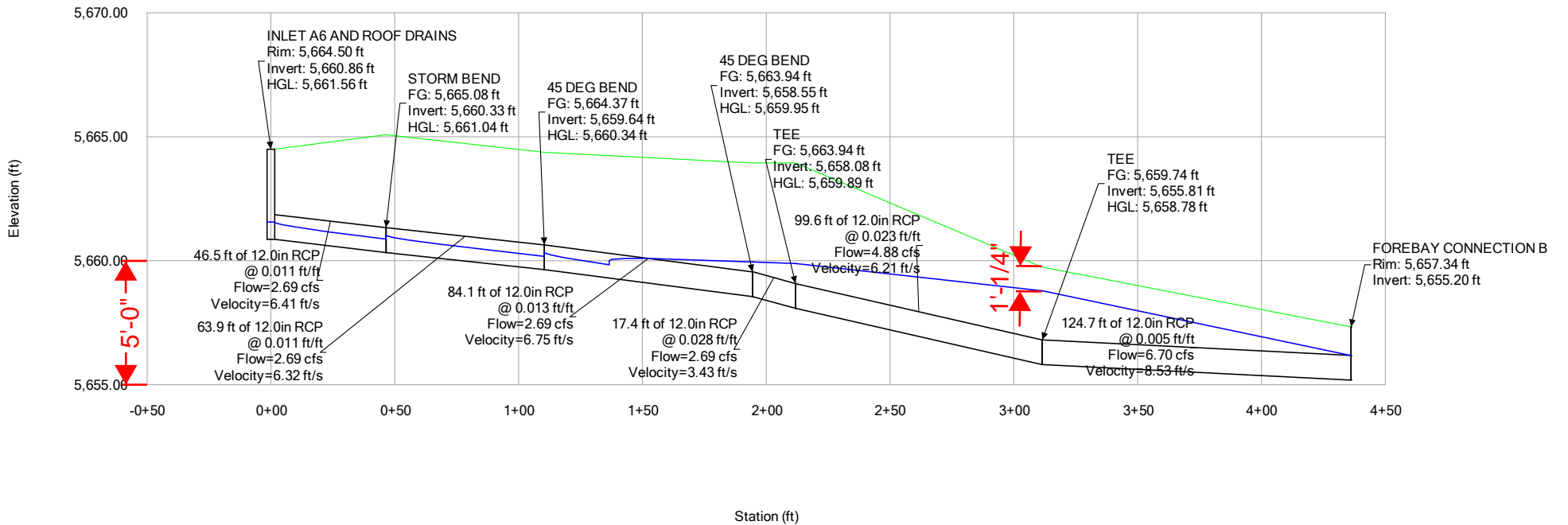

WEBSTER ELEMENTARY

Active Scenario: 5-YR

FlexTable: Conduit Table

Label	Length (3D) (ft)	Slope (Calculated) (ft/ft)	Diameter (in)	Manning' s n	Flow (cfs)	Velocity (ft/s)	Capacity (Full Flow) (cfs)	Flow / Capacity (Design) (%)	Material	Hydraulic Grade Line (In) (ft)	Elevation Ground (Start) (ft)	Hydraulic Grade Line (Out) (ft)	Elevation Ground (Stop) (ft)	Froude Number (Normal)	Depth (Normal) (ft)
B2	99.6	0.023	12.0	0.010	2.18	7.87	6.99	31.2	PVC	5,658.71	5,663.94	5,656.53	5,659.74	2.600	0.38
B3	17.4	0.028	12.0	0.010	1.25	7.20	7.68	16.3	PVC	5,659.03	5,663.94	5,658.71	5,663.94	2.876	0.27
A2	45.0	0.018	12.0	0.010	2.41	7.47	6.28	38.4	PVC	5,656.55	5,663.67	5,655.51	5,664.44	2.307	0.43
A1	111.9	0.006	12.0	0.010	2.41	4.75	3.45	69.9	PVC	5,655.72	5,664.44	5,655.06	5,656.00	1.159	0.62
B6	46.5	0.011	12.0	0.010	1.25	5.23	4.92	25.4	PVC	5,661.33	5,664.50	5,660.68	5,665.08	1.840	0.34
B5	63.9	0.011	12.0	0.010	1.25	5.16	4.83	25.9	PVC	5,660.81	5,665.08	5,659.99	5,664.37	1.804	0.35
B4	84.1	0.013	12.0	0.010	1.25	5.51	5.28	23.7	PVC	5,660.11	5,664.37	5,659.03	5,663.94	1.976	0.33
B1	124.7	0.005	12.0	0.010	2.82	4.69	3.28	86.1	PVC	5,656.53	5,659.74	5,655.90	5,657.34	1.014	0.72

WEBSTER ELEMENTARY
Active Scenario: 100-YR
FlexTable: Conduit Table

Label	Length (3D) (ft)	Slope (Calculated) (ft/ft)	Diameter (in)	Manning' s n	Flow (cfs)	Velocity (ft/s)	Capacity (Full Flow) (cfs)	Flow / Capacity (Design) (%)	Material	Hydraulic Grade Line (In) (ft)	Elevation Ground (Start) (ft)	Hydraulic Grade Line (Out) (ft)	Elevation Ground (Stop) (ft)	Froude Number (Normal)	Depth (Normal) (ft)
B2	99.6	0.023	12.0	0.010	4.88	6.21	6.99	69.8	PVC	5,659.89	5,663.94	5,658.78	5,659.74	2.351	0.62
B3	17.4	0.028	12.0	0.010	2.69	3.43	7.68	35.0	PVC	5,659.95	5,663.94	5,659.89	5,663.94	2.835	0.41
A2	45.0	0.018	12.0	0.010	5.54	7.05	6.28	88.3	PVC	5,657.66	5,663.67	5,657.02	5,664.44	1.912	0.73
A1	111.9	0.006	12.0	0.010	5.54	7.05	3.45	160.7	PVC	5,657.02	5,664.44	5,655.38	5,656.00	1.244	(N/A)
B6	46.5	0.011	12.0	0.010	2.69	6.41	4.92	54.6	PVC	5,661.56	5,664.50	5,660.87	5,665.08	1.743	0.53
B5	63.9	0.011	12.0	0.010	2.69	6.32	4.83	55.7	PVC	5,661.04	5,665.08	5,660.18	5,664.37	1.704	0.53
B4	84.1	0.013	12.0	0.010	2.69	6.75	5.28	51.0	PVC	5,660.34	5,664.37	5,659.95	5,663.94	1.887	0.51
B1	124.7	0.005	12.0	0.010	6.70	8.53	3.28	204.5	PVC	5,658.78	5,659.74	5,656.16	5,657.34	1.504	(N/A)

APPENDIX D: OPERATIONS AND MAINTENANCE MANUAL



Standard Operation Procedures
for
Inspection and Maintenance
of
Extended Detention Basin(s)

Webster Elementary School
Expansion

Owner:
Widefield School District 3
Dave Gish 719-391-3531
El Paso County Department of Public Works
3275 Akers Drive
Colorado Springs, CO 80922

dotweb@elpasoco.com
719-520-6900

Introduction

This plan addresses operation and maintenance of public detention / water quality facilities for the South Pond constructed as part of the Webster Elementary School Expansion development project at the southeast corner of Jersey Lane and Syracuse Street (PCD File Number: PPR 22-009). The plat number of Webster Elementary School is under Schedule Number 5519313001.

Background

The State of Colorado Department of Public Health and Environment, Water Quality Control Division (CDPHE), has implemented federal regulations within the State of Colorado through permitting, and has included El Paso County as one of numerous Municipal Separate Storm Sewer Systems (MS4s) required to be permitted in compliance with National Pollutant Discharge Elimination System (NPDES) Phase 2 Regulations, as defined within Colorado's Phase 2 Municipal Guidance.

NPDES Phase 2 MS4s stormwater discharges are covered under a general permit under the Colorado Discharge Permit System (CDPS) under Regulation 61, and as a minimum require the MS4's operator (e.g., El Paso County) to develop, implement, and enforce a stormwater management program to reduce the discharge of pollutants to the maximum extent practicable to protect water quality requirements of the Colorado Water Quality Control Act, Colorado Code of Regulations [CCR] 61.8(11)(a)(i).

This Stormwater Facilities Operation and Maintenance Plan (O&M Plan) is for public subregional detention facilities South Pond constructed as part of the development project referenced above.

Associated Agreements

There are currently no agreements in place for this project.

Funding for and Organization of Facility Operation and Maintenance

Widefield School district 3 will be responsible for operations and maintenance of the South Pond detention facilities upon acceptance of the facilities.

Site and Facilities Description

The South Pond is located at the southwest corner of the Site mentioned above. Water flows into the South Pond via vegetated swales and piped flows from the Building and surrounding areas. Developed pipe flows will enter through two (2) proposed forebays. Flows will convey through a concrete trickle channel to a proposed outlet structure, where flows will exit the pond at or below historic rates through an 18" pipe. It will enter an existing drainage ditch at the southwest corner of this site. A cross access easement for the pipe will be in place with the adjacent owner to clarify who will be responsible for maintenance.

Extended Detention Basin (EDB) Description

The subsections below describe general EDB operations and maintenance.

EDB-1 GENERAL EDB CONCEPT

Extended Detention Basins (EDBs) are one of the most common types of permanent stormwater control measures utilized within the Front Range of Colorado. An EDB is a sedimentation basin designed to "extend" the runoff detention time, but to drain completely sometime after stormwater runoff ends. An EDB's drain time for the water quality portion of the facility is typically 40 hours. The basins are considered to be "dry" because the majority of the basin is designed not to have a significant permanent pool of water remaining between runoff events.

EDBs are an adaptation of a detention basin used for flood control, with the primary difference being the addition of forebays, micropools and a slow release outlet design. Forebays are shallow concrete "pans" located at the inflow points to the basin and are provided to facilitate sediment removal within a contained area prior to releasing into the pond. The forebays collect and briefly hold stormwater runoff resulting in a process called sedimentation, dropping sediment out of the stormwater. The stormwater is then routed from the forebay into the concrete trickle channel and upper basin, the large grassy portion of the basin. The EDB includes an outlet structure that extends the drain time of frequently occurring runoff events to facilitate pollutant removal. An EDB also includes a small micropool just upstream of the outlet structure or built into the outlet structure. The micropool is designed to hold a small amount of water to keep sediment and floatables from blocking the outlet orifices.

EDB-2 INSPECTING EXTENDED DETENTION BASINS (EDBs)

EDB-2.1 Access and Easements

Inspection and maintenance personnel may utilize the attached stormwater facility map containing the location(s) of the access points and maintenance easements of the EDB(s) within this development.

EDB-2.2 Stormwater Management Facilities Locations

Inspection and maintenance personnel may utilize the attached stormwater facility map located in containing the location(s) of the EDB(s) within this development.

EDB-2.3 Extended Detention Basin (EDB) Features

EDBs have a number of features that are designed to serve a particular function. Many times the proper function of one feature depends on another. For example, if a forebay is not properly maintained, it could negatively affect the performance of a downstream feature (trickle channel, micropool, etc.).

Therefore, it is critical that each feature of the EDB is properly inspected and maintained to ensure that the overall facility functions as it was intended. Below is a list and description of the most common features within an EDB and the corresponding maintenance inspection items that can be anticipated:

Table EDB-1: Typical Inspection & Maintenance Requirements Matrix

EDB Features	Sediment Removal	Mowing/ Weed Control	Trash & Debris Removal	Erosion	Over-grown Vegetation Removal	Standing Water (mosquito/ algae control)	Structure Repair
Inflow Points (outfalls)	X		X	X			X
Forebays	X		X				X
Low-Flow Channel	X		X	X	X		X
Bottom Stage	X	X	X	X	X	X	
Micropool	X		X		X	X	X
Outlet Works	X		X				X
Emergency Spillway			X	X	X		X
Upper Stage			X	X			
Embankment		X		X	X		

EDB-2.3.1 Inflow Points

Inflow Points or Outfalls into EDBs are the point source of the stormwater discharge into the facility. An inflow point is commonly a storm sewer pipe with a flared end section that discharges into the EDB. In some instances, an inflow point could be a drainage channel or ditch that flows into the facility.

An energy dissipater (riprap or hard armor protection) is typically immediately downstream of the discharge point into the EDB to protect from erosion. In some cases, the storm sewer outfall can have a toe- wall or cut-off wall immediately below the structure to prevent undercutting of the outfall from erosion.

The typical maintenance items that are found with inflow points are as follows:

a. Riprap Displaced – Many times, because the repeated impact/force of water, the riprap can shift and settle. If any portion of the riprap apron appears to have settled, soil is present between the riprap, or the riprap has shifted, maintenance may be required to ensure future erosion is prevented.

b. Erosion Present/Outfall Undercut – In some situations, the energy dissipater may not have been sized, constructed, or maintained appropriately and erosion has occurred. Any erosion within the vicinity of the inflow point will require maintenance to prevent damage to the structure(s) and sediment transport within the facility.

c. Sediment Accumulation – Because of the turbulence in the water created by the energy dissipater, sediment often deposits immediately downstream of the inflow point. To prevent a loss in hydraulic performance of the upstream infrastructure, sediment that accumulates in this area must be removed in a timely manner.

d. Structural Damage – Structural damage can occur at any time during the life of the facility. Typically, for an inflow, the structural damage occurs to the pipe flared end section (concrete or steel). Structural damage can lead to additional operating problems with the facility, including loss of hydraulic performance.

e. Woody Growth/Weeds Present – Undesirable vegetation can grow in and around

the inflow area to an EDB that can significantly affect the performance of the drainage facilities discharging into the facility. This type of vegetation includes trees (typically cottonwoods) and dense areas of shrubs (willows). If woody vegetation is not routinely mowed/removed, the growth can cause debris/sediment to accumulate, resulting in blockage of the discharge. Also, tree roots can cause damage to the structural components of the inflow. Routine maintenance is essential for trees (removing a small tree/sapling is much cheaper and “quieter” than a mature tree). In addition, noxious weeds growing in the facility can result in the loss of desirable native vegetation and impact adjacent open spaces/land.

EDB-2.3.2 Forebay

A forebay is a solid surface (pad), typically constructed of concrete, immediately downstream of the inflow point. The forebay is designed to capture larger particles and trash to prevent them from entering the main portion of the EDB. The solid surface is designed to facilitate mechanical sediment removal (via a skid steer or shovel). The forebay typically includes a small diameter discharge pipe or weir on the downstream end, which is designed to drain the forebay in a specified period of time to promote sedimentation. Forebays vary in size and depth depending on the design and site constraints.

The typical maintenance items that are found with forebays are as follows:

- a. Sediment/Debris Accumulation* – Because this feature of the EDB is designed to provide the initial sedimentation, debris and sediment frequently accumulate in this area. If the sediment and debris is not removed from the forebay on a regular basis, it can significantly affect the function of other features within the EDB. Routine sediment removal from the forebay can significantly reduce the need for dredging of the main portion of the EDB using specialized equipment (long reach excavators). Routine removal of sediment from the forebay can substantially decrease the long-term sediment removal costs of an EDB.
- b. Concrete Cracking/Failing* – The forebay is primarily constructed of concrete, which cracks, spalls, and settles. Damage to the forebay can result in decreased performance and impact maintenance efforts.
- c. Drain Pipe/Weir Clogged* – Many times the drainpipe or weir can be clogged with debris, and prevent the forebay from draining properly. If standing water is present in the forebay (and there is not a base flow), the forebay is most likely not draining properly. This can result in a decrease in performance and create potential nuisances with stagnant water (mosquitoes).
- d. Weir/Drain Pipe Damaged* – Routine maintenance activities, vandalism, or age may cause the weir or drain pipe in the forebay to become damaged. Weirs are typically constructed of concrete, which cracks and spalls. The drainpipe is typically constructed with plastic, which can fracture.

EDB-2.3.3 Trickle Channel (Low-Flow)

The trickle channel conveys stormwater from the forebay to the micro- pool of the EDB. The trickle channel is typically made of concrete.

However, grass lined (riprap sides protected) is also common and can provide for an additional means of water quality within the EDB. The trickle channel is typically 6-9 inches in depth and can vary in width.

The typical maintenance items that are found with trickle channels are as follows:

- a. Sediment/Debris Accumulation* – Trickle channels are typically designed with a relatively flat slope that can promote sedimentation and the collection of debris. Also, if a trickle channel is grass lined it can accumulate sediment and debris at a much quicker rate. Routine removal of accumulated sediment and debris is essential in preventing flows from circumventing the trickle channel and affecting the dry storage portion of the pond.
- b. Concrete/Riprap Damage* – Concrete can crack, spall, and settle and must be repaired to ensure proper function of the trickle channel. Riprap can also shift over time and must be replaced/repared as necessary.
- c. Woody Growth/Weeds Present* – Because of the constant moisture in the area surrounding the trickle channel, woody growth (cottonwoods/willows) can become a problem. Trees and dense shrub type vegetation can affect the capacity of the trickle channel and can allow flows to circumvent the feature.
- d. Erosion Outside of Channel* – In larger precipitation events, the trickle channel capacity will likely be exceeded. This can result in erosion immediately adjacent to the trickle channel and must be repaired to prevent further damage to the structural components of the EDB.

EDB-2.3.4 Bottom Stage (Initial Surge)

The bottom stage is at least 4 inches deeper than the upper stage and is located directly in front of the outlet works structure, and typically above the permanent water surface of the micropool and the invert of the trickle channel. The bottom stage is designed to store the smaller runoff events, assists in keeping the majority of the basin bottom dry resulting in easier maintenance operations, and enhances the facility's pollutant removal capabilities. This area of the EDB may develop wetland vegetation.

The typical maintenance items that are found with the bottom stage are as follows:

- a. Sediment/Debris Accumulation* – The micropool can frequently accumulate sediment and debris. This material must be removed to maintain pond volume and proper function of the outlet structure.
- b. Woody Growth/Weeds Present* – Because of the constant moisture in the soil surrounding the micropool, woody growth (cottonwoods/willows) can create operational problems for the EDB. If woody vegetation is not routinely mowed/removed, the growth can cause debris/sediment to accumulate outside of the micropool, which can cause problems with other EDB features. Also, tree roots can cause damage to the structural components of the outlet works. Routine management is essential for trees (removing a small tree/sapling is much cheaper and less disruptive than removing a mature tree).
- c. Bank Erosion* – The micropool is usually a couple feet deeper than the other areas of the ponds. Erosion can be caused by water dropping into the micropool if

adequate protection/armor is not present. Erosion in this area must be mitigated to prevent sediment transport and other EDB feature damage.

d. Mosquitoes/Algae Treatment – Nuisance created by stagnant water can result from improper maintenance/treatment of the micropool. Mosquito larvae can be laid by adult mosquitoes within the permanent pool. Also, aquatic vegetation that grows in shallow pools of water can decompose causing foul odors. Chemical/mechanical treatment of the micropool may be necessary to reduce these impacts to adjacent homeowners.

e. Petroleum/Chemical Sheen – Many indicators of illicit discharges into the storm sewer systems will be present in the micropool area of the EDB. These indicators can include sheens, odors, discolored soil, and dead vegetation. If it is suspected that an illicit discharge has occurred, contact County Stormwater immediately. Proper removal/mitigation of contaminated soils and water in the EDB is necessary to minimize any environmental impacts downstream.

EDB-2.3.5 Micropool

The micropool is a concrete or grouted boulder walled structure directly in front of the outlet works. At a minimum, the micropool is 2.5 feet deep and is designed to hold water. The micropool is critical in the proper function of the EDB; it allows suspended sediment to be deposited at the bottom of the micropool and prevents these sediments from being deposited in front of the outlet works causing clogging of the outlet structure, which results in marshy areas within the top and bottom stages.

The typical maintenance items that are found with micropools are as follows:

a. Sediment/Debris Accumulation – The micropool can frequently accumulate sediment and debris. This material must be removed to maintain pond volume and proper function of the outlet structure.

b. Woody Growth/Weeds Present – Because of the constant moisture in the soil surrounding the micropool, woody growth (cottonwoods/willows) can create operational problems for the EDB. If woody vegetation is not routinely mowed/removed, the growth can cause debris/sediment to accumulate outside of the micropool, which can cause problems with other EDB features. Also, tree roots can cause damage to the structural components of the outlet works. Routine management is essential for trees (removing a small tree/sapling is much cheaper and less disruptive than removing a mature tree).

c. Mosquitoes/Algae Treatment – Nuisance created by stagnant water can result from improper maintenance/treatment of the micropool. Mosquito larvae can be laid by adult mosquitoes within the permanent pool. Also, aquatic vegetation that grows in shallow pools of water can decompose causing foul odors. Chemical/mechanical treatment of the micropool may be necessary to reduce these impacts to adjacent homeowners.

d. Petroleum/Chemical Sheen – Many indicators of illicit discharges into the storm sewer systems will be present in the micropool area of the EDB. These indicators can include sheens, odors, discolored soil, and dead vegetation. If it is suspected that an illicit discharge has occurred, contact the supervisor immediately. Proper removal of contaminated soils and water in the EDB is necessary to minimize any environmental impacts downstream.

EDB-2.3.6 Outlet Works

The outlet works is the feature that drains the EDB in specified release rates and periods of time. The outlet works is typically constructed of reinforced concrete into the embankment of the EDB. The concrete structure typically has steel orifice plates anchored/embedded into it to control stormwater release rates. The larger openings for flood control on the outlet structure typically have trash racks over them to prevent clogging. The water quality orifice plate with small diameter holes will typically have a well screen covering it to prevent smaller materials from clogging it. The outlet structure is the single-most important feature in the EDB operation. Proper inspection and maintenance of the outlet works is essential in ensuring the long-term operation of the EDB.

The typical maintenance items that are found with the outlet works are as follows:

- a. Trash Rack/Well Screen Clogged* – Floatable material that enters the EDB will most likely make its way to the outlet structure. This material is trapped against the trash racks and well screens on the outlet structure (which is why they are there). This material must be removed on a routine basis to ensure the outlet structure drains in the specified design period.
- b. Structural Damage* – The outlet structure is primarily constructed of concrete, which can crack, spall, and settle. The steel trash racks and well screens are also susceptible to damage.
- c. Orifice Plate Missing/Not Secure* – Many times residents, property owners, or maintenance personnel will remove or loosen orifice plates if they believe the pond is not draining properly. Any modification to the orifice plate(s) will significantly affect the designed discharge rates for water quality and/or flood control. Modification of the orifice plates is not allowed without EPC approval.
- d. Manhole Access* – Access to the outlet structure is necessary to properly inspect and maintain the facility. If access is difficult or not available to inspect the structure, chances are it will be difficult to maintain as well.
- e. Woody Growth/Weeds Present* – Because of the constant moisture in the soil surrounding the outlet works, woody growth (cottonwoods/willows) can create operational problems for the EDB. If woody vegetation is not routinely mowed/removed, the growth can cause debris/sediment to accumulate around the outlet works, which can cause problems with other EDB features. Also, tree roots can cause damage to the structural components of the outlet works. Routine management is essential for trees (removing a small tree/sapling is much cheaper and less disruptive than removing a mature tree).

EDB-2.3.7 Emergency Spillway

An emergency spillway is typical of all EDBs and designed to serve as the overflow in the event the volume of the pond is exceeded. The emergency spillway is typically armored with riprap (or other hard armor) and is sometimes buried with soil. The emergency spillway is typically a weir (notch) in the pond embankment. Proper function of the emergency spillway is essential to ensure flooding does not affect adjacent properties.

The typical maintenance items that are found with emergency spillways are as follows:

- a. Riprap Displaced* – As mentioned before, the emergency spillway is typically armored with riprap to provide erosion protection. Over the life of an EDB, the riprap may shift or dislodge due to flow.

b. Erosion Present – Although the spillway is typically armored, stormwater flowing through the spillway can cause erosion damage. Erosion must be repaired to ensure the integrity of the basin embankment, and proper function of the spillway.

c. Woody Growth/Weeds Present – Management of woody vegetation is essential in the proper long-term function of the spillway. Larger trees or dense shrubs can capture larger debris entering the EDB and reduce the capacity of the spillway.

d. Obstruction Debris – The spillway must be cleared of any obstruction (man-made or natural) to ensure the proper design capacity.

EDB-2.3.8 Upper Stage (Dry Storage)

The upper stage of the EDB provides the majority of the water quality flood detention volume. This area of the EDB is higher than the micro- pool and typically stays dry, except during storm events. The upper stage is the largest feature/area of the basin. Sometimes, the upper stage can be utilized for park space and other uses in larger EDBs.

With proper maintenance of the micropool and forebay(s), the upper stage should not experience much sedimentation; however, bottom elevations should be monitored to ensure adequate volume.

The typical maintenance items that are found with upper stages are as follows:

a. Vegetation Sparse – The upper basin is the most visible part of the EDB, and therefore aesthetics is important. Adequate and properly maintained vegetation can greatly increase the overall appearance and acceptance of the EDB by the public. In addition, vegetation can reduce the potential for erosion and subsequent sediment transport to the other areas of the pond.

b. Woody Growth/Undesirable Vegetation – Although some trees and woody vegetation may be acceptable in the upper basin, some thinning of cottonwoods and willows may be necessary. Remember, the basin will have to be dredged to ensure volume, and large trees and shrubs will be difficult to protect during that operation.

c. Standing Water/Boggy Areas – Standing water or boggy areas in the upper stage is typically a sign that some other feature in the pond is not functioning properly. Routine maintenance (mowing, trash removal, etc.) can be extremely difficult for the upper stage if the ground is saturated. If this inspection item is checked, make sure you have identified the root cause of the problem.

d. Sediment Accumulation – Although other features within the EDB are designed to capture sediment, the upper storage area will collect sediment over time. Excessive amounts of sedimentation will result in a loss of storage volume. It may be more difficult to determine if this area has accumulated sediment without conducting a field survey.

Below is a list of indicators:

1. Ground adjacent to the trickle channel appears to be several inches higher than concrete/riprap
2. Standing water or boggy areas in upper stage
3. Uneven grades or mounds
4. Micropool or Forebay has excessive amounts of sediment

e. *Erosion (banks and bottom)* – The bottom grades of the dry storage are typically flat enough that erosion should not occur. However, inadequate vegetative cover may result in erosion of the upper stage. Erosion that occurs in the upper stage can result in increased dredging/maintenance of the micropool.

f. *Trash/Debris* – Trash and debris can accumulate in the upper area after large events, or from illegal dumping. Over time, this material can accumulate and clog the EDB outlet works.

g. *Maintenance Access* – Most EDBs typically have a gravel/concrete maintenance access path to either the upper stage, outlet works, and/or forebay. This access path should be inspected to ensure the surface is still drivable. Some of the smaller EDBs may not have maintenance access paths; however, the inspector should verify that access is available from adjacent properties.

EDB-2.3.9 Miscellaneous

There are a variety of inspection/maintenance issues that may not be attributed to a single feature within the EDB. This category on the inspection form is for maintenance items that are commonly found in the EDB but may not be attributed to an individual feature.

a. *Encroachment in Easement Area* – Private lots/property can sometimes be located very close to the EDBs, even though they are required to be located in tracts with drainage easements. Property owners may place landscaping, trash, fencing, or other items within the easement area that may affect maintenance or the operation of the facility.

b. *Graffiti/Vandalism* – Damage to the EDB infrastructure can be caused by vandals. If criminal mischief is evident, the inspector should forward this information to the local Sheriff's Office.

c. *Public Hazards* – Public hazards include items such as vertical drops of greater than 4-feet, containers of unknown/suspicious substances, exposed metal/jagged concrete on structures. If any hazard is found within the facility area that poses an immediate threat to public safety, contact the Sheriff at 911 immediately!

d. *Burrowing Animals/Pests* – Prairie dogs and other burrowing rodents may cause damage to the EDB features and negatively affect the vegetation within the EDB. Consult EPC Environmental Division if this becomes an issue.

e. *Other* – Any miscellaneous inspection/maintenance items not contained on the form should be entered here.

EDB-3 MAINTAINING EXTENDED DETENTION BASINS (EDBS)

EDB-3.1 Maintenance Personnel

Maintenance personnel must be qualified to properly maintain EDBs. Inadequately trained personnel can cause additional problems resulting in additional maintenance costs.

EDB-3.2 Equipment

It is imperative that the appropriate equipment and tools are taken to the field with the operations crew. The types of equipment/tools will vary depending on the task at hand. Below is a list of tools, equipment, and material(s) that may be necessary to perform maintenance on an EDB:

- 1.) Loppers/Tree Trimming Tools
- 2.) Mowing Tractors

- 3.) Trimmers (extra string)
- 4.) Shovels
- 5.) Rakes
- 6.) All Surface Vehicle (ASVs)
- 7.) Skid Steer
- 8.) Backhoe
- 9.) Track Hoe/Long Reach Excavator
- 10.) Dump Truck
- 11.) Jet-Vac Machine
- 12.) Engineers Level (laser)
- 13.) Riprap (Minimum - Type M)
- 14.) Filter Fabric
- 15.) Erosion Control Blanket(s)
- 16.) Seed Mix (Native)
- 17.) Illicit Discharge Cleanup Kits
- 18.) Trash Bags
- 19.) Tools (wrenches, screw drivers, hammers, etc.)
- 20.) Chain Saw
- 21.) Confined Space Entry Equipment
- 22.) Approved Stormwater Facility Operation and Maintenance Manual

Some of the items identified above may not be needed for every maintenance operation. However, this equipment should be available to the maintenance operations crews should the need arise.

EDB-3.3 Safety

Vertical drops may be encountered in areas located within and around the facility. Avoid walking on top of retaining walls or other structures that have a significant vertical drop. If a vertical drop is identified within the EDB that is greater than 48" in height, make the appropriate note/comment on the maintenance inspection form.

EDB-3.4 Maintenance Categories and Activities

A typical EDB Maintenance Program will consist of three broad categories of work: routine, minor, and major maintenance activities. Within each category of work, a variety of maintenance activities can be performed on an EDB. A maintenance activity can be specific to each feature within the EDB, or general to the overall facility. A variety of maintenance activities are typical of EDBs. The maintenance activities range in magnitude from routine trash pickup to the reconstruction of drainage infrastructure. The following three sub-sections (3.5, 3.6, and 3.7) explain each of the categories and briefly describes the typical maintenance activities for an EDB, including the objectives and frequency of actions.

EDB-3.5 Routine Maintenance Activities

The majority of this work consists of regularly scheduled mowing and trash and debris pickups for stormwater management facilities during the growing season. This includes items such as the removal of debris/material that may be clogging the outlet structure well screens and trash racks. It also includes activities such as weed control, mosquito treatment, and algae treatment. These activities will normally be performed numerous times during the year. These items can be completed without any prior correspondence with the EPC Stormwater; however, completed

inspection and maintenance forms shall be retained for each inspection and maintenance activity.

The Maintenance Activities are summarized below, and further described in the following sub-sections.

TABLE – EDB-2 Summary of Routine Maintenance Activities

MAINTENANCE ACTIVITY	MINIMUM FREQUENCY	LOOK FOR	MAINTENANCE ACTION
Mowing	Twice annually	Excessive grass height/aesthetics	Mow grass to a height of 4” to 6”
Trash/Debris Removal	Twice annually	Trash & debris in EDB	Remove and dispose of trash and debris
Outlet Works Cleaning	As needed – after significant rain events – twice annually at a minimum	Clogged outlet structure; ponding water	Remove and dispose of debris/trash/sediment to allow outlet to function properly
Weed control	Minimum twice annually	Noxious weeds; Unwanted vegetation	Treat w/ herbicide or hand pull; Consult the local weed specialist
Mosquito Treatment	As needed	Standing water/ mosquito habitat	Treat w/ EPA approved chemicals
Algae Treatment	As needed	Standing water/ Algal growth/green color	Treat w/ EPA approved chemicals

EDB-3.5.1 Mowing

Occasional mowing is necessary to limit unwanted vegetation and to improve the overall appearance of the EDB. Native vegetation should be mowed to a height of 4-to-6 inches tall. Grass clippings should be collected and disposed of properly.

Frequency – Routine - Minimum of twice annually or depending on aesthetics.

EDB-3.5.2 Trash/Debris Removal

Trash and debris must be removed from the entire EDB area to minimize outlet clogging and to improve aesthetics. This activity must be performed prior to mowing operations.

Frequency – Routine – Prior to mowing operations and minimum of twice annually.

EDB-3.5.3 Outlet Works Cleaning

Debris and other materials can clog the outlet work’s well screen, orifice plate(s), and trash rack. This activity must be performed anytime other maintenance activities are conducted to ensure proper operation.

Frequency - Routine – After significant rainfall event or concurrently with other maintenance activities.

EDB-3.5.4 Weed Control

Noxious weeds and other unwanted vegetation must be treated as needed throughout the EDB. This activity can be performed either through mechanical means (mowing/pulling) or with herbicide. Consultation with the Environmental Division at 719-520-7878 is highly recommended prior to the use of herbicide.

Frequency – Routine – As needed based on inspections.

EDB-3.5.5 Mosquito/Algae Treatment

Treatment of permanent pools is necessary to control mosquitoes and undesirable aquatic vegetation that can create nuisances. Only EPA approved chemicals/materials can be used in areas that are warranted.

Frequency – As needed.

EDB- 3.6 Minor Maintenance Activities

This work consists of a variety of isolated or small-scale maintenance or operational problems. Most of this work can be completed by a small crew, tools, and small equipment. These items may require prior correspondence with EPC Stormwater and require completed inspection and maintenance forms to be submitted to EPC upon request for each inspection and maintenance activity.

Table – EDB-3 Summary of Minor Maintenance Activities

MAINTENANCE ACTIVITY	MINIMUM FREQUENCY	LOOK FOR	MAINTENANCE ACTION
Sediment Removal	As needed; typically every 1–2 years	Sediment build-up; decrease in pond volume	Remove and dispose of sediment
Erosion Repair	As needed, based upon inspection	Rills/gullies forming on side slopes, trickle channel, other areas	Repair eroded areas Revegetate; address source of erosion
Vegetation Removal/Tree Thinning	As needed, based upon inspection	Large trees/wood vegetation in lower stage of pond	Remove vegetation; restore grade and surface
Drain Cleaning/Jet Vac	As needed, based upon inspection	Sediment build-up/ non draining system	Clean drains; Jet Vac if needed

EDB-3.6.1 Sediment Removal

Sediment removal is necessary to maintain the original design volume of the EDB and to ensure proper function of the infrastructure. Regular sediment removal (minor) from the forebay, inflow(s), and trickle channel can significantly reduce the frequency of major sediment removal activities (dredging) in the upper and lower stages. The minor sediment removal activities can typically be addressed with shovels and smaller equipment. Major sediment removal activities will require larger and more specialized equipment. The major sediment activities will also require surveying with an engineer’s level, and consultation with EPC Stormwater Staff to ensure design volumes/grades are achieved.

Stormwater sediments removed from EDBs do not meet the criteria of “hazardous waste”. However, these sediments are contaminated with a wide array of organic and inorganic pollutants and handling must be done with care. Sediments from permanent pools must be carefully removed to minimize turbidity, further sedimentation, or other adverse water quality impacts. Sediments should be transported by motor vehicle only after they are dewatered. All sediments must be taken to a landfill for proper disposal. Prompt and thorough cleanup is important should a spill occur during transportation.

Frequency – Nonroutine – As necessary based upon inspections. Sediment removal in the

forebay and trickle channel may be necessary as frequently as every 1-2 years.

EDB-3.6.2 Erosion Repair

The repair of eroded areas is necessary to ensure the proper function of the EDB, minimize sediment transport, and to reduce potential impacts to other features. Erosion can vary in magnitude from minor repairs to trickle channels, energy dissipaters, and rilling to major gullies in the embankments and spillways. The repair of eroded areas may require the use of excavators, earthmoving equipment, riprap, concrete, erosion control blankets, and turf reinforcement mats. Major erosion repair to the pond embankments, spillways, and adjacent to structures will require consultation with EPC Stormwater Staff.

Frequency – Nonroutine – As necessary based upon inspections.

EDB-3.6.3 Vegetation Removal/Tree Thinning

Dense stands of woody vegetation (willows, shrubs, etc) or trees can create maintenance problems for the infrastructure within an EDB. Tree roots can damage structures and invade pipes/channels thereby blocking flows. Also, trees growing in the upper and lower stages of the EDB will most likely have to be removed when sediment/dredging operations occur. A small tree is easier to remove than a large tree, therefore, regular removal/thinning is preferred. All trees and woody vegetation that is growing in the bottom of the EDB or near structures (inflows, trickle channels, outlet works, emergency spillways, etc) should be removed. Any trees or woody vegetation in the EDB should be limited to the upper portions of the pond banks.

Frequency – Nonroutine – As necessary based upon inspections.

EDB-3.6.4 Clearing Drains/Jet-Vac

An EDB contains many structures, openings, and pipes that can be frequently clogged with debris. These blockages can result in a decrease of hydraulic capacity and create standing water in areas outside of the micropool. Often the blockage to this infrastructure can be difficult to access and/or clean. Specialized equipment (jet-vac machines) may be necessary to clear debris from these difficult areas.

Frequency – Nonroutine – As necessary based upon inspections.

EDB-3.7 Major Maintenance Activities

This work consists of larger maintenance/operational problems and failures within the stormwater management facilities. All of this work requires consultation with EPC Stormwater Staff to ensure the proper maintenance is performed. This work requires that the staff review the original design and construction drawings to assess the situation and assign the necessary maintenance. **An ESQCP permit may be required for major maintenance activities.** This work may also require more specialized maintenance equipment, design/details, surveying, or assistance through private contractors and consultants.

Table – EDB-4 Summary of Major Maintenance Activities

MAINTENANCE ACTIVITY	MINIMUM FREQUENCY	LOOK FOR	MAINTENANCE ACTION
Major Sediment Removal	As needed – based upon scheduled inspections	Large quantities of sediment; reduced pond capacity	Remove and dispose of sediment. Repair vegetation as needed
Major Erosion Repair	As needed – based upon scheduled inspections	Severe erosion including gullies, excessive soil displacement, areas of settlement, holes	Repair erosion – find cause of problem and address to avoid future erosion
Structural Repair	As needed – based upon scheduled inspections	Deterioration and/or damage to structural components – broken concrete, damaged pipes, outlet works	Structural repair to restore the structure to its original design

EDB-3.7.1 Major Sediment Removal

Major sediment removal consists of removal of large quantities of sediment or removal of sediment from vegetated areas. Care shall be given when removing large quantities of sediment and sediment deposited in vegetated areas. Large quantities of sediment need to be carefully removed, transported and disposed of. Vegetated areas need special care to ensure design volumes and grades are preserved.

Frequency – Nonroutine – Repair as needed based upon inspections.

EDB-3.7.2 Major Erosion Repair

Major erosion repair consists of filling and revegetating areas of severe erosion. Determining the cause of the erosion as well as correcting the condition that caused the erosion should also be part of the erosion repair. Care should be given to ensure design grades and volumes are preserved.

Frequency – Nonroutine – Repair as needed based upon inspections.

EDB-3.7.3 Structural Repair

An EDB includes a variety of structures that can deteriorate or be damaged during the course of routine maintenance. These structures are constructed of steel and concrete that can degrade or be damaged and may need to be repaired or re-constructed from time to time.

These structures include items like outlet works, trickle channels, forebays, inflows, and other features. In-house operations staff can perform some of the minor structural repairs. Major repairs to structures may require input from a structural engineer and specialized contractors. Consultation with EPC Stormwater Staff should take place prior to all structural repairs.

Frequency – Nonroutine – Repair as needed based upon inspections.

Reference:

This manual is adapted from SEMSWA and the Town of Parker, Colorado, STORMWATER PERMANENT BEST MANAGEMENT PRACTICES (PBMP) LONG-TERM OPERATION AND MAINTENANCE MANUAL, October 2004

For additional resources and contact info, visit the EPC Stormwater website:
<https://publicworks.elpasoco.com/stormwater/>

O & M Appendix:
(Inspection Forms, Pond Vicinity
Figure, and Pond Details)

APPENDIX E: GEOTECHNICAL SUBSURFACE EXPLORATION

GROUND

ENGINEERING

**Geotechnical Subsurface Exploration Program
Widefield Parks and Recreation Facility Expansion
705 Aspen Drive
Colorado Springs, Colorado
*Draft Submittal***



**Prepared For:
Widefield School District 3
1820 Main Street
Colorado Springs, Colorado**

Attention: Mr. Dennis Neal

Job Number: 21-8004

August 6, 2021

TABLE OF CONTENTS

	Page
Purpose and Scope of Study	1
Proposed Construction.....	2
Site Conditions	3
Existing Foundation Considerations.....	4
Geologic Setting.....	5
Geologic Hazards.....	5
Subsurface Exploration	6
Laboratory Testing	7
Subsurface Conditions	7
Engineering Seismicity.....	9
Geotechnical Considerations For Design.....	10
Foundation/Floor Systems Overview	12
Foundation System	14
Floor Systems	22
Mechanical Rooms/Mechanical Pads/Trash Enclosures	28
Water-Soluble Sulfates	28
Soil Corrosivity	29
Lateral Earth Pressures	31
Retaining Walls	32
Project Earthwork.....	33
Excavation Considerations.....	37
Utility Pipe Installation And Backfilling	38
Surface Drainage	41
Subsurface Drainage	44
Exterior Flatwork	52
Temporary Fire Truck Access	56
Closure.....	56
Locations of Test Holes.....	Figure 1
Logs of the Test Holes	Figure 2
Legend and Notes.....	Figure 3
Axial Capacity Reduction Factors	Figure 4
Lateral Capacity Reduction Factors	Figure 5
Summary of Laboratory Test Results.....	Table 1
Summary of Soil Corrosion Test Results	Table 2
Detailed Test Hole Logs.....	Appendix A
Gradation Testing Results.....	Appendix B

PURPOSE AND SCOPE OF STUDY

This report presents the results of a geotechnical evaluation performed by GROUND Engineering Consultants, Inc. (GROUND) for Widefield School District 3 in support of design of the proposed new building and improvements to be constructed at the Widefield Parks and Recreation facility located at 705 Aspen Drive in Colorado Springs, Colorado. Our study was conducted in general accordance with GROUND's Proposal No. 2105-0978, dated May 12, 2021.

A field exploration program was conducted to obtain information on the subsurface conditions. Material samples obtained during the subsurface exploration were tested in the laboratory to provide data on the engineering characteristics of the on-site soils and bedrock. The results of the field exploration and laboratory testing are presented herein.

This report has been prepared to summarize the data obtained and to present our findings and conclusions based on the proposed developments and the subsurface conditions encountered. Design parameters and a discussion of engineering considerations related to the proposed improvements are included herein. This report should be understood and utilized in its entirety; specific sections of the text, drawings, graphs, tables, and other information contained within this report are intended to be understood in the context of the entire report. This includes the *Closure* section of the report which outlines important limitations on the information contained herein.

This report was prepared for design purposes of Widefield School District 3 based on our understanding of the proposed project at the time of preparation of this report. The data, conclusions, opinions, and geotechnical parameters provided herein should not be construed to be sufficient for other purposes, including the use by contractors, or any other parties for any reason not specifically related to the design of the project. Furthermore, the information provided in this report was based on the exploration and testing methods described below. Deviations between what was reported herein and the actual surface and/or subsurface conditions may exist, and in some cases those deviations may be significant.

Webster Elementary School Addition
Colorado Springs, Colorado
Final Submittal

It is GROUND's opinion that wherever possible, excavations be backfilled with approved, on-site soils placed as properly compacted fill. Where this is not feasible, use of "Controlled Low Strength Material" (CLSM), i.e., a lean, sand-cement slurry ("flowable fill") or a similar material for backfilling should be considered.

Where "squeegee" or similar materials are proposed for use by the contractor, the design team should be notified by means of a Request for Information (RFI), so that the proposed use can be considered on a case-by-case basis. Where "squeegee" meets the project requirements for pipe bedding material, however, it is acceptable for that use.

Settlements: Settlements will occur in filled ground, typically on the order of 1 to 2 percent of the fill depth. If fill placement is performed properly and is tightly controlled, in GROUND's experience the majority (on the order of 60 to 80 percent) of that settlement will typically take place during earthwork construction, provided the contractor achieves the compaction levels herein. The remaining potential settlements likely will take several months or longer to be realized, and may be exacerbated if these fills are subjected to changes in moisture content.

Cut and Filled Slopes: Permanent site slopes supported by on-site soils up to 10 feet in height may be constructed no steeper than 3:1 (horizontal : vertical). Minor raveling or surficial sloughing should be anticipated on slopes cut at this angle until vegetation is well re-established. Surface drainage should be designed to direct water away from slope faces.

Wet Subgrade Preparation: The following subgrade preparation parameters and considerations should be utilized where soft, wet, and unstable subgrade conditions are encountered:

- 1) In areas where apparently stable conditions are found, the subgrade should be proof-rolled.
- 2) Pockets of weak or pumping soils should be excavated and replaced with pre-approved coarse granular fill or road base. The depth of over-excavation will be on the order of 1 to 3 feet or more to provide a stable surface. The use of recycled concrete aggregate may be a cost-effective alternative in this application.

Widefield Parks and Recreation Facility Expansion
Colorado Springs, Colorado
Draft Submittal

- 9) Inspections must be made by facility representatives to make sure that the landscape irrigation is functioning properly throughout operation and that excess moisture is not applied.
- 10) Plastic membranes should not be used to cover the ground surface adjacent to the building as soil moisture tends to increase beneath these membranes. Perforated “weed barrier” membranes that allow ready evaporation from the underlying soils may be used.

Cobbles or other materials that tend to act as baffles and restrict surface flow should not be used to cover the ground surface near the foundations.

- 11) Maintenance as described herein may include complete removal and replacement of site improvements in order to maintain effective surface drainage.
- 12) Detention ponds commonly are incorporated into drainage design. When a detention pond fills, the rate of release of the water is controlled and water is retained in the pond for a period of time. Where in-ground storm sewers direct surface water to the pond, the granular pipe bedding also can direct shallow groundwater or infiltrating surface water toward the pond. Thus, detention ponds can become locations of enhanced and concentrated infiltration into the subsurface, leading to wetting of foundation soils in the vicinity with consequent heave or settlement. Therefore, unless the pond is clearly down-gradient from the proposed building and other structures that would be adversely affected by wetting of the subgrade soils, including off-site improvements, the detention pond should be provided with an effective, low permeability liner. In addition, cut-off walls and/or drainage provisions should be provided for the bedding materials surrounding storm sewer lines flowing to the pond.

SUBSURFACE DRAINAGE

As a component of project civil design, properly functioning, subsurface drain systems (underdrains) can be beneficial for collecting and discharging saturated subsurface waters. Underdrains will not collect water infiltrating under unsaturated (vadose) conditions, or moving via capillarity, however. In addition, if not properly constructed and maintained, underdrains can transfer water into foundation soils, rather than remove it.

APPENDIX F: MESA RIDGE SELF STORAGE DRAINAGE REPORT

VERSION: 3
DATE: 9/22/14
3:30 p.m.

MESA RIDGE SELF STORAGE PRELIMINARY/FINAL DRAINAGE REPORT

March 2014
Revised July 9, 2014
Revised September 20, 2014

Prepared for:

Alpine West Investment Company LLC
1531 Market Street
Denver, CO 80202
Jonathan Kamins

Prepared by:

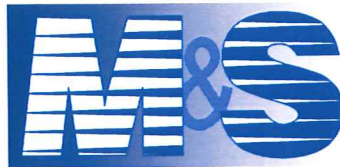

CIVIL CONSULTANTS, INC.
102 East Pikes Peak Avenue, Suite 306
Colorado Springs, CO 80903
(719) 955-5485

Project #10-004

**MESA RIDGE SELF STORAGE
PRELIMINARY/FINAL DRAINAGE REPORT**

DRAINAGE PLAN STATEMENTS

ENGINEER'S STATEMENT

The attached drainage plan and report were prepared under my direction and supervision and are correct to the best of my knowledge and belief. Said drainage report has been prepared according to the criteria established by the County for drainage reports and said report is in conformity with the applicable master plan of the drainage basin. I accept responsibility for any liability caused by any negligent acts, errors or omissions on my part in preparing this report.

Virgil A. Sanchez, P.E. #37160
For and on Behalf of M & S Civil Consultants, Inc.

DEVELOPER'S STATEMENT

I, the developer, have read and will comply with all the requirements specified in this drainage report and plan.

BY: _____ DATE: _____
Jonathan Kamins

TITLE: Manager

ADDRESS: Alpine West Investment Company, LLC
1531 Market Street
Denver, CO 80202

EL PASO COUNTY

Filed in accordance with requirements of the El Paso County Land Development Code and the Drainage Criteria Manual Volumes 1 and 2, and the El Paso County Engineering Criteria Manual, latest version.

Andre Brackin, P.E.
County Engineer/ECM Administrator

Date

**MESA RIDGE SELF STORAGE
PRELIMINARY/FINAL DRAINAGE REPORT**

TABLE OF CONTENTS

PURPOSE	4
GENERAL LOCATION AND DESCRIPTION	4
SOILS	4
HYDROLOGIC CALCULATIONS	4
HYDRAULIC CALCULATIONS	4
CLIMATE	5
FLOODPLAIN STATEMENT	5
DRAINAGE CRITERIA	5
EXISTING DRAINAGE CONDITIONS	5
PROPOSED DRAINAGE CONDITIONS	6
EROSION CONTROL	7
DRAINAGE FEES	7
SUMMARY	7
REFERENCES	8

APPENDIX
Vicinity Map
Soils Map
Floodplain Map
Hydrologic Calculations
Hydraulic Calculations
Drainage Maps

infrastructure from this site has already been incorporated and constructed. However, WQCV will be provided onsite for the proposed run off.

The site was originally studied in the "Powers Boulevard/Peaceful Valley Road Storm Drainage Detention Study" (PPVDDS), prepared by Wilson & Company dated September 1996.

PROPOSED DRAINAGE CONDITIONS

The Mesa Ridge Self Storage site proposes 11 self-storage buildings with associated drive aisles, parking, and landscaping. The proposed construction will not adversely impact the existing surrounding infrastructure. The proposed BMP's in this plan and report shall be installed and maintained to accomplish this task.

The following is a description of the onsite basins, offsite flows and the overall proposed drainage characteristics for the development of Mesa Ridge Self Storage. The following Design Points, and Basins were determined using the Rational Method since each individual basin is less than 100 acres and the combined acreage at any Design Point is also less than 100 acres. This method offers a more conservative approach for calculating swale cross sections and storm drains.

Basin A, D, E, F, & G include the north and west portion of the site and contains 5.4 acres of self-storage units, landscaping, and concrete drives plus 1.2 acres of adjacent off-site church property (Basin E). These Basins are routed via internal roads (inverted crowns) to proposed CDOT Type 'C' grated inlets and routed via storm drain to the proposed Sand Filter Basin (SFB). In the event of clogging, flows from these Basins will overflow DP-2 directly into the SFB.

Sand Filter Basin (SFB)

A proposed SFB will serve as a permanent stormwater quality BMP for the site plus some off-site tributary area (Basins A, D, E, F, & G). The required water quality capture volume is 0.25 AC-FT where 0.25 AF-FT is provided. The required surface area of the sand filter is 1,845 SF where 1,975 SF are provided. Flows through the filter media will be routed to DP-13 via 4" perforated pipes. Discharge from the SFB will be over a riprap lined weir and rundown to a 30" RCP connecting to a new inlet over the existing 48" RCP culvert under Syracuse Street. The SFB is intended to provide stormwater quality only and not detention but does provide some flow attenuation. Stormwater detention is provided in the adjacent regional pond A to the south of Syracuse Street. The SFB will privately owned and maintained.

Basin B is located in the east portion of the site and contains 3.1 acres of future development and a portion of the off-site church property. Runoff from Basin B will sheet flow to Design Point 1 (18" RCP culvert). Collected flows at Design Point 1 will discharge under Syracuse Street and into Pond 'A'. In the event clogging or total inlet failure, flows from Design Point 1 will over top Syracuse Street into Pond A.

Basin C is located in the west and north perimeter portion of the site and contains 0.2 acres of drainage swale. **Basin OS-2** includes a 4.0 acre portion of the adjacent school site to the north of the site. Runoff from Basin OS-2 will be conveyed in the proposed concrete chase along the north boundary of the site diverting flows west to DP-9. DP-9 is a proposed 18" RCP culvert. **Basin OS-1** includes 22.5 acres of the existing neighborhood and school site to the north and west of the

site along with half of the proposed curb & gutter section of Syracuse Street along the Site frontage. DP-8 is a proposed 10' Type 'R' sump inlet. This inlet and 30" pipe outfall are designed to accommodate the maximum street flow for this half of Syracuse Street. Street flows in excess of this will overtop the roadway to the west and south and drain into Pond A. Flows from DP-8, DP-9, and Basin C are conveyed via swale to DP-3. DP-3 is a proposed 30" RCP culvert the will route flows to the proposed inlet in Syracuse at DP-4 and into the existing 48" RCP culvert under Syracuse (DP-13) to the existing Detention Area A (PPVDDS) located on the south of the site. The existing flows from north of the site remain unchanged.

Basin OS-3 includes 82.7 acres of off-site area to the north and northeast of the site. It appears that this basin has little or no storm drain system, therefore it is assumed that all runoff from this basin will end up in the undeveloped portion of Quebec Street along the east boundary of the site. This is an existing off-site condition. These flows will combine with flows from Basin OS-A2 at DP-12.

Basin OS-A2 is taken directly from the PPVDDS report. Flows from this off-site neighborhood discharge onto playing fields just east of the site (Drew Drive ROW). Flows from Basin OS-A2 combine with flows from Basin OS-3 at DP-12. DP-12 is a proposed dual 54" RCP culvert crossing under Syracuse to existing Regional Pond A. Flows from both Basins OS-3 and OS-A2 are intended to end up in Pond A. The dual 54" culverts will convey 355 CFS of the $Q_{100} = 397$ CFS. Overtopping of Syracuse to Pond A at a depth of approximately 0.4' is less than the maximum allowable.

The PPVDDS study assumed single-family residential for this area. A portion is developed as single-family (same imperviousness), a portion is now part of Pond A (less imperviousness), and a portion is developed as a church (less imperviousness). This project includes proposed development of mini-warehouse (more imperviousness) and an undeveloped Tract (no imperviousness). Given that a portion of the basin is developed with less imperviousness and that this project includes an on-site SFB which provides some flow attenuation, the overall flow from this area is essentially equivalent to the assumptions made in the PPVDDS (portion of Basin A-3).

EROSION CONTROL PLAN

The City of Colorado Springs/El Paso County Drainage Criteria Manual specifies that an Erosion Control Plan and associated cost estimate be submitted in conjunction with the Final Drainage Report. The erosion control plan and associated cost estimate are to be submitted concurrently and are considered a portion of this final drainage report.

DRAINAGE FEES

The site is in the East Big Johnson Drainage Basin. There are no Drainage or Bridge Fees associated with this Basin.

SUMMARY

Development of this site will not adversely affect the surrounding development. The developed flows from MESA RIDGE SELF STORAGE will outfall into the existing Detention Area A, as accounted for in the (PPVDDS). A proposed Sand Filter Basin (SFB) will provide WQCV for this

MESA RIDGE SELF STORAGE FINAL DRAINAGE REPORT (Time of Concentration Summary)

From Composite Runoff Coefficient Summary				OVERLAND				STREET / CHANNEL FLOW				Time of Travel (T _t)				
BASIN	AREA TOTAL (Acres)	C ₅	C ₁₀₀	C _s	Length (ft)	Height (ft)	T _c (min)	Length (ft)	Slope (%)	Velocity (fps)	T _t (min)	TOTAL (min)				
		From DCM Table 5-1														
OS-1	22.10	0.60	0.70	0.25	150	3	15.5	2200	1.2%	3.8	9.6	25.1				
OS-2	3.70	XXX	0.38	0.25	300	3	27.5	1	1.0%	3.5	0.0	27.5				
OS-3	80.50	0.55	0.65	0.25	120	2	14.7	2200	1.1%	3.7	10.0	24.7				

* Intensity equations assume a minimum travel time of 5 minutes.

Calculated by: CDK
 Date: 9/18/2014
 Checked by: _____

5YR-DEVELOPED*El Paso County 5-Year Duration=25 min, Inten=2.68 in/hr*

Prepared by WestWorks Engineering

Page 1

HydroCAD® 7.00 s/n 002053 © 1986-2003 Applied Microcomputer Systems

9/20/2014

Subcatchment OS-1:

Runoff = 36.08 cfs @ 0.42 hrs, Volume= 1.251 af, Depth= 0.67"

Runoff by Rational method, Rise/Fall=1.0/1.0 xTc, Time Span= 0.00-3.00 hrs, dt= 0.01 hrs
El Paso County 5-Year Duration=25 min, Inten=2.68 in/hr

Area (ac)	C	Description
22.500	0.60	

Tc (min)	Length (feet)	Slope (ft/ft)	Velocity (ft/sec)	Capacity (cfs)	Description
25.1					Direct Entry,

Link DP-8:

Inflow Area = 22.500 ac, Inflow Depth = 0.67" for 5-Year event
 Inflow = 36.08 cfs @ 0.42 hrs, Volume= 1.251 af
 Primary = 24.50 cfs @ 0.29 hrs, Volume= 1.118 af, Atten= 32%, Lag= 0.0 min
 Secondary = 11.58 cfs @ 0.42 hrs, Volume= 0.133 af

Primary outflow = Inflow below 24.50 cfs, Time Span= 0.00-3.00 hrs, dt= 0.01 hrs

Link SD-4:

Inflow Area = 22.500 ac, Inflow Depth = 0.60" for 5-Year event
 Inflow = 24.50 cfs @ 0.29 hrs, Volume= 1.118 af
 Primary = 24.50 cfs @ 0.29 hrs, Volume= 1.118 af, Atten= 0%, Lag= 0.0 min

Primary outflow = Inflow, Time Span= 0.00-3.00 hrs, dt= 0.01 hrs

5YR-DEVELOPED*El Paso County 5-Year Duration=28 min, Inten=2.52 in/hr*

Prepared by WestWorks Engineering

Page 1

HydroCAD® 7.00 s/n 002053 © 1986-2003 Applied Microcomputer Systems

9/20/2014

Subcatchment OS-2:

Runoff = 2.85 cfs @ 0.46 hrs, Volume= 0.110 af, Depth= 0.33"

Runoff by Rational method, Rise/Fall=1.0/1.0 xTc, Time Span= 0.00-3.00 hrs, dt= 0.01 hrs
El Paso County 5-Year Duration=28 min, Inten=2.52 in/hr

Area (ac)	C	Description
0.200	0.90	HARDSCAPE
3.800	0.25	LANDSCAPE
4.000	0.28	Weighted Average

Tc (min)	Length (feet)	Slope (ft/ft)	Velocity (ft/sec)	Capacity (cfs)	Description
27.5					Direct Entry,

Link DP-13:

Inflow Area = 33.300 ac, Inflow Depth = 0.54" for 5-Year event

Inflow = 38.04 cfs @ 0.47 hrs, Volume= 1.505 af

Primary = 38.04 cfs @ 0.47 hrs, Volume= 1.505 af, Atten= 0%, Lag= 0.0 min

Primary outflow = Inflow, Time Span= 0.00-3.00 hrs, dt= 0.01 hrs

Link DP-3:

Inflow Area = 26.700 ac, Inflow Depth = 0.58" for 5-Year event

Inflow = 27.47 cfs @ 0.46 hrs, Volume= 1.302 af

Primary = 27.47 cfs @ 0.46 hrs, Volume= 1.302 af, Atten= 0%, Lag= 0.0 min

Primary outflow = Inflow, Time Span= 0.00-3.00 hrs, dt= 0.01 hrs

Link DP-9:

Inflow Area = 4.000 ac, Inflow Depth = 0.33" for 5-Year event

Inflow = 2.85 cfs @ 0.46 hrs, Volume= 0.110 af

Primary = 2.85 cfs @ 0.46 hrs, Volume= 0.110 af, Atten= 0%, Lag= 0.0 min

Primary outflow = Inflow, Time Span= 0.00-3.00 hrs, dt= 0.01 hrs

100YR-DEVELOPED*El Paso County 100-Year Duration=25 min, Inten=4.77 in/hr*

Prepared by WestWorks Engineering

Page 1

HydroCAD® 7.00 s/n 002053 © 1986-2003 Applied Microcomputer Systems

9/20/2014

Subcatchment OS-1:

Runoff = 74.92 cfs @ 0.42 hrs, Volume= 2.598 af, Depth= 1.39"

Runoff by Rational method, Rise/Fall=1.0/1.0 xTc, Time Span= 0.00-3.00 hrs, dt= 0.01 hrs
El Paso County 100-Year Duration=25 min, Inten=4.77 in/hr

Area (ac)	C	Description
22.500	0.70	

Tc (min)	Length (feet)	Slope (ft/ft)	Velocity (ft/sec)	Capacity (cfs)	Description
25.1					Direct Entry,

Link DP-8:

Inflow Area = 22.500 ac, Inflow Depth = 1.39" for 100-Year event
 Inflow = 74.92 cfs @ 0.42 hrs, Volume= 2.598 af
 Primary = 24.50 cfs @ 0.14 hrs, Volume= 1.413 af, Atten= 67%, Lag= 0.0 min
 Secondary = 50.42 cfs @ 0.42 hrs, Volume= 1.185 af

Primary outflow = Inflow below 24.50 cfs, Time Span= 0.00-3.00 hrs, dt= 0.01 hrs

Link SD-4:

Inflow Area = 22.500 ac, Inflow Depth = 0.75" for 100-Year event
 Inflow = 24.50 cfs @ 0.14 hrs, Volume= 1.413 af
 Primary = 24.50 cfs @ 0.14 hrs, Volume= 1.413 af, Atten= 0%, Lag= 0.0 min

Primary outflow = Inflow, Time Span= 0.00-3.00 hrs, dt= 0.01 hrs

100YR-DEVELOPED

El Paso County 100-Year Duration=28 min, Inten=4.48 in/hr

Prepared by WestWorks Engineering

Page 1

HydroCAD® 7.00 s/n 002053 © 1986-2003 Applied Microcomputer Systems

9/20/2014

Subcatchment OS-2:

Runoff = 6.87 cfs @ 0.46 hrs, Volume= 0.265 af, Depth= 0.79"

Runoff by Rational method, Rise/Fall=1.0/1.0 xTc, Time Span= 0.00-3.00 hrs, dt= 0.01 hrs
El Paso County 100-Year Duration=28 min, Inten=4.48 in/hr

Area (ac)	C	Description
0.200	0.95	HARDSCAPE
3.800	0.35	LANDSCAPE
4.000	0.38	Weighted Average

Tc (min)	Length (feet)	Slope (ft/ft)	Velocity (ft/sec)	Capacity (cfs)	Description
27.5					Direct Entry,

Link DP-13:

Inflow Area = 33.300 ac, Inflow Depth = 0.87" for 100-Year event
Inflow = 54.28 cfs @ 0.46 hrs, Volume= 2.403 af
Primary = 54.28 cfs @ 0.46 hrs, Volume= 2.403 af, Atten= 0%, Lag= 0.0 min

Primary outflow = Inflow, Time Span= 0.00-3.00 hrs, dt= 0.01 hrs

Link DP-3:

Inflow Area = 26.700 ac, Inflow Depth = 0.80" for 100-Year event
Inflow = 31.69 cfs @ 0.46 hrs, Volume= 1.777 af
Primary = 31.69 cfs @ 0.46 hrs, Volume= 1.777 af, Atten= 0%, Lag= 0.0 min

Primary outflow = Inflow, Time Span= 0.00-3.00 hrs, dt= 0.01 hrs

Link DP-9:

Inflow Area = 4.000 ac, Inflow Depth = 0.79" for 100-Year event
Inflow = 6.87 cfs @ 0.46 hrs, Volume= 0.265 af
Primary = 6.87 cfs @ 0.46 hrs, Volume= 0.265 af, Atten= 0%, Lag= 0.0 min

Primary outflow = Inflow, Time Span= 0.00-3.00 hrs, dt= 0.01 hrs

ALLOWABLE CAPACITY FOR ONE-HALF OF STREET (Minor & Major Storm)

(Based on Regulated Criteria for Maximum Allowable Flow Depth and Spread)

Project:
Inlet ID:

MESA RIDGE
DP-8

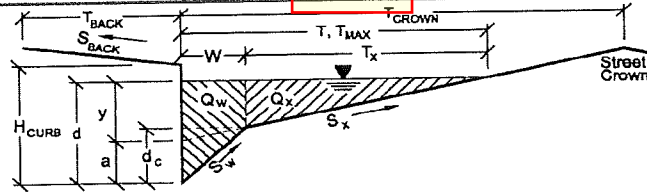

Gutter Geometry (Enter data in the blue cells)

Maximum Allowable Width for Spread Behind Curb
 Side Slope Behind Curb (leave blank for no conveyance credit behind curb)
 Manning's Roughness Behind Curb (typically between 0.012 and 0.020)

Height of Curb at Gutter Flow Line
 Distance from Curb Face to Street Crown
 Gutter Width
 Street Transverse Slope
 Gutter Cross Slope (typically 2 inches over 24 inches or 0.083 ft/ft)
 Street Longitudinal Slope - Enter 0 for sump condition
 Manning's Roughness for Street Section (typically between 0.012 and 0.020)

T _{BACK} =	12.0	ft
S _{BACK} =	0.020	ft/ft
n _{BACK} =	0.020	
H _{CURB} =	6.00	inches
T _{CROWN} =	17.0	ft
W =	2.00	ft
S _x =	0.020	ft/ft
S _w =	0.083	ft/ft
S _o =	0.004	ft/ft
n _{STREET} =	0.020	

Max. Allowable Spread for Minor & Major Storm
 Max. Allowable Depth at Gutter Flowline for Minor & Major Storm
 Allow Flow Depth at Street Crown (leave blank for no)

	Minor Storm	Major Storm	
T _{MAX} =	17.0	17.0	ft
d _{MAX} =	6.0	8.4	inches
	<input checked="" type="checkbox"/>	<input checked="" type="checkbox"/>	check = yes

MINOR STORM Allowable Capacity is based on Depth Criterion
MAJOR STORM Allowable Capacity is based on Depth Criterion
 WARNING: MINOR STORM max. allowable capacity is less than flow given on sheet 'Q-Peak'
 WARNING: MAJOR STORM max. allowable capacity is less than flow given on sheet 'Q-Peak'

	Minor Storm	Major Storm	
Q _{allow} =	7.0	20.2	cfs

INLET IN A SUMP OR SAG LOCATION

Project = _____
 Inlet ID = _____

MESA RIDGE
DP-8

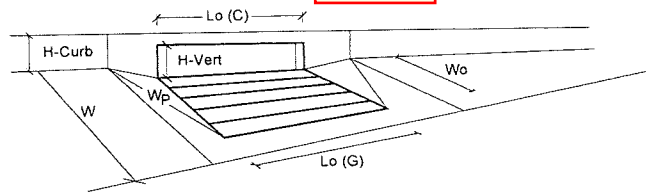







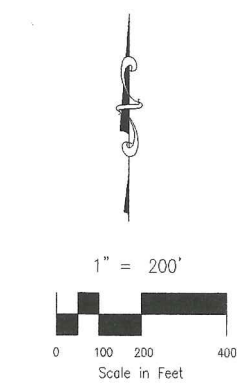
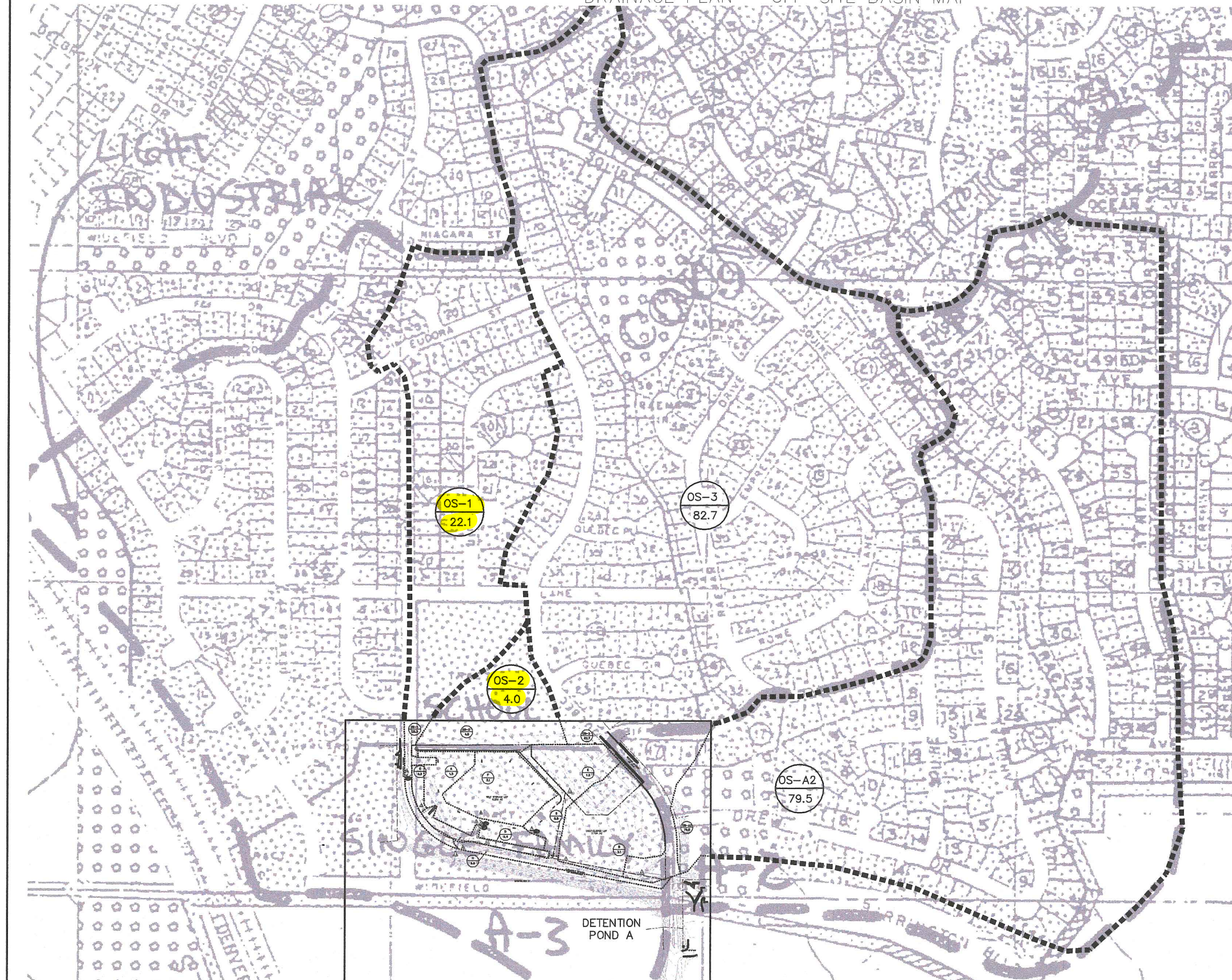



Design Information (Input)	MINOR	MAJOR	
Type of Inlet	CDOT Type R Curb Opening		
Local Depression (additional to continuous gutter depression 'a' from 'Q-Allow')	3.00	3.00	inches
Number of Unit Inlets (Grate or Curb Opening)	1	1	
Water Depth at Flowline (outside of local depression)	6.0	11.0	inches
Grate Information	MINOR	MAJOR	<input checked="" type="checkbox"/> Override Depths
Length of a Unit Grate	N/A	N/A	feet
Width of a Unit Grate	N/A	N/A	feet
Area Opening Ratio for a Grate (typical values 0.15-0.90)	N/A	N/A	
Clogging Factor for a Single Grate (typical value 0.50 - 0.70)	N/A	N/A	
Grate Weir Coefficient (typical value 2.15 - 3.60)	N/A	N/A	
Grate Orifice Coefficient (typical value 0.60 - 0.80)	N/A	N/A	
Curb Opening Information	MINOR	MAJOR	
Length of a Unit Curb Opening	10.00	10.00	feet
Height of Vertical Curb Opening in Inches	6.00	6.00	inches
Height of Curb Orifice Throat in Inches	6.00	6.00	inches
Angle of Throat (see USDCM Figure ST-5)	63.40	63.40	degrees
Side Width for Depression Pan (typically the gutter width of 2 feet)	2.00	2.00	feet
Clogging Factor for a Single Curb Opening (typical value 0.10)	0.10	0.10	
Curb Opening Weir Coefficient (typical value 2.3-3.7)	3.60	3.60	
Curb Opening Orifice Coefficient (typical value 0.60 - 0.70)	0.67	0.67	
Total Inlet Interception Capacity (assumes clogged condition)	MINOR	MAJOR	
Q_a =	8.3	24.5	cfs
Q_{PEAK REQUIRED} =	38.0	75.0	cfs

MESA RIDGE SELF STORAGE & APARTMENTS

EL PASO COUNTY, STATE OF COLORADO
DRAINAGE PLAN - OFF-SITE BASIN MAP



LEGEND

-  BASIN DESCRIPTION
-  BASIN AREA, ACRES
-  SURFACE ROUTING DESIGN POINT
-  EX MAJ CONT
-  EX MIN CONT
-  PROP MAJ CONT
-  PROP MIN CONT
-  X LP
-  X HP
-  CDW
-  DRAINAGE FLOW ARROW

FOR BURIED UTILITIES INFORMATION
48 HRS BEFORE YOU DIG CALL 811
FOR BURIED UTILITIES INFORMATION
ELECTRIC, WATER & TELEPHONE 811
WATER EMERGENCIES 303-440-1234

MESA RIDGE SELF STORAGE & APARTMENTS DRAINAGE PLAN
JOB NO. 10-004
DATE PREPARED: MARCH 2014
DATE REVISED: JULY 2014



102 E. Pikes Peak Ave. Ste 306
Colorado Springs,
Colorado 80903

Y 719.255.5485
F 719.444.8427

W:\projects\91407 - Mesa Ridge.dwg - DR\10004_Drainage.dwg, off-site, 9/22/2014 12:25:24 PM, CDK

MESA RIDGE SELF STORAGE & APARTMENTS

EL PASO COUNTY, STATE OF COLORADO
DRAINAGE PLAN

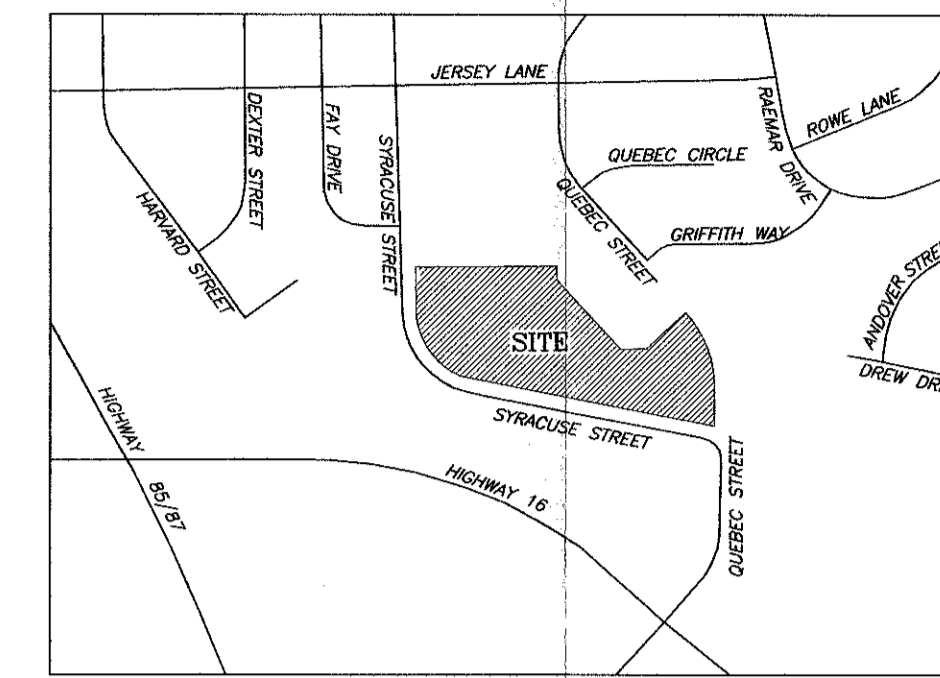

VICINITY MAP
NTS

LEGEND

- BASIN DESCRIPTION
- BASIN AREA, ACRES
- SURFACE ROUTING DESIGN POINT
- EX MAJ CONT
- EX MIN CONT
- PROP MAJ CONT
- PROP MIN CONT
- LOW POINT
- HIGH POINT
- CONCRETE DRIVEWAY
- DRAINAGE FLOW ARROW

BASIN SUMMARY

BASIN	AREA (acres)	Q _s (c.f.s.)	Q ₁₀₀ (c.f.s.)
A	1.5	5.6	10.5
B	3.1	3.9	9.3
C	0.2	0.2	0.5
D	0.4	0.4	1.1
E	1.2	1.5	3.3
F	2.1	7.9	14.8
G	0.8	2.2	4.2
H	0.6	1.8	3.5
OS-1	22.5	35	75
OS-2	4.0	4.7	6.9
OS-3	82.7	105	210
OS-A2	79.5	90	186

NOTE: FLOWS FOR OS-3, A-2, DP-4, AND DP-12 ARE 10-YR AND 100-YR.

SURFACED ROUTING DESIGN POINT

Design Point	Q _s (c.f.s.)	Q ₁₀₀ (c.f.s.)	DESCRIPTION
1	3.9	9.3	18" RCP CULVERT
2	5.6	10.5	CDOT TYPE 'C' GRATE INLET
3	27.5	31.7	30" RCP CULVERT
4	1.8	3.5	5" TYPE 'R' AT-GRADE INLET
5	—	—	NOT USED
6	7.9	14.8	CDOT TYPE 'C' GRATE INLETS
7	3.3	6.7	CDOT TYPE 'C' GRATE INLET
8	36	75	10" TYPE 'R' SLUMP INLET
9	2.9	6.9	18" RCP CULVERT
10	5.5	3.3	SHEET FLOW ONTO SITE
11	0.4	1.1	RAINFALL ONTO SITE
12	195	397	DUAL 54" RCP CULVERTS
13	36	54	EX 48" RCP CULVERT

STORM ROUTING DESIGN POINT

Design Point	Q _s (c.f.s.)	Q ₁₀₀ (c.f.s.)	DESCRIPTION
SD1	3.3	6.7	18" RCP
SD2	9.5	18.4	24" RCP
SD3	13.8	26.7	24" RCP
SD4	24.5	24.5	30" RCP

SAND FILTER BASIN DATA

SAND FILTER BASIN	
TRIBUTARY AREA	6.00 ACRES
IMPERVIOUSNESS	65.0%
WQCV VOLUME REQ.	0.25 AC-FT
AREA REQUIRED	1,845 SF
DEPTH REQ.	2.3 FEET
AREA PROVIDED	1,975 SF
WQCV PROVIDED	0.25 AC-FT
Q(5) IN/OUT	17.1/1 CFS
Q(100) IN/OUT	32.9/16.3 CFS

FOR BURIED UTILITY INFORMATION
48 HRS BEFORE YOU DIG
CALL 811
FOR LOCATING & MARKING GAS,
ELECTRIC, WATER & TELEPHONE LINES
WATER EMERGENCIES 520-0300

MESA RIDGE SELF STORAGE & APARTMENTS DRAINAGE PLAN
JOB NO. 10-004
DATE PREPARED: MARCH 2014
DATE REVISED: SEPTEMBER 2014

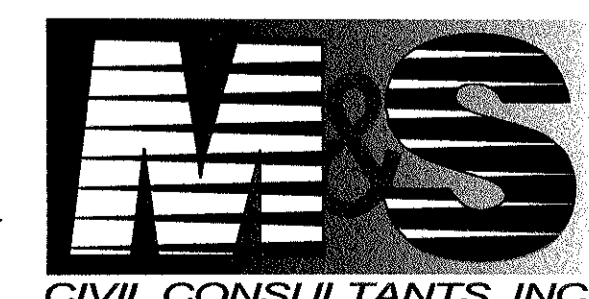

102 E. Pikes Peak Ave. Ste 306
Colorado Springs,
Colorado 80903

719.555.5485
719.444.8427

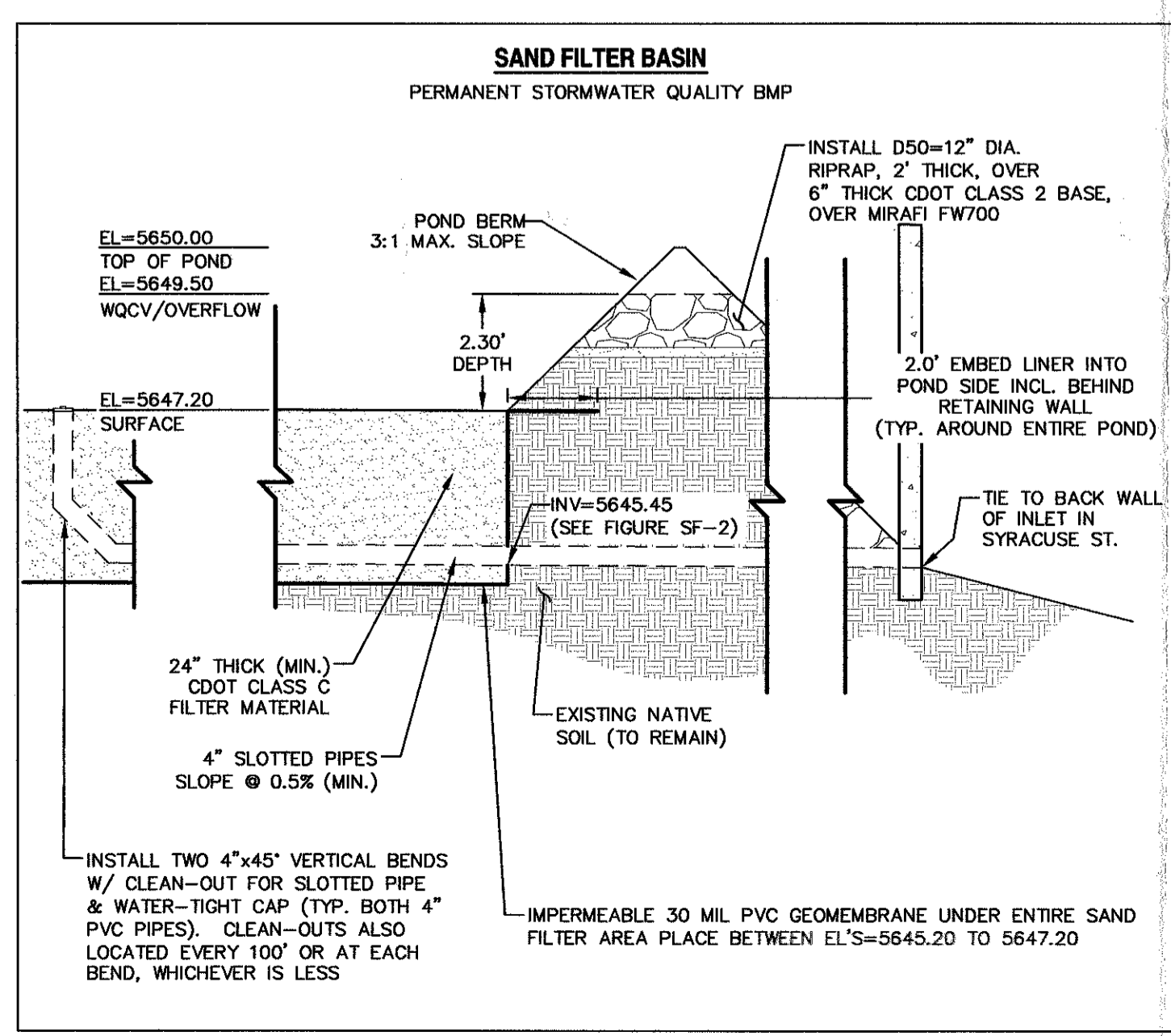
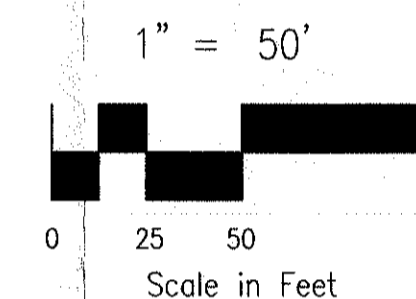
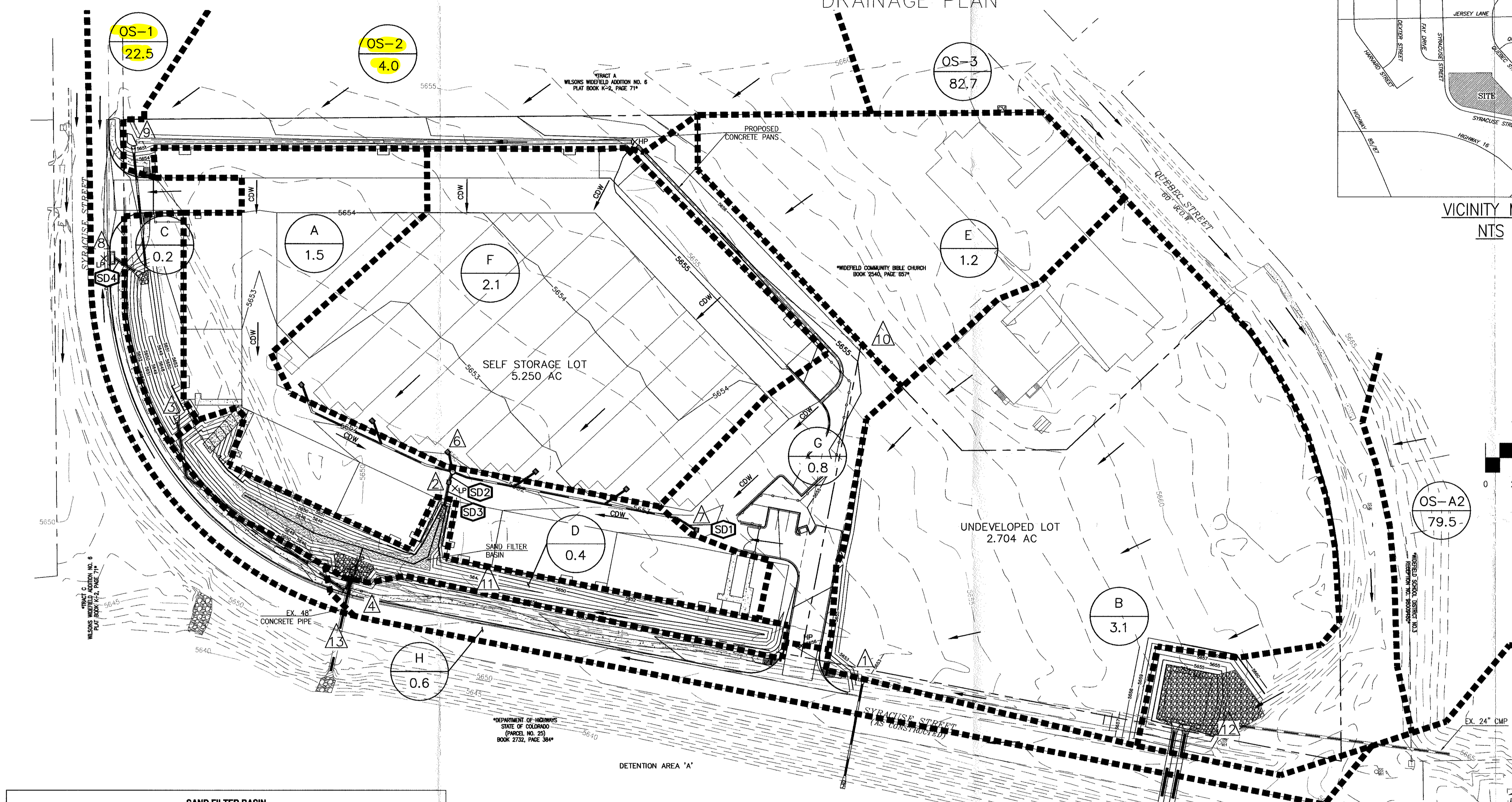

REQUIRED ACTION	MAINTENANCE OBJECTIVES	FREQUENCY
LAWN MOWING AND VEGETATIVE CARE	OCCASIONAL MOWING OF GRASSES AND WEED REMOVAL TO LIMIT UNWANTED VEGETATION. MAINTAIN IRRIGATED TURF GRASSES AS 2 TO 4 INCHES TALL AND NON-IRRIGATED TURF GRASSES AT 4 TO 6 INCHES. RECOMMEND USING SMALLER MOWING EQUIPMENT & MACHINERY (<1,000 LB) TO LIMIT WEIGHT, PRESSURE, AND COMPACTION OF SAND MEDIA.	ROUTINE - DEPENDING ON AESTHETIC REQUIREMENTS.
DEBRIS AND LITTER REMOVAL	REMOVE DEBRIS AND LITTER FROM DETENTION AREA TO MINIMIZE CLOGGING OF THE SAND MEDIA.	ROUTINE - DEPENDING ON AESTHETIC REQUIREMENTS.
LANDSCAPING REMOVAL AND REPLACEMENT	THE SANDY LOAM TURF AND LANDSCAPING LAYER WILL CLOG WITH TIME. THIS LAYER WILL NEED TO BE REMOVED AND REPLACED, ALONG WITH ALL TURF AND VEGETATION GROWING ON THE SURFACE, TO REHABILITATE INFILTRATION RATES.	EVERY 5 TO 10 YEARS, DEPENDING ON INFILTRATION RATES NEEDED TO DRAIN THE WQCV IN 12-HOURS OR LESS.
INSPECTIONS	INSPECT DETENTION AREA TO DETERMINE IF SAND MEDIA IS ALLOWING ACCEPTABLE INFILTRATION.	ROUTINE - BI-ANNUAL INSPECTION OF HYDRAULIC PERFORMANCE.

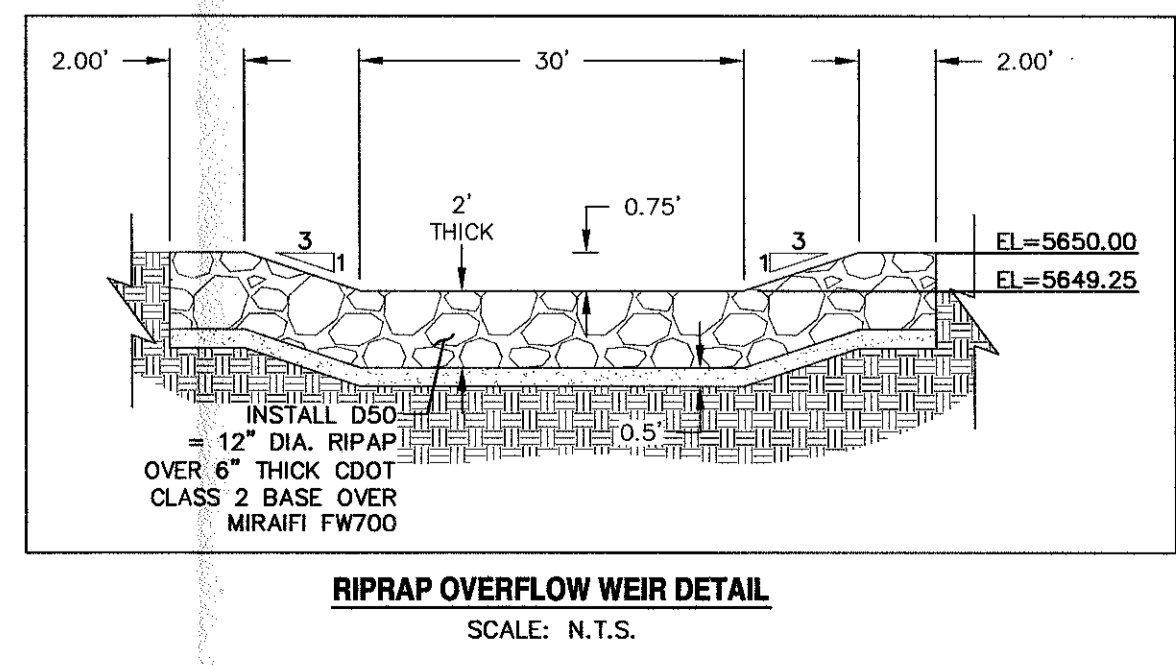

APPENDIX G: COST ESTIMATE

2022 Financial Assurance Estimate Form (with pre-plat construction)

Updated: 12/22/2020

PROJECT INFORMATION		
Webster Elementary	4/11/2022	PPR-22-009
Project Name	Date	PCD File No.

Description	Quantity	Units	Unit Cost		Total	(with Pre-Plat Construction)		
						% Complete	Remaining	
SECTION 1 - GRADING AND EROSION CONTROL (Construction and Permanent BMPs)								
* Earthwork								
less than 1,000; \$5,300 min		CY	\$ 8.00	=	\$ -		\$ -	
1,000-5,000; \$8,000 min		CY	\$ 6.00	=	\$ -		\$ -	
5,001-20,000; \$30,000 min	8,864	CY	\$ 5.00	=	\$ 44,320.00		\$ 44,320.00	
20,001-50,000; \$100,000 min		CY	\$ 3.50	=	\$ -		\$ -	
50,001-200,000; \$175,000 min		CY	\$ 2.50	=	\$ -		\$ -	
greater than 200,000; \$500,000 min		CY	\$ 2.00	=	\$ -		\$ -	
* Permanent Seeding (inc. noxious weed mgmnt.)	2.0	AC	\$ 886.00	=	\$ 1,772.00		\$ 1,772.00	
* Mulching	2.0	AC	\$ 831.00	=	\$ 1,662.00		\$ 1,662.00	
* Permanent Erosion Control Blanket	2,009	SY	\$ 7.00	=	\$ 14,063.00		\$ 14,063.00	
* Permanent Pond/BMP Construction	1,810	CY	\$ 22.00	=	\$ 39,820.00		\$ 39,820.00	
* Permanent Pond/BMP (provide engineer's estimate)	1	EA	\$ 75,682.00	=	\$ 75,682.00		\$ 75,682.00	
		EA		=	\$ -		\$ -	
Safety Fence	2,161	LF	\$ 3.00	=	\$ 6,483.00		\$ 6,483.00	
Temporary Erosion Control Blanket		SY	\$ 3.00	=	\$ -		\$ -	
Vehicle Tracking Control	1	EA	\$ 2,625.00	=	\$ 2,625.00		\$ 2,625.00	
Silt Fence	1,220	LF	\$ 3.00	=	\$ 3,660.00		\$ 3,660.00	
Temporary Seeding		AC	\$ 695.00	=	\$ -		\$ -	
Temporary Mulch		AC	\$ 831.00	=	\$ -		\$ -	
Erosion Bales		EA	\$ 28.00	=	\$ -		\$ -	
Erosion Logs/Straw Wattles		LF	\$ 6.00	=	\$ -		\$ -	
Rock Check Dams	6	EA	\$ 554.00	=	\$ 3,324.00		\$ 3,324.00	
Inlet Protection	3	EA	\$ 185.00	=	\$ 555.00		\$ 555.00	
Sediment Basin	1	EA	\$ 1,952.00	=	\$ 1,952.00		\$ 1,952.00	
Concrete Washout Basin	1	EA	\$ 997.00	=	\$ 997.00		\$ 997.00	
Rock Sock	5	EA	\$ 10.00	=	\$ 50.00		\$ 50.00	
<i>[insert items not listed but part of construction plans]</i>				=	\$ -		\$ -	
MAINTENANCE (35% of Construction BMPs)					=	\$ 4,607.05		\$ 4,607.05
Section 1 Subtotal					=	\$ 201,572.05		\$ 201,572.05
* - Subject to defect warranty financial assurance. A minimum of 20% shall be retained until final acceptance (MAXIMUM OF 80% COMPLETE ALLOWED)								
SECTION 2 - PUBLIC IMPROVEMENTS *								
ROADWAY IMPROVEMENTS								
Construction Traffic Control	1	LS	\$ 5,000.00	=	\$ 5,000.00		\$ 5,000.00	
Aggregate Base Course (135 lbs/cf)		Tons	\$ 31.00	=	\$ -		\$ -	
Aggregate Base Course (135 lbs/cf)		CY	\$ 56.00	=	\$ -		\$ -	
Asphalt Pavement (3" thick)		SY	\$ 16.00	=	\$ -		\$ -	
Asphalt Pavement (4" thick)		SY	\$ 21.00	=	\$ -		\$ -	
Asphalt Pavement (6" thick)		SY	\$ 32.00	=	\$ -		\$ -	
Asphalt Pavement (147 lbs/cf) ___" thick		Tons	\$ 97.00	=	\$ -		\$ -	
Raised Median, Paved		SF	\$ 9.00	=	\$ -		\$ -	
Regulatory Sign/Advisory Sign		EA	\$ 333.00	=	\$ -		\$ -	
Guide/Street Name Sign		EA		=	\$ -		\$ -	
Epoxy Pavement Marking		SF	\$ 15.00	=	\$ -		\$ -	
Thermoplastic Pavement Marking		SF	\$ 26.00	=	\$ -		\$ -	
Barricade - Type 3		EA	\$ 221.00	=	\$ -		\$ -	
Delineator - Type I		EA	\$ 27.00	=	\$ -		\$ -	
Curb and Gutter, Type A (6" Vertical)		LF	\$ 32.00	=	\$ -		\$ -	
Curb and Gutter, Type B (Median)		LF	\$ 32.00	=	\$ -		\$ -	
Curb and Gutter, Type C (Ramp)	111	LF	\$ 32.00	=	\$ 3,552.00		\$ 3,552.00	
4" Sidewalk (common areas only)	197	SY	\$ 53.00	=	\$ 10,441.00		\$ 10,441.00	
5" Sidewalk		SY	\$ 66.00	=	\$ -		\$ -	
6" Sidewalk		SY	\$ 80.00	=	\$ -		\$ -	
8" Sidewalk		SY	\$ 106.00	=	\$ -		\$ -	
Pedestrian Ramp		EA	\$ 1,273.00	=	\$ -		\$ -	
Cross Pan, local (8" thick, 6' wide to include return)		LF	\$ 67.00	=	\$ -		\$ -	
Cross Pan, collector (9" thick, 8' wide to include return)	74	LF	\$ 102.00	=	\$ 7,548.00		\$ 7,548.00	
Curb Chase		EA	\$ 1,639.00	=	\$ -		\$ -	
Guardrail Type 3 (W-Beam)		LF	\$ 55.00	=	\$ -		\$ -	
Guardrail Type 7 (Concrete)		LF	\$ 80.00	=	\$ -		\$ -	
Guardrail End Anchorage		EA	\$ 2,324.00	=	\$ -		\$ -	
Guardrail Impact Attenuator		EA	\$ 4,172.00	=	\$ -		\$ -	
Sound Barrier Fence (CMU block, 6' high)		LF	\$ 87.00	=	\$ -		\$ -	
Sound Barrier Fence (panels, 6' high)		LF	\$ 89.00	=	\$ -		\$ -	
Electrical Conduit, Size =		LF	\$ 18.00	=	\$ -		\$ -	
Traffic Signal, complete intersection		EA	\$ 470,666	=	\$ -		\$ -	

PROJECT INFORMATION		
Webster Elementary	4/11/2022	PPR-22-009
Project Name	Date	PCD File No.

Description	Quantity	Units	Unit Cost		Total	(with Pre-Plat Construction)	
						% Complete	Remaining
				=	\$ -		\$ -
<i>[insert items not listed but part of construction plans]</i>				=	\$ -		\$ -
STORM DRAIN IMPROVEMENTS							
Concrete Box Culvert (M Standard), Size (W x H)		LF		=	\$ -		\$ -
18" Reinforced Concrete Pipe		LF	\$ 70.00	=	\$ -		\$ -
24" Reinforced Concrete Pipe		LF	\$ 83.00	=	\$ -		\$ -
30" Reinforced Concrete Pipe		LF	\$ 104.00	=	\$ -		\$ -
36" Reinforced Concrete Pipe		LF	\$ 128.00	=	\$ -		\$ -
42" Reinforced Concrete Pipe		LF	\$ 171.00	=	\$ -		\$ -
48" Reinforced Concrete Pipe		LF	\$ 209.00	=	\$ -		\$ -
54" Reinforced Concrete Pipe		LF	\$ 272.00	=	\$ -		\$ -
60" Reinforced Concrete Pipe		LF	\$ 319.00	=	\$ -		\$ -
66" Reinforced Concrete Pipe		LF	\$ 368.00	=	\$ -		\$ -
72" Reinforced Concrete Pipe		LF	\$ 421.00	=	\$ -		\$ -
18" Corrugated Steel Pipe		LF	\$ 90.00	=	\$ -		\$ -
24" Corrugated Steel Pipe		LF	\$ 103.00	=	\$ -		\$ -
30" Corrugated Steel Pipe		LF	\$ 131.00	=	\$ -		\$ -
36" Corrugated Steel Pipe		LF	\$ 157.00	=	\$ -		\$ -
42" Corrugated Steel Pipe		LF	\$ 180.00	=	\$ -		\$ -
48" Corrugated Steel Pipe		LF	\$ 190.00	=	\$ -		\$ -
54" Corrugated Steel Pipe		LF	\$ 278.00	=	\$ -		\$ -
60" Corrugated Steel Pipe		LF	\$ 300.00	=	\$ -		\$ -
66" Corrugated Steel Pipe		LF	\$ 364.00	=	\$ -		\$ -
72" Corrugated Steel Pipe		LF	\$ 428.00	=	\$ -		\$ -
78" Corrugated Steel Pipe		LF	\$ 492.00	=	\$ -		\$ -
84" Corrugated Steel Pipe		LF	\$ 588.00	=	\$ -		\$ -
Flared End Section (FES) RCP Size = <i>(unit cost = 6x pipe unit cost)</i>		EA		=	\$ -		\$ -
Flared End Section (FES) CSP Size = <i>(unit cost = 6x pipe unit cost)</i>		EA		=	\$ -		\$ -
End Treatment- Headwall		EA		=	\$ -		\$ -
End Treatment- Wingwall		EA		=	\$ -		\$ -
End Treatment - Cutoff Wall		EA		=	\$ -		\$ -
Curb Inlet (Type R) L=5', Depth < 5'		EA	\$ 6,138.00	=	\$ -		\$ -
Curb Inlet (Type R) L=5', 5' ≤ Depth < 10'		EA	\$ 7,981.00	=	\$ -		\$ -
Curb Inlet (Type R) L=5', 10' ≤ Depth < 15'		EA	\$ 9,242.00	=	\$ -		\$ -
Curb Inlet (Type R) L=10', Depth < 5'		EA	\$ 8,447.00	=	\$ -		\$ -
Curb Inlet (Type R) L=10', 5' ≤ Depth < 10'		EA	\$ 8,706.00	=	\$ -		\$ -
Curb Inlet (Type R) L=10', 10' ≤ Depth < 15'		EA	\$ 10,898.00	=	\$ -		\$ -
Curb Inlet (Type R) L=15', Depth < 5'		EA	\$ 10,984.00	=	\$ -		\$ -
Curb Inlet (Type R) L=15', 5' ≤ Depth < 10'		EA	\$ 11,775.00	=	\$ -		\$ -
Curb Inlet (Type R) L=15', 10' ≤ Depth < 15'		EA	\$ 12,876.00	=	\$ -		\$ -
Curb Inlet (Type R) L=20', Depth < 5'		EA	\$ 11,706.00	=	\$ -		\$ -
Curb Inlet (Type R) L=20', 5' ≤ Depth < 10'		EA	\$ 12,920.00	=	\$ -		\$ -
Grated Inlet (Type C), Depth < 5'		EA	\$ 5,138.00	=	\$ -		\$ -
Grated Inlet (Type D), Depth < 5'		EA	\$ 6,347.00	=	\$ -		\$ -
Storm Sewer Manhole, Box Base		EA	\$ 12,876.00	=	\$ -		\$ -
Storm Sewer Manhole, Slab Base		EA	\$ 7,082.00	=	\$ -		\$ -
Geotextile (Erosion Control)		SY	\$ 7.00	=	\$ -		\$ -
Rip Rap, d50 size from 6" to 24"		Tons	\$ 89.00	=	\$ -		\$ -
Rip Rap, Grouted		Tons	\$ 105.00	=	\$ -		\$ -
Drainage Channel Construction, Size (W x H)		LF	\$ -	=	\$ -		\$ -
Drainage Channel Lining, Concrete		CY	\$ 631.00	=	\$ -		\$ -
Drainage Channel Lining, Rip Rap		CY	\$ 124.00	=	\$ -		\$ -
Drainage Channel Lining, Grass		AC	\$ 1,626.00	=	\$ -		\$ -
Drainage Channel Lining, Other Stabilization				=	\$ -		\$ -
				=	\$ -		\$ -
<i>[insert items not listed but part of construction plans]</i>				=	\$ -		\$ -
				Section 2 Subtotal	= \$ 26,541.00		\$ 26,541.00

* - Subject to defect warranty financial assurance. A minimum of 20% shall be retained until final acceptance (MAXIMUM OF 80% COMPLETE ALLOWED)

PROJECT INFORMATION		
Webster Elementary	4/11/2022	PPR-22-009
Project Name	Date	PCD File No.

Description	Quantity	Units	Unit Cost		Total	(with Pre-Plat Construction)		
						% Complete	Remaining	
SECTION 3 - COMMON DEVELOPMENT IMPROVEMENTS (Private or District and NOT Maintained by EPC)**								
ROADWAY IMPROVEMENTS								
				=	\$ -		\$ -	
				=	\$ -		\$ -	
				=	\$ -		\$ -	
				=	\$ -		\$ -	
				=	\$ -		\$ -	
				=	\$ -		\$ -	
STORM DRAIN IMPROVEMENTS (Exception: Permanent Pond/BMP shall be itemized under Section 1)								
4" PVC Pipe	185	LF	\$ 65.00	=	\$ 12,025.00		\$ 12,025.00	
6" PVC Pipe	787	LF	\$ 75.00	=	\$ 59,025.00		\$ 59,025.00	
8" PVC Pipe	785	LF	\$ 55.00	=	\$ 43,175.00		\$ 43,175.00	
12" PVC Pipe	380	LF	\$ 45.00	=	\$ 17,100.00		\$ 17,100.00	
18" PVC Pipe	193	LF	\$ 50.00	=	\$ 9,650.00		\$ 9,650.00	
Type C Inlet		EA	\$ 3,000.00		\$ -		\$ -	
5' Type R Inlet		EA	\$ 3,000.00		\$ -		\$ -	
15' Type R Inlet		EA	\$ 10,000.00		\$ -		\$ -	
Rip Rap, d50 size from 6" to 24"	1	Tons	\$ 80.00	=	\$ 40.00		\$ 40.00	
WATER SYSTEM IMPROVEMENTS								
Water Main Pipe (PVC), Size 8"		LF	\$ 71.00	=	\$ -		\$ -	
Water Main Pipe (Ductile Iron), Size 8"		LF	\$ 83.00	=	\$ -		\$ -	
Gate Valves, 8"		EA	\$ 2,058.00	=	\$ -		\$ -	
Fire Hydrant Assembly, w/ all valves		EA	\$ 7,306.00	=	\$ -		\$ -	
Water Service Line Installation, inc. tap and valves		EA	\$ 1,466.00	=	\$ -		\$ -	
Fire Cistern Installation, complete		EA		=	\$ -		\$ -	
				=	\$ -		\$ -	
<i>[insert items not listed but part of construction plans]</i>				=	\$ -		\$ -	
SANITARY SEWER IMPROVEMENTS								
Sewer Main Pipe (PVC), Size 8"		LF	\$ 71.00	=	\$ -		\$ -	
Sanitary Sewer Manhole, Depth < 15 feet		EA	\$ 4,858.00	=	\$ -		\$ -	
Sanitary Service Line Installation, complete		EA	\$ 1,553.00	=	\$ -		\$ -	
Sanitary Sewer Lift Station, complete		EA		=	\$ -		\$ -	
				=	\$ -		\$ -	
<i>[insert items not listed but part of construction plans]</i>				=	\$ -		\$ -	
LANDSCAPING IMPROVEMENTS (For subdivision specific condition of approval, or PUD)								
		EA		=	\$ -		\$ -	
		EA		=	\$ -		\$ -	
		EA		=	\$ -		\$ -	
		EA		=	\$ -		\$ -	
		EA		=	\$ -		\$ -	
Section 3 Subtotal					=	\$ 141,015.00		\$ 141,015.00

** - Section 3 is not subject to defect warranty requirements

PROJECT INFORMATION

Webster Elementary	4/11/2022	PPR-22-009
Project Name	Date	PCD File No.

Description	Quantity	Units	Unit Cost		Total	(with Pre-Plat Construction)	
						% Complete	Remaining
AS-BUILT PLANS (Public Improvements inc. Permanent WQCV BMPs)		LS	\$ 1,500.00	=	\$ 1,500.00		\$ 1,500.00
POND/BMP CERTIFICATION (inc. elevations and volume calculations)		LS	\$ 1,500.00	=	\$ 1,500.00		\$ 1,500.00
Total Construction Financial Assurance						\$	372,128.05
(Sum of all section subtotals plus as-builts and pond/BMP certification)							
Total Remaining Construction Financial Assurance (with Pre-Plat Construction)						\$	372,128.05
(Sum of all section totals less credit for items complete plus as-builts and pond/BMP certification)							
Total Defect Warranty Financial Assurance						\$	40,772.00
(20% of all items identified as (*). To be collateralized at time of preliminary acceptance)							

Approvals

I hereby certify that this is an accurate and complete estimate of costs for the work as shown on the Grading and Erosion Control Plan and Construction Drawings associated with the Project.

 Engineer (P.E. Seal Required)

 Approved by Owner / Applicant

 Date

 Approved by El Paso County Engineer / ECM Administrator

 Date

APPENDIX H: DRAINAGE MAPS

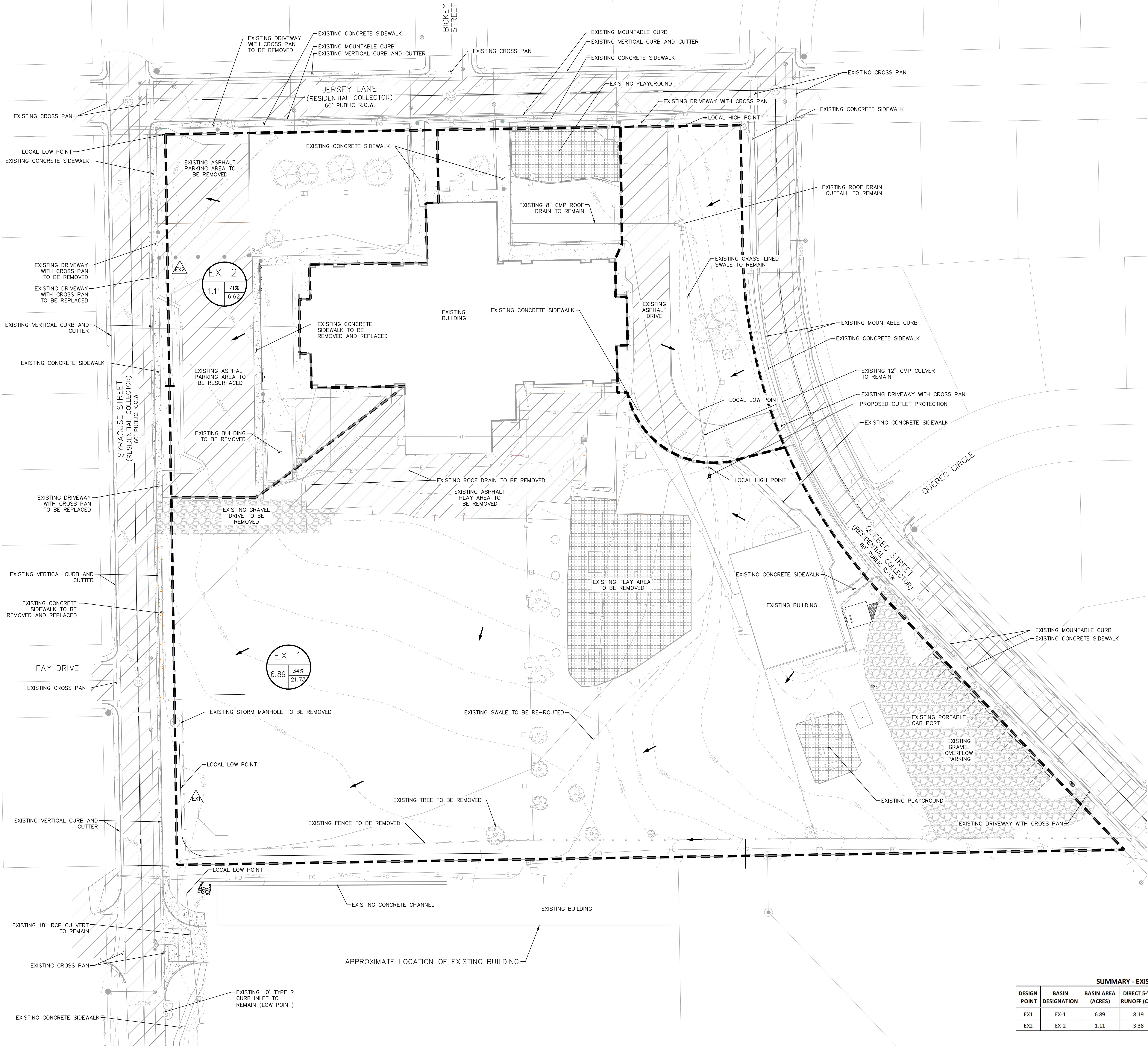

LEGEND

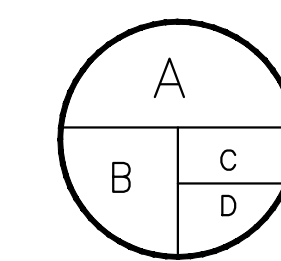

A = BASIN DESIGNATION
 B = AREA (ACRES)
 C = 100-YR COMPOSITE RUNOFF COEFFICIENT
 D = 100-YR DESIGN STORM RUNOFF (CFS)

- DESIGN POINT
- FLOW DIRECTION
- DRAINAGE BASIN BOUNDARY
- PROPERTY LINE
- PROPOSED MAJOR CONTOUR
- PROPOSED MINOR CONTOUR
- EXISTING MAJOR CONTOUR
- EXISTING MINOR CONTOUR
- EXISTING CONCRETE SIDEWALK
- EXISTING GRAVEL PARKING/DRIVING SURFACE
- EXISTING GRAVEL/MULCH PLAY AREA
- EXISTING ASPHALT PARKING/DRIVING SURFACE

NOTES

1. THESE DETAILED PLANS AND SPECIFICATIONS WERE PREPARED UNDER MY DIRECTION AND SUPERVISION. SAID DETAILED PLANS AND SPECIFICATIONS HAVE BEEN PREPARED ACCORDING TO THE ESTABLISHED CRITERIA FOR DETAILED DRAINAGE PLANS AND SPECIFICATIONS, AND SAID DETAILED PLANS AND SPECIFICATIONS ARE IN CONFORMITY WITH THE MASTER PLAN OF THE DRAINAGE BASIN. SAID DETAILED DRAINAGE PLANS AND SPECIFICATIONS MEET THE PURPOSES FOR WHICH THE PARTICULAR DRAINAGE FACILITY(S) IS DESIGNED. I ACCEPT RESPONSIBILITY FOR ANY LIABILITY CAUSED BY ANY NEGLIGENT ACTS, ERRORS OR COMMISSIONS ON MY PART IN PREPARATION OF THE DETAILED DRAINAGE PLANS AND SPECIFICATIONS.
2. PLAN REVIEW BY EL PASO COUNTY IS PROVIDED ONLY FOR GENERAL CONFORMANCE WITH DESIGN CRITERIA. EL PASO COUNTY IS NOT RESPONSIBLE FOR THE ACCURACY AND ADEQUACY OF THE DESIGN, DIMENSIONS, AND/OR ELEVATIONS WHICH SHALL BE CONFIRMED AT THE JOB SITE. EL PASO COUNTY, THROUGH APPROVAL OF THIS DOCUMENT, ASSUMES NO RESPONSIBILITY FOR COMPLETENESS AND/OR ACCURACY OF THIS DOCUMENT.

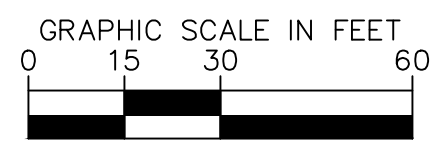
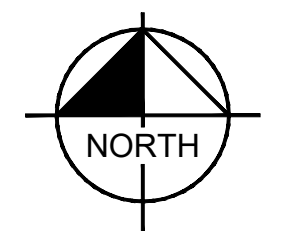

SUMMARY - EXISTING RUNOFF TABLE						
DESIGN POINT	BASIN DESIGNATION	BASIN AREA (ACRES)	DIRECT 5-YR RUNOFF (CFS)	DIRECT 100-YR RUNOFF (CFS)	CUMULATIVE 5-YR RUNOFF (CFS)	CUMULATIVE 100-YR RUNOFF (CFS)
EX1	EX-1	6.89	8.19	21.73	8.19	21.73
EX2	EX-2	1.11	3.38	6.62	3.38	6.62

L K A PART N E R S
 I N C O R P O R A T E D
 A Professional Corporation for Architecture and Planning
Kimley-Horn
 430 North Tejon Street, Suite 205
 Colorado Springs, Colorado 80903
 P: 719.473.8446 F: 719.473.8448
 www.kimley-horn.com

Webster Elementary School Addition and Alterations
 445 Jersey Lane, Colorado Springs, CO 80911
Widefield School District 3
 1620 Main Street



Construction Documents

Drawn: _____ J
 Checked: _____ E
 Issued: _____ 6 APRIL 21
 Revised: _____
 CCD-036 SEPTEMBER 19, 20

Area Key Plan
 EXISTING DRAINAGE MAP

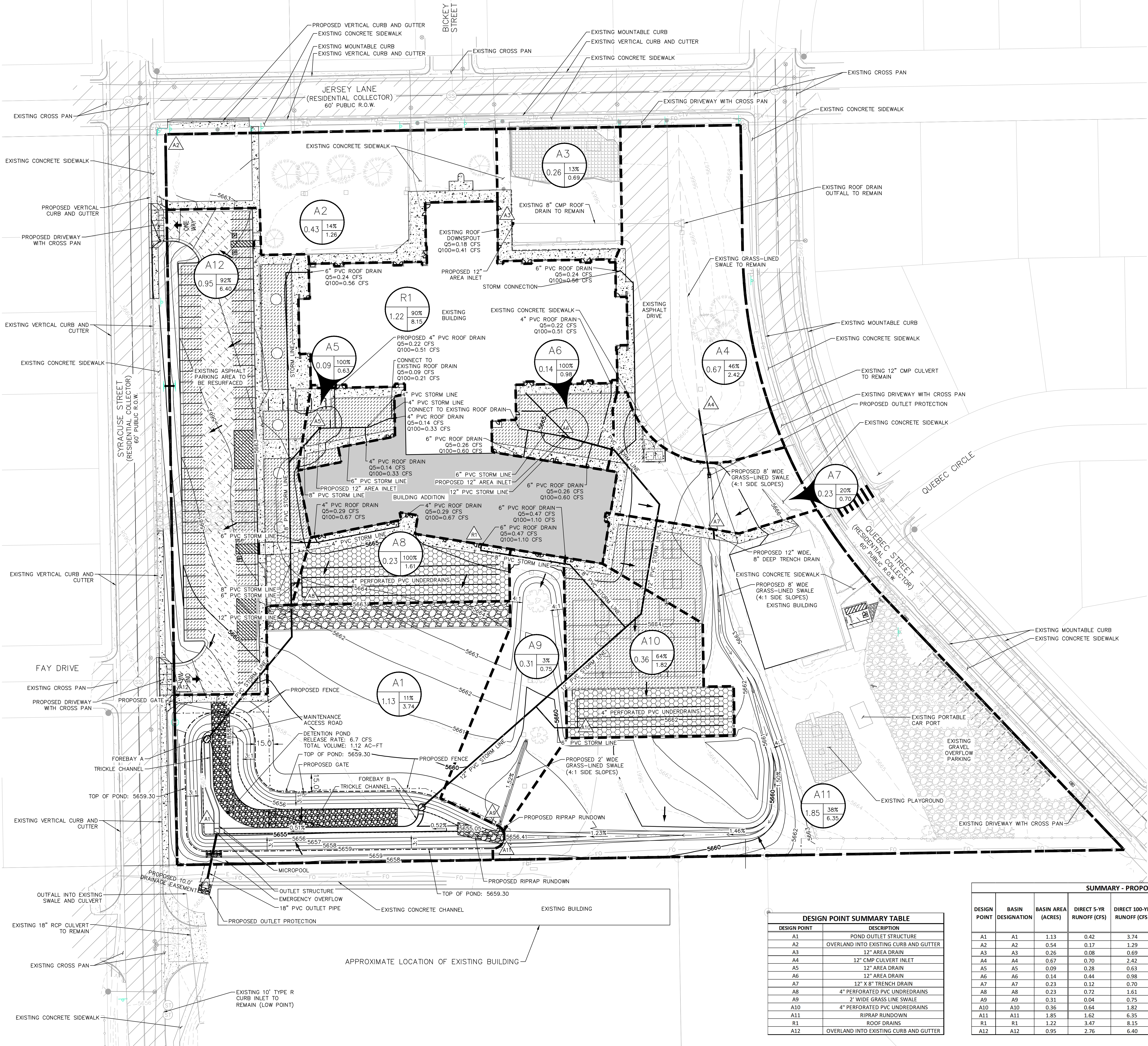

LEGEND

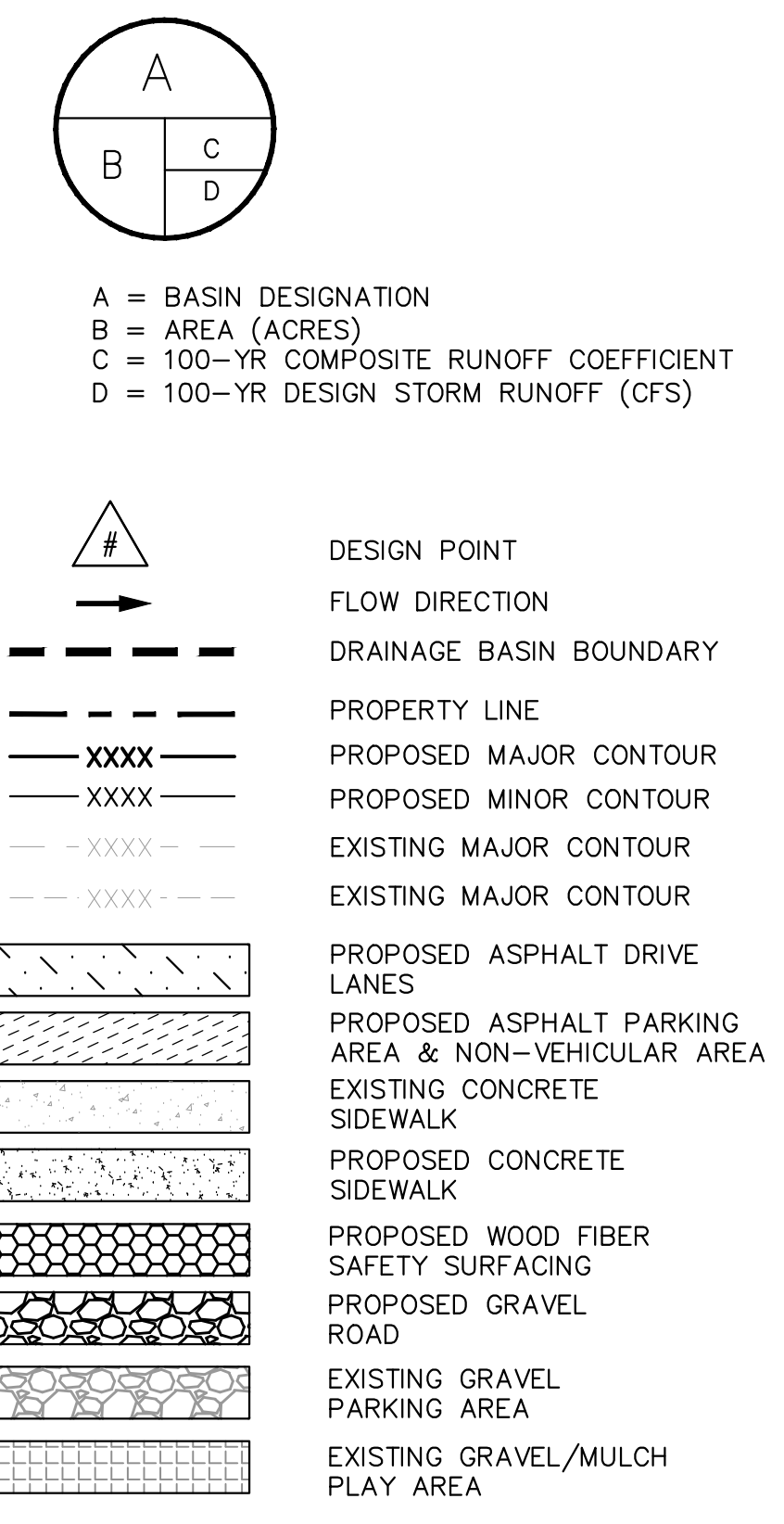

NOTES

- THESE DETAILED PLANS AND SPECIFICATIONS WERE PREPARED UNDER MY DIRECTION AND SUPERVISION. SAID DETAILED PLANS AND SPECIFICATIONS HAVE BEEN PREPARED ACCORDING TO THE ESTABLISHED CRITERIA FOR DETAILED DRAINAGE PLANS AND SPECIFICATIONS, AND SAID DETAILED PLANS AND SPECIFICATIONS ARE IN CONFORMITY WITH THE MASTER PLAN OF THE DRAINAGE BASIN. SAID DETAILED DRAINAGE PLANS AND SPECIFICATIONS MEET THE PURPOSES FOR WHICH THE PARTICULAR DRAINAGE FACILITY(S) IS DESIGNED. I ACCEPT RESPONSIBILITY FOR ANY LIABILITY CAUSED BY ANY NEGLIGENT ACTS, ERRORS OR OMISSIONS ON MY PART IN PREPARATION OF THE DETAILED DRAINAGE PLANS AND SPECIFICATIONS.
- PLAN REVIEW BY EL PASO COUNTY IS PROVIDED ONLY FOR GENERAL CONFORMANCE WITH DESIGN CRITERIA. EL PASO COUNTY IS NOT RESPONSIBLE FOR THE ACCURACY AND ADEQUACY OF THE DESIGN, DIMENSIONS, AND/OR ELEVATIONS WHICH SHALL BE CONFIRMED AT THE JOB SITE. EL PASO COUNTY, THROUGH APPROVAL OF THIS DOCUMENT, ASSUMES NO RESPONSIBILITY FOR COMPLETENESS AND/OR ACCURACY OF THIS DOCUMENT.
- PLEASE SEE THE FINAL DRAINAGE REPORT FOR THIS WEBSTER ELEMENTARY FOR PROPOSED 5 AND 100 YEAR FLOW VALUES.
- ALL PROPOSED STORM DRAINAGE INFRASTRUCTURE IS PRIVATE UNLESS NOTED OTHERWISE.

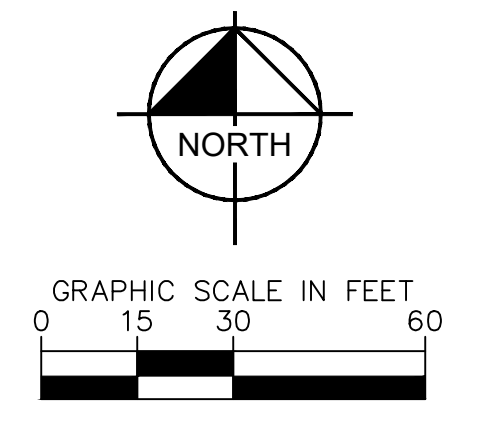

DESIGN POINT SUMMARY TABLE

DESIGN POINT	DESIGN POINT	DESCRIPTION
A1	A1	POND OUTLET STRUCTURE
A2	A2	OVERLAND INTO EXISTING CURB AND GUTTER
A3	A3	12" AREA DRAIN
A4	A4	12" CMP CULVERT INLET
A5	A5	12" AREA DRAIN
A6	A6	12" AREA DRAIN
A7	A7	12" X 8" TRENCH DRAIN
A8	A8	4" PERFORATED PVC UNDREDRAINS
A9	A9	2" WIDE GRASS LINE SWALE
A10	A10	4" PERFORATED PVC UNDREDRAINS
A11	A11	RIPRAP RUNDOWN
R1	R1	ROOF DRAINS
A12	A12	OVERLAND INTO EXISTING CURB AND GUTTER

SUMMARY - PROPOSED RUNOFF TABLE

DESIGN POINT	BASIN DESIGNATION	BASIN AREA (ACRES)	DIRECT 5-YR RUNOFF (CFS)	DIRECT 100-YR RUNOFF (CFS)	CUMULATIVE 5-YR RUNOFF (CFS)	CUMULATIVE 100-YR RUNOFF (CFS)	FLOW ROUTING FOR CUMULATIVE FLOWS
A1	A1	1.13	0.42	3.74	8.53	27.84	INCLUDES: A1, A3-R1
A2	A2	0.54	0.17	1.29	0.17	1.29	
A3	A3	0.26	0.08	0.69	0.08	0.69	
A4	A4	0.67	0.20	2.42	0.78	3.11	INCLUDES: A3-A4
A5	A5	0.09	0.28	0.63	0.28	0.63	
A6	A6	0.14	0.44	0.98	0.44	0.98	
A7	A7	0.23	0.12	0.70	0.90	3.81	INCLUDES: A3-A4, A7
A8	A8	0.23	0.72	1.61	0.72	1.61	
A9	A9	0.31	0.04	0.75	0.04	0.75	
A10	A10	0.36	0.64	1.82	0.64	1.82	
A11	A11	1.85	1.62	6.35	2.52	10.16	INCLUDES: A3-A4, A7, A11
R1	R1	1.22	3.47	8.15	3.47	8.15	
A12	A12	0.95	2.76	6.40	2.76	6.40	



Construction Documents

Drawn: _____ J
Checked: _____ E
Issued: _____ 6 APRIL 21
Revised: _____
CCD-036 SEPTEMBER 19, 20

Area Key Map
PROPOSED DRAINAGE MAP