



ENTECH
ENGINEERING, INC.

505 ELKTON DRIVE
COLORADO SPRINGS, CO 80907
PHONE (719) 531-5599

**SOILS AND GEOLOGY STUDY
FLYING HORSE NORTH FILING NO. 3
EL PASO COUNTY, COLORADO**

Prepared for:

Flying Horse North, LLC
2138 Flying Horse Club Drive
Colorado Springs, Colorado 80921

Attn: Drew Balsick

This is the incorrect report. The report submitted with the 1st review was the correct report. Comments from that review have not been addressed. The report submitted with the 2nd report was not the correct type of report, and not specific to the current proposal. This report appears to just be for Filing 3 and not the entire Phase 2 area. Please submit the correct report for review with the next submittal to prevent further delays in processing.

Please address the review 1 comments.

August 23, 2023
Revised February 29, 2024

Respectfully Submitted,

ENTECH ENGINEERING, INC.

Reviewed by:

Logan L. Langford, P.G.
Sr. Geologist



Joseph C. Goode Jr., P.E.
President

LLL

PCD No. SF2326

Table of Contents

1 SUMMARY..... 1

2 GENERAL SITE CONDITIONS AND PROJECT DESCRIPTION 1

3 SCOPE OF THE REPORT 2

4 FIELD INVESTIGATION 2

5 SOIL, GEOLOGY, AND ENGINEERING GEOLOGY..... 3

 5.1 General Geology 3

 5.2 Soil Conservation Survey 4

 5.3 Site Stratigraphy 4

 5.4 Soil Conditions 5

 5.5 Groundwater 6

6 ENGINEERING GEOLOGY – IDENTIFICATION AND MITIGATION OF GEOLOGIC HAZARDS..... 6

 6.1 Relevance of Geologic Conditions to Land Use Planning 10

7 ECONOMIC MINERAL RESOURCES 12

8 EROSION CONTROL 13

9 ROADWAY AND EMBANKMENT CONSTRUCTION RECOMMENDATIONS 14

10 CLOSURE..... 15

11 REFERENCES..... 16

FIGURES

- Figure 1: Vicinity Map
- Figure 2: USGS Map
- Figure 3: Development Plan/Test Boring Location Map
- Figure 4: Soil Survey Map
- Figure 5: Black Forest Quadrangle Geology Map
- Figure 6: Geology Map/Engineering Geology
- Figure 7: Floodplain Map
- Figure 8: Typical Perimeter Drain Details
- Figure 9: Underslab Drainage Layer (Capillary Break)
- Figure 10: Interceptor Drain Detail
- Figure 11: Lateral Pressure Diagram

- APPENDIX A: Site Photographs
- APPENDIX B: Test Boring Logs
- APPENDIX C: Laboratory Test Results
- APPENDIX D: EEI Laboratory Testing Summary and Test Boring Logs Job No. 220404
- APPENDIX E: Soil Survey Descriptions

1 SUMMARY

Project Location

The project is located in portions of the S½ and NE¼ of Section 36, Township 11 South, Range 66 West of the 6th Principal Meridian in El Paso County, Colorado. The site is located approximately 4 miles southeast of Monument, Colorado.

Project Description

Flying Horse North Filing No. 3 Subdivision is 164.4 acres. Fifty (50) lots are proposed for the filing. The proposed development is to consist of 2.5 to 3.9-acre single-family residential estate lots, two drainage tracts, and other associated site improvements. The development will be serviced by individual water wells and on-site wastewater systems (OWTS).

Scope of Report

This report presents the results of our geologic evaluation and treatment of engineering geologic hazard study.

Land Use and Engineering Geology

This site was found to be suitable for the proposed development. Areas were encountered where the geologic conditions will impose some constraints on development and land use. These include areas of seasonal and potentially seasonal shallow groundwater areas, drainage areas, areas of ponded water, floodplain, erosion, artificial fill, expansive soils, and areas of downslope creep. Based on the proposed development plan, it appears that these areas will have some impact on the development. These conditions will be discussed in greater detail in the report.

In general, it is our opinion that the development can be achieved if the observed geologic conditions on site are either avoided or properly mitigated. All recommendations are subject to the limitations discussed in the report.

2 GENERAL SITE CONDITIONS AND PROJECT DESCRIPTION

The site consists of portions of the S½ and NE¼ of Section 36, Township 11 South, Range 66 West of the 6th Principal Meridian in El Paso County, Colorado. The site is located approximately 4 miles southwest of Monument, Colorado, at the east end of Stagecoach Road between Highway 83 and Black Forest Road. The location of the site is as shown on the Vicinity Map, Figure 1.

The topography of the site varies from gently to moderately sloping generally to the west and southwest with some steeper slopes along the drainages in portions of the site. The Palmer Divide is located along the northeastern portion of Filing No. 3. The drainages on site flow in westerly direction through the property. Water was observed flowing in the drainage in the southwestern portion of the site, and the remaining drainages were at the time of this investigation. Areas of ponded water were observed behind erosion berms in low-lying areas along the future roadway. The site boundaries are indicated on the USGS Map, Figure 2. Previous land uses have included grazing and pasture land. Flying Horse North Filing Nos. 1 and 2 have been mostly developed and the golf course has been completed. The site contains primarily field grasses and weeds in with areas of ponderosa pine tree coverage across Filing No. 3. Site photographs are included in Appendix A. The locations and directions of the photographs are indicated in Figure 3.

Flying Horse North Filing No. 3 Subdivision is 164.4 acres. Fifty (50) lots are proposed for the filing. The proposed development is to consist of 2.5 to 3.9-acre single-family residential estate lots, two drainage tracts, and other associated site improvements. Grading is expected to be primarily associated with the construction of roads. The Development Plan/Test Boring Location Map is presented in Figure 3.

3 SCOPE OF THE REPORT

The scope of the report will include a general geologic analysis utilizing published geologic data. Detailed site-specific mapping will be conducted to obtain general information in respect to major geographic and geologic features, geologic descriptions and their effects on the development of the property.

4 FIELD INVESTIGATION

Our field investigation consisted of the preparation of a geologic map of any bedrock features and significant surficial deposits. The Natural Resource Conservation Service (NRCS), previously the Soil Conservation Service (SCS) survey was also reviewed to evaluate the site. The position of mappable units within the subject property are shown on the Geologic Map. Our mapping procedures involved both field reconnaissance and measurements and air photo reconnaissance and interpretation. The same mapping procedures have also been utilized to produce the Engineering Geology Map which identified pertinent geologic conditions affecting development. The field mapping was initially performed by personnel of Entech Engineering, Inc. on November 21 and December 2, 2014. Field mapping was updated by Entech Engineering, Inc., on October

31 and November 3, 2017 (References 1 and 2). The site was revisited and additional mapping completed on July 31 and August 2, 2023. Site photographs are included in Appendix A.

Six (6) test borings were drilled and four (4) test pits excavated across the site as part of this study to determine the soils classification and engineering characteristics. The borings were drilled to depths of 20 feet using a truck-mounted, continuous flight auger drilling rig supplied and operated by Entech Engineering, Inc., and the test pits were excavated to depths ranging from 6 to 8 feet.

The previous field investigation consisted of six (6) test borings and eighteen (18) test pits to determine general suitability of the site for construction (Reference 3). The location of the previous Test Borings and Test Pits indicated on the Site Map/Testing Location Map, Figure 3. Additionally, fourteen (14) profile holes were performed on the entire Flying Horse North property in previous studies

Laboratory testing was performed on some of the soils to classify and determine the soils engineering characteristics. Laboratory tests included moisture content testing, ASTM D-2216, tests included grain-size analysis ASTM D-422, Atterberg Limits ASTM D-4318, volume change testing using Swell/Consolidation test. Sulfate testing was performed on select samples to evaluate potential for below grade concrete degradation due to sulfate attack. Results of the laboratory testing are included in Appendix C. A Summary of Laboratory Test Results is presented in Table C-1. Previous Laboratory Testing Summary and Test Boring Logs are included in Appendix D.

5 SOIL, GEOLOGY, AND ENGINEERING GEOLOGY

5.1 General Geology

Physiographically, the site lies in the western portion of the Great Plains Physiographic Province. Approximately 10 miles to the west is a major structural feature known as the Rampart Range Fault. This fault marks the boundary between the Great Plains Physiographic Province and the Southern Rocky Mountain Province. The site exists within the southeastern edge of a large structural feature known as the Physiographically, the site lies in the western portion of the Great Plains Physiographic Province. The site exists within the southeastern edge of a large structural feature known as the Denver Basin. Bedrock in the area tends to be very gently dipping in a northerly direction (Reference 4). The rocks in the area of the site are sedimentary in nature, and typically Tertiary to Cretaceous in age. The bedrock underlying the site consists of the Dawson Arkose Formation. Overlying this formation are unconsolidated deposits of residual, colluvial,

man-made, and alluvial soils of the Quaternary Age. The residual soils are produced by the in-situ action of weathering of the bedrock on site. Some colluvial soils exist which are deposited by gravity and sheetwash. The alluvial soils were deposited by water in the drainages on site. Man-made soils exist as earthen dams and erosion berms. The site's stratigraphy will be discussed in more detail in Section 5.3.

5.2 Soil Conservation Survey

The Natural Resource Conservation Service (Reference 5), previously the Soil Conservation Service (Reference 6) has mapped two soil types on the site (Figure 4). In general, the soils classify as coarse sandy loam, and sandy loam. The soils are described as follows:

| <u>Type</u> | <u>Description</u> |
|-------------|--------------------------------------|
| 26 | Elbeth – sandy loam, 8 to 15% slopes |
| 67 | Peyton –sandy loam, 5 to 9% slopes |

Complete descriptions of each soil type are presented in Appendix E. The soils have generally been described to have moderate to rapid permeabilities. Limitations on development include, limited ability to support a load, shrink swell potential, slopes and frost action potential. Possible hazards with soil erosion are present on the site. The erosion potential can be controlled with vegetation. The majority of the soils have been described to have moderate erosion hazards

5.3 Site Stratigraphy

The Black Forest Quadrangle Geology Map showing the site is presented in Figure 6 (Reference 7). The Geology Map prepared for the site is presented in Figure 7. Three mappable units were identified on this site which are described as follows:

Qaf Artificial Fill of Holocene Age: These are man placed fill deposits associated with erosion berms and earthen dams on-site. Additionally, temporary stockpiles were observed on the site. Other areas of fill may exist on the site other than those mapped due to on-going construction.

Qal Recent Alluvium of Quaternary Age: These are recent stream deposits associated with the drainages on-site. These materials generally consist of silty to clayey sands and may contain clay lenses. Highly organic soils may be encountered in some of these areas.

Tkd Dawson Formation of Tertiary to Cretaceous Age: The Dawson formation typically consists of arkosic sandstone with interbedded fine-grained sandstone, siltstone and claystone. Overlying this formation is a variable layer of residual soil. The residual soils were derived from the in-situ weathering of the bedrock materials on-site. These soils consisted of silty to clayey sands and sandy clays. Areas of colluvial soils may exist on some of the slopes on site. These materials are derived from the bedrock materials and have been re-deposited by the action of sheetwash and gravity.

The bedrock underlying the site consists of the Dawson Formation of Tertiary to Cretaceous Age. The Dawson Formation typically consists of arkosic sandstone with interbedded fine-grained sandstone, siltstone and claystone. Overlying this formation are variable layers of man placed fill deposits, alluvial deposits, and residual soil. The residual soils were derived from the in-situ weathering of the bedrock materials on-site. These soils consisted of silty to clayey sands and sandy clays.

The soils listed above were mapped from site-specific mapping, the *Geologic Map of the Black Forest Quadrangle* distributed by the Colorado Geological Survey in 2003 (References 7), the *Geologic Map of the Colorado Springs-Castle Rock Area*, distributed by the US Geological Survey in 1979 (Reference 8), and the *Geologic Map of the Denver 1⁰ x 2⁰ Quadrangle*, distributed by the US Geological Survey in 1981 (Reference 9). The Test Borings and Test Pit Logs used in evaluating the site and are included in Appendix B. The Geology Map prepared for the site is presented in Figure 7.

5.4 Soil Conditions

The soils encountered in the Test Borings can be grouped into four general soil and rock types. The soils were classified using the Unified Soil Classification System (USCS).

Soil Type 1 classified as sand with silt to silty sand with gravel (SW-SM, SM). The sand was encountered in all of the test borings at the ground surface extending to depths ranging from 3 to 19 feet bgs and to the termination of TB-2 (20 feet). The sand was encountered at loose to dense states. The majority of the samples indicated medium dense states.

Soil Type 2 classified as sandy clay (CL). The clay was encountered in TB-2 and TB-6 at the ground surface extending to a depth of 5 feet bgs. The clay was encountered at medium stiff to very stiff consistencies. Swell/Consolidation Testing on a sample of the clay resulted in a consolidation of 0.2 percent, indicating a low expansion potential.

Soil Type 3 classified as sandstone with silt and silty sandstone (SM-SW, SM), or as a sand with silt and silty sand when classified as a soil. The sandstone was encountered in TB-1, 3 – 5 at depths ranging from the 3 to 19 feet bgs, and extended to the termination of the borings (20 feet). The sandstone was encountered at very dense states.

Soil Type 4 classified as sandy claystone (CL). The claystone was encountered in TB-5 at 13 feet bgs, and extended to the termination of the test boring (20 feet). The claystone was encountered at hard consistencies. Swell/Consolidation Testing on a sample of claystone resulted in an expansion of 1.2 percent, indicating a low consolidation potential.

The Test Boring Logs are presented in Appendix B, and the depth to bedrock and groundwater are presented on Table B-1. Laboratory Test Results are presented in Appendix C, and a Summary of Laboratory Test Results is presented in Table C-1.

5.5 Groundwater

Groundwater was not encountered in any of the test borings which were drilled to 20 feet. Areas of seasonal, potentially seasonal shallow groundwater, and ponded water have been mapped in the drainages and low-lying areas on the site. These areas are discussed in the following section. Fluctuation in groundwater conditions may occur due to variations in rainfall and other factors not readily apparent at this time. It should be noted that in the sandy materials on-site, some groundwater conditions might be encountered due to the variability in the soil profile. Isolated sand and gravel layers within the soils, sometimes only a few feet in thickness and width, can carry water in the subsurface. Groundwater may also flow on top of the underlying bedrock. Builders and planners should be cognizant of the potential for the occurrence of such subsurface water features during construction on-site and deal with each individual problem as necessary at the time of construction.

6 ENGINEERING GEOLOGY – IDENTIFICATION AND MITIGATION OF GEOLOGIC HAZARDS

Detailed mapping has been performed on this site to produce an Engineering Geology Map Figure 6. This map shows the location of various geologic conditions of which the developers should be cognizant during the planning, design and construction stages of the project. These hazards and the recommended mitigation techniques are as follows:

Artificial Fill – Constraint

These are areas of man-placed fill associated with minor fill piles in the future road areas, and erosion berms on the site.

Mitigation: The fill piles in the areas of future roadways and erosion berms will be mitigated with the proposed roadway site grading. The erosion berms can either be avoided or removed. The fill on this site is considered uncontrolled for construction purposes. Any uncontrolled fill encountered beneath foundations or drainage structures will require removal and recompaction at a minimum of 95% of its maximum Modified Proctor Dry Density, ASTM D-1557.

Areas of Erosion – Constraint

These are areas that are undergoing erosion by water and sheetwash producing gullies and rill erosion and primarily located along portions of the drainage in the southern portion of the site.

Mitigation: Due to the nature of the soils on this site, virtually all the soils are subject to erosion by wind and water. Other minor areas of erosion were observed on site other than those mapped, particularly where some rill erosion has occurred. Areas of erosion can occur across the entire site, particularly if the soils are disturbed during construction. Vegetation reduces the potential for erosion. The areas identified where erosion is actually taking place may require check dams, regrading and revegetation using channel lining mats to anchor vegetation. Further recommendations for erosion control are discussed under Section 9.0 "Erosion Control" of this report. Recommendations pertaining to revegetation may require input from a qualified landscape architect and/or the Natural Resource Conservation Service (previously Soil Conservation Service)

Expansive Soils – Constraint

The site is classified in an area of low to moderate swell potential according to *the Map of Potentially Swelling Soil and Rock in the Front Range Urban Corridor, Colorado* by Hart, 1974 (Reference 10). Expansive soils were encountered in some of the test borings drilled on the site as a part of the entire Flying Horse North Subdivision (References 1 – 3). These occurrences are typically sporadic; therefore, none have been indicated on the maps. These clays or claystone, if encountered beneath foundations, can cause differential movement in the structure foundation. These occurrences should be identified and dealt with on an individual basis.

Mitigation Should expansive soils be encountered beneath the foundation; mitigation will be necessary. Mitigation of expansive soils will require special foundation design. Overexcavation and replacement with non-expansive soils at a minimum of 95% of its maximum Modified Proctor Dry Density, ASTM D-1557 is a suitable mitigation, which is common in the area. Another

alternative in areas of highly expansive soils is the use of drilled pier foundation systems. Typical minimum pier depths are on the order of 25 feet or more and require penetration into the bedrock material a minimum of 4 to 6 feet, depending upon building loads. Floor slabs on expansive soils should be expected to experience movement. Overexcavation and replacement has been successful in minimizing slab movements. The use of structural floors should be considered for basement construction on highly expansive clays. Final recommendations should be determined after additional investigation of each building site.

Groundwater and Floodplain Areas – Constraint

Drainages are located in the northern and southern portions site, and several minor drainages are located across the site that generally flow in westerly directions. None of the drainages on the site have been mapped within floodplain zones according to the FEMA Map No. 08041CO315G, (Figure 7, Reference 11). Areas where potentially seasonal shallow, seasonal shallow, and ponded water have been indicated on the site geology/engineering geology map, Figure 6. Lots adjacent to the drainages may experience higher groundwater levels during peak flows. Subsurface perimeter drains are recommended for structures with useable below grade space, and additional drains may be required in building areas close drainages to help prevent the intrusion of water into areas below grade. Typical drain details are presented in Figures 8 – 10. Finished floor levels must be a minimum of one floor above the floodplain level. **Exact floodplain locations and drainage studies are beyond the scope of this report.**

Groundwater was not encountered in the test borings drilled within Filing No. 3. Areas of seasonally shallow and potential seasonally shallow groundwater, and ponded water were observed on the site and are further discussed below. Buildings should maintain a minimum separation of 3 feet between the lowest foundation grade and the maximum anticipated groundwater level. Shallow groundwater areas can be mitigated with the installation of drains. Typical drain options/details are presented in Figures 8 through 11. These areas are discussed as follows:

Seasonal Shallow and Potential Seasonally Shallow Groundwater – Constraint

In these areas, we would anticipate periodic high subsurface moisture conditions and frost heave potential on a seasonal basis. Additional, highly organic soils could be encountered in these areas. These areas lie within defined drainages and it is anticipated they will be avoided by development. Minor drainage swales in building areas should be properly diverted away from the structures. Any structures in or adjacent to these areas should follow the mitigation discussed below.

Mitigation: In these locations, foundations subject to severe frost heave potential should penetrate sufficient depth so as to discourage the formation of ice lenses beneath foundations. At this location and elevation, foundation depth for frost protection is 30 inches. In areas where high subsurface moisture conditions are anticipated periodically, a subsurface perimeter drain will be necessary to help prevent the intrusion of water into areas located below grade. Subsurface perimeter drains may be necessary to prevent the intrusion of water into areas below grade. Typical drain details are presented in Figure 8. Where shallow groundwater is encountered, underslab drains or interceptor drains may be necessary Figures 9 and 10. Specific recommendations should be made after additional investigation has been completed and building locations have been identified on a lot by lot basis. Swales should be created to intercept surface runoff and carry it safely around and away from structures.

Areas of Ponded Water – Constraint

These are areas of standing water behind temporary erosion berms on the site, and flowing water within the drainage in the southwestern corner of the site in the area of proposed drainage Tract B. Temporary erosion berms will be removed during the site grading; shallow groundwater may affect the construction of the proposed detention pond located on Tract B. Temporary dewatering during construction may be required. Should complete regrading of the site be considered, all organic matter and soft, wet soils should be completely removed before filling. Any drainage into these areas should be rerouted in a non-erosive manner off of the site where it does not create areas of ponded water around proposed structures.

Downslope Creep Areas – Constraint

These areas are acceptable as building sites, however, in areas identified with this hazard classification, we would anticipate accelerated lateral and vertical movement of the near surface soils in the downslope direction.

Mitigation: The design of foundations in these areas should account for the additional pressure on the uphill side of the structure due to the creep potential. The lateral pressure distribution for sloping conditions in downslope creep area is presented in Figure 11. Tie-beams, buttresses and counterforts may be necessary in some areas. Where possible, in areas of downslope creep, structures should be designed to be as compact and rigid as possible. This will help them better tolerate the vertical and lateral movements to which the foundation system may be subjected with minimal damage. Long, rambling, irregular structures should be avoided, as they are associated with much greater potential for damaging differential movement. Additionally, structures should be designed to step up the slope. Deep cuts in these areas should be avoided. Any retaining

walls proposed in these areas should also be properly designed for by a qualified professional engineer for the global slope stability. Proper control of drainage at both the surface and subsurface is important. Saturation of materials should be avoided that may create unstable conditions.

Shallow Bedrock – Constraint

Bedrock was encountered in five of the test borings located within Filing No. 3 at depths ranging from the 3 to 19 feet. A Summary of the Depth to Bedrock is included in Table B-1. Shallow bedrock will be encountered across the majority of this site. Where shallow bedrock is encountered, excavation/grading may be difficult requiring track-mounted excavators with ripper attachments. Bedrock will likely be encountered in cuts for utility excavations.

Radon – Hazard

Radon levels for the area have been reported by the Colorado Geologic Survey in the open file, Report No. 91-4 (Reference 12). Average Radon levels for the 80908-zip code is 3.40 pCi/l. The following is a table of radon levels in this area:

| <u>80831</u> | |
|---------------|--------|
| 0 < 4 pCi/l | 50.00% |
| 4 < 10 pCi/l | 50.00% |
| 10 < 20 pCi/l | 0.00% |
| > 20 pCi/l | 0.00% |

Mitigation:

The potential for high radon levels is present for the site. Build-up of radon gas can usually be mitigated by providing increased ventilation of basement and crawlspace and sealing joints. **Specific requirements for mitigation should be based on site specific testing.**

6.1 Relevance of Geologic Conditions to Land Use Planning

The development will be single-family rural residential utilizing individual water wells and OWTS. It is our opinion that the existing geologic and engineering geologic conditions will impose some constraints on the proposed development and construction. The most significant problems affecting development will be those associated with the drainages on site that can be avoided or mitigated. Other hazards on site may be satisfactorily mitigated through proper engineering design and construction practices.

The upper residual soils are typically at medium to very dense states. The granular soils encountered in the upper soil profiles of the test borings should provide good support for

foundations. Expansive soils were encountered on portions of the site that will require mitigation. Foundations anticipated for the site are standard spread footings possibly in conjunction with overexcavation in areas of expansive soils. Areas containing arkosic sandstone will have high allowable bearing conditions. Difficult excavation should be anticipated in areas of shallow bedrock. Expansive layers may also be encountered in the soil and bedrock on this site. Areas of expansive soils encountered on site are sporadic; therefore, none have been indicated on the maps. Expansive soils, if encountered, will require special foundation design and/or overexcavation. These soils will not prohibit development.

Areas of seasonal and potentially seasonal high groundwater areas and ponded water were encountered on the site. Due to the size of the lots and the proposed development, these areas can be avoided by construction or properly mitigated. Absorption fields are not recommended in these areas. Structures should not block drainages. Drains may be necessary for structures adjacent to these areas to help prevent the intrusion of water into areas below grade. Buildings should maintain a minimum separation of 3 feet between the lowest foundation grade and the maximum anticipated groundwater level. Shallow groundwater areas can be mitigated with the installation of drains. Typical drain options/details are presented in Figures 8 through 11. Typical drain details are presented in Figure 8 – 10. The site is not mapped within any floodplain zones according to FEMA Map No. 08041CO315G, dated December 7, 2018 (Figure 7, Reference 11). A floodplain is mapped in the extreme northwestern portion of the site. A detention pond is proposed in this area which will be located in an open space. Exact locations of floodplain and specific drainage studies are beyond the scope of this report.

Areas of fill were observed on site associated with man-placed fill piles in future road areas, and temporary erosion control berms. It is anticipated the fill piles/erosion berms will be mitigated during site grading. Any uncontrolled fill encountered beneath foundations should be removed and recompacted at a minimum of 95% of its maximum Modified Proctor Dry Density, ASTM D-1557.

Areas of erosion and gulying may require the construction of check dams and revegetation if construction encroaches on these areas. General recommendations for erosion control are discussed under Section 8 "Erosion Control".

Areas of downslope creep areas have been identified on this site. In areas of downslope creep, structures should be designed to be as compact and rigid as possible. Foundations may require tie-beams or additional reinforcement in these areas. Foundations should be designed to step up

the slopes to avoid deep cuts. Deep cuts should be avoided on all steeper sloping areas of the site. Any retaining walls proposed should be designed for the global slope stability by a qualified professional engineer. This includes cuts made for terracing in backyards. Proper control of drainage at both the surface and subsurface is important. Saturation of materials should be avoided that may create unstable conditions.

In summary, development of the site can be achieved if the items mentioned above are mitigated. These items can be mitigated through proper design and construction or through avoidance. Investigation on each lot is also recommended prior to construction.

7 ECONOMIC MINERAL RESOURCES

Some of the sandy materials on-site could be considered a low grade sand resource. According to the *El Paso County Aggregate Resource Evaluation Map* (Reference 13), portions of the area are mapped as stream terrace and floodplain deposits. According to the *Atlas of Sand, Gravel and Quarry Aggregate Resources, Colorado Front Range Counties* distributed by the Colorado Geological Survey (Reference 14), areas of the site are not mapped with any resources. According to the *Evaluation of Mineral and Mineral Fuel Potential* (Reference 15), the area of the site has been mapped as “Little or No Potential” for industrial minerals. It is possible sand materials on site could be an aggregate resource. However, considering the silty to clayey nature of much of these materials and abundance of similar materials through the region and the close proximity to developed land, they would be considered to have little significance as an economic resource.

According to *the Evaluation of Mineral and Mineral Fuel Potential of El Paso County State Mineral Lands* (Reference 15), the site is mapped within the Denver Basin Coal Region. However, the area of the site has been mapped as “Poor” for coal resources. No active or inactive mines have been mapped in the area of the site. No metallic mineral resources have been mapped on the site (Reference 15).

The site has been mapped as “Fair” for oil and gas resources (Reference 15). No oil or gas fields have been discovered in the area of the site. The sedimentary rocks in the area may lack the geologic structure for trapping oil or gas; therefore, it may not be considered a significant resource. Hydraulic fracturing is a new method that is being used to extract oil and gas from rocks. It utilizes pressurized fluid to extract oil and gas from rocks that would not normally be productive. The area of the site has not been explored to determine if the rocks underlying the site would be

commercially viable utilizing hydraulic fracturing. The practice of hydraulic fracturing has come under review due to concerns about environmental impacts, health and safety.

8 EROSION CONTROL

The soil types observed on the site are mildly to highly susceptible to wind erosion, and moderately to highly susceptible to water erosion. A minor wind erosion and dust problem may be created for a short time during and immediately after construction. Should the problem be considered severe enough during this time, watering of the cut areas or the use of chemical palliative may be required to control dust. However, once construction has been completed and vegetation re-established, the potential for wind erosion should be considerably reduced.

With regard to water erosion, loosely compacted soils will be the most susceptible to water erosion, residually weathered soils and weathered bedrock materials become increasingly less susceptible to water erosion. For the typical soils observed on site, allowable velocities or unvegetated and unlined earth channels would be on the order of 3 to 4 feet/second, depending upon the sediment load carried by the water. Permissible velocities may be increased through the use of vegetation to something on the order of 4 to 7 feet/second, depending upon the type of vegetation established. Should the anticipated velocities exceed these values, some form of channel lining material may be required to reduce erosion potential. These might consist of some of the synthetic channel lining materials on the market or conventional riprap. In cases where ditch-lining materials are still insufficient to control erosion, small check dams or sediment traps may be required. The check dams will serve to reduce flow velocities, as well as provide small traps for containing sediment. The determination of the amount, location and placement of ditch linings, check dams and of the special erosion control features should be performed by or in conjunction with the drainage engineer who is more familiar with the flow quantities and velocities.

Cut and fill slope areas will be subjected primarily to sheetwash and rill erosion. Unchecked rill erosion can eventually lead to concentrated flows of water and gully erosion. The best means to combat this type of erosion is, where possible, the adequate re-vegetation of cut and fill slopes. Cut and fill slopes having gradients more than three (3) horizontal to one (1) vertical become increasingly more difficult to revegetate successfully. Therefore, recommendations pertaining to the vegetation of the cut and fill slopes may require input from a qualified landscape architect and/or the Soil Conservation Service.

9 ROADWAY AND EMBANKMENT CONSTRUCTION RECOMMENDATIONS

In general, the site soils are suitable for the proposed roadways and embankments. Groundwater should be expected to be encountered in deeper cuts and along or near drainages and low-lying areas. If road or embankment excavations encroach on the groundwater level unstable soil conditions may be encountered. Unstable soils are not anticipated in areas of shallow bedrock. Excavation of saturated soils will be difficult with rubber-tired equipment. Stabilization using shot rock or geogrids may be necessary.

Any areas to receive fill should have all topsoil, organic material or debris removed. Prior to fill placement Entech should observe the subgrade. Fill must be properly benched and compacted to minimize potentially unstable conditions in slope areas. Fill slopes should be 3:1. The subgrade should be scarified and moisture conditioned to within 2% of optimum moisture content and compacted to a minimum of 95% of its maximum Modified Proctor Dry Density, ASTM D-1557, prior to placing new fill. Areas receiving fill may require stabilization with rock or fabric if shallow groundwater conditions are encountered.

New fill should be placed in thin lifts not to exceed 6 inches after compaction while maintaining at least 95% of its maximum Modified Proctor Dry Density, ASTM D-1557. These materials should be placed at a moisture content conducive to compaction, usually 0 to $\pm 2\%$ of Proctor optimum moisture content. The placement and compaction of fill should be observed and tested by Entech during construction. Entech should approve any import materials prior to placing or hauling them to the site. Additional investigation will be required for pavement designs once roadway grading is completed and utilities are installed.

10 CLOSURE

It is our opinion that the existing geologic engineering and geologic conditions will impose some constraints on development and construction of the site. The majority of these conditions can be mitigated through proper engineering design and construction practices. The proposed development and use are consistent with anticipated geologic and engineering geologic conditions.

It should be pointed out that because of the nature of data obtained by random sampling of such variable and non-homogeneous materials as soil and rock, it is important that we be informed of any differences observed between surface and subsurface conditions encountered in construction and those assumed in the body of this report. Individual investigations for building sites will be required prior to construction. Construction and design personnel should be made familiar with the contents of this report. Reporting such discrepancies to Entech Engineering, Inc. soon after they are discovered would be greatly appreciated and could possibly help avoid construction and development problems.

This report has been prepared for Flying Horse Development, LLC for application to the proposed project in accordance with generally accepted geologic soil and engineering practices. No other warranty expressed or implied is made.

We trust that this report has provided you with all the information that you required. Should you require additional information, please do not hesitate to contact Entech Engineering, Inc.

11 REFERENCES

1. Entech Engineering, Inc., February 26, 2015. *Soil, Geology, Geologic Hazard, and Wastewater Study, Shamrock Ranch, El Paso County, Colorado*. Entech Job No. 141588
2. Entech Engineering, Inc., February 22, 2016. *Soil, Geology, Geologic Hazard, and Wastewater Study, Flying Horse North, PUD Submittal, El Paso County, Colorado*. Entech Job No. 160118.
3. Entech Engineering, Inc., revised date May 2, 2022. *Soil, Geology, Geologic Hazard, and Wastewater Study, Flying Horse North, Sketch Plan, El Paso County, Colorado*. Entech Job No. 220404.
4. Bryant, Bruce; McGrew, Laura W. and Wobus, Reinhard A. 1981. *Geologic Structure Map of the Denver 1° x 2° Quadrangle, North-Central Colorado*. U.S. Geologic Survey. Map 1-1163.
5. Natural Resource Conservation Service, June 20, 2007. *Web Soil Survey*. United States Department Agriculture, <http://web soil survey.nrcs.usda.gov>.
6. United States Department of Agriculture Soil Conservation Service. June 1981. *Soil Survey of El Paso County Area, Colorado*.
7. Thorson, Jon P. 2003. *Geologic Map of the Black Forest Quadrangle, El Paso County, Colorado*. Colorado Geological Survey. Open-File Report 03-6.
8. Trimble, Donald E. and Machette, Michael N. 1979. *Geologic Map of the Colorado Springs-Castle Rock Area, Front Range Urban Corridor, Colorado*. USGS, Map I-857-F.
9. Bryant, Bruce; McGrew, Laura W. and Wobus, Reinhard A. 1981. *Geologic Map of the Denver 1° x 2° Quadrangle, North-Central Colorado*. U.S. Geologic Survey. Map 1-1163.
10. Hart, Stephen S. 1974. *Potentially Swelling Soil and Rock in the Front Range Urban Corridor, Colorado*. Colorado Springs-Castle Rock Map. Colorado Geological Survey. Environmental Geology 7.
11. Federal Emergency Management Agency. December 7, 2018. *Flood Insurance Rate Maps for the City of Colorado Springs, Colorado*. Map Number 08041CO315G.
12. Colorado Geological Survey. 1991. *Results of the 1987-88 EPA Supported Radon Study in Colorado*. Open-file Report 91-4.
13. El Paso County Planning Development. December 1995. *El Paso County Aggregate Resource Evaluation Maps*.
14. Schwochow, S.D.; Shroba, R.R. and Wicklein, P.C. 1974. *Atlas of Sand, Gravel, and Quarry Aggregate Resources, Colorado Front Range Counties*. Colorado Geological Survey. Special Publication 5-B.
15. Keller, John W.; TerBest, Harry and Garrison, Rachel E. 2003. *Evaluation of Mineral and Mineral Fuel Potential of El Paso County State Mineral Lands Administered by the Colorado State Land Board*. Colorado Geological Survey. Open-File Report 03-07.

FIGURES

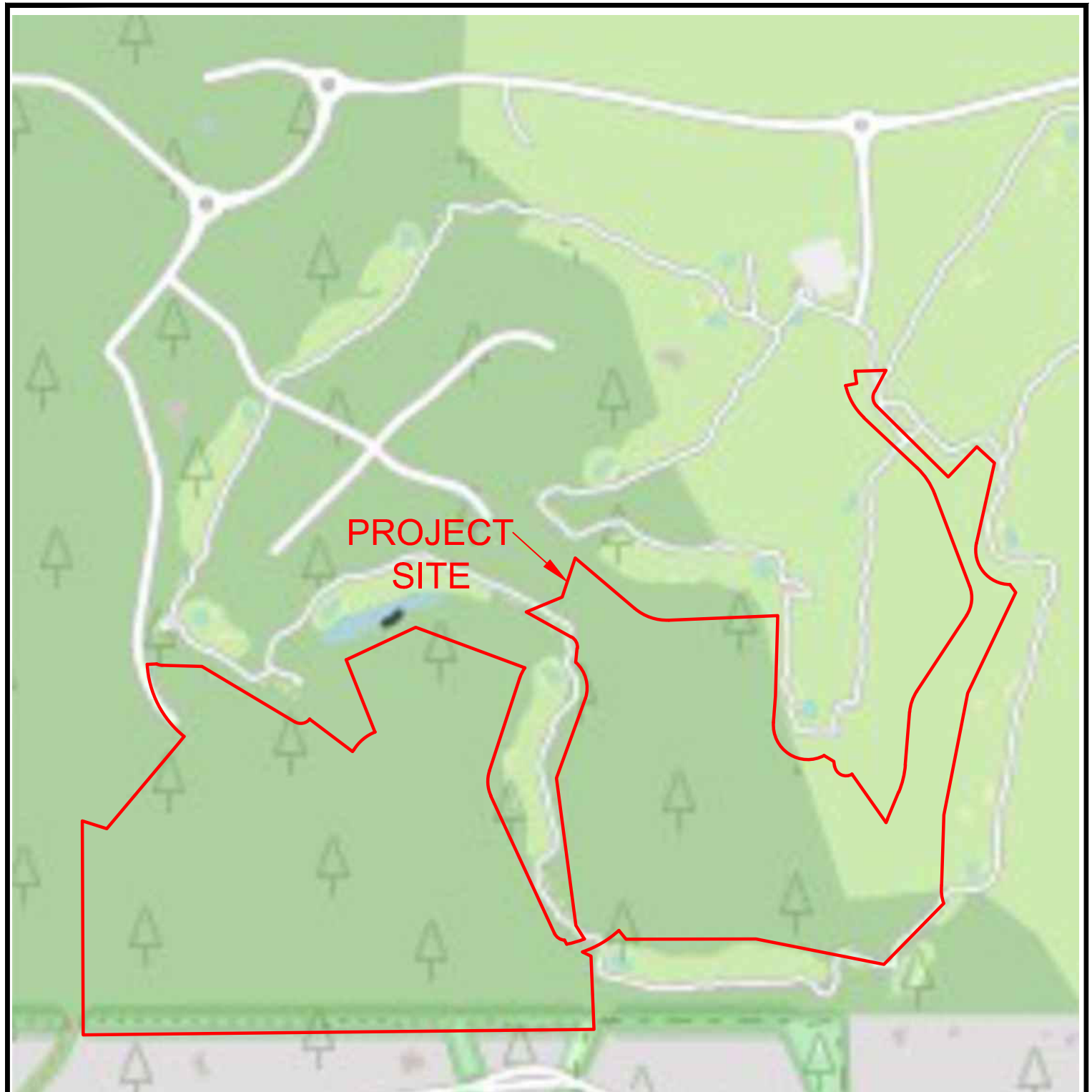

VICINITY MAP
FLYING HORSE NORTH FILING NO. 3
EL PASO COUNTY, COLORADO
FLYING HORSE NORTH, LLC

JOB NO.
231192

FIG. 1

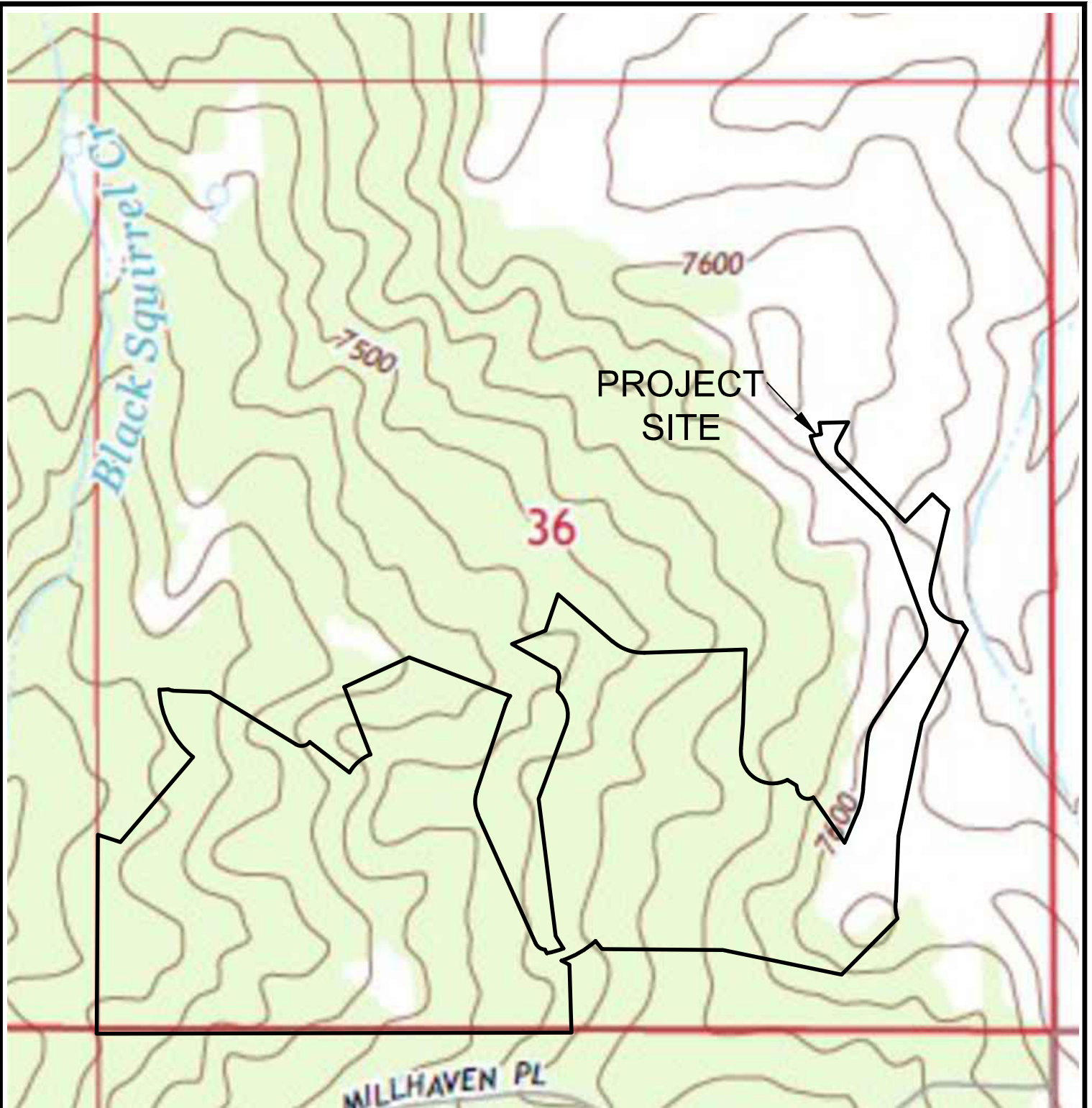





ENTECH
ENGINEERING, INC.

USGS TOPOGRAPHY MAP
FLYING HORSE NORTH FILING NO. 3
EL PASO COUNTY, COLORADO
FLYING HORSE NORTH, LLC

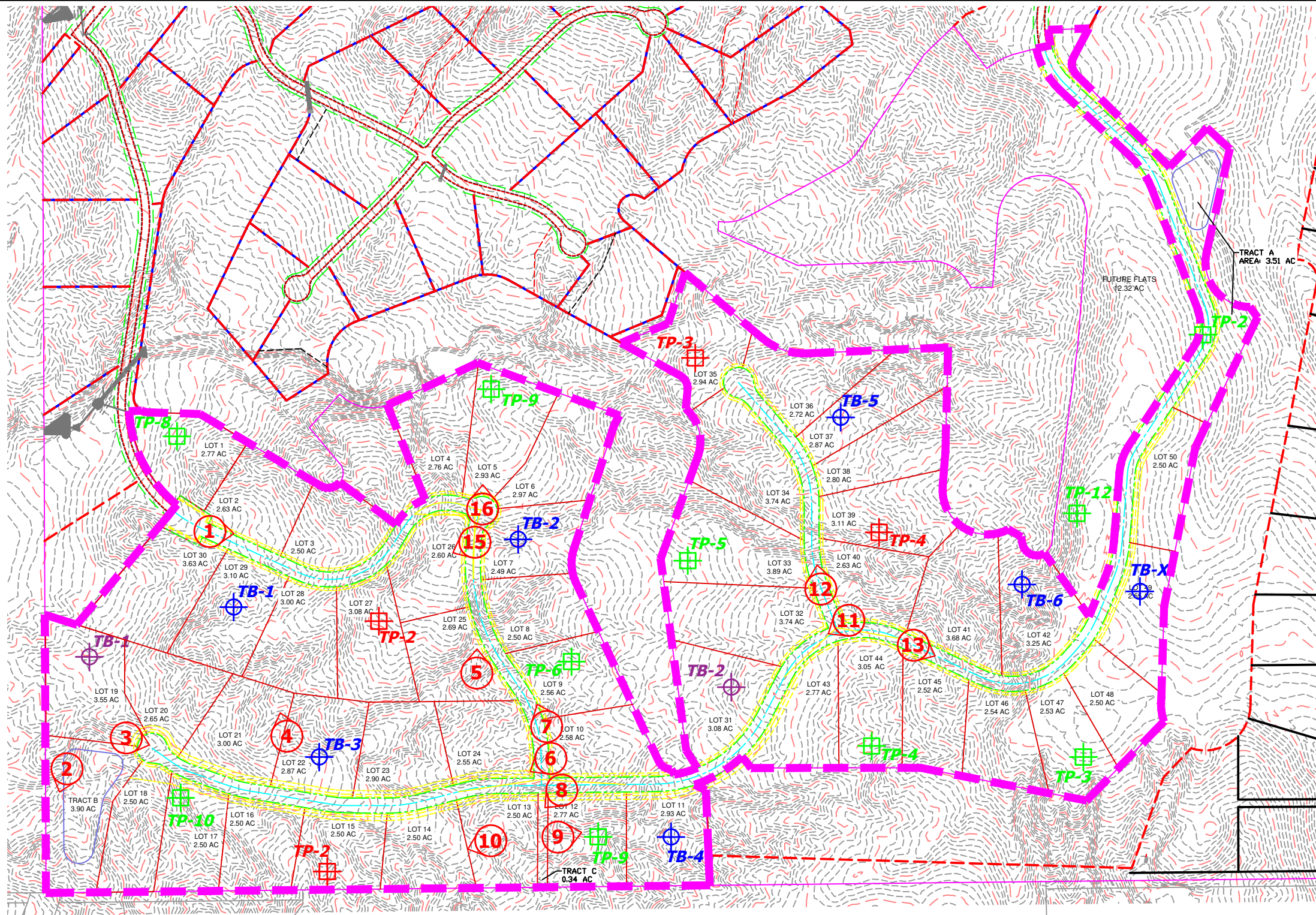
JOB NO.
231192

FIG. 2



-  - APPROXIMATE TEST PIT LOCATION AND NUMBER (OLD, NEW)
-  - APPROXIMATE TEST BORING LOCATION AND NUMBER (OLD, NEW)
-  - APPROXIMATE PHOTOGRAPH LOCATION AND NUMBER

| REVISION | BY |
|----------|----|
| | |
| | |
| | |
| | |
| | |
| | |
| | |
| | |
| | |
| | |



SITE PLANT/TESTING LOCATION MAP
 FLYING HORSE NORTH FILING NO. 3
 EL PASO COUNTY, COLORADO
 FLYING HORSE NORTH, LLC

JOB NO.
231192

FIG. 3

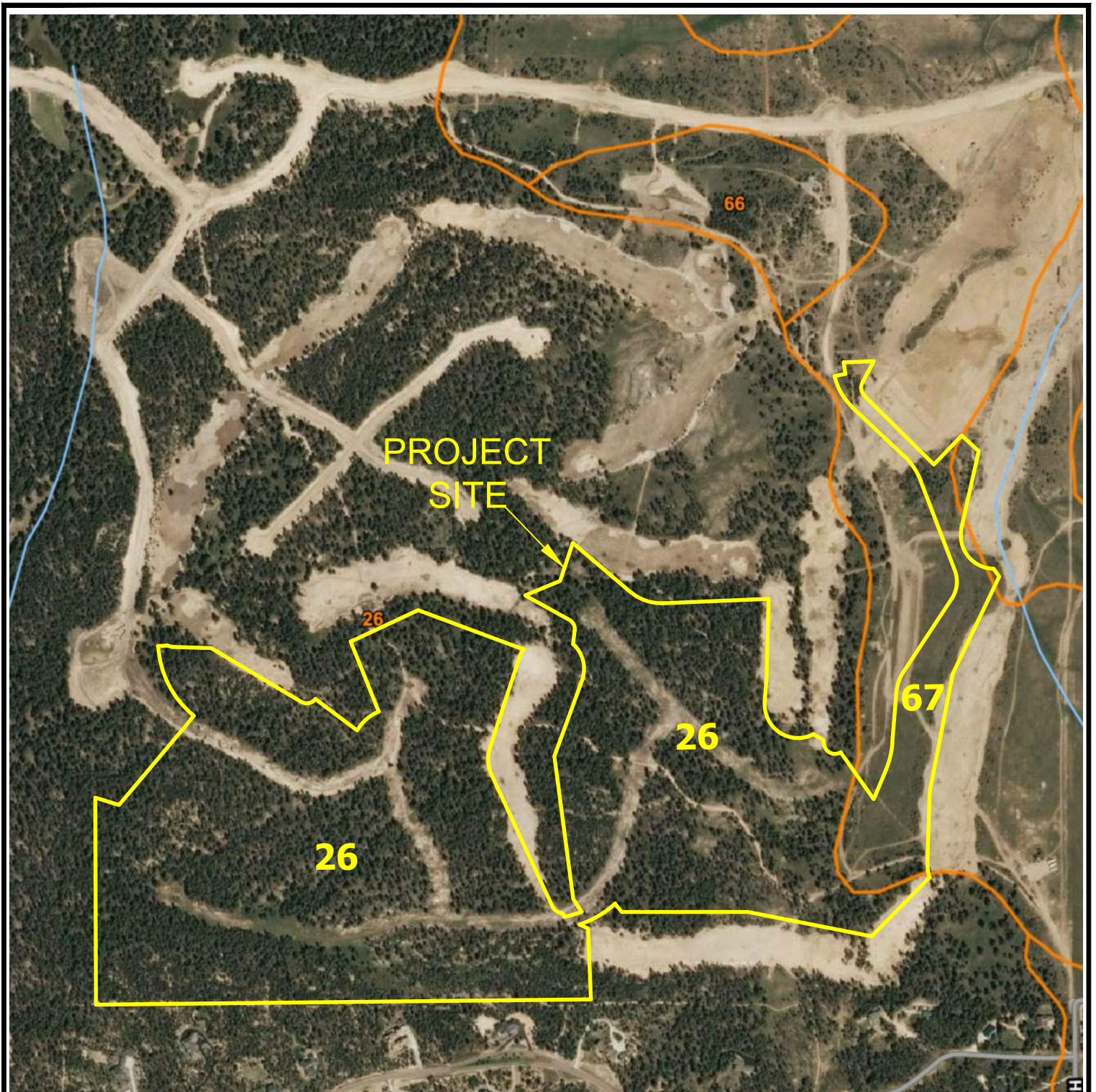

SOIL SURVEY MAP
FLYING HORSE NORTH FILING NO. 3
EL PASO COUNTY, COLORADO
FLYING HORSE NORTH, LLC

JOB NO.
231192

FIG. 4

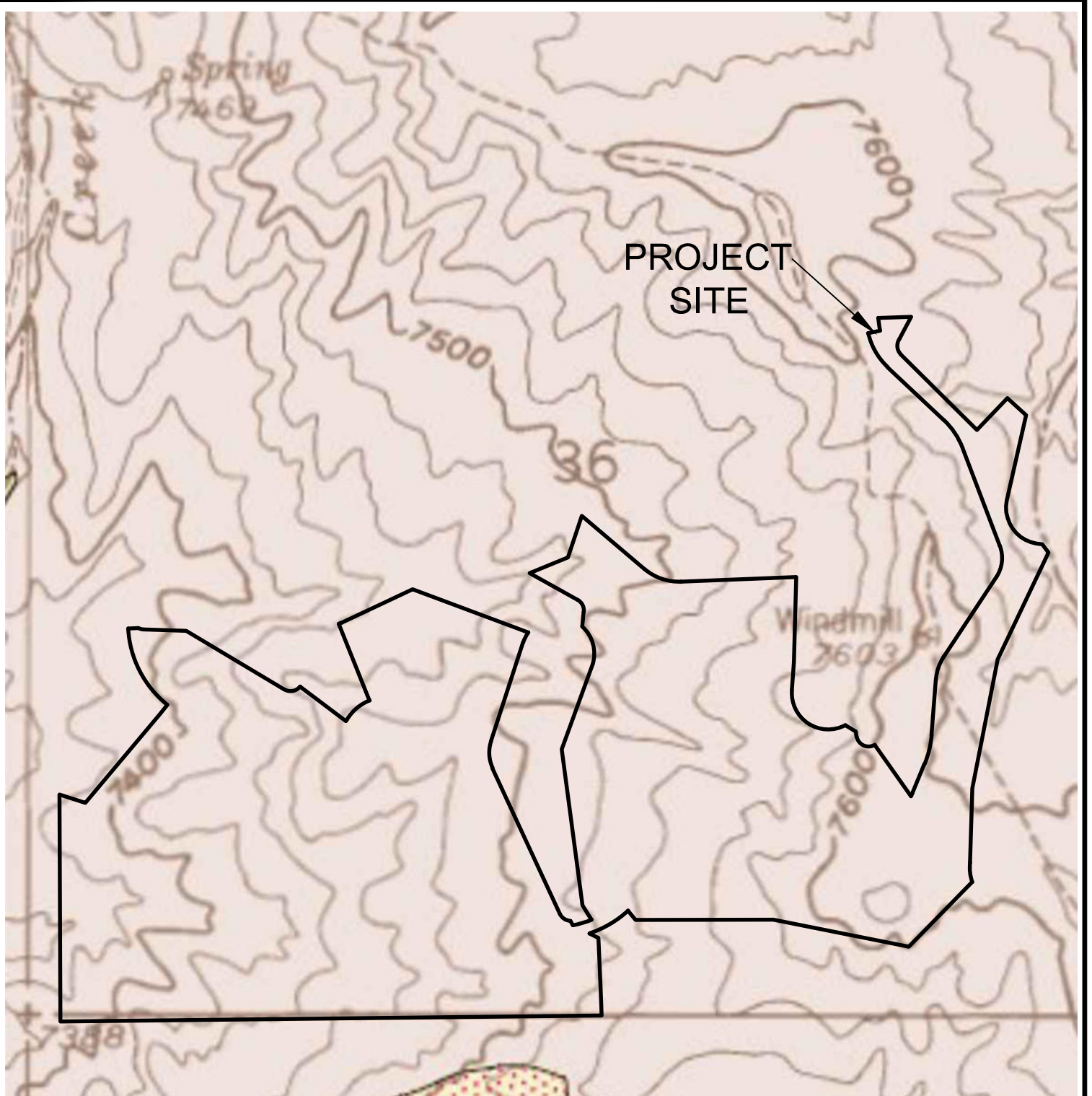

**BLACKFOREST QUADRANGLE
GEOLOGIC MAP**

FLYING HORSE NORTH FILING NO. 3
EL PASO COUNTY, COLORADO
FLYING HORSE NORTH, LLC

JOB NO.
231192

FIG. 5

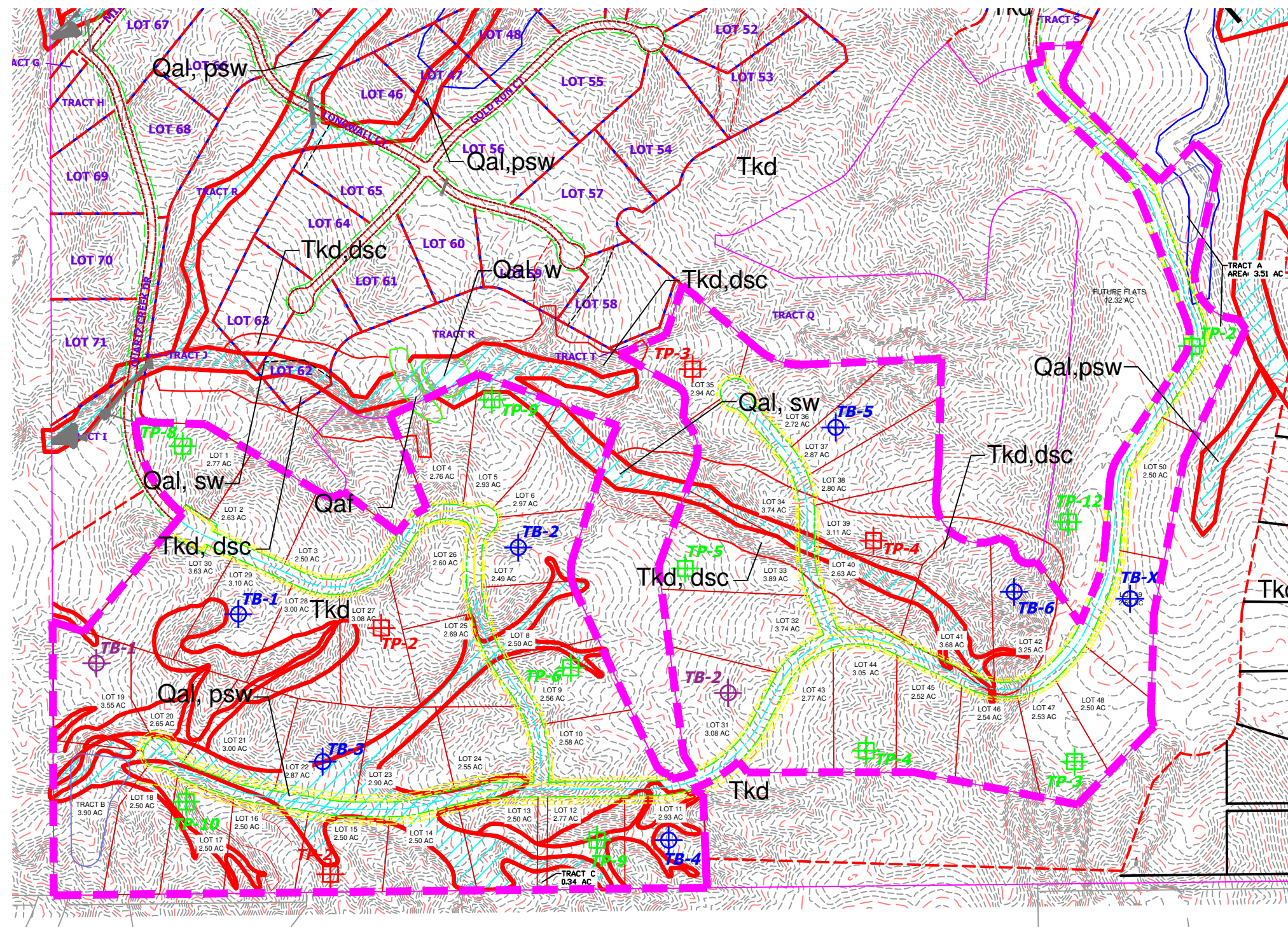

- Legend:**
- Qaf - **Artificial Fill of Quaternary Age:**
man-made fill deposits associated with erosion berms, and earthen dams
 - Qal - **Alluvium of Quaternary Age:**
recent stream deposited materials
 - TKd - **Dawson Formation of Tertiary to Cretaceous Age:**
colluvial and residual soils overlying arkosic sandstone with interbedded fine-grained sandstone, siltstone, and claystone
 - dsc - downslope creep
 - er - erosion
 - fp - floodplain
 - psw - potentially seasonal shallow groundwater area
 - sw - seasonally wet areas
 - w - ponded water

| REVISION | BY |
|----------|----|
| | |
| | |
| | |
| | |
| | |
| | |
| | |
| | |
| | |
| | |



GEOLOGY/ENGINEERING MAP
 FLYING HORSE NORTH FILING NO. 3
 EL PASO COUNTY, COLORADO
 FLYING HORSE NORTH, LLC

JOB NO.
231192

FIG. 6

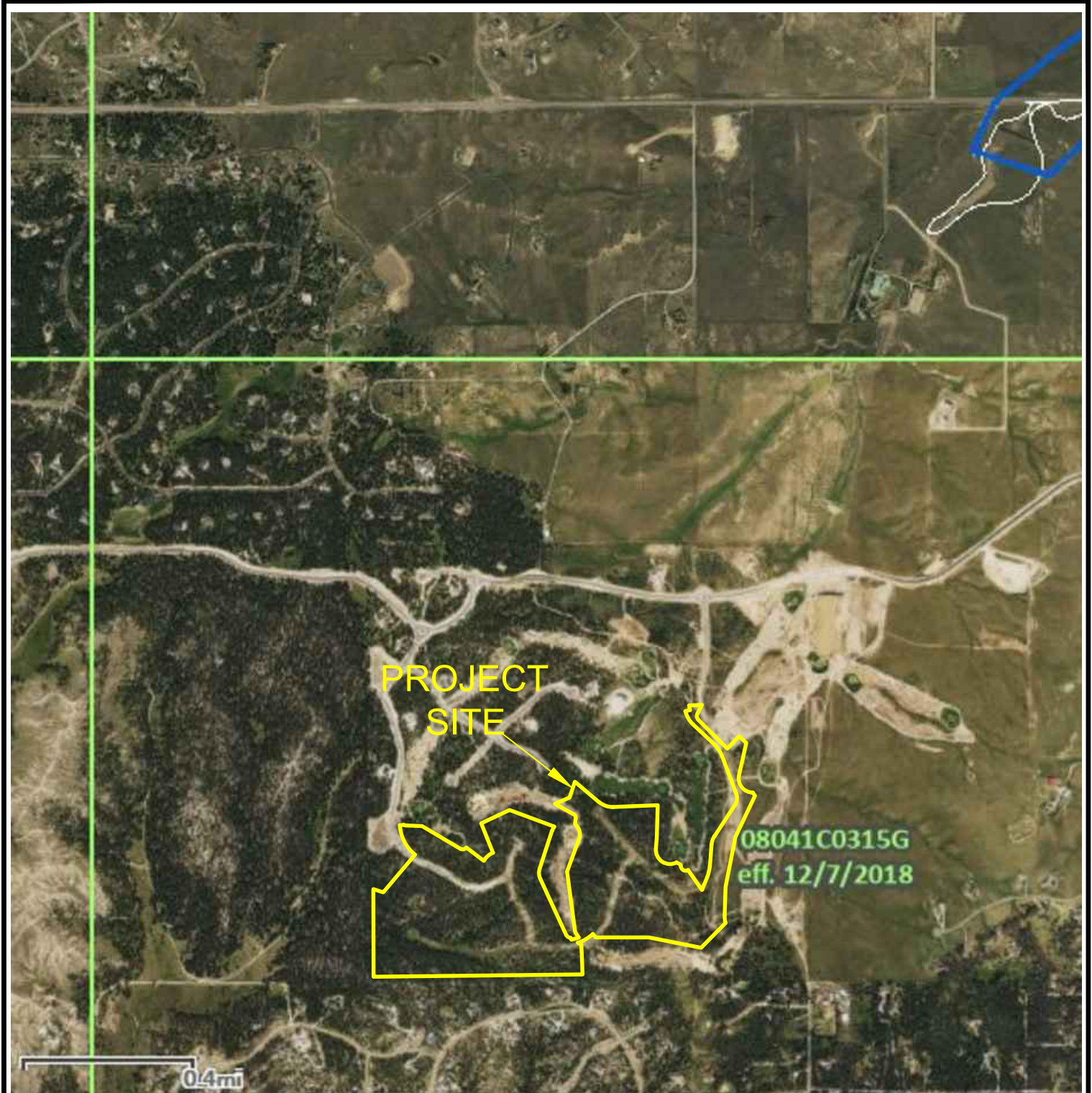

FEMA FLOODPLAIN MAP
FLYING HORSE NORTH FILING NO. 3
EL PASO COUNTY, COLORADO
FLYING HORSE NORTH, LLC

JOB NO.
231192

FIG. 7

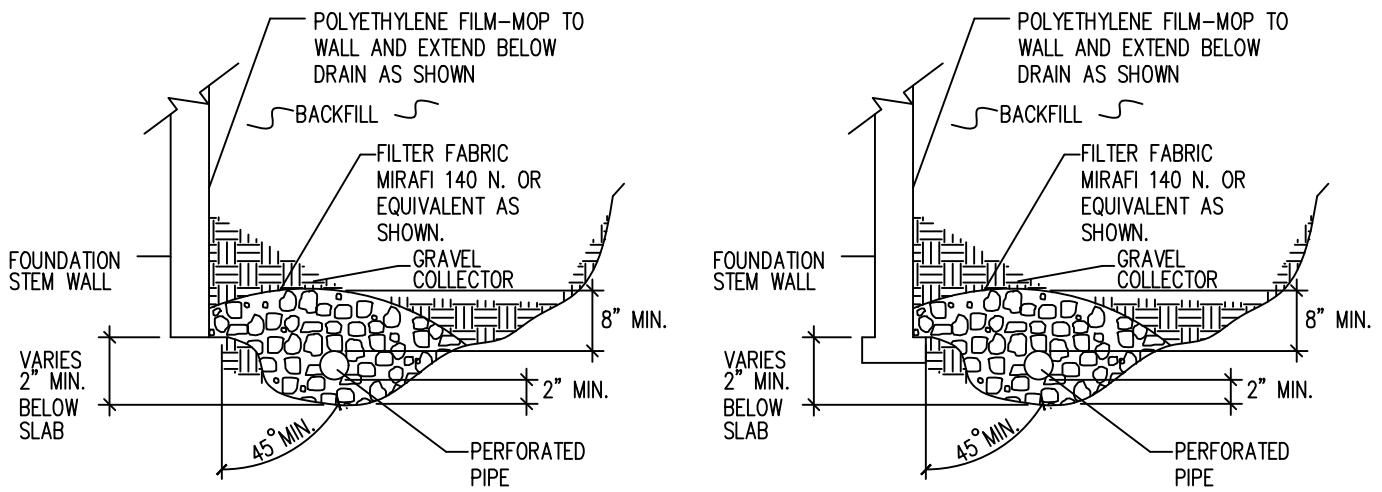

NOTES:

-GRAVEL SIZE IS RELATED TO DIAMETER OF PIPE PERFORATIONS-85% GRAVEL GREATER THAN 2x PERFORATION DIAMETER.

-PIPE DIAMETER DEPENDS UPON EXPECTED SEEPAGE. 4-INCH DIAMETER IS MOST OFTEN USED.

-ALL PIPE SHALL BE PERFORATED PLASTIC. THE DISCHARGE PORTION OF THE PIPE SHOULD BE NON-PERFORATED PIPE.

-FLEXIBLE PIPE MAY BE USED UP TO 8 FEET IN DEPTH, IF SUCH PIPE IS DESIGNED TO WITHSTAND THE PRESSURES. RIGID PLASTIC PIPE WOULD OTHERWISE BE REQUIRED.

-MINIMUM GRADE FOR DRAIN PIPE TO BE 1% OR 3 INCHES OF FALL IN 25 FEET.

-DRAIN TO BE PROVIDED WITH A FREE GRAVITY OUTFALL, IF POSSIBLE. A SUMP AND PUMP MAY BE USED IF GRAVITY OUTFALL IS NOT AVAILABLE.

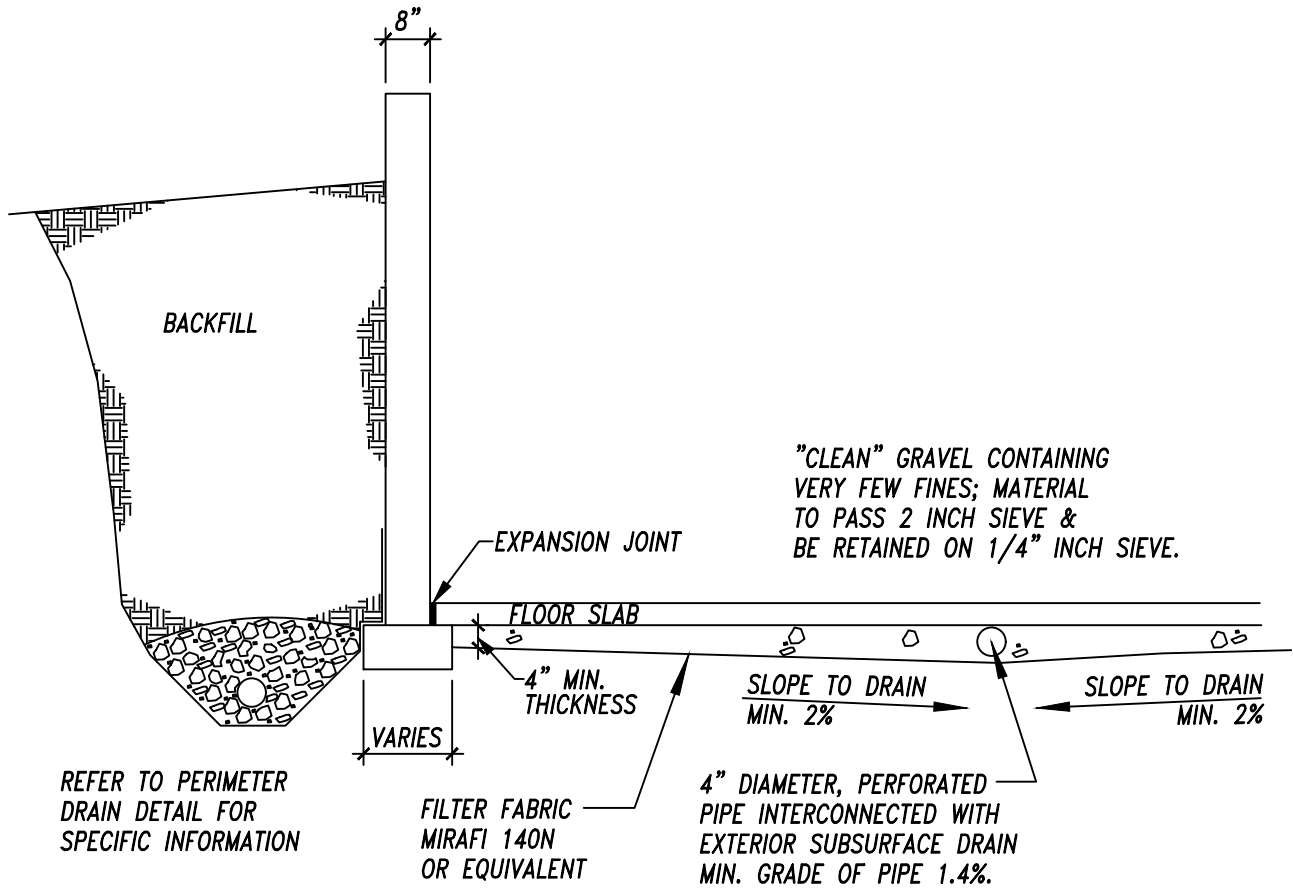

**TYP. UNDERSLAB DRAINAGE LAYER
(CAPILLARY BREAK)**

FLYING HORSE NORTH FILING NO. 3
EL PASO COUNTY, COLORADO
FLYING HORSE NORTH, LLC

JOB NO.
231192

FIG. 9



ENTECH
ENGINEERING, INC.

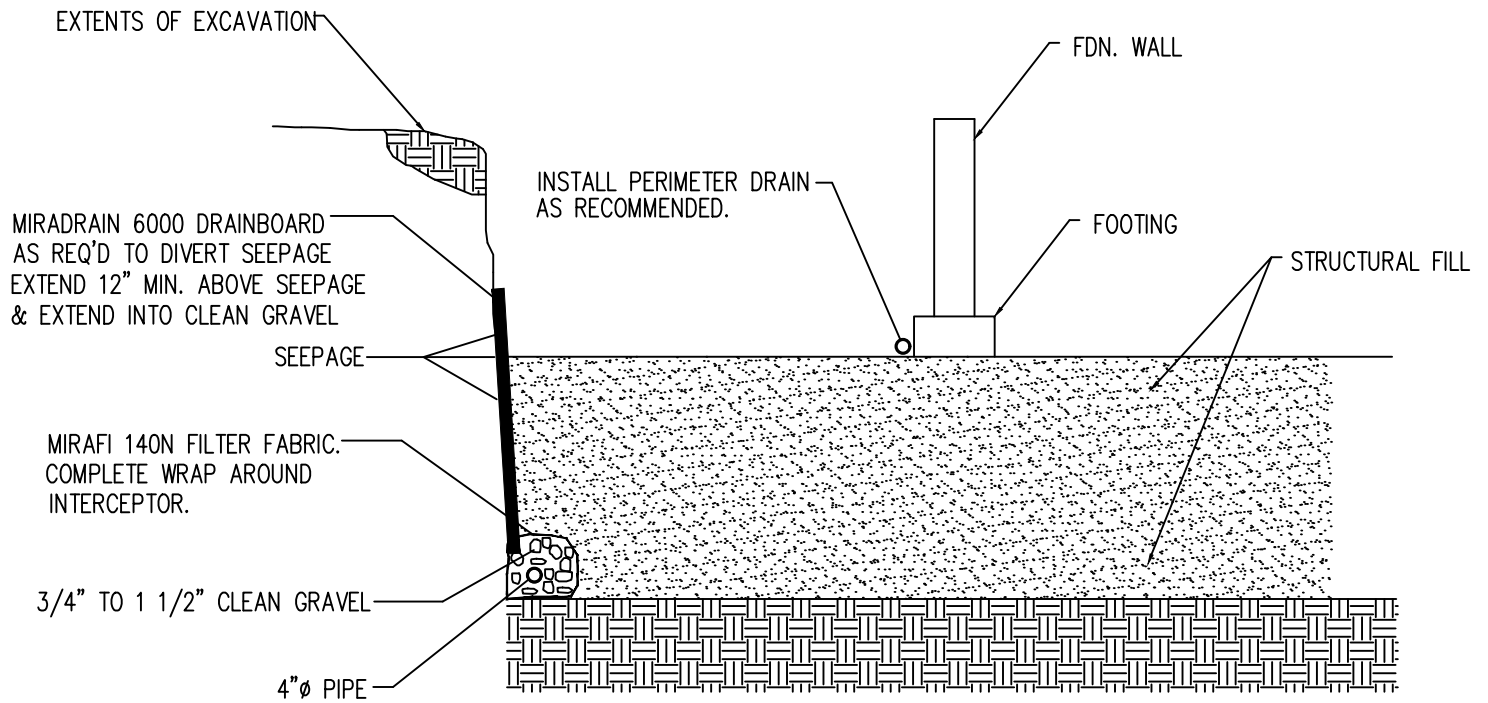

NOTE:
EXTEND INTERCEPTOR DRAIN TO UNDERDRAIN OR TO SUMP.
BENCH DRAIN INTO NATIVE SOILS 12 INCHES MINIMUM.

INTERCEPTOR DRAIN DETAIL

N.T.S.



INTERCEPTOR DRAIN DETAIL
FLYING HORSE NORTH FILING NO. 3
EL PASO COUNTY, COLORADO
FLYING HORSE NORTH, LLC

JOB NO.
231192

FIG. 10

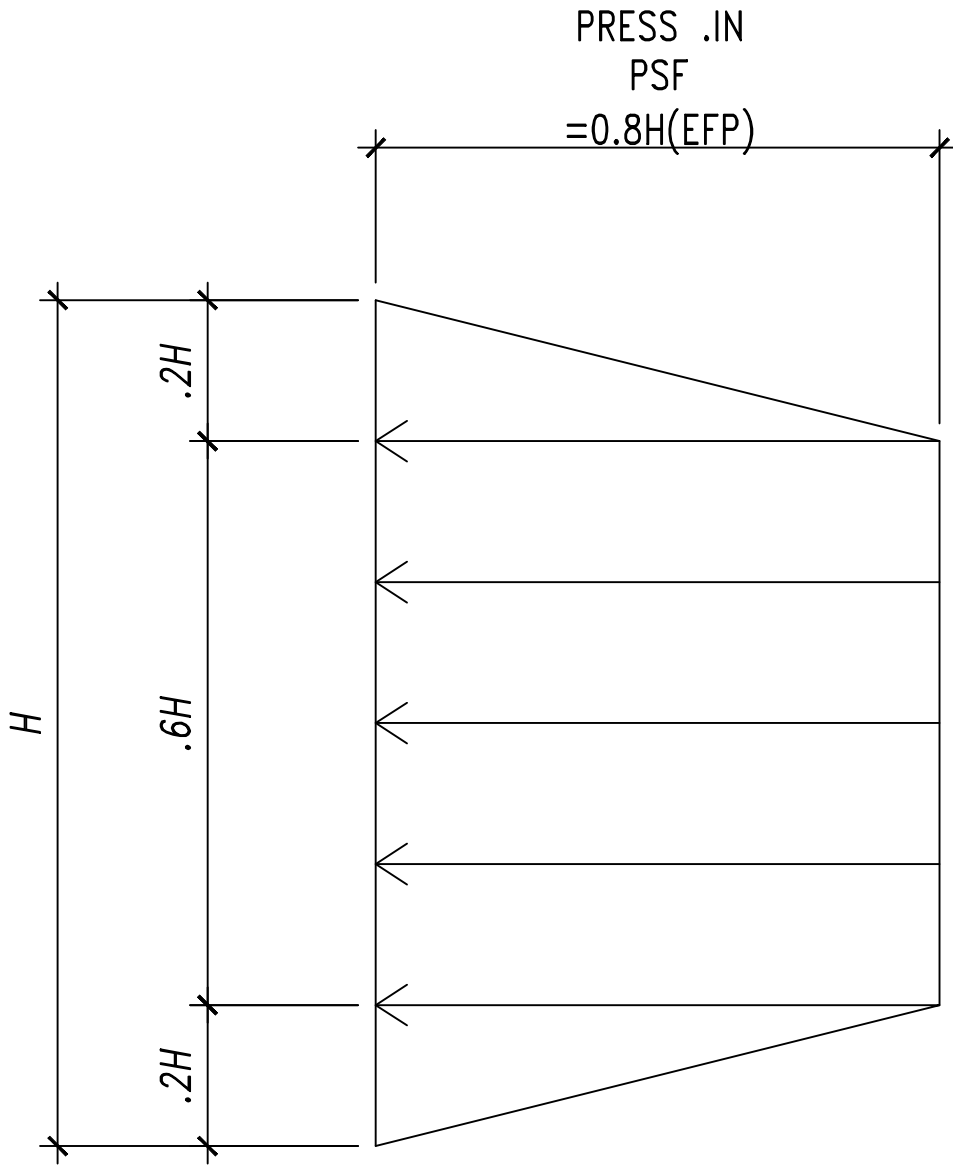

PRESSURE DISTRIBUTION



ENTECH
ENGINEERING, INC.

LATERAL PRESSURE DIAGRAM
FLYING HORSE NORTH FILING NO. 3
EL PASO COUNTY, COLORADO
FLYING HORSE NORTH, LLC

JOB NO.
231192

FIG. 11



APPENDIX A: Site Photographs

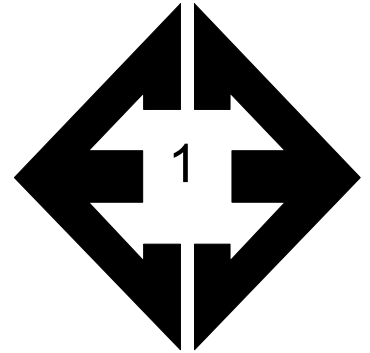

**Looking east from the
northwestern side of
the site.**

August 2, 2023

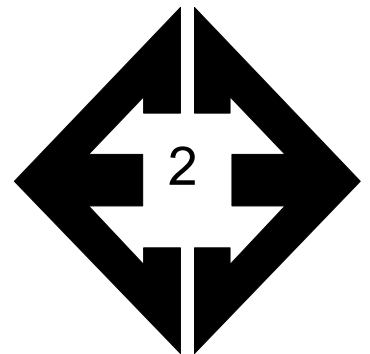

**Looking west from the
southwestern side of
the site in the area of
Proposed Detention
Pond A.**

August 2, 2023

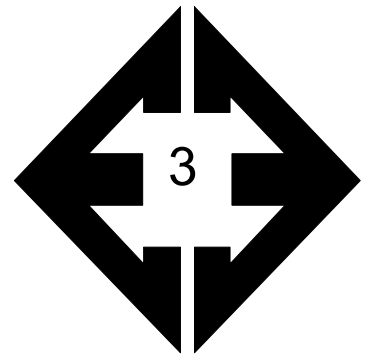

**Looking east from the
north-central portion
of the site.**

August 2, 2023

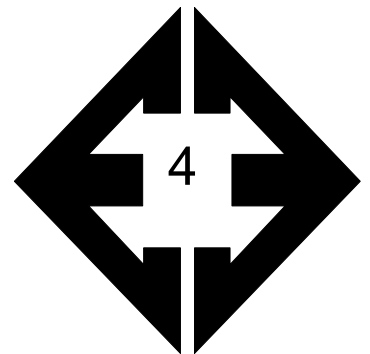

**Looking northeast
from the central
portion of the site.**

August 2, 2023

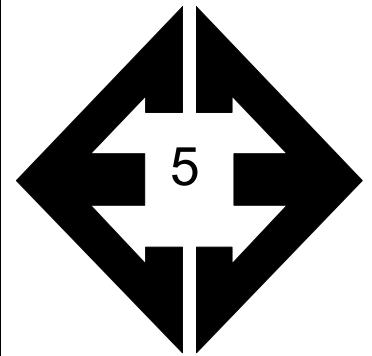

Looking north from the southern portion of the site.

August 2, 2023

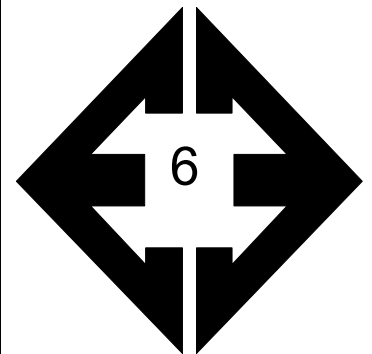

Looking south from the central portion of the site.

August 2, 2023

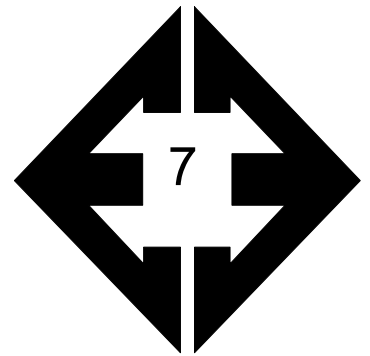

Looking west from the west-central portion of the site.

August 2, 2023

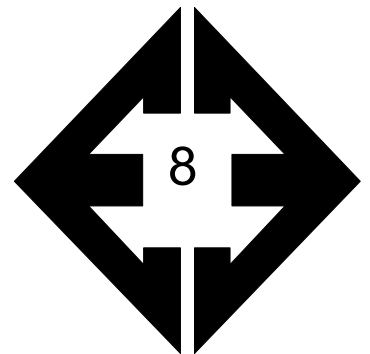

Looking east from the southwestern side of the site.

August 2, 2023

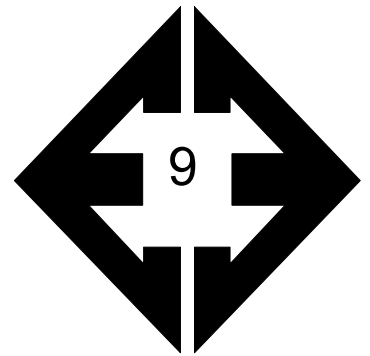

Looking west from the west-central portion of the site.

July 31, 2023

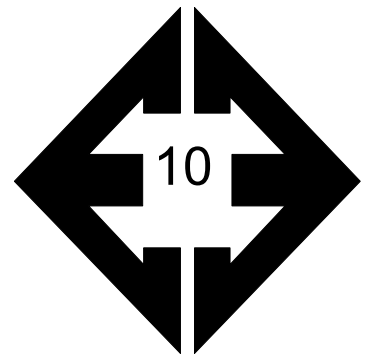

Looking east from the southwestern side of the site.

July 31, 2023

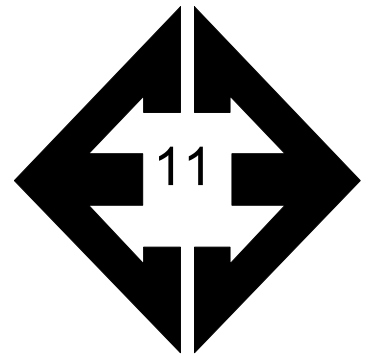

Looking west from the west-central portion of the site.

July 31, 2023

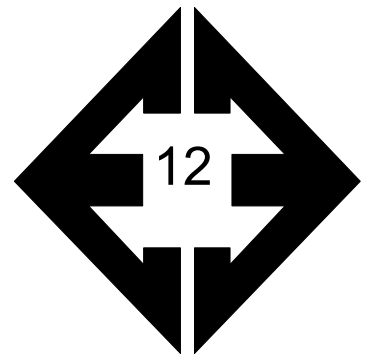

Looking east from the southwestern side of the site.

July 31, 2023

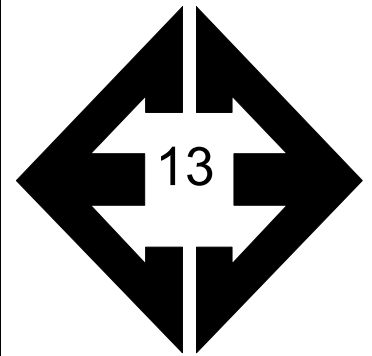

Looking west from the west-central portion of the site.

July 31, 2023

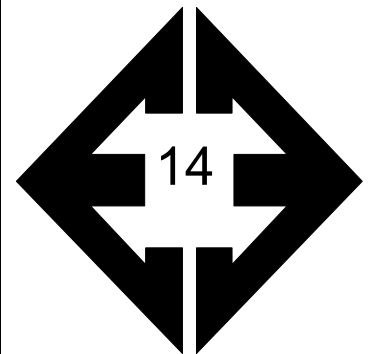

Looking east from the southwestern side of the site.

July 31, 2023

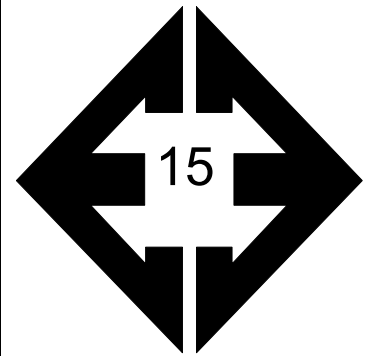

Looking west from the west-central portion of the site.

July 31, 2023

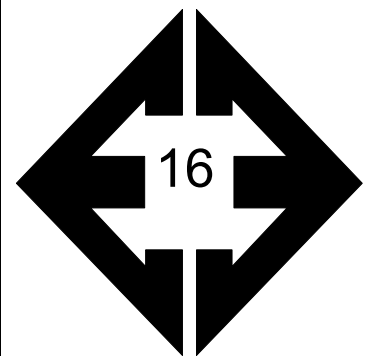

Looking east from the southwestern side of the site.

July 31, 2023



APPENDIX B: Test Boring and Piezometer Logs

TABLE B-1
DEPTH TO BEDROCK & GROUNDWATER

| TEST BORING | DEPTH TO BEDROCK (ft.) | DEPTH TO GROUNDWATER (ft.) |
|-------------|------------------------|----------------------------|
| 1 | 3 | >20 |
| 2 | >20 | >20 |
| 3 | 11 | >20 |
| 4 | 19 | >20 |
| 5 | 4 | >20 |
| 6 | >20 | >20 |

TEST BORING 1
 DATE DRILLED 8/2/2023

TEST BORING 2
 DATE DRILLED 8/2/2023

| REMARKS | | | | | | REMARKS | | | | | |
|---|--------|---------|-----------------|----------------|-----------|--|--------|---------|----------------|----------------|-----------|
| Depth (ft) | Symbol | Samples | Blows per foot | Watercontent % | Soil Type | Depth (ft) | Symbol | Samples | Blows per foot | Watercontent % | Soil Type |
| DRY TO 20', 8/10/23 | | | | | | DRY TO 20', 8/10/23 | | | | | |
| SAND, WITH SILT and GRAVEL, TAN, DENSE, MOIST | | | | | | CLAY, SANDY, LIGHT BROWN, STIFF to VERY STIFF, MOIST | | | | | |
| | | | 42 | 16.5 | 1 | | | | 7 | 12.9 | 2 |
| 5 | | | 40 | 8.7 | 3 | 5 | | | 17 | 11.2 | 2 |
| | | | <u>50</u> 5" | 12.1 | 3 | | | | 12 | 6.2 | 1 |
| | | | <u>50</u> 2" | 9.0 | 3 | | | | 12 | 9.0 | 1 |
| 20 | | | <u>50</u> 5" | 10.7 | 3 | 20 | | | 50 | 4.3 | 1 |
| SANDSTONE, VERY WEAK, TAN, HIGHLY WEATHERED. (SAND, SILTY, VERY DENSE, MOIST) | | | | | | SAND, WITH SILT and GRAVEL, LIGHT BROWN, MEDIUM DENSE to VERY DENSE, MOIST | | | | | |



TEST BORING LOGS
 FLYING HORSE NORTH, FILING 3
 FLYING HORSE NORTH, LLC

JOB NO.
 231192
FIG. B-1

TEST BORING 3
 DATE DRILLED 8/2/2023

TEST BORING 4
 DATE DRILLED 8/2/2023

REMARKS

REMARKS

DRY TO 20', 8/10/23

DRY TO 20', 8/10/23

SAND, WITH SILT and GRAVEL,
 LIGHT BROWN to TAN, LOOSE to
 DENSE, MOIST

SAND, GRAVELLY, SILTY, TAN,
 LOOSE to DENSE, MOIST

SANDSTONE, VERY WEAK, TAN,
 HIGHLY WEATHERED, (SAND,
 WITH SILT, VERY DENSE, MOIST)

SANDSTONE, EXTREMELY WEAK,
 TAN, SLIGHTLY WEATHERED.
 (SAND, SILTY, VERY DENSE,

| Depth (ft) | Symbol | Samples | Blows per foot | Watercontent % | Soil Type | Depth (ft) | Symbol | Samples | Blows per foot | Watercontent % | Soil Type |
|------------|--------|---------|----------------|----------------|-----------|------------|--------|---------|----------------|----------------|-----------|
| 5 | | | 7 | 7.9 | 1 | 5 | | | 8 | 11.4 | 1 |
| | | | 14 | 6.7 | 1 | | | | 13 | 4.8 | 1 |
| 10 | | | 36 | 7.2 | 1 | 10 | | | 12 | 6.4 | 1 |
| 15 | | | 50 | 10.0 | 3 | 15 | | | 37 | 4.3 | 1 |
| | | | 11" | | | | | | | | |
| 20 | | | 50 | 10.0 | 3 | 20 | | | 50 | 7.5 | 3 |
| | | | 5" | | | | | | 10" | | |



TEST BORING LOGS
 FLYING HORSE NORTH, FILING 3
 FLYING HORSE NORTH, LLC

JOB NO.
 231192

FIG. B-2

TEST BORING 5
 DATE DRILLED 8/2/2023

TEST BORING 6
 DATE DRILLED 8/2/2023

REMARKS

REMARKS

DRY TO 20', 8/10/23

DRY TO 20', 8/10/23

SAND, GRAVELLY, SILTY, LIGHT BROWN, MEDIUM DENSE, MOIST

CLAY, SANDY, LIGHT BROWN, MEDIUM STIFF to STIFF, MOIST

SANDSTONE, VERY WEAK, TAN, FRESH to SLIGHTLY WEATHERED. (SAND, SILTY, VERY DENSE, MOIST)

SAND, GRAVELLY, SILTY, LIGHT BROWN, MEDIUM DENSE, MOIST

CLAYSTONE, VERY WEAK, TAN, SLIGHTLY WEATHERED. (CLAY, SANDY, HARD, MOIST)

| Depth (ft) | Symbol | Samples | Blows per foot | Watercontent % | Soil Type | Depth (ft) | Symbol | Samples | Blows per foot | Watercontent % | Soil Type |
|------------|--------|---------|----------------|----------------|-----------|------------|--------|---------|----------------|----------------|-----------|
| | | | 15 | 4.6 | | | | | 6 | 8.3 | 2 |
| 5 | | | 50 7" | 7.3 | 3 | 5 | | | 13 | 7.2 | 2 |
| 10 | | | 50 4" | 7.6 | 3 | 10 | | | 16 | 4.2 | 1 |
| 15 | | | 50 7" | 7.3 | 4 | 15 | | | 10 | 7.5 | 1 |
| 20 | | | 50 8" | 7.5 | 4 | 20 | | | 20 | 8.4 | 1 |



TEST BORING LOGS
 FLYING HORSE NORTH, FILING 3
 FLYING HORSE NORTH, LLC

JOB NO.
 231192

FIG. B-3

APPENDIX C: Laboratory Testing Results

**TABLE C-1
SUMMARY OF LABORATORY TEST RESULTS**

| SOIL TYPE | TEST BORING NO. | DEPTH (FT) | WATER (%) | DRY DENSITY (PCF) | PASSING NO. 200 SIEVE (%) | LIQUID LIMIT | PLASTIC LIMIT | PLASTIC INDEX | SULFATE (WT %) | SWELL/ CONSOL (%) | USCS | SOIL DESCRIPTION |
|-----------|-----------------|------------|-----------|-------------------|---------------------------|--------------|---------------|---------------|----------------|-------------------|-------|------------------------------|
| 1 | 1 | 2-3 | | | 11.8 | NV | NP | NP | <0.01 | | SW-SM | SAND, WITH SILT |
| 1 | 4 | 5 | | | 41.0 | | | | <0.01 | | SM | SAND, SILTY |
| 2 | 2 | 5 | 7.8 | 115.2 | 51.5 | | | | 0.01 | -0.2 | CL | CLAY, SANDY |
| 2 | 6 | 2-3 | | | 51.1 | | | | | | CL | CLAY, SANDY |
| 3 | 3 | 15 | | | 9.1 | | | | <0.01 | | SW-SM | SANDSTONE, (SAND, WITH SILT) |
| 4 | 5 | 15 | 14.9 | 110.6 | 64.9 | 35 | 11 | 24 | | 1.2 | CL | CLAYSTONE, (CLAY, SANDY) |

TEST BORING 1
 DEPTH (FT) 2-3

SOIL DESCRIPTION SAND, WITH SILT
 SOIL TYPE 1

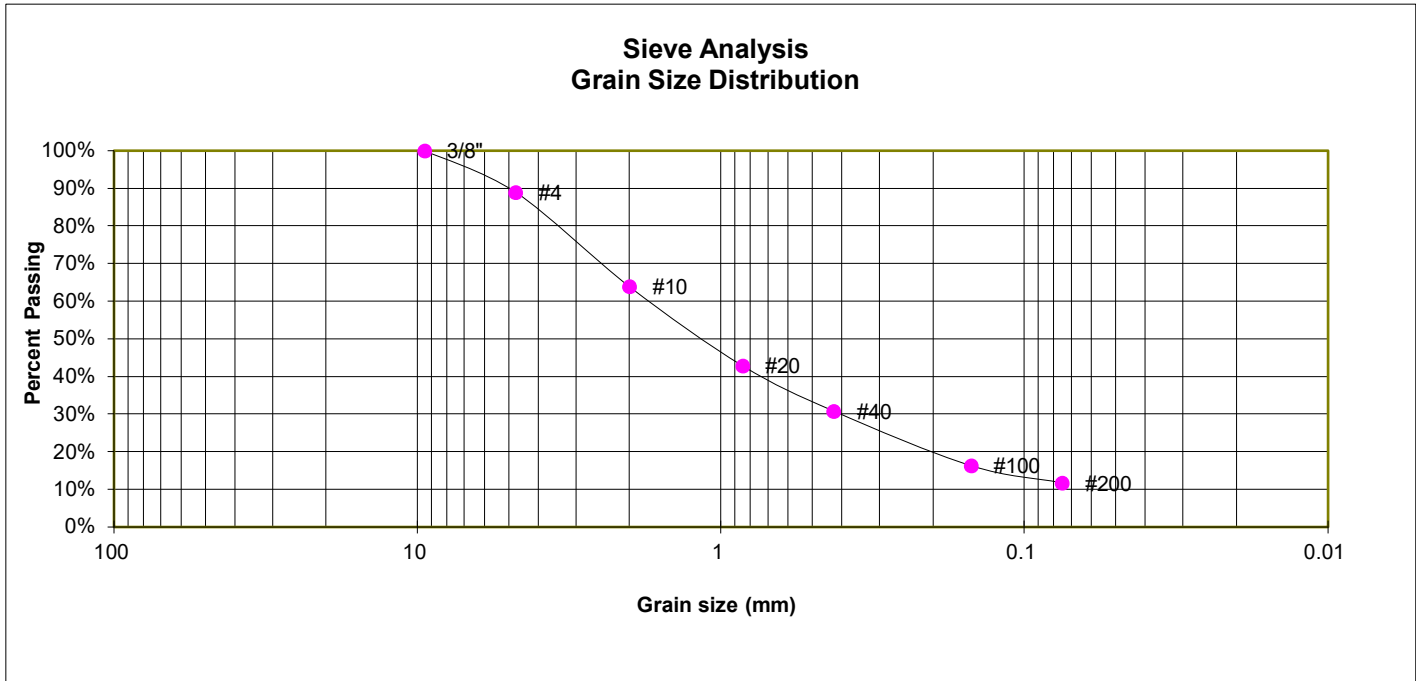

GRAIN SIZE ANALYSIS

| U.S. Sieve # | Percent Finer |
|--------------|---------------|
| 3" | |
| 1 1/2" | |
| 3/4" | |
| 1/2" | |
| 3/8" | 100.0% |
| 4 | 88.9% |
| 10 | 63.9% |
| 20 | 42.9% |
| 40 | 30.8% |
| 100 | 16.3% |
| 200 | 11.8% |

ATTERBERG LIMITS

| | |
|---------------|----|
| Plastic Limit | NP |
| Liquid Limit | NV |
| Plastic Index | NP |

SOIL CLASSIFICATION

USCS CLASSIFICATION: SW-SM



LABORATORY TEST RESULTS

FLYING HORSE NORTH, FILING 3
 FLYING HORSE NORTH, LLC

JOB NO.
 231192

FIG. C-1

TEST BORING 4
 DEPTH (FT) 5

SOIL DESCRIPTION SAND, SILTY
 SOIL TYPE 1

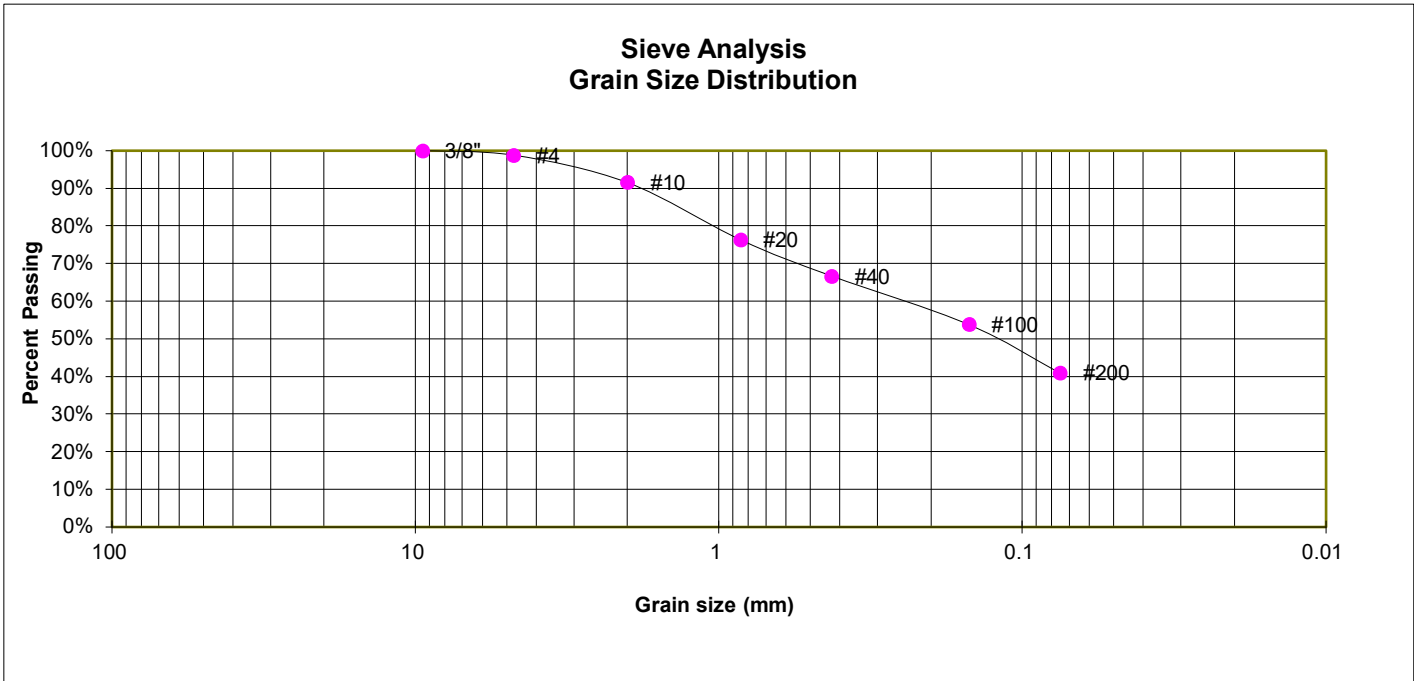

GRAIN SIZE ANALYSIS

| U.S. Sieve # | Percent Finer |
|--------------|---------------|
| 3" | |
| 1 1/2" | |
| 3/4" | |
| 1/2" | |
| 3/8" | 100.0% |
| 4 | 98.8% |
| 10 | 91.6% |
| 20 | 76.3% |
| 40 | 66.7% |
| 100 | 53.9% |
| 200 | 41.0% |

SOIL CLASSIFICATION

USCS CLASSIFICATION: SM



LABORATORY TEST RESULTS

FLYING HORSE NORTH, FILING 3
 FLYING HORSE NORTH, LLC

JOB NO.
 231192

FIG. C-2

TEST BORING 2
DEPTH (FT) 5

SOIL DESCRIPTION CLAY, SANDY
SOIL TYPE 2

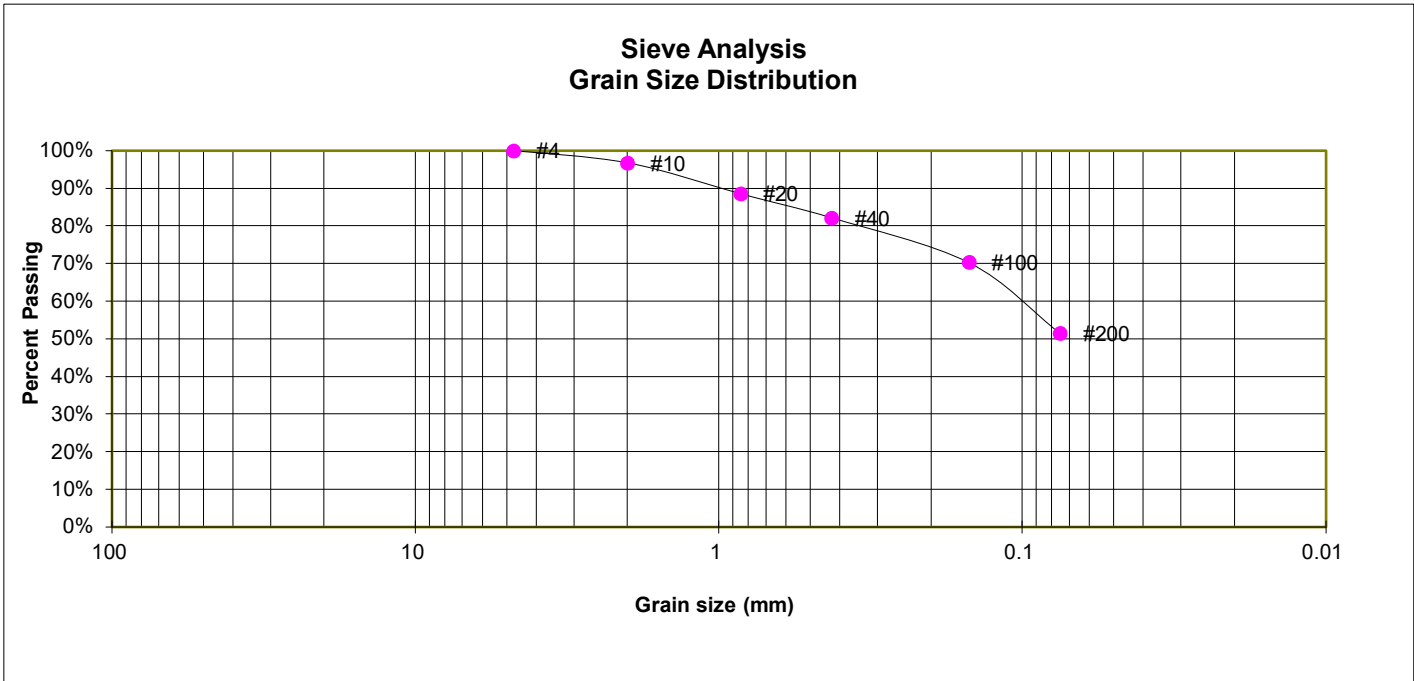

GRAIN SIZE ANALYSIS

| U.S. Sieve # | Percent Finer |
|-----------------|------------------|
| 3" | |
| 1 1/2" | |
| 3/4" | |
| 1/2" | |
| 3/8" | |
| 4 | 100.0% |
| 10 | 96.8% |
| 20 | 88.6% |
| 40 | 82.1% |
| 100 | 70.4% |
| 200 | 51.5% |

SOIL CLASSIFICATION

USCS CLASSIFICATION: CL



LABORATORY TEST RESULTS

FLYING HORSE NORTH, FILING 3
FLYING HORSE NORTH, LLC

JOB NO.
231192

FIG. C-3

TEST BORING 6
 DEPTH (FT) 2-3

SOIL DESCRIPTION CLAY, SANDY
 SOIL TYPE 2

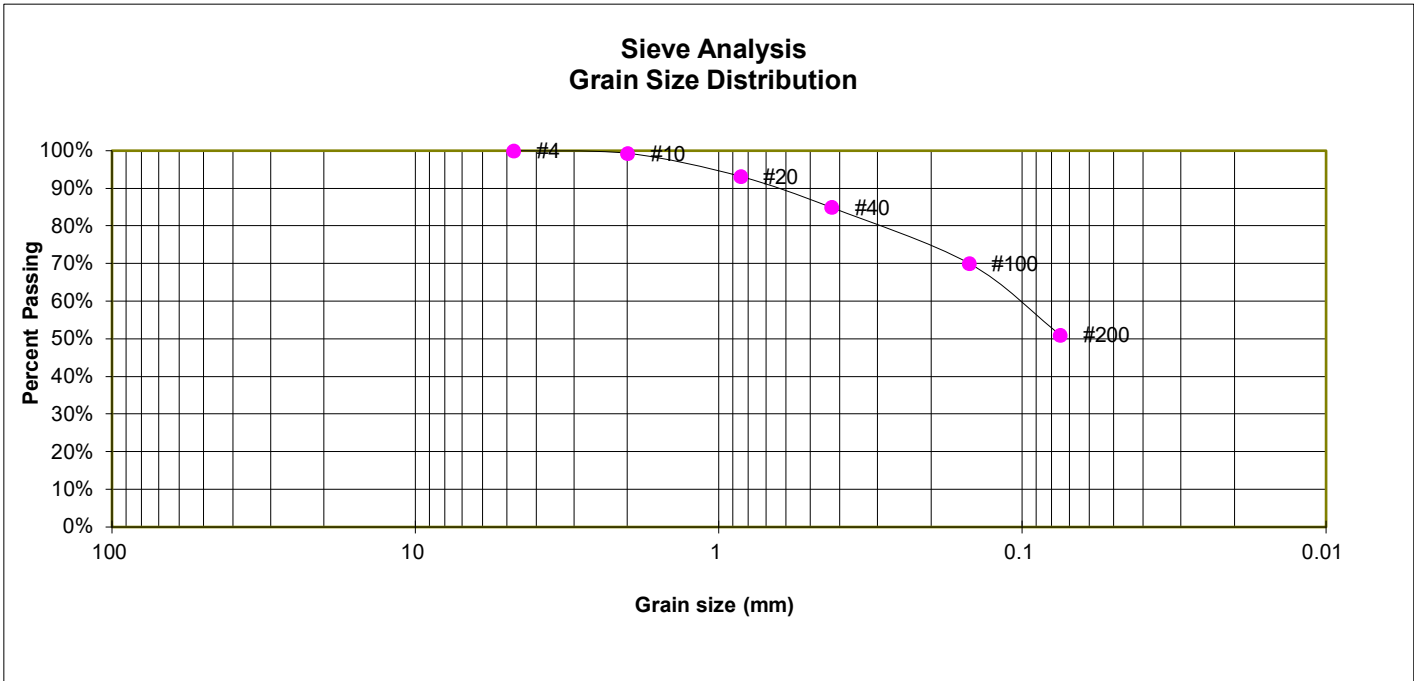

GRAIN SIZE ANALYSIS

| U.S. Sieve # | Percent Finer |
|--------------|---------------|
| 3" | |
| 1 1/2" | |
| 3/4" | |
| 1/2" | |
| 3/8" | |
| 4 | 100.0% |
| 10 | 99.3% |
| 20 | 93.2% |
| 40 | 84.9% |
| 100 | 70.1% |
| 200 | 51.1% |

SOIL CLASSIFICATION

USCS CLASSIFICATION: CL



LABORATORY TEST RESULTS

FLYING HORSE NORTH, FILING 3
 FLYING HORSE NORTH, LLC

JOB NO.
 231192

FIG. C-4

TEST BORING 3
DEPTH (FT) 15

SOIL DESCRIPTION SANDSTONE, (SAND, WITH SILT)
SOIL TYPE 3

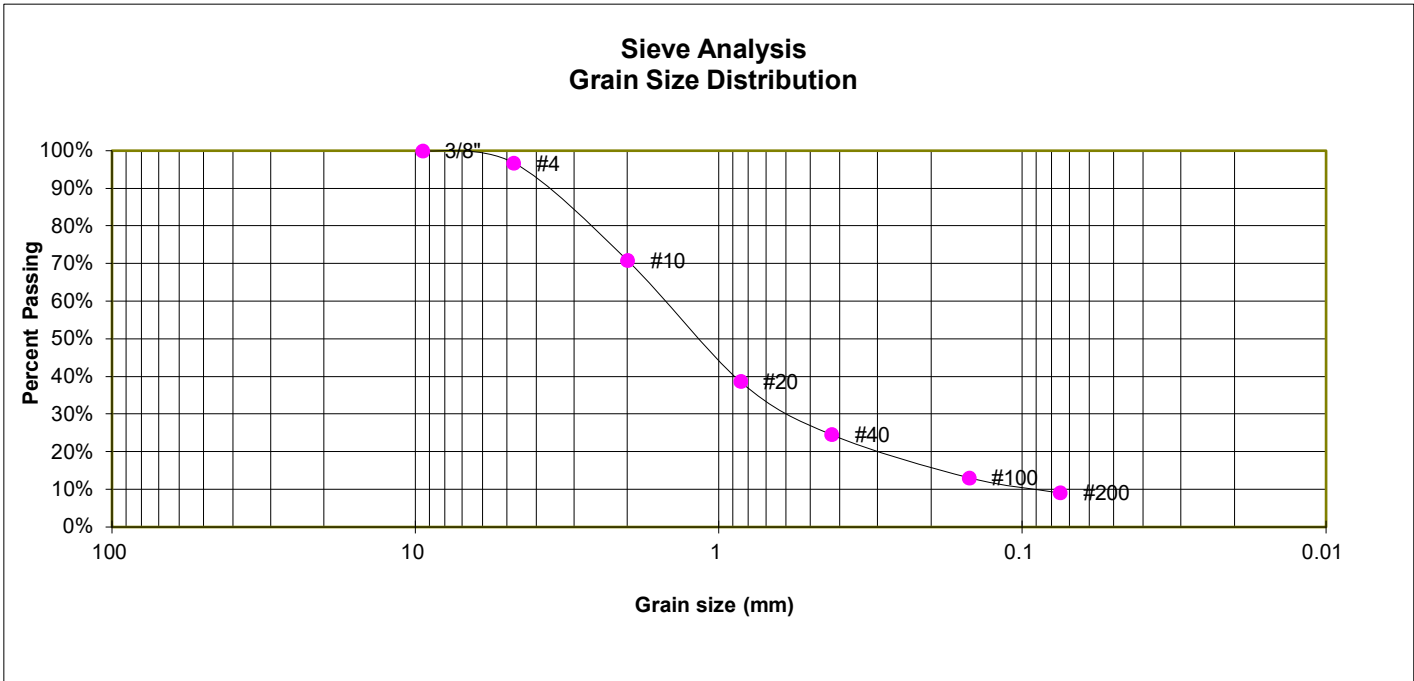

GRAIN SIZE ANALYSIS

| U.S. Sieve # | Percent Finer |
|-----------------|------------------|
| 3" | |
| 1 1/2" | |
| 3/4" | |
| 1/2" | |
| 3/8" | 100.0% |
| 4 | 96.8% |
| 10 | 70.8% |
| 20 | 38.7% |
| 40 | 24.6% |
| 100 | 13.1% |
| 200 | 9.1% |

SOIL CLASSIFICATION

USCS CLASSIFICATION: SW-SM



LABORATORY TEST RESULTS

FLYING HORSE NORTH, FILING 3
FLYING HORSE NORTH, LLC

JOB NO.
231192

FIG. C-5

TEST BORING 5
 DEPTH (FT) 15

SOIL DESCRIPTION CLAYSTONE, (CLAY, SANDY)
 SOIL TYPE 4

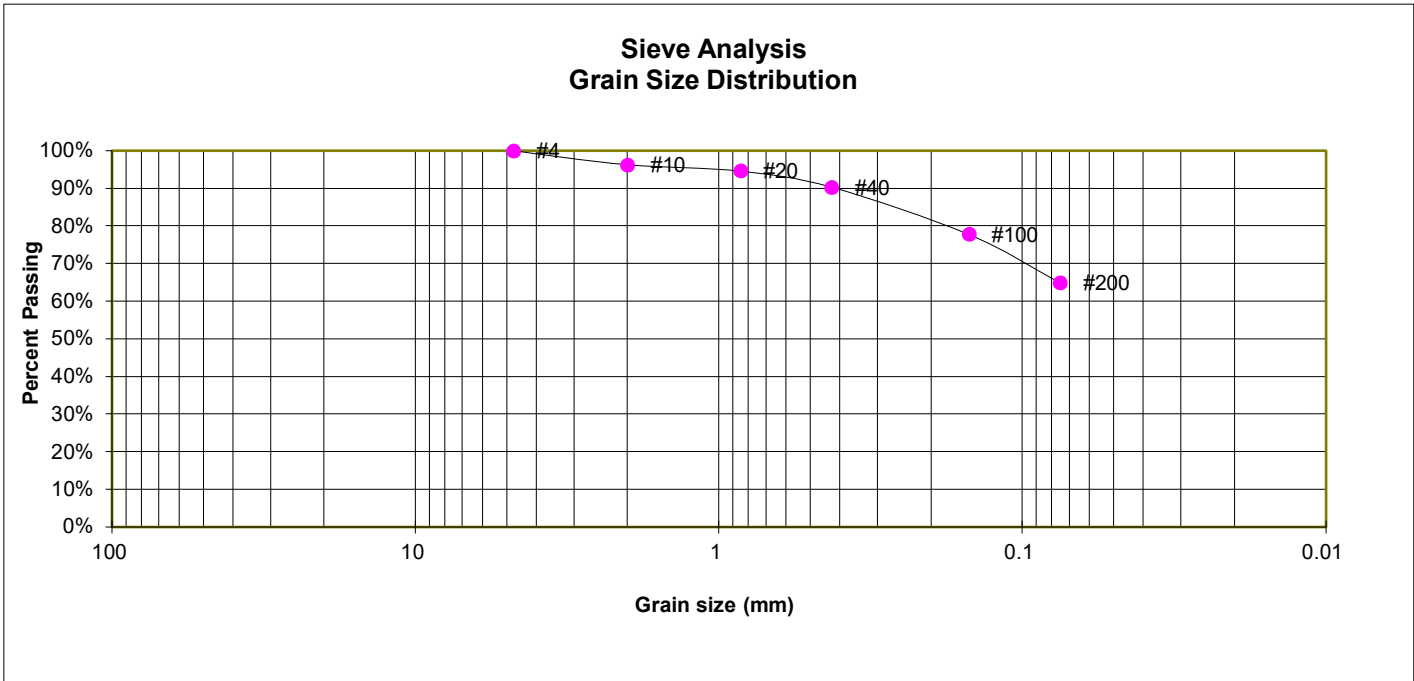

GRAIN SIZE ANALYSIS

| U.S. Sieve # | Percent Finer |
|--------------|---------------|
| 3" | |
| 1 1/2" | |
| 3/4" | |
| 1/2" | |
| 3/8" | |
| 4 | 100.0% |
| 10 | 96.3% |
| 20 | 94.7% |
| 40 | 90.3% |
| 100 | 77.8% |
| 200 | 64.9% |

ATTERBERG LIMITS

| | |
|---------------|----|
| Plastic Limit | 11 |
| Liquid Limit | 35 |
| Plastic Index | 24 |

SOIL CLASSIFICATION

USCS CLASSIFICATION: CL



LABORATORY TEST RESULTS

FLYING HORSE NORTH, FILING 3
 FLYING HORSE NORTH, LLC

JOB NO.
 231192

FIG. C-6

TEST BORING 2
DEPTH (FT) 5

SOIL DESCRIPTION CLAY, SANDY
SOIL TYPE 2

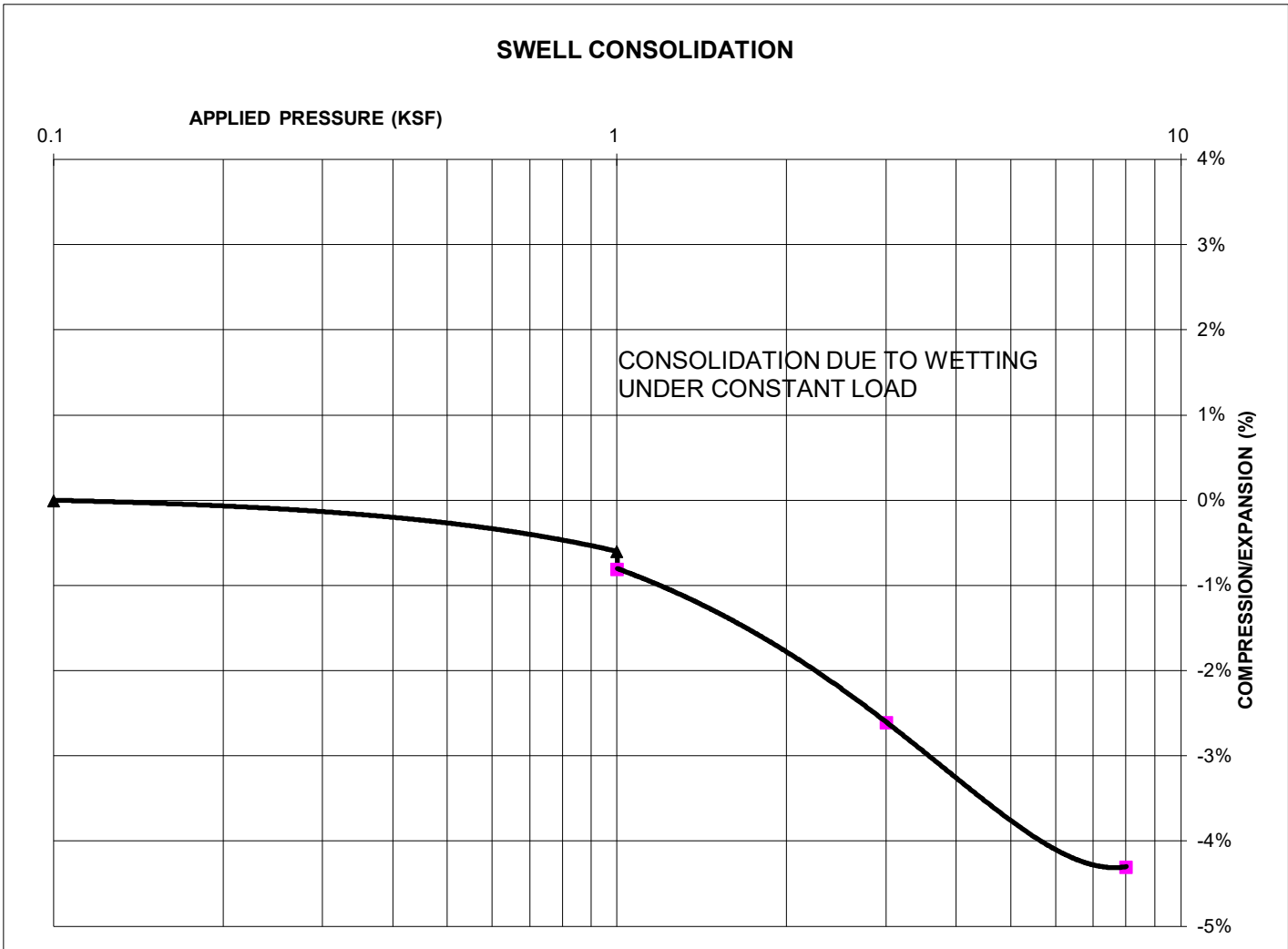

SWELL/CONSOLIDATION TEST RESULTS

NATURAL UNIT DRY WEIGHT (PCF): 115
NATURAL MOISTURE CONTENT: 7.8%
SWELL/CONSOLIDATION (%): -0.2%



**SWELL/CONSOLIDATION
TEST RESULTS**

FLYING HORSE NORTH, FILING 3
FLYING HORSE NORTH, LLC

JOB NO.
231192

FIG. C-7

TEST BORING 5
DEPTH (FT) 15

SOIL DESCRIPTION CLAYSTONE, (CLAY, SANDY)
SOIL TYPE 4

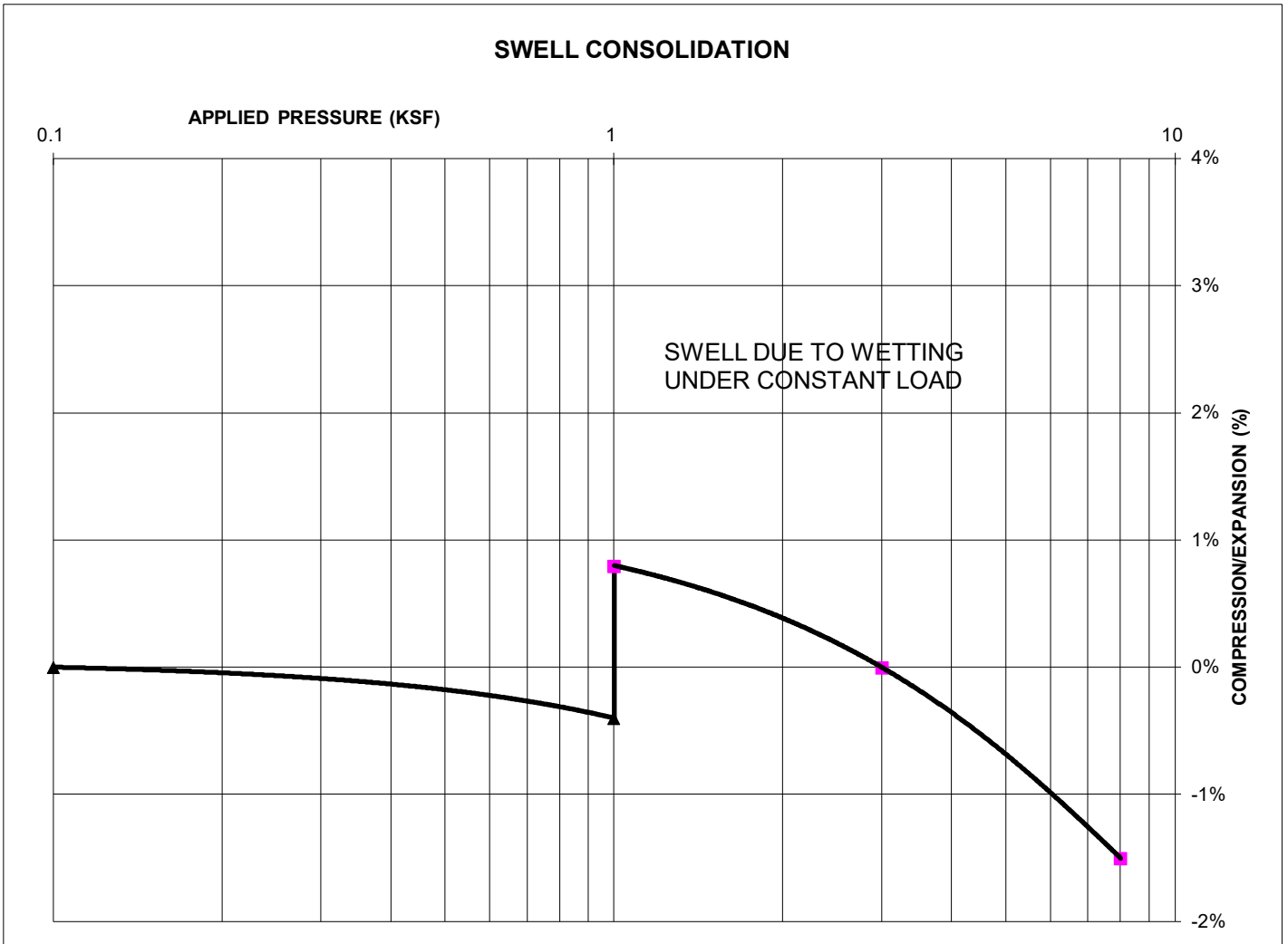

SWELL/CONSOLIDATION TEST RESULTS

NATURAL UNIT DRY WEIGHT (PCF): 111
NATURAL MOISTURE CONTENT: 14.9%
SWELL/CONSOLIDATION (%): 1.2%



**SWELL/CONSOLIDATION
TEST RESULTS**

FLYING HORSE NORTH, FILING 3
FLYING HORSE NORTH, LLC

JOB NO.
231192

FIG. C-8



**APPENDIX D: EEI Laboratory Testing Summary and
Test Boring Logs Job No. 220404**

TABLE 1
SUMMARY OF LABORATORY TEST RESULTS

CLIENT FLYING HORSE DEV.
PROJECT FLYING HORSE NORTH, F-2
JOB NO. 220404

| SOIL TYPE | TEST BORING NO. | DEPTH (FT) | WATER (%) | DRY DENSITY (PCF) | PASSING NO. 200 SIEVE (%) | LIQUID LIMIT (%) | PLASTIC INDEX (%) | SULFATE (WT %) | FHA SWELL (PSF) | SWELL/ CONSOL (%) | UNIFIED CLASSIFICATION | SOIL DESCRIPTION |
|-----------|-----------------|------------|-----------|-------------------|---------------------------|------------------|-------------------|----------------|-----------------|-------------------|------------------------|---------------------------|
| 1 | 1 | 2-3 | | | 20.0 | NV | NP | 0.01 | | | SM | SAND, SILTY |
| 1 | 5 | 2-3 | | | 11.6 | | | | | | SM-SW | SAND, SLIGHTLY SILTY |
| 1 | 6 | 15 | | | 47.3 | | | | | | SC | SAND, VERY CLAYEY |
| 2 | 3 | 5 | | | 82.8 | 38 | 21 | <0.01 | 930 | | CL | CLAY, SANDY |
| 2 | 6 | 2-3 | | | 52.1 | | | | 270 | | CL | CLAY, VERY SANDY |
| 3 | 5 | 20 | | | 16.7 | | | | | | SM | SANDSTONE, SILTY |
| 3 | 6 | 20 | | | 9.1 | | | | | | SM-SW | SANDSTONE, SLIGHTLY SILTY |
| 3 | 2 | 5 | | | 18.8 | NV | NP | <0.01 | | | SM | SANDSTONE, SILTY |
| 3 | 4 | 10 | | | 20.0 | | | | | | SM | SANDSTONE, SILTY |

TEST BORING NO. 1
 DATE DRILLED 2/14/2018
 Job # 220404

TEST BORING NO. 2
 DATE DRILLED 2/14/2018
 CLIENT FLYING HORSE DEV.
 LOCATION FLYING HORSE NORTH, F-2

REMARKS

DRY TO 20', 2/14/18

SAND, SILTY, FINE TO COARSE
 GRAINED, TAN, MEDIUM
 DENSE, MOIST

THIN CLAYEY LENSES

| Depth (ft) | Symbol | Samples | Blows per foot | Watercontent % | Soil Type |
|------------|--------|---------|----------------|----------------|-----------|
| 5 | | | 10 | 4.1 | 1 |
| | | | 12 | 6.8 | 1 |
| 10 | | | 13 | 14.1 | 1 |
| 15 | | | 10 | 3.6 | 1 |
| 20 | | | 14 | 10.6 | 1 |

REMARKS

DRY TO 20', 2/14/18

SAND, SILTY, TAN
 SANDSTONE, SILTY TO
 CLAYEY, FINE TO COARSE
 GRAINED, RED BROWN, VERY
 DENSE, MOIST

| Depth (ft) | Symbol | Samples | Blows per foot | Watercontent % | Soil Type |
|------------|--------|---------|----------------|----------------|-----------|
| 5 | | | 50 | 7.0 | 3 |
| | | | 10" | | |
| | | | 50 | 7.0 | 3 |
| 10 | | | 50 | 12.1 | 3 |
| | | | 6" | | |
| 15 | | | 50 | 10.7 | 3 |
| | | | 7" | | |
| 20 | | | 50 | 9.8 | 3 |
| | | | 6" | | |



ENTECH
ENGINEERING, INC.

505 ELKTON DRIVE
 COLORADO SPRINGS, COLORADO 80907

TEST BORING LOG

DRAWN:

DATE:

CHECKED:

DATE:

LLL

3/8/22

JOB NO.:
 220404

FIG NO.:

B-1



APPENDIX E: Soil Survey Descriptions

El Paso County Area, Colorado

26—Elbeth sandy loam, 8 to 15 percent slopes

Map Unit Setting

National map unit symbol: 367y

Elevation: 7,300 to 7,600 feet

Farmland classification: Not prime farmland

Map Unit Composition

Elbeth and similar soils: 85 percent

Estimates are based on observations, descriptions, and transects of the mapunit.

Description of Elbeth

Setting

Landform: Hills

Landform position (three-dimensional): Side slope

Down-slope shape: Linear

Across-slope shape: Linear

Parent material: Alluvium derived from arkose

Typical profile

A - 0 to 3 inches: sandy loam

E - 3 to 23 inches: loamy sand

Bt - 23 to 68 inches: sandy clay loam

C - 68 to 74 inches: sandy clay loam

Properties and qualities

Slope: 8 to 15 percent

Depth to restrictive feature: More than 80 inches

Drainage class: Well drained

Runoff class: Medium

Capacity of the most limiting layer to transmit water

(Ksat): Moderately high (0.20 to 0.60 in/hr)

Depth to water table: More than 80 inches

Frequency of flooding: None

Frequency of ponding: None

Available water supply, 0 to 60 inches: Moderate (about 7.1 inches)

Interpretive groups

Land capability classification (irrigated): None specified

Land capability classification (nonirrigated): 4e

Hydrologic Soil Group: B

Ecological site: F048AY908CO - Mixed Conifer

Hydric soil rating: No

Minor Components

Other soils

Percent of map unit:

Hydric soil rating: No

Pleasant

Percent of map unit:

Landform: Depressions

Hydric soil rating: Yes

Data Source Information

Soil Survey Area: El Paso County Area, Colorado

Survey Area Data: Version 20, Sep 2, 2022

El Paso County Area, Colorado

67—Peyton sandy loam, 5 to 9 percent slopes

Map Unit Setting

National map unit symbol: 369d

Elevation: 6,800 to 7,600 feet

Mean annual air temperature: 43 to 45 degrees F

Frost-free period: 115 to 125 days

Farmland classification: Not prime farmland

Map Unit Composition

Peyton and similar soils: 85 percent

Estimates are based on observations, descriptions, and transects of the mapunit.

Description of Peyton

Setting

Landform: Hills

Landform position (three-dimensional): Side slope

Down-slope shape: Linear

Across-slope shape: Linear

Parent material: Arkosic alluvium derived from sedimentary rock and/or arkosic residuum weathered from sedimentary rock

Typical profile

A - 0 to 12 inches: sandy loam

Bt - 12 to 25 inches: sandy clay loam

BC - 25 to 35 inches: sandy loam

C - 35 to 60 inches: sandy loam

Properties and qualities

Slope: 5 to 9 percent

Depth to restrictive feature: More than 80 inches

Drainage class: Well drained

Runoff class: Medium

Capacity of the most limiting layer to transmit water

(Ksat): Moderately high (0.20 to 0.60 in/hr)

Depth to water table: More than 80 inches

Frequency of flooding: None

Frequency of ponding: None

Available water supply, 0 to 60 inches: Moderate (about 7.3 inches)

Interpretive groups

Land capability classification (irrigated): None specified

Land capability classification (nonirrigated): 4e

Hydrologic Soil Group: B

Ecological site: R049XY216CO - Sandy Divide

Hydric soil rating: No

Minor Components

Other soils

Percent of map unit:

Hydric soil rating: No

Pleasant

Percent of map unit:

Landform: Depressions

Hydric soil rating: Yes

Data Source Information

Soil Survey Area: El Paso County Area, Colorado

Survey Area Data: Version 20, Sep 2, 2022