

PCD File No. SP201

TRANSPORTATION IMPACT STUDY

Solace Apartments
El Paso County, CO

Prepared for:

Jackson Dearborn Partners
404 S Wells Street, Suite 400
Chicago, IL 60607



5-15-20

Prepared by:

Felsburg Holt & Ullevig
6300 South Syracuse Way, Suite 600
Centennial, CO 80111
303.721.1440

Project Manager: Lyle DeVries, PE, PTOE
Project Engineer: Clay Gattey

The attached traffic report and supporting information were prepared under my responsible charge and they comport with the standard of care. So far as is consistent with the standard of care, said report was prepared in general conformance with the criteria established by the County for traffic reports.

I, the Developer, have read and will comply with all commitments made on my behalf within this report.

Mr. Dane Olmstead
Jackson Dearborn Partners
404 S Wells Street, Suite 400
Chicago, IL 60607

Signature: _____

FHU Reference No. 116504-01
May 2020

TABLE OF CONTENTS

	<u>Page</u>
I. INTRODUCTION.....	1
II. EXISTING CONDITIONS.....	3
II.A. Surrounding Land Use.....	3
II.B. Roadway Network.....	3
II.C. Traffic Volumes.....	4
II.D. Traffic Operations.....	5
II.E. Traffic Safety.....	5
II.F. Traffic Control Needs.....	7
III. PROJECTED CONDITIONS.....	9
III.A. Background Traffic Conditions.....	9
III.B. Traffic Control.....	10
IV. PROPOSED PROJECT.....	13
IV.A. Site Access.....	13
IV.B. Site Trip Generation.....	13
IV.C. Trip Distribution and Traffic Assignment.....	13
V. TRAFFIC IMPACT ANALYSIS.....	15
V.A. Short Term Total Traffic.....	15
V.B. Long Term Total Traffic.....	15
V.C. Traffic Control.....	18
V.D. Internal Circulation.....	18
V.E. Pedestrian and Bicyclist Safety.....	18
V.F. Transit Services.....	19
VI. IMPROVEMENT ANALYSIS.....	20
VI.A. Galley Road/Paonia Street Intersection.....	20
VI.B. Auxiliary Turn Lanes.....	20
VI.C. Paonia Street Extension.....	20
VI.D. Striping/Sidewalks.....	21
VII. SUMMARY AND RECOMMENDATIONS.....	23

Appendices

- Appendix A. Existing Traffic Counts
- Appendix B. Existing Level of Service Worksheets
- Appendix C. Short Term Background Level of Service Worksheets
- Appendix D. Long Term Background Level of Service Worksheets
- Appendix E. Short Term Total Level of Service Worksheets
- Appendix F. Long Term Total Level of Service Worksheets
- Appendix G. Signal Warrant Analyses Galley Rd/Paonia St

List of Figures

	<u>Page</u>
Figure 1. Vicinity Map.....	2
Figure 2. Site Plan.....	4
Figure 3. Existing Traffic Volumes and Levels of Service.....	6
Figure 4. Galley Road/Paonia Street Crash by Type.....	7
Figure 5. Short Term Background Traffic Conditions.....	11
Figure 6. Long Term Background Traffic Conditions.....	12
Figure 7. Trip Distribution and Site Generated Traffic.....	14
Figure 8. Short Term Total Traffic Volumes and Levels of Service.....	16
Figure 9. Long Term Total Traffic Volumes and Levels of Service.....	17
Figure 10. Typical Urban Residential Collector Cross Section.....	21
Figure 11. Roadway Design Standards for Urban Collectors.....	22

List of Tables

	<u>Page</u>
Table 1. Current Traffic Control.....	7
Table 2. Trip Generation Summary.....	13
Table 3. Summary of Signal Warrant Findings.....	18
Table 4. Recommended Turn Lanes and Lengths.....	20
Table 5. Improvements.....	24

I. INTRODUCTION

The proposed Solace Apartments development is located within the northeast quadrant of the Powers Boulevard (Blvd) and Galley Road (Rd) intersection in El Paso County, Colorado. The project is expected to consist of 348 multifamily dwelling units. The roadway network adjacent to the site can be seen on **Figure 1**.

As part of this project, Paonia Street (St) is anticipated to be extended from Galley Rd north to connect with the existing Paonia St terminus located south of Omaha Blvd. The proposed development would have two accesses located along the Paonia St extension.

The anticipated magnitude of site trip generation requires that a full Transportation Impact Study (TIS) be prepared according to El Paso County's *Appendix B Transportation Impact Study Guidelines to the County's Engineering Criteria Manual*. Accordingly, this report assesses the traffic impacts on the adjacent roadways related to the proposed residential development. The report includes information on existing traffic conditions, estimated vehicle-trips associated with the planned development, total traffic volume projections, and recommendations on roadway improvements. Two future scenarios have been analyzed for this report:

- **Short Term Future** – Time period for the completion of the residential development, currently anticipated as the Year 2021.
- **Long Term Future** – The Long Term Future scenario reflects projected Year 2040 traffic conditions.



II. EXISTING CONDITIONS

II.A. Surrounding Land Use

Much of the area adjacent to the project site has been developed. The land uses surrounding the site are primarily commercial and light industrial.

II.B. Relevant Studies

This Solace Apartments Development TIS is an update to a previously conducted traffic analysis for this development completed by FHU in October 2016 entitled *Powers/Galley Residential Development Traffic Impact Analysis*. The methodology and assumptions used in this study are generally consistent with the prior study, with differences noted as follows due mostly to the passage of time since the prior study:

- Vehicle-trip generation calculations are performed using information contained in the 10th Edition of the Institute of Transportation Engineers (ITE) *Trip Generation Manual*, which is current as of 2017. This update was performed to provide consistency with the most up-to-date information
- Updated crash history was analyzed for the intersection of Galley Road with Paonia Street, addressing the 2015-2018 time frame instead of the 2010-2014 time frame.
- Traffic counts were recorded at the study intersections in October of 2019 to accurately reflect current conditions, including the limitation of the Omaha Street/Powers Boulevard intersection to right-turn movements only.

The findings and recommendations provided in this TIS are generally consistent with the prior TIS.

II.C. Roadway Network

The existing roadway network adjacent to the vicinity of the site includes Galley Rd, Powers Blvd, Paonia St, Conrad St and Omaha Blvd. The roadway network is as follows:

Powers Boulevard: Powers Blvd (Colorado State Highway 21) is a six-lane north-south expressway that runs adjacent to the west property boundary. The posted speed limit is 55 miles per hour (mph).

Galley Road: Galley Rd is a three-lane east-west arterial that runs adjacent to the south property boundary. The posted speed limit is 40 mph.

Paonia Street: Paonia St is a two-lane north-south roadway that runs through the eastern side of the project site. As previously mentioned, Paonia St is expected to be extended as a urban non-residential collector to connect Galley Rd to Omaha Blvd as part of the project. Illustrated on **Figure 2**, the extension of Paonia St is anticipated to divide the project site. All residential development within the site is expected to be constructed west of the Paonia St extension and the portion of land to the east of Paonia St is expected to be natural marshland and a dog park. The posted speed limit is 25 mph.

Conrad Street: Conrad St is a two-lane local road that serves development located south of Galley Rd. Conrad St runs on a north-south alignment between the Powers Blvd and Paonia St alignments. The posted speed limit is 25 mph.

Omaha Boulevard: Omaha Blvd is a four-lane east-west arterial that intersects Paonia St and Powers Blvd approximately ¼ mile north of the property. The Powers Blvd/Omaha St intersection serves right-turn movements to/from the west along Omaha Blvd only.



GALLEY ROAD

PAONIA ST.

II.D. Traffic Volumes

Weekday AM and PM peak hour turning movement counts (TMCs) were collected on Tuesday, October 15, 2019, at the following intersections:

- Powers Blvd/Galley Rd
- Galley Rd/Paonia St
- Conrad St/Galley Rd
- Paonia St/Omaha Blvd
- Omaha Blvd/Powers Blvd

The peak hour traffic counts were collected in 15-minute intervals between the hours of 7:00 to 9:00 AM and 4:00 to 6:00 PM. **Appendix A** contains the TMCs, and traffic volumes are shown on **Figure 3**. Daily traffic volumes along Powers Boulevard were gathered from CDOT's online OTIS database. Based on these counts, the peak hour comprised approximately 8 percent of the daily total. Using this factor, additional daily volumes were estimated along Galley, Paonia and Omaha Streets by factoring peak hour counts to daily assuming peak hour levels comprise approximately 8 percent of the daily total.

II.E. Traffic Operations

Existing operational conditions were analyzed at each study intersection. The analysis is based on procedures documented in the *Highway Capacity Manual (6th Edition)*. This analysis procedure provides a Level of Service (LOS), a qualitative measure of traffic operational conditions, based on intersection capacity and vehicle delay. LOS is described by a letter designation ranging from A to F, with LOS A representing almost free-flow conditions, while LOS F represents congested conditions. For unsignalized intersections, the LOS is calculated for movements which must yield right-of-way to other traffic movements. The El Paso County standards cite a goal of LOS D conditions for vehicles passing through intersections during peak hours. The existing conditions analysis used the current traffic signal timing data for each intersection.

Figure 3 shows the results of the existing conditions analysis, including existing traffic control and current intersection geometry and **Appendix B** contains the LOS worksheets. As shown, the signalized intersection of Powers Blvd and Galley Rd currently operates at LOS D during the AM peak and LOS D during the PM peak.

The controlled movements at all stop-controlled intersections operate at LOS D or better during the peak hours with the following exceptions:

- The northbound left turn at Paonia St and Galley Rd operates at a LOS D during the AM peak hour and LOS F during the PM peak hour.
- The northbound approach at Conrad St and Galley Rd operates at LOS E in the AM peak hour and LOS F during the PM peak hour. This condition is due primarily to delay experienced by northbound left turning vehicles, and it is possible that such vehicles currently divert to alternate routes during peak hours to avoid this delay.

II.F. Traffic Safety

The crash history for the period of 1/1/2014 through 12/31/2018 was examined and summarized for the intersection of Galley Rd and Paonia St. During the five-year period, there were a total of 21 crashes. Of the 21 crashes, 7 were Property Damage Only (PDO) and 14 crashes caused injury. **Figure 4** shows the breakdown of crash types. Broadside crashes (14) are the most predominant type observed.

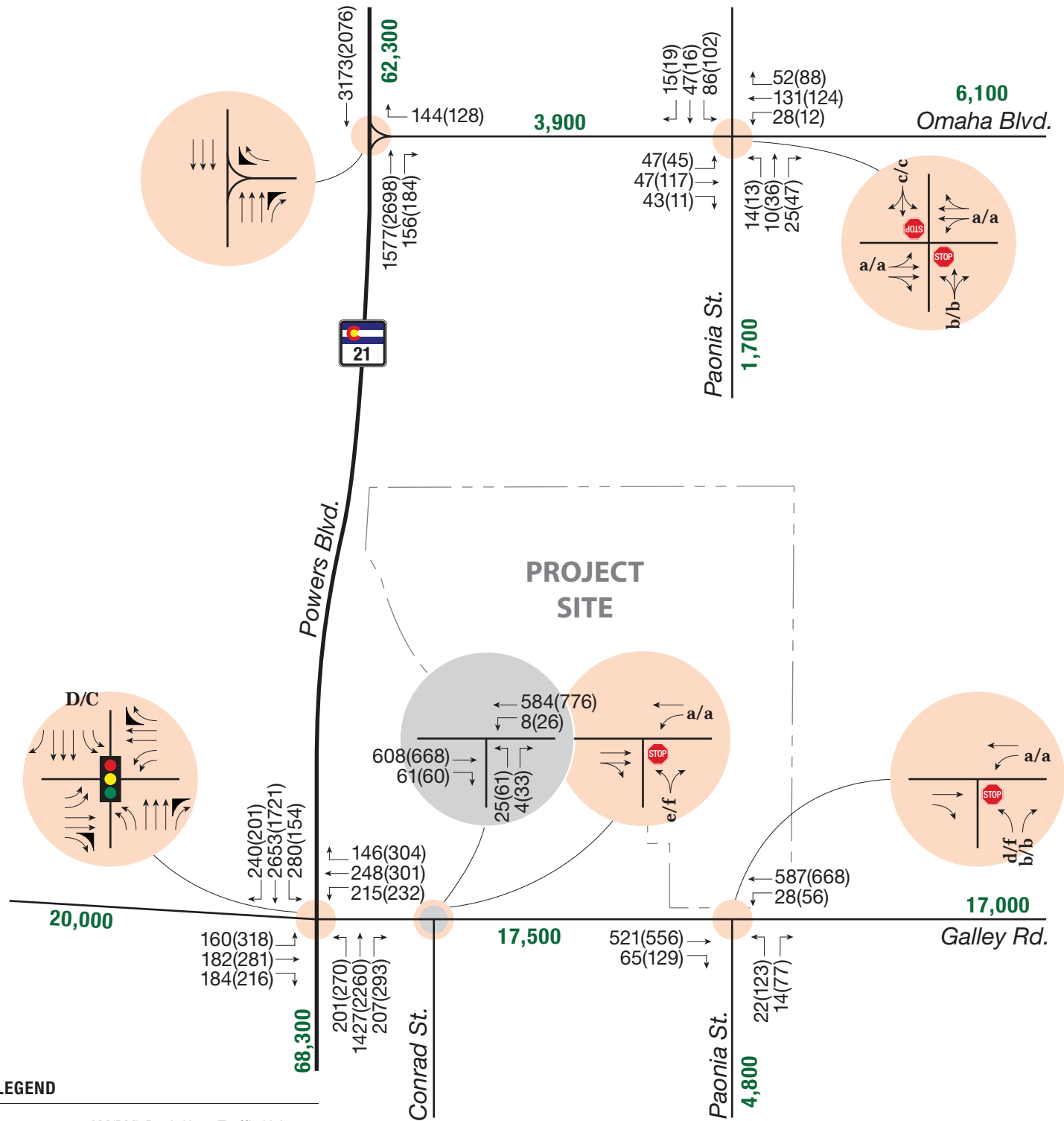

LEGEND

- XXX(XXX) = AM(PM) Peak Hour Traffic Volumes
- XXXX = Daily Traffic Volumes
- X/X = AM/PM Peak Hour Signalized Intersection Level of Service
- x/x = AM/PM Peak Hour Unsignalized Intersection Level of Service
- STOP = Stop Sign
- Traffic Signal Icon = Traffic Signal



FIGURE 3
Existing Traffic Conditions

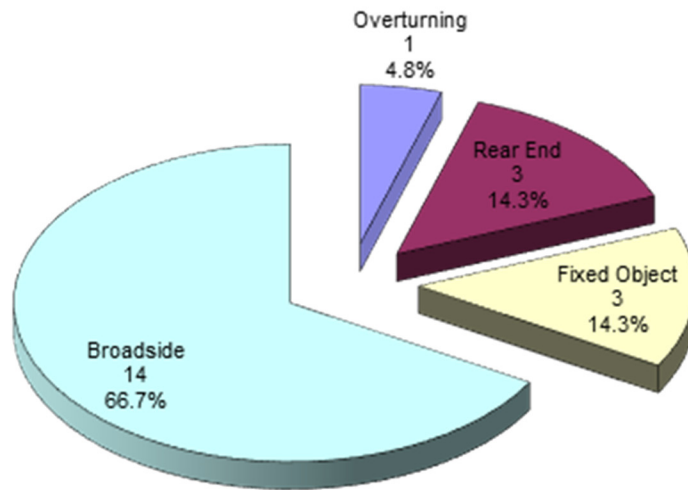

Figure 4. Galley Road/Paonia Street Crash by Type

As many as 5 broadside crashes occurred in a single year at the intersection (2015) and all of the broadside crashes occurred during daylight hours. Of the 14 broadside crashes, 11 occurred between northbound vehicles seeking to turn left onto westbound Galley Rd and vehicles traveling eastbound on Galley Rd. Potential actions to correct the prevalence of broadside crashes could include providing additional sight distance for left-turns entering Galley Rd, providing improved stop sign visibility, or installing a traffic signal at the intersection upon meeting signalization warrants.

II.G. Traffic Control Needs

Current traffic control at the study intersections is shown in **Table I**.

Table I. Current Traffic Control

Intersection	Traffic Control Type
Powers Blvd/Galley Rd	Signalized
Galley Rd/Paonia St	Unsignalized (Stop Control for Paonia St approach)
Conrad St/Galley Rd	Unsignalized (Stop Control for Conrad St approach)
Paonia St/Omaha Blvd	Unsignalized (Stop Control for Paonia St approach)
Omaha Blvd/Powers Blvd	Unsignalized (Stop Control for Omaha St approaches)

As shown, all of the study intersections are currently unsignalized with the exception of the Powers Blvd/Galley Rd intersection. It is appropriate to gauge current and projected traffic conditions to determine whether the conditions at any of the current unsignalized intersections would warrant the need for signalization.

The *Manual on Uniform Traffic Control Devices* (MUTCD, 2009 Edition) outlines 9 warrants that may be used to justify installing a traffic signal at an intersection. The warrants are listed as follows:

1. Eight-Hour Vehicular Volume
2. Four-Hour Vehicular Volume

3. Peak Hour
4. Pedestrian Volume
5. School Crossing
6. Coordinated Signal System
7. Crash Experience
8. Roadway Network
9. Intersection Near a Grade Crossing

Of these nine, warrants 1, 2, and 7 are applicable to conditions at the study intersections. A cursory evaluation of current traffic levels at the study intersections indicated that only the Galley Rd/Paonia St intersection shows potential to meet warrants. In addition, the history of crash experience at the intersection shows potential to meet Warrant 7 criteria. Existing traffic volumes and crash history were compared with warrant criteria to assess this potential. Because the intersection traffic counts only covered peak periods, a scaling factor was used to estimate the fourth and eighth highest hour volumes using information from the Missouri Department of Transportation (MoDOT). The MoDOT methodology used is provided in **Appendix G**. Based on this information, it is estimated that the eighth highest hour comprises approximately 75 percent of the peak recorded hour. Each of the eight highest hours are estimated by scaling in linear fashion.

Utilizing the scaling assumptions, the evaluation of traffic-volume based Warrant 1 (eight-hour volume) and 2 (Four-Hour Volume) indicates that existing traffic volumes meet Condition B of Warrant 1.

The occurrence of 5 broadside crashes during 2015 indicates potential to meet Warrant 7. Warrant 7 has three criteria: A, B, and C. Criteria A addresses actions taken to address safety, stating that adequate trial of alternatives with satisfactory observance and enforcement has failed to reduce the crash frequency. Criteria B addresses crash experience at the intersection, requiring that five or more crashes of a type susceptible to correction by signalization have occurred in a single 12-month period. Criteria C address minimum traffic volume levels. In order to meet Warrant 7, all three criteria must be met.

In coordination with El Paso County Staff, FHU has learned that alternatives have not been implemented at the subject intersection to address crash frequency, therefore not meeting Criteria A. The history of reported broadside crashes in the calendar year 2015 satisfies the numeric threshold of Criteria B, and traffic volumes at the intersection exceed the minimum levels within Criteria C.

Based on the evaluation in this TIS, current conditions at the intersection satisfy signal Warrant 1 criteria and two of the three Warrant 7 criteria. It is recommended that further evaluation occur before signalization is implemented. Evaluation should focus on conducting a greater time span of traffic counts at the intersection covering 10-12 hours to provide a full examination of current traffic levels without relying upon scaling assumptions to satisfy Warrant 1. Also, possible alternative safety treatments (to signalization) should be considered to address crash experience.

Signal warrant 1 and 2 tabulations for the Galley Rd/Paonia St intersection are provided in **Appendix G**.

III. PROJECTED CONDITIONS

III.A. Background Traffic Conditions

Background traffic was estimated for the short term and long term timeframes and accounts for existing traffic already using the transportation system, plus a general upward factoring of current traffic levels to capture the effects of anticipated future growth in the area. The background traffic is unrelated to the proposed development that is projected to utilize the adjacent roadway system. The background traffic volume used in this analysis reflects the year 2040.

Short Term Background Traffic Operations

Year 2040 traffic projections were developed assuming two percent growth per year until the year 2040, translating to a 21 year growth factor of 1.52. These growth assumptions were developed based on traffic forecasts contained in the Pikes Peak Area Council of Governments (PPACG) travel demand model. Short term (Year 2021) background traffic volumes were interpolated assuming linear growth between existing and projected Year 2040. It is important to note that the growth factor was applied to all through and turning movements on Powers Blvd but only to the through movements on Galley Rd and Omaha Blvd.

Figure 5 depicts short term background AM and PM peak hour turning movement projections for the study area intersections and **Appendix C** contains the LOS worksheets. The intersection of Powers Blvd with Galley Rd is forecasted to operate at LOS F during both peak hours in the future.

The yielding movements at all stop controlled intersections would operate at LOS C or better during the peak hours with the following exceptions:

- The northbound left turn at Paonia St and Galley Rd operates at a LOS E during the AM peak hour and LOS F during the PM peak hour.
- The northbound approach at Conrad St and Galley Rd operates at LOS E in the AM peak hour and LOS F during the PM peak hour. This condition could be improved by restricting northbound left turn movements. Such an action would force drivers seeking to travel west along Galley Rd to find alternate routes, which may already occur during peak periods.

Long Term Background Traffic Operations

Long term background traffic volumes were developed with an assumption of a two percent growth per year until the year 2040 – a 21 year growth factor of 1.52. This growth rate was developed based on traffic forecasts in the Pikes Peak Area Council of Government travel demand model. **Figure 6** shows the long term peak hour turning movement projections for the study area intersections and **Appendix D** contains the LOS worksheets. It is important to note that the growth factor was applied to all through and turning movements on Powers Blvd but only to the east-west through movements on Galley Rd and Omaha Blvd.

Intersections that were shown under existing conditions as being unproblematic present operational challenges in the long term scenario without the influence of traffic from the project development. The intersection of Powers Blvd with Galley Rd is forecasted to operate at LOS F during both peak hours in the future.

The yielding movements at all stop controlled intersections operate at LOS C or better during the peak hours with the following exceptions:

- The northbound left turn at Paonia St and Galley Rd would operate at LOS F during the AM and PM peak hour.
- The northbound approach at Conrad St and Galley Rd would operate at LOS F during the AM and PM peak hours. This condition could be improved by restricting northbound left turn movements. Such an action would force drivers seeking to travel west along Galley Rd to find alternate routes, which may already occur during peak periods.

III.B. Traffic Control

Using the Missouri DOT signal warrant criteria mentioned in **Section II.F**, the short term and long term background conditions at the stop controlled intersection of Galley Rd with Paonia St meet traffic volume-based signal warrant criteria. If signalized in the short term future, the intersection would operate at LOS B during peak hours. In the long term future background condition, a signalized Galley Road/Paonia Street intersection would operate at LOS C during peak hours.

Signal warrant analyses are provided in **Appendix G**.

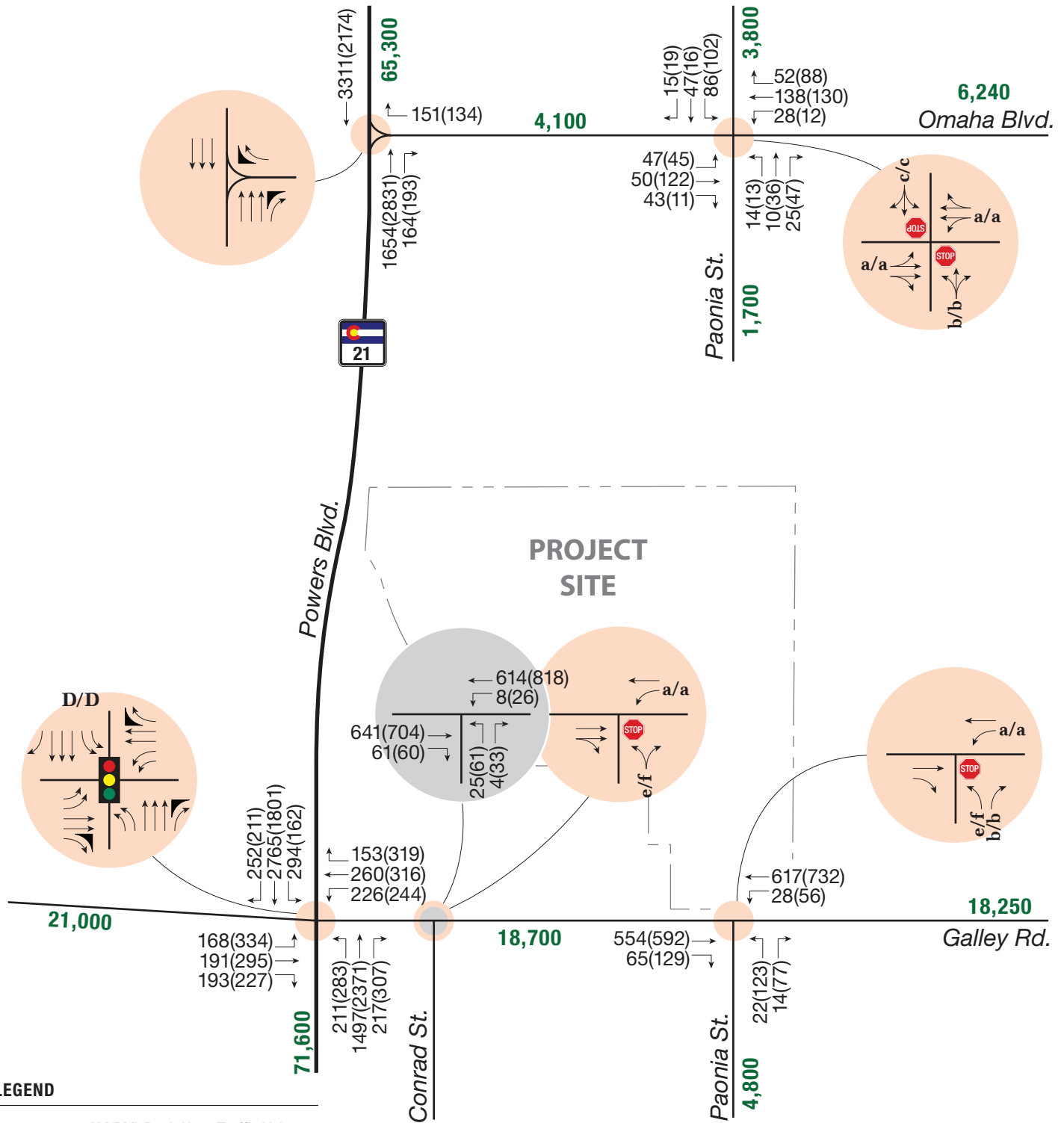

LEGEND

XXX(XXX) = AM(PM) Peak Hour Traffic Volumes

XXXX = Daily Traffic Volumes

X/X = AM/PM Peak Hour Signalized Intersection Level of Service

x/x = AM/PM Peak Hour Unsignalized Intersection Level of Service

STOP = Stop Sign

Traffic Signal = Traffic Signal



FIGURE 5

Short Term Background Traffic Conditions

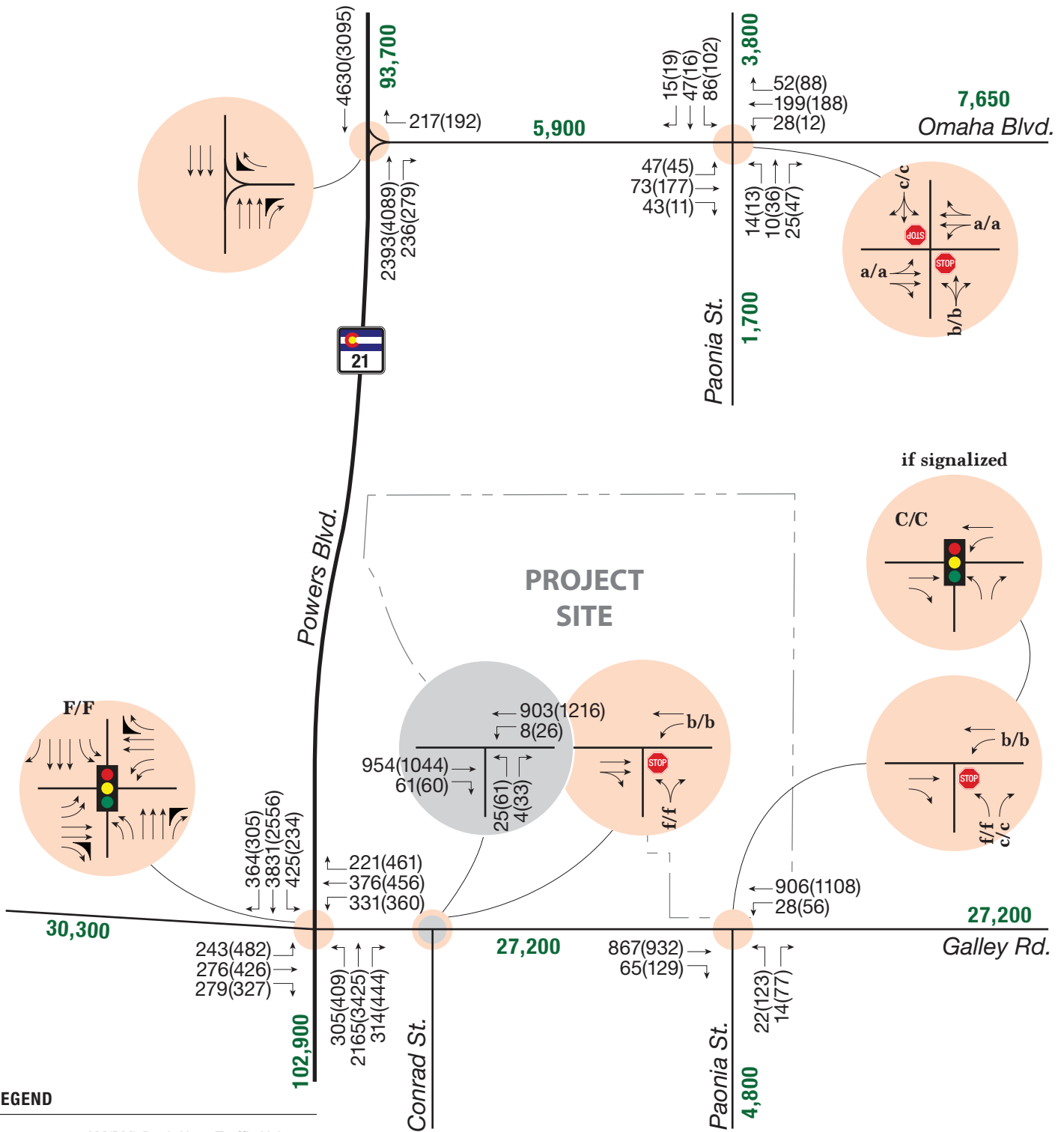

LEGEND

- XXX(XXX) = AM(PM) Peak Hour Traffic Volumes
- XXXX = Daily Traffic Volumes
- X/X = AM/PM Peak Hour Signalized Intersection Level of Service
- x/x = AM/PM Peak Hour Unsignalized Intersection Level of Service
- STOP = Stop Sign
- Traffic Signal = Traffic Signal



FIGURE 6
Long Term Background Traffic Conditions

IV. PROPOSED PROJECT

IV.A. Site Access

Site access is proposed to be provided via two full movement accesses to the extension of Paonia St east of the residential development within the project site.

IV.B. Site Trip Generation

Table 2 provides the trip generation estimates. Trip generation rates and equations for the specific land use planned to be developed on the site are documented in the *ITE Trip Generation Manual, 10th Edition* (2017). Trip generation information corresponding to the ITE Land Use Code (LUC) 220 – Multifamily Centerload (Low-Rise) was used to calculate the trip generation estimates for the site.

Table 2. Trip Generation Summary

Land Use Type	Size	ITE Code	Daily	AM			PM		
				In	Out	Total	In	Out	Total
Apartments	348 DU	220	2547	37	123	160	123	72	195

As shown in **Table 2**, the Solace Apartments Development site is anticipated to generate an estimated total of approximately 160 trips during the AM peak hour and 195 trips during the PM peak hour. The estimated new weekday daily trip generation potential is 2547 vehicle-trips per day.

IV.C. Trip Distribution and Traffic Assignment

The site trip distribution assumptions for the analysis periods are shown on **Figure 7**. The distribution percentages are consistent with the prior TIS, originally developed by reviewing travel travel patterns from intersection turning movement counts and understanding the location of the site relative to major area trip origins and destinations. The trip distribution allocates the greatest percentage of site trips to Powers Boulevard at 42 percent (24 percent to/from the north and 18 percent to/from the south). This assumption reflects the regional reach and higher-speed nature of Powers Boulevard. A slightly higher percentage (24%) is assigned north along Powers Boulevard due to the presence of major commercial and employment activity north along Powers as well as the Denver metropolitan area. 30 percent of site trips are assigned to Galley Road west of Powers Boulevard, reflecting the use of Galley Road as a means to reach the downtown Colorado Springs area. The remaining distribution includes 3 percent from north and south on Paonia St and 2 percent to/from east of Omaha Blvd. Trips to and from the site were assigned to the roadway system based on the above trip distribution percentages. The site generated traffic is shown on **Figure 7**.

In addition to site generated vehicle-trips, **Figure 7** depicts anticipated adjustments to existing turning movements due to the extension of Paonia St, anticipated to occur with the proposed development. This extension would provide an alternate travel route for existing development north of the site, and additional traffic is anticipated to utilize the extension to connect to Galley Rd and Powers Blvd, particularly in light of the limited movements (Right-turns only) currently available at the Omaha Blvd/Powers Blvd intersection.

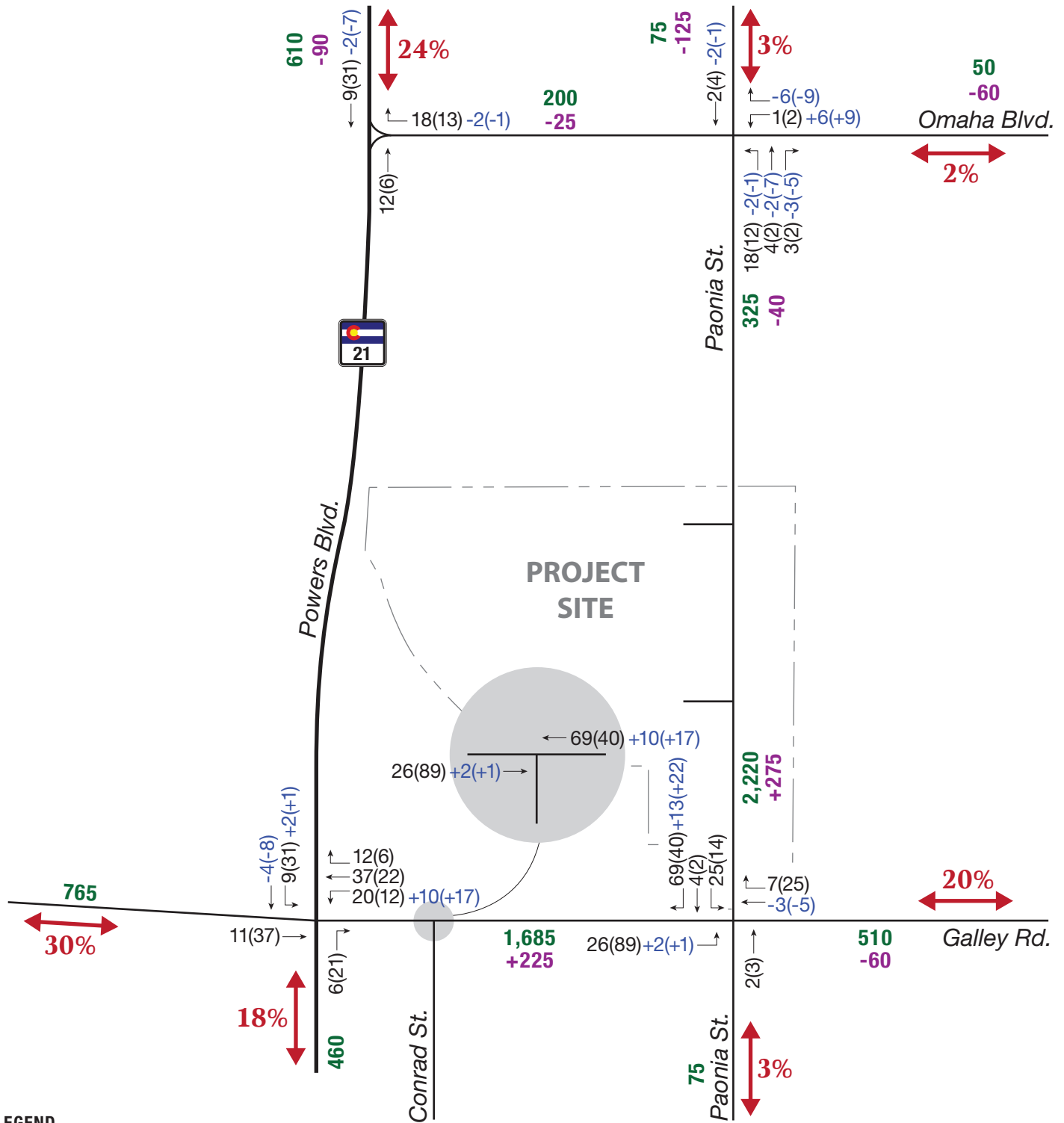

LEGEND

- XXX(XXX) = AM(PM) Peak Hour Traffic Volumes
- XXX(XXX) = AM(PM) Vehicle-Trip Adjustments due to Paonia St. Extension
- XXXX = Daily Traffic Volumes
- XXXX = AM(PM) Vehicle-Trip Adjustments due to Paonia St. Extension
- XX% = Site Trip Distribution



FIGURE 7

Trip Distribution and Site Generated Traffic

V. TRAFFIC IMPACT ANALYSIS

V.A. Short Term Total Traffic

The inclusion of the proposed development traffic is anticipated to have some impact to the operation of the study intersections. **Figure 8** illustrates the geometry, traffic control, and capacity analyses for the short term future total condition, and **Appendix D** contains LOS worksheets.

As shown on **Figure 8**, the signalized intersection of Powers Blvd with Galley Rd is projected to operate at LOS D during both peak hours.

The yielding movements at all stop controlled intersections operate at LOS C or better during the peak hours with the following exceptions:

- The northbound and southbound left turns at Paonia St and Galley Rd would operate at LOS F during the AM and PM peak hours. The southbound through movement would operate at LOS E/F during the AM/PM peak hour.
- The northbound approach at Conrad St and Galley Rd would operate at LOS F during the AM and PM peak hours. This condition could be improved by restricting northbound left turn movements. Such an action would force drivers seeking to travel west along Galley Rd to find alternate routes, which may currently occur during peak periods without restrictions in place.

Section V.C below elaborates on the potential for signalization at the intersection of Paonia St and Galley Rd for the short term total scenario. If this intersection was to be signalized it would operate at LOS C during peak hours. The signalized LOS can be seen on **Figure 8**.

V.B. Long Term Total Traffic

Operational analyses were conducted to quantify the impact of site traffic on Long Term Future traffic operations at the study area intersections. **Figure 9** illustrates the geometry, traffic control, and capacity analyses for the long term future total condition. **Appendix E** contains the total traffic LOS worksheets.

As shown on **Figure 9**, consistent with the long term future background condition the signalized intersection of Powers Blvd with Galley Rd is projected to operate at LOS F during both peak hours. Though expansion of the intersection could assist in improving LOS, major widening is unlikely to occur given the current maximized condition of the intersection (dual left turn lanes on all approaches and six travel lanes along Powers Blvd).

The yielding movements at all stop controlled intersections operate at LOS D or better during the peak hours with the following exceptions:

- The northbound and southbound left turns at Paonia St and Galley Rd would operate at LOS F during the AM and PM peak hours. The southbound through movement would operate at LOS F during peak hours and the northbound through movement would operate at LOS E during the PM peak hour.
- The northbound approach at Conrad St and Galley Rd would operate at LOS F in the AM peak hour and LOS F during the PM peak hour. This condition could be improved by restricting northbound left turn movements. Such an action would force drivers seeking to travel west along Galley Rd to find alternate routes, which may already occur during peak periods without restrictions in place.

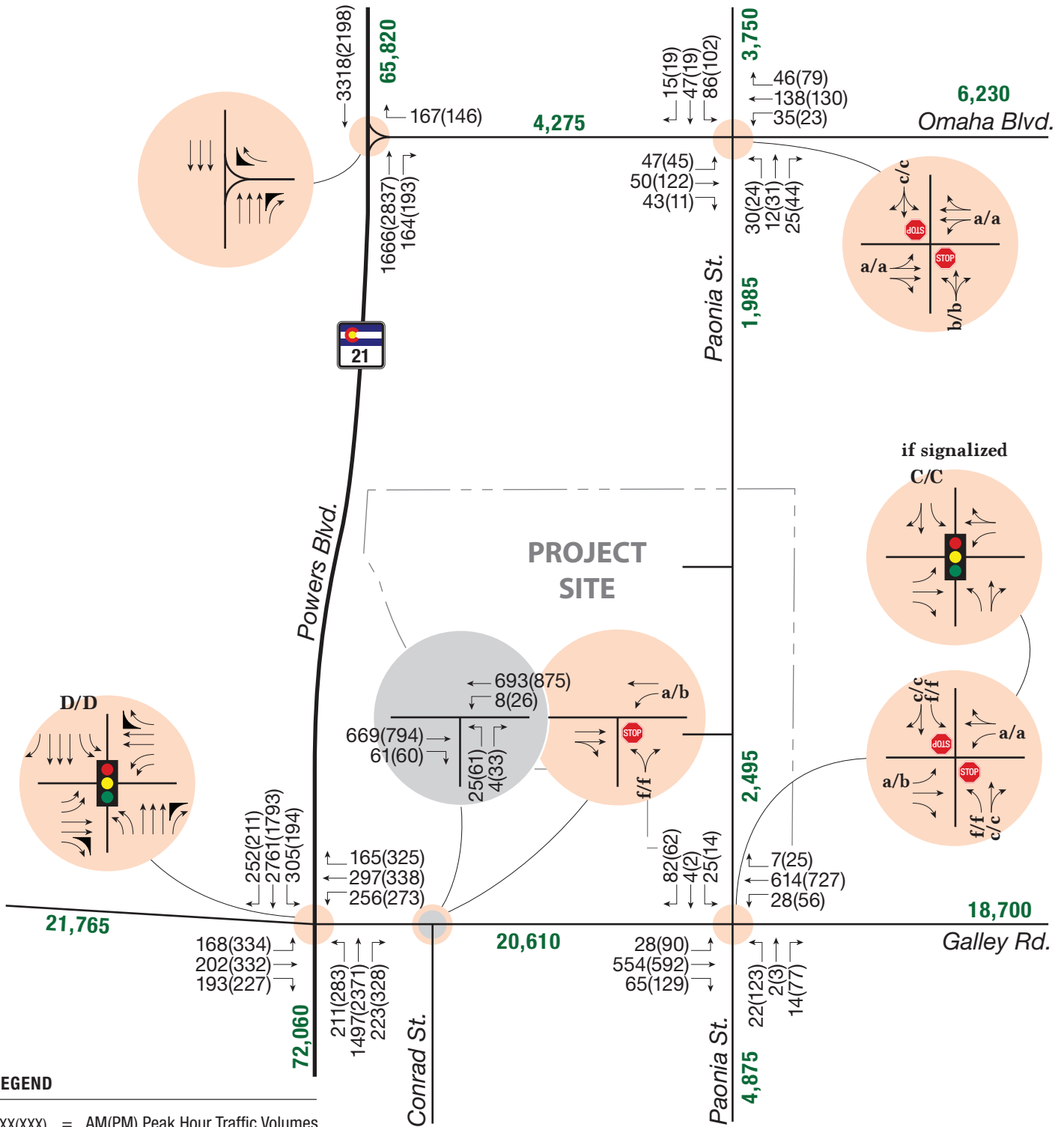

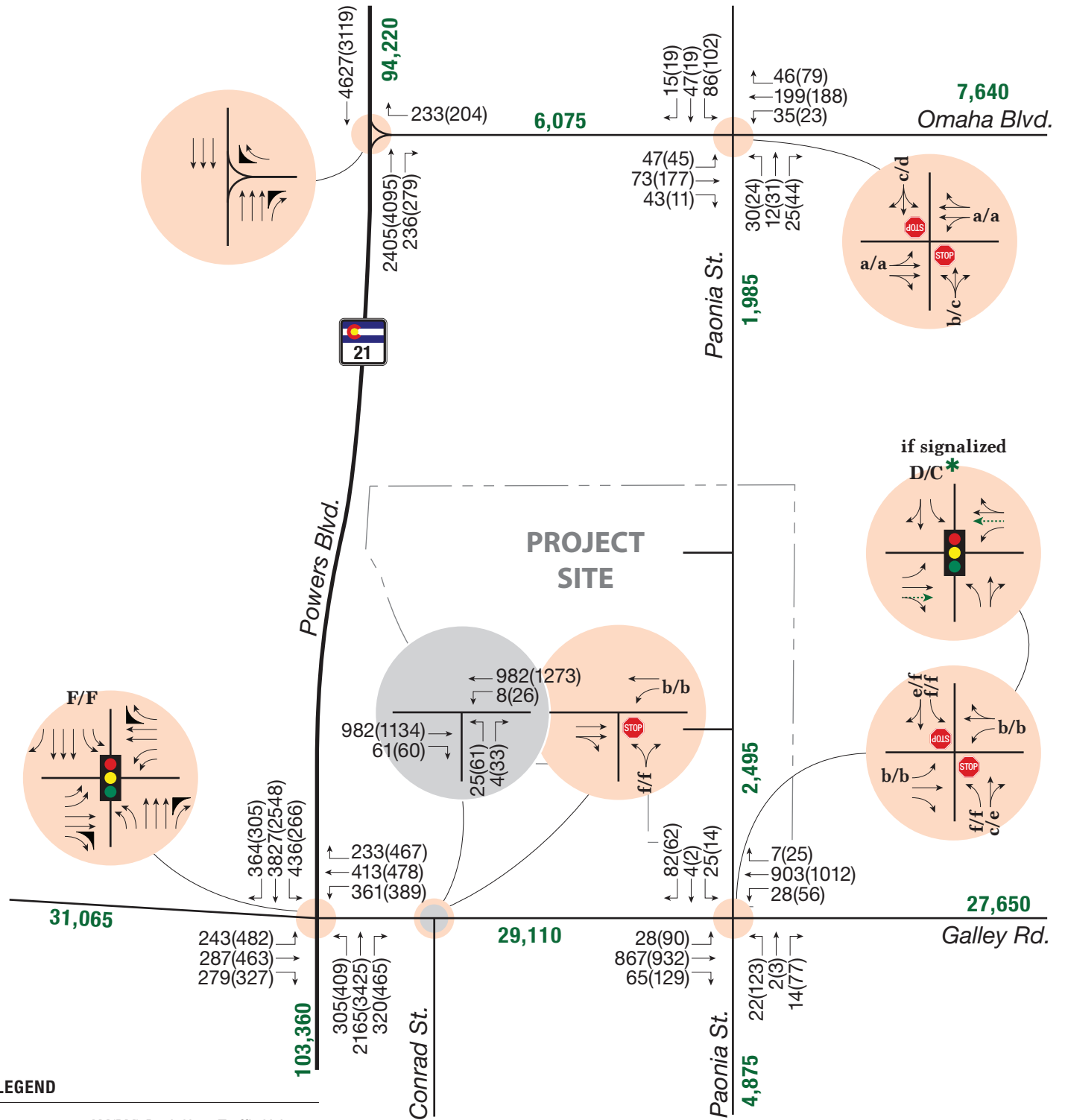

LEGEND

XXX(XXX) = AM(PM) Peak Hour Traffic Volumes

XXXX = Daily Traffic Volumes

X/X = AM/PM Peak Hour Signalized Intersection Level of Service

x/x = AM/PM Peak Hour Unsignalized Intersection Level of Service

= Stop Sign

= Traffic Signal

* Dashed green improvements needed to provide shown PM Peak Hour LOS.



FIGURE 9

Long Term Total Traffic Conditions

Section V.C elaborates on the potential for signalization of the intersection of Paonia St and Galley Rd for the long term total scenario. If this intersection was to be signalized it would operate at LOS D in the AM peak hour and LOS C during the PM peak hour. The PM peak hour result of LOS C would require the addition of a second through travel lane through the intersection in both the eastbound and westbound directions. If no second through lane were added, the signalized intersection would operate at LOS F in the PM peak hour. This condition can be seen on **Figure 9**.

V.C. Traffic Control

Existing, short term and long term future total conditions demonstrate the ability to meet signal warrant thresholds at the Paonia St/Galley Rd intersection. **Appendix G** provides signal warrant summaries and **Figure 8** and **Figure 9** illustrate the Galley Rd and Paonia St intersection for both signalized and unsignalized conditions. **Table 3** depicts the results of warrant reviews for each of the unsignalized full movement intersections within the study area.

Table 3. Summary of Signal Warrant Findings

Intersection	Existing	Background		Total	
		Short Term	Long Term	Short Term	Long Term
Galley Rd/Paonia St	Yes	Yes	Yes	Yes	Yes
Galley Rd/Conrad St	No	No	No	No	No
Omaha Blvd/Paonia St	No	No	No	No	No

As shown, signal warrants are met at the Galley Rd/Paonia St intersection in all analysis scenarios based on scaling assumptions used to approximate the 8 highest traffic volume hours.

V.D. Internal Circulation

The proposed residential development will have two full movement site accesses onto Paonia St with full access to the entire site from each access point. There are not expected to be any issues in internal circulation or safety based on the current design of the site. Based on El Paso County's Engineering Criteria Manual (ECM), a minimum of 455 feet of distance along Paonia Street must be provided between the accesses (assuming Paonia Street is identified as a school bus route). The current site plan shows spacing exceeding this minimum criterion. The accesses will be designed to provide sight distance consistent with ECM guidance.

V.E. Pedestrian and Bicyclist Safety

Pedestrian and bicyclist counts by direction were taken at each intersection within the study area. Pedestrian and bicyclist volumes were generally low with no more than 5 crossings at any location during the peak hours. There is currently a separated sidewalk along Galley Road's south edge from Powers Blvd to beyond Paonia St.

Due to the low volume of pedestrians and cyclists in this area, the lack of sidewalks, crosswalks, and bicycle lanes may not be an issue. However, McAuliffe Elementary School is less than a mile from the project site; therefore, it is essential to have adequate sidewalks to the school access. It is recommended that a six-foot sidewalk be constructed on the north side of Galley Rd from Powers Blvd to the east of Paonia St. Consider striping a crosswalk on the west leg of the Galley Rd/Paonia St intersection when it is signalized and on the north leg of the Galley Rd/Paonia St intersection prior to signalization. Other recommendations include adding sharrow markings to indicate that motorists and cyclists share the travel lane along Galley Rd.

V.F. Transit Services

Mountain Metropolitan Transit provides bus service in El Paso County. Currently there are existing bus stops located adjacent to the project site. Route #23 runs east/west on Galley Rd and have frequent stops that are less than 0.2 mile apart.

V.G. Funding Options

Based on the current El Paso County Road Impact Fee Implementation Document, it is possible that improvements to the Galley Rd/Paonia St intersection are reimbursable, pending further coordination. The MTCP does not call for any improvements in the immediate area.

El Paso County Road Impact Fees are applicable in accordance with the current implementation document, Multi-family land use category. The developer had not yet selected a payment option as of the time of this TIS.

VI. IMPROVEMENT ANALYSIS

The total deceleration lane length should be 315 ft. Please revise

VI.A. Galley Road/Paonia Street Intersection

The only study intersection in need of intersection modifications is the Galley Rd/Paonia St intersection. Left turns entering Galley Rd currently experience poor LOS, a condition anticipated to persist into the future regardless of the proposed development. Crash history indicates numerous recent crash types that could be improved with installation of a traffic signal. Forecasts indicate that the intersection would warrant signalization with the addition of site traffic in the short term future. In the long term future with site development, additional travel lanes along Galley Rd are necessary to provide acceptable signalized LOS. It is recommended that upon completion of the development and the Paonia St extension adds a new north leg to the Galley Rd/Paonia St intersection that the intersection remain under unsignalized control. It is recommended that an annual warrant study based on turning movement counts recorded over a 10-hour period be conducted by the developer to monitor conditions relative to signal warrants and that the intersection be signalized when field conditions satisfy signal warrants.

VI.B. Auxiliary Turn Lanes

Galley Rd is classified as a minor arterial and Paonia St is to be classified as a Urban non-residential collector. With these functional classifications, County standards require a left- turn lane deceleration lane when peak hour left turn volumes are equal to or exceed 25 vehicles per hour (vph) and a right turn deceleration lane when peak hour right turn volumes are equal to or exceed 50 vph. According to long term total traffic forecasts, the westbound and eastbound left turns and eastbound right turn would meet this threshold. i believe you meant table 4 instead of 54.

Based on ECM criteria it is recommended that southbound exclusive left turn and right turn lanes be provided along Paonia St approaching Galley Road. It is also recommended that the site accesses to Paonia St be provided with northbound left turn lanes striped into a center painted median. The site accesses points are not projected to warrant exclusive right turn lanes based on traffic volume forecasts. **Table 54** provides recommended lane lengths for turn lanes serving the new north leg of the intersection.

Table 4. Recommended Turn Lanes and Lengths

Intersection	Approach	Turn Lane	Lane Dimensions (ft)			Total Lane Length
			Bay/Approach Taper	Lane Length	Storage Length	
Galley Rd/Paonia St	Southbound	Left Turn	160	155	100	260
		Right Turn	160	155	100	260
	Eastbound	Left Turn	160	155	100	260
Paonia St/South site access	Northbound	Left Turn	160	155	75	235
Paonia St/North site access	Northbound	Left Turn	160	155	75	235

Please also include westbound left turn lane. The volumes provided warrant a westbound left turn.

VI.C. Paonia Street Extension

As mentioned, Paonia St is anticipated to be extended and is classified as a urban non-residential collector. **Figure 10** depicts the proposed Paonia St typical section and **Figure 11** shows the ECM standards for an urban non-residential collector. The proposed typical section should be reviewed and

approved by the County Engineer. It includes a deviation from the El Paso County Engineering Criteria Manual (ECM) guidelines. The ECM criterion includes an 80' ROW width (Urban Non-Residential Collector) typical section, which includes 48' of pavement (lip-lip) typical, typical curb and gutter, and 14' tree lawns with a 5' detached sidewalk on both sides of the roadway.

The proposed typical section, as depicted on **Figure 10**, would provide 36' of paved width and a 5' walk on the west side only. The reason for the requested deviation for an alternate road section is that Paonia Street to the north and south of the development exists as a 60' ROW with 36' (lip-lip) pavement area. The proposed design is to maintain a consistent paved surface section through the Solace development and the entire Paonia corridor while still providing the requested 80' ROW associated with an Urban Non-Residential Collector. The walk is proposed on the west side to continue pedestrian movement from south to north through the corridor. No walks currently exist on the east side of the road, north or south of this development, so no east side walk is proposed. Furthermore, there is currently no space for an east side walk to be considered in the existing adjacent developments due to the existing infrastructure. This removes the likelihood of any potential future connectivity for a walk on the east side of Paonia St through this corridor. Although no walk is proposed, the horizontal space for a walk is still being dedicated should future redevelopment of this corridor warrant additional connectivity.

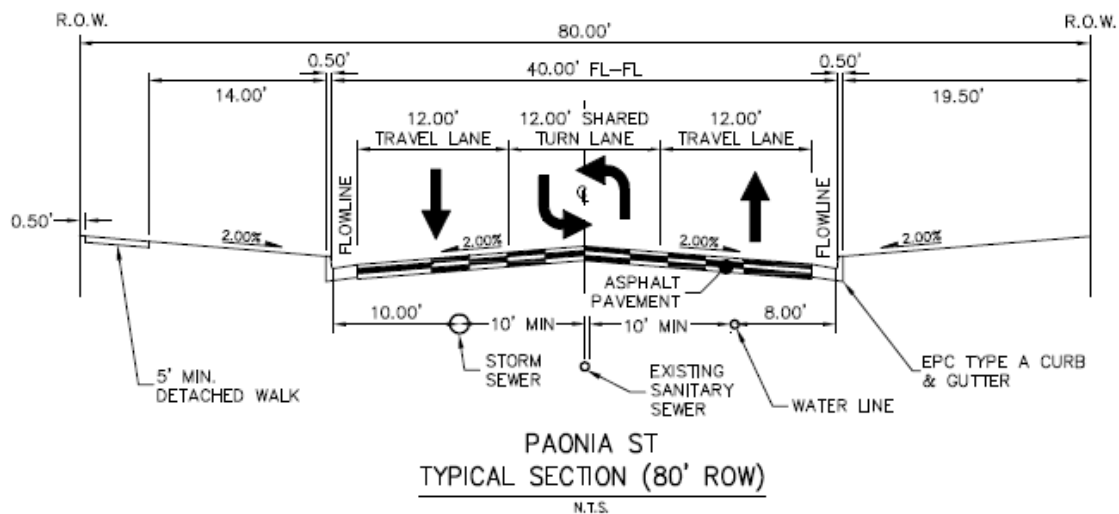

Figure 10. Proposed Paonia Street Cross Section

No improvements to existing Paonia St north of the site are required.

VI.D. Striping/Sidewalks

There is missing sidewalk along the north edge of Galley Rd between Paonia St and Powers Blvd. The sidewalk should be constructed and sharrows should be striped along the roadway.

Criteria	Collectors		Local	
	Non-Residential	Residential	Local	Local ⁴ (low volume)
Design Speed / Posted Speed (MPH)	40 / 35	40 / 35	25 / 25	20 / 20
Clear Zone	14'	14'	12'	7'
Minimum Centerline Curve Radius	565'	565'	200'	100'
Number of Through Lanes	2	2	2	2
Lane Width	12'	12'	12'	12'
Right-of-Way	80'	60'	60 ³	60 ³
Paved Width (Excluding Gutter Pan)	48'	36'	30'	24'
Median Width (Including Curb & Gutter)	12'	n/a	n/a	n/a
Shoulder Width (Ext., Excluding Gutter)	6'	6'	n/a	n/a
Shoulder Width (Int., Excluding Gutter)	n/a	n/a	n/a	n/a
Required Curb/ Gutter Type (Vertical)	6"	6"	6" (or ramp)	6" (or ramp)
Sidewalk Width (@ FL)	5' detached	5' detached	5' attached	5' attached
Design ADT	20,000	10,000	3,000	300
Design Vehicle	WB-50	WB-50	WB-50	SU-30
Bike Lanes Permitted	No	Yes	No	No
Access Permitted	No ⁵	No ⁵	Yes	Yes
Access Spacing	See Table 2-35	See Table 2-35	Frontage	Frontage
Intersection Spacing	660 ²	660 ²	175'	150'
Parking Permitted	No	No	Yes	Yes
Minimum Flowline Grade of Curb	.50%	.50%	.50%	.50%
Centerline Grade (Min.-Max.)	0.5-6% ¹	0.5-8% ¹	0.5-8% ¹	0.5-8% ¹
Intersection Grades (Min.-Max.)	0.5-4%	0.5-4%	0.5-4%	0.5-4%
¹ 10% maximum grade permitted at the discretion of the ECM Administrator ² 330 feet when intersecting local roadways ³ 50-foot right-of-way plus two 5-foot Public Improvements Easements granted to El Paso County ⁴ Section can be used for cul-de-sacs, or roads with two ways out having a maximum of 300 ADT and a maximum length of 1,200 feet ⁵ Where no local public or private roadway can provide access, temporary or partial turn movement parcel access may be permitted				

Figure 11. Roadway Design Standards for Urban Collectors

VII. SUMMARY AND RECOMMENDATIONS

The proposed residential development of 348 multifamily apartments would be constructed within the northeast quadrant of the Powers Blvd and Galley Rd intersection in El Paso County, Colorado. Surrounding areas are primarily commercial spaces. The project would include an extension of Paonia St, which will provide access to the new residential development.

Two future scenarios were analyzed for this report:

- **Short Term Future** – Time period for the completion of the residential development, estimated as the Year 2021.
- **Long Term Future** – The year 2040 was used to assess traffic impacts of the development in the long term future.

The following is a summary of the findings and recommendations related to the analysis for the development:

- When constructed, this development would generate an estimated 2,547 vehicle-trips during the day with 160 of these trips occurring during the AM peak and 195 trips occurring during the PM peak.
- No improvements to existing Paonia St north of the site are required. The proposed Paonia St extension should provide 80' of ROW with a deviation from ECM criteria to allow for a 36' paved width instead of the specified 48' to maintain consistency with existing adjacent sections. Also for reasons of consistency/continuity with adjacent sections of Paonia St, a detached walk is proposed on the west side of the Paonia St extension but not the east side, a deviation from ECM criteria.
- Based on the results of this analysis, current and future conditions at the intersection of Galley Rd and Paonia St would meet signal warrants. This intersection should be monitored to determine when signalization is necessary. An annual warrant study should be performed, starting with a study approximately 1 month after completion of the intersection reconstruction adding a new north leg. The warrant study should be based upon 10-12 hours of turning movement counts in order to provide actual rather than scaled values, and the evaluation should incorporate the most recent crash history. The proposed development is expected to generate approximately 9 percent of the traffic traveling through the intersection in the short term and 7 percent in the long term. Coordination with the Engineering Manager and/or County Engineer may be required to determine further responsibility of the developer.
- Consideration should be given to restricting the northbound left turn movement at the Galley Rd/Conrad St intersection to reduce congestion at this location.
- Auxiliary turn lanes should be installed along the southbound and eastbound approaches to the Galley Rd/Paonia St intersection and left turn lanes should be provided at the site accesses to Paonia St.
- When the intersection of Galley Rd and Paonia St is reconstructed with a new north leg as an unsignalized intersection, a crosswalk should be striped on the north leg of the intersection, and, when signalized, on the west leg of the intersection.
- McAuliffe Elementary School is within 2 miles of the project site; therefore, missing sidewalk gaps and improvements to existing sidewalks should be made for better access. A six-foot sidewalk will need to be constructed on the north side of Galley Rd between Powers Blvd and east of Paonia St.

Table 5 summarizes traffic mitigation measures for this development.

Table 5. Improvements

Intersection/ Location	Improvement	Improvement Timing	Responsibility
Galley Rd/Paonia St	Signal Warrant Studies	Short-Term (2021) + annually as needed	Developer
	Signalization	When warrants met	Developer
	Turn Lanes (SB left and right, EB left)	Short-Term (2021)	Developer
	Construction of Paonia St Extension	Short-Term (2021)	Developer
Site Accesses to Paonia St	Turn Lanes	Short-Term (2021)	Developer
Galley Rd	Sidewalk along north edge	Long-Term (2040)	County/ Developer

The developer will be responsible for constructing the sidewalk along the property frontage with Phase1/initial final plat application. The rest of the sidewalk that will extend to Powers blvd may be listed as long-term

The timing of the improvements should be listed in terms of the Phases/Final Plat filings proposed. Looking at the preliminary plan, it appears that these improvements would be required with Phase 1/Initial Final Plat application as both access points and most of the buildings are part of Phase 1. Please revise.

APPENDIX A. EXISTING TRAFFIC COUNTS



(303) 216-2439
www.alltrafficdata.net

Location: 1 POWERS BLVD & OMAHA ST AM
Date and Start Time: Tuesday, October 15, 2019
Peak Hour: 06:45 AM - 07:45 AM
Peak 15-Minutes: 07:15 AM - 07:30 AM

Peak Hour - All Vehicles

Peak Hour - Pedestrians/Bicycles on Crosswalk

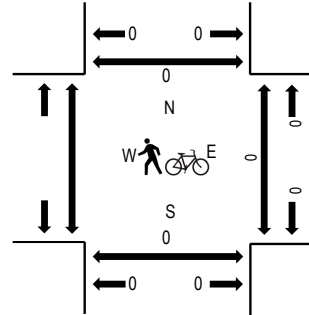
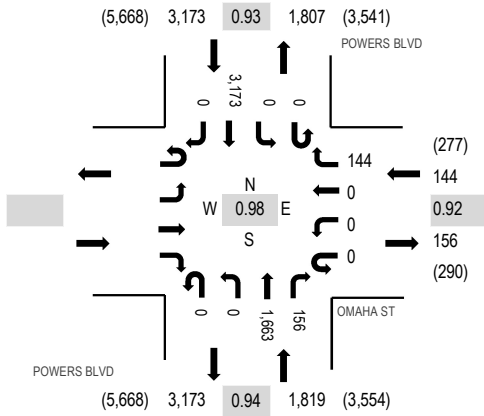

Note: Total study counts contained in parentheses.

Traffic Counts

Interval Start Time	Eastbound				OMAHA ST Westbound				POWERS BLVD Northbound				POWERS BLVD Southbound				Total	Rolling Hour	Pedestrian Crossings			
	U-Turn	Left	Thru	Right	U-Turn	Left	Thru	Right	U-Turn	Left	Thru	Right	U-Turn	Left	Thru	Right			West	East	South	North
6:30 AM					0	0	0	30	0	0	328	38	0	0	727	0	1,123	4,997	0	0	0	
6:45 AM					0	0	0	39	0	0	412	54	0	0	799	0	1,304	5,136	0	0	0	
7:00 AM					0	0	0	38	0	0	406	37	0	0	773	0	1,254	5,032	0	0	0	
7:15 AM					0	0	0	30	0	0	394	37	0	0	855	0	1,316	4,804	0	0	0	
7:30 AM					0	0	0	37	0	0	451	28	0	0	746	0	1,262	4,502	0	0	0	
7:45 AM					0	0	0	33	0	0	450	44	0	0	673	0	1,200		0	0	0	
8:00 AM					0	0	0	36	0	0	408	29	0	0	553	0	1,026		0	0	0	
8:15 AM					0	0	0	34	0	0	415	23	0	0	542	0	1,014		0	0	0	
Count Total					0	0	0	277	0	0	3,264	290	0	0	5,668	0	9,499		0	0	0	
Peak Hour					0	0	0	144	0	0	1,663	156	0	0	3,173	0	5,136		0	0	0	



(303) 216-2439
www.alltrafficdata.net

Location: 2 PAONIA ST & OMAHA BLVD AM
Date and Start Time: Tuesday, October 15, 2019
Peak Hour: 06:45 AM - 07:45 AM
Peak 15-Minutes: 06:45 AM - 07:00 AM

Peak Hour - All Vehicles

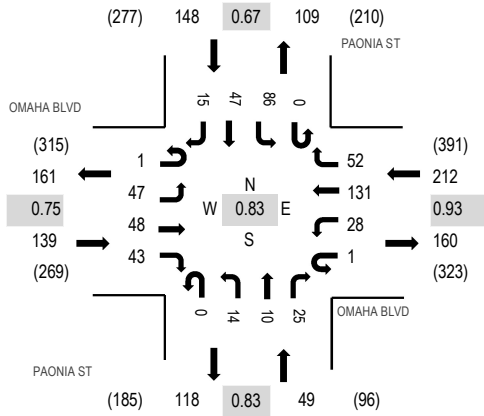

Peak Hour - Pedestrians/Bicycles on Crosswalk

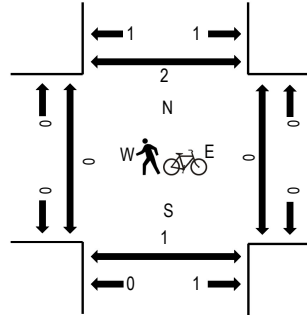

Note: Total study counts contained in parentheses.

Traffic Counts

Interval Start Time	OMAHA BLVD Eastbound				OMAHA BLVD Westbound				PAONIA ST Northbound			PAONIA ST Southbound				Total	Rolling Hour	Pedestrian Crossings				
	U-Turn	Left	Thru	Right	U-Turn	Left	Thru	Right	U-Turn	Left	Thru	Right	U-Turn	Left	Thru			Right	West	East	South	North
6:30 AM	0	15	7	9	0	6	24	9	0	3	0	1	0	21	5	5	105	516	0	0	0	0
6:45 AM	1	19	15	12	0	14	33	7	0	1	2	6	0	32	20	3	165	548	0	0	1	0
7:00 AM	0	10	8	11	0	4	37	16	0	3	1	3	0	19	10	3	125	526	0	0	0	1
7:15 AM	0	8	11	15	0	5	28	11	0	5	3	6	0	14	10	5	121	546	0	0	0	0
7:30 AM	0	10	14	5	1	5	33	18	0	5	4	10	0	21	7	4	137	517	0	0	0	1
7:45 AM	0	10	19	7	0	3	31	15	0	4	3	6	0	27	9	9	143		0	0	0	1
8:00 AM	0	15	16	8	0	2	38	15	0	5	4	8	0	25	5	4	145		0	0	0	7
8:15 AM	0	7	13	4	0	4	25	7	0	5	1	7	0	13	5	1	92		0	0	0	2
Count Total	1	94	103	71	1	43	249	98	0	31	18	47	0	172	71	34	1,033		0	0	1	12
Peak Hour	1	47	48	43	1	28	131	52	0	14	10	25	0	86	47	15	548		0	0	1	2



(303) 216-2439
www.alltrafficdata.net

Location: 3 POWERS BLVD & GALLEY RD AM
Date and Start Time: Tuesday, October 15, 2019
Peak Hour: 07:00 AM - 08:00 AM
Peak 15-Minutes: 07:30 AM - 07:45 AM

Peak Hour - All Vehicles

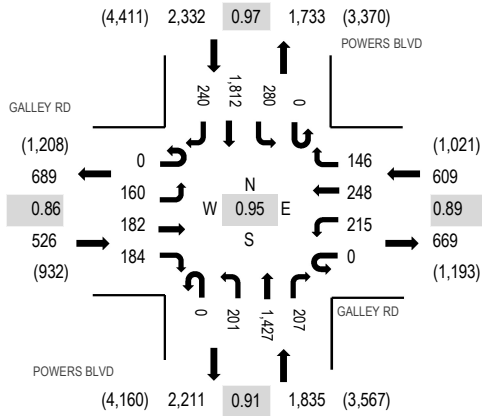

Peak Hour - Pedestrians/Bicycles on Crosswalk

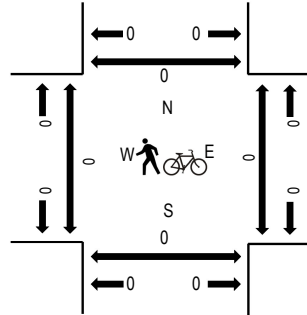

Note: Total study counts contained in parentheses.

Traffic Counts

Interval Start Time	GALLEY RD Eastbound				GALLEY RD Westbound				POWERS BLVD Northbound				POWERS BLVD Southbound				Total	Rolling Hour	Pedestrian Crossings			
	U-Turn	Left	Thru	Right	U-Turn	Left	Thru	Right	U-Turn	Left	Thru	Right	U-Turn	Left	Thru	Right			West	East	South	North
6:30 AM	0	30	29	48	0	32	32	21	0	28	299	44	0	47	542	36	1,188	5,076	0	0	0	0
6:45 AM	0	28	45	43	0	25	36	29	0	42	396	70	0	56	456	63	1,289	5,277	0	0	0	0
7:00 AM	0	36	38	52	0	53	34	30	0	52	321	48	0	66	482	52	1,264	5,302	0	0	0	0
7:15 AM	0	30	51	43	0	53	69	41	0	51	332	49	0	61	505	50	1,335	5,165	0	0	0	0
7:30 AM	0	43	43	37	0	59	76	39	0	46	374	53	0	74	482	63	1,389	4,855	0	0	0	0
7:45 AM	0	51	50	52	0	50	69	36	0	52	400	57	0	79	343	75	1,314		0	0	0	0
8:00 AM	0	35	39	30	0	43	48	39	0	32	364	44	1	51	350	51	1,127		0	0	0	0
8:15 AM	0	26	27	26	0	26	37	44	0	50	325	38	0	34	328	64	1,025		0	0	0	0
Count Total	0	279	322	331	0	341	401	279	0	353	2,811	403	1	468	3,488	454	9,931		0	0	0	0
Peak Hour	0	160	182	184	0	215	248	146	0	201	1,427	207	0	280	1,812	240	5,302		0	0	0	0



(303) 216-2439
www.alltrafficdata.net

Location: 4 CONRAD ST & GALLEY RD AM
Date and Start Time: Tuesday, October 15, 2019
Peak Hour: 07:15 AM - 08:15 AM
Peak 15-Minutes: 07:30 AM - 07:45 AM

Peak Hour - All Vehicles

Peak Hour - Pedestrians/Bicycles on Crosswalk

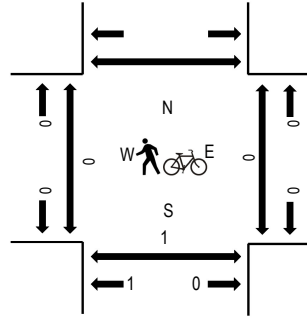
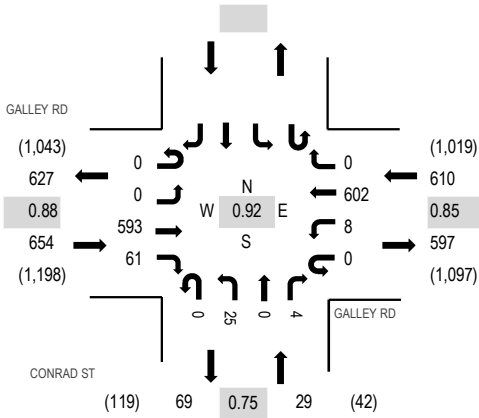

Note: Total study counts contained in parentheses.

Traffic Counts

Interval Start Time	GALLEY RD Eastbound				GALLEY RD Westbound				CONRAD ST Northbound				Southbound				Total	Rolling Hour	Pedestrian Crossings			
	U-Turn	Left	Thru	Right	U-Turn	Left	Thru	Right	U-Turn	Left	Thru	Right	U-Turn	Left	Thru	Right			West	East	South	North
6:30 AM	0	0	116	3	0	0	91	0	0	0	0	0	0	0	0	0	210	1,071	0	0	0	
6:45 AM	0	0	156	19	0	3	97	0	0	2	0	0	0	0	0	0	277	1,212	0	0	0	
7:00 AM	0	0	140	9	0	0	105	0	0	3	0	0	0	0	0	0	257	1,283	0	0	0	
7:15 AM	0	0	153	11	0	1	155	0	0	7	0	0	0	0	0	0	327	1,293	0	0	0	
7:30 AM	0	0	151	16	0	2	178	0	0	2	0	2	0	0	0	0	351	1,188	0	0	0	
7:45 AM	0	0	167	22	0	3	148	0	0	7	0	1	0	0	0	0	348		0	0	1	
8:00 AM	0	0	122	12	0	2	121	0	0	9	0	1	0	0	0	0	267		0	0	0	
8:15 AM	0	0	87	14	0	2	111	0	0	7	0	1	0	0	0	0	222		0	0	0	
Count Total	0	0	1,092	106	0	13	1,006	0	0	37	0	5	0	0	0	0	2,259		0	0	1	
Peak Hour	0	0	593	61	0	8	602	0	0	25	0	4	0	0	0	0	1,293		0	0	1	



(303) 216-2439
www.alltrafficdata.net

Location: 5 PAONIA ST & GALLEY RD AM
Date and Start Time: Tuesday, October 15, 2019
Peak Hour: 07:15 AM - 08:15 AM
Peak 15-Minutes: 07:30 AM - 07:45 AM

Peak Hour - All Vehicles

Peak Hour - Pedestrians/Bicycles on Crosswalk

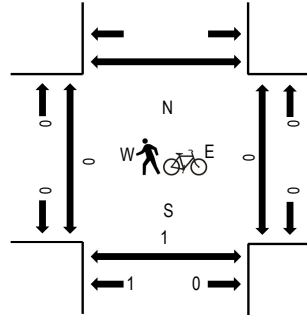
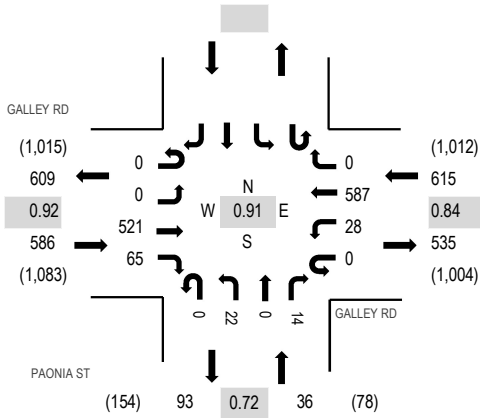

Note: Total study counts contained in parentheses.

Traffic Counts

Interval Start Time	GALLEY RD Eastbound				GALLEY RD Westbound				PAONIA ST Northbound				Southbound				Total	Rolling Hour	Pedestrian Crossings						
	U-Turn	Left	Thru	Right	U-Turn	Left	Thru	Right	U-Turn	Left	Thru	Right	U-Turn	Left	Thru	Right			West	East	South	North			
6:30 AM	0	0	107	11	0	2	84	0	0	0	5	0	5	0	0	0	0	0	0	0	214	1,044	0	0	0
6:45 AM	0	0	138	14	0	5	98	0	0	0	2	0	2	0	0	0	0	0	0	0	259	1,169	0	0	0
7:00 AM	0	0	131	10	0	4	97	0	0	0	10	0	6	0	0	0	0	0	0	0	258	1,235	0	0	0
7:15 AM	0	0	133	14	0	7	147	0	0	0	7	0	5	0	0	0	0	0	0	0	313	1,237	0	0	0
7:30 AM	0	0	136	11	0	7	175	0	0	0	6	0	4	0	0	0	0	0	0	0	339	1,129	0	0	1
7:45 AM	0	0	139	24	0	8	146	0	0	0	6	0	2	0	0	0	0	0	0	0	325		0	0	0
8:00 AM	0	0	113	16	0	6	119	0	0	0	3	0	3	0	0	0	0	0	0	0	260		0	0	0
8:15 AM	0	0	76	10	0	5	102	0	0	0	8	0	4	0	0	0	0	0	0	0	205		0	0	0
Count Total	0	0	973	110	0	44	968	0	0	0	47	0	31	0	0	0	0	0	0	0	2,173		0	0	1
Peak Hour	0	0	521	65	0	28	587	0	0	0	22	0	14	0	0	0	0	0	0	0	1,237		0	0	1



(303) 216-2439
www.alltrafficdata.net

Location: 1 POWERS BLVD & OMAHA ST PM
Date and Start Time: Tuesday, October 15, 2019
Peak Hour: 04:30 PM - 05:30 PM
Peak 15-Minutes: 05:00 PM - 05:15 PM

Peak Hour - All Vehicles

Peak Hour - Pedestrians/Bicycles on Crosswalk

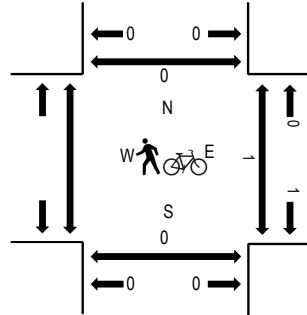
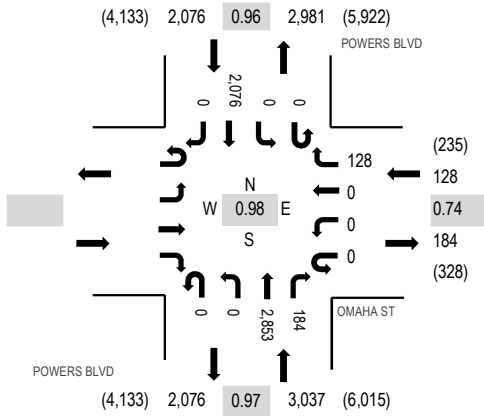

Note: Total study counts contained in parentheses.

Traffic Counts

Interval Start Time	Eastbound				OMAHA ST Westbound				POWERS BLVD Northbound				POWERS BLVD Southbound				Total	Rolling Hour	Pedestrian Crossings			
	U-Turn	Left	Thru	Right	U-Turn	Left	Thru	Right	U-Turn	Left	Thru	Right	U-Turn	Left	Thru	Right			West	East	South	North
4:00 PM					0	0	0	34	0	0	758	38	0	0	508	0	1,338	5,200	0	0	0	
4:15 PM					0	0	0	21	0	0	733	31	0	0	477	0	1,262	5,202	0	0	0	
4:30 PM					0	0	0	31	0	0	722	40	0	0	520	0	1,313	5,241	0	0	0	
4:45 PM					0	0	0	31	0	0	711	40	0	0	505	0	1,287	5,228	0	0	0	
5:00 PM					0	0	0	43	0	0	702	60	0	0	535	0	1,340	5,183	0	0	0	
5:15 PM					0	0	0	23	0	0	718	44	0	0	516	0	1,301		1	0	0	
5:30 PM					0	0	0	24	0	0	680	42	0	0	554	0	1,300		0	0	0	
5:45 PM					0	0	0	28	0	0	663	33	0	0	518	0	1,242		0	0	0	
Count Total					0	0	0	235	0	0	5,687	328	0	0	4,133	0	10,383		1	0	0	
Peak Hour					0	0	0	128	0	0	2,853	184	0	0	2,076	0	5,241		1	0	0	



(303) 216-2439
www.alltrafficdata.net

Location: 2 PAONIA ST & OMAHA BLVD PM
Date and Start Time: Tuesday, October 15, 2019
Peak Hour: 04:15 PM - 05:15 PM
Peak 15-Minutes: 05:00 PM - 05:15 PM

Peak Hour - All Vehicles

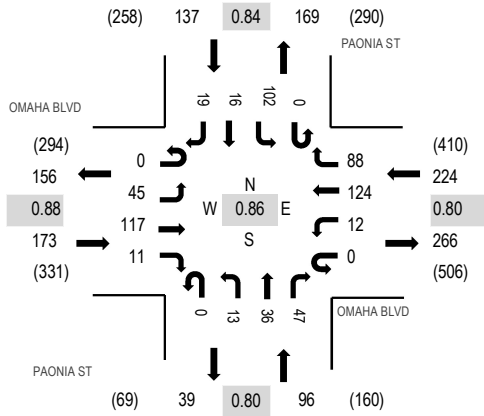

Peak Hour - Pedestrians/Bicycles on Crosswalk

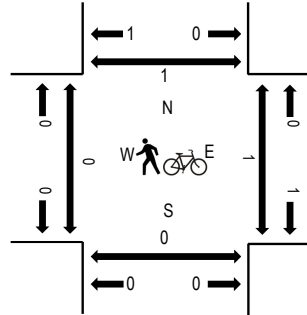

Note: Total study counts contained in parentheses.

Traffic Counts

Interval Start Time	OMAHA BLVD Eastbound				OMAHA BLVD Westbound				PAONIA ST Northbound				PAONIA ST Southbound				Total	Rolling Hour	Pedestrian Crossings			
	U-Turn	Left	Thru	Right	U-Turn	Left	Thru	Right	U-Turn	Left	Thru	Right	U-Turn	Left	Thru	Right			West	East	South	North
4:00 PM	0	4	26	7	0	1	32	20	0	6	4	14	0	25	5	2	146	592	0	0	0	0
4:15 PM	0	2	29	5	0	4	19	19	0	3	4	12	0	21	6	5	129	630	0	0	0	0
4:30 PM	0	16	27	2	0	5	31	27	0	3	9	14	0	25	2	4	165	626	0	0	0	0
4:45 PM	0	12	28	2	0	3	32	13	0	2	10	9	0	31	4	6	152	605	0	0	0	1
5:00 PM	0	15	33	2	0	0	42	29	0	5	13	12	0	25	4	4	184	567	0	1	0	0
5:15 PM	0	11	23	1	0	1	26	19	0	4	6	6	0	26	1	1	125		0	0	0	0
5:30 PM	0	12	29	8	0	1	28	17	0	3	7	7	0	27	1	4	144		0	0	0	0
5:45 PM	0	5	32	0	0	2	26	13	0	3	3	1	0	24	2	3	114		0	0	0	0
Count Total	0	77	227	27	0	17	236	157	0	29	56	75	0	204	25	29	1,159		0	1	0	1
Peak Hour	0	45	117	11	0	12	124	88	0	13	36	47	0	102	16	19	630		0	1	0	1



(303) 216-2439
www.alltrafficdata.net

Location: 3 POWERS BLVD & GALLEY RD PM
Date and Start Time: Tuesday, October 15, 2019
Peak Hour: 04:15 PM - 05:15 PM
Peak 15-Minutes: 05:00 PM - 05:15 PM

Peak Hour - All Vehicles

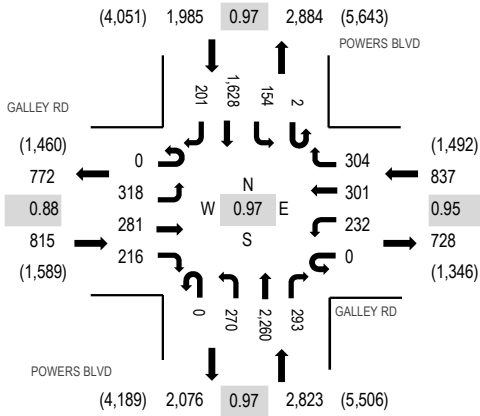

Peak Hour - Pedestrians/Bicycles on Crosswalk

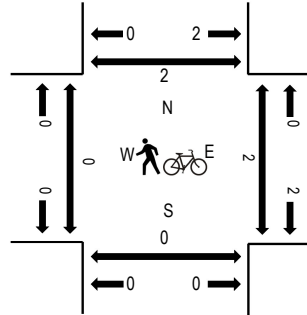

Note: Total study counts contained in parentheses.

Traffic Counts

Interval Start Time	GALLEY RD Eastbound				GALLEY RD Westbound				POWERS BLVD Northbound				POWERS BLVD Southbound				Total	Rolling Hour	Pedestrian Crossings			
	U-Turn	Left	Thru	Right	U-Turn	Left	Thru	Right	U-Turn	Left	Thru	Right	U-Turn	Left	Thru	Right			West	East	South	North
4:00 PM	0	70	62	66	0	38	81	101	0	85	589	57	2	43	413	41	1,648	6,437	0	0	0	0
4:15 PM	0	95	65	56	0	63	69	79	0	65	575	82	1	35	357	61	1,603	6,460	0	0	0	0
4:30 PM	0	58	78	45	0	54	79	77	0	54	547	69	0	45	409	55	1,570	6,455	0	0	0	0
4:45 PM	0	74	69	42	0	46	77	76	0	80	577	83	1	42	406	43	1,616	6,427	0	2	0	2
5:00 PM	0	91	69	73	0	69	76	72	0	71	561	59	0	32	456	42	1,671	6,201	0	0	0	0
5:15 PM	0	71	68	64	0	35	59	55	0	50	584	67	0	28	466	51	1,598		0	0	0	0
5:30 PM	0	74	69	57	0	35	53	51	0	79	526	56	2	35	458	47	1,542		0	0	0	0
5:45 PM	0	70	59	44	0	38	50	59	0	49	504	37	1	37	399	43	1,390		0	0	0	0
Count Total	0	603	539	447	0	378	544	570	0	533	4,463	510	7	297	3,364	383	12,638		0	2	0	2
Peak Hour	0	318	281	216	0	232	301	304	0	270	2,260	293	2	154	1,628	201	6,460		0	2	0	2



(303) 216-2439
www.alltrafficdata.net

Location: 4 CONRAD ST & GALLEY RD PM
Date and Start Time: Tuesday, October 15, 2019
Peak Hour: 04:00 PM - 05:00 PM
Peak 15-Minutes: 04:30 PM - 04:45 PM

Peak Hour - All Vehicles

Peak Hour - Pedestrians/Bicycles on Crosswalk

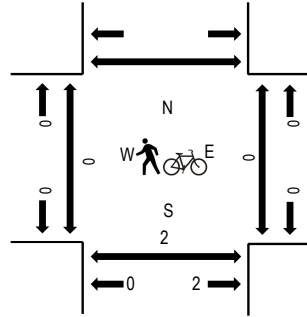
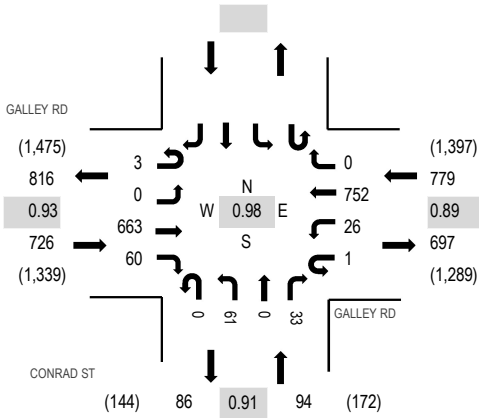

Note: Total study counts contained in parentheses.

Traffic Counts

Interval Start Time	GALLEY RD Eastbound				GALLEY RD Westbound				CONRAD ST Northbound				Southbound				Total	Rolling Hour	Pedestrian Crossings			
	U-Turn	Left	Thru	Right	U-Turn	Left	Thru	Right	U-Turn	Left	Thru	Right	U-Turn	Left	Thru	Right			West	East	South	North
4:00 PM	0	0	147	12	0	7	211	0	0	16	0	12					405	1,599	0	0	0	
4:15 PM	0	0	160	18	1	7	178	0	0	15	0	5					384	1,591	0	0	0	
4:30 PM	1	0	180	14	0	4	188	0	0	13	0	10					410	1,531	0	0	0	
4:45 PM	2	0	176	16	0	8	175	0	0	17	0	6					400	1,429	0	0	2	
5:00 PM	0	0	153	8	0	4	205	0	1	19	0	7					397	1,309	0	0	1	
5:15 PM	1	0	152	10	0	5	131	0	0	18	0	7					324		0	0	0	
5:30 PM	0	0	149	13	0	3	133	0	0	7	0	3					308		0	0	0	
5:45 PM	0	0	117	10	0	4	133	0	0	12	0	4					280		0	0	0	
Count Total	4	0	1,234	101	1	42	1,354	0	1	117	0	54					2,908		0	0	3	
Peak Hour	3	0	663	60	1	26	752	0	0	61	0	33					1,599		0	0	2	



(303) 216-2439
www.alltrafficdata.net

Location: 5 PAONIA ST & GALLEY RD PM
Date and Start Time: Tuesday, October 15, 2019
Peak Hour: 04:00 PM - 05:00 PM
Peak 15-Minutes: 04:30 PM - 04:45 PM

Peak Hour - All Vehicles

Peak Hour - Pedestrians/Bicycles on Crosswalk

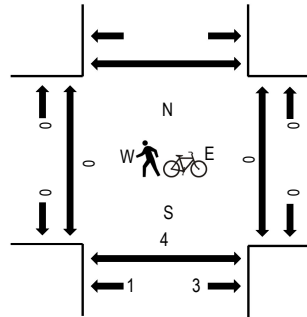
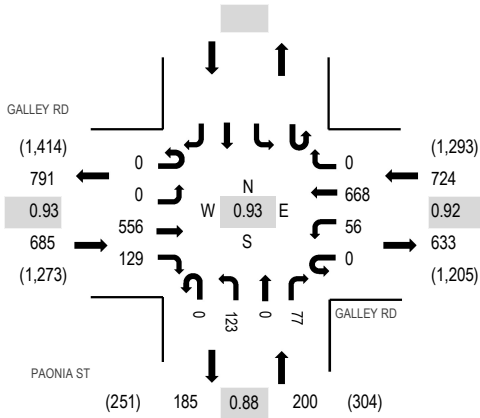

Note: Total study counts contained in parentheses.

Traffic Counts

Interval Start Time	GALLEY RD Eastbound				GALLEY RD Westbound				PAONIA ST Northbound				Southbound				Total	Rolling Hour	Pedestrian Crossings			
	U-Turn	Left	Thru	Right	U-Turn	Left	Thru	Right	U-Turn	Left	Thru	Right	U-Turn	Left	Thru	Right			West	East	South	North
4:00 PM	0	0	129	29	0	10	170	0	0	44	0	13	0	0	0	0	395	1,609	0	0	2	
4:15 PM	0	0	128	34	0	15	161	0	0	29	0	14	0	0	0	0	381	1,599	0	0	0	
4:30 PM	0	0	146	34	0	17	179	0	0	22	0	33	0	0	0	0	431	1,520	0	0	0	
4:45 PM	0	0	153	32	0	14	158	0	0	28	0	17	0	0	0	0	402	1,387	0	0	2	
5:00 PM	0	0	146	14	0	7	173	0	0	35	0	10	0	0	0	0	385	1,261	0	0	0	
5:15 PM	0	0	146	14	0	2	121	0	0	14	0	5	0	0	0	0	302		0	0	1	
5:30 PM	0	0	137	11	0	5	120	0	0	15	0	10	0	0	0	0	298		0	0	0	
5:45 PM	0	0	112	8	0	5	136	0	0	9	0	6	0	0	0	0	276		0	0	0	
Count Total	0	0	1,097	176	0	75	1,218	0	0	196	0	108	0	0	0	0	2,870		0	0	5	
Peak Hour	0	0	556	129	0	56	668	0	0	123	0	77	0	0	0	0	1,609		0	0	4	

APPENDIX B. EXISTING LEVEL OF SERVICE WORKSHEETS

Timings
1: Powers & Galley

Existing Conditions
AM Peak Hour

Lane Group	EBL	EBT	EBR	WBL	WBT	WBR	NBL	NBT	NBR	SBL	SBT	SBR
Lane Configurations												
Traffic Volume (vph)	160	182	184	215	248	146	201	1427	207	280	2653	240
Future Volume (vph)	160	182	184	215	248	146	201	1427	207	280	2653	240
Turn Type	Prot	NA	Perm	Prot	NA	Perm	Prot	NA	Perm	Prot	NA	Perm
Protected Phases	7	4		3	8		5	2		1	6	
Permitted Phases			4			8			2			6
Detector Phase	7	4	4	3	8	8	5	2	2	1	6	6
Switch Phase												
Minimum Initial (s)	4.0	4.0	4.0	4.0	4.0	4.0	4.0	20.0	20.0	4.0	20.0	20.0
Minimum Split (s)	10.5	44.5	44.5	10.5	44.5	44.5	11.5	42.5	42.5	10.5	42.5	42.5
Total Split (s)	21.0	33.0	33.0	21.0	33.0	33.0	21.0	71.0	71.0	21.0	71.0	71.0
Total Split (%)	14.4%	22.6%	22.6%	14.4%	22.6%	22.6%	14.4%	48.6%	48.6%	14.4%	48.6%	48.6%
Yellow Time (s)	3.0	4.5	4.5	3.0	4.5	4.5	5.5	5.5	5.5	3.0	5.5	5.5
All-Red Time (s)	2.0	2.0	2.0	2.0	2.0	2.0	2.0	2.0	2.0	2.0	2.0	2.0
Lost Time Adjust (s)	0.0	0.0	0.0	0.0	0.0	0.0	0.0	0.0	0.0	0.0	0.0	0.0
Total Lost Time (s)	5.0	6.5	6.5	5.0	6.5	6.5	7.5	7.5	7.5	5.0	7.5	7.5
Lead/Lag	Lead	Lag	Lag	Lead	Lag	Lag	Lead	Lag	Lag	Lead	Lag	Lag
Lead-Lag Optimize?	Yes	Yes	Yes	Yes	Yes	Yes	Yes	Yes	Yes	Yes	Yes	Yes
Recall Mode	None	None	None	None	None	None	None	C-Max	C-Max	None	C-Max	C-Max
Act Effct Green (s)	13.0	15.7	15.7	14.5	17.2	17.2	14.5	74.4	74.4	17.4	74.8	74.8
Actuated g/C Ratio	0.09	0.11	0.11	0.10	0.12	0.12	0.10	0.51	0.51	0.12	0.51	0.51
v/c Ratio	0.61	0.56	0.67	0.71	0.67	0.50	0.65	0.60	0.25	0.71	1.05	0.27
Control Delay	72.3	67.0	26.0	75.3	69.6	13.1	72.0	27.8	5.7	71.6	67.4	3.4
Queue Delay	0.0	0.0	0.0	0.0	0.0	0.0	0.0	0.0	0.0	0.0	0.0	0.0
Total Delay	72.3	67.0	26.0	75.3	69.6	13.1	72.0	27.8	5.7	71.6	67.4	3.4
LOS	E	E	C	E	E	B	E	C	A	E	E	A
Approach Delay		54.3			58.1			30.2			62.9	
Approach LOS		D			E			C			E	

Intersection Summary

Cycle Length: 146
 Actuated Cycle Length: 146
 Offset: 54 (37%), Referenced to phase 2:NBT and 6:SBT, Start of Yellow
 Natural Cycle: 150
 Control Type: Actuated-Coordinated
 Maximum v/c Ratio: 1.05
 Intersection Signal Delay: 51.6
 Intersection Capacity Utilization 90.5%
 Analysis Period (min) 15
 Intersection LOS: D
 ICU Level of Service E

Splits and Phases: 1: Powers & Galley

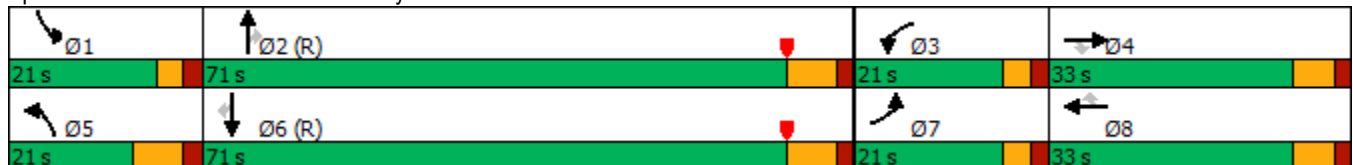

HCM 6th Signalized Intersection Summary
1: Powers & Galley

Existing Conditions
AM Peak Hour

Movement	EBL	EBT	EBR	WBL	WBT	WBR	NBL	NBT	NBR	SBL	SBT	SBR
Lane Configurations												
Traffic Volume (veh/h)	160	182	184	215	248	146	201	1427	207	280	2653	240
Future Volume (veh/h)	160	182	184	215	248	146	201	1427	207	280	2653	240
Initial Q (Qb), veh	0	0	0	0	0	0	0	0	0	0	0	0
Ped-Bike Adj(A_pbT)	1.00		1.00	1.00		1.00	1.00		1.00	1.00		1.00
Parking Bus, Adj	1.00	1.00	1.00	1.00	1.00	1.00	1.00	1.00	1.00	1.00	1.00	1.00
Work Zone On Approach		No			No			No			No	
Adj Sat Flow, veh/h/ln	1870	1870	1870	1870	1870	1870	1870	1870	1870	1870	1870	1870
Adj Flow Rate, veh/h	186	212	0	242	279	0	221	1568	0	289	2735	247
Peak Hour Factor	0.86	0.86	0.86	0.89	0.89	0.89	0.91	0.91	0.91	0.97	0.97	0.97
Percent Heavy Veh, %	2	2	2	2	2	2	2	2	2	2	2	2
Cap, veh/h	237	298		292	355		269	2908		337	2921	907
Arrive On Green	0.07	0.08	0.00	0.08	0.10	0.00	0.08	0.57	0.00	0.10	0.57	0.57
Sat Flow, veh/h	3456	3554	1585	3456	3554	1585	3456	5106	1585	3456	5106	1585
Grp Volume(v), veh/h	186	212	0	242	279	0	221	1568	0	289	2735	247
Grp Sat Flow(s),veh/h/ln	1728	1777	1585	1728	1777	1585	1728	1702	1585	1728	1702	1585
Q Serve(g_s), s	7.7	8.5	0.0	10.1	11.2	0.0	9.2	27.9	0.0	12.0	72.1	11.5
Cycle Q Clear(g_c), s	7.7	8.5	0.0	10.1	11.2	0.0	9.2	27.9	0.0	12.0	72.1	11.5
Prop In Lane	1.00		1.00	1.00		1.00	1.00		1.00	1.00		1.00
Lane Grp Cap(c), veh/h	237	298		292	355		269	2908		337	2921	907
V/C Ratio(X)	0.78	0.71		0.83	0.79		0.82	0.54		0.86	0.94	0.27
Avail Cap(c_a), veh/h	379	645		379	645		320	2908		379	2921	907
HCM Platoon Ratio	1.00	1.00	1.00	1.00	1.00	1.00	1.00	1.00	1.00	1.00	1.00	1.00
Upstream Filter(I)	1.00	1.00	0.00	1.00	1.00	0.00	1.00	1.00	0.00	1.00	1.00	1.00
Uniform Delay (d), s/veh	66.9	65.1	0.0	65.8	64.2	0.0	66.3	19.5	0.0	64.9	28.8	15.8
Incr Delay (d2), s/veh	5.6	3.1	0.0	11.2	3.9	0.0	13.6	0.7	0.0	16.2	7.2	0.7
Initial Q Delay(d3),s/veh	0.0	0.0	0.0	0.0	0.0	0.0	0.0	0.0	0.0	0.0	0.0	0.0
%ile BackOfQ(50%),veh/ln	3.6	4.0	0.0	4.9	5.3	0.0	4.6	11.2	0.0	6.1	30.3	4.4
Unsig. Movement Delay, s/veh												
LnGrp Delay(d),s/veh	72.5	68.3	0.0	77.0	68.0	0.0	80.0	20.2	0.0	81.1	36.0	16.6
LnGrp LOS	E	E		E	E		E	C		F	D	B
Approach Vol, veh/h		398	A		521	A		1789	A		3271	
Approach Delay, s/veh		70.3			72.2			27.6			38.5	
Approach LOS		E			E			C			D	
Timer - Assigned Phs	1	2	3	4	5	6	7	8				
Phs Duration (G+Y+Rc), s	19.2	90.7	17.4	18.8	18.9	91.0	15.0	21.1				
Change Period (Y+Rc), s	5.0	7.5	5.0	6.5	7.5	7.5	5.0	6.5				
Max Green Setting (Gmax), s	16.0	63.5	16.0	26.5	13.5	63.5	16.0	26.5				
Max Q Clear Time (g_c+I1), s	14.0	29.9	12.1	10.5	11.2	74.1	9.7	13.2				
Green Ext Time (p_c), s	0.2	15.6	0.3	1.1	0.2	0.0	0.3	1.4				

Intersection Summary

HCM 6th Ctrl Delay	40.3
HCM 6th LOS	D

Notes

User approved pedestrian interval to be less than phase max green.
Unsignalized Delay for [NBR, EBR, WBR] is excluded from calculations of the approach delay and intersection delay.

Intersection						
Int Delay, s/veh	1.1					
Movement	EBT	EBR	WBL	WBT	NBL	NBR
Lane Configurations	↑	↗	↘	↑	↘	↗
Traffic Vol, veh/h	521	65	28	587	22	14
Future Vol, veh/h	521	65	28	587	22	14
Conflicting Peds, #/hr	0	0	0	0	0	0
Sign Control	Free	Free	Free	Free	Stop	Stop
RT Channelized	-	None	-	None	-	None
Storage Length	-	0	100	-	0	0
Veh in Median Storage, #	0	-	-	0	0	-
Grade, %	0	-	-	0	0	-
Peak Hour Factor	92	92	84	84	72	72
Heavy Vehicles, %	2	2	2	2	2	2
Mvmt Flow	566	71	33	699	31	19

Major/Minor	Major1	Major2	Minor1		
Conflicting Flow All	0	0	637	0	1331 566
Stage 1	-	-	-	-	566 -
Stage 2	-	-	-	-	765 -
Critical Hdwy	-	-	4.12	-	6.42 6.22
Critical Hdwy Stg 1	-	-	-	-	5.42 -
Critical Hdwy Stg 2	-	-	-	-	5.42 -
Follow-up Hdwy	-	-	2.218	-	3.518 3.318
Pot Cap-1 Maneuver	-	-	947	-	170 524
Stage 1	-	-	-	-	568 -
Stage 2	-	-	-	-	459 -
Platoon blocked, %	-	-	-	-	-
Mov Cap-1 Maneuver	-	-	947	-	164 524
Mov Cap-2 Maneuver	-	-	-	-	164 -
Stage 1	-	-	-	-	568 -
Stage 2	-	-	-	-	443 -

Approach	EB	WB	NB
HCM Control Delay, s	0	0.4	24.2
HCM LOS			C

Minor Lane/Major Mvmt	NBLn1	NBLn2	EBT	EBR	WBL	WBT
Capacity (veh/h)	164	524	-	-	947	-
HCM Lane V/C Ratio	0.186	0.037	-	-	0.035	-
HCM Control Delay (s)	31.9	12.1	-	-	8.9	-
HCM Lane LOS	D	B	-	-	A	-
HCM 95th %tile Q(veh)	0.7	0.1	-	-	0.1	-

Intersection												
Int Delay, s/veh	7.8											
Movement	EBL	EBT	EBR	WBL	WBT	WBR	NBL	NBT	NBR	SBL	SBT	SBR
Lane Configurations		↔			↔			↔			↔	
Traffic Vol, veh/h	47	48	43	28	131	52	14	10	25	86	47	15
Future Vol, veh/h	47	48	43	28	131	52	14	10	25	86	47	15
Conflicting Peds, #/hr	0	0	0	0	0	0	0	0	0	0	0	0
Sign Control	Free	Free	Free	Free	Free	Free	Stop	Stop	Stop	Stop	Stop	Stop
RT Channelized	-	-	None	-	-	None	-	-	None	-	-	None
Storage Length	-	-	-	-	-	-	-	-	-	-	-	-
Veh in Median Storage, #	-	0	-	-	0	-	-	0	-	-	0	-
Grade, %	-	0	-	-	0	-	-	0	-	-	0	-
Peak Hour Factor	75	75	75	93	93	93	83	83	83	67	67	67
Heavy Vehicles, %	2	2	2	2	2	2	2	2	2	2	2	2
Mvmt Flow	63	64	57	30	141	56	17	12	30	128	70	22

Major/Minor	Major1			Major2			Minor1			Minor2		
Conflicting Flow All	197	0	0	121	0	0	385	476	61	393	476	99
Stage 1	-	-	-	-	-	-	219	219	-	229	229	-
Stage 2	-	-	-	-	-	-	166	257	-	164	247	-
Critical Hdwy	4.14	-	-	4.14	-	-	7.54	6.54	6.94	7.54	6.54	6.94
Critical Hdwy Stg 1	-	-	-	-	-	-	6.54	5.54	-	6.54	5.54	-
Critical Hdwy Stg 2	-	-	-	-	-	-	6.54	5.54	-	6.54	5.54	-
Follow-up Hdwy	2.22	-	-	2.22	-	-	3.52	4.02	3.32	3.52	4.02	3.32
Pot Cap-1 Maneuver	1373	-	-	1464	-	-	548	486	991	541	486	937
Stage 1	-	-	-	-	-	-	763	721	-	753	713	-
Stage 2	-	-	-	-	-	-	820	694	-	822	701	-
Platoon blocked, %		-	-		-	-						
Mov Cap-1 Maneuver	1373	-	-	1464	-	-	446	451	991	486	451	937
Mov Cap-2 Maneuver	-	-	-	-	-	-	446	451	-	486	451	-
Stage 1	-	-	-	-	-	-	725	685	-	715	697	-
Stage 2	-	-	-	-	-	-	703	678	-	744	666	-

Approach	EB			WB			NB			SB		
HCM Control Delay, s	2.7			1.1			11.4			17.9		
HCM LOS							B			C		

Minor Lane/Major Mvmt	NBLn1	EBL	EBT	EBR	WBL	WBT	WBR	SBLn1
Capacity (veh/h)	622	1373	-	-	1464	-	-	498
HCM Lane V/C Ratio	0.095	0.046	-	-	0.021	-	-	0.444
HCM Control Delay (s)	11.4	7.7	0.1	-	7.5	0.1	-	17.9
HCM Lane LOS	B	A	A	-	A	A	-	C
HCM 95th %tile Q(veh)	0.3	0.1	-	-	0.1	-	-	2.2

Intersection						
Int Delay, s/veh	1					
Movement	EBT	EBR	WBL	WBT	NBL	NBR
Lane Configurations	↑↑		↖	↑	↘	
Traffic Vol, veh/h	608	61	8	584	25	4
Future Vol, veh/h	608	61	8	584	25	4
Conflicting Peds, #/hr	0	0	0	0	0	0
Sign Control	Free	Free	Free	Free	Stop	Stop
RT Channelized	-	None	-	None	-	None
Storage Length	-	-	125	-	0	-
Veh in Median Storage, #	0	-	-	0	0	-
Grade, %	0	-	-	0	0	-
Peak Hour Factor	88	88	85	85	75	75
Heavy Vehicles, %	2	2	2	2	2	2
Mvmt Flow	691	69	9	687	33	5

Major/Minor	Major1	Major2	Minor1	Minor2	Minor3
Conflicting Flow All	0	0	760	0	1431
Stage 1	-	-	-	-	726
Stage 2	-	-	-	-	705
Critical Hdwy	-	-	4.13	-	6.63
Critical Hdwy Stg 1	-	-	-	-	5.83
Critical Hdwy Stg 2	-	-	-	-	5.43
Follow-up Hdwy	-	-	2.219	-	3.519
Pot Cap-1 Maneuver	-	-	850	-	136
Stage 1	-	-	-	-	441
Stage 2	-	-	-	-	489
Platoon blocked, %	-	-	-	-	-
Mov Cap-1 Maneuver	-	-	850	-	135
Mov Cap-2 Maneuver	-	-	-	-	135
Stage 1	-	-	-	-	441
Stage 2	-	-	-	-	484

Approach	EB	WB	NB
HCM Control Delay, s	0	0.1	36.9
HCM LOS			E

Minor Lane/Major Mvmt	NBLn1	EBT	EBR	WBL	WBT
Capacity (veh/h)	151	-	-	850	-
HCM Lane V/C Ratio	0.256	-	-	0.011	-
HCM Control Delay (s)	36.9	-	-	9.3	-
HCM Lane LOS	E	-	-	A	-
HCM 95th %tile Q(veh)	1	-	-	0	-

Timings
1: Powers & Galley

Existing Conditions
PM Peak Hour

Lane Group	EBL	EBT	EBR	WBL	WBT	WBR	NBL	NBT	NBR	SBL	SBT	SBR
Lane Configurations												
Traffic Volume (vph)	318	281	216	232	301	304	270	2260	293	154	1721	201
Future Volume (vph)	318	281	216	232	301	304	270	2260	293	154	1721	201
Turn Type	Prot	NA	Perm	Prot	NA	Perm	Prot	NA	Perm	Prot	NA	Perm
Protected Phases	7	4		3	8		5	2		1	6	
Permitted Phases			4			8			2			6
Detector Phase	7	4	4	3	8	8	5	2	2	1	6	6
Switch Phase												
Minimum Initial (s)	4.0	4.0	4.0	4.0	4.0	4.0	4.0	20.0	20.0	4.0	20.0	20.0
Minimum Split (s)	10.5	44.5	44.5	10.5	44.5	44.5	11.5	42.5	42.5	10.5	42.5	42.5
Total Split (s)	21.0	33.0	33.0	21.0	33.0	33.0	21.0	71.0	71.0	21.0	71.0	71.0
Total Split (%)	14.4%	22.6%	22.6%	14.4%	22.6%	22.6%	14.4%	48.6%	48.6%	14.4%	48.6%	48.6%
Yellow Time (s)	3.0	4.5	4.5	3.0	4.5	4.5	5.5	5.5	5.5	3.0	5.5	5.5
All-Red Time (s)	2.0	2.0	2.0	2.0	2.0	2.0	2.0	2.0	2.0	2.0	2.0	2.0
Lost Time Adjust (s)	0.0	0.0	0.0	0.0	0.0	0.0	0.0	0.0	0.0	0.0	0.0	0.0
Total Lost Time (s)	5.0	6.5	6.5	5.0	6.5	6.5	7.5	7.5	7.5	5.0	7.5	7.5
Lead/Lag	Lead	Lag	Lag	Lead	Lag	Lag	Lead	Lag	Lag	Lead	Lag	Lag
Lead-Lag Optimize?	Yes	Yes	Yes	Yes	Yes	Yes	Yes	Yes	Yes	Yes	Yes	Yes
Recall Mode	None	None	None	None	None	None	None	C-Max	C-Max	None	C-Max	C-Max
Act Effct Green (s)	16.0	23.1	23.1	14.6	21.7	21.7	14.6	72.2	72.2	12.1	67.2	67.2
Actuated g/C Ratio	0.11	0.16	0.16	0.10	0.15	0.15	0.10	0.49	0.49	0.08	0.46	0.46
v/c Ratio	0.96	0.57	0.62	0.71	0.60	0.86	0.81	0.93	0.35	0.56	0.76	0.25
Control Delay	101.3	60.6	25.1	75.5	62.4	51.3	82.5	42.5	11.6	71.8	36.0	3.8
Queue Delay	0.0	0.0	0.0	0.0	0.0	0.0	0.0	0.0	0.0	0.0	0.0	0.0
Total Delay	101.3	60.6	25.1	75.5	62.4	51.3	82.5	42.5	11.6	71.8	36.0	3.8
LOS	F	E	C	E	E	D	F	D	B	E	D	A
Approach Delay		67.1			62.0			43.1			35.5	
Approach LOS		E			E			D			D	

Intersection Summary





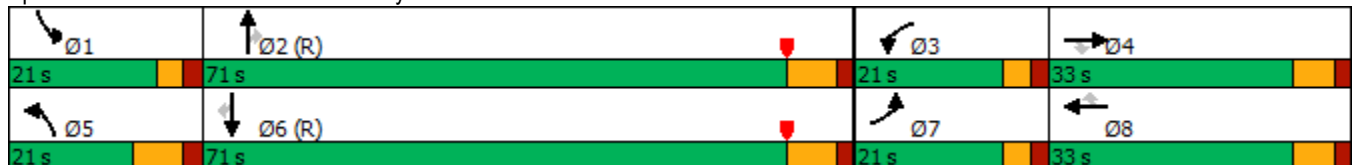





























Cycle Length: 146
 Actuated Cycle Length: 146
 Offset: 54 (37%), Referenced to phase 2:NBT and 6:SBT, Start of Yellow
 Natural Cycle: 150
 Control Type: Actuated-Coordinated
 Maximum v/c Ratio: 0.96
 Intersection Signal Delay: 46.4
 Intersection LOS: D
 Intersection Capacity Utilization 87.4%
 ICU Level of Service E
 Analysis Period (min) 15

Splits and Phases: 1: Powers & Galley



HCM 6th Signalized Intersection Summary
1: Powers & Galley

Existing Conditions
PM Peak Hour

												
Movement	EBL	EBT	EBR	WBL	WBT	WBR	NBL	NBT	NBR	SBL	SBT	SBR
Lane Configurations	 	 		 	 		 	  		 	  	
Traffic Volume (veh/h)	318	281	216	232	301	304	270	2260	293	154	1721	201
Future Volume (veh/h)	318	281	216	232	301	304	270	2260	293	154	1721	201
Initial Q (Qb), veh	0	0	0	0	0	0	0	0	0	0	0	0
Ped-Bike Adj(A_pbT)	1.00		1.00	1.00		1.00	1.00		1.00	1.00		1.00
Parking Bus, Adj	1.00	1.00	1.00	1.00	1.00	1.00	1.00	1.00	1.00	1.00	1.00	1.00
Work Zone On Approach		No			No			No			No	
Adj Sat Flow, veh/h/ln	1870	1870	1870	1870	1870	1870	1870	1870	1870	1870	1870	1870
Adj Flow Rate, veh/h	361	319	0	244	317	0	278	2330	0	159	1774	207
Peak Hour Factor	0.88	0.88	0.88	0.95	0.95	0.95	0.97	0.97	0.97	0.97	0.97	0.97
Percent Heavy Veh, %	2	2	2	2	2	2	2	2	2	2	2	2
Cap, veh/h	379	482		294	395		320	2830		210	2580	801
Arrive On Green	0.11	0.14	0.00	0.09	0.11	0.00	0.09	0.55	0.00	0.06	0.51	0.51
Sat Flow, veh/h	3456	3554	1585	3456	3554	1585	3456	5106	1585	3456	5106	1585
Grp Volume(v), veh/h	361	319	0	244	317	0	278	2330	0	159	1774	207
Grp Sat Flow(s),veh/h/ln	1728	1777	1585	1728	1777	1585	1728	1702	1585	1728	1702	1585
Q Serve(g_s), s	15.2	12.4	0.0	10.1	12.7	0.0	11.6	54.6	0.0	6.6	38.5	10.8
Cycle Q Clear(g_c), s	15.2	12.4	0.0	10.1	12.7	0.0	11.6	54.6	0.0	6.6	38.5	10.8
Prop In Lane	1.00		1.00	1.00		1.00	1.00		1.00	1.00		1.00
Lane Grp Cap(c), veh/h	379	482		294	395		320	2830		210	2580	801
V/C Ratio(X)	0.95	0.66		0.83	0.80		0.87	0.82		0.76	0.69	0.26
Avail Cap(c_a), veh/h	379	645		379	645		320	2830		379	2580	801
HCM Platoon Ratio	1.00	1.00	1.00	1.00	1.00	1.00	1.00	1.00	1.00	1.00	1.00	1.00
Upstream Filter(I)	1.00	1.00	0.00	1.00	1.00	0.00	1.00	1.00	0.00	1.00	1.00	1.00
Uniform Delay (d), s/veh	64.6	59.9	0.0	65.7	63.3	0.0	65.4	26.7	0.0	67.5	27.4	20.6
Incr Delay (d2), s/veh	34.2	1.6	0.0	11.4	3.8	0.0	21.9	2.9	0.0	5.5	1.5	0.8
Initial Q Delay(d3),s/veh	0.0	0.0	0.0	0.0	0.0	0.0	0.0	0.0	0.0	0.0	0.0	0.0
%ile BackOfQ(50%),veh/ln	8.5	5.7	0.0	5.0	6.0	0.0	6.1	22.5	0.0	3.1	15.9	4.3
Unsig. Movement Delay, s/veh												
LnGrp Delay(d),s/veh	98.8	61.5	0.0	77.1	67.2	0.0	87.2	29.6	0.0	73.0	28.9	21.3
LnGrp LOS	F	E		E	E		F	C		E	C	C
Approach Vol, veh/h		680	A		561	A		2608	A		2140	
Approach Delay, s/veh		81.3			71.5			35.7			31.4	
Approach LOS		F			E			D			C	
Timer - Assigned Phs	1	2	3	4	5	6	7	8				
Phs Duration (G+Y+Rc), s	13.9	88.4	17.4	26.3	21.0	81.3	21.0	22.7				
Change Period (Y+Rc), s	5.0	7.5	5.0	6.5	7.5	7.5	5.0	6.5				
Max Green Setting (Gmax), s	16.0	63.5	16.0	26.5	13.5	63.5	16.0	26.5				
Max Q Clear Time (g_c+I1), s	8.6	56.6	12.1	14.4	13.6	40.5	17.2	14.7				
Green Ext Time (p_c), s	0.3	6.3	0.3	1.5	0.0	15.4	0.0	1.5				

Intersection Summary

HCM 6th Ctrl Delay	42.7
HCM 6th LOS	D

Notes

User approved pedestrian interval to be less than phase max green.
Unsignalized Delay for [NBR, EBR, WBR] is excluded from calculations of the approach delay and intersection delay.

Intersection						
Int Delay, s/veh	13.1					
Movement	EBT	EBR	WBL	WBT	NBL	NBR
Lane Configurations	↑	↗	↘	↑	↘	↗
Traffic Vol, veh/h	556	129	56	668	123	77
Future Vol, veh/h	556	129	56	668	123	77
Conflicting Peds, #/hr	0	0	0	0	0	0
Sign Control	Free	Free	Free	Free	Stop	Stop
RT Channelized	-	None	-	None	-	None
Storage Length	-	0	100	-	0	0
Veh in Median Storage, #	0	-	-	0	0	-
Grade, %	0	-	-	0	0	-
Peak Hour Factor	93	93	92	92	88	88
Heavy Vehicles, %	2	2	2	2	2	2
Mvmt Flow	598	139	61	726	140	88

Major/Minor	Major1	Major2	Minor1		
Conflicting Flow All	0	0	737	0	1446 598
Stage 1	-	-	-	-	598 -
Stage 2	-	-	-	-	848 -
Critical Hdwy	-	-	4.12	-	6.42 6.22
Critical Hdwy Stg 1	-	-	-	-	5.42 -
Critical Hdwy Stg 2	-	-	-	-	5.42 -
Follow-up Hdwy	-	-	2.218	-	3.518 3.318
Pot Cap-1 Maneuver	-	-	869	-	145 502
Stage 1	-	-	-	-	549 -
Stage 2	-	-	-	-	420 -
Platoon blocked, %	-	-	-	-	-
Mov Cap-1 Maneuver	-	-	869	-	~ 135 502
Mov Cap-2 Maneuver	-	-	-	-	~ 135 -
Stage 1	-	-	-	-	549 -
Stage 2	-	-	-	-	391 -

Approach	EB	WB	NB
HCM Control Delay, s	0	0.7	98.4
HCM LOS			F

Minor Lane/Major Mvmt	NBLn1	NBLn2	EBT	EBR	WBL	WBT
Capacity (veh/h)	135	502	-	-	869	-
HCM Lane V/C Ratio	1.035	0.174	-	-	0.07	-
HCM Control Delay (s)	151.4	13.7	-	-	9.5	-
HCM Lane LOS	F	B	-	-	A	-
HCM 95th %tile Q(veh)	7.5	0.6	-	-	0.2	-

Notes
 ~: Volume exceeds capacity \$: Delay exceeds 300s +: Computation Not Defined *: All major volume in platoon

Intersection												
Int Delay, s/veh	6.3											
Movement	EBL	EBT	EBR	WBL	WBT	WBR	NBL	NBT	NBR	SBL	SBT	SBR
Lane Configurations		↔↔			↔↔			↔			↔	
Traffic Vol, veh/h	45	117	11	12	124	88	13	36	47	102	16	19
Future Vol, veh/h	45	117	11	12	124	88	13	36	47	102	16	19
Conflicting Peds, #/hr	0	0	0	0	0	0	0	0	0	0	0	0
Sign Control	Free	Free	Free	Free	Free	Free	Stop	Stop	Stop	Stop	Stop	Stop
RT Channelized	-	-	None	-	-	None	-	-	None	-	-	None
Storage Length	-	-	-	-	-	-	-	-	-	-	-	-
Veh in Median Storage, #	-	0	-	-	0	-	-	0	-	-	0	-
Grade, %	-	0	-	-	0	-	-	0	-	-	0	-
Peak Hour Factor	88	88	88	80	80	80	80	80	80	84	84	84
Heavy Vehicles, %	2	2	2	2	2	2	2	2	2	2	2	2
Mvmt Flow	51	133	13	15	155	110	16	45	59	121	19	23

Major/Minor	Major1			Major2			Minor1			Minor2		
Conflicting Flow All	265	0	0	146	0	0	359	537	73	431	488	133
Stage 1	-	-	-	-	-	-	242	242	-	240	240	-
Stage 2	-	-	-	-	-	-	117	295	-	191	248	-
Critical Hdwy	4.14	-	-	4.14	-	-	7.54	6.54	6.94	7.54	6.54	6.94
Critical Hdwy Stg 1	-	-	-	-	-	-	6.54	5.54	-	6.54	5.54	-
Critical Hdwy Stg 2	-	-	-	-	-	-	6.54	5.54	-	6.54	5.54	-
Follow-up Hdwy	2.22	-	-	2.22	-	-	3.52	4.02	3.32	3.52	4.02	3.32
Pot Cap-1 Maneuver	1296	-	-	1434	-	-	572	449	974	508	479	892
Stage 1	-	-	-	-	-	-	740	704	-	742	706	-
Stage 2	-	-	-	-	-	-	875	668	-	792	700	-
Platoon blocked, %		-	-		-	-						
Mov Cap-1 Maneuver	1296	-	-	1434	-	-	517	425	974	421	453	892
Mov Cap-2 Maneuver	-	-	-	-	-	-	517	425	-	421	453	-
Stage 1	-	-	-	-	-	-	708	674	-	710	698	-
Stage 2	-	-	-	-	-	-	820	660	-	665	670	-

Approach	EB			WB			NB			SB		
HCM Control Delay, s	2.1			0.4			12.4			17.1		
HCM LOS							B			C		

Minor Lane/Major Mvmt	NBLn1	EBL	EBT	EBR	WBL	WBT	WBR	SBLn1
Capacity (veh/h)	607	1296	-	-	1434	-	-	458
HCM Lane V/C Ratio	0.198	0.039	-	-	0.01	-	-	0.356
HCM Control Delay (s)	12.4	7.9	0.1	-	7.5	0	-	17.1
HCM Lane LOS	B	A	A	-	A	A	-	C
HCM 95th %tile Q(veh)	0.7	0.1	-	-	0	-	-	1.6

Intersection						
Int Delay, s/veh	5.7					
Movement	EBT	EBR	WBL	WBT	NBL	NBR
Lane Configurations	↑↑		↖	↑	↘	
Traffic Vol, veh/h	668	60	26	776	61	33
Future Vol, veh/h	668	60	26	776	61	33
Conflicting Peds, #/hr	0	0	0	0	0	0
Sign Control	Free	Free	Free	Free	Stop	Stop
RT Channelized	-	None	-	None	-	None
Storage Length	-	-	125	-	0	-
Veh in Median Storage, #	0	-	-	0	0	-
Grade, %	0	-	-	0	0	-
Peak Hour Factor	93	93	89	89	91	91
Heavy Vehicles, %	2	2	2	2	2	2
Mvmt Flow	718	65	29	872	67	36

Major/Minor	Major1	Major2	Minor1	Minor2	Minor3
Conflicting Flow All	0	0	783	0	1681
Stage 1	-	-	-	-	751
Stage 2	-	-	-	-	930
Critical Hdwy	-	-	4.13	-	6.63
Critical Hdwy Stg 1	-	-	-	-	5.83
Critical Hdwy Stg 2	-	-	-	-	5.43
Follow-up Hdwy	-	-	2.219	-	3.519
Pot Cap-1 Maneuver	-	-	833	-	94
Stage 1	-	-	-	-	428
Stage 2	-	-	-	-	383
Platoon blocked, %	-	-	-	-	-
Mov Cap-1 Maneuver	-	-	833	-	91
Mov Cap-2 Maneuver	-	-	-	-	91
Stage 1	-	-	-	-	428
Stage 2	-	-	-	-	370

Approach	EB	WB	NB
HCM Control Delay, s	0	0.3	96.2
HCM LOS			F

Minor Lane/Major Mvmt	NBLn1	EBT	EBR	WBL	WBT
Capacity (veh/h)	130	-	-	833	-
HCM Lane V/C Ratio	0.795	-	-	0.035	-
HCM Control Delay (s)	96.2	-	-	9.5	-
HCM Lane LOS	F	-	-	A	-
HCM 95th %tile Q(veh)	4.8	-	-	0.1	-

**APPENDIX C. SHORT TERM BACKGROUND LEVEL
OF SERVICE WORKSHEETS**

Timings
1: Powers & Galley

Short Term Background
AM Peak Hour

Lane Group	EBL	EBT	EBR	WBL	WBT	WBR	NBL	NBT	NBR	SBL	SBT	SBR
Lane Configurations												
Traffic Volume (vph)	168	191	193	226	260	153	211	1497	217	294	2765	252
Future Volume (vph)	168	191	193	226	260	153	211	1497	217	294	2765	252
Turn Type	Prot	NA	Perm	Prot	NA	Perm	Prot	NA	Perm	Prot	NA	Perm
Protected Phases	7	4		3	8		5	2		1	6	
Permitted Phases			4			8			2			6
Detector Phase	7	4	4	3	8	8	5	2	2	1	6	6
Switch Phase												
Minimum Initial (s)	4.0	4.0	4.0	4.0	4.0	4.0	4.0	20.0	20.0	4.0	20.0	20.0
Minimum Split (s)	10.5	44.5	44.5	10.5	44.5	44.5	11.5	42.5	42.5	10.5	42.5	42.5
Total Split (s)	21.0	33.0	33.0	21.0	33.0	33.0	21.0	71.0	71.0	21.0	71.0	71.0
Total Split (%)	14.4%	22.6%	22.6%	14.4%	22.6%	22.6%	14.4%	48.6%	48.6%	14.4%	48.6%	48.6%
Yellow Time (s)	3.0	4.5	4.5	3.0	4.5	4.5	5.5	5.5	5.5	3.0	5.5	5.5
All-Red Time (s)	2.0	2.0	2.0	2.0	2.0	2.0	2.0	2.0	2.0	2.0	2.0	2.0
Lost Time Adjust (s)	0.0	0.0	0.0	0.0	0.0	0.0	0.0	0.0	0.0	0.0	0.0	0.0
Total Lost Time (s)	5.0	6.5	6.5	5.0	6.5	6.5	7.5	7.5	7.5	5.0	7.5	7.5
Lead/Lag	Lead	Lag	Lag	Lead	Lag	Lag	Lead	Lag	Lag	Lead	Lag	Lag
Lead-Lag Optimize?	Yes	Yes	Yes	Yes	Yes	Yes	Yes	Yes	Yes	Yes	Yes	Yes
Recall Mode	None	None	None	None	None	None	None	C-Max	C-Max	None	C-Max	C-Max
Act Effct Green (s)	13.3	16.4	16.4	14.8	17.8	17.8	14.7	73.2	73.2	17.7	73.6	73.6
Actuated g/C Ratio	0.09	0.11	0.11	0.10	0.12	0.12	0.10	0.50	0.50	0.12	0.50	0.50
v/c Ratio	0.62	0.56	0.69	0.73	0.68	0.50	0.67	0.65	0.27	0.73	1.11	0.28
Control Delay	72.6	66.2	28.3	76.2	69.0	12.6	73.2	29.5	6.6	72.6	90.9	3.5
Queue Delay	0.0	0.0	0.0	0.0	0.0	0.0	0.0	0.0	0.0	0.0	0.0	0.0
Total Delay	72.6	66.2	28.3	76.2	69.0	12.6	73.2	29.5	6.6	72.6	90.9	3.5
LOS	E	E	C	E	E	B	E	C	A	E	F	A
Approach Delay		54.9			58.0			31.8			82.6	
Approach LOS		D			E			C			F	

Intersection Summary





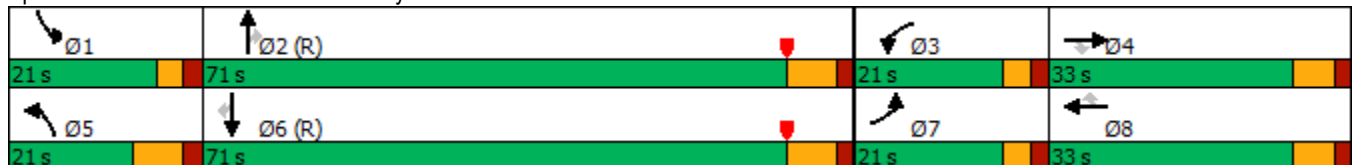



















Cycle Length: 146
 Actuated Cycle Length: 146
 Offset: 54 (37%), Referenced to phase 2:NBT and 6:SBT, Start of Yellow
 Natural Cycle: 150
 Control Type: Actuated-Coordinated
 Maximum v/c Ratio: 1.11
 Intersection Signal Delay: 61.9
 Intersection LOS: E
 Intersection Capacity Utilization 93.5%
 ICU Level of Service F
 Analysis Period (min) 15

Splits and Phases: 1: Powers & Galley



HCM 6th Signalized Intersection Summary
1: Powers & Galley

Short Term Background
AM Peak Hour

												
Movement	EBL	EBT	EBR	WBL	WBT	WBR	NBL	NBT	NBR	SBL	SBT	SBR
Lane Configurations												
Traffic Volume (veh/h)	168	191	193	226	260	153	211	1497	217	294	2765	252
Future Volume (veh/h)	168	191	193	226	260	153	211	1497	217	294	2765	252
Initial Q (Qb), veh	0	0	0	0	0	0	0	0	0	0	0	0
Ped-Bike Adj(A_pbT)	1.00		1.00	1.00		1.00	1.00		1.00	1.00		1.00
Parking Bus, Adj	1.00	1.00	1.00	1.00	1.00	1.00	1.00	1.00	1.00	1.00	1.00	1.00
Work Zone On Approach		No			No			No			No	
Adj Sat Flow, veh/h/ln	1870	1870	1870	1870	1870	1870	1870	1870	1870	1870	1870	1870
Adj Flow Rate, veh/h	195	222	0	254	292	0	232	1645	0	303	2851	260
Peak Hour Factor	0.86	0.86	0.86	0.89	0.89	0.89	0.91	0.91	0.91	0.97	0.97	0.97
Percent Heavy Veh, %	2	2	2	2	2	2	2	2	2	2	2	2
Cap, veh/h	246	309		304	369		279	2856		350	2873	892
Arrive On Green	0.07	0.09	0.00	0.09	0.10	0.00	0.08	0.56	0.00	0.10	0.56	0.56
Sat Flow, veh/h	3456	3554	1585	3456	3554	1585	3456	5106	1585	3456	5106	1585
Grp Volume(v), veh/h	195	222	0	254	292	0	232	1645	0	303	2851	260
Grp Sat Flow(s),veh/h/ln	1728	1777	1585	1728	1777	1585	1728	1702	1585	1728	1702	1585
Q Serve(g_s), s	8.1	8.9	0.0	10.6	11.7	0.0	9.7	30.6	0.0	12.6	80.7	12.5
Cycle Q Clear(g_c), s	8.1	8.9	0.0	10.6	11.7	0.0	9.7	30.6	0.0	12.6	80.7	12.5
Prop In Lane	1.00		1.00	1.00		1.00	1.00		1.00	1.00		1.00
Lane Grp Cap(c), veh/h	246	309		304	369		279	2856		350	2873	892
V/C Ratio(X)	0.79	0.72		0.84	0.79		0.83	0.58		0.87	0.99	0.29
Avail Cap(c_a), veh/h	379	645		379	645		320	2856		379	2873	892
HCM Platoon Ratio	1.00	1.00	1.00	1.00	1.00	1.00	1.00	1.00	1.00	1.00	1.00	1.00
Upstream Filter(I)	1.00	1.00	0.00	1.00	1.00	0.00	1.00	1.00	0.00	1.00	1.00	1.00
Uniform Delay (d), s/veh	66.7	64.9	0.0	65.5	63.9	0.0	66.1	20.9	0.0	64.6	31.6	16.7
Incr Delay (d2), s/veh	6.2	3.1	0.0	12.4	3.8	0.0	15.1	0.9	0.0	17.7	15.1	0.8
Initial Q Delay(d3),s/veh	0.0	0.0	0.0	0.0	0.0	0.0	0.0	0.0	0.0	0.0	0.0	0.0
%ile BackOfQ(50%),veh/ln	3.8	4.2	0.0	5.2	5.5	0.0	4.9	12.3	0.0	6.4	36.0	4.8
Unsig. Movement Delay, s/veh												
LnGrp Delay(d),s/veh	73.0	68.0	0.0	78.0	67.7	0.0	81.2	21.8	0.0	82.4	46.7	17.5
LnGrp LOS	E	E		E	E		F	C		F	D	B
Approach Vol, veh/h		417	A		546	A		1877	A		3414	
Approach Delay, s/veh		70.3			72.5			29.1			47.7	
Approach LOS		E			E			C			D	
Timer - Assigned Phs	1	2	3	4	5	6	7	8				
Phs Duration (G+Y+Rc), s	19.8	89.2	17.8	19.2	19.3	89.6	15.4	21.7				
Change Period (Y+Rc), s	5.0	7.5	5.0	6.5	7.5	7.5	5.0	6.5				
Max Green Setting (Gmax), s	16.0	63.5	16.0	26.5	13.5	63.5	16.0	26.5				
Max Q Clear Time (g_c+I1), s	14.6	32.6	12.6	10.9	11.7	82.7	10.1	13.7				
Green Ext Time (p_c), s	0.2	16.0	0.3	1.1	0.1	0.0	0.3	1.4				

Intersection Summary

HCM 6th Ctrl Delay	45.8
HCM 6th LOS	D

Notes

User approved pedestrian interval to be less than phase max green.
Unsignalized Delay for [NBR, EBR, WBR] is excluded from calculations of the approach delay and intersection delay.

Intersection						
Int Delay, s/veh	1.1					
Movement	EBT	EBR	WBL	WBT	NBL	NBR
Lane Configurations	↑	↗	↘	↑	↘	↗
Traffic Vol, veh/h	554	65	28	617	22	14
Future Vol, veh/h	554	65	28	617	22	14
Conflicting Peds, #/hr	0	0	0	0	0	0
Sign Control	Free	Free	Free	Free	Stop	Stop
RT Channelized	-	None	-	None	-	None
Storage Length	-	0	100	-	0	0
Veh in Median Storage, #	0	-	-	0	0	-
Grade, %	0	-	-	0	0	-
Peak Hour Factor	92	92	84	84	72	72
Heavy Vehicles, %	2	2	2	2	2	2
Mvmt Flow	602	71	33	735	31	19

Major/Minor	Major1	Major2	Minor1		
Conflicting Flow All	0	0	673	0	1403 602
Stage 1	-	-	-	-	602 -
Stage 2	-	-	-	-	801 -
Critical Hdwy	-	-	4.12	-	6.42 6.22
Critical Hdwy Stg 1	-	-	-	-	5.42 -
Critical Hdwy Stg 2	-	-	-	-	5.42 -
Follow-up Hdwy	-	-	2.218	-	3.518 3.318
Pot Cap-1 Maneuver	-	-	918	-	154 500
Stage 1	-	-	-	-	547 -
Stage 2	-	-	-	-	442 -
Platoon blocked, %	-	-	-	-	-
Mov Cap-1 Maneuver	-	-	918	-	148 500
Mov Cap-2 Maneuver	-	-	-	-	148 -
Stage 1	-	-	-	-	547 -
Stage 2	-	-	-	-	426 -

Approach	EB	WB	NB
HCM Control Delay, s	0	0.4	26.6
HCM LOS			D

Minor Lane/Major Mvmt	NBLn1	NBLn2	EBT	EBR	WBL	WBT
Capacity (veh/h)	148	500	-	-	918	-
HCM Lane V/C Ratio	0.206	0.039	-	-	0.036	-
HCM Control Delay (s)	35.5	12.5	-	-	9.1	-
HCM Lane LOS	E	B	-	-	A	-
HCM 95th %tile Q(veh)	0.7	0.1	-	-	0.1	-

Intersection												
Int Delay, s/veh	7.7											
Movement	EBL	EBT	EBR	WBL	WBT	WBR	NBL	NBT	NBR	SBL	SBT	SBR
Lane Configurations		↔			↔			↔			↔	
Traffic Vol, veh/h	47	50	43	28	138	52	14	10	25	86	47	15
Future Vol, veh/h	47	50	43	28	138	52	14	10	25	86	47	15
Conflicting Peds, #/hr	0	0	0	0	0	0	0	0	0	0	0	0
Sign Control	Free	Free	Free	Free	Free	Free	Stop	Stop	Stop	Stop	Stop	Stop
RT Channelized	-	-	None	-	-	None	-	-	None	-	-	None
Storage Length	-	-	-	-	-	-	-	-	-	-	-	-
Veh in Median Storage, #	-	0	-	-	0	-	-	0	-	-	0	-
Grade, %	-	0	-	-	0	-	-	0	-	-	0	-
Peak Hour Factor	75	75	75	93	93	93	83	83	83	67	67	67
Heavy Vehicles, %	2	2	2	2	2	2	2	2	2	2	2	2
Mvmt Flow	63	67	57	30	148	56	17	12	30	128	70	22

Major/Minor	Major1			Major2			Minor1			Minor2		
Conflicting Flow All	204	0	0	124	0	0	391	486	62	402	486	102
Stage 1	-	-	-	-	-	-	222	222	-	236	236	-
Stage 2	-	-	-	-	-	-	169	264	-	166	250	-
Critical Hdwy	4.14	-	-	4.14	-	-	7.54	6.54	6.94	7.54	6.54	6.94
Critical Hdwy Stg 1	-	-	-	-	-	-	6.54	5.54	-	6.54	5.54	-
Critical Hdwy Stg 2	-	-	-	-	-	-	6.54	5.54	-	6.54	5.54	-
Follow-up Hdwy	2.22	-	-	2.22	-	-	3.52	4.02	3.32	3.52	4.02	3.32
Pot Cap-1 Maneuver	1365	-	-	1461	-	-	543	480	990	533	480	933
Stage 1	-	-	-	-	-	-	760	718	-	746	708	-
Stage 2	-	-	-	-	-	-	816	689	-	820	699	-
Platoon blocked, %	-	-	-	-	-	-	-	-	-	-	-	-
Mov Cap-1 Maneuver	1365	-	-	1461	-	-	441	445	990	479	445	933
Mov Cap-2 Maneuver	-	-	-	-	-	-	441	445	-	479	445	-
Stage 1	-	-	-	-	-	-	722	682	-	709	692	-
Stage 2	-	-	-	-	-	-	699	673	-	742	664	-

Approach	EB	WB	NB	SB
HCM Control Delay, s	2.6	1	11.5	18.2
HCM LOS			B	C

Minor Lane/Major Mvmt	NBLn1	EBL	EBT	EBR	WBL	WBT	WBR	SBLn1
Capacity (veh/h)	617	1365	-	-	1461	-	-	491
HCM Lane V/C Ratio	0.096	0.046	-	-	0.021	-	-	0.45
HCM Control Delay (s)	11.5	7.8	0.1	-	7.5	0.1	-	18.2
HCM Lane LOS	B	A	A	-	A	A	-	C
HCM 95th %tile Q(veh)	0.3	0.1	-	-	0.1	-	-	2.3

Intersection						
Int Delay, s/veh	1.1					
Movement	EBT	EBR	WBL	WBT	NBL	NBR
Lane Configurations	↑↑		↖	↑	↘	
Traffic Vol, veh/h	641	61	8	614	25	4
Future Vol, veh/h	641	61	8	614	25	4
Conflicting Peds, #/hr	0	0	0	0	0	0
Sign Control	Free	Free	Free	Free	Stop	Stop
RT Channelized	-	None	-	None	-	None
Storage Length	-	-	125	-	0	-
Veh in Median Storage, #	0	-	-	0	0	-
Grade, %	0	-	-	0	0	-
Peak Hour Factor	88	88	85	85	75	75
Heavy Vehicles, %	2	2	2	2	2	2
Mvmt Flow	728	69	9	722	33	5

Major/Minor	Major1	Major2	Minor1	Minor2	Minor3
Conflicting Flow All	0	0	797	0	1503
Stage 1	-	-	-	-	763
Stage 2	-	-	-	-	740
Critical Hdwy	-	-	4.13	-	6.63
Critical Hdwy Stg 1	-	-	-	-	5.83
Critical Hdwy Stg 2	-	-	-	-	5.43
Follow-up Hdwy	-	-	2.219	-	3.519
Pot Cap-1 Maneuver	-	-	823	-	123
Stage 1	-	-	-	-	422
Stage 2	-	-	-	-	471
Platoon blocked, %	-	-	-	-	-
Mov Cap-1 Maneuver	-	-	823	-	122
Mov Cap-2 Maneuver	-	-	-	-	122
Stage 1	-	-	-	-	422
Stage 2	-	-	-	-	466

Approach	EB	WB	NB
HCM Control Delay, s	0	0.1	41.3
HCM LOS			E

Minor Lane/Major Mvmt	NBLn1	EBT	EBR	WBL	WBT
Capacity (veh/h)	137	-	-	823	-
HCM Lane V/C Ratio	0.282	-	-	0.011	-
HCM Control Delay (s)	41.3	-	-	9.4	-
HCM Lane LOS	E	-	-	A	-
HCM 95th %tile Q(veh)	1.1	-	-	0	-

Timings
1: Powers & Galley

Short Term Background
PM Peak Hour

Lane Group	EBL	EBT	EBR	WBL	WBT	WBR	NBL	NBT	NBR	SBL	SBT	SBR
Lane Configurations												
Traffic Volume (vph)	334	295	227	244	316	319	283	2371	307	162	1801	211
Future Volume (vph)	334	295	227	244	316	319	283	2371	307	162	1801	211
Turn Type	Prot	NA	Perm	Prot	NA	Perm	Prot	NA	Perm	Prot	NA	Perm
Protected Phases	7	4		3	8		5	2		1	6	
Permitted Phases			4			8			2			6
Detector Phase	7	4	4	3	8	8	5	2	2	1	6	6
Switch Phase												
Minimum Initial (s)	4.0	4.0	4.0	4.0	4.0	4.0	4.0	20.0	20.0	4.0	20.0	20.0
Minimum Split (s)	10.5	44.5	44.5	10.5	44.5	44.5	11.5	42.5	42.5	10.5	42.5	42.5
Total Split (s)	21.0	33.0	33.0	21.0	33.0	33.0	21.0	71.0	71.0	21.0	71.0	71.0
Total Split (%)	14.4%	22.6%	22.6%	14.4%	22.6%	22.6%	14.4%	48.6%	48.6%	14.4%	48.6%	48.6%
Yellow Time (s)	3.0	4.5	4.5	3.0	4.5	4.5	5.5	5.5	5.5	3.0	5.5	5.5
All-Red Time (s)	2.0	2.0	2.0	2.0	2.0	2.0	2.0	2.0	2.0	2.0	2.0	2.0
Lost Time Adjust (s)	0.0	0.0	0.0	0.0	0.0	0.0	0.0	0.0	0.0	0.0	0.0	0.0
Total Lost Time (s)	5.0	6.5	6.5	5.0	6.5	6.5	7.5	7.5	7.5	5.0	7.5	7.5
Lead/Lag	Lead	Lag	Lag	Lead	Lag	Lag	Lead	Lag	Lag	Lead	Lag	Lag
Lead-Lag Optimize?	Yes	Yes	Yes	Yes	Yes	Yes	Yes	Yes	Yes	Yes	Yes	Yes
Recall Mode	None	None	None	None	None	None	None	C-Max	C-Max	None	C-Max	C-Max
Act Effct Green (s)	16.0	23.8	23.8	14.9	22.7	22.7	14.7	70.9	70.9	12.4	66.2	66.2
Actuated g/C Ratio	0.11	0.16	0.16	0.10	0.16	0.16	0.10	0.49	0.49	0.08	0.45	0.45
v/c Ratio	1.01	0.58	0.65	0.74	0.61	0.88	0.85	0.99	0.37	0.57	0.81	0.26
Control Delay	112.4	60.4	27.6	76.7	61.8	55.2	86.0	52.9	12.7	71.8	38.4	3.8
Queue Delay	0.0	0.0	0.0	0.0	0.0	0.0	0.0	0.0	0.0	0.0	0.0	0.0
Total Delay	112.4	60.4	27.6	76.7	61.8	55.2	86.0	52.9	12.7	71.8	38.4	3.8
LOS	F	E	C	E	E	E	F	D	B	E	D	A
Approach Delay		72.0			63.5			51.9			37.5	
Approach LOS		E			E			D			D	

Intersection Summary

Cycle Length: 146
 Actuated Cycle Length: 146
 Offset: 54 (37%), Referenced to phase 2:NBT and 6:SBT, Start of Yellow
 Natural Cycle: 150
 Control Type: Actuated-Coordinated
 Maximum v/c Ratio: 1.01
 Intersection Signal Delay: 51.6
 Intersection Capacity Utilization 90.9%
 Analysis Period (min) 15

Intersection LOS: D
 ICU Level of Service E

Splits and Phases: 1: Powers & Galley



HCM 6th Signalized Intersection Summary
1: Powers & Galley

Short Term Background
PM Peak Hour

Movement	EBL	EBT	EBR	WBL	WBT	WBR	NBL	NBT	NBR	SBL	SBT	SBR
Lane Configurations												
Traffic Volume (veh/h)	334	295	227	244	316	319	283	2371	307	162	1801	211
Future Volume (veh/h)	334	295	227	244	316	319	283	2371	307	162	1801	211
Initial Q (Qb), veh	0	0	0	0	0	0	0	0	0	0	0	0
Ped-Bike Adj(A_pbT)	1.00		1.00	1.00		1.00	1.00		1.00	1.00		1.00
Parking Bus, Adj	1.00	1.00	1.00	1.00	1.00	1.00	1.00	1.00	1.00	1.00	1.00	1.00
Work Zone On Approach		No			No			No			No	
Adj Sat Flow, veh/h/ln	1870	1870	1870	1870	1870	1870	1870	1870	1870	1870	1870	1870
Adj Flow Rate, veh/h	380	335	0	257	333	0	292	2444	0	167	1857	218
Peak Hour Factor	0.88	0.88	0.88	0.95	0.95	0.95	0.97	0.97	0.97	0.97	0.97	0.97
Percent Heavy Veh, %	2	2	2	2	2	2	2	2	2	2	2	2
Cap, veh/h	379	485		307	412		320	2794		218	2556	794
Arrive On Green	0.11	0.14	0.00	0.09	0.12	0.00	0.09	0.55	0.00	0.06	0.50	0.50
Sat Flow, veh/h	3456	3554	1585	3456	3554	1585	3456	5106	1585	3456	5106	1585
Grp Volume(v), veh/h	380	335	0	257	333	0	292	2444	0	167	1857	218
Grp Sat Flow(s),veh/h/ln	1728	1777	1585	1728	1777	1585	1728	1702	1585	1728	1702	1585
Q Serve(g_s), s	16.0	13.1	0.0	10.7	13.3	0.0	12.2	60.7	0.0	6.9	41.7	11.6
Cycle Q Clear(g_c), s	16.0	13.1	0.0	10.7	13.3	0.0	12.2	60.7	0.0	6.9	41.7	11.6
Prop In Lane	1.00		1.00	1.00		1.00	1.00		1.00	1.00		1.00
Lane Grp Cap(c), veh/h	379	485		307	412		320	2794		218	2556	794
V/C Ratio(X)	1.00	0.69		0.84	0.81		0.91	0.87		0.77	0.73	0.27
Avail Cap(c_a), veh/h	379	645		379	645		320	2794		379	2556	794
HCM Platoon Ratio	1.00	1.00	1.00	1.00	1.00	1.00	1.00	1.00	1.00	1.00	1.00	1.00
Upstream Filter(I)	1.00	1.00	0.00	1.00	1.00	0.00	1.00	1.00	0.00	1.00	1.00	1.00
Uniform Delay (d), s/veh	65.0	60.1	0.0	65.5	63.0	0.0	65.7	28.7	0.0	67.3	28.6	21.1
Incr Delay (d2), s/veh	47.1	2.0	0.0	12.8	4.3	0.0	29.4	4.2	0.0	5.5	1.8	0.9
Initial Q Delay(d3),s/veh	0.0	0.0	0.0	0.0	0.0	0.0	0.0	0.0	0.0	0.0	0.0	0.0
%ile BackOfQ(50%),veh/ln	9.5	6.1	0.0	5.3	6.3	0.0	6.7	25.3	0.0	3.2	17.3	4.6
Unsig. Movement Delay, s/veh												
LnGrp Delay(d),s/veh	112.1	62.1	0.0	78.2	67.2	0.0	95.1	32.9	0.0	72.9	30.5	22.0
LnGrp LOS	F	E		E	E		F	C		E	C	C
Approach Vol, veh/h		715	A		590	A		2736	A		2242	
Approach Delay, s/veh		88.7			72.0			39.5			32.8	
Approach LOS		F			E			D			C	
Timer - Assigned Phs	1	2	3	4	5	6	7	8				
Phs Duration (G+Y+Rc), s	14.2	87.4	18.0	26.4	21.0	80.6	21.0	23.4				
Change Period (Y+Rc), s	5.0	7.5	5.0	6.5	7.5	7.5	5.0	6.5				
Max Green Setting (Gmax), s	16.0	63.5	16.0	26.5	13.5	63.5	16.0	26.5				
Max Q Clear Time (g_c+I1), s	8.9	62.7	12.7	15.1	14.2	43.7	18.0	15.3				
Green Ext Time (p_c), s	0.3	0.8	0.3	1.6	0.0	14.4	0.0	1.6				

Intersection Summary

HCM 6th Ctrl Delay	45.8
HCM 6th LOS	D

Notes

User approved pedestrian interval to be less than phase max green.
Unsignalized Delay for [NBR, EBR, WBR] is excluded from calculations of the approach delay and intersection delay.

Intersection						
Int Delay, s/veh	17.9					
Movement	EBT	EBR	WBL	WBT	NBL	NBR
Lane Configurations	↑	↗	↘	↑	↘	↗
Traffic Vol, veh/h	592	129	56	732	123	77
Future Vol, veh/h	592	129	56	732	123	77
Conflicting Peds, #/hr	0	0	0	0	0	0
Sign Control	Free	Free	Free	Free	Stop	Stop
RT Channelized	-	None	-	None	-	None
Storage Length	-	0	100	-	0	0
Veh in Median Storage, #	0	-	-	0	0	-
Grade, %	0	-	-	0	0	-
Peak Hour Factor	93	93	92	92	88	88
Heavy Vehicles, %	2	2	2	2	2	2
Mvmt Flow	637	139	61	796	140	88

Major/Minor	Major1	Major2	Minor1		
Conflicting Flow All	0	0	776	0	1555 637
Stage 1	-	-	-	-	637 -
Stage 2	-	-	-	-	918 -
Critical Hdwy	-	-	4.12	-	6.42 6.22
Critical Hdwy Stg 1	-	-	-	-	5.42 -
Critical Hdwy Stg 2	-	-	-	-	5.42 -
Follow-up Hdwy	-	-	2.218	-	3.518 3.318
Pot Cap-1 Maneuver	-	-	840	-	~ 124 477
Stage 1	-	-	-	-	527 -
Stage 2	-	-	-	-	389 -
Platoon blocked, %	-	-	-	-	-
Mov Cap-1 Maneuver	-	-	840	-	~ 115 477
Mov Cap-2 Maneuver	-	-	-	-	~ 115 -
Stage 1	-	-	-	-	527 -
Stage 2	-	-	-	-	361 -

Approach	EB	WB	NB
HCM Control Delay, s	0	0.7	143.4
HCM LOS			F

Minor Lane/Major Mvmt	NBLn1	NBLn2	EBT	EBR	WBL	WBT
Capacity (veh/h)	115	477	-	-	840	-
HCM Lane V/C Ratio	1.215	0.183	-	-	0.072	-
HCM Control Delay (s)	224.3	14.2	-	-	9.6	-
HCM Lane LOS	F	B	-	-	A	-
HCM 95th %tile Q(veh)	9	0.7	-	-	0.2	-

Notes
 ~: Volume exceeds capacity \$: Delay exceeds 300s +: Computation Not Defined *: All major volume in platoon

Intersection												
Int Delay, s/veh	6.3											
Movement	EBL	EBT	EBR	WBL	WBT	WBR	NBL	NBT	NBR	SBL	SBT	SBR
Lane Configurations		↔↔			↔↔			↔			↔	
Traffic Vol, veh/h	45	122	11	12	130	88	13	36	47	102	16	19
Future Vol, veh/h	45	122	11	12	130	88	13	36	47	102	16	19
Conflicting Peds, #/hr	0	0	0	0	0	0	0	0	0	0	0	0
Sign Control	Free	Free	Free	Free	Free	Free	Stop	Stop	Stop	Stop	Stop	Stop
RT Channelized	-	-	None	-	-	None	-	-	None	-	-	None
Storage Length	-	-	-	-	-	-	-	-	-	-	-	-
Veh in Median Storage, #	-	0	-	-	0	-	-	0	-	-	0	-
Grade, %	-	0	-	-	0	-	-	0	-	-	0	-
Peak Hour Factor	88	88	88	80	80	80	80	80	80	84	84	84
Heavy Vehicles, %	2	2	2	2	2	2	2	2	2	2	2	2
Mvmt Flow	51	139	13	15	163	110	16	45	59	121	19	23

Major/Minor	Major1			Major2			Minor1			Minor2		
Conflicting Flow All	273	0	0	152	0	0	369	551	76	442	502	137
Stage 1	-	-	-	-	-	-	248	248	-	248	248	-
Stage 2	-	-	-	-	-	-	121	303	-	194	254	-
Critical Hdwy	4.14	-	-	4.14	-	-	7.54	6.54	6.94	7.54	6.54	6.94
Critical Hdwy Stg 1	-	-	-	-	-	-	6.54	5.54	-	6.54	5.54	-
Critical Hdwy Stg 2	-	-	-	-	-	-	6.54	5.54	-	6.54	5.54	-
Follow-up Hdwy	2.22	-	-	2.22	-	-	3.52	4.02	3.32	3.52	4.02	3.32
Pot Cap-1 Maneuver	1287	-	-	1426	-	-	562	441	970	499	470	886
Stage 1	-	-	-	-	-	-	734	700	-	734	700	-
Stage 2	-	-	-	-	-	-	870	662	-	789	696	-
Platoon blocked, %		-	-	-	-	-						
Mov Cap-1 Maneuver	1287	-	-	1426	-	-	507	417	970	412	444	886
Mov Cap-2 Maneuver	-	-	-	-	-	-	507	417	-	412	444	-
Stage 1	-	-	-	-	-	-	702	670	-	702	691	-
Stage 2	-	-	-	-	-	-	814	653	-	662	666	-

Approach	EB			WB			NB			SB		
HCM Control Delay, s	2.1			0.4			12.5			17.5		
HCM LOS							B			C		

Minor Lane/Major Mvmt	NBLn1	EBL	EBT	EBR	WBL	WBT	WBR	SBLn1
Capacity (veh/h)	598	1287	-	-	1426	-	-	449
HCM Lane V/C Ratio	0.201	0.04	-	-	0.011	-	-	0.363
HCM Control Delay (s)	12.5	7.9	0.1	-	7.6	0	-	17.5
HCM Lane LOS	B	A	A	-	A	A	-	C
HCM 95th %tile Q(veh)	0.7	0.1	-	-	0	-	-	1.6

Intersection						
Int Delay, s/veh	7.2					
Movement	EBT	EBR	WBL	WBT	NBL	NBR
Lane Configurations	↑↑		↖	↑	↘	
Traffic Vol, veh/h	704	60	26	818	61	33
Future Vol, veh/h	704	60	26	818	61	33
Conflicting Peds, #/hr	0	0	0	0	0	0
Sign Control	Free	Free	Free	Free	Stop	Stop
RT Channelized	-	None	-	None	-	None
Storage Length	-	-	125	-	0	-
Veh in Median Storage, #	0	-	-	0	0	-
Grade, %	0	-	-	0	0	-
Peak Hour Factor	93	93	89	89	91	91
Heavy Vehicles, %	2	2	2	2	2	2
Mvmt Flow	757	65	29	919	67	36

Major/Minor	Major1	Major2	Minor1		
Conflicting Flow All	0	0	822	0	1767 411
Stage 1	-	-	-	-	790 -
Stage 2	-	-	-	-	977 -
Critical Hdwy	-	-	4.13	-	6.63 6.93
Critical Hdwy Stg 1	-	-	-	-	5.83 -
Critical Hdwy Stg 2	-	-	-	-	5.43 -
Follow-up Hdwy	-	-	2.219	-	3.519 3.319
Pot Cap-1 Maneuver	-	-	805	-	83 591
Stage 1	-	-	-	-	409 -
Stage 2	-	-	-	-	364 -
Platoon blocked, %	-	-	-	-	-
Mov Cap-1 Maneuver	-	-	805	-	80 591
Mov Cap-2 Maneuver	-	-	-	-	80 -
Stage 1	-	-	-	-	409 -
Stage 2	-	-	-	-	351 -

Approach	EB	WB	NB
HCM Control Delay, s	0	0.3	128.2
HCM LOS			F

Minor Lane/Major Mvmt	NBLn1	EBT	EBR	WBL	WBT
Capacity (veh/h)	115	-	-	805	-
HCM Lane V/C Ratio	0.898	-	-	0.036	-
HCM Control Delay (s)	128.2	-	-	9.6	-
HCM Lane LOS	F	-	-	A	-
HCM 95th %tile Q(veh)	5.5	-	-	0.1	-

APPENDIX D. LONG TERM BACKGROUND LEVEL OF SERVICE WORKSHEETS

Timings
1: Powers & Galley

Long Term Background
AM Peak Hour

Lane Group	EBL	EBT	EBR	WBL	WBT	WBR	NBL	NBT	NBR	SBL	SBT	SBR
Lane Configurations												
Traffic Volume (vph)	243	276	279	331	376	221	305	2165	314	425	3831	364
Future Volume (vph)	243	276	279	331	376	221	305	2165	314	425	3831	364
Turn Type	Prot	NA	Perm	Prot	NA	Perm	Prot	NA	Perm	Prot	NA	Perm
Protected Phases	7	4		3	8		5	2		1	6	
Permitted Phases			4			8			2			6
Detector Phase	7	4	4	3	8	8	5	2	2	1	6	6
Switch Phase												
Minimum Initial (s)	4.0	4.0	4.0	4.0	4.0	4.0	4.0	20.0	20.0	4.0	20.0	20.0
Minimum Split (s)	10.5	44.5	44.5	10.5	44.5	44.5	11.5	42.5	42.5	10.5	42.5	42.5
Total Split (s)	21.0	33.0	33.0	21.0	33.0	33.0	21.0	71.0	71.0	21.0	71.0	71.0
Total Split (%)	14.4%	22.6%	22.6%	14.4%	22.6%	22.6%	14.4%	48.6%	48.6%	14.4%	48.6%	48.6%
Yellow Time (s)	3.0	4.5	4.5	3.0	4.5	4.5	5.5	5.5	5.5	3.0	5.5	5.5
All-Red Time (s)	2.0	2.0	2.0	2.0	2.0	2.0	2.0	2.0	2.0	2.0	2.0	2.0
Lost Time Adjust (s)	0.0	0.0	0.0	0.0	0.0	0.0	0.0	0.0	0.0	0.0	0.0	0.0
Total Lost Time (s)	5.0	6.5	6.5	5.0	6.5	6.5	7.5	7.5	7.5	5.0	7.5	7.5
Lead/Lag	Lead	Lag	Lag	Lead	Lag	Lag	Lead	Lag	Lag	Lead	Lag	Lag
Lead-Lag Optimize?	Yes	Yes	Yes	Yes	Yes	Yes	Yes	Yes	Yes	Yes	Yes	Yes
Recall Mode	None	None	None	None	None	None	None	C-Max	C-Max	None	C-Max	C-Max
Act Effct Green (s)	15.3	22.5	22.5	16.0	23.2	23.2	16.9	63.5	63.5	20.0	64.2	64.2
Actuated g/C Ratio	0.10	0.15	0.15	0.11	0.16	0.16	0.12	0.43	0.43	0.14	0.44	0.44
v/c Ratio	0.79	0.59	0.85	0.99	0.75	0.64	0.85	1.08	0.43	0.93	1.77	0.44
Control Delay	79.7	61.5	50.9	107.8	67.3	27.1	82.1	82.7	14.0	88.8	375.1	9.4
Queue Delay	0.0	0.0	0.0	0.0	0.0	0.0	0.0	0.0	0.0	0.0	0.0	0.0
Total Delay	79.7	61.5	50.9	107.8	67.3	27.1	82.1	82.7	14.0	88.8	375.1	9.4
LOS	E	E	D	F	E	C	F	F	B	F	F	A
Approach Delay		63.3			72.2			74.9			320.0	
Approach LOS		E			E			E			F	

Intersection Summary



































Cycle Length: 146
 Actuated Cycle Length: 146
 Offset: 54 (37%), Referenced to phase 2:NBT and 6:SBT, Start of Yellow
 Natural Cycle: 150
 Control Type: Actuated-Coordinated
 Maximum v/c Ratio: 1.77
 Intersection Signal Delay: 192.7
 Intersection Capacity Utilization 122.1%
 Analysis Period (min) 15

Splits and Phases: 1: Powers & Galley



HCM 6th Signalized Intersection Summary
1: Powers & Galley

Long Term Background
AM Peak Hour

												
Movement	EBL	EBT	EBR	WBL	WBT	WBR	NBL	NBT	NBR	SBL	SBT	SBR
Lane Configurations	 	 		 	 		 	  		 	  	
Traffic Volume (veh/h)	243	276	279	331	376	221	305	2165	314	425	3831	364
Future Volume (veh/h)	243	276	279	331	376	221	305	2165	314	425	3831	364
Initial Q (Qb), veh	0	0	0	0	0	0	0	0	0	0	0	0
Ped-Bike Adj(A_pbT)	1.00		1.00	1.00		1.00	1.00		1.00	1.00		1.00
Parking Bus, Adj	1.00	1.00	1.00	1.00	1.00	1.00	1.00	1.00	1.00	1.00	1.00	1.00
Work Zone On Approach		No			No			No			No	
Adj Sat Flow, veh/h/ln	1870	1870	1870	1870	1870	1870	1870	1870	1870	1870	1870	1870
Adj Flow Rate, veh/h	283	321	0	372	422	0	335	2379	0	438	3949	375
Peak Hour Factor	0.86	0.86	0.86	0.89	0.89	0.89	0.91	0.91	0.91	0.97	0.97	0.97
Percent Heavy Veh, %	2	2	2	2	2	2	2	2	2	2	2	2
Cap, veh/h	331	451		379	500		320	2500		379	2500	776
Arrive On Green	0.10	0.13	0.00	0.11	0.14	0.00	0.09	0.49	0.00	0.11	0.49	0.49
Sat Flow, veh/h	3456	3554	1585	3456	3554	1585	3456	5106	1585	3456	5106	1585
Grp Volume(v), veh/h	283	321	0	372	422	0	335	2379	0	438	3949	375
Grp Sat Flow(s),veh/h/ln	1728	1777	1585	1728	1777	1585	1728	1702	1585	1728	1702	1585
Q Serve(g_s), s	11.8	12.7	0.0	15.7	16.9	0.0	13.5	65.0	0.0	16.0	71.5	23.1
Cycle Q Clear(g_c), s	11.8	12.7	0.0	15.7	16.9	0.0	13.5	65.0	0.0	16.0	71.5	23.1
Prop In Lane	1.00		1.00	1.00		1.00	1.00		1.00	1.00		1.00
Lane Grp Cap(c), veh/h	331	451		379	500		320	2500		379	2500	776
V/C Ratio(X)	0.85	0.71		0.98	0.84		1.05	0.95		1.16	1.58	0.48
Avail Cap(c_a), veh/h	379	645		379	645		320	2500		379	2500	776
HCM Platoon Ratio	1.00	1.00	1.00	1.00	1.00	1.00	1.00	1.00	1.00	1.00	1.00	1.00
Upstream Filter(I)	1.00	1.00	0.00	1.00	1.00	0.00	1.00	1.00	0.00	1.00	1.00	1.00
Uniform Delay (d), s/veh	65.0	61.2	0.0	64.9	61.2	0.0	66.3	35.6	0.0	65.0	37.3	24.9
Incr Delay (d2), s/veh	15.5	2.1	0.0	41.4	8.1	0.0	63.6	9.8	0.0	96.2	262.8	2.1
Initial Q Delay(d3),s/veh	0.0	0.0	0.0	0.0	0.0	0.0	0.0	0.0	0.0	0.0	0.0	0.0
%ile BackOfQ(50%),veh/ln	5.9	5.9	0.0	9.1	8.2	0.0	8.8	28.7	0.0	12.1	89.9	9.2
Unsig. Movement Delay, s/veh												
LnGrp Delay(d),s/veh	80.5	63.3	0.0	106.2	69.2	0.0	129.8	45.4	0.0	161.2	300.1	27.1
LnGrp LOS	F	E		F	E		F	D		F	F	C
Approach Vol, veh/h		604	A		794	A		2714	A		4762	
Approach Delay, s/veh		71.4			86.6			55.8			265.8	
Approach LOS		E			F			E			F	
Timer - Assigned Phs	1	2	3	4	5	6	7	8				
Phs Duration (G+Y+Rc), s	21.0	79.0	21.0	25.0	21.0	79.0	19.0	27.0				
Change Period (Y+Rc), s	5.0	7.5	5.0	6.5	7.5	7.5	5.0	6.5				
Max Green Setting (Gmax), s	16.0	63.5	16.0	26.5	13.5	63.5	16.0	26.5				
Max Q Clear Time (g_c+I1), s	18.0	67.0	17.7	14.7	15.5	73.5	13.8	18.9				
Green Ext Time (p_c), s	0.0	0.0	0.0	1.5	0.0	0.0	0.2	1.6				

Intersection Summary

HCM 6th Ctrl Delay	172.3
HCM 6th LOS	F

Notes

User approved pedestrian interval to be less than phase max green.
Unsignalized Delay for [NBR, EBR, WBR] is excluded from calculations of the approach delay and intersection delay.

Intersection						
Int Delay, s/veh	2.2					
Movement	EBT	EBR	WBL	WBT	NBL	NBR
Lane Configurations	↑	↗	↘	↑	↘	↗
Traffic Vol, veh/h	867	65	28	906	22	14
Future Vol, veh/h	867	65	28	906	22	14
Conflicting Peds, #/hr	0	0	0	0	0	0
Sign Control	Free	Free	Free	Free	Stop	Stop
RT Channelized	-	None	-	None	-	None
Storage Length	-	0	100	-	0	0
Veh in Median Storage, #	0	-	-	0	0	-
Grade, %	0	-	-	0	0	-
Peak Hour Factor	92	92	84	84	72	72
Heavy Vehicles, %	2	2	2	2	2	2
Mvmt Flow	942	71	33	1079	31	19

Major/Minor	Major1	Major2	Minor1			
Conflicting Flow All	0	0	1013	0	2087	942
Stage 1	-	-	-	-	942	-
Stage 2	-	-	-	-	1145	-
Critical Hdwy	-	-	4.12	-	6.42	6.22
Critical Hdwy Stg 1	-	-	-	-	5.42	-
Critical Hdwy Stg 2	-	-	-	-	5.42	-
Follow-up Hdwy	-	-	2.218	-	3.518	3.318
Pot Cap-1 Maneuver	-	-	684	-	58	319
Stage 1	-	-	-	-	379	-
Stage 2	-	-	-	-	303	-
Platoon blocked, %	-	-	-	-	-	-
Mov Cap-1 Maneuver	-	-	684	-	55	319
Mov Cap-2 Maneuver	-	-	-	-	55	-
Stage 1	-	-	-	-	379	-
Stage 2	-	-	-	-	288	-

Approach	EB	WB	NB
HCM Control Delay, s	0	0.3	87.8
HCM LOS			F

Minor Lane/Major Mvmt	NBLn1	NBLn2	EBT	EBR	WBL	WBT
Capacity (veh/h)	55	319	-	-	684	-
HCM Lane V/C Ratio	0.556	0.061	-	-	0.049	-
HCM Control Delay (s)	132.8	17	-	-	10.5	-
HCM Lane LOS	F	C	-	-	B	-
HCM 95th %tile Q(veh)	2.2	0.2	-	-	0.2	-

Intersection												
Int Delay, s/veh	7.9											
Movement	EBL	EBT	EBR	WBL	WBT	WBR	NBL	NBT	NBR	SBL	SBT	SBR
Lane Configurations		↔↔			↔↔			↔			↔	
Traffic Vol, veh/h	47	73	43	28	199	52	14	10	25	86	47	15
Future Vol, veh/h	47	73	43	28	199	52	14	10	25	86	47	15
Conflicting Peds, #/hr	0	0	0	0	0	0	0	0	0	0	0	0
Sign Control	Free	Free	Free	Free	Free	Free	Stop	Stop	Stop	Stop	Stop	Stop
RT Channelized	-	-	None	-	-	None	-	-	None	-	-	None
Storage Length	-	-	-	-	-	-	-	-	-	-	-	-
Veh in Median Storage, #	-	0	-	-	0	-	-	0	-	-	0	-
Grade, %	-	0	-	-	0	-	-	0	-	-	0	-
Peak Hour Factor	75	75	75	93	93	93	83	83	83	67	67	67
Heavy Vehicles, %	2	2	2	2	2	2	2	2	2	2	2	2
Mvmt Flow	63	97	57	30	214	56	17	12	30	128	70	22

Major/Minor	Major1			Major2			Minor1			Minor2		
Conflicting Flow All	270	0	0	154	0	0	454	582	77	483	582	135
Stage 1	-	-	-	-	-	-	252	252	-	302	302	-
Stage 2	-	-	-	-	-	-	202	330	-	181	280	-
Critical Hdwy	4.14	-	-	4.14	-	-	7.54	6.54	6.94	7.54	6.54	6.94
Critical Hdwy Stg 1	-	-	-	-	-	-	6.54	5.54	-	6.54	5.54	-
Critical Hdwy Stg 2	-	-	-	-	-	-	6.54	5.54	-	6.54	5.54	-
Follow-up Hdwy	2.22	-	-	2.22	-	-	3.52	4.02	3.32	3.52	4.02	3.32
Pot Cap-1 Maneuver	1290	-	-	1424	-	-	489	423	968	467	423	889
Stage 1	-	-	-	-	-	-	730	697	-	682	663	-
Stage 2	-	-	-	-	-	-	781	644	-	803	678	-
Platoon blocked, %		-	-		-	-						
Mov Cap-1 Maneuver	1290	-	-	1424	-	-	387	390	968	416	390	889
Mov Cap-2 Maneuver	-	-	-	-	-	-	387	390	-	416	390	-
Stage 1	-	-	-	-	-	-	691	659	-	645	646	-
Stage 2	-	-	-	-	-	-	662	628	-	723	641	-

Approach	EB			WB			NB			SB		
HCM Control Delay, s	2.3			0.8			12.2			21.9		
HCM LOS							B			C		

Minor Lane/Major Mvmt	NBLn1	EBL	EBT	EBR	WBL	WBT	WBR	SBLn1
Capacity (veh/h)	559	1290	-	-	1424	-	-	430
HCM Lane V/C Ratio	0.106	0.049	-	-	0.021	-	-	0.514
HCM Control Delay (s)	12.2	7.9	0.1	-	7.6	0.1	-	21.9
HCM Lane LOS	B	A	A	-	A	A	-	C
HCM 95th %tile Q(veh)	0.4	0.2	-	-	0.1	-	-	2.9

Intersection						
Int Delay, s/veh	3.6					
Movement	EBT	EBR	WBL	WBT	NBL	NBR
Lane Configurations	↑↑		↖	↑	↘	
Traffic Vol, veh/h	954	61	8	903	25	4
Future Vol, veh/h	954	61	8	903	25	4
Conflicting Peds, #/hr	0	0	0	0	0	0
Sign Control	Free	Free	Free	Free	Stop	Stop
RT Channelized	-	None	-	None	-	None
Storage Length	-	-	125	-	0	-
Veh in Median Storage, #	0	-	-	0	0	-
Grade, %	0	-	-	0	0	-
Peak Hour Factor	88	88	85	85	75	75
Heavy Vehicles, %	2	2	2	2	2	2
Mvmt Flow	1084	69	9	1062	33	5

Major/Minor	Major1	Major2	Minor1	Minor2	Minor3
Conflicting Flow All	0	0	1153	0	2199
Stage 1	-	-	-	-	1119
Stage 2	-	-	-	-	1080
Critical Hdwy	-	-	4.13	-	6.63
Critical Hdwy Stg 1	-	-	-	-	5.83
Critical Hdwy Stg 2	-	-	-	-	5.43
Follow-up Hdwy	-	-	2.219	-	3.519
Pot Cap-1 Maneuver	-	-	604	-	43
Stage 1	-	-	-	-	275
Stage 2	-	-	-	-	325
Platoon blocked, %	-	-	-	-	-
Mov Cap-1 Maneuver	-	-	604	-	42
Mov Cap-2 Maneuver	-	-	-	-	42
Stage 1	-	-	-	-	275
Stage 2	-	-	-	-	320

Approach	EB	WB	NB
HCM Control Delay, s	0	0.1	206.8
HCM LOS			F

Minor Lane/Major Mvmt	NBLn1	EBT	EBR	WBL	WBT
Capacity (veh/h)	48	-	-	604	-
HCM Lane V/C Ratio	0.806	-	-	0.016	-
HCM Control Delay (s)	206.8	-	-	11.1	-
HCM Lane LOS	F	-	-	B	-
HCM 95th %tile Q(veh)	3.3	-	-	0	-

Timings
2: Paonia & Galley

Long Term Background-Paonia/Galley Signal
AM Peak Hour

	→	↘	↙	←	↖	↗
Lane Group	EBT	EBR	WBL	WBT	NBL	NBR
Lane Configurations	↑	↗	↘	↑	↘	↗
Traffic Volume (vph)	867	65	28	906	22	14
Future Volume (vph)	867	65	28	906	22	14
Turn Type	NA	Perm	Perm	NA	Prot	Perm
Protected Phases	4			8	2	
Permitted Phases		4	8			2
Detector Phase	4	4	8	8	2	2
Switch Phase						
Minimum Initial (s)	5.0	5.0	5.0	5.0	5.0	5.0
Minimum Split (s)	23.5	23.5	23.5	23.5	23.5	23.5
Total Split (s)	52.0	52.0	52.0	52.0	23.5	23.5
Total Split (%)	68.9%	68.9%	68.9%	68.9%	31.1%	31.1%
Yellow Time (s)	3.5	3.5	3.5	3.5	3.5	3.5
All-Red Time (s)	2.0	2.0	2.0	2.0	2.0	2.0
Lost Time Adjust (s)	0.0	0.0	0.0	0.0	0.0	0.0
Total Lost Time (s)	5.5	5.5	5.5	5.5	5.5	5.5
Lead/Lag						
Lead-Lag Optimize?						
Recall Mode	None	None	None	None	C-Max	C-Max
Act Effct Green (s)	46.1	46.1	46.1	46.1	18.4	18.4
Actuated g/C Ratio	0.61	0.61	0.61	0.61	0.24	0.24
v/c Ratio	0.83	0.07	0.22	0.95	0.07	0.05
Control Delay	19.7	1.8	10.8	32.5	23.0	10.9
Queue Delay	0.0	0.0	0.0	0.0	0.0	0.0
Total Delay	19.7	1.8	10.8	32.5	23.0	10.9
LOS	B	A	B	C	C	B
Approach Delay	18.5			31.9	18.4	
Approach LOS	B			C	B	

Intersection Summary

Cycle Length: 75.5
 Actuated Cycle Length: 75.5
 Offset: 0 (0%), Referenced to phase 2:NBL and 6:, Start of Green
 Natural Cycle: 80
 Control Type: Actuated-Coordinated
 Maximum v/c Ratio: 0.95
 Intersection Signal Delay: 25.3
 Intersection Capacity Utilization 61.0%
 Analysis Period (min) 15





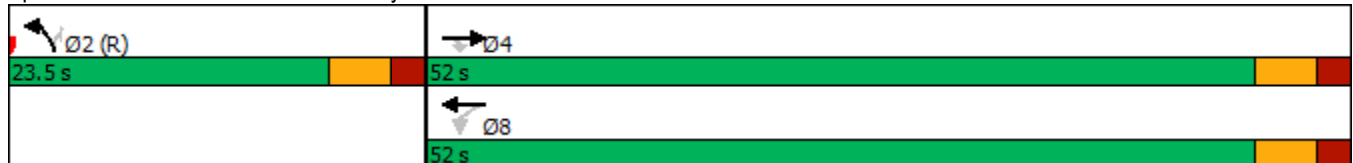

Intersection LOS: C
 ICU Level of Service B

Splits and Phases: 2: Paonia & Galley



HCM 6th Signalized Intersection Summary
2: Paonia & Galley

Long Term Background-Paonia/Galley Signal
AM Peak Hour

						
Movement	EBT	EBR	WBL	WBT	NBL	NBR
Lane Configurations	↑	↑	↑	↑	↑	↑
Traffic Volume (veh/h)	867	65	28	906	22	14
Future Volume (veh/h)	867	65	28	906	22	14
Initial Q (Qb), veh	0	0	0	0	0	0
Ped-Bike Adj(A_pbT)		1.00	1.00		1.00	1.00
Parking Bus, Adj	1.00	1.00	1.00	1.00	1.00	1.00
Work Zone On Approach	No			No	No	
Adj Sat Flow, veh/h/ln	1870	1870	1870	1870	1870	1870
Adj Flow Rate, veh/h	942	71	33	1079	31	19
Peak Hour Factor	0.92	0.92	0.84	0.84	0.72	0.72
Percent Heavy Veh, %	2	2	2	2	2	2
Cap, veh/h	1123	952	203	1123	454	404
Arrive On Green	0.60	0.60	0.60	0.60	0.25	0.25
Sat Flow, veh/h	1870	1585	556	1870	1781	1585
Grp Volume(v), veh/h	942	71	33	1079	31	19
Grp Sat Flow(s),veh/h/ln	1870	1585	556	1870	1781	1585
Q Serve(g_s), s	30.8	1.4	3.9	41.4	1.0	0.7
Cycle Q Clear(g_c), s	30.8	1.4	34.7	41.4	1.0	0.7
Prop In Lane		1.00	1.00		1.00	1.00
Lane Grp Cap(c), veh/h	1123	952	203	1123	454	404
V/C Ratio(X)	0.84	0.07	0.16	0.96	0.07	0.05
Avail Cap(c_a), veh/h	1144	970	210	1144	454	404
HCM Platoon Ratio	1.00	1.00	1.00	1.00	1.00	1.00
Upstream Filter(I)	1.00	1.00	1.00	1.00	1.00	1.00
Uniform Delay (d), s/veh	12.2	6.3	26.2	14.3	21.5	21.4
Incr Delay (d2), s/veh	5.6	0.0	0.4	17.8	0.3	0.2
Initial Q Delay(d3),s/veh	0.0	0.0	0.0	0.0	0.0	0.0
%ile BackOfQ(50%),veh/ln	12.3	0.4	0.5	19.7	0.4	0.3
Unsig. Movement Delay, s/veh						
LnGrp Delay(d),s/veh	17.8	6.4	26.5	32.1	21.8	21.6
LnGrp LOS	B	A	C	C	C	C
Approach Vol, veh/h	1013			1112	50	
Approach Delay, s/veh	17.0			31.9	21.7	
Approach LOS	B			C	C	
Timer - Assigned Phs		2		4		8
Phs Duration (G+Y+Rc), s		24.9		51.1		51.1
Change Period (Y+Rc), s		5.5		5.5		5.5
Max Green Setting (Gmax), s		18.0		46.5		46.5
Max Q Clear Time (g_c+I1), s		3.0		32.8		43.4
Green Ext Time (p_c), s		0.1		6.4		2.2
Intersection Summary						
HCM 6th Ctrl Delay			24.8			
HCM 6th LOS			C			

Timings
1: Powers & Galley

Long Term Background
PM Peak Hour

Lane Group	EBL	EBT	EBR	WBL	WBT	WBR	NBL	NBT	NBR	SBL	SBT	SBR
Lane Configurations												
Traffic Volume (vph)	482	426	327	360	456	461	409	3425	444	234	2556	305
Future Volume (vph)	482	426	327	360	456	461	409	3425	444	234	2556	305
Turn Type	Prot	NA	Perm	Prot	NA	Perm	Prot	NA	Perm	Prot	NA	Perm
Protected Phases	7	4		3	8		5	2		1	6	
Permitted Phases			4			8			2			6
Detector Phase	7	4	4	3	8	8	5	2	2	1	6	6
Switch Phase												
Minimum Initial (s)	4.0	4.0	4.0	4.0	4.0	4.0	4.0	20.0	20.0	4.0	20.0	20.0
Minimum Split (s)	10.5	44.5	44.5	10.5	44.5	44.5	11.5	42.5	42.5	10.5	42.5	42.5
Total Split (s)	21.0	33.0	33.0	21.0	33.0	33.0	21.0	71.0	71.0	21.0	71.0	71.0
Total Split (%)	14.4%	22.6%	22.6%	14.4%	22.6%	22.6%	14.4%	48.6%	48.6%	14.4%	48.6%	48.6%
Yellow Time (s)	3.0	4.5	4.5	3.0	4.5	4.5	5.5	5.5	5.5	3.0	5.5	5.5
All-Red Time (s)	2.0	2.0	2.0	2.0	2.0	2.0	2.0	2.0	2.0	2.0	2.0	2.0
Lost Time Adjust (s)	0.0	0.0	0.0	0.0	0.0	0.0	0.0	0.0	0.0	0.0	0.0	0.0
Total Lost Time (s)	5.0	6.5	6.5	5.0	6.5	6.5	7.5	7.5	7.5	5.0	7.5	7.5
Lead/Lag	Lead	Lag	Lag	Lead	Lag	Lag	Lead	Lag	Lag	Lead	Lag	Lag
Lead-Lag Optimize?	Yes	Yes	Yes	Yes	Yes	Yes	Yes	Yes	Yes	Yes	Yes	Yes
Recall Mode	None	None	None	None	None	None	None	C-Max	C-Max	None	C-Max	C-Max
Act Effct Green (s)	16.0	26.5	26.5	16.0	26.5	26.5	13.5	65.0	65.0	14.5	63.5	63.5
Actuated g/C Ratio	0.11	0.18	0.18	0.11	0.18	0.18	0.09	0.45	0.45	0.10	0.43	0.43
v/c Ratio	1.46	0.75	0.89	1.01	0.75	1.16	1.33	1.56	0.57	0.70	1.19	0.36
Control Delay	263.6	65.0	56.6	111.9	64.7	131.1	217.6	285.1	21.6	75.2	128.2	3.7
Queue Delay	0.0	0.0	0.0	0.0	0.0	0.0	0.0	0.0	0.0	0.0	0.0	0.0
Total Delay	263.6	65.0	56.6	111.9	64.7	131.1	217.6	285.1	21.6	75.2	128.2	3.7
LOS	F	E	E	F	E	F	F	F	C	E	F	A
Approach Delay		140.3			102.0			251.3			112.0	
Approach LOS		F			F			F			F	

Intersection Summary

























Cycle Length: 146
 Actuated Cycle Length: 146
 Offset: 54 (37%), Referenced to phase 2:NBT and 6:SBT, Start of Yellow
 Natural Cycle: 150
 Control Type: Actuated-Coordinated
 Maximum v/c Ratio: 1.56
 Intersection Signal Delay: 173.9
 Intersection Capacity Utilization 124.3%
 Analysis Period (min) 15
 Intersection LOS: F
 ICU Level of Service H

Splits and Phases: 1: Powers & Galley



HCM 6th Signalized Intersection Summary
1: Powers & Galley

Long Term Background
PM Peak Hour

												
Movement	EBL	EBT	EBR	WBL	WBT	WBR	NBL	NBT	NBR	SBL	SBT	SBR
Lane Configurations												
Traffic Volume (veh/h)	482	426	327	360	456	461	409	3425	444	234	2556	305
Future Volume (veh/h)	482	426	327	360	456	461	409	3425	444	234	2556	305
Initial Q (Qb), veh	0	0	0	0	0	0	0	0	0	0	0	0
Ped-Bike Adj(A_pbT)	1.00		1.00	1.00		1.00	1.00		1.00	1.00		1.00
Parking Bus, Adj	1.00	1.00	1.00	1.00	1.00	1.00	1.00	1.00	1.00	1.00	1.00	1.00
Work Zone On Approach		No			No			No			No	
Adj Sat Flow, veh/h/ln	1870	1870	1870	1870	1870	1870	1870	1870	1870	1870	1870	1870
Adj Flow Rate, veh/h	548	484	0	379	480	0	422	3531	0	241	2635	314
Peak Hour Factor	0.88	0.88	0.88	0.95	0.95	0.95	0.97	0.97	0.97	0.97	0.97	0.97
Percent Heavy Veh, %	2	2	2	2	2	2	2	2	2	2	2	2
Cap, veh/h	379	556		379	556		320	2478		292	2349	729
Arrive On Green	0.11	0.16	0.00	0.11	0.16	0.00	0.09	0.49	0.00	0.08	0.46	0.46
Sat Flow, veh/h	3456	3554	1585	3456	3554	1585	3456	5106	1585	3456	5106	1585
Grp Volume(v), veh/h	548	484	0	379	480	0	422	3531	0	241	2635	314
Grp Sat Flow(s),veh/h/ln	1728	1777	1585	1728	1777	1585	1728	1702	1585	1728	1702	1585
Q Serve(g_s), s	16.0	19.4	0.0	16.0	19.2	0.0	13.5	70.9	0.0	10.0	67.2	19.5
Cycle Q Clear(g_c), s	16.0	19.4	0.0	16.0	19.2	0.0	13.5	70.9	0.0	10.0	67.2	19.5
Prop In Lane	1.00		1.00	1.00		1.00	1.00		1.00	1.00		1.00
Lane Grp Cap(c), veh/h	379	556		379	556		320	2478		292	2349	729
V/C Ratio(X)	1.45	0.87		1.00	0.86		1.32	1.42		0.83	1.12	0.43
Avail Cap(c_a), veh/h	379	645		379	645		320	2478		379	2349	729
HCM Platoon Ratio	1.00	1.00	1.00	1.00	1.00	1.00	1.00	1.00	1.00	1.00	1.00	1.00
Upstream Filter(I)	1.00	1.00	0.00	1.00	1.00	0.00	1.00	1.00	0.00	1.00	1.00	1.00
Uniform Delay (d), s/veh	65.0	60.2	0.0	65.0	60.1	0.0	66.3	37.6	0.0	65.8	39.4	26.5
Incr Delay (d2), s/veh	215.5	11.2	0.0	46.4	10.5	0.0	164.6	193.6	0.0	11.1	61.1	1.9
Initial Q Delay(d3),s/veh	0.0	0.0	0.0	0.0	0.0	0.0	0.0	0.0	0.0	0.0	0.0	0.0
%ile BackOfQ(50%),veh/ln	18.4	9.6	0.0	9.5	9.5	0.0	13.3	73.3	0.0	4.9	40.9	7.8
Unsig. Movement Delay, s/veh												
LnGrp Delay(d),s/veh	280.5	71.3	0.0	111.4	70.6	0.0	230.9	231.2	0.0	76.9	100.5	28.4
LnGrp LOS	F	E		F	E		F	F		E	F	C
Approach Vol, veh/h		1032	A		859	A		3953	A		3190	
Approach Delay, s/veh		182.4			88.6			231.1			91.6	
Approach LOS		F			F			F			F	
Timer - Assigned Phs	1	2	3	4	5	6	7	8				
Phs Duration (G+Y+Rc), s	17.3	78.4	21.0	29.3	21.0	74.7	21.0	29.3				
Change Period (Y+Rc), s	5.0	7.5	5.0	6.5	7.5	7.5	5.0	6.5				
Max Green Setting (Gmax), s	16.0	63.5	16.0	26.5	13.5	63.5	16.0	26.5				
Max Q Clear Time (g_c+I1), s	12.0	72.9	18.0	21.4	15.5	69.2	18.0	21.2				
Green Ext Time (p_c), s	0.3	0.0	0.0	1.4	0.0	0.0	0.0	1.4				

Intersection Summary

HCM 6th Ctrl Delay	162.7
HCM 6th LOS	F

Notes

User approved pedestrian interval to be less than phase max green.
Unsignalized Delay for [NBR, EBR, WBR] is excluded from calculations of the approach delay and intersection delay.

Intersection						
Int Delay, s/veh	79.2					
Movement	EBT	EBR	WBL	WBT	NBL	NBR
Lane Configurations	↑	↗	↘	↑	↘	↗
Traffic Vol, veh/h	932	129	56	1108	123	77
Future Vol, veh/h	932	129	56	1108	123	77
Conflicting Peds, #/hr	0	0	0	0	0	0
Sign Control	Free	Free	Free	Free	Stop	Stop
RT Channelized	-	None	-	None	-	None
Storage Length	-	0	100	-	0	0
Veh in Median Storage, #	0	-	-	0	0	-
Grade, %	0	-	-	0	0	-
Peak Hour Factor	93	93	92	92	88	88
Heavy Vehicles, %	2	2	2	2	2	2
Mvmt Flow	1002	139	61	1204	140	88

Major/Minor	Major1	Major2	Minor1			
Conflicting Flow All	0	0	1141	0	2328	1002
Stage 1	-	-	-	-	1002	-
Stage 2	-	-	-	-	1326	-
Critical Hdwy	-	-	4.12	-	6.42	6.22
Critical Hdwy Stg 1	-	-	-	-	5.42	-
Critical Hdwy Stg 2	-	-	-	-	5.42	-
Follow-up Hdwy	-	-	2.218	-	3.518	3.318
Pot Cap-1 Maneuver	-	-	612	-	~ 41	294
Stage 1	-	-	-	-	355	-
Stage 2	-	-	-	-	248	-
Platoon blocked, %	-	-	-	-	-	-
Mov Cap-1 Maneuver	-	-	612	-	~ 37	294
Mov Cap-2 Maneuver	-	-	-	-	~ 37	-
Stage 1	-	-	-	-	355	-
Stage 2	-	-	-	-	223	-

Approach	EB	WB	NB
HCM Control Delay, s	0	0.6	\$ 914.5
HCM LOS			F

Minor Lane/Major Mvmt	NBLn1	NBLn2	EBT	EBR	WBL	WBT
Capacity (veh/h)	37	294	-	-	612	-
HCM Lane V/C Ratio	3.778	0.298	-	-	0.099	-
HCM Control Delay (s)	\$ 1472.9	22.4	-	-	11.5	-
HCM Lane LOS	F	C	-	-	B	-
HCM 95th %tile Q(veh)	16.1	1.2	-	-	0.3	-

Notes
 ~: Volume exceeds capacity \$: Delay exceeds 300s +: Computation Not Defined *: All major volume in platoon

Intersection												
Int Delay, s/veh	6.4											
Movement	EBL	EBT	EBR	WBL	WBT	WBR	NBL	NBT	NBR	SBL	SBT	SBR
Lane Configurations		↔↔			↔↔			↔			↔	
Traffic Vol, veh/h	45	177	11	12	188	88	13	36	47	102	16	19
Future Vol, veh/h	45	177	11	12	188	88	13	36	47	102	16	19
Conflicting Peds, #/hr	0	0	0	0	0	0	0	0	0	0	0	0
Sign Control	Free	Free	Free	Free	Free	Free	Stop	Stop	Stop	Stop	Stop	Stop
RT Channelized	-	-	None	-	-	None	-	-	None	-	-	None
Storage Length	-	-	-	-	-	-	-	-	-	-	-	-
Veh in Median Storage, #	-	0	-	-	0	-	-	0	-	-	0	-
Grade, %	-	0	-	-	0	-	-	0	-	-	0	-
Peak Hour Factor	88	88	88	80	80	80	80	80	80	84	84	84
Heavy Vehicles, %	2	2	2	2	2	2	2	2	2	2	2	2
Mvmt Flow	51	201	13	15	235	110	16	45	59	121	19	23

Major/Minor	Major1			Major2			Minor1			Minor2		
Conflicting Flow All	345	0	0	214	0	0	467	685	107	545	636	173
Stage 1	-	-	-	-	-	-	310	310	-	320	320	-
Stage 2	-	-	-	-	-	-	157	375	-	225	316	-
Critical Hdwy	4.14	-	-	4.14	-	-	7.54	6.54	6.94	7.54	6.54	6.94
Critical Hdwy Stg 1	-	-	-	-	-	-	6.54	5.54	-	6.54	5.54	-
Critical Hdwy Stg 2	-	-	-	-	-	-	6.54	5.54	-	6.54	5.54	-
Follow-up Hdwy	2.22	-	-	2.22	-	-	3.52	4.02	3.32	3.52	4.02	3.32
Pot Cap-1 Maneuver	1211	-	-	1353	-	-	479	369	926	421	394	840
Stage 1	-	-	-	-	-	-	675	658	-	666	651	-
Stage 2	-	-	-	-	-	-	829	615	-	757	654	-
Platoon blocked, %		-	-		-	-						
Mov Cap-1 Maneuver	1211	-	-	1353	-	-	427	346	926	339	370	840
Mov Cap-2 Maneuver	-	-	-	-	-	-	427	346	-	339	370	-
Stage 1	-	-	-	-	-	-	643	626	-	634	642	-
Stage 2	-	-	-	-	-	-	772	606	-	626	623	-

Approach	EB			WB			NB			SB		
HCM Control Delay, s	1.6			0.3			14			21.9		
HCM LOS							B			C		

Minor Lane/Major Mvmt	NBLn1	EBL	EBT	EBR	WBL	WBT	WBR	SBLn1
Capacity (veh/h)	518	1211	-	-	1353	-	-	374
HCM Lane V/C Ratio	0.232	0.042	-	-	0.011	-	-	0.436
HCM Control Delay (s)	14	8.1	0.1	-	7.7	0	-	21.9
HCM Lane LOS	B	A	A	-	A	A	-	C
HCM 95th %tile Q(veh)	0.9	0.1	-	-	0	-	-	2.1

Intersection						
Int Delay, s/veh	44.9					
Movement	EBT	EBR	WBL	WBT	NBL	NBR
Lane Configurations	↑↑		↖	↑	↗	
Traffic Vol, veh/h	1044	60	26	1216	61	33
Future Vol, veh/h	1044	60	26	1216	61	33
Conflicting Peds, #/hr	0	0	0	0	0	0
Sign Control	Free	Free	Free	Free	Stop	Stop
RT Channelized	-	None	-	None	-	None
Storage Length	-	-	125	-	0	-
Veh in Median Storage, #	0	-	-	0	0	-
Grade, %	0	-	-	0	0	-
Peak Hour Factor	93	93	89	89	91	91
Heavy Vehicles, %	2	2	2	2	2	2
Mvmt Flow	1123	65	29	1366	67	36

Major/Minor	Major1	Major2	Minor1		
Conflicting Flow All	0	0	1188	0	2580 594
Stage 1	-	-	-	-	1156 -
Stage 2	-	-	-	-	1424 -
Critical Hdwy	-	-	4.13	-	6.63 6.93
Critical Hdwy Stg 1	-	-	-	-	5.83 -
Critical Hdwy Stg 2	-	-	-	-	5.43 -
Follow-up Hdwy	-	-	2.219	-	3.519 3.319
Pot Cap-1 Maneuver	-	-	586	-	~ 24 449
Stage 1	-	-	-	-	263 -
Stage 2	-	-	-	-	221 -
Platoon blocked, %	-	-	-	-	-
Mov Cap-1 Maneuver	-	-	586	-	~ 23 449
Mov Cap-2 Maneuver	-	-	-	-	~ 23 -
Stage 1	-	-	-	-	263 -
Stage 2	-	-	-	-	210 -

Approach	EB	WB	NB
HCM Control Delay, s	0	0.2	\$ 1165.3
HCM LOS			F

Minor Lane/Major Mvmt	NBLn1	EBT	EBR	WBL	WBT
Capacity (veh/h)	34	-	-	586	-
HCM Lane V/C Ratio	3.038	-	-	0.05	-
HCM Control Delay (s)	\$ 1165.3	-	-	11.5	-
HCM Lane LOS	F	-	-	B	-
HCM 95th %tile Q(veh)	11.9	-	-	0.2	-

Notes
 ~: Volume exceeds capacity \$: Delay exceeds 300s +: Computation Not Defined *: All major volume in platoon

Timings
2: Paonia & Galley

Long Term Background-Paonia/Galley Signal
PM Peak Hour

	→	↘	↙	←	↖	↗
Lane Group	EBT	EBR	WBL	WBT	NBL	NBR
Lane Configurations	↑	↑	↑	↑	↑	↑
Traffic Volume (vph)	932	129	56	1108	123	77
Future Volume (vph)	932	129	56	1108	123	77
Turn Type	NA	Perm	Perm	NA	Prot	Perm
Protected Phases	4			8	2	
Permitted Phases		4	8			2
Detector Phase	4	4	8	8	2	2
Switch Phase						
Minimum Initial (s)	5.0	5.0	5.0	5.0	5.0	5.0
Minimum Split (s)	23.5	23.5	23.5	23.5	23.5	23.5
Total Split (s)	66.0	66.0	66.0	66.0	24.0	24.0
Total Split (%)	73.3%	73.3%	73.3%	73.3%	26.7%	26.7%
Yellow Time (s)	3.5	3.5	3.5	3.5	3.5	3.5
All-Red Time (s)	2.0	2.0	2.0	2.0	2.0	2.0
Lost Time Adjust (s)	0.0	0.0	0.0	0.0	0.0	0.0
Total Lost Time (s)	5.5	5.5	5.5	5.5	5.5	5.5
Lead/Lag						
Lead-Lag Optimize?						
Recall Mode	None	None	None	None	C-Max	C-Max
Act Effct Green (s)	60.5	60.5	60.5	60.5	18.5	18.5
Actuated g/C Ratio	0.67	0.67	0.67	0.67	0.21	0.21
v/c Ratio	0.80	0.13	0.34	0.96	0.39	0.22
Control Delay	16.8	1.2	12.6	33.3	34.5	8.5
Queue Delay	0.0	0.0	0.0	0.0	0.0	0.0
Total Delay	16.8	1.2	12.6	33.3	34.5	8.5
LOS	B	A	B	C	C	A
Approach Delay	14.9			32.3	24.5	
Approach LOS	B			C	C	

Intersection Summary





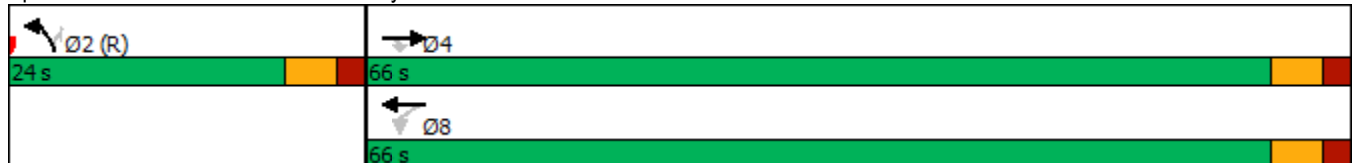

Cycle Length: 90
 Actuated Cycle Length: 90
 Offset: 0 (0%), Referenced to phase 2:NBL and 6:, Start of Green
 Natural Cycle: 90
 Control Type: Actuated-Coordinated
 Maximum v/c Ratio: 0.96
 Intersection Signal Delay: 24.1
 Intersection LOS: C
 Intersection Capacity Utilization 74.3%
 ICU Level of Service D
 Analysis Period (min) 15

Splits and Phases: 2: Paonia & Galley



HCM 6th Signalized Intersection Summary
2: Paonia & Galley

Long Term Background-Paonia/Galley Signal
PM Peak Hour

						
Movement	EBT	EBR	WBL	WBT	NBL	NBR
Lane Configurations	↑	↑	↑	↑	↑	↑
Traffic Volume (veh/h)	932	129	56	1108	123	77
Future Volume (veh/h)	932	129	56	1108	123	77
Initial Q (Qb), veh	0	0	0	0	0	0
Ped-Bike Adj(A_pbT)		1.00	1.00		1.00	1.00
Parking Bus, Adj	1.00	1.00	1.00	1.00	1.00	1.00
Work Zone On Approach	No			No	No	
Adj Sat Flow, veh/h/ln	1870	1870	1870	1870	1870	1870
Adj Flow Rate, veh/h	1002	139	61	1204	140	88
Peak Hour Factor	0.93	0.93	0.92	0.92	0.88	0.88
Percent Heavy Veh, %	2	2	2	2	2	2
Cap, veh/h	1241	1052	216	1241	382	340
Arrive On Green	0.66	0.66	0.66	0.66	0.21	0.21
Sat Flow, veh/h	1870	1585	493	1870	1781	1585
Grp Volume(v), veh/h	1002	139	61	1204	140	88
Grp Sat Flow(s),veh/h/ln	1870	1585	493	1870	1781	1585
Q Serve(g_s), s	34.9	2.9	9.2	54.7	6.0	4.2
Cycle Q Clear(g_c), s	34.9	2.9	44.1	54.7	6.0	4.2
Prop In Lane		1.00	1.00		1.00	1.00
Lane Grp Cap(c), veh/h	1241	1052	216	1241	382	340
V/C Ratio(X)	0.81	0.13	0.28	0.97	0.37	0.26
Avail Cap(c_a), veh/h	1257	1066	220	1257	382	340
HCM Platoon Ratio	1.00	1.00	1.00	1.00	1.00	1.00
Upstream Filter(I)	1.00	1.00	1.00	1.00	1.00	1.00
Uniform Delay (d), s/veh	11.0	5.6	27.0	14.3	30.2	29.4
Incr Delay (d2), s/veh	4.0	0.1	0.7	18.5	2.7	1.8
Initial Q Delay(d3),s/veh	0.0	0.0	0.0	0.0	0.0	0.0
%ile BackOfQ(50%),veh/ln	13.3	0.9	1.1	25.0	2.8	1.7
Unsig. Movement Delay, s/veh						
LnGrp Delay(d),s/veh	14.9	5.6	27.7	32.8	32.9	31.3
LnGrp LOS	B	A	C	C	C	C
Approach Vol, veh/h	1141			1265	228	
Approach Delay, s/veh	13.8			32.5	32.2	
Approach LOS	B			C	C	
Timer - Assigned Phs		2		4		8
Phs Duration (G+Y+Rc), s		24.8		65.2		65.2
Change Period (Y+Rc), s		5.5		5.5		5.5
Max Green Setting (Gmax), s		18.5		60.5		60.5
Max Q Clear Time (g_c+I1), s		8.0		36.9		56.7
Green Ext Time (p_c), s		0.5		9.7		3.0
Intersection Summary						
HCM 6th Ctrl Delay			24.4			
HCM 6th LOS			C			

APPENDIX E. SHORT TERM TOTAL LEVEL OF SERVICE WORKSHEETS

Timings
1: Powers & Galley

Short Term Total
AM Peak Hour

Lane Group	EBL	EBT	EBR	WBL	WBT	WBR	NBL	NBT	NBR	SBL	SBT	SBR
Lane Configurations												
Traffic Volume (vph)	168	202	193	256	297	165	211	1497	223	305	2761	252
Future Volume (vph)	168	202	193	256	297	165	211	1497	223	305	2761	252
Lane Group Flow (vph)	195	235	224	288	334	185	232	1645	245	314	2846	260
Turn Type	Prot	NA	Perm	Prot	NA	Perm	Prot	NA	Perm	Prot	NA	Perm
Protected Phases	7	4		3	8		5	2		1	6	
Permitted Phases			4			8			2			6
Detector Phase	7	4	4	3	8	8	5	2	2	1	6	6
Switch Phase												
Minimum Initial (s)	4.0	4.0	4.0	4.0	4.0	4.0	4.0	20.0	20.0	4.0	20.0	20.0
Minimum Split (s)	10.5	44.5	44.5	10.5	44.5	44.5	11.5	42.5	42.5	10.5	42.5	42.5
Total Split (s)	21.0	33.0	33.0	21.0	33.0	33.0	21.0	71.0	71.0	21.0	71.0	71.0
Total Split (%)	14.4%	22.6%	22.6%	14.4%	22.6%	22.6%	14.4%	48.6%	48.6%	14.4%	48.6%	48.6%
Yellow Time (s)	3.0	4.5	4.5	3.0	4.5	4.5	5.5	5.5	5.5	3.0	5.5	5.5
All-Red Time (s)	2.0	2.0	2.0	2.0	2.0	2.0	2.0	2.0	2.0	2.0	2.0	2.0
Lost Time Adjust (s)	0.0	0.0	0.0	0.0	0.0	0.0	0.0	0.0	0.0	0.0	0.0	0.0
Total Lost Time (s)	5.0	6.5	6.5	5.0	6.5	6.5	7.5	7.5	7.5	5.0	7.5	7.5
Lead/Lag	Lead	Lag	Lag	Lead	Lag	Lag	Lead	Lag	Lag	Lead	Lag	Lag
Lead-Lag Optimize?	Yes	Yes	Yes	Yes	Yes	Yes	Yes	Yes	Yes	Yes	Yes	Yes
Recall Mode	None	None	None	None	None	None	None	C-Max	C-Max	None	C-Max	C-Max
v/c Ratio	0.62	0.55	0.67	0.80	0.70	0.50	0.69	0.66	0.28	0.75	1.13	0.28
Control Delay	72.6	64.4	27.3	80.2	68.1	12.7	74.8	31.1	6.8	74.0	100.1	3.5
Queue Delay	0.0	0.0	0.0	0.0	0.0	0.0	0.0	0.0	0.0	0.0	0.0	0.0
Total Delay	72.6	64.4	27.3	80.2	68.1	12.7	74.8	31.1	6.8	74.0	100.1	3.5
Queue Length 50th (ft)	93	112	53	139	162	4	111	436	25	149	~1165	0
Queue Length 95th (ft)	127	142	123	#191	205	70	158	532	85	#215	#1335	53
Internal Link Dist (ft)		926			325			844			2578	
Turn Bay Length (ft)	150			175			600			600		575
Base Capacity (vph)	376	642	421	376	642	434	347	2481	872	423	2512	913
Starvation Cap Reductn	0	0	0	0	0	0	0	0	0	0	0	0
Spillback Cap Reductn	0	0	0	0	0	0	0	0	0	0	0	0
Storage Cap Reductn	0	0	0	0	0	0	0	0	0	0	0	0
Reduced v/c Ratio	0.52	0.37	0.53	0.77	0.52	0.43	0.67	0.66	0.28	0.74	1.13	0.28

Intersection Summary



























Cycle Length: 146
 Actuated Cycle Length: 146
 Offset: 117.5 (80%), Referenced to phase 2:NBT and 6:SBT, Start of Yellow
 Natural Cycle: 150
 Control Type: Actuated-Coordinated
 ~ Volume exceeds capacity, queue is theoretically infinite.
 Queue shown is maximum after two cycles.
 # 95th percentile volume exceeds capacity, queue may be longer.
 Queue shown is maximum after two cycles.

Splits and Phases: 1: Powers & Galley



HCM 6th Signalized Intersection Summary
1: Powers & Galley

Short Term Total
AM Peak Hour

													
Movement	EBL	EBT	EBR	WBL	WBT	WBR	NBL	NBT	NBR	SBL	SBT	SBR	
Lane Configurations													
Traffic Volume (veh/h)	168	202	193	256	297	165	211	1497	223	305	2761	252	
Future Volume (veh/h)	168	202	193	256	297	165	211	1497	223	305	2761	252	
Initial Q (Qb), veh	0	0	0	0	0	0	0	0	0	0	0	0	
Ped-Bike Adj(A_pbT)	1.00		1.00	1.00		1.00	1.00		1.00	1.00		1.00	
Parking Bus, Adj	1.00	1.00	1.00	1.00	1.00	1.00	1.00	1.00	1.00	1.00	1.00	1.00	
Work Zone On Approach		No			No			No			No		
Adj Sat Flow, veh/h/ln	1870	1870	1870	1870	1870	1870	1870	1870	1870	1870	1870	1870	
Adj Flow Rate, veh/h	195	235	0	288	334	0	232	1645	0	314	2846	260	
Peak Hour Factor	0.86	0.86	0.86	0.89	0.89	0.89	0.91	0.91	0.91	0.97	0.97	0.97	
Percent Heavy Veh, %	2	2	2	2	2	2	2	2	2	2	2	2	
Cap, veh/h	246	320		336	413		279	2779		360	2810	872	
Arrive On Green	0.07	0.09	0.00	0.10	0.12	0.00	0.08	0.54	0.00	0.10	0.55	0.55	
Sat Flow, veh/h	3456	3554	1585	3456	3554	1585	3456	5106	1585	3456	5106	1585	
Grp Volume(v), veh/h	195	235	0	288	334	0	232	1645	0	314	2846	260	
Grp Sat Flow(s),veh/h/ln	1728	1777	1585	1728	1777	1585	1728	1702	1585	1728	1702	1585	
Q Serve(g_s), s	8.1	9.4	0.0	12.0	13.4	0.0	9.7	31.6	0.0	13.1	80.3	12.9	
Cycle Q Clear(g_c), s	8.1	9.4	0.0	12.0	13.4	0.0	9.7	31.6	0.0	13.1	80.3	12.9	
Prop In Lane	1.00		1.00	1.00		1.00	1.00		1.00	1.00		1.00	
Lane Grp Cap(c), veh/h	246	320		336	413		279	2779		360	2810	872	
V/C Ratio(X)	0.79	0.73		0.86	0.81		0.83	0.59		0.87	1.01	0.30	
Avail Cap(c_a), veh/h	379	645		379	645		320	2779		379	2810	872	
HCM Platoon Ratio	1.00	1.00	1.00	1.00	1.00	1.00	1.00	1.00	1.00	1.00	1.00	1.00	
Upstream Filter(I)	1.00	1.00	0.00	1.00	1.00	0.00	1.00	1.00	0.00	1.00	1.00	1.00	
Uniform Delay (d), s/veh	66.7	64.7	0.0	64.9	63.0	0.0	66.1	22.4	0.0	64.5	32.8	17.7	
Incr Delay (d2), s/veh	6.2	3.3	0.0	16.1	4.3	0.0	15.1	0.9	0.0	19.0	20.2	0.9	
Initial Q Delay(d3),s/veh	0.0	0.0	0.0	0.0	0.0	0.0	0.0	0.0	0.0	0.0	0.0	0.0	
%ile BackOfQ(50%),veh/ln	3.8	4.4	0.0	6.0	6.3	0.0	4.9	12.9	0.0	6.7	37.2	5.0	
Unsig. Movement Delay, s/veh													
LnGrp Delay(d),s/veh	73.0	68.0	0.0	81.0	67.3	0.0	81.2	23.3	0.0	83.4	53.0	18.5	
LnGrp LOS	E	E		F	E		F	C		F	F	B	
Approach Vol, veh/h		430	A		622	A		1877	A		3420		
Approach Delay, s/veh		70.2			73.6			30.5			53.2		
Approach LOS		E			E			C			D		
Timer - Assigned Phs	1	2	3	4	5	6	7	8					
Phs Duration (G+Y+Rc), s	20.2	87.0	19.2	19.7	19.3	87.8	15.4	23.4					
Change Period (Y+Rc), s	5.0	7.5	5.0	6.5	7.5	7.5	5.0	6.5					
Max Green Setting (Gmax), s	16.0	63.5	16.0	26.5	13.5	63.5	16.0	26.5					
Max Q Clear Time (g_c+I1), s	15.1	33.6	14.0	11.4	11.7	82.3	10.1	15.4					
Green Ext Time (p_c), s	0.1	15.7	0.2	1.2	0.1	0.0	0.3	1.6					

Intersection Summary

HCM 6th Ctrl Delay	49.6
HCM 6th LOS	D

Notes

User approved pedestrian interval to be less than phase max green.
Unsignalized Delay for [NBR, EBR, WBR] is excluded from calculations of the approach delay and intersection delay.

Intersection												
Int Delay, s/veh	4.2											
Movement	EBL	EBT	EBR	WBL	WBT	WBR	NBL	NBT	NBR	SBL	SBT	SBR
Lane Configurations	↖	↑	↗	↖	↑	↗	↖	↗		↖	↑	↗
Traffic Vol, veh/h	28	554	65	28	614	7	22	2	14	25	4	82
Future Vol, veh/h	28	554	65	28	614	7	22	2	14	25	4	82
Conflicting Peds, #/hr	0	0	0	0	0	0	0	0	0	0	0	0
Sign Control	Free	Free	Free	Free	Free	Free	Stop	Stop	Stop	Stop	Stop	Stop
RT Channelized	-	-	None	-	-	None	-	-	None	-	-	None
Storage Length	100	-	0	100	-	-	0	-	-	200	-	0
Veh in Median Storage, #	-	0	-	-	0	-	-	0	-	-	0	-
Grade, %	-	0	-	-	0	-	-	0	-	-	0	-
Peak Hour Factor	92	92	92	84	84	92	72	92	72	92	92	92
Heavy Vehicles, %	2	2	2	2	2	2	2	2	2	2	2	2
Mvmt Flow	30	602	71	33	731	8	31	2	19	27	4	89

Major/Minor	Major1			Major2			Minor1			Minor2		
Conflicting Flow All	739	0	0	673	0	0	1510	1467	602	1509	1534	735
Stage 1	-	-	-	-	-	-	662	662	-	801	801	-
Stage 2	-	-	-	-	-	-	848	805	-	708	733	-
Critical Hdwy	4.12	-	-	4.12	-	-	7.12	6.52	6.22	7.12	6.52	6.22
Critical Hdwy Stg 1	-	-	-	-	-	-	6.12	5.52	-	6.12	5.52	-
Critical Hdwy Stg 2	-	-	-	-	-	-	6.12	5.52	-	6.12	5.52	-
Follow-up Hdwy	2.218	-	-	2.218	-	-	3.518	4.018	3.318	3.518	4.018	3.318
Pot Cap-1 Maneuver	867	-	-	918	-	-	99	128	500	99	116	420
Stage 1	-	-	-	-	-	-	451	459	-	378	397	-
Stage 2	-	-	-	-	-	-	356	395	-	426	426	-
Platoon blocked, %	-	-	-	-	-	-	-	-	-	-	-	-
Mov Cap-1 Maneuver	867	-	-	918	-	-	72	119	500	89	108	420
Mov Cap-2 Maneuver	-	-	-	-	-	-	72	119	-	89	108	-
Stage 1	-	-	-	-	-	-	435	443	-	365	383	-
Stage 2	-	-	-	-	-	-	267	381	-	393	411	-

Approach	EB			WB			NB			SB		
HCM Control Delay, s	0.4			0.4			57.6			27.2		
HCM LOS							F			D		

Minor Lane/Major Mvmt	NBLn1	NBLn2	EBL	EBT	EBR	WBL	WBT	WBR	SBLn1	SBLn2	SBLn3
Capacity (veh/h)	72	378	867	-	-	918	-	-	89	108	420
HCM Lane V/C Ratio	0.424	0.057	0.035	-	-	0.036	-	-	0.305	0.04	0.212
HCM Control Delay (s)	87.7	15.1	9.3	-	-	9.1	-	-	62.3	39.7	15.9
HCM Lane LOS	F	C	A	-	-	A	-	-	F	E	C
HCM 95th %tile Q(veh)	1.7	0.2	0.1	-	-	0.1	-	-	1.1	0.1	0.8

Timings
2: Paonia & Galley

Short Term Total - Paonia/Galley Signal
AM Peak Hour

Lane Group	EBL	EBT	EBR	WBL	WBT	NBL	NBT	SBL	SBT	SBR
Lane Configurations										
Traffic Volume (vph)	28	554	65	28	614	22	2	25	4	82
Future Volume (vph)	28	554	65	28	614	22	2	25	4	82
Turn Type	Perm	NA	Perm	Perm	NA	pm+pt	NA	Perm	NA	Perm
Protected Phases		4			8	5	2		6	
Permitted Phases	4		4	8		2		6		6
Detector Phase	4	4	4	8	8	5	2	6	6	6
Switch Phase										
Minimum Initial (s)	5.0	5.0	5.0	5.0	5.0	5.0	5.0	5.0	5.0	5.0
Minimum Split (s)	23.5	23.5	23.5	23.5	23.5	10.5	23.5	23.5	23.5	23.5
Total Split (s)	36.0	36.0	36.0	36.0	36.0	10.5	34.0	23.5	23.5	23.5
Total Split (%)	51.4%	51.4%	51.4%	51.4%	51.4%	15.0%	48.6%	33.6%	33.6%	33.6%
Yellow Time (s)	3.0	3.0	3.0	3.0	3.0	3.0	3.0	3.0	3.0	3.0
All-Red Time (s)	2.0	2.0	2.0	2.0	2.0	2.0	2.0	2.0	2.0	2.0
Lost Time Adjust (s)	0.0	0.0	0.0	0.0	0.0	0.0	0.0	0.0	0.0	0.0
Total Lost Time (s)	5.0	5.0	5.0	5.0	5.0	5.0	5.0	5.0	5.0	5.0
Lead/Lag						Lead		Lag	Lag	Lag
Lead-Lag Optimize?						Yes		Yes	Yes	Yes
Recall Mode	None	None	None	None	None	None	C-Max	Max	Max	Max
Act Effct Green (s)	30.1	30.1	30.1	30.1	30.1	29.9	29.9	25.7	25.7	25.7
Actuated g/C Ratio	0.43	0.43	0.43	0.43	0.43	0.43	0.43	0.37	0.37	0.37
v/c Ratio	0.28	0.75	0.10	0.19	0.92	0.06	0.03	0.05	0.01	0.14
Control Delay	21.0	23.6	1.5	15.3	38.4	12.6	6.4	18.4	18.5	4.1
Queue Delay	0.0	0.0	0.0	0.0	0.0	0.0	0.0	0.0	0.0	0.0
Total Delay	21.0	23.6	1.5	15.3	38.4	12.6	6.4	18.4	18.5	4.1
LOS	C	C	A	B	D	B	A	B	B	A
Approach Delay		21.3			37.4		10.1		7.8	
Approach LOS		C			D		B		A	

Intersection Summary





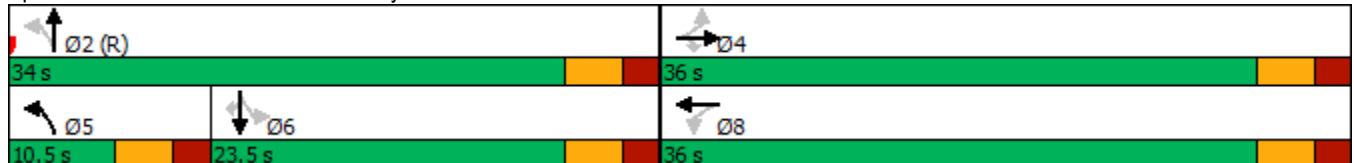

















Cycle Length: 70
 Actuated Cycle Length: 70
 Offset: 0 (0%), Referenced to phase 2:NBTL, Start of Green
 Natural Cycle: 70
 Control Type: Actuated-Coordinated
 Maximum v/c Ratio: 0.92
 Intersection Signal Delay: 27.5
 Intersection LOS: C
 Intersection Capacity Utilization 54.5%
 ICU Level of Service A
 Analysis Period (min) 15

Splits and Phases: 2: Paonia & Galley



HCM 6th Signalized Intersection Summary
2: Paonia & Galley

Short Term Total - Paonia/Galley Signal
AM Peak Hour

												
Movement	EBL	EBT	EBR	WBL	WBT	WBR	NBL	NBT	NBR	SBL	SBT	SBR
Lane Configurations												
Traffic Volume (veh/h)	28	554	65	28	614	7	22	2	14	25	4	82
Future Volume (veh/h)	28	554	65	28	614	7	22	2	14	25	4	82
Initial Q (Qb), veh	0	0	0	0	0	0	0	0	0	0	0	0
Ped-Bike Adj(A_pbT)	1.00		1.00	1.00		1.00	1.00		1.00	1.00		1.00
Parking Bus, Adj	1.00	1.00	1.00	1.00	1.00	1.00	1.00	1.00	1.00	1.00	1.00	1.00
Work Zone On Approach		No			No			No			No	
Adj Sat Flow, veh/h/ln	1870	1870	1870	1870	1870	1870	1870	1870	1870	1870	1870	1870
Adj Flow Rate, veh/h	30	602	71	33	731	8	31	2	19	27	4	89
Peak Hour Factor	0.92	0.92	0.92	0.84	0.84	0.92	0.72	0.92	0.72	0.92	0.92	0.92
Percent Heavy Veh, %	2	2	2	2	2	2	2	2	2	2	2	2
Cap, veh/h	155	822	697	236	811	9	568	64	608	540	587	498
Arrive On Green	0.44	0.44	0.44	0.44	0.44	0.44	0.03	0.42	0.42	0.31	0.31	0.31
Sat Flow, veh/h	720	1870	1585	765	1847	20	1781	153	1455	1391	1870	1585
Grp Volume(v), veh/h	30	602	71	33	0	739	31	0	21	27	4	89
Grp Sat Flow(s),veh/h/ln	720	1870	1585	765	0	1867	1781	0	1608	1391	1870	1585
Q Serve(g_s), s	2.8	18.6	1.8	2.6	0.0	25.7	0.8	0.0	0.5	1.0	0.1	2.9
Cycle Q Clear(g_c), s	28.5	18.6	1.8	21.2	0.0	25.7	0.8	0.0	0.5	1.0	0.1	2.9
Prop In Lane	1.00		1.00	1.00		0.01	1.00		0.90	1.00		1.00
Lane Grp Cap(c), veh/h	155	822	697	236	0	820	568	0	672	540	587	498
V/C Ratio(X)	0.19	0.73	0.10	0.14	0.00	0.90	0.05	0.00	0.03	0.05	0.01	0.18
Avail Cap(c_a), veh/h	157	828	702	238	0	827	650	0	672	540	587	498
HCM Platoon Ratio	1.00	1.00	1.00	1.00	1.00	1.00	1.00	1.00	1.00	1.00	1.00	1.00
Upstream Filter(I)	1.00	1.00	1.00	1.00	0.00	1.00	1.00	0.00	1.00	1.00	1.00	1.00
Uniform Delay (d), s/veh	31.4	16.2	11.5	25.0	0.0	18.2	14.0	0.0	12.0	16.8	16.5	17.5
Incr Delay (d2), s/veh	0.6	3.3	0.1	0.3	0.0	12.9	0.0	0.0	0.1	0.2	0.0	0.8
Initial Q Delay(d3),s/veh	0.0	0.0	0.0	0.0	0.0	0.0	0.0	0.0	0.0	0.0	0.0	0.0
%ile BackOfQ(50%),veh/ln	0.5	7.9	0.6	0.5	0.0	12.8	0.3	0.0	0.2	0.3	0.0	1.1
Unsig. Movement Delay, s/veh												
LnGrp Delay(d),s/veh	32.0	19.6	11.6	25.3	0.0	31.1	14.0	0.0	12.1	17.0	16.5	18.2
LnGrp LOS	C	B	B	C	A	C	B	A	B	B	B	B
Approach Vol, veh/h		703			772			52			120	
Approach Delay, s/veh		19.3			30.9			13.2			17.9	
Approach LOS		B			C			B			B	
Timer - Assigned Phs		2		4	5	6		8				
Phs Duration (G+Y+Rc), s		34.2		35.8	7.3	27.0		35.8				
Change Period (Y+Rc), s		5.0		5.0	5.0	5.0		5.0				
Max Green Setting (Gmax), s		29.0		31.0	5.5	18.5		31.0				
Max Q Clear Time (g_c+I1), s		2.5		30.5	2.8	4.9		27.7				
Green Ext Time (p_c), s		0.1		0.2	0.0	0.3		1.6				
Intersection Summary												
HCM 6th Ctrl Delay				24.4								
HCM 6th LOS				C								

Intersection												
Int Delay, s/veh	8.3											
Movement	EBL	EBT	EBR	WBL	WBT	WBR	NBL	NBT	NBR	SBL	SBT	SBR
Lane Configurations		↔↔			↔↔			↔			↔	
Traffic Vol, veh/h	47	50	43	35	138	46	30	12	25	86	47	15
Future Vol, veh/h	47	50	43	35	138	46	30	12	25	86	47	15
Conflicting Peds, #/hr	0	0	0	0	0	0	0	0	0	0	0	0
Sign Control	Free	Free	Free	Free	Free	Free	Stop	Stop	Stop	Stop	Stop	Stop
RT Channelized	-	-	None	-	-	None	-	-	None	-	-	None
Storage Length	-	-	-	-	-	-	-	-	-	-	-	-
Veh in Median Storage, #	-	0	-	-	0	-	-	0	-	-	0	-
Grade, %	-	0	-	-	0	-	-	0	-	-	0	-
Peak Hour Factor	75	75	75	93	93	93	83	83	83	67	67	67
Heavy Vehicles, %	2	2	2	2	2	2	2	2	2	2	2	2
Mvmt Flow	63	67	57	38	148	49	36	14	30	128	70	22

Major/Minor	Major1			Major2			Minor1			Minor2		
Conflicting Flow All	197	0	0	124	0	0	407	495	62	416	499	99
Stage 1	-	-	-	-	-	-	222	222	-	249	249	-
Stage 2	-	-	-	-	-	-	185	273	-	167	250	-
Critical Hdwy	4.14	-	-	4.14	-	-	7.54	6.54	6.94	7.54	6.54	6.94
Critical Hdwy Stg 1	-	-	-	-	-	-	6.54	5.54	-	6.54	5.54	-
Critical Hdwy Stg 2	-	-	-	-	-	-	6.54	5.54	-	6.54	5.54	-
Follow-up Hdwy	2.22	-	-	2.22	-	-	3.52	4.02	3.32	3.52	4.02	3.32
Pot Cap-1 Maneuver	1373	-	-	1461	-	-	529	474	990	521	472	937
Stage 1	-	-	-	-	-	-	760	718	-	733	699	-
Stage 2	-	-	-	-	-	-	799	683	-	818	699	-
Platoon blocked, %	-	-	-	-	-	-	-	-	-	-	-	-
Mov Cap-1 Maneuver	1373	-	-	1461	-	-	426	437	990	463	435	937
Mov Cap-2 Maneuver	-	-	-	-	-	-	426	437	-	463	435	-
Stage 1	-	-	-	-	-	-	722	682	-	696	679	-
Stage 2	-	-	-	-	-	-	679	663	-	737	664	-

Approach	EB			WB			NB			SB		
HCM Control Delay, s	2.6			1.3			12.8			18.8		
HCM LOS							B			C		

Minor Lane/Major Mvmt	NBLn1	EBL	EBT	EBR	WBL	WBT	WBR	SBLn1
Capacity (veh/h)	544	1373	-	-	1461	-	-	478
HCM Lane V/C Ratio	0.148	0.046	-	-	0.026	-	-	0.462
HCM Control Delay (s)	12.8	7.7	0.1	-	7.5	0.1	-	18.8
HCM Lane LOS	B	A	A	-	A	A	-	C
HCM 95th %tile Q(veh)	0.5	0.1	-	-	0.1	-	-	2.4

Intersection						
Int Delay, s/veh	1.2					
Movement	EBT	EBR	WBL	WBT	NBL	NBR
Lane Configurations	↑↑		↖	↑	↘	
Traffic Vol, veh/h	669	61	8	693	25	4
Future Vol, veh/h	669	61	8	693	25	4
Conflicting Peds, #/hr	0	0	0	0	0	0
Sign Control	Free	Free	Free	Free	Stop	Stop
RT Channelized	-	None	-	None	-	None
Storage Length	-	-	125	-	0	-
Veh in Median Storage, #	0	-	-	0	0	-
Grade, %	0	-	-	0	0	-
Peak Hour Factor	88	88	85	85	75	75
Heavy Vehicles, %	2	2	2	2	2	2
Mvmt Flow	760	69	9	815	33	5

Major/Minor	Major1	Major2	Minor1	Minor2	Minor3
Conflicting Flow All	0	0	829	0	1628
Stage 1	-	-	-	-	795
Stage 2	-	-	-	-	833
Critical Hdwy	-	-	4.13	-	6.63
Critical Hdwy Stg 1	-	-	-	-	5.83
Critical Hdwy Stg 2	-	-	-	-	5.43
Follow-up Hdwy	-	-	2.219	-	3.519
Pot Cap-1 Maneuver	-	-	800	-	102
Stage 1	-	-	-	-	406
Stage 2	-	-	-	-	426
Platoon blocked, %	-	-	-	-	-
Mov Cap-1 Maneuver	-	-	800	-	101
Mov Cap-2 Maneuver	-	-	-	-	101
Stage 1	-	-	-	-	406
Stage 2	-	-	-	-	421

Approach	EB	WB	NB
HCM Control Delay, s	0	0.1	52
HCM LOS			F

Minor Lane/Major Mvmt	NBLn1	EBT	EBR	WBL	WBT
Capacity (veh/h)	114	-	-	800	-
HCM Lane V/C Ratio	0.339	-	-	0.012	-
HCM Control Delay (s)	52	-	-	9.6	-
HCM Lane LOS	F	-	-	A	-
HCM 95th %tile Q(veh)	1.3	-	-	0	-

Timings
1: Powers & Galley

Short Term Total
PM Peak Hour

Lane Group	EBL	EBT	EBR	WBL	WBT	WBR	NBL	NBT	NBR	SBL	SBT	SBR
Lane Configurations												
Traffic Volume (vph)	334	332	227	273	338	325	283	2371	328	194	1793	211
Future Volume (vph)	334	332	227	273	338	325	283	2371	328	194	1793	211
Lane Group Flow (vph)	388	386	264	307	380	365	311	2605	360	200	1848	218
Turn Type	Prot	NA	Perm	Prot	NA	Perm	Prot	NA	Perm	Prot	NA	Perm
Protected Phases	7	4		3	8		5	2		1	6	
Permitted Phases			4			8			2			6
Detector Phase	7	4	4	3	8	8	5	2	2	1	6	6
Switch Phase												
Minimum Initial (s)	4.0	4.0	4.0	4.0	4.0	4.0	4.0	20.0	20.0	4.0	20.0	20.0
Minimum Split (s)	10.5	44.5	44.5	10.5	44.5	44.5	11.5	45.5	45.5	10.5	42.5	42.5
Total Split (s)	21.0	33.0	33.0	21.0	33.0	33.0	21.0	71.0	71.0	21.0	71.0	71.0
Total Split (%)	14.4%	22.6%	22.6%	14.4%	22.6%	22.6%	14.4%	48.6%	48.6%	14.4%	48.6%	48.6%
Yellow Time (s)	3.0	4.5	4.5	3.0	4.5	4.5	5.5	5.5	5.5	3.0	5.5	5.5
All-Red Time (s)	2.0	2.0	2.0	2.0	2.0	2.0	2.0	2.0	2.0	2.0	2.0	2.0
Lost Time Adjust (s)	0.0	0.0	0.0	0.0	0.0	0.0	0.0	0.0	0.0	0.0	0.0	0.0
Total Lost Time (s)	5.0	6.5	6.5	5.0	6.5	6.5	7.5	7.5	7.5	5.0	7.5	7.5
Lead/Lag	Lead	Lag	Lag	Lead	Lag	Lag	Lead	Lag	Lag	Lead	Lag	Lag
Lead-Lag Optimize?	Yes	Yes	Yes	Yes	Yes	Yes	Yes	Yes	Yes	Yes	Yes	Yes
Recall Mode	None	None	None	None	None	None	None	C-Max	C-Max	None	C-Max	C-Max
v/c Ratio	1.03	0.64	0.65	0.84	0.65	0.92	0.91	1.10	0.43	0.63	0.82	0.27
Control Delay	116.9	61.7	28.7	83.7	61.9	62.0	94.5	87.7	14.7	72.9	39.7	3.8
Queue Delay	0.0	0.0	0.0	0.0	0.0	0.0	0.0	0.0	0.0	0.0	0.0	0.0
Total Delay	116.9	61.7	28.7	83.7	61.9	62.0	94.5	87.7	14.7	72.9	39.7	3.8
Queue Length 50th (ft)	~203	180	85	149	176	201	154	~1055	110	95	564	0
Queue Length 95th (ft)	#288	224	168	#216	230	#371	#255	#1166	202	137	630	49
Internal Link Dist (ft)		926			325			844			2578	
Turn Bay Length (ft)	150			175			600			600		575
Base Capacity (vph)	376	642	422	376	642	418	342	2376	835	376	2249	821
Starvation Cap Reductn	0	0	0	0	0	0	0	0	0	0	0	0
Spillback Cap Reductn	0	0	0	0	0	0	0	0	0	0	0	0
Storage Cap Reductn	0	0	0	0	0	0	0	0	0	0	0	0
Reduced v/c Ratio	1.03	0.60	0.63	0.82	0.59	0.87	0.91	1.10	0.43	0.53	0.82	0.27

Intersection Summary

Cycle Length: 146
 Actuated Cycle Length: 146
 Offset: 54 (37%), Referenced to phase 2:NBT and 6:SBT, Start of Yellow
 Natural Cycle: 145
 Control Type: Actuated-Coordinated
 ~ Volume exceeds capacity, queue is theoretically infinite.
 Queue shown is maximum after two cycles.
 # 95th percentile volume exceeds capacity, queue may be longer.
 Queue shown is maximum after two cycles.

Splits and Phases: 1: Powers & Galley



HCM 6th Signalized Intersection Summary
1: Powers & Galley

Short Term Total
PM Peak Hour

Movement	EBL	EBT	EBR	WBL	WBT	WBR	NBL	NBT	NBR	SBL	SBT	SBR
Lane Configurations												
Traffic Volume (veh/h)	334	332	227	273	338	325	283	2371	328	194	1793	211
Future Volume (veh/h)	334	332	227	273	338	325	283	2371	328	194	1793	211
Initial Q (Qb), veh	0	0	0	0	0	0	0	0	0	0	0	0
Ped-Bike Adj(A_pbT)	1.00		1.00	1.00		1.00	1.00		1.00	1.00		1.00
Parking Bus, Adj	1.00	1.00	1.00	1.00	1.00	1.00	1.00	1.00	1.00	1.00	1.00	1.00
Work Zone On Approach		No			No			No			No	
Adj Sat Flow, veh/h/ln	1870	1870	1870	1870	1870	1870	1870	1870	1870	1870	1870	1870
Adj Flow Rate, veh/h	388	386	0	307	380	0	311	2605	0	200	1848	218
Peak Hour Factor	0.86	0.86	0.86	0.89	0.89	0.89	0.91	0.91	0.91	0.97	0.97	0.97
Percent Heavy Veh, %	2	2	2	2	2	2	2	2	2	2	2	2
Cap, veh/h	379	485		353	459		320	2676		251	2488	772
Arrive On Green	0.11	0.14	0.00	0.10	0.13	0.00	0.09	0.52	0.00	0.07	0.49	0.49
Sat Flow, veh/h	3456	3554	1585	3456	3554	1585	3456	5106	1585	3456	5106	1585
Grp Volume(v), veh/h	388	386	0	307	380	0	311	2605	0	200	1848	218
Grp Sat Flow(s),veh/h/ln	1728	1777	1585	1728	1777	1585	1728	1702	1585	1728	1702	1585
Q Serve(g_s), s	16.0	15.4	0.0	12.8	15.2	0.0	13.1	72.4	0.0	8.3	42.5	11.9
Cycle Q Clear(g_c), s	16.0	15.4	0.0	12.8	15.2	0.0	13.1	72.4	0.0	8.3	42.5	11.9
Prop In Lane	1.00		1.00	1.00		1.00	1.00		1.00	1.00		1.00
Lane Grp Cap(c), veh/h	379	485		353	459		320	2676		251	2488	772
V/C Ratio(X)	1.02	0.80		0.87	0.83		0.97	0.97		0.80	0.74	0.28
Avail Cap(c_a), veh/h	379	645		379	645		320	2676		379	2488	772
HCM Platoon Ratio	1.00	1.00	1.00	1.00	1.00	1.00	1.00	1.00	1.00	1.00	1.00	1.00
Upstream Filter(I)	1.00	1.00	0.00	1.00	1.00	0.00	1.00	1.00	0.00	1.00	1.00	1.00
Uniform Delay (d), s/veh	65.0	61.1	0.0	64.6	62.0	0.0	66.1	33.7	0.0	66.6	30.1	22.2
Incr Delay (d2), s/veh	52.7	5.1	0.0	18.2	6.2	0.0	43.0	12.2	0.0	6.8	2.1	0.9
Initial Q Delay(d3),s/veh	0.0	0.0	0.0	0.0	0.0	0.0	0.0	0.0	0.0	0.0	0.0	0.0
%ile BackOfQ(50%),veh/ln	9.8	7.3	0.0	6.5	7.3	0.0	7.7	32.1	0.0	3.9	17.8	4.7
Unsig. Movement Delay, s/veh												
LnGrp Delay(d),s/veh	117.7	66.1	0.0	82.7	68.2	0.0	109.1	45.9	0.0	73.4	32.1	23.2
LnGrp LOS	F	E		F	E		F	D		E	C	C
Approach Vol, veh/h		774	A		687	A		2916	A		2266	
Approach Delay, s/veh		92.0			74.7			52.7			34.9	
Approach LOS		F			E			D			C	
Timer - Assigned Phs	1	2	3	4	5	6	7	8				
Phs Duration (G+Y+Rc), s	15.6	84.0	19.9	26.4	21.0	78.6	21.0	25.4				
Change Period (Y+Rc), s	5.0	7.5	5.0	6.5	7.5	7.5	5.0	6.5				
Max Green Setting (Gmax), s	16.0	63.5	16.0	26.5	13.5	63.5	16.0	26.5				
Max Q Clear Time (g_c+I1), s	10.3	74.4	14.8	17.4	15.1	44.5	18.0	17.2				
Green Ext Time (p_c), s	0.3	0.0	0.1	1.6	0.0	13.9	0.0	1.6				

Intersection Summary

HCM 6th Ctrl Delay	53.5
HCM 6th LOS	D

Notes

User approved pedestrian interval to be less than phase max green.
Unsignalized Delay for [NBR, EBR, WBR] is excluded from calculations of the approach delay and intersection delay.

Intersection												
Int Delay, s/veh	151.6											
Movement	EBL	EBT	EBR	WBL	WBT	WBR	NBL	NBT	NBR	SBL	SBT	SBR
Lane Configurations	↖	↑	↗	↖	↗		↖	↗		↖	↑	↗
Traffic Vol, veh/h	90	592	129	56	727	25	123	3	77	14	2	62
Future Vol, veh/h	90	592	129	56	727	25	123	3	77	14	2	62
Conflicting Peds, #/hr	0	0	0	0	0	0	0	0	0	0	0	0
Sign Control	Free	Free	Free	Free	Free	Free	Stop	Stop	Stop	Stop	Stop	Stop
RT Channelized	-	-	None	-	-	None	-	-	None	-	-	None
Storage Length	100	-	0	100	-	-	0	-	-	100	-	0
Veh in Median Storage, #	-	0	-	-	0	-	-	0	-	-	0	-
Grade, %	-	0	-	-	0	-	-	0	-	-	0	-
Peak Hour Factor	92	92	92	84	84	92	72	92	72	92	92	92
Heavy Vehicles, %	2	2	2	2	2	2	2	2	2	2	2	2
Mvmt Flow	98	643	140	67	865	27	171	3	107	15	2	67

Major/Minor	Major1			Major2			Minor1			Minor2		
Conflicting Flow All	892	0	0	783	0	0	1886	1865	643	1977	1992	879
Stage 1	-	-	-	-	-	-	839	839	-	1013	1013	-
Stage 2	-	-	-	-	-	-	1047	1026	-	964	979	-
Critical Hdwy	4.12	-	-	4.12	-	-	7.12	6.52	6.22	7.12	6.52	6.22
Critical Hdwy Stg 1	-	-	-	-	-	-	6.12	5.52	-	6.12	5.52	-
Critical Hdwy Stg 2	-	-	-	-	-	-	6.12	5.52	-	6.12	5.52	-
Follow-up Hdwy	2.218	-	-	2.218	-	-	3.518	4.018	3.318	3.518	4.018	3.318
Pot Cap-1 Maneuver	760	-	-	835	-	-	~ 54	73	473	46	61	347
Stage 1	-	-	-	-	-	-	360	381	-	288	316	-
Stage 2	-	-	-	-	-	-	276	312	-	307	328	-
Platoon blocked, %	-	-	-	-	-	-	-	-	-	-	-	-
Mov Cap-1 Maneuver	760	-	-	835	-	-	~ 36	58	473	29	49	347
Mov Cap-2 Maneuver	-	-	-	-	-	-	~ 36	58	-	29	49	-
Stage 1	-	-	-	-	-	-	314	332	-	251	291	-
Stage 2	-	-	-	-	-	-	203	287	-	205	286	-

Approach	EB			WB			NB			SB		
HCM Control Delay, s	1.2			0.7			\$ 1167.3			56.6		
HCM LOS							F			F		

Minor Lane/Major Mvmt	NBLn1	NBLn2	EBL	EBT	EBR	WBL	WBT	WBR	SBLn1	SBLn2	SBLn3
Capacity (veh/h)	36	390	760	-	-	835	-	-	29	49	347
HCM Lane V/C Ratio	4.745	0.283	0.129	-	-	0.08	-	-	0.525	0.044	0.194
HCM Control Delay (s)	\$ 1908.8	17.8	10.4	-	-	9.7	-	-	224.1	81.9	17.9
HCM Lane LOS	F	C	B	-	-	A	-	-	F	F	C
HCM 95th %tile Q(veh)	20	1.1	0.4	-	-	0.3	-	-	1.7	0.1	0.7

Notes
 ~: Volume exceeds capacity \$: Delay exceeds 300s +: Computation Not Defined *: All major volume in platoon

Timings
2: Paonia & Galley

Short Term Total-Paonia/Galley Signal
PM Peak Hour

Lane Group	EBL	EBT	EBR	WBL	WBT	NBL	NBT	SBL	SBT	SBR
Lane Configurations										
Traffic Volume (vph)	90	592	129	56	727	123	3	14	2	62
Future Volume (vph)	90	592	129	56	727	123	3	14	2	62
Turn Type	Perm	NA	Perm	Perm	NA	pm+pt	NA	Perm	NA	Perm
Protected Phases		4			8	5	2		6	
Permitted Phases	4		4	8		2		6		6
Detector Phase	4	4	4	8	8	5	2	6	6	6
Switch Phase										
Minimum Initial (s)	5.0	5.0	5.0	5.0	5.0	5.0	5.0	5.0	5.0	5.0
Minimum Split (s)	23.5	23.5	23.5	23.5	23.5	23.5	23.5	23.5	23.5	23.5
Total Split (s)	63.0	63.0	63.0	63.0	63.0	23.5	47.0	23.5	23.5	23.5
Total Split (%)	57.3%	57.3%	57.3%	57.3%	57.3%	21.4%	42.7%	21.4%	21.4%	21.4%
Yellow Time (s)	3.5	3.5	3.5	3.5	3.5	3.5	3.5	3.5	3.5	3.5
All-Red Time (s)	2.0	2.0	2.0	2.0	2.0	2.0	2.0	2.0	2.0	2.0
Lost Time Adjust (s)	0.0	0.0	0.0	0.0	0.0	0.0	0.0	0.0	0.0	0.0
Total Lost Time (s)	5.5	5.5	5.5	5.5	5.5	5.5	5.5	5.5	5.5	5.5
Lead/Lag						Lead		Lag	Lag	Lag
Lead-Lag Optimize?						Yes		Yes	Yes	Yes
Recall Mode	None	None	None	None	None	Max	C-Max	Max	Max	Max
Act Effct Green (s)	57.5	57.5	57.5	57.5	57.5	41.5	41.5	18.0	18.0	18.0
Actuated g/C Ratio	0.52	0.52	0.52	0.52	0.52	0.38	0.38	0.16	0.16	0.16
v/c Ratio	1.46	0.66	0.16	0.28	0.92	0.33	0.17	0.07	0.01	0.21
Control Delay	299.7	23.2	2.7	18.7	40.3	25.7	5.3	40.1	38.5	8.6
Queue Delay	0.0	0.0	0.0	0.0	0.0	0.0	0.0	0.0	0.0	0.0
Total Delay	299.7	23.2	2.7	18.7	40.3	25.7	5.3	40.1	38.5	8.6
LOS	F	C	A	B	D	C	A	D	D	A
Approach Delay		50.7			38.8		17.7		15.0	
Approach LOS		D			D		B		B	

Intersection Summary

Cycle Length: 110
 Actuated Cycle Length: 110
 Offset: 0 (0%), Referenced to phase 2:NBTL, Start of Green
 Natural Cycle: 110
 Control Type: Actuated-Coordinated
 Maximum v/c Ratio: 1.46
 Intersection Signal Delay: 40.0
 Intersection LOS: D
 Intersection Capacity Utilization 72.0%
 ICU Level of Service C
 Analysis Period (min) 15

Splits and Phases: 2: Paonia & Galley

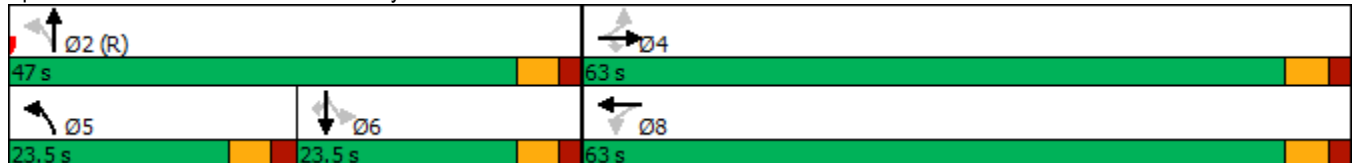

HCM 6th Signalized Intersection Summary

2: Paonia & Galley

Short Term Total-Paonia/Galley Signal

PM Peak Hour

Movement	EBL	EBT	EBR	WBL	WBT	WBR	NBL	NBT	NBR	SBL	SBT	SBR
Lane Configurations												
Traffic Volume (veh/h)	90	592	129	56	727	25	123	3	77	14	2	62
Future Volume (veh/h)	90	592	129	56	727	25	123	3	77	14	2	62
Initial Q (Qb), veh	0	0	0	0	0	0	0	0	0	0	0	0
Ped-Bike Adj(A_pbT)	1.00		1.00	1.00		1.00	1.00		1.00	1.00		1.00
Parking Bus, Adj	1.00	1.00	1.00	1.00	1.00	1.00	1.00	1.00	1.00	1.00	1.00	1.00
Work Zone On Approach		No			No			No			No	
Adj Sat Flow, veh/h/ln	1870	1870	1870	1870	1870	1870	1870	1870	1870	1870	1870	1870
Adj Flow Rate, veh/h	98	643	140	67	865	27	171	3	107	15	2	67
Peak Hour Factor	0.92	0.92	0.92	0.84	0.84	0.92	0.72	0.92	0.72	0.92	0.92	0.92
Percent Heavy Veh, %	2	2	2	2	2	2	2	2	2	2	2	2
Cap, veh/h	117	978	829	254	943	29	574	16	584	275	306	259
Arrive On Green	0.52	0.52	0.52	0.52	0.52	0.52	0.16	0.38	0.38	0.16	0.16	0.16
Sat Flow, veh/h	624	1870	1585	691	1804	56	1781	43	1548	1283	1870	1585
Grp Volume(v), veh/h	98	643	140	67	0	892	171	0	110	15	2	67
Grp Sat Flow(s),veh/h/ln	624	1870	1585	691	0	1860	1781	0	1592	1283	1870	1585
Q Serve(g_s), s	9.1	27.5	5.1	8.6	0.0	48.4	7.6	0.0	5.1	1.1	0.1	4.1
Cycle Q Clear(g_c), s	57.5	27.5	5.1	36.1	0.0	48.4	7.6	0.0	5.1	1.1	0.1	4.1
Prop In Lane	1.00		1.00	1.00		0.03	1.00		0.97	1.00		1.00
Lane Grp Cap(c), veh/h	117	978	829	254	0	972	574	0	600	275	306	259
V/C Ratio(X)	0.84	0.66	0.17	0.26	0.00	0.92	0.30	0.00	0.18	0.05	0.01	0.26
Avail Cap(c_a), veh/h	117	978	829	254	0	972	574	0	600	275	306	259
HCM Platoon Ratio	1.00	1.00	1.00	1.00	1.00	1.00	1.00	1.00	1.00	1.00	1.00	1.00
Upstream Filter(I)	1.00	1.00	1.00	1.00	0.00	1.00	1.00	0.00	1.00	1.00	1.00	1.00
Uniform Delay (d), s/veh	52.6	19.1	13.7	32.2	0.0	24.1	26.1	0.0	22.9	38.9	38.5	40.2
Incr Delay (d2), s/veh	38.3	1.6	0.1	0.5	0.0	13.2	1.3	0.0	0.7	0.4	0.0	2.4
Initial Q Delay(d3),s/veh	0.0	0.0	0.0	0.0	0.0	0.0	0.0	0.0	0.0	0.0	0.0	0.0
%ile BackOfQ(50%),veh/ln	4.0	11.9	1.8	1.5	0.0	23.6	3.4	0.0	2.0	0.4	0.0	1.8
Unsig. Movement Delay, s/veh												
LnGrp Delay(d),s/veh	90.9	20.7	13.8	32.8	0.0	37.3	27.4	0.0	23.6	39.3	38.6	42.6
LnGrp LOS	F	C	B	C	A	D	C	A	C	D	D	D
Approach Vol, veh/h		881			959			281			84	
Approach Delay, s/veh		27.4			37.0			25.9			41.9	
Approach LOS		C			D			C			D	
Timer - Assigned Phs		2		4	5	6		8				
Phs Duration (G+Y+Rc), s		47.0		63.0	23.5	23.5		63.0				
Change Period (Y+Rc), s		5.5		5.5	5.5	5.5		5.5				
Max Green Setting (Gmax), s		41.5		57.5	18.0	18.0		57.5				
Max Q Clear Time (g_c+I1), s		7.1		59.5	9.6	6.1		50.4				
Green Ext Time (p_c), s		0.7		0.0	0.3	0.1		3.9				
Intersection Summary												
HCM 6th Ctrl Delay				31.9								
HCM 6th LOS				C								

Intersection												
Int Delay, s/veh	7.9											
Movement	EBL	EBT	EBR	WBL	WBT	WBR	NBL	NBT	NBR	SBL	SBT	SBR
Lane Configurations		↔↔			↔↔			↔			↔	
Traffic Vol, veh/h	45	122	11	23	130	79	24	31	44	102	19	19
Future Vol, veh/h	45	122	11	23	130	79	24	31	44	102	19	19
Conflicting Peds, #/hr	0	0	0	0	0	0	0	0	0	0	0	0
Sign Control	Free	Free	Free	Free	Free	Free	Stop	Stop	Stop	Stop	Stop	Stop
RT Channelized	-	-	None	-	-	None	-	-	None	-	-	None
Storage Length	-	-	-	-	-	-	-	-	-	-	-	-
Veh in Median Storage, #	-	0	-	-	0	-	-	0	-	-	0	-
Grade, %	-	0	-	-	0	-	-	0	-	-	0	-
Peak Hour Factor	75	75	75	93	93	93	83	83	83	67	67	67
Heavy Vehicles, %	2	2	2	2	2	2	2	2	2	2	2	2
Mvmt Flow	60	163	15	25	140	85	29	37	53	152	28	28

Major/Minor	Major1			Major2			Minor1			Minor2		
Conflicting Flow All	225	0	0	178	0	0	425	566	89	453	531	113
Stage 1	-	-	-	-	-	-	291	291	-	233	233	-
Stage 2	-	-	-	-	-	-	134	275	-	220	298	-
Critical Hdwy	4.14	-	-	4.14	-	-	7.54	6.54	6.94	7.54	6.54	6.94
Critical Hdwy Stg 1	-	-	-	-	-	-	6.54	5.54	-	6.54	5.54	-
Critical Hdwy Stg 2	-	-	-	-	-	-	6.54	5.54	-	6.54	5.54	-
Follow-up Hdwy	2.22	-	-	2.22	-	-	3.52	4.02	3.32	3.52	4.02	3.32
Pot Cap-1 Maneuver	1341	-	-	1395	-	-	513	432	951	490	452	918
Stage 1	-	-	-	-	-	-	693	670	-	749	711	-
Stage 2	-	-	-	-	-	-	855	681	-	762	666	-
Platoon blocked, %		-	-		-	-						
Mov Cap-1 Maneuver	1341	-	-	1395	-	-	446	402	951	407	420	918
Mov Cap-2 Maneuver	-	-	-	-	-	-	446	402	-	407	420	-
Stage 1	-	-	-	-	-	-	658	637	-	712	696	-
Stage 2	-	-	-	-	-	-	778	667	-	643	633	-

Approach	EB			WB			NB			SB		
HCM Control Delay, s	2			0.8			13.2			20.2		
HCM LOS							B			C		

Minor Lane/Major Mvmt	NBLn1	EBL	EBT	EBR	WBL	WBT	WBR	SBLn1
Capacity (veh/h)	559	1341	-	-	1395	-	-	442
HCM Lane V/C Ratio	0.213	0.045	-	-	0.018	-	-	0.473
HCM Control Delay (s)	13.2	7.8	0.1	-	7.6	0.1	-	20.2
HCM Lane LOS	B	A	A	-	A	A	-	C
HCM 95th %tile Q(veh)	0.8	0.1	-	-	0.1	-	-	2.5

Intersection						
Int Delay, s/veh	23.8					
Movement	EBT	EBR	WBL	WBT	NBL	NBR
Lane Configurations	↑↑		↖	↑	↘	
Traffic Vol, veh/h	794	60	26	875	61	33
Future Vol, veh/h	794	60	26	875	61	33
Conflicting Peds, #/hr	0	0	0	0	0	0
Sign Control	Free	Free	Free	Free	Stop	Stop
RT Channelized	-	None	-	None	-	None
Storage Length	-	-	125	-	0	-
Veh in Median Storage, #	0	-	-	0	0	-
Grade, %	0	-	-	0	0	-
Peak Hour Factor	88	88	85	85	75	75
Heavy Vehicles, %	2	2	2	2	2	2
Mvmt Flow	902	68	31	1029	81	44

Major/Minor	Major1	Major2	Minor1		
Conflicting Flow All	0	0	970	0	2027 485
Stage 1	-	-	-	-	936 -
Stage 2	-	-	-	-	1091 -
Critical Hdwy	-	-	4.13	-	6.63 6.93
Critical Hdwy Stg 1	-	-	-	-	5.83 -
Critical Hdwy Stg 2	-	-	-	-	5.43 -
Follow-up Hdwy	-	-	2.219	-	3.519 3.319
Pot Cap-1 Maneuver	-	-	708	-	~ 56 529
Stage 1	-	-	-	-	343 -
Stage 2	-	-	-	-	321 -
Platoon blocked, %	-	-	-	-	-
Mov Cap-1 Maneuver	-	-	708	-	~ 54 529
Mov Cap-2 Maneuver	-	-	-	-	~ 54 -
Stage 1	-	-	-	-	343 -
Stage 2	-	-	-	-	307 -

Approach	EB	WB	NB
HCM Control Delay, s	0	0.3	\$ 406
HCM LOS			F

Minor Lane/Major Mvmt	NBLn1	EBT	EBR	WBL	WBT
Capacity (veh/h)	79	-	-	708	-
HCM Lane V/C Ratio	1.586	-	-	0.043	-
HCM Control Delay (s)	\$ 406	-	-	10.3	-
HCM Lane LOS	F	-	-	B	-
HCM 95th %tile Q(veh)	10.3	-	-	0.1	-

Notes
 ~: Volume exceeds capacity \$: Delay exceeds 300s +: Computation Not Defined *: All major volume in platoon

**APPENDIX F. LONG TERM TOTAL LEVEL OF
SERVICE WORKSHEETS**

Timings
1: Powers & Galley

Long Term Total
AM Peak Hour

Lane Group	EBL	EBT	EBR	WBL	WBT	WBR	NBL	NBT	NBR	SBL	SBT	SBR
Lane Configurations												
Traffic Volume (vph)	243	287	279	361	413	233	305	2165	320	436	3827	364
Future Volume (vph)	243	287	279	361	413	233	305	2165	320	436	3827	364
Lane Group Flow (vph)	283	334	324	406	464	262	335	2379	352	449	3945	375
Turn Type	Prot	NA	Perm	Prot	NA	Perm	Prot	NA	Perm	Prot	NA	Perm
Protected Phases	7	4		3	8		5	2		1	6	
Permitted Phases			4			8			2			6
Detector Phase	7	4	4	3	8	8	5	2	2	1	6	6
Switch Phase												
Minimum Initial (s)	4.0	4.0	4.0	4.0	4.0	4.0	4.0	20.0	20.0	4.0	20.0	20.0
Minimum Split (s)	10.5	44.5	44.5	10.5	44.5	44.5	11.5	42.5	42.5	10.5	42.5	42.5
Total Split (s)	21.0	33.0	33.0	21.0	33.0	33.0	21.0	71.0	71.0	21.0	71.0	71.0
Total Split (%)	14.4%	22.6%	22.6%	14.4%	22.6%	22.6%	14.4%	48.6%	48.6%	14.4%	48.6%	48.6%
Yellow Time (s)	3.0	4.5	4.5	3.0	4.5	4.5	5.5	5.5	5.5	3.0	5.5	5.5
All-Red Time (s)	2.0	2.0	2.0	2.0	2.0	2.0	2.0	2.0	2.0	2.0	2.0	2.0
Lost Time Adjust (s)	0.0	0.0	0.0	0.0	0.0	0.0	0.0	0.0	0.0	0.0	0.0	0.0
Total Lost Time (s)	5.0	6.5	6.5	5.0	6.5	6.5	7.5	7.5	7.5	5.0	7.5	7.5
Lead/Lag	Lead	Lag	Lag	Lead	Lag	Lag	Lead	Lag	Lag	Lead	Lag	Lag
Lead-Lag Optimize?	Yes	Yes	Yes	Yes	Yes	Yes	Yes	Yes	Yes	Yes	Yes	Yes
Recall Mode	None	None	None	None	None	None	None	C-Max	C-Max	None	C-Max	C-Max
v/c Ratio	0.79	0.58	0.84	1.08	0.79	0.66	0.88	1.08	0.44	1.01	1.78	0.44
Control Delay	79.7	60.6	48.2	128.6	68.6	29.0	87.1	82.7	14.0	106.5	380.0	9.3
Queue Delay	0.0	0.0	0.0	0.0	0.0	0.0	0.0	0.0	0.0	0.0	0.0	0.0
Total Delay	79.7	60.6	48.2	128.6	68.6	29.0	87.1	82.7	14.0	106.5	380.0	9.3
Queue Length 50th (ft)	137	153	156	~221	222	85	~169	~920	98	~258	~2052	59
Queue Length 95th (ft)	178	194	252	#325	282	181	#282	#1006	183	#378	#2100	142
Internal Link Dist (ft)		926			325			844			2578	
Turn Bay Length (ft)	150			175			600			600		575
Base Capacity (vph)	376	642	417	376	642	421	381	2211	798	445	2218	844
Starvation Cap Reductn	0	0	0	0	0	0	0	0	0	0	0	0
Spillback Cap Reductn	0	0	0	0	0	0	0	0	0	0	0	0
Storage Cap Reductn	0	0	0	0	0	0	0	0	0	0	0	0
Reduced v/c Ratio	0.75	0.52	0.78	1.08	0.72	0.62	0.88	1.08	0.44	1.01	1.78	0.44

Intersection Summary



































Cycle Length: 146
 Actuated Cycle Length: 146
 Offset: 54 (37%), Referenced to phase 2:NBT and 6:SBT, Start of Yellow
 Natural Cycle: 150
 Control Type: Actuated-Coordinated
 ~ Volume exceeds capacity, queue is theoretically infinite.
 Queue shown is maximum after two cycles.
 # 95th percentile volume exceeds capacity, queue may be longer.
 Queue shown is maximum after two cycles.

Splits and Phases: 1: Powers & Galley



HCM 6th Signalized Intersection Summary
1: Powers & Galley

Long Term Total
AM Peak Hour

												
Movement	EBL	EBT	EBR	WBL	WBT	WBR	NBL	NBT	NBR	SBL	SBT	SBR
Lane Configurations	 	 		 	 		 	  		 	  	
Traffic Volume (veh/h)	243	287	279	361	413	233	305	2165	320	436	3827	364
Future Volume (veh/h)	243	287	279	361	413	233	305	2165	320	436	3827	364
Initial Q (Qb), veh	0	0	0	0	0	0	0	0	0	0	0	0
Ped-Bike Adj(A_pbT)	1.00		1.00	1.00		1.00	1.00		1.00	1.00		1.00
Parking Bus, Adj	1.00	1.00	1.00	1.00	1.00	1.00	1.00	1.00	1.00	1.00	1.00	1.00
Work Zone On Approach		No			No			No			No	
Adj Sat Flow, veh/h/ln	1870	1870	1870	1870	1870	1870	1870	1870	1870	1870	1870	1870
Adj Flow Rate, veh/h	283	334	0	406	464	0	335	2379	0	449	3945	375
Peak Hour Factor	0.86	0.86	0.86	0.89	0.89	0.89	0.91	0.91	0.91	0.97	0.97	0.97
Percent Heavy Veh, %	2	2	2	2	2	2	2	2	2	2	2	2
Cap, veh/h	331	489		379	538		320	2444		379	2444	759
Arrive On Green	0.10	0.14	0.00	0.11	0.15	0.00	0.09	0.48	0.00	0.11	0.48	0.48
Sat Flow, veh/h	3456	3554	1585	3456	3554	1585	3456	5106	1585	3456	5106	1585
Grp Volume(v), veh/h	283	334	0	406	464	0	335	2379	0	449	3945	375
Grp Sat Flow(s),veh/h/ln	1728	1777	1585	1728	1777	1585	1728	1702	1585	1728	1702	1585
Q Serve(g_s), s	11.8	13.1	0.0	16.0	18.6	0.0	13.5	66.4	0.0	16.0	69.9	23.6
Cycle Q Clear(g_c), s	11.8	13.1	0.0	16.0	18.6	0.0	13.5	66.4	0.0	16.0	69.9	23.6
Prop In Lane	1.00		1.00	1.00		1.00	1.00		1.00	1.00		1.00
Lane Grp Cap(c), veh/h	331	489		379	538		320	2444		379	2444	759
V/C Ratio(X)	0.85	0.68		1.07	0.86		1.05	0.97		1.19	1.61	0.49
Avail Cap(c_a), veh/h	379	645		379	645		320	2444		379	2444	759
HCM Platoon Ratio	1.00	1.00	1.00	1.00	1.00	1.00	1.00	1.00	1.00	1.00	1.00	1.00
Upstream Filter(I)	1.00	1.00	0.00	1.00	1.00	0.00	1.00	1.00	0.00	1.00	1.00	1.00
Uniform Delay (d), s/veh	65.0	59.9	0.0	65.0	60.5	0.0	66.3	37.1	0.0	65.0	38.1	26.0
Incr Delay (d2), s/veh	15.5	1.9	0.0	66.8	10.1	0.0	63.6	12.9	0.0	107.2	278.2	2.3
Initial Q Delay(d3),s/veh	0.0	0.0	0.0	0.0	0.0	0.0	0.0	0.0	0.0	0.0	0.0	0.0
%ile BackOfQ(50%),veh/ln	5.9	6.0	0.0	10.6	9.2	0.0	8.8	30.1	0.0	12.7	91.5	9.4
Unsig. Movement Delay, s/veh												
LnGrp Delay(d),s/veh	80.5	61.8	0.0	131.8	70.5	0.0	129.8	50.1	0.0	172.2	316.2	28.3
LnGrp LOS	F	E		F	E		F	D		F	F	C
Approach Vol, veh/h		617	A		870	A		2714	A		4769	
Approach Delay, s/veh		70.4			99.1			59.9			280.0	
Approach LOS		E			F			E			F	
Timer - Assigned Phs	1	2	3	4	5	6	7	8				
Phs Duration (G+Y+Rc), s	21.0	77.4	21.0	26.6	21.0	77.4	19.0	28.6				
Change Period (Y+Rc), s	5.0	7.5	5.0	6.5	7.5	7.5	5.0	6.5				
Max Green Setting (Gmax), s	16.0	63.5	16.0	26.5	13.5	63.5	16.0	26.5				
Max Q Clear Time (g_c+I1), s	18.0	68.4	18.0	15.1	15.5	71.9	13.8	20.6				
Green Ext Time (p_c), s	0.0	0.0	0.0	1.6	0.0	0.0	0.2	1.5				

Intersection Summary

HCM 6th Ctrl Delay	181.5
HCM 6th LOS	F

Notes

User approved pedestrian interval to be less than phase max green.
Unsignalized Delay for [NBR, EBR, WBR] is excluded from calculations of the approach delay and intersection delay.

Intersection												
Int Delay, s/veh	17.6											
Movement	EBL	EBT	EBR	WBL	WBT	WBR	NBL	NBT	NBR	SBL	SBT	SBR
Lane Configurations		↑	↑	↑	↑		↑	↑		↑	↑	↑
Traffic Vol, veh/h	28	867	65	28	903	7	22	2	14	25	4	82
Future Vol, veh/h	28	867	65	28	903	7	22	2	14	25	4	82
Conflicting Peds, #/hr	0	0	0	0	0	0	0	0	0	0	0	0
Sign Control	Free	Free	Free	Free	Free	Free	Stop	Stop	Stop	Stop	Stop	Stop
RT Channelized	-	-	None	-	-	None	-	-	None	-	-	None
Storage Length	-	-	0	100	-	-	0	-	-	100	-	0
Veh in Median Storage, #	-	0	-	-	0	-	-	0	-	-	0	-
Grade, %	-	0	-	-	0	-	-	0	-	-	0	-
Peak Hour Factor	92	92	92	84	84	92	72	92	72	92	92	92
Heavy Vehicles, %	2	2	2	2	2	2	2	2	2	2	2	2
Mvmt Flow	30	942	71	33	1075	8	31	2	19	27	4	89

Major/Minor	Major1			Major2			Minor1			Minor2		
Conflicting Flow All	1083	0	0	1013	0	0	2194	2151	942	2193	2218	1079
Stage 1	-	-	-	-	-	-	1002	1002	-	1145	1145	-
Stage 2	-	-	-	-	-	-	1192	1149	-	1048	1073	-
Critical Hdwy	4.12	-	-	4.12	-	-	7.12	6.52	6.22	7.12	6.52	6.22
Critical Hdwy Stg 1	-	-	-	-	-	-	6.12	5.52	-	6.12	5.52	-
Critical Hdwy Stg 2	-	-	-	-	-	-	6.12	5.52	-	6.12	5.52	-
Follow-up Hdwy	2.218	-	-	2.218	-	-	3.518	4.018	3.318	3.518	4.018	3.318
Pot Cap-1 Maneuver	644	-	-	684	-	-	32	48	319	32	44	265
Stage 1	-	-	-	-	-	-	292	320	-	243	274	-
Stage 2	-	-	-	-	-	-	228	273	-	275	297	-
Platoon blocked, %		-	-		-	-						
Mov Cap-1 Maneuver	644	-	-	684	-	-	~ 17	41	319	~ 26	37	265
Mov Cap-2 Maneuver	-	-	-	-	-	-	~ 17	41	-	~ 26	37	-
Stage 1	-	-	-	-	-	-	260	285	-	217	261	-
Stage 2	-	-	-	-	-	-	142	260	-	229	265	-

Approach	EB	WB	NB	SB
HCM Control Delay, s	0.3	0.3	\$ 507.2	114.9
HCM LOS			F	F

Minor Lane/Major Mvmt	NBLn1	NBLn2	EBL	EBT	EBR	WBL	WBT	WBR	SBLn1	SBLn2	SBLn3
Capacity (veh/h)	17	190	644	-	-	684	-	-	26	37	265
HCM Lane V/C Ratio	1.797	0.114	0.047	-	-	0.049	-	-	1.045	0.118	0.336
HCM Control Delay (s)	\$ 847.3	26.4	10.9	-	-	10.5	-	-	\$ 409	114.9	25.3
HCM Lane LOS	F	D	B	-	-	B	-	-	F	F	D
HCM 95th %tile Q(veh)	4.3	0.4	0.1	-	-	0.2	-	-	3.3	0.4	1.4

Notes
 ~: Volume exceeds capacity \$: Delay exceeds 300s +: Computation Not Defined *: All major volume in platoon

Timings
2: Paonia & Galley

Long Term Total-Paonia/Galley Signal
AM Peak Hour

Lane Group	EBL	EBT	EBR	WBL	WBT	NBL	NBT	SBL	SBT	SBR
Lane Configurations										
Traffic Volume (vph)	28	867	65	28	903	22	2	25	4	82
Future Volume (vph)	28	867	65	28	903	22	2	25	4	82
Turn Type	Perm	NA	Perm	Perm	NA	pm+pt	NA	Perm	NA	Perm
Protected Phases		4			8	5	2		6	
Permitted Phases	4		4	8		2		6		6
Detector Phase	4	4	4	8	8	5	2	6	6	6
Switch Phase										
Minimum Initial (s)	5.0	5.0	5.0	5.0	5.0	5.0	5.0	5.0	5.0	5.0
Minimum Split (s)	23.5	23.5	23.5	23.5	23.5	23.5	23.5	23.5	23.5	23.5
Total Split (s)	73.0	73.0	73.0	73.0	73.0	23.5	47.0	23.5	23.5	23.5
Total Split (%)	60.8%	60.8%	60.8%	60.8%	60.8%	19.6%	39.2%	19.6%	19.6%	19.6%
Yellow Time (s)	3.5	3.5	3.5	3.5	3.5	3.5	3.5	3.5	3.5	3.5
All-Red Time (s)	2.0	2.0	2.0	2.0	2.0	2.0	2.0	2.0	2.0	2.0
Lost Time Adjust (s)	0.0	0.0	0.0	0.0	0.0	0.0	0.0	0.0	0.0	0.0
Total Lost Time (s)	5.5	5.5	5.5	5.5	5.5	5.5	5.5	5.5	5.5	5.5
Lead/Lag							Lead	Lag	Lag	Lag
Lead-Lag Optimize?							Yes	Yes	Yes	Yes
Recall Mode	None	None	None	None	None	Max	C-Max	Max	Max	Max
Act Effct Green (s)	67.5	67.5	67.5	67.5	67.5	41.5	41.5	18.0	18.0	18.0
Actuated g/C Ratio	0.56	0.56	0.56	0.56	0.56	0.35	0.35	0.15	0.15	0.15
v/c Ratio	0.49	0.90	0.08	0.44	1.03	0.07	0.04	0.13	0.01	0.28
Control Delay	48.2	36.4	2.8	37.8	63.9	26.7	11.6	46.1	43.8	11.7
Queue Delay	0.0	0.0	0.0	0.0	0.0	0.0	0.0	0.0	0.0	0.0
Total Delay	48.2	36.4	2.8	37.8	63.9	26.7	11.6	46.1	43.8	11.7
LOS	D	D	A	D	E	C	B	D	D	B
Approach Delay		34.4			63.2		20.6		20.5	
Approach LOS		C			E		C		C	

Intersection Summary





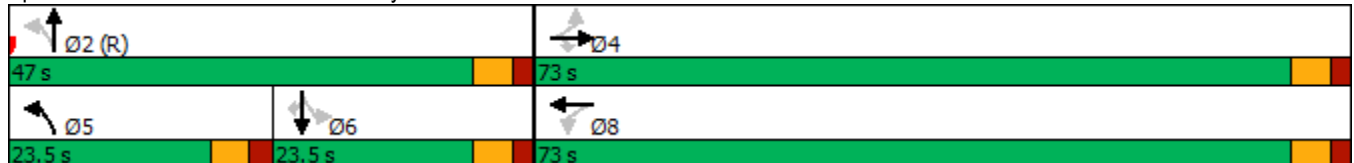

















Cycle Length: 120
 Actuated Cycle Length: 120
 Offset: 0 (0%), Referenced to phase 2:NBTL, Start of Green
 Natural Cycle: 120
 Control Type: Actuated-Coordinated
 Maximum v/c Ratio: 1.03
 Intersection Signal Delay: 47.2
 Intersection LOS: D
 Intersection Capacity Utilization 70.9%
 ICU Level of Service C
 Analysis Period (min) 15

Splits and Phases: 2: Paonia & Galley



HCM 6th Signalized Intersection Summary
2: Paonia & Galley

Long Term Total-Paonia/Galley Signal
AM Peak Hour

												
Movement	EBL	EBT	EBR	WBL	WBT	WBR	NBL	NBT	NBR	SBL	SBT	SBR
Lane Configurations												
Traffic Volume (veh/h)	28	867	65	28	903	7	22	2	14	25	4	82
Future Volume (veh/h)	28	867	65	28	903	7	22	2	14	25	4	82
Initial Q (Qb), veh	0	0	0	0	0	0	0	0	0	0	0	0
Ped-Bike Adj(A_pbT)	1.00		1.00	1.00		1.00	1.00		1.00	1.00		1.00
Parking Bus, Adj	1.00	1.00	1.00	1.00	1.00	1.00	1.00	1.00	1.00	1.00	1.00	1.00
Work Zone On Approach		No			No			No			No	
Adj Sat Flow, veh/h/ln	1870	1870	1870	1870	1870	1870	1870	1870	1870	1870	1870	1870
Adj Flow Rate, veh/h	30	942	71	33	1075	8	31	2	19	27	4	89
Peak Hour Factor	0.92	0.92	0.92	0.84	0.84	0.92	0.72	0.92	0.72	0.92	0.92	0.92
Percent Heavy Veh, %	2	2	2	2	2	2	2	2	2	2	2	2
Cap, veh/h	60	1052	892	126	1043	8	520	53	503	269	281	238
Arrive On Green	0.56	0.56	0.56	0.56	0.56	0.56	0.15	0.35	0.35	0.15	0.15	0.15
Sat Flow, veh/h	521	1870	1585	556	1854	14	1781	153	1455	1391	1870	1585
Grp Volume(v), veh/h	30	942	71	33	0	1083	31	0	21	27	4	89
Grp Sat Flow(s),veh/h/ln	521	1870	1585	556	0	1868	1781	0	1608	1391	1870	1585
Q Serve(g_s), s	0.0	53.3	2.5	6.7	0.0	67.5	1.5	0.0	1.0	2.0	0.2	6.1
Cycle Q Clear(g_c), s	67.5	53.3	2.5	59.9	0.0	67.5	1.5	0.0	1.0	2.0	0.2	6.1
Prop In Lane	1.00		1.00	1.00		0.01	1.00		0.90	1.00		1.00
Lane Grp Cap(c), veh/h	60	1052	892	126	0	1051	520	0	556	269	281	238
V/C Ratio(X)	0.50	0.90	0.08	0.26	0.00	1.03	0.06	0.00	0.04	0.10	0.01	0.37
Avail Cap(c_a), veh/h	60	1052	892	126	0	1051	520	0	556	269	281	238
HCM Platoon Ratio	1.00	1.00	1.00	1.00	1.00	1.00	1.00	1.00	1.00	1.00	1.00	1.00
Upstream Filter(I)	1.00	1.00	1.00	1.00	0.00	1.00	1.00	0.00	1.00	1.00	1.00	1.00
Uniform Delay (d), s/veh	60.0	23.1	12.0	49.6	0.0	26.3	28.5	0.0	26.0	44.2	43.4	45.9
Incr Delay (d2), s/veh	6.3	10.1	0.0	1.1	0.0	35.9	0.2	0.0	0.1	0.7	0.1	4.5
Initial Q Delay(d3),s/veh	0.0	0.0	0.0	0.0	0.0	0.0	0.0	0.0	0.0	0.0	0.0	0.0
%ile BackOfQ(50%),veh/ln	1.0	25.1	0.9	1.0	0.0	38.6	0.7	0.0	0.4	0.8	0.1	2.7
Unsig. Movement Delay, s/veh												
LnGrp Delay(d),s/veh	66.3	33.2	12.1	50.6	0.0	62.2	28.8	0.0	26.1	45.0	43.5	50.4
LnGrp LOS	E	C	B	D	A	F	C	A	C	D	D	D
Approach Vol, veh/h		1043			1116			52			120	
Approach Delay, s/veh		32.7			61.9			27.7			48.9	
Approach LOS		C			E			C			D	
Timer - Assigned Phs		2		4	5	6		8				
Phs Duration (G+Y+Rc), s		47.0		73.0	23.5	23.5		73.0				
Change Period (Y+Rc), s		5.5		5.5	5.5	5.5		5.5				
Max Green Setting (Gmax), s		41.5		67.5	18.0	18.0		67.5				
Max Q Clear Time (g_c+I1), s		3.0		69.5	3.5	8.1		69.5				
Green Ext Time (p_c), s		0.1		0.0	0.0	0.2		0.0				
Intersection Summary												
HCM 6th Ctrl Delay				47.4								
HCM 6th LOS				D								

Intersection												
Int Delay, s/veh	8.5											
Movement	EBL	EBT	EBR	WBL	WBT	WBR	NBL	NBT	NBR	SBL	SBT	SBR
Lane Configurations		↔↔			↔↔			↔			↔↔	
Traffic Vol, veh/h	47	73	43	35	199	46	30	12	25	86	47	15
Future Vol, veh/h	47	73	43	35	199	46	30	12	25	86	47	15
Conflicting Peds, #/hr	0	0	0	0	0	0	0	0	0	0	0	0
Sign Control	Free	Free	Free	Free	Free	Free	Stop	Stop	Stop	Stop	Stop	Stop
RT Channelized	-	-	None	-	-	None	-	-	None	-	-	None
Storage Length	-	-	-	-	-	-	-	-	-	-	-	-
Veh in Median Storage, #	-	0	-	-	0	-	-	0	-	-	0	-
Grade, %	-	0	-	-	0	-	-	0	-	-	0	-
Peak Hour Factor	75	75	75	93	93	93	83	83	83	67	67	67
Heavy Vehicles, %	2	2	2	2	2	2	2	2	2	2	2	2
Mvmt Flow	63	97	57	38	214	49	36	14	30	128	70	22

Major/Minor	Major1			Major2			Minor1			Minor2		
Conflicting Flow All	263	0	0	154	0	0	470	591	77	497	595	132
Stage 1	-	-	-	-	-	-	252	252	-	315	315	-
Stage 2	-	-	-	-	-	-	218	339	-	182	280	-
Critical Hdwy	4.14	-	-	4.14	-	-	7.54	6.54	6.94	7.54	6.54	6.94
Critical Hdwy Stg 1	-	-	-	-	-	-	6.54	5.54	-	6.54	5.54	-
Critical Hdwy Stg 2	-	-	-	-	-	-	6.54	5.54	-	6.54	5.54	-
Follow-up Hdwy	2.22	-	-	2.22	-	-	3.52	4.02	3.32	3.52	4.02	3.32
Pot Cap-1 Maneuver	1298	-	-	1424	-	-	477	418	968	456	416	893
Stage 1	-	-	-	-	-	-	730	697	-	671	654	-
Stage 2	-	-	-	-	-	-	764	638	-	802	678	-
Platoon blocked, %	-	-	-	-	-	-	-	-	-	-	-	-
Mov Cap-1 Maneuver	1298	-	-	1424	-	-	375	384	968	402	382	893
Mov Cap-2 Maneuver	-	-	-	-	-	-	375	384	-	402	382	-
Stage 1	-	-	-	-	-	-	691	660	-	635	634	-
Stage 2	-	-	-	-	-	-	642	618	-	720	642	-

Approach	EB	WB	NB	SB
HCM Control Delay, s	2.3	1	13.8	22.9
HCM LOS			B	C

Minor Lane/Major Mvmt	NBLn1	EBL	EBT	EBR	WBL	WBT	WBR	SBLn1
Capacity (veh/h)	489	1298	-	-	1424	-	-	418
HCM Lane V/C Ratio	0.165	0.048	-	-	0.026	-	-	0.528
HCM Control Delay (s)	13.8	7.9	0.1	-	7.6	0.1	-	22.9
HCM Lane LOS	B	A	A	-	A	A	-	C
HCM 95th %tile Q(veh)	0.6	0.2	-	-	0.1	-	-	3

Intersection						
Int Delay, s/veh	4.7					
Movement	EBT	EBR	WBL	WBT	NBL	NBR
Lane Configurations	↑↑		↖	↑	↘	
Traffic Vol, veh/h	982	61	8	982	25	4
Future Vol, veh/h	982	61	8	982	25	4
Conflicting Peds, #/hr	0	0	0	0	0	0
Sign Control	Free	Free	Free	Free	Stop	Stop
RT Channelized	-	None	-	None	-	None
Storage Length	-	-	125	-	0	-
Veh in Median Storage, #	0	-	-	0	0	-
Grade, %	0	-	-	0	0	-
Peak Hour Factor	88	88	85	85	75	75
Heavy Vehicles, %	2	2	2	2	2	2
Mvmt Flow	1116	69	9	1155	33	5

Major/Minor	Major1	Major2	Minor1	Minor2	Minor3
Conflicting Flow All	0	0	1185	0	2324
Stage 1	-	-	-	-	1151
Stage 2	-	-	-	-	1173
Critical Hdwy	-	-	4.13	-	6.63
Critical Hdwy Stg 1	-	-	-	-	5.83
Critical Hdwy Stg 2	-	-	-	-	5.43
Follow-up Hdwy	-	-	2.219	-	3.519
Pot Cap-1 Maneuver	-	-	587	-	36
Stage 1	-	-	-	-	264
Stage 2	-	-	-	-	293
Platoon blocked, %	-	-	-	-	-
Mov Cap-1 Maneuver	-	-	587	-	35
Mov Cap-2 Maneuver	-	-	-	-	35
Stage 1	-	-	-	-	264
Stage 2	-	-	-	-	289

Approach	EB	WB	NB
HCM Control Delay, s	0	0.1	285.5
HCM LOS			F

Minor Lane/Major Mvmt	NBLn1	EBT	EBR	WBL	WBT
Capacity (veh/h)	40	-	-	587	-
HCM Lane V/C Ratio	0.967	-	-	0.016	-
HCM Control Delay (s)	285.5	-	-	11.2	-
HCM Lane LOS	F	-	-	B	-
HCM 95th %tile Q(veh)	3.7	-	-	0	-

Timings
1: Powers & Galley

Long Term Total
PM Peak Hour



Lane Group	EBL	EBT	EBR	WBL	WBT	WBR	NBL	NBT	NBR	SBL	SBT	SBR
Lane Configurations	↖↗	↕	↖	↖↗	↕	↖	↖↗	↕	↖	↖↗	↕	↖
Traffic Volume (vph)	482	463	327	389	478	467	409	3425	465	266	2548	305
Future Volume (vph)	482	463	327	389	478	467	409	3425	465	266	2548	305
Lane Group Flow (vph)	560	538	380	437	537	525	449	3764	511	274	2627	314
Turn Type	Prot	NA	Perm	Prot	NA	Perm	Prot	NA	Perm	Prot	NA	Perm
Protected Phases	7	4		3	8		5	2		1	6	
Permitted Phases			4			8			2			6
Detector Phase	7	4	4	3	8	8	5	2	2	1	6	6
Switch Phase												
Minimum Initial (s)	4.0	4.0	4.0	4.0	4.0	4.0	4.0	20.0	20.0	4.0	20.0	20.0
Minimum Split (s)	10.5	44.5	44.5	10.5	44.5	44.5	11.5	42.5	42.5	10.5	42.5	42.5
Total Split (s)	21.0	33.0	33.0	21.0	33.0	33.0	21.0	71.0	71.0	21.0	71.0	71.0
Total Split (%)	14.4%	22.6%	22.6%	14.4%	22.6%	22.6%	14.4%	48.6%	48.6%	14.4%	48.6%	48.6%
Yellow Time (s)	3.0	4.5	4.5	3.0	4.5	4.5	5.5	5.5	5.5	3.0	5.5	5.5
All-Red Time (s)	2.0	2.0	2.0	2.0	2.0	2.0	2.0	2.0	2.0	2.0	2.0	2.0
Lost Time Adjust (s)	0.0	0.0	0.0	0.0	0.0	0.0	0.0	0.0	0.0	0.0	0.0	0.0
Total Lost Time (s)	5.0	6.5	6.5	5.0	6.5	6.5	7.5	7.5	7.5	5.0	7.5	7.5
Lead/Lag	Lead	Lag	Lag	Lead	Lag	Lag	Lead	Lag	Lag	Lead	Lag	Lag
Lead-Lag Optimize?	Yes	Yes	Yes	Yes	Yes	Yes	Yes	Yes	Yes	Yes	Yes	Yes
Recall Mode	None	None	None	None	None	None	None	C-Max	C-Max	None	C-Max	C-Max
v/c Ratio	1.49	0.84	0.91	1.16	0.84	1.26	1.42	1.68	0.64	0.77	1.19	0.36
Control Delay	276.4	70.2	60.4	153.4	70.1	169.0	250.5	336.5	24.3	78.7	126.7	3.7
Queue Delay	0.0	0.0	0.0	0.0	0.0	0.0	0.0	0.0	0.0	0.0	0.0	0.0
Total Delay	276.4	70.2	60.4	153.4	70.1	169.0	250.5	336.5	24.3	78.7	126.7	3.7
Queue Length 50th (ft)	~378	263	220	~253	262	~497	~295	~1920	251	131	~1099	0
Queue Length 95th (ft)	#467	314	#373	#358	#330	#715	#408	#1975	382	182	#1181	56
Internal Link Dist (ft)		926			325			844			2578	
Turn Bay Length (ft)	150			175			600			600		575
Base Capacity (vph)	376	642	417	376	642	416	317	2242	797	376	2211	865
Starvation Cap Reductn	0	0	0	0	0	0	0	0	0	0	0	0
Spillback Cap Reductn	0	0	0	0	0	0	0	0	0	0	0	0
Storage Cap Reductn	0	0	0	0	0	0	0	0	0	0	0	0
Reduced v/c Ratio	1.49	0.84	0.91	1.16	0.84	1.26	1.42	1.68	0.64	0.73	1.19	0.36

Intersection Summary

























Cycle Length: 146
 Actuated Cycle Length: 146
 Offset: 54 (37%), Referenced to phase 2:NBT and 6:SBT, Start of Yellow
 Natural Cycle: 150
 Control Type: Actuated-Coordinated
 ~ Volume exceeds capacity, queue is theoretically infinite.
 Queue shown is maximum after two cycles.
 # 95th percentile volume exceeds capacity, queue may be longer.
 Queue shown is maximum after two cycles.

Splits and Phases: 1: Powers & Galley



HCM 6th Signalized Intersection Summary
1: Powers & Galley

Long Term Total
PM Peak Hour

												
Movement	EBL	EBT	EBR	WBL	WBT	WBR	NBL	NBT	NBR	SBL	SBT	SBR
Lane Configurations												
Traffic Volume (veh/h)	482	463	327	389	478	467	409	3425	465	266	2548	305
Future Volume (veh/h)	482	463	327	389	478	467	409	3425	465	266	2548	305
Initial Q (Qb), veh	0	0	0	0	0	0	0	0	0	0	0	0
Ped-Bike Adj(A_pbT)	1.00		1.00	1.00		1.00	1.00		1.00	1.00		1.00
Parking Bus, Adj	1.00	1.00	1.00	1.00	1.00	1.00	1.00	1.00	1.00	1.00	1.00	1.00
Work Zone On Approach		No			No			No			No	
Adj Sat Flow, veh/h/ln	1870	1870	1870	1870	1870	1870	1870	1870	1870	1870	1870	1870
Adj Flow Rate, veh/h	560	538	0	437	537	0	449	3764	0	274	2627	314
Peak Hour Factor	0.86	0.86	0.86	0.89	0.89	0.89	0.91	0.91	0.91	0.97	0.97	0.97
Percent Heavy Veh, %	2	2	2	2	2	2	2	2	2	2	2	2
Cap, veh/h	379	599		379	599		320	2369		323	2286	710
Arrive On Green	0.11	0.17	0.00	0.11	0.17	0.00	0.09	0.46	0.00	0.09	0.45	0.45
Sat Flow, veh/h	3456	3554	1585	3456	3554	1585	3456	5106	1585	3456	5106	1585
Grp Volume(v), veh/h	560	538	0	437	537	0	449	3764	0	274	2627	314
Grp Sat Flow(s),veh/h/ln	1728	1777	1585	1728	1777	1585	1728	1702	1585	1728	1702	1585
Q Serve(g_s), s	16.0	21.7	0.0	16.0	21.6	0.0	13.5	67.7	0.0	11.4	65.4	19.9
Cycle Q Clear(g_c), s	16.0	21.7	0.0	16.0	21.6	0.0	13.5	67.7	0.0	11.4	65.4	19.9
Prop In Lane	1.00		1.00	1.00		1.00	1.00		1.00	1.00		1.00
Lane Grp Cap(c), veh/h	379	599		379	599		320	2369		323	2286	710
V/C Ratio(X)	1.48	0.90		1.15	0.90		1.41	1.59		0.85	1.15	0.44
Avail Cap(c_a), veh/h	379	645		379	645		320	2369		379	2286	710
HCM Platoon Ratio	1.00	1.00	1.00	1.00	1.00	1.00	1.00	1.00	1.00	1.00	1.00	1.00
Upstream Filter(I)	1.00	1.00	0.00	1.00	1.00	0.00	1.00	1.00	0.00	1.00	1.00	1.00
Uniform Delay (d), s/veh	65.0	59.4	0.0	65.0	59.4	0.0	66.3	39.1	0.0	65.2	40.3	27.8
Incr Delay (d2), s/veh	229.2	14.7	0.0	95.2	14.5	0.0	200.1	267.1	0.0	14.6	72.7	2.0
Initial Q Delay(d3),s/veh	0.0	0.0	0.0	0.0	0.0	0.0	0.0	0.0	0.0	0.0	0.0	0.0
%ile BackOfQ(50%),veh/ln	19.1	11.0	0.0	12.1	11.0	0.0	14.9	86.4	0.0	5.7	42.3	8.0
Unsig. Movement Delay, s/veh												
LnGrp Delay(d),s/veh	294.2	74.2	0.0	160.2	74.0	0.0	266.4	306.3	0.0	79.7	113.0	29.8
LnGrp LOS	F	E		F	E		F	F		E	F	C
Approach Vol, veh/h		1098	A		974	A		4213	A		3215	
Approach Delay, s/veh		186.4			112.6			302.0			102.0	
Approach LOS		F			F			F			F	
Timer - Assigned Phs	1	2	3	4	5	6	7	8				
Phs Duration (G+Y+Rc), s	18.6	75.2	21.0	31.1	21.0	72.9	21.0	31.1				
Change Period (Y+Rc), s	5.0	7.5	5.0	6.5	7.5	7.5	5.0	6.5				
Max Green Setting (Gmax), s	16.0	63.5	16.0	26.5	13.5	63.5	16.0	26.5				
Max Q Clear Time (g_c+I1), s	13.4	69.7	18.0	23.7	15.5	67.4	18.0	23.6				
Green Ext Time (p_c), s	0.2	0.0	0.0	1.0	0.0	0.0	0.0	1.0				
Intersection Summary												
HCM 6th Ctrl Delay			201.6									
HCM 6th LOS			F									
Notes												
User approved pedestrian interval to be less than phase max green.												
Unsignalized Delay for [NBR, EBR, WBR] is excluded from calculations of the approach delay and intersection delay.												

Intersection												
Int Delay, s/veh	781											
Movement	EBL	EBT	EBR	WBL	WBT	WBR	NBL	NBT	NBR	SBL	SBT	SBR
Lane Configurations	↖	↑	↗	↖	↑		↖	↗		↖	↑	↗
Traffic Vol, veh/h	90	932	129	56	1103	25	123	3	77	14	2	62
Future Vol, veh/h	90	932	129	56	1103	25	123	3	77	14	2	62
Conflicting Peds, #/hr	0	0	0	0	0	0	0	0	0	0	0	0
Sign Control	Free	Free	Free	Free	Free	Free	Stop	Stop	Stop	Stop	Stop	Stop
RT Channelized	-	-	None	-	-	None	-	-	None	-	-	None
Storage Length	100	-	0	100	-	-	0	-	-	100	-	0
Veh in Median Storage, #	-	0	-	-	0	-	-	0	-	-	0	-
Grade, %	-	0	-	-	0	-	-	0	-	-	0	-
Peak Hour Factor	92	92	92	84	84	92	72	92	72	92	92	92
Heavy Vehicles, %	2	2	2	2	2	2	2	2	2	2	2	2
Mvmt Flow	98	1013	140	67	1313	27	171	3	107	15	2	67

Major/Minor	Major1			Major2			Minor1			Minor2		
Conflicting Flow All	1340	0	0	1153	0	0	2704	2683	1013	2795	2810	1327
Stage 1	-	-	-	-	-	-	1209	1209	-	1461	1461	-
Stage 2	-	-	-	-	-	-	1495	1474	-	1334	1349	-
Critical Hdwy	4.12	-	-	4.12	-	-	7.12	6.52	6.22	7.12	6.52	6.22
Critical Hdwy Stg 1	-	-	-	-	-	-	6.12	5.52	-	6.12	5.52	-
Critical Hdwy Stg 2	-	-	-	-	-	-	6.12	5.52	-	6.12	5.52	-
Follow-up Hdwy	2.218	-	-	2.218	-	-	3.518	4.018	3.318	3.518	4.018	3.318
Pot Cap-1 Maneuver	514	-	-	606	-	-	~ 14	22	290	~ 12	18	190
Stage 1	-	-	-	-	-	-	223	256	-	160	193	-
Stage 2	-	-	-	-	-	-	~ 153	191	-	190	219	-
Platoon blocked, %	-	-	-	-	-	-	-	-	-	-	-	-
Mov Cap-1 Maneuver	514	-	-	606	-	-	~ 6	16	290	~ 5	13	190
Mov Cap-2 Maneuver	-	-	-	-	-	-	~ 6	16	-	~ 5	13	-
Stage 1	-	-	-	-	-	-	180	207	-	129	172	-
Stage 2	-	-	-	-	-	-	~ 87	170	-	96	177	-

Approach	EB			WB			NB			SB		
HCM Control Delay, s	1.1			0.6			\$ 8261.3			\$ 444.6		
HCM LOS							F			F		

Minor Lane/Major Mvmt	NBLn1	NBLn2	EBL	EBT	EBR	WBL	WBT	WBR	SBLn1	SBLn2	SBLn3
Capacity (veh/h)	6	192	514	-	-	606	-	-	5	13	190
HCM Lane V/C Ratio	28.472	0.574	0.19	-	-	0.11	-	-	3.043	0.167	0.355
HCM Control Delay (s)	\$ 13560.9	46.3	13.6	-	-	11.7	-	-	\$ 2279.1	\$ 331.1	34
HCM Lane LOS	F	E	B	-	-	B	-	-	F	F	D
HCM 95th %tile Q(veh)	23.3	3.1	0.7	-	-	0.4	-	-	3.1	0.5	1.5

Notes
 ~: Volume exceeds capacity \$: Delay exceeds 300s +: Computation Not Defined *: All major volume in platoon

Timings
2: Paonia & Galley

Long Term Total-Paonia/Galley Signal
PM Peak Hour

Lane Group	EBL	EBT	EBR	WBL	WBT	NBL	NBT	SBL	SBT	SBR
Lane Configurations										
Traffic Volume (vph)	90	932	129	56	1103	123	3	14	2	62
Future Volume (vph)	90	932	129	56	1103	123	3	14	2	62
Turn Type	Perm	NA	Perm	Perm	NA	pm+pt	NA	Perm	NA	Perm
Protected Phases		4			8	5	2		6	
Permitted Phases	4		4	8		2		6		6
Detector Phase	4	4	4	8	8	5	2	6	6	6
Switch Phase										
Minimum Initial (s)	5.0	5.0	5.0	5.0	5.0	5.0	5.0	5.0	5.0	5.0
Minimum Split (s)	22.5	22.5	22.5	22.5	22.5	22.5	22.5	22.5	22.5	22.5
Total Split (s)	75.0	75.0	75.0	75.0	75.0	22.5	45.0	22.5	22.5	22.5
Total Split (%)	62.5%	62.5%	62.5%	62.5%	62.5%	18.8%	37.5%	18.8%	18.8%	18.8%
Yellow Time (s)	3.5	3.5	3.5	3.5	3.5	3.5	3.5	3.5	3.5	3.5
All-Red Time (s)	1.0	1.0	1.0	1.0	1.0	1.0	1.0	1.0	1.0	1.0
Lost Time Adjust (s)	0.0	0.0	0.0	0.0	0.0	0.0	0.0	0.0	0.0	0.0
Total Lost Time (s)	4.5	4.5	4.5	4.5	4.5	4.5	4.5	4.5	4.5	4.5
Lead/Lag						Lead		Lag	Lag	Lag
Lead-Lag Optimize?						Yes		Yes	Yes	Yes
Recall Mode	None	None	None	None	None	Max	C-Max	Max	Max	Max
Act Effct Green (s)	63.1	63.1	63.1	63.1	63.1	47.9	47.9	18.0	18.0	18.0
Actuated g/C Ratio	0.53	0.53	0.53	0.53	0.53	0.40	0.40	0.15	0.15	0.15
v/c Ratio	1.01	0.58	0.15	0.39	0.72	0.29	0.16	0.08	0.01	0.23
Control Delay	123.0	20.2	2.3	22.4	23.7	27.9	6.1	45.2	43.5	12.6
Queue Delay	0.0	0.0	0.0	0.0	0.0	0.0	0.0	0.0	0.0	0.0
Total Delay	123.0	20.2	2.3	22.4	23.7	27.9	6.1	45.2	43.5	12.6
LOS	F	C	A	C	C	C	A	D	D	B
Approach Delay		26.5			23.7		19.4		19.2	
Approach LOS		C			C		B		B	

Intersection Summary

Cycle Length: 120
 Actuated Cycle Length: 120
 Offset: 0 (0%), Referenced to phase 2:NBTL, Start of Green
 Natural Cycle: 100
 Control Type: Actuated-Coordinated
 Maximum v/c Ratio: 1.01
 Intersection Signal Delay: 24.3
 Intersection LOS: C
 Intersection Capacity Utilization 61.0%
 ICU Level of Service B
 Analysis Period (min) 15

Splits and Phases: 2: Paonia & Galley

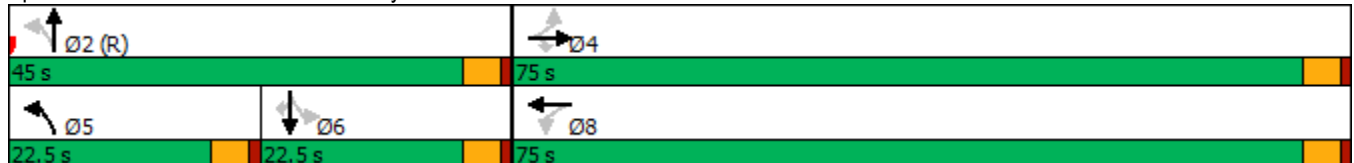

HCM 6th Signalized Intersection Summary
2: Paonia & Galley

Long Term Total-Paonia/Galley Signal
PM Peak Hour

Movement	EBL	EBT	EBR	WBL	WBT	WBR	NBL	NBT	NBR	SBL	SBT	SBR
Lane Configurations												
Traffic Volume (veh/h)	90	932	129	56	1103	25	123	3	77	14	2	62
Future Volume (veh/h)	90	932	129	56	1103	25	123	3	77	14	2	62
Initial Q (Qb), veh	0	0	0	0	0	0	0	0	0	0	0	0
Ped-Bike Adj(A_pbT)	1.00		1.00	1.00		1.00	1.00		1.00	1.00		1.00
Parking Bus, Adj	1.00	1.00	1.00	1.00	1.00	1.00	1.00	1.00	1.00	1.00	1.00	1.00
Work Zone On Approach		No			No			No			No	
Adj Sat Flow, veh/h/ln	1870	1870	1870	1870	1870	1870	1870	1870	1870	1870	1870	1870
Adj Flow Rate, veh/h	98	1013	140	67	1313	27	171	3	107	15	2	67
Peak Hour Factor	0.92	0.92	0.92	0.84	0.84	0.92	0.72	0.92	0.72	0.92	0.92	0.92
Percent Heavy Veh, %	2	2	2	2	2	2	2	2	2	2	2	2
Cap, veh/h	179	2069	877	249	1970	40	572	16	576	297	345	292
Arrive On Green	0.55	0.55	0.55	0.55	0.55	0.55	0.15	0.37	0.37	0.18	0.18	0.18
Sat Flow, veh/h	408	3741	1585	487	3561	73	1781	43	1548	1283	1870	1585
Grp Volume(v), veh/h	98	1013	140	67	655	685	171	0	110	15	2	67
Grp Sat Flow(s),veh/h/ln	408	1870	1585	487	1777	1857	1781	0	1592	1283	1870	1585
Q Serve(g_s), s	26.9	19.9	5.2	11.7	31.3	31.3	8.3	0.0	5.6	1.2	0.1	4.3
Cycle Q Clear(g_c), s	58.2	19.9	5.2	31.6	31.3	31.3	8.3	0.0	5.6	1.2	0.1	4.3
Prop In Lane	1.00		1.00	1.00		0.04	1.00		0.97	1.00		1.00
Lane Grp Cap(c), veh/h	179	2069	877	249	983	1027	572	0	592	297	345	292
V/C Ratio(X)	0.55	0.49	0.16	0.27	0.67	0.67	0.30	0.00	0.19	0.05	0.01	0.23
Avail Cap(c_a), veh/h	193	2198	931	265	1044	1091	572	0	592	297	345	292
HCM Platoon Ratio	1.00	1.00	1.00	1.00	1.00	1.00	1.00	1.00	1.00	1.00	1.00	1.00
Upstream Filter(I)	1.00	1.00	1.00	1.00	1.00	1.00	1.00	0.00	1.00	1.00	1.00	1.00
Uniform Delay (d), s/veh	39.6	16.4	13.1	26.1	19.0	19.0	28.0	0.0	25.4	40.4	40.0	41.7
Incr Delay (d2), s/veh	2.7	0.2	0.1	0.6	1.5	1.4	1.3	0.0	0.7	0.3	0.0	1.8
Initial Q Delay(d3),s/veh	0.0	0.0	0.0	0.0	0.0	0.0	0.0	0.0	0.0	0.0	0.0	0.0
%ile BackOfQ(50%),veh/ln	2.8	8.4	1.9	1.4	12.9	13.5	3.7	0.0	2.2	0.4	0.1	1.8
Unsig. Movement Delay, s/veh												
LnGrp Delay(d),s/veh	42.3	16.6	13.2	26.7	20.5	20.4	29.3	0.0	26.1	40.7	40.0	43.5
LnGrp LOS	D	B	B	C	C	C	C	A	C	D	D	D
Approach Vol, veh/h		1251			1407			281			84	
Approach Delay, s/veh		18.2			20.8			28.1			42.9	
Approach LOS		B			C			C			D	
Timer - Assigned Phs		2		4	5	6		8				
Phs Duration (G+Y+Rc), s		49.1		70.9	22.5	26.6		70.9				
Change Period (Y+Rc), s		4.5		4.5	4.5	4.5		4.5				
Max Green Setting (Gmax), s		40.5		70.5	18.0	18.0		70.5				
Max Q Clear Time (g_c+I1), s		7.6		60.2	10.3	6.3		33.6				
Green Ext Time (p_c), s		0.7		6.2	0.3	0.1		13.9				

Intersection Summary

HCM 6th Ctrl Delay	21.0
HCM 6th LOS	C

Notes

User approved volume balancing among the lanes for turning movement.

Intersection												
Int Delay, s/veh	8.5											
Movement	EBL	EBT	EBR	WBL	WBT	WBR	NBL	NBT	NBR	SBL	SBT	SBR
Lane Configurations		↔↔			↔↔			↔			↔	
Traffic Vol, veh/h	45	177	11	23	188	79	24	31	44	102	19	19
Future Vol, veh/h	45	177	11	23	188	79	24	31	44	102	19	19
Conflicting Peds, #/hr	0	0	0	0	0	0	0	0	0	0	0	0
Sign Control	Free	Free	Free	Free	Free	Free	Stop	Stop	Stop	Stop	Stop	Stop
RT Channelized	-	-	None	-	-	None	-	-	None	-	-	None
Storage Length	-	-	-	-	-	-	-	-	-	-	-	-
Veh in Median Storage, #	-	0	-	-	0	-	-	0	-	-	0	-
Grade, %	-	0	-	-	0	-	-	0	-	-	0	-
Peak Hour Factor	75	75	75	93	93	93	83	83	83	67	67	67
Heavy Vehicles, %	2	2	2	2	2	2	2	2	2	2	2	2
Mvmt Flow	60	236	15	25	202	85	29	37	53	152	28	28

Major/Minor	Major1			Major2			Minor1			Minor2		
Conflicting Flow All	287	0	0	251	0	0	529	701	126	552	666	144
Stage 1	-	-	-	-	-	-	364	364	-	295	295	-
Stage 2	-	-	-	-	-	-	165	337	-	257	371	-
Critical Hdwy	4.14	-	-	4.14	-	-	7.54	6.54	6.94	7.54	6.54	6.94
Critical Hdwy Stg 1	-	-	-	-	-	-	6.54	5.54	-	6.54	5.54	-
Critical Hdwy Stg 2	-	-	-	-	-	-	6.54	5.54	-	6.54	5.54	-
Follow-up Hdwy	2.22	-	-	2.22	-	-	3.52	4.02	3.32	3.52	4.02	3.32
Pot Cap-1 Maneuver	1272	-	-	1311	-	-	433	361	901	416	379	877
Stage 1	-	-	-	-	-	-	627	622	-	689	668	-
Stage 2	-	-	-	-	-	-	821	640	-	725	618	-
Platoon blocked, %		-	-		-	-						
Mov Cap-1 Maneuver	1272	-	-	1311	-	-	370	333	901	337	350	877
Mov Cap-2 Maneuver	-	-	-	-	-	-	370	333	-	337	350	-
Stage 1	-	-	-	-	-	-	593	588	-	651	653	-
Stage 2	-	-	-	-	-	-	742	625	-	604	584	-

Approach	EB			WB			NB			SB		
HCM Control Delay, s	1.6			0.7			15			26.6		
HCM LOS							C			D		

Minor Lane/Major Mvmt	NBLn1	EBL	EBT	EBR	WBL	WBT	WBR	SBLn1
Capacity (veh/h)	479	1272	-	-	1311	-	-	370
HCM Lane V/C Ratio	0.249	0.047	-	-	0.019	-	-	0.565
HCM Control Delay (s)	15	8	0.1	-	7.8	0.1	-	26.6
HCM Lane LOS	C	A	A	-	A	A	-	D
HCM 95th %tile Q(veh)	1	0.1	-	-	0.1	-	-	3.3

Intersection						
Int Delay, s/veh	108.5					
Movement	EBT	EBR	WBL	WBT	NBL	NBR
Lane Configurations	↑↑		↖	↑	↘	
Traffic Vol, veh/h	1134	60	26	1273	61	33
Future Vol, veh/h	1134	60	26	1273	61	33
Conflicting Peds, #/hr	0	0	0	0	0	0
Sign Control	Free	Free	Free	Free	Stop	Stop
RT Channelized	-	None	-	None	-	None
Storage Length	-	-	125	-	0	-
Veh in Median Storage, #	0	-	-	0	0	-
Grade, %	0	-	-	0	0	-
Peak Hour Factor	88	88	85	85	75	75
Heavy Vehicles, %	2	2	2	2	2	2
Mvmt Flow	1289	68	31	1498	81	44

Major/Minor	Major1	Major2	Minor1		
Conflicting Flow All	0	0	1357	0	2883 679
Stage 1	-	-	-	-	1323 -
Stage 2	-	-	-	-	1560 -
Critical Hdwy	-	-	4.13	-	6.63 6.93
Critical Hdwy Stg 1	-	-	-	-	5.83 -
Critical Hdwy Stg 2	-	-	-	-	5.43 -
Follow-up Hdwy	-	-	2.219	-	3.519 3.319
Pot Cap-1 Maneuver	-	-	505	-	~ 15 395
Stage 1	-	-	-	-	214 -
Stage 2	-	-	-	-	190 -
Platoon blocked, %	-	-	-	-	-
Mov Cap-1 Maneuver	-	-	505	-	~ 14 395
Mov Cap-2 Maneuver	-	-	-	-	~ 14 -
Stage 1	-	-	-	-	214 -
Stage 2	-	-	-	-	178 -

Approach	EB	WB	NB
HCM Control Delay, s	0	0.3	\$ 2602
HCM LOS			F

Minor Lane/Major Mvmt	NBLn1	EBT	EBR	WBL	WBT
Capacity (veh/h)	21	-	-	505	-
HCM Lane V/C Ratio	5.968	-	-	0.061	-
HCM Control Delay (s)	\$ 2602	-	-	12.6	-
HCM Lane LOS	F	-	-	B	-
HCM 95th %tile Q(veh)	16	-	-	0.2	-

Notes
 ~: Volume exceeds capacity \$: Delay exceeds 300s +: Computation Not Defined *: All major volume in platoon

APPENDIX G. SIGNAL WARRANT ANALYSES GALLEY
RD/PAONIA ST



CHAPTER VIII TRAFFIC CONTROL DEVICES

SECTION 8-02

TRAFFIC SIGNALS

8-02.1 GENERAL. Traffic signals are electrically powered traffic control devices which warn or direct vehicular and pedestrian traffic to take some specific action. Traffic signals provide for the orderly assignment of right of way to conflicting traffic movements at intersections.

Traffic signals are not a complete solution for traffic problems. Traffic signals can sometimes create additional congestion and cause additional delay to vehicles if improperly designed, installed, or maintained. Correctly designed and operated traffic signals installed at warranted locations will provide for the orderly movement of traffic, increase the intersection capacity, and in some instances, tend to reduce accidents.

Traffic signals are listed on the Highway Right of Way and Construction Program in the description of the type of improvement if there is a probability of future signal control. If it is found that signals cannot be justified, they should be eliminated from the program at the earliest possible date.

8-02.2 OBTAINING TRAFFIC COUNTS. All traffic volumes used to warrant traffic signals and develop signal plans are obtained from the Transportation Planning Division or the Transportation Management System database. The Transportation Planning Division furnishes three types of traffic volumes: program, location study, and design. Design traffic volumes include volumes that are projected to the year the project is to be completed (Construction ADT) and volumes that are projected 20 years beyond project completion (Design ADT). Construction year projected volumes are used to warrant signals and develop signal plans. *The Design year (20th year) projected volumes are not used to warrant signals but are requested to determine future geometric requirements.* If the 20-year projection shows signals would be warranted, a 10-year count should be requested. If signals are warranted based on the 10-year count, provisions for future signal installation shall be made (see [Subsection 8-02.17 \(6\)](#)). When requesting traffic volumes from the Transportation Planning Division, the letterhead should state "TRAFFIC VOLUME REQUEST FOR SIGNAL WARRANTS". This will alert the Transportation Planning Division as to the type of traffic volumes required. Projected ADT volumes and turning movements are furnished on Form HP-770. A sample of this form is shown in [Figure 8-02.6](#). It is very important to request the percent peak hour on major and minor approaches if warrants are based on projected traffic. Percent peak hour is the percentage of ADT that occurs in the peak hour. The percent peak hour is not the same as the "Peak Hour Factor" (PHF) used in making a capacity analysis.

8-02.3 WARRANTS. Justification of traffic signals is developed on Form D-22. This form can be found in the Design Forms on the computer system. Form D-22 is required on all new signal locations and existing signals that are being upgraded from temporary to permanent signals or where significant geometric or signal revisions are being made. This form should be completed by district Design, with assistance from district Traffic personnel. It is not necessary to complete all eleven warrants on the form (i.e. If Warrant 1, Eight-Hour Vehicular Volume, is satisfied, Warrant 3, Peak Hour, does not have to be filled out). Traffic counts, or Form HP-770, must be completed and accompany Form D-22. A location sketch or title sheet showing the location of the intersection and any available drawings showing the existing or proposed intersection layout should be included with the warrants. Signal upgrades, such as the addition of interconnect, vehicle actuations, replacement of control equipment or minor geometric revisions do not require Form D-22. Traffic counts or Form HP-770 are not required for these type of upgrades, but may be desired in evaluating the need for improvements or determining signal timing. The district will be responsible for approving the warrants.

Traffic signals are installed only when one or more of the warrants given in Form D-22 is satisfied. The warrants correspond to the warrant numbers in the Manual on Uniform Traffic Control Devices Millennium Edition (MUTCD). When signal warrants are satisfied, basic lighting at the intersection is also warranted (see [Section 8-01](#)).

When installation of a traffic signal is warranted, the cost of the signal, its installation and maintenance, and electrical power for its operation, except as otherwise herein provided, will be borne by the Commission. Where possible, the state takes advantage of any reduced power rates by including in the municipal and/or county

agreement a phrase whereby the city will pay for the power, with reimbursement to be made by the state.

Where city/county power is not available, the state pays for the power directly.

When the posted speed limit or field measured 85th-percentile speed on the major street exceeds 40 mph [60 km/h], or when the intersection is located in a community having a population of less than 10,000, the volume of traffic to satisfy these warrants can be 70 percent of the stated values. Seventy percent values are shown in [Figure 8-02.2](#) and on Form D-22.

8-02.3 (1) WARRANT 1 – EIGHT-HOUR VEHICULAR VOLUME.

8-02.3 (1) (a) CONDITION A – MINIMUM VEHICULAR VOLUME. This warrant is based upon present (current) traffic volumes at an intersection. The volume warrant is used when the volume of intersecting traffic is the principal reason for consideration of traffic signal installation. The warrant is satisfied when the traffic volumes given in [Figure 8-02.2](#) for Warrant 1 Condition A exist on the major street and higher volume minor street approaches for each of eight hours of an average day.

Major and minor street volumes shown on this warrant must occur during the same eight hour period. The volumes used for the minor street may be on one approach during some hours and on the opposite approach during other hours. Traffic counts must be attached to Form D-22 when this warrant is used.

8-02.3 (1) (b) CONDITION B – INTERRUPTION OF CONTINUOUS TRAFFIC. This warrant is also based on present (current) traffic volumes at an intersection. The interruption warrant is used when the traffic volume on the major street is such that traffic on an intersecting minor street suffers excessive delay or hazard in entering or crossing the major street. The warrant is satisfied when the traffic volumes given in [Figure 8-02.2](#) for Warrant 1 Condition B exist on the major street and higher volume minor street approaches for each of eight hours of an average day.

Major and minor street volumes shown on this warrant must occur during the same eight hour period and under the same conditions explained in Warrant 1 Condition A. Traffic counts must be attached to Form D-22 when this warrant is used.

The 80 percent columns in [Figure 8-02.2](#) may be used for a combination of Conditions A and B. The major and minor street volumes shall be for the same eight hours for each condition; however, the eight hours satisfied in Condition A shall not be required to be the same eight hours satisfied in Condition B. On the minor street, the higher volume shall not be required to be on the same approach during each of the eight hours.

8-02.3 (1) (c) WARRANT 1A – CONDITION A – MINIMUM VEHICULAR VOLUME, AND CONDITION B – INTERRUPTION OF CONTINUOUS TRAFFIC. These warrants are based on projected traffic volumes for the construction year at an intersection. The Transportation Planning Division furnishes projected ADT volumes on Form HP-770. A factor, determined from the percent peak hour, is applied to the ADT volume on the major and higher volume minor street approaches to obtain the lowest hour of the eight highest hours (8th hour).

A method of estimating the 8th hour, based upon the projected peak hour, is as follows:

% Peak Hour	Factor to Obtain 8th Hour
7	0.0614
8	0.0600
9	0.0586
10	0.0571
11	0.0557
12	0.0543
13	0.0529
14	0.0514
15	0.0500

The warrants are satisfied using the same procedure as outlined for Warrant 1 Condition A or B.

8-02.3 (2) WARRANT 2 – FOUR-HOUR VEHICULAR VOLUME. This warrant in the MUTCD is based on existing traffic and is not normally used by designers during project development.

8-02.3 (3) WARRANT 3 - PEAK HOUR, CONDITION A – MINIMUM VEHICULAR VOLUME AND CONDITION B – INTERRUPTION OF CONTINUOUS TRAFFIC. The need for a traffic signal may exist at locations for peak hours of traffic demand. In order to provide a criterion for evaluation of a heavy peak hour location, a warrant has been adopted for public street, industrial or plant entrances, and public institutions.

The warrant for a traffic signal installed under peak hour volume consists of a modification to the volumes used for an eight hour time period. The construction ADT volumes for the highest (peak) hour and highest two hours, required to satisfy signal Warrant 3, Condition A or B, are shown in [Figure 8-02.2](#).

Unless the signal is to become a part of a progressive signal system, traffic signals installed under this warrant will be traffic actuated.

The type of signal control at an industrial plant or factory entrance will be traffic actuated. This method of control will guarantee a minimum period of right of way to the state highway. Upon actuation of the entrance loop, a pre-determined range of green time will be available to the entrance traffic. Outside of the warranted peak hours, this traffic signal will operate in a flash mode. This flash operation will be yellow for the state highway and red for the entrance. The plant or factory will be required to execute a traffic control easement.

8-02.3 (3) (a) INSTALLATION COSTS.

8-02.3 (3) (a) 1. PUBLIC STREET OR PUBLIC INSTITUTION ENTRANCE. A traffic signal will be installed when the need is established by a traffic study and the intersection meets the signal warrant. The entire cost of the signal (installation, power, and maintenance) will be borne by the Commission. A signal to be installed under this policy will be placed on the Highway Right of Way and Construction Program and scheduled to allow orderly development of the plans and acquisition of right of way.

8-02.3 (3) (a) 2. INDUSTRIAL PLANT OR FACTORY ENTRANCE. The plant or factory owner provides, at no cost to the state, the traffic signal and the intersection geometric improvements. The signal and geometric improvements are designed and constructed in accordance with existing Commission practices. The traffic signal, after installation, becomes the property of the state. At no cost to the plant owner, the state will provide power, maintain, replace, or upgrade the traffic signal at its discretion in order to provide a satisfactory level of service.

8-02.3 (3) (a) 3. COMMERCIAL ENTRANCES. These signal installations are usually completed through the permit process. These are permanent signals. When a design project is in an area where a commercial

MUTCD Volume-based Warrant Evaluation - Existing Traffic Conditions
Galley / Paonia Intersection

Major Street: **Galley** Critical Approach Speed: **40 MPH** Peak Hour Factor: **8**
 Minor Street: **Paonia** Critical Approach Speed: **25 MPH** Intersection type: **Urban**
 Major Street Peak Hour Volume (Both Approaches): **1280** Major Street Lanes: **2 or more**
 Minor Street Peak Hour Volume (Highest Approach): **162** Minor Street Lanes: **2 or more**

Update Charts

Warrant 1A	No
Warrant 1B	Yes
Warrant 1A & 1B at 80%	No
Warrant 2	No
Warrant 3	No

WARRANT 1 - Condition A, Minimum Vehicular Volume

	100%	80%
Major	Yes	Yes
Minor	No	No

APPROACH LANES	MINIMUM REQUIREMENTS (80% SHOWN IN BRACKETS)				Peak Hour	2nd Highest	3rd Highest	4th Highest	5th Highest	6th Highest	7th Highest	8th Highest
	1		2 or more									
	U	R	U	R								
Both Approch. Major Street	500 (400)	350 (280)	600 (480)	420 (336)	1280	1234	1189	1143	1097	1051	1006	960
Highest Approach. Minor Street	150 (120)	105 (84)	200 (160)	140 (112)	162	156	150	145	139	133	127	122

WARRANT 1, Condition B - Interruption of Continuous Traffic

	100%	80%
Major	Yes	Yes
Minor	Yes	Yes

APPROACH LANES	MINIMUM REQUIREMENTS (80% SHOWN IN BRACKETS)				Peak Hour	2nd Highest	3rd Highest	4th Highest	5th Highest	6th Highest	7th Highest	8th Highest
	1		2 or more									
	U	R	U	R								
Both Approch. Major Street	750 (600)	525 (420)	900 (720)	630 (504)	1280	1234	1189	1143	1097	1051	1006	960
Highest Approach. Minor Street	75 (60)	53 (42)	100 (80)	70 (56)	162	156	150	145	139	133	127	122

WARRANT 2 - Four Hour Volume

100 % Satisfied	YES	NO
-----------------	-----	----

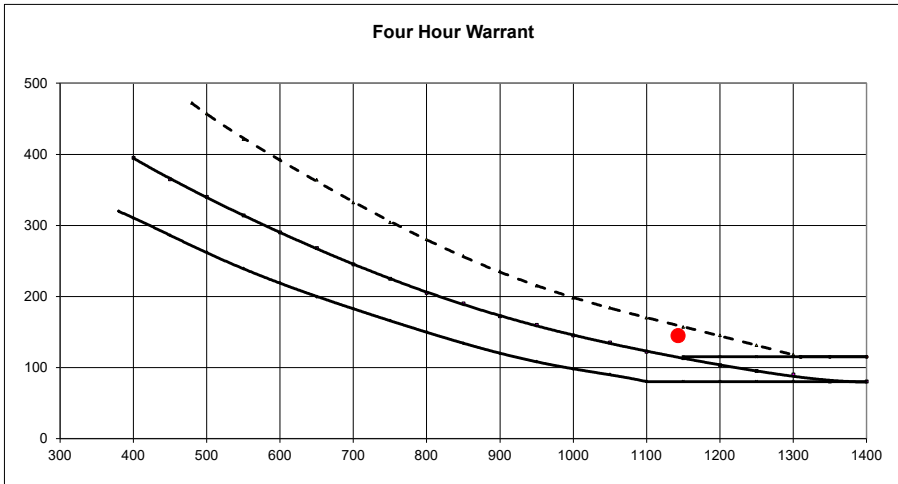

WARRANT 3 - Peak Hour Volume

100 % Satisfied	YES	NO
-----------------	-----	----

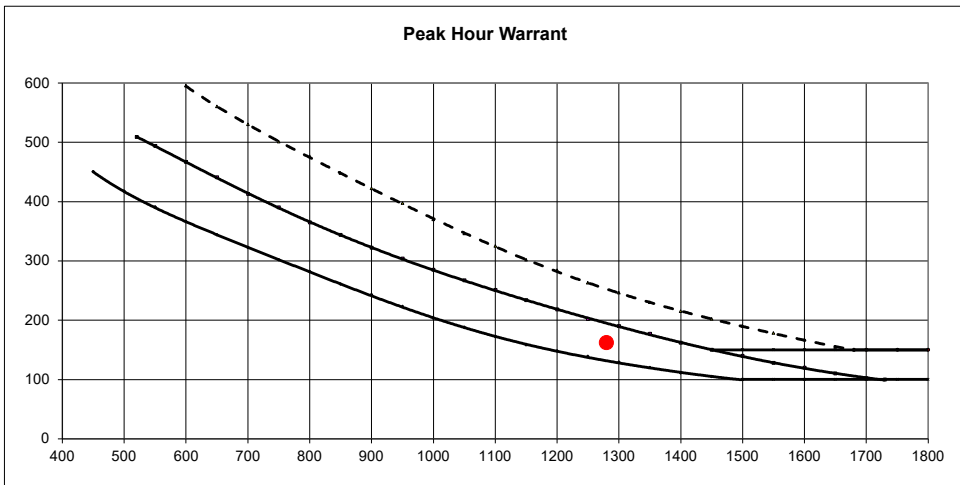

MUTCD Volume-based Warrant Evaluation - Short Term Future Background Traffic
Galley / Paonia Intersection

Major Street: **Galley** Critical Approach Speed: **40 MPH** Peak Hour Factor: **8**
 Minor Street: **Paonia** Critical Approach Speed: **25 MPH**
 Intersection type: **Urban**
 Major Street Peak Hour Volume (Both Approaches): **1380**
 Minor Street Peak Hour Volume (Highest Approach): **162**
 Major Street Lanes: **2 or more**
 Minor Street Lanes: **2 or more**

Update Charts

Warrant 1A	No
Warrant 1B	Yes
Warrant 1A & 1B at 80%	No
Warrant 2	Yes
Warrant 3	No

WARRANT 1 - Condition A, Minimum Vehicular Volume

	100%	80%
Major	Yes	Yes
Minor	No	No

APPROACH LANES	MINIMUM REQUIREMENTS (80% SHOWN IN BRACKETS)				Peak Hour	2nd Highest	3rd Highest	4th Highest	5th Highest	6th Highest	7th Highest	8th Highest
	1		2 or more									
	U	R	U	R								
Both Approch. Major Street	500 (400)	350 (280)	600 (480)	420 (336)	1380	1331	1281	1232	1183	1134	1084	1035
Highest Approach. Minor Street	150 (120)	105 (84)	200 (160)	140 (112)	162	156	150	145	139	133	127	122

WARRANT 1, Condition B - Interruption of Continuous Traffic

	100%	80%
Major	Yes	Yes
Minor	Yes	Yes

APPROACH LANES	MINIMUM REQUIREMENTS (80% SHOWN IN BRACKETS)				Peak Hour	2nd Highest	3rd Highest	4th Highest	5th Highest	6th Highest	7th Highest	8th Highest
	1		2 or more									
	U	R	U	R								
Both Approch. Major Street	750 (600)	525 (420)	900 (720)	630 (504)	1380	1331	1281	1232	1183	1134	1084	1035
Highest Approach. Minor Street	75 (60)	53 (42)	100 (80)	70 (56)	162	156	150	145	139	133	127	122

WARRANT 2 - Four Hour Volume

100 % Satisfied	YES	NO
-----------------	-----	----

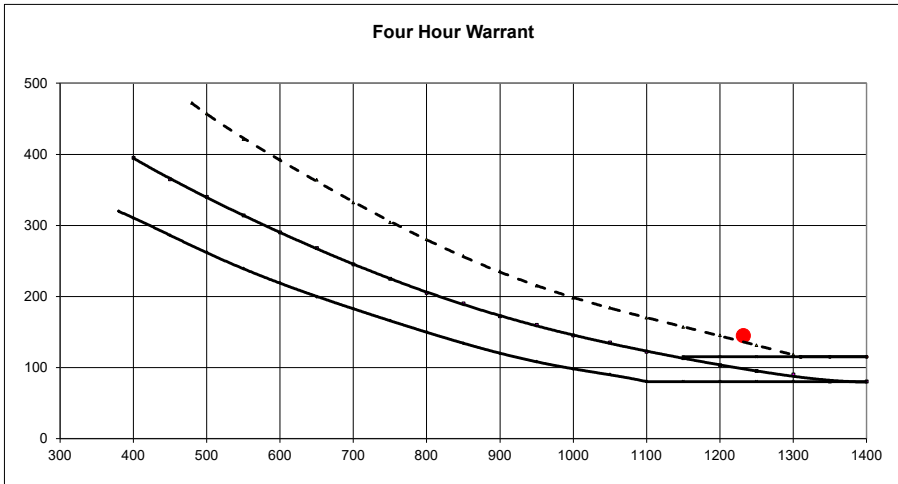

WARRANT 3 - Peak Hour Volume

100 % Satisfied	YES	NO
-----------------	-----	----

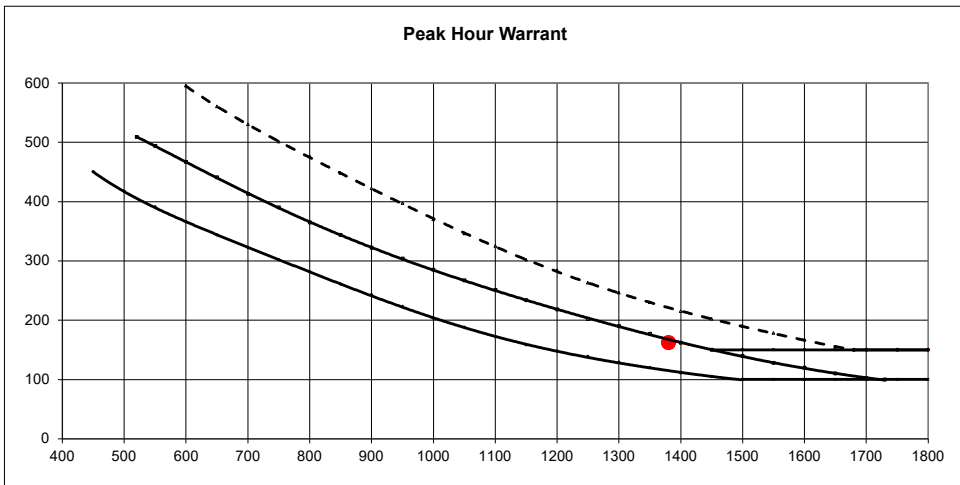

MUTCD Volume-based Warrant Evaluation - Short Term Future Total Traffic
Galley / Paonia Intersection

Major Street: **Galley**
Minor Street: **Paonia**

Critical Approach Speed: **40 MPH**
Critical Approach Speed: **25 MPH**

Peak Hour Factor: **8**

Intersection type: **Urban**

Major Street Peak Hour Volume (Both Approaches): **1478**
Minor Street Peak Hour Volume (Highest Approach): **183**

Major Street Lanes: **2 or more**
Minor Street Lanes: **2 or more**

Update Charts

Warrant 1A	No
Warrant 1B	Yes
Warrant 1A & 1B at 80%	No
Warrant 2	Yes
Warrant 3	No

WARRANT 1 - Condition A, Minimum Vehicular Volume

	100%	80%
Major	Yes	Yes
Minor	No	No

APPROACH LANES	MINIMUM REQUIREMENTS (80% SHOWN IN BRACKETS)				Peak Hour	2nd Highest	3rd Highest	4th Highest	5th Highest	6th Highest	7th Highest	8th Highest
	1		2 or more									
	U	R	U	R								
Both Approch. Major Street	500 (400)	350 (280)	600 (480)	420 (336)	1478	1425	1372	1320	1267	1214	1161	1109
Highest Approach. Minor Street	150 (120)	105 (84)	200 (160)	140 (112)	183	176	170	163	157	150	144	137

WARRANT 1, Condition B - Interruption of Continuous Traffic

	100%	80%
Major	Yes	Yes
Minor	Yes	Yes

APPROACH LANES	MINIMUM REQUIREMENTS (80% SHOWN IN BRACKETS)				Peak Hour	2nd Highest	3rd Highest	4th Highest	5th Highest	6th Highest	7th Highest	8th Highest
	1		2 or more									
	U	R	U	R								
Both Approch. Major Street	750 (600)	525 (420)	900 (720)	630 (504)	1478	1425	1372	1320	1267	1214	1161	1109
Highest Approach. Minor Street	75 (60)	53 (42)	100 (80)	70 (56)	183	176	170	163	157	150	144	137

WARRANT 2 - Four Hour Volume

100 % Satisfied	YES	NO
-----------------	-----	----



WARRANT 3 - Peak Hour Volume

100 % Satisfied	YES	NO
-----------------	-----	----

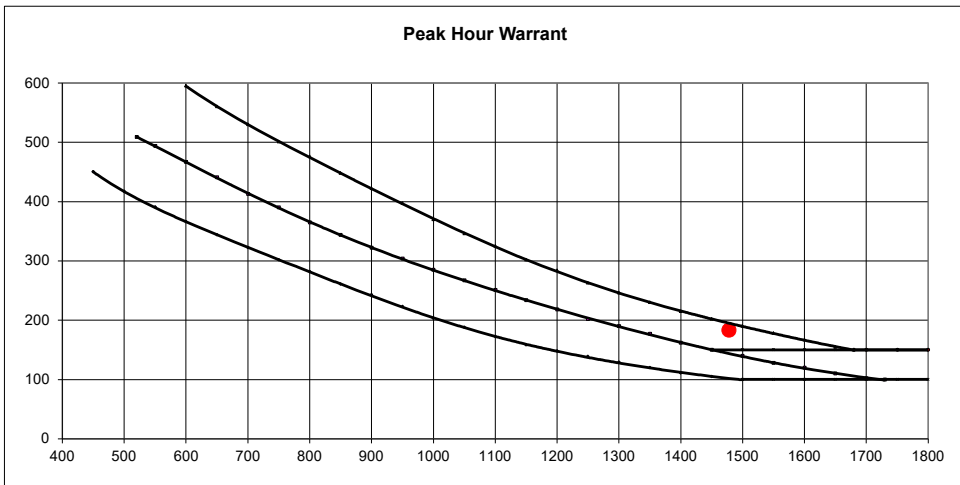

MUTCD Volume-based Warrant Evaluation - Long Term Future Background Traffic
Galley / Paonia Intersection

Major Street: **Galley** Critical Approach Speed: **40 MPH** Peak Hour Factor: **8**
 Minor Street: **Paonia** Critical Approach Speed: **25 MPH**
 Intersection type: **Urban**
 Major Street Peak Hour Volume (Both Approaches): **2096**
 Minor Street Peak Hour Volume (Highest Approach): **162**
 Major Street Lanes: **2 or more**
 Minor Street Lanes: **2 or more**

Update Charts

Warrant 1A	No
Warrant 1B	Yes
Warrant 1A & 1B at 80%	No
Warrant 2	Yes
Warrant 3	Yes

WARRANT 1 - Condition A, Minimum Vehicular Volume

	100%	80%
Major	Yes	Yes
Minor	No	No

APPROACH LANES	MINIMUM REQUIREMENTS (80% SHOWN IN BRACKETS)				Peak Hour	2nd Highest	3rd Highest	4th Highest	5th Highest	6th Highest	7th Highest	8th Highest
	U		R									
	1	2 or more	1	2 or more								
Both Approchs. Major Street	500 (400)	350 (280)	600 (480)	420 (336)	2096	2021	1946	1871	1797	1722	1647	1572
Highest Approach. Minor Street	150 (120)	105 (84)	200 (160)	140 (112)	162	156	150	145	139	133	127	122

WARRANT 1, Condition B - Interruption of Continuous Traffic

	100%	80%
Major	Yes	Yes
Minor	Yes	Yes

APPROACH LANES	MINIMUM REQUIREMENTS (80% SHOWN IN BRACKETS)				Peak Hour	2nd Highest	3rd Highest	4th Highest	5th Highest	6th Highest	7th Highest	8th Highest
	U		R									
	1	2 or more	1	2 or more								
Both Approchs. Major Street	750 (600)	525 (420)	900 (720)	630 (504)	2096	2021	1946	1871	1797	1722	1647	1572
Highest Approach. Minor Street	75 (60)	53 (42)	100 (80)	70 (56)	162	156	150	145	139	133	127	122

WARRANT 2 - Four Hour Volume

100 % Satisfied	YES	NO
-----------------	-----	----

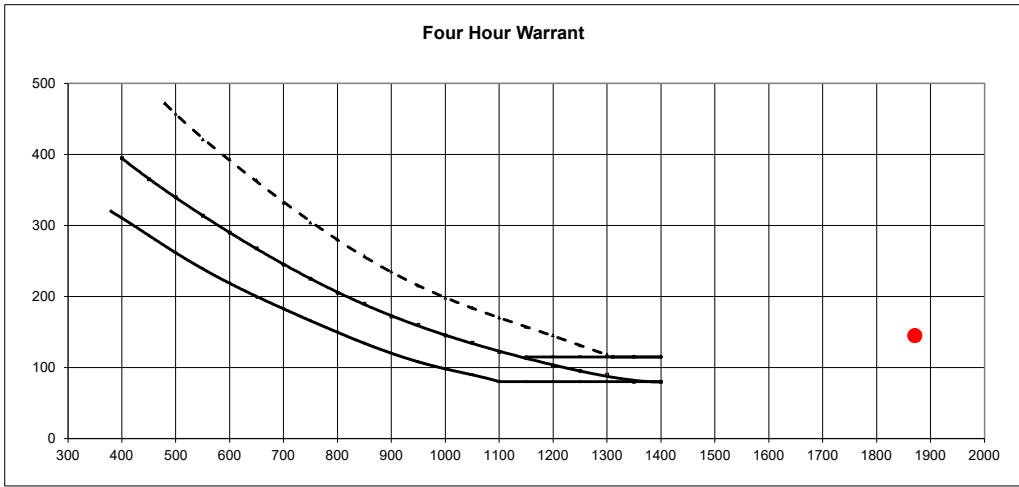

WARRANT 3 - Peak Hour Volume

100 % Satisfied	YES	NO
-----------------	-----	----

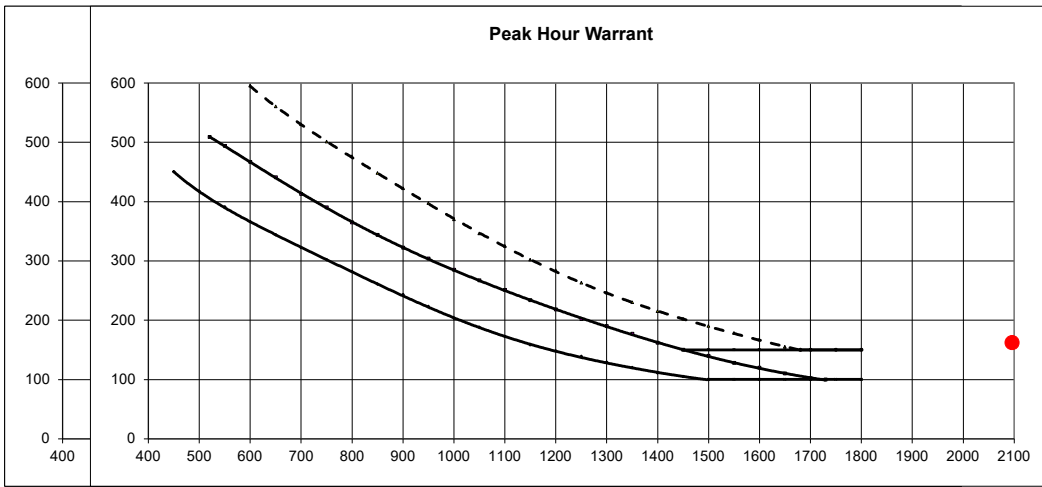

MUTCD Volume-based Warrant Evaluation - Long Term Future Total Traffic
Galley / Paonia Intersection

Major Street: **Galley** Critical Approach Speed: **40 MPH** Peak Hour Factor: **8**
 Minor Street: **Paonia** Critical Approach Speed: **25 MPH** Intersection type: **Urban**
 Major Street Peak Hour Volume (Both Approaches): **2194** Major Street Lanes: **2 or more**
 Minor Street Peak Hour Volume (Highest Approach): **183** Minor Street Lanes: **2 or more**

Update Charts

Warrant 1A	No
Warrant 1B	Yes
Warrant 1A & 1B at 80%	No
Warrant 2	Yes
Warrant 3	Yes

WARRANT 1 - Condition A, Minimum Vehicular Volume

	100%	80%
Major	Yes	Yes
Minor	No	No

APPROACH LANES	MINIMUM REQUIREMENTS (80% SHOWN IN BRACKETS)				Peak Hour	2nd Highest	3rd Highest	4th Highest	5th Highest	6th Highest	7th Highest	8th Highest
	U		R									
	1	2 or more	1	2 or more								
Both Approch. Major Street	500 (400)	350 (280)	600 (480)	420 (336)	2194	2116	2037	1959	1881	1802	1724	1646
Highest Approach. Minor Street	150 (120)	105 (84)	200 (160)	140 (112)	183	176	170	163	157	150	144	137

WARRANT 1, Condition B - Interruption of Continuous Traffic

	100%	80%
Major	Yes	Yes
Minor	Yes	Yes

APPROACH LANES	MINIMUM REQUIREMENTS (80% SHOWN IN BRACKETS)				Peak Hour	2nd Highest	3rd Highest	4th Highest	5th Highest	6th Highest	7th Highest	8th Highest
	U		R									
	1	2 or more	1	2 or more								
Both Approch. Major Street	750 (600)	525 (420)	900 (720)	630 (504)	2194	2116	2037	1959	1881	1802	1724	1646
Highest Approach. Minor Street	75 (60)	53 (42)	100 (80)	70 (56)	183	176	170	163	157	150	144	137

WARRANT 2 - Four Hour Volume

100 % Satisfied	YES	NO
-----------------	-----	----

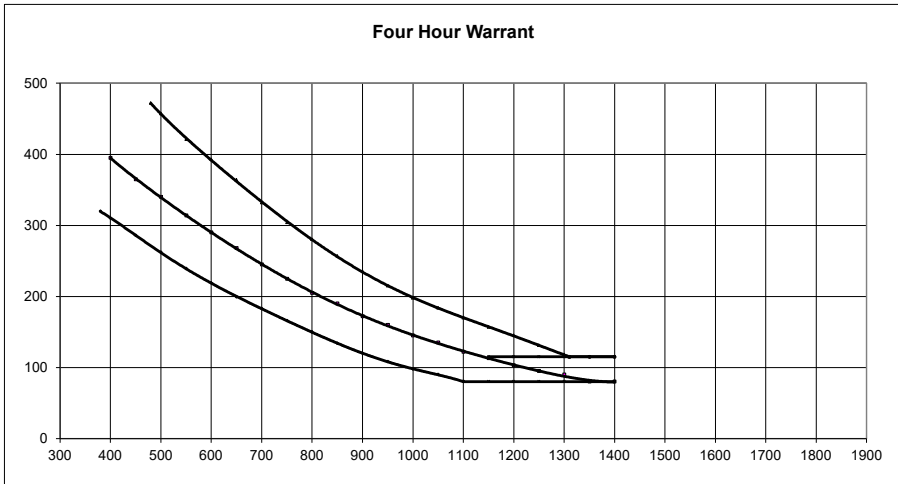

WARRANT 3 - Peak Hour Volume

100 % Satisfied	YES	NO
-----------------	-----	----

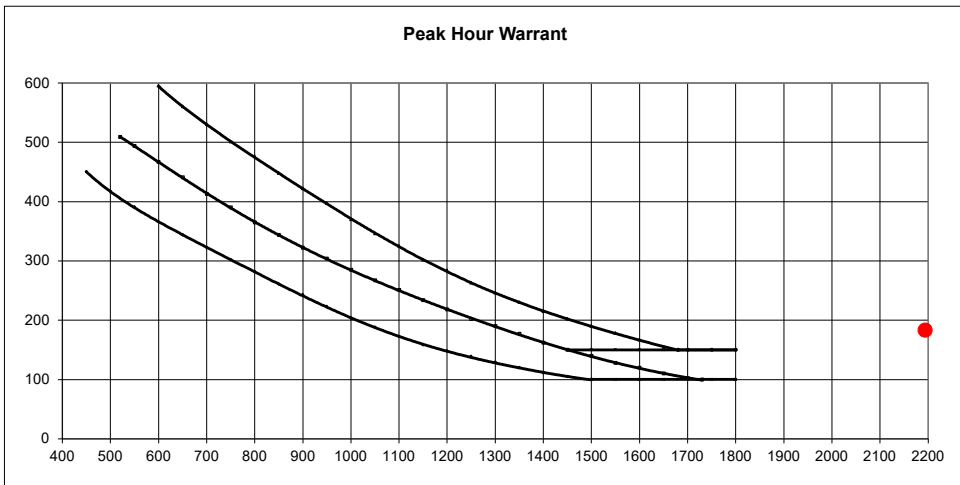

TIS_V2.pdf Markup Summary

Daniel Torres (5)



Page Label: 25
Subject: Callout
Lock: Locked
Author: Daniel Torres
Date: 6/11/2020 8:41:17 PM
Status:
Color: ■
Layer:
Space:

i believe you meant table 4 instead of 54.

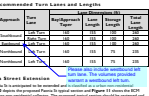

Page Label: 25
Subject: Callout
Lock: Locked
Author: Daniel Torres
Date: 6/11/2020 8:41:18 PM
Status:
Color: ■
Layer:
Space:

Please also include westbound left turn lane. The volumes provided warrant a westbound left turn.



Page Label: 25
Subject: Cloud+
Lock: Locked
Author: Daniel Torres
Date: 6/11/2020 8:41:19 PM
Status:
Color: ■
Layer:
Space:

The total deceleration lane length should be 315 ft. Please revise

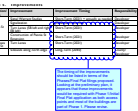

Page Label: 29
Subject: Cloud+
Lock: Locked
Author: Daniel Torres
Date: 6/11/2020 8:41:25 PM
Status:
Color: ■
Layer:
Space:

The timing of the improvements should be listed in terms of the Phases/Final Plat filings proposed. Looking at the preliminary plan, it appears that these improvements would be required with Phase 1/Initial Final Plat application as both access points and most of the buildings are part of Phase 1. Please revise.

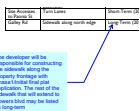

Page Label: 29
Subject: Callout
Lock: Locked
Author: Daniel Torres
Date: 6/11/2020 8:41:30 PM
Status:
Color: ■
Layer:
Space:

The developer will be responsible for constructing the sidewalk along the property frontage with Phase1/initial final plat application. The rest of the sidewalk that will extend to Powers blvd may be listed as long-term