

THE COMMONS AT FALCON FIELD

A SUBDIVISION OF LAND LOCATED IN SECTION 7, TOWNSHIP 13 SOUTH, RANGE 64 WEST OF THE SIXTH PRINCIPAL MERIDIAN, COUNTY OF EL PASO, STATE OF COLORADO

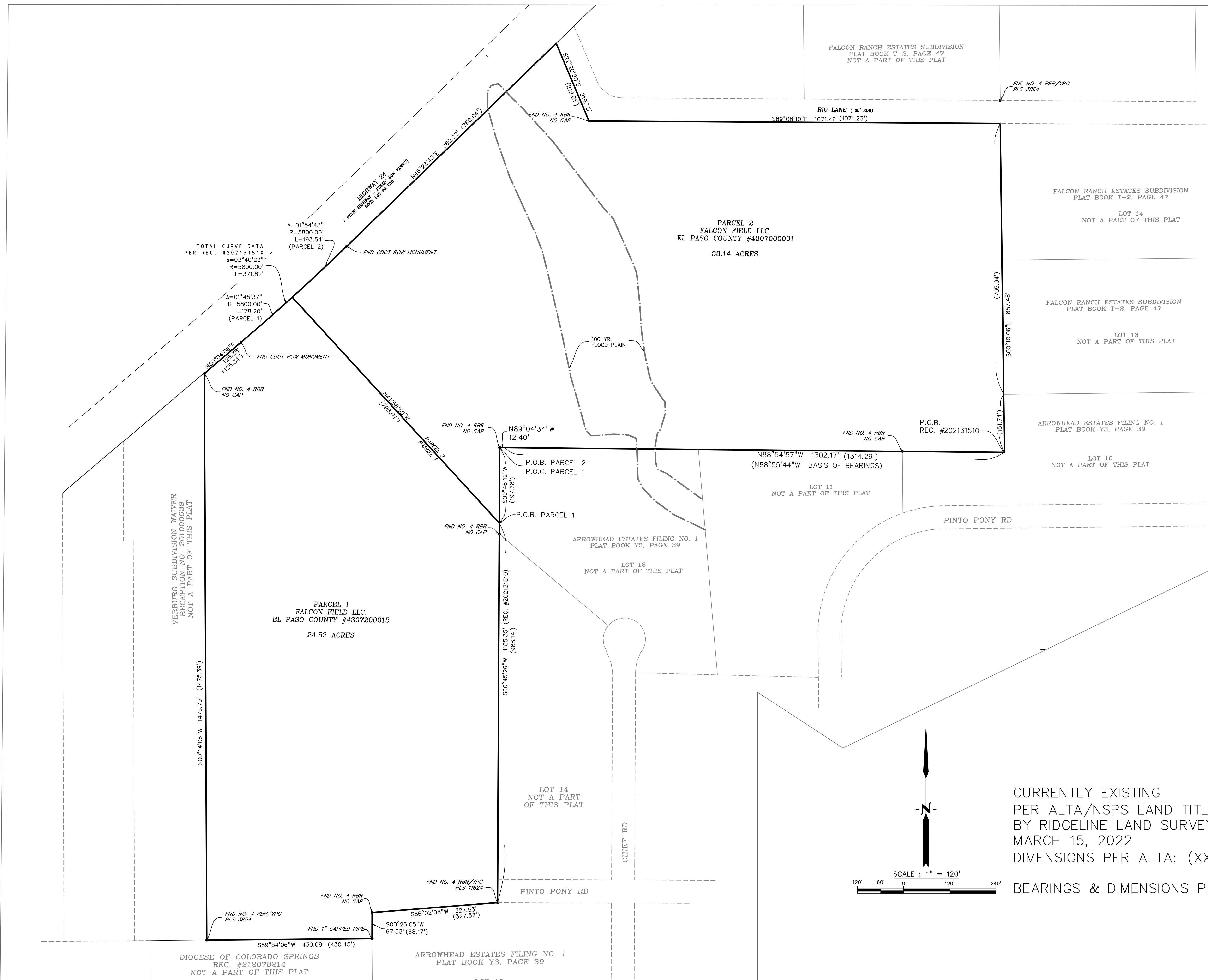

LEGEND	
FOUND #4 REBAR WITH 1" YELLOW PLASTIC CAP PLS 3854	⊙
FOUND #4 REBAR-NO CAP	⊗
FOUND #4 REBAR WITH 1" YELLOW PLASTIC CAP PLS 11624	⊗
FOUND 3.25" CDOT ROW MONUMENT	⊙
SET #5 REBAR & 1.5" ALUMINUM CAP "DBCO PLS 37913"	●
FOUND 1" DIAMETER CAPPED PIPE	○
RECORD DIMENSION	(R)
RECEPTION NUMBER	Rec. No.
PLUS OR MINUS (MORE OR LESS)	+/-
RIGHT OF WAY	ROW
ACRE	AC.
PROPOSED UTILITY, ACCESS, AND DRAINAGE EASEMENT	----
PROPOSED DRAINAGE EASEMENT	----
PROPOSED DRAINAGE & UTILITY EASEMENT	----
PROPOSED RIGHT-OF-WAY LINE	----
SUBDIVISION BOUNDARY	=====
SITE TRIANGLE EASEMENT LINES	-----
EXISTING R.O.W.	-----
R.O.W. PER ROAD BOOK A, PAGE 78	-----

CURRENTLY EXISTING PER ALTA/NSPS LAND TITLE SURVEY BY RIDGELINE LAND SURVEYING MARCH 15, 2022 DIMENSIONS PER ALTA: (XXX.XX)

BEARINGS & DIMENSIONS PER WARRANTY DEED REC. #202131510

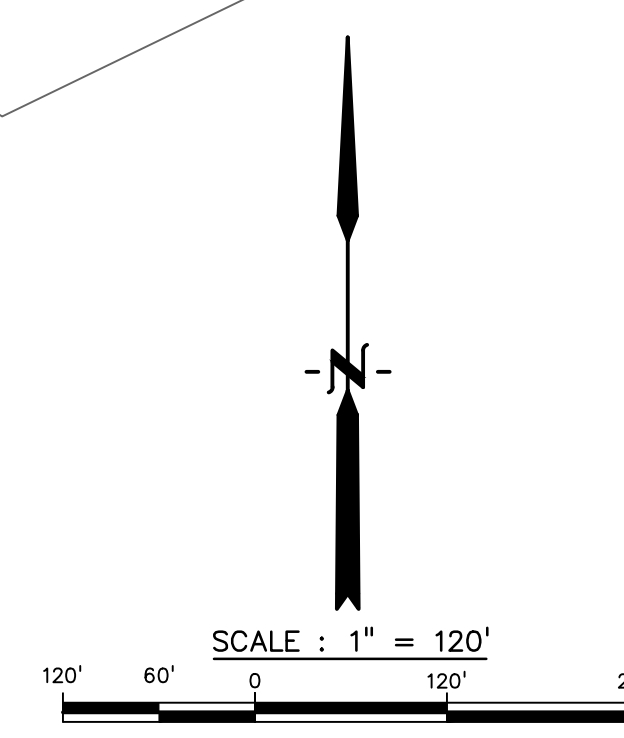

THE COMMONS AT FALCON FIELD FILING NO. 1

A SUBDIVISION OF LAND LOCATED IN SECTION 7, TOWNSHIP 13 SOUTH, RANGE 64 WEST OF THE SIXTH PRINCIPAL MERIDIAN, COUNTY OF EL PASO, STATE OF COLORADO

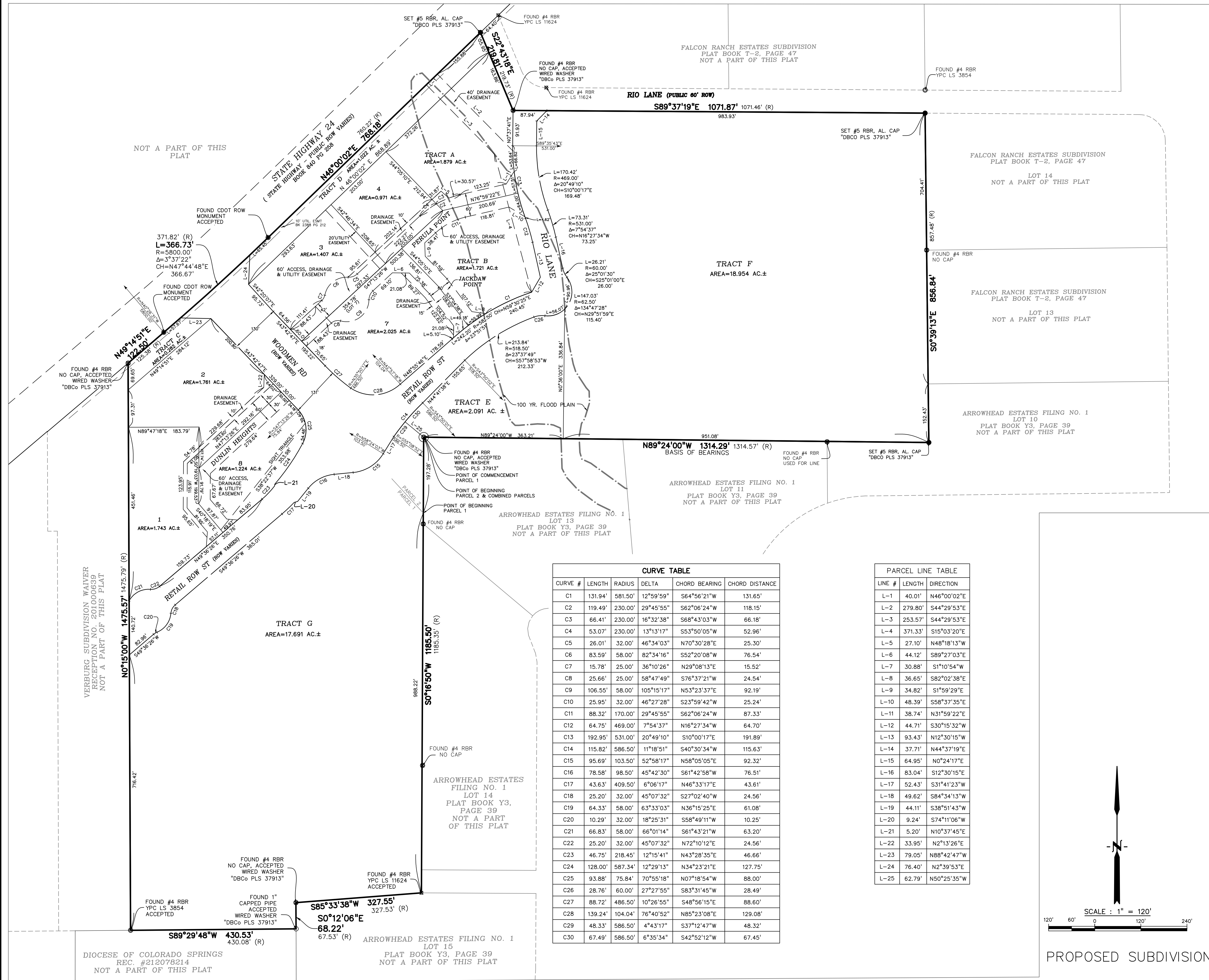

FALCON RANCH ESTATES SUBDIVISION
PLAT BOOK T-2, PAGE 47
NOT A PART OF THIS PLAT

FALCON RANCH ESTATES SUBDIVISION
PLAT BOOK T-2, PAGE 47
LOT 14
NOT A PART OF THIS PLAT

FALCON RANCH ESTATES SUBDIVISION
PLAT BOOK T-2, PAGE 47
LOT 13
NOT A PART OF THIS PLAT

ARROWHEAD ESTATES FILING NO. 1
PLAT BOOK Y3, PAGE 39
NOT A PART OF THIS PLAT

ARROWHEAD ESTATES FILING NO. 1
PLAT BOOK Y3, PAGE 39
NOT A PART OF THIS PLAT

ARROWHEAD ESTATES FILING NO. 1
LOT 13
PLAT BOOK Y3, PAGE 39
NOT A PART OF THIS PLAT

VERBURG SUBDIVISION WAIVER
RECEPTION NO. 20100639
NOT A PART OF THIS PLAT

DIocese OF COLORADO SPRINGS
REC. #212078214
NOT A PART OF THIS PLAT

ARROWHEAD ESTATES FILING NO. 1
LOT 15
PLAT BOOK Y3, PAGE 39
NOT A PART OF THIS PLAT

CURVE TABLE

CURVE #	LENGTH	RADIUS	DELTA	CHORD BEARING	CHORD DISTANCE
C1	131.94'	581.50'	12°59'59"	S64°56'21"W	131.65'
C2	119.49'	230.00'	29°45'55"	S62°06'24"W	118.15'
C3	66.41'	230.00'	16°32'38"	S68°43'03"W	66.18'
C4	53.07'	230.00'	13°13'17"	S53°50'05"W	52.96'
C5	26.01'	32.00'	46°34'03"	N70°30'28"E	25.30'
C6	83.59'	58.00'	82°34'16"	S52°20'08"W	76.54'
C7	15.78'	25.00'	36°10'26"	N29°08'13"E	15.52'
C8	25.66'	25.00'	58°47'49"	S76°37'21"W	24.54'
C9	106.55'	58.00'	105°15'17"	N53°23'37"E	92.19'
C10	25.95'	32.00'	46°27'28"	S23°59'42"W	25.24'
C11	88.32'	170.00'	29°45'55"	S62°06'24"W	87.33'
C12	64.75'	469.00'	7°54'37"	N16°27'34"W	64.70'
C13	192.95'	531.00'	20°49'10"	S10°00'17"E	191.89'
C14	115.82'	586.50'	11°18'51"	S40°30'34"W	115.63'
C15	95.69'	103.50'	52°58'17"	N58°05'05"E	92.32'
C16	78.58'	98.50'	45°42'30"	S61°42'58"W	76.51'
C17	43.63'	409.50'	6°06'17"	N46°33'17"E	43.61'
C18	25.20'	32.00'	45°07'32"	S27°02'40"W	24.56'
C19	64.33'	58.00'	63°33'03"	N36°15'25"E	61.08'
C20	10.29'	32.00'	18°25'31"	S58°49'11"W	10.25'
C21	66.83'	58.00'	66°01'14"	S61°43'21"W	63.20'
C22	25.20'	32.00'	45°07'32"	N72°10'12"E	24.56'
C23	46.75'	218.45'	12°15'41"	N43°28'35"E	46.66'
C24	128.00'	587.34'	12°29'13"	N34°23'21"E	127.75'
C25	93.88'	75.84'	70°55'18"	N07°18'54"W	88.00'
C26	28.76'	60.00'	27°27'55"	S83°31'45"W	28.49'
C27	88.72'	486.50'	10°26'55"	S48°56'15"E	88.60'
C28	139.24'	104.04'	76°40'52"	N85°23'08"E	129.08'
C29	48.33'	586.50'	4°43'17"	S37°12'47"W	48.32'
C30	67.49'	586.50'	6°35'34"	S42°52'12"W	67.45'

PARCEL LINE TABLE

LINE #	LENGTH	DIRECTION
L-1	40.01'	N46°00'02"E
L-2	279.80'	S44°29'53"E
L-3	253.57'	S44°29'53"E
L-4	371.33'	S15°03'20"E
L-5	27.10'	N48°18'13"W
L-6	44.12'	S89°27'03"E
L-7	30.88'	S1°10'54"W
L-8	36.65'	S82°02'38"E
L-9	34.82'	S1°59'29"E
L-10	48.39'	S58°37'35"E
L-11	38.74'	N31°59'22"E
L-12	44.71'	S30°15'32"W
L-13	93.43'	N12°30'15"W
L-14	37.71'	N44°37'19"E
L-15	64.95'	N0°24'17"E
L-16	83.04'	S12°30'15"E
L-17	52.43'	S31°41'23"W
L-18	49.62'	S84°34'13"W
L-19	44.11'	S38°51'43"W
L-20	9.24'	S74°11'06"W
L-21	5.20'	N10°37'45"E
L-22	33.95'	N2°13'26"E
L-23	79.05'	N88°42'47"W
L-24	76.40'	N2°39'53"E
L-25	62.79'	N50°25'35"W

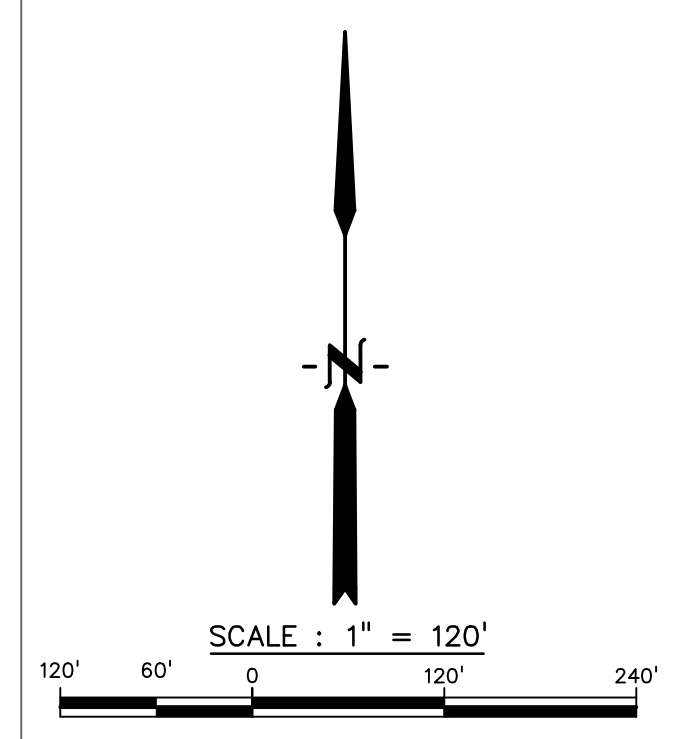

LEGEND

- FOUND #4 REBAR WITH 1" YELLOW PLASTIC CAP PLS 3854
- FOUND #4 REBAR-NO CAP
- FOUND #4 REBAR WITH 1" YELLOW PLASTIC CAP PLS 11624
- FOUND 3.25" CDOT ROW MONUMENT
- SET #5 REBAR & 1.5" ALUMINUM CAP "DBCO PLS 37913"
- FOUND 1" DIAMETER CAPPED PIPE
- RECORD DIMENSION
- RECEPTION NUMBER
- PLUS OR MINUS (MORE OR LESS)
- RIGHT OF WAY
- ACRE
- PROPOSED UTILITY, ACCESS, AND DRAINAGE EASEMENT
- PROPOSED DRAINAGE & UTILITY EASEMENT
- PROPOSED RIGHT-OF-WAY LINE
- SUBDIVISION BOUNDARY
- SITE TRIANGLE EASEMENT LINES
- EXISTING R.O.W.
- R.O.W. PER ROAD BOOK A, PAGE 78

PROPOSED SUBDIVISION