



**ENTECH**  
ENGINEERING, INC.

505 ELKTON DRIVE  
COLORADO SPRINGS, CO 80907  
PHONE (719) 531-5599

**PAVEMENT DESIGN REPORT  
SADDLEHORN RANCH  
FILING 2  
EL PASO COUNTY, COLORADO**

Prepared for:  
**Gorilla Capital Colorado Saddlehorn Ranch, LLC  
1345 High Street  
Eugene, OR 97401**

Attn: John Helmick

February 15, 2024  
Revised April 5, 2024

Respectfully Submitted,

ENTECH ENGINEERING, INC.

Stuart Wood  
Geologist

Reviewed by:



Digitally signed by Joseph C Goode  
Jr.

Date: 04/05/24

Joseph C. Goode Jr., P.E.  
President

SW:JCG/LLL

Entech Job No. 222258

**Table of Contents**

**1 Introduction ..... 1**

**2 Project and Site Description..... 1**

**3 Subsurface Explorations and Laboratory Testing ..... 1**

    3.1 Subsurface Exploration Program ..... 1

    3.2 Geotechnical Index and Engineering Property Testing ..... 2

**4 Subsurface Conditions ..... 2**

    4.1 Soil and Bedrock ..... 3

    4.2 Groundwater ..... 3

**5 Pavement Design Recommendations ..... 3**

    5.1 Subgrade Conditions ..... 3

    5.2 Swell Mitigation ..... 4

    5.3 Traffic Loading..... 4

    5.4 Pavement Design ..... 4

**6 Construction Recommendations ..... 5**

    6.1 Earthwork Recommendations for Pavement Subgrade ..... 5

        6.1.1 Overexcavation ..... 5

        6.1.2 Subgrade Preparation – Aggregate Base Course Alternatives ..... 5

        6.1.3 Fill Placement and Compaction ..... 6

    6.2 Aggregate Base Course ..... 6

    6.3 Concrete Degradation Due to Sulfate Attack ..... 6

    6.4 Construction Observation ..... 7

**7 Closure..... 7**

**Figures**

*Figure 1: Vicinity Map*

*Figure 2: Site and Exploration Plan*

*Figure 3: Site and Exploration Plan (Curtis Road)*

**List of Appendices**

*Appendix A: Test Boring Logs*

*Appendix B: Laboratory Test Results*

*Appendix C: Pavement Design Calculations*

## **1 Introduction**

Entech Engineering, Inc. (Entech) completed a subsurface exploration program, laboratory testing, and pavement design recommendations for Saddlehorn Ranch, Filing No. 2, in eastern El Paso County, Colorado. This report describes the subsurface exploration program conducted for the proposed roadway improvements and provides pavement section alternatives and construction recommendations. Entech participated in this project as a subconsultant to Gorilla Capital Colorado Saddlehorn Ranch, LLC. The contents of this report, including the pavement design recommendations, are subject to the limitations and assumptions presented in Section 7.

## **2 Project and Site Description**

The proposed improvements include sections of Benito Wells Trail, Del Cerro Trail, El Raiceno Trail, and Estacado Place Cul-de-Sac in the Saddlehorn Ranch, Filing No. 2, Subdivision (Figure 1). Improvements will also include widening of approximately 2,100 feet on the east shoulder of Curtis Road with new acceleration and deceleration lanes from the filing north and south of Benito Wells Trail. The extent of the improvements will include a 2-inch mill and overlay to tie in with the existing roadway at Curtis Road.

The existing topography includes rolling hills, vacant pasture land, and land being developed for future residential lots. The roadways in the filing have been rough-graded, and Curtis Road is currently a 2-lane roadway paved with asphalt and is without curbs and gutters. Curtis Road will be designated as an urban principal arterial, and the roadways within the filing designated as rural local roads.

## **3 Subsurface Explorations and Laboratory Testing**

### **3.1 Subsurface Exploration Program**

Subsurface conditions at the project site were explored by 23 test borings, designated TB-1 through TB-23, drilled on December 26 and 27, 2023. Five of the borings (TB-19 through TB-23) were drilled along the east shoulder of Curtis Road. The locations of the test borings are shown on the Site and Exploration Plans (Figures 2 and 3). The borings were drilled to depths of 5 to 10 feet below the existing ground surface (bgs). The drilling was performed using a truck-mounted, continuous flight auger drill rig supplied and operated by Entech. Descriptive boring logs providing

the lithologies of the subsurface conditions encountered during drilling are presented in Appendix A. Groundwater levels were measured in each open borehole at the conclusion of drilling.

Soil and bedrock samples were obtained from the borings utilizing the Standard Penetration Test (ASTM D1586) using a split-barrel California sampler. Results of the Standard Penetration Test (SPT) are included on the boring logs in terms of N-values expressed in blows per foot (bpf). Soil and bedrock samples recovered from the borings were visually classified and recorded on the boring logs. The soil classifications were later verified utilizing laboratory testing and grouped by soil type. The soil type numbers are included on the boring logs. It should be understood that the soil descriptions shown on the boring logs may vary between boring locations and sample depths. It should also be noted that the lines of stratigraphic separation shown on the boring logs represent approximate boundaries between soil types and the actual stratigraphic transitions may be more gradual or variable with location.

### **3.2 Geotechnical Index and Engineering Property Testing**

Water content testing (ASTM D2216) was performed on the samples recovered from the borings, and the results are shown on the boring logs. Grain-Size Analysis (ASTM D422) and Atterberg Limits testing (ASTM D4318) were performed on selected samples to assist in classifying the materials encountered in the borings.

For pavement design, a modified proctor (ASTM D1557) and California Bearing Ratio (CBR) test (ASTM D1883) were completed. Soluble sulfate testing was performed on select soil samples to evaluate the potential for below-grade degradation of concrete due to sulfate attack. The laboratory testing results are presented in Appendix B and summarized in Table B-1.

## **4 Subsurface Conditions**

Two primary soil types were encountered in the test borings drilled for the subsurface investigation. Each soil type was classified in accordance with the Unified Soil Classification System (USCS) and the American Association of State Highway and Transportation Officials (AASHTO) soil classification system using the laboratory testing results and the observations made during drilling.

#### 4.1 Soil and Bedrock

Subsurface conditions along the proposed roadways consisted of native loose to dense silty sand to sand with silt to slightly silty sand (Soil Type 1), and native hard slightly sandy clay to clay with sand (Soil Type 2). Soil types and corresponding AASHTO soil classifications are listed as follows:

- Soil Type 1: A-2-4, A-1-b, and A-4
- Soil Type 2: A-7-6

Laboratory test results are presented in Appendix B and are summarized in Table B-1.

#### 4.2 Groundwater

Groundwater was encountered in ten of the test borings at depths between 3 and 9 feet bgs. Groundwater fluctuations are possible and will depend on seasonal variations, local precipitation, runoff, and other factors. Shallow groundwater may create unstable conditions on portions of the site and stabilization using shotrock and/or geofabrics may be required.

### 5 Pavement Design Recommendations

Pavement design recommendations were made in accordance with the *El Paso County Pavement Engineering Criteria Manual*.

#### 5.1 Subgrade Conditions

California Bearing Ratio (CBR) testing was performed on a representative sample of the subgrade silty sand (Soil Type 1) from TB-1 to determine the support characteristic of the subgrade soils for the roadway section. The results of the CBR testing are presented in Appendix B and summarized in Exhibit 1.

**Exhibit 1: Subsurface Laboratory Testing Summary**

Design Parameter	Value
Soil Type	1 - Silty Sand
CBR at 95%	11.88
Design CBR	10
Liquid Limit	NV
Plasticity Index	NP
Percent Passing 200	27.9
AASHTO Classification	A-2-4
Unified Soils Classification	SM

## 5.2 Swell Mitigation

El Paso County requires swell mitigation of expansive soils criteria for soils with swell testing results greater than 2% under a 150 pounds per square foot (psf) surcharge. Based on the granular nature of the site materials encountered, mitigation for expansive soils is not required. Localized areas of higher clay contents such as the A-7-6 material encountered in boring TB-18 may be encountered during subgrade preparation. Overexcavation of cohesive soils is recommended to provide proper subgrade support as discussed in Section 6.1.1.

## 5.3 Traffic Loading

Traffic Impact Study was completed with PCD File number SF2133. Please include this reference in the pavement report

Traffic data is not available for the Curtis Road widening alignment; however, after improvements the east half of the roadway will be classified as a rural principal arterial. The *El Paso County Engineering Criteria Manual* provides default 18-kip equivalent single axle loading (ESAL) based street classifications. For design, a default ESAL value of 2,628,000 was used for the rural principal arterial designation (Curtis Road), and a default ESAL value of 36,500 was used for the interior roads designated as rural local roadways.

## 5.4 Pavement Design

The pavement sections were determined utilizing the *El Paso County Engineering Criteria Manual*, the CBR testing, and default ESAL values. Design parameters used in the pavement analysis are presented in Exhibit 2.

**Exhibit 2: Pavement Design Parameters**

Design Parameter	Value
Reliability	
Principal Arterial	85%
Rural Local	75%
Standard Deviation	0.44
Serviceability Loss ( $\Delta$ psi)	
Principal Arterial	2.5
Rural Local	2.0
Design CBR	10.0
Resilient Modulus	15,000 psi
Structural Coefficients	
Hot Mix Asphalt	0.44
Aggregate Base Course	0.11

Pavement sections recommended for roads are summarized in Exhibit 3. The pavement design calculations are presented in Appendix C.

**Exhibit 3: Recommended Pavement Sections**

Pavement Area	Roadway Designation	Design ESAL	Alternative <sup>1</sup>
Interior Roads	Rural Local	36,500	1. 3.0 inches HMA over 4.0 inches ABC
Curtis Road	Rural Principal Arterial	2,628,000	2. 5.0 inches HMA over 8.0 inches ABC

ABC = Aggregate Base Course; ESAL = equivalent single axle loads; HMA = Hot Mix Asphalt  
 Notes:

1. All pavement alternatives meet the minimum sections required per the *El Paso County Pavement Design Criteria*.
2. Interior roads include Benito Wells Trail, El Raiceno Trail, Del Cerro Trail, and Estacado Place

**6 Construction Recommendations**

Pavement design recommendations provided herein are contingent on good construction practices, and poor construction techniques may result in poor performance. Our analyses assumed that this project will be constructed according to the *El Paso County Engineering Criteria Manual* and the *Pikes Peak Region Asphalt Paving Specifications*.

**6.1 Earthwork Recommendations for Pavement Subgrade**

Proper subgrade preparation is required for adequate pavement performance. Paving areas should be cleared of all deleterious materials including but not limited to existing pavements, utility poles, and fence poles. Surface vegetation, if any, should be removed by stripping, with the depth to be field determined.

**6.1.1 Overexcavation**

Where encountered, cohesive soils, such as the A-7-6 material encountered in TB-18, should be removed to a depth of 18 inches and replaced with Soil Type 1 granular fill (Section 6.1.3) to provide uniform subgrade support. The compacted surface below pavements should be proof-rolled with a fully loaded, tandem-axle, 10-yard dump truck or equivalent. Any areas that are delineated to be soft, loose, or yielding during proof-rolling should be removed and reconditioned or replaced. The extent of any cohesive material overexcavation should be field determined.

**6.1.2 Subgrade Preparation – Aggregate Base Course Alternatives**

If pavement section alternatives are selected utilizing aggregate base course (ABC), the final subgrade surface should be scarified to a depth of 12 inches, moisture conditioned within +/-2%

over the optimum water content, and recompacted to 95% of its maximum Modified Proctor dry density, ASTM D1557.

### **6.1.3 Fill Placement and Compaction**

Granular fill placed as part of the pavement subgrade shall consist of non-expansive, granular soil, free of organic matter, unsuitable materials, debris, and cobbles greater than 3 inches in diameter. Additionally, any granular fill placed as part of the roadway subgrade should have a minimum CBR of 10. All granular fill placed within the pavement subgrade should be compacted to a minimum of 95% of its maximum Modified Proctor Dry Density (ASTM D1557) at +/-2% of optimum moisture content. Fill material should be placed in horizontal lifts such that each finished lift has a compacted thickness of 6 inches or less. Entech should approve any imported fill to be used within the pavement subgrade area prior to delivery to the site.

### **6.2 Aggregate Base Course**

ABC materials shall conform to the *El Paso County Standard Specifications Manual*, Table D-6, Aggregate Base Course Materials. ABC materials should be compacted to a minimum of 95% of its maximum Modified Proctor Dry Density (ASTM D1557) at +/-2% of optimum moisture content

### **6.3 Concrete Degradation Due to Sulfate Attack**

Sulfate solubility testing was conducted on several samples recovered from the test borings to evaluate the potential for sulfate attack on concrete. The test results indicated less than 0.01% soluble sulfate (by weight). The test results indicate the sulfate component of the in-place soils presents a negligible exposure threat to concrete placed below the site grade.

Type II or Type 1L cement is recommended for concrete on the site. To further avoid concrete degradation during construction, it is recommended that concrete not be placed on frozen or wet ground. Care should be taken to prevent the accumulation or ponding of water in the foundation excavation prior to the placement of concrete. If standing water is present in the foundation excavation, it should be removed by ditching to sumps and pumping the water away from the foundation area prior to concrete placement. If concrete is placed during periods of cold temperatures, the concrete must be kept from freezing. This may require covering the concrete with insulated blankets and adding heat to prohibit freezing.



#### **6.4 Construction Observation**

Subgrade preparation for pavement structures should be observed by Entech in order to verify that (1) no anomalies are present, (2) materials similar to those described in this report have been encountered or placed, and (3) no soft spots, expansive or organic soil, or debris are present in the pavement subgrade prior to paving.

### **7 Closure**

The subsurface investigation, geotechnical evaluation, and recommendations presented in this report are intended for use by Gorilla Capital Colorado Saddlehorn Ranch, LLC with application to the Curtis Road improvements and Saddlehorn Ranch Filing 2 paving project in El Paso County, Colorado. In conducting the subsurface exploration program, laboratory testing, engineering evaluation, and reporting, Entech Engineering, Inc. endeavored to work in accordance with generally accepted professional geotechnical and geologic practices and principles consistent with the level of care and skill ordinarily exercised by members of the geotechnical profession currently practicing in the same locality and under similar conditions. No other warranty, expressed or implied, is made. During final design and/or construction, if conditions are encountered that appear different from those described in this report, Entech Engineering, Inc. requests to be notified so that the evaluation and recommendations presented herein can be reviewed and modified as appropriate.

If there are any questions regarding the information provided herein, or if Entech Engineering, Inc. can be of further assistance, please do not hesitate to contact us.



**VICINITY MAP**  
SADDLEHORN RANCH, FILING 2  
GORILLA CAPITAL CO.

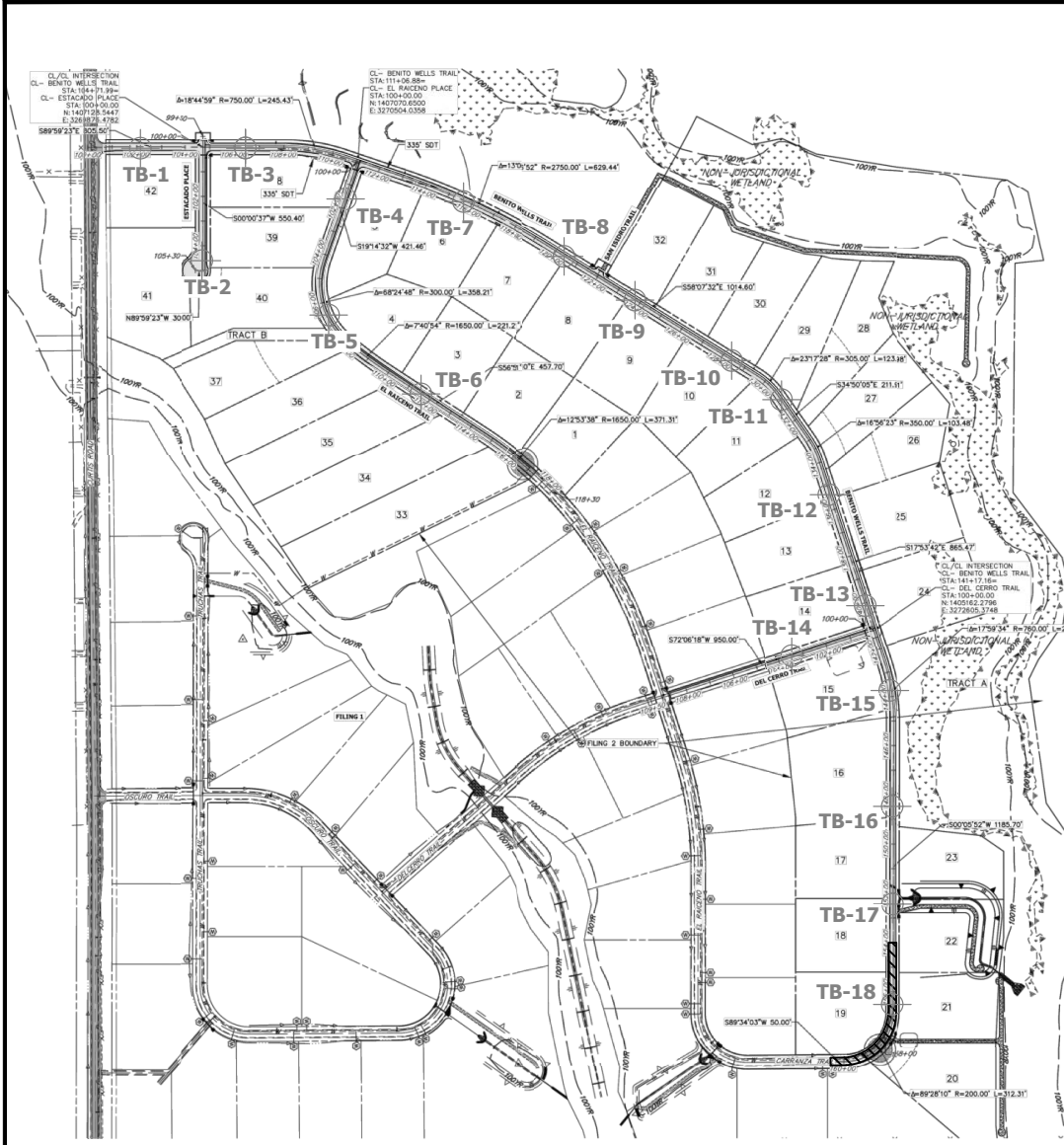

JOB NO.  
222258

**FIG. 1**



Please include an additional figure or add hatching depicting which roads are included in the pavement report

**LEGEND**

-  RURAL PRINCIPAL ARTERIAL ROADWAY CLASSIFICATION  
DESIGN 18-KIP ESAL=2,628,000  
SOIL TYPE 1 (AASHTO A-1-b, A-2-4, & A-4)  
PAVEMENT ALTERNATIVE 1) 5" HMA OVER 8" ABC
-  RURAL LOCAL ROADWAY CLASSIFICATION  
DESIGN 18-KIP ESAL=36,500  
SOIL TYPE 1 (AASHTO A-1-b, A-2-4, & A-4)  
PAVEMENT ALTERNATIVE 1) 3" HMA OVER 4" ABC
-  HATCHED AREA DENOTES AREA OF A-7-6 SOILS TO BE OVEREXCAVATED AND REPLACED.

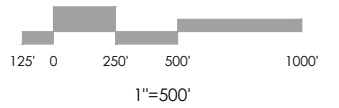

 TB- APPROXIMATE TEST BORING LOCATION AND NUMBER





**ENTECH**  
ENGINEERING, INC.

**SITE AND EXPLORATION PLAN**  
SADDLEHORN RANCH, FILING 2  
GORILLA CAPITAL CO.

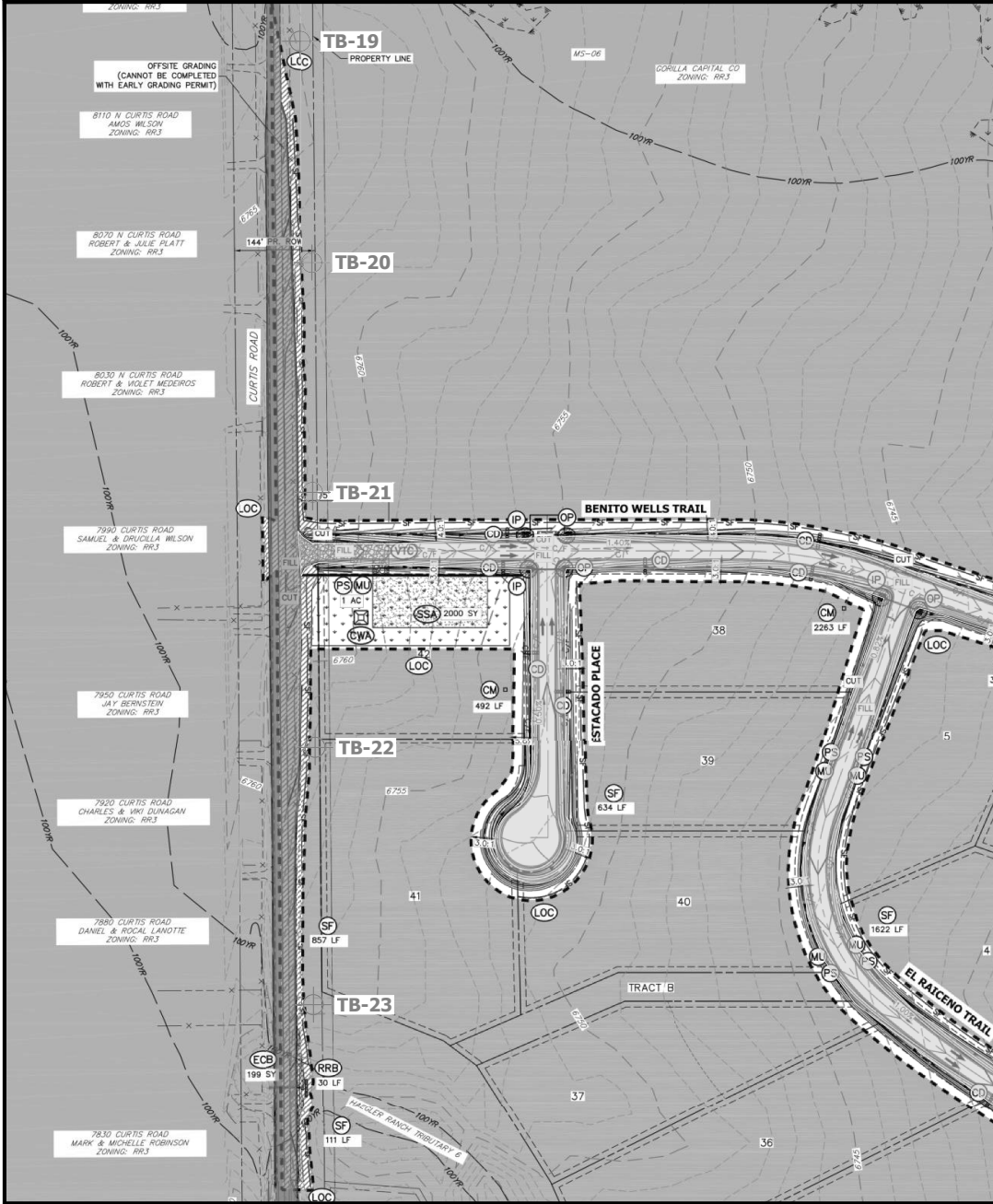
JOB NO.  
222258  
**FIG. 2**



**LEGEND**

-  RURAL PRINCIPAL ARTERIAL ROADWAY CLASSIFICATION  
DESIGN 18-KIP ESAL=2,628,000  
SOIL TYPE 1 (AASHTO A-1-b, A-2-4, & A-4)  
PAVEMENT ALTERNATIVE 1) 5" HMA OVER 8" ABC
-  RURAL LOCAL ROADWAY CLASSIFICATION  
DESIGN 18-KIP ESAL=36,500  
SOIL TYPE 1 (AASHTO A-1-b, A-2-4, & A-4)  
PAVEMENT ALTERNATIVE 1) 3" HMA OVER 4" ABC

 TB- APPROXIMATE TEST BORING LOCATION AND NUMBER

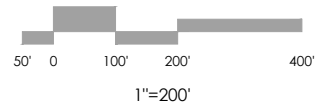

**SITE AND EXPLORATION PLAN**

SADDLEHORN RANCH, FILING 2  
GORILLA CAPITAL CO.

JOB NO.  
222258

**FIG. 3**



## **APPENDIX A: Test Boring Logs**

TEST BORING 1  
DATE DRILLED 12/26/2023

TEST BORING 2  
DATE DRILLED 12/26/2023

REMARKS	Depth (ft)	Symbol	Samples	Blows per foot	Watercontent %	Soil Type	REMARKS	Depth (ft)	Symbol	Samples	Blows per foot	Watercontent %	Soil Type
DRY TO 5', 12/26/23							DRY TO 5', 12/26/23						
SAND, SILTY, BROWN to TAN, MEDIUM DENSE to DENSE, MOIST to DRY	5			10	3.2	1	SAND, SILTY, BROWN to TAN, MEDIUM DENSE, MOIST to DRY	5			12	6.8	1
	5			44	2.9	1		5			14	2.8	1
	10							10					
	15							15					
	20							20					



**TEST BORING LOGS**  
SADDLEHORN RANCH, FILING 2  
GORILLA CAPITAL CO.

JOB NO.  
222258  
**FIG. A-1**

TEST BORING 3  
 DATE DRILLED 12/26/2023

TEST BORING 4  
 DATE DRILLED 12/26/2023

REMARKS

REMARKS

WATER @ 8', 12/26/23

DRY TO 5', 12/26/23

SAND, SILTY, BROWN to TAN,  
 MEDIUM DENSE, DRY to MOIST

SAND, WITH SILT, BROWN to  
 OLIVE, MEDIUM DENSE, DRY to  
 MOIST

Depth (ft)	Symbol	Samples	Blows per foot	Watercontent %	Soil Type	Depth (ft)	Symbol	Samples	Blows per foot	Watercontent %	Soil Type
5			19	2.6	1	5			24	1.2	1
5			26	1.9	1	5			20	4.9	1
10			21	8.3	1	10					
15						15					
20						20					



**TEST BORING LOGS**  
 SADDLEHORN RANCH, FILING 2  
 GORILLA CAPITAL CO.

JOB NO.  
 222258

**FIG. A-2**

TEST BORING 5  
 DATE DRILLED 12/26/2023

TEST BORING 6  
 DATE DRILLED 12/26/2023

REMARKS	Depth (ft)	Symbol	Samples	Blows per foot	Watercontent %	Soil Type
DRY TO 5', 12/26/23						
SAND, SILTY, BROWN to OLIVE, MEDIUM DENSE, DRY	5			22	2.0	1
	5			19	1.6	1

REMARKS	Depth (ft)	Symbol	Samples	Blows per foot	Watercontent %	Soil Type
DRY TO 10', 12/26/23						
SAND, SILTY, BROWN, MEDIUM DENSE, DRY to MOIST	5			19	2.2	1
CLAY, SANDY, OLIVE, STIFF, MOIST	5			20	6.4	1
	10			14	18.1	2



**TEST BORING LOGS**  
 SADDLEHORN RANCH, FILING 2  
 GORILLA CAPITAL CO.

JOB NO.  
 222258

**FIG. A-3**



TEST BORING 7  
 DATE DRILLED 12/26/2023

TEST BORING 8  
 DATE DRILLED 12/26/2023

REMARKS	Depth (ft)	Symbol	Samples	Blows per foot	Watercontent %	Soil Type
DRY TO 5', 12/26/23						
SAND, WITH SILT, BROWN, MEDIUM DENSE, DRY to MOIST	5			13	1.0	1
	5			21	9.3	1

REMARKS	Depth (ft)	Symbol	Samples	Blows per foot	Watercontent %	Soil Type
DRY TO 5', 12/26/23						
SAND, WITH SILT, OLIVE, MEDIUM DENSE, DRY	5			13	1.2	1
SAND, CLAYEY, OLIVE, MEDIUM DENSE, MOIST	5			21	11.3	1



**TEST BORING LOGS**  
 SADDLEHORN RANCH, FILING 2  
 GORILLA CAPITAL CO.

JOB NO.  
 222258  
**FIG. A-4**

TEST BORING 9  
DATE DRILLED 12/26/2024

TEST BORING 10  
DATE DRILLED 12/26/2024

REMARKS

REMARKS

WATER @ 7', 12/26/23

SAND, SILTY, BROWN to TAN,  
MEDIUM DENSE, MOIST to WET

Depth (ft)	Symbol	Samples	Blows per foot	Watercontent %	Soil Type
5			13	3.8	1
5			22	7.7	1
10			14	14.0	1
15					
20					



WATER @ 4', 12/26/23

SAND, WITH SILT, BROWN,  
MEDIUM DENSE to LOOSE, DRY  
to WET

Depth (ft)	Symbol	Samples	Blows per foot	Watercontent %	Soil Type
5			20	2.1	1
5			8	21.2	1
10					
15					
20					



**TEST BORING LOGS**  
SADDLEHORN RANCH, FILING 2  
GORILLA CAPITAL CO.

JOB NO.  
222258

**FIG. A-5**

TEST BORING 11  
 DATE DRILLED 12/26/2024

TEST BORING 12  
 DATE DRILLED 12/26/2024

REMARKS

REMARKS

DRY TO 5', 12/26/23

SAND, SILTY, BROWN to OLIVE,  
 MEDIUM DENSE, DRY to MOIST

Depth (ft)	Symbol	Samples	Blows per foot	Watercontent %	Soil Type
5			27	1.2	1
5			19	3.7	1
10					
15					
20					

WATER @ 8', 12/26/23

SAND, WITH SILT, OLIVE to  
 BROWN, MEDIUM DENSE, MOIST  
 to WET



Depth (ft)	Symbol	Samples	Blows per foot	Watercontent %	Soil Type
5			23	4.9	1
5			18	5.7	1
10			18	12.0	1
15					
20					



**TEST BORING LOGS**

SADDLEHORN RANCH, FILING 2  
 GORILLA CAPITAL CO.

JOB NO.  
 222258

**FIG. A-6**

TEST BORING 13  
 DATE DRILLED 12/26/2024

TEST BORING 14  
 DATE DRILLED 12/26/2024

REMARKS

REMARKS

WATER @ 4', 12/26/23

SAND, WITH SILT, OLIVE to BROWN, MEDIUM DENSE, DRY to WET

Depth (ft)	Symbol	Samples	Blows per foot	Watercontent %	Soil Type
5			15	0.6	1
5			12	14.4	1
10					
15					
20					



WATER @ 4', 12/26/23

SAND, SILTY, DARK BROWN to BROWN, LOOSE to MEDIUM DENSE, MOIST to WET

Depth (ft)	Symbol	Samples	Blows per foot	Watercontent %	Soil Type
5			6	12.4	1
5			10	17.4	1
10					
15					
20					



**TEST BORING LOGS**

SADDLEHORN RANCH, FILING 2  
 GORILLA CAPITAL CO.

JOB NO.  
 222258

**FIG. A-7**

TEST BORING 15  
 DATE DRILLED 12/27/2023

TEST BORING 16  
 DATE DRILLED 12/27/2023

REMARKS	Depth (ft)	Symbol	Samples	Blows per foot	Watercontent %	Soil Type
WATER @ 3', 12/27/23						
SAND, WITH SILT, OLIVE, MEDIUM DENSE, MOIST to WET	5			10	13.0	1
	5			23	13.6	1
	10					
	15					
	20					

REMARKS	Depth (ft)	Symbol	Samples	Blows per foot	Watercontent %	Soil Type
WATER @ 4', 12/27/23						
SAND, WITH SILT, OLIVE, MEDIUM DENSE to LOOSE, MOIST to WET	5			11	6.5	1
	5			8	20.4	1
	10			15	11.0	1
	15					
	20					



**TEST BORING LOGS**  
 SADDLEHORN RANCH, FILING 2  
 GORILLA CAPITAL CO.

JOB NO.  
 222258  
**FIG. A-8**

TEST BORING 17  
 DATE DRILLED 12/27/2023

TEST BORING 18  
 DATE DRILLED 12/27/2023

REMARKS

REMARKS

DRY TO 5', 12/27/23

SAND, SILTY, LOOSE, BROWN,  
 MOIST

Depth (ft)	Symbol	Samples	Blows per foot	Watercontent %	Soil Type
5	(Symbol: dots)	(Symbol: solid black)	9	7.3	1
5	(Symbol: dots)	(Symbol: solid black)	5	17.2	1

DRY TO 5', 12/27/23

CLAY, SANDY, GRAY, HARD, MOIST

Depth (ft)	Symbol	Samples	Blows per foot	Watercontent %	Soil Type
5	(Symbol: diagonal lines)	(Symbol: solid black)	33	21.6	2
5	(Symbol: diagonal lines)	(Symbol: solid black)	42	21.7	2



**TEST BORING LOGS**

SADDLEHORN RANCH, FILING 2  
 GORILLA CAPITAL CO.

JOB NO.  
 222258

**FIG. A-9**

TEST BORING 19  
 DATE DRILLED 12/27/2023

TEST BORING 20  
 DATE DRILLED 12/27/2023

REMARKS	Depth (ft)	Symbol	Samples	Blows per foot	Watercontent %	Soil Type
WATER @ 4', 12/27/23						
SAND, SILTY, OLIVE, LOOSE to MEDIUM DENSE, MOIST to WET	0-4	(Symbol)		8	7.1	1
	4-5	(Symbol)		25	9.0	1
	5-10	(Symbol)				
	10-15	(Symbol)				
	15-20	(Symbol)				
	20-25	(Symbol)				

REMARKS	Depth (ft)	Symbol	Samples	Blows per foot	Watercontent %	Soil Type
DRY TO 5', 12/27/23						
SAND, WITH SILT, BROWN to OLIVE, MEDIUM DENSE, DRY to MOIST	0-5	(Symbol)		14	1.9	1
	5-10	(Symbol)		14	3.9	1
	10-15	(Symbol)				
	15-20	(Symbol)				
	20-25	(Symbol)				



**TEST BORING LOGS**  
 SADDLEHORN RANCH, FILING 2  
 GORILLA CAPITAL CO.

JOB NO.  
 222258  
**FIG. A-10**

TEST BORING 21  
 DATE DRILLED 12/27/2023

TEST BORING 22  
 DATE DRILLED 12/27/2023

REMARKS

REMARKS

WATER @ 9', 12/27/23

DRY TO 5', 12/27/23

SAND, SILTY, BROWN to GREEN-GRAY, MEDIUM DENSE, DRY to MOIST

SAND, SILTY, BROWN to TAN, MEDIUM DENSE, MOIST to DRY

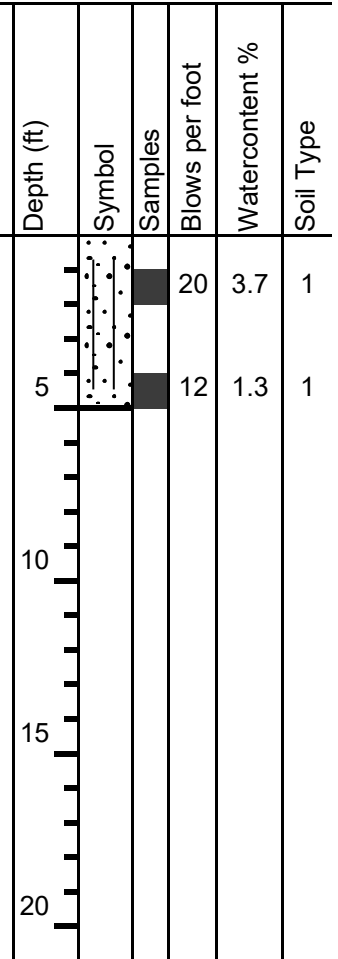
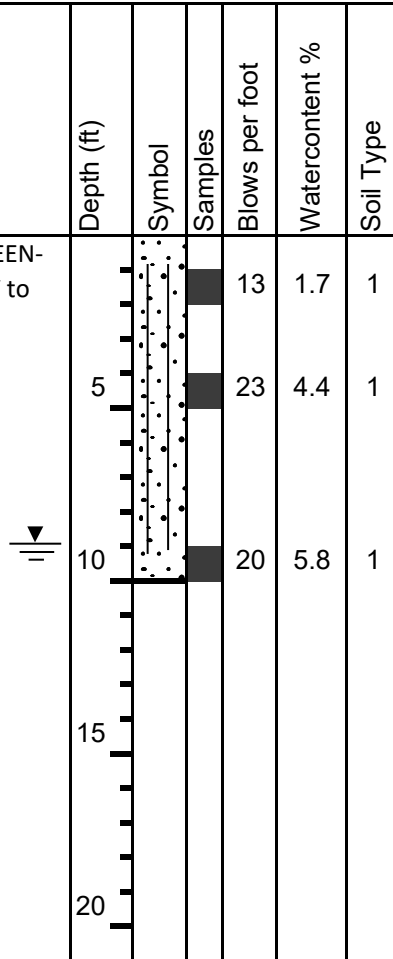

**TEST BORING LOGS**

SADDLEHORN RANCH, FILING 2  
 GORILLA CAPITAL CO.

JOB NO.  
 222258

**FIG. A-11**



TEST BORING 23  
 DATE DRILLED 12/27/2023

REMARKS	Depth (ft)	Symbol	Samples	Blows per foot	Watercontent %	Soil Type
DRY TO 5', 12/27/23						
SAND, SLIGHTLY SILTY, TAN, MEDIUM DENSE, MOIST				10	3.0	1
	5			11	3.5	1
	10					
	15					
	20					



**TEST BORING LOGS**  
 SADDLEHORN RANCH, FILING 2  
 GORILLA CAPITAL CO.

JOB NO.  
 222258  
**FIG. A-12**



## **APPENDIX B: Laboratory Test Results**

**TABLE B-1  
SUMMARY OF LABORATORY TEST RESULTS**

SOIL TYPE	TEST BORING NO.	DEPTH (FT)	PASSING NO. 200 SIEVE (%)	LIQUID LIMIT	PLASTIC LIMIT	PLASTIC INDEX	SULFATE (WT %)	AASHTO CLASS.	USCS	SOIL DESCRIPTION
1, CBR	1	0-3	27.9	NV	NP	NP		A-2-4	SM	SAND, SILTY
1	1	1-2	32.2	NV	NP	NP		A-2-4	SM	SAND, SILTY
1	2	1-2	26.1	NV	NP	NP		A-2-4	SM	SAND, SILTY
1	3	1-2	21.7	NV	NP	NP		A-2-4	SM	SAND, SILTY
1	4	1-2	6.8	NV	NP	NP	<0.01	A-1-b	SM-SW	SAND, WITH SILT
1	5	1-2	34.2	NV	NP	NP		A-2-4	SM	SAND, SILTY
1	6	1-2	32.8	NV	NP	NP	<0.01	A-2-4	SM	SAND, SILTY
1	7	1-2	7.6	NV	NP	NP		A-1-b	SW-SM	SAND, WITH SILT
1	8	1-2	6.6	NV	NP	NP	<0.01	A-1-b	SW-SM	SAND, WITH SILT
1	9	1-2	12.1	NV	NP	NP		A-1-b	SM	SAND, SILTY
1	10	1-2	10.1	NV	NP	NP		A-1-b	SW-SM	SAND, WITH SILT
1	11	1-2	49.6	NV	NP	NP		A-4	SM	SAND, SILTY
1	12	1-2	8.1	NV	NP	NP	<0.01	A-1-b	SW-SM	SAND, WITH SILT
1	13	1-2	6.5	NV	NP	NP		A-1-b	SW-SM	SAND, WITH SILT
1	14	1-2	19.1	NV	NP	NP	<0.01	A-2-4	SM	SAND, SILTY
1	15	1-2	11.0	NV	NP	NP		A-1-b	SW-SM	SAND, WITH SILT
1	16	1-2	10.0	NV	NP	NP		A-1-b	SW-SM	SAND, WITH SILT
1	17	1-2	19.2	NV	NP	NP		A-2-4	SM	SAND, SILTY
1	19	1-2	28.9	NV	NP	NP		A-2-4	SM	SAND, SILTY
1	20	1-2	8.2	NV	NP	NP		A-1-b	SW-SM	SAND, WITH SILT
1	21	1-2	14.7	NV	NP	NP		A-1-b	SM	SAND, SILTY
1	22	1-2	32.4	NV	NP	NP		A-2-4	SM	SAND, SILTY
1	23	1-2	4.2	NV	NP	NP		A-2-4	SW	SAND, SLIGHTLY SILTY
1	14	0-3	27.6	NV	NP	NP		A-2-4	SM	SAND, SILTY
1	12	0-3	16.6	NV	NP	NP		A-1-b	SM	SAND, SILTY
1	17	0-3	27.3						SM	SAND, SILTY
2	18	1-2	90.4	57	28	29		A-7-6	CH	CLAY, SLIGHTLY SANDY
2	18	0-3	74.4						CL	CLAY, WITH SANDY

TEST BORING 1  
 DEPTH (FT) 0-3

SOIL DESCRIPTION SAND, SILTY  
 SOIL TYPE 1, CBR

**Sieve Analysis  
 Grain Size Distribution**

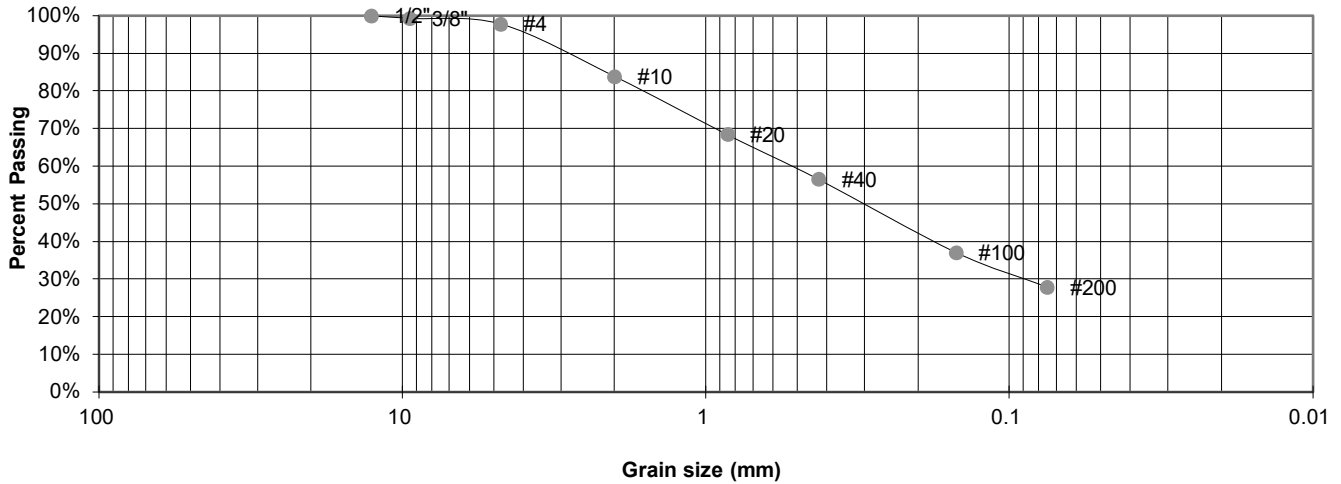

**GRAIN SIZE ANALYSIS**

U.S. Sieve #	Percent Finer
3"	
1 1/2"	
3/4"	
1/2"	100.0%
3/8"	99.3%
4	97.8%
10	83.9%
20	68.5%
40	56.5%
100	37.1%
200	27.9%

**ATTERBERG LIMITS**

Plastic Limit	NP
Liquid Limit	NV
Plastic Index	NP

**SOIL CLASSIFICATION**

USCS CLASSIFICATION: SM  
 AASHTO CLASSIFICATION: A-2-4  
 AASHTO GROUP INDEX: 0



**LABORATORY TEST RESULTS**

SADDLEHORN RANCH, FILING 2  
 GORILLA CAPITAL CO.

JOB NO.  
 222258

**FIG. B-1**

TEST BORING 1  
DEPTH (FT) 1-2

SOIL DESCRIPTION SAND, SILTY  
SOIL TYPE 1

**Sieve Analysis  
Grain Size Distribution**

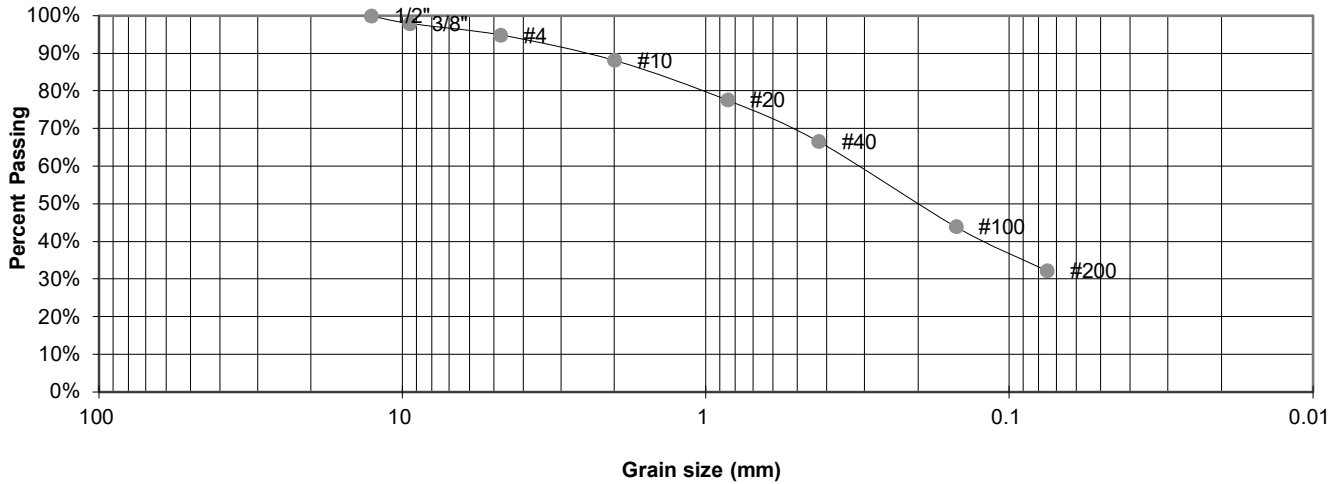

**GRAIN SIZE ANALYSIS**

U.S. Sieve #	Percent Finer
3"	
1 1/2"	
3/4"	
1/2"	100.0%
3/8"	98.0%
4	94.9%
10	88.2%
20	77.6%
40	66.6%
100	44.0%
200	32.2%

**ATTERBERG LIMITS**

Plastic Limit	NP
Liquid Limit	NV
Plastic Index	NP

**SOIL CLASSIFICATION**

USCS CLASSIFICATION:	SM
AASHTO CLASSIFICATION:	A-2-4
AASHTO GROUP INDEX:	0



**LABORATORY TEST RESULTS**

SADDLEHORN RANCH, FILING 2  
GORILLA CAPITAL CO.

JOB NO.  
222258

**FIG. B-2**

TEST BORING 2  
 DEPTH (FT) 1-2

SOIL DESCRIPTION SAND, SILTY  
 SOIL TYPE 1

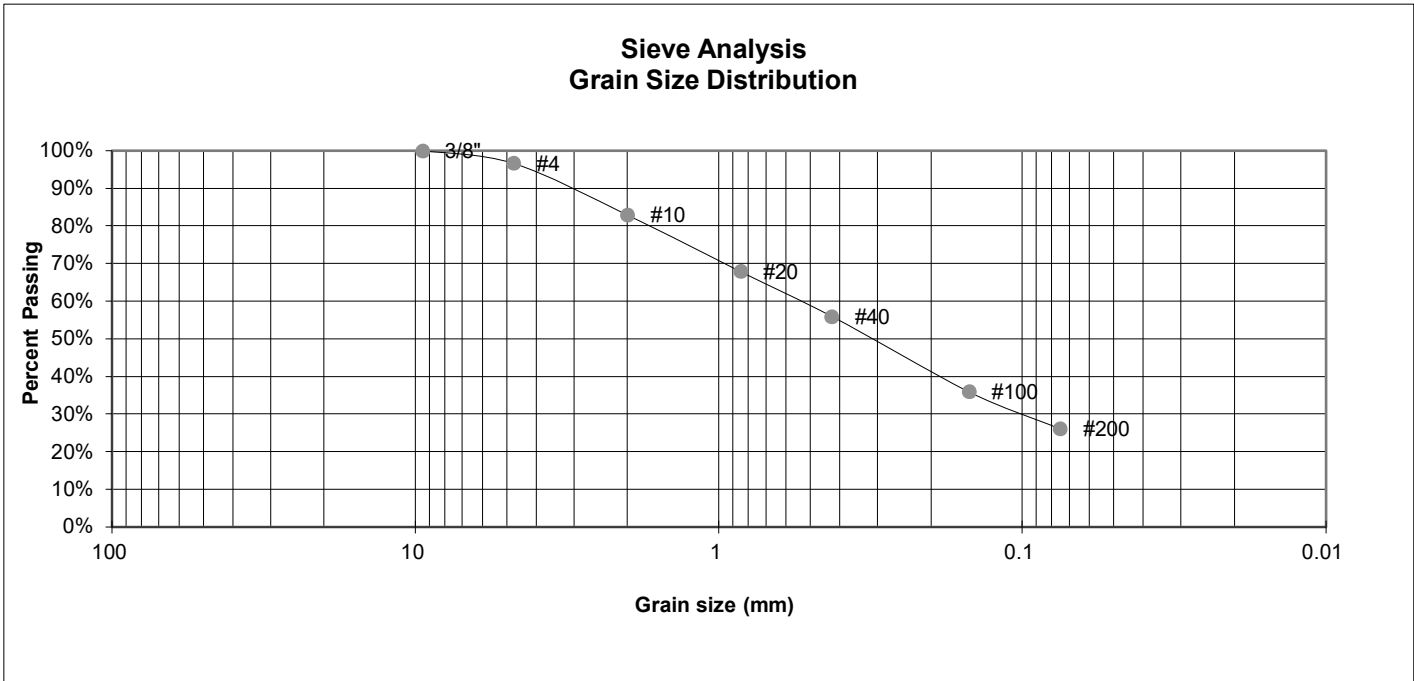

**GRAIN SIZE ANALYSIS**

U.S. Sieve #	Percent Finer
3"	
1 1/2"	
3/4"	
1/2"	
3/8"	100.0%
4	96.7%
10	82.9%
20	68.0%
40	56.0%
100	36.0%
200	26.1%

**ATTERBERG LIMITS**

Plastic Limit	NP
Liquid Limit	NV
Plastic Index	NP

**SOIL CLASSIFICATION**

USCS CLASSIFICATION: SM  
 AASHTO CLASSIFICATION: A-2-4  
 AASHTO GROUP INDEX: 0



**LABORATORY TEST RESULTS**

SADDLEHORN RANCH, FILING 2  
 GORILLA CAPITAL CO.

JOB NO.  
 222258

**FIG. B-3**

TEST BORING 3  
 DEPTH (FT) 1-2

SOIL DESCRIPTION SAND, SILTY  
 SOIL TYPE 1

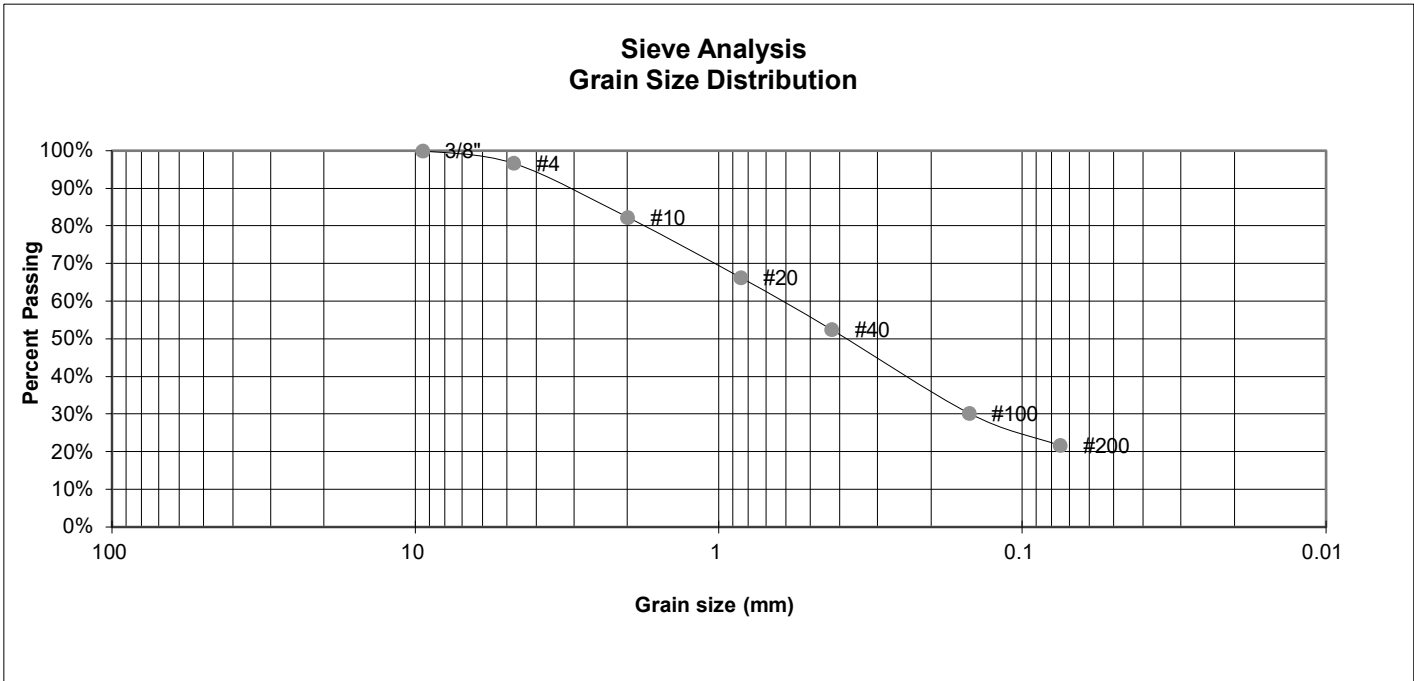

**GRAIN SIZE ANALYSIS**

U.S. Sieve #	Percent Finer
3"	
1 1/2"	
3/4"	
1/2"	
3/8"	100.0%
4	96.7%
10	82.3%
20	66.4%
40	52.5%
100	30.3%
200	21.7%

**ATTERBERG LIMITS**

Plastic Limit	NP
Liquid Limit	NV
Plastic Index	NP

**SOIL CLASSIFICATION**

USCS CLASSIFICATION: SM  
 AASHTO CLASSIFICATION: A-2-4  
 AASHTO GROUP INDEX: 0



**LABORATORY TEST RESULTS**

SADDLEHORN RANCH, FILING 2  
 GORILLA CAPITAL CO.

JOB NO.  
 222258

**FIG. B-4**

TEST BORING 4  
 DEPTH (FT) 1-2

SOIL DESCRIPTION SAND, WITH SILT  
 SOIL TYPE 1

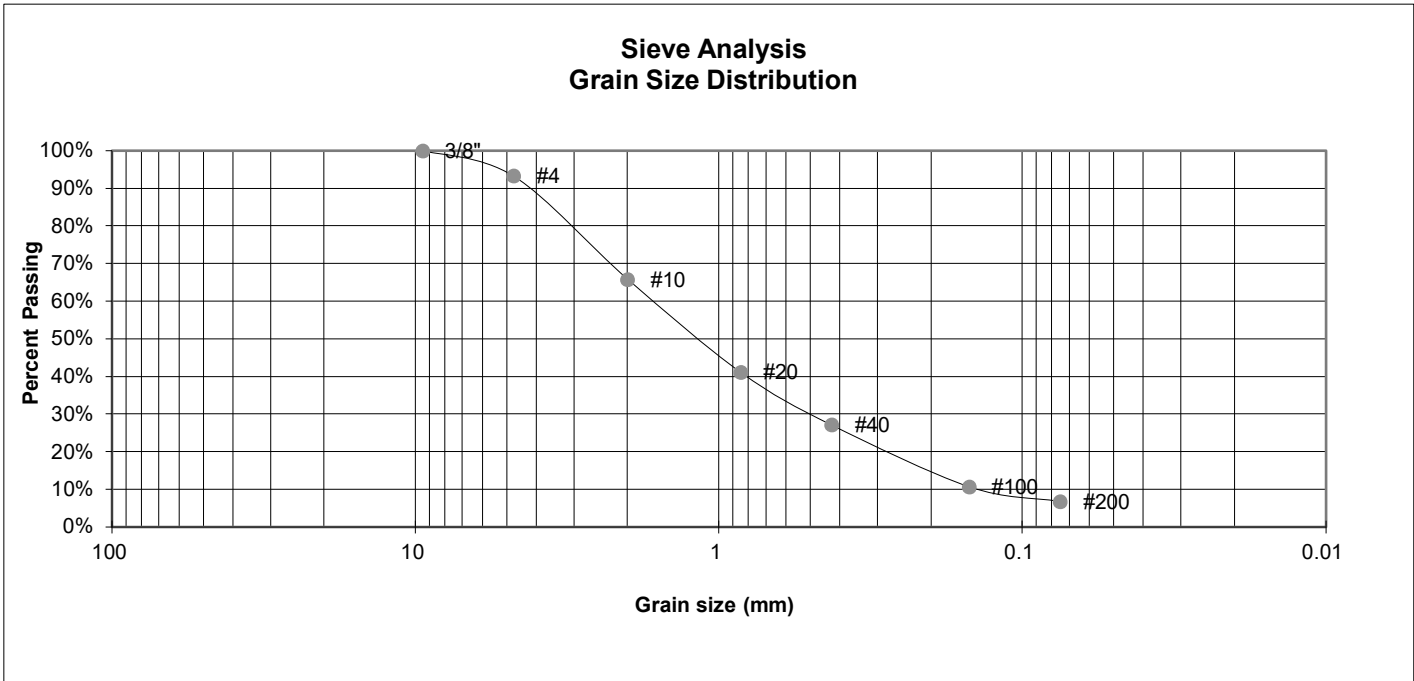

**GRAIN SIZE ANALYSIS**

U.S. Sieve #	Percent Finer
3"	
1 1/2"	
3/4"	
1/2"	
3/8"	100.0%
4	93.3%
10	65.8%
20	41.2%
40	27.2%
100	10.7%
200	6.8%

**ATTERBERG LIMITS**

Plastic Limit	NP
Liquid Limit	NV
Plastic Index	NP

**SOIL CLASSIFICATION**

USCS CLASSIFICATION: SM-SW  
 AASHTO CLASSIFICATION: A-1-b  
 AASHTO GROUP INDEX: 0



**LABORATORY TEST RESULTS**

SADDLEHORN RANCH, FILING 2  
 GORILLA CAPITAL CO.

JOB NO.  
 222258

**FIG. B-5**



TEST BORING 5  
 DEPTH (FT) 1-2

SOIL DESCRIPTION SAND, SILTY  
 SOIL TYPE 1

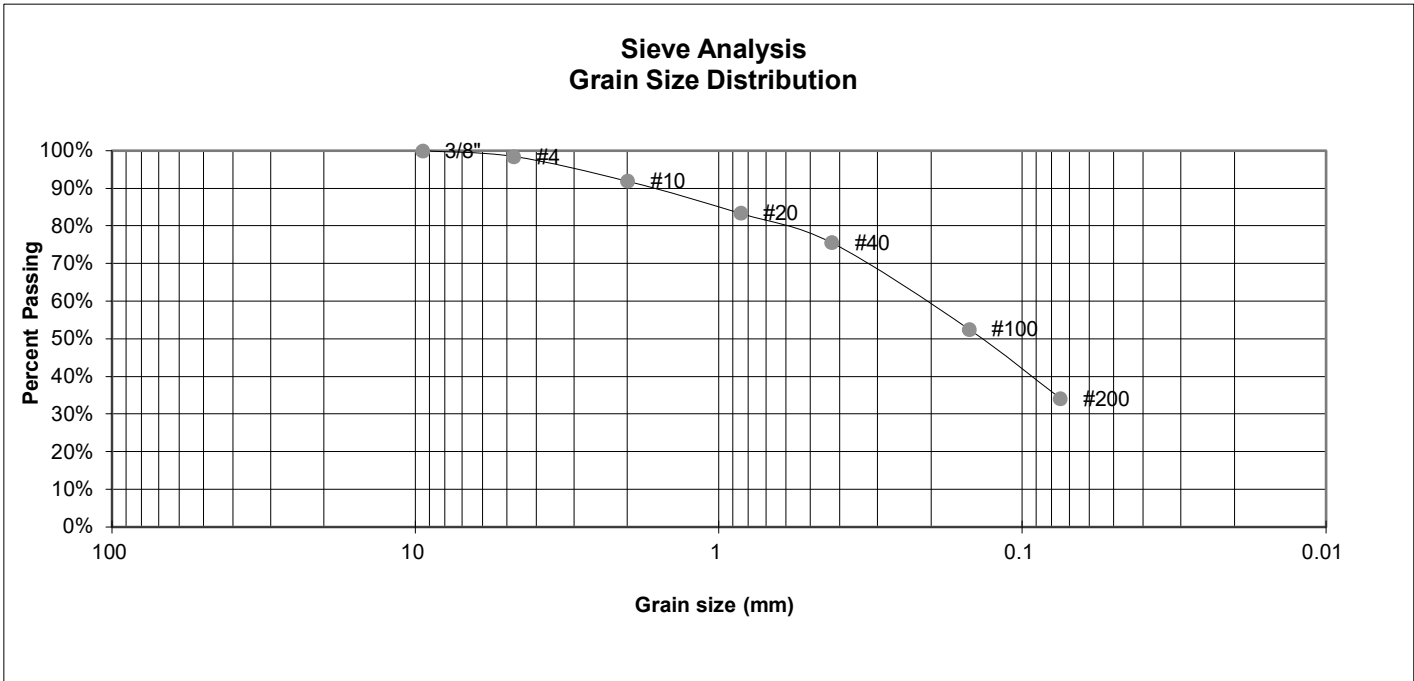

**GRAIN SIZE ANALYSIS**

U.S. Sieve #	Percent Finer
3"	
1 1/2"	
3/4"	
1/2"	
3/8"	100.0%
4	98.5%
10	91.9%
20	83.4%
40	75.6%
100	52.6%
200	34.2%

**ATTERBERG LIMITS**

Plastic Limit	NP
Liquid Limit	NV
Plastic Index	NP

**SOIL CLASSIFICATION**

USCS CLASSIFICATION: SM  
 AASHTO CLASSIFICATION: A-2-4  
 AASHTO GROUP INDEX: 0



**LABORATORY TEST RESULTS**

SADDLEHORN RANCH, FILING 2  
 GORILLA CAPITAL CO.

JOB NO.  
 222258

**FIG. B-6**

TEST BORING 6  
 DEPTH (FT) 1-2

SOIL DESCRIPTION SAND, SILTY  
 SOIL TYPE 1

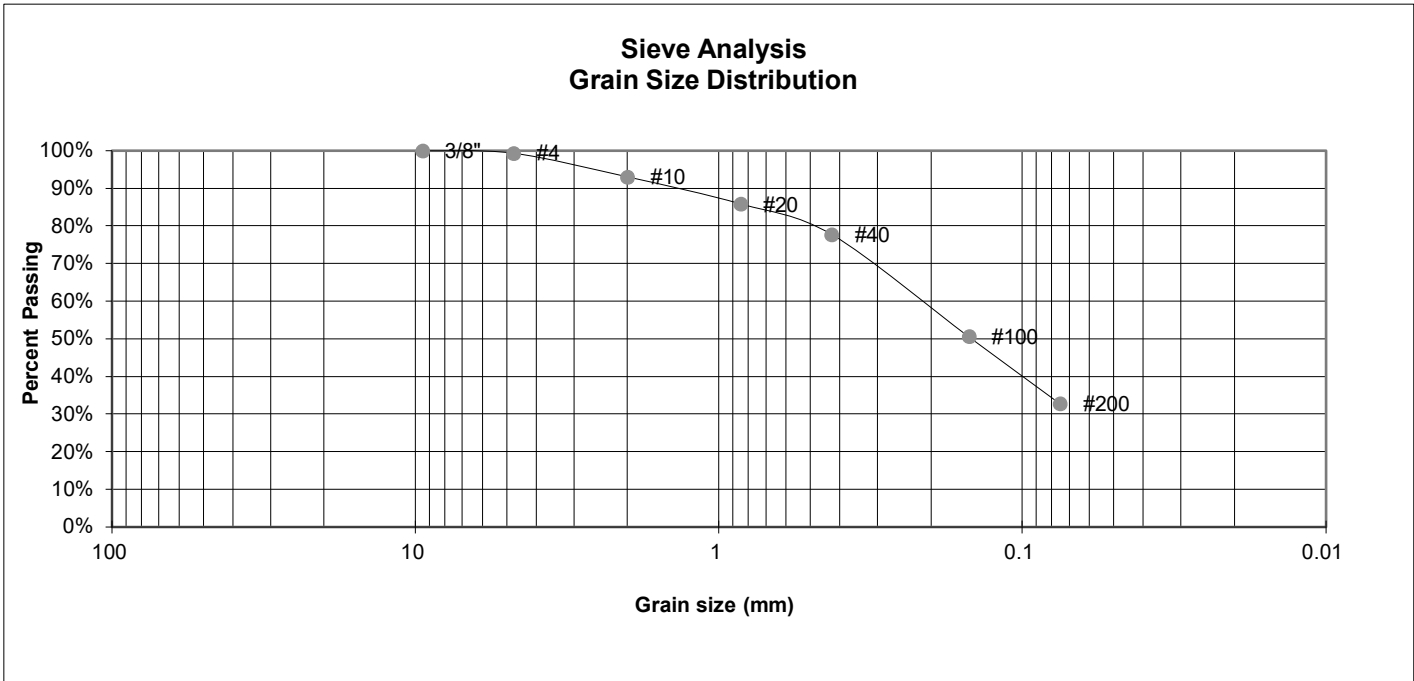

**GRAIN SIZE ANALYSIS**

U.S. Sieve #	Percent Finer
3"	
1 1/2"	
3/4"	
1/2"	
3/8"	100.0%
4	99.4%
10	93.1%
20	85.9%
40	77.7%
100	50.6%
200	32.8%

**ATTERBERG LIMITS**

Plastic Limit	NP
Liquid Limit	NV
Plastic Index	NP

**SOIL CLASSIFICATION**

USCS CLASSIFICATION: SM  
 AASHTO CLASSIFICATION: A-2-4  
 AASHTO GROUP INDEX: 0



**LABORATORY TEST RESULTS**

SADDLEHORN RANCH, FILING 2  
 GORILLA CAPITAL CO.

JOB NO.  
 222258

**FIG. B-7**

TEST BORING 7  
 DEPTH (FT) 1-2

SOIL DESCRIPTION SAND, WITH SILT  
 SOIL TYPE 1

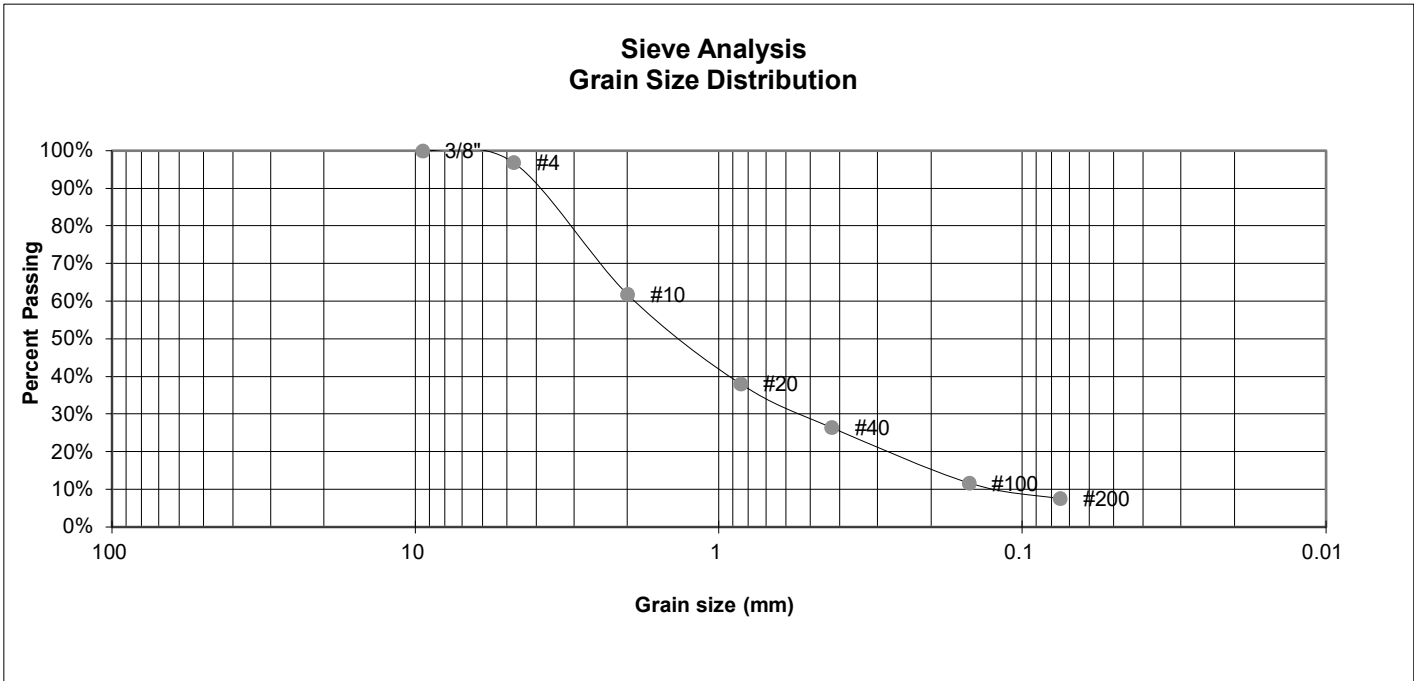

**GRAIN SIZE ANALYSIS**

U.S. Sieve #	Percent Finer
3"	
1 1/2"	
3/4"	
1/2"	
3/8"	100.0%
4	96.9%
10	61.9%
20	38.1%
40	26.5%
100	11.7%
200	7.6%

**ATTERBERG LIMITS**

Plastic Limit	NP
Liquid Limit	NV
Plastic Index	NP

**SOIL CLASSIFICATION**

USCS CLASSIFICATION: SW-SM  
 AASHTO CLASSIFICATION: A-1-b  
 AASHTO GROUP INDEX: 0



**LABORATORY TEST RESULTS**

SADDLEHORN RANCH, FILING 2  
 GORILLA CAPITAL CO.

JOB NO.  
 222258

**FIG. B-8**

TEST BORING 8  
 DEPTH (FT) 1-2

SOIL DESCRIPTION SAND, WITH SILT  
 SOIL TYPE 1

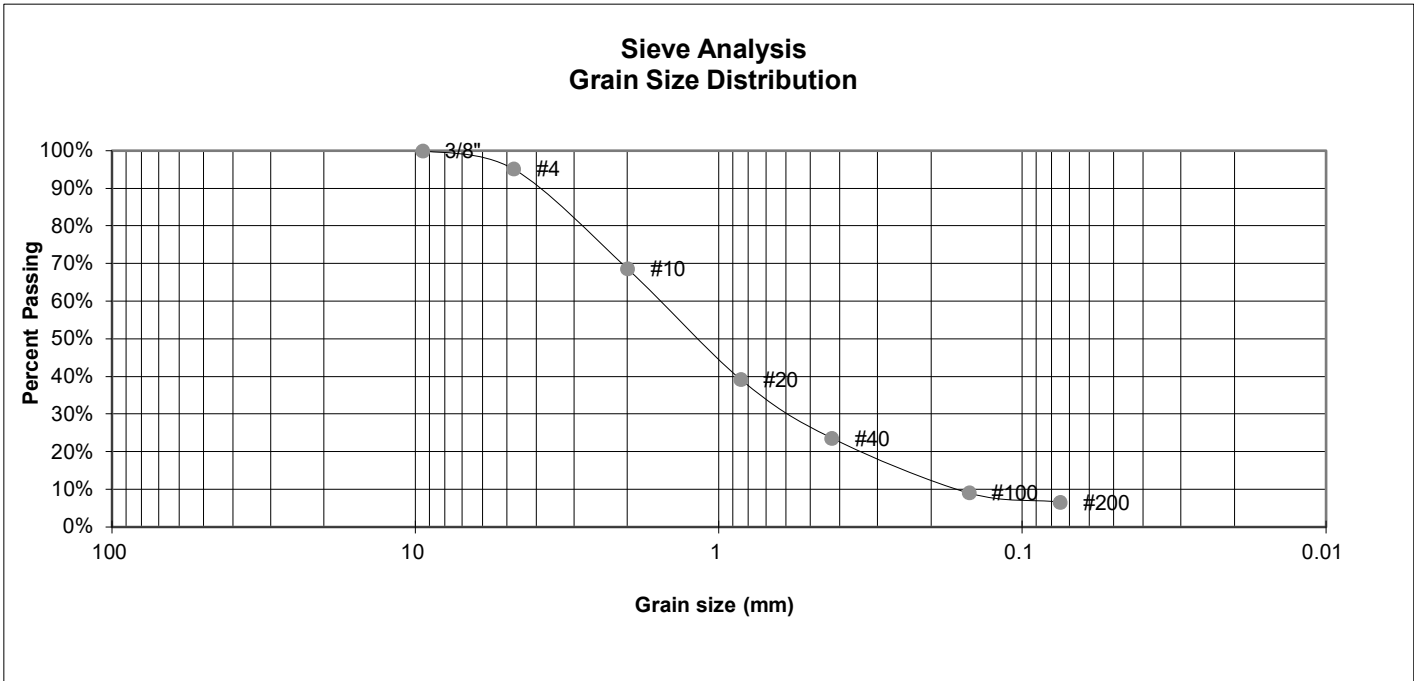

**GRAIN SIZE ANALYSIS**

U.S. Sieve #	Percent Finer
3"	
1 1/2"	
3/4"	
1/2"	
3/8"	100.0%
4	95.1%
10	68.6%
20	39.3%
40	23.6%
100	9.1%
200	6.6%

**ATTERBERG LIMITS**

Plastic Limit	NP
Liquid Limit	NV
Plastic Index	NP

**SOIL CLASSIFICATION**

USCS CLASSIFICATION: SW-SM  
 AASHTO CLASSIFICATION: A-1-b  
 AASHTO GROUP INDEX: 0



**LABORATORY TEST RESULTS**

SADDLEHORN RANCH, FILING 2  
 GORILLA CAPITAL CO.

JOB NO.  
 222258

**FIG. B-9**

TEST BORING 9  
 DEPTH (FT) 1-2

SOIL DESCRIPTION SAND, SILTY  
 SOIL TYPE 1

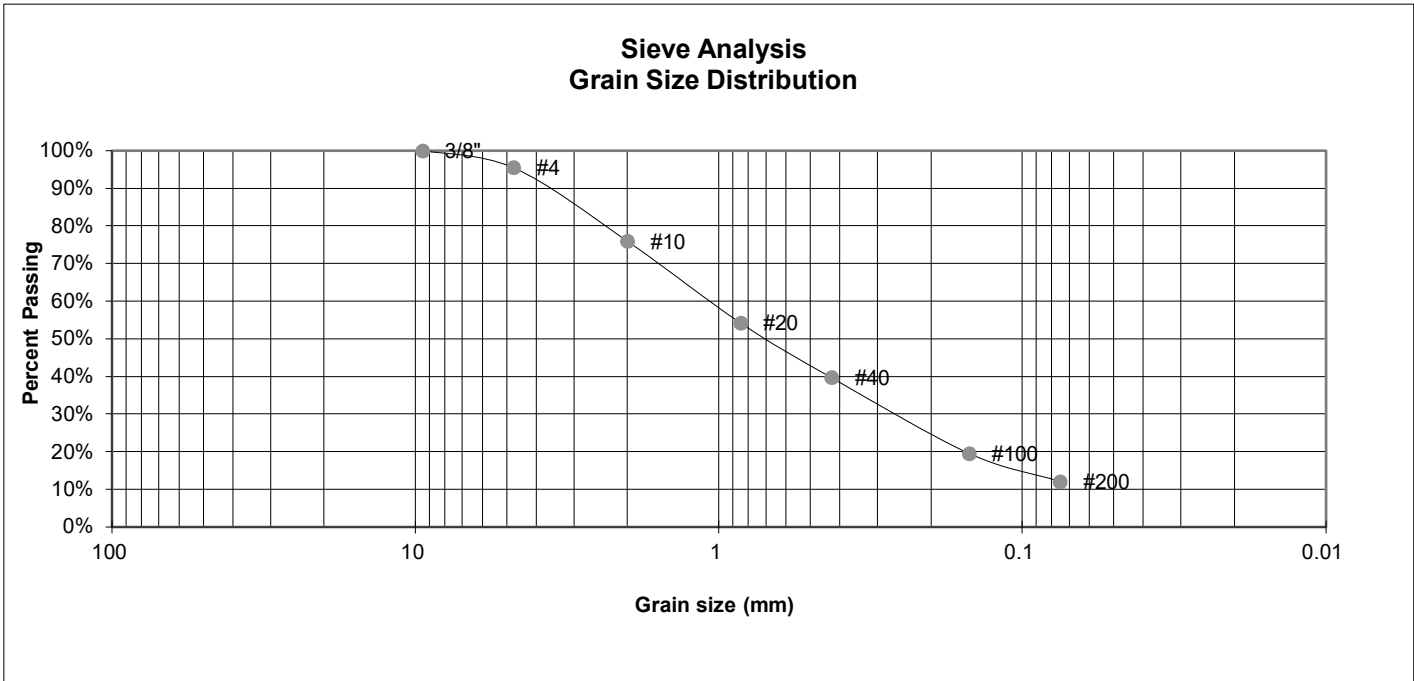

**GRAIN SIZE ANALYSIS**

U.S. Sieve #	Percent Finer
3"	
1 1/2"	
3/4"	
1/2"	
3/8"	100.0%
4	95.5%
10	75.9%
20	54.3%
40	39.7%
100	19.6%
200	12.1%

**ATTERBERG LIMITS**

Plastic Limit	NP
Liquid Limit	NV
Plastic Index	NP

**SOIL CLASSIFICATION**

USCS CLASSIFICATION: SM  
 AASHTO CLASSIFICATION: A-1-b  
 AASHTO GROUP INDEX: 0



**LABORATORY TEST RESULTS**

SADDLEHORN RANCH, FILING 2  
 GORILLA CAPITAL CO.

JOB NO.  
 222258

**FIG. B-10**

TEST BORING 10  
 DEPTH (FT) 1-2

SOIL DESCRIPTION SAND, WITH SILT  
 SOIL TYPE 1

**Sieve Analysis  
 Grain Size Distribution**

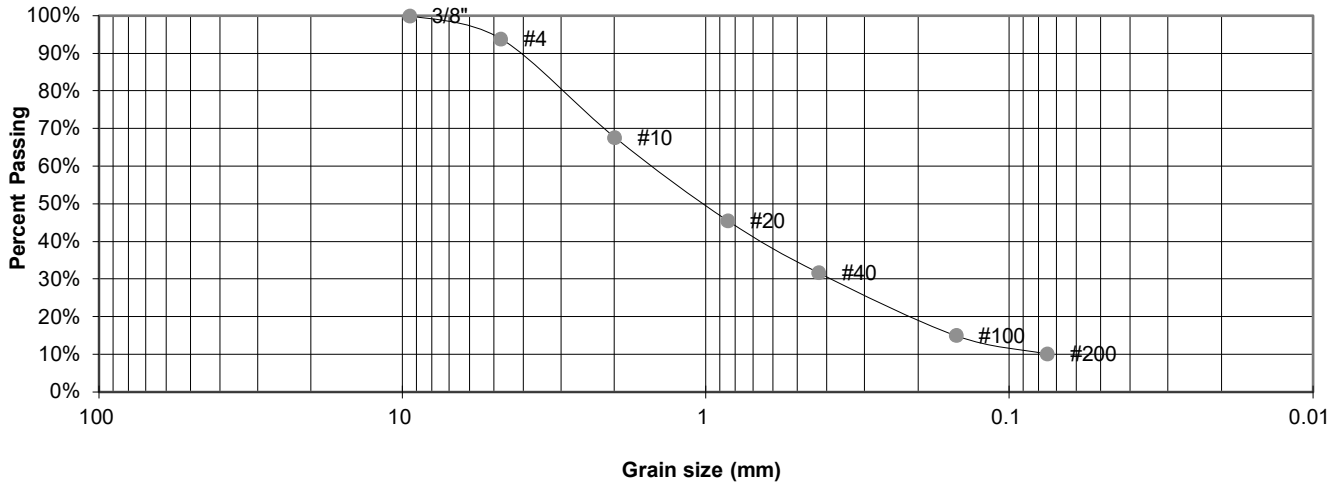

**GRAIN SIZE ANALYSIS**

U.S. Sieve #	Percent Finer
3"	
1 1/2"	
3/4"	
1/2"	
3/8"	100.0%
4	93.9%
10	67.7%
20	45.6%
40	31.7%
100	15.1%
200	10.1%

**ATTERBERG LIMITS**

Plastic Limit	NP
Liquid Limit	NV
Plastic Index	NP

**SOIL CLASSIFICATION**

USCS CLASSIFICATION: SW-SM  
 AASHTO CLASSIFICATION: A-1-b  
 AASHTO GROUP INDEX: 0



**LABORATORY TEST RESULTS**

SADDLEHORN RANCH, FILING 2  
 GORILLA CAPITAL CO.

JOB NO.  
 222258

**FIG. B-11**

TEST BORING 11  
 DEPTH (FT) 1-2

SOIL DESCRIPTION SAND, SILTY  
 SOIL TYPE 1

**Sieve Analysis  
 Grain Size Distribution**

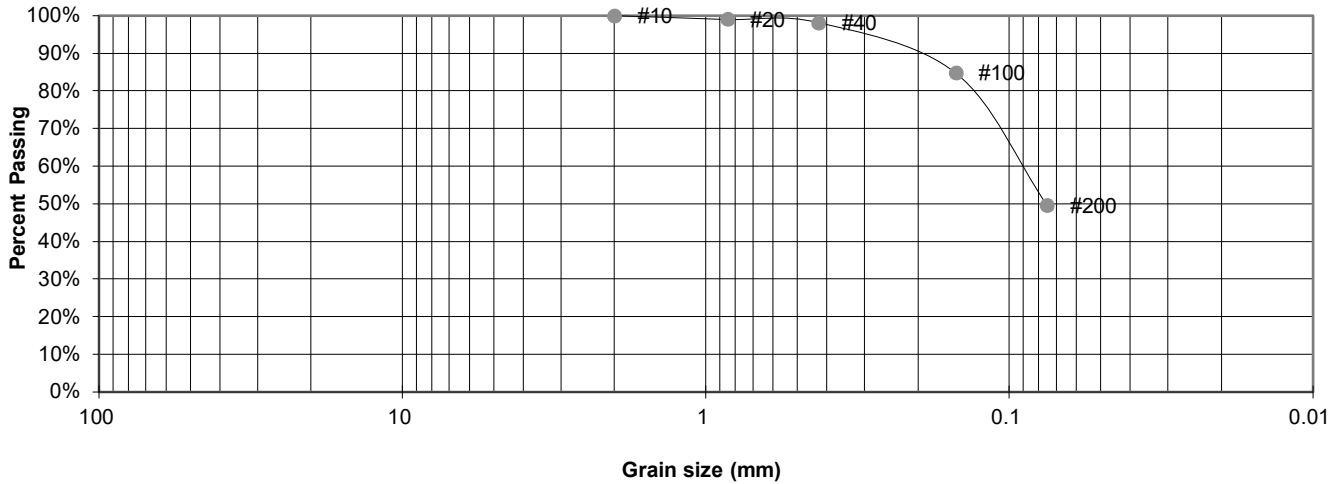

**GRAIN SIZE ANALYSIS**

U.S. Sieve #	Percent Finer
3"	
1 1/2"	
3/4"	
1/2"	
3/8"	
4	
10	100.0%
20	99.1%
40	98.2%
100	84.8%
200	49.6%

**ATTERBERG LIMITS**

Plastic Limit	NP
Liquid Limit	NV
Plastic Index	NP

**SOIL CLASSIFICATION**

USCS CLASSIFICATION:	SM
AASHTO CLASSIFICATION:	A-4
AASHTO GROUP INDEX:	0



**LABORATORY TEST RESULTS**

SADDLEHORN RANCH, FILING 2  
 GORILLA CAPITAL CO.

JOB NO.  
 222258

**FIG. B-12**

TEST BORING 12  
 DEPTH (FT) 1-2

SOIL DESCRIPTION SAND, WITH SILT  
 SOIL TYPE 1

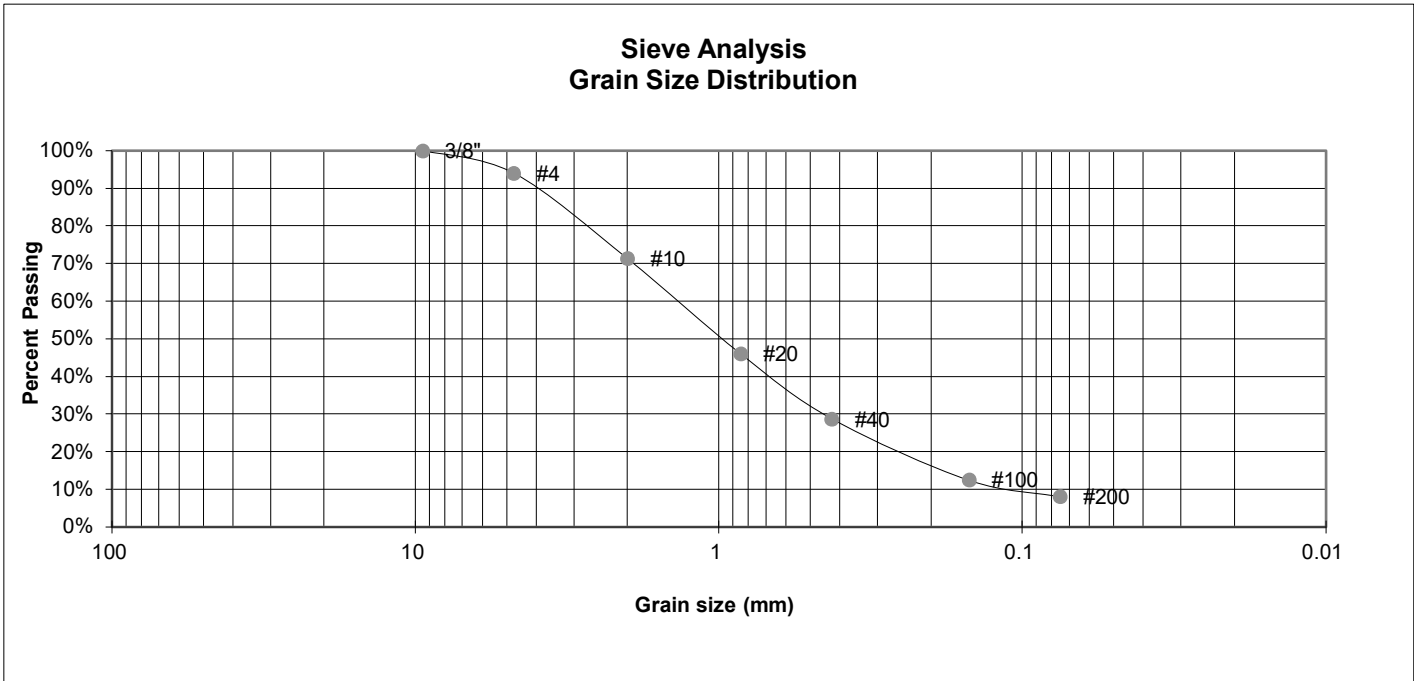

**GRAIN SIZE ANALYSIS**

U.S. Sieve #	Percent Finer
3"	
1 1/2"	
3/4"	
1/2"	
3/8"	100.0%
4	94.1%
10	71.3%
20	46.1%
40	28.7%
100	12.5%
200	8.1%

**ATTERBERG LIMITS**

Plastic Limit	NP
Liquid Limit	NV
Plastic Index	NP

**SOIL CLASSIFICATION**

USCS CLASSIFICATION: SW-SM  
 AASHTO CLASSIFICATION: A-1-b  
 AASHTO GROUP INDEX: 0



**LABORATORY TEST RESULTS**

SADDLEHORN RANCH, FILING 2  
 GORILLA CAPITAL CO.

JOB NO.  
 222258

**FIG. B-13**



TEST BORING 13  
 DEPTH (FT) 1-2

SOIL DESCRIPTION SAND, WITH SILT  
 SOIL TYPE 1

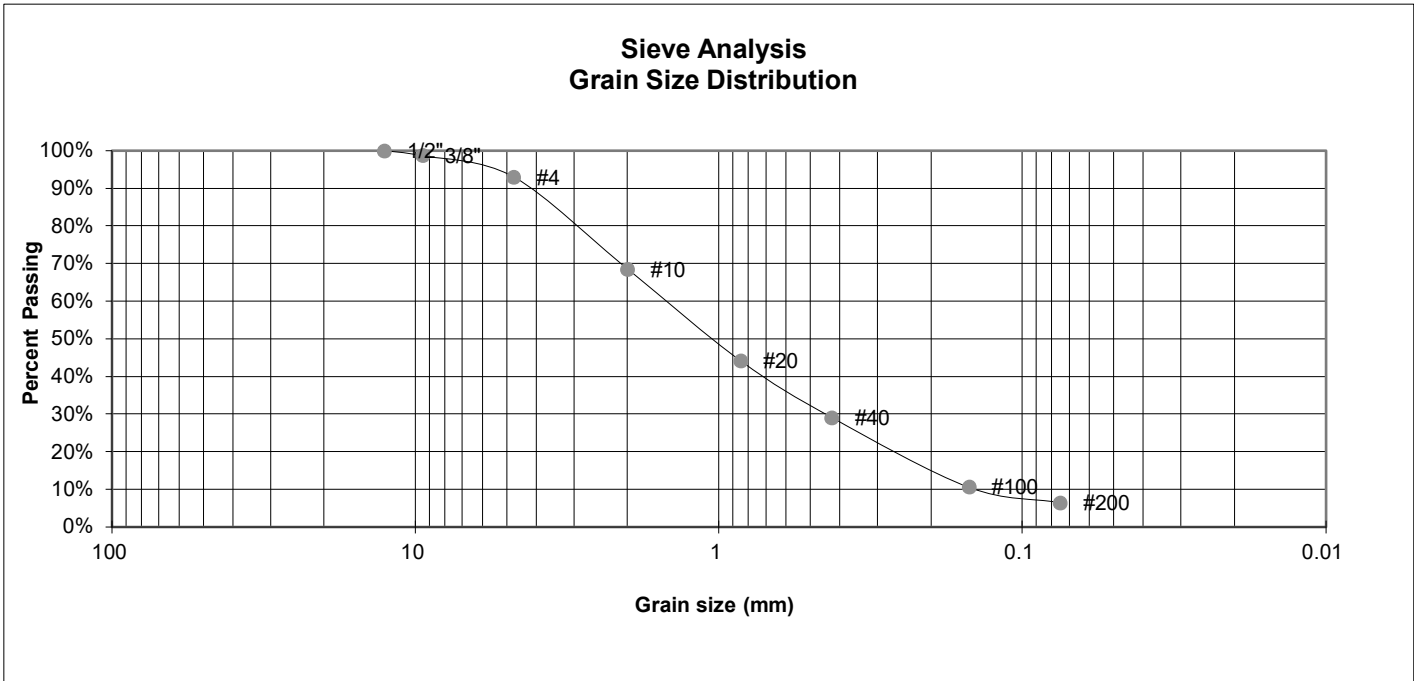

**GRAIN SIZE ANALYSIS**

U.S. Sieve #	Percent Finer
3"	
1 1/2"	
3/4"	
1/2"	100.0%
3/8"	98.8%
4	93.0%
10	68.5%
20	44.2%
40	29.1%
100	10.6%
200	6.5%

**ATTERBERG LIMITS**

Plastic Limit	NP
Liquid Limit	NV
Plastic Index	NP

**SOIL CLASSIFICATION**

USCS CLASSIFICATION: SW-SM  
 AASHTO CLASSIFICATION: A-1-b  
 AASHTO GROUP INDEX: 0



**LABORATORY TEST RESULTS**

SADDLEHORN RANCH, FILING 2  
 GORILLA CAPITAL CO.

JOB NO.  
 222258

**FIG. B-14**

TEST BORING 14  
 DEPTH (FT) 1-2

SOIL DESCRIPTION SAND, SILTY  
 SOIL TYPE 1

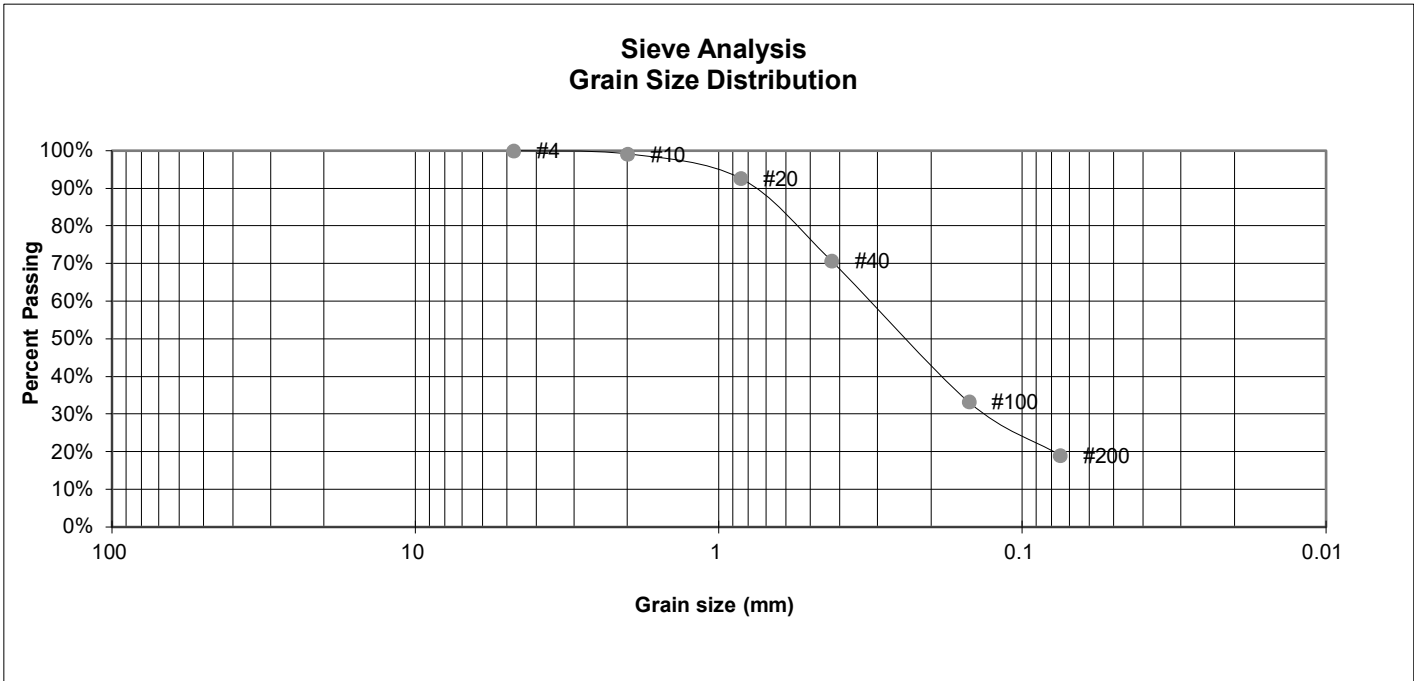

**GRAIN SIZE ANALYSIS**

U.S. Sieve #	Percent Finer
3"	
1 1/2"	
3/4"	
1/2"	
3/8"	
4	100.0%
10	99.2%
20	92.7%
40	70.7%
100	33.3%
200	19.1%

**ATTERBERG LIMITS**

Plastic Limit	NP
Liquid Limit	NV
Plastic Index	NP

**SOIL CLASSIFICATION**

USCS CLASSIFICATION: SM  
 AASHTO CLASSIFICATION: A-2-4  
 AASHTO GROUP INDEX: 0



**LABORATORY TEST RESULTS**

SADDLEHORN RANCH, FILING 2  
 GORILLA CAPITAL CO.

JOB NO.  
 222258

**FIG. B-15**

TEST BORING 15  
 DEPTH (FT) 1-2

SOIL DESCRIPTION SAND, WITH SILT  
 SOIL TYPE 1

**Sieve Analysis  
 Grain Size Distribution**

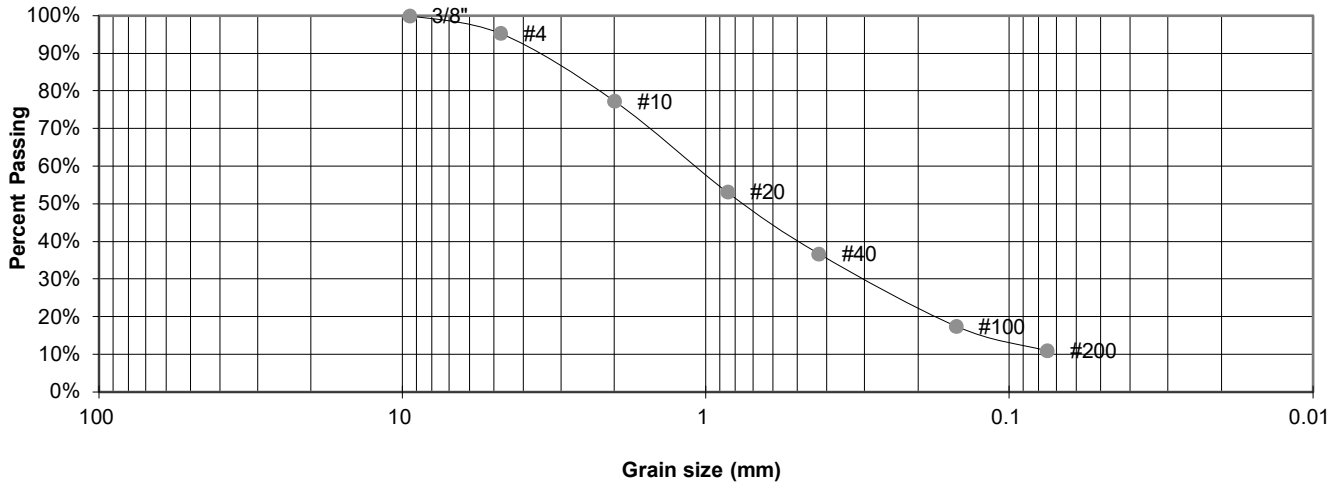

**GRAIN SIZE ANALYSIS**

U.S. Sieve #	Percent Finer
3"	
1 1/2"	
3/4"	
1/2"	
3/8"	100.0%
4	95.3%
10	77.3%
20	53.2%
40	36.8%
100	17.5%
200	11.0%

**ATTERBERG LIMITS**

Plastic Limit	NP
Liquid Limit	NV
Plastic Index	NP

**SOIL CLASSIFICATION**

USCS CLASSIFICATION: SW-SM  
 AASHTO CLASSIFICATION: A-1-b  
 AASHTO GROUP INDEX: 0



**LABORATORY TEST RESULTS**

SADDLEHORN RANCH, FILING 2  
 GORILLA CAPITAL CO.

JOB NO.  
 222258

**FIG. B-16**

TEST BORING 16  
 DEPTH (FT) 1-2

SOIL DESCRIPTION SAND, WITH SILT  
 SOIL TYPE 1

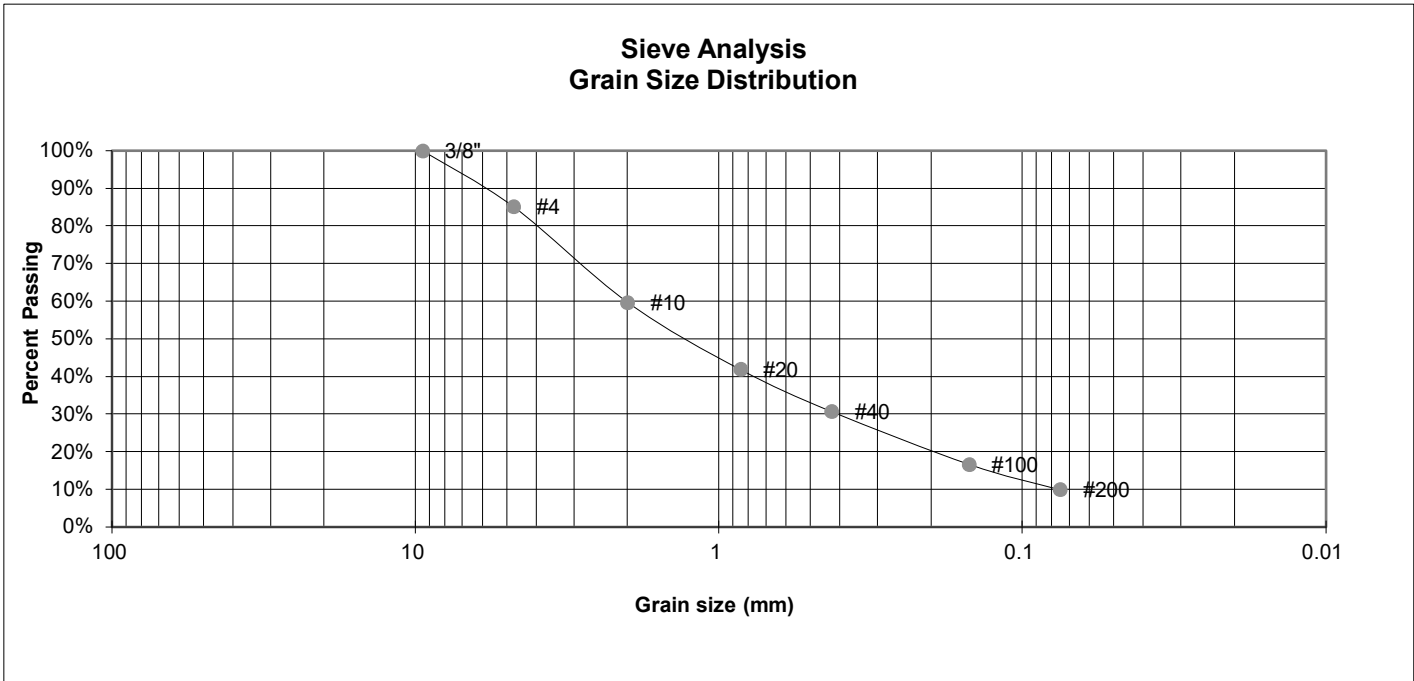

**GRAIN SIZE ANALYSIS**

U.S. Sieve #	Percent Finer
3"	
1 1/2"	
3/4"	
1/2"	
3/8"	100.0%
4	85.2%
10	59.7%
20	41.9%
40	30.7%
100	16.6%
200	10.0%

**ATTERBERG LIMITS**

Plastic Limit	NP
Liquid Limit	NV
Plastic Index	NP

**SOIL CLASSIFICATION**

USCS CLASSIFICATION: SW-SM  
 AASHTO CLASSIFICATION: A-1-b  
 AASHTO GROUP INDEX: 0



**LABORATORY TEST RESULTS**

SADDLEHORN RANCH, FILING 2  
 GORILLA CAPITAL CO.

JOB NO.  
 222258

**FIG. B-17**

TEST BORING 17  
 DEPTH (FT) 1-2

SOIL DESCRIPTION SAND, SILTY  
 SOIL TYPE 1

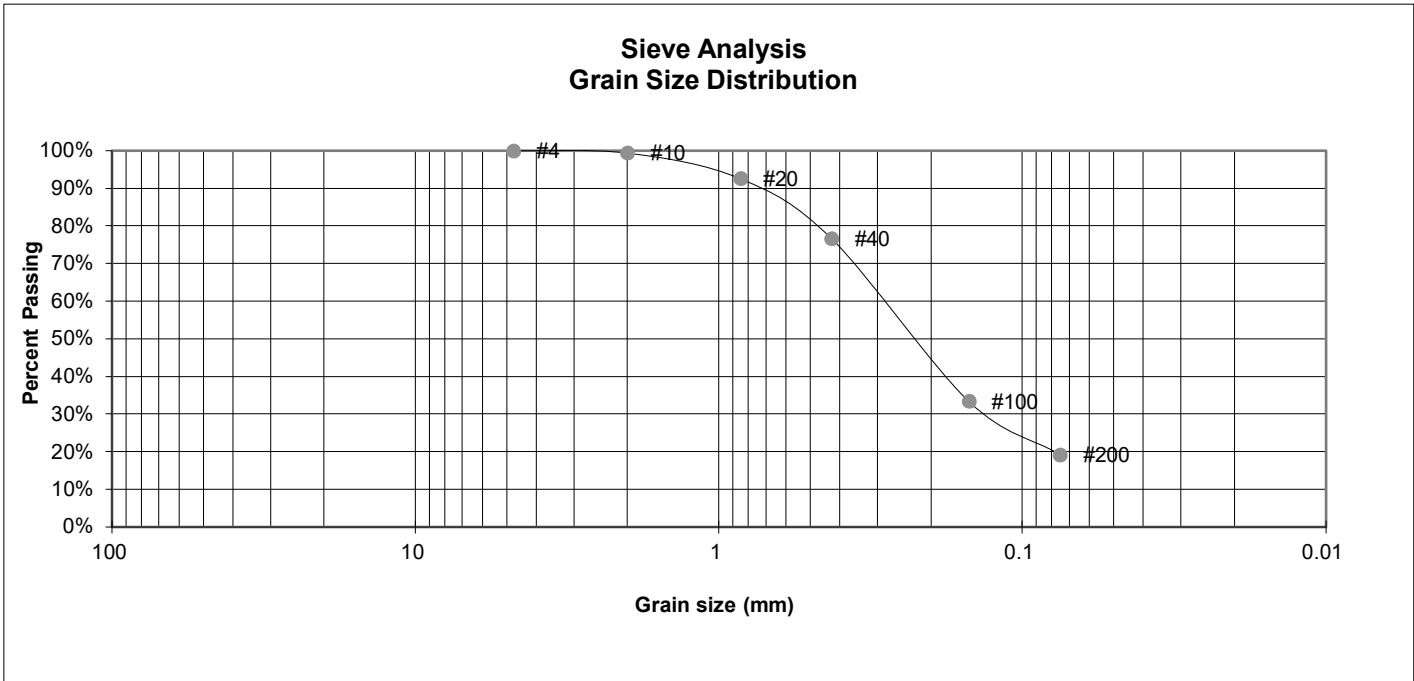

**GRAIN SIZE ANALYSIS**

U.S. Sieve #	Percent Finer
3"	
1 1/2"	
3/4"	
1/2"	
3/8"	
4	100.0%
10	99.5%
20	92.6%
40	76.6%
100	33.4%
200	19.2%

**ATTERBERG LIMITS**

Plastic Limit	NP
Liquid Limit	NV
Plastic Index	NP

**SOIL CLASSIFICATION**

USCS CLASSIFICATION: SM  
 AASHTO CLASSIFICATION: A-2-4  
 AASHTO GROUP INDEX: 0



**LABORATORY TEST RESULTS**

SADDLEHORN RANCH, FILING 2  
 GORILLA CAPITAL CO.

JOB NO.  
 222258

**FIG. B-18**

TEST BORING 19  
 DEPTH (FT) 1-2

SOIL DESCRIPTION SAND, SILTY  
 SOIL TYPE 1

**Sieve Analysis  
 Grain Size Distribution**

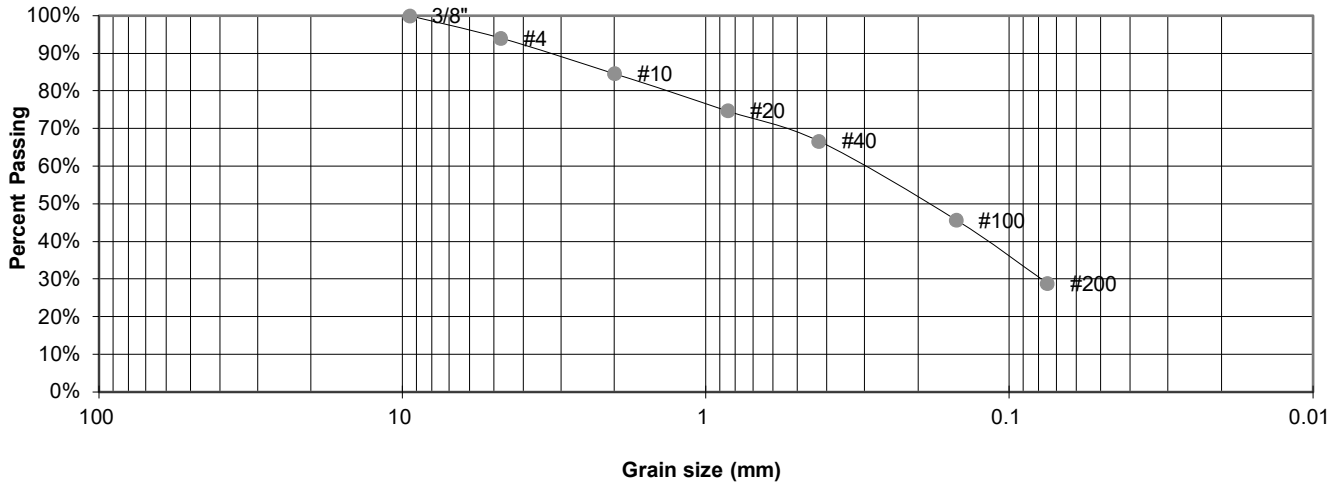

**GRAIN SIZE ANALYSIS**

U.S. Sieve #	Percent Finer
3"	
1 1/2"	
3/4"	
1/2"	
3/8"	100.0%
4	94.0%
10	84.7%
20	74.8%
40	66.7%
100	45.8%
200	28.9%

**ATTERBERG LIMITS**

Plastic Limit	NP
Liquid Limit	NV
Plastic Index	NP

**SOIL CLASSIFICATION**

USCS CLASSIFICATION: SM  
 AASHTO CLASSIFICATION: A-2-4  
 AASHTO GROUP INDEX: 0



**LABORATORY TEST RESULTS**

SADDLEHORN RANCH, FILING 2  
 GORILLA CAPITAL CO.

JOB NO.  
 222258

**FIG. B-19**

TEST BORING 20  
 DEPTH (FT) 1-2

SOIL DESCRIPTION SAND, WITH SILT  
 SOIL TYPE 1

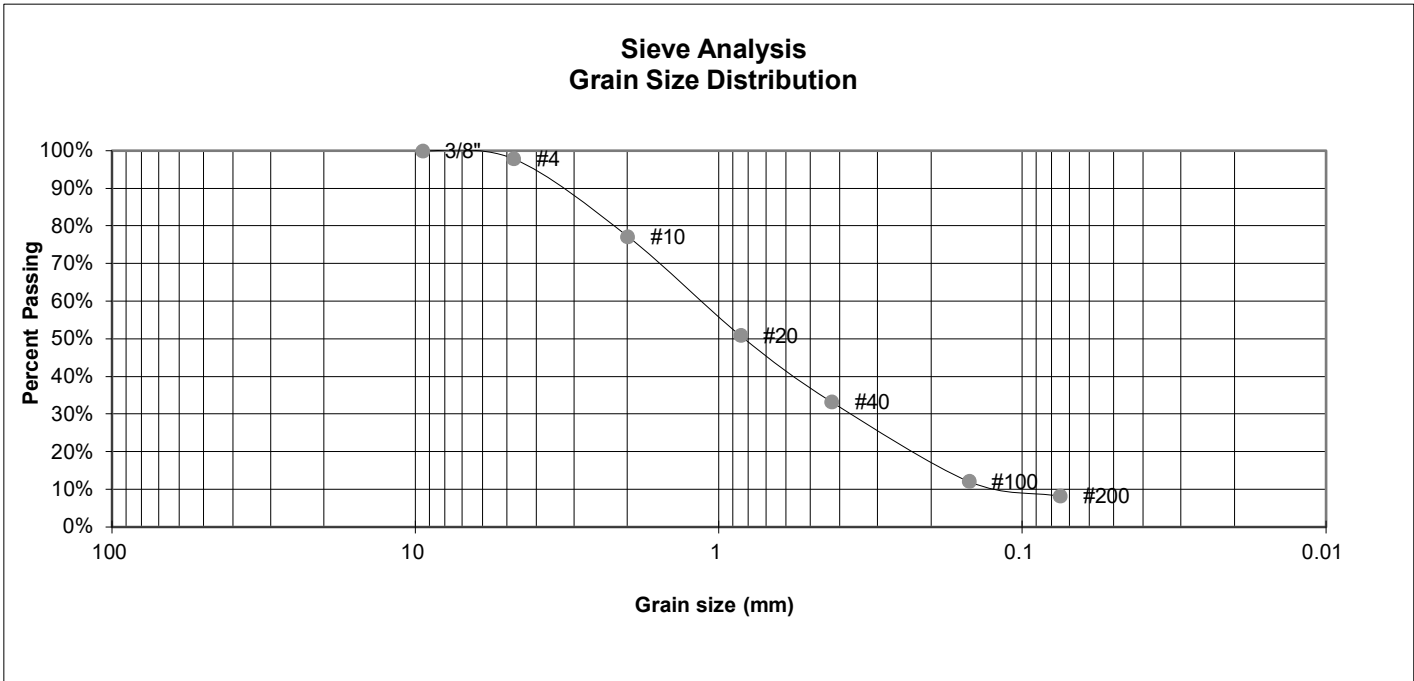

**GRAIN SIZE ANALYSIS**

U.S. Sieve #	Percent Finer
3"	
1 1/2"	
3/4"	
1/2"	
3/8"	100.0%
4	97.9%
10	77.2%
20	50.9%
40	33.3%
100	12.1%
200	8.2%

**ATTERBERG LIMITS**

Plastic Limit	NP
Liquid Limit	NV
Plastic Index	NP

**SOIL CLASSIFICATION**

USCS CLASSIFICATION: SW-SM  
 AASHTO CLASSIFICATION: A-1-b  
 AASHTO GROUP INDEX: 0



**LABORATORY TEST RESULTS**

SADDLEHORN RANCH, FILING 2  
 GORILLA CAPITAL CO.

JOB NO.  
 222258

**FIG. B-20**

TEST BORING 21  
 DEPTH (FT) 1-2

SOIL DESCRIPTION SAND, SILTY  
 SOIL TYPE 1

**Sieve Analysis  
 Grain Size Distribution**

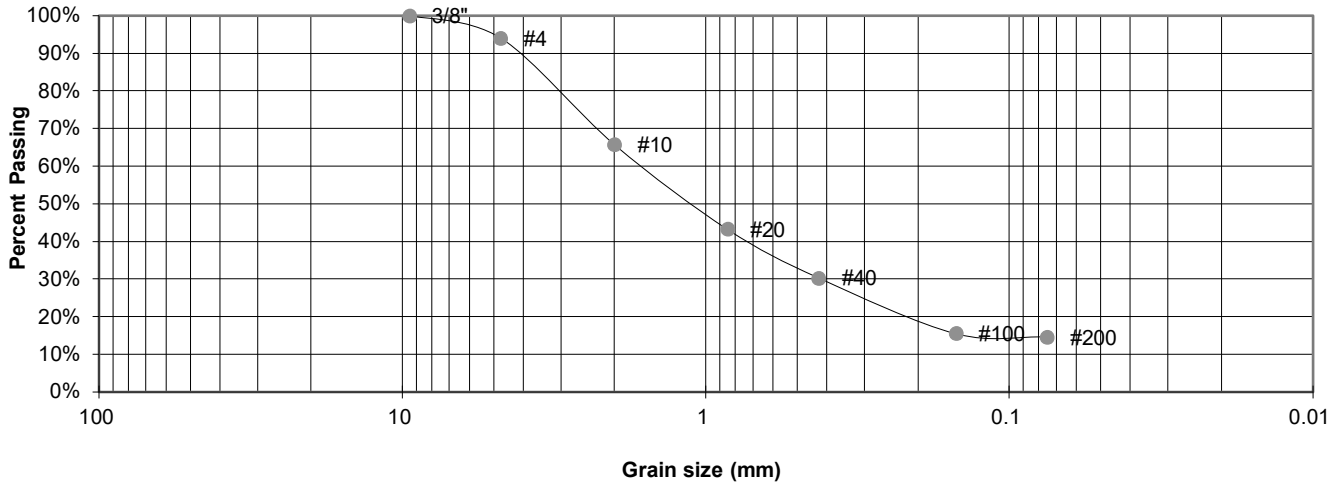

**GRAIN SIZE ANALYSIS**

U.S. Sieve #	Percent Finer
3"	
1 1/2"	
3/4"	
1/2"	
3/8"	100.0%
4	94.0%
10	65.7%
20	43.3%
40	30.3%
100	15.5%
200	14.7%

**ATTERBERG LIMITS**

Plastic Limit	NP
Liquid Limit	NV
Plastic Index	NP

**SOIL CLASSIFICATION**

USCS CLASSIFICATION: SM  
 AASHTO CLASSIFICATION: A-1-b  
 AASHTO GROUP INDEX: 0



**LABORATORY TEST RESULTS**

SADDLEHORN RANCH, FILING 2  
 GORILLA CAPITAL CO.

JOB NO.  
 222258

**FIG. B-21**



TEST BORING 22  
 DEPTH (FT) 1-2

SOIL DESCRIPTION SAND, SILTY  
 SOIL TYPE 1

**Sieve Analysis  
 Grain Size Distribution**

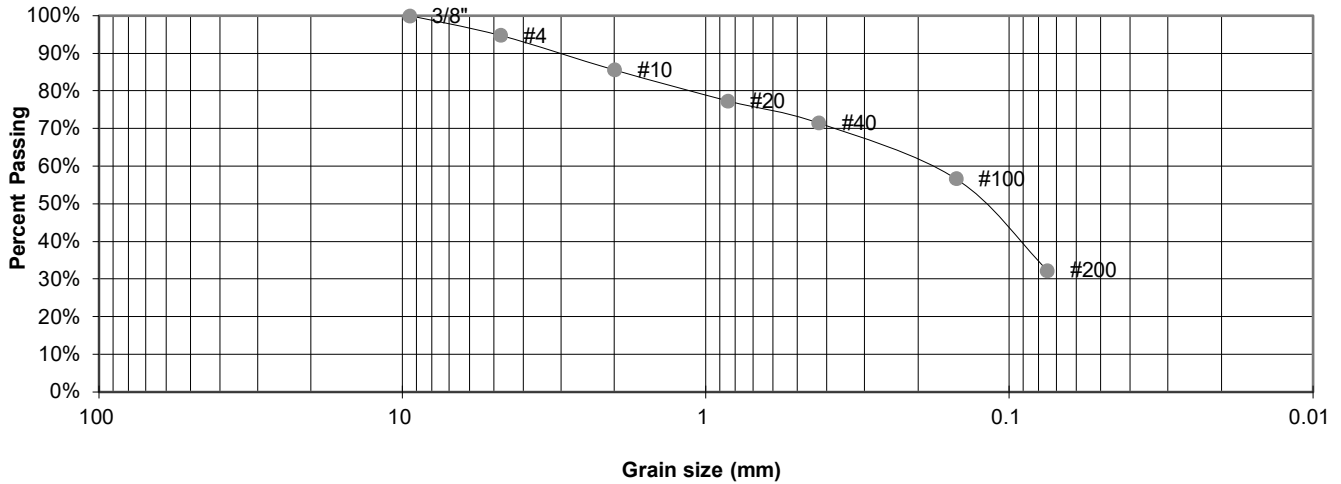

**GRAIN SIZE ANALYSIS**

U.S. Sieve #	Percent Finer
3"	
1 1/2"	
3/4"	
1/2"	
3/8"	100.0%
4	94.8%
10	85.7%
20	77.4%
40	71.6%
100	56.7%
200	32.4%

**ATTERBERG LIMITS**

Plastic Limit	NP
Liquid Limit	NV
Plastic Index	NP

**SOIL CLASSIFICATION**

USCS CLASSIFICATION: SM  
 AASHTO CLASSIFICATION: A-2-4  
 AASHTO GROUP INDEX: 0



**LABORATORY TEST RESULTS**

SADDLEHORN RANCH, FILING 2  
 GORILLA CAPITAL CO.

JOB NO.  
 222258

**FIG. B-22**

TEST BORING 23  
 DEPTH (FT) 1-2

SOIL DESCRIPTION SAND, SLIGHTLY SILTY  
 SOIL TYPE 1

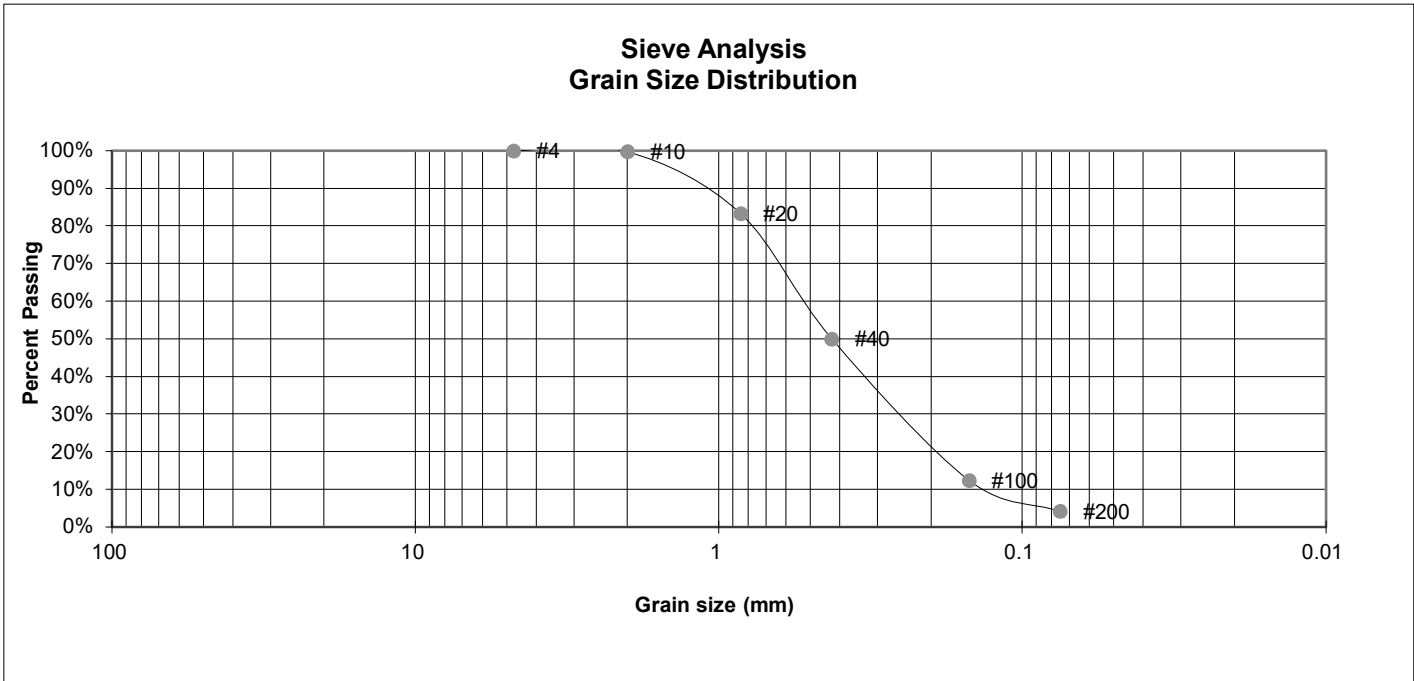

**GRAIN SIZE ANALYSIS**

U.S. Sieve #	Percent Finer
3"	
1 1/2"	
3/4"	
1/2"	
3/8"	
4	100.0%
10	99.8%
20	83.4%
40	50.0%
100	12.4%
200	4.2%

**ATTERBERG LIMITS**

Plastic Limit	NP
Liquid Limit	NV
Plastic Index	NP

**SOIL CLASSIFICATION**

USCS CLASSIFICATION: SW  
 AASHTO CLASSIFICATION: A-2-4  
 AASHTO GROUP INDEX: 0



**LABORATORY TEST RESULTS**

SADDLEHORN RANCH, FILING 2  
 GORILLA CAPITAL CO.

JOB NO.  
 222258

**FIG. B-23**

TEST BORING 14  
 DEPTH (FT) 0-3

SOIL DESCRIPTION SAND, SILTY  
 SOIL TYPE 1

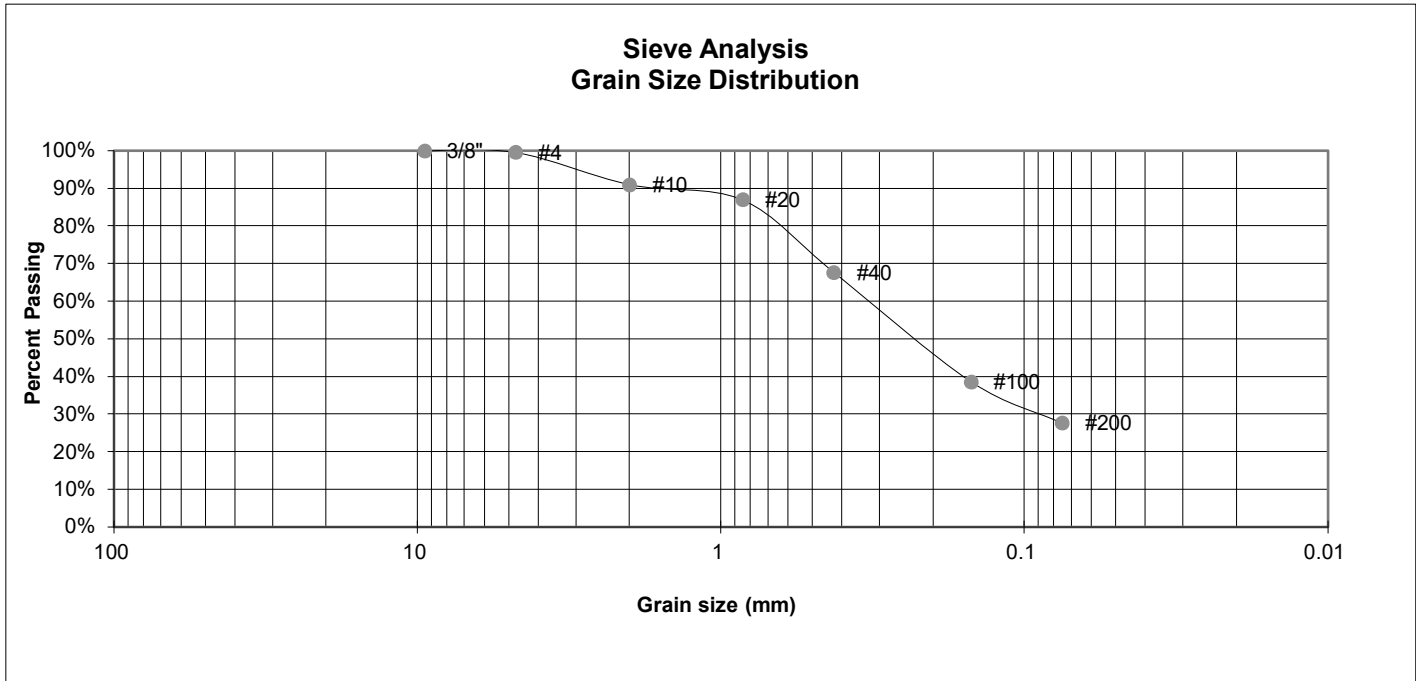

**GRAIN SIZE ANALYSIS**

U.S. Sieve #	Percent Finer
3"	
1 1/2"	
3/4"	
1/2"	
3/8"	100.0%
4	99.6%
10	91.0%
20	87.0%
40	67.7%
100	38.6%
200	27.6%

**ATTERBERG LIMITS**

Plastic Limit	NP
Liquid Limit	NV
Plastic Index	NP

**SOIL CLASSIFICATION**

USCS CLASSIFICATION: SM  
 AASHTO CLASSIFICATION: A-2-4  
 AASHTO GROUP INDEX: 0



**LABORATORY TEST RESULTS**

SADDLEHORN RANCH, FILING 2  
 GORILLA CAPITAL CO.

JOB NO.  
 222258

**FIG. B-24**

TEST BORING 12  
 DEPTH (FT) 0-3

SOIL DESCRIPTION SAND, SILTY  
 SOIL TYPE 1

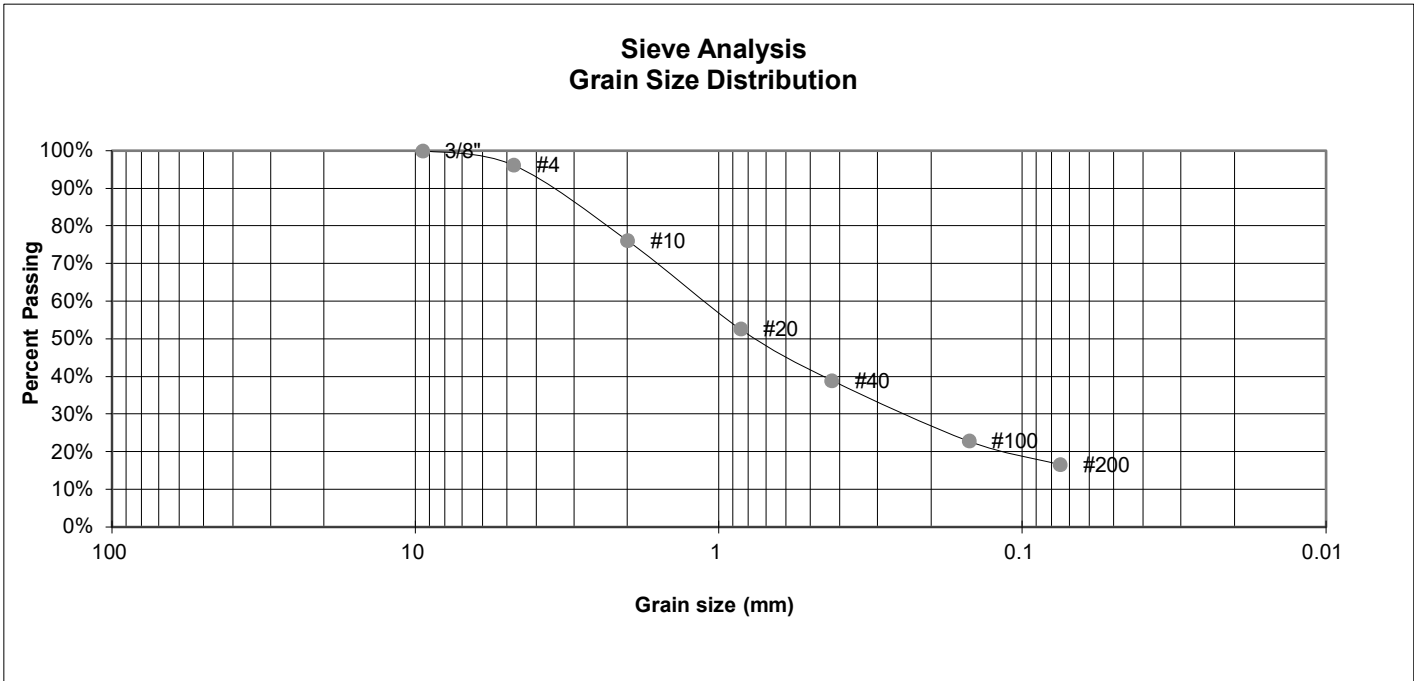

**GRAIN SIZE ANALYSIS**

U.S. Sieve #	Percent Finer
3"	
1 1/2"	
3/4"	
1/2"	
3/8"	100.0%
4	96.2%
10	76.1%
20	52.7%
40	39.0%
100	22.9%
200	16.6%

**ATTERBERG LIMITS**

Plastic Limit	NP
Liquid Limit	NV
Plastic Index	NP

**SOIL CLASSIFICATION**

USCS CLASSIFICATION: SM  
 AASHTO CLASSIFICATION: A-1-b  
 AASHTO GROUP INDEX: 0



**LABORATORY TEST RESULTS**

SADDLEHORN RANCH, FILING 2  
 GORILLA CAPITAL CO.

JOB NO.  
 222258

**FIG. B-25**

TEST BORING 17  
DEPTH (FT) 0-3

SOIL DESCRIPTION SAND, SILTY  
SOIL TYPE 1

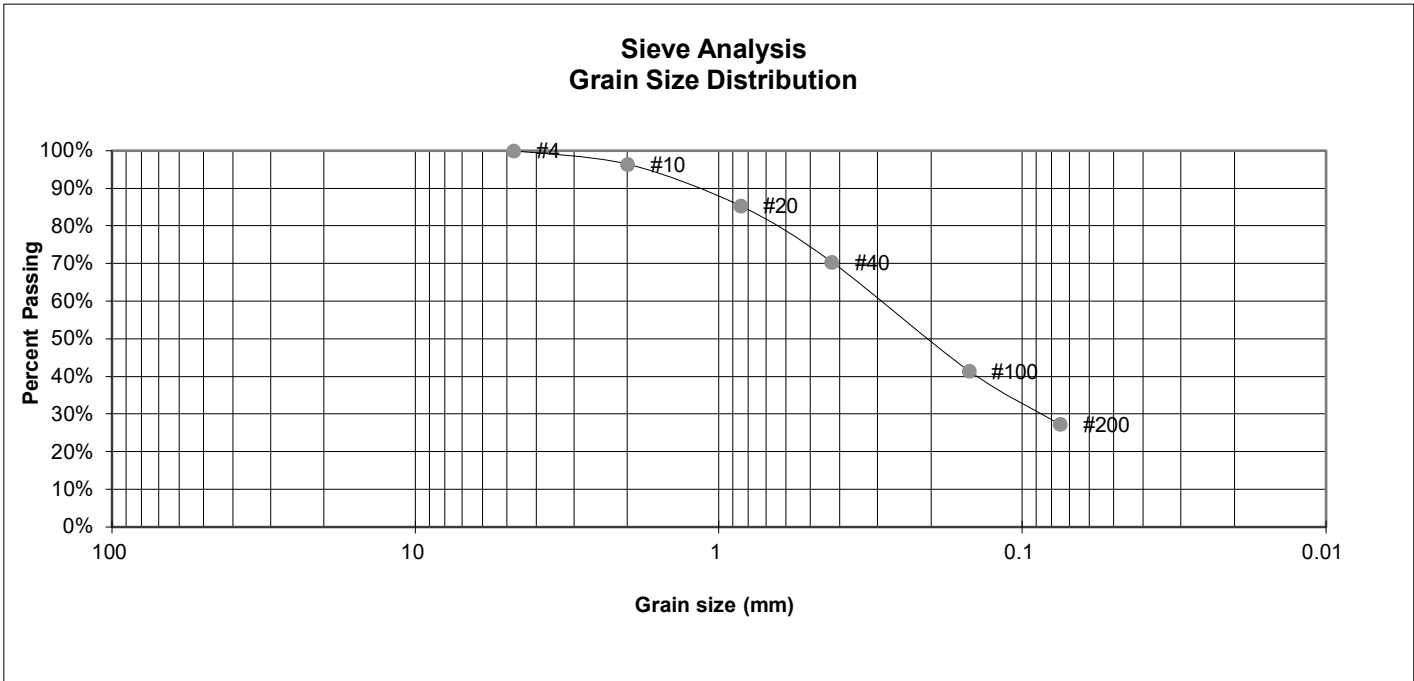

**GRAIN SIZE ANALYSIS**

U.S. Sieve #	Percent Finer
3"	
1 1/2"	
3/4"	
1/2"	
3/8"	
4	100.0%
10	96.4%
20	85.4%
40	70.4%
100	41.5%
200	27.3%

**SOIL CLASSIFICATION**

USCS CLASSIFICATION: SM  
AASHTO CLASSIFICATION:  
AASHTO GROUP INDEX:



**LABORATORY TEST RESULTS**

SADDLEHORN RANCH, FILING 2  
GORILLA CAPITAL CO.

JOB NO.  
222258

**FIG. B-26**

TEST BORING 18  
 DEPTH (FT) 1-2

SOIL DESCRIPTION CLAY, SLIGHTLY SANDY  
 SOIL TYPE 2

**Sieve Analysis  
 Grain Size Distribution**

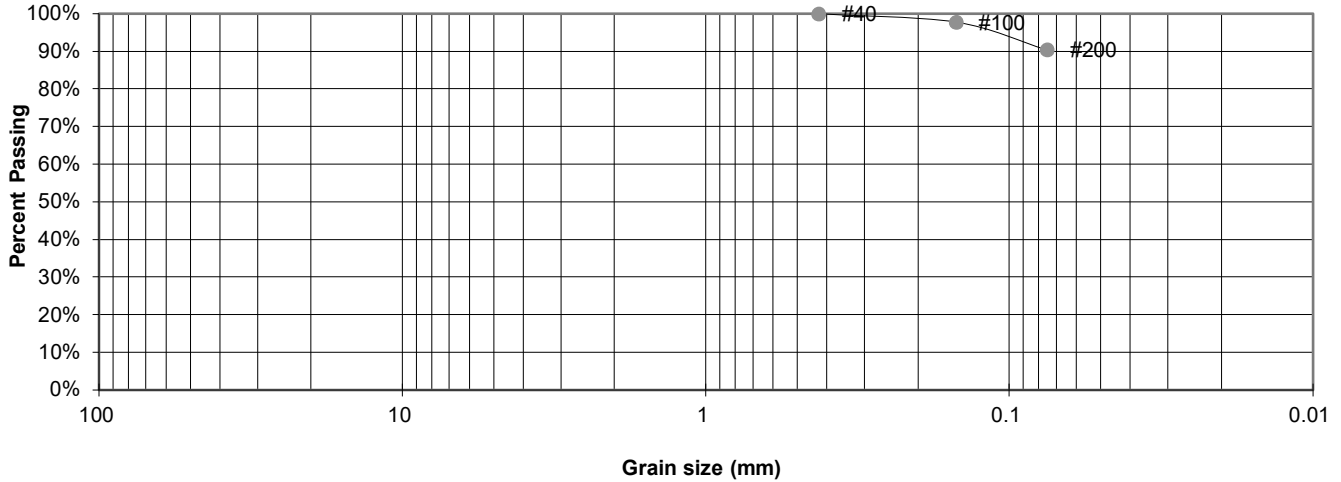

**GRAIN SIZE ANALYSIS**

U.S. Sieve #	Percent Finer
3"	
1 1/2"	
3/4"	
1/2"	
3/8"	
4	
10	
20	
40	100.0%
100	97.8%
200	90.4%

**ATTERBERG LIMITS**

Plastic Limit	28
Liquid Limit	57
Plastic Index	29

**SOIL CLASSIFICATION**

USCS CLASSIFICATION: CH  
 AASHTO CLASSIFICATION: A-7-6  
 AASHTO GROUP INDEX: 20



**LABORATORY TEST RESULTS**

SADDLEHORN RANCH, FILING 2  
 GORILLA CAPITAL CO.

JOB NO.  
 222258

**FIG. B-27**

TEST BORING 18  
 DEPTH (FT) 0-3

SOIL DESCRIPTION CLAY, WITH SANDY  
 SOIL TYPE 2

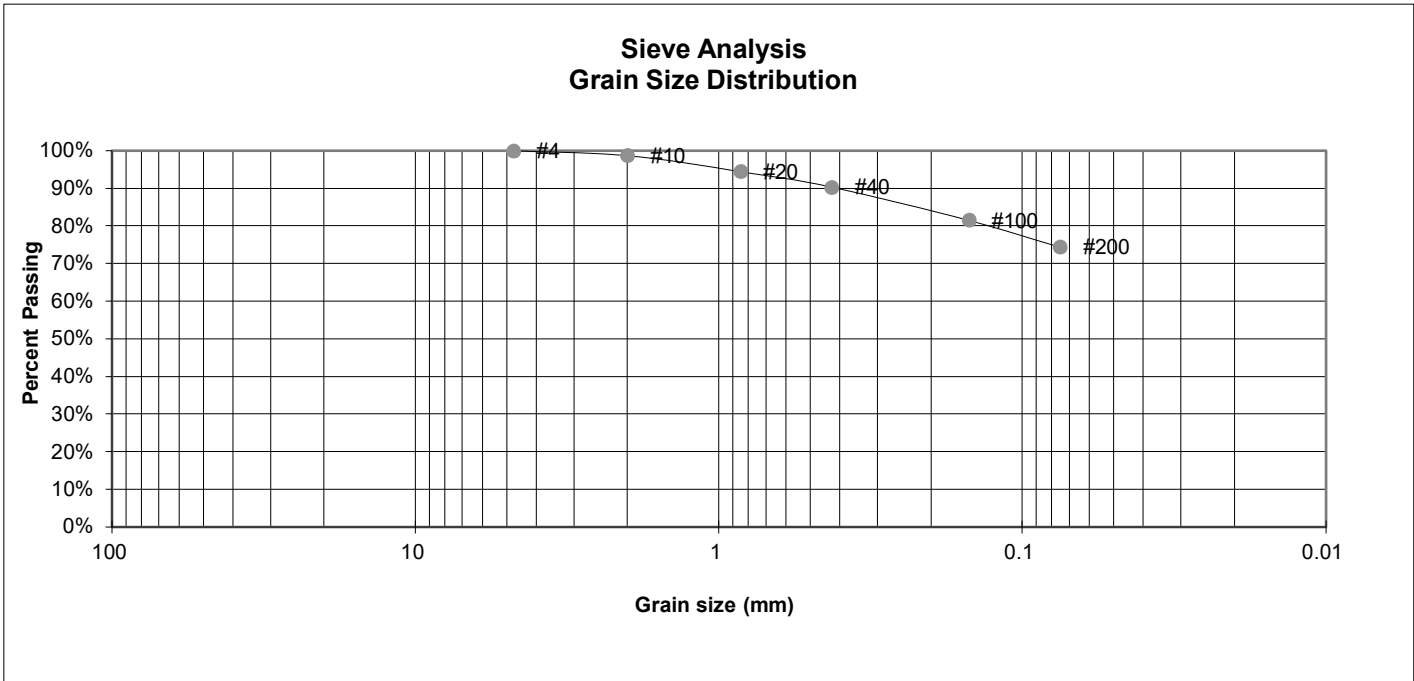

**GRAIN SIZE ANALYSIS**

U.S. Sieve #	Percent Finer
3"	
1 1/2"	
3/4"	
1/2"	
3/8"	
4	100.0%
10	98.8%
20	94.5%
40	90.4%
100	81.5%
200	74.4%

**SOIL CLASSIFICATION**

USCS CLASSIFICATION: CL  
 AASHTO CLASSIFICATION:  
 AASHTO GROUP INDEX:



**LABORATORY TEST RESULTS**

SADDLEHORN RANCH, FILING 2  
 GORILLA CAPITAL CO.

JOB NO.  
 222258

**FIG. B-28**

SAMPLE LOCATION 0

SOIL DESCRIPTION SAND, SILTY, BROWN  
SOIL TYPE 1

**PROCTOR DATA**

IDENTIFICATION: SM  
PROCTOR TEST #: 1  
TEST BY: DK  
TEST DESIGNATION: ASTM-1557-A  
MAXIMUM DRY DENSITY (PCF): 122.7  
OPTIMUM MOISTURE: 8.9

**Compaction Curve**

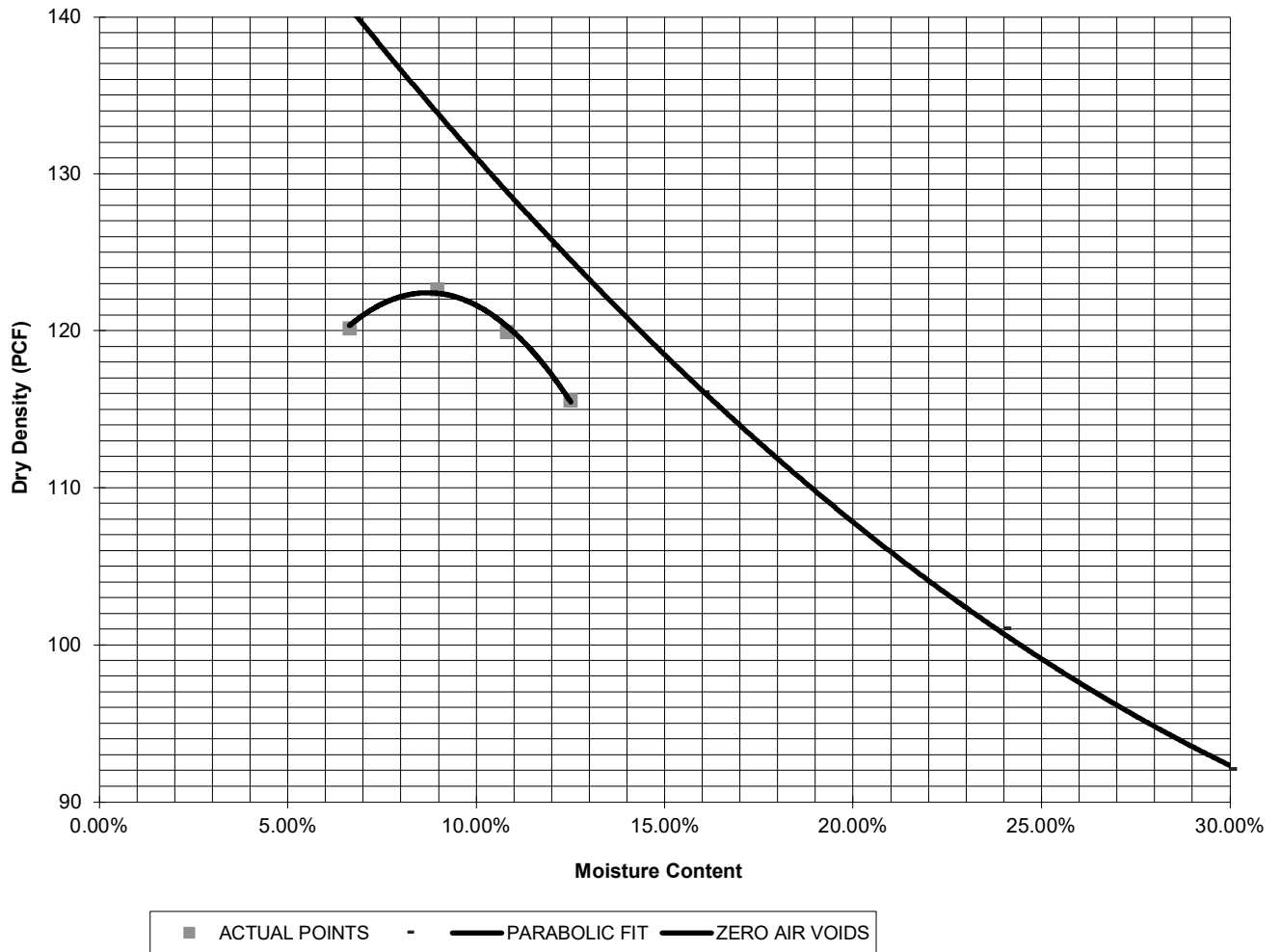

**LABORATORY TEST RESULTS**

SADDLEHORN RANCH, FILING 2  
GORILLA CAPITAL CO.

JOB NO.  
222258

**FIG. B-29**



SAMPLE LOCATION 0  
DEPTH (FT) 0

SOIL DESCRIPTION SAND, SILTY, BROWN  
SOIL TYPE 1

**CBR TEST LOAD DATA**

Piston Diameter (cm): 4.958  
Piston Area (in<sup>2</sup>): 2.993

Penetration Depth (inches)	10 BLOWS Mold # 1		25 BLOWS Mold # 2		56 BLOWS Mold # 3	
	Load (lbs)	Stress (psi)	Load (lbs)	Stress (psi)	Load (lbs)	Stress (psi)
0.000	0	0.00	0	0.00	0	0.00
0.025	64	21.39	128	42.77	191	63.83
0.050	106	35.42	211	70.51	340	113.62
0.075	154	51.46	307	102.59	476	159.06
0.100	193	64.49	385	128.65	641	214.20
0.125	244	81.54	488	163.07	790	263.99
0.150	294	98.25	588	196.49	950	317.46
0.175	345	115.29	689	230.24	1103	368.59
0.200	395	132.00	789	263.66	1248	417.04
0.300	665	222.22	1329	444.11	1937	647.28
0.400	853	285.05	1706	570.09	2323	776.27
0.500	974	325.48	2192	732.50	2788	931.66

**MOISTURE AND DENSITY DATA**

	Mold # 1	Mold # 2	Mold # 3
Can #	303	352	420
Wt. Can	8.21	7.92	8.17
Wt. Can+Wet	154.74	224.68	268.59
Wt. Can+Dry	141.21	199.89	238.69
Wt. H2O	13.53	24.79	29.9
Wt. Dry Soil	133	191.97	230.52
Moisture Content	10.17%	12.91%	12.97%
Wet Density (PCF)	119.1	128.4	133.5
Dry Density (PCF)	109.3	117.9	122.6
% Compaction	89%	96%	100%
CBR	6.45	12.87	21.42

**PROCTOR DATA**

Maximum Dry Density (pcf) 122.7  
Optimum Moisture 8.9  
90% of Max. Dry Density (pcf) 110.4  
95% of Max. Dry Density (pcf) 116.6

CBR at 90% of Max. Density = 7.26 ~ R VALUE 17  
CBR at 95% of Max. Density = 11.88 ~ R VALUE 35



**LABORATORY TEST RESULTS**

SADDLEHORN RANCH, FILING 2  
GORILLA CAPITAL CO.

JOB NO.  
222258

**FIG. B-30**

SAMPLE LOCATION 0  
DEPTH (FT) 0

SOIL DESCRIPTION SAND, SILTY, BROWN  
SOIL TYPE 0

Stress VS Penetration

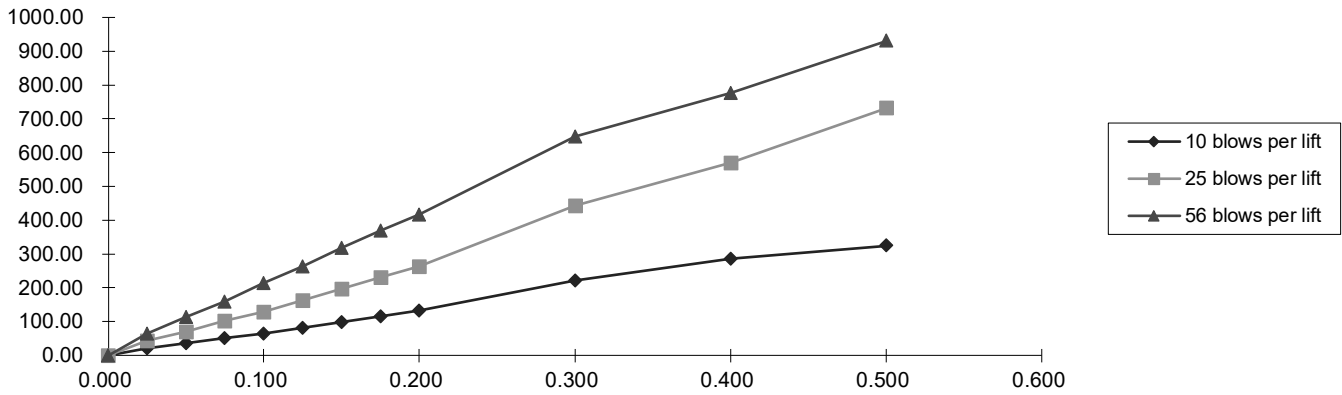

Bearing Ratio VS Dry Density

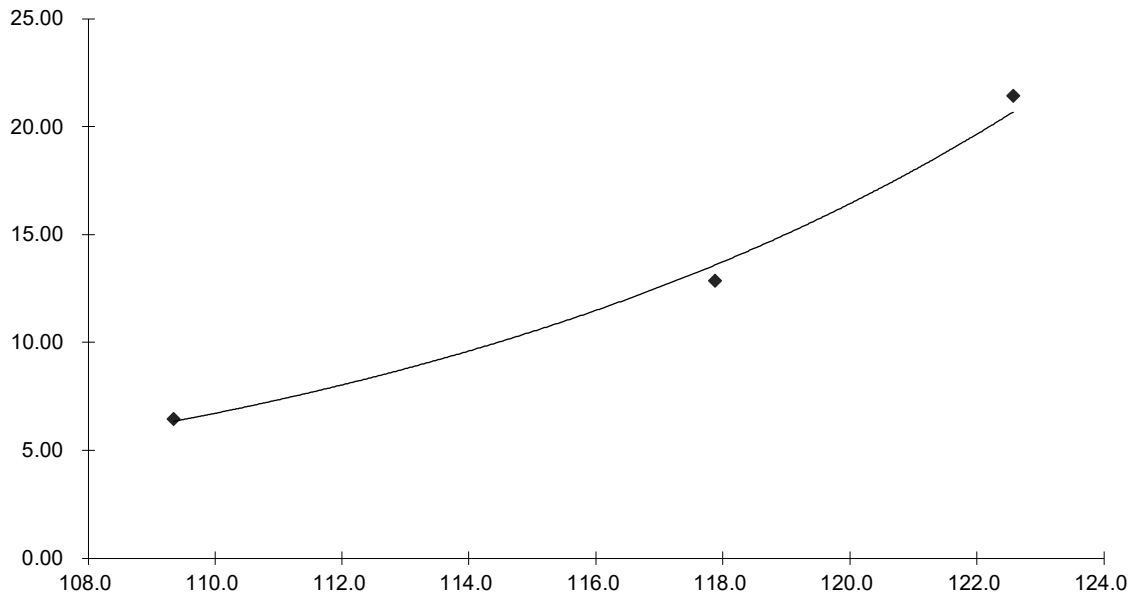

LABORATORY TEST RESULTS

SADDLEHORN RANCH, FILING 2  
GORILLA CAPITAL CO.

JOB NO.  
222258

FIG. B-31



## **APPENDIX C: Pavement Design Calculations**

# FLEXIBLE PAVEMENT DESIGN

## PROJECT DATA

Project Location Saddlehorn Ranch F2 Interior Rural Local Roads  
 Job Number: 222258

## DESIGN DATA

Equivalent (18-kip) Single Axle Load Applications (ESAL):	ESAL ( $W_{18}$ ) =	36,500
Design CBR	CBR =	10
Standard Deviation	$S_o$ =	0.44
Loss in Serviceability	$\Delta\psi$ =	2.0
Reliability	Reliability =	75
Reliability (z-statistic)	$Z_R$ =	-0.67
Soil Resilient Modulus	$M_R$ =	15,000 psi

Required Structural Number (SN): ➔ SN = 1.34

## DESIGN EQUATIONS

### Resilient Modulus

If using CBR:

$$M_R = (\text{CBR}) \times 1,500$$

If using R-Value:

$$M_R = 10^{[(S_1 + 18.72) / 6.24]} \text{ where: } S_1 = [(R\text{-value} - 5) / 11.29] + 3$$

### Required Structural Number

$$\log_{10} W_{18} = Z_R \cdot S_o + 9.36 \cdot \log_{10} (\text{SN}+1) - 0.20 + \frac{\log_{10} \left[ \frac{\Delta \text{PSI}}{4.2 - 1.5} \right]}{0.40 + \frac{1094}{(\text{SN}+1)^{5.19}}} + 2.32 \cdot \log_{10} M_R - 8.07$$

### Pavement Section Thickness

$$\text{SN}^* = C_1 D_1 + C_2 D_2$$

where:

$C_1$  = Strength Coefficient - Hot Bituminous Asphalt

$C_2$  = Strength Coefficient - Aggregate Base Course

$D_1$  = Depth of Asphalt (inches)

$D_2$  = Depth of Base Course (inches)

## RECOMMENDED THICKNESSES

Layer	Material	Structural Layer	Thickness ( $D^*_i$ )	$\text{SN}^*_i$	SN
1	HMA	$C_1 = 0.44$	3.0 inches	1.320	-
2	ABC	$C_2 = 0.12$	4.0 inches	0.480	
				<b><math>\text{SN}^* = 1.800</math></b>	<b>1.34</b>

Pavement SN > Required SN, Design is Acceptable

Please revise, value does not match ECM Table D-3 for ABC Strength Coefficient

FIG. C-1

# FLEXIBLE PAVEMENT DESIGN

## PROJECT DATA

Project Location Saddlehorn Ranch F2 Curtis Road Rural Principal Arterial  
 Job Number: 222258

## DESIGN DATA

Equivalent (18-kip) Single Axle Load Applications (ESAL):	ESAL ( $W_{18}$ ) =	2,628,000
Design CBR:	CBR =	10
Standard Deviation	$S_o$ =	0.44
Loss in Serviceability	$\Delta\psi$ =	2.5
Reliability	Reliability =	85
Reliability (z-statistic)	$Z_R$ =	-1.04
Soil Resilient Modulus	$M_R$ =	15,000 psi

Required Structural Number (SN): ➔ SN = 2.85

## DESIGN EQUATIONS

### Resilient Modulus

If using CBR:

$$M_R = (\text{CBR}) \times 1,500$$

If using R-Value:

$$M_R = 10^{[(S_1 + 18.72) / 6.24]} \text{ where: } S_1 = [(R\text{-value} - 5) / 11.29] + 3$$

### Required Structural Number

$$\log_{10} W_{18} = Z_R \cdot S_o + 9.36 \cdot \log_{10} (SN+1) - 0.20 + \frac{\log_{10} \left[ \frac{\Delta \text{PSI}}{4.2 - 1.5} \right]}{0.40 + \frac{1.094}{(SN+1)^{5.14}}} + 2.32 \cdot \log_{10} M_R - 8.07$$

### Pavement Section Thickness

$$SN^* = C_1 D_1 + C_2 D_2$$

where:

$C_1$  = Strength Coefficient - Hot Bituminous Asphalt

$C_2$  = Strength Coefficient - Aggregate Base Course

$D_1$  = Depth of Asphalt (inches)

$D_2$  = Depth of Base Course (inches)

## RECOMMENDED THICKNESSES

Layer	Material	Structural Layer	Thickness ( $D_i^*$ )	$SN_i^*$	SN
1	HMA	$C_1 = 0.44$	5.0 inches	2.200	-
2	ABC	$C_2 = 0.12$	8.0 inches	0.960	
				$SN^* = 3.160$	2.85

Pavement SN > Required SN, Design is Acceptable

Please revise, value does not match ECM Table D-3 for ABC Strength Coefficient

FIG. C-2

# V1\_Pavement Report\_BB.pdf Markup Summary

Engineer (5)

Region of aggregate with criteria for soils with sand content 100 percent per square foot (pcf) percentage. Based on the information, mitigation for aggregate soils is not required with soils as per A-2.5 material incorporated in layer. The 100 aggregate preparation. Overconsolidation of cohesion soils is required as per procedure in Section 6.1.1.

Soils from Section 6.1.1 was compared with A-2.5 per Section 6.1.1. Please include the information in the pavement report.

Curbs Road widening alignment, however, after improvements is classified as a road project area. The 41 Pace County as defined. This report area was tested (ESAL) based a initial ESAL value of 2,000,000 was used for the total a ESAL, with a initial ESAL value of 20,000 was used for the total number.

**Subject:** Engineer  
**Page Label:** 6  
**Author:** dotdilts  
**Date:** 7/18/2024 1:42:18 PM  
**Status:**  
**Color:** ■  
**Layer:**  
**Space:**

Traffic Impact Study was completed with PCD File number SF2133. Please include this reference in the pavement report

0.44  
 0.12

**Subject:** Engineer  
**Page Label:** 60  
**Author:** dotdilts  
**Date:** 7/18/2024 2:53:39 PM  
**Status:**  
**Color:** ■  
**Layer:**  
**Space:**

0.12

= 0.44  
 = 0.12

**Subject:** Engineer  
**Page Label:** 61  
**Author:** dotdilts  
**Date:** 7/18/2024 2:53:46 PM  
**Status:**  
**Color:** ■  
**Layer:**  
**Space:**

RECOMMENDED THICKNESSES

Layer	Material	Structural Layer	ESAL
1	HMA	C <sub>s</sub> = 0.44	5
2	ABC	C <sub>s</sub> = 0.12	5

Please revise, value does not match ECM Table D-3 for ABC Strength Coefficient

**Subject:** Engineer  
**Page Label:** 60  
**Author:** dotdilts  
**Date:** 7/18/2024 2:55:17 PM  
**Status:**  
**Color:** ■  
**Layer:**  
**Space:**

Please revise, value does not match ECM Table D-3 for ABC Strength Coefficient

RECOMMENDED THICKNESSES

Layer	Material	Structural Layer	ESAL
1	HMA	C <sub>s</sub> = 0.44	5
2	ABC	C <sub>s</sub> = 0.12	5

Please revise, value does not match ECM Table D-3 for ABC Strength Coefficient

**Subject:** Engineer  
**Page Label:** 61  
**Author:** dotdilts  
**Date:** 7/18/2024 2:55:59 PM  
**Status:**  
**Color:** ■  
**Layer:**  
**Space:**

Please revise, value does not match ECM Table D-3 for ABC Strength Coefficient

# V1\_Pavement Report\_BB.pdf Markup Summary

## Engineer (6)

Application of aggregate with criteria for soils with sand content 100 percent per square foot (sqft) percentage. Based on the information, mitigation for aggregate soils is not required. Note that as per the AASHTO manual recommendation to bring the 10-15 aggregate preparation. Overconsolidation of coarse soils is required when not processed in Section 6.1.5.

Quality Control (QC) was completed with the following results:

The information in the proposed report, Curbs Road, showing alignment, however, after improvements, is classified as a road project within the 4th Place Corridor as defined in the proposed report. The 4th Place Corridor is defined in the proposed report and the 4th Place Corridor is defined in the proposed report. A value of 2.000,000 was used for the total of 2.000,000 and a value of 2.000,000 was used for the total of 2.000,000.

**Subject:** Engineer  
**Page Label:** 6  
**Author:** dotdilts  
**Date:** 7/18/2024 1:42:18 PM  
**Status:**  
**Color:** ■  
**Layer:**  
**Space:**

Traffic Impact Study was completed with PCD File number SF2133. Please include this reference in the pavement report

0.44  
 0.12

**Subject:** Engineer  
**Page Label:** 60  
**Author:** dotdilts  
**Date:** 7/18/2024 2:53:39 PM  
**Status:**  
**Color:** ■  
**Layer:**  
**Space:**

0.12

= 0.44  
 = 0.12

**Subject:** Engineer  
**Page Label:** 61  
**Author:** dotdilts  
**Date:** 7/18/2024 2:53:46 PM  
**Status:**  
**Color:** ■  
**Layer:**  
**Space:**

Layer	Mix	Structural Layer	TSI
1	HMA	C <sub>s</sub> = 0.44	1
2	ABC	C <sub>s</sub> = 0.12	1

Please revise, value does not match ECM Table D-3 for ABC Strength Coefficient

**Subject:** Engineer  
**Page Label:** 60  
**Author:** dotdilts  
**Date:** 7/18/2024 2:55:17 PM  
**Status:**  
**Color:** ■  
**Layer:**  
**Space:**

Please revise, value does not match ECM Table D-3 for ABC Strength Coefficient

Layer	Mix	Structural Layer	TSI
1	HMA	C <sub>s</sub> = 0.44	5
2	ABC	C <sub>s</sub> = 0.12	5

Please revise, value does not match ECM Table D-3 for ABC Strength Coefficient

**Subject:** Engineer  
**Page Label:** 61  
**Author:** dotdilts  
**Date:** 7/18/2024 2:55:59 PM  
**Status:**  
**Color:** ■  
**Layer:**  
**Space:**

Please revise, value does not match ECM Table D-3 for ABC Strength Coefficient

Please include an additional figure or add hatching depicting which roads are included in the pavement report



**Subject:** Engineer  
**Page Label:** 11  
**Author:** dotdilts  
**Date:** 7/18/2024 3:17:13 PM  
**Status:**  
**Color:** ■  
**Layer:**  
**Space:**

Please include an additional figure or add hatching depicting which roads are included in the pavement report