



Early Grading Permit - Final Drainage Report

Overlook at Homestead Subdivision Filing No. 1 El Paso County, Colorado

Prepared for:
PT Overlook LLC
1864 Woodmoor Drive, Suite 100
Monument, CO 80132

Prepared by:
Kimley-Horn and Associates, Inc.
2 North Nevada Avenue, Suite 900
Colorado Springs, Colorado 80903
(719) 453-0180
Contact: Kevin Kofford, P.E.

Project #: 196239003

PCD Filing No.: EGP241

Prepared: May 7, 2024

Kimley»Horn



CERTIFICATION

DESIGN ENGINEER'S STATEMENT

The attached drainage plan and report were prepared under my direction and supervision and are correct to the best of my knowledge and belief. Said drainage report has been prepared according to the criteria established by the County for drainage reports and said report is in conformity with the master plan of the drainage basin. I accept responsibility for any liability caused by any negligent acts, errors or omissions on my part in preparation of this report.

SIGNATURE (Affix Seal): _____
Kevin Kofford, P.E. Date

OWNER/DEVELOPER'S STATEMENT

I, the developer, have read and will comply with all of the requirements specified in this Drainage Report and Plan.

PT Overlook LLC
Name of Developer

Authorized Signature Date

Joe DesJardin
Printed Name

Director of Entitlements
Title

1864 Woodmoor Drive Suite 100, Monument, CO 80132
Address

EL PASO COUNTY

Filed in accordance with the requirements of the Drainage Criteria Manual, Volumes 1 and 2, El Paso County Engineering Criteria Manual and Land Development Code as amended.

Joshua Palmer, P.E. Date
County Engineer/ ECM Administrator

Conditions:

TABLE OF CONTENTS

CERTIFICATION1
 DESIGN ENGINEER’S STATEMENT1
 OWNER/DEVELOPER’S STATEMENT1
 EL PASO COUNTY1

TABLE OF CONTENTS2

INTRODUCTION3
 PURPOSE AND SCOPE OF STUDY3
 LOCATION3
 DESCRIPTION OF PROPERTY3

FLOODPLAIN STATEMENT4

DRAINAGE BASINS4
 MAJOR BASIN DESCRIPTIONS4
 COMPLIANCE WITH PREVIOUS FINAL DRAINAGE REPORT4
 EXISTING SUB-BASIN DESCRIPTIONS4
 PROPOSED SUB-BASIN DESCRIPTIONS6

DRAINAGE DESIGN CRITERIA.....9
 DEVELOPMENT CRITERIA REFERENCE9
 HYDROLOGIC CRITERIA9
 HYDRAULIC CRITERIA10

THE FOUR STEP PROCESS10

DRAINAGE FACILITY DESIGN11
 GENERAL CONCEPT11

DRAINAGE FEES11
 FEES11

SUMMARY12

REFERENCES12

APPENDIX
 APPENDIX A: VICINITY MAP
 APPENDIX B: FEMA MAP & SOILS REPORT
 APPENDIX C: HYDROLOGY
 APPENDIX D: HYDRUALICS
 APPENDIX E: EL PASO COUNTY DRAINAGE BASIN MAP
 APPENDIX F: APEX RANCH DRAINAGE REPORT
 APPENDIX G: DRAINAGE MAPS

INTRODUCTION

PURPOSE AND SCOPE OF STUDY

The purpose of this Final Drainage Report (FDR) is to document the drainage design in support of early grading improvements for the proposed Overlook at Homestead Subdivision Filing No. 1 (“the Project”) on behalf of PT Overlook LLC. The Project is located within the jurisdictional limits of El Paso County (“the County”). Therefore, the hydrologic and hydraulic design is based on the County’s criteria which is described in further detail within the report.

LOCATION

The Project Site located east of Elbert Road within El Paso County, Colorado including parcels 4122000005, 4100000255, 4100000256. More specifically, the site is a Portion of Section 22 and a Portion of Section 27, Township 11 South, Range 64 West of the 6th PM, County of El Paso, State of Colorado. North of the project site is agricultural and rural residential land, to the east is Homestead Ranch Park owned and maintained by El Paso County, and to the south and west is Homestead Ranch subdivisions. Filing No.1 consists of 36, five acre lots and is located just south the Apex Ranch Subdivision and the large butte. A vicinity map has been provided in the **Appendix** of this report.

The Site is currently owned by PT Overlook LLC and will be developed by PT Overlook LLC.

DESCRIPTION OF PROPERTY

The entire Overlook project is approximately 350.8 acres consisting of mostly vacant, undeveloped land with native vegetation and a rural single-family residential home situated in the northwest corner of the Site and is classified as Agricultural Grazing Land to be subdivided into 62 total lots. Filing No. 1 consists of approximately 202.72 acres which will be subdivided into 36 5-acre parcels. Vegetation within the site is characterized primarily by prairie grasses along with some area of scrub brush and trees. The Site does not currently provide water quality or detention for the Project area.

The existing topography consists of slopes ranging from 1% to 33% with an existing butte covering much of the northern portion of the Site. Filing No. 1 includes a roadway and temporary cul-de-sac on the top of the existing butte, but the majority of the site is located south of the butte. Flows in the existing conditions run off site into one of four major drainage basins. Filing No. 1 only discharges into the Upper Black Squirrel Creek and La Vega Ranch drainage basins, to the south. Detailed descriptions of the existing major drainage basins can be found later in the report.

According to NRCS soil mapping data, USCS Type B soils are the primary soil type within the site. Type B soils having a moderate infiltration rate when thoroughly wet. These consist chiefly of moderately deep or deep, moderately well drained, or well drained soils that have moderately fine texture to moderately coarse texture. These soils have a moderate rate of water transmission. Soils mapping information has been provided in the **Appendix**.

The Filing No. 1 development of this site will consist of 36, five-acre residential lots with roadway improvements, roadway grading, three full spectrum detention ponds, roadside ditches, culverts, and drainage swales.

FLOODPLAIN STATEMENT

The Site is located outside the 100-year floodplain and within Zone X (an area of minimal flood hazard) as noted on the FEMA FIRM Map No. 08041C0350G revised on December 7, 2018 (See **Appendix**).

DRAINAGE BASINS

MAJOR BASIN DESCRIPTIONS

The Project Site is tributary to four major drainage basins in the El Paso County Drainage Basin Map. Bijou Creek, East Kiowa Creek, Upper Black Squirrel, and La Vega Ranch Drainage Basins. These drainage basins are located in the north central portion of El Paso County. The northeast portion of the site is tributary to Bijou Creek Drainage Basin, the northwest portion of the site is tributary to East Kiowa Creek Drainage Basin, the southwest portion of the site is tributary to Upper Black Squirrel Drainage Basin, and the southeast portion of the site is tributary to La Vega Ranch Drainage Basin. Filing No. 1 only discharges into the Upper Black Squirrel Creek and La Vega Ranch Drainage Basins, to the south. In an effort to simplify basin nomenclature, the following naming conventions have been used for both existing and proposed drainage sub-basins labeling. Proposed Basins have been designed in effort to keep runoff within the same existing basins, as to not transfer runoff between basins.

- A - Upper Black Squirrel Drainage Basin (CHBS2000)
- B - La Vega Ranch Drainage Basin (CHBR0400)
- C - East Kiowa Creek Drainage Basin (KIKI0400)
- D - Bijou Creek Drainage Basin (BIBI0200)

El Paso County Drainage Basin map has been provided in the **Appendix**. A summary of flows in existing and proposed conditions has been added to the **Appendix**.

COMPLIANCE WITH PREVIOUS FINAL DRAINAGE REPORT

A portion of the proposed Project Site falls within the existing approved “Final Drainage Report for Apex Ranch Estates” by Terra Nova Engineering, Inc. approval date September 3, 2008. Flows from these basins will be at or below history values. These flows are not included in the calculation for the existing detention facility for Filing No. 1. Excerpts from the previously approved FDR have been provided in the **Appendix**.

A Preliminary Drainage Report was submitted to the County as part of the SP238 Application for the Preliminary Plat.

EXISTING SUB-BASIN DESCRIPTIONS

Historically the runoff from the Site drains into one of two major drainage basins for Filing No. 1 as described above. Slopes vary from 2-33% throughout the site with various natural features. The Site has been divided into 8 onsite basins A1-A2, B1-B3, and B3A, and 2 offsite basins OS-A1 and OS-A2. The offsite basins are located west of the Site and generally flow west towards to existing stormwater infrastructure. Descriptions of each individual sub-basin can be found below.

In the existing conditions flows within the existing sub-basins are conveyed and collected into

natural drainage channels. These channels can be found on the existing conditions drainage map, and hydraulic analysis of these channels in existing conditions have been completed. Both of these items can be found in the **Appendix**. Flows will generally follow historic drainage patterns with regards to the existing natural drainage channels.

Sub-Basin A1

This on-site sub-basin consists of an area of 19.92 acres, located in the southwest corner of the Site. Drainage flows overland from the northeast to the southwest where it is captured by an existing 36" CMP culvert at DP 1 and outfalls west of Elbert Rd. The weighted imperviousness for this sub-basin is 8%. Runoff during the 5-year and 100-year events are 8.43 cfs and 38.41 cfs respectively. Refer to the **Appendix** for the Existing Conditions Drainage Map.

Sub-Basin A2

This on-site sub-basin consists of an area of 61.50 acres, located in the southwest corner of the Site. Drainage flows overland from the northeast to the southwest where it flows offsite at DP 2 into Reata subdivision south of the Site. The weighted imperviousness for this sub-basin is 1%. Runoff during the 5-year and 100-year events are 13.00 cfs and 87.58 cfs respectively. Refer to the **Appendix** for the Existing Conditions Drainage Map.

Sub-Basin B1

This on-site sub-basin consists of an area of 45.75 acres, located in the south-central portion of the Site. Drainage flows overland from the north to the south where it flows offsite at DP 3 into Reata subdivision south of the Site. The weighted imperviousness for this sub-basin is 0%. Runoff during the 5-year and 100-year events are 9.87 cfs and 72.48 cfs respectively. Refer to the **Appendix** for the Existing Conditions Drainage Map.

Sub-Basin B2

This on-site sub-basin consists of an area of 42.42 acres, located in the south-central portion of the Site. Drainage flows overland from the north to the south where it flows offsite at DP 4 into Reata subdivision south of the Site. The weighted imperviousness for this sub-basin is 0%. Runoff during the 5-year and 100-year events are 9.41 cfs and 69.09 cfs respectively. Refer to the **Appendix** for the Existing Conditions Drainage Map.

Sub-Basin B3

This on-site sub-basin consists of an area of 25.42 acres, located in the southeast portion of the Site. Drainage flows overland from the north to the south where it flows offsite at DP 5 into Reata subdivision south of the Site. The weighted imperviousness for this sub-basin is 0%. Runoff during the 5-year and 100-year events are 5.91 cfs and 43.40 cfs respectively. Refer to the **Appendix** for the Existing Conditions Drainage Map.

Sub-Basin B3A

This on-site sub-basin consists of an area of 24.23 acres, located in the southeast corner of the Site. Drainage flows overland from the north to the south where it flows offsite at DP 5A into Reata subdivision south of the Site. The weighted imperviousness for this sub-basin is 0%. Runoff during the 5-year and 100-year events are 5.99 cfs and 43.98 cfs respectively. Refer to the **Appendix** for the Existing Conditions Drainage Map.

Sub-Basin OS-A1

The off-site sub-basin consists of an area of 4.06 acres, located in the western central portion of the drainage study area. Drainage flows overland from the northeast to southwest where it is captured by an existing drainage culvert at DP 14 and directed west of Elbert Road. The weighted

imperviousness for this sub-basin is 19%. Runoff during the 5-year and 100-year events are 3.76 cfs and 12.49 cfs respectively. Refer to the **Appendix** for the Existing Conditions Drainage Map.

Sub-Basin OS-A2

The off-site sub-basin consists of an area of 4.45 acres, located in the central portion of the drainage study area. Drainage flows overland from the north to south where it enters sub-basin A2 at DP 15 and follows the patterns described in sub-basin A2. The weighted imperviousness for this sub-basin is 19%. Runoff during the 5-year and 100-year events are 3.76 cfs and 12.49 cfs respectively. Refer to the **Appendix** for the Existing Conditions Drainage Map.

PROPOSED SUB-BASIN DESCRIPTIONS

For the proposed condition, stormwater will generally maintain historic flow patterns. The proposed roadways will alter some of the existing flow paths. The roadway ditches will capture runoff from the roadways and direct flows via proposed culverts back to the existing flow paths, which will ultimately follow historic patterns or be capture by one of the three (3) proposed storm water ponds. The proposed Site has been divided into 10 onsite basins A1-A2, B1-B3, B6-B8, and 2 offsite basins OS-A1 and OS-A2. Descriptions of each individual sub-basin can be found below. The off-site basins are fully developed and no changes to the upstream basins are anticipated. Per Final Drainage Report for Apex Ranch Estates by Terra Nova Engineering, dated September 3, 2008, the existing extended detention basin, on the northwest corner of Apex Ranch Road and Fletcherville Lane was designed and sized to provide water quality for the entire basins A-J of the Apex Ranch Estates Final Drainage Report. This area includes all the proposed roadway extensions through the ROW preservation within the Apex Ranch Estates Subdivision. This project does not rely on the water quality or detention volumes provided by the existing detention basin within Apex Ranch Estates.

In the proposed conditions flows within the proposed sub-basins are conveyed and collected into natural drainage channels. These channels can be found on the proposed conditions drainage map, and hydraulic analysis of these channels in proposed conditions have been completed. Both of these items can be found in the **Appendix**. Flows will generally follow historic drainage patterns with regards to the existing natural drainage channels. Due to the increase in site imperviousness some channels will see an increase in flows. All channels that have an increase of flows in proposed conditions currently have capacity to accept the additional flows. Hydraulic analysis was done to determine need for erosion control measures. Any channel with a proposed velocity greater than 6.0 ft/s shall have Turf Reinforcement Mat (TRM) added as an erosion control measure. Details regarding channel velocity and TRM can be found in the **Appendix**.

There are several drainage culverts proposed within Filing 1 of the Site. Locations of the proposed culverts were chosen to ensure historic drainage patterns are maintained. Culvert sizing including outlet protection analysis has been included in the **Appendix** of this report.

The three proposed full spectrum extended detention basins (EDB) will be designed to release developed flows from Filing No. 1 at less than or equal to historic rates for this project before passing the property line. In the early grading condition these three EDBs will be proposed temporary sediment basins (TSB) and will not be fully constructed until final plat and final design. The full design of these full spectrum extended detention basins will be provided at the Final Plat-Final Drainage Report. While the proposed full spectrum extended detention basins will not be constructed as part of this early grading package, the proposed conditions in this report represent final conditions. As erosion control measures are required to be shown for pond outfall and are proposed for the temporary standpipes and temporary spillways. These measures are displayed and discussed in text and drainage maps. More detail regarding the proposed Temporary

Sediment Basins can be found in the detention basin section of this report.

Sub-Basin A1

This on-site sub-basin consists of an area of 19.55 acres, located in the southwest corner of the Site. Drainage flows overland from the northeast to the southwest where it is captured by an existing 36" CMP culvert at DP 1 and outfalls west of Elbert Rd. There are no proposed improvements in sub-basin A1. The weighted imperviousness for this sub-basin is 15%. Runoff during the 5-year and 100-year events are 10.41 cfs and 41.24 cfs respectively. Due to the slight increase in sub-basin imperviousness, the 100-yr runoff increases from 38.41 to 41.24 cfs. The additional runoff will be accepted and mitigated through the nearly 1500 ft long, 50 ft wide existing drainage channel located within the sub-basin. Refer to the **Appendix** for the Proposed Conditions Drainage Map.

Sub-Basin A2

This on-site sub-basin consists of an area of 59.51 acres, located in the southwest corner of the Site. Improvements within this sub-basin include proposed roads, roadside ditches, culverts, and proposed private full spectrum detention basin A2. Drainage flows overland from the northeast to the southwest where it flows into proposed roadside ditches, is conveyed through proposed stormwater culverts, and is ultimately captured by propose private full spectrum detention basin A2. Flows will be released at or below historic levels to the existing roadside ditch along Elbert Road located at DP 2. Flows will generally follow historic drainage patterns. The weighted imperviousness for this sub-basin is 11%. Runoff during the 5-year and 100-year events are 20.23 cfs and 93.46 cfs respectively. Due to the increase in sub-basin imperviousness, the 100-yr runoff for DP 2 is anticipated to increases from 87.58 cfs to 93.46 cfs. The additional runoff will be collected and released at less than historic rates via a proposed private full spectrum detention basin. Flows from this basin will not be released into the Reata subdivision south of the Site. The minor increase in flows will be mitigated by the proposed full spectrum detention basin A2 and released a less than historic rates. Refer to the **Appendix** for the Proposed Conditions Drainage Map.

Sub-Basin B1

This on-site sub-basin consists of an area of 40.74 acres, located in the south-central portion of the Site. Improvements within this sub-basin include proposed roads, roadside ditches, culverts, and proposed private full spectrum detention basin B1. Drainage flows overland from the north to the south where it flows into proposed roadside ditches, is conveyed through proposed stormwater culverts, and is ultimately captured by propose private full spectrum detention basin B1 at DP 3. The weighted imperviousness for this sub-basin is 10%. Runoff during the 5-year and 100-year events are 16.77 cfs and 80.40 cfs respectively. Due to the increase in sub-basin imperviousness, the 100-yr runoff for DP 3 is anticipated to increases from 72.48 cfs to 80.40 cfs. The additional runoff will be collected and released at less than historic rates via a proposed private full spectrum detention basin with a proposed concrete level spreader. Flows from this basin will exit into the Reata subdivision south of the Site via existing, vegetated natural drainage channels and outfall to an existing stock pond within the adjacent property south of the Site. To maintain outfall erosion protection, a level spreader is proposed prior to flows entering the Reata Subdivision. The minor increase in flows will be mitigated by the proposed full spectrum detention basin B1 and released at less than historic rates. Refer to the **Appendix** for the Proposed Conditions Drainage Map.

Sub-Basin B2

This on-site sub-basin consists of an area of 16.00 acres, located in the south-central portion of the Site. Drainage flows overland from the north to the south where it flows offsite at DP 4. Improvements within this sub-basin include proposed public roads. This sub-basin includes an approx. 14,351 sq ft improved area of roadway that will not be receiving water quality treatment. A detailed discussion regarding water quality treatment has been included in Step-2 of the Four Step Process. The weighted imperviousness for this sub-basin is 9%. Runoff during the 5-year and 100-year events are 7.82 cfs and 38.64 cfs respectively. It is anticipated in a 100-yr storm event the total runoff for DP 4 will reduce from 69.09 cfs to 38.64 cfs, as the proposed roadway will cut off much of the upstream portion of the existing drainage basin and route those flows to a proposed full spectrum detention basin. As such there are no anticipated downstream impacts. Refer to the **Appendix** for the Proposed Conditions Drainage Map.

Sub-Basin B3

This on-site sub-basin consists of an area of 19.11 acres, located in the southeastern portion of the Site. Drainage flows overland from the northwest to southeast where it flows off site at DP 5. There are no proposed public improvements within this sub-basin, but single-family homes will be constructed and excluded the large lot exclusion I.7.1.B.5 and discussed in step 2 of the four-step process. The weighted imperviousness for this sub-basin is 7%. Runoff during the 5-year and 100-year events are 7.83 cfs and 42.71 cfs respectively. In the proposed conditions, it is anticipated in a 100-yr storm event the total runoff for DP 5A (DP 5 in proposed conditions) will reduce from 43.98 to 42.71, as such there are no anticipated downstream impacts. Refer to the **Appendix** for the Proposed Conditions Drainage Map.

Sub-Basin B6

This on-site sub-basin consists of an area of 52.07 acres, located in the central portion of the Site. Improvements within this sub-basin include proposed roads, roadside ditches, and culverts. Drainage flows overland from the northeast to the southwest where it flows into proposed roadside ditches, is conveyed through a proposed stormwater culvert at DP 8, and into sub-basin B8. From there, flows will follow path as described in sub-basin B8 where it will ultimately be captured in proposed full spectrum detention basin B8. The weighted imperviousness for this sub-basin is 10%. Runoff during the 5-year and 100-year events are 22.13 cfs and 104.60 cfs respectively. Refer to the **Appendix** for the Proposed Conditions Drainage Map.

Sub-Basin B7

This on-site sub-basin consists of an area of 2.46 acres, located in the southern portion of the Site. Drainage flows overland from the north to south where it flows off site at DP 9. There are no proposed improvements within this sub-basin. The weighted imperviousness for this sub-basin is 7%. Runoff during the 5-year and 100-year events are 1.13 cfs and 6.17 cfs respectively. Refer to the **Appendix** for the Proposed Conditions Drainage Map.

Sub-Basin B8

This on-site sub-basin consists of an area of 9.52 acres, located in the southern portion of the Site. Drainage flows overland from the north to south where it is captured by proposed private full spectrum extended detention basin B8 at DP 10. It should be noted that sub-basin B8 accepts flows from sub-basin B6 at DP 8. Refer to sub-basin B6 for information regarding the proposed flows from sub-basin B6. Aside from the proposed extended detention basin there are no proposed improvements within this sub-basin. The weighted imperviousness for this sub-basin is 7%. Runoff during the 5-year and 100-year events are 4.22 cfs and 23.05 cfs respectively. In addition to the increase of imperviousness, sub-basin B8 is also accepting flows from sub-basin B6 to the north. The combination of these factors results in a proposed increase of flows at DP 10 (DP 5 in existing conditions) from 43.40 cfs to 130.00 cfs. The additional runoff will be collected and released at less than historic rates via a proposed private full spectrum detention basin. Flows

from this basin will exit into the Reata subdivision south of the Site via existing, vegetated natural drainage channel and outfall to an existing established vegetated area within the adjacent property south of the Site. The increase in flows will be mitigated by the proposed full spectrum detention basin B8 and released at less than historic rates. Refer to the **Appendix** for the Proposed Conditions Drainage Map.

Sub-Basin OS-A1

The off-site sub-basin consists of an area of 4.06 acres, located in the western central portion of the drainage study area. Drainage flows overland from the northeast to southwest where it is captured by an existing drainage culvert at DP 18 and directed west of Elbert Road. The weighted imperviousness for this sub-basin is 25%. Runoff during the 5-year and 100-year events are 4.12 cfs and 12.86 cfs respectively. Refer to the **Appendix** for the Proposed Conditions Drainage Map.

Sub-Basin OS-A2

The off-site sub-basin consists of an area of 4.45 acres, located in the central portion of the drainage study area. Drainage flows overland from the north to south where it enters sub-basin A2 at DP 19 and follows the patterns described in sub-basin A2. The weighted imperviousness for this sub-basin is 7%. Runoff during the 5-year and 100-year events are 2.10 cfs and 11.46 cfs respectively. Refer to the **Appendix** for the Proposed Conditions Drainage Map.

DRAINAGE DESIGN CRITERIA

DEVELOPMENT CRITERIA REFERENCE

The proposed storm facilities are designed to be in compliance with El Paso County “Drainage Criteria Manual (DCM)” dated October 2018 (“the MANUAL”), El Paso County “Engineering Criteria Manual” (“the Engineering Manual”), Chapter 6 and Section 3.2.1 of Chapter 13 of the City of Colorado Springs Drainage Criteria Manual dated May 2014 (“the Colorado Springs MANUAL”), and Mile High Flood District (MHFD), Urban Drainage and Flood Control District Drainage Criteria Manuals (UDFCDM), (Volumes 1, 2 and 3), prepared by Wright-McLaughlin Engineers, June 2001, with latest revisions.

Site drainage is not significantly impacted by such constraints as utilities or existing development.

A Preliminary Drainage Report was completed for the overall Overlook Subdivision (SP238). This Final Drainage Report uses the Preliminary Drainage Report to assist with the drainage design for Filing No. 1.

HYDROLOGIC CRITERIA

The 5-year and 100-year design storm events were used in determining rainfall and runoff for the proposed drainage system per chapter 6 of the CRITERIA. Table 6-2 of the CRITERIA is the source for rainfall data for the 5-year and 100-year design storm events. Design runoff was calculated using the Rational Method for developed conditions as established in the CRITERIA and MANUAL. Runoff coefficients for the proposed development were determined using Table 6-6 of the CRITERIA by calculating weighted impervious values for each specific site basin as outlined and shown in the Preliminary Drainage Report.

HYDRAULIC CRITERIA

Applicable design methods were utilized to analyze the proposed ponds, culverts, and existing drainage channels which includes the use of the UD-Detention spreadsheet, rational calculations spreadsheet, and FlowMaster, and UD-Culvert.

Proposed Drainage features on-site have been analyzed and sized for the following design storm events:

- Major Storm: 100-year Storm Event

Three temporary sediment basins are proposed in order to capture eroded or disturbed soil transported in storm runoff prior to discharge from the site. The temporary sediment basins will contain perforated outlet pipes with a release time of approximately 72 hours. The table below outlines the sediment basin sizing, which was based on MHFD temporary sediment basin sizing calculations. Detailed design of the temporary sediment basins has been included in the **Appendix**.

Temporary Sediment Basin ID	Tributary Basin Area (Acres)	TSB Volume (Ac-ft)
TSB A2	63.96	4.718
TSB B1	40.70	2.196
TSB B8	61.60	3.954

The existing natural drainage channels and proposed roadside ditches are designed to carry flows to the temporary sediment basins. The natural channels have varying bottom widths, slopes, and side slopes. The Project intends on using existing natural drainage channels to convey flow where appropriate. Natural channels through Filing No. 1 have been labeled and identified on the Proposed Drainage Map. Channel calculations and summary table have been provided in the **Appendix**. It is not anticipated channel upgrades or improvements will be required for this project. Proposed drainage easements have been proposed on the Early Grading Plans in locations where the natural channels convey flow a substantial amount of flow between properties.

Roadside ditches are provided along the proposed roadways to route flows to the proposed culverts. The roadside ditches are sized to convey the major event flow. The roadside ditched have been designed to have an average depth of 3 feet, a v-ditch, a left-side slope of 3:1, and a right-side slope of 4:1. No channels were determined to have velocities above the allowable permissible velocities for grass lines channels. Roadside ditch calculations and summary table has been provided in the **Appendix**.

Culverts were sized to convey flows from the ditches and channels, underneath the sites paved roads. The proposed culverts range from 18" to 36" and have been designed to convey the 100-year storm event. Culvert calculations and summary table has been provided in the **Appendix**.

THE FOUR STEP PROCESS

The Project was designed in accordance with the four-step process to minimize adverse impacts of urbanization, as outlined in the El Paso County Engineering Manual for BMP selection as noted below:

Step 1. Employ Runoff Reduction Practices – The project is proposing a low-density residential development that will be designed to minimize the impact to the current existing terrain. Per Section I.7.1B of Appendix I of the ECM, the single-family residences fall under

the large lot exemption as the total impervious area is less than 10% of the area. Homes are typically placed in the center of the lot and provide long distances for infiltration across natural terrain. The Site's proposed paved roadways will increase the Site's impervious area; however, roadside ditches and channels will be constructed to slow down the runoff velocity and reduce runoff peaks. The three proposed detention ponds will be used to capture stormwater, provide water quality treatment, and maintain flows discharging off site at or below historic levels.

Step 2. Provide a Water Quality Capture Volume – Permanent water quality measures and detention facilities will be necessary for the Project. Temporary water quality and erosion control measures will be provided during construction to prevent sediment laden water from discharging from the Site. Water quality measures are being used for all stormwater that contacts roadways. Three (3) temporary sediment basins will treat the areas not excluded with either the Large Lot or 20% exclusion. Per ECM Appendix I Section 1.7.B.5: Large Lot Single Family exclusion, most of the proposed site will be excluded from water quality, lot imperviousness shall be limited to 10 percent or less. Per ECM Appendix I Section 1.7.C.1.a., 20% of the development site or less than 1 acre can be excluded from providing water quality. As mentioned, 0.99 acres (43,197 sq ft) of impervious area will not be able to be treated which is less than 20% of the overall site.

Step 3 Stabilize Drainageways– Stabilizing proposed roadside ditches, and channels by designing them with slopes that control the flow rates. Placement of riprap upstream and downstream of culverts to help reduce erosion of the roadside ditches. Existing drainage ways will be graded to reduce the velocity of the water to minimize erosion. The existing natural channels have been analyzed for width and velocity for the 100-yr storm event. Easements are proposed to accommodate the full width of the major storm event.

Step 4. Implement Site Specific and Other Source Control BMPs – The erosion control construction BMPs of the Project were designed to reduce contamination. Source control BMPs include the use of vehicle tracking control, culvert protection, stockpile management, and stabilized staging areas.

DRAINAGE FACILITY DESIGN

GENERAL CONCEPT

The proposed drainage patterns will match historic patterns. To maintain historic flows, three full spectrum detention ponds are being proposed and will capture and control the flows from the proposed development into a series of channels and culverts. The Temporary Sediment Basins described in this report TSB A2, B1, B8 will be converted into the extended detention basins as part of the Final Drainage Report to be processed with the Final Plat application.

DRAINAGE FEES

FEES

The project is within the Upper Black Squirrel Drainage Basin (CHBS2000), La Vega Ranch Drainage Basin (CHBR0400), East Kiowa Creek Drainage Basin (KIKI0400), and Bijou Creek

Drainage Basin (BIBI0200) all four of which are not part of the El Paso County Drainage Basin Fee Program. As such, no drainage fees are due with this Project.

SUMMARY

This report has been prepared in accordance with El Paso County stormwater criteria. It outlines the Site design for the 5-year and 100-year storm events drainage system. The drainage design presented within this report conforms to the criteria presented in the MANUAL. Additionally, as the proposed temporary sediment basin release rates are to be designed less than historic rates, the Site runoff and storm drain facilities will not adversely affect the downstream and surrounding developments.

REFERENCES

1. Final Drainage Report for Apex Ranch Estates by Terra Nova Engineering, Inc. dated September 3, 2008
2. El Paso County “Engineering Criteria Manual” Volumes 1 & 2, dated October 31, 2018
3. Natural Resources Conservation Service, Web Soil Survey, dated June 21, 2023.
4. Urban Drainage and Flood Control District Drainage Criteria Manuals (UDFCDM), (Volumes 1, 2 and 3), prepared by Wright-McLaughlin Engineers, June 2001, with latest revisions.
5. Flood Insurance Rate Map, El Paso County, Colorado and Incorporated Areas, Map Number 08041C0350G, Effective Date December 7, 2018, prepared by the Federal Emergency Management Agency (FEMA).

APPENDIX

APPENDIX A: VICINITY MAP

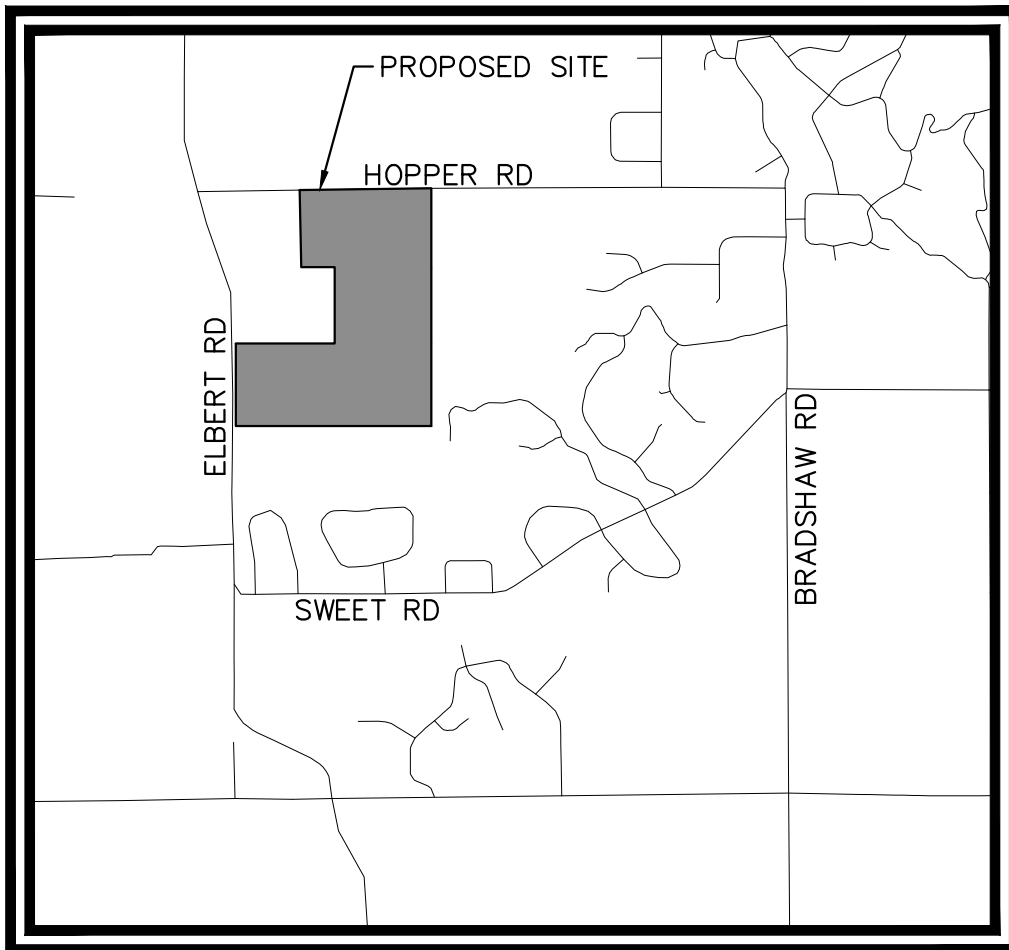

VICINITY MAP

SCALE: 1":5000'

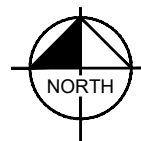

APPENDIX B: FEMA MAP & SOILS REPORT

NOTES TO USERS

This map is for use in administering the National Flood Insurance Program. It does not necessarily identify all areas subject to flooding, particularly from local drainage sources of small size. The community map repository should be consulted for possible updated or additional flood hazard information.

To obtain more detailed information in areas where **Base Flood Elevations (BFEs)** and/or **floodways** have been determined, users are encouraged to consult the Flood Profiles and Floodway Data and/or Summary of Stillwater Elevations tables contained within the Flood Insurance Study (FIS) report that accompanies this FIRM. Users should be aware that BFEs shown on the FIRM represent rounded whole-foot elevations. These BFEs are intended for flood insurance rating purposes only and should not be used as the sole source of flood elevation information. Accordingly, flood elevation data presented in the FIS report should be utilized in conjunction with the FIRM for purposes of construction and/or floodplain management.

Coastal Base Flood Elevations shown on this map apply only landward of 0.0' North American Vertical Datum of 1988 (NAVD88). Users of this FIRM should be aware that coastal flood elevations are also provided in the Summary of Stillwater Elevations table in the Flood Insurance Study report for this jurisdiction. Elevations shown in the Summary of Stillwater Elevations table should be used for construction and/or floodplain management purposes when they are higher than the elevations shown on this FIRM.

Boundaries of the **floodways** were computed at cross sections and interpolated between cross sections. The floodways were based on hydraulic considerations with regard to requirements of the National Flood Insurance Program. Floodway widths and other pertinent floodway data are provided in the Flood Insurance Study report for this jurisdiction.

Certain areas not in Special Flood Hazard Areas may be protected by **flood control structures**. Refer to section 2.4 "Flood Protection Measures" of the Flood Insurance Study report for information on flood control structures for this jurisdiction.

The **projection** used in the preparation of this map was Universal Transverse Mercator (UTM) zone 13. The **horizontal datum** was NAD83, GRS80 spheroid. Differences in datum, spheroid, projection or UTM zones zones used in the production of FIRMs for adjacent jurisdictions may result in slight positional differences in map features across jurisdiction boundaries. These differences do not affect the accuracy of this FIRM.

Flood elevations on this map are referenced to the **North American Vertical Datum of 1988 (NAVD88)**. These flood elevations must be compared to structure and ground elevations referenced to the same **vertical datum**. For information regarding conversion between the National Geodetic Vertical Datum of 1929 and the North American Vertical Datum of 1988, visit the National Geodetic Survey website at <http://www.ngs.noaa.gov/> or contact the National Geodetic Survey at the following address:

NGS Information Services
NOAA, NUNCS12
National Geodetic Survey
SSMC-3, #9202
1315 East-West Highway
Silver Spring, MD 20910-3282

To obtain current elevation, description, and/or location information for **bench marks** shown on this map, please contact the Information Services Branch of the National Geodetic Survey at (301) 713-3242 or visit its website at <http://www.ngs.noaa.gov/>.

Base Map information shown on this FIRM was provided in digital format by El Paso County, Colorado Springs Utilities, City of Fountain, Bureau of Land Management, National Oceanic and Atmospheric Administration, United States Geological Survey, and Anderson Consulting Engineers, Inc. These data are current as of 2006.

This map reflects more detailed and up-to-date **stream channel configurations and floodplain delineations** than those shown on the previous FIRM for this jurisdiction. The floodplains and floodways that were transferred from the previous FIRM may have been adjusted to conform to these new stream channel configurations. As a result, the Flood Profiles and Floodway Data tables in the Flood Insurance Study Report (which contains authoritative hydraulic data) may reflect stream channel distances that differ from what is shown on this map. The profile baselines depicted on this map represent the hydraulic modeling baselines that match the flood profiles and Floodway Data Tables if applicable, in the FIS report. As a result, the profile baselines may deviate significantly from the new base map channel representation and may appear outside of the floodplain.

Corporate limits shown on this map are based on the best data available at the time of publication. Because changes due to annexations or de-annexations may have occurred after this map was published, map users should contact appropriate community officials to verify current corporate limit locations.

Please refer to the separately printed **Map Index** for an overview map of the county showing the layout of map panels; community map repository addresses; and a Listing of Communities table containing National Flood Insurance Program dates for each community as well as a listing of the panels on which each community is located.

Contact **FEMA Map Service Center (MSC)** via the FEMA Map Information eXchange (FMIX) 1-877-336-2627 for information on available products associated with this FIRM. Available products may include previously issued Letters of Map Change, a Flood Insurance Study Report, and/or digital versions of this map. The MSC may also be reached by Fax at 1-800-358-9620 and its website at <http://www.msc.fema.gov/>.

If you have **questions about this map** or questions concerning the National Flood Insurance Program in general, please call 1-877-FEMA MAP (1-877-336-2627) or visit the FEMA website at <http://www.fema.gov/business/nfp>.

El Paso County Vertical Datum Offset Table

Flooding Source	Vertical Datum Offset (ft)
REFER TO SECTION 3.3 OF THE EL PASO COUNTY FLOOD INSURANCE STUDY FOR STREAM BY STREAM VERTICAL DATUM CONVERSION INFORMATION	

Panel Location Map

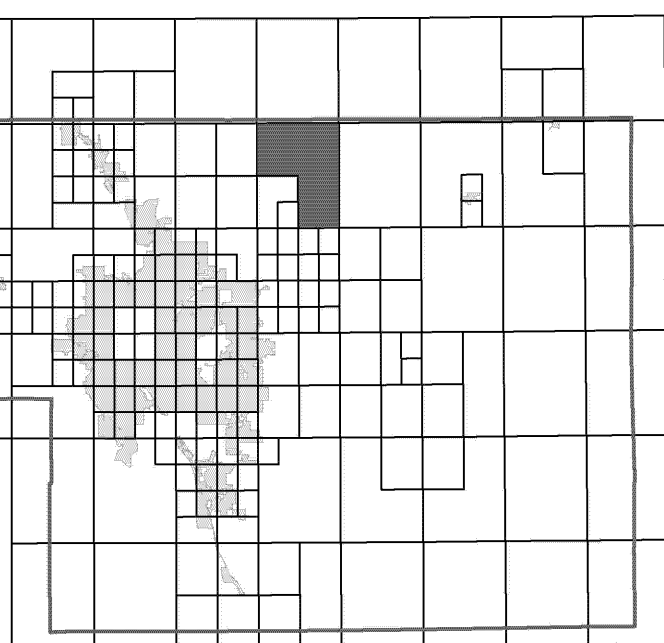

This Digital Flood Insurance Rate Map (DFIRM) was produced through a Cooperating Technical Partner (CTP) agreement between the State of Colorado Water Conservation Board (CWCB) and the Federal Emergency Management Agency (FEMA).



Additional Flood Hazard information and resources are available from local communities and the Colorado Water Conservation Board.

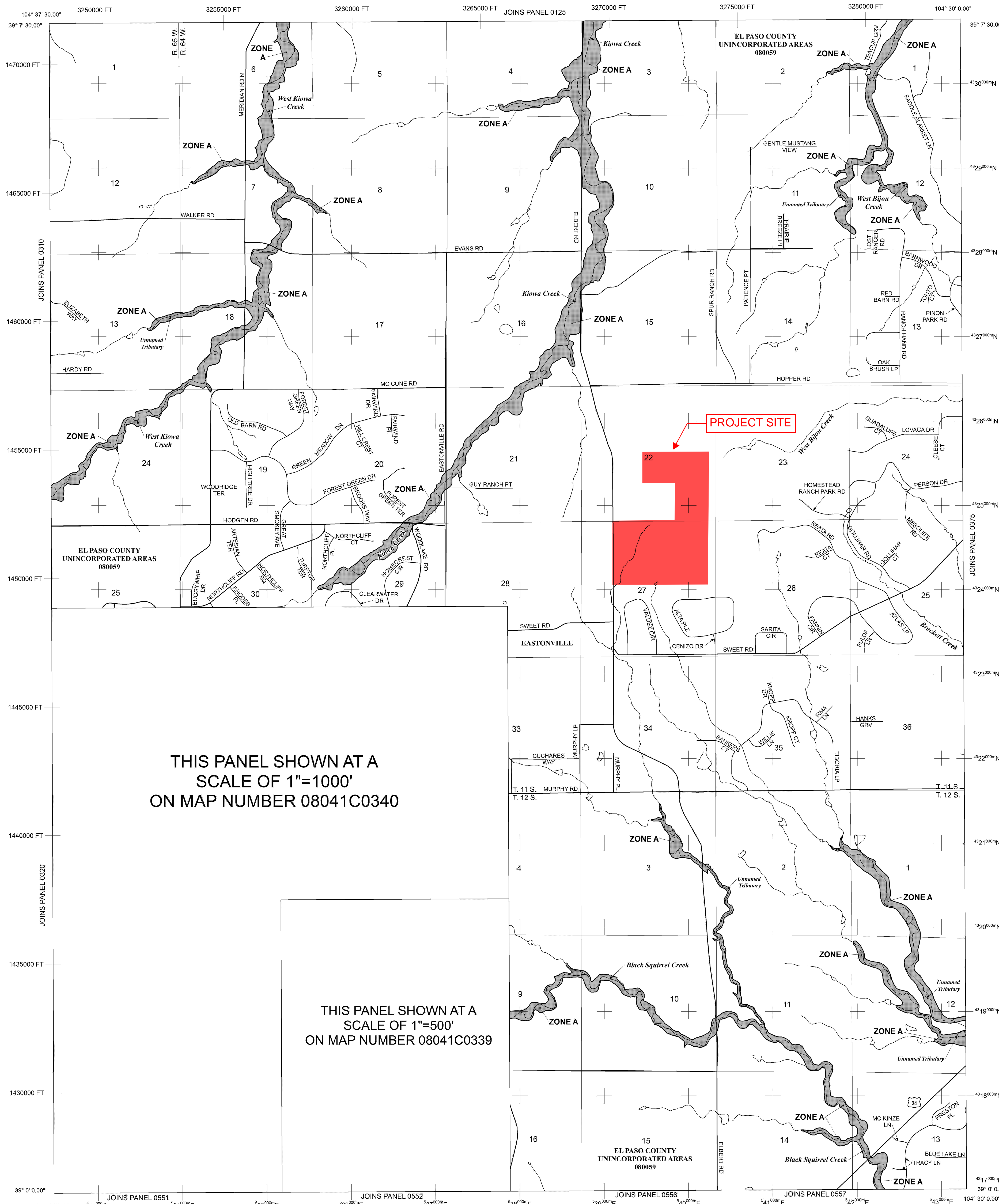

THIS PANEL SHOWN AT A
SCALE OF 1"=1000'
ON MAP NUMBER 08041C0340

THIS PANEL SHOWN AT A
SCALE OF 1"=500'
ON MAP NUMBER 08041C0339

LEGEND

SPECIAL FLOOD HAZARD AREAS (SFHAS) SUBJECT TO INUNDATION BY THE 1% ANNUAL CHANCE FLOOD

The 1% annual chance flood (100-year flood), also known as the base flood, is the flood that has a 1% chance of being equalled or exceeded in any given year. The Special Flood Hazard Area is the area subject to flooding by the 1% annual chance flood. Areas of Special Flood Hazard include Zones A, AE, AH, AO, AR, A99, V, and VE. The Base Flood Elevation is the water-surface elevation of the 1% annual chance flood.

- ZONE A** No Base Flood Elevations determined.
- ZONE AE** Base Flood Elevations determined.
- ZONE AH** Flood depths of 1 to 3 feet (usually areas of ponding); Base Flood Elevations determined.
- ZONE AO** Flood depths of 1 to 3 feet (usually sheet flow on sloping terrain); average depths determined. For areas of alluvial fan flooding, velocities also determined.
- ZONE AR** Special Flood Hazard Area Formerly protected from the 1% annual chance flood by a flood control system that was subsequently decertified. Zone AR indicates that the former flood control system is being restored to provide protection from the 1% annual chance or greater flood.
- ZONE A99** Area to be protected from 1% annual chance flood by a Federal flood protection system under construction; no Base Flood Elevations determined.
- ZONE V** Coastal flood zone with velocity hazard (wave action); no Base Flood Elevations determined.
- ZONE VE** Coastal flood zone with velocity hazard (wave action); Base Flood Elevations determined.

FLOODWAY AREAS IN ZONE AE

The floodway is the channel of a stream plus any adjacent floodplain areas that must be kept free of encroachment so that the 1% annual chance flood can be carried without substantial increases in flood heights.

OTHER FLOOD AREAS

ZONE X Areas of 0.2% annual chance flood; areas of 1% annual chance flood with average depths of less than 1 foot, or with drainage areas less than 1 square mile; and areas protected by levees from 1% annual chance flood.

OTHER AREAS

ZONE X Areas determined to be outside the 0.2% annual chance floodplain.

ZONE D Areas in which flood hazards are undetermined, but possible.

COASTAL BARRIER RESOURCES SYSTEM (CBRS) AREAS

OTHERWISE PROTECTED AREAS (OPAs)

CBRS areas and OPAs are normally located within or adjacent to Special Flood Hazard Areas.

- Floodplain boundary
- Floodway boundary
- Zone D Boundary
- CBRS and OPA boundary

Boundary dividing Special Flood Hazard Areas of different Base Flood Elevations, flood depths or flood velocities.

Base Flood Elevation line and value; elevation in feet* (EL 987)

* Referenced to the North American Vertical Datum of 1988 (NAVD 88)

513 Cross section line

23-23 Transsect line

Geographic coordinates referenced to the North American Datum of 1983 (NAD 83)

1000-meter Universal Transverse Mercator grid ticks, zone 13

5000-foot grid ticks: Colorado State Plane coordinate system, central zone (FIPS ZONE 0502), Lambert Conformal Conic Projection

Bench mark (see explanation in Notes to Users section of this FIRM map)

M1.5 River Mile

MAP REPOSITORIES

Refer to Map Repositories list on Map Index

EFFECTIVE DATE OF COUNTYWIDE FLOOD INSURANCE RATE MAP

MARCH 17, 1997

EFFECTIVE DATE(S) OF REVISION(S) TO THIS PANEL

DECEMBER 7, 2018 - to update corporate limits, to change Base Flood Elevations and Special Flood Hazard Areas, to update map format, to add roads and road names, and to incorporate previously issued Letters of Map Revision

For community map revision history prior to countywide mapping, refer to the Community Map History Table located in the Flood Insurance Study report for this jurisdiction.

To determine if flood insurance is available in this community, contact your insurance agent or call the National Flood Insurance Program at 1-800-638-6620.

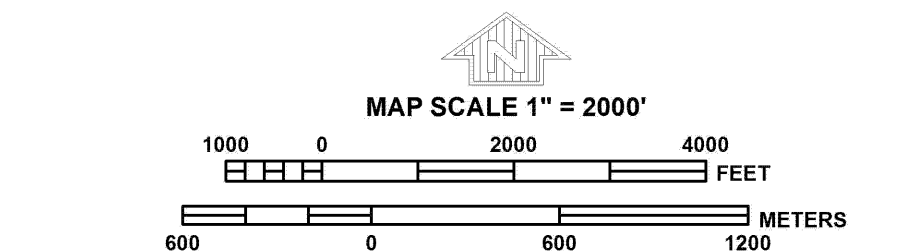

NFIP

PANEL 0350G

FIRM

FLOOD INSURANCE RATE MAP

EL PASO COUNTY, COLORADO AND INCORPORATED AREAS

PANEL 350 OF 1300

(SEE MAP INDEX FOR FIRM PANEL LAYOUT)

CONTAINS:

COMMUNITY	NUMBER	PANEL	SUFFIX
EL PASO COUNTY	08059	0350	G

Notice to User: The Map Number shown below should be used when placing map orders. The Community Number shown above should be used on insurance applications for the subject community.

MAP NUMBER 08041C0350G

MAP REVISED DECEMBER 7, 2018

Federal Emergency Management Agency

Hydrologic Soil Group—El Paso County Area, Colorado

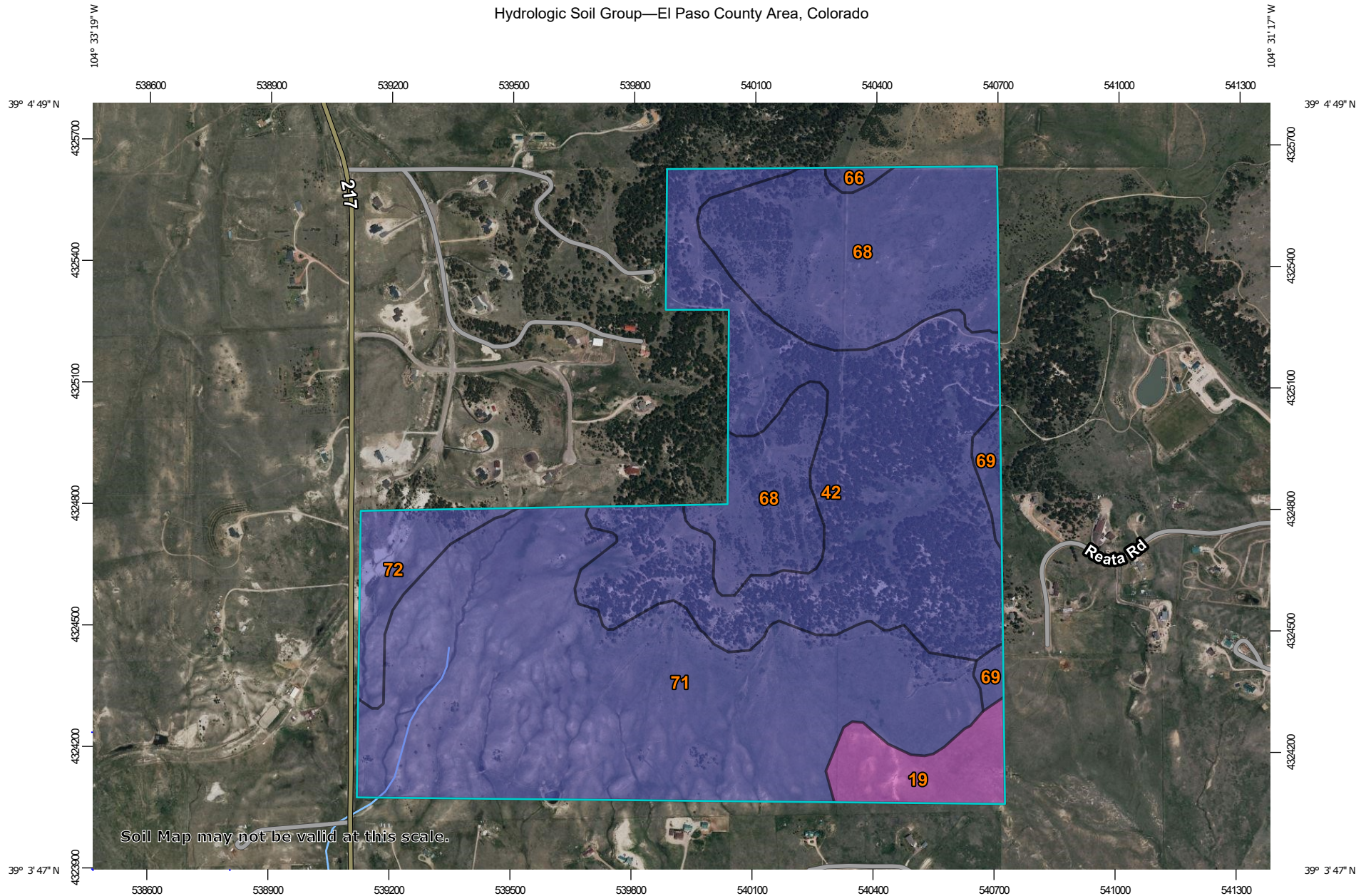





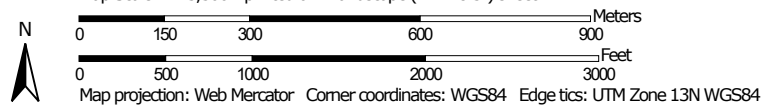



























Soil Map may not be valid at this scale.

Map Scale: 1:13,300 if printed on A landscape (11" x 8.5") sheet.



MAP LEGEND

- Area of Interest (AOI)**
 -  Area of Interest (AOI)
- Soils**
 - Soil Rating Polygons**
 -  A
 -  A/D
 -  B
 -  B/D
 -  C
 -  C/D
 -  D
 -  Not rated or not available
 - Soil Rating Lines**
 -  A
 -  A/D
 -  B
 -  B/D
 -  C
 -  C/D
 -  D
 -  Not rated or not available
 - Soil Rating Points**
 -  A
 -  A/D
 -  B
 -  B/D
- Water Features**
 -  Streams and Canals
- Transportation**
 -  Rails
 -  Interstate Highways
 -  US Routes
 -  Major Roads
 -  Local Roads
- Background**
 -  Aerial Photography
- Other**
 -  C
 -  C/D
 -  D
 -  Not rated or not available

MAP INFORMATION

The soil surveys that comprise your AOI were mapped at 1:24,000.

Warning: Soil Map may not be valid at this scale.
 Enlargement of maps beyond the scale of mapping can cause misunderstanding of the detail of mapping and accuracy of soil line placement. The maps do not show the small areas of contrasting soils that could have been shown at a more detailed scale.

Please rely on the bar scale on each map sheet for map measurements.

Source of Map: Natural Resources Conservation Service
 Web Soil Survey URL:
 Coordinate System: Web Mercator (EPSG:3857)

Maps from the Web Soil Survey are based on the Web Mercator projection, which preserves direction and shape but distorts distance and area. A projection that preserves area, such as the Albers equal-area conic projection, should be used if more accurate calculations of distance or area are required.

This product is generated from the USDA-NRCS certified data as of the version date(s) listed below.

Soil Survey Area: El Paso County Area, Colorado
 Survey Area Data: Version 20, Sep 2, 2022

Soil map units are labeled (as space allows) for map scales 1:50,000 or larger.

Date(s) aerial images were photographed: Jun 9, 2021—Jun 12, 2021

The orthophoto or other base map on which the soil lines were compiled and digitized probably differs from the background imagery displayed on these maps. As a result, some minor shifting of map unit boundaries may be evident.

Hydrologic Soil Group

Map unit symbol	Map unit name	Rating	Acres in AOI	Percent of AOI
19	Columbine gravelly sandy loam, 0 to 3 percent slopes	A	18.1	4.1%
42	Kettle-Rock outcrop complex	B	135.4	30.8%
66	Peyton sandy loam, 1 to 5 percent slopes	B	1.7	0.4%
68	Peyton-Pring complex, 3 to 8 percent slopes	B	91.1	20.7%
69	Peyton-Pring complex, 8 to 15 percent slopes	B	5.6	1.3%
71	Pring coarse sandy loam, 3 to 8 percent slopes	B	171.8	39.0%
72	Pring coarse sandy loam, 8 to 15 percent slopes	B	16.2	3.7%
Totals for Area of Interest			440.0	100.0%

Description

Hydrologic soil groups are based on estimates of runoff potential. Soils are assigned to one of four groups according to the rate of water infiltration when the soils are not protected by vegetation, are thoroughly wet, and receive precipitation from long-duration storms.

The soils in the United States are assigned to four groups (A, B, C, and D) and three dual classes (A/D, B/D, and C/D). The groups are defined as follows:

Group A. Soils having a high infiltration rate (low runoff potential) when thoroughly wet. These consist mainly of deep, well drained to excessively drained sands or gravelly sands. These soils have a high rate of water transmission.

Group B. Soils having a moderate infiltration rate when thoroughly wet. These consist chiefly of moderately deep or deep, moderately well drained or well drained soils that have moderately fine texture to moderately coarse texture. These soils have a moderate rate of water transmission.

Group C. Soils having a slow infiltration rate when thoroughly wet. These consist chiefly of soils having a layer that impedes the downward movement of water or soils of moderately fine texture or fine texture. These soils have a slow rate of water transmission.

Group D. Soils having a very slow infiltration rate (high runoff potential) when thoroughly wet. These consist chiefly of clays that have a high shrink-swell potential, soils that have a high water table, soils that have a claypan or clay layer at or near the surface, and soils that are shallow over nearly impervious material. These soils have a very slow rate of water transmission.

If a soil is assigned to a dual hydrologic group (A/D, B/D, or C/D), the first letter is for drained areas and the second is for undrained areas. Only the soils that in their natural condition are in group D are assigned to dual classes.

Rating Options

Aggregation Method: Dominant Condition

Component Percent Cutoff: None Specified

Tie-break Rule: Higher

APPENDIX C: HYDROLOGY



STANDARD FORM SF-1
RUNOFF COEFFICIENTS - IMPERVIOUS CALCULATION
 EXISTING CONDITIONS

PROJECT NAME: Overlook
 PROJECT NUMBER: 196239003
 CALCULATED BY: GKS
 CHECKED BY: KRK

DATE: 1/24/2024

SOIL: B		RESIDENTIAL (>5AC)	PASTURE/MEADOW (SOIL GROUP A/B)	PAVEMENT							
LAND USE:		AREA	AREA	AREA	AREA						
2-YEAR COEFF.		0.05	0.02	0.89							
5-YEAR COEFF.		0.12	0.08	0.90							
10-YEAR COEFF.		0.20	0.15	0.92							
100-YEAR COEFF.		0.39	0.35	0.96							
IMPERVIOUS %		7%	0%	100%							
DESIGN BASIN	DESIGN POINT	RESIDENTIAL (>5AC) AREA (AC)	PASTURE/MEADOW (SOIL GROUP A/B) AREA (AC)	PAVEMENT AREA (AC)	AREA (AC)	TOTAL AREA (AC)	C(2)	C(5)	C(10)	C(100)	Imp %
FDR Basins											
A1	1		18.28	1.64		19.92	0.09	0.15	0.21	0.40	8%
A2	2		60.84	0.66		61.50	0.03	0.09	0.16	0.36	1%
B1	3		45.75			45.75	0.02	0.08	0.15	0.35	0%
B2	4		42.42			42.42	0.02	0.08	0.15	0.35	0%
B3	5		25.42			25.42	0.02	0.08	0.15	0.35	0%
B3A	5A		24.23			24.23	0.02	0.08	0.15	0.35	0%
OS-A1	14		3.29	0.77		4.06	0.19	0.24	0.30	0.47	19%
OS-A2	15	4.45				4.45	0.05	0.12	0.20	0.39	7%
TOTAL - OVERALL		4.45	230.23	3.87	0.00	237.75	0.03	0.09	0.16	0.36	1%
		2%	97%	1%	0%	100%					

Note: Land use coefficients sourced from City of Colorado Springs Drainage Criteria Manual, Volume 1, Table 6-6.

**STANDARD FORM SF-2
Time of Concentration**

PROJECT NAME: **Overlook**
 PROJECT NUMBER: **196239003**
 CALCULATED BY: **GKS**
 CHECKED BY: **KRK**

EXISTING CONDITIONS

DATE: 1/24/2024

SUB-BASIN DATA			INITIAL TIME (T _i)			TRAVEL TIME (T _i)					T _c CHECK (URBANIZED BASINS)				FINAL T _c	
DESIGN BASIN (1)	AREA Ac (2)	C5 (3)	LENGTH Ft (4)	SLOPE % (5)	T _i Min. (6)	LENGTH Ft. (7)	SLOPE % (8)	C _v (9)	VEL fps (11)	T _i Min. (12)	COMP. t _c (13)	TOTAL LENGTH (14)	TOTAL SLOPE (15)	TOTAL IMP. (16)	T _c Min. (17)	Min.
FDR Basins																
A1	19.92	0.15	300	18.0%	11.5	2,066	5.7%	2.5	0.6	57.7	69.2	2366	7.3%	8%	23.1	23.1
A2	61.50	0.09	300	18.0%	12.3	3,677	5.7%	2.5	0.6	102.7	114.9	3977	6.6%	1%	32.1	32.1
B1	45.75	0.08	300	25.0%	11.1	2,577	6.5%	2.5	0.6	67.4	78.5	2877	8.4%		26.0	26.0
B2	42.42	0.08	300	6.9%	17.0	2,347	10.3%	2.5	0.8	48.8	65.8	2647	9.9%		24.7	24.7
B3	25.42	0.08	300	23.0%	11.4	1,968	9.9%	2.5	0.8	41.7	53.1	2268	11.6%		22.6	22.6
B3A	24.23	0.08	300	20.0%	11.9	1,500	10.0%	2.5	0.8	31.6	43.6	1800	11.7%		20.0	20.0
OS-A1	4.06	0.24	300	5.0%	16.1	161	5.0%	2.5	0.6	4.8	20.9	461	5.0%	19%	12.6	12.6
OS-A2	4.45	0.12	250	10.0%	13.2			2.5			13.2	250	10.0%	7%	11.4	11.4

$$t_i = \frac{0.395(1.1 - C_5)\sqrt{L_i}}{S_0^{0.33}} \quad t_c = \frac{L}{180} + 10 \quad V = C_v S_w^{0.5}$$

Note: Conveyance coefficient from Table 6-7 of DCM



**STANDARD FORM SF-3
STORM DRAINAGE DESIGN - RATIONAL METHOD 5 YEAR EVENT**

PROJECT NAME: Overlook
 PROJECT NUMBER: 196239003
 CALCULATED BY: GKS
 CHECKED BY: KRK

EXISTING CONDITIONS

DATE: 1/24/2024

STORM LINE	DESIGN POINT	DIRECT RUNOFF							TOTAL RUNOFF				STREET		PIPE		TRAVEL TIME			REMARKS	
		DESIGN BASIN	AREA (AC)	RUNOFF COEFF	t _c (min)	C*A (ac)	I (in/hr)	Q (cfs)	t _c (max)	S(C*A) (ac)	I (in/hr)	Q (cfs)	SLOPE (%)	STREET FLOW(cfs)	DESIGN FLOW(cfs)	SLOPE (%)	PIPE SIZE (in)	LENGTH (ft)	VELOCITY		t _t (min)
(1)	(2)	(3)	(4)	(5)	(6)	(7)	(8)	(9)	(10)	(11)	(12)	(13)	(14)	(15)	(16)	(17)	(18)	(19)	(20)	(21)	(22)
	1	A1	19.92	0.15	23.14	2.94	2.87	8.43													
	2	A2	61.50	0.09	32.09	5.46	2.38	13.00													
	3	B1	45.75	0.08	25.98	3.66	2.70	9.87													
	4	B2	42.42	0.08	24.71	3.39	2.77	9.41													
	5	B3	25.42	0.08	22.60	2.03	2.91	5.91													
	5A	B3A	24.23	0.08	20.00	1.94	3.09	5.99													
	14	OS-A1	4.06	0.24	12.56	0.96	3.79	3.62													
	15	OS-A2	4.45	0.12	11.39	0.53	3.93	2.10													

Note: Rainfall intensity from Figure 6-5 IDF Equations

$$I_5 = -1.5 \ln(t_{c,min}) + 7.583$$



**STANDARD FORM SF-3
STORM DRAINAGE DESIGN - RATIONAL METHOD 100 YEAR EVENT**

PROJECT NAME: Overlook
PROJECT NUMBER: 196239003
CALCULATED BY: GKS
CHECKED BY: KRK

EXISTING CONDITIONS

DATE: 1/24/2024

STORM LINE	DESIGN POINT	DIRECT RUNOFF							TOTAL RUNOFF				STREET		PIPE			TRAVEL TIME			REMARKS
		DESIGN BASIN	AREA (AC)	RUNOFF COEFF	t _c (min)	C*A(ac)	I (in/hr)	Q (cfs)	t _c (max)	S(C*A) (ac)	I (in/hr)	Q (cfs)	SLOPE (%)	STREET FLOW(cfs)	DESIGN FLOW(cfs)	SLOPE (%)	PIPE SIZE (in)	LENGTH (ft)	VELOCIT Y	t _t (min)	
(1)	(2)	(3)	(4)	(5)	(6)	(7)	(8)	(9)	(10)	(11)	(12)	(13)	(14)	(15)	(16)	(17)	(18)	(19)	(20)	(21)	(22)
	1	A1	19.92	0.40	23.14	7.97	4.82	38.41													
	2	A2	61.50	0.36	32.09	21.93	3.99	87.58													
	3	B1	45.75	0.35	25.98	16.01	4.53	72.48													
	4	B2	42.42	0.35	24.71	14.85	4.65	69.09													
	5	B3	25.42	0.35	22.60	8.90	4.88	43.40													
	5A	B3A	24.23	0.35	20.00	8.48	5.19	43.98													
	14	OS-A1	4.06	0.47	12.56	1.89	6.36	12.02													
	15	OS-A2	4.45	0.39	11.39	1.74	6.60	11.46													

Note: Rainfall intensity from Figure 6-5 IDF Equations

$$I_{100} = -2.52 \ln(t_{c,min}) + 12.735$$



PROJECT NAME: Overlook
 PROJECT NUMBER: 196239003
 CALCULATED BY: GKS
 CHECKED BY: KRK

1/24/2024

EXISTING CONDITIONS RATIONAL CALCULATIONS SUMMARY

DESIGN POINT	TRIBUTARY BASINS	TRIBUTARY AREA (AC)	CFS			% IMPERVIOUS
			Q2	Q5	Q100	
FDR Basins						
1	A1	19.92	4.19	8.43	38.41	8%
2	A2	61.50	3.44	13.00	87.58	1%
3	B1	45.75	1.98	9.87	72.48	0%
4	B2	42.42	1.88	9.41	69.09	0%
5	B3	25.42	1.18	5.91	43.40	0%
5A	B3A	24.23	1.20	5.99	43.98	0%
14	OS-A1	4.06	2.27	3.62	12.02	19%
15	OS-A2	4.45	0.70	2.10	11.46	7%
ON-SITE BASIN TOTAL						
BASIN A TOTAL		81.42	7.63	21.43	125.99	3%
BASIN B TOTAL		137.82	6.24	31.18	228.94	0%
ON-SITE TOTAL		219.24	13.87	52.61	354.92	1%
OFF-SITE BASIN TOTAL						
OFF-SITE BASIN A		8.51	2.97	5.72	23.48	13%
OFF-SITE TOTAL		8.51	2.97	5.72	23.48	13%
SITE TOTAL		227.75	16.84	58.33	378.41	1%



STANDARD FORM SF-1
RUNOFF COEFFICIENTS - IMPERVIOUS CALCULATION
 PROPOSED CONDITIONS

PROJECT NAME: Overlook
 PROJECT NUMBER: 196239003
 CALCULATED BY: GKS
 CHECKED BY: KKK

DATE: 5/7/2024

SOIL: B		RESIDENTIAL (>5AC)	PASTURE/MEADOW (SOIL GROUP A/B)	PAVEMENT							
LAND USE:		AREA	AREA	AREA	AREA						
2-YEAR COEFF.		0.05	0.02	0.89							
5-YEAR COEFF.		0.12	0.08	0.90							
10-YEAR COEFF.		0.20	0.15	0.92							
100-YEAR COEFF.		0.39	0.35	0.96							
IMPERVIOUS %		7%	0%	100%							
DESIGN BASIN	DESIGN POINT	RESIDENTIAL (>5AC) AREA (AC)	PASTURE/MEADOW (SOIL GROUP A/B) AREA (AC)	PAVEMENT AREA (AC)	AREA (AC)	TOTAL AREA (AC)	C(2)	C(5)	C(10)	C(100)	Imp %
FDR Basins											
A1	1	17.91		1.64		19.55	0.12	0.19	0.26	0.44	15%
A2	2	57.26		2.25		59.51	0.08	0.15	0.23	0.41	11%
B1	3	39.58		1.16		40.74	0.07	0.14	0.22	0.41	10%
B2	4	15.66		0.34		16.00	0.07	0.14	0.22	0.40	9%
B3	5	19.11				19.11	0.05	0.12	0.20	0.39	7%
B6	8	50.40		1.67		52.07	0.08	0.15	0.22	0.41	10%
B7	9	2.46				2.46	0.05	0.12	0.20	0.39	7%
B8	10	9.52				9.52	0.05	0.12	0.20	0.39	7%
OS-A1	18	3.29		0.77		4.06	0.21	0.27	0.34	0.50	25%
OS-A2	19	4.45				4.45	0.05	0.12	0.20	0.39	7%
TOTAL - OVERALL		219.64	0.00	7.83	0.00	227.47	0.08	0.15	0.22	0.41	10%
		97%	0%	3%	0%	100%					

Note: Land use coefficients sourced from City of Colorado Springs Drainage Criteria Manual, Volume 1, Table 6-6.



**STANDARD FORM SF-2
Time of Concentration**

PROJECT NAME: **Overlook**
 PROJECT NUMBER: **196239003**
 CALCULATED BY: **GKS**
 CHECKED BY: **KRK**

PROPOSED CONDITIONS

DATE: 5/7/2024

SUB-BASIN DATA			INITIAL TIME (T _i)			TRAVEL TIME (T _c)					T _c CHECK (URBANIZED BASINS)				FINAL T _c	
DESIGN BASIN (1)	AREA Ac (2)	C5 (3)	LENGTH Ft (4)	SLOPE % (5)	T _i Min. (6)	LENGTH Ft (7)	SLOPE % (8)	C _v (9)	VEL fps (11)	T _i Min. (12)	COMP. t _c (13)	TOTAL LENGTH (14)	TOTAL SLOPE (15)	TOTAL IMP. (16)	T _c Min. (17)	Min. (18)
FDR Basins																
A1	19.55	0.19	300	18.0%	11.1	2,066	5.0%	2.5	0.6	61.6	72.7	2366	6.6%	15%	23.1	23.1
A2	59.51	0.15	300	18.0%	11.5	4,100	4.0%	2.5	0.5	136.7	148.2	4400	5.0%	11%	34.4	34.4
B1	40.74	0.14	300	8.0%	15.2	2,000	4.5%	2.5	0.5	62.9	78.1	2300	5.0%	10%	22.8	22.8
B2	16.00	0.14	300	7.0%	16.0	500	6.0%	2.5	0.6	13.6	29.6	800	6.4%	9%	14.4	14.4
B3	19.11	0.12	300	21.0%	11.3	800	8.0%	2.5	0.7	18.9	30.1	1100	11.5%	7%	16.1	16.1
B6	52.07	0.15	300	22.0%	10.8	1,900	3.0%	2.5	0.4	73.1	84.0	2200	5.6%	10%	22.2	22.2
B7	2.46	0.12	300	6.0%	17.1	100	6.0%	2.2	0.5	3.1	20.2	400	6.0%	7%	12.2	12.2
B8	9.52	0.12	300	6.0%	17.1	300	10.0%	2.5	0.8	6.3	23.5	600	8.0%	7%	13.3	13.3
OS-A1	4.06	0.27	300	5.0%	15.5	161	5.0%	2.5	0.6	4.8	20.3	461	5.0%	25%	12.6	12.6
OS-A2	4.45	0.12	250	10.0%	13.2			2.5			13.2	250	10.0%	7%	11.4	11.4

$$t_i = \frac{0.395(1.1 - C_5)\sqrt{L_i}}{S_0^{0.33}} \quad t_c = \frac{L}{180} + 10 \quad V = C_v S_w^{0.5}$$

Note: Conveyance coefficient from Table 6-7 of DCM



**STANDARD FORM SF-3
STORM DRAINAGE DESIGN - RATIONAL METHOD 5 YEAR EVENT**

PROJECT NAME: Overlook
PROJECT NUMBER: 196239003
CALCULATED BY: GKS
CHECKED BY: KRK

PROPOSED CONDITIONS

DATE: 5/7/2024

STORM LINE	DESIGN POINT	DIRECT RUNOFF							TOTAL RUNOFF				STREET		PIPE		TRAVEL TIME			REMARKS	
		DESIGN BASIN	AREA (AC)	RUNOFF COEFF	t _c (min)	C*A(ac)	I (in/hr)	Q (cfs)	t _c (max)	S(C*A) (ac)	I (in/hr)	Q (cfs)	SLOPE (%)	STREET FLOW(cfs)	DESIGN FLOW(cfs)	SLOPE (%)	PIPE SIZE (in)	LENGTH (ft)	VELOCITY		t _t (min)
(1)	(2)	(3)	(4)	(5)	(6)	(7)	(8)	(9)	(10)	(11)	(12)	(13)	(14)	(15)	(16)	(17)	(18)	(19)	(20)	(21)	(22)
	1	A1	19.55	0.19	23.14	3.63	2.87	10.41													
	2	A2	59.51	0.15	34.44	8.90	2.27	20.23													
	3	B1	40.74	0.14	22.78	5.79	2.89	16.77													
	4	B2	16.00	0.14	14.44	2.19	3.58	7.82													
	5	B3	19.11	0.12	16.11	2.29	3.41	7.83													
	8	B6	52.07	0.15	22.22	7.55	2.93	22.13													
	9	B7	2.46	0.12	12.22	0.30	3.83	1.13													
	10	B8	9.52	0.12	13.33	1.14	3.70	4.22													
	18	OS-A1	4.06	0.27	12.56	1.09	3.79	4.12													
	19	OS-A2	4.45	0.12	11.39	0.53	3.93	2.10													

Note: Rainfall intensity from Figure 6-5 IDF Equations

$$I_5 = -1.5 \ln(t_{c,min}) + 7.583$$



**STANDARD FORM SF-3
STORM DRAINAGE DESIGN - RATIONAL METHOD 100 YEAR EVENT**

PROJECT NAME: Overlook
 PROJECT NUMBER: 196239003
 CALCULATED BY: GKS
 CHECKED BY: KRK

PROPOSED CONDITIONS

DATE: 5/7/2024

STORM LINE	DESIGN POINT	DIRECT RUNOFF							TOTAL RUNOFF				STREET		PIPE			TRAVEL TIME			REMARKS
		DESIGN BASIN	AREA (AC)	RUNOFF COEFF	t _c (min)	C*A(ac)	I (in/hr)	Q (cfs)	t _c (max)	S(C*A) (ac)	I (in/hr)	Q (cfs)	SLOPE (%)	STREET FLOW(cfs)	DESIGN FLOW(cfs)	SLOPE (%)	PIPE SIZE (in)	LENGTH (ft)	VELOCIT Y	t _t (min)	
(1)	(2)	(3)	(4)	(5)	(6)	(7)	(8)	(9)	(10)	(11)	(12)	(13)	(14)	(15)	(16)	(17)	(18)	(19)	(20)	(21)	(22)
	1	A1	19.55	0.44	23.14	8.56	4.82	41.24													
	2	A2	59.51	0.41	34.44	24.49	3.82	93.46													
	3	B1	40.74	0.41	22.78	16.55	4.86	80.40													
	4	B2	16.00	0.40	14.44	6.43	6.01	38.64													
	5	B3	19.11	0.39	16.11	7.45	5.73	42.71													
	8	B6	52.07	0.41	22.22	21.26	4.92	104.60													
	9	B7	2.46	0.39	12.22	0.96	6.43	6.17													
	10	B8	9.52	0.39	13.33	3.71	6.21	23.05													
	18	OS-A1	4.06	0.50	12.56	2.02	6.36	12.86													
	19	OS-A2	4.45	0.39	11.39	1.74	6.60	11.46													

Note: Rainfall intensity from Figure 6-5 IDF Equations

$$I_{100} = -2.52 \ln(t_{c,min}) + 12.735$$



PROJECT NAME: Overlook
 PROJECT NUMBER: 196239003
 CALCULATED BY: GKS
 CHECKED BY: KRK

5/7/2024

PROPOSED CONDITIONS RATIONAL CALCULATIONS SUMMARY

DESIGN POINT	TRIBUTARY BASINS	TRIBUTARY AREA (AC)	CFS			% IMPERVIOUS
			Q2	Q5	Q100	
PDR Basins						
1	A1	19.55	5.41	10.41	41.24	15%
2	A2	59.51	8.87	20.23	93.46	11%
3	B1	40.74	6.97	16.77	80.40	10%
4	B2	16.00	3.10	7.82	38.64	9%
5	B3	19.11	2.61	7.83	42.71	7%
8	B6	52.07	9.39	22.13	104.60	10%
9	B7	2.46	0.38	1.13	6.17	7%
10	B8	9.52	1.41	4.22	23.05	7%
18	OS-A1	4.06	2.57	4.12	12.86	25%
19	OS-A2	4.45	0.70	2.10	11.46	7%
ON-SITE BASIN TOTAL						
BASIN A TOTAL		79.06	14.28	30.64	134.69	12%
BASIN B TOTAL		139.90	23.86	59.90	295.56	9%
ON-SITE TOTAL		218.96	23.86	59.90	295.56	10%
OFF-SITE BASIN TOTAL						
OFF-SITE BASIN A		8.51	3.27	6.22	24.32	15%
OFF-SITE TOTAL		8.51	3.27	6.22	24.32	15%
SITE TOTAL		227.47	27.12	66.12	319.88	10%

APPENDIX D: HYDRUALICS

DETENTION BASIN STAGE-STORAGE TABLE BUILDER

MHFD-Detention, Version 4.06 (July 2022)

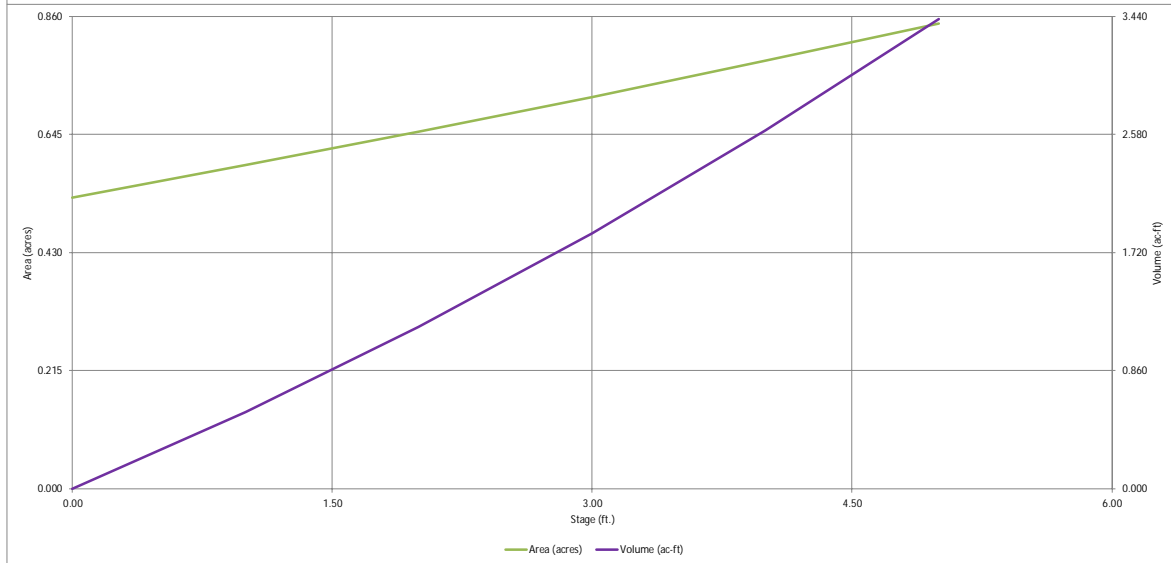
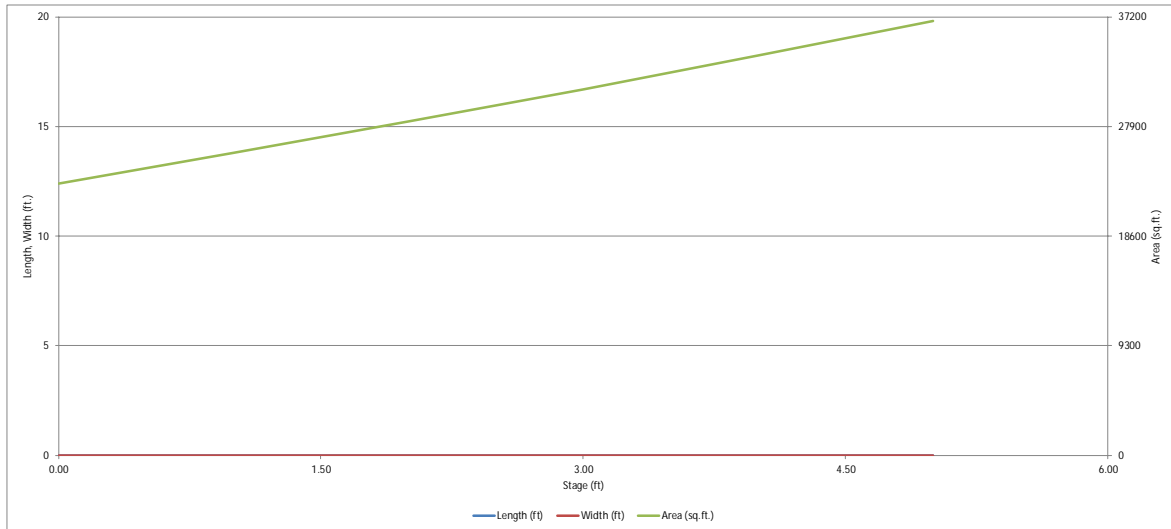

DETENTION BASIN STAGE-STORAGE TABLE BUILDER

MHFD-Detention, Version 4.06 (July 2022)

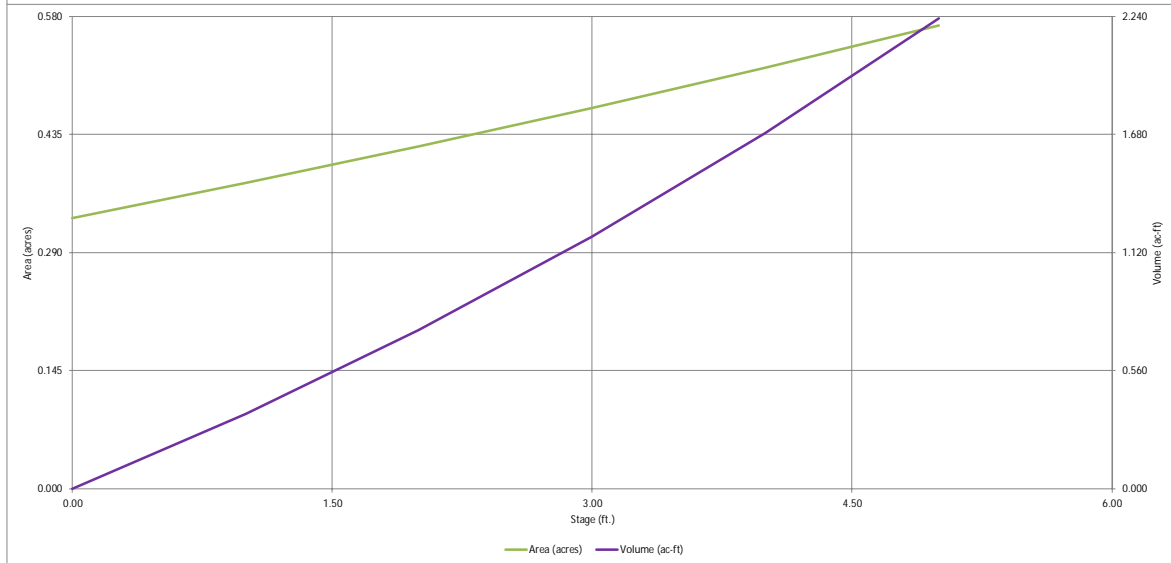
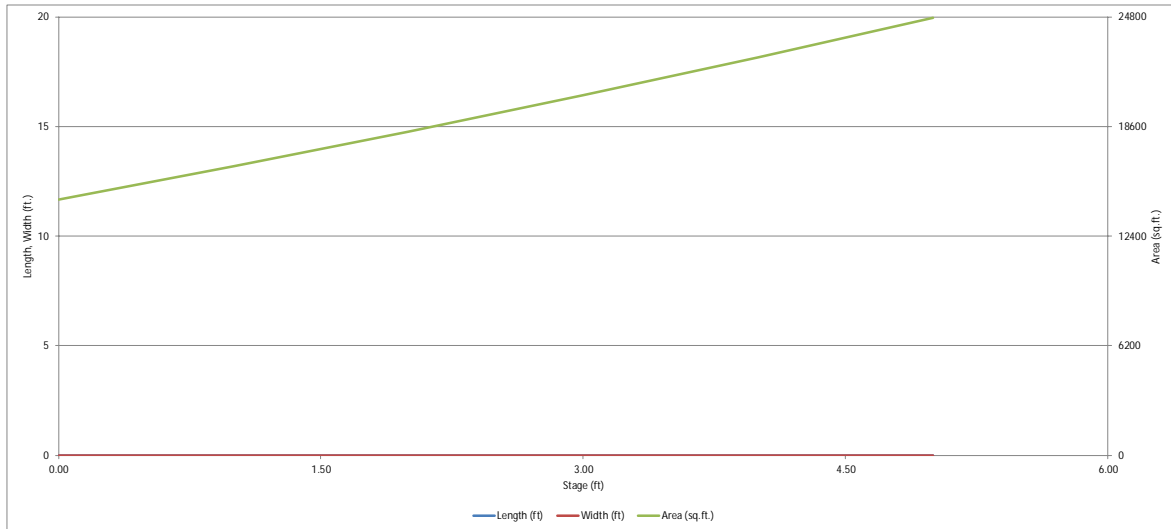

DETENTION BASIN STAGE-STORAGE TABLE BUILDER

MHFD-Detention, Version 4.06 (July 2022)

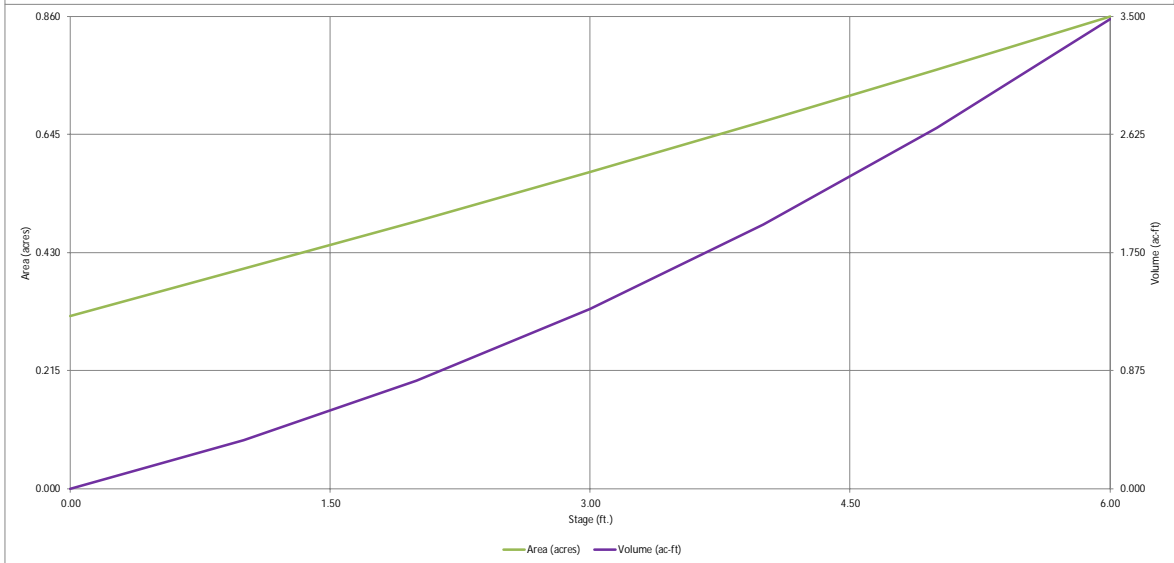
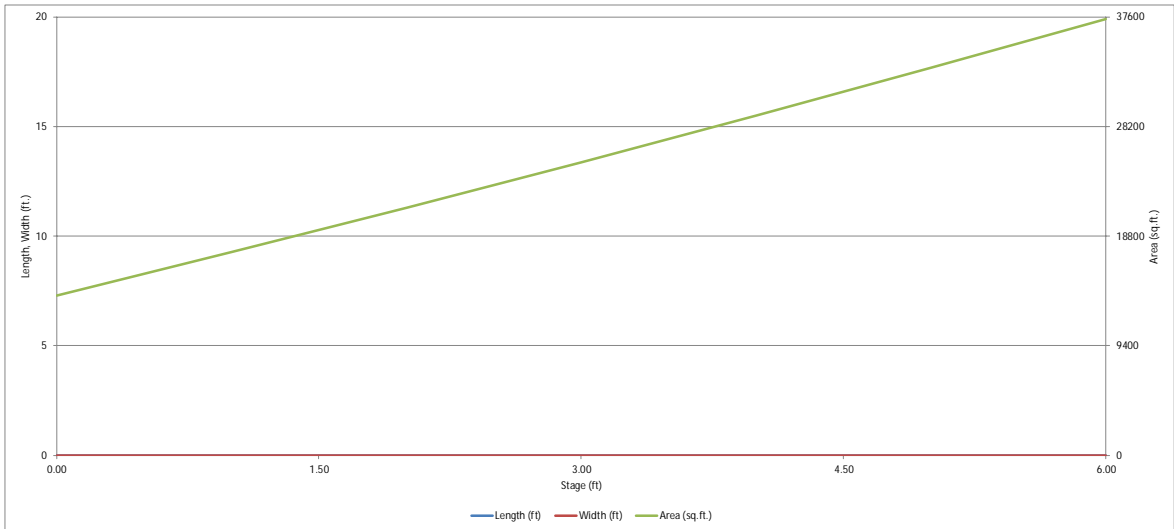

DETENTION BASIN STAGE-STORAGE TABLE BUILDER

MHFD-Detention, Version 4.06 (July 2022)

Project: **Overlook**
Basin ID: **TSB B1**

TSB B1 AND STANDPIPE SIZING

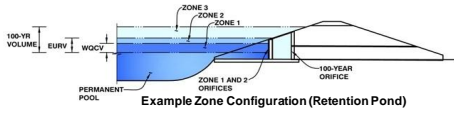

Example Zone Configuration (Retention Pond)

Watershed Information

Selected BMP Type =	EDB	
Watershed Area =	40.70	acres
Watershed Length =	1,600	ft
Watershed Length to Centroid =	800	ft
Watershed Slope =	0.060	ft/ft
Watershed Imperviousness =	10.00%	percent
Percentage Hydrologic Soil Group A =	0.0%	percent
Percentage Hydrologic Soil Group B =	100.0%	percent
Percentage Hydrologic Soil Groups C/D =	0.0%	percent
Target WQCV Drain Time =	72.0	hours
Location for 1-hr Rainfall Depths =	User Input	

Drain Time Too Long

After providing required inputs above including 1-hour rainfall depths, click "Run CUHP" to generate runoff hydrographs using the embedded Colorado Urban Hydrograph Procedure.

Water Quality Capture Volume (WQCV) =	0.227	acre-feet
Excess Urban Runoff Volume (EURV) =	0.383	acre-feet
2-yr Runoff Volume (P1 = 1.19 in.) =	0.541	acre-feet
5-yr Runoff Volume (P1 = 1.5 in.) =	1.195	acre-feet
10-yr Runoff Volume (P1 = 1.75 in.) =	1.848	acre-feet
25-yr Runoff Volume (P1 = 2 in.) =	3.010	acre-feet
50-yr Runoff Volume (P1 = 2.25 in.) =	3.803	acre-feet
100-yr Runoff Volume (P1 = 2.52 in.) =	4.945	acre-feet
500-yr Runoff Volume (P1 = 3.14 in.) =	7.025	acre-feet
Approximate 2-yr Detention Volume =	0.244	acre-feet
Approximate 5-yr Detention Volume =	0.383	acre-feet
Approximate 10-yr Detention Volume =	0.795	acre-feet
Approximate 25-yr Detention Volume =	1.110	acre-feet
Approximate 50-yr Detention Volume =	1.162	acre-feet
Approximate 100-yr Detention Volume =	1.502	acre-feet

Optional User Overrides

	1.19	inches
	1.50	inches
	1.75	inches
	2.00	inches
	2.25	inches
	2.52	inches
		inches

Define Zones and Basin Geometry

Zone 1 Volume (User Defined) =	0.939	acre-feet
Select Zone 2 Storage Volume (Optional) =		acre-feet
Select Zone 3 Storage Volume (Optional) =		acre-feet
Total Detention Basin Volume =	0.939	acre-feet
Initial Surcharge Volume (ISV) =	user	ft ³
Initial Surcharge Depth (ISD) =	user	ft
Total Available Detention Depth (H _{total}) =	user	ft
Depth of Trickle Channel (H _{tc}) =	user	ft
Slope of Trickle Channel (S _{tc}) =	user	ft/ft
Slopes of Main Basin Sides (S _{main}) =	user	H:V
Basin Length-to-Width Ratio (R _{L/W}) =	user	
Initial Surcharge Area (A _{ISV}) =	user	ft ²
Surcharge Volume Length (L _{ISV}) =	user	ft
Surcharge Volume Width (W _{ISV}) =	user	ft
Depth of Basin Floor (H _{FLOOR}) =	user	ft
Length of Basin Floor (L _{FLOOR}) =	user	ft
Width of Basin Floor (W _{FLOOR}) =	user	ft
Area of Basin Floor (A _{FLOOR}) =	user	ft ²
Volume of Basin Floor (V _{FLOOR}) =	user	ft ³
Depth of Main Basin (H _{MAIN}) =	user	ft
Length of Main Basin (L _{MAIN}) =	user	ft
Width of Main Basin (W _{MAIN}) =	user	ft
Area of Main Basin (A _{MAIN}) =	user	ft ²
Volume of Main Basin (V _{MAIN}) =	user	ft ³
Calculated Total Basin Volume (V _{total}) =	user	acre-feet

Total detention volume is less than 100-year volume.

7192.5

Stage - Storage Description	Stage (ft)	Optional Override Stage (ft)	Length (ft)	Width (ft)	Area (ft ²)	Optional Override Area (ft ²)	Area (acre)	Volume (ft ³)	Volume (ac-ft)
Top of Micropool	--	0.00	--	--	--	16	0.000		
7193	--	0.50	--	--	--	2,596	0.060	653	0.015
7194	--	1.50	--	--	--	22,714	0.521	13,308	0.306
7195	--	2.50	--	--	--	25,811	0.593	37,570	0.862
7196	--	3.50	--	--	--	29,009	0.666	64,980	1.492
7197	--	4.50	--	--	--	32,308	0.742	95,639	2.196

DETENTION BASIN STAGE-STORAGE TABLE BUILDER

MHFD-Detention, Version 4.06 (July 2022)

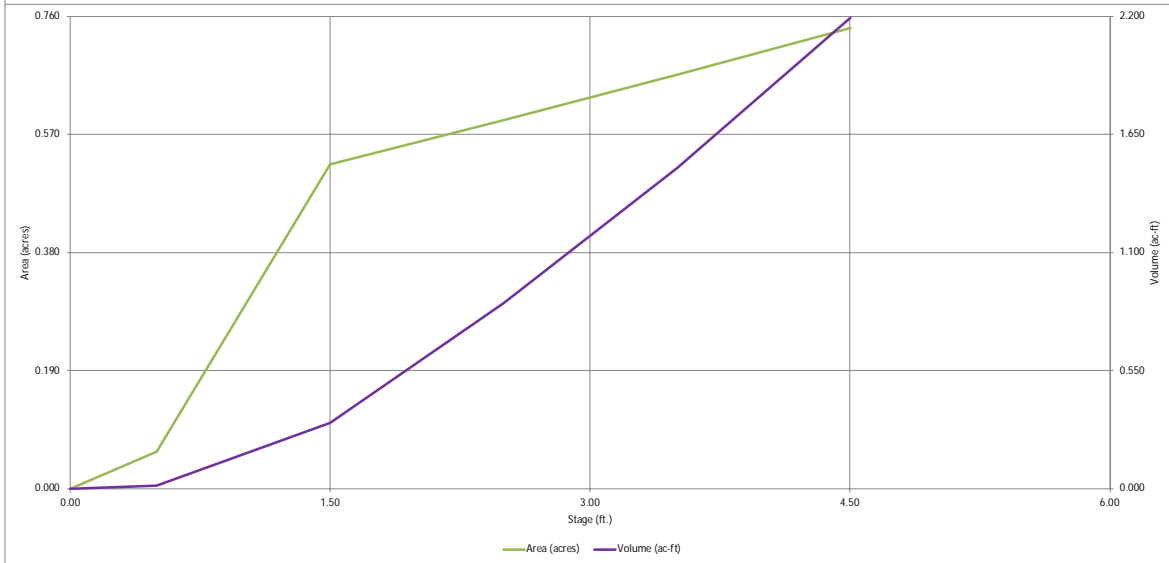
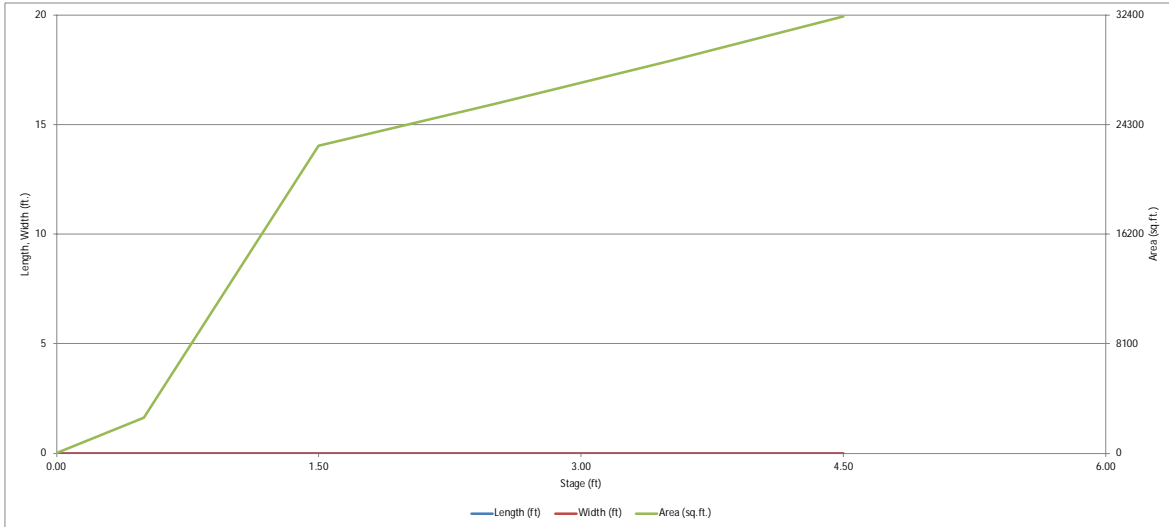

DETENTION BASIN OUTLET STRUCTURE DESIGN

MHFD-Detention, Version 4.06 (July 2022)

Project: Overlook
Basin ID: TSB B1

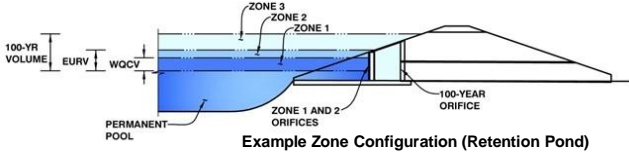

	Estimated Stage (ft)	Estimated Volume (ac-ft)	Outlet Type
Zone 1 (User)	2.63	0.939	Orifice Plate
Zone 2			Not Utilized
Zone 3			Not Utilized
Total (all zones)		0.939	

User Input: Orifice at Underdrain Outlet (typically used to drain WQCV in a Filtration BMP)

Underdrain Orifice Invert Depth = ft (distance below the filtration media surface)
Underdrain Orifice Diameter = inches

Calculated Parameters for Underdrain
Underdrain Orifice Area = ft²
Underdrain Orifice Centroid = feet

User Input: Orifice Plate with one or more orifices or Elliptical Slot Weir (typically used to drain WQCV and/or EURV in a sedimentation BMP)

Centroid of Lowest Orifice = ft (relative to basin bottom at Stage = 0 ft)
Depth at top of Zone using Orifice Plate = ft (relative to basin bottom at Stage = 0 ft)
Orifice Plate: Orifice Vertical Spacing = inches
Orifice Plate: Orifice Area per Row = sq. inches

Calculated Parameters for Plate
WO Orifice Area per Row = ft²
Elliptical Half-Width = feet
Elliptical Slot Centroid = feet
Elliptical Slot Area = ft²

User Input: Stage and Total Area of Each Orifice Row (numbered from lowest to highest)

	Row 1 (required)	Row 2 (optional)	Row 3 (optional)	Row 4 (optional)	Row 5 (optional)	Row 6 (optional)	Row 7 (optional)	Row 8 (optional)
Stage of Orifice Centroid (ft)	0.15	0.65	0.85					
Orifice Area (sq. inches)	0.78	0.78	0.78					

	Row 9 (optional)	Row 10 (optional)	Row 11 (optional)	Row 12 (optional)	Row 13 (optional)	Row 14 (optional)	Row 15 (optional)	Row 16 (optional)
Stage of Orifice Centroid (ft)								
Orifice Area (sq. inches)								

User Input: Vertical Orifice (Circular or Rectangular)

Invert of Vertical Orifice = ft (relative to basin bottom at Stage = 0 ft)
Depth at top of Zone using Vertical Orifice = ft (relative to basin bottom at Stage = 0 ft)
Vertical Orifice Diameter = inches

Calculated Parameters for Vertical Orifice
Vertical Orifice Area = ft²
Vertical Orifice Centroid = feet

User Input: Overflow Weir (Dropbox with Flat or Sloped Grate and Outlet Pipe OR Rectangular/Trapezoidal Weir and No Outlet Pipe)

Overflow Weir Front Edge Height, H_o = ft (relative to basin bottom at Stage = 0 ft)
Overflow Weir Front Edge Length = feet
Overflow Weir Grate Slope = H:V
Horiz. Length of Weir Sides = feet
Overflow Grate Type =
Debris Clogging % = %

Calculated Parameters for Overflow Weir
Height of Grate Upper Edge, H₁ = ft
Overflow Weir Slope Length = feet
Grate Open Area / 100-yr Orifice Area =
Overflow Grate Open Area w/o Debris = ft²
Overflow Grate Open Area w/ Debris = ft²

User Input: Outlet Pipe w/ Flow Restriction Plate (Circular Orifice, Restrictor Plate, or Rectangular Orifice)

Depth to Invert of Outlet Pipe = ft (distance below basin bottom at Stage = 0 ft)
Circular Orifice Diameter = inches

Calculated Parameters for Outlet Pipe w/ Flow Restriction Plate
Outlet Orifice Area = ft²
Outlet Orifice Centroid = feet
Half-Central Angle of Restrictor Plate on Pipe = degrees

User Input: Emergency Spillway (Rectangular or Trapezoidal)

Spillway Invert Stage = ft (relative to basin bottom at Stage = 0 ft)
Spillway Crest Length = feet
Spillway End Slopes = H:V
Freeboard above Max Water Surface = feet

Calculated Parameters for Spillway
Spillway Design Flow Depth = feet
Stage at Top of Freeboard = feet
Basin Area at Top of Freeboard = acres
Basin Volume at Top of Freeboard = acre-ft

Routed Hydrograph Results

The user can override the default CUHP hydrographs and runoff volumes by entering new values in the Inflow Hydrographs table (Columns W through AF).

	WQCV	EURV	2 Year	5 Year	10 Year	25 Year	50 Year	100 Year
Design Storm Return Period								
One-Hour Rainfall Depth (in)	N/A	N/A	1.19	1.50	1.75	2.00	2.25	2.52
CUHP Runoff Volume (acre-ft)	0.227	0.383	0.541	1.195	1.848	3.010	3.803	4.945
Inflow Hydrograph Volume (acre-ft)	N/A	N/A	0.541	1.195	1.848	3.010	3.803	4.945
CUHP Predevelopment Peak Q (cfs)	N/A	N/A	6.3	17.4	25.9	45.4	56.9	71.2
OPTIONAL Override Predevelopment Peak Q (cfs)	N/A	N/A						
Predevelopment Unit Peak Flow, q (cfs/acre)	N/A	N/A	0.15	0.43	0.64	1.12	1.40	1.75
Peak Inflow Q (cfs)	N/A	N/A	9.8	21.1	29.6	48.9	60.3	74.6
Peak Outflow Q (cfs)	0.1	0.1	0.1	0.1	0.1	0.2	0.2	0.2
Ratio Peak Outflow to Predevelopment Q	N/A	N/A	N/A	0.0	0.0	0.0	0.0	0.0
Structure Controlling Flow	Plate	Plate	Plate	Plate	Plate	N/A	N/A	N/A
Max Velocity through Grate 1 (fps)	N/A	N/A	N/A	N/A	N/A	N/A	N/A	N/A
Max Velocity through Grate 2 (fps)	N/A	N/A	N/A	N/A	N/A	N/A	N/A	N/A
Time to Drain 97% of Inflow Volume (hours)	68	89	108	>120	>120	>120	>120	>120
Time to Drain 99% of Inflow Volume (hours)	75	97	118	>120	>120	>120	>120	>120
Maximum Ponding Depth (ft)	1.34	1.65	1.91	3.01	3.98	4.50	4.50	4.50
Area at Maximum Ponding Depth (acres)	0.45	0.53	0.55	0.63	0.70	0.74	0.74	0.74
Maximum Volume Stored (acre-ft)	0.228	0.385	0.525	1.168	1.820	2.196	2.196	2.196

DETENTION BASIN STAGE-STORAGE TABLE BUILDER

MHFD-Detention, Version 4.06 (July 2022)

TSB A2 AND STANDPIPE SIZING

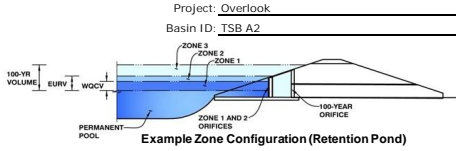

Watershed Information

Table with watershed parameters: Selected BMP Type (EDB), Watershed Area (63.96 acres), Watershed Length (2,400 ft), Watershed Length to Centroid (1,200 ft), Watershed Slope (0.030 ft/ft), Watershed Imperviousness (11.009% percent), Percentage Hydrologic Soil Group A (0.0% percent), Percentage Hydrologic Soil Group B (100.0% percent), Percentage Hydrologic Soil Groups C/D (0.0% percent), Target WQCV Drain Time (72.0 hours).

After providing required inputs above including 1-hour rainfall depths, click 'Run CUHP' to generate runoff hydrographs using the embedded Colorado Urban Hydrograph Procedure.

Table with runoff and detention volumes: Water Quality Capture Volume (0.387 acre-feet), Excess Urban Runoff Volume (0.666 acre-feet), 2-yr Runoff Volume (0.906 acre-feet), 5-yr Runoff Volume (1.951 acre-feet), 10-yr Runoff Volume (2.988 acre-feet), 25-yr Runoff Volume (4.818 acre-feet), 50-yr Runoff Volume (6.073 acre-feet), 100-yr Runoff Volume (7.872 acre-feet), 500-yr Runoff Volume (11.161 acre-feet), Approximate 2-yr Detention Volume (0.429 acre-feet), Approximate 5-yr Detention Volume (0.669 acre-feet), Approximate 10-yr Detention Volume (1.332 acre-feet), Approximate 25-yr Detention Volume (1.832 acre-feet), Approximate 50-yr Detention Volume (1.921 acre-feet), Approximate 100-yr Detention Volume (2.469 acre-feet).

Optional User Overrides

Table for optional user overrides: Excess Urban Runoff Volume (1.19 inches), 2-yr Runoff Volume (1.50 inches), 5-yr Runoff Volume (1.75 inches), 10-yr Runoff Volume (2.00 inches), 25-yr Runoff Volume (2.25 inches), 50-yr Runoff Volume (2.52 inches).

Define Zones and Basin Geometry

Table for defining zones and basin geometry: Zone 1 Volume (1.500 acre-feet), Select Zone 2 Storage Volume (Optional), Select Zone 3 Storage Volume (Optional), Total Detention Basin Volume (1.500 acre-feet), Initial Surcharge Volume (ISV) (user ft^3), Initial Surcharge Depth (ISD) (user ft), Total Available Detention Depth (Htotal) (user ft), Depth of Trickle Channel (Htc) (user ft), Slope of Trickle Channel (Strc) (user ft/ft), Slopes of Main Basin Sides (Smain) (user H:V), Basin Length-to-Width Ratio (RLWR) (user), Initial Surcharge Area (AISV) (user ft^2), Surcharge Volume Length (LISV) (user ft), Surcharge Volume Width (WISV) (user ft), Depth of Basin Floor (Hfloor) (user ft), Length of Basin Floor (LFLOOR) (user ft), Width of Basin Floor (WFLOOR) (user ft), Area of Basin Floor (AFLOOR) (user ft^2), Volume of Basin Floor (VFLOOR) (user ft^3), Depth of Main Basin (HMAIN) (user ft), Length of Main Basin (LMAIN) (user ft), Width of Main Basin (WMAIN) (user ft), Area of Main Basin (AMAIN) (user ft^2), Volume of Main Basin (VMAIN) (user ft^3), Calculated Total Basin Volume (Vtotal) (user acre-feet).

Total detention volume is less than 100-year volume.

7192.5

Main stage-storage table with columns: Depth Increment (ft), Stage - Storage Description, Stage (ft), Optional Override Stage (ft), Length (ft), Width (ft), Area (ft^2), Optional Override Area (ft^2), Area (acre), Volume (ft^3), Volume (ac-ft). Includes rows for Top of Micropool, stages 7193-7200, and multiple empty rows.

DETENTION BASIN STAGE-STORAGE TABLE BUILDER

MHFD-Detention, Version 4.06 (July 2022)

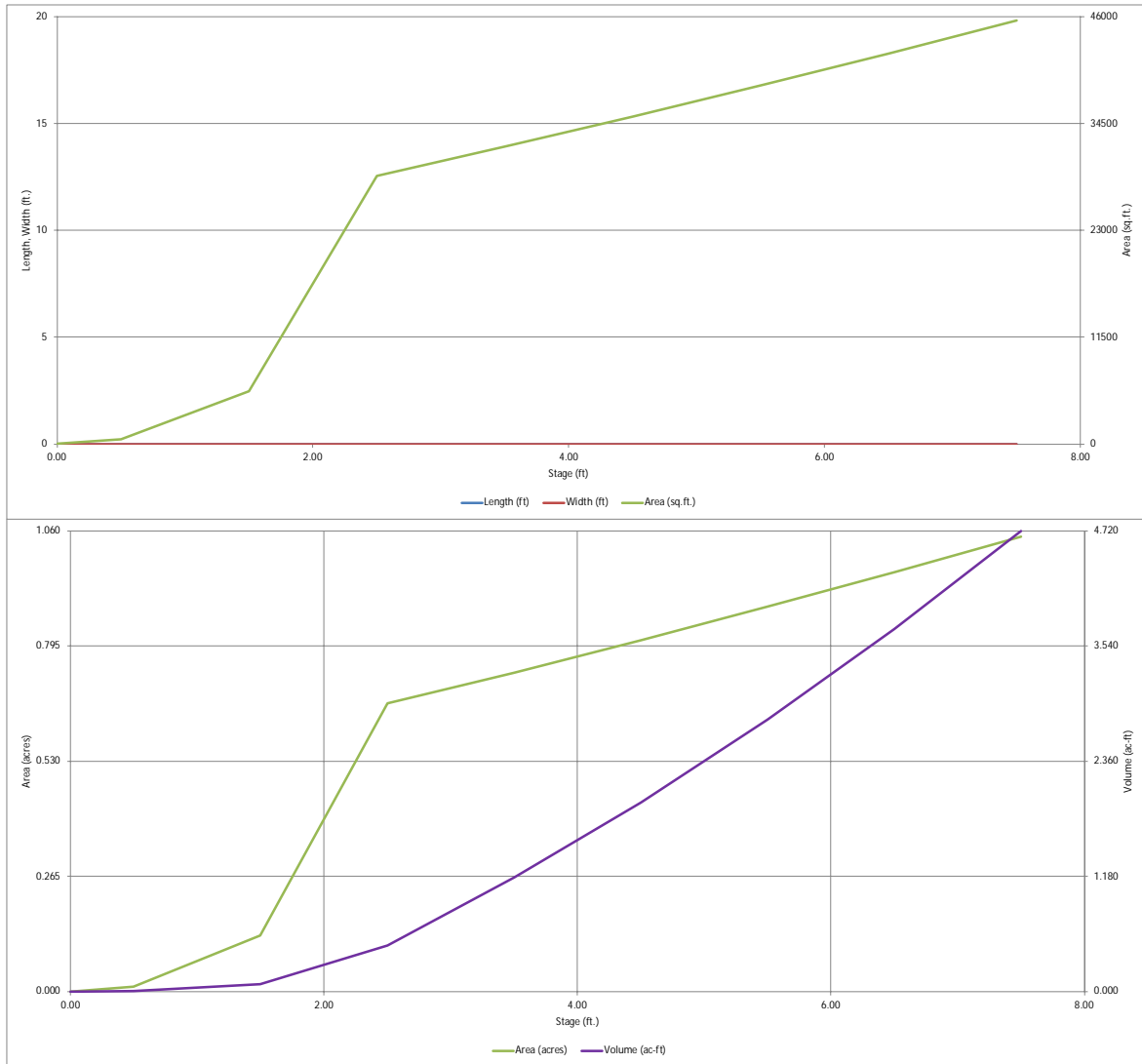

DETENTION BASIN OUTLET STRUCTURE DESIGN

MHFD-*Detention, Version 4.06 (July 2022)*

Project: **Overlook**
Basin ID: **TSB A2**

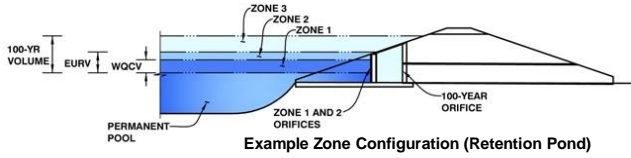

	Estimated Stage (ft)	Estimated Volume (ac-ft)	Outlet Type
Zone 1 (User)	3.95	1.500	Orifice Plate
Zone 2			Not Utilized
Zone 3			Not Utilized
Total (all zones)		1.500	

User Input: Orifice at Underdrain Outlet (typically used to drain WQCV in a Filtration BMP)

Underdrain Orifice Invert Depth = ft (distance below the filtration media surface)
Underdrain Orifice Diameter = inches

Calculated Parameters for Underdrain
Underdrain Orifice Area = ft²
Underdrain Orifice Centroid = feet

User Input: Orifice Plate with one or more orifices or Elliptical Slot Weir (typically used to drain WQCV and/or EURV in a sedimentation BMP)

Centroid of Lowest Orifice = ft (relative to basin bottom at Stage = 0 ft)
Depth at top of Zone using Orifice Plate = ft (relative to basin bottom at Stage = 0 ft)
Orifice Plate: Orifice Vertical Spacing = inches
Orifice Plate: Orifice Area per Row = sq. inches

Calculated Parameters for Plate
WO Orifice Area per Row = ft²
Elliptical Half-Width = feet
Elliptical Slot Centroid = feet
Elliptical Slot Area = ft²

User Input: Stage and Total Area of Each Orifice Row (numbered from lowest to highest)

	Row 1 (required)	Row 2 (optional)	Row 3 (optional)	Row 4 (optional)	Row 5 (optional)	Row 6 (optional)	Row 7 (optional)	Row 8 (optional)
Stage of Orifice Centroid (ft)	0.50	0.75	1.25					
Orifice Area (sq. inches)	0.78	0.78	0.78					

	Row 9 (optional)	Row 10 (optional)	Row 11 (optional)	Row 12 (optional)	Row 13 (optional)	Row 14 (optional)	Row 15 (optional)	Row 16 (optional)
Stage of Orifice Centroid (ft)								
Orifice Area (sq. inches)								

User Input: Vertical Orifice (Circular or Rectangular)

Invert of Vertical Orifice = ft (relative to basin bottom at Stage = 0 ft)
Depth at top of Zone using Vertical Orifice = ft (relative to basin bottom at Stage = 0 ft)
Vertical Orifice Diameter = inches

Calculated Parameters for Vertical Orifice
Vertical Orifice Area = ft²
Vertical Orifice Centroid = feet

User Input: Overflow Weir (Dropbox with Flat or Sloped Grate and Outlet Pipe OR Rectangular/Trapezoidal Weir and No Outlet Pipe)

Overflow Weir Front Edge Height, H_o = ft (relative to basin bottom at Stage = 0 ft)
Overflow Weir Front Edge Length = feet
Overflow Weir Grate Slope = H:V
Horiz. Length of Weir Sides = feet
Overflow Grate Type =
Debris Clogging % = %

Calculated Parameters for Overflow Weir
Height of Grate Upper Edge, H₁ = feet
Overflow Weir Slope Length = feet
Grate Open Area / 100-yr Orifice Area =
Overflow Grate Open Area w/o Debris = ft²
Overflow Grate Open Area w/ Debris = ft²

User Input: Outlet Pipe w/ Flow Restriction Plate (Circular Orifice, Restrictor Plate, or Rectangular Orifice)

Depth to Invert of Outlet Pipe = ft (distance below basin bottom at Stage = 0 ft)
Circular Orifice Diameter = inches

Calculated Parameters for Outlet Pipe w/ Flow Restriction Plate
Outlet Orifice Area = ft²
Outlet Orifice Centroid = feet
Half-Central Angle of Restrictor Plate on Pipe = degrees

User Input: Emergency Spillway (Rectangular or Trapezoidal)

Spillway Invert Stage = ft (relative to basin bottom at Stage = 0 ft)
Spillway Crest Length = feet
Spillway End Slopes = H:V
Freeboard above Max Water Surface = feet

Calculated Parameters for Spillway
Spillway Design Flow Depth = feet
Stage at Top of Freeboard = feet
Basin Area at Top of Freeboard = acres
Basin Volume at Top of Freeboard = acre-ft

Routed Hydrograph Results

The user can override the default CUHP hydrographs and runoff volumes by entering new values in the Inflow Hydrographs table (Columns W through AF).

	WQCV	EURV	2 Year	5 Year	10 Year	25 Year	50 Year	100 Year
Design Storm Return Period								
One-Hour Rainfall Depth (in)	N/A	N/A	1.19	1.50	1.75	2.00	2.25	2.52
CUHP Runoff Volume (acre-ft)	0.387	0.666	0.906	1.951	2.988	4.818	6.073	7.872
Inflow Hydrograph Volume (acre-ft)	N/A	N/A	0.906	1.951	2.988	4.818	6.073	7.872
CUHP Predevelopment Peak Q (cfs)	N/A	N/A	7.3	20.3	30.7	55.1	69.1	88.0
OPTIONAL Override Predevelopment Peak Q (cfs)	N/A	N/A						
Predevelopment Unit Peak Flow, q (cfs/acre)	N/A	N/A	0.11	0.32	0.48	0.86	1.08	1.38
Peak Inflow Q (cfs)	N/A	N/A	12.2	25.7	36.4	59.9	73.9	93.1
Peak Outflow Q (cfs)	0.1	0.1	0.1	0.1	0.2	0.2	0.2	0.2
Ratio Peak Outflow to Predevelopment Q	N/A	N/A	N/A	0.0	0.0	0.0	0.0	0.0
Structure Controlling Flow	Plate	Plate	Plate	Plate	Plate	N/A	N/A	N/A
Max Velocity through Grate 1 (fps)	N/A	N/A	N/A	N/A	N/A	N/A	N/A	N/A
Max Velocity through Grate 2 (fps)	N/A	N/A	N/A	N/A	N/A	N/A	N/A	N/A
Time to Drain 97% of Inflow Volume (hours)	65	93	117	>120	>120	>120	>120	>120
Time to Drain 99% of Inflow Volume (hours)	73	102	>120	>120	>120	>120	>120	>120
Maximum Ponding Depth (ft)	2.37	2.80	3.10	4.47	5.68	7.50	7.50	7.50
Area at Maximum Ponding Depth (acres)	0.59	0.68	0.71	0.81	0.90	1.05	1.05	1.05
Maximum Volume Stored (acre-ft)	0.388	0.672	0.880	1.915	2.947	4.718	4.718	4.718

DETENTION BASIN STAGE-STORAGE TABLE BUILDER

MHFD-Detention, Version 4.06 (July 2022)

Project: _____
Basin ID: _____

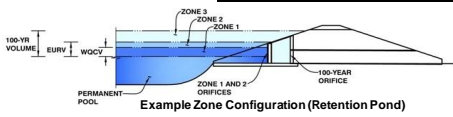

TSB B8 AND STANDPIPE SIZING

Watershed Information

Selected BMP Type =	EDB	
Watershed Area =	61.60	acres
Watershed Length =	1,900	ft
Watershed Length to Centroid =	950	ft
Watershed Slope =	0.085	ft/ft Steep Slope > 0.06 ft/ft
Watershed Imperviousness =	8.00%	percent
Percentage Hydrologic Soil Group A =	0.0%	percent
Percentage Hydrologic Soil Group B =	100.0%	percent
Percentage Hydrologic Soil Groups C/D =	0.0%	percent
Target WQCV Drain Time =	72.0	hours Drain Time Too Long
Location for 1-hr Rainfall Depths =	User Input	

After providing required inputs above including 1-hour rainfall depths, click "Run CUHP" to generate runoff hydrographs using the embedded Colorado Urban Hydrograph Procedure.

Water Quality Capture Volume (WQCV) =	0.284	acre-feet	
Excess Urban Runoff Volume (EURV) =	0.455	acre-feet	
2-yr Runoff Volume (P1 = 1.19 in.) =	0.726	acre-feet	1.19 inches
5-yr Runoff Volume (P1 = 1.5 in.) =	1.688	acre-feet	1.50 inches
10-yr Runoff Volume (P1 = 1.75 in.) =	2.660	acre-feet	1.75 inches
25-yr Runoff Volume (P1 = 2 in.) =	4.432	acre-feet	2.00 inches
50-yr Runoff Volume (P1 = 2.25 in.) =	5.623	acre-feet	2.25 inches
100-yr Runoff Volume (P1 = 2.52 in.) =	7.355	acre-feet	2.52 inches
500-yr Runoff Volume (P1 = 3.14 in.) =	10.487	acre-feet	
Approximate 2-yr Detention Volume =	0.284	acre-feet	
Approximate 5-yr Detention Volume =	0.454	acre-feet	
Approximate 10-yr Detention Volume =	1.044	acre-feet	
Approximate 25-yr Detention Volume =	1.509	acre-feet	
Approximate 50-yr Detention Volume =	1.567	acre-feet	
Approximate 100-yr Detention Volume =	2.051	acre-feet	

Define Zones and Basin Geometry

Zone 1 Volume (User Defined) =	1.330	acre-feet	
Select Zone 2 Storage Volume (Optional) =		acre-feet	
Select Zone 3 Storage Volume (Optional) =		acre-feet	
Total Detention Basin Volume =	1.330	acre-feet	Total detention volume is less than 100-year volume.
Initial Surcharge Volume (ISV) =	user	ft ³	
Initial Surcharge Depth (ISD) =	user	ft	
Total Available Detention Depth (H _{total}) =	user	ft	
Depth of Trickle Channel (H _{tc}) =	user	ft	
Slope of Trickle Channel (S _{tc}) =	user	ft/ft	
Slopes of Main Basin Sides (S _{main}) =	user	H:V	
Basin Length-to-Width Ratio (R _{L/W}) =	user		
Initial Surcharge Area (A _{ISV}) =	user	ft ²	
Surcharge Volume Length (L _{ISV}) =	user	ft	
Surcharge Volume Width (W _{ISV}) =	user	ft	
Depth of Basin Floor (H _{FLOOR}) =	user	ft	
Length of Basin Floor (L _{FLOOR}) =	user	ft	
Width of Basin Floor (W _{FLOOR}) =	user	ft	
Area of Basin Floor (A _{FLOOR}) =	user	ft ²	
Volume of Basin Floor (V _{FLOOR}) =	user	ft ³	
Depth of Main Basin (H _{MAIN}) =	user	ft	
Length of Main Basin (L _{MAIN}) =	user	ft	
Width of Main Basin (W _{MAIN}) =	user	ft	
Area of Main Basin (A _{MAIN}) =	user	ft ²	
Volume of Main Basin (V _{MAIN}) =	user	ft ³	
Calculated Total Basin Volume (V _{total}) =	user	acre-feet	

Stage - Storage Description	Stage (ft)	Optional Override Stage (ft)	Length (ft)	Width (ft)	Area (ft ²)	Optional Override Area (ft ²)	Area (acre)	Volume (ft ³)	Volume (ac-ft)
Top of Micropool	--	0.00	--	--	--	16	0.000		
7185	--	0.50	--	--	--	833	0.019	212	0.005
7186	--	1.50	--	--	--	5,730	0.132	3,494	0.080
7187	--	2.50	--	--	--	14,884	0.342	13,801	0.317
7188	--	3.50	--	--	--	18,561	0.426	30,523	0.701
7189	--	4.50	--	--	--	22,345	0.513	50,976	1.170
7190	--	5.50	--	--	--	26,237	0.602	75,267	1.728
7191	--	6.50	--	--	--	30,235	0.694	103,503	2.376
7192	--	7.50	--	--	--	34,340	0.788	135,791	3.117
7193	--	8.50	--	--	--	38,551	0.885	172,236	3.954

DETENTION BASIN STAGE-STORAGE TABLE BUILDER

MHFD-Detention, Version 4.06 (July 2022)

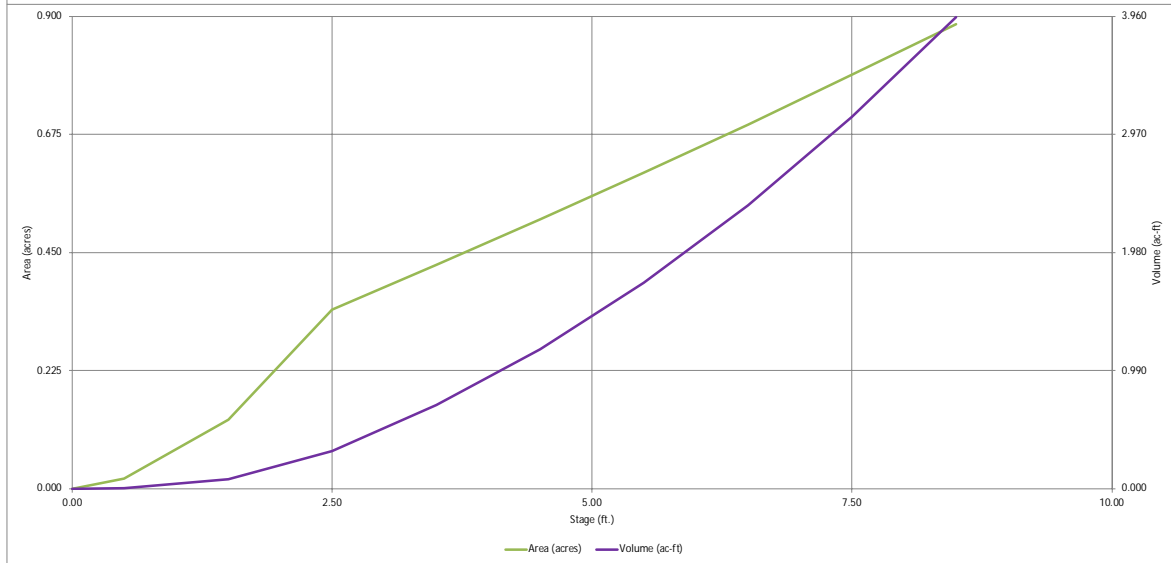
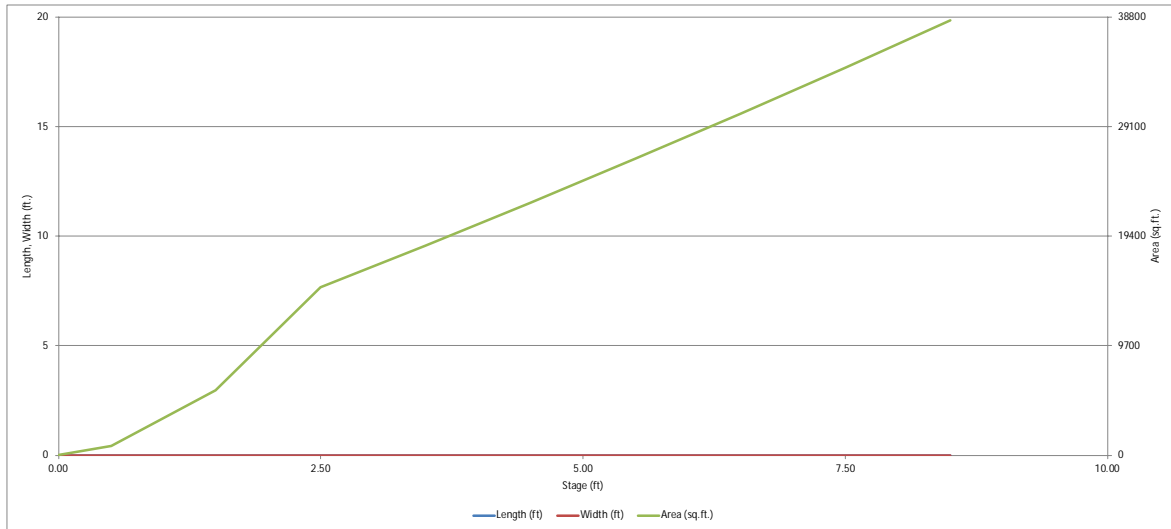

DETENTION BASIN OUTLET STRUCTURE DESIGN

MHFD-*Detention, Version 4.06 (July 2022)*

Project: _____
Basin ID: _____

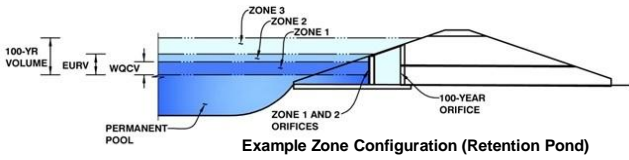

Example Zone Configuration (Retention Pond)

	Estimated Stage (ft)	Estimated Volume (ac-ft)	Outlet Type
Zone 1 (User)	4.81	1.330	Orifice Plate
Zone 2			Not Utilized
Zone 3			Not Utilized
Total (all zones)		1.330	

User Input: Orifice at Underdrain Outlet (typically used to drain WQCV in a Filtration BMP)

Underdrain Orifice Invert Depth = ft (distance below the filtration media surface)
Underdrain Orifice Diameter = inches

Calculated Parameters for Underdrain
Underdrain Orifice Area = ft²
Underdrain Orifice Centroid = feet

User Input: Orifice Plate with one or more orifices or Elliptical Slot Weir (typically used to drain WQCV and/or EURV in a sedimentation BMP)

Centroid of Lowest Orifice = ft (relative to basin bottom at Stage = 0 ft)
Depth at top of Zone using Orifice Plate = ft (relative to basin bottom at Stage = 0 ft)
Orifice Plate: Orifice Vertical Spacing = inches
Orifice Plate: Orifice Area per Row = sq. inches

Calculated Parameters for Plate
WO Orifice Area per Row = ft²
Elliptical Half-Width = feet
Elliptical Slot Centroid = feet
Elliptical Slot Area = ft²

User Input: Stage and Total Area of Each Orifice Row (numbered from lowest to highest)

	Row 1 (required)	Row 2 (optional)	Row 3 (optional)	Row 4 (optional)	Row 5 (optional)	Row 6 (optional)	Row 7 (optional)	Row 8 (optional)
Stage of Orifice Centroid (ft)	0.25	1.00	2.25					
Orifice Area (sq. inches)	0.78	0.78	0.78					

	Row 9 (optional)	Row 10 (optional)	Row 11 (optional)	Row 12 (optional)	Row 13 (optional)	Row 14 (optional)	Row 15 (optional)	Row 16 (optional)
Stage of Orifice Centroid (ft)								
Orifice Area (sq. inches)								

User Input: Vertical Orifice (Circular or Rectangular)

Invert of Vertical Orifice = ft (relative to basin bottom at Stage = 0 ft)
Depth at top of Zone using Vertical Orifice = ft (relative to basin bottom at Stage = 0 ft)
Vertical Orifice Diameter = inches

Calculated Parameters for Vertical Orifice
Vertical Orifice Area = ft²
Vertical Orifice Centroid = feet

User Input: Overflow Weir (Dropbox with Flat or Sloped Grate and Outlet Pipe OR Rectangular/Trapezoidal Weir and No Outlet Pipe)

Overflow Weir Front Edge Height, H_o = ft (relative to basin bottom at Stage = 0 ft)
Overflow Weir Front Edge Length = feet
Overflow Weir Grate Slope = H:V
Horiz. Length of Weir Sides = feet
Overflow Grate Type =
Debris Clogging % = %

Calculated Parameters for Overflow Weir
Height of Grate Upper Edge, H₁ = ft
Overflow Weir Slope Length = feet
Grate Open Area / 100-yr Orifice Area =
Overflow Grate Open Area w/o Debris = ft²
Overflow Grate Open Area w/ Debris = ft²

User Input: Outlet Pipe w/ Flow Restriction Plate (Circular Orifice, Restrictor Plate, or Rectangular Orifice)

Depth to Invert of Outlet Pipe = ft (distance below basin bottom at Stage = 0 ft)
Circular Orifice Diameter = inches

Calculated Parameters for Outlet Pipe w/ Flow Restriction Plate
Outlet Orifice Area = ft²
Outlet Orifice Centroid = feet
Half-Central Angle of Restrictor Plate on Pipe = degrees

User Input: Emergency Spillway (Rectangular or Trapezoidal)

Spillway Invert Stage = ft (relative to basin bottom at Stage = 0 ft)
Spillway Crest Length = feet
Spillway End Slopes = H:V
Freeboard above Max Water Surface = feet

Calculated Parameters for Spillway
Spillway Design Flow Depth = feet
Stage at Top of Freeboard = feet
Basin Area at Top of Freeboard = acres
Basin Volume at Top of Freeboard = acre-ft

Routed Hydrograph Results

The user can override the default CUHP hydrographs and runoff volumes by entering new values in the Inflow Hydrographs table (Columns W through AF).

	WQCV	EURV	2 Year	5 Year	10 Year	25 Year	50 Year	100 Year
Design Storm Return Period								
One-Hour Rainfall Depth (in)	N/A	N/A	1.19	1.50	1.75	2.00	2.25	2.52
CUHP Runoff Volume (acre-ft)	0.284	0.455	0.726	1.688	2.660	4.432	5.623	7.355
Inflow Hydrograph Volume (acre-ft)	N/A	N/A	0.726	1.688	2.660	4.432	5.623	7.355
CUHP Predevelopment Peak Q (cfs)	N/A	N/A	10.4	28.6	42.2	73.6	92.1	115.4
OPTIONAL Override Predevelopment Peak Q (cfs)	N/A	N/A						
Predevelopment Unit Peak Flow, q (cfs/acre)	N/A	N/A	0.17	0.46	0.69	1.20	1.50	1.87
Peak Inflow Q (cfs)	N/A	N/A	14.7	32.9	46.6	77.4	95.7	119.0
Peak Outflow Q (cfs)	0.1	0.1	0.1	0.2	0.2	0.2	0.2	0.2
Ratio Peak Outflow to Predevelopment Q	N/A	N/A	N/A	0.0	0.0	0.0	0.0	0.0
Structure Controlling Flow	Plate	Plate	Plate	Plate	Plate	N/A	N/A	N/A
Max Velocity through Gate 1 (fps)	N/A	N/A	N/A	N/A	N/A	N/A	N/A	N/A
Max Velocity through Gate 2 (fps)	N/A	N/A	N/A	N/A	N/A	N/A	N/A	N/A
Time to Drain 97% of Inflow Volume (hours)	69	89	114	>120	>120	>120	>120	>120
Time to Drain 99% of Inflow Volume (hours)	74	95	>120	>120	>120	>120	>120	>120
Maximum Ponding Depth (ft)	2.41	2.89	3.52	5.39	6.85	8.50	8.50	8.50
Area at Maximum Ponding Depth (acres)	0.32	0.37	0.43	0.59	0.73	0.89	0.89	0.89
Maximum Volume Stored (acre-ft)	0.287	0.456	0.705	1.656	2.625	3.954	3.954	3.954

Exiting Conditions Natural Channels Flow Summary

Channel ID	Contributing Basins	Tributary Area (ac)	Basin Area (ac)	Basin 100-yr Flow (cfs)	Channel 100-yr Flow (cfs)	Velocity (ft/s)	Normal Depth (ft)
A1-1	A1	19.92	19.92	38.41	38.41	2.56	0.47
A2-3	A2, OS-A2	48.30 (A2) + 4.45 (OS-A2)	61.50 (A2) + 4.45 (OS-A2)	87.58 (A2) + 11.46 (OS-A2)	80.24	4.88	0.89
A2-4	A2	2.73	61.50	87.58	2.71	1.49	0.23
A2-5	A2, B1	7.38 (A2) + 2.81 (B1)	61.50 (A2) + 45.75 (B1)	87.58 (A2) + 72.48 (B1)	14.96	1.99	0.26
B1-2	B1	16.60	45.75	72.48	26.30	3.66	0.23
B1-3	B1	6.15	45.75	72.48	9.74	2.52	0.27
B1-6	B1	13.08	45.75	72.48	20.72	2.96	0.36
B2-1	B2	4.52	42.42	69.09	7.36	2.25	0.19
B2-2	B2	36.7	42.42	69.09	59.77	4.90	0.49
B7-1	B3	2.20	25.42	43.40	3.76	1.73	0.20
B8-1	B3	17.57	25.42	43.40	30.00	3.41	0.29

Proposed Conditions Natural Channels Flow Summary

Channel ID	Contributing Basins	Tributary Area (ac)	Basin Area (ac)	Basin 100-yr Flow (cfs)	Channel 100-yr Flow (cfs)	Velocity (ft/s)	Normal Depth (ft)	Lining
A1-1	A1	19.55	19.55	41.24	41.24	2.62	0.48	
A2-1	A2, OS-A2	32.76 (A2) + 3.25 (OS-A2)	58.72 (A2) + 4.45 (OS-A2)	92.96 (A2) + 11.46 (OS-A2)	60.42	3.82	0.59	
A2-2	A2	9.06	58.27	92.96	14.45	2.48	0.18	
A2-3	A2	11.45	58.27	92.96	18.27	3.09	0.40	
A2-4	A2	1.70	58.27	92.96	2.71	1.49	0.02	
A2-5	A2, B1	7.75 (A2) + 3.44 (B1)	58.72 (A2) + 40.74 (B1)	92.96 (A2) + 80.40 (B1)	19.06	2.17	0.3	
A2-6	A2, B1	2.46 (A2) + 3.44 (B1)	58.72 (A2) + 40.74 (B1)	92.96 (A2) + 80.40 (B1)	10.72	1.86	0.18	
A2-7	A2	1.74	58.27	92.96	2.78	0.94	0.08	
B1-1	B1	10.19	40.74	80.40	20.11	2.71	0.28	
B1-2	B1	14.29	40.74	80.40	28.20	3.76	0.24	
B1-3	B1	13.43	40.74	80.40	26.50	3.46	0.47	
B1-4	B1	4.03	40.74	80.40	7.95	2.52	0.02	
B1-5	B1	2.54	40.74	80.40	5.01	1.68	0.11	
B1-6	B1	2.72	40.74	80.40	5.37	1.84	0.17	
B2-1	B2	4.92	16.00	38.64	11.88	2.69	0.25	
B2-2	B2	9.77	16.00	38.64	23.59	3.54	0.29	
B6-1	B6	11.58	53.31	106.95	23.23	6.67	0.29	TRM
B7-1	B7	2.25	2.46	6.17	5.64	1.91	0.23	
B8-1	B8, B6	3.32 (B8) + 53.31 (B6)	9.52 (B8) + 53.31 (B6)	23.05 (B8) + 106.95 (B6)	114.99	5.39	0.63	

Worksheet for A1-1 (Existing Conditions)

Project Description

Friction Method	Manning Formula
Solve For	Normal Depth

Input Data

Channel Slope	0.015 ft/ft
Discharge	38.41 cfs

Section Definitions

	Station (ft)	Elevation (ft)
	0+00	41.00
	0+35	36.00
	0+64	36.00
	1+00	41.00

Roughness Segment Definitions

Start Station	Ending Station	Roughness Coefficient
(0+00, 41.00)	(0+35, 36.00)	0.040
(0+35, 36.00)	(0+64, 36.00)	0.040
(0+64, 36.00)	(1+00, 41.00)	0.040

Options

Current Roughness Weighted Method	Pavlovskii's Method
Open Channel Weighting Method	Pavlovskii's Method
Closed Channel Weighting Method	Pavlovskii's Method

Results

Normal Depth	5.6 in
Roughness Coefficient	0.040
Elevation	36.47 ft
Elevation Range	36.0 to 41.0 ft
Flow Area	15.0 ft ²
Wetted Perimeter	35.7 ft
Hydraulic Radius	5.1 in
Top Width	35.61 ft
Normal Depth	5.6 in
Critical Depth	4.4 in
Critical Slope	0.033 ft/ft
Velocity	2.56 ft/s
Velocity Head	0.10 ft
Specific Energy	0.57 ft
Froude Number	0.694

Worksheet for A1-1 (Existing Conditions)

Results	
Flow Type	Subcritical
GVF Input Data	
Downstream Depth	0.0 in
Length	0.0 ft
Number Of Steps	0
GVF Output Data	
Upstream Depth	0.0 in
Profile Description	N/A
Profile Headloss	0.00 ft
Downstream Velocity	0.00 ft/s
Upstream Velocity	0.00 ft/s
Normal Depth	5.6 in
Critical Depth	4.4 in
Channel Slope	0.015 ft/ft
Critical Slope	0.033 ft/ft

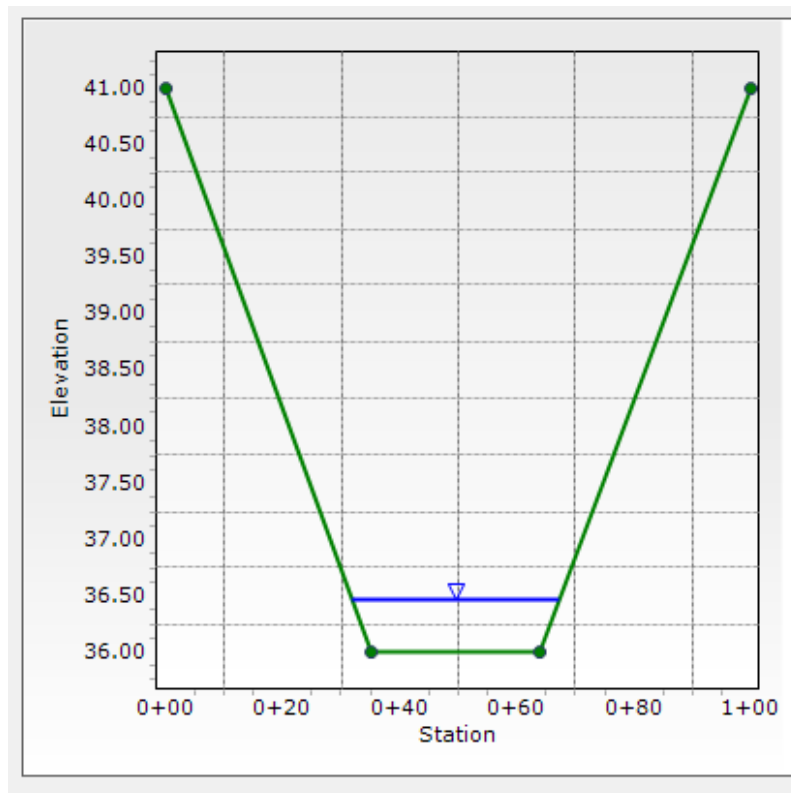

Worksheet for A2-3 (Existing Conditions)

Project Description

Friction Method	Manning Formula
Solve For	Normal Depth

Input Data

Channel Slope	0.030 ft/ft
Discharge	80.24 cfs

Section Definitions

	Station (ft)	Elevation (ft)
	0+00	11.00
	0+51	4.00
	0+63	4.00
	0+98	9.00

Roughness Segment Definitions

Start Station	Ending Station	Roughness Coefficient
(0+00, 11.00)	(0+51, 4.00)	0.040
(0+51, 4.00)	(0+63, 4.00)	0.040
(0+63, 4.00)	(0+98, 9.00)	0.040

Options

Current Roughness Weighted Method	Pavlovskii's Method
Open Channel Weighting Method	Pavlovskii's Method
Closed Channel Weighting Method	Pavlovskii's Method

Results

Normal Depth	10.7 in
Roughness Coefficient	0.040
Elevation	4.89 ft
Elevation Range	4.0 to 11.0 ft
Flow Area	16.4 ft ²
Wetted Perimeter	24.9 ft
Hydraulic Radius	7.9 in
Top Width	24.77 ft
Normal Depth	10.7 in
Critical Depth	11.1 in
Critical Slope	0.027 ft/ft
Velocity	4.88 ft/s
Velocity Head	0.37 ft
Specific Energy	1.26 ft
Froude Number	1.056
Flow Type	Supercritical

Worksheet for A2-3 (Existing Conditions)

GVF Input Data	
Downstream Depth	0.0 in
Length	0.0 ft
Number Of Steps	0
GVF Output Data	
Upstream Depth	0.0 in
Profile Description	N/A
Profile Headloss	0.00 ft
Downstream Velocity	Infinity ft/s
Upstream Velocity	Infinity ft/s
Normal Depth	10.7 in
Critical Depth	11.1 in
Channel Slope	0.030 ft/ft
Critical Slope	0.027 ft/ft

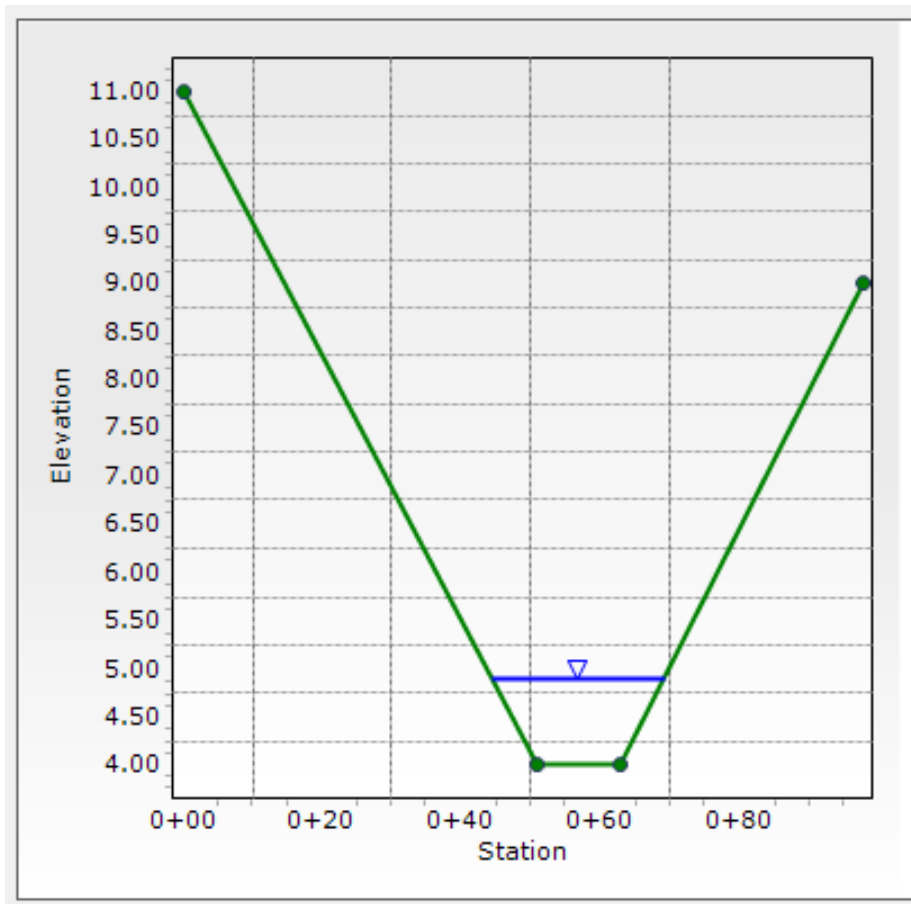

Worksheet for A2-4 (Existing Conditions)

Project Description	
Friction Method	Manning Formula
Solve For	Normal Depth

Input Data	
Channel Slope	0.029 ft/ft
Discharge	2.71 cfs

Section Definitions

	Station (ft)	Elevation (ft)
	0+15	14.00
	0+32	12.75
	0+47	12.50
	0+98	18.00

Roughness Segment Definitions

Start Station	Ending Station	Roughness Coefficient
(0+15, 14.00)	(0+32, 12.75)	0.040
(0+32, 12.75)	(0+47, 12.50)	0.040
(0+47, 12.50)	(0+98, 18.00)	0.040

Options

Current Roughness Weighted Method	Pavlovskii's Method
Open Channel Weighting Method	Pavlovskii's Method
Closed Channel Weighting Method	Pavlovskii's Method

Results

Normal Depth	2.7 in
Roughness Coefficient	0.040
Elevation	12.73 ft
Elevation Range	12.5 to 18.0 ft
Flow Area	1.8 ft ²
Wetted Perimeter	15.9 ft
Hydraulic Radius	1.4 in
Top Width	15.86 ft
Normal Depth	2.7 in
Critical Depth	2.5 in
Critical Slope	0.050 ft/ft
Velocity	1.49 ft/s
Velocity Head	0.03 ft
Specific Energy	0.26 ft
Froude Number	0.778

Worksheet for A2-4 (Existing Conditions)

Results	
Flow Type	Subcritical
GVF Input Data	
Downstream Depth	0.0 in
Length	0.0 ft
Number Of Steps	0
GVF Output Data	
Upstream Depth	0.0 in
Profile Description	N/A
Profile Headloss	0.00 ft
Downstream Velocity	0.00 ft/s
Upstream Velocity	0.00 ft/s
Normal Depth	2.7 in
Critical Depth	2.5 in
Channel Slope	0.029 ft/ft
Critical Slope	0.050 ft/ft

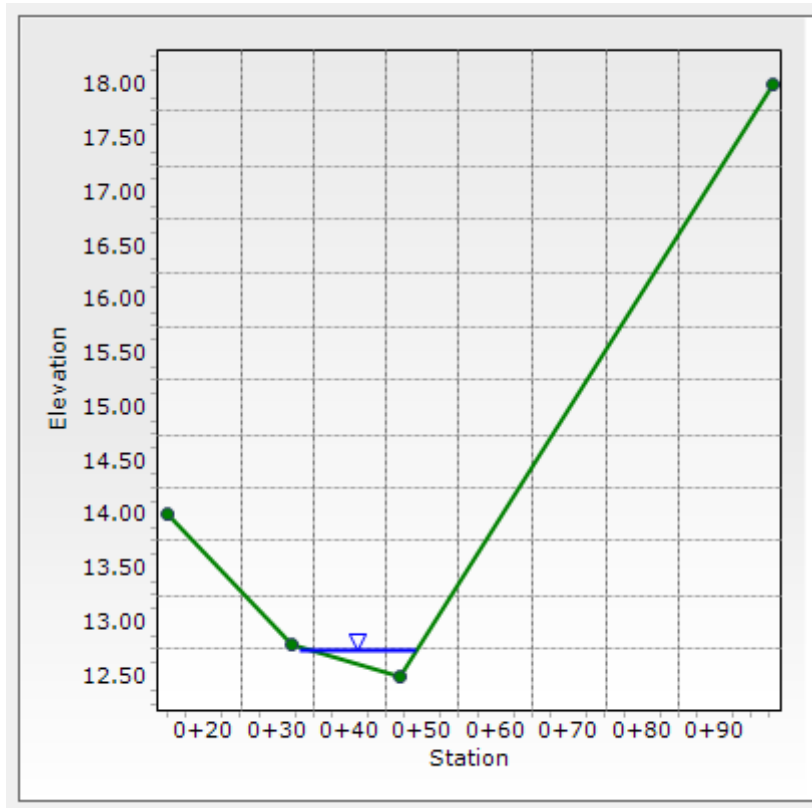

Worksheet for A2-5 (Existing Conditions)

Project Description	
Friction Method	Manning Formula
Solve For	Normal Depth

Input Data	
Channel Slope	0.020 ft/ft
Discharge	14.96 cfs

Section Definitions

Station (ft)	Elevation (ft)
0+00	15.00
0+43	12.00
0+68	12.00
1+25	16.75

Roughness Segment Definitions

Start Station	Ending Station	Roughness Coefficient
(0+00, 15.00)	(0+43, 12.00)	0.040
(0+43, 12.00)	(0+68, 12.00)	0.040
(0+68, 12.00)	(1+25, 16.75)	0.040

Options

Current Roughness Weighted Method	Pavlovskii's Method
Open Channel Weighting Method	Pavlovskii's Method
Closed Channel Weighting Method	Pavlovskii's Method

Results

Normal Depth	3.1 in
Roughness Coefficient	0.040
Elevation	12.26 ft
Elevation Range	12.0 to 16.8 ft
Flow Area	7.5 ft ²
Wetted Perimeter	32.2 ft
Hydraulic Radius	2.8 in
Top Width	32.15 ft
Normal Depth	3.1 in
Critical Depth	2.6 in
Critical Slope	0.040 ft/ft
Velocity	1.99 ft/s
Velocity Head	0.06 ft
Specific Energy	0.32 ft
Froude Number	0.727

Worksheet for A2-5 (Existing Conditions)

Results	
Flow Type	Subcritical
GVF Input Data	
Downstream Depth	0.0 in
Length	0.0 ft
Number Of Steps	0
GVF Output Data	
Upstream Depth	0.0 in
Profile Description	N/A
Profile Headloss	0.00 ft
Downstream Velocity	0.00 ft/s
Upstream Velocity	0.00 ft/s
Normal Depth	3.1 in
Critical Depth	2.6 in
Channel Slope	0.020 ft/ft
Critical Slope	0.040 ft/ft

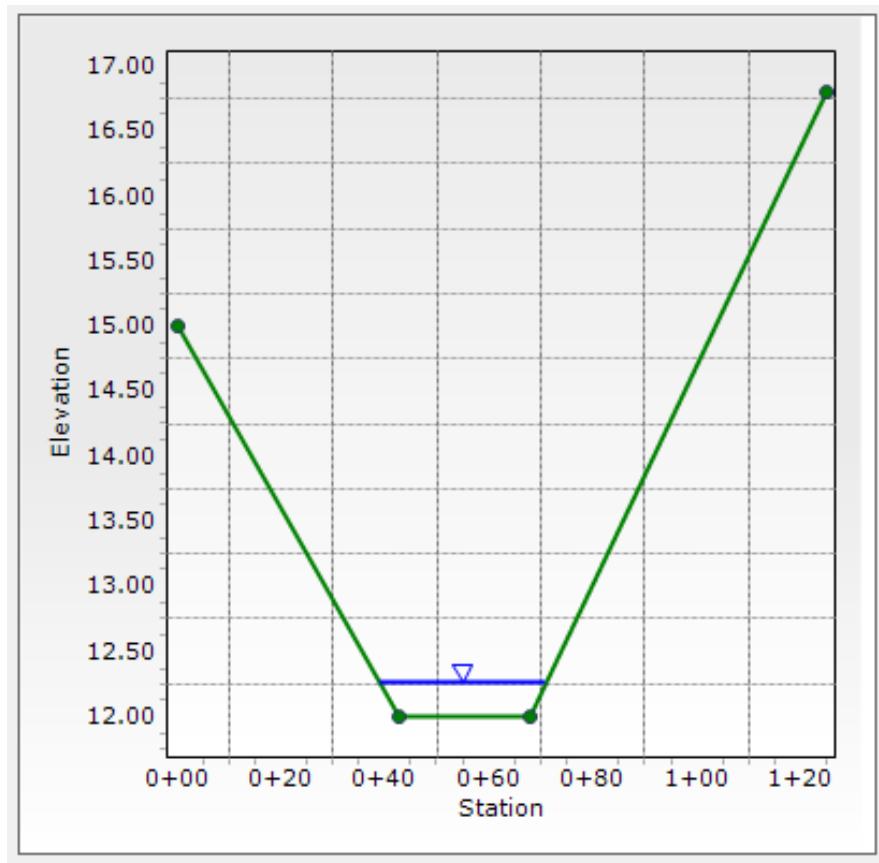

Worksheet for B1-2 (Existing Conditions)

Project Description

Friction Method	Manning Formula
Solve For	Normal Depth

Input Data

Channel Slope	0.075 ft/ft
Discharge	26.30 cfs

Section Definitions

	Station (ft)	Elevation (ft)	
	0+00		3.00
	0+31		0.00
	0+60		0.00
	1+00		4.84

Roughness Segment Definitions

Start Station	Ending Station	Roughness Coefficient	
(0+00, 3.00)	(0+31, 0.00)	0.040	
(0+31, 0.00)	(0+60, 0.00)	0.040	
(0+60, 0.00)	(1+00, 4.84)	0.040	

Options

Current Roughness Weighted Method	Pavlovskii's Method
Open Channel Weighting Method	Pavlovskii's Method
Closed Channel Weighting Method	Pavlovskii's Method

Results

Normal Depth	2.8 in
Roughness Coefficient	0.040
Elevation	0.23 ft
Elevation Range	0.0 to 4.8 ft
Flow Area	7.2 ft ²
Wetted Perimeter	33.2 ft
Hydraulic Radius	2.6 in
Top Width	33.16 ft
Normal Depth	2.8 in
Critical Depth	3.4 in
Critical Slope	0.036 ft/ft
Velocity	3.66 ft/s
Velocity Head	0.21 ft
Specific Energy	0.44 ft
Froude Number	1.386
Flow Type	Supercritical

Worksheet for B1-2 (Existing Conditions)

GVF Input Data	
Downstream Depth	0.0 in
Length	0.0 ft
Number Of Steps	0
GVF Output Data	
Upstream Depth	0.0 in
Profile Description	N/A
Profile Headloss	0.00 ft
Downstream Velocity	Infinity ft/s
Upstream Velocity	Infinity ft/s
Normal Depth	2.8 in
Critical Depth	3.4 in
Channel Slope	0.075 ft/ft
Critical Slope	0.036 ft/ft

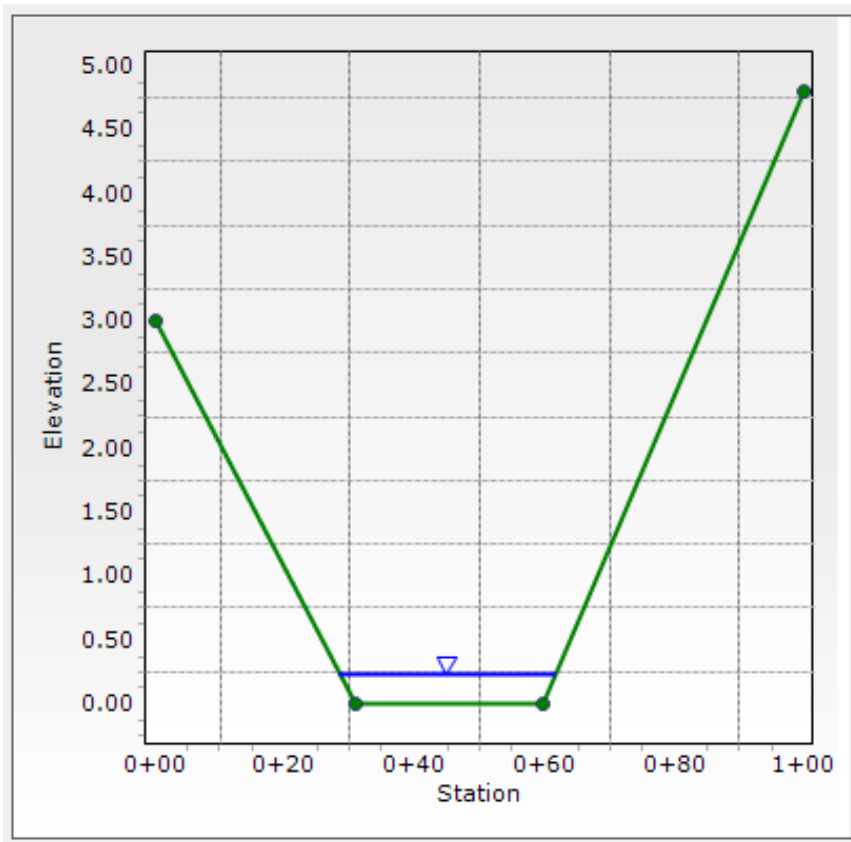

Worksheet for B1-3 (Existing Conditions)

Project Description	
Friction Method	Manning Formula
Solve For	Normal Depth

Input Data	
Channel Slope	0.033 ft/ft
Discharge	9.74 cfs

Section Definitions

Station (ft)	Elevation (ft)
0+00	19.00
0+45	14.00
0+56	14.00
0+98	18.00

Roughness Segment Definitions

Start Station	Ending Station	Roughness Coefficient
(0+00, 19.00)	(0+45, 14.00)	0.040
(0+45, 14.00)	(0+56, 14.00)	0.040
(0+56, 14.00)	(0+98, 18.00)	0.040

Options

Current Roughness Weighted Method	Pavlovskii's Method
Open Channel Weighting Method	Pavlovskii's Method
Closed Channel Weighting Method	Pavlovskii's Method

Results

Normal Depth	3.2 in
Roughness Coefficient	0.040
Elevation	14.27 ft
Elevation Range	14.0 to 19.0 ft
Flow Area	3.9 ft ²
Wetted Perimeter	17.0 ft
Hydraulic Radius	2.7 in
Top Width	16.96 ft
Normal Depth	3.2 in
Critical Depth	3.1 in
Critical Slope	0.039 ft/ft
Velocity	2.52 ft/s
Velocity Head	0.10 ft
Specific Energy	0.37 ft
Froude Number	0.929

Worksheet for B1-3 (Existing Conditions)

Results	
Flow Type	Subcritical
GVF Input Data	
Downstream Depth	0.0 in
Length	0.0 ft
Number Of Steps	0
GVF Output Data	
Upstream Depth	0.0 in
Profile Description	N/A
Profile Headloss	0.00 ft
Downstream Velocity	Infinity ft/s
Upstream Velocity	Infinity ft/s
Normal Depth	3.2 in
Critical Depth	3.1 in
Channel Slope	0.033 ft/ft
Critical Slope	0.039 ft/ft

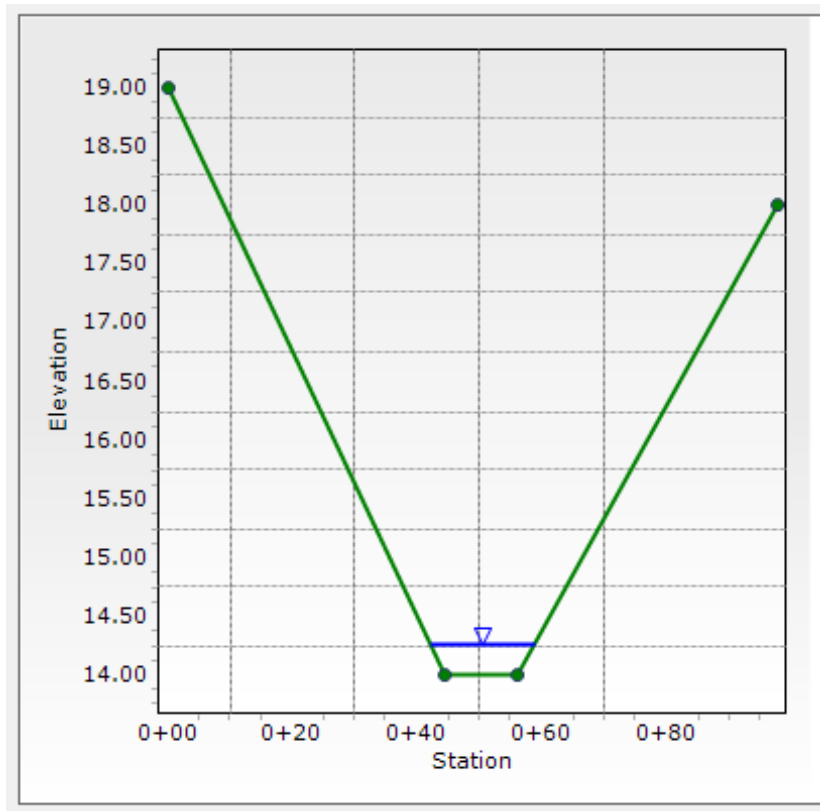

Worksheet for B1-6 (Existing Conditions)

Project Description

Friction Method	Manning Formula
Solve For	Normal Depth

Input Data

Channel Slope	0.030 ft/ft
Discharge	20.72 cfs

Section Definitions

	Station (ft)		Elevation (ft)
	0+00		22.00
	0+35		18.00
	0+51		18.00
	0+92		23.00

Roughness Segment Definitions

Start Station	Ending Station	Roughness Coefficient
(0+00, 22.00)	(0+35, 18.00)	0.040
(0+35, 18.00)	(0+51, 18.00)	0.040
(0+51, 18.00)	(0+92, 23.00)	0.040

Options

Current Roughness Weighted Method	Pavlovskii's Method
Open Channel Weighting Method	Pavlovskii's Method
Closed Channel Weighting Method	Pavlovskii's Method

Results

Normal Depth	4.3 in
Roughness Coefficient	0.040
Elevation	18.36 ft
Elevation Range	18.0 to 23.0 ft
Flow Area	7.0 ft ²
Wetted Perimeter	22.4 ft
Hydraulic Radius	3.7 in
Top Width	22.37 ft
Normal Depth	4.3 in
Critical Depth	4.2 in
Critical Slope	0.035 ft/ft
Velocity	2.96 ft/s
Velocity Head	0.14 ft
Specific Energy	0.50 ft
Froude Number	0.934

Worksheet for B1-6 (Existing Conditions)

Results	
Flow Type	Subcritical
GVF Input Data	
Downstream Depth	0.0 in
Length	0.0 ft
Number Of Steps	0
GVF Output Data	
Upstream Depth	0.0 in
Profile Description	N/A
Profile Headloss	0.00 ft
Downstream Velocity	0.00 ft/s
Upstream Velocity	0.00 ft/s
Normal Depth	4.3 in
Critical Depth	4.2 in
Channel Slope	0.030 ft/ft
Critical Slope	0.035 ft/ft

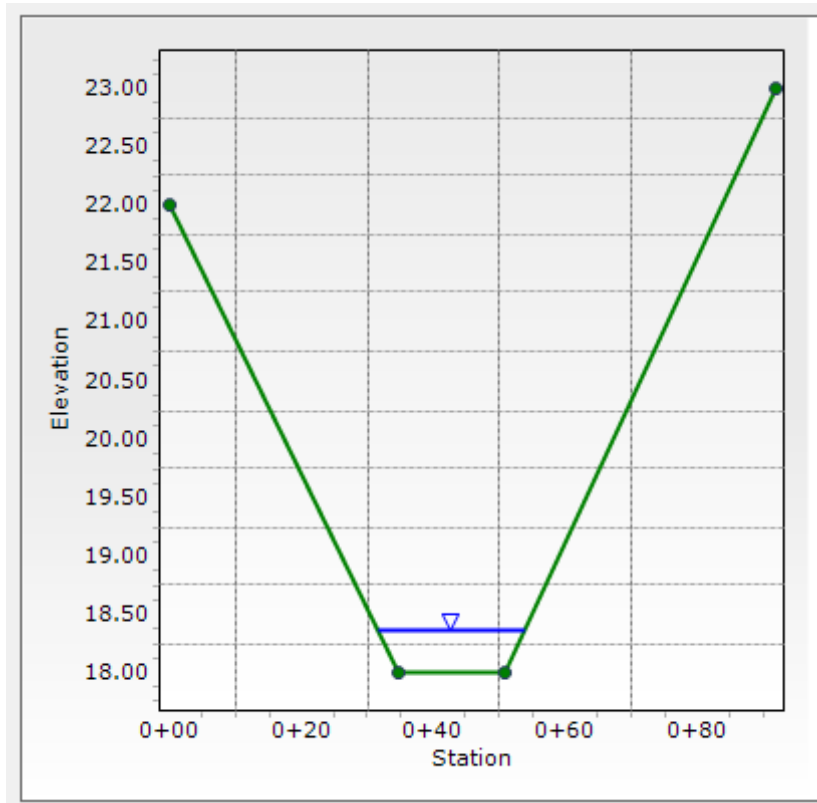

Worksheet for B2-1 (Existing Conditions)

Project Description

Friction Method	Manning Formula
Solve For	Normal Depth

Input Data

Channel Slope	0.037 ft/ft
Discharge	7.36 cfs

Section Definitions

	Station (ft)	Elevation (ft)
	0+00	5.00
	0+42	0.00
	0+58	0.00
	0+75	4.50

Roughness Segment Definitions

Start Station	Ending Station	Roughness Coefficient
(0+00, 5.00)	(0+42, 0.00)	0.040
(0+42, 0.00)	(0+58, 0.00)	0.040
(0+58, 0.00)	(0+75, 4.50)	0.040

Options

Current Roughness Weighted Method	Pavlovskii's Method
Open Channel Weighting Method	Pavlovskii's Method
Closed Channel Weighting Method	Pavlovskii's Method

Results

Normal Depth	2.3 in
Roughness Coefficient	0.040
Elevation	0.19 ft
Elevation Range	0.0 to 5.0 ft
Flow Area	3.3 ft ²
Wetted Perimeter	18.4 ft
Hydraulic Radius	2.1 in
Top Width	18.32 ft
Normal Depth	2.3 in
Critical Depth	2.2 in
Critical Slope	0.042 ft/ft
Velocity	2.25 ft/s
Velocity Head	0.08 ft
Specific Energy	0.27 ft
Froude Number	0.942
Flow Type	Subcritical

Worksheet for B2-1 (Existing Conditions)

GVF Input Data	
Downstream Depth	0.0 in
Length	0.0 ft
Number Of Steps	0
GVF Output Data	
Upstream Depth	0.0 in
Profile Description	N/A
Profile Headloss	0.00 ft
Downstream Velocity	0.00 ft/s
Upstream Velocity	0.00 ft/s
Normal Depth	2.3 in
Critical Depth	2.2 in
Channel Slope	0.037 ft/ft
Critical Slope	0.042 ft/ft

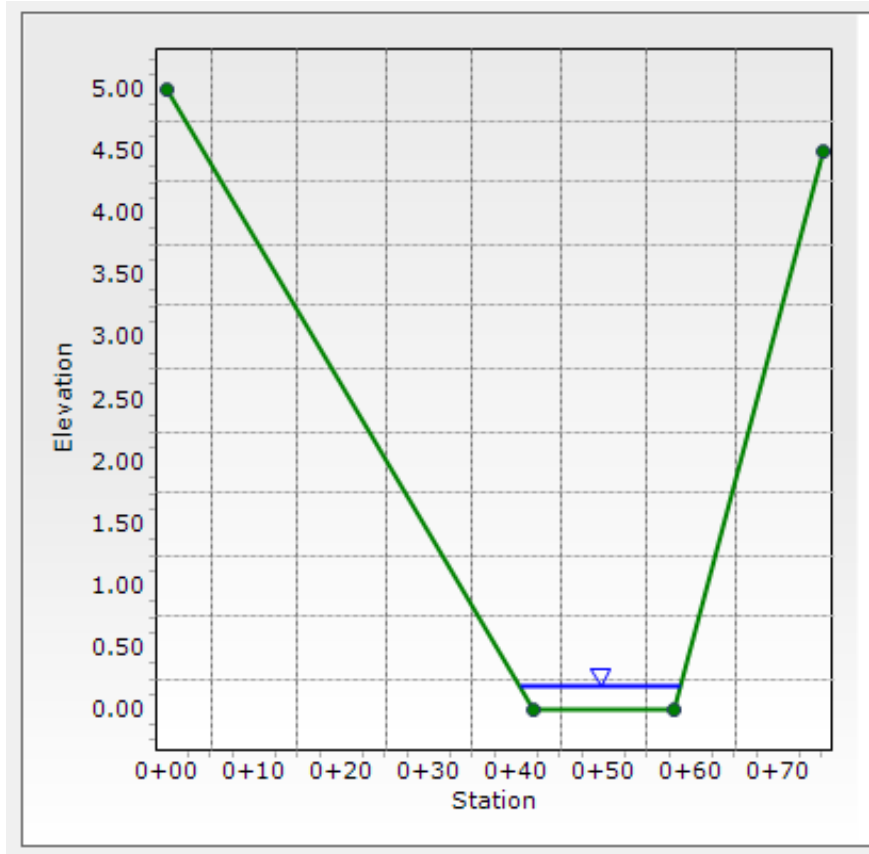

Worksheet for B2-2 (Existing Conditions)

Project Description

Friction Method	Manning Formula
Solve For	Normal Depth

Input Data

Channel Slope	0.054 ft/ft
Discharge	59.77 cfs

Section Definitions

	Station (ft)	Elevation (ft)
	0+00	13.00
	0+38	8.00
	0+59	8.00
	0+96	13.00

Roughness Segment Definitions

Start Station	Ending Station	Roughness Coefficient
(0+00, 13.00)	(0+38, 8.00)	0.040
(0+38, 8.00)	(0+59, 8.00)	0.040
(0+59, 8.00)	(0+96, 13.00)	0.040

Options

Current Roughness Weighted Method	Pavlovskii's Method
Open Channel Weighting Method	Pavlovskii's Method
Closed Channel Weighting Method	Pavlovskii's Method

Results

Normal Depth	5.9 in
Roughness Coefficient	0.040
Elevation	8.49 ft
Elevation Range	8.0 to 13.0 ft
Flow Area	12.2 ft ²
Wetted Perimeter	28.5 ft
Hydraulic Radius	5.1 in
Top Width	28.40 ft
Normal Depth	5.9 in
Critical Depth	7.0 in
Critical Slope	0.029 ft/ft
Velocity	4.90 ft/s
Velocity Head	0.37 ft
Specific Energy	0.87 ft
Froude Number	1.320
Flow Type	Supercritical

Worksheet for B2-2 (Existing Conditions)

GVF Input Data	
Downstream Depth	0.0 in
Length	0.0 ft
Number Of Steps	0
GVF Output Data	
Upstream Depth	0.0 in
Profile Description	N/A
Profile Headloss	0.00 ft
Downstream Velocity	Infinity ft/s
Upstream Velocity	Infinity ft/s
Normal Depth	5.9 in
Critical Depth	7.0 in
Channel Slope	0.054 ft/ft
Critical Slope	0.029 ft/ft

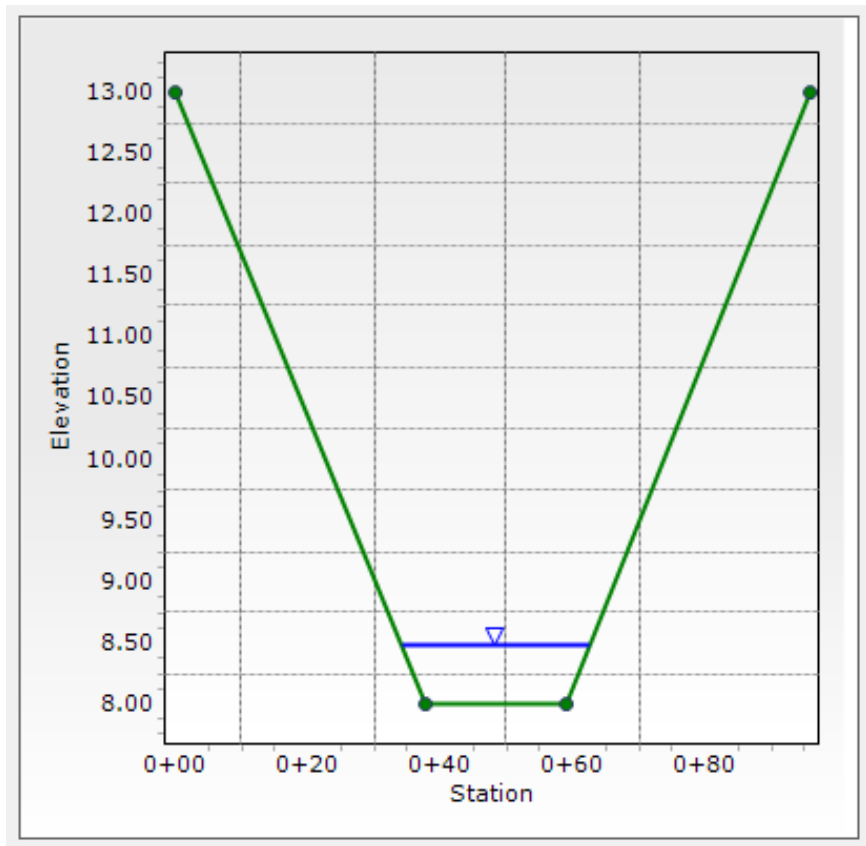

Worksheet for B7-1 (Existing Conditions)

Project Description

Friction Method	Manning Formula
Solve For	Normal Depth

Input Data

Channel Slope	0.046 ft/ft
Discharge	3.76 cfs

Section Definitions

	Station (ft)		Elevation (ft)
	0+00		95.00
	0+25		92.00
	0+50		91.75
	0+90		98.00

Roughness Segment Definitions

Start Station	Ending Station	Roughness Coefficient
(0+00, 95.00)	(0+25, 92.00)	0.040
(0+25, 92.00)	(0+50, 91.75)	0.040
(0+50, 91.75)	(0+90, 98.00)	0.040

Options

Current Roughness Weighted Method	Pavlovskii's Method
Open Channel Weighting Method	Pavlovskii's Method
Closed Channel Weighting Method	Pavlovskii's Method

Results

Normal Depth	2.4 in
Roughness Coefficient	0.040
Elevation	91.95 ft
Elevation Range	91.8 to 98.0 ft
Flow Area	2.2 ft ²
Wetted Perimeter	21.5 ft
Hydraulic Radius	1.2 in
Top Width	21.51 ft
Normal Depth	2.4 in
Critical Depth	2.4 in
Critical Slope	0.050 ft/ft
Velocity	1.73 ft/s
Velocity Head	0.05 ft
Specific Energy	0.25 ft
Froude Number	0.959

Worksheet for B7-1 (Existing Conditions)

Results	
Flow Type	Subcritical
GVF Input Data	
Downstream Depth	0.0 in
Length	0.0 ft
Number Of Steps	0
GVF Output Data	
Upstream Depth	0.0 in
Profile Description	N/A
Profile Headloss	0.00 ft
Downstream Velocity	0.00 ft/s
Upstream Velocity	0.00 ft/s
Normal Depth	2.4 in
Critical Depth	2.4 in
Channel Slope	0.046 ft/ft
Critical Slope	0.050 ft/ft

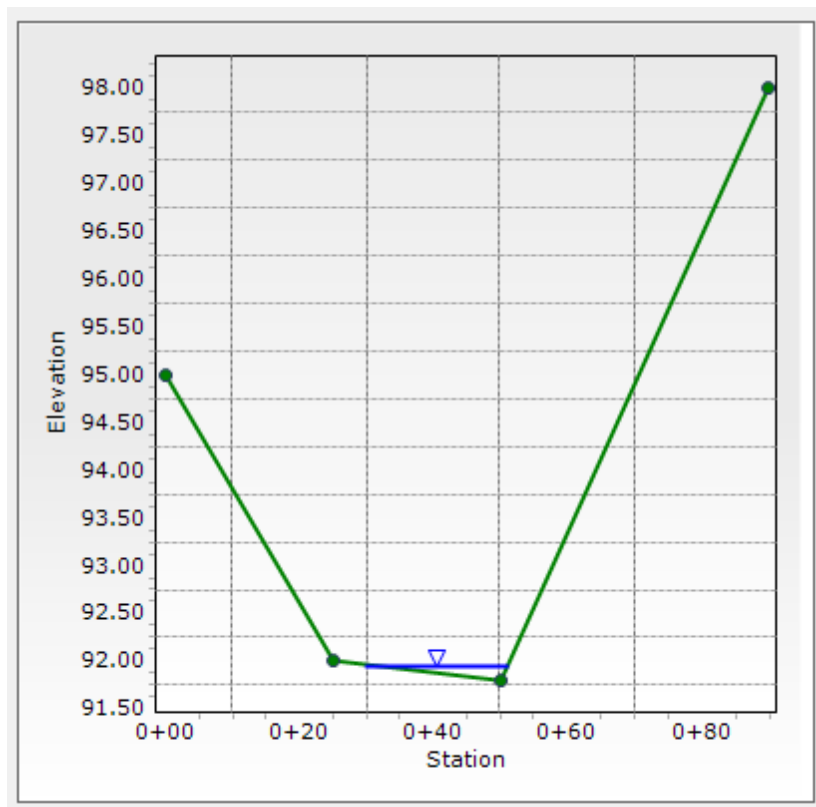

Worksheet for B8-1 (Existing Conditions)

Project Description

Friction Method	Manning Formula
Solve For	Normal Depth

Input Data

Channel Slope	0.050 ft/ft
Discharge	30.00 cfs

Section Definitions

Station (ft)	Elevation (ft)
0+00	202.00
0+52	198.00
0+79	198.00
1+06	201.00

Roughness Segment Definitions

Start Station	Ending Station	Roughness Coefficient
(0+00, 202.00)	(0+52, 198.00)	0.040
(0+52, 198.00)	(0+79, 198.00)	0.040
(0+79, 198.00)	(1+06, 201.00)	0.040

Options

Current Roughness Weighted Method	Pavlovskii's Method
Open Channel Weighting Method	Pavlovskii's Method
Closed Channel Weighting Method	Pavlovskii's Method

Results

Normal Depth	3.5 in
Roughness Coefficient	0.040
Elevation	198.29 ft
Elevation Range	198.0 to 202.0 ft
Flow Area	8.8 ft ²
Wetted Perimeter	33.4 ft
Hydraulic Radius	3.2 in
Top Width	33.41 ft
Normal Depth	3.5 in
Critical Depth	3.9 in
Critical Slope	0.035 ft/ft
Velocity	3.41 ft/s
Velocity Head	0.18 ft
Specific Energy	0.47 ft
Froude Number	1.172

Worksheet for B8-1 (Existing Conditions)

Results	
Flow Type	Supercritical
GVF Input Data	
Downstream Depth	0.0 in
Length	0.0 ft
Number Of Steps	0
GVF Output Data	
Upstream Depth	0.0 in
Profile Description	N/A
Profile Headloss	0.00 ft
Downstream Velocity	Infinity ft/s
Upstream Velocity	Infinity ft/s
Normal Depth	3.5 in
Critical Depth	3.9 in
Channel Slope	0.050 ft/ft
Critical Slope	0.035 ft/ft

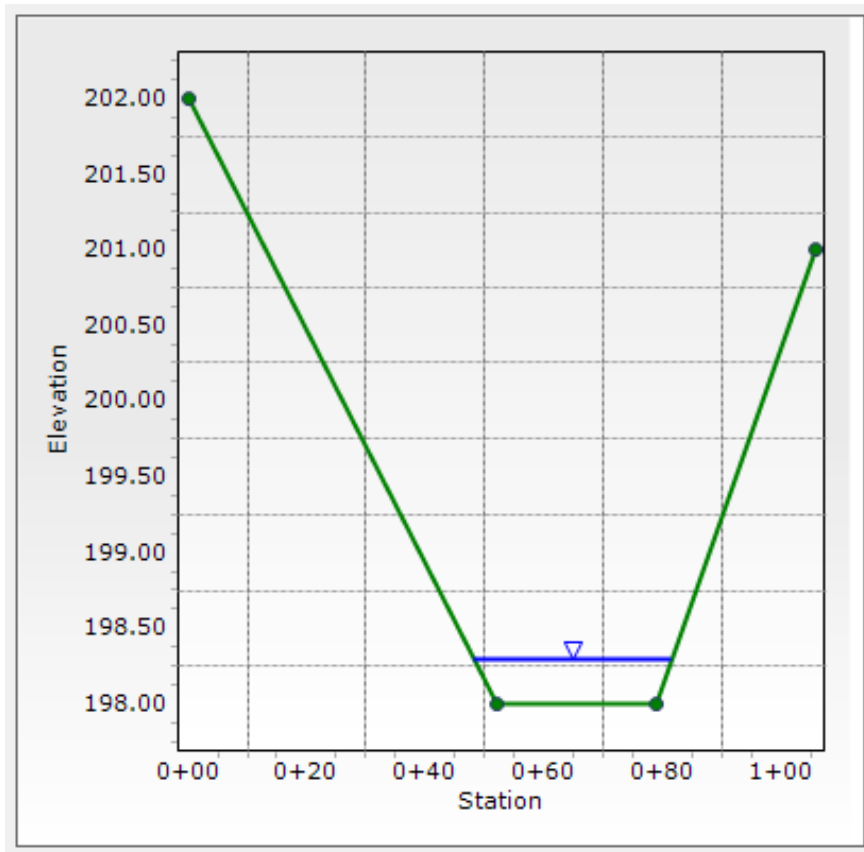

Worksheet for A1-1

Project Description	
Friction Method	Manning Formula
Solve For	Normal Depth

Input Data	
Channel Slope	0.015 ft/ft
Discharge	41.24 cfs

Section Definitions

	Station (ft)		Elevation (ft)
	0+00		41.00
	0+35		36.00
	0+64		36.00
	1+00		41.00

Roughness Segment Definitions

Start Station	Ending Station	Roughness Coefficient
(0+00, 41.00)	(0+35, 36.00)	0.040
(0+35, 36.00)	(0+64, 36.00)	0.040
(0+64, 36.00)	(1+00, 41.00)	0.040

Options

Current Roughness Weighted Method	Pavlovskii's Method
Open Channel Weighting Method	Pavlovskii's Method
Closed Channel Weighting Method	Pavlovskii's Method

Results

Normal Depth	5.8 in
Roughness Coefficient	0.040
Elevation	36.48 ft
Elevation Range	36.0 to 41.0 ft
Flow Area	15.7 ft ²
Wetted Perimeter	36.0 ft
Hydraulic Radius	5.3 in
Top Width	35.89 ft
Normal Depth	5.8 in
Critical Depth	4.6 in
Critical Slope	0.033 ft/ft
Velocity	2.62 ft/s
Velocity Head	0.11 ft
Specific Energy	0.59 ft
Froude Number	0.698

Worksheet for A1-1

Results	
Flow Type	Subcritical
GVF Input Data	
Downstream Depth	0.0 in
Length	0.0 ft
Number Of Steps	0
GVF Output Data	
Upstream Depth	0.0 in
Profile Description	N/A
Profile Headloss	0.00 ft
Downstream Velocity	0.00 ft/s
Upstream Velocity	0.00 ft/s
Normal Depth	5.8 in
Critical Depth	4.6 in
Channel Slope	0.015 ft/ft
Critical Slope	0.033 ft/ft

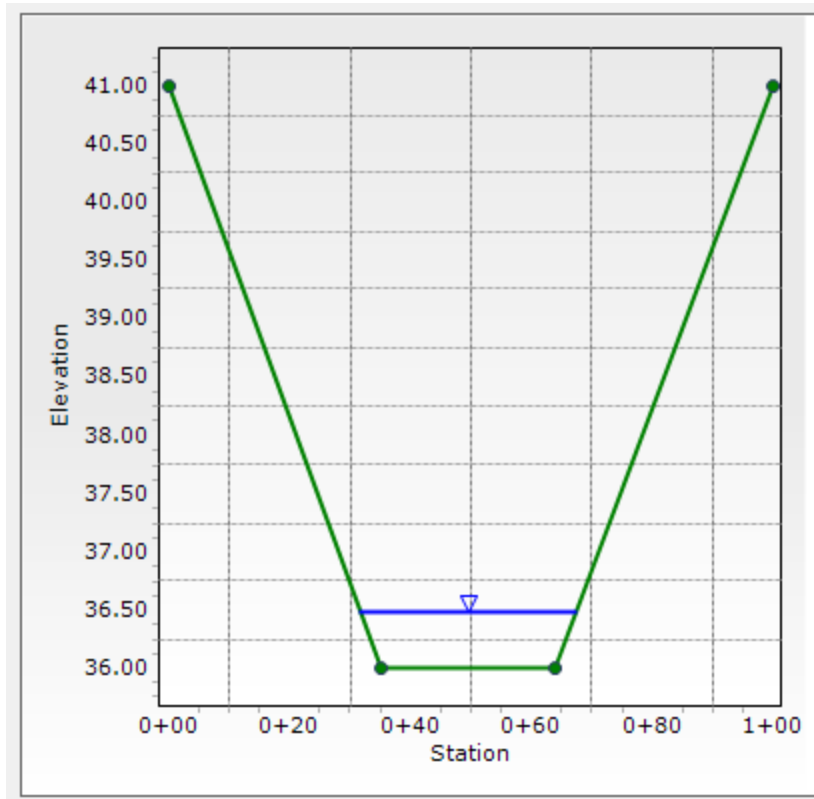

Worksheet for A2-1

Project Description	
Friction Method	Manning Formula
Solve For	Normal Depth

Input Data	
Channel Slope	0.028 ft/ft
Discharge	60.42 cfs

Section Definitions

	Station (ft)	Elevation (ft)
	0+00	47.00
	0+66	42.00
	0+87	42.00
	1+25	47.75

Roughness Segment Definitions

Start Station	Ending Station	Roughness Coefficient
(0+00, 47.00)	(0+66, 42.00)	0.040
(0+66, 42.00)	(0+87, 42.00)	0.040
(0+87, 42.00)	(1+25, 47.75)	0.040

Options

Current Roughness Weighted Method	Pavlovskii's Method
Open Channel Weighting Method	Pavlovskii's Method
Closed Channel Weighting Method	Pavlovskii's Method

Results

Normal Depth	7.1 in
Roughness Coefficient	0.040
Elevation	42.59 ft
Elevation Range	42.0 to 47.8 ft
Flow Area	15.8 ft ²
Wetted Perimeter	32.7 ft
Hydraulic Radius	5.8 in
Top Width	32.67 ft
Normal Depth	7.1 in
Critical Depth	6.9 in
Critical Slope	0.030 ft/ft
Velocity	3.82 ft/s
Velocity Head	0.23 ft
Specific Energy	0.82 ft
Froude Number	0.969

Worksheet for A2-1

Results	
Flow Type	Subcritical
GVF Input Data	
Downstream Depth	0.0 in
Length	0.0 ft
Number Of Steps	0
GVF Output Data	
Upstream Depth	0.0 in
Profile Description	N/A
Profile Headloss	0.00 ft
Downstream Velocity	Infinity ft/s
Upstream Velocity	Infinity ft/s
Normal Depth	7.1 in
Critical Depth	6.9 in
Channel Slope	0.028 ft/ft
Critical Slope	0.030 ft/ft

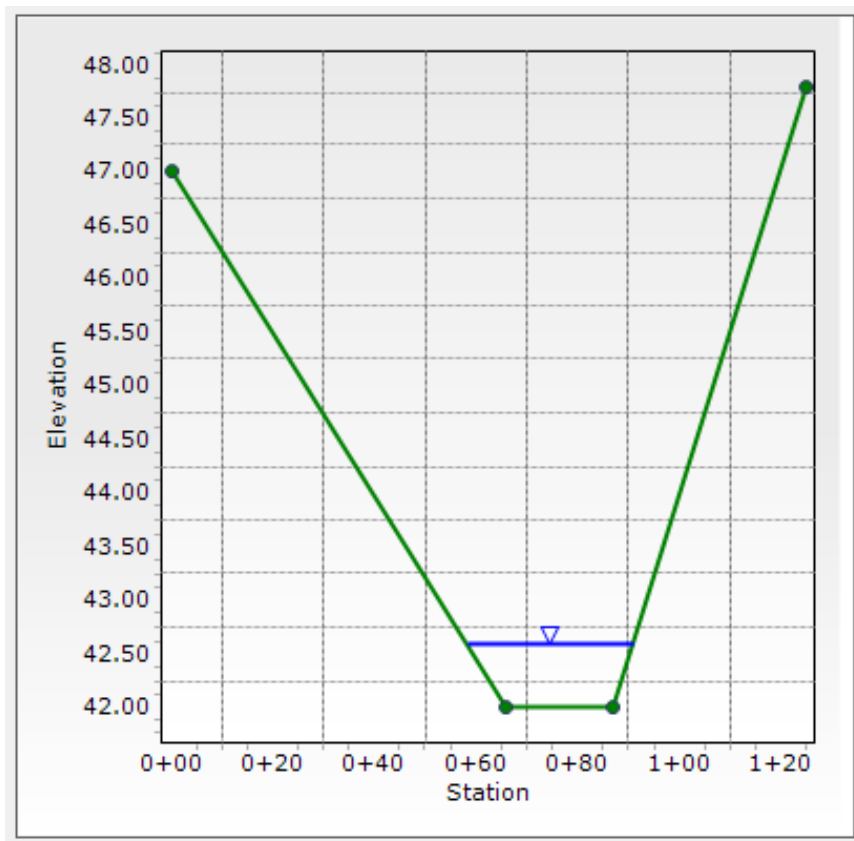

Worksheet for A2-2

Project Description	
Friction Method	Manning Formula
Solve For	Normal Depth

Input Data	
Channel Slope	0.046 ft/ft
Discharge	14.45 cfs

Section Definitions

	Station (ft)	Elevation (ft)
	0+00	23.00
	0+43	16.00
	0+72	16.00
	1+25	20.00

Roughness Segment Definitions

Start Station	Ending Station	Roughness Coefficient
(0+00, 23.00)	(0+43, 16.00)	0.040
(0+43, 16.00)	(0+72, 16.00)	0.040
(0+72, 16.00)	(1+25, 20.00)	0.040

Options	
Current Roughness Weighted Method	Pavlovskii's Method
Open Channel Weighting Method	Pavlovskii's Method
Closed Channel Weighting Method	Pavlovskii's Method

Results	
Normal Depth	2.2 in
Roughness Coefficient	0.040
Elevation	16.18 ft
Elevation Range	16.0 to 23.0 ft
Flow Area	5.8 ft ²
Wetted Perimeter	33.3 ft
Hydraulic Radius	2.1 in
Top Width	33.30 ft
Normal Depth	2.2 in
Critical Depth	2.3 in
Critical Slope	0.041 ft/ft
Velocity	2.48 ft/s
Velocity Head	0.10 ft
Specific Energy	0.28 ft
Froude Number	1.048

Worksheet for A2-2

Results	
Flow Type	Supercritical
GVF Input Data	
Downstream Depth	0.0 in
Length	0.0 ft
Number Of Steps	0
GVF Output Data	
Upstream Depth	0.0 in
Profile Description	N/A
Profile Headloss	0.00 ft
Downstream Velocity	Infinity ft/s
Upstream Velocity	Infinity ft/s
Normal Depth	2.2 in
Critical Depth	2.3 in
Channel Slope	0.046 ft/ft
Critical Slope	0.041 ft/ft

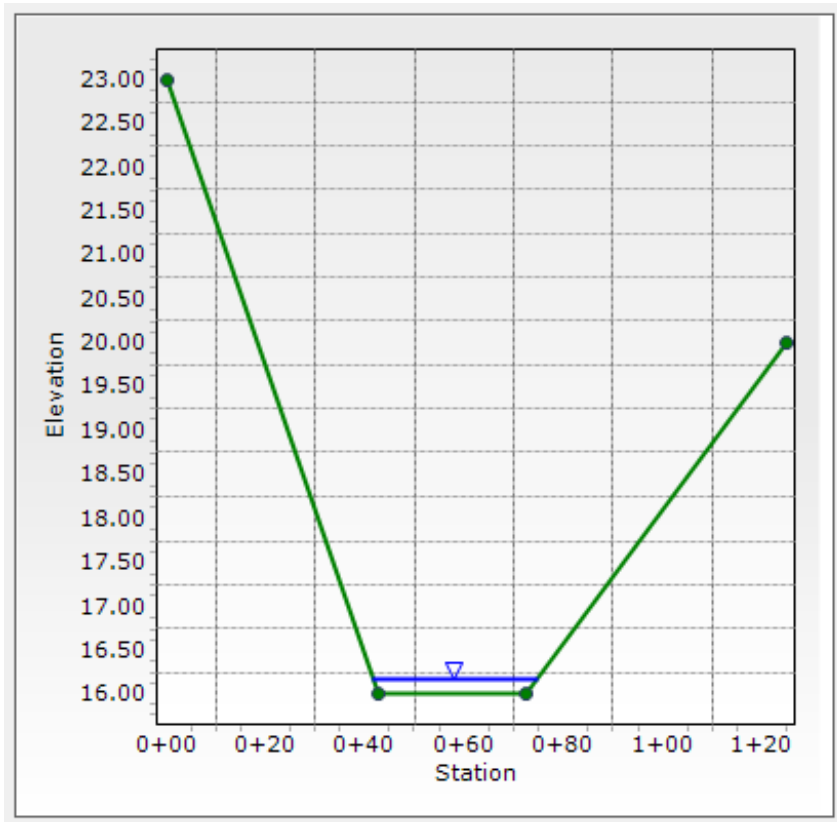

Worksheet for A2-3

Project Description

Friction Method	Manning Formula
Solve For	Normal Depth

Input Data

Channel Slope	0.030 ft/ft
Discharge	18.27 cfs

Section Definitions

	Station (ft)	Elevation (ft)	
	0+00		11.00
	0+51		4.00
	0+63		4.00
	0+98		9.00

Roughness Segment Definitions

Start Station	Ending Station	Roughness Coefficient	
(0+00, 11.00)	(0+51, 4.00)	0.040	
(0+51, 4.00)	(0+63, 4.00)	0.040	
(0+63, 4.00)	(0+98, 9.00)	0.040	

Options

Current Roughness Weighted Method	Pavlovskii's Method
Open Channel Weighting Method	Pavlovskii's Method
Closed Channel Weighting Method	Pavlovskii's Method

Results

Normal Depth	4.8 in
Roughness Coefficient	0.040
Elevation	4.40 ft
Elevation Range	4.0 to 11.0 ft
Flow Area	5.9 ft ²
Wetted Perimeter	17.7 ft
Hydraulic Radius	4.0 in
Top Width	17.69 ft
Normal Depth	4.8 in
Critical Depth	4.6 in
Critical Slope	0.034 ft/ft
Velocity	3.09 ft/s
Velocity Head	0.15 ft
Specific Energy	0.55 ft
Froude Number	0.942
Flow Type	Subcritical

Worksheet for A2-3

GVF Input Data	
Downstream Depth	0.0 in
Length	0.0 ft
Number Of Steps	0
GVF Output Data	
Upstream Depth	0.0 in
Profile Description	N/A
Profile Headloss	0.00 ft
Downstream Velocity	0.00 ft/s
Upstream Velocity	0.00 ft/s
Normal Depth	4.8 in
Critical Depth	4.6 in
Channel Slope	0.030 ft/ft
Critical Slope	0.034 ft/ft

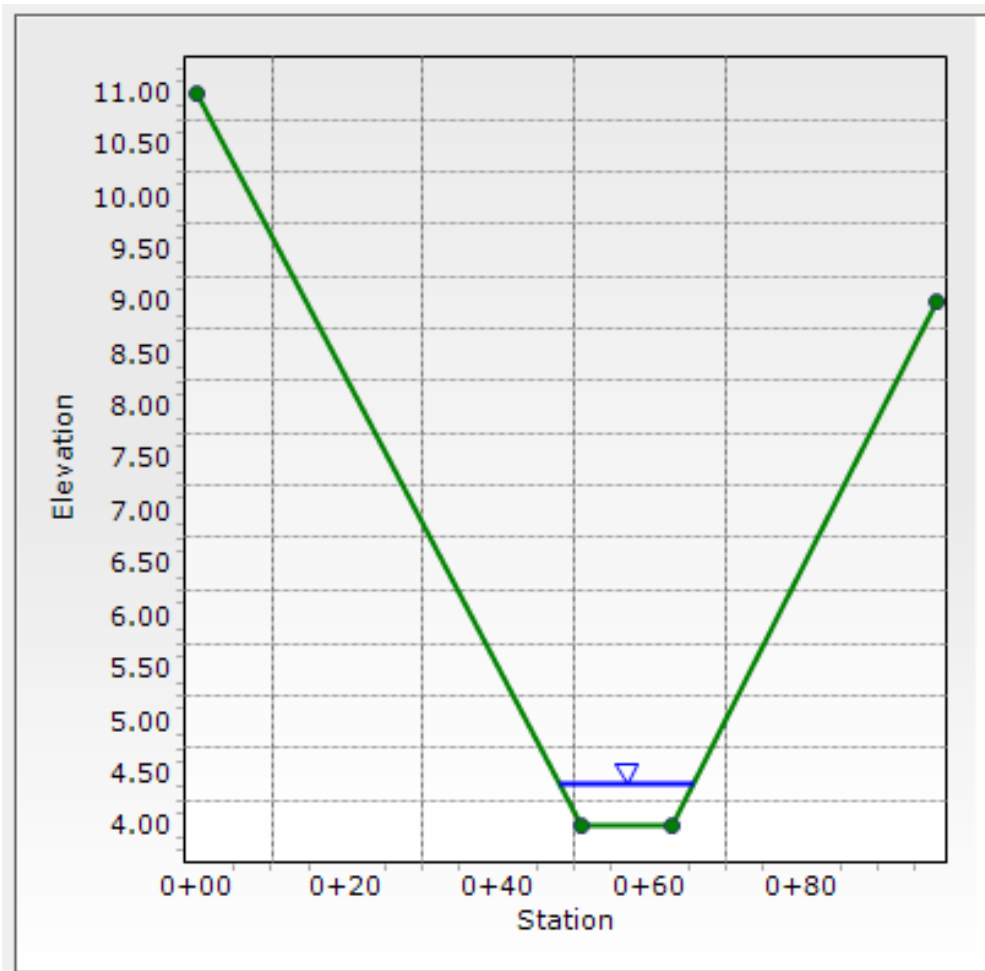

Worksheet for A2-4

Project Description

Friction Method	Manning Formula
Solve For	Normal Depth

Input Data

Channel Slope	0.029 ft/ft
Discharge	2.71 cfs

Section Definitions

	Station (ft)	Elevation (ft)
	0+15	14.00
	0+32	12.75
	0+47	12.50
	0+98	18.00

Roughness Segment Definitions

Start Station	Ending Station	Roughness Coefficient
(0+15, 14.00)	(0+32, 12.75)	0.040
(0+32, 12.75)	(0+47, 12.50)	0.040
(0+47, 12.50)	(0+98, 18.00)	0.040

Options

Current Roughness Weighted Method	Pavlovskii's Method
Open Channel Weighting Method	Pavlovskii's Method
Closed Channel Weighting Method	Pavlovskii's Method

Results

Normal Depth	2.7 in
Roughness Coefficient	0.040
Elevation	12.73 ft
Elevation Range	12.5 to 18.0 ft
Flow Area	1.8 ft ²
Wetted Perimeter	15.9 ft
Hydraulic Radius	1.4 in
Top Width	15.86 ft
Normal Depth	2.7 in
Critical Depth	2.5 in
Critical Slope	0.050 ft/ft
Velocity	1.49 ft/s
Velocity Head	0.03 ft
Specific Energy	0.26 ft
Froude Number	0.778

Worksheet for A2-4

Results	
Flow Type	Subcritical
GVF Input Data	
Downstream Depth	0.0 in
Length	0.0 ft
Number Of Steps	0
GVF Output Data	
Upstream Depth	0.0 in
Profile Description	N/A
Profile Headloss	0.00 ft
Downstream Velocity	0.00 ft/s
Upstream Velocity	0.00 ft/s
Normal Depth	2.7 in
Critical Depth	2.5 in
Channel Slope	0.029 ft/ft
Critical Slope	0.050 ft/ft

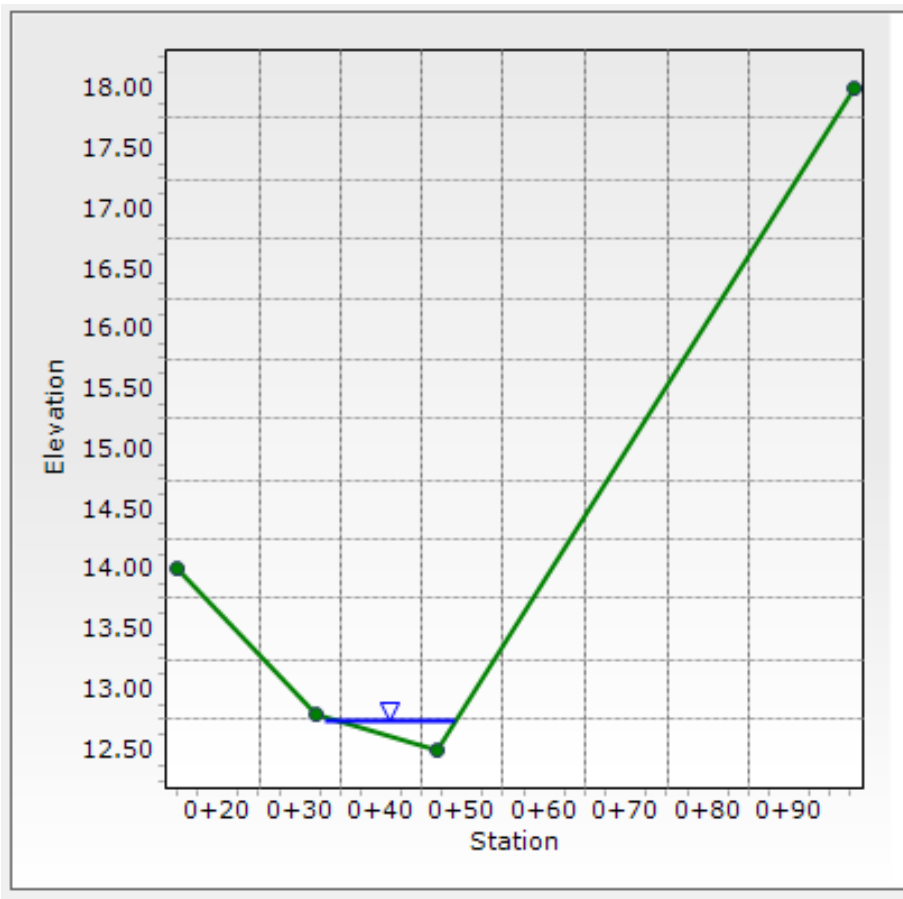

Worksheet for A2-5

Project Description

Friction Method	Manning Formula
Solve For	Normal Depth

Input Data

Channel Slope	0.020 ft/ft
Discharge	19.06 cfs

Section Definitions

	Station (ft)	Elevation (ft)
	0+00	15.00
	0+43	12.00
	0+68	12.00
	1+25	16.75

Roughness Segment Definitions

Start Station	Ending Station	Roughness Coefficient
(0+00, 15.00)	(0+43, 12.00)	0.040
(0+43, 12.00)	(0+68, 12.00)	0.040
(0+68, 12.00)	(1+25, 16.75)	0.040

Options

Current Roughness Weighted Method	Pavlovskii's Method
Open Channel Weighting Method	Pavlovskii's Method
Closed Channel Weighting Method	Pavlovskii's Method

Results

Normal Depth	3.6 in
Roughness Coefficient	0.040
Elevation	12.30 ft
Elevation Range	12.0 to 16.8 ft
Flow Area	8.8 ft ²
Wetted Perimeter	33.2 ft
Hydraulic Radius	3.2 in
Top Width	33.18 ft
Normal Depth	3.6 in
Critical Depth	3.0 in
Critical Slope	0.038 ft/ft
Velocity	2.17 ft/s
Velocity Head	0.07 ft
Specific Energy	0.37 ft
Froude Number	0.742

Worksheet for A2-5

Results	
Flow Type	Subcritical
GVF Input Data	
Downstream Depth	0.0 in
Length	0.0 ft
Number Of Steps	0
GVF Output Data	
Upstream Depth	0.0 in
Profile Description	N/A
Profile Headloss	0.00 ft
Downstream Velocity	0.00 ft/s
Upstream Velocity	0.00 ft/s
Normal Depth	3.6 in
Critical Depth	3.0 in
Channel Slope	0.020 ft/ft
Critical Slope	0.038 ft/ft

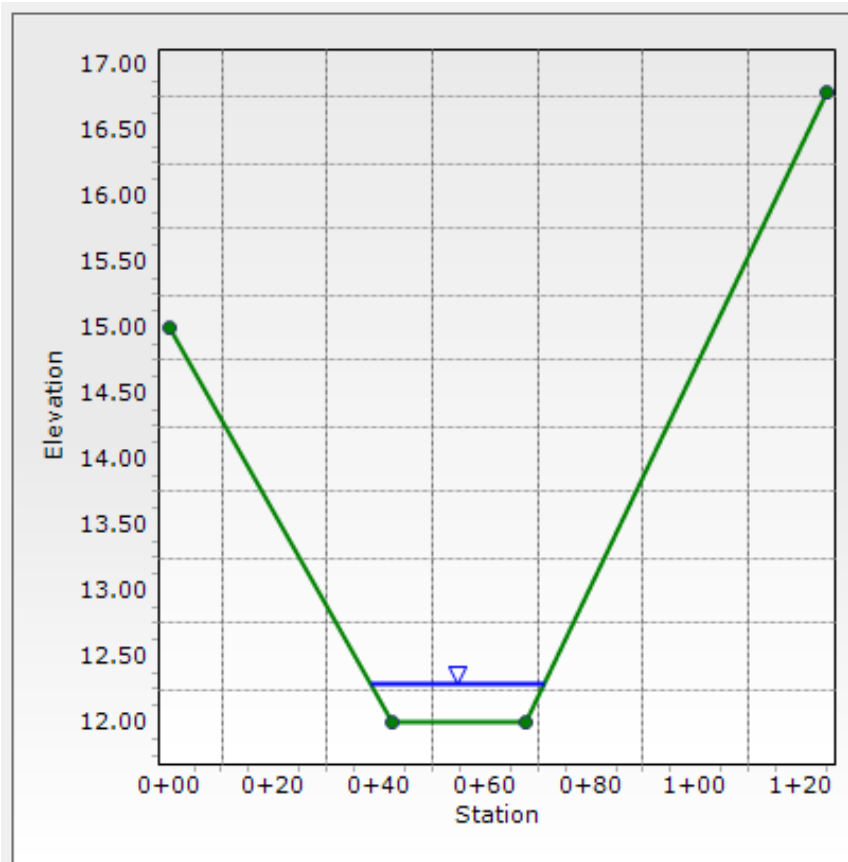

Worksheet for A2-6

Project Description	
Friction Method	Manning Formula
Solve For	Normal Depth

Input Data	
Channel Slope	0.027 ft/ft
Discharge	10.72 cfs

Section Definitions

	Station (ft)	Elevation (ft)
	0+00	30.00
	0+31	28.00
	0+59	28.00
	0+94	30.25

Roughness Segment Definitions

Start Station	Ending Station	Roughness Coefficient
(0+00, 30.00)	(0+31, 28.00)	0.040
(0+31, 28.00)	(0+59, 28.00)	0.040
(0+59, 28.00)	(0+94, 30.25)	0.040

Options

Current Roughness Weighted Method	Pavlovskii's Method
Open Channel Weighting Method	Pavlovskii's Method
Closed Channel Weighting Method	Pavlovskii's Method

Results

Normal Depth	2.2 in
Roughness Coefficient	0.040
Elevation	28.18 ft
Elevation Range	28.0 to 30.3 ft
Flow Area	5.8 ft ²
Wetted Perimeter	34.2 ft
Hydraulic Radius	2.0 in
Top Width	34.16 ft
Normal Depth	2.2 in
Critical Depth	1.9 in
Critical Slope	0.044 ft/ft
Velocity	1.86 ft/s
Velocity Head	0.05 ft
Specific Energy	0.24 ft
Froude Number	0.800

Worksheet for A2-6

Results	
Flow Type	Subcritical
GVF Input Data	
Downstream Depth	0.0 in
Length	0.0 ft
Number Of Steps	0
GVF Output Data	
Upstream Depth	0.0 in
Profile Description	N/A
Profile Headloss	0.00 ft
Downstream Velocity	0.00 ft/s
Upstream Velocity	0.00 ft/s
Normal Depth	2.2 in
Critical Depth	1.9 in
Channel Slope	0.027 ft/ft
Critical Slope	0.044 ft/ft

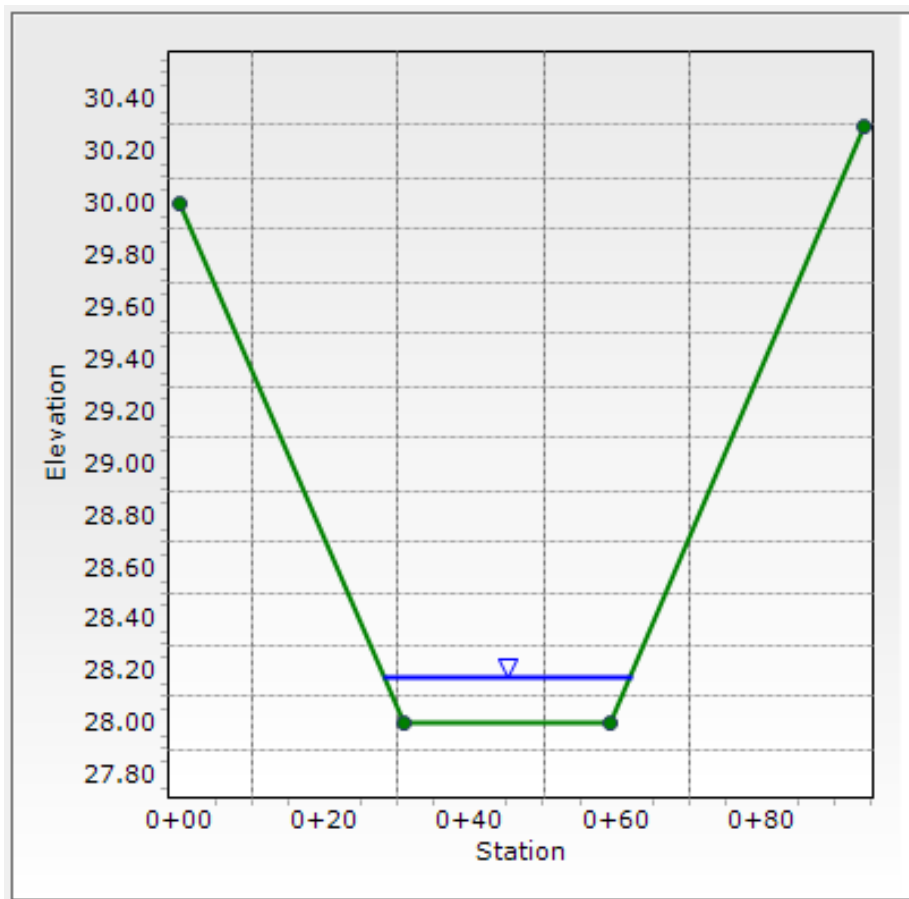

Worksheet for A2-7

Project Description

Friction Method	Manning Formula
Solve For	Normal Depth

Input Data

Channel Slope	0.020 ft/ft
Discharge	2.78 cfs

Section Definitions

	Station (ft)	Elevation (ft)
	0+18	201.00
	0+36	200.00
	0+73	200.00
	1+00	202.00

Roughness Segment Definitions

Start Station	Ending Station	Roughness Coefficient
(0+18, 201.00)	(0+36, 200.00)	0.040
(0+36, 200.00)	(0+73, 200.00)	0.040
(0+73, 200.00)	(1+00, 202.00)	0.040

Options

Current Roughness Weighted Method	Pavlovskii's Method
Open Channel Weighting Method	Pavlovskii's Method
Closed Channel Weighting Method	Pavlovskii's Method

Results

Normal Depth	0.9 in
Roughness Coefficient	0.040
Elevation	200.08 ft
Elevation Range	200.0 to 202.0 ft
Flow Area	3.0 ft ²
Wetted Perimeter	39.5 ft
Hydraulic Radius	0.9 in
Top Width	39.45 ft
Normal Depth	0.9 in
Critical Depth	0.7 in
Critical Slope	0.062 ft/ft
Velocity	0.94 ft/s
Velocity Head	0.01 ft
Specific Energy	0.09 ft
Froude Number	0.602

Worksheet for A2-7

Results	
Flow Type	Subcritical
GVF Input Data	
Downstream Depth	0.0 in
Length	0.0 ft
Number Of Steps	0
GVF Output Data	
Upstream Depth	0.0 in
Profile Description	N/A
Profile Headloss	0.00 ft
Downstream Velocity	0.00 ft/s
Upstream Velocity	0.00 ft/s
Normal Depth	0.9 in
Critical Depth	0.7 in
Channel Slope	0.020 ft/ft
Critical Slope	0.062 ft/ft

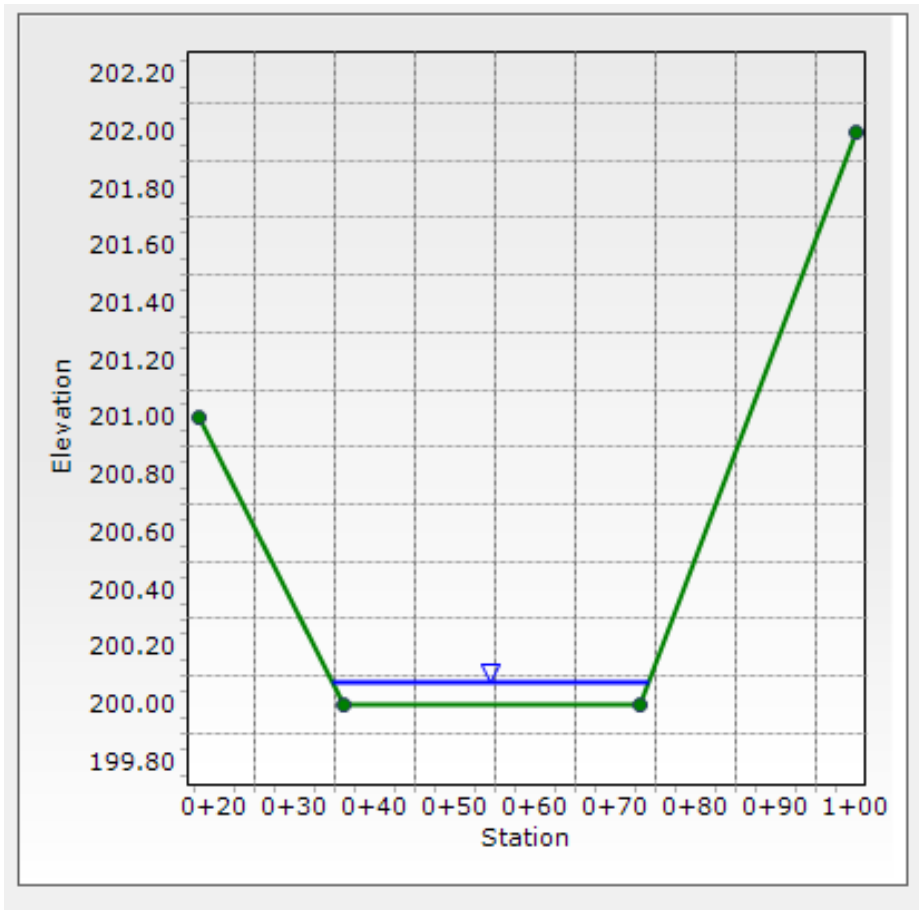

Worksheet for B1-1

Project Description

Friction Method	Manning Formula
Solve For	Normal Depth

Input Data

Channel Slope	0.034 ft/ft
Discharge	20.11 cfs

Section Definitions

	Station (ft)	Elevation (ft)
	0+00	26.00
	0+54	20.00
	0+76	20.00
	1+25	22.75

Roughness Segment Definitions

Start Station	Ending Station	Roughness Coefficient
(0+00, 26.00)	(0+54, 20.00)	0.040
(0+54, 20.00)	(0+76, 20.00)	0.040
(0+76, 20.00)	(1+25, 22.75)	0.040

Options

Current Roughness Weighted Method	Pavlovskii's Method
Open Channel Weighting Method	Pavlovskii's Method
Closed Channel Weighting Method	Pavlovskii's Method

Results

Normal Depth	3.4 in
Roughness Coefficient	0.040
Elevation	20.29 ft
Elevation Range	20.0 to 26.0 ft
Flow Area	7.4 ft ²
Wetted Perimeter	29.7 ft
Hydraulic Radius	3.0 in
Top Width	29.69 ft
Normal Depth	3.4 in
Critical Depth	3.3 in
Critical Slope	0.037 ft/ft
Velocity	2.71 ft/s
Velocity Head	0.11 ft
Specific Energy	0.40 ft
Froude Number	0.958

Worksheet for B1-1

Results	
Flow Type	Subcritical
GVF Input Data	
Downstream Depth	0.0 in
Length	0.0 ft
Number Of Steps	0
GVF Output Data	
Upstream Depth	0.0 in
Profile Description	N/A
Profile Headloss	0.00 ft
Downstream Velocity	0.00 ft/s
Upstream Velocity	0.00 ft/s
Normal Depth	3.4 in
Critical Depth	3.3 in
Channel Slope	0.034 ft/ft
Critical Slope	0.037 ft/ft

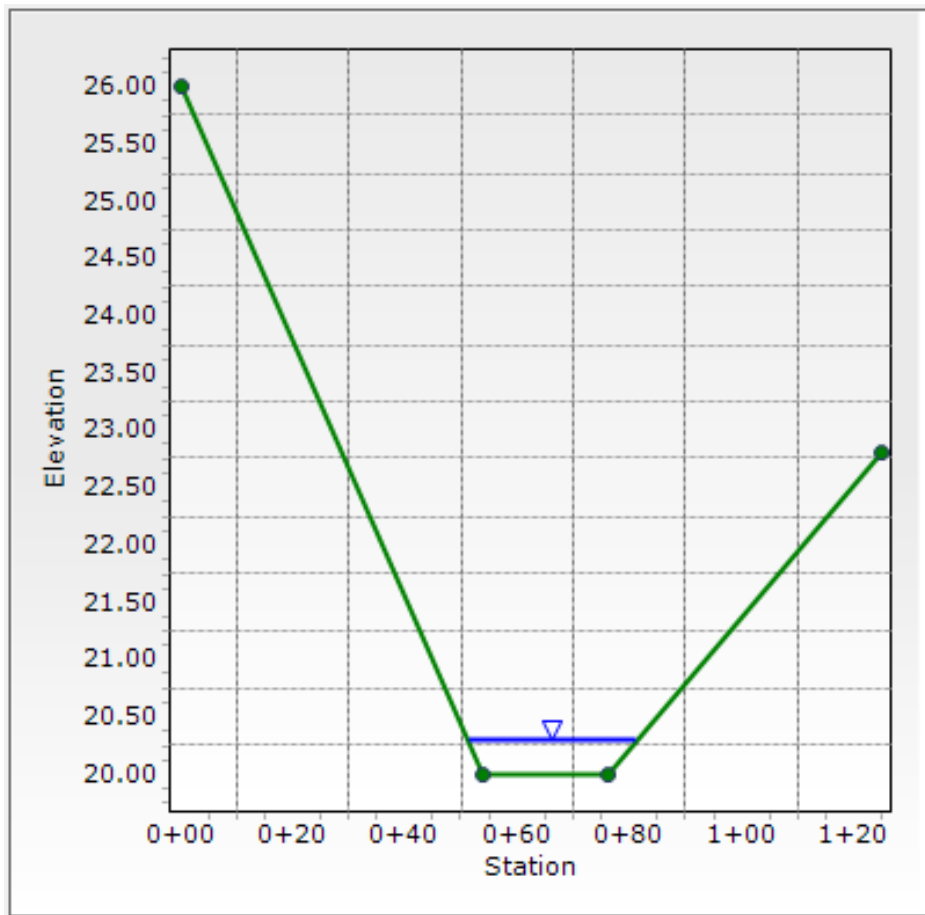

Worksheet for B1-2

Project Description

Friction Method	Manning Formula
Solve For	Normal Depth

Input Data

Channel Slope	0.075 ft/ft
Discharge	28.20 cfs

Section Definitions

	Station (ft)	Elevation (ft)	
	0+00		3.00
	0+31		0.00
	0+60		0.00
	1+00		4.84

Roughness Segment Definitions

Start Station	Ending Station	Roughness Coefficient	
(0+00, 3.00)	(0+31, 0.00)	0.040	
(0+31, 0.00)	(0+60, 0.00)	0.040	
(0+60, 0.00)	(1+00, 4.84)	0.040	

Options

Current Roughness Weighted Method	Pavlovskii's Method
Open Channel Weighting Method	Pavlovskii's Method
Closed Channel Weighting Method	Pavlovskii's Method

Results

Normal Depth	2.9 in
Roughness Coefficient	0.040
Elevation	0.24 ft
Elevation Range	0.0 to 4.8 ft
Flow Area	7.5 ft ²
Wetted Perimeter	33.4 ft
Hydraulic Radius	2.7 in
Top Width	33.34 ft
Normal Depth	2.9 in
Critical Depth	3.6 in
Critical Slope	0.036 ft/ft
Velocity	3.76 ft/s
Velocity Head	0.22 ft
Specific Energy	0.46 ft
Froude Number	1.396
Flow Type	Supercritical

Worksheet for B1-2

GVF Input Data

Downstream Depth	0.0 in
Length	0.0 ft
Number Of Steps	0

GVF Output Data

Upstream Depth	0.0 in
Profile Description	N/A
Profile Headloss	0.00 ft
Downstream Velocity	Infinity ft/s
Upstream Velocity	Infinity ft/s
Normal Depth	2.9 in
Critical Depth	3.6 in
Channel Slope	0.075 ft/ft
Critical Slope	0.036 ft/ft

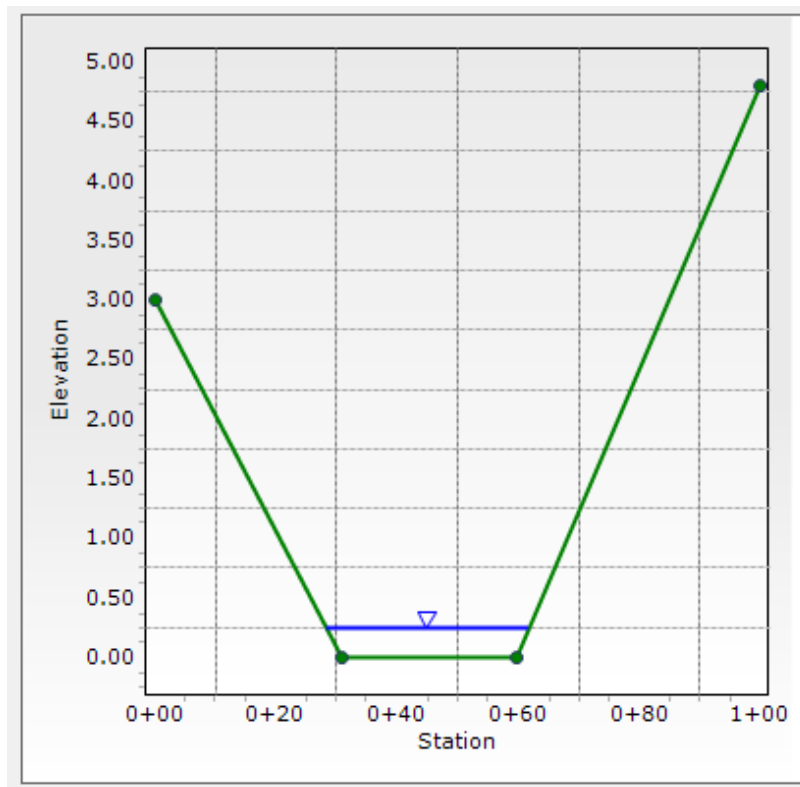

Worksheet for B1-3

Project Description

Friction Method	Manning Formula
Solve For	Normal Depth

Input Data

Channel Slope	0.033 ft/ft
Discharge	26.50 cfs

Section Definitions

	Station (ft)	Elevation (ft)
	0+00	19.00
	0+45	14.00
	0+56	14.00
	0+98	18.00

Roughness Segment Definitions

Start Station	Ending Station	Roughness Coefficient
(0+00, 19.00)	(0+45, 14.00)	0.040
(0+45, 14.00)	(0+56, 14.00)	0.040
(0+56, 14.00)	(0+98, 18.00)	0.040

Options

Current Roughness Weighted Method	Pavlovskii's Method
Open Channel Weighting Method	Pavlovskii's Method
Closed Channel Weighting Method	Pavlovskii's Method

Results

Normal Depth	5.6 in
Roughness Coefficient	0.040
Elevation	14.47 ft
Elevation Range	14.0 to 19.0 ft
Flow Area	7.7 ft ²
Wetted Perimeter	20.9 ft
Hydraulic Radius	4.4 in
Top Width	20.85 ft
Normal Depth	5.6 in
Critical Depth	5.7 in
Critical Slope	0.033 ft/ft
Velocity	3.46 ft/s
Velocity Head	0.19 ft
Specific Energy	0.66 ft
Froude Number	1.005

Worksheet for B1-3

Results	
Flow Type	Supercritical
GVF Input Data	
Downstream Depth	0.0 in
Length	0.0 ft
Number Of Steps	0
GVF Output Data	
Upstream Depth	0.0 in
Profile Description	N/A
Profile Headloss	0.00 ft
Downstream Velocity	Infinity ft/s
Upstream Velocity	Infinity ft/s
Normal Depth	5.6 in
Critical Depth	5.7 in
Channel Slope	0.033 ft/ft
Critical Slope	0.033 ft/ft

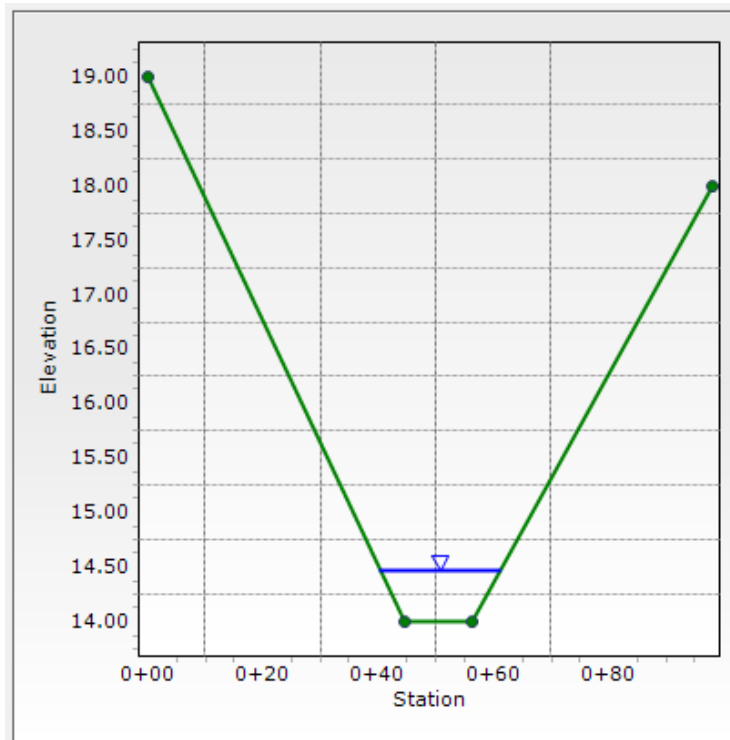

Worksheet for B1-4

Project Description

Friction Method	Manning Formula
Solve For	Normal Depth

Input Data

Channel Slope	0.063 ft/ft
Discharge	7.95 cfs

Section Definitions

	Station (ft)	Elevation (ft)
	0+00	34.00
	0+26	30.00
	0+47	30.00
	0+75	35.00

Roughness Segment Definitions

Start Station	Ending Station	Roughness Coefficient
(0+00, 34.00)	(0+26, 30.00)	0.040
(0+26, 30.00)	(0+47, 30.00)	0.040
(0+47, 30.00)	(0+75, 35.00)	0.040

Options

Current Roughness Weighted Method	Pavlovskii's Method
Open Channel Weighting Method	Pavlovskii's Method
Closed Channel Weighting Method	Pavlovskii's Method

Results

Normal Depth	1.8 in
Roughness Coefficient	0.040
Elevation	30.15 ft
Elevation Range	30.0 to 35.0 ft
Flow Area	3.2 ft ²
Wetted Perimeter	22.5 ft
Hydraulic Radius	1.7 in
Top Width	22.52 ft
Normal Depth	1.8 in
Critical Depth	2.0 in
Critical Slope	0.043 ft/ft
Velocity	2.52 ft/s
Velocity Head	0.10 ft
Specific Energy	0.24 ft
Froude Number	1.185

Worksheet for B1-4

Results	
Flow Type	Supercritical
GVF Input Data	
Downstream Depth	0.0 in
Length	0.0 ft
Number Of Steps	0
GVF Output Data	
Upstream Depth	0.0 in
Profile Description	N/A
Profile Headloss	0.00 ft
Downstream Velocity	Infinity ft/s
Upstream Velocity	Infinity ft/s
Normal Depth	1.8 in
Critical Depth	2.0 in
Channel Slope	0.063 ft/ft
Critical Slope	0.043 ft/ft

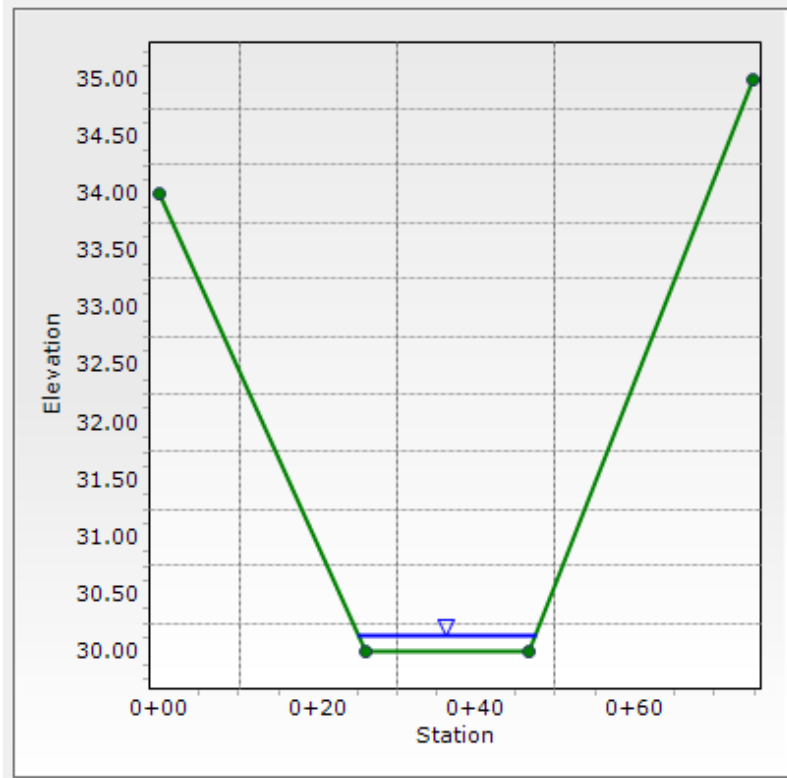

Worksheet for B1-5

Project Description	
Friction Method	Manning Formula
Solve For	Normal Depth

Input Data	
Channel Slope	0.039 ft/ft
Discharge	5.01 cfs

Section Definitions

	Station (ft)	Elevation (ft)	
	0+00		35.00
	0+29		32.00
	0+54		32.00
	0+73		35.00

Roughness Segment Definitions

Start Station	Ending Station	Roughness Coefficient	
(0+00, 35.00)	(0+29, 32.00)	0.040	
(0+29, 32.00)	(0+54, 32.00)	0.040	
(0+54, 32.00)	(0+73, 35.00)	0.040	

Options

Current Roughness Weighted Method	Pavlovskii's Method
Open Channel Weighting Method	Pavlovskii's Method
Closed Channel Weighting Method	Pavlovskii's Method

Results

Normal Depth	1.4 in
Roughness Coefficient	0.040
Elevation	32.11 ft
Elevation Range	32.0 to 35.0 ft
Flow Area	3.0 ft ²
Wetted Perimeter	27.1 ft
Hydraulic Radius	1.3 in
Top Width	27.07 ft
Normal Depth	1.4 in
Critical Depth	1.3 in
Critical Slope	0.050 ft/ft
Velocity	1.68 ft/s
Velocity Head	0.04 ft
Specific Energy	0.16 ft
Froude Number	0.894

Worksheet for B1-5

Results	
Flow Type	Subcritical
GVF Input Data	
Downstream Depth	0.0 in
Length	0.0 ft
Number Of Steps	0
GVF Output Data	
Upstream Depth	0.0 in
Profile Description	N/A
Profile Headloss	0.00 ft
Downstream Velocity	0.00 ft/s
Upstream Velocity	0.00 ft/s
Normal Depth	1.4 in
Critical Depth	1.3 in
Channel Slope	0.039 ft/ft
Critical Slope	0.050 ft/ft

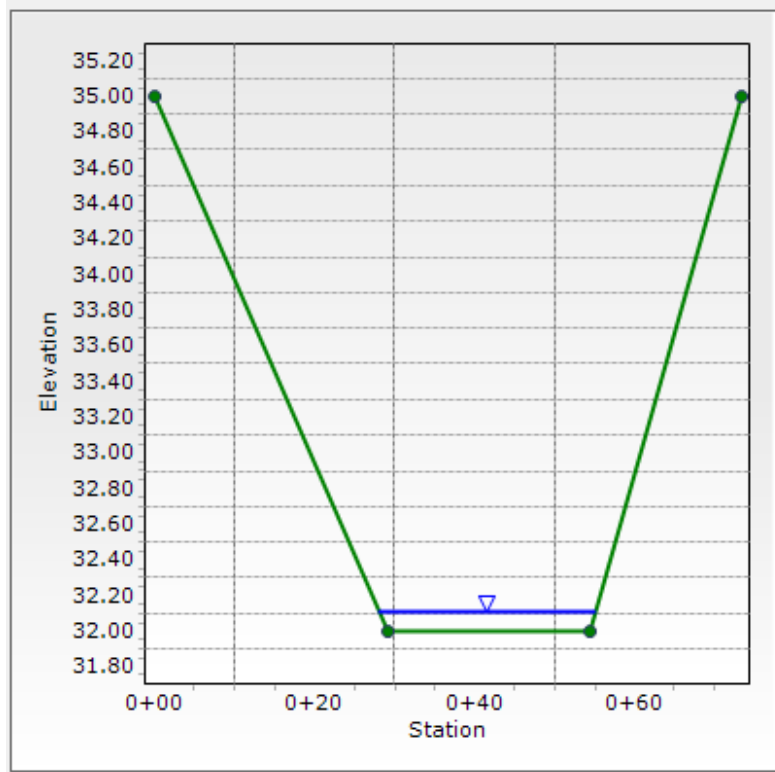

Worksheet for B1-6

Project Description

Friction Method	Manning Formula
Solve For	Normal Depth

Input Data

Channel Slope	0.030 ft/ft
Discharge	5.37 cfs

Section Definitions

	Station (ft)	Elevation (ft)	
	0+00		22.00
	0+35		18.00
	0+51		18.00
	0+92		23.00

Roughness Segment Definitions

Start Station	Ending Station	Roughness Coefficient
(0+00, 22.00)	(0+35, 18.00)	0.040
(0+35, 18.00)	(0+51, 18.00)	0.040
(0+51, 18.00)	(0+92, 23.00)	0.040

Options

Current Roughness Weighted Method	Pavlovskii's Method
Open Channel Weighting Method	Pavlovskii's Method
Closed Channel Weighting Method	Pavlovskii's Method

Results

Normal Depth	2.0 in
Roughness Coefficient	0.040
Elevation	18.17 ft
Elevation Range	18.0 to 23.0 ft
Flow Area	2.9 ft ²
Wetted Perimeter	19.1 ft
Hydraulic Radius	1.8 in
Top Width	19.04 ft
Normal Depth	2.0 in
Critical Depth	1.8 in
Critical Slope	0.045 ft/ft
Velocity	1.84 ft/s
Velocity Head	0.05 ft
Specific Energy	0.22 ft
Froude Number	0.829

Worksheet for B1-6

Results	
Flow Type	Subcritical
GVF Input Data	
Downstream Depth	0.0 in
Length	0.0 ft
Number Of Steps	0
GVF Output Data	
Upstream Depth	0.0 in
Profile Description	N/A
Profile Headloss	0.00 ft
Downstream Velocity	0.00 ft/s
Upstream Velocity	0.00 ft/s
Normal Depth	2.0 in
Critical Depth	1.8 in
Channel Slope	0.030 ft/ft
Critical Slope	0.045 ft/ft

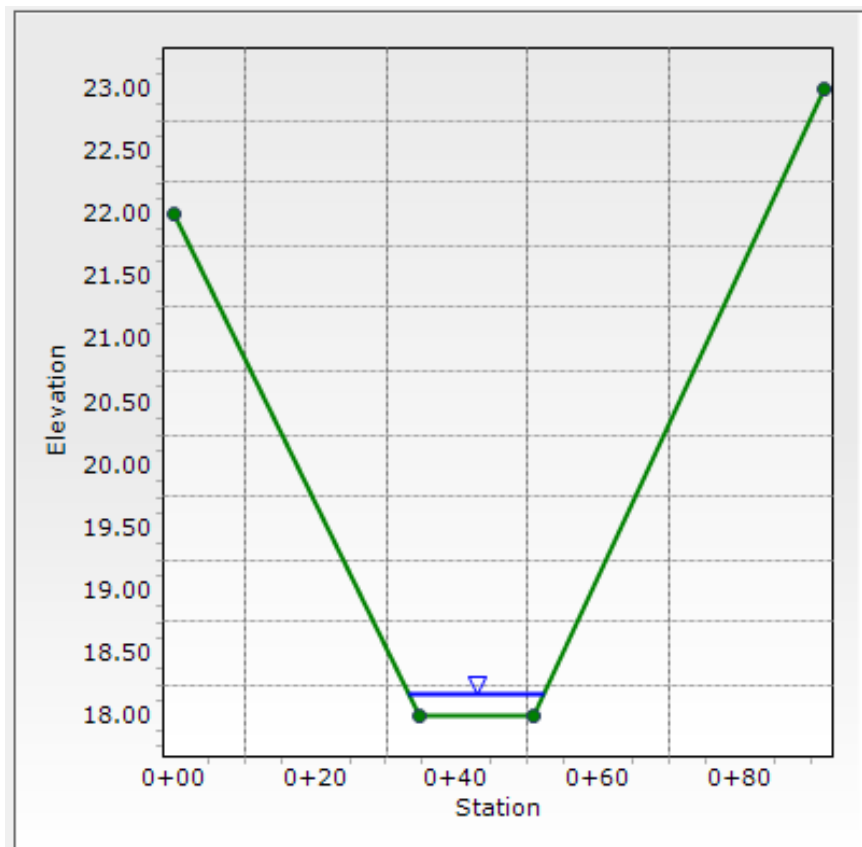

Worksheet for B2-1

Project Description	
Friction Method	Manning Formula
Solve For	Normal Depth

Input Data	
Channel Slope	0.037 ft/ft
Discharge	11.88 cfs

Section Definitions

	Station (ft)	Elevation (ft)
	0+00	5.00
	0+42	0.00
	0+58	0.00
	0+75	4.50

Roughness Segment Definitions

Start Station	Ending Station	Roughness Coefficient
(0+00, 5.00)	(0+42, 0.00)	0.040
(0+42, 0.00)	(0+58, 0.00)	0.040
(0+58, 0.00)	(0+75, 4.50)	0.040

Options	
Current Roughness Weighted Method	Pavlovskii's Method
Open Channel Weighting Method	Pavlovskii's Method
Closed Channel Weighting Method	Pavlovskii's Method

Results	
Normal Depth	3.0 in
Roughness Coefficient	0.040
Elevation	0.25 ft
Elevation Range	0.0 to 5.0 ft
Flow Area	4.4 ft ²
Wetted Perimeter	19.1 ft
Hydraulic Radius	2.8 in
Top Width	19.07 ft
Normal Depth	3.0 in
Critical Depth	3.0 in
Critical Slope	0.038 ft/ft
Velocity	2.69 ft/s
Velocity Head	0.11 ft
Specific Energy	0.36 ft
Froude Number	0.984
Flow Type	Subcritical

Worksheet for B2-1

GVF Input Data

Downstream Depth	0.0 in
Length	0.0 ft
Number Of Steps	0

GVF Output Data

Upstream Depth	0.0 in
Profile Description	N/A
Profile Headloss	0.00 ft
Downstream Velocity	0.00 ft/s
Upstream Velocity	0.00 ft/s
Normal Depth	3.0 in
Critical Depth	3.0 in
Channel Slope	0.037 ft/ft
Critical Slope	0.038 ft/ft

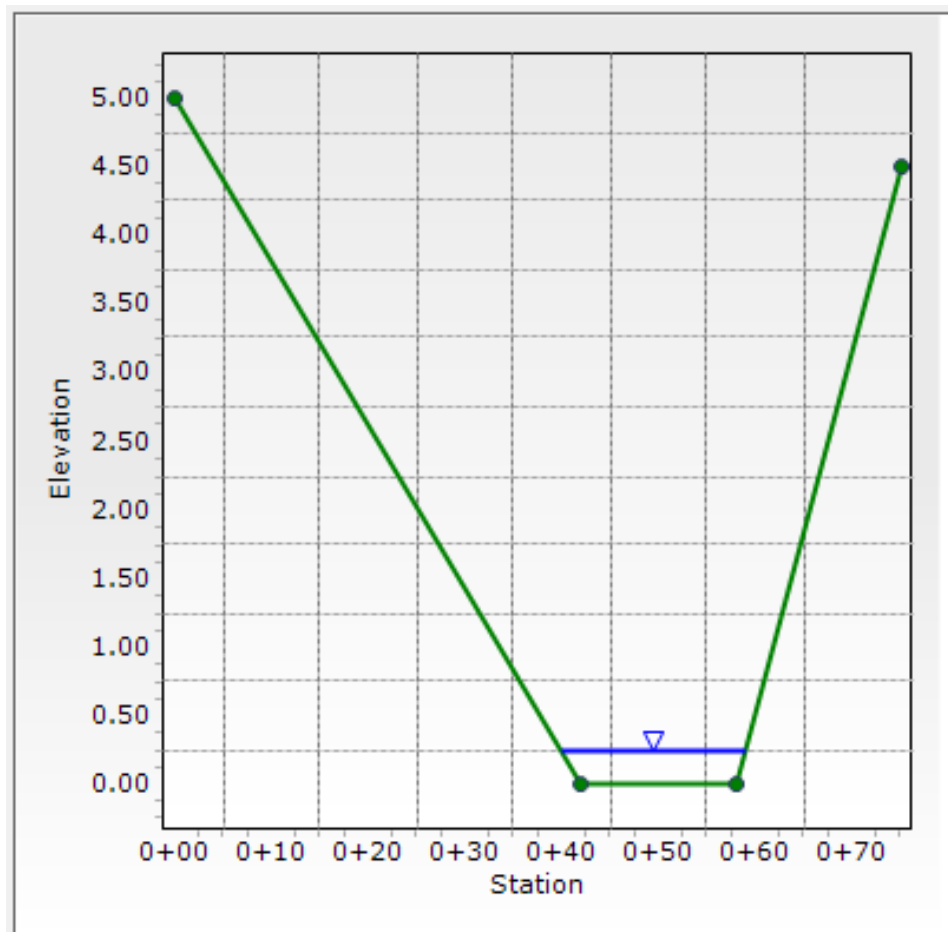

Worksheet for B2-2

Project Description

Friction Method	Manning Formula
Solve For	Normal Depth

Input Data

Channel Slope	0.054 ft/ft
Discharge	23.59 cfs

Section Definitions

	Station (ft)	Elevation (ft)	
	0+00		13.00
	0+38		8.00
	0+59		8.00
	0+96		13.00

Roughness Segment Definitions

Start Station	Ending Station	Roughness Coefficient	
(0+00, 13.00)	(0+38, 8.00)	0.040	
(0+38, 8.00)	(0+59, 8.00)	0.040	
(0+59, 8.00)	(0+96, 13.00)	0.040	

Options

Current Roughness Weighted Method	Pavlovskii's Method
Open Channel Weighting Method	Pavlovskii's Method
Closed Channel Weighting Method	Pavlovskii's Method

Results

Normal Depth	3.5 in
Roughness Coefficient	0.040
Elevation	8.29 ft
Elevation Range	8.0 to 13.0 ft
Flow Area	6.7 ft ²
Wetted Perimeter	25.4 ft
Hydraulic Radius	3.2 in
Top Width	25.31 ft
Normal Depth	3.5 in
Critical Depth	3.9 in
Critical Slope	0.035 ft/ft
Velocity	3.54 ft/s
Velocity Head	0.19 ft
Specific Energy	0.48 ft
Froude Number	1.217
Flow Type	Supercritical

Worksheet for B2-2

GVF Input Data

Downstream Depth	0.0 in
Length	0.0 ft
Number Of Steps	0

GVF Output Data

Upstream Depth	0.0 in
Profile Description	N/A
Profile Headloss	0.00 ft
Downstream Velocity	Infinity ft/s
Upstream Velocity	Infinity ft/s
Normal Depth	3.5 in
Critical Depth	3.9 in
Channel Slope	0.054 ft/ft
Critical Slope	0.035 ft/ft

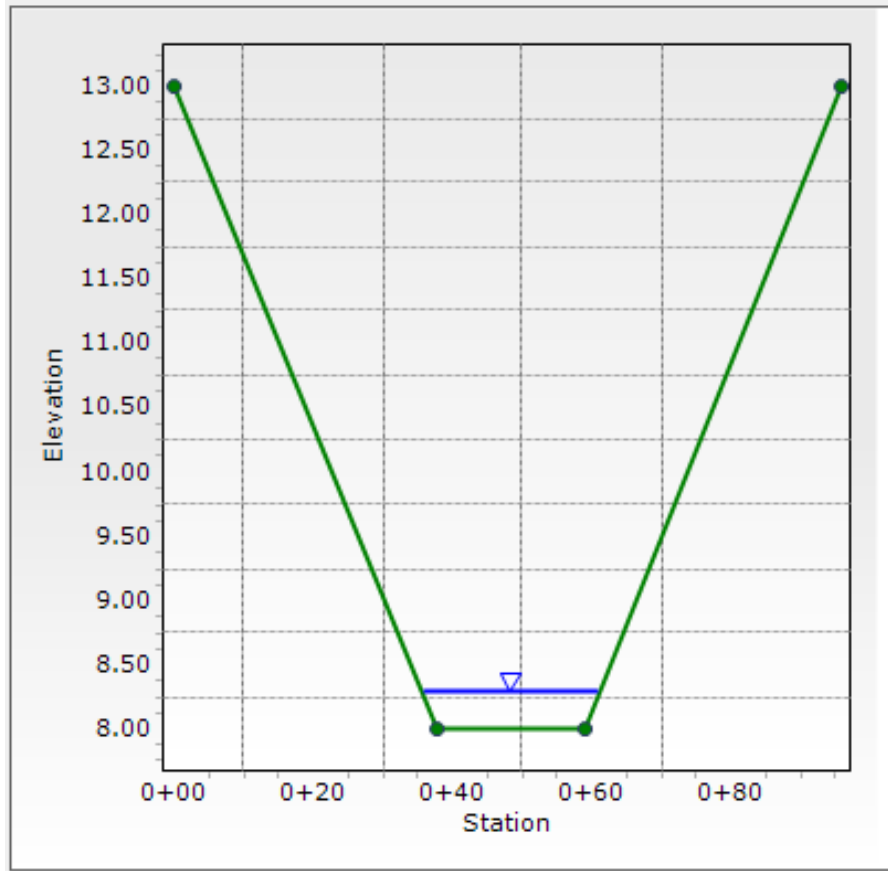

Worksheet for B6-1

Project Description

Friction Method	Manning Formula
Solve For	Normal Depth

Input Data

Channel Slope	0.190 ft/ft
Discharge	23.23 cfs

Section Definitions

	Station (ft)	Elevation (ft)	
	0+00		14.00
	0+39		6.00
	0+50		6.00
	0+63		11.50

Roughness Segment Definitions

Start Station	Ending Station	Roughness Coefficient	
(0+00, 14.00)	(0+39, 6.00)	0.040	
(0+39, 6.00)	(0+50, 6.00)	0.040	
(0+50, 6.00)	(0+63, 11.50)	0.040	

Options

Current Roughness Weighted Method	Pavlovskii's Method
Open Channel Weighting Method	Pavlovskii's Method
Closed Channel Weighting Method	Pavlovskii's Method

Results

Normal Depth	3.5 in
Roughness Coefficient	0.040
Elevation	6.29 ft
Elevation Range	6.0 to 14.0 ft
Flow Area	3.5 ft ²
Wetted Perimeter	13.2 ft
Hydraulic Radius	3.2 in
Top Width	13.09 ft
Normal Depth	3.5 in
Critical Depth	5.9 in
Critical Slope	0.031 ft/ft
Velocity	6.67 ft/s
Velocity Head	0.69 ft
Specific Energy	0.98 ft
Froude Number	2.280
Flow Type	Supercritical

Worksheet for B6-1

GVF Input Data	
Downstream Depth	0.0 in
Length	0.0 ft
Number Of Steps	0
GVF Output Data	
Upstream Depth	0.0 in
Profile Description	N/A
Profile Headloss	0.00 ft
Downstream Velocity	Infinity ft/s
Upstream Velocity	Infinity ft/s
Normal Depth	3.5 in
Critical Depth	5.9 in
Channel Slope	0.190 ft/ft
Critical Slope	0.031 ft/ft

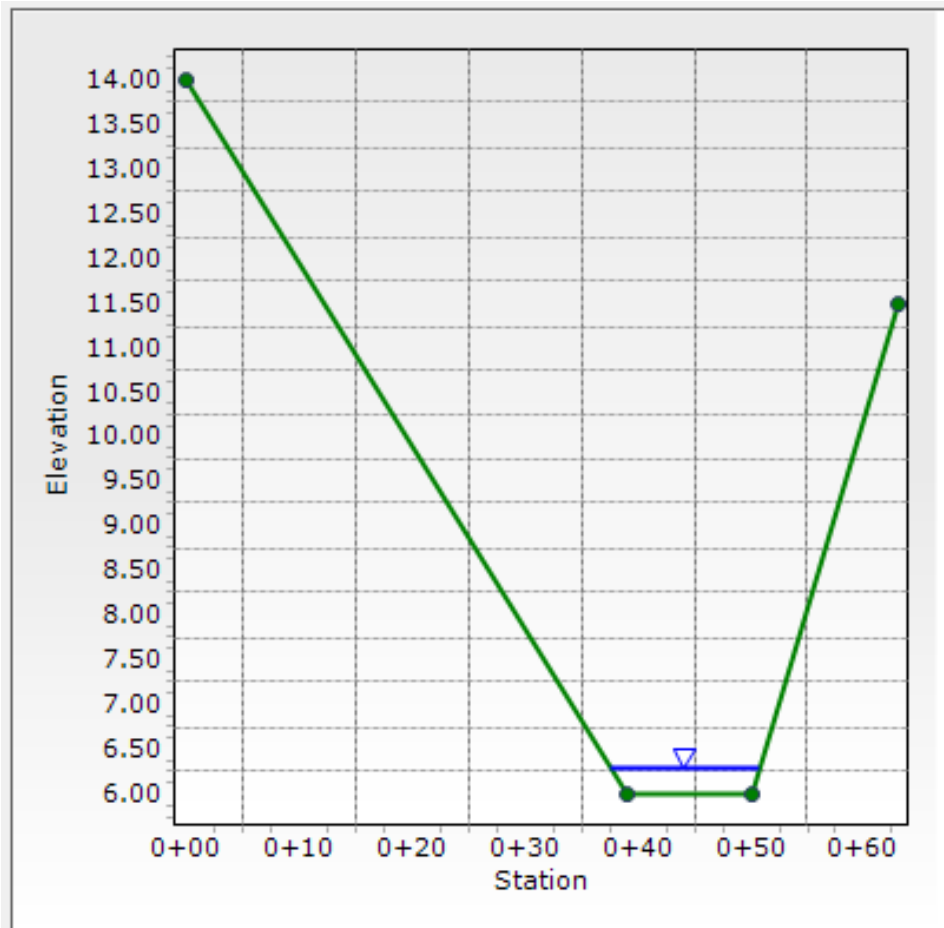

Worksheet for B7-1

Project Description	
Friction Method	Manning Formula
Solve For	Normal Depth

Input Data	
Channel Slope	0.046 ft/ft
Discharge	5.64 cfs

Section Definitions

	Station (ft)	Elevation (ft)
	0+00	95.00
	0+25	92.00
	0+50	91.75
	0+90	98.00

Roughness Segment Definitions

Start Station	Ending Station	Roughness Coefficient
(0+00, 95.00)	(0+25, 92.00)	0.040
(0+25, 92.00)	(0+50, 91.75)	0.040
(0+50, 91.75)	(0+90, 98.00)	0.040

Options	
Current Roughness Weighted Method	Pavlovskii's Method
Open Channel Weighting Method	Pavlovskii's Method
Closed Channel Weighting Method	Pavlovskii's Method

Results	
Normal Depth	2.8 in
Roughness Coefficient	0.040
Elevation	91.99 ft
Elevation Range	91.8 to 98.0 ft
Flow Area	2.9 ft ²
Wetted Perimeter	25.1 ft
Hydraulic Radius	1.4 in
Top Width	25.05 ft
Normal Depth	2.8 in
Critical Depth	2.8 in
Critical Slope	0.048 ft/ft
Velocity	1.91 ft/s
Velocity Head	0.06 ft
Specific Energy	0.29 ft
Froude Number	0.983

Worksheet for B7-1

Results	
Flow Type	Subcritical
GVF Input Data	
Downstream Depth	0.0 in
Length	0.0 ft
Number Of Steps	0
GVF Output Data	
Upstream Depth	0.0 in
Profile Description	N/A
Profile Headloss	0.00 ft
Downstream Velocity	0.00 ft/s
Upstream Velocity	0.00 ft/s
Normal Depth	2.8 in
Critical Depth	2.8 in
Channel Slope	0.046 ft/ft
Critical Slope	0.048 ft/ft

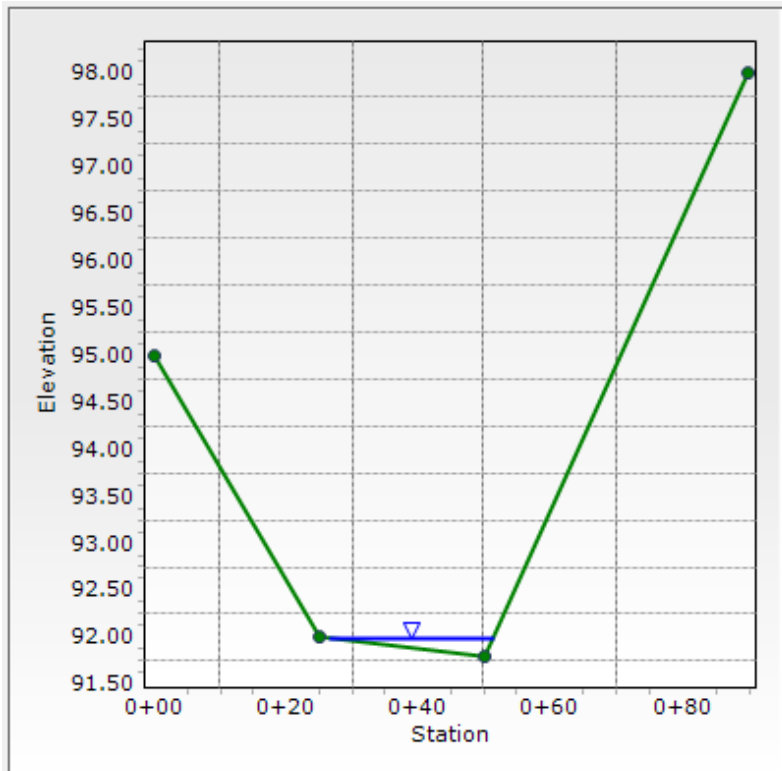

Worksheet for B8-1

Project Description	
Friction Method	Manning Formula
Solve For	Normal Depth

Input Data	
Channel Slope	0.050 ft/ft
Discharge	114.99 cfs

Section Definitions

	Station (ft)	Elevation (ft)
	0+00	202.00
	0+52	198.00
	0+79	198.00
	1+06	201.00

Roughness Segment Definitions

Start Station	Ending Station	Roughness Coefficient
(0+00, 202.00)	(0+52, 198.00)	0.040
(0+52, 198.00)	(0+79, 198.00)	0.040
(0+79, 198.00)	(1+06, 201.00)	0.040

Options	
Current Roughness Weighted Method	Pavlovskii's Method
Open Channel Weighting Method	Pavlovskii's Method
Closed Channel Weighting Method	Pavlovskii's Method

Results	
Normal Depth	7.6 in
Roughness Coefficient	0.040
Elevation	198.63 ft
Elevation Range	198.0 to 202.0 ft
Flow Area	21.4 ft ²
Wetted Perimeter	40.9 ft
Hydraulic Radius	6.3 in
Top Width	40.85 ft
Normal Depth	7.6 in
Critical Depth	8.9 in
Critical Slope	0.028 ft/ft
Velocity	5.39 ft/s
Velocity Head	0.45 ft
Specific Energy	1.08 ft
Froude Number	1.313

Worksheet for B8-1

Results	
Flow Type	Supercritical
GVF Input Data	
Downstream Depth	0.0 in
Length	0.0 ft
Number Of Steps	0
GVF Output Data	
Upstream Depth	0.0 in
Profile Description	N/A
Profile Headloss	0.00 ft
Downstream Velocity	Infinity ft/s
Upstream Velocity	Infinity ft/s
Normal Depth	7.6 in
Critical Depth	8.9 in
Channel Slope	0.050 ft/ft
Critical Slope	0.028 ft/ft

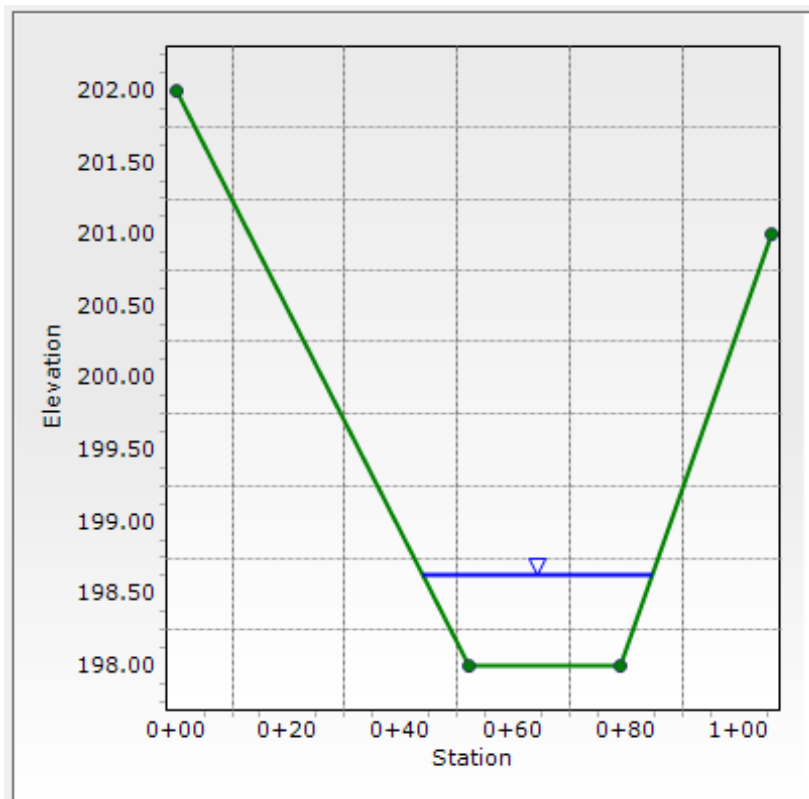

ROADSIDE DITCH SUMMARY TABLE

ROADWAY	FROM STA	TO STA	PROPOSED SLOPE (%)	SIDE	SIDE SLOPE	CHANNEL DEPTH (FT)	FRICTION FACTOR	BASIN	Q100 FLOW (CFS)	DITCH FLOW % OF BASIN	DITCH FLOW (CFS)	Q100 DEPTH (FT)	Q100 VELOCITY (FT/S)	DITCH LINING	NOTES
HATBAND DRIVE	1+30	2+80	2.75%	LEFT	4:1/3:1	3	0.04	A1	41.29	100.0%	41.29	1.53	5.02	GRASS	
HATBAND DRIVE	1+30	3+40	2.75%	RIGHT	4:1/3:1	3	0.04	A2	92.96	1.0%	0.93	0.37	1.95	GRASS	
HATBAND DRIVE	2+80	3+80	2.75%	LEFT	4:1/3:1	3	0.04	A2	92.96	1.0%	0.93	0.37	1.95	GRASS	
HATBAND DRIVE	4+90	7+20	2.75%	LEFT	4:1/3:1	3	0.04	A2	92.96	1.0%	0.93	0.37	1.95	GRASS	
HATBAND DRIVE	6+13	7+20	2.75%	RIGHT	4:1/3:1	3	0.04	A2	92.96	1.0%	0.93	0.37	1.95	GRASS	
HATBAND DRIVE	12+60	15+00	1.00%	LEFT	4:1/3:1	3	0.04	B1	80.40	0.7%	0.56	0.37	1.17	GRASS	
HATBAND DRIVE	12+60	15+00	1.00%	RIGHT	4:1/3:1	3	0.04	B1	80.40	0.5%	0.40	0.33	1.08	GRASS	
HATBAND DRIVE	15+00	18+00	2.00%	LEFT	4:1/3:1	3	0.04	B1	80.40	25.0%	20.10	1.24	3.72	GRASS	
HATBAND DRIVE	15+00	18+00	2.00%	RIGHT	4:1/3:1	3	0.04	B1	80.40	0.6%	0.48	0.31	1.46	GRASS	
HATBAND DRIVE	19+75	20+45	3.00%	RIGHT	4:1/3:1	3	0.04	B1	80.40	0.1%	0.08	0.14	1.09	GRASS	
HATBAND DRIVE	20+45	22+00	2.00%	RIGHT	4:1/3:1	3	0.04	B2	38.64	1.0%	0.39	0.28	1.39	GRASS	
HATBAND DRIVE	20+20	22+75	2.40%	LEFT	4:1/3:1	3	0.04	B1	80.40	1.3%	1.05	0.40	1.90	GRASS	
SALOON DRIVE	3+30	5+70	1.25%	LEFT	4:1/3:1	3	0.04	A2	92.96	0.40%	0.37	0.30	1.15	GRASS	
SALOON DRIVE	3+30	6+10	1.50%	RIGHT	4:1/3:1	3	0.04	A2	92.96	45.0%	41.83	1.75	4.02	GRASS	
SALOON DRIVE	7+00	10+80	6.00%	LEFT	4:1/3:1	3	0.04	A2	92.96	2.0%	1.86	0.42	3.10	GRASS	
SALOON DRIVE	10+80	END	1.30%	LEFT	4:1/3:1	3	0.04	A2	92.96	1.0%	0.93	0.43	1.47	GRASS	
CAMPOUT DRIVE	7+95	8+90	9.50%	RIGHT	4:1/3:1	3	0.04	B1	80.40	0.2%	0.16	0.15	1.99	GRASS	
CAMPOUT DRIVE	11+10	12+40	7.75%	RIGHT	4:1/3:1	3	0.04	B1	80.40	0.4%	0.32	0.20	2.20	GRASS	
CAMPOUT DRIVE	11+20	14+50	5.15%	LEFT	4:1/3:1	3	0.04	B6	106.95	23.0%	24.60	1.13	5.58	GRASS	
CAMPOUT DRIVE	16+80	25+80	1.00%	LEFT	4:1/3:1	3	0.04	B6	106.95	85.0%	90.91	2.49	4.19	GRASS	
CAMPOUT DRIVE	25+80	END	1.00%	LEFT	4:1/3:1	3	0.04	B6	106.95	13.0%	13.90	1.23	2.62	GRASS	
CAMPOUT DRIVE	27+80	29+60	1.00%	RIGHT	4:1/3:1	3	0.04	B6	106.95	0.3%	0.28	0.28	0.99	GRASS	
APEX RANCH ROAD	START	3+65	2.20%	LEFT	4:1/3:1	3	0.04	OS-C1	59.93	4.3%	15.90*	1.12	3.64	GRASS	* INLCUDES FOLW FROM SUB-BASINS OS-C1, OS-A2, AND A2
APEX RANCH ROAD	3+65	4+85	4.65%	LEFT	4:1/3:1	3	0.04	OS-A2	11.46	27.0%	13.31*	0.91	4.62	GRASS	* INLCUDES FLOW FROM SUB-BASINS OS-A2, AND A2
APEX RANCH ROAD	3+70	4+30	4.20%	RIGHT	4:1/3:1	3	0.04	OS-A2	11.46	1.4%	0.16	0.18	1.47	GRASS	
APEX RANCH ROAD	12+20	16+60	10.00%	LEFT	4:1/3:1	3	0.04	A2	92.96	2.0%	1.86	0.38	3.75	GRASS	
APEX RANCH ROAD	16+60	18+30	5.15%	LEFT	4:1/3:1	3	0.04	A2	92.96	0.7%	0.65	0.28	2.25	GRASS	
APEX RANCH ROAD	12+65	16+60	10.00%	RIGHT	4:1/3:1	3	0.04	B6	106.95	2.0%	2.14	0.40	3.89	GRASS	
APEX RANCH ROAD	16+60	18+65	5.15%	RIGHT	4:1/3:1	3	0.04	B6	106.95	0.4%	0.43	0.25	2.03	GRASS	

Culvert & Riprap Summary

<i>Culvert Details</i>							<i>Riprap Details</i>					Normal Depth in Pipe (ft)	Upstream Headwater Elevation (ft)
Culvert ID	Basin	Q100 flow (cfs)	Flow % of Basin	Flows (cfs)	HW/D Ratio	Diameter (in)	Length (ft)	Width (ft)	D50 Type	D50 Size (in)	D50 Thickness (in)		
A2-A	A2	92.96	10.00%	9.30	1.39	18	7	4	VL	6	12	0.75	7211.83
A2-B	A2	92.96	8.00%	7.44	1.12	18	5	3	VL	6	12	0.56	7221.28
A2-C	A2	92.96	49.00%	45.55	1.21	36	21	8	L	9	18	1.17	7223.80
A2-D	A2	92.96	11.00%	10.23	0.86	24	6	4	VL	6	12	0.89	7315.02
B1-A	B1	80.40	28.00%	22.51	0.99	30	11	5	VL	6	12	0.85	7218.23
B1-B	B1	80.40	34.00%	27.34	1.16	30	14	6	L	9	18	1.52	7221.92
B6	B6	106.95	100.00%	106.95	1.01	36 (3 Barrels)	30	15	L	9	18	1.50	7231.07

DETERMINATION OF CULVERT HEADWATER AND OUTLET PROTECTION

MHFD-Culvert, Version 4.00 (May 2020)

Project: OVERLOOK
 ID: CULVERT A2-A

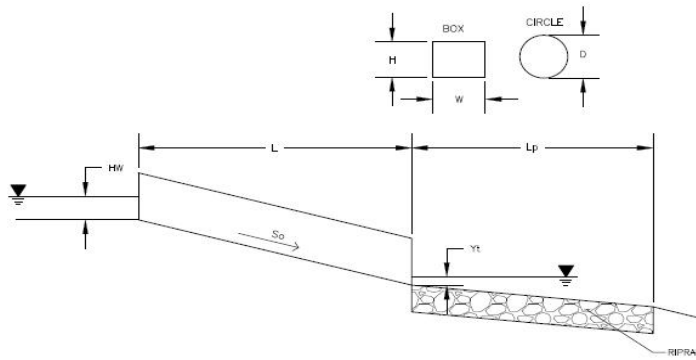

Soil Type:
 Choose One:
 Sandy
 Non-Sandy

Supercritical Flow! Using Adjusted Diameter to calculate protection type.

Design Information:	
Design Discharge	Q = <input type="text" value="9.3"/> cfs
Circular Culvert:	
Barrel Diameter in Inches	D = <input type="text" value="18"/> inches
Inlet Edge Type (Choose from pull-down list)	Square Edge with Headwall
<u>OR:</u>	
Box Culvert:	
Barrel Height (Rise) in Feet	H (Rise) = <input type="text" value="OR"/> ft
Barrel Width (Span) in Feet	W (Span) = <input type="text" value="OR"/> ft
Inlet Edge Type (Choose from pull-down list)	
Number of Barrels	# Barrels = <input type="text" value="1"/>
Inlet Elevation	Elev IN = <input type="text" value="7209.75"/> ft
Outlet Elevation <u>OR</u> Slope	Elev OUT = <input type="text" value="7207.31"/> ft
Culvert Length	L = <input type="text" value="93"/> ft
Manning's Roughness	n = <input type="text" value="0.012"/>
Bend Loss Coefficient	k _b = <input type="text" value="0"/>
Exit Loss Coefficient	k _x = <input type="text" value="1"/>
Tailwater Surface Elevation	Y _t , Elevation = <input type="text" value=""/> ft
Max Allowable Channel Velocity	V = <input type="text" value="5"/> ft/s
Calculated Results:	
Culvert Cross Sectional Area Available	A = <input type="text" value="1.77"/> ft ²
Culvert Normal Depth	Y _n = <input type="text" value="0.75"/> ft
Culvert Critical Depth	Y _c = <input type="text" value="1.18"/> ft
Froude Number	Fr = <input type="text" value="2.40"/> Supercritical!
Entrance Loss Coefficient	k _e = <input type="text" value="0.50"/>
Friction Loss Coefficient	k _f = <input type="text" value="1.44"/>
Sum of All Loss Coefficients	k _s = <input type="text" value="2.94"/> ft
Headwater:	
Inlet Control Headwater	HW _i = <input type="text" value="2.08"/> ft
Outlet Control Headwater	HW _o = <input type="text" value="N/A"/> ft
Design Headwater Elevation	HW = <input type="text" value="7211.83"/> ft
Headwater/Diameter <u>OR</u> Headwater/Rise Ratio	HW/D = <input type="text" value="1.39"/>
Outlet Control Headwater Approximation Method Inaccurate for Low Flow - Backwater Calculations Required	
Outlet Protection:	
Flow/(Diameter ^{2.5})	Q/D ^{2.5} = <input type="text" value="3.37"/> ft ^{0.5} /s
Tailwater Surface Height	Y _t = <input type="text" value="0.60"/> ft
Tailwater/Diameter	Y _t /D = <input type="text" value="0.40"/>
Expansion Factor	1/(2*tan(Θ)) = <input type="text" value="4.05"/>
Flow Area at Max Channel Velocity	A _t = <input type="text" value="1.86"/> ft ²
Width of Equivalent Conduit for Multiple Barrels	W _{eq} = <input type="text" value="-"/> ft
Length of Riprap Protection	L _p = <input type="text" value="7"/> ft
Width of Riprap Protection at Downstream End	T = <input type="text" value="4"/> ft
Adjusted Diameter for Supercritical Flow	Da = <input type="text" value="1.13"/> ft
Minimum Theoretical Riprap Size	d ₅₀ min = <input type="text" value="5"/> in
Nominal Riprap Size	d ₅₀ nominal = <input type="text" value="6"/> in
MHFD Riprap Type	Type = <input type="text" value="VL"/>

DETERMINATION OF CULVERT HEADWATER AND OUTLET PROTECTION

MHFD-Culvert, Version 4.00 (May 2020)

Project: OVERLOOK
 ID: CULVERT A2-B

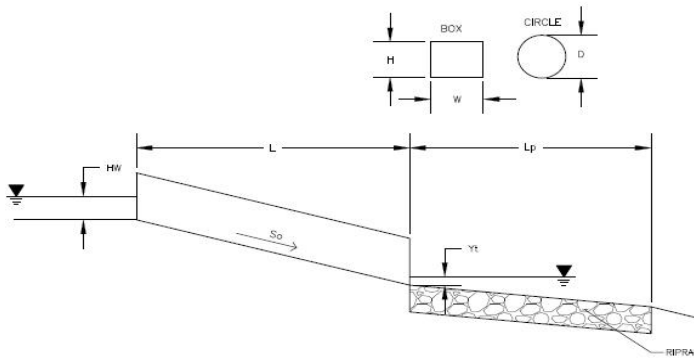

Soil Type:
 Choose One:
 Sandy
 Non-Sandy

Supercritical Flow! Using Adjusted Diameter to calculate protection type.

Design Information:	
Design Discharge	Q = <input type="text" value="7.44"/> cfs
Circular Culvert:	
Barrel Diameter in Inches	D = <input type="text" value="18"/> inches
Inlet Edge Type (Choose from pull-down list)	Square Edge with Headwall
OR:	
Box Culvert:	
Barrel Height (Rise) in Feet	H (Rise) = <input type="text" value="OR"/> ft
Barrel Width (Span) in Feet	W (Span) = <input type="text" value="OR"/> ft
Inlet Edge Type (Choose from pull-down list)	
Number of Barrels	# Barrels = <input type="text" value="1"/>
Inlet Elevation	Elev IN = <input type="text" value="7219.6"/> ft
Outlet Elevation <u>OR</u> Slope	Elev OUT = <input type="text" value="7215.35"/> ft
Culvert Length	L = <input type="text" value="87.8"/> ft
Manning's Roughness	n = <input type="text" value="0.012"/>
Bend Loss Coefficient	k _b = <input type="text" value="0"/>
Exit Loss Coefficient	k _x = <input type="text" value="1"/>
Tailwater Surface Elevation	Y _t , Elevation = <input type="text" value=""/> ft
Max Allowable Channel Velocity	V = <input type="text" value="5"/> ft/s
Calculated Results:	
Culvert Cross Sectional Area Available	A = <input type="text" value="1.77"/> ft ²
Culvert Normal Depth	Y _n = <input type="text" value="0.56"/> ft
Culvert Critical Depth	Y _c = <input type="text" value="1.06"/> ft
Froude Number	Fr = <input type="text" value="3.39"/> Supercritical!
Entrance Loss Coefficient	k _e = <input type="text" value="0.50"/>
Friction Loss Coefficient	k _f = <input type="text" value="1.36"/>
Sum of All Loss Coefficients	k _s = <input type="text" value="2.86"/> ft
Headwater:	
Inlet Control Headwater	HW _I = <input type="text" value="1.68"/> ft
Outlet Control Headwater	HW _O = <input type="text" value="N/A"/> ft
Design Headwater Elevation	HW = <input type="text" value="7221.28"/> ft
Headwater/Diameter <u>OR</u> Headwater/Rise Ratio	HW/D = <input type="text" value="1.12"/>
Outlet Control Headwater Approximation Method Inaccurate for Low Flow - Backwater Calculations Required	
Outlet Protection:	
Flow/(Diameter ^{2.5})	Q/D ^{2.5} = <input type="text" value="2.70"/> ft ^{0.5} /s
Tailwater Surface Height	Y _t = <input type="text" value="0.60"/> ft
Tailwater/Diameter	Y _t /D = <input type="text" value="0.40"/>
Expansion Factor	1/(2*tan(Θ)) = <input type="text" value="4.79"/>
Flow Area at Max Channel Velocity	A _t = <input type="text" value="1.49"/> ft ²
Width of Equivalent Conduit for Multiple Barrels	W _{eq} = <input type="text" value="-"/> ft
Length of Riprap Protection	L _p = <input type="text" value="5"/> ft
Width of Riprap Protection at Downstream End	T = <input type="text" value="3"/> ft
Adjusted Diameter for Supercritical Flow	Da = <input type="text" value="1.03"/> ft
Minimum Theoretical Riprap Size	d ₅₀ min = <input type="text" value="4"/> in
Nominal Riprap Size	d ₅₀ nominal = <input type="text" value="6"/> in
MHFD Riprap Type	Type = <input type="text" value="VL"/>

DETERMINATION OF CULVERT HEADWATER AND OUTLET PROTECTION

MHFD-Culvert, Version 4.00 (May 2020)

Project: OVERLOOK
 ID: CULVERT A2-C

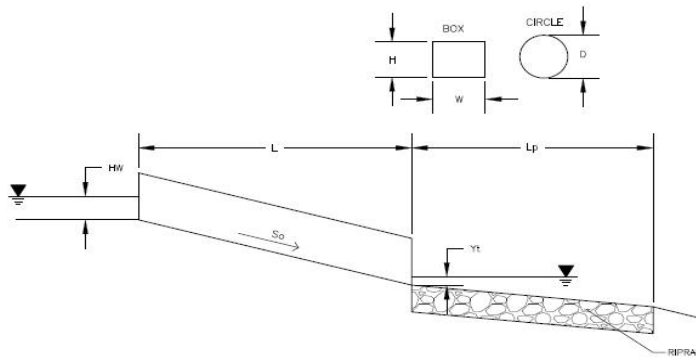

Soil Type:
 Choose One:
 Sandy
 Non-Sandy

Supercritical Flow! Using Adjusted Diameter to calculate protection type.

Design Information:	
Design Discharge	Q = <input type="text" value="45.55"/> cfs
Circular Culvert:	
Barrel Diameter in Inches	D = <input type="text" value="36"/> inches
Inlet Edge Type (Choose from pull-down list)	Square Edge with Headwall
OR:	
Box Culvert:	
Barrel Height (Rise) in Feet	H (Rise) = <input type="text" value="OR"/> ft
Barrel Width (Span) in Feet	W (Span) = <input type="text" value="OR"/> ft
Inlet Edge Type (Choose from pull-down list)	
Number of Barrels	# Barrels = <input type="text" value="1"/>
Inlet Elevation	Elev IN = <input type="text" value="7220.18"/> ft
Outlet Elevation <u>OR</u> Slope	Elev OUT = <input type="text" value="7216.35"/> ft
Culvert Length	L = <input type="text" value="101.4"/> ft
Manning's Roughness	n = <input type="text" value="0.012"/>
Bend Loss Coefficient	k _b = <input type="text" value="0"/>
Exit Loss Coefficient	k _x = <input type="text" value="1"/>
Tailwater Surface Elevation	Y _t , Elevation = <input type="text" value=""/> ft
Max Allowable Channel Velocity	V = <input type="text" value="5"/> ft/s
Calculated Results:	
Culvert Cross Sectional Area Available	A = <input type="text" value="7.07"/> ft ²
Culvert Normal Depth	Y _n = <input type="text" value="1.17"/> ft
Culvert Critical Depth	Y _c = <input type="text" value="2.20"/> ft
Froude Number	Fr = <input type="text" value="3.35"/> Supercritical!
Entrance Loss Coefficient	k _e = <input type="text" value="0.50"/>
Friction Loss Coefficient	k _f = <input type="text" value="0.62"/>
Sum of All Loss Coefficients	k _s = <input type="text" value="2.12"/> ft
Headwater:	
Inlet Control Headwater	HW _i = <input type="text" value="3.62"/> ft
Outlet Control Headwater	HW _o = <input type="text" value="N/A"/> ft
Design Headwater Elevation	HW = <input type="text" value="7223.80"/> ft
Headwater/Diameter <u>OR</u> Headwater/Rise Ratio	HW/D = <input type="text" value="1.21"/>
Outlet Control Headwater Approximation Method Inaccurate for Low Flow - Backwater Calculations Required	
Outlet Protection:	
Flow/(Diameter ^{2.5})	Q/D ^{2.5} = <input type="text" value="2.92"/> ft ^{0.5} /s
Tailwater Surface Height	Y _t = <input type="text" value="1.20"/> ft
Tailwater/Diameter	Y _t /D = <input type="text" value="0.40"/>
Expansion Factor	1/(2*tan(Θ)) = <input type="text" value="4.49"/>
Flow Area at Max Channel Velocity	A _t = <input type="text" value="9.11"/> ft ²
Width of Equivalent Conduit for Multiple Barrels	W _{eq} = <input type="text" value="-"/> ft
Length of Riprap Protection	L _p = <input type="text" value="21"/> ft
Width of Riprap Protection at Downstream End	T = <input type="text" value="8"/> ft
Adjusted Diameter for Supercritical Flow	Da = <input type="text" value="2.09"/> ft
Minimum Theoretical Riprap Size	d ₅₀ min = <input type="text" value="8"/> in
Nominal Riprap Size	d ₅₀ nominal = <input type="text" value="9"/> in
MHFD Riprap Type	Type = <input type="text" value="L"/>

DETERMINATION OF CULVERT HEADWATER AND OUTLET PROTECTION

MHFD-Culvert, Version 4.00 (May 2020)

Project: Overlook
ID: A2-D

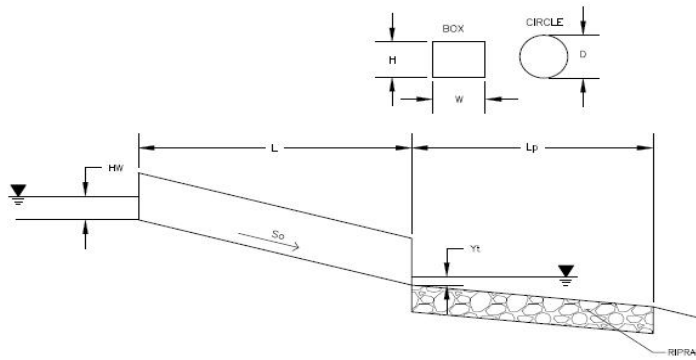

Soil Type:
Choose One:
 Sandy
 Non-Sandy

Supercritical Flow! Using Adjusted Diameter to calculate protection type.

Design Information:	
Design Discharge	Q = <input type="text" value="10.23"/> cfs
Circular Culvert:	
Barrel Diameter in Inches	D = <input type="text" value="24"/> inches
Inlet Edge Type (Choose from pull-down list)	Square Edge with Headwall
<u>OR:</u>	
Box Culvert:	
Barrel Height (Rise) in Feet	H (Rise) = <input type="text" value="OR"/> ft
Barrel Width (Span) in Feet	W (Span) = <input type="text" value="OR"/> ft
Inlet Edge Type (Choose from pull-down list)	
Number of Barrels	# Barrels = <input type="text" value="1"/>
Inlet Elevation	Elev IN = <input type="text" value="7313.3"/> ft
Outlet Elevation <u>OR</u> Slope	Elev OUT = <input type="text" value="7312.4"/> ft
Culvert Length	L = <input type="text" value="86.6"/> ft
Manning's Roughness	n = <input type="text" value="0.012"/>
Bend Loss Coefficient	k _b = <input type="text" value="0"/>
Exit Loss Coefficient	k _x = <input type="text" value="1"/>
Tailwater Surface Elevation	Y _t , Elevation = <input type="text" value=""/> ft
Max Allowable Channel Velocity	V = <input type="text" value="5"/> ft/s
Calculated Results:	
Culvert Cross Sectional Area Available	A = <input type="text" value="3.14"/> ft ²
Culvert Normal Depth	Y _n = <input type="text" value="0.89"/> ft
Culvert Critical Depth	Y _c = <input type="text" value="1.14"/> ft
Froude Number	Fr = <input type="text" value="1.62"/> Supercritical!
Entrance Loss Coefficient	k _e = <input type="text" value="0.50"/>
Friction Loss Coefficient	k _f = <input type="text" value="0.91"/>
Sum of All Loss Coefficients	k _s = <input type="text" value="2.41"/> ft
Headwater:	
Inlet Control Headwater	HW _I = <input type="text" value="1.72"/> ft
Outlet Control Headwater	HW _O = <input type="text" value="N/A"/> ft
Design Headwater Elevation	HW = <input type="text" value="7315.02"/> ft
Headwater/Diameter <u>OR</u> Headwater/Rise Ratio	HW/D = <input type="text" value="0.86"/>
Outlet Control Headwater Approximation Method Inaccurate for Low Flow - Backwater Calculations Required	
Outlet Protection:	
Flow/(Diameter ^{2.5})	Q/D ^{2.5} = <input type="text" value="1.81"/> ft ^{0.5} /s
Tailwater Surface Height	Y _t = <input type="text" value="0.80"/> ft
Tailwater/Diameter	Y _t /D = <input type="text" value="0.40"/>
Expansion Factor	1/(2*tan(Θ)) = <input type="text" value="5.93"/>
Flow Area at Max Channel Velocity	A _t = <input type="text" value="2.05"/> ft ²
Width of Equivalent Conduit for Multiple Barrels	W _{eq} = <input type="text" value="-"/> ft
Length of Riprap Protection	L _p = <input type="text" value="6"/> ft
Width of Riprap Protection at Downstream End	T = <input type="text" value="4"/> ft
Adjusted Diameter for Supercritical Flow	Da = <input type="text" value="1.45"/> ft
Minimum Theoretical Riprap Size	d ₅₀ min = <input type="text" value="3"/> in
Nominal Riprap Size	d ₅₀ nominal = <input type="text" value="6"/> in
MHFD Riprap Type	Type = <input type="text" value="VL"/>

DETERMINATION OF CULVERT HEADWATER AND OUTLET PROTECTION

MHFD-Culvert, Version 4.00 (May 2020)

Project: OVERLOOK
 ID: CULVERT B1-A

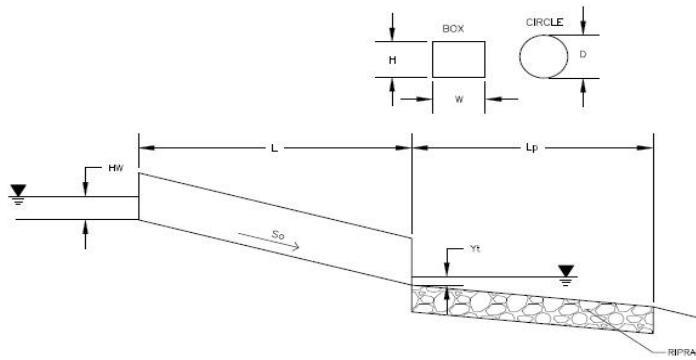

Soil Type:
 Choose One:
 Sandy
 Non-Sandy

Supercritical Flow! Using Adjusted Diameter to calculate protection type.

Design Information:	
Design Discharge	Q = <input type="text" value="22.51"/> cfs
Circular Culvert:	
Barrel Diameter in Inches	D = <input type="text" value="30"/> inches
Inlet Edge Type (Choose from pull-down list)	Square Edge with Headwall
OR:	
Box Culvert:	
Barrel Height (Rise) in Feet	H (Rise) = <input type="text" value="OR"/> ft
Barrel Width (Span) in Feet	W (Span) = <input type="text" value="OR"/> ft
Inlet Edge Type (Choose from pull-down list)	
Number of Barrels	# Barrels = <input type="text" value="1"/>
Inlet Elevation	Elev IN = <input type="text" value="7215.76"/> ft
Outlet Elevation <u>OR</u> Slope	Elev OUT = <input type="text" value="7210.52"/> ft
Culvert Length	L = <input type="text" value="125.2"/> ft
Manning's Roughness	n = <input type="text" value="0.012"/>
Bend Loss Coefficient	k _b = <input type="text" value="0"/>
Exit Loss Coefficient	k _x = <input type="text" value="1"/>
Tailwater Surface Elevation	Y _t , Elevation = <input type="text" value=""/> ft
Max Allowable Channel Velocity	V = <input type="text" value="5"/> ft/s
Calculated Results:	
Culvert Cross Sectional Area Available	A = <input type="text" value="4.91"/> ft ²
Culvert Normal Depth	Y _n = <input type="text" value="0.85"/> ft
Culvert Critical Depth	Y _c = <input type="text" value="1.61"/> ft
Froude Number	Fr = <input type="text" value="3.45"/> Supercritical!
Entrance Loss Coefficient	k _e = <input type="text" value="0.50"/>
Friction Loss Coefficient	k _f = <input type="text" value="0.98"/>
Sum of All Loss Coefficients	k _s = <input type="text" value="2.48"/> ft
Headwater:	
Inlet Control Headwater	HW _i = <input type="text" value="2.47"/> ft
Outlet Control Headwater	HW _o = <input type="text" value="N/A"/> ft
Design Headwater Elevation	HW = <input type="text" value="7218.23"/> ft
Headwater/Diameter <u>OR</u> Headwater/Rise Ratio	HW/D = <input type="text" value="0.99"/>
Outlet Control Headwater Approximation Method Inaccurate for Low Flow - Backwater Calculations Required	
Outlet Protection:	
Flow/(Diameter ^{2.5})	Q/D ^{2.5} = <input type="text" value="2.28"/> ft ^{0.5} /s
Tailwater Surface Height	Y _t = <input type="text" value="1.00"/> ft
Tailwater/Diameter	Y _t /D = <input type="text" value="0.40"/>
Expansion Factor	1/(2*tan(Θ)) = <input type="text" value="5.36"/>
Flow Area at Max Channel Velocity	A _t = <input type="text" value="4.50"/> ft ²
Width of Equivalent Conduit for Multiple Barrels	W _{eq} = <input type="text" value="-"/> ft
Length of Riprap Protection	L _p = <input type="text" value="11"/> ft
Width of Riprap Protection at Downstream End	T = <input type="text" value="5"/> ft
Adjusted Diameter for Supercritical Flow	Da = <input type="text" value="1.67"/> ft
Minimum Theoretical Riprap Size	d ₅₀ min = <input type="text" value="5"/> in
Nominal Riprap Size	d ₅₀ nominal = <input type="text" value="6"/> in
MHFD Riprap Type	Type = <input type="text" value="VL"/>

DETERMINATION OF CULVERT HEADWATER AND OUTLET PROTECTION

MHFD-Culvert, Version 4.00 (May 2020)

Project: OVERLOOK
ID: CULVERT B1-B

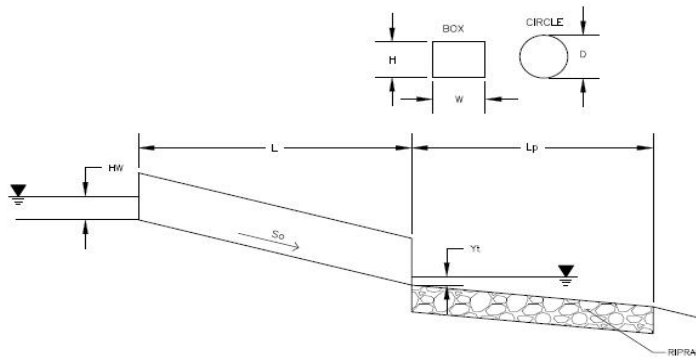

Soil Type:
Choose One:
 Sandy
 Non-Sandy

Supercritical Flow! Using Adjusted Diameter to calculate protection type.

Design Information:	
Design Discharge	Q = <input type="text" value="27.34"/> cfs
Circular Culvert:	
Barrel Diameter in Inches	D = <input type="text" value="30"/> inches
Inlet Edge Type (Choose from pull-down list)	Square Edge with Headwall
OR:	
Box Culvert:	
Barrel Height (Rise) in Feet	H (Rise) = <input type="text" value="OR"/> ft
Barrel Width (Span) in Feet	W (Span) = <input type="text" value="OR"/> ft
Inlet Edge Type (Choose from pull-down list)	
Number of Barrels	# Barrels = <input type="text" value="1"/>
Inlet Elevation	Elev IN = <input type="text" value="7219.01"/> ft
Outlet Elevation <u>OR</u> Slope	Elev OUT = <input type="text" value="7218.46"/> ft
Culvert Length	L = <input type="text" value="68.26"/> ft
Manning's Roughness	n = <input type="text" value="0.012"/>
Bend Loss Coefficient	k _b = <input type="text" value="0"/>
Exit Loss Coefficient	k _x = <input type="text" value="1"/>
Tailwater Surface Elevation	Y _t , Elevation = <input type="text" value=""/> ft
Max Allowable Channel Velocity	V = <input type="text" value="5"/> ft/s
Calculated Results:	
Culvert Cross Sectional Area Available	A = <input type="text" value="4.91"/> ft ²
Culvert Normal Depth	Y _n = <input type="text" value="1.52"/> ft
Culvert Critical Depth	Y _c = <input type="text" value="1.78"/> ft
Froude Number	Fr = <input type="text" value="1.37"/> Supercritical!
Entrance Loss Coefficient	k _e = <input type="text" value="0.50"/>
Friction Loss Coefficient	k _f = <input type="text" value="0.53"/>
Sum of All Loss Coefficients	k _s = <input type="text" value="2.03"/> ft
Headwater:	
Inlet Control Headwater	HW _i = <input type="text" value="2.91"/> ft
Outlet Control Headwater	HW _o = <input type="text" value="2.57"/> ft
Design Headwater Elevation	HW = <input type="text" value="7221.92"/> ft
Headwater/Diameter <u>OR</u> Headwater/Rise Ratio	HW/D = <input type="text" value="1.16"/>
Outlet Protection:	
Flow/(Diameter ^{2.5})	Q/D ^{2.5} = <input type="text" value="2.77"/> ft ^{0.5} /s
Tailwater Surface Height	Y _t = <input type="text" value="1.00"/> ft
Tailwater/Diameter	Y _t /D = <input type="text" value="0.40"/>
Expansion Factor	1/(2*tan(Θ)) = <input type="text" value="4.70"/>
Flow Area at Max Channel Velocity	A _t = <input type="text" value="5.47"/> ft ²
Width of Equivalent Conduit for Multiple Barrels	W _{eq} = <input type="text" value="-"/> ft
Length of Riprap Protection	L _p = <input type="text" value="14"/> ft
Width of Riprap Protection at Downstream End	T = <input type="text" value="6"/> ft
Adjusted Diameter for Supercritical Flow	Da = <input type="text" value="2.01"/> ft
Minimum Theoretical Riprap Size	d ₅₀ min = <input type="text" value="6"/> in
Nominal Riprap Size	d ₅₀ nominal = <input type="text" value="9"/> in
MHFD Riprap Type	Type = <input type="text" value="L"/>

DETERMINATION OF CULVERT HEADWATER AND OUTLET PROTECTION

MHFD-Culvert, Version 4.00 (May 2020)

Project: Overlook
 ID: CULVERT B6

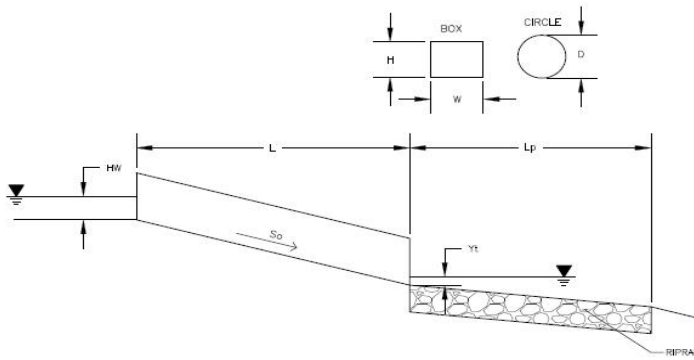

Soil Type:
 Choose One:
 Sandy
 Non-Sandy

Supercritical Flow! Using Adjusted Diameter to calculate protection type.

Design Information:	
Design Discharge	Q = <input type="text" value="106.95"/> cfs
Circular Culvert:	
Barrel Diameter in Inches	D = <input type="text" value="36"/> inches
Inlet Edge Type (Choose from pull-down list)	Square Edge with Headwall
OR:	
Box Culvert:	
Barrel Height (Rise) in Feet	H (Rise) = <input type="text" value="OR"/> ft
Barrel Width (Span) in Feet	W (Span) = <input type="text" value="OR"/> ft
Inlet Edge Type (Choose from pull-down list)	
Number of Barrels	# Barrels = <input type="text" value="3"/>
Inlet Elevation	Elev IN = <input type="text" value="7228.05"/> ft
Outlet Elevation <u>OR</u> Slope	Elev OUT = <input type="text" value="7227.55"/> ft
Culvert Length	L = <input type="text" value="51.93"/> ft
Manning's Roughness	n = <input type="text" value="0.012"/>
Bend Loss Coefficient	k_b = <input type="text" value="0"/>
Exit Loss Coefficient	k_x = <input type="text" value="1"/>
Tailwater Surface Elevation	Y_t , Elevation = <input type="text" value=""/> ft
Max Allowable Channel Velocity	V = <input type="text" value="5"/> ft/s
Calculated Results:	
Culvert Cross Sectional Area Available	A = <input type="text" value="7.07"/> ft ²
Culvert Normal Depth	Y_n = <input type="text" value="1.50"/> ft
Culvert Critical Depth	Y_c = <input type="text" value="1.94"/> ft
Froude Number	Fr = <input type="text" value="1.63"/> Supercritical!
Entrance Loss Coefficient	k_e = <input type="text" value="0.50"/>
Friction Loss Coefficient	k_f = <input type="text" value="0.32"/>
Sum of All Loss Coefficients	k_s = <input type="text" value="1.82"/> ft
Headwater:	
Inlet Control Headwater	HW_i = <input type="text" value="3.02"/> ft
Outlet Control Headwater	HW_o = <input type="text" value="2.69"/> ft
Design Headwater Elevation	HW = <input type="text" value="7231.07"/> ft
Headwater/Diameter <u>OR</u> Headwater/Rise Ratio	HW/D = <input type="text" value="1.01"/>
Outlet Protection:	
Flow/(Diameter ^{2.5})	Q/D ^{2.5} = <input type="text" value="2.29"/> ft ^{0.5} /s
Tailwater Surface Height	Y_t = <input type="text" value="1.20"/> ft
Tailwater/Diameter	Y_t/D = <input type="text" value="0.40"/>
Expansion Factor	$1/(2*\tan(\Theta))$ = <input type="text" value="5.35"/>
Flow Area at Max Channel Velocity	A_t = <input type="text" value="21.39"/> ft ²
Width of Equivalent Conduit for Multiple Barrels	W_{eq} = <input type="text" value="9.00"/> ft
Length of Riprap Protection	L_p = <input type="text" value="30"/> ft
Width of Riprap Protection at Downstream End	T = <input type="text" value="15"/> ft
Adjusted Diameter for Supercritical Flow	Da = <input type="text" value="2.25"/> ft
Minimum Theoretical Riprap Size	d_{50} min = <input type="text" value="6"/> in
Nominal Riprap Size	d_{50} nominal = <input type="text" value="9"/> in
MHFD Riprap Type	Type = <input type="text" value="L"/>

APPENDIX E: EL PASO COUNTY DRAINAGE BASIN MAP

Douglas County

Elbert County

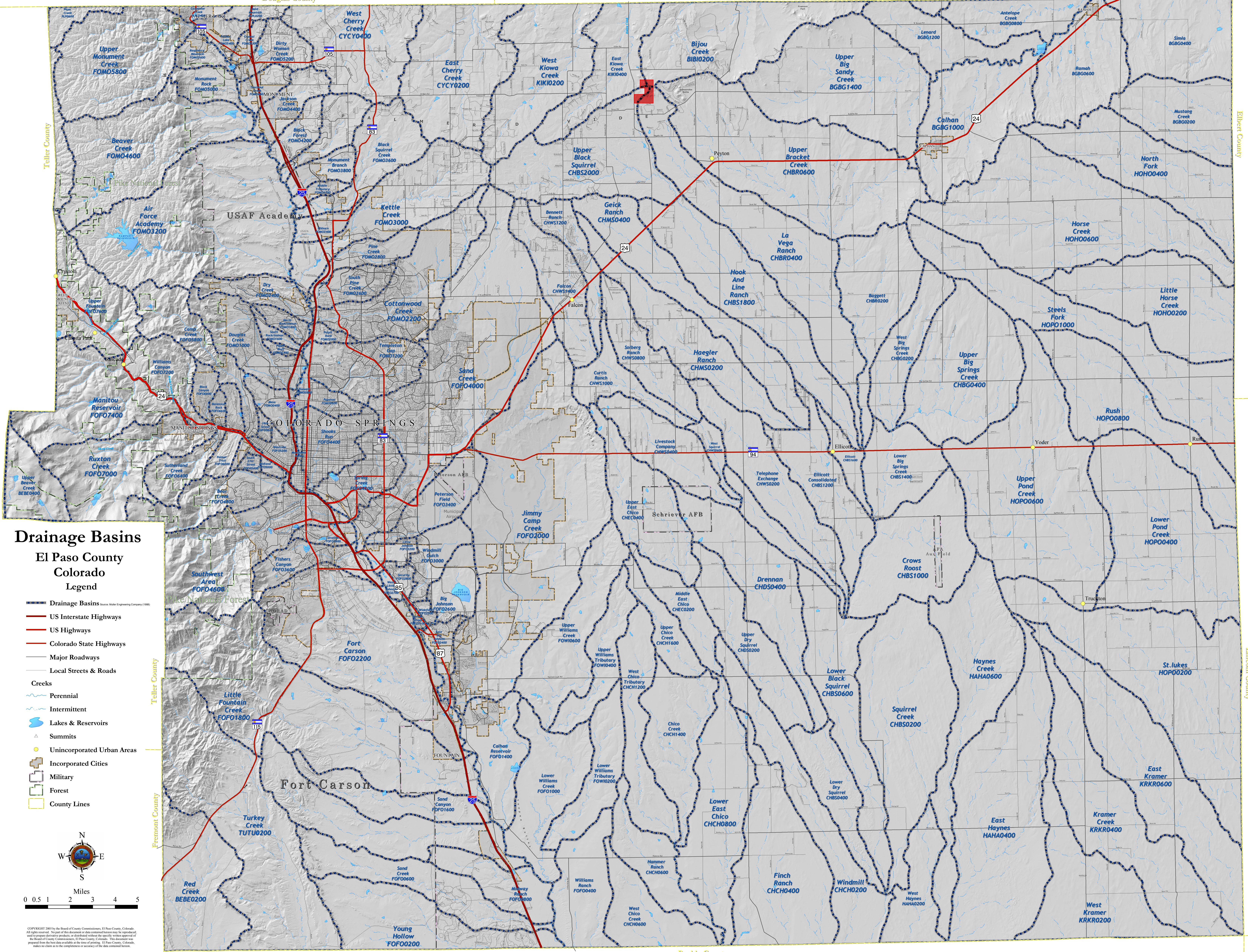

Drainage Basins

El Paso County Colorado Legend

- Drainage Basins (Source: Muler Engineering Company 1988)
- US Interstate Highways
- US Highways
- Colorado State Highways
- Major Roadways
- Local Streets & Roads
- Creeks**
- Perennial
- Intermittent
- Lakes & Reservoirs
- Summits
- Unincorporated Urban Areas
- Incorporated Cities
- Military
- Forest
- County Lines

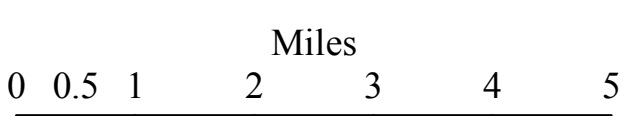

Copyright 2007 by the Board of County Commissioners, El Paso County, Colorado. All rights reserved. No part of this document or data contained herein may be reproduced or transmitted in any form or by any means, electronic or mechanical, including photocopying, recording, or by any information storage and retrieval system, without the prior written permission of the Board of County Commissioners, El Paso County, Colorado. This document was prepared from the best data available at the time of printing. El Paso County, Colorado, makes no claim as to the completeness or accuracy of the data contained herein.

APPENDIX F: APEX RANCH DRAINAGE REPORT

Design Procedure Form: Extended Detention Basin (EDB) - Sedimentation Facility

Designer: QUENTIN ARMIJO
 Company: TERRA NOVA ENG.
 Date: April 2, 2008
 Project: APEX RANCH ESTATES
 Location: PEYTON, CO

<p>1. Basin Storage Volume</p> <p>A) Tributary Area's Imperviousness Ratio ($i = I_a / 100$)</p> <p>B) Contributing Watershed Area (Area)</p> <p>C) Water Quality Capture Volume (WQCV) $(WQCV = 1.0 * (0.91 * I^3 - 1.19 * I^2 + 0.78 * I))$</p> <p>D) Design Volume: $Vol = (WQCV / 12) * Area * 1.2$</p>	<p>$I_a =$ <u>10.00</u> %</p> <p>$i =$ <u>0.10</u></p> <p>Area = <u>76.80</u> acres</p> <p>WQCV = <u>0.07</u> watershed inches</p> <p>Vol = <u>0.515</u> acre-feet</p>
<p>2. Outlet Works</p> <p>A) Outlet Type (Check One)</p> <p>B) Depth at Outlet Above Lowest Perforation (H)</p> <p>C) Required Maximum Outlet Area per Row, (A_o)</p> <p>D) Perforation Dimensions (enter one only): i) Circular Perforation Diameter OR ii) 2" Height Rectangular Perforation Width</p> <p>E) Number of Columns (nc, See Table 6a-1 For Maximum)</p> <p>F) Actual Design Outlet Area per Row (A_o)</p> <p>G) Number of Rows (nr)</p> <p>H) Total Outlet Area (A_{ot})</p>	<p><input checked="" type="checkbox"/> Orifice Plate <input type="checkbox"/> Perforated Riser Pipe Other: _____</p> <p>H = <u>2.50</u> feet</p> <p>$A_o =$ <u>0.81</u> square inches</p> <p>D = <u>1.0000</u> inches, OR W = _____ inches</p> <p>$nc =$ <u>1</u> number</p> <p>$A_o =$ <u>0.79</u> square inches</p> <p>$nr =$ <u>8</u> number</p> <p>$A_{ot} =$ <u>5.89</u> square inches</p>
<p>3. Trash Rack</p> <p>A) Needed Open Area: $A_t = 0.5 * (\text{Figure 7 Value}) * A_{ot}$</p> <p>B) Type of Outlet Opening (Check One)</p> <p>C) For 2", or Smaller, Round Opening (Ref.: Figure 6a): i) Width of Trash Rack and Concrete Opening (W_{conc}) from Table 6a-1 ii) Height of Trash Rack Screen (H_{TR})</p>	<p>$A_t =$ <u>200</u> square inches</p> <p><input checked="" type="checkbox"/> < 2" Diameter Round <input type="checkbox"/> 2" High Rectangular Other: _____</p> <p>$W_{conc} =$ <u>9</u> inches</p> <p>$H_{TR} =$ <u>54</u> inches</p>

APEX RANCH ESTATES EL PASO COUNTY, COLORADO FINAL DRAINAGE MAP AUGUST 2008

412200006
COLLEEN KRASOVICH
3650 GARRISON ST
WHEAT RIDGE, CO.
ZONED A-35

DEVELOPED CONDITIONS

BASIN	ACRES	Q5 CFS	Q100 CFS
OS-1	72.1	45	102
OS-2	5.2	4	9
OS-3	21.9	13	29
OS-4	1.9	4	8
OS-5	0.7	1	3
A	28.2	29	64
B	0.6	2	3
C	6.9	6	12
D	4.7	4	9
E	10.0	8	18
G	4.7	5	10
H	13.0	10	22
I	4.2	4	8
J	4.4	5	11
K	23.2	22	50
M	18.2	15	33
N	4.2	5	10
O	4.0	4	9

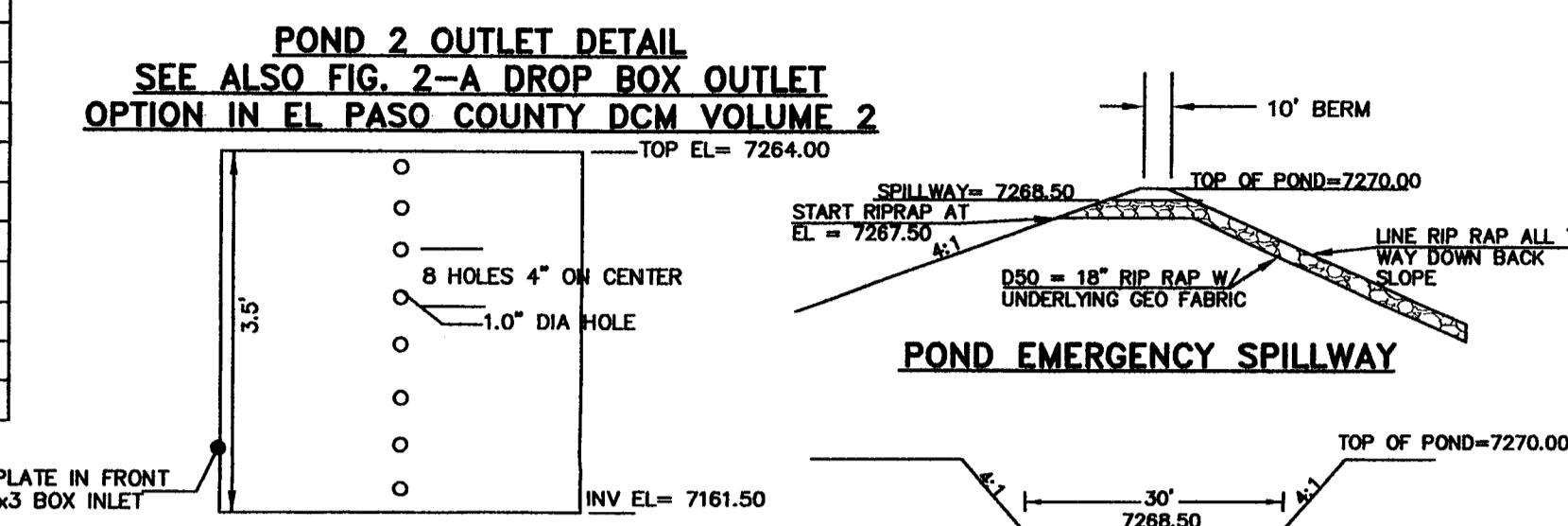
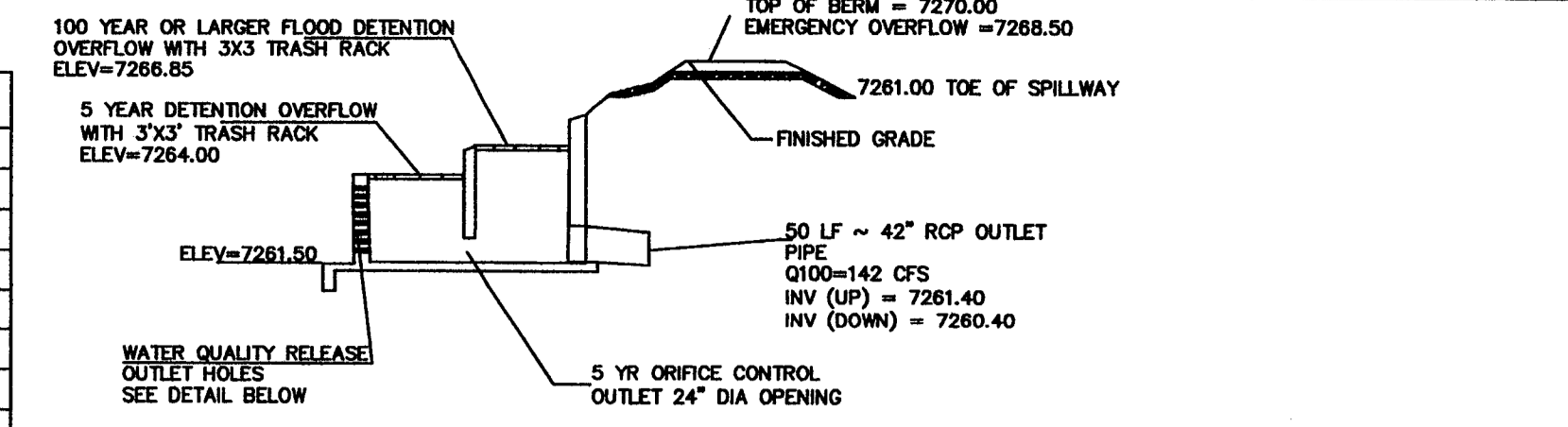

DESIGN POINT SUMMARY

DP	CONTRIBUTING BASINS	Q5 CFS	Q100 CFS
1	OS-1 & A	58	130
2	DP-1 & B	59	131
3	DP-2 & C	61	134
4	DP-3, D & E	68	148
5	DP-4, G & H	78	170
6	OS-2 & I	8	18
7	DP-5, DP-6, J & OS-4	87	188
8	OS-3 & K	29	64
9	DP-8, L, M, OS-5 & POND RELEASE	102	227
10	N & O	8	19

POND PERFORATED HOLE PATTERN

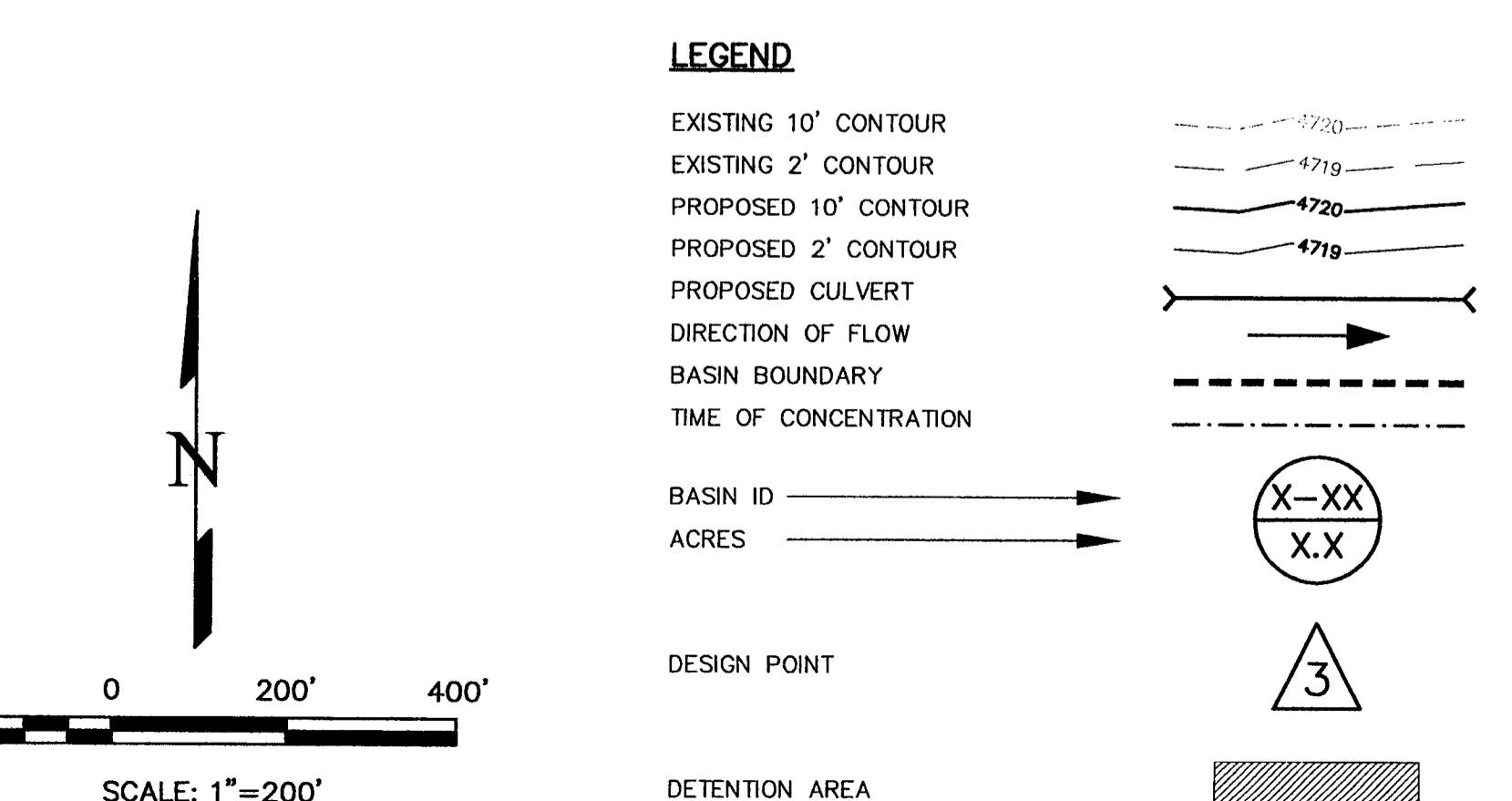
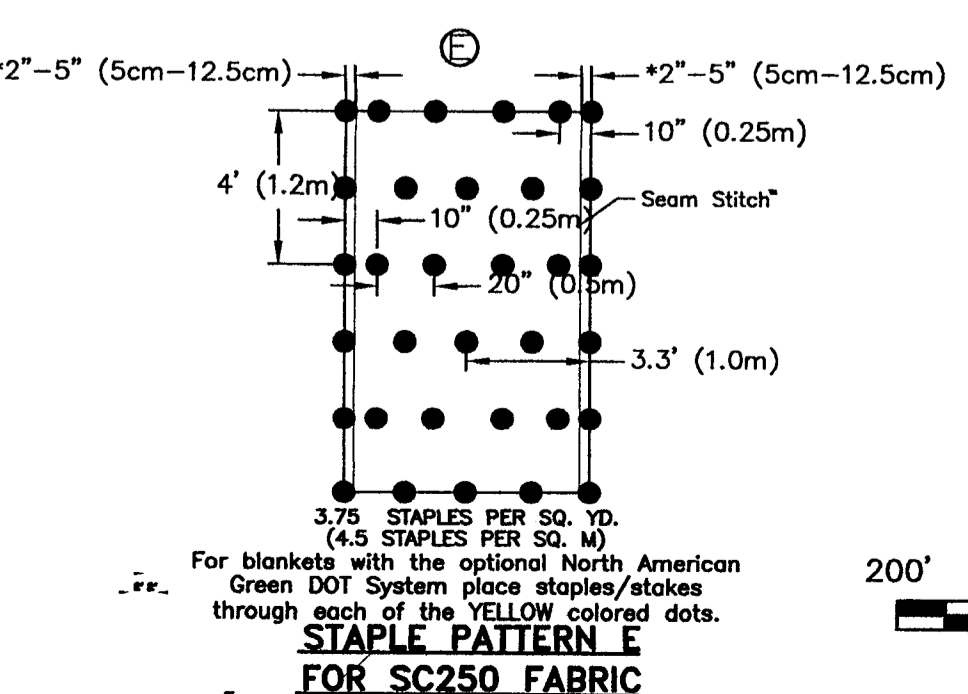
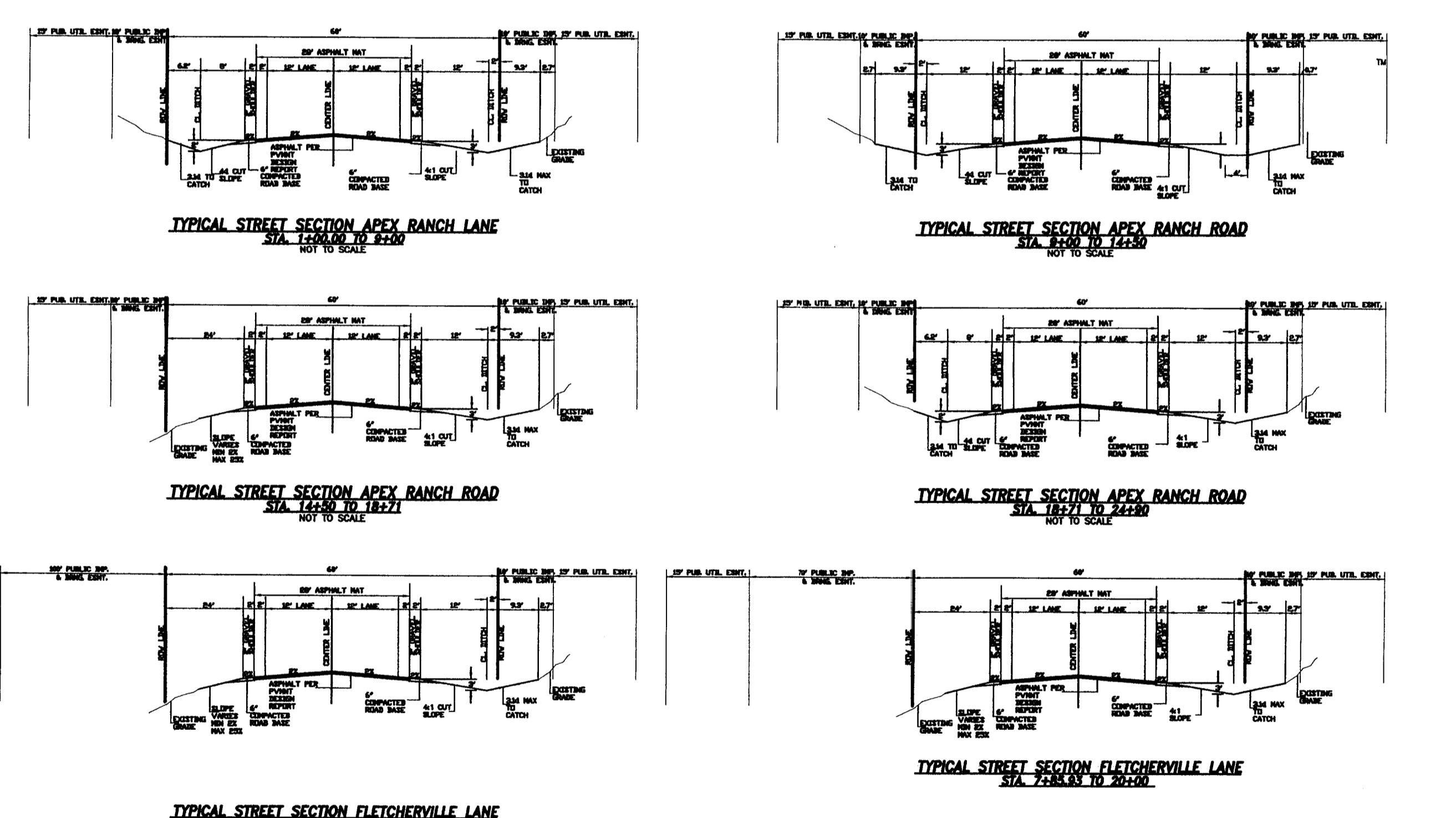
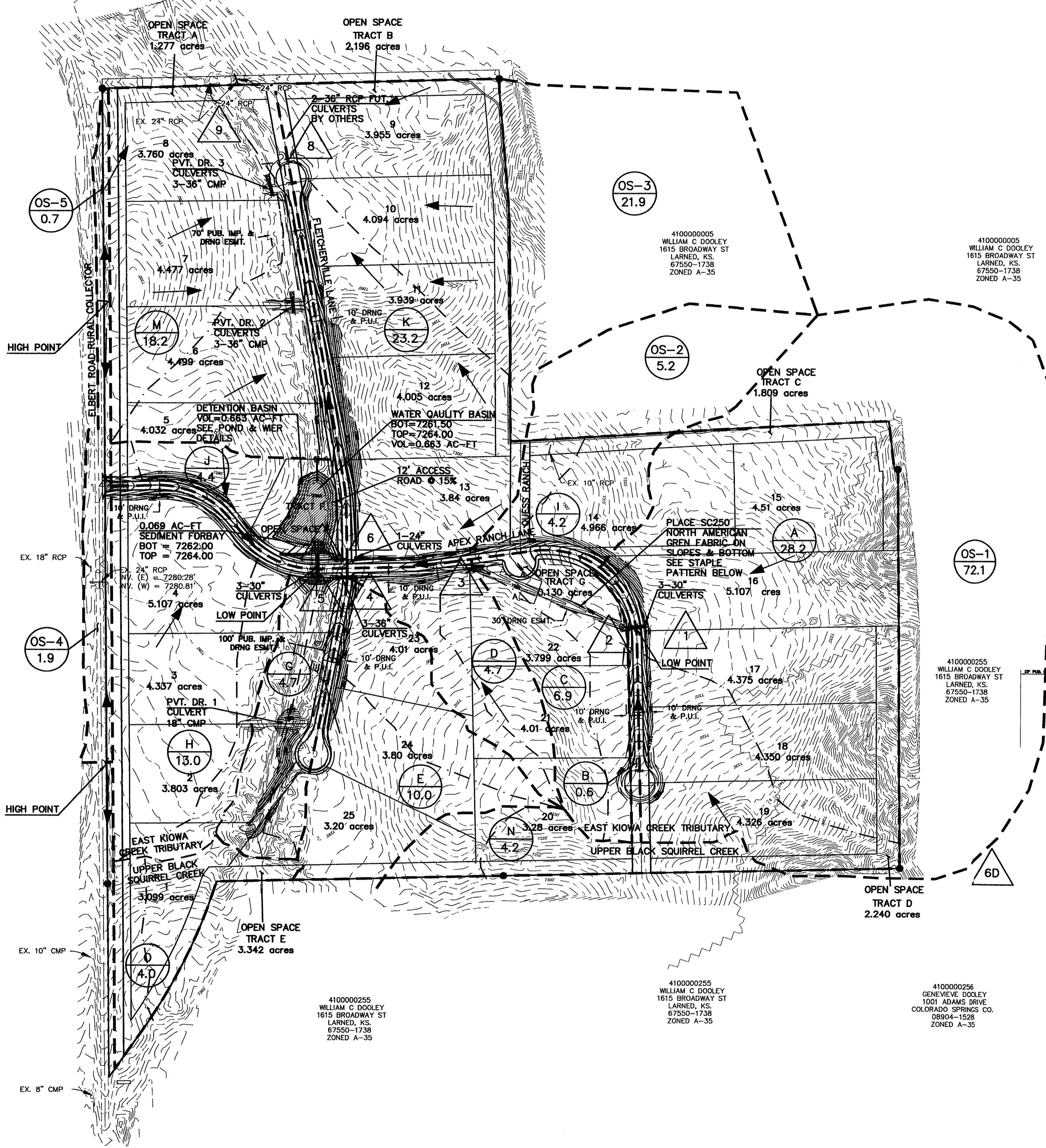
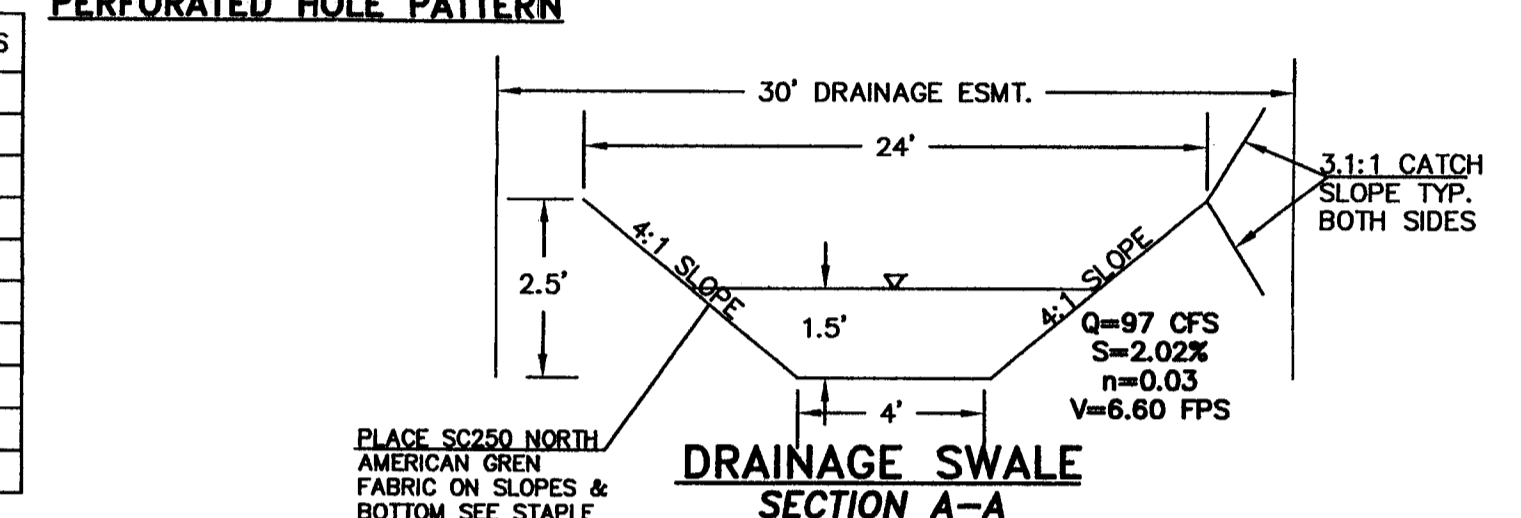

<p>REVISIONS</p> <table border="1" style="width: 100%; border-collapse: collapse;"> <thead> <tr> <th>NO.</th> <th>DESCRIPTION</th> <th>DATE</th> </tr> </thead> <tbody> <tr> <td>1.</td> <td>REVISED PER COUNTY COMMENTS</td> <td>11/9/07</td> </tr> </tbody> </table>	NO.	DESCRIPTION	DATE	1.	REVISED PER COUNTY COMMENTS	11/9/07	<p>UNTIL SUCH TIME AS THESE DRAWINGS ARE APPROVED BY THE APPROPRIATE TERRA NOVA ENGINEERING, INC. APPROVES THEIR USE ONLY FOR THE PURPOSES DESIGNATED BY WRITTEN AUTHORIZATION.</p> <p>PREPARED FOR: APEX RANCH ESTATES, LLC ATTN: CRAIG MCCONNELL P.O. BOX 267 PEYTON, COLORADO 80831</p> <p style="text-align: right;"> Terra Nova Engineering, Inc. 125 N. WAHSATCH AVE., SUITE 101 COLORADO SPRINGS, CO. 80903 OFFICE: 719-635-6422 FAX: 719-635-6426 www.tnainc.com </p>
NO.	DESCRIPTION	DATE					
1.	REVISED PER COUNTY COMMENTS	11/9/07					
<p>APEX RANCH ESTATES</p>	<p>FINAL DRAINAGE MAP DEVELOPED CONDITIONS</p>						
<p>DESIGNED BY QNA DRAWN BY LAE CHECKED BY LDR</p>							
<p>H=SCALE 1"=200' V=SCALE</p>							
<p>JOB NO. 0565.00 DATE ISSUED 8/26/08 SHEET NO. 1 OF 1</p>							

APPENDIX G: DRAINAGE MAPS

THIS DOCUMENT, TOGETHER WITH THE CONCEPTS AND DESIGNS PRESENTED HEREIN, AS AN INSTRUMENT OF SERVICE, IS INTENDED ONLY FOR THE SPECIFIC PURPOSE AND CLIENT FOR WHICH IT WAS PREPARED. REUSE OF AND IMPROPER RELIANCE ON THIS DOCUMENT WITHOUT WRITTEN AUTHORIZATION AND ADAPTATION BY KIMLEY-HORN AND ASSOCIATES, INC. SHALL BE WITHOUT LIABILITY TO KIMLEY-HORN AND ASSOCIATES, INC.

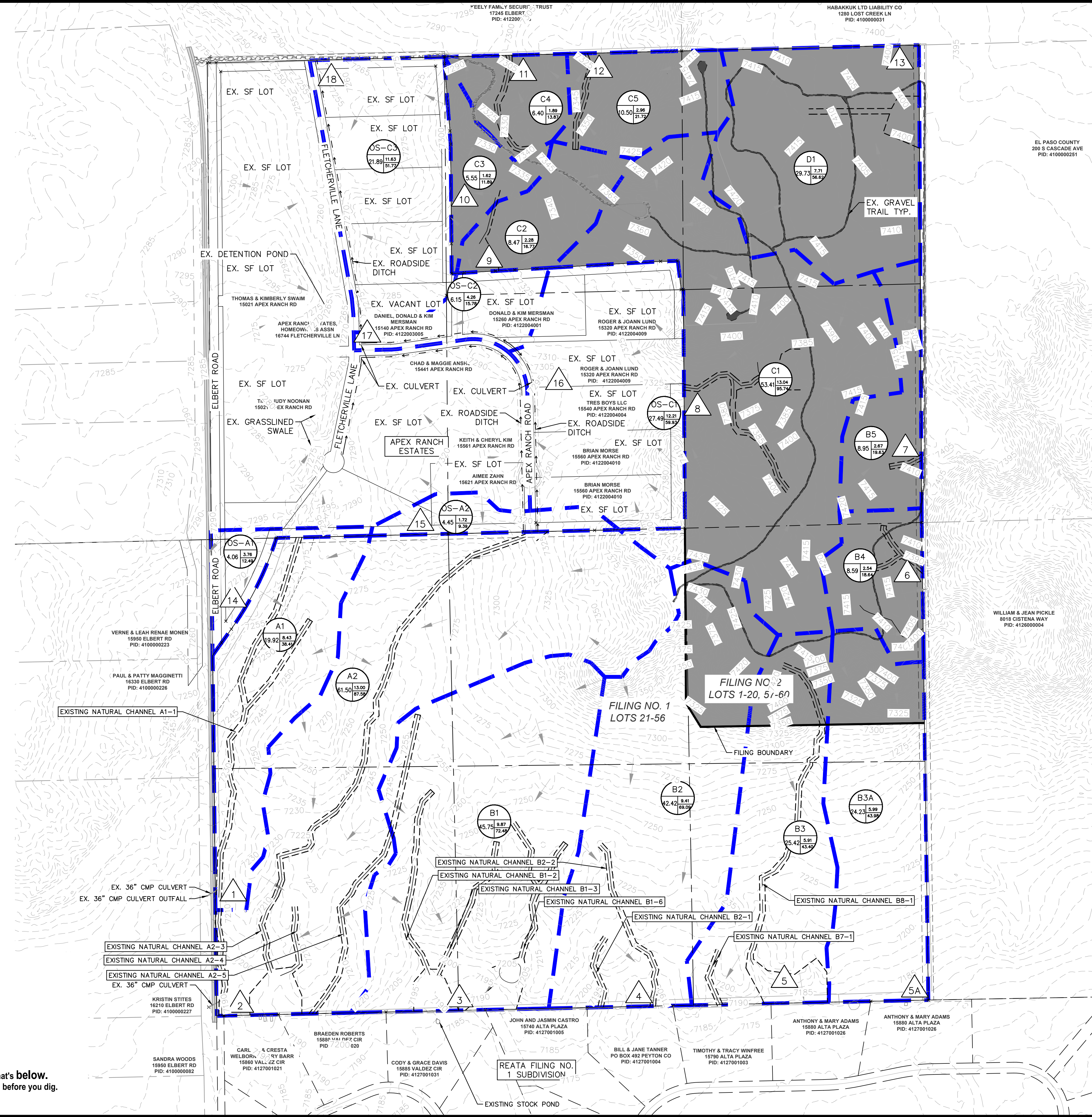

LEGEND

	A = BASIN DESIGNATION
	B = AREA (ACRES)
	C = BASIN IMPERVIOUSNESS
	D = 100YR DESIGN STORM RUNOFF (CFS)
	# = DESIGN POINT
	EXISTING FLOW DIRECTION
	PROPOSED PROPERTY LINE
	EXISTING PROPERTY LINE
	PROPOSED EASEMENT LINE
	DRAINAGE BASIN BOUNDARY
	EXISTING MAJOR CONTOUR
	EXISTING MINOR CONTOUR
	PHASE 2 OF DEVELOPMENT

- A - Upper Black Squirrel Drainage Basin (CHBS2000)
- B - La Vega Ranch Drainage Basin (CHBR0400)
- C - East Kiowa Creek Drainage Basin (KIKI0400)
- D - Bijou Creek Drainage Basin (BIBI0200)

EXISTING CONDITIONS RATIONAL CALCULATIONS SUMMARY						
DESIGN POINT	TRIBUTARY BASINS	TRIBUTARY AREA (AC)	CFS			% IMPERVIOUS
			Q2	Q5	Q100	
FDR Basins						
1	A1	19.92	4.19	8.43	38.41	8%
2	A2	61.50	3.44	13.00	87.58	1%
3	B1	45.75	1.98	9.87	72.48	0%
4	B2	42.42	1.88	9.41	69.09	0%
5	B3	25.42	1.18	5.91	43.40	0%
5A	B3A	24.23	1.20	5.99	43.98	0%
14	OS-A1	4.06	2.27	3.62	12.02	19%
15	OS-A2	4.45	0.70	2.10	11.46	7%
ON-SITE BASIN TOTAL						
BASIN A TOTAL		81.42	7.63	21.43	125.99	3%
BASIN B TOTAL		137.82	6.24	31.18	228.94	0%
ON-SITE TOTAL		219.24	13.87	52.61	354.92	1%
OFF-SITE BASIN TOTAL						
OFF-SITE BASIN A		8.51	2.97	5.72	23.48	13%
OFF-SITE TOTAL		8.51	2.97	5.72	23.48	13%
SITE TOTAL		227.75	16.84	58.33	378.41	1%

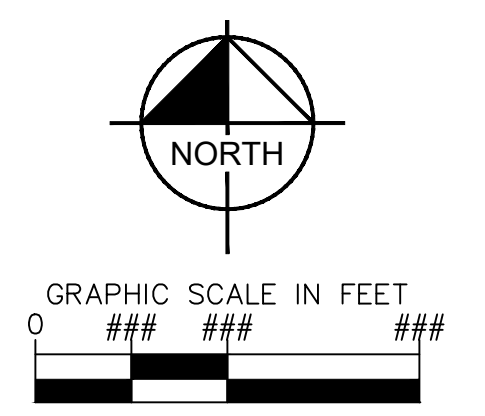

2023 KIMLEY-HORN AND ASSOCIATES, INC.
2 N NEVADA ST., SUITE 900
COLORADO SPRINGS, CO 80903 719-453-0180

DESIGNED BY: KRK DRAWN BY: AJL CHECKED BY: KRK DATE: 11/27/23	BY: DATE REVISION: APPR
--	----------------------------

OVERLOOK FILING NO. 1
EL PASO COUNTY, COLORADO
PRELIMINARY DESIGN PLANS
EXISTING DRAINAGE MAP

PRELIMINARY
FOR REVIEW ONLY
NOT FOR
CONSTRUCTION

PROJECT NO. 196239003
SHEET EX-1

THIS DOCUMENT, TOGETHER WITH THE CONCEPTS AND DESIGNS PRESENTED HEREIN, AS AN INSTRUMENT OF SERVICE, IS INTENDED ONLY FOR THE SPECIFIC PURPOSE AND CLIENT FOR WHICH IT WAS PREPARED. REUSE OF AND IMPROPER RELIANCE ON THIS DOCUMENT WITHOUT WRITTEN AUTHORIZATION AND ADAPTATION BY KIMLEY-HORN AND ASSOCIATES, INC. SHALL BE WITHOUT LIABILITY TO KIMLEY-HORN AND ASSOCIATES, INC.

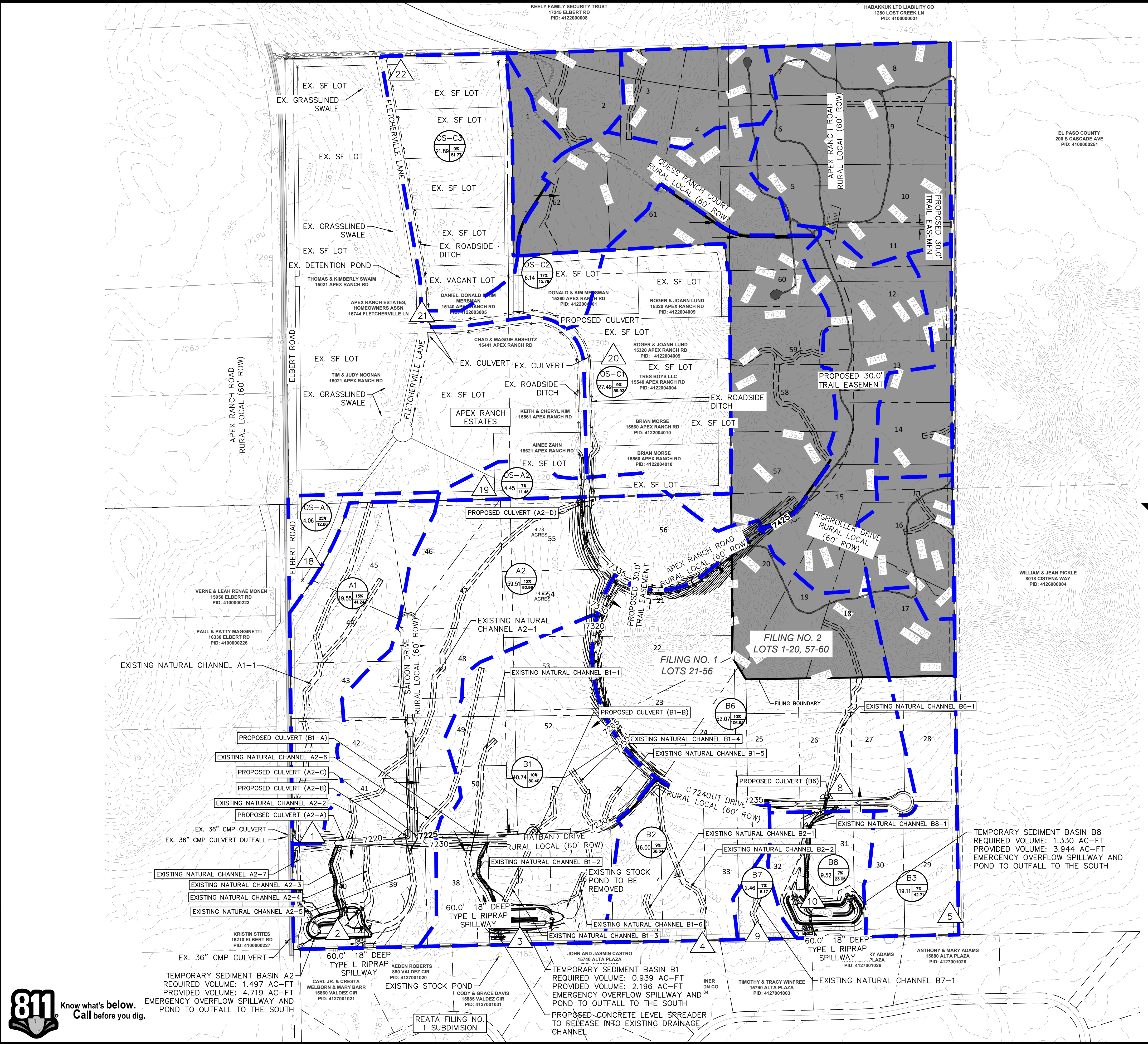

LEGEND

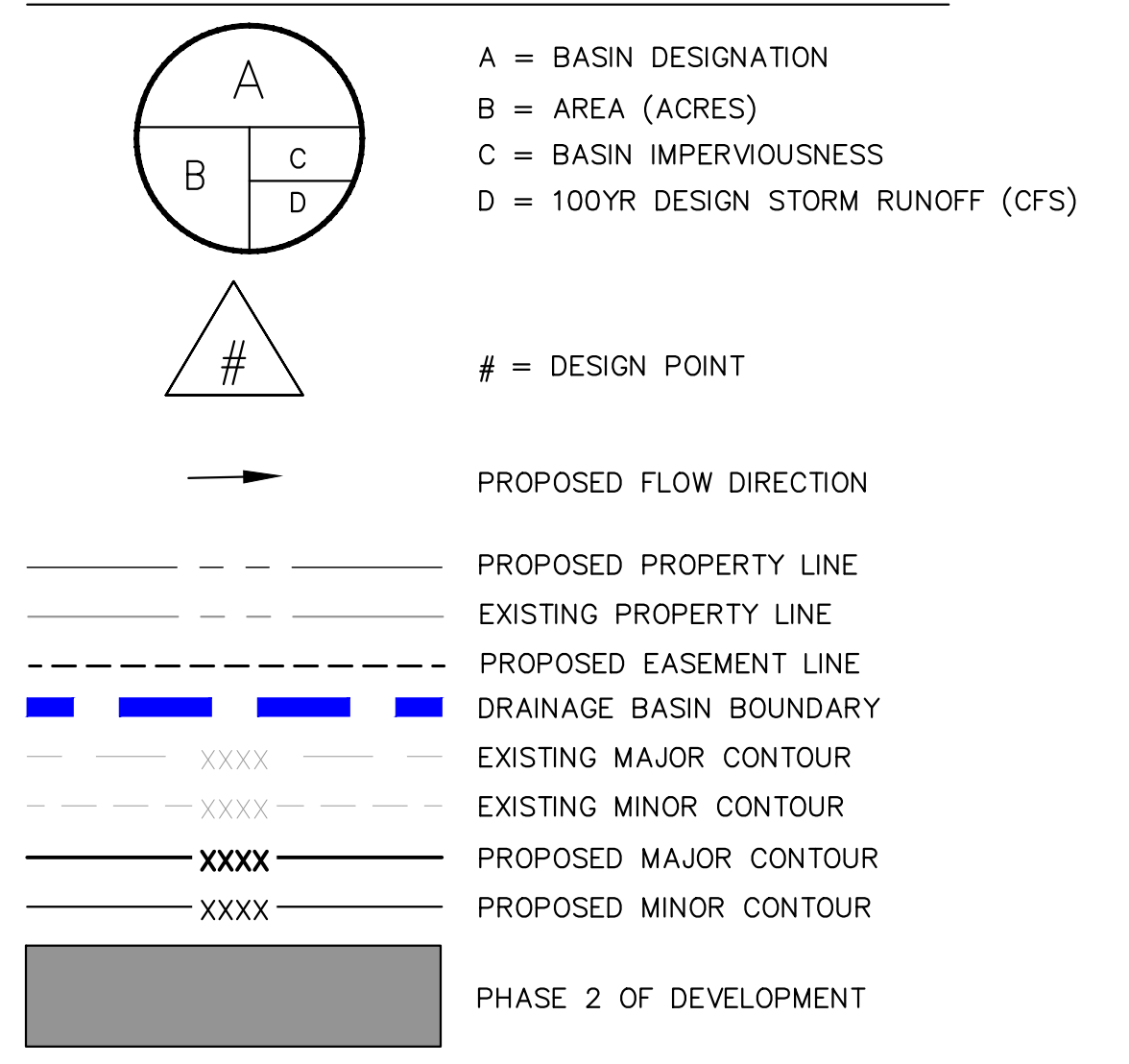

NOTES

1. ALL PROPOSED EASEMENTS ARE 30' DRAINAGE EASEMENTS UNLESS OTHERWISE NOTED
2. ALL PROPOSED CULVERTS ARE TO BE CMP UNLESS OTHERWISE NOTED.

- A - Upper Black Squirrel Drainage Basin (CHBS2000)
- B - La Vega Ranch Drainage Basin (CHBR0400)
- C - East Kiowa Creek Drainage Basin (KIKI0400)
- D - Bijou Creek Drainage Basin (BIBI0200)

PROPOSED CONDITIONS RATIONAL CALCULATIONS SUMMARY						
DESIGN POINT	TRIBUTARY BASINS	TRIBUTARY AREA (AC)	CFS			% IMPERVIOUS
			Q2	Q5	Q100	
PDR Basins						
1	A1	19.55	5.41	10.41	41.24	15%
2	A2	59.51	8.87	20.23	93.46	11%
3	B1	40.74	6.97	16.77	80.40	10%
4	B2	16.00	3.10	7.82	38.64	9%
5	B3	19.11	2.61	7.83	42.71	7%
8	B6	52.07	9.39	22.13	104.60	10%
9	B7	2.46	0.38	1.13	6.17	7%
10	B8	9.52	1.41	4.22	23.05	7%
18	OS-A1	4.06	2.57	4.12	12.86	25%
19	OS-A2	4.45	0.70	2.10	11.46	7%
ON-SITE BASIN TOTAL						
BASIN A TOTAL		79.06	14.28	30.64	134.69	12%
BASIN B TOTAL		139.90	23.86	59.90	295.56	9%
ON-SITE TOTAL		218.96	23.86	59.90	295.56	10%
OFF-SITE BASIN TOTAL						
OFF-SITE BASIN A		8.51	3.27	6.22	24.32	15%
OFF-SITE TOTAL		8.51	3.27	6.22	24.32	15%
SITE TOTAL		227.47	27.12	66.12	319.88	10%

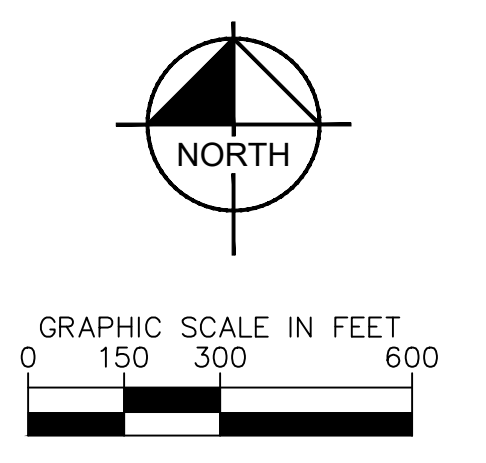

NO.	REVISION	BY	DATE	APPR

Kimley»Horn
 2025 KIMLEY-HORN AND ASSOCIATES, INC.
 2 N NEVADA ST., SUITE 900
 COLORADO SPRINGS, CO 80903 719-453-0180

DESIGNED BY: KRK
 DRAWN BY: AJL
 CHECKED BY: KRK
 DATE: 11/27/23

OVERLOOK FILING NO. 1
 EL PASO COUNTY, COLORADO
 PRELIMINARY DESIGN PLANS
 PROPOSED DRAINAGE MAP

PRELIMINARY
 FOR REVIEW ONLY
 NOT FOR
 CONSTRUCTION

PROJECT NO.
196239003
 SHEET
EX-2

THIS DOCUMENT, TOGETHER WITH THE CONCEPTS AND DESIGNS PRESENTED HEREIN, AS AN INSTRUMENT OF SERVICE, IS INTENDED ONLY FOR THE SPECIFIC PURPOSE AND CLIENT FOR WHICH IT WAS PREPARED. REUSE OF AND IMPROPER RELEASE OF THIS DOCUMENT WITHOUT WRITTEN AUTHORIZATION AND ADAPTATION BY KIMLEY-HORN AND ASSOCIATES, INC. SHALL BE WITHOUT LIABILITY TO KIMLEY-HORN AND ASSOCIATES, INC.

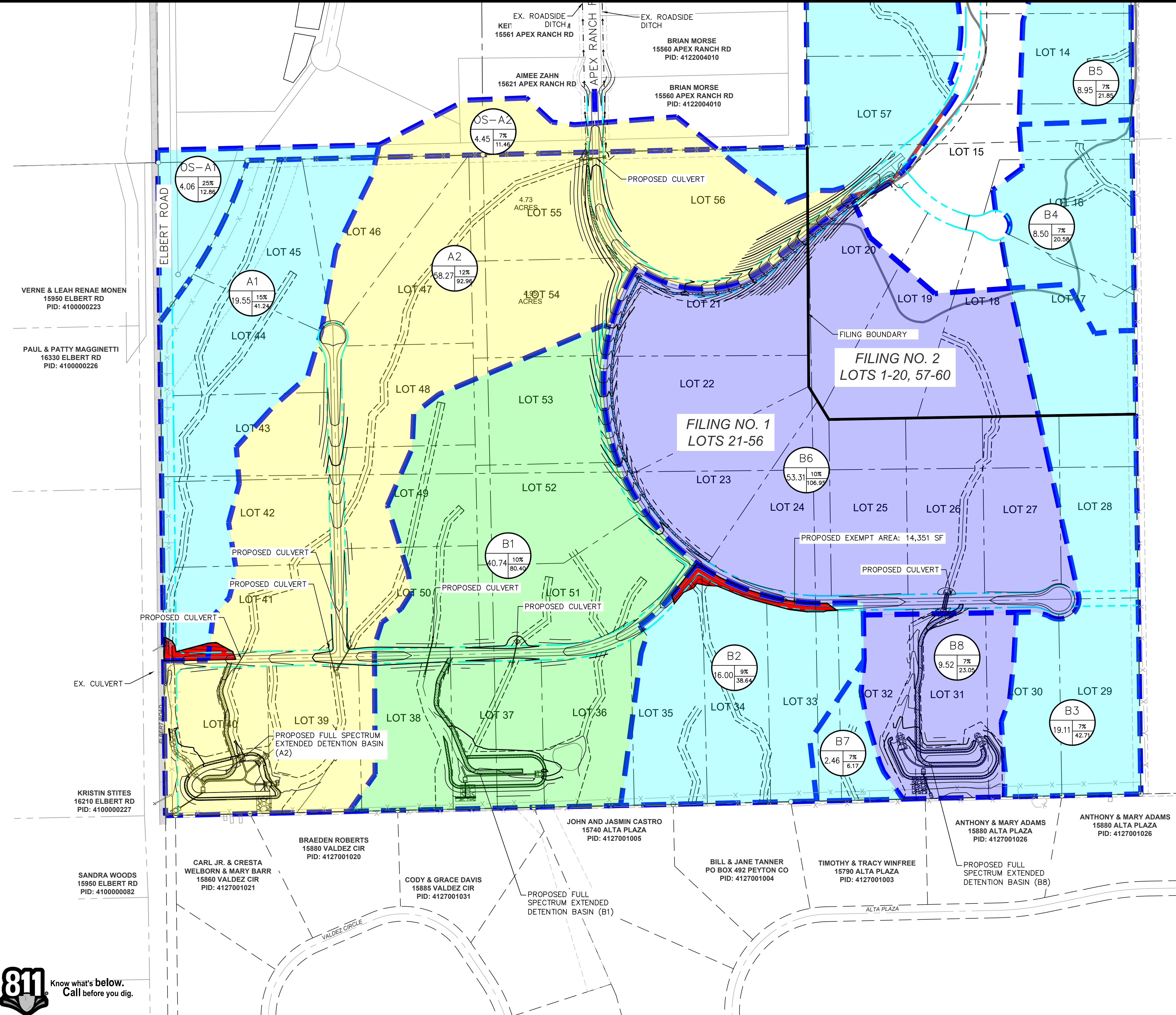

LEGEND

	A = BASIN DESIGNATION
	B = AREA (ACRES)
	C = BASIN IMPERVIOUSNESS
	D = 100YR DESIGN STORM RUNOFF (CFS)

- PROPOSED PROPERTY LINE
- EXISTING PROPERTY LINE
- PROPOSED EASEMENT LINE
- DRAINAGE BASIN BOUNDARY
- THE LARGE LOT EXCLUSION I.7.1.B.5
- TRIBUTARY TO POND A2
- TRIBUTARY TO POND B1
- TRIBUTARY TO POND B8
- PROPOSED EXEMPT AREA

EXEMPT AREAS (ECM I.7.1.C.1)

BASIN A1	= ±16,482 SF
BASIN B2	= ±26,947 SF
TOTAL	= ±43,429 SF (0.99 ACRES)

VERNE & LEAH RENAE MONEN
15950 ELBERT RD
PID: 4100000223

PAUL & PATTY MAGGINETTI
16330 ELBERT RD
PID: 4100000226

KRISTIN STITES
16210 ELBERT RD
PID: 4100000227

SANDRA WOODS
15950 ELBERT RD
PID: 4100000082

CARL JR. & CRESTA WELBORN & MARY BARR
15880 VALDEZ CIR
PID: 4127001021

BRAEDEN ROBERTS
15880 VALDEZ CIR
PID: 4127001020

CODY & GRACE DAVIS
15885 VALDEZ CIR
PID: 4127001031

PROPOSED FULL SPECTRUM EXTENDED DETENTION BASIN (B1)

JOHN AND JASMIN CASTRO
15740 ALTA PLAZA
PID: 4127001005

BILL & JANE TANNER
PO BOX 492 PEYTON CO
PID: 4127001004

TIMOTHY & TRACY WINFREE
15790 ALTA PLAZA
PID: 4127001003

ANTHONY & MARY ADAMS
15880 ALTA PLAZA
PID: 4127001026

ANTHONY & MARY ADAMS
15880 ALTA PLAZA
PID: 4127001026

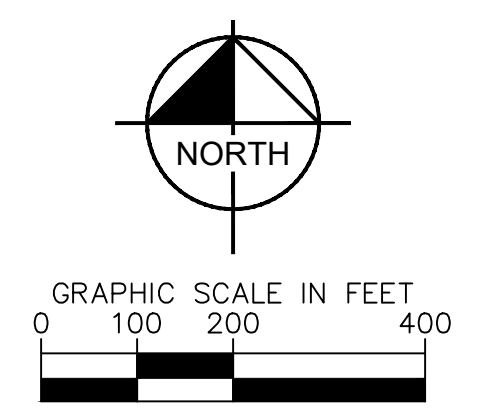

NO.	REVISION	BY	DATE	APPR

Kimley-Horn
2023 KIMLEY-HORN AND ASSOCIATES, INC.
2 N NEVADA ST, SUITE 900
COLORADO SPRINGS, CO 80903 719-453-0180

DESIGNED BY: KRK
DRAWN BY: AJL
CHECKED BY: KRK
DATE: 11/27/23

OVERLOOK FILING NO. 1
EL PASO COUNTY, COLORADO
PRELIMINARY DESIGN PLANS
EXCLUSION EXHIBIT DRAINAGE MAP-FILING NO. 1

PRELIMINARY
FOR REVIEW ONLY
NOT FOR
CONSTRUCTION
Kimley-Horn
Kimley-Horn and Associates, Inc.

PROJECT NO.
196239003
SHEET

EX-3

Drainage Basin Exhibit

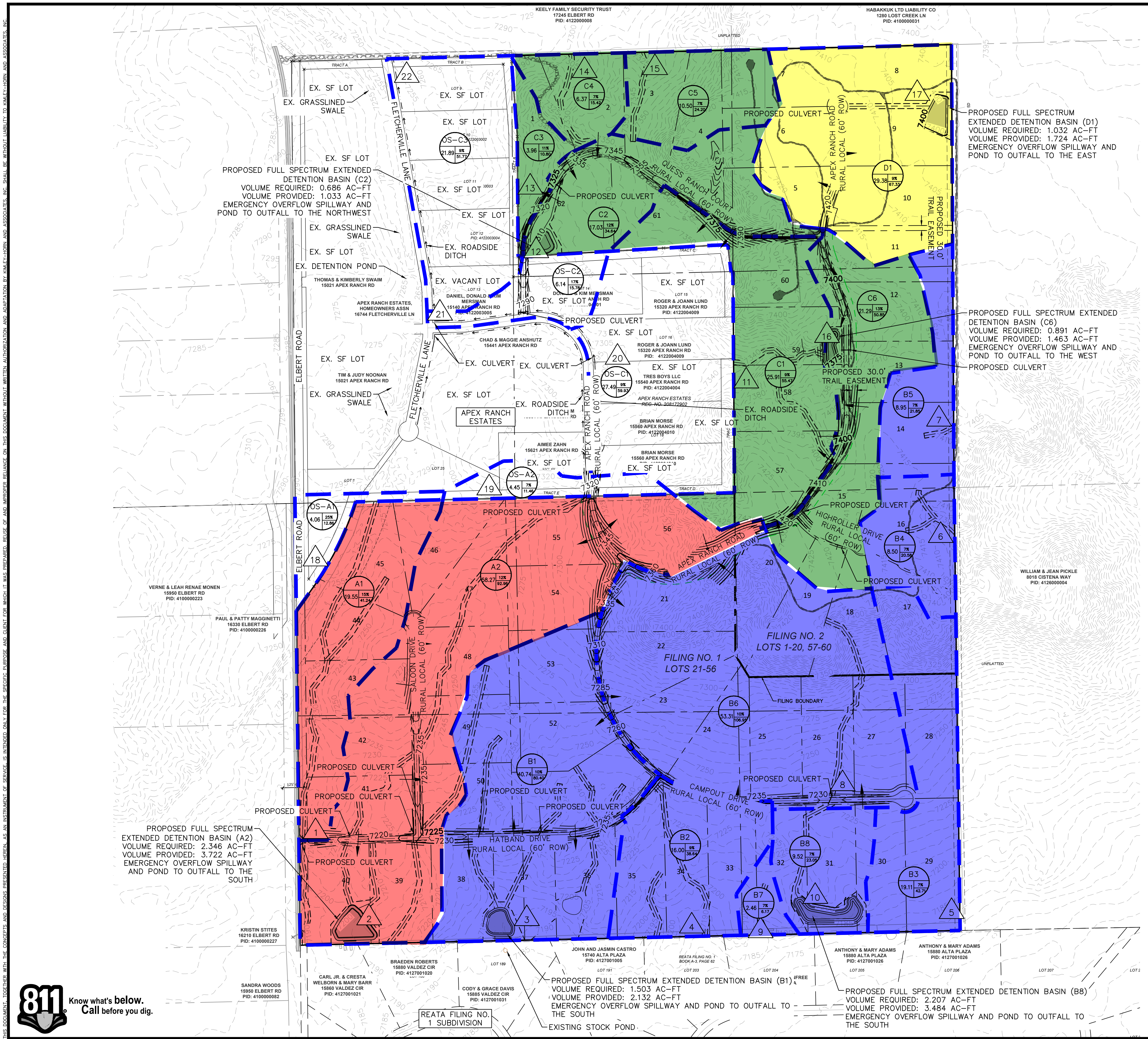

LEGEND

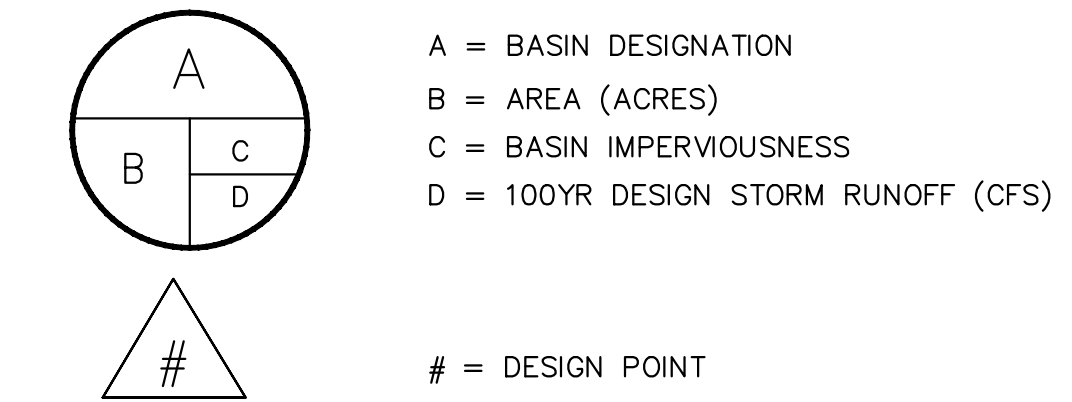

EASEMENT NOTE

1. ALL PROPOSED EASEMENTS ARE 30' DRAINAGE EASEMENTS UNLESS OTHERWISE NOTED

- A - Upper Black Squirrel Drainage Basin (CHBS2000)
- B - La Vega Ranch Drainage Basin (CHBR0400)
- C - East Kiowa Creek Drainage Basin (KIKI0400)
- D - Bijou Creek Drainage Basin (BIBI0200)

PROPOSED CONDITIONS RATIONAL CALCULATIONS SUMMARY

DESIGN POINT	TRIBUTARY BASINS	TRIBUTARY AREA (AC)	CFS			% IMPERVIOUS
			Q2	Q5	Q100	
PDR Basins						
1	A1	19.55	5.41	10.41	41.24	15%
2	A2	58.27	9.71	20.99	92.96	12%
3	B1	40.74	6.97	16.77	80.40	10%
4	B2	16.00	3.10	7.82	38.64	9%
5	B3	19.11	2.61	7.83	42.71	7%
6	B4	8.50	1.25	3.77	20.58	7%
7	B5	8.95	1.33	4.01	21.85	7%
8	B6	53.31	9.52	22.55	106.95	10%
9	B7	2.46	0.38	1.13	6.17	7%
10	B8	9.52	1.41	4.22	23.05	7%
11	C1	25.91	4.42	11.18	55.47	9%
12	C2	17.03	3.87	8.08	34.64	12%
13	C3	3.96	1.04	2.36	10.80	11%
14	C4	6.37	0.94	2.83	15.42	7%
15	C5	10.50	1.48	4.44	24.20	7%
16	C6	21.29	6.09	12.27	50.85	13%
17	D1	29.38	5.34	13.56	67.33	9%
18	OS-A1	4.06	2.57	4.12	12.86	25%
19	OS-A2	4.45	0.70	2.10	11.46	7%
20	OS-C1	27.49	4.90	12.21	59.93	9%
21	OS-C2	6.15	2.35	4.26	15.78	17%
22	OS-C3	21.89	5.33	11.63	51.77	11%
ON-SITE BASIN TOTAL						
BASIN A TOTAL		77.82	15.12	31.40	134.20	12%
BASIN B TOTAL		158.59	26.57	68.09	340.34	8%
BASIN C TOTAL		85.06	17.84	41.15	191.38	10%
BASIN D TOTAL		29.38	4.90	12.21	59.93	9%
ON-SITE TOTAL		350.85	49.75	122.80	599.06	10%
OFF-SITE BASIN TOTAL						
OFF-SITE BASIN A		8.51	3.27	6.22	24.32	15%
OFF-SITE BASIN C		55.53	12.58	28.11	127.48	11%
OFF-SITE TOTAL		64.04	15.85	34.33	151.80	12%
SITE TOTAL		414.89	65.60	157.13	750.86	10%

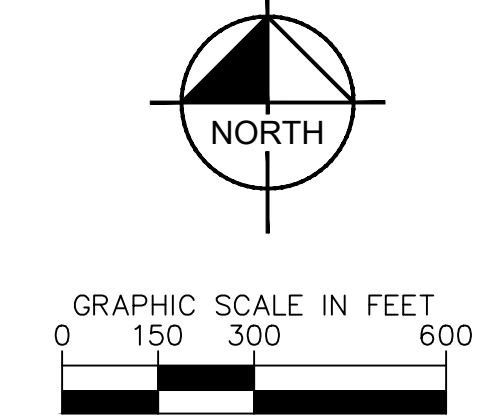

NO.	REVISION	BY	DATE	APPR

Kimley»Horn

2023 KIMLEY-HORN AND ASSOCIATES, INC.
2 N NEVADA ST., SUITE 900
COLORADO SPRINGS, CO 80903 719-453-0180

DESIGNED BY: KRK
DRAWN BY: AJL
CHECKED BY: KRK
DATE: 11/27/23

OVERLOOK FILING NO. 1
 EL PASO COUNTY, COLORADO
 PRELIMINARY DESIGN PLANS
PROPOSED DRAINAGE MAP

PRELIMINARY
 FOR REVIEW ONLY
 NOT FOR
 CONSTRUCTION

PROJECT NO.
196239003
SHEET
EX-2



THIS DOCUMENT, TOGETHER WITH THE CONCEPTS AND DESIGNS PRESENTED HEREIN, IS AN INSTRUMENT OF SERVICE. IT IS INTENDED ONLY FOR THE SPECIFIC PURPOSE AND CLIENT FOR WHICH IT WAS PREPARED. REUSE OF AND IMPROPER RELIANCE ON THIS DOCUMENT WITHOUT WRITTEN AUTHORIZATION AND ADAPTATION BY KIMLEY-HORN AND ASSOCIATES, INC. SHALL BE WITHOUT LIABILITY TO KIMLEY-HORN AND ASSOCIATES, INC.