



EPC STORMWATER REVIEW COMMENTS  
IN ORANGE BOXES WITH BLACK TEXT

Item Numbers refer to SWMP Checklist

# SCHMIDT DISTRICT INFRASTRUCTURE

## STORMWATER MANAGEMENT PLAN

ALL TERRAIN ENGINEERING PROJECT NO: 24013

EL PASO COUNTY REVIEW NO: **CDR2413**

DECEMBER 2024

### APPLICANT

TURKEY CANYON QUARRY INC.

CONTACT: JIM MORLEY

20 BOULDER CRESCENT STREET, SUITE 100

COLORADO SPRINGS, CO 80903

### PREPARED BY

ALL TERRAIN ENGINEERING LLC

CONTACT: NICHOLAS Q. JOKERST

NJOKERST@ALLTERRAINENG.COM

QUALIFIED STORMWATER MANAGER

TBD

Item 1. Add Qualified Stormwater Manager and Contractor Information to cover/title sheet. If unknown, add a placeholder to be updated prior to the pre-construction meeting:

~~QUALIFIED STORMWATER MANAGER~~

Name: \_\_\_\_\_

Company: \_\_\_\_\_

Address: \_\_\_\_\_

~~CONTRACTOR~~

Name: \_\_\_\_\_

Company: \_\_\_\_\_

Address: \_\_\_\_\_



## Table of Contents

I.	Site Location & Description .....	4
II.	Construction Phasing .....	4
III.	Self-Inspections .....	5
IV.	Materials Handling .....	7
V.	Spill Prevention & Response Plan.....	8
VI.	Potential Sources of Pollution .....	9
VII.	Implementation of Control Measures .....	9
VIII.	Final Stabilization & Long Term Stormwater Management Plan .....	9
IX.	References .....	10

## Appendices

- A. Vicinity Map, FEMA Map & NRCS Soil Survey
- B. Geotechnical Report
- C. GEC Plans
- D. GEC Administrator Certification
- E. Construction Control Measure Details



**PREPARING ENGINEER:**

Name: Nicholas Q. Jokerst

Company: All Terrain Engineering

Title: Project Manager

Phone Number: (530) 391-7635

Address: 1004 West Van Buren Street, Colorado Springs, CO 80907

**PERMITTEE:**

Name: JIM MORLEY

Company: TURKEY CANYON QUARRY INC.

Title: PROJECT MANAGER

Phone Number: (719) 491-3024

Address: 20 BOULDER CRESCENT STREET, SUITE 100, COLORADO SPRINGS, CO 80903



**APPLICANT’S STATEMENT**

The Stormwater Management Plan was prepared under my direction and supervision and is correct to the best of my knowledge and belief. Said Plan has been prepared according to the criteria established by the County and State for Stormwater Management Plans.

---

Engineer of Record and/or Qualified Stormwater Manager Date

**REVIEW ENGINEER**

The Stormwater Management Plan was reviewed and found to meet the checklist requirements except where otherwise noted or allowed by an approved deviation request.

---

Review Engineer Date



## I. Site Location & Description

The Schmidt Parcel District Infrastructure (hereby referred to as the “site”) is a proposed development with a total area of approximately 96.8 acres.

The site is located in the south half of Section 32, Township 12 South, Range 65 West of the Sixth Principal Meridian in the County of El Paso, State of Colorado. The site is located to the west of the Vollmer Road and Marksheffel Road intersection. The site is bounded by Holiday Hills Filing No.1 to the north, by Vollmer Road to the east, by the Trails at Forest Meadows Filing No. 3 to the south, and by proposed Brush Top Road extension to the west. The parcel is planned to be platted after approval of the Preliminary Plan. Refer to the vicinity map in Appendix A for additional information.

Item 8. Discuss the erosion potential of each soil type identified.

The site is approximately 96.8 acres and 37 acres will be disturbed. The existing condition of the undeveloped site consists of 90% native grass coverage and open space, determined via field observation. In general, the site slopes southwesterly towards Trails at Forest Meadows Filing 3. Onsite elevations range from 6990' - 7034' with slopes ranging 1 – 10%. Per a NRCS soil survey, the site soil is comprised of Blakeland Loamy Sand (Type A), Columbine gravelly sandy loam (Type A), Pring coarse sandy loam (Type B) and Stapleton-Bernal sandy loams (Type B). The NRCS soil survey is presented in Appendix A.

Cottonwood Creek traverses the site along the western boundary. The ultimate stormwater outfall for the site is Cottonwood Creek. Stormwater will be captured in a series of inlets and piped to a permanent water quality and detention pond, located on the east side of Brush Top Road. There are no allowable non-stormwater discharges allowed from the site associated with the below construction activities.

## II. Construction Phasing

The construction activity associated with this SWMP is the grading of the Stonebridge parcel, construction of a permanent full spectrum water quality and detention pond, utility main extensions including storm sewer, sanitary sewer and water and the construction of Marksheffel Road and Brush Top Road. There are no control measures located outside the construction limits. The proposed sequence of major construction activities and Construction Control Measures for the project as are follows:

1. Install VTC, SSA and other perimeter erosion and stormwater control measures (i.e. silt fence, construction fence etc.) (February 2025)
2. Construct permanent water quality & detention pond and outfall channel. (February 2025)
3. Clear, grub and grade site for improvements. Install SCL and ECB per GEC plans. (February 2025)

Item 6. Given that this project is currently under review in Feb 2025, update anticipated construction schedule accordingly

Item 14. Discharge of concrete wash water to ground (e.g. a concrete washout area) is an allowable non-stormwater discharge per the COR400000 Permit if properly identified in the SWMP and if the appropriate control measures are implemented. Revise discussion. Reference COR400000 Part I.A.1.b.ii for more information if needed.

Item 6. Given that this project is currently under review in Feb 2025, update anticipated construction schedule accordingly

4. Excavate and install improvements including underground piping and drainage structures. (Mar 2025– Apr 2025)
5. Asphalt paving & curb and gutter installation. (May 2025 – Jun 2025)
6. Landscaping, restoration and final stabilization. Ensure final stabilization achieved prior to site closure. (Apr 2025 – Aug 2025)

### III. Self-Inspections

Self-inspections of the Construction Control Measures must be completed by the certified GEC Administrator. The below provides the minimum to satisfy the El Paso County self-inspection requirements. A more frequent self-inspection schedule may be required to ensure Control Measures are operating in compliance with the approved GEC plan.

#### 1. Inspection Schedules:

a. The GEC Administrator shall make a thorough inspection of the Control Measures:

- i. At least once every fourteen (14) calendar days.
- ii. Within 24 hours following any precipitation event (i.e. rain, snow, hail etc.) that causes surface erosion.

- Alternatively, the GEC Administrator can perform a thorough inspection of the Control Measures once every seven (7) days and forego post-precipitation inspections.

Item 24. Revise to "At least once every 30 calendar days"

b. For sites where construction activities have completed and final stabilization measures installed but final stabilization has not yet been achieved, the GEC Administrator shall make a thorough inspection of the Control Measures:

- i. At least once every month
- ii. Within 72 hours following any precipitation event that causes surface erosion

**\*\*Note\*\*** post-storm inspections for sites awaiting final stabilization are not required by EPC or the COR400000 permit.

#### 2. Inspection Procedures:

a. Site Inspection & Observation Items:

- i. Limits of disturbance perimeter and stormwater discharge points
- ii. All disturbed areas to ensure necessary Construction Control Measures are in place to control potential stormwater runoff
- iii. Areas used for material/waste storage
- iv. Any areas having a signification potential for storm water pollution (i.e site entrances, concrete washout areas etc.)
- v. All Construction Control Measures identified on the GEC plans.

b. Inspection Requirements:

- i. Determine any locations, or potential locations, where pollutants and stormwater may be exiting the site/entering the receiving waters
- ii. Evaluate Construction Control measures and determine if they are

**\*\*Note\*\* self-inspection reports are not required to be submitted to EPC, but must be available to the EPC inspector for review during an inspection either physically on-site or electronically**

constructed in accordance with the latest revision of the approved GEC plan and operating effectively

- iii. Provide recommendations for the need of additional Construction Control measures and the maintenance of existing measures in disrepair to ensure complication with the El Paso County Stormwater Construction Manual.
- c. Construction Control Measure Maintenance/Replacement:
  - i. The GEC administrator shall ensure sediment has been removed from perimeter controls and relocated to an area without the potential for sediment to discharge from the site
  - ii. The GEC administrator shall ensure diversion ditches and temporary sediment ponds have not accumulated excess sediment that impedes their functionality.
  - iii. The GEC administrator shall ensure that failed Control Measures are repaired/reinstalled within three (3) calendar days, according to the El Paso County Stormwater Control Measure details, to ensure pollutants and/or sediment do not discharge from the site. GEC details are provided in Appendix B.
- d. Documentation:
  - i. Update the GEC plan to document the installation/revision of Control Measures
  - ii. Identify Control Measure deficiencies and that noncompliance is resolved within three(3) calendar days.
  - iii. Identify Self-Inspection schedule in most recent inspection form
  - iv. **Complete and submit Self-Inspection forms to the El Paso County within five (5) business days of the completed inspection**
  - v. **Ensure Self-Inspections are available**, either physically or electronically, throughout the duration of the project
  - vi. Self-Inspection Report shall contain at least the following:
    1. Inspection Date
    2. Name and title of the GEC Administrator performing inspection
    3. Location(s) of illicit discharges of stormwater, sediment or pollutants from the site
    4. Location(s) of Construction Control Measures in need of maintenance/repair
    5. Location(s) of Construction Control Measures that failed to operate as designed or proved inadequate
    6. Location(s) of additional Construction Control Measures not shown on the latest, approved revision of the GEC plan
    7. Any deviations from the minimum inspection schedule

**Item 25. The entire SWMP (to include 1. this document, 2. the current GEC map, and 3. self-inspection reports) are to be available on-site or electronically**

**Item 21. Add text stating that the SWMP should be viewed as a “living document” that is continuously being reviewed and modified as a part of the overall process of evaluating and managing SW quality issues at the site. The QSM shall amend the SWMP when there is a change in design, construction, O&M of the site which would require the implementation of new or revised BMPs or if the SWMP proves to be ineffective in achieving the general objectives of controlling pollutants in SW discharges associated with construction activity or when BMPs are no longer necessary and are removed. The QSM shall maintain a record of amendments made to the SWMP that includes the date and identification of the changes.**

## IV. Materials Handling

1. General Materials Handling Practices:
  - a. Potential pollutants shall be stored and used in a manner consistent with the manufacturer's instructions in a secure location. To the extent practical, material storage areas should be located away from storm drain inlets and should be equipped with covers, roofs or secondary containment as required to prevent stormwater from contacting stored materials. Chemicals that are not compatible shall be stored in segregated areas so that spill materials cannot combine and react.
  - b. Disposal of materials shall be in accordance with the manufacturer's instructions and applicable local, state, and federal regulations.
  - c. Materials no longer required for construction shall be removed from the site as soon as possible.
  - d. Adequate garbage, construction waste, and sanitary waste handling and disposal facilities shall be provided as necessary to keep the site clear of obstruction and Control Measures clear and functional.
2. Specific Materials Handling Practices:
  - e. All pollutants, including waste materials and demolition debris, that occur onsite during construction shall be handled in a way that does not contaminate stormwater.
  - f. All chemicals including liquid products, petroleum products, water treatment chemicals, and wastes stored onsite shall be covered and protected from vandalism.
  - g. Maintenance, fueling, and repair of all equipment and vehicles involving oil changes, hydraulic system drain down, degreasing operation, fuel tank drain down and removal, and other activities which may result in the accidental release of contaminants, shall be conducted under cover during wet weather and on an impervious surface to prevent release of contaminants onto the ground. Materials spilled during maintenance operations shall be cleaned up immediately and properly disposed of.
  - h. Wheel wash water shall be settled and discharged onsite by infiltration.
  - i. Application of agricultural chemicals, including fertilizers and pesticides, shall be conducted in a manner and at application rates that will not result in loss of chemical to stormwater runoff. Follow manufacturer's recommendations for application rates and procedures.
  - j. pH-modifying sources shall be managed to prevent contamination of runoff and stormwater collected onsite. The most common sources of pH-modifying materials are bulk cement, cement kiln dust (CKD), fly ash, new concrete washing and curing waters, wastestreams generated from concrete grinding and sawing, exposed aggregate

## V. Spill Prevention & Response Plan

1. The primary objective in responding to a spill is to quickly contain the material and prevent or minimize their mitigation into stormwater runoff and conveyance systems. If the release has impacted onsite stormwater, it is critical to contain the released materials onsite and prevent their release into receiving waters.
2. Spill Response Procedures:
  - a. Notify site superintendent immediately when a spill, or the threat of a spill, is observed. The superintendent shall assess the situation and determine the appropriate response
  - b. If spills represent an imminent threat of escaping onsite facilities and entering the receiving waters, site personnel shall respond immediately to contain the release and notify the superintendent once the situation has stabilized.
  - c. The site superintendent shall be responsible for completing a spill reporting form and for reporting the spill to the appropriate agency.
  - d. Spill response equipment shall be inspected and maintained as necessary to replace any materials used in spill response activities.
3. Spill kits shall be on-hand at all fueling sites. Spill kit locations shall be reported to the GEC administrator.
4. Absorbent materials shall be on-hand at all fueling areas for use in containing advertent spills. Containers shall be on-hand at all fueling sites for disposal of used absorbents.
5. Recommended components of spill kits include the following:
  - a. Oil absorbent pads
  - b. Oil absorbent booms
  - c. 55-gallon drums
  - d. 9-mil plastic bags
  - e. Personal protective equipment including gloves and goggles
6. Concrete wash water: unless confined in a pre-defined, bermed containment area, the cleaning of concrete truck delivery chutes is prohibited at the job site.
7. Notification procedures:
  - e. In the event of an accident or spill, the GEC administrator shall be notified.
  - f. Depending on the nature of the spill and material involved, the Colorado Department of Public Health and Environment, downstream water users, or other agencies may also need to be notified.
  - g. Any spill of oil which 1) violates water quality standards, 2) produces a “sheen” on a surface water, or 3) causes a sludge or emulsion, or any hazardous substance release, or hazardous waste release which exceeds the reportable quantity, must be reported immediately by telephone to the National Response Center Hotline at (800) 424-8802.

Item 12. Is an asphalt or concrete batch plant anticipated on site? If no, remove. If yes, update SWMP to include material handling and spill prevention/response plan procedures specific to batch plants.

## VI. Potential Sources of Pollution

1. Potential sources of pollution from construction activities include
  - a. Disturbed or stored soils
  - b. Vehicle tracking of sediment
  - c. Loading & unloading operations
  - d. Outdoor Storage activities
  - e. Vehicle and Equipment Maintenance/Fueling
  - f. Dust or Particulate Generating Processes
  - g. Routine maintenance activities involving fertilizers, pesticides, detergents, fuels, solvents etc.
  - h. On-site waste management (waste piles, liquid wastes, dumpsters)
  - i. Concrete truck/equipment washing (washing truck chute and associated fixtures)
  - j. **Dedicated asphalt, concrete batch plants and masonry mixing stations**
  - k. Non-industrial waste (worker trash and portable toilets)

Item 18. Sediment control logs, rock socks and concrete washout area are shown on submitted GEC plan.

## VII. Implementation of Control Measures

Stormwater control measures must be installed according to El Paso County design specifications, presented in Appendix D, and the approved Grading and Erosion Control plan this report supports. Within the context of this CSWMP's construction activities the following control measures, at a minimum, are required:

- Perimeter Silt Fence
- Vehicle Tracking Control
- Stabilized Staging Area
- Inlet Protection
- Erosion Control Blanket
- Temporary Sediment Basin
- Seeding & Mulching

Additional control measures may be required at the discretion of the City Stormwater Inspector.

Revise to "County"

## VIII. Final Stabilization & Long Term Stormwater Management Plan

1. Temporary seeding and mulching will be installed to provide interim stabilization prior to final landscaping installation. Final stabilization will be achieved at time of final landscaping. See approved landscaping plans for final stabilization details. Final stabilization is met when 70% of pre disturbance levels, not including noxious weeds, are stabilized. Final stabilization must be achieved prior to removal of temporary stormwater control measures. **Anticipated date of final stabilization is December 2022**; however this is subject to change. Long term stormwater management will be provided in the onsite, private full spectrum detention pond. See the Permanent Control Measure Plans for construction details of the permanent full spectrum detention pond. See below for seeding and mulching details:
  - a. Prior to seeding, fill any eroded rills and gullies with topsoil.

Item 22. Update info specific to this project.

Item 24. Self-inspections at sites awaiting final stabilization are to be conducted at least once every 30 calendar days.

- b. Ensure all areas are seeded and mulched per the City Stormwater Construction Manual.
- c. Continue **monthly self-inspections** of final stabilization methods and the stormwater management system to ensure proper function. If repairs are needed, reseed and re-mulch as needed.
- d. Control noxious weeds in a manner acceptable to the **GEC** inspector.
- e. Seed Mix: **See Appendix D** for approved seed mixes.
- f. Seeding Requirements:
  - i. Drill seed whenever possible, seed depth must be 1/3 to 1/2 inch when drill-seeding. Cross drilling should be used whenever possible with the seed divided between the two operations. The second drilling should be perpendicular to the first.
  - ii. When drill seeding is not possible or on slopes greater than 3:1, hydro-seeding with tackifier may be substituted at the discretion of the **GEC** inspector. Hydro-seeding must be lightly raked into soil. Seeding rates are presented in **Appendix D**.
  - iii. All seeded areas must be mulched.
- g. Mulching Requirements:
  - i. Mulching shall be completed as soon as practical after seeding but no more than fourteen (14) days after planting. Erosion control blanket can be used in place of the below mulching methods.
  - ii. Hay or straw mulch:
    - 1. Only certified weed-free and certified-seed free mulch may be used. Must be applied at 2 tons/acre and adequately secured.
    - 2. Crimping shall not be used on slopes greater than 3:1, tackifier must be used in place.
  - iii. Hydraulic mulching
    - 1. Allowable on steep slopes or areas with limited access
    - 2. If hydro-seeding is used, mulching must be applied secondly.
    - 3. Wood cellulose fibers mixed with water must be applied at a rate of 2,000-2,500 lbs/acre, and tackifier applied at a rate of 100 lbs/acre.

Revise to "County"

Item 22. Appx D is the GEC Administrator Certification. Update to reference document where specific seed mix specs will be located (e.g. landscape plan, GEC plan) or add seed mix specs in SWMP narrative.

## IX. References

- Drainage Criteria Manual of El Paso County, Colorado - October 2018
- Colorado Springs Stormwater Construction Manual – December 2020



## **APPENDIX A – VICINITY MAP, FEMA & NRCS WEB SOIL SURVEY**



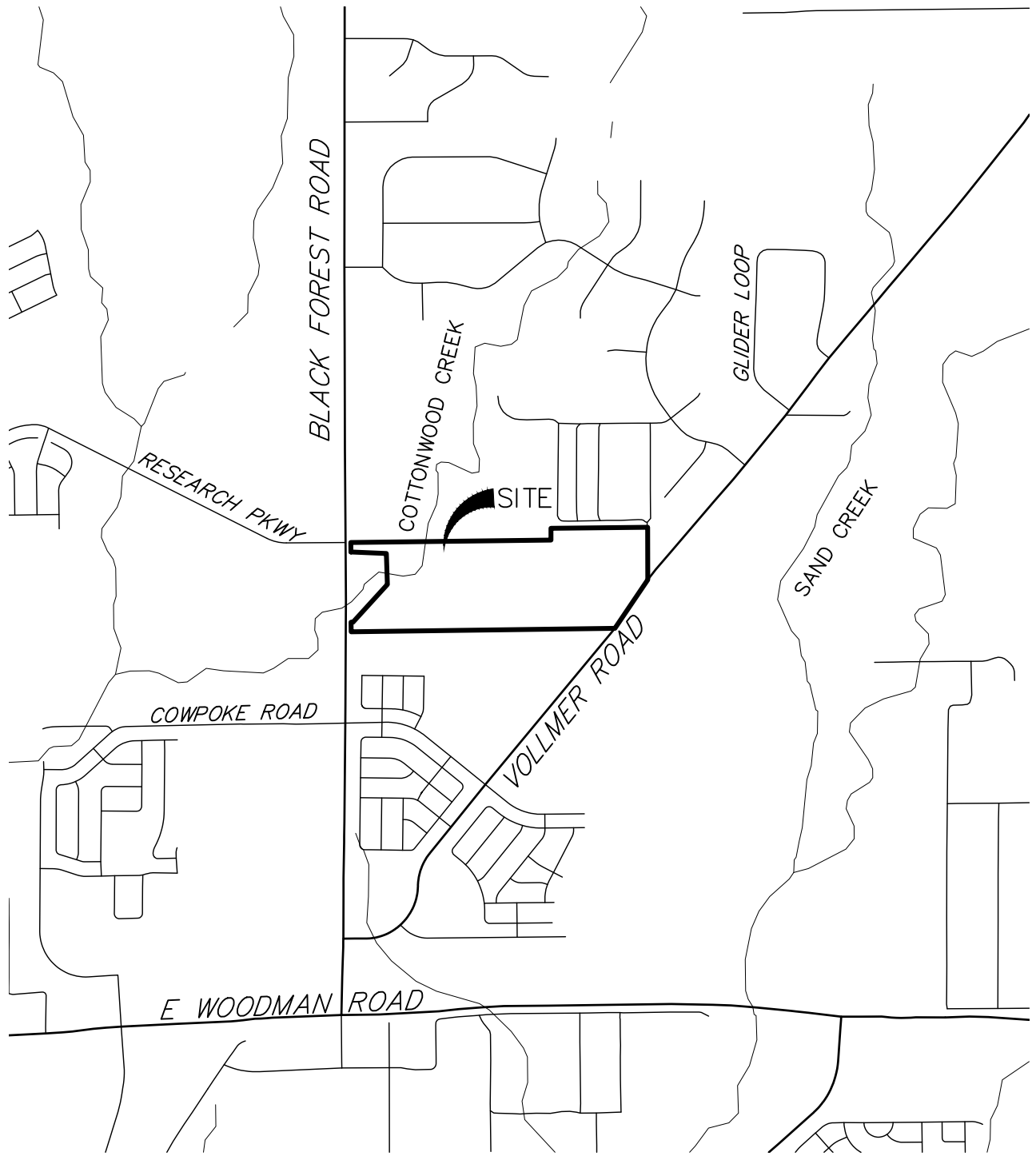

2000 1000 0 2000



ORIGINAL SCALE: 1" = 2000'

VICINITY MAP  
SCHMIDT PARCEL  
JOB NO. 25188.13  
03/31/2022  
SHEET 1 OF 1

Hydrologic Soil Group—El Paso County Area, Colorado

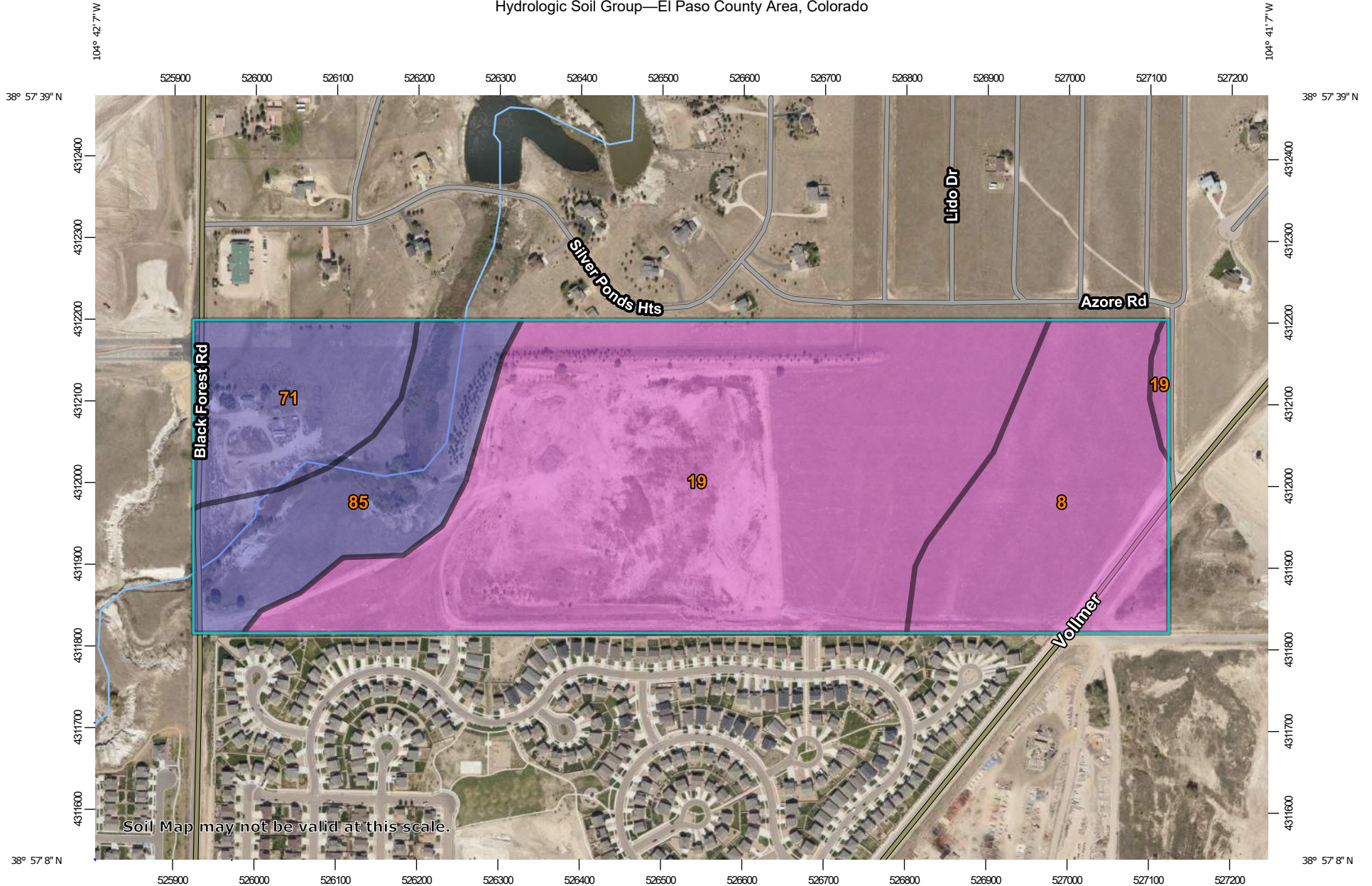



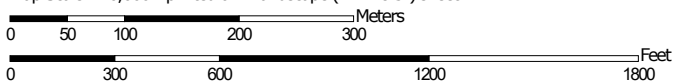





























Map Scale: 1:6,600 if printed on A landscape (11" x 8.5") sheet.



Map projection: Web Mercator Corner coordinates: WGS84 Edge tics: UTM Zone 13N WGS84



### MAP LEGEND

- Area of Interest (AOI)**
  -  Area of Interest (AOI)
- Soils**
  - Soil Rating Polygons**
    -  A
    -  A/D
    -  B
    -  B/D
    -  C
    -  C/D
    -  D
    -  Not rated or not available
  - Soil Rating Lines**
    -  A
    -  A/D
    -  B
    -  B/D
    -  C
    -  C/D
    -  D
    -  Not rated or not available
  - Soil Rating Points**
    -  A
    -  A/D
    -  B
    -  B/D
- Water Features**
  -  Streams and Canals
- Transportation**
  -  Rails
  -  Interstate Highways
  -  US Routes
  -  Major Roads
  -  Local Roads
- Background**
  -  Aerial Photography
- Other**
  -  C
  -  C/D
  -  D
  -  Not rated or not available

### MAP INFORMATION

The soil surveys that comprise your AOI were mapped at 1:24,000.

**Warning:** Soil Map may not be valid at this scale.  
 Enlargement of maps beyond the scale of mapping can cause misunderstanding of the detail of mapping and accuracy of soil line placement. The maps do not show the small areas of contrasting soils that could have been shown at a more detailed scale.

Please rely on the bar scale on each map sheet for map measurements.

Source of Map: Natural Resources Conservation Service  
 Web Soil Survey URL:  
 Coordinate System: Web Mercator (EPSG:3857)

Maps from the Web Soil Survey are based on the Web Mercator projection, which preserves direction and shape but distorts distance and area. A projection that preserves area, such as the Albers equal-area conic projection, should be used if more accurate calculations of distance or area are required.

This product is generated from the USDA-NRCS certified data as of the version date(s) listed below.

Soil Survey Area: El Paso County Area, Colorado  
 Survey Area Data: Version 19, Aug 31, 2021

Soil map units are labeled (as space allows) for map scales 1:50,000 or larger.

Date(s) aerial images were photographed: Aug 19, 2018—Sep 23, 2018

The orthophoto or other base map on which the soil lines were compiled and digitized probably differs from the background imagery displayed on these maps. As a result, some minor shifting of map unit boundaries may be evident.

## Hydrologic Soil Group

Map unit symbol	Map unit name	Rating	Acres in AOI	Percent of AOI
8	Blakeland loamy sand, 1 to 9 percent slopes	A	22.3	19.5%
19	Columbine gravelly sandy loam, 0 to 3 percent slopes	A	64.2	56.2%
71	Pring coarse sandy loam, 3 to 8 percent slopes	B	12.1	10.6%
85	Stapleton-Bernal sandy loams, 3 to 20 percent slopes	B	15.6	13.6%
<b>Totals for Area of Interest</b>			<b>114.1</b>	<b>100.0%</b>

## Description

Hydrologic soil groups are based on estimates of runoff potential. Soils are assigned to one of four groups according to the rate of water infiltration when the soils are not protected by vegetation, are thoroughly wet, and receive precipitation from long-duration storms.

The soils in the United States are assigned to four groups (A, B, C, and D) and three dual classes (A/D, B/D, and C/D). The groups are defined as follows:

Group A. Soils having a high infiltration rate (low runoff potential) when thoroughly wet. These consist mainly of deep, well drained to excessively drained sands or gravelly sands. These soils have a high rate of water transmission.

Group B. Soils having a moderate infiltration rate when thoroughly wet. These consist chiefly of moderately deep or deep, moderately well drained or well drained soils that have moderately fine texture to moderately coarse texture. These soils have a moderate rate of water transmission.

Group C. Soils having a slow infiltration rate when thoroughly wet. These consist chiefly of soils having a layer that impedes the downward movement of water or soils of moderately fine texture or fine texture. These soils have a slow rate of water transmission.

Group D. Soils having a very slow infiltration rate (high runoff potential) when thoroughly wet. These consist chiefly of clays that have a high shrink-swell potential, soils that have a high water table, soils that have a claypan or clay layer at or near the surface, and soils that are shallow over nearly impervious material. These soils have a very slow rate of water transmission.

If a soil is assigned to a dual hydrologic group (A/D, B/D, or C/D), the first letter is for drained areas and the second is for undrained areas. Only the soils that in their natural condition are in group D are assigned to dual classes.

## Rating Options

*Aggregation Method:* Dominant Condition

*Component Percent Cutoff:* None Specified

*Tie-break Rule:* Higher



**NOTES TO USERS**

This map is for use in administering the National Flood Insurance Program. It does not necessarily identify all areas subject to flooding, particularly from local drainage sources of small size. The community map repository should be consulted for possible updated or additional flood hazard information.

To obtain more detailed information in areas where **Base Flood Elevations (BFEs)** and/or **floodways** have been determined, users are encouraged to consult the Flood Profiles and Floodway Data and/or Summary of Stillwater Elevations tables contained within the Flood Insurance Study (FIS) report that accompanies this FIRM. Users should be aware that BFEs shown on the FIRM represent rounded whole-foot elevations. These BFEs are intended for flood insurance rating purposes only and should not be used as the sole source of flood elevation information. Accordingly, flood elevation data presented in the FIS report should be utilized in conjunction with the FIRM for purposes of construction and/or floodplain management.

**Coastal Base Flood Elevations** shown on this map apply only to landward of 0.0' North American Vertical Datum of 1988 (NAVD88). Users of this FIRM should be aware that coastal flood elevations are also provided in the Summary of Stillwater Elevations table in the Flood Insurance Study report for this jurisdiction. Elevations shown in the Summary of Stillwater Elevations table should be used for construction and/or floodplain management purposes when they are higher than the elevations shown on this FIRM.

Boundaries of the **floodways** were computed at cross sections and interpolated between cross sections. The floodways were based on hydraulic considerations with regard to requirements of the National Flood Insurance Program. Floodway widths and other pertinent floodway data are provided in the Flood Insurance Study report for this jurisdiction.

Certain areas not in Special Flood Hazard Areas may be protected by **flood control structures**. Refer to section 2.4 "Flood Protection Measures" of the Flood Insurance Study report for information on flood control structures for this jurisdiction.

The **projection** used in the preparation of this map was Universal Transverse Mercator (UTM) zone 13. The **horizontal datum** was NAD83, GRS80 spheroid. Differences in datum, spheroid, projection or UTM zones used in the production of FIRMs for adjacent jurisdictions may result in slight positional differences in map features across jurisdiction boundaries. These differences do not affect the accuracy of this FIRM.

Flood elevations on this map are referenced to the **North American Vertical Datum of 1988 (NAVD88)**. These flood elevations must be compared to structure and ground elevations referenced to the same vertical datum. For information regarding conversion between the National Geodetic Vertical Datum of 1929 and the North American Vertical Datum of 1988, visit the National Geodetic Survey website at <http://www.ngs.noaa.gov/> or contact the National Geodetic Survey at the following address:

NGS Information Services  
NOAA, NINGS12  
National Geodetic Survey  
SSMC-3, #9202  
1315 East-West Highway  
Silver Spring, MD 20910-3282

To obtain current elevation, description, and/or location information for **bench marks** shown on this map, please contact the Information Services Branch of the National Geodetic Survey at (301) 713-3242 or visit its website at <http://www.ngs.noaa.gov/>.

**Base Map** information shown on this FIRM was provided in digital format by El Paso County, Colorado Springs Utilities, and Anderson Consulting Engineers, Inc. These data are current as of 2008.

This map reflects more detailed and up-to-date stream channel configurations and floodplain delineations than those shown on the previous FIRM for this jurisdiction. The floodplains and floodways that were transferred from the previous FIRM may have been adjusted to conform to these new stream channel configurations. As a result, the Flood Profiles and Floodway Data tables in the Flood Insurance Study Report (which contains authoritative hydraulic data) may reflect stream channel distances that differ from what is shown on this map. The profile baselines depicted on this map represent the hydraulic modeling baselines that match the flood profiles and Floodway Data Tables if applicable, in the FIS report. As a result, the profile baselines may deviate significantly from the new base map channel representation and may appear outside of the floodplain.

**Corporate limits** shown on this map are based on the best data available at the time of publication. Because changes due to annexations or de-annexations may have occurred after this map was published, map users should contact appropriate community officials to verify current corporate limit locations.

Please refer to the separately printed **Map Index** for an overview map of the county showing the layout of map panels, community map repository addresses, and a Listing of Communities table containing National Flood Insurance Program dates for each community as well as a listing of the panels on which each community is located.

Contact **FEMA Map Service Center (MSC)** via the FEMA Map Information eXchange (FMIX) 1-877-336-2627 for information on available products associated with this FIRM. Available products may include previously issued Letters of Map Change, a Flood Insurance Study Report, and/or digital versions of this map. The MSC may also be reached by Fax at 1-800-358-9620 and its website at <http://www.msc.fema.gov/>.

If you have **questions about this map** or questions concerning the National Flood Insurance Program in general, please call 1-877-FEMA MAP (1-877-336-2627) or visit the FEMA website at <http://www.fema.gov/business/nfp>.

**El Paso County Vertical Datum Offset Table**

Flooding Source	Vertical Datum Offset (ft)
REFER TO SECTION 3.3 OF THE EL PASO COUNTY FLOOD INSURANCE STUDY FOR STREAM BY STREAM VERTICAL DATUM CONVERSION INFORMATION	

**Panel Location Map**

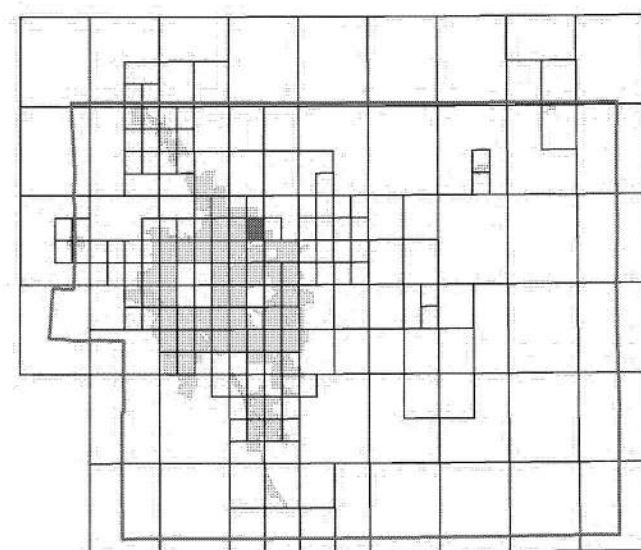

This Digital Flood Insurance Rate Map (DFIRM) was produced through a Cooperating Technical Partner (CTP) agreement between the State of Colorado Water Conservation Board (CWCB) and the Federal Emergency Management Agency (FEMA).



Additional Flood Hazard information and resources are available from local communities and the Colorado Water Conservation Board.

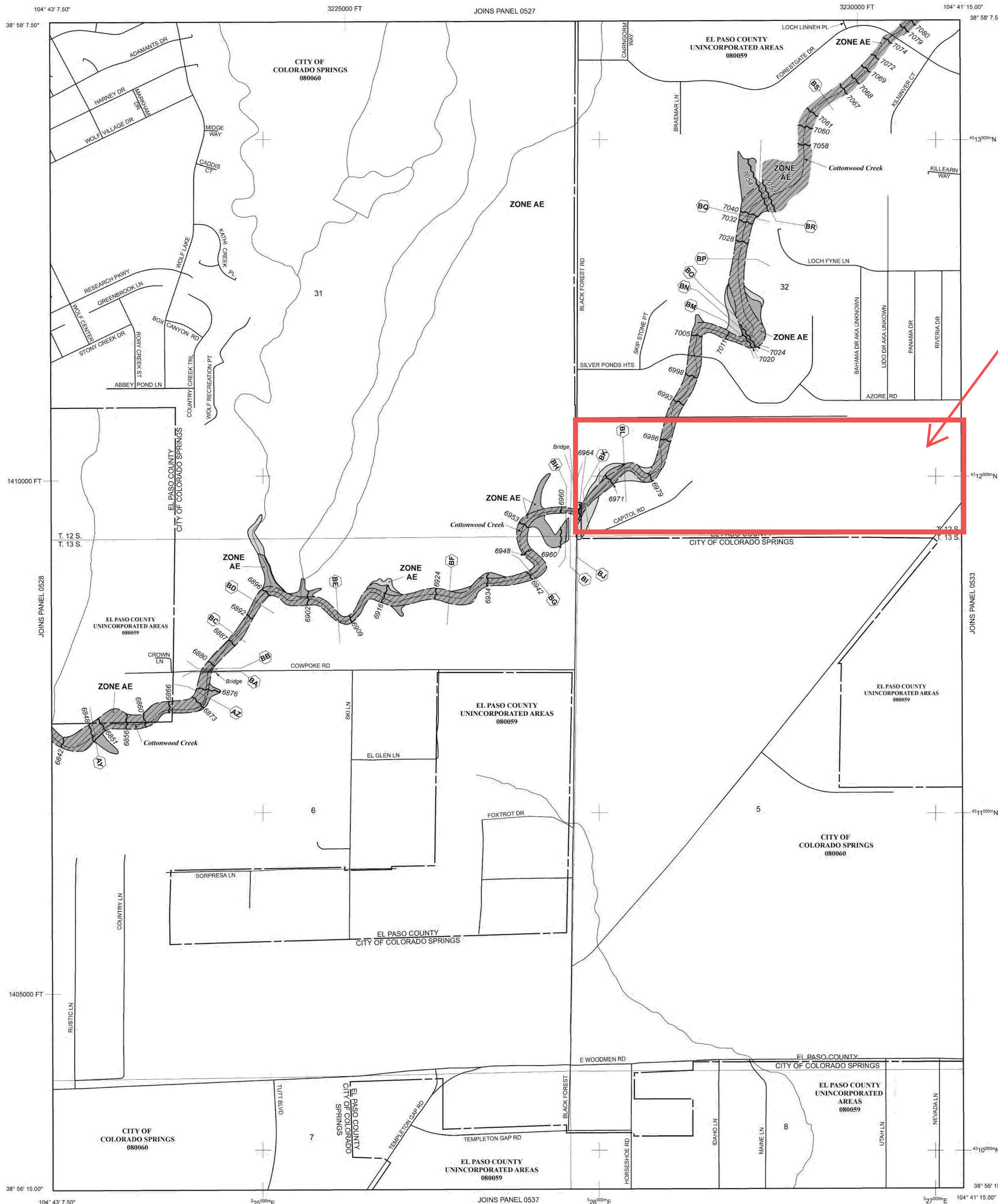

NOTE: MAP AREA SHOWN ON THIS PANEL IS LOCATED WITHIN TOWNSHIP 12 SOUTH, RANGE 65 WEST, AND TOWNSHIP 13 SOUTH, RANGE 65 WEST.

**LEGEND**

- SPECIAL FLOOD HAZARD AREAS (SFHAs) SUBJECT TO INUNDATION BY THE 1% ANNUAL CHANCE FLOOD
- The 1% annual chance flood (100-year flood), also known as the base flood, is the flood that has a 1% chance of being equaled or exceeded in any given year. The Special Flood Hazard Area is the area subject to flooding by the 1% annual chance flood. Areas of Special Flood Hazard include Zones A, AE, AH, AO, AR, A99, V, and VE. The Base Flood Elevation is the water-surface elevation of the 1% annual chance flood.
- ZONE A** No Base Flood Elevations determined.
- ZONE AE** Base Flood Elevations determined.
- ZONE AH** Flood depths of 1 to 3 feet (usually areas of ponding); Base Flood Elevations determined.
- ZONE AO** Flood depths of 1 to 3 feet (usually sheet flow on sloping terrain); average depths determined. For areas of alluvial fan flooding, velocities also determined.
- ZONE AR** Special Flood Hazard Area Formerly protected from the 1% annual chance flood by a flood control system that was subsequently derelictified. Zone AR indicates that the former flood control system is being restored to provide protection from the 1% annual chance or greater flood.
- ZONE A99** Area to be protected from 1% annual chance flood by a Federal flood protection system under construction; no Base Flood Elevations determined.
- ZONE V** Coastal flood zone with velocity hazard (wave action); no Base Flood Elevations determined.
- ZONE VE** Coastal flood zone with velocity hazard (wave action); Base Flood Elevations determined.
- FLOODWAY AREAS IN ZONE AE
- The floodway is the channel of a stream plus any adjacent floodplain areas that must be kept free of encroachment so that the 1% annual chance flood can be carried without substantial increases in flood heights.
- OTHER FLOOD AREAS
- ZONE X** Areas of 0.2% annual chance flood; areas of 1% annual chance flood with average depths of less than 1 foot or with drainage areas less than 1 square mile; and areas protected by levees from 1% annual chance flood.
- OTHER AREAS
- ZONE D** Areas determined to be outside the 0.2% annual chance floodplain.
- ZONE D** Areas in which flood hazards are undetermined, but possible.
- COASTAL BARRIER RESOURCES SYSTEM (CBRS) AREAS
- OTHERWISE PROTECTED AREAS (OPAs)
- CBRS areas and OPAs are normally located within or adjacent to Special Flood Hazard Areas.
- Floodplain boundary
- Floodway boundary
- Zone D boundary
- CBRS and OPA boundary
- Boundary dividing Special Flood Hazard Areas of different Base Flood Elevations, flood depths or flood velocities.
- Base Flood Elevation line and value, elevation in feet\* (EL 987)
- Base Flood Elevation value where uniform within zone; elevation in feet
- \* Referenced to the North American Vertical Datum of 1988 (NAVD 88)
- Cross section line
- Transect line
- Geographic coordinates referenced to the North American Datum of 1983 (NAD 83)
- 1000-meter Universal Transverse Mercator grid ticks, zone 13
- 5000-foot grid ticks: Colorado State Plane coordinate system, central zone (FIPSZONE 0502), Lambert Conformal Conic Projection
- Bench mark (see explanation in Notes to Users section of this FIRM panel)
- River Mile
- MAP REPOSITORIES
- Refer to Map Repositories list on Map Index
- EFFECTIVE DATE OF COUNTYWIDE FLOOD INSURANCE RATE MAP  
**MARCH 17, 1997**
- EFFECTIVE DATE(S) OF REVISION(S) TO THIS PANEL  
**DECEMBER 7, 2018** - to update corporate limits, to change Base Flood Elevations and Special Flood Hazard Areas, to update map format, to add roads and road names, and to incorporate previously issued Letters of Map Revision.
- For community map revision prior to countywide mapping, refer to the Community Map History Tables located in the Flood Insurance Study report for this jurisdiction.
- To determine if flood insurance is available in this community, contact your insurance agent or call the National Flood Insurance Program at 1-800-638-6620.

**NATIONAL FLOOD INSURANCE PROGRAM**

**PANEL 0529G**

**FIRM**  
FLOOD INSURANCE RATE MAP  
**EL PASO COUNTY, COLORADO AND INCORPORATED AREAS**

**PANEL 529 OF 1300**  
(SEE MAP INDEX FOR FIRM PANEL LAYOUT)

CONTAINS:

COMMUNITY	NUMBER	PANEL	SUFFIX
COLORADO SPRINGS, CITY OF	08006	0529	G
EL PASO COUNTY	08029	0529	G

Notice to User: The Map Number shown below should be used when placing map orders. The Community Number shown above should be used on insurance applications for the subject community.

**MAP NUMBER 08041C0529G**

**MAP REVISED DECEMBER 7, 2018**

Federal Emergency Management Agency





## **APPENDIX B – GEOTECH REPORT**

**\*\*TO BE PROVIDED WITH SUBSEQUENT SUBMITTAL\*\***



## **APPENDIX C – GEC PLANS**



# SCHMIDT PHASE 1 - DISTRICT INFRASTRUCTURE

## EL PASO COUNTY, CO

### GRADING AND EROSION CONTROL PLANS

#### GRADING AND EROSION CONTROL STANDARD NOTES

- STORMWATER DISCHARGES FROM CONSTRUCTION SITES SHALL NOT CAUSE OR THREATEN TO CAUSE POLLUTION, CONTAMINATION, OR DEGRADATION OF STATE WATERS. ALL WORK AND EARTH DISTURBANCE SHALL BE DONE IN A MANNER THAT MINIMIZES POLLUTION OF ANY ON-SITE OR OFF-SITE WATERS, INCLUDING WETLANDS.
- NOTWITHSTANDING ANYTHING DEPICTED IN THESE PLANS IN WORDS OR GRAPHIC REPRESENTATION, ALL DESIGN AND CONSTRUCTION RELATED TO ROADS, STORM DRAINAGE AND EROSION CONTROL SHALL CONFORM TO THE STANDARDS AND REQUIREMENTS OF THE MOST RECENT VERSION OF THE RELEVANT ADOPTED EL PASO COUNTY STANDARDS, INCLUDING THE LAND DEVELOPMENT CODE, THE ENGINEERING CRITERIA MANUAL, THE DRAINAGE CRITERIA MANUAL, AND THE DRAINAGE CRITERIA MANUAL VOLUME 2. ANY DEVIATIONS FROM REGULATIONS AND STANDARDS MUST BE REQUESTED, AND APPROVED, IN WRITING.
- A SEPARATE STORMWATER MANAGEMENT PLAN (SMWP) FOR THIS PROJECT SHALL BE COMPLETED AND AN EROSION AND STORMWATER QUALITY CONTROL PERMIT (ESQCP) ISSUED PRIOR TO COMMENCING CONSTRUCTION. MANAGEMENT OF THE SWMP DURING CONSTRUCTION IS THE RESPONSIBILITY OF THE DESIGNATED QUALIFIED STORMWATER MANAGER OR CERTIFIED EROSION CONTROL INSPECTOR. THE SWMP SHALL BE LOCATED ON SITE AT ALL TIMES DURING CONSTRUCTION AND SHALL BE KEPT UP TO DATE WITH WORK PROGRESS AND CHANGES IN THE FIELD.
- ONCE THE ESQCP IS APPROVED AND A "NOTICE TO PROCEED" HAS BEEN ISSUED, THE CONTRACTOR MAY INSTALL THE INITIAL STAGE EROSION AND SEDIMENT CONTROL MEASURES AS INDICATED ON THE APPROVED GEC. A PRECONSTRUCTION MEETING BETWEEN THE CONTRACTOR, ENGINEER, AND EL PASO COUNTY WILL BE HELD PRIOR TO ANY CONSTRUCTION. IT IS THE RESPONSIBILITY OF THE APPLICANT TO COORDINATE THE MEETING TIME AND PLACE WITH COUNTY STAFF.
- CONTROL MEASURES MUST BE INSTALLED PRIOR TO COMMENCEMENT OF ACTIVITIES THAT COULD CONTRIBUTE POLLUTANTS TO STORMWATER. CONTROL MEASURES FOR ALL SLOPES, CHANNELS, DITCHES, AND DISTURBED LAND AREAS SHALL BE INSTALLED IMMEDIATELY UPON COMPLETION OF THE DISTURBANCE.
- ALL TEMPORARY SEDIMENT AND EROSION CONTROL MEASURES SHALL BE MAINTAINED AND REMAIN IN EFFECTIVE OPERATING CONDITION UNTIL PERMANENT SOIL EROSION CONTROL MEASURES ARE IMPLEMENTED AND FINAL STABILIZATION IS ESTABLISHED. ALL PERSONS ENGAGED IN LAND DISTURBANCE ACTIVITIES SHALL ASSESS THE ADEQUACY OF CONTROL MEASURES AT THE SITE AND IDENTIFY IF CHANGES TO THOSE CONTROL MEASURES ARE NEEDED TO ENSURE THE CONTINUED EFFECTIVE PERFORMANCE OF THE CONTROL MEASURES. ALL CHANGES TO TEMPORARY SEDIMENT AND EROSION CONTROL MEASURES MUST BE INCORPORATED INTO THE STORMWATER MANAGEMENT PLAN.
- TEMPORARY STABILIZATION SHALL BE IMPLEMENTED ON DISTURBED AREAS AND STOCKPILES WHERE GROUND DISTURBING CONSTRUCTION ACTIVITY HAS PERMANENTLY CEASED OR TEMPORARILY CEASED FOR LONGER THAN 14 DAYS.
- FINAL STABILIZATION MUST BE IMPLEMENTED AT ALL APPLICABLE CONSTRUCTION SITES. FINAL STABILIZATION IS ACHIEVED WHEN ALL GROUND DISTURBING ACTIVITIES ARE COMPLETE AND ALL DISTURBED AREAS EITHER HAVE A UNIFORM VEGETATIVE COVER WITH INDIVIDUAL PLANT DENSITY OF 70 PERCENT OF PRE-DISTURBANCE LEVELS ESTABLISHED OR EQUIVALENT PERMANENT ALTERNATIVE STABILIZATION METHOD IS IMPLEMENTED. ALL TEMPORARY SEDIMENT AND EROSION CONTROL MEASURES SHALL BE REMOVED UPON FINAL STABILIZATION AND BEFORE PERMIT CLOSURE.
- ALL PERMANENT STORMWATER MANAGEMENT FACILITIES SHALL BE INSTALLED AS DESIGNED IN THE APPROVED PLANS. ANY PROPOSED CHANGES THAT AFFECT THE DESIGN OR FUNCTION OF PERMANENT STORMWATER MANAGEMENT STRUCTURES MUST BE APPROVED BY THE ECM ADMINISTRATOR PRIOR TO IMPLEMENTATION.
- EARTH DISTURBANCES SHALL BE CONDUCTED IN SUCH A MANNER SO AS TO EFFECTIVELY MINIMIZE ACCELERATED SOIL EROSION AND RESULTING SEDIMENTATION. ALL DISTURBANCES SHALL BE DESIGNED, CONSTRUCTED, AND COMPLETED SO THAT THE EXPOSED AREA OF ANY DISTURBED LAND SHALL BE LIMITED TO THE SHORTEST PRACTICAL PERIOD OF TIME. PRE-EXISTING VEGETATION SHALL BE PROTECTED AND MAINTAINED WITHIN 50 HORIZONTAL FEET OF A WATERS OF THE STATE UNLESS SHOWN TO BE INFEASIBLE AND SPECIFICALLY REQUESTED AND APPROVED.
- COMPACTION OF SOIL MUST BE PREVENTED IN AREAS DESIGNATED FOR INFILTRATION CONTROL MEASURES OR WHERE FINAL STABILIZATION WILL BE ACHIEVED BY VEGETATIVE COVER. AREAS DESIGNATED FOR INFILTRATION CONTROL MEASURES SHALL ALSO BE PROTECTED FROM SEDIMENTATION DURING CONSTRUCTION UNTIL FINAL STABILIZATION IS ACHIEVED. IF COMPACTION PREVENTION IS NOT FEASIBLE DUE TO SITE CONSTRAINTS, ALL AREAS DESIGNATED FOR INFILTRATION AND VEGETATION CONTROL MEASURES MUST BE LOOSENED PRIOR TO INSTALLATION OF THE CONTROL MEASURE(S).
- ANY TEMPORARY OR PERMANENT FACILITY DESIGNED AND CONSTRUCTED FOR THE CONVEYANCE OF STORMWATER AROUND, THROUGH, OR FROM THE EARTH DISTURBANCE AREA SHALL BE A STABILIZED CONVEYANCE DESIGNED TO MINIMIZE EROSION AND THE DISCHARGE OF SEDIMENT OFF SITE.
- CONCRETE WASH WATER SHALL BE CONTAINED AND DISPOSED OF IN ACCORDANCE WITH THE SWMP. NO WASH WATER SHALL BE DISCHARGED TO OR ALLOWED TO ENTER STATE WATERS, INCLUDING ANY SURFACE OR SUBSURFACE STORM DRAINAGE SYSTEM OR FACILITIES. CONCRETE WASHOUTS SHALL NOT BE LOCATED IN AN AREA WHERE SHALLOW GROUNDWATER MAY BE PRESENT, OR WITHIN 50 FEET OF A SURFACE WATER BODY, CREEK OR STREAM.
- DURING DEWATERING OPERATIONS OF UNCONTAMINATED GROUND WATER MAY BE DISCHARGED ON SITE, BUT SHALL NOT LEAVE THE SITE IN THE FORM OF SURFACE RUNOFF UNLESS AN APPROVED STATE DEWATERING PERMIT IS IN PLACE.
- EROSION CONTROL BLANKETING OR OTHER PROTECTIVE COVERING SHALL BE USED ON SLOPES STEEPER THAN 3:1.
- CONTRACTOR SHALL BE RESPONSIBLE FOR THE REMOVAL OF ALL WASTES FROM THE CONSTRUCTION SITE FOR DISPOSAL IN ACCORDANCE WITH LOCAL AND STATE REGULATORY REQUIREMENTS. NO CONSTRUCTION DEBRIS, TREE SLASH, BUILDING MATERIAL WASTES OR UNUSED BUILDING MATERIALS SHALL BE BURIED, DUMPED, OR DISCHARGED AT THE SITE.
- WASTE MATERIALS SHALL NOT BE TEMPORARILY PLACED OR STORED IN THE STREET, ALLEY, OR OTHER PUBLIC WAY, UNLESS IN ACCORDANCE WITH AN APPROVED TRAFFIC CONTROL PLAN. CONTROL MEASURES MAY BE REQUIRED BY EL PASO COUNTY ENGINEERING IF DEEMED NECESSARY, BASED ON SPECIFIC CONDITIONS AND CIRCUMSTANCES.
- TRACKING OF SOILS AND CONSTRUCTION DEBRIS OFF-SITE SHALL BE MINIMIZED. MATERIALS TRACKED OFF-SITE SHALL BE CLEANED UP AND PROPERLY DISPOSED OF IMMEDIATELY.
- THE OWNER/DEVELOPER SHALL BE RESPONSIBLE FOR THE REMOVAL OF ALL CONSTRUCTION DEBRIS, DIRT, TRASH, ROCK, SEDIMENT, SOIL, AND SAND THAT MAY ACCUMULATE IN ROADS, STORM DRAINS AND OTHER DRAINAGE CONVEYANCE SYSTEMS AND STORMWATER APPURTENANCES AS A RESULT OF SITE DEVELOPMENT.
- THE QUANTITY OF MATERIALS STORED ON THE PROJECT SITE SHALL BE LIMITED, AS MUCH AS PRACTICAL, TO THAT QUANTITY REQUIRED TO PERFORM THE WORK IN AN ORDERLY SEQUENCE. ALL MATERIALS STORED ON-SITE SHALL BE STORED IN A NEAT, ORDERLY MANNER, IN THEIR ORIGINAL CONTAINERS, WITH ORIGINAL MANUFACTURER'S LABELS.
- NO CHEMICAL(S) HAVING THE POTENTIAL TO BE RELEASED IN STORMWATER ARE TO BE STORED OR USED ONSITE UNLESS PERMISSION FOR THE USE OF SUCH CHEMICAL(S) IS GRANTED IN WRITING BY THE ECM ADMINISTRATOR. IN GRANTING APPROVAL FOR THE USE OF SUCH CHEMICAL(S), SPECIAL CONDITIONS AND MONITORING MAY BE REQUIRED.
- BULK STORAGE OF ALLOWED PETROLEUM PRODUCTS OR OTHER ALLOWED LIQUID CHEMICALS IN EXCESS OF 55 GALLONS SHALL REQUIRE ADEQUATE SECONDARY CONTAINMENT PROTECTION TO CONTAIN ALL SPILLS ONSITE AND TO PREVENT ANY SPILLED MATERIALS FROM ENTERING STATE WATERS, ANY SURFACE OR SUBSURFACE STORM DRAINAGE SYSTEM OR OTHER FACILITIES.
- NO PERSON SHALL CAUSE THE IMPEDIMENT OF STORMWATER FLOW IN THE CURB AND GUTTER OR DITCH EXCEPT WITH APPROVED SEDIMENT CONTROL MEASURES.
- OWNER/DEVELOPER AND THEIR AGENTS SHALL COMPLY WITH THE "COLORADO WATER QUALITY CONTROL ACT" (TITLE 25, ARTICLE 8, CRS), AND THE "CLEAN WATER ACT" (33 USC 1344), IN ADDITION TO THE REQUIREMENTS OF THE LAND DEVELOPMENT CODE, DCM VOLUME II AND THE ECM APPENDIX I. ALL APPROPRIATE PERMITS MUST BE OBTAINED BY THE CONTRACTOR PRIOR TO CONSTRUCTION (1041, NPDES, FLOODPLAIN, 404, FUGITIVE DUST, ETC.). IN THE EVENT OF CONFLICTS BETWEEN THESE REQUIREMENTS AND OTHER LAWS, RULES, OR REGULATIONS OF OTHER FEDERAL, STATE, LOCAL, OR COUNTY AGENCIES, THE MOST RESTRICTIVE LAWS, RULES, OR REGULATIONS SHALL APPLY.
- ALL CONSTRUCTION TRAFFIC MUST ENTER/EXIT THE SITE ONLY AT APPROVED CONSTRUCTION ACCESS POINTS.
- PRIOR TO CONSTRUCTION THE PERMITTEE SHALL VERIFY THE LOCATION OF EXISTING UTILITIES.
- A WATER SOURCE SHALL BE AVAILABLE ON SITE DURING EARTHWORK OPERATIONS AND SHALL BE UTILIZED AS REQUIRED TO MINIMIZE DUST FROM EARTHWORK EQUIPMENT AND WIND.
- THE SOILS REPORT FOR THIS SITE HAS BEEN PREPARED BY ENTECH ENGINEERING INC. ON MAY 25, 2022 AND SHALL BE CONSIDERED A PART OF THESE PLANS.
- AT LEAST TEN (10) DAYS PRIOR TO THE ANTICIPATED START OF CONSTRUCTION, FOR PROJECTS THAT WILL DISTURB ONE (1) ACRE OR MORE, THE OWNER OR OPERATOR OF CONSTRUCTION ACTIVITY SHALL SUBMIT A PERMIT APPLICATION FOR STORMWATER DISCHARGE TO THE COLORADO DEPARTMENT OF PUBLIC HEALTH AND ENVIRONMENT, WATER QUALITY DIVISION. THE APPLICATION CONTAINS CERTIFICATION OF COMPLETION OF A STORMWATER MANAGEMENT PLAN (SMWP), OF WHICH THIS GRADING AND EROSION CONTROL PLAN MAY BE A PART. FOR INFORMATION OR APPLICATION MATERIALS CONTACT:

COLORADO DEPARTMENT OF PUBLIC HEALTH AND ENVIRONMENT  
WATER QUALITY CONTROL DIVISION  
WOOD - PERMITS  
4300 CHERRY CREEK DRIVE SOUTH  
DENVER, CO 80246-1530  
ATTN: PERMITS UNIT



Know what's below.  
Call before you dig.

#### DISTRICT APPROVALS

THESE DOCUMENTS HAVE BEEN REVIEWED AND APPROVED FOR STORM DRAIN AND ASSOCIATED UTILITY SERVICE CONSTRUCTION.

FOR AND ON BEHALF OF THE STERLING RANCH METRO DISTRICT DATE



VICINITY MAP  
SCALE: 1"=1000'

#### AGENCIES

OWNER/DEVELOPER:	TURKEY CANON QUARRY, LLC 20 BOULDER CRESCENT, SUITE 201 COLORADO SPRINGS, CO 80903 JAMES F. MORLEY (719) 471-1742	WATER RESOURCES:	STERLING RANCH METRO DISTRICT ENGINEERS JDS-HYDRO CONSULTANTS 545 E. PIKES PEAK AVE., SUITE 300 COLORADO SPRINGS, CO 80903 JOHN MCGINN (719) 668-8769
CIVIL ENGINEER:	ALL TERRAIN ENGINEERING LLC 1004 WEST VAN BUREN STREET COLORADO SPRINGS, CO 80907 RYAN BURNS P.E.	FIRE DISTRICT:	BLACK FOREST FIRE PROTECTION DISTRICT 11445 TEACHOUT ROAD COLORADO SPRINGS, CO 80908 CHIEF BRYAN JACK (719) 495-4300
COUNTY ENGINEERING:	EL PASO COUNTY PLANNING AND COMMUNITY DEVELOPMENT 2880 INTERNATIONAL CIRCLE, SUITE 110 COLORADO SPRINGS, CO 80910 JEFF RICE, P.E. (719) 520-6300	GAS DEPARTMENT:	COLORADO SPRINGS UTILITIES 7710 DURANT DR. COLORADO SPRINGS, CO 80947 TIM WENDT (719) 668-3556
TRAFFIC ENGINEERING:	EL PASO COUNTY DEPARTMENT OF PUBLIC WORKS 3275 AKERS DRIVE COLORADO SPRINGS, CO 80922 JENNIFER IRVINE, P.E. (719) 520-6460	ELECTRIC DEPARTMENT:	MOUNTAIN VIEW ELECTRIC 11140 E. WOODMEN ROAD FALCON, CO 80831 (719) 495-2283

#### BASIS OF BEARINGS

THE NORTH LINE OF THE NORTHWEST QUARTER OF THE NORTHEAST QUARTER OF SECTION 5, TOWNSHIP 13 SOUTH, RANGE 65 WEST OF THE 6TH PRINCIPAL MERIDIAN, BEING MONUMENTED AT THE NORTHEAST CORNER OF THE NORTHWEST QUARTER OF THE NORTHEAST QUARTER OF SECTION 5, BY A 3-1/4" ALUMINUM CAP STAMPED "LS 10376" AND AT THE NORTH QUARTER CORNER BY A 3-1/4" ALUMINUM CAP STAMPED "LS 4842 1996", BEARING S89°14'13"W.

#### SHEET INDEX

1	- COVER SHEET
2	- LEGEND
3-5	- INITIAL-INTERIM GEC
6-8	- FINAL GEC
9	- OUTFALL CHANNEL PLAN & PROFILE
10-11	- GEC DETAILS

#### BENCHMARKS

- THE TOP OF AN ALUMINUM SURVEYORS CAP, STAMPED "9853", AT THE SOUTHEAST BOUNDARY CORNER OF BARBARICK SUBDIVISION  
NORTHING = 41145.273  
EASTING = 235167.071  
ELEVATION = 7023.42
- THE TOP OF A RED PLASTIC SURVEYORS CAP, ILLEGIBLE, AT THE NORTHWEST BOUNDARY CORNER OF PANWEE RANCHEROS SUBDIVISION  
NORTHING = 410095.404  
EASTING = 235052.131  
ELEVATION = 7000.40
- THE TOP OF A RED PLASTIC SURVEYORS CAP, STAMPED "38141", AT THE SOUTHWEST BOUNDARY CORNER OF BARBARICK SUBDIVISION  
NORTHING = 411399.962  
EASTING = 233849.817  
ELEVATION = 7030.82

#### STANDARD NOTES FOR EL PASO COUNTY CONSTRUCTION PLANS:

- ALL DRAINAGE AND ROADWAY CONSTRUCTION SHALL MEET THE STANDARDS AND SPECIFICATIONS OF THE CITY OF COLORADO SPRINGS/EL PASO COUNTY DRAINAGE CRITERIA MANUAL, VOLUMES 1 AND 2, AND THE EL PASO COUNTY ENGINEERING CRITERIA MANUAL.
- CONTRACTOR SHALL BE RESPONSIBLE FOR THE NOTIFICATION AND FIELD NOTIFICATION OF ALL EXISTING UTILITIES, WHETHER SHOWN ON THE PLANS OR NOT, BEFORE BEGINNING CONSTRUCTION. LOCATION OF EXISTING UTILITIES SHALL BE VERIFIED BY THE CONTRACTOR PRIOR TO CONSTRUCTION. CALL 811 TO CONTACT THE UTILITY NOTIFICATION CENTER OF COLORADO (UNCC).
- CONTRACTOR SHALL KEEP A COPY OF THESE APPROVED PLANS, THE GRADING AND EROSION CONTROL PLAN, THE STORMWATER MANAGEMENT PLAN (SMWP), THE SOILS AND GEOTECHNICAL REPORT, AND THE APPROPRIATE DESIGN AND CONSTRUCTION STANDARDS AND SPECIFICATIONS AT THE JOB SITE AT ALL TIMES, INCLUDING THE FOLLOWING:
  - EL PASO COUNTY ENGINEERING CRITERIA MANUAL (ECM)
  - CITY OF COLORADO SPRINGS/EL PASO COUNTY DRAINAGE CRITERIA MANUAL, VOLUMES 1 AND 2
  - COLORADO DEPARTMENT OF TRANSPORTATION (CDOT) STANDARD SPECIFICATIONS FOR ROAD AND BRIDGE CONSTRUCTION
  - CDOT M & S STANDARDS
- NOTWITHSTANDING ANYTHING DEPICTED IN THESE PLANS IN WORDS OR GRAPHIC REPRESENTATION, ALL DESIGN AND CONSTRUCTION RELATED TO ROADS, STORM DRAINAGE AND EROSION CONTROL SHALL CONFORM TO THE STANDARDS AND REQUIREMENTS OF THE MOST RECENT VERSION OF THE RELEVANT ADOPTED EL PASO COUNTY STANDARDS, INCLUDING THE LAND DEVELOPMENT CODE, THE ENGINEERING CRITERIA MANUAL, THE DRAINAGE CRITERIA MANUAL, AND THE DRAINAGE CRITERIA MANUAL VOLUME 2. ANY DEVIATIONS FROM REGULATIONS AND STANDARDS MUST BE REQUESTED, AND APPROVED, IN WRITING. ANY MODIFICATIONS NECESSARY TO MEET CRITERIA AFTER-THE-FACT WILL BE ENTIRELY THE DEVELOPER'S RESPONSIBILITY TO RECTIFY.
- IT IS THE DESIGN ENGINEER'S RESPONSIBILITY TO ACCURATELY SHOW EXISTING CONDITIONS, BOTH ONSITE AND OFFSITE, ON THE CONSTRUCTION PLANS. ANY MODIFICATIONS NECESSARY DUE TO CONFLICTS, OMISSIONS, OR CHANGED CONDITIONS WILL BE ENTIRELY THE DEVELOPER'S RESPONSIBILITY TO RECTIFY.
- CONTRACTOR SHALL SCHEDULE A PRE-CONSTRUCTION MEETING WITH EL PASO COUNTY PLANNING AND COMMUNITY DEVELOPMENT (PCD) - INSPECTIONS, PRIOR TO STARTING CONSTRUCTION.
- IT IS THE CONTRACTOR'S RESPONSIBILITY TO UNDERSTAND THE REQUIREMENTS OF ALL JURISDICTIONAL AGENCIES AND TO OBTAIN ALL REQUIRED PERMITS, INCLUDING BUT NOT LIMITED TO EL PASO COUNTY EROSION AND STORMWATER QUALITY CONTROL PERMIT (ESQCP), REGIONAL BUILDING FLOODPLAIN DEVELOPMENT PERMIT, U.S. ARMY CORPS OF ENGINEERS-ISSUED 401 AND/OR 404 PERMITS, AND COUNTY AND STATE FUGITIVE DUST PERMITS.
- CONTRACTOR SHALL NOT DEVIATE FROM THE PLANS WITHOUT FIRST OBTAINING WRITTEN APPROVAL FROM THE DESIGN ENGINEER AND PCD. CONTRACTOR SHALL NOTIFY THE DESIGN ENGINEER IMMEDIATELY UPON DISCOVERY OF ANY ERRORS OR INCONSISTENCIES.
- ALL STORM DRAIN PIPE SHALL BE CLASS III RCP UNLESS OTHERWISE NOTED AND APPROVED BY PCD.
- CONTRACTOR SHALL COORDINATE GEOTECHNICAL TESTING PER ECM STANDARDS. PAVEMENT DESIGN SHALL BE APPROVED BY EL PASO COUNTY PCD PRIOR TO PLACEMENT OF CURB AND GUTTER AND PAVEMENT.
- ALL CONSTRUCTION TRAFFIC MUST ENTER/EXIT THE SITE AT APPROVED CONSTRUCTION ACCESS POINTS.
- SIGHT VISIBILITY TRIANGLES AS IDENTIFIED IN THE PLANS SHALL BE PROVIDED AT ALL INTERSECTIONS. OBSTRUCTIONS GREATER THAN 18 INCHES ABOVE FLOWLINE ARE NOT ALLOWED WITHIN SIGHT TRIANGLES.
- SIGNING AND STRIPING SHALL COMPLY WITH EL PASO COUNTY PCD AND MUTCD CRITERIA. [IF APPLICABLE, ADDITIONAL SIGNING AND STRIPING NOTES WILL BE PROVIDED.]
- CONTRACTOR SHALL OBTAIN ANY PERMITS REQUIRED BY EL PASO COUNTY DPW, INCLUDING WORK WITHIN THE RIGHT-OF-WAY AND SPECIAL TRANSPORT PERMITS.
- THE LIMITS OF CONSTRUCTION SHALL REMAIN WITHIN THE PROPERTY LINE UNLESS OTHERWISE NOTED. THE OWNER/DEVELOPER SHALL OBTAIN WRITTEN PERMISSION AND EASEMENTS, WHERE REQUIRED, FROM ADJOINING PROPERTY OWNER(S) PRIOR TO ANY OFF-SITE DISTURBANCE, GRADING, OR CONSTRUCTION.

#### EL PASO COUNTY STATEMENT

COUNTY PLAN REVIEW IS PROVIDED ONLY FOR GENERAL CONFORMANCE WITH COUNTY DESIGN CRITERIA. THE COUNTY IS NOT RESPONSIBLE FOR THE ACCURACY AND ADEQUACY OF THE DESIGN, DIMENSIONS, AND/OR ELEVATIONS WHICH SHALL BE CONFIRMED AT THE JOB SITE. THE COUNTY THROUGH THE APPROVAL OF THIS DOCUMENT ASSUMES NO RESPONSIBILITY FOR COMPLETENESS AND/OR ACCURACY OF THIS DOCUMENT.

FILED IN ACCORDANCE WITH THE REQUIREMENTS OF THE EL PASO COUNTY LAND DEVELOPMENT CODE, DRAINAGE CRITERIA MANUAL, VOLUMES 1 AND 2, AND ENGINEERING CRITERIA MANUAL AS AMENDED.

IN ACCORDANCE WITH ECM SECTION 1.12, THESE CONSTRUCTION DOCUMENTS WILL BE VALID FOR CONSTRUCTION FOR A PERIOD OF 2 YEARS FROM THE DATE SIGNED BY THE EL PASO COUNTY ENGINEER. IF CONSTRUCTION HAS NOT STARTED WITHIN THOSE 2 YEARS, THE PLANS WILL NEED TO BE RESUBMITTED FOR APPROVAL, INCLUDING PAYMENT OF REVIEW FEES AT THE PLANNING AND COMMUNITY DEVELOPMENT DIRECTORS DISCRETION.

JOSHUA PALMER, P.E. DATE

COUNTY ENGINEER/ECM ADMINISTRATOR

#### OWNER/DEVELOPER STATEMENT

I, THE OWNER/DEVELOPER HAVE READ AND WILL COMPLY WITH THE REQUIREMENTS OF THE GRADING AND EROSION CONTROL PLAN.

ERIC HOWARD DATE

RHETORIC, LLC  
20 BOULDER CRESCENT, SUITE 200  
COLORADO SPRINGS, CO 80903

#### ENGINEER'S STATEMENT

THIS GRADING AND EROSION CONTROL PLAN WAS PREPARED UNDER MY DIRECTION AND SUPERVISION AND IS CORRECT TO THE BEST OF MY KNOWLEDGE AND BELIEF. SAID PLAN HAS BEEN PREPARED ACCORDING TO THE CRITERIA ESTABLISHED BY THE COUNTY FOR GRADING AND EROSION CONTROL PLANS. I ACCEPT RESPONSIBILITY FOR ANY LIABILITY CAUSED BY ANY NEGLIGENT ACTS, ERRORS OR OMISSIONS ON MY PART IN PREPARING THESE PLANS.

RYAN E. BURNS, P.E.  
COLORADO P.E. 54412  
FOR AND ON BEHALF OF ALL TERRAIN ENGINEERING, LLC

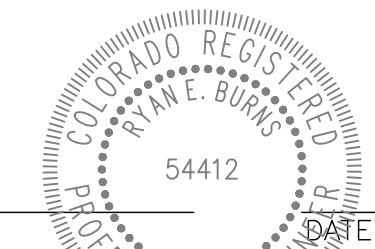

PREPARED FOR:

TURKEY CANON QUARRY INC.  
20 BOULDER CRESCENT STREET, SUITE 201  
COLORADO SPRINGS, CO 80903  
ATTN: JIM MORLEY  
(719) 491-3024  
###

UNTIL SUCH TIME AS THESE DRAWINGS ARE APPROVED BY THE APPROPRIATE REVIEWING AGENCIES, ALL TERRAIN ENGINEERING APPROVES THEIR USE ONLY FOR THE PURPOSES DESIGNATED BY WRITTEN AUTHORIZATION.

DATE	LOCATION: ###	JOB NO: 24013	REV DESCRIPTION

SCHMIDT PHASE 1 - DISTRICT INFRASTRUCTURE

COVER SHEET

DESIGN: REB

REVIEW: NOJ

DATE: 08/10/2024

H-SCALE: 1" = 50'

V-SCALE: 1" = 5'

SHEET

1 OF 12

RYAN E. BURNS, P.E.  
 54412  
 COLORADO P.E. REGISTRATION NO. 54412  
 ALL TERRAIN ENGINEERING, LLC









SEE SHEET 3

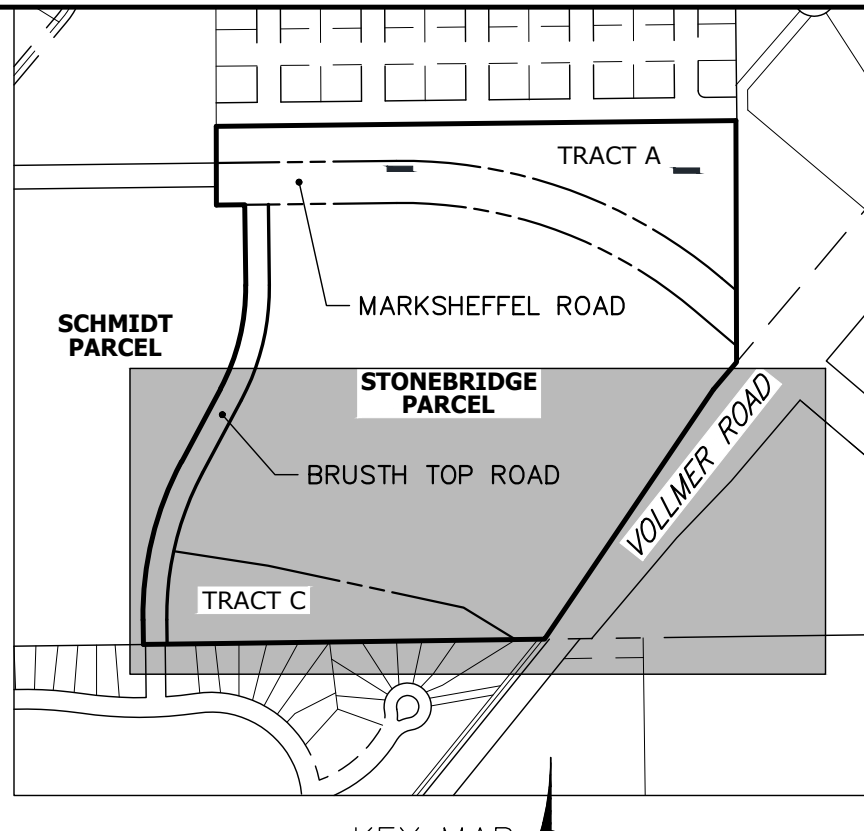
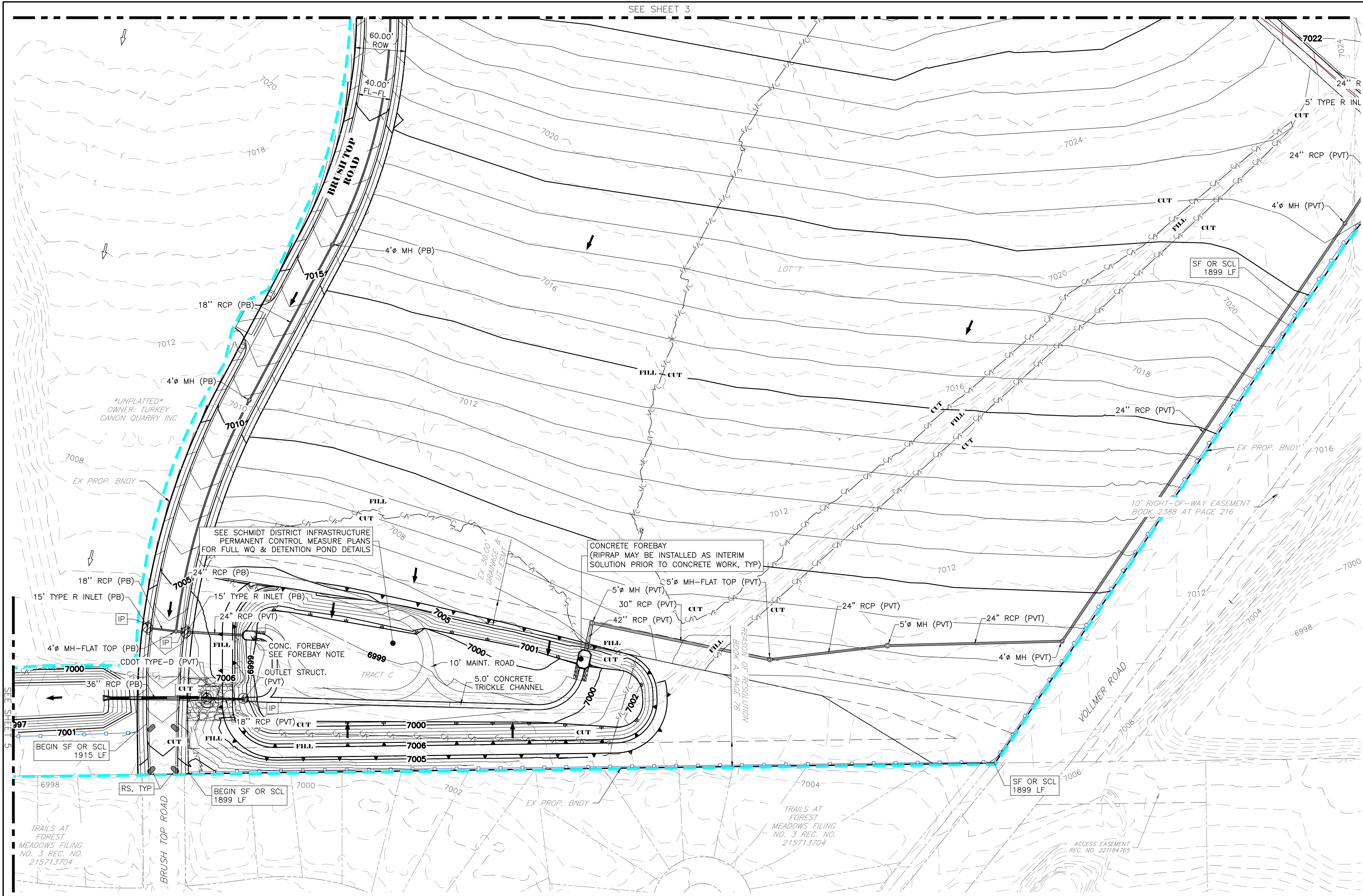

- GEC LEGEND:**
- CULVERT PROTECTION
  - CONCRETE WASHOUT AREA
  - INLET PROTECTION
  - EX FLOW DIRECTION  
PR FLOW DIRECTION
  - SEDIMENT CONTROL LOG
  - DIVERSION DITCH
  - SILT FENCE
  - LIMITS OF DISTURBANCE
  - STABILIZED STAGING AREA
  - STOCKPILE PROTECTION
  - VEHICLE TRACKING CONTROL
  - SEEDING & MULCHING
  - EROSION CONTROL BLANKET
  - DO NOT DISTURB



PREPARED FOR:  
TURKEY CANYON QUARRY INC.  
100  
OLD CREST STREET, SUITE 100  
COLORADO SPRINGS, CO 80903  
ATTN: JIM MORLEY  
(719) 491-3024  
#####

UNTIL SUCH TIME AS THESE  
DRAWINGS ARE APPROVED BY THE  
APPROPRIATE REVIEWING 20  
AGENCIES, ALL TERRAIN  
ENGINEERING APPROVES THEIR  
USE ONLY FOR THE PURPOSES  
DESIGNATED BY WRITTEN  
AUTHORIZATION.

DATE	REV DESCRIPTION

JOB NO: 24013 LOCATION: COS  
SCHMIDT PHASE 1 - DISTRICT INFRASTRUCTURE  
INITIAL-INTERIM GEC (2)



THE LOCATIONS OF EXISTING ABOVE GROUND AND UNDERGROUND UTILITIES ARE SHOWN IN AN APPROXIMATE WAY ONLY. THE CONTRACTOR SHALL DETERMINE THE EXACT LOCATION OF ALL EXISTING UTILITIES BEFORE COMMENCING WORK. THE CONTRACTOR SHALL BE FULLY RESPONSIBLE FOR ANY AND ALL DAMAGES WHICH MIGHT BE CAUSED BY HIS FAILURE TO EXACTLY LOCATE AND PRESERVE ANY AND ALL ABOVE GROUND AND UNDERGROUND UTILITIES.

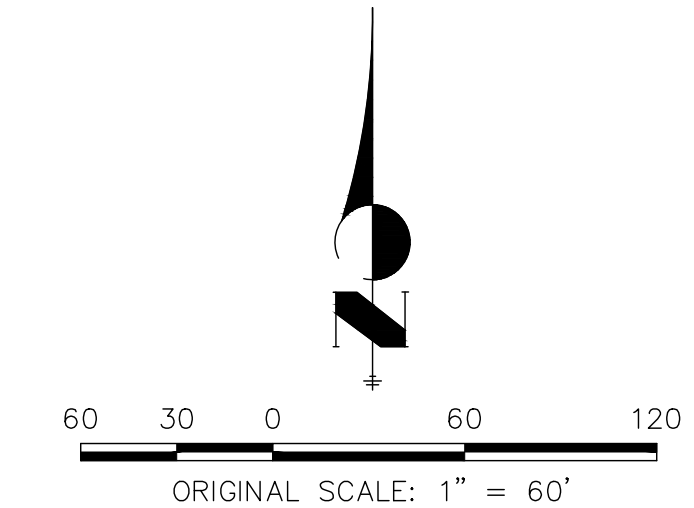

**ENGINEER'S STATEMENT**  
PREPARED UNDER MY DIRECT SUPERVISION AND ON BEHALF OF ALL TERRAIN ENGINEERING

DATE

RYAN E. BURNS, P.E.  
COLORADO P.E. 54412  
FOR AND ON BEHALF OF JR ENGINEERING, LLC

DESIGN: REB  
REVIEW: NOJ  
DATE: 08/10/2024  
H-SCALE: 1" = 60'  
V-SCALE: 1" = 6'  
SHEET  
4 OF 12



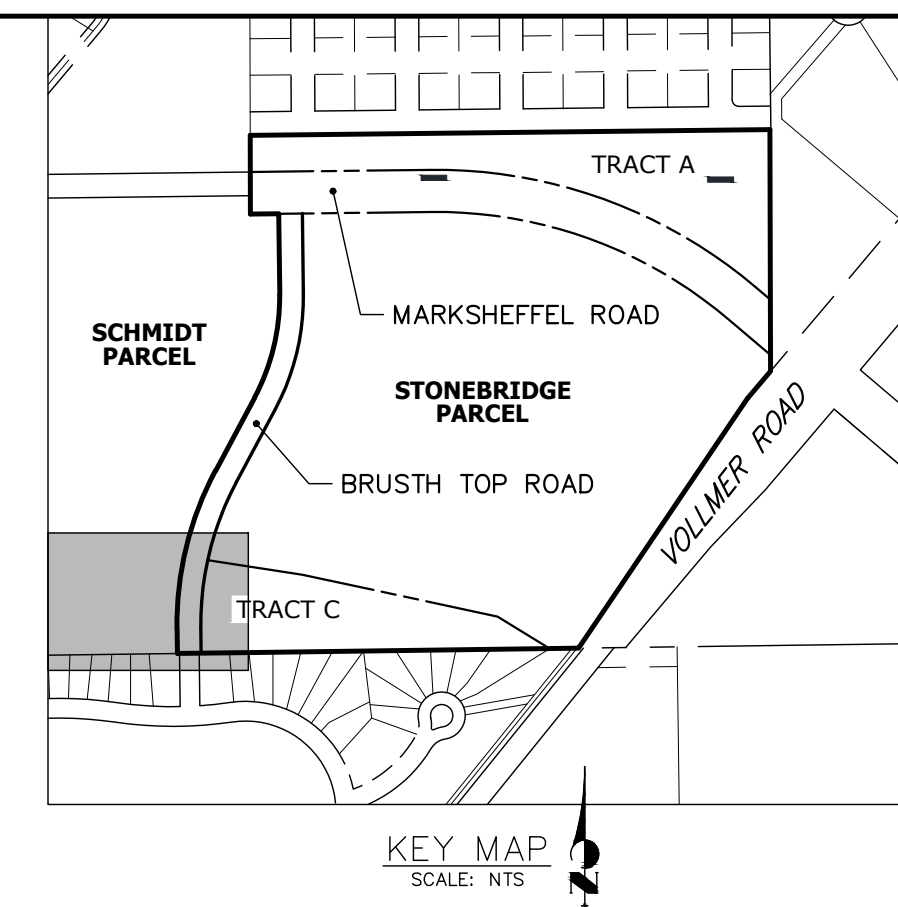

ALL TERRAIN  
ENGINEERING

PREPARED FOR:  
TURKEY CANON QUARRY INC.  
20 BOULDER CRESCENT STREET, SUITE 100  
COLORADO SPRINGS, CO 80903  
ATTN: JIM MORLEY  
(719) 491-3024  
####

UNTIL SUCH TIME AS THESE  
DRAWINGS ARE APPROVED BY THE  
APPROPRIATE REVIEWING  
AGENCIES, ALL TERRAIN  
ENGINEERING APPROVES THEIR  
USE ONLY FOR THE PURPOSES  
DESIGNATED BY WRITTEN  
AUTHORIZATION.

DATE	REVISION

JOB NO: 24013  
LOCATION: CO  
REV DESCRIPTION

SCHMIDT PHASE 1 - DISTRICT INFRASTRUCTURE

INITIAL-INTERM-GEC (3)

DESIGN: REB  
REVIEW: NOJ  
DATE: 08/10/2024  
H-SCALE: 1" = 60'  
V-SCALE: 1" = 6'  
SHEET  
5 OF 12

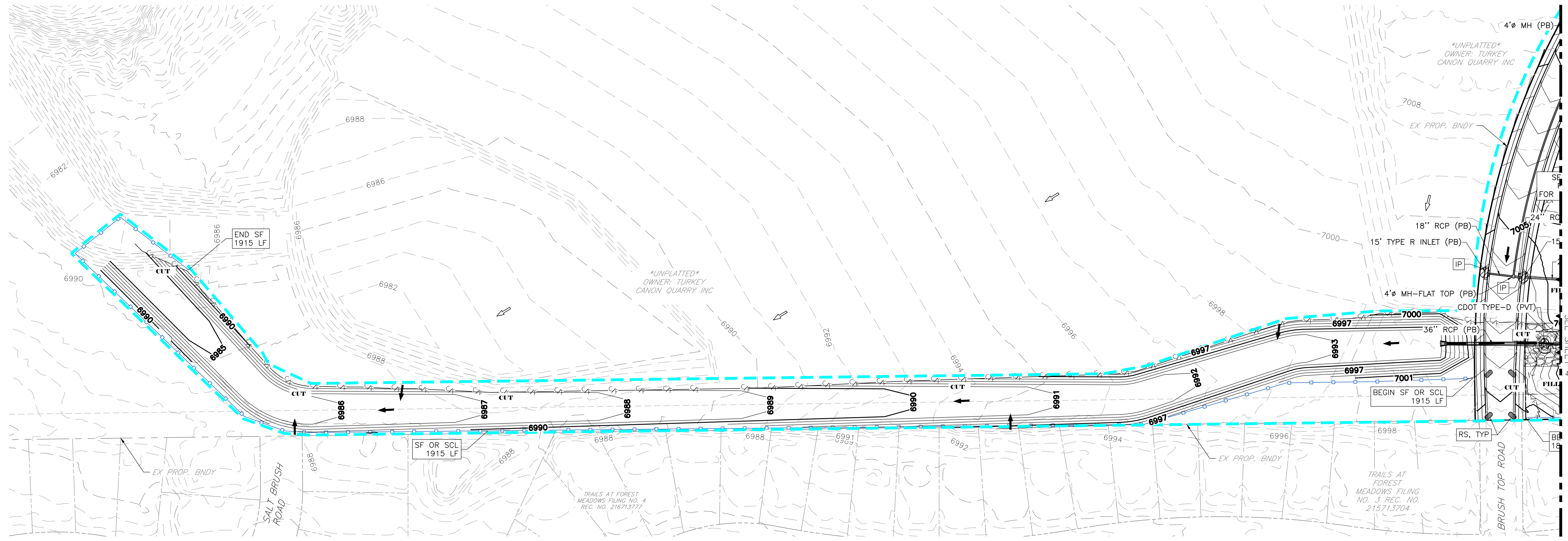

- GEC LEGEND:**
- CULVERT PROTECTION
  - CONCRETE WASHOUT AREA
  - INLET PROTECTION
  - EX FLOW DIRECTION  
PR FLOW DIRECTION
  - SEDIMENT CONTROL LOG
  - DIVERSION DITCH
  - SILT FENCE
  - LIMITS OF DISTURBANCE
  - STABILIZED STAGING AREA
  - STOCKPILE PROTECTION
  - VEHICLE TRACKING CONTROL
  - SEEDING & MULCHING
  - EROSION CONTROL BLANKET
  - DO NOT DISTURB



THE LOCATIONS OF EXISTING ABOVE GROUND AND UNDERGROUND UTILITIES ARE SHOWN IN AN APPROXIMATE WAY ONLY. THE CONTRACTOR SHALL DETERMINE THE EXACT LOCATION OF ALL EXISTING UTILITIES BEFORE COMMENCING WORK. THE CONTRACTOR SHALL BE FULLY RESPONSIBLE FOR ANY AND ALL DAMAGES WHICH MIGHT BE CAUSED BY HIS FAILURE TO EXACTLY LOCATE AND PRESERVE ANY AND ALL ABOVE GROUND AND UNDERGROUND UTILITIES.

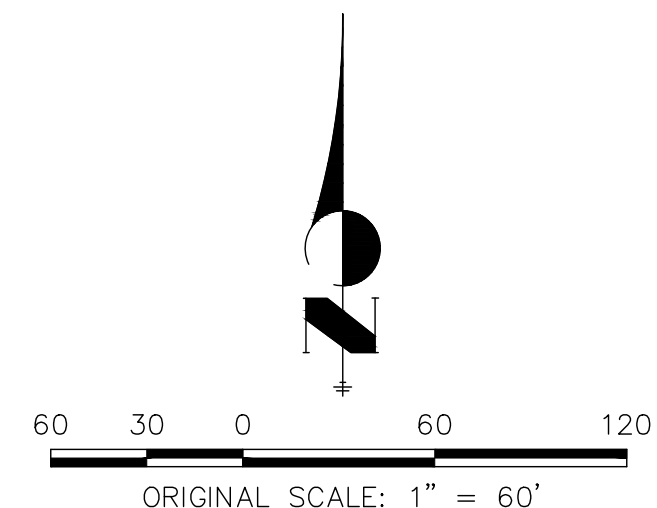

**ENGINEER'S STATEMENT**  
PREPARED UNDER MY DIRECT SUPERVISION AND ON BEHALF OF ALL TERRAIN ENGINEERING

RYAN E. BURNS, P.E.  
COLORADO P.E. 54412  
FOR AND ON BEHALF OF JR ENGINEERING, LLC

DATE

RYAN E. BURNS, P.E.  
54412  
ALL TERRAIN ENGINEERING, LLC  
1001 17th Ave. Suite 100  
Colorado Springs, CO 80903  
719.491.3024



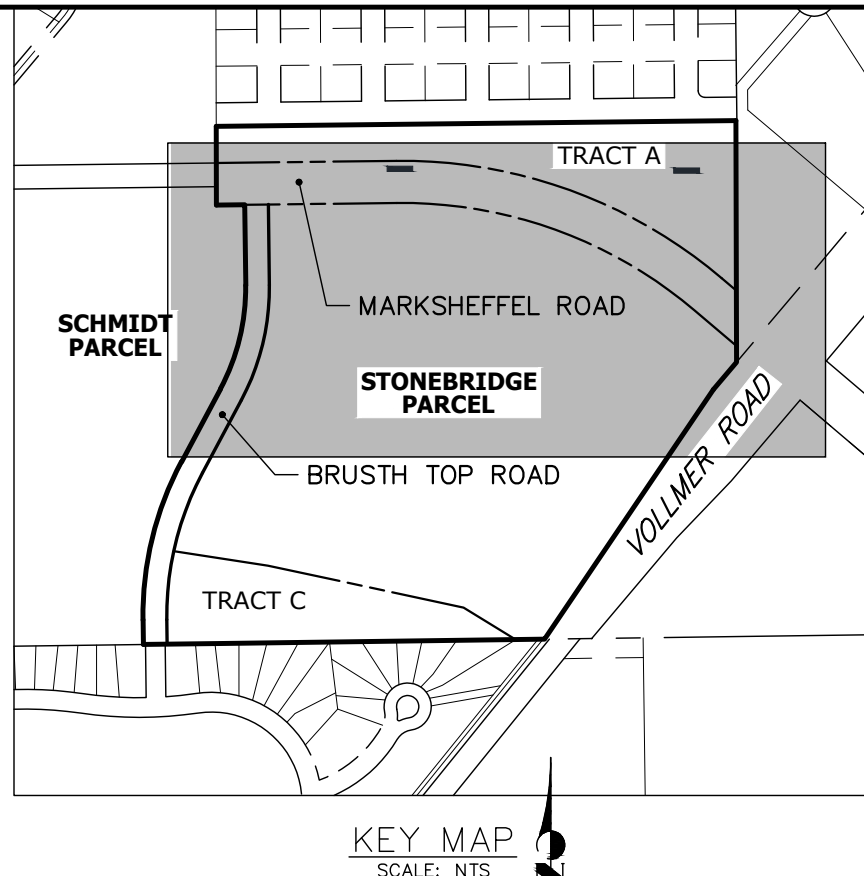
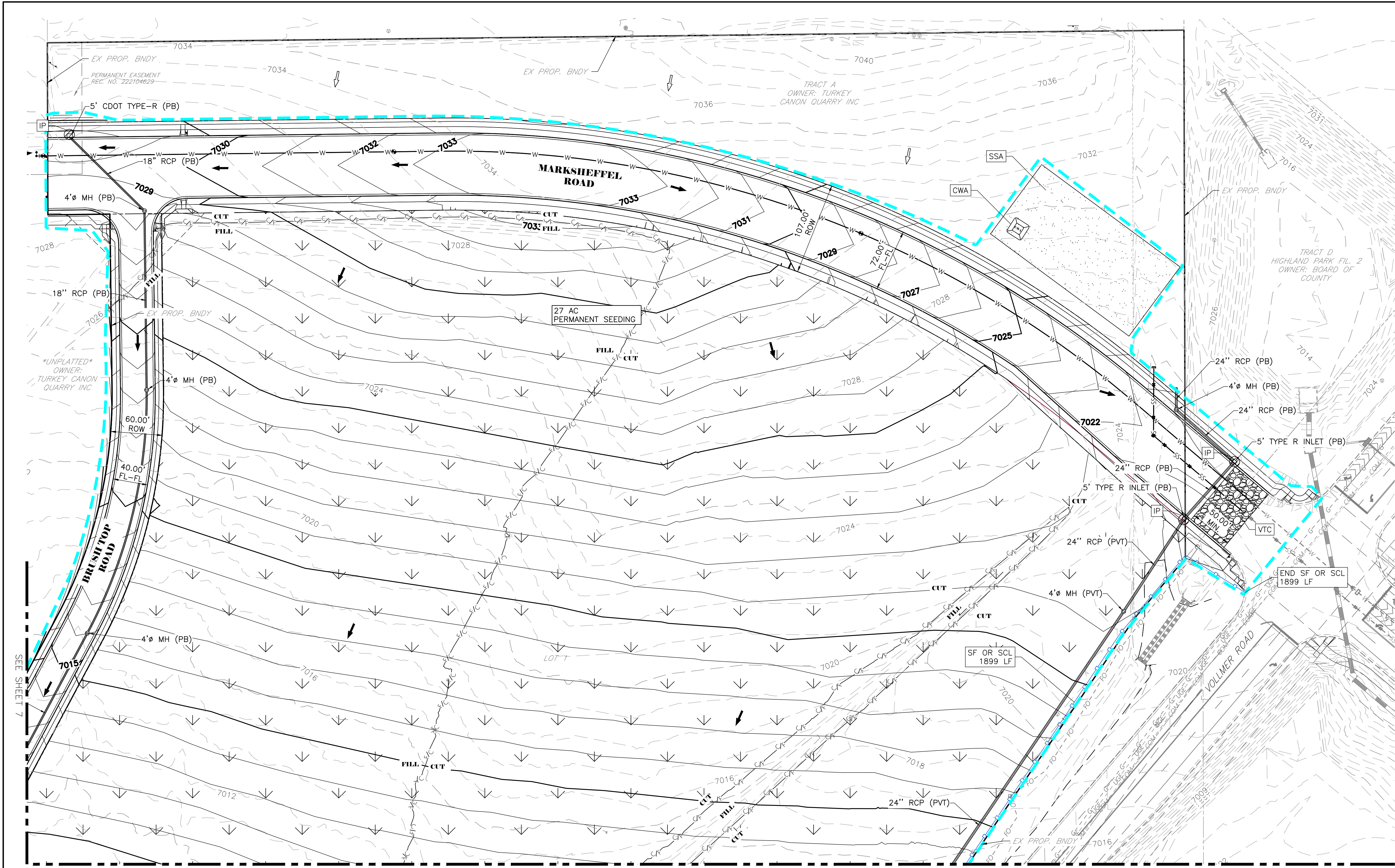

**GEC LEGEND:**

	CULVERT PROTECTION
	CONCRETE WASHOUT AREA
	INLET PROTECTION
	EX FLOW DIRECTION PR FLOW DIRECTION
	SEDIMENT CONTROL LOG
	DIVERSION DITCH
	SILT FENCE
	LIMITS OF DISTURBANCE
	STABILIZED STAGING AREA
	STOCKPILE PROTECTION
	VEHICLE TRACKING CONTROL
	SEEDING & MULCHING
	EROSION CONTROL BLANKET
	DO NOT DISTURB



PREPARED FOR:  
 TURKEY CANYON QUARRY INC.  
 20 BOULDER CRESCENT STREET, SUITE 100  
 COLORADO SPRINGS, CO 80903  
 ATTN: JIM MORLEY  
 (719) 491-3024  
 #####

UNTIL SUCH TIME AS THESE  
 DRAWINGS ARE APPROVED BY THE  
 APPROPRIATE REVIEWING  
 AGENCIES, ALL TERRAIN  
 ENGINEERING APPROVES THEIR  
 USE ONLY FOR THE PURPOSES  
 DESIGNATED BY WRITTEN  
 AUTHORIZATION.

DATE	
LOCATION: COS	
JOB NO: 24013	
REV DESCRIPTION	

SCHMIDT PHASE 1 - DISTRICT INFRASTRUCTURE

FINAL GEC



THE LOCATIONS OF EXISTING ABOVE GROUND AND UNDERGROUND UTILITIES ARE SHOWN IN AN APPROXIMATE WAY ONLY. THE CONTRACTOR SHALL DETERMINE THE EXACT LOCATION OF ALL EXISTING UTILITIES BEFORE COMMENCING WORK. THE CONTRACTOR SHALL BE FULLY RESPONSIBLE FOR ANY AND ALL DAMAGES WHICH MIGHT BE CAUSED BY HIS FAILURE TO EXACTLY LOCATE AND PRESERVE ANY AND ALL ABOVE GROUND AND UNDERGROUND UTILITIES.

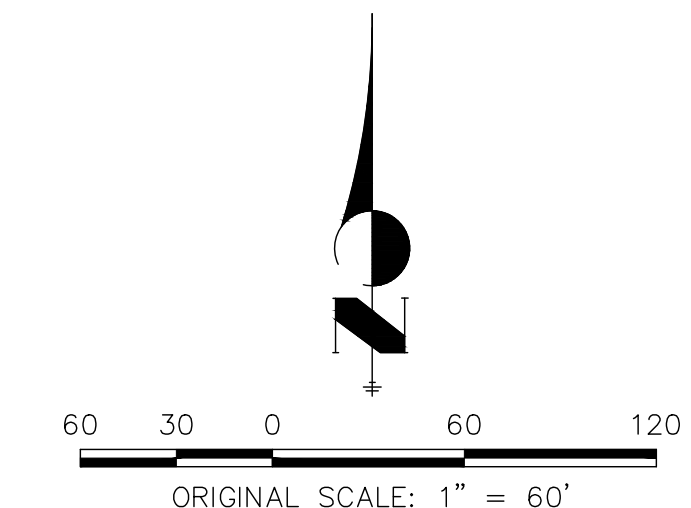

**ENGINEER'S STATEMENT**  
 PREPARED UNDER MY DIRECT SUPERVISION AND ON BEHALF OF ALL TERRAIN ENGINEERING

DATE

RYAN E. BURNS, P.E.  
 COLORADO P.E. 54412  
 FOR AND ON BEHALF OF JR ENGINEERING, LLC

DESIGN: REB
REVIEW: NOJ
DATE: 08/10/2024
H-SCALE: 1" = 60'
V-SCALE: 1" = 6'
SHEET
6 OF 12



SEE SHEET 6

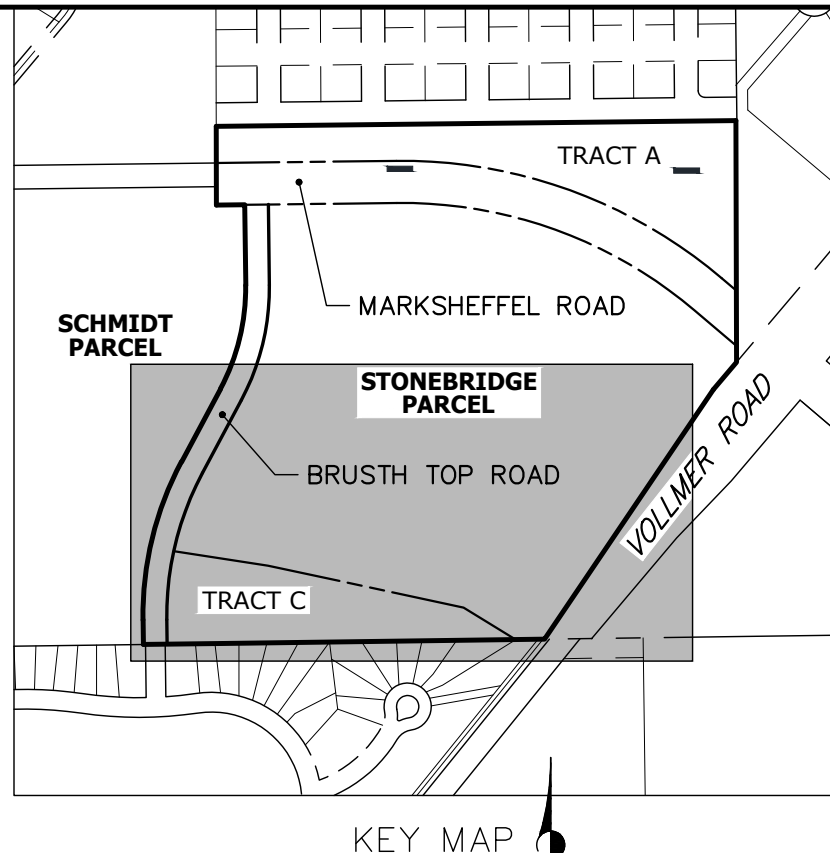
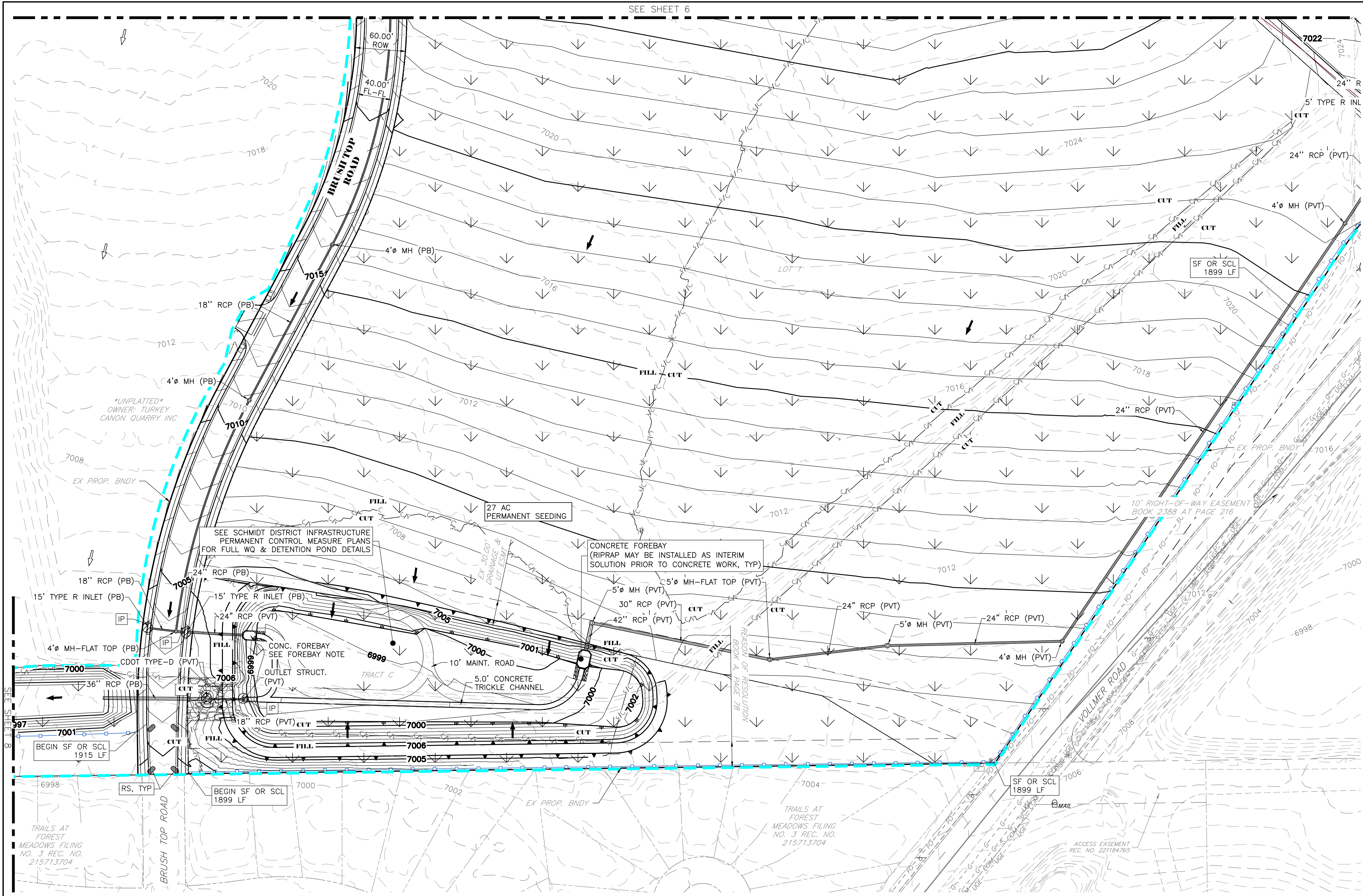

- GEC LEGEND:**
- CULVERT PROTECTION
  - CONCRETE WASHOUT AREA
  - INLET PROTECTION
  - EX FLOW DIRECTION  
PR FLOW DIRECTION
  - SEDIMENT CONTROL LOG
  - DIVERSION DITCH
  - SILT FENCE
  - LIMITS OF DISTURBANCE
  - STABILIZED STAGING AREA
  - STOCKPILE PROTECTION
  - VEHICLE TRACKING CONTROL
  - SEEDING & MULCHING
  - EROSION CONTROL BLANKET
  - DO NOT DISTURB



PREPARED FOR:  
TURKEY CANYON QUARRY INC.  
100  
OLD CREST STREET, SUITE  
COLORADO SPRINGS, CO 80903  
ATTN: JIM MORLEY  
(719) 491-3024  
#####

UNTIL SUCH TIME AS THESE  
DRAWINGS ARE APPROVED BY THE  
APPROPRIATE REVIEWING AGENCIES, ALL TERRAIN  
ENGINEERING APPROVES THEIR  
USE ONLY FOR THE PURPOSES  
DESIGNATED BY WRITTEN  
AUTHORIZATION.

DATE	DESCRIPTION

JOB NO: 24013 LOCATION: COS  
SCHMIDT PHASE 1 - DISTRICT INFRASTRUCTURE  
FINAL GEC (2)



Know what's below.  
Call before you dig.

THE LOCATIONS OF EXISTING ABOVE GROUND AND UNDERGROUND UTILITIES ARE SHOWN IN AN APPROXIMATE WAY ONLY. THE CONTRACTOR SHALL DETERMINE THE EXACT LOCATION OF ALL EXISTING UTILITIES BEFORE COMMENCING WORK. THE CONTRACTOR SHALL BE FULLY RESPONSIBLE FOR ANY AND ALL DAMAGES WHICH MIGHT BE CAUSED BY HIS FAILURE TO EXACTLY LOCATE AND PRESERVE ANY AND ALL ABOVE GROUND AND UNDERGROUND UTILITIES.

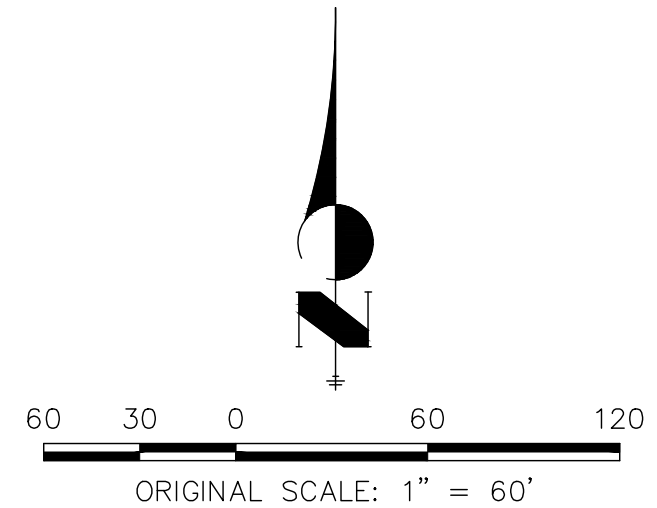

**ENGINEER'S STATEMENT**  
PREPARED UNDER MY DIRECT SUPERVISION AND ON BEHALF OF ALL TERRAIN ENGINEERING

RYAN E. BURNS, P.E.  
COLORADO P.E. 54412  
FOR AND ON BEHALF OF JR ENGINEERING, LLC

DESIGN: REB  
REVIEW: NOJ  
DATE: 08/10/2024  
H-SCALE: 1" = 60'  
V-SCALE: 1" = 6'  
SHEET  
7 OF 12



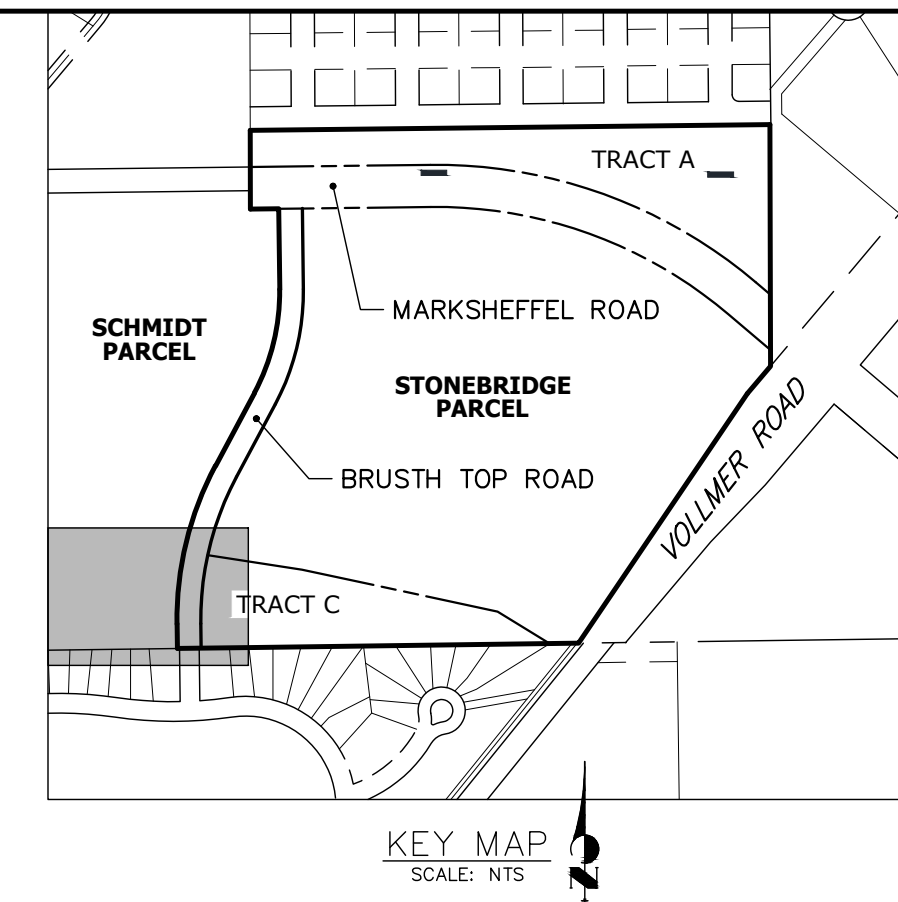

PREPARED FOR:  
 TURKEY CANON QUARRY INC.  
 20 BOULDER CRESCENT STREET, SUITE 100  
 COLORADO SPRINGS, CO 80903  
 ATTN: JIM MORLEY  
 (719) 491-3024  
 #####

UNTIL SUCH TIME AS THESE  
 DRAWINGS ARE APPROVED BY THE  
 APPROPRIATE REVIEWING  
 AGENCIES, ALL TERRAIN  
 ENGINEERING APPROVES THEIR  
 USE ONLY FOR THE PURPOSES  
 DESIGNATED BY WRITTEN  
 AUTHORIZATION.

DATE	REV	DESCRIPTION

JOB NO: 24013  
 LOCATION: CO  
 SCHMIDT PHASE 1 - DISTRICT INFRASTRUCTURE  
 FINAL GEC (3)

DESIGN: REB  
 REVIEW: NOJ  
 DATE: 08/10/2024  
 H-SCALE: 1" = 60'  
 V-SCALE: 1" = 6'  
 SHEET  
 8 OF 12

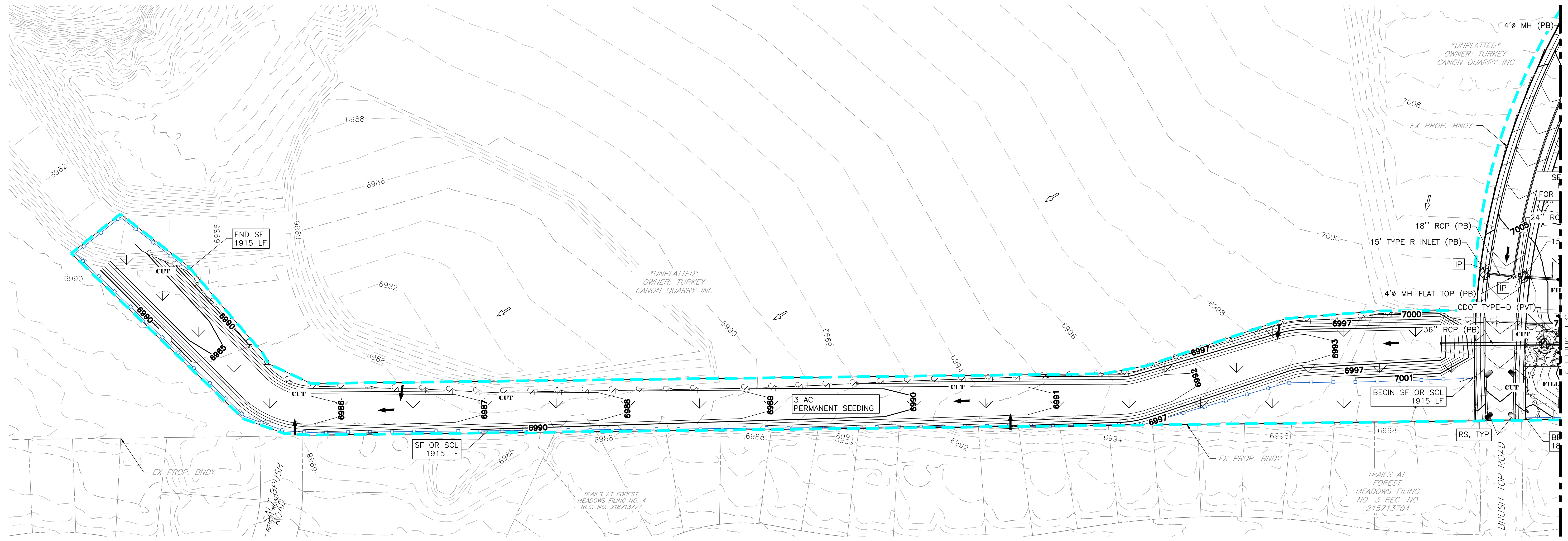

- GEC LEGEND:**
- CULVERT PROTECTION
  - CONCRETE WASHOUT AREA
  - INLET PROTECTION
  - EX FLOW DIRECTION  
PR FLOW DIRECTION
  - SEDIMENT CONTROL LOG
  - DIVERSION DITCH
  - SILT FENCE
  - LIMITS OF DISTURBANCE
  - STABILIZED STAGING AREA
  - STOCKPILE PROTECTION
  - VEHICLE TRACKING CONTROL
  - SEEDING & MULCHING
  - EROSION CONTROL BLANKET
  - DO NOT DISTURB



Know what's below.  
 Call before you dig.

THE LOCATIONS OF EXISTING ABOVE GROUND AND UNDERGROUND UTILITIES ARE SHOWN IN AN APPROXIMATE WAY ONLY. THE CONTRACTOR SHALL DETERMINE THE EXACT LOCATION OF ALL EXISTING UTILITIES BEFORE COMMENCING WORK. THE CONTRACTOR SHALL BE FULLY RESPONSIBLE FOR ANY AND ALL DAMAGES WHICH MIGHT BE CAUSED BY HIS FAILURE TO EXACTLY LOCATE AND PRESERVE ANY AND ALL ABOVE GROUND AND UNDERGROUND UTILITIES.

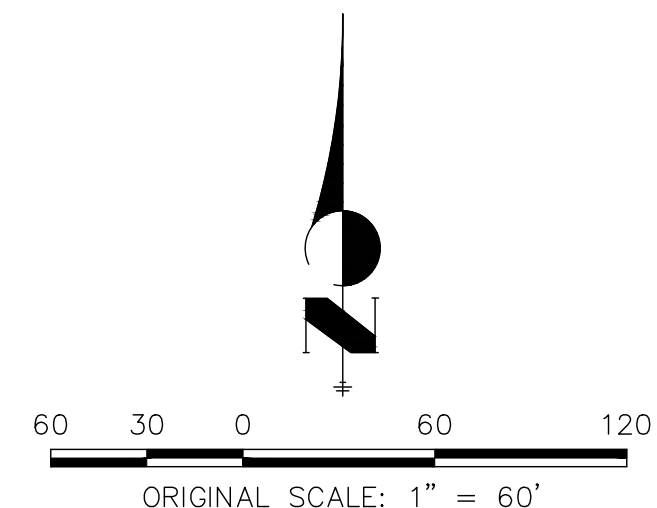

**ENGINEER'S STATEMENT**  
 PREPARED UNDER MY DIRECT SUPERVISION AND ON BEHALF OF ALL TERRAIN ENGINEERING  
 RYAN E. BURNS, P.E.  
 COLORADO P.E. 54412  
 FOR AND ON BEHALF OF JR ENGINEERING, LLC  
 DATE



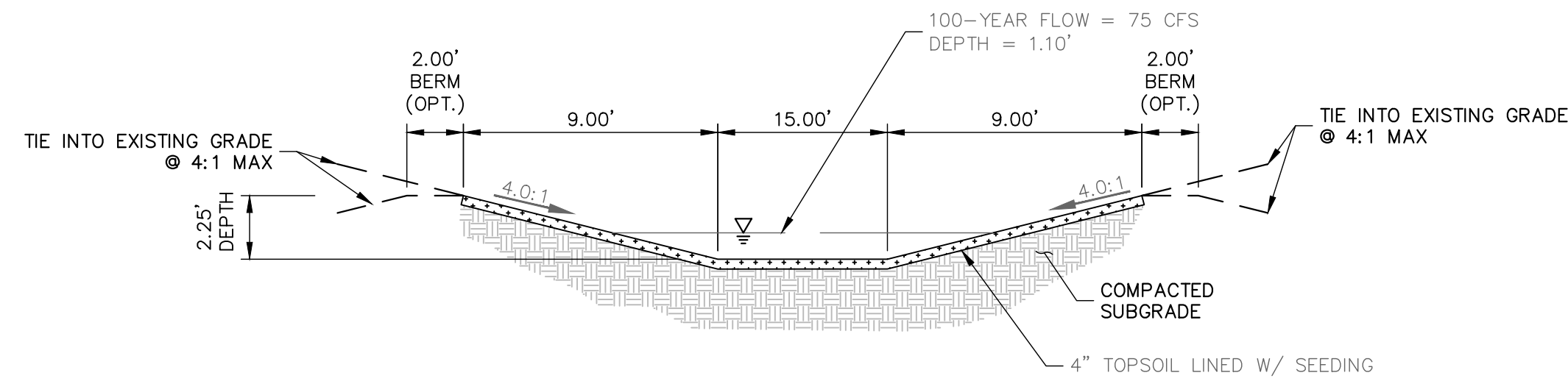

**OUTFALL CHANNEL TYPICAL SECTION**

SCALE: NTS

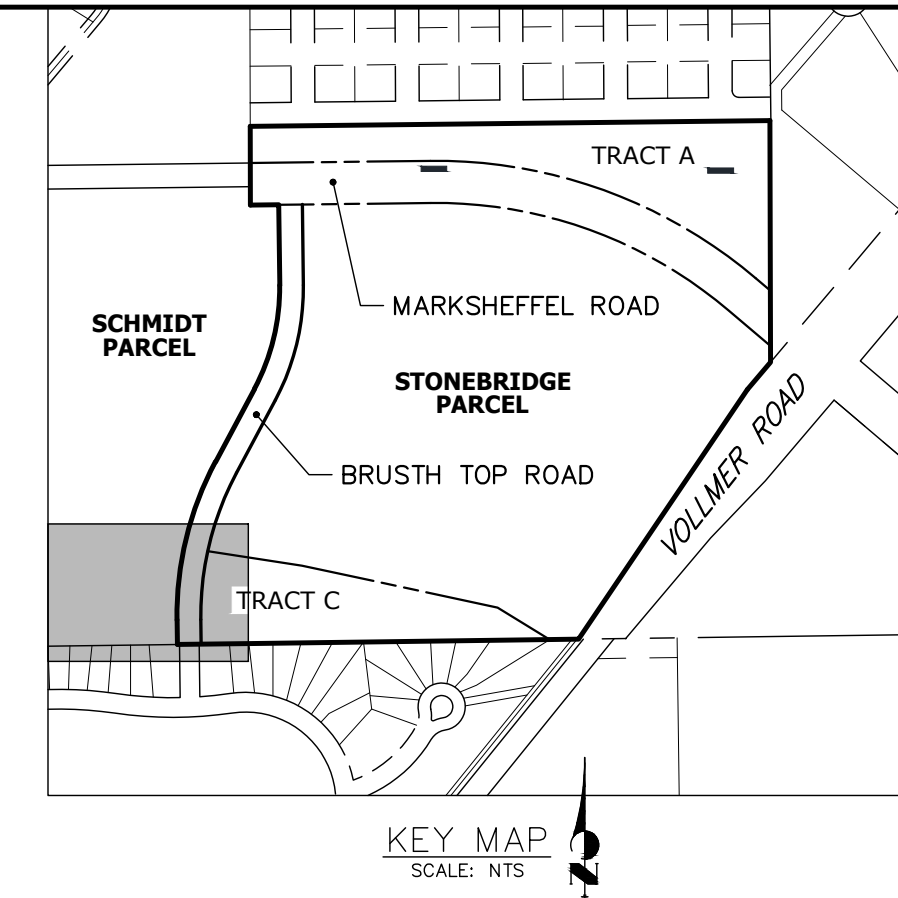

**KEY MAP**

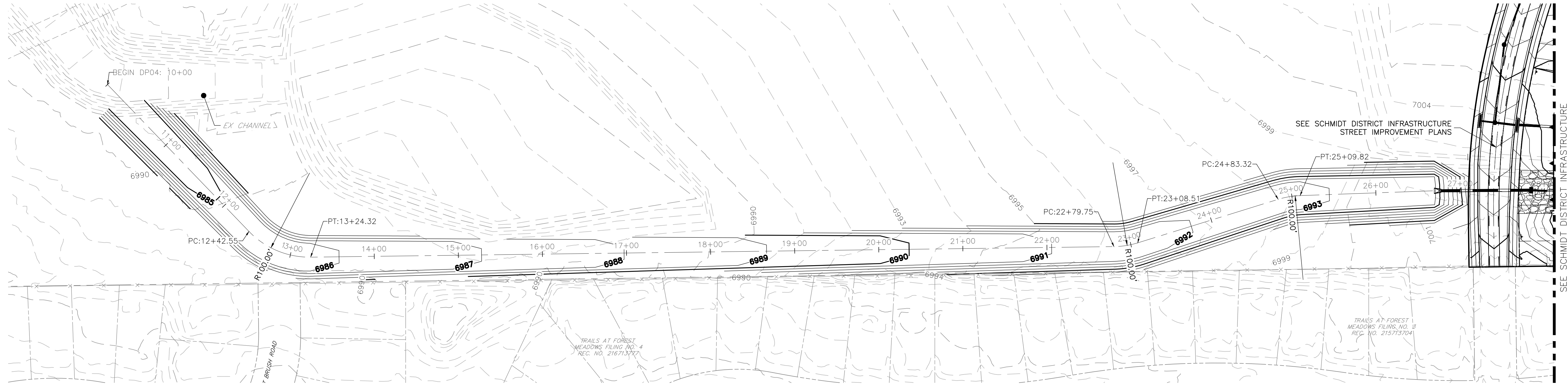

**DP04  
STA 10+00.00 TO 27+50.00**

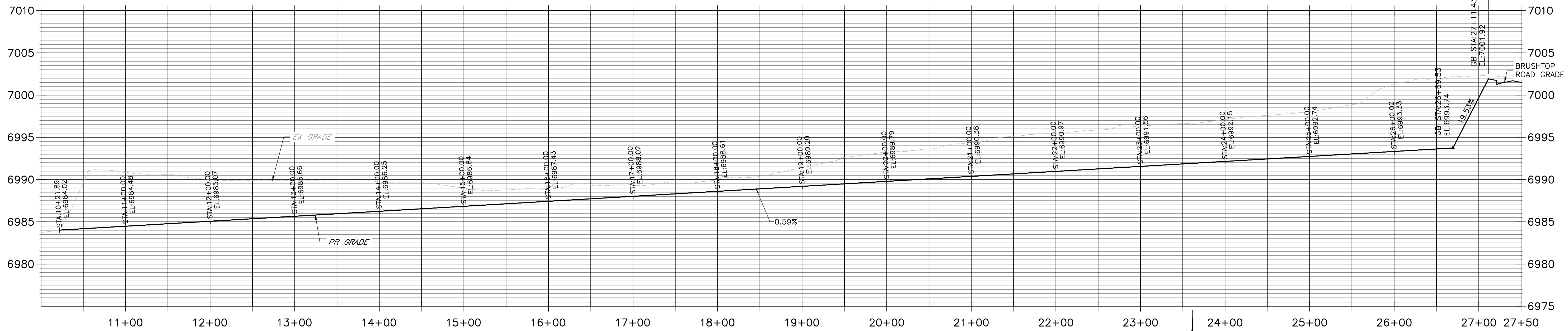

THE LOCATIONS OF EXISTING ABOVE GROUND AND UNDERGROUND UTILITIES ARE SHOWN IN AN APPROXIMATE WAY ONLY. THE CONTRACTOR SHALL DETERMINE THE EXACT LOCATION OF ALL EXISTING UTILITIES BEFORE COMMENCING WORK. THE CONTRACTOR SHALL BE FULLY RESPONSIBLE FOR ANY AND ALL DAMAGES WHICH MIGHT BE CAUSED BY HIS FAILURE TO EXACTLY LOCATE AND PRESERVE ANY AND ALL ABOVE GROUND AND UNDERGROUND UTILITIES.

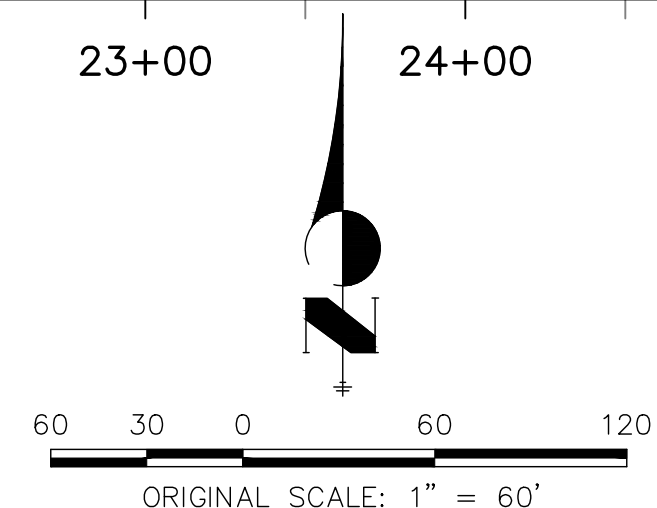

**ENGINEER'S STATEMENT**  
 PREPARED UNDER MY DIRECT SUPERVISION AND ON BEHALF OF ALL TERRAIN ENGINEERING  
 RYAN E. BURNS, P.E.  
 COLORADO P.E. 54412  
 FOR AND ON BEHALF OF JR ENGINEERING, LLC

**JR ENGINEERING**  
 PREPARED FOR:  
 TURKEY CANON QUARRY INC.  
 20 BOULDER CRESSENT STREET, SUITE 100  
 COLORADO SPRINGS, CO 80903  
 ATTN: JIM MORLEY  
 (719) 491-3024  
 #####

UNTIL SUCH TIME AS THESE DRAWINGS ARE APPROVED BY THE APPROPRIATE REVIEWING AGENCIES, ALL TERRAIN ENGINEERING APPROVES THEIR USE ONLY FOR THE PURPOSES DESIGNATED BY WRITTEN AUTHORIZATION.

DATE	DESCRIPTION

SCHMIDT PHASE 1 - DISTRICT INFRASTRUCTURE  
 OUTFALL CHANNEL PLAN & PROFILE

DESIGN: REB  
 REVIEW: NOJ  
 DATE: 08/10/2024  
 H-SCALE: 1" = 60'  
 V-SCALE: 1" = 6'  
 SHEET  
 9 OF 12



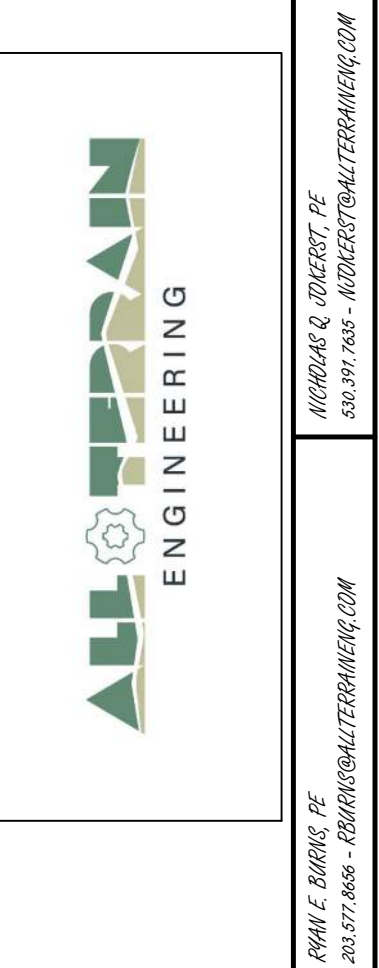
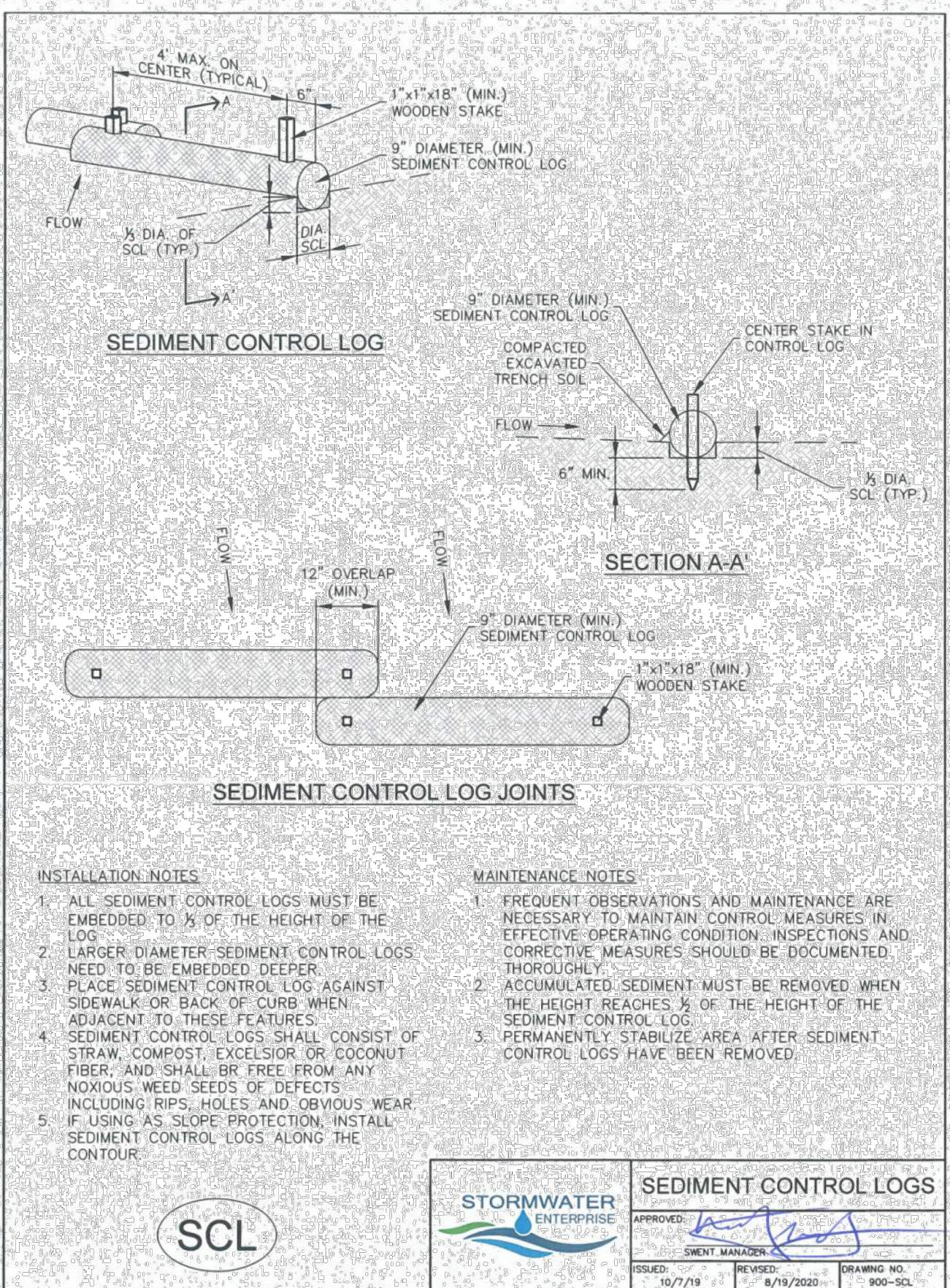
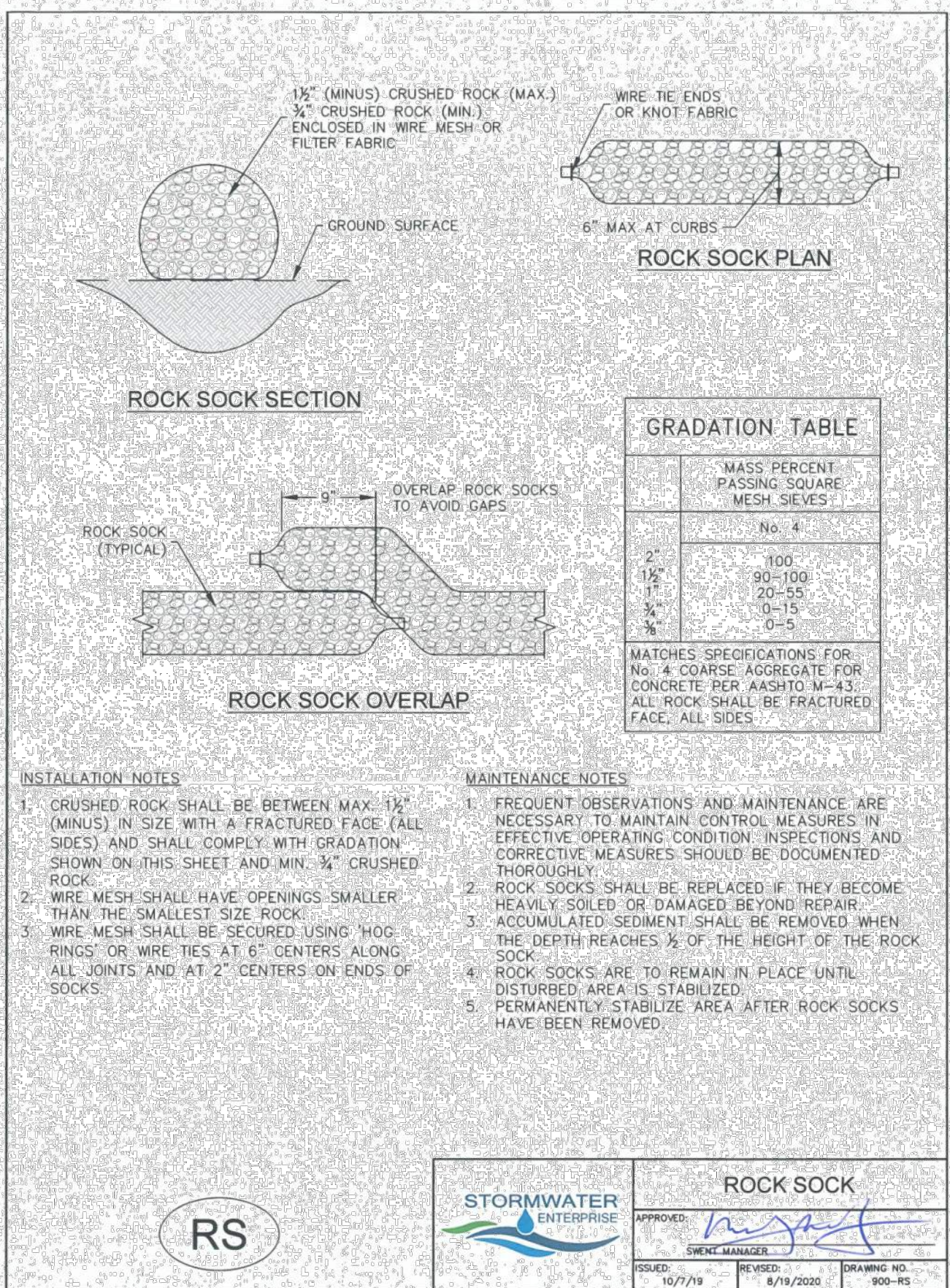
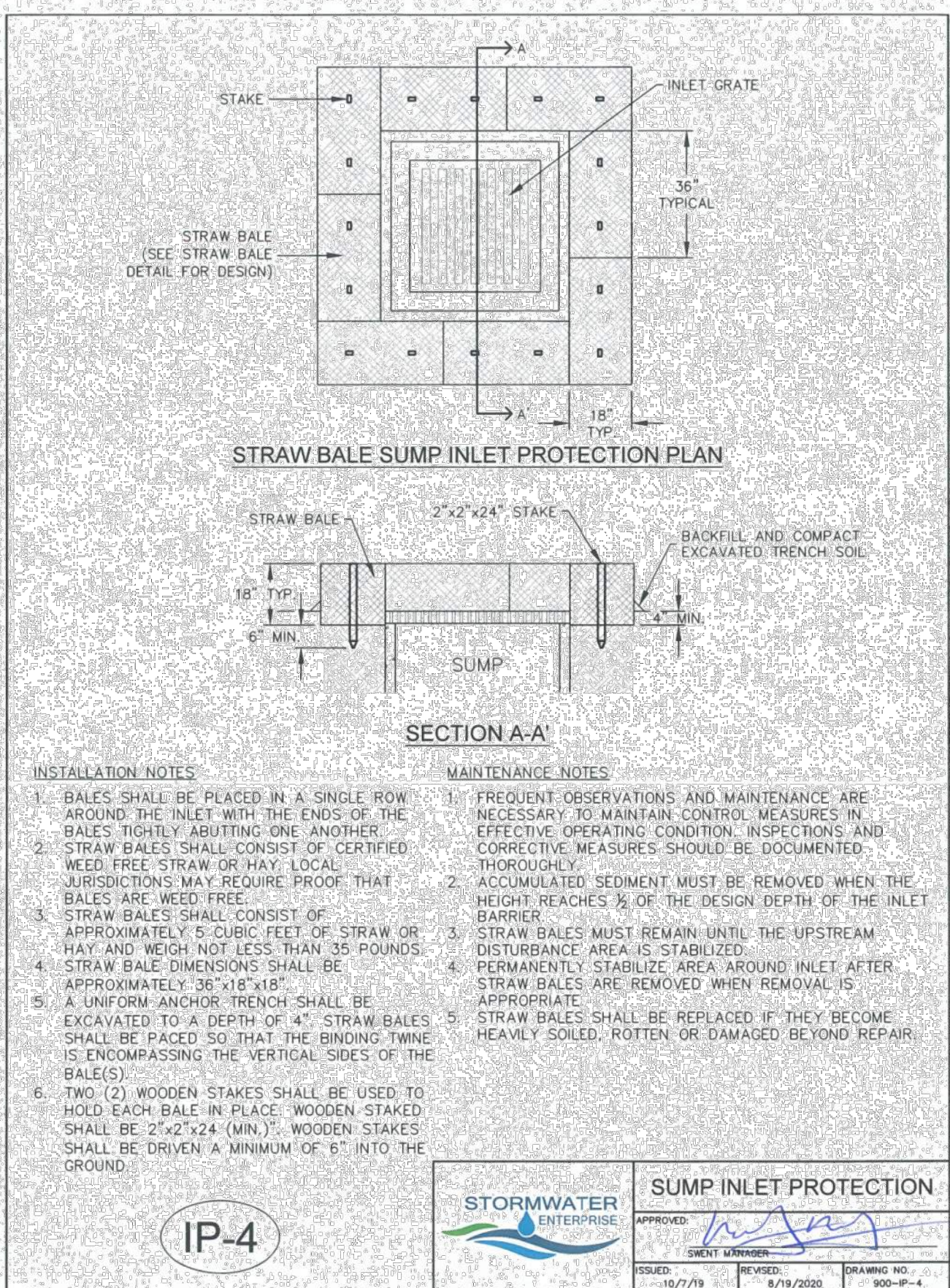
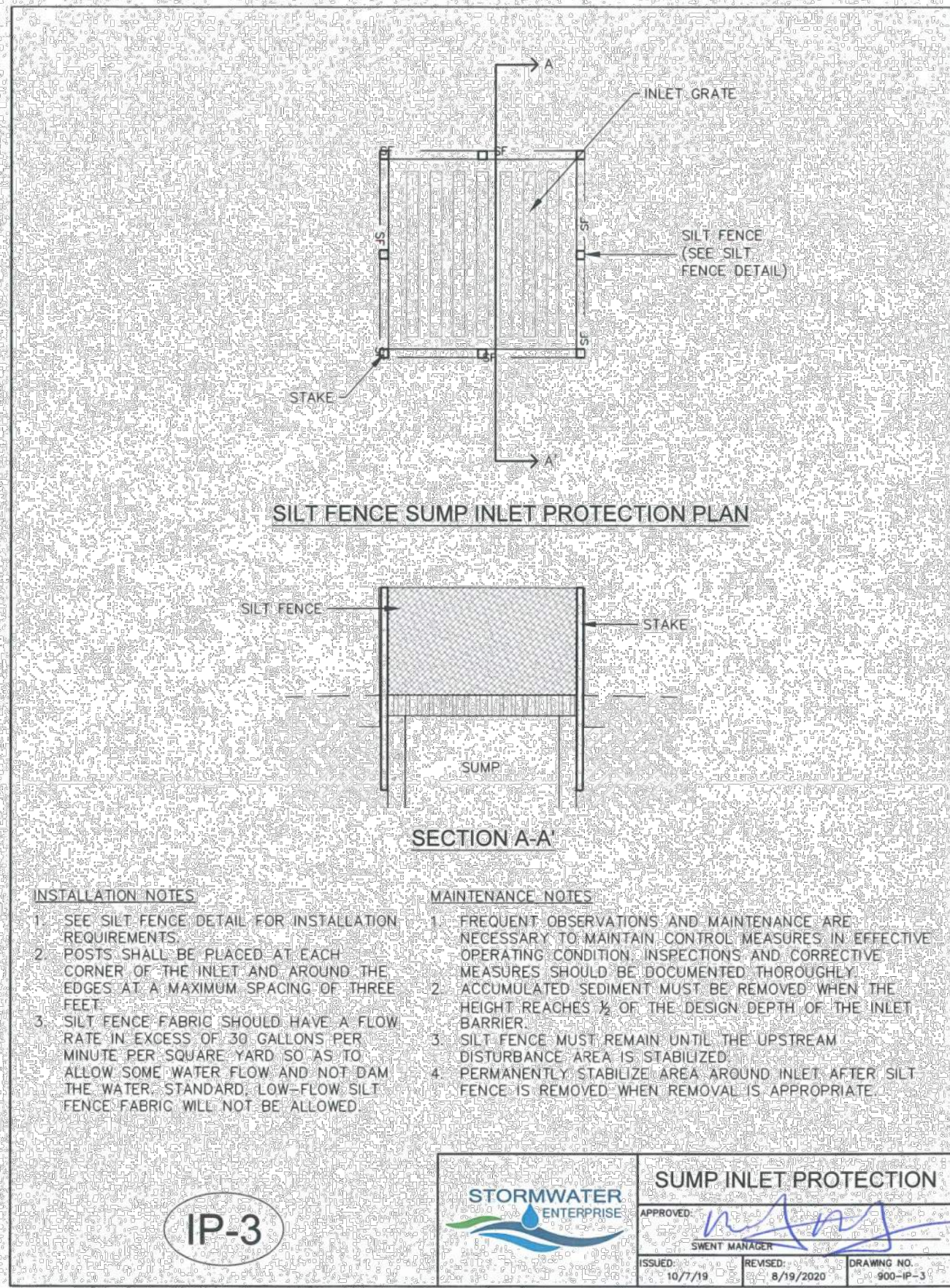
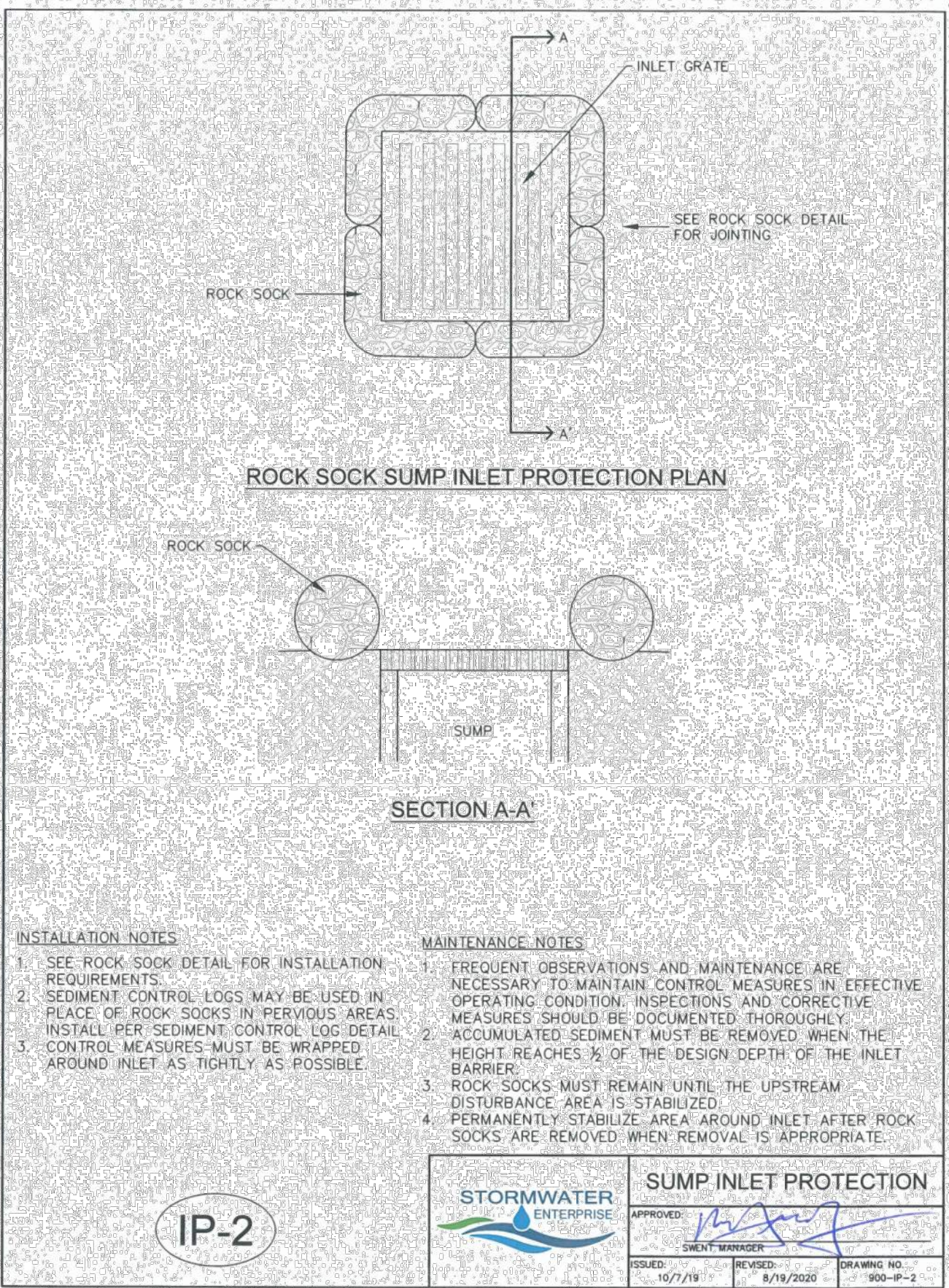
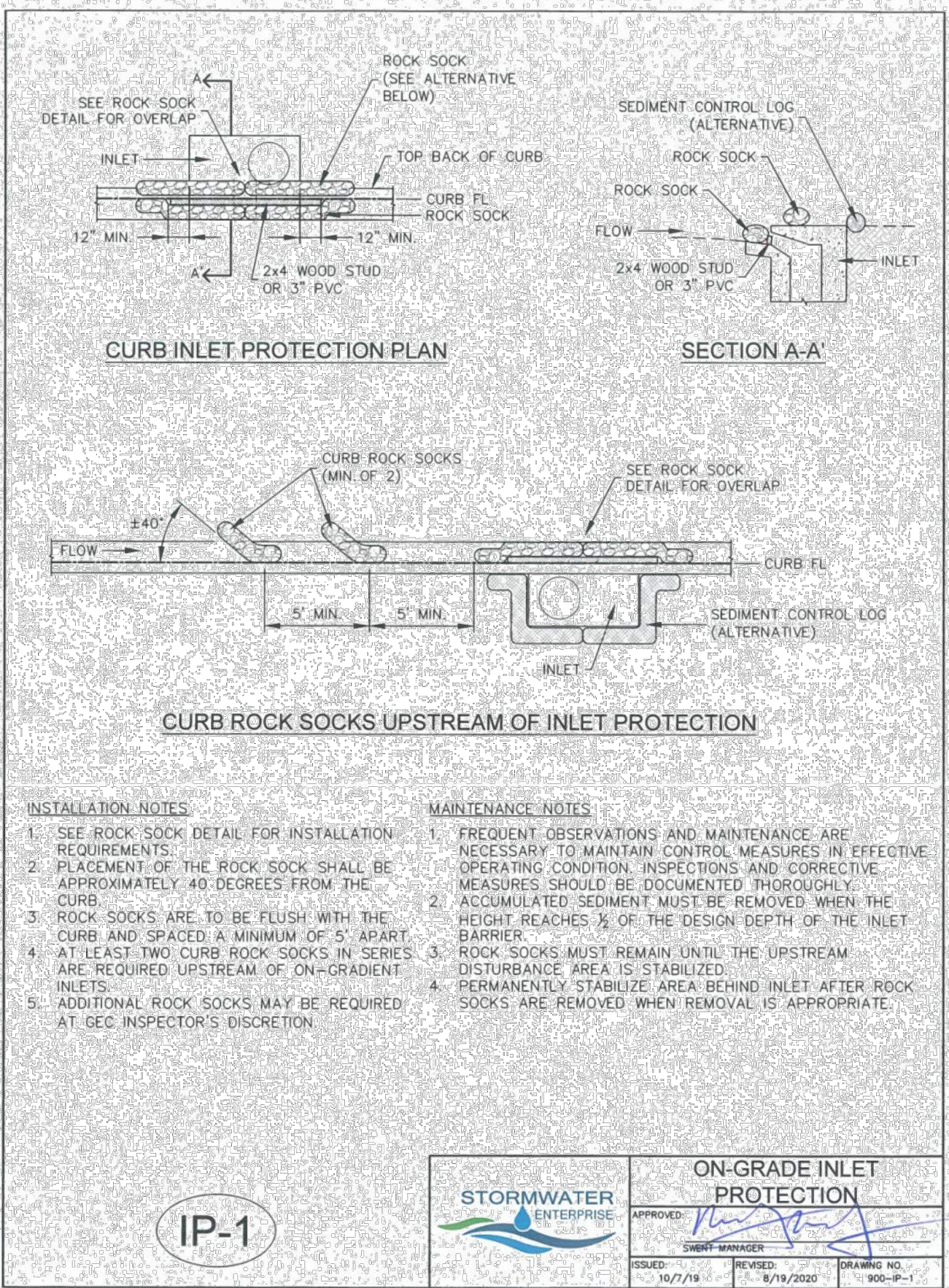
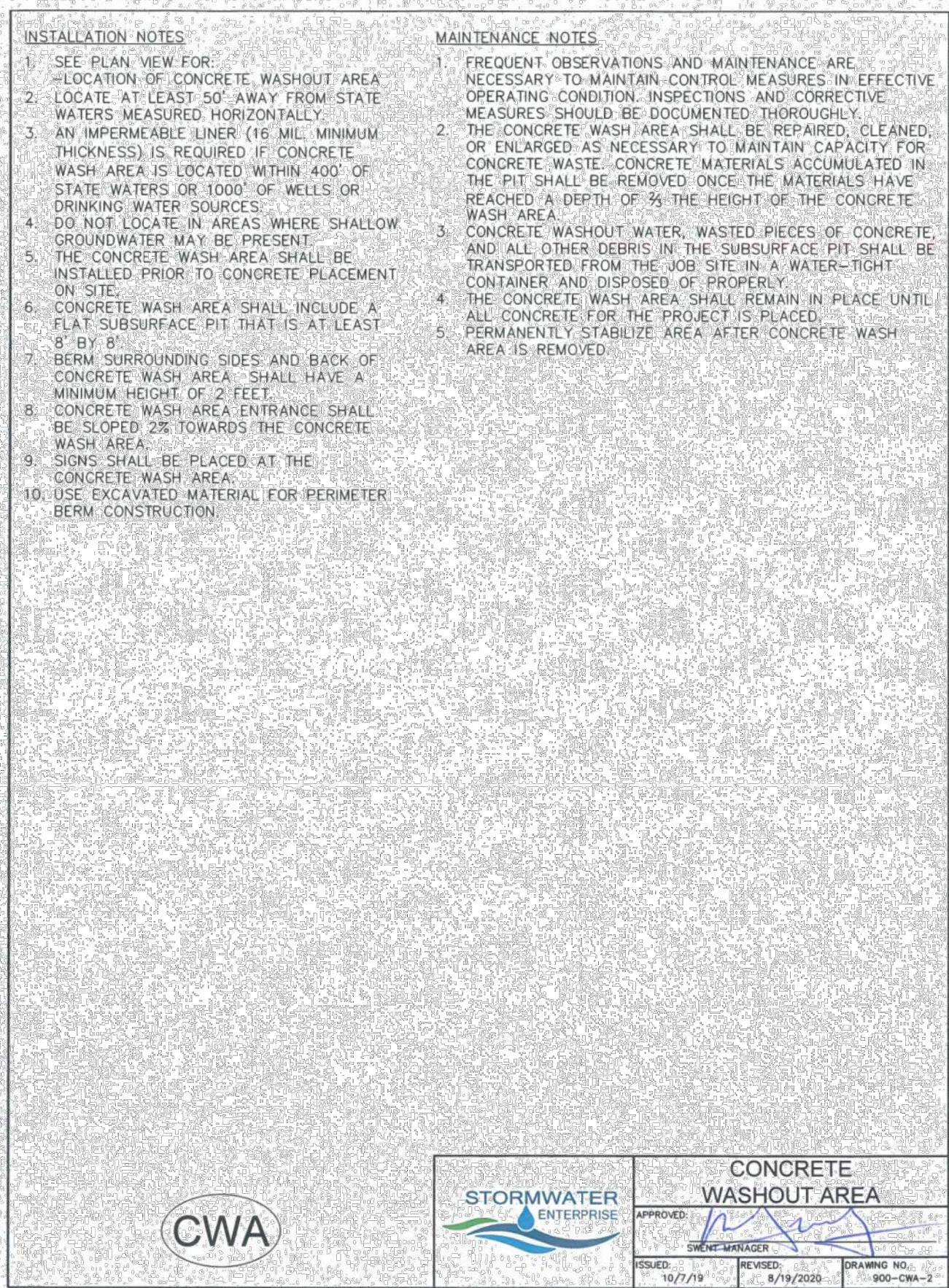
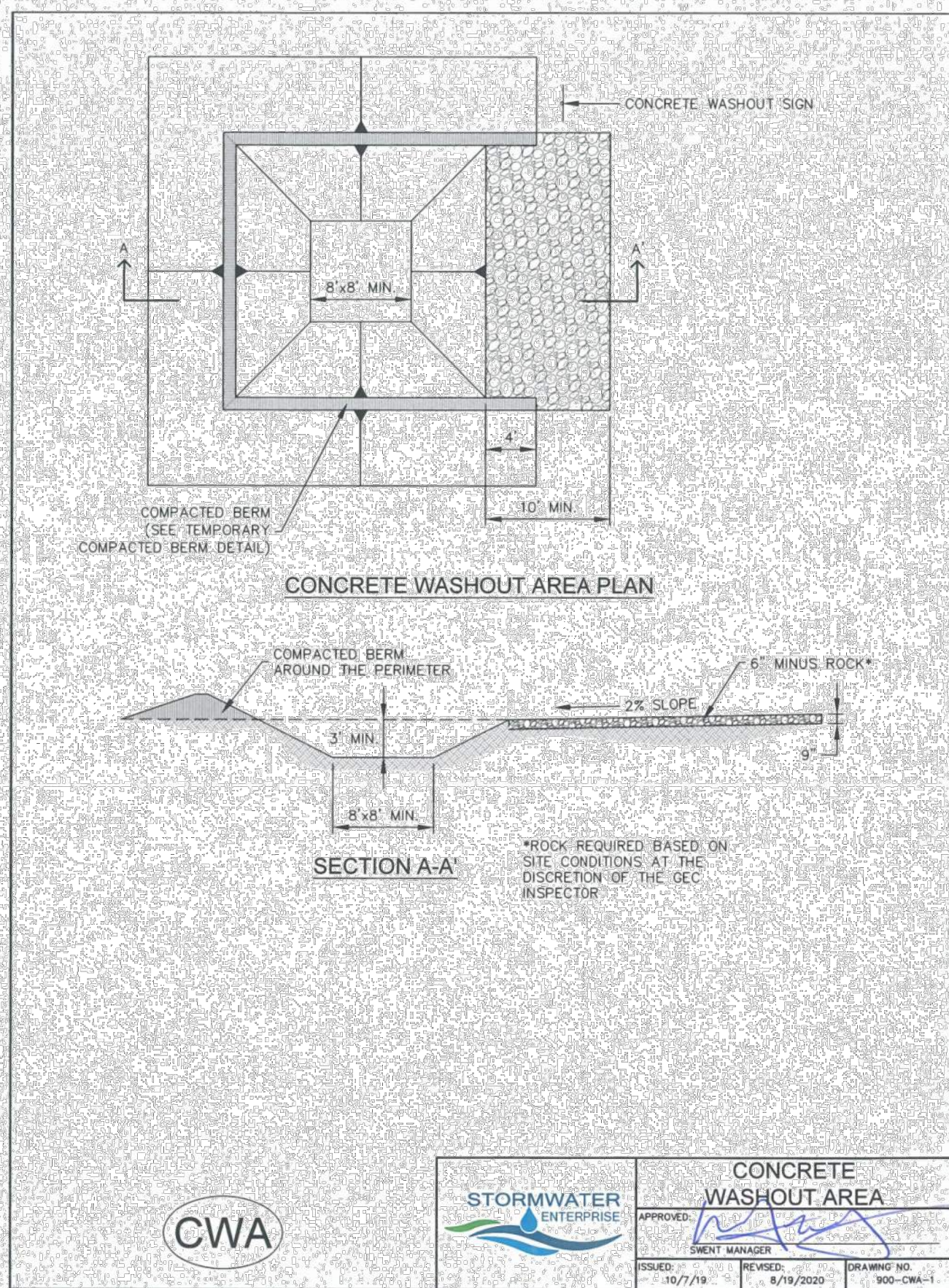

PREPARED FOR:  
TURKEY CANON QUARRY INC.  
20 BOULDER CREEK STREET, SUITE 100  
COLORADO SPRINGS, CO 80903  
ATTN: JIM MORLEY  
(719) 491-3024  
###

UNTIL SUCH TIME AS THESE DRAWINGS ARE APPROVED BY THE APPROPRIATE REVIEWING AGENCIES, ALL TERRAIN ENGINEERING APPROVES THEIR USE ONLY FOR THE PURPOSES DESIGNATED BY WRITTEN AUTHORIZATION.

DATE	REV. DESCRIPTION

JOB NO. 24013  
LOCATION: COS  
SCHMIDT PHASE 1 - DISTRICT INFRASTRUCTURE  
GEC DETAILS

**ENGINEER'S STATEMENT**  
PREPARED UNDER MY DIRECT SUPERVISION AND ON BEHALF OF ALL TERRAIN ENGINEERING

DATE

RYAN E. BURNS, P.E.  
COLORADO P.E. 54412  
FOR AND ON BEHALF OF JR ENGINEERING, LLC

DESIGN: REB  
REVIEW: NOJ  
DATE: 08/10/2024  
H-SCALE: N/A  
V-SCALE: N/A  
SHEET  
10 OF 12









## **APPENDIX D – GEC ADMINISTRATOR CERTIFICATION**



## **APPENDIX E – CONSTRUCTION CONTROL MEASURE DETAILS**

# CHECK DAM

## CD



## 1.0 DESCRIPTION

- Check dams are small temporary rock dams constructed across a swale or drainage ditch.

## 2.0 PURPOSE

- Used to slow down the velocity of concentrated flow to limit erosion and to promote sedimentation.
- Placed in areas of concentrated flow, such as a ditch or swale.

## 3.0 IMPLEMENTATION

- Place check dams at regular intervals perpendicular to the direction of flow.
- Use check dams on mild or moderately steep slopes.
- Install wide enough check dams to reach from bank to bank of the ditch or swale.
- In general, the maximum spacing between check dams should be such that the toe of the upstream check dam is at the same elevation as the top of the downstream check dam.
- During installation, place rock mechanically or by hand.

## 4.0 TIMING

- Install prior to land disturbing activities.
- Remove after surrounding area has been permanently stabilized, or immediately prior to installation of a non-erodible lining. Permanently stabilize bare areas caused by check dams after removal.

## 5.0 MAINTENANCE

- Remove and properly dispose of sediment when it has accumulated to 1/2 of the height of the check dam crest.
- Replace missing rocks causing voids in the check dam.
- Inspect for erosion along the ends of check dams and repair when necessary.

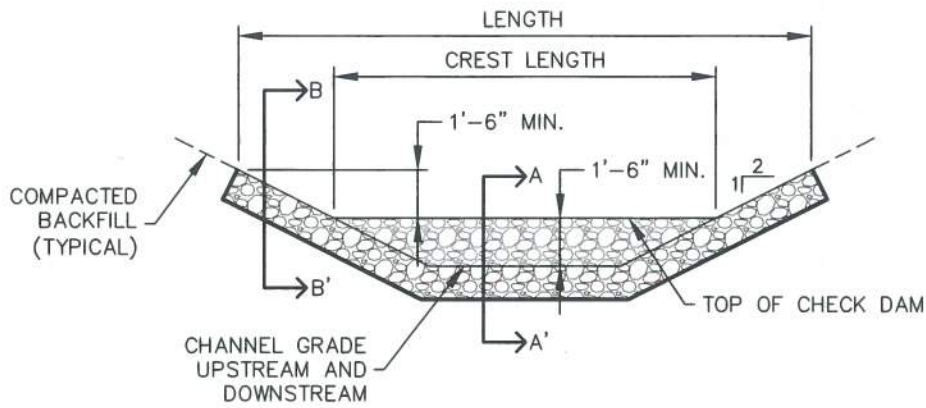

**CHECK DAM ELEVATION VIEW**

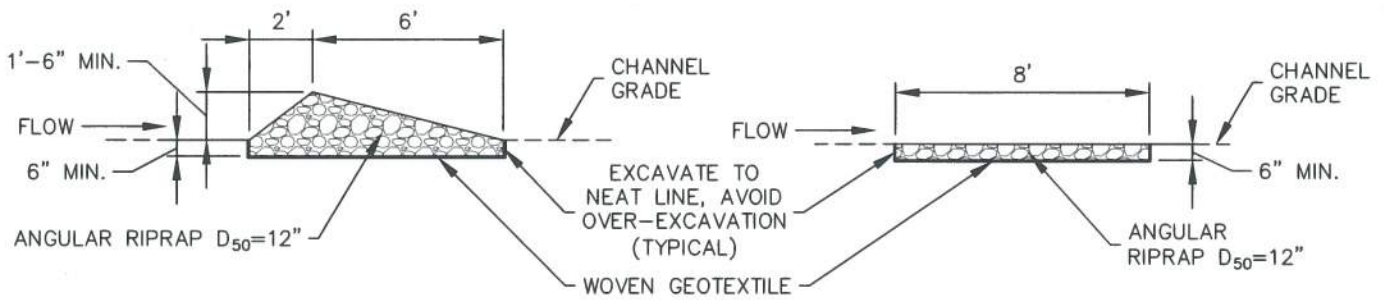

**SECTION A-A'**

**SECTION B-B'**

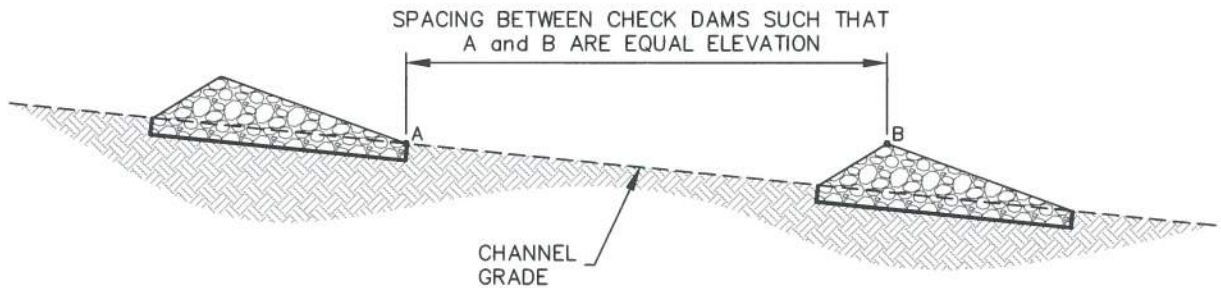

**PROFILE**

**INSTALLATION NOTES**

1. CHECK DAMS SHOULD BE INSTALLED BEFORE UPSTREAM LAND DISTURBING ACTIVITIES.
2. RIPRAP PAD SHOULD BE TRENCHED INTO GROUND BY A MINIMUM OF 6".

**MAINTENANCE NOTES**

1. FREQUENT OBSERVATIONS AND MAINTENANCE ARE NECESSARY TO MAINTAIN CONTROL MEASURES IN EFFECTIVE OPERATING CONDITION. INSPECTIONS AND CORRECTIVE MEASURES SHOULD BE DOCUMENTED THOROUGHLY.
2. ACCUMULATED SEDIMENT MUST BE REMOVED WHEN THE HEIGHT REACHES 1/2 THE HEIGHT OF THE CHECK DAM CREST.
3. CHECK DAMS MUST REMAIN UNTIL THE UPSTREAM DISTURBANCE AREA IS STABILIZED.
4. PERMANENTLY STABILIZE AREA AFTER CHECK DAMS ARE REMOVED IF REMOVAL IS REQUIRED.



<b>CHECK DAM</b>		
APPROVED: 		
SWENT MANAGER		
ISSUED: 10/7/19	REVISED: 8/19/2020	DRAWING NO. 900-CD



# CULVERT INLET PROTECTION

## CIP



## 1.0 DESCRIPTION

- Culvert inlet protection consists of a permeable sediment barrier installed upstream of a flared end section entrance to a culvert or storm sewer.

## 2.0 PURPOSE

- Used to prevent sediment and debris from entering a culvert or storm drainage system prior to permanent stabilization of the contributing disturbed area.
- Culvert inlet protection slows down runoff velocity to filter runoff and to promote sedimentation prior to entry into a culvert or storm drainage system.

## 3.0 IMPLEMENTATION

- Install culvert inlet protection at flared end section inlets to culverts and storm sewers that are operable and receiving runoff from disturbed areas during construction.
- Culvert inlet protection is not a stand-alone control measure and should be used in conjunction with other upgradient control measures. Culvert inlet protection with a contributing drainage area including of one acre or more of disturbed area must be part of a treatment train.

## 4.0 TIMING

- Install prior to land disturbing activities, or immediately after pipe installation.
- Remove and properly dispose of culvert inlet protection after the contributing drainage area has been permanently stabilized.

## 5.0 MAINTENANCE

- Remove and properly dispose of sediment when it has accumulated to 1/2 of the height of the rock sock.
- Inspect for displaced rock socks that are no longer protecting the inlet.

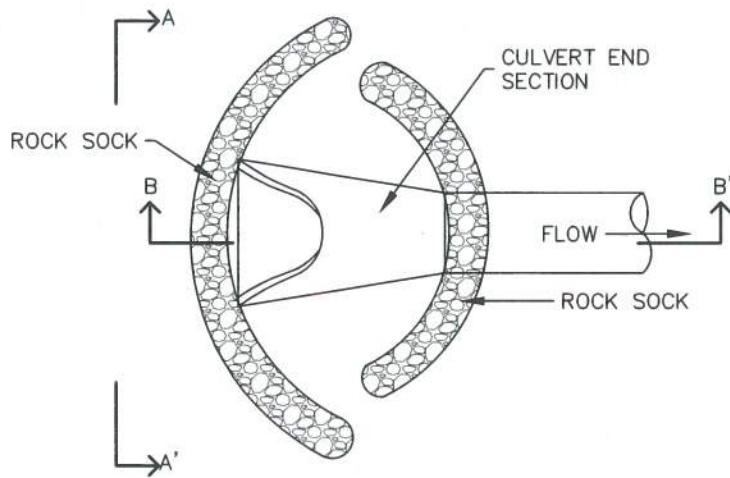

**CULVERT INLET PROTECTION PLAN**

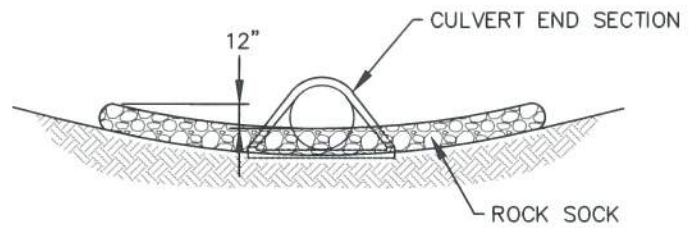

**SECTION A-A'**

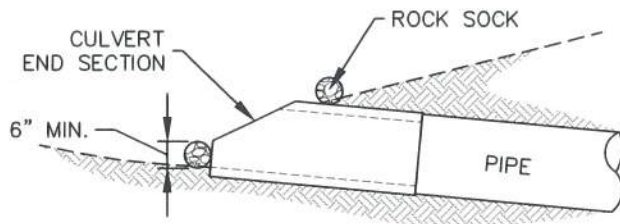

**SECTION B-B'**

**INSTALLATION NOTES**

1. SEE ROCK SOCK DETAIL.

**MAINTENANCE NOTES**

1. FREQUENT OBSERVATIONS AND MAINTENANCE ARE NECESSARY TO MAINTAIN CONTROL MEASURES IN EFFECTIVE OPERATING CONDITION. INSPECTIONS AND CORRECTIVE MEASURES SHOULD BE DOCUMENTED THOROUGHLY.
2. ACCUMULATED SEDIMENT UPSTREAM OF THE CULVERT SHALL BE REMOVED WHEN THE SEDIMENT DEPTH IS  $\frac{1}{2}$  HEIGHT OF THE ROCK SOCK.
3. CULVERT INLET PROTECTION SHALL REMAIN UNTIL THE UPSTREAM AREA IS PERMANENTLY STABILIZED.



<b>CULVERT INLET PROTECTION</b>		
APPROVED: 		
SWENT MANAGER		
ISSUED: 10/7/19	REVISED: 8/19/2020	DRAWING NO. 900-CIP

# CONCRETE WASHOUT AREA

## CWA





## 1.0 DESCRIPTION

- Concrete washout areas consist of either an excavated pit or a prefabricated haul-away container designed to contain concrete and concrete waste water.

## 2.0 PURPOSE

- Used to contain concrete and concrete waste water when the chutes of concrete mixers and hoppers of concrete pumps are rinsed out after delivery.
- Concrete washout areas consolidate solids for easier disposal and prevent runoff of concrete waste water, which is alkaline and contains high levels of chromium.

## 3.0 IMPLEMENTATION

- Locate at least 50 feet away from State Waters, measured horizontally. Unlined concrete washout areas must be located at least 400 feet away from State Waters, and at least 1000 feet away from wells or drinking water sources.
- Do not locate in areas where shallow groundwater may be present, such as near natural drainages, springs, or wetlands.
- Do not place in areas subject to run-on.
- Label areas with appropriate signage.
- The addition of solvents, flocculents, or acid to wash water is prohibited.

## 4.0 TIMING

- Install prior to concrete activities.
- Remove after concrete activities have concluded.

## 5.0 MAINTENANCE

- Clean out facilities once they are 2/3 full, or construct new facilities for additional capacity.
- Concrete waste must be permanently disposed of off-site in an appropriate manner.

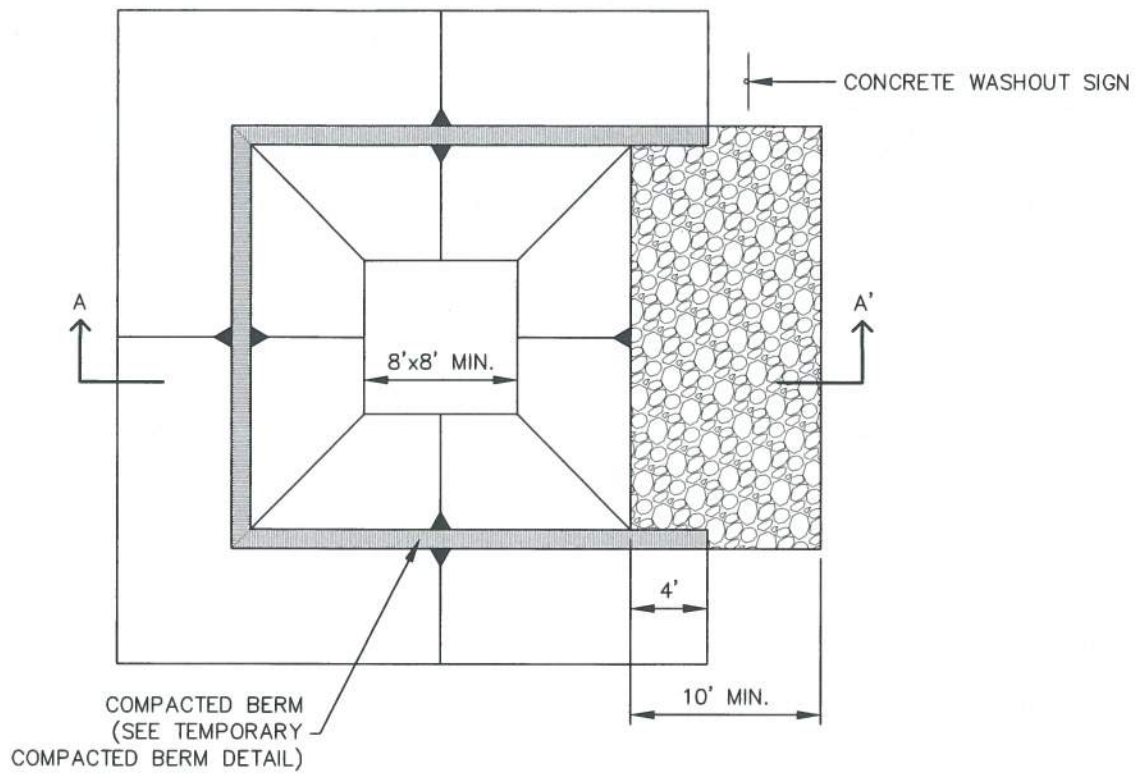

**CONCRETE WASHOUT AREA PLAN**

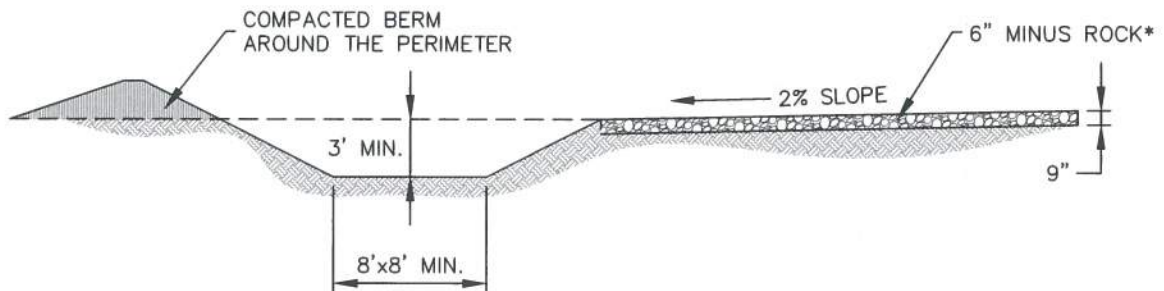

**SECTION A-A'**

\*ROCK REQUIRED BASED ON  
SITE CONDITIONS AT THE  
DISCRETION OF THE GEC  
INSPECTOR



**CONCRETE  
WASHOUT AREA**

APPROVED: 		
SWENT MANAGER		
ISSUED: 10/7/19	REVISED: 8/19/2020	DRAWING NO. 900-CWA-1

INSTALLATION NOTES

1. SEE PLAN VIEW FOR:  
-LOCATION OF CONCRETE WASHOUT AREA
2. LOCATE AT LEAST 50' AWAY FROM STATE WATERS MEASURED HORIZONTALLY.
3. AN IMPERMEABLE LINER (16 MIL. MINIMUM THICKNESS) IS REQUIRED IF CONCRETE WASH AREA IS LOCATED WITHIN 400' OF STATE WATERS OR 1000' OF WELLS OR DRINKING WATER SOURCES.
4. DO NOT LOCATE IN AREAS WHERE SHALLOW GROUNDWATER MAY BE PRESENT.
5. THE CONCRETE WASH AREA SHALL BE INSTALLED PRIOR TO CONCRETE PLACEMENT ON SITE.
6. CONCRETE WASH AREA SHALL INCLUDE A FLAT SUBSURFACE PIT THAT IS AT LEAST 8' BY 8'.
7. BERM SURROUNDING SIDES AND BACK OF CONCRETE WASH AREA SHALL HAVE A MINIMUM HEIGHT OF 2 FEET.
8. CONCRETE WASH AREA ENTRANCE SHALL BE SLOPED 2% TOWARDS THE CONCRETE WASH AREA.
9. SIGNS SHALL BE PLACED AT THE CONCRETE WASH AREA.
10. USE EXCAVATED MATERIAL FOR PERIMETER BERM CONSTRUCTION.

MAINTENANCE NOTES

1. FREQUENT OBSERVATIONS AND MAINTENANCE ARE NECESSARY TO MAINTAIN CONTROL MEASURES IN EFFECTIVE OPERATING CONDITION. INSPECTIONS AND CORRECTIVE MEASURES SHOULD BE DOCUMENTED THOROUGHLY.
2. THE CONCRETE WASH AREA SHALL BE REPAIRED, CLEANED, OR ENLARGED AS NECESSARY TO MAINTAIN CAPACITY FOR CONCRETE WASTE. CONCRETE MATERIALS ACCUMULATED IN THE PIT SHALL BE REMOVED ONCE THE MATERIALS HAVE REACHED A DEPTH OF  $\frac{2}{3}$  THE HEIGHT OF THE CONCRETE WASH AREA.
3. CONCRETE WASHOUT WATER, WASTED PIECES OF CONCRETE, AND ALL OTHER DEBRIS IN THE SUBSURFACE PIT SHALL BE TRANSPORTED FROM THE JOB SITE IN A WATER-TIGHT CONTAINER AND DISPOSED OF PROPERLY.
4. THE CONCRETE WASH AREA SHALL REMAIN IN PLACE UNTIL ALL CONCRETE FOR THE PROJECT IS PLACED.
5. PERMANENTLY STABILIZE AREA AFTER CONCRETE WASH AREA IS REMOVED.

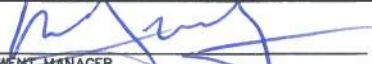

<b>CONCRETE WASHOUT AREA</b>		
APPROVED: 		
SWENT MANAGER		
ISSUED: 10/7/19	REVISED: 8/19/2020	DRAWING NO. 900-CWA-2

# EROSION CONTROL BLANKET

## ECB





## 1.0 DESCRIPTION

- Woven blankets made of natural and biodegradable materials placed on disturbed areas and secured to the ground with staples or stakes.

## 2.0 PURPOSE

- Used to control erosion, retain sediment resulting from sheet flow, and protect newly seeded areas.

## 3.0 IMPLEMENTATION

- Install erosion control blankets over uniform surfaces, with no large rocks, vegetation, or rills.
- Properly prepare topsoil and apply seed prior to blanket installation.
- Erosion control blankets must be made from 100% natural and biodegradable materials.
- Turf reinforcement mats may be used in place of erosion control blankets when specified by engineer.

## 4.0 TIMING

- Install in disturbed areas after final grading and seeding has been completed.
- Leave erosion control blankets in place to biodegrade, or remove if required by the GEC Inspector.

## 5.0 MAINTENANCE

- Any erosion control blanket pulled out, torn, or otherwise damaged shall be repaired or reinstalled.
- Any subgrade areas below the geotextile that have eroded to create a void under the blanket, or that remain devoid of grass shall be repaired, reseeded and mulched and the erosion control blanket reinstalled.
- Broken or damaged staking must be repaired immediately when identified.

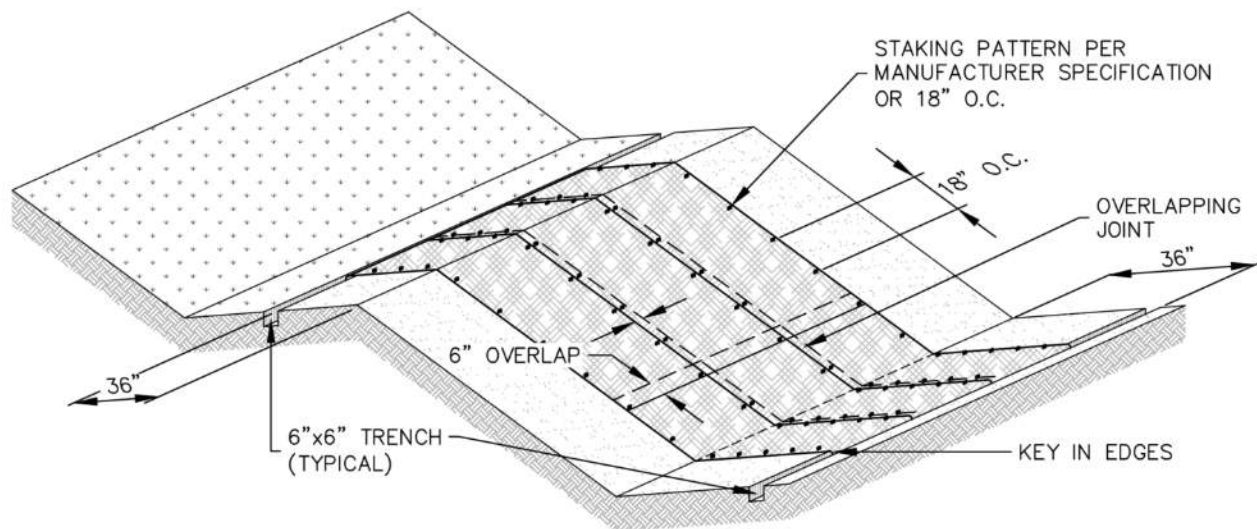

**EROSION CONTROL BLANKET**

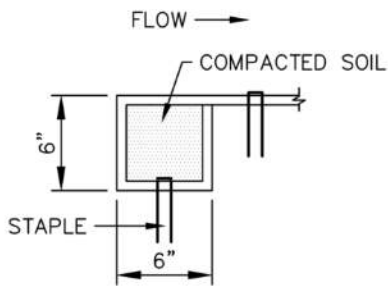

**PERIMETER ANCHOR TRENCH**

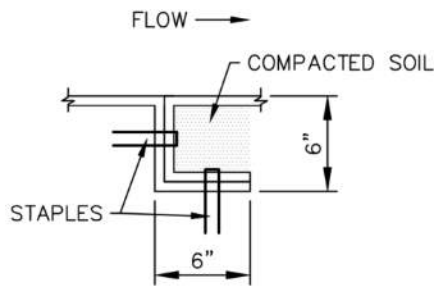

**JOINT ANCHOR TRENCH**

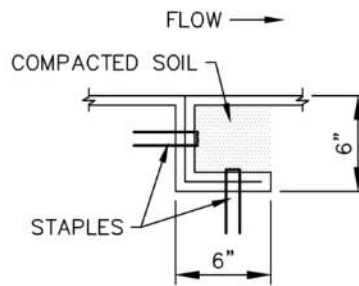

**INTERMEDIATE CHECK SLOT**

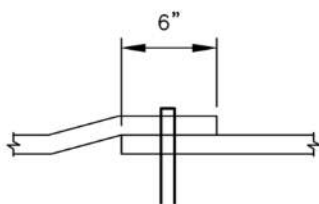

**OVERLAPPING JOINT**

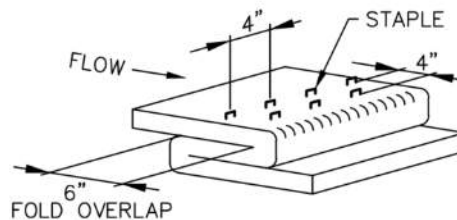

**STAPLE CHECK**  
TO BE USED ON SLOPE EVERY 15 FEET



<b>EROSION CONTROL BLANKET</b>		
APPROVED: 		
SWENT MANAGER		
ISSUED: 10/7/19	REVISED: 8/19/2020	DRAWING NO. 900-ECB-1

**INSTALLATION NOTES**

1. 100% NATURAL AND BIODEGRADABLE MATERIALS ARE REQUIRED FOR EROSION CONTROL BLANKETS. TRM PRODUCTS MAY BE USED WHERE APPROPRIATE AS DESIGNATED BY THE ENGINEER.
2. IN AREAS WHERE EROSION CONTROL BLANKETS ARE SHOWN ON THE PLANS, THE PERMITTEE SHALL PLACE TOPSOIL AND PERFORM FINAL GRADING, SURFACE PREPARATION, AND SEEDING AND MULCHING. SUBGRADE SHALL BE SMOOTH AND MOIST PRIOR TO EROSION CONTROL BLANKET INSTALLATION, AND THE EROSION CONTROL BLANKET SHALL BE IN FULL CONTACT WITH THE SUBGRADE. NO GAPS OR VOIDS SHALL EXIST UNDER THE BLANKET.
3. PERIMETER ANCHOR TRENCH SHALL BE USED ALONG THE OUTSIDE PERIMETER OF ALL BLANKET AREAS.
4. JOINT ANCHOR TRENCH SHALL BE USED TO JOIN ROLLS OF EROSION CONTROL BLANKETS TOGETHER (LONGITUDINALLY AND TRANSVERSELY) FOR ALL EROSION CONTROL BLANKETS.
5. INTERMEDIATE CHECK SLOT OR STAPLE CHECK SHALL BE INSTALLED EVERY 15' DOWN SLOPES. IN DRAINAGEWAYS, INSTALL CHECK SLOTS EVERY 25' PERPENDICULAR TO FLOW DIRECTION.
6. OVERLAPPING JOINT DETAIL SHALL BE USED TO JOIN ROLLS OF EROSION CONTROL BLANKETS TOGETHER FOR EROSION CONTROL BLANKETS ON SLOPES.
7. MATERIAL SPECIFICATIONS OF EROSION CONTROL BLANKETS SHALL CONFORM TO TABLE ECB-1.
8. ANY AREAS OF SEEDING AND MULCHING DISTURBED IN THE PROCESS OF INSTALLING EROSION CONTROL BLANKETS SHALL BE RESEEDED AND MULCHED.
9. STRAW EROSION CONTROL BLANKETS SHALL NOT BE USED WITHIN STREAMS AND DRAINAGE CHANNELS.
10. COMPACT ALL TRENCHES.

**MAINTENANCE NOTES**

1. FREQUENT OBSERVATIONS AND MAINTENANCE ARE NECESSARY TO MAINTAIN CONTROL MEASURES IN EFFECTIVE OPERATING CONDITION. INSPECTIONS AND CORRECTIVE MEASURES SHOULD BE DOCUMENTED THOROUGHLY.
2. EROSION CONTROL BLANKETS SHALL BE LEFT IN PLACE TO EVENTUALLY BIODEGRADE. TRM MUST BE REMOVED AT THE DISCRETION OF THE GEC INSPECTOR.
3. ANY EROSION CONTROL BLANKET PULLED OUT, TORN, OR OTHERWISE DAMAGED SHALL BE REPAIRED OR REINSTALLED. ANY SUBGRADE AREAS BELOW GEOTEXTILE THAT HAVE ERODED TO CREATE A VOID UNDER THE BLANKET, OR THAT REMAIN DEVOID OF GRASS SHALL BE REPAIRED, RESEEDED AND MULCHED AND THE EROSION CONTROL BLANKET REINSTALLED.

TABLE ECB-1, EROSION CONTROL BLANKET MATERIAL SPECIFICATIONS

TYPE	COCONUT CONTENT	STRAW CONTENT	EXCELSIOR CONTENT	RECOMMENDED NETTING
STRAW	-	100%	-	DOUBLE/NATURAL
STRAW-COCONUT	30% MIN.	70% MAX.	-	DOUBLE/NATURAL
COCONUT	100%	-	-	DOUBLE/NATURAL
EXCELSIOR	-	-	100%	DOUBLE/NATURAL



**EROSION CONTROL BLANKET**

APPROVED:   
SWENT MANAGER

ISSUED: 10/7/19	REVISED: 8/19/2020	DRAWING NO. 900-ECB-2
--------------------	-----------------------	--------------------------



# INLET PROTECTION

## IP





## 1.0 DESCRIPTION

- Inlet protection consists of a permeable sediment barrier installed around a storm inlet.

## 2.0 PURPOSE

- Used to minimize the amount of sediment and debris entering a storm drainage system prior to permanent stabilization of the contributing disturbed area.
- Inlet protection slows down runoff velocity to filter runoff and to promote sedimentation prior to entry into a storm drainage system.

## 3.0 IMPLEMENTATION

- Install inlet protection at storm sewer inlets that are operable and receiving runoff from disturbed areas during construction.
- Place inlet protection to allow the inlet to function without completely blocking flows into the inlet in a manner than causes localized flooding.
- Inlet protection is not a stand-alone control measure and should be used in conjunction with other upgradient control measures. Inlet protection in areas with a contributing drainage area of one acre or larger must be part of a treatment train.
- When selecting the type of inlet protection, consider factors such as type of inlet, traffic, anticipated flows, ability to secure the inlet protection, safety, and other site-specific conditions.

## 4.0 TIMING

- Install prior to land disturbing activities, or immediately after inlet installation.
- Remove and properly dispose of inlet protection after the contributing drainage area has been permanently stabilized.

## 5.0 MAINTENANCE

- Remove and properly dispose of sediment when it has accumulated to 1/2 of the design depth of the inlet barrier.
- Inspect for holes or tears that can result in sediment directly entering the inlet.
- Inspect for displaced inlet protection that is no longer protecting the inlet.

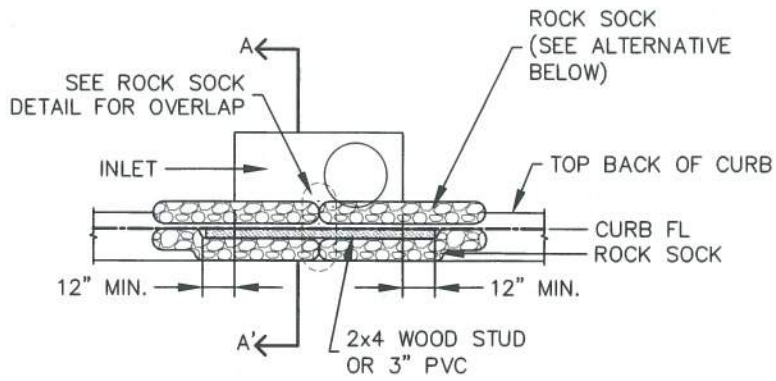

**CURB INLET PROTECTION PLAN**

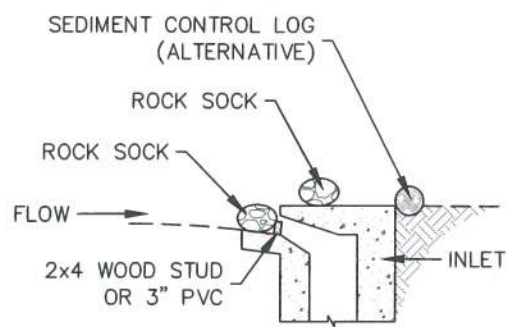

**SECTION A-A'**

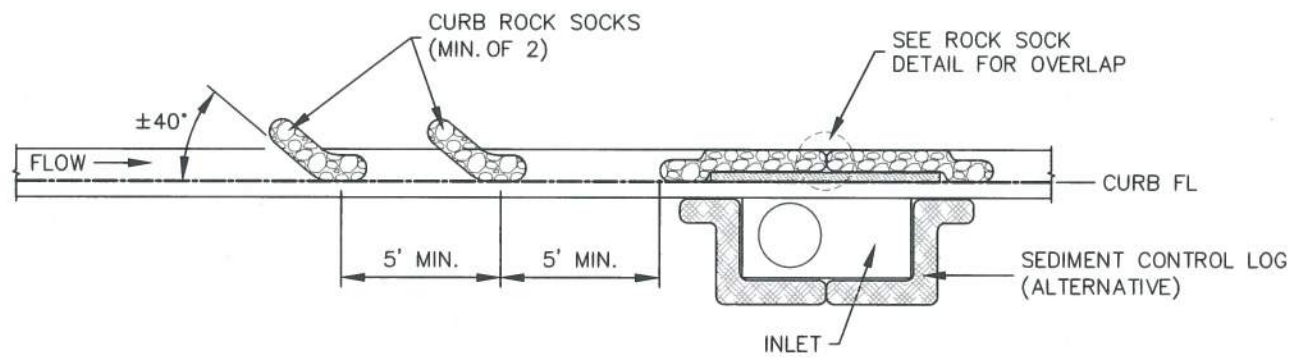

**CURB ROCK SOCKS UPSTREAM OF INLET PROTECTION**

**INSTALLATION NOTES**

1. SEE ROCK SOCK DETAIL FOR INSTALLATION REQUIREMENTS.
2. PLACEMENT OF THE ROCK SOCK SHALL BE APPROXIMATELY 40 DEGREES FROM THE CURB.
3. ROCK SOCKS ARE TO BE FLUSH WITH THE CURB AND SPACED A MINIMUM OF 5' APART.
4. AT LEAST TWO CURB ROCK SOCKS IN SERIES ARE REQUIRED UPSTREAM OF ON-GRADE INLETS.
5. ADDITIONAL ROCK SOCKS MAY BE REQUIRED AT GEC INSPECTOR'S DISCRETION.

**MAINTENANCE NOTES**

1. FREQUENT OBSERVATIONS AND MAINTENANCE ARE NECESSARY TO MAINTAIN CONTROL MEASURES IN EFFECTIVE OPERATING CONDITION. INSPECTIONS AND CORRECTIVE MEASURES SHOULD BE DOCUMENTED THOROUGHLY.
2. ACCUMULATED SEDIMENT MUST BE REMOVED WHEN THE HEIGHT REACHES 1/2 OF THE DESIGN DEPTH OF THE INLET BARRIER.
3. ROCK SOCKS MUST REMAIN UNTIL THE UPSTREAM DISTURBANCE AREA IS STABILIZED.
4. PERMANENTLY STABILIZE AREA BEHIND INLET AFTER ROCK SOCKS ARE REMOVED WHEN REMOVAL IS APPROPRIATE.

IP-1



<b>ON-GRADE INLET PROTECTION</b>		
APPROVED: <i>[Signature]</i>		
SWENT MANAGER		
ISSUED: 10/7/19	REVISED: 8/19/2020	DRAWING NO. 900-IP-1

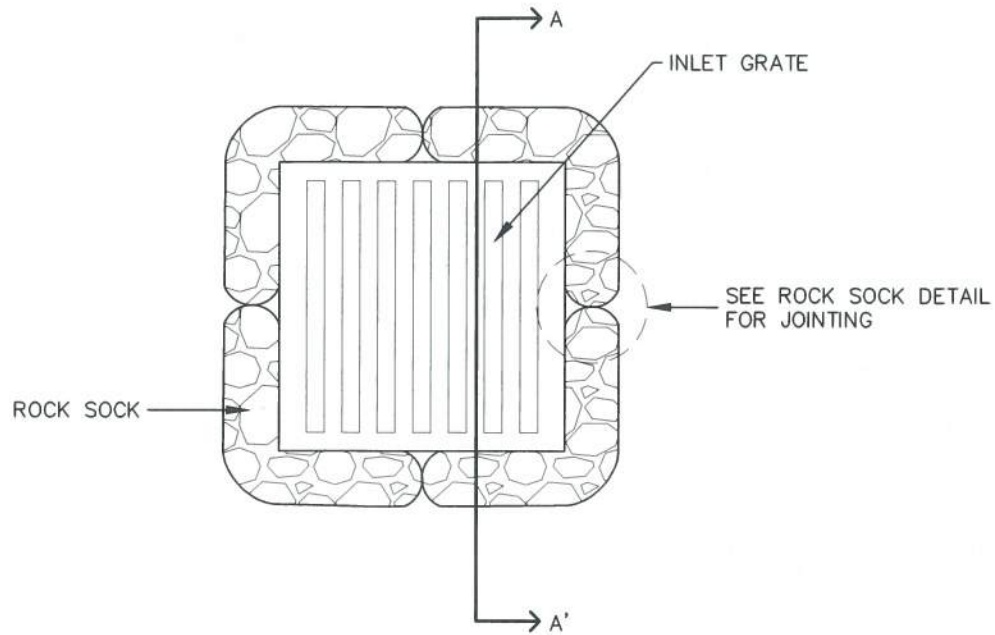

**ROCK SOCK SUMP INLET PROTECTION PLAN**

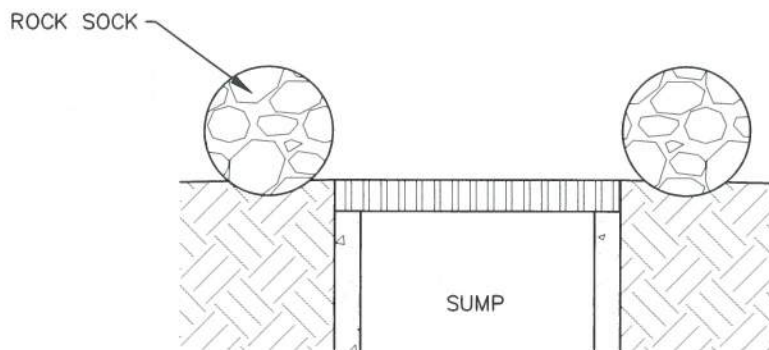

**SECTION A-A'**



**INSTALLATION NOTES**

1. SEE ROCK SOCK DETAIL FOR INSTALLATION REQUIREMENTS.
2. SEDIMENT CONTROL LOGS MAY BE USED IN PLACE OF ROCK SOCKS IN PERVIOUS AREAS. INSTALL PER SEDIMENT CONTROL LOG DETAIL
3. CONTROL MEASURES MUST BE WRAPPED AROUND INLET AS TIGHTLY AS POSSIBLE.

**MAINTENANCE NOTES**

1. FREQUENT OBSERVATIONS AND MAINTENANCE ARE NECESSARY TO MAINTAIN CONTROL MEASURES IN EFFECTIVE OPERATING CONDITION. INSPECTIONS AND CORRECTIVE MEASURES SHOULD BE DOCUMENTED THOROUGHLY.
2. ACCUMULATED SEDIMENT MUST BE REMOVED WHEN THE HEIGHT REACHES 1/2 OF THE DESIGN DEPTH OF THE INLET BARRIER.
3. ROCK SOCKS MUST REMAIN UNTIL THE UPSTREAM DISTURBANCE AREA IS STABILIZED.
4. PERMANENTLY STABILIZE AREA AROUND INLET AFTER ROCK SOCKS ARE REMOVED WHEN REMOVAL IS APPROPRIATE.

IP-2

	<b>SUMP INLET PROTECTION</b>		
	APPROVED:	 <small>SWENT MANAGER</small>	
ISSUED:	REVISED:	DRAWING NO.	
10/7/19	8/19/2020	900-IP-2	



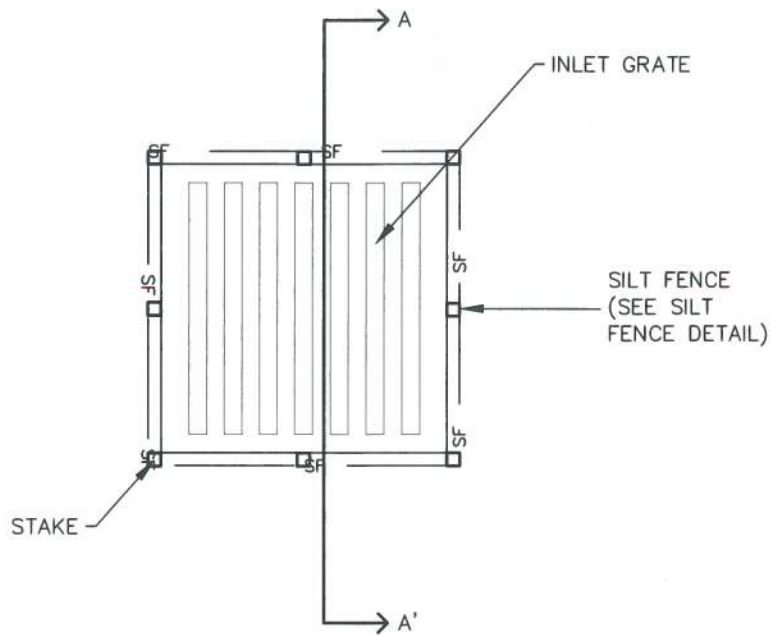

**SILT FENCE SUMP INLET PROTECTION PLAN**

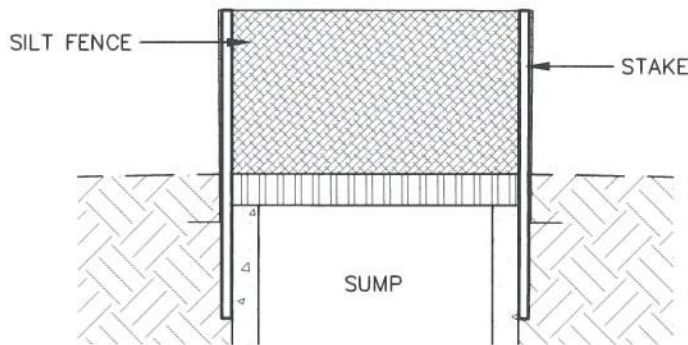

**SECTION A-A'**

**INSTALLATION NOTES**

1. SEE SILT FENCE DETAIL FOR INSTALLATION REQUIREMENTS.
2. POSTS SHALL BE PLACED AT EACH CORNER OF THE INLET AND AROUND THE EDGES AT A MAXIMUM SPACING OF THREE FEET.
3. SILT FENCE FABRIC SHOULD HAVE A FLOW RATE IN EXCESS OF 30 GALLONS PER MINUTE PER SQUARE YARD SO AS TO ALLOW SOME WATER FLOW AND NOT DAM THE WATER. STANDARD, LOW-FLOW SILT FENCE FABRIC WILL NOT BE ALLOWED.

**MAINTENANCE NOTES**

1. FREQUENT OBSERVATIONS AND MAINTENANCE ARE NECESSARY TO MAINTAIN CONTROL MEASURES IN EFFECTIVE OPERATING CONDITION. INSPECTIONS AND CORRECTIVE MEASURES SHOULD BE DOCUMENTED THOROUGHLY.
2. ACCUMULATED SEDIMENT MUST BE REMOVED WHEN THE HEIGHT REACHES 1/2 OF THE DESIGN DEPTH OF THE INLET BARRIER.
3. SILT FENCE MUST REMAIN UNTIL THE UPSTREAM DISTURBANCE AREA IS STABILIZED.
4. PERMANENTLY STABILIZE AREA AROUND INLET AFTER SILT FENCE IS REMOVED WHEN REMOVAL IS APPROPRIATE.

IP-3

	<b>SUMP INLET PROTECTION</b>		
	APPROVED:		
	SWENT MANAGER		
ISSUED: 10/7/19	REVISED: 8/19/2020	DRAWING NO. 900-IP-3	



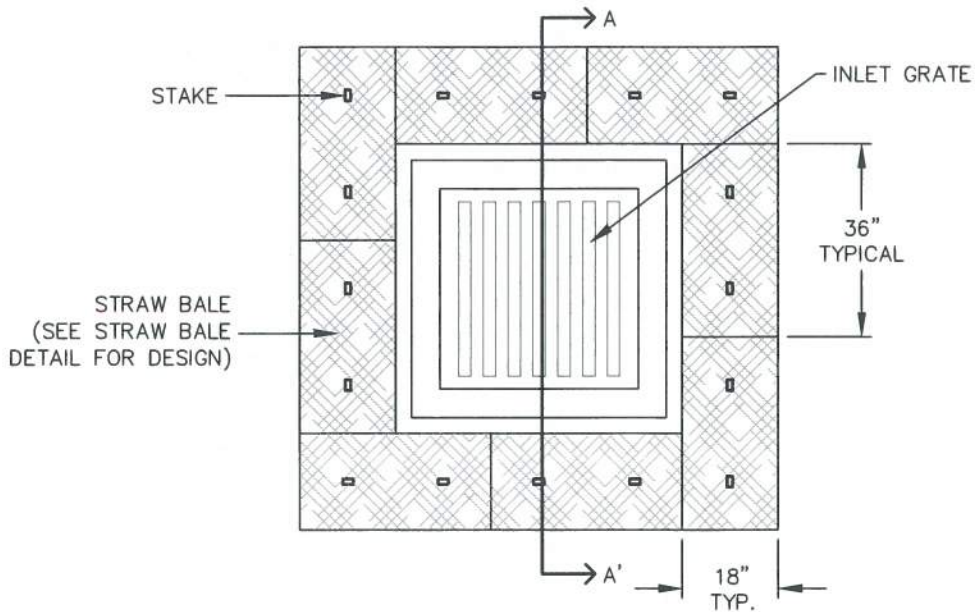

**STRAW BALE SUMP INLET PROTECTION PLAN**

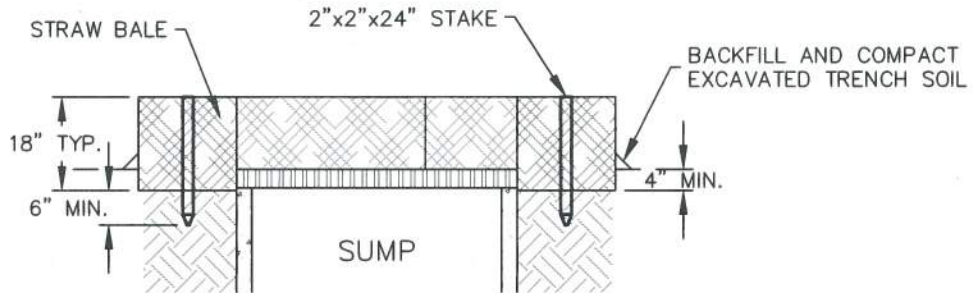

**SECTION A-A'**

**INSTALLATION NOTES**

1. BALES SHALL BE PLACED IN A SINGLE ROW AROUND THE INLET WITH THE ENDS OF THE BALES TIGHTLY ABUTTING ONE ANOTHER.
2. STRAW BALES SHALL CONSIST OF CERTIFIED WEED FREE STRAW OR HAY. LOCAL JURISDICTIONS MAY REQUIRE PROOF THAT BALES ARE WEED FREE.
3. STRAW BALES SHALL CONSIST OF APPROXIMATELY 5 CUBIC FEET OF STRAW OR HAY AND WEIGH NOT LESS THAN 35 POUNDS.
4. STRAW BALE DIMENSIONS SHALL BE APPROXIMATELY 36"x18"x18".
5. A UNIFORM ANCHOR TRENCH SHALL BE EXCAVATED TO A DEPTH OF 4". STRAW BALES SHALL BE PAVED SO THAT THE BINDING TWINE IS ENCOMPASSING THE VERTICAL SIDES OF THE BALE(S).
6. TWO (2) WOODEN STAKES SHALL BE USED TO HOLD EACH BALE IN PLACE. WOODEN STAKES SHALL BE 2"x2"x24 (MIN.)". WOODEN STAKES SHALL BE DRIVEN A MINIMUM OF 6" INTO THE GROUND.

**MAINTENANCE NOTES**

1. FREQUENT OBSERVATIONS AND MAINTENANCE ARE NECESSARY TO MAINTAIN CONTROL MEASURES IN EFFECTIVE OPERATING CONDITION. INSPECTIONS AND CORRECTIVE MEASURES SHOULD BE DOCUMENTED THOROUGHLY.
2. ACCUMULATED SEDIMENT MUST BE REMOVED WHEN THE HEIGHT REACHES 1/2 OF THE DESIGN DEPTH OF THE INLET BARRIER.
3. STRAW BALES MUST REMAIN UNTIL THE UPSTREAM DISTURBANCE AREA IS STABILIZED.
4. PERMANENTLY STABILIZE AREA AROUND INLET AFTER STRAW BALES ARE REMOVED WHEN REMOVAL IS APPROPRIATE.
5. STRAW BALES SHALL BE REPLACED IF THEY BECOME HEAVILY SOILED, ROTTEN OR DAMAGED BEYOND REPAIR.

IP-4



**SUMP INLET PROTECTION**

APPROVED:   
SWENT MANAGER

ISSUED: 10/7/19	REVISED: 8/19/2020	DRAWING NO. 900-IP-4
--------------------	-----------------------	-------------------------

# PORTABLE TOILET

## PT



## 1.0 DESCRIPTION

- The portable toilet detail provides requirements for portable toilet use on construction sites.

## 2.0 PURPOSE

- Used to minimize the risk of pollutant migration to State Waters.

## 3.0 IMPLEMENTATION

- Place portable toilet a minimum of 10 feet from the back of curb or on a trailer for road projects or sites that are mostly paved.
- Anchor portable toilet to the ground, at a minimum of two opposing corners (on a diagonal) using U-shaped rebar stakes.

## 4.0 TIMING

- Install as needed.
- Remove prior to the end of construction. Permanently stabilize any disturbed areas associated with the installation, maintenance, and/or removal of the toilets.

## 5.0 MAINTENANCE

- Portable toilets shall be serviced at the necessary intervals to eliminate the possibility of overflow.



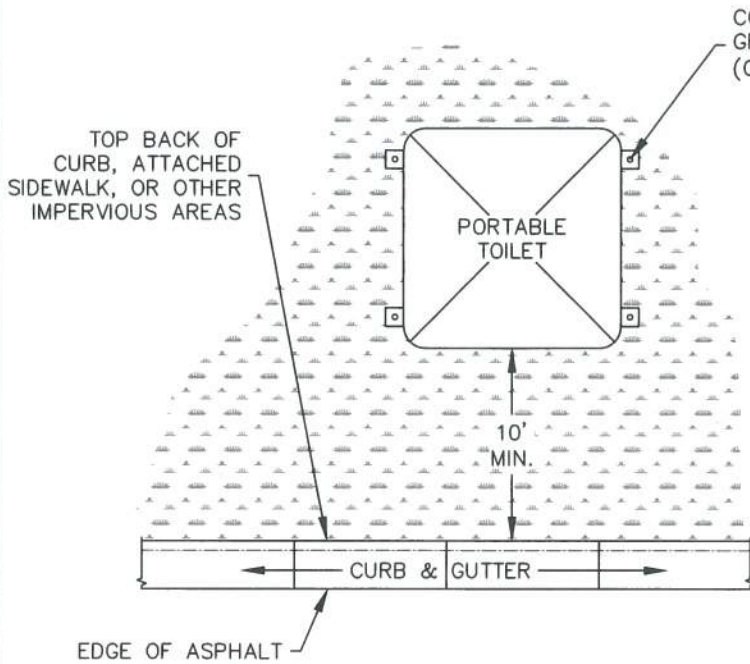

**PORTABLE TOILET PLAN**

CONTRACTOR SHALL ANCHOR PORTABLE TOILET TO THE GROUND, AT A MINIMUM OF TWO OPPOSING CORNERS (ON A DIAGONAL) USING U-SHAPED REBAR STAKES

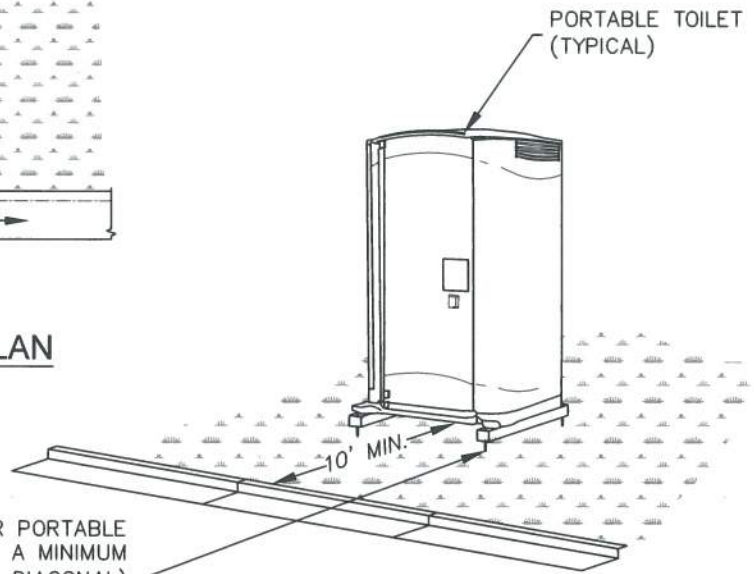

**ISOMETRIC**

CONTRACTOR SHALL ANCHOR PORTABLE TOILET TO THE GROUND, AT A MINIMUM OF TWO OPPOSING CORNERS (ON A DIAGONAL) USING U-SHAPED REBAR STAKES OR OTHER EFFECTIVE ANCHORING

**INSTALLATION NOTES**

1. PORTABLE TOILETS SHALL BE PLACED A MINIMUM OF 10 FEET BEHIND ALL CURBS, SIDEWALKS, AND OTHER IMPERVIOUS AREAS; 50 FEET FROM STORM INLETS, AND 100 FEET FROM WATERWAYS.
2. PORTABLE TOILETS IN THE RIGHT-OF-WAY ARE REQUIRED TO BE PLACED ON MOBILE TRAILERS AND MUST BE ANCHORED OR WEIGHTED DOWN. PORTABLE TOILETS MAY BE INSTALLED IN ACCORDANCE WITH NOTE #1 IN STAGING AREAS/YARDS.
3. PORTABLE TOILETS SHALL BE SECURELY ANCHORED TO THE GROUND USING U-SHAPED REBAR STAKES, OR OTHER EFFECTIVE ANCHORING.
4. ANCHORING SHALL BE POSITIONED ON AT LEAST TWO OPPOSING (DIAGONAL) CORNERS.
5. TOILET CONTAINMENT PANS MAY BE USED IN PLACE OF A TRAILER AT THE GEC INSPECTOR'S DISCRETION. TOILET CONTAINMENT PANS MUST BE ANCHORED IN PLACE AND MUST NOT BE USED WITHIN THE CITY R.O.W.

**MAINTENANCE NOTES**

1. FREQUENT OBSERVATIONS AND MAINTENANCE ARE NECESSARY TO MAINTAIN CONTROL MEASURES IN EFFECTIVE OPERATING CONDITION. INSPECTIONS AND CORRECTIVE MEASURES SHOULD BE DOCUMENTED THOROUGHLY.
2. PORTABLE TOILETS SHALL BE SERVICED AT THE NECESSARY INTERVALS TO ELIMINATE THE POSSIBILITY OF OVERFLOW.
3. WHEN THE PORTABLE TOILETS ARE REMOVED, ANY DISTURBED AREAS ASSOCIATED WITH THE INSTALLATION, MAINTENANCE, AND/OR REMOVAL OF THE TOILETS MUST BE PERMANENTLY STABILIZED.

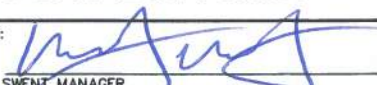

<b>PORTABLE TOILET</b>		
APPROVED: 		
SWENT MANAGER		
ISSUED: 2/19/19	REVISED: 8/19/2020	DRAWING NO. 900-PTM



# ROCK SOCK

## RS



## 1.0 DESCRIPTION

- A rock sock consists of gravel that has been wrapped by wire mesh or a geotextile to form an elongated cylindrical filter.

## 2.0 PURPOSE

- Used to slow down the velocity of runoff to filter runoff and to promote sedimentation.
- Rock socks are typically used as either perimeter control or as a part of inlet protection.

## 3.0 IMPLEMENTATION

- Rock socks do not require trenching or staking, and are able to be placed on hard surfaces where trenching or staking would be impossible.
- The maximum tributary drainage area per 100 liner feet of rock socks is 1/4 acre.
- When placed in a gutter adjacent to a curb, rock socks should protrude no more than two feet from the curb in order for traffic to pass safely.
- Proprietary rock socks can be used in place of wire mesh rock socks.

## 4.0 TIMING

- Install prior to land disturbing activities, or immediately after inlet installation.
- Remove and properly dispose of inlet protection after the contributing drainage area has been permanently stabilized.

## 5.0 MAINTENANCE

- Remove and properly dispose of sediment when it has accumulated to 1/2 of the height of the rock sock.
- Inspect for and replace damaged or displaced rock socks.

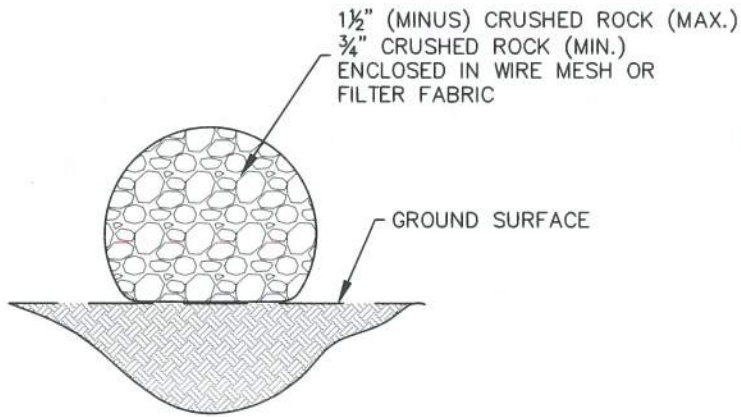

**ROCK SOCK SECTION**

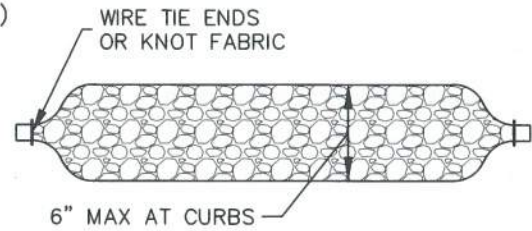

**ROCK SOCK PLAN**

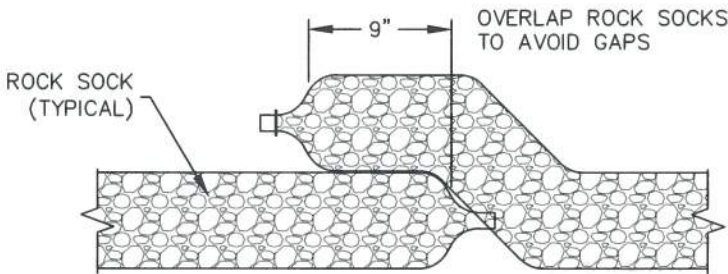

**ROCK SOCK OVERLAP**

**GRADATION TABLE**

	MASS PERCENT PASSING SQUARE MESH SIEVES
	No. 4
2"	100
1 1/2"	90-100
1"	20-55
3/4"	0-15
3/8"	0-5

MATCHES SPECIFICATIONS FOR  
No. 4 COARSE AGGREGATE FOR  
CONCRETE PER AASHTO M-43.  
ALL ROCK SHALL BE FRACTURED  
FACE, ALL SIDES

**INSTALLATION NOTES**

1. CRUSHED ROCK SHALL BE BETWEEN MAX. 1 1/2" (MINUS) IN SIZE WITH A FRACTURED FACE (ALL SIDES) AND SHALL COMPLY WITH GRADATION SHOWN ON THIS SHEET AND MIN. 3/4" CRUSHED ROCK.
2. WIRE MESH SHALL HAVE OPENINGS SMALLER THAN THE SMALLEST SIZE ROCK.
3. WIRE MESH SHALL BE SECURED USING 'HOG RINGS' OR WIRE TIES AT 6" CENTERS ALONG ALL JOINTS AND AT 2" CENTERS ON ENDS OF SOCKS.

**MAINTENANCE NOTES**

1. FREQUENT OBSERVATIONS AND MAINTENANCE ARE NECESSARY TO MAINTAIN CONTROL MEASURES IN EFFECTIVE OPERATING CONDITION. INSPECTIONS AND CORRECTIVE MEASURES SHOULD BE DOCUMENTED THOROUGHLY.
2. ROCK SOCKS SHALL BE REPLACED IF THEY BECOME HEAVILY SOILED OR DAMAGED BEYOND REPAIR.
3. ACCUMULATED SEDIMENT SHALL BE REMOVED WHEN THE DEPTH REACHES 1/2 OF THE HEIGHT OF THE ROCK SOCK.
4. ROCK SOCKS ARE TO REMAIN IN PLACE UNTIL DISTURBED AREA IS STABILIZED.
5. PERMANENTLY STABILIZE AREA AFTER ROCK SOCKS HAVE BEEN REMOVED.



**ROCK SOCK**

APPROVED:   
SWENT MANAGER

ISSUED: 10/7/19	REVISED: 8/19/2020	DRAWING NO. 900-RS
--------------------	-----------------------	-----------------------



# SEDIMENT CONTROL LOG

## SCL





## 1.0 DESCRIPTION

- A sediment control log is a temporary sediment barrier consisting of a linear roll of natural materials such as straw, compost, excelsior or coconut fiber.

## 2.0 PURPOSE

- Used to intercept sheet flow prior to leaving a construction site.
- May be used around the perimeter of a construction site.
- Placed on long slopes to slow down flows.

## 3.0 IMPLEMENTATION

- Install sediment control logs to intercept sheet flow runoff from disturbed areas.
- Install sediment control logs along the contour of slopes or in a manner to avoid creating concentrated flow.
- Place sediment control logs against sidewalk or back of curb when adjacent to these features.
- The maximum tributary drainage area per 100 linear feet of sediment control logs is 1/4 acre.
- Sediment control logs shall consist of straw, compost, excelsior or coconut fiber, and shall be free from any noxious weed seeds or defects.

## 4.0 TIMING

- Install prior to land disturbing activities.
- Remove sediment control logs after the upstream area has been permanently stabilized.

## 5.0 MAINTENANCE

- Remove and properly dispose of sediment when it has accumulated to 1/2 of the height of the exposed sediment control log.
- Inspect for and repair or replace damaged sediment control logs.

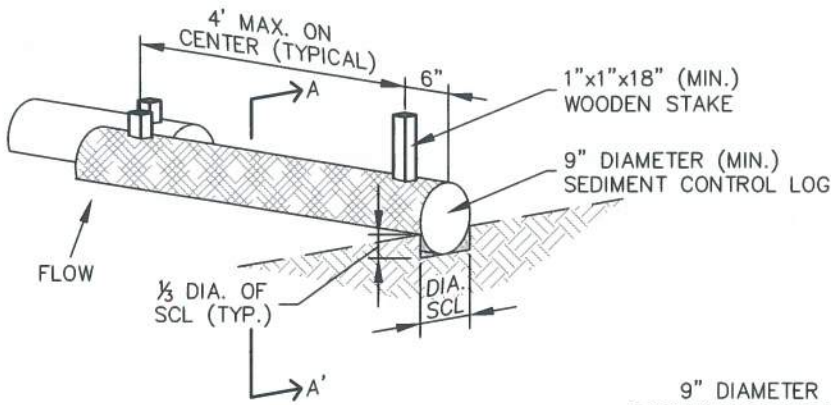

**SEDIMENT CONTROL LOG**

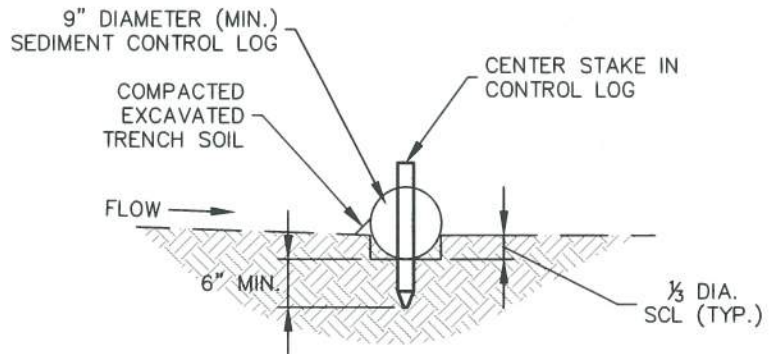

**SECTION A-A'**

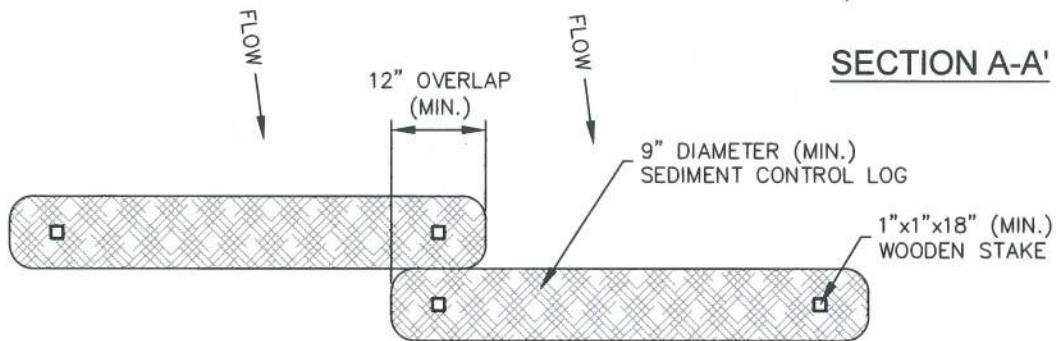

**SEDIMENT CONTROL LOG JOINTS**

**INSTALLATION NOTES**

1. ALL SEDIMENT CONTROL LOGS MUST BE EMBEDDED TO  $\frac{1}{3}$  OF THE HEIGHT OF THE LOG
2. LARGER DIAMETER SEDIMENT CONTROL LOGS NEED TO BE EMBEDDED DEEPER.
3. PLACE SEDIMENT CONTROL LOG AGAINST SIDEWALK OR BACK OF CURB WHEN ADJACENT TO THESE FEATURES.
4. SEDIMENT CONTROL LOGS SHALL CONSIST OF STRAW, COMPOST, EXCELSIOR OR COCONUT FIBER, AND SHALL BE FREE FROM ANY NOXIOUS WEED SEEDS OR DEFECTS INCLUDING RIPS, HOLES AND OBVIOUS WEAR.
5. IF USING AS SLOPE PROTECTION, INSTALL SEDIMENT CONTROL LOGS ALONG THE CONTOUR.

**MAINTENANCE NOTES**

1. FREQUENT OBSERVATIONS AND MAINTENANCE ARE NECESSARY TO MAINTAIN CONTROL MEASURES IN EFFECTIVE OPERATING CONDITION. INSPECTIONS AND CORRECTIVE MEASURES SHOULD BE DOCUMENTED THOROUGHLY.
2. ACCUMULATED SEDIMENT MUST BE REMOVED WHEN THE HEIGHT REACHES  $\frac{1}{2}$  OF THE HEIGHT OF THE SEDIMENT CONTROL LOG.
3. PERMANENTLY STABILIZE AREA AFTER SEDIMENT CONTROL LOGS HAVE BEEN REMOVED.



**SEDIMENT CONTROL LOGS**

APPROVED:   
SWENT MANAGER

ISSUED: 10/7/19	REVISED: 8/19/2020	DRAWING NO. 900-SCL
--------------------	-----------------------	------------------------

# SILT FENCE

## SF



## 1.0 DESCRIPTION

- Silt fence is a temporary sediment barrier consisting of woven geotextile fabric attached to supporting posts and trenched into the soil.

## 2.0 PURPOSE

- Used to intercept sheet flow prior to leaving a construction site.
- May be used around the perimeter of a construction site.

## 3.0 IMPLEMENTATION

- Install silt fence to intercept sheet flow runoff from disturbed areas.
- Silt fence is not designed to be used as a filter fabric.
- Do not install silt fence across streams, channels, swales, ditches, or other drainageways.
- Install silt fence along the contour of slopes or in a manner to avoid creating concentrated flow (i.e. "J-hook" installation).
- The maximum tributary drainage area per 100 liner feet of silt fence is 1/4 acre.
- Properly installed silt fence should not be easily pulled out by hand and there should be no gaps between the ground and fabric.

## 4.0 TIMING

- Install prior to land disturbing activities.
- Remove silt fence after the upstream area has been permanently stabilized.

## 5.0 MAINTENANCE

- Remove and properly dispose of sediment when it has accumulated to 1/2 of the height of the exposed silt fence.
- Inspect for and repair or replace damaged silt fence.



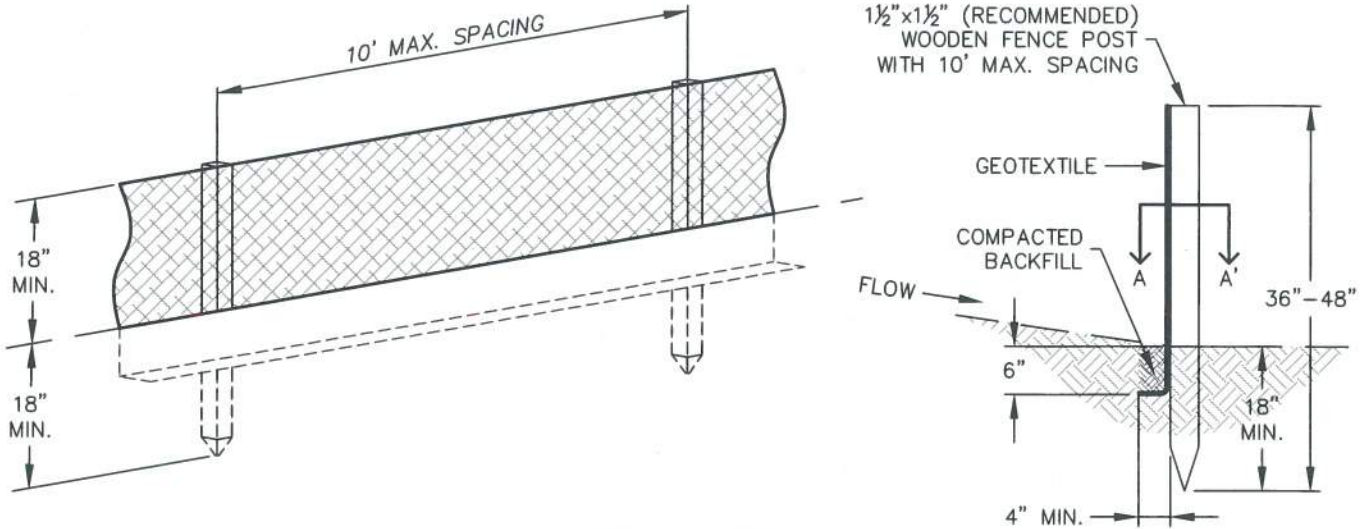

### SILT FENCE

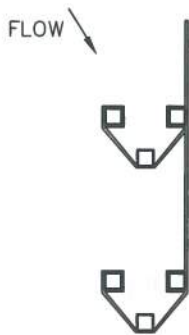

### J-HOOK INSTALLATION

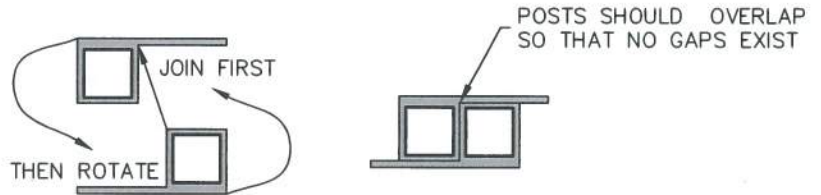

### SECTION A-A'

#### INSTALLATION NOTES

1. SILT FENCE MUST BE PLACED ON A FLAT SURFACE 2'-5' AWAY FROM TOE OF THE SLOPE TO ALLOW FOR PONDING AND DEPOSITION.
2. COMPACT THE TRENCH USING A JUMPING JACK OR WHEEL ROLLING TO THE POINT THAT THE FENCE RESISTS BEING PULLED OUT OF THE GROUND BY HAND.
3. SILT FENCE SHALL BE TAUT WITH NO SAGS AFTER IT HAS BEEN ANCHORED.
4. FABRIC SHALL BE ATTACHED TO POSTS WITH 1" HEAVY DUTY STAPLES OR 1" NAILS. THESE SHOULD BE PLACED VERTICALLY DOWN THE POST, 3" APART.
5. THE PREFERRED INSTALLATION METHOD USES A TRENCHER OR SILT FENCE INSTALLATION DEVICE.
6. INSTALL SILT FENCE ALONG THE CONTOUR OF THE SLOPES OR IN A MANNER TO AVOID CREATING CONCENTRATED FLOW (SUCH AS A "J-HOOK" INSTALLATION).

#### MAINTENANCE NOTES

1. FREQUENT OBSERVATIONS AND MAINTENANCE ARE NECESSARY TO MAINTAIN CONTROL MEASURES IN EFFECTIVE OPERATING CONDITION. INSPECTIONS AND CORRECTIVE MEASURES SHOULD BE DOCUMENTED THOROUGHLY.
2. ACCUMULATED SEDIMENT MUST BE REMOVED WHEN THE HEIGHT REACHES 1/2 OF THE DESIGN HEIGHT OF THE SILT FENCE.
3. SILT FENCE MUST REMAIN UNTIL THE UPSTREAM DISTURBANCE AREA IS STABILIZED.
4. PERMANENTLY STABILIZE AREA AFTER SILT FENCE IS REMOVED.



### SILT FENCE

APPROVED:   
SWENT MANAGER

ISSUED: 10/7/19	REVISED: 8/19/2020	DRAWING NO. 900-SF
--------------------	-----------------------	-----------------------

# SEEDING AND MULCHING

## SM



## 1.0 DESCRIPTION

- The preparation of soil, application of mulch, and application of seed to disturbed areas.

## 2.0 PURPOSE

- Used to control runoff and erosion on disturbed areas by establishing vegetative cover.
- Reduces erosion and sediment loss.
- Provides permanent stabilization in disturbed areas.

## 3.0 IMPLEMENTATION

- All soil testing, soil amendment and fertilizer documentation, and seed load and bag tickets must be added to the CSWMP.
- Properly prepare soil prior to seeding and mulching.
- Apply seed mixes as specified in the City of Colorado Springs Stormwater Construction Manual. Alternative seed mixes are acceptable if included in an approved Landscaping Plan.
- Mulch seeded areas using hay or straw mulch, hydraulic mulching, or install erosion control blanket.

## 4.0 TIMING

- Seed and mulch disturbed areas after final grading.
- Seeding and mulching may also be used as a temporary erosion control measure during construction.

## 5.0 MAINTENANCE

- Repair and reseed bare areas as necessary.
- Restrict vehicle access to seeded areas.



## SEEDING & MULCHING

ALL SOIL TESTING, SOILS AMENDMENT AND FERTILIZER DOCUMENTATION, AND SEED LOAD AND BAG TICKETS MUST BE ADDED TO THE CSWMP.

### SOIL PREPARATION

1. IN AREAS TO BE SEEDED, THE UPPER 6 INCHES OF THE SOIL MUST NOT BE HEAVILY COMPACTED, AND SHOULD BE IN FRIABLE CONDITION. LESS THAN 85% STANDARD PROCTOR DENSITY IS ACCEPTABLE. AREAS OF COMPACTION OR GENERAL CONSTRUCTION ACTIVITY MUST BE SCARIFIED TO A DEPTH OF 6 TO 12 INCHES PRIOR TO SPREADING TOPSOIL TO BREAK UP COMPACTED LAYERS AND PROVIDE A BLENDING ZONE BETWEEN DIFFERENT SOIL LAYERS.
2. AREAS TO BE PLANTED SHALL HAVE AT LEAST 4 INCHES OF TOPSOIL SUITABLE TO SUPPORT PLANT GROWTH.
3. THE CITY RECOMMENDS THAT EXISTING AND/OR IMPORTED TOPSOIL BE TESTED TO IDENTIFY SOIL DEFICIENCIES AND ANY SOIL AMENDMENTS NECESSARY TO ADDRESS THESE DEFICIENCIES. SOIL AMENDMENTS AND/OR FERTILIZERS SHOULD BE ADDED TO CORRECT TOPSOIL DEFICIENCIES BASED ON SOIL TESTING RESULTS.
4. TOPSOIL SHALL BE PROTECTED DURING THE CONSTRUCTION PERIOD TO RETAIN ITS STRUCTURE AVOID COMPACTION, AND TO PREVENT EROSION AND CONTAMINATION. STRIPPED TOPSOIL MUST BE STORED IN AN AREA AWAY FROM MACHINERY AND CONSTRUCTION OPERATIONS, AND CARE MUST BE TAKEN TO PROTECT THE TOPSOIL AS A VALUABLE COMMODITY. TOPSOIL MUST NOT BE STRIPPED DURING UNDESIRABLE WORKING CONDITIONS (E.G. DURING WET WEATHER OR WHEN SOILS ARE SATURATED). TOPSOIL SHALL NOT BE STORED IN SWALES OR IN AREAS WITH POOR DRAINAGE.

### SEEDING

1. ALLOWABLE SEED MIXES ARE INCLUDED IN THE CITY OF COLORADO SPRINGS STORMWATER CONSTRUCTION MANUAL. ALTERNATIVE SEED MIXES ARE ACCEPTABLE IF INCLUDED IN AN APPROVED LANDSCAPING PLAN.
2. SEED SHOULD BE DRILL-SEEDED WHENEVER POSSIBLE
  - SEED DEPTH MUST BE  $\frac{1}{2}$  TO  $\frac{1}{4}$  INCHES WHEN DRILL-SEEDED IS USED
3. BROADCAST SEEDING OR HYDRO-SEEDED WITH TACKIFIER MAY BE SUBSTITUTED ON SLOPES STEEPER THAN 3:1 OR ON OTHER AREAS NOT PRACTICAL TO DRILL SEED.
  - SEEDING RATES MUST BE DOUBLED FOR BROADCAST SEEDING OR INCREASED BY 50% IF USING A BRILLION DRILL OR HYDRO-SEEDED
  - BROADCAST SEEDING MUST BE LIGHTLY HAND-RAKED INTO THE SOIL

### MULCHING

1. MULCHING SHOULD BE COMPLETED AS SOON AS PRACTICABLE AFTER SEEDING, HOWEVER PLANTED AREAS MUST BE MULCHED NO LATER THAN 14 DAYS AFTER PLANTING.
2. MULCHING REQUIREMENTS INCLUDE:
  - HAY OR STRAW MULCH
    - ONLY CERTIFIED WEED-FREE AND CERTIFIED SEED-FREE MULCH MAY BE USED. MULCH MUST BE APPLIED AT 2 TONS/ACRE AND ADEQUATELY SECURED BY CRIMPING AND/OR TACKIFIER.
    - CRIMPING MUST NOT BE USED ON SLOPES GREATER THAN 3:1 AND MULCH FIBERS MUST BE TUCKED INTO THE SOIL TO A DEPTH OF 3 TO 4 INCHES.
    - TACKIFIER MUST BE USED IN PLACE OF CRIMPING ON SLOPES STEEPER THAN 3:1.
  - HYDRAULIC MULCHING
    - HYDRAULIC MULCHING IS AN OPTION ON STEEP SLOPES OR WHERE ACCESS IS LIMITED.
    - IF HYDRO-SEEDED IS USED, MULCHING MUST BE APPLIED AS A SEPARATE, SECOND OPERATION.
    - WOOD CELLULOSE FIBERS MIXED WITH WATER MUST BE APPLIED AT A RATE OF 2,000 TO 2,500 POUNDS/ACRE, AND TACKIFIER MUST BE APPLIED AT A RATE OF 100 POUNDS/ACRE.
  - EROSION CONTROL BLANKET
    - EROSION CONTROL BLANKET MAY BE USED IN PLACE OF TRADITIONAL MULCHING METHODS.



<b>SEEDING &amp; MULCHING</b>		
APPROVED: 		
SWENT MANAGER		
ISSUED: 10/7/19	REVISED: 8/19/2020	DRAWING NO. 900-SM



# STOCKPILE PROTECTION

## SP



## 1.0 DESCRIPTION

- Perimeter control placed around stockpiles of soil and other erodible materials.

## 2.0 PURPOSE

- Used to avoid the migration of sediment and other materials from stockpiles.

## 3.0 IMPLEMENTATION

- Install perimeter control around stockpile on downgradient side.
- Stockpile perimeter controls may not be required for stockpiles on the interior portion of a construction site where other downgradient controls including perimeter control are in place.

## 4.0 TIMING

- Install immediately after stockpile has formed or limits are known, whichever occurs first.
- Remove stockpile protection after the stockpile has been removed.

## 5.0 MAINTENANCE

- Remove and properly dispose of sediment according to the perimeter control detail.
- If perimeter controls must be moved to access stockpile, replace perimeter controls by the end of the work day.
- Inspect for and repair and/or replace perimeter controls as needed to maintain functionality.

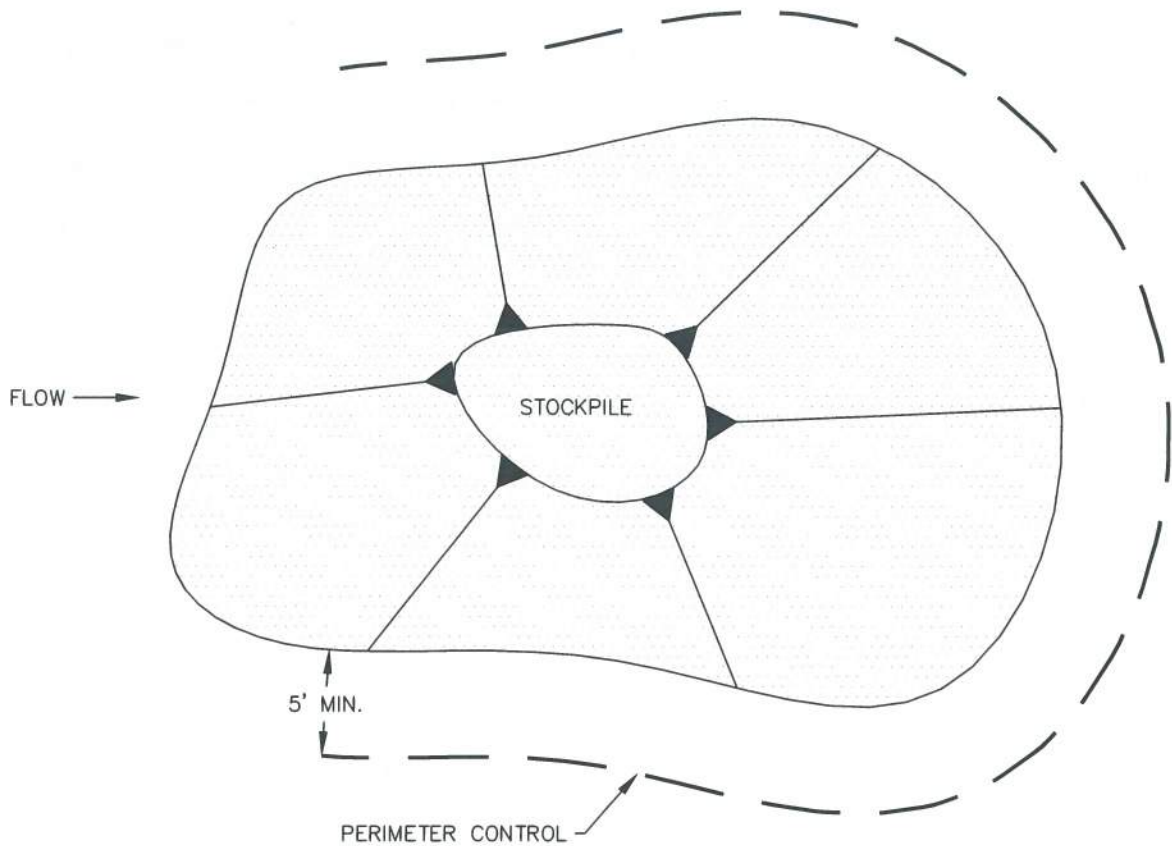

**STOCKPILE PROTECTION PLAN**

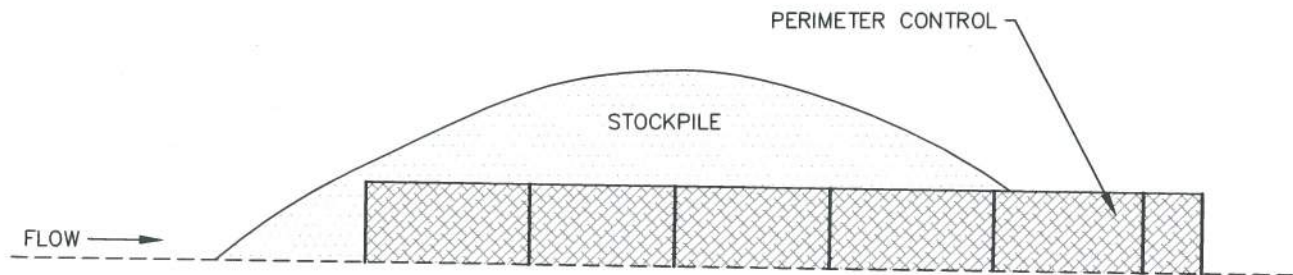

**STOCKPILE PROTECTION ELEVATION**

**INSTALLATION NOTES**

1. INSTALL PERIMETER CONTROL AROUND STOCKPILE ON DOWNGRAIDENT SIDE. PERIMETER CONTROL MUST BE SUITABLE TO SITE CONDITIONS AND INSTALLED ACCORDING TO THE RELEVANT DETAIL.
2. FOR STOCKPILES ON THE INTERIOR PORTION OF A CONSTRUCTION SITE, WHERE OTHER DOWNGRAIDENT CONTROLS INCLUDING PERIMETER CONTROL ARE IN PLACE, STOCKPILE PERIMETER CONTROLS MAY NOT BE REQUIRED.

**MAINTENANCE NOTES**

1. FREQUENT OBSERVATIONS AND MAINTENANCE ARE NECESSARY TO MAINTAIN CONTROL MEASURES IN EFFECTIVE OPERATING CONDITION. INSPECTIONS AND CORRECTIVE MEASURES SHOULD BE DOCUMENTED THOROUGHLY.
2. IF PERIMETER CONTROLS MUST BE MOVED TO ACCESS STOCKPILE, REPLACE PERIMETER CONTROLS BY THE END OF THE WORK DAY.
3. ACCUMULATED SEDIMENT MUST BE REMOVED ACCORDING TO PERIMETER CONTROL DETAIL.



**STOCKPILE PROTECTION**

APPROVED: 		
SWENT MANAGER		
ISSUED: 10/7/19	REVISED: 8/19/2020	DRAWING NO. 900-SP

# SURFACE ROUGHENING

## SR





## 1.0 DESCRIPTION

- Surface roughening is a practice where the soil surface is roughened by the creation of grooves and depressions that run parallel to the contour of the land.

## 2.0 PURPOSE

- Used to create variations in the soil surface that slow down the velocity of runoff, increase infiltration, reduce erosion, and trap soil.
- May be used to help establish vegetative cover by reducing runoff velocity and giving seed an opportunity to take hold.

## 3.0 IMPLEMENTATION

- Roughen soil in areas flatter than 3:1.
- Surface roughening may be completed by furrowing, scarifying, ripping, or disking soil.
- Grooves must be installed along contours to avoid concentrating flow.
- Do not use in areas with extremely sandy or rocky soils.

## 4.0 TIMING

- Install after overlot grading activities when area is in an interim condition or at final grade.
- Remove prior to permanent stabilization during soil preparation.

## 5.0 MAINTENANCE

- Inspect roughened areas for signs of erosion. Repeat surface roughening as needed.
- Do not allow vehicles to drive over surface roughened areas.

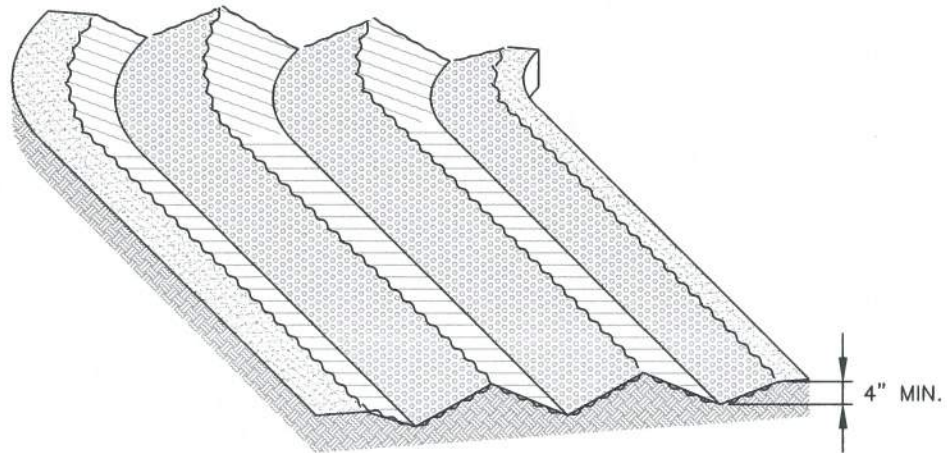

## SURFACE ROUGHENING

### INSTALLATION NOTES

1. SURFACE ROUGHENING MAY BE USED IN AREAS FLATTER THAN 3:1. INSTALL FURROWS ALONG CONTOUR TO INTERCEPT SHEET FLOW.
2. SURFACE ROUGHENING MAY BE ACCOMPLISHED BY FURROWING, SCARIFYING, RIPPING OR DISKING THE SOIL.
3. FURROWS MUST BE A MINIMUM OF 4" IN DEPTH.
4. SURFACE ROUGHENING SHALL NOT BE USED ON EXTREMELY SANDY OR ROCKY SOILS.

### MAINTENANCE NOTES

1. FREQUENT OBSERVATIONS AND MAINTENANCE ARE NECESSARY TO MAINTAIN CONTROL MEASURES IN EFFECTIVE OPERATING CONDITION. INSPECTIONS AND CORRECTIVE MEASURES SHOULD BE DOCUMENTED THOROUGHLY.
2. VEHICLES AND EQUIPMENT SHALL NOT BE DRIVEN OVER AREAS THAT HAVE BEEN SURFACE ROUGHENED.



 <p><b>STORMWATER ENTERPRISE</b></p>	<b>SURFACE ROUGHENING</b>		
	APPROVED:  SWENT MANAGER		
	ISSUED: 10/7/19	REVISED: 8/19/2020	DRAWING NO. 900-SR



# SLOPE TRACKING

## ST



## 1.0 DESCRIPTION

- Slope tracking is a practice where construction equipment is used to create grooves and depressions that run parallel to the contour of the land on slopes.

## 2.0 PURPOSE

- Used to create variations in the soil surface that slow down the velocity of runoff, increase infiltration, reduce erosion, and trap soil.

## 3.0 IMPLEMENTATION

- Use slope tracking on slopes 3:1 or steeper.
- Grooves must be installed along contours to avoid concentrating flow.
- Do not use in areas with extremely sandy or rocky soils.

## 4.0 TIMING

- Install after land disturbing activities when area is in an interim condition or at final grade.
- Remove prior to permanent stabilization during soil preparation.

## 5.0 MAINTENANCE

- Inspect areas with tracking for signs of erosion. Repeat slope tracking as needed.
- Do not allow vehicles to drive over tracked areas.



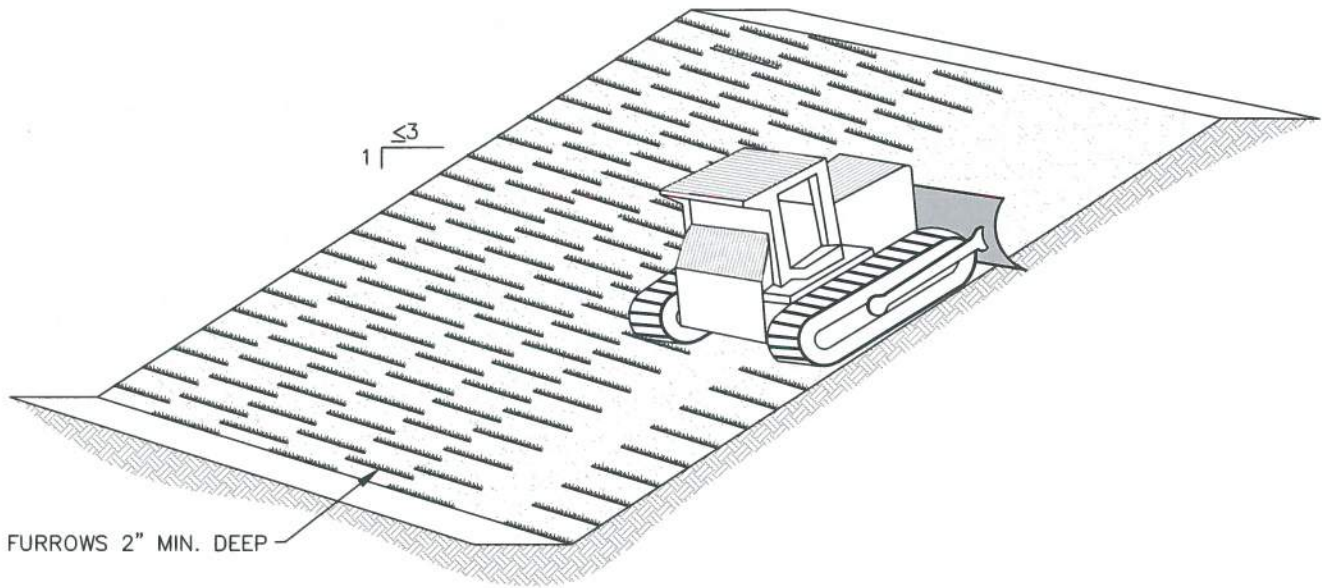

## SLOPE TRACKING



### INSTALLATION NOTES

1. SLOPE TRACKING MAY BE USED ON SLOPES 3:1 OR STEEPER.
2. TRACKING GROOVES SHALL BE PERPENDICULAR TO THE SLOPE.
3. SLOPE TRACKING SHALL NOT BE USED ON EXTREMELY SANDY OR ROCKY SOILS.

### MAINTENANCE NOTES

1. FREQUENT OBSERVATIONS AND MAINTENANCE ARE NECESSARY TO MAINTAIN CONTROL MEASURES IN EFFECTIVE OPERATING CONDITION. INSPECTIONS AND CORRECTIVE MEASURES SHOULD BE DOCUMENTED THOROUGHLY.
2. VEHICLES AND EQUIPMENT SHALL NOT BE DRIVEN OVER AREAS THAT HAVE BEEN SLOPE TRACKED.



 <p><b>STORMWATER ENTERPRISE</b></p>	<b>SLOPE TRACKING</b>		
	APPROVED:  SWENT MANAGER		
	ISSUED: 10/7/19	REVISED: 8/19/2020	DRAWING NO. 900-ST

# TEMPORARY COMPACTED BERM

## TCB





## 1.0 DESCRIPTION

- A temporary compacted berm is a compacted ridge that slows and diverts stormwater from disturbed areas.

## 2.0 PURPOSE

- Used to intercept sheet flow prior to leaving a construction site.
- May be used around the perimeter of a construction site.
- Placed on long slopes to slow down flows.

## 3.0 IMPLEMENTATION

- Compacted berms must be a minimum height of one foot.
- Adequately compact berms. Not all soils are suitable for compacted berms. Soils may need to be adequately watered down to facilitate compaction.
- Install compacted berms along the contour of slopes or in a manner to avoid creating concentrated flow.
- The maximum tributary drainage area per 100 linear feet of an installed compacted berm is 1/4 acre.

## 4.0 TIMING

- Install prior to land disturbing activities.
- Remove compacted berms after the upstream area has been permanently stabilized. Permanently stabilize area after compacted berms have been removed.

## 5.0 MAINTENANCE

- Remove and properly dispose of sediment when it has accumulated to 1/2 of the height of the compacted berm.
- Inspect for and repair damaged compacted berms.
- Do not allow vehicles to drive over berms.

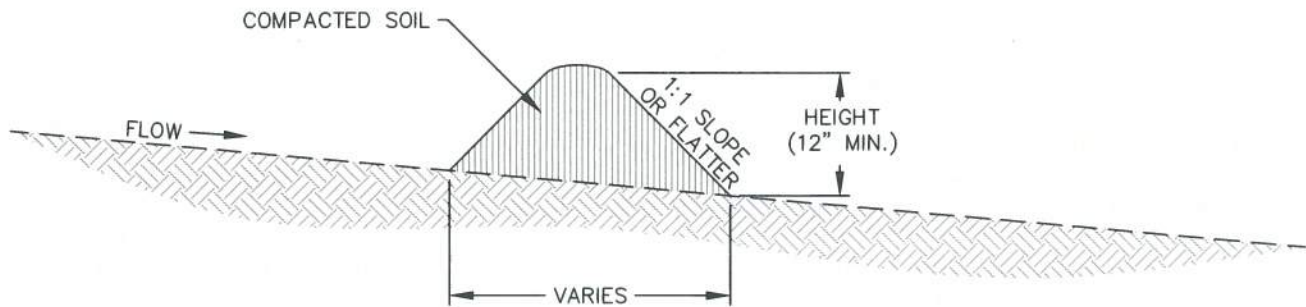

## TEMPORARY COMPACTED BERM

### INSTALLATION NOTES

1. COMPACTED BERM MUST BE A MINIMUM HEIGHT OF ONE FOOT. BASE WIDTH IS DETERMINED BY HEIGHT.
2. COMPACTED BERMS MUST BE ADEQUATELY COMPACTED. NOT ALL SOILS ARE SUITABLE FOR COMPACTED BERMS.
3. INSTALL COMPACTED BERMS ALONG CONTOUR; DO NOT INSTALL PERPENDICULAR TO SLOPE.
4. THE MAXIMUM TRIBUTARY DRAINAGE AREA PER 100 LINEAR FEET OF COMPACTED BERMS SHALL BE  $\frac{1}{4}$  ACRE.

### MAINTENANCE NOTES

1. FREQUENT OBSERVATIONS AND MAINTENANCE ARE NECESSARY TO MAINTAIN CONTROL MEASURES IN EFFECTIVE OPERATING CONDITION. INSPECTIONS AND CORRECTIVE MEASURES SHOULD BE DOCUMENTED THOROUGHLY.
2. ACCUMULATED SEDIMENT MUST BE REMOVED WHEN THE HEIGHT REACHES  $\frac{1}{2}$  OF THE DESIGN DEPTH OF THE BERM.



### TEMPORARY COMPACTED BERM

APPROVED:		
SWENT MANAGER		
ISSUED: 10/7/19	REVISED: 8/19/2020	DRAWING NO. 900-TCB



# TEMPORARY SEDIMENT BASIN

## TSB



## 1.0 DESCRIPTION

- Temporary sediment basins are small impoundments of water with a small outlet structure built on a construction site.

## 2.0 PURPOSE

- Used to capture and slowly release runoff prior to discharge from a construction site to allow sediment to settle out.

## 3.0 IMPLEMENTATION

- Temporary sediment basins for drainage areas larger than 15 acres must be individually designed by engineer.
- Erosion and other sediment controls should be implemented upstream of temporary sediment basins.

## 4.0 TIMING

- Install prior to upstream land disturbance.
- Remove temporary sediment basin after upstream area has been stabilized. Permanently stabilize area after basin has been removed.

## 5.0 MAINTENANCE

- Remove sediment from basin as needed to maintain the effectiveness of the temporary sediment basin. This is typically when sediment depth reaches one foot.
- Inspect sediment basin embankments for stability and seepage.
- Inspect the inlet and outlet of the basin, repair damage, and remove debris.



INLETS TO SEDIMENT BASIN SHALL ENTER AT FURTHEST DISTANCE TO OUTLET AND SHALL CONSIST OF A TEMPORARY SLOPE DRAIN

1" to 2" CRUSHED ROCK

RISER PIPE

6" PVC

RIPRAP PAD

L=2xW MIN.  
BOTTOM LENGTH

W  
BOTTOM WIDTH

0.0  
1.0  
2.0  
3.0  
4.0

**SEDIMENT BASIN PLAN**

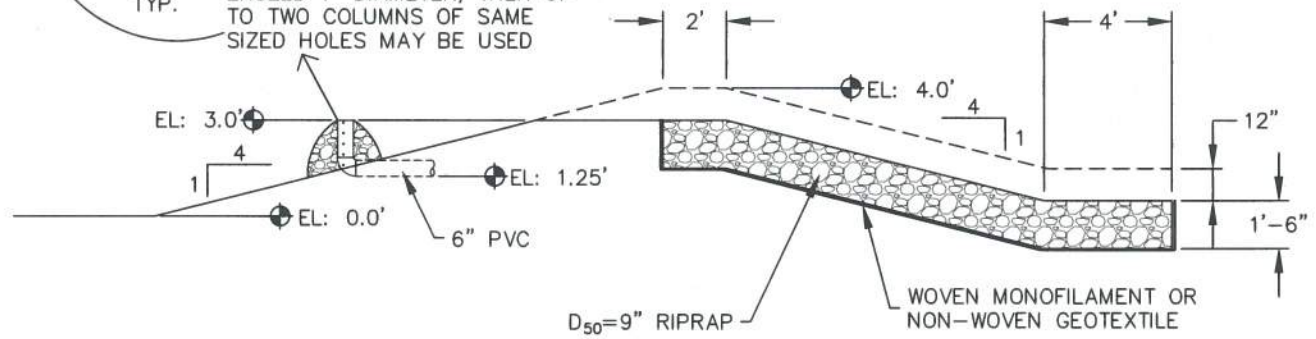
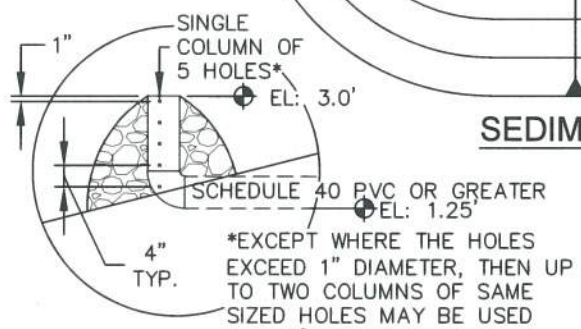

**SECTION A-A'**

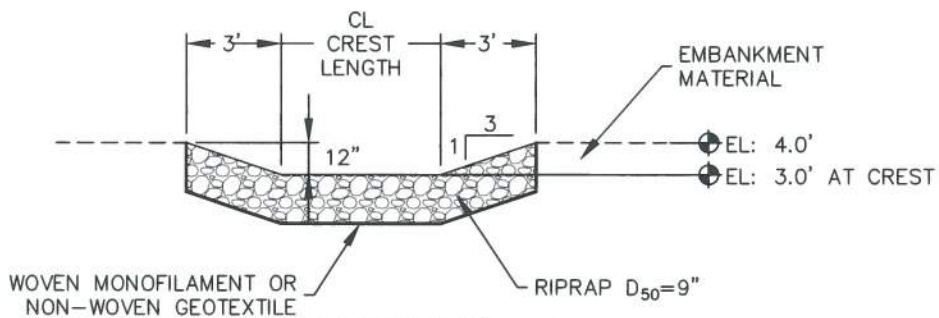

**SECTION B-B'**



<b>TEMPORARY SEDIMENT BASIN</b>		
APPROVED:		
SWENT MANAGER		
ISSUED: 10/7/19	REVISED: 8/19/2020	DRAWING NO. 900-TSB-1

TABLE SB-1, SIZING INFORMATION FOR  
STANDARD SEDIMENT BASIN

UPSTREAM DRAINAGE AREA (ROUNDED TO NEAREST ACRE), (AC)	BASIN BOTTOM WIDTH (W), (FT)	SPILLWAY CREST LENGTH (CL), (FT)	HOLE DIAMETER (HD), (IN)
1	12½"	2	9/32
2	21	3	13/16
3	28	5	½
4	33½	6	9/16
5	38½	8	2½/32
6	43	9	2½/32
7	47¼	11	25/32
8	51	12	27/32
9	55	13	7/8
10	58¼	15	15/16
11	61	16	3½/32
12	64	18	1
13	67½	19	1¼/6
14	70½	21	1½/8
15	73¼	22	1¾/6

INSTALLATION NOTES

- FOR STANDARD BASIN, BOTTOM DIMENSION MAY BE MODIFIED AS LONG AS BOTTOM AREA IS NOT REDUCED.
- EMBANKMENT MATERIAL SHALL CONSIST OF SOIL FREE OF DEBRIS, ORGANIC MATERIAL, AND ROCKS OR CONCRETE GREATER THAN 3 INCHES, AND SHALL HAVE A MINIMUM OF 15 PERCENT BY WEIGHT PASSING THE No. 200 SIEVE
- EMBANKMENT MATERIAL SHALL BE COMPACTED TO AT LEAST 95 PERCENT OF MAXIMUM DENSITY IN ACCORDANCE WITH ASTM D-698.
- PIPE SCHEDULE 40 OR GREATER SHALL BE USED.
- THE DETAILS SHOWN ON THESE SHEETS PERTAIN TO STANDARD SEDIMENT BASIN(S) FOR DRAINAGE AREAS LESS THAN 15 ACRES. SEE CONSTRUCTION DRAWINGS FOR EMBANKMENT, STORAGE VOLUME, SPILLWAY, OUTLET, AND OUTLET PROTECTION DETAILS FOR ANY SEDIMENT BASIN(S) THAT HAVE BEEN INDIVIDUALLY DESIGNED FOR DRAINAGE AREAS LARGER THAN 15 ACRES. DESIGN CALCULATIONS MUST BE APPROVED PRIOR TO IMPLEMENTATION.

MAINTENANCE NOTES

- FREQUENT OBSERVATIONS AND MAINTENANCE ARE NECESSARY TO MAINTAIN CONTROL MEASURES IN EFFECTIVE OPERATING CONDITION. INSPECTIONS AND CORRECTIVE MEASURES SHOULD BE DOCUMENTED THOROUGHLY.
- SEDIMENT ACCUMULATED IN BASIN SHALL BE REMOVED AS NEEDED TO MAINTAIN CONTROL MEASURE EFFECTIVENESS, TYPICALLY WHEN SEDIMENT DEPTH REACHES ONE FOOT (I.E. TWO FEET BELOW SPILLWAY CREST).
- SEDIMENT BASINS ARE TO REMAIN IN PLACE UNTIL THE UPSTREAM DISTURBED AREA IS PERMANENTLY STABILIZED.
- PERMANENTLY STABILIZE AREA AFTER SEDIMENT BASIN REMOVAL.



	<b>TEMPORARY SEDIMENT BASIN</b>	
	APPROVED:	
	SWENT MANAGER	
ISSUED: 10/7/19	REVISED: 8/19/2020	DRAWING NO. 900-TSB-2



# TEMPORARY SLOPE DRAIN

## TSD



## 1.0 DESCRIPTION

- A temporary slope drain is a flexible conduit for stormwater that extends down the length of a disturbed slope to divert stormwater and serve as a temporary outlet.

## 2.0 PURPOSE

- Used to convey runoff during construction without causing erosion on or at the bottom of a slope.

## 3.0 IMPLEMENTATION

- Direct runoff into flexible pipe using a temporary compacted embankment berm.
- Anchor pipe to slope.
- Install riprap pad at pipe outlet.

## 4.0 TIMING

- Install prior to upstream land disturbing activities.
- Remove temporary slope drain prior to the end of construction after the contributing drainage area has been permanently stabilized.

## 5.0 MAINTENANCE

- Inspect for erosion and accumulated debris at the inlet and outlet.
- Breaches in pipes should be repaired as soon as feasibly possible.



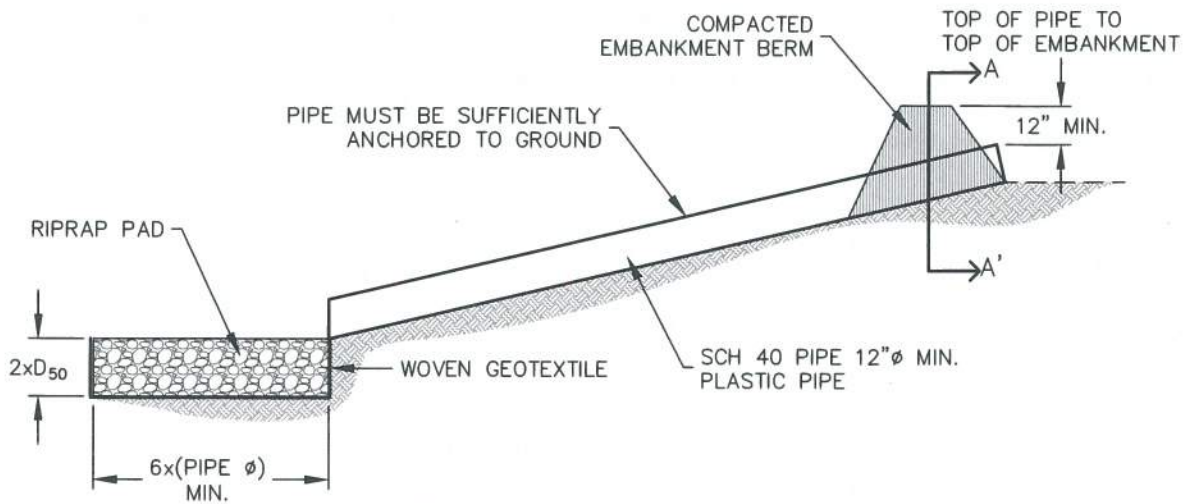

**TEMPORARY SLOPE DRAIN**

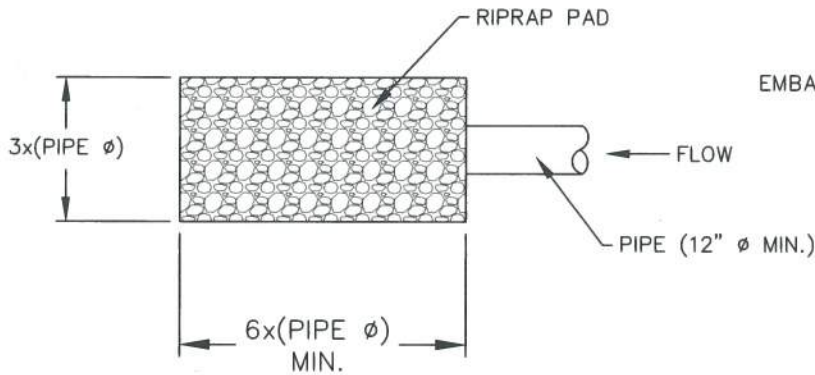

**RIPRAP PAD PLAN**

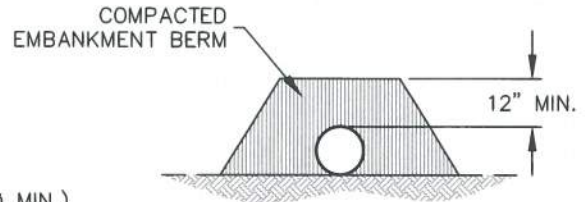

**SECTION A-A'**

**INSTALLATION NOTES**

1. THE LISTED DIMENSIONS ARE CONSIDERED A MINIMUM; LARGER DRAINS CAN BE IMPLEMENTED BY THE CONTRACTOR.
2. DETAILS SHOW MINIMUM COVER; INCREASE COVER AS NECESSARY.

**MAINTENANCE NOTES**

1. FREQUENT OBSERVATIONS AND MAINTENANCE ARE NECESSARY TO MAINTAIN CONTROL MEASURES IN EFFECTIVE OPERATING CONDITION. INSPECTIONS AND CORRECTIVE MEASURES SHOULD BE DOCUMENTED THOROUGHLY.
2. INSPECT INLETS AND OUTLETS AFTER STORMS TO PREVENT EXCESS CLOGGING. BREACHES IN PIPES SHOULD BE REPAIRED AS SOON AS FEASIBLY POSSIBLE.
3. INSPECT RIPRAP PAD AT OUTLET FOR SIGNS OF EROSION. IF SIGNS OF EROSION EXIST, ADDITIONAL ARMORING MAY BE INSTALLED.
4. TEMPORARY SLOPE DRAINS SHOULD REMAIN UNTIL THEY ARE NOT NEEDED, BUT SHOULD BE REMOVED BEFORE THE END OF CONSTRUCTION.
5. PERMANENTLY STABILIZE AREA AFTER TEMPORARY SLOPE DRAINS ARE REMOVED.



**TEMPORARY SLOPE DRAIN**

APPROVED:   
SWENT MANAGER

ISSUED: 10/7/19	REVISED: 8/19/2020	DRAWING NO. 900-TSD
--------------------	-----------------------	------------------------

# VEHICLE TRACKING CONTROL

## VTC





## 1.0 DESCRIPTION

- Vehicle tracking control consists of a pad of coarse stone aggregate placed on a geotextile filter fabric.

## 2.0 PURPOSE

- Used to reduce the tracking of sediment onto roadways by construction vehicles.
- As vehicles drive over the VTC device, mud and sediment is removed from the tires.

## 3.0 IMPLEMENTATION

- Locate at construction entrance/exit.
- Organize site to ensure that all vehicles use the vehicle tracking control device.
- Where possible, grade VTC device to drain to construction site rather than to street.
- Proprietary VTC devices may be used if approved as an alternative Construction Control Measure.

## 4.0 TIMING

- Install prior to land disturbing activities.
- Remove when the potential for sediment migration onto adjacent roadways no longer exists (typically after site has been stabilized). Permanently stabilized area after vehicle tracking control is removed.

## 5.0 MAINTENANCE

- Roughen, replace, and/or add rock as needed to maintain a consistent depth and to prevent sediment tracking onto adjacent street.
- Sediment tracked onto the adjacent road shall be removed daily, by sweeping or shoveling, and never washed down storm drains.

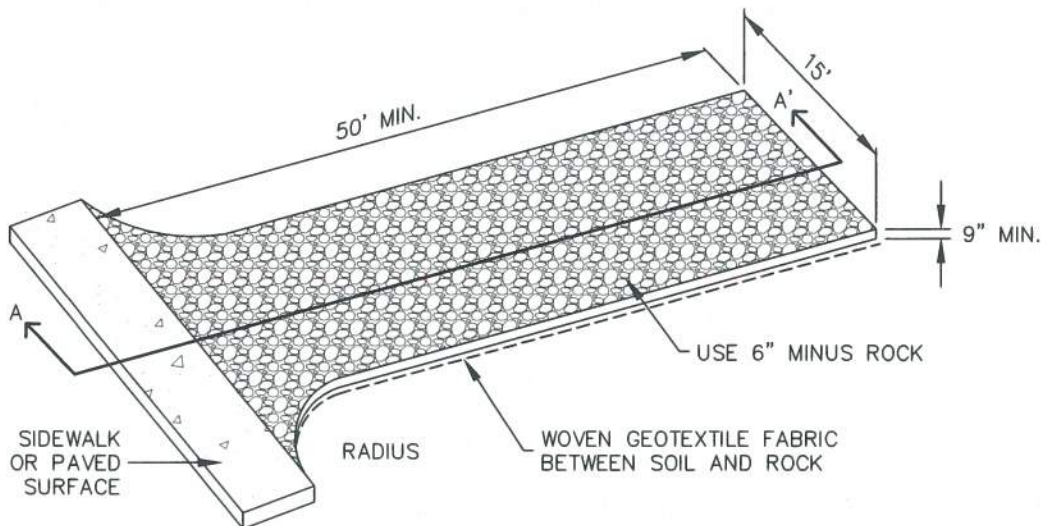

## AGGREGATE VEHICLE TRACKING CONTROL

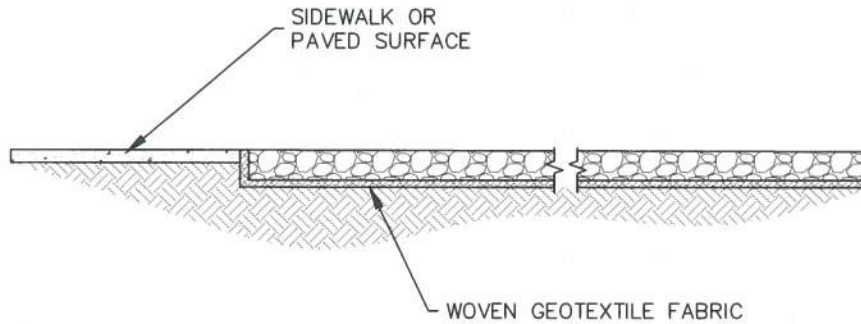

### SECTION A-A'

#### INSTALLATION NOTES

1. A STABILIZED CONSTRUCTION ENTRANCE/EXIT SHOULD BE LOCATED AT ALL POINTS WHERE VEHICLES EXIT THE CONSTRUCTION SITE TO ADJACENT ROADWAY.
2. STABILIZED CONSTRUCTION ENTRANCE/EXITS SHALL BE INSTALLED PRIOR TO ANY LAND DISTURBING ACTIVITIES.
3. RADIUS MUST BE ADEQUATE FOR INTENDED CONSTRUCTION VEHICLE TURNING.
4. ROCK SHOULD CONSIST OF 6" MINUS ROCK.
5. INSTALL CONSTRUCTION FENCE ON BOTH SIDES OF VEHICLE TRACKING CONTROL PAD WHEN NEEDED OR REQUIRED BY INSPECTOR.

#### MAINTENANCE NOTES

1. FREQUENT OBSERVATIONS AND MAINTENANCE ARE NECESSARY TO MAINTAIN CONTROL MEASURES IN EFFECTIVE OPERATING CONDITION. INSPECTIONS AND CORRECTIVE MEASURES SHOULD BE DOCUMENTED THOROUGHLY.
2. SEDIMENT TRACKED ONTO THE ADJACENT ROAD SHALL BE REMOVED DAILY, BY SWEEPING OR SHOVELING, AND NEVER WASHED DOWN STORM DRAINS.
3. ROUGHEN, REPLACE AND/OR ADD ROCK AS NEEDED TO MAINTAIN CONSISTENT DEPTH AND TO PREVENT SEDIMENT TRACKING ONTO ADJACENT STREET.
4. PERMANENTLY STABILIZE AREA AFTER VEHICLE TRACKING CONTROL IS REMOVED.



### VEHICLE TRACKING CONTROL

APPROVED:		
SWENT MANAGER		
ISSUED: 10/7/19	REVISED: 8/19/2020	DRAWING NO. 900-VTC