



LSC TRANSPORTATION CONSULTANTS, INC.  
2504 East Pikes Peak Avenue, Suite 304  
Colorado Springs, CO 80909  
(719) 633-2868  
FAX (719) 633-5430  
E-mail: [lsc@lsctrans.com](mailto:lsc@lsctrans.com)  
Website: <http://www.lsctrans.com>

Villages at Sterling Ranch  
Traffic Impact Study  
(LSC #S224580)  
April 12, 2024

Traffic Engineer's Statement

This traffic report and supporting information were prepared under my responsible charge and they comport with the standard of care. So far as is consistent with the standard of care, said report was prepared in general conformance with the criteria established by the County for traffic reports.



Developer's Statement

I, the Developer, have read and will comply with all commitments made on my behalf within this report.

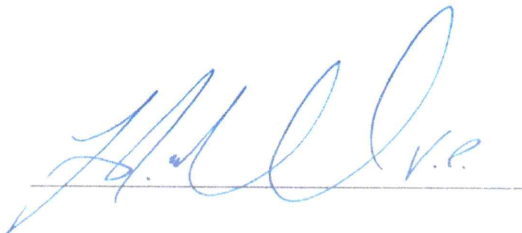
  
\_\_\_\_\_

4/16/2024  
Date

# Villages at Sterling Ranch

## Traffic Impact Study

Prepared for:  
Loren J. Moreland  
Vice President/ Project Manager  
Classic SRJ  
2138 Flying Horse Club Drive  
Colorado Springs, CO 80921

APRIL 10, 2024

---

LSC Transportation Consultants  
Prepared by: Kirstin D. Ferrin, P.E.  
Reviewed by: Jeffrey C. Hodsdon, P.E.

LSC #S224580

**CONTENTS**

REPORT CONTENTS ..... 1

RECENT TRAFFIC REPORTS ..... 2

STUDY AREA ..... 2

    Land Use..... 2

    Pedestrian Plan ..... 2

    Proposed Access Points ..... 3

    Sight Distance Analysis..... 3

REPORT SCENARIOS ..... 4

    Short-Term Scenario ..... 4

    Long-Term Scenario ..... 4

EXISTING ROAD AND TRAFFIC CONDITIONS ..... 4

    Existing Traffic Volumes ..... 5

    Existing Levels of Service ..... 5

        Burgess Road/Vollmer Road ..... 6

    Safety and Accident Analysis ..... 6

BASELINE CONDITIONS ..... 7

    Short-Term Scenario Baseline Conditions ..... 7

    Long-Term Scenario Baseline Conditions ..... 7

TRIP GENERATION ..... 8

TRIP DISTRIBUTION AND ASSIGNMENT ..... 8

TOTAL TRAFFIC..... 8

    Short-Term Total Traffic..... 8

    2044 Total Traffic ..... 9

ALL-WAY, STOP-SIGN-CONTROL WARRANT ANALYSIS – VOLLMER ROAD/BURGESS ROAD..... 9

SIGNAL WARRANT ANALYSIS – VOLLMER ROAD/BURGESS ROAD ..... 10

PRELIMINARY SIGNAL WARRANT THRESHOLD ANALYSIS (AM AND PM PEAK HOURS) –  
MARKSHEFFEL ROAD/VOLLMER ROAD AND MARKSHEFFEL ROAD/STERLING RANCH ROAD ..... 10

LEVEL OF SERVICE ANALYSIS ..... 11

    Intersection #1: Vollmer Road/Burgess Road..... 11

    Intersection #4: Vollmer Road/Briargate Parkway ..... 11

    Intersection #5: Briargate Parkway/Sterling Ranch Road ..... 12

Intersection #8: Oak Park Drive/Sterling Ranch Road .....	12
Intersection #12: Marksheffel Road/Vollmer Road .....	12
Intersection #13: Marksheffel Road/Sterling Ranch Road .....	13
Intersection #501 and #502: Oak Park Drive Access Points .....	13
ROADWAY FUNCTIONAL CLASSIFICATIONS AND LANEAGE .....	13
WAIVER AND DEVIATION REQUESTS .....	13
AREA MTCP 2040 ROADWAY IMPROVEMENT PROJECTS.....	13
CONCLUSIONS AND RECOMMENDATIONS.....	14
Trip Generation .....	14
Level of Service .....	14
Recommended Improvements .....	15
TRANSPORTATION IMPROVEMENT FEE PROGRAM AND CREDIT AGREEMENTS.....	15
Enclosures: .....	16
Tables 2-8	
Figures 1-14	
Traffic Count Reports	
Level of Service Reports	
Appendix Table 1	
MTCP Maps	
Crash History	



LSC TRANSPORTATION CONSULTANTS, INC.  
2504 East Pikes Peak Avenue, Suite 304  
Colorado Springs, CO 80909  
(719) 633-2868  
FAX (719) 633-5430  
E-mail: [lsc@lsctrans.com](mailto:lsc@lsctrans.com)  
Website: <http://www.lsctrans.com>

April 10, 2024

Loren J. Moreland  
Vice President/ Project Manager  
Classic SRJ  
2138 Flying Horse Club Drive  
Colorado Springs, CO 80921

RE: Villages at Sterling Ranch  
Traffic Impact Study  
El Paso County, Colorado  
LSC #S224580

Dear Mr. Moreland:

LSC Transportation Consultants, Inc. has prepared this Traffic Impact Study for the proposed Villages at Sterling Ranch. As shown in Figure 1, the site is located east of the future Sterling Ranch Road and south of the future Stapleton Drive in El Paso County, Colorado.

## REPORT CONTENTS

The preparation of this report included the following:

- A list of previous Sterling Ranch traffic reports and the context of this project;
- The existing roadway and traffic conditions in the site's vicinity including the roadway widths, surface conditions, lane geometries, traffic controls, and posted speed limits;
- A summary of the proposed land use and access plan;
- Existing traffic volume data;
- Estimates of projected short-term long-term baseline traffic volumes;
- The projected average weekday and peak-hour vehicle trips to be generated by the proposed future development within the preliminary plan area;
- The assignment of the projected preliminary-plan site-generated traffic volumes to the area roadways;
- The projected short-term and long-term total traffic volumes on the area roadways;
- The projected levels of service at the key intersections within the study area;
- Signal-warrant threshold analysis;
- The recommended street classifications;

- Findings and recommendations for study-area roadways and intersections, including number of lanes, auxiliary turn lanes, intersection traffic control, etc.; and
- The project's obligation to the County roadway improvement fee program.

## RECENT TRAFFIC REPORTS

LSC prepared a previous master traffic impact study (TIS) for the entire Sterling Ranch development, Sterling Ranch Updated Traffic Impact Analysis ([SKP07007](#)) dated June 5, 2008. **This master study was recently updated. The most current version of the Sterling Ranch Sketch Plan Amendment Master Traffic Impact Study ([SKP224](#)) is dated February 10, 2023.** Since 2008, LSC and SM Rocha, LLC have completed multiple studies for individual filings and phases within Sterling Ranch. Appendix Table 1, which includes a list of other traffic studies within Sterling Ranch and in the vicinity of area of study completed within the past five years (that LSC is aware of), is attached for reference.

El Paso County is currently studying the Briargate Stapleton Corridor as part of a Pikes Peak Rural Transportation Authority (PPRTA) study. A draft version of the Briargate-Stapleton Corridor Study by Wilson & Company was published December 9, 2021.

## STUDY AREA

Figure 1 shows the location of the Villages at Sterling Ranch relative to the overall Sterling Ranch Sketch Plan Area. As shown in Figure 1, the site is located generally in the middle of the Sketch Plan Area adjacent to the future extensions of Sterling Ranch Road and Briargate Parkway.

## Land Use

Figure 2 shows the proposed Villages at Sterling Ranch Plan. The site is planned to be developed with 237 residential dwelling units, including 49 townhomes, 68 duplexes, 45 detached single-family homes with an accessory dwelling unit, and 75 very small (550 to 950 square feet) single-family detached family homes. This is nine fewer residential dwelling units than was assumed in the Sterling Ranch MTIS.

## Pedestrian Plan

Figure 2 also shows the location of all planned trails and sidewalks in the vicinity of the site. There are no proposed regional trails within the boundary of the site. Multiple community trails are included for circulation and recreational use through the Sterling Ranch Phase 1 Preliminary Plan located west and south of the Sterling Ranch East Filing 5 Preliminary Plan.

A detached sidewalk will be provided along Briargate Parkway, Sterling Ranch Road, and Oak Park Drive. The multi-use paved shoulder on Sterling Ranch Road will accommodate bicycles. Attached

5-foot-wide concrete sidewalks are planned on all of the local streets within Villages at Sterling Ranch.

There are no existing schools within two miles of the site. However, there are multiple future school sites in the area, including a future K-8 school site west of the site on the west side of Sterling Ranch Road and elementary school sites south and east of the site. No information or plans are available for the school sites and a separate site-specific traffic impact study including pedestrian plans will be required to be approved prior to school site development.

### **Proposed Access Points**

Figure 3 shows the roadway connections that are planned to be constructed in the short term. As shown in Figure 3, in the short term, Briargate Parkway is planned to be constructed to its final cross section between Vollmer Road and Sterling Ranch Road, Marksheffel Road is planned to be completed between Vollmer Road and Woodmen Road, and Sterling Ranch Road is planned to be constructed from Marksheffel Road to the northmost access point within the Sterling Ranch East Phase 1 Preliminary Plan area.

Figure 2 shows the proposed access plan. Two full-movement access points are proposed to Oak Park Drive. The proposed spacing is greater than the 330-foot minimum intersection spacing for Urban Non-Residential Collectors when intersecting local roadways contained in Table 2-7 of the *El Paso County Engineering Criteria Manual (ECM)*.

### **Sight Distance Analysis**

Figure 4a shows the intersection sight-distance analysis at the intersection of Sterling Ranch Road (Urban Non-Residential Collector)/Oak Park Drive (Urban Non-Residential Collector). Based on a design speed of 40 miles per hour (mph) and the criteria contained in Table 2-21 of the *Engineering Criteria Manual (ECM)*, the required intersection sight distance at this intersection is 445 feet. As shown in Figure 4a, the intersection sight distance can be met.

Figure 4b shows the intersection sight-distance analysis at the future site access points to Oak Park Drive (Non-Residential Collector). Based on a design speed of 40 miles per hour (mph) and the criteria contained in Table 2-21 of the *Engineering Criteria Manual (ECM)*, the required intersection sight distance at the future intersections is 445 feet. As shown on Figure 4b the intersection sight distance can be met at both of the future intersections.

## REPORT SCENARIOS

### Short-Term Scenario

The short-term scenario includes the roadway segments to be added in the short term only, as shown in Figure 3. This scenario includes the Villages at Sterling Ranch area (“the site”) as well as traffic to be generated in the short term by buildout of Homestead at Sterling Ranch, Branding Iron at Sterling Ranch, Sterling Ranch Filings 2-4, Copper Chase at Sterling Ranch, Homestead North at Sterling Ranch Filings 1-3, the Retreat at TimberRidge Filings 1-4, the planned FourSquare at Sterling Ranch East development, the approved filings within Sterling Ranch East Preliminary Plan 1 (Sterling Ranch East Filings 1 and 2), and Sterling Ranch East Filing 5. Note that the short-term scenario assumes no traffic due to future anticipated land uses within Sterling Ranch East Preliminary Plan 1 beyond Sterling Ranch East Filings 1 and 2, including the residential areas east of Sterling Ranch Road and north of Idaho Falls Drive and the future school sites. Trips projected from these other short-term developments outside of the Villages at Sterling Ranch boundary are included as short-term “background traffic” in this report.

### Long-Term Scenario

The long-term scenario is essentially the same as the 2044 long-term scenario contained in the LSC February 10, 2023 Master TIS with additional detail added for this application. The study area of this report is more focused than the Sketch Plan.

## EXISTING ROAD AND TRAFFIC CONDITIONS

The adjacent streets are shown in Figure 1 and are described below. Copies of the *2016 El Paso County Major Transportation Corridors Plan (MTCP) 2040 Roadway Plan and 2016 MTCP 2060 Corridor Preservation Plan* with the site location identified on them have been attached to this report.

**Vollmer Road** is currently a five-lane urban street within the City of Colorado Springs limits between Black Forest Road and Cowpoke Road and a two-lane, rural, paved roadway north of Cowpoke Road extending to north of Hodgen Road. In the southbound direction, Vollmer Road has a posted speed limit of 45 mph. South of Cowpoke Road, Vollmer Road has a 40-mph posted speed limit. The *2040 El Paso County Major Transportation Corridors Plan (MTCP)* and the prior Sterling Ranch master traffic study show Vollmer Road as a four-lane Urban Minor Arterial in the vicinity of the site. Note: The new *Connect COS* City of Colorado Springs transportation plan shows Vollmer as a Principal Arterial. The South Vollmer Road improvements ([CDR2116](#)) which will provide two through lanes in each direction on Vollmer Road in the vicinity of Marksheffel Road, are currently under construction and are anticipated to be completed in the near term. The North Vollmer Road improvements ([CDR217](#)), which will provide two through lanes in each direction on Vollmer Road in the vicinity of Briargate Parkway, are currently under construction and are anticipated to be completed by 2024.



**Marksheffel Road** is a Principal Arterial extending north from the City of Fountain to Woodmen Road. Marksheffel Road is planned to ultimately be widened to six lanes and extended north and west from Woodmen Road to connect to Research Parkway at Black Forest Road. Marksheffel Road is shown as a four-lane Principal Arterial through the site on the El Paso County *MTCP*. The City of Colorado Springs intends to take ownership and maintenance of Marksheffel Road when it is constructed from Vollmer to the east and south to where it will connect to the segment constructed north of Woodmen Road in the City.

The section of Marksheffel Road adjacent to Sterling Ranch has been or is planned to be constructed on 107 feet of right-of-way to the City's required cross section(s) and criteria. The section of Marksheffel Road between Sterling Ranch Road and Vollmer Road has recently been completed and the section of Marksheffel Road southeast of Sterling Ranch Road (to connect to the segment recently constructed) will be completed in the short term and will open the connection to Woodmen Road. Marksheffel will be constructed as a four-lane roadway to the previously agreed upon cross section.

**Briargate Parkway** is a Principal Arterial that extends east from I-25 to Grand Lawn Circle (about one-half mile east of Powers Boulevard). Briargate Parkway is planned ultimately to extend to Towner Drive. The segment of Briargate Parkway between Vollmer Road and Sterling Ranch Road is planned to be constructed to its full 4-lane cross section in the very short term.

**Sterling Ranch Road** is a planned Non-Residential Collector shown extending through the Sterling Ranch development between Marksheffel Road and the north end of the Sketch Plan area (Arroya Road). Sterling Ranch Road has been constructed between Marksheffel Road and Dines Boulevard and will be constructed north to Briargate Parkway in the short term with the Sterling Ranch East Phase 1 Preliminary Plan.

### **Existing Traffic Volumes**

Figures 5a and 5b show the existing average weekday and peak-hour traffic volumes at the key study-area intersections. The peak-hour traffic volumes shown are based on manual turning-movement counts by LSC Transportation Consultants in March and April 2024. The average weekday traffic volume on Vollmer Road north of Marksheffel Road shown in Figure 5a are based on machine counts by LSC in April 2024. The traffic count sheets are attached.

### **Existing Levels of Service**

Level of service (LOS) is a quantitative measure of the level of congestion or delay at an intersection. Level of service is indicated on a scale from "A" to "F." LOS A represents control delay of less than 10 seconds for unsignalized intersections. LOS F represents control delay of more than 50 seconds for unsignalized intersections. Table 1 shows the level of service delay ranges.

**Table 1: Intersection Levels of Service Delay Ranges**

Level of Service	Signalized Intersections	Unsignalized Intersections
	Average Control Delay (seconds per vehicle)	Average Control Delay (seconds per vehicle) <sup>(1)</sup>
A	10.0 sec or less	10.0 sec or less
B	10.1-20.0 sec	10.1-15.0 sec
C	20.1-35.0 sec	15.1-25.0 sec
D	35.1-55.0 sec	25.1-35.0 sec
E	55.1-80.0 sec	35.1-50.0 sec
F	80.1 sec or more	50.1 sec or more

(1) For unsignalized intersections, if V/C ratio is greater than 1.0 the level of service is LOS F, regardless of the projected average control delay per vehicle.

The intersection of Burgess Road/Vollmer Road has been analyzed based on the unsignalized-intersection analysis procedures from the *Highway Capacity Manual, 6th Edition* by the Transportation Research Board. The results of the analysis are shown in Figure 5c.

**Burgess Road/Vollmer Road**

The stop-sign-controlled intersection of Burgess/Vollmer is currently operating at LOS E for the eastbound approach and LOS D for the westbound approach during the afternoon peak hour.

All movements at the stop-sign-controlled intersection of Marksheffel/Vollmer are currently operating at LOS B or better during the peak hours.

**Safety and Accident Analysis**

The Colorado State Patrol (CSP) provided LSC with crash history data for Vollmer Road between Tahiti Drive and Burgess Road from September 2019 through September 2022. During the reported time period, there were twelve reported crashes. Of the twelve reports, ten were single-vehicle non-intersection-related crashes on Vollmer Road. One crash involved a southbound vehicle that turned right onto Poco Road and crashed into several cars parked on Poco Road partially in the lane. The only intersection-related crash occurred in June 2022. A vehicle heading northbound on Vollmer Road was slowing to turn left at Lochwinnoch Road and the vehicle behind them attempted to pass on the left side. The crash history data has been attached.

## **BASELINE CONDITIONS**

Baseline traffic is the traffic estimated to be on the adjacent roadways and at adjacent intersections without the proposed development's trip generation of site-generated traffic volumes. Baseline traffic (for a specified horizon year) includes the through traffic and the traffic generated by nearby developments (existing and planned, including traffic generated by existing and planned developments within the greater Sterling Ranch overall development) but assumes zero traffic generated by land uses within the site (the Villages at Sterling Ranch boundary area).

### **Short-Term Scenario Baseline Conditions**

Please refer to the description of the short-term scenario above. Figures 6a and 6b show the projected volumes for the short-term baseline scenario. Note that the short-term baseline scenario assumes only the approved filings within Sterling Ranch East Preliminary Plan 1 (Filing Nos 1 and 2) and Sterling Ranch East Filing 5 have been constructed in the short-term. No traffic due to future anticipated land uses within Sterling Ranch East Preliminary Plan 1 beyond Filings 1 and 2, including the residential areas east of Sterling Ranch Road and north of Idaho Falls Drive and the future school sites, are included in the volumes shown in Figures 6a and 6b.

Figure 6c shows the lane geometry, traffic control, and level of service at the key area intersections, based on the short-term scenario baseline volumes.

### **Long-Term Scenario Baseline Conditions**

Figure 7a shows the projected 2044 baseline daily traffic volumes on key street segments at the key area intersections and Figure 7b shows the projected 2044 peak-hour baseline traffic volumes at the key area intersections. These volumes assume buildout of the area street network, including the completion of Marksheffel Road between Vollmer Road and Black Forest Road, Briargate Parkway between Meridian Road and Black Forest Road, and Sterling Ranch Road between Marksheffel Road and Briargate Parkway.

The 2044 baseline traffic volumes are estimates by LSC, based on the traffic projections in the LSC February 10, 2023 Master TIS report. The 2044 baseline daily traffic volumes assume buildout of the land uses within the Sterling Ranch Master Plan that are not included in the Sterling Ranch East Phase 1 Preliminary Plan area.

Figure 7c shows the lane geometry, traffic control, and level of service at the key area intersections, based on the 2044 baseline volumes.

## **TRIP GENERATION**

The site-generated vehicle trips were estimated using the nationally-published trip-generation rates from *Trip Generation, 11th Edition, 2021* by the Institute of Transportation Engineers (ITE). Table 2 shows the trip-generation estimates. Table 2 also shows the trip generation estimate assumed for the same area in the Sterling Ranch MTIS for comparison.

Villages at Sterling Ranch is projected to generate about 1,967 new external vehicle trips on the average weekday, with about half entering and half exiting the site during a 24-hour period. This is about 27 fewer vehicle trips per day than were assumed for the same area in the MTIS. During the morning peak hour, which generally occurs for one hour between 6:30 and 8:30 a.m., about 34 vehicles would enter and 104 vehicles would exit the site. During the afternoon peak hour, which generally occurs for one hour between 4:15 and 6:15 p.m., about 109 vehicles would enter and 69 vehicles would exit the site.

## **TRIP DISTRIBUTION AND ASSIGNMENT**

The directional distribution of the site-generated traffic volumes on the street and roadway system serving the site is an important factor in determining the site's traffic impacts. The distribution estimates for short-term and long-term residential-related traffic are shown in Figure 8. The short-term directional-distribution estimate assumes the short-term roadway network shown in Figure 3 only and the long-term directional-distribution estimate assumes buildout of the roadway network. The directional-distribution estimates are based, in part, on the estimates contained in the sketch plan TIS report. Factors include: the location of the site with respect to the Colorado Springs metropolitan area, the planned access system for the site, the street and roadway system serving the site, and the land uses proposed for the site.

When the distribution percentages (from Figure 8) are applied to the new, external trip-generation estimates (from Table 2), the resulting site-generated traffic volumes can be determined. Figures 9a and 9b show the short-term site-generated traffic volumes. These volumes assume only the street network shown in Figure 3. Figures 10a and 10b show the long-term residential site-generated traffic volumes assuming buildout of the area roadway network.

## **TOTAL TRAFFIC**

### **Short-Term Total Traffic**

Figure 11a shows the projected short-term total daily traffic volumes on key street segments and Figure 11b shows the projected short-term-total peak-hour traffic volumes at the key study-area intersections. These volumes are the sum of the short-term-baseline traffic volumes (from Figures 6a and 6b) and the short-term site-generated traffic volumes (from Figures 9a and 9b).

Figure 11c shows the level of service analysis results for the key area intersections based on the projected short-term total volumes. The figure also shows the general intersection lane geometry and intersection traffic control used in the analysis.

### **2044 Total Traffic**

Figure 12a shows the projected 2044 total daily traffic volumes on key street segments and Figure 12b shows the projected 2044 total peak-hour traffic volumes at the key study-area intersections. These volumes are the sum of the 2044 baseline traffic volumes (from Figures 7a and 7b) and the long-term site-generated traffic volumes (from Figures 10a and 10b).

Figure 12c shows the level of service analysis results for the key area intersections, based on the projected 2044 total volumes. The figure also shows the general intersection lane geometry and intersection traffic control used in the analysis.

### **ALL-WAY, STOP-SIGN-CONTROL WARRANT ANALYSIS – VOLLMER ROAD/BURGESS ROAD**

The intersection of Vollmer Road/Burgess Road was analyzed to determine if a multi-way stop-control warrant is projected to be met, based on the existing total traffic volumes. The analysis is based on the following guidance contained in section 2B.07.04.C of the *2009 Manual on Uniform Traffic Control Devices (MUTCD)*

Minimum volumes:

1. The vehicular volume entering the intersection from the major street approaches (total of both approaches) averages at least 300 vehicles per hour for any 8 hours of an average day; and
2. The combined vehicular, pedestrian, and bicycle volume entering the intersection from the minor street approaches (total of both approaches) averages at least 200 units per hour for the same 8 hours, with an average delay to minor-street vehicular traffic of at least 30 seconds per vehicle during the highest hour; but
3. If the 85th-percentile approach speed of the major-street traffic exceeds 40 mph, the minimum vehicular volume warrants are 70 percent of the values provided in Items 1 and 2.

Table 3 shows the results of the analysis. As the posted speed limit on both Vollmer Road and Burgess Road is 45 miles per hour, the analysis is based on 70 percent of the values provided in Items 1 and 2 as allowed for under Item 3.

As shown in Table 3, the All-Way, Stop-Sign-Control Warrant is currently met at the intersection of Vollmer/Burgess.

### **SIGNAL WARRANT ANALYSIS – VOLLMER ROAD/BURGESS ROAD**

The intersection of Vollmer/Burgess was analyzed to determine if the thresholds for Four-Hour and/or Eight-Hour Vehicular-Volume Traffic-Signal Warrant thresholds are currently met based on the existing and short-term total traffic volumes. Table 4 shows the results of the analysis.

As shown in Table 4, the intersection of Vollmer/Burgess currently meets the criteria for a Four-Hour Vehicular-Volume Traffic-Signal Warrant but is not anticipated to meet the criteria for an Eight-Hour Vehicular-Volume Traffic-Signal Warrant, based on both the existing and short-term total traffic volumes.

### **PRELIMINARY SIGNAL WARRANT THRESHOLD ANALYSIS (AM AND PM PEAK HOURS) – MARKSHEFFEL ROAD/VOLLMER ROAD AND MARKSHEFFEL ROAD/STERLING RANCH ROAD**

The intersections of Marksheffel/Vollmer and Marksheffel/Sterling Ranch were analyzed to determine if the thresholds for Four-Hour and/or Eight-Hour Vehicular-Volume Traffic-Signal Warrant thresholds would be reached or exceeded, based on the projected short-term peak-hour traffic volumes only. In order for an Eight-Hour Vehicular-Volume Traffic-Signal Warrant to be satisfied, the volume threshold would need to be met for six additional hours of the day and in order for a Four-Hour Vehicular Volume Traffic Signal Warrant to be satisfied, the volume threshold would need to be met for two additional hours of the day. For example, the four-hour warrant would be satisfied with the volume thresholds met for one hour in the morning, two hours (instead of the one-hour peak) during the afternoon peak period, and an hour during the mid-afternoon.

This “cursory”/planning-level analysis has been provided at the Preliminary Plan level to identify intersections which may need to be signalized in the short-term future. Detailed analysis of all applicable signal warrants should be evaluated with each filing submitted. The satisfaction of warrants does not indicate that a signal must be installed. The decision to require a signal to be installed rests with the County.

Table 5 shows the results of the analysis for the intersection of Marksheffel/Vollmer. Based on the projected short-term total traffic volumes, three of the eight hours analyzed are projected to meet the criteria for an Eight-Hour Vehicular Volume Warrant but none of the hours analyzed are projected to meet the criteria for a Four-Hour Vehicular-Volume Traffic-Signal Warrant. This analysis indicates that traffic-signal warrant(s) may not be met in the short-term. Detailed analysis should be provided with each future filing within Sterling Ranch. Escrow towards this improvement may also need to be provided with this filing.

Table 6 shows the results of the analysis for the intersection of Marksheffel/Sterling Ranch. Based on the projected short-term total traffic volumes only five of the eight hours analyzed are projected to meet the criteria for an Eight-Hour Vehicular-Volume Warrant and only three of the hours analyzed are projected to meet the criteria for a Four-Hour Vehicular-Volume Traffic-Signal

Warrant. This analysis indicates that traffic-signal warrant(s) may not be met in the short-term. Detailed analysis should be provided with each future filing within Sterling Ranch. Escrow towards this improvement may also need to be provided with this filing.

### **LEVEL OF SERVICE ANALYSIS**

The key area future signalized intersections have been analyzed to determine the projected intersection levels of service for short-term and 2044 baseline and total traffic scenarios for the morning and afternoon peak-hour periods using Synchro. The key area future stop-sign-controlled and modern-roundabout-controlled intersections have been analyzed based on the unsignalized-intersection analysis procedures from the *Highway Capacity Manual 6th Edition*. Figures 6c, 7c, 11c, and 12c show the level of service analysis results. The level of service reports are attached.

#### **Intersection #1: Vollmer Road/Burgess Road**

The stop-sign-controlled intersection of Vollmer/Burgess is currently operating at LOS E for the eastbound approach during the afternoon peak hour. The intersection currently has one-lane approaches in all directions. If this intersection were converted to all-way, stop-sign control, all approaches are projected to operate at LOS C or better, based on the short-term total traffic volumes and the existing lane geometry. Based on existing traffic volumes shown in Figure 5 and the criteria contained in the *El Paso County Engineering Criteria Manual (ECM)*, multiple auxiliary turn lanes would be required to meet the *ECM* standard. LSC recommends this intersection instead be reconstructed as a modern one-lane roundabout. As a modern roundabout, it is projected to operate at LOS C or better for all approaches during the peak hours, based on the projected short-term and 2044 total traffic volumes.

#### **Intersection #4: Vollmer Road/Briargate Parkway**

The section of Briargate Parkway between Vollmer Road and Sterling Ranch Road is planned to be constructed to its final cross section in the short term. The intersection of Vollmer/Briargate could operate at a satisfactory level of service (LOS B or better) in the short term as a stop-sign-controlled intersection.

By 2044, it was assumed Briargate Parkway would be extended west to Black Forest Road and East to Towner Avenue and that the intersection of Vollmer/Briargate will be converted to traffic-signal control. The intersection of Vollmer/Briargate is projected to operate at an overall LOS C during the peak hours as a signalized intersection, based on the projected 2044 total traffic volumes shown in Figure 12b and the lane geometry shown in Figure 12c.

### **Intersection #5: Briargate Parkway/Sterling Ranch Road**

The section of Briargate Parkway between Vollmer Road and Sterling Ranch Road is planned to be constructed to its final cross section in the short term. The intersection of Briargate/Sterling Ranch is projected to operate at LOS A for all movements in the short term as a stop-sign-controlled intersection.

By 2044, it was assumed Briargate Parkway would be extended west to Black Forest Road and East to Towner Avenue and that the intersection of Briargate/Sterling Ranch will be converted to traffic-signal control. The intersection of Briargate/Sterling Ranch is projected to operate at an overall LOS C during the peak hours as a signalized intersection, based on the projected 2044 total traffic volumes shown in Figure 12b and the lane geometry shown in Figure 12c.

### **Intersection #8: Oak Park Drive/Sterling Ranch Road**

Old Park Drive is planned to be constructed east from Sterling Ranch Road to the east site boundary as part of the Villages at Sterling Ranch development. Based on the short-term total traffic volumes shown in Figure 11b and the lane geometry shown in Figure 11c, the intersection of Oak Park/Sterling Ranch is projected to operate at LOS B or better for all movements during the peak hours as a stop-sign controlled intersection.

By 2044, it was assumed that Oak Park Drive would be constructed east of the site to Banning Lewis Parkway. It was also assumed that the future K-8 School planned for the parcel southwest of Briargate/Sterling Ranch would be constructed and that an **exit-only** access would be constructed aligning with the Oak Park/Sterling Ranch intersection. Based on the 2044 total traffic volumes shown in Figure 12b and the lane geometry shown in Figure 12c, the eastbound and westbound left-turn movements are projected to operate at LOS E during the morning peak hour and LOS C during the afternoon peak hour. Alternate traffic control may be needed to achieve a satisfactory level of service at this intersection. Further analysis of this intersection should be conducted when the number of students, site layout, and proposed access plan for the school site are determined.

### **Intersection #12: Marksheffel Road/Vollmer Road**

Marksheffel Road has been recently constructed between Vollmer Road and Sterling Ranch Road. Based on the projected short-term total traffic volumes, the westbound left-turn movement is projected to operate at LOS E during the afternoon peak hour. This intersection is planned as a future signalized intersection. However, traffic-signal warrant(s) may not be met in the short term. It is not uncommon for the minor movements at a stop-sign-controlled intersection to operate at LOS E or F as the traffic volumes approach the levels needed to meet vehicular-volume traffic-signal warrants.



By 2044, it was assumed that Marksheffel Road would be constructed west to Briargate Parkway and that the intersection of Marksheffel/Vollmer will be converted to traffic-signal control. The intersection of Marksheffel/Vollmer is projected to operate at an overall LOS C or better during the peak hours as a signalized intersection, based on the projected 2044 total traffic volumes shown in Figure 12b and the lane geometry shown in Figure 12c.

### **Intersection #13: Marksheffel Road/Sterling Ranch Road**

Marksheffel Road was recently constructed between Sterling Ranch Road and Vollmer Road and the section southeast of Sterling Ranch Road (to connect to the segment recently constructed) will be completed in the short term and will open the connection to Woodmen Road. Based on the projected short-term total traffic volumes, the southbound left-turn movement is projected to operate at LOS F during the afternoon peak hour if it remains stop-sign controlled. This intersection is projected to meet multiple traffic-signal warrants with buildout of the currently proposed Villages at Sterling Ranch currently approved filings discussed in the Short-Term Scenario Baseline Conditions section above. If this intersection is converted to signal control, it is projected to operate at an overall LOS C or better during the peak hours through 2044.

### **Intersection #501 and #502: Oak Park Drive Access Points**

Both of the proposed full-movement site access points to Oak Park Drive are projected to operate at LOS B or better for all movements as stop-sign controlled intersections, based on the projected short-term and 2044 total traffic volumes.

### **ROADWAY FUNCTIONAL CLASSIFICATIONS AND LANEAGE**

Figure 13 shows the recommended functional classifications and number of through lanes for the streets in the study area.

### **WAIVER AND DEVIATION REQUESTS**

No waivers to the *Land Development Code* (LDC) or deviations to the criteria contained in the *El Paso County Engineering Criteria Manual* (ECM) are needed for the proposed preliminary plan.

### **AREA MTCP 2040 ROADWAY IMPROVEMENT PROJECTS**

The *El Paso County 2016 Major Transportation Corridors Plan Update* identified the following 2040 roadway improvement projects within the study area:

- C13: Vollmer Road from Marksheffel Road to Stapleton Drive as a Rural 4-Lane Minor Arterial;
- N5: Stapleton Drive [Briargate Parkway] from Towner Road to Black Forest Road as a 4-Lane Urban Principal Arterial;

- N12: Marksheffel Road from Woodman Road to Research Parkway as a 4-Lane Urban Principal Arterial; and
- M11: Vollmer Road Bicycle & Primary Regional Trail from Marksheffel Road to Shoup Road.

## CONCLUSIONS AND RECOMMENDATIONS

### Trip Generation

- Villages at Sterling Ranch is projected to generate about 1,097 new external vehicle trips on the average weekday, with about half entering and half exiting the site during a 24-hour period. During the morning peak hour, which generally occurs for one hour between 6:30 and 8:30 a.m., about 34 vehicles would enter and 104 vehicles would exit the site. During the afternoon peak hour, which generally occurs for one hour between 4:15 and 6:15 p.m., about 109 vehicles would enter and 69 vehicles would exit the site.

### Level of Service

- The stop-sign-controlled intersection of Vollmer/Burgess is currently operating at LOS E for the eastbound approach during the afternoon peak hour. This intersection currently meets the criteria for all-way, stop-sign control. Based on the short-term total traffic volumes and the existing lane geometry, all approaches at this intersection are projected to operate at LOS C or better during the peak hours. This intersection also currently meets the criteria for a 4-Hour Vehicular-Volume Traffic-Signal Warrant. However, as it is not anticipated to meet an 8-Hour Vehicular-Volume Traffic-Signal Warrant in the short term and it is projected to operate at a satisfactory level of service as an all-way, stop-sign-controlled intersection, LSC does not recommend this intersection be converted to signal control in the short-term future. Additionally, this intersection currently has one-lane approaches in all directions. Based on existing traffic volumes shown in Figure 5 and the criteria contained in the El Paso County *Engineering Criteria Manual (ECM)*, multiple auxiliary turn lanes would be required to meet the *ECM* standard. LSC recommends this intersection be reconstructed as a modern one-lane roundabout. As a modern roundabout, it is projected to operate at LOS C or better for all approaches during the peak hours, based on the projected short-term and 2044 total traffic volumes. This project may be required to contribute to future improvements at this intersection. Based on the projected site-generated traffic volumes (shown in Figure 9b) and the short-term total traffic volumes (shown in Figure 11b), the site is projected to contribute about 1.3% of the morning and 1.5% of the afternoon peak-hour volumes at this intersection.
- The intersections of Vollmer/Briargate and Briargate/Sterling Ranch are projected to operate at a satisfactory level of service as stop-sign-controlled intersections in the short-term future. By 2044, these intersections will likely need to be converted to traffic-signal control. As signalized intersections, all movements are projected to operate

at LOS D or better during the peak hours, based on the projected 2044 total traffic volumes.

- Some of the movements at the intersections of Marksheffel Road/Vollmer Road and Marksheffel Road/Sterling Ranch Road are projected to operate at LOS E or LOS F during the peak hours, if they remain stop-sign controlled in the short-term future. Once signalized, all movements at these intersections are projected to operate at LOS D or better, based on the projected short-term and 2044 total traffic volumes.
- Old Park Drive is planned to be constructed east from Sterling Ranch Road to the east site boundary as part of the Villages at Sterling Ranch development. Based on the short-term total traffic volumes shown in Figure 11b and the lane geometry shown in Figure 11c, the intersection of Oak Park/Sterling Ranch is projected to operate at LOS B or better for all movements during the peak hours as a stop-sign-controlled intersection. By 2044, it was assumed that Oak Park Drive would be constructed between Sterling Ranch Road and Banning Lewis Parkway. It was also assumed that the future K-8 School planned for the parcel southwest of Briargate/Sterling Ranch would be constructed and that an **exit-only** access would be constructed aligning with the Oak Park Drive/Sterling Ranch Road intersection. Based on the 2044 total traffic volumes shown in Figure 12b and the lane geometry shown in Figure 12c, the eastbound and westbound left-turn movements are projected to operate at LOS E during the morning peak hour and LOS C during the afternoon peak hour. Alternate traffic control may be needed to achieve a satisfactory level of service at this intersection. Further analysis of this intersection should be conducted when the number of students, site layout, and proposed access plan for the school site are determined.

### Recommended Improvements

- Table 7 shows detailed **intersection** improvements needed with the Villages at Sterling Ranch. The recommended improvements are based on the short-term and 2044 total traffic volumes shown in Figures 12b and 12b and the criteria contained in the El Paso County *Engineering Criteria Manual (ECM)*.
- Table 8 shows a list of the **roadway segment** improvements in the vicinity of the site. Please see Figure 14 for a map of the key street segment locations. These recommendations are consistent with the LSC Sketch Plan TIS report.

### TRANSPORTATION IMPROVEMENT FEE PROGRAM AND CREDIT AGREEMENTS

The applicant will be required to participate in the Countywide Transportation Improvement Fee Program. These projects will annex into the 5 mil PID, which has a per-lot upfront building permit fee of \$2,527 per single-family dwelling unit. The total building permit fee amount for the 137 residential dwelling units would be \$543,056. Note: This is based on the current rate, which is subject to change. El Paso County updates this rate periodically.

A road fee credit agreement and development agreement and Subdivision Improvements Agreement will be required to address developer's road fee credits for construction of Vollmer Road. Additional credit agreements will be needed with each phase of construction to account for reimbursement of costs for the additional lanes and major intersection improvements.

\* \* \* \* \*

Please contact me if you have any questions regarding this report.

Sincerely,

LSC TRANSPORTATION CONSULTANTS, INC.

By Jeffrey C. Hodsdon, P.E.  
Principal

JCH/KDF:jas

Enclosures: Tables 2-8  
Figures 1-14  
Traffic Count Reports  
Level of Service Reports  
Appendix Table 1  
MTCP Maps  
Crash History

# Tables 2-8

---



**Table 2**  
**Trip Generation Estimate**  
Villages at Sterling Ranch

ITE Code	ITE Land Use	Quantity	Unit	Daily	Trip Generation Rates <sup>(1)</sup>				Total Trips Generated				
					AM Peak Hour		PM Peak Hour		Daily	AM Peak Hour		PM Peak Hour	
					In	Out	In	Out		In	Out	In	Out
<b>Trip Generation Estimate Based on the Currently Proposed Land Uses</b>													
215	Single-Family Attached Housing	120	DU	7.20	0.12	0.36	0.34	0.23	864	14	43	40	28
210	Single-Family Detached Housing	117	DU	9.43	0.18	0.53	0.59	0.35	1,103	20	61	69	41
		<b>237</b>	<b>DU</b>						<b>1,967</b>	<b>34</b>	<b>104</b>	<b>109</b>	<b>69</b>
<b>Trip Generation Estimate For the Same Parcel (TAZs 14, 15, 20 &amp; 21) From the Sterling Ranch Sketch Plan Amendment Master Traffic Impact Study (SKP 22-004) March 15, 2023</b>													
215	Single-Family Attached Housing	146	DU	7.20	0.12	0.36	0.34	0.23	1,051	18	53	49	34
210	Single-Family Detached Housing	100	DU	9.43	0.18	0.53	0.59	0.35	943	18	53	59	35
		<b>246</b>	<b>DU</b>						<b>1,994</b>	<b>35</b>	<b>105</b>	<b>108</b>	<b>69</b>
Change (Increase) in Trip Generation Estimate									<b>-27</b>	<b>-1</b>	<b>-1</b>	<b>1</b>	<b>0</b>

Notes:

(1) Source: "Trip Generation, 11th Edition, 2021" by the Institute of Transportation Engineers (ITE)

(2) DU = Dwelling Unit

Source: LSC Transportation Consultants, Inc.

**Table 3**  
**All Way Stop Sign Control Warrant Analysis**  
 Burgess Road/Vollmer Road

Hour	Existing Traffic <sup>(1)</sup>		All-Way, Stop-Sign Control Warrant Analysis <sup>(2)</sup>		
	Traffic Volumes (vehicles per hour)		Warrant Analysis <sup>(2)</sup>		
	Major Approach Burgess Road EB & WB	Minor Approach Vollmer Road NB & SB	Volume Thresholds		Warrant Threshold
	Left/Thru/Right	Left/Thru/Right	Major	Minor	Met?
12-1 AM	12	12	210	140	No
1-2 AM	9	9	210	140	No
2-3 AM	9	9	210	140	No
3-4 AM	10	10	210	140	No
4-5 AM	23	23	210	140	No
5-6 AM	118	118	210	140	No
6-7 AM	330	330	210	140	Yes
7-8 AM	535	535	210	140	Yes
8-9 AM	508	508	210	140	Yes
9-10 AM	432	432	210	140	Yes
10-11 AM	427	427	210	140	Yes
11-12 PM	435	435	210	140	Yes
12-1 PM	800	75	210	140	No
1-2 PM	268	135	210	140	No
2-3 PM	291	143	210	140	Yes
3-4 PM	291	144	210	140	Yes
4-5 PM	363	157	210	140	Yes
5-6 PM	426	176	210	140	Yes
6-7 PM	253	100	210	140	No
7-8 PM	186	66	210	140	No
8-9 PM	137	46	210	140	No
9-10 PM	109	30	210	140	No
10-11 PM	38	8	210	140	No
11-12 AM	19	6	210	140	No
<b>Total Hours That Meet the Threshold</b>					<b>10</b>
<b>Warrant Met?</b>					<b>Yes</b>

Notes:

- (1) Based on peak-hour traffic counts by LSC July 2022. Off peak traffic volumes are based on 24-hour CDOT traffic count data
- (2) The all-way, stop-stop control warrant analysis is based on the guidance found in the *Manual of Uniform Traffic Control Devices (MUTCD) Section 2B.07.04.C*

Per Section 2B.07.04.C.1 the major-street approach volumes include all eastbound and westbound traffic movements (left, through, and right) on Vollmer Road

Per Section 2B.07.04.C.2 the minor-street approach volumes include all northbound and southbound traffic movements on Burgess Road

As the posted speed limit on both Burgess Road and Vollmer Road exceeds 45 mph, the minimum vehicular volume warrants shown are 70 percent of the values provided in items 1 and 2.

No pedestrian volumes were included in the warrant analysis

**Table 4  
Traffic Signal Warrant Analysis  
Burgess Road/Vollmer Road**

Warrant Analysis<sup>(1)</sup>

Hour	Warrant 1: Eight-Hour Vehicular-Volume Evaluation											Warrant 2: Four-Hour Vehicular-Volume Evaluation					
	Major <sup>(2)</sup> Vollmer	Minor 1 <sup>(3)</sup>		Minor 2 <sup>(3)</sup>		Warrant Thresholds				Warrant Threshold Met?				70% Warrant Threshold Minor Minimum	Warrant Threshold Met?		
		EB	WB	Condition A (70%)		Condition B (70%)		North Leg		South Leg		EB	WB				
		Burgess	Burgess	Major	Minor	Major	Minor	A	B	A	B						
Existing Traffic <sup>(4)</sup>																	
7-8 AM	184	68	467	350	105	525	53	No	No	No	No	Low Vol	No	No			
8-9 AM	160	148	360	350	105	525	53	No	No	No	No	Low Vol	No	No			
9-10 AM	173	130	302	350	105	525	53	No	No	No	No	Low Vol	No	No			
10-11 AM	167	186	241	350	105	525	53	No	No	No	No	Low Vol	No	No			
11-12 PM	195	190	245	350	105	525	53	No	No	No	No	Low Vol	No	No			
12-1 PM	290	725	75	350	105	525	53	No	No	No	No	Low Vol	No	No			
1-2 PM	450	133	135	350	105	525	53	Yes	No	Yes	No	165	No	No			
2-3 PM	599	148	143	350	105	525	53	Yes	Yes	Yes	Yes	130	Yes	Yes			
3-4 PM	616	147	144	350	105	525	53	Yes	Yes	Yes	Yes	90	Yes	Yes			
4-5 PM	486	206	157	350	105	525	53	Yes	No	Yes	No	165	Yes	No			
5-6 PM	333	250	176	350	105	525	53	No	No	No	No	205	Yes	No			

Numbers of Hours the Warrant is Met				4	2	4	2
Warrant Met?				No			

4	2
Yes	

Short-Term Background Traffic <sup>(4)</sup>																
6-7 AM	264	131	204	350	105	525	53	No	No	No	No	Low Vol	No	No		
7-8 AM	260	135	359	350	105	525	53	No	No	No	No	Low Vol	No	No		
8-9 AM	221	294	276	350	105	525	53	No	No	No	No	Low Vol	No	No		
9-10 AM	234	257	232	350	105	525	53	No	No	No	No	Low Vol	No	No		
10-11 AM	224	369	186	350	105	525	53	No	No	No	No	Low Vol	No	No		
11-12 PM	262	378	188	350	105	525	53	No	No	No	No	Low Vol	No	No		
12-1 PM	340	1079	93	350	105	525	53	No	No	No	No	205	Yes	No		
1-2 PM	537	198	169	350	105	525	53	Yes	Yes	Yes	Yes	130	Yes	Yes		
2-3 PM	717	219	177	350	105	525	53	Yes	Yes	Yes	Yes	65	Yes	Yes		
3-4 PM	738	218	181	350	105	525	53	Yes	Yes	Yes	Yes	65	Yes	Yes		
4-5 PM	583	306	196	350	105	525	53	Yes	Yes	Yes	Yes	130	Yes	Yes		
5-6 PM	395	372	220	350	105	525	53	Yes	No	Yes	No	205	Yes	Yes		
6-7 PM	286	229	123	350	105	525	53	No	No	No	No	Low Vol	No	No		

Numbers of Hours the Warrant is Met				5	4	5	4
Warrant Met?				No			

6	5
Yes	

Short-Term Total Traffic <sup>(4)</sup>																
6-7 AM	260	128	204	350	105	525	53	No	No	No	No	Low Vol	No	No		
7-8 AM	256	132	359	350	105	525	53	No	No	No	No	Low Vol	No	No		
8-9 AM	218	287	276	350	105	525	53	No	No	No	No	Low Vol	No	No		
9-10 AM	232	252	232	350	105	525	53	No	No	No	No	Low Vol	No	No		
10-11 AM	221	361	186	350	105	525	53	No	No	No	No	Low Vol	No	No		
11-12 PM	259	369	188	350	105	525	53	No	No	No	No	Low Vol	No	No		
12-1 PM	338	1059	93	350	105	525	53	No	No	No	No	205	Yes	No		
1-2 PM	531	194	169	350	105	525	53	Yes	Yes	Yes	Yes	130	Yes	Yes		
2-3 PM	710	215	177	350	105	525	53	Yes	Yes	Yes	Yes	65	Yes	Yes		
3-4 PM	730	214	181	350	105	525	53	Yes	Yes	Yes	Yes	65	Yes	Yes		
4-5 PM	576	300	196	350	105	525	53	Yes	Yes	Yes	Yes	130	Yes	Yes		
5-6 PM	391	365	220	350	105	525	53	Yes	No	Yes	No	205	Yes	Yes		
6-7 PM	284	225	123	350	105	525	53	No	No	No	No	Low Vol	No	No		

Numbers of Hours the Warrant is Met				5	4	5	4
Warrant Met?				No			

6	5
Yes	

Notes:

- (1) Thresholds are based on 1 lane on the major approach and 1 lane on the minor approach with the 70% factor applied for a posted speed limit above 40 mph
- (2) The major-street traffic includes all movements (left, through, and right)
- (3) The minor-street traffic includes all movements (left, through, and right)
- (4) Off-peak-traffic volumes are based on the 24-hour CDOT traffic-count data



**Table 5**  
**Traffic Signal Warrant Analysis**  
Marksheffel Road/Vollmer Road

Warrant Analysis <sup>(1)</sup>																						
Short-Term Background Traffic Villages at Sterling Ranch Generated Traffic Short-Term Total Traffic							Warrant 1: Eight-Hour Vehicular-Volume Evaluation								Warrant 2: Four-Hour Vehicular-Volume Evaluation							
							Warrant Thresholds								Warrant Threshold Met?				Short-Term Background		Short-Term Total	
							Condition A				Condition B				Short-Term Background		Short-Term Total		Warrant Threshold Minimum	Warrant Threshold Met? WB	Warrant Threshold Minimum	Warrant Threshold Met? WB
							Major	Minor	Major	Minor	Major	Minor	Major	Minor	Condition A	Condition B	Condition A	Condition B				
Hour	Major <sup>(2)</sup> Vollmer	Minor <sup>(3)</sup> Marksheffel	Major Vollmer	Minor Marksheffel	Major Vollmer	Minor Marksheffel	Major	Minor	Major	Minor	Condition A	Condition B	Condition A	Condition B	Minimum	WB	Minimum	WB				
<b>Short-Term Total Traffic<sup>(4)</sup></b>																						
12-1 AM	42	3	1	0	43	3	600	150	900	75	No	No	No	No	Low Volume	No	Low Volume	No				
1-2 AM	18	3	0	0	18	3	600	150	900	75	No	No	No	No	Low Volume	No	Low Volume	No				
2-3 AM	13	0	0	0	13	0	600	150	900	75	No	No	No	No	Low Volume	No	Low Volume	No				
3-4 AM	25	3	0	0	25	3	600	150	900	75	No	No	No	No	Low Volume	No	Low Volume	No				
4-5 AM	47	12	3	0	50	12	600	150	900	75	No	No	No	No	Low Volume	No	Low Volume	No				
5-6 AM	103	30	5	1	108	31	600	150	900	75	No	No	No	No	Low Volume	No	Low Volume	No				
6-7 AM	389	87	17	2	406	89	600	150	900	75	No	No	No	No	Low Volume	No	Low Volume	No				
7-8 AM	798	151	28	3	826	154	600	150	900	75	Yes	No	Yes	No	201	No	194	No				
8-9 AM	719	127	26	3	745	130	600	150	900	75	No	No	No	No	241	No	228	No				
9-10 AM	591	80	19	2	610	82	600	150	900	75	No	No	No	No	295	No	286	No				
10-11 AM	612	80	21	2	633	82	600	150	900	75	No	No	No	No	285	No	277	No				
11-12 PM	767	76	24	2	791	78	600	150	900	75	No	No	No	No	217	No	205	No				
12-1 PM	733	75	23	1	756	76	600	150	900	75	No	No	No	No	234	No	222	No				
1-2 PM	750	79	24	2	774	81	600	150	900	75	No	No	No	No	225	No	213	No				
2-3 PM	850	83	27	2	877	85	600	150	900	75	No	No	No	No	188	No	181	No				
3-4 PM	956	81	29	2	985	83	600	150	900	75	No	Yes	No	Yes	161	No	154	No				
4-5 PM	1078	101	37	2	1115	103	600	150	900	75	No	Yes	No	Yes	127	No	117	No				
5-6 PM	1026	100	37	2	1063	102	600	150	900	75	No	Yes	No	Yes	142	No	131	No				
6-7 PM	628	79	29	2	657	81	600	150	900	75	No	No	No	No	279	No	267	No				
7-8 PM	546	58	21	1	567	59	600	150	900	75	No	No	No	No	Low Volume	No	Low Volume	No				
8-9 PM	435	42	20	1	455	43	600	150	900	75	No	No	No	No	Low Volume	No	Low Volume	No				
9-10 PM	283	32	14	1	297	33	600	150	900	75	No	No	No	No	Low Volume	No	Low Volume	No				
10-11 PM	148	15	7	0	155	15	600	150	900	75	No	No	No	No	Low Volume	No	Low Volume	No				
11-12 AM	63	9	4	0	67	9	600	150	900	75	No	No	No	No	Low Volume	No	Low Volume	No				
Numbers of Hours the Warrant Thresholds Are Met											1	3	1	3		0		0				
Warrant Met?											No		No			No		No				

Notes:  
 (1) Thresholds are based on 2 or more lanes on the major approach and 1 lane on the minor approach (Warrant evaluation assuming the westbound left turn only for the minor street)  
 (2) The major-street traffic includes all movements (left, through, and right)  
 (3) The minor-street traffic includes only the left turns from the minor street  
 (5) Off-peak-hour traffic volumes are based on the projected peak-hour traffic volumes, 72-hour machine counts conducted on Vollmer Road in April 2024 and vehicle time-of-day distribution data for single-family residential published by the Institute of Transportation Engineers

**Table 6**  
**Traffic Signal Warrant Analysis**  
 Marksheffel Road/Sterling Ranch Road

Warrant Analysis <sup>(1)</sup>																				
Warrant 1: Eight-Hour Vehicular-Volume Evaluation												Warrant 2: Four-Hour Vehicular-Volume Evaluation								
Hour	Short-Term Background Traffic		Sterling Ranch Filing No. 5 Generated Traffic		Short-Term Total Traffic		Warrant Thresholds				Warrant Threshold Met?		Short-Term Background		Short-Term Total		Warrant Threshold Minimum	Warrant Threshold Met?	Warrant Threshold Minimum	Warrant Threshold Met?
	Major <sup>(2)</sup> Marksheffel	Minor <sup>(3)</sup> Sterling Ranch	Major Marksheffel	Minor Sterling Ranch	Major Marksheffel	Minor Sterling Ranch	Condition A		Condition B		Condition A	Condition B	Condition A	Condition B	Condition A	Condition B				
							Major	Minor	Major	Minor										
<b>Short-Term Total Traffic<sup>(4)</sup></b>																				
12-1 AM	31	7	4	1	35	8	600	150	900	75	No	No	No	No	Low Volume	No	Low Volume	No	No	
1-2 AM	12	7	2	1	14	8	600	150	900	75	No	No	No	No	Low Volume	No	Low Volume	No	No	
2-3 AM	10	0	2	0	12	0	600	150	900	75	No	No	No	No	Low Volume	No	Low Volume	No	No	
3-4 AM	14	7	2	1	16	8	600	150	900	75	No	No	No	No	Low Volume	No	Low Volume	No	No	
4-5 AM	26	28	2	6	28	34	600	150	900	75	No	No	No	No	Low Volume	No	Low Volume	No	No	
5-6 AM	51	70	4	15	55	85	600	150	900	75	No	No	No	No	Low Volume	No	Low Volume	No	No	
6-7 AM	181	206	13	43	194	249	600	150	900	75	No	No	No	No	Low Volume	No	Low Volume	No	No	
7-8 AM	367	356	25	74	392	430	600	150	900	75	No	No	No	No	Low Volume	No	Low Volume	No	No	
8-9 AM	361	300	29	62	390	362	600	150	900	75	No	No	No	No	Low Volume	No	#N/A	#N/A	#N/A	
9-10 AM	300	188	25	39	325	227	600	150	900	75	No	No	No	No	Low Volume	No	Low Volume	No	No	
10-11 AM	342	188	33	39	375	227	600	150	900	75	No	No	No	No	Low Volume	No	#N/A	#N/A	#N/A	
11-12 PM	434	178	43	37	477	215	600	150	900	75	No	No	No	No	373	No	352	No	No	
12-1 PM	479	177	43	37	522	214	600	150	900	75	No	No	No	No	351	No	329	No	No	
1-2 PM	508	186	47	39	555	225	600	150	900	75	No	No	No	No	Low Volume	No	313	No	No	
2-3 PM	583	196	54	41	637	237	600	150	900	75	No	No	Yes	No	299	No	275	No	No	
3-4 PM	684	190	65	39	749	229	600	150	900	75	Yes	No	Yes	No	256	No	226	Yes	Yes	
4-5 PM	812	237	81	49	893	286	600	150	900	75	Yes	No	Yes	No	197	Yes	177	Yes	Yes	
5-6 PM	786	234	80	48	866	282	600	150	900	75	Yes	No	Yes	No	207	Yes	184	Yes	Yes	
6-7 PM	584	186	66	39	650	225	600	150	900	75	No	No	Yes	No	Low Volume	No	270	No	No	
7-8 PM	451	136	48	28	499	164	600	150	900	75	No	No	No	No	Low Volume	No	Low Volume	No	No	
8-9 PM	418	98	49	20	467	118	600	150	900	75	No	No	No	No	Low Volume	No	Low Volume	No	No	
9-10 PM	291	76	34	16	325	92	600	150	900	75	No	No	No	No	Low Volume	No	Low Volume	No	No	
10-11 PM	145	35	17	7	162	42	600	150	900	75	No	No	No	No	Low Volume	No	Low Volume	No	No	
11-12 AM	79	22	10	5	89	27	600	150	900	75	No	No	No	No	Low Volume	No	Low Volume	No	No	
<b>Numbers of Hours the Warrant Thresholds Are Met</b>												3	0	5	0		2		3	
<b>Warrant Met?</b>												No		No			No		No	

Notes:

- (1) Thresholds are based on 2 or more lanes on the major approach and 1 lane on the minor approach (Warrant evaluation assuming the southbound left turn only for the minor street)
- (2) The major-street traffic includes all movements (left, through, and right)
- (3) The minor-street traffic includes only the left turns from the minor street
- (4) Off-peak-hour traffic volumes are based on the projected peak-hour traffic volumes, 72-hour machine counts conducted on Vollmer Road in April 2024 and vehicle time-of-day distribution data for single-family residential published by the Institute of Transportation Engineers

Source: LSC Transportation Consultants, Inc.

**Table 7  
Villages Sterling Ranch  
Intersection Improvements**

<b>Item #</b>	<b>Improvement</b>	<b>Trigger</b>	<b>Timing</b>	<b>Responsibility</b>
<b>1) Burgess Road/Vollmer Road</b>				
1	Re-sign as an All-Way, Stop-Sign Controlled Intersection or Reconstruct as a modern one-lane roundabout	When the LOS degrades below LOS F	Existing deficiency	This intersection may be an eligible intersection under the fee impact program
<b>5) Briargate Parkway/Sterling Ranch Road</b>				
2	Construct an eastbound left-turn lane on Briargate Parkway approaching Sterling Ranch Road. The lane should be 435' long plus a 200' taper.	eastbound left-turn volume > 10 vph	With Sterling Ranch East Filing 1	Sterling Ranch
3	Construct an eastbound right-turn deceleration lane on Briargate Parkway approaching Sterling Ranch Road. The lane should be 235' long plus a 200' taper.	eastbound right-turn volume > 25 vph	With Sterling Ranch East Filing 1	Sterling Ranch
4	Construct a northbound to eastbound right-turn acceleration lane on Briargate Parkway at Sterling Ranch Road. The lane should be 580' long plus a 180' taper.	northbound right-turn volume > 50 vph	Long Term (with the construction of Briargate Parkway east of Sterling Ranch Road)	Sterling Ranch
5	Construct a westbound left-turn lane on Briargate Parkway approaching Sterling Ranch Road. The lane should be 285' long plus a 200' taper.	westbound left-turn volume > 10 vph	Long Term (with the construction of Briargate Parkway east of Sterling Ranch Road)	Sterling Ranch
6	Construct an eastbound right-turn deceleration lane on Briargate Parkway approaching Sterling Ranch Road. The lane should be 235' long plus a 200' taper.	eastbound right-turn volume > 25 vph	Long Term (with the construction of Briargate Parkway east of Sterling Ranch Road)	Sterling Ranch
7	Construct a southbound to westbound right-turn acceleration lane on Briargate Parkway at Sterling Ranch Road. The lane should be 580' long plus a 180' taper.	southbound right-turn volume > 50 vph	With Sterling Ranch East Filing 2	Sterling Ranch
<b>8) Sterling Ranch Road/Oak Park Place</b>				
8	Construct a southbound left-turn lane on Sterling Ranch Road approaching Oak Park Place. The lane should be 220' long plus a 160' taper.	southbound left-turn volume > 25 vph	A center painter median is part of the standard Non-Residential Collector cross section and a left-turn lane is planned with Sterling Ranch East Filing 1	Sterling Ranch
9	Construct a northbound right-turn deceleration lane on Sterling Ranch Road approaching Oak Park Place. The lane should be 155' long plus a 160' taper.	northboundbound right-turn volume > 50 vph	Required With Villages at Sterling Ranch Planned with Sterling Ranch East Filing 5	Sterling Ranch
<b>12) Marksheffel Road/Vollmer Road</b>				
10	Signalization of the intersection	Once warrants are met. The decision on timing of traffic signal installation rests with El Paso County Public Works.	Not Anticipated With Villages at Sterling Ranch	This intersection may be an eligible intersection under the fee impact program
<b>13) Marksheffel Road/Sterling Ranch Road</b>				
11	Signalization of the intersection	Once warrants are met. The decision on timing of traffic signal installation rests with The City of Colorado Springs.	Not Anticipated With Villages at Sterling Ranch	SRMD#3

Source: LSC Transportation Consultants, Inc. (April 2024)

**Table 8**

**Roadway Segment Improvements**

**Villages at Sterling Ranch**

(Page 1 of 2)

Segment ID <sup>(1)</sup> (See Figure 14 for map)	Improvement Description	Timing	Design ADT (vpd)	Projected 2044 ADT (vpd)	Responsibility
V1 (Short-Term) Northbound	UPDATE (November 2023): It is our understanding that a meeting(s) with JR Engineering/the applicant, City staff and County staff were held, that a short-term/interim improvement to segment V1 will not be required. The original LSC recommendation for this segment was for restriping. However, City staff indicated that the striped bike lane in the southbound direction needs to remain.	Updated November 2023 - It is our understanding that following a meeting with the City of Colorado Springs and El Paso County, a V1 interim shoulder improvement will no longer be required.	5,500 (Directional northbound)	16,275	N/A
V1 (Short-Term) Southbound			10,000 (Directional southbound)		
V1	Improve Vollmer Road between Dry Needle Place and the Sterling Ranch south boundary to a standard 4-Lane Urban Minor Arterial Cross Section (Add a second northbound through lane and painted center median) <sup>(2)</sup>	Intermediate-Term Future	20,000		Updated November 2023 Adjacent parcel owner which could potentially include: <ul style="list-style-type: none"> <li>“Pioneer Landscape Center Parcel” (5300000742) (redevelopment is unlikely in the foreseeable future)</li> <li>“Schmidt Parcel” west of Vollmer Rd (5200000571)</li> <li>The triangular parcels southeast of Vollmer/Marksheffel (5232400001 and 5232400003)</li> </ul>
V2	Improve Vollmer Road between the Sterling Ranch south boundary to Lochwinnoch Lane/Sterling property boundary to a standard 4-Lane Urban Minor Arterial Cross Section <sup>(2)</sup>	Short-Term Future (With Sterling Ranch Fil No. 2 Or Sterling Ranch Phase 2) Updated April 2024: In Progress	20,000 (Note: Existing Capacity 8,000 <sup>(3)</sup> )	17,475	Sterling Ranch
V3	<b>Short Term:</b> Improve Vollmer Road from Lochwinnoch Lane to Sterling Ranch boundary (northeast of Glider Loop) to provide 36’ of pavement (existing pavement 1 approx. 23.38’) and stripe for one through lane and plus a 6’ paved, striped outside shoulder in each direction <sup>(2)</sup>	Updated November 2023 – Future as required due to net increase traffic demand. The construction documents have been approved.	11,000 (Note: Existing Capacity 8,000)	17,380	Sterling Ranch
	<b>Long Term:</b> Improve Vollmer Road from Lochwinnoch Lane to Sterling Ranch boundary (northeast of Glider Loop) to a standard 4-Lane Urban Minor Arterial Cross Section <sup>(2)</sup>	Long-Term Future	20,000		By others - pursuant to the recent development agreement between Sterling Ranch and EPC.
V4	Improve Vollmer Road from Sterling Ranch boundary (northeast of Glider Loop) to Briargate Parkway to a standard 4-Lane Urban Minor Arterial Cross Section <sup>(2)</sup> Update November 2023 - with transition section to the existing two-lane section to the south as shown on the Vollmer North CDs. Improvements consist of curb and gutter on west side (as most of the east side is already built) and repaving.	Sections V4, V5, V6 to be constructed by <b>May 2024</b>	20,000	16,445	Sterling Ranch
V5	Improve Vollmer Road from Briargate Parkway to Jane Kirkham Drive to a standard 4-Lane Urban Minor Arterial Cross Section <sup>(2)</sup>	Sections V4, V5, v6 to be constructed by <b>May 2024</b>	20,000	11,690	Sterling Ranch
V6	Improve Vollmer Road from Jane Kirkham Drive to Sam Bass Drive to a standard 4-Lane Urban Minor Arterial Cross Section <sup>(2)</sup>	Sections V4, V5, v6 to be constructed by <b>May 2024</b>	20,000	11,425	Sterling Ranch
V7	Improve Vollmer Road between Sam Bass Drive and Poco Road to a 4-lane Urban Minor Arterial but with necessary lane transitions, redirect tapers, etc. south of Poco to adequately transition between the 4-Lane Urban Minor Arterial Cross Section and the 2-Lane Rural Arterial Cross Section north of Poco Road.	Sections V4, V5, v6 to be constructed by <b>May 2024</b>	20,000	10,090	Sterling Ranch
V8	Improve Vollmer Road from Poco Road to Shoup Road to a Rural 2-Lane Arterial Cross Section <sup>(2)</sup>	Long-Term Future	10,000	11,790	El Paso County Project ID U-12

Part 1/2 of this table (see Part 2 on next page)

**Notes:**

(1) See Figure 14

(2) Adequate transition/redirect tapers would be needed between the various cross sections on Vollmer Road. Based on the criteria contained in Table 2-29 of the *El Paso Engineering Criteria Manual* an appropriate taper ratio for a roadway with a design speed of 40 miles per hour is 20:1

(3) Source: Table 20 Road Impact Fee Study Updated November 16, 2016

Source: LSC Transportation Consultants, Inc. (April, 2024)

**Table 8**

**Roadway Segment Improvements**

**Sterling Ranch East Filing 5 Preliminary Plan**

(Page 2 of 2)

Segment ID <sup>(1)</sup> (See Figure 14 for map)	Improvement Description	Timing	Design ADT (vpd)	Projected 2042 ADT (vpd)	Responsibility
SR1	Construct Sterling Ranch Road as an Urban Non-Residential Collector from Marksheffel Road to Dines Boulevard	<u>Completed</u>	20,000	14,840	Sterling Ranch
SR2	Construct Sterling Ranch Road as an Urban Non-Residential Collector from Dines Boulevard to Briargate Parkway	<b>Short-Term - with SRE Preliminary Plan 1</b>	20,000	10,275	Sterling Ranch
SR3	Construct Sterling Ranch Road as an Urban Collector from Briargate Parkway to Vancouver Street.	<b>Short-Term - with SRE Preliminary Plan 1</b>	10,000	9,300	Sterling Ranch
SR4	Construct Sterling Ranch Road from Vancouver Street north to Arroya (or ultimate north terminus)	Long-Term Future	10,000	4,260	Sterling Ranch
M1	Construct Marksheffel Road as an Urban Principal Arterial to City of Colorado Springs standards in 107' of right-of-way between Vollmer Road and Sterling Ranch Road	<u>Completed</u>	40,000	23,370	Sterling Ranch
M2	Construct Marksheffel Road as an Urban Principal Arterial to City of Colorado Springs standards in 107' of right-of-way between Sterling Ranch Road and the south boundary of the Sterling Ranch Master Plan Area. <b>NOTE: With the completion of this improvement, the connection between Vollmer Road and Woodmen Road will be completed</b>	To be completed in 2024	40,000	29,600	Sterling Ranch
M3	Construct Marksheffel Road between the south boundary of the Sterling Ranch Master Plan Area and Woodmen Road (Note this segment is located within the City of Colorado Springs)	<u>Completed</u> (by Others)	40,000	24,525	Others (Completed)
M4	Construct Marksheffel Road between Black Forest Road and Vollmer Road	Long-Term Future	40,000	27,910	Others
B1	Construct the full section of Briargate Pkwy (4-Lane Principal Arterial) between Vollmer Road and Wheatland Drive	<u>Completed</u>	40,000	24,745	Sterling Ranch
B2	Construct Briargate Pkwy ( <b>full section</b> ) as a 4-Lane Principal Arterial between Wheatland Dr and Sterling Ranch Road	<b>Full section In Progress</b>	40,000	26,375	Sterling Ranch
B3	Construct Briargate Pkwy as a 4-Lane Principal Arterial between Sterling Ranch Road and Banning Lewis Parkway	Intermediate Term	40,000	22,365	Sterling Ranch
B4	Construct Stapleton Road as a 4-Lane Principal Arterial between Banning Lewis Parkway and Meridian Road (including upgrade of existing rural two-lane segment between Towner and Meridian)	Long-Term Future	40,000	17,945	Others
B5	Construct Briargate Pkwy as a 4-Lane Principal Arterial between its current terminus and Black Forest Road and between Black Forest Road and Vollmer Road	Long-Term Future	40,000	24,340	Others
BL1	Construct Banning Lewis Parkway as a 4-Lane Principal Arterial between the south Sterling Ranch boundary and Briargate Pkwy	Long-Term Future	40,000	20,320	Future - TBD with the future preliminary plan for that area - potentially, financial assurances for half-section, west-side half-section or full-section w/ cost recover may be required
BL2	Construct Banning Lewis Parkway as a 4-Lane Principal Arterial between Woodmen Road and the south Sterling Ranch boundary (Note this segment will be located within the City of Colorado Springs)	Long-Term Future	40,000	28,480	Others
W1	Widen Woodmen Road from 4-lane to 6-lane section from Powers Boulevard to US 24	Long-Term Future	72,000	66,690	Others

**Part 2/2 of this table**

**Notes:**

(1) See Figure 14

(2) Adequate transition/redirect tapers would be needed between the various cross sections on Vollmer Road. Based on the criteria contained in Table 2-29 of the *El Paso Engineering Criteria Manual* an appropriate taper ratio for a roadway with a design speed of 40 miles per hour is 20:1

(3) Source: Table 20 *Road Impact Fee Study Updated* November 16, 2016

Source: LSC Transportation Consultants, Inc. (April, 2024)

# Figures 1-14

---





Not to scale

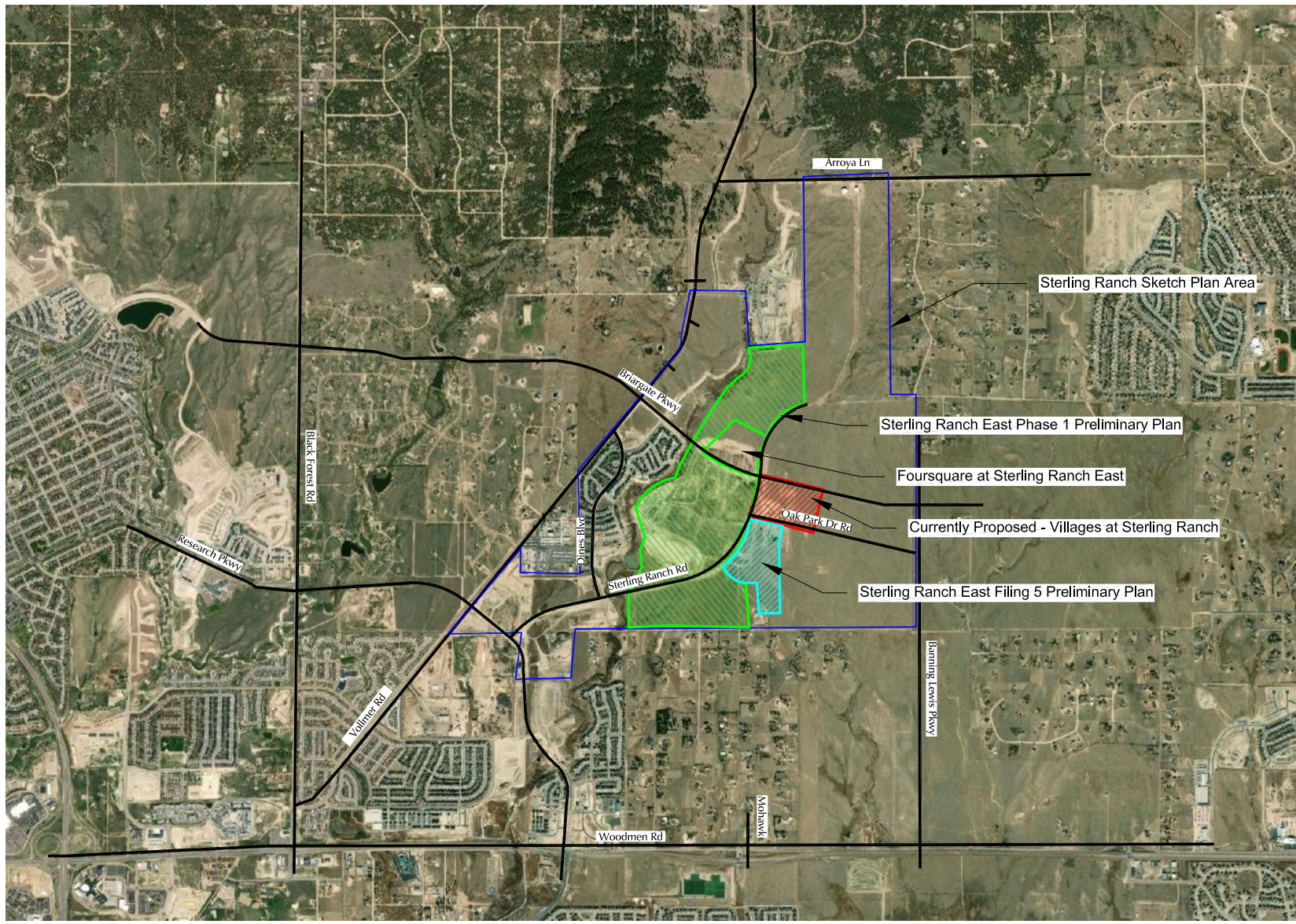

Figure 1

# Vicinity Map

Villages at Sterling Ranch (LSC# S224580)





Approximate  
Scale:  
1"=300'

Figure 2  
Site Plan

Villages at Sterling Ranch (LSC# S224580)





Not to scale

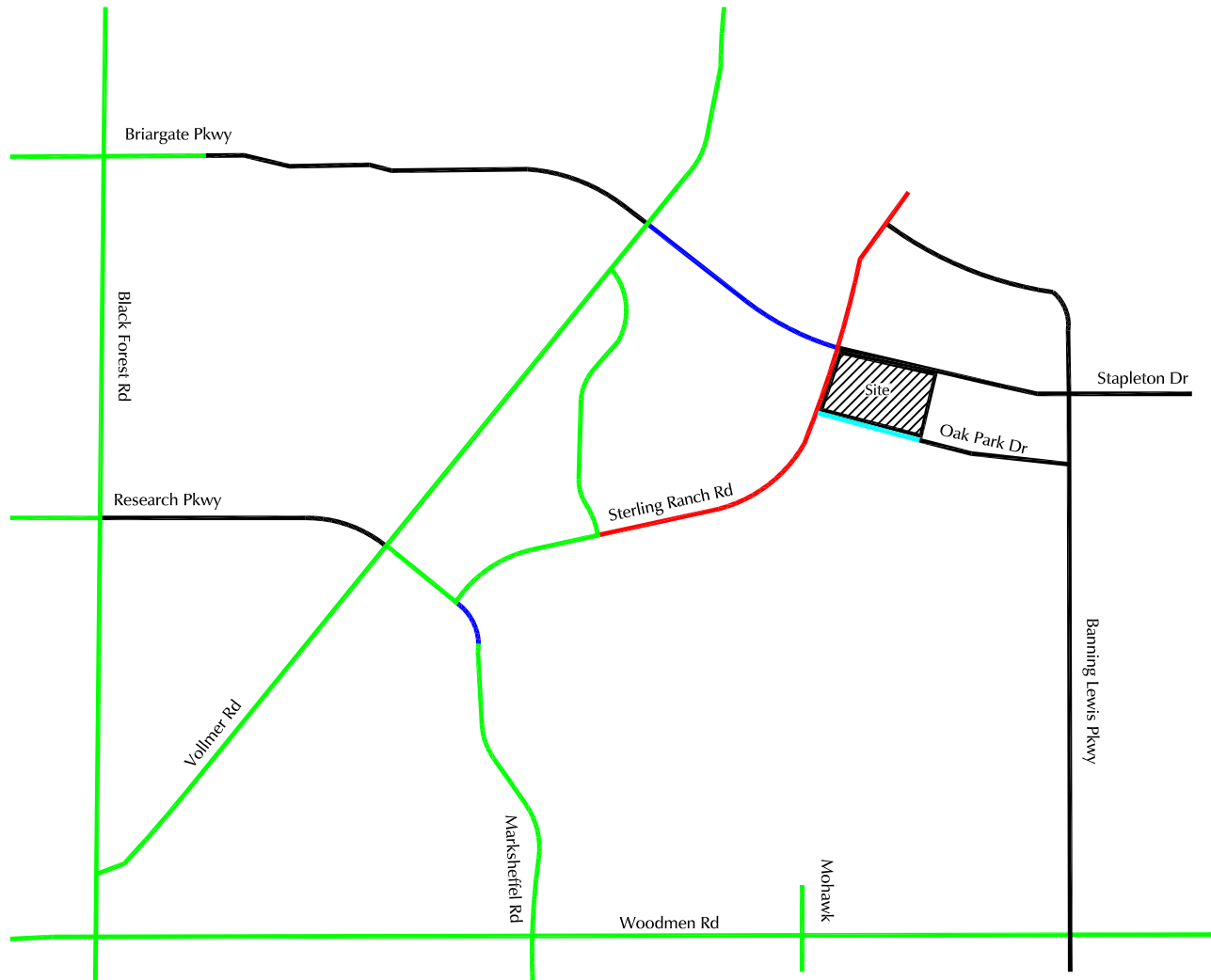

- Roadway connection planned with Sterling Ranch East Preliminary Plan 1
- Roadway connection planned with Villages at Sterling Ranch
- Roadway connection planned to be completed in 2024
- Existing Roadway
- Future Roadway

## Short-Term Roadway Connections

Villages at Sterling Ranch (LSC# S224580)





Approximate  
Scale  
1" = 200'

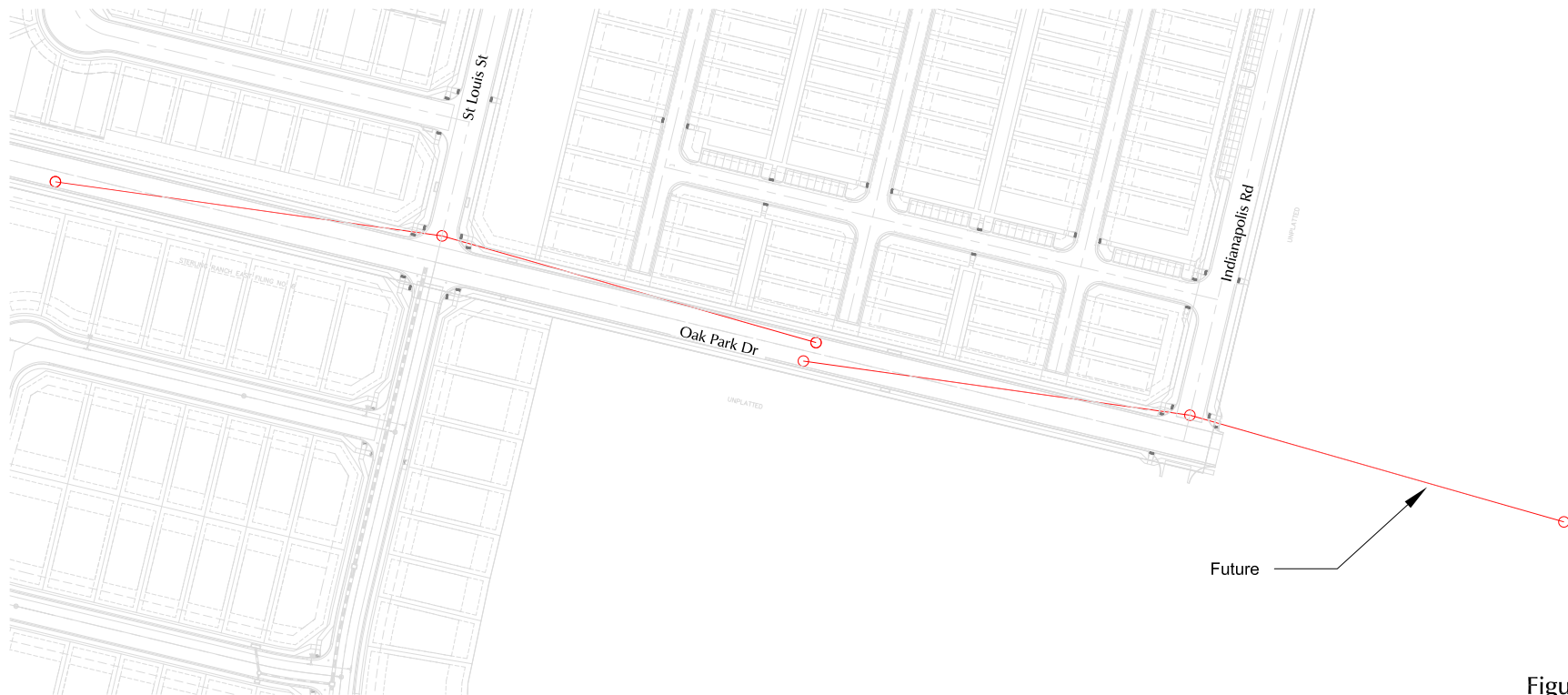

Future

— ECM Required Intersection Sight Distance (445' from Table 2-21 based on a Design Speed of 40 mph)

## Figure 4b Sight Distance Analysis - Oak Park Drive Intersections

Villages at Sterling Ranch (LSC# S224580)



Not to scale

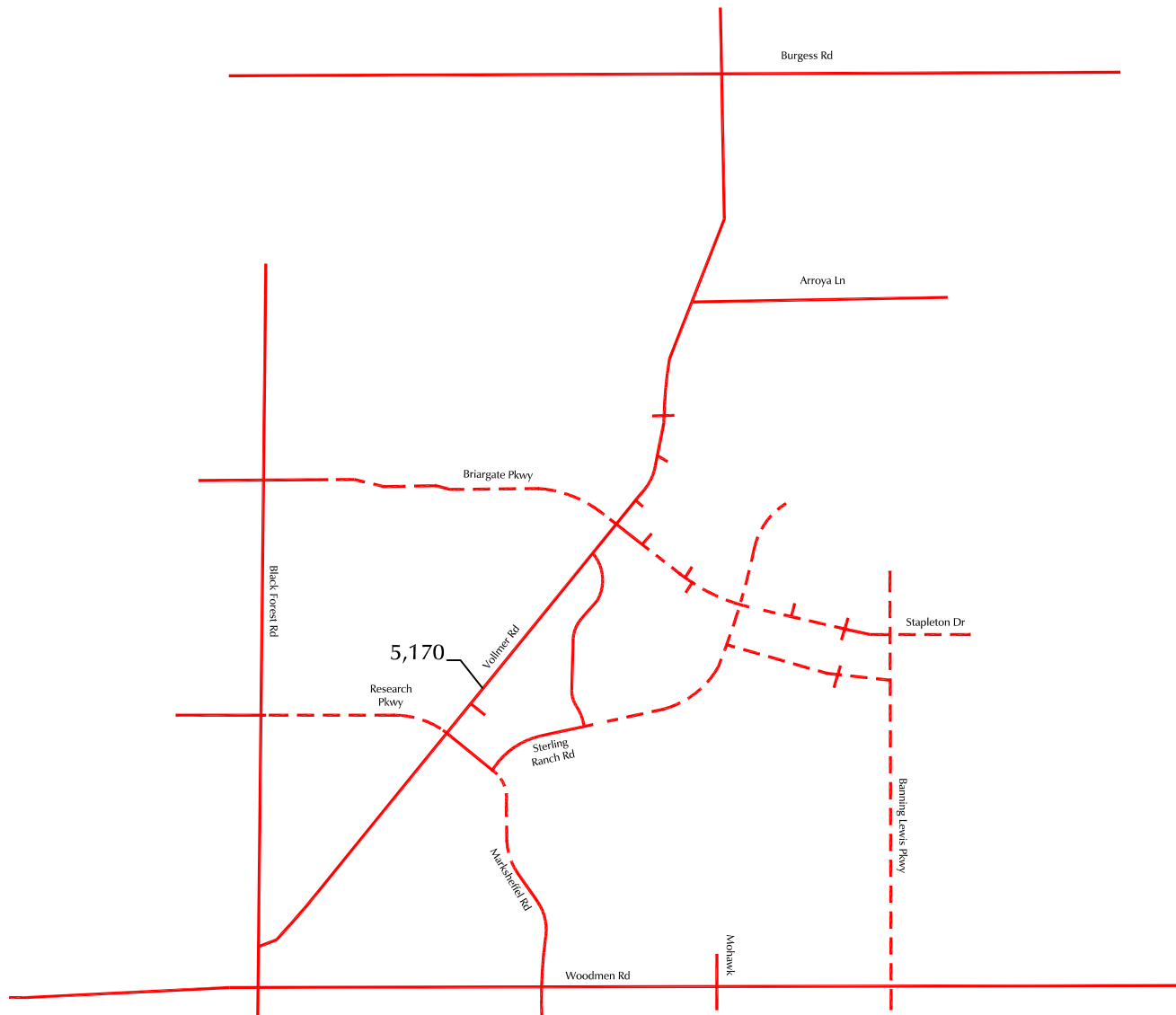

LEGEND:

XXX = Average Weekday Traffic (vehicles per day)(AWT) Based on counts by LSC April 2024

- Existing Roadway
- - - Future Roadway



# Existing Average Weekday Traffic

Villages at Sterling Ranch (LSC# S224580)

Figure 5a

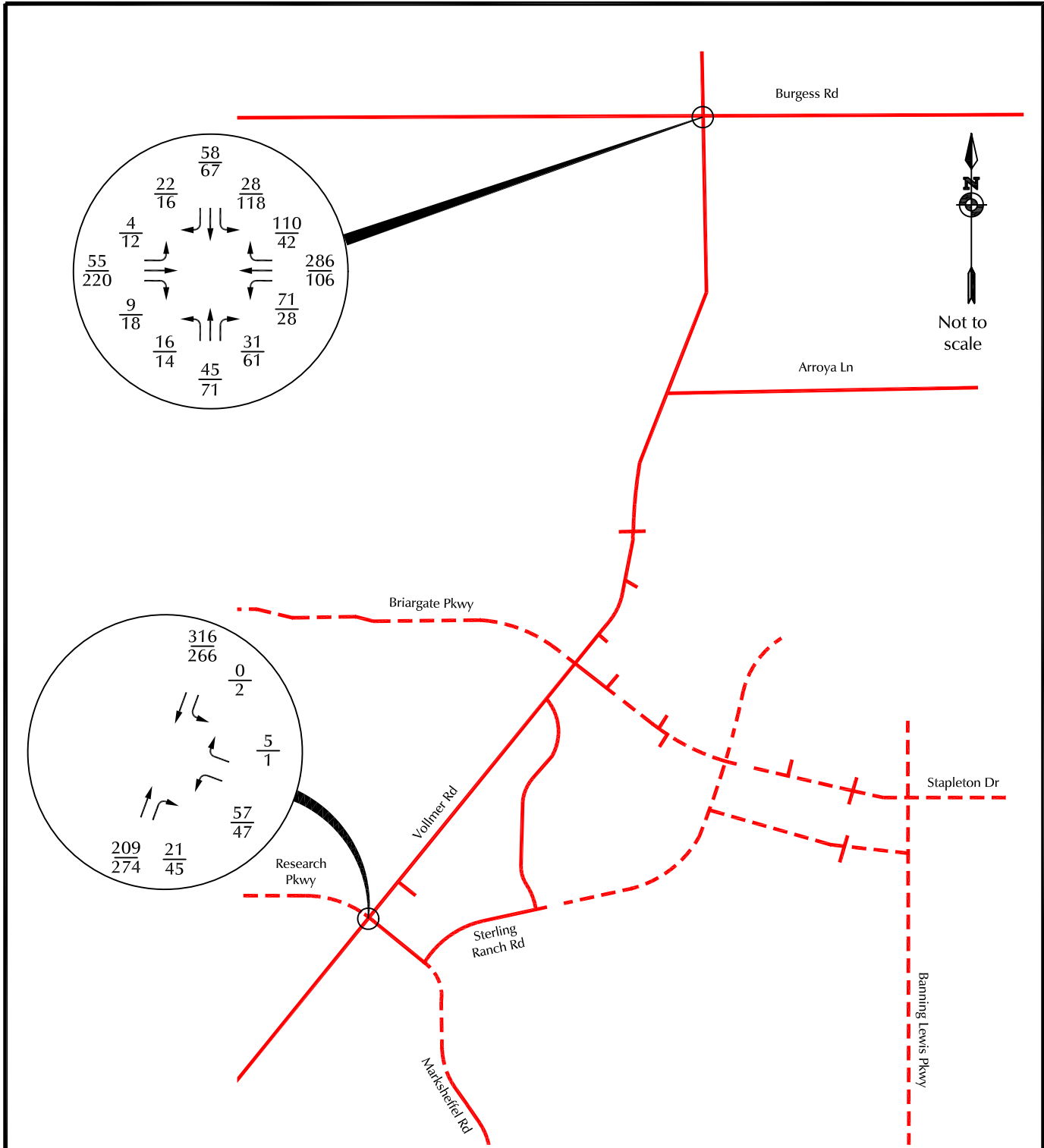

Not to scale

LEGEND:

$\frac{XX}{XX}$  = AM Peak-Hour Traffic (veh/hr) / PM Peak-Hour Traffic (veh/hr) Counts by LSC March/April 2024

- Existing Roadway
- - - Future Roadway



# Existing Peak-Hour Traffic

Figure 5b

Villages at Sterling Ranch (LSC# S224580)

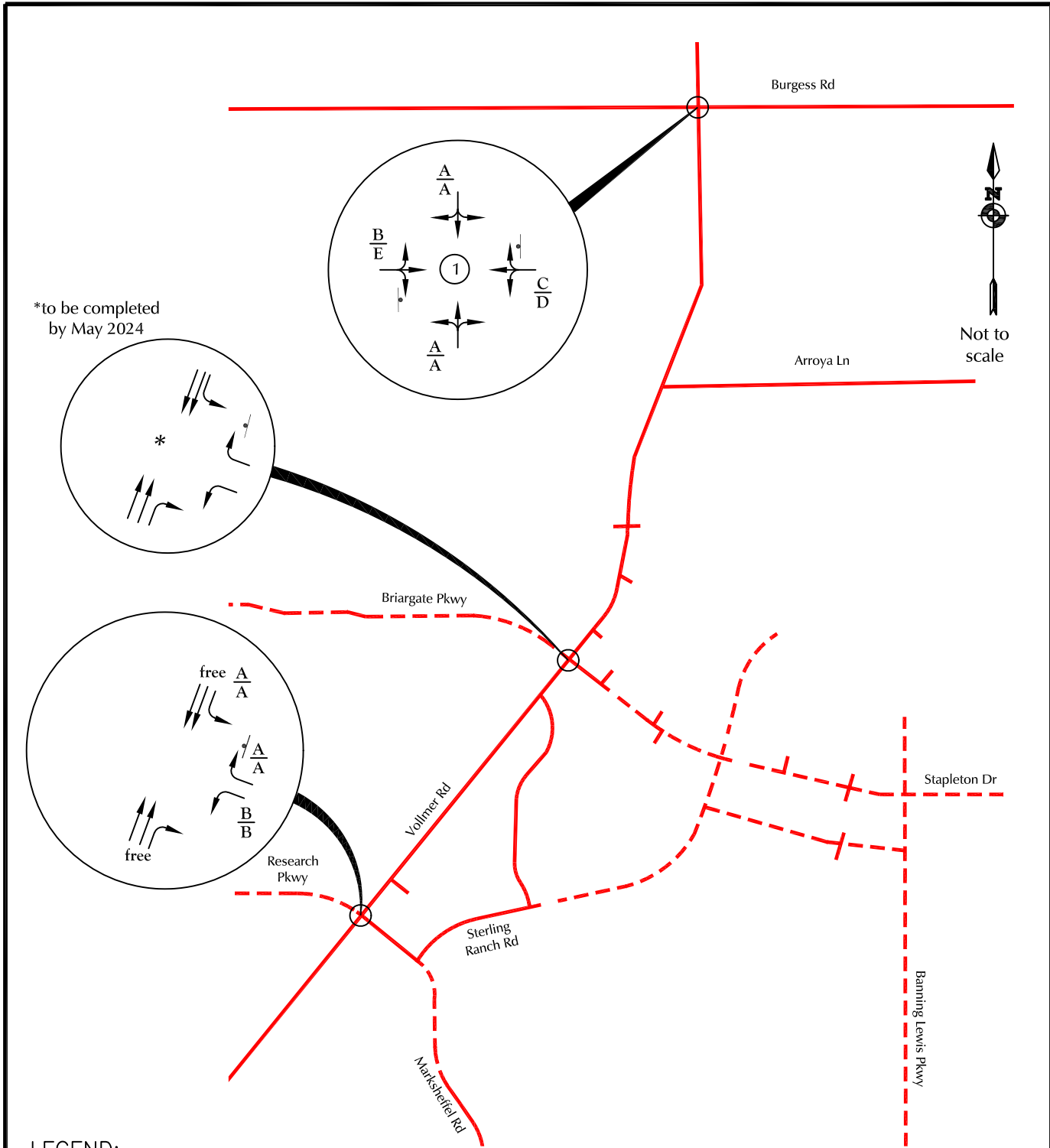

\*to be completed  
by May 2024



Not to scale

LEGEND:

$$\frac{A}{B} = \frac{\text{AM Individual Movement Peak-Hour Level of Service}}{\text{PM Individual Movement Peak-Hour Level of Service}}$$

⊥ = Stop Sign

- Existing Roadway
- - - Future Roadway

Figure 5c

# Existing Lane Geometry, Traffic Control, and Level of Service

Villages at Sterling Ranch (LSC# S224580)



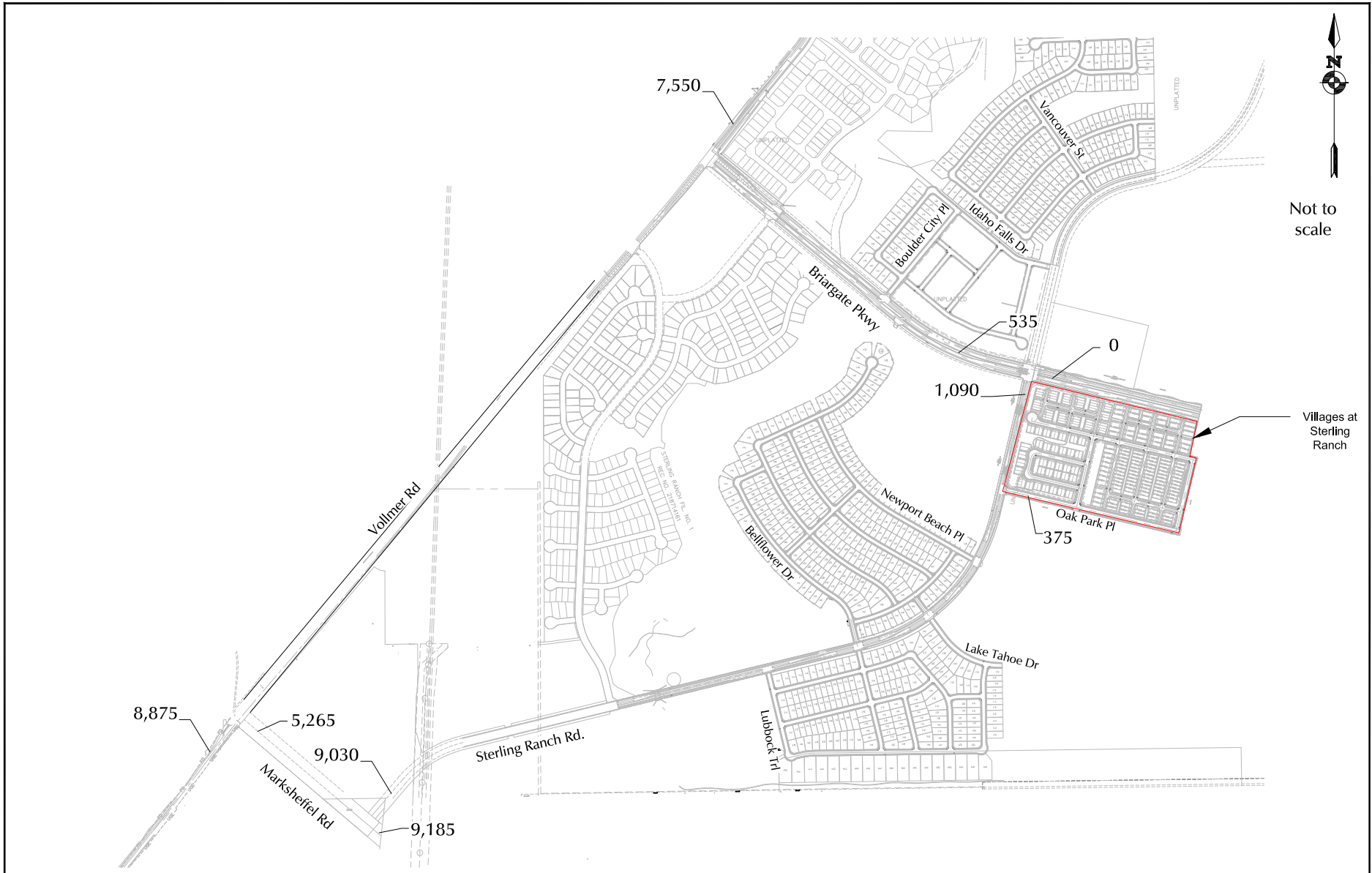

LEGEND: XXX = Average Weekday Traffic (vehicles per day)(AWT)

Figure 6a

# Short-Term Background Average Weekday Traffic

Villages at Sterling Ranch (LSC# S224580)



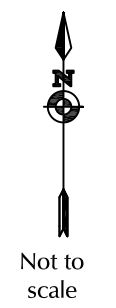
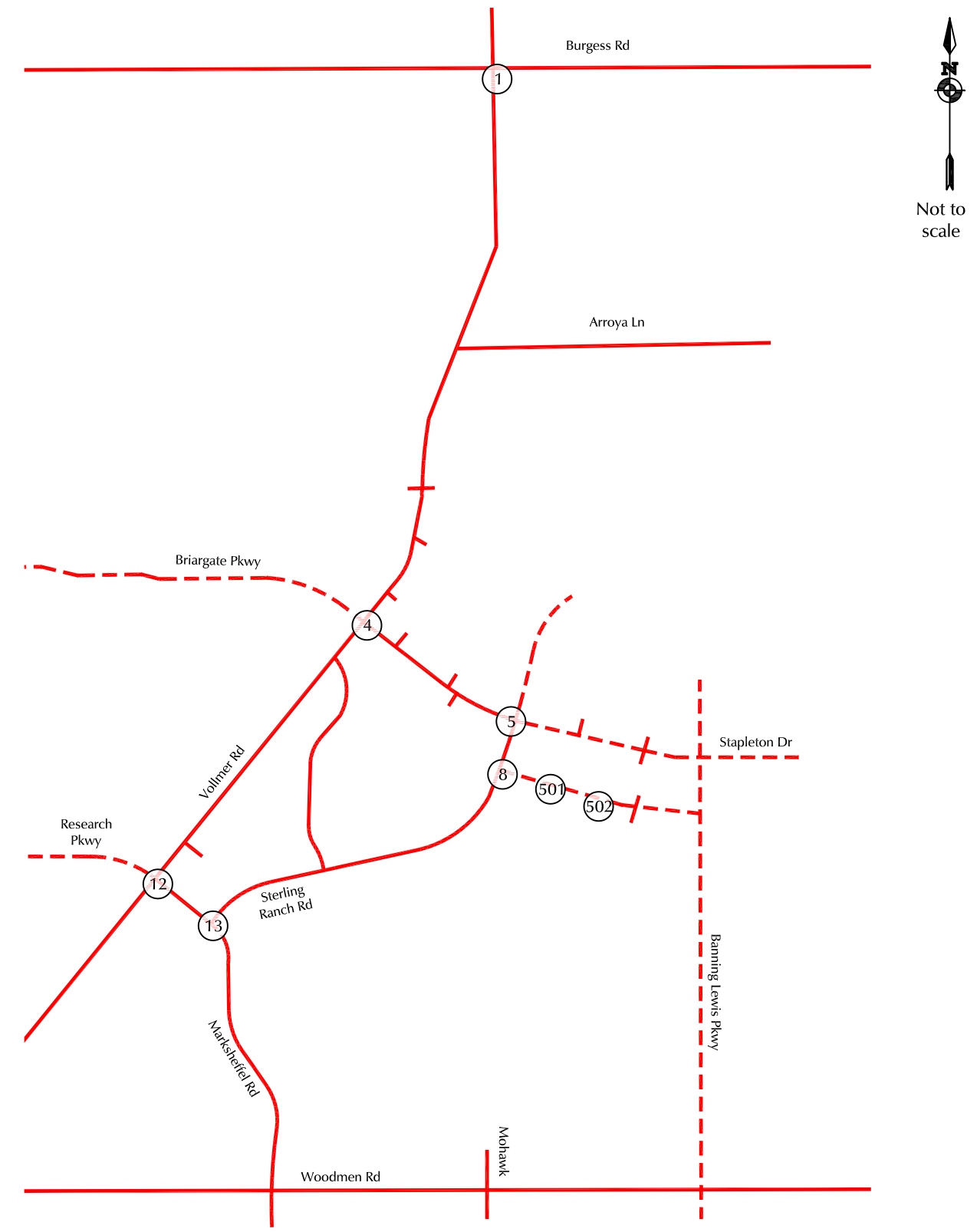
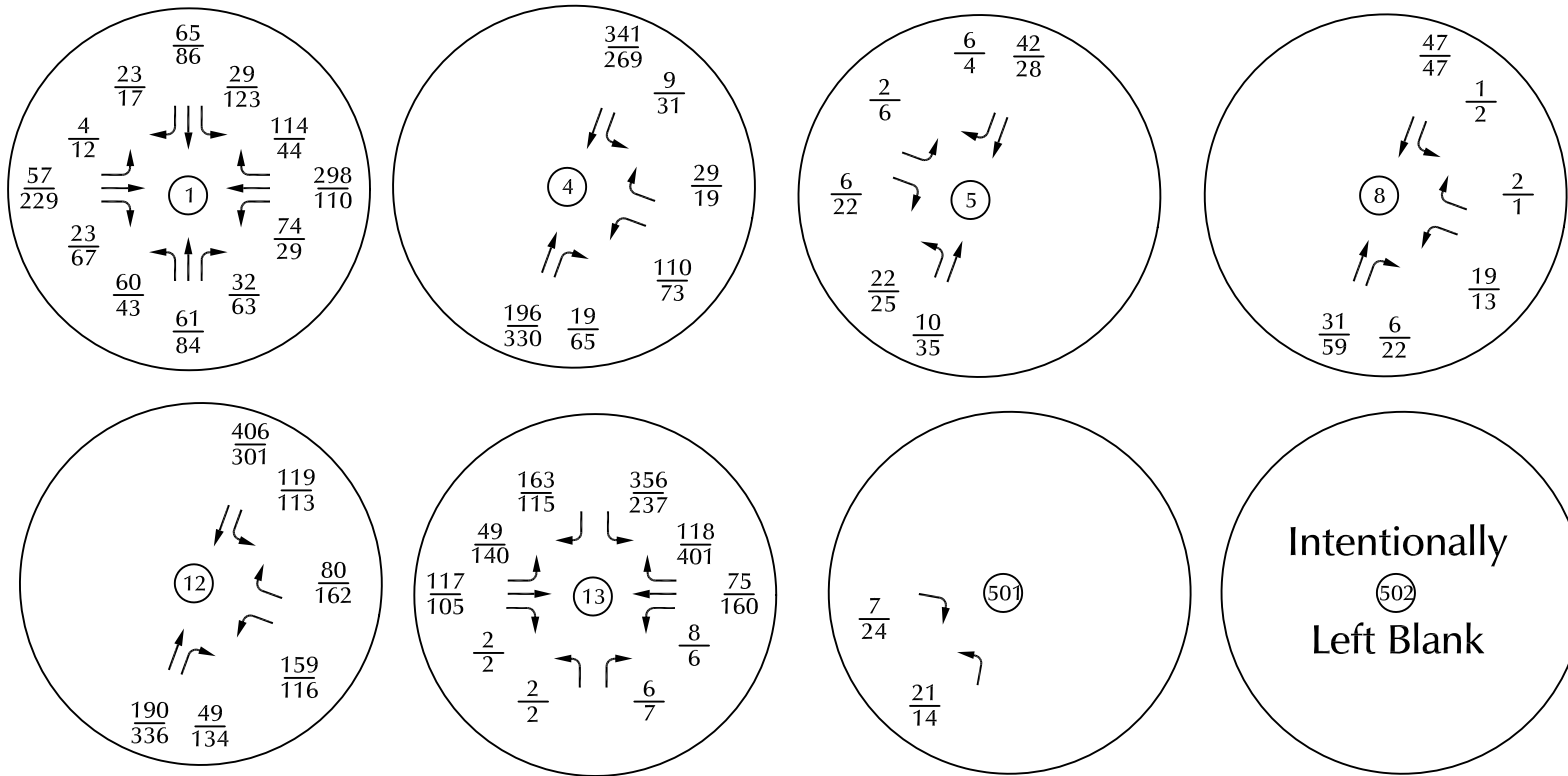

LEGEND:  $\frac{XX}{XX}$  = AM Peak-Hour Traffic (veh/hr)  
 $\frac{XX}{XX}$  = PM Peak-Hour Traffic (veh/hr)

— Existing Roadway  
 - - - Future Roadway



Figure 6b  
 Short-Term Background Traffic

Villages at Sterling Ranch (LSC# S224580)



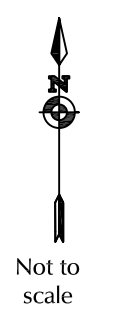
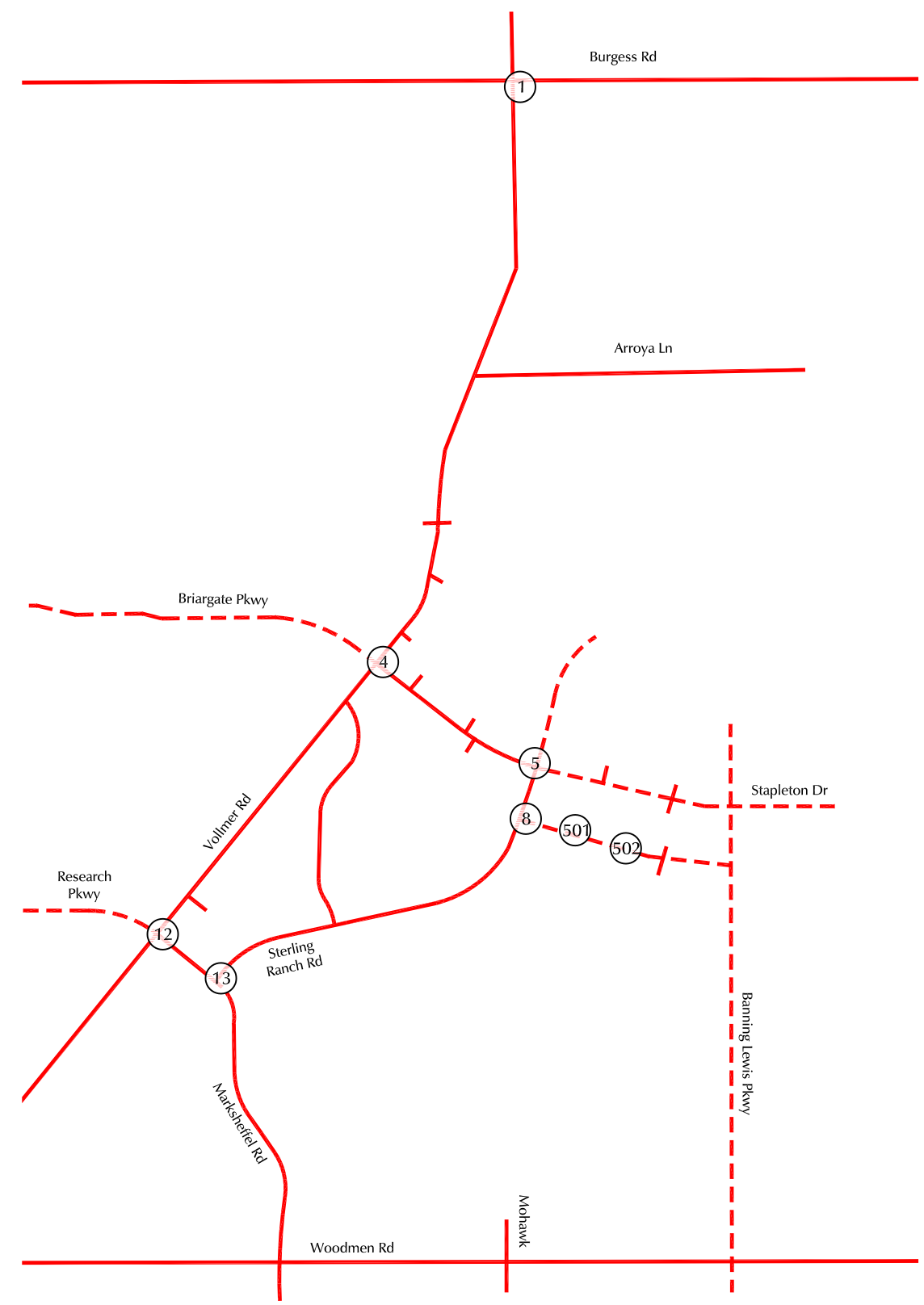
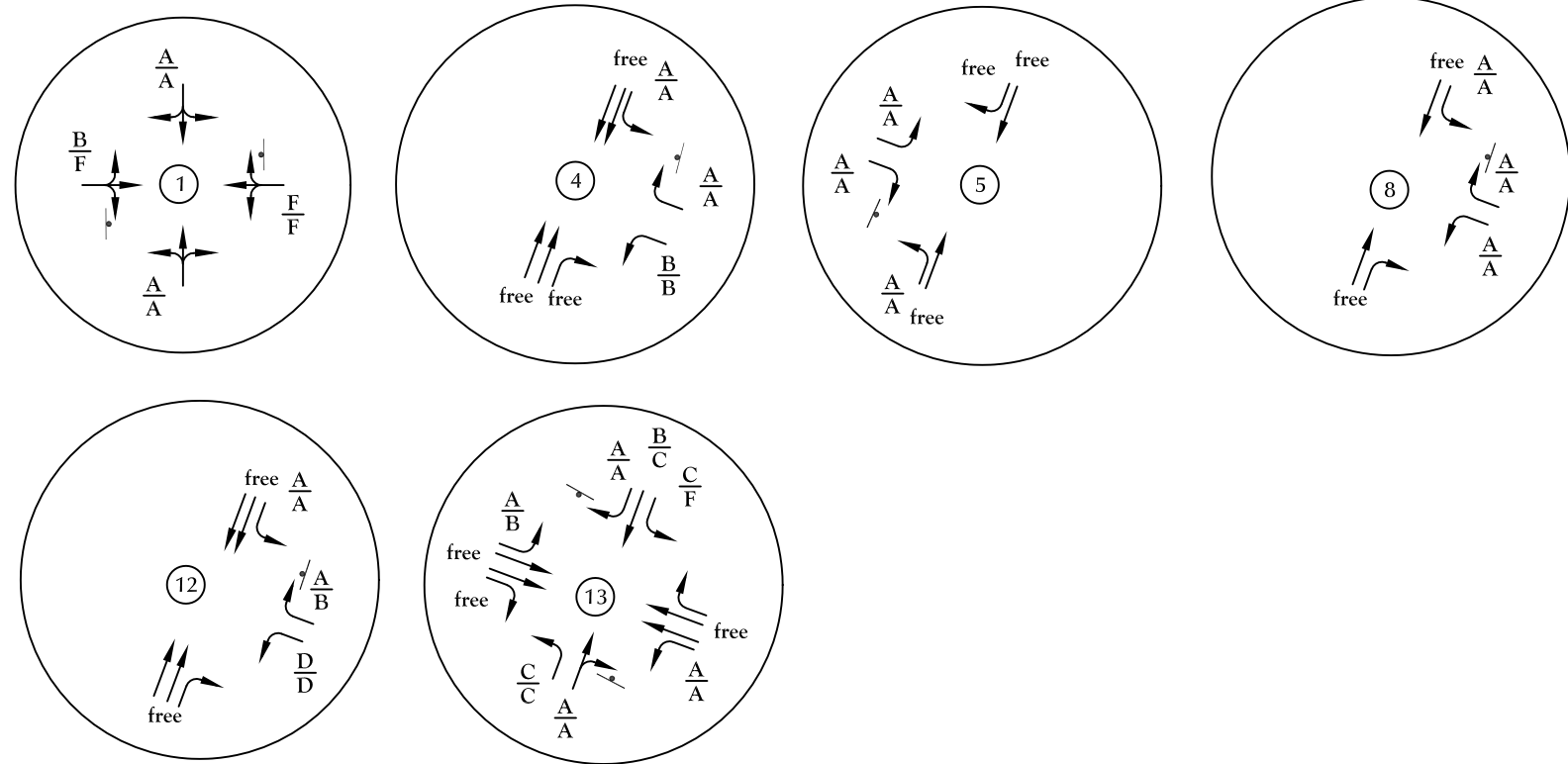

LEGEND:

$\frac{A}{A}$  = AM Individual Movement Peak-Hour Level of Service  
 $\frac{B}{B}$  = PM Individual Movement Peak-Hour Level of Service  
 $\frac{C}{C}$  = AM Entire Intersection Peak-Hour Level of Service  
 $\frac{D}{D}$  = PM Entire Intersection Peak-Hour Level of Service

⊥ = Stop Sign  
 = Traffic Signal

— Existing Roadway  
 - - - Future Roadway

Figure 6c  
 Short-Term Lane Geometry,  
 Traffic Control, and Level of Service

Villages at Sterling Ranch (LSC# S224580)



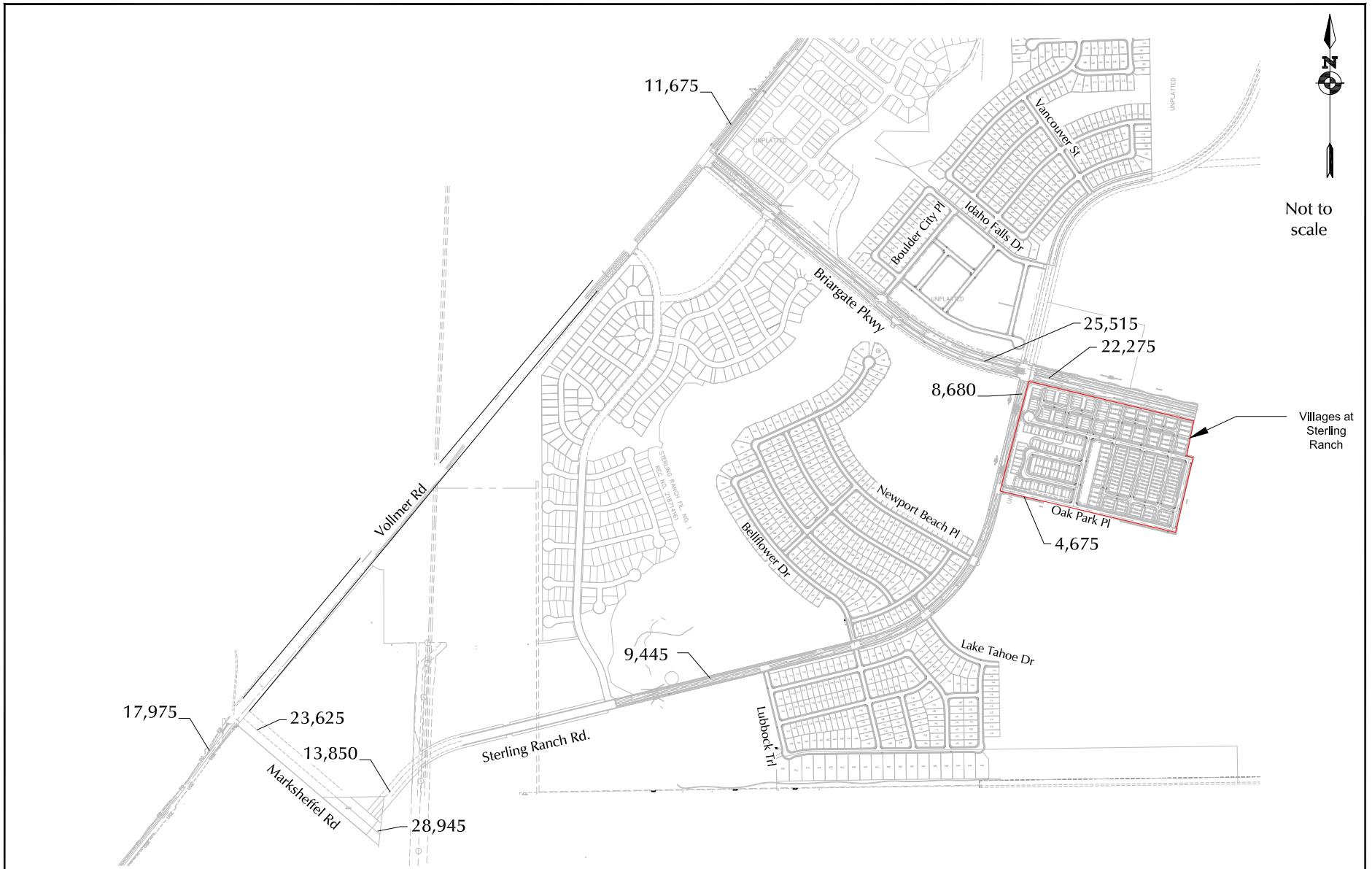

LEGEND: XXX = Average Weekday Traffic (vehicles per day)(AWT)

## 2044 Background Average Weekday Traffic

Figure 7a

Villages at Sterling Ranch (LSC# S224580)

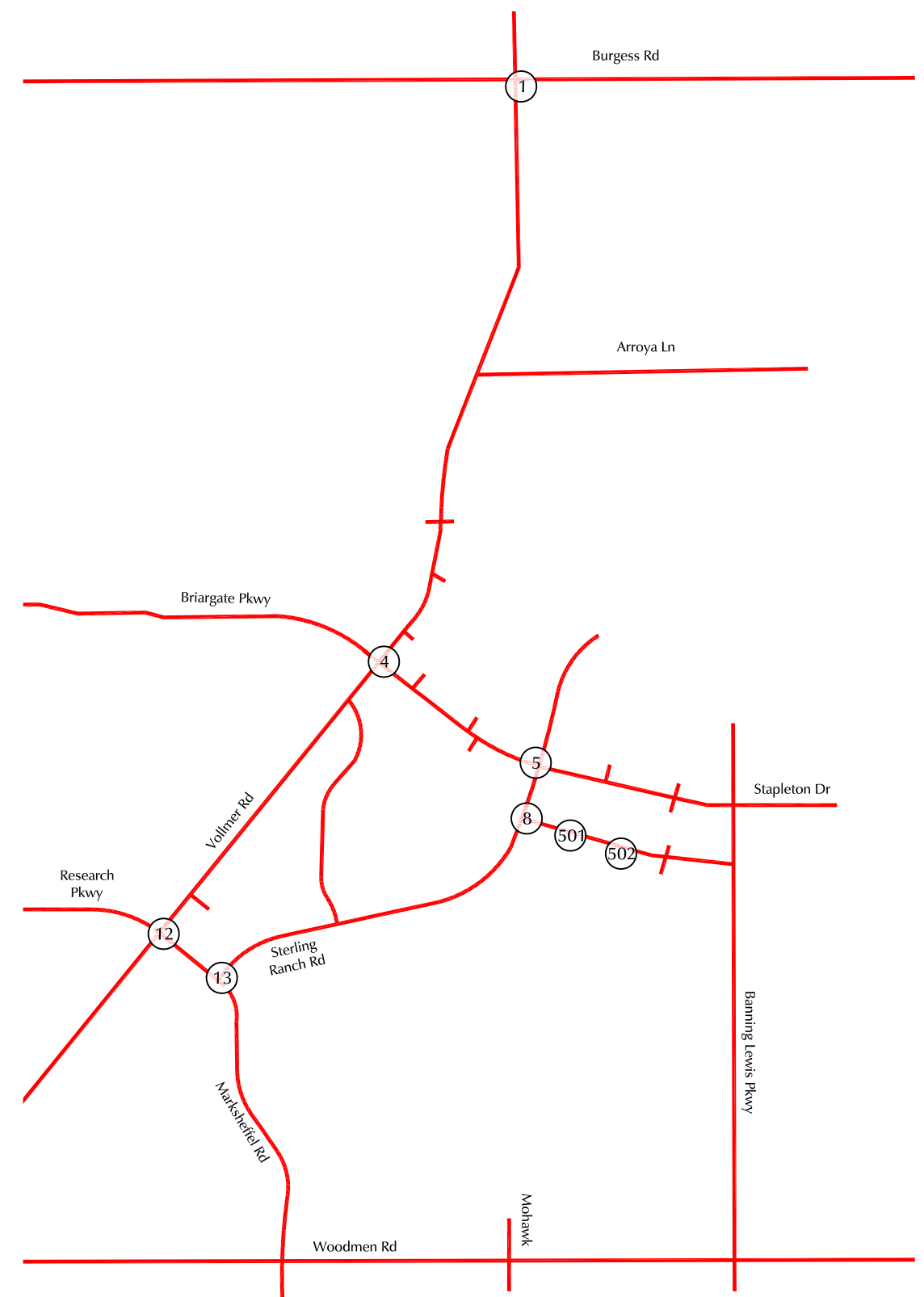
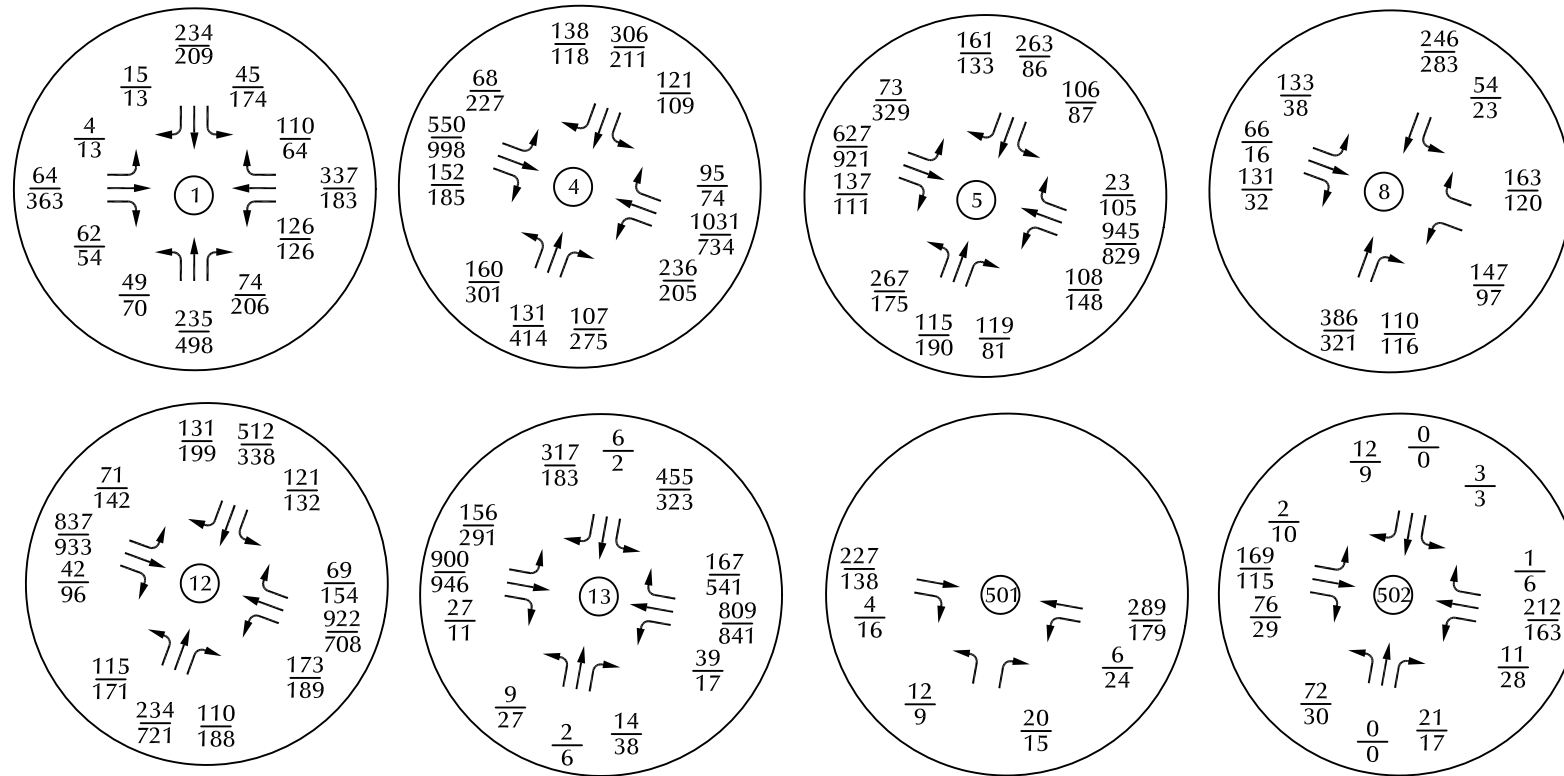

LEGEND:  $\frac{XX}{XX}$  = AM Peak-Hour Traffic (veh/hr)  
 $\frac{XX}{XX}$  = PM Peak-Hour Traffic (veh/hr)



Figure 7b  
 2044 Background Traffic

Villages at Sterling Ranch (LSC# S224580)

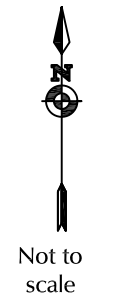
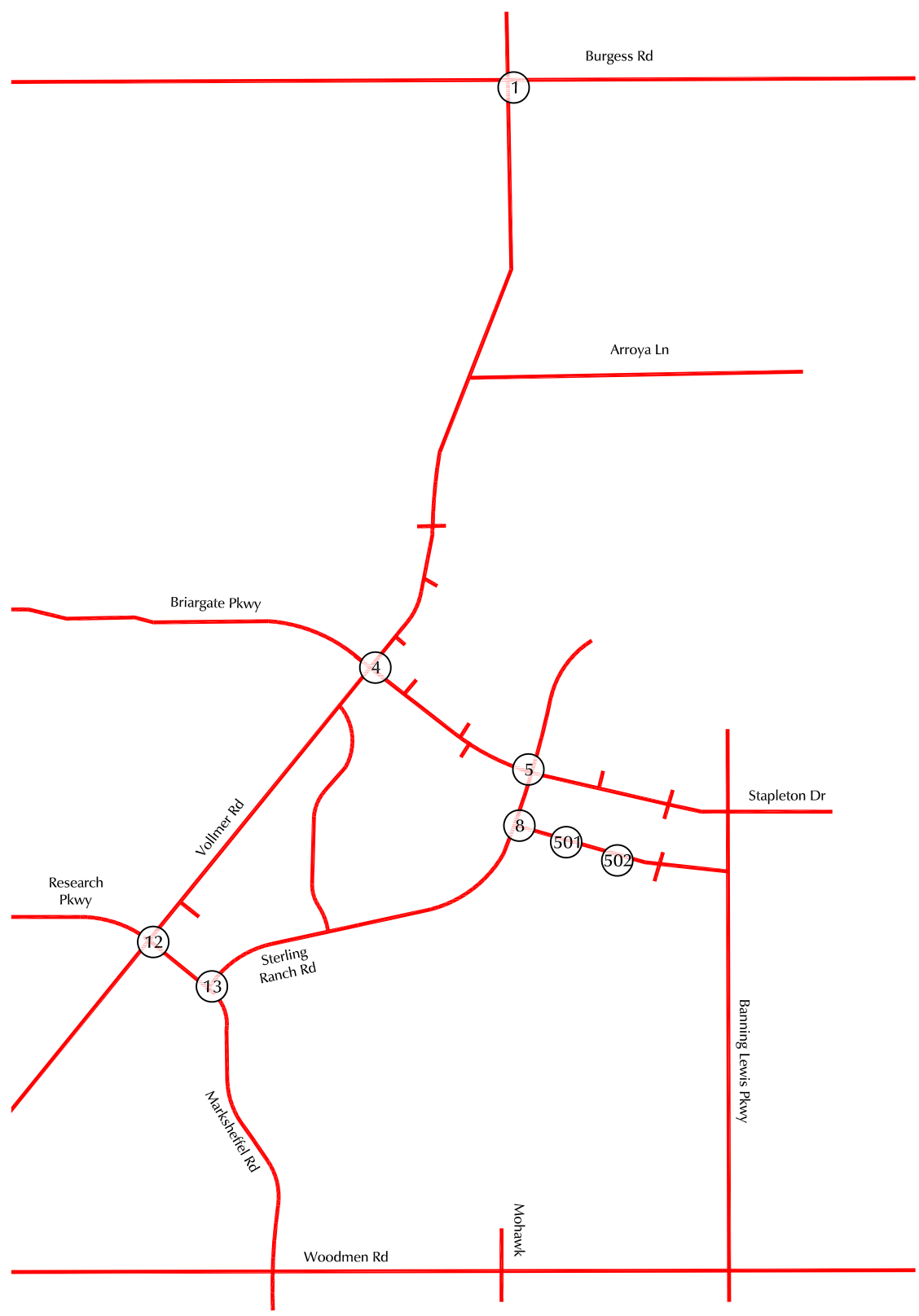
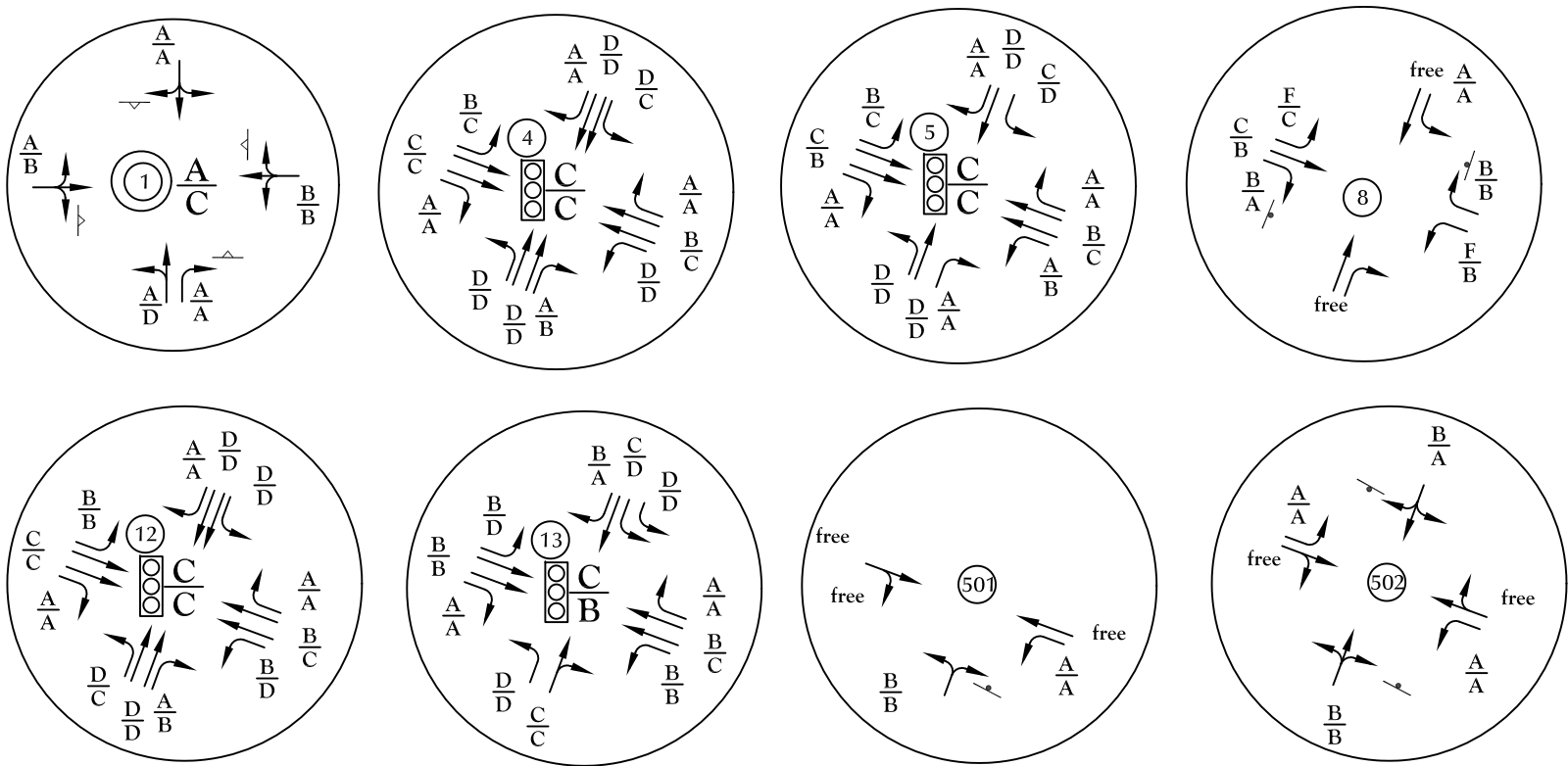

LEGEND:

$\frac{A}{B}$  = AM Individual Movement Peak-Hour Level of Service  
 PM Individual Movement Peak-Hour Level of Service  
 $\frac{C}{D}$  = AM Entire Intersection Peak-Hour Level of Service  
 PM Entire Intersection Peak-Hour Level of Service

▤ = Stop Sign                      ▤ = Yield Sign  
 = Traffic Signal                      ○ = Roundabout

Figure 7c  
**2044 Background Lane Geometry,  
 Traffic Control, and Level of Service**





Not to scale

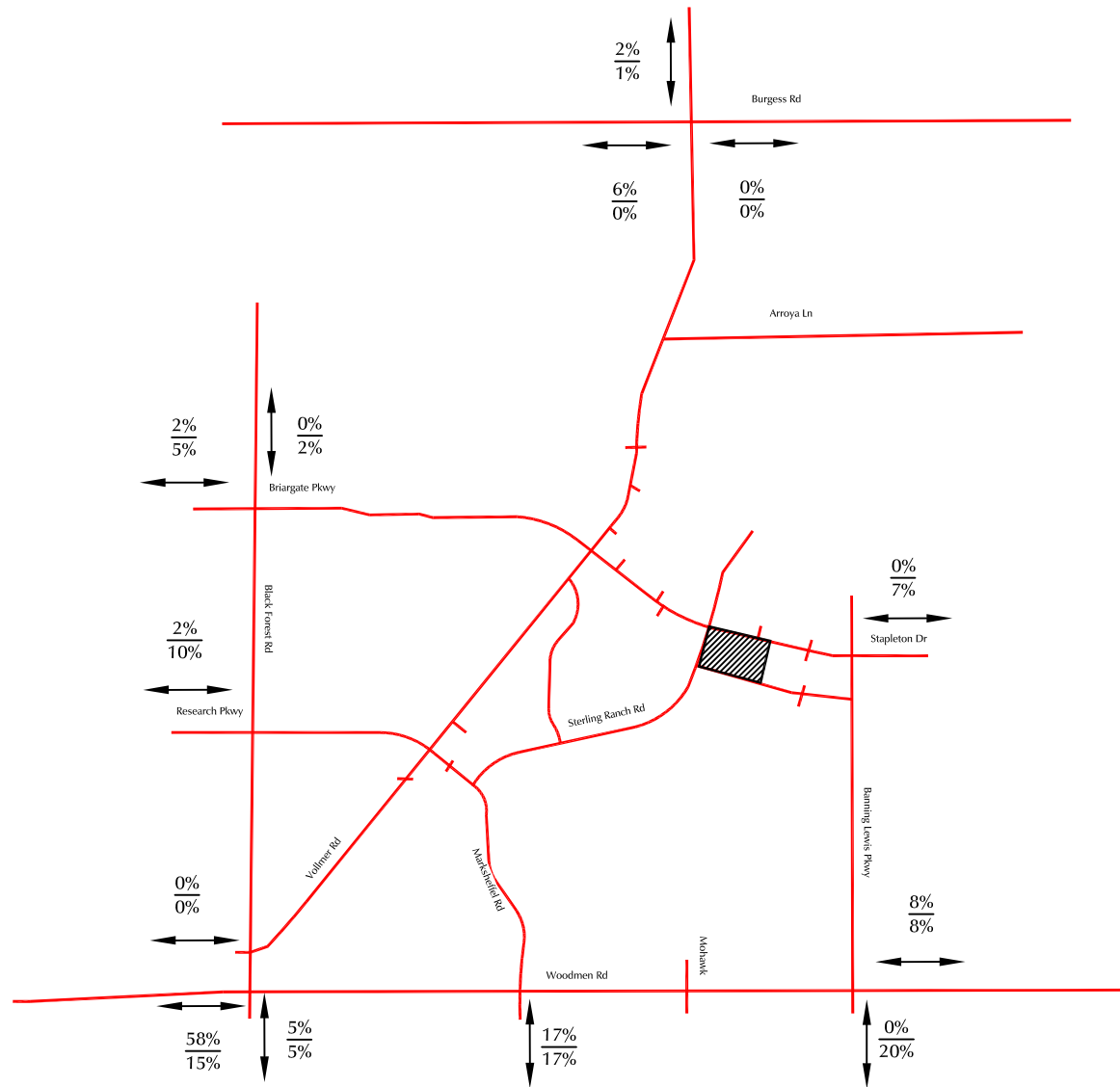

LEGEND:

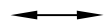

XX%  
XX%

= Percent of Short-Term Trips  
Percent of Buildout Long-Term Trips

## Estimated Directional Distribution of Site-Generated Trips

Figure 8

Villages at Sterling Ranch (LSC# S224580)

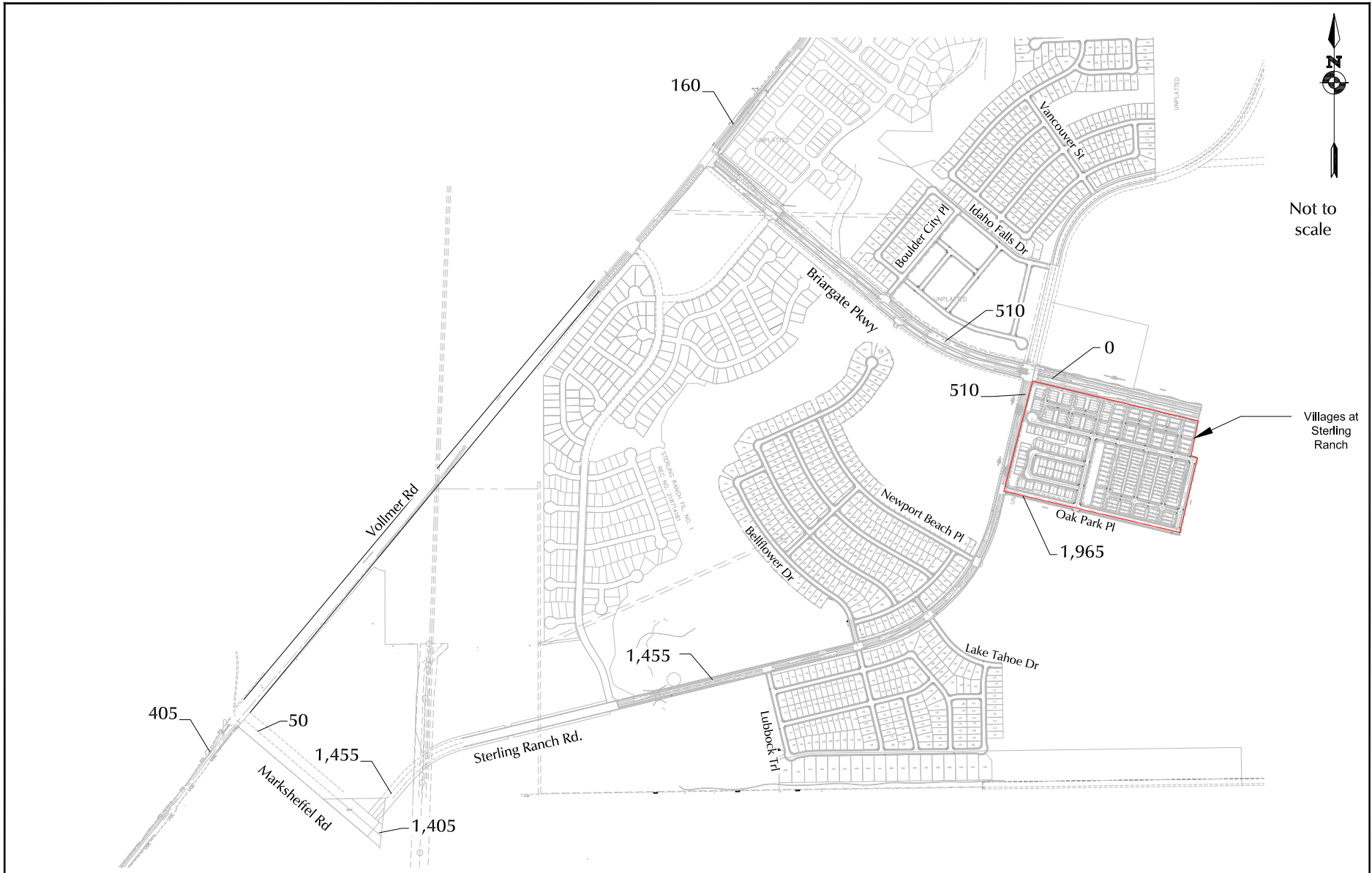

LEGEND: XXX = Average Weekday Traffic (vehicles per day)(AWT)

## Short-Term Site Generated Average Weekday Traffic

Villages at Sterling Ranch (LSC# S224580)

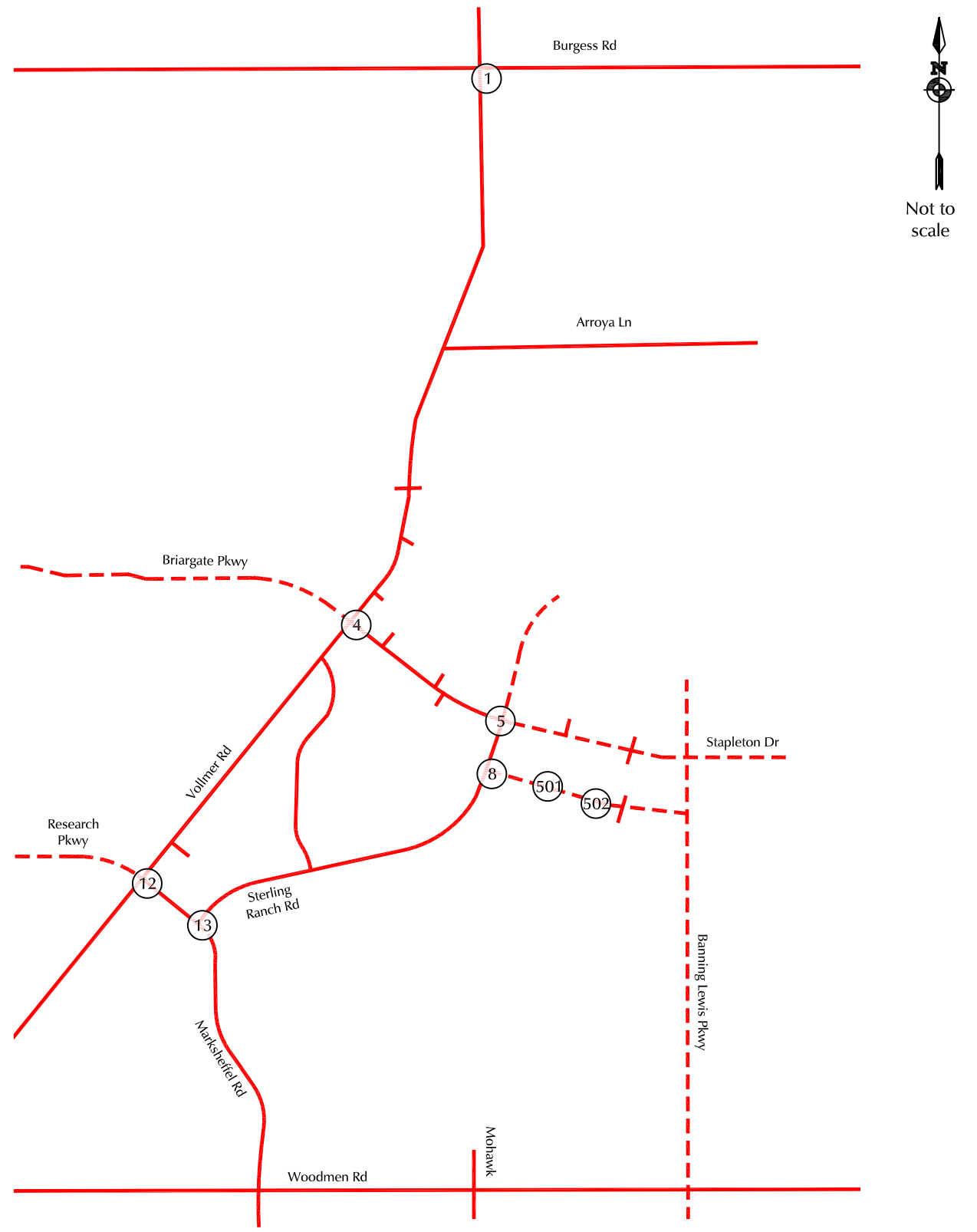
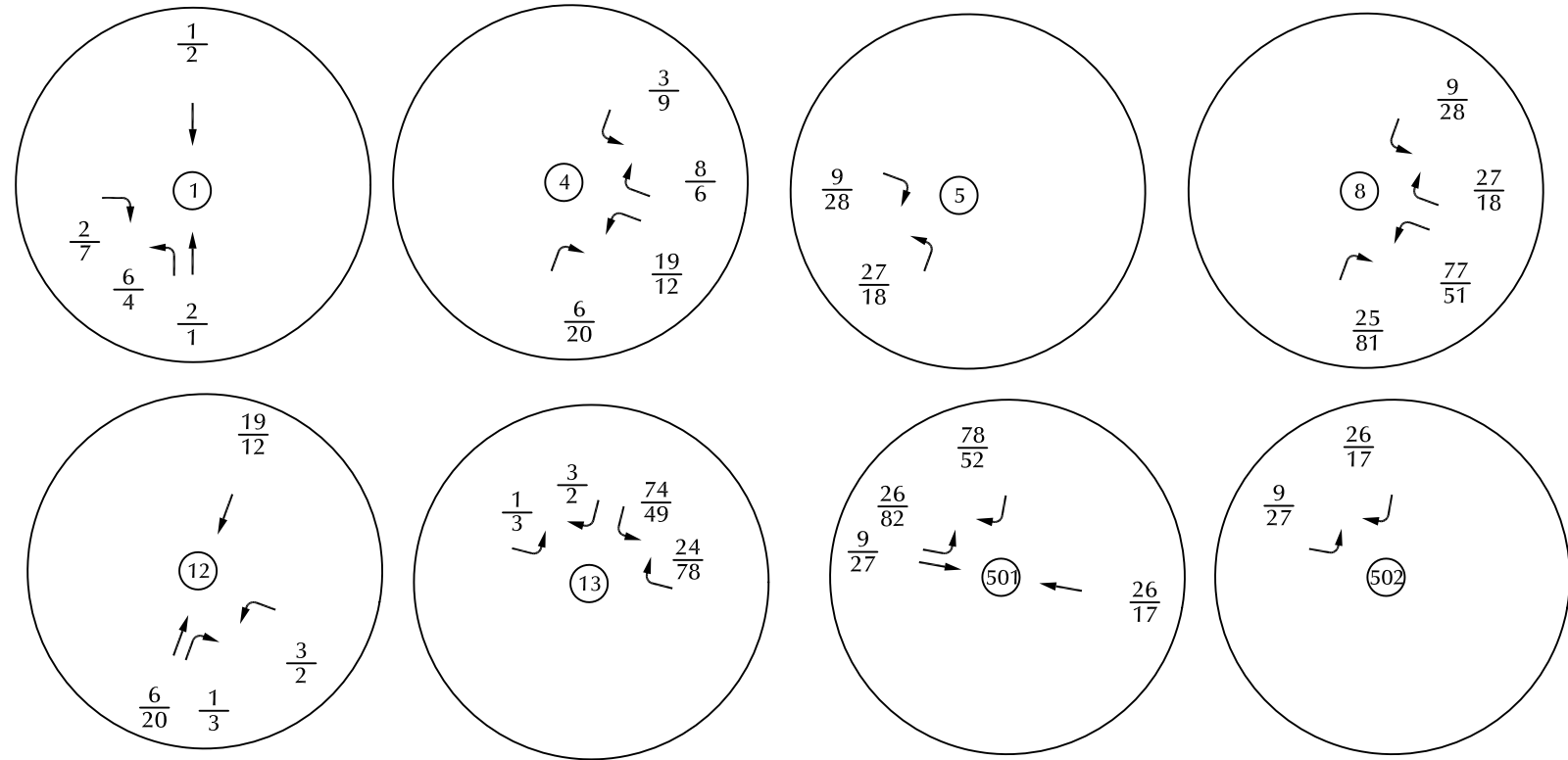

LEGEND:  $\frac{XX}{XX}$  = AM Peak-Hour Traffic (veh/hr)  
 $\frac{XX}{XX}$  = PM Peak-Hour Traffic (veh/hr)

— Existing Roadway  
 - - - Future Roadway



Figure 9b  
 Short-Term Site-Generated Traffic  
 Villages at Sterling Ranch (LSC# S224580)

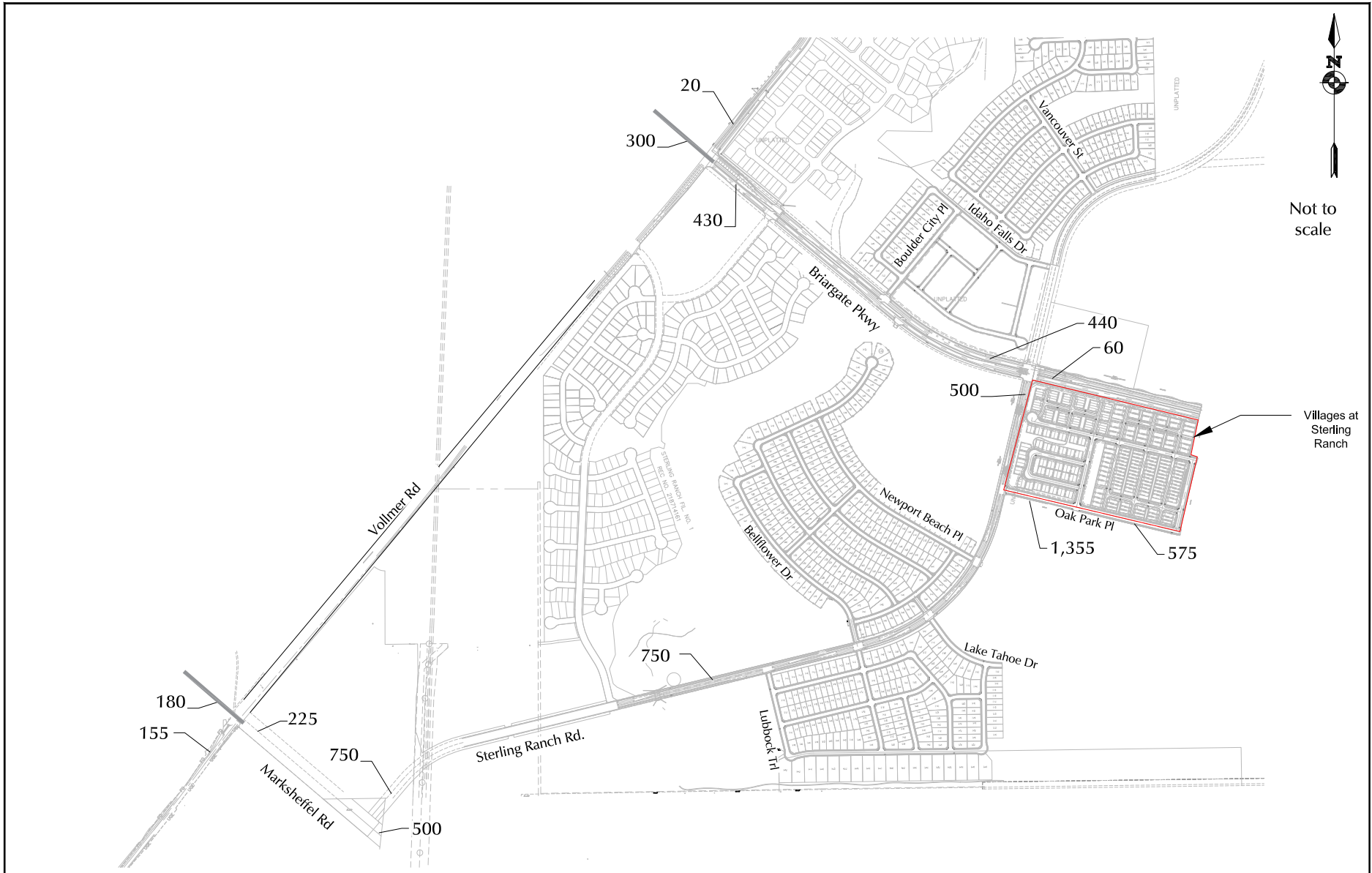

LEGEND: **XXX** = Average Weekday Traffic (vehicles per day)(AWT)

# Long-Term Site-Generated Average Weekday Traffic

Villages at Sterling Ranch (LSC# S224580)



Figure 10a



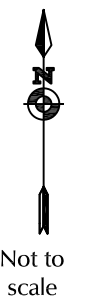
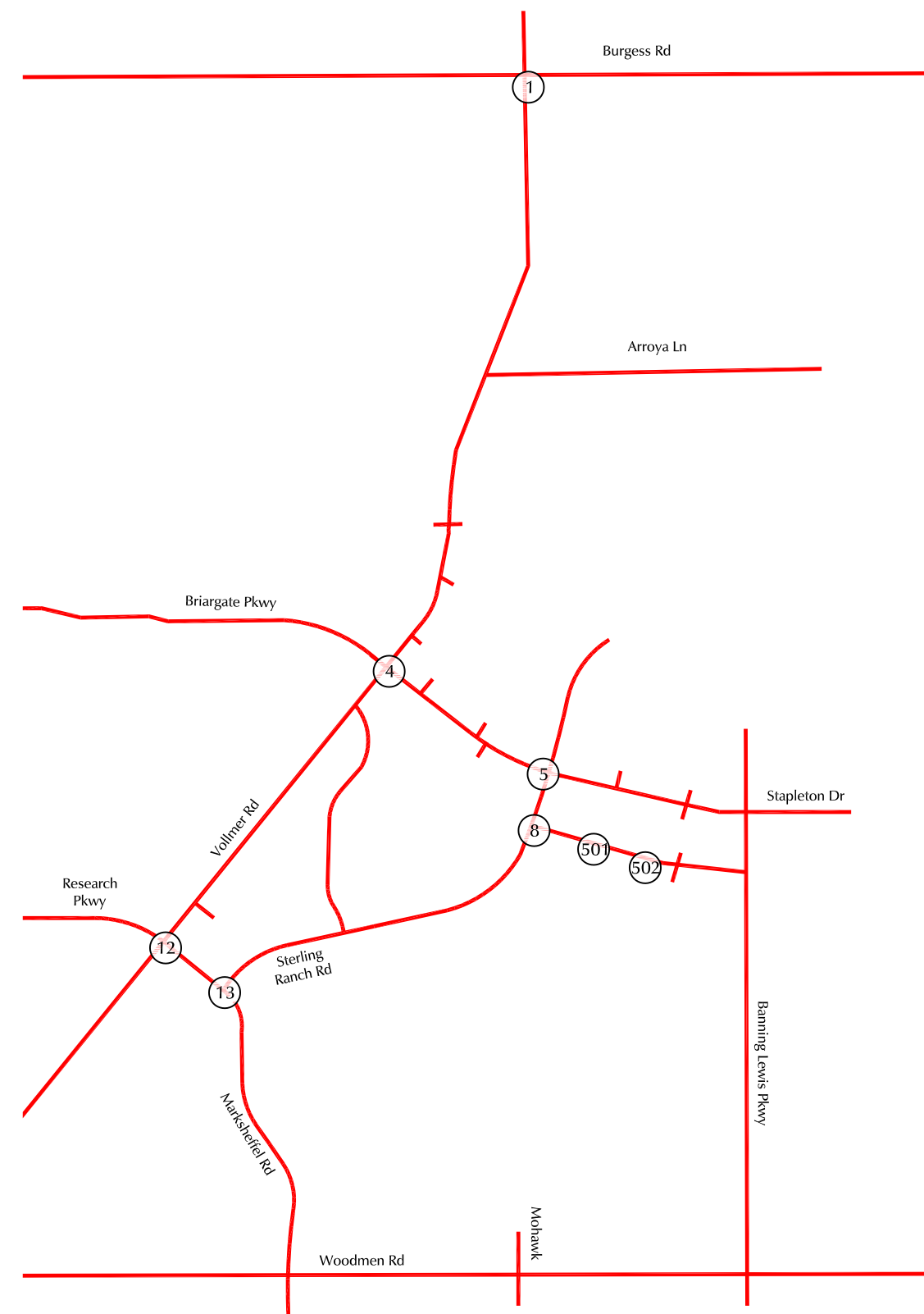
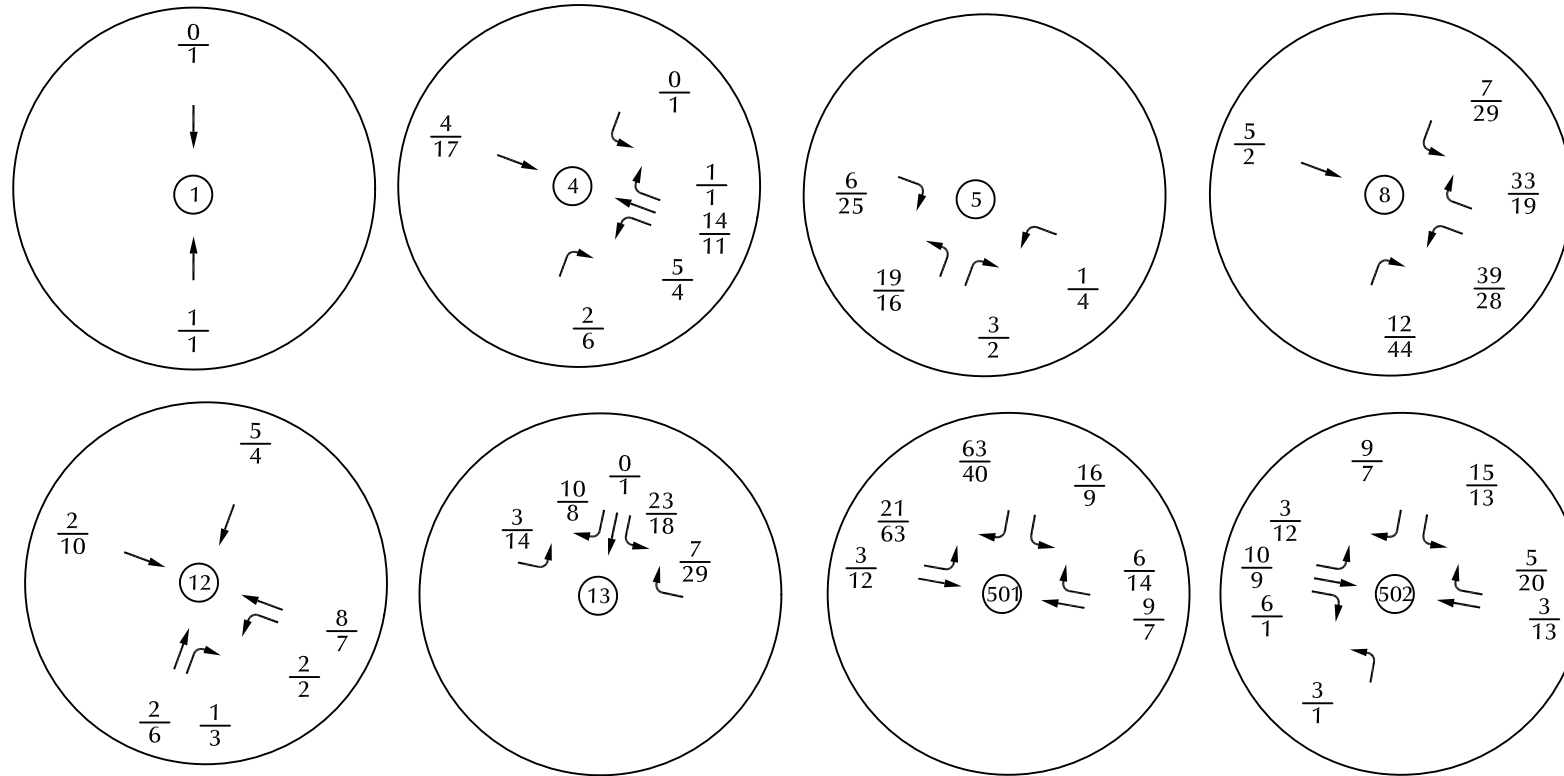

LEGEND:  $\frac{XX}{XX}$  = AM Peak-Hour Traffic (veh/hr)  
 $\frac{XX}{XX}$  = PM Peak-Hour Traffic (veh/hr)



Figure 10b  
 Long-Term Site-Generated Traffic

Villages at Sterling Ranch (LSC# S224580)

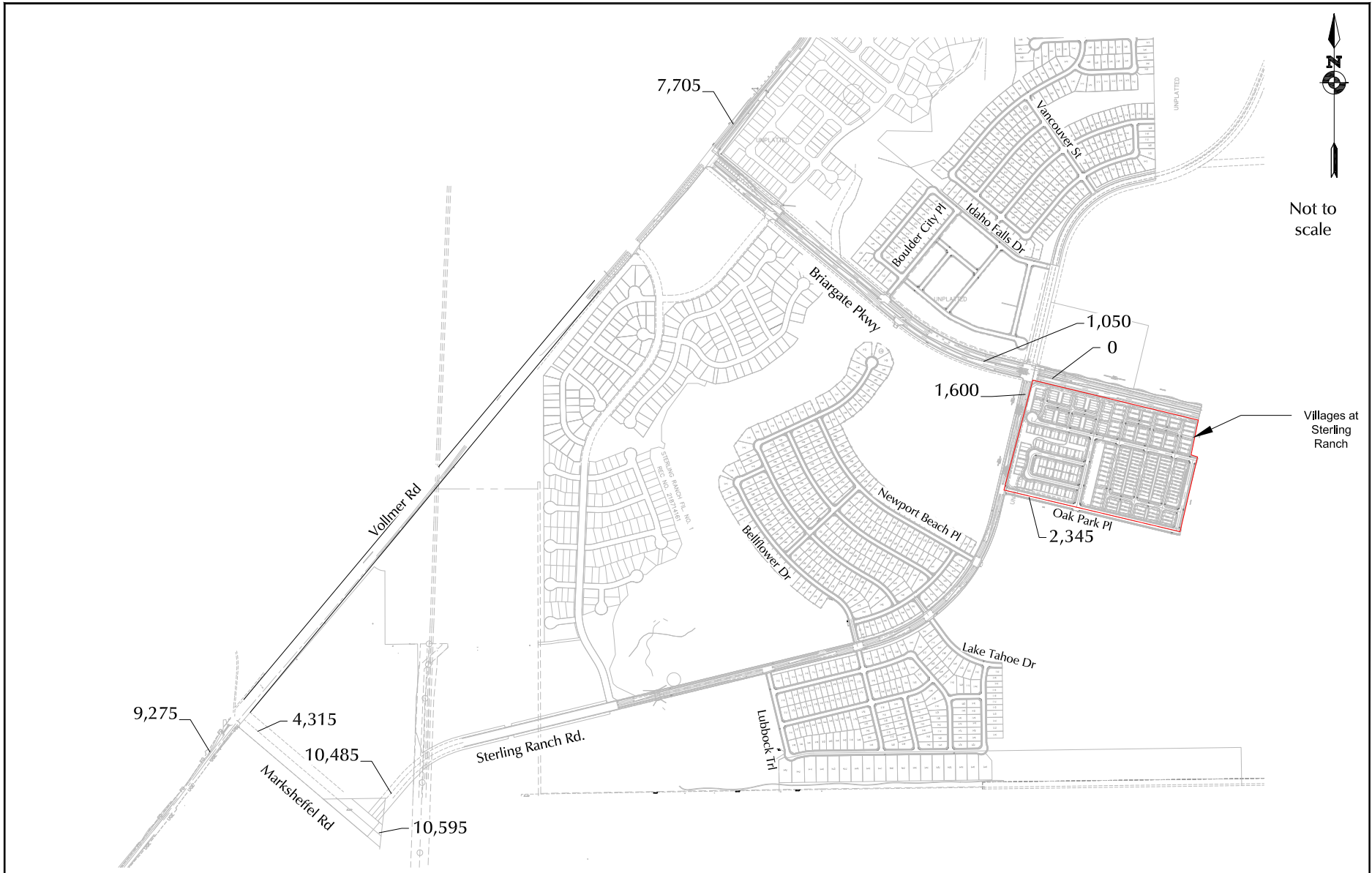

LEGEND: XXX = Average Weekday Traffic (vehicles per day)(AWT)

# Short-Term Total Average Weekday Traffic

Villages at Sterling Ranch (LSC# S224580)



Figure 11a

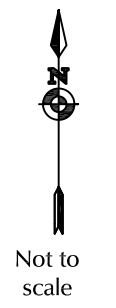
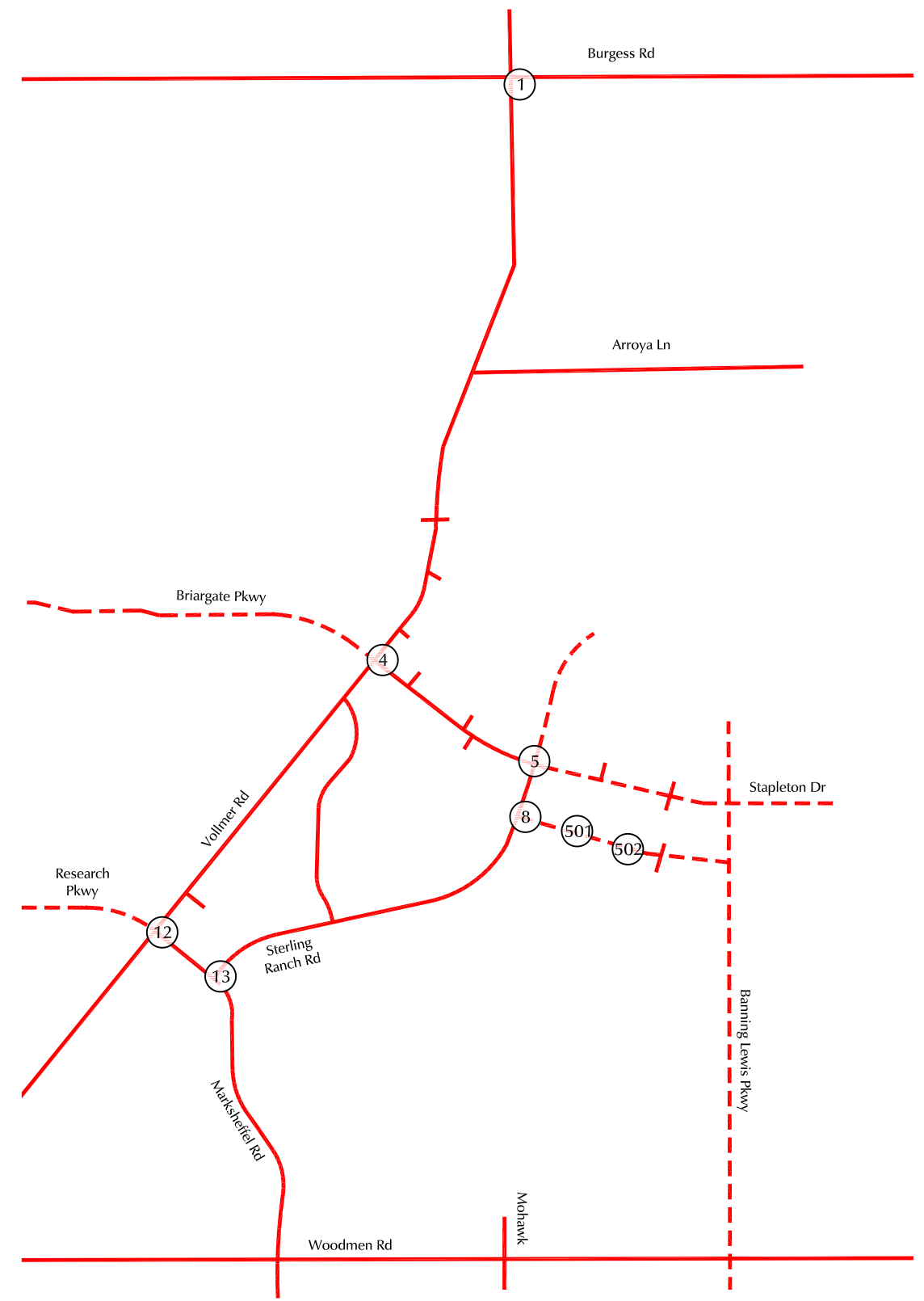
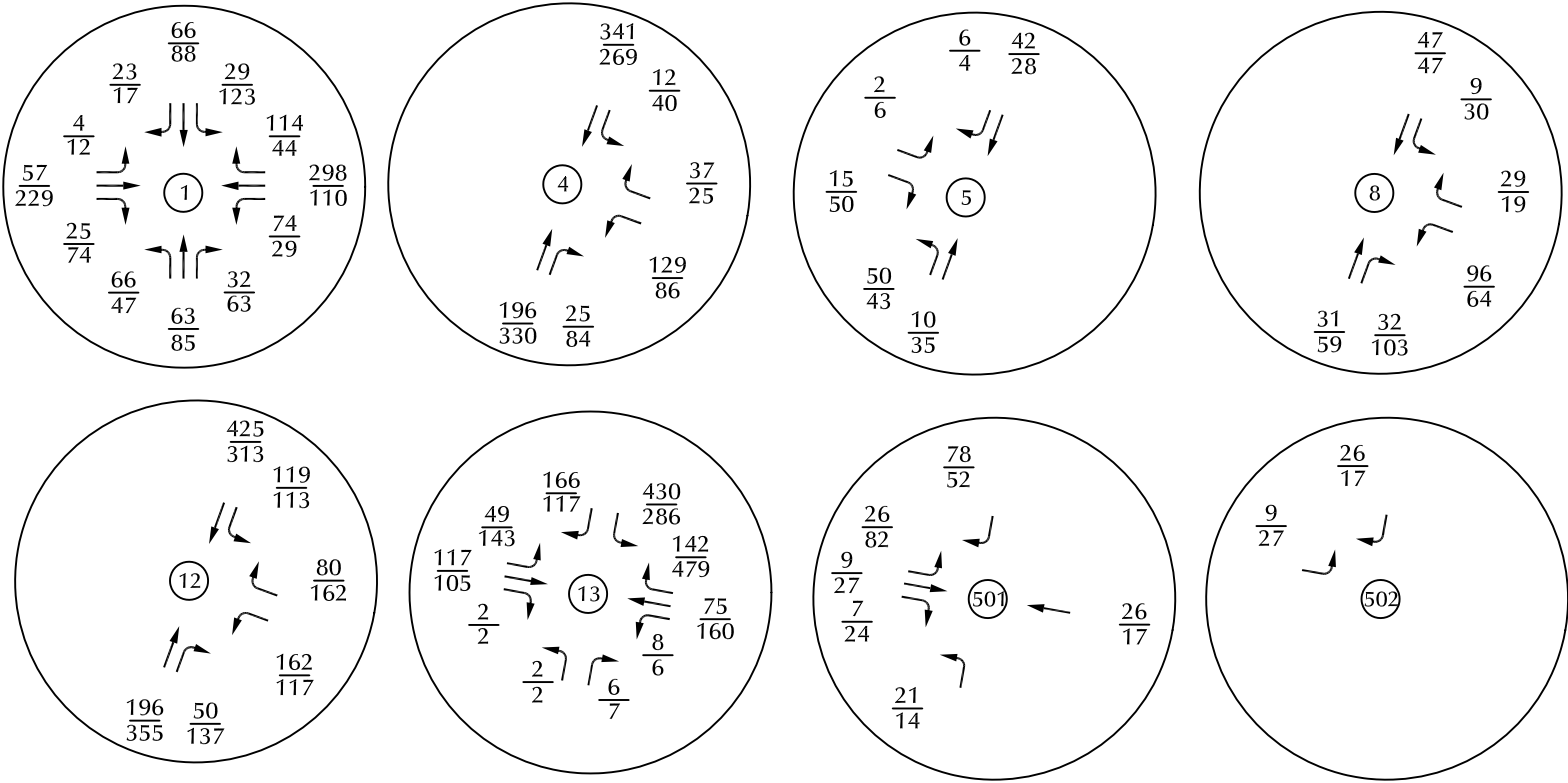

LEGEND:  $\frac{XX}{XX} = \frac{\text{AM Peak-Hour Traffic (veh/hr)}}{\text{PM Peak-Hour Traffic (veh/hr)}}$

— Existing Roadway  
 - - - Future Roadway



Figure 11b  
 Short-Term Total Traffic

Villages at Sterling Ranch (LSC# S224580)

One-lane Modern Roundabout

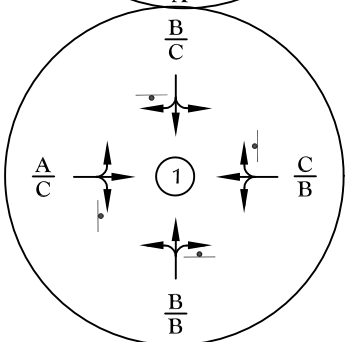
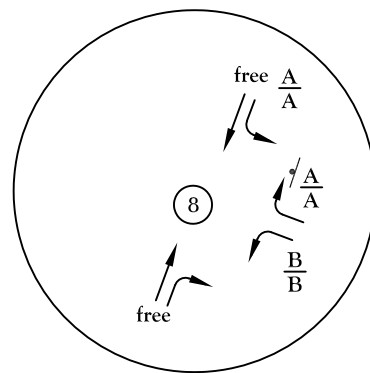
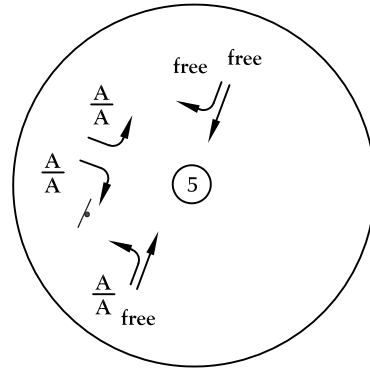
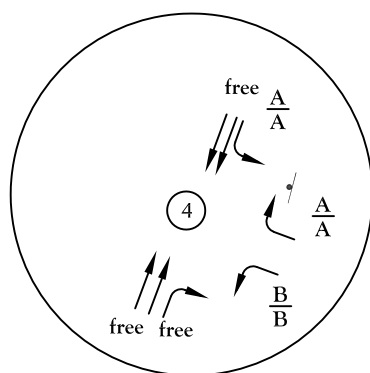
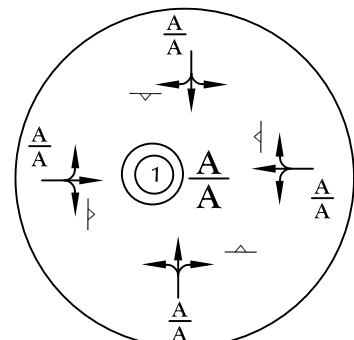

All-way Stop-sign Control

Stop-Sign Controlled

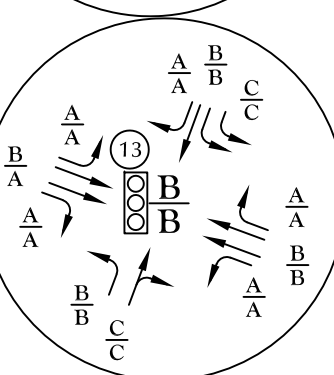
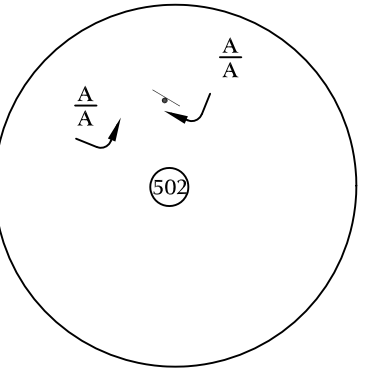
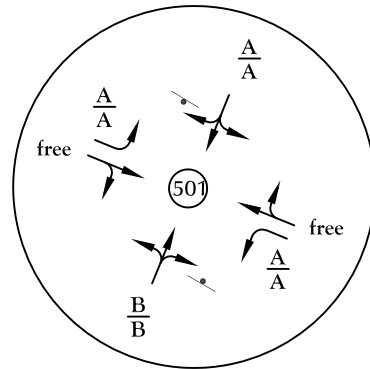
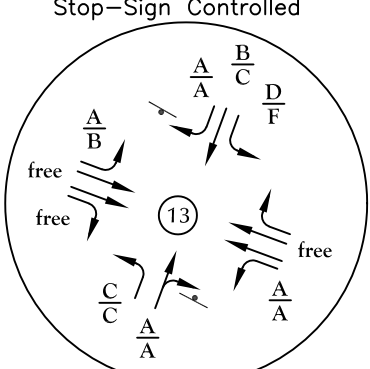
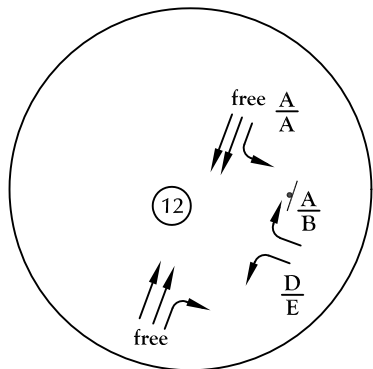

Signal Controlled

LEGEND:

$\frac{A}{B}$  = AM Individual Movement Peak-Hour Level of Service  
 PM Individual Movement Peak-Hour Level of Service  
 $\frac{C}{D}$  = AM Entire Intersection Peak-Hour Level of Service  
 PM Entire Intersection Peak-Hour Level of Service

= Yield Sign

= Stop Sign

= Traffic Signal

= Roundabout

Existing Roadway  
 Future Roadway

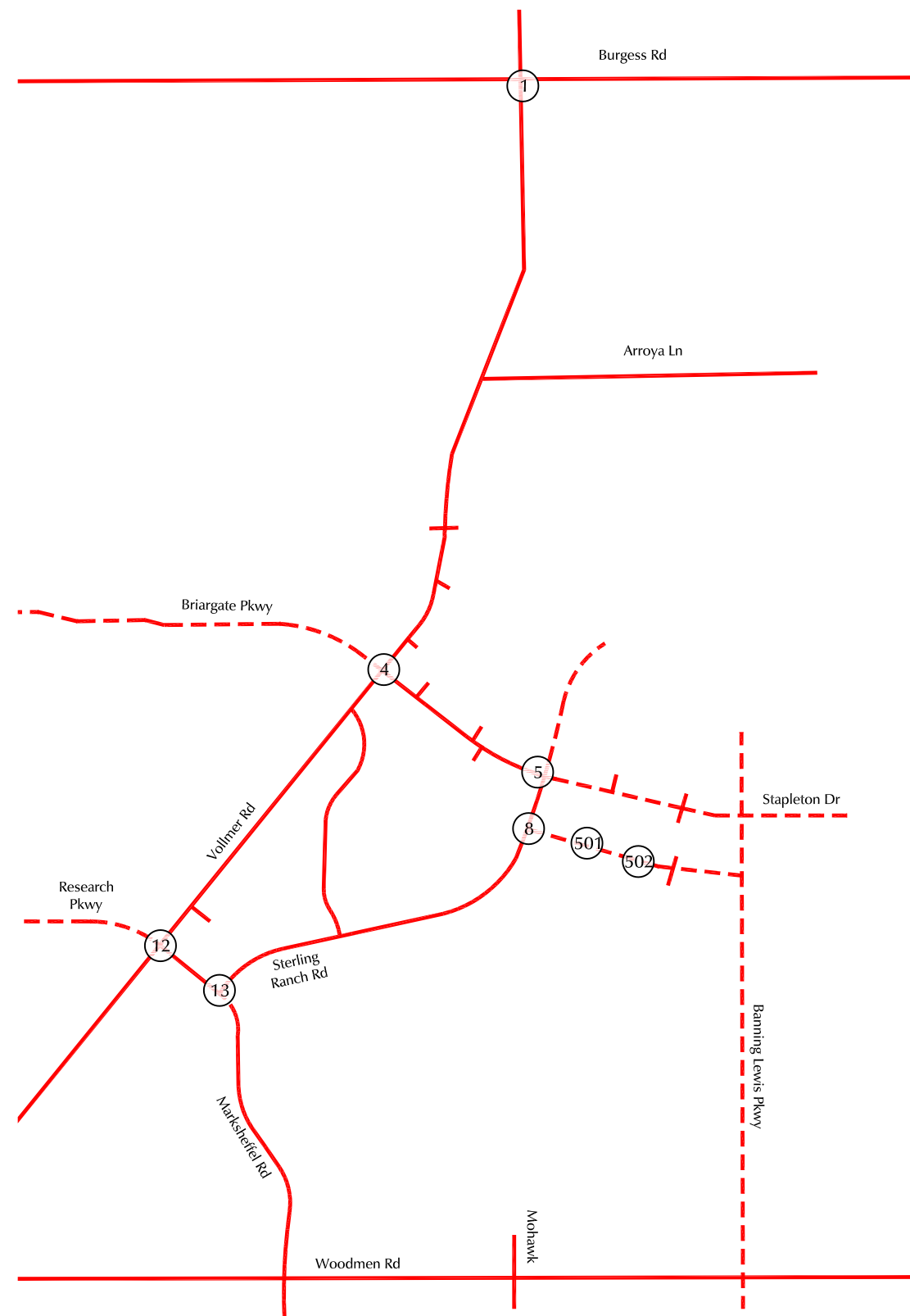

Not to scale

Figure 11c  
**Short-Term Total Lane Geometry,  
 Traffic Control, and Level of Service**

Villages at Sterling Ranch (LSC# S224580)



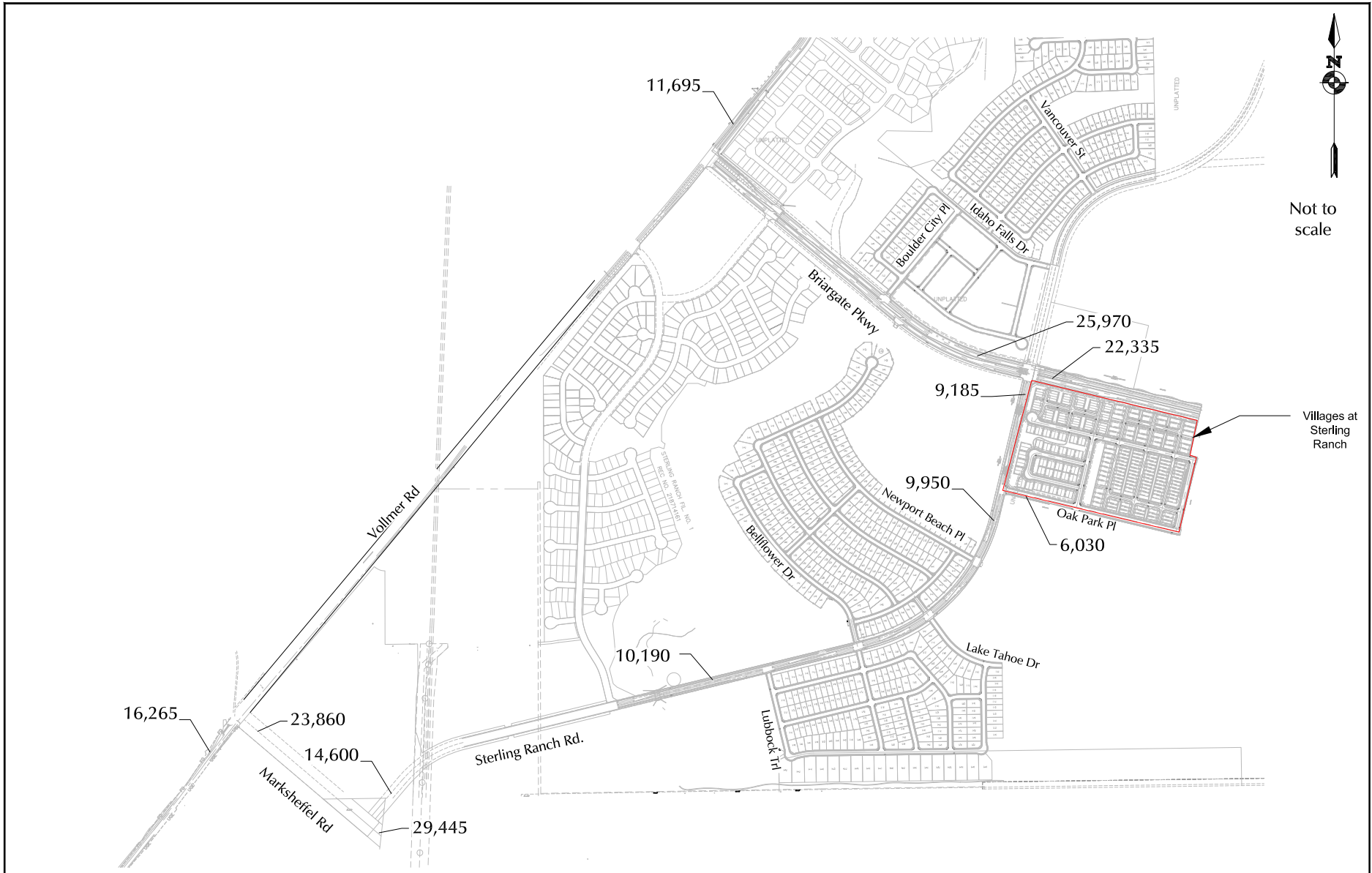

LEGEND:

XXX = Average Weekday Traffic (vehicles per day)(AWT)

Figure 12a  
**2044 Total Average Weekday Traffic**  
 Villages at Sterling Ranch (LSC# S224580)



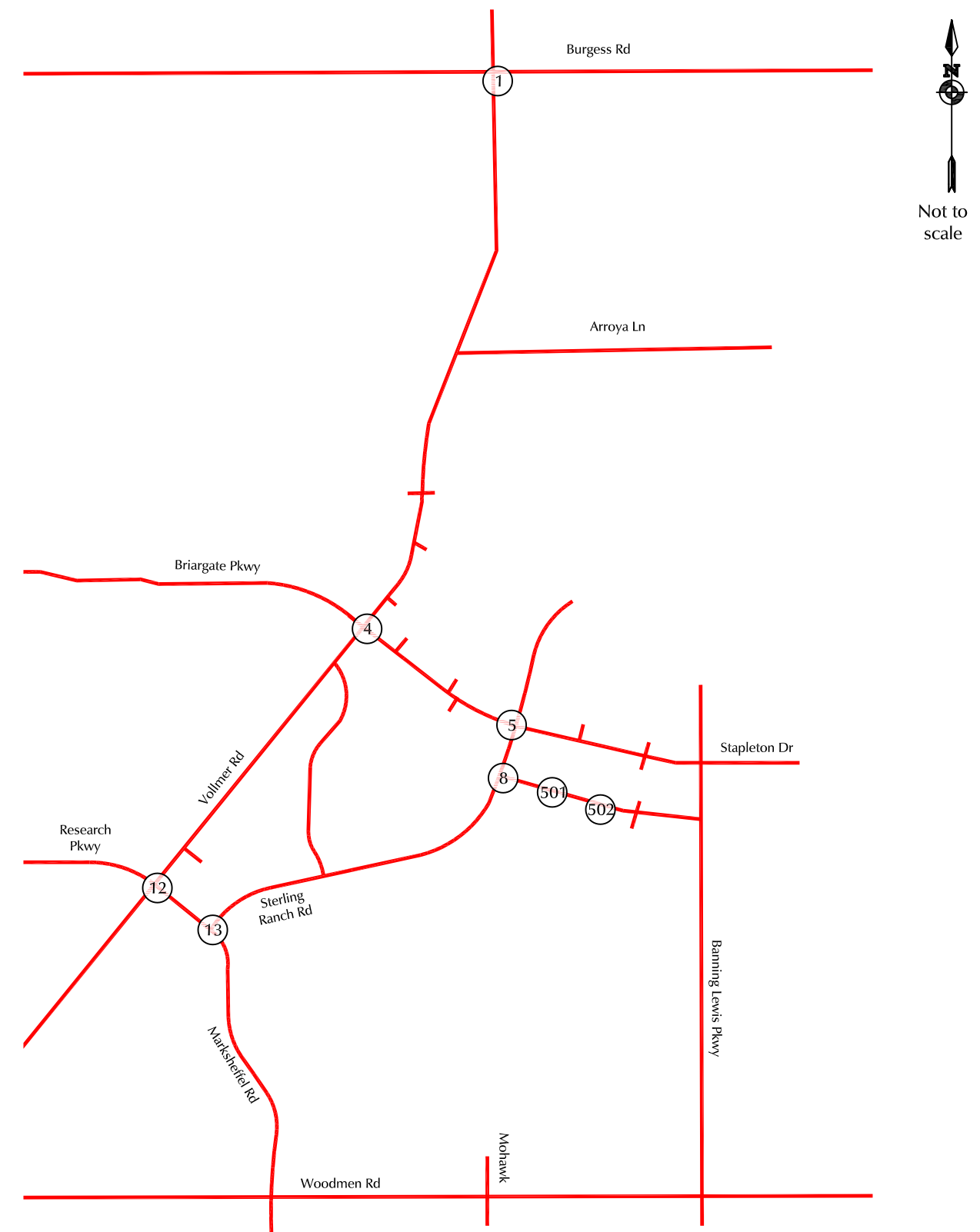
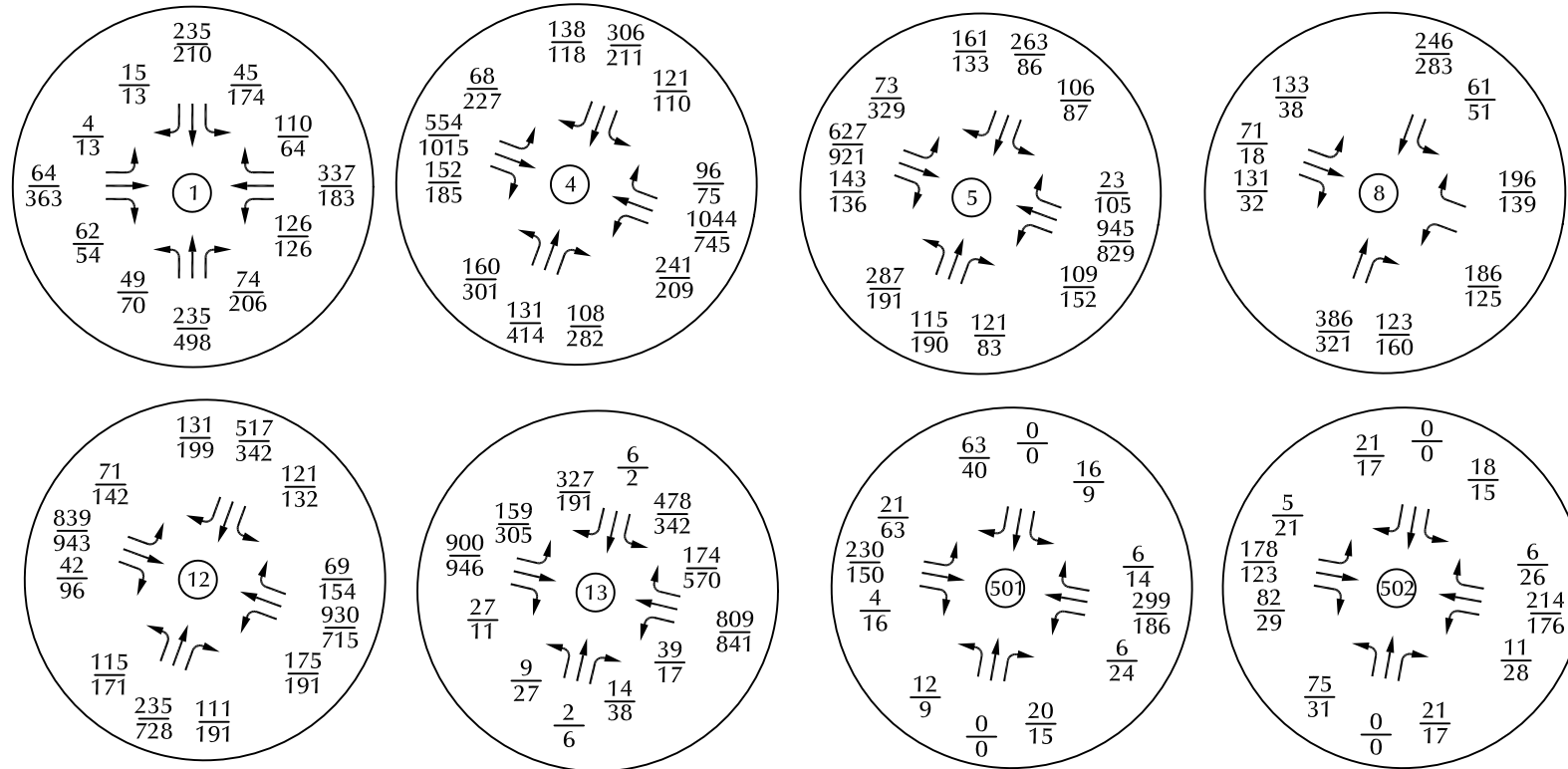

LEGEND:  $\frac{XX}{XX} = \frac{\text{AM Peak-Hour Traffic (veh/hr)}}{\text{PM Peak-Hour Traffic (veh/hr)}}$



Figure 12b  
2044 Total Traffic

Villages at Sterling Ranch (LSC# S224580)

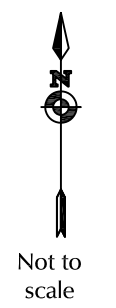
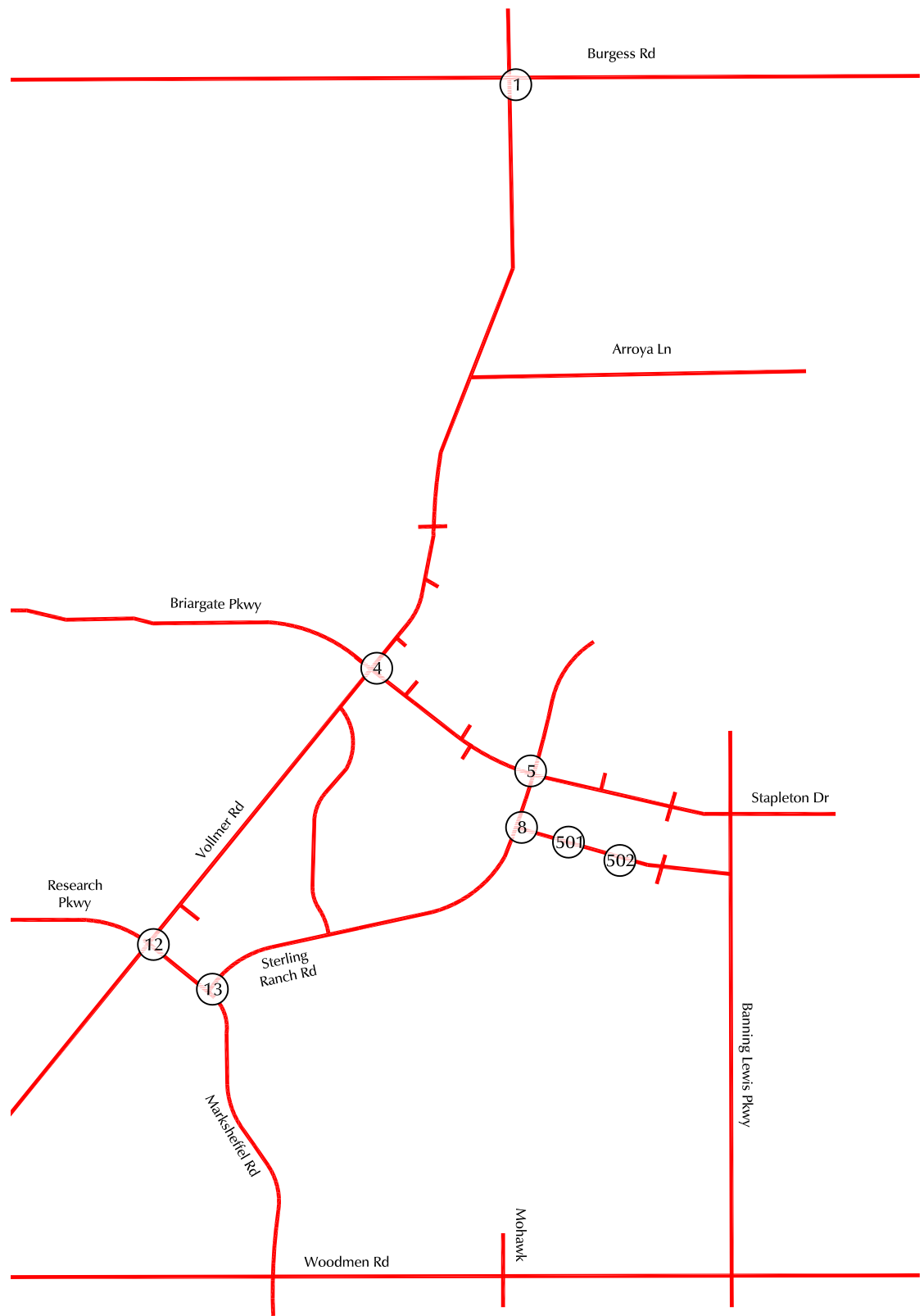
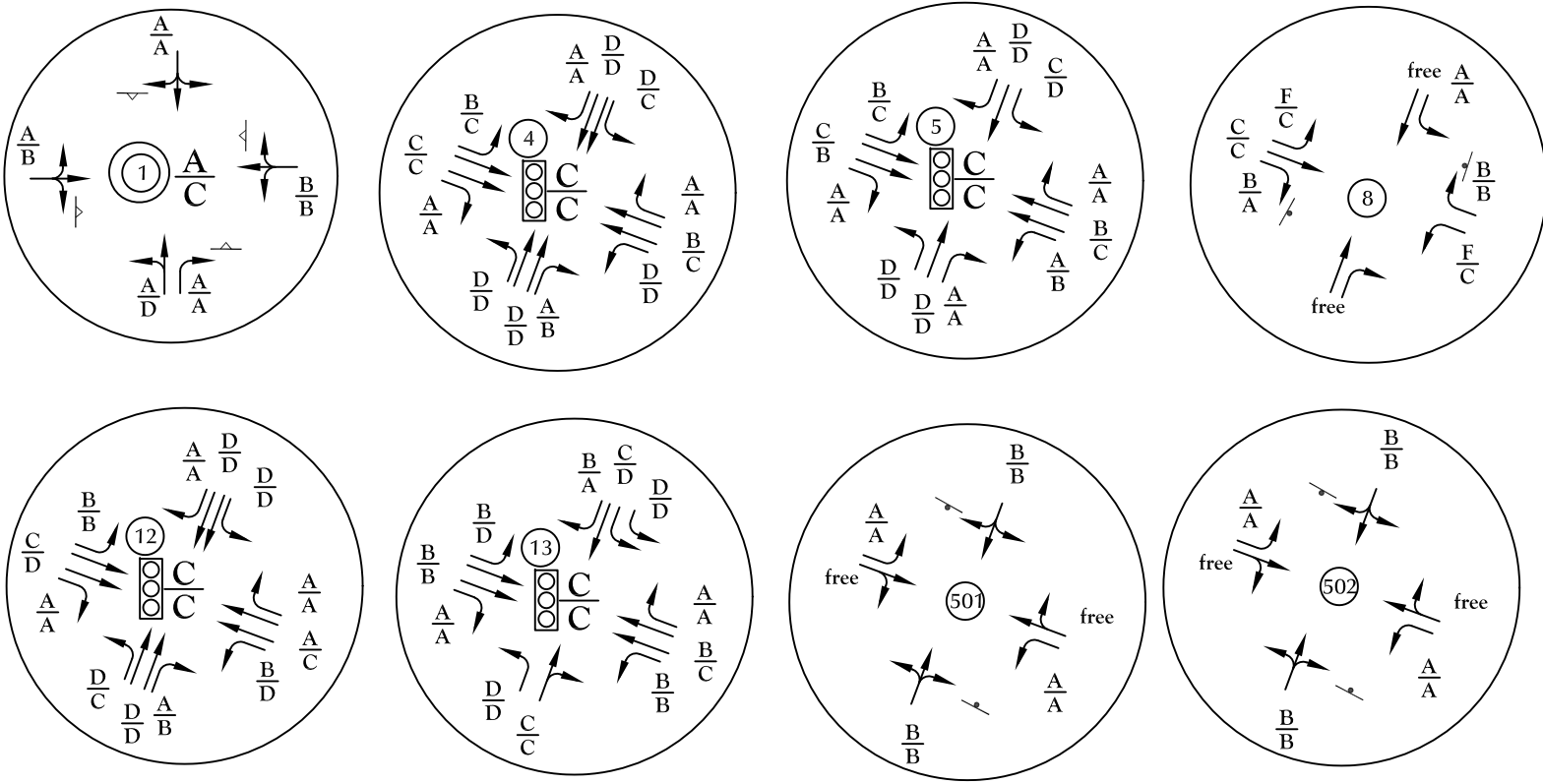

LEGEND:

$\frac{A}{B}$  = AM Individual Movement Peak-Hour Level of Service  
 PM Individual Movement Peak-Hour Level of Service  
 $\frac{C}{D}$  = AM Entire Intersection Peak-Hour Level of Service  
 PM Entire Intersection Peak-Hour Level of Service

⊥ = Stop Sign      ⊤ = Yield Sign  
 = Traffic Signal      ○ = Roundabout



Figure 12c  
 2044 Total Lane Geometry,  
 Traffic Control, and Level of Service



Approximate  
Scale: NTS

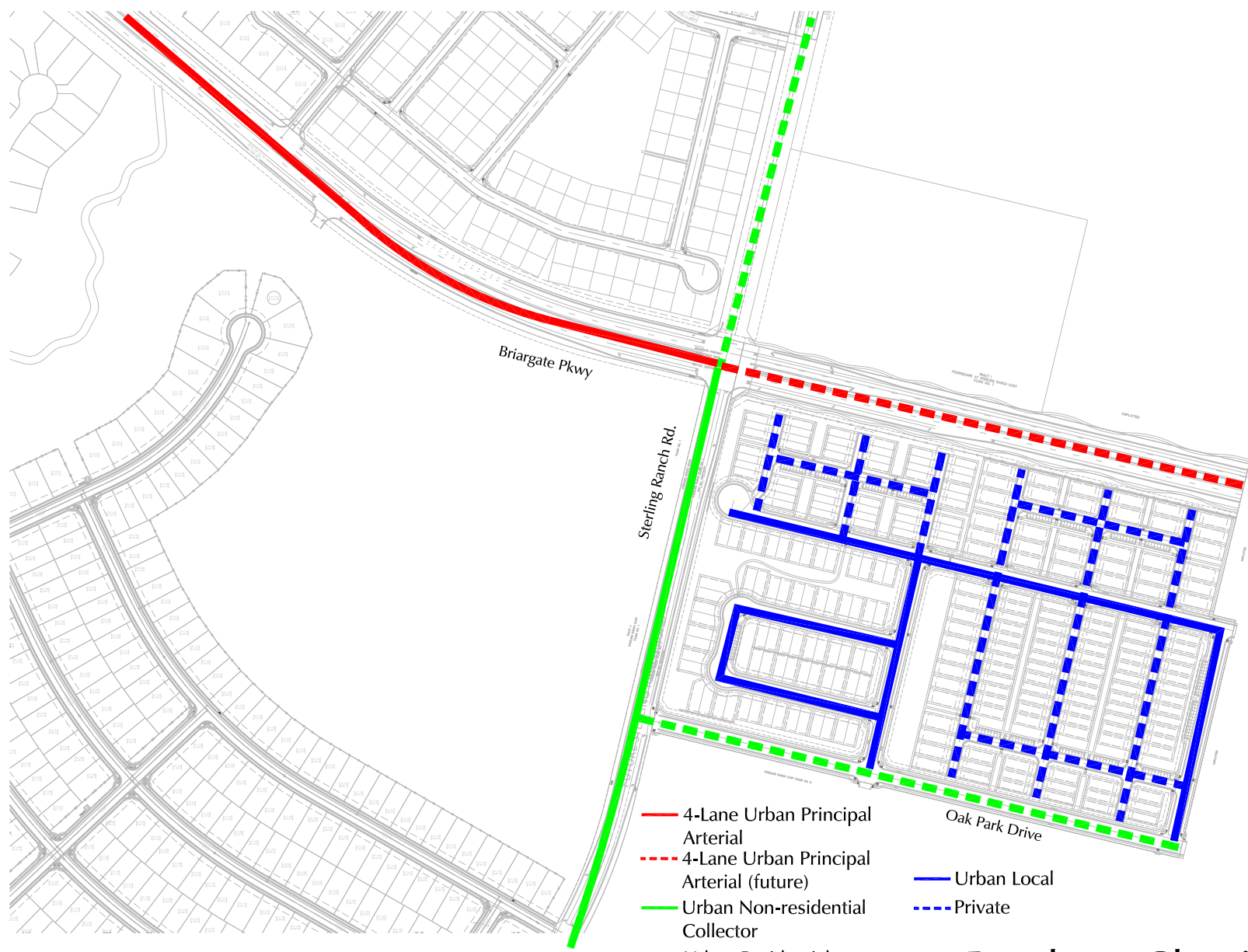

- 4-Lane Urban Principal Arterial
- - - 4-Lane Urban Principal Arterial (future)
- Urban Non-residential Collector
- - - Urban Residential Collector
- Urban Local
- - - Private

Figure 13  
**Roadway Classification**  
Villages at Sterling Ranch (LSC# S224580)



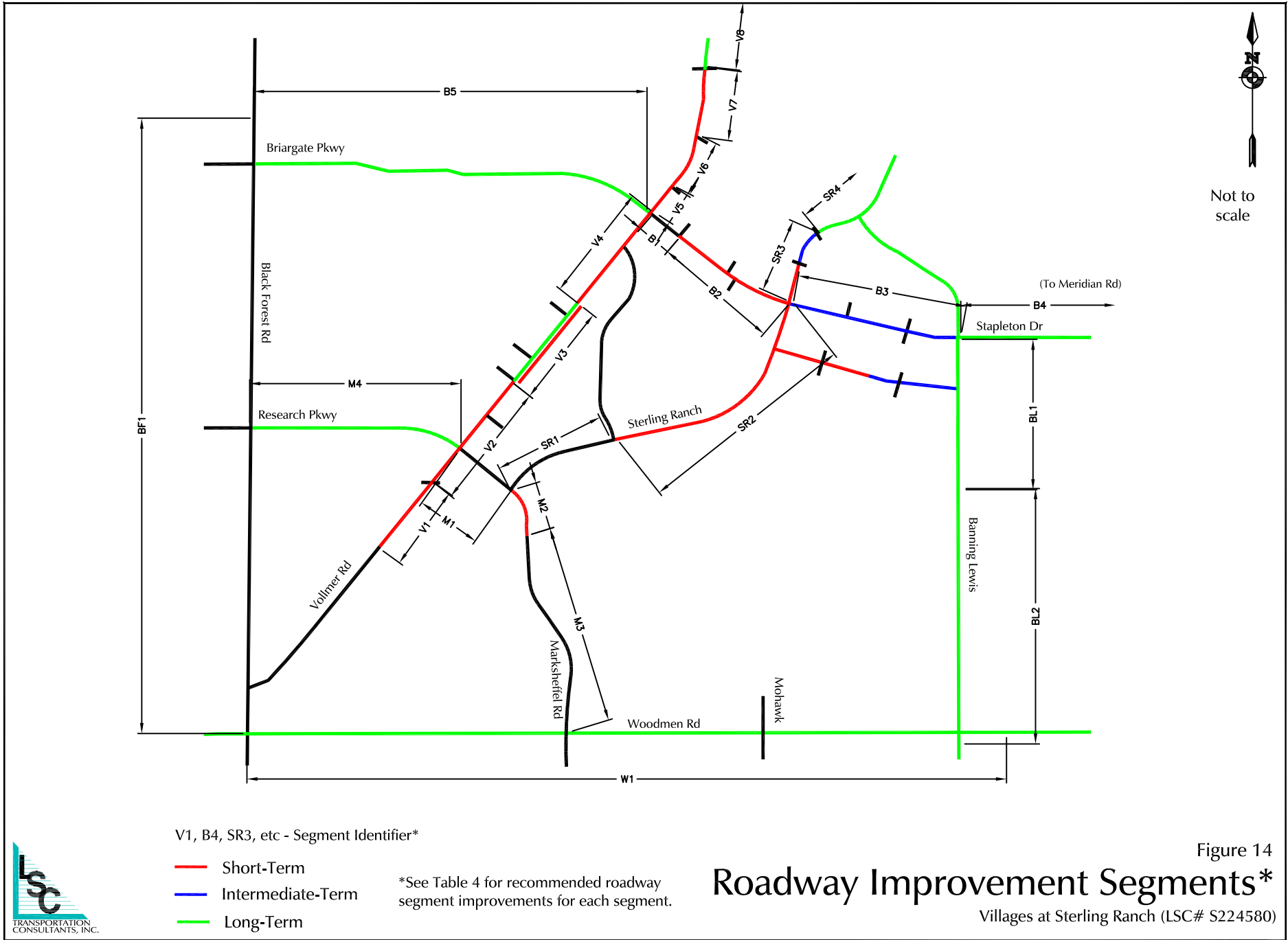

# Traffic Counts

---



# LSC Transportation Consultants, Inc.

2504 E. Pikes Peak Ave, Suite 304  
 Colorado Springs, CO 80909  
 719-633-2868

File Name : Vollmer Rd - Burgess Rd AM 3-6-24

Site Code : S224580

Start Date : 3/6/2024

Page No : 1

Start Time	Vollmer Rd Southbound					Burgess Rd Westbound					Vollmer Rd Northbound					Burgess Rd Eastbound					Int. Total
	Right	Thru	Left	Peds	App. Total	Right	Thru	Left	Peds	App. Total	Right	Thru	Left	Peds	App. Total	Right	Thru	Left	Peds	App. Total	
06:30	1	7	0	0	8	10	16	3	0	29	1	2	0	0	3	0	0	0	0	0	40
06:35	0	5	3	0	8	4	16	5	0	25	0	1	0	0	1	3	3	0	0	6	40
06:40	1	5	0	0	6	4	12	1	0	17	1	5	0	0	6	0	6	0	0	6	35
06:45	0	0	3	0	3	5	19	4	0	28	3	2	0	0	5	1	4	1	0	6	42
06:50	1	2	1	0	4	9	13	5	0	27	0	2	0	0	2	0	2	0	0	2	35
06:55	4	2	2	0	8	4	10	8	0	22	2	0	2	0	4	0	4	0	0	4	38
<b>Total</b>	<b>7</b>	<b>21</b>	<b>9</b>	<b>0</b>	<b>37</b>	<b>36</b>	<b>86</b>	<b>26</b>	<b>0</b>	<b>148</b>	<b>7</b>	<b>12</b>	<b>2</b>	<b>0</b>	<b>21</b>	<b>4</b>	<b>19</b>	<b>1</b>	<b>0</b>	<b>24</b>	<b>230</b>
07:00	0	0	1	0	1	11	30	4	0	45	2	3	3	0	8	1	4	0	0	5	59
07:05	2	1	0	0	3	7	25	4	0	36	2	8	2	0	12	0	4	0	0	4	55
07:10	1	15	2	0	18	9	27	5	0	41	2	3	1	0	6	1	3	0	0	4	69
07:15	2	1	1	0	4	5	27	7	0	39	1	5	2	0	8	0	2	0	0	2	53
07:20	1	5	3	0	9	14	17	2	0	33	1	7	1	0	9	1	5	1	0	7	58
07:25	2	5	6	0	13	12	19	5	0	36	2	2	0	0	4	0	3	0	0	3	56
07:30	2	1	1	0	4	10	28	5	0	43	2	2	1	0	5	0	6	0	0	6	58
07:35	2	12	0	0	14	7	22	9	0	38	4	4	0	0	8	0	6	1	0	7	67
07:40	4	5	3	0	12	6	28	9	0	43	5	2	1	0	8	2	5	1	0	8	71
07:45	1	4	3	0	8	14	28	8	0	50	1	1	3	0	5	1	7	0	0	8	71
07:50	3	8	5	0	16	8	12	9	0	29	2	3	1	0	6	1	5	1	0	7	58
07:55	2	1	3	0	6	7	23	4	0	34	7	5	1	0	13	2	5	0	0	7	60
<b>Total</b>	<b>22</b>	<b>58</b>	<b>28</b>	<b>0</b>	<b>108</b>	<b>110</b>	<b>286</b>	<b>71</b>	<b>0</b>	<b>467</b>	<b>31</b>	<b>45</b>	<b>16</b>	<b>0</b>	<b>92</b>	<b>9</b>	<b>55</b>	<b>4</b>	<b>0</b>	<b>68</b>	<b>735</b>
08:00	2	1	0	0	3	3	16	1	0	20	4	4	1	0	9	3	11	2	0	16	48
08:05	1	7	1	0	9	7	17	0	0	24	5	6	0	0	11	1	1	2	0	4	48
08:10	1	6	3	0	10	6	18	3	0	27	2	3	3	0	8	0	4	0	0	4	49
08:15	3	3	0	0	6	8	10	2	0	20	2	3	1	0	6	0	1	1	0	2	34
08:20	3	9	4	0	16	5	19	4	0	28	3	7	1	0	11	1	3	3	0	7	62
08:25	4	7	5	0	16	4	8	2	0	14	3	6	1	0	10	1	4	3	0	8	48
<b>Grand Total</b>	<b>43</b>	<b>112</b>	<b>50</b>	<b>0</b>	<b>205</b>	<b>179</b>	<b>460</b>	<b>109</b>	<b>0</b>	<b>748</b>	<b>57</b>	<b>86</b>	<b>25</b>	<b>0</b>	<b>168</b>	<b>19</b>	<b>98</b>	<b>16</b>	<b>0</b>	<b>133</b>	<b>1254</b>
<b>Apprch %</b>	<b>21</b>	<b>54.6</b>	<b>24.4</b>	<b>0</b>		<b>23.9</b>	<b>61.5</b>	<b>14.6</b>	<b>0</b>		<b>33.9</b>	<b>51.2</b>	<b>14.9</b>	<b>0</b>		<b>14.3</b>	<b>73.7</b>	<b>12</b>	<b>0</b>		
<b>Total %</b>	<b>3.4</b>	<b>8.9</b>	<b>4</b>	<b>0</b>	<b>16.3</b>	<b>14.3</b>	<b>36.7</b>	<b>8.7</b>	<b>0</b>	<b>59.6</b>	<b>4.5</b>	<b>6.9</b>	<b>2</b>	<b>0</b>	<b>13.4</b>	<b>1.5</b>	<b>7.8</b>	<b>1.3</b>	<b>0</b>	<b>10.6</b>	

# LSC Transportation Consultants, Inc.

2504 E. Pikes Peak Ave, Suite 304  
 Colorado Springs, CO 80909  
 719-633-2868

File Name : Vollmer Rd - Burgess Rd AM 3-6-24

Site Code : S224580

Start Date : 3/6/2024

Page No : 2

Start Time	Vollmer Rd Southbound					Burgess Rd Westbound					Vollmer Rd Northbound					Burgess Rd Eastbound					Int. Total
	Right	Thru	Left	Peds	App. Total	Right	Thru	Left	Peds	App. Total	Right	Thru	Left	Peds	App. Total	Right	Thru	Left	Peds	App. Total	
Peak Hour Analysis From 06:30 to 08:25 - Peak 1 of 1																					
Peak Hour for Entire Intersection Begins at 07:00																					
07:00	0	0	1	0	1	11	<b>30</b>	4	0	45	2	3	<b>3</b>	0	8	1	4	0	0	5	59
07:05	2	1	0	0	3	7	25	4	0	36	2	<b>8</b>	2	0	12	0	4	0	0	4	55
07:10	1	<b>15</b>	2	0	<b>18</b>	9	27	5	0	41	2	3	1	0	6	1	3	0	0	4	69
07:15	2	1	1	0	4	5	27	7	0	39	1	5	2	0	8	0	2	0	0	2	53
07:20	1	5	3	0	9	<b>14</b>	17	2	0	33	1	7	1	0	9	1	5	<b>1</b>	0	7	58
07:25	2	5	<b>6</b>	0	13	12	19	5	0	36	2	2	0	0	4	0	3	0	0	3	56
07:30	2	1	1	0	4	10	28	5	0	43	2	2	1	0	5	0	6	0	0	6	58
07:35	2	12	0	0	14	7	22	<b>9</b>	0	38	4	4	0	0	8	0	6	1	0	7	67
07:40	<b>4</b>	5	3	0	12	6	28	9	0	43	5	2	1	0	8	<b>2</b>	5	1	0	<b>8</b>	<b>71</b>
07:45	1	4	3	0	8	14	28	8	0	<b>50</b>	1	1	3	0	5	1	<b>7</b>	0	0	8	71
07:50	3	8	5	0	16	8	12	9	0	29	2	3	1	0	6	1	5	1	0	7	58
07:55	2	1	3	0	6	7	23	4	0	34	<b>7</b>	5	1	0	<b>13</b>	2	5	0	0	7	60
Total Volume	22	58	28	0	108	110	286	71	0	467	31	45	16	0	92	9	55	4	0	68	735
% App. Total	20.4	53.7	25.9	0		23.6	61.2	15.2	0		33.7	48.9	17.4	0		13.2	80.9	5.9	0		
PHF	.458	.322	.389	.000	.500	.655	.794	.657	.000	.778	.369	.469	.444	.000	.590	.375	.655	.333	.000	.708	.863

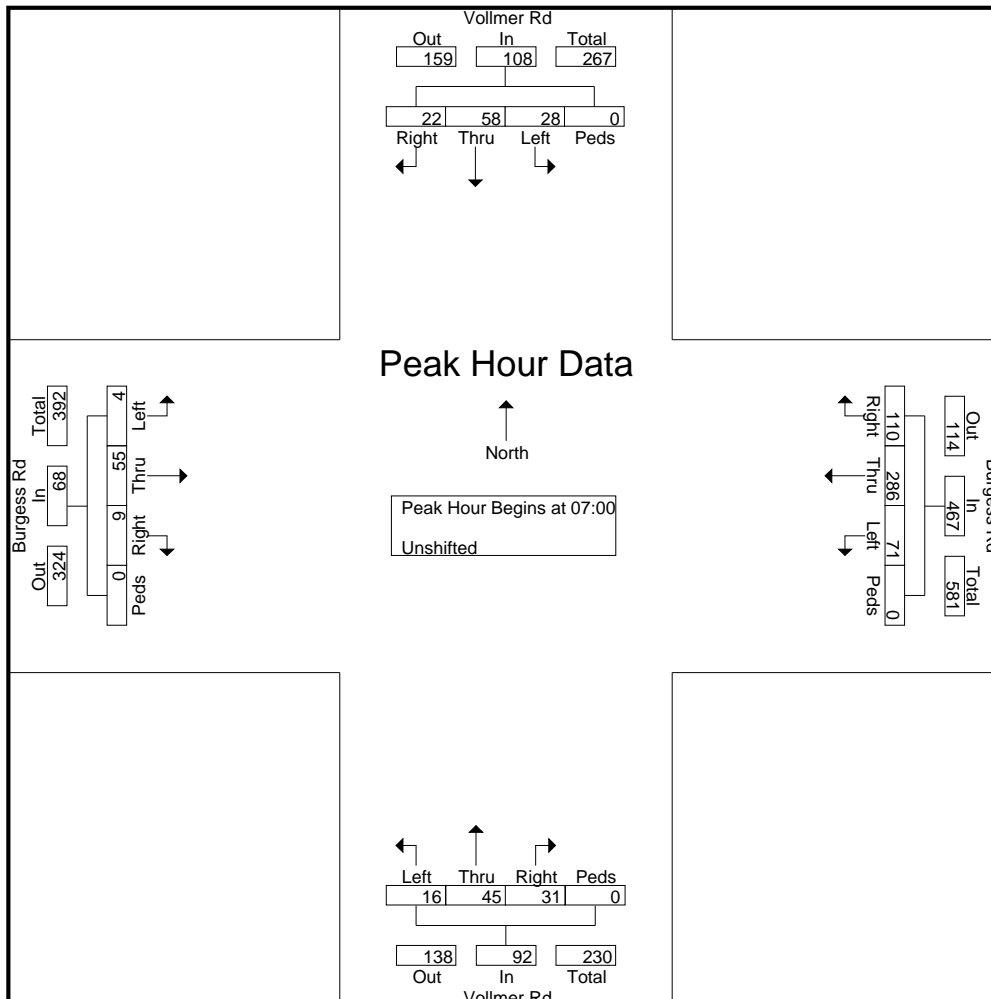

# LSC Transportation Consultants, Inc.

2504 E. Pikes Peak Ave, Suite 304  
 Colorado Springs, CO 80909  
 719-633-2868

File Name : Vollmer Rd - Burgess Rd PM 3-5-24

Site Code : S224580

Start Date : 3/5/2024

Page No : 1

Start Time	Vollmer Rd Southbound					Burgess Rd Westbound					Vollmer Rd Northbound					Burgess Rd Eastbound					Int. Total
	Right	Thru	Left	Peds	App. Total	Right	Thru	Left	Peds	App. Total	Right	Thru	Left	Peds	App. Total	Right	Thru	Left	Peds	App. Total	
16:00	1	8	13	0	22	4	8	4	0	16	4	1	2	0	7	5	15	1	0	21	66
16:05	3	4	6	0	13	4	9	2	0	15	9	5	1	0	15	4	19	1	0	24	67
16:10	1	4	9	0	14	7	7	3	0	17	6	3	2	0	11	1	12	2	0	15	57
16:15	0	6	13	0	19	4	5	1	0	10	3	7	3	0	13	1	18	4	0	23	65
16:20	3	8	8	0	19	2	13	5	0	20	4	8	1	0	13	0	21	1	0	22	74
16:25	1	9	17	0	27	3	9	1	0	13	5	7	1	0	13	2	17	0	0	19	72
16:30	0	7	6	0	13	5	8	0	0	13	5	3	1	0	9	0	19	1	0	20	55
16:35	4	4	11	0	19	4	7	3	0	14	2	6	2	0	10	0	19	1	0	20	63
16:40	1	4	7	0	12	2	11	1	0	14	5	6	0	0	11	1	25	0	0	26	63
16:45	0	6	5	0	11	1	9	2	0	12	8	9	0	0	17	2	19	0	0	21	61
16:50	0	5	14	0	19	4	12	6	0	22	6	8	0	0	14	1	22	1	0	24	79
16:55	2	2	9	0	13	2	8	0	0	10	4	8	1	0	13	1	14	0	0	15	51
<b>Total</b>	<b>16</b>	<b>67</b>	<b>118</b>	<b>0</b>	<b>201</b>	<b>42</b>	<b>106</b>	<b>28</b>	<b>0</b>	<b>176</b>	<b>61</b>	<b>71</b>	<b>14</b>	<b>0</b>	<b>146</b>	<b>18</b>	<b>220</b>	<b>12</b>	<b>0</b>	<b>250</b>	<b>773</b>
17:00	1	2	4	0	7	3	7	2	0	12	1	4	2	0	7	1	17	1	0	19	45
17:05	0	8	11	0	19	4	4	0	0	8	2	5	0	0	7	2	16	1	0	19	53
17:10	3	2	5	0	10	2	13	6	0	21	4	2	0	0	6	0	11	0	0	11	48
17:15	1	4	8	0	13	2	9	3	0	14	10	8	0	0	18	4	14	0	0	18	63
17:20	0	4	8	0	12	7	13	3	0	23	4	2	1	0	7	3	36	1	0	40	82
17:25	0	3	6	0	9	1	7	3	0	11	2	4	1	0	7	2	15	3	0	20	47
17:30	0	2	8	0	10	5	7	1	0	13	8	4	0	0	12	1	15	2	0	18	53
17:35	3	4	13	0	20	9	9	1	0	19	6	4	2	0	12	0	21	1	0	22	73
17:40	1	4	11	0	16	4	5	1	0	10	3	5	0	0	8	0	18	1	0	19	53
17:45	1	0	8	0	9	2	3	0	0	5	4	1	0	0	5	0	13	2	0	15	34
17:50	1	3	6	0	10	2	4	1	0	7	5	2	0	0	7	2	15	1	0	18	42
17:55	2	3	4	0	9	3	3	4	0	10	5	2	1	0	8	1	15	2	0	18	45
<b>Total</b>	<b>13</b>	<b>39</b>	<b>92</b>	<b>0</b>	<b>144</b>	<b>44</b>	<b>84</b>	<b>25</b>	<b>0</b>	<b>153</b>	<b>54</b>	<b>43</b>	<b>7</b>	<b>0</b>	<b>104</b>	<b>16</b>	<b>206</b>	<b>15</b>	<b>0</b>	<b>237</b>	<b>638</b>
<b>Grand Total</b>	<b>29</b>	<b>106</b>	<b>210</b>	<b>0</b>	<b>345</b>	<b>86</b>	<b>190</b>	<b>53</b>	<b>0</b>	<b>329</b>	<b>115</b>	<b>114</b>	<b>21</b>	<b>0</b>	<b>250</b>	<b>34</b>	<b>426</b>	<b>27</b>	<b>0</b>	<b>487</b>	<b>1411</b>
<b>Apprch %</b>	<b>8.4</b>	<b>30.7</b>	<b>60.9</b>	<b>0</b>		<b>26.1</b>	<b>57.8</b>	<b>16.1</b>	<b>0</b>		<b>46</b>	<b>45.6</b>	<b>8.4</b>	<b>0</b>		<b>7</b>	<b>87.5</b>	<b>5.5</b>	<b>0</b>		
<b>Total %</b>	<b>2.1</b>	<b>7.5</b>	<b>14.9</b>	<b>0</b>	<b>24.5</b>	<b>6.1</b>	<b>13.5</b>	<b>3.8</b>	<b>0</b>	<b>23.3</b>	<b>8.2</b>	<b>8.1</b>	<b>1.5</b>	<b>0</b>	<b>17.7</b>	<b>2.4</b>	<b>30.2</b>	<b>1.9</b>	<b>0</b>	<b>34.5</b>	

# LSC Transportation Consultants, Inc.

2504 E. Pikes Peak Ave, Suite 304  
 Colorado Springs, CO 80909  
 719-633-2868

File Name : Vollmer Rd - Burgess Rd PM 3-5-24

Site Code : S224580

Start Date : 3/5/2024

Page No : 2

Start Time	Vollmer Rd Southbound					Burgess Rd Westbound					Vollmer Rd Northbound					Burgess Rd Eastbound					Int. Total
	Right	Thru	Left	Peds	App. Total	Right	Thru	Left	Peds	App. Total	Right	Thru	Left	Peds	App. Total	Right	Thru	Left	Peds	App. Total	
Peak Hour Analysis From 16:00 to 17:55 - Peak 1 of 1																					
Peak Hour for Entire Intersection Begins at 16:00																					
16:00	1	8	13	0	22	4	8	4	0	16	4	1	2	0	7	5	15	1	0	21	66
16:05	3	4	6	0	13	4	9	2	0	15	9	5	1	0	15	4	19	1	0	24	67
16:10	1	4	9	0	14	7	7	3	0	17	6	3	2	0	11	1	12	2	0	15	57
16:15	0	6	13	0	19	4	5	1	0	10	3	7	3	0	13	1	18	4	0	23	65
16:20	3	8	8	0	19	2	13	5	0	20	4	8	1	0	13	0	21	1	0	22	74
16:25	1	9	17	0	27	3	9	1	0	13	5	7	1	0	13	2	17	0	0	19	72
16:30	0	7	6	0	13	5	8	0	0	13	5	3	1	0	9	0	19	1	0	20	55
16:35	4	4	11	0	19	4	7	3	0	14	2	6	2	0	10	0	19	1	0	20	63
16:40	1	4	7	0	12	2	11	1	0	14	5	6	0	0	11	1	25	0	0	26	63
16:45	0	6	5	0	11	1	9	2	0	12	8	9	0	0	17	2	19	0	0	21	61
16:50	0	5	14	0	19	4	12	6	0	22	6	8	0	0	14	1	22	1	0	24	79
16:55	2	2	9	0	13	2	8	0	0	10	4	8	1	0	13	1	14	0	0	15	51
Total Volume	16	67	118	0	201	42	106	28	0	176	61	71	14	0	146	18	220	12	0	250	773
% App. Total	8	33.3	58.7	0		23.9	60.2	15.9	0		41.8	48.6	9.6	0		7.2	88	4.8	0		
PHF	.333	.620	.578	.000	.620	.500	.679	.389	.000	.667	.565	.657	.389	.000	.716	.300	.733	.250	.000	.801	.815

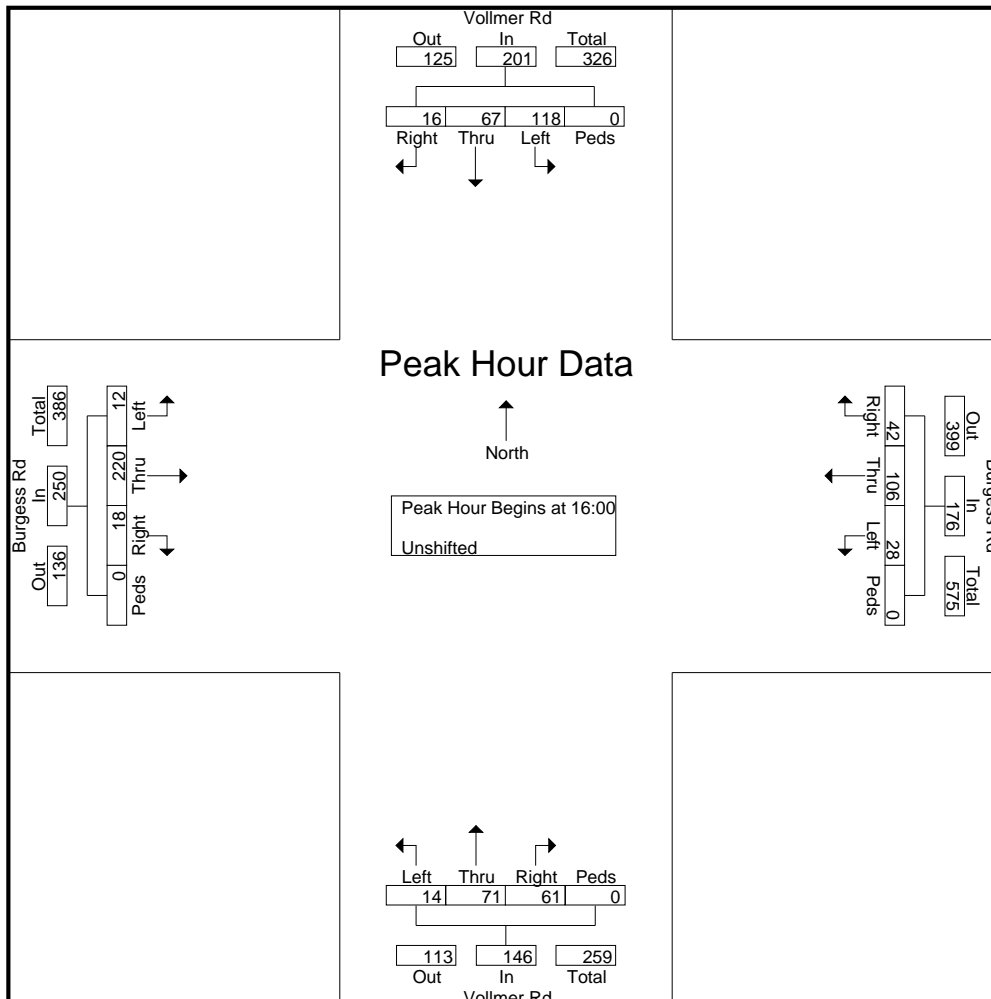

# LSC Transportation Consultants, Inc.

2504 E. Pikes Peak Ave, Suite 304  
 Colorado Springs, CO 80909  
 719-633-2868

File Name : Vollmer Rd - Marksheffel Rd AM  
 Site Code : S224580  
 Start Date : 4/4/2024  
 Page No : 1

Start Time	Vollmer Rd Southbound					Marksheffel Rd Westbound					Vollmer Rd Northbound					Eastbound					Int. Total
	Right	Thru	Left	Peds	App. Total	Right	Thru	Left	Peds	App. Total	Right	Thru	Left	Peds	App. Total	Right	Thru	Left	Peds	App. Total	
06:30	0	19	0	0	19	0	0	1	0	1	0	8	0	0	8	0	0	0	0	0	28
06:35	0	7	0	0	7	0	0	2	0	2	6	10	0	0	16	0	0	0	0	0	25
06:40	0	21	0	0	21	1	0	1	0	2	2	12	0	0	14	0	0	0	0	0	37
06:45	0	17	0	0	17	0	0	4	0	4	2	13	0	0	15	0	0	0	0	0	36
06:50	0	17	0	0	17	0	0	2	0	2	0	18	0	0	18	0	0	0	0	0	37
06:55	0	26	0	0	26	0	0	4	0	4	3	19	0	0	22	0	0	0	0	0	52
<b>Total</b>	0	107	0	0	107	1	0	14	0	15	13	80	0	0	93	0	0	0	0	0	215
07:00	0	20	0	0	20	1	0	6	0	7	2	16	0	0	18	0	0	0	0	0	45
07:05	0	28	0	0	28	1	0	5	0	6	5	17	0	0	22	0	0	0	0	0	56
07:10	0	25	0	0	25	1	0	4	0	5	1	20	0	0	21	0	0	0	0	0	51
07:15	0	22	0	0	22	0	0	5	0	5	1	11	0	0	12	0	0	0	0	0	39
07:20	0	37	0	0	37	0	0	4	0	4	0	12	0	0	12	0	0	0	0	0	53
07:25	0	32	0	0	32	0	0	4	0	4	0	13	0	0	13	0	0	0	0	0	49
07:30	0	28	0	0	28	0	0	6	0	6	0	17	0	0	17	0	0	0	0	0	51
07:35	0	31	0	0	31	1	0	3	0	4	0	16	0	0	16	0	0	0	0	0	51
07:40	0	23	0	0	23	1	0	4	0	5	2	22	0	0	24	0	0	0	0	0	52
07:45	0	22	0	0	22	0	0	9	0	9	1	19	0	0	20	0	0	0	0	0	51
07:50	0	27	0	0	27	0	0	5	0	5	4	16	0	0	20	0	0	0	0	0	52
07:55	0	21	0	0	21	0	0	2	0	2	5	30	0	0	35	0	0	0	0	0	58
<b>Total</b>	0	316	0	0	316	5	0	57	0	62	21	209	0	0	230	0	0	0	0	0	608
08:00	0	12	1	0	13	0	0	2	0	2	1	20	0	0	21	0	0	0	0	0	36
08:05	0	21	0	0	21	0	0	1	0	1	1	17	0	0	18	0	0	0	0	0	40
08:10	0	18	0	0	18	0	0	2	0	2	7	19	0	0	26	0	0	0	0	0	46
08:15	0	26	0	0	26	0	0	1	0	1	8	15	0	0	23	0	0	0	0	0	50
08:20	0	13	0	0	13	0	0	3	0	3	1	14	0	0	15	0	0	0	0	0	31
08:25	0	21	0	0	21	0	0	2	0	2	4	13	0	0	17	0	0	0	0	0	40
<b>Grand Total</b>	0	534	1	0	535	6	0	82	0	88	56	387	0	0	443	0	0	0	0	0	1066
<b>Apprch %</b>	0	99.8	0.2	0		6.8	0	93.2	0		12.6	87.4	0	0		0	0	0	0		
<b>Total %</b>	0	50.1	0.1	0	50.2	0.6	0	7.7	0	8.3	5.3	36.3	0	0	41.6	0	0	0	0	0	

# LSC Transportation Consultants, Inc.

2504 E. Pikes Peak Ave, Suite 304  
 Colorado Springs, CO 80909  
 719-633-2868

File Name : Vollmer Rd - Marksheffel Rd AM

Site Code : S224580

Start Date : 4/4/2024

Page No : 2

Start Time	Vollmer Rd Southbound					Marksheffel Rd Westbound					Vollmer Rd Northbound					Eastbound					Int. Total
	Right	Thru	Left	Peds	App. Total	Right	Thru	Left	Peds	App. Total	Right	Thru	Left	Peds	App. Total	Right	Thru	Left	Peds	App. Total	
Peak Hour Analysis From 06:30 to 08:25 - Peak 1 of 1																					
Peak Hour for Entire Intersection Begins at 07:00																					
07:00	0	20	0	0	20	1	0	6	0	7	2	16	0	0	18	0	0	0	0	0	45
07:05	0	28	0	0	28	1	0	5	0	6	5	17	0	0	22	0	0	0	0	0	56
07:10	0	25	0	0	25	1	0	4	0	5	1	20	0	0	21	0	0	0	0	0	51
07:15	0	22	0	0	22	0	0	5	0	5	1	11	0	0	12	0	0	0	0	0	39
07:20	0	37	0	0	37	0	0	4	0	4	0	12	0	0	12	0	0	0	0	0	53
07:25	0	32	0	0	32	0	0	4	0	4	0	13	0	0	13	0	0	0	0	0	49
07:30	0	28	0	0	28	0	0	6	0	6	0	17	0	0	17	0	0	0	0	0	51
07:35	0	31	0	0	31	1	0	3	0	4	0	16	0	0	16	0	0	0	0	0	51
07:40	0	23	0	0	23	1	0	4	0	5	2	22	0	0	24	0	0	0	0	0	52
07:45	0	22	0	0	22	0	0	9	0	9	1	19	0	0	20	0	0	0	0	0	51
07:50	0	27	0	0	27	0	0	5	0	5	4	16	0	0	20	0	0	0	0	0	52
07:55	0	21	0	0	21	0	0	2	0	2	5	30	0	0	35	0	0	0	0	0	58
Total Volume	0	316	0	0	316	5	0	57	0	62	21	209	0	0	230	0	0	0	0	0	608
% App. Total	0	100	0	0		8.1	0	91.9	0		9.1	90.9	0	0		0	0	0	0		
PHF	.000	.712	.000	.000	.712	.417	.000	.528	.000	.574	.350	.581	.000	.000	.548	.000	.000	.000	.000	.000	.874

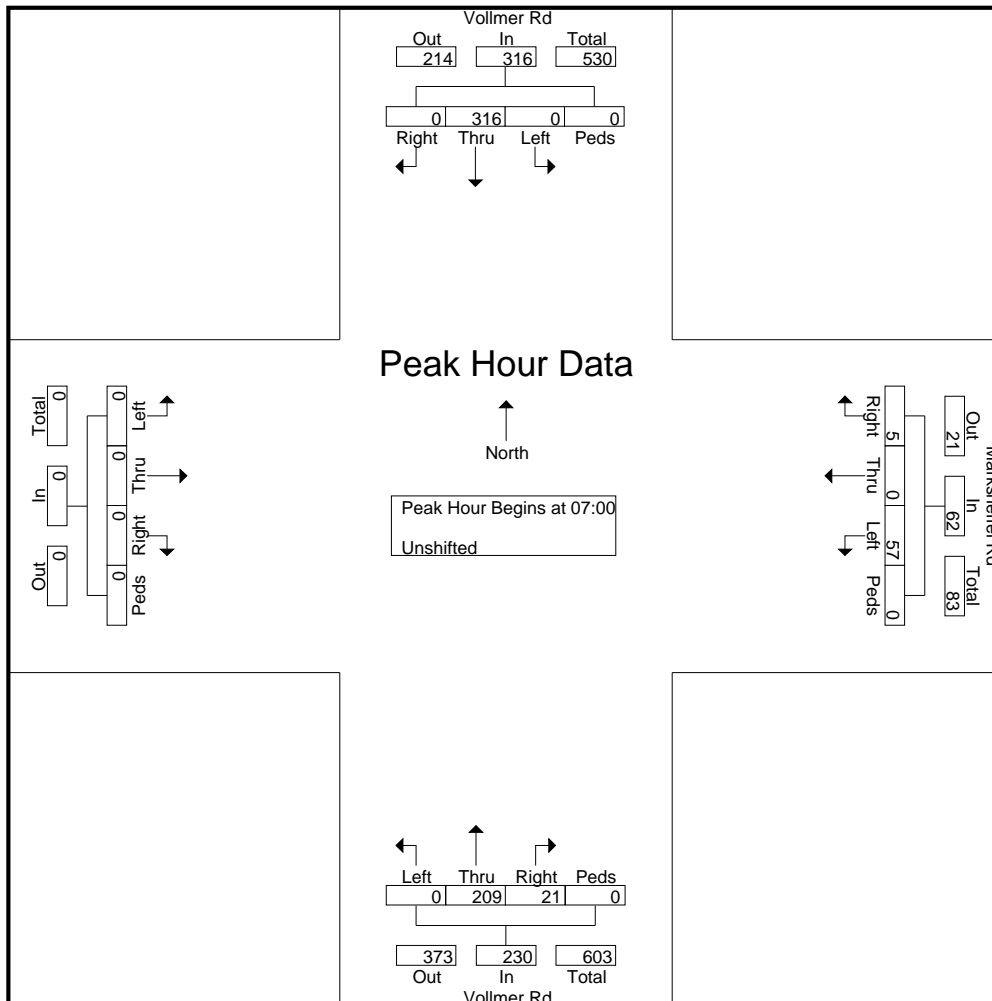



# LSC Transportation Consultants, Inc.

2504 E. Pikes Peak Ave, Suite 304  
 Colorado Springs, CO 80909  
 719-633-2868

File Name : Vollmer Rd - Marksheffel Rd PM

Site Code : S224580

Start Date : 4/4/2024

Page No : 1

Start Time	Vollmer Rd Southbound					Marksheffel Rd Westbound					Vollmer Rd Northbound					Eastbound					Int. Total
	Right	Thru	Left	Peds	App. Total	Right	Thru	Left	Peds	App. Total	Right	Thru	Left	Peds	App. Total	Right	Thru	Left	Peds	App. Total	
16:00	0	26	0	0	26	0	0	0	0	0	1	22	0	0	23	0	0	0	0	0	49
16:05	0	20	0	0	20	0	0	1	0	1	3	25	0	0	28	0	0	0	0	0	49
16:10	0	21	0	0	21	0	0	4	0	4	6	23	0	0	29	0	0	0	0	0	54
16:15	0	21	1	0	22	0	0	4	0	4	4	24	0	0	28	0	0	0	0	0	54
16:20	0	16	0	0	16	1	0	1	0	2	2	26	0	0	28	0	0	0	0	0	46
16:25	0	26	0	0	26	0	0	6	0	6	2	13	0	0	15	0	0	0	0	0	47
16:30	0	24	0	0	24	0	0	3	0	3	3	22	0	0	25	0	0	0	0	0	52
16:35	0	19	0	0	19	0	0	2	0	2	1	29	0	0	30	0	0	0	0	0	51
16:40	0	23	0	0	23	0	0	3	0	3	4	23	0	0	27	0	0	0	0	0	53
16:45	0	22	1	0	23	0	0	6	0	6	6	22	0	0	28	0	0	0	0	0	57
16:50	0	24	0	0	24	0	0	3	0	3	5	26	0	0	31	0	0	0	0	0	58
16:55	0	18	0	0	18	0	0	5	0	5	2	24	0	0	26	0	0	0	0	0	49
Total	0	260	2	0	262	1	0	38	0	39	39	279	0	0	318	0	0	0	0	0	619
17:00	0	29	0	0	29	0	0	6	0	6	3	20	0	0	23	0	0	0	0	0	58
17:05	0	23	0	0	23	0	0	4	0	4	7	22	0	0	29	0	0	0	0	0	56
17:10	0	8	1	0	9	0	0	1	0	1	4	17	0	0	21	0	0	0	0	0	31
17:15	0	19	0	0	19	0	0	4	0	4	4	16	0	0	20	0	0	0	0	0	43
17:20	0	30	0	0	30	0	0	1	0	1	5	14	0	0	19	0	0	0	0	0	50
17:25	0	16	0	0	16	0	0	2	0	2	3	26	0	0	29	0	0	0	0	0	47
17:30	0	14	0	0	14	0	0	0	0	0	0	18	0	0	18	0	0	0	0	0	32
17:35	0	18	0	0	18	0	0	3	0	3	4	27	0	0	31	0	0	0	0	0	52
17:40	0	17	0	0	17	0	0	4	0	4	3	14	0	0	17	0	0	0	0	0	38
17:45	0	16	0	0	16	0	0	3	0	3	9	19	0	0	28	0	0	0	0	0	47
17:50	0	14	0	0	14	0	0	3	0	3	2	22	0	0	24	0	0	0	0	0	41
17:55	0	17	0	0	17	0	0	3	0	3	3	27	0	0	30	0	0	0	0	0	50
Total	0	221	1	0	222	0	0	34	0	34	47	242	0	0	289	0	0	0	0	0	545
Grand Total	0	481	3	0	484	1	0	72	0	73	86	521	0	0	607	0	0	0	0	0	1164
Apprch %	0	99.4	0.6	0		1.4	0	98.6	0		14.2	85.8	0	0		0	0	0	0		
Total %	0	41.3	0.3	0	41.6	0.1	0	6.2	0	6.3	7.4	44.8	0	0	52.1	0	0	0	0	0	

# LSC Transportation Consultants, Inc.

2504 E. Pikes Peak Ave, Suite 304  
 Colorado Springs, CO 80909  
 719-633-2868

File Name : Vollmer Rd - Marksheffel Rd PM

Site Code : S224580

Start Date : 4/4/2024

Page No : 2

Start Time	Vollmer Rd Southbound					Marksheffel Rd Westbound					Vollmer Rd Northbound					Eastbound					Int. Total
	Right	Thru	Left	Peds	App. Total	Right	Thru	Left	Peds	App. Total	Right	Thru	Left	Peds	App. Total	Right	Thru	Left	Peds	App. Total	
Peak Hour Analysis From 16:00 to 17:55 - Peak 1 of 1																					
Peak Hour for Entire Intersection Begins at 16:10																					
16:10	0	21	0	0	21	0	0	4	0	4	6	23	0	0	29	0	0	0	0	0	54
16:15	0	21	1	0	22	0	0	4	0	4	4	24	0	0	28	0	0	0	0	0	54
16:20	0	16	0	0	16	1	0	1	0	2	2	26	0	0	28	0	0	0	0	0	46
16:25	0	26	0	0	26	0	0	6	0	6	2	13	0	0	15	0	0	0	0	0	47
16:30	0	24	0	0	24	0	0	3	0	3	3	22	0	0	25	0	0	0	0	0	52
16:35	0	19	0	0	19	0	0	2	0	2	1	29	0	0	30	0	0	0	0	0	51
16:40	0	23	0	0	23	0	0	3	0	3	4	23	0	0	27	0	0	0	0	0	53
16:45	0	22	1	0	23	0	0	6	0	6	6	22	0	0	28	0	0	0	0	0	57
16:50	0	24	0	0	24	0	0	3	0	3	5	26	0	0	31	0	0	0	0	0	58
16:55	0	18	0	0	18	0	0	5	0	5	2	24	0	0	26	0	0	0	0	0	49
17:00	0	29	0	0	29	0	0	6	0	6	3	20	0	0	23	0	0	0	0	0	58
17:05	0	23	0	0	23	0	0	4	0	4	7	22	0	0	29	0	0	0	0	0	56
Total Volume	0	266	2	0	268	1	0	47	0	48	45	274	0	0	319	0	0	0	0	0	635
% App. Total	0	99.3	0.7	0		2.1	0	97.9	0		14.1	85.9	0	0		0	0	0	0		
PHF	.000	.764	.167	.000	.770	.083	.000	.653	.000	.667	.536	.787	.000	.000	.858	.000	.000	.000	.000	.000	.912

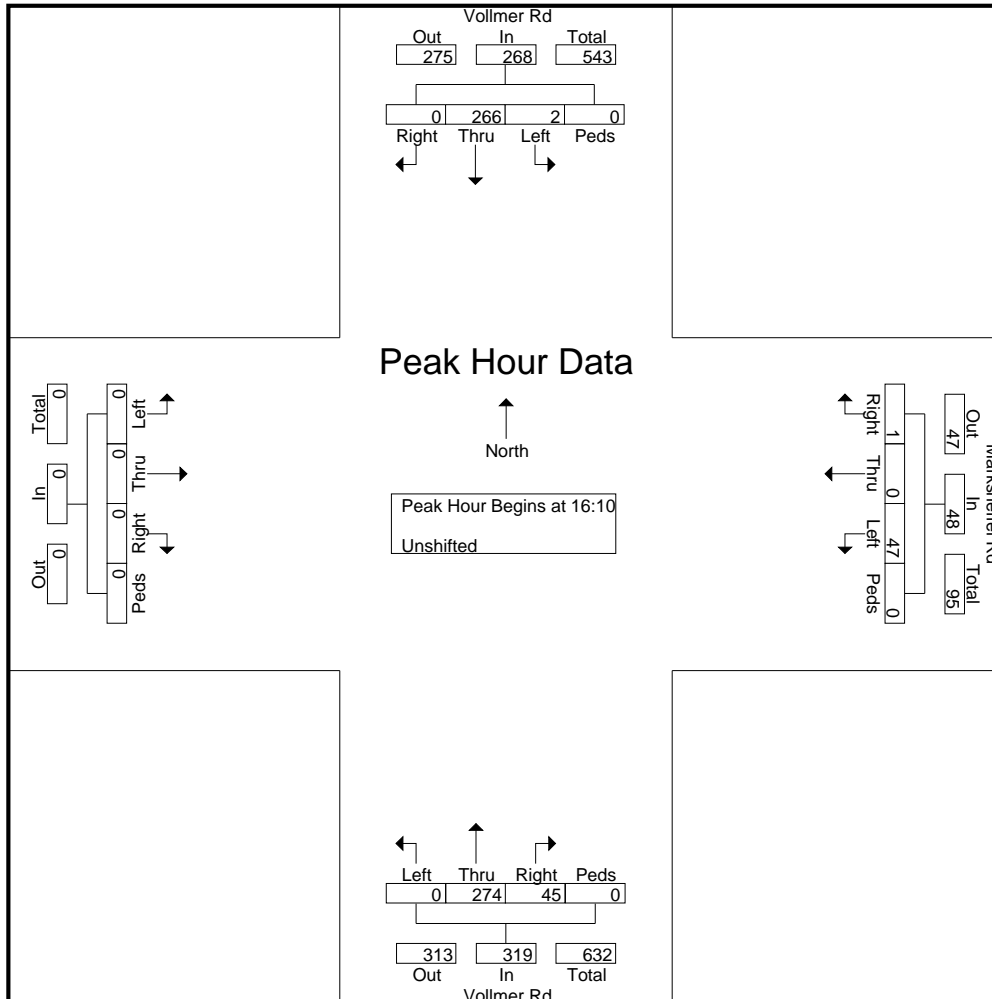

Vollmer Road North of Marksheffel Road

Site Code: 00244080

Station ID:

Location 1:

Location 2:

Location 3:

Location 4:

Comment 1:

Comment 2:

Comment 3:

Comment 4:

Latitude: 0.000000

Longitude: 0.000000

4/2/2024	NB	SB	Total
Time			
12:00 AM	*	*	0
1:00	*	*	0
2:00	*	*	0
3:00	*	*	0
4:00	*	*	0
5:00	*	*	0
6:00	*	*	0
7:00	*	*	0
8:00	*	*	0
9:00	*	*	0
10:00	*	*	0
11:00	*	*	0
12:00 PM	*	*	0
1:00	*	*	0
2:00	*	*	0
3:00	197	159	356
4:00	232	174	406
5:00	208	173	381
6:00	175	107	282
7:00	116	83	199
8:00	91	32	123
9:00	61	20	81
10:00	43	10	53
11:00	13	2	15
Total	1136	760	1896
Percent	59.9%	40.1%	
AM Peak			
Volume			
PM Peak	4:00	4:00	4:00
Volume	232	174	406

Vollmer Road North of Marksheffel Road

Site Code: 00244080

Station ID:

Location 1:

Location 2:

Location 3:

Location 4:

Comment 1:

Comment 2:

Comment 3:

Comment 4:

Latitude: 0.000000

Longitude: 0.000000

4/3/2024	NB	SB	Total
Time			
12:00 AM	7	2	9
1:00	1	5	6
2:00	1	2	3
3:00	5	9	14
4:00	8	20	28
5:00	13	51	64
6:00	88	149	237
7:00	164	333	497
8:00	182	209	391
9:00	141	184	325
10:00	127	159	286
11:00	143	192	335
12:00 PM	132	161	293
1:00	147	154	301
2:00	186	173	359
3:00	215	189	404
4:00	223	195	418
5:00	206	238	444
6:00	196	122	318
7:00	139	73	212
8:00	119	43	162
9:00	71	24	95
10:00	32	10	42
11:00	13	6	19
Total	2559	2703	5262
Percent	48.6%	51.4%	
AM Peak	8:00	7:00	7:00
Volume	182	333	497
PM Peak	4:00	5:00	5:00
Volume	223	238	444

Vollmer Road North of Marksheffel Road

Site Code: 00244080

Station ID:

Location 1:

Location 2:

Location 3:

Location 4:

Comment 1:

Comment 2:

Comment 3:

Comment 4:

Latitude: 0.000000

Longitude: 0.000000

4/4/2024	NB	SB	Total
Time			
12:00 AM	9	5	14
1:00	3	1	4
2:00	1	0	1
3:00	3	4	7
4:00	4	15	19
5:00	10	45	55
6:00	78	152	230
7:00	169	302	471
8:00	191	210	401
9:00	144	171	315
10:00	136	165	301
11:00	197	191	388
12:00 PM	174	175	349
1:00	168	178	346
2:00	173	194	367
3:00	227	201	428
4:00	250	231	481
5:00	218	198	416
6:00	34	19	53
7:00	*	*	0
8:00	*	*	0
9:00	*	*	0
10:00	*	*	0
11:00	*	*	0
Total	2189	2457	4646
Percent	47.1%	52.9%	
AM Peak	11:00	7:00	7:00
Volume	197	302	471
PM Peak	4:00	4:00	4:00
Volume	250	231	481
Grand Total	5884	5920	11804
Percent	49.8%	50.2%	
ADT		ADT: 5,172	AADT: 5,172

# Level of Service Reports

---



HCM 6th TWSC  
1: Vollmer Rd & Burgess Rd

Existing Traffic  
AM Peak Hour

Intersection												
Int Delay, s/veh	16.3											
Movement	EBL	EBT	EBR	WBL	WBT	WBR	NBL	NBT	NBR	SBL	SBT	SBR
Lane Configurations		↕			↕			↕			↕	
Traffic Vol, veh/h	4	55	9	71	286	110	16	45	31	28	58	22
Future Vol, veh/h	4	55	9	71	286	110	16	45	31	28	58	22
Conflicting Peds, #/hr	0	0	0	0	0	0	0	0	0	0	0	0
Sign Control	Stop	Stop	Stop	Stop	Stop	Stop	Free	Free	Free	Free	Free	Free
RT Channelized	-	-	None	-	-	None	-	-	None	-	-	None
Storage Length	-	-	-	-	-	-	-	-	-	-	-	-
Veh in Median Storage, #	-	0	-	-	0	-	-	0	-	-	0	-
Grade, %	-	0	-	-	0	-	-	0	-	-	0	-
Peak Hour Factor	81	81	81	94	94	94	83	83	83	90	90	90
Heavy Vehicles, %	2	2	2	2	2	2	2	2	2	2	2	2
Mvmt Flow	5	68	11	76	304	117	19	54	37	31	64	24

Major/Minor	Minor2		Minor1		Major1		Major2					
Conflicting Flow All	459	267	76	289	261	73	88	0	0	91	0	0
Stage 1	138	138	-	111	111	-	-	-	-	-	-	-
Stage 2	321	129	-	178	150	-	-	-	-	-	-	-
Critical Hdwy	7.12	6.52	6.22	7.12	6.52	6.22	4.12	-	-	4.12	-	-
Critical Hdwy Stg 1	6.12	5.52	-	6.12	5.52	-	-	-	-	-	-	-
Critical Hdwy Stg 2	6.12	5.52	-	6.12	5.52	-	-	-	-	-	-	-
Follow-up Hdwy	3.518	4.018	3.318	3.518	4.018	3.318	2.218	-	-	2.218	-	-
Pot Cap-1 Maneuver	512	639	985	663	644	989	1508	-	-	1504	-	-
Stage 1	865	782	-	894	804	-	-	-	-	-	-	-
Stage 2	691	789	-	824	773	-	-	-	-	-	-	-
Platoon blocked, %								-	-	-	-	-
Mov Cap-1 Maneuver	271	617	985	585	621	989	1508	-	-	1504	-	-
Mov Cap-2 Maneuver	271	617	-	585	621	-	-	-	-	-	-	-
Stage 1	854	765	-	882	794	-	-	-	-	-	-	-
Stage 2	371	779	-	726	756	-	-	-	-	-	-	-

Approach	EB		WB		NB		SB	
HCM Control Delay, s	11.9		23.8		1.3		1.9	
HCM LOS	B		C					

Minor Lane/Major Mvmt	NBL	NBT	NBR	EBLn1	WBLn1	SBL	SBT	SBR
Capacity (veh/h)	1508	-	-	602	674	1504	-	-
HCM Lane V/C Ratio	0.013	-	-	0.139	0.737	0.021	-	-
HCM Control Delay (s)	7.4	0	-	11.9	23.8	7.4	0	-
HCM Lane LOS	A	A	-	B	C	A	A	-
HCM 95th %tile Q(veh)	0	-	-	0.5	6.5	0.1	-	-

Intersection						
Int Delay, s/veh	1.3					
Movement	WBL	WBR	NBT	NBR	SBL	SBT
Lane Configurations	↘	↗	↑↑	↗	↘	↑↑
Traffic Vol, veh/h	57	5	209	21	0	316
Future Vol, veh/h	57	5	209	21	0	316
Conflicting Peds, #/hr	0	0	0	0	0	0
Sign Control	Stop	Stop	Free	Free	Free	Free
RT Channelized	-	None	-	None	-	None
Storage Length	300	-	-	155	300	-
Veh in Median Storage, #	0	-	0	-	-	0
Grade, %	0	-	0	-	-	0
Peak Hour Factor	78	78	77	77	87	87
Heavy Vehicles, %	2	2	2	2	2	2
Mvmt Flow	73	6	271	27	0	363

Major/Minor	Minor1	Major1	Major2		
Conflicting Flow All	453	136	0	0	298
Stage 1	271	-	-	-	-
Stage 2	182	-	-	-	-
Critical Hdwy	6.84	6.94	-	-	4.14
Critical Hdwy Stg 1	5.84	-	-	-	-
Critical Hdwy Stg 2	5.84	-	-	-	-
Follow-up Hdwy	3.52	3.32	-	-	2.22
Pot Cap-1 Maneuver	535	888	-	-	1260
Stage 1	750	-	-	-	-
Stage 2	831	-	-	-	-
Platoon blocked, %			-	-	-
Mov Cap-1 Maneuver	535	888	-	-	1260
Mov Cap-2 Maneuver	535	-	-	-	-
Stage 1	750	-	-	-	-
Stage 2	831	-	-	-	-

Approach	WB	NB	SB
HCM Control Delay, s	12.5	0	0
HCM LOS	B		

Minor Lane/Major Mvmt	NBT	NBR	WBLn1	WBLn2	SBL	SBT
Capacity (veh/h)	-	-	535	888	1260	-
HCM Lane V/C Ratio	-	-	0.137	0.007	-	-
HCM Control Delay (s)	-	-	12.8	9.1	0	-
HCM Lane LOS	-	-	B	A	A	-
HCM 95th %tile Q(veh)	-	-	0.5	0	0	-



HCM 6th TWSC  
1: Vollmer Rd & Burgess Rd

Existing Traffic  
PM Peak Hour

Intersection												
Int Delay, s/veh	21											
Movement	EBL	EBT	EBR	WBL	WBT	WBR	NBL	NBT	NBR	SBL	SBT	SBR
Lane Configurations		↕			↕			↕			↕	
Traffic Vol, veh/h	12	220	18	28	106	42	14	71	61	118	67	16
Future Vol, veh/h	12	220	18	28	106	42	14	71	61	118	67	16
Conflicting Peds, #/hr	0	0	0	0	0	0	0	0	0	0	0	0
Sign Control	Stop	Stop	Stop	Stop	Stop	Stop	Free	Free	Free	Free	Free	Free
RT Channelized	-	-	None	-	-	None	-	-	None	-	-	None
Storage Length	-	-	-	-	-	-	-	-	-	-	-	-
Veh in Median Storage, #	-	0	-	-	0	-	-	0	-	-	0	-
Grade, %	-	0	-	-	0	-	-	0	-	-	0	-
Peak Hour Factor	87	87	87	87	87	87	83	83	83	77	77	77
Heavy Vehicles, %	2	2	2	2	2	2	2	2	2	2	2	2
Mvmt Flow	14	253	21	32	122	48	17	86	73	153	87	21

Major/Minor	Minor2		Minor1		Major1		Major2					
Conflicting Flow All	646	597	98	698	571	123	108	0	0	159	0	0
Stage 1	404	404	-	157	157	-	-	-	-	-	-	-
Stage 2	242	193	-	541	414	-	-	-	-	-	-	-
Critical Hdwy	7.12	6.52	6.22	7.12	6.52	6.22	4.12	-	-	4.12	-	-
Critical Hdwy Stg 1	6.12	5.52	-	6.12	5.52	-	-	-	-	-	-	-
Critical Hdwy Stg 2	6.12	5.52	-	6.12	5.52	-	-	-	-	-	-	-
Follow-up Hdwy	3.518	4.018	3.318	3.518	4.018	3.318	2.218	-	-	2.218	-	-
Pot Cap-1 Maneuver	385	416	958	355	431	928	1483	-	-	1420	-	-
Stage 1	623	599	-	845	768	-	-	-	-	-	-	-
Stage 2	762	741	-	525	593	-	-	-	-	-	-	-
Platoon blocked, %								-	-	-	-	-
Mov Cap-1 Maneuver	248	363	958	139	376	928	1483	-	-	1420	-	-
Mov Cap-2 Maneuver	248	363	-	139	376	-	-	-	-	-	-	-
Stage 1	615	530	-	834	758	-	-	-	-	-	-	-
Stage 2	598	731	-	238	525	-	-	-	-	-	-	-

Approach	EB		WB		NB		SB	
HCM Control Delay, s	41.1		31.2		0.7		4.6	
HCM LOS	E		D					

Minor Lane/Major Mvmt	NBL	NBT	NBR	EBLn1	WBLn1	SBL	SBT	SBR
Capacity (veh/h)	1483	-	-	371	333	1420	-	-
HCM Lane V/C Ratio	0.011	-	-	0.775	0.608	0.108	-	-
HCM Control Delay (s)	7.5	0	-	41.1	31.2	7.8	0	-
HCM Lane LOS	A	A	-	E	D	A	A	-
HCM 95th %tile Q(veh)	0	-	-	6.4	3.8	0.4	-	-

Intersection						
Int Delay, s/veh	1.2					
Movement	WBL	WBR	NBT	NBR	SBL	SBT
Lane Configurations	↘	↗	↑↑	↗	↘	↑↑
Traffic Vol, veh/h	47	1	274	45	2	266
Future Vol, veh/h	47	1	274	45	2	266
Conflicting Peds, #/hr	0	0	0	0	0	0
Sign Control	Stop	Stop	Free	Free	Free	Free
RT Channelized	-	None	-	None	-	None
Storage Length	300	-	-	155	300	-
Veh in Median Storage, #	0	-	0	-	-	0
Grade, %	0	-	0	-	-	0
Peak Hour Factor	78	78	93	96	96	96
Heavy Vehicles, %	2	2	2	2	2	2
Mvmt Flow	60	1	295	47	2	277

Major/Minor	Minor1	Major1	Major2			
Conflicting Flow All	438	148	0	0	342	0
Stage 1	295	-	-	-	-	-
Stage 2	143	-	-	-	-	-
Critical Hdwy	6.84	6.94	-	-	4.14	-
Critical Hdwy Stg 1	5.84	-	-	-	-	-
Critical Hdwy Stg 2	5.84	-	-	-	-	-
Follow-up Hdwy	3.52	3.32	-	-	2.22	-
Pot Cap-1 Maneuver	547	872	-	-	1214	-
Stage 1	730	-	-	-	-	-
Stage 2	869	-	-	-	-	-
Platoon blocked, %			-	-		-
Mov Cap-1 Maneuver	546	872	-	-	1214	-
Mov Cap-2 Maneuver	546	-	-	-	-	-
Stage 1	730	-	-	-	-	-
Stage 2	867	-	-	-	-	-

Approach	WB	NB	SB
HCM Control Delay, s	12.3	0	0.1
HCM LOS	B		

Minor Lane/Major Mvmt	NBT	NBRWBLn1	WBLn2	SBL	SBT
Capacity (veh/h)	-	-	546	872	1214
HCM Lane V/C Ratio	-	-	0.11	0.001	0.002
HCM Control Delay (s)	-	-	12.4	9.1	8
HCM Lane LOS	-	-	B	A	A
HCM 95th %tile Q(veh)	-	-	0.4	0	0

Intersection												
Int Delay, s/veh	31.6											
Movement	EBL	EBT	EBR	WBL	WBT	WBR	NBL	NBT	NBR	SBL	SBT	SBR
Lane Configurations		↕			↕			↕			↕	
Traffic Vol, veh/h	4	57	23	74	298	114	60	61	32	29	65	23
Future Vol, veh/h	4	57	23	74	298	114	60	61	32	29	65	23
Conflicting Peds, #/hr	0	0	0	0	0	0	0	0	0	0	0	0
Sign Control	Stop	Stop	Stop	Stop	Stop	Stop	Free	Free	Free	Free	Free	Free
RT Channelized	-	-	None	-	-	None	-	-	None	-	-	None
Storage Length	-	-	-	-	-	-	-	-	-	-	-	-
Veh in Median Storage, #	-	0	-	-	0	-	-	0	-	-	0	-
Grade, %	-	0	-	-	0	-	-	0	-	-	0	-
Peak Hour Factor	81	81	81	94	94	94	83	83	83	90	90	90
Heavy Vehicles, %	2	2	2	2	2	2	2	2	2	2	2	2
Mvmt Flow	5	70	28	79	317	121	72	73	39	32	72	26

Major/Minor	Minor2		Minor1		Major1			Major2				
Conflicting Flow All	605	405	85	435	399	93	98	0	0	112	0	0
Stage 1	149	149	-	237	237	-	-	-	-	-	-	-
Stage 2	456	256	-	198	162	-	-	-	-	-	-	-
Critical Hdwy	7.12	6.52	6.22	7.12	6.52	6.22	4.12	-	-	4.12	-	-
Critical Hdwy Stg 1	6.12	5.52	-	6.12	5.52	-	-	-	-	-	-	-
Critical Hdwy Stg 2	6.12	5.52	-	6.12	5.52	-	-	-	-	-	-	-
Follow-up Hdwy	3.518	4.018	3.318	3.518	4.018	3.318	2.218	-	-	2.218	-	-
Pot Cap-1 Maneuver	410	535	974	531	539	964	1495	-	-	1478	-	-
Stage 1	854	774	-	766	709	-	-	-	-	-	-	-
Stage 2	584	696	-	804	764	-	-	-	-	-	-	-
Platoon blocked, %								-	-	-	-	-
Mov Cap-1 Maneuver	167	495	974	434	499	964	1495	-	-	1478	-	-
Mov Cap-2 Maneuver	167	495	-	434	499	-	-	-	-	-	-	-
Stage 1	810	756	-	726	672	-	-	-	-	-	-	-
Stage 2	256	660	-	692	746	-	-	-	-	-	-	-

Approach	EB		WB		NB		SB	
HCM Control Delay, s	13.7		52.8		3		1.9	
HCM LOS	B		F					

Minor Lane/Major Mvmt	NBL	NBT	NBR	EBLn1	WBLn1	SBL	SBT	SBR
Capacity (veh/h)	1495	-	-	516	549	1478	-	-
HCM Lane V/C Ratio	0.048	-	-	0.201	0.942	0.022	-	-
HCM Control Delay (s)	7.5	0	-	13.7	52.8	7.5	0	-
HCM Lane LOS	A	A	-	B	F	A	A	-
HCM 95th %tile Q(veh)	0.2	-	-	0.7	12.1	0.1	-	-

Intersection						
Int Delay, s/veh	2.4					
Movement	WBL	WBR	NBT	NBR	SBL	SBT
Lane Configurations	↘	↗	↑↑	↗	↘	↑↑
Traffic Vol, veh/h	110	29	196	19	9	341
Future Vol, veh/h	110	29	196	19	9	341
Conflicting Peds, #/hr	0	0	0	0	0	0
Sign Control	Stop	Stop	Free	Free	Free	Free
RT Channelized	-	None	-	None	-	None
Storage Length	485	-	-	235	385	-
Veh in Median Storage, #	0	-	0	-	-	0
Grade, %	0	-	0	-	-	0
Peak Hour Factor	85	85	85	85	85	85
Heavy Vehicles, %	2	2	2	2	2	2
Mvmt Flow	129	34	231	22	11	401

Major/Minor	Minor1	Major1	Major2		
Conflicting Flow All	454	116	0	0	253
Stage 1	231	-	-	-	-
Stage 2	223	-	-	-	-
Critical Hdwy	6.84	6.94	-	-	4.14
Critical Hdwy Stg 1	5.84	-	-	-	-
Critical Hdwy Stg 2	5.84	-	-	-	-
Follow-up Hdwy	3.52	3.32	-	-	2.22
Pot Cap-1 Maneuver	535	914	-	-	1309
Stage 1	785	-	-	-	-
Stage 2	793	-	-	-	-
Platoon blocked, %			-	-	-
Mov Cap-1 Maneuver	531	914	-	-	1309
Mov Cap-2 Maneuver	601	-	-	-	-
Stage 1	785	-	-	-	-
Stage 2	787	-	-	-	-

Approach	WB	NB	SB
HCM Control Delay, s	11.9	0	0.2
HCM LOS	B		

Minor Lane/Major Mvmt	NBT	NBRWBLn1	WBLn2	SBL	SBT
Capacity (veh/h)	-	-	601	914	1309
HCM Lane V/C Ratio	-	-	0.215	0.037	0.008
HCM Control Delay (s)	-	-	12.6	9.1	7.8
HCM Lane LOS	-	-	B	A	A
HCM 95th %tile Q(veh)	-	-	0.8	0.1	0

Intersection												
Int Delay, s/veh	8.4											
Movement	EBL	EBT	EBR	WBL	WBT	WBR	NBL	NBT	NBR	SBL	SBT	SBR
Lane Configurations	↘	↑↑	↗	↘	↑↑	↗	↘	↑	↗	↘	↑	↗
Traffic Vol, veh/h	2	0	6	0	0	0	22	10	0	0	42	6
Future Vol, veh/h	2	0	6	0	0	0	22	10	0	0	42	6
Conflicting Peds, #/hr	0	0	0	0	0	0	0	0	0	0	0	0
Sign Control	Free	Free	Free	Free	Free	Free	Stop	Stop	Stop	Stop	Stop	Stop
RT Channelized	-	-	None	-	-	None	-	-	None	-	-	None
Storage Length	535	-	0	310	-	0	410	-	155	235	-	155
Veh in Median Storage, #	-	0	-	-	0	-	-	0	-	-	0	-
Grade, %	-	0	-	-	0	-	-	0	-	-	0	-
Peak Hour Factor	85	85	85	85	85	85	85	85	85	85	85	85
Heavy Vehicles, %	2	2	2	2	2	2	2	2	2	2	2	2
Mvmt Flow	2	0	7	0	0	0	26	12	0	0	49	7

Major/Minor	Major1		Major2			Minor1			Minor2			
Conflicting Flow All	1	0	0	7	0	0	29	5	0	11	12	1
Stage 1	-	-	-	-	-	-	4	4	-	1	1	-
Stage 2	-	-	-	-	-	-	25	1	-	10	11	-
Critical Hdwy	4.14	-	-	4.14	-	-	7.54	6.54	6.94	7.54	6.54	6.94
Critical Hdwy Stg 1	-	-	-	-	-	-	6.54	5.54	-	6.54	5.54	-
Critical Hdwy Stg 2	-	-	-	-	-	-	6.54	5.54	-	6.54	5.54	-
Follow-up Hdwy	2.22	-	-	2.22	-	-	3.52	4.02	3.32	3.52	4.02	3.32
Pot Cap-1 Maneuver	1620	-	-	1612	-	-	976	890	-	1005	882	1083
Stage 1	-	-	-	-	-	-	1017	892	-	1021	895	-
Stage 2	-	-	-	-	-	-	989	895	-	1009	886	-
Platoon blocked, %	-	-	-	-	-	-	-	-	-	-	-	-
Mov Cap-1 Maneuver	1620	-	-	1612	-	-	927	889	-	-	881	1083
Mov Cap-2 Maneuver	-	-	-	-	-	-	927	889	-	-	881	-
Stage 1	-	-	-	-	-	-	1016	891	-	1020	895	-
Stage 2	-	-	-	-	-	-	928	895	-	994	885	-

Approach	EB	WB	NB	SB
HCM Control Delay, s	1.8	0	9	9.2
HCM LOS			A	A

Minor Lane/Major Mvmt	NBLn1	NBLn2	NBLn3	EBL	EBT	EBR	WBL	WBT	WBR	SBLn1	SBLn2	SBLn3
Capacity (veh/h)	927	889	-	1620	-	-	1612	-	-	-	881	1083
HCM Lane V/C Ratio	0.028	0.013	-	0.001	-	-	-	-	-	-	0.056	0.007
HCM Control Delay (s)	9	9.1	0	7.2	-	-	0	-	-	0	9.3	8.3
HCM Lane LOS	A	A	A	A	-	-	A	-	-	A	A	A
HCM 95th %tile Q(veh)	0.1	0	-	0	-	-	0	-	-	-	0.2	0

Intersection						
Int Delay, s/veh	1.9					
Movement	WBL	WBR	NBT	NBR	SBL	SBT
Lane Configurations	↘	↗	↑	↗	↘	↑
Traffic Vol, veh/h	19	2	31	6	1	47
Future Vol, veh/h	19	2	31	6	1	47
Conflicting Peds, #/hr	0	0	0	0	0	0
Sign Control	Stop	Stop	Free	Free	Free	Free
RT Channelized	-	None	-	None	-	None
Storage Length	205	0	-	205	205	-
Veh in Median Storage, #	0	-	0	-	-	0
Grade, %	0	-	0	-	-	0
Peak Hour Factor	85	85	85	85	85	85
Heavy Vehicles, %	2	2	2	2	2	2
Mvmt Flow	22	2	36	7	1	55

Major/Minor	Minor1	Major1	Major2		
Conflicting Flow All	93	36	0	0	43
Stage 1	36	-	-	-	-
Stage 2	57	-	-	-	-
Critical Hdwy	6.42	6.22	-	-	4.12
Critical Hdwy Stg 1	5.42	-	-	-	-
Critical Hdwy Stg 2	5.42	-	-	-	-
Follow-up Hdwy	3.518	3.318	-	-	2.218
Pot Cap-1 Maneuver	907	1037	-	-	1566
Stage 1	986	-	-	-	-
Stage 2	966	-	-	-	-
Platoon blocked, %			-	-	-
Mov Cap-1 Maneuver	906	1037	-	-	1566
Mov Cap-2 Maneuver	858	-	-	-	-
Stage 1	986	-	-	-	-
Stage 2	965	-	-	-	-

Approach	WB	NB	SB
HCM Control Delay, s	9.2	0	0.2
HCM LOS	A		

Minor Lane/Major Mvmt	NBT	NBRWBLn1	WBLn2	SBL	SBT
Capacity (veh/h)	-	-	858	1037	1566
HCM Lane V/C Ratio	-	-	0.026	0.002	0.001
HCM Control Delay (s)	-	-	9.3	8.5	7.3
HCM Lane LOS	-	-	A	A	A
HCM 95th %tile Q(veh)	-	-	0.1	0	0

Intersection						
Int Delay, s/veh	6.9					
Movement	WBL	WBR	NBT	NBR	SBL	SBT
Lane Configurations	↘	↗	↑↑	↗	↘	↑↑
Traffic Vol, veh/h	159	80	190	49	119	406
Future Vol, veh/h	159	80	190	49	119	406
Conflicting Peds, #/hr	0	0	0	0	0	0
Sign Control	Stop	Stop	Free	Free	Free	Free
RT Channelized	-	None	-	None	-	None
Storage Length	300	-	-	155	300	-
Veh in Median Storage, #	0	-	0	-	-	0
Grade, %	0	-	0	-	-	0
Peak Hour Factor	85	85	85	85	85	85
Heavy Vehicles, %	2	2	2	2	2	2
Mvmt Flow	187	94	224	58	140	478

Major/Minor	Minor1	Major1	Major2			
Conflicting Flow All	743	112	0	0	282	0
Stage 1	224	-	-	-	-	-
Stage 2	519	-	-	-	-	-
Critical Hdwy	6.84	6.94	-	-	4.14	-
Critical Hdwy Stg 1	5.84	-	-	-	-	-
Critical Hdwy Stg 2	5.84	-	-	-	-	-
Follow-up Hdwy	3.52	3.32	-	-	2.22	-
Pot Cap-1 Maneuver	351	920	-	-	1277	-
Stage 1	792	-	-	-	-	-
Stage 2	562	-	-	-	-	-
Platoon blocked, %			-	-		-
Mov Cap-1 Maneuver	312	920	-	-	1277	-
Mov Cap-2 Maneuver	312	-	-	-	-	-
Stage 1	792	-	-	-	-	-
Stage 2	500	-	-	-	-	-

Approach	WB	NB	SB
HCM Control Delay, s	24.7	0	1.9
HCM LOS	C		

Minor Lane/Major Mvmt	NBT	NBRWBLn1	WBLn2	SBL	SBT
Capacity (veh/h)	-	-	312	920	1277
HCM Lane V/C Ratio	-	-	0.6	0.102	0.11
HCM Control Delay (s)	-	-	32.4	9.4	8.2
HCM Lane LOS	-	-	D	A	A
HCM 95th %tile Q(veh)	-	-	3.6	0.3	0.4

Intersection												
Int Delay, s/veh	11.4											
Movement	EBL	EBT	EBR	WBL	WBT	WBR	NBL	NBT	NBR	SBL	SBT	SBR
Lane Configurations	↘	↑↑	↗	↘	↑↑	↗	↘	↗	↘	↘	↑	↗
Traffic Vol, veh/h	49	117	2	8	75	118	2	0	6	356	1	163
Future Vol, veh/h	49	117	2	8	75	118	2	0	6	356	1	163
Conflicting Peds, #/hr	0	0	0	0	0	0	0	0	0	0	0	0
Sign Control	Free	Free	Free	Free	Free	Free	Stop	Stop	Stop	Stop	Stop	Stop
RT Channelized	-	-	None	-	-	None	-	-	None	-	-	None
Storage Length	300	-	200	250	-	205	0	-	-	155	-	0
Veh in Median Storage, #	-	0	-	-	0	-	-	0	-	-	0	-
Grade, %	-	0	-	-	0	-	-	0	-	-	0	-
Peak Hour Factor	85	85	85	85	85	85	85	85	85	85	85	85
Heavy Vehicles, %	2	2	70	70	2	2	88	2	88	2	2	2
Mvmt Flow	58	138	2	9	88	139	2	0	7	419	1	192

Major/Minor	Major1			Major2			Minor1			Minor2		
Conflicting Flow All	227	0	0	140	0	0	317	499	69	291	362	44
Stage 1	-	-	-	-	-	-	254	254	-	106	106	-
Stage 2	-	-	-	-	-	-	63	245	-	185	256	-
Critical Hdwy	4.14	-	-	5.5	-	-	9.26	6.54	8.66	7.54	6.54	6.94
Critical Hdwy Stg 1	-	-	-	-	-	-	8.26	5.54	-	6.54	5.54	-
Critical Hdwy Stg 2	-	-	-	-	-	-	8.26	5.54	-	6.54	5.54	-
Follow-up Hdwy	2.22	-	-	2.9	-	-	4.38	4.02	4.18	3.52	4.02	3.32
Pot Cap-1 Maneuver	1339	-	-	1060	-	-	438	472	759	639	564	1017
Stage 1	-	-	-	-	-	-	533	696	-	888	807	-
Stage 2	-	-	-	-	-	-	739	702	-	799	694	-
Platoon blocked, %	-	-	-	-	-	-	-	-	-	-	-	-
Mov Cap-1 Maneuver	1339	-	-	1060	-	-	341	448	759	608	535	1017
Mov Cap-2 Maneuver	-	-	-	-	-	-	341	448	-	608	535	-
Stage 1	-	-	-	-	-	-	510	666	-	850	801	-
Stage 2	-	-	-	-	-	-	594	696	-	757	664	-

Approach	EB			WB			NB			SB		
HCM Control Delay, s	2.3			0.3			11.3			18.7		
HCM LOS							B			C		

Minor Lane/Major Mvmt	NBLn1	NBLn2	EBL	EBT	EBR	WBL	WBT	WBR	SBLn1	SBLn2	SBLn3
Capacity (veh/h)	341	759	1339	-	-	1060	-	-	608	535	1017
HCM Lane V/C Ratio	0.007	0.009	0.043	-	-	0.009	-	-	0.689	0.002	0.189
HCM Control Delay (s)	15.6	9.8	7.8	-	-	8.4	-	-	23	11.7	9.4
HCM Lane LOS	C	A	A	-	-	A	-	-	C	B	A
HCM 95th %tile Q(veh)	0	0	0.1	-	-	0	-	-	5.4	0	0.7



Intersection												
Int Delay, s/veh	33.8											
Movement	EBL	EBT	EBR	WBL	WBT	WBR	NBL	NBT	NBR	SBL	SBT	SBR
Lane Configurations		↕			↕			↕			↕	
Traffic Vol, veh/h	12	229	67	29	110	44	43	84	63	123	86	17
Future Vol, veh/h	12	229	67	29	110	44	43	84	63	123	86	17
Conflicting Peds, #/hr	0	0	0	0	0	0	0	0	0	0	0	0
Sign Control	Stop	Stop	Stop	Stop	Stop	Stop	Free	Free	Free	Free	Free	Free
RT Channelized	-	-	None	-	-	None	-	-	None	-	-	None
Storage Length	-	-	-	-	-	-	-	-	-	-	-	-
Veh in Median Storage, #	-	0	-	-	0	-	-	0	-	-	0	-
Grade, %	-	0	-	-	0	-	-	0	-	-	0	-
Peak Hour Factor	87	87	87	87	87	100	83	83	83	92	92	92
Heavy Vehicles, %	2	2	2	2	2	2	2	2	2	2	2	2
Mvmt Flow	14	263	77	33	126	44	52	101	76	134	93	18

Major/Minor	Minor2		Minor1		Major1		Major2					
Conflicting Flow All	698	651	102	783	622	139	111	0	0	177	0	0
Stage 1	370	370	-	243	243	-	-	-	-	-	-	-
Stage 2	328	281	-	540	379	-	-	-	-	-	-	-
Critical Hdwy	7.12	6.52	6.22	7.12	6.52	6.22	4.12	-	-	4.12	-	-
Critical Hdwy Stg 1	6.12	5.52	-	6.12	5.52	-	-	-	-	-	-	-
Critical Hdwy Stg 2	6.12	5.52	-	6.12	5.52	-	-	-	-	-	-	-
Follow-up Hdwy	3.518	4.018	3.318	3.518	4.018	3.318	2.218	-	-	2.218	-	-
Pot Cap-1 Maneuver	355	388	953	311	403	909	1479	-	-	1399	-	-
Stage 1	650	620	-	761	705	-	-	-	-	-	-	-
Stage 2	685	678	-	526	615	-	-	-	-	-	-	-
Platoon blocked, %								-	-	-	-	-
Mov Cap-1 Maneuver	219	335	953	91	348	909	1479	-	-	1399	-	-
Mov Cap-2 Maneuver	219	335	-	91	348	-	-	-	-	-	-	-
Stage 1	625	557	-	731	678	-	-	-	-	-	-	-
Stage 2	510	652	-	229	552	-	-	-	-	-	-	-

Approach	EB		WB		NB		SB	
HCM Control Delay, s	63.4		54.2		1.7		4.3	
HCM LOS	F		F					

Minor Lane/Major Mvmt	NBL	NBT	NBR	EBLn1	WBLn1	SBL	SBT	SBR
Capacity (veh/h)	1479	-	-	381	262	1399	-	-
HCM Lane V/C Ratio	0.035	-	-	0.929	0.778	0.096	-	-
HCM Control Delay (s)	7.5	0	-	63.4	54.2	7.8	0	-
HCM Lane LOS	A	A	-	F	F	A	A	-
HCM 95th %tile Q(veh)	0.1	-	-	10	5.8	0.3	-	-

Intersection						
Int Delay, s/veh	1.8					
Movement	WBL	WBR	NBT	NBR	SBL	SBT
Lane Configurations	↘	↗	↕↕	↗	↘	↕↕
Traffic Vol, veh/h	73	19	330	65	31	269
Future Vol, veh/h	73	19	330	65	31	269
Conflicting Peds, #/hr	0	0	0	0	0	0
Sign Control	Stop	Stop	Free	Free	Free	Free
RT Channelized	-	None	-	None	-	None
Storage Length	485	-	-	235	385	-
Veh in Median Storage, #	0	-	0	-	-	0
Grade, %	0	-	0	-	-	0
Peak Hour Factor	85	85	85	85	85	85
Heavy Vehicles, %	2	2	2	2	2	2
Mvmt Flow	86	22	388	76	36	316

Major/Minor	Minor1	Major1	Major2		
Conflicting Flow All	618	194	0	0	464
Stage 1	388	-	-	-	-
Stage 2	230	-	-	-	-
Critical Hdwy	6.84	6.94	-	-	4.14
Critical Hdwy Stg 1	5.84	-	-	-	-
Critical Hdwy Stg 2	5.84	-	-	-	-
Follow-up Hdwy	3.52	3.32	-	-	2.22
Pot Cap-1 Maneuver	421	815	-	-	1094
Stage 1	655	-	-	-	-
Stage 2	786	-	-	-	-
Platoon blocked, %			-	-	-
Mov Cap-1 Maneuver	407	815	-	-	1094
Mov Cap-2 Maneuver	504	-	-	-	-
Stage 1	655	-	-	-	-
Stage 2	760	-	-	-	-

Approach	WB	NB	SB
HCM Control Delay, s	12.8	0	0.9
HCM LOS	B		

Minor Lane/Major Mvmt	NBT	NBR	WBLn1	WBLn2	SBL	SBT
Capacity (veh/h)	-	-	504	815	1094	-
HCM Lane V/C Ratio	-	-	0.17	0.027	0.033	-
HCM Control Delay (s)	-	-	13.6	9.5	8.4	-
HCM Lane LOS	-	-	B	A	A	-
HCM 95th %tile Q(veh)	-	-	0.6	0.1	0.1	-

Intersection												
Int Delay, s/veh	7.4											
Movement	EBL	EBT	EBR	WBL	WBT	WBR	NBL	NBT	NBR	SBL	SBT	SBR
Lane Configurations	↘	↑↑	↗	↘	↑↑	↗	↘	↑	↗	↘	↑	↗
Traffic Vol, veh/h	6	0	22	0	0	0	25	35	0	0	28	4
Future Vol, veh/h	6	0	22	0	0	0	25	35	0	0	28	4
Conflicting Peds, #/hr	0	0	0	0	0	0	0	0	0	0	0	0
Sign Control	Free	Free	Free	Free	Free	Free	Stop	Stop	Stop	Stop	Stop	Stop
RT Channelized	-	-	None	-	-	None	-	-	None	-	-	None
Storage Length	535	-	0	310	-	0	410	-	155	235	-	155
Veh in Median Storage, #	-	0	-	-	0	-	-	0	-	-	0	-
Grade, %	-	0	-	-	0	-	-	0	-	-	0	-
Peak Hour Factor	85	85	85	85	85	85	85	85	85	85	85	85
Heavy Vehicles, %	2	2	2	2	2	2	2	2	2	2	2	2
Mvmt Flow	7	0	26	0	0	0	29	41	0	0	33	5

Major/Minor	Major1			Major2			Minor1			Minor2		
Conflicting Flow All	1	0	0	26	0	0	31	15	0	36	41	1
Stage 1	-	-	-	-	-	-	14	14	-	1	1	-
Stage 2	-	-	-	-	-	-	17	1	-	35	40	-
Critical Hdwy	4.14	-	-	4.14	-	-	7.54	6.54	6.94	7.54	6.54	6.94
Critical Hdwy Stg 1	-	-	-	-	-	-	6.54	5.54	-	6.54	5.54	-
Critical Hdwy Stg 2	-	-	-	-	-	-	6.54	5.54	-	6.54	5.54	-
Follow-up Hdwy	2.22	-	-	2.22	-	-	3.52	4.02	3.32	3.52	4.02	3.32
Pot Cap-1 Maneuver	1620	-	-	1587	-	-	973	879	-	965	850	1083
Stage 1	-	-	-	-	-	-	1004	883	-	1021	895	-
Stage 2	-	-	-	-	-	-	1000	895	-	976	861	-
Platoon blocked, %	-	-	-	-	-	-	-	-	-	-	-	-
Mov Cap-1 Maneuver	1620	-	-	1587	-	-	937	875	-	-	847	1083
Mov Cap-2 Maneuver	-	-	-	-	-	-	937	875	-	-	847	-
Stage 1	-	-	-	-	-	-	1000	879	-	1017	895	-
Stage 2	-	-	-	-	-	-	959	895	-	926	858	-

Approach	EB			WB			NB			SB		
HCM Control Delay, s	1.5			0			9.2			9.3		
HCM LOS							A			A		

Minor Lane/Major Mvmt	NBLn1	NBLn2	NBLn3	EBL	EBT	EBR	WBL	WBT	WBR	SBLn1	SBLn2	SBLn3
Capacity (veh/h)	937	875	-	1620	-	-	1587	-	-	-	847	1083
HCM Lane V/C Ratio	0.031	0.047	-	0.004	-	-	-	-	-	-	0.039	0.004
HCM Control Delay (s)	9	9.3	0	7.2	-	-	0	-	-	0	9.4	8.3
HCM Lane LOS	A	A	A	A	-	-	A	-	-	A	A	A
HCM 95th %tile Q(veh)	0.1	0.1	-	0	-	-	0	-	-	-	0.1	0

Intersection						
Int Delay, s/veh	1					
Movement	WBL	WBR	NBT	NBR	SBL	SBT
Lane Configurations	↘	↗	↑	↗	↘	↑
Traffic Vol, veh/h	13	1	59	22	2	47
Future Vol, veh/h	13	1	59	22	2	47
Conflicting Peds, #/hr	0	0	0	0	0	0
Sign Control	Stop	Stop	Free	Free	Free	Free
RT Channelized	-	None	-	None	-	None
Storage Length	205	0	-	205	205	-
Veh in Median Storage, #	0	-	0	-	-	0
Grade, %	0	-	0	-	-	0
Peak Hour Factor	85	85	85	85	85	85
Heavy Vehicles, %	2	2	2	2	2	2
Mvmt Flow	15	1	69	26	2	55

Major/Minor	Minor1	Major1	Major2		
Conflicting Flow All	128	69	0	0	95
Stage 1	69	-	-	-	-
Stage 2	59	-	-	-	-
Critical Hdwy	6.42	6.22	-	-	4.12
Critical Hdwy Stg 1	5.42	-	-	-	-
Critical Hdwy Stg 2	5.42	-	-	-	-
Follow-up Hdwy	3.518	3.318	-	-	2.218
Pot Cap-1 Maneuver	866	994	-	-	1499
Stage 1	954	-	-	-	-
Stage 2	964	-	-	-	-
Platoon blocked, %			-	-	-
Mov Cap-1 Maneuver	865	994	-	-	1499
Mov Cap-2 Maneuver	832	-	-	-	-
Stage 1	954	-	-	-	-
Stage 2	963	-	-	-	-

Approach	WB	NB	SB
HCM Control Delay, s	9.3	0	0.3
HCM LOS	A		

Minor Lane/Major Mvmt	NBT	NBRWBLn1	WBLn2	SBL	SBT
Capacity (veh/h)	-	-	832	994	1499
HCM Lane V/C Ratio	-	-	0.018	0.001	0.002
HCM Control Delay (s)	-	-	9.4	8.6	7.4
HCM Lane LOS	-	-	A	A	A
HCM 95th %tile Q(veh)	-	-	0.1	0	0

Intersection						
Int Delay, s/veh	5.6					
Movement	WBL	WBR	NBT	NBR	SBL	SBT
Lane Configurations	↘	↗	↑↑	↗	↘	↑↑
Traffic Vol, veh/h	116	162	336	134	113	301
Future Vol, veh/h	116	162	336	134	113	301
Conflicting Peds, #/hr	0	0	0	0	0	0
Sign Control	Stop	Stop	Free	Free	Free	Free
RT Channelized	-	None	-	None	-	None
Storage Length	300	-	-	155	300	-
Veh in Median Storage, #	0	-	0	-	-	0
Grade, %	0	-	0	-	-	0
Peak Hour Factor	85	85	85	85	85	85
Heavy Vehicles, %	2	2	2	2	2	2
Mvmt Flow	136	191	395	158	133	354

Major/Minor	Minor1	Major1	Major2			
Conflicting Flow All	838	198	0	0	553	0
Stage 1	395	-	-	-	-	-
Stage 2	443	-	-	-	-	-
Critical Hdwy	6.84	6.94	-	-	4.14	-
Critical Hdwy Stg 1	5.84	-	-	-	-	-
Critical Hdwy Stg 2	5.84	-	-	-	-	-
Follow-up Hdwy	3.52	3.32	-	-	2.22	-
Pot Cap-1 Maneuver	305	810	-	-	1013	-
Stage 1	650	-	-	-	-	-
Stage 2	614	-	-	-	-	-
Platoon blocked, %			-	-	-	-
Mov Cap-1 Maneuver	265	810	-	-	1013	-
Mov Cap-2 Maneuver	265	-	-	-	-	-
Stage 1	650	-	-	-	-	-
Stage 2	534	-	-	-	-	-

Approach	WB	NB	SB
HCM Control Delay, s	19.7	0	2.5
HCM LOS	C		

Minor Lane/Major Mvmt	NBT	NBR	WBLn1	WBLn2	SBL	SBT
Capacity (veh/h)	-	-	265	810	1013	-
HCM Lane V/C Ratio	-	-	0.515	0.235	0.131	-
HCM Control Delay (s)	-	-	32.2	10.8	9.1	-
HCM Lane LOS	-	-	D	B	A	-
HCM 95th %tile Q(veh)	-	-	2.7	0.9	0.5	-

Intersection												
Int Delay, s/veh	13.2											
Movement	EBL	EBT	EBR	WBL	WBT	WBR	NBL	NBT	NBR	SBL	SBT	SBR
Lane Configurations	↘	↑↑	↗	↘	↑↑	↗	↘	↗	↘	↘	↑	↗
Traffic Vol, veh/h	140	105	2	6	160	401	2	0	7	237	1	115
Future Vol, veh/h	140	105	2	6	160	401	2	0	7	237	1	115
Conflicting Peds, #/hr	0	0	0	0	0	0	0	0	0	0	0	0
Sign Control	Free	Free	Free	Free	Free	Free	Stop	Stop	Stop	Stop	Stop	Stop
RT Channelized	-	-	None	-	-	None	-	-	None	-	-	None
Storage Length	300	-	200	250	-	205	0	-	-	155	-	0
Veh in Median Storage, #	-	0	-	-	0	-	-	0	-	-	0	-
Grade, %	-	0	-	-	0	-	-	0	-	-	0	-
Peak Hour Factor	85	85	85	85	85	85	85	85	85	85	85	85
Heavy Vehicles, %	2	2	88	88	2	2	78	2	78	2	2	2
Mvmt Flow	165	124	2	7	188	472	2	0	8	279	1	135

Major/Minor	Major1			Major2			Minor1			Minor2		
Conflicting Flow All	660	0	0	126	0	0	563	1128	62	594	658	94
Stage 1	-	-	-	-	-	-	454	454	-	202	202	-
Stage 2	-	-	-	-	-	-	109	674	-	392	456	-
Critical Hdwy	4.14	-	-	5.86	-	-	9.06	6.54	8.46	7.54	6.54	6.94
Critical Hdwy Stg 1	-	-	-	-	-	-	8.06	5.54	-	6.54	5.54	-
Critical Hdwy Stg 2	-	-	-	-	-	-	8.06	5.54	-	6.54	5.54	-
Follow-up Hdwy	2.22	-	-	3.08	-	-	4.28	4.02	4.08	3.52	4.02	3.32
Pot Cap-1 Maneuver	924	-	-	1004	-	-	280	203	790	389	383	944
Stage 1	-	-	-	-	-	-	394	568	-	781	733	-
Stage 2	-	-	-	-	-	-	703	452	-	604	567	-
Platoon blocked, %	-	-	-	-	-	-	-	-	-	-	-	-
Mov Cap-1 Maneuver	924	-	-	1004	-	-	205	165	790	330	312	944
Mov Cap-2 Maneuver	-	-	-	-	-	-	205	165	-	330	312	-
Stage 1	-	-	-	-	-	-	323	466	-	641	728	-
Stage 2	-	-	-	-	-	-	597	449	-	491	466	-

Approach	EB			WB			NB			SB		
HCM Control Delay, s	5.5			0.1			12.5			39.6		
HCM LOS							B			E		

Minor Lane/Major Mvmt	NBLn1	NBLn2	EBL	EBT	EBR	WBL	WBT	WBR	SBLn1	SBLn2	SBLn3
Capacity (veh/h)	205	790	924	-	-	1004	-	-	330	312	944
HCM Lane V/C Ratio	0.011	0.01	0.178	-	-	0.007	-	-	0.845	0.004	0.143
HCM Control Delay (s)	22.8	9.6	9.7	-	-	8.6	-	-	54.3	16.6	9.5
HCM Lane LOS	C	A	A	-	-	A	-	-	F	C	A
HCM 95th %tile Q(veh)	0	0	0.6	-	-	0	-	-	7.5	0	0.5

Intersection	
Intersection Delay, s/veh	15.4
Intersection LOS	C

Movement	EBL	EBT	EBR	WBL	WBT	WBR	NBL	NBT	NBR	SBL	SBT	SBR
Lane Configurations		↕			↕			↕			↕	
Traffic Vol, veh/h	4	57	25	74	298	114	66	63	32	29	66	23
Future Vol, veh/h	4	57	25	74	298	114	66	63	32	29	66	23
Peak Hour Factor	0.81	0.81	0.81	0.94	0.94	0.94	0.83	0.83	0.83	0.90	0.90	0.90
Heavy Vehicles, %	2	2	2	2	2	2	2	2	2	2	2	2
Mvmt Flow	5	70	31	79	317	121	80	76	39	32	73	26
Number of Lanes	0	1	0	0	1	0	0	1	0	0	1	0

Approach	EB	WB	NB	SB
Opposing Approach	WB	EB	SB	NB
Opposing Lanes	1	1	1	1
Conflicting Approach Left	SB	NB	EB	WB
Conflicting Lanes Left	1	1	1	1
Conflicting Approach Right	NB	SB	WB	EB
Conflicting Lanes Right	1	1	1	1
HCM Control Delay	9.6	19.3	11.4	10.5
HCM LOS	A	C	B	B

Lane	NBLn1	EBLn1	WBLn1	SBLn1
Vol Left, %	41%	5%	15%	25%
Vol Thru, %	39%	66%	61%	56%
Vol Right, %	20%	29%	23%	19%
Sign Control	Stop	Stop	Stop	Stop
Traffic Vol by Lane	161	86	486	118
LT Vol	66	4	74	29
Through Vol	63	57	298	66
RT Vol	32	25	114	23
Lane Flow Rate	194	106	517	131
Geometry Grp	1	1	1	1
Degree of Util (X)	0.31	0.162	0.711	0.213
Departure Headway (Hd)	5.762	5.496	4.952	5.856
Convergence, Y/N	Yes	Yes	Yes	Yes
Cap	623	651	729	611
Service Time	3.81	3.545	2.984	3.908
HCM Lane V/C Ratio	0.311	0.163	0.709	0.214
HCM Control Delay	11.4	9.6	19.3	10.5
HCM Lane LOS	B	A	C	B
HCM 95th-tile Q	1.3	0.6	6	0.8

HCM 6th Roundabout  
1: Vollmer Rd & Burgess Rd

Short-Term Total Traffic  
AM Peak Hour

Intersection				
Intersection Delay, s/veh	6.5			
Intersection LOS	A			
Approach	EB	WB	NB	SB
Entry Lanes	1	1	1	1
Conflicting Circle Lanes	1	1	1	1
Adj Approach Flow, veh/h	106	517	195	131
Demand Flow Rate, veh/h	108	527	200	134
Vehicles Circulating, veh/h	188	165	109	486
Vehicles Exiting, veh/h	432	144	187	206
Ped Vol Crossing Leg, #/h	0	0	0	0
Ped Cap Adj	1.000	1.000	1.000	1.000
Approach Delay, s/veh	4.0	8.0	4.4	6.0
Approach LOS	A	A	A	A
Lane	Left	Left	Left	Left
Designated Moves	LTR	LTR	LTR	LTR
Assumed Moves	LTR	LTR	LTR	LTR
RT Channelized				
Lane Util	1.000	1.000	1.000	1.000
Follow-Up Headway, s	2.609	2.609	2.609	2.609
Critical Headway, s	4.976	4.976	4.976	4.976
Entry Flow, veh/h	108	527	200	134
Cap Entry Lane, veh/h	1139	1166	1235	841
Entry HV Adj Factor	0.978	0.980	0.977	0.974
Flow Entry, veh/h	106	517	195	131
Cap Entry, veh/h	1114	1143	1207	819
V/C Ratio	0.095	0.452	0.162	0.159
Control Delay, s/veh	4.0	8.0	4.4	6.0
LOS	A	A	A	A
95th %tile Queue, veh	0	2	1	1



Intersection						
Int Delay, s/veh	2.9					
Movement	WBL	WBR	NBT	NBR	SBL	SBT
Lane Configurations	↘	↗	↕↕	↗	↘	↕↕
Traffic Vol, veh/h	129	37	196	25	12	341
Future Vol, veh/h	129	37	196	25	12	341
Conflicting Peds, #/hr	0	0	0	0	0	0
Sign Control	Stop	Stop	Free	Free	Free	Free
RT Channelized	-	None	-	None	-	None
Storage Length	485	-	-	235	385	-
Veh in Median Storage, #	0	-	0	-	-	0
Grade, %	0	-	0	-	-	0
Peak Hour Factor	85	85	85	85	85	85
Heavy Vehicles, %	2	2	2	2	2	2
Mvmt Flow	152	44	231	29	14	401

Major/Minor	Minor1	Major1	Major2		
Conflicting Flow All	460	116	0	0	260
Stage 1	231	-	-	-	-
Stage 2	229	-	-	-	-
Critical Hdwy	6.84	6.94	-	-	4.14
Critical Hdwy Stg 1	5.84	-	-	-	-
Critical Hdwy Stg 2	5.84	-	-	-	-
Follow-up Hdwy	3.52	3.32	-	-	2.22
Pot Cap-1 Maneuver	530	914	-	-	1302
Stage 1	785	-	-	-	-
Stage 2	787	-	-	-	-
Platoon blocked, %			-	-	-
Mov Cap-1 Maneuver	524	914	-	-	1302
Mov Cap-2 Maneuver	596	-	-	-	-
Stage 1	785	-	-	-	-
Stage 2	778	-	-	-	-

Approach	WB	NB	SB
HCM Control Delay, s	12.2	0	0.3
HCM LOS	B		

Minor Lane/Major Mvmt	NBT	NBRWBLn1	WBLn2	SBL	SBT
Capacity (veh/h)	-	-	596	914	1302
HCM Lane V/C Ratio	-	-	0.255	0.048	0.011
HCM Control Delay (s)	-	-	13.1	9.1	7.8
HCM Lane LOS	-	-	B	A	A
HCM 95th %tile Q(veh)	-	-	1	0.1	0

HCM 6th TWSC  
5: Sterling Ranch Rd & Briargate Pkwy

Short-Term Total Traffic  
AM Peak Hour

Intersection												
Int Delay, s/veh	8											
Movement	EBL	EBT	EBR	WBL	WBT	WBR	NBL	NBT	NBR	SBL	SBT	SBR
Lane Configurations	↘	↗	↗	↘	↗	↗	↘	↗	↗	↘	↗	↗
Traffic Vol, veh/h	2	0	15	0	0	0	50	10	0	0	42	6
Future Vol, veh/h	2	0	15	0	0	0	50	10	0	0	42	6
Conflicting Peds, #/hr	0	0	0	0	0	0	0	0	0	0	0	0
Sign Control	Free	Free	Free	Free	Free	Free	Stop	Stop	Stop	Stop	Stop	Stop
RT Channelized	-	-	None	-	-	None	-	-	None	-	-	None
Storage Length	535	-	0	310	-	0	410	-	155	235	-	155
Veh in Median Storage, #	-	0	-	-	0	-	-	0	-	-	0	-
Grade, %	-	0	-	-	0	-	-	0	-	-	0	-
Peak Hour Factor	85	85	85	85	85	85	85	85	85	85	85	85
Heavy Vehicles, %	2	2	2	2	2	2	2	2	2	2	2	2
Mvmt Flow	2	0	18	0	0	0	59	12	0	0	49	7

Major/Minor	Major1			Major2			Minor1			Minor2		
Conflicting Flow All	1	0	0	18	0	0	29	5	0	11	23	1
Stage 1	-	-	-	-	-	-	4	4	-	1	1	-
Stage 2	-	-	-	-	-	-	25	1	-	10	22	-
Critical Hdwy	4.14	-	-	4.14	-	-	7.54	6.54	6.94	7.54	6.54	6.94
Critical Hdwy Stg 1	-	-	-	-	-	-	6.54	5.54	-	6.54	5.54	-
Critical Hdwy Stg 2	-	-	-	-	-	-	6.54	5.54	-	6.54	5.54	-
Follow-up Hdwy	2.22	-	-	2.22	-	-	3.52	4.02	3.32	3.52	4.02	3.32
Pot Cap-1 Maneuver	1620	-	-	1597	-	-	976	890	-	1005	870	1083
Stage 1	-	-	-	-	-	-	1017	892	-	1021	895	-
Stage 2	-	-	-	-	-	-	989	895	-	1009	876	-
Platoon blocked, %	-	-	-	-	-	-	-	-	-	-	-	-
Mov Cap-1 Maneuver	1620	-	-	1597	-	-	926	889	-	-	869	1083
Mov Cap-2 Maneuver	-	-	-	-	-	-	926	889	-	-	869	-
Stage 1	-	-	-	-	-	-	1016	891	-	1020	895	-
Stage 2	-	-	-	-	-	-	928	895	-	994	875	-

Approach	EB	WB	NB	SB
HCM Control Delay, s	0.9	0	9.2	9.3
HCM LOS			A	A

Minor Lane/Major Mvmt	NBLn1	NBLn2	NBLn3	EBL	EBT	EBR	WBL	WBT	WBR	SBLn1	SBLn2	SBLn3
Capacity (veh/h)	926	889	-	1620	-	-	1597	-	-	-	-	869 1083
HCM Lane V/C Ratio	0.064	0.013	-	0.001	-	-	-	-	-	-	-	0.057 0.007
HCM Control Delay (s)	9.2	9.1	0	7.2	-	-	0	-	-	0	9.4	8.3
HCM Lane LOS	A	A	A	A	-	-	A	-	-	A	A	A
HCM 95th %tile Q(veh)	0.2	0	-	0	-	-	0	-	-	-	0.2	0

Intersection						
Int Delay, s/veh	5.2					
Movement	WBL	WBR	NBT	NBR	SBL	SBT
Lane Configurations	↘	↗	↑	↗	↘	↑
Traffic Vol, veh/h	96	29	31	32	9	47
Future Vol, veh/h	96	29	31	32	9	47
Conflicting Peds, #/hr	0	0	0	0	0	0
Sign Control	Stop	Stop	Free	Free	Free	Free
RT Channelized	-	None	-	None	-	None
Storage Length	205	0	-	205	205	-
Veh in Median Storage, #	0	-	0	-	-	0
Grade, %	0	-	0	-	-	0
Peak Hour Factor	85	85	85	85	85	85
Heavy Vehicles, %	2	2	2	2	2	2
Mvmt Flow	113	34	36	38	11	55

Major/Minor	Minor1	Major1	Major2			
Conflicting Flow All	113	36	0	0	74	0
Stage 1	36	-	-	-	-	-
Stage 2	77	-	-	-	-	-
Critical Hdwy	6.42	6.22	-	-	4.12	-
Critical Hdwy Stg 1	5.42	-	-	-	-	-
Critical Hdwy Stg 2	5.42	-	-	-	-	-
Follow-up Hdwy	3.518	3.318	-	-	2.218	-
Pot Cap-1 Maneuver	884	1037	-	-	1526	-
Stage 1	986	-	-	-	-	-
Stage 2	946	-	-	-	-	-
Platoon blocked, %			-	-		-
Mov Cap-1 Maneuver	878	1037	-	-	1526	-
Mov Cap-2 Maneuver	837	-	-	-	-	-
Stage 1	986	-	-	-	-	-
Stage 2	939	-	-	-	-	-

Approach	WB	NB	SB
HCM Control Delay, s	9.7	0	1.2
HCM LOS	A		

Minor Lane/Major Mvmt	NBT	NBR	WBLn1	WBLn2	SBL	SBT
Capacity (veh/h)	-	-	837	1037	1526	-
HCM Lane V/C Ratio	-	-	0.135	0.033	0.007	-
HCM Control Delay (s)	-	-	10	8.6	7.4	-
HCM Lane LOS	-	-	B	A	A	-
HCM 95th %tile Q(veh)	-	-	0.5	0.1	0	-

Intersection						
Int Delay, s/veh	7.1					
Movement	WBL	WBR	NBT	NBR	SBL	SBT
Lane Configurations	↘	↗	↕↕	↗	↘	↕↕
Traffic Vol, veh/h	162	80	196	50	119	425
Future Vol, veh/h	162	80	196	50	119	425
Conflicting Peds, #/hr	0	0	0	0	0	0
Sign Control	Stop	Stop	Free	Free	Free	Free
RT Channelized	-	None	-	None	-	None
Storage Length	300	-	-	155	300	-
Veh in Median Storage, #	0	-	0	-	-	0
Grade, %	0	-	0	-	-	0
Peak Hour Factor	85	85	85	85	85	85
Heavy Vehicles, %	2	2	2	2	2	2
Mvmt Flow	191	94	231	59	140	500

Major/Minor	Minor1	Major1	Major2		
Conflicting Flow All	761	116	0	0	290
Stage 1	231	-	-	-	-
Stage 2	530	-	-	-	-
Critical Hdwy	6.84	6.94	-	-	4.14
Critical Hdwy Stg 1	5.84	-	-	-	-
Critical Hdwy Stg 2	5.84	-	-	-	-
Follow-up Hdwy	3.52	3.32	-	-	2.22
Pot Cap-1 Maneuver	342	914	-	-	1269
Stage 1	785	-	-	-	-
Stage 2	555	-	-	-	-
Platoon blocked, %			-	-	-
Mov Cap-1 Maneuver	304	914	-	-	1269
Mov Cap-2 Maneuver	304	-	-	-	-
Stage 1	785	-	-	-	-
Stage 2	494	-	-	-	-

Approach	WB	NB	SB
HCM Control Delay, s	26.4	0	1.8
HCM LOS	D		

Minor Lane/Major Mvmt	NBT	NBR	WBLn1	WBLn2	SBL	SBT
Capacity (veh/h)	-	-	304	914	1269	-
HCM Lane V/C Ratio	-	-	0.627	0.103	0.11	-
HCM Control Delay (s)	-	-	34.8	9.4	8.2	-
HCM Lane LOS	-	-	D	A	A	-
HCM 95th %tile Q(veh)	-	-	3.9	0.3	0.4	-

Intersection												
Int Delay, s/veh	16.6											
Movement	EBL	EBT	EBR	WBL	WBT	WBR	NBL	NBT	NBR	SBL	SBT	SBR
Lane Configurations	↘	↑↑	↗	↘	↑↑	↗	↘	↗	↘	↘	↑	↗
Traffic Vol, veh/h	49	117	2	8	75	142	2	0	6	430	1	166
Future Vol, veh/h	49	117	2	8	75	142	2	0	6	430	1	166
Conflicting Peds, #/hr	0	0	0	0	0	0	0	0	0	0	0	0
Sign Control	Free	Free	Free	Free	Free	Free	Stop	Stop	Stop	Stop	Stop	Stop
RT Channelized	-	-	None	-	-	None	-	-	None	-	-	None
Storage Length	300	-	200	250	-	205	0	-	-	155	-	0
Veh in Median Storage, #	-	0	-	-	0	-	-	0	-	-	0	-
Grade, %	-	0	-	-	0	-	-	0	-	-	0	-
Peak Hour Factor	85	85	85	85	85	85	85	85	85	85	85	85
Heavy Vehicles, %	2	2	70	70	2	2	88	2	88	2	2	2
Mvmt Flow	58	138	2	9	88	167	2	0	7	506	1	195

Major/Minor	Major1			Major2			Minor1			Minor2		
Conflicting Flow All	255	0	0	140	0	0	317	527	69	291	362	44
Stage 1	-	-	-	-	-	-	254	254	-	106	106	-
Stage 2	-	-	-	-	-	-	63	273	-	185	256	-
Critical Hdwy	4.14	-	-	5.5	-	-	9.26	6.54	8.66	7.54	6.54	6.94
Critical Hdwy Stg 1	-	-	-	-	-	-	8.26	5.54	-	6.54	5.54	-
Critical Hdwy Stg 2	-	-	-	-	-	-	8.26	5.54	-	6.54	5.54	-
Follow-up Hdwy	2.22	-	-	2.9	-	-	4.38	4.02	4.18	3.52	4.02	3.32
Pot Cap-1 Maneuver	1307	-	-	1060	-	-	438	455	759	639	564	1017
Stage 1	-	-	-	-	-	-	533	696	-	888	807	-
Stage 2	-	-	-	-	-	-	739	683	-	799	694	-
Platoon blocked, %	-	-	-	-	-	-	-	-	-	-	-	-
Mov Cap-1 Maneuver	1307	-	-	1060	-	-	339	431	759	608	535	1017
Mov Cap-2 Maneuver	-	-	-	-	-	-	339	431	-	608	535	-
Stage 1	-	-	-	-	-	-	510	665	-	849	801	-
Stage 2	-	-	-	-	-	-	591	678	-	756	663	-

Approach	EB			WB			NB			SB		
HCM Control Delay, s	2.3			0.3			11.3			26.8		
HCM LOS							B			D		

Minor Lane/Major Mvmt	NBLn1	NBLn2	EBL	EBT	EBR	WBL	WBT	WBR	SBLn1	SBLn2	SBLn3
Capacity (veh/h)	339	759	1307	-	-	1060	-	-	608	535	1017
HCM Lane V/C Ratio	0.007	0.009	0.044	-	-	0.009	-	-	0.832	0.002	0.192
HCM Control Delay (s)	15.7	9.8	7.9	-	-	8.4	-	-	33.5	11.7	9.4
HCM Lane LOS	C	A	A	-	-	A	-	-	D	B	A
HCM 95th %tile Q(veh)	0	0	0.1	-	-	0	-	-	8.8	0	0.7

Timings  
13: Sterling Ranch Rd & Marksheffel Rd

Short-Term Total Traffic  
AM Peak Hour

Lane Group	EBL	EBT	EBR	WBL	WBT	WBR	NBL	NBT	SBL	SBT	SBR	
Lane Configurations												
Traffic Volume (vph)	49	117	2	8	75	142	2	0	430	1	166	
Future Volume (vph)	49	117	2	8	75	142	2	0	430	1	166	
Turn Type	pm+pt	NA	Perm	pm+pt	NA	Perm	pm+pt	NA	Prot	NA	Perm	
Protected Phases	5	2		1	6		3	8	7	4		
Permitted Phases	2		2	6		6	8				4	
Detector Phase	5	2	2	1	6	6	3	8	7	4	4	
Switch Phase												
Minimum Initial (s)	5.0	15.0	15.0	5.0	15.0	15.0	5.0	10.0	5.0	10.0	10.0	
Minimum Split (s)	10.0	23.0	23.0	10.0	23.0	23.0	10.0	23.0	10.0	23.0	23.0	
Total Split (s)	10.0	40.0	40.0	10.0	40.0	40.0	10.0	25.0	15.0	30.0	30.0	
Total Split (%)	11.1%	44.4%	44.4%	11.1%	44.4%	44.4%	11.1%	27.8%	16.7%	33.3%	33.3%	
Yellow Time (s)	3.0	3.0	3.0	3.0	3.0	3.0	3.0	3.0	3.0	3.0	3.0	
All-Red Time (s)	2.0	2.0	2.0	2.0	2.0	2.0	2.0	2.0	2.0	2.0	2.0	
Lost Time Adjust (s)	0.0	0.0	0.0	0.0	0.0	0.0	0.0	0.0	0.0	0.0	0.0	
Total Lost Time (s)	5.0	5.0	5.0	5.0	5.0	5.0	5.0	5.0	5.0	5.0	5.0	
Lead/Lag	Lead	Lag	Lag	Lead	Lag	Lag	Lead	Lag	Lead	Lag	Lag	
Lead-Lag Optimize?	Yes	Yes	Yes	Yes	Yes	Yes	Yes	Yes	Yes	Yes	Yes	
Recall Mode	None	Min	Min	None	Min	Min	None	None	None	None	None	
Act Effct Green (s)	18.3	17.6	17.6	17.3	15.7	15.7	6.6	10.5	10.5	11.2	11.2	
Actuated g/C Ratio	0.44	0.42	0.42	0.41	0.37	0.37	0.16	0.25	0.25	0.27	0.27	
v/c Ratio	0.10	0.09	0.00	0.03	0.07	0.24	0.01	0.01	0.59	0.00	0.35	
Control Delay	8.2	10.4	0.0	8.4	12.2	4.6	13.5	0.0	21.3	15.0	5.5	
Queue Delay	0.0	0.0	0.0	0.0	0.0	0.0	0.0	0.0	0.0	0.0	0.0	
Total Delay	8.2	10.4	0.0	8.4	12.2	4.6	13.5	0.0	21.3	15.0	5.5	
LOS	A	B	A	A	B	A	B	A	C	B	A	
Approach Delay		9.6			7.2			3.0		16.9		
Approach LOS		A			A			A		B		

Intersection Summary

Cycle Length: 90  
 Actuated Cycle Length: 42  
 Natural Cycle: 70  
 Control Type: Actuated-Uncoordinated  
 Maximum v/c Ratio: 0.59  
 Intersection Signal Delay: 13.4  
 Intersection LOS: B  
 Intersection Capacity Utilization 39.8%  
 ICU Level of Service A  
 Analysis Period (min) 15

Splits and Phases: 13: Sterling Ranch Rd & Marksheffel Rd

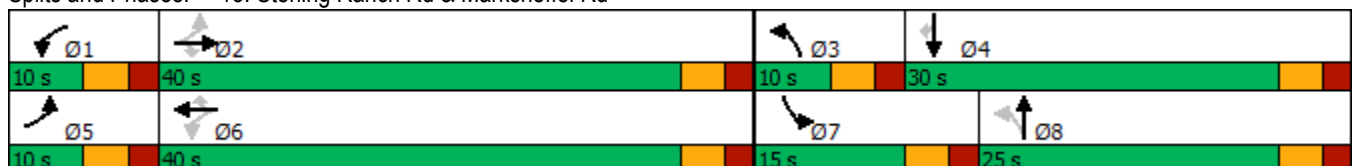

Intersection												
Int Delay, s/veh	6.5											
Movement	EBL	EBT	EBR	WBL	WBT	WBR	NBL	NBT	NBR	SBL	SBT	SBR
Lane Configurations	↖	↗		↖	↗			↕			↕	
Traffic Vol, veh/h	26	9	7	0	26	0	21	0	0	0	0	78
Future Vol, veh/h	26	9	7	0	26	0	21	0	0	0	0	78
Conflicting Peds, #/hr	0	0	0	0	0	0	0	0	0	0	0	0
Sign Control	Free	Free	Free	Free	Free	Free	Stop	Stop	Stop	Stop	Stop	Stop
RT Channelized	-	-	None	-	-	None	-	-	None	-	-	None
Storage Length	205	-	-	205	-	-	-	-	-	-	-	-
Veh in Median Storage, #	-	0	-	-	0	-	-	0	-	-	0	-
Grade, %	-	0	-	-	0	-	-	0	-	-	0	-
Peak Hour Factor	85	85	85	85	85	85	85	85	85	85	85	85
Heavy Vehicles, %	2	2	2	2	2	2	2	2	2	2	2	2
Mvmt Flow	31	11	8	0	31	0	25	0	0	0	0	92

Major/Minor	Major1		Major2			Minor1			Minor2			
Conflicting Flow All	31	0	0	19	0	0	154	108	15	108	112	31
Stage 1	-	-	-	-	-	-	77	77	-	31	31	-
Stage 2	-	-	-	-	-	-	77	31	-	77	81	-
Critical Hdwy	4.12	-	-	4.12	-	-	7.12	6.52	6.22	7.12	6.52	6.22
Critical Hdwy Stg 1	-	-	-	-	-	-	6.12	5.52	-	6.12	5.52	-
Critical Hdwy Stg 2	-	-	-	-	-	-	6.12	5.52	-	6.12	5.52	-
Follow-up Hdwy	2.218	-	-	2.218	-	-	3.518	4.018	3.318	3.518	4.018	3.318
Pot Cap-1 Maneuver	1582	-	-	1597	-	-	813	782	1065	871	778	1043
Stage 1	-	-	-	-	-	-	932	831	-	986	869	-
Stage 2	-	-	-	-	-	-	932	869	-	932	828	-
Platoon blocked, %	-	-	-	-	-	-	-	-	-	-	-	-
Mov Cap-1 Maneuver	1582	-	-	1597	-	-	730	766	1065	858	762	1043
Mov Cap-2 Maneuver	-	-	-	-	-	-	730	766	-	858	762	-
Stage 1	-	-	-	-	-	-	913	814	-	966	869	-
Stage 2	-	-	-	-	-	-	850	869	-	914	811	-

Approach	EB	WB	NB	SB
HCM Control Delay, s	4.5	0	10.1	8.8
HCM LOS			B	A

Minor Lane/Major Mvmt	NBLn1	EBL	EBT	EBR	WBL	WBT	WBR	SBLn1
Capacity (veh/h)	730	1582	-	-	1597	-	-	1043
HCM Lane V/C Ratio	0.034	0.019	-	-	-	-	-	0.088
HCM Control Delay (s)	10.1	7.3	-	-	0	-	-	8.8
HCM Lane LOS	B	A	-	-	A	-	-	A
HCM 95th %tile Q(veh)	0.1	0.1	-	-	0	-	-	0.3

Intersection						
Int Delay, s/veh	7.9					
Movement	EBL	EBT	WBT	WBR	SBL	SBR
Lane Configurations						
Traffic Vol, veh/h	9	0	0	0	0	26
Future Vol, veh/h	9	0	0	0	0	26
Conflicting Peds, #/hr	0	0	0	0	0	0
Sign Control	Free	Free	Free	Free	Stop	Stop
RT Channelized	-	None	-	None	-	None
Storage Length	205	-	-	-	0	-
Veh in Median Storage, #	-	0	0	-	0	-
Grade, %	-	0	0	-	0	-
Peak Hour Factor	85	85	85	85	85	85
Heavy Vehicles, %	2	2	2	2	2	2
Mvmt Flow	11	0	0	0	0	31

Major/Minor	Major1	Major2	Minor2		
Conflicting Flow All	1	0	-	0	23
Stage 1	-	-	-	-	1
Stage 2	-	-	-	-	22
Critical Hdwy	4.12	-	-	-	6.42
Critical Hdwy Stg 1	-	-	-	-	5.42
Critical Hdwy Stg 2	-	-	-	-	5.42
Follow-up Hdwy	2.218	-	-	-	3.518
Pot Cap-1 Maneuver	1622	-	-	-	993
Stage 1	-	-	-	-	1022
Stage 2	-	-	-	-	1001
Platoon blocked, %		-	-	-	
Mov Cap-1 Maneuver	1622	-	-	-	986
Mov Cap-2 Maneuver	-	-	-	-	986
Stage 1	-	-	-	-	1015
Stage 2	-	-	-	-	1001

Approach	EB	WB	SB
HCM Control Delay, s	7.2	0	8.4
HCM LOS			A

Minor Lane/Major Mvmt	EBL	EBT	WBT	WBR	SBLn1
Capacity (veh/h)	1622	-	-	-	1084
HCM Lane V/C Ratio	0.007	-	-	-	0.028
HCM Control Delay (s)	7.2	-	-	-	8.4
HCM Lane LOS	A	-	-	-	A
HCM 95th %tile Q(veh)	0	-	-	-	0.1



Intersection	
Intersection Delay, s/veh	15.4
Intersection LOS	C

Movement	EBL	EBT	EBR	WBL	WBT	WBR	NBL	NBT	NBR	SBL	SBT	SBR
Lane Configurations		↕			↕			↕			↕	
Traffic Vol, veh/h	12	229	74	29	110	44	47	85	63	123	88	17
Future Vol, veh/h	12	229	74	29	110	44	47	85	63	123	88	17
Peak Hour Factor	0.87	0.87	0.87	0.87	0.87	0.87	0.83	0.83	0.83	0.77	0.77	0.77
Heavy Vehicles, %	2	2	2	2	2	2	2	2	2	2	2	2
Mvmt Flow	14	263	85	33	126	51	57	102	76	160	114	22
Number of Lanes	0	1	0	0	1	0	0	1	0	0	1	0

Approach	EB	WB	NB	SB
Opposing Approach	WB	EB	SB	NB
Opposing Lanes	1	1	1	1
Conflicting Approach Left	SB	NB	EB	WB
Conflicting Lanes Left	1	1	1	1
Conflicting Approach Right	NB	SB	WB	EB
Conflicting Lanes Right	1	1	1	1
HCM Control Delay	17.5	13	13.5	15.9
HCM LOS	C	B	B	C

Lane	NBLn1	EBLn1	WBLn1	SBLn1
Vol Left, %	24%	4%	16%	54%
Vol Thru, %	44%	73%	60%	39%
Vol Right, %	32%	23%	24%	7%
Sign Control	Stop	Stop	Stop	Stop
Traffic Vol by Lane	195	315	183	228
LT Vol	47	12	29	123
Through Vol	85	229	110	88
RT Vol	63	74	44	17
Lane Flow Rate	235	362	210	296
Geometry Grp	1	1	1	1
Degree of Util (X)	0.407	0.598	0.367	0.517
Departure Headway (Hd)	6.23	5.945	6.288	6.286
Convergence, Y/N	Yes	Yes	Yes	Yes
Cap	576	605	570	571
Service Time	4.283	3.992	4.345	4.335
HCM Lane V/C Ratio	0.408	0.598	0.368	0.518
HCM Control Delay	13.5	17.5	13	15.9
HCM Lane LOS	B	C	B	C
HCM 95th-tile Q	2	3.9	1.7	3

HCM 6th Roundabout  
1: Vollmer Rd & Burgess Rd

Short-Term Total Traffic  
AM Peak Hour

Intersection				
Intersection Delay, s/veh	6.5			
Intersection LOS	A			
Approach	EB	WB	NB	SB
Entry Lanes	1	1	1	1
Conflicting Circle Lanes	1	1	1	1
Adj Approach Flow, veh/h	106	517	195	131
Demand Flow Rate, veh/h	108	527	200	134
Vehicles Circulating, veh/h	188	165	109	486
Vehicles Exiting, veh/h	432	144	187	206
Ped Vol Crossing Leg, #/h	0	0	0	0
Ped Cap Adj	1.000	1.000	1.000	1.000
Approach Delay, s/veh	4.0	8.0	4.4	6.0
Approach LOS	A	A	A	A
Lane	Left	Left	Left	Left
Designated Moves	LTR	LTR	LTR	LTR
Assumed Moves	LTR	LTR	LTR	LTR
RT Channelized				
Lane Util	1.000	1.000	1.000	1.000
Follow-Up Headway, s	2.609	2.609	2.609	2.609
Critical Headway, s	4.976	4.976	4.976	4.976
Entry Flow, veh/h	108	527	200	134
Cap Entry Lane, veh/h	1139	1166	1235	841
Entry HV Adj Factor	0.978	0.980	0.977	0.974
Flow Entry, veh/h	106	517	195	131
Cap Entry, veh/h	1114	1143	1207	819
V/C Ratio	0.095	0.452	0.162	0.159
Control Delay, s/veh	4.0	8.0	4.4	6.0
LOS	A	A	A	A
95th %tile Queue, veh	0	2	1	1

Intersection						
Int Delay, s/veh	2.2					
Movement	WBL	WBR	NBT	NBR	SBL	SBT
Lane Configurations	↘	↗	↕↕	↗	↘	↕↕
Traffic Vol, veh/h	86	25	330	84	40	269
Future Vol, veh/h	86	25	330	84	40	269
Conflicting Peds, #/hr	0	0	0	0	0	0
Sign Control	Stop	Stop	Free	Free	Free	Free
RT Channelized	-	None	-	None	-	None
Storage Length	485	-	-	235	385	-
Veh in Median Storage, #	0	-	0	-	-	0
Grade, %	0	-	0	-	-	0
Peak Hour Factor	85	85	85	85	85	85
Heavy Vehicles, %	2	2	2	2	2	2
Mvmt Flow	101	29	388	99	47	316

Major/Minor	Minor1	Major1	Major2		
Conflicting Flow All	640	194	0	0	487
Stage 1	388	-	-	-	-
Stage 2	252	-	-	-	-
Critical Hdwy	6.84	6.94	-	-	4.14
Critical Hdwy Stg 1	5.84	-	-	-	-
Critical Hdwy Stg 2	5.84	-	-	-	-
Follow-up Hdwy	3.52	3.32	-	-	2.22
Pot Cap-1 Maneuver	408	815	-	-	1072
Stage 1	655	-	-	-	-
Stage 2	767	-	-	-	-
Platoon blocked, %			-	-	-
Mov Cap-1 Maneuver	390	815	-	-	1072
Mov Cap-2 Maneuver	492	-	-	-	-
Stage 1	655	-	-	-	-
Stage 2	733	-	-	-	-

Approach	WB	NB	SB
HCM Control Delay, s	13.2	0	1.1
HCM LOS	B		

Minor Lane/Major Mvmt	NBT	NBRWBLn1	WBLn2	SBL	SBT
Capacity (veh/h)	-	-	492	815	1072
HCM Lane V/C Ratio	-	-	0.206	0.036	0.044
HCM Control Delay (s)	-	-	14.2	9.6	8.5
HCM Lane LOS	-	-	B	A	A
HCM 95th %tile Q(veh)	-	-	0.8	0.1	0.1

HCM 6th TWSC  
5: Sterling Ranch Rd & Briargate Pkwy

Short-Term Total Traffic  
PM Peak Hour

Intersection												
Int Delay, s/veh	6.4											
Movement	EBL	EBT	EBR	WBL	WBT	WBR	NBL	NBT	NBR	SBL	SBT	SBR
Lane Configurations	↘	↑↑	↗	↘	↑↑	↗	↘	↑	↗	↘	↑	↗
Traffic Vol, veh/h	6	0	50	0	0	0	43	35	0	0	28	4
Future Vol, veh/h	6	0	50	0	0	0	43	35	0	0	28	4
Conflicting Peds, #/hr	0	0	0	0	0	0	0	0	0	0	0	0
Sign Control	Free	Free	Free	Free	Free	Free	Stop	Stop	Stop	Stop	Stop	Stop
RT Channelized	-	-	None	-	-	None	-	-	None	-	-	None
Storage Length	535	-	0	310	-	0	410	-	155	235	-	155
Veh in Median Storage, #	-	0	-	-	0	-	-	0	-	-	0	-
Grade, %	-	0	-	-	0	-	-	0	-	-	0	-
Peak Hour Factor	85	85	85	85	85	85	85	85	85	85	85	85
Heavy Vehicles, %	2	2	2	2	2	2	2	2	2	2	2	2
Mvmt Flow	7	0	59	0	0	0	51	41	0	0	33	5

Major/Minor	Major1			Major2			Minor1			Minor2		
Conflicting Flow All	1	0	0	59	0	0	31	15	0	36	74	1
Stage 1	-	-	-	-	-	-	14	14	-	1	1	-
Stage 2	-	-	-	-	-	-	17	1	-	35	73	-
Critical Hdwy	4.14	-	-	4.14	-	-	7.54	6.54	6.94	7.54	6.54	6.94
Critical Hdwy Stg 1	-	-	-	-	-	-	6.54	5.54	-	6.54	5.54	-
Critical Hdwy Stg 2	-	-	-	-	-	-	6.54	5.54	-	6.54	5.54	-
Follow-up Hdwy	2.22	-	-	2.22	-	-	3.52	4.02	3.32	3.52	4.02	3.32
Pot Cap-1 Maneuver	1620	-	-	1543	-	-	973	879	-	965	816	1083
Stage 1	-	-	-	-	-	-	1004	883	-	1021	895	-
Stage 2	-	-	-	-	-	-	1000	895	-	976	833	-
Platoon blocked, %	-	-	-	-	-	-	-	-	-	-	-	-
Mov Cap-1 Maneuver	1620	-	-	1543	-	-	936	875	-	-	813	1083
Mov Cap-2 Maneuver	-	-	-	-	-	-	936	875	-	-	813	-
Stage 1	-	-	-	-	-	-	1000	879	-	1017	895	-
Stage 2	-	-	-	-	-	-	959	895	-	926	830	-

Approach	EB	WB	NB	SB
HCM Control Delay, s	0.8	0	9.2	9.4
HCM LOS			A	A

Minor Lane/Major Mvmt	NBLn1	NBLn2	NBLn3	EBL	EBT	EBR	WBL	WBT	WBR	SBLn1	SBLn2	SBLn3
Capacity (veh/h)	936	875	-	1620	-	-	1543	-	-	-	-	813 1083
HCM Lane V/C Ratio	0.054	0.047	-	0.004	-	-	-	-	-	-	-	0.041 0.004
HCM Control Delay (s)	9.1	9.3	0	7.2	-	-	0	-	-	0	9.6	8.3
HCM Lane LOS	A	A	A	A	-	-	A	-	-	A	A	A
HCM 95th %tile Q(veh)	0.2	0.1	-	0	-	-	0	-	-	-	0.1	0

Intersection						
Int Delay, s/veh	3.3					
Movement	WBL	WBR	NBT	NBR	SBL	SBT
Lane Configurations	↘	↗	↑	↗	↘	↑
Traffic Vol, veh/h	64	19	59	103	30	47
Future Vol, veh/h	64	19	59	103	30	47
Conflicting Peds, #/hr	0	0	0	0	0	0
Sign Control	Stop	Stop	Free	Free	Free	Free
RT Channelized	-	None	-	None	-	None
Storage Length	205	0	-	205	205	-
Veh in Median Storage, #	0	-	0	-	-	0
Grade, %	0	-	0	-	-	0
Peak Hour Factor	85	85	85	85	85	85
Heavy Vehicles, %	2	2	2	2	2	2
Mvmt Flow	75	22	69	121	35	55

Major/Minor	Minor1	Major1	Major2		
Conflicting Flow All	194	69	0	0	190
Stage 1	69	-	-	-	-
Stage 2	125	-	-	-	-
Critical Hdwy	6.42	6.22	-	-	4.12
Critical Hdwy Stg 1	5.42	-	-	-	-
Critical Hdwy Stg 2	5.42	-	-	-	-
Follow-up Hdwy	3.518	3.318	-	-	2.218
Pot Cap-1 Maneuver	795	994	-	-	1384
Stage 1	954	-	-	-	-
Stage 2	901	-	-	-	-
Platoon blocked, %			-	-	-
Mov Cap-1 Maneuver	775	994	-	-	1384
Mov Cap-2 Maneuver	767	-	-	-	-
Stage 1	954	-	-	-	-
Stage 2	878	-	-	-	-

Approach	WB	NB	SB
HCM Control Delay, s	9.9	0	3
HCM LOS	A		

Minor Lane/Major Mvmt	NBT	NBRWBLn1	WBLn2	SBL	SBT
Capacity (veh/h)	-	-	767	994	1384
HCM Lane V/C Ratio	-	-	0.098	0.022	0.026
HCM Control Delay (s)	-	-	10.2	8.7	7.7
HCM Lane LOS	-	-	B	A	A
HCM 95th %tile Q(veh)	-	-	0.3	0.1	0.1

Intersection						
Int Delay, s/veh	5.7					
Movement	WBL	WBR	NBT	NBR	SBL	SBT
Lane Configurations	↘	↗	↑↑	↗	↘	↑↑
Traffic Vol, veh/h	117	162	355	137	113	313
Future Vol, veh/h	117	162	355	137	113	313
Conflicting Peds, #/hr	0	0	0	0	0	0
Sign Control	Stop	Stop	Free	Free	Free	Free
RT Channelized	-	None	-	None	-	None
Storage Length	300	-	-	155	300	-
Veh in Median Storage, #	0	-	0	-	-	0
Grade, %	0	-	0	-	-	0
Peak Hour Factor	85	85	85	85	85	85
Heavy Vehicles, %	2	2	2	2	2	2
Mvmt Flow	138	191	418	161	133	368

Major/Minor	Minor1	Major1	Major2			
Conflicting Flow All	868	209	0	0	579	0
Stage 1	418	-	-	-	-	-
Stage 2	450	-	-	-	-	-
Critical Hdwy	6.84	6.94	-	-	4.14	-
Critical Hdwy Stg 1	5.84	-	-	-	-	-
Critical Hdwy Stg 2	5.84	-	-	-	-	-
Follow-up Hdwy	3.52	3.32	-	-	2.22	-
Pot Cap-1 Maneuver	292	797	-	-	991	-
Stage 1	632	-	-	-	-	-
Stage 2	609	-	-	-	-	-
Platoon blocked, %			-	-	-	-
Mov Cap-1 Maneuver	253	797	-	-	991	-
Mov Cap-2 Maneuver	253	-	-	-	-	-
Stage 1	632	-	-	-	-	-
Stage 2	527	-	-	-	-	-

Approach	WB	NB	SB
HCM Control Delay, s	21	0	2.4
HCM LOS	C		

Minor Lane/Major Mvmt	NBT	NBR	WBLn1	WBLn2	SBL	SBT
Capacity (veh/h)	-	-	253	797	991	-
HCM Lane V/C Ratio	-	-	0.544	0.239	0.134	-
HCM Control Delay (s)	-	-	35	10.9	9.2	-
HCM Lane LOS	-	-	E	B	A	-
HCM 95th %tile Q(veh)	-	-	3	0.9	0.5	-

Intersection												
Int Delay, s/veh	24.1											
Movement	EBL	EBT	EBR	WBL	WBT	WBR	NBL	NBT	NBR	SBL	SBT	SBR
Lane Configurations	↘	↑↑	↗	↘	↑↑	↗	↘	↗	↘	↘	↑	↗
Traffic Vol, veh/h	143	105	2	6	160	479	2	0	7	286	1	117
Future Vol, veh/h	143	105	2	6	160	479	2	0	7	286	1	117
Conflicting Peds, #/hr	0	0	0	0	0	0	0	0	0	0	0	0
Sign Control	Free	Free	Free	Free	Free	Free	Stop	Stop	Stop	Stop	Stop	Stop
RT Channelized	-	-	None	-	-	None	-	-	None	-	-	None
Storage Length	300	-	200	250	-	205	0	-	-	155	-	0
Veh in Median Storage, #	-	0	-	-	0	-	-	0	-	-	0	-
Grade, %	-	0	-	-	0	-	-	0	-	-	0	-
Peak Hour Factor	85	85	85	85	85	85	85	85	85	85	85	85
Heavy Vehicles, %	2	2	88	88	2	2	78	2	78	2	2	2
Mvmt Flow	168	124	2	7	188	564	2	0	8	336	1	138

Major/Minor	Major1			Major2			Minor1			Minor2		
Conflicting Flow All	752	0	0	126	0	0	569	1226	62	600	664	94
Stage 1	-	-	-	-	-	-	460	460	-	202	202	-
Stage 2	-	-	-	-	-	-	109	766	-	398	462	-
Critical Hdwy	4.14	-	-	5.86	-	-	9.06	6.54	8.46	7.54	6.54	6.94
Critical Hdwy Stg 1	-	-	-	-	-	-	8.06	5.54	-	6.54	5.54	-
Critical Hdwy Stg 2	-	-	-	-	-	-	8.06	5.54	-	6.54	5.54	-
Follow-up Hdwy	2.22	-	-	3.08	-	-	4.28	4.02	4.08	3.52	4.02	3.32
Pot Cap-1 Maneuver	853	-	-	1004	-	-	276	177	790	385	380	944
Stage 1	-	-	-	-	-	-	390	564	-	781	733	-
Stage 2	-	-	-	-	-	-	703	410	-	599	563	-
Platoon blocked, %	-	-	-	-	-	-	-	-	-	-	-	-
Mov Cap-1 Maneuver	853	-	-	1004	-	-	198	141	790	~ 321	303	944
Mov Cap-2 Maneuver	-	-	-	-	-	-	198	141	-	~ 321	303	-
Stage 1	-	-	-	-	-	-	313	453	-	627	728	-
Stage 2	-	-	-	-	-	-	595	407	-	476	452	-

Approach	EB			WB			NB			SB		
HCM Control Delay, s	5.9			0.1			12.7			74		
HCM LOS							B			F		

Minor Lane/Major Mvmt	NBLn1	NBLn2	EBL	EBT	EBR	WBL	WBT	WBR	SBLn1	SBLn2	SBLn3
Capacity (veh/h)	198	790	853	-	-	1004	-	-	321	303	944
HCM Lane V/C Ratio	0.012	0.01	0.197	-	-	0.007	-	-	1.048	0.004	0.146
HCM Control Delay (s)	23.4	9.6	10.3	-	-	8.6	-	-	100.6	16.9	9.5
HCM Lane LOS	C	A	B	-	-	A	-	-	F	C	A
HCM 95th %tile Q(veh)	0	0	0.7	-	-	0	-	-	12.2	0	0.5

Notes  
 ~: Volume exceeds capacity    \$: Delay exceeds 300s    +: Computation Not Defined    \*: All major volume in platoon

Timings  
13: Sterling Ranch Rd & Marksheffel Rd

Short-Term Total Traffic  
AM Peak Hour

Lane Group	EBL	EBT	EBR	WBL	WBT	WBR	NBL	NBT	SBL	SBT	SBR	
Lane Configurations												
Traffic Volume (vph)	49	117	2	8	75	142	2	0	430	1	166	
Future Volume (vph)	49	117	2	8	75	142	2	0	430	1	166	
Turn Type	pm+pt	NA	Perm	pm+pt	NA	Perm	pm+pt	NA	Prot	NA	Perm	
Protected Phases	5	2		1	6		3	8	7	4		
Permitted Phases	2		2	6		6	8				4	
Detector Phase	5	2	2	1	6	6	3	8	7	4	4	
Switch Phase												
Minimum Initial (s)	5.0	15.0	15.0	5.0	15.0	15.0	5.0	10.0	5.0	10.0	10.0	
Minimum Split (s)	10.0	23.0	23.0	10.0	23.0	23.0	10.0	23.0	10.0	23.0	23.0	
Total Split (s)	10.0	40.0	40.0	10.0	40.0	40.0	10.0	25.0	15.0	30.0	30.0	
Total Split (%)	11.1%	44.4%	44.4%	11.1%	44.4%	44.4%	11.1%	27.8%	16.7%	33.3%	33.3%	
Yellow Time (s)	3.0	3.0	3.0	3.0	3.0	3.0	3.0	3.0	3.0	3.0	3.0	
All-Red Time (s)	2.0	2.0	2.0	2.0	2.0	2.0	2.0	2.0	2.0	2.0	2.0	
Lost Time Adjust (s)	0.0	0.0	0.0	0.0	0.0	0.0	0.0	0.0	0.0	0.0	0.0	
Total Lost Time (s)	5.0	5.0	5.0	5.0	5.0	5.0	5.0	5.0	5.0	5.0	5.0	
Lead/Lag	Lead	Lag	Lag	Lead	Lag	Lag	Lead	Lag	Lead	Lag	Lag	
Lead-Lag Optimize?	Yes	Yes	Yes	Yes	Yes	Yes	Yes	Yes	Yes	Yes	Yes	
Recall Mode	None	Min	Min	None	Min	Min	None	None	None	None	None	
Act Effct Green (s)	18.3	17.6	17.6	17.3	15.7	15.7	6.6	10.5	10.5	11.2	11.2	
Actuated g/C Ratio	0.44	0.42	0.42	0.41	0.37	0.37	0.16	0.25	0.25	0.27	0.27	
v/c Ratio	0.10	0.09	0.00	0.03	0.07	0.24	0.01	0.01	0.59	0.00	0.35	
Control Delay	8.2	10.4	0.0	8.4	12.2	4.6	13.5	0.0	21.3	15.0	5.5	
Queue Delay	0.0	0.0	0.0	0.0	0.0	0.0	0.0	0.0	0.0	0.0	0.0	
Total Delay	8.2	10.4	0.0	8.4	12.2	4.6	13.5	0.0	21.3	15.0	5.5	
LOS	A	B	A	A	B	A	B	A	C	B	A	
Approach Delay		9.6			7.2			3.0		16.9		
Approach LOS		A			A			A		B		

Intersection Summary

Cycle Length: 90  
 Actuated Cycle Length: 42  
 Natural Cycle: 70  
 Control Type: Actuated-Uncoordinated  
 Maximum v/c Ratio: 0.59  
 Intersection Signal Delay: 13.4  
 Intersection LOS: B  
 Intersection Capacity Utilization 39.8%  
 ICU Level of Service A  
 Analysis Period (min) 15

Splits and Phases: 13: Sterling Ranch Rd & Marksheffel Rd

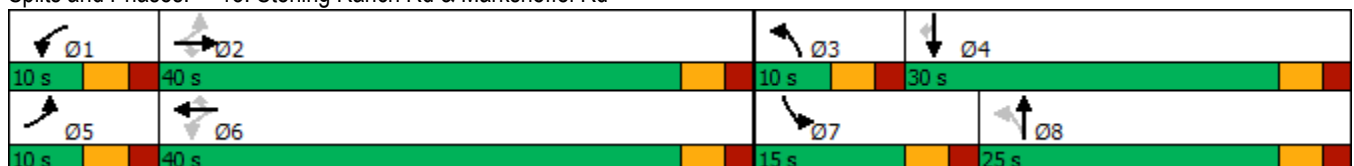



Intersection												
Int Delay, s/veh	5.6											
Movement	EBL	EBT	EBR	WBL	WBT	WBR	NBL	NBT	NBR	SBL	SBT	SBR
Lane Configurations	↖	↗		↖	↗			↕			↕	
Traffic Vol, veh/h	82	27	24	0	17	0	14	0	0	0	0	52
Future Vol, veh/h	82	27	24	0	17	0	14	0	0	0	0	52
Conflicting Peds, #/hr	0	0	0	0	0	0	0	0	0	0	0	0
Sign Control	Free	Free	Free	Free	Free	Free	Stop	Stop	Stop	Stop	Stop	Stop
RT Channelized	-	-	None	-	-	None	-	-	None	-	-	None
Storage Length	205	-	-	205	-	-	-	-	-	-	-	-
Veh in Median Storage, #	-	0	-	-	0	-	-	0	-	-	0	-
Grade, %	-	0	-	-	0	-	-	0	-	-	0	-
Peak Hour Factor	85	85	85	85	85	85	85	85	85	85	85	85
Heavy Vehicles, %	2	2	2	2	2	2	2	2	2	2	2	2
Mvmt Flow	96	32	28	0	20	0	16	0	0	0	0	61

Major/Minor	Major1			Major2			Minor1			Minor2		
Conflicting Flow All	20	0	0	60	0	0	289	258	46	258	272	20
Stage 1	-	-	-	-	-	-	238	238	-	20	20	-
Stage 2	-	-	-	-	-	-	51	20	-	238	252	-
Critical Hdwy	4.12	-	-	4.12	-	-	7.12	6.52	6.22	7.12	6.52	6.22
Critical Hdwy Stg 1	-	-	-	-	-	-	6.12	5.52	-	6.12	5.52	-
Critical Hdwy Stg 2	-	-	-	-	-	-	6.12	5.52	-	6.12	5.52	-
Follow-up Hdwy	2.218	-	-	2.218	-	-	3.518	4.018	3.318	3.518	4.018	3.318
Pot Cap-1 Maneuver	1596	-	-	1544	-	-	663	646	1023	695	635	1058
Stage 1	-	-	-	-	-	-	765	708	-	999	879	-
Stage 2	-	-	-	-	-	-	962	879	-	765	698	-
Platoon blocked, %	-	-	-	-	-	-	-	-	-	-	-	-
Mov Cap-1 Maneuver	1596	-	-	1544	-	-	596	607	1023	663	597	1058
Mov Cap-2 Maneuver	-	-	-	-	-	-	596	607	-	663	597	-
Stage 1	-	-	-	-	-	-	719	666	-	939	879	-
Stage 2	-	-	-	-	-	-	906	879	-	719	656	-

Approach	EB			WB			NB			SB		
HCM Control Delay, s	4.6			0			11.2			8.6		
HCM LOS							B			A		

Minor Lane/Major Mvmt	NBLn1	EBL	EBT	EBR	WBL	WBT	WBR	SBLn1
Capacity (veh/h)	596	1596	-	-	1544	-	-	1058
HCM Lane V/C Ratio	0.028	0.06	-	-	-	-	-	0.058
HCM Control Delay (s)	11.2	7.4	-	-	0	-	-	8.6
HCM Lane LOS	B	A	-	-	A	-	-	A
HCM 95th %tile Q(veh)	0.1	0.2	-	-	0	-	-	0.2

Intersection						
Int Delay, s/veh	7.6					
Movement	EBL	EBT	WBT	WBR	SBL	SBR
Lane Configurations						
Traffic Vol, veh/h	27	0	0	0	0	17
Future Vol, veh/h	27	0	0	0	0	17
Conflicting Peds, #/hr	0	0	0	0	0	0
Sign Control	Free	Free	Free	Free	Stop	Stop
RT Channelized	-	None	-	None	-	None
Storage Length	205	-	-	-	0	-
Veh in Median Storage, #	-	0	0	-	0	-
Grade, %	-	0	0	-	0	-
Peak Hour Factor	85	85	85	85	85	85
Heavy Vehicles, %	2	2	2	2	2	2
Mvmt Flow	32	0	0	0	0	20

Major/Minor	Major1	Major2	Minor2		
Conflicting Flow All	1	0	-	0	65
Stage 1	-	-	-	-	1
Stage 2	-	-	-	-	64
Critical Hdwy	4.12	-	-	-	6.42
Critical Hdwy Stg 1	-	-	-	-	5.42
Critical Hdwy Stg 2	-	-	-	-	5.42
Follow-up Hdwy	2.218	-	-	-	3.518
Pot Cap-1 Maneuver	1622	-	-	-	941
Stage 1	-	-	-	-	1022
Stage 2	-	-	-	-	959
Platoon blocked, %		-	-	-	
Mov Cap-1 Maneuver	1622	-	-	-	922
Mov Cap-2 Maneuver	-	-	-	-	922
Stage 1	-	-	-	-	1002
Stage 2	-	-	-	-	959

Approach	EB	WB	SB
HCM Control Delay, s	7.3	0	8.4
HCM LOS			A

Minor Lane/Major Mvmt	EBL	EBT	WBT	WBR	SBLn1
Capacity (veh/h)	1622	-	-	-	1084
HCM Lane V/C Ratio	0.02	-	-	-	0.018
HCM Control Delay (s)	7.3	-	-	-	8.4
HCM Lane LOS	A	-	-	-	A
HCM 95th %tile Q(veh)	0.1	-	-	-	0.1

Intersection					
Intersection Delay, s/veh	9.0				
Intersection LOS	A				
Approach	EB	WB	NB	SB	
Entry Lanes	1	1	1	1	
Conflicting Circle Lanes	1	1	1	1	
Adj Approach Flow, veh/h	136	604	377	309	
Demand Flow Rate, veh/h	138	616	385	315	
Vehicles Circulating, veh/h	435	309	120	551	
Vehicles Exiting, veh/h	431	116	453	374	
Ped Vol Crossing Leg, #/h	0	0	0	0	
Ped Cap Adj	1.000	1.000	1.000	1.000	
Approach Delay, s/veh	5.7	12.3	4.2	9.7	
Approach LOS	A	B	A	A	
Lane	Left	Left	Left	Bypass	Left
Designated Moves	LTR	LTR	LT	R	LTR
Assumed Moves	LTR	LTR	LT	R	LTR
RT Channelized				Free	
Lane Util	1.000	1.000	1.000		1.000
Follow-Up Headway, s	2.609	2.609	2.609		2.609
Critical Headway, s	4.976	4.976	4.976	80	4.976
Entry Flow, veh/h	138	616	305	1938	315
Cap Entry Lane, veh/h	885	1007	1221	0.980	787
Entry HV Adj Factor	0.983	0.980	0.981	78	0.981
Flow Entry, veh/h	136	604	299	1900	309
Cap Entry, veh/h	870	987	1197	0.041	772
V/C Ratio	0.156	0.612	0.250	0.0	0.400
Control Delay, s/veh	5.7	12.3	5.3	A	9.7
LOS	A	B	A	0	A
95th %tile Queue, veh	1	4	1		2

Timings  
4: Vollmer Rd & Briargate Pkwy

2044 Background Traffic  
AM Peak Hour

Lane Group	EBL	EBT	EBR	WBL	WBT	WBR	NBL	NBT	NBR	SBL	SBT	SBR
Lane Configurations												
Traffic Volume (vph)	68	550	152	236	1031	95	160	131	107	121	306	138
Future Volume (vph)	68	550	152	236	1031	95	160	131	107	121	306	138
Turn Type	pm+pt	NA	Perm	Prot	NA	Perm	pm+pt	NA	Perm	pm+pt	NA	Perm
Protected Phases	5	2		1	6		3	8		7	4	
Permitted Phases	2		2			6	8		8	4		4
Detector Phase	5	2	2	1	6	6	3	8	8	7	4	4
Switch Phase												
Minimum Initial (s)	5.0	15.0	15.0	15.0	15.0	15.0	5.0	5.0	5.0	5.0	5.0	5.0
Minimum Split (s)	10.0	20.0	20.0	20.0	20.0	20.0	10.0	10.0	10.0	10.0	10.0	10.0
Total Split (s)	12.0	57.0	57.0	20.0	65.0	65.0	17.0	28.0	28.0	15.0	26.0	26.0
Total Split (%)	10.0%	47.5%	47.5%	16.7%	54.2%	54.2%	14.2%	23.3%	23.3%	12.5%	21.7%	21.7%
Yellow Time (s)	3.0	3.0	3.0	3.0	3.0	3.0	3.0	3.0	3.0	3.0	3.0	3.0
All-Red Time (s)	2.0	2.0	2.0	2.0	2.0	2.0	2.0	2.0	2.0	2.0	2.0	2.0
Lost Time Adjust (s)	0.0	0.0	0.0	0.0	0.0	0.0	0.0	0.0	0.0	0.0	0.0	0.0
Total Lost Time (s)	5.0	5.0	5.0	5.0	5.0	5.0	5.0	5.0	5.0	5.0	5.0	5.0
Lead/Lag	Lead	Lag	Lag	Lead	Lag	Lag	Lead	Lag	Lag	Lead	Lag	Lag
Lead-Lag Optimize?	Yes	Yes	Yes	Yes	Yes	Yes	Yes	Yes	Yes	Yes	Yes	Yes
Recall Mode	None	Max	Max	None	Max	Max	None	None	None	None	None	None
Act Effct Green (s)	58.7	52.1	52.1	15.0	62.7	62.7	29.2	17.8	17.8	25.4	15.9	15.9
Actuated g/C Ratio	0.51	0.46	0.46	0.13	0.55	0.55	0.26	0.16	0.16	0.22	0.14	0.14
v/c Ratio	0.25	0.35	0.20	0.55	0.56	0.11	0.62	0.24	0.30	0.40	0.66	0.41
Control Delay	12.3	21.5	3.7	52.5	19.6	2.7	43.0	43.3	4.4	35.7	53.4	9.5
Queue Delay	0.0	0.0	0.0	0.0	0.0	0.0	0.0	0.0	0.0	0.0	0.0	0.0
Total Delay	12.3	21.5	3.7	52.5	19.6	2.7	43.0	43.3	4.4	35.7	53.4	9.5
LOS	B	C	A	D	B	A	D	D	A	D	D	A
Approach Delay		17.1			24.1			32.6			38.9	
Approach LOS		B			C			C			D	

Intersection Summary

Cycle Length: 120  
 Actuated Cycle Length: 114.4  
 Natural Cycle: 60  
 Control Type: Actuated-Uncoordinated  
 Maximum v/c Ratio: 0.66  
 Intersection Signal Delay: 26.2  
 Intersection LOS: C  
 Intersection Capacity Utilization 66.7%  
 ICU Level of Service C  
 Analysis Period (min) 15

Splits and Phases: 4: Vollmer Rd & Briargate Pkwy





Intersection												
Int Delay, s/veh	9.2											
Movement	EBL	EBT	EBR	WBL	WBT	WBR	NBL	NBT	NBR	SBL	SBT	SBR
Lane Configurations	↘	↑	↗	↘		↗		↑	↗	↘	↑	
Traffic Vol, veh/h	133	66	131	147	0	163	0	386	110	54	246	0
Future Vol, veh/h	133	66	131	147	0	163	0	386	110	54	246	0
Conflicting Peds, #/hr	0	0	0	0	0	0	0	0	0	0	0	0
Sign Control	Stop	Stop	Stop	Stop	Stop	Stop	Free	Free	Free	Free	Free	Free
RT Channelized	-	-	None	-	-	None	-	-	None	-	-	None
Storage Length	0	-	0	150	-	0	-	-	205	205	-	-
Veh in Median Storage, #	-	0	-	-	0	-	-	0	-	-	0	-
Grade, %	-	0	-	-	0	-	-	0	-	-	0	-
Peak Hour Factor	95	95	95	95	95	95	95	95	95	95	95	95
Heavy Vehicles, %	2	2	2	2	2	2	2	2	2	2	2	2
Mvmt Flow	140	69	138	155	0	172	0	406	116	57	259	0

Major/Minor	Minor2		Minor1		Major1			Major2				
Conflicting Flow All	923	895	259	883	-	406	-	0	0	522	0	0
Stage 1	373	373	-	406	-	-	-	-	-	-	-	-
Stage 2	550	522	-	477	-	-	-	-	-	-	-	-
Critical Hdwy	7.12	6.52	6.22	7.12	-	6.22	-	-	-	4.12	-	-
Critical Hdwy Stg 1	6.12	5.52	-	6.12	-	-	-	-	-	-	-	-
Critical Hdwy Stg 2	6.12	5.52	-	6.12	-	-	-	-	-	-	-	-
Follow-up Hdwy	3.518	4.018	3.318	3.518	-	3.318	-	-	-	2.218	-	-
Pot Cap-1 Maneuver	250	274	897	269	0	645	0	-	-	1044	-	0
Stage 1	716	647	-	622	0	-	0	-	-	-	-	0
Stage 2	519	531	-	613	0	-	0	-	-	-	-	0
Platoon blocked, %	1	1	1	1				-	-			
Mov Cap-1 Maneuver	176	259	897	186	-	645	-	-	-	1044	-	-
Mov Cap-2 Maneuver	267	358	-	314	-	-	-	-	-	-	-	-
Stage 1	716	611	-	622	-	-	-	-	-	-	-	-
Stage 2	381	531	-	435	-	-	-	-	-	-	-	-

Approach	EB		WB		NB			SB		
HCM Control Delay, s	20.4		19.5		0			1.6		
HCM LOS	C		C							

Minor Lane/Major Mvmt	NBT	NBR	EBLn1	EBLn2	EBLn3	WBLn1	WBLn2	SBL	SBT
Capacity (veh/h)	-	-	267	358	897	314	645	1044	-
HCM Lane V/C Ratio	-	-	0.524	0.194	0.154	0.493	0.266	0.054	-
HCM Control Delay (s)	-	-	32.4	17.5	9.7	27.1	12.6	8.6	-
HCM Lane LOS	-	-	D	C	A	D	B	A	-
HCM 95th %tile Q(veh)	-	-	2.8	0.7	0.5	2.6	1.1	0.2	-

Timings  
12: Vollmer Rd & Marksheffel Rd

2044 Background Traffic  
AM Peak Hour

Lane Group	EBL	EBT	EBR	WBL	WBT	WBR	NBL	NBT	NBR	SBL	SBT	SBR
Lane Configurations												
Traffic Volume (vph)	71	837	42	173	922	69	115	234	110	121	512	131
Future Volume (vph)	71	837	42	173	922	69	115	234	110	121	512	131
Turn Type	pm+pt	NA	Perm	pm+pt	NA	Perm	pm+pt	NA	Perm	pm+pt	NA	Perm
Protected Phases	5	2		1	6		3	8		7	4	
Permitted Phases	2		2	6		6	8		8	4		4
Detector Phase	5	2	2	1	6	6	3	8	8	7	4	4
Switch Phase												
Minimum Initial (s)	5.0	5.0	5.0	5.0	5.0	5.0	5.0	10.0	10.0	5.0	10.0	10.0
Minimum Split (s)	10.0	23.0	23.0	10.0	23.0	23.0	10.0	23.0	23.0	10.0	23.0	23.0
Total Split (s)	12.0	66.0	66.0	12.0	66.0	66.0	12.0	30.0	30.0	12.0	30.0	30.0
Total Split (%)	10.0%	55.0%	55.0%	10.0%	55.0%	55.0%	10.0%	25.0%	25.0%	10.0%	25.0%	25.0%
Yellow Time (s)	3.0	3.0	3.0	3.0	3.0	3.0	3.0	3.0	3.0	3.0	3.0	3.0
All-Red Time (s)	2.0	2.0	2.0	2.0	2.0	2.0	2.0	2.0	2.0	2.0	2.0	2.0
Lost Time Adjust (s)	0.0	0.0	0.0	0.0	0.0	0.0	0.0	0.0	0.0	0.0	0.0	0.0
Total Lost Time (s)	5.0	5.0	5.0	5.0	5.0	5.0	5.0	5.0	5.0	5.0	5.0	5.0
Lead/Lag	Lead	Lag	Lag	Lead	Lag	Lag	Lead	Lag	Lag	Lead	Lag	Lag
Lead-Lag Optimize?	Yes	Yes	Yes	Yes	Yes	Yes	Yes	Yes	Yes	Yes	Yes	Yes
Recall Mode	None	C-Max	C-Max	None	C-Max	C-Max	None	Max	Max	None	Max	Max
Act Effct Green (s)	67.7	61.0	61.0	69.0	63.4	63.4	32.0	25.0	25.0	32.0	25.0	25.0
Actuated g/C Ratio	0.56	0.51	0.51	0.58	0.53	0.53	0.27	0.21	0.21	0.27	0.21	0.21
v/c Ratio	0.25	0.49	0.05	0.55	0.52	0.08	0.64	0.33	0.28	0.41	0.73	0.32
Control Delay	11.8	20.5	0.1	17.3	9.7	0.2	48.6	41.9	8.9	36.2	51.1	9.4
Queue Delay	0.0	0.0	0.0	0.0	0.0	0.0	0.0	0.0	0.0	0.0	0.0	0.0
Total Delay	11.8	20.5	0.1	17.3	9.7	0.2	48.6	41.9	8.9	36.2	51.1	9.4
LOS	B	C	A	B	A	A	D	D	A	D	D	A
Approach Delay		18.9			10.3			35.7			41.6	
Approach LOS		B			B			D			D	

Intersection Summary

Cycle Length: 120  
 Actuated Cycle Length: 120  
 Offset: 0 (0%), Referenced to phase 2:EBTL and 6:WBTL, Start of Green  
 Natural Cycle: 70  
 Control Type: Actuated-Coordinated  
 Maximum v/c Ratio: 0.73  
 Intersection Signal Delay: 23.4  
 Intersection LOS: C  
 Intersection Capacity Utilization 69.9%  
 ICU Level of Service C  
 Analysis Period (min) 15

Splits and Phases: 12: Vollmer Rd & Marksheffel Rd

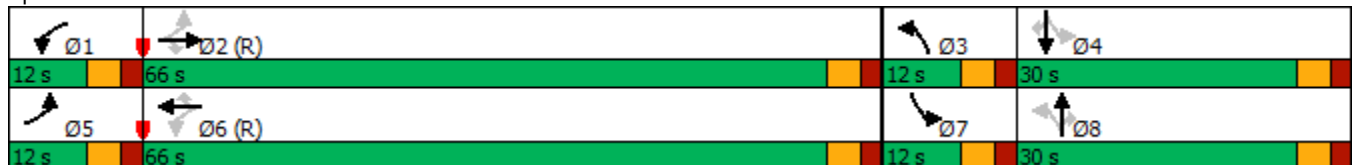

Timings  
13: Sterling Ranch Rd & Marksheffel Rd

2044 Background Traffic  
AM Peak Hour

Lane Group	EBL	EBT	EBR	WBL	WBT	WBR	NBL	NBT	NBR	SBL	SBT	SBR
Lane Configurations												
Traffic Volume (vph)	156	900	10	47	809	167	39	8	55	455	10	317
Future Volume (vph)	156	900	10	47	809	167	39	8	55	455	10	317
Turn Type	pm+pt	NA	Perm	pm+pt	NA	Perm	pm+pt	NA	Perm	Prot	NA	Perm
Protected Phases	5	2		1	6		3	8		7	4	
Permitted Phases	2		2	6		6	8		8			4
Detector Phase	5	2	2	1	6	6	3	8	8	7	4	4
Switch Phase												
Minimum Initial (s)	5.0	15.0	15.0	5.0	15.0	15.0	5.0	10.0	10.0	20.0	10.0	10.0
Minimum Split (s)	10.0	20.0	20.0	10.0	20.0	20.0	10.0	15.0	15.0	25.0	20.0	20.0
Total Split (s)	12.0	51.0	51.0	12.0	51.0	51.0	12.0	25.0	25.0	32.0	45.0	45.0
Total Split (%)	10.0%	42.5%	42.5%	10.0%	42.5%	42.5%	10.0%	20.8%	20.8%	26.7%	37.5%	37.5%
Yellow Time (s)	3.0	3.0	3.0	3.0	3.0	3.0	3.0	3.0	3.0	3.0	3.0	3.0
All-Red Time (s)	2.0	2.0	2.0	2.0	2.0	2.0	2.0	2.0	2.0	2.0	2.0	2.0
Lost Time Adjust (s)	0.0	0.0	0.0	0.0	0.0	0.0	0.0	0.0	0.0	0.0	0.0	0.0
Total Lost Time (s)	5.0	5.0	5.0	5.0	5.0	5.0	5.0	5.0	5.0	5.0	5.0	5.0
Lead/Lag	Lead	Lag	Lag	Lead	Lag	Lag	Lead	Lag	Lag	Lead	Lag	Lag
Lead-Lag Optimize?	Yes	Yes	Yes	Yes	Yes	Yes	Yes	Yes	Yes	Yes	Yes	Yes
Recall Mode	None	C-Max	C-Max	None	C-Max	C-Max	None	None	None	None	None	None
Act Effct Green (s)	74.1	64.8	64.8	67.3	59.6	59.6	14.7	10.0	10.0	22.7	25.1	25.1
Actuated g/C Ratio	0.62	0.54	0.54	0.56	0.50	0.50	0.12	0.08	0.08	0.19	0.21	0.21
v/c Ratio	0.44	0.50	0.02	0.23	0.49	0.20	0.32	0.09	0.26	0.75	0.04	0.62
Control Delay	20.2	15.8	0.0	13.6	23.1	3.9	37.0	52.9	2.7	53.5	36.1	15.2
Queue Delay	0.0	0.0	0.0	0.0	0.0	0.0	0.0	0.0	0.0	0.0	0.0	0.0
Total Delay	20.2	15.8	0.0	13.6	23.1	3.9	37.0	52.9	2.7	53.5	36.1	15.2
LOS	C	B	A	B	C	A	D	D	A	D	D	B
Approach Delay		16.3			19.5			19.7			37.7	
Approach LOS		B			B			B			D	

Intersection Summary

Cycle Length: 120  
 Actuated Cycle Length: 120  
 Offset: 0 (0%), Referenced to phase 2:EBTL and 6:WBTL, Start of Green  
 Natural Cycle: 75  
 Control Type: Actuated-Coordinated  
 Maximum v/c Ratio: 0.75  
 Intersection Signal Delay: 23.2  
 Intersection LOS: C  
 Intersection Capacity Utilization 63.2%  
 ICU Level of Service B  
 Analysis Period (min) 15

Splits and Phases: 13: Sterling Ranch Rd & Marksheffel Rd

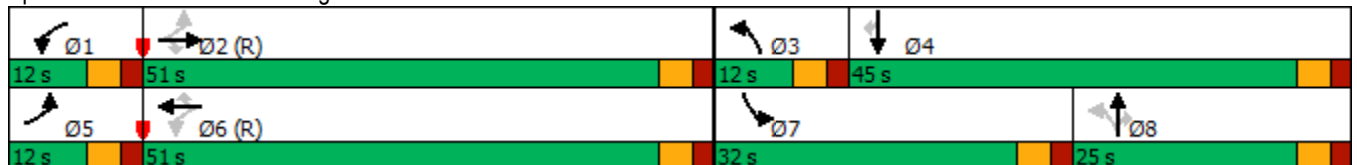



Intersection												
Int Delay, s/veh	0.7											
Movement	EBL	EBT	EBR	WBL	WBT	WBR	NBL	NBT	NBR	SBL	SBT	SBR
Lane Configurations	↵	↵		↵	↵			↕			↕	
Traffic Vol, veh/h	0	227	4	6	289	0	12	0	20	0	0	0
Future Vol, veh/h	0	227	4	6	289	0	12	0	20	0	0	0
Conflicting Peds, #/hr	0	0	0	0	0	0	0	0	0	0	0	0
Sign Control	Free	Free	Free	Free	Free	Free	Stop	Stop	Stop	Stop	Stop	Stop
RT Channelized	-	-	None	-	-	None	-	-	None	-	-	None
Storage Length	205	-	-	205	-	-	-	-	-	-	-	-
Veh in Median Storage, #	-	0	-	-	0	-	-	0	-	-	0	-
Grade, %	-	0	-	-	0	-	-	0	-	-	0	-
Peak Hour Factor	95	95	95	95	95	95	95	95	95	95	95	95
Heavy Vehicles, %	2	2	2	2	2	2	2	2	2	2	2	2
Mvmt Flow	0	239	4	6	304	0	13	0	21	0	0	0

Major/Minor	Major1			Major2			Minor1			Minor2		
Conflicting Flow All	304	0	0	243	0	0	557	557	241	568	559	304
Stage 1	-	-	-	-	-	-	241	241	-	316	316	-
Stage 2	-	-	-	-	-	-	316	316	-	252	243	-
Critical Hdwy	4.12	-	-	4.12	-	-	7.12	6.52	6.22	7.12	6.52	6.22
Critical Hdwy Stg 1	-	-	-	-	-	-	6.12	5.52	-	6.12	5.52	-
Critical Hdwy Stg 2	-	-	-	-	-	-	6.12	5.52	-	6.12	5.52	-
Follow-up Hdwy	2.218	-	-	2.218	-	-	3.518	4.018	3.318	3.518	4.018	3.318
Pot Cap-1 Maneuver	1257	-	-	1323	-	-	441	439	798	434	438	736
Stage 1	-	-	-	-	-	-	762	706	-	695	655	-
Stage 2	-	-	-	-	-	-	695	655	-	752	705	-
Platoon blocked, %		-	-		-	-						
Mov Cap-1 Maneuver	1257	-	-	1323	-	-	440	437	798	421	436	736
Mov Cap-2 Maneuver	-	-	-	-	-	-	440	437	-	421	436	-
Stage 1	-	-	-	-	-	-	762	706	-	695	652	-
Stage 2	-	-	-	-	-	-	692	652	-	732	705	-

Approach	EB			WB			NB			SB		
HCM Control Delay, s	0			0.2			11.2			0		
HCM LOS							B			A		

Minor Lane/Major Mvmt	NBLn1	EBL	EBT	EBR	WBL	WBT	WBR	SBLn1
Capacity (veh/h)	611	1257	-	-	1323	-	-	-
HCM Lane V/C Ratio	0.055	-	-	-	0.005	-	-	-
HCM Control Delay (s)	11.2	0	-	-	7.7	-	-	0
HCM Lane LOS	B	A	-	-	A	-	-	A
HCM 95th %tile Q(veh)	0.2	0	-	-	0	-	-	-

Intersection												
Int Delay, s/veh	2.6											
Movement	EBL	EBT	EBR	WBL	WBT	WBR	NBL	NBT	NBR	SBL	SBT	SBR
Lane Configurations	↖	↗		↖	↗			↕			↕	
Traffic Vol, veh/h	2	169	76	11	212	1	72	0	21	3	0	12
Future Vol, veh/h	2	169	76	11	212	1	72	0	21	3	0	12
Conflicting Peds, #/hr	0	0	0	0	0	0	0	0	0	0	0	0
Sign Control	Free	Free	Free	Free	Free	Free	Stop	Stop	Stop	Stop	Stop	Stop
RT Channelized	-	-	None	-	-	None	-	-	None	-	-	None
Storage Length	205	-	-	205	-	-	-	-	-	-	-	-
Veh in Median Storage, #	-	0	-	-	0	-	-	0	-	-	0	-
Grade, %	-	0	-	-	0	-	-	0	-	-	0	-
Peak Hour Factor	95	95	95	95	95	95	95	95	95	95	95	95
Heavy Vehicles, %	2	2	2	2	2	2	2	2	2	2	2	2
Mvmt Flow	2	178	80	12	223	1	76	0	22	3	0	13

Major/Minor	Major1			Major2			Minor1			Minor2		
Conflicting Flow All	224	0	0	258	0	0	476	470	218	481	510	224
Stage 1	-	-	-	-	-	-	222	222	-	248	248	-
Stage 2	-	-	-	-	-	-	254	248	-	233	262	-
Critical Hdwy	4.12	-	-	4.12	-	-	7.12	6.52	6.22	7.12	6.52	6.22
Critical Hdwy Stg 1	-	-	-	-	-	-	6.12	5.52	-	6.12	5.52	-
Critical Hdwy Stg 2	-	-	-	-	-	-	6.12	5.52	-	6.12	5.52	-
Follow-up Hdwy	2.218	-	-	2.218	-	-	3.518	4.018	3.318	3.518	4.018	3.318
Pot Cap-1 Maneuver	1345	-	-	1307	-	-	499	492	822	495	467	815
Stage 1	-	-	-	-	-	-	780	720	-	756	701	-
Stage 2	-	-	-	-	-	-	750	701	-	770	691	-
Platoon blocked, %	-	-	-	-	-	-	-	-	-	-	-	-
Mov Cap-1 Maneuver	1345	-	-	1307	-	-	487	487	822	478	462	815
Mov Cap-2 Maneuver	-	-	-	-	-	-	487	487	-	478	462	-
Stage 1	-	-	-	-	-	-	779	719	-	755	695	-
Stage 2	-	-	-	-	-	-	732	695	-	748	690	-

Approach	EB			WB			NB			SB		
HCM Control Delay, s	0.1			0.4			13.2			10.2		
HCM LOS							B			B		

Minor Lane/Major Mvmt	NBLn1	EBL	EBT	EBR	WBL	WBT	WBR	SBLn1
Capacity (veh/h)	536	1345	-	-	1307	-	-	714
HCM Lane V/C Ratio	0.183	0.002	-	-	0.009	-	-	0.022
HCM Control Delay (s)	13.2	7.7	-	-	7.8	-	-	10.2
HCM Lane LOS	B	A	-	-	A	-	-	B
HCM 95th %tile Q(veh)	0.7	0	-	-	0	-	-	0.1

Intersection					
Intersection Delay, s/veh	15.0				
Intersection LOS	C				
Approach	EB	WB	NB	SB	
Entry Lanes	1	1	1	1	
Conflicting Circle Lanes	1	1	1	1	
Adj Approach Flow, veh/h	453	393	815	417	
Demand Flow Rate, veh/h	462	401	830	425	
Vehicles Circulating, veh/h	547	623	591	408	
Vehicles Exiting, veh/h	286	577	418	616	
Ped Vol Crossing Leg, #/h	0	0	0	0	
Ped Cap Adj	1.000	1.000	1.000	1.000	
Approach Delay, s/veh	13.9	13.7	19.0	9.9	
Approach LOS	B	B	C	A	
Lane	Left	Left	Left	Bypass	Left
Designated Moves	LTR	LTR	LT	R	LTR
Assumed Moves	LTR	LTR	LT	R	LTR
RT Channelized				Free	
Lane Util	1.000	1.000	1.000		1.000
Follow-Up Headway, s	2.609	2.609	2.609		2.609
Critical Headway, s	4.976	4.976	4.976	221	4.976
Entry Flow, veh/h	462	401	609	1938	425
Cap Entry Lane, veh/h	790	731	755	0.980	910
Entry HV Adj Factor	0.981	0.980	0.981	217	0.980
Flow Entry, veh/h	453	393	598	1900	417
Cap Entry, veh/h	775	717	741	0.114	892
V/C Ratio	0.585	0.549	0.806	0.0	0.467
Control Delay, s/veh	13.9	13.7	25.8	A	9.9
LOS	B	B	D	0	A
95th %tile Queue, veh	4	3	8		3

Timings  
4: Vollmer Rd & Briargate Pkwy

2044 Background Traffic  
PM Peak Hour

Lane Group	EBL	EBT	EBR	WBL	WBT	WBR	NBL	NBT	NBR	SBL	SBT	SBR
Lane Configurations												
Traffic Volume (vph)	227	998	185	205	734	74	301	414	275	109	211	118
Future Volume (vph)	227	998	185	205	734	74	301	414	275	109	211	118
Turn Type	pm+pt	NA	Perm	Prot	NA	Perm	pm+pt	NA	Perm	pm+pt	NA	Perm
Protected Phases	5	2		1	6		3	8		7	4	
Permitted Phases	2		2			6	8		8	4		4
Detector Phase	5	2	2	1	6	6	3	8	8	7	4	4
Switch Phase												
Minimum Initial (s)	5.0	15.0	15.0	15.0	15.0	15.0	8.0	5.0	5.0	5.0	5.0	5.0
Minimum Split (s)	10.0	20.0	20.0	20.0	20.0	20.0	13.0	10.0	10.0	10.0	10.0	10.0
Total Split (s)	12.0	53.0	53.0	20.0	61.0	61.0	22.0	28.0	28.0	19.0	25.0	25.0
Total Split (%)	10.0%	44.2%	44.2%	16.7%	50.8%	50.8%	18.3%	23.3%	23.3%	15.8%	20.8%	20.8%
Yellow Time (s)	3.0	3.0	3.0	3.0	3.0	3.0	3.0	3.0	3.0	3.0	3.0	3.0
All-Red Time (s)	2.0	2.0	2.0	2.0	2.0	2.0	2.0	2.0	2.0	2.0	2.0	2.0
Lost Time Adjust (s)	0.0	0.0	0.0	0.0	0.0	0.0	0.0	0.0	0.0	0.0	0.0	0.0
Total Lost Time (s)	5.0	5.0	5.0	5.0	5.0	5.0	5.0	5.0	5.0	5.0	5.0	5.0
Lead/Lag	Lead	Lag	Lag	Lead	Lag	Lag	Lead	Lag	Lag	Lead	Lag	Lag
Lead-Lag Optimize?	Yes	Yes	Yes	Yes	Yes	Yes	Yes	Yes	Yes	Yes	Yes	Yes
Recall Mode	None	Max	Max	None	Max	Max	None	None	None	None	None	None
Act Effct Green (s)	55.1	48.1	48.1	15.0	56.1	56.1	35.4	20.1	20.1	25.1	14.3	14.3
Actuated g/C Ratio	0.48	0.42	0.42	0.13	0.49	0.49	0.31	0.18	0.18	0.22	0.13	0.13
v/c Ratio	0.65	0.68	0.25	0.48	0.44	0.09	0.84	0.68	0.57	0.43	0.50	0.37
Control Delay	24.9	30.3	4.4	50.7	20.5	1.6	53.3	50.2	11.1	34.0	50.3	6.5
Queue Delay	0.0	0.0	0.0	0.0	0.0	0.0	0.0	0.0	0.0	0.0	0.0	0.0
Total Delay	24.9	30.3	4.4	50.7	20.5	1.6	53.3	50.2	11.1	34.0	50.3	6.5
LOS	C	C	A	D	C	A	D	D	B	C	D	A
Approach Delay		26.0			25.2			40.1			34.5	
Approach LOS		C			C			D			C	

Intersection Summary

Cycle Length: 120  
 Actuated Cycle Length: 114.1  
 Natural Cycle: 80  
 Control Type: Actuated-Uncoordinated  
 Maximum v/c Ratio: 0.84  
 Intersection Signal Delay: 30.4  
 Intersection LOS: C  
 Intersection Capacity Utilization 79.3%  
 ICU Level of Service D  
 Analysis Period (min) 15

Splits and Phases: 4: Vollmer Rd & Briargate Pkwy



Timings  
5: Sterling Ranch Rd & Briargate Pkwy

2044 Background Traffic  
PM Peak Hour

Lane Group	EBL	EBT	EBR	WBL	WBT	WBR	NBL	NBT	NBR	SBL	SBT	SBR
Lane Configurations												
Traffic Volume (vph)	329	921	111	148	829	105	175	190	81	87	86	133
Future Volume (vph)	329	921	111	148	829	105	175	190	81	87	86	133
Turn Type	pm+pt	NA	Perm	pm+pt	NA	Perm	pm+pt	NA	Free	pm+pt	NA	Free
Protected Phases	5	2		1	6		3	8		7	4	
Permitted Phases	2		2	6		6	8		Free	4		Free
Detector Phase	5	2	2	1	6	6	3	8		7	4	
Switch Phase												
Minimum Initial (s)	5.0	5.0	5.0	5.0	5.0	5.0	5.0	20.0		5.0	20.0	
Minimum Split (s)	10.0	23.0	23.0	10.0	23.0	23.0	10.0	25.0		10.0	25.0	
Total Split (s)	22.0	68.0	68.0	12.0	58.0	58.0	15.0	30.0		10.0	25.0	
Total Split (%)	18.3%	56.7%	56.7%	10.0%	48.3%	48.3%	12.5%	25.0%		8.3%	20.8%	
Yellow Time (s)	3.0	3.0	3.0	3.0	3.0	3.0	3.0	3.0		3.0	3.0	
All-Red Time (s)	2.0	2.0	2.0	2.0	2.0	2.0	2.0	2.0		2.0	2.0	
Lost Time Adjust (s)	0.0	0.0	0.0	0.0	0.0	0.0	0.0	0.0		0.0	0.0	
Total Lost Time (s)	5.0	5.0	5.0	5.0	5.0	5.0	5.0	5.0		5.0	5.0	
Lead/Lag	Lead	Lag	Lag	Lead	Lag	Lag	Lead	Lag		Lead	Lag	
Lead-Lag Optimize?	Yes	Yes	Yes	Yes	Yes	Yes	Yes	Yes		Yes	Yes	
Recall Mode	None	C-Max	C-Max	None	C-Max	C-Max	None	None		None	None	
Act Effct Green (s)	76.0	64.0	64.0	62.3	55.3	55.3	34.0	24.0	120.0	21.0	20.0	120.0
Actuated g/C Ratio	0.63	0.53	0.53	0.52	0.46	0.46	0.28	0.20	1.00	0.18	0.17	1.00
v/c Ratio	0.83	0.51	0.13	0.50	0.53	0.14	0.50	0.54	0.05	0.40	0.29	0.09
Control Delay	30.3	19.4	2.9	17.6	25.1	5.4	39.7	48.7	0.1	40.8	46.8	0.1
Queue Delay	0.0	0.0	0.0	0.0	0.0	0.0	0.0	0.0	0.0	0.0	0.0	0.0
Total Delay	30.3	19.4	2.9	17.6	25.1	5.4	39.7	48.7	0.1	40.8	46.8	0.1
LOS	C	B	A	B	C	A	D	D	A	D	D	A
Approach Delay		20.7			22.2			36.3			24.8	
Approach LOS		C			C			D			C	

Intersection Summary

Cycle Length: 120  
 Actuated Cycle Length: 120  
 Offset: 0 (0%), Referenced to phase 2:EBTL and 6:WBTL, Start of Green  
 Natural Cycle: 80  
 Control Type: Actuated-Coordinated  
 Maximum v/c Ratio: 0.83  
 Intersection Signal Delay: 23.8  
 Intersection LOS: C  
 Intersection Capacity Utilization 84.2%  
 ICU Level of Service E  
 Analysis Period (min) 15

Splits and Phases: 5: Sterling Ranch Rd & Briargate Pkwy



Intersection												
Int Delay, s/veh	3.9											
Movement	EBL	EBT	EBR	WBL	WBT	WBR	NBL	NBT	NBR	SBL	SBT	SBR
Lane Configurations	↘	↑	↗	↘		↗		↑	↗	↘	↑	
Traffic Vol, veh/h	38	16	32	97	0	120	0	321	116	23	283	0
Future Vol, veh/h	38	16	32	97	0	120	0	321	116	23	283	0
Conflicting Peds, #/hr	0	0	0	0	0	0	0	0	0	0	0	0
Sign Control	Stop	Stop	Stop	Stop	Stop	Stop	Free	Free	Free	Free	Free	Free
RT Channelized	-	-	None	-	-	None	-	-	None	-	-	None
Storage Length	0	-	0	150	-	0	-	-	205	205	-	-
Veh in Median Storage, #	-	0	-	-	0	-	-	0	-	-	0	-
Grade, %	-	0	-	-	0	-	-	0	-	-	0	-
Peak Hour Factor	95	95	95	95	95	95	95	95	95	95	95	95
Heavy Vehicles, %	2	2	2	2	2	2	2	2	2	2	2	2
Mvmt Flow	40	17	34	102	0	126	0	338	122	24	298	0

Major/Minor	Minor2		Minor1		Major1			Major2				
Conflicting Flow All	808	806	298	710	-	338	-	0	0	460	0	0
Stage 1	346	346	-	338	-	-	-	-	-	-	-	-
Stage 2	462	460	-	372	-	-	-	-	-	-	-	-
Critical Hdwy	7.12	6.52	6.22	7.12	-	6.22	-	-	-	4.12	-	-
Critical Hdwy Stg 1	6.12	5.52	-	6.12	-	-	-	-	-	-	-	-
Critical Hdwy Stg 2	6.12	5.52	-	6.12	-	-	-	-	-	-	-	-
Follow-up Hdwy	3.518	4.018	3.318	3.518	-	3.318	-	-	-	2.218	-	-
Pot Cap-1 Maneuver	312	318	867	377	0	704	0	-	-	1101	-	0
Stage 1	760	676	-	676	0	-	0	-	-	-	-	0
Stage 2	580	566	-	731	0	-	0	-	-	-	-	0
Platoon blocked, %	1	1	1	1				-	-			
Mov Cap-1 Maneuver	252	311	867	345	-	704	-	-	-	1101	-	-
Mov Cap-2 Maneuver	361	411	-	464	-	-	-	-	-	-	-	-
Stage 1	760	661	-	676	-	-	-	-	-	-	-	-
Stage 2	476	566	-	669	-	-	-	-	-	-	-	-

Approach	EB	WB	NB	SB
HCM Control Delay, s	13.2	12.9	0	0.6
HCM LOS	B	B		

Minor Lane/Major Mvmt	NBT	NBR	EBLn1	EBLn2	EBLn3	WBLn1	WBLn2	SBL	SBT
Capacity (veh/h)	-	-	361	411	867	464	704	1101	-
HCM Lane V/C Ratio	-	-	0.111	0.041	0.039	0.22	0.179	0.022	-
HCM Control Delay (s)	-	-	16.2	14.1	9.3	14.9	11.2	8.3	-
HCM Lane LOS	-	-	C	B	A	B	B	A	-
HCM 95th %tile Q(veh)	-	-	0.4	0.1	0.1	0.8	0.7	0.1	-

Timings  
12: Vollmer Rd & Marksheffel Rd

2044 Background Traffic  
PM Peak Hour

Lane Group	EBL	EBT	EBR	WBL	WBT	WBR	NBL	NBT	NBR	SBL	SBT	SBR
Lane Configurations												
Traffic Volume (vph)	142	933	96	189	708	154	171	721	188	132	338	199
Future Volume (vph)	142	933	96	189	708	154	171	721	188	132	338	199
Turn Type	pm+pt	NA	Perm	pm+pt	NA	Perm	pm+pt	NA	Perm	pm+pt	NA	Perm
Protected Phases	5	2		1	6		3	8		7	4	
Permitted Phases	2		2	6		6	8		8	4		4
Detector Phase	5	2	2	1	6	6	3	8	8	7	4	4
Switch Phase												
Minimum Initial (s)	5.0	5.0	5.0	5.0	5.0	5.0	5.0	10.0	10.0	5.0	10.0	10.0
Minimum Split (s)	10.0	23.0	23.0	10.0	23.0	23.0	10.0	23.0	23.0	10.0	23.0	23.0
Total Split (s)	20.0	50.0	50.0	19.0	49.0	49.0	15.0	36.0	36.0	15.0	36.0	36.0
Total Split (%)	16.7%	41.7%	41.7%	15.8%	40.8%	40.8%	12.5%	30.0%	30.0%	12.5%	30.0%	30.0%
Yellow Time (s)	3.0	3.0	3.0	3.0	3.0	3.0	3.0	3.0	3.0	3.0	3.0	3.0
All-Red Time (s)	2.0	2.0	2.0	2.0	2.0	2.0	2.0	2.0	2.0	2.0	2.0	2.0
Lost Time Adjust (s)	0.0	0.0	0.0	0.0	0.0	0.0	0.0	0.0	0.0	0.0	0.0	0.0
Total Lost Time (s)	5.0	5.0	5.0	5.0	5.0	5.0	5.0	5.0	5.0	5.0	5.0	5.0
Lead/Lag	Lead	Lag	Lag	Lead	Lag	Lag	Lead	Lag	Lag	Lead	Lag	Lag
Lead-Lag Optimize?	Yes	Yes	Yes	Yes	Yes	Yes	Yes	Yes	Yes	Yes	Yes	Yes
Recall Mode	None	C-Max	C-Max	None	C-Max	C-Max	None	Max	Max	None	Max	Max
Act Effct Green (s)	57.6	46.9	46.9	60.4	48.3	48.3	41.2	31.4	31.4	40.8	31.2	31.2
Actuated g/C Ratio	0.48	0.39	0.39	0.50	0.40	0.40	0.34	0.26	0.26	0.34	0.26	0.26
v/c Ratio	0.43	0.71	0.15	0.71	0.52	0.22	0.50	0.82	0.38	0.68	0.39	0.37
Control Delay	18.6	34.6	4.5	50.7	22.6	5.5	31.3	50.3	13.4	42.8	38.1	6.7
Queue Delay	0.0	0.0	0.0	0.0	0.0	0.0	0.0	0.0	0.0	0.0	0.0	0.0
Total Delay	18.6	34.6	4.5	50.7	22.6	5.5	31.3	50.3	13.4	42.8	38.1	6.7
LOS	B	C	A	D	C	A	C	D	B	D	D	A
Approach Delay		30.2			25.2			40.8			29.7	
Approach LOS		C			C			D			C	

Intersection Summary

Cycle Length: 120  
 Actuated Cycle Length: 120  
 Offset: 0 (0%), Referenced to phase 2:EBTL and 6:WBTL, Start of Green  
 Natural Cycle: 70  
 Control Type: Actuated-Coordinated  
 Maximum v/c Ratio: 0.82  
 Intersection Signal Delay: 31.7  
 Intersection LOS: C  
 Intersection Capacity Utilization 80.2%  
 ICU Level of Service D  
 Analysis Period (min) 15

Splits and Phases: 12: Vollmer Rd & Marksheffel Rd

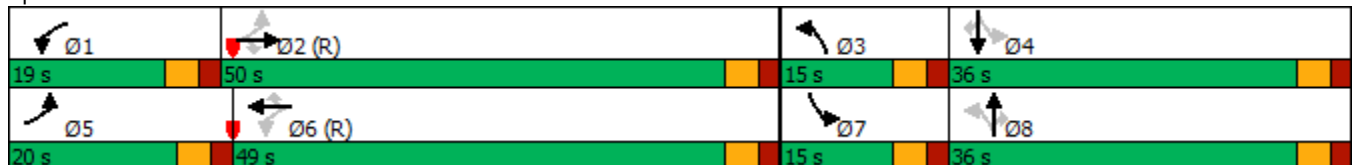





Intersection												
Int Delay, s/veh	1.1											
Movement	EBL	EBT	EBR	WBL	WBT	WBR	NBL	NBT	NBR	SBL	SBT	SBR
Lane Configurations	↶	↷		↶	↷			↕			↕	
Traffic Vol, veh/h	0	138	16	24	179	0	9	0	15	0	0	0
Future Vol, veh/h	0	138	16	24	179	0	9	0	15	0	0	0
Conflicting Peds, #/hr	0	0	0	0	0	0	0	0	0	0	0	0
Sign Control	Free	Free	Free	Free	Free	Free	Stop	Stop	Stop	Stop	Stop	Stop
RT Channelized	-	-	None	-	-	None	-	-	None	-	-	None
Storage Length	205	-	-	205	-	-	-	-	-	-	-	-
Veh in Median Storage, #	-	0	-	-	0	-	-	0	-	-	0	-
Grade, %	-	0	-	-	0	-	-	0	-	-	0	-
Peak Hour Factor	95	95	95	95	95	95	95	95	95	95	95	95
Heavy Vehicles, %	2	2	2	2	2	2	2	2	2	2	2	2
Mvmt Flow	0	145	17	25	188	0	9	0	16	0	0	0

Major/Minor	Major1			Major2			Minor1			Minor2		
Conflicting Flow All	188	0	0	162	0	0	392	392	154	400	400	188
Stage 1	-	-	-	-	-	-	154	154	-	238	238	-
Stage 2	-	-	-	-	-	-	238	238	-	162	162	-
Critical Hdwy	4.12	-	-	4.12	-	-	7.12	6.52	6.22	7.12	6.52	6.22
Critical Hdwy Stg 1	-	-	-	-	-	-	6.12	5.52	-	6.12	5.52	-
Critical Hdwy Stg 2	-	-	-	-	-	-	6.12	5.52	-	6.12	5.52	-
Follow-up Hdwy	2.218	-	-	2.218	-	-	3.518	4.018	3.318	3.518	4.018	3.318
Pot Cap-1 Maneuver	1386	-	-	1417	-	-	567	544	892	560	538	854
Stage 1	-	-	-	-	-	-	848	770	-	765	708	-
Stage 2	-	-	-	-	-	-	765	708	-	840	764	-
Platoon blocked, %	-	-	-	-	-	-	-	-	-	-	-	-
Mov Cap-1 Maneuver	1386	-	-	1417	-	-	560	534	892	543	528	854
Mov Cap-2 Maneuver	-	-	-	-	-	-	560	534	-	543	528	-
Stage 1	-	-	-	-	-	-	848	770	-	765	695	-
Stage 2	-	-	-	-	-	-	752	695	-	825	764	-

Approach	EB	WB	NB	SB
HCM Control Delay, s	0	0.9	10.1	0
HCM LOS			B	A

Minor Lane/Major Mvmt	NBLn1	EBL	EBT	EBR	WBL	WBT	WBR	SBLn1
Capacity (veh/h)	730	1386	-	-	1417	-	-	-
HCM Lane V/C Ratio	0.035	-	-	-	0.018	-	-	-
HCM Control Delay (s)	10.1	0	-	-	7.6	-	-	0
HCM Lane LOS	B	A	-	-	A	-	-	A
HCM 95th %tile Q(veh)	0.1	0	-	-	0.1	-	-	-

Intersection												
Int Delay, s/veh	2.3											
Movement	EBL	EBT	EBR	WBL	WBT	WBR	NBL	NBT	NBR	SBL	SBT	SBR
Lane Configurations	↖	↗		↖	↗			↕			↕	
Traffic Vol, veh/h	10	115	29	28	163	6	30	0	17	3	0	9
Future Vol, veh/h	10	115	29	28	163	6	30	0	17	3	0	9
Conflicting Peds, #/hr	0	0	0	0	0	0	0	0	0	0	0	0
Sign Control	Free	Free	Free	Free	Free	Free	Stop	Stop	Stop	Stop	Stop	Stop
RT Channelized	-	-	None	-	-	None	-	-	None	-	-	None
Storage Length	205	-	-	205	-	-	-	-	-	-	-	-
Veh in Median Storage, #	-	0	-	-	0	-	-	0	-	-	0	-
Grade, %	-	0	-	-	0	-	-	0	-	-	0	-
Peak Hour Factor	95	95	95	95	95	95	95	95	95	95	95	95
Heavy Vehicles, %	2	2	2	2	2	2	2	2	2	2	2	2
Mvmt Flow	11	121	31	29	172	6	32	0	18	3	0	9

Major/Minor	Major1			Major2			Minor1			Minor2		
Conflicting Flow All	178	0	0	152	0	0	397	395	137	401	407	175
Stage 1	-	-	-	-	-	-	159	159	-	233	233	-
Stage 2	-	-	-	-	-	-	238	236	-	168	174	-
Critical Hdwy	4.12	-	-	4.12	-	-	7.12	6.52	6.22	7.12	6.52	6.22
Critical Hdwy Stg 1	-	-	-	-	-	-	6.12	5.52	-	6.12	5.52	-
Critical Hdwy Stg 2	-	-	-	-	-	-	6.12	5.52	-	6.12	5.52	-
Follow-up Hdwy	2.218	-	-	2.218	-	-	3.518	4.018	3.318	3.518	4.018	3.318
Pot Cap-1 Maneuver	1398	-	-	1429	-	-	563	542	911	560	533	868
Stage 1	-	-	-	-	-	-	843	766	-	770	712	-
Stage 2	-	-	-	-	-	-	765	710	-	834	755	-
Platoon blocked, %	-	-	-	-	-	-	-	-	-	-	-	-
Mov Cap-1 Maneuver	1398	-	-	1429	-	-	545	527	911	537	518	868
Mov Cap-2 Maneuver	-	-	-	-	-	-	545	527	-	537	518	-
Stage 1	-	-	-	-	-	-	836	760	-	764	698	-
Stage 2	-	-	-	-	-	-	741	696	-	811	749	-

Approach	EB			WB			NB			SB		
HCM Control Delay, s	0.5			1.1			11.1			9.9		
HCM LOS							B			A		

Minor Lane/Major Mvmt	NBLn1	EBL	EBT	EBR	WBL	WBT	WBR	SBLn1
Capacity (veh/h)	638	1398	-	-	1429	-	-	752
HCM Lane V/C Ratio	0.078	0.008	-	-	0.021	-	-	0.017
HCM Control Delay (s)	11.1	7.6	-	-	7.6	-	-	9.9
HCM Lane LOS	B	A	-	-	A	-	-	A
HCM 95th %tile Q(veh)	0.3	0	-	-	0.1	-	-	0.1

Intersection					
Intersection Delay, s/veh	9.0				
Intersection LOS	A				
Approach	EB	WB	NB	SB	
Entry Lanes	1	1	1	1	
Conflicting Circle Lanes	1	1	1	1	
Adj Approach Flow, veh/h	136	604	377	310	
Demand Flow Rate, veh/h	138	616	385	316	
Vehicles Circulating, veh/h	436	309	120	551	
Vehicles Exiting, veh/h	431	116	454	374	
Ped Vol Crossing Leg, #/h	0	0	0	0	
Ped Cap Adj	1.000	1.000	1.000	1.000	
Approach Delay, s/veh	5.7	12.3	4.2	9.8	
Approach LOS	A	B	A	A	
Lane	Left	Left	Left	Bypass	Left
Designated Moves	LTR	LTR	LT	R	LTR
Assumed Moves	LTR	LTR	LT	R	LTR
RT Channelized				Free	
Lane Util	1.000	1.000	1.000		1.000
Follow-Up Headway, s	2.609	2.609	2.609		2.609
Critical Headway, s	4.976	4.976	4.976	80	4.976
Entry Flow, veh/h	138	616	305	1938	316
Cap Entry Lane, veh/h	885	1007	1221	0.980	787
Entry HV Adj Factor	0.983	0.980	0.981	78	0.981
Flow Entry, veh/h	136	604	299	1900	310
Cap Entry, veh/h	870	987	1197	0.041	772
V/C Ratio	0.156	0.612	0.250	0.0	0.402
Control Delay, s/veh	5.7	12.3	5.3	A	9.8
LOS	A	B	A	0	A
95th %tile Queue, veh	1	4	1		2

Timings  
4: Vollmer Rd & Briargate Pkwy

2044 Total Traffic  
AM Peak Hour

Lane Group	EBL	EBT	EBR	WBL	WBT	WBR	NBL	NBT	NBR	SBL	SBT	SBR
Lane Configurations												
Traffic Volume (vph)	68	554	152	241	1044	96	160	131	108	121	306	138
Future Volume (vph)	68	554	152	241	1044	96	160	131	108	121	306	138
Turn Type	pm+pt	NA	Perm	Prot	NA	Perm	pm+pt	NA	Perm	pm+pt	NA	Perm
Protected Phases	5	2		1	6		3	8		7	4	
Permitted Phases	2		2			6	8		8	4		4
Detector Phase	5	2	2	1	6	6	3	8	8	7	4	4
Switch Phase												
Minimum Initial (s)	5.0	15.0	15.0	15.0	15.0	15.0	5.0	5.0	5.0	5.0	5.0	5.0
Minimum Split (s)	10.0	20.0	20.0	20.0	20.0	20.0	10.0	10.0	10.0	10.0	10.0	10.0
Total Split (s)	12.0	57.0	57.0	20.0	65.0	65.0	17.0	28.0	28.0	15.0	26.0	26.0
Total Split (%)	10.0%	47.5%	47.5%	16.7%	54.2%	54.2%	14.2%	23.3%	23.3%	12.5%	21.7%	21.7%
Yellow Time (s)	3.0	3.0	3.0	3.0	3.0	3.0	3.0	3.0	3.0	3.0	3.0	3.0
All-Red Time (s)	2.0	2.0	2.0	2.0	2.0	2.0	2.0	2.0	2.0	2.0	2.0	2.0
Lost Time Adjust (s)	0.0	0.0	0.0	0.0	0.0	0.0	0.0	0.0	0.0	0.0	0.0	0.0
Total Lost Time (s)	5.0	5.0	5.0	5.0	5.0	5.0	5.0	5.0	5.0	5.0	5.0	5.0
Lead/Lag	Lead	Lag	Lag	Lead	Lag	Lag	Lead	Lag	Lag	Lead	Lag	Lag
Lead-Lag Optimize?	Yes	Yes	Yes	Yes	Yes	Yes	Yes	Yes	Yes	Yes	Yes	Yes
Recall Mode	None	Max	Max	None	Max	Max	None	None	None	None	None	None
Act Effct Green (s)	58.7	52.1	52.1	15.0	62.7	62.7	29.2	17.8	17.8	25.4	15.9	15.9
Actuated g/C Ratio	0.51	0.46	0.46	0.13	0.55	0.55	0.26	0.16	0.16	0.22	0.14	0.14
v/c Ratio	0.26	0.35	0.20	0.56	0.57	0.11	0.62	0.24	0.30	0.40	0.66	0.41
Control Delay	12.4	21.6	3.7	52.8	19.7	2.8	43.0	43.3	4.5	35.7	53.4	9.5
Queue Delay	0.0	0.0	0.0	0.0	0.0	0.0	0.0	0.0	0.0	0.0	0.0	0.0
Total Delay	12.4	21.6	3.7	52.8	19.7	2.8	43.0	43.3	4.5	35.7	53.4	9.5
LOS	B	C	A	D	B	A	D	D	A	D	D	A
Approach Delay		17.1			24.3			32.5			38.9	
Approach LOS		B			C			C			D	

Intersection Summary

Cycle Length: 120  
 Actuated Cycle Length: 114.4  
 Natural Cycle: 60  
 Control Type: Actuated-Uncoordinated  
 Maximum v/c Ratio: 0.66  
 Intersection Signal Delay: 26.3  
 Intersection LOS: C  
 Intersection Capacity Utilization 67.0%  
 ICU Level of Service C  
 Analysis Period (min) 15

Splits and Phases: 4: Vollmer Rd & Briargate Pkwy



Timings  
5: Sterling Ranch Rd & Briargate Pkwy

2044 Total Traffic  
AM Peak Hour

Lane Group	EBL	EBT	EBR	WBL	WBT	WBR	NBL	NBT	NBR	SBL	SBT	SBR
Lane Configurations												
Traffic Volume (vph)	73	627	143	109	945	23	287	115	121	106	263	161
Future Volume (vph)	73	627	143	109	945	23	287	115	121	106	263	161
Turn Type	pm+pt	NA	Perm	pm+pt	NA	Perm	pm+pt	NA	Free	pm+pt	NA	Free
Protected Phases	5	2		1	6		3	8		7	4	
Permitted Phases	2		2	6		6	8		Free	4		Free
Detector Phase	5	2	2	1	6	6	3	8		7	4	
Switch Phase												
Minimum Initial (s)	5.0	5.0	5.0	5.0	5.0	5.0	5.0	20.0		5.0	20.0	
Minimum Split (s)	10.0	10.0	10.0	10.0	10.0	10.0	10.0	25.0		10.0	25.0	
Total Split (s)	12.0	56.0	56.0	12.0	56.0	56.0	20.0	32.0		20.0	32.0	
Total Split (%)	10.0%	46.7%	46.7%	10.0%	46.7%	46.7%	16.7%	26.7%		16.7%	26.7%	
Yellow Time (s)	3.0	3.0	3.0	3.0	3.0	3.0	3.0	3.0		3.0	3.0	
All-Red Time (s)	2.0	2.0	2.0	2.0	2.0	2.0	2.0	2.0		2.0	2.0	
Lost Time Adjust (s)	0.0	0.0	0.0	0.0	0.0	0.0	0.0	0.0		0.0	0.0	
Total Lost Time (s)	5.0	5.0	5.0	5.0	5.0	5.0	5.0	5.0		5.0	5.0	
Lead/Lag	Lead	Lag	Lag	Lead	Lag	Lag	Lead	Lag		Lead	Lag	
Lead-Lag Optimize?	Yes	Yes	Yes	Yes	Yes	Yes	Yes	Yes		Yes	Yes	
Recall Mode	None	C-Max	C-Max	None	C-Max	C-Max	None	Max		None	Max	
Act Effct Green (s)	57.8	51.0	51.0	59.0	53.4	53.4	45.8	31.5	120.0	37.5	27.0	120.0
Actuated g/C Ratio	0.48	0.42	0.42	0.49	0.44	0.44	0.38	0.26	1.00	0.31	0.22	1.00
v/c Ratio	0.33	0.44	0.20	0.33	0.63	0.03	0.85	0.25	0.08	0.26	0.66	0.11
Control Delay	18.3	25.5	3.9	9.5	18.7	0.7	51.1	37.4	0.1	25.8	51.0	0.1
Queue Delay	0.0	0.0	0.0	0.0	0.0	0.0	0.0	0.0	0.0	0.0	0.0	0.0
Total Delay	18.3	25.5	3.9	9.5	18.7	0.7	51.1	37.4	0.1	25.8	51.0	0.1
LOS	B	C	A	A	B	A	D	D	A	C	D	A
Approach Delay		21.2			17.4			36.3			30.5	
Approach LOS		C			B			D			C	

Intersection Summary

Cycle Length: 120  
 Actuated Cycle Length: 120  
 Offset: 63 (53%), Referenced to phase 2:EBTL and 6:WBTL, Start of Green  
 Natural Cycle: 70  
 Control Type: Actuated-Coordinated  
 Maximum v/c Ratio: 0.85  
 Intersection Signal Delay: 24.1  
 Intersection LOS: C  
 Intersection Capacity Utilization 79.5%  
 ICU Level of Service D  
 Analysis Period (min) 15

Splits and Phases: 5: Sterling Ranch Rd & Briargate Pkwy

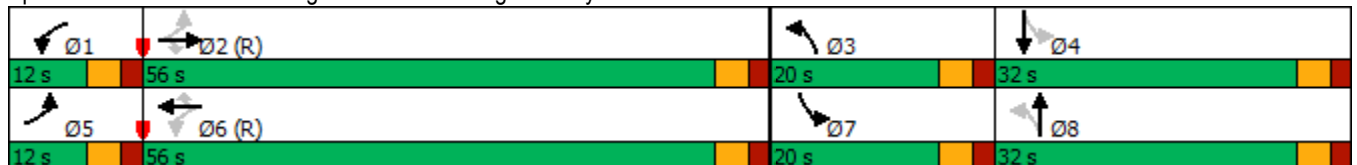

HCM 6th TWSC  
 8: Sterling Ranch Rd & School Access/Oak Park Dr

2044 Total Traffic  
 AM Peak Hour

Intersection												
Int Delay, s/veh	11.7											
Movement	EBL	EBT	EBR	WBL	WBT	WBR	NBL	NBT	NBR	SBL	SBT	SBR
Lane Configurations	↖	↗	↖	↖		↖		↗	↖	↖	↗	
Traffic Vol, veh/h	133	71	131	186	0	196	0	386	123	61	246	0
Future Vol, veh/h	133	71	131	186	0	196	0	386	123	61	246	0
Conflicting Peds, #/hr	0	0	0	0	0	0	0	0	0	0	0	0
Sign Control	Stop	Stop	Stop	Stop	Stop	Stop	Free	Free	Free	Free	Free	Free
RT Channelized	-	-	None	-	-	None	-	-	None	-	-	None
Storage Length	0	-	0	150	-	0	-	-	205	205	-	-
Veh in Median Storage, #	-	0	-	-	0	-	-	0	-	-	0	-
Grade, %	-	0	-	-	0	-	-	0	-	-	0	-
Peak Hour Factor	95	95	95	95	95	95	95	95	95	95	95	95
Heavy Vehicles, %	2	2	2	2	2	2	2	2	2	2	2	2
Mvmt Flow	140	75	138	196	0	206	0	406	129	64	259	0

Major/Minor	Minor2		Minor1		Major1			Major2				
Conflicting Flow All	961	922	259	900	-	406	-	0	0	535	0	0
Stage 1	387	387	-	406	-	-	-	-	-	-	-	-
Stage 2	574	535	-	494	-	-	-	-	-	-	-	-
Critical Hdwy	7.12	6.52	6.22	7.12	-	6.22	-	-	-	4.12	-	-
Critical Hdwy Stg 1	6.12	5.52	-	6.12	-	-	-	-	-	-	-	-
Critical Hdwy Stg 2	6.12	5.52	-	6.12	-	-	-	-	-	-	-	-
Follow-up Hdwy	3.518	4.018	3.318	3.518	-	3.318	-	-	-	2.218	-	-
Pot Cap-1 Maneuver	233	263	897	261	0	645	0	-	-	1033	-	0
Stage 1	701	636	-	622	0	-	0	-	-	-	-	0
Stage 2	504	524	-	598	0	-	0	-	-	-	-	0
Platoon blocked, %	1	1	1	1				-	-	-	-	
Mov Cap-1 Maneuver	151	246	897	~ 176	-	645	-	-	-	1033	-	-
Mov Cap-2 Maneuver	233	346	-	303	-	-	-	-	-	-	-	-
Stage 1	701	597	-	622	-	-	-	-	-	-	-	-
Stage 2	343	524	-	415	-	-	-	-	-	-	-	-

Approach	EB	WB	NB	SB
HCM Control Delay, s	24	24.4	0	1.7
HCM LOS	C	C		

Minor Lane/Major Mvmt	NBT	NBR	EBLn1	EBLn2	EBLn3	WBLn1	WBLn2	SBL	SBT
Capacity (veh/h)	-	-	233	346	897	303	645	1033	-
HCM Lane V/C Ratio	-	-	0.601	0.216	0.154	0.646	0.32	0.062	-
HCM Control Delay (s)	-	-	41.3	18.2	9.7	36.2	13.2	8.7	-
HCM Lane LOS	-	-	E	C	A	E	B	A	-
HCM 95th %tile Q(veh)	-	-	3.5	0.8	0.5	4.2	1.4	0.2	-

Notes  
 ~: Volume exceeds capacity    \$: Delay exceeds 300s    +: Computation Not Defined    \*: All major volume in platoon



Timings  
13: Sterling Ranch Rd & Marksheffel Rd

2044 Total Traffic  
AM Peak Hour

Lane Group	EBL	EBT	EBR	WBL	WBT	WBR	NBL	NBT	NBR	SBL	SBT	SBR
Lane Configurations												
Traffic Volume (vph)	159	900	10	47	809	174	39	8	55	478	10	327
Future Volume (vph)	159	900	10	47	809	174	39	8	55	478	10	327
Turn Type	pm+pt	NA	Perm	pm+pt	NA	Perm	pm+pt	NA	Perm	Prot	NA	Perm
Protected Phases	5	2		1	6		3	8		7	4	
Permitted Phases	2		2	6		6	8		8			4
Detector Phase	5	2	2	1	6	6	3	8	8	7	4	4
Switch Phase												
Minimum Initial (s)	5.0	15.0	15.0	5.0	15.0	15.0	5.0	10.0	10.0	20.0	10.0	10.0
Minimum Split (s)	10.0	20.0	20.0	10.0	20.0	20.0	10.0	15.0	15.0	25.0	20.0	20.0
Total Split (s)	12.0	51.0	51.0	12.0	51.0	51.0	12.0	25.0	25.0	32.0	45.0	45.0
Total Split (%)	10.0%	42.5%	42.5%	10.0%	42.5%	42.5%	10.0%	20.8%	20.8%	26.7%	37.5%	37.5%
Yellow Time (s)	3.0	3.0	3.0	3.0	3.0	3.0	3.0	3.0	3.0	3.0	3.0	3.0
All-Red Time (s)	2.0	2.0	2.0	2.0	2.0	2.0	2.0	2.0	2.0	2.0	2.0	2.0
Lost Time Adjust (s)	0.0	0.0	0.0	0.0	0.0	0.0	0.0	0.0	0.0	0.0	0.0	0.0
Total Lost Time (s)	5.0	5.0	5.0	5.0	5.0	5.0	5.0	5.0	5.0	5.0	5.0	5.0
Lead/Lag	Lead	Lag	Lag	Lead	Lag	Lag	Lead	Lag	Lag	Lead	Lag	Lag
Lead-Lag Optimize?	Yes	Yes	Yes	Yes	Yes	Yes	Yes	Yes	Yes	Yes	Yes	Yes
Recall Mode	None	C-Max	C-Max	None	C-Max	C-Max	None	None	None	None	None	None
Act Effct Green (s)	73.8	64.3	64.3	66.6	58.9	58.9	14.7	10.0	10.0	23.1	25.5	25.5
Actuated g/C Ratio	0.62	0.54	0.54	0.56	0.49	0.49	0.12	0.08	0.08	0.19	0.21	0.21
v/c Ratio	0.45	0.50	0.02	0.23	0.50	0.21	0.32	0.09	0.26	0.77	0.04	0.64
Control Delay	21.2	16.1	0.0	13.9	23.6	3.9	36.7	52.9	2.7	54.1	35.8	16.2
Queue Delay	0.0	0.0	0.0	0.0	0.0	0.0	0.0	0.0	0.0	0.0	0.0	0.0
Total Delay	21.2	16.1	0.0	13.9	23.6	3.9	36.7	52.9	2.7	54.1	35.8	16.2
LOS	C	B	A	B	C	A	D	D	A	D	D	B
Approach Delay		16.7			19.9			19.6			38.7	
Approach LOS		B			B			B			D	

Intersection Summary

Cycle Length: 120  
 Actuated Cycle Length: 120  
 Offset: 0 (0%), Referenced to phase 2:EBTL and 6:WBTL, Start of Green  
 Natural Cycle: 75  
 Control Type: Actuated-Coordinated  
 Maximum v/c Ratio: 0.77  
 Intersection Signal Delay: 23.8  
 Intersection LOS: C  
 Intersection Capacity Utilization 64.0%  
 ICU Level of Service B  
 Analysis Period (min) 15

Splits and Phases: 13: Sterling Ranch Rd & Marksheffel Rd

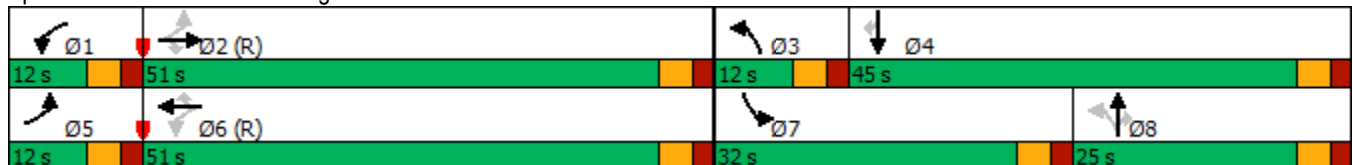



Intersection												
Int Delay, s/veh	2.3											
Movement	EBL	EBT	EBR	WBL	WBT	WBR	NBL	NBT	NBR	SBL	SBT	SBR
Lane Configurations	↖	↗		↖	↗			↕			↕	
Traffic Vol, veh/h	21	230	4	6	299	6	12	0	20	16	0	63
Future Vol, veh/h	21	230	4	6	299	6	12	0	20	16	0	63
Conflicting Peds, #/hr	0	0	0	0	0	0	0	0	0	0	0	0
Sign Control	Free	Free	Free	Free	Free	Free	Stop	Stop	Stop	Stop	Stop	Stop
RT Channelized	-	-	None	-	-	None	-	-	None	-	-	None
Storage Length	205	-	-	205	-	-	-	-	-	-	-	-
Veh in Median Storage, #	-	0	-	-	0	-	-	0	-	-	0	-
Grade, %	-	0	-	-	0	-	-	0	-	-	0	-
Peak Hour Factor	95	95	95	95	95	95	95	95	95	95	95	95
Heavy Vehicles, %	2	2	2	2	2	2	2	2	2	2	2	2
Mvmt Flow	22	242	4	6	315	6	13	0	21	17	0	66

Major/Minor	Major1			Major2			Minor1			Minor2		
Conflicting Flow All	321	0	0	246	0	0	651	621	244	629	620	318
Stage 1	-	-	-	-	-	-	288	288	-	330	330	-
Stage 2	-	-	-	-	-	-	363	333	-	299	290	-
Critical Hdwy	4.12	-	-	4.12	-	-	7.12	6.52	6.22	7.12	6.52	6.22
Critical Hdwy Stg 1	-	-	-	-	-	-	6.12	5.52	-	6.12	5.52	-
Critical Hdwy Stg 2	-	-	-	-	-	-	6.12	5.52	-	6.12	5.52	-
Follow-up Hdwy	2.218	-	-	2.218	-	-	3.518	4.018	3.318	3.518	4.018	3.318
Pot Cap-1 Maneuver	1239	-	-	1320	-	-	382	403	795	395	404	723
Stage 1	-	-	-	-	-	-	720	674	-	683	646	-
Stage 2	-	-	-	-	-	-	656	644	-	710	672	-
Platoon blocked, %	-	-	-	-	-	-	-	-	-	-	-	-
Mov Cap-1 Maneuver	1239	-	-	1320	-	-	341	394	795	378	395	723
Mov Cap-2 Maneuver	-	-	-	-	-	-	341	394	-	378	395	-
Stage 1	-	-	-	-	-	-	707	662	-	671	643	-
Stage 2	-	-	-	-	-	-	593	641	-	679	660	-

Approach	EB			WB			NB			SB		
HCM Control Delay, s	0.7			0.1			12.3			11.8		
HCM LOS							B			B		

Minor Lane/Major Mvmt	NBLn1	EBL	EBT	EBR	WBL	WBT	WBR	SBLn1
Capacity (veh/h)	530	1239	-	-	1320	-	-	610
HCM Lane V/C Ratio	0.064	0.018	-	-	0.005	-	-	0.136
HCM Control Delay (s)	12.3	8	-	-	7.7	-	-	11.8
HCM Lane LOS	B	A	-	-	A	-	-	B
HCM 95th %tile Q(veh)	0.2	0.1	-	-	0	-	-	0.5

Intersection												
Int Delay, s/veh	3											
Movement	EBL	EBT	EBR	WBL	WBT	WBR	NBL	NBT	NBR	SBL	SBT	SBR
Lane Configurations	↶	↷		↶	↷			↕			↕	
Traffic Vol, veh/h	5	178	82	11	214	6	75	0	21	18	0	21
Future Vol, veh/h	5	178	82	11	214	6	75	0	21	18	0	21
Conflicting Peds, #/hr	0	0	0	0	0	0	0	0	0	0	0	0
Sign Control	Free	Free	Free	Free	Free	Free	Stop	Stop	Stop	Stop	Stop	Stop
RT Channelized	-	-	None	-	-	None	-	-	None	-	-	None
Storage Length	205	-	-	205	-	-	-	-	-	-	-	-
Veh in Median Storage, #	-	0	-	-	0	-	-	0	-	-	0	-
Grade, %	-	0	-	-	0	-	-	0	-	-	0	-
Peak Hour Factor	95	95	95	95	95	95	95	95	95	95	95	95
Heavy Vehicles, %	2	2	2	2	2	2	2	2	2	2	2	2
Mvmt Flow	5	187	86	12	225	6	79	0	22	19	0	22

Major/Minor	Major1			Major2			Minor1			Minor2		
Conflicting Flow All	231	0	0	273	0	0	503	495	230	503	535	228
Stage 1	-	-	-	-	-	-	240	240	-	252	252	-
Stage 2	-	-	-	-	-	-	263	255	-	251	283	-
Critical Hdwy	4.12	-	-	4.12	-	-	7.12	6.52	6.22	7.12	6.52	6.22
Critical Hdwy Stg 1	-	-	-	-	-	-	6.12	5.52	-	6.12	5.52	-
Critical Hdwy Stg 2	-	-	-	-	-	-	6.12	5.52	-	6.12	5.52	-
Follow-up Hdwy	2.218	-	-	2.218	-	-	3.518	4.018	3.318	3.518	4.018	3.318
Pot Cap-1 Maneuver	1337	-	-	1290	-	-	479	476	809	479	452	811
Stage 1	-	-	-	-	-	-	763	707	-	752	698	-
Stage 2	-	-	-	-	-	-	742	696	-	753	677	-
Platoon blocked, %	-	-	-	-	-	-	-	-	-	-	-	-
Mov Cap-1 Maneuver	1337	-	-	1290	-	-	461	470	809	461	446	811
Mov Cap-2 Maneuver	-	-	-	-	-	-	461	470	-	461	446	-
Stage 1	-	-	-	-	-	-	760	704	-	749	692	-
Stage 2	-	-	-	-	-	-	715	690	-	730	674	-

Approach	EB			WB			NB			SB		
HCM Control Delay, s	0.1			0.4			13.8			11.4		
HCM LOS							B			B		

Minor Lane/Major Mvmt	NBLn1	EBL	EBT	EBR	WBL	WBT	WBR	SBLn1
Capacity (veh/h)	509	1337	-	-	1290	-	-	601
HCM Lane V/C Ratio	0.199	0.004	-	-	0.009	-	-	0.068
HCM Control Delay (s)	13.8	7.7	-	-	7.8	-	-	11.4
HCM Lane LOS	B	A	-	-	A	-	-	B
HCM 95th %tile Q(veh)	0.7	0	-	-	0	-	-	0.2

Intersection					
Intersection Delay, s/veh	15.0				
Intersection LOS	C				
Approach	EB	WB	NB	SB	
Entry Lanes	1	1	1	1	
Conflicting Circle Lanes	1	1	1	1	
Adj Approach Flow, veh/h	453	393	815	418	
Demand Flow Rate, veh/h	462	401	830	426	
Vehicles Circulating, veh/h	548	623	591	408	
Vehicles Exiting, veh/h	286	577	419	616	
Ped Vol Crossing Leg, #/h	0	0	0	0	
Ped Cap Adj	1.000	1.000	1.000	1.000	
Approach Delay, s/veh	13.9	13.7	19.0	9.9	
Approach LOS	B	B	C	A	
Lane	Left	Left	Left	Bypass	Left
Designated Moves	LTR	LTR	LT	R	LTR
Assumed Moves	LTR	LTR	LT	R	LTR
RT Channelized				Free	
Lane Util	1.000	1.000	1.000		1.000
Follow-Up Headway, s	2.609	2.609	2.609		2.609
Critical Headway, s	4.976	4.976	4.976	221	4.976
Entry Flow, veh/h	462	401	609	1938	426
Cap Entry Lane, veh/h	789	731	755	0.980	910
Entry HV Adj Factor	0.981	0.980	0.981	217	0.980
Flow Entry, veh/h	453	393	598	1900	418
Cap Entry, veh/h	774	717	741	0.114	892
V/C Ratio	0.586	0.549	0.806	0.0	0.468
Control Delay, s/veh	13.9	13.7	25.8	A	9.9
LOS	B	B	D	0	A
95th %tile Queue, veh	4	3	8		3

Timings  
4: Vollmer Rd & Briargate Pkwy

2044 Total Traffic  
PM Peak Hour

Lane Group	EBL	EBT	EBR	WBL	WBT	WBR	NBL	NBT	NBR	SBL	SBT	SBR
Lane Configurations												
Traffic Volume (vph)	227	1015	185	209	745	75	301	414	282	110	211	118
Future Volume (vph)	227	1015	185	209	745	75	301	414	282	110	211	118
Turn Type	pm+pt	NA	Perm	Prot	NA	Perm	pm+pt	NA	Perm	pm+pt	NA	Perm
Protected Phases	5	2		1	6		3	8		7	4	
Permitted Phases	2		2			6	8		8	4		4
Detector Phase	5	2	2	1	6	6	3	8	8	7	4	4
Switch Phase												
Minimum Initial (s)	5.0	15.0	15.0	15.0	15.0	15.0	8.0	5.0	5.0	5.0	5.0	5.0
Minimum Split (s)	10.0	20.0	20.0	20.0	20.0	20.0	13.0	10.0	10.0	10.0	10.0	10.0
Total Split (s)	12.0	53.0	53.0	20.0	61.0	61.0	22.0	28.0	28.0	19.0	25.0	25.0
Total Split (%)	10.0%	44.2%	44.2%	16.7%	50.8%	50.8%	18.3%	23.3%	23.3%	15.8%	20.8%	20.8%
Yellow Time (s)	3.0	3.0	3.0	3.0	3.0	3.0	3.0	3.0	3.0	3.0	3.0	3.0
All-Red Time (s)	2.0	2.0	2.0	2.0	2.0	2.0	2.0	2.0	2.0	2.0	2.0	2.0
Lost Time Adjust (s)	0.0	0.0	0.0	0.0	0.0	0.0	0.0	0.0	0.0	0.0	0.0	0.0
Total Lost Time (s)	5.0	5.0	5.0	5.0	5.0	5.0	5.0	5.0	5.0	5.0	5.0	5.0
Lead/Lag	Lead	Lag	Lag	Lead	Lag	Lag	Lead	Lag	Lag	Lead	Lag	Lag
Lead-Lag Optimize?	Yes	Yes	Yes	Yes	Yes	Yes	Yes	Yes	Yes	Yes	Yes	Yes
Recall Mode	None	Max	Max	None	Max	Max	None	None	None	None	None	None
Act Effct Green (s)	55.1	48.1	48.1	15.0	56.1	56.1	35.6	20.3	20.3	25.3	14.5	14.5
Actuated g/C Ratio	0.48	0.42	0.42	0.13	0.49	0.49	0.31	0.18	0.18	0.22	0.13	0.13
v/c Ratio	0.66	0.70	0.25	0.49	0.45	0.09	0.83	0.67	0.59	0.43	0.50	0.37
Control Delay	25.6	30.9	4.7	51.0	20.7	1.7	52.9	49.9	12.3	33.9	50.1	6.5
Queue Delay	0.0	0.0	0.0	0.0	0.0	0.0	0.0	0.0	0.0	0.0	0.0	0.0
Total Delay	25.6	30.9	4.7	51.0	20.7	1.7	52.9	49.9	12.3	33.9	50.1	6.5
LOS	C	C	A	D	C	A	D	D	B	C	D	A
Approach Delay		26.5			25.5			40.1			34.3	
Approach LOS		C			C			D			C	

Intersection Summary

Cycle Length: 120  
 Actuated Cycle Length: 114.3  
 Natural Cycle: 80  
 Control Type: Actuated-Uncoordinated  
 Maximum v/c Ratio: 0.83  
 Intersection Signal Delay: 30.6  
 Intersection LOS: C  
 Intersection Capacity Utilization 79.7%  
 ICU Level of Service D  
 Analysis Period (min) 15

Splits and Phases: 4: Vollmer Rd & Briargate Pkwy



Timings  
5: Sterling Ranch Rd & Briargate Pkwy

2044 Total Traffic  
PM Peak Hour

Lane Group	EBL	EBT	EBR	WBL	WBT	WBR	NBL	NBT	NBR	SBL	SBT	SBR
Lane Configurations												
Traffic Volume (vph)	329	921	136	152	829	105	191	190	83	87	86	133
Future Volume (vph)	329	921	136	152	829	105	191	190	83	87	86	133
Turn Type	pm+pt	NA	Perm	pm+pt	NA	Perm	pm+pt	NA	Free	pm+pt	NA	Free
Protected Phases	5	2		1	6		3	8		7	4	
Permitted Phases	2		2	6		6	8		Free	4		Free
Detector Phase	5	2	2	1	6	6	3	8		7	4	
Switch Phase												
Minimum Initial (s)	5.0	5.0	5.0	5.0	5.0	5.0	5.0	20.0		5.0	20.0	
Minimum Split (s)	10.0	23.0	23.0	10.0	23.0	23.0	10.0	25.0		10.0	25.0	
Total Split (s)	22.0	68.0	68.0	12.0	58.0	58.0	15.0	30.0		10.0	25.0	
Total Split (%)	18.3%	56.7%	56.7%	10.0%	48.3%	48.3%	12.5%	25.0%		8.3%	20.8%	
Yellow Time (s)	3.0	3.0	3.0	3.0	3.0	3.0	3.0	3.0		3.0	3.0	
All-Red Time (s)	2.0	2.0	2.0	2.0	2.0	2.0	2.0	2.0		2.0	2.0	
Lost Time Adjust (s)	0.0	0.0	0.0	0.0	0.0	0.0	0.0	0.0		0.0	0.0	
Total Lost Time (s)	5.0	5.0	5.0	5.0	5.0	5.0	5.0	5.0		5.0	5.0	
Lead/Lag	Lead	Lag	Lag	Lead	Lag	Lag	Lead	Lag		Lead	Lag	
Lead-Lag Optimize?	Yes	Yes	Yes	Yes	Yes	Yes	Yes	Yes		Yes	Yes	
Recall Mode	None	C-Max	C-Max	None	C-Max	C-Max	None	None		None	None	
Act Effct Green (s)	76.0	64.0	64.0	62.4	55.3	55.3	34.0	24.0	120.0	21.0	20.0	120.0
Actuated g/C Ratio	0.63	0.53	0.53	0.52	0.46	0.46	0.28	0.20	1.00	0.18	0.17	1.00
v/c Ratio	0.83	0.51	0.16	0.51	0.53	0.14	0.55	0.54	0.05	0.40	0.29	0.09
Control Delay	30.3	19.4	2.7	18.1	25.1	5.4	41.3	48.7	0.1	40.8	46.8	0.1
Queue Delay	0.0	0.0	0.0	0.0	0.0	0.0	0.0	0.0	0.0	0.0	0.0	0.0
Total Delay	30.3	19.4	2.7	18.1	25.1	5.4	41.3	48.7	0.1	40.8	46.8	0.1
LOS	C	B	A	B	C	A	D	D	A	D	D	A
Approach Delay		20.4			22.2			37.0			24.8	
Approach LOS		C			C			D			C	

Intersection Summary

Cycle Length: 120  
 Actuated Cycle Length: 120  
 Offset: 0 (0%), Referenced to phase 2:EBTL and 6:WBTL, Start of Green  
 Natural Cycle: 80  
 Control Type: Actuated-Coordinated  
 Maximum v/c Ratio: 0.83  
 Intersection Signal Delay: 23.8  
 Intersection LOS: C  
 Intersection Capacity Utilization 85.1%  
 ICU Level of Service E  
 Analysis Period (min) 15

Splits and Phases: 5: Sterling Ranch Rd & Briargate Pkwy



Intersection												
Int Delay, s/veh	4.7											
Movement	EBL	EBT	EBR	WBL	WBT	WBR	NBL	NBT	NBR	SBL	SBT	SBR
Lane Configurations	↘	↑	↗	↘		↗		↑	↗	↘	↑	
Traffic Vol, veh/h	38	18	32	125	0	139	0	321	160	51	283	0
Future Vol, veh/h	38	18	32	125	0	139	0	321	160	51	283	0
Conflicting Peds, #/hr	0	0	0	0	0	0	0	0	0	0	0	0
Sign Control	Stop	Stop	Stop	Stop	Stop	Stop	Free	Free	Free	Free	Free	Free
RT Channelized	-	-	None	-	-	None	-	-	None	-	-	None
Storage Length	0	-	0	150	-	0	-	-	205	205	-	-
Veh in Median Storage, #	-	0	-	-	0	-	-	0	-	-	0	-
Grade, %	-	0	-	-	0	-	-	0	-	-	0	-
Peak Hour Factor	95	95	95	95	95	95	95	95	95	95	95	95
Heavy Vehicles, %	2	2	2	2	2	2	2	2	2	2	2	2
Mvmt Flow	40	19	34	132	0	146	0	338	168	54	298	0

Major/Minor	Minor2		Minor1		Major1			Major2				
Conflicting Flow All	901	912	298	771	-	338	-	0	0	506	0	0
Stage 1	406	406	-	338	-	-	-	-	-	-	-	-
Stage 2	495	506	-	433	-	-	-	-	-	-	-	-
Critical Hdwy	7.12	6.52	6.22	7.12	-	6.22	-	-	-	4.12	-	-
Critical Hdwy Stg 1	6.12	5.52	-	6.12	-	-	-	-	-	-	-	-
Critical Hdwy Stg 2	6.12	5.52	-	6.12	-	-	-	-	-	-	-	-
Follow-up Hdwy	3.518	4.018	3.318	3.518	-	3.318	-	-	-	2.218	-	-
Pot Cap-1 Maneuver	262	266	867	336	0	704	0	-	-	1059	-	0
Stage 1	694	628	-	676	0	-	0	-	-	-	-	0
Stage 2	556	540	-	666	0	-	0	-	-	-	-	0
Platoon blocked, %	1	1	1	1				-	-			
Mov Cap-1 Maneuver	199	253	867	298	-	704	-	-	-	1059	-	-
Mov Cap-2 Maneuver	306	358	-	422	-	-	-	-	-	-	-	-
Stage 1	694	596	-	676	-	-	-	-	-	-	-	-
Stage 2	440	540	-	588	-	-	-	-	-	-	-	-

Approach	EB		WB		NB			SB	
HCM Control Delay, s	14.6		14.2		0			1.3	
HCM LOS	B		B						

Minor Lane/Major Mvmt	NBT	NBR	EBLn1	EBLn2	EBLn3	WBLn1	WBLn2	SBL	SBT
Capacity (veh/h)	-	-	306	358	867	422	704	1059	-
HCM Lane V/C Ratio	-	-	0.131	0.053	0.039	0.312	0.208	0.051	-
HCM Control Delay (s)	-	-	18.5	15.6	9.3	17.3	11.5	8.6	-
HCM Lane LOS	-	-	C	C	A	C	B	A	-
HCM 95th %tile Q(veh)	-	-	0.4	0.2	0.1	1.3	0.8	0.2	-

Timings  
12: Vollmer Rd & Marksheffel Rd

2044 Total Traffic  
PM Peak Hour

Lane Group	EBL	EBT	EBR	WBL	WBT	WBR	NBL	NBT	NBR	SBL	SBT	SBR
Lane Configurations												
Traffic Volume (vph)	142	943	96	191	715	154	171	728	191	132	342	199
Future Volume (vph)	142	943	96	191	715	154	171	728	191	132	342	199
Turn Type	pm+pt	NA	Perm	pm+pt	NA	Perm	pm+pt	NA	Perm	pm+pt	NA	Perm
Protected Phases	5	2		1	6		3	8		7	4	
Permitted Phases	2		2	6		6	8		8	4		4
Detector Phase	5	2	2	1	6	6	3	8	8	7	4	4
Switch Phase												
Minimum Initial (s)	5.0	5.0	5.0	5.0	5.0	5.0	5.0	10.0	10.0	5.0	10.0	10.0
Minimum Split (s)	10.0	23.0	23.0	10.0	23.0	23.0	10.0	23.0	23.0	10.0	23.0	23.0
Total Split (s)	20.0	50.0	50.0	19.0	49.0	49.0	15.0	36.0	36.0	15.0	36.0	36.0
Total Split (%)	16.7%	41.7%	41.7%	15.8%	40.8%	40.8%	12.5%	30.0%	30.0%	12.5%	30.0%	30.0%
Yellow Time (s)	3.0	3.0	3.0	3.0	3.0	3.0	3.0	3.0	3.0	3.0	3.0	3.0
All-Red Time (s)	2.0	2.0	2.0	2.0	2.0	2.0	2.0	2.0	2.0	2.0	2.0	2.0
Lost Time Adjust (s)	0.0	0.0	0.0	0.0	0.0	0.0	0.0	0.0	0.0	0.0	0.0	0.0
Total Lost Time (s)	5.0	5.0	5.0	5.0	5.0	5.0	5.0	5.0	5.0	5.0	5.0	5.0
Lead/Lag	Lead	Lag	Lag	Lead	Lag	Lag	Lead	Lag	Lag	Lead	Lag	Lag
Lead-Lag Optimize?	Yes	Yes	Yes	Yes	Yes	Yes	Yes	Yes	Yes	Yes	Yes	Yes
Recall Mode	None	C-Max	C-Max	None	C-Max	C-Max	None	Max	Max	None	Max	Max
Act Effct Green (s)	57.4	46.8	46.8	60.6	48.3	48.3	41.2	31.4	31.4	40.8	31.2	31.2
Actuated g/C Ratio	0.48	0.39	0.39	0.50	0.40	0.40	0.34	0.26	0.26	0.34	0.26	0.26
v/c Ratio	0.43	0.72	0.15	0.72	0.53	0.22	0.50	0.83	0.39	0.68	0.39	0.37
Control Delay	18.7	35.1	4.5	52.1	22.7	5.6	31.4	50.7	13.7	43.5	38.2	6.7
Queue Delay	0.0	0.0	0.0	0.0	0.0	0.0	0.0	0.0	0.0	0.0	0.0	0.0
Total Delay	18.7	35.1	4.5	52.1	22.7	5.6	31.4	50.7	13.7	43.5	38.2	6.7
LOS	B	D	A	D	C	A	C	D	B	D	D	A
Approach Delay		30.6			25.5			41.2			29.9	
Approach LOS		C			C			D			C	

Intersection Summary

Cycle Length: 120  
 Actuated Cycle Length: 120  
 Offset: 0 (0%), Referenced to phase 2:EBTL and 6:WBTL, Start of Green  
 Natural Cycle: 70  
 Control Type: Actuated-Coordinated  
 Maximum v/c Ratio: 0.83  
 Intersection Signal Delay: 32.0  
 Intersection LOS: C  
 Intersection Capacity Utilization 80.8%  
 ICU Level of Service D  
 Analysis Period (min) 15

Splits and Phases: 12: Vollmer Rd & Marksheffel Rd

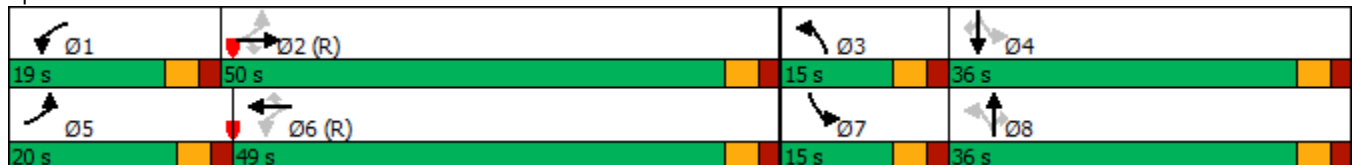





Intersection												
Int Delay, s/veh	2.7											
Movement	EBL	EBT	EBR	WBL	WBT	WBR	NBL	NBT	NBR	SBL	SBT	SBR
Lane Configurations	↶	↷		↶	↷			↕			↕	
Traffic Vol, veh/h	63	150	16	24	186	14	9	0	15	9	0	40
Future Vol, veh/h	63	150	16	24	186	14	9	0	15	9	0	40
Conflicting Peds, #/hr	0	0	0	0	0	0	0	0	0	0	0	0
Sign Control	Free	Free	Free	Free	Free	Free	Stop	Stop	Stop	Stop	Stop	Stop
RT Channelized	-	-	None	-	-	None	-	-	None	-	-	None
Storage Length	205	-	-	205	-	-	-	-	-	-	-	-
Veh in Median Storage, #	-	0	-	-	0	-	-	0	-	-	0	-
Grade, %	-	0	-	-	0	-	-	0	-	-	0	-
Peak Hour Factor	95	95	95	95	95	95	95	95	95	95	95	95
Heavy Vehicles, %	2	2	2	2	2	2	2	2	2	2	2	2
Mvmt Flow	66	158	17	25	196	15	9	0	16	9	0	42

Major/Minor	Major1			Major2			Minor1			Minor2		
Conflicting Flow All	211	0	0	175	0	0	574	560	167	561	561	204
Stage 1	-	-	-	-	-	-	299	299	-	254	254	-
Stage 2	-	-	-	-	-	-	275	261	-	307	307	-
Critical Hdwy	4.12	-	-	4.12	-	-	7.12	6.52	6.22	7.12	6.52	6.22
Critical Hdwy Stg 1	-	-	-	-	-	-	6.12	5.52	-	6.12	5.52	-
Critical Hdwy Stg 2	-	-	-	-	-	-	6.12	5.52	-	6.12	5.52	-
Follow-up Hdwy	2.218	-	-	2.218	-	-	3.518	4.018	3.318	3.518	4.018	3.318
Pot Cap-1 Maneuver	1360	-	-	1401	-	-	430	437	877	438	436	837
Stage 1	-	-	-	-	-	-	710	666	-	750	697	-
Stage 2	-	-	-	-	-	-	731	692	-	703	661	-
Platoon blocked, %	-	-	-	-	-	-	-	-	-	-	-	-
Mov Cap-1 Maneuver	1360	-	-	1401	-	-	388	408	877	409	407	837
Mov Cap-2 Maneuver	-	-	-	-	-	-	388	408	-	409	407	-
Stage 1	-	-	-	-	-	-	675	633	-	713	684	-
Stage 2	-	-	-	-	-	-	682	680	-	657	629	-

Approach	EB			WB			NB			SB		
HCM Control Delay, s	2.1			0.8			11.3			10.5		
HCM LOS							B			B		

Minor Lane/Major Mvmt	NBLn1	EBL	EBT	EBR	WBL	WBT	WBR	SBLn1
Capacity (veh/h)	596	1360	-	-	1401	-	-	702
HCM Lane V/C Ratio	0.042	0.049	-	-	0.018	-	-	0.073
HCM Control Delay (s)	11.3	7.8	-	-	7.6	-	-	10.5
HCM Lane LOS	B	A	-	-	A	-	-	B
HCM 95th %tile Q(veh)	0.1	0.2	-	-	0.1	-	-	0.2

Intersection												
Int Delay, s/veh	2.6											
Movement	EBL	EBT	EBR	WBL	WBT	WBR	NBL	NBT	NBR	SBL	SBT	SBR
Lane Configurations	↶	↷		↶	↷			↕			↕	
Traffic Vol, veh/h	21	123	29	28	176	26	31	0	17	15	0	17
Future Vol, veh/h	21	123	29	28	176	26	31	0	17	15	0	17
Conflicting Peds, #/hr	0	0	0	0	0	0	0	0	0	0	0	0
Sign Control	Free	Free	Free	Free	Free	Free	Stop	Stop	Stop	Stop	Stop	Stop
RT Channelized	-	-	None	-	-	None	-	-	None	-	-	None
Storage Length	205	-	-	205	-	-	-	-	-	-	-	-
Veh in Median Storage, #	-	0	-	-	0	-	-	0	-	-	0	-
Grade, %	-	0	-	-	0	-	-	0	-	-	0	-
Peak Hour Factor	95	95	95	95	95	95	95	95	95	95	95	95
Heavy Vehicles, %	2	2	2	2	2	2	2	2	2	2	2	2
Mvmt Flow	22	129	31	29	185	27	33	0	18	16	0	18

Major/Minor	Major1			Major2			Minor1			Minor2		
Conflicting Flow All	212	0	0	160	0	0	455	459	145	455	461	199
Stage 1	-	-	-	-	-	-	189	189	-	257	257	-
Stage 2	-	-	-	-	-	-	266	270	-	198	204	-
Critical Hdwy	4.12	-	-	4.12	-	-	7.12	6.52	6.22	7.12	6.52	6.22
Critical Hdwy Stg 1	-	-	-	-	-	-	6.12	5.52	-	6.12	5.52	-
Critical Hdwy Stg 2	-	-	-	-	-	-	6.12	5.52	-	6.12	5.52	-
Follow-up Hdwy	2.218	-	-	2.218	-	-	3.518	4.018	3.318	3.518	4.018	3.318
Pot Cap-1 Maneuver	1358	-	-	1419	-	-	515	499	902	515	497	842
Stage 1	-	-	-	-	-	-	813	744	-	748	695	-
Stage 2	-	-	-	-	-	-	739	686	-	804	733	-
Platoon blocked, %	-	-	-	-	-	-	-	-	-	-	-	-
Mov Cap-1 Maneuver	1358	-	-	1419	-	-	490	481	902	491	479	842
Mov Cap-2 Maneuver	-	-	-	-	-	-	490	481	-	491	479	-
Stage 1	-	-	-	-	-	-	800	732	-	736	681	-
Stage 2	-	-	-	-	-	-	709	672	-	775	721	-

Approach	EB			WB			NB			SB		
HCM Control Delay, s	0.9			0.9			11.7			11		
HCM LOS							B			B		

Minor Lane/Major Mvmt	NBLn1	EBL	EBT	EBR	WBL	WBT	WBR	SBLn1
Capacity (veh/h)	585	1358	-	-	1419	-	-	631
HCM Lane V/C Ratio	0.086	0.016	-	-	0.021	-	-	0.053
HCM Control Delay (s)	11.7	7.7	-	-	7.6	-	-	11
HCM Lane LOS	B	A	-	-	A	-	-	B
HCM 95th %tile Q(veh)	0.3	0.1	-	-	0.1	-	-	0.2

# Appendix Table 1



**Appendix Table 1  
Area Traffic Impact Studies  
Villages Sterling Ranch**

<b>Study</b>	<b>PCD File No<sup>(1)</sup></b>	<b>Consultant</b>	<b>Date</b>
<b>Sterling Ranch Reports</b>			
Sterling Ranch Updated Traffic Impact Analysis	<a href="#">SKP07007</a>	LSC Transportation Consultants, Inc	June 5, 2008
Sterling Ranch Phase 1 Traffic Impact Study	<a href="#">P151</a>	LSC Transportation Consultants, Inc	March 16, 2015
Sterling Ranch Phases 1-3 Transportation Memorandum	<a href="#">SP1415</a>	LSC Transportation Consultants, Inc	October 2, 2017
Branding Iron at Sterling Ranch Filing No. 1 and Homestead at Sterling Ranch Filing No. 1 Transportation Memorandum	<a href="#">SF1724</a> <a href="#">SF1725</a>	LSC Transportation Consultants, Inc	December 19, 2017
Sterling Ranch Filing No. 2 Transportation Memorandum	<a href="#">SF1820</a>	LSC Transportation Consultants, Inc	April 3, 2018
Sterling Ranch Phase 2 Preliminary Plan Traffic Impact Study	<a href="#">SP203</a>	LSC Transportation Consultants, Inc	December 20, 2018
Homestead at Sterling Ranch Filing No. 2 Transportation Memorandum	<a href="#">SF194</a>	LSC Transportation Consultants, Inc	March 3, 2020
Branding Iron at Sterling Ranch Filing No. 2 Transportation Memorandum	<a href="#">SF1918</a>	LSC Transportation Consultants, Inc	May 6, 2020
Sterling Ranch Filing No. 2 and Phase 2 Traffic Impact Study	<a href="#">SF2015</a> <a href="#">SP191</a>	LSC Transportation Consultants, Inc	June 23, 2021
Sterling Ranch Filing No. 3 Transportation Memorandum	<a href="#">SF2132</a>	LSC Transportation Consultants, Inc	April 19, 2022
Homestead North Phase 1 Updated Transportation Memorandum	<a href="#">SP208</a>	LSC Transportation Consultants, Inc	January 11, 2022
Homestead North Filing No. 1 Traffic Technical Memorandum	<a href="#">SF2213</a>	LSC Transportation Consultants, Inc	February 2, 2022
Homestead North Filing No. 2 Traffic Technical Memorandum	<a href="#">SF2218</a>	LSC Transportation Consultants, Inc	April 15, 2022
Homestead North Filing 3 Traffic Impact Study	<a href="#">SF2229</a>	LSC Transportation Consultants, Inc	June 17, 2022
The Villages at Sterling Ranch East Preliminary Plan/Traffic Generation Analysis	<a href="#">PUDSP226</a>	SM Rocha, LLC	July 1, 2022
Sterling Ranch Sketch Plan Amendment Master Traffic Impact Study	<a href="#">SKP224</a>	LSC Transportation Consultants, Inc	March 17, 2023
Sterling Ranch East - Rezoning & Preliminary Plan Traffic Impact Study	<a href="#">SP-22-004, P-22-012, P-22-013</a>	LSC Transportation Consultants, Inc	March 17, 2023 <sup>(2)</sup>
Sterling Ranch East Filing Nos 1 & 2 Traffic Technical Memorandum	<a href="#">SF2235</a> <a href="#">SF2237</a>	LSC Transportation Consultants, Inc	February 10, 2023
Sterling Ranch Filing No. 4 Transportation Memorandum	<a href="#">SF2230</a>	LSC Transportation Consultants, Inc	February 21, 2023
Foursquare at Sterling Ranch East Transportation Memorandum	<a href="#">SF2236</a>	LSC Transportation Consultants, Inc	April 20, 2023
Copper Chase at Sterling Ranch Traffic Impact Study	<a href="#">PUDSP222</a>	LSC Transportation Consultants, Inc	April 28, 2023
Sterling Ranch Filing No. 5 Traffic Impact Study	<a href="#">PUDSP-23-002</a>	LSC Transportation Consultants, Inc	November 15, 2023
Sterling Ranch Sketch Plan 2023 Amendment & Rezone Traffic Technical Memorandum	<a href="#">SKP235, P239, P2311</a>	LSC Transportation Consultants, Inc	January 17, 2024
Sterling Ranch East - Filing 5 Rezone & Preliminary Plan Traffic Impact Study	<a href="#">P237 &amp; SP235</a>	LSC Transportation Consultants, Inc	January 15, 2024
<b>Retreat at TimberRidge Reports</b>			
The Retreat at TimberRidge Traffic Impact Analysis	<a href="#">PUD173</a>	LSC Transportation Consultants, Inc	January 25, 2018
The Retreat at TimberRidge Preliminary Plan Traffic Technical Memorandum	<a href="#">SP182</a>	LSC Transportation Consultants, Inc	June 29, 2018
The Retreat at TimberRidge Filing No. 1 Traffic Technical Memorandum	<a href="#">SF199</a>	LSC Transportation Consultants, Inc	April 3, 2020
The Retreat at TimberRidge Filing No. 2 Updated Traffic Technical Memorandum	<a href="#">SF2121</a>	LSC Transportation Consultants, Inc	October 4, 2021
The Retreat at TimberRidge Filing No. 3 Traffic Technical Memorandum	<a href="#">SF2241</a>	LSC Transportation Consultants, Inc	November 15, 2023
The Retreat at TimberRidge Filing No. 4 Traffic Technical Memorandum	<a href="#">SF1827</a>	LSC Transportation Consultants, Inc	February 21, 2024
<b>Other Area Reports</b>			
Wolf Ranch School Site Traffic Impact Study	<a href="#">OAR1720</a>	Matrix Design Group, Inc.	5-May-17
The Ranch Sketch Plan Traffic Impact Analysis	<a href="#">SKP186</a>	LSC Transportation Consultants, Inc	July 9, 2019
Lodge III Traffic Impact Study	OAR	LSC Transportation Consultants, Inc	December 13, 2019
Continental 613 Traffic Impact Study	<a href="#">OAR2177</a>	LSC Transportation Consultants, Inc	July 16, 2021
Solace at Black Forest Traffic Impact and Access Analysis	<a href="#">OAR2134</a>	LSC Transportation Consultants, Inc	August 13, 2021
Traffic Impact Study Addendum for Percheron	<a href="#">OAR2173</a>	SM Rocha, LLC	October, 2021
Woodmen East Commercial Center Traffic Impact Analysis	<a href="#">OAR2191</a>	LSC Transportation Consultants, Inc	December 8, 2021
Traffic Impact Study for Jaynes Property	<a href="#">SKP225</a>	SM Rocha, LLC	May, 2022
Briargate-Stapleton Corridor Study (DRAFT)	<a href="#">briargate-stapleton.com</a>	Wilson & Company	December 9, 2021
Sterling Recycling Facility Transportation Memorandum	<a href="#">PPR2341</a>	LSC Transportation Consultants, Inc	August 24, 2023

**Notes:**

(1) Follow the links listed below to obtain the most recent version of each listed study. To obtain a copy of the version of each study used in preparing this report please contact LSC Transportation Consultants, Inc.

(2) With minor revision 4/3/2023

Source: LSC Transportation Consultants, Inc.

Feb-24

# MTCP Maps

---



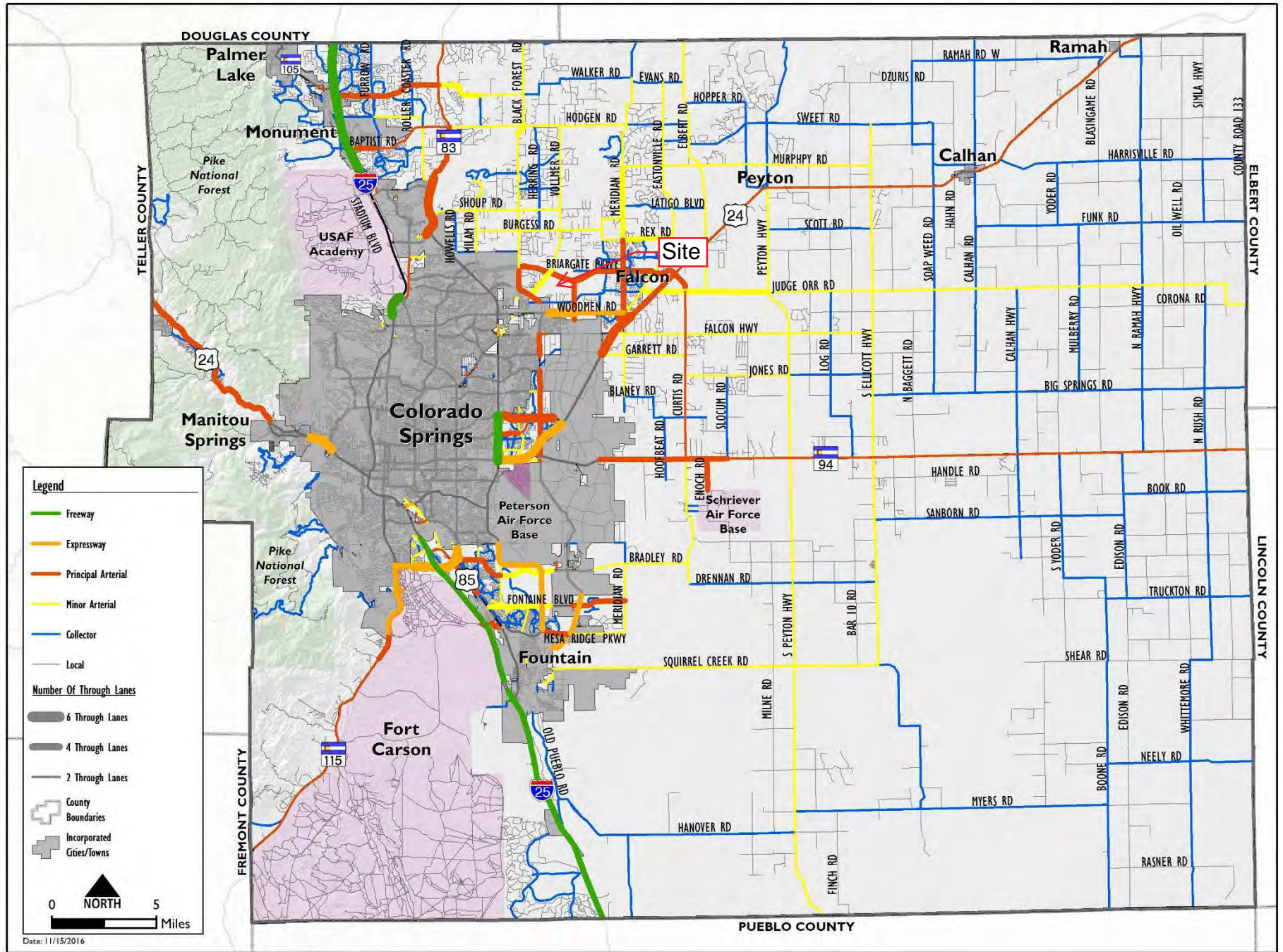

Map 14: 2040 Roadway Plan (Classification and Lanes)

# Map 17: 2060 Corridor Preservation

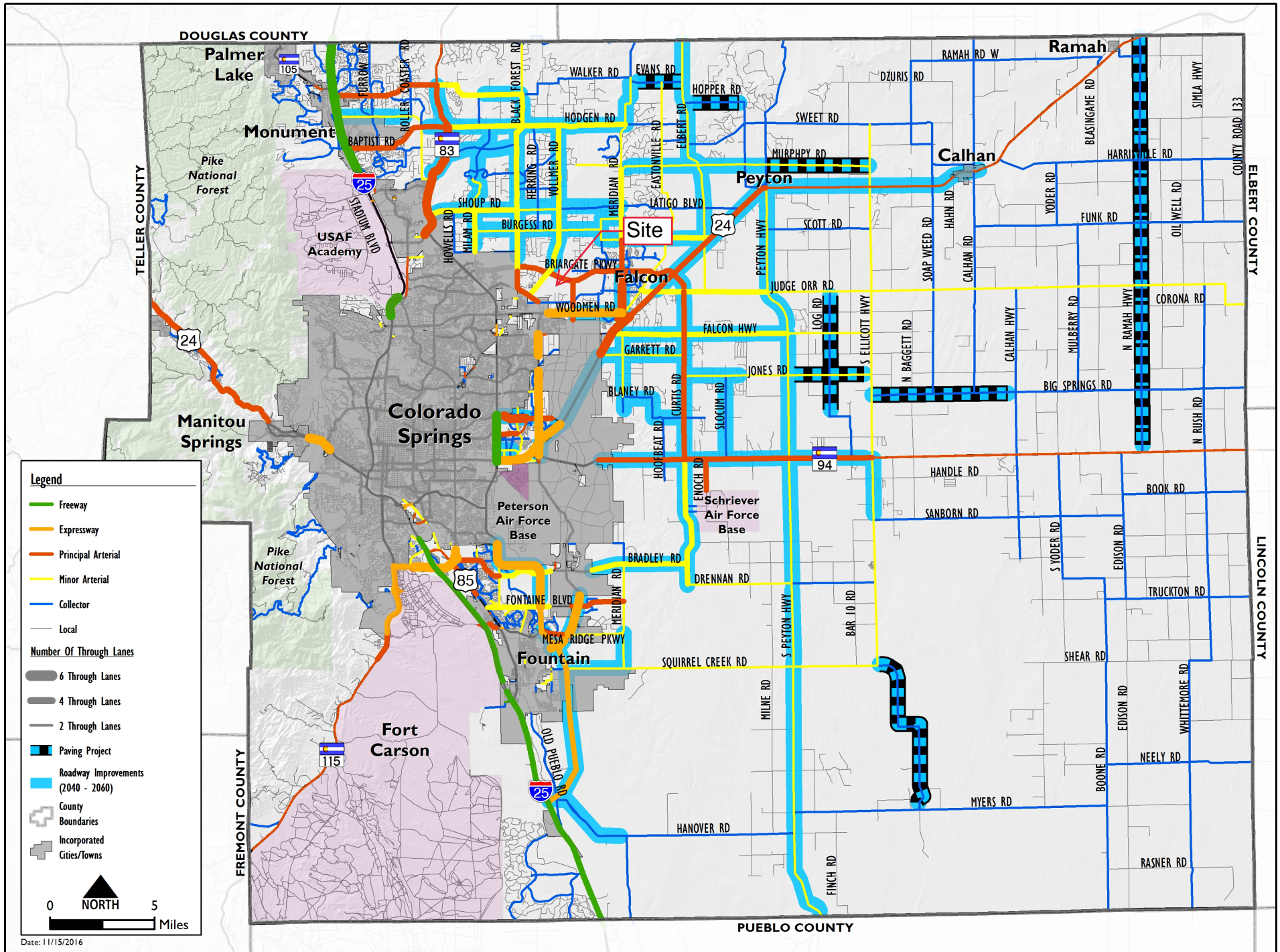

# Crash History

---





AccidentDate	TotalVehicles	ReferencePointName	ReferencePointAtName	AccidentNarrative
2019-09-29	1	VOLLMER RD	GLIDER LP	Vehicle # 1 was traveling northbound Vollmer Road .8 miles north of Glider Loop. Vehicle # 1's right side tires dropped off the right side of the roadway as it entered a sharp left curve. Vehicle #1 lost control on the roadway for approximately 131' before it traveled approximately 100' off the right side of the roadway. Vehicle # 1 collided its rear with a barbed-wire fence. Vehicle # 1 was moved prior to investigation.
2019-10-01	1	VOLLMER RD	S POCO RD	Vehicle #1 was northbound on Vollmer Road in a left hand curve. Vehicle #1 ran off the right side of the road for 107.3'. Vehicle over corrected, reentered the roadway, spinning counter clockwise. Vehicle #1 was out of control for 98.5'. Vehicle #1 ran off the left side of the road for 99.8', rolling 1 1/2 times. Vehicle #1 came to rest on its top facing west.
2019-11-14	1	VOLLMER RD	GLIDER PL	Vehicle 1 was southbound on Vollmer Road south of Burgess Road. Vehicle 1 was travelling in excessive speed, when it failed to negotiate a right hand bend in the roadway. Vehicle left heavy left side tire skids marks for 115.8 feet in the northbound lane, afterwhich it traveled for 59.4 across the southbound lane. Vehicle 1 ran off the right side of the road for 130.9 feet where it began to overturn, airborne for 20.7 feet, colliding with the ground, traveled another 25.9 feet and rolled another 52.2 feet where it came to final rest facing east on its right side 23.9 feet from the west road edge.
2020-04-23	1	VOLLMER RD	WILDFLOWER RD	Vehicle #1 was traveling south on Vollmer Rd approaching Wildflower Rd. Vehicle #1 failed to navigate the slight left curve in the roadway at which point it ran off the right side of the road. Vehicle #1 crashed through the fence on the right side of the road, traveled southwest into the yard of 8455 Wildflower Rd, rolled, crashed into a well, and came to rest on its wheels facing south.
2020-05-26	1	VOLLMER	WILD FLOWER	Vehicle #1 was southbound on Vollmer. Driver of vehicle #1 lost control and went off the right side of the road and overturned. Vehicle #1 was moved prior to investigation.
2020-07-25	1	VOLLMER RD	POCO RD	Vehicle 1 was traveling in an easterly direction on Vollmer Road approaching a left curve. Vehicle 1 drove on the wrong side of the road to avoid a deceased raccoon in the middle of its lane. Vehicle 1 returned to its lane while navigating the curve. Vehicle 1's right tires dropped off the right edge of the road. Driver 1 pulled the wheel to the left causing Vehicle 1 to spin out of control. Driver 1 overcorrected to the right and the vehicle rolled 3/4 times off the right side of the road. Vehicle 1 came to final rest on top of a fence facing south on its right side.
2021-03-24	1	VOLLMER RD	POCO RD	Vehicle #1 was southbound on Vollmer Road just south of Poco Road. Vehicle #1 lost control on the icy covered roadway and slid off of the west edge of the roadway for approximately 50 feet while rotating 1/4 times clockwise. Vehicle #1 then collided with a barbed wire fence approximately 15 feet west of the road edge and overturned 1/4 times onto it's left. Vehicle #1 came to final rest on its left side, approximately 15 feet west of the road edge facing west.
2021-09-13	3	VOLLMER RD	POCO RD	Vehicle #1 was traveling southbound on Vollmer Road. Vehicle #2 was parked on Poco Road, facing east, just west of the intersection of Vollmer Rd. and Poco Rd. Vehicle #2 was partially in the lane and partially on what would be a shoulder, as the entire road is dirt. Vehicle #3 was parked likewise, behind vehicle #2. Vehicle #1 made a right hand turn, to travel westbound on Poco Rd. The left front of vehicle #1 crashed into the left front of vehicle #2. Vehicle #2, being on dirt, slid backwards into the front of vehicle #3. Both vehicles #2 and #3 were unoccupied. Vehicle #1 pulled through and pulled over further down Poco Road to a safe location.
2021-11-11	1	VOLLMER RD	POCO RD	Vehicle #1 was travelling northbound on Vollmer Rd approaching Poco Rd. Vehicle #1 failed to negotiate a curve to the left and travelled off the right side of the road. Vehicle #1 overcorrected to the left, travelled across both lanes of traffic, and drove off the left side of the road. Vehicle #1 rotated counter-clockwise and hit a trip point in the soft dirt. Vehicle #1 rolled 1 and 3/4 times, coming to rest on its left side facing southwest approximately 30 feet off the road. The driver of the vehicle was ejected out of the passenger window during the rollover and came to rest in the field approximately 50 feet northwest of the vehicle.
2022-04-07	1	VOLLMER RD	WILDFLOWER RD	Vehicle 1 was traveling southbound on Vollmer Rd approaching the intersection of Wildflower Rd. Vehicle 1 failed to negotiate a curve and drove off the right side of the roadway at the intersection of Wildflower Rd. Vehicle 1 drove approximately 19 feet off of the right side of the roadway impacting an embankment and came to final rest 85 feet south of Wildflower Rd on the southwest side of the intersection facing south.
2022-06-19	2	VOLLMER RD	LOCHWINNOCH LN	VEHICLE 1 WAS NORTHBOUND ON VOLLMER ROAD. VEHICLE 2 WAS NORTHBOUND ON VOLLMER ROAD, IN FRONT OF VEHICLE 1. VEHICLE 2 BEGAN TO SLOW TO MAKE A LEFT TURN ONTO LOCHWINNOCH ROAD. VEHICLE 1 ATTEMPTED TO PASS VEHICLE 2 ON THE LEFT SIDE IN A MARKED NO PASSING ZONE. VEHICLE 2 BEGAN TO MAKE THE LEFT TURN WHERE VEHICLE 2 WAS STRUCK IN THE FRONT DRIVERS SIDE, BY THE FRONT PASSENGER SIDE OF VEHICLE 1. THE COLLISION OCCURRED WITHIN THE SOUTHBOUND LANE OF VOLLMER ROAD. VEHICLE 1 THEN ROTATED 1/2 TIME CLOCKWISE ACROSS THE NORTHBOUND LANE. VEHICLE 1 THEN DROVE OFF THE NORTHBOUND SIDE OF THE ROAD AND OVERTURNED 1/2 TIME, COMING TO FINAL REST ON ITS ROOF FACING SOUTH. VEHICLE 2 CAME TO A CONTROLLED FINAL REST ON LOCHWINNOCH LN.
2022-07-03	1	VOLLMER RD	POCO RD	Motorcycle was traveling on Vollmer Rd headed northbound. Motorcycle traveled off the right side of the road. Motorcycle lost control and rolled multiple times, the rider was ejected. Motorcycle came to rest on the left side. Rider came to rest on his back.