



Final Drainage Report

Renehan Subdivision
5740 Burgess Road,
Colorado Springs, CO 80908

Prepared for (Owner):
Jeffrey Renehan
9548 Stoneglenn Dr
Colorado Springs CO, 80920
(719) 600-4951

Prepared by:
Kimley-Horn and Associates, Inc.
2 North Nevada Ave., Suite 900
Colorado Springs, Colorado 80903
Contact: Kevin Kofford, P.E.
(719) 453-0181

Project #: 196624000
PCD File No. MS238

Prepared: January 5, 2024

Kimley»»Horn



CERTIFICATION

ENGINEERS STATEMENT

The attached drainage plan and report were prepared under my direction and supervision and are correct to the best of my knowledge and belief. Said drainage report has been prepared according to the criteria established by the County for drainage reports and said report is in conformity with the applicable master plan of the drainage basin. I accept responsibility for any liability caused by any negligent acts, errors, or omissions on my part in preparing this report.



SIGNATURE (Affix Seal): _____ 1/5/2024
Kevin Kofford, Colorado P.E. No. 57234 Date

DEVELOPER'S STATEMENT

I, the owner/developer have read and will comply with all of the requirements specified in this drainage report and plan.

Name of Developer

Jeff Renehan

Digitally signed by Jeff Renehan
Date: 2024.06.11 15:08:46 -06'00'

Authorized Signature Date

Jeffrey N. Renehan

Printed Name

Title

9548 Stoneglen Dr, Colo Springs 80920

Address:

EL PASO COUNTY

Filed in accordance with the requirements of the Drainage Criteria Manual, Volumes 1 and 2, El Paso County Engineering Criteria Manual and Land Development Code as amended.

Joshua Palmer, P.E.

County Engineer / ECM Administrator

Date

Conditions:

TABLE OF CONTENTS

CERTIFICATION 1

ENGINEERS STATEMENT 1

DEVELOPER’S STATEMENT 1

EL PASO COUNTY 1

INTRODUCTION 3

PURPOSE AND SCOPE OF STUDY 3

GENERAL PROJECT DESCRIPTION 3

SITE CHARACTERISTICS 3

DRAINAGE BASIN PLANNING STUDY INFRASTRUCTURE AND ANALYSIS 3

SOILS CONDITIONS 4

DRAINAGE DESIGN CRITERIA 4

DEVELOPMENT DESIGN CRITERIA REFERENCE AND CONSTRAINTS 4

HYDROLOGIC CRITERIA 4

HYDRAULIC CRITERIA 4

VARIANCES FROM CRITERIA 4

EXISTING DRAINAGE CONDITIONS 4

EXISTING DRAINAGE CONDITIONS 4

PROPOSED DRAINAGE CONDITIONS 7

PROPOSED DRAINAGE BASINS 8

EMERGENCY OVERFLOW ROUTING 9

HYDRAULIC ANALYSIS METHODOLOGY 9

Four-Step Process 10

DETENTION AND WATER QUALITY REQUIREMENTS 11

EROSION CONTROL PLAN 12

FLOODPLAIN STATEMENT 12

FEES DEVELOPMENT 12

APPLICABLE FEES 12

CONSTRUCTION COST OPINION 12

MAINTENANCE AND OPERATIONS 12

SUMMARY 12

COMPLIANCE WITH STANDARDS 12

REFERENCES 13

APPENDIX 14

APPENDIX A – VICINITY MAP

APPENDIX B – SOILS MAP

APPENDIX C – FEMA FIRM PANEL

APPENDIX D – HYDROLOGIC CALCULATIONS

APPENDIX E – HYDRAULIC CALCULATIONS

APPENDIX F – DRAINAGE EXHIBITS

APPENDIX G – SITE PHOTOS

APPENDIX H– KETTLE CREEK DBPS

INTRODUCTION

PURPOSE AND SCOPE OF STUDY

The purpose of this Final Drainage Report (FDR) is to provide the hydrologic and hydraulic calculations and to document and finalize the drainage design methodology in support of the proposed Renehan Minor Subdivision (“the Project”) located at 5740 Burgess Road (“the Property”). The Project is located within the jurisdictional limits of El Paso County (“the County”). Thus, the guidelines for the hydrologic and hydraulic design components were based on the criteria for El Paso County, described below.

GENERAL PROJECT DESCRIPTION

The Site is located at 5740 Burgess Road and is bounded Burgess Road to the south and privately owned residential properties in each direction. The existing property is vacant.

The Property is to be platted as three individual lots. Lot 1 (southern region of the property) being 8.62 acres, Lot 2 (central/northeast region of the property) being 17.06 acres, and Lot 3 (northwestern region of the property) being 8.69 acres. A proposed wildlife protection zone is located at the Northwestern corner of the property (Proposed Lot 3). A shared private driveway is anticipated. Stormwater will ultimately outfall to Kettle Creek.

The confluence point for Kettle Creek and tributary Burgess Creek exists just to the north of the site.

The property is currently owned by Bradley, Sandra, Jeffrey, Julie Renehan. The Survey for the Renehan Subdivision was completed on 01/04/2023 by Land Development Consultants, Inc. This is the basis for design for the drainage map and report.

SITE CHARACTERISTICS

The Project Site is approximately 34.37 acres in size. The Project involves the division of property into three single family lots ranging in size: 8.62 acres, 17.06 acres, and 8.69 acres, respectively. The existing site is vacant and undeveloped land, with an unmaintained driveway/trail providing access from Burgess Road. The Site is heavily wooded with pine trees covering about 80% of the Site.

The existing Project Site generally slopes from east to west & south to north, towards Kettle Creek, which meanders just north of the property. Slopes vary from 2% - 25% in grade, forming numerous on-site and off-site drainage basins facilitating flows towards Kettle Creek. There are no irrigation facilities located within the Site.

DRAINAGE BASIN PLANNING STUDY INFRASTRUCTURE AND ANALYSIS

The Property is located in the Kettle Creek drainage basin and is tributary to Black Squirrel Creek. The Drainage Basin Planning Study for the Kettle Creek drainage basin was prepared May 5th, 2015 by JR Engineering LLC. See Drainage Basin Planning Study in Appendix B

SOILS CONDITIONS

NRCS soil data is available for this Site and it has been noted that onsite soils are USCS Type B. The NRCS Soils map has been provided in Appendix C.

DRAINAGE DESIGN CRITERIA

DEVELOPMENT DESIGN CRITERIA REFERENCE AND CONSTRAINTS

The report is to be in compliance with the El Paso County “Drainage Criteria Manual (DCM)” dated October 2018 (“the MANUAL”), El Paso County “Engineering Criteria Manual” (“the Engineering Manual”), Chapter 6 and Section 3.2.1 of Chapter 13 of the City of Colorado Springs Drainage Criteria Manual dated May 2014 (“the Colorado Springs MANUAL”).

HYDROLOGIC CRITERIA

The 5-year and 100-year design storm events were used in determining rainfall and runoff for the proposed drainage scenario per Volume 1 Update-Chapter 6 of the MANUAL. Table 6-2 of the MANUAL is the source for rainfall data for the 5-year and 100-year design storm events. Design runoff was calculated using the Rational Method for developed conditions as established in the MANUAL. Runoff coefficients for the proposed development were determined using Table 6-6 of the MANUAL by calculating weighted impervious values for each specific site sub-basin. A “forest” surface characteristic was used for this project, given the entirety of the Site is within a densely wooded forest.

HYDRAULIC CRITERIA

Applicable design methods were utilized to determine the culvert and drainage channels sizes which includes the use of the rational calculation’s spreadsheet and FlowMaster, V8i software.

Existing drainage features on-site have been analyzed for the following design storm events:

- Minor Storm: 5-year Storm Event
- Major Storm: 100-year Storm Event

VARIANCES FROM CRITERIA

There are no proposed variances from the El Paso County Criteria for the Project.

EXISTING DRAINAGE CONDITIONS

EXISTING DRAINAGE CONDITIONS

The existing drainage conditions for the site consists of numerous basins ranging in size from 0.59 acres to 8.56 acres, with slopes varying from 2% - 25%. Flow is accepted to the site from adjacent residential lots to the east. Runoff associated with the site flows from south to north and east to west, towards Kettle Creek. Runoff from the area south of Burgess Road is collected in existing roadside ditches along the south side of Burgess and does not flow across the roadway into the Site.

Existing Basin E-A

Drainage Basin E-A is 3.65 acres with a weighted imperviousness of 0.0%. The basin encompasses the southernmost region of the property and is bounded by basin E-B to the north and OE-A to the east. Drainage Basin E-A will also accept flows from off-site basin OE-A. The Direct Runoff values for the 5-year and 100-year storm events are 1.03 and 7.59 cubic feet per second (cfs), respectively. All runoff conveyed within the basin's existing conditions will approximately flow to design point E1 and into the adjacent property at 5650 Burgess Road.

Existing Basin E-B

Drainage Basin E-B is 6.08 acres with a weighted imperviousness of 0.0%. The basin encompasses the south-central region of the property and is bounded by the property line to the east & west and basins E-C & E-A to the north and south. Drainage Basin E-B will also accept flows from off-site basin OE-B. The Direct Runoff values for the 5-year and 100-year storm events are 1.66 and 12.08 cfs, respectively. All runoff conveyed within the basin's existing conditions will approximately flow to design point E2 and into the adjacent properties at 5650 and 5680 Burgess Road.

Existing Basin E-C

Drainage Basin E-C is 8.56 acres with a weighted imperviousness of 0.0%. The basin encompasses the central region of the property and is bound by the property line to the East & West and basins E-D & E-B to the north and south. Drainage Basin E-C will also accept flows from off-site basin OE-C and partially from OE-D. The Direct Runoff values for the 5-year and 100-year storm events are 1.92 and 14.13 cfs, respectively. All runoff conveyed within the basin's existing conditions will approximately flow to design point E3 and into the adjacent property 5680 Burgess Road.

Existing Basin E-D

Drainage Basin E-D is 7.50 acres with a weighted imperviousness of 0.0%. The basin encompasses the northeastern region of the property and is bounded by the property lines to the north and east, basin E-G to the west, and E-C to the south. Drainage Basin E-D will also accept flows from off-site basin OE-D and OE-E. The Direct Runoff values for the 5-year and 100-year storm events are 1.80 and 13.19 cfs, respectively. All runoff conveyed within the basin's existing conditions will approximately flow to design point E4. From design point E-4, channelized flows continue north towards Kettle Creek.

Existing Basin E-E

Drainage Basin E-E is 0.83 acres with a weighted imperviousness of 0.0%. The basin encompasses the northern region of the property, bounded by basin E-G and the northern property line. The Direct Runoff values for the 5-year and 100-year storm events are 0.25 and 1.87 cfs, respectively. All runoff conveyed within the basin's existing conditions will approximately flow northwest to design point E5. From design point E-5, channelized flows continue north towards Kettle Creek.

Existing Basin E-F

Drainage Basin E-F is 0.59 acres with a weighted imperviousness of 0.0%. The basin encompasses a small portion of the northern region of the property, bounded by basin E-G to the north/west and the site's property line to the south. The Direct Runoff values for the 5-year and 100-year storm events are 0.19 and 1.39 cfs, respectively. All runoff conveyed within the basin's existing conditions will approximately flow northwest to design point E6. From design point E-6, channelized flows continue northwest towards Kettle Creek.

Existing Basin E-G

Drainage Basin E-G is 7.15 acres with a weighted imperviousness of 0.0%. The basin encompasses most of the northwestern region of the property, and accepts flows from offsite basin OE-H. E-G is bounded by property lines to the north, west, and south, and basins E-E, E-F, E-C, and E-D. E-G. The Direct Runoff values for the 5-year and 100-year storm events are 2.01 and 14.80 cfs, respectively. All runoff conveyed within the basin's existing conditions will approximately flow northwest to design point E7. From design point E-7, channelized flows continue northwest towards Kettle Creek.

Existing Basin OE-A

Drainage Basin OE-A is 0.10 acres with a weighted imperviousness of 0.0%. The basin encompasses a small off-site area bounded by the site's property line to the west and basin OE-B to the north and east. The Direct Runoff values for the 5-year and 100-year storm events are 0.04 and 0.27 cfs, respectively. All runoff conveyed within the basin's existing conditions will approximately flow to design point E8 and into basin E-A.

Existing Basin OE-B

Drainage Basin OE-B is 0.86 acres with a weighted imperviousness of 0.0%. The basin encompasses a small off-site area bounded by the site's property line to the west, basin OE-C to the north, basin OE-D to the east, and basin OE-A to the south. The Direct Runoff values for the 5-year and 100-year storm events are 0.27 and 1.96 cfs, respectively. All runoff conveyed within the basin's existing conditions will approximately flow to design point E9 and into basin E-B.

Existing Basin OE-C

Drainage Basin OE-C is 2.19 acres with a weighted imperviousness of 0.0%. The basin encompasses an off-site area bounded by the site's property line to the west, basin OE-D to the north and east, and basin OE-B to the south. The Direct Runoff values for the 5-year and 100-year storm events are 0.66 and 4.86 cfs, respectively. All runoff conveyed within the basin's existing conditions will approximately flow to design point E10 and into basin E-C.

Existing Basin OE-D

Drainage Basin OE-D is 20.33 acres with a weighted imperviousness of 0.0%. The basin encompasses an off-site area bounded by the site's property line to the west, basin OE-E to the north and east, and basin OE-C to the south. The Direct Runoff values for the 5-year and 100-year storm events are 5.63 and 41.36 cfs, respectively. All runoff conveyed within the basin's existing conditions will approximately flow to design point E11 and into basin E-D.

Existing Basin OE-E

Drainage Basin OE-E is 10.52 acres with a weighted imperviousness of 0.0%. The basin encompasses an off-site area bounded by the site's property line to the west and adjacent residential property to the north and east. Kettle Creek runs westward, directly north of this basin. The Direct Runoff values for the 5-year and 100-year storm events are 2.70 and 19.82 cfs, respectively. All runoff conveyed within the basin's existing conditions will approximately flow to design point E12 and into basin E-D towards design point E4 and eventually northwards towards Kettle Creek.

Existing Basin OE-H

Drainage Basin OE-H is 5.36 acres with a weighted imperviousness of 0.0%. The basin encompasses an off-site area bounded by the site's property line to the north and east and adjacent residential property to the south and west. The Direct Runoff values for the 5-year and 100-year storm events are 1.52 and 11.16 cfs, respectively. All runoff conveyed within the basin's existing conditions will approximately flow to design point E13 and into basin E-G through an existing natural channel towards design point E7 and continue north towards Kettle Creek.

PROPOSED DRAINAGE CONDITIONS

Drainage conditions for the proposed site are similar to that of the existing site, with improvements that prevent flows generated on-site from flowing into the adjacent properties to the west: 5650 and 5680 Burgess Road. These improvements are associated with the potential proposed shared driveway access for the three residential lots included in the plat. Along the eastern edge of the future driveway is a proposed ditch, conveying runoff northwards. Within the northern vicinity of proposed basin P-A is where a proposed culvert is identified to facilitate flow from the swale, beneath the potential future driveway, and northwest towards Kettle Creek. For this crossing a 36-inch CMP culvert will have the capacity for the 100-year storm or an 18-inch CMP for the 5-year storm with larger storm events topping the driveway. A concrete lowering with riprap placed both upstream and downstream of the lowering would also be acceptable. These improvements will be completed by home builder of Lot 3. Reference Appendix E for capacity calculations. The location and placement of the culvert will be determined with the driveway design but should be placed north of the existing property to corner to allow flows to remain on the Site without accumulated runoff entering the adjacent properties to the west.

There is natural drainage swale that conveys existing flows in existing conditions and the culvert accommodates the proposed flows. A 30-foot drainage easement is proposed along this drainage swale. The natural channel conveys these flows to a heavily vegetated forest and stable outfall. In existing conditions, no further alteration to the topography would be necessary.

Given the numerous unknowns regarding future development of the site, a generous assumption/estimate for weighted imperviousness was made regarding the quantity of proposed houses, and overall size of building footprints and driveways. The proposed conditions assume four total houses each with separate paved (future material unknown) driveways. Additionally, each building footprint is 10,000 SF, which is an extremely large size for this project (assuming a large house footprint and accessory structure). Even with utilizing these conservative parameters for imperviousness, the total weighted imperviousness for the site was calculated at approximately 3.3%. For a typical 5-acre lot, a 7% imperviousness has been widely accepted. The average lot size for these three lots is over 11 acres in size. In taking a general trend of

imperviousness vs. lot size, a 3.5% to 4% imperviousness is in line with an over 11-acre size. The provided 3.3% imperviousness matches these empirical assumptions.

PROPOSED DRAINAGE BASINS

Proposed Basin P-A

Drainage Basin P-A is 18.28 acres with a weighted imperviousness of 10.0%. The basin encompasses the southern and central regions of the property and is bounded by site property line to the south and west, basin OP-A to the east, and basin P-B to the north. Drainage Basin P-A will also accept flows from off-site basin OP-A and part of OP-B. The Direct Runoff values for the 5-year and 100-year storm events are 7.60 and 36.26 cfs, respectively. All runoff conveyed within the basin's proposed conditions will approximately flow to design point P1 into a proposed 18 inch CMP culvert (5 Year) 36 inch CMP culvert (100 YR) or concrete lowering to be design with the driveway of the home, and westwards to Kettle Creek.

Proposed Basin P-B

Drainage Basin P-B is 7.50 acres with a weighted imperviousness of 1.8%. The basin encompasses the northeastern region of the property and is bounded by site property line to the north, P-C to the west, OP-B & OP-C to the east, and basin P-A to the south. Basin P-B will also accept flows from off-site basin OP-B and part of OP-C. The Direct Runoff values for the 5-year and 100-year storm events are 2.06 and 15.16 cfs, respectively. All runoff conveyed within the basin's proposed conditions will approximately flow to design point P2, then northwards towards Kettle Creek.

Proposed Basin P-C

Drainage Basin P-C is 7.17 acres with a weighted imperviousness of 6.3%. The basin encompasses most of the northwestern region of the property and accepts flows from Drainage Basin P-A. P-C is bounded by the site property line to the north, west, and south, and basins P-A and P-B to the east and south. The Direct Runoff values for the 5-year and 100-year storm events are 2.57 and 15.01 cfs, respectively. All runoff conveyed within the basin's proposed conditions will approximately flow to design point P3, then north/west towards Kettle Creek.

Proposed Basin P-D

Drainage Basin P-D is 0.83 acres with a weighted imperviousness of 0.0%. The basin encompasses a small area within the northwestern region of the property. P-D is bounded by the site property line to the north and P-C to the west, east, and south. The Direct Runoff values for the 5-year and 100-year storm events are 0.25 and 1.87 cfs, respectively. All runoff conveyed within the basin's proposed conditions will approximately flow to design point P4, then north/west towards Kettle Creek.

Proposed Basin P-E

Drainage Basin P-E is 0.59 acres with a weighted imperviousness of 0.0%. The basin encompasses a small area within the northwestern region of the property. P-E is bounded by the site property line to the west & south and basin P-C to the north and east. The Direct Runoff

values for the 5-year and 100-year storm events are 0.19 and 1.39 cfs, respectively. All runoff conveyed within the basin's proposed conditions will approximately flow to design point P5, then north/west towards Kettle Creek.

Proposed Basin OP-A

Drainage Basin OP-A is 3.15 acres with a weighted imperviousness of 0.0%. The basin encompasses a small area within the northwestern region of the property. OP-A is bounded by the site property line to the west, Burgess Road to the south, and basin OP-B to the north and east. The Direct Runoff values for the 5-year and 100-year storm events are 0.95 and 6.98 cfs, respectively. All runoff conveyed within the basin's proposed conditions will approximately flow to design point P6, then north/west into basin P-A.

Proposed Basin OP-B

Drainage Basin OP-B is 20.33 acres with a weighted imperviousness of 0.0%. The basin encompasses a small area within the northwestern region of the property. OP-B is bounded by the site property line to the west, Burgess Road to the south, and basin OP-C to the north and east. The Direct Runoff values for the 5-year and 100-year storm events are 5.51 and 40.46 cfs, respectively. All runoff conveyed within the basin's proposed conditions will approximately flow to design point P7, then north/west into basin P-B.

Proposed Basin OP-C

Drainage Basin OP-C is 10.52 acres with a weighted imperviousness of 0.0%. The basin encompasses a small area within the northwestern region of the property. OP-C is bounded by the site property line to the west and OP-B to the south. The Direct Runoff values for the 5-year and 100-year storm events are 2.66 and 19.57 cfs, respectively. All runoff conveyed within the basin's proposed conditions will approximately flow to design point P8, then north/west into basin P-B.

Proposed Basin OP-H

Drainage Basin OP-H is 5.36 acres with a weighted imperviousness of 0.0%. The basin encompasses an off-site area bounded by the site's property line to the north and east and adjacent residential property to the south and west. The Direct Runoff values for the 5-year and 100-year storm events are 1.52 and 11.16 cfs, respectively. All runoff conveyed within the basin's existing conditions will approximately flow to design point P13 and into basin P-C through an existing natural channel towards design point P3 and continue north towards Kettle Creek.

EMERGENCY OVERFLOW ROUTING

All overflow routing will be directed to the Kettle Creek drainageway north of the site. This flow path is consistent with the historical stormwater runoff path.

HYDRAULIC ANALYSIS METHODOLOGY

The proposed drainage facilities were designed in accordance with the CRITERIA and MANUAL. Floodplain identification was determined using a custom FIRMette map by FEMA and information provided in the CRITERIA. Culvert capacity calculations were computed using Flow master.

There is no stormwater infrastructure proposed with the replat.

Guidance for future improvements is as follows: If platted lots are built out as single-family residential homes, a 18 inch CMP culvert (5 Year) or 36 CMP culvert (100 YR) would be an adequate solution to facilitate flow beneath the potential location for a driveway in Proposed Lot 2. FlowMaster modeling was used to size the potential proposed driveway culvert. See Appendix E for FlowMaster Calculations.

Four-Step Process

The Site was designed in accordance with the four-step process to minimize adverse impacts of urbanization, as outlined in Section I.7.2 BMP Selection of the MANUAL. The four-step process per the MANUAL provides guidance and requirements for the selection of siting of structural Best Management Practices (BMPs) for new development and significant redevelopment.

Step 1: Employ Runoff Reduction Practices

The purpose of this project is to replat the existing property, into three separate single-family lots. No infrastructure improvements are included with the replat. Per Section I.7.1B of Appendix I of the ECM, the single-family residences fall under the large lot exemption as the total impervious area is less than 10% of the area. A BESQCP permit will be required by the County to prevent erosion and mitigate any runoff due to those activities.

Step 2: Stabilize Drainageways

The Kettle Creek Drainageway flows just north of the Site. During a Site visit, it was found that the area (basins) tributary to the drainageway is currently well-stabilized and well-vegetated. As the drainageway is currently stable the existing drainageway can be left as-is in its stable condition. As noted in Chapter 1, Section 1.4 of the MANUAL, “Natural channel systems, primarily the designated Major Drainageways and Primary outfalls, serve to store flood waters, enhance water quality, provide for ground water recharge and preserve riparian corridors. The use of historical channels to convey storm water runoff from developed and developing areas is acceptable. However, if historical storm water flows are increased, or if historical channels are unstable in their natural conditions, these channels must be adequately stabilized to prevent excessive erosion.” Additionally, Chapter 2, Section 2.2 of the MANUAL states, “A stable natural channel reaches ‘equilibrium’ over many years. Therefore, channel modifications should be minimal.” Because the existing drainageway is properly stabilized, it is felt that attempts to change the natural channel may lead to destabilization of the drainageway and therefore, no changes to the drainageway, with the exception of stabilization at the location of the proposed ditches, or future accesses are driveways are recommended.

Step 3: Provide Water Quality Capture Volume (WQCV)

Per Section I.7.1B of Appendix I of the ECM, detention and water-quality facilities are not required for the Project. The purpose of this project is to replat the existing property into three separate single-family lots. No infrastructure improvements are included with the replat.

Full Exclusions per I.7.1.B.5

Large Lot Single Family Sites

A single-family residential lot, or agricultural zoned lands, greater than or equal to 2.5 acres in size per dwelling and having a total lot impervious area of less than 10 percent. A total lot imperviousness greater than 10 percent is allowed when a study specific to the watershed and/or MS4 shows that expected soil and vegetation conditions are suitable for infiltration/filtration of the WQCV for a typical site, and the permittee accepts such study as applicable within its MS4 boundaries. The maximum total lot impervious covered under this exclusion shall be 20 percent.

The 10% imperviousness includes the proposed shared private driveway within the calculations for the total impervious area for the lot. The builder will be forced to comply with the criteria to ensure the final impervious area is less than 10%.

Step 4: Consider Need for Industrial and Commercial BMPs

The proposed Project consists of a single-family subdivision. No industrial and commercial uses or developments are anticipated as part of the proposed development.

DETENTION AND WATER QUALITY REQUIREMENTS

As discussed in Section I.7.1B of Appendix I of the ECM, detention and water-quality facilities are not required for the Project as no improvements are to be made in association with the platting process. Therefore, there is also no addition of impervious area with the project.

Overall, the existing flows are approximately 25.57 CFS and 144.57 CFS for the 5-year and 100-year respectively. The proposed flows are approximately 23.33 CFS and 147.88 CFS for the 5-year and 100-year respectively.

There are two locations where the site outfalls in route to Kettle Creek. The first outfall is in the northwest corner of the site at design point E7 (existing) and P3 (proposed). Flows that are conveyed to this design point will travel via existing stabilized natural channels through forest and wooded vegetation (reference existing site photos). Total flows entering this area in existing conditions (sub-basins E-G, OE-H, E-C, OE-C, E-F, E-E, E-A, OE-A, E-B, OE-B) are approximately 9.56 CFS in the 5-year and 70.21 CFS in 100-year. In proposed conditions, the flows entering the area (sub-basins P-A, OP-A, OE-H, P-D, P-C, P-E) are approximately 13.09 CFS in the 5-year and 72.68 CFS in the 100-year. Refer to **Appendix G**, photos 1-6 for design point E7 (existing) P3 (proposed).

The second outfall is on the north end of the property of the site at design point E4 (existing) and P2 (proposed). Flows that are conveyed to this design point will travel via existing wooded vegetation. Total flows entering this area in existing conditions (sub-basins E-D, OE-E, OE-D) are approximately 10.12 CFS in the 5-year and 75.37 CFS in the 100-year. In proposed conditions, the flows entering the area (sub-basins P-B, OP-B, OP-C) are approximately 10.24 CFS in the 5-year and 75.20 CFS in the 100-year. Refer to **Appendix G**, photos 11-14 for design point E4 (existing) P2 (proposed).

Overall, the flows increase slightly from 144.57 CFS to 147.88 CFS in the 100-year event, a 3.31 CFS increase. Additionally, the proposed shared driveway is under 1-acre and less than 10% of total imperviousness for the entire proposed development. Additionally, the runoff generated from the proposed basins will sheet flow over densely wooded and naturally vegetated areas prior to entering Kettle Creek. These overland flow areas are extremely stable and the minimal increase in overall flow in the 100-year event will have a negligible impact. Subsequently, the proposed project would not pose any risk to existing downstream waterways or infrastructure.

Kettle Creek is a stable, healthy, and heavily vegetated existing waterway that has capacity and capability to accommodate the existing and proposed runoff. Additionally, flows conveyed to the design points travel approximately 700 ft before reaching Kettle Creek. Therefore, runoff flows have a major opportunity to infiltrate into the existing Type B soils.

The proposed project is adjacent to two existing properties on the west side of the site. The project proposes a shared driveway and a drainage ditch on the east side of the driveway to convey

runoff to the existing design point. Additionally, this drainage ditch will protect neighboring properties to the west by capturing any runoff that was conveyed in that direction pre-development and the new post-development flows. No proposed additional flows will negatively impact the adjacent properties.

EROSION CONTROL PLAN

Erosion Control Plans with the Minor Subdivision are not required. A BESQCP permit will be required by the County to prevent erosion and mitigate any runoff due to those activities.

FLOODPLAIN STATEMENT

The area within the site exists outside of any special flood hazard areas and are completely outside the 0.2% annual chance floodplain. This is represented on FEMA Maps 08041C0315G and 08041C0526 (Appendix D), revised on December 7, 2018; also, FEMA Firmette Map exported on December 1, 2021. The El Paso County Requirements specify that the Base Flood Elevation be shown on the Final Plat per section RBC313.18.5, as necessary.

FEES DEVELOPMENT

APPLICABLE FEES

The project is within the Kettle Creek Drainage Basin and per El Paso County Drainage Basin Fees for Kettle Creek the fee per acre of impervious area is \$12,463.00. The total proposed weighted imperviousness for the site is 3.3%, so that is multiplied by the total site area and then multiplied by the fee per impervious area. The total fee would be \$14,135.66 (see below breakdown). There are no bridge fees for Kettle Creek Drainage Basin.

Receiving Waters	Drainage Basin	Fee per Impervious Acre	Total Acres	Weighted Imperviousness	Total * WI	Total Fee
Monument Creek	Kettle Creek	\$ 12,463.00	34.37	3.3%	1.13421	\$ 14,135.66

CONSTRUCTION COST OPINION

There are no public drainage ponds or permanent control measures proposed as part of the Project.

MAINTENANCE AND OPERATIONS

There are no public drainage ponds or permanent control measures proposed as part of the Project.

SUMMARY

COMPLIANCE WITH STANDARDS

The drainage design presented within this report conforms to the El Paso County Storm Drainage Criteria and the Mile High Flood Control District Manual. Additionally, the minor subdivision plat will not adversely affect the downstream and surrounding developments or waterways.

REFERENCES

1. The City of Colorado Springs Drainage Criteria Manual, May 2014
2. El Paso County Drainage Criteria Manual, Vol. 1 and 2, October 1994
3. Urban Drainage and Flood Control District Drainage Criteria Manual (UDFCDCM), Vol. 1, prepared by Wright-McLaughlin Engineers, June 2001, with latest revisions.
4. Flood Insurance Rate Map, El Paso County, Colorado and Incorporated Areas, Map Number 08041C03040G, Effective Date December 7, 2018, prepared by the Federal Emergency Management Agency (FEMA).

APPENDIX

APPENDIX A - VICINITY MAP

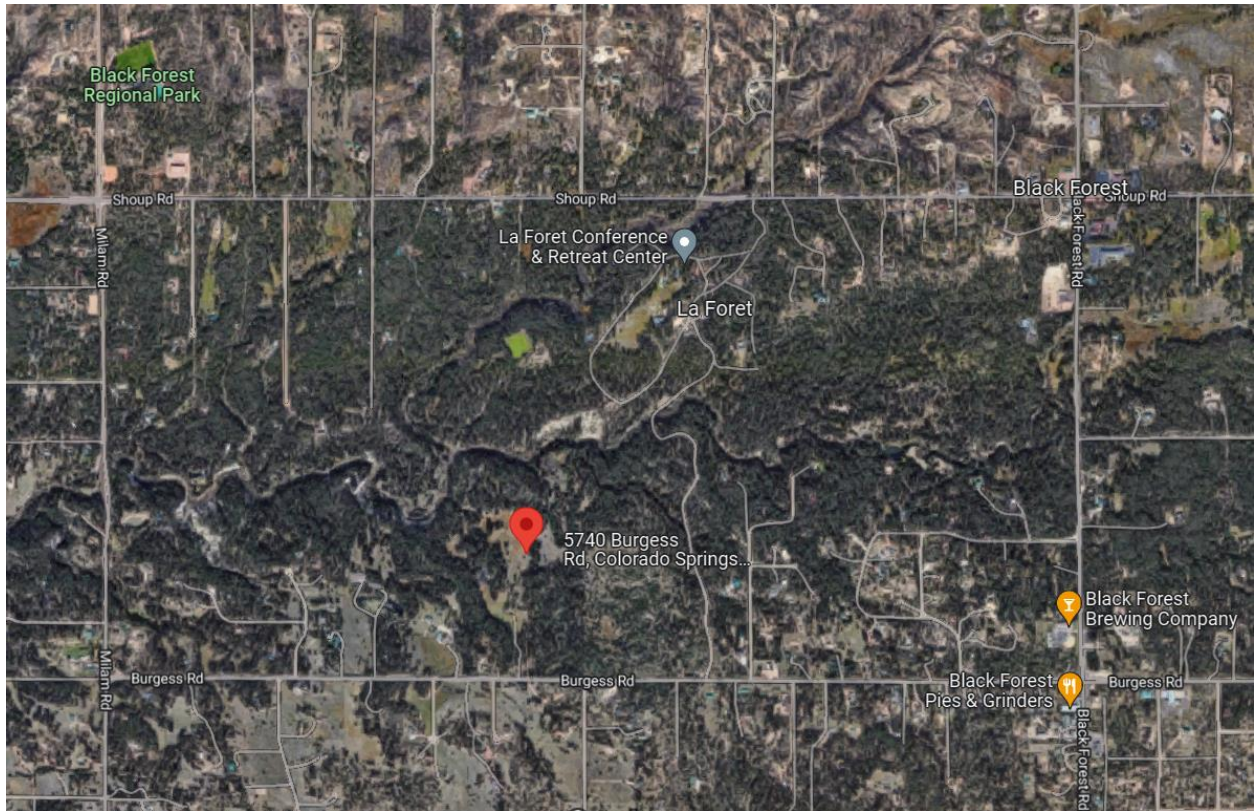

Appendix A

APPENDIX B – NRCS SOIL SURVEY

Custom Soil Resource Report for El Paso County Area, Colorado

Renehan Subdivision

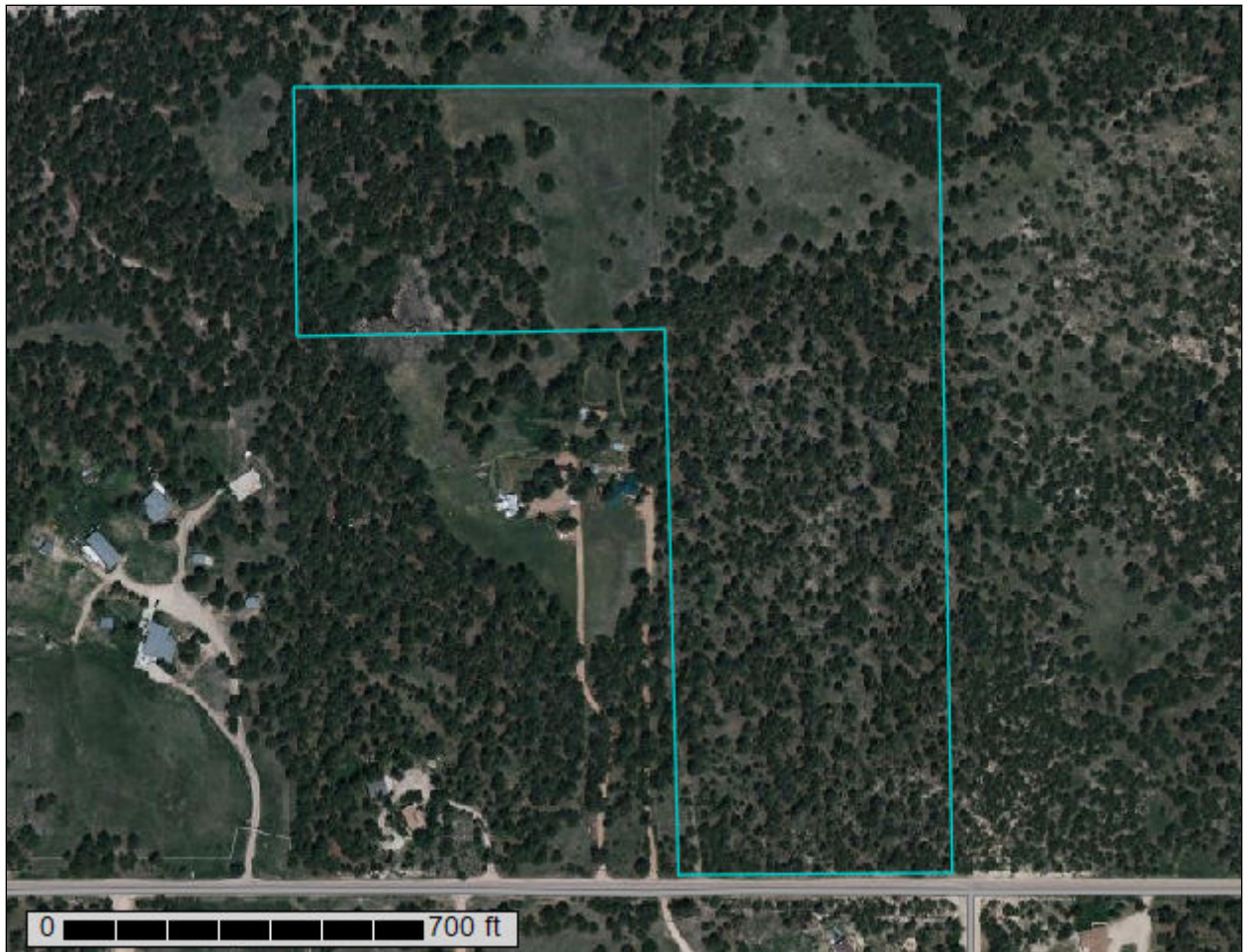

Preface

Soil surveys contain information that affects land use planning in survey areas. They highlight soil limitations that affect various land uses and provide information about the properties of the soils in the survey areas. Soil surveys are designed for many different users, including farmers, ranchers, foresters, agronomists, urban planners, community officials, engineers, developers, builders, and home buyers. Also, conservationists, teachers, students, and specialists in recreation, waste disposal, and pollution control can use the surveys to help them understand, protect, or enhance the environment.

Various land use regulations of Federal, State, and local governments may impose special restrictions on land use or land treatment. Soil surveys identify soil properties that are used in making various land use or land treatment decisions. The information is intended to help the land users identify and reduce the effects of soil limitations on various land uses. The landowner or user is responsible for identifying and complying with existing laws and regulations.

Although soil survey information can be used for general farm, local, and wider area planning, onsite investigation is needed to supplement this information in some cases. Examples include soil quality assessments (<http://www.nrcs.usda.gov/wps/portal/nrcs/main/soils/health/>) and certain conservation and engineering applications. For more detailed information, contact your local USDA Service Center (<https://offices.sc.egov.usda.gov/locator/app?agency=nrcs>) or your NRCS State Soil Scientist (http://www.nrcs.usda.gov/wps/portal/nrcs/detail/soils/contactus/?cid=nrcs142p2_053951).

Great differences in soil properties can occur within short distances. Some soils are seasonally wet or subject to flooding. Some are too unstable to be used as a foundation for buildings or roads. Clayey or wet soils are poorly suited to use as septic tank absorption fields. A high water table makes a soil poorly suited to basements or underground installations.

The National Cooperative Soil Survey is a joint effort of the United States Department of Agriculture and other Federal agencies, State agencies including the Agricultural Experiment Stations, and local agencies. The Natural Resources Conservation Service (NRCS) has leadership for the Federal part of the National Cooperative Soil Survey.

Information about soils is updated periodically. Updated information is available through the NRCS Web Soil Survey, the site for official soil survey information.

The U.S. Department of Agriculture (USDA) prohibits discrimination in all its programs and activities on the basis of race, color, national origin, age, disability, and where applicable, sex, marital status, familial status, parental status, religion, sexual orientation, genetic information, political beliefs, reprisal, or because all or a part of an individual's income is derived from any public assistance program. (Not all prohibited bases apply to all programs.) Persons with disabilities who require

alternative means for communication of program information (Braille, large print, audiotape, etc.) should contact USDA's TARGET Center at (202) 720-2600 (voice and TDD). To file a complaint of discrimination, write to USDA, Director, Office of Civil Rights, 1400 Independence Avenue, S.W., Washington, D.C. 20250-9410 or call (800) 795-3272 (voice) or (202) 720-6382 (TDD). USDA is an equal opportunity provider and employer.

Contents

Preface	2
How Soil Surveys Are Made	5
Soil Map	8
Soil Map.....	9
Legend.....	10
Map Unit Legend.....	11
Map Unit Descriptions.....	11
El Paso County Area, Colorado.....	13
40—Kettle gravelly loamy sand, 3 to 8 percent slopes.....	13
41—Kettle gravelly loamy sand, 8 to 40 percent slopes.....	14
References	16

How Soil Surveys Are Made

Soil surveys are made to provide information about the soils and miscellaneous areas in a specific area. They include a description of the soils and miscellaneous areas and their location on the landscape and tables that show soil properties and limitations affecting various uses. Soil scientists observed the steepness, length, and shape of the slopes; the general pattern of drainage; the kinds of crops and native plants; and the kinds of bedrock. They observed and described many soil profiles. A soil profile is the sequence of natural layers, or horizons, in a soil. The profile extends from the surface down into the unconsolidated material in which the soil formed or from the surface down to bedrock. The unconsolidated material is devoid of roots and other living organisms and has not been changed by other biological activity.

Currently, soils are mapped according to the boundaries of major land resource areas (MLRAs). MLRAs are geographically associated land resource units that share common characteristics related to physiography, geology, climate, water resources, soils, biological resources, and land uses (USDA, 2006). Soil survey areas typically consist of parts of one or more MLRA.

The soils and miscellaneous areas in a survey area occur in an orderly pattern that is related to the geology, landforms, relief, climate, and natural vegetation of the area. Each kind of soil and miscellaneous area is associated with a particular kind of landform or with a segment of the landform. By observing the soils and miscellaneous areas in the survey area and relating their position to specific segments of the landform, a soil scientist develops a concept, or model, of how they were formed. Thus, during mapping, this model enables the soil scientist to predict with a considerable degree of accuracy the kind of soil or miscellaneous area at a specific location on the landscape.

Commonly, individual soils on the landscape merge into one another as their characteristics gradually change. To construct an accurate soil map, however, soil scientists must determine the boundaries between the soils. They can observe only a limited number of soil profiles. Nevertheless, these observations, supplemented by an understanding of the soil-vegetation-landscape relationship, are sufficient to verify predictions of the kinds of soil in an area and to determine the boundaries.

Soil scientists recorded the characteristics of the soil profiles that they studied. They noted soil color, texture, size and shape of soil aggregates, kind and amount of rock fragments, distribution of plant roots, reaction, and other features that enable them to identify soils. After describing the soils in the survey area and determining their properties, the soil scientists assigned the soils to taxonomic classes (units). Taxonomic classes are concepts. Each taxonomic class has a set of soil characteristics with precisely defined limits. The classes are used as a basis for comparison to classify soils systematically. Soil taxonomy, the system of taxonomic classification used in the United States, is based mainly on the kind and character of soil properties and the arrangement of horizons within the profile. After the soil

Custom Soil Resource Report

scientists classified and named the soils in the survey area, they compared the individual soils with similar soils in the same taxonomic class in other areas so that they could confirm data and assemble additional data based on experience and research.

The objective of soil mapping is not to delineate pure map unit components; the objective is to separate the landscape into landforms or landform segments that have similar use and management requirements. Each map unit is defined by a unique combination of soil components and/or miscellaneous areas in predictable proportions. Some components may be highly contrasting to the other components of the map unit. The presence of minor components in a map unit in no way diminishes the usefulness or accuracy of the data. The delineation of such landforms and landform segments on the map provides sufficient information for the development of resource plans. If intensive use of small areas is planned, onsite investigation is needed to define and locate the soils and miscellaneous areas.

Soil scientists make many field observations in the process of producing a soil map. The frequency of observation is dependent upon several factors, including scale of mapping, intensity of mapping, design of map units, complexity of the landscape, and experience of the soil scientist. Observations are made to test and refine the soil-landscape model and predictions and to verify the classification of the soils at specific locations. Once the soil-landscape model is refined, a significantly smaller number of measurements of individual soil properties are made and recorded. These measurements may include field measurements, such as those for color, depth to bedrock, and texture, and laboratory measurements, such as those for content of sand, silt, clay, salt, and other components. Properties of each soil typically vary from one point to another across the landscape.

Observations for map unit components are aggregated to develop ranges of characteristics for the components. The aggregated values are presented. Direct measurements do not exist for every property presented for every map unit component. Values for some properties are estimated from combinations of other properties.

While a soil survey is in progress, samples of some of the soils in the area generally are collected for laboratory analyses and for engineering tests. Soil scientists interpret the data from these analyses and tests as well as the field-observed characteristics and the soil properties to determine the expected behavior of the soils under different uses. Interpretations for all of the soils are field tested through observation of the soils in different uses and under different levels of management. Some interpretations are modified to fit local conditions, and some new interpretations are developed to meet local needs. Data are assembled from other sources, such as research information, production records, and field experience of specialists. For example, data on crop yields under defined levels of management are assembled from farm records and from field or plot experiments on the same kinds of soil.

Predictions about soil behavior are based not only on soil properties but also on such variables as climate and biological activity. Soil conditions are predictable over long periods of time, but they are not predictable from year to year. For example, soil scientists can predict with a fairly high degree of accuracy that a given soil will have a high water table within certain depths in most years, but they cannot predict that a high water table will always be at a specific level in the soil on a specific date.

After soil scientists located and identified the significant natural bodies of soil in the survey area, they drew the boundaries of these bodies on aerial photographs and

Custom Soil Resource Report

identified each as a specific map unit. Aerial photographs show trees, buildings, fields, roads, and rivers, all of which help in locating boundaries accurately.

Soil Map

The soil map section includes the soil map for the defined area of interest, a list of soil map units on the map and extent of each map unit, and cartographic symbols displayed on the map. Also presented are various metadata about data used to produce the map, and a description of each soil map unit.

Custom Soil Resource Report Soil Map



Map Scale: 1:3,030 if printed on A portrait (8.5" x 11") sheet.

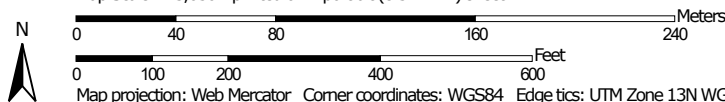

Map projection: Web Mercator Corner coordinates: WGS84 Edge tics: UTM Zone 13N WGS84

MAP LEGEND

Area of Interest (AOI)

 Area of Interest (AOI)

Soils

 Soil Map Unit Polygons

 Soil Map Unit Lines

 Soil Map Unit Points

Special Point Features





-  Blowout
-  Borrow Pit
-  Clay Spot
-  Closed Depression
-  Gravel Pit
-  Gravelly Spot
-  Landfill
-  Lava Flow
-  Marsh or swamp
-  Mine or Quarry
-  Miscellaneous Water
-  Perennial Water
-  Rock Outcrop
-  Saline Spot
-  Sandy Spot
-  Severely Eroded Spot
-  Sinkhole
-  Slide or Slip
-  Sodic Spot

-  Spoil Area
-  Stony Spot
-  Very Stony Spot
-  Wet Spot
-  Other
-  Special Line Features

Water Features

 Streams and Canals

Transportation

-  Rails
-  Interstate Highways
-  US Routes
-  Major Roads
-  Local Roads

Background

 Aerial Photography

MAP INFORMATION

The soil surveys that comprise your AOI were mapped at 1:24,000.

Warning: Soil Map may not be valid at this scale.

Enlargement of maps beyond the scale of mapping can cause misunderstanding of the detail of mapping and accuracy of soil line placement. The maps do not show the small areas of contrasting soils that could have been shown at a more detailed scale.

Please rely on the bar scale on each map sheet for map measurements.

Source of Map: Natural Resources Conservation Service
 Web Soil Survey URL:
 Coordinate System: Web Mercator (EPSG:3857)

Maps from the Web Soil Survey are based on the Web Mercator projection, which preserves direction and shape but distorts distance and area. A projection that preserves area, such as the Albers equal-area conic projection, should be used if more accurate calculations of distance or area are required.

This product is generated from the USDA-NRCS certified data as of the version date(s) listed below.

Soil Survey Area: El Paso County Area, Colorado
 Survey Area Data: Version 20, Sep 2, 2022

Soil map units are labeled (as space allows) for map scales 1:50,000 or larger.

Date(s) aerial images were photographed: Jun 9, 2021—Jun 12, 2021

The orthophoto or other base map on which the soil lines were compiled and digitized probably differs from the background imagery displayed on these maps. As a result, some minor shifting of map unit boundaries may be evident.

Map Unit Legend

Map Unit Symbol	Map Unit Name	Acres in AOI	Percent of AOI
40	Kettle gravelly loamy sand, 3 to 8 percent slopes	26.6	98.6%
41	Kettle gravelly loamy sand, 8 to 40 percent slopes	0.4	1.4%
Totals for Area of Interest		27.0	100.0%

Map Unit Descriptions

The map units delineated on the detailed soil maps in a soil survey represent the soils or miscellaneous areas in the survey area. The map unit descriptions, along with the maps, can be used to determine the composition and properties of a unit.

A map unit delineation on a soil map represents an area dominated by one or more major kinds of soil or miscellaneous areas. A map unit is identified and named according to the taxonomic classification of the dominant soils. Within a taxonomic class there are precisely defined limits for the properties of the soils. On the landscape, however, the soils are natural phenomena, and they have the characteristic variability of all natural phenomena. Thus, the range of some observed properties may extend beyond the limits defined for a taxonomic class. Areas of soils of a single taxonomic class rarely, if ever, can be mapped without including areas of other taxonomic classes. Consequently, every map unit is made up of the soils or miscellaneous areas for which it is named and some minor components that belong to taxonomic classes other than those of the major soils.

Most minor soils have properties similar to those of the dominant soil or soils in the map unit, and thus they do not affect use and management. These are called noncontrasting, or similar, components. They may or may not be mentioned in a particular map unit description. Other minor components, however, have properties and behavioral characteristics divergent enough to affect use or to require different management. These are called contrasting, or dissimilar, components. They generally are in small areas and could not be mapped separately because of the scale used. Some small areas of strongly contrasting soils or miscellaneous areas are identified by a special symbol on the maps. If included in the database for a given area, the contrasting minor components are identified in the map unit descriptions along with some characteristics of each. A few areas of minor components may not have been observed, and consequently they are not mentioned in the descriptions, especially where the pattern was so complex that it was impractical to make enough observations to identify all the soils and miscellaneous areas on the landscape.

The presence of minor components in a map unit in no way diminishes the usefulness or accuracy of the data. The objective of mapping is not to delineate pure taxonomic classes but rather to separate the landscape into landforms or landform segments that have similar use and management requirements. The delineation of such segments on the map provides sufficient information for the development of resource plans. If intensive use of small areas is planned, however,

Custom Soil Resource Report

onsite investigation is needed to define and locate the soils and miscellaneous areas.

An identifying symbol precedes the map unit name in the map unit descriptions. Each description includes general facts about the unit and gives important soil properties and qualities.

Soils that have profiles that are almost alike make up a *soil series*. Except for differences in texture of the surface layer, all the soils of a series have major horizons that are similar in composition, thickness, and arrangement.

Soils of one series can differ in texture of the surface layer, slope, stoniness, salinity, degree of erosion, and other characteristics that affect their use. On the basis of such differences, a soil series is divided into *soil phases*. Most of the areas shown on the detailed soil maps are phases of soil series. The name of a soil phase commonly indicates a feature that affects use or management. For example, Alpha silt loam, 0 to 2 percent slopes, is a phase of the Alpha series.

Some map units are made up of two or more major soils or miscellaneous areas. These map units are complexes, associations, or undifferentiated groups.

A *complex* consists of two or more soils or miscellaneous areas in such an intricate pattern or in such small areas that they cannot be shown separately on the maps. The pattern and proportion of the soils or miscellaneous areas are somewhat similar in all areas. Alpha-Beta complex, 0 to 6 percent slopes, is an example.

An *association* is made up of two or more geographically associated soils or miscellaneous areas that are shown as one unit on the maps. Because of present or anticipated uses of the map units in the survey area, it was not considered practical or necessary to map the soils or miscellaneous areas separately. The pattern and relative proportion of the soils or miscellaneous areas are somewhat similar. Alpha-Beta association, 0 to 2 percent slopes, is an example.

An *undifferentiated group* is made up of two or more soils or miscellaneous areas that could be mapped individually but are mapped as one unit because similar interpretations can be made for use and management. The pattern and proportion of the soils or miscellaneous areas in a mapped area are not uniform. An area can be made up of only one of the major soils or miscellaneous areas, or it can be made up of all of them. Alpha and Beta soils, 0 to 2 percent slopes, is an example.

Some surveys include *miscellaneous areas*. Such areas have little or no soil material and support little or no vegetation. Rock outcrop is an example.

El Paso County Area, Colorado

40—Kettle gravelly loamy sand, 3 to 8 percent slopes

Map Unit Setting

National map unit symbol: 368g
Elevation: 7,000 to 7,700 feet
Farmland classification: Not prime farmland

Map Unit Composition

Kettle and similar soils: 85 percent
Estimates are based on observations, descriptions, and transects of the mapunit.

Description of Kettle

Setting

Landform: Hills
Landform position (three-dimensional): Side slope
Down-slope shape: Linear
Across-slope shape: Linear
Parent material: Sandy alluvium derived from arkose

Typical profile

E - 0 to 16 inches: gravelly loamy sand
Bt - 16 to 40 inches: gravelly sandy loam
C - 40 to 60 inches: extremely gravelly loamy sand

Properties and qualities

Slope: 3 to 8 percent
Depth to restrictive feature: More than 80 inches
Drainage class: Somewhat excessively drained
Runoff class: Low
Capacity of the most limiting layer to transmit water (Ksat): High (2.00 to 6.00 in/hr)
Depth to water table: More than 80 inches
Frequency of flooding: None
Frequency of ponding: None
Available water supply, 0 to 60 inches: Low (about 3.4 inches)

Interpretive groups

Land capability classification (irrigated): None specified
Land capability classification (nonirrigated): 4e
Hydrologic Soil Group: B
Ecological site: F048AY908CO - Mixed Conifer
Hydric soil rating: No

Minor Components

Other soils

Percent of map unit:
Hydric soil rating: No

Pleasant

Percent of map unit:
Landform: Depressions
Hydric soil rating: Yes

41—Kettle gravelly loamy sand, 8 to 40 percent slopes

Map Unit Setting

National map unit symbol: 368h
Elevation: 7,000 to 7,700 feet
Farmland classification: Not prime farmland

Map Unit Composition

Kettle and similar soils: 85 percent
Estimates are based on observations, descriptions, and transects of the mapunit.

Description of Kettle

Setting

Landform: Hills
Landform position (three-dimensional): Side slope
Down-slope shape: Linear
Across-slope shape: Linear
Parent material: Sandy alluvium derived from arkose

Typical profile

E - 0 to 16 inches: gravelly loamy sand
Bt - 16 to 40 inches: gravelly sandy loam
C - 40 to 60 inches: extremely gravelly loamy sand

Properties and qualities

Slope: 8 to 40 percent
Depth to restrictive feature: More than 80 inches
Drainage class: Somewhat excessively drained
Runoff class: Medium
Capacity of the most limiting layer to transmit water (Ksat): High (2.00 to 6.00 in/hr)
Depth to water table: More than 80 inches
Frequency of flooding: None
Frequency of ponding: None
Available water supply, 0 to 60 inches: Low (about 3.4 inches)

Interpretive groups

Land capability classification (irrigated): None specified
Land capability classification (nonirrigated): 7e
Hydrologic Soil Group: B
Ecological site: F048AY908CO - Mixed Conifer
Hydric soil rating: No

Minor Components

Other soils

Percent of map unit:
Hydric soil rating: No

Custom Soil Resource Report

Pleasant

Percent of map unit:

Landform: Depressions

Hydric soil rating: Yes

References

- American Association of State Highway and Transportation Officials (AASHTO). 2004. Standard specifications for transportation materials and methods of sampling and testing. 24th edition.
- American Society for Testing and Materials (ASTM). 2005. Standard classification of soils for engineering purposes. ASTM Standard D2487-00.
- Cowardin, L.M., V. Carter, F.C. Golet, and E.T. LaRoe. 1979. Classification of wetlands and deep-water habitats of the United States. U.S. Fish and Wildlife Service FWS/OBS-79/31.
- Federal Register. July 13, 1994. Changes in hydric soils of the United States.
- Federal Register. September 18, 2002. Hydric soils of the United States.
- Hurt, G.W., and L.M. Vasilas, editors. Version 6.0, 2006. Field indicators of hydric soils in the United States.
- National Research Council. 1995. Wetlands: Characteristics and boundaries.
- Soil Survey Division Staff. 1993. Soil survey manual. Soil Conservation Service. U.S. Department of Agriculture Handbook 18. http://www.nrcs.usda.gov/wps/portal/nrcs/detail/national/soils/?cid=nrcs142p2_054262
- Soil Survey Staff. 1999. Soil taxonomy: A basic system of soil classification for making and interpreting soil surveys. 2nd edition. Natural Resources Conservation Service, U.S. Department of Agriculture Handbook 436. http://www.nrcs.usda.gov/wps/portal/nrcs/detail/national/soils/?cid=nrcs142p2_053577
- Soil Survey Staff. 2010. Keys to soil taxonomy. 11th edition. U.S. Department of Agriculture, Natural Resources Conservation Service. http://www.nrcs.usda.gov/wps/portal/nrcs/detail/national/soils/?cid=nrcs142p2_053580
- Tiner, R.W., Jr. 1985. Wetlands of Delaware. U.S. Fish and Wildlife Service and Delaware Department of Natural Resources and Environmental Control, Wetlands Section.
- United States Army Corps of Engineers, Environmental Laboratory. 1987. Corps of Engineers wetlands delineation manual. Waterways Experiment Station Technical Report Y-87-1.
- United States Department of Agriculture, Natural Resources Conservation Service. National forestry manual. http://www.nrcs.usda.gov/wps/portal/nrcs/detail/soils/home/?cid=nrcs142p2_053374
- United States Department of Agriculture, Natural Resources Conservation Service. National range and pasture handbook. <http://www.nrcs.usda.gov/wps/portal/nrcs/detail/national/landuse/rangepasture/?cid=stelprdb1043084>

Custom Soil Resource Report

United States Department of Agriculture, Natural Resources Conservation Service. National soil survey handbook, title 430-VI. http://www.nrcs.usda.gov/wps/portal/nrcs/detail/soils/scientists/?cid=nrcs142p2_054242

United States Department of Agriculture, Natural Resources Conservation Service. 2006. Land resource regions and major land resource areas of the United States, the Caribbean, and the Pacific Basin. U.S. Department of Agriculture Handbook 296. http://www.nrcs.usda.gov/wps/portal/nrcs/detail/national/soils/?cid=nrcs142p2_053624

United States Department of Agriculture, Soil Conservation Service. 1961. Land capability classification. U.S. Department of Agriculture Handbook 210. http://www.nrcs.usda.gov/Internet/FSE_DOCUMENTS/nrcs142p2_052290.pdf

APPENDIX C – FEMA FIRM MAP

NOTES TO USERS

This map is for use in administering the National Flood Insurance Program. It does not necessarily identify all areas subject to flooding, particularly from local drainage sources of small size. The community map repository should be consulted for possible updated or additional flood hazard information.

To obtain more detailed information in areas where **Base Flood Elevations (BFEs)** and/or **floodways** have been determined, users are encouraged to consult the Flood Profiles and Floodway Data and/or Summary of Stillwater Elevations tables contained within the Flood Insurance Study (FIS) report that accompanies this FIRM. Users should be aware that BFEs shown on the FIRM represent rounded whole-foot elevations. These BFEs are intended for flood insurance rating purposes only and should not be used as the sole source of flood elevation information. Accordingly, flood elevation data presented in the FIS report should be utilized in conjunction with the FIRM for purposes of construction and/or floodplain management.

Coastal Base Flood Elevations shown on this map apply only landward of 0.0' North American Vertical Datum of 1988 (NAVD88). Users of this FIRM should be aware that coastal flood elevations are also provided in the Summary of Stillwater Elevations table in the Flood Insurance Study report for this jurisdiction. Elevations shown in the Summary of Stillwater Elevations table should be used for construction and/or floodplain management purposes when they are higher than the elevations shown on this FIRM.

Boundaries of the **floodways** were computed at cross sections and interpolated between cross sections. The floodways were based on hydraulic considerations with regard to requirements of the National Flood Insurance Program. Floodway widths and other pertinent floodway data are provided in the Flood Insurance Study report for this jurisdiction.

Certain areas not in Special Flood Hazard Areas may be protected by **flood control structures**. Refer to section 2.4 "Flood Protection Measures" of the Flood Insurance Study report for information on flood control structures for this jurisdiction.

The **projection** used in the preparation of this map was Universal Transverse Mercator (UTM) zone 13. The **horizontal datum** was NAD83, GRS80 spheroid. Differences in datum, spheroid, projection or UTM zones zones used in the production of FIRMs for adjacent jurisdictions may result in slight positional differences in map features across jurisdiction boundaries. These differences do not affect the accuracy of this FIRM.

Flood elevations on this map are referenced to the **North American Vertical Datum of 1988 (NAVD88)**. These flood elevations must be compared to structure and ground elevations referenced to the same **vertical datum**. For information regarding conversion between the National Geodetic Vertical Datum of 1929 and the North American Vertical Datum of 1988, visit the National Geodetic Survey website at <http://www.ngs.noaa.gov/> or contact the National Geodetic Survey at the following address:

NGS Information Services
NOAA, NUNCS12
National Geodetic Survey
SSMC-3, #9202
1315 East-West Highway
Silver Spring, MD 20910-3282

To obtain current elevation, description, and/or location information for **bench marks** shown on this map, please contact the Information Services Branch of the National Geodetic Survey at (301) 713-3242 or visit its website at <http://www.ngs.noaa.gov/>.

Base Map information shown on this FIRM was provided in digital format by El Paso County, Colorado Springs Utilities, City of Fountain, Bureau of Land Management, National Oceanic and Atmospheric Administration, United States Geological Survey, and Anderson Consulting Engineers, Inc. These data are current as of 2006.

This map reflects more detailed and up-to-date **stream channel configurations and floodplain delineations** than those shown on the previous FIRM for this jurisdiction. The floodplains and floodways that were transferred from the previous FIRM may have been adjusted to conform to these new stream channel configurations. As a result, the Flood Profiles and Floodway Data tables in the Flood Insurance Study Report (which contains authoritative hydraulic data) may reflect stream channel distances that differ from what is shown on this map. The profile baselines depicted on this map represent the hydraulic modeling baselines that match the flood profiles and Floodway Data Tables if applicable, in the FIS report. As a result, the profile baselines may deviate significantly from the new base map channel representation and may appear outside of the floodplain.

Corporate limits shown on this map are based on the best data available at the time of publication. Because changes due to annexations or de-annexations may have occurred after this map was published, map users should contact appropriate community officials to verify current corporate limit locations.

Please refer to the separately printed **Map Index** for an overview map of the county showing the layout of map panels; community map repository addresses; and a Listing of Communities table containing National Flood Insurance Program dates for each community as well as a listing of the panels on which each community is located.

Contact **FEMA Map Service Center (MSC)** via the FEMA Map Information eXchange (FMIX) 1-877-336-2627 for information on available products associated with this FIRM. Available products may include previously issued Letters of Map Change, a Flood Insurance Study Report, and/or digital versions of this map. The MSC may also be reached by Fax at 1-800-358-9620 and its website at <http://www.msc.fema.gov/>.

If you have **questions about this map** or questions concerning the National Flood Insurance Program in general, please call 1-877-FEMA MAP (1-877-336-2627) or visit the FEMA website at <http://www.fema.gov/business/nfp/>.

El Paso County Vertical Datum Offset Table

Flooding Source	Vertical Datum Offset (ft)
REFER TO SECTION 3.3 OF THE EL PASO COUNTY FLOOD INSURANCE STUDY FOR STREAM BY STREAM VERTICAL DATUM CONVERSION INFORMATION	

Panel Location Map

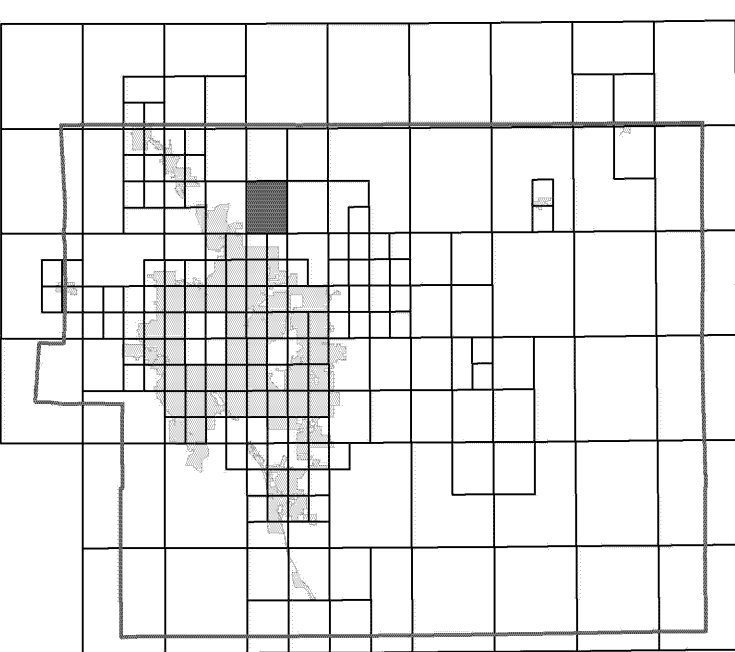

This Digital Flood Insurance Rate Map (DFIRM) was produced through a Cooperating Technical Partner (CTP) agreement between the State of Colorado Water Conservation Board (CWCB) and the Federal Emergency Management Agency (FEMA).



Additional Flood Hazard information and resources are available from local communities and the Colorado Water Conservation Board.

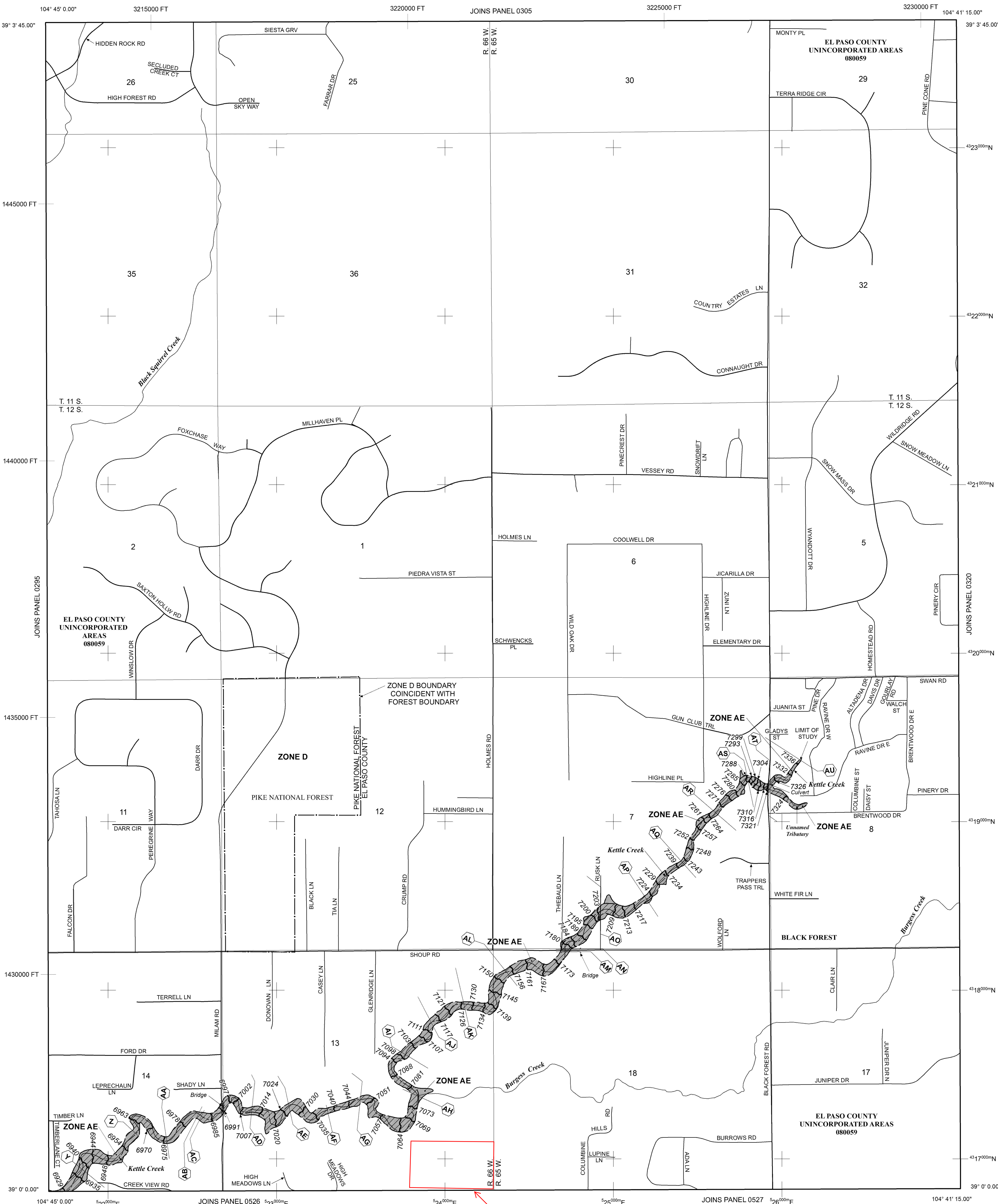

APPROXIMATE SITE LIMITS

LEGEND

- SPECIAL FLOOD HAZARD AREAS (SFHAs) SUBJECT TO INUNDATION BY THE 1% ANNUAL CHANCE FLOOD
- The 1% annual chance flood (100-year flood), also known as the base flood, is the flood that has a 1% chance of being equalled or exceeded in any given year. The Special Flood Hazard Area is the area subject to flooding by the 1% annual chance flood. Areas of Special Flood Hazard include Zones A, AE, AH, AO, AR, A99, V, and VE. The Base Flood Elevation is the water-surface elevation of the 1% annual chance flood.
- ZONE A** No Base Flood Elevations determined.
- ZONE AE** Base Flood Elevations determined.
- ZONE AH** Flood depths of 1 to 3 feet (usually areas of ponding); Base Flood Elevations determined.
- ZONE AO** Flood depths of 1 to 3 feet (usually sheet flow on sloping terrain); average depths determined. For areas of alluvial fan flooding, velocities also determined.
- ZONE AR** Special Flood Hazard Area Formerly protected from the 1% annual chance flood by a flood control system that was subsequently decertified. Zone AR indicates that the former flood control system is being restored to provide protection from the 1% annual chance or greater flood.
- ZONE A99** Area to be protected from 1% annual chance flood by a Federal flood protection system under construction; no Base Flood Elevations determined.
- ZONE V** Coastal flood zone with velocity hazard (wave action); no Base Flood Elevations determined.
- ZONE VE** Coastal flood zone with velocity hazard (wave action); Base Flood Elevations determined.
- FLOODWAY AREAS IN ZONE AE
- The floodway is the channel of a stream plus any adjacent floodplain areas that must be kept free of encroachment so that the 1% annual chance flood can be carried without substantial increases in flood heights.
- OTHER FLOOD AREAS
- ZONE X** Areas of 0.2% annual chance flood; areas of 1% annual chance flood with average depths of less than 1 foot, or with drainage areas less than 1 square mile; and areas protected by levees from 1% annual chance flood.
- OTHER AREAS
- ZONE X** Areas determined to be outside the 0.2% annual chance floodplain.
- ZONE D** Areas in which flood hazards are undetermined, but possible.
- COASTAL BARRIER RESOURCES SYSTEM (CBRS) AREAS
- OTHERWISE PROTECTED AREAS (OPAs)

- CBRS areas and OPAs are normally located within or adjacent to Special Flood Hazard Areas.
- Floodplain boundary
- Floodway boundary
- Zone D boundary
- CBRS and OPA boundary
- Boundary dividing Special Flood Hazard Areas of different Base Flood Elevations, flood depths or flood velocities.

- Base Flood Elevation line and value; elevation in feet* (EL 987)
- * Referenced to the North American Vertical Datum of 1988 (NAVD 88)
- Cross section line
- Transsect line

- Geographic coordinates referenced to the North American Datum of 1983 (NAD 83)
- 1000-meter Universal Transverse Mercator grid ticks, zone 13
- 5000-foot grid ticks; Colorado State Plane coordinate system, central zone (FIPSZONE 0502), Lambert Conformal Conic Projection
- Bench mark (see explanation in Notes to Users section of this FIRM map)
- River Mile

- MAP REPOSITORIES
- Refer to Map Repositories list on Map Index
- EFFECTIVE DATE OF COUNTYWIDE FLOOD INSURANCE RATE MAP MARCH 17, 1997
- EFFECTIVE DATE(S) OF REVISION(S) TO THIS PANEL DECEMBER 7, 2018 - to update corporate limits, to change Base Flood Elevations and Special Flood Hazard Areas, to update map format, to add roads and road names, and to incorporate previously issued Letters of Map Revision.

For community map revision history prior to countywide mapping, refer to the Community Map History Table located in the Flood Insurance Study report for this jurisdiction.

To determine if flood insurance is available in this community, contact your insurance agent or call the National Flood Insurance Program at 1-800-638-6620.

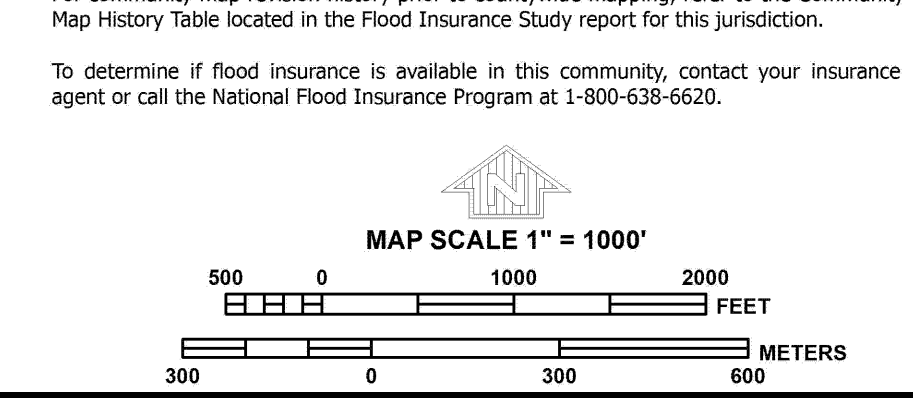

PANEL 0315G

FIRM
FLOOD INSURANCE RATE MAP
EL PASO COUNTY,
COLORADO
AND INCORPORATED AREAS

PANEL 315 OF 1300
(SEE MAP INDEX FOR FIRM PANEL LAYOUT)

CONTAINS:
COMMUNITY NUMBER PANEL SUFFIX
EL PASO COUNTY 080059 0315 0

Notice to User: The Map Number shown below should be used when placing map orders. The Community Number shown above should be used on insurance applications for the subject community.

MAP NUMBER
08041C0315G

MAP REVISED
DECEMBER 7, 2018

Federal Emergency Management Agency

NOTES TO USERS

This map is for use in administering the National Flood Insurance Program. It does not necessarily identify all areas subject to flooding, particularly from local drainage sources of small size. The community map repository should be consulted for possible updated or additional flood hazard information.

To obtain more detailed information in areas where **Base Flood Elevations (BFEs)** and/or **floodways** have been determined, users are encouraged to consult the Flood Profiles and Floodway Data and/or Summary of Stillwater Elevations tables contained within the Flood Insurance Study (FIS) report that accompanies this FIRM. Users should be aware that BFEs shown on the FIRM represent rounded whole-foot elevations. These BFEs are intended for flood insurance rating purposes only and should not be used as the sole source of flood elevation information. Accordingly, flood elevation data presented in the FIS report should be utilized in conjunction with the FIRM for purposes of construction and/or floodplain management.

Coastal Base Flood Elevations shown on this map apply only landward of 0.0' North American Vertical Datum of 1988 (NAVD88). Users of this FIRM should be aware that coastal flood elevations are also provided in the Summary of Stillwater Elevations table in the Flood Insurance Study report for this jurisdiction. Elevations shown in the Summary of Stillwater Elevations table should be used for construction and/or floodplain management purposes when they are higher than the elevations shown on this FIRM.

Boundaries of the **floodways** were computed at cross sections and interpolated between cross sections. The floodways were based on hydraulic considerations with regard to requirements of the National Flood Insurance Program. Floodway widths and other pertinent floodway data are provided in the Flood Insurance Study report for this jurisdiction.

Certain areas not in Special Flood Hazard Areas may be protected by **flood control structures**. Refer to section 2.4 "Flood Protection Measures" of the Flood Insurance Study report for information on flood control structures for this jurisdiction.

The **projection** used in the preparation of this map was Universal Transverse Mercator (UTM) zone 13. The **horizontal datum** was NAD83, GRS80 spheroid. Differences in datum, spheroid, projection or UTM zones zones used in the production of FIRMs for adjacent jurisdictions may result in slight positional differences in map features across jurisdiction boundaries. These differences do not affect the accuracy of this FIRM.

Flood elevations on this map are referenced to the **North American Vertical Datum of 1988 (NAVD88)**. These flood elevations must be compared to structure and ground elevations referenced to the same **vertical datum**. For information regarding conversion between the National Geodetic Vertical Datum of 1929 and the North American Vertical Datum of 1988, visit the National Geodetic Survey website at <http://www.ngs.noaa.gov/> or contact the National Geodetic Survey at the following address:

NGS Information Services
 NOAA, NINGS12
 National Geodetic Survey
 SSMC-3, #9202
 1315 East-West Highway
 Silver Spring, MD 20910-3282

To obtain current elevation, description, and/or location information for **bench marks** shown on this map, please contact the Information Services Branch of the National Geodetic Survey at (301) 713-3242 or visit its website at <http://www.ngs.noaa.gov/>.

Base Map information shown on this FIRM was provided in digital format by El Paso County, Colorado Springs Utilities, and Anderson Consulting Engineers, Inc. These data are current as of 2008.

This map reflects more detailed and up-to-date **stream channel configurations and floodplain delineations** than those shown on the previous FIRM for this jurisdiction. The floodplains and floodways that were transferred from the previous FIRM may have been adjusted to conform to these new stream channel configurations. As a result, the Flood Profiles and Floodway Data tables in the Flood Insurance Study Report (which contains authoritative hydraulic data) may reflect stream channel distances that differ from what is shown on this map. The profile baselines depicted on this map represent the hydraulic modeling baselines that match the flood profiles and Floodway Data Tables if applicable, in the FIS report. As a result, the profile baselines may deviate significantly from the new base map channel representation and may appear outside of the floodplain.

Corporate limits shown on this map are based on the best data available at the time of publication. Because changes due to annexations or de-annexations may have occurred after this map was published, map users should contact appropriate community officials to verify current corporate limit locations.

Please refer to the separately printed **Map Index** for an overview map of the county showing the layout of map panels; community map repository addresses; and a Listing of Communities table containing National Flood Insurance Program dates for each community as well as a listing of the panels on which each community is located.

Contact **FEMA Map Service Center (MSC)** via the FEMA Map Information eXchange (FMIX) 1-877-336-2627 for information on available products associated with this FIRM. Available products may include previously issued Letters of Map Change, a Flood Insurance Study Report, and/or digital versions of this map. The MSC may also be reached by Fax at 1-800-358-9620 and its website at <http://www.msc.fema.gov/>.

If you have **questions about this map** or questions concerning the National Flood Insurance Program in general, please call **1-877-FEMA MAP** (1-877-336-2627) or visit the FEMA website at <http://www.fema.gov/business/nfip>.

El Paso County Vertical Datum Offset Table

Flooding Source	Vertical Datum Offset (ft)
REFER TO SECTION 3.3 OF THE EL PASO COUNTY FLOOD INSURANCE STUDY FOR STREAM BY STREAM VERTICAL DATUM CONVERSION INFORMATION	

Panel Location Map

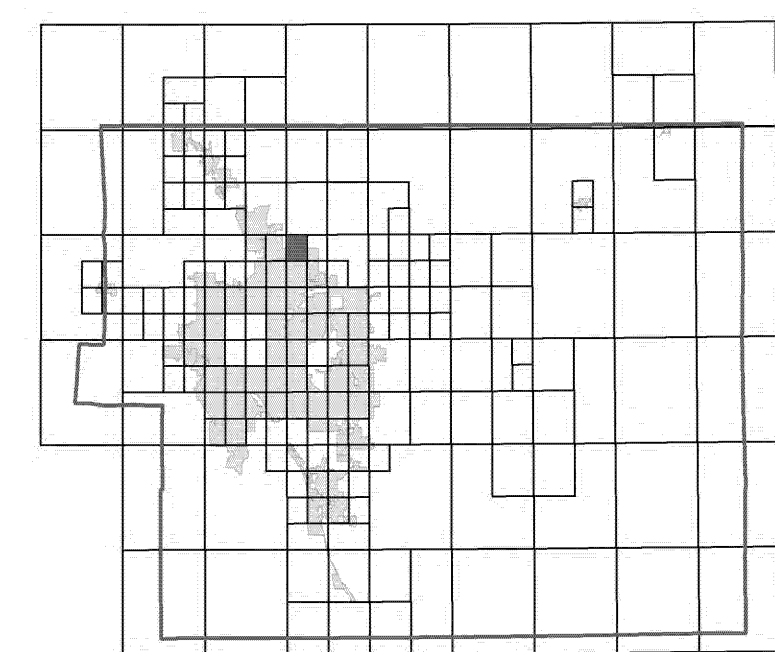

This Digital Flood Insurance Rate Map (DFIRM) was produced through a Cooperating Technical Partner (CTP) agreement between the State of Colorado Water Conservation Board (CWCB) and the Federal Emergency Management Agency (FEMA).



Additional Flood Hazard information and resources are available from local communities and the Colorado Water Conservation Board.



NOTE: MAP AREA SHOWN ON THIS PANEL IS LOCATED WITHIN TOWNSHIP 12 SOUTH, RANGE 65 WEST, AND TOWNSHIP 12 SOUTH, RANGE 66 WEST.

LEGEND

- SPECIAL FLOOD HAZARD AREAS (SFHAS) SUBJECT TO INUNDATION BY THE 1% ANNUAL CHANCE FLOOD
- The 1% annual chance flood (100-year flood), also known as the base flood, is the flood that has a 1% chance of being equalled or exceeded in any given year. The Special Flood Hazard Area is the area subject to flooding by the 1% annual chance flood. Areas of Special Flood Hazard include Zones A, AE, AH, AO, AR, A99, V, and VE. The Base Flood Elevation is the water-surface elevation of the 1% annual chance flood.
- ZONE A** No Base Flood Elevations determined.
- ZONE AE** Base Flood Elevations determined.
- ZONE AH** Flood depths of 1 to 3 feet (usually areas of ponding); Base Flood Elevations determined.
- ZONE AO** Flood depths of 1 to 3 feet (usually sheet flow on sloping terrain); average depths determined. For areas of alluvial fan flooding, velocities also determined.
- ZONE AR** Special Flood Hazard Area Formerly protected from the 1% annual chance flood by a flood control system that was subsequently de-certified. Zone AR indicates that the former flood control system is being restored to provide protection from the 1% annual chance or greater flood.
- ZONE A99** Area to be protected from 1% annual chance flood by a Federal flood protection system under construction; no Base Flood Elevations determined.
- ZONE V** Coastal flood zone with velocity hazard (wave action); no Base Flood Elevations determined.
- ZONE VE** Coastal flood zone with velocity hazard (wave action); Base Flood Elevations determined.
- FLOODWAY AREAS IN ZONE AE
- The floodway is the channel of a stream plus any adjacent floodplain areas that must be kept free of encroachment so that the 1% annual chance flood can be carried without substantial increases in flood heights.
- OTHER FLOOD AREAS
- ZONE X** Areas of 0.2% annual chance flood; areas of 1% annual chance flood with average depths of less than 1 foot, or with drainage areas less than 1 square mile; and areas protected by levees from 1% annual chance flood.
- OTHER AREAS
- ZONE X** Areas determined to be outside the 0.2% annual chance floodplain.
- ZONE D** Areas in which flood hazards are undetermined, but possible.
- COASTAL BARRIER RESOURCES SYSTEM (CBRS) AREAS
- OTHERWISE PROTECTED AREAS (OPAs)

- CBRS areas and OPAs are normally located within or adjacent to Special Flood Hazard Areas.
- Floodplain boundary
- Floodway boundary
- Zone D boundary
- CBRS and OPA boundary
- Boundary dividing Special Flood Hazard Areas of different Base Flood Elevations, flood depths or flood velocities.

- Base Flood Elevation line and value; elevation in feet* (EL 987)
- * Referenced to the North American Vertical Datum of 1988 (NAVD 88)
- Cross section line
- Transsect line

- Geographic coordinates referenced to the North American Datum of 1983 (NAD 83)
- 1000-meter Universal Transverse Mercator grid ticks, zone 13
- 5000-foot grid ticks; Colorado State Plane coordinate system, central zone (FIPSZONE 0502), Lambert Conformal Conic Projection
- Bench mark (see explanation in Notes to Users section of this FIRM panel)
- River Mile

MAP REPOSITORIES
 Refer to Map Repositories list on Map Index

EFFECTIVE DATE OF COUNTYWIDE FLOOD INSURANCE RATE MAP
MARCH 17, 1997

EFFECTIVE DATE(S) OF REVISION(S) TO THIS PANEL
DECEMBER 7, 2018 - to update corporate limits, to change Base Flood Elevations and Special Flood Hazard Areas, to update map format, to add roads and road names, and to incorporate previously issued Letters of Map Revision.

For community map revision history prior to countywide mapping, refer to the Community Map History Table located in the Flood Insurance Study report for this jurisdiction.

To determine if flood insurance is available in this community, contact your insurance agent or call the National Flood Insurance Program at 1-800-638-6620.

PANEL 0526G

FIRM FLOOD INSURANCE RATE MAP

EL PASO COUNTY, COLORADO AND INCORPORATED AREAS

PANEL 526 OF 1300

(SEE MAP INDEX FOR FIRM PANEL LAYOUT)

CONTAINS:

COMMUNITY	NUMBER	PANEL	SUFFIX
COLORADO SPRINGS, CITY OF	080060	0526	G
EL PASO COUNTY	080059	0526	G

Notice to User: The Map Number shown below should be used when placing map orders. The Community Number shown above should be used on insurance applications for the subject community.

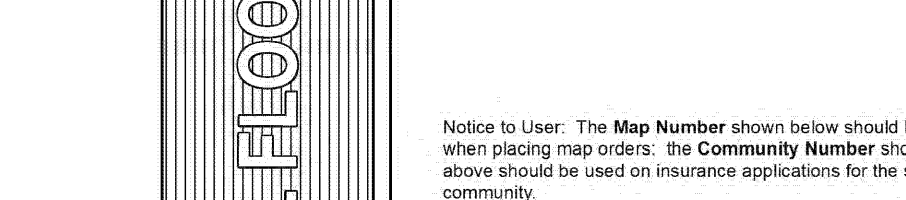

MAP NUMBER 08041C0526G

MAP REVISED DECEMBER 7, 2018

Federal Emergency Management Agency

APPENDIX D – HYDROLOGIC CALCULATIONS

Weighted Imperviousness Existing Calculations: Existing

SUB-BASIN	AREA (SF)	AREA (Acres)	GRAVEL ROAD AREA	GRAVEL ROAD IMPERVIOUSNESS	GRAVEL ROAD				LANDSCAPE AREA	LANDSCAPE IMPERVIOUSNESS	LANDSCAPE				ROOF AREA	ROOF IMPERVIOUSNESS	ROOF				WEIGHTED IMPERVIOUSNESS	WEIGHTED COEFFICIENTS			
					C2	C5	C10	C100			C2	C5	C10	C100			C2	C5	C10	C100		C2	C5	C10	C100
A	158,991	3.65	0	80%	0.00	0	0	0	158,991	0%	0.02	0.08	0.15	0.35	0	90%	0.00	0.00	0	0	0.0%	0.02	0.08	0.15	0.35
B	265,057	6.08	0	80%	0.00	0	0	0	265,057	0%	0.02	0.08	0.15	0.35	0	90%	0.00	0.00	0	0	0.0%	0.02	0.08	0.15	0.35
C	373,006	8.56	0	80%	0.00	0	0	0	373,006	0%	0.02	0.08	0.15	0.35	0	90%	0.00	0.00	0	0	0.0%	0.02	0.08	0.15	0.35
D	326,517	7.50	0	80%	0.00	0	0	0	326,517	0%	0.02	0.08	0.15	0.35	0	90%	0.00	0.00	0	0	0.0%	0.02	0.08	0.15	0.35
E	36,355	0.83	0	80%	0.00	0	0	0	36,355	0%	0.02	0.08	0.15	0.35	0	90%	0.00	0.00	0	0	0.0%	0.02	0.08	0.15	0.35
F	25,618	0.59	0	80%	0.00	0	0	0	25,618	0%	0.02	0.08	0.15	0.35	0	90%	0.00	0.00	0	0	0.0%	0.02	0.08	0.15	0.35
G	311,534	7.15	0	80%	0.00	0	0	0	311,534	0%	0.02	0.08	0.15	0.35	0	90%	0.00	0.00	0	0	0.0%	0.02	0.08	0.15	0.35
OE-A	4,445	0.10	0	80%	0.00	0	0	0	4,445	0%	0.02	0.08	0.15	0.35	0	90%	0.00	0.00	0	0	0.0%	0.02	0.08	0.15	0.35
OE-B	37,383	0.86	0	80%	0.00	0	0	0	37,383	0%	0.02	0.08	0.15	0.35	0	90%	0.00	0.00	0	0	0.0%	0.02	0.08	0.15	0.35
OE-C	95,469	2.19	0	80%	0.00	0	0	0	95,469	0%	0.02	0.08	0.15	0.35	0	90%	0.00	0.00	0	0	0.0%	0.02	0.08	0.15	0.35
OE-D	885,654	20.33	0	80%	0.00	0	0	0	885,654	0%	0.02	0.08	0.15	0.35	0	90%	0.00	0.00	0	0	0.0%	0.02	0.08	0.15	0.35
OE-E	458,281	10.52	0	80%	0.00	0	0	0	458,281	0%	0.02	0.08	0.15	0.35	0	90%	0.00	0.00	0	0	0.0%	0.02	0.08	0.15	0.35
OE-H	233,578	5.36	0	80%	0.00	0	0	0	233,578	0%	0.02	0.08	0.15	0.35	0	90%	0.00	0.00	0	0	0.0%	0.02	0.08	0.15	0.35
TOTAL	3,211,887	73.73	0	80%	10.00	0	0	0	2,520,028	0%	0.02	0.08	0.15	0.35	0	90%	0.00	0.00	0	0	0.0%	0.02	0.06	0.12	0.27

Renehah Subdivision																				
Time of Concentration Existing Calculations																				
Watercourse Coefficient																				
					Forest & Meadow	2.50						Short Grass Pasture & Lawns	7.00						Grassed Waterway	15.00
					Fallow or Cultivation	5.00						Nearly Bare Ground	10.00						Paved Area & Shallow Gutter	20.00
DESIGN POINT	SUB-BASIN DATA				INITIAL / OVERLAND* TIME			TRAVEL TIME T(t)					T(c) CHECK (URBANIZED BASINS)			FINAL T©* min.				
	DRAIN BASIN	AREA sq. ft.	AREA ac.	C(5)	Length ft.	Slope %	T(i) min	Length ft.	Slope %	Coeff.	Velocity fps	T(t) min.	COMP. T(c)	TOTAL LENGTH	L/180+10					
E1	A	158,991	3.65	0.08	118	14.0%	8.4	742	13.0%	2.50	0.9	13.7	22.1	859.889	14.8	14.8				
E2	B	265,057	6.08	0.08	119	6.0%	11.2	991	14.0%	2.50	0.9	17.7	28.9	1109.89	16.2	16.2				
E3	C	373,006	8.56	0.08	300	13.0%	13.8	2237	20.0%	2.50	1.1	33.3	47.1	2537	24.1	24.1				
E4	D	326,517	7.50	0.08	206	17.0%	10.4	1832	19.0%	2.50	1.1	28.0	38.5	2038	21.3	21.3				
E5	E	36,355	0.83	0.08	287	13.0%	13.5	133	25.0%	2.50	1.3	1.8	15.2	420	12.3	12.3				
E6	F	25,618	0.59	0.08	157	13.0%	10.0	46	20.0%	2.50	1.1	0.7	10.7	203	11.1	10.7				
E7	G	311,534	7.15	0.08	194	8.0%	13.0	708	12.0%	2.50	0.9	13.6	26.6	902	15.0	15.0				
E8	OE-A	4,445	0.10	0.08	38	5.0%	6.7	31	5.0%	2.50	0.6	0.9	7.7	69	10.4	7.7				
E9	OE-B	37,383	0.86	0.08	111	7.0%	10.3	208	7.0%	2.50	0.7	5.2	15.5	319	11.8	11.8				
E10	OE-C	95,469	2.19	0.08	69	5.0%	9.1	412	12.0%	2.50	0.9	7.9	17.0	481	12.7	12.7				
E11	OE-D	885,654	20.33	0.08	107	5.0%	11.3	895	14.0%	2.50	0.9	15.9	27.3	1002	15.6	15.6				
E12	OE-E	458,281	10.52	0.08	169	18.0%	9.3	1366	13.0%	2.50	0.9	25.3	34.5	1535	18.5	18.5				
E13	OE-H	233,578	5.36	0.08	105	9.0%	9.2	753	7.0%	2.50	0.7	19.0	28.2	858	14.8	14.8				
TOTAL	TOTAL	3,211,887	73.73																	

*Note: El Paso County Drainage Manual Chapter 6 indicates that the maximum overland flow length is 100ft for urbanized areas and 300ft for rural areas. The minimum time of concentration is 5 min for developed conditions, 10 min for undeveloped conditions.

Renehan Subdivision Time of Concentration Existing Calculations <i>Design Storm 100 Year Storm Event</i> (Rational Method Procedure)												
BASIN INFORMATION				DIRECT RUNOFF				CUMMULATIVE RUNOFF				NOTES
DESIGN POINT	DRAIN BASIN	AREA ac.	RUNOFF COEFF	T(c) min	C x A	I in/hr	Q cfs	T(c) min	C x A	I in/hr	Q cfs	
E1	A	3.65	0.35	14.8	1.28	5.94	7.59					
E2	B	6.08	0.35	16.2	2.13	5.72	12.18					
E3	C	8.56	0.35	24.1	3.00	4.72	14.13					
E4	D	7.50	0.35	21.3	2.62	5.03	13.19					
E5	E	0.83	0.35	12.3	0.29	6.41	1.87					
E6	F	0.59	0.35	10.7	0.21	6.77	1.39					
E7	G	7.15	0.35	15.0	2.50	5.91	14.80					
E8	OE-A	0.10	0.35	7.7	0.04	7.60	0.27					
E9	OE-B	0.86	0.35	11.8	0.30	6.52	1.96					
E10	OE-C	2.19	0.35	12.7	0.77	6.33	4.86					
E11	OE-D	20.33	0.35	15.6	7.12	5.81	41.36					
E12	OE-E	10.52	0.35	18.5	3.68	5.38	19.82					
E13	OE-H	5.36	0.35	14.8	1.88	5.94	11.16					
TOTAL	TOTAL	73.73	0.35				19.77					

Renehan Subdivision Time of Concentration Existing Calculations <i>Design Storm 5 Year Storm Event</i> (Rational Method Procedure)												
BASIN INFORMATION				DIRECT RUNOFF				CUMMULATIVE RUNOFF				NOTES
DESIGN POINT	DRAIN BASIN	AREA ac.	RUNOFF COEFF	T(c) min	C x A	I in/hr	Q cfs	T(c) min	C x A	I in/hr	Q cfs	
E1	A	3.65	0.08	14.8	0.29	3.54	1.03					0.00
E2	B	6.08	0.08	16.2	0.49	3.41	1.66					0.00
E3	C	8.56	0.08	24.1	0.69	2.81	1.92					
E4	D	7.50	0.08	21.3	0.60	2.99	1.80					
E5	E	0.83	0.08	12.3	0.07	3.82	0.25					
E6	F	0.59	0.08	10.7	0.05	4.03	0.19					
E7	G	7.15	0.08	15.0	0.57	3.52	2.01					
E8	OE-A	0.10	0.08	7.7	0.01	4.53	0.04					
E9	OE-B	0.86	0.08	11.8	0.07	3.88	0.27					
E10	OE-C	2.19	0.08	12.7	0.18	3.77	0.66					
E11	OE-D	20.33	0.08	15.6	1.63	3.46	5.63					
E12	OE-E	10.52	0.08	18.5	0.84	3.21	2.70					
E13	OE-H	5.36	0.08	14.8	0.43	3.54	1.52					
TOTAL	TOTAL	73.73	0.08				2.69					

Weighted Imperviousness Calculations: Proposed

SUB-BASIN	AREA (SF)	AREA (Acres)	PAVEMENT AREA	PAVEMENT IMPERVIOUSNESS	PAVEMENT				LANDSCAPE AREA	LANDSCAPE IMPERVIOUSNESS	LANDSCAPE				ROOF AREA	ROOF IMPERVIOUSNESS	ROOF				WEIGHTED IMPERVIOUSNESS	WEIGHTED COEFFICIENTS			
					C2	C5	C10	C100			C2	C5	C10	C100			C2	C5	C10	C100					
P-A	796,440	18.28	56,872	100%	0.89	0.9	0.92	0.96	739,568	0%	0.02	0.08	0.15	0.35	25,165	90%	0.00	0.00	0	0	10.0%	0.08	0.14	0.20	0.39
P-B	326,515	7.50	0	100%	0.89	0.9	0.92	0.96	326,515	0%	0.02	0.08	0.15	0.35	6,676	90%	0.00	0.00	0	0	1.8%	0.02	0.08	0.15	0.35
P-C	312,137	7.17	9,973	100%	0.89	0.9	0.92	0.96	302,164	0%	0.02	0.08	0.15	0.35	10,614	90%	0.00	0.00	0	0	6.3%	0.05	0.11	0.17	0.37
P-D	36,355	0.83	0	100%	0.89	0.9	0.92	0.96	36,355	0%	0.02	0.08	0.15	0.35	0	90%	0.00	0.00	0	0	0.0%	0.02	0.08	0.15	0.35
P-E	25,618	0.59	0	100%	0.89	0.9	0.92	0.96	25,618	0%	0.02	0.08	0.15	0.35	0	90%	0.00	0.00	0	0	0.0%	0.02	0.08	0.15	0.35
OP-A	137,304	3.15	0	100%	0.89	0.9	0.92	0.96	137,304	0%	0.02	0.08	0.15	0.35	0	90%	0.00	0.00	0	0	0.0%	0.02	0.08	0.15	0.35
OP-B	885,656	20.33	0	100%	0.89	0.9	0.92	0.96	885,656	0%	0.02	0.08	0.15	0.35	0	90%	0.00	0.00	0	0	0.0%	0.02	0.08	0.15	0.35
OP-C	458,281	10.52	0	100%	0.89	0.9	0.92	0.96	458,281	0%	0.02	0.08	0.15	0.35	0	90%	0.00	0.00	0	0	0.0%	0.02	0.08	0.15	0.35
OP-H	233,578	5.36	0	100%	0.89	0.9	0.92	0.96	233,578	0%	0.02	0.08	0.15	0.35	0	90%	0.00	0.00	0	0	0.0%	0.02	0.08	0.15	0.35
TOTAL	3,211,884	73.73	66,845	100%	0.89	0.9	0.92	0.96	2,911,461	0%	0.02	0.08	0.15	0.35	42,455	90%	0.00	0.00	0	0	3.3%	0.04	0.09	0.16	0.34

Renehan Subdivision Time of Concentration Proposed Calculations Design Storm 100 Year Storm Event <i>(Rational Method Procedure)</i>												
BASIN INFORMATION				DIRECT RUNOFF				CUMMULATIVE RUNOFF				NOTES
DESIGN POINT	DRAIN BASIN	AREA ac.	RUNOFF COEFF	T(c) min	C x A	I in/hr	Q cfs	T(c) min	C x A	I in/hr	Q cfs	
P1	P-A	18.28	0.39	21.2	7.20	5.04	36.26					
P2	P-B	7.50	0.35	15.8	2.62	5.78	15.16					
P3	P-C	7.17	0.37	16.5	2.65	5.67	15.01					
P4	P-D	0.83	0.35	12.3	0.29	6.41	1.87					
P5	P-E	0.59	0.35	10.7	0.21	6.77	1.39					
P6	OP-A	3.15	0.35	12.7	1.10	6.33	6.98					
P7	OP-B	20.33	0.35	16.4	7.12	5.69	40.46					
P8	OP-C	10.52	0.35	19.0	3.68	5.32	19.57					
P9	OP-H	5.36	0.35	14.8	1.88	5.94	11.16					
TOTAL		73.73					147.88					

Renehan Subdivision												
Time of Concentration Proposed Calculations Design Storm 5 Year Storm Event												
<i>(Rational Method Procedure)</i>												
BASIN INFORMATION				DIRECT RUNOFF				CUMMULATIVE RUNOFF				NOTES
DESIGN POINT	DRAIN BASIN	AREA ac.	RUNOFF COEFF	T(c) min	C x A	I in/hr	Q cfs	T(c) min	C x A	I in/hr	Q cfs	
P1	P-A	18.28	0.14	21.2	2.53	3.00	7.60					
P2	P-B	7.50	0.08	15.8	0.60	3.44	2.06					
P3	P-C	7.17	0.11	16.5	0.76	3.38	2.57					
P4	P-D	0.83	0.08	12.3	0.07	3.82	0.25					
P5	P-E	0.59	0.08	10.7	0.05	4.03	0.19					
P6	OP-A	3.15	0.08	12.7	0.25	3.77	0.95					
P7	OP-B	20.33	0.08	16.4	1.63	3.39	5.51					
P8	OP-C	10.52	0.08	19.0	0.84	3.17	2.66					
P9	OP-H	5.36	0.08	14.8	0.43	3.54	1.52					
TOTAL		73.73					23.33					

APPENDIX E – HYDRAULIC CALCULATIONS

CIRCULAR CONDUIT FLOW (Normal & Critical Depth Computation)

MHFD-Culvert, Version 4.00 (May 2020)

Project: **Renehon Subdivision**

Pipe ID: **C-01**

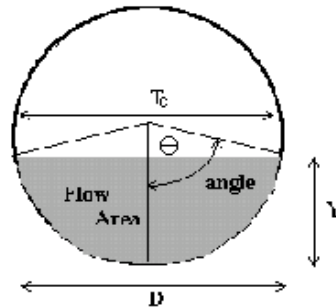

Design Information (Input)	
Pipe Invert Slope	So = 0.0200 ft/ft
Pipe Manning's n-value	n = 0.0230 *
Pipe Diameter	D = 18.00 inches
Design discharge	Q = 7.60 cfs
Full-Flow Capacity (Calculated)	
Full-flow area	Af = 1.77 sq ft
Full-flow wetted perimeter	Pf = 4.71 ft
Half Central Angle	Theta = 3.14 radians
Full-flow capacity	Qf = 8.42 cfs
Calculation of Normal Flow Condition	
Half Central Angle ($0 < \text{Theta} < 3.14$)	Theta = 2.08 radians
Flow area	An = 1.41 sq ft
Top width	Tn = 1.31 ft
Wetted perimeter	Pn = 3.12 ft
Flow depth	Yn = 1.12 ft
Flow velocity	Vn = 5.39 fps
Discharge	Qn = 7.60 cfs
Percent of Full Flow	Flow = 90.3% of full flow
Normal Depth Froude Number	Fr _n = 0.92 subcritical
Calculation of Critical Flow Condition	
Half Central Angle ($0 < \text{Theta-c} < 3.14$)	Theta-c = 2.01 radians
Critical flow area	Ac = 1.35 sq ft
Critical top width	Tc = 1.36 ft
Critical flow depth	Yc = 1.07 ft
Critical flow velocity	Vc = 5.65 fps
Critical Depth Froude Number	Fr _c = 1.00

* Unexpected value for Manning's n

DETERMINATION OF CULVERT HEADWATER AND OUTLET PROTECTION

MHFD-Culvert, Version 4.00 (May 2020)

Project: Renehan Subdivision
ID: R-01

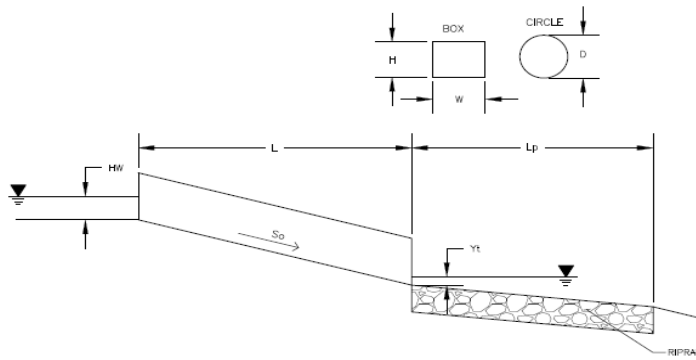

Soil Type:

Choose One:

- Sandy
 Non-Sandy

Supercritical Flow! Using Adjusted Diameter to calculate protection type.

Design Information:

Design Discharge	Q = <input type="text" value="41.98"/> cfs
Circular Culvert:	
Barrel Diameter in Inches	D = <input type="text" value="36"/> inches
Inlet Edge Type (Choose from pull-down list)	Grooved Edge Projecting
OR:	
Box Culvert:	
Barrel Height (Rise) in Feet	H (Rise) = <input type="text"/> ft
Barrel Width (Span) in Feet	W (Span) = <input type="text"/> ft
Inlet Edge Type (Choose from pull-down list)	
Number of Barrels	# Barrels = <input type="text" value="1"/>
Inlet Elevation	Elev IN = <input type="text" value="7154.46"/> ft
Outlet Elevation OR Slope	So = <input type="text" value="0.02"/> ft/ft
Culvert Length	L = <input type="text" value="54"/> ft
Manning's Roughness	n = <input type="text" value="0.023"/>
Bend Loss Coefficient	k _b = <input type="text" value="0"/>
Exit Loss Coefficient	k _x = <input type="text" value="1"/>
Tailwater Surface Elevation	Y _t , Elevation = <input type="text" value="1"/> ft
Max Allowable Channel Velocity	V = <input type="text" value="7"/> ft/s

Tailwater ELEVATION is less than outlet elevation, using 0.4 x Rise as Yt.

Calculated Results:

Culvert Cross Sectional Area Available	A = <input type="text" value="7.07"/> ft ²
Culvert Normal Depth	Y _n = <input type="text" value="2.00"/> ft
Culvert Critical Depth	Y _c = <input type="text" value="2.11"/> ft
Froude Number	Fr = <input type="text" value="1.11"/> Supercritical!
Entrance Loss Coefficient	k _e = <input type="text" value="0.20"/>
Friction Loss Coefficient	k _f = <input type="text" value="1.22"/>
Sum of All Loss Coefficients	k _s = <input type="text" value="2.42"/> ft
Headwater:	
Inlet Control Headwater	HW _I = <input type="text" value="3.16"/> ft
Outlet Control Headwater	HW _O = <input type="text" value="2.80"/> ft
Design Headwater Elevation	HW = <input type="text" value="7157.62"/> ft
Headwater/Diameter OR Headwater/Rise Ratio	HW/D = <input type="text" value="1.05"/>
Outlet Protection:	
Flow/(Diameter ^{2.5})	Q/D ^{2.5} = <input type="text" value="2.69"/> ft ^{0.5} /s
Tailwater Surface Height	Y _t = <input type="text" value="1.20"/> ft
Tailwater/Diameter	Y _t /D = <input type="text" value="0.40"/>
Expansion Factor	1/(2*tan(θ)) = <input type="text" value="4.80"/>
Flow Area at Max Channel Velocity	A _t = <input type="text" value="6.00"/> ft ²
Width of Equivalent Conduit for Multiple Barrels	W _{eq} = <input type="text" value="-"/> ft
Length of Riprap Protection	L_p = <input type="text" value="10"/> ft
Width of Riprap Protection at Downstream End	T = <input type="text" value="6"/> ft
Adjusted Diameter for Supercritical Flow	Da = <input type="text" value="2.50"/> ft
Minimum Theoretical Riprap Size	d _{50 min} = <input type="text" value="7"/> in
Nominal Riprap Size	d _{50 nominal} = <input type="text" value="9"/> in
MHFD Riprap Type	Type = <input type="text" value="L"/>

Driveway/Roadside Ditch Capacity Calculation

Project Description	
Friction Method	Manning
	Formula
Solve For	Discharge
Input Data	
Roughness Coefficient	0.035
Channel Slope	0.050 ft/ft
Normal Depth	24.0 in
Left Side Slope	3.000 H:V
Right Side Slope	4.000 H:V
Results	
Discharge	129.41 cfs
Flow Area	14.0 ft ²
Wetted Perimeter	14.6 ft
Hydraulic Radius	11.5 in
Top Width	14.00 ft
Critical Depth	29.2 in
Critical Slope	0.018 ft/ft
Velocity	9.24 ft/s
Velocity Head	1.33 ft
Specific Energy	3.33 ft
Froude Number	1.630
Flow Type	Supercritical
GVF Input Data	
Downstream Depth	0.0 in
Length	0.0 ft
Number Of Steps	0
GVF Output Data	
Upstream Depth	0.0 in
Profile Description	N/A
Profile Headloss	0.00 ft
Downstream Velocity	Infinity ft/s
Upstream Velocity	Infinity ft/s
Normal Depth	24.0 in
Critical Depth	29.2 in
Channel Slope	0.050 ft/ft
Critical Slope	0.018 ft/ft

Driveway/Roadside Ditch Capacity Calculation

Project Description	
Friction Method	Manning Formula
Solve For	Discharge

Input Data	
Roughness Coefficient	0.035
Channel Slope	0.050 ft/ft
Normal Depth	24.0 in
Left Side Slope	3.000 H:V
Right Side Slope	4.000 H:V
Discharge	129.41 cfs

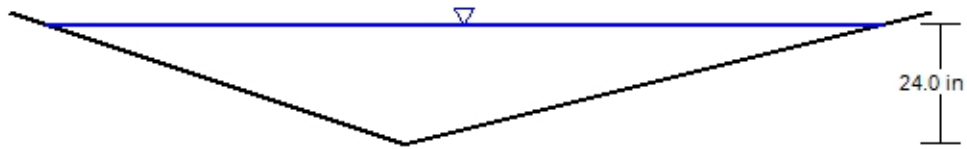

V: 1
H: 1

APPENDIX F – DRAINAGE EXHIBITS

K:\COS_Civil\196624000_5740_Burgess Road\CADD\PlanSheets\Drainage\DrainagePlan_EX_196624000.dwg McClain, Drew 1/4/2024 11:48 AM

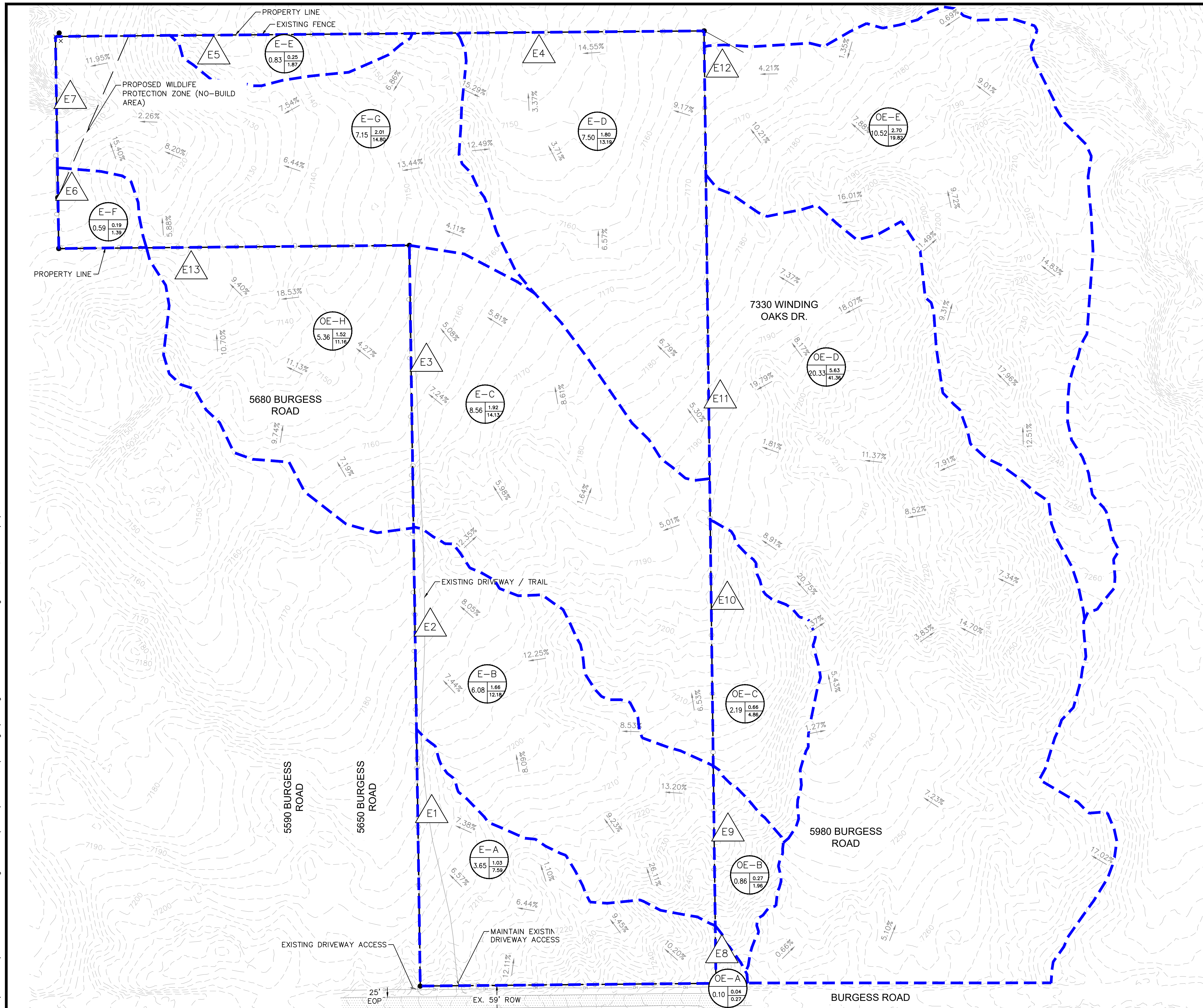

LEGEND

- PROPERTY LINE
- PROPOSED PROPERTY LINE
- MAJOR CONTOUR
- MINOR CONTOUR
- EX. DRAINAGE BASIN BOUNDARY
- PROPOSED PRIVATE ACCESS EASEMENT
- PROPOSED WILDLIFE PROTECTION ZONE

A = BASIN DESIGNATION
 B = AREA IN ACRES
 C = 5-YR RUNOFF
 D = 100-YR RUNOFF

= DESIGN POINT DESIGNATION

X.XXX% EXISTING SLOPE ARROW

SUMMARY - EXISTING RUNOFF TABLE

DESIGN POINT	BASIN DESIGNATION	BASIN AREA (ACRES)	DIRECT 5-YR RUNOFF (CFS)	DIRECT 100-YR RUNOFF (CFS)
E1	A	3.65	1.03	7.59
E2	B	6.08	1.66	12.18
E3	C	8.56	1.92	14.13
E4	D	7.50	1.80	13.19
E5	E	0.83	0.25	1.87
E6	F	0.59	0.19	1.39
E7	G	7.15	2.01	14.80
E8	OE-A	0.10	0.04	0.27
E9	OE-B	0.86	0.27	1.96
E10	OE-C	2.19	0.66	4.86
E11	OE-D	20.33	5.63	41.36
E12	OE-E	10.52	2.70	19.82
E13	OE-H	5.36	1.52	11.16
TOTAL		73.73	25.57	144.57

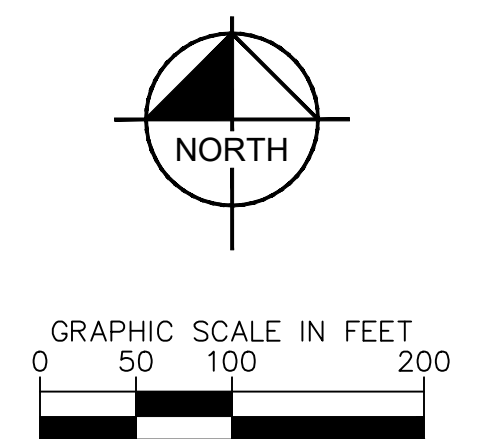

811 Know what's below. Call before you dig.

CALL UTILITY NOTIFICATION CENTER OF COLORADO 1-800-922-1987
 CALL 2-BUSINESS DAYS IN ADVANCE BEFORE YOU DIG, GRADE, OR EXCAVATE FOR THE MARKING OF UNDERGROUND MEMBER UTILITIES

	NO. _____
	REVISION _____
	DATE _____
	APPR. _____

2023 KIMLEY-HORN AND ASSOCIATES, INC.
 2 North Nevada Avenue Suite 900
 Colorado Springs, Colorado 80903 (719) 453-0180

DESIGNED BY: RES
 DRAWN BY: RES
 CHECKED BY: KRR
 DATE: 1/12/2023

**RENEHAN SUBDIVISION
 EL PASO COUNTY, COLORADO
 EXISTING DRAINAGE MAP**

PRELIMINARY
 FOR REVIEW ONLY
 NOT FOR CONSTRUCTION

Kimley-Horn and Associates, Inc.

PROJECT NO. 196624000
 SHEET 1

K:\COS_Civil\196624000_5740_Burgess Road\CADD\PlanSheets\Drainage\DrainagePlan_PR_196624000.dwg McClinton, Drew 1/4/2024 11:48 AM

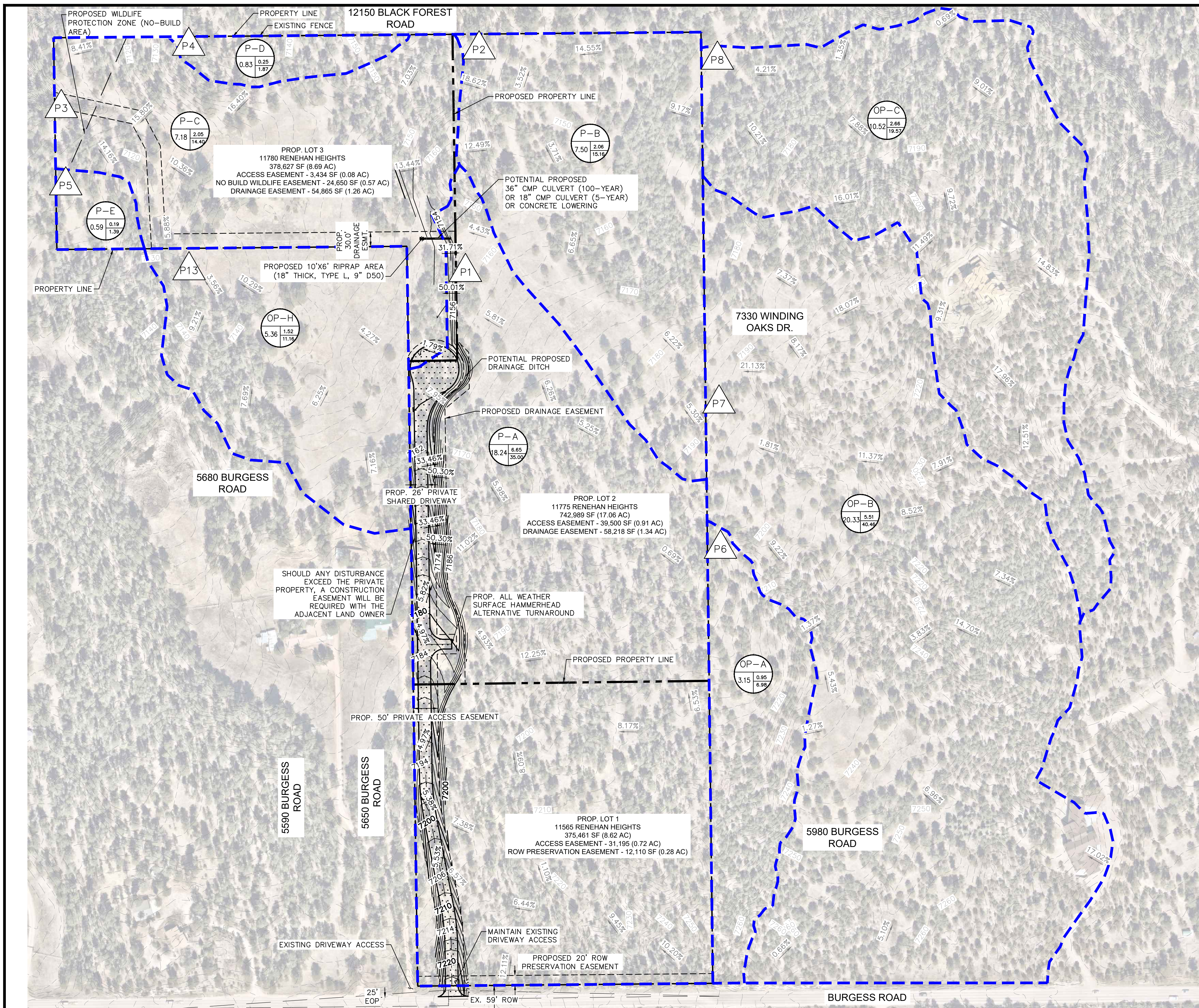

LEGEND

- PROPERTY LINE
- - - - PROPOSED PROPERTY LINE
- - - - - MAJOR CONTOUR
- - - - - MINOR CONTOUR
- PROPOSED DRAINAGE BASIN BOUNDARY
- - - - - PROPOSED PRIVATE ACCESS EASEMENT
- PROPOSED WILDLIFE PROTECTION ZONE

A = BASIN DESIGNATION
 B = AREA IN ACRES
 C = 5-YR RUNOFF
 D = 100-YR RUNOFF

= DESIGN POINT DESIGNATION

X.XX% EXISTING SLOPE ARROW

 X.XX% PROPOSED SLOPE ARROW

SUMMARY - PROPOSED RUNOFF TABLE

DESIGN POINT	BASIN DESIGNATION	BASIN AREA (ACRES)	DIRECT 5-YR RUNOFF (CFS)	DIRECT 100-YR RUNOFF (CFS)
P1	P-A	18.28	7.60	36.26
P2	P-B	7.50	2.06	15.16
P3	P-C	7.17	2.57	15.01
P4	P-D	0.83	0.25	1.87
P5	P-E	0.59	0.19	1.39
P6	OP-A	3.15	0.95	6.98
P7	OP-B	20.33	5.51	40.46
P8	OP-C	10.52	2.66	19.57
P13	OP-H	5.36	1.52	11.16
TOTAL		73.73	23.33	147.88

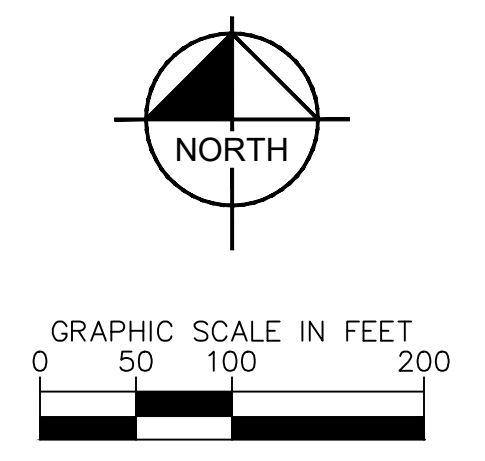

811 Know what's below. Call before you dig.

CALL UTILITY NOTIFICATION CENTER OF COLORADO 1-800-922-1987
CALL 2-BUSINESS DAYS IN ADVANCE BEFORE YOU DIG, GRADE, OR EXCAVATE FOR THE MARKING OF UNDERGROUND MEMBER UTILITIES

Kimley»Horn
2023 KIMLEY-HORN AND ASSOCIATES, INC.
2 North Nevada Avenue Suite 900
Colorado Springs, Colorado 80903 (719) 453-0180

RENEHAN SUBDIVISION
EL PASO COUNTY, COLORADO
PROPOSED DRAINAGE MAP

DESIGNED BY: RES
DRAWN BY: RES
CHECKED BY: KKK
DATE: 1/12/2023

PRELIMINARY
FOR REVIEW ONLY
NOT FOR CONSTRUCTION
Kimley»Horn
Kimley-Horn and Associates, Inc.

PROJECT NO. 196624000
SHEET 1

NO.	REVISION	DATE	APPR.

APPENDIX G – SITE PHOTOS



Standing within the vicinity of design point P1, looking northwest towards design points P5 and P3.



Standing within the vicinity of proposed culvert, looking west along the proposed drainage easement adjacent to the southern property line (of the northwest area of the site) towards design points P5.



Moving west from the proposed culvert, walking through the proposed drainage easement towards the western property line.



Standing in the center of the northwest area of the site, looking northwest towards design point P3 along proposed drainage easement.



Standing in the center of the northwest area of the site, looking north towards northern property line and design point P4.



Standing in the center of the northwest area of the site, looking northwest towards western property line and design point P3 along the existing natural channel.



Standing at the central northern area of the site within proposed basin P-D, looking south.



Standing at the central northern area of the site within proposed basin P-D, looking east.



Standing at the central northern area of the site within proposed basin P-D, looking west.



Moving east from proposed basin P-D along the northern property line, looking west.



Moving east from proposed basin P-D and looking northeast, approaching design point P2.



Standing at same position from photo 11, looking southeast to show existing natural channel leading up to design point P2.



Standing at design point P2 along northern property boundary looking northeast.



Moving east from design point P2 standing at northern property boundary looking west towards design point P2.



Moving east from design point P2, standing at northern property line, looking east towards northeast corner of site.



Standing at the northeast corner of the property, looking west along northern property line towards design point P2.















































APPENDIX H – KETTLE CREEK DBPS

**Drainage Basin Planning Study
For
Kettle Creek Basin**

Prepared for:

High Valley Land Company, Inc.
1755 Telestar Drive, Suite 211
Colorado Springs, CO 80920
Contact: Tom Taylor

Prepared by:

JR Engineering LLC
3730 Sinton Road, Suite
Colorado Springs, CO 80903
(719) 593-2593
Contact: Steve Rossoll

JR Project Number: 25100.00
May 5, 2015

X:\2510000.all\2510000\Word\Reports\Kettle Creek DBPS

**Drainage Basin Planning Study
For Kettle Creek**

ENGINEER'S STATEMENT:

The attached Drainage Basin Planning Study was prepared under my direction and supervision and is correct to the best of my knowledge and belief. Said Drainage Basin Planning Study has been prepared according to the criteria established by the City for Drainage Basin Planning Studies and said report is in conformity with the master plan of the drainage basin area. I accept responsibility for any liability caused by any negligent acts, errors, or omissions on my part in preparing this report.



Steve Rossoll, Colorado P.E. # 34655
For and On Behalf of JR Engineering, LLC



5/6/15
Date

DEVELOPER'S STATEMENT:

I, the developer, have read and will comply with all of the requirements specified in this Drainage Basin Planning Study.

Business Name: High Valley Land Company, Inc.

By: 

Title: Vice President

Address: 1755 Telestar Drive, Suite 211

Colorado Springs, CO 80920

Phone Number: (719) 260-7477

CITY OF COLORADO SPRINGS ONLY:

Filed in accordance with Section 7.7.906 of the Code of the City of Colorado Springs, 2001, as amended.



For the City Engineer

Conditions:

5/13/15
Date

DISCLAIMER:

This report has been prepared based on certain key assumptions made by JR Engineering, which substantially affect the conclusions and recommendations of this report. These assumptions, although thought to be reasonable and appropriate, may not prove true in the future. The conclusions and recommendations made by JR Engineering are conditioned upon these assumptions.

Background information, design bases, and other data have been furnished to JR Engineering by third parties, which JR Engineering has used in preparing this report. JR Engineering has relied on this information as furnished, and is not responsible for and has not confirmed the accuracy of this information. Information that became available after data procurement was complete was not incorporated.

THIS REPORT IS A PLANNING DOCUMENT AND IS NOT TO BE USED AS THE BASIS FOR FINAL DESIGN, CONSTRUCTION OR REMEDIAL ACTION, NOR AS A BASIS FOR MAJOR CAPITAL DECISIONS.

TABLE OF CONTENTS

1	INTRODUCTION	1-1		
1.1	Contract Authorization	1-1		
1.2	Purpose and Scope	1-1		
1.3	Past Studies	1-1		
1.4	Stakeholder Process	1-1		
1.5	Agency Jurisdictions	1-1		
1.6	General Basin Description	1-1		
1.7	Data Sources	1-2		
1.8	Applicable Criteria and Standards	1-2		
2	BASIN CHARACTERISTICS	2-1		
2.1	Location in Watershed, Offsite Flows, Size	2-1		
2.2	Climate, Geology, and Environmental	2-1		
2.2.1	Climate	2-1		
2.2.2	Geology and Vegetation	2-1		
2.2.3	Groundwater	2-1		
2.2.4	Development	2-1		
2.3	Major Drainageways and Structures	2-1		
2.3.1	Voyager Parkway/State Highway 83	2-2		
2.4	Existing and Proposed Land Uses	2-2		
3	HYDROLOGIC ANALYSIS	3-1		
3.1	Major Basins and Sub-basins	3-1		
3.1.1	Major Basin	3-1		
3.1.2	Sub-basins	3-1		
3.2	Methodology	3-1		
3.2.1	Computer Models	3-1		
3.3	Basin Hydrology	3-4		
3.3.1	Historic Flows	3-4		
3.3.2	Existing Flows	3-4		
3.3.3	Future Flows	3-4		
3.3.4	Flows Comparison	3-5		
4	HYDRAULIC ANALYSIS	4-1		
4.1	Major Drainageways	4-1		
4.2	Methodology	4-1		
4.2.1	Parameters	4-1		
4.2.2	Structures	4-1		
4.2.3	Reaches	4-1		
4.2.4	Manning's <i>n</i> Values	4-1		
4.2.5	Cross-Sections	4-2		
4.2.6	Ineffective Flow Areas	4-2		
4.2.7	Bridges	4-2		
4.2.8	Detention Ponds	4-2		
4.2.9	Steady Flow and Boundary Conditions	4-2		
4.3	Approximate Floodplains	4-2		
4.4	Drainageway Crossing Deficiencies	4-3		
4.5	Areas of Geomorphic Instability	4-3		
5	ENVIRONMENTAL EVALUATIONS	5-1		
5.1	Significant Existing or Potential Wetland and Riparian Areas Impact	5-1		
5.1.1	Riparian Areas	5-1		
5.1.2	Wildlife	5-1		
5.1.3	Preble's Meadow Jumping Mouse	5-2		
5.2	Stormwater Quality Considerations	5-2		
5.2.1	Hazardous Materials	5-2		
5.2.2	Water Quality	5-2		
5.3	Permitting Requirements	5-2		
6	ALTERNATIVES EVALUATION	6-1		
6.1	Evaluation Criteria	6-1		
6.2	Regional Detention Alternatives	6-1		
6.3	Sub-Regional Detention	6-2		
6.3.1	Full Spectrum Detention	6-2		
6.3.2	Water Quality	6-2		
6.4	Limited Channel Stabilization Alternative	6-2		
7	SELECTED PLAN	7-1		
8	FEE DEVELOPMENT	8-1		
8.1	General	8-1		
8.2	Developable Land	8-1		
8.3	Fee Calculation	8-1		
9	REFERENCES	9-1		

FIGURES

Figure 1-1	Vicinity Map
Figure 3-1	Routing Schematic
Figure 3-2	Basin Map
Figure 3-3	Hydrologic Soil Group Map
Figure 3-4	Land Use Map – Historic
Figure 3-5	Land Use Map – Existing
Figure 3-6	Land Use Map – Future
Figure 3-7	Curve Number Map – Historic
Figure 3-8	Curve Number Map – Existing
Figure 3-9	Curve Number Map – Future
Figure 3-10	Hydrologic Results – Minor Storm
Figure 3-11	Hydrologic Results – Major Storm
Figure 3-12	Hydrologic Results – Historic
Figure 3-13	Hydrologic Results – Existing
Figure 3-14	Hydrologic Results – Future
Figure 4-1	Kettle Creek Hydraulic Work Map
Figure 4-2	Kettle Creek Hydraulic Work Map
Figure 4-3	Flood Profiles
Figure 4-4	Flood Profiles
Figure 4-5	Flood Profiles
Figure 4-6	Flood Profiles
Figure 4-7	Flood Profiles
Figure 4-8	Conceptual Channel Stabilization Profiles
Figure 4-9	Conceptual Channel Stabilization Profiles
Figure 4-10	Conceptual Channel Stabilization Profiles
Figure 4-11	Conceptual Channel Stabilization Profiles
Figure 4-12	Conceptual Channel Stabilization Profiles
Figure 6-1	Conceptual Sub-Regional Detention Pond Locations

APPENDICES

A.	Stakeholder Meeting Summaries
B.	Hydrologic Calculations and Data
C.	Hydraulic Calculations and Data
D.	Photo Logs
E.	Unplatted Area Calculations
F.	Fee Calculations

1 INTRODUCTION

1.1 Contract Authorization

This Drainage Basin Planning Study was authorized under the terms of an agreement between the City of Colorado Springs Engineering Development Review and Stormwater Departments and High Valley Land Company, Inc. and paid for with private funds. This study covers drainage development only within the Kettle Creek Drainage Basin.

1.2 Purpose and Scope

The purpose of the drainage basin planning study is to give an initial comprehensive study of the entire Kettle Creek Basin. This Study shall show the conduits, channels, natural drainage courses, detention reservoirs, easements, culverts and all other hydraulic facilities required to control surface water from the 100-year event within the Kettle Creek Basin and to carry such waters to points of insignificant impact and to develop a plan to address future stormwater and infrastructure needs within the Kettle Creek Watershed. The process used to develop a DBPS provides opportunity for interested parties to offer input on drainage issues, needs, and facilities within the watershed. The DBPS is intended to provide an inventory of required drainage facilities and determine a drainage fee per developed acre.

1.3 Past Studies

A complete Drainage Basin Planning Study (DBPS) has not been performed for the entire Kettle Creek Watershed. However, Master Development Drainage Plans (MDDP) and Final Drainage Reports (FDR) have been prepared for areas within the study area that have been developed in the last 13 years. A number of previous studies and reports were reviewed during the preparation of the current study. The most relevant studies are listed below along with a brief synopsis of the relevance of the current study. Additional reports that were reviewed are noted in the reference section of this study.

Fountain Creek Watershed Study, January 2009, U.S. Army Corps of Engineers.

The Fountain Creek Watershed Study ties together four separate studies, a hydrology report, a hydraulics report, and environmental conditions report, and a geomorphology report, into a watershed study establishing the objectives for reduced flood risk, erosion, and sedimentation in the Fountain Creek Basin. The Watershed Study presents percent change data for existing versus future peak discharges and volumes in Monument Creek and adjacent tributaries, although no Kettle Creek flow data is presented in the Watershed Study. The hydrologic study and hydraulic study were not available from the City of Colorado Springs or from the U.S. Army Corps of Engineers to compare hydrology for common basins at the time of the preparation of this DBPS.

Master Development Drainage Plan For North Fork at Briargate, May, 2014, by JR Engineering.

A proposed mixed use development comprised of a single family residential, multifamily, an elementary school, and park site. The Site covers 267 acres located north-east of Powers Boulevard and Old Ranch Road.

Kettle Creek Drainage Basin Old Ranch Road Tributary Drainage Basin Planning Study and Master Development Drainage Plan, April 2001, by JR Engineering. (Kettle Creek MDDP/DBPS)

This MDDP/DBPS covers the portion of the Kettle Creek Basin along old Ranch Road. This study provides hydrologic data for the existing and future development along Old Ranch Road, Creekside Estates, and drainage facilities at Pine Creek High School.

U.S. Air Force Academy Kettle Creek Watershed Hydrology Study Findings and Recommendations Report, March 2002, by URS Group, Inc. (AFA Study)

This report was prepared for the U.S. Air Force Academy to study the hydrologic, hydraulic, and sediment transport for the entire Kettle Creek basin. The report recommends alternatives to reduce sediment accumulation, evaluate Preble's meadow jumping mouse habitat, and enhance existing wetlands on Academy property.

Flood Insurance Study for El Paso County and Incorporated Areas

FEMA performed a Flood Insurance Study (FIS) in 1999 with detailed analysis and base flood elevations from State Highway 83 to Templeton Gap Road at the headwaters of Kettle Creek in the Black Forest. The FEMA FIRM maps and FIS data are included in **Appendix B**.

1.4 Stakeholder Process

Stakeholders who may be affected by this study results must be identified and included in numerous public meetings and presentations to committees, council and commissions. This DBPS is prepared for the High Valley Land Company, Inc. and is the only stakeholder that is affected in the Kettle Creek Basin study. Thus there are no stakeholder meetings and presentations required.

1.5 Agency Jurisdictions

Future development in the Kettle Creek basin will predominately be located within the City of Colorado Springs city limits. Improvements outside the city limits will be located and governed by El Paso County.

1.6 General Basin Description

The Kettle Creek watershed is located in the north central portion of El Paso County, Colorado. Kettle Creek and its tributaries originate on the southern slope of the Black Forest and flow in a southwesterly direction towards the City of Colorado Springs. The Kettle Creek watershed has a contributing area of approximately 16.41 square miles at its junction with Interstate Highway 25 (I-25).

The headwaters of Kettle Creek are located in the Black Forest, an area dominated by ponderosa pine forest and grassland on undeveloped large acreage tracts and 2- to 5-acre rural residential lots. In the vicinity of Powers Boulevard, the watershed changes to predominately undeveloped grassland. Downstream of Powers Boulevard, the watershed is dominated by residential development consisting of single-family homes, commercial centers, and vacant land. A vicinity map is provided in **Figure 1-1**.

1.7 Data Sources

Data used to complete the analysis for this DBPS, includes digital topography, aerial photography, soils classification, land use, existing stormwater infrastructure, rainfall data, U.S. Geological Survey (USGS) gage data, and pertinent information from previously completed studies. Topography covering the entire Kettle Creek watershed was obtained from USGS quadrangle maps (Black Forest, Falcon NW, Monument, Pikeview). Topographic data was imported using NAD83 (Colorado State Planes, Central Zone, US Foot) in accordance with the notes on the USGS quad maps. Aerial imagery was orthorectified using approximate methods of analysis. This USGS topographic data was only used for the hydrologic analysis. City of Colorado Springs FIMS topographic data was obtained for the reach of Kettle Creek studied in the hydraulic analysis.

Rainfall data was obtained from the City of Colorado Springs Drainage Criteria Manual (DCM), Volume 1, dated May 2014. One-hour depths were obtained from the DCM and adjusted for elevation using the NOAA procedure. Soils data were obtained from the Natural Resources Conservation Service Web Soil Survey for El Paso County.

A hydrologic model for the Kettle Creek watershed was developed using the US Army Corps of Engineers (USACE) Hydrologic Engineering Center – Hydrologic Modeling System Version 4.0 (HEC-HMS) to simulate the rainfall-runoff process and generate flood hydrographs for select storm events.

A hydraulic model for the Kettle Creek channel was developed using the US Army Corps of Engineers (USACE) Hydrologic Engineering Center – River Analysis System Version 4.1.0 (HEC-RAS) to perform steady-state river hydraulics calculations with bridge analysis and stable channel analysis. City of Colorado Springs FIMS topographic data was used for the hydraulic analysis.

1.8 Applicable Criteria and Standards

The criteria and standards set forth in the City of Colorado Springs Drainage Criteria Manual (DCM), Volume 1 were applied to the entirety of the Kettle Creek DBPS for consistency, although much of the basin lies within unincorporated El Paso County. The Kettle Creek DBPS was prepared in accordance with the policies and procedures established in the DCM.

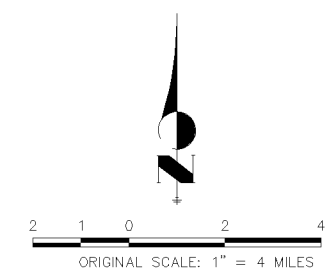
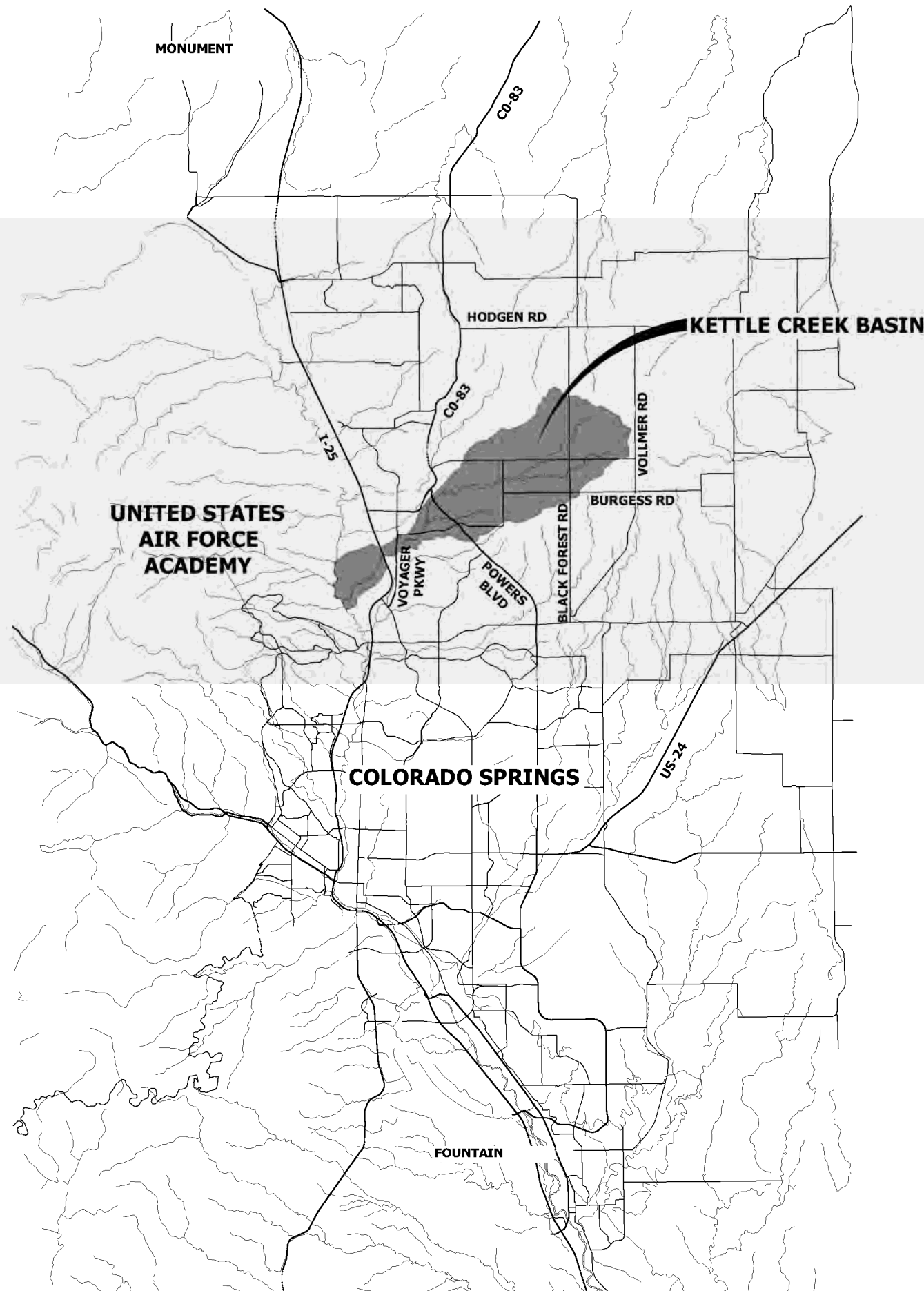

FIGURE 1-1 VICINITY MAP
 KETTLE CREEK DBPS
 JOB NO. 25100.00
 MAY 2015

2 BASIN CHARACTERISTICS

2.1 Location in Watershed, Offsite Flows, Size

The Kettle Creek watershed is located in the north central portion of El Paso County and flows southwesterly from the southern slope of the Black Forest towards the U.S. Air Force Academy. The Kettle Creek watershed contains perennial streams and has a contributing drainage area of approximately 16.41 square miles at its junction with Interstate Highway 25 (I-25). The entire Kettle Creek basin upstream of the U.S. Air Force Academy was studied for this DBPS, from the Kettle Creek headwaters in the Black Forest to I-25. Accordingly, no offsite flows are accounted for in this study.

The headwaters of Kettle Creek are located in the Black Forest, an area dominated by ponderosa pine forest and grassland on undeveloped large acreage tracts and 2- to 5-acre rural residential lots. In the vicinity of Powers Boulevard, the watershed changes to predominately undeveloped grassland. Downstream of Powers Boulevard, the watershed is dominated by residential development consisting of single-family homes, commercial centers, and vacant land.

2.2 Climate, Geology, and Environmental

2.2.1 Climate

The Kettle Creek watershed is located northeast of the City of Colorado Springs. The watershed ranges in elevation from approximately 6,410 feet at I-25 to approximately 7,600 feet at the north end of the basin in the Black Forest. Kettle Creek is tributary to Monument Creek and the confluence with Monument Creek is located near I-25 and Academy Boulevard. Kettle Creek is located at the north end of the Fountain Creek basin, which is tributary to the Arkansas River.

The climate of the region is classified as a mid-latitude steppe, with total annual precipitation averaging 16.2 inches annually. Eighty percent of the region's precipitation comes in the growing season from March to October. Monsoon moisture in the form of thunderstorms in July and August contributes the most. Winter is the driest season of the year. The mean annual snowfall in the region is 84 inches with the peak amount in March.

2.2.2 Geology and Vegetation

The soils in the upper reaches of the Kettle Creek watershed, east of Power Boulevard, are predominately Kettle gravelly-loamy sand and Peyton-Pring complex. Smaller areas of Elbeth sandy loam and Tomah-Crowfoot sandy loam exist at higher elevations in the watershed. The dominant landform in this region is defined as hills, and the parent material is defined as arkosic alluvium derived from sedimentary rock and/or arkosic residuum weathered from sedimentary rock. The ecological site is specified as Sandy Divide. The soils in this region are all classified as Hydrologic Soils Group B. Group B soils are soils having a moderate infiltration rate when thoroughly wet. These consist chiefly of moderately deep or deep, moderately well drained or well drained soils that have moderately fine texture to moderately coarse texture. These soils have a moderate rate of water transmission. Surface runoff is slow, creating a low-to-moderate hazard of erosion.

Native vegetation of the Kettle soil is predominately woodland ponderosa pine with a rooting depth of 60 inches.

West of Powers Boulevard, the soils composition changes. In the vicinity of Kettle Creek the soils composition remains similar with Kettle gravelly-loamy sand and Peyton-Pring complex, however away from the creek the dominant soils types are Blakeland loamy sand and Columbine gravelly sand, both of which belong to Hydrologic Soils Group A. Group A soils are soils having a high infiltration rate (low runoff potential) when thoroughly wet. These consist mainly of deep, well drained to excessively drained sands or gravelly sands. These soils have a high rate of water transmission. This region is located in a transition zone between forest, shrubland, and prairie. Much of the lower elevations are covered in Gambel oak and prairie grasses. The dominant landform in this region is defined as fans, fan terraces, floodplains, and swales, and the parent material is defined as alluvium derived from sedimentary rock and/or eolian deposits derived from sedimentary rock. The ecological site is specified as Gravelly Foothill.

2.2.3 Groundwater

Planning studies in adjacent basins (Falcon DBPS, prepared by Matrix Design Group, 2013) mapped the depth to groundwater in the Black Forest area and show that the water table is generally greater than 20 feet and more commonly greater than 100 feet below ground surface. It is assumed that these characteristics are typical throughout the upper reaches of the Black Forest area watersheds. The Falcon study speculated that the Black Forest is an infiltration area that recharges the Dawson aquifer because of the course-textured soils that dominate the forest. As groundwater from the Dawson aquifer flows south and southeasterly, it perches on the lower units of the formation (claystone and siltstone) and is 10 to 20 feet below the surface in some places. As elevation decreases in a southeasterly direction, the groundwater surfaces as low discharge springs or seeps. The hydraulic connection between the unconsolidated alluvial deposits in the unnamed tributaries and the Dawson aquifer is greatest where stream valleys have been eroded into the Dawson formation.

2.2.4 Development

Residential and commercial construction throughout the past 13 years has resulted in changes to the drainage pattern throughout the Kettle Creek watershed, particularly downstream of the Black Forest. These changes can either increase or decrease flows to various parts of the watershed. In multiple places, roadside ditches, culverts, and detention ponds have been constructed to manipulate historic flow patterns. These alterations can impact the drainage in two ways. First, the loss of hydrology from reducing flows to particular reaches will result in a change in vegetative structure. These areas have likely lost both wetland function and biodiversity. Second, diverted water may overload reaches that have not adapted to historic high flows. This condition usually results in bank erosion along the channel.

2.3 Major Drainageways and Structures

The major drainageway for the basin is Kettle Creek. Upstream of Powers Boulevard, storm runoff is captured in natural channels and conveyed to Kettle Creek predominately according to historic patterns. Kettle Creek has incised deep channels into the bedrock for much of its length.

Road crossings exist on Black Forest Road, Shoup Road, Milam Road, Powers Boulevard, Old Ranch Road, Voyager Parkway, and I-25. Many small culverts exist for Kettle Creek's smaller tributaries within the Black Forest, but were not considered in this analysis. These crossings were assumed to be adequate because minimal future development in the Black Forest area is expected to occur.

The existing bridges over Kettle Creek at Powers Boulevard, Old Ranch Road, and Voyager Parkway, as well as the regional detention facility at I-25, are assumed to be adequate for the current level of development and will remain for the future condition with no proposed modifications. Future development will be required to detain on-site to preserve the existing conditions discharges in Kettle Creek.

There are no known irrigation facilities in the Kettle Creek watershed.

2.3.1 Voyager Parkway/State Highway 83

It should be noted that later discussions refer to the Voyager Parkway crossing as "State Highway 83". Where the road is now owned by the City it is known as Voyager Parkway. Where the road remains CDOT controlled it is referred to as State Highway 83. Previous drainage studies use the old terminology and the designation State Highway 83 is kept herein to avoid confusion.

2.4 Existing and Proposed Land Uses

The Kettle Creek watershed reflects a variety of existing land uses including rural residential (5 acres, 2.5 acres, 0.5 acres), residential suburban (5000, 6000, 20000, some vacant), agricultural, planned unit development, commercial, and rights-of-way. Due to urban growth, land use is expected to change in the future condition with significant residential development planned in the lower-middle portion of the watershed. It is anticipated that the land uses in the Black Forest area will remain unchanged in the future condition.

3 HYDROLOGIC ANALYSIS

3.1 Major Basins and Sub-basins

3.1.1 Major Basin

The major basin was defined as the entire Kettle Creek watershed from its headwaters in the Black Forest to the I-25 crossing, approximately 16.41 square miles (10,506 acres). The I-25 crossing was determined to represent an adequate termination for the DBPS due to the proximity to the US Air Force Academy grounds (no basin development expected to occur) and the crossing is sufficiently downstream of future development within the Kettle Creek basin.

3.1.2 Sub-basins

The Kettle Creek watershed was divided into 32 sub-basins ranging from 0.12 square miles (79 acres) up to 1.33 square miles (853 acres). Slopes for areas of concentrated flow in the Kettle Creek watershed range from 0.69 percent to 9.64 percent, with shallower and steeper slopes located in the overland flow areas. Sub-basins were delineated at tributaries, major road crossings, changes in slope, changes in land use, and major drainage features. A routing schematic is provided in **Figure 3-1**. A drainage basin map is included as **Figure 3-2**.

3.1.2.1 Sub-basin Delineation

Topographic data for the hydrologic analysis of the entire watershed was obtained from USGS quadrangle maps (Black Forest, Falcon NW, Monument, Pikeview) and approximately traced into AutoCAD Civil 3D at 5-foot intervals.

The Kettle Creek watershed was divided into 3 major reaches: West Tributary, South Tributary, and East Tributary as shown on the basin map, **Figure 3-2**. The West Tributary consists of 19 sub-basins and 5 minor tributaries along the entire length of the watershed from the headwaters in the Black Forest to the crossing at I-25. These sub-basins primarily encompass rural land with pockets of residential development along the main stem of Kettle Creek. The East Tributary consists of 4 sub-basins and 1 minor tributary and encompasses rural residential land in the Black Forest. The Black Forest drains to The South Tributary. The South Tributary consists of 9 sub-basins and 2 minor tributaries. The area consists primarily of suburban residential located within the City of Colorado Springs city limits. This reach is where future development is expected to occur.

3.2 Methodology

3.2.1 Computer Models

A hydrology model for the Kettle Creek watershed was developed using the US Army Corps of Engineers (USACE) Hydrologic Engineering Center – Hydrologic Modeling System Version 4.0 (HEC-HMS) to simulate the rainfall-runoff process and generate flood hydrographs for select storm events. Each component of the model is described in detail following this section.

Sub-basin and stream reach physical characteristics including area, longest hydraulic flow path, reach length, slope, and topological connectivity were extracted for calculation of hydrologic parameters. Hydrologic parameters were calculated as outlined below and populated to the basin and meteorological components of the HEC-HMS model. A summary of selected methodologies for each HEC-HMS model component is provided in Table 3-1.

3.2.1.1 Rainfall Characteristics

The Specified Hyetograph method was chosen to model the hypothetical storm events as outlined in the City of Colorado Springs Drainage Criteria Manual (DCM), Volume 1, dated May 2014. Both the thunderstorm-type 2-Hour Design Storm Distribution (DCM Table 6-3) and the frontal-type NRCS 24-Hour Type II Design Storm Distribution (DCM Table 6-4) were applied to the point precipitation in order to generate the runoff hydrographs. Rainfall depths were obtained from Table 6-2 of the DCM and were verified for the higher elevations in the Kettle Creek watershed using the Urban Drainage and Flood Control District’s UD-Rain Version 1.01 spreadsheet. At an average watershed elevation of 7120 feet, the 1-hour storm depth is 2.50 inches and the 24-hour storm depth is 4.60 inches. Point precipitation is shown in **Table 3-1**, below. Design storm input is included in **Appendix B**.

Table 3-1

Return Period	Rainfall Depth in Inches at Time Duration								
	5-min	10-min	15-min	30-min	1-hr	2-hr	3-hr	6-hr	24-hr
2-yr	0.34	0.54	0.68	0.78	1.19	1.37	1.50	1.70	2.10
5-yr	0.43	0.68	0.86	1.00	1.52	1.72	1.87	2.10	2.70
10-yr	0.49	0.78	0.98	1.14	1.73	1.96	2.13	2.40	3.20
25-yr	0.57	0.90	1.14	1.31	2.00	2.31	2.54	2.90	3.60
50-yr	0.64	1.02	1.28	1.48	2.26	2.58	2.82	3.20	4.20
100-yr	0.71	1.13	1.42	1.64	2.50	2.84	3.10	3.50	4.60

Depth Area Reduction Factors (DARFs) are used to adjust point rainfall depths to average depths as the size of drainage basins increase. The largest sub-basin analyzed was slightly larger than one square mile in area, therefore, all sub-basins received the same design storm distribution and no DARFs were applied. Although design storms for a 24-hour NRCS Type II distribution are integrated into the HEC-HMS software program and the program will create a DARF-adjusted design storm, the program’s storm distribution was bypassed and the Specified Hyetograph method was selected. This results in a slightly conservative analysis for both storm distributions for the sub-basins above one square mile in area, which are all located in the upper segments of the Kettle Creek watershed.

The rainfall hyetographs were imported into the HEC-HMS precipitation gage manager and applied to each sub-basin within the Kettle Creek watershed. The Colorado Springs frontal-type NRCS 24-Hour Type II Design Storm Distribution yielded higher discharges and this storm was selected as the basis for analysis in the Kettle Creek DBPS.

3.2.1.2 Model Parameters

Infiltration and runoff volumes were modeled using the NRCS Runoff Curve Number (CN) Loss Method. The composite runoff CN was calculated for each sub-basin using the NRCS Curve Numbers for Frontal Storms & Thunderstorms for Developed Conditions (ARCI) (Table 6-10) from the DCM and the composite CNs were imported into HEC-HMS. For modeling purposes, initial infiltration loss rates were automatically calculated as functions of composite runoff CNs by HEC-HMS.

Peak flow rate and hydrographs for this study were computed using the SCS design storm method, which utilizes rainfall together with each sub-basin’s physical characteristics to determine rainfall runoff for each sub-basin. Sub-basin lag times were calculated from the time of concentration as computed using the method outlined in the Colorado Springs Drainage Criteria Manual, Section 3. The process is described in more detail in the sections below.

a) Hydrologic Soil Groups

Soils are classified into hydrologic soil groups (HSG) by the NRCS for hydrologic modeling. The HSG is a parameter assigned to each soil series by the NRCS to reflect the relative rate of infiltration of water into the soil profile and is ranked according to infiltration potential from soils of high infiltration (HSG A) to soils of low infiltration (HSG D).

The HSG was determined for each of the soil mapping units from the NRCS Soil Survey data for the El Paso County. Of the four hydrologic soil groups, only A and B soils are found within the Kettle Creek watershed. Group B soils, with moderate infiltration rates, dominate the Kettle Creek watershed at 97.3% coverage. A hydrologic soil group map is provided in Figure 3-3 that shows the distribution and coverage of each group within the Kettle Creek watershed.

Table 3-2
Soil Coverage by Hydrologic Soil Group

Land Use	Acreage	Coverage
HSG A	307	2.9%
HSG B	10,194	97.1%

b) Land Use

Historical land use conditions were assigned based on the land use categories defined in the DCM that are consistent with the native land uses within the watershed. Historical land use conditions represent an undeveloped watershed condition and were used as the underlying land use for runoff CN development as described below. Undeveloped land use conditions were classified under the appropriate category of “Other Agricultural Lands” in Table 6-9 of the DCM for NRCS Curve Numbers for Pre-Development Thunderstorms Conditions (ARC I). The land uses are classified as being in good, fair, or poor condition. Woods (Good Condition) is the dominant underlying land use in upper portion of the Kettle Creek watershed while

Rangeland (Good Condition) is the dominant underlying land use throughout the remainder of the watershed. Each of these land uses categories were assigned a good condition based on field observation of ground cover.

Existing and future land use information for the Kettle Creek watershed was obtained from aerial imagery and El Paso County zoning information. Existing land uses were estimated from the aerial imagery (2011 and 2013). It was assumed that the land zoning can be used as a good indicator of fully developed conditions. The future land use data represents the current prediction of a full build-out scenario, sometime after 2030.

The Kettle Creek watershed reflects a variety of existing land uses including rural residential (5 acres, 2.5 acres, 0.5 acres), residential suburban (5000, 6000, 20000, some vacant), agricultural, planned unit development, commercial, and rights-of-way. Due to urban growth, land use is expected to change in the future condition with significant residential development planned in the lower middle portion of the watershed. It is anticipated that the land uses in the Black Forest area will remain unchanged in the future condition. Land use maps are shown in Figure 3-4, Figure 3-5, and Figure 3-6 for historic, existing, and future conditions respectively. Summaries of land uses are shown in Table 3-3, Table 3-4, and Table 3-5, below.

Table 3-3
Historic Land Use Classes

Land Use	Coverage
Meadows, Good Condition, HSG A	2.3%
Herbaceous, Good Condition, HSG B	32.1%
Woods, Good Condition, HSG B	65.6%

Table 3-4
Existing Land Use Classes

Land Use	Coverage
Asphalt, HSG A	0.1%
Asphalt, HSG B	2.8%
Commercial Office, HSG A	0.3%
Commercial Retail, HSG B	0.4%
School, HSG B	0.6%
Meadows, Good Condition, HSG A	1.6%
Open Space Herbaceous, Good Condition, HSG B	14.3%
Residential (5 ac lots) and Herbaceous, HSG B	13.2%
Residential (5 ac lots) and Wooded, HSG B	55.7%
Residential (2.5 ac lots) and Wooded, HSG B	1.2%
Residential (2 lots per ac) and Wooded, HSG B	2.6%
Residential 1/4 ac lots, HSG A	0.8%
Residential 1/4 ac lots, HSG B	2.3%
Special Uses	4.2%

Table 3-5
Future Land Use Classes

Land Use	Coverage
Asphalt, HSG A	0.1%
Asphalt, HSG B	2.8%
Commercial Office, HSG A	1.0%
Commercial Retail, HSG B	0.6%
School, HSG B	0.7%
Meadows, Good Condition, HSG A	0.5%
Open Space Herbaceous, Good Condition, HSG B	4.3%
Residential (5 ac lots) and Herbaceous, HSG B	14.9%
Residential (5 ac lots) and Wooded, HSG B	55.6%
Residential (2.5 ac lots) and Wooded, HSG B	3.1%
Residential (2 lots per ac) and Wooded, HSG B	2.6%
Residential 1/4 ac lots, HSG A	0.8%
Residential 1/4 ac lots, HSG B	8.9%
Special Uses	4.2%

c) *Runoff Curve Number Development*

The Natural Resources Conservation Service (NRCS), U.S. Department of Agriculture, has instituted a soil classification system that relates the drainage characteristics of soil groups to a curve number, CN (SCS, 1972 and 1975). The NRCS provides information on relating soil group type to the curve number as a function of soil cover, antecedent moisture condition, and land use type. Curve number values were determined for each sub-basin. For the Kettle Creek basin, the predominant hydrologic soil group is B with an antecedent moisture condition of ARCI. The CN values differ between the existing and future conditions primarily to reflect the changes in the land use. Based on existing land use, zoning and known development plans, the basin is expected to generally change in places from an undeveloped pasture/woodland to low density residential. This is reflected by a 7% increase in the average basin CN from existing to future conditions. Tables illustrating the determination of the CN values are presented in **Appendix B**. Curve Number maps are shown in **Figure 3-7**, **Figure 3-8**, and **Figure 3-9** for historic, existing, and future conditions respectively. Curve number values for the respective land uses are shown in **Table 3-6**, below.

Table 3-6
Representative CN Values and Impervious Percentage by Land Use

Land Use	CN	Percent Impervious
Meadows, Good Condition, HSG A (Existing)	15	2
Herbaceous, Good Condition, HSG B (Existing)	41	2
Woods, Good Condition, HSG B (Existing)	34	2
Asphalt, HSG A	83	100
Asphalt, HSG B	89	100
Commercial Office, HSG A	89	95
Commercial Retail, HSG B	92	85
School, HSG B	72	40
Meadows, Good Condition, HSG A	39	2
Open Space Herbaceous, Good Condition, HSG B	62	2
Residential (5 ac lots) and Herbaceous, HSG B	65	15
Residential (5 ac lots) and Wooded, HSG B	65	15
Residential (2.5 ac lots) and Wooded, HSG B	65	20
Residential (2 lots per ac) and Wooded, HSG B	70	35
Residential 1/4 ac lots, HSG A	61	60
Residential 1/4 ac lots, HSG B	75	60
Special Uses	74	10

Average weighted curve numbers for the whole Kettle Creek basin are shown in Table 3-7, below.

Table 3-7
Average Weighted Runoff Curve Numbers

Condition	Curve Number
Historic ¹	36
Historic ²	57
Existing	66
Future	69

¹ Uses Pre-Development curve numbers (ARC-I) for 2-Hour Storm

² Uses Post-Development curve numbers (ARC-II) for 24-Hour Storm

d) *Initial Abstraction*

The initial abstraction (I_a) represents a volume of rainfall that must fall to satisfy losses in a drainage basin before runoff begins. Per the DCM chapter 6, the default value for I_a is 0.10 times the potential maximum retention (S). To apply this adjustment when using HEC-HMS it is necessary to provide the initial abstraction as a depth in inches. The initial abstraction in inches is calculated according to the equation:

$$I_a = 0.1 [(1000/CN) - 10].$$

e) *Time of Concentration*

The times of concentration for the sub-basins were calculated according to the procedures outlined in the DCM, Chapter 6. The time of concentration is calculated following the guidance provided in TR-55 (NRCS 2005) by dividing the flow path into multiple segments. These segments can generally be categorized as overland flow, shallow concentrated flow and concentrated or channelized flow. For each of the flow segments, the estimated 2-year flow or the “low flow” should be used to calculate velocity. The time of concentration for the sub-basin is taken as the sum of the three flow regimes from the headwaters of the sub-basin to its discharge point.

f) *Channel Routing*

The Lag method was used for channel routing with lag times applied on an individual basis for each river reach. Lag times were calculated in accordance with Chapter 6 of the City DCM using Manning’s equation to define average flow velocity. Approximate hydraulic characteristics for concentrated flow were used, taken from the UDFCD DCM Runoff chapter (Table RO-2). Reach delineations were performed for existing conditions and are unlikely to change significantly through later stages of development, as Kettle Creek and its tributaries are typically defined by deep earth channels with large areas of exposed bedrock.

3.2.1.3 *Model Flow Diagram and Design Points*

Design points were taken at every sub-basin junction where flow routing affected peak flows. In the model, reaches were used to connect junctions and provide routing of the concentrated flows at the specified length, slope, and roughness. A routing schematic is provided in **Figure 3-1**.

3.3 Basin Hydrology

The HEC-HMS model for the Kettle Creek watershed was run to simulate the rainfall-runoff process and generate flood hydrographs for historic, existing, and future land use conditions by applying a 2-hour and a 24-hour storm event with 2-, 5-, 10-, 25-, 50-, and 100-year recurrence intervals. As expected, future peak flows increased over existing conditions in conjunction with planned development. When compared to the 2-hour event, the 24-hour event has overall higher peak flows for the Kettle Creek basin and is therefore used for peak flow rates in the Kettle Creek DBPS hydraulic analysis and for floodplain delineation.

The results of the Kettle Creek Drainage Basin Old Ranch Road Tributary DBPS/MDDP by JR Engineering (2001) were used to represent the developed conditions discharge into Kettle Creek for existing and future

development in the DBPS/MDDP study. The hydrographs for the detained releases into Kettle Creek replace the undetained sub-basin discharges in the HEC-HMS model.

The existing and future conditions hydrologic model results reported herein do not reflect any other existing, proposed, or conceptual future detention, channel improvements, or other alternatives described in later sections of this report. The intent of this DBPS is to provide a baseline for future development in the Kettle Creek Basin. Historic, existing, and future results are illustrated in **Figure 3-12**, **Figure 3-13**, and **Figure 3-14**, respectively.

3.3.1 Historic Flows

The Kettle Creek DBPS presented herein assumed an undeveloped condition throughout the entire basin for historic conditions. Historic land uses consisted of woods and semi-arid Herbaceous rangeland (See **Figure 3-4**). Using the aforementioned methods of analysis, the historic conditions analysis determined a peak historic flow of 705 cfs (5-year) and 2,381 cfs (100-year) at State Highway 83. Historic conditions flow data is presented in **Figure 3-10** and **Figure 3-11**.

3.3.2 Existing Flows

The existing conditions analysis used 2013 land uses as shown in **Figure 3-5** to determine curve numbers and percent impervious for the Kettle Creek Basin. The existing conditions analysis yielded flows of 1,766 cfs (5-year) and 4,114 cfs (100-year) at State Highway 83. To incorporate the existing regional detention ponds, Sub-basins 24 through 27 have been replaced by outflow hydrographs gathered from the Kettle Creek Drainage Basin Old Ranch Tributary MDDP/DBPS. Existing conditions flow data is presented in **Figure 3-10** and **Figure 3-11**.

3.3.3 Future Flows

The future conditions analysis made use of available City of Colorado Springs and El Paso County zoning information to determine the land uses at full basin build-out. Future land uses are shown in **Figure 3-6**. The future conditions analysis yielded flows of 1,796 cfs (5-year) and 4,152 cfs (100-year) at State Highway 83. To incorporate the existing regional detention ponds, Sub-basins 24 through 27 have been replaced by outflow hydrographs gathered from the Kettle Creek Drainage Basin Old Ranch Tributary MDDP/DBPS. Future conditions flow data is presented in **Figure 3-10** and **Figure 3-11**.

3.3.4 Flows Comparison

The results of this hydrologic analysis were compared with previous reports. In this DBPS, 5-year and 100-year peak inflows to the Kettle Creek detention facility at I-25 of 1,845 cfs and 4,250 cfs, respectively, were generated under existing watershed conditions. This study employed SCS methodologies along with NRCS-based soils and land use data specific to the Kettle Creek watershed. Composite CNs were calculated using NRCS attributes. The location of Kettle Creek at State Highway 83 (now Voyager Parkway) was used as a basis of comparison because it is presented in Volume I of the FIS. Detailed hydrologic results are presented in **Appendix B**. Flow results at State Highway 83 are shown in **Table 3-8** below:

Table 3-8
Flow Comparison at State Highway 83

Storm Recurrence Interval	Historic Flows (cfs)			Existing Flows (cfs)		Future Flows (cfs)	
	AFA Study	Kettle Creek DBPS	FIS Study	AFA Study	Kettle Creek DBPS	AFA Study	Kettle Creek DBPS
24 Hr Duration							
2	115	354	---	271	1,174	285	1,199
5	334	705	---	743	1,766	783	1,796
10	686	1,073	2,600	1,308	2,332	1,372	2,364
25	1,328	1,410	---	2,246	2,814	2,355	2,849
50	2,142	1,972	---	3,327	3,580	3,486	3,617
100	2,912	2,381	9,300	4,287	4,114	4,475	4,152



There are no previous DBPS studies for the entire Kettle Creek basin. An existing study available for flows comparison is the FEMA FIS for El Paso County and Incorporated Areas, dated August 23, 1999. The FIS used a joint Colorado Water Conservation Board (CWCB), a USACE study conducted on Monument and Fountain creeks with the USGS hydrologic report, Manual for Estimating Flood Characteristics of Natural-Flow Streams in Colorado (1976), and rainfall data from the Flood Hazard Analyses, Portions of Jimmy Camp Creek and Tributaries (October 1975) report, combined with the SCS Soil Survey for El Paso County (July 1981) to determine peak flow rates, using the empirical USGS regression equations for the southwestern United States. The FIS presents Kettle Creek as having a drainage area of 16.3 square miles, with peak discharges of 2,600 cfs (10-year) and 9,300 cfs (100-year) at State Highway 83 (now known as Voyager Parkway). No other hydrologic data is presented in the FIS. The discrepancies between the FIS, the AFA Study, and this DBPS are potentially due to the differing USGS and SCS methodologies.

The AFA Study reported 2-, 5-, 10-, 25-, 50-, and 100-year peak inflows as shown in **Table 3-8**. The study also employed SCS methodologies along with GIS-based soils and land use data specific to the Kettle Creek watershed. The discrepancies in peak flows between the Air Force Academy (AFA) and this study were due to minor differences in composite CNs, sub basin delineation and lag time calculations. The AFA also used a Kinematic Wave method for Channel Routing instead of the Lag Method used herein. Two sub-regional ponds in Sub-basins 24-27 were also modeled herein, whereas the ponds did not exist during the time of the

AFA Study. The absence of these ponds would result in higher peak flows. The greater discrepancies in discharges with the smaller storm recurrence intervals are due to the Initial Abstraction values determined from the CNs. This DBPS uses an Initial Abstraction value of 0.1 times the potential maximum retention (S) in accordance with current City criteria, while the AFA study uses an Initial Abstraction value of 0.2 times S. Thus, the amount of water lost to infiltration during minor storm events is much greater in the AFA study.

Topography covering the entire Kettle Creek watershed was obtained from USGS quadrangle maps (Black Forest, Falcon NW, Monument, Pikeview) and was used for the hydrologic analysis of the basin only, and current electronic contours were obtained from the City for the hydraulic analysis. Hydrologic modeling inputs were obtained from this topographic data as well as following the SCS methodologies stated in the City of Colorado Springs Drainage Criteria Manual (May 2014). Version 4.0 of the HEC-HMS modeling software was employed. With a percent error of only five percent, the resulting 100-year peak flows from this model was comparable with results found from the AFA Study.

LEGEND

-  SUBBASIN IDENTIFIER
-  JUNCTION IDENTIFIER
-  STREAM REACH IDENTIFIER

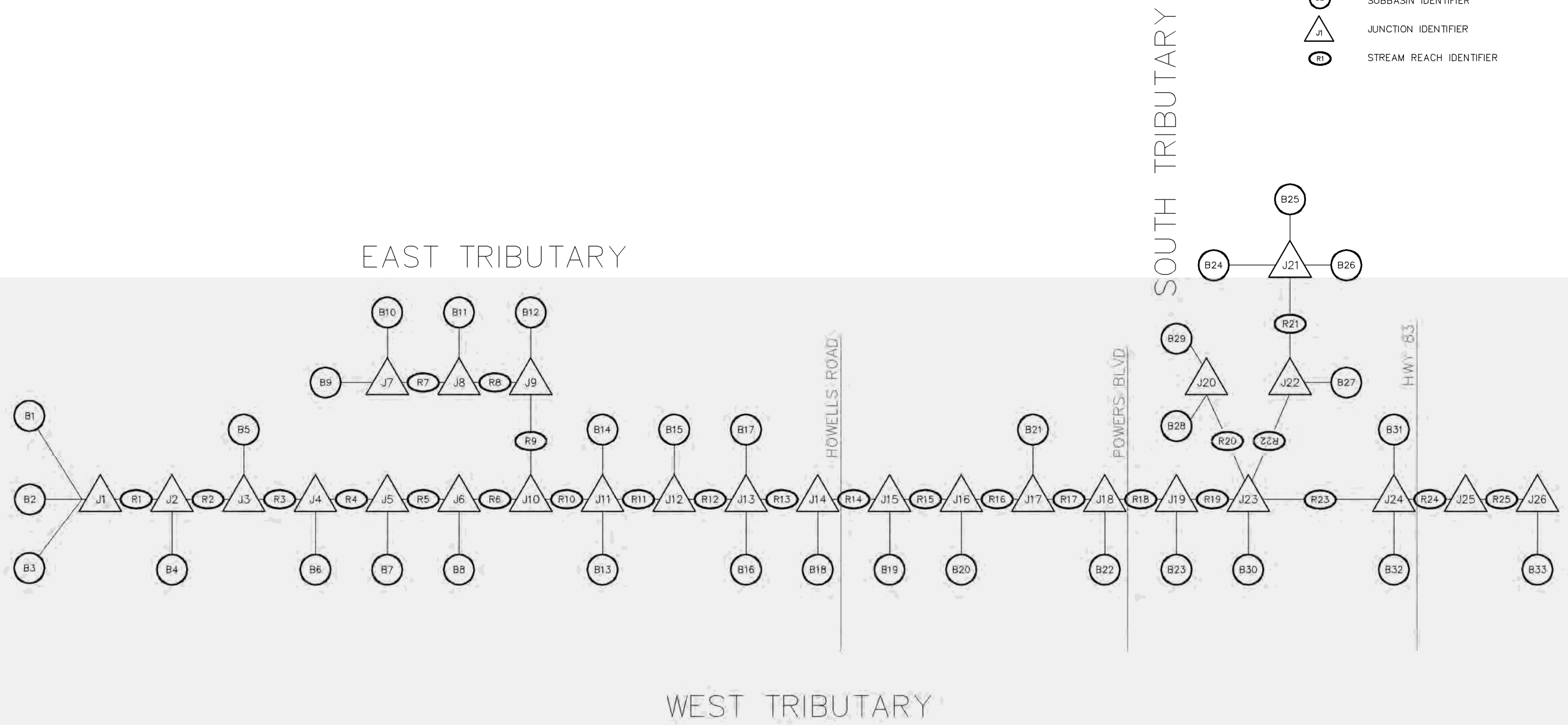







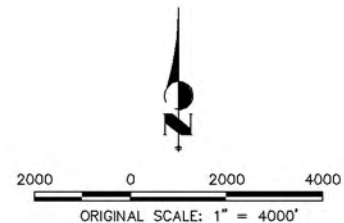
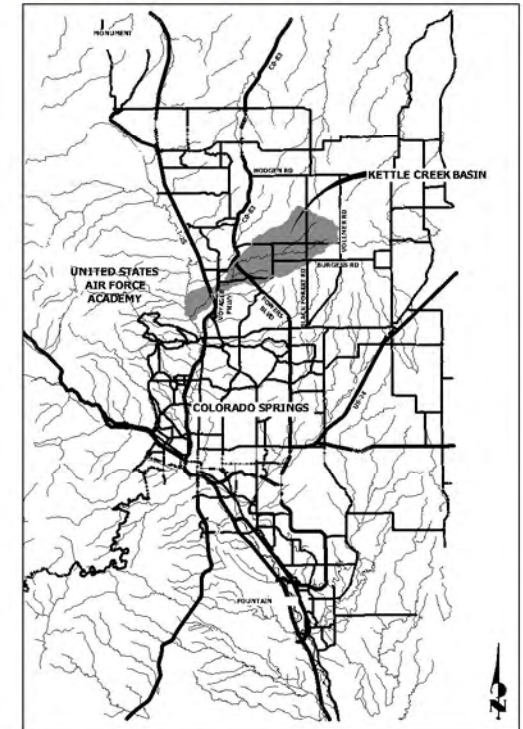
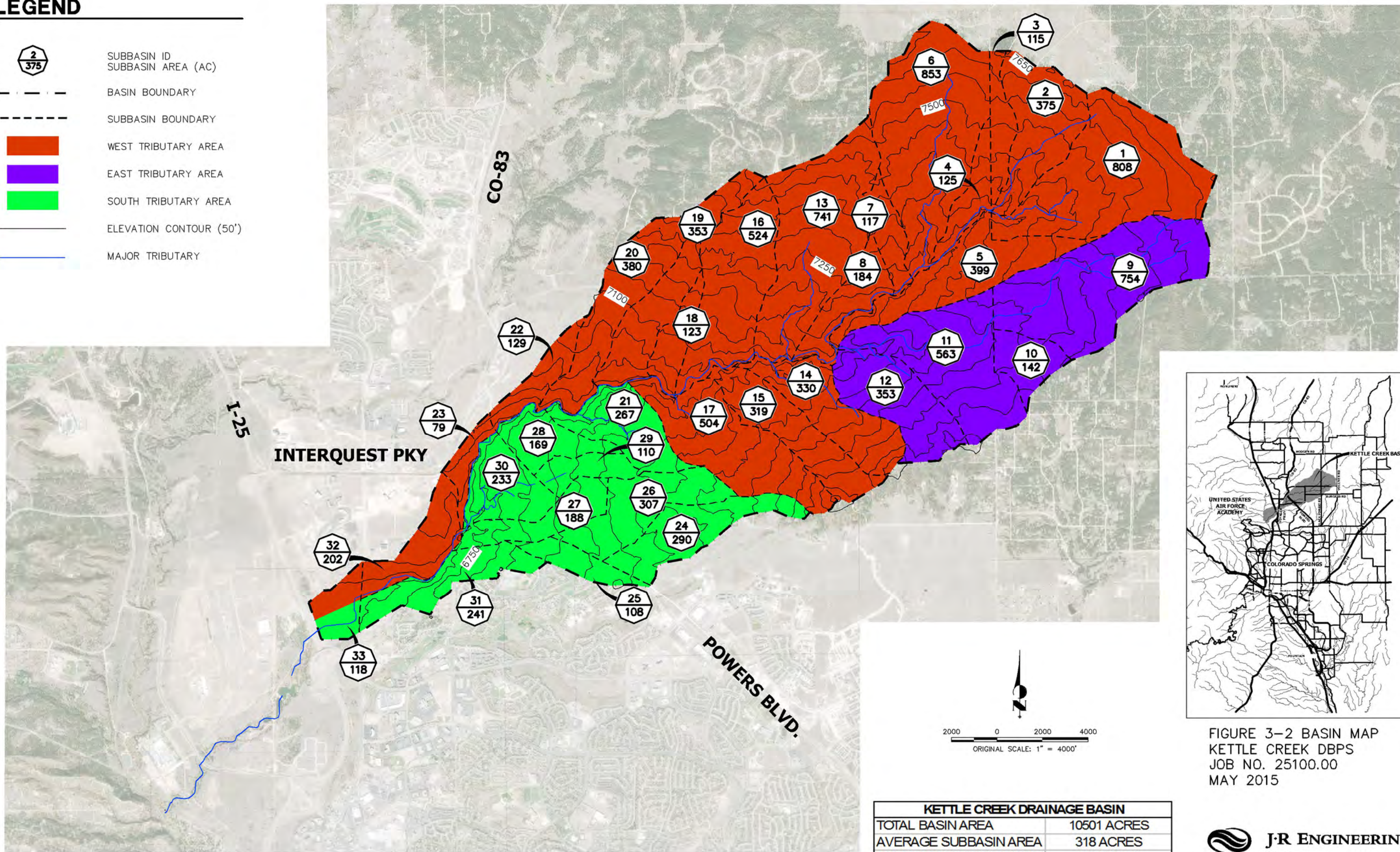

FIGURE 3-1
 ROUTING SCHEMATIC
 KETTLE CREEK DBPS
 JOB NO. 25100.00
 MAY 2015

LEGEND

-  SUBBASIN ID
SUBBASIN AREA (AC)
-  BASIN BOUNDARY
-  SUBBASIN BOUNDARY
-  WEST TRIBUTARY AREA
-  EAST TRIBUTARY AREA
-  SOUTH TRIBUTARY AREA
-  ELEVATION CONTOUR (50')
-  MAJOR TRIBUTARY









KETTLE CREEK DRAINAGE BASIN	
TOTAL BASIN AREA	10501 ACRES
AVERAGE SUBBASIN AREA	318 ACRES
MINIMUM SUBBASIN AREA	79 ACRES
MAXIMUM SUBBASIN AREA	853 ACRES

FIGURE 3-2 BASIN MAP
KETTLE CREEK DBPS
JOB NO. 25100.00
MAY 2015



Centennial 303-740-9999 • Colorado Springs 719-593-2593
Fort Collins 970-491-9888 • www.jrengineering.com

LEGEND

-  SUBBASIN ID
SUBBASIN AREA (AC)
-  BASIN BOUNDARY
-  SUBBASIN BOUNDARY
-  HYDROLOGIC SOIL GROUP A
-  HYDROLOGIC SOIL GROUP B
-  MAJOR TRIBUTARY

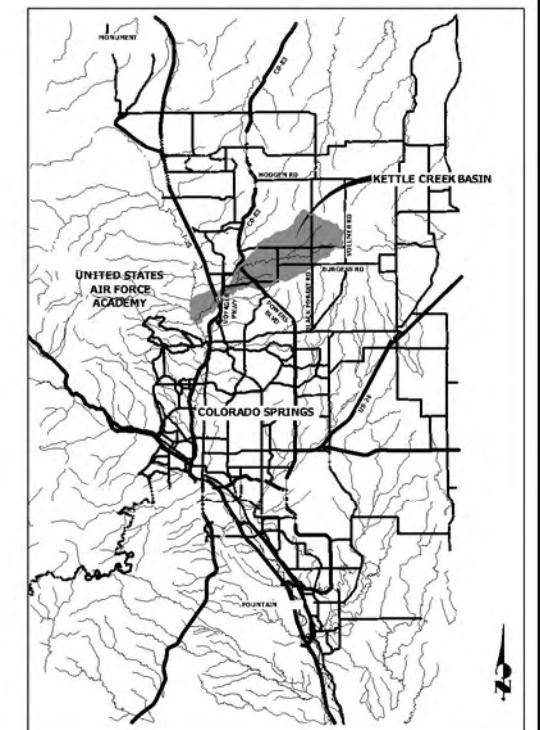
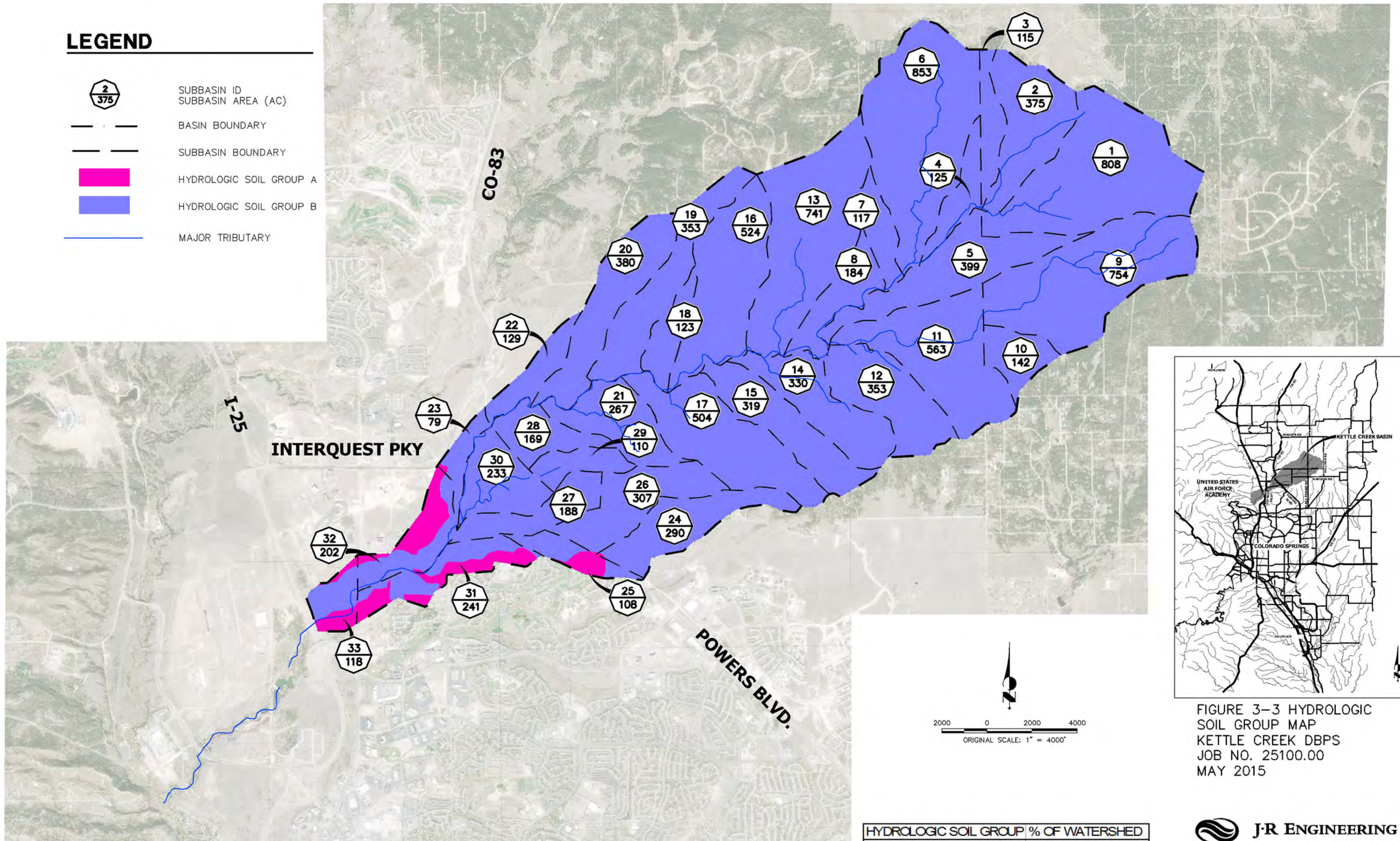







FIGURE 3-3 HYDROLOGIC SOIL GROUP MAP
KETTLE CREEK DBPS
JOB NO. 25100.00
MAY 2015

HYDROLOGIC SOIL GROUP	% OF WATERSHED
A	2.9
B	97.1

LEGEND

-  SUBBASIN ID
SUBBASIN AREA (AC)
-  BASIN BOUNDARY
-  SUBBASIN BOUNDARY
-  WOODED AREA
-  HERBACEOUS AREA
-  MAJOR TRIBUTARY

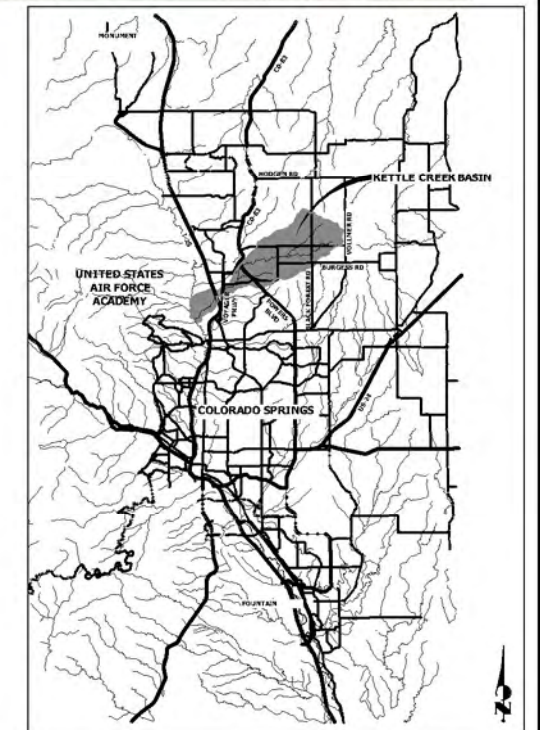
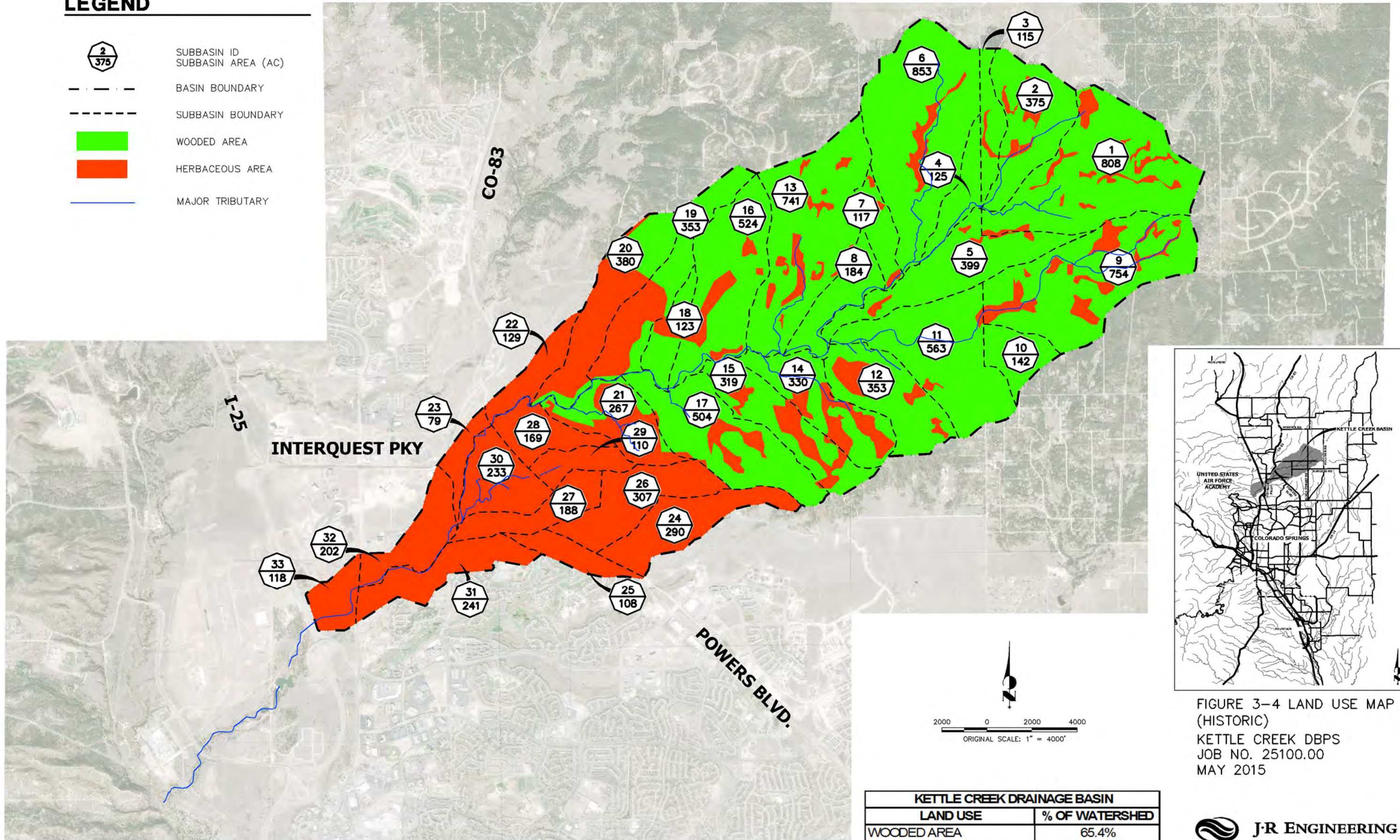
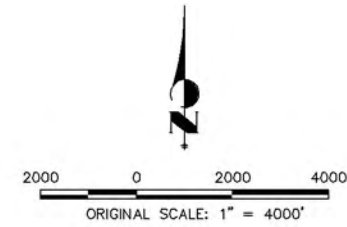

FIGURE 3-4 LAND USE MAP (HISTORIC)
KETTLE CREEK DBPS
JOB NO. 25100.00
MAY 2015



KETTLE CREEK DRAINAGE BASIN	
LAND USE	% OF WATERSHED
WOODED AREA	65.4%
HERBACEOUS AREA	34.6%
TOTAL	100.0%



Centennial 303-740-9898 • Colorado Springs 719-593-2593
Fort Collins 970-491-9888 • www.jrengineering.com

LEGEND

-  SUBBASIN ID
SUBBASIN AREA (AC)
-  BASIN BOUNDARY
-  SUBBASIN BOUNDARY
-  RESIDENTIAL (RURAL 5 ACRES)
-  RESIDENTIAL (RURAL 2.5 ACRES)
-  RESIDENTIAL (2 LOTS PER ACRE)
-  RESIDENTIAL (3-4 LOTS PER ACRE)
-  COMMERCIAL (OFFICE SPACE)
-  COMMERCIAL (RETAIL SPACE)
-  SCHOOL
-  OPEN SPACE
-  ASPHALT PAVED ROAD AREA
-  SPECIAL USES
-  MAJOR TRIBUTARY

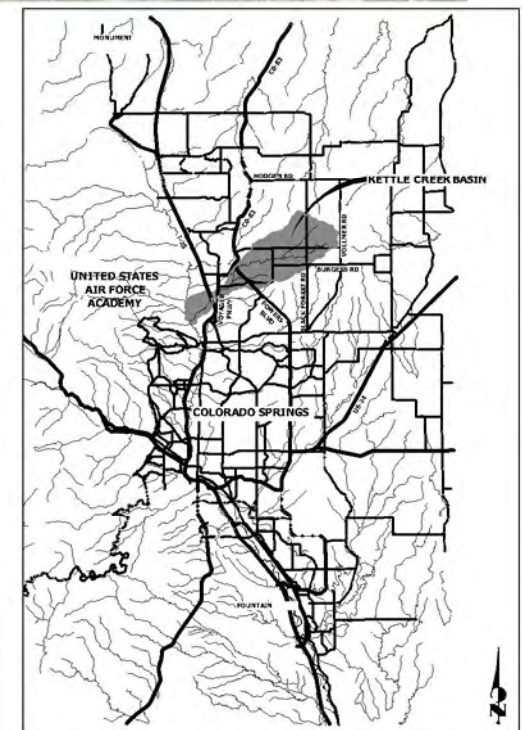
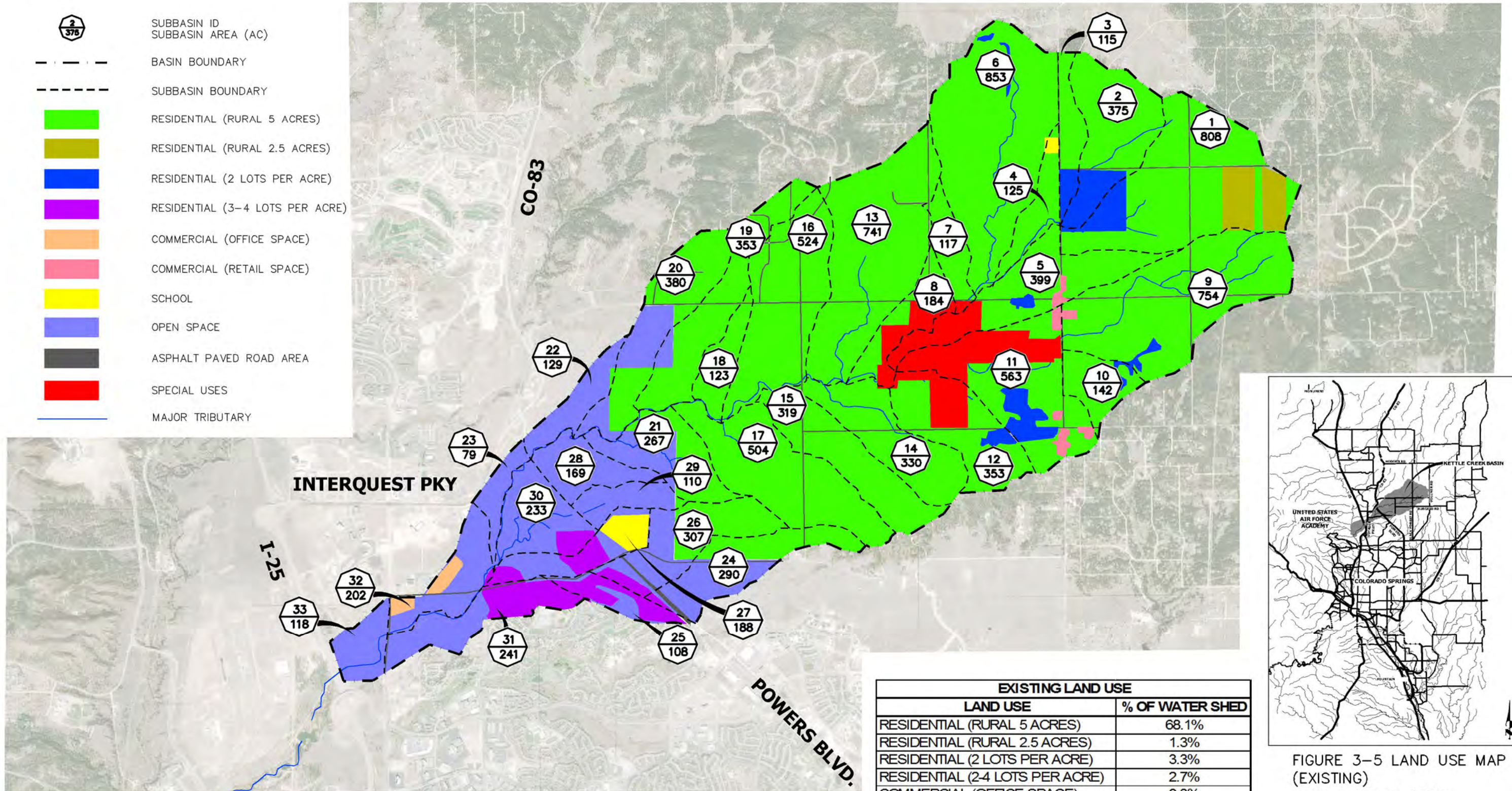





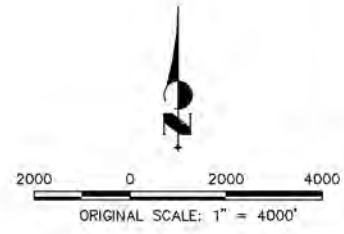









EXISTING LAND USE	
LAND USE	% OF WATER SHED
RESIDENTIAL (RURAL 5 ACRES)	68.1%
RESIDENTIAL (RURAL 2.5 ACRES)	1.3%
RESIDENTIAL (2 LOTS PER ACRE)	3.3%
RESIDENTIAL (2-4 LOTS PER ACRE)	2.7%
COMMERCIAL (OFFICE SPACE)	0.3%
COMMERCIAL (RETAIL)	1.0%
SCHOOL	0.6%
OPEN SPACE	16.7%
ASPHALT PAVED ROAD	1.8%
SPECIAL USES	4.2%
TOTAL	100.0%

FIGURE 3-5 LAND USE MAP (EXISTING)
KETTLE CREEK DBPS
JOB NO. 25100.00
MAY 2015

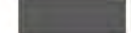

LEGEND



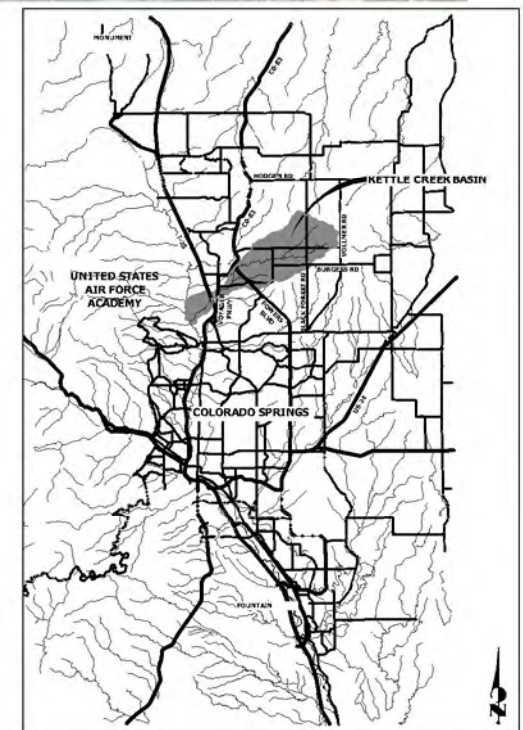
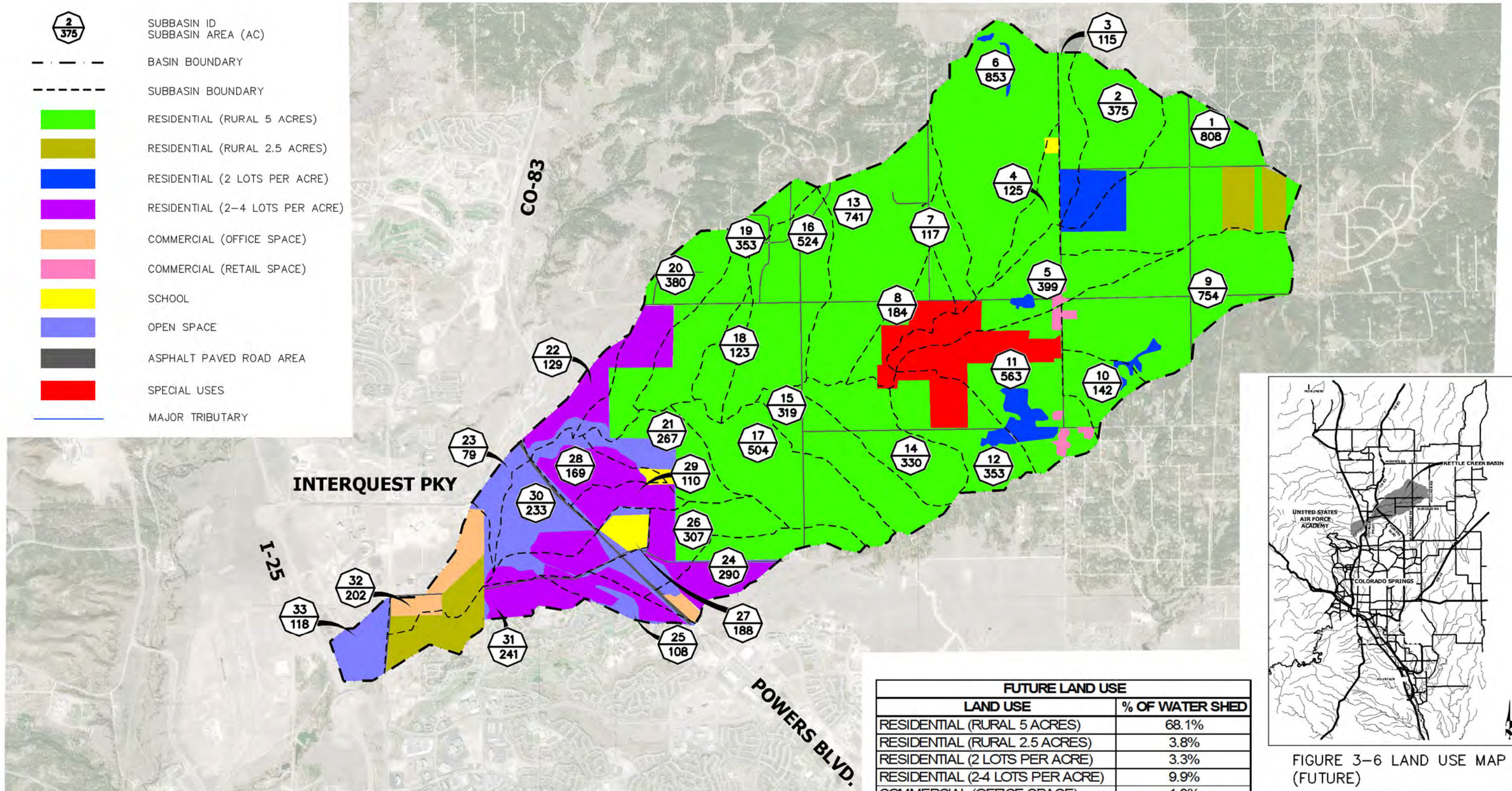



-  SUBBASIN ID
SUBBASIN AREA (AC)
-  BASIN BOUNDARY
-  SUBBASIN BOUNDARY
-  RESIDENTIAL (RURAL 5 ACRES)
-  RESIDENTIAL (RURAL 2.5 ACRES)
-  RESIDENTIAL (2 LOTS PER ACRE)
-  RESIDENTIAL (2-4 LOTS PER ACRE)
-  COMMERCIAL (OFFICE SPACE)
-  COMMERCIAL (RETAIL SPACE)
-  SCHOOL
-  OPEN SPACE
-  ASPHALT PAVED ROAD AREA
-  SPECIAL USES
-  MAJOR TRIBUTARY



FUTURE LAND USE	
LAND USE	% OF WATER SHED
RESIDENTIAL (RURAL 5 ACRES)	68.1%
RESIDENTIAL (RURAL 2.5 ACRES)	3.8%
RESIDENTIAL (2 LOTS PER ACRE)	3.3%
RESIDENTIAL (2-4 LOTS PER ACRE)	9.9%
COMMERCIAL (OFFICE SPACE)	1.9%
COMMERCIAL (RETAIL)	1.0%
SCHOOL	1.3%
OPEN SPACE	4.6%
ASPHALT PAVED ROAD	1.8%
SPECIAL USES	4.2%
TOTAL	100.0%

FIGURE 3-6 LAND USE MAP (FUTURE)
KETTLE CREEK DBPS
JOB NO. 25100.00
MAY 2015

LEGEND

-  SUBBASIN ID
CURVE NUMBER(2HR/24HR)
-  BASIN BOUNDARY
-  SUBBASIN BOUNDARY
-  WOODED AREA
-  HERBACEOUS AREA
-  MAJOR TRIBUTARY

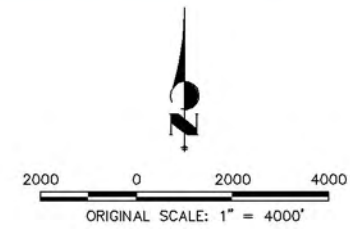
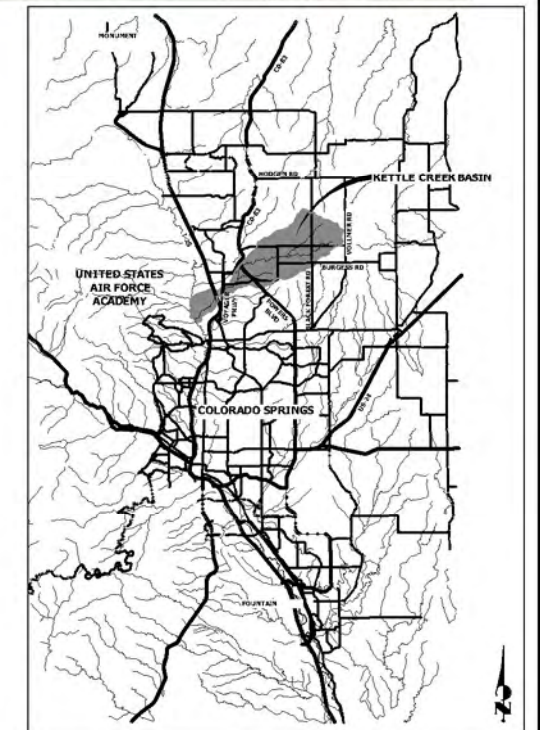
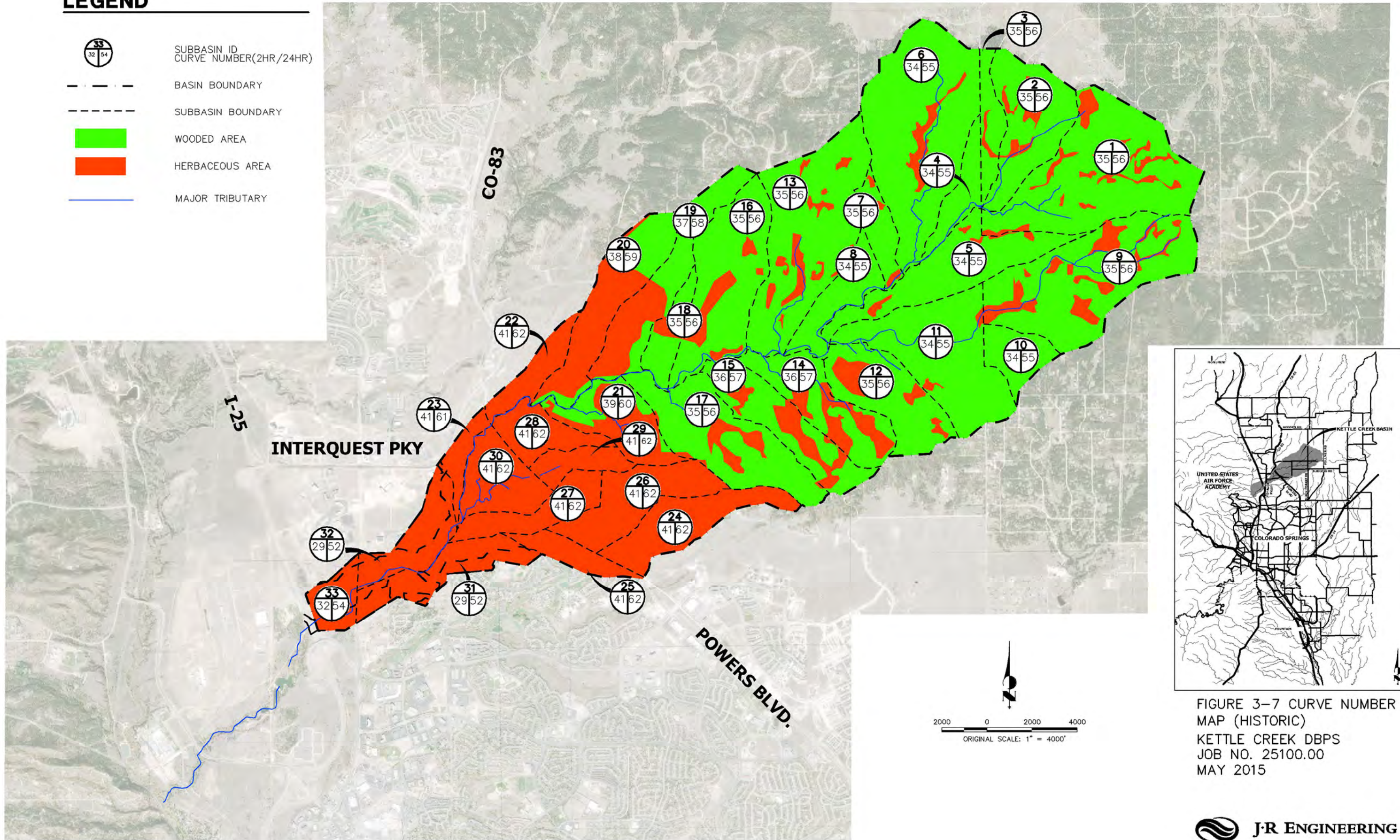

FIGURE 3-7 CURVE NUMBER
MAP (HISTORIC)
KETTLE CREEK DBPS
JOB NO. 25100.00
MAY 2015

LEGEND

-  SUBBASIN ID
CURVE NUMBER
-  BASIN BOUNDARY
-  SUBBASIN BOUNDARY
-  RESIDENTIAL (RURAL 5 ACRES)
-  RESIDENTIAL (RURAL 2.5 ACRES)
-  RESIDENTIAL (2 LOTS PER ACRE)
-  RESIDENTIAL (3-4 LOTS PER ACRE)
-  COMMERCIAL (OFFICE SPACE)
-  COMMERCIAL (RETAIL SPACE)
-  SCHOOL
-  OPEN SPACE
-  ASPHALT PAVED ROAD AREA
-  SPECIAL USES
-  MAJOR TRIBUTARY

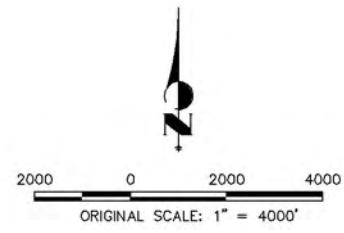
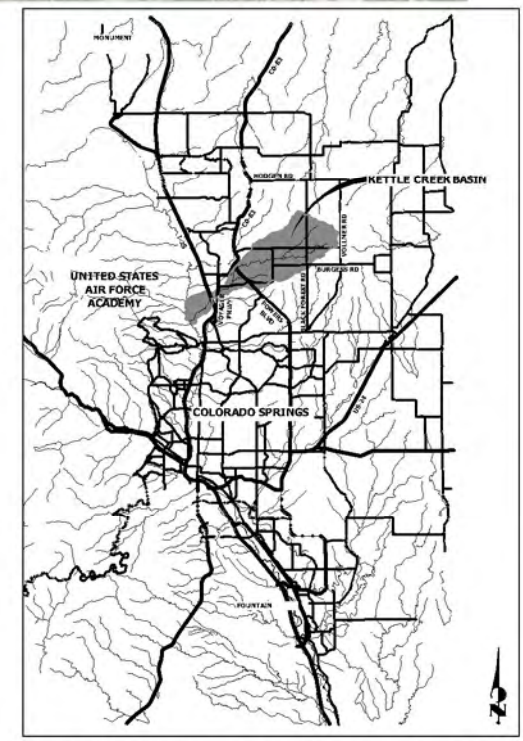
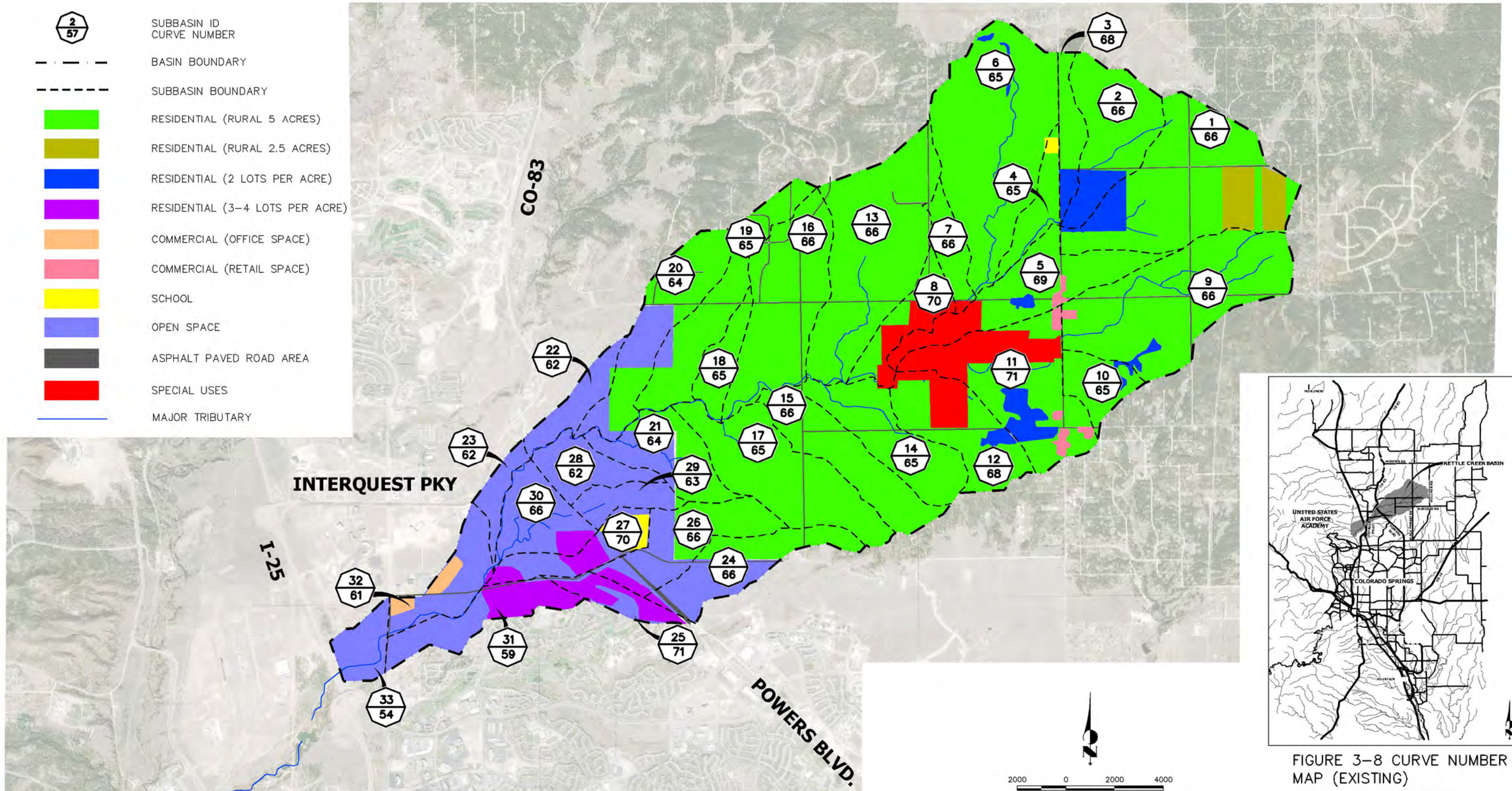















FIGURE 3-8 CURVE NUMBER MAP (EXISTING)
 KETTLE CREEK DBPS
 JOB NO. 25100.00
 MAY 2015

LEGEND

-  SUBBASIN ID
CURVE NUMBER
-  BASIN BOUNDARY
-  SUBBASIN BOUNDARY
-  RESIDENTIAL (RURAL 5 ACRES)
-  RESIDENTIAL (RURAL 2.5 ACRES)
-  RESIDENTIAL (2 LOTS PER ACRE)
-  RESIDENTIAL (2-4 LOTS PER ACRE)
-  COMMERCIAL (OFFICE SPACE)
-  COMMERCIAL (RETAIL SPACE)
-  SCHOOL
-  OPEN SPACE
-  ASPHALT PAVED ROAD AREA
-  SPECIAL USES
-  MAJOR TRIBUTARY

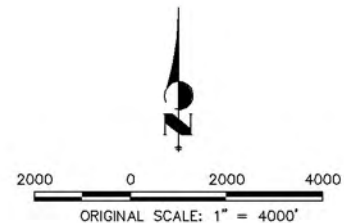
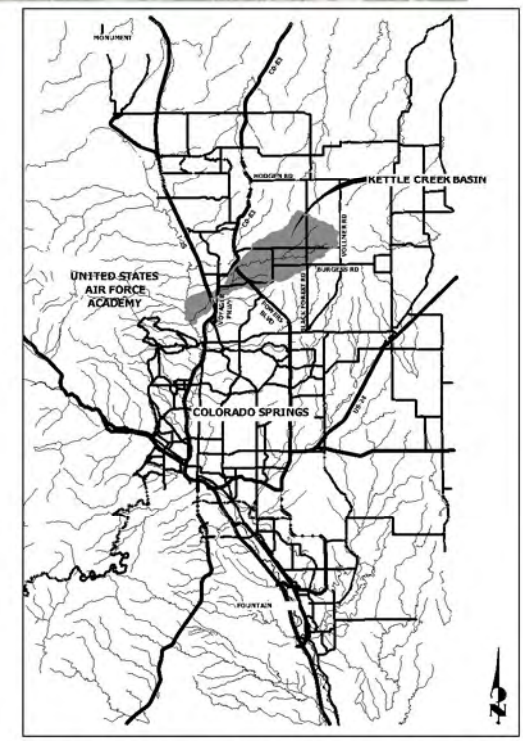
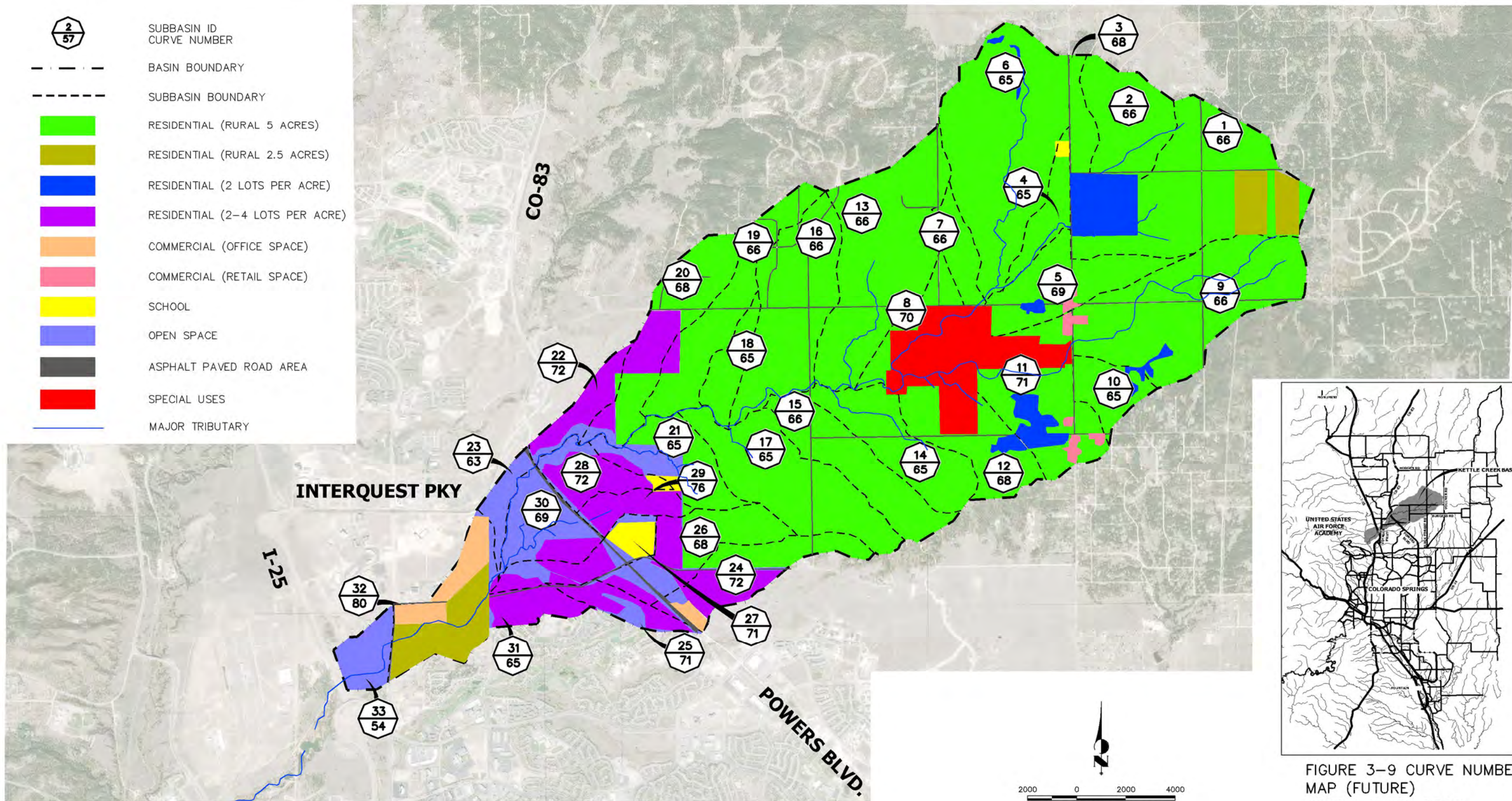

FIGURE 3-9 CURVE NUMBER MAP (FUTURE)
 KETTLE CREEK DBPS
 JOB NO. 25100.00
 MAY 2015

**HISTORIC CONDITIONS
MODEL RESULTS
(5-YEAR)**

5-Year, 24-Hour Storm			
Hydrologic Element	Drainage Area (mi ²)	Peak Discharge (CFS)	Volume (in)
Subbasin-1	1.263	111	0.42
Subbasin-2	0.586	59	0.42
Subbasin-3	0.18	17	0.42
Junction-1	2.029	185	0.42
Reach-1	2.029	184	0.42
Subbasin-4	0.195	20	0.4
Junction-2	2.224	202	0.42
Reach-2	2.224	195	0.42
Subbasin-5	0.625	42	0.4
Junction-3	2.849	235	0.41
Reach-3	2.849	235	0.41
Subbasin-6	1.333	93	0.4
Junction-4	4.182	328	0.41
Reach-4	4.182	323	0.41
Subbasin-7	0.183	20	0.42
Junction-5	4.365	333	0.41
Reach-5	4.365	324	0.41
Subbasin-8	0.288	35	0.4
Junction-6	4.653	337	0.41
Reach-6	4.653	336	0.41
Subbasin-9	1.177	81	0.42
Subbasin-10	0.222	24	0.4
Junction-7	1.399	93	0.42
Reach-7	1.399	92	0.42
Subbasin-11	0.88	89	0.4
Junction-8	2.279	152	0.41
Reach-8	2.279	150	0.41
Subbasin-12	0.552	52	0.43
Junction-9	2.831	193	0.41
Reach-9	2.831	191	0.41
Junction-10	7.484	508	0.41
Reach-10	7.484	500	0.41
Subbasin-13	1.156	80	0.42
Subbasin-14	0.516	59	0.45
Junction-11	9.156	578	0.41
Reach-11	9.156	576	0.41
Subbasin-15	0.498	57	0.44
Junction-12	9.654	590	0.42
Reach-12	9.654	589	0.42
Subbasin-16	0.819	68	0.42
Subbasin-17	0.788	74	0.42
Junction-13	11.261	631	0.42

**EXISTING CONDITIONS
MODEL RESULTS
(5-YEAR)**

5-Year, 24-Hour Storm			
Hydrologic Element	Drainage Area (mi ²)	Peak Discharge (CFS)	Volume (in)
Reach-13	11.261	627	0.42
Subbasin-18	0.192	23	0.42
Junction-14	11.453	631	0.42
Reach-14	11.453	624	0.42
Subbasin-19	0.552	46	0.47
Junction-15	12.005	641	0.42
Reach-15	12.005	640	0.42
Subbasin-20	0.594	73	0.5
Junction-16	12.599	654	0.42
Reach-16	12.599	653	0.42
Subbasin-21	0.417	65	0.52
Junction-17	13.016	661	0.43
Reach-17	13.016	658	0.43
Subbasin-22	0.2	35	0.57
Junction-18	13.216	662	0.43
Reach-18	13.216	660	0.43
Subbasin-23	0.123	35	0.55
Junction-19	13.339	662	0.43
Reach-19	13.339	660	0.43
Subbasin-24	0.453	54	0.57
Subbasin-25	0.169	51	0.57
Subbasin-26	0.48	64	0.57
Junction-21	1.102	128	0.57
Reach-21	1.102	125	0.57
Subbasin-27	0.294	52	0.57
Junction-22	1.396	164	0.57
Reach-22	1.396	161	0.57
Subbasin-28	0.264	38	0.57
Subbasin-29	0.172	30	0.57
Junction-20	0.436	68	0.57
Reach-20	0.436	64	0.57
Subbasin-30	0.364	65	0.57
Junction-23	15.535	702	0.45
Reach-23	15.535	697	0.45
Subbasin-31	0.377	58	0.33
Subbasin-32	0.316	37	0.33
Junction-24	16.228	705	0.44
Reach-24	16.228	702	0.44
Subbasin-33	0.184	24	0.37
Junction-25	16.412	704	0.44
Reach-25	16.412	698	0.44
Junction-26	16.412	698	0.44

5-Year, 24-Hour Storm			
Hydrologic Element	Drainage Area (mi ²)	Peak Discharge (CFS)	Volume (in)
Subbasin-1	1.263	315	1.06
Subbasin-2	0.586	173	1.06
Subbasin-3	0.180	56	1.27
Junction-1	2.029	527	1.08
Reach-1	2.029	526	1.08
Subbasin-4	0.195	56	0.97
Junction-2	2.224	572	1.07
Reach-2	2.224	568	1.07
Subbasin-5	0.625	134	1.14
Junction-3	2.849	689	1.08
Reach-3	2.849	689	1.08
Subbasin-6	1.333	240	0.94
Junction-4	4.182	928	1.04
Reach-4	4.182	917	1.04
Subbasin-7	0.183	51	0.97
Junction-5	4.365	940	1.03
Reach-5	4.365	929	1.03
Subbasin-8	0.288	117	1.1
Junction-6	4.653	959	1.04
Reach-6	4.653	944	1.04
Subbasin-9	1.177	223	1.05
Subbasin-10	0.222	62	0.93
Junction-7	1.399	252	1.03
Reach-7	1.399	250	1.03
Subbasin-11	0.880	322	1.23
Junction-8	2.279	484	1.11
Reach-8	2.279	484	1.11
Subbasin-12	0.552	144	1.06
Junction-9	2.831	609	1.1
Reach-9	2.831	594	1.1
Junction-10	7.484	1,444	1.06
Reach-10	7.484	1,428	1.06
Subbasin-13	1.156	212	1
Subbasin-14	0.516	138	0.95
Junction-11	9.156	1,605	1.05
Reach-11	9.156	1,604	1.05
Subbasin-15	0.498	143	1
Junction-12	9.654	1,636	1.05
Reach-12	9.654	1,634	1.05

5-Year, 24-Hour Storm			
Hydrologic Element	Drainage Area (mi ²)	Peak Discharge (CFS)	Volume (in)
Subbasin-16	0.819	193	1.06
Subbasin-17	0.788	184	0.95
Junction-13	11.261	1,730	1.04
Reach-13	11.261	1,705	1.04
Subbasin-18	0.192	55	0.95
Junction-14	11.453	1,711	1.04
Reach-14	11.453	1,710	1.04
Subbasin-19	0.552	101	0.95
Junction-15	12.005	1,745	1.03
Reach-15	12.005	1,741	1.03
Subbasin-20	0.594	134	0.86
Junction-16	12.599	1,760	1.03
Reach-16	12.599	1,741	1.03
Subbasin-21	0.417	100	0.79
Junction-17	13.016	1,752	1.02
Reach-17	13.016	1,752	1.02
Subbasin-22	0.200	36	0.59
Junction-18	13.216	1,756	1.01
Reach-18	13.216	1,746	1.01
Subbasin-23	0.123	42	0.66
Junction-19	13.339	1,748	1.01
Reach-19	13.339	1,747	1.01
Source-1	1.396	109	0.58
Subbasin-28	0.264	38	0.57
Subbasin-29	0.172	37	0.7
Junction-20	0.436	75	0.62
Reach-20	0.436	70	0.62
Subbasin-30	0.364	116	1
Junction-23	15.535	1,764	0.96
Reach-23	15.535	1,751	0.96
Subbasin-31	0.377	217	1.05
Subbasin-32	0.316	124	1.01
Junction-24	16.228	1,766	0.96
Reach-24	16.228	1,754	0.96
Subbasin-33	0.184	24	0.37
Junction-25	16.412	1,756	0.96
Reach-11	9.156	1,604	1.05
Reach-25	16.412	1,750	0.96
Junction-26	16.412	1,750	0.96

**FUTURE CONDITIONS
MODEL RESULTS
(5-YEAR)**

5-Year, 24-Hour Storm			
Hydrologic Element	Drainage Area (mi ²)	Peak Discharge (CFS)	Volume (in)
Subbasin-1	1.263	315	1.06
Subbasin-2	0.586	173	1.06
Subbasin-3	0.180	56	1.27
Junction-1	2.029	527	1.08
Reach-1	2.029	526	1.08
Subbasin-4	0.195	56	0.97
Junction-2	2.224	572	1.07
Reach-2	2.224	568	1.07
Subbasin-5	0.625	134	1.14
Junction-3	2.849	689	1.08
Reach-3	2.849	689	1.08
Subbasin-6	1.333	240	0.94
Junction-4	4.182	928	1.04
Reach-4	4.182	917	1.04
Subbasin-7	0.183	51	0.97
Junction-5	4.365	940	1.03
Reach-5	4.365	929	1.03
Subbasin-8	0.288	117	1.1
Junction-6	4.653	959	1.04
Reach-6	4.653	944	1.04
Subbasin-9	1.177	223	1.05
Subbasin-10	0.222	62	0.93
Junction-7	1.399	252	1.03
Reach-7	1.399	250	1.03
Subbasin-11	0.880	322	1.23
Junction-8	2.279	484	1.11
Reach-8	2.279	484	1.11
Subbasin-12	0.552	144	1.06
Junction-9	2.831	609	1.1
Reach-9	2.831	594	1.1
Junction-10	7.484	1,444	1.06
Reach-10	7.484	1,428	1.06
Subbasin-13	1.156	212	1
Subbasin-14	0.516	138	0.95
Junction-11	9.156	1,605	1.05
Reach-11	9.156	1,604	1.05
Subbasin-15	0.498	143	1
Junction-12	9.654	1,636	1.05
Reach-12	9.654	1,634	1.05

5-Year, 24-Hour Storm			
Hydrologic Element	Drainage Area (mi ²)	Peak Discharge (CFS)	Volume (in)
Subbasin-16	0.819	193	1.06
Subbasin-17	0.788	184	0.95
Junction-13	11.261	1,730	1.04
Reach-13	11.261	1,705	1.04
Subbasin-18	0.192	55	0.95
Junction-14	11.453	1,711	1.04
Reach-14	11.453	1,710	1.04
Subbasin-19	0.552	111	1.03
Junction-15	12.005	1,747	1.04
Reach-15	12.005	1,743	1.04
Subbasin-20	0.594	206	1.29
Junction-16	12.599	1,769	1.05
Reach-16	12.599	1,750	1.05
Subbasin-21	0.417	114	0.9
Junction-17	13.016	1,761	1.04
Reach-17	13.016	1,761	1.04
Subbasin-22	0.200	112	1.76
Junction-18	13.216	1,769	1.06
Reach-18	13.216	1,760	1.06
Subbasin-23	0.123	44	0.68
Junction-19	13.339	1,763	1.05
Reach-19	13.339	1,761	1.05
Source-1	1.396	109	0.58
Subbasin-28	0.264	123	1.74
Subbasin-29	0.172	111	2.06
Junction-20	0.436	230	1.86
Reach-20	0.436	220	1.86
Subbasin-30	0.364	158	1.34
Junction-23	15.535	1,788	1.04
Reach-23	15.535	1,774	1.04
Subbasin-31	0.377	290	1.38
Subbasin-32	0.316	274	2.2
Junction-24	16.228	1,796	1.07
Reach-24	16.228	1,785	1.07
Subbasin-33	0.184	24	0.37
Junction-25	16.412	1,787	1.06
Reach-25	16.412	1,781	1.06
Junction-26	16.412	1,781	1.06

**FIGURE 3-10 HYDROLOGY
MINOR STORM RESULTS
KETTLE CREEK DBPS
JOB NO. 25100.00
MAY 2015**

NOTE

1. FUTURE AND EXISTING SUBBASIN 24-27 DATA IS REPLACED WITH DATA FROM THE KETTLE CREEK DRAINAGE BASIN OLD RANCH ROAD TRIBUTARY MASTER DEVELOPMENT DRAINAGE PLAN AND LABELED AS SOURCE-1 (S1).



**HISTORIC CONDITIONS
MODEL RESULTS
(100-YEAR)**

100-Year, 24-Hour Storm			
Hydrologic Element	Drainage Area (mi ²)	Peak Discharge (CFS)	Volume (in)
Subbasin-1	1.263	402	1.31
Subbasin-2	0.586	217	1.31
Subbasin-3	0.180	60	1.31
Junction-1	2.029	663	1.31
Reach-1	2.029	661	1.31
Subbasin-4	0.195	75	1.26
Junction-2	2.224	724	1.31
Reach-2	2.224	703	1.31
Subbasin-5	0.625	150	1.27
Junction-3	2.849	840	1.30
Reach-3	2.849	840	1.30
Subbasin-6	1.333	332	1.27
Junction-4	4.182	1,168	1.29
Reach-4	4.182	1,167	1.29
Subbasin-7	0.183	71	1.31
Junction-5	4.365	1,201	1.29
Reach-5	4.365	1,179	1.29
Subbasin-8	0.288	133.1	1.26
Junction-6	4.653	1218.6	1.29
Reach-6	4.653	1,205	1.29
Subbasin-9	1.177	287	1.32
Subbasin-10	0.222	87	1.26
Junction-7	1.399	325	1.31
Reach-7	1.399	325	1.31
Subbasin-11	0.880	332	1.26
Junction-8	2.279	556	1.29
Reach-8	2.279	540	1.29
Subbasin-12	0.552	184	1.32
Junction-9	2.831	704	1.30
Reach-9	2.831	694	1.30
Junction-10	7.484	1,793	1.29
Reach-10	7.484	1,788	1.29
Subbasin-13	1.156	285	1.31
Subbasin-14	0.516	207	1.37
Junction-11	9.156	2,036	1.30
Reach-11	9.156	2,022	1.30
Subbasin-15	0.498	201	1.36
Junction-12	9.654	2,064	1.30
Reach-12	9.654	2,055	1.30
Subbasin-16	0.819	241	1.31
Subbasin-17	0.788	264	1.31
Junction-13	11.261	2,194	1.30

**EXISTING CONDITIONS
MODEL RESULTS
(100-YEAR)**

100-Year, 24-Hour Storm			
Hydrologic Element	Drainage Area (mi ²)	Peak Discharge (CFS)	Volume (in)
Reach-13	11.261	2,185	1.30
Subbasin-18	0.192	80	1.32
Junction-14	11.453	2,196	1.30
Reach-14	11.453	2,176	1.30
Subbasin-19	0.552	157	1.41
Junction-15	12.005	2,234	1.31
Reach-15	12.005	2,232	1.31
Subbasin-20	0.594	244	1.48
Junction-16	12.599	2,269	1.32
Reach-16	12.599	2,255	1.32
Subbasin-21	0.417	207	1.53
Junction-17	13.016	2,276	1.32
Reach-17	13.016	2,271	1.32
Subbasin-22	0.200	107	1.63
Junction-18	13.216	2,281	1.33
Reach-18	13.216	2,254	1.33
Subbasin-23	0.123	109	1.58
Junction-19	13.339	2,259	1.33
Reach-19	13.339	2,253	1.33
Subbasin-24	0.453	166	1.63
Subbasin-25	0.169	159	1.63
Subbasin-26	0.480	199	1.63
Junction-21	1.102	395	1.63
Reach-21	1.102	387	1.63
Subbasin-27	0.294	157	1.63
Junction-22	1.396	505	1.63
Reach-22	1.396	505	1.63
Subbasin-28	0.264	120	1.63
Subbasin-29	0.172	92	1.63
Junction-20	0.436	212	1.63
Reach-20	0.436	197	1.63
Subbasin-30	0.364	200	1.63
Junction-23	15.535	2,362	1.37
Reach-23	15.535	2,358	1.37
Subbasin-31	0.377	241	1.12
Subbasin-32	0.316	147	1.12
Junction-24	16.228	2,381	1.36
Reach-24	16.228	2,357	1.36
Subbasin-33	0.184	93	1.21
Junction-25	16.412	2,362	1.36
Reach-25	16.412	2,357	1.36
Junction-26	16.412	2,357	1.36

100-Year, 24-Hour Storm			
Hydrologic Element	Drainage Area (mi ²)	Peak Discharge (CFS)	Volume (in)
Subbasin-1	1.263	735	2.36
Subbasin-2	0.586	403	2.37
Subbasin-3	0.180	122	2.67
Junction-1	2.029	1,217	2.39
Reach-1	2.029	1,216	2.39
Subbasin-4	0.195	135	2.22
Junction-2	2.224	1,325	2.38
Reach-2	2.224	1,322	2.38
Subbasin-5	0.625	308	2.52
Junction-3	2.849	1,602	2.41
Reach-3	2.849	1,602	2.41
Subbasin-6	1.333	588	2.18
Junction-4	4.182	2,190	2.34
Reach-4	4.182	2,153	2.34
Subbasin-7	0.183	125	2.24
Junction-5	4.365	2,208	2.33
Reach-5	4.365	2,186	2.33
Subbasin-8	0.288	273.3	2.48
Junction-6	4.653	2,253.3	2.34
Reach-6	4.653	2,213	2.34
Subbasin-9	1.177	520	2.35
Subbasin-10	0.222	152	2.17
Junction-7	1.399	593	2.32
Reach-7	1.399	588	2.32
Subbasin-11	0.880	720	2.66
Junction-8	2.279	1,114	2.45
Reach-8	2.279	1,112	2.45
Subbasin-12	0.552	338	2.39
Junction-9	2.831	1,403	2.44
Reach-9	2.831	1,368	2.44
Junction-10	7.484	3,375	2.38
Reach-10	7.484	3,329	2.38
Subbasin-13	1.156	505	2.28
Subbasin-14	0.516	337	2.20
Junction-11	9.156	3,761	2.36
Reach-11	9.156	3,756	2.36
Subbasin-15	0.498	342	2.28
Junction-12	9.654	3,828	2.35
Reach-12	9.654	3,823	2.35

100-Year, 24-Hour Storm			
Hydrologic Element	Drainage Area (mi ²)	Peak Discharge (CFS)	Volume (in)
Subbasin-16	0.819	449	2.37
Subbasin-17	0.788	447	2.20
Junction-13	11.261	4,038	2.34
Reach-13	11.261	3,975	2.34
Subbasin-18	0.192	134.1	2.2
Junction-14	11.453	3,992	2.34
Reach-14	11.453	3,987	2.34
Subbasin-19	0.552	248	2.19
Junction-15	12.005	4,069	2.33
Reach-15	12.005	4,058	2.33
Subbasin-20	0.594	343	2.06
Junction-16	12.599	4,103	2.32
Reach-16	12.599	4,064	2.32
Subbasin-21	0.417	264	1.96
Junction-17	13.016	4,091	2.31
Reach-17	13.016	4,081	2.31
Subbasin-22	0.200	109	1.66
Junction-18	13.216	4,091	2.30
Reach-18	13.216	4,080	2.30
Subbasin-23	0.123	121	1.75
Junction-19	13.339	4,086	2.29
Reach-19	13.339	4,081	2.29
Source-1	1.396	576	1.58
Subbasin-28	0.264	120	1.63
Subbasin-29	0.172	102	1.83
Junction-20	0.436	222	1.71
Reach-20	0.436	207	1.71
Subbasin-30	0.364	279	2.28
Junction-23	15.535	4,121	2.21
Reach-23	15.535	4,081	2.21
Subbasin-31	0.377	490	2.26
Subbasin-32	0.316	289	2.22
Junction-24	16.228	4,114	2.22
Reach-24	16.228	4,096	2.22
Subbasin-33	0.184	93	1.21
Junction-25	16.412	4,102	2.20
Reach-25	16.412	4,084	2.20
Junction-26	16.412	4,084	2.20

100-Year, 24-Hour Storm			
Hydrologic Element	Drainage Area (mi ²)	Peak Discharge (CFS)	Volume (in)
Subbasin-1	1.263	735	2.36
Subbasin-2	0.586	403	2.37
Subbasin-3	0.180	122	2.67
Junction-1	2.029	1,217	2.39
Reach-1	2.029	1,216	2.39
Subbasin-4	0.195	135	2.22
Junction-2	2.224	1,325	2.38
Reach-2	2.224	1,322	2.38
Subbasin-5	0.625	308	2.52
Junction-3	2.849	1,602	2.41
Reach-3	2.849	1,602	2.41
Subbasin-6	1.333	588	2.18
Junction-4	4.182	2,190	2.34
Reach-4	4.182	2,153	2.34
Subbasin-7	0.183	125	2.24
Junction-5	4.365	2,208	2.33
Reach-5	4.365	2,186	2.33
Subbasin-8	0.288	273.3	2.48
Junction-6	4.653	2,253.3	2.34
Reach-6	4.653	2,213	2.34
Subbasin-9	1.177	520	2.35
Subbasin-10	0.222	152	2.17
Junction-7	1.399	593	2.32
Reach-7	1.399	588	2.32
Subbasin-11	0.880	720	2.66
Junction-8	2.279	1,114	2.45
Reach-8	2.279	1,112	2.45
Subbasin-12	0.552	338	2.39
Junction-9	2.831	1,403	2.44
Reach-9	2.831	1,368	2.44
Junction-10	7.484	3,375	2.38
Reach-10	7.484	3,329	2.38
Subbasin-13	1.156	505	2.28
Subbasin-14	0.516	337	2.20
Junction-11	9.156	3,761	2.36
Reach-11	9.156	3,756	2.36
Subbasin-15	0.498	342	2.28
Junction-12	9.654	3,828	2.35
Reach-12	9.654	3,823	2.35

100-Year, 24-Hour Storm			
Hydrologic Element	Drainage Area (mi ²)	Peak Discharge (CFS)	Volume (in)
Subbasin-16	0.819	449	2.37
Subbasin-17	0.788	447	2.20
Junction-13	11.261	4,038	2.34
Reach-13	11.261	3,975	2.34
Subbasin-18	0.192	134.1	2.2
Junction-14	11.453	3,992	2.34
Reach-14	11.453	3,987	2.34
Subbasin-19	0.552	262	2.32
Junction-15	12.005	4,072	2.34
Reach-15	12.005	4,061	2.34
Subbasin-20	0.594	448	2.70
Junction-16	12.599	4,115	2.36
Reach-16	12.599	4,077	2.36
Subbasin-21	0.417	284	2.12
Junction-17	13.016	4,105	2.35
Reach-17	13.016	4,093	2.35
Subbasin-22	0.200	219	3.37
Junction-18	13.216	4,108	2.37
Reach-18	13.216	4,099	2.37
Subbasin-23	0.123	124	1.80
Junction-19	13.339	4,104	2.36
Reach-19	13.339	4,099	2.36
Source-1	1.396	576	1.58
Subbasin-28	0.264	241	3.34
Subbasin-29	0.172	207	3.78
Junction-20	0.436	439	3.51
Reach-20	0.436	421	3.51
Subbasin-30	0.364	340	2.78
Junction-23	15.535	4,152	2.33
Reach-23	15.535	4,110	2.33
Subbasin-31	0.377	606	2.79
Subbasin-32	0.316	500	3.98
Junction-24	16.228	4,152	2.38
Reach-24	16.228	4,137	2.38
Subbasin-33	0.184	93	1.21
Junction-25	16.412	4,142	2.36
Reach-25	16.412	4,123	2.36
Junction-26	16.412	4,123	2.36

FIGURE 3-11 HYDROLOGY
MAJOR STORM RESULTS
KETTLE CREEK DBPS
JOB NO. 25100.00
MAY 2015

NOTE

1. FUTURE AND EXISTING SUBBASIN 24-27 DATA IS REPLACED WITH DATA FROM THE KETTLE CREEK DRAINAGE BASIN OLD RANCH ROAD TRIBUTARY MASTER DEVELOPMENT DRAINAGE PLAN AND LABELED AS SOURCE-1 (S1).



LEGEND

- SUBBASIN ID
- 100-YEAR 24-HOUR FLOWS (CFS)
- 5-YEAR 24-HOUR FLOWS (CFS)
- BASIN BOUNDARY
- SUBBASIN BOUNDARY
- MAJOR TRIBUTARY
- JUNCTION

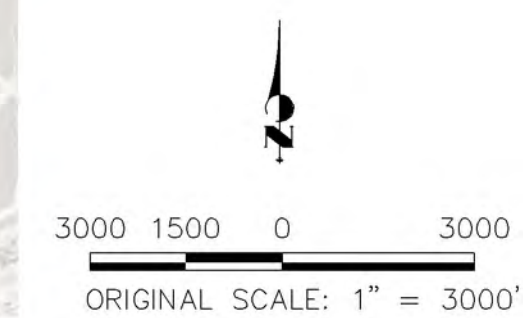
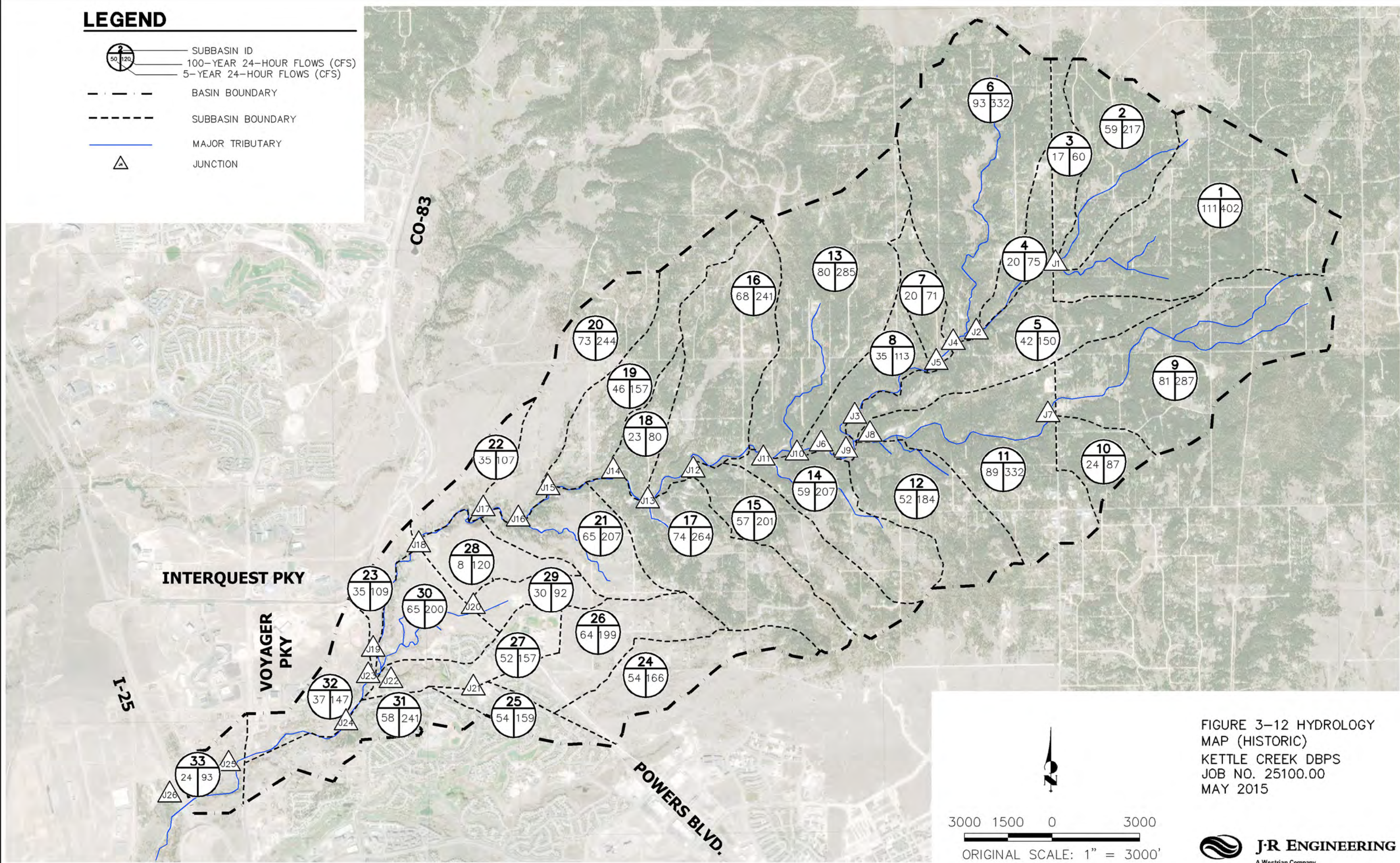



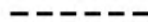



FIGURE 3-12 HYDROLOGY MAP (HISTORIC)
 KETTLE CREEK DBPS
 JOB NO. 25100.00
 MAY 2015

LEGEND

-  SUBBASIN ID
-  100-YEAR 24-HOUR FLOWS (CFS)
-  5-YEAR 24-HOUR FLOWS (CFS)
-  BASIN BOUNDARY
-  SUBBASIN BOUNDARY
-  MAJOR TRIBUTARY
-  JUNCTION

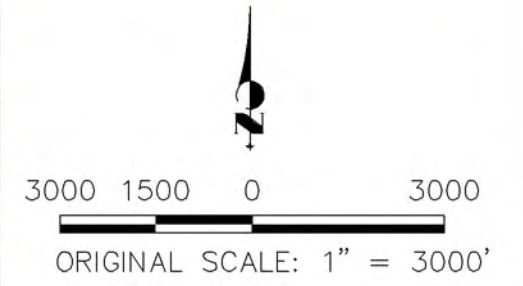
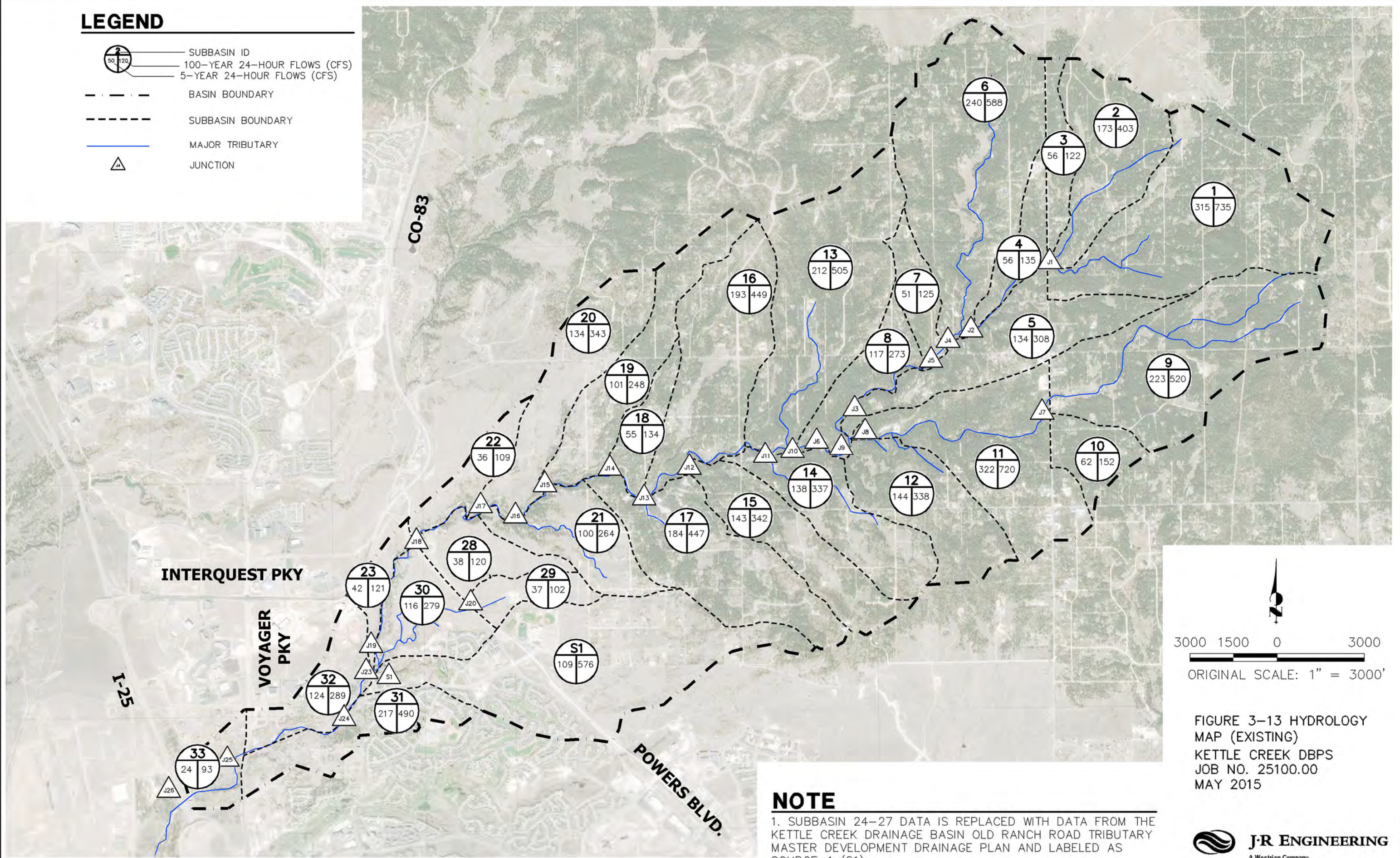









FIGURE 3-13 HYDROLOGY MAP (EXISTING)
 KETTLE CREEK DBPS
 JOB NO. 25100.00
 MAY 2015

NOTE

1. SUBBASIN 24-27 DATA IS REPLACED WITH DATA FROM THE KETTLE CREEK DRAINAGE BASIN OLD RANCH ROAD TRIBUTARY MASTER DEVELOPMENT DRAINAGE PLAN AND LABELED AS SOURCE-1 (S1).



LEGEND

-  SUBBASIN ID
-  100-YEAR 24-HOUR FLOWS (CFS)
-  5-YEAR 24-HOUR FLOWS (CFS)
-  BASIN BOUNDARY
-  SUBBASIN BOUNDARY
-  MAJOR TRIBUTARY
-  JUNCTION

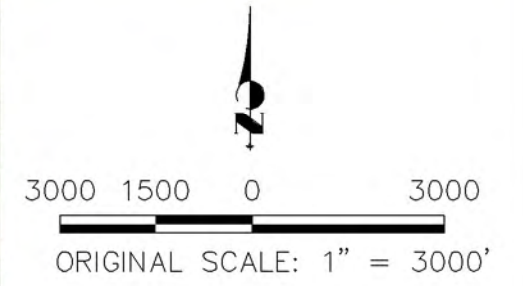
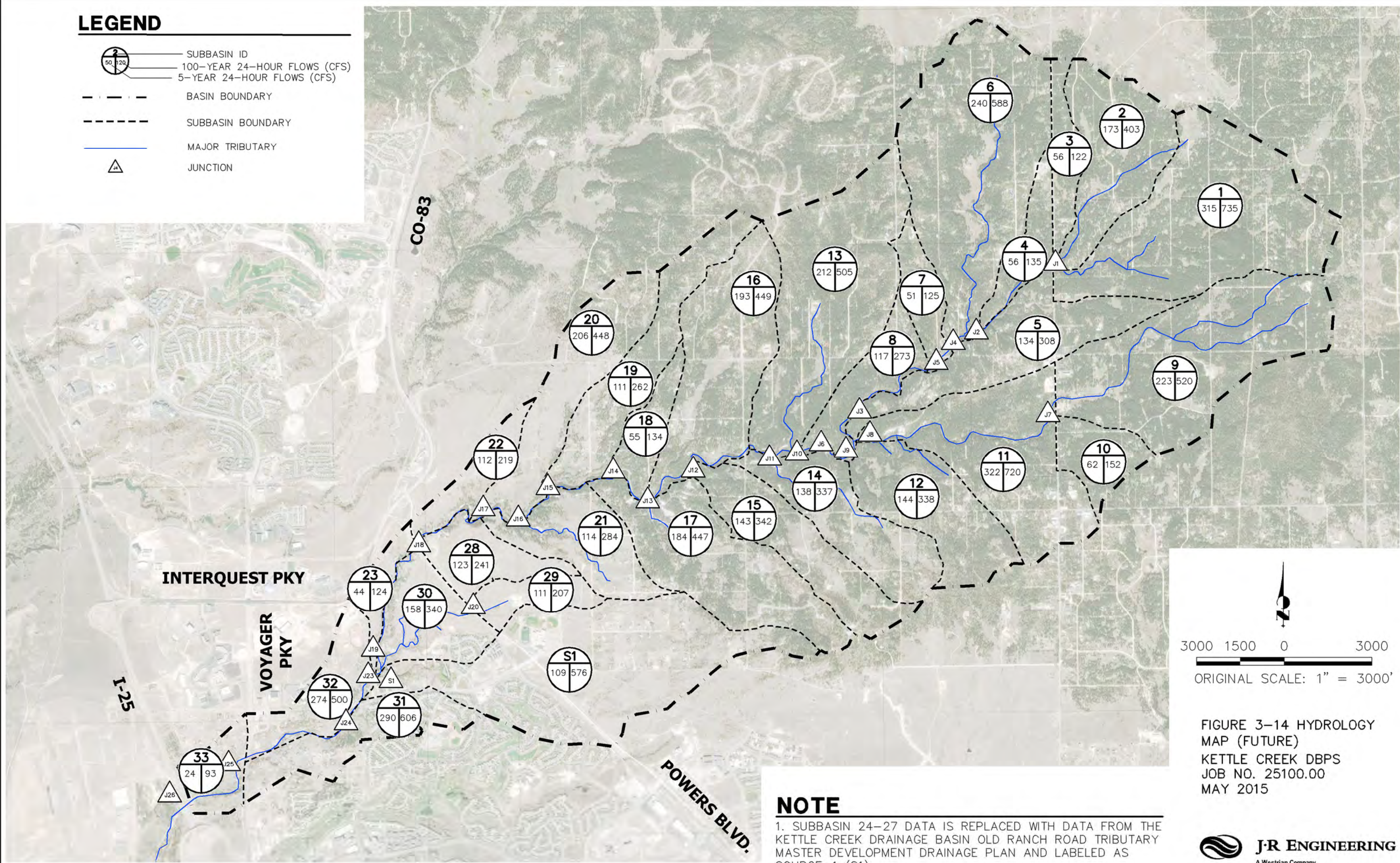

FIGURE 3-14 HYDROLOGY MAP (FUTURE)
KETTLE CREEK DBPS
JOB NO. 25100.00
MAY 2015

NOTE

1. SUBBASIN 24-27 DATA IS REPLACED WITH DATA FROM THE KETTLE CREEK DRAINAGE BASIN OLD RANCH ROAD TRIBUTARY MASTER DEVELOPMENT DRAINAGE PLAN AND LABELED AS SOURCE-1 (S1).



Centennial 303-740-9999 • Colorado Springs 719-593-2593
Fort Collins 970-491-9888 • www.jrengineering.com

4 HYDRAULIC ANALYSIS

4.1 Major Drainageways

A hydraulic analysis was undertaken to evaluate the distribution of flow, determine areas covered by water during flooding events, and related characteristics of the water flow in the channel and overbank areas along Kettle Creek. While the hydrologic computations define the rate of flow for floods of selected frequencies at various points within the drainage basin, the hydraulic computations reflect dynamic conditions of the water flowing downstream as affected by the channel size, subsurface roughness, structures along the channel, channel vegetation, and similar physical characteristics. The physical characteristics of Kettle Creek and its tributaries in combination with the peak flood discharge rates described in Section 3 of this report provide the primary input characteristics to the hydraulic analysis, and the basis for evaluating the hydraulic adequacy of the outfall system.

Kettle Creek and its tributaries in the Black Forest area are defined in many places by deep channels with steep side slopes. A field investigation was conducted throughout the lower portion of the drainage basin, which will be the segment primarily affected by future development. It is understood that little future development is expected to occur in the Black Forest.

A field investigation was conducted from Powers Boulevard to I-25 in August 2014. The site investigation established a basis to define any areas in need of improvements, and determine the adequacy of the assumed channel characteristics and existing structures in this area. The visit also identified some areas where stream bank and bed erosion exists in the lower portion of the basin, and where other physical problems have resulted due to the stream hydraulics. Some of these areas are presented in **Appendix D** with photos taken in August 2014.

4.2 Methodology

Hydraulic calculations were performed on Kettle Creek to determine the existing and future floodplain limits. This was accomplished by utilizing the U.S. Army Corps of Engineer's HEC-RAS River Analysis System program (version 4.1.0, January 2010). For this study, Kettle Creek was divided into separate reaches corresponding to the designations as shown on **Figure 3-2**, and described in Section 3 of this report. The delineated historic, existing and future floodplain boundaries can be seen on the work maps, **Figures 4-1** and **4-2**, and the depths are depicted on the profile sheets included as **Figure 4-3** through **Figure 4-7**.

4.2.1 Parameters

Hydraulic analyses for existing and future hydrologic conditions were completed for the main stem of Kettle Creek from Howells Road to I-25. These analyses were completed to represent peak flows for the flood events with 2-, 5-, 10-, 25-, 50- and 100-year recurrence intervals. Cross-section topography data was obtained from a triangulated irregular network (TIN) in AutoCAD that was created from the contour information obtained from City of Colorado Springs FIMS topographic data.

4.2.2 Structures

Bridges and ineffective flow areas were added to the HEC-RAS model. Physical parameters for measured structures were incorporated into the hydraulic model using HEC-RAS bridge and cross-section data editors. All of the drainageway crossings from Powers Boulevard to I-25 were modeled to represent existing conditions which consist of bridges over Kettle Creek. These crossings are located at Powers Boulevard (bridge), Old Ranch Road (bridge), Otero Avenue (bridge), and Voyager Parkway (State Highway 83) (bridge).

4.2.3 Reaches

The reach analyzed consists of the Kettle Creek main stem from Howells Road (approximate, Howells Road does not cross Kettle Creek) to the Kettle Creek Detention Facility just east of I-25, approximately 24,850 linear feet or 4.7 miles of channel. This downstream limit extends 3,000 feet past the FIS and FEMA FIRM maps. The upstream limit of model was taken to be the approximate limit of significant planned future development at the east city limits. Upstream of Howells Road is the Black Forest (El Paso County jurisdiction), where land use is expected to remain unchanged in the future. The downstream limit was taken to be the embankment of the regional detention pond at I-25. Information from the U.S. Air Force Academy Kettle Creek Watershed Hydrology Study (April 2002) was used to determine the water surface elevations of the Kettle Creek detention facility for each respective storm recurrence interval.

The main stem of Kettle Creek in the subject reach is defined by a deeply incised main channel with heavy brush and wetland-type vegetation. Above the banks of the main channel, overbanks exist within the Kettle Creek drainageway with steep side slopes and natural grasses and sparse scrub vegetation.

4.2.4 Manning's *n* Values

The Manning's *n* values were applied across the channel cross-section to reflect changes in vegetative cover between the main channel and overbank areas. Manning's *n* values were obtained from the Major Drainage chapter of the UDFCD Drainage Criteria Manual. The Manning's *n* values for the channels and floodplains are summarized in Table 4-1.

Table 4-1
Manning's *n* Values

Parameter	Historic Conditions	Existing Conditions	Future Conditions
Main Channel <i>n</i>	0.100	0.100	0.100
Overbank <i>n</i>	0.030	0.030	0.030

The Manning's *n* for the main channel was selected for "very weedy reaches, deep pools, or floodways with heavy stand of timber and underbrush". Manning's *n* values for the overbank areas reflect conditions of

“clean, straight, full stage, no rifts or deep pools”. The channel characteristics are assumed to remain consistent through all stages of development.

4.2.5 Cross-Sections

A total of 44 cross-sections were modeled along the reach, with cross-sections located at geometry changes and downstream of all crossings. Channel cross-section locations were manually selected to represent confluences, changes in channel geometry and slope. Each cross-section was adjusted to extend across the estimated floodplain and was placed perpendicular to the anticipated direction of flow in both the main channel and left/right floodplains. The cross-sections were bent in some locations to accomplish the requirement to lie perpendicular to the flow path as described in Chapter 3 of HEC-RAS Hydraulic Reference Manual.

There are existing bridges over Kettle Creek located at Powers Boulevard, Old Ranch Road, Otero Avenue, and Voyager Parkway (State Highway 83). At each of these locations, four cross-sections were added to the HEC-RAS model that included an upstream cross-section prior to flow contraction, a cross-section at the upstream face of the structure, a cross-section at the downstream face of the structure, and a downstream cross-section where flow is fully expanded. Pier location and dimensions and deck elevations were roughly measured in the field. Photos are included in **Appendix D**.

The cross sections generated from the surface TIN in AutoCAD Civil 3D may potentially represent the top of the vegetated surface and not necessarily the true channel invert. In locations where vegetation is sparse, and not deep, the channel invert is assumed to be accurately represented. In locations of dense and deep vegetative cover, the channel invert may not be accurately represented and could be shallower than what actually exists. This condition may result in cross sections with less flood capacity than actually exists and leads to a conservative estimation of floodplain widths.

Several non-critical model warnings were generated during model runs. To address model warnings by either defining numerous additional cross sections or by interpolating cross sections between every defined cross section would be necessary. Neither of these solutions was determined to be necessary given the level of detail required for this study and as such were not completed.

Expansion and contraction coefficients in the cross-sections were estimated based on the ratio of expansion and contraction of the effective flow area in the floodplain occurring at cross-sections and at major drainageway crossings. For subcritical flow conditions where the change in the stream cross-section is gradual, a contraction coefficient of 0.1 and expansion coefficient of 0.3 are typically used for hydraulic modeling. The channel characteristics for the study reach justified the use of these typical values. An contraction coefficient of 0.3 and an expansion coefficient of 0.5 were used at the two upstream sections and immediate downstream section at each bridge crossing in accordance with standard practice, which reflects the energy loss resulting from increased flow contraction approaching the bridge, and increased flow expansion when leaving the bridge.

4.2.6 Ineffective Flow Areas

Ineffective flow areas are used to describe portions of a cross section in which water does not actively flow. Ineffective flow is typically used at the upstream and downstream bounding cross sections of a drainageway crossing and for a side channel with stagnant storage. All ineffective flow is considered permanent and will not become effective flow until the barrier is overtopped. Ineffective flow areas were used at major drainageway crossings only and it was assumed that channel invert irregularities are all contributing flow areas for the purposes of this study.

4.2.7 Bridges

The surface TIN was used to develop the bounding cross sections upstream and downstream of each major drainageway crossing, in addition to the approximate roadway characteristics at each crossing. The required inputs for bridge modeling include data for the deck/roadway, pier, and sloping abutments. This data was obtained from the surface topography and approximate measurements taken during the site inspection.

4.2.8 Detention Ponds

No existing detention ponds lie along the study reach except for the regional detention facility located on the upstream side of I-25. Information from the U.S. Air Force Academy Kettle Creek Watershed Hydrology Study (AFA Study) was used to determine the storage and water surface elevations of the Kettle Creek detention facility.

4.2.9 Steady Flow and Boundary Conditions

Steady flow data were entered for the study reach based on the results of the hydrologic modeling in Section 3. Steady flow data corresponding to the peak flow for flood events with recurrence intervals of 2-, 5-, 10-, 25-, 50- and 100-years for historic, existing, and future hydrologic conditions was entered for each reach at points of significant hydrologic change as determined in the hydrologic model. A summary of hydrologic flows for each tributary at different points is provided in tabular form in **Appendix B**.

The upstream boundary condition for the reach was based on the estimated normal depth of Kettle Creek based on invert slope. The downstream boundary conditions were based on water surface elevations in the I-25 regional detention pond obtained from the AFA Study. A mix of supercritical and subcritical flow conditions was evaluated. The mixed flow regime was selected to provide conservative water surface elevations while reflecting maximum velocities, in order to present the results most consistent with actual flood conditions in the channel.

4.3 Approximate Floodplains

After the HEC-RAS model analysis was complete, the 100-year water surface elevations were exported back to AutoCAD Civil 3D. Approximate floodplains for the existing and future 100-year floods were delineated for Kettle Creek and are shown in **Figures 4-1** and **4-2**. Due to negligible differences in the water surface profiles at the scale shown, the existing and future flow results are shown as one water surface profile. The FEMA floodplains for the Kettle Creek watershed are overlaid in the plan for comparison to the results of this analysis. Flood profiles for the existing and future 100-year floods are shown in **Figure 4-3** through **Figure**

4-7. The approximate floodplains and profiles were used to assess where potential drainageway crossing deficiencies exist along the major drainageways and identify areas of potential flooding.

The approximate floodplain information shown on the figures above is intended primarily for the identification of flood prone areas along the main stem of Kettle Creek and to aid in the evaluation of potential future alternatives. The approximate floodplain data contained herein is not intended to replace the information presented in the City of Colorado Springs and El Paso County Flood Insurance studies (FEMA 1999) but should be used as a planning tool for potential future drainageway development projects. The FEMA floodplain remains as the regulatory floodplain.

4.4 Drainageway Crossing Deficiencies

The four bridges over Kettle Creek in the hydraulic study area are sufficient based on approximate measurements of the structures during the site visit and estimates from aerial topography when compared to the calculated water surface elevation.

4.5 Areas of Geomorphic Instability

Several areas of erosion were located during the site visit and are noted in Appendix D. Due to the length of the reach and the heavy vegetation in the study reach, not all areas of instability may have been located.

The results of the hydraulic analysis show areas where flows approach or exceed critical depth, and the fluctuation of flows between subcritical and supercritical is a known cause of channel instability. Additionally, due to the Kettle gravelly loamy sand soil type, channel velocities in these areas that exceed five feet per second may be erosive. **Figures 4-8 to 4-12** shows areas that check structures could be implemented to accomplish a stabilized channel. These structures were placed in areas where the calculated cross section velocities of future flows were greater than five feet per second. Conceptual stable channel calculations are provided in **Figure 4-12**. Due to permitting requirements and the Preble's meadow jumping mouse critical habitat along Kettle Creek, the conceptual future improvements shown herein may not be feasible in some or all areas.

Future development in the lower Kettle Creek basin should address stabilization of the main channel in further detail. It will be the responsibility of each developer to perform a geotechnical analysis and detailed hydraulic study on the channel to determine the appropriate setbacks from the channel. Environmental considerations including Preble's meadow jumping mouse critical habitat will also dictate limits of development adjacent to Kettle Creek.



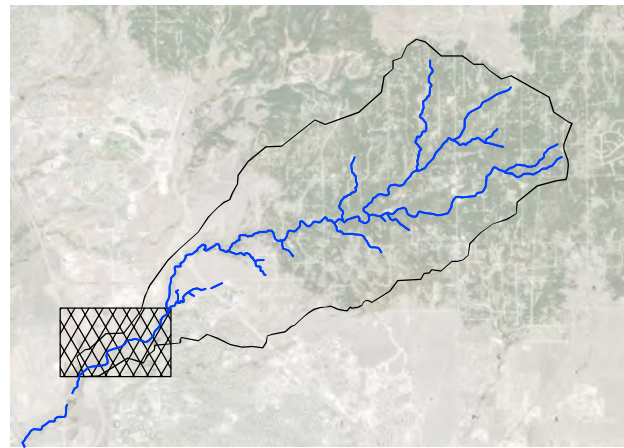

SEE FIG 4-2 STA:105+00

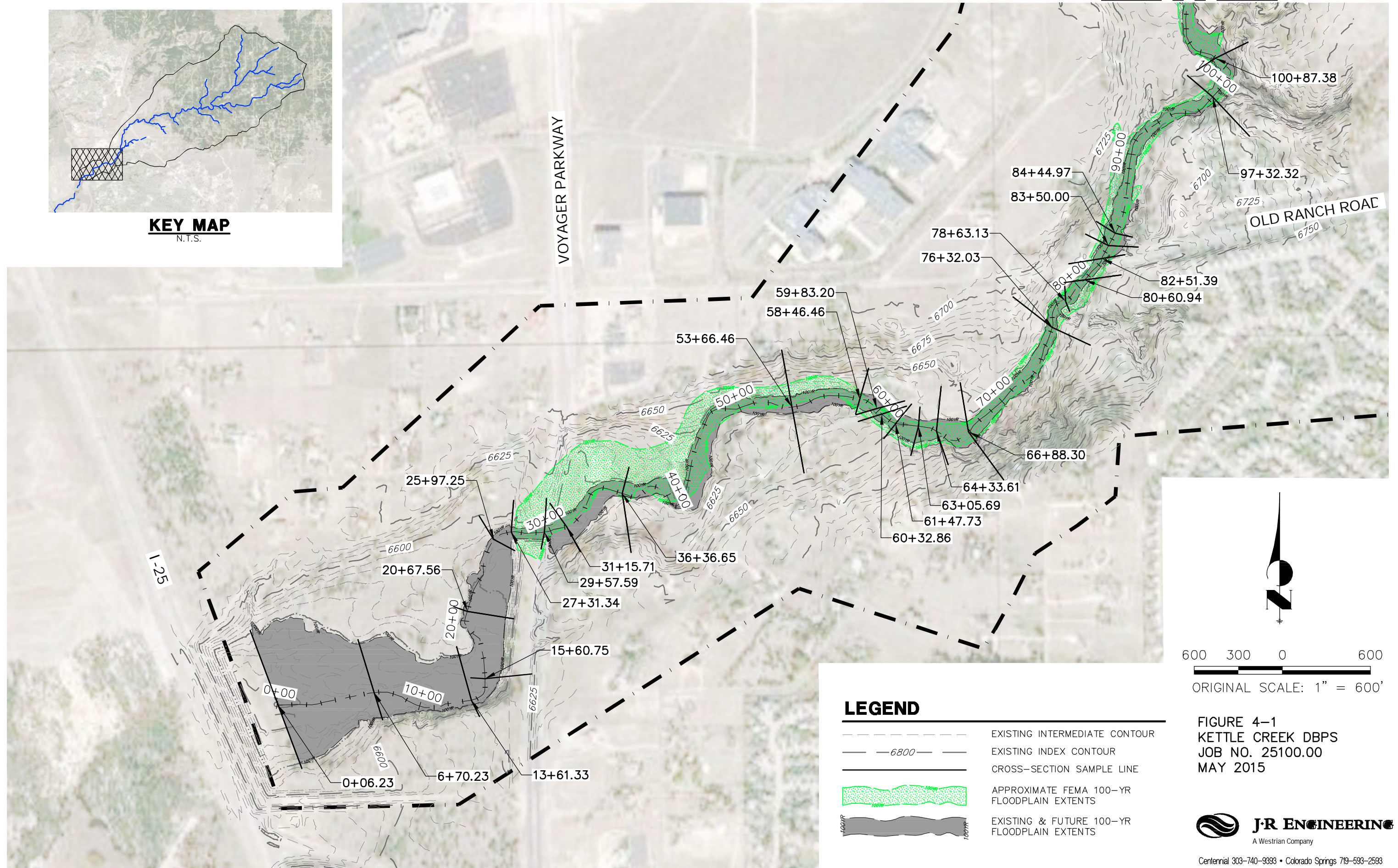

KEY MAP
N.T.S.

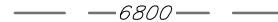

LEGEND

-  EXISTING INTERMEDIATE CONTOUR
-  EXISTING INDEX CONTOUR
-  CROSS-SECTION SAMPLE LINE
-  APPROXIMATE FEMA 100-YR FLOODPLAIN EXTENTS
-  EXISTING & FUTURE 100-YR FLOODPLAIN EXTENTS

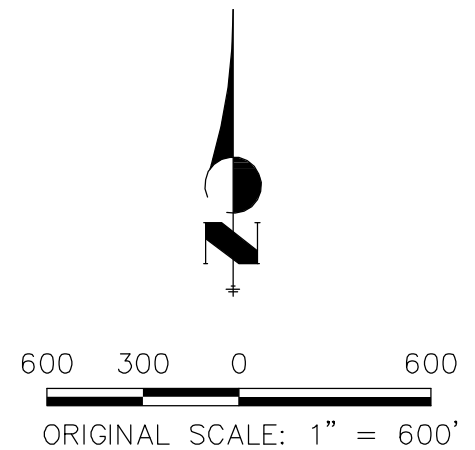
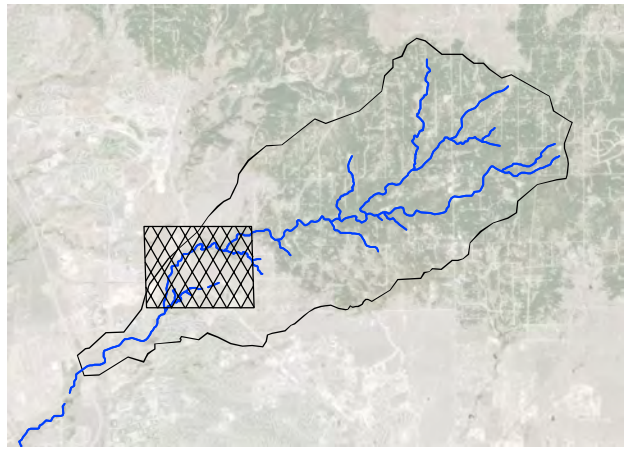

FIGURE 4-1
KETTLE CREEK DBPS
JOB NO. 25100.00
MAY 2015



Centennial 303-740-9393 • Colorado Springs 719-593-2593
Fort Collins 970-491-9888 • www.jrengineering.com



KEY MAP
N.T.S.

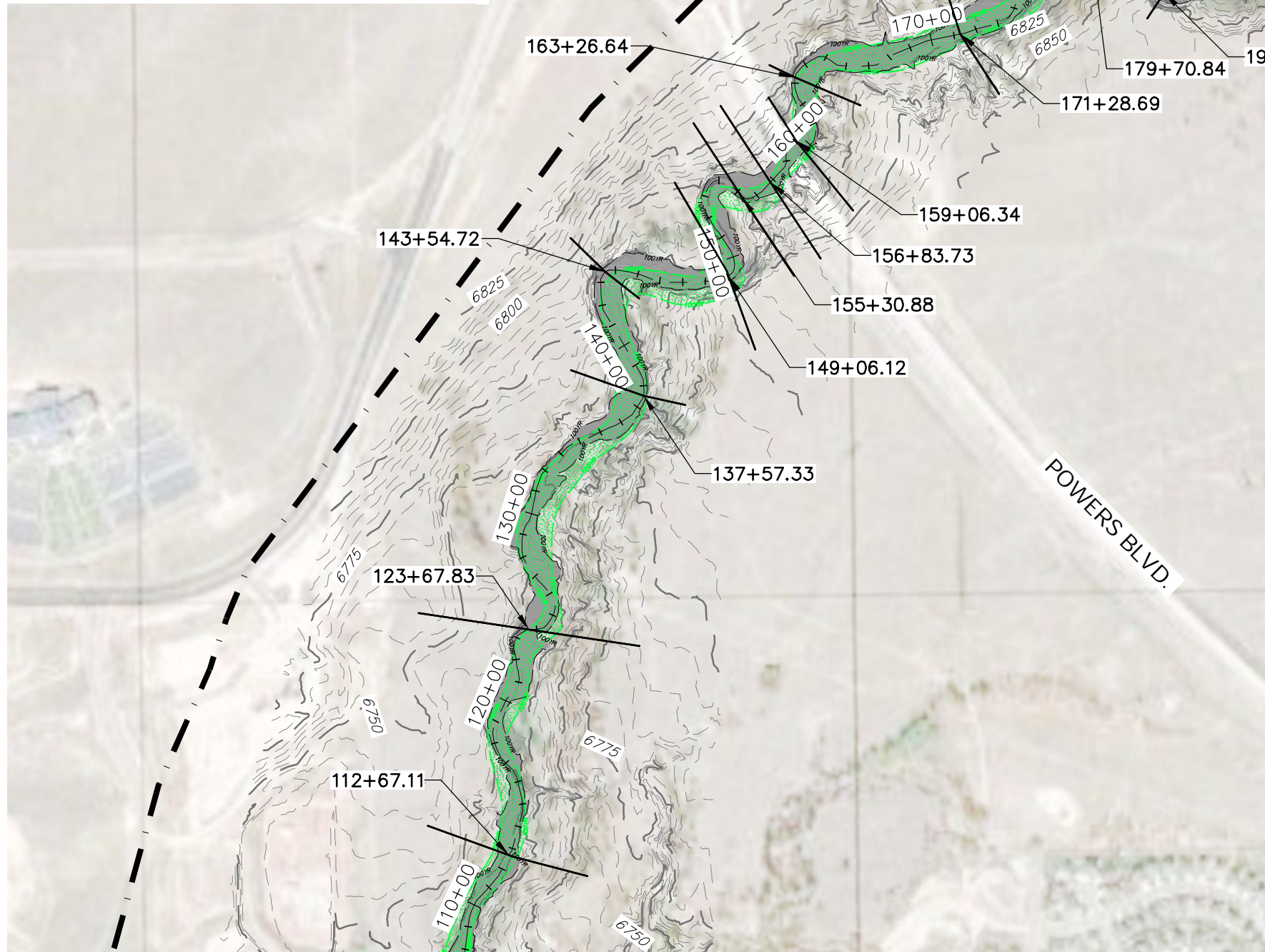

SEE FIG 4-1 STA: 105+00

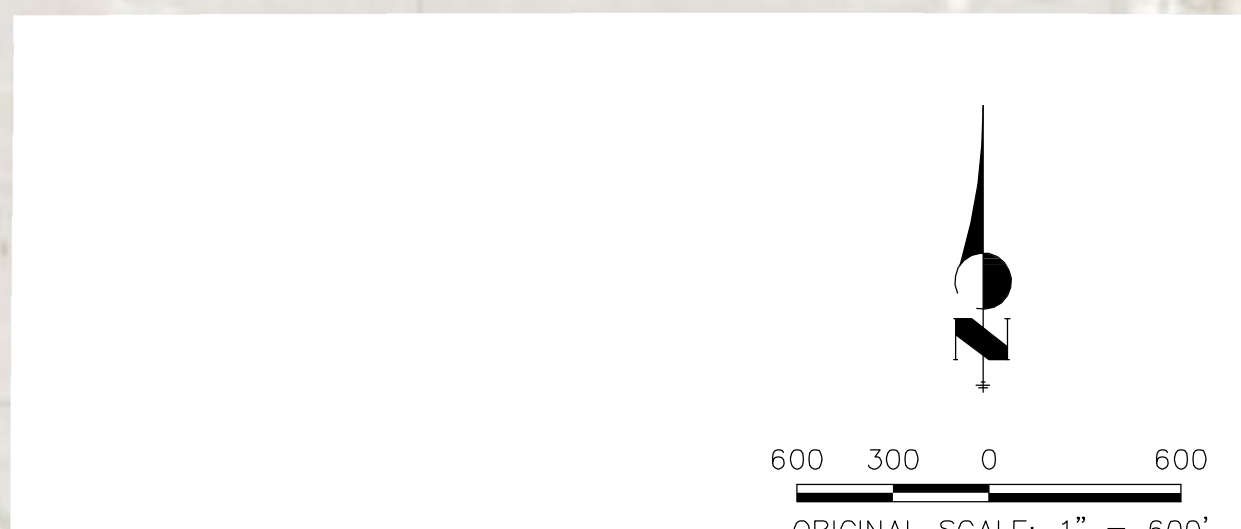
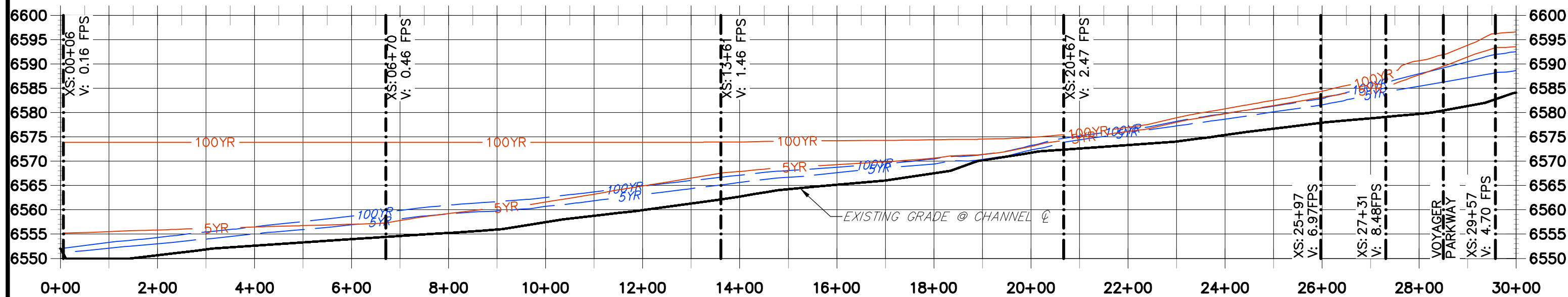

FIGURE 4-2
KETTLE CREEK DBPS
JOB NO. 25100.00
MAY 2015



Centennial 303-740-9393 • Colorado Springs 719-593-2593
Fort Collins 970-491-9888 • www.jrengineering.com

KETTLE CREEK CL ALIGNMENT (1)
STA 0+00.00 TO 30+00.00



KETTLE CREEK CL ALIGNMENT (2)
STA 30+00.00 TO 60+00.00

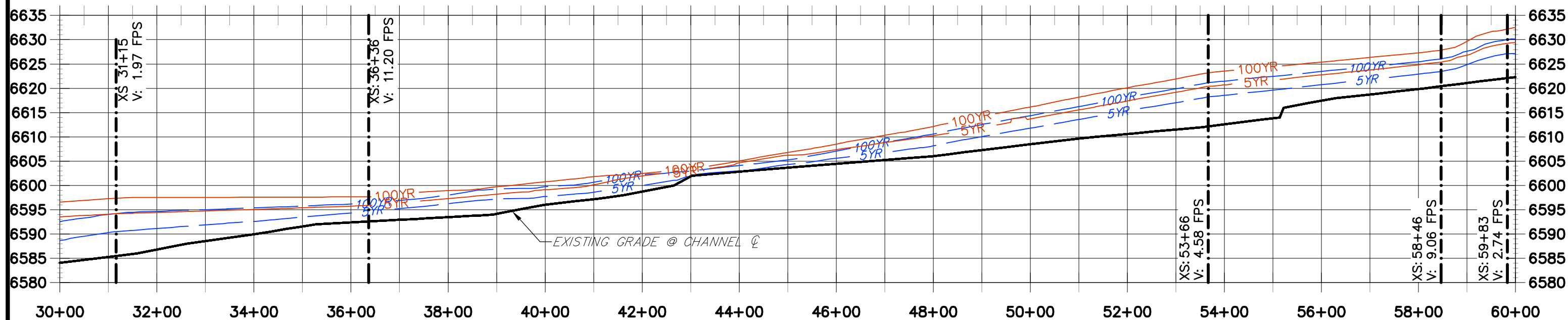

LEGEND

- HISTORIC 5 YR WATER SURFACE ELEVATION
- HISTORIC 100 YR WATER SURFACE ELEVATION
- EXISTING & FUTURE 5 YR WATER SURFACE ELEVATION
- EXISTING & FUTURE 100 YR WATER SURFACE ELEVATION
- APPROXIMATE GRADE @ KETTLE CREEK C

NOTE

1. VELOCITY SHOWN ON PROFILES ARE FUTURE FLOWS

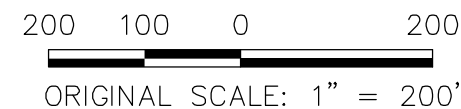
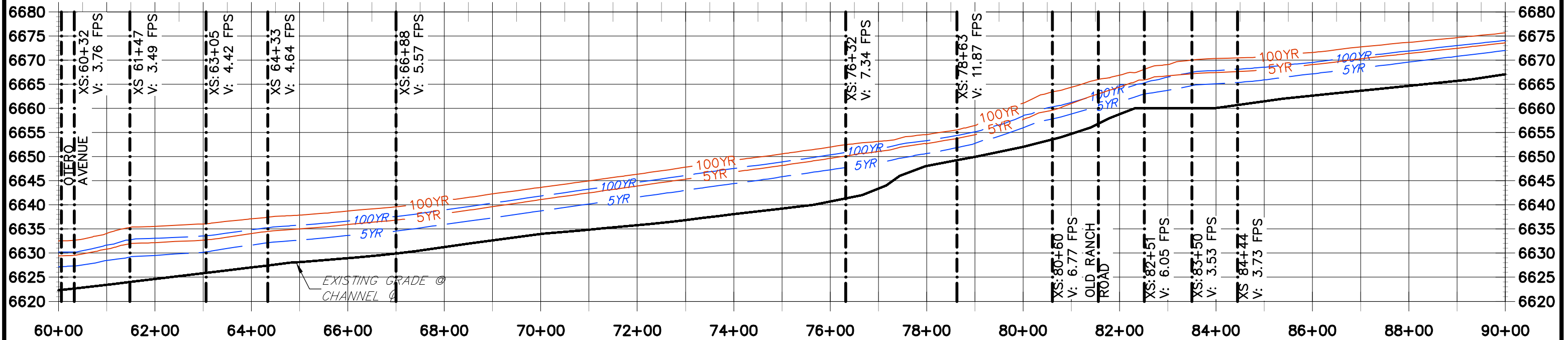

FIGURE 4-3
KETTLE CREEK DBPS
JOB NO. 25100.00
MAY 2015



KETTLE CREEK CL ALIGNMENT (3)
STA 60+00.00 TO 90+00.00



KETTLE CREEK CL ALIGNMENT (4)
STA 90+00.00 TO 120+00.00

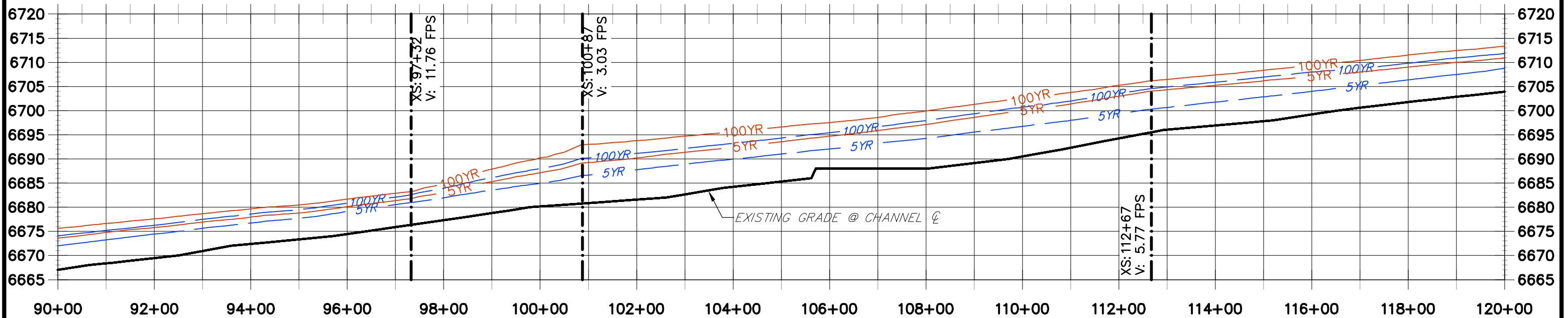

LEGEND

- HISTORIC 5 YR WATER SURFACE ELEVATION
- HISTORIC 100 YR WATER SURFACE ELEVATION
- EXISTING & FUTURE 5 YR WATER SURFACE ELEVATION
- EXISTING & FUTURE 100 YR WATER SURFACE ELEVATION
- APPROXIMATE GRADE @ KETTLE CREEK C

NOTE

1. VELOCITY SHOWN ON PROFILES ARE FUTURE FLOWS

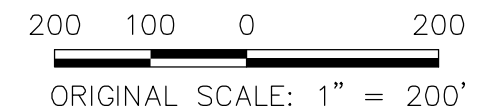
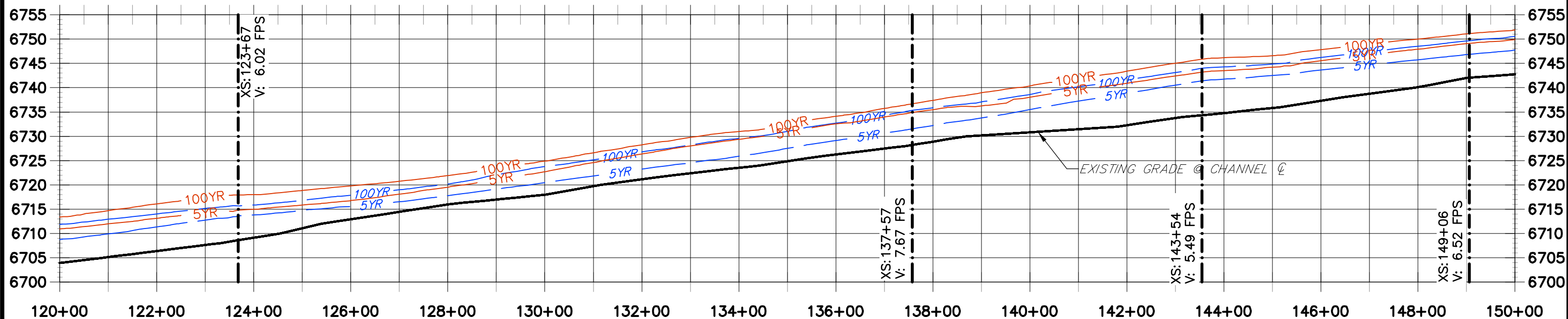

FIGURE 4-4
KETTLE CREEK DBPS
JOB NO. 25100.00
MAY 2015



KETTLE CREEK CL ALIGNMENT (5)
STA 120+00.00 TO 150+00.00



KETTLE CREEK CL ALIGNMENT (6)
STA 150+00.00 TO 180+00.00

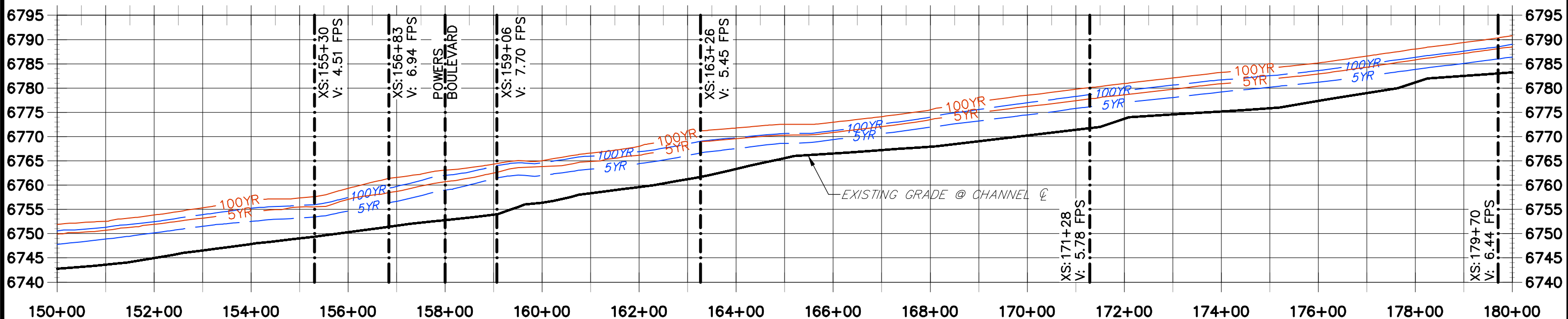

LEGEND

- HISTORIC 5 YR WATER SURFACE ELEVATION
- HISTORIC 100 YR WATER SURFACE ELEVATION
- EXISTING & FUTURE 5 YR WATER SURFACE ELEVATION
- EXISTING & FUTURE 100 YR WATER SURFACE ELEVATION
- APPROXIMATE GRADE @ KETTLE CREEK C

NOTE

1. VELOCITY SHOWN ON PROFILES ARE FUTURE FLOWS

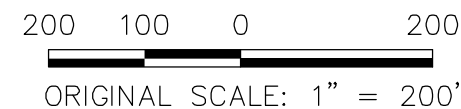
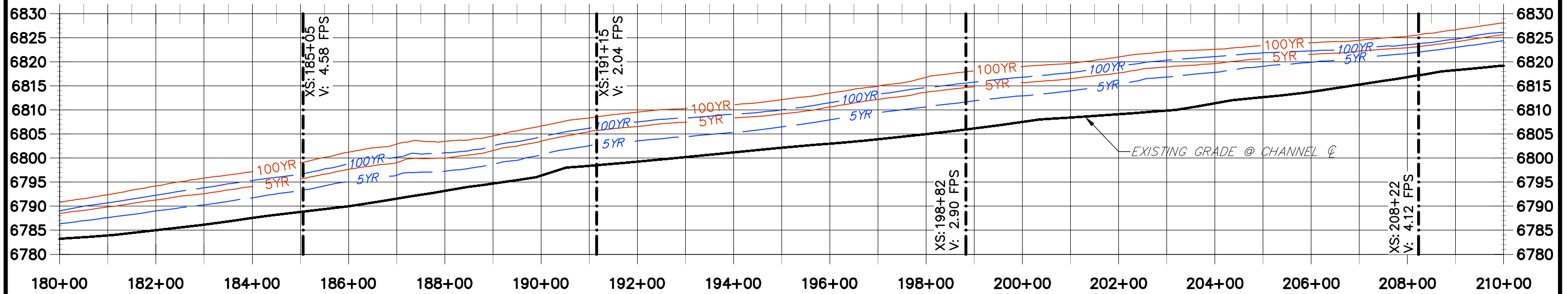

FIGURE 4-5
KETTLE CREEK DBPS
JOB NO. 25100.00
MAY 2015



KETTLE CREEK CL ALIGNMENT (7)
STA 180+00.00 TO 210+00.00



KETTLE CREEK CL ALIGNMENT (8)
STA 210+00.00 TO 240+00.00

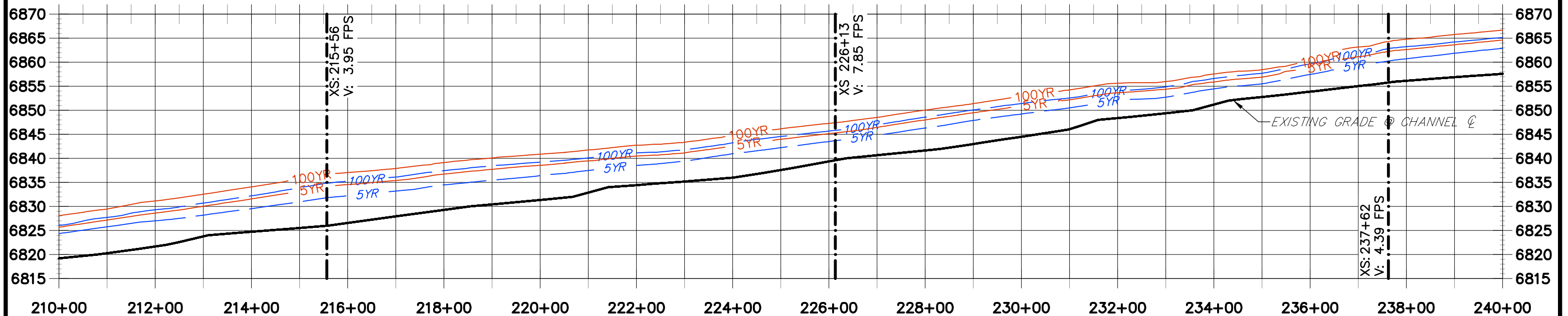

LEGEND

- HISTORIC 5 YR WATER SURFACE ELEVATION
- HISTORIC 100 YR WATER SURFACE ELEVATION
- EXISTING & FUTURE 5 YR WATER SURFACE ELEVATION
- EXISTING & FUTURE 100 YR WATER SURFACE ELEVATION
- APPROXIMATE GRADE @ KETTLE CREEK C

NOTE

1. VELOCITY SHOWN ON PROFILES ARE FUTURE FLOWS

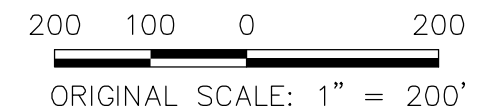
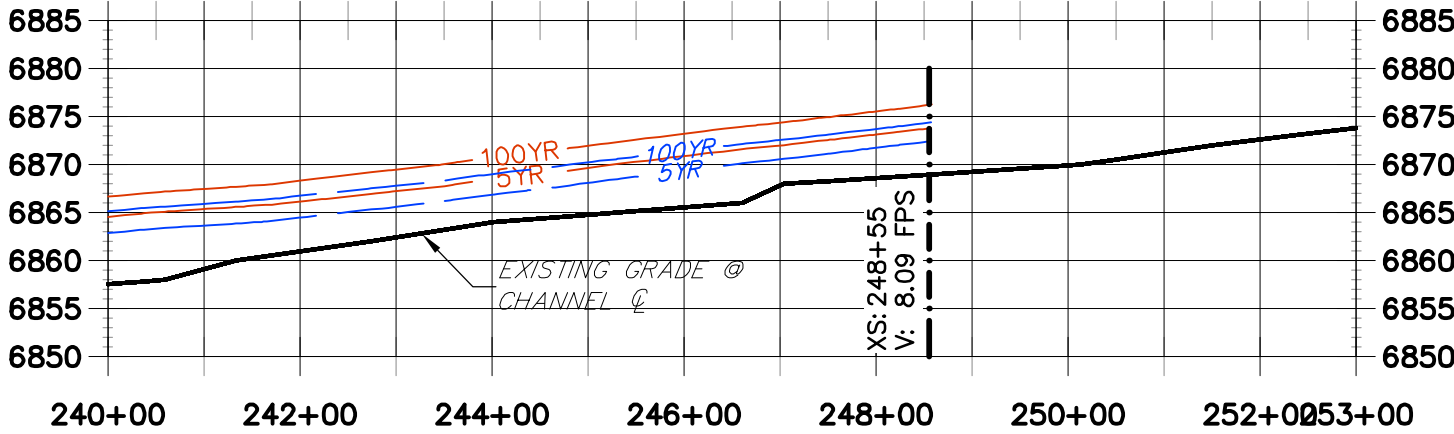

FIGURE 4-6
KETTLE CREEK DBPS
JOB NO. 25100.00
MAY 2015







Centennial 303-740-9393 • Colorado Springs 719-593-2593
Fort Collins 970-491-9888 • www.jrengineering.com

KETTLE CREEK CL ALIGNMENT (9)
 STA 240+00.00 TO 253+00.00



LEGEND

-  HISTORIC 5 YR WATER SURFACE ELEVATION
-  HISTORIC 100 YR WATER SURFACE ELEVATION
-  EXISTING & FUTURE 5 YR WATER SURFACE ELEVATION
-  EXISTING & FUTURE 100 YR WATER SURFACE ELEVATION
-  APPROXIMATE GRADE @ KETTLE CREEK C

NOTE

1. VELOCITY SHOWN ON PROFILES ARE FUTURE FLOWS

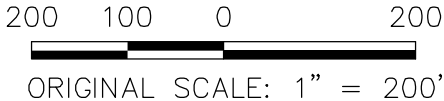
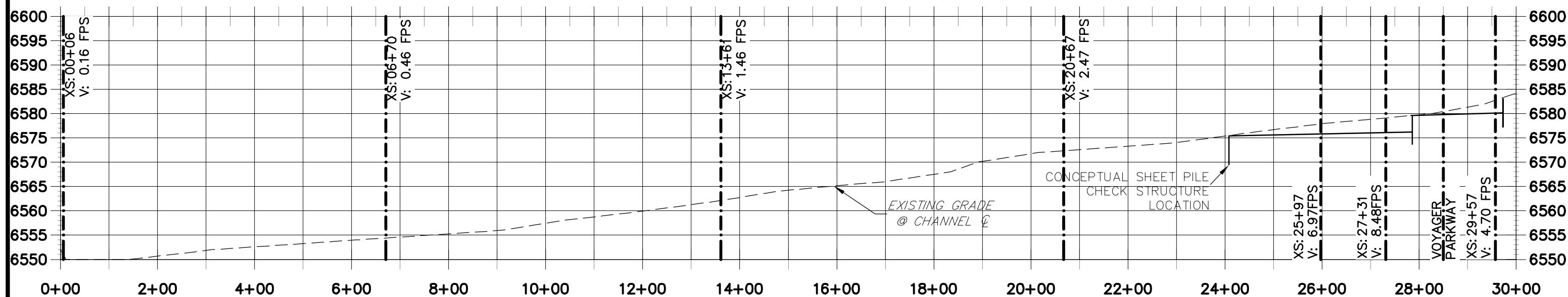

FIGURE 4-7
 KETTLE CREEK DBPS
 JOB NO. 25100.00
 MAY 2015



KETTLE CREEK CL ALIGNMENT (1)
STA 0+00.00 TO 30+00.00



KETTLE CREEK CL ALIGNMENT (2)
STA 30+00.00 TO 60+00.00

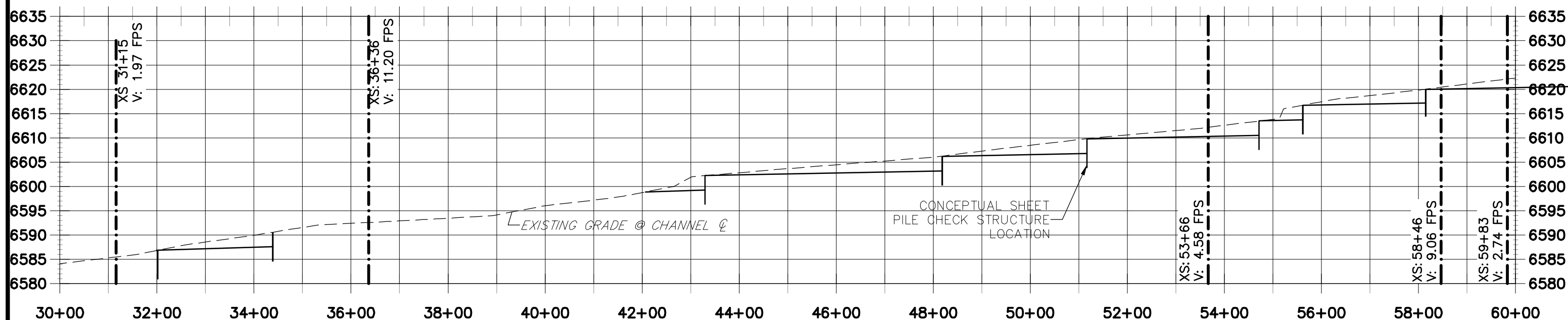

LEGEND

- CONCEPTUAL CHECK STRUCTURE
- FUTURE STABILIZED GRADE (0.20% GRADE)
- EXISTING GRADE

NOTE

1. VELOCITY SHOWN ON PROFILES ARE FUTURE FLOWS
2. CHECK STRUCTURES ARE FOR ILLUSTRATION PURPOSE ONLY. PERMITTING LIMITATIONS OF KETTLE CREEK CAN NOT ALLOW FOR CHANNEL IMPROVEMENTS DUE TO PREBLES MEADOW JUMPING MOUSE HABITAT.

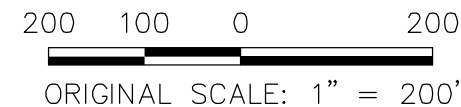
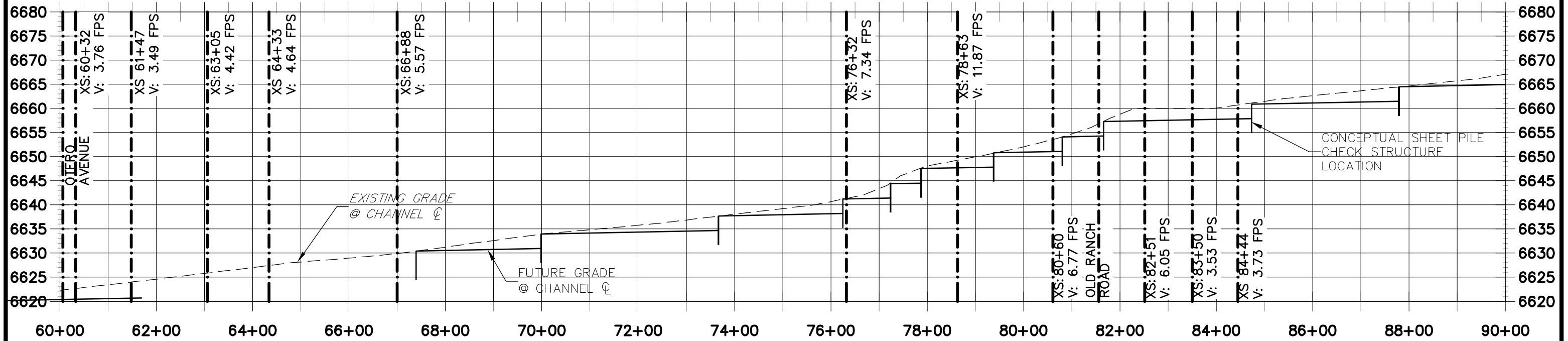

FIGURE 4-8
KETTLE CREEK DBPS
JOB NO. 25100.00
MAY 2015





KETTLE CREEK CL ALIGNMENT (3)
STA 60+00.00 TO 90+00.00

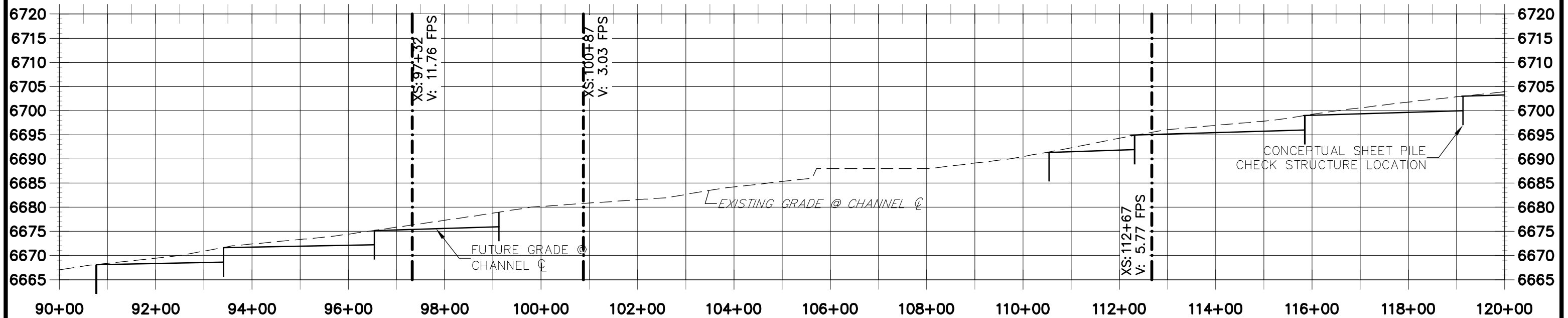

KETTLE CREEK CL ALIGNMENT (4)
STA 90+00.00 TO 120+00.00



LEGEND

-  CONCEPTUAL CHECK STRUCTURE
-  FUTURE STABILIZED GRADE (0.20% GRADE)
-  EXISTING GRADE

NOTE

1. VELOCITY SHOWN ON PROFILES ARE FUTURE FLOWS
2. CHECK STRUCTURES ARE FOR ILLUSTRATION PURPOSE ONLY. PERMITTING LIMITATIONS OF KETTLE CREEK CAN NOT ALLOW FOR CHANNEL IMPROVEMENTS DUE TO PREBLES MEADOW JUMPING MOUSE HABITAT.

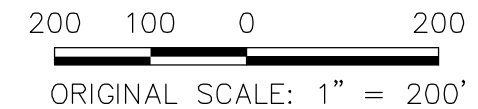
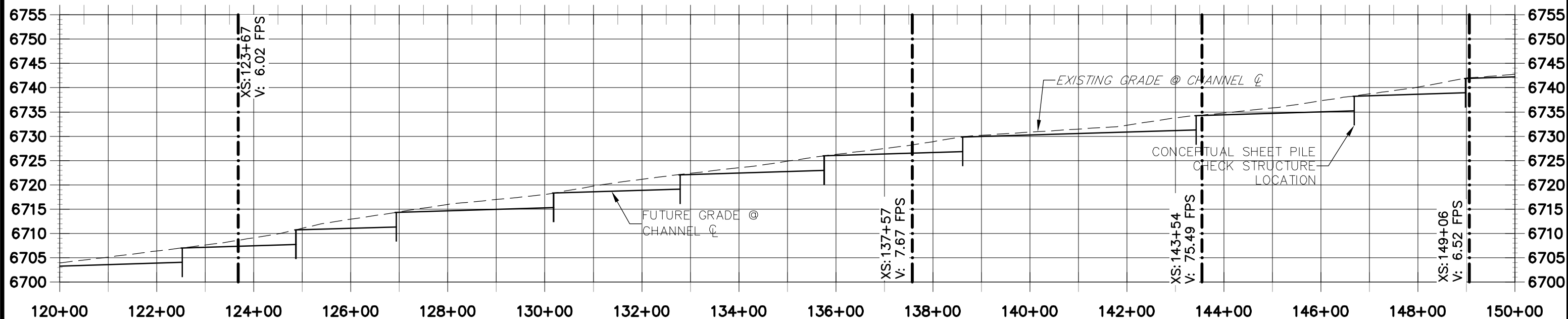

FIGURE 4-9
KETTLE CREEK DBPS
JOB NO. 25100.00
MAY 2015





KETTLE CREEK CL ALIGNMENT (5)
STA 120+00.00 TO 150+00.00

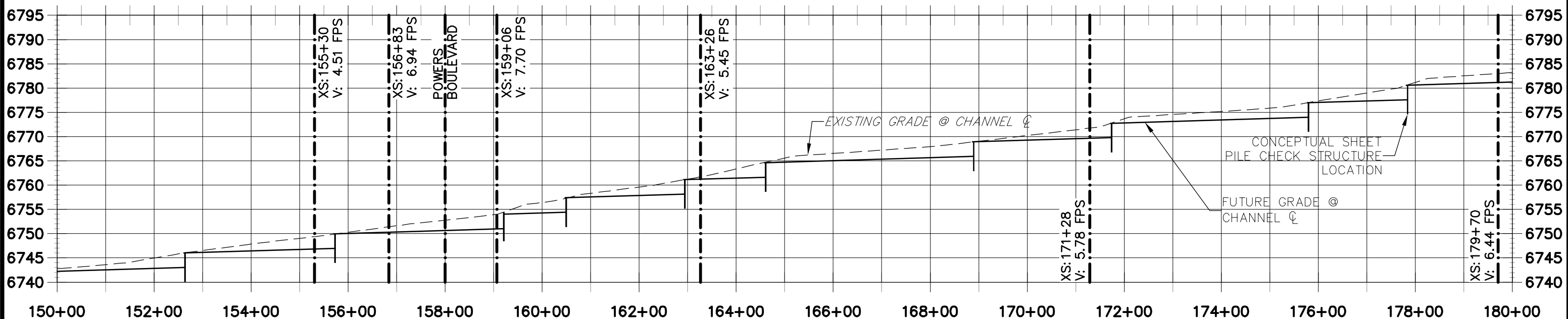

KETTLE CREEK CL ALIGNMENT (6)
STA 150+00.00 TO 180+00.00



LEGEND

-  CONCEPTUAL CHECK STRUCTURE
-  FUTURE STABILIZED GRADE (0.20% GRADE)
-  EXISTING GRADE

NOTE

1. VELOCITY SHOWN ON PROFILES ARE FUTURE FLOWS
2. CHECK STRUCTURES ARE FOR ILLUSTRATION PURPOSE ONLY. PERMITTING LIMITATIONS OF KETTLE CREEK CAN NOT ALLOW FOR CHANNEL IMPROVEMENTS DUE TO PREBLES MEADOW JUMPING MOUSE HABITAT.

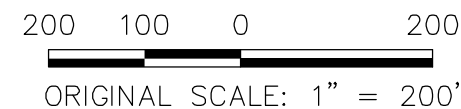
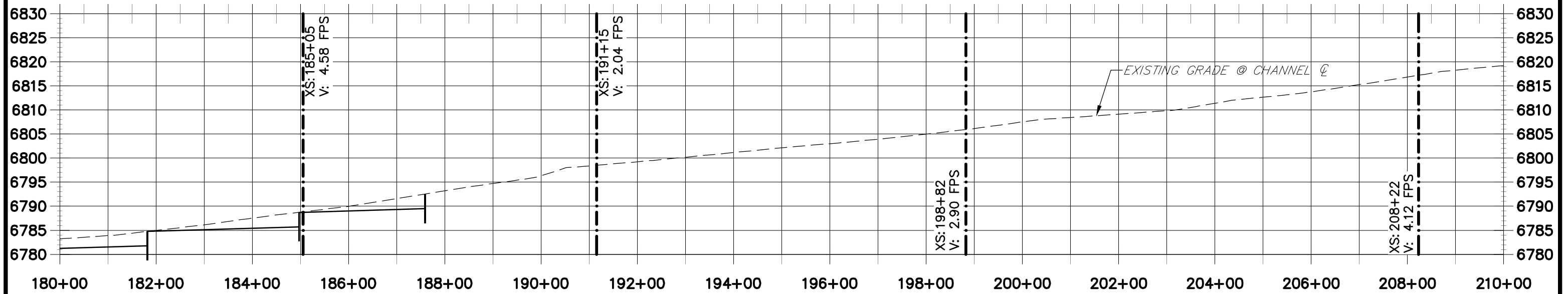

FIGURE 4-10
KETTLE CREEK DBPS
JOB NO. 25100.00
MAY 2015



KETTLE CREEK CL ALIGNMENT (7)
STA 180+00.00 TO 210+00.00



KETTLE CREEK CL ALIGNMENT (8)
STA 210+00.00 TO 240+00.00

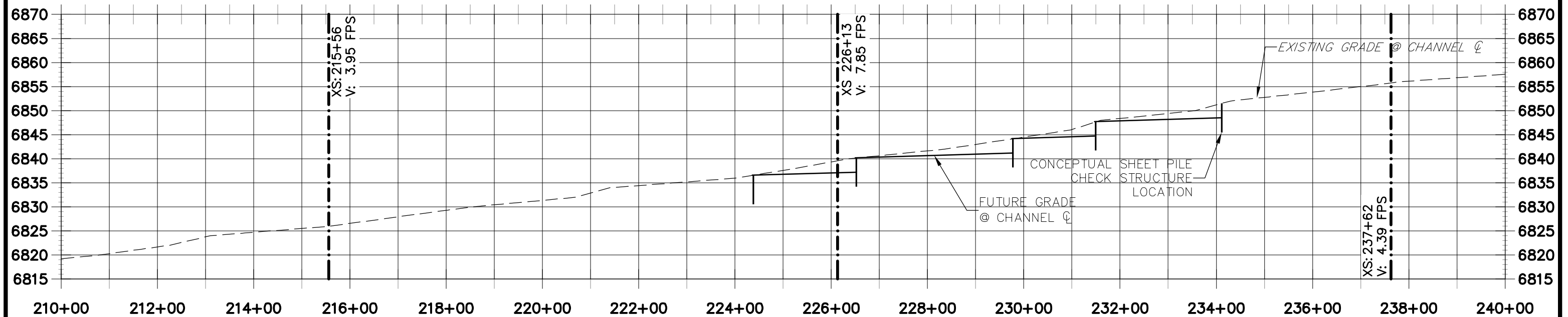

LEGEND

- CONCEPTUAL CHECK STRUCTURE
- FUTURE STABILIZED GRADE (0.20% GRADE)
- EXISTING GRADE

NOTE

1. VELOCITY SHOWN ON PROFILES ARE FUTURE FLOWS
2. CHECK STRUCTURES ARE FOR ILLUSTRATION PURPOSE ONLY. PERMITTING LIMITATIONS OF KETTLE CREEK CAN NOT ALLOW FOR CHANNEL IMPROVEMENTS DUE TO PREBLES MEADOW JUMPING MOUSE HABITAT.

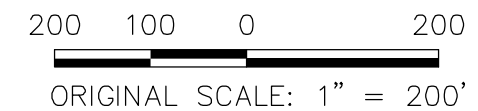

FIGURE 4-11
KETTLE CREEK DBPS
JOB NO. 25100.00
MAY 2015



CONCEPTUAL STABLE CHANNEL
TYPICAL SECTION CALCULATIONS

Design of Trapezoidal Grass-Lined Channel

Project: **Kettle Creek Drainage Basin Planning Study**
Channel ID:

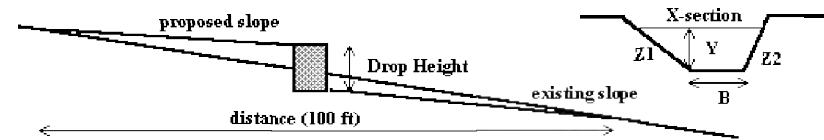

Existing Channel Condition (Input)	
Design Discharge	$Q_D = 1199.00$ cfs
Design Discharge Return Period	Year _D = 5 years
Existing Ground Slope Along Channel Centerline	$S_o = 0.0136$ ft/ft
100-Year Discharge	$Q_{100} = 4152.00$ cfs
Left Side Slope	$Z1 = 4.00$ ft/ft
Right Side Slope	$Z2 = 4.00$ ft/ft
Channel Manning's N (New Condition .030 typ.)	$n_{new} = 0.035$
Channel Manning's N (Mature Condition .040 typ.)	$n_{mature} = 0.035$
Check one of the following soil types	
Sandy Soil	<input checked="" type="checkbox"/> check, OR
Non-Sandy Soil	<input type="checkbox"/> check

Proposed Channel Condition (Calculated)		New Channel	Mature Channel
Bottom Width	$B =$	146.08 ft	146.08 ft
100-Year Flow Depth (5' maximum)	$Y_{100} =$	5.00 ft	5.00 ft
100-Year Flow Velocity	$V_{100} =$	5.00 fps	5.00 fps
100-Year Top Width	$T =$	186.08 ft	186.08 ft
100-Year Flow Area	$A =$	830.40 sq ft	830.40 sq ft
100-Year Froude Number	$Fr =$	0.42	0.42
100-Year Wetted Perimeter	$P =$	187.31 ft	187.31 ft
100-Year Hydraulic Radius	$R =$	4.43 ft	4.43 ft
Design Discharge Flow Depth	$Y_D =$	2.41 ft	2.41 ft
Design Discharge Flow Velocity	$V_D =$	3.19 fps	3.19 fps
Design Discharge Top Width	$T =$	165.38 ft	165.38 ft
Design Discharge Flow Area	$A =$	375.62 sq ft	375.62 sq ft
Design Discharge Froude Number	$Fr =$	0.37	0.37
Design Discharge Wetted Perimeter	$P =$	165.97 ft	165.97 ft
Design Discharge Hydraulic Radius	$R =$	2.26 ft	2.26 ft

Drop Height	
Proposed New Channel Slope	$S_d = 0.0019$ ft/ft
Drop Height per 100 ft	$D = 1.17$ ft/100 ft

KETTLE CREEK CL ALIGNMENT (9)
STA 240+00.00 TO 253+00.00

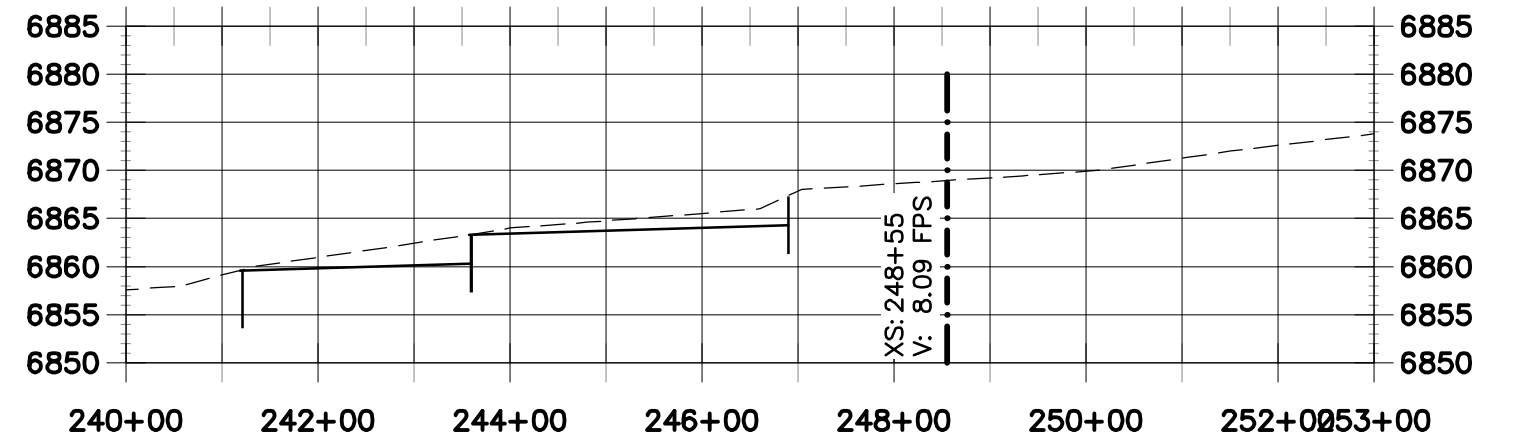

LEGEND

- CONCEPTUAL CHECK STRUCTURE
- FUTURE STABILIZED GRADE (0.20% GRADE)
- EXISTING GRADE

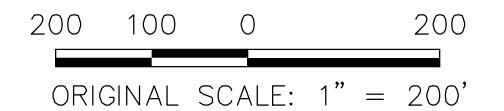

NOTE

1. VELOCITY SHOWN ON PROFILES ARE FUTURE FLOWS
2. CHECK STRUCTURES ARE FOR ILLUSTRATION PURPOSE ONLY. PERMITTING LIMITATIONS OF KETTLE CREEK CAN NOT ALLOW FOR CHANNEL IMPROVEMENTS DUE TO PREBLES MEADOW JUMPING MOUSE HABITAT.

FIGURE 4-12
KETTLE CREEK DBPS
JOB NO. 25100.00
MAY 2015

5 ENVIRONMENTAL EVALUATIONS

5.1 Significant Existing or Potential Wetland and Riparian Areas Impact

The EPA and US Army Corps of Engineers (Corps) defines wetlands as “those areas that are inundated or saturated by surface or ground water at a frequency and duration sufficient to support, and that under normal circumstances do support, a prevalence of vegetation typically adapted for life in saturated soil conditions. Wetlands generally include swamps, marshes, bogs, and similar areas”. Wetlands are areas that are covered by water or have waterlogged soils for long periods during the growing season.

Per the Colorado Division of Wildlife Wetlands Mapping Inventory, Kettle Creek from just upstream of Old Ranch Road to its confluence with Monument Creek is located in a designated Colorado Natural Heritage Program Wetland Conservation Area.

At the time of development planning in the Kettle Creek basin, a Corps Jurisdictional Determination (JD) will need to be requested by the developer to determine if jurisdictional waters of the United States or navigable waters of the United States, or both, are either present or absent on a particular site.

5.1.1 Riparian Areas

Monument Creek and several tributaries, including Kettle Creek, are reported in the Survey of Critical Wetlands and Riparian Areas in El Paso and Pueblo Counties, Colorado, prepared by the Colorado Natural Heritage Program of Colorado State University for the Colorado Department of Natural Resources, dated June 27, 2001. Per the report, the Monument Creek systems has a biodiversity rank of B2 (very high biodiversity significance).

Downstream of the Black Forest, the riparian vegetation is dominated by coyote willow (*Salix exigua*), peachleaf willow (*Salix amygdaloides*), and crack willow (*Salix fragilis*) with scattered stands of narrowleaf cottonwood (*Populus angustifolia*). Also found in these mesic habitats are snowberry (*Symphoricarpos occidentalis*), wild plum (*Prunus americana*), and Russian olive (*Elaeagnus angustifolia*). Stream banks retain native graminoid vegetation in the form of sedges (*Carex* spp.) and rushes (*Juncus* spp.).

Surrounding uplands are generally midgrass prairie that is composed of smooth brome (*Bromopsis inermis*), cheatgrass (*Bromus tectorum*), big bluestem (*Andropogon gerardii*), needle-and-thread (*Stipa comata*), and little blue stem (*Schizachyrium scoparium*). Ponderosa pine (*Pinus ponderosa*) and Gambel's oak (*Quercus gambelii*) occur in patches on either side of Kettle Creek and its tributaries and increase in density at higher elevations in the watershed.

5.1.2 Wildlife

Several hundred birds, mammals, reptiles and amphibians inhabit the Kettle Creek watershed either as year-round residents or seasonally; all of which contribute to the functioning ecosystem as a whole. However, some species are of greater state and federal concern and are therefore either protected or managed for

conservation and sustainability. For the purpose of the environmental evaluation, wildlife species described herein were selected based on regulatory priority.

5.1.2.1 Migratory Birds

The Migratory Bird Treaty Act (MBTA) of 1918, as amended protects the majority of birds in the United States with few exceptions (invasive birds). All active wild bird nests and bird eggs are federally protected under the MBTA. It is also illegal to wound or kill any bird protected by the MBTA except for those managed under regulated hunting seasons. Migratory birds within the Kettle Creek watershed can be found nesting in wetland and riparian areas, grassland/rangelands, forests, and within urban habitats. Migratory birds include perching birds (sparrows, warblers etc.), water fowl, game birds, and raptors (birds of prey).

5.1.2.2 State and Federal Threatened and Endangered Species

The U.S. Fish and Wildlife Service lists ten species as Threatened, Endangered, or Candidate under the Endangered Species Act in El Paso County. The State of Colorado also lists several dozen species as either State Endangered, State Threatened, or State Special Concern. While not federally protected, species of State Special Concern have a higher management priority by the Colorado Division of Wildlife.

The ten species listed under the Endangered Species Act in El Paso County include the Preble's meadow jumping mouse, whooping crane, Mexican spotted owl, piping plover, least tern, greenback cutthroat trout, Pallid sturgeon, Arkansas darter, Western Prairie Fringed Orchid, and Ute-ladies' tresses orchid. Of those species, the Preble's meadow jumping mouse, Mexican spotted owl, and greenback cutthroat trout are the more likely to be encountered. The remaining species may either be found as occasional migrants or are listed for the County based on historical records.

5.1.2.3 Big Game

Big Game distribution within the Kettle Creek drainage basin includes the American black bear (*Ursus americanus*), pronghorn (*Antilocapra americana*), mule deer (*Odocoileus hemionus*), white-tailed deer (*Odocoileus virginianus*), and mountain lion (*puma concolor*). Both the mountain lion and black bear are known to occur in El Paso County and the ponderosa pine forest, riparian corridors, and forested wetlands within the Kettle Creek watershed provide suitable habitat. While it is possible for both species to follow drainages and forested areas from the mountains to the Kettle Creek watershed in search of food, their occurrence in the drainage area is likely uncommon. The drainage area has suitable habitat for elk, but their occurrence is also uncommon in the area. White-tailed deer, mule deer, and pronghorn are common both in El Paso County and within the Kettle Creek area. The construction of roads, water diversion structures, above-ground power lines, residential communities, and commercial sites impacts wildlife by fragmenting their habitat. Fragmentation can prevent animal movement or change movement patterns.

5.1.2.4 Other Significant Wildlife

The Bald and Golden Eagle Protection Act of 1940 provides further protections for eagles. While both Bald and Golden eagles are uncommon to rare in El Paso County, potentially suitable habitat does exist in the Kettle Creek watershed.

5.1.3 Preble's Meadow Jumping Mouse

The Monument Creek site supports an excellent (A-ranked) and a fair (C-ranked) occurrence of the globally and state imperiled Preble's meadow jumping mouse (*Zapus hudsonius preblei*), a species designated as sensitive, as federally threatened, and as a species of special concern. It is estimated that stresses may reduce the viability of the Preble's meadow jumping mice in the potential conservation area if protection action is not taken. Jumping mice have been documented in Kettle Creek outside of the U.S. Air Force Academy boundaries. This potential conservation area is of high significance because it is one of the best-known occurrences of Preble's meadow jumping mice in the Arkansas River drainage. The biggest threat to this conservation area is the encroachment of urban impacts.

The boundaries of the conservation area as presented in the Colorado Natural Heritage Program study were defined based on the presence of Preble's meadow jumping mice throughout the system. The boundary includes 300 meters on either side of the creek. This is designed to include the riparian vegetation and associated upland grass communities that have been documented as part of Preble's meadow jumping mouse habitat. The distance of 300 meters was intended to be conservative, likely including a greater amount of upland habitat than most mice will utilize, but sufficient to entirely cover the jumping mice habitat.

The City's Critical Habitat for the Preble's Meadow Jumping Mouse exhibit (see Appendix B) utilizes the stream width plus 120 meters (394 feet) on each side of the creek for the lower portion of Kettle Creek and tributaries, and the stream width plus 100 meters (361 feet) on each side of the creek for the middle portion of Kettle Creek (from approximately Old Ranch Road into unincorporated El Paso County). This Preble's meadow jumping mouse critical habitat width will dictate limits of development adjacent to Kettle Creek, in conjunction with the findings of geotechnical analyses and detailed hydraulic studies to be provided by each developer.

5.2 Stormwater Quality Considerations

The Colorado Department of Public Health and Environment (CDPHE) Water Quality Division has assembled a list of impaired waters in Colorado that have Total Maximum Daily Load (TMDL) restrictions for certain pollutants as required by Section 303d of the Clean Water Act. Kettle Creek is tributary to Monument Creek, which is tributary to Fountain Creek. Fountain Creek is tributary to the Arkansas River. The Arkansas River has 303d list TMDL restrictions to the state border, and Fountain Creek and Monument Creek are subject to E. coli monitoring and evaluation (CDPHE, 2012). The selenium water quality standard for Fountain Creek has a temporary modification for uncertainty. Kettle Creek and the unnamed tributaries in the Kettle Creek Watershed are not listed and, therefore, are not subject to Section 303d TMDL restrictions.

5.2.1 Hazardous Materials

A search of EPA Superfund sites and National Priorities List sites yielded no sites in the Kettle Creek watershed or in the vicinity of the watershed. Multiple facilities were listed on the EPA Facility Index System/Facility Registry System (FINDS) database in the Kettle Creek watershed, reflecting facilities which are regulated by the EPA but not necessarily in violation.

5.2.2 Water Quality

Water quality treatment shall be required for all stormwater detention basins within the City of Colorado Springs. The City will hold all development tributary to Kettle Creek to USAFA release standards.

5.3 Permitting Requirements

The portions of the Kettle Creek watershed to be developed must comply with all applicable El Paso County, and where applicable, City of Colorado Springs requirements for planning and zoning. A Permit from the Corps will be required to discharge fill or dredged material into jurisdictional waters. Additionally, due to the presence of the Preble's meadow jumping mouse, appropriate permits from the U.S. Fish and Wildlife Service may be required. Ongoing coordination with the U.S. Fish and Wildlife Service will be required to identify outfall points and limits of disturbance. Maintenance of the natural drainageways and features while providing stability for the Kettle Creek channel will be required. City and County review and approval will be necessary at all stages.

6 ALTERNATIVES EVALUATION

6.1 Evaluation Criteria

The purpose of an alternatives analysis for a DBPS is to synthesize the study results and to evaluate detention and reach improvement options. The outcome of detention alternatives and reach alternatives is typically presented at public meetings for shareholder and public discussion. The outcome of this section is a recommended detention alternative and prioritization to be carried forward to the plan development design phase for further analysis.

The full spectrum detention approach, as defined in Chapter 13 of the City Drainage Criteria Manual, shall be implemented as the standard detention approach. A result of full spectrum detention is that discharges from storms smaller than approximately the 2-year event will be reduced to very low flows near or below the sediment carrying threshold value for downstream drainageways. Full spectrum detention provides better control of the full range of runoff rates that pass through detention facilities than the conventional multi-stage concept. This concept also provides some mitigation of increased runoff volumes by releasing a portion of the increased runoff volume at a low rate over an extended period of time (up to 72 hours). The full spectrum detention approach is necessary for development in the Kettle Creek watershed because it reduces the flooding and stream degradation impacts associated with urban development by controlling peak flows in the stream for a wider range of events than traditional multi-stage detention outlet concepts.

6.2 Regional Detention Alternatives

The channel and structure capacities were determined to be sufficient for the historic, existing, and future conditions 100-year flood event, as presented in Section 4. However, it was determined that the existing and future levels of development in the Kettle Creek basin have an appreciable impact on the flow rates compared to historic rates, with potentially adverse impacts of erosion and deposition resulting from the higher flows.

As shown in the hydrologic results, the post-development hydrographs for Kettle Creek leaving the Black Forest reflect significant increases in flow rates. The objective of regional detention at this location is to mitigate impacts to the downstream channel caused by development in the Black Forest. To adjust the Kettle Creek flow rates to historic levels, two regional detention alternatives are viable along with a do-nothing alternative as it relates to regional detention:

- Regional detention upstream of Powers Boulevard within City open space,
- Regional detention upstream of Old Ranch Road within City open space, and
- No new regional detention facilities.

While it has been shown that multiple ponds placed in a parallel configuration (located on tributaries to major drainageways and serving relatively small drainage areas, as opposed to being placed on the major drainageways themselves) provide a better opportunity to accomplish stormwater management goals and results in lower overall system costs, development has taken place in the Black Forest over the last few

decades without stormwater detention considerations and existing land use and ownership makes sub-regional detention in the Black Forest impractical. Therefore, the regional detention alternatives proposed herein are by necessity located downstream of the Black Forest.

Per the City DCM, a regional detention facility should not serve a contributing area larger than 640 acres (one square mile). The design assumptions used to size the facilities, including uniform rainfall and undeveloped allowable release rates become less reliable with larger basins. Larger basins also increase long term sediment loads and maintenance requirements. Limiting the contributing area to 640 acres also reduces the likelihood of the structure being regulated by the State Engineer's Office as a jurisdictional dam. The conceptual alternatives proposed herein would serve a contributing area larger than 640 acres, but the limitations in location for new regional detention facilities in the Black Forest preclude adherence to City and County criteria for the subject regional detention facility alternatives.

The regional detention option upstream of Powers Boulevard would be located within City open space (City of Colorado Springs 2020 Land Use map) and would detain flows from the Black Forest area just inside City limits. This would protect the Kettle Creek drainageway from Powers Boulevard to I-25 by discharging at historic rates.

Regional detention upstream of Old Ranch Road would accomplish the same objective but would make use of more available land (as determined from the City of Colorado Springs 2020 Land Use map). The larger tributary area would result in an overall increase in the storage requirements of the pond.

For both aforementioned regional detention options, off-line storage via a diversion of a portion of the Kettle Creek flows would allow for more usable open space with an attractive, multipurpose facility that is readily maintainable and safe for the public, under both dry and wet conditions. A facility that is located in-line with the drainageway and captures and routes the entire flood hydrograph is feasible, but is less advantageous because an in-line facility must be large enough to handle the total flood volume of the entire tributary catchment.

The do-nothing approach as it relates to regional detention would allow developed conditions discharges from the upper portion of the basin to continue to impact the stability of the channel in the lower reach of Kettle Creek. This alternative would make use of the existing regional detention at I-25 but would not provide any additional flood flow attenuation for managing channel-forming flows or flood flows higher in the watershed. This option may put Kettle Creek at risk for continued erosion, deposition, and flooding. However, the mandatory sub-regional detention approach as described in the following sections would limit discharges from new development to historic rates. Without regional detention higher in the reach, however, the Kettle Creek channel within City of Colorado Springs limits would still be subject to periodic flooding above historic rates caused by development higher in the basin.

The regional detention alternatives presented herein only are considered for the purposes of attenuating developed flow rates. Consideration of regional detention alternatives will have significant environmental impacts as discussed in Section 5. Sub-regional detention alone will not reduce flow rates in Kettle Creek to historic levels, as past development in the upper portion of the basin is a contributing factor to the increased flows under existing conditions. Regional detention must be owned and maintained by a public entity, with ownership and maintenance responsibilities clearly defined to ensure the proper function of the facility in perpetuity.

6.3 Sub-Regional Detention

The anticipated approach is sub-regional detention with full spectrum detention and water quality treatment. Any future development in the Kettle Creek basin within the City of Colorado Springs shall have sub-regional detention for each development/phase. Detention facilities serving drainage basins between 20 and 130 acres are considered “sub-regional detention”. Sub-regional detention may be constructed by a public entity such as a municipality or special district to serve several landowners in the upstream watershed or by a single landowner. It may be possible for a single landowner to construct sub-regional detention if the upper part of the watershed is owned by others and if the necessary conditions are achieved. Sub-regional detention should be addressed in subsequent Master Development Drainage Plans (MDDP) for individual development projects. The ownership and maintenance of these ponds are anticipated to be public or quasi-public. In order to be considered for public maintenance the contributory area shall be in the range of 70-120 acres. A conceptual map illustrating the locations of required sub-regional detention facilities is shown in **Figure 6-1**.

6.3.1 Full Spectrum Detention

The full spectrum detention approach, as defined in Chapter 13 of the DCM, shall be implemented as the standard detention approach. Impervious surfaces associated with development increase peak flows, frequency of runoff and total volume of stormwater surface runoff when compared to pre-development conditions. This increase is most pronounced for the smaller, more frequent storms and can result in stream degradation and water quality impacts as well as flooding during large storm events.

In addition to detaining developed conditions stormwater discharge for flood control and for water quality considerations, it is also important to expand the focus to the range of flows responsible for transporting the most bedload in the receiving stream. This range depends on reach specific characteristics but is between the annual event and the 5-year event. Runoff events in this range can produce geomorphic changes in local receiving streams resulting in severe erosion, loss of riparian habitat, and water quality degradation.

Outflow hydrographs from traditional flood-control detention facilities tend to maintain flows near the maximum release rates for relatively long periods of time. This allows hydrographs released from multiple independent ponds to overlap and add to each other to generate flows exceeding pre-development conditions. Traditional flood-control detention concepts can result in an increase in total watershed discharges even if individual detention facilities each control peak discharges to pre-developed conditions. Full spectrum detention modeling reduces urban runoff peaks to levels similar to pre-development conditions for a wide range of storms over an entire watershed, even with multiple independent detention facilities. A result of full

spectrum detention is that discharges from storms smaller than approximately the 2-year event will be reduced to very low flows near or below the sediment carrying threshold value for downstream drainageways.

6.3.2 Water Quality

Each sub-regional detention pond shall detain flows not only for flood control, but also for water quality. The Water Quality Capture Volume (WQCV) is intended to capture most runoff events and reduce their pollutant load prior to discharging into drainageways. The size of this storage element depends primarily on the amount of tributary impervious area and can be reduced by implementing development practices that reduce the effective imperviousness, discussed in more detail below.

Future development in the basin shall consider other land planning and engineering design approaches to manage stormwater runoff and water quality. Low Impact Development (LID) is a comprehensive approach with the goal of mimicking the pre-development hydrologic regime. LID emphasizes conservation of natural features and use of engineered, on-site, small-scale hydrologic controls that infiltrate, filter, store, evaporate, and detain runoff close to its source. Portions of the site that aid in reducing the developed conditions discharge should be preserved, which may include mature trees, stream corridors, wetlands, and NRCS Type A/B soils with higher infiltration rates.

Minimizing Directly Connected Impervious Area (MDCIA) includes a variety of runoff reduction strategies based on reducing impervious areas and routing runoff from impervious surfaces over grassy areas to slow runoff and promote infiltration. MDCIA is a technique for reducing runoff peaks and volumes following urbanization. Paved areas can be reduced in extent to the minimum amount practical, and implement methods to route runoff over grassed areas rather than directly into storm sewer. When soils vary over the site, concentrate new impervious areas over NRCS Type C and D soils, while preserving NRCS Type A and B soils for landscape areas and other permeable surfaces. Increasing the number and lengths of flow paths will all reduce the impact of the development.

Volume reduction is a key hydrologic objective, as opposed to peak flow reduction being the only objective. Volume reduction is emphasized not only to reduce pollutant loading and peak flows, but also to move toward hydrologic regimes with flow durations and frequencies closer to the natural hydrologic regime.

6.4 Limited Channel Stabilization Alternative

Channel improvements may be necessary in the main study reach of Kettle Creek to limit erosion and deposition resulting from high velocities as determined in Section 4. However, grading and grade control structures may not be feasible in Kettle Creek due to the disturbance they would cause with the presence of the Preble’s meadow jumping mouse. Conceptual check structure placement is provided for reference, should grade control structures become an option in the future.

The locations of these conceptual check structures were determined by areas where mean channel velocities exceeded 5 feet per second for the 100-year event. Future grade between check structures was estimated to stabilize at approximately 0.20 percent. Check structure placement was shown to lower velocities above 5

feet per second and to stabilize the channel. Channel improvements may be determined to be necessary in locations where public or private facilities would be in danger if the creek migrates.

LEGEND

- JOVENCHI-I LLC
- 260 EB LLC
- HIGH VALLEY LAND COMPANY INC
- KETTLE CREEK LLC & VENEZIA JOHN FAMILY TRUST
- ① ESTIMATED LOCATION OF PROPOSED SUBREGIONAL PONDS
- EXISTING LOCATION OF SUBREGIONAL PONDS
- KETTLE CREEK BASIN BOUNDARY

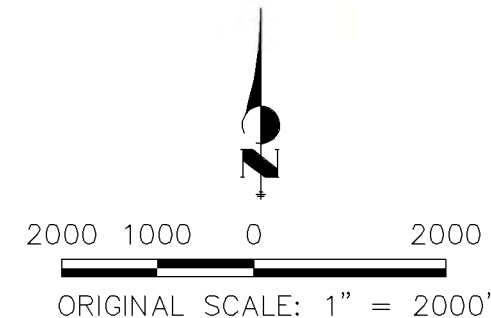
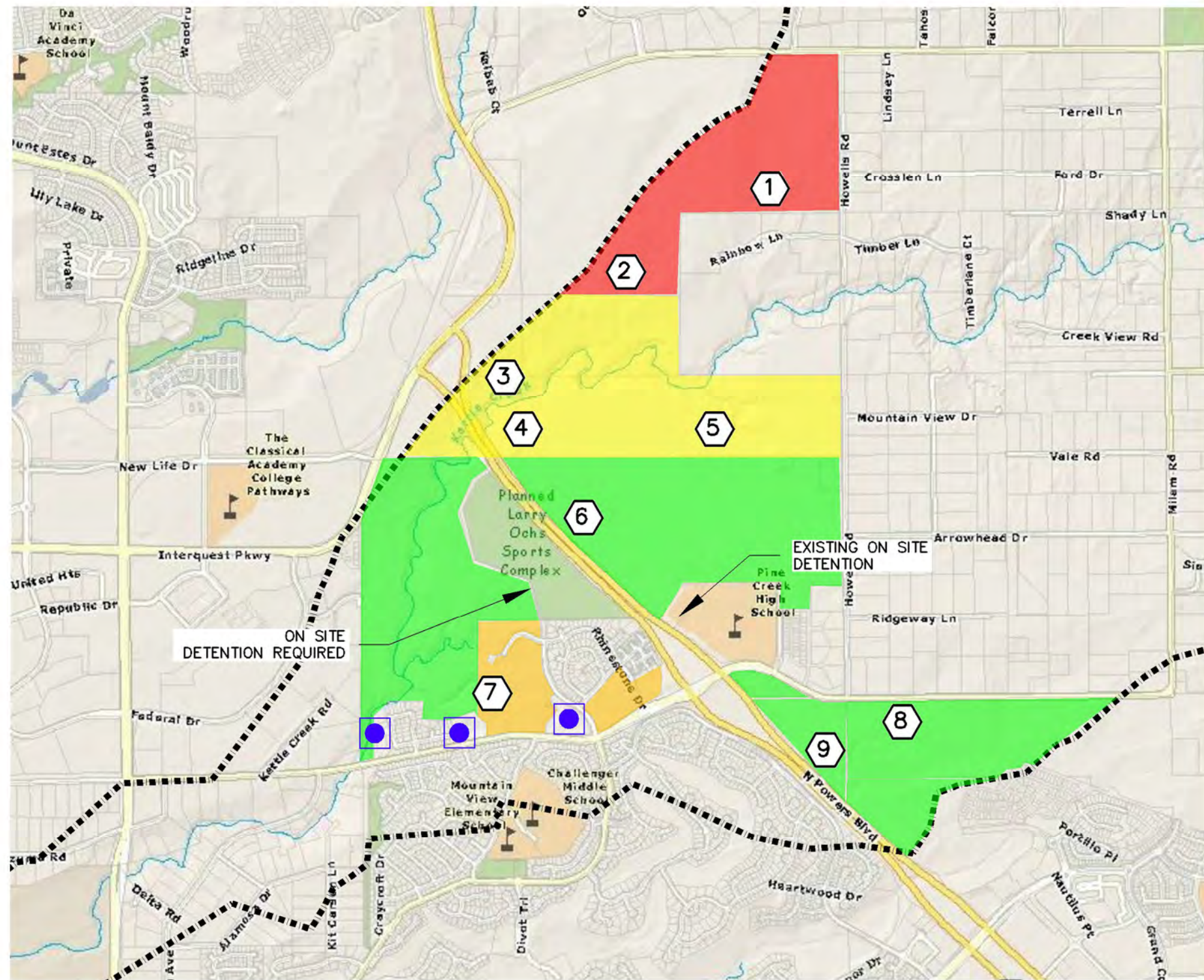

FIGURE 6-1
 SUBREGIONAL POND
 LOCATIONS
 KETTLE CREEK DBPS
 JOB NO. 25100.00
 MAY 2015

7 SELECTED PLAN

The anticipated approach is sub-regional detention with water quality treatment. Any future development in the Kettle Creek basin within the City of Colorado Springs shall have sub-regional detention for each development/phase. No regional detention is considered at this time.

Water quality treatment shall be required for all stormwater detention basins within the City of Colorado Springs. The City will hold all development tributary to Kettle Creek to USAFA release standards.

8 FEE DEVELOPMENT

8.1 General

The objective of the fee development exercise is to determine the equitable share of drainage improvement costs that a developer is responsible for paying to the City of Colorado Springs if they wish to plat a property. The end product of this section is typically a unit fee (cost/acre) that is a one-time charge to the developer for their portion of the reimbursable infrastructure. In the case of Kettle Creek it is expected that no drainage fees will be required and will be considered a closed basin

The City of Colorado Springs map “City of Colorado Springs Fee Basins” shows Kettle Creek as “misc. – unstudied”. There has been a master development drainage report completed on a portion of Kettle Creek, which is currently a closed subbasin with no City drainage, bridge, or detention/land fees and no reimbursement for constructed improvements. El Paso County assesses an \$8,100 drainage basin fee for development in the Kettle Creek basin.

8.2 Developable Land

The Kettle Creek watershed has a total area of 10,506 acres. The majority of the watershed is within El Paso County 8,500 acres, with only approximately 1,253 acres of City land unplatted, according to calculations taken from the County Assessor’s site. This land calculation also includes unplatted areas that cannot be developed because of specific land use designations. A complete summary of unplatted area land use is provided in **Appendix E**.

Classification	Area (ac)
Unplatted	1,253

8.3 Fee Calculation

The Kettle Creek Drainage Basin Old Ranch Road Tributary Drainage Basin Planning Study and Master Development Drainage Plan, prepared by JR Engineering April 2001 (Kettle Creek MDDP/DBPS), states that the MDDP/DBPS study area is a closed basin. Developers of the properties within the MDDP/DBPS subbasin study are responsible for construction of the drainage improvements. This existing closed basin area can be seen in **Appendix F**.

For all other undeveloped land, shown in **Appendix E**, developers will have direct access to Kettle Creek, and do not have upstream neighboring properties that will require additional infrastructure with the exception of parcel owned by 260 EB, LLC. All undeveloped property within the Kettle Creek basin will not be required to pay drainage fees and will not be reimbursed for any drainage infrastructure required for development.

After analyzing the parcel of land owned by 260 EB LLC, it is found that a subbasin boundary runs through the middle of the property. Because of this, approximately 47 acres of the 180 total acres will flow onto the Jovenchi-I LLC property to the south. The 260 EB, LLC property will be required to detain their developed flows to historic levels in conformance with drainage criteria. Jovenchi-I LLC will have to accommodate the undeveloped (historic) flows from 260 EB, LLC (see Appendix F). The 260 EB, LLC developed flows will be detained in the proposed Pond 2. If necessary, the owners of 260 EB, LLC and Jovenchi-I, LLC will need to work cooperatively to determine an outfall point for the proposed Pond 2. Furthermore, they may opt to work together to combine Pond 2 and Pond 3 by allowing developed flows to pass through the downstream property and locating the combined pond at the site of Pond 3.

With the anticipated approach of having sub-regional detention for any future development in the Kettle Creek basin within the City of Colorado Springs, it is anticipated that the developed runoff from 260 EB, LLC will not generate enough stormwater runoff to necessitate the Jovenchi-I LLC development to construct reimbursable infrastructure. The remaining 133 acres from the 260 EB, LLC property will be required to detain to historic rates prior to the release onto platted county property.

It is proposed that the study area be considered a closed drainage basin. As a closed basin, development would not be required to pay drainage fees. The landowners/developers will not be reimbursed for the construction of these facilities and thus the financial implications to the City are negligible.

9 REFERENCES

Amendment No. 2 To Pine Creek Drainage Basin Planning Study And Master Development Drainage Plan For Pine Creek Subdivision (Portion Contributing to Pine Creek), JR Engineering, October 1998.

Black Forest Quadrangle, Colorado-El Paso Co.; U.S. Department of the Interior U.S. Geological Survey, 2013.

Black Forest Regional Park Forestry and Noxious Weed Management Plan; Mountain High Tree, Inc., 2010.

Briargate Master Plan; DHM Design, June 18, 2007.

City of Colorado Springs Fee Basins; Colorado Springs Public Works - City Engineering, 2001.

City of Colorado Springs 2020 Land Use; City of Colorado Springs, January 2014.

Colorado's Section 303(d) List of Impaired Waters; Colorado Department of Public Health and Environment Water Quality Control Commission 5 CCR 1002-93 Regulation #93, March 2012.

Drainage Criteria Manual, Volume 1; City of Colorado Springs, March 2013.

Envirofacts Search Results Envirofacts; US EPA.

Final Drainage Report for "Briargate Crossing East Filing No. 2" – Pine Creek Drainage Basin, Matrix Design Group, Inc., Revised October 2006.

Final Drainage Report for "Cordera Filing No. 3A" & Master Development Drainage Plan – Cordera Filing No. 3 – Pine Creek & Kettle Creek Drainage Basins; Matrix Design Group, Inc., October 2007.

Flood Insurance Study: El Paso County Colorado and Incorporated Areas, Volumes 1-4, Rev. ed. GPO Publications No. 1999-454-605/00106. Federal Emergency Management Agency, 1999.

Flood Insurance Rate Map Number 08041C0315 F (Panels 295, 315) El Paso County and Incorporated Areas; Federal Emergency Management Agency, March 17, 1997.

Flood Insurance Rate Map Number 08041C0506 F (Panels 506, 507) El Paso County and Incorporated Areas; Federal Emergency Management Agency, March 17, 1997.

Fountain Creek Watershed Study; U.S. Army Corps of Engineers January 2009.

HEC-RAS River Analysis System Hydraulic Reference Manual Version 4.1; US Army Corps of Engineers, January 2010.

Hydrologic Modeling System HEC-HMS User's Manual Version 4.0; US Army Corps of Engineers, December 2013

Kettle Creek Watershed Hydrology Study; Air Force Civil Engineer Center, April 2002

Kettle Creek Drainage Basin Old Ranch Road Tributary Drainage Basin Planning Study and Master Development Drainage Plan; April 2001, JR Engineering.

Land Use Compatibility Analysis and Watershed Growth Analysis Study; Pikes Peak Area Council of Governments, 2004.

Low Effect Habitat Conservation Plan for Preble's Meadow Jumping Mouse on the Kettle Creek Ranch, El Paso County, Colorado; SWCA Environmental Consultants, August 2012.

Master Development Drainage Plan For North Fork at Briargate; May, 2014, JR Engineering.

Permanent Stormwater Quality Report, I-25 North Design Build, El Paso County, Colorado; RESPEC Engineering, August 2012.

Pikeview Quadrangle, Colorado-El Paso Co.; U.S. Department of the Interior U.S. Geological Survey, 2013.

Soil Report for El Paso County, Colorado; United States Department of Agriculture, Natural Resources Conservation Service, December 2013.

Survey of Critical Wetlands and Riparian Areas in El Paso and Pueblo Counties; Colorado; Colorado Natural Heritage Program, June 2001.

Urban Storm Drainage Criteria Manual; Urban Drainage and Flood Control District, June 2001, revised April 2008.

U.S. Air Force Academy Kettle Creek Watershed Hydrology Study Findings and Recommendations Report; URS Group, Inc., March 2002.

Zone Map (Map Numbers 522, 613, 621, 623, 624); El Paso County Development Services Department, March 2012.

Appendix A – Stakeholder Meeting Summaries

-No Stakeholder Meetings Required

Appendix B – Hydrologic Calculations and Data

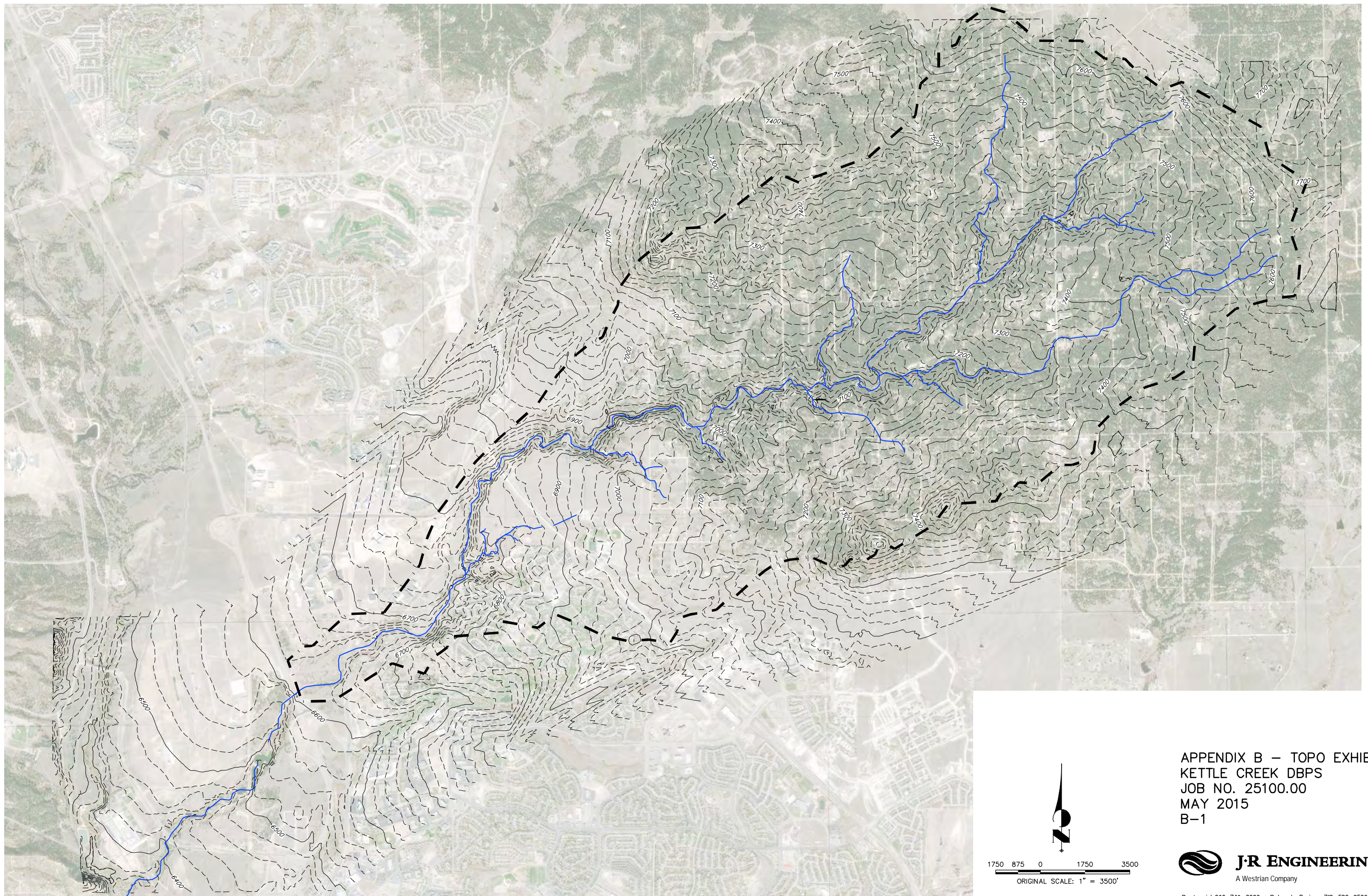

APPENDIX B – TOPO EXHIBIT
KETTLE CREEK DBPS
JOB NO. 25100.00
MAY 2015
B-1

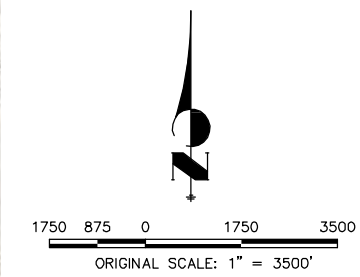

 **J-R ENGINEERING**
A Westrian Company

Centennial 303-740-9393 • Colorado Springs 719-593-2593
Fort Collins 970-491-9888 • www.jrengineering.com

**Depth-Duration-Frequency and Intensity-Duration-Frequency
Tables for Colorado Hydrologic Zones 1 through 4**

**Depth-Duration-Frequency and Intensity-Duration-Frequency
Tables for Colorado Hydrologic Zones 1 through 4**

Blue cells are inputs.

Project: Kettle Creek DBPS - Lower Sub-Basins

Where is the Watershed Located?

- Located within UDFCD Boundary
- Located outside of UDFCD Boundary

Hydrologic Zone (1, 2, 3, or 4) = (see map)
 Elevation at Center of Watershed = ft
 Watershed Area (Optional) = sq. mi.

(Optional) Select a location within the UDFCD boundary:

1. Rainfall Depth-Duration-Frequency Table

If within the UDFCD Boundary, Enter the 1-hour and 6-hour rainfall depths from the USDCM Volume 1.
 Otherwise, Enter the 6-hour and 24-hour rainfall depths from the NOAA Atlas 2 Volume III.

Return Period	Rainfall Depth in Inches at Time Duration								
	5-min	10-min	15-min	30-min	1-hr	2-hr	3-hr	6-hr	24-hr
2-yr	0.34	0.54	0.68	0.78	1.19	1.37	1.50	1.70	2.10
5-yr	0.43	0.68	0.86	1.00	1.52	1.72	1.87	2.10	2.70
10-yr	0.49	0.78	0.98	1.14	1.73	1.96	2.13	2.40	3.20
25-yr	0.57	0.90	1.14	1.31	2.00	2.31	2.54	2.90	3.60
50-yr	0.64	1.02	1.28	1.48	2.26	2.58	2.82	3.20	4.20
100-yr	0.71	1.13	1.42	1.64	2.50	2.84	3.10	3.50	4.60
500-yr	0.85	1.36	1.71	1.98	3.01	3.44	3.76	4.27	5.61

Note: Refer to Figures 4-1 through 4-12 of USDCM Volume 1 for 1-hr and 6-hr rainfall depths.
 Refer to NOAA Atlas 2 Volume III isopleth maps for 6-hr and 24-hr rainfall depths.
 Rainfall depths for durations less than 1-hr are calculated using Equation 4-4 in USDCM Volume 1.

2. Rainfall Intensity-Duration-Frequency Table

Return Period	Rainfall Intensity in Inches Per Hour at Time Duration								
	5-min	10-min	15-min	30-min	1-hr	2-hr	3-hr	6-hr	24-hr
2-yr	4.05	3.23	2.71	1.87	1.19	0.74	0.55	0.33	0.11
5-yr	5.15	4.11	3.45	2.38	1.52	0.94	0.70	0.41	0.14
10-yr	5.88	4.69	3.93	2.72	1.73	1.08	0.80	0.47	0.16
25-yr	6.79	5.42	4.55	3.14	2.00	1.24	0.92	0.55	0.19
50-yr	7.66	6.11	5.12	3.54	2.26	1.40	1.04	0.62	0.21
100-yr	8.47	6.75	5.67	3.92	2.50	1.55	1.15	0.68	0.23
500-yr	10.22	8.15	6.84	4.73	3.01	1.87	1.39	0.82	0.28

Note: Intensity approximated using 1-hr rainfall depths and Equation 4-3 in USDCM Volume 1.

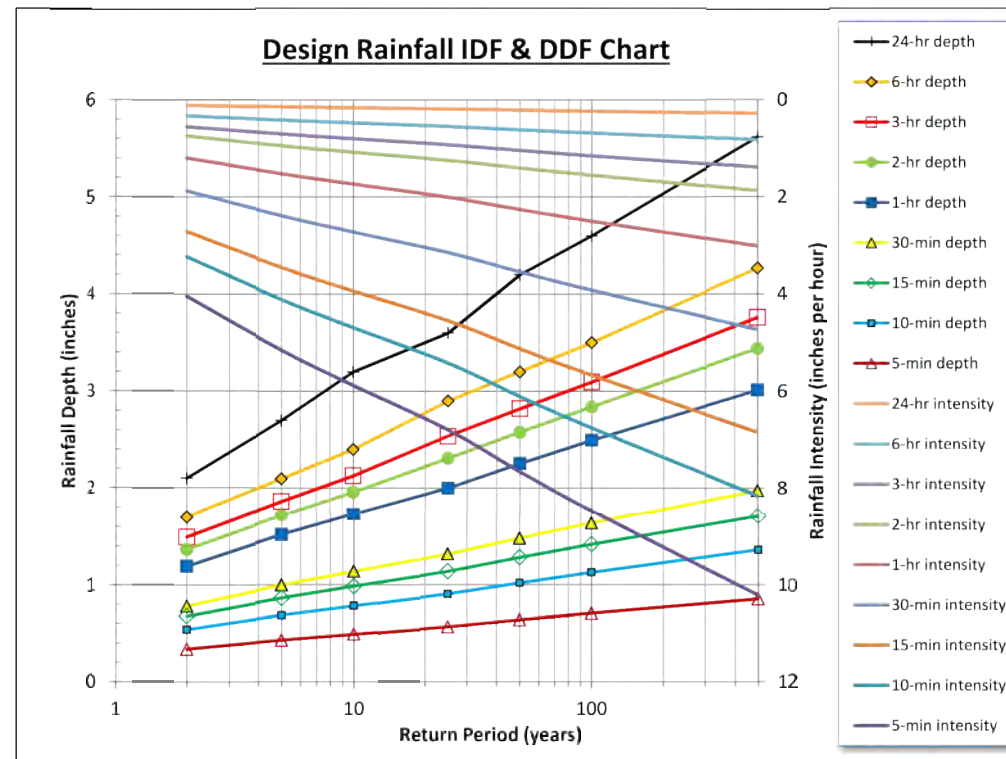
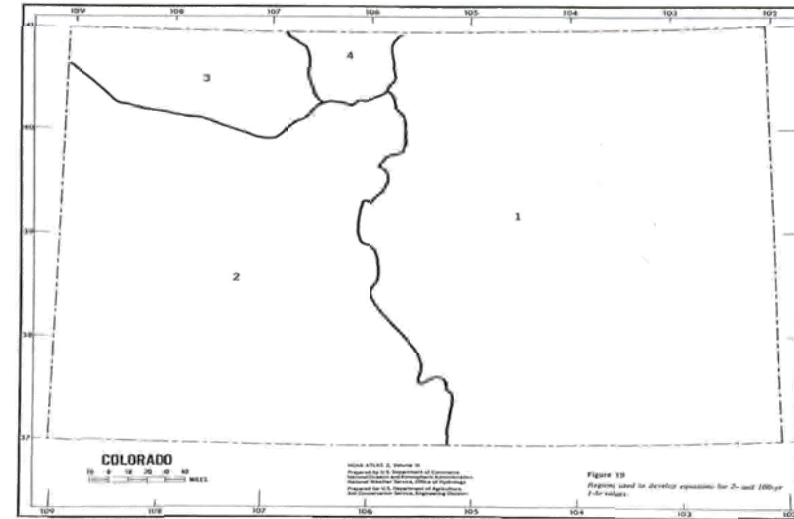

2-Hour Design Storm Distribution

Time	Fraction of 1-Hour Rainfall Depth*
0:00	0.000
0:05	0.014
0:10	0.046
0:15	0.079
0:20	0.120
0:25	0.179
0:30	0.258
0:35	0.421
0:40	0.712
0:45	0.824
0:50	0.892
0:55	0.935
1:00	0.972
1:05	1.004
1:10	1.018
1:15	1.030
1:20	1.041
1:25	1.052
1:30	1.063
1:35	1.072
1:40	1.082
1:45	1.091
1:50	1.100
1:55	1.109
2:00	1.119

NRCS 24-Hour Design Storm Distribution, <10mi²

Time	Fraction of 24-Hour Rainfall Depth*	Time	Fraction of 24-Hour Rainfall Depth*	Time	Fraction of 24-Hour Rainfall Depth*	Time	Fraction of 24-Hour Rainfall Depth*
0:00	0.0000	6:15	0.0850	12:30	0.7350	18:45	0.9340
0:15	0.0020	6:30	0.0900	12:45	0.7580	19:00	0.9380
0:30	0.0050	6:45	0.0950	13:00	0.7760	19:15	0.9420
0:45	0.0080	7:00	0.1000	13:15	0.7910	19:30	0.9460
1:00	0.0110	7:15	0.1050	13:30	0.8040	19:45	0.9500
1:15	0.0140	7:30	0.1100	13:45	0.8150	20:00	0.9530
1:30	0.0170	7:45	0.1150	14:00	0.8250	20:15	0.9560
1:45	0.0200	8:00	0.1200	14:15	0.8340	20:30	0.9590
2:00	0.0230	8:15	0.1260	14:30	0.8420	20:45	0.9620
2:15	0.0260	8:30	0.1330	14:45	0.8490	21:00	0.9650
2:30	0.0290	8:45	0.1400	15:00	0.8560	21:15	0.9680
2:45	0.0320	9:00	0.1470	15:15	0.8630	21:30	0.9710
3:00	0.0350	9:15	0.1550	15:30	0.8690	21:45	0.9740
3:15	0.0380	9:30	0.1630	15:45	0.8750	22:00	0.9770
3:30	0.0410	9:45	0.1720	16:00	0.8810	22:15	0.9800
3:45	0.0440	10:00	0.1810	16:15	0.8870	22:30	0.9830
4:00	0.0480	10:15	0.1910	16:30	0.8930	22:45	0.9860
4:15	0.0520	10:30	0.2030	16:45	0.8980	23:00	0.9890
4:30	0.0560	10:45	0.2180	17:00	0.9030	23:15	0.9920
4:45	0.0600	11:00	0.2360	17:15	0.9080	23:30	0.9950
5:00	0.0604	11:15	0.2570	17:30	0.9130	23:45	0.9980
5:15	0.0680	11:30	0.2830	17:45	0.9180	24:00	1.0000
5:30	0.0720	11:45	0.3870	18:00	0.9220		
5:45	0.0760	12:00	0.6630	18:15	0.9260		
6:00	0.0800	12:15	0.7070	18:30	0.9300		

APPENDIX B – DESIGN STORM
 DISTRIBUTION DATA
 KETTLE CREEK DBPS
 JOB NO. 25100.00
 MAY 2015
 B-3



	Thunderstrom Analysis	Frontal Analysis
	z=7120'	z=7415'
Return Period (Year)	1-Hour Depth (Inches)	24-Hour Depth (Inches)
2	1.19	2.10

Cumulative Rainfall Depth									
2-Hour Design Storm		24-Hour Design Storm							
Time (5 min)	Cumulative 2-Hour Depth (in)	Time (15 min)	Cumulative 24-Hour Depth (in)	Time (15 min)	Cumulative 24-Hour Depth (in)	Time (15 min)	Cumulative 24-Hour Depth (in)	Time (15 min)	Cumulative 24-Hour Depth (in)
0:00	0.000	0:00	0.000	6:00	0.168	12:00	1.392	18:00	1.936
0:05	0.017	0:15	0.004	6:15	0.179	12:15	1.485	18:15	1.945
0:10	0.055	0:30	0.011	6:30	0.189	12:30	1.544	18:30	1.953
0:15	0.094	0:45	0.017	6:45	0.200	12:45	1.592	18:45	1.961
0:20	0.143	1:00	0.023	7:00	0.210	13:00	1.630	19:00	1.970
0:25	0.213	1:15	0.029	7:15	0.221	13:15	1.661	19:15	1.978
0:30	0.307	1:30	0.036	7:30	0.231	13:30	1.688	19:30	1.987
0:35	0.501	1:45	0.042	7:45	0.242	13:45	1.712	19:45	1.995
0:40	0.847	2:00	0.048	8:00	0.252	14:00	1.733	20:00	2.001
0:45	0.981	2:15	0.055	8:15	0.265	14:15	1.751	20:15	2.008
0:50	1.061	2:30	0.061	8:30	0.279	14:30	1.768	20:30	2.014
0:55	1.113	2:45	0.067	8:45	0.294	14:45	1.783	20:45	2.020
1:00	1.157	3:00	0.074	9:00	0.309	15:00	1.798	21:00	2.027
1:05	1.195	3:15	0.080	9:15	0.326	15:15	1.812	21:15	2.033
1:10	1.211	3:30	0.086	9:30	0.342	15:30	1.825	21:30	2.039
1:15	1.226	3:45	0.092	9:45	0.361	15:45	1.838	21:45	2.045
1:20	1.239	4:00	0.101	10:00	0.380	16:00	1.850	22:00	2.052
1:25	1.252	4:15	0.109	10:15	0.401	16:15	1.863	22:15	2.058
1:30	1.265	4:30	0.118	10:30	0.426	16:30	1.875	22:30	2.064
1:35	1.276	4:45	0.126	10:45	0.458	16:45	1.886	22:45	2.071
1:40	1.288	5:00	0.127	11:00	0.496	17:00	1.896	23:00	2.077
1:45	1.298	5:15	0.143	11:15	0.540	17:15	1.907	23:15	2.083
1:50	1.309	5:30	0.151	11:30	0.594	17:30	1.917	23:30	2.090
1:55	1.320	5:45	0.160	11:45	0.813	17:45	1.928	23:45	2.096
2:00	1.332								

*DARFs not used for sub-basins (<1 sq mi).

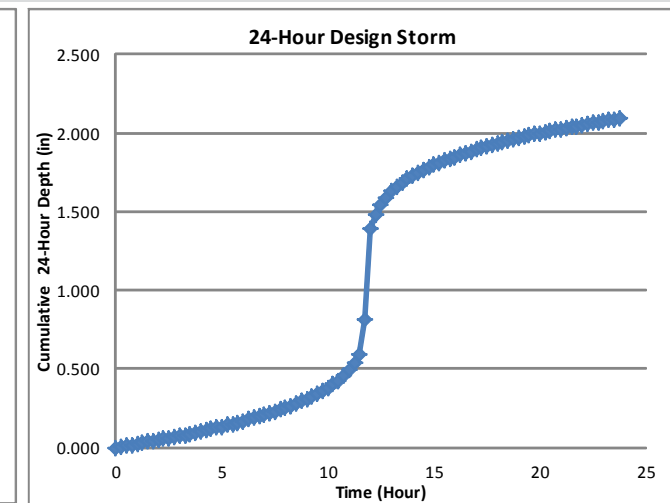
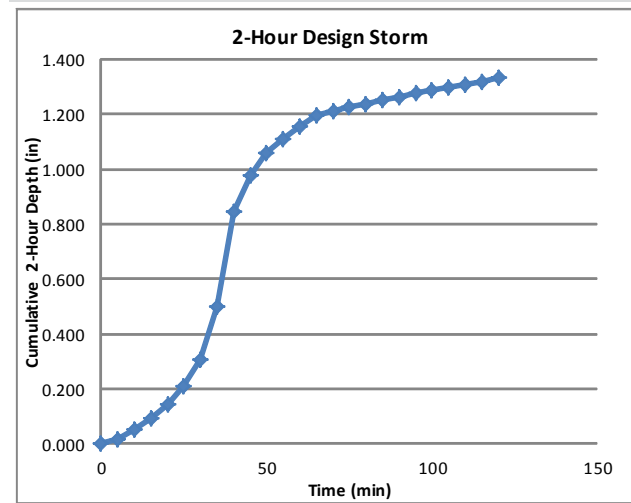

	Thunderstrom Analysis	Frontal Analysis
	z=7120'	z=7415'
Return Period (Year)	1-Hour Depth (Inches)	24-Hour Depth (Inches)
5	1.51	2.70

Cumulative Rainfall Depth									
2-Hour Design Storm		24-Hour Design Storm							
Time (5 min)	Cumulative 2-Hour Depth (in)	Time (15 min)	Cumulative 24-Hour Depth (in)	Time (15 min)	Cumulative 24-Hour Depth (in)	Time (15 min)	Cumulative 24-Hour Depth (in)	Time (15 min)	Cumulative 24-Hour Depth (in)
0:00	0.000	0:00	0.000	6:00	0.216	12:00	1.790	18:00	2.489
0:05	0.021	0:15	0.005	6:15	0.230	12:15	1.909	18:15	2.500
0:10	0.069	0:30	0.014	6:30	0.243	12:30	1.985	18:30	2.511
0:15	0.119	0:45	0.022	6:45	0.257	12:45	2.047	18:45	2.522
0:20	0.181	1:00	0.030	7:00	0.270	13:00	2.095	19:00	2.533
0:25	0.270	1:15	0.038	7:15	0.284	13:15	2.136	19:15	2.543
0:30	0.390	1:30	0.046	7:30	0.297	13:30	2.171	19:30	2.554
0:35	0.636	1:45	0.054	7:45	0.311	13:45	2.201	19:45	2.565
0:40	1.075	2:00	0.062	8:00	0.324	14:00	2.228	20:00	2.573
0:45	1.244	2:15	0.070	8:15	0.340	14:15	2.252	20:15	2.581
0:50	1.347	2:30	0.078	8:30	0.359	14:30	2.273	20:30	2.589
0:55	1.412	2:45	0.086	8:45	0.378	14:45	2.292	20:45	2.597
1:00	1.468	3:00	0.095	9:00	0.397	15:00	2.311	21:00	2.606
1:05	1.516	3:15	0.103	9:15	0.419	15:15	2.330	21:15	2.614
1:10	1.537	3:30	0.111	9:30	0.440	15:30	2.346	21:30	2.622
1:15	1.555	3:45	0.119	9:45	0.464	15:45	2.363	21:45	2.630
1:20	1.572	4:00	0.130	10:00	0.489	16:00	2.379	22:00	2.638
1:25	1.589	4:15	0.140	10:15	0.516	16:15	2.395	22:15	2.646
1:30	1.605	4:30	0.151	10:30	0.548	16:30	2.411	22:30	2.654
1:35	1.619	4:45	0.162	10:45	0.589	16:45	2.425	22:45	2.662
1:40	1.634	5:00	0.163	11:00	0.637	17:00	2.438	23:00	2.670
1:45	1.647	5:15	0.184	11:15	0.694	17:15	2.452	23:15	2.678
1:50	1.661	5:30	0.194	11:30	0.764	17:30	2.465	23:30	2.687
1:55	1.675	5:45	0.205	11:45	1.045	17:45	2.479	23:45	2.695
2:00	1.690								

*DARFs not used for sub-basins (<1 sq mi).

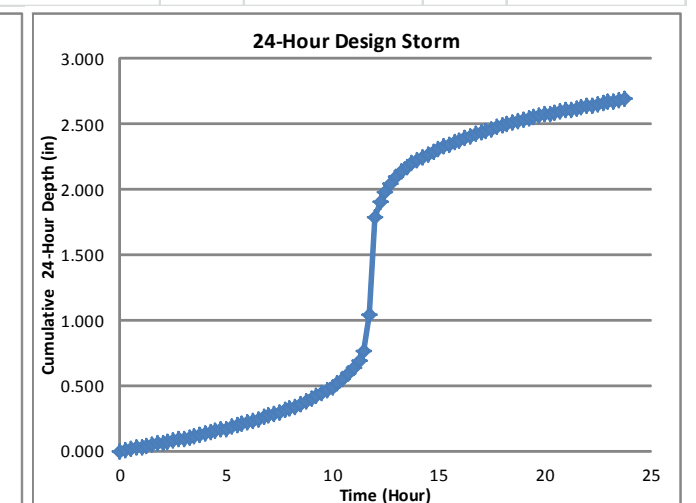
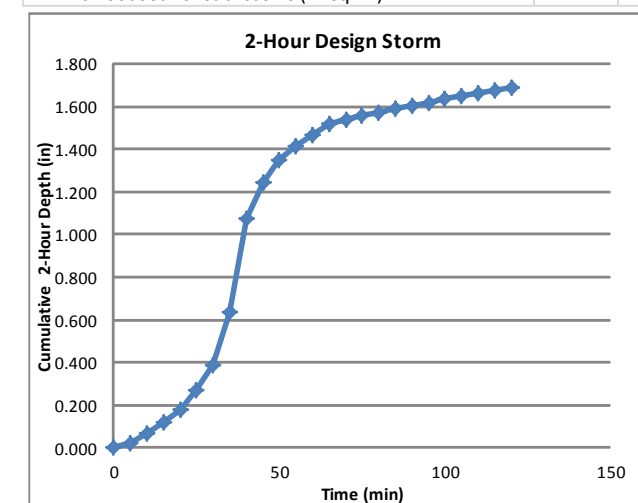

HYDROLOGIC DATA – DESIGN
STORM 2 & 5 YR
KETTLE CREEK DBPS
JOB NO. 25100.00
MAY 2015
B-4



Centennial 303-740-9393 • Colorado Springs 719-593-2593
Fort Collins 970-491-9888 • www.jrengineering.com

	Thunderstrom Analysis	Frontal Analysis
	z=7120'	z=7415'
Return Period (Year)	1-Hour Depth (Inches)	24-Hour Depth (Inches)
10	1.72	3.20

Cumulative Rainfall Depth									
2-Hour Design Storm		24-Hour Design Storm							
Time	Cumulative	Time	Cumulative	Time	Cumulative	Time	Cumulative	Time	Cumulative
(5 min)	2-Hour Depth (in)	(15 min)	24-Hour Depth (in)	(15 min)	24-Hour Depth (in)	(15 min)	24-Hour Depth (in)	(15 min)	24-Hour Depth (in)
0:00	0.000	0:00	0.000	6:00	0.256	12:00	2.122	18:00	2.950
0:05	0.024	0:15	0.006	6:15	0.272	12:15	2.262	18:15	2.963
0:10	0.079	0:30	0.016	6:30	0.288	12:30	2.352	18:30	2.976
0:15	0.136	0:45	0.026	6:45	0.304	12:45	2.426	18:45	2.989
0:20	0.206	1:00	0.035	7:00	0.320	13:00	2.483	19:00	3.002
0:25	0.308	1:15	0.045	7:15	0.336	13:15	2.531	19:15	3.014
0:30	0.444	1:30	0.054	7:30	0.352	13:30	2.573	19:30	3.027
0:35	0.724	1:45	0.064	7:45	0.368	13:45	2.608	19:45	3.040
0:40	1.225	2:00	0.074	8:00	0.384	14:00	2.640	20:00	3.050
0:45	1.417	2:15	0.083	8:15	0.403	14:15	2.669	20:15	3.059
0:50	1.534	2:30	0.093	8:30	0.426	14:30	2.694	20:30	3.069
0:55	1.608	2:45	0.102	8:45	0.448	14:45	2.717	20:45	3.078
1:00	1.672	3:00	0.112	9:00	0.470	15:00	2.739	21:00	3.088
1:05	1.727	3:15	0.122	9:15	0.496	15:15	2.762	21:15	3.098
1:10	1.751	3:30	0.131	9:30	0.522	15:30	2.781	21:30	3.107
1:15	1.772	3:45	0.141	9:45	0.550	15:45	2.800	21:45	3.117
1:20	1.791	4:00	0.154	10:00	0.579	16:00	2.819	22:00	3.126
1:25	1.809	4:15	0.166	10:15	0.611	16:15	2.838	22:15	3.136
1:30	1.828	4:30	0.179	10:30	0.650	16:30	2.858	22:30	3.146
1:35	1.844	4:45	0.192	10:45	0.698	16:45	2.874	22:45	3.155
1:40	1.861	5:00	0.193	11:00	0.755	17:00	2.890	23:00	3.165
1:45	1.877	5:15	0.218	11:15	0.822	17:15	2.906	23:15	3.174
1:50	1.892	5:30	0.230	11:30	0.906	17:30	2.922	23:30	3.184
1:55	1.907	5:45	0.243	11:45	1.238	17:45	2.938	23:45	3.194
2:00	1.925								

*DARFs not used for sub-basins (<1 sq mi).

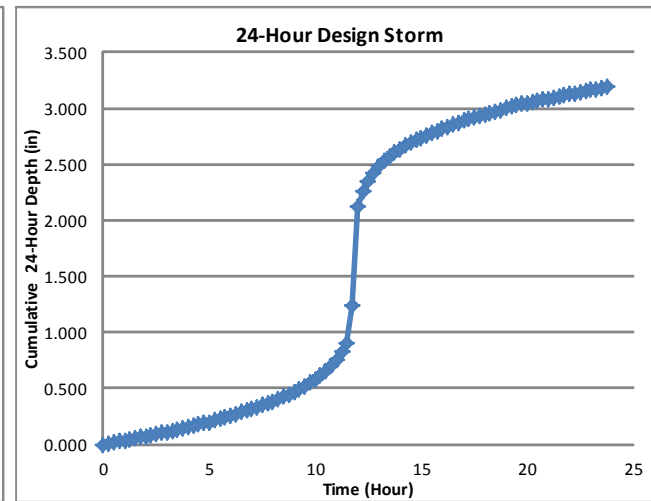
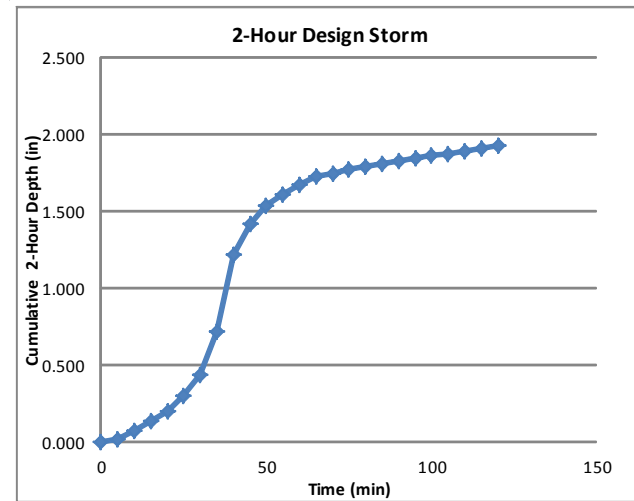

	Thunderstrom Analysis	Frontal Analysis
	z=7120'	z=7415'
Return Period (Year)	1-Hour Depth (Inches)	24-Hour Depth (Inches)
25	1.99	3.60

Cumulative Rainfall Depth									
2-Hour Design Storm		24-Hour Design Storm							
Time	Cumulative	Time	Cumulative	Time	Cumulative	Time	Cumulative	Time	Cumulative
(5 min)	2-Hour Depth (in)	(15 min)	24-Hour Depth (in)	(15 min)	24-Hour Depth (in)	(15 min)	24-Hour Depth (in)	(15 min)	24-Hour Depth (in)
0:00	0.000	0:00	0.000	6:00	0.288	12:00	2.387	18:00	3.319
0:05	0.028	0:15	0.007	6:15	0.306	12:15	2.545	18:15	3.334
0:10	0.092	0:30	0.018	6:30	0.324	12:30	2.646	18:30	3.348
0:15	0.157	0:45	0.029	6:45	0.342	12:45	2.729	18:45	3.362
0:20	0.239	1:00	0.040	7:00	0.360	13:00	2.794	19:00	3.377
0:25	0.356	1:15	0.050	7:15	0.378	13:15	2.848	19:15	3.391
0:30	0.513	1:30	0.061	7:30	0.396	13:30	2.894	19:30	3.406
0:35	0.838	1:45	0.072	7:45	0.414	13:45	2.934	19:45	3.420
0:40	1.417	2:00	0.083	8:00	0.432	14:00	2.970	20:00	3.431
0:45	1.640	2:15	0.094	8:15	0.454	14:15	3.002	20:15	3.442
0:50	1.775	2:30	0.104	8:30	0.479	14:30	3.031	20:30	3.452
0:55	1.861	2:45	0.115	8:45	0.504	14:45	3.056	20:45	3.463
1:00	1.934	3:00	0.126	9:00	0.529	15:00	3.082	21:00	3.474
1:05	1.998	3:15	0.137	9:15	0.558	15:15	3.107	21:15	3.485
1:10	2.026	3:30	0.148	9:30	0.587	15:30	3.128	21:30	3.496
1:15	2.050	3:45	0.158	9:45	0.619	15:45	3.150	21:45	3.506
1:20	2.072	4:00	0.173	10:00	0.652	16:00	3.172	22:00	3.517
1:25	2.093	4:15	0.187	10:15	0.688	16:15	3.193	22:15	3.528
1:30	2.115	4:30	0.202	10:30	0.731	16:30	3.215	22:30	3.539
1:35	2.133	4:45	0.216	10:45	0.785	16:45	3.233	22:45	3.550
1:40	2.153	5:00	0.217	11:00	0.850	17:00	3.251	23:00	3.560
1:45	2.171	5:15	0.245	11:15	0.925	17:15	3.269	23:15	3.571
1:50	2.189	5:30	0.259	11:30	1.019	17:30	3.287	23:30	3.582
1:55	2.207	5:45	0.274	11:45	1.393	17:45	3.305	23:45	3.593
2:00	2.227								

*DARFs not used for sub-basins (<1 sq mi).

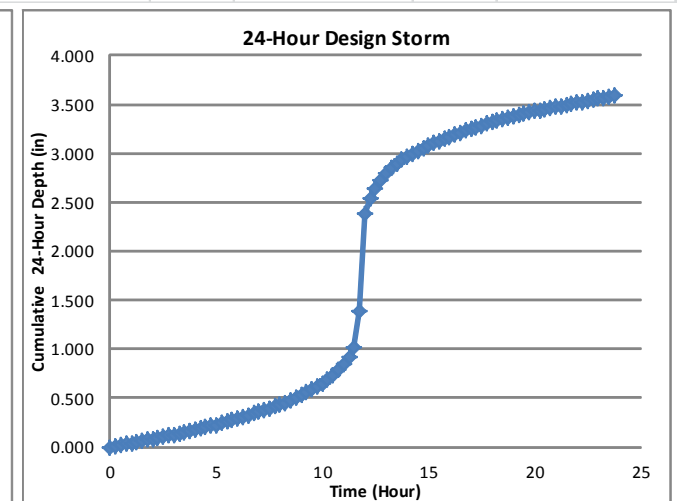
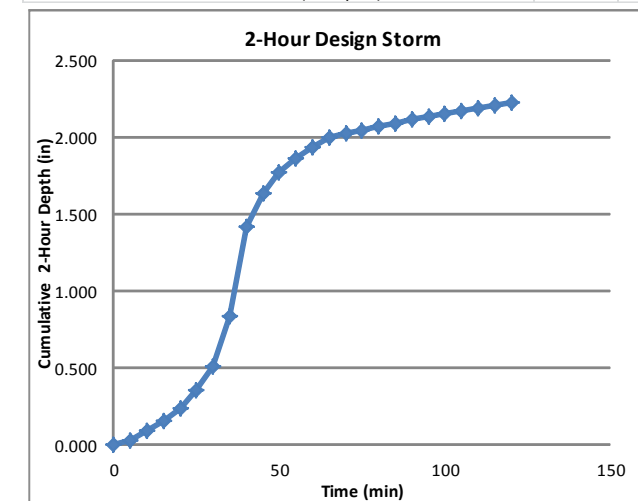

HYDROLOGIC DATA – DESIGN
STORM 10 & 25 YR
KETTLE CREEK DBPS
JOB NO. 25100.00
MAY 2015
B-5



	Thunderstrom Analysis	Frontal Analysis
	z=7120'	z=7415'
Return Period (Year)	1-Hour Depth (Inches)	24-Hour Depth (Inches)
50	2.24	4.20

Cumulative Rainfall Depth									
2-Hour Design Storm		24-Hour Design Storm							
Time	Cumulative	Time	Cumulative	Time	Cumulative	Time	Cumulative	Time	Cumulative
(5 min)	2-Hour Depth (in)	(15 min)	24-Hour Depth (in)	(15 min)	24-Hour Depth (in)	(15 min)	24-Hour Depth (in)	(15 min)	24-Hour Depth (in)
0:00	0.000	0:00	0.000	6:00	0.336	12:00	2.785	18:00	3.872
0:05	0.031	0:15	0.008	6:15	0.357	12:15	2.969	18:15	3.889
0:10	0.103	0:30	0.021	6:30	0.378	12:30	3.087	18:30	3.906
0:15	0.177	0:45	0.034	6:45	0.399	12:45	3.184	18:45	3.923
0:20	0.269	1:00	0.046	7:00	0.420	13:00	3.259	19:00	3.940
0:25	0.401	1:15	0.059	7:15	0.441	13:15	3.322	19:15	3.956
0:30	0.578	1:30	0.071	7:30	0.462	13:30	3.377	19:30	3.973
0:35	0.943	1:45	0.084	7:45	0.483	13:45	3.423	19:45	3.990
0:40	1.595	2:00	0.097	8:00	0.504	14:00	3.465	20:00	4.003
0:45	1.846	2:15	0.109	8:15	0.529	14:15	3.503	20:15	4.015
0:50	1.998	2:30	0.122	8:30	0.559	14:30	3.536	20:30	4.028
0:55	2.094	2:45	0.134	8:45	0.588	14:45	3.566	20:45	4.040
1:00	2.177	3:00	0.147	9:00	0.617	15:00	3.595	21:00	4.053
1:05	2.249	3:15	0.160	9:15	0.651	15:15	3.625	21:15	4.066
1:10	2.280	3:30	0.172	9:30	0.685	15:30	3.650	21:30	4.078
1:15	2.307	3:45	0.185	9:45	0.722	15:45	3.675	21:45	4.091
1:20	2.332	4:00	0.202	10:00	0.760	16:00	3.700	22:00	4.103
1:25	2.356	4:15	0.218	10:15	0.802	16:15	3.725	22:15	4.116
1:30	2.381	4:30	0.235	10:30	0.853	16:30	3.751	22:30	4.129
1:35	2.401	4:45	0.252	10:45	0.916	16:45	3.772	22:45	4.141
1:40	2.424	5:00	0.254	11:00	0.991	17:00	3.793	23:00	4.154
1:45	2.444	5:15	0.286	11:15	1.079	17:15	3.814	23:15	4.166
1:50	2.464	5:30	0.302	11:30	1.189	17:30	3.835	23:30	4.179
1:55	2.484	5:45	0.319	11:45	1.625	17:45	3.856	23:45	4.192
2:00	2.507								

*DARFs not used for sub-basins (<1 sq mi).

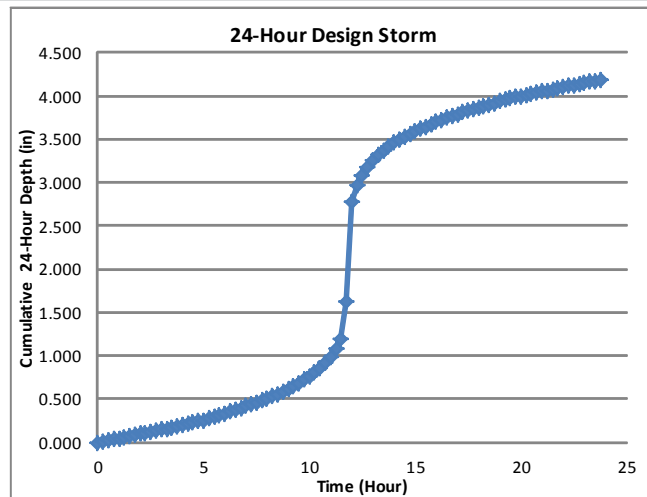
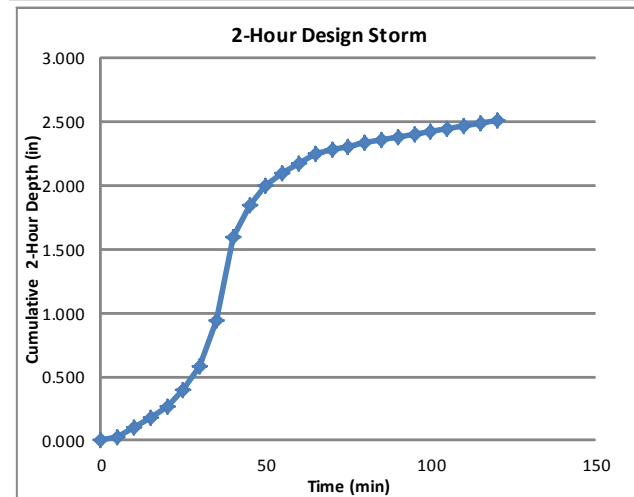

	Thunderstrom Analysis	Frontal Analysis
	z=7120'	z=7415'
Return Period (Year)	1-Hour Depth (Inches)	24-Hour Depth (Inches)
100	2.47	4.60

Cumulative Rainfall Depth									
2-Hour Design Storm		24-Hour Design Storm							
Time	Cumulative	Time	Cumulative	Time	Cumulative	Time	Cumulative	Time	Cumulative
(5 min)	2-Hour Depth (in)	(15 min)	24-Hour Depth (in)	(15 min)	24-Hour Depth (in)	(15 min)	24-Hour Depth (in)	(15 min)	24-Hour Depth (in)
0:00	0.000	0:00	0.000	6:00	0.368	12:00	3.050	18:00	4.241
0:05	0.035	0:15	0.009	6:15	0.391	12:15	3.252	18:15	4.260
0:10	0.114	0:30	0.023	6:30	0.414	12:30	3.381	18:30	4.278
0:15	0.195	0:45	0.037	6:45	0.437	12:45	3.487	18:45	4.296
0:20	0.296	1:00	0.051	7:00	0.460	13:00	3.570	19:00	4.315
0:25	0.442	1:15	0.064	7:15	0.483	13:15	3.639	19:15	4.333
0:30	0.637	1:30	0.078	7:30	0.506	13:30	3.698	19:30	4.352
0:35	1.040	1:45	0.092	7:45	0.529	13:45	3.749	19:45	4.370
0:40	1.759	2:00	0.106	8:00	0.552	14:00	3.795	20:00	4.384
0:45	2.035	2:15	0.120	8:15	0.580	14:15	3.836	20:15	4.398
0:50	2.203	2:30	0.133	8:30	0.612	14:30	3.873	20:30	4.411
0:55	2.309	2:45	0.147	8:45	0.644	14:45	3.905	20:45	4.425
1:00	2.401	3:00	0.161	9:00	0.676	15:00	3.938	21:00	4.439
1:05	2.480	3:15	0.175	9:15	0.713	15:15	3.970	21:15	4.453
1:10	2.514	3:30	0.189	9:30	0.750	15:30	3.997	21:30	4.467
1:15	2.544	3:45	0.202	9:45	0.791	15:45	4.025	21:45	4.480
1:20	2.571	4:00	0.221	10:00	0.833	16:00	4.053	22:00	4.494
1:25	2.598	4:15	0.239	10:15	0.879	16:15	4.080	22:15	4.508
1:30	2.626	4:30	0.258	10:30	0.934	16:30	4.108	22:30	4.522
1:35	2.648	4:45	0.276	10:45	1.003	16:45	4.131	22:45	4.536
1:40	2.673	5:00	0.278	11:00	1.086	17:00	4.154	23:00	4.549
1:45	2.695	5:15	0.313	11:15	1.182	17:15	4.177	23:15	4.563
1:50	2.717	5:30	0.331	11:30	1.302	17:30	4.200	23:30	4.577
1:55	2.739	5:45	0.350	11:45	1.780	17:45	4.223	23:45	4.591
2:00	2.764								

*DARFs not used for sub-basins (<1 sq mi).

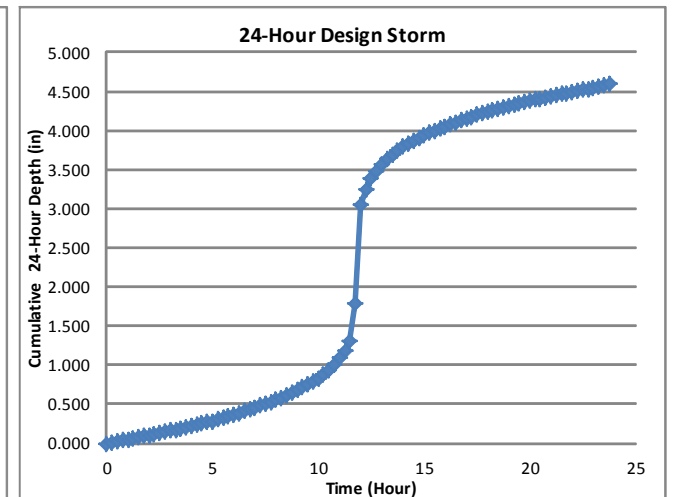
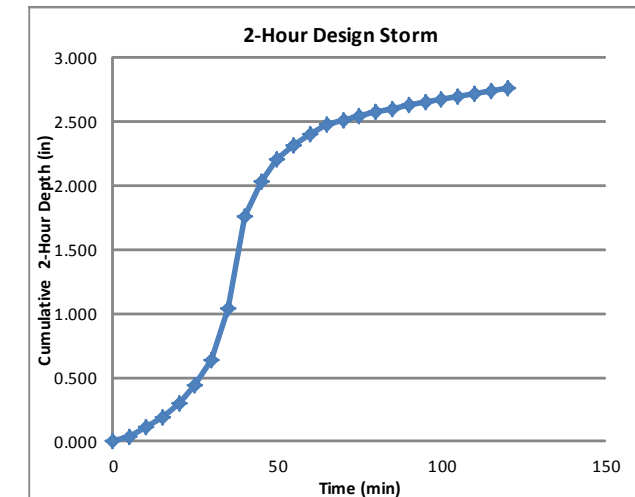

HYDROLOGIC DATA – DESIGN
STORM 50 & 100 YR
KETTLE CREEK DBPS
JOB NO. 25100.00
MAY 2015
B-6



Custom Soil Resource Report
Map—Hydrologic Soil Group

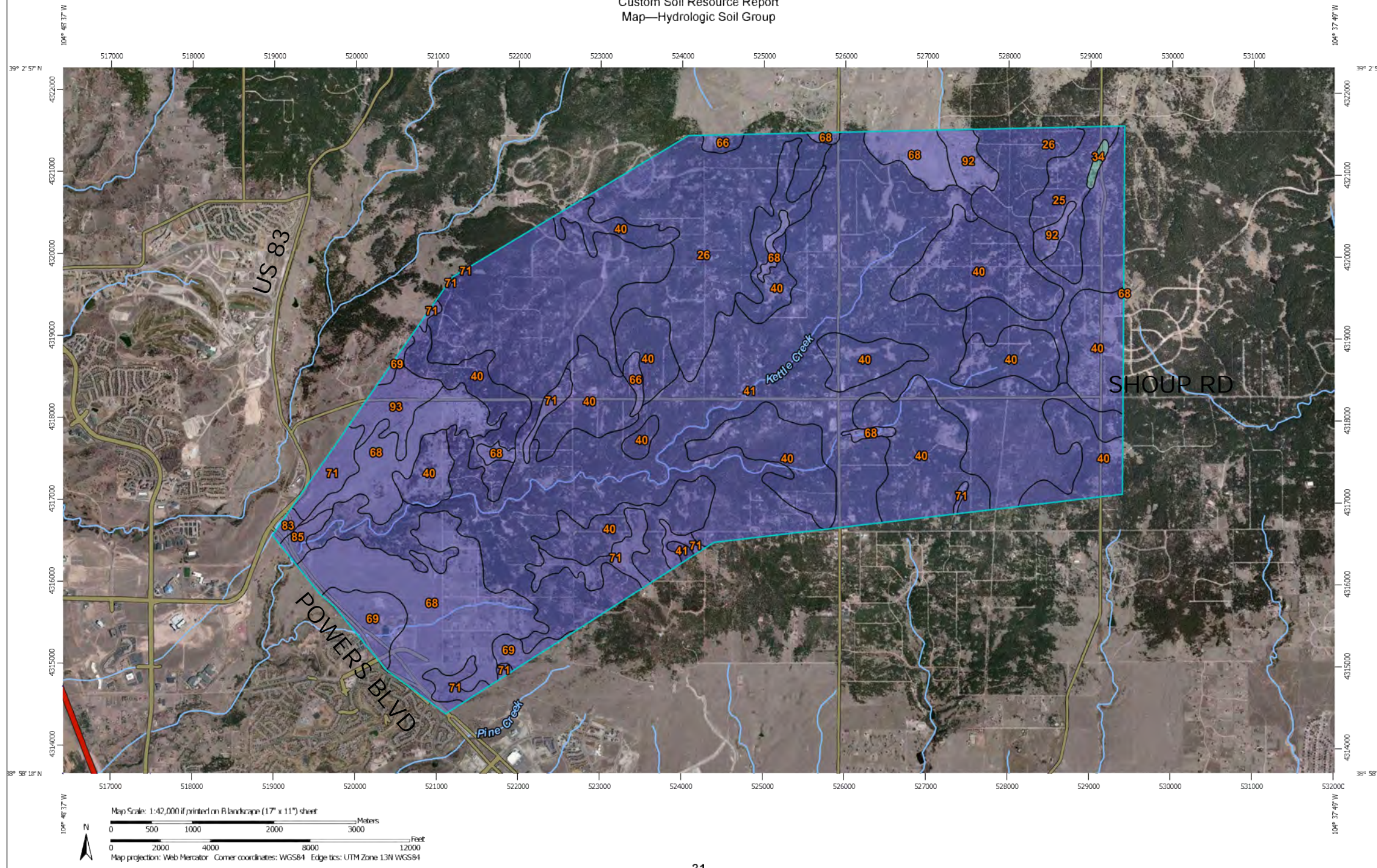

Table—Hydrologic Soil Group

Hydrologic Soil Group— Summary by Map Unit — El Paso County Area, Colorado (CO625)					
Map unit symbol	Map unit name	Rating	Acres in AOI	Percent of AOI	
25	Elbeth sandy loam, 3 to 8 percent slopes	B	198.1	1.7%	
26	Elbeth sandy loam, 8 to 15 percent slopes	B	1,562.3	13.5%	
34	Holderness loam, 1 to 5 percent slopes	C	15.5	0.1%	
40	Kettle gravelly loamy sand, 3 to 8 percent slopes	B	3,089.3	26.7%	
41	Kettle gravelly loamy sand, 8 to 40 percent slopes	B	4,596.5	39.8%	
66	Peyton sandy loam, 1 to 5 percent slopes	B	51.1	0.4%	
68	Peyton-Pring complex, 3 to 8 percent slopes	B	1,205.5	10.4%	
69	Peyton-Pring complex, 8 to 15 percent slopes	B	186.8	1.6%	
71	Pring coarse sandy loam, 3 to 8 percent slopes	B	340.9	2.9%	
83	Stapleton sandy loam, 3 to 8 percent slopes	B	17.8	0.2%	
85	Stapleton-Bernal sandy loams, 3 to 20 percent slopes	B	38.9	0.3%	
92	Tomah-Crowfoot loamy sands, 3 to 8 percent slopes	B	120.7	1.0%	
93	Tomah-Crowfoot complex, 8 to 15 percent slopes	B	134.2	1.2%	
Totals for Area of Interest			11,557.7	100.0%	

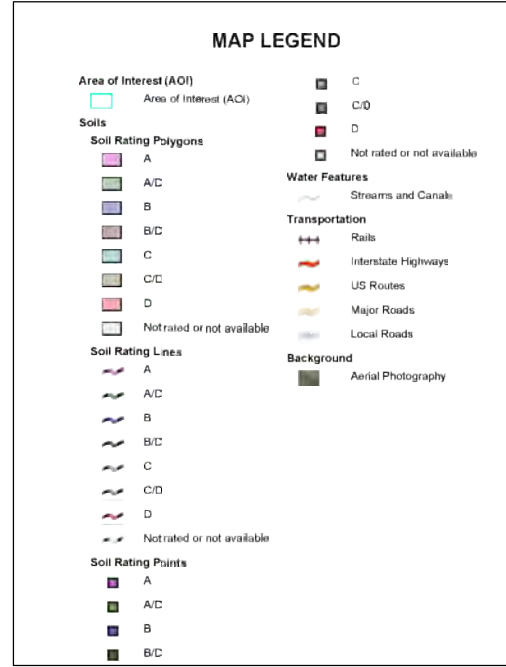

APPENDIX B — HYDROLOGIC SOIL GROUP MAP
KETTLE CREEK DBPS
JOB NO. 25100.00
MAY 2015
B-7



Centennial 303-740-9393 • Colorado Springs 719-593-2593
Fort Collins 970-491-9888 • www.jrengineering.com

Custom Soil Resource Report
Map—Hydrologic Soil Group

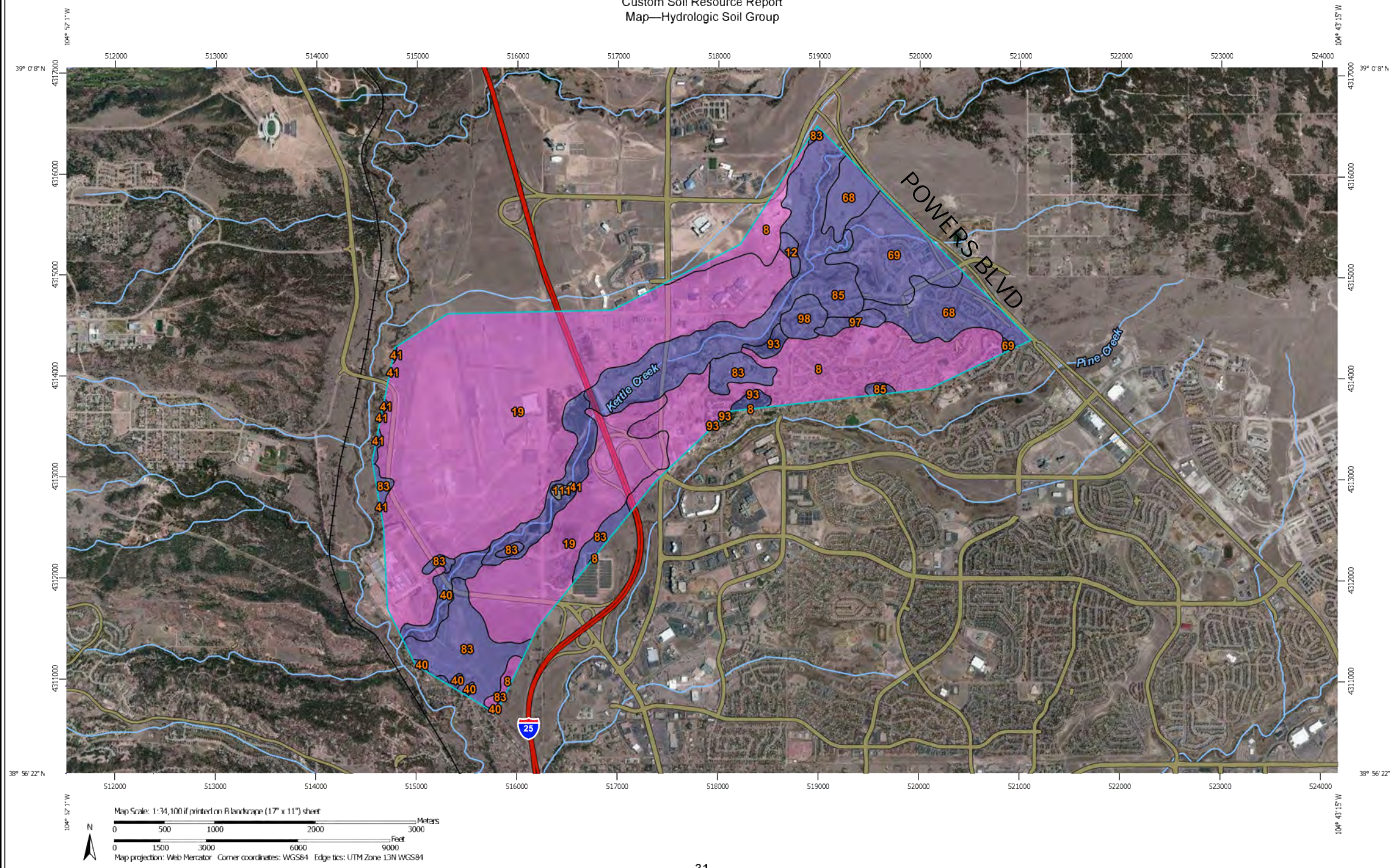

Table—Hydrologic Soil Group

Hydrologic Soil Group— Summary by Map Unit — El Paso County Area, Colorado (CO625)					
Map unit symbol	Map unit name	Rating	Acres in AOI	Percent of AOI	
8	Blakeland loamy sand, 1 to 9 percent slopes	A	523.1	14.6%	
12	Bresser sandy loam, 3 to 5 percent slopes	B	12.6	0.4%	
19	Columbine gravelly sandy loam, 0 to 3 percent slopes	A	1,782.3	49.1%	
40	Kettle gravelly loamy sand, 3 to 8 percent slopes	B	59.3	1.7%	
41	Kettle gravelly loamy sand, 8 to 40 percent slopes	B	103.8	2.9%	
68	Peyton-Pring complex, 3 to 8 percent slopes	B	199.8	5.6%	
69	Peyton-Pring complex, 8 to 15 percent slopes	B	191.2	5.3%	
83	Stapleton sandy loam, 3 to 8 percent slopes	B	250.4	7.0%	
85	Stapleton-Bernal sandy loams, 3 to 20 percent slopes	B	391.5	10.9%	
93	Tomah-Crowfoot complex, 8 to 15 percent slopes	B	28.1	0.8%	
97	Truckton sandy loam, 3 to 9 percent slopes	B	22.5	0.6%	
98	Truckton-Blakeland complex, 9 to 20 percent slopes	B	36.8	1.0%	
111	Water		5.6	0.2%	
Totals for Area of Interest			3,587.0	100.0%	

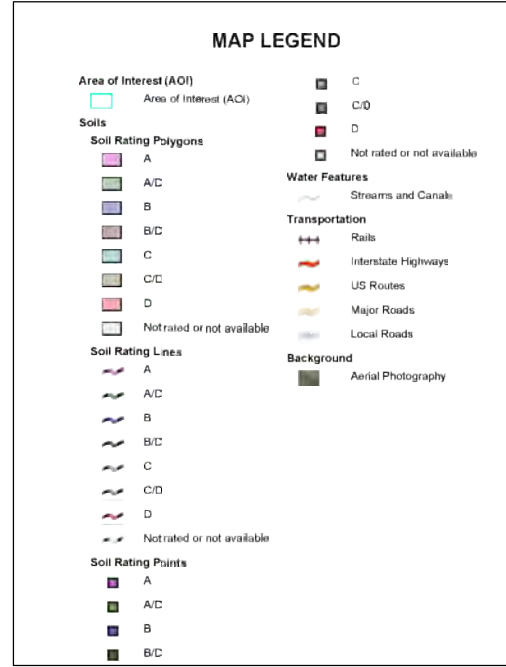

APPENDIX B — HYDROLOGIC
SOIL GROUP MAP
KETTLE CREEK DBPS
JOB NO. 25100.00
MAY 2015
B-8



Centennial 303-740-9393 • Colorado Springs 719-593-2593
Fort Collins 970-491-9888 • www.jrengineering.com

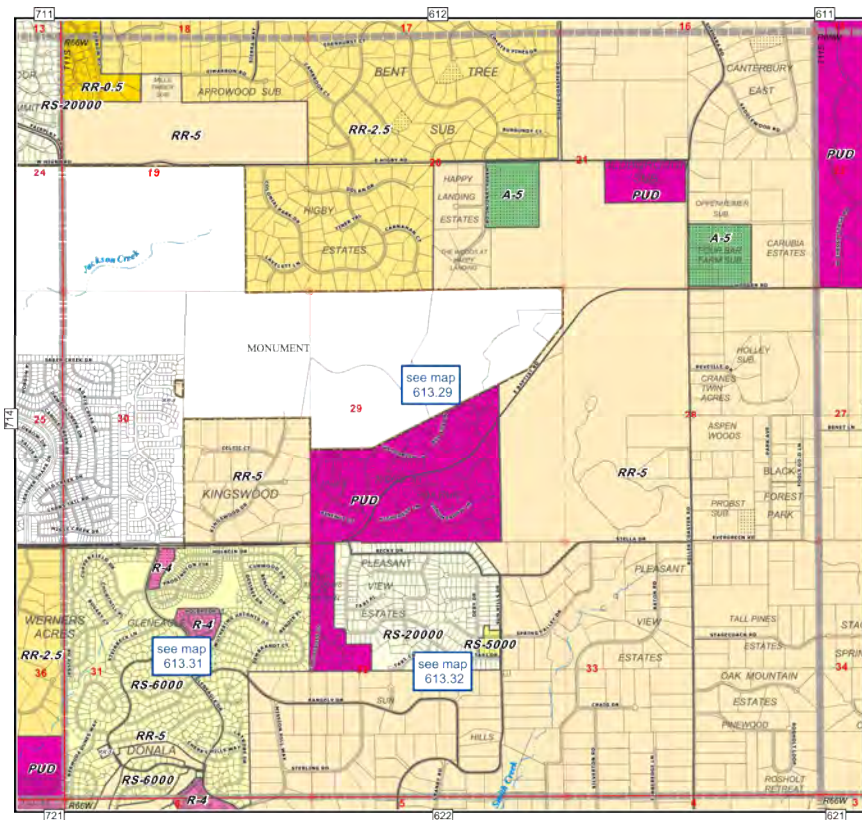

Zone Map 613

- El Paso County -
Development Services Department

Zoning Designations

RS-20000 Residential Suburban (20,000 sq. ft.)	F-1 Forest & Recreation (5 acres)
RS-6000 Residential Suburban (6,000 sq. ft.)	PUD Planned Unit Development
RS-3000 Residential Suburban (3,000 sq. ft.)	CC Commercial Community
RM-12 Residential Multi-Dwelling (12 DUs/acre)	CR Commercial Regional
RM-30 Residential Multi-Dwelling (30 DUs/acre)	CS Commercial Service
RR-0.5 Residential Rural (0.5 acres)	L-2 Limited Industrial
RR-2.5 Residential Rural (2.5 acres)	L-3 Heavy Industrial
RR-5 Residential Rural (5 acres)	A-3 Agricultural (5 acres)
R-1 Residential - Topographic	A-35 Agricultural (35 acres)
MHP Mobile Home Park	C-1 Commercial
MHP-R Mobile Home Park, Rural	C-2 Commercial
MHS Mobile Home Subdivision	M Industrial
RVP Recreational Vehicle Park	R-4 Planned Development

Supporting Data

- Highways
- Major Roadways
- Creeks - Perennial
- Creeks - Intermittent
- Section Corner Nodes
- Sections
- Parcels
- Zone Map Boundary
- Incorporated Cities
- Military
- Pine National Forest
- Zoning Overlay
- Special Uses

Scale: 1 inch = 1,600 feet
Mar 21, 2012

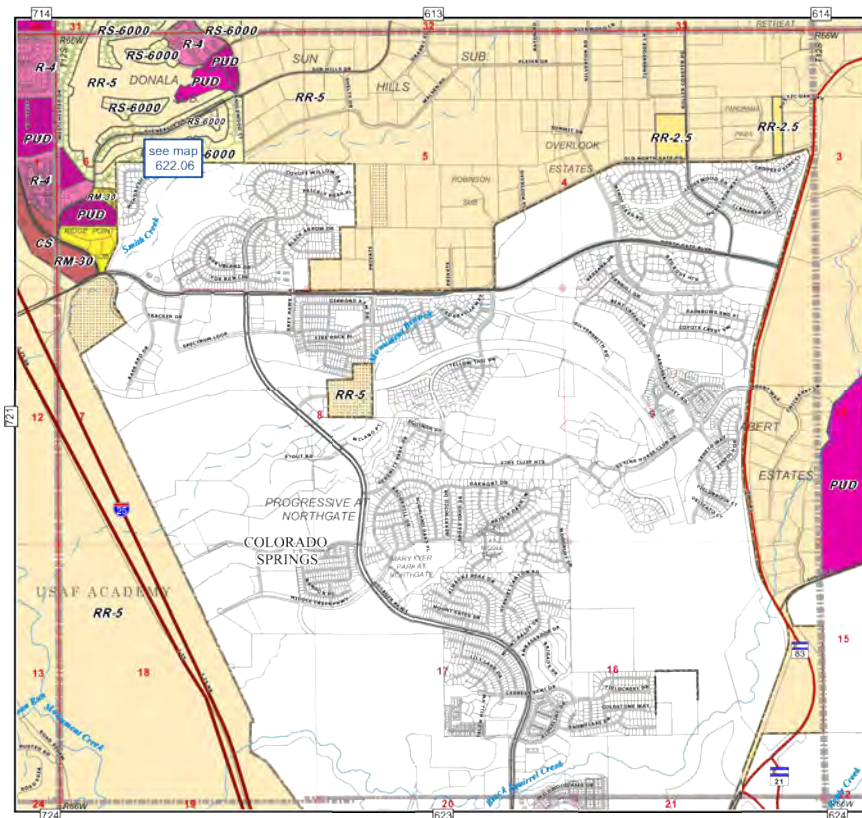
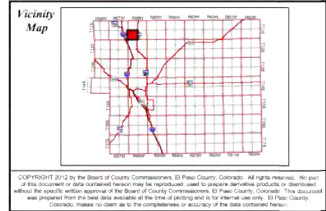

Zone Map 622

- El Paso County -
Development Services Department

Zoning Designations

RS-20000 Residential Suburban (20,000 sq. ft.)	F-1 Forest & Recreation (5 acres)
RS-6000 Residential Suburban (6,000 sq. ft.)	PUD Planned Unit Development
RS-3000 Residential Suburban (3,000 sq. ft.)	CC Commercial Community
RM-12 Residential Multi-Dwelling (12 DUs/acre)	CR Commercial Regional
RM-30 Residential Multi-Dwelling (30 DUs/acre)	CS Commercial Service
RR-0.5 Residential Rural (0.5 acres)	L-2 Limited Industrial
RR-2.5 Residential Rural (2.5 acres)	L-3 Heavy Industrial
RR-5 Residential Rural (5 acres)	A-3 Agricultural (5 acres)
R-1 Residential - Topographic	A-35 Agricultural (35 acres)
MHP Mobile Home Park	C-1 Commercial
MHP-R Mobile Home Park, Rural	C-2 Commercial
MHS Mobile Home Subdivision	M Industrial
RVP Recreational Vehicle Park	R-4 Planned Development

Supporting Data

- Highways
- Major Roadways
- Creeks - Perennial
- Creeks - Intermittent
- Section Corner Nodes
- Sections
- Parcels
- Zone Map Boundary
- Incorporated Cities
- Military
- Pine National Forest
- Zoning Overlay
- Special Uses

Scale: 1 inch = 1,600 feet
Mar 26, 2014

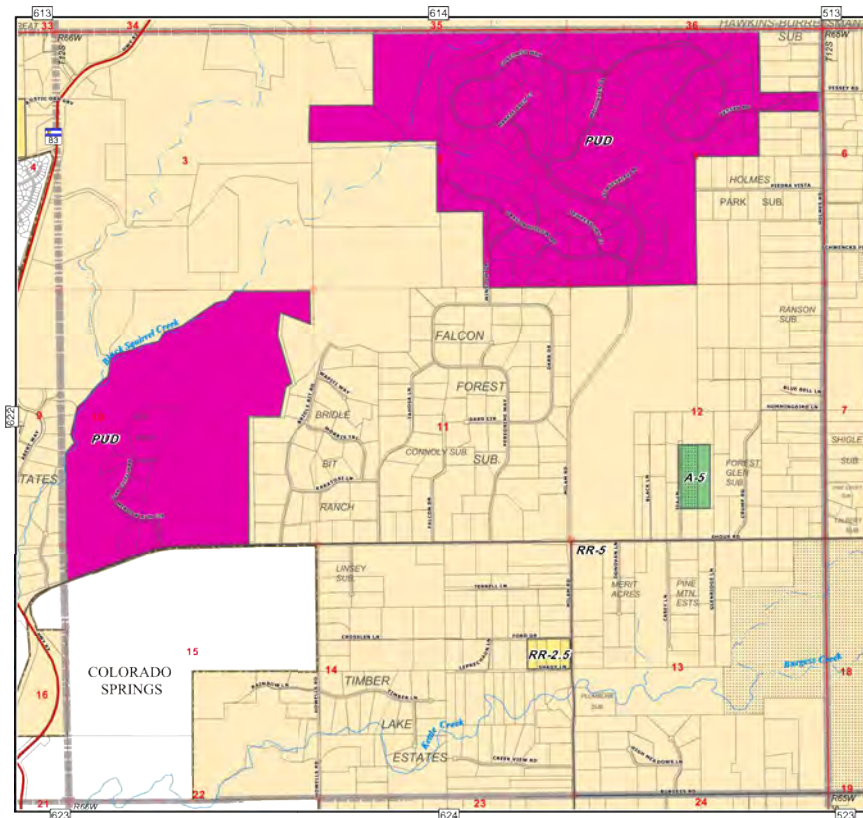
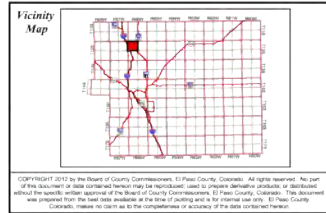

Zone Map 621

- El Paso County -
Development Services Department

Zoning Designations

RS-20000 Residential Suburban (20,000 sq. ft.)	F-1 Forest & Recreation (5 acres)
RS-6000 Residential Suburban (6,000 sq. ft.)	PUD Planned Unit Development
RS-3000 Residential Suburban (3,000 sq. ft.)	CC Commercial Community
RM-12 Residential Multi-Dwelling (12 DUs/acre)	CR Commercial Regional
RM-30 Residential Multi-Dwelling (30 DUs/acre)	CS Commercial Service
RR-0.5 Residential Rural (0.5 acres)	L-2 Limited Industrial
RR-2.5 Residential Rural (2.5 acres)	L-3 Heavy Industrial
RR-5 Residential Rural (5 acres)	A-3 Agricultural (5 acres)
R-1 Residential - Topographic	A-35 Agricultural (35 acres)
MHP Mobile Home Park	C-1 Commercial
MHP-R Mobile Home Park, Rural	C-2 Commercial
MHS Mobile Home Subdivision	M Industrial
RVP Recreational Vehicle Park	R-4 Planned Development

Supporting Data

- Highways
- Major Roadways
- Creeks - Perennial
- Creeks - Intermittent
- Section Corner Nodes
- Sections
- Parcels
- Zone Map Boundary
- Incorporated Cities
- Military
- Pine National Forest
- Zoning Overlay
- Special Uses

Scale: 1 inch = 1,600 feet
Mar 21, 2012

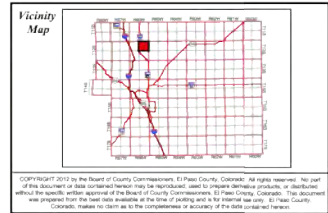

APPENDIX B – ZONING MAPS
KETTLE CREEK DBPS
JOB NO. 25100.00
MAY 2015
B-9



Centennial 303-740-9393 • Colorado Springs 719-593-2593
Fort Collins 970-491-9888 • www.jrengineering.com

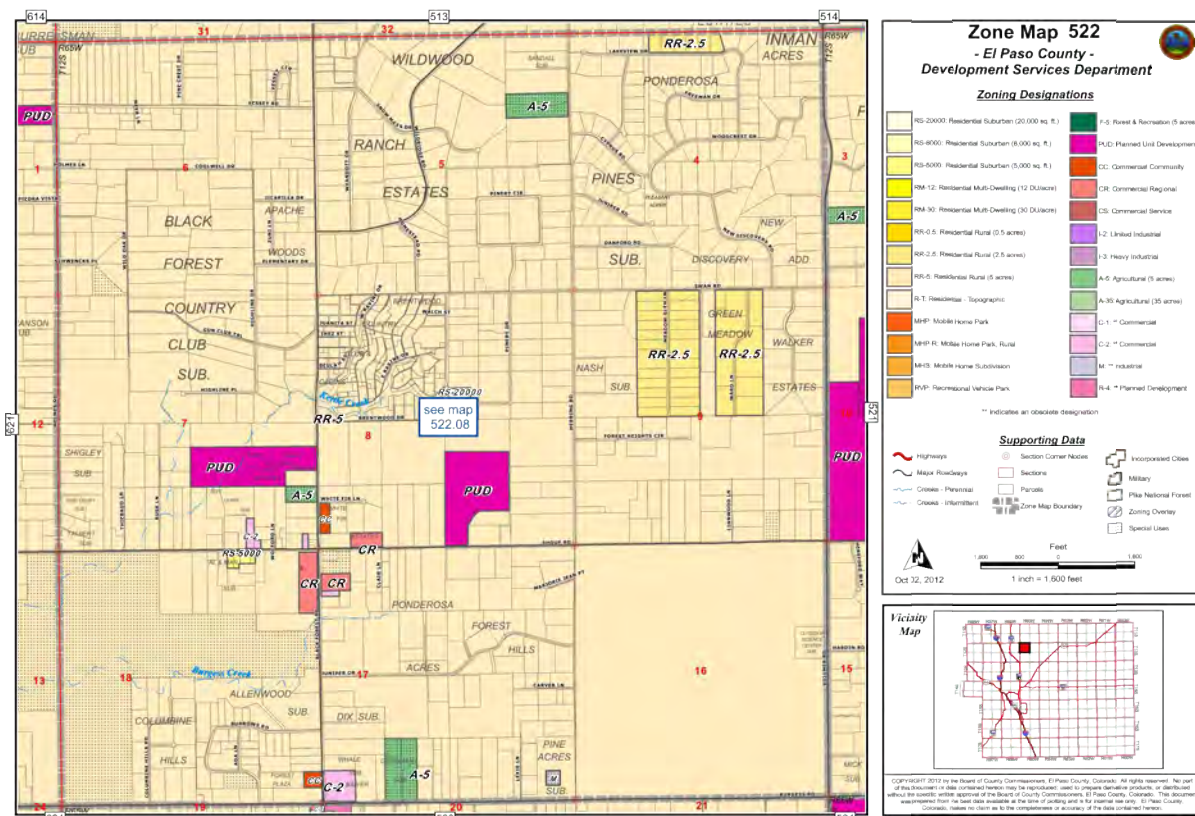
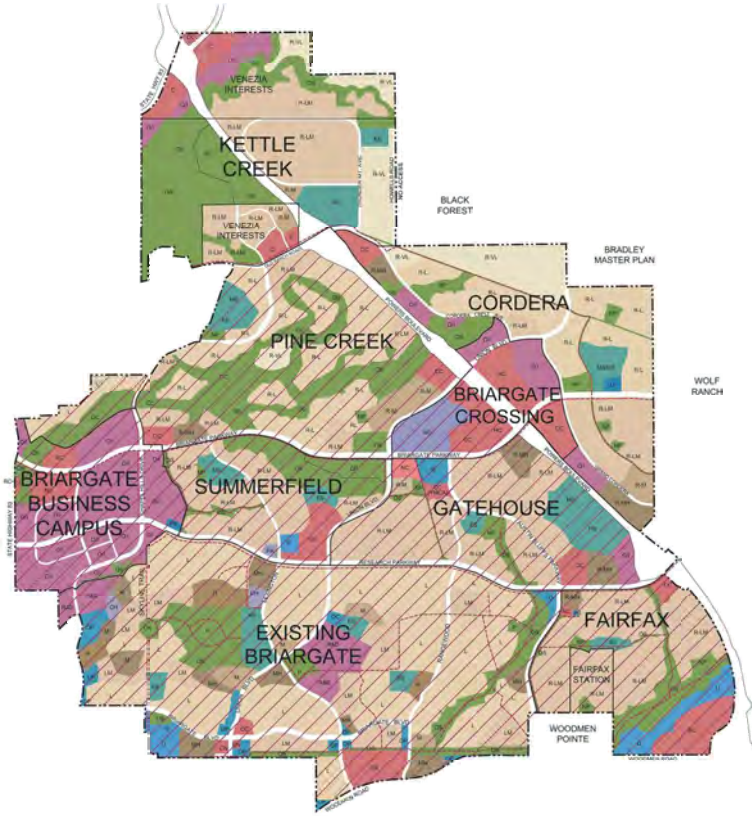
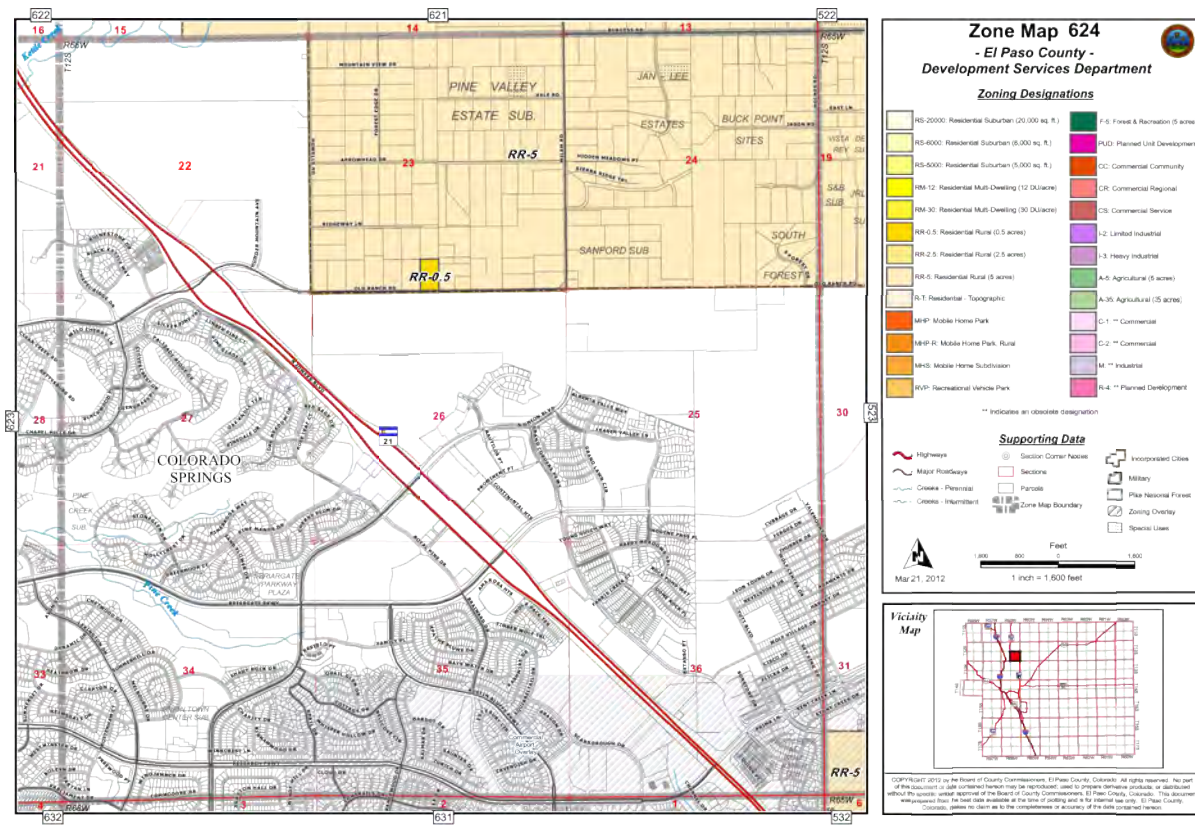
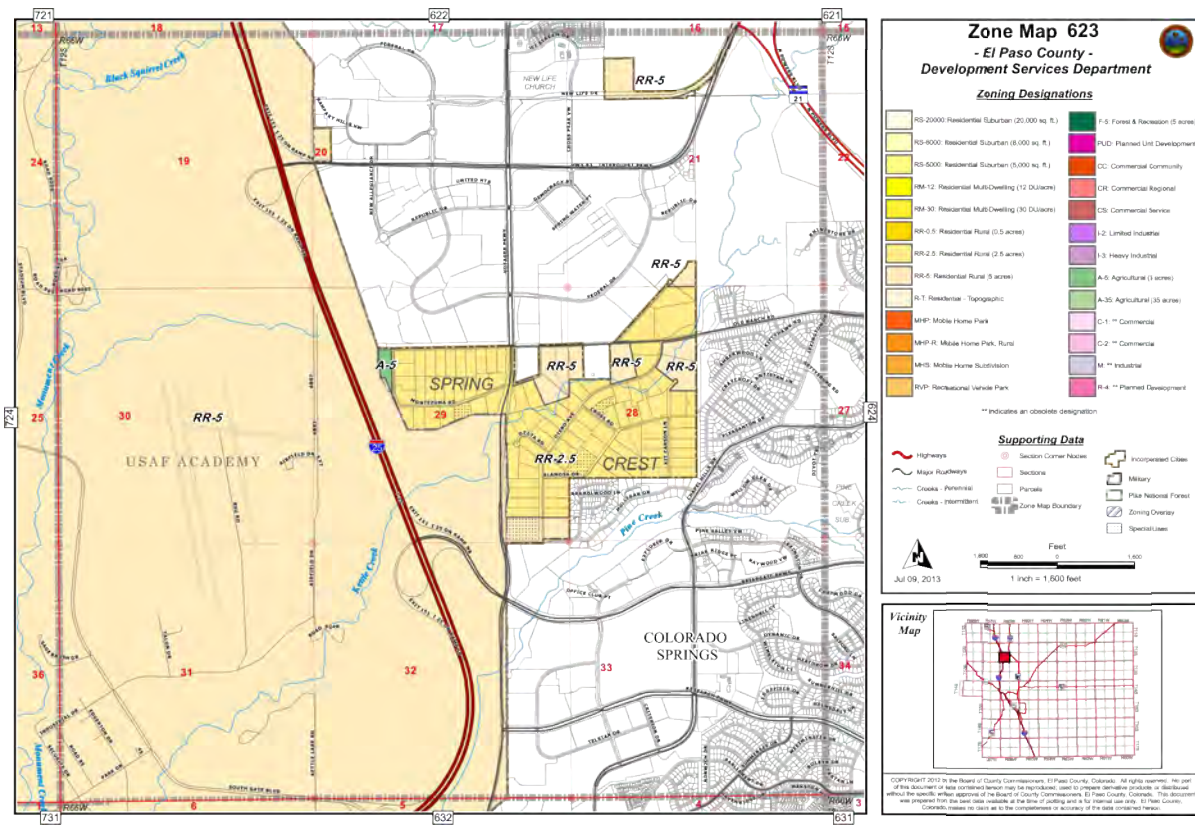

APPENDIX B – ZONING MAPS
KETTLE CREEK DBPS
JOB NO. 25100.00
MAY 2015
B-10



Centennial 303-740-9393 • Colorado Springs 719-593-2593
Fort Collins 970-491-9888 • www.jrengineering.com

Existing Land Use

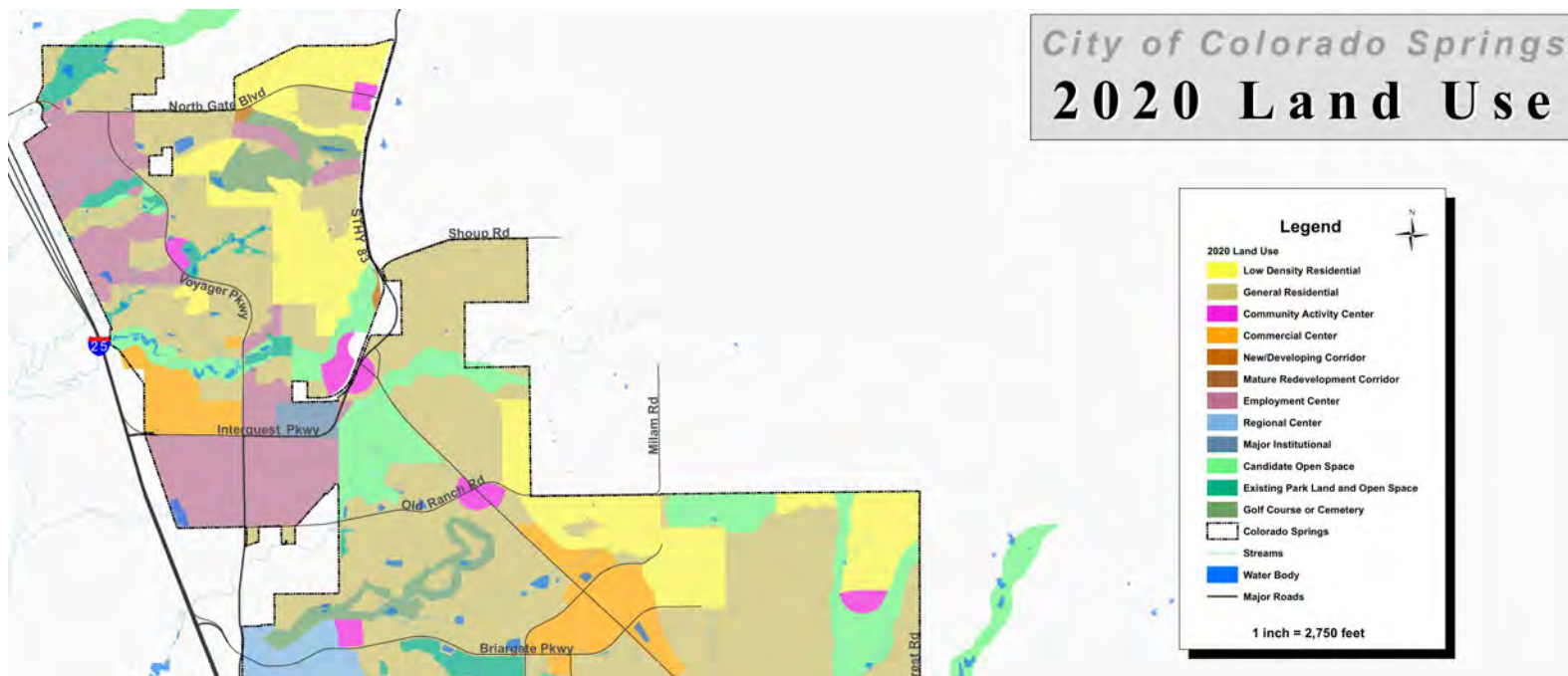
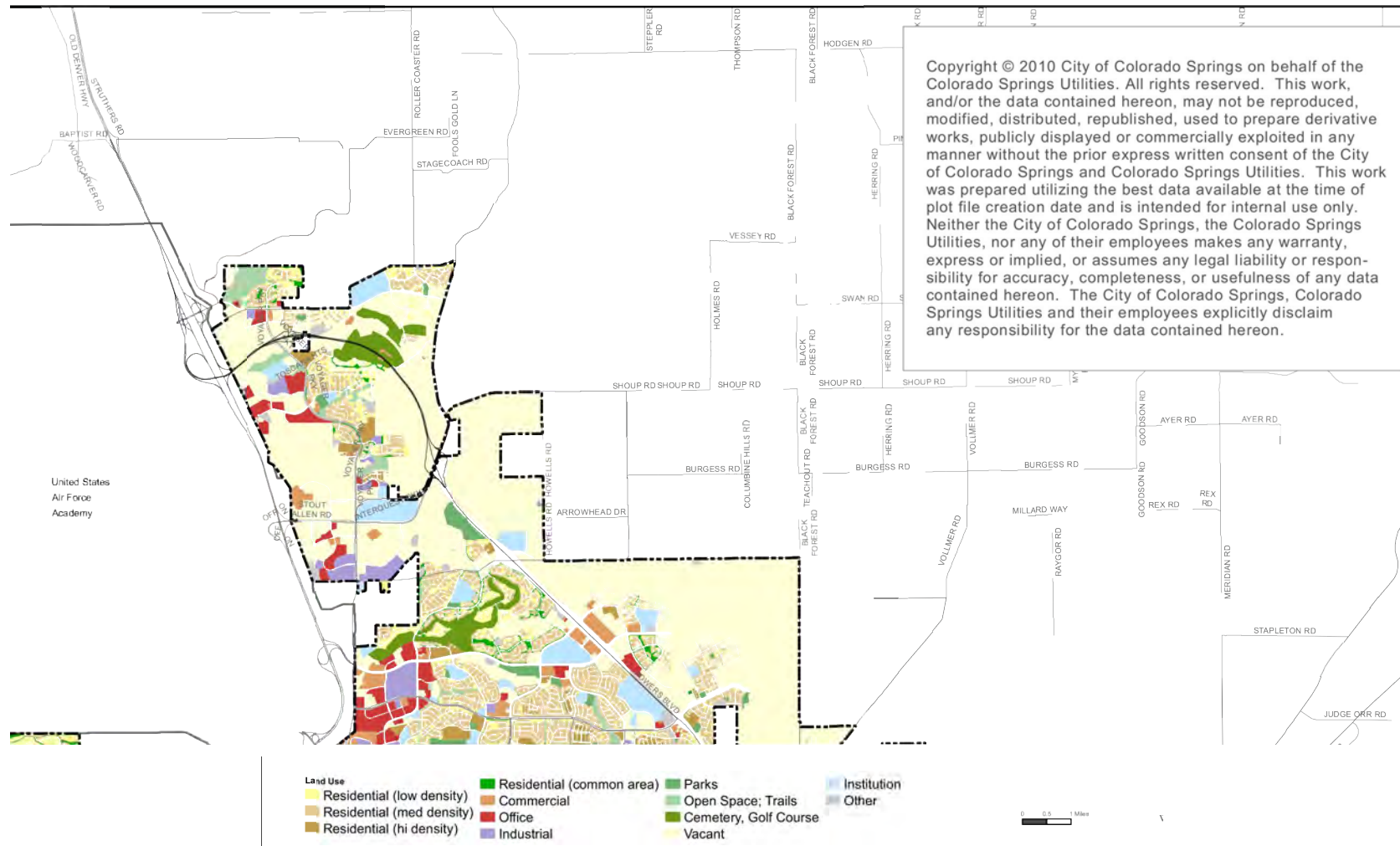

APPENDIX B – ZONING MAPS
KETTLE CREEK DBPS
JOB NO. 25100.00
MAY 2015
B-11



Centennial 303-740-9393 • Colorado Springs 719-593-2593
Fort Collins 970-491-9888 • www.jrengineering.com

Historic Land Use and Curve Number Data (2-Hour Duration Storms) ¹												
							% Imperv.	2	2	2		
							CN Values ¹	15	41	34		
Basin number	Area (mi)	Area (ac)	Soil Type A Area (ac)	Soil Type A Area (%)	Soil Type B Area (ac)	Soil Type B Area (%)	Meadows, Good Condition, HSG A (ac)	Herbaceous, Good Condition, HSG B (ac)	Woods, Good Condition, HSG B (ac)	Composite CN Value	Initial Abstraction (in)	Percent Impervious
1	1.263	808	0	0.0%	808	100.0%	0	92	716	35	1.87	2.0
2	0.586	375	0	0.0%	375	100.0%	0	35	340	35	1.89	2.0
3	0.180	115	0	0.0%	115	100.0%	0	9	106	35	1.89	2.0
4	0.195	125	0	0.0%	125	100.0%	0	0	125	34	1.94	2.0
5	0.623	399	0	0.0%	399	100.0%	0	19	380	34	1.91	2.0
6	1.333	853	0	0.0%	853	100.0%	0	51	802	34	1.91	2.0
7	0.183	117	0	0.0%	117	100.0%	0	11	106	35	1.89	2.0
8	0.288	184	0	0.0%	184	100.0%	0	0	184	34	1.94	2.0
9	1.177	753	0	0.0%	753	100.0%	0	139	614	35	1.83	2.0
10	0.222	142	0	0.0%	142	100.0%	0	0	142	34	1.94	2.0
11	0.880	563	0	0.0%	563	100.0%	0	6	557	34	1.93	2.0
12	0.552	353	0	0.0%	353	100.0%	0	70	283	35	1.83	2.0
13	1.156	740	0	0.0%	740	100.0%	0	70	670	35	1.88	2.0
14	0.516	330	0	0.0%	330	100.0%	0	115	215	36	1.74	2.0
15	0.498	319	0	0.0%	319	100.0%	0	90	229	36	1.78	2.0
16	0.819	524	0	0.0%	524	100.0%	0	67	457	35	1.87	2.0
17	0.788	504	0	0.0%	504	100.0%	0	58	446	35	1.87	2.0
18	0.192	123	0	0.0%	123	100.0%	0	23	100	35	1.83	2.0
19	0.552	353	0	0.0%	353	100.0%	0	148	205	37	1.71	2.0
20	0.594	380	0	0.0%	380	100.0%	0	238	142	38	1.61	2.0
21	0.417	267	0	0.0%	267	100.0%	0	197	70	39	1.55	2.0
22	0.200	128	0	0.0%	128	100.0%	0	128	0	41	1.44	2.0
23	0.123	79	0	0.0%	79	100.0%	0	79	0	41	1.44	2.0
24	0.453	290	0	0.0%	290	100.0%	0	290	0	41	1.44	2.0
25	0.169	108	0	0.0%	108	100.0%	0	108	0	41	1.44	2.0
26	0.480	307	0	0.0%	307	100.0%	0	307	0	41	1.44	2.0
27	0.294	188	0	0.0%	188	100.0%	0	188	0	41	1.44	2.0
28	0.264	169	0	0.0%	169	100.0%	0	169	0	41	1.44	2.0
29	0.172	110	0	0.0%	110	100.0%	0	110	0	41	1.44	2.0
30	0.364	233	0	0.0%	233	100.0%	0	233	0	41	1.44	2.0
31	0.377	241	144	59.8%	97	40.2%	107	134	0	29	2.39	2.0
32	0.316	202	121	59.9%	81	40.1%	90	112	0	29	2.40	2.0
33	0.184	118	42	35.6%	76	64.4%	43	75	0	32	2.17	2.0
Total/Avg.	16.406	10,500	307	2.9%	10,193	97.1%	240	3,371	6,889	35.8	1.81	2.0

¹ Uses Pre-Development curve numbers (ARC-I)

APPENDIX B – HYDROLOGIC
DATA – HISTORIC
KETTLE CREEK DBPS
JOB NO. 25100.00
MAY 2015
B-12



Historic Land Use and Curve Number Data (24-Hour Duration Storms) ²												
							% Imperv.	2	2	2		
							CN Values ²	39	62	55		
Basin number	Area (mi)	Area (ac)	Soil Type A Area (ac)	Soil Type A Area (%)	Soil Type B Area (ac)	Soil Type B Area (%)	Meadows, Good Condition, HSG A (ac)	Herbaceous, Good Condition, HSG B (ac)	Woods, Good Condition, HSG B (ac)	Composite CN Value	Initial Abstraction (in)	Percent Impervious
1	1.263	808	0	0.0%	808	100.0%	0	92	716	56	0.79	2.0
2	0.586	375	0	0.0%	375	100.0%	0	35	340	56	0.80	2.0
3	0.180	115	0	0.0%	115	100.0%	0	9	106	56	0.80	2.0
4	0.195	125	0	0.0%	125	100.0%	0	0	125	55	0.82	2.0
5	0.625	400	0	0.0%	400	100.0%	0	20	380	55	0.81	2.0
6	1.333	853	0	0.0%	853	100.0%	0	51	802	55	0.80	2.0
7	0.183	117	0	0.0%	117	100.0%	0	11	106	56	0.80	2.0
8	0.288	184	0	0.0%	184	100.0%	0	0	184	55	0.82	2.0
9	1.177	753	0	0.0%	753	100.0%	0	139	614	56	0.78	2.0
10	0.222	142	0	0.0%	142	100.0%	0	0	142	55	0.82	2.0
11	0.880	563	0	0.0%	563	100.0%	0	6	557	55	0.82	2.0
12	0.552	353	0	0.0%	353	100.0%	0	70	283	56	0.77	2.0
13	1.156	740	0	0.0%	740	100.0%	0	70	670	56	0.80	2.0
14	0.516	330	0	0.0%	330	100.0%	0	115	215	57	0.74	2.0
15	0.498	319	0	0.0%	319	100.0%	0	90	229	57	0.76	2.0
16	0.819	524	0	0.0%	524	100.0%	0	67	457	56	0.79	2.0
17	0.788	504	0	0.0%	504	100.0%	0	58	446	56	0.79	2.0
18	0.192	123	0	0.0%	123	100.0%	0	23	100	56	0.78	2.0
19	0.552	353	0	0.0%	353	100.0%	0	148	205	58	0.73	2.0
20	0.594	380	0	0.0%	380	100.0%	0	238	142	59	0.68	2.0
21	0.417	267	0	0.0%	267	100.0%	0	197	70	60	0.66	2.0
22	0.200	128	0	0.0%	128	100.0%	0	128	0	62	0.61	2.0
23	0.123	79	0	0.0%	79	100.0%	2	77	0	61	0.63	2.0
24	0.453	290	0	0.0%	290	100.0%	0	290	0	62	0.61	2.0
25	0.169	108	0	0.0%	108	100.0%	0	108	0	62	0.61	2.0
26	0.480	307	0	0.0%	307	100.0%	0	307	0	62	0.61	2.0
27	0.294	188	0	0.0%	188	100.0%	0	188	0	62	0.61	2.0
28	0.264	169	0	0.0%	169	100.0%	0	169	0	62	0.61	2.0
29	0.172	110	0	0.0%	110	100.0%	0	110	0	62	0.61	2.0
30	0.364	233	0	0.0%	233	100.0%	0	233	0	62	0.61	2.0
31	0.377	241	144	59.8%	97	40.2%	107	134	0	52	0.93	2.0
32	0.316	202	121	59.9%	81	40.1%	90	112	0	52	0.93	2.0
33	0.184	118	42	35.6%	76	64.4%	43	75	0	54	0.87	2.0
Total/Avg.	16.408	10,501	307	2.9%	10,194	97.1%	242	3,370	6,889	56.9	0.76	2.0

² Uses Post-Development curve numbers (ARC-II)

APPENDIX B – HYDROLOGIC
DATA – HISTORIC
KETTLE CREEK DBPS
JOB NO. 25100.00
MAY 2015
B-13



Existing Land Use and Curve Number Data (2-Hour & 24-Hour Duration Storms)¹

Basin number	Area (mi)	Area (ac)	Soil Type A Area (ac)	Soil Type A Area (%)	Soil Type B Area (ac)	Soil Type B Area (%)	C values										Composite CN Value	Initial Abstraction (in)	Percent Impervious				
							% Imperv.	100	100	95	85	40	2	2	15	15				20	35	60	60
							83	89	89	92	72	39	62	65	65	65	70	61	75	74			
							Asphalt, HSG A (ac)	Asphalt, HSG B (ac)	Commercial Office, HSG A (ac)	Commercial Retail, HSG B (ac)	School, HSG B (ac)	Meadows, HSG A (ac)	Open Space Herbaceous, Good Condition, HSG B (ac)	Residential (5 ac lots) Herbaceous, HSG B (ac)	Residential (5 ac lots) Wooded, HSG B (ac)	Residential (2.5 ac lots) Wooded, HSG B (ac)	Residential (0.5 ac lots) Wooded, HSG B (ac)	Residential (0.25 ac lots) HSG A (ac)	Residential (0.25 ac lots) HSG B (ac)	Special Uses (ac)			
1	1.263	808	0	0.0%	808	100.0%		24						72	525	130	57				66	0.51	19.7
2	0.586	375	0	0.0%	375	100.0%		5						36	260		74				66	0.51	20.1
3	0.180	115	0	0.0%	115	100.0%		11						9	70		25				68	0.46	27.5
4	0.195	125	0	0.0%	125	100.0%					8			4	113						65	0.53	16.6
5	0.625	400	0	0.0%	400	100.0%		19		10				20	255		10			86	69	0.45	20.2
6	1.333	853	0	0.0%	853	100.0%					1			52	789		11				65	0.54	15.3
7	0.183	117	0	0.0%	117	100.0%		1						12	98					6	66	0.52	15.5
8	0.288	184	0	0.0%	184	100.0%		8							96					80	70	0.43	16.5
9	1.177	753	0	0.0%	753	100.0%		32		5				140	564		12				66	0.51	19.4
10	0.222	142	0	0.0%	142	100.0%									142						65	0.54	15.0
11	0.880	563	0	0.0%	563	100.0%		24		22				10	259		66			182	71	0.42	22.1
12	0.552	353	0	0.0%	353	100.0%		10						70	171		17			85	68	0.47	17.2
13	1.156	740	0	0.0%	740	100.0%		19						90	631						66	0.52	17.2
14	0.516	330	0	0.0%	330	100.0%		3						115	212						65	0.53	15.8
15	0.498	319	0	0.0%	319	100.0%		8						90	221						66	0.52	17.1
16	0.819	524	0	0.0%	524	100.0%		31						65	428						66	0.51	20.0
17	0.788	504	0	0.0%	504	100.0%		5						58	441						65	0.53	15.8
18	0.192	123	0	0.0%	123	100.0%		1						23	99						65	0.53	15.7
19	0.552	353	0	0.0%	353	100.0%		5					19	131	198						65	0.53	15.5
20	0.594	380	0	0.0%	380	100.0%		7					123	120	130						64	0.55	12.4
21	0.417	267	0	0.0%	267	100.0%							111	69	87						64	0.57	9.6
22	0.200	128	0	0.0%	128	100.0%							119	6	3						62	0.61	2.9
23	0.123	79	0	0.0%	79	100.0%		3				2	74								62	0.60	5.7
24	0.453	290	0	0.0%	290	100.0%		20					145	84	31				10		66	0.53	15.9
25	0.169	108	35	32.4%	73	67.6%		7					7					32	62		71	0.41	58.8
26	0.480	307	0	0.0%	307	100.0%		16					123	108	21						66	0.51	19.9
27	0.294	188	0	0.0%	188	100.0%		8			50		75							55	70	0.44	33.2
28	0.264	169	0	0.0%	169	100.0%							169								62	0.61	2.0
29	0.172	110	0	0.0%	110	100.0%		5					105								63	0.58	6.5
30	0.364	233	0	0.0%	233	100.0%		18					185								66	0.52	17.0
31	0.377	241	144	59.8%	97	40.2%	2	1				59	81					48	50		59	0.69	26.8
32	0.316	202	121	59.9%	81	40.1%	5	5	29	7		65	91								61	0.65	23.1
33	0.184	118	42	35.6%	76	64.4%						43	75								54	0.87	2.0
Total	16.408	10,501	342	3.3%	10,159	96.7%	7	296	29	44	59	169	1502	1,384	5,844	130	272	80	246	439	66	0.52	17.8
Percent of Total							0.07%	2.82%	0.28%	0.42%	0.56%	1.61%	14.30%	13.18%	55.65%	1.24%	2.59%	0.76%	2.34%	4.18%			

¹ Uses Post-Development curve numbers (ARC-II)

NOTE

1. SUBBASINS 24-27 DATA HAS BEEN REPLACED WITH KETTLE CREEK DRAINAGE BASIN OLD RANCH ROAD TRIBUTARY MASTER DEVELOPMENT PLAN FLOW DATA (JR ENG. 2001)

APPENDIX B – HYDROLOGIC DATA – EXISTING KETTLE CREEK DBPS JOB NO. 25100.00 MAY 2015 B-14



Future Land Use and Curve Number Data (2-Hour & 24-Hour Duration Storms)¹

Basin number	Area (mi)	Area (ac)	Soil Type A Area (ac)	Soil Type A Area (%)	Soil Type B Area (ac)	Soil Type B Area (%)	% Imperv.		Commercial Office, HSG A (ac)	Commercial Retail, HSG B (ac)	School, HSG B (ac)	Meadows, HSG A (ac)	Open Space Herbaceous, Good Condition, HSG B (ac)	Residential (5 ac lots) Herbaceous, HSG B (ac)	Residential (5 ac lots) Wooded, HSG B (ac)	Residential (2.5 ac lots) Wooded, HSG B (ac)	Residential (0.5 ac lots) Wooded, HSG B (ac)	Residential (0.25 ac lots) HSG A (ac)	Residential (0.25 ac lots) HSG B (ac)	Special Uses (ac)	Composite CN Value	Initial Abstraction (in)	Percent Impervious
							100	100															
							83	89	89	92	72	39	62	65	65	65	70	61	75	74			
1	1.263	808	0	0.0%	808	100.0%		24						72	525	130	57				66	0.51	19.7
2	0.586	375	0	0.0%	375	100.0%		5						36	260		74				66	0.51	20.1
3	0.180	115	0	0.0%	115	100.0%		11						9	70		25				68	0.46	27.5
4	0.195	125	0	0.0%	125	100.0%					8			4	113						65	0.53	16.6
5	0.625	400	0	0.0%	400	100.0%		19		10				20	255		10			86	69	0.45	20.2
6	1.333	853	0	0.0%	853	100.0%					1			52	789		11				65	0.54	15.3
7	0.183	117	0	0.0%	117	100.0%		1						12	98					6	66	0.52	15.5
8	0.288	184	0	0.0%	184	100.0%		8							96					80	70	0.43	16.5
9	1.177	753	0	0.0%	753	100.0%		32		5				140	564		12				66	0.51	19.4
10	0.222	142	0	0.0%	142	100.0%									142						65	0.54	15.0
11	0.880	563	0	0.0%	563	100.0%		24		22				10	259		66			182	71	0.42	22.1
12	0.552	353	0	0.0%	353	100.0%		10						70	171		17			85	68	0.47	17.2
13	1.156	740	0	0.0%	740	100.0%		19						90	631						66	0.52	17.2
14	0.516	330	0	0.0%	330	100.0%		3						115	212						65	0.53	15.8
15	0.498	319	0	0.0%	319	100.0%		8						90	221						66	0.52	17.1
16	0.819	524	0	0.0%	524	100.0%		31						65	428						66	0.51	20.0
17	0.788	504	0	0.0%	504	100.0%		5						58	441						65	0.53	15.8
18	0.192	123	0	0.0%	123	100.0%		1						23	99						65	0.53	15.7
19	0.552	353	0	0.0%	353	100.0%		5						131	198				19		66	0.52	18.6
20	0.594	380	0	0.0%	380	100.0%		7					15	120	130				108		68	0.47	28.8
21	0.417	267	0	0.0%	267	100.0%					6			91	69	87			14		65	0.55	13.5
22	0.200	128	0	0.0%	128	100.0%								18	6	3			101		72	0.38	48.7
23	0.123	79	0	0.0%	79	100.0%		3						76							63	0.59	5.7
24	0.453	290	0	0.0%	290	100.0%		20		16				16	84	30			124		72	0.38	43.2
25	0.169	108	35	32.4%	73	67.6%		7						7				32	62		71	0.41	58.8
26	0.480	307	0	0.0%	307	100.0%		16						72	108	21			90		68	0.46	29.6
27	0.294	188	0	0.0%	188	100.0%		8			50			50					80		71	0.40	41.0
28	0.264	169	0	0.0%	169	100.0%					8			34					127		72	0.38	47.4
29	0.172	110	0	0.0%	110	100.0%		5											105		76	0.32	61.8
30	0.364	233	0	0.0%	233	100.0%		18						170					45		69	0.45	30.3
31	0.377	241	144	59.8%	97	40.2%	2	1			10						130	48	50		65	0.53	36.5
32	0.316	202	121	59.9%	81	40.1%	5	5	102	12				10			63		5		80	0.25	66.4
33	0.184	118	42	35.6%	76	64.4%					43			75							54	0.87	2.0
Total	16.408	10,501	342	3.3%	10,159	96.7%	7	296	102	65	73	53	454	1,564	5,843	323	272	80	930	439	67	0.49	23.0
Percent of Total							0.07%	2.82%	0.97%	0.62%	0.70%	0.50%	4.32%	14.89%	55.64%	3.08%	2.59%	0.76%	8.86%	4.18%			
Percent Increase from Existing							0.00%	0.00%	0.70%	0.20%	0.13%	-1.10%	-9.98%	1.71%	-0.01%	1.84%	0.00%	0.00%	6.51%	0.00%			

¹ Uses Post-Development curve numbers (ARC-II)

NOTE

1. SUBBASINS 24-27 DATA HAS BEEN REPLACED WITH KETTLE CREEK DRAINAGE BASIN OLD RANCH ROAD TRIBUTARY MASTER DEVELOPMENT PLAN FLOW DATA (JR ENG. 2001)

APPENDIX B – HYDROLOGIC DATA – FUTURE KETTLE CREEK DBPS JOB NO. 25100.00 MAY 2015 B-15



Time of Concentration and Lag Time Data

Basin	Overland Flow					Shallow Concentrated Flow							Concentrated Flow							Time of concentration (hr)	Total Time of Concentration (min)	Lag time (min)
	Manning's n	Flow Length (ft)	2yr, 24hr rainfall (in)	Slope	Overland Flow time (hr)	Conveyance Coefficient	Length	Top Elevation (ft)	Bottom Elevation (ft)	Slope	Velocity (ft/s)	Concentrated Flow time (hr)	Conveyance Coefficient	Length (ft)	Top Elevation (ft)	Bottom Elevation (ft)	Slope	Velocity (ft/s)	Concentrated Flow time (hr)			
1	0.20	300	2.1	65.10%	0.15	9	2,726	7660	7410	9.17%	2.73	0.28	17	6,820	7410	7310	1.47%	2.06	0.92	1.35	80.99	48.59
2	0.20	300	2.1	9.25%	0.33	9	2,175	7625	7500	5.75%	2.16	0.28	16	4,907	7500	7310	3.87%	3.15	0.43	1.04	62.65	37.59
3	0.20	200	2.1	4.27%	0.33	10	6,373	7650	7370	4.39%	2.10	0.84	20	1,131	7370	7310	5.31%	4.61	0.07	1.24	74.34	44.60
Reach 1													20	465	7310	7285	5.38%	4.64	0.03	0.03	1.67	1.67
4	0.20	300	2.1	5.22%	0.42	9	3,142	7505	7350	4.93%	2.00	0.44	16	944	7350	7290	6.36%	4.03	0.07	0.92	55.08	33.05
Reach 2													20	1,790	7285	7250	1.96%	2.80	0.18	0.18	10.67	10.67
5	0.20	300	2.1	3.92%	0.47	9	6,683	7517	7354	2.44%	1.41	1.32	15	1,787	7354	7250	5.82%	3.62	0.14	1.92	115.49	69.29
Reach 3													20	2,460	7250	7205	1.83%	2.71	0.25	0.25	15.16	15.16
6	0.15	300	2.1	4.35%	0.36	10	6,911	7650	7380	3.91%	1.98	0.97	17	5,490	7380	7205	3.19%	3.04	0.50	1.83	109.77	65.86
Reach 4													20	1,230	7205	7174	2.52%	3.18	0.11	0.11	6.46	6.46
7	0.15	300	2.1	5.02%	0.34	9	3,600	7455	7270	5.14%	2.04	0.49	16	1,850	7270	7174	5.19%	3.64	0.14	0.97	58.03	34.82
Reach 5													20	700	7174	7160	2.00%	2.83	0.07	0.07	4.12	4.12
8	0.20	300	2.1	6.32%	0.39	9	1,970	7340	7213	6.45%	2.29	0.24	14	605	7213	7160	8.76%	4.14	0.04	0.67	39.94	23.97
Reach 6													20	4,123	7160	7090	1.70%	2.61	0.44	0.44	26.37	26.37
9	0.18	300	2.1	3.99%	0.43	9	5,070	7668	7460	4.10%	1.82	0.77	14	6,816	7460	7280	2.64%	2.28	0.83	2.03	121.85	73.11
10	0.20	300	2.1	3.88%	0.47	9	2,271	7430	7320	4.84%	1.98	0.32	12	838	7320	7280	4.77%	2.62	0.09	0.88	52.56	31.54
Reach 7													18	1,470	7280	7255	1.70%	2.35	0.17	0.17	10.44	10.44
11	0.18	300	2.1	4.83%	0.39	9	4,020	7455	7260	4.85%	1.98	0.56							0.96	57.49	34.49	
Reach 8													18	4,450	7260	7120	3.15%	3.19	0.39	0.39	23.23	23.23
12	0.15	200	2.1	5.06%	0.24	9	4,890	7450	7200	5.11%	2.03	0.67	17	3,402	7200	7120	2.35%	2.61	0.36	1.27	76.33	45.80
Reach 9													18	1,670	7120	7090	1.80%	2.41	0.19	0.19	11.54	11.54
Reach 10													20	3,671	7090	7020	1.91%	2.76	0.37	0.37	22.15	22.15
13	0.20	300	2.1	7.81%	0.35	9	8,650	7545	7163	4.42%	1.89	1.27	17	3,900	7163	7020	3.67%	3.26	0.33	1.96	117.45	70.47
14	0.15	300	2.1	20.37%	0.19	9	5,047	7424	7130	5.83%	2.17	0.65	18	2,428	7130	7020	4.53%	3.83	0.18	1.01	60.80	36.48
Reach 11													20	2,027	7020	6990	1.48%	2.43	0.23	0.23	13.88	13.88
15	0.20	300	2.1	17.32%	0.26	11	5,510	7405	7090	5.72%	2.63	0.58	17	2,020	7090	6990	4.95%	3.78	0.15	0.99	59.28	35.57
Reach 12													20	3,658	6990	6950	1.09%	2.09	0.49	0.49	29.15	29.15
16	0.20	300	2.1	12.32%	0.19	9	7,271	7440	7070	5.09%	2.03	0.99	18	3,520	7070	6950	3.41%	3.32	0.29	1.48	88.85	53.31
17	0.20	300	2.1	8.01%	0.35	10	6,365	7440	7040	6.28%	2.51	0.71	18	2,160	7040	6950	4.17%	3.67	0.16	1.22	73.16	43.90
Reach 13													20	1,624	6950	6900	3.08%	3.51	0.13	0.13	7.71	7.71
18	0.20	300	2.1	4.58%	0.30	10	3,532	7185	7010	4.95%	2.23	0.44	15	1,623	7010	6900	6.78%	3.91	0.12	0.85	51.09	30.65
Reach 14													20	1,000	6900	6885	1.50%	2.45	0.11	0.11	6.80	6.80
19	0.20	300	2.1	2.85%	0.53	9	6,563	7475	7130	5.26%	2.06	0.88	15	4,741	7130	6885	5.17%	3.41	0.39	1.80	108.00	64.80
Reach 15													20	1,450	6885	6875	0.69%	1.66	0.24	0.24	14.55	14.55
20	0.15	300	2.1	14.35%	0.22	11	5,234	7260	7010	4.78%	2.40	0.60	18	3,413	7010	6880	3.81%	3.51	0.27	1.10	65.72	39.43
Reach 16													20	1,660	6875	6850	1.51%	2.45	0.19	0.19	11.27	11.27
21	0.15	300	2.1	6.38%	0.31	12	3,500	7110	6975	3.86%	2.36	0.41	19	1,873	6975	6850	6.67%	4.91	0.11	0.82	49.43	29.66
Reach 17													20	2,382	6850	6820	1.26%	2.24	0.29	0.29	17.69	17.69
22	0.15	300	2.1	3.15%	0.40	11	1,954	7060	6950	5.63%	2.61	0.21	18	2,680	6950	6820	4.85%	3.96	0.19	0.80	48.03	28.82
Reach 18													20	5,850	6820	6730	1.54%	2.48	0.66	0.66	39.30	39.30

APPENDIX B – HYDROLOGIC DATA – TC
 KETTLE CREEK DBPS
 JOB NO. 25100.00
 MAY 2015
 B-16



Time of Concentration and Lag Time Data

Basin	Overland Flow					Shallow Concentrated Flow							Concentrated Flow							Time of concentration (hr)	Total Time of Concentration (min)	Lag time (min)
	Manning's n	Flow Length (ft)	2yr, 24hr rainfall (in)	Slope	Overland Flow time (hr)	Conveyance Coefficient	Length	Top Elevation (ft)	Bottom Elevation (ft)	Slope	Velocity (ft/s)	Concentrated Flow time (hr)	Conveyance Coefficient	Length (ft)	Top Elevation (ft)	Bottom Elevation (ft)	Slope	Velocity (ft/s)	Concentrated Flow time (hr)			
23	0.15	150	2.1	4.41%	0.20	15	750	6800	6760	5.33%	3.46	0.06	20	401	6760	6730	7.48%	5.47	0.02	0.28	17.02	10.21
Reach 19													20	2,067	6730	6700	1.45%	2.41	0.24	0.24	14.30	14.30
24	0.20	300	2.1	16.14%	0.27	13	8,554	7323	6990	3.89%	2.56	0.93	16	3,600	6990	6888	2.83%	2.69	0.37	1.56	93.76	56.26
25	0.01	100	2.1	6.60%	0.01	20	3,404	7000	6888	3.29%	3.63	0.26								0.27	16.50	9.90
26	0.15	300	2.1	2.60%	0.44	15	6,084	7185	6990	3.21%	2.69	0.63	19	3,180	6990	6885	3.30%	3.45	0.26	1.32	79.34	47.60
Reach 21													20	1,175	6888	6840	4.09%	4.04	0.08	0.08	4.84	4.84
Reach 22													20	2,934	6840	6700	4.77%	4.37	0.19	0.19	11.19	11.19
27	0.18	300	2.1	3.10%	0.47	18	2,126	7000	6910	4.23%	3.70	0.16	20	2,345	6910	6840	2.99%	3.46	0.19	0.82	49.16	29.50
28	0.15	300	2.1	2.80%	0.42	13	3,410	7015	6885	3.81%	2.54	0.37	15	1,939	6885	6860	1.29%	1.70	0.32	1.11	66.82	40.09
29	0.15	300	2.1	3.10%	0.41	14	3,075	7045	6935	3.58%	2.65	0.32	16	1,166	6935	6870	5.57%	3.78	0.09	0.82	48.94	29.37
Reach 20													17	4,516	6870	6700	3.76%	3.30	0.38	0.38	22.82	22.82
30	0.15	300	2.1	5.62%	0.32	12	1,693	6893	6835	3.43%	2.22	0.21	19	3,350	6835	6700	4.03%	3.81	0.24	0.78	46.61	27.97
Reach 23													20	1,528	6700	6668	2.09%	2.89	0.15	0.15	8.80	8.80
31	0.01	100	2.1	3.08%	0.02	18	1,396	6890	6850	2.87%	3.05	0.13	20	1,890	6850	6730	6.35%	5.04	0.10	0.25	15.05	9.03
32	0.15	100	2.1	2.84%	0.18	15	2,355	6775	6700	3.18%	2.68	0.24	20	332	6700	6668	9.64%	6.21	0.01	0.43	26.07	15.64
Reach 24													20	5,047	6668	6610	1.15%	2.14	0.65	0.65	39.23	39.23
33	0.15	300	2.1	3.00%	0.41	15	563	6680	6658	3.91%	2.97	0.05	20	691	6658	6612	6.66%	5.16	0.04	0.50	30.16	18.10
Reach 25													20	3,106	6612	6580	1.03%	2.03	0.43	0.43	25.50	25.50

APPENDIX B – HYDROLOGIC
 DATA – TC
 KETTLE CREEK DBPS
 JOB NO. 25100.00
 MAY 2015
 B-17



HISTORIC CONDITIONS
MODEL RESULTS
(2-YEAR)

2-Year, 2-Hour Storm			
Hydrologic Element	Drainage Area (mi ²)	Peak Discharge (CFS)	Volume (in)
Subbasin-1	1.263	11	0.03
Subbasin-2	0.586	6	0.03
Subbasin-3	0.180	2	0.03
Junction-1	2.029	19	0.03
Reach-1	2.029	19	0.03
Subbasin-4	0.195	2	0.03
Junction-2	2.224	21	0.03
Reach-2	2.224	21	0.03
Subbasin-5	0.625	4	0.03
Junction-3	2.849	25	0.03
Reach-3	2.849	25	0.03
Subbasin-6	1.333	9	0.03
Junction-4	4.182	34	0.03
Reach-4	4.182	34	0.03
Subbasin-7	0.183	2	0.03
Junction-5	4.365	35	0.03
Reach-5	4.365	35	0.03
Subbasin-8	0.288	4	0.03
Junction-6	4.653	35	0.03
Reach-6	4.653	35	0.03
Subbasin-9	1.177	8	0.03
Subbasin-10	0.222	3	0.03
Junction-7	1.399	9	0.03
Reach-7	1.399	9	0.03
Subbasin-11	0.880	10	0.03
Junction-8	2.279	16	0.03
Reach-8	2.279	16	0.03
Subbasin-12	0.552	5	0.03
Junction-9	2.831	20	0.03
Reach-9	2.831	20	0.03
Junction-10	7.484	51	0.03
Reach-10	7.484	51	0.03
Subbasin-13	1.156	8	0.03
Subbasin-14	0.516	6	0.03
Junction-11	9.156	56	0.03
Reach-11	9.156	56	0.03
Subbasin-15	0.498	6	0.03
Junction-12	9.654	57	0.03
Reach-12	9.654	57	0.03
Subbasin-16	0.819	7	0.03
Subbasin-17	0.788	8	0.03
Junction-13	11.261	59	0.03

2-Year, 2-Hour Storm			
Hydrologic Element	Drainage Area (mi ²)	Peak Discharge (CFS)	Volume (in)
Reach-13	11.261	59	0.03
Subbasin-18	0.192	2	0.03
Junction-14	11.453	59	0.03
Reach-14	11.453	59	0.03
Subbasin-19	0.552	4	0.03
Junction-15	12.005	60	0.03
Reach-15	12.005	60	0.03
Subbasin-20	0.594	6	0.03
Junction-16	12.599	61	0.03
Reach-16	12.599	61	0.03
Subbasin-21	0.417	5	0.03
Junction-17	13.016	61	0.03
Reach-17	13.016	61	0.03
Subbasin-22	0.200	3	0.03
Junction-18	13.216	61	0.03
Reach-18	13.216	61	0.03
Subbasin-23	0.123	3	0.03
Junction-19	13.339	61	0.03
Reach-19	13.339	61	0.03
Subbasin-24	0.453	4	0.03
Subbasin-25	0.169	4	0.03
Subbasin-26	0.480	4	0.03
Junction-21	1.102	8	0.03
Reach-21	1.102	8	0.03
Subbasin-27	0.294	4	0.03
Junction-22	1.396	11	0.03
Reach-22	1.396	11	0.03
Subbasin-28	0.264	3	0.03
Subbasin-29	0.172	2	0.03
Junction-20	0.436	5	0.03
Reach-20	0.436	5	0.03
Subbasin-30	0.364	5	0.03
Junction-23	15.535	62	0.03
Reach-23	15.535	62	0.03
Subbasin-31	0.377	10	0.03
Subbasin-32	0.316	6	0.03
Junction-24	16.228	62	0.03
Reach-24	16.228	62	0.03
Subbasin-33	0.184	3	0.03
Junction-25	16.412	62	0.03
Reach-25	16.412	62	0.03
Junction-26	16.412	62	0.03

2-Year, 24-Hour Storm			
Hydrologic Element	Drainage Area (mi ²)	Peak Discharge (CFS)	Volume (in)
Subbasin-1	1.263	52	0.23
Subbasin-2	0.586	27	0.22
Subbasin-3	0.180	8	0.22
Junction-1	2.029	87	0.22
Reach-1	2.029	86	0.22
Subbasin-4	0.195	9	0.21
Junction-2	2.224	95	0.22
Reach-2	2.224	93	0.22
Subbasin-5	0.625	20	0.21
Junction-3	2.849	111	0.22
Reach-3	2.849	111	0.22
Subbasin-6	1.333	44	0.22
Junction-4	4.182	156	0.22
Reach-4	4.182	152	0.22
Subbasin-7	0.183	9	0.22
Junction-5	4.365	158	0.22
Reach-5	4.365	155	0.22
Subbasin-8	0.288	16	0.21
Junction-6	4.653	161	0.22
Reach-6	4.653	160	0.22
Subbasin-9	1.177	39	0.23
Subbasin-10	0.222	11	0.21
Junction-7	1.399	45	0.23
Reach-7	1.399	45	0.23
Subbasin-11	0.880	41	0.21
Junction-8	2.279	71	0.22
Reach-8	2.279	71	0.22
Subbasin-12	0.552	25	0.23
Junction-9	2.831	91	0.22
Reach-9	2.831	91	0.22
Junction-10	7.484	244	0.22
Reach-10	7.484	240	0.22
Subbasin-13	1.156	38	0.22
Subbasin-14	0.516	28	0.25
Junction-11	9.156	279	0.22
Reach-11	9.156	279	0.22
Subbasin-15	0.498	27	0.24
Junction-12	9.654	287	0.22
Reach-12	9.654	286	0.22
Subbasin-16	0.819	32	0.23
Subbasin-17	0.788	35	0.23
Junction-13	11.261	309	0.22

2-Year, 24-Hour Storm			
Hydrologic Element	Drainage Area (mi ²)	Peak Discharge (CFS)	Volume (in)
Reach-13	11.261	306	0.22
Subbasin-18	0.192	11	0.23
Junction-14	11.453	308	0.22
Reach-14	11.453	307	0.22
Subbasin-19	0.552	23	0.26
Junction-15	12.005	317	0.23
Reach-15	12.005	316	0.23
Subbasin-20	0.594	37	0.28
Junction-16	12.599	323	0.23
Reach-16	12.599	322	0.23
Subbasin-21	0.417	33	0.29
Junction-17	13.016	327	0.23
Reach-17	13.016	325	0.23
Subbasin-22	0.200	19	0.33
Junction-18	13.216	328	0.23
Reach-18	13.216	327	0.23
Subbasin-23	0.123	18	0.31
Junction-19	13.339	329	0.23
Reach-19	13.339	328	0.23
Subbasin-24	0.453	29	0.33
Subbasin-25	0.169	27	0.33
Subbasin-26	0.480	34	0.33
Junction-21	1.102	67	0.33
Reach-21	1.102	66	0.33
Subbasin-27	0.294	27	0.33
Junction-22	1.396	87	0.33
Reach-22	1.396	85	0.33
Subbasin-28	0.264	20	0.33
Subbasin-29	0.172	16	0.33
Junction-20	0.436	36	0.33
Reach-20	0.436	34	0.33
Subbasin-30	0.364	34	0.33
Junction-23	15.535	353	0.25
Reach-23	15.535	350	0.25
Subbasin-31	0.377	23	0.17
Subbasin-32	0.316	15	0.17
Junction-24	16.228	354	0.24
Reach-24	16.228	354	0.24
Subbasin-33	0.184	10	0.19
Junction-25	16.412	354.9	0.24
Reach-25	16.412	352.9	0.24
Junction-26	16.412	352.9	0.24

APPENDIX B – HYDROLOGIC
RESULTS – HISTORIC 2-YR
KETTLE CREEK DBPS
JOB NO. 25100.00
MAY 2015
B-18



HISTORIC CONDITIONS
MODEL RESULTS
(5-YEAR)

5-Year, 2-Hour Storm			
Hydrologic Element	Drainage Area (mi ²)	Peak Discharge (CFS)	Volume (in)
Subbasin-1	1.263	20	0.03
Subbasin-2	0.586	11	0.03
Subbasin-3	0.18	3	0.03
Junction-1	2.029	33	0.03
Reach-1	2.029	33	0.03
Subbasin-4	0.195	4	0.03
Junction-2	2.224	37	0.03
Reach-2	2.224	37	0.03
Subbasin-5	0.625	8	0.03
Junction-3	2.849	43	0.03
Reach-3	2.849	43	0.03
Subbasin-6	1.333	17	0.03
Junction-4	4.182	60	0.03
Reach-4	4.182	60	0.03
Subbasin-7	0.183	4	0.03
Junction-5	4.365	61	0.03
Reach-5	4.365	61	0.03
Subbasin-8	0.288	7	0.03
Junction-6	4.653	62	0.03
Reach-6	4.653	62	0.03
Subbasin-9	1.177	14	0.03
Subbasin-10	0.222	5	0.03
Junction-7	1.399	15	0.03
Reach-7	1.399	15	0.03
Subbasin-11	0.88	17	0.03
Junction-8	2.279	28	0.03
Reach-8	2.279	28	0.03
Subbasin-12	0.552	9	0.03
Junction-9	2.831	35	0.03
Reach-9	2.831	35	0.03
Junction-10	7.484	89	0.03
Reach-10	7.484	89	0.03
Subbasin-13	1.156	14	0.03
Subbasin-14	0.516	10	0.03
Junction-11	9.156	98	0.03
Reach-11	9.156	98	0.03
Subbasin-15	0.498	10	0.03
Junction-12	9.654	99	0.03
Reach-12	9.654	99	0.03
Subbasin-16	0.819	12	0.03
Subbasin-17	0.788	13	0.03
Junction-13	11.261	101	0.03

5-Year, 2-Hour Storm			
Hydrologic Element	Drainage Area (mi ²)	Peak Discharge (CFS)	Volume (in)
Reach-13	11.261	101	0.03
Subbasin-18	0.192	4	0.03
Junction-14	11.453	101	0.03
Reach-14	11.453	101	0.03
Subbasin-19	0.552	7	0.03
Junction-15	12.005	102	0.03
Reach-15	12.005	102	0.03
Subbasin-20	0.594	11	0.03
Junction-16	12.599	102	0.03
Reach-16	12.599	102	0.03
Subbasin-21	0.417	9	0.04
Junction-17	13.016	102	0.03
Reach-17	13.016	102	0.03
Subbasin-22	0.2	5	0.04
Junction-18	13.216	102	0.03
Reach-18	13.216	102	0.03
Subbasin-23	0.123	5	0.04
Junction-19	13.339	102	0.03
Reach-19	13.339	101	0.03
Subbasin-24	0.453	7	0.04
Subbasin-25	0.169	6	0.04
Subbasin-26	0.48	8	0.04
Junction-21	1.102	15	0.04
Reach-21	1.102	15	0.04
Subbasin-27	0.294	7	0.04
Junction-22	1.396	20	0.04
Reach-22	1.396	20	0.04
Subbasin-28	0.264	5	0.04
Subbasin-29	0.172	4	0.04
Junction-20	0.436	8	0.04
Reach-20	0.436	8	0.04
Subbasin-30	0.364	8	0.04
Junction-23	15.535	102	0.03
Reach-23	15.535	101	0.03
Subbasin-31	0.377	15	0.03
Subbasin-32	0.316	10	0.03
Junction-24	16.228	101	0.03
Reach-24	16.228	101	0.03
Subbasin-33	0.184	5	0.03
Junction-25	16.412	101	0.03
Reach-25	16.412	101	0.03
Junction-26	16.412	101	0.03

5-Year, 24-Hour Storm			
Hydrologic Element	Drainage Area (mi ²)	Peak Discharge (CFS)	Volume (in)
Subbasin-1	1.263	111	0.42
Subbasin-2	0.586	59	0.42
Subbasin-3	0.18	17	0.42
Junction-1	2.029	185	0.42
Reach-1	2.029	184	0.42
Subbasin-4	0.195	20	0.4
Junction-2	2.224	202	0.42
Reach-2	2.224	195	0.42
Subbasin-5	0.625	42	0.4
Junction-3	2.849	235	0.41
Reach-3	2.849	235	0.41
Subbasin-6	1.333	93	0.4
Junction-4	4.182	328	0.41
Reach-4	4.182	323	0.41
Subbasin-7	0.183	20	0.42
Junction-5	4.365	333	0.41
Reach-5	4.365	324	0.41
Subbasin-8	0.288	35	0.4
Junction-6	4.653	337	0.41
Reach-6	4.653	336	0.41
Subbasin-9	1.177	81	0.42
Subbasin-10	0.222	24	0.4
Junction-7	1.399	93	0.42
Reach-7	1.399	92	0.42
Subbasin-11	0.88	89	0.4
Junction-8	2.279	152	0.41
Reach-8	2.279	150	0.41
Subbasin-12	0.552	52	0.43
Junction-9	2.831	193	0.41
Reach-9	2.831	191	0.41
Junction-10	7.484	508	0.41
Reach-10	7.484	500	0.41
Subbasin-13	1.156	80	0.42
Subbasin-14	0.516	59	0.45
Junction-11	9.156	578	0.41
Reach-11	9.156	576	0.41
Subbasin-15	0.498	57	0.44
Junction-12	9.654	590	0.42
Reach-12	9.654	589	0.42
Subbasin-16	0.819	68	0.42
Subbasin-17	0.788	74	0.42
Junction-13	11.261	631	0.42

5-Year, 24-Hour Storm			
Hydrologic Element	Drainage Area (mi ²)	Peak Discharge (CFS)	Volume (in)
Reach-13	11.261	627	0.42
Subbasin-18	0.192	23	0.42
Junction-14	11.453	631	0.42
Reach-14	11.453	624	0.42
Subbasin-19	0.552	46	0.47
Junction-15	12.005	641	0.42
Reach-15	12.005	640	0.42
Subbasin-20	0.594	73	0.5
Junction-16	12.599	654	0.42
Reach-16	12.599	653	0.42
Subbasin-21	0.417	65	0.52
Junction-17	13.016	661	0.43
Reach-17	13.016	658	0.43
Subbasin-22	0.2	35	0.57
Junction-18	13.216	662	0.43
Reach-18	13.216	660	0.43
Subbasin-23	0.123	35	0.55
Junction-19	13.339	662	0.43
Reach-19	13.339	660	0.43
Subbasin-24	0.453	54	0.57
Subbasin-25	0.169	51	0.57
Subbasin-26	0.48	64	0.57
Junction-21	1.102	128	0.57
Reach-21	1.102	125	0.57
Subbasin-27	0.294	52	0.57
Junction-22	1.396	164	0.57
Reach-22	1.396	161	0.57
Subbasin-28	0.264	38	0.57
Subbasin-29	0.172	30	0.57
Junction-20	0.436	68	0.57
Reach-20	0.436	64	0.57
Subbasin-30	0.364	65	0.57
Junction-23	15.535	702	0.45
Reach-23	15.535	697	0.45
Subbasin-31	0.377	58	0.33
Subbasin-32	0.316	37	0.33
Junction-24	16.228	705	0.44
Reach-24	16.228	702	0.44
Subbasin-33	0.184	24	0.37
Junction-25	16.412	704	0.44
Reach-25	16.412	698	0.44
Junction-26	16.412	698	0.44

APPENDIX B – HYDROLOGIC
RESULTS – HISTORIC 5-YR
KETTLE CREEK DBPS
JOB NO. 25100.00
MAY 2015
B-19



HISTORIC CONDITIONS
MODEL RESULTS
(10-YEAR)

10-Year, 2-Hour Storm			
Hydrologic Element	Drainage Area (mi ²)	Peak Discharge (CFS)	Volume (in)
Subbasin-1	1.263	23	0.04
Subbasin-2	0.586	13	0.04
Subbasin-3	0.180	3	0.04
Junction-1	2.029	38	0.04
Reach-1	2.029	38	0.04
Subbasin-4	0.195	5	0.04
Junction-2	2.224	42	0.04
Reach-2	2.224	42	0.04
Subbasin-5	0.625	9	0.04
Junction-3	2.849	50	0.04
Reach-3	2.849	50	0.04
Subbasin-6	1.333	19	0.04
Junction-4	4.182	69	0.04
Reach-4	4.182	69	0.04
Subbasin-7	0.183	4	0.04
Junction-5	4.365	70	0.04
Reach-5	4.365	70	0.04
Subbasin-8	0.288	8	0.04
Junction-6	4.653	71	0.04
Reach-6	4.653	71	0.04
Subbasin-9	1.177	15	0.04
Subbasin-10	0.222	5	0.04
Junction-7	1.399	17	0.04
Reach-7	1.399	17	0.04
Subbasin-11	0.880	20	0.04
Junction-8	2.279	32	0.04
Reach-8	2.279	32	0.04
Subbasin-12	0.552	10	0.04
Junction-9	2.831	41	0.04
Reach-9	2.831	40	0.04
Junction-10	7.484	102	0.04
Reach-10	7.484	102	0.04
Subbasin-13	1.156	16	0.04
Subbasin-14	0.516	11	0.04
Junction-11	9.156	113	0.04
Reach-11	9.156	113	0.04
Subbasin-15	0.498	11	0.04
Junction-12	9.654	114	0.04
Reach-12	9.654	114	0.04
Subbasin-16	0.819	14	0.04
Subbasin-17	0.788	15	0.04
Junction-13	11.261	117	0.04

10-Year, 2-Hour Storm			
Hydrologic Element	Drainage Area (mi ²)	Peak Discharge (CFS)	Volume (in)
Reach-13	11.261	117	0.04
Subbasin-18	0.192	5	0.04
Junction-14	11.453	117	0.04
Reach-14	11.453	116	0.04
Subbasin-19	0.552	8	0.04
Junction-15	12.005	118	0.04
Reach-15	12.005	118	0.04
Subbasin-20	0.594	13	0.05
Junction-16	12.599	118	0.04
Reach-16	12.599	118	0.04
Subbasin-21	0.417	11	0.05
Junction-17	13.016	118	0.04
Reach-17	13.016	118	0.04
Subbasin-22	0.200	6	0.06
Junction-18	13.216	118	0.04
Reach-18	13.216	118	0.04
Subbasin-23	0.123	5	0.06
Junction-19	13.339	118	0.04
Reach-19	13.339	118	0.04
Subbasin-24	0.453	9	0.06
Subbasin-25	0.169	7	0.06
Subbasin-26	0.480	10	0.06
Junction-21	1.102	21	0.06
Reach-21	1.102	21	0.06
Subbasin-27	0.294	8	0.06
Junction-22	1.396	27	0.06
Reach-22	1.396	27	0.06
Subbasin-28	0.264	6	0.06
Subbasin-29	0.172	5	0.06
Junction-20	0.436	11	0.06
Reach-20	0.436	11	0.06
Subbasin-30	0.364	10	0.06
Junction-23	15.535	118	0.04
Reach-23	15.535	118	0.04
Subbasin-31	0.377	17	0.04
Subbasin-32	0.316	11	0.04
Junction-24	16.228	118	0.04
Reach-24	16.228	118	0.04
Subbasin-33	0.184	6	0.04
Junction-25	16.412	117.8	0.04
Reach-25	16.412	117.8	0.04
Junction-26	16.412	117.8	0.04

10-Year, 24-Hour Storm			
Hydrologic Element	Drainage Area (mi ²)	Peak Discharge (CFS)	Volume (in)
Subbasin-1	1.263	174	0.62
Subbasin-2	0.586	93	0.61
Subbasin-3	0.180	26	0.61
Junction-1	2.029	290	0.62
Reach-1	2.029	288	0.62
Subbasin-4	0.195	32	0.59
Junction-2	2.224	316	0.61
Reach-2	2.224	304	0.61
Subbasin-5	0.625	65	0.59
Junction-3	2.849	367	0.61
Reach-3	2.849	367	0.61
Subbasin-6	1.333	144	0.60
Junction-4	4.182	511	0.61
Reach-4	4.182	506	0.61
Subbasin-7	0.183	31	0.61
Junction-5	4.365	522	0.61
Reach-5	4.365	509	0.61
Subbasin-8	0.288	56.3	0.59
Junction-6	4.653	528	0.61
Reach-6	4.653	525	0.61
Subbasin-9	1.177	126	0.62
Subbasin-10	0.222	38	0.59
Junction-7	1.399	144	0.62
Reach-7	1.399	142	0.62
Subbasin-11	0.880	142	0.59
Junction-8	2.279	239	0.61
Reach-8	2.279	234	0.61
Subbasin-12	0.552	81	0.63
Junction-9	2.831	303	0.61
Reach-9	2.831	300	0.61
Junction-10	7.484	789	0.61
Reach-10	7.484	779	0.61
Subbasin-13	1.156	124	0.61
Subbasin-14	0.516	92	0.66
Junction-11	9.156	896	0.61
Reach-11	9.156	891	0.61
Subbasin-15	0.498	88	0.65
Junction-12	9.654	912	0.61
Reach-12	9.654	910	0.61
Subbasin-16	0.819	105	0.62
Subbasin-17	0.788	116	0.62
Junction-13	11.261	970	0.61

10-Year, 24-Hour Storm			
Hydrologic Element	Drainage Area (mi ²)	Peak Discharge (CFS)	Volume (in)
Reach-13	11.261	967	0.61
Subbasin-18	0.192	35.2	0.62
Junction-14	11.453	973	0.61
Reach-14	11.453	959	0.61
Subbasin-19	0.552	70	0.68
Junction-15	12.005	987	0.62
Reach-15	12.005	987	0.62
Subbasin-20	0.594	111	0.72
Junction-16	12.599	1,007	0.62
Reach-16	12.599	1,004	0.62
Subbasin-21	0.417	97	0.75
Junction-17	13.016	1,015	0.63
Reach-17	13.016	1,011	0.63
Subbasin-22	0.200	52	0.82
Junction-18	13.216	1,017	0.63
Reach-18	13.216	1,010	0.63
Subbasin-23	0.123	52	0.79
Junction-19	13.339	1,012	0.63
Reach-19	13.339	1,010	0.63
Subbasin-24	0.453	80	0.82
Subbasin-25	0.169	76	0.82
Subbasin-26	0.480	95	0.82
Junction-21	1.102	189	0.82
Reach-21	1.102	184	0.82
Subbasin-27	0.294	76	0.82
Junction-22	1.396	241	0.82
Reach-22	1.396	239	0.82
Subbasin-28	0.264	57	0.82
Subbasin-29	0.172	44	0.82
Junction-20	0.436	101	0.82
Reach-20	0.436	95	0.82
Subbasin-30	0.364	95	0.82
Junction-23	15.535	1,066	0.66
Reach-23	15.535	1,062	0.66
Subbasin-31	0.377	97	0.50
Subbasin-32	0.316	60	0.50
Junction-24	16.228	1,073	0.65
Reach-24	16.228	1,067	0.65
Subbasin-33	0.184	39	0.55
Junction-25	16.412	1,070	0.65
Reach-25	16.412	1,060	0.65
Junction-26	16.412	1,060	0.65

APPENDIX B – HYDROLOGIC
RESULTS – HISTORIC 10-YR
KETTLE CREEK DBPS
JOB NO. 25100.00
MAY 2015
B-20



HISTORIC CONDITIONS
MODEL RESULTS
(25-YEAR)

25-Year, 2-Hour Storm			
Hydrologic Element	Drainage Area (mi ²)	Peak Discharge (CFS)	Volume (in)
Subbasin-1	1.263	27	0.05
Subbasin-2	0.586	15	0.05
Subbasin-3	0.180	4	0.05
Junction-1	2.029	45	0.05
Reach-1	2.029	44	0.05
Subbasin-4	0.195	5	0.05
Junction-2	2.224	49	0.05
Reach-2	2.224	49	0.05
Subbasin-5	0.625	10	0.05
Junction-3	2.849	58	0.05
Reach-3	2.849	58	0.05
Subbasin-6	1.333	23	0.05
Junction-4	4.182	81	0.05
Reach-4	4.182	81	0.05
Subbasin-7	0.183	5	0.05
Junction-5	4.365	83	0.05
Reach-5	4.365	83	0.05
Subbasin-8	0.288	9	0.05
Junction-6	4.653	85	0.05
Reach-6	4.653	85	0.05
Subbasin-9	1.177	19	0.05
Subbasin-10	0.222	6	0.05
Junction-7	1.399	21	0.05
Reach-7	1.399	21	0.05
Subbasin-11	0.880	23	0.05
Junction-8	2.279	37	0.05
Reach-8	2.279	37	0.05
Subbasin-12	0.552	12	0.05
Junction-9	2.831	48	0.05
Reach-9	2.831	48	0.05
Junction-10	7.484	124	0.05
Reach-10	7.484	123	0.05
Subbasin-13	1.156	19	0.05
Subbasin-14	0.516	14	0.06
Junction-11	9.156	139	0.05
Reach-11	9.156	139	0.05
Subbasin-15	0.498	13	0.06
Junction-12	9.654	141	0.05
Reach-12	9.654	141	0.05
Subbasin-16	0.819	16	0.05
Subbasin-17	0.788	18	0.05
Junction-13	11.261	145	0.05

25-Year, 2-Hour Storm			
Hydrologic Element	Drainage Area (mi ²)	Peak Discharge (CFS)	Volume (in)
Reach-13	11.261	145	0.05
Subbasin-18	0.192	6	0.05
Junction-14	11.453	145	0.05
Reach-14	11.453	145	0.05
Subbasin-19	0.552	11	0.06
Junction-15	12.005	147	0.05
Reach-15	12.005	147	0.05
Subbasin-20	0.594	17	0.07
Junction-16	12.599	148	0.05
Reach-16	12.599	148	0.05
Subbasin-21	0.417	15	0.07
Junction-17	13.016	148	0.05
Reach-17	13.016	148	0.05
Subbasin-22	0.200	9	0.08
Junction-18	13.216	148	0.05
Reach-18	13.216	147	0.05
Subbasin-23	0.123	7	0.08
Junction-19	13.339	147	0.05
Reach-19	13.339	147	0.05
Subbasin-24	0.453	14	0.08
Subbasin-25	0.169	10	0.08
Subbasin-26	0.480	16	0.08
Junction-21	1.102	32	0.08
Reach-21	1.102	32	0.08
Subbasin-27	0.294	13	0.08
Junction-22	1.396	41	0.08
Reach-22	1.396	41	0.08
Subbasin-28	0.264	10	0.08
Subbasin-29	0.172	7	0.08
Junction-20	0.436	17	0.08
Reach-20	0.436	17	0.08
Subbasin-30	0.364	16	0.08
Junction-23	15.535	148	0.06
Reach-23	15.535	147	0.06
Subbasin-31	0.377	20	0.04
Subbasin-32	0.316	13	0.04
Junction-24	16.228	147	0.06
Reach-24	16.228	147	0.06
Subbasin-33	0.184	7	0.04
Junction-25	16.412	147.4	0.06
Reach-25	16.412	147.4	0.06
Junction-26	16.412	147.4	0.06

25-Year, 24-Hour Storm			
Hydrologic Element	Drainage Area (mi ²)	Peak Discharge (CFS)	Volume (in)
Subbasin-1	1.263	233	0.80
Subbasin-2	0.586	125	0.79
Subbasin-3	0.180	35	0.79
Junction-1	2.029	385	0.80
Reach-1	2.029	384	0.80
Subbasin-4	0.195	43	0.76
Junction-2	2.224	421	0.79
Reach-2	2.224	404	0.79
Subbasin-5	0.625	87	0.77
Junction-3	2.849	489	0.79
Reach-3	2.849	489	0.79
Subbasin-6	1.333	191	0.77
Junction-4	4.182	680	0.78
Reach-4	4.182	675	0.78
Subbasin-7	0.183	41	0.79
Junction-5	4.365	696	0.78
Reach-5	4.365	681	0.78
Subbasin-8	0.288	76	0.76
Junction-6	4.653	705	0.78
Reach-6	4.653	699	0.78
Subbasin-9	1.177	168	0.80
Subbasin-10	0.222	50	0.76
Junction-7	1.399	190	0.80
Reach-7	1.399	189	0.80
Subbasin-11	0.880	190	0.76
Junction-8	2.279	320	0.78
Reach-8	2.279	312	0.78
Subbasin-12	0.552	107	0.81
Junction-9	2.831	405	0.79
Reach-9	2.831	401	0.79
Junction-10	7.484	1,046	0.78
Reach-10	7.484	1,037	0.78
Subbasin-13	1.156	166	0.79
Subbasin-14	0.516	122	0.84
Junction-11	9.156	1,188	0.79
Reach-11	9.156	1,181	0.79
Subbasin-15	0.498	117	0.83
Junction-12	9.654	1,208	0.79
Reach-12	9.654	1,204	0.79
Subbasin-16	0.819	140	0.80
Subbasin-17	0.788	154	0.80
Junction-13	11.261	1,281	0.79

25-Year, 24-Hour Storm			
Hydrologic Element	Drainage Area (mi ²)	Peak Discharge (CFS)	Volume (in)
Reach-13	11.261	1,280	0.79
Subbasin-18	0.192	47	0.80
Junction-14	11.453	1,287	0.79
Reach-14	11.453	1,270	0.79
Subbasin-19	0.552	93	0.87
Junction-15	12.005	1,307	0.80
Reach-15	12.005	1,306	0.80
Subbasin-20	0.594	146	0.92
Junction-16	12.599	1,330	0.80
Reach-16	12.599	1,325	0.80
Subbasin-21	0.417	126	0.95
Junction-17	13.016	1,339	0.81
Reach-17	13.016	1,335	0.81
Subbasin-22	0.200	66	1.03
Junction-18	13.216	1,341	0.81
Reach-18	13.216	1,330	0.81
Subbasin-23	0.123	67	1.00
Junction-19	13.339	1,333	0.81
Reach-19	13.339	1,329	0.81
Subbasin-24	0.453	102	1.03
Subbasin-25	0.169	98	1.03
Subbasin-26	0.480	122	1.03
Junction-21	1.102	243	1.03
Reach-21	1.102	237	1.03
Subbasin-27	0.294	97	1.03
Junction-22	1.396	310	1.03
Reach-22	1.396	309	1.03
Subbasin-28	0.264	73	1.03
Subbasin-29	0.172	57	1.03
Junction-20	0.436	130	1.03
Reach-20	0.436	121	1.03
Subbasin-30	0.364	122	1.03
Junction-23	15.535	1,399	0.84
Reach-23	15.535	1,395	0.84
Subbasin-31	0.377	133	0.66
Subbasin-32	0.316	82	0.66
Junction-24	16.228	1,410	0.83
Reach-24	16.228	1,399	0.83
Subbasin-33	0.184	53	0.72
Junction-25	16.412	1402.8	0.83
Reach-25	16.412	1393.8	0.83
Junction-26	16.412	1393.8	0.83

APPENDIX B – HYDROLOGIC
RESULTS – HISTORIC 25-YR
KETTLE CREEK DBPS
JOB NO. 25100.00
MAY 2015
B-21



HISTORIC CONDITIONS
MODEL RESULTS
(50-YEAR)

50-Year, 2-Hour Storm			
Hydrologic Element	Drainage Area (mi ²)	Peak Discharge (CFS)	Volume (in)
Subbasin-1	1.263	35	0.07
Subbasin-2	0.586	18	0.07
Subbasin-3	0.180	5	0.07
Junction-1	2.029	57	0.07
Reach-1	2.029	57	0.07
Subbasin-4	0.195	6	0.07
Junction-2	2.224	62	0.07
Reach-2	2.224	62	0.07
Subbasin-5	0.625	13	0.07
Junction-3	2.849	75	0.07
Reach-3	2.849	75	0.07
Subbasin-6	1.333	29	0.07
Junction-4	4.182	104	0.07
Reach-4	4.182	103	0.07
Subbasin-7	0.183	6	0.07
Junction-5	4.365	107	0.07
Reach-5	4.365	107	0.07
Subbasin-8	0.288	11	0.07
Junction-6	4.653	110	0.07
Reach-6	4.653	110	0.07
Subbasin-9	1.177	26	0.07
Subbasin-10	0.222	7	0.07
Junction-7	1.399	29	0.07
Reach-7	1.399	29	0.07
Subbasin-11	0.880	28	0.07
Junction-8	2.279	47	0.07
Reach-8	2.279	46	0.07
Subbasin-12	0.552	16	0.07
Junction-9	2.831	61	0.07
Reach-9	2.831	61	0.07
Junction-10	7.484	164	0.07
Reach-10	7.484	164	0.07
Subbasin-13	1.156	25	0.07
Subbasin-14	0.516	19	0.08
Junction-11	9.156	186	0.07
Reach-11	9.156	185	0.07
Subbasin-15	0.498	18	0.08
Junction-12	9.654	188	0.07
Reach-12	9.654	188	0.07
Subbasin-16	0.819	21	0.07
Subbasin-17	0.788	23	0.07
Junction-13	11.261	193	0.07

50-Year, 2-Hour Storm			
Hydrologic Element	Drainage Area (mi ²)	Peak Discharge (CFS)	Volume (in)
Reach-13	11.261	193	0.07
Subbasin-18	0.192	7	0.07
Junction-14	11.453	193	0.07
Reach-14	11.453	193	0.07
Subbasin-19	0.552	15	0.09
Junction-15	12.005	197	0.07
Reach-15	12.005	197	0.07
Subbasin-20	0.594	25	0.10
Junction-16	12.599	197	0.07
Reach-16	12.599	197	0.07
Subbasin-21	0.417	22	0.10
Junction-17	13.016	197	0.07
Reach-17	13.016	197	0.07
Subbasin-22	0.200	13	0.12
Junction-18	13.216	197	0.07
Reach-18	13.216	197	0.07
Subbasin-23	0.123	11	0.12
Junction-19	13.339	197	0.07
Reach-19	13.339	197	0.07
Subbasin-24	0.453	20	0.12
Subbasin-25	0.169	15	0.12
Subbasin-26	0.480	24	0.12
Junction-21	1.102	47	0.12
Reach-21	1.102	47	0.12
Subbasin-27	0.294	19	0.12
Junction-22	1.396	61	0.12
Reach-22	1.396	61	0.12
Subbasin-28	0.264	14	0.12
Subbasin-29	0.172	11	0.12
Junction-20	0.436	25	0.12
Reach-20	0.436	25	0.12
Subbasin-30	0.364	24	0.12
Junction-23	15.535	197	0.08
Reach-23	15.535	197	0.08
Subbasin-31	0.377	22	0.05
Subbasin-32	0.316	15	0.05
Junction-24	16.228	197	0.08
Reach-24	16.228	197	0.08
Subbasin-33	0.184	8	0.06
Junction-25	16.412	196.9	0.08
Reach-25	16.412	196.9	0.08
Junction-26	16.412	196.9	0.08

50-Year, 24-Hour Storm			
Hydrologic Element	Drainage Area (mi ²)	Peak Discharge (CFS)	Volume (in)
Subbasin-1	1.263	330	1.10
Subbasin-2	0.586	178	1.09
Subbasin-3	0.180	49	1.09
Junction-1	2.029	546	1.09
Reach-1	2.029	544	1.09
Subbasin-4	0.195	62	1.05
Junction-2	2.224	596	1.09
Reach-2	2.224	577	1.09
Subbasin-5	0.625	124	1.06
Junction-3	2.849	692	1.08
Reach-3	2.849	692	1.08
Subbasin-6	1.333	273	1.06
Junction-4	4.182	962	1.08
Reach-4	4.182	959	1.08
Subbasin-7	0.183	59	1.09
Junction-5	4.365	988	1.08
Reach-5	4.365	969	1.08
Subbasin-8	0.288	109	1.05
Junction-6	4.653	1,002	1.08
Reach-6	4.653	992	1.08
Subbasin-9	1.177	237	1.10
Subbasin-10	0.222	72	1.05
Junction-7	1.399	268	1.09
Reach-7	1.399	267	1.09
Subbasin-11	0.880	272	1.05
Junction-8	2.279	456	1.08
Reach-8	2.279	443	1.08
Subbasin-12	0.552	152	1.11
Junction-9	2.831	578	1.08
Reach-9	2.831	570	1.08
Junction-10	7.484	1,478	1.08
Reach-10	7.484	1,471	1.08
Subbasin-13	1.156	234	1.09
Subbasin-14	0.516	171	1.15
Junction-11	9.156	1,678	1.08
Reach-11	9.156	1,668	1.08
Subbasin-15	0.498	166	1.14
Junction-12	9.654	1,703	1.09
Reach-12	9.654	1,696	1.09
Subbasin-16	0.819	198	1.10
Subbasin-17	0.788	218	1.10
Junction-13	11.261	1,808	1.09

50-Year, 24-Hour Storm			
Hydrologic Element	Drainage Area (mi ²)	Peak Discharge (CFS)	Volume (in)
Reach-13	11.261	1,804	1.09
Subbasin-18	0.192	66	1.10
Junction-14	11.453	1,813	1.09
Reach-14	11.453	1,794	1.09
Subbasin-19	0.552	130	1.19
Junction-15	12.005	1,844	1.09
Reach-15	12.005	1,842	1.09
Subbasin-20	0.594	203	1.24
Junction-16	12.599	1,874	1.10
Reach-16	12.599	1,863	1.10
Subbasin-21	0.417	173	1.29
Junction-17	13.016	1,882	1.11
Reach-17	13.016	1,877	1.11
Subbasin-22	0.200	90	1.38
Junction-18	13.216	1,885	1.11
Reach-18	13.216	1,865	1.11
Subbasin-23	0.123	92	1.34
Junction-19	13.339	1,869	1.11
Reach-19	13.339	1,864	1.11
Subbasin-24	0.453	139	1.38
Subbasin-25	0.169	133	1.38
Subbasin-26	0.480	167	1.38
Junction-21	1.102	331	1.38
Reach-21	1.102	324	1.38
Subbasin-27	0.294	132	1.38
Junction-22	1.396	423	1.38
Reach-22	1.396	423	1.38
Subbasin-28	0.264	100	1.38
Subbasin-29	0.172	77	1.38
Junction-20	0.436	178	1.38
Reach-20	0.436	165	1.38
Subbasin-30	0.364	167	1.38
Junction-23	15.535	1,953	1.15
Reach-23	15.535	1,953	1.15
Subbasin-31	0.377	195	0.92
Subbasin-32	0.316	120	0.92
Junction-24	16.228	1,972	1.14
Reach-24	16.228	1,954	1.14
Subbasin-33	0.184	76	1.00
Junction-25	16.412	1,958.8	1.14
Reach-25	16.412	1,951.7	1.14
Junction-26	16.412	1,951.7	1.14

APPENDIX B – HYDROLOGIC
RESULTS – HISTORIC 50-YR
KETTLE CREEK DBPS
JOB NO. 25100.00
MAY 2015
B-22



HISTORIC CONDITIONS
MODEL RESULTS
(100-YEAR)

100-Year, 2-Hour Storm			
Hydrologic Element	Drainage Area (mi ²)	Peak Discharge (CFS)	Volume (in)
Subbasin-1	1.263	49	0.10
Subbasin-2	0.586	25	0.10
Subbasin-3	0.180	7	0.10
Junction-1	2.029	80	0.10
Reach-1	2.029	80	0.10
Subbasin-4	0.195	8	0.09
Junction-2	2.224	87	0.10
Reach-2	2.224	87	0.10
Subbasin-5	0.625	18	0.09
Junction-3	2.849	104	0.10
Reach-3	2.849	104	0.10
Subbasin-6	1.333	41	0.09
Junction-4	4.182	144	0.10
Reach-4	4.182	144	0.10
Subbasin-7	0.183	8	0.10
Junction-5	4.365	149	0.10
Reach-5	4.365	149	0.10
Subbasin-8	0.288	14	0.09
Junction-6	4.653	154	0.10
Reach-6	4.653	154	0.10
Subbasin-9	1.177	37	0.10
Subbasin-10	0.222	10	0.09
Junction-7	1.399	42	0.10
Reach-7	1.399	42	0.10
Subbasin-11	0.880	38	0.09
Junction-8	2.279	65	0.10
Reach-8	2.279	65	0.10
Subbasin-12	0.552	23	0.10
Junction-9	2.831	85	0.10
Reach-9	2.831	84	0.10
Junction-10	7.484	230	0.10
Reach-10	7.484	230	0.10
Subbasin-13	1.156	35	0.10
Subbasin-14	0.516	27	0.11
Junction-11	9.156	260	0.10
Reach-11	9.156	259	0.10
Subbasin-15	0.498	25	0.11
Junction-12	9.654	262	0.10
Reach-12	9.654	262	0.10
Subbasin-16	0.819	30	0.10
Subbasin-17	0.788	32	0.10
Junction-13	11.261	269	0.10

100-Year, 2-Hour Storm			
Hydrologic Element	Drainage Area (mi ²)	Peak Discharge (CFS)	Volume (in)
Reach-13	11.261	269	0.10
Subbasin-18	0.192	10	0.10
Junction-14	11.453	269	0.10
Reach-14	11.453	269	0.10
Subbasin-19	0.552	22	0.12
Junction-15	12.005	274	0.10
Reach-15	12.005	274	0.10
Subbasin-20	0.594	36	0.14
Junction-16	12.599	274	0.10
Reach-16	12.599	274	0.10
Subbasin-21	0.417	32	0.15
Junction-17	13.016	274	0.10
Reach-17	13.016	274	0.10
Subbasin-22	0.200	19	0.17
Junction-18	13.216	274	0.10
Reach-18	13.216	274	0.10
Subbasin-23	0.123	17	0.17
Junction-19	13.339	274	0.10
Reach-19	13.339	274	0.10
Subbasin-24	0.453	29	0.17
Subbasin-25	0.169	23	0.17
Subbasin-26	0.480	34	0.17
Junction-21	1.102	68	0.17
Reach-21	1.102	67	0.17
Subbasin-27	0.294	27	0.17
Junction-22	1.396	86	0.17
Reach-22	1.396	86	0.17
Subbasin-28	0.264	21	0.17
Subbasin-29	0.172	16	0.17
Junction-20	0.436	35	0.17
Reach-20	0.436	35	0.17
Subbasin-30	0.364	34	0.17
Junction-23	15.535	274	0.11
Reach-23	15.535	274	0.11
Subbasin-31	0.377	25	0.06
Subbasin-32	0.316	16	0.06
Junction-24	16.228	274	0.11
Reach-24	16.228	274	0.11
Subbasin-33	0.184	9	0.07
Junction-25	16.412	274	0.11
Reach-25	16.412	274	0.11
Junction-26	16.412	274	0.11

100-Year, 24-Hour Storm			
Hydrologic Element	Drainage Area (mi ²)	Peak Discharge (CFS)	Volume (in)
Subbasin-1	1.263	402	1.31
Subbasin-2	0.586	217	1.31
Subbasin-3	0.180	60	1.31
Junction-1	2.029	663	1.31
Reach-1	2.029	661	1.31
Subbasin-4	0.195	75	1.26
Junction-2	2.224	724	1.31
Reach-2	2.224	703	1.31
Subbasin-5	0.625	150	1.27
Junction-3	2.849	840	1.30
Reach-3	2.849	840	1.30
Subbasin-6	1.333	332	1.27
Junction-4	4.182	1,168	1.29
Reach-4	4.182	1,167	1.29
Subbasin-7	0.183	71	1.31
Junction-5	4.365	1,201	1.29
Reach-5	4.365	1,179	1.29
Subbasin-8	0.288	133.1	1.26
Junction-6	4.653	1218.6	1.29
Reach-6	4.653	1,205	1.29
Subbasin-9	1.177	287	1.32
Subbasin-10	0.222	87	1.26
Junction-7	1.399	325	1.31
Reach-7	1.399	325	1.31
Subbasin-11	0.880	332	1.26
Junction-8	2.279	556	1.29
Reach-8	2.279	540	1.29
Subbasin-12	0.552	184	1.32
Junction-9	2.831	704	1.30
Reach-9	2.831	694	1.30
Junction-10	7.484	1,793	1.29
Reach-10	7.484	1,788	1.29
Subbasin-13	1.156	285	1.31
Subbasin-14	0.516	207	1.37
Junction-11	9.156	2,036	1.30
Reach-11	9.156	2,022	1.30
Subbasin-15	0.498	201	1.36
Junction-12	9.654	2,064	1.30
Reach-12	9.654	2,055	1.30
Subbasin-16	0.819	241	1.31
Subbasin-17	0.788	264	1.31
Junction-13	11.261	2,194	1.30

100-Year, 24-Hour Storm			
Hydrologic Element	Drainage Area (mi ²)	Peak Discharge (CFS)	Volume (in)
Reach-13	11.261	2,185	1.30
Subbasin-18	0.192	80	1.32
Junction-14	11.453	2,196	1.30
Reach-14	11.453	2,176	1.30
Subbasin-19	0.552	157	1.41
Junction-15	12.005	2,234	1.31
Reach-15	12.005	2,232	1.31
Subbasin-20	0.594	244	1.48
Junction-16	12.599	2,269	1.32
Reach-16	12.599	2,255	1.32
Subbasin-21	0.417	207	1.53
Junction-17	13.016	2,276	1.32
Reach-17	13.016	2,271	1.32
Subbasin-22	0.200	107	1.63
Junction-18	13.216	2,281	1.33
Reach-18	13.216	2,254	1.33
Subbasin-23	0.123	109	1.58
Junction-19	13.339	2,259	1.33
Reach-19	13.339	2,253	1.33
Subbasin-24	0.453	166	1.63
Subbasin-25	0.169	159	1.63
Subbasin-26	0.480	199	1.63
Junction-21	1.102	395	1.63
Reach-21	1.102	387	1.63
Subbasin-27	0.294	157	1.63
Junction-22	1.396	505	1.63
Reach-22	1.396	505	1.63
Subbasin-28	0.264	120	1.63
Subbasin-29	0.172	92	1.63
Junction-20	0.436	212	1.63
Reach-20	0.436	197	1.63
Subbasin-30	0.364	200	1.63
Junction-23	15.535	2,362	1.37
Reach-23	15.535	2,358	1.37
Subbasin-31	0.377	241	1.12
Subbasin-32	0.316	147	1.12
Junction-24	16.228	2,381	1.36
Reach-24	16.228	2,357	1.36
Subbasin-33	0.184	93	1.21
Junction-25	16.412	2,362	1.36
Reach-25	16.412	2,357	1.36
Junction-26	16.412	2,357	1.36

APPENDIX B – HYDROLOGIC
RESULTS – HISTORIC 100-YR
KETTLE CREEK DBPS
JOB NO. 25100.00
MAY 2015
B-23



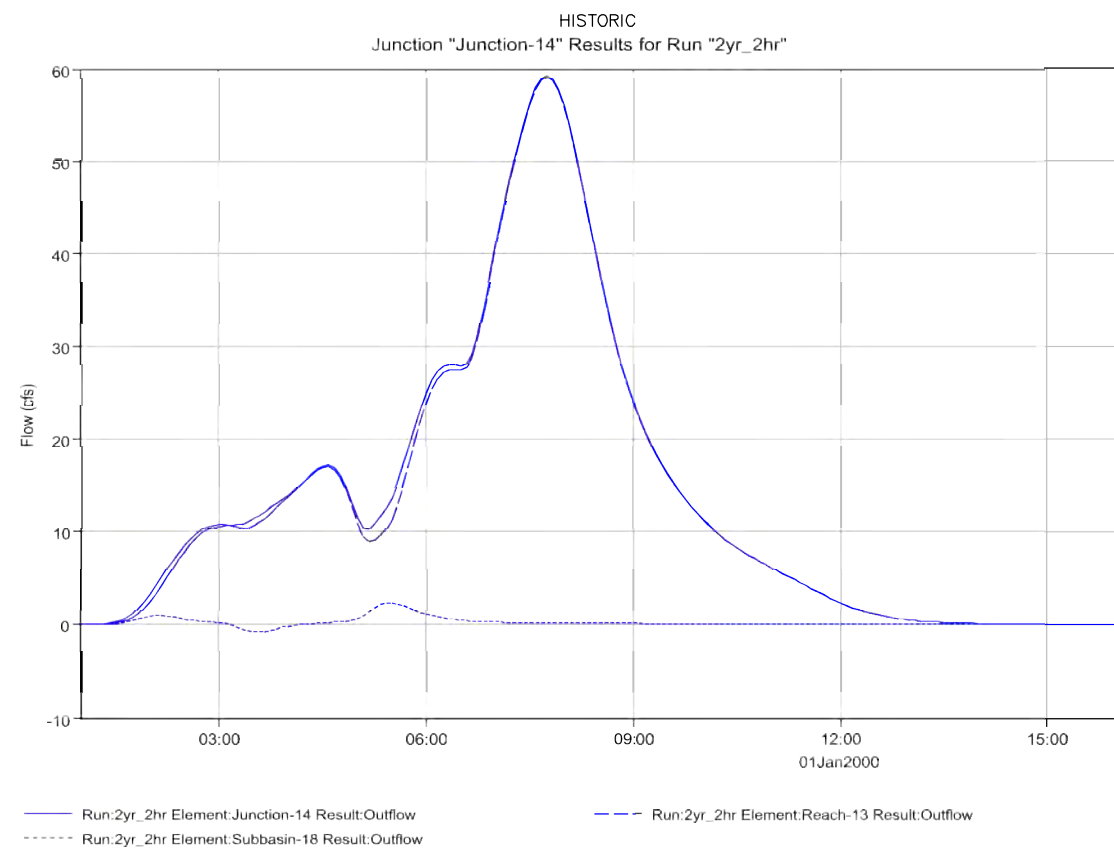

2-YR
2-HR

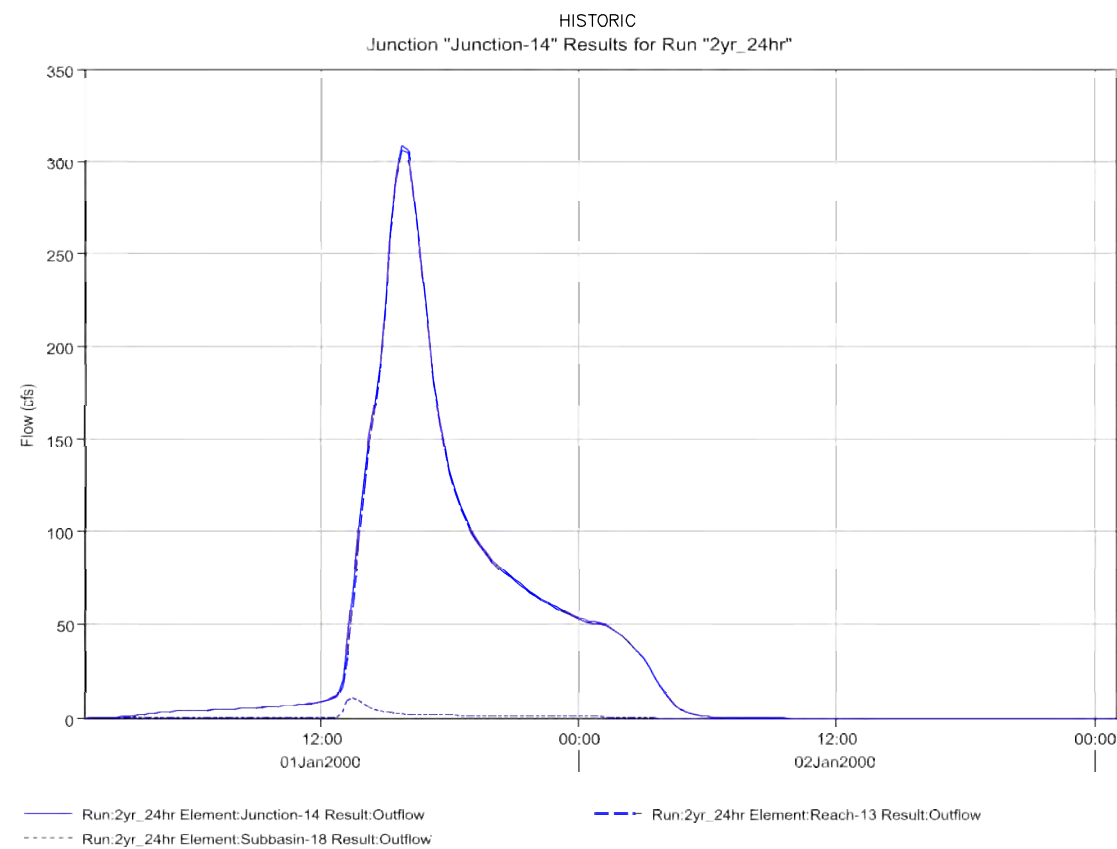

2-YR
24-HR

JUNCTION 14
HOWELLS ROAD (APPROXIMATE)
HISTORIC CONDITIONS HYDROGRAPHS
AT SELECT LOCATIONS
2-YEAR

APPENDIX B – HYDROLOGIC
RESULTS – HISTORIC
HYDROGRAPHS 2-YR J-14
KETTLE CREEK DBPS
JOB NO. 25100.00
MAY 2015
B-24



Centennial 303-740-9393 • Colorado Springs 719-593-2593
Fort Collins 970-491-9888 • www.jrengineering.com

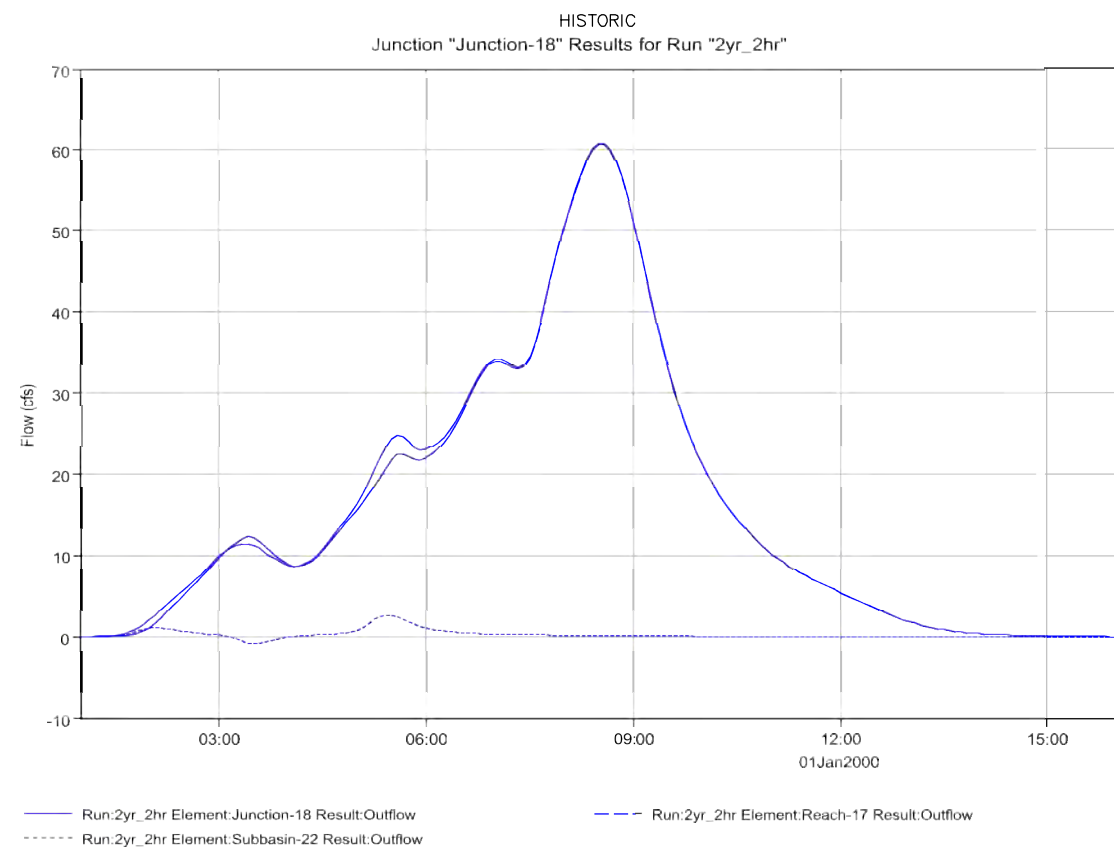

2-YR
2-HR

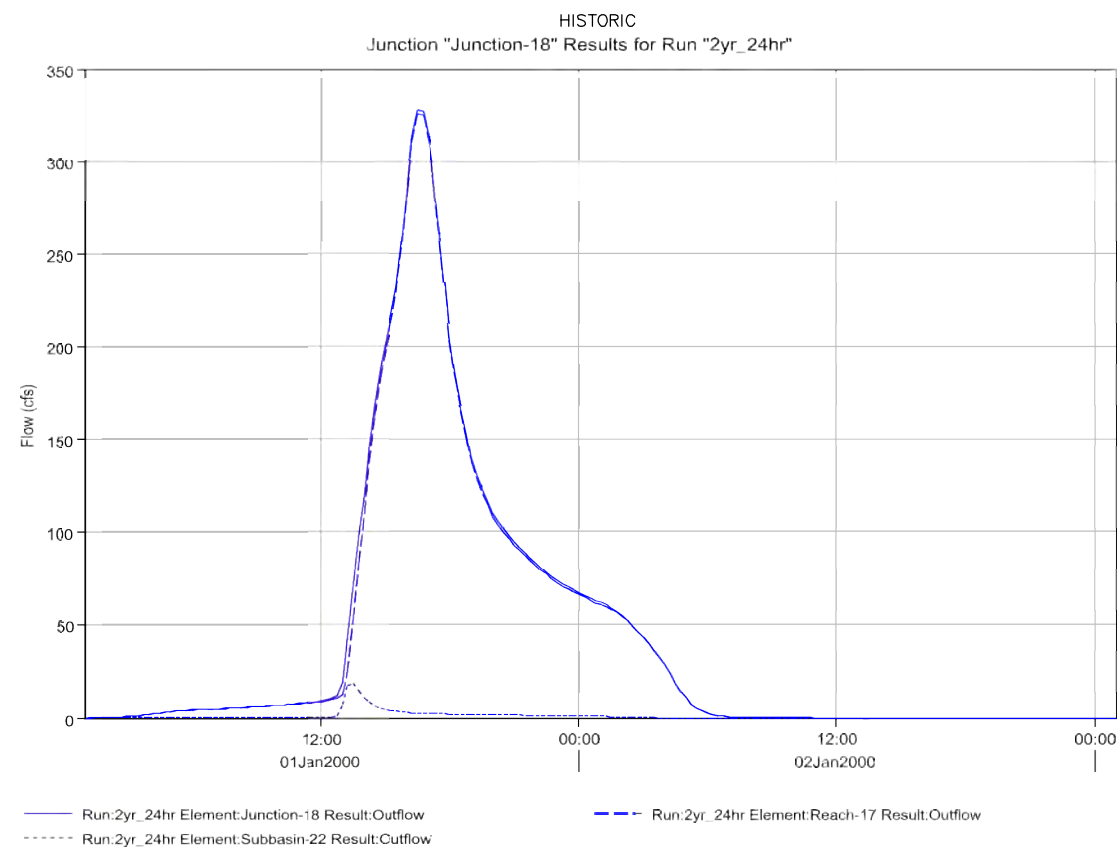

2-YR
24-HR

JUNCTION 18
POWERS BLVD BRIDGE

HISTORIC CONDITIONS HYDROGRAPHS
AT SELECT LOCATIONS
2-YEAR

APPENDIX B – HYDROLOGIC
RESULTS – HISTORIC
HYDROGRAPHS 2-YR J-18
KETTLE CREEK DBPS
JOB NO. 25100.00
MAY 2015
B-25



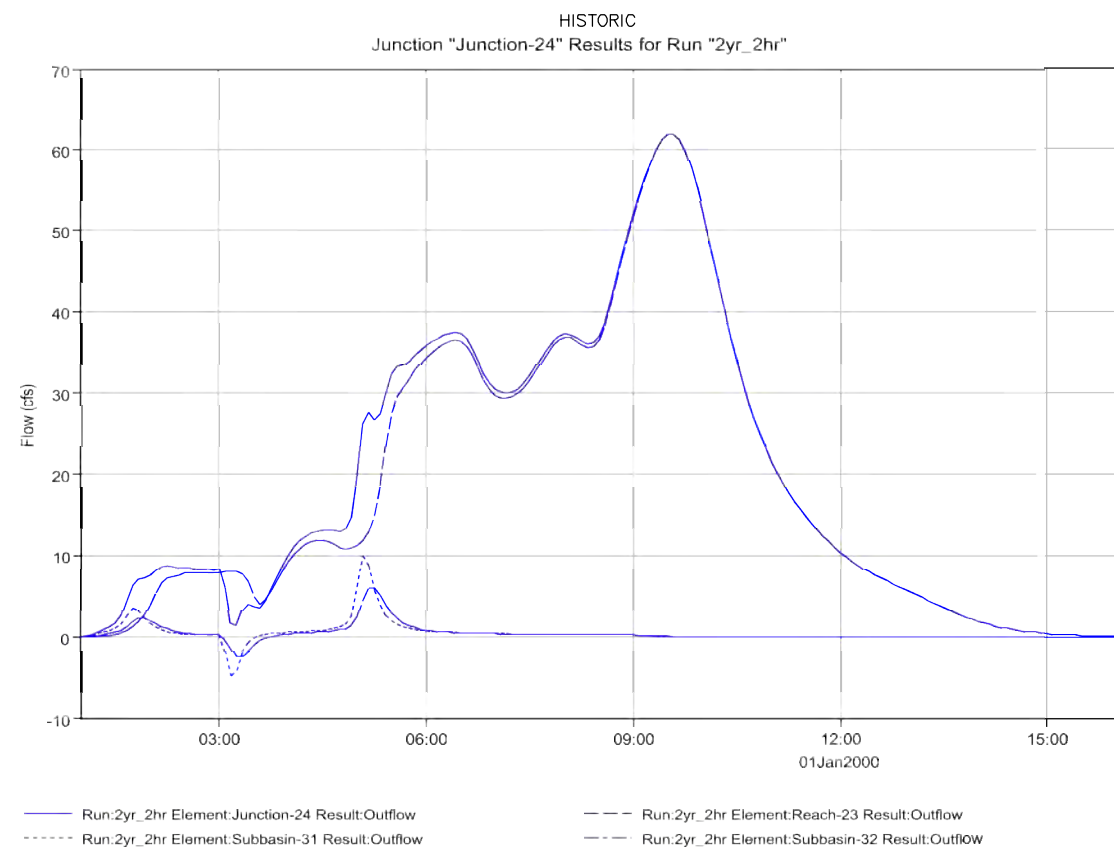

2-YR
2-HR

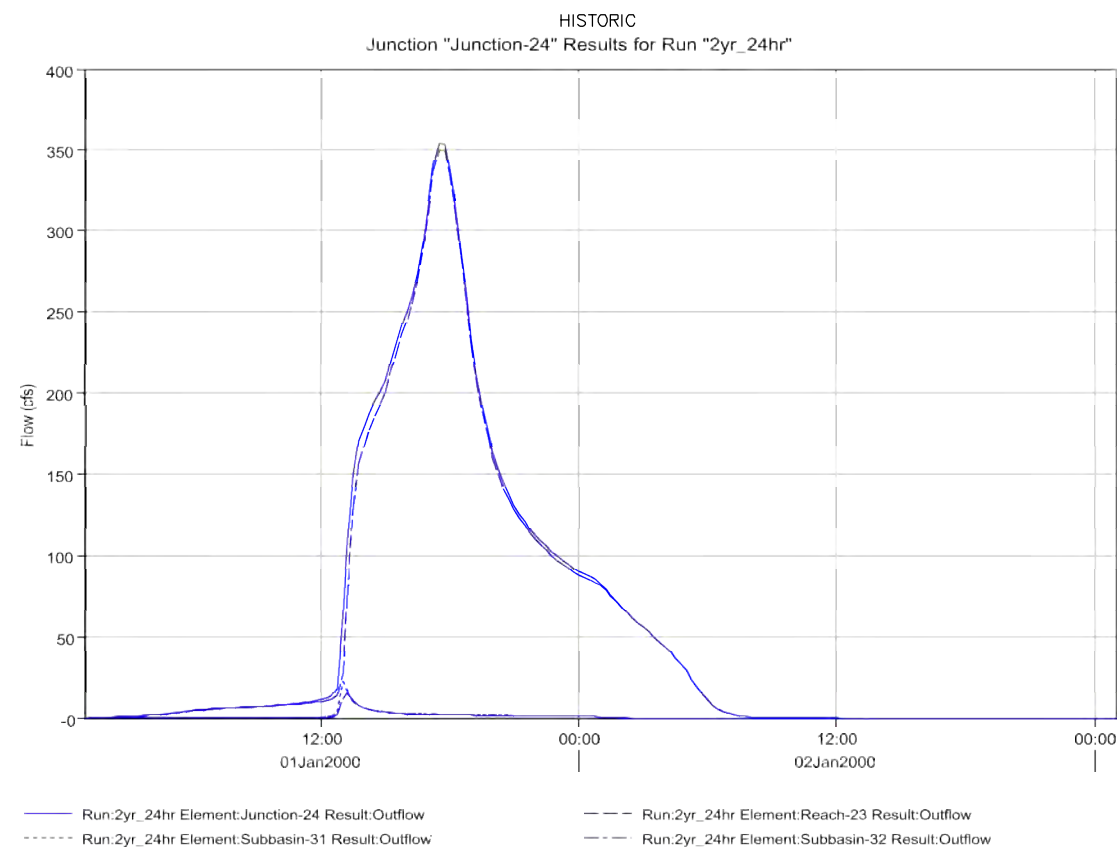

2-YR
24-HR

JUNCTION 24
HWY 83 BRIDGE
HISTORIC CONDITIONS HYDROGRAPHS
AT SELECT LOCATIONS
2-YEAR

APPENDIX B – HYDROLOGIC
RESULTS – HISTORIC
HYDROGRAPHS 2-YR J-24
KETTLE CREEK DBPS
JOB NO. 25100.00
MAY 2015
B-26



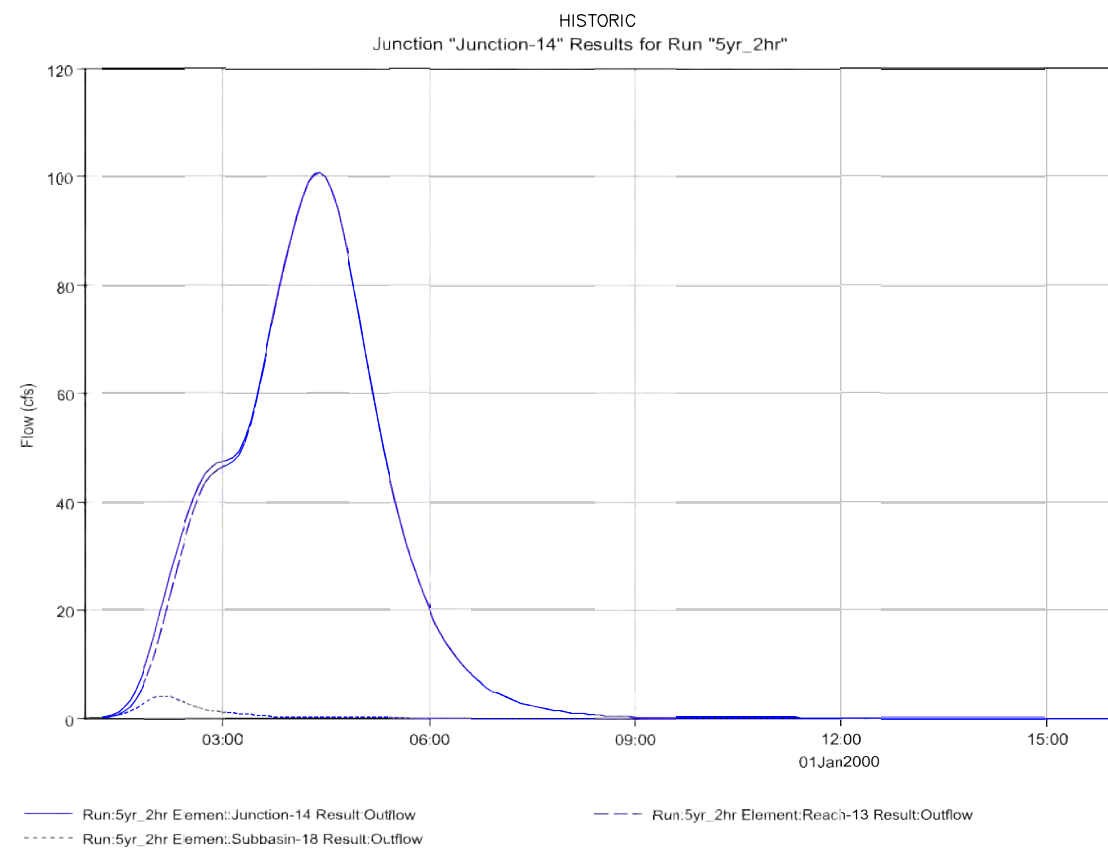

5-YR
2-HR

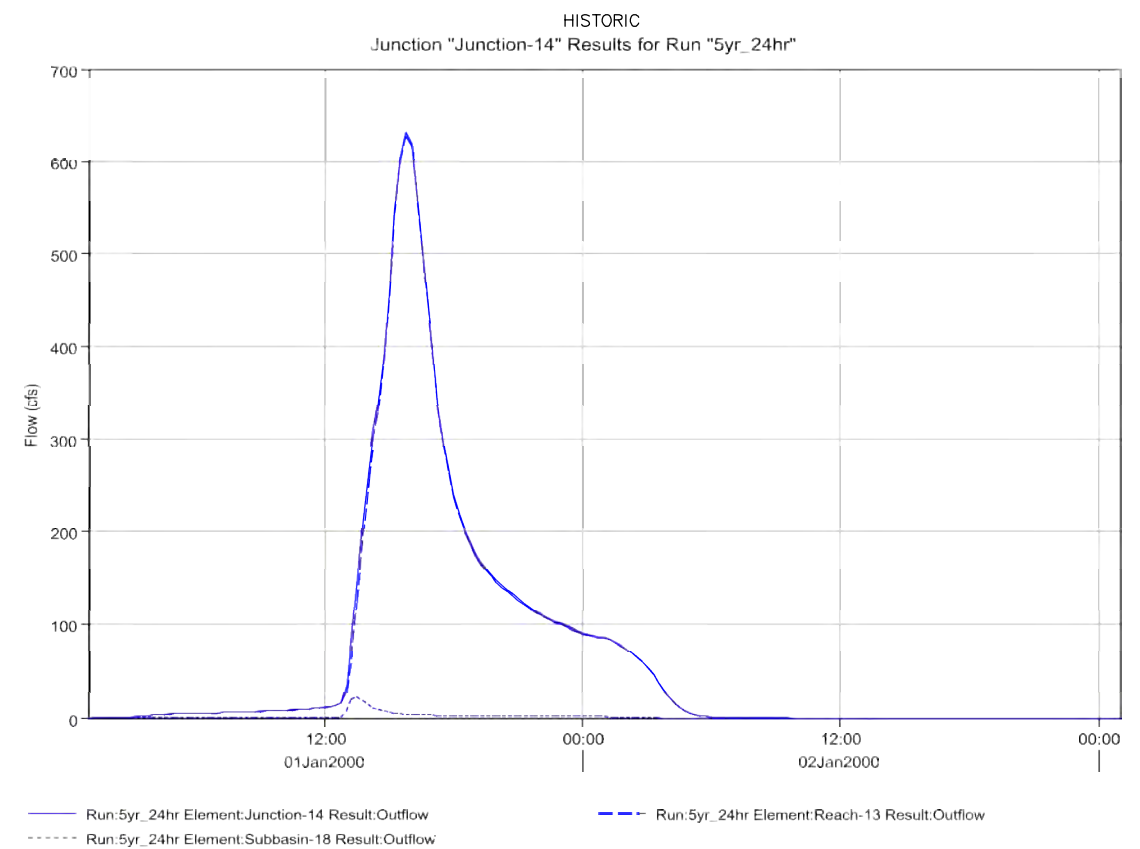

5-YR
24-HR

JUNCTION 14
HOWELLS ROAD (APPROXIMATE)
HISTORIC CONDITIONS HYDROGRAPHS
AT SELECT LOCATIONS
5-YEAR

APPENDIX B – HYDROLOGIC
RESULTS – HISTORIC
HYDROGRAPHS 5-YR J-14
KETTLE CREEK DBPS
JOB NO. 25100.00
MAY 2015
B-27



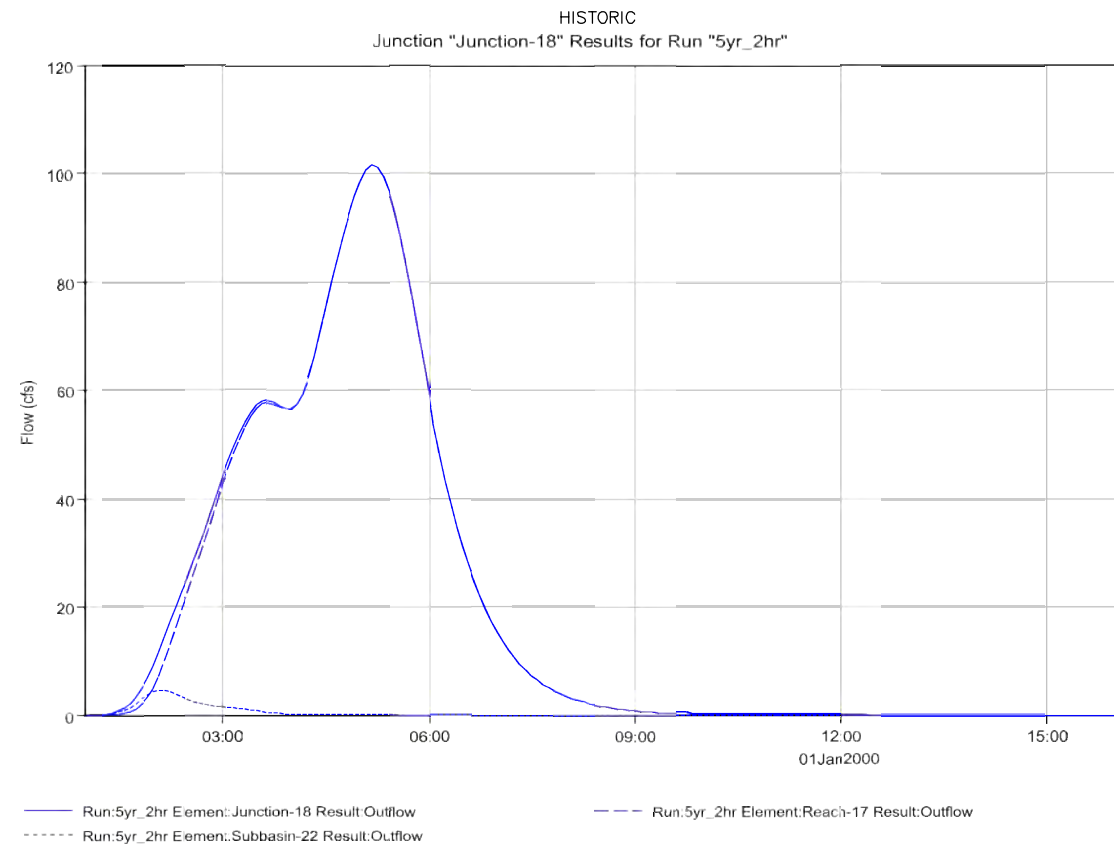

5-YR
2-HR

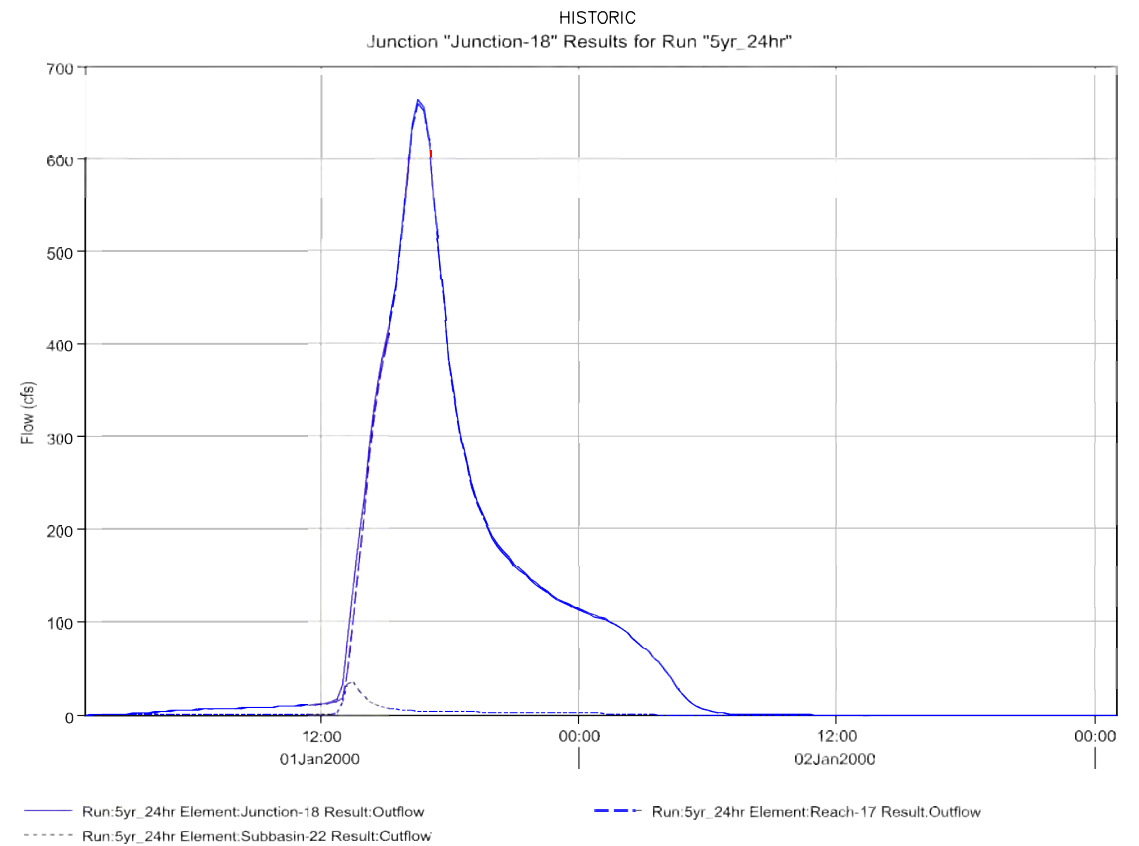

5-YR
24-HR

JUNCTION 18
POWERS BLVD BRIDGE
HISTORIC CONDITIONS HYDROGRAPHS
AT SELECT LOCATIONS
5-YEAR

APPENDIX B – HYDROLOGIC
RESULTS – HISTORIC
HYDROGRAPHS 5-YR J-18
KETTLE CREEK DBPS
JOB NO. 25100.00
MAY 2015
B-28



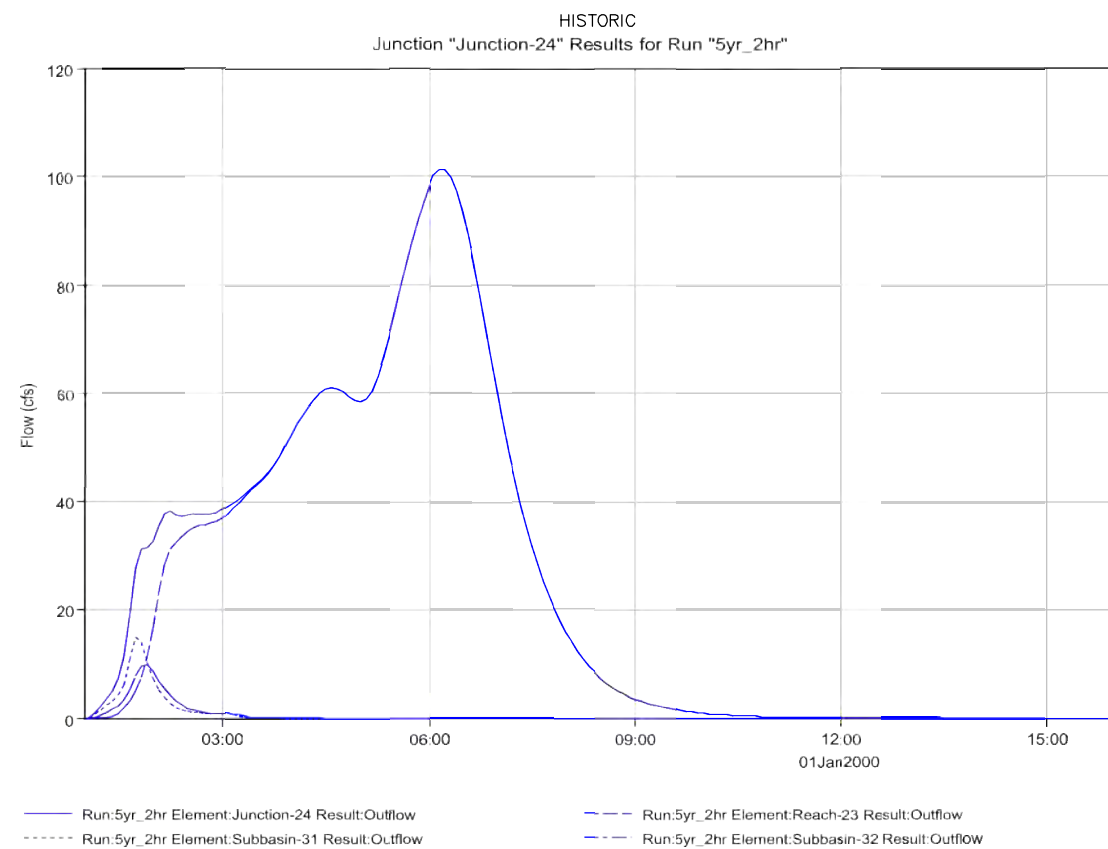

5-YR
2-HR

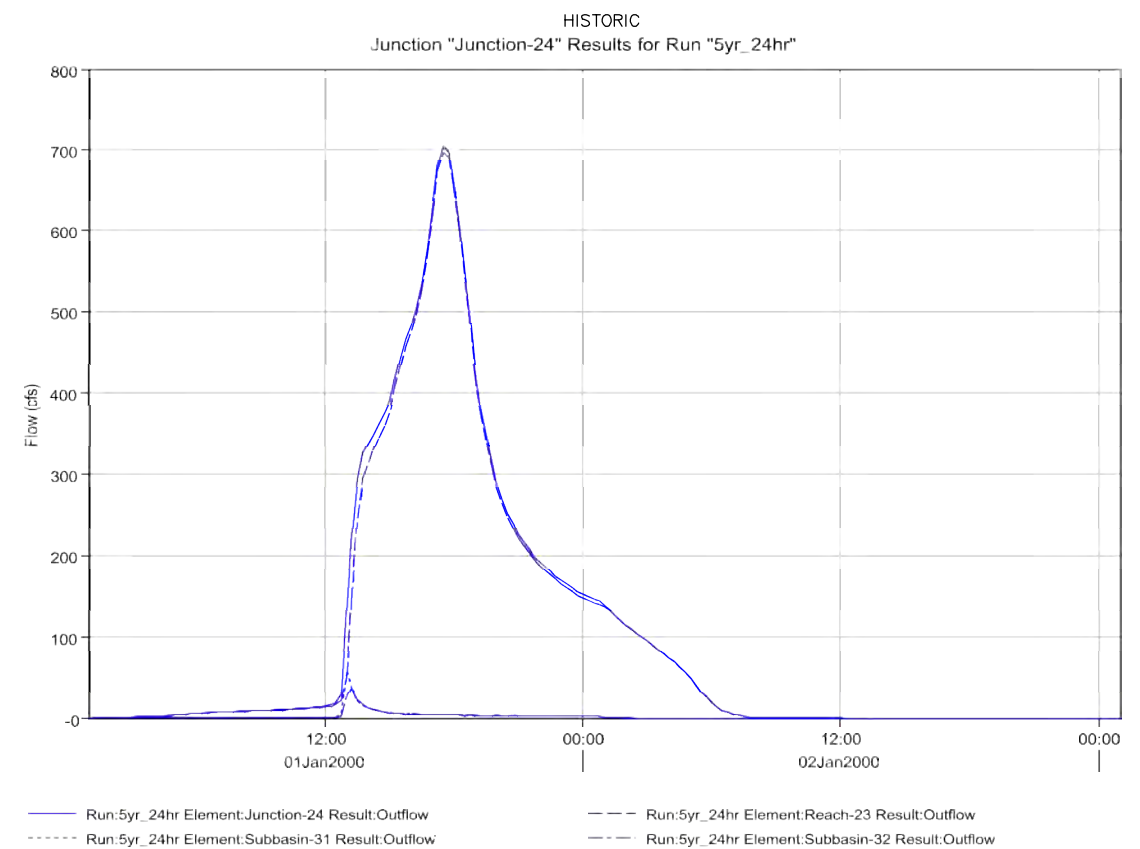

5-YR
24-HR

JUNCTION 24
HWY 83 BRIDGE
HISTORIC CONDITIONS HYDROGRAPHS
AT SELECT LOCATIONS
5-YEAR

APPENDIX B – HYDROLOGIC
RESULTS – HISTORIC
HYDROGRAPHS 5-YR J-24
KETTLE CREEK DBPS
JOB NO. 25100.00
MAY 2015
B-29



Centennial 303-740-9393 • Colorado Springs 719-593-2593
Fort Collins 970-491-9888 • www.jrengineering.com

JUNCTION 18
POWERS BLVD BRIDGE

JUNCTION 24
HWY 83 BRIDGE

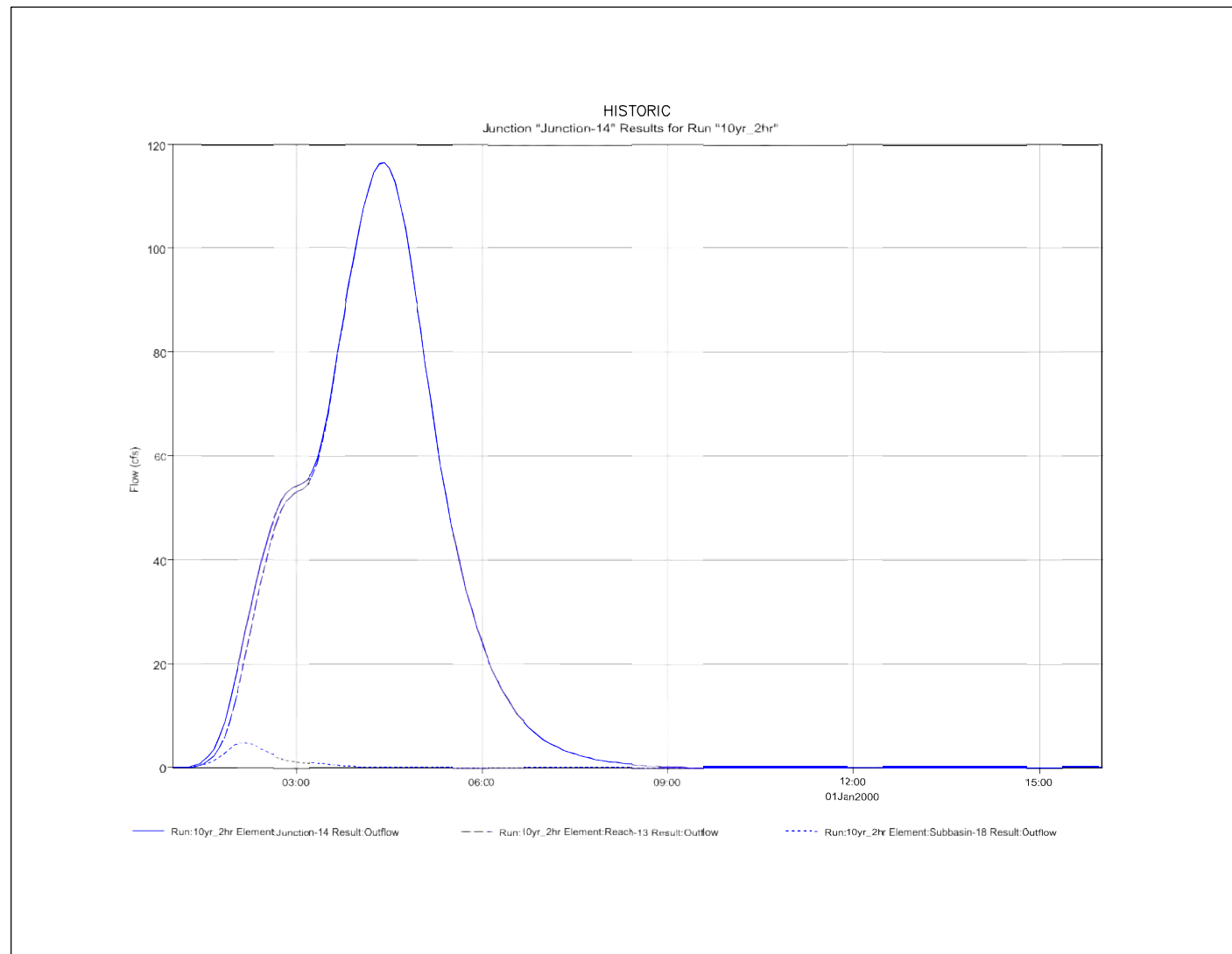

10-YR
24-HR

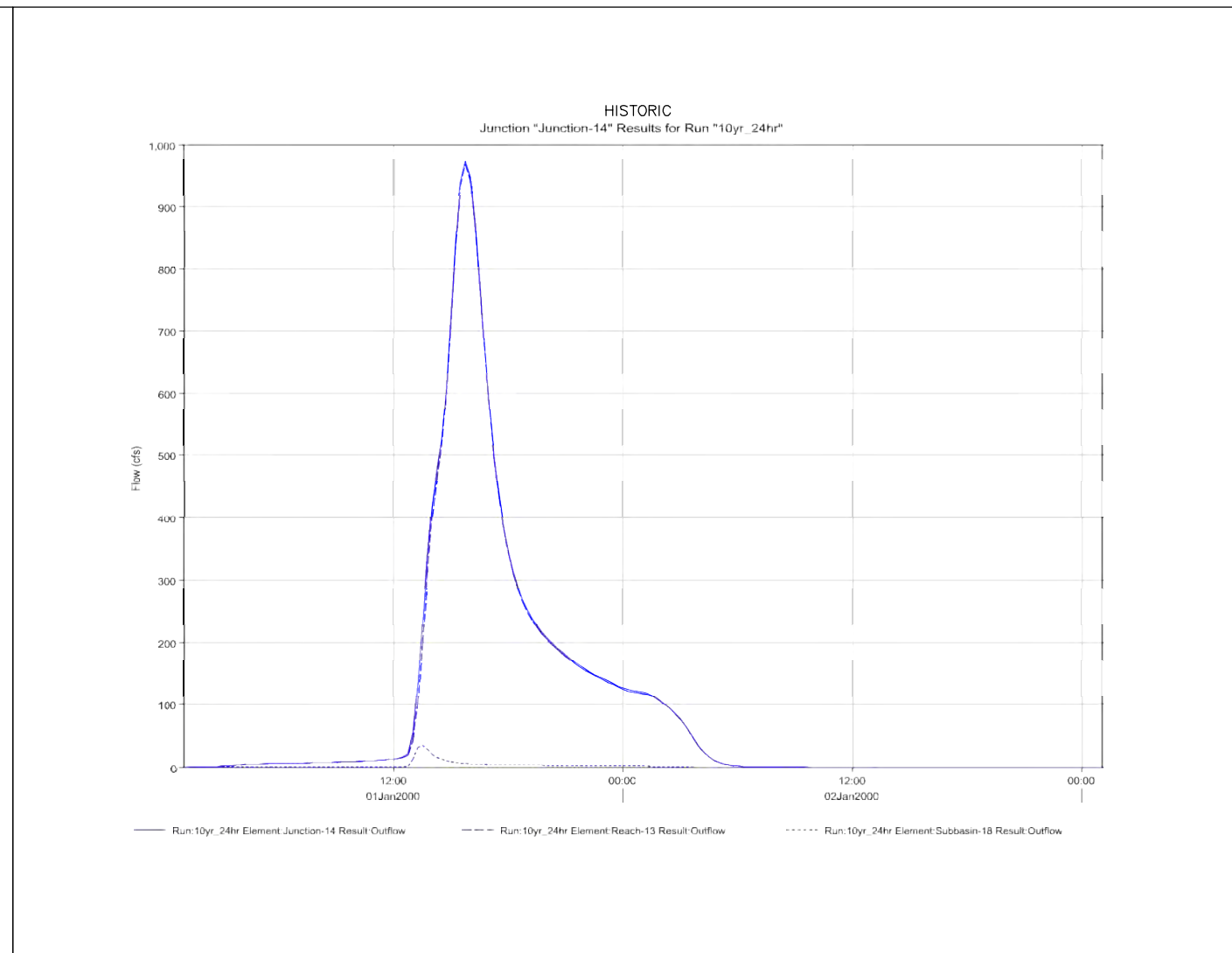

10-YR
2-HR

JUNCTION 14
HOWELLS ROAD (APPROXIMATE)
HISTORIC CONDITIONS HYDROGRAPHS
AT SELECT LOCATIONS
10-YEAR

APPENDIX B – HYDROLOGIC
RESULTS – HISTORIC
HYDROGRAPHS 10-YR-J-14
KETTLE CREEK DBPS
JOB NO. 25100.00
MAY 2015
B-30



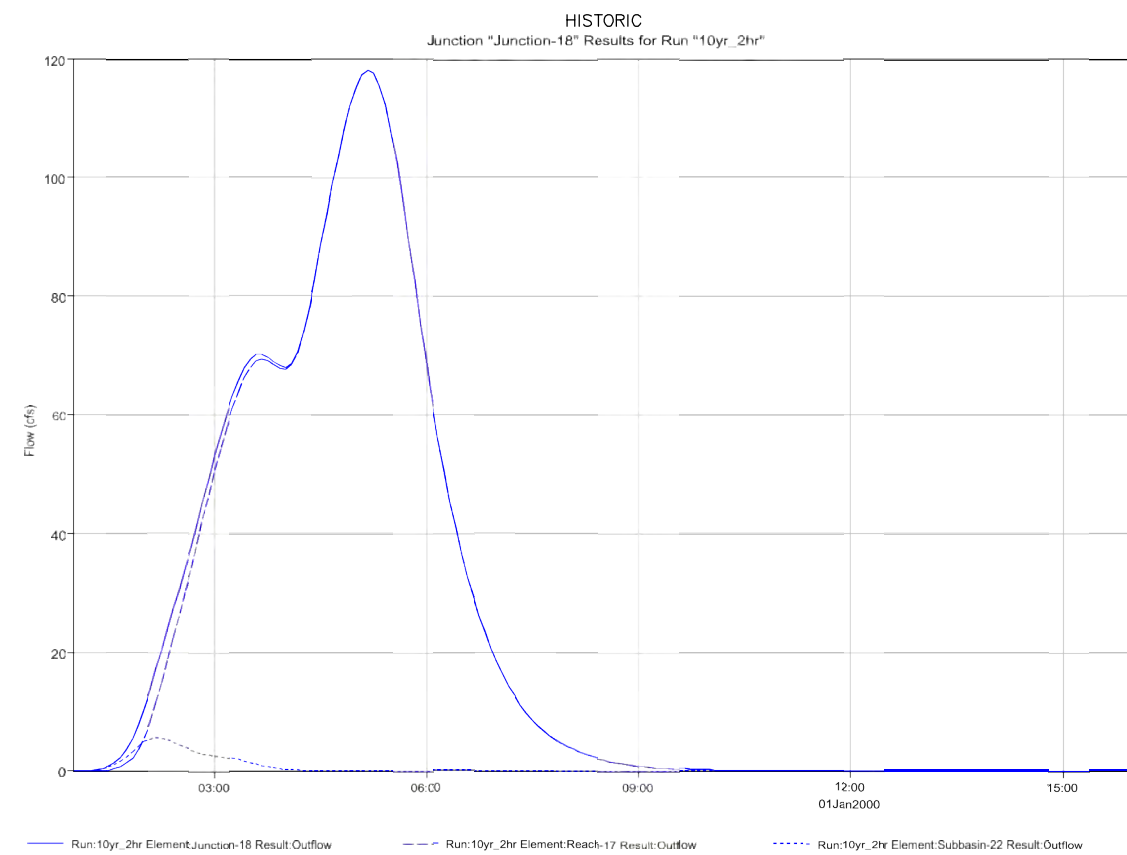

10-YR
24-HR

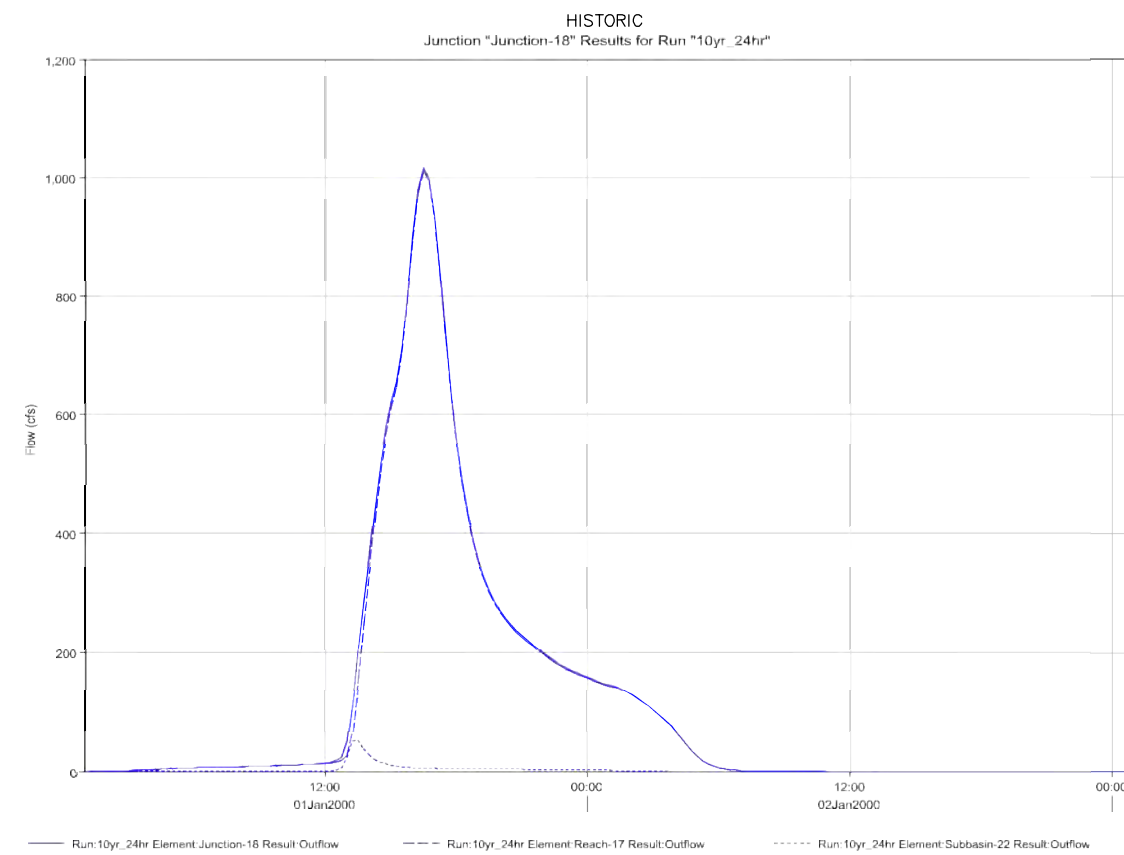

10-YR
2-HR

JUNCTION 18
POWERS BLVD BRIDGE
HISTORIC CONDITIONS HYDROGRAPHS
AT SELECT LOCATIONS
10-YEAR

APPENDIX B – HYDROLOGIC
RESULTS – HISTORIC
HYDROGRAPHS 10-YRJ-18
KETTLE CREEK DBPS
JOB NO. 25100.00
MAY 2015
B-31



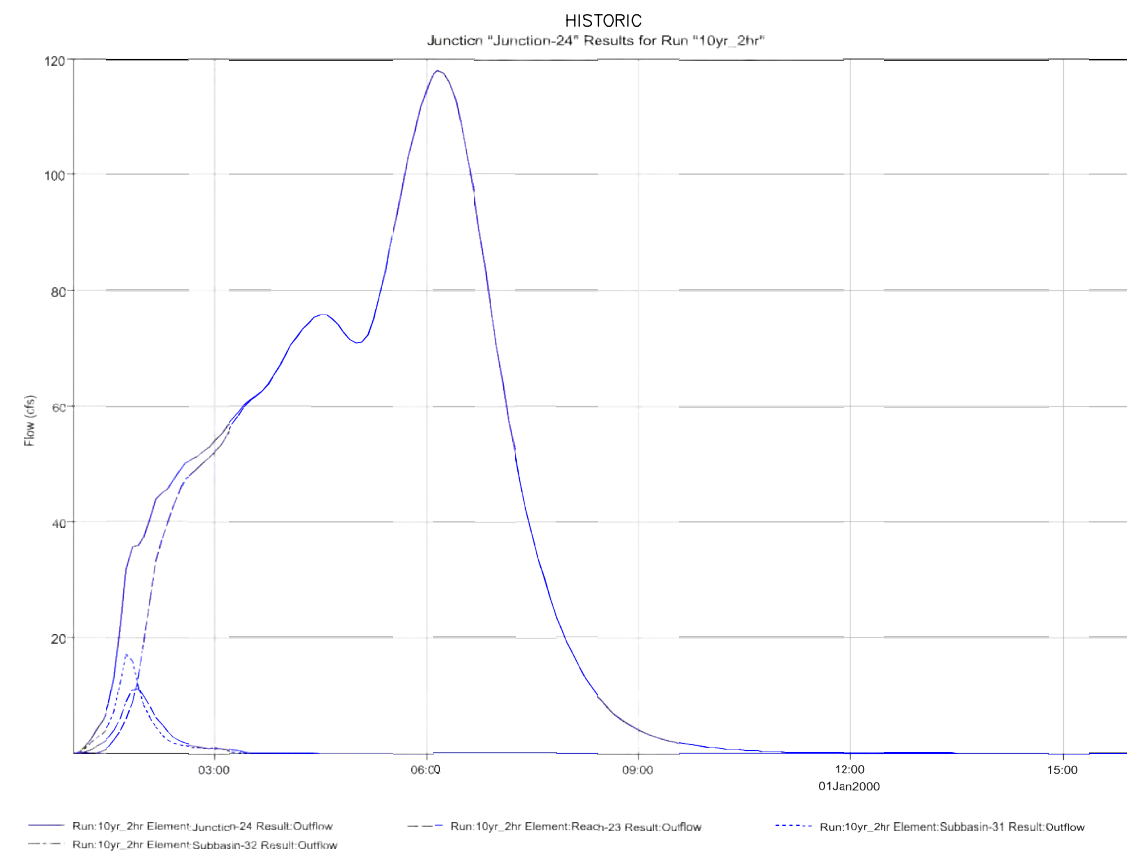

10-YR
24-HR

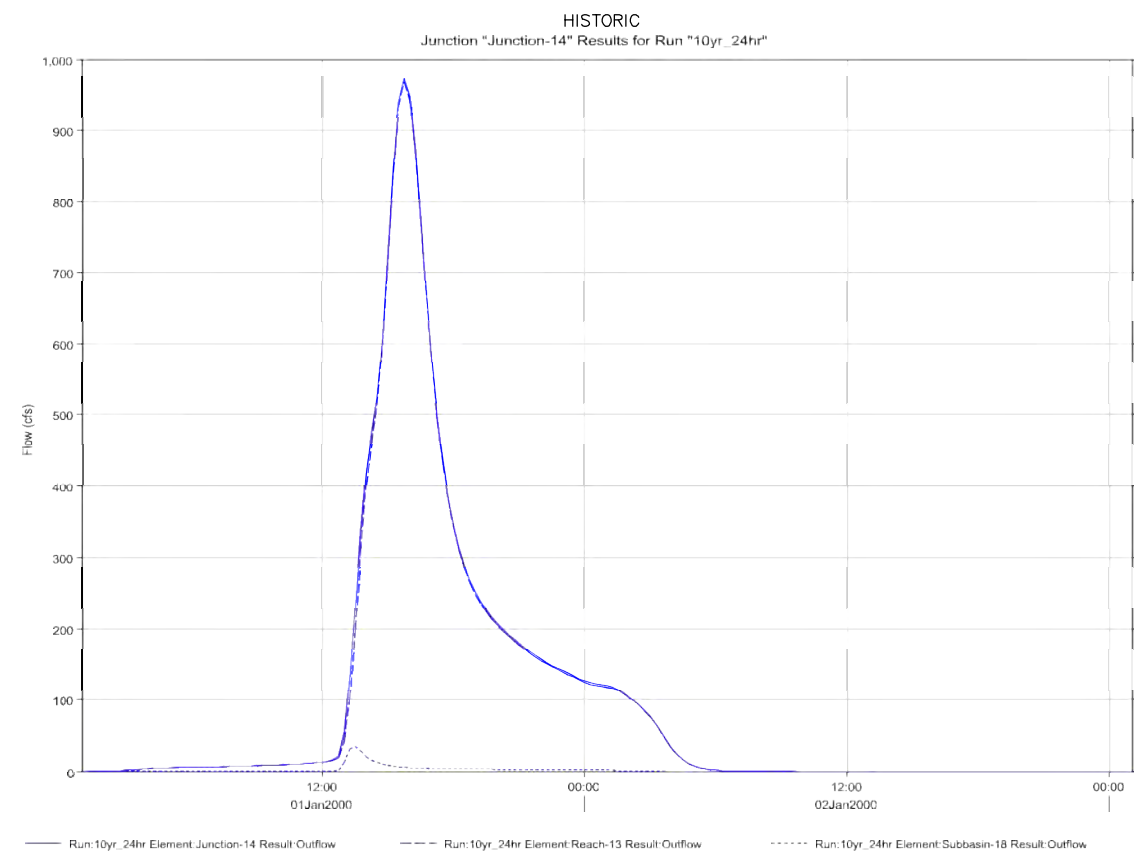

10-YR
2-HR

JUNCTION 24
HWY 83 BRIDGE
HISTORIC CONDITIONS HYDROGRAPHS
AT SELECT LOCATIONS
10-YEAR

APPENDIX B – HYDROLOGIC
RESULTS – HISTORIC
HYDROGRAPHS 10-YR-J-24
KETTLE CREEK DBPS
JOB NO. 25100.00
MAY 2015
B-32



JUNCTION 18
POWERS BLVD BRIDGE

JUNCTION 24
HWY 83 BRIDGE

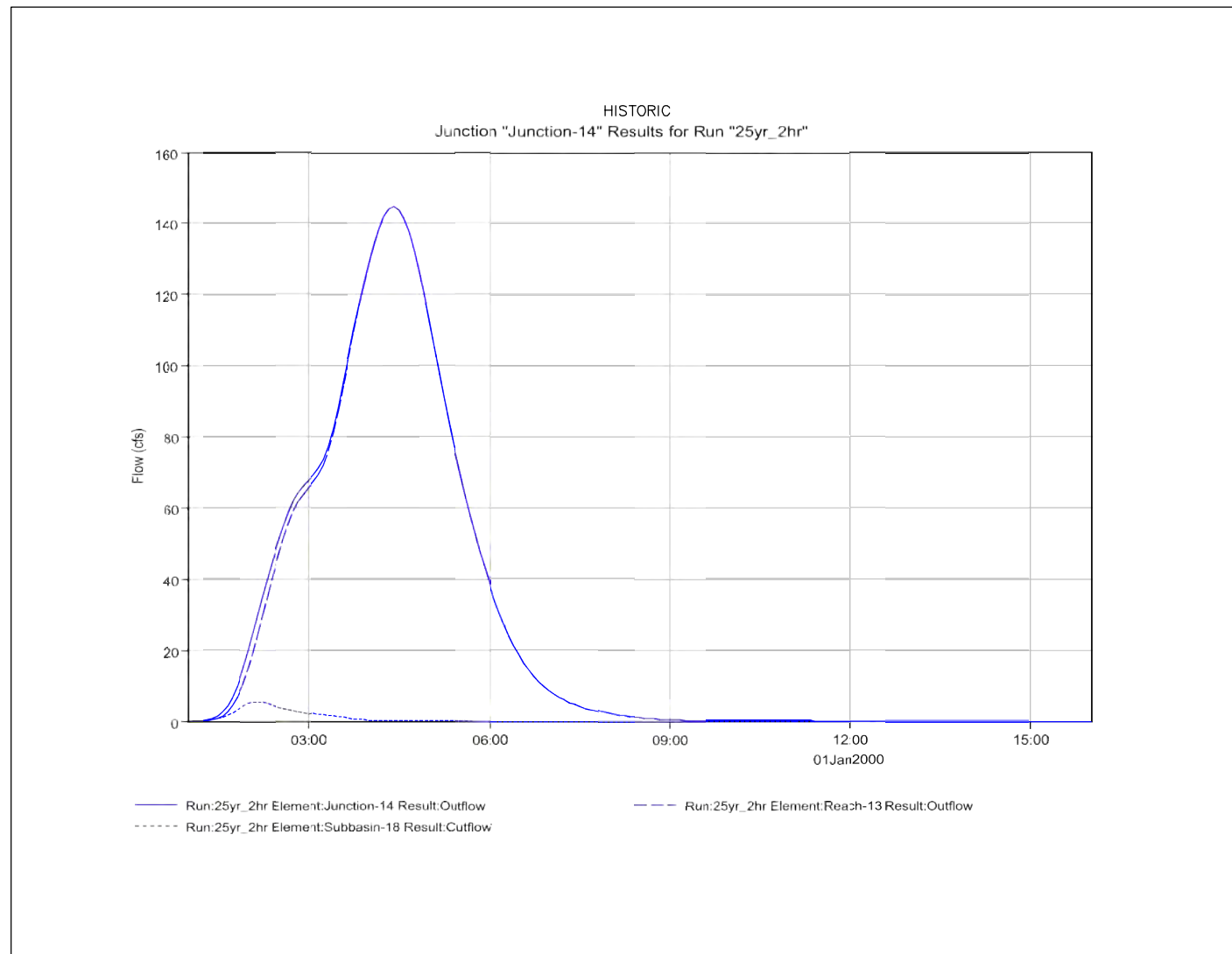

25-YR
2-HR

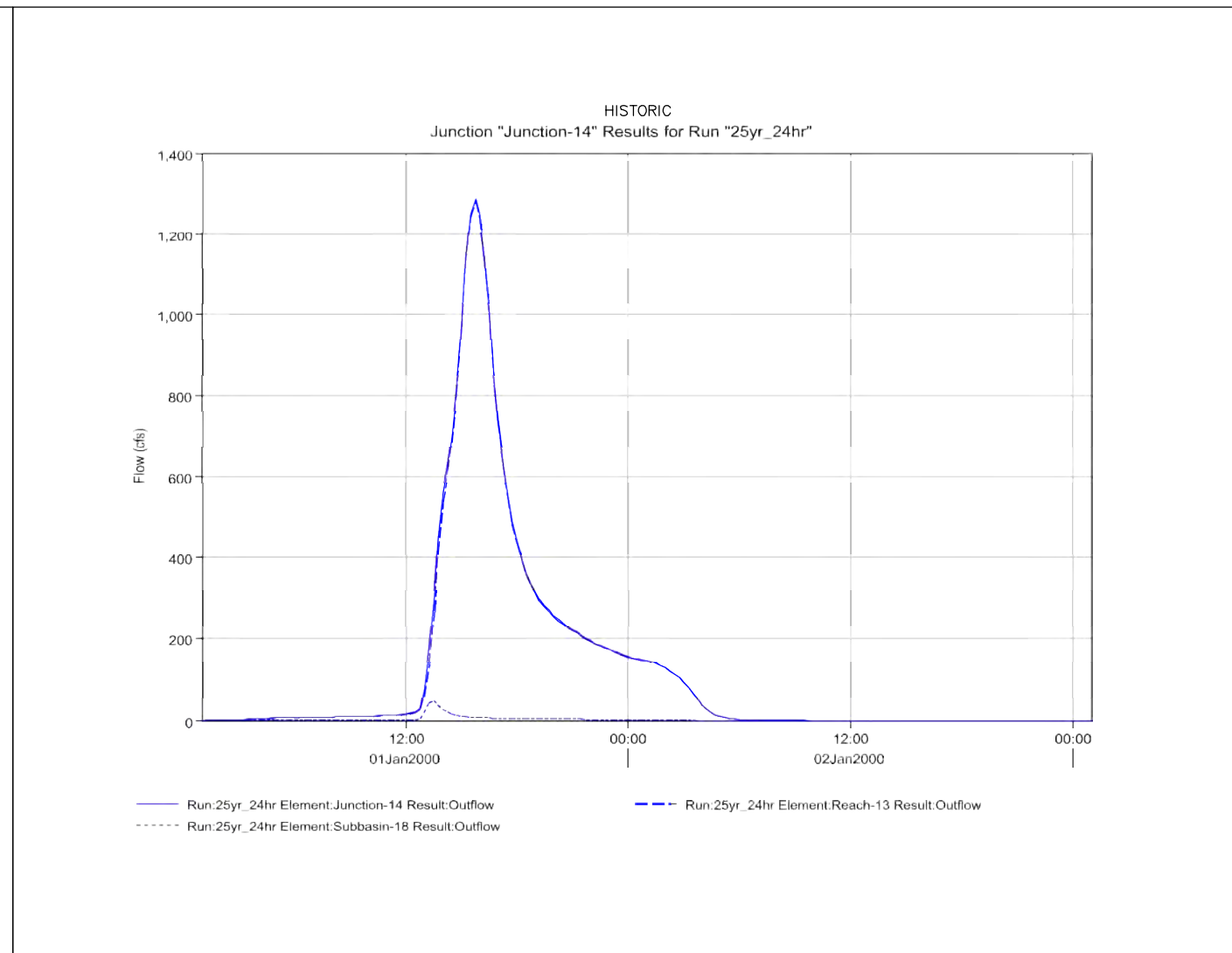

25-YR
24-HR

JUNCTION 14
HOWELLS ROAD (APPROXIMATE)

HISTORIC CONDITIONS HYDROGRAPHS
AT SELECT LOCATIONS
25-YEAR

APPENDIX B – HYDROLOGIC
RESULTS – HISTORIC
HYDROGRAPHS 25-YRJ-14
KETTLE CREEK DBPS
JOB NO. 25100.00
MAY 2015
B-33



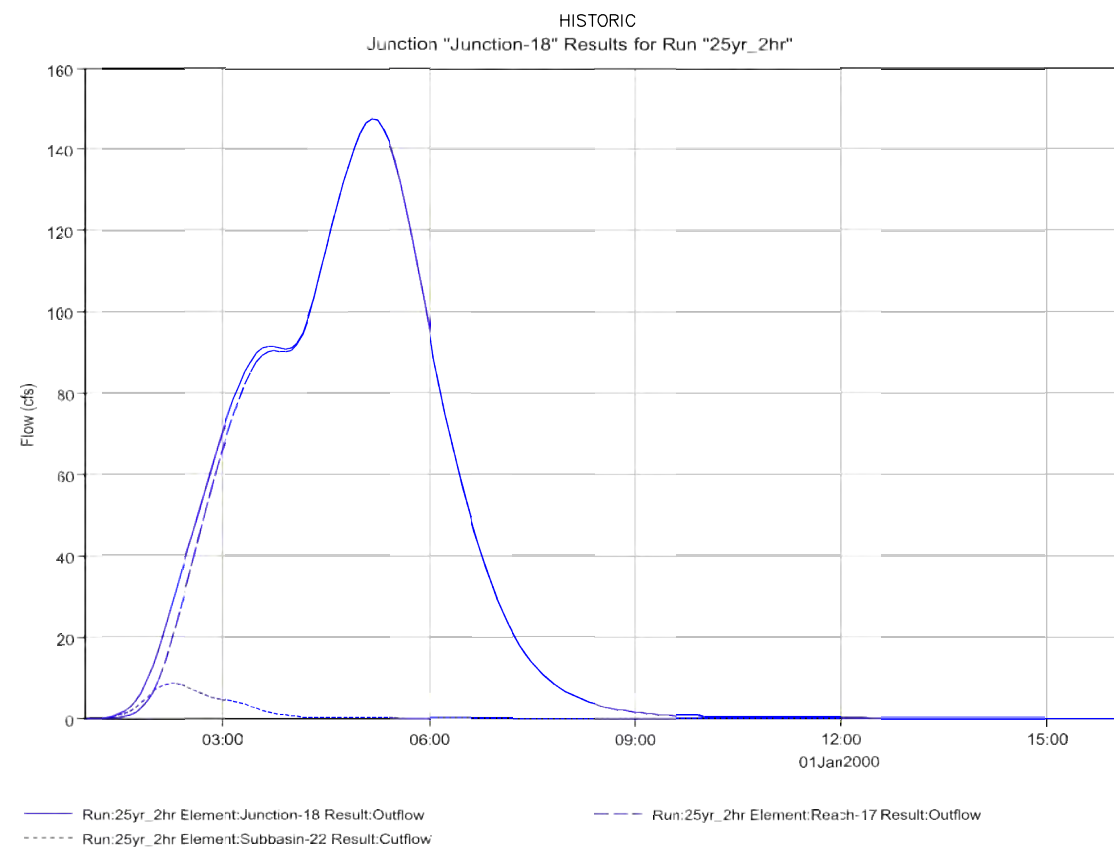

25-YR
2-HR

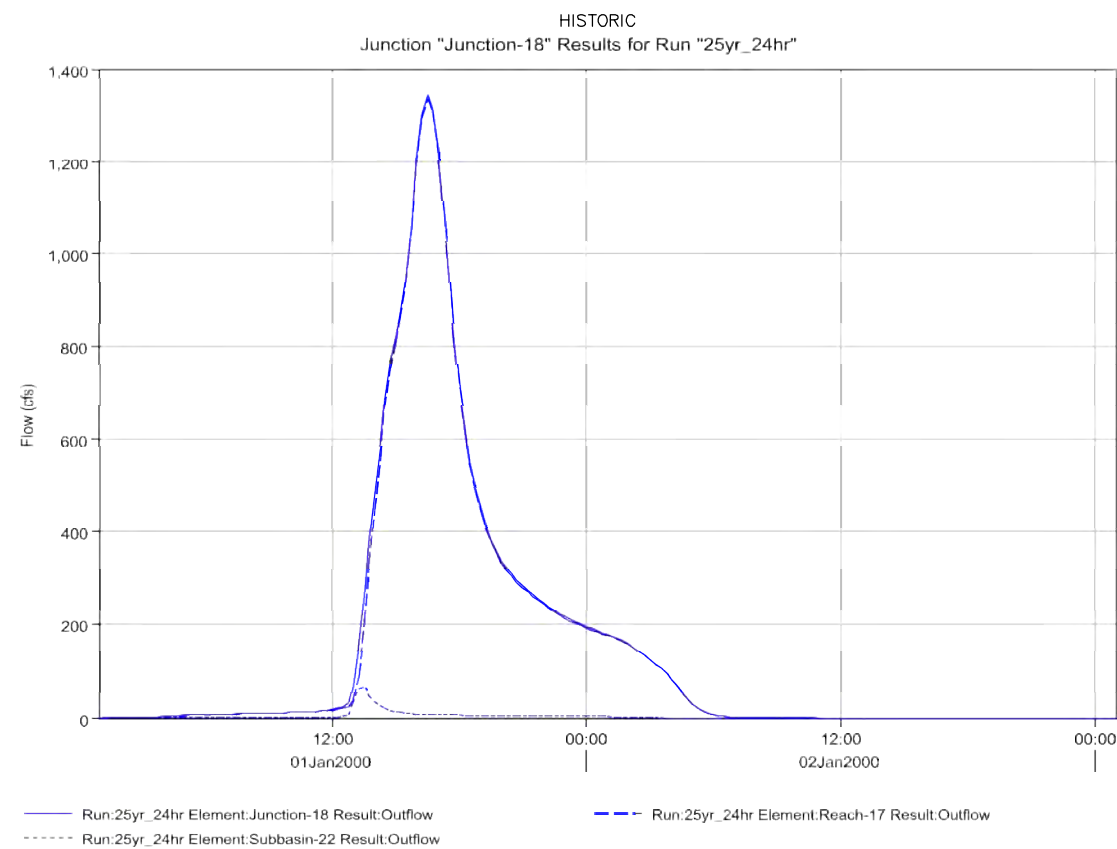

25-YR
24-HR

JUNCTION 18
POWERS BLVD BRIDGE
HISTORIC CONDITIONS HYDROGRAPHS
AT SELECT LOCATIONS
25-YEAR

APPENDIX B – HYDROLOGIC
RESULTS – HISTORIC
HYDROGRAPHS 25-YRJ-18
KETTLE CREEK DBPS
JOB NO. 25100.00
MAY 2015
B-34



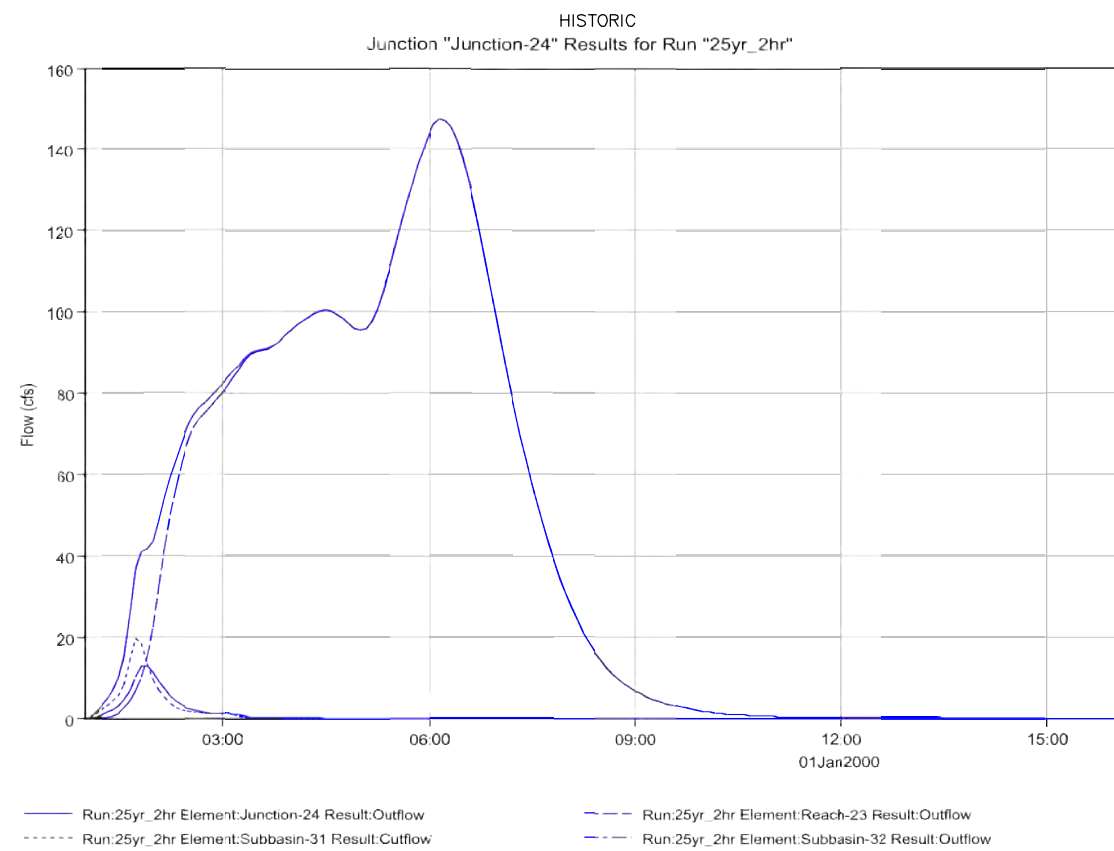

25-YR
2-HR

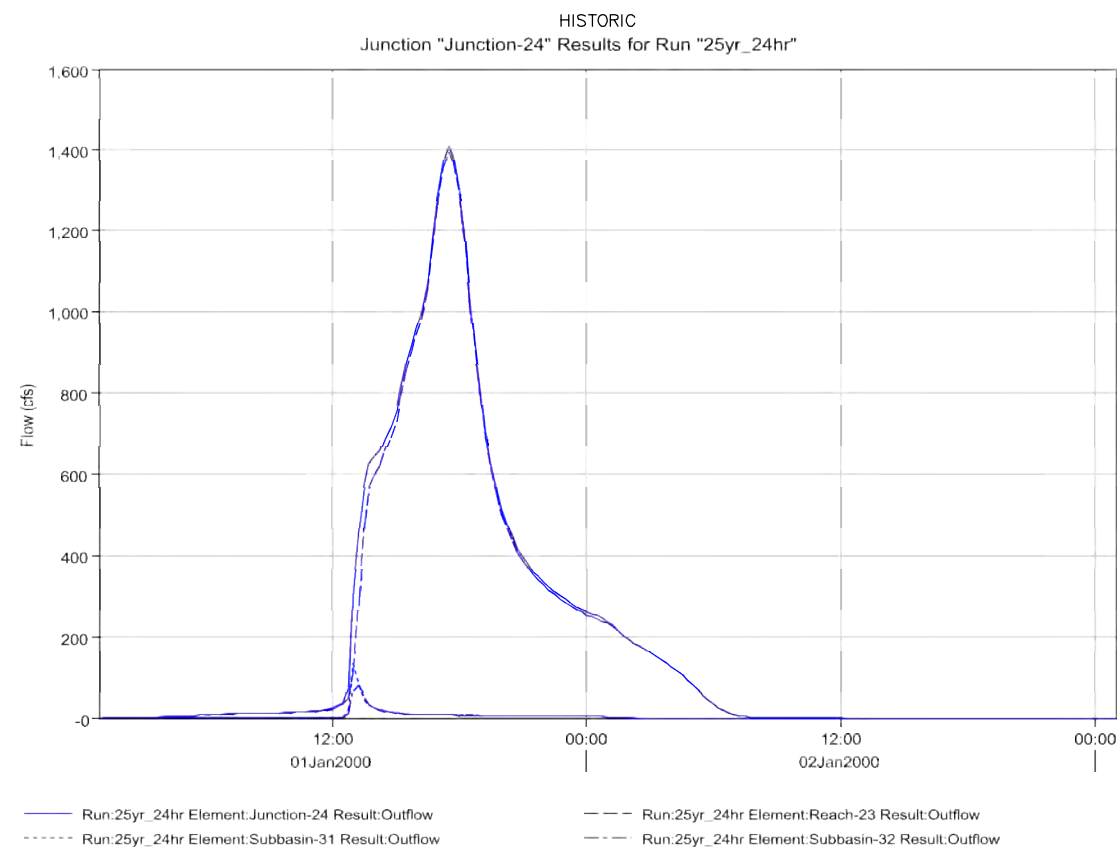

25-YR
24-HR

JUNCTION 24
HWY 83 BRIDGE
HISTORIC CONDITIONS HYDROGRAPHS
AT SELECT LOCATIONS
25-YEAR

APPENDIX B – HYDROLOGIC
RESULTS – HISTORIC
HYDROGRAPHS 25-YRJ-24
KETTLE CREEK DBPS
JOB NO. 25100.00
MAY 2015
B-35



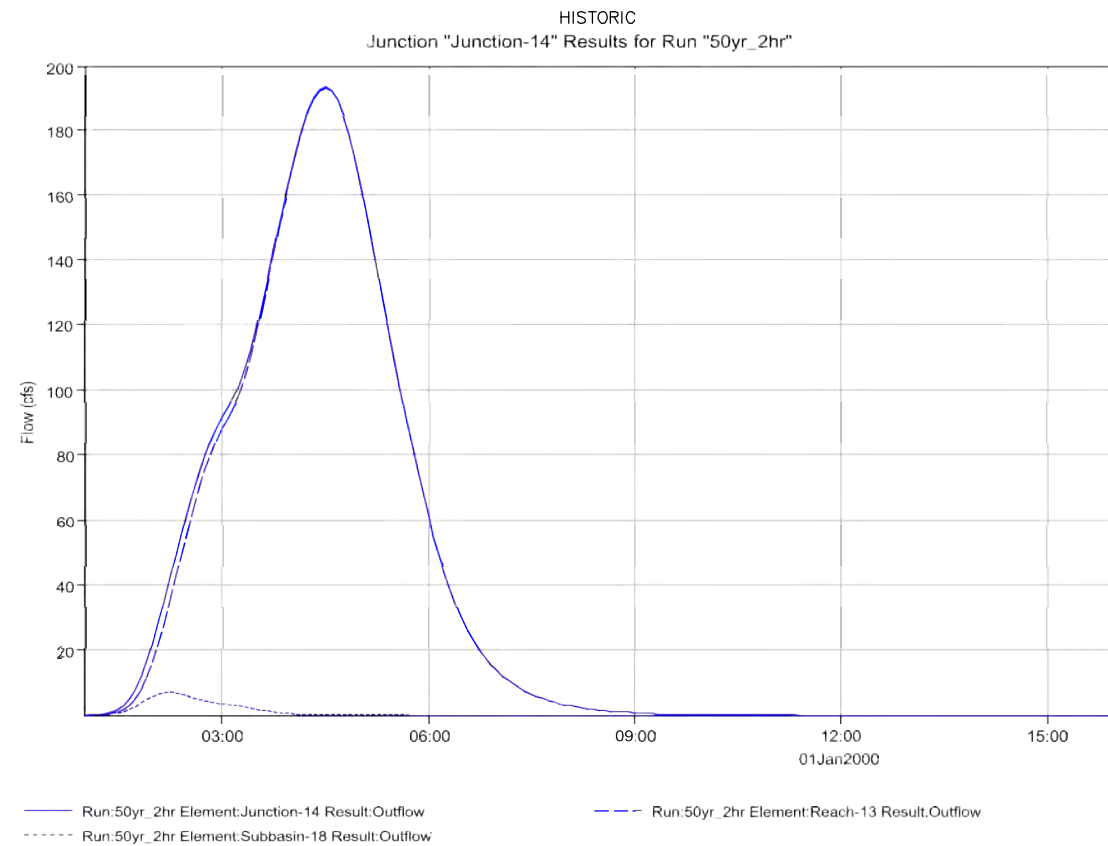

50-YR
2-HR

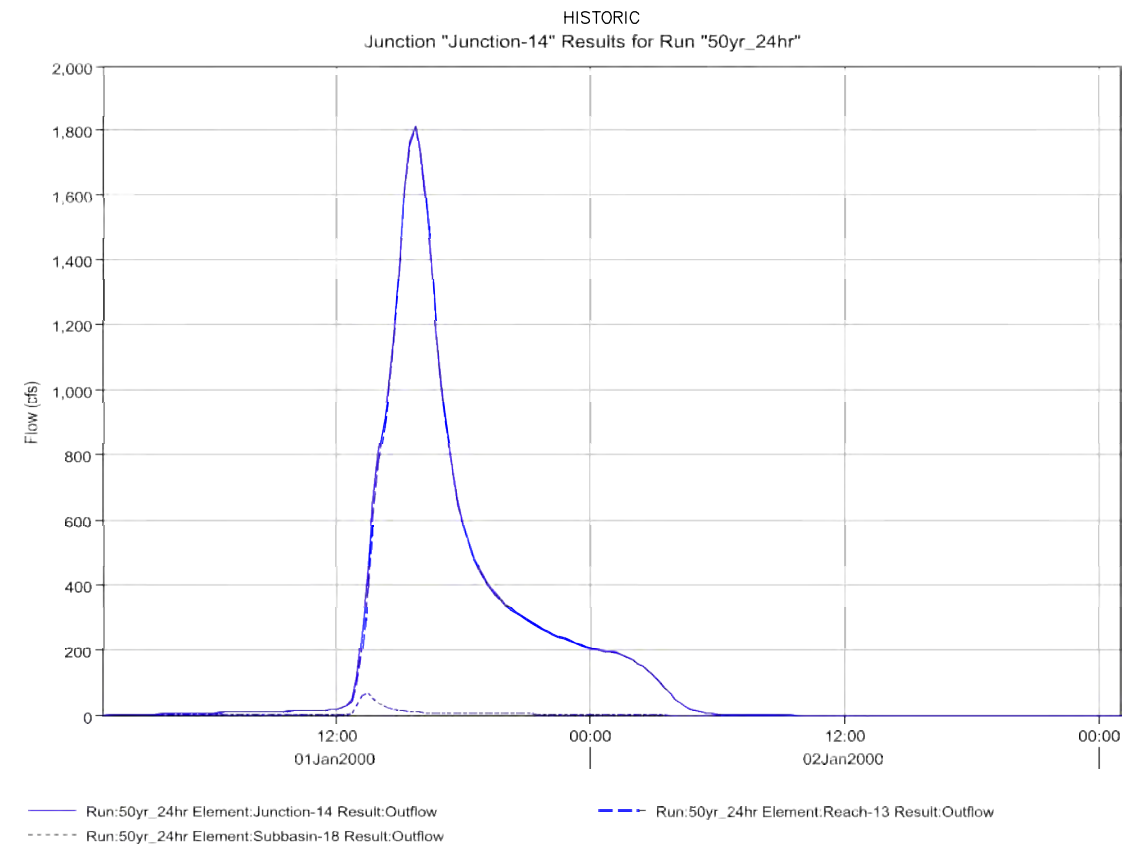

50-YR
24-HR

JUNCTION 14
HOWELLS ROAD (APPROXIMATE)
HISTORIC CONDITIONS HYDROGRAPHS
AT SELECT LOCATIONS
50-YEAR

APPENDIX B – HYDROLOGIC
RESULTS – HISTORIC
HYDROGRAPHS 50-YRJ-14
KETTLE CREEK DBPS
JOB NO. 25100.00
MAY 2015
B-36



Centennial 303-740-9393 • Colorado Springs 719-593-2593
Fort Collins 970-491-9888 • www.jrengineering.com

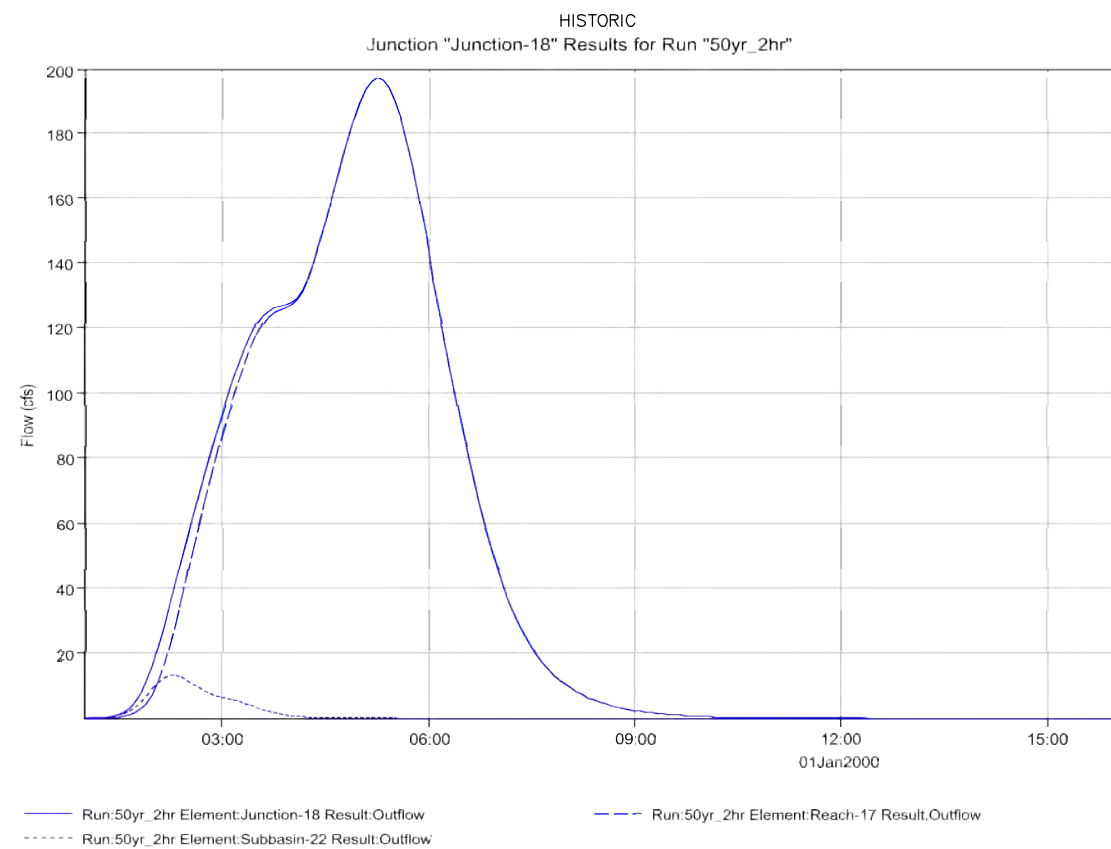

50-YR
2-HR

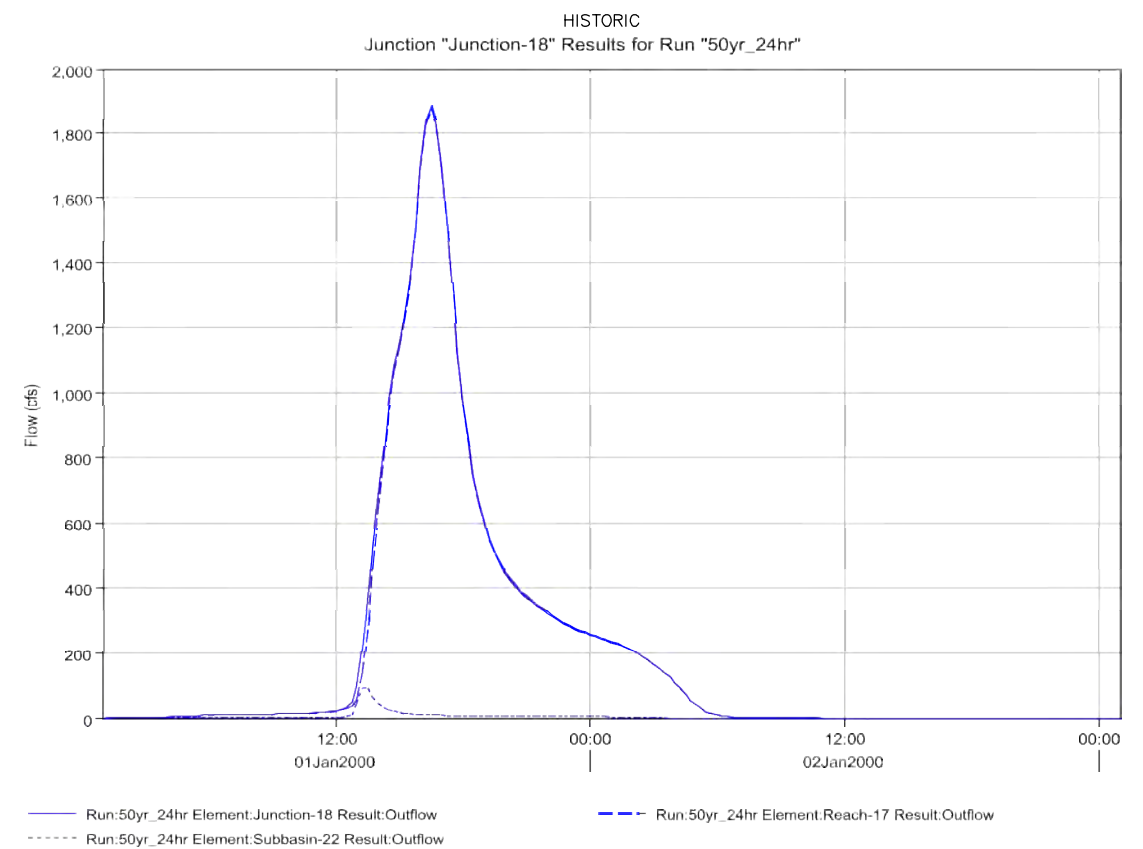

50-YR
24-HR

JUNCTION 18
POWERS BLVD BRIDGE
HISTORIC CONDITIONS HYDROGRAPHS
AT SELECT LOCATIONS
50-YEAR

APPENDIX B – HYDROLOGIC
RESULTS – HISTORIC
HYDROGRAPHS 50-YRJ-18
KETTLE CREEK DBPS
JOB NO. 25100.00
MAY 2015
B-37



Centennial 303-740-9393 • Colorado Springs 719-593-2593
Fort Collins 970-491-9888 • www.jrengineering.com

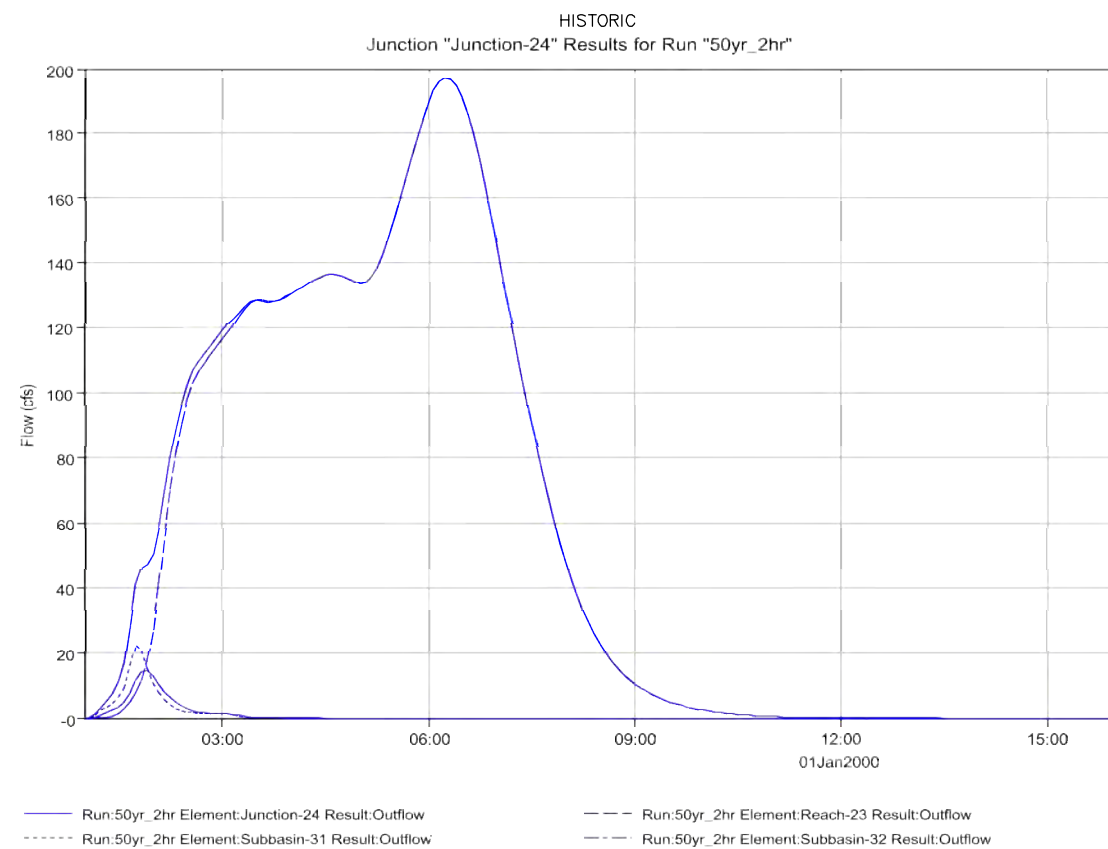

50-YR
2-HR

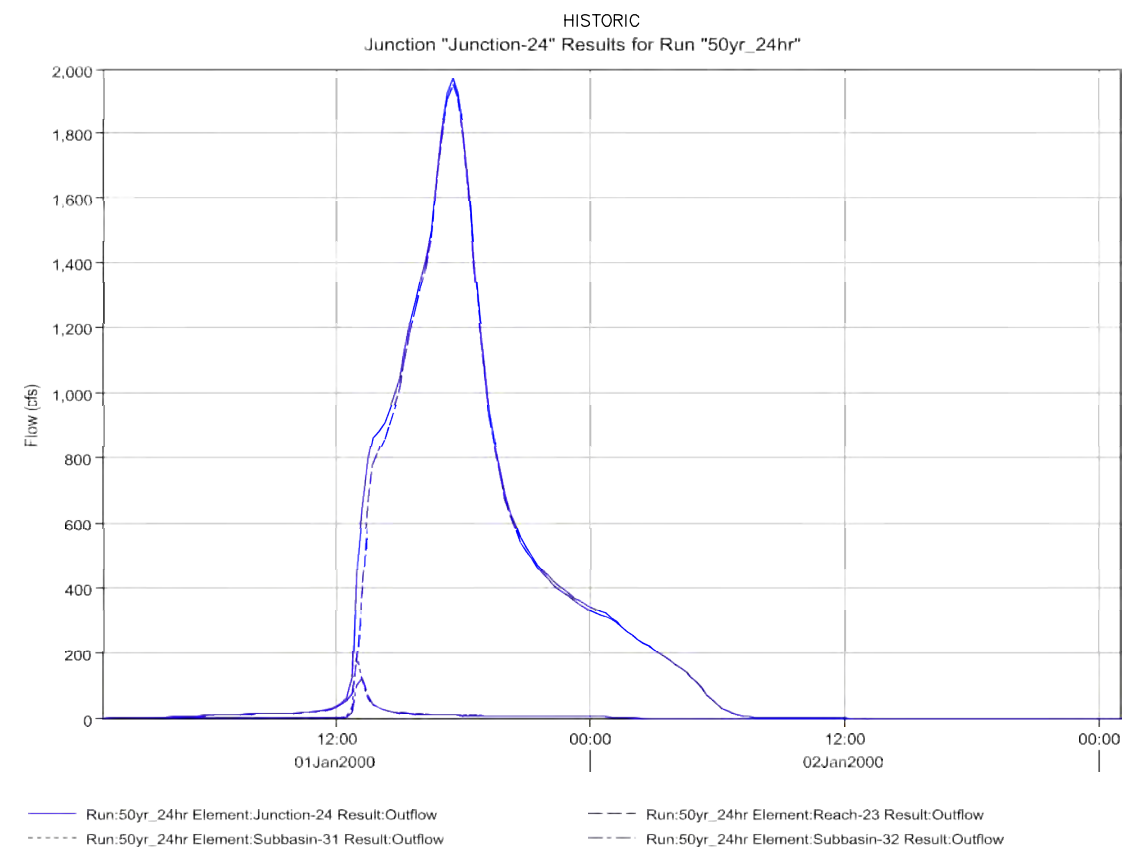

50-YR
24-HR

JUNCTION 24
HWY 83 BRIDGE
HISTORIC CONDITIONS HYDROGRAPHS
AT SELECT LOCATIONS
50-YEAR

APPENDIX B – HYDROLOGIC
RESULTS – HISTORIC
HYDROGRAPHS 50-YR-J-24
KETTLE CREEK DBPS
JOB NO. 25100.00
MAY 2015
B-38



Centennial 303-740-9393 • Colorado Springs 719-593-2593
Fort Collins 970-491-9888 • www.jrengineering.com

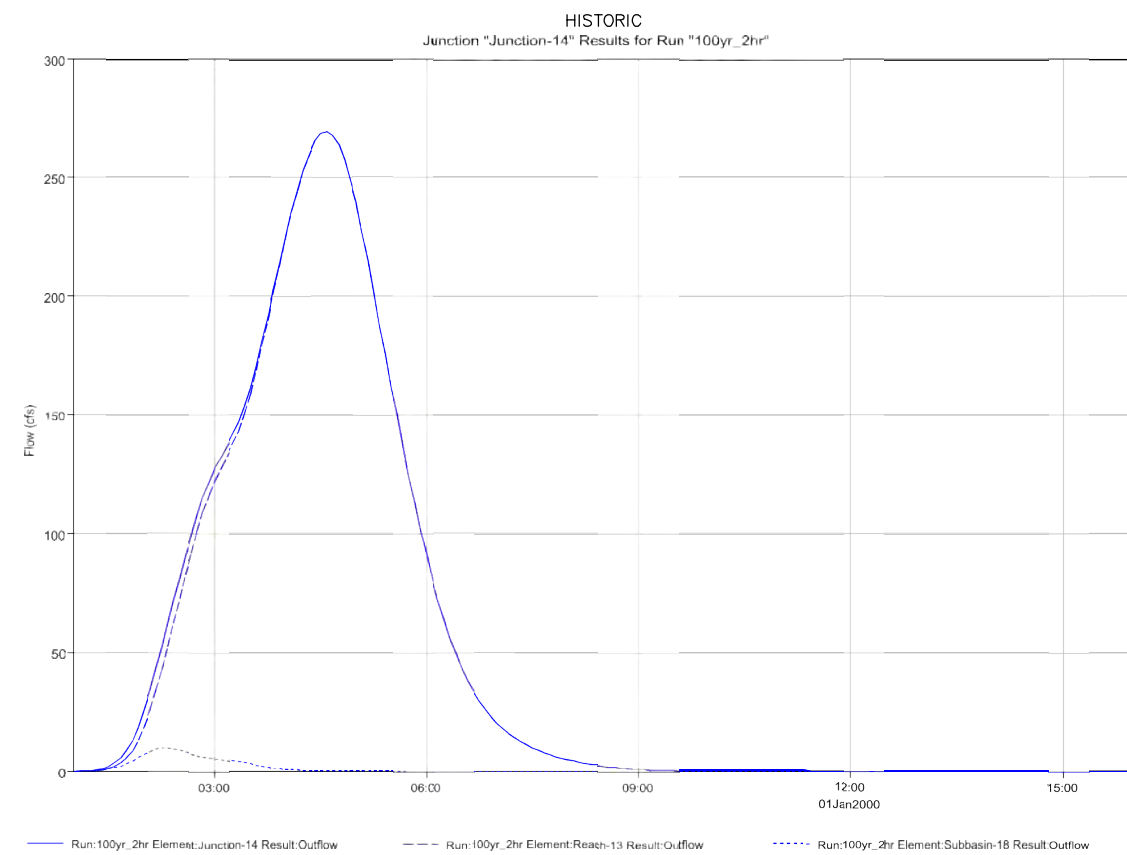

100-YR
2-HR

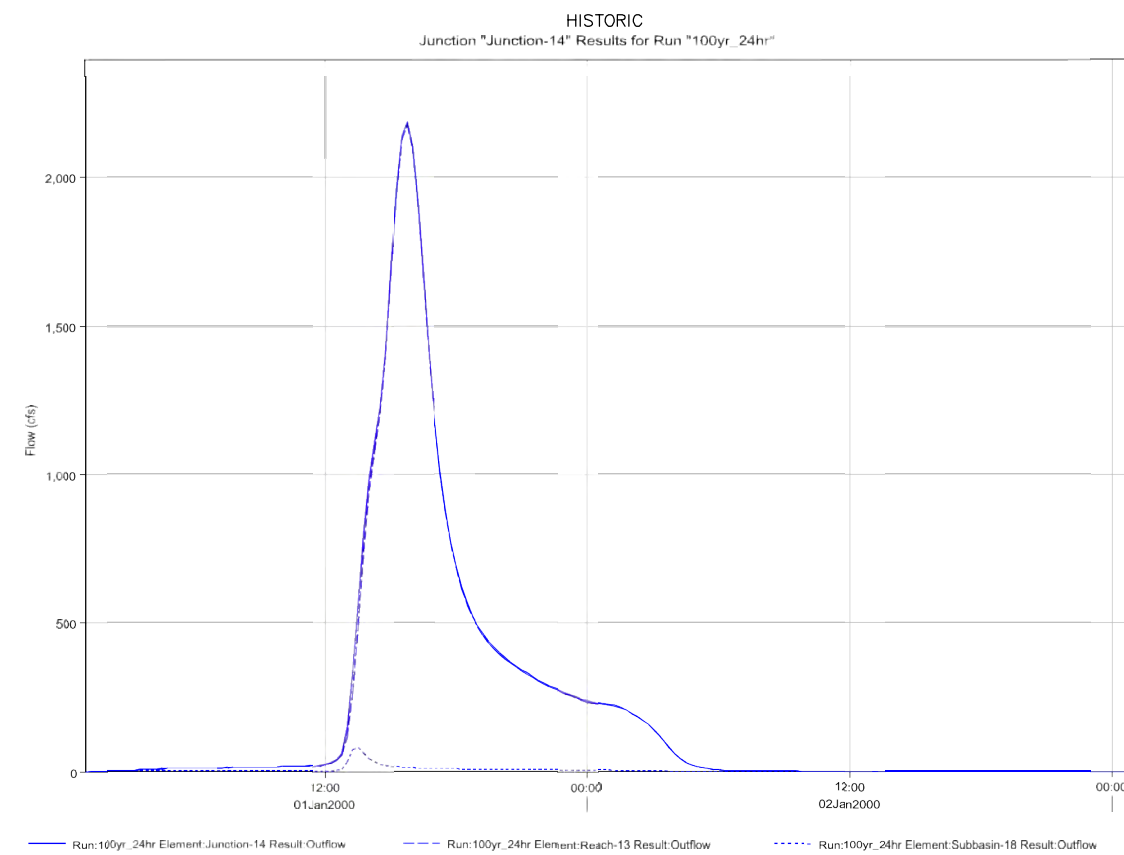

100-YR
24-HR

JUNCTION 14
HOWELLS ROAD (APPROXIMATE)
HISTORIC CONDITIONS HYDROGRAPHS
AT SELECT LOCATIONS
100-YEAR

APPENDIX B – HYDROLOGIC
RESULTS HISTORIC
HYDROGRAPHS 100-YRJ-14
KETTLE CREEK DBPS
JOB NO. 25100.00
MAY 2015
B-39



Centennial 303-740-9393 • Colorado Springs 719-593-2593
Fort Collins 970-491-9888 • www.jrengineering.com

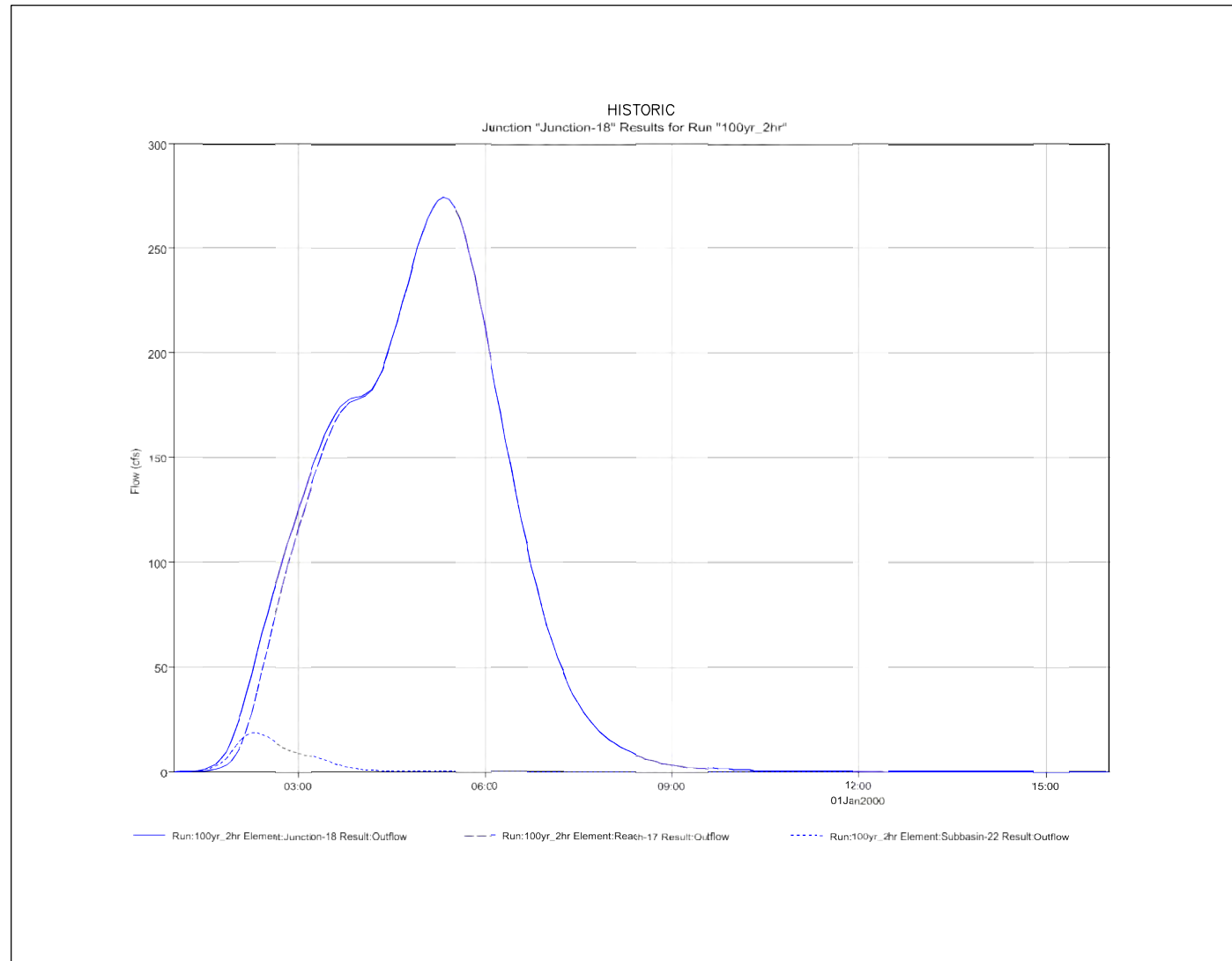

100-YR
2-HR

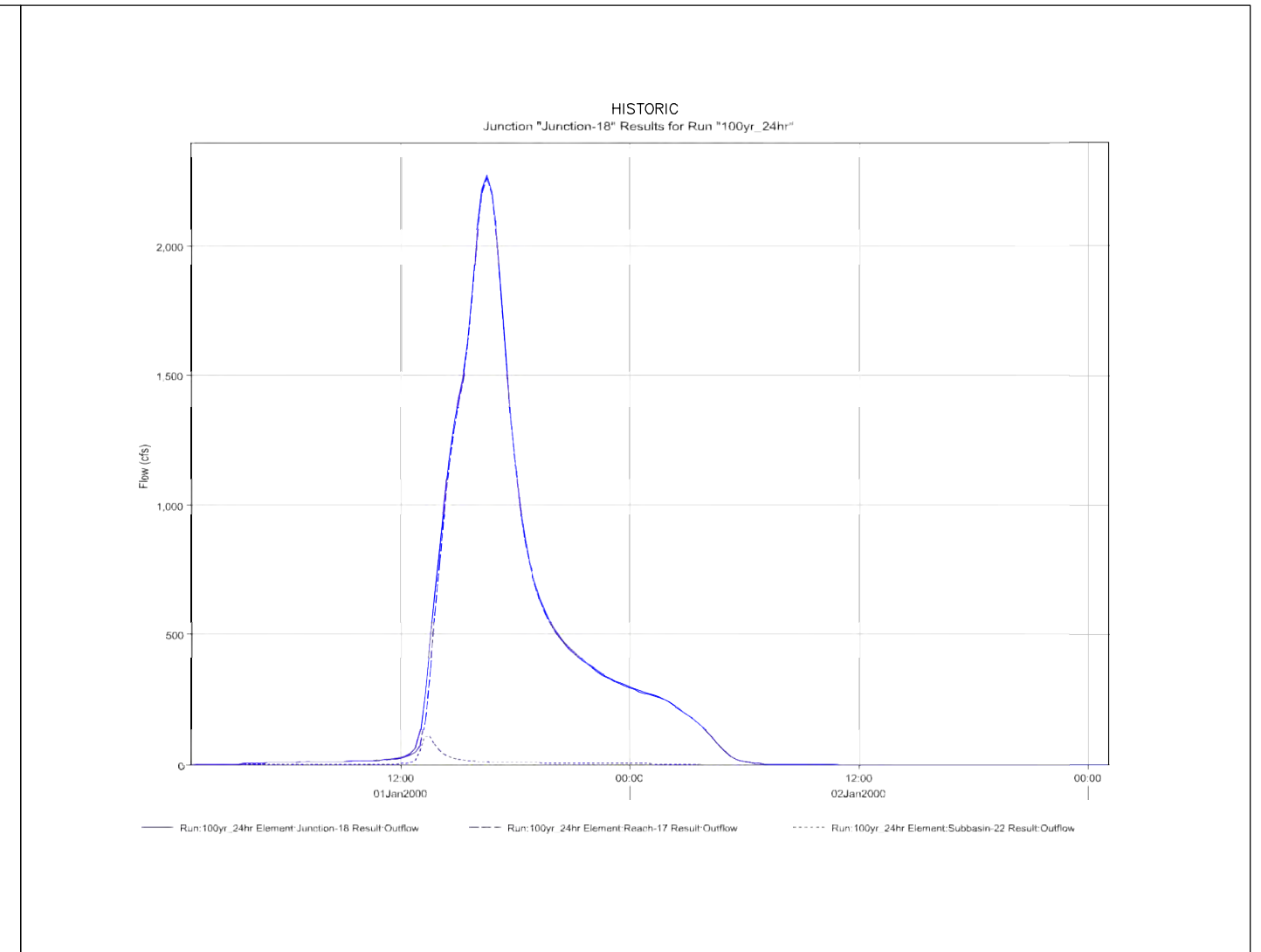

100-YR
24-HR

JUNCTION 18
POWERS BLVD BRIDGE
HISTORIC CONDITIONS HYDROGRAPHS
AT SELECT LOCATIONS
100-YEAR

APPENDIX B – HYDROLOGIC
RESULTS HISTORIC
HYDROGRAPHS 100-YR-J-18
KETTLE CREEK DBPS
JOB NO. 25100.00
MAY 2015
B-40



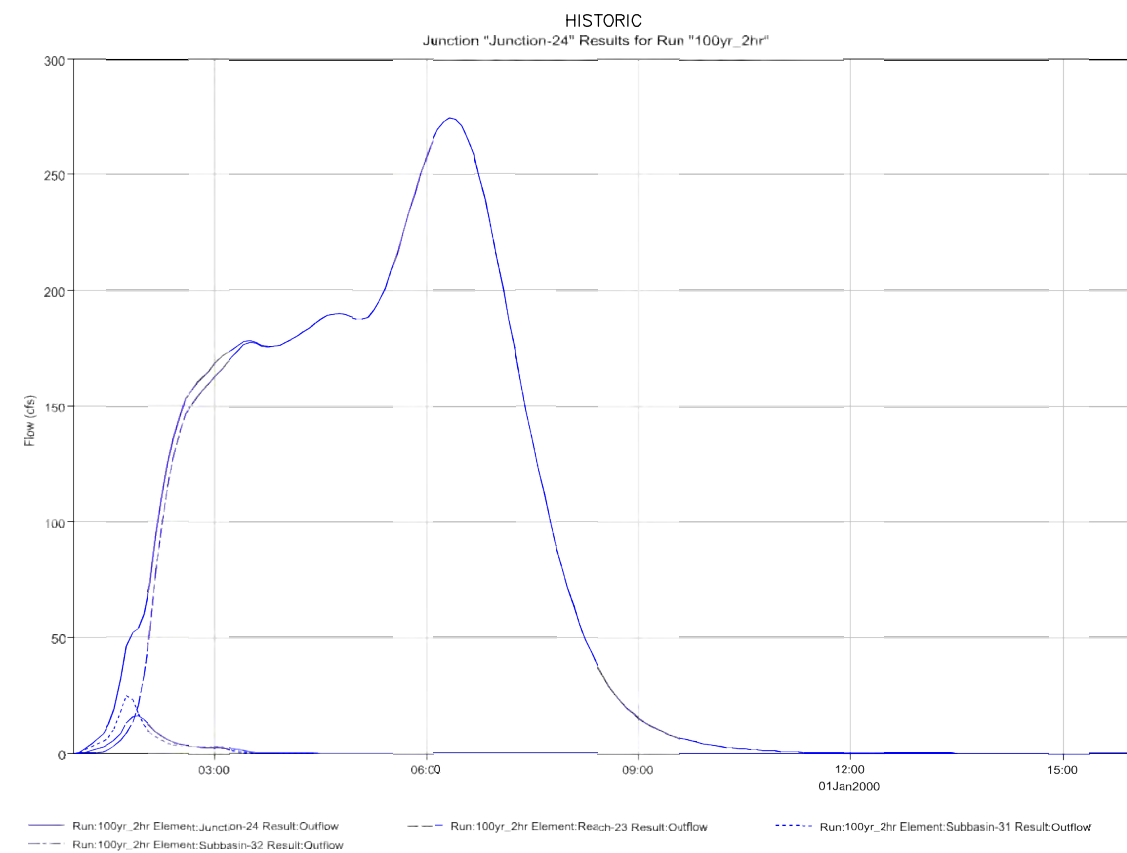

100-YR
2-HR

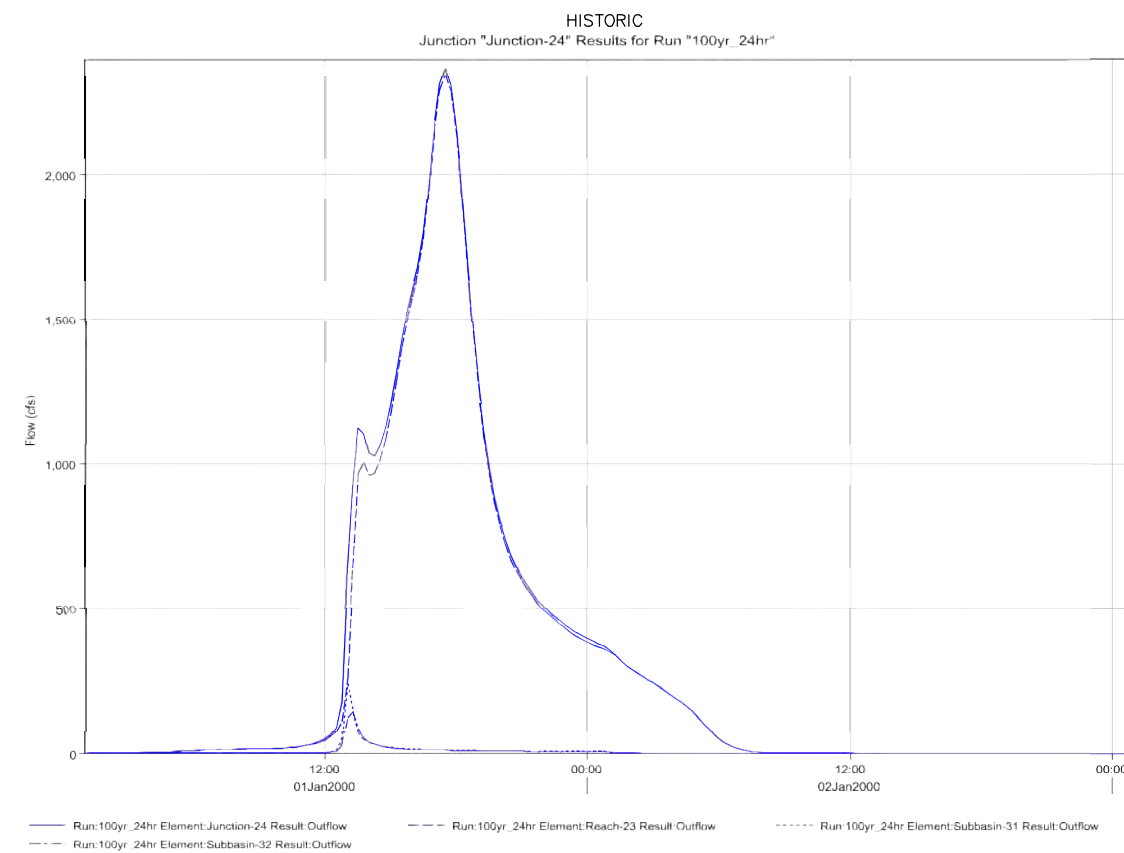

100-YR
24-HR

JUNCTION 24
HWY 83 BRIDGE
HISTORIC CONDITIONS HYDROGRAPHS
AT SELECT LOCATIONS
100-YEAR

APPENDIX B – HYDROLOGIC
RESULTS HISTORIC
HYDROGRAPHS 100-YRJ-24
KETTLE CREEK DBPS
JOB NO. 25100.00
MAY 2015
B-41



Centennial 303-740-9393 • Colorado Springs 719-593-2593
Fort Collins 970-491-9888 • www.jrengineering.com

EXISTING CONDITIONS
MODEL RESULTS
(2-YEAR)

2-Year, 2-Hour Storm			
Hydrologic Element	Drainage Area (mi ²)	Peak Discharge (CFS)	Volume (in)
Subbasin-1	1.263	140	0.35
Subbasin-2	0.586	79	0.36
Subbasin-3	0.180	29	0.47
Junction-1	2.029	242	0.36
Reach-1	2.029	242	0.39
Subbasin-4	0.195	24	0.31
Junction-2	2.224	263	0.38
Reach-2	2.224	263	0.38
Subbasin-5	0.625	59	0.38
Junction-3	2.849	316	0.38
Reach-3	2.849	316	0.39
Subbasin-6	1.333	96	0.29
Junction-4	4.182	412	0.36
Reach-4	4.182	410	0.36
Subbasin-7	0.183	21	0.3
Junction-5	4.365	420	0.36
Reach-5	4.365	420	0.36
Subbasin-8	0.288	51	0.35
Junction-6	4.653	431	0.36
Reach-6	4.653	430	0.36
Subbasin-9	1.177	95	0.35
Subbasin-10	0.222	26	0.29
Junction-7	1.399	106	0.34
Reach-7	1.399	106	0.35
Subbasin-11	0.880	152	0.42
Junction-8	2.279	215	0.38
Reach-8	2.279	215	0.39
Subbasin-12	0.552	61	0.34
Junction-9	2.831	268	0.38
Reach-9	2.831	268	0.38
Junction-10	7.484	639	0.37
Reach-10	7.484	638	0.37
Subbasin-13	1.156	88	0.32
Subbasin-14	0.516	58	0.3
Junction-11	9.156	709	0.36
Reach-11	9.156	708	0.36
Subbasin-15	0.498	61	0.32
Junction-12	9.654	719	0.35
Reach-12	9.654	718	0.35
Subbasin-16	0.819	86	0.36
Subbasin-17	0.788	78	0.3
Junction-13	11.261	754	0.35

2-Year, 2-Hour Storm			
Hydrologic Element	Drainage Area (mi ²)	Peak Discharge (CFS)	Volume (in)
Reach-13	11.261	754	0.35
Subbasin-18	0.192	24	0.3
Junction-14	11.453	756	0.35
Reach-14	11.453	756	0.35
Subbasin-19	0.552	41	0.29
Junction-15	12.005	769	0.35
Reach-15	12.005	768	0.35
Subbasin-20	0.594	52	0.25
Junction-16	12.599	776	0.34
Reach-16	12.599	776	0.34
Subbasin-21	0.417	36	0.21
Junction-17	13.016	780	0.34
Reach-17	13.016	779	0.34
Subbasin-22	0.200	8	0.11
Junction-18	13.216	780	0.33
Reach-18	13.216	779	0.33
Subbasin-23	0.123	13	0.15
Junction-19	13.339	780	0.33
Reach-19	13.339	779	0.33
Subbasin-24	0.453	38	0.3
Subbasin-25	0.169	131	0.85
Subbasin-26	0.480	54	0.36
Junction-21	1.102	151	0.41
Reach-21	1.102	149	0.43
Subbasin-27	0.294	73	0.54
Junction-22	1.396	200	0.46
Reach-22	1.396	198	0.47
Subbasin-28	0.264	8	0.1
Subbasin-29	0.172	11	0.17
Junction-20	0.436	18	0.13
Reach-20	0.436	18	0.13
Subbasin-30	0.364	52	0.32
Junction-23	15.535	800	0.34
Reach-23	15.535	800	0.34
Subbasin-31	0.377	139	0.4
Subbasin-32	0.316	75	0.36
Junction-24	16.228	800	0.34
Reach-24	16.228	799	0.34
Subbasin-33	0.184	4	0.05
Junction-25	16.412	1841.3	0.6
Reach-25	16.412	1841.3	0.6
Junction-26	16.412	1841.3	0.6

2-Year, 24-Hour Storm			
Hydrologic Element	Drainage Area (mi ²)	Peak Discharge (CFS)	Volume (in)
Subbasin-1	1.263	207	0.71
Subbasin-2	0.586	114	0.72
Subbasin-3	0.180	38	0.88
Junction-1	2.029	348	0.73
Reach-1	2.029	348	0.73
Subbasin-4	0.195	36	0.64
Junction-2	2.224	377	0.72
Reach-2	2.224	373	0.72
Subbasin-5	0.625	89	0.78
Junction-3	2.849	453	0.74
Reach-3	2.849	453	0.74
Subbasin-6	1.333	152	0.62
Junction-4	4.182	606	0.70
Reach-4	4.182	600	0.70
Subbasin-7	0.183	33	0.64
Junction-5	4.365	615	0.70
Reach-5	4.365	607	0.70
Subbasin-8	0.288	75.7	0.74
Junction-6	4.653	626.9	0.7
Reach-6	4.653	617	0.70
Subbasin-9	1.177	146	0.71
Subbasin-10	0.222	39	0.61
Junction-7	1.399	165	0.69
Reach-7	1.399	164	0.69
Subbasin-11	0.880	216	0.85
Junction-8	2.279	321	0.75
Reach-8	2.279	321	0.75
Subbasin-12	0.552	93	0.71
Junction-9	2.831	402	0.74
Reach-9	2.831	393	0.74
Junction-10	7.484	946	0.72
Reach-10	7.484	937	0.72
Subbasin-13	1.156	137	0.67
Subbasin-14	0.516	88	0.63
Junction-11	9.156	1,051	0.70
Reach-11	9.156	1,051	0.70
Subbasin-15	0.498	92	0.67
Junction-12	9.654	1,072	0.70
Reach-12	9.654	1,071	0.70

2-Year, 24-Hour Storm			
Hydrologic Element	Drainage Area (mi ²)	Peak Discharge (CFS)	Volume (in)
Subbasin-16	0.819	127	0.72
Subbasin-17	0.788	118	0.63
Junction-13	11.261	1,134	0.70
Reach-13	11.261	1,119	0.70
Subbasin-18	0.192	35.3	0.63
Junction-14	11.453	1,123	0.70
Reach-14	11.453	1,121	0.70
Subbasin-19	0.552	65	0.62
Junction-15	12.005	1,144	0.69
Reach-15	12.005	1,141	0.69
Subbasin-20	0.594	83	0.55
Junction-16	12.599	1,154	0.69
Reach-16	12.599	1,142	0.69
Subbasin-21	0.417	60	0.50
Junction-17	13.016	1,149	0.68
Reach-17	13.016	1,149	0.68
Subbasin-22	0.200	20	0.34
Junction-18	13.216	1,151	0.68
Reach-18	13.216	1,144	0.68
Subbasin-23	0.123	24	0.40
Junction-19	13.339	1,145	0.67
Reach-19	13.339	1,145	0.67
Subbasin-28	0.264	20	0.33
Subbasin-29	0.172	21	0.43
Junction-20	0.436	41	0.37
Reach-20	0.436	38	0.37
Subbasin-30	0.364	74	0.66
Source-1	1.396	87	0.33
Junction-23	15.535	1,172	0.63
Reach-23	15.535	1,164	0.63
Subbasin-31	0.377	147	0.74
Subbasin-32	0.316	83	0.69
Junction-24	16.228	1,174	0.64
Reach-24	16.228	1,166	0.64
Subbasin-33	0.184	10	0.19
Junction-25	16.412	1,167	0.63
Reach-25	16.412	1,164	0.63
Junction-26	16.412	1,164	0.63

NOTE:

1. SOURCE-1 IS THE 24 HOUR FLOW DATA FOR SUBBASINS 24-27, JUNCTION 22, AND REACHES 21-22. SUBBASINS 24-27 DATA HAS BEEN REPLACED WITH KETTLE CREEK DRAINAGE BASIN OLD RANCH ROAD TRIBUTARY MASTER DEVELOPMENT PLAN FLOW DATA (JR ENG. 2001).

APPENDIX B – HYDROLOGIC
RESULTS – EXISTING 2-YR
KETTLE CREEK DBPS
JOB NO. 25100.00
MAY 2015
B-42



EXISTING CONDITIONS
MODEL RESULTS
(5-YEAR)

5-Year, 2-Hour Storm			
Hydrologic Element	Drainage Area (mi ²)	Peak Discharge (CFS)	Volume (in)
Subbasin-1	1.263	286	0.51
Subbasin-2	0.586	160	0.52
Subbasin-3	0.180	56	0.65
Junction-1	2.029	492	0.52
Reach-1	2.029	490	0.52
Subbasin-4	0.195	50	0.45
Junction-2	2.224	536	0.52
Reach-2	2.224	536	0.52
Subbasin-5	0.625	119	0.56
Junction-3	2.849	644	0.53
Reach-3	2.849	644	0.53
Subbasin-6	1.333	203	0.43
Junction-4	4.182	846	0.5
Reach-4	4.182	846	0.5
Subbasin-7	0.183	45	0.44
Junction-5	4.365	865	0.49
Reach-5	4.365	862	0.49
Subbasin-8	0.288	104	0.52
Junction-6	4.653	885	0.49
Reach-6	4.653	883	0.49
Subbasin-9	1.177	195	0.51
Subbasin-10	0.222	55	0.43
Junction-7	1.399	217	0.49
Reach-7	1.399	217	0.49
Subbasin-11	0.880	302	0.61
Junction-8	2.279	437	0.54
Reach-8	2.279	434	0.54
Subbasin-12	0.552	127	0.5
Junction-9	2.831	546	0.53
Reach-9	2.831	545	0.53
Junction-10	7.484	1,305	0.51
Reach-10	7.484	1,305	0.51
Subbasin-13	1.156	183	0.47
Subbasin-14	0.516	122	0.44
Junction-11	9.156	1,437	0.5
Reach-11	9.156	1,435	0.5
Subbasin-15	0.498	127	0.47
Junction-12	9.654	1,445	0.5
Reach-12	9.654	1,442	0.5
Subbasin-16	0.819	175	0.51
Subbasin-17	0.788	164	0.44
Junction-13	11.261	1,475	0.49

5-Year, 2-Hour Storm			
Hydrologic Element	Drainage Area (mi ²)	Peak Discharge (CFS)	Volume (in)
Reach-13	11.261	1,473	0.49
Subbasin-18	0.192	50	0.44
Junction-14	11.453	1,473	0.49
Reach-14	11.453	1,473	0.49
Subbasin-19	0.552	86	0.44
Junction-15	12.005	1,488	0.49
Reach-15	12.005	1,485	0.49
Subbasin-20	0.594	113	0.38
Junction-16	12.599	1,487	0.49
Reach-16	12.599	1,487	0.49
Subbasin-21	0.417	82	0.33
Junction-17	13.016	1,487	0.48
Reach-17	13.016	1,486	0.48
Subbasin-22	0.200	24	0.21
Junction-18	13.216	1,486	0.48
Reach-18	13.216	1,484	0.48
Subbasin-23	0.123	30	0.25
Junction-19	13.339	1,484	0.47
Reach-19	13.339	1,482	0.47
Subbasin-24	0.453	81	0.45
Subbasin-25	0.169	206	1.12
Subbasin-26	0.480	111	0.51
Junction-21	1.102	250	0.58
Reach-21	1.102	245	0.58
Subbasin-27	0.294	139	0.75
Junction-22	1.396	346	0.61
Reach-22	1.396	344	0.61
Subbasin-28	0.264	25	0.19
Subbasin-29	0.172	28	0.27
Junction-20	0.436	50	0.22
Reach-20	0.436	50	0.22
Subbasin-30	0.364	107	0.47
Junction-23	15.535	1,484	0.48
Reach-23	15.535	1,482	0.48
Subbasin-31	0.377	219	0.55
Subbasin-32	0.316	137	0.5
Junction-24	16.228	1,482	0.48
Reach-24	16.228	1,481	0.48
Subbasin-33	0.184	13	0.1
Junction-25	16.412	1481.1	0.48
Reach-25	16.412	1481.1	0.48
Junction-26	16.412	1481.1	0.48

5-Year, 24-Hour Storm			
Hydrologic Element	Drainage Area (mi ²)	Peak Discharge (CFS)	Volume (in)
Subbasin-1	1.263	315	1.06
Subbasin-2	0.586	173	1.06
Subbasin-3	0.180	56	1.27
Junction-1	2.029	527	1.08
Reach-1	2.029	526	1.08
Subbasin-4	0.195	56	0.97
Junction-2	2.224	572	1.07
Reach-2	2.224	568	1.07
Subbasin-5	0.625	134	1.14
Junction-3	2.849	689	1.08
Reach-3	2.849	689	1.08
Subbasin-6	1.333	240	0.94
Junction-4	4.182	928	1.04
Reach-4	4.182	917	1.04
Subbasin-7	0.183	51	0.97
Junction-5	4.365	940	1.03
Reach-5	4.365	929	1.03
Subbasin-8	0.288	117	1.1
Junction-6	4.653	959	1.04
Reach-6	4.653	944	1.04
Subbasin-9	1.177	223	1.05
Subbasin-10	0.222	62	0.93
Junction-7	1.399	252	1.03
Reach-7	1.399	250	1.03
Subbasin-11	0.880	322	1.23
Junction-8	2.279	484	1.11
Reach-8	2.279	484	1.11
Subbasin-12	0.552	144	1.06
Junction-9	2.831	609	1.1
Reach-9	2.831	594	1.1
Junction-10	7.484	1,444	1.06
Reach-10	7.484	1,428	1.06
Subbasin-13	1.156	212	1
Subbasin-14	0.516	138	0.95
Junction-11	9.156	1,605	1.05
Reach-11	9.156	1,604	1.05
Subbasin-15	0.498	143	1
Junction-12	9.654	1,636	1.05
Reach-12	9.654	1,634	1.05

5-Year, 24-Hour Storm			
Hydrologic Element	Drainage Area (mi ²)	Peak Discharge (CFS)	Volume (in)
Subbasin-16	0.819	193	1.06
Subbasin-17	0.788	184	0.95
Junction-13	11.261	1,730	1.04
Reach-13	11.261	1,705	1.04
Subbasin-18	0.192	55	0.95
Junction-14	11.453	1,711	1.04
Reach-14	11.453	1,710	1.04
Subbasin-19	0.552	101	0.95
Junction-15	12.005	1,745	1.03
Reach-15	12.005	1,741	1.03
Subbasin-20	0.594	134	0.86
Junction-16	12.599	1,760	1.03
Reach-16	12.599	1,741	1.03
Subbasin-21	0.417	100	0.79
Junction-17	13.016	1,752	1.02
Reach-17	13.016	1,752	1.02
Subbasin-22	0.200	36	0.59
Junction-18	13.216	1,756	1.01
Reach-18	13.216	1,746	1.01
Subbasin-23	0.123	42	0.66
Junction-19	13.339	1,748	1.01
Reach-19	13.339	1,747	1.01
Source-1	1.396	109	0.58
Subbasin-28	0.264	38	0.57
Subbasin-29	0.172	37	0.7
Junction-20	0.436	75	0.62
Reach-20	0.436	70	0.62
Subbasin-30	0.364	116	1
Junction-23	15.535	1,764	0.96
Reach-23	15.535	1,751	0.96
Subbasin-31	0.377	217	1.05
Subbasin-32	0.316	124	1.01
Junction-24	16.228	1,766	0.96
Reach-24	16.228	1,754	0.96
Subbasin-33	0.184	24	0.37
Junction-25	16.412	1,756	0.96
Reach-25	16.412	1,750	0.96
Junction-26	16.412	1,750	0.96

NOTE:

1. SOURCE-1 IS THE 24 HOUR FLOW DATA FOR SUBBASINS 24-27, JUNCTION 22, AND REACHES 21-22. SUBBASINS 24-27 DATA HAS BEEN REPLACED WITH KETTLE CREEK DRAINAGE BASIN OLD RANCH ROAD TRIBUTARY MASTER DEVELOPMENT PLAN FLOW DATA (JR ENG. 2001).

APPENDIX B – HYDROLOGIC
RESULTS – EXISTING 5-YR
KETTLE CREEK DBPS
JOB NO. 25100.00
MAY 2015
B-43



EXISTING CONDITIONS
MODEL RESULTS
(10-YEAR)

10-Year, 2-Hour Storm			
Hydrologic Element	Drainage Area (mi ²)	Peak Discharge (CFS)	Volume (in)
Subbasin-1	1.263	354	0.63
Subbasin-2	0.586	198	0.64
Subbasin-3	0.180	68	0.79
Junction-1	2.029	608	0.65
Reach-1	2.029	606	0.65
Subbasin-4	0.195	63	0.57
Junction-2	2.224	663	0.64
Reach-2	2.224	663	0.64
Subbasin-5	0.625	147	0.69
Junction-3	2.849	797	0.65
Reach-3	2.849	797	0.65
Subbasin-6	1.333	255	0.54
Junction-4	4.182	1,051	0.62
Reach-4	4.182	1,051	0.62
Subbasin-7	0.183	56	0.56
Junction-5	4.365	1,074	0.61
Reach-5	4.365	1,071	0.61
Subbasin-8	0.288	131	0.65
Junction-6	4.653	1,099	0.62
Reach-6	4.653	1,097	0.62
Subbasin-9	1.177	242	0.63
Subbasin-10	0.222	70	0.54
Junction-7	1.399	269	0.61
Reach-7	1.399	269	0.61
Subbasin-11	0.880	373	0.75
Junction-8	2.279	540	0.67
Reach-8	2.279	537	0.67
Subbasin-12	0.552	159	0.62
Junction-9	2.831	677	0.66
Reach-9	2.831	675	0.66
Junction-10	7.484	1,619	0.63
Reach-10	7.484	1,619	0.63
Subbasin-13	1.156	229	0.59
Subbasin-14	0.516	153	0.55
Junction-11	9.156	1,784	0.62
Reach-11	9.156	1,782	0.62
Subbasin-15	0.498	159	0.59
Junction-12	9.654	1,795	0.62
Reach-12	9.654	1,792	0.62
Subbasin-16	0.819	217	0.64
Subbasin-17	0.788	206	0.55
Junction-13	11.261	1,833	0.62

10-Year, 2-Hour Storm			
Hydrologic Element	Drainage Area (mi ²)	Peak Discharge (CFS)	Volume (in)
Reach-13	11.261	1,830	0.62
Subbasin-18	0.192	63	0.55
Junction-14	11.453	1,831	0.62
Reach-14	11.453	1,830	0.62
Subbasin-19	0.552	108	0.55
Junction-15	12.005	1,850	0.61
Reach-15	12.005	1,847	0.61
Subbasin-20	0.594	145	0.48
Junction-16	12.599	1,849	0.61
Reach-16	12.599	1,849	0.61
Subbasin-21	0.417	107	0.43
Junction-17	13.016	1,849	0.6
Reach-17	13.016	1,847	0.6
Subbasin-22	0.200	35	0.29
Junction-18	13.216	1,847	0.6
Reach-18	13.216	1,845	0.6
Subbasin-23	0.123	41	0.34
Junction-19	13.339	1,845	0.59
Reach-19	13.339	1,843	0.59
Subbasin-24	0.453	102	0.56
Subbasin-25	0.169	242	1.31
Subbasin-26	0.480	138	0.63
Junction-21	1.102	295	0.71
Reach-21	1.102	289	0.71
Subbasin-27	0.294	167	0.9
Junction-22	1.396	410	0.75
Reach-22	1.396	409	0.75
Subbasin-28	0.264	35	0.27
Subbasin-29	0.172	38	0.37
Junction-20	0.436	70	0.31
Reach-20	0.436	69	0.31
Subbasin-30	0.364	135	0.58
Junction-23	15.535	1,845	0.6
Reach-23	15.535	1,842	0.6
Subbasin-31	0.377	264	0.66
Subbasin-32	0.316	168	0.61
Junction-24	16.228	1,842	0.6
Reach-24	16.228	1,841	0.6
Subbasin-33	0.184	20	0.16
Junction-25	16.412	1841.3	0.6
Reach-25	16.412	1841.3	0.6
Junction-26	16.412	1841.3	0.6

10-Year, 24-Hour Storm			
Hydrologic Element	Drainage Area (mi ²)	Peak Discharge (CFS)	Volume (in)
Subbasin-1	1.263	416	1.37
Subbasin-2	0.586	228	1.38
Subbasin-3	0.180	72	1.61
Junction-1	2.029	693	1.40
Reach-1	2.029	692	1.40
Subbasin-4	0.195	75	1.27
Junction-2	2.224	753	1.38
Reach-2	2.224	748	1.38
Subbasin-5	0.625	176	1.48
Junction-3	2.849	908	1.41
Reach-3	2.849	908	1.41
Subbasin-6	1.333	322	1.23
Junction-4	4.182	1,230	1.35
Reach-4	4.182	1,213	1.35
Subbasin-7	0.183	69	1.27
Junction-5	4.365	1,244	1.35
Reach-5	4.365	1,230	1.35
Subbasin-8	0.288	154.4	1.44
Junction-6	4.653	1269	1.35
Reach-6	4.653	1,248	1.35
Subbasin-9	1.177	294	1.36
Subbasin-10	0.222	84	1.23
Junction-7	1.399	333	1.34
Reach-7	1.399	331	1.34
Subbasin-11	0.880	419	1.58
Junction-8	2.279	636	1.44
Reach-8	2.279	635	1.44
Subbasin-12	0.552	190	1.38
Junction-9	2.831	800	1.43
Reach-9	2.831	781	1.43
Junction-10	7.484	1,907	1.38
Reach-10	7.484	1,885	1.38
Subbasin-13	1.156	282	1.31
Subbasin-14	0.516	185	1.25
Junction-11	9.156	2,122	1.36
Reach-11	9.156	2,120	1.36
Subbasin-15	0.498	190	1.31
Junction-12	9.654	2,162	1.36
Reach-12	9.654	2,160	1.36

10-Year, 24-Hour Storm			
Hydrologic Element	Drainage Area (mi ²)	Peak Discharge (CFS)	Volume (in)
Subbasin-16	0.819	254	1.38
Subbasin-17	0.788	247	1.25
Junction-13	11.261	2,284	1.35
Reach-13	11.261	2,250	1.35
Subbasin-18	0.192	74	1.25
Junction-14	11.453	2,258	1.35
Reach-14	11.453	2,257	1.35
Subbasin-19	0.552	136	1.24
Junction-15	12.005	2,304	1.35
Reach-15	12.005	2,298	1.35
Subbasin-20	0.594	183	1.14
Junction-16	12.599	2,324	1.34
Reach-16	12.599	2,298	1.34
Subbasin-21	0.417	139	1.06
Junction-17	13.016	2,312	1.33
Reach-17	13.016	2,312	1.33
Subbasin-22	0.200	53	0.84
Junction-18	13.216	2,318	1.32
Reach-18	13.216	2,307	1.32
Subbasin-23	0.123	60	0.91
Junction-19	13.339	2,310	1.32
Reach-19	13.339	2,308	1.32
Source-1	1.396	188	0.77
Subbasin-28	0.264	57	0.82
Subbasin-29	0.172	52	0.96
Junction-20	0.436	109	0.88
Reach-20	0.436	101	0.88
Subbasin-30	0.364	155	1.31
Junction-23	15.535	2,331	1.26
Reach-23	15.535	2,311	1.26
Subbasin-31	0.377	282	1.35
Subbasin-32	0.316	164	1.30
Junction-24	16.228	2,332	1.26
Reach-24	16.228	2,317	1.26
Subbasin-33	0.184	39	0.55
Junction-25	16.412	2,320	1.25
Reach-25	16.412	2,312	1.25
Junction-26	16.412	2,312	1.25

NOTE:

1. SOURCE-1 IS THE 24 HOUR FLOW DATA FOR SUBBASINS 24-27, JUNCTION 22, AND REACHES 21-22. SUBBASINS 24-27 DATA HAS BEEN REPLACED WITH KETTLE CREEK DRAINAGE BASIN OLD RANCH ROAD TRIBUTARY MASTER DEVELOPMENT PLAN FLOW DATA (JR ENG. 2001).

APPENDIX B – HYDROLOGIC
RESULTS – EXISTING 10-YR
KETTLE CREEK DBPS
JOB NO. 25100.00
MAY 2015
B-44



EXISTING CONDITIONS
MODEL RESULTS
(25-YEAR)

25-Year, 2-Hour Storm			
Hydrologic Element	Drainage Area (mi ²)	Peak Discharge (CFS)	Volume (in)
Subbasin-1	1.263	442	0.78
Subbasin-2	0.586	248	0.79
Subbasin-3	0.180	83	0.96
Junction-1	2.029	757	0.80
Reach-1	2.029	755	0.80
Subbasin-4	0.195	80	0.71
Junction-2	2.224	827	0.79
Reach-2	2.224	827	0.79
Subbasin-5	0.625	184	0.85
Junction-3	2.849	994	0.81
Reach-3	2.849	994	0.81
Subbasin-6	1.333	324	0.68
Junction-4	4.182	1,316	0.77
Reach-4	4.182	1,316	0.77
Subbasin-7	0.183	72	0.70
Junction-5	4.365	1,346	0.76
Reach-5	4.365	1,341	0.76
Subbasin-8	0.288	166	0.81
Junction-6	4.653	1,376	0.77
Reach-6	4.653	1,374	0.77
Subbasin-9	1.177	302	0.78
Subbasin-10	0.222	89	0.68
Junction-7	1.399	337	0.76
Reach-7	1.399	337	0.76
Subbasin-11	0.880	463	0.92
Junction-8	2.279	672	0.82
Reach-8	2.279	669	0.82
Subbasin-12	0.552	201	0.78
Junction-9	2.831	844	0.82
Reach-9	2.831	843	0.82
Junction-10	7.484	2,025	0.79
Reach-10	7.484	2,023	0.79
Subbasin-13	1.156	288	0.73
Subbasin-14	0.516	194	0.69
Junction-11	9.156	2,228	0.77
Reach-11	9.156	2,226	0.77
Subbasin-15	0.498	201	0.73
Junction-12	9.654	2,242	0.77
Reach-12	9.654	2,238	0.77
Subbasin-16	0.819	270	0.79
Subbasin-17	0.788	261	0.69
Junction-13	11.261	2,288	0.77

25-Year, 2-Hour Storm			
Hydrologic Element	Drainage Area (mi ²)	Peak Discharge (CFS)	Volume (in)
Reach-13	11.261	2,285	0.77
Subbasin-18	0.192	80	0.69
Junction-14	11.453	2,286	0.77
Reach-14	11.453	2,284	0.77
Subbasin-19	0.552	137	0.69
Junction-15	12.005	2,309	0.76
Reach-15	12.005	2,305	0.76
Subbasin-20	0.594	186	0.61
Junction-16	12.599	2,308	0.76
Reach-16	12.599	2,307	0.76
Subbasin-21	0.417	141	0.55
Junction-17	13.016	2,307	0.75
Reach-17	13.016	2,305	0.75
Subbasin-22	0.200	48	0.39
Junction-18	13.216	2,305	0.74
Reach-18	13.216	2,303	0.74
Subbasin-23	0.123	57	0.45
Junction-19	13.339	2,303	0.74
Reach-19	13.339	2,300	0.74
Subbasin-24	0.453	129	0.71
Subbasin-25	0.169	285	1.54
Subbasin-26	0.480	172	0.79
Junction-21	1.102	349	0.87
Reach-21	1.102	343	0.87
Subbasin-27	0.294	203	1.09
Junction-22	1.396	496	0.92
Reach-22	1.396	495	0.92
Subbasin-28	0.264	49	0.38
Subbasin-29	0.172	51	0.48
Junction-20	0.436	96	0.42
Reach-20	0.436	95	0.42
Subbasin-30	0.364	171	0.73
Junction-23	15.535	2,302	0.75
Reach-23	15.535	2,298	0.75
Subbasin-31	0.377	325	0.80
Subbasin-32	0.316	209	0.75
Junction-24	16.228	2,298	0.75
Reach-24	16.228	2,298	0.75
Subbasin-33	0.184	31	0.23
Junction-25	16.412	2297.5	0.74
Reach-25	16.412	2297.5	0.74
Junction-26	16.412	2297.5	0.74

25-Year, 24-Hour Storm			
Hydrologic Element	Drainage Area (mi ²)	Peak Discharge (CFS)	Volume (in)
Subbasin-1	1.263	502	1.64
Subbasin-2	0.586	276	1.65
Subbasin-3	0.180	86	1.90
Junction-1	2.029	835	1.67
Reach-1	2.029	834	1.67
Subbasin-4	0.195	91	1.53
Junction-2	2.224	907	1.65
Reach-2	2.224	903	1.65
Subbasin-5	0.625	212	1.76
Junction-3	2.849	1,095	1.68
Reach-3	2.849	1,095	1.68
Subbasin-6	1.333	393	1.49
Junction-4	4.182	1,488	1.62
Reach-4	4.182	1,467	1.62
Subbasin-7	0.183	84	1.53
Junction-5	4.365	1,504	1.61
Reach-5	4.365	1,488	1.61
Subbasin-8	0.288	187	1.72
Junction-6	4.653	1,535	1.62
Reach-6	4.653	1,509	1.62
Subbasin-9	1.177	355	1.63
Subbasin-10	0.222	102	1.48
Junction-7	1.399	403	1.61
Reach-7	1.399	401	1.61
Subbasin-11	0.880	501	1.88
Junction-8	2.279	766	1.71
Reach-8	2.279	764	1.71
Subbasin-12	0.552	230	1.65
Junction-9	2.831	964	1.70
Reach-9	2.831	941	1.70
Junction-10	7.484	2,304	1.65
Reach-10	7.484	2,276	1.65
Subbasin-13	1.156	342	1.57
Subbasin-14	0.516	226	1.51
Junction-11	9.156	2,565	1.63
Reach-11	9.156	2,563	1.63
Subbasin-15	0.498	231	1.57
Junction-12	9.654	2,613	1.63
Reach-12	9.654	2,609	1.63

25-Year, 24-Hour Storm			
Hydrologic Element	Drainage Area (mi ²)	Peak Discharge (CFS)	Volume (in)
Subbasin-16	0.819	307	1.65
Subbasin-17	0.788	301	1.51
Junction-13	11.261	2,759	1.62
Reach-13	11.261	2,715	1.62
Subbasin-18	0.192	90	1.50
Junction-14	11.453	2,726	1.62
Reach-14	11.453	2,725	1.62
Subbasin-19	0.552	166	1.50
Junction-15	12.005	2,781	1.62
Reach-15	12.005	2,774	1.62
Subbasin-20	0.594	226	1.39
Junction-16	12.599	2,806	1.60
Reach-16	12.599	2,774	1.60
Subbasin-21	0.417	172	1.30
Junction-17	13.016	2,793	1.59
Reach-17	13.016	2,791	1.59
Subbasin-22	0.200	68	1.06
Junction-18	13.216	2,798	1.59
Reach-18	13.216	2,787	1.59
Subbasin-23	0.123	76	1.13
Junction-19	13.339	2,791	1.58
Reach-19	13.339	2,788	1.58
Source-1	1.396	333	1.11
Subbasin-28	0.264	73	1.03
Subbasin-29	0.172	65	1.19
Junction-20	0.436	138	1.10
Reach-20	0.436	129	1.10
Subbasin-30	0.364	188	1.57
Junction-23	15.535	2,816	1.53
Reach-23	15.535	2,791	1.53
Subbasin-31	0.377	338	1.59
Subbasin-32	0.316	197	1.55
Junction-24	16.228	2,814	1.53
Reach-24	16.228	2,798	1.53
Subbasin-33	0.184	53	0.72
Junction-25	16.412	2,802	1.52
Reach-25	16.412	2,791	1.52
Junction-26	16.412	2,791	1.52

NOTE:

1. SOURCE-1 IS THE 24 HOUR FLOW DATA FOR SUBBASINS 24-27, JUNCTION 22, AND REACHES 21-22. SUBBASINS 24-27 DATA HAS BEEN REPLACED WITH KETTLE CREEK DRAINAGE BASIN OLD RANCH ROAD TRIBUTARY MASTER DEVELOPMENT PLAN FLOW DATA (JR ENG. 2001).

APPENDIX B – HYDROLOGIC
RESULTS – EXISTING 25-YR
KETTLE CREEK DBPS
JOB NO. 25100.00
MAY 2015
B-45



EXISTING CONDITIONS
MODEL RESULTS
(50-YEAR)

50-Year, 2-Hour Storm			
Hydrologic Element	Drainage Area (mi ²)	Peak Discharge (CFS)	Volume (in)
Subbasin-1	1.263	533	0.94
Subbasin-2	0.586	299	0.95
Subbasin-3	0.180	98	1.14
Junction-1	2.029	911	0.96
Reach-1	2.029	909	0.96
Subbasin-4	0.195	97	0.86
Junction-2	2.224	996	0.95
Reach-2	2.224	996	0.95
Subbasin-5	0.625	221	1.02
Junction-3	2.849	1,197	0.97
Reach-3	2.849	1,197	0.97
Subbasin-6	1.333	395	0.83
Junction-4	4.182	1,590	0.92
Reach-4	4.182	1,589	0.92
Subbasin-7	0.183	88	0.86
Junction-5	4.365	1,626	0.92
Reach-5	4.365	1,620	0.92
Subbasin-8	0.288	202	0.98
Junction-6	4.653	1,662	0.92
Reach-6	4.653	1,659	0.92
Subbasin-9	1.177	364	0.94
Subbasin-10	0.222	109	0.82
Junction-7	1.399	406	0.92
Reach-7	1.399	406	0.92
Subbasin-11	0.880	555	1.10
Junction-8	2.279	808	0.99
Reach-8	2.279	804	0.99
Subbasin-12	0.552	243	0.94
Junction-9	2.831	1,017	0.98
Reach-9	2.831	1,015	0.98
Junction-10	7.484	2,442	0.95
Reach-10	7.484	2,440	0.95
Subbasin-13	1.156	349	0.89
Subbasin-14	0.516	237	0.84
Junction-11	9.156	2,688	0.93
Reach-11	9.156	2,686	0.93
Subbasin-15	0.498	245	0.89
Junction-12	9.654	2,705	0.93
Reach-12	9.654	2,700	0.93
Subbasin-16	0.819	325	0.95
Subbasin-17	0.788	318	0.84
Junction-13	11.261	2,759	0.93

50-Year, 2-Hour Storm			
Hydrologic Element	Drainage Area (mi ²)	Peak Discharge (CFS)	Volume (in)
Reach-13	11.261	2,757	0.93
Subbasin-18	0.192	98	0.84
Junction-14	11.453	2,757	0.92
Reach-14	11.453	2,756	0.92
Subbasin-19	0.552	167	0.84
Junction-15	12.005	2,786	0.92
Reach-15	12.005	2,781	0.92
Subbasin-20	0.594	230	0.75
Junction-16	12.599	2,784	0.91
Reach-16	12.599	2,784	0.91
Subbasin-21	0.417	177	0.69
Junction-17	13.016	2,784	0.91
Reach-17	13.016	2,780	0.91
Subbasin-22	0.200	63	0.51
Junction-18	13.216	2,780	0.90
Reach-18	13.216	2,778	0.90
Subbasin-23	0.123	74	0.57
Junction-19	13.339	2,778	0.90
Reach-19	13.339	2,775	0.90
Subbasin-24	0.453	157	0.86
Subbasin-25	0.169	329	1.77
Subbasin-26	0.480	207	0.95
Junction-21	1.102	404	1.04
Reach-21	1.102	397	1.04
Subbasin-27	0.294	240	1.28
Junction-22	1.396	587	1.09
Reach-22	1.396	586	1.09
Subbasin-28	0.264	65	0.49
Subbasin-29	0.172	65	0.61
Junction-20	0.436	124	0.54
Reach-20	0.436	123	0.54
Subbasin-30	0.364	208	0.89
Junction-23	15.535	2,777	0.90
Reach-23	15.535	2,772	0.90
Subbasin-31	0.377	388	0.95
Subbasin-32	0.316	251	0.90
Junction-24	16.228	2,772	0.90
Reach-24	16.228	2,772	0.90
Subbasin-33	0.184	43	0.31
Junction-25	16.412	2771.5	0.9
Reach-25	16.412	2771.5	0.9
Junction-26	16.412	2771.5	0.9

50-Year, 24-Hour Storm			
Hydrologic Element	Drainage Area (mi ²)	Peak Discharge (CFS)	Volume (in)
Subbasin-1	1.263	639	2.06
Subbasin-2	0.586	351	2.07
Subbasin-3	0.180	107	2.36
Junction-1	2.029	1,060	2.09
Reach-1	2.029	1,059	2.09
Subbasin-4	0.195	117	1.94
Junction-2	2.224	1,153	2.08
Reach-2	2.224	1,150	2.08
Subbasin-5	0.625	268	2.21
Junction-3	2.849	1,393	2.11
Reach-3	2.849	1,393	2.11
Subbasin-6	1.333	508	1.90
Junction-4	4.182	1,901	2.04
Reach-4	4.182	1,871	2.04
Subbasin-7	0.183	108	1.95
Junction-5	4.365	1,918	2.04
Reach-5	4.365	1,899	2.04
Subbasin-8	0.288	238	2.17
Junction-6	4.653	1,958	2.04
Reach-6	4.653	1,923	2.04
Subbasin-9	1.177	452	2.06
Subbasin-10	0.222	132	1.89
Junction-7	1.399	515	2.03
Reach-7	1.399	511	2.03
Subbasin-11	0.880	631	2.34
Junction-8	2.279	971	2.15
Reach-8	2.279	969	2.15
Subbasin-12	0.552	294	2.09
Junction-9	2.831	1,223	2.14
Reach-9	2.831	1,193	2.14
Junction-10	7.484	2,934	2.08
Reach-10	7.484	2,896	2.08
Subbasin-13	1.156	438	1.99
Subbasin-14	0.516	291	1.92
Junction-11	9.156	3,269	2.06
Reach-11	9.156	3,265	2.06
Subbasin-15	0.498	296	1.99
Junction-12	9.654	3,328	2.06
Reach-12	9.654	3,324	2.06

50-Year, 24-Hour Storm			
Hydrologic Element	Drainage Area (mi ²)	Peak Discharge (CFS)	Volume (in)
Subbasin-16	0.819	391	2.07
Subbasin-17	0.788	387	1.92
Junction-13	11.261	3,512	2.05
Reach-13	11.261	3,456	2.05
Subbasin-18	0.192	116	1.91
Junction-14	11.453	3,471	2.05
Reach-14	11.453	3,469	2.05
Subbasin-19	0.552	214	1.91
Junction-15	12.005	3,540	2.04
Reach-15	12.005	3,530	2.04
Subbasin-20	0.594	294	1.78
Junction-16	12.599	3,570	2.03
Reach-16	12.599	3,534	2.03
Subbasin-21	0.417	226	1.69
Junction-17	13.016	3,557	2.02
Reach-17	13.016	3,551	2.02
Subbasin-22	0.200	92	1.41
Junction-18	13.216	3,560	2.01
Reach-18	13.216	3,549	2.01
Subbasin-23	0.123	102	1.50
Junction-19	13.339	3,553	2.00
Reach-19	13.339	3,549	2.00
Source-1	1.396	459	1.34
Subbasin-28	0.264	100	1.38
Subbasin-29	0.172	87	1.56
Junction-20	0.436	187	1.45
Reach-20	0.436	174	1.45
Subbasin-30	0.364	242	1.99
Junction-23	15.535	3,584	1.93
Reach-23	15.535	3,551	1.93
Subbasin-31	0.377	427	1.99
Subbasin-32	0.316	251	1.94
Junction-24	16.228	3,580	1.93
Reach-24	16.228	3,563	1.93
Subbasin-33	0.184	76	1.00
Junction-25	16.412	3,568	1.92
Reach-25	16.412	3,553	1.92
Junction-26	16.412	3,553	1.92

NOTE:

1. SOURCE-1 IS THE 24 HOUR FLOW DATA FOR SUBBASINS 24-27, JUNCTION 22, AND REACHES 21-22. SUBBASINS 24-27 DATA HAS BEEN REPLACED WITH KETTLE CREEK DRAINAGE BASIN OLD RANCH ROAD TRIBUTARY MASTER DEVELOPMENT PLAN FLOW DATA (JR ENG. 2001).

APPENDIX B – HYDROLOGIC
RESULTS – EXISTING 50-YR
KETTLE CREEK DBPS
JOB NO. 25100.00
MAY 2015
B-46



EXISTING CONDITIONS
MODEL RESULTS
(100-YEAR)

100-Year, 2-Hour Storm			
Hydrologic Element	Drainage Area (mi ²)	Peak Discharge (CFS)	Volume (in)
Subbasin-1	1.263	634	1.12
Subbasin-2	0.586	355	1.13
Subbasin-3	0.180	115	1.33
Junction-1	2.029	1,082	1.14
Reach-1	2.029	1,080	1.14
Subbasin-4	0.195	117	1.03
Junction-2	2.224	1,184	1.13
Reach-2	2.224	1,184	1.13
Subbasin-5	0.625	262	1.21
Junction-3	2.849	1,423	1.15
Reach-3	2.849	1,423	1.15
Subbasin-6	1.333	474	0.99
Junction-4	4.182	1,895	1.10
Reach-4	4.182	1,894	1.10
Subbasin-7	0.183	106	1.03
Junction-5	4.365	1,938	1.10
Reach-5	4.365	1,931	1.10
Subbasin-8	0.288	242	1.17
Junction-6	4.653	1,980	1.10
Reach-6	4.653	1,977	1.10
Subbasin-9	1.177	433	1.11
Subbasin-10	0.222	132	0.99
Junction-7	1.399	483	1.09
Reach-7	1.399	483	1.09
Subbasin-11	0.880	657	1.30
Junction-8	2.279	959	1.17
Reach-8	2.279	953	1.17
Subbasin-12	0.552	291	1.12
Junction-9	2.831	1,208	1.16
Reach-9	2.831	1,205	1.16
Junction-10	7.484	2,905	1.12
Reach-10	7.484	2,903	1.12
Subbasin-13	1.156	418	1.06
Subbasin-14	0.516	285	1.01
Junction-11	9.156	3,198	1.11
Reach-11	9.156	3,195	1.11
Subbasin-15	0.498	293	1.06
Junction-12	9.654	3,218	1.11
Reach-12	9.654	3,213	1.11
Subbasin-16	0.819	387	1.12
Subbasin-17	0.788	382	1.01
Junction-13	11.261	3,283	1.10

100-Year, 2-Hour Storm			
Hydrologic Element	Drainage Area (mi ²)	Peak Discharge (CFS)	Volume (in)
Reach-13	11.261	3,280	1.10
Subbasin-18	0.192	118	1.01
Junction-14	11.453	3,281	1.10
Reach-14	11.453	3,279	1.10
Subbasin-19	0.552	201	1.00
Junction-15	12.005	3,314	1.09
Reach-15	12.005	3,309	1.09
Subbasin-20	0.594	279	0.91
Junction-16	12.599	3,313	1.09
Reach-16	12.599	3,312	1.09
Subbasin-21	0.417	217	0.84
Junction-17	13.016	3,312	1.08
Reach-17	13.016	3,308	1.08
Subbasin-22	0.200	81	0.64
Junction-18	13.216	3,308	1.07
Reach-18	13.216	3,305	1.07
Subbasin-23	0.123	93	0.71
Junction-19	13.339	3,305	1.07
Reach-19	13.339	3,302	1.07
Subbasin-24	0.453	188	1.03
Subbasin-25	0.169	374	2.01
Subbasin-26	0.480	247	1.12
Junction-21	1.102	463	1.22
Reach-21	1.102	463	1.22
Subbasin-27	0.294	279	1.49
Junction-22	1.396	689	1.28
Reach-22	1.396	687	1.28
Subbasin-28	0.264	83	0.62
Subbasin-29	0.172	80	0.75
Junction-20	0.436	157	0.67
Reach-20	0.436	156	0.67
Subbasin-30	0.364	250	1.06
Junction-23	15.535	3,305	1.08
Reach-23	15.535	3,298	1.08
Subbasin-31	0.377	458	1.11
Subbasin-32	0.316	298	1.06
Junction-24	16.228	3,298	1.08
Reach-24	16.228	3,297	1.08
Subbasin-33	0.184	57	0.41
Junction-25	16.412	3297.4	1.07
Reach-25	16.412	3297.4	1.07
Junction-26	16.412	3297.4	1.07

100-Year, 24-Hour Storm			
Hydrologic Element	Drainage Area (mi ²)	Peak Discharge (CFS)	Volume (in)
Subbasin-1	1.263	735	2.36
Subbasin-2	0.586	403	2.37
Subbasin-3	0.180	122	2.67
Junction-1	2.029	1,217	2.39
Reach-1	2.029	1,216	2.39
Subbasin-4	0.195	135	2.22
Junction-2	2.224	1,325	2.38
Reach-2	2.224	1,322	2.38
Subbasin-5	0.625	308	2.52
Junction-3	2.849	1,602	2.41
Reach-3	2.849	1,602	2.41
Subbasin-6	1.333	588	2.18
Junction-4	4.182	2,190	2.34
Reach-4	4.182	2,153	2.34
Subbasin-7	0.183	125	2.24
Junction-5	4.365	2,208	2.33
Reach-5	4.365	2,186	2.33
Subbasin-8	0.288	273.3	2.48
Junction-6	4.653	2253.3	2.34
Reach-6	4.653	2,213	2.34
Subbasin-9	1.177	520	2.35
Subbasin-10	0.222	152	2.17
Junction-7	1.399	593	2.32
Reach-7	1.399	588	2.32
Subbasin-11	0.880	720	2.66
Junction-8	2.279	1,114	2.45
Reach-8	2.279	1,112	2.45
Subbasin-12	0.552	338	2.39
Junction-9	2.831	1,403	2.44
Reach-9	2.831	1,368	2.44
Junction-10	7.484	3,375	2.38
Reach-10	7.484	3,329	2.38
Subbasin-13	1.156	505	2.28
Subbasin-14	0.516	337	2.20
Junction-11	9.156	3,761	2.36
Reach-11	9.156	3,756	2.36
Subbasin-15	0.498	342	2.28
Junction-12	9.654	3,828	2.35
Reach-12	9.654	3,823	2.35

100-Year, 24-Hour Storm			
Hydrologic Element	Drainage Area (mi ²)	Peak Discharge (CFS)	Volume (in)
Subbasin-16	0.819	449	2.37
Subbasin-17	0.788	447	2.20
Junction-13	11.261	4,038	2.34
Reach-13	11.261	3,975	2.34
Subbasin-18	0.192	134.1	2.2
Junction-14	11.453	3,992	2.34
Reach-14	11.453	3,987	2.34
Subbasin-19	0.552	248	2.19
Junction-15	12.005	4,069	2.33
Reach-15	12.005	4,058	2.33
Subbasin-20	0.594	343	2.06
Junction-16	12.599	4,103	2.32
Reach-16	12.599	4,064	2.32
Subbasin-21	0.417	264	1.96
Junction-17	13.016	4,091	2.31
Reach-17	13.016	4,081	2.31
Subbasin-22	0.200	109	1.66
Junction-18	13.216	4,091	2.30
Reach-18	13.216	4,080	2.30
Subbasin-23	0.123	121	1.75
Junction-19	13.339	4,086	2.29
Reach-19	13.339	4,081	2.29
Source-1	1.396	576	1.58
Subbasin-28	0.264	120	1.63
Subbasin-29	0.172	102	1.83
Junction-20	0.436	222	1.71
Reach-20	0.436	207	1.71
Subbasin-30	0.364	279	2.28
Junction-23	15.535	4,121	2.21
Reach-23	15.535	4,081	2.21
Subbasin-31	0.377	490	2.26
Subbasin-32	0.316	289	2.22
Junction-24	16.228	4,114	2.22
Reach-24	16.228	4,096	2.22
Subbasin-33	0.184	93	1.21
Junction-25	16.412	4,102	2.20
Reach-25	16.412	4,084	2.20
Junction-26	16.412	4,084	2.20

NOTE:

1. SOURCE-1 IS THE 24 HOUR FLOW DATA FOR SUBBASINS 24-27, JUNCTION 22, AND REACHES 21-22. SUBBASINS 24-27 DATA HAS BEEN REPLACED WITH KETTLE CREEK DRAINAGE BASIN OLD RANCH ROAD TRIBUTARY MASTER DEVELOPMENT PLAN FLOW DATA (JR ENG. 2001).

APPENDIX B – HYDROLOGIC
RESULTS – EXISTING 100-YR
KETTLE CREEK DBPS
JOB NO. 25100.00
MAY 2015
B-47



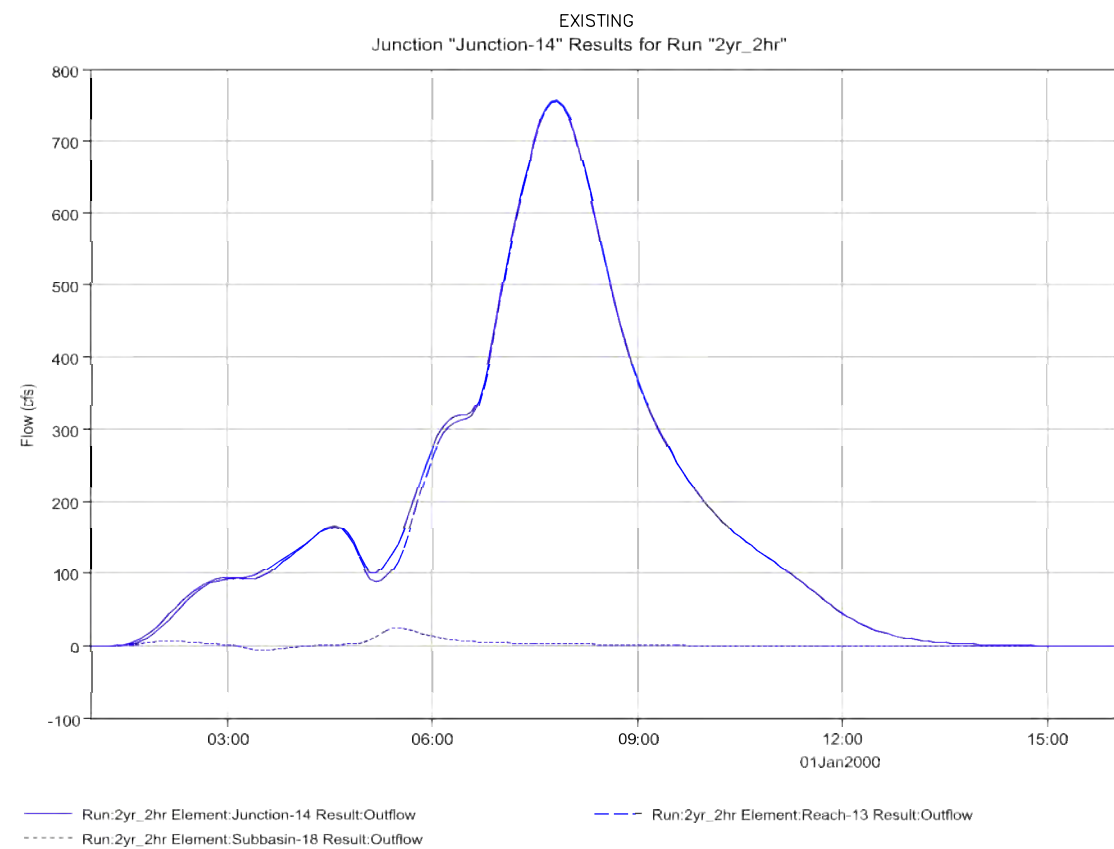

2-YR
2-HR

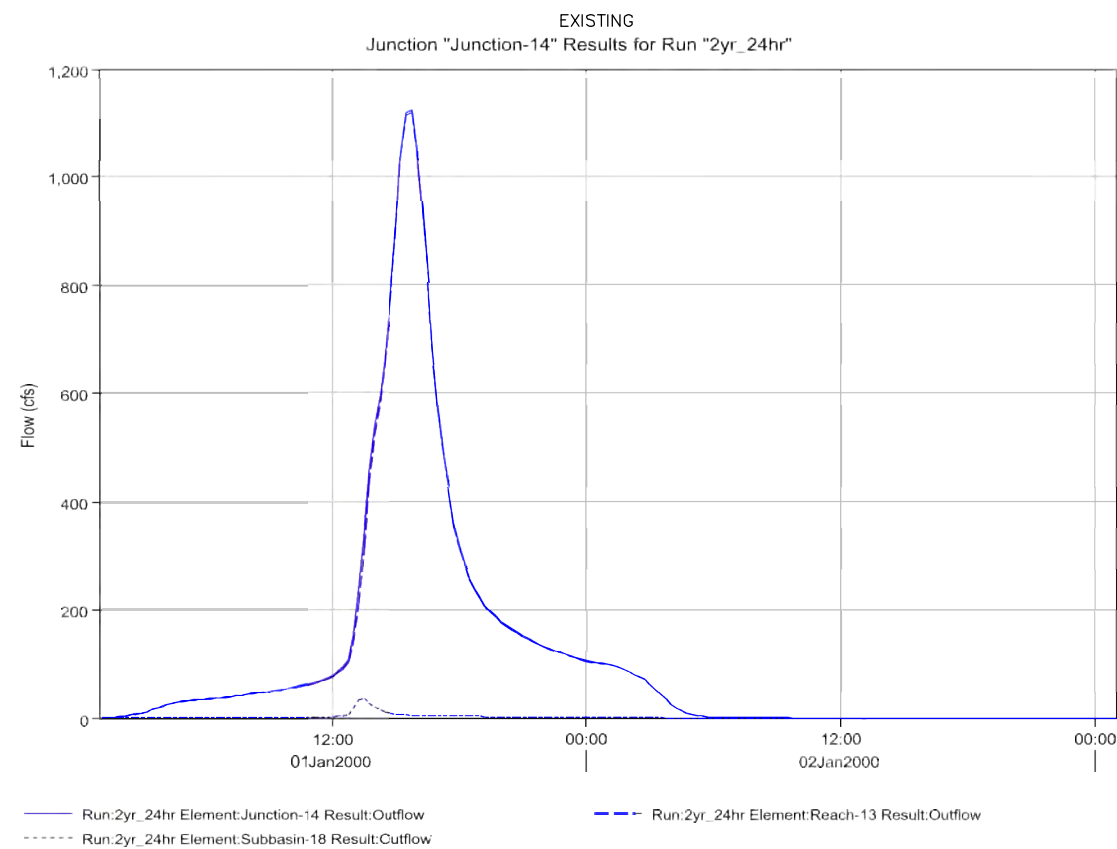

2-YR
24-HR

JUNCTION 14
HOWELLS ROAD (APPROXIMATE)
EXISTING CONDITIONS HYDROGRAPHS
AT SELECT LOCATIONS
2-YEAR

APPENDIX B – HYDROLOGIC
RESULTS – EXISTING
HYDROGRAPHS 2-YR J-14
KETTLE CREEK DBPS
JOB NO. 25100.00
MAY 2015
B-48



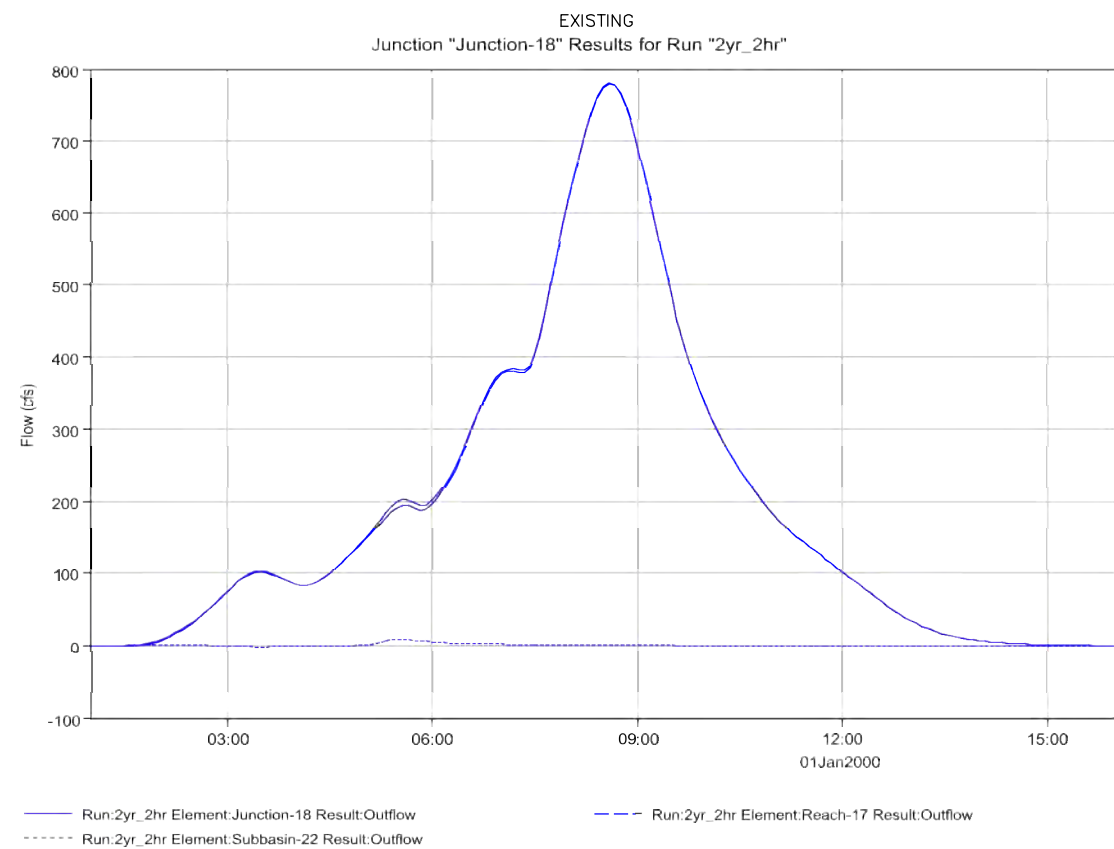

2-YR
2-HR

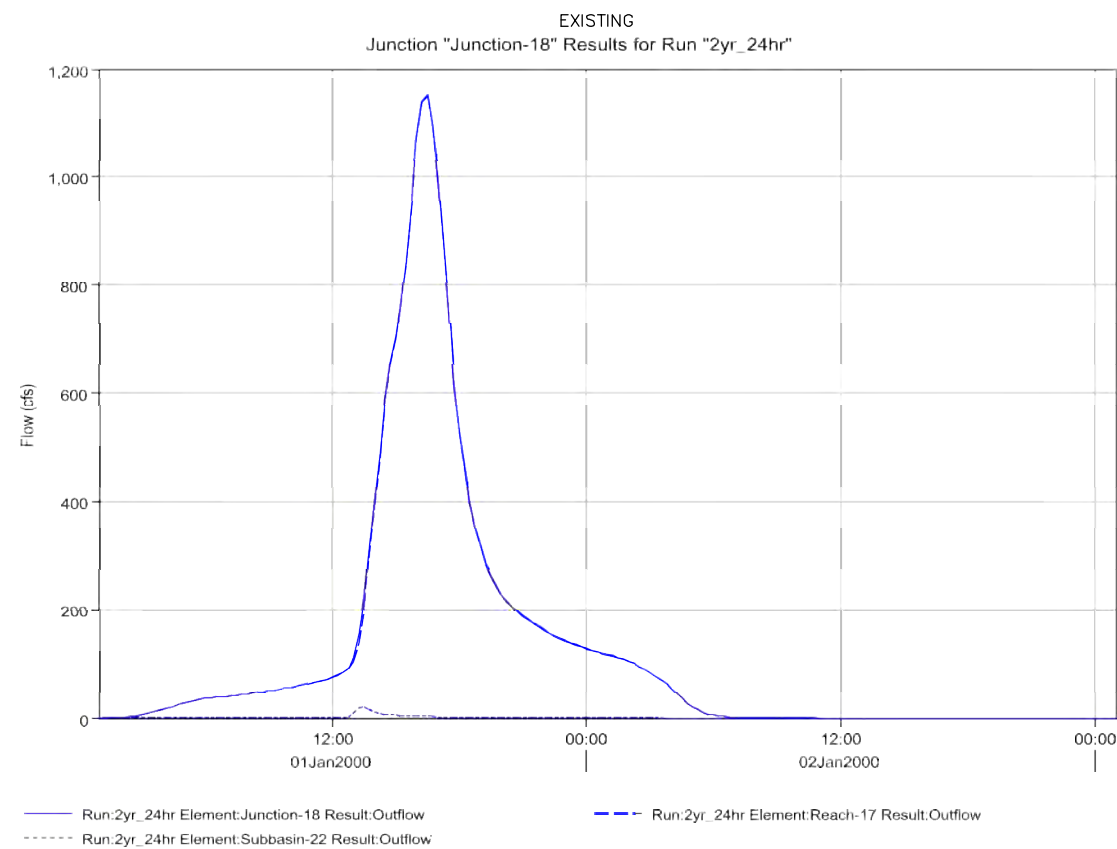

2-YR
24-HR

JUNCTION 18
POWERS BLVD BRIDGE
EXISTING CONDITIONS HYDROGRAPHS
AT SELECT LOCATIONS
2-YEAR

APPENDIX B – HYDROLOGIC
RESULTS – EXISTING
HYDROGRAPHS 2-YR J-18
KETTLE CREEK DBPS
JOB NO. 25100.00
MAY 2015
B-49



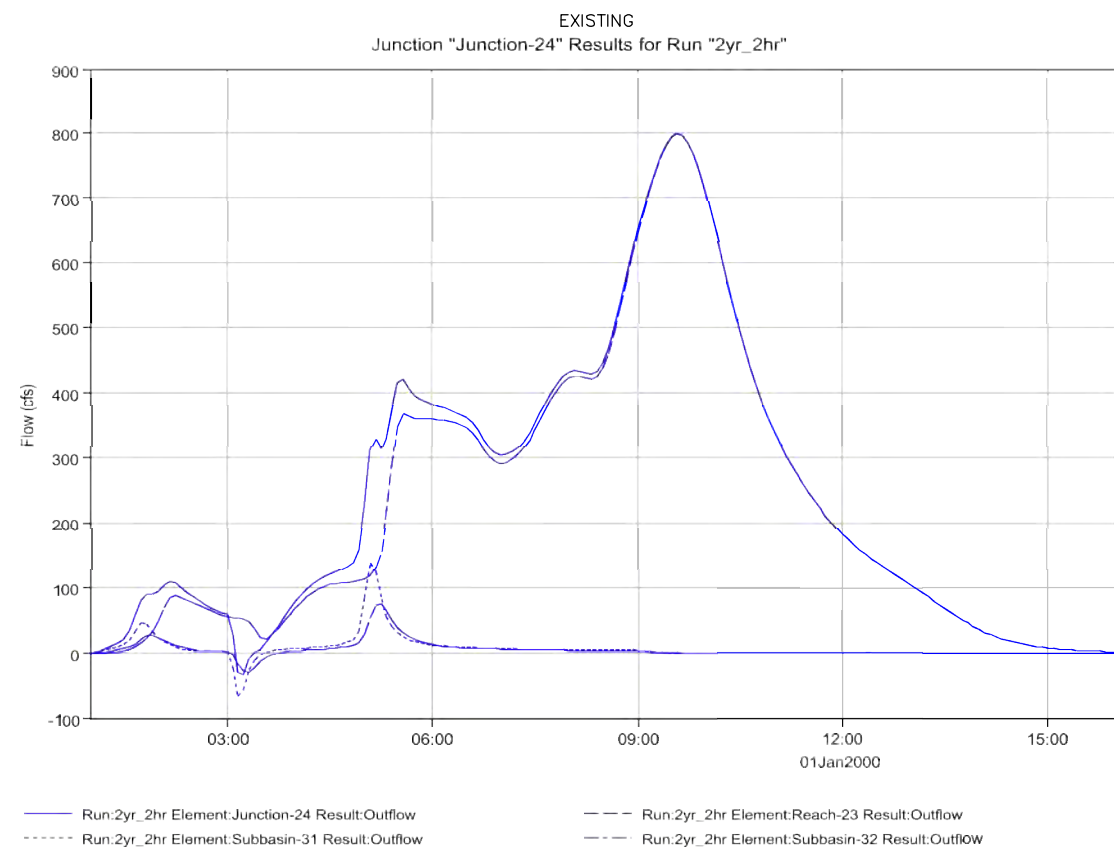

2-YR
2-HR

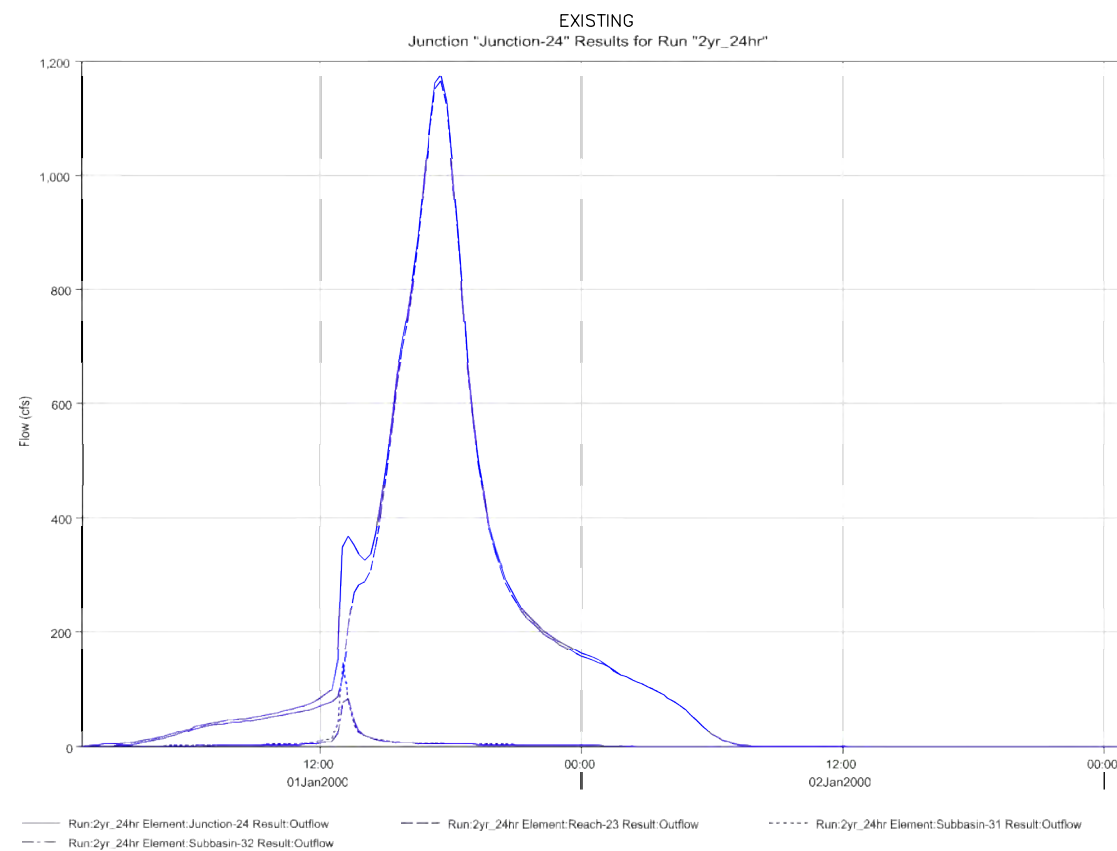

2-YR
24-HR

JUNCTION 24
HWY 83 BRIDGE
EXISTING CONDITIONS HYDROGRAPHS
AT SELECT LOCATIONS
2-YEAR

APPENDIX B – HYDROLOGIC
RESULTS – EXISTING
HYDROGRAPHS 2-YR J-24
KETTLE CREEK DBPS
JOB NO. 25100.00
MAY 2015
B-50



Centennial 303-740-9393 • Colorado Springs 719-593-2593
Fort Collins 970-491-9888 • www.jrengineering.com

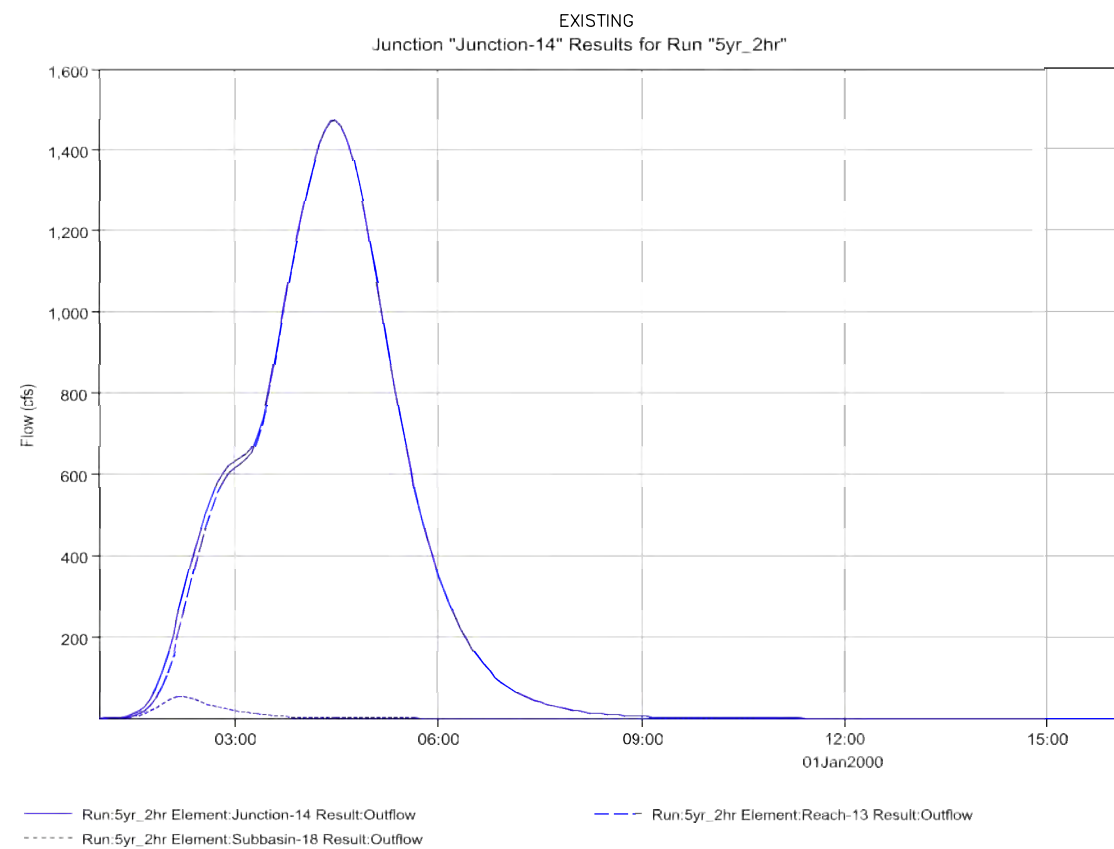

5-YR
2-HR

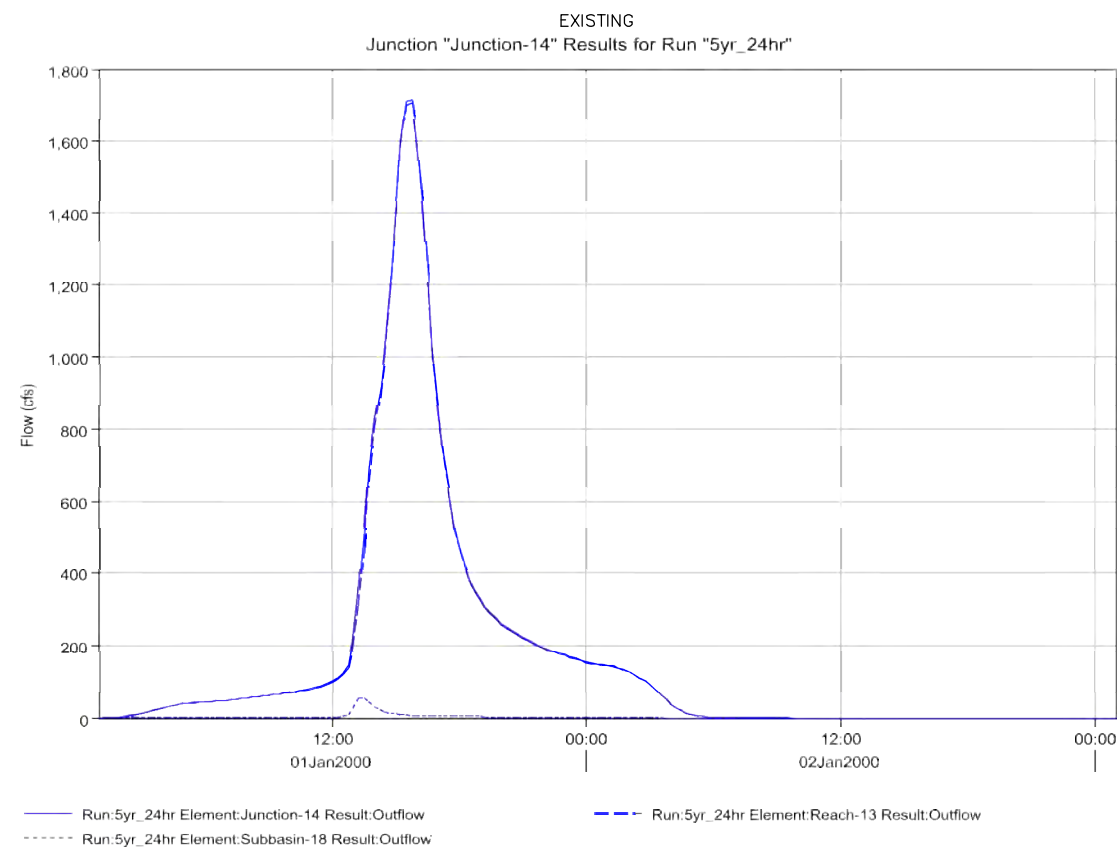

5-YR
24-HR

JUNCTION 14
HOWELLS ROAD (APPROXIMATE)
EXISTING CONDITIONS HYDROGRAPHS
AT SELECT LOCATIONS
5-YEAR

APPENDIX B – HYDROLOGIC
RESULTS – EXISTING
HYDROGRAPHS 5-YR J-14
KETTLE CREEK DBPS
JOB NO. 25100.00
MAY 2015
B-51



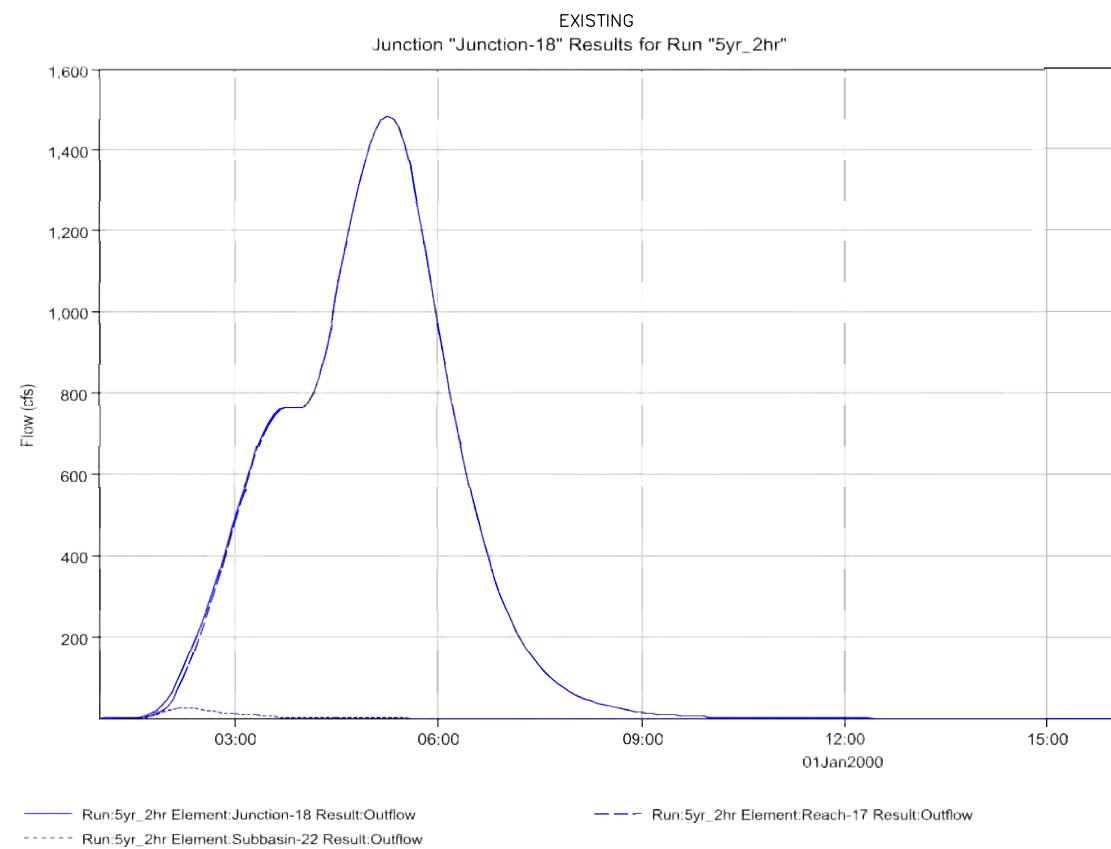

5-YR
2-HR

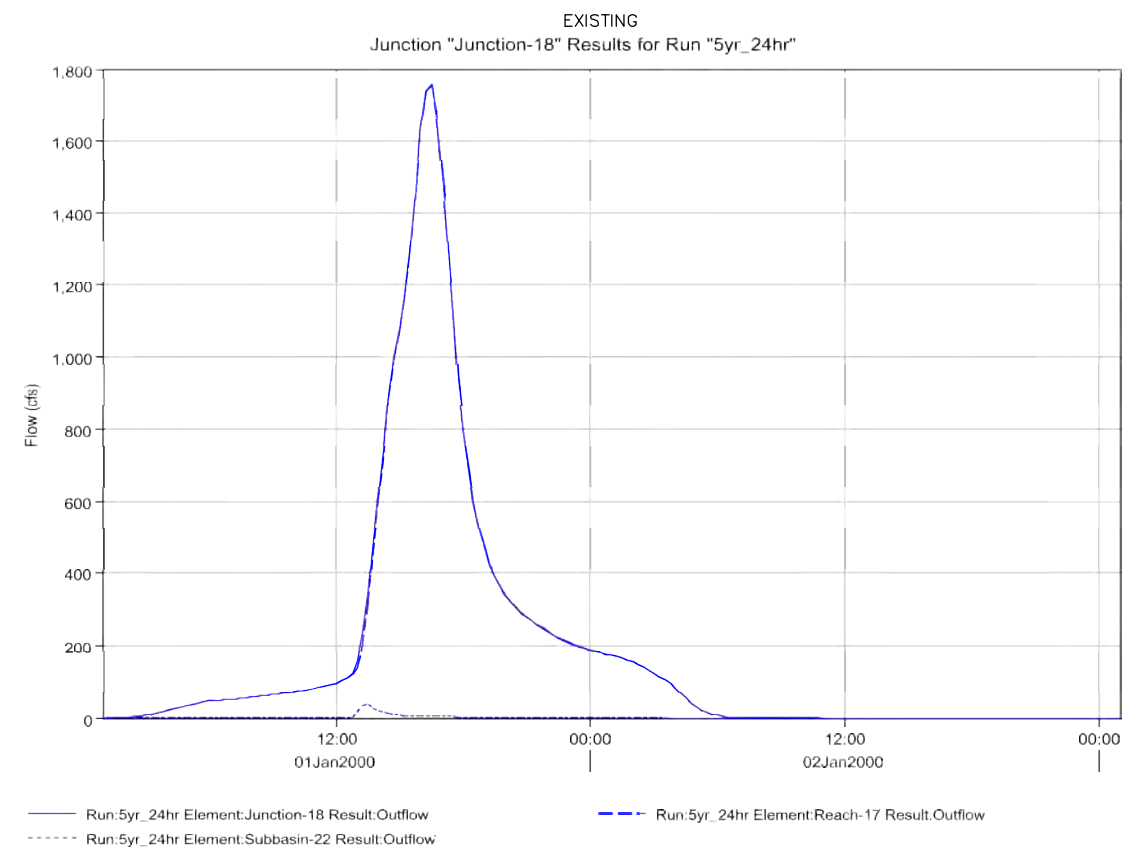

5-YR
24-HR

JUNCTION 18
POWERS BLVD BRIDGE
EXISTING CONDITIONS HYDROGRAPHS
AT SELECT LOCATIONS
5-YEAR

APPENDIX B – HYDROLOGIC
RESULTS – EXISTING
HYDROGRAPHS 5-YR J-18
KETTLE CREEK DBPS
JOB NO. 25100.00
MAY 2015
B-52



Centennial 303-740-9393 • Colorado Springs 719-593-2593
Fort Collins 970-491-9888 • www.jrengineering.com

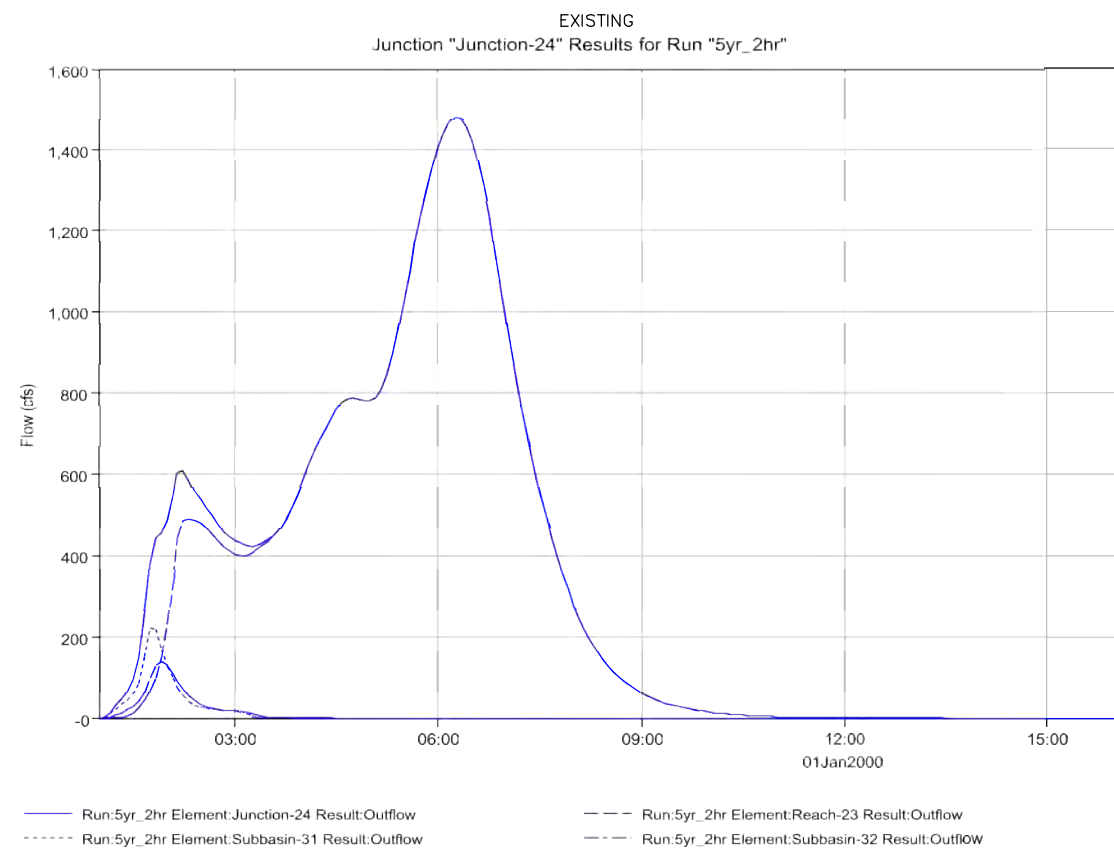

5-YR
2-HR

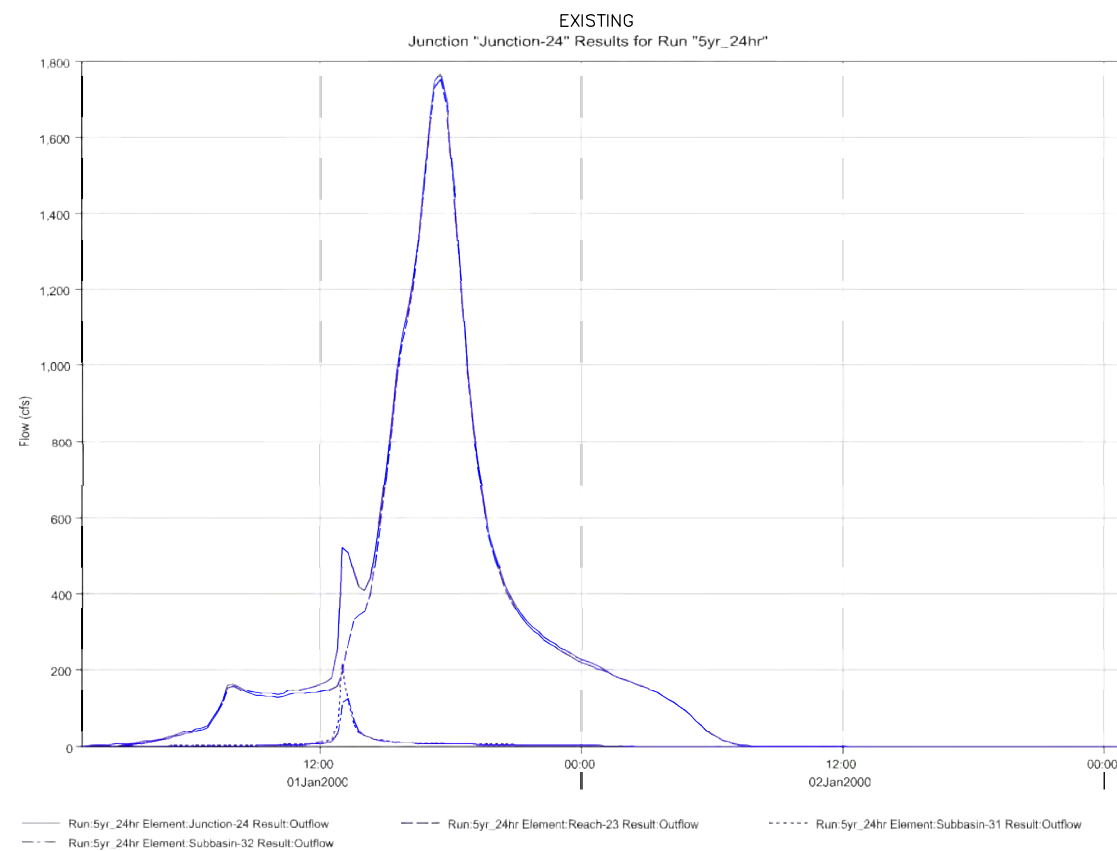

5-YR
24-HR

JUNCTION 24
HWY 83 BRIDGE
EXISTING CONDITIONS HYDROGRAPHS
AT SELECT LOCATIONS
5-YEAR

APPENDIX B – HYDROLOGIC
RESULTS – EXISTING
HYDROGRAPHS 5-YR J-24
KETTLE CREEK DBPS
JOB NO. 25100.00
MAY 2015
B-53



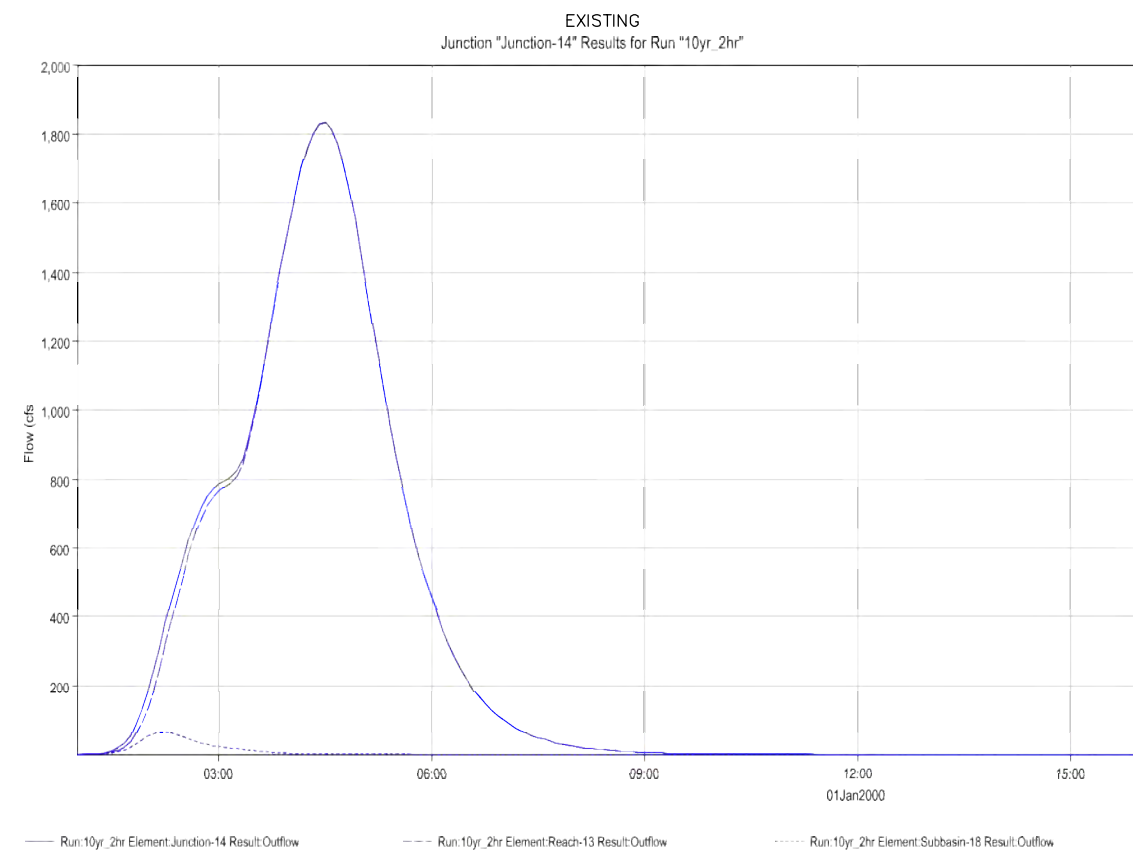

10-YR
2-HR

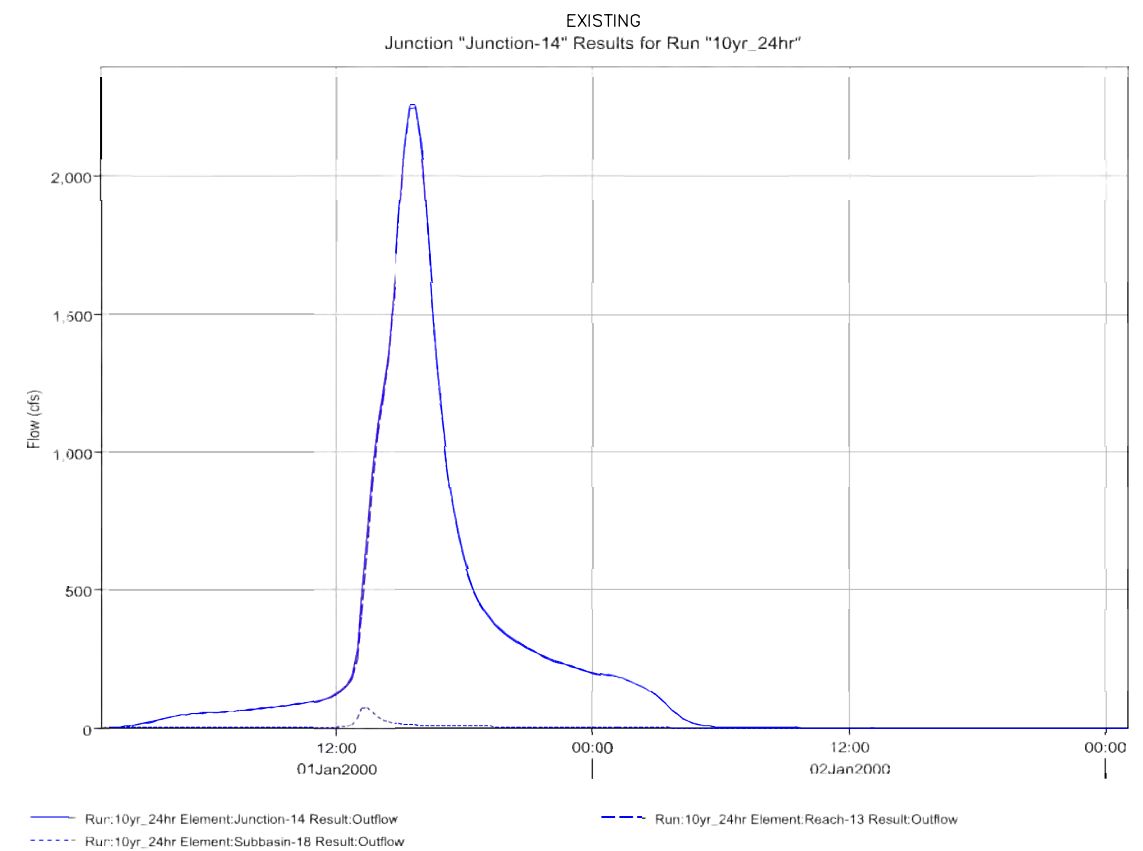

10-YR
24-HR

JUNCTION 14
HOWELLS ROAD (APPROXIMATE)
EXISTING CONDITIONS HYDROGRAPHS
AT SELECT LOCATIONS
10-YEAR

APPENDIX B – HYDROLOGIC
RESULTS– EXISTING
HYDROGRAPHS 10-YR J-14
KETTLE CREEK DBPS
JOB NO. 25100.00
MAY 2015
B-54



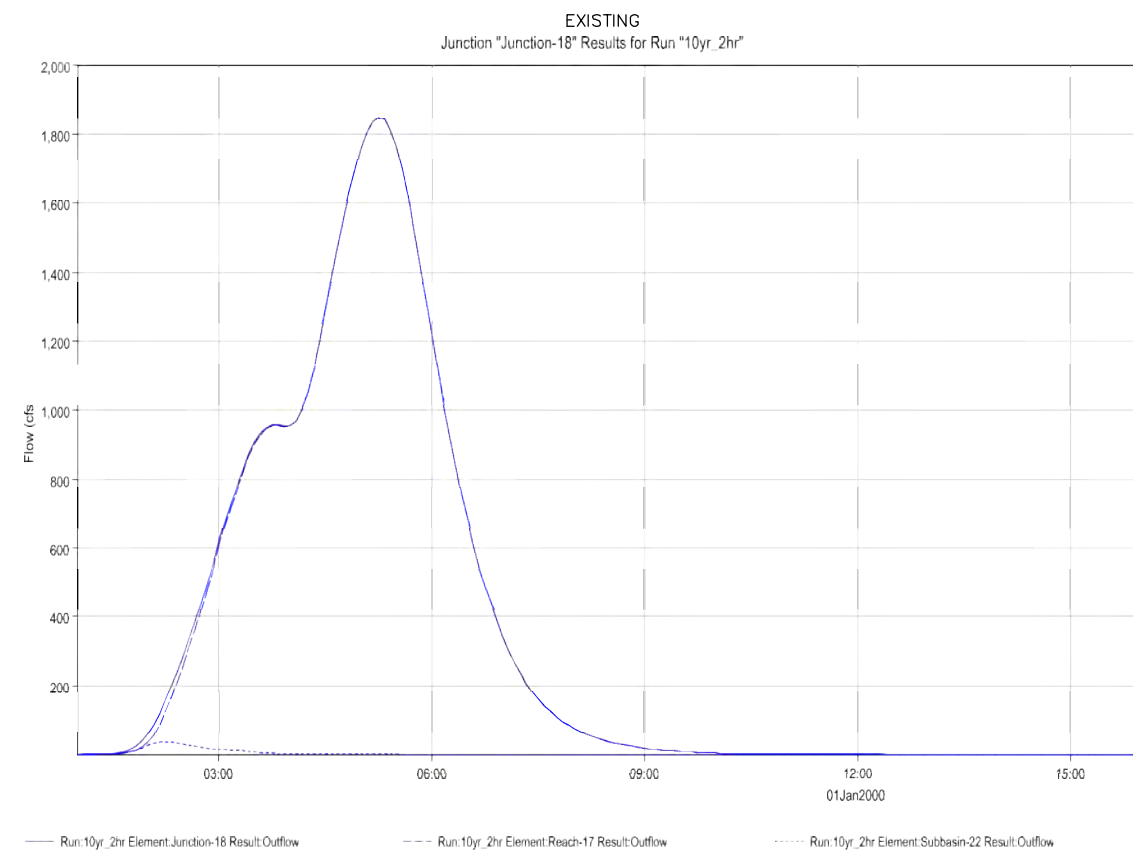

10-YR
2-HR

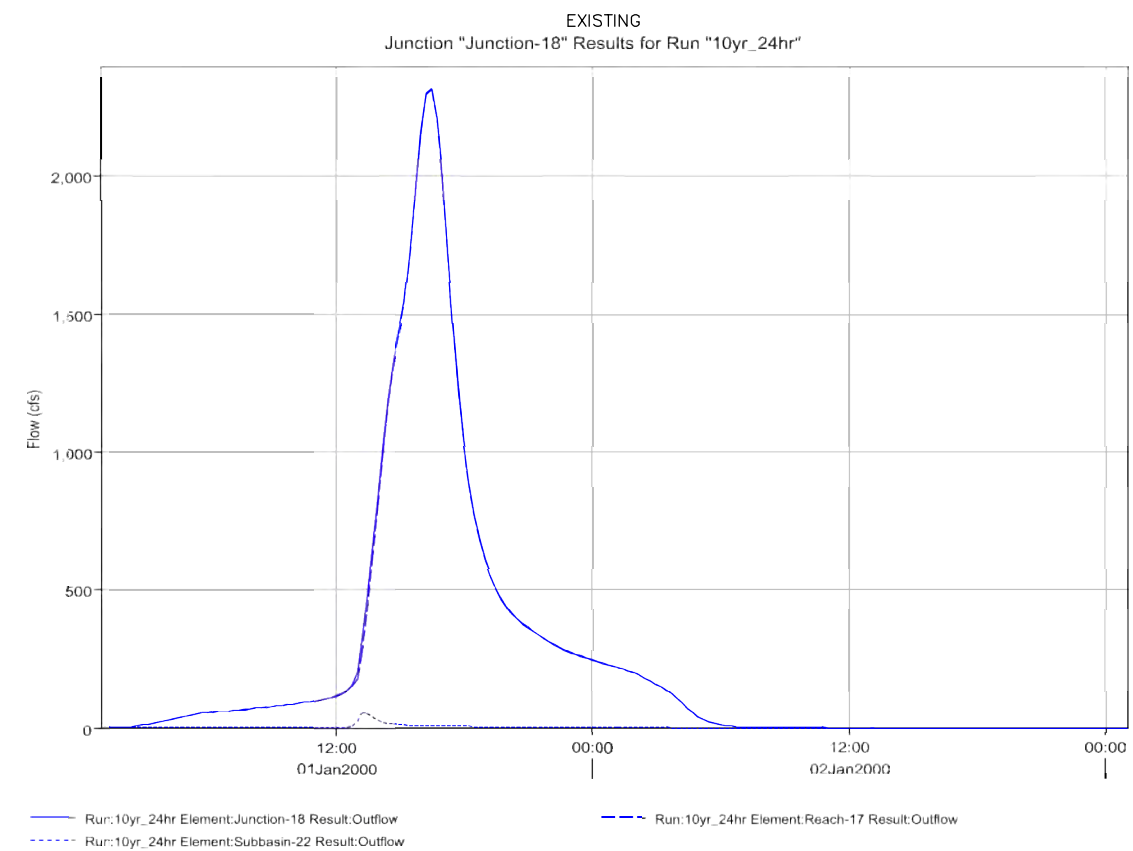

10-YR
24-HR

JUNCTION 18
POWERS BLVD BRIDGE
EXISTING CONDITIONS HYDROGRAPHS
AT SELECT LOCATIONS
10-YEAR

APPENDIX B – HYDROLOGIC
RESULTS– EXISTING
HYDROGRAPHS 10-YR J-18
KETTLE CREEK DBPS
JOB NO. 25100.00
MAY 2015
B-55



Centennial 303-740-9393 • Colorado Springs 719-593-2593
Fort Collins 970-491-9888 • www.jrengineering.com

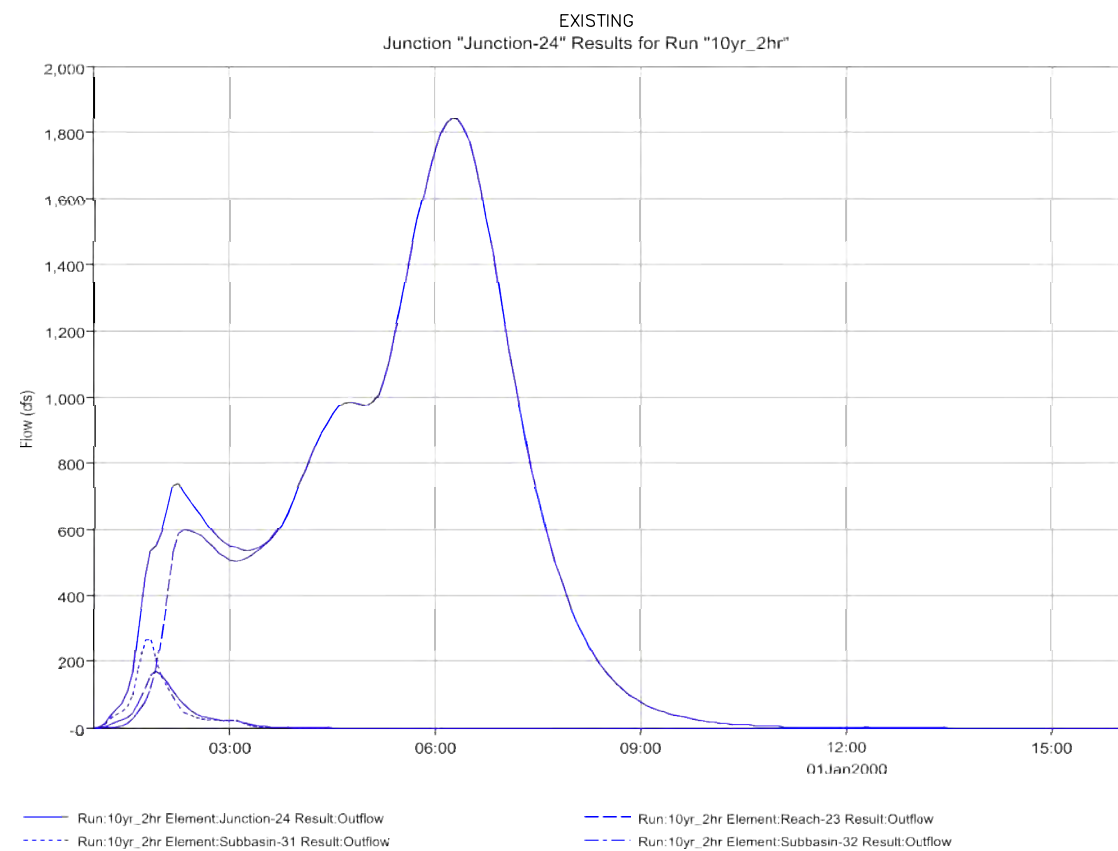

10-YR
2-HR

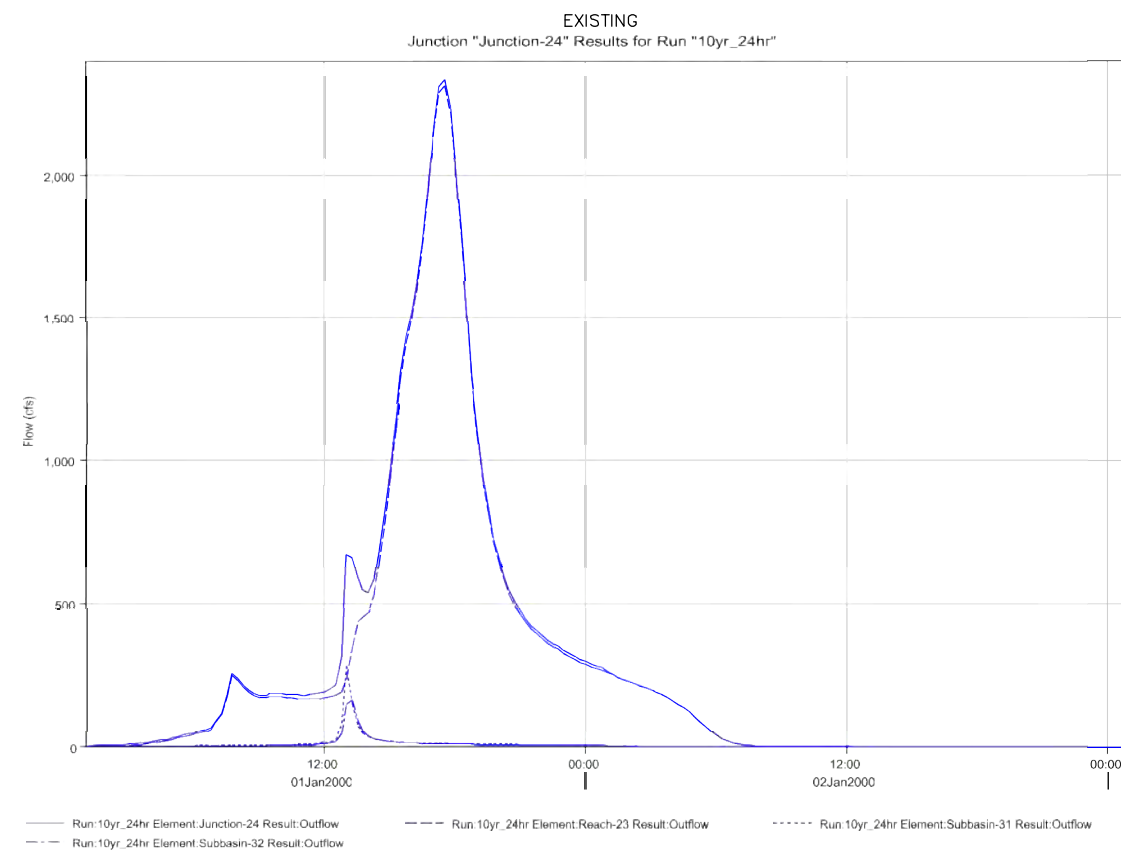

10-YR
24-HR

JUNCTION 24
HWY 83 BRIDGE
EXISTING CONDITIONS HYDROGRAPHS
AT SELECT LOCATIONS
10-YEAR

APPENDIX B – HYDROLOGIC
RESULTS– EXISTING
HYDROGRAPHS 10-YR J-24
KETTLE CREEK DBPS
JOB NO. 25100.00
MAY 2015
B-56



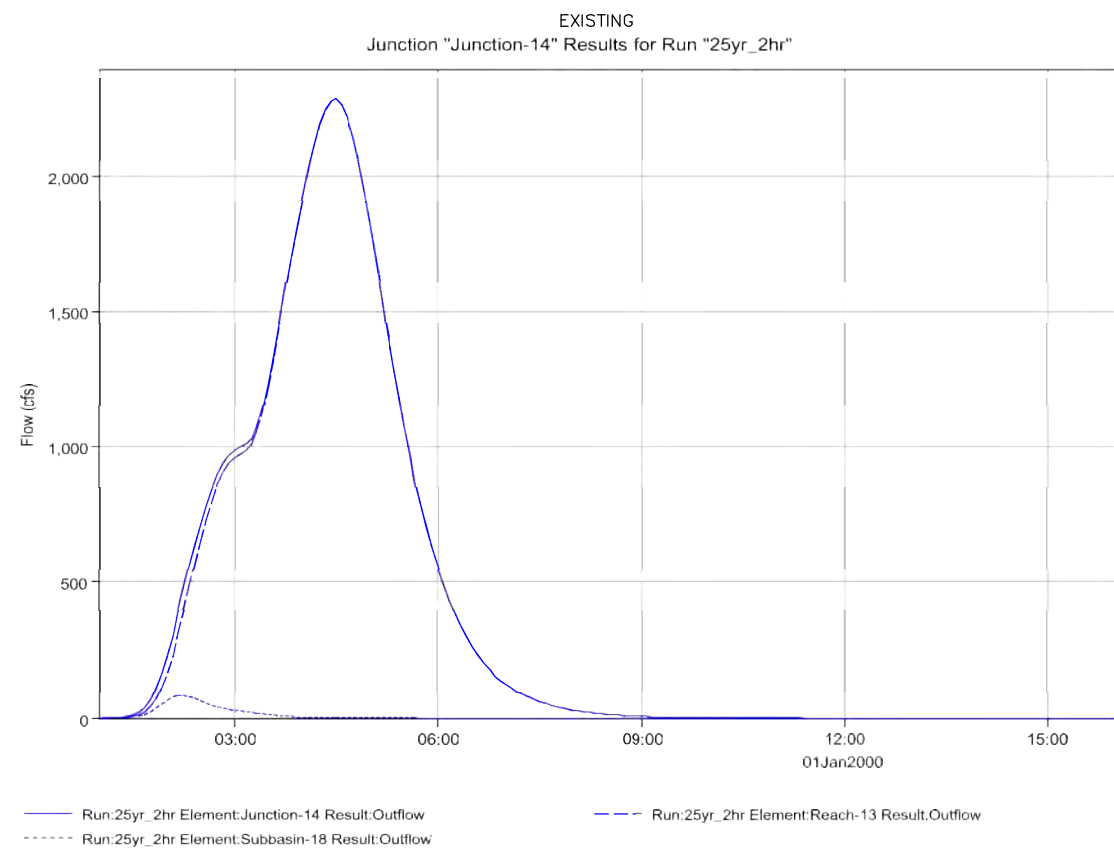

25-YR
2-HR

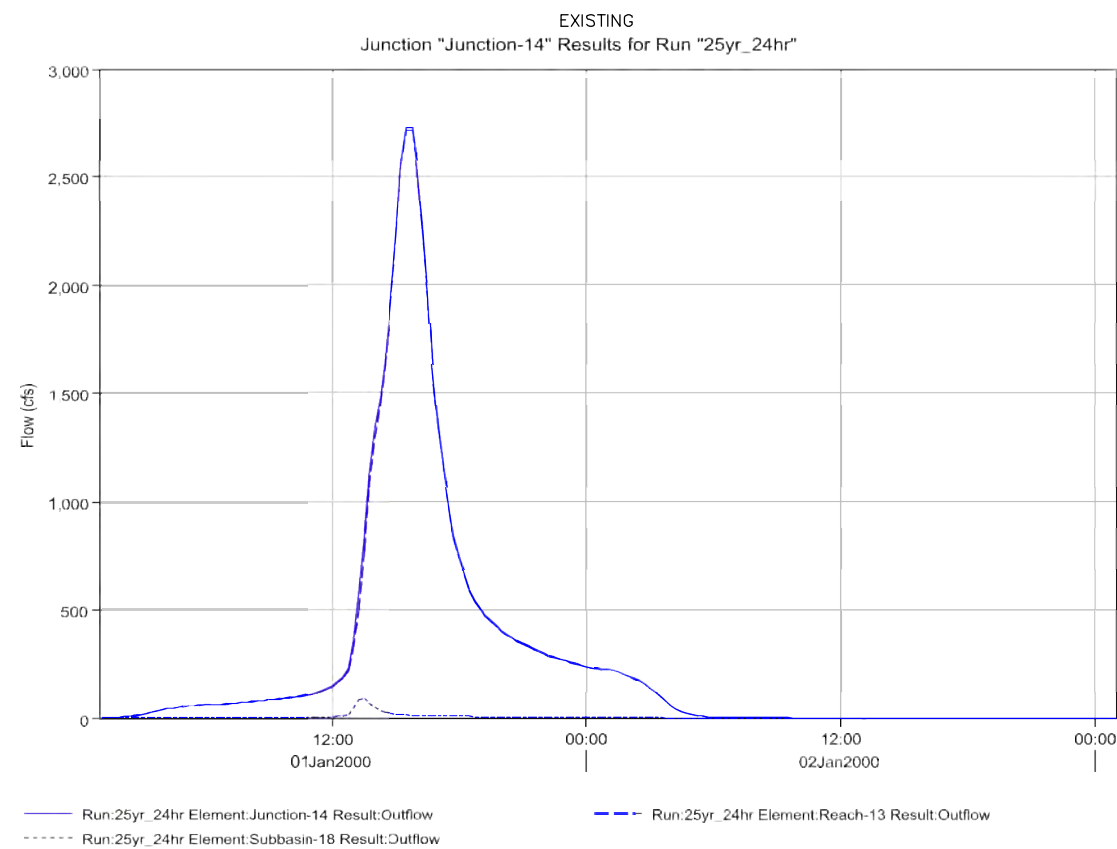

25-YR
24-HR

JUNCTION 14
HOWELLS ROAD (APPROXIMATE)
EXISTING CONDITIONS HYDROGRAPHS
AT SELECT LOCATIONS
25-YEAR

APPENDIX B – HYDROLOGIC
RESULTS– EXISTING
HYDROGRAPHS 25-YR J-14
KETTLE CREEK DBPS
JOB NO. 25100.00
MAY 2015
B-57



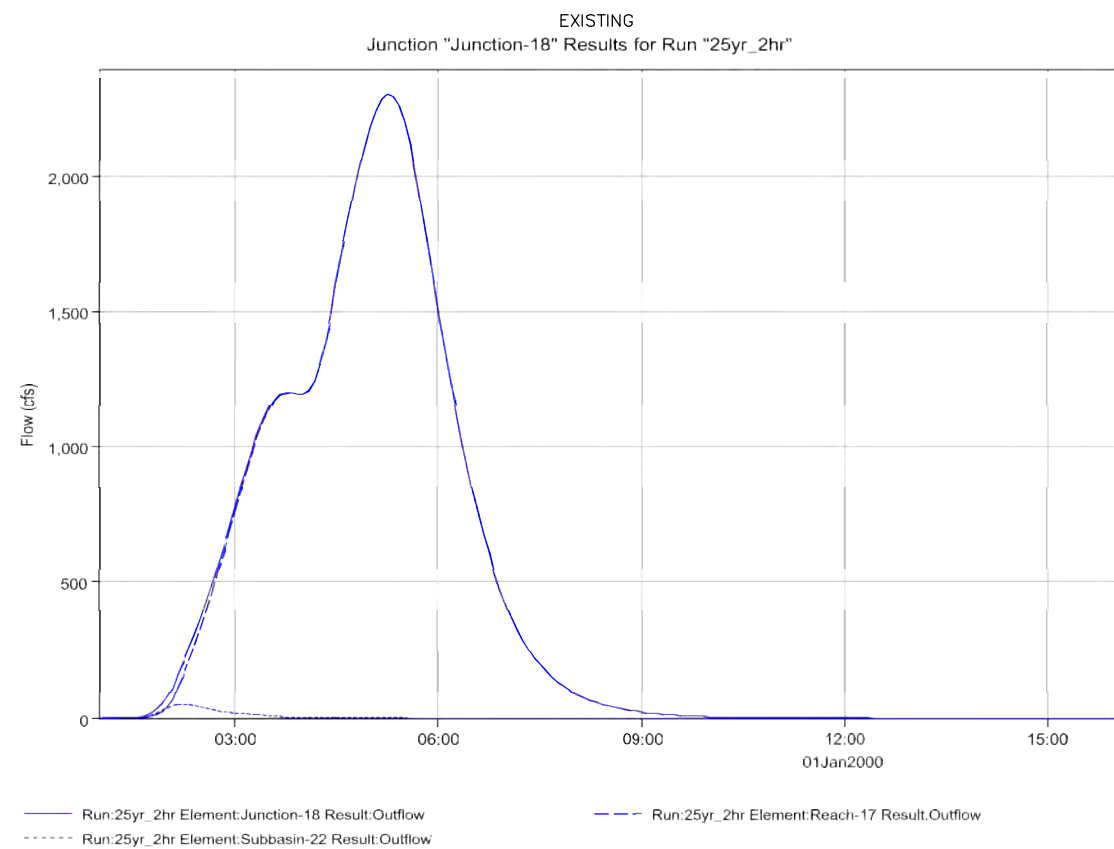

25-YR
2-HR

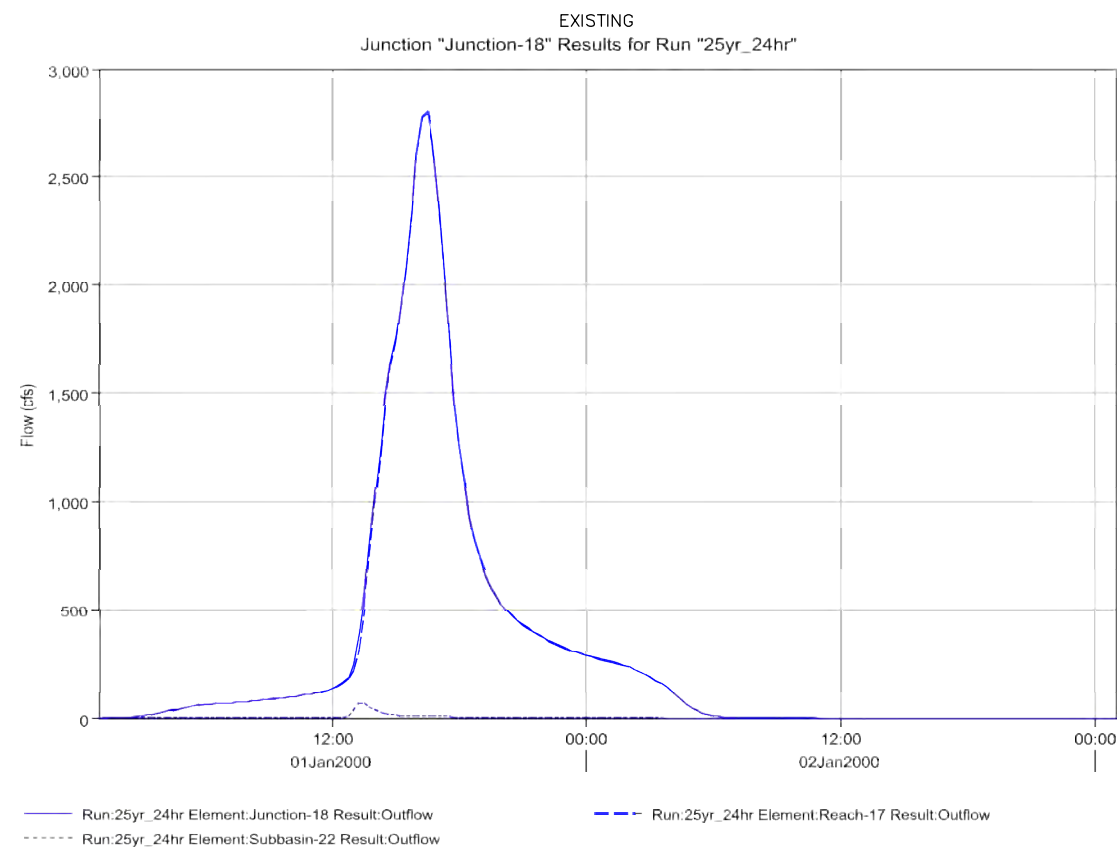

25-YR
24-HR

JUNCTION 18
POWERS BLVD BRIDGE
EXISTING CONDITIONS HYDROGRAPHS
AT SELECT LOCATIONS
25-YEAR

APPENDIX B – HYDROLOGIC
RESULTS– EXISTING
HYDROGRAPHS 25-YR J-18
KETTLE CREEK DBPS
JOB NO. 25100.00
MAY 2015
B-58



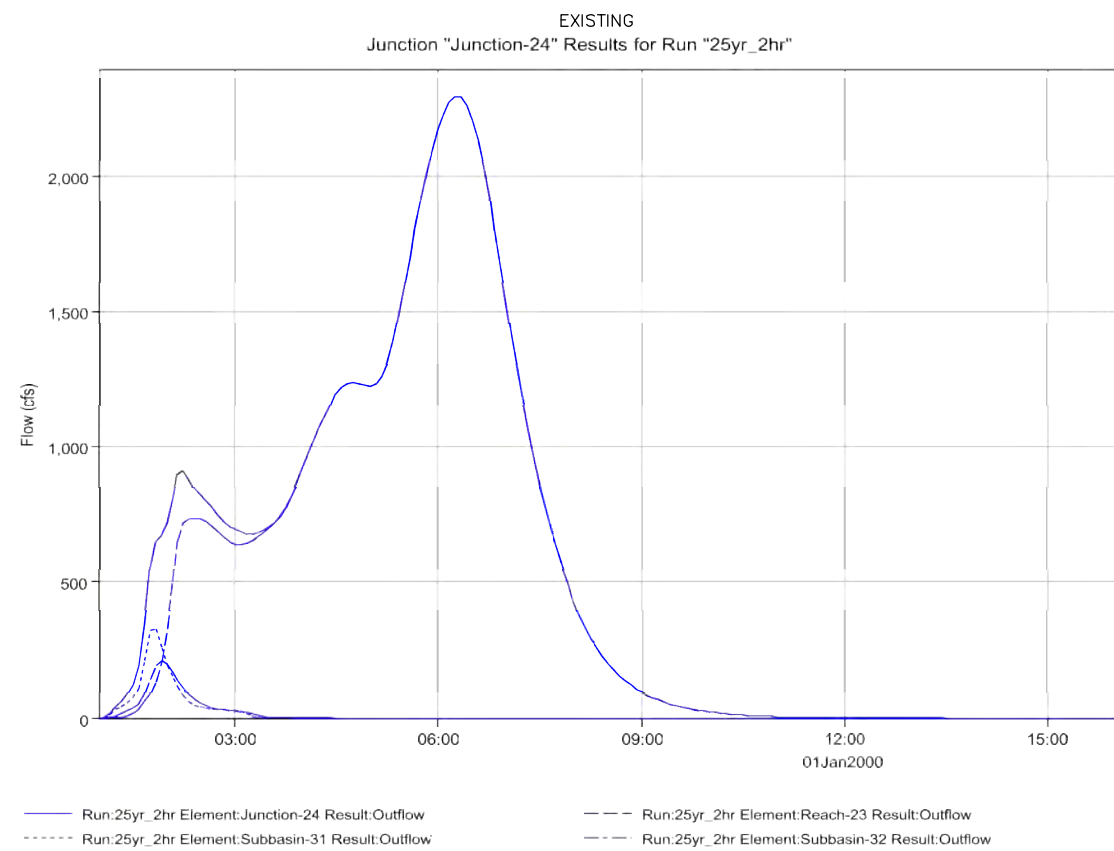

25-YR
2-HR

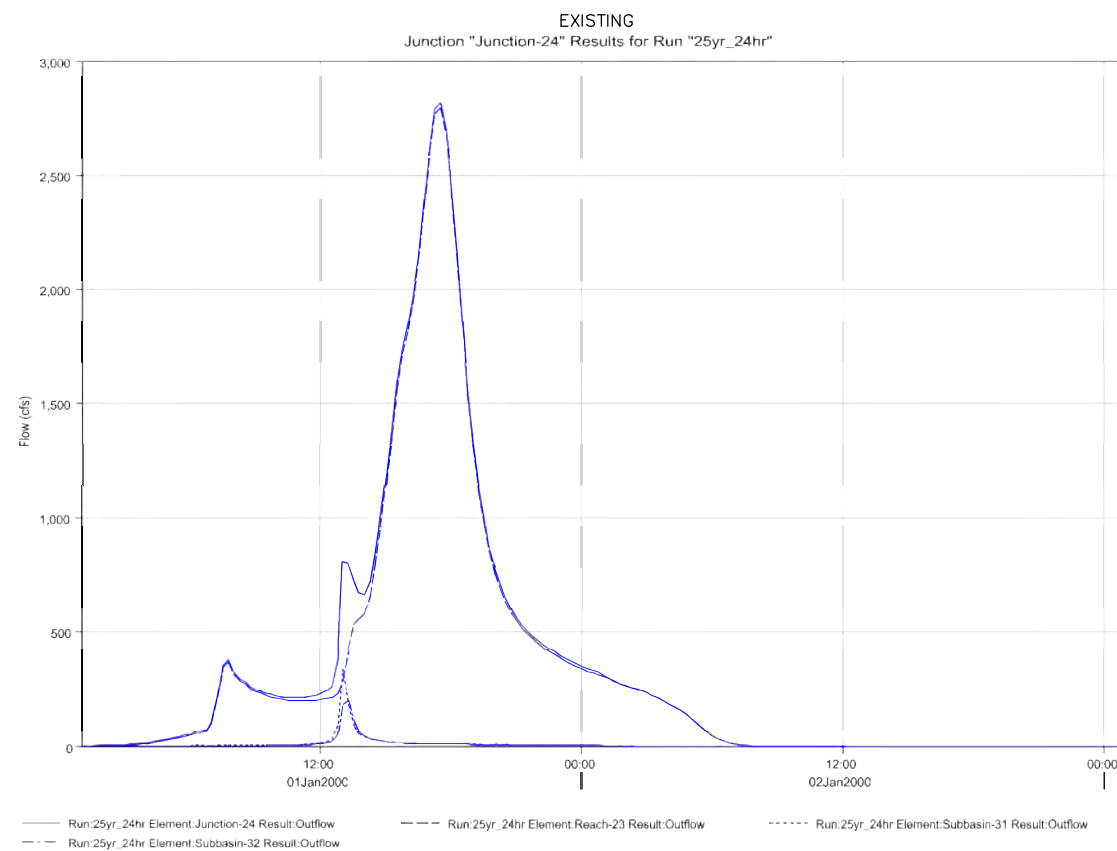

25-YR
24-HR

JUNCTION 24
HWY 83 BRIDGE
EXISTING CONDITIONS HYDROGRAPHS
AT SELECT LOCATIONS
25-YEAR

APPENDIX B – HYDROLOGIC
RESULTS– EXISTING
HYDROGRAPHS 25-YR J-24
KETTLE CREEK DBPS
JOB NO. 25100.00
MAY 2015
B-59



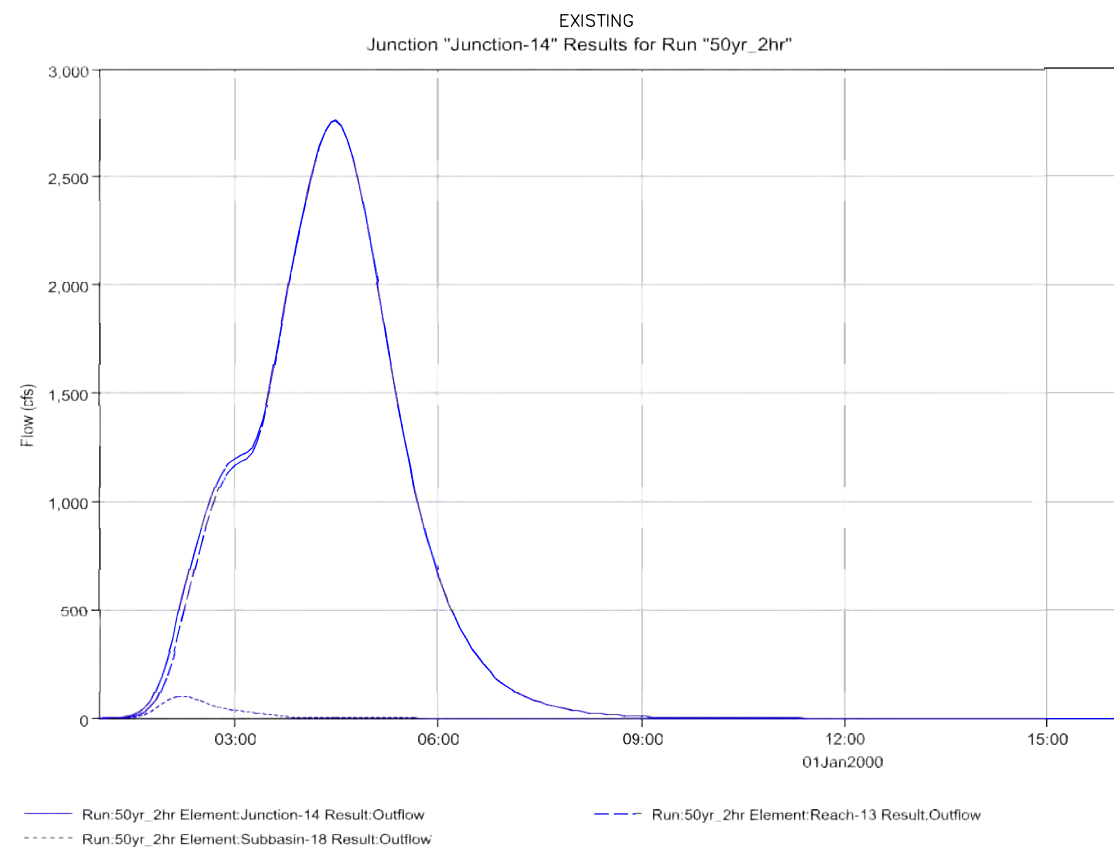

50-YR
2-HR

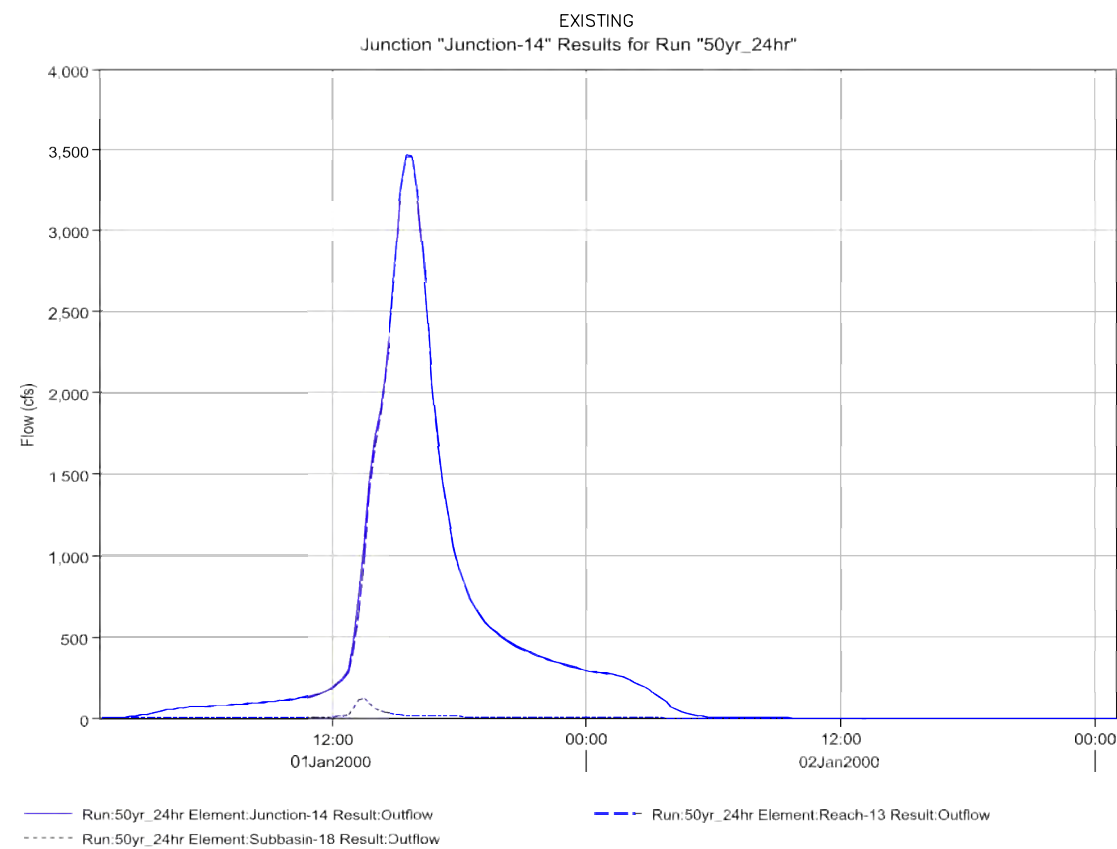

50-YR
24-HR

JUNCTION 14
HOWELLS ROAD (APPROXIMATE)
EXISTING CONDITIONS HYDROGRAPHS
AT SELECT LOCATIONS
50-YEAR

APPENDIX B – HYDROLOGIC
RESULTS– EXISTING
HYDROGRAPHS 50-YR J-14
KETTLE CREEK DBPS
JOB NO. 25100.00
MAY 2015
B-60



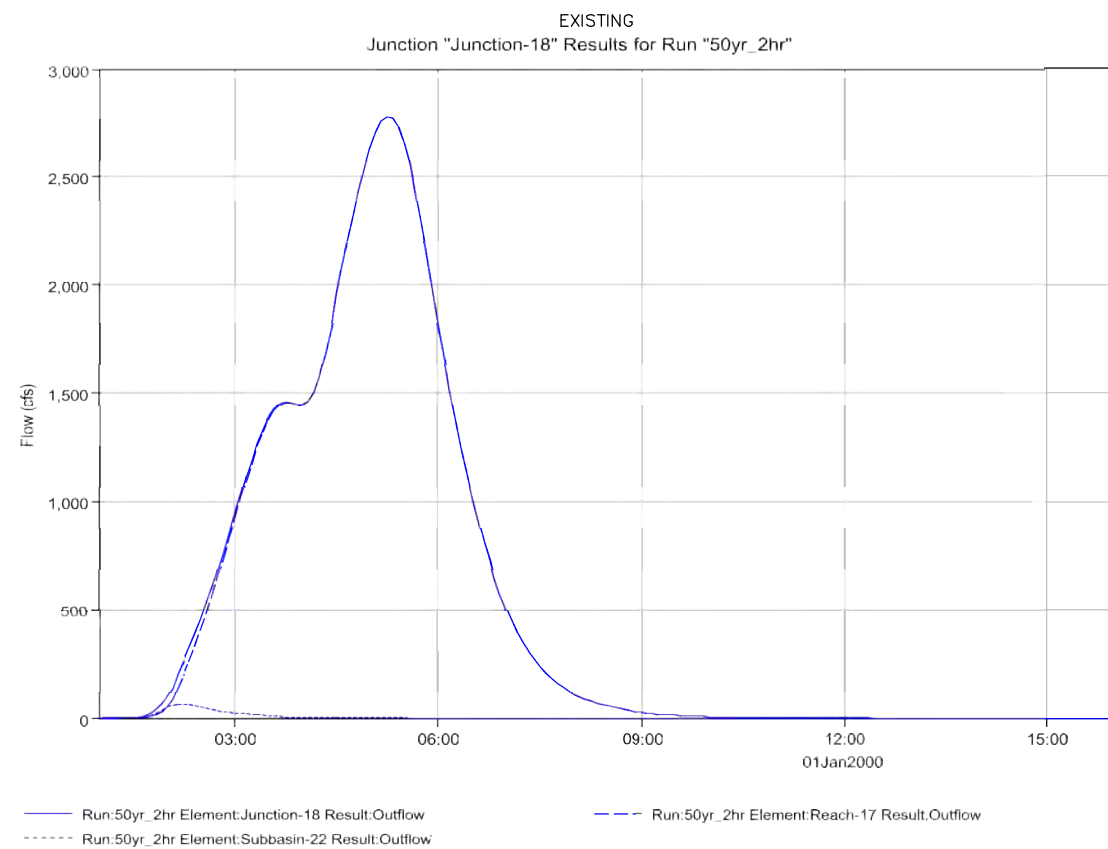

50-YR
2-HR

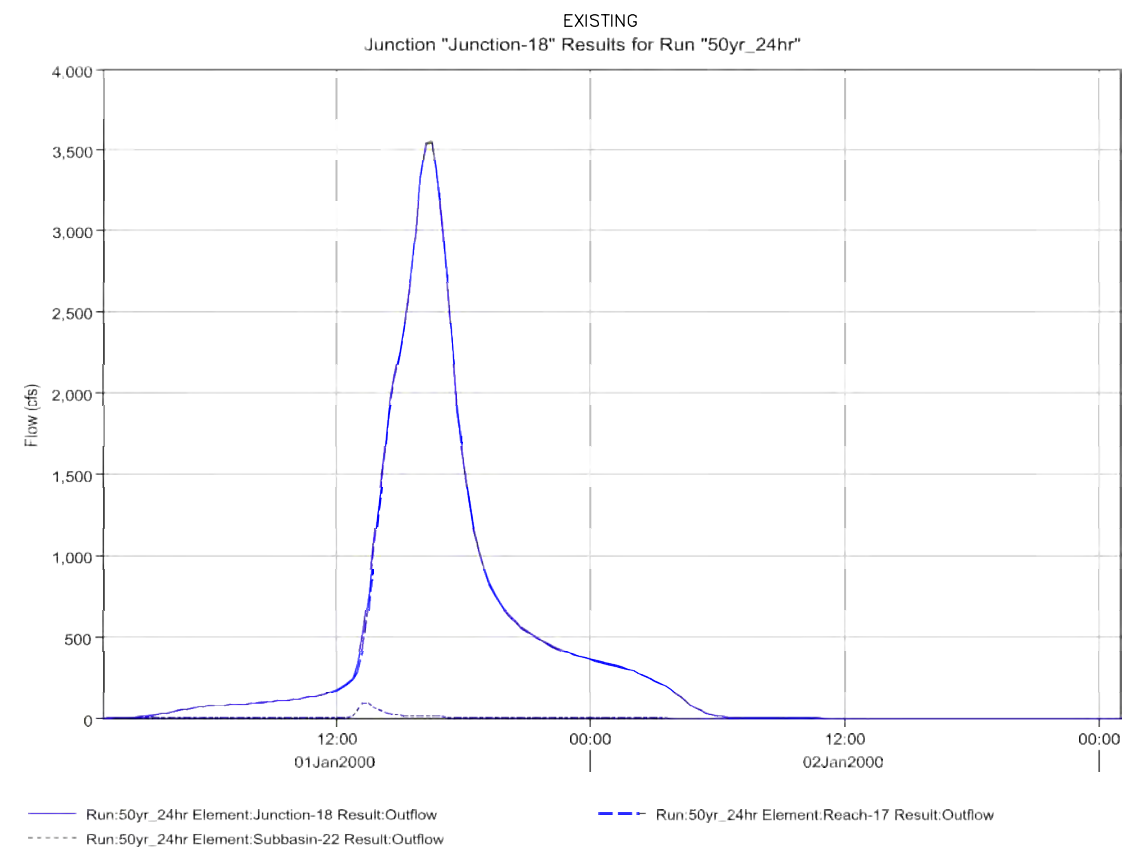

50-YR
24-HR

JUNCTION 18
POWERS BLVD BRIDGE
EXISTING CONDITIONS HYDROGRAPHS
AT SELECT LOCATIONS
50-YEAR

APPENDIX B – HYDROLOGIC
RESULTS– EXISTING
HYDROGRAPHS 50-YR J-18
KETTLE CREEK DBPS
JOB NO. 25100.00
MAY 2015
B-61



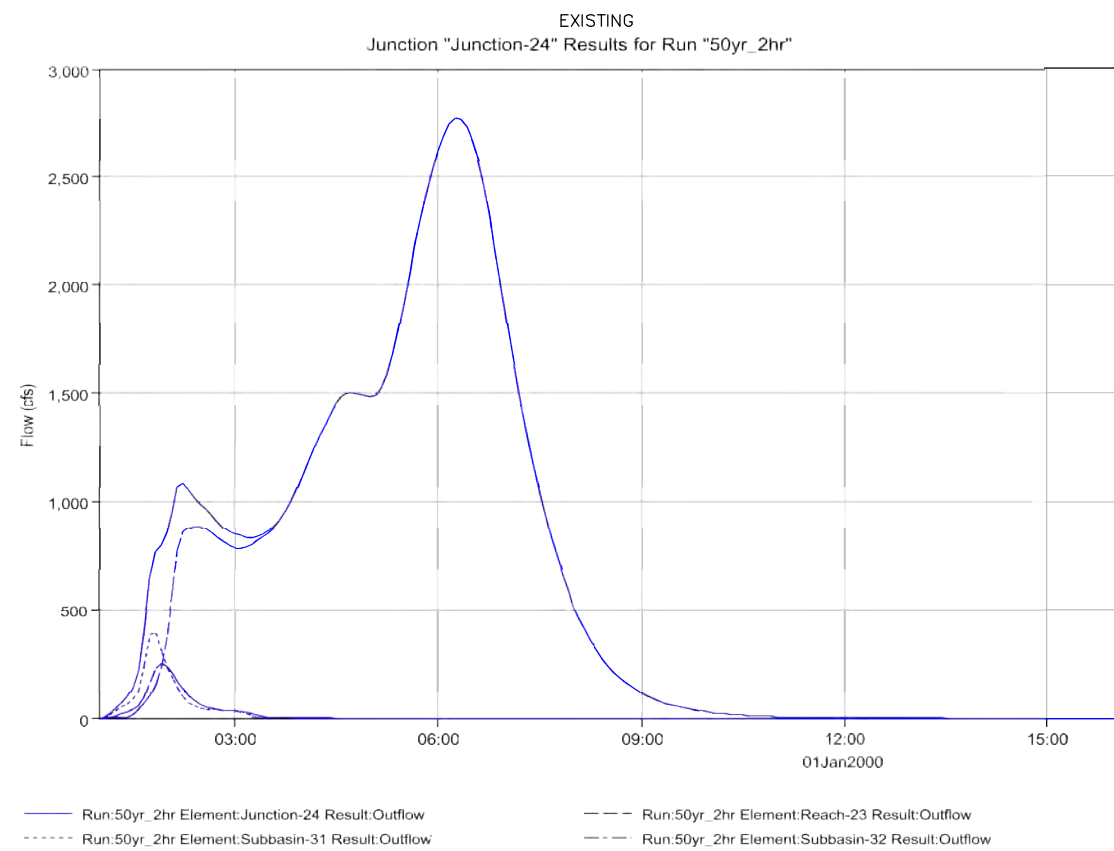

50-YR
2-HR

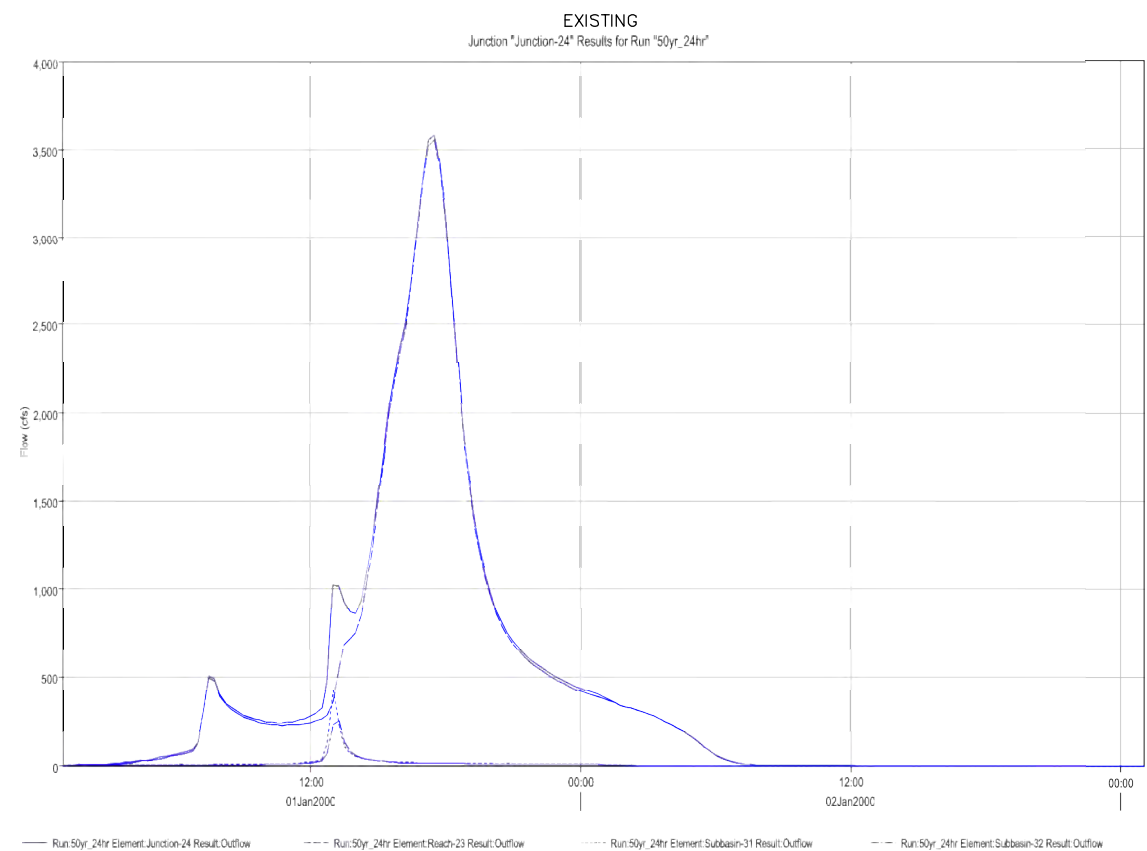

50-YR
24-HR

JUNCTION 24
HWY 83 BRIDGE
EXISTING CONDITIONS HYDROGRAPHS
AT SELECT LOCATIONS
50-YEAR

APPENDIX B – HYDROLOGIC
RESULTS– EXISTING
HYDROGRAPHS 50-YR J-28
KETTLE CREEK DBPS
JOB NO. 25100.00
MAY 2015
B-62



JUNCTION 18
POWERS BLVD BRIDGE

JUNCTION 24
HWY 83 BRIDGE

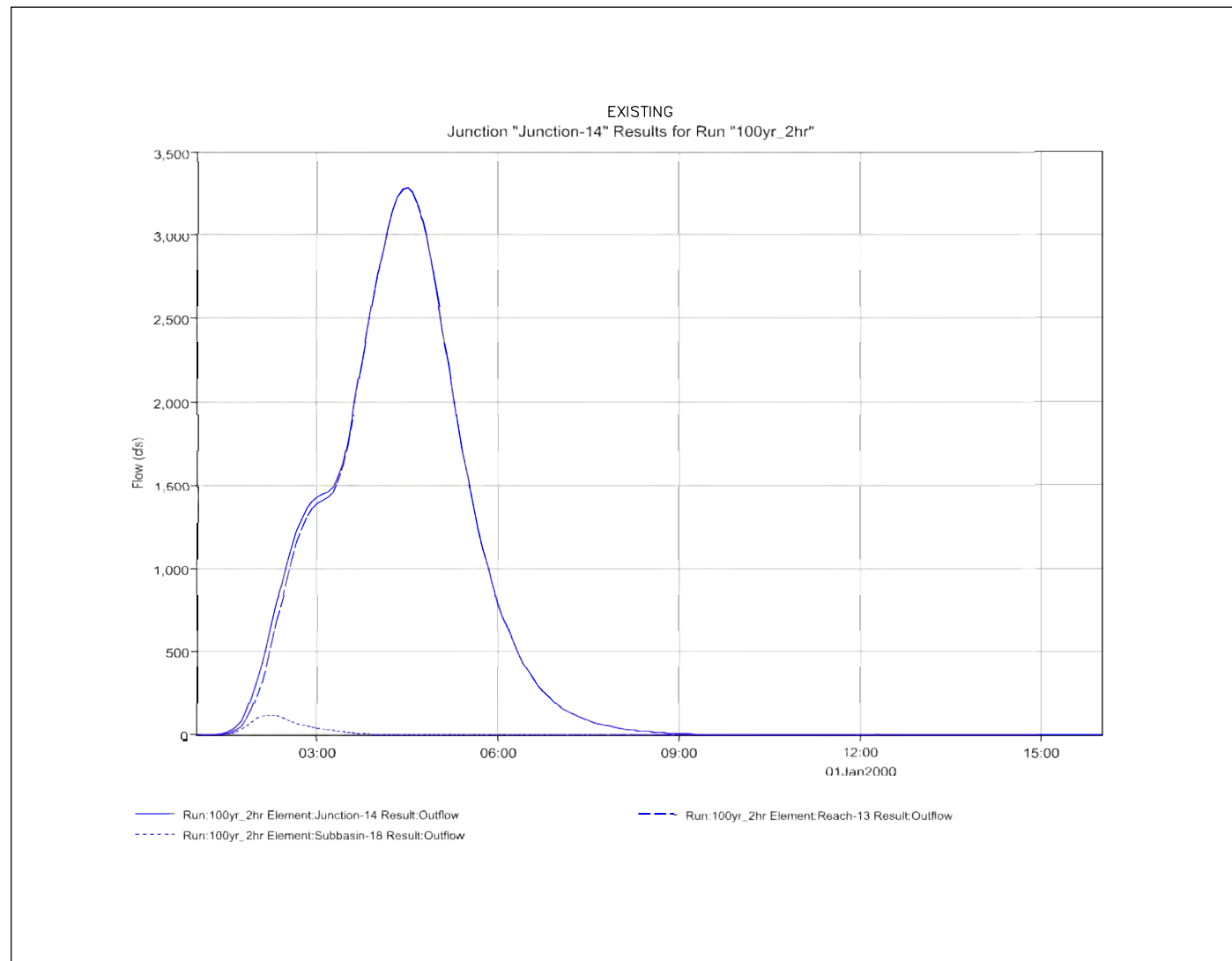

100-YR
2-HR

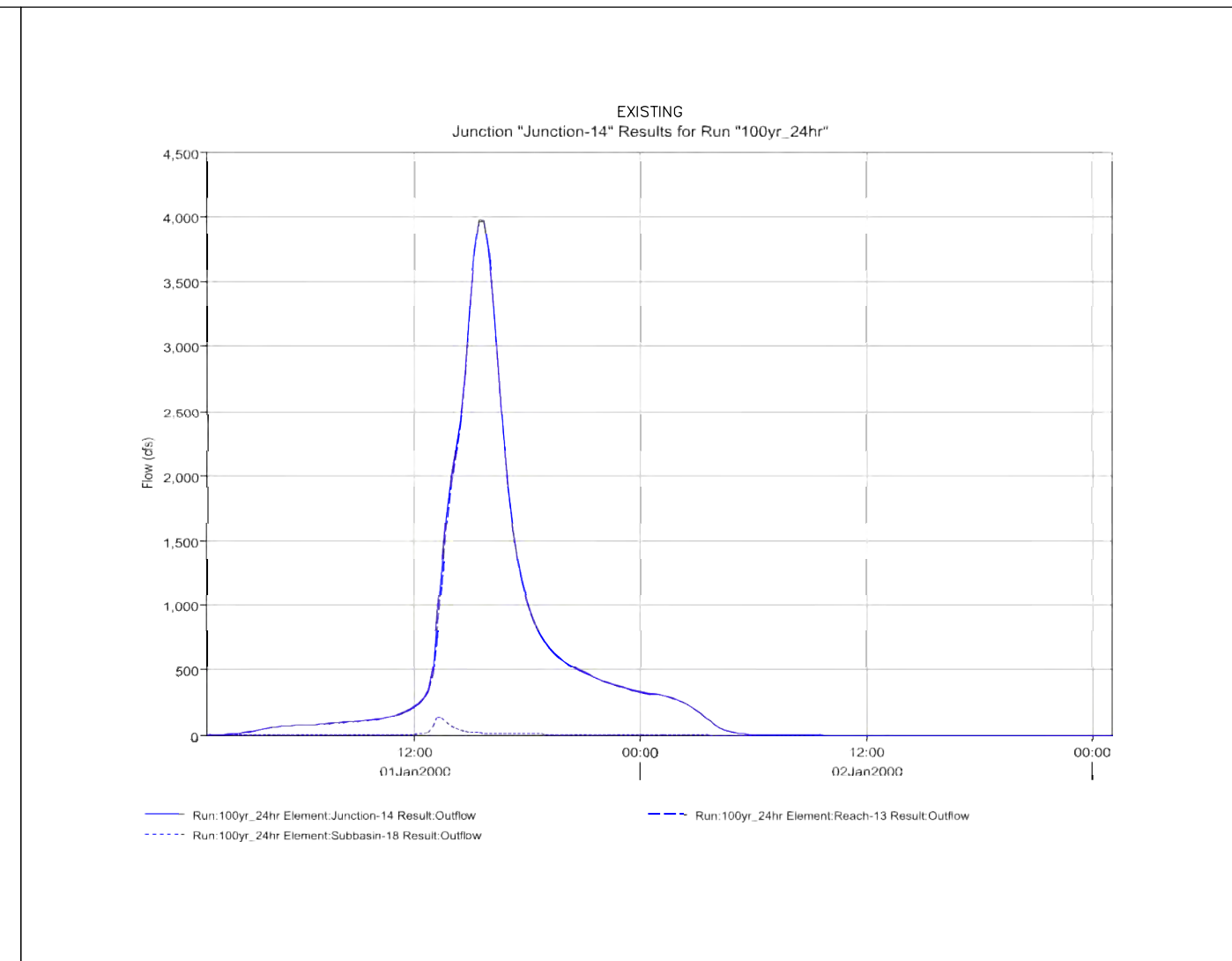

100-YR
24-HR

JUNCTION 14
HOWELLS ROAD (APPROXIMATE)
EXISTING CONDITIONS HYDROGRAPHS
AT SELECT LOCATIONS
100-YEAR

APPENDIX B- HYDROLOGIC
RESULTS- EXISTING
HYDROGRAPHS 100-YR J-14
KETTLE CREEK DBPS
JOB NO. 25100.00
MAY 2015
B-63



Centennial 303-740-9393 • Colorado Springs 719-593-2593
Fort Collins 970-491-9888 • www.jrengineering.com

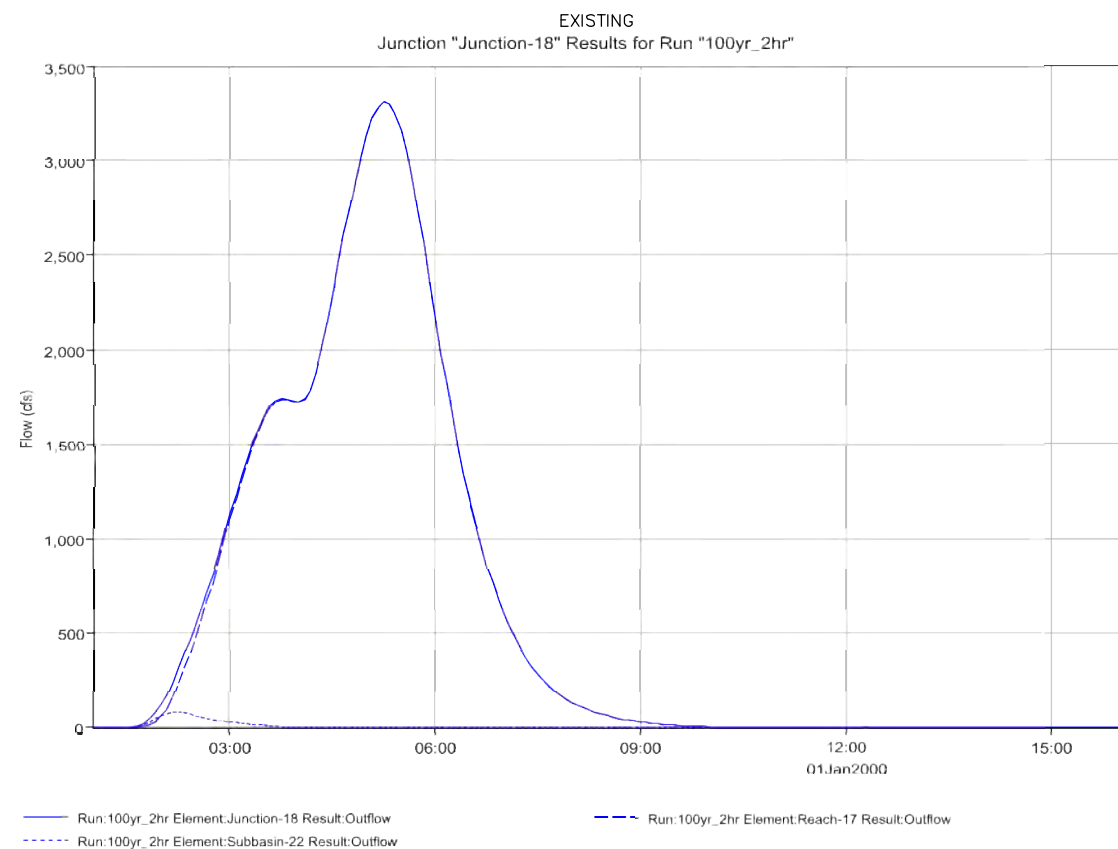

100-YR
2-HR

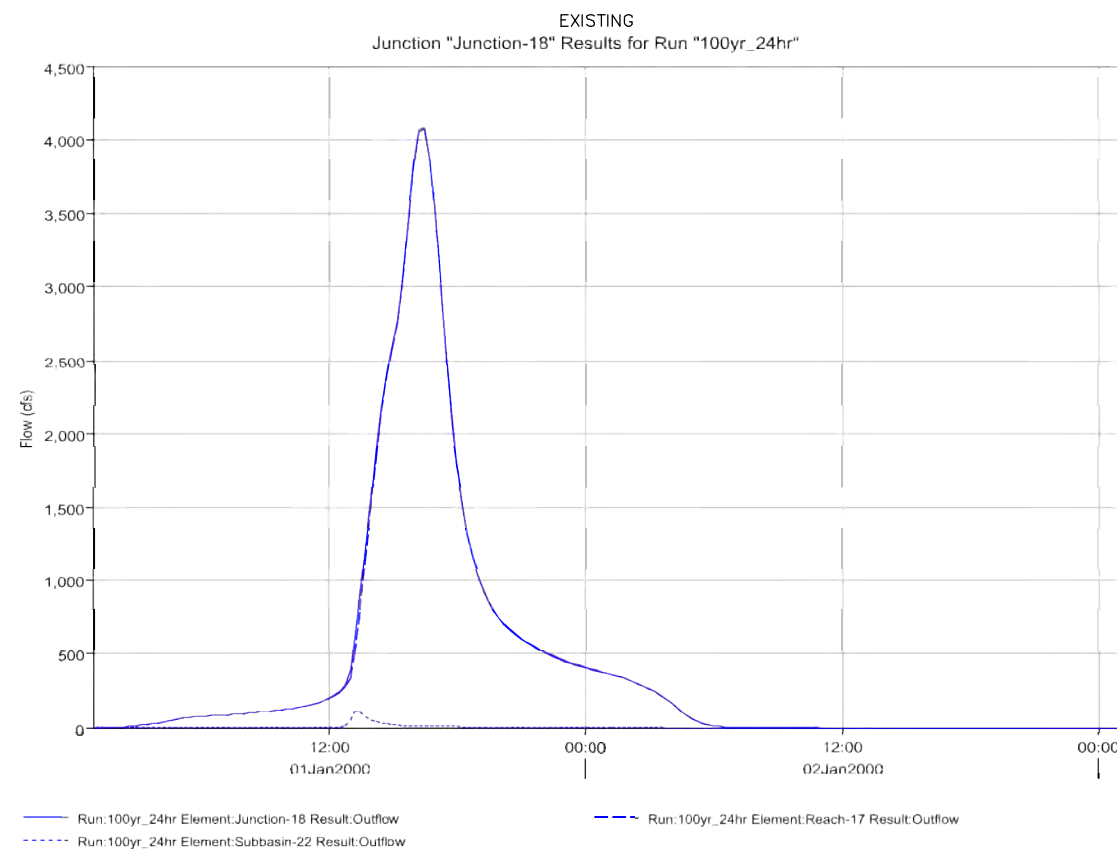

100-YR
24-HR

JUNCTION 18
POWERS BLVD BRIDGE
EXISTING CONDITIONS HYDROGRAPHS
AT SELECT LOCATIONS
100-YEAR

APPENDIX B- HYDROLOGIC
RESULTS- EXISTING
HYDROGRAPHS 100-YR J-18
KETTLE CREEK DBPS
JOB NO. 25100.00
MAY 2015
B-64



Centennial 303-740-9393 • Colorado Springs 719-593-2593
Fort Collins 970-491-9888 • www.jrengineering.com

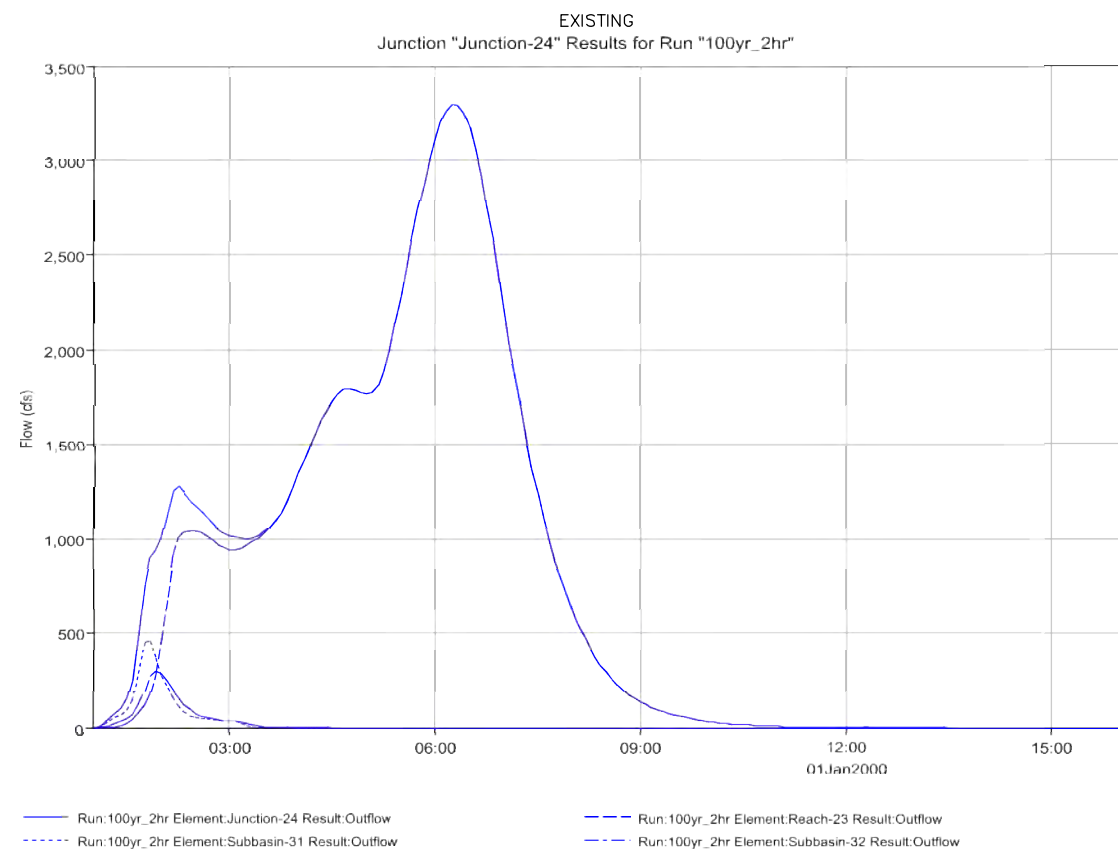

100-YR
2-HR

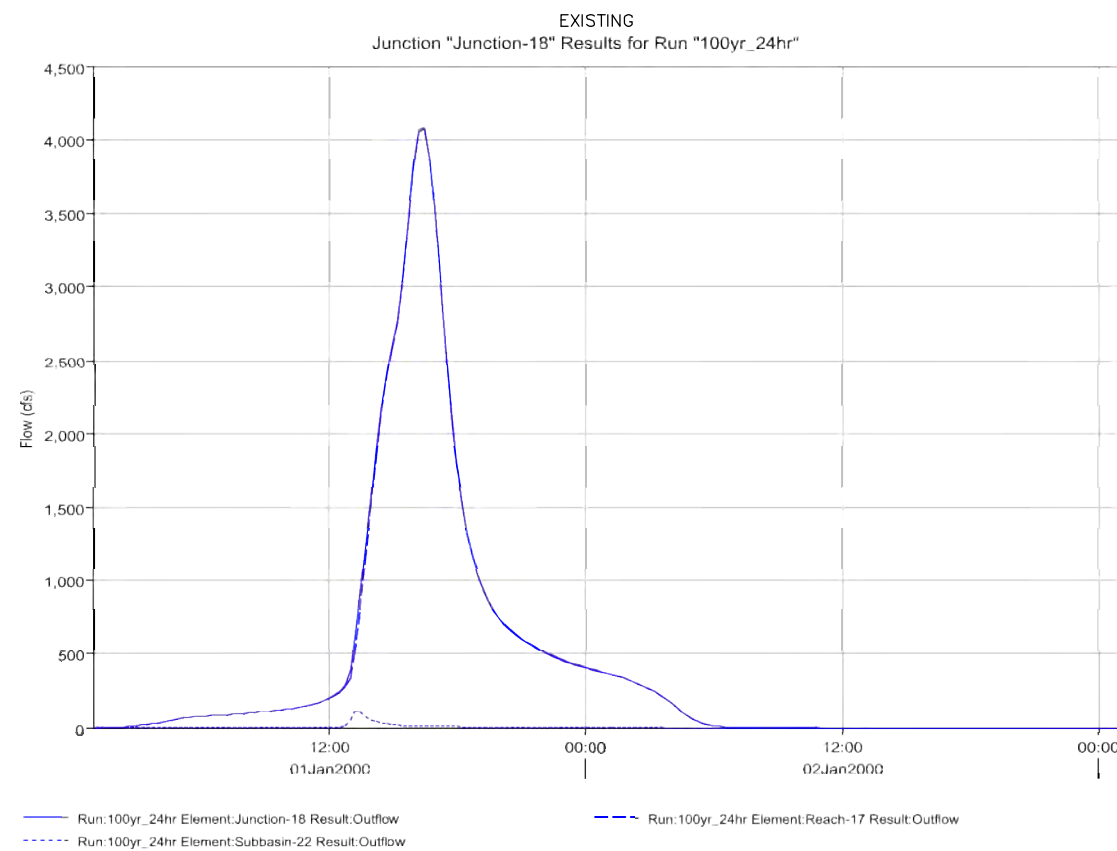

100-YR
24-HR

JUNCTION 24
 HWY 83 BRIDGE
 EXISTING CONDITIONS HYDROGRAPHS
 AT SELECT LOCATIONS
 100-YEAR

APPENDIX B- HYDROLOGIC
 RESULTS- EXISTING
 HYDROGRAPHS 100-YR J-24
 KETTLE CREEK DBPS
 JOB NO. 25100.00
 MAY 2015
 B-65



FUTURE CONDITIONS
MODEL RESULTS
(2-YEAR)

2-Year, 2-Hour Storm			
Hydrologic Element	Drainage Area (mi ²)	Peak Discharge (CFS)	Volume (in)
Subbasin-1	1.263	140	0.35
Subbasin-2	0.586	79	0.36
Subbasin-3	0.180	29	0.47
Junction-1	2.029	242	0.36
Reach-1	2.029	242	0.39
Subbasin-4	0.195	24	0.31
Junction-2	2.224	263	0.38
Reach-2	2.224	263	0.38
Subbasin-5	0.625	59	0.38
Junction-3	2.849	316	0.38
Reach-3	2.849	316	0.39
Subbasin-6	1.333	96	0.29
Junction-4	4.182	412	0.36
Reach-4	4.182	410	0.36
Subbasin-7	0.183	21	0.3
Junction-5	4.365	420	0.36
Reach-5	4.365	420	0.36
Subbasin-8	0.288	51	0.35
Junction-6	4.653	431	0.36
Reach-6	4.653	430	0.36
Subbasin-9	1.177	95	0.35
Subbasin-10	0.222	26	0.29
Junction-7	1.399	106	0.34
Reach-7	1.399	106	0.35
Subbasin-11	0.880	152	0.42
Junction-8	2.279	215	0.38
Reach-8	2.279	215	0.39
Subbasin-12	0.552	61	0.34
Junction-9	2.831	268	0.38
Reach-9	2.831	268	0.38
Junction-10	7.484	639	0.37
Reach-10	7.484	638	0.37
Subbasin-13	1.156	88	0.32
Subbasin-14	0.516	58	0.3
Junction-11	9.156	709	0.36
Reach-11	9.156	708	0.36
Subbasin-15	0.498	61	0.32
Junction-12	9.654	719	0.35
Reach-12	9.654	718	0.35
Subbasin-16	0.819	86	0.36
Subbasin-17	0.788	78	0.3
Junction-13	11.261	754	0.35

2-Year, 2-Hour Storm			
Hydrologic Element	Drainage Area (mi ²)	Peak Discharge (CFS)	Volume (in)
Reach-13	11.261	754	0.35
Subbasin-18	0.192	24	0.3
Junction-14	11.453	756	0.35
Reach-14	11.453	756	0.35
Subbasin-19	0.552	47	0.34
Junction-15	12.005	771	0.35
Reach-15	12.005	770	0.35
Subbasin-20	0.594	106	0.48
Junction-16	12.599	782	0.35
Reach-16	12.599	781	0.35
Subbasin-21	0.417	47	0.27
Junction-17	13.016	786	0.35
Reach-17	13.016	785	0.35
Subbasin-22	0.200	70	0.74
Junction-18	13.216	790	0.36
Reach-18	13.216	789	0.36
Subbasin-23	0.123	14	0.15
Junction-19	13.339	789	0.36
Reach-19	13.339	788	0.36
Subbasin-24	0.453	90	0.68
Subbasin-25	0.169	131	0.85
Subbasin-26	0.480	77	0.49
Junction-21	1.102	179	0.62
Reach-21	1.102	179	0.66
Subbasin-27	0.294	88	0.65
Junction-22	1.396	242	0.66
Reach-22	1.396	242	0.67
Subbasin-28	0.264	73	0.73
Subbasin-29	0.172	74	0.92
Junction-20	0.436	142	0.8
Reach-20	0.436	142	0.89
Subbasin-30	0.364	86	0.5
Junction-23	15.535	823	0.4
Reach-23	15.535	823	0.4
Subbasin-31	0.377	197	0.55
Subbasin-32	0.316	225	0.99
Junction-24	16.228	824	0.42
Reach-24	16.228	823	0.42
Subbasin-33	0.184	4	0.05
Junction-25	16.412	822.7	0.41
Reach-25	16.412	822.7	0.41
Junction-26	16.412	822.7	0.41

2-Year, 24-Hour Storm			
Hydrologic Element	Drainage Area (mi ²)	Peak Discharge (CFS)	Volume (in)
Subbasin-1	1.263	207	0.71
Subbasin-2	0.586	114	0.72
Subbasin-3	0.180	38	0.88
Junction-1	2.029	348	0.73
Reach-1	2.029	348	0.73
Subbasin-4	0.195	36	0.64
Junction-2	2.224	377	0.72
Reach-2	2.224	373	0.72
Subbasin-5	0.625	89	0.78
Junction-3	2.849	453	0.74
Reach-3	2.849	453	0.74
Subbasin-6	1.333	152	0.62
Junction-4	4.182	606	0.7
Reach-4	4.182	600	0.7
Subbasin-7	0.183	33	0.64
Junction-5	4.365	615	0.7
Reach-5	4.365	607	0.7
Subbasin-8	0.288	76	0.74
Junction-6	4.653	627	0.7
Reach-6	4.653	617	0.7
Subbasin-9	1.177	146	0.71
Subbasin-10	0.222	39	0.61
Junction-7	1.399	165	0.69
Reach-7	1.399	164	0.69
Subbasin-11	0.880	216	0.85
Junction-8	2.279	321	0.75
Reach-8	2.279	321	0.75
Subbasin-12	0.552	93	0.71
Junction-9	2.831	402	0.74
Reach-9	2.831	393	0.74
Junction-10	7.484	946	0.72
Reach-10	7.484	937	0.72
Subbasin-13	1.156	137	0.67
Subbasin-14	0.516	88	0.63
Junction-11	9.156	1,051	0.7
Reach-11	9.156	1,051	0.7
Subbasin-15	0.498	92	0.67
Junction-12	9.654	1,072	0.7
Reach-12	9.654	1,071	0.7

2-Year, 24-Hour Storm			
Hydrologic Element	Drainage Area (mi ²)	Peak Discharge (CFS)	Volume (in)
Subbasin-16	0.819	127	0.72
Subbasin-17	0.788	118	0.63
Junction-13	11.261	1,134	0.7
Reach-13	11.261	1,119	0.7
Subbasin-18	0.192	35	0.63
Junction-14	11.453	1,123	0.7
Reach-14	11.453	1,121	0.7
Subbasin-19	0.552	72	0.69
Junction-15	12.005	1,146	0.7
Reach-15	12.005	1,143	0.7
Subbasin-20	0.594	142	0.9
Junction-16	12.599	1,161	0.71
Reach-16	12.599	1,149	0.71
Subbasin-21	0.417	71	0.58
Junction-17	13.016	1,157	0.7
Reach-17	13.016	1,156	0.7
Subbasin-22	0.200	81	1.29
Junction-18	13.216	1,162	0.71
Reach-18	13.216	1,156	0.71
Subbasin-23	0.123	24	0.41
Junction-19	13.339	1,157	0.71
Reach-19	13.339	1,156	0.71
Subbasin-28	0.264	89	1.27
Subbasin-29	0.172	83	1.54
Junction-20	0.436	169	1.38
Reach-20	0.436	162	1.38
Subbasin-30	0.364	109	0.95
Source-1	1.396	87	0.33
Junction-23	15.535	1,192	0.7
Reach-23	15.535	1,183	0.7
Subbasin-31	0.377	205	0.99
Subbasin-32	0.316	205	1.66
Junction-24	16.228	1,199	0.72
Reach-24	16.228	1,192	0.72
Subbasin-33	0.184	10	0.19
Junction-25	16.412	1,193	0.72
Reach-25	16.412	1,189	0.72
Junction-26	16.412	1,189	0.72

NOTE:

1. SOURCE-1 IS THE 24 HOUR FLOW DATA FOR SUBBASINS 24-27, JUNCTION 22, AND REACHES 21-22. SUBBASINS 24-27 DATA HAS BEEN REPLACED WITH KETTLE CREEK DRAINAGE BASIN OLD RANCH ROAD TRIBUTARY MASTER DEVELOPMENT PLAN FLOW DATA (JR ENG. 2001).

APPENDIX B – HYDROLOGIC RESULTS – FUTURE 2-YR KETTLE CREEK DBPS
JOB NO. 25100.00
MAY 2015
B-66



FUTURE CONDITIONS
MODEL RESULTS
(5-YEAR)

5-Year, 2-Hour Storm			
Hydrologic Element	Drainage Area (mi ²)	Peak Discharge (CFS)	Volume (in)
Subbasin-1	1.263	286	0.51
Subbasin-2	0.586	160	0.52
Subbasin-3	0.180	56	0.65
Junction-1	2.029	492	0.52
Reach-1	2.029	490	0.52
Subbasin-4	0.195	50	0.45
Junction-2	2.224	536	0.52
Reach-2	2.224	536	0.52
Subbasin-5	0.625	119	0.56
Junction-3	2.849	644	0.53
Reach-3	2.849	644	0.53
Subbasin-6	1.333	203	0.43
Junction-4	4.182	846	0.5
Reach-4	4.182	846	0.5
Subbasin-7	0.183	45	0.44
Junction-5	4.365	865	0.49
Reach-5	4.365	862	0.49
Subbasin-8	0.288	104	0.52
Junction-6	4.653	885	0.49
Reach-6	4.653	883	0.49
Subbasin-9	1.177	195	0.51
Subbasin-10	0.222	55	0.43
Junction-7	1.399	217	0.49
Reach-7	1.399	217	0.49
Subbasin-11	0.880	302	0.61
Junction-8	2.279	437	0.54
Reach-8	2.279	434	0.54
Subbasin-12	0.552	127	0.5
Junction-9	2.831	546	0.53
Reach-9	2.831	545	0.53
Junction-10	7.484	1,305	0.51
Reach-10	7.484	1,305	0.51
Subbasin-13	1.156	183	0.47
Subbasin-14	0.516	122	0.44
Junction-11	9.156	1,437	0.5
Reach-11	9.156	1,435	0.5
Subbasin-15	0.498	127	0.47
Junction-12	9.654	1,445	0.5
Reach-12	9.654	1,442	0.5
Subbasin-16	0.819	175	0.51
Subbasin-17	0.788	164	0.44
Junction-13	11.261	1,475	0.49

5-Year, 2-Hour Storm			
Hydrologic Element	Drainage Area (mi ²)	Peak Discharge (CFS)	Volume (in)
Reach-13	11.261	1,473	0.49
Subbasin-18	0.192	50	0.44
Junction-14	11.453	1,473	0.49
Reach-14	11.453	1,473	0.49
Subbasin-19	0.552	98	0.49
Junction-15	12.005	1,490	0.49
Reach-15	12.005	1,487	0.49
Subbasin-20	0.594	205	0.67
Junction-16	12.599	1,490	0.5
Reach-16	12.599	1,489	0.5
Subbasin-21	0.417	100	0.4
Junction-17	13.016	1,489	0.5
Reach-17	13.016	1,488	0.5
Subbasin-22	0.200	128	0.99
Junction-18	13.216	1,488	0.51
Reach-18	13.216	1,487	0.51
Subbasin-23	0.123	31	0.26
Junction-19	13.339	1,487	0.5
Reach-19	13.339	1,485	0.5
Subbasin-24	0.453	170	0.92
Subbasin-25	0.169	206	1.12
Subbasin-26	0.480	149	0.68
Junction-21	1.102	337	0.84
Reach-21	1.102	336	0.84
Subbasin-27	0.294	163	0.88
Junction-22	1.396	458	0.85
Reach-22	1.396	458	0.85
Subbasin-28	0.264	134	0.97
Subbasin-29	0.172	133	1.2
Junction-20	0.436	258	1.06
Reach-20	0.436	258	1.06
Subbasin-30	0.364	164	0.7
Junction-23	15.535	1,487	0.56
Reach-23	15.535	1,486	0.56
Subbasin-31	0.377	309	0.75
Subbasin-32	0.316	377	1.3
Junction-24	16.228	1,486	0.57
Reach-24	16.228	1,485	0.57
Subbasin-33	0.184	13	0.1
Junction-25	16.412	1484.7	0.57
Reach-25	16.412	1484.7	0.57
Junction-26	16.412	1484.7	0.57

5-Year, 24-Hour Storm			
Hydrologic Element	Drainage Area (mi ²)	Peak Discharge (CFS)	Volume (in)
Subbasin-1	1.263	315	1.06
Subbasin-2	0.586	173	1.06
Subbasin-3	0.180	56	1.27
Junction-1	2.029	527	1.08
Reach-1	2.029	526	1.08
Subbasin-4	0.195	56	0.97
Junction-2	2.224	572	1.07
Reach-2	2.224	568	1.07
Subbasin-5	0.625	134	1.14
Junction-3	2.849	689	1.08
Reach-3	2.849	689	1.08
Subbasin-6	1.333	240	0.94
Junction-4	4.182	928	1.04
Reach-4	4.182	917	1.04
Subbasin-7	0.183	51	0.97
Junction-5	4.365	940	1.03
Reach-5	4.365	929	1.03
Subbasin-8	0.288	117	1.1
Junction-6	4.653	959	1.04
Reach-6	4.653	944	1.04
Subbasin-9	1.177	223	1.05
Subbasin-10	0.222	62	0.93
Junction-7	1.399	252	1.03
Reach-7	1.399	250	1.03
Subbasin-11	0.880	322	1.23
Junction-8	2.279	484	1.11
Reach-8	2.279	484	1.11
Subbasin-12	0.552	144	1.06
Junction-9	2.831	609	1.1
Reach-9	2.831	594	1.1
Junction-10	7.484	1,444	1.06
Reach-10	7.484	1,428	1.06
Subbasin-13	1.156	212	1
Subbasin-14	0.516	138	0.95
Junction-11	9.156	1,605	1.05
Reach-11	9.156	1,604	1.05
Subbasin-15	0.498	143	1
Junction-12	9.654	1,636	1.05
Reach-12	9.654	1,634	1.05

5-Year, 24-Hour Storm			
Hydrologic Element	Drainage Area (mi ²)	Peak Discharge (CFS)	Volume (in)
Subbasin-16	0.819	193	1.06
Subbasin-17	0.788	184	0.95
Junction-13	11.261	1,730	1.04
Reach-13	11.261	1,705	1.04
Subbasin-18	0.192	55	0.95
Junction-14	11.453	1,711	1.04
Reach-14	11.453	1,710	1.04
Subbasin-19	0.552	111	1.03
Junction-15	12.005	1,747	1.04
Reach-15	12.005	1,743	1.04
Subbasin-20	0.594	206	1.29
Junction-16	12.599	1,769	1.05
Reach-16	12.599	1,750	1.05
Subbasin-21	0.417	114	0.9
Junction-17	13.016	1,761	1.04
Reach-17	13.016	1,761	1.04
Subbasin-22	0.200	112	1.76
Junction-18	13.216	1,769	1.06
Reach-18	13.216	1,760	1.06
Subbasin-23	0.123	44	0.68
Junction-19	13.339	1,763	1.05
Reach-19	13.339	1,761	1.05
Source-1	1.396	109	0.58
Subbasin-28	0.264	123	1.74
Subbasin-29	0.172	111	2.06
Junction-20	0.436	230	1.86
Reach-20	0.436	220	1.86
Subbasin-30	0.364	158	1.34
Junction-23	15.535	1,788	1.04
Reach-23	15.535	1,774	1.04
Subbasin-31	0.377	290	1.38
Subbasin-32	0.316	274	2.2
Junction-24	16.228	1,796	1.07
Reach-24	16.228	1,785	1.07
Subbasin-33	0.184	24	0.37
Junction-25	16.412	1,787	1.06
Reach-25	16.412	1,781	1.06
Junction-26	16.412	1,781	1.06

NOTE:

1. SOURCE-1 IS THE 24 HOUR FLOW DATA FOR SUBBASINS 24-27, JUNCTION 22, AND REACHES 21-22. SUBBASINS 24-27 DATA HAS BEEN REPLACED WITH KETTLE CREEK DRAINAGE BASIN OLD RANCH ROAD TRIBUTARY MASTER DEVELOPMENT PLAN FLOW DATA (JR ENG. 2001).

APPENDIX B – HYDROLOGIC
RESULTS – FUTURE 5-YR
KETTLE CREEK DBPS
JOB NO. 25100.00
MAY 2015
B-67



FUTURE CONDITIONS
MODEL RESULTS
(10-YEAR)

10-Year, 2-Hour Storm			
Hydrologic Element	Drainage Area (mi ²)	Peak Discharge (CFS)	Volume (in)
Subbasin-1	1.263	354	0.63
Subbasin-2	0.586	198	0.64
Subbasin-3	0.180	68	0.79
Junction-1	2.029	608	0.65
Reach-1	2.029	606	0.65
Subbasin-4	0.195	63	0.57
Junction-2	2.224	663	0.64
Reach-2	2.224	663	0.64
Subbasin-5	0.625	147	0.69
Junction-3	2.849	797	0.65
Reach-3	2.849	797	0.65
Subbasin-6	1.333	255	0.54
Junction-4	4.182	1,051	0.62
Reach-4	4.182	1,051	0.62
Subbasin-7	0.183	56	0.56
Junction-5	4.365	1,074	0.61
Reach-5	4.365	1,071	0.61
Subbasin-8	0.288	131	0.65
Junction-6	4.653	1,099	0.62
Reach-6	4.653	1,097	0.62
Subbasin-9	1.177	242	0.63
Subbasin-10	0.222	70	0.54
Junction-7	1.399	269	0.61
Reach-7	1.399	269	0.61
Subbasin-11	0.880	373	0.75
Junction-8	2.279	540	0.67
Reach-8	2.279	537	0.67
Subbasin-12	0.552	159	0.62
Junction-9	2.831	677	0.66
Reach-9	2.831	675	0.66
Junction-10	7.484	1,619	0.63
Reach-10	7.484	1,619	0.63
Subbasin-13	1.156	229	0.59
Subbasin-14	0.516	153	0.55
Junction-11	9.156	1,784	0.62
Reach-11	9.156	1,782	0.62
Subbasin-15	0.498	159	0.59
Junction-12	9.654	1,795	0.62
Reach-12	9.654	1,792	0.62
Subbasin-16	0.819	217	0.64
Subbasin-17	0.788	206	0.55
Junction-13	11.261	1,833	0.62

10-Year, 2-Hour Storm			
Hydrologic Element	Drainage Area (mi ²)	Peak Discharge (CFS)	Volume (in)
Reach-13	11.261	1,830	0.62
Subbasin-18	0.192	63	0.55
Junction-14	11.453	1,831	0.62
Reach-14	11.453	1,830	0.62
Subbasin-19	0.552	121	0.61
Junction-15	12.005	1,852	0.61
Reach-15	12.005	1,849	0.61
Subbasin-20	0.594	249	0.81
Junction-16	12.599	1,851	0.62
Reach-16	12.599	1,851	0.62
Subbasin-21	0.417	128	0.51
Junction-17	13.016	1,852	0.62
Reach-17	13.016	1,850	0.62
Subbasin-22	0.200	151	1.17
Junction-18	13.216	1,850	0.63
Reach-18	13.216	1,848	0.63
Subbasin-23	0.123	43	0.35
Junction-19	13.339	1,848	0.63
Reach-19	13.339	1,846	0.63
Subbasin-24	0.453	201	1.09
Subbasin-25	0.169	242	1.31
Subbasin-26	0.480	181	0.82
Junction-21	1.102	403	1.01
Reach-21	1.102	402	1.01
Subbasin-27	0.294	195	1.04
Junction-22	1.396	546	1.02
Reach-22	1.396	545	1.02
Subbasin-28	0.264	159	1.15
Subbasin-29	0.172	156	1.41
Junction-20	0.436	304	1.25
Reach-20	0.436	303	1.25
Subbasin-30	0.364	199	0.85
Junction-23	15.535	1,848	0.68
Reach-23	15.535	1,846	0.68
Subbasin-31	0.377	369	0.89
Subbasin-32	0.316	440	1.52
Junction-24	16.228	1,846	0.71
Reach-24	16.228	1,845	0.71
Subbasin-33	0.184	20	0.16
Junction-25	16.412	1845.4	0.7
Reach-25	16.412	1845.4	0.7
Junction-26	16.412	1845.4	0.7

10-Year, 24-Hour Storm			
Hydrologic Element	Drainage Area (mi ²)	Peak Discharge (CFS)	Volume (in)
Subbasin-1	1.263	416	1.37
Subbasin-2	0.586	228	1.38
Subbasin-3	0.180	72	1.61
Junction-1	2.029	693	1.40
Reach-1	2.029	692	1.40
Subbasin-4	0.195	75	1.27
Junction-2	2.224	753	1.38
Reach-2	2.224	748	1.38
Subbasin-5	0.625	176	1.48
Junction-3	2.849	908	1.41
Reach-3	2.849	908	1.41
Subbasin-6	1.333	322	1.23
Junction-4	4.182	1,230	1.35
Reach-4	4.182	1,213	1.35
Subbasin-7	0.183	69	1.27
Junction-5	4.365	1,244	1.35
Reach-5	4.365	1,230	1.35
Subbasin-8	0.288	154.4	1.44
Junction-6	4.653	1269	1.35
Reach-6	4.653	1,248	1.35
Subbasin-9	1.177	294	1.36
Subbasin-10	0.222	84	1.23
Junction-7	1.399	333	1.34
Reach-7	1.399	331	1.34
Subbasin-11	0.880	419	1.58
Junction-8	2.279	636	1.44
Reach-8	2.279	635	1.44
Subbasin-12	0.552	190	1.38
Junction-9	2.831	800	1.43
Reach-9	2.831	781	1.43
Junction-10	7.484	1,907	1.38
Reach-10	7.484	1,885	1.38
Subbasin-13	1.156	282	1.31
Subbasin-14	0.516	185	1.25
Junction-11	9.156	2,122	1.36
Reach-11	9.156	2,120	1.36
Subbasin-15	0.498	190	1.31
Junction-12	9.654	2,162	1.36
Reach-12	9.654	2,160	1.36

10-Year, 24-Hour Storm			
Hydrologic Element	Drainage Area (mi ²)	Peak Discharge (CFS)	Volume (in)
Subbasin-16	0.819	254	1.38
Subbasin-17	0.788	247	1.25
Junction-13	11.261	2,284	1.35
Reach-13	11.261	2,250	1.35
Subbasin-18	0.192	74	1.25
Junction-14	11.453	2,258	1.35
Reach-14	11.453	2,257	1.35
Subbasin-19	0.552	147	1.34
Junction-15	12.005	2,306	1.35
Reach-15	12.005	2,301	1.35
Subbasin-20	0.594	265	1.64
Junction-16	12.599	2,333	1.37
Reach-16	12.599	2,307	1.37
Subbasin-21	0.417	154	1.19
Junction-17	13.016	2,323	1.36
Reach-17	13.016	2,322	1.36
Subbasin-22	0.200	139	2.17
Junction-18	13.216	2,332	1.37
Reach-18	13.216	2,323	1.37
Subbasin-23	0.123	62	0.94
Junction-19	13.339	2,326	1.37
Reach-19	13.339	2,323	1.37
Source-1	1.396	188	0.77
Subbasin-28	0.264	153	2.14
Subbasin-29	0.172	136	2.50
Junction-20	0.436	283	2.28
Reach-20	0.436	271	2.28
Subbasin-30	0.364	203	1.70
Junction-23	15.535	2,357	1.35
Reach-23	15.535	2,337	1.35
Subbasin-31	0.377	368	1.73
Subbasin-32	0.316	332	2.66
Junction-24	16.228	2,364	1.38
Reach-24	16.228	2,351	1.38
Subbasin-33	0.184	39	0.55
Junction-25	16.412	2,354	1.37
Reach-25	16.412	2,345	1.37
Junction-26	16.412	2,345	1.37

NOTE:

1. SOURCE-1 IS THE 24 HOUR FLOW DATA FOR SUBBASINS 24-27, JUNCTION 22, AND REACHES 21-22. SUBBASINS 24-27 DATA HAS BEEN REPLACED WITH KETTLE CREEK DRAINAGE BASIN OLD RANCH ROAD TRIBUTARY MASTER DEVELOPMENT PLAN FLOW DATA (JR ENG. 2001).

APPENDIX B – HYDROLOGIC
RESULTS – FUTURE 10-YR
KETTLE CREEK DBPS
JOB NO. 25100.00
MAY 2015
B-68



FUTURE CONDITIONS
MODEL RESULTS
(25-YEAR)

25-Year, 2-Hour Storm			
Hydrologic Element	Drainage Area (mi ²)	Peak Discharge (CFS)	Volume (in)
Subbasin-1	1.263	442	0.78
Subbasin-2	0.586	248	0.79
Subbasin-3	0.180	83	0.96
Junction-1	2.029	757	0.80
Reach-1	2.029	755	0.80
Subbasin-4	0.195	80	0.71
Junction-2	2.224	827	0.79
Reach-2	2.224	827	0.79
Subbasin-5	0.625	184	0.85
Junction-3	2.849	994	0.81
Reach-3	2.849	994	0.81
Subbasin-6	1.333	324	0.68
Junction-4	4.182	1,316	0.77
Reach-4	4.182	1,316	0.77
Subbasin-7	0.183	72	0.70
Junction-5	4.365	1,346	0.76
Reach-5	4.365	1,341	0.76
Subbasin-8	0.288	166	0.81
Junction-6	4.653	1,376	0.77
Reach-6	4.653	1,374	0.77
Subbasin-9	1.177	302	0.78
Subbasin-10	0.222	89	0.68
Junction-7	1.399	337	0.76
Reach-7	1.399	337	0.76
Subbasin-11	0.880	463	0.92
Junction-8	2.279	672	0.82
Reach-8	2.279	669	0.82
Subbasin-12	0.552	201	0.78
Junction-9	2.831	844	0.82
Reach-9	2.831	843	0.82
Junction-10	7.484	2,025	0.79
Reach-10	7.484	2,023	0.79
Subbasin-13	1.156	288	0.73
Subbasin-14	0.516	194	0.69
Junction-11	9.156	2,228	0.77
Reach-11	9.156	2,226	0.77
Subbasin-15	0.498	201	0.73
Junction-12	9.654	2,242	0.77
Reach-12	9.654	2,238	0.77
Subbasin-16	0.819	270	0.79
Subbasin-17	0.788	261	0.69
Junction-13	11.261	2,288	0.77

25-Year, 2-Hour Storm			
Hydrologic Element	Drainage Area (mi ²)	Peak Discharge (CFS)	Volume (in)
Reach-13	11.261	2,285	0.77
Subbasin-18	0.192	80	0.69
Junction-14	11.453	2,286	0.77
Reach-14	11.453	2,284	0.77
Subbasin-19	0.552	152	0.76
Junction-15	12.005	2,311	0.77
Reach-15	12.005	2,307	0.77
Subbasin-20	0.594	304	0.98
Junction-16	12.599	2,311	0.78
Reach-16	12.599	2,310	0.78
Subbasin-21	0.417	164	0.65
Junction-17	13.016	2,311	0.77
Reach-17	13.016	2,308	0.77
Subbasin-22	0.200	180	1.39
Junction-18	13.216	2,308	0.78
Reach-18	13.216	2,306	0.78
Subbasin-23	0.123	59	0.46
Junction-19	13.339	2,306	0.78
Reach-19	13.339	2,303	0.78
Subbasin-24	0.453	241	1.30
Subbasin-25	0.169	285	1.54
Subbasin-26	0.480	220	1.00
Junction-21	1.102	485	1.21
Reach-21	1.102	484	1.21
Subbasin-27	0.294	234	1.25
Junction-22	1.396	656	1.21
Reach-22	1.396	655	1.21
Subbasin-28	0.264	189	1.37
Subbasin-29	0.172	183	1.65
Junction-20	0.436	360	1.48
Reach-20	0.436	358	1.48
Subbasin-30	0.364	243	1.03
Junction-23	15.535	2,306	0.84
Reach-23	15.535	2,303	0.84
Subbasin-31	0.377	446	1.07
Subbasin-32	0.316	516	1.77
Junction-24	16.228	2,303	0.87
Reach-24	16.228	2,302	0.87
Subbasin-33	0.184	31	0.23
Junction-25	16.412	2302	0.86
Reach-25	16.412	2302	0.86
Junction-26	16.412	2302	0.86

25-Year, 24-Hour Storm			
Hydrologic Element	Drainage Area (mi ²)	Peak Discharge (CFS)	Volume (in)
Subbasin-1	1.263	502	1.64
Subbasin-2	0.586	276	1.65
Subbasin-3	0.180	86	1.90
Junction-1	2.029	835	1.67
Reach-1	2.029	834	1.67
Subbasin-4	0.195	91	1.53
Junction-2	2.224	907	1.65
Reach-2	2.224	903	1.65
Subbasin-5	0.625	212	1.76
Junction-3	2.849	1,095	1.68
Reach-3	2.849	1,095	1.68
Subbasin-6	1.333	393	1.49
Junction-4	4.182	1,488	1.62
Reach-4	4.182	1,467	1.62
Subbasin-7	0.183	84	1.53
Junction-5	4.365	1,504	1.61
Reach-5	4.365	1,488	1.61
Subbasin-8	0.288	187	1.72
Junction-6	4.653	1,535	1.62
Reach-6	4.653	1,509	1.62
Subbasin-9	1.177	355	1.63
Subbasin-10	0.222	102	1.48
Junction-7	1.399	403	1.61
Reach-7	1.399	401	1.61
Subbasin-11	0.880	501	1.88
Junction-8	2.279	766	1.71
Reach-8	2.279	764	1.71
Subbasin-12	0.552	230	1.65
Junction-9	2.831	964	1.70
Reach-9	2.831	941	1.70
Junction-10	7.484	2,304	1.65
Reach-10	7.484	2,276	1.65
Subbasin-13	1.156	342	1.57
Subbasin-14	0.516	226	1.51
Junction-11	9.156	2,565	1.63
Reach-11	9.156	2,563	1.63
Subbasin-15	0.498	231	1.57
Junction-12	9.654	2,613	1.63
Reach-12	9.654	2,609	1.63

25-Year, 24-Hour Storm			
Hydrologic Element	Drainage Area (mi ²)	Peak Discharge (CFS)	Volume (in)
Subbasin-16	0.819	307	1.65
Subbasin-17	0.788	301	1.51
Junction-13	11.261	2,759	1.62
Reach-13	11.261	2,715	1.62
Subbasin-18	0.192	90	1.50
Junction-14	11.453	2,726	1.62
Reach-14	11.453	2,725	1.62
Subbasin-19	0.552	178	1.61
Junction-15	12.005	2,784	1.62
Reach-15	12.005	2,777	1.62
Subbasin-20	0.594	315	1.93
Junction-16	12.599	2,816	1.63
Reach-16	12.599	2,786	1.63
Subbasin-21	0.417	189	1.44
Junction-17	13.016	2,805	1.63
Reach-17	13.016	2,802	1.63
Subbasin-22	0.200	161	2.50
Junction-18	13.216	2,813	1.64
Reach-18	13.216	2,804	1.64
Subbasin-23	0.123	79	1.17
Junction-19	13.339	2,807	1.64
Reach-19	13.339	2,804	1.64
Source-1	1.396	333	1.11
Subbasin-28	0.264	177	2.47
Subbasin-29	0.172	156	2.86
Junction-20	0.436	327	2.63
Reach-20	0.436	313	2.63
Subbasin-30	0.364	241	2.00
Junction-23	15.535	2,843	1.63
Reach-23	15.535	2,817	1.63
Subbasin-31	0.377	433	2.02
Subbasin-32	0.316	380	3.03
Junction-24	16.228	2,849	1.66
Reach-24	16.228	2,835	1.66
Subbasin-33	0.184	53	0.72
Junction-25	16.412	2,838	1.65
Reach-25	16.412	2,827	1.65
Junction-26	16.412	2,827	1.65

NOTE:

1. SOURCE-1 IS THE 24 HOUR FLOW DATA FOR SUBBASINS 24-27, JUNCTION 22, AND REACHES 21-22. SUBBASINS 24-27 DATA HAS BEEN REPLACED WITH KETTLE CREEK DRAINAGE BASIN OLD RANCH ROAD TRIBUTARY MASTER DEVELOPMENT PLAN FLOW DATA (JR ENG. 2001).

APPENDIX B – HYDROLOGIC
RESULTS – FUTURE 25-YR
KETTLE CREEK DBPS
JOB NO. 25100.00
MAY 2015
B-69



FUTURE CONDITIONS
MODEL RESULTS
(50-YEAR)

50-Year, 2-Hour Storm			
Hydrologic Element	Drainage Area (mi ²)	Peak Discharge (CFS)	Volume (in)
Subbasin-1	1.263	533	0.94
Subbasin-2	0.586	299	0.95
Subbasin-3	0.180	98	1.14
Junction-1	2.029	911	0.96
Reach-1	2.029	909	0.96
Subbasin-4	0.195	97	0.86
Junction-2	2.224	996	0.95
Reach-2	2.224	996	0.95
Subbasin-5	0.625	221	1.02
Junction-3	2.849	1,197	0.97
Reach-3	2.849	1,197	0.97
Subbasin-6	1.333	395	0.83
Junction-4	4.182	1,590	0.92
Reach-4	4.182	1,589	0.92
Subbasin-7	0.183	88	0.86
Junction-5	4.365	1,626	0.92
Reach-5	4.365	1,620	0.92
Subbasin-8	0.288	202	0.98
Junction-6	4.653	1,662	0.92
Reach-6	4.653	1,659	0.92
Subbasin-9	1.177	364	0.94
Subbasin-10	0.222	109	0.82
Junction-7	1.399	406	0.92
Reach-7	1.399	406	0.92
Subbasin-11	0.880	555	1.10
Junction-8	2.279	808	0.99
Reach-8	2.279	804	0.99
Subbasin-12	0.552	243	0.94
Junction-9	2.831	1,017	0.98
Reach-9	2.831	1,015	0.98
Junction-10	7.484	2,442	0.95
Reach-10	7.484	2,440	0.95
Subbasin-13	1.156	349	0.89
Subbasin-14	0.516	237	0.84
Junction-11	9.156	2,688	0.93
Reach-11	9.156	2,686	0.93
Subbasin-15	0.498	245	0.89
Junction-12	9.654	2,705	0.93
Reach-12	9.654	2,700	0.93
Subbasin-16	0.819	325	0.95
Subbasin-17	0.788	318	0.84
Junction-13	11.261	2,759	0.93

50-Year, 2-Hour Storm			
Hydrologic Element	Drainage Area (mi ²)	Peak Discharge (CFS)	Volume (in)
Reach-13	11.261	2,757	0.93
Subbasin-18	0.192	98	0.84
Junction-14	11.453	2,757	0.92
Reach-14	11.453	2,756	0.92
Subbasin-19	0.552	183	0.92
Junction-15	12.005	2,788	0.92
Reach-15	12.005	2,783	0.92
Subbasin-20	0.594	361	1.16
Junction-16	12.599	2,788	0.93
Reach-16	12.599	2,787	0.93
Subbasin-21	0.417	203	0.79
Junction-17	13.016	2,787	0.93
Reach-17	13.016	2,784	0.93
Subbasin-22	0.200	208	1.61
Junction-18	13.216	2,784	0.94
Reach-18	13.216	2,782	0.94
Subbasin-23	0.123	76	0.59
Junction-19	13.339	2,782	0.94
Reach-19	13.339	2,778	0.94
Subbasin-24	0.453	280	1.51
Subbasin-25	0.169	329	1.77
Subbasin-26	0.480	261	1.18
Junction-21	1.102	568	1.41
Reach-21	1.102	567	1.41
Subbasin-27	0.294	273	1.45
Junction-22	1.396	766	1.41
Reach-22	1.396	764	1.41
Subbasin-28	0.264	219	1.58
Subbasin-29	0.172	210	1.89
Junction-20	0.436	415	1.71
Reach-20	0.436	413	1.71
Subbasin-30	0.364	287	1.21
Junction-23	15.535	2,782	1.01
Reach-23	15.535	2,777	1.01
Subbasin-31	0.377	524	1.25
Subbasin-32	0.316	591	2.02
Junction-24	16.228	2,777	1.03
Reach-24	16.228	2,776	1.03
Subbasin-33	0.184	43	0.31
Junction-25	16.412	2,776.4	1.03
Reach-25	16.412	2,776.4	1.03
Junction-26	16.412	2,776.4	1.03

50-Year, 24-Hour Storm			
Hydrologic Element	Drainage Area (mi ²)	Peak Discharge (CFS)	Volume (in)
Subbasin-1	1.26	533.20	0.94
Subbasin-2	0.59	298.70	0.95
Subbasin-3	0.18	98.40	1.14
Junction-1	2.03	910.80	0.96
Reach-1	2.03	909.20	0.96
Subbasin-4	0.20	97.30	0.86
Junction-2	2.22	995.80	0.95
Reach-2	2.22	995.80	0.95
Subbasin-5	0.63	220.70	1.02
Junction-3	2.85	1,197.40	0.97
Reach-3	2.85	1,197.40	0.97
Subbasin-6	1.33	394.70	0.83
Junction-4	4.18	1,590.30	0.92
Reach-4	4.18	1,589.40	0.92
Subbasin-7	0.18	87.60	0.86
Junction-5	4.37	1,625.90	0.92
Reach-5	4.37	1,620.10	0.92
Subbasin-8	0.29	201.70	0.98
Junction-6	4.65	1,661.80	0.92
Reach-6	4.65	1,659.30	0.92
Subbasin-9	1.18	364.20	0.94
Subbasin-10	0.22	109.00	0.82
Junction-7	1.40	406.10	0.92
Reach-7	1.40	406.10	0.92
Subbasin-11	0.88	555.40	1.10
Junction-8	2.28	808.10	0.99
Reach-8	2.28	803.50	0.99
Subbasin-12	0.55	243.30	0.94
Junction-9	2.83	1,016.70	0.98
Reach-9	2.83	1,014.60	0.98
Junction-10	7.48	2,442.20	0.95
Reach-10	7.48	2,440.30	0.95
Subbasin-13	1.16	349.30	0.89
Subbasin-14	0.52	236.80	0.84
Junction-11	9.16	2,687.70	0.93
Reach-11	9.16	2,685.80	0.93
Subbasin-15	0.50	244.50	0.89
Junction-12	9.65	2,704.90	0.93
Reach-12	9.65	2,700.30	0.93

50-Year, 24-Hour Storm			
Hydrologic Element	Drainage Area (mi ²)	Peak Discharge (CFS)	Volume (in)
Subbasin-16	0.82	325.40	0.95
Subbasin-17	0.79	317.90	0.84
Junction-13	11.26	2,759.40	0.93
Reach-13	11.26	2,756.60	0.93
Subbasin-18	0.19	97.90	0.84
Junction-14	11.45	2,757.30	0.92
Reach-14	11.45	2,755.70	0.92
Subbasin-19	0.55	183.40	0.92
Junction-15	12.01	2,787.70	0.92
Reach-15	12.01	2,783.40	0.92
Subbasin-20	0.59	360.50	1.16
Junction-16	12.60	2,787.50	0.93
Reach-16	12.60	2,787.00	0.93
Subbasin-21	0.42	202.80	0.79
Junction-17	13.02	2,787.20	0.93
Reach-17	13.02	2,783.60	0.93
Subbasin-22	0.20	208.40	1.61
Junction-18	13.22	2,783.70	0.94
Reach-18	13.22	2,781.60	0.94
Subbasin-23	0.12	76.20	0.59
Junction-19	13.34	2,781.60	0.94
Reach-19	13.34	2,778.30	0.94
Source-1	1.40	485.70	1.33
Subbasin-28	0.26	218.90	1.58
Subbasin-29	0.17	210.10	1.89
Junction-20	0.44	414.50	1.71
Reach-20	0.44	412.90	1.71
Subbasin-30	0.36	287.40	1.21
Junction-23	15.54	2,779.50	1.00
Reach-23	15.54	2,774.50	1.00
Subbasin-31	0.38	524.10	1.25
Subbasin-32	0.32	590.70	2.02
Junction-24	16.23	2,774.50	1.03
Reach-24	16.23	2,773.70	1.02
Subbasin-33	0.18	42.80	0.31
Junction-25	16.41	2,773.70	1.01
Reach-25	16.41	2,773.70	1.01
Junction-26	16.41	2,773.70	1.01

NOTE:

1. SOURCE-1 IS THE 24 HOUR FLOW DATA FOR SUBBASINS 24-27, JUNCTION 22, AND REACHES 21-22. SUBBASINS 24-27 DATA HAS BEEN REPLACED WITH KETTLE CREEK DRAINAGE BASIN OLD RANCH ROAD TRIBUTARY MASTER DEVELOPMENT PLAN FLOW DATA (JR ENG. 2001).

APPENDIX B – HYDROLOGIC
RESULTS – FUTURE 50-YR
KETTLE CREEK DBPS
JOB NO. 25100.00
MAY 2015
B-70



FUTURE CONDITIONS
MODEL RESULTS
(100-YEAR)

100-Year, 2-Hour Storm			
Hydrologic Element	Drainage Area (mi ²)	Peak Discharge (CFS)	Volume (in)
Subbasin-1	1.263	634	1.12
Subbasin-2	0.586	355	1.13
Subbasin-3	0.180	115	1.33
Junction-1	2.029	1,082	1.14
Reach-1	2.029	1,080	1.14
Subbasin-4	0.195	117	1.03
Junction-2	2.224	1,184	1.13
Reach-2	2.224	1,184	1.13
Subbasin-5	0.625	262	1.21
Junction-3	2.849	1,423	1.15
Reach-3	2.849	1,423	1.15
Subbasin-6	1.333	474	0.99
Junction-4	4.182	1,895	1.10
Reach-4	4.182	1,894	1.10
Subbasin-7	0.183	106	1.03
Junction-5	4.365	1,938	1.10
Reach-5	4.365	1,931	1.10
Subbasin-8	0.288	242	1.17
Junction-6	4.653	1,980	1.10
Reach-6	4.653	1,977	1.10
Subbasin-9	1.177	433	1.11
Subbasin-10	0.222	132	0.99
Junction-7	1.399	483	1.09
Reach-7	1.399	483	1.09
Subbasin-11	0.880	657	1.30
Junction-8	2.279	959	1.17
Reach-8	2.279	953	1.17
Subbasin-12	0.552	291	1.12
Junction-9	2.831	1,208	1.16
Reach-9	2.831	1,205	1.16
Junction-10	7.484	2,905	1.12
Reach-10	7.484	2,903	1.12
Subbasin-13	1.156	418	1.06
Subbasin-14	0.516	285	1.01
Junction-11	9.156	3,198	1.11
Reach-11	9.156	3,195	1.11
Subbasin-15	0.498	293	1.06
Junction-12	9.654	3,218	1.11
Reach-12	9.654	3,213	1.11
Subbasin-16	0.819	387	1.12
Subbasin-17	0.788	382	1.01
Junction-13	11.261	3,283	1.10

100-Year, 2-Hour Storm			
Hydrologic Element	Drainage Area (mi ²)	Peak Discharge (CFS)	Volume (in)
Reach-13	11.261	3,280	1.10
Subbasin-18	0.192	118	1.01
Junction-14	11.453	3,281	1.10
Reach-14	11.453	3,279	1.10
Subbasin-19	0.552	219	1.09
Junction-15	12.005	3,317	1.10
Reach-15	12.005	3,312	1.10
Subbasin-20	0.594	422	1.36
Junction-16	12.599	3,316	1.11
Reach-16	12.599	3,316	1.11
Subbasin-21	0.417	246	0.95
Junction-17	13.016	3,316	1.11
Reach-17	13.016	3,312	1.11
Subbasin-22	0.200	239	1.84
Junction-18	13.216	3,312	1.12
Reach-18	13.216	3,309	1.12
Subbasin-23	0.123	96	0.73
Junction-19	13.339	3,309	1.11
Reach-19	13.339	3,305	1.11
Subbasin-24	0.453	322	1.74
Subbasin-25	0.169	374	2.01
Subbasin-26	0.480	305	1.38
Junction-21	1.102	657	1.62
Reach-21	1.102	656	1.62
Subbasin-27	0.294	315	1.67
Junction-22	1.396	886	1.63
Reach-22	1.396	884	1.63
Subbasin-28	0.264	251	1.82
Subbasin-29	0.172	239	2.15
Junction-20	0.436	473	1.95
Reach-20	0.436	471	1.95
Subbasin-30	0.364	336	1.41
Junction-23	15.535	3,310	1.19
Reach-23	15.535	3,304	1.19
Subbasin-31	0.377	608	1.45
Subbasin-32	0.316	669	2.29
Junction-24	16.228	3,304	1.22
Reach-24	16.228	3,303	1.22
Subbasin-33	0.184	57	0.41
Junction-25	16.412	3302.7	1.21
Reach-25	16.412	3302.7	1.21
Junction-26	16.412	3302.7	1.21

100-Year, 24-Hour Storm			
Hydrologic Element	Drainage Area (mi ²)	Peak Discharge (CFS)	Volume (in)
Subbasin-1	1.263	735	2.36
Subbasin-2	0.586	403	2.37
Subbasin-3	0.180	122	2.67
Junction-1	2.029	1,217	2.39
Reach-1	2.029	1,216	2.39
Subbasin-4	0.195	135	2.22
Junction-2	2.224	1,325	2.38
Reach-2	2.224	1,322	2.38
Subbasin-5	0.625	308	2.52
Junction-3	2.849	1,602	2.41
Reach-3	2.849	1,602	2.41
Subbasin-6	1.333	588	2.18
Junction-4	4.182	2,190	2.34
Reach-4	4.182	2,153	2.34
Subbasin-7	0.183	125	2.24
Junction-5	4.365	2,208	2.33
Reach-5	4.365	2,186	2.33
Subbasin-8	0.288	273.3	2.48
Junction-6	4.653	2253.3	2.34
Reach-6	4.653	2,213	2.34
Subbasin-9	1.177	520	2.35
Subbasin-10	0.222	152	2.17
Junction-7	1.399	593	2.32
Reach-7	1.399	588	2.32
Subbasin-11	0.880	720	2.66
Junction-8	2.279	1,114	2.45
Reach-8	2.279	1,112	2.45
Subbasin-12	0.552	338	2.39
Junction-9	2.831	1,403	2.44
Reach-9	2.831	1,368	2.44
Junction-10	7.484	3,375	2.38
Reach-10	7.484	3,329	2.38
Subbasin-13	1.156	505	2.28
Subbasin-14	0.516	337	2.20
Junction-11	9.156	3,761	2.36
Reach-11	9.156	3,756	2.36
Subbasin-15	0.498	342	2.28
Junction-12	9.654	3,828	2.35
Reach-12	9.654	3,823	2.35

100-Year, 24-Hour Storm			
Hydrologic Element	Drainage Area (mi ²)	Peak Discharge (CFS)	Volume (in)
Subbasin-16	0.819	449	2.37
Subbasin-17	0.788	447	2.20
Junction-13	11.261	4,038	2.34
Reach-13	11.261	3,975	2.34
Subbasin-18	0.192	134.1	2.2
Junction-14	11.453	3,992	2.34
Reach-14	11.453	3,987	2.34
Subbasin-19	0.552	262	2.32
Junction-15	12.005	4,072	2.34
Reach-15	12.005	4,061	2.34
Subbasin-20	0.594	448	2.70
Junction-16	12.599	4,115	2.36
Reach-16	12.599	4,077	2.36
Subbasin-21	0.417	284	2.12
Junction-17	13.016	4,105	2.35
Reach-17	13.016	4,093	2.35
Subbasin-22	0.200	219	3.37
Junction-18	13.216	4,108	2.37
Reach-18	13.216	4,099	2.37
Subbasin-23	0.123	124	1.80
Junction-19	13.339	4,104	2.36
Reach-19	13.339	4,099	2.36
Source-1	1.396	576	1.58
Subbasin-28	0.264	241	3.34
Subbasin-29	0.172	207	3.78
Junction-20	0.436	439	3.51
Reach-20	0.436	421	3.51
Subbasin-30	0.364	340	2.78
Junction-23	15.535	4,152	2.33
Reach-23	15.535	4,110	2.33
Subbasin-31	0.377	606	2.79
Subbasin-32	0.316	500	3.98
Junction-24	16.228	4,152	2.38
Reach-24	16.228	4,137	2.38
Subbasin-33	0.184	93	1.21
Junction-25	16.412	4,142	2.36
Reach-25	16.412	4,123	2.36
Junction-26	16.412	4,123	2.36

NOTE:

1. SOURCE-1 IS THE 24 HOUR FLOW DATA FOR SUBBASINS 24-27, JUNCTION 22, AND REACHES 21-22. SUBBASINS 24-27 DATA HAS BEEN REPLACED WITH KETTLE CREEK DRAINAGE BASIN OLD RANCH ROAD TRIBUTARY MASTER DEVELOPMENT PLAN FLOW DATA (JR ENG. 2001).

APPENDIX B – HYDROLOGIC
RESULTS – FUTURE 100-YR
KETTLE CREEK DBPS
JOB NO. 25100.00
MAY 2015
B-71



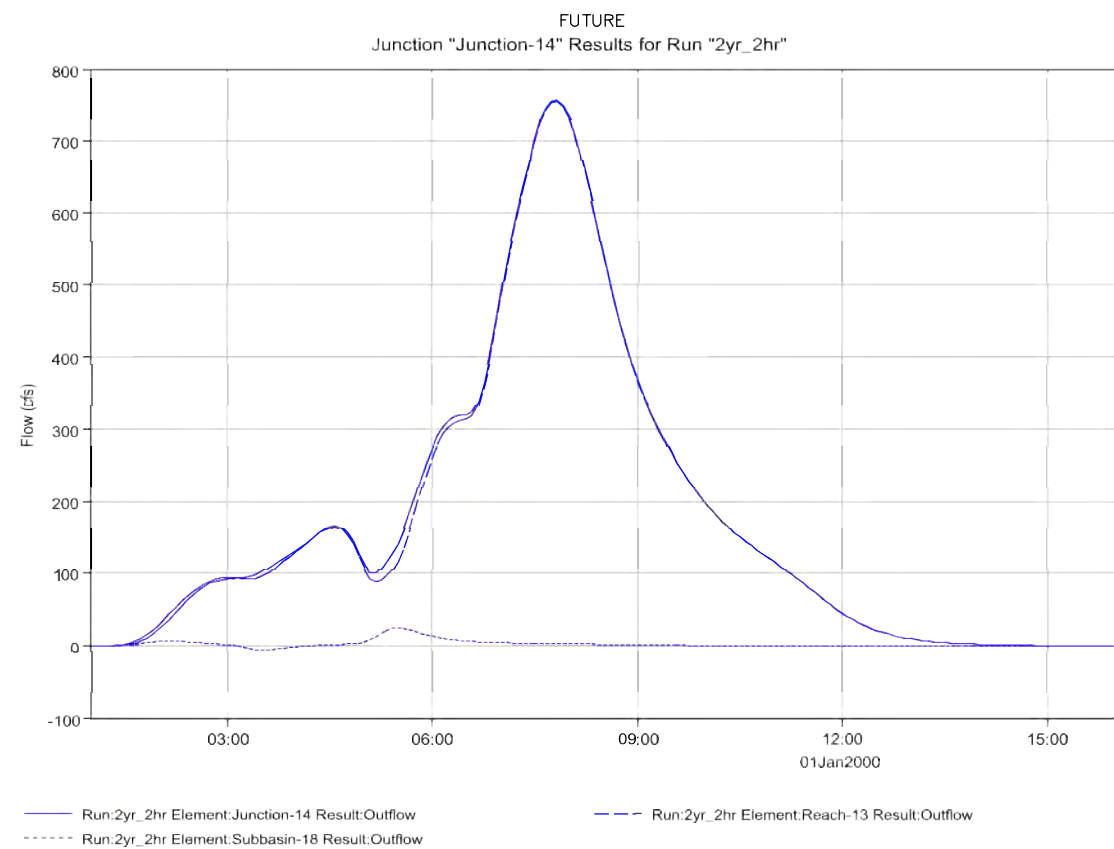

2-YR
2-HR

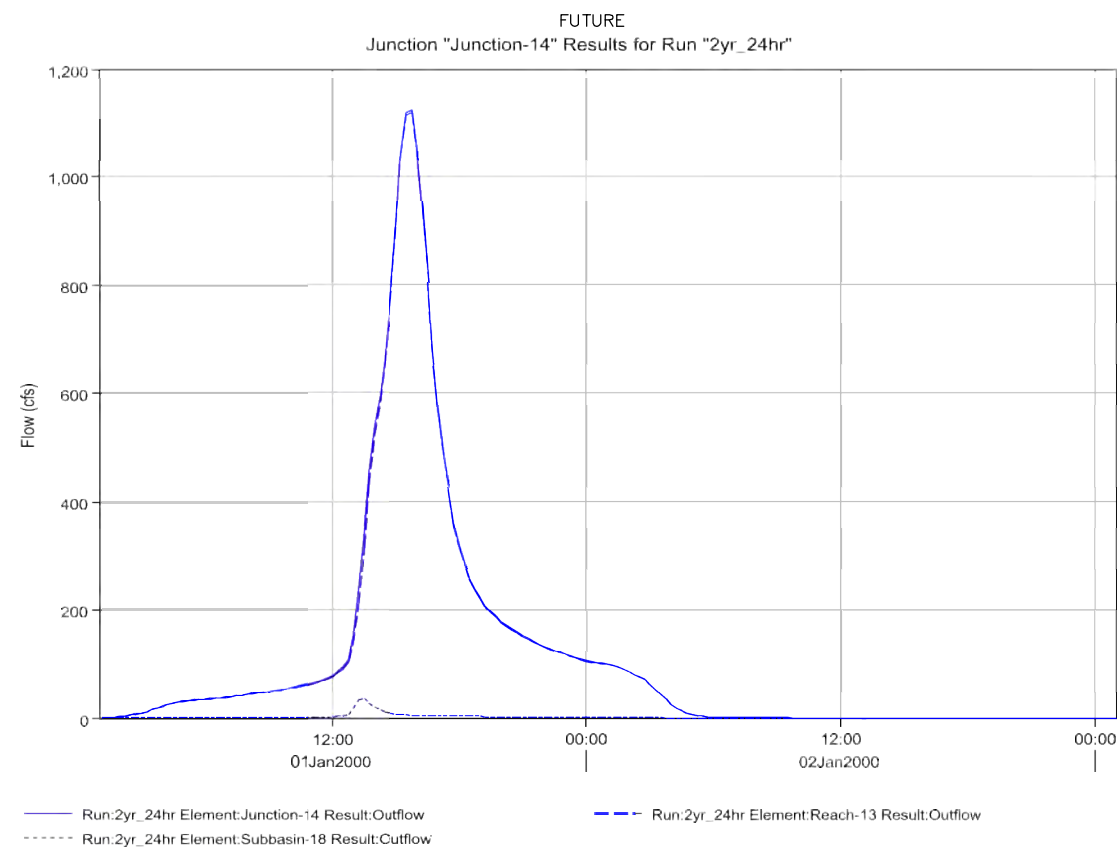

2-YR
24-HR

JUNCTION 14
HOWELLS ROAD (APPROXIMATE)
FUTURE CONDITIONS HYDROGRAPHS
AT SELECT LOCATIONS
2-YEAR

APPENDIX B – HYDROLOGIC
RESULTS– FUTURE
HYDROGRAPHS 2-YR J-14
KETTLE CREEK DBPS
JOB NO. 25100.00
MAY 2015
B-72



Centennial 303-740-9393 • Colorado Springs 719-593-2593
Fort Collins 970-491-9888 • www.jrengineering.com

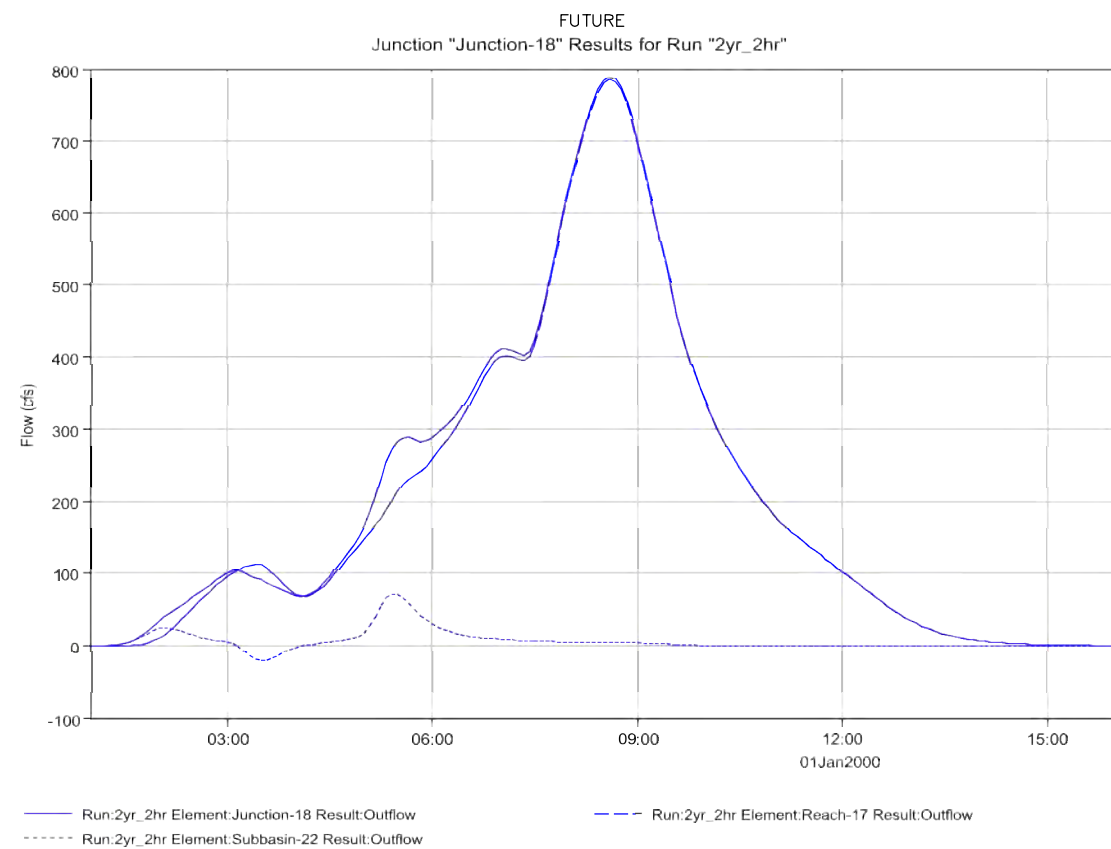

2-YR
2-HR

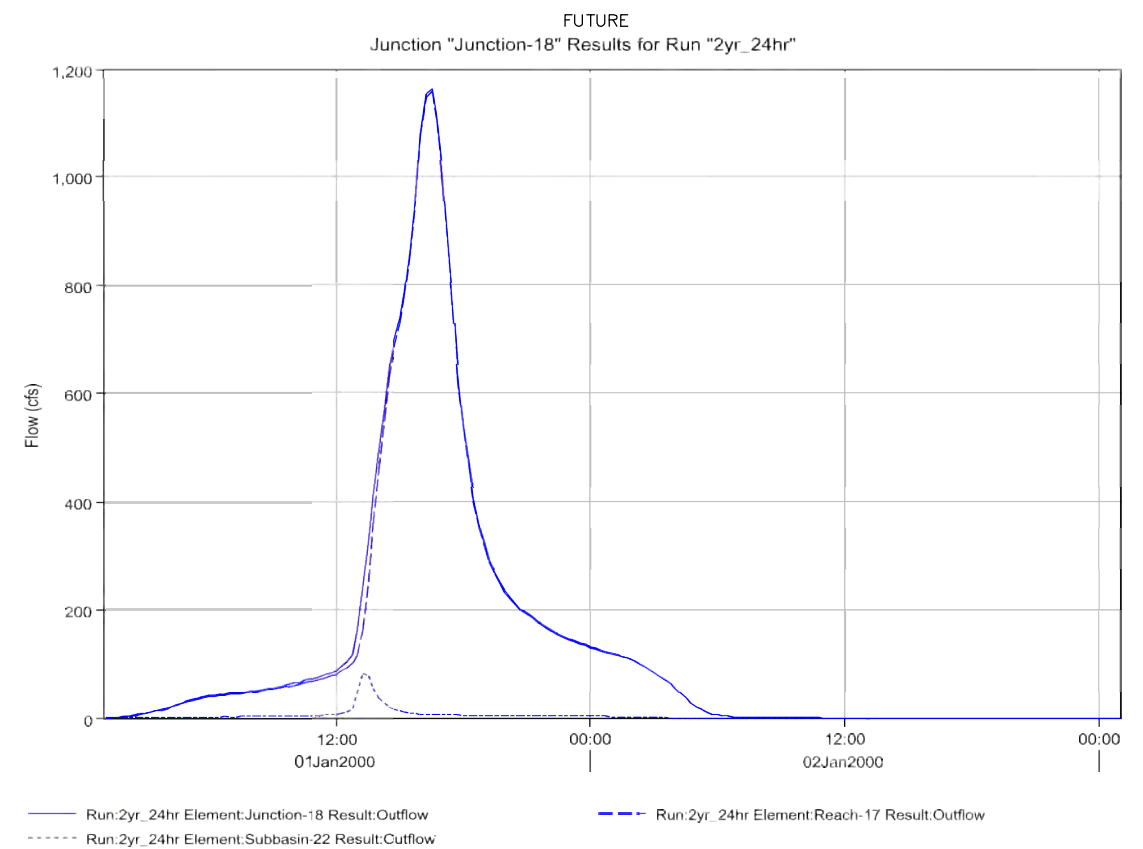

2-YR
24-HR

JUNCTION 18
POWERS BLVD BRIDGE
FUTURE CONDITIONS HYDROGRAPHS
AT SELECT LOCATIONS
2-YEAR

APPENDIX B – HYDROLOGIC
RESULTS– FUTURE
HYDROGRAPHS 2-YR J-18
KETTLE CREEK DBPS
JOB NO. 25100.00
MAY 2015
B-73



Centennial 303-740-9393 • Colorado Springs 719-593-2593
Fort Collins 970-491-9888 • www.jrengineering.com

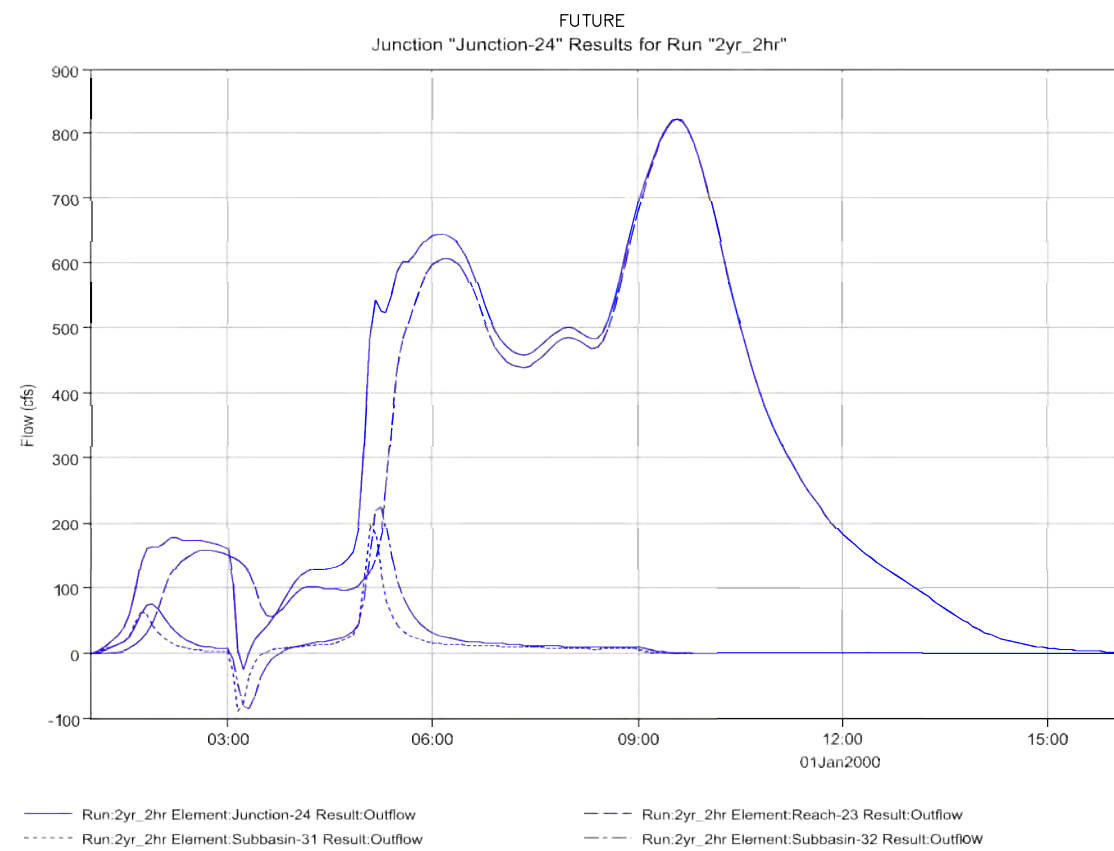

2-YR
2-HR

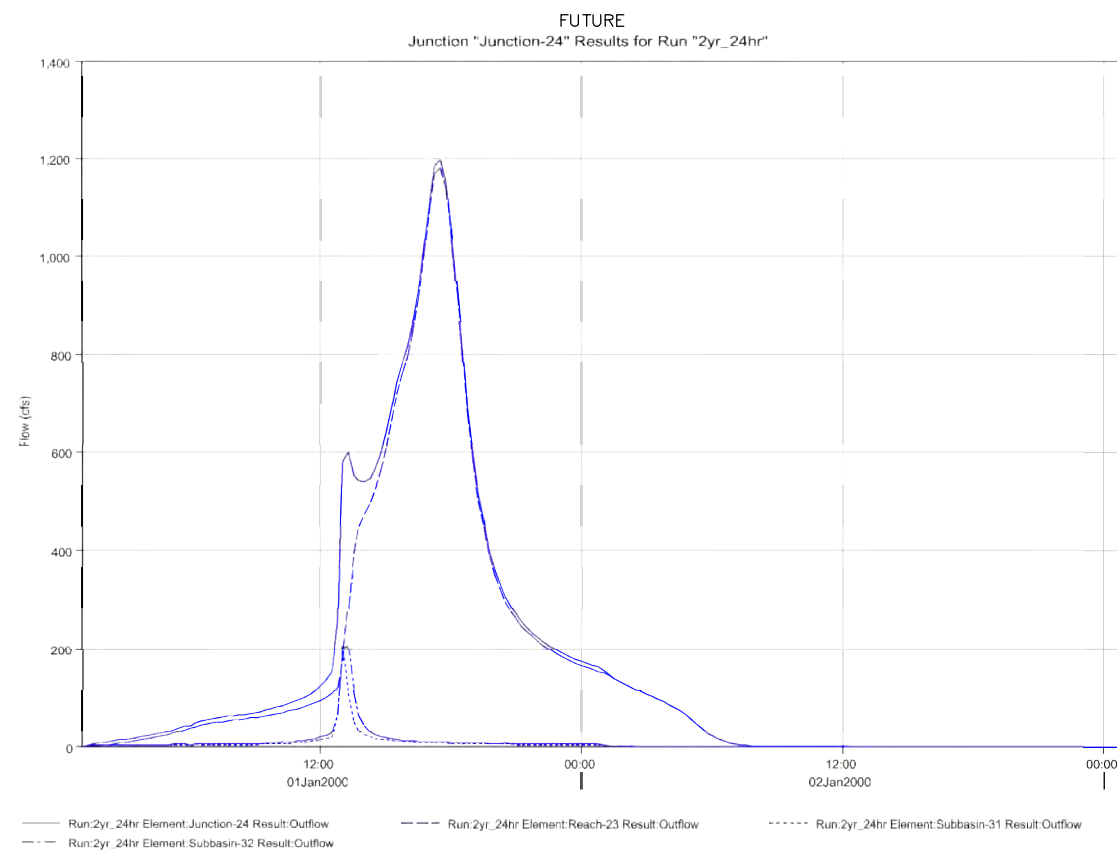

2-YR
24-HR

JUNCTION 18
POWERS BLVD BRIDGE
FUTURE CONDITIONS HYDROGRAPHS
AT SELECT LOCATIONS
2-YEAR

APPENDIX B – HYDROLOGIC
RESULTS– FUTURE
HYDROGRAPHS 2-YR J-24
KETTLE CREEK DBPS
JOB NO. 25100.00
MAY 2015
B-74



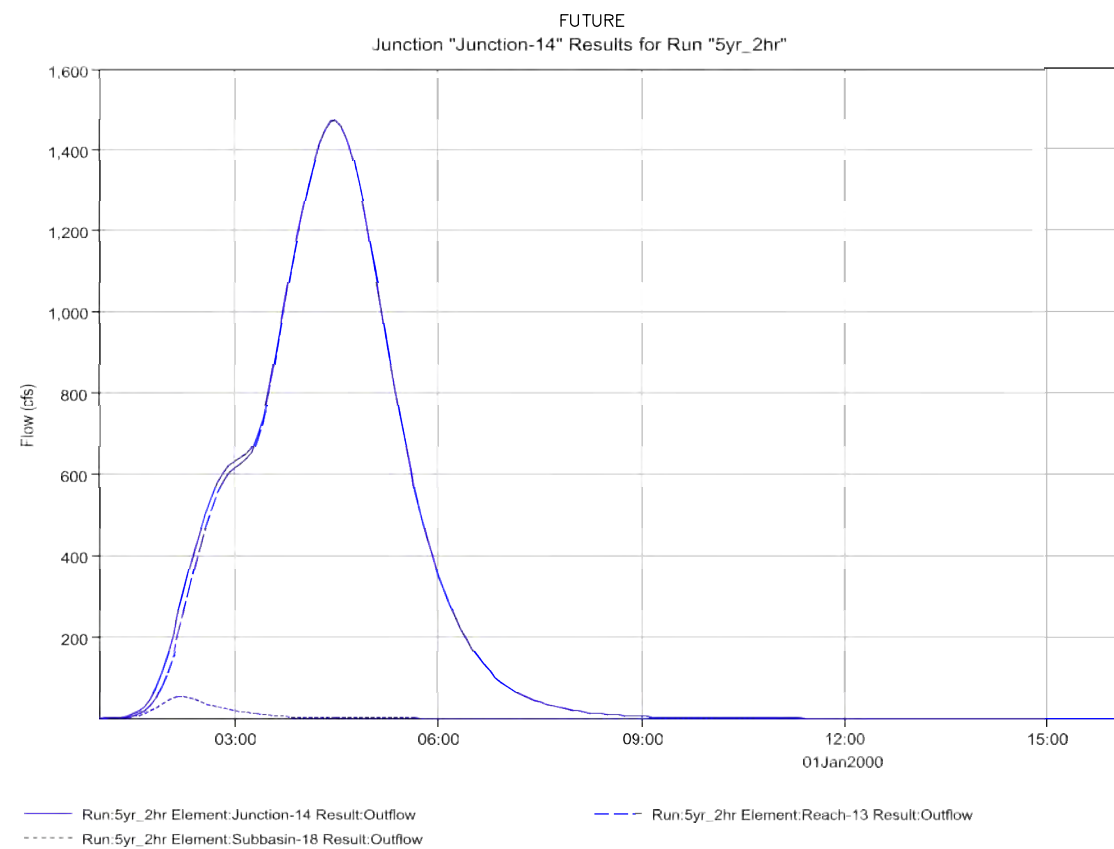

5-YR
2-HR

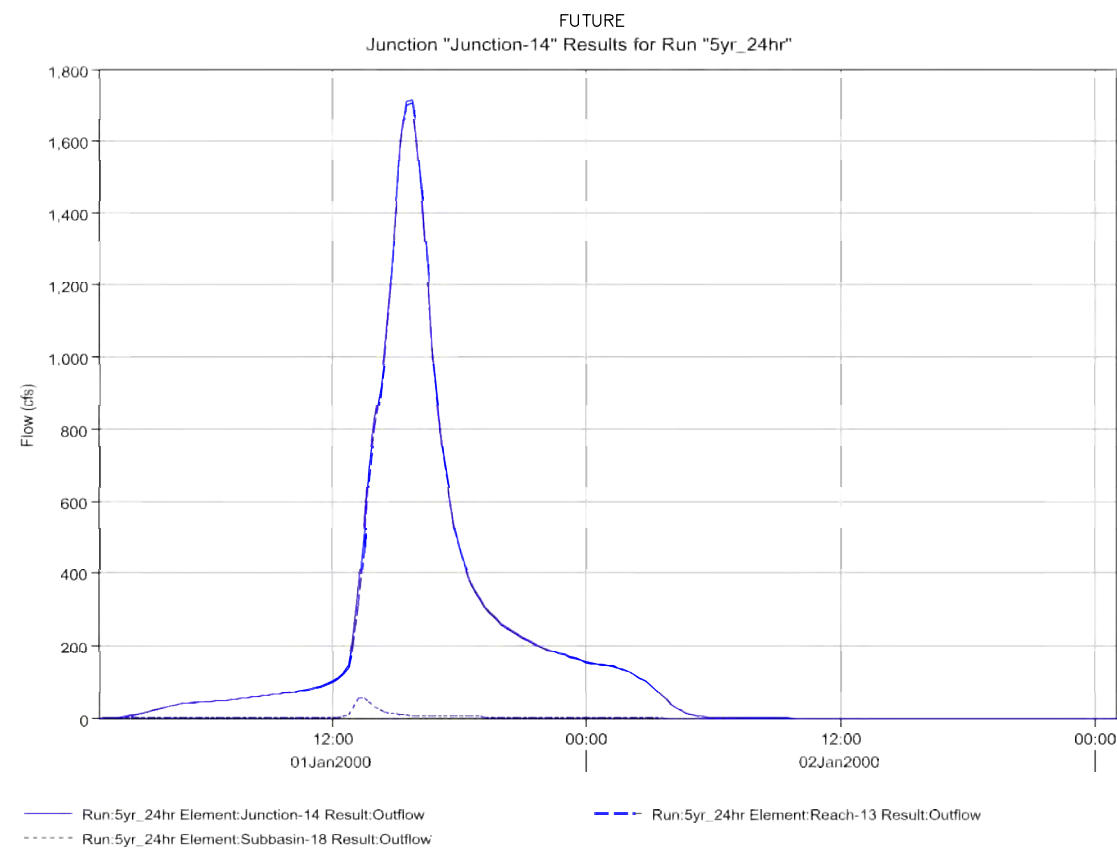

5-YR
24-HR

JUNCTION 14
HOWELLS ROAD (APPROXIMATE)
FUTURE CONDITIONS HYDROGRAPHS
AT SELECT LOCATIONS
5-YEAR

APPENDIX B – HYDROLOGIC
RESULTS– FUTURE
HYDROGRAPHS 5-YR J-14
KETTLE CREEK DBPS
JOB NO. 25100.00
MAY 2015
B-75



Centennial 303-740-9393 • Colorado Springs 719-593-2593
Fort Collins 970-491-9888 • www.jrengineering.com

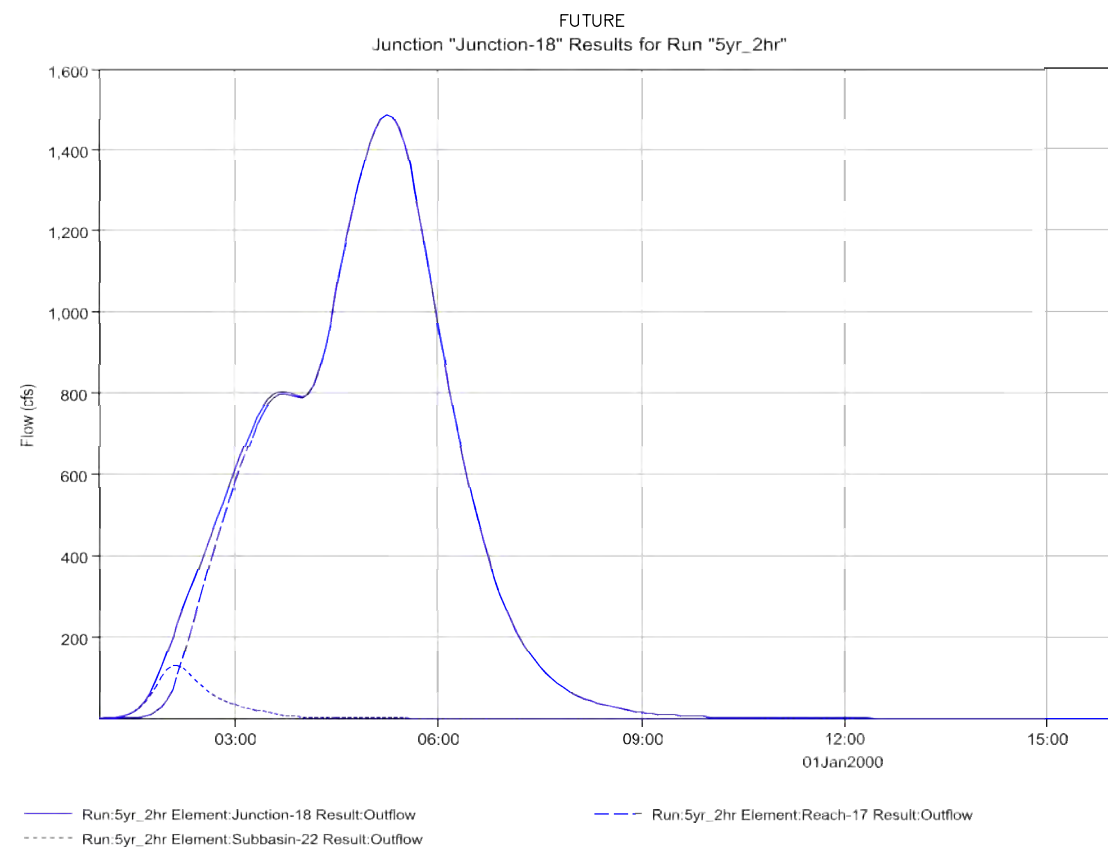

5-YR
2-HR

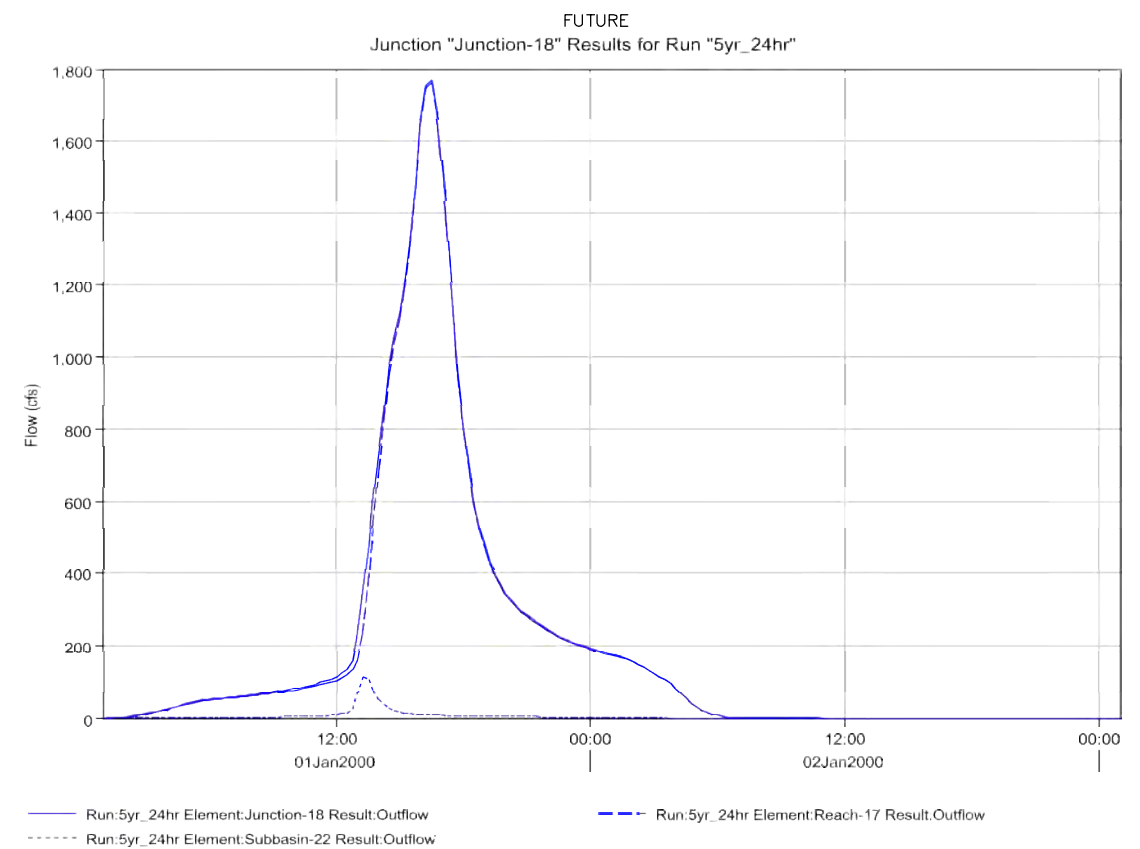

5-YR
24-HR

JUNCTION 18
POWERS BLVD BRIDGE
FUTURE CONDITIONS HYDROGRAPHS
AT SELECT LOCATIONS
5-YEAR

APPENDIX B – HYDROLOGIC
RESULTS– FUTURE
HYDROGRAPHS 5-YR J-18
KETTLE CREEK DBPS
JOB NO. 25100.00
MAY 2015
B-76



Centennial 303-740-9393 • Colorado Springs 719-593-2593
Fort Collins 970-491-9888 • www.jrengineering.com

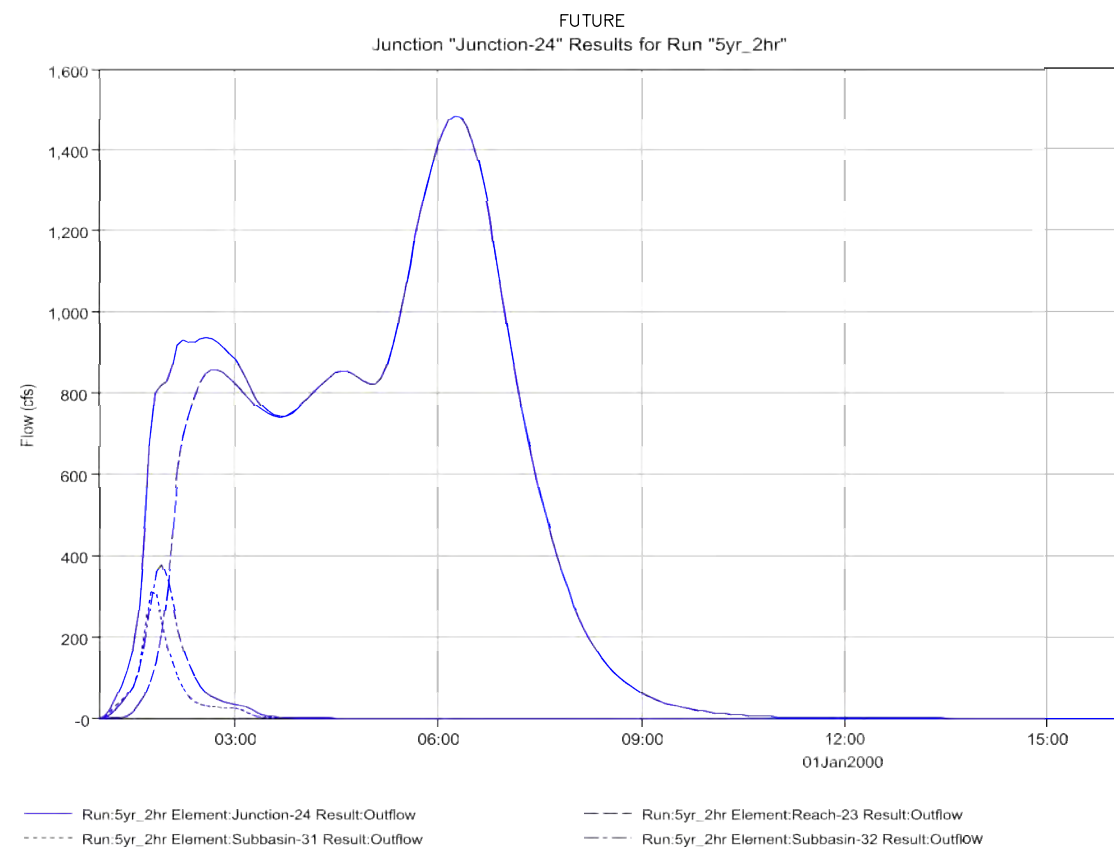

5-YR
2-HR

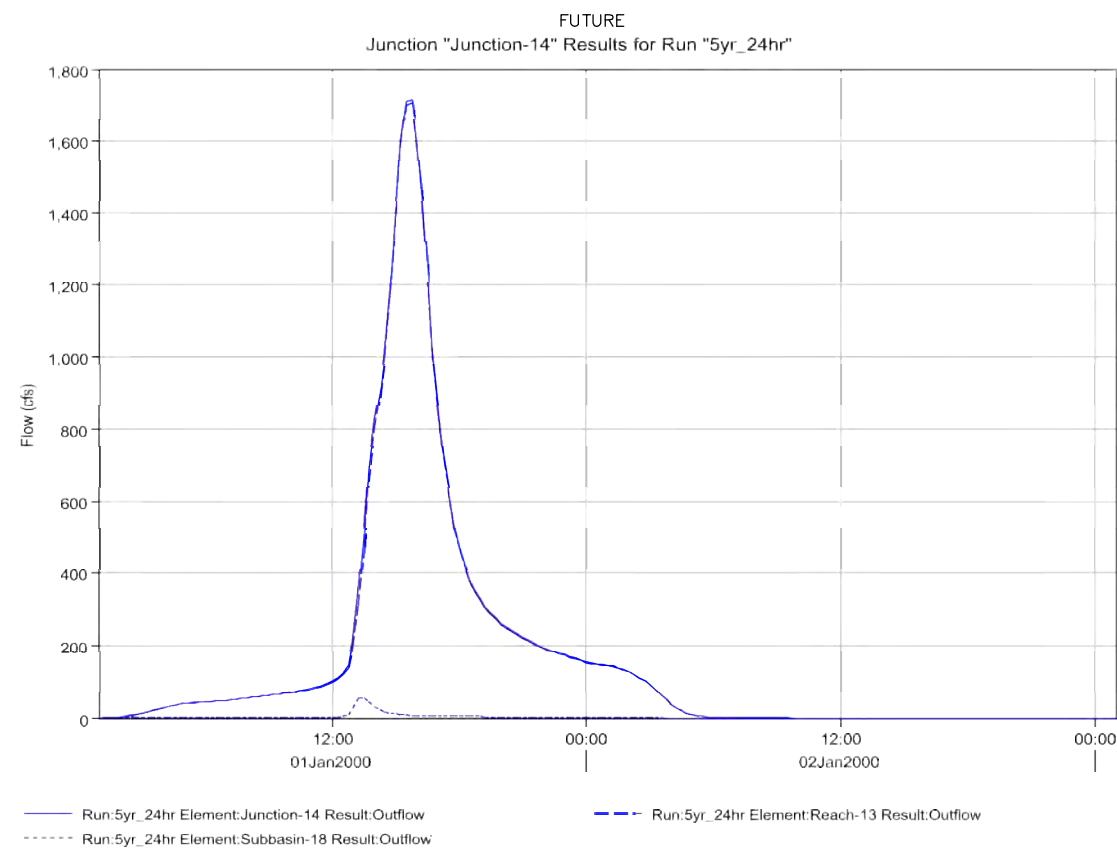

5-YR
24-HR

JUNCTION 24
HWY 83 BRIDGE
FUTURE CONDITIONS HYDROGRAPHS
AT SELECT LOCATIONS
5-YEAR

APPENDIX B – HYDROLOGIC
RESULTS– FUTURE
HYDROGRAPHS 5-YR J-24
KETTLE CREEK DBPS
JOB NO. 25100.00
MAY 2015
B-77



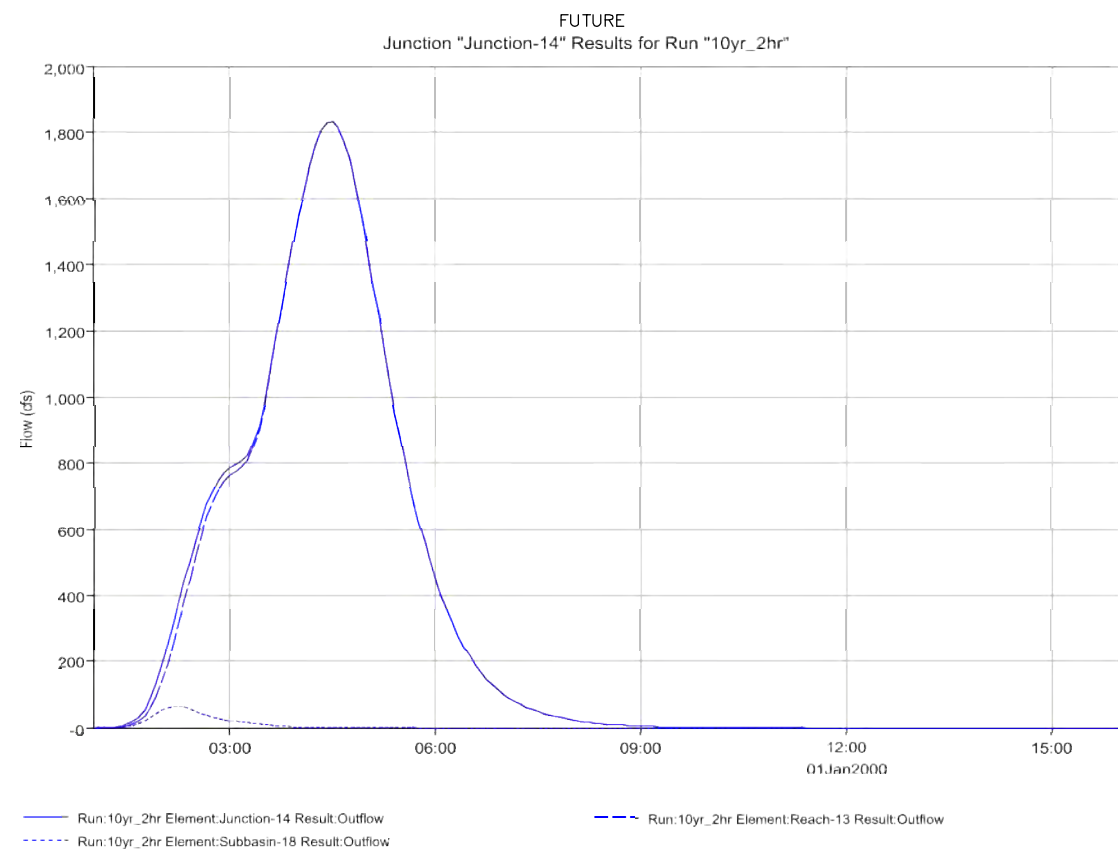

10-YR
2-HR

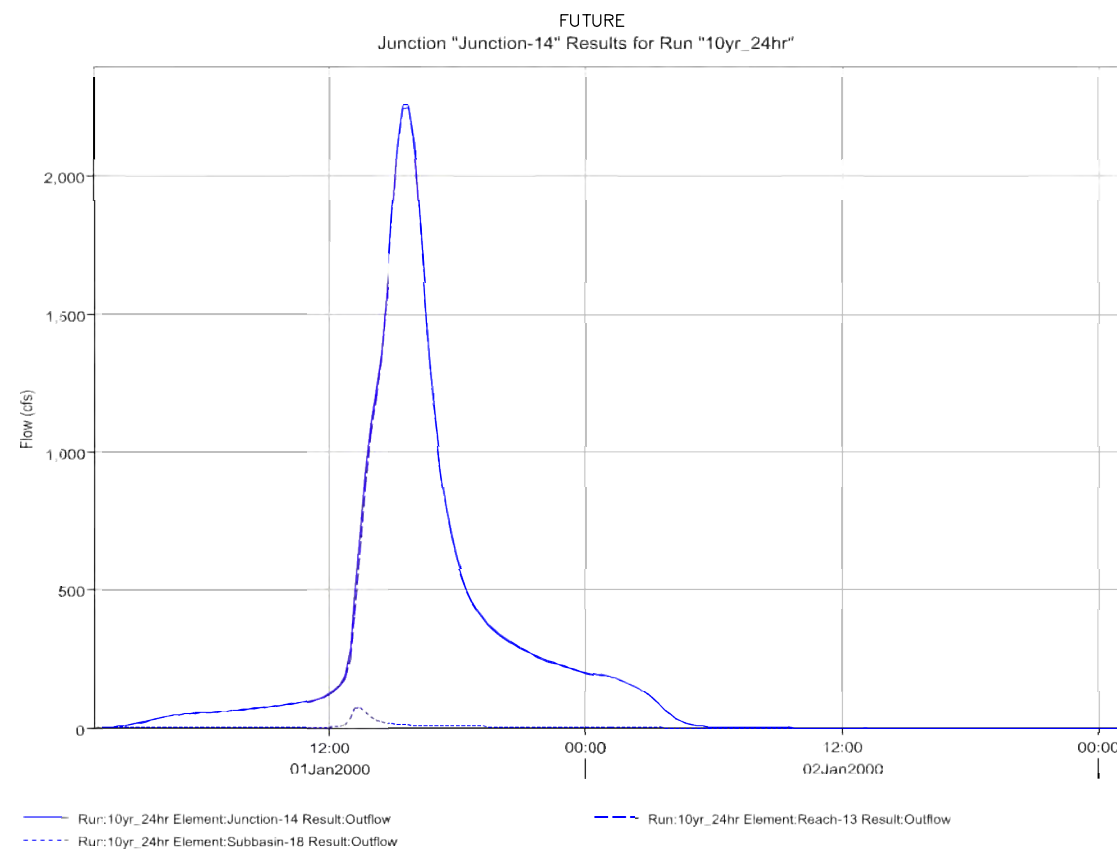

10-YR
24-HR

JUNCTION 14
HOWELLS ROAD (APPROXIMATE)
FUTURE CONDITIONS HYDROGRAPHS
AT SELECT LOCATIONS
10-YEAR

APPENDIX B – HYDROLOGIC
RESULTS– FUTURE
HYDROGRAPHS 10-YR J-14
KETTLE CREEK DBPS
JOB NO. 25100.00
MAY 2015
B-78



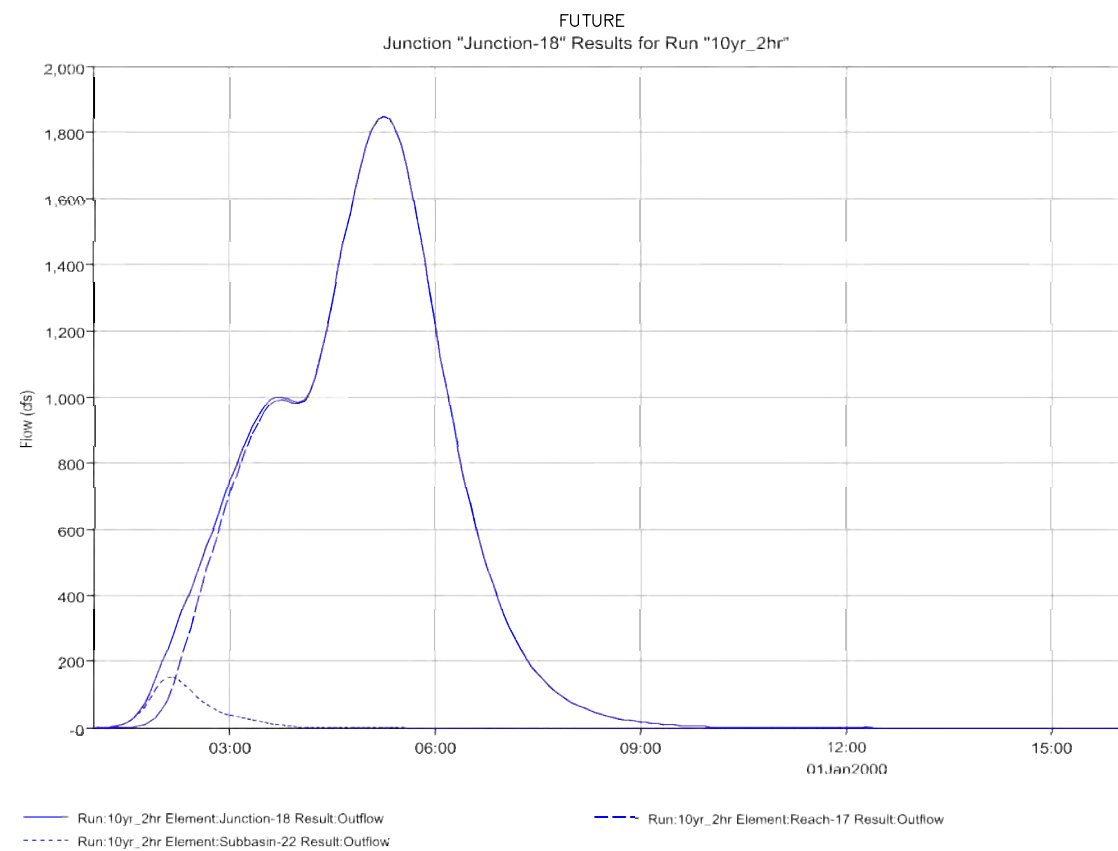

10-YR
2-HR

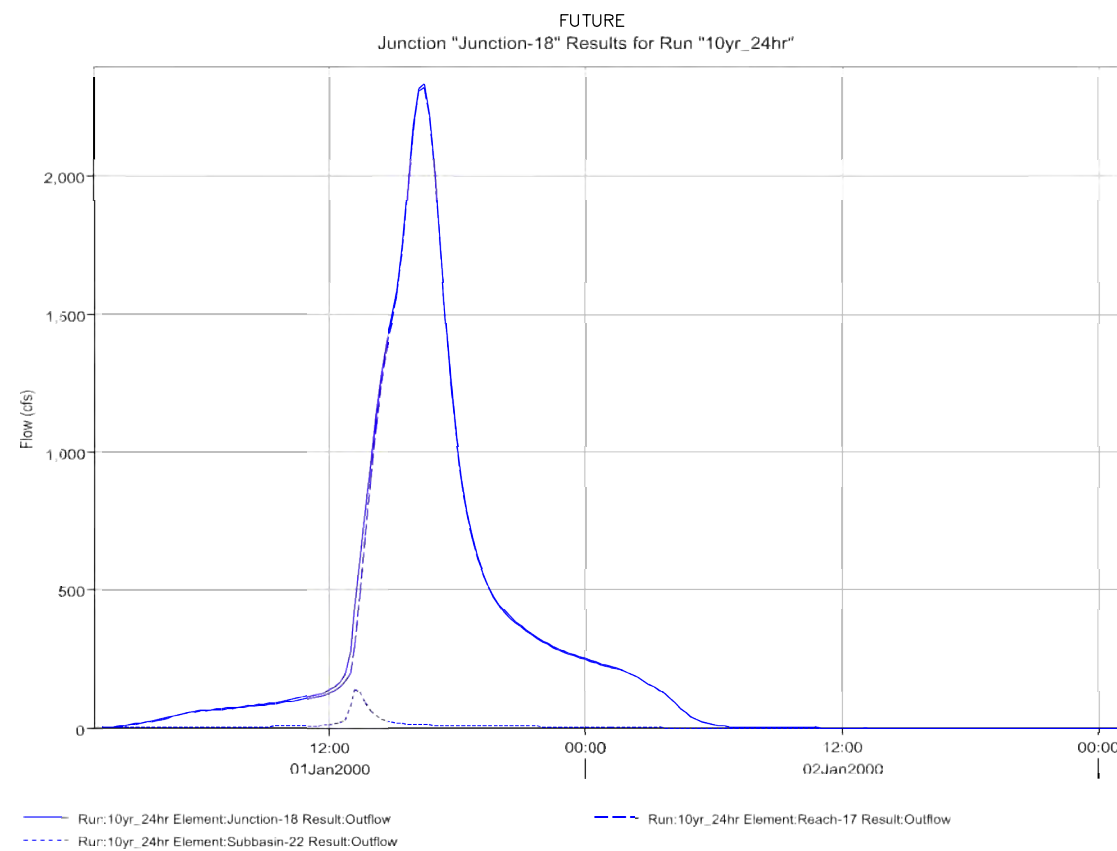

10-YR
24-HR

JUNCTION 18
POWERS BLVD BRIDGE
FUTURE CONDITIONS HYDROGRAPHS
AT SELECT LOCATIONS
10-YEAR

APPENDIX B – HYDROLOGIC
RESULTS– FUTURE
HYDROGRAPHS 10-YR J-18
KETTLE CREEK DBPS
JOB NO. 25100.00
MAY 2015
B-79



Centennial 303-740-9393 • Colorado Springs 719-593-2593
Fort Collins 970-491-9888 • www.jrengineering.com

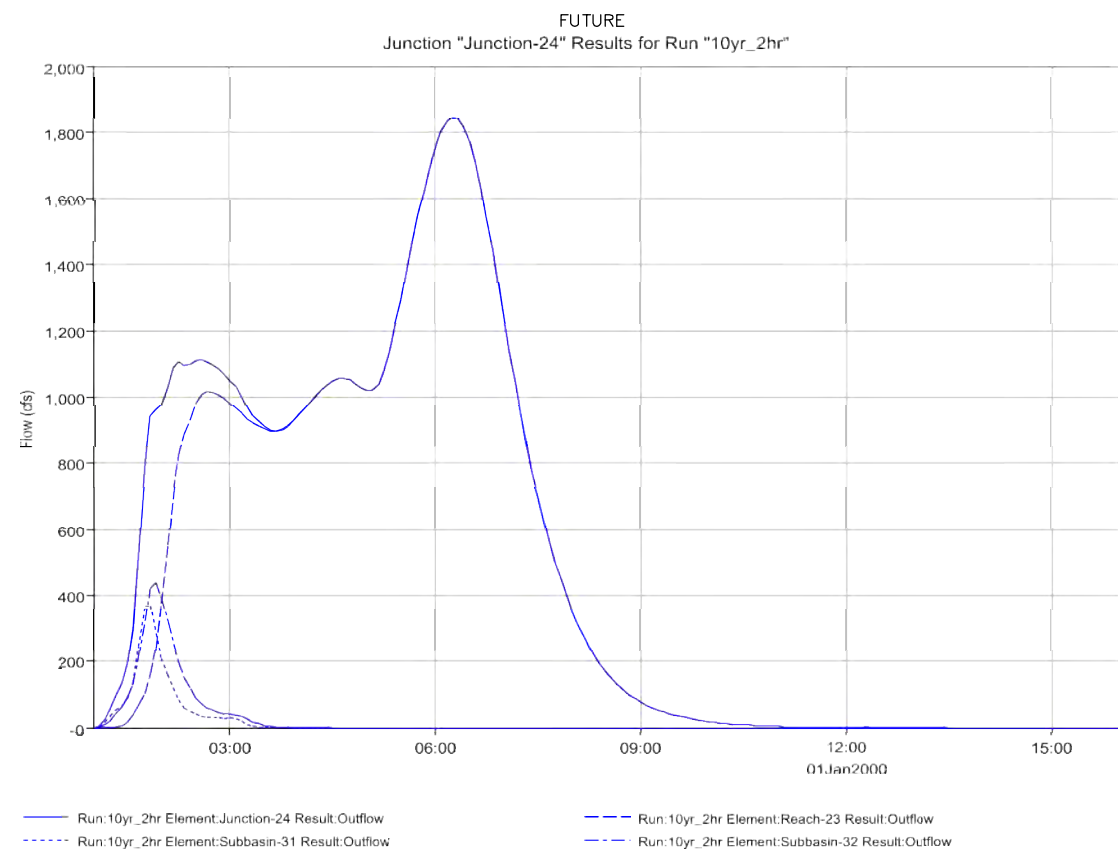

10-YR
2-HR

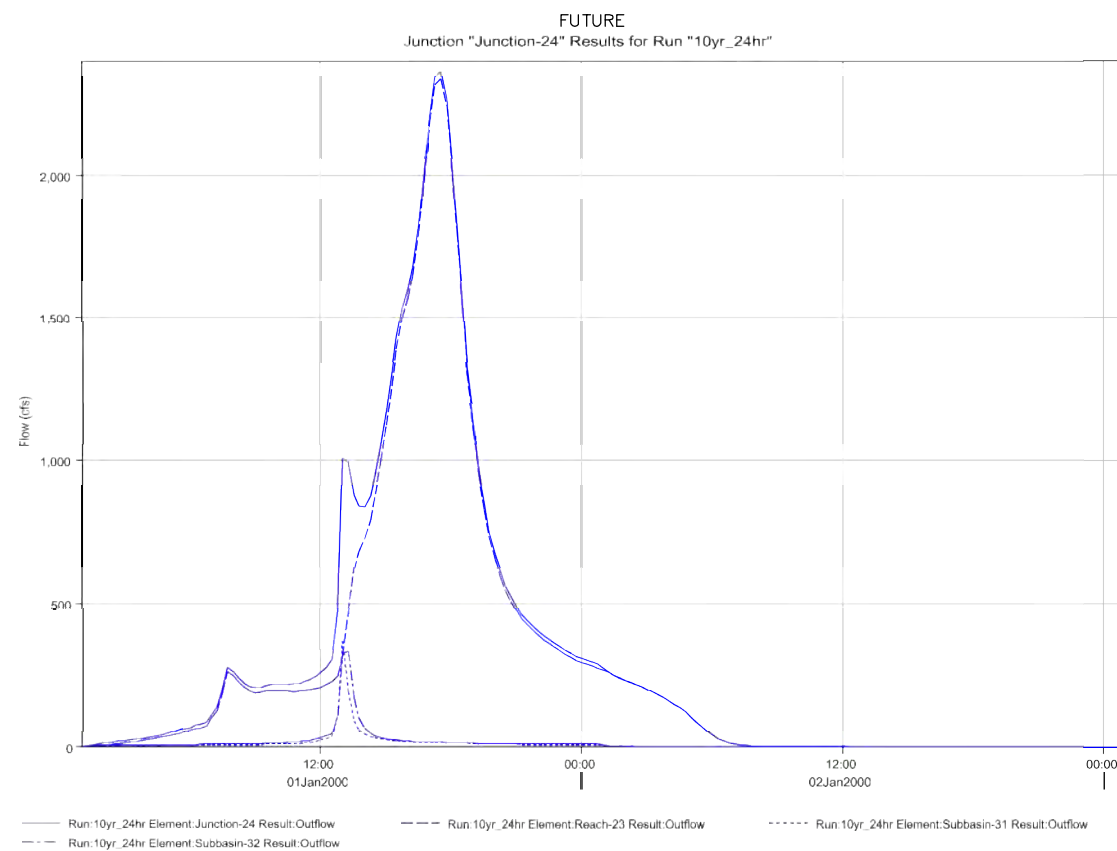

10-YR
24-HR

JUNCTION 24
HWY 83 BRIDGE
FUTURE CONDITIONS HYDROGRAPHS
AT SELECT LOCATIONS
10-YEAR

APPENDIX B – HYDROLOGIC
RESULTS– FUTURE
HYDROGRAPHS 10-YR J-24
KETTLE CREEK DBPS
JOB NO. 25100.00
MAY 2015
B-80



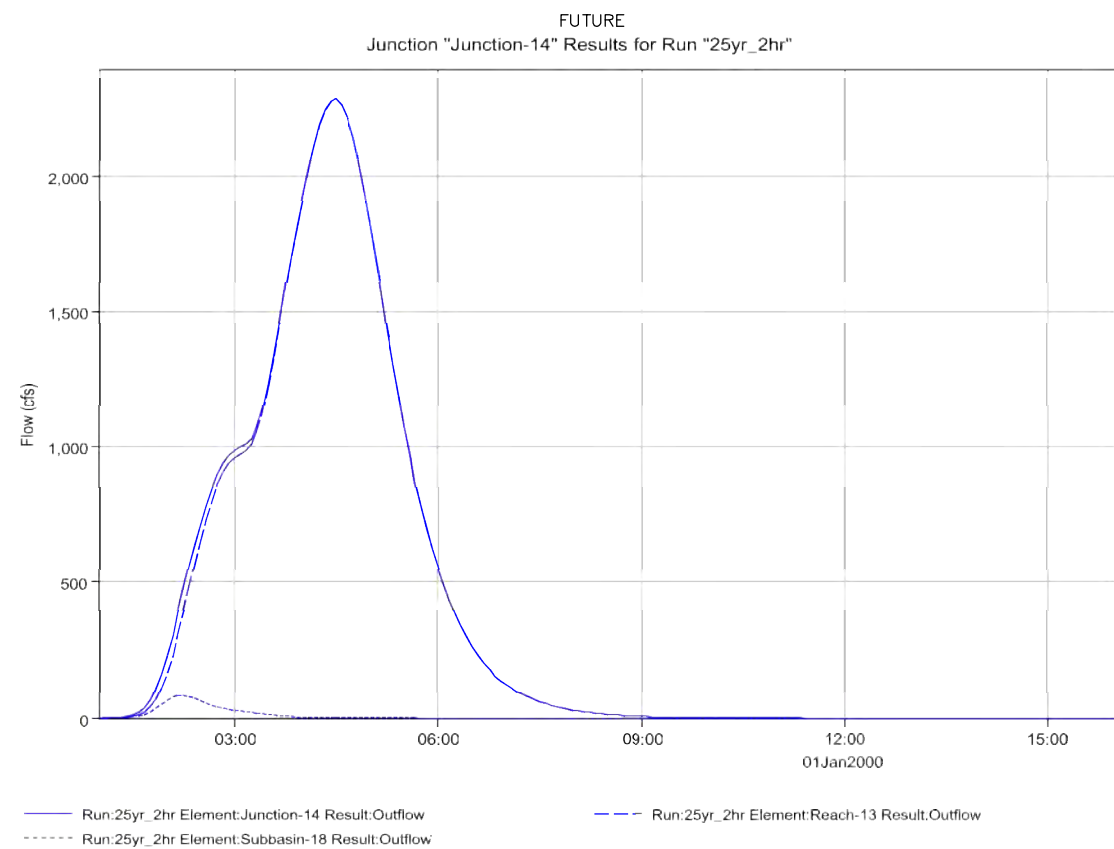

25-YR
2-HR

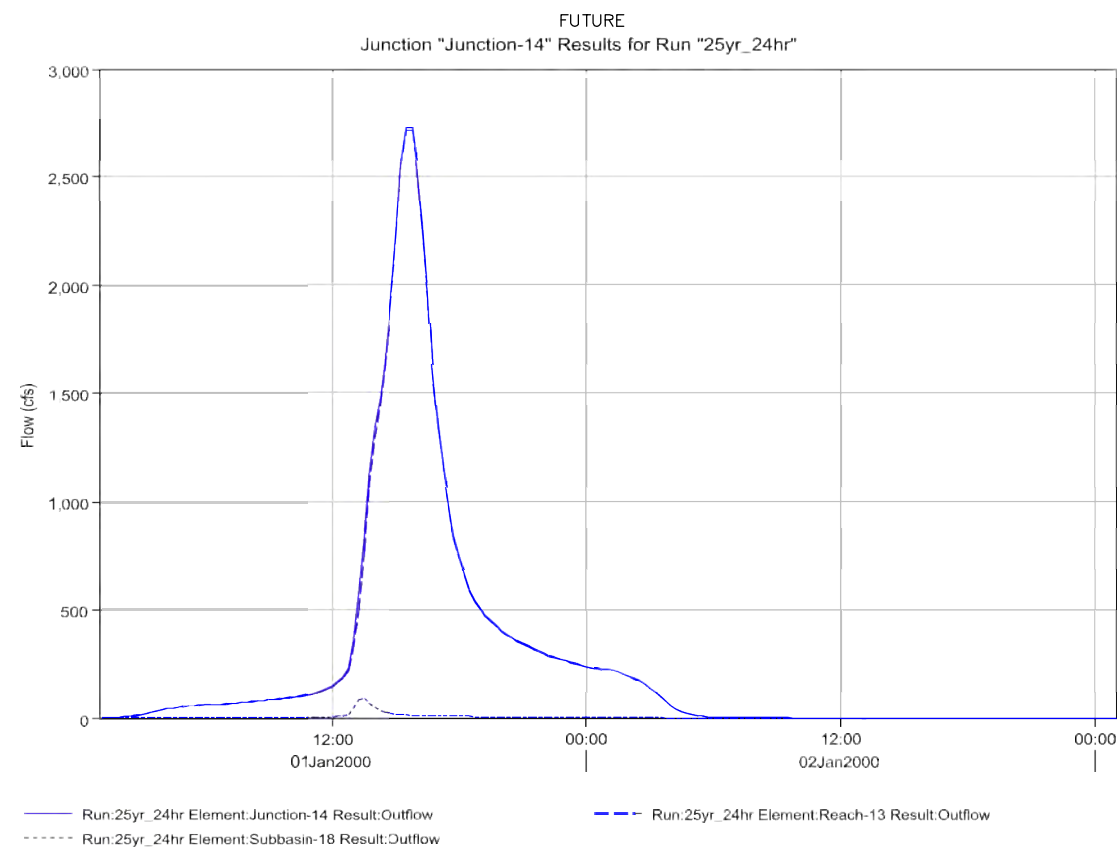

25-YR
24-HR

JUNCTION 14
HOWELLS ROAD (APPROXIMATE)
FUTURE CONDITIONS HYDROGRAPHS
AT SELECT LOCATIONS
25-YEAR

APPENDIX B – HYDROLOGIC
RESULTS– FUTURE
HYDROGRAPHS 25-YR J-14
KETTLE CREEK DBPS
JOB NO. 25100.00
MAY 2015
B-81



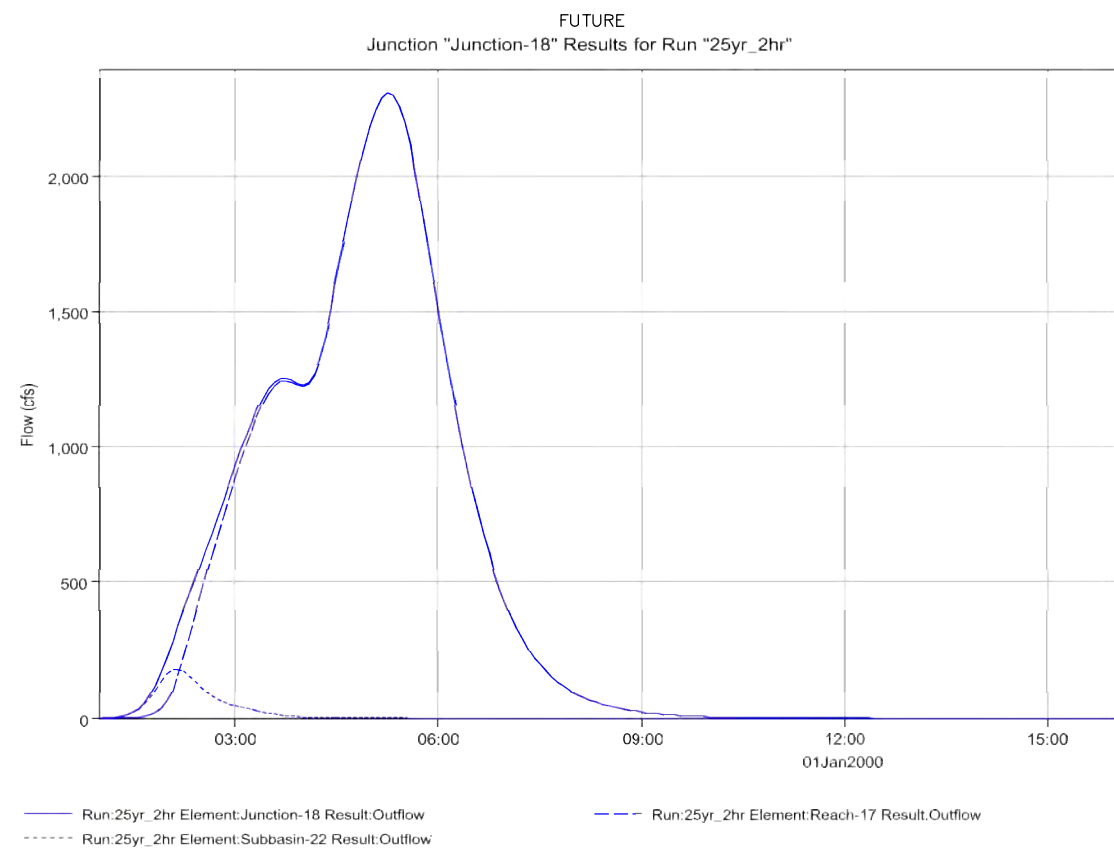

25-YR
2-HR

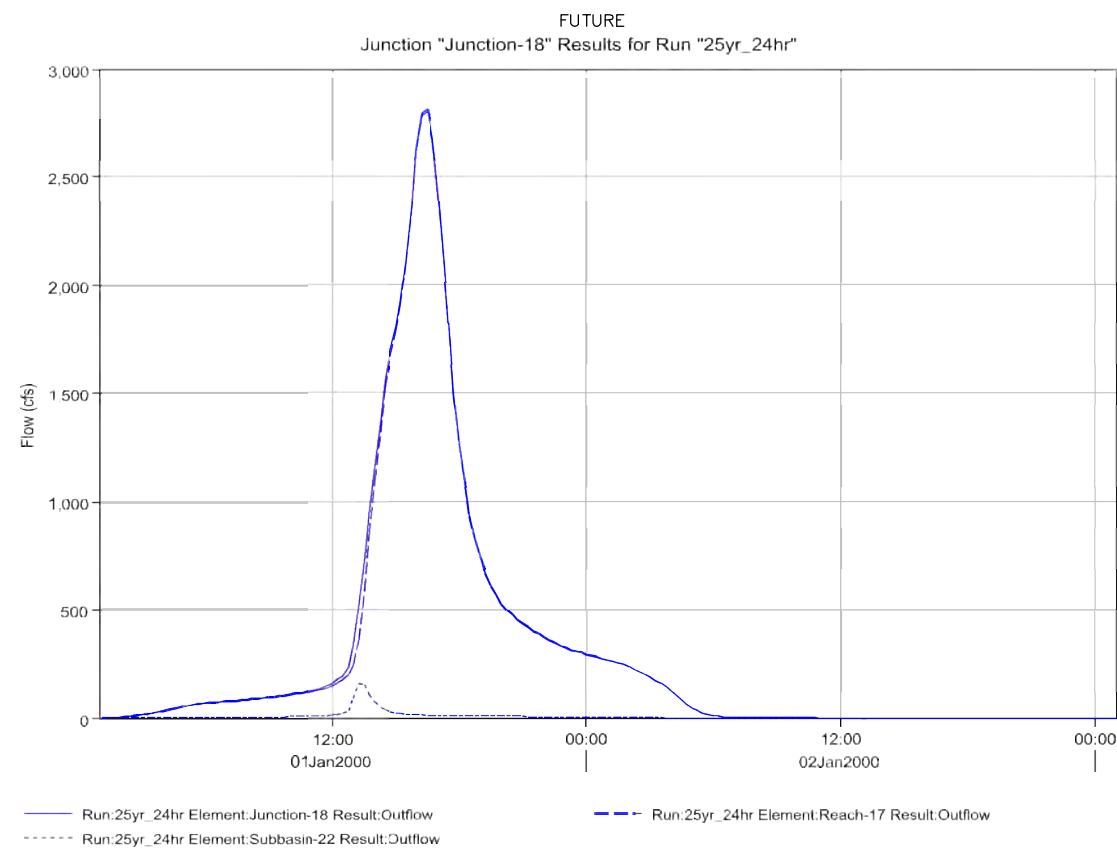

25-YR
24-HR

JUNCTION 18
POWERS BLVD BRIDGE
FUTURE CONDITIONS HYDROGRAPHS
AT SELECT LOCATIONS
25-YEAR

APPENDIX B – HYDROLOGIC
RESULTS– FUTURE
HYDROGRAPHS 25-YR J-18
KETTLE CREEK DBPS
JOB NO. 25100.00
MAY 2015
B-82



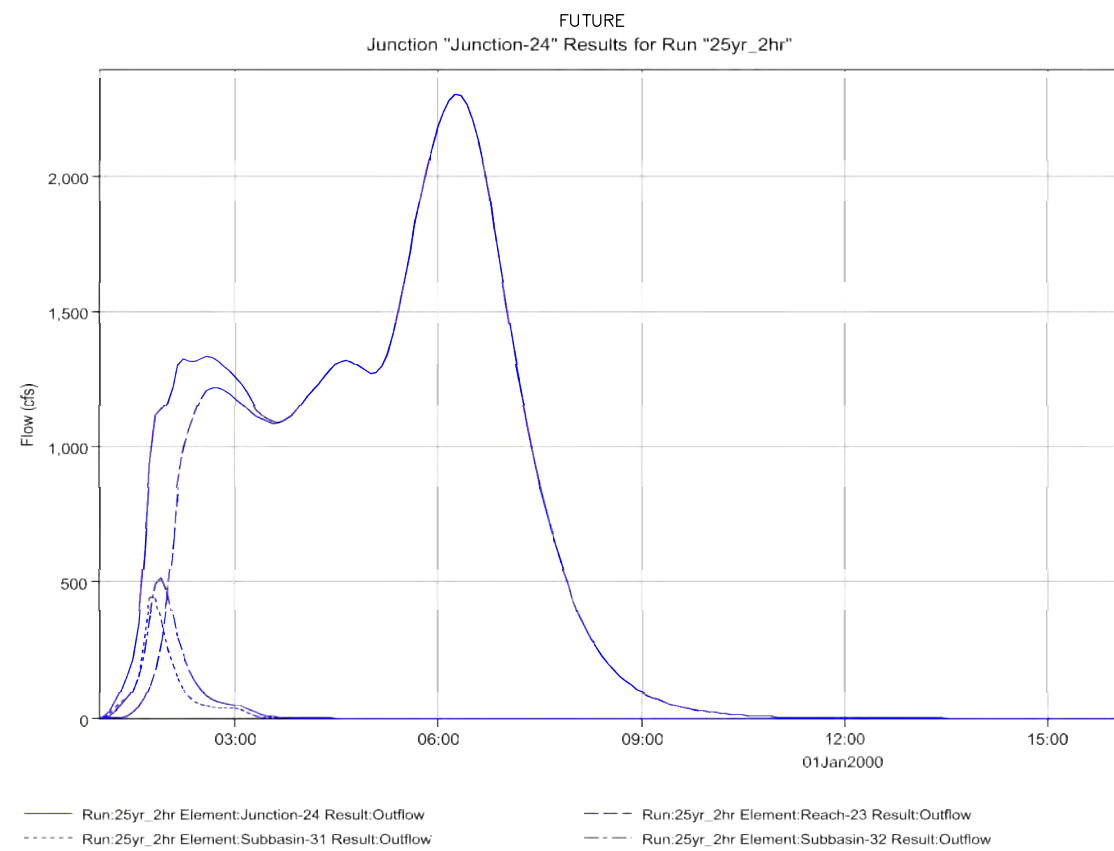

25-YR
2-HR

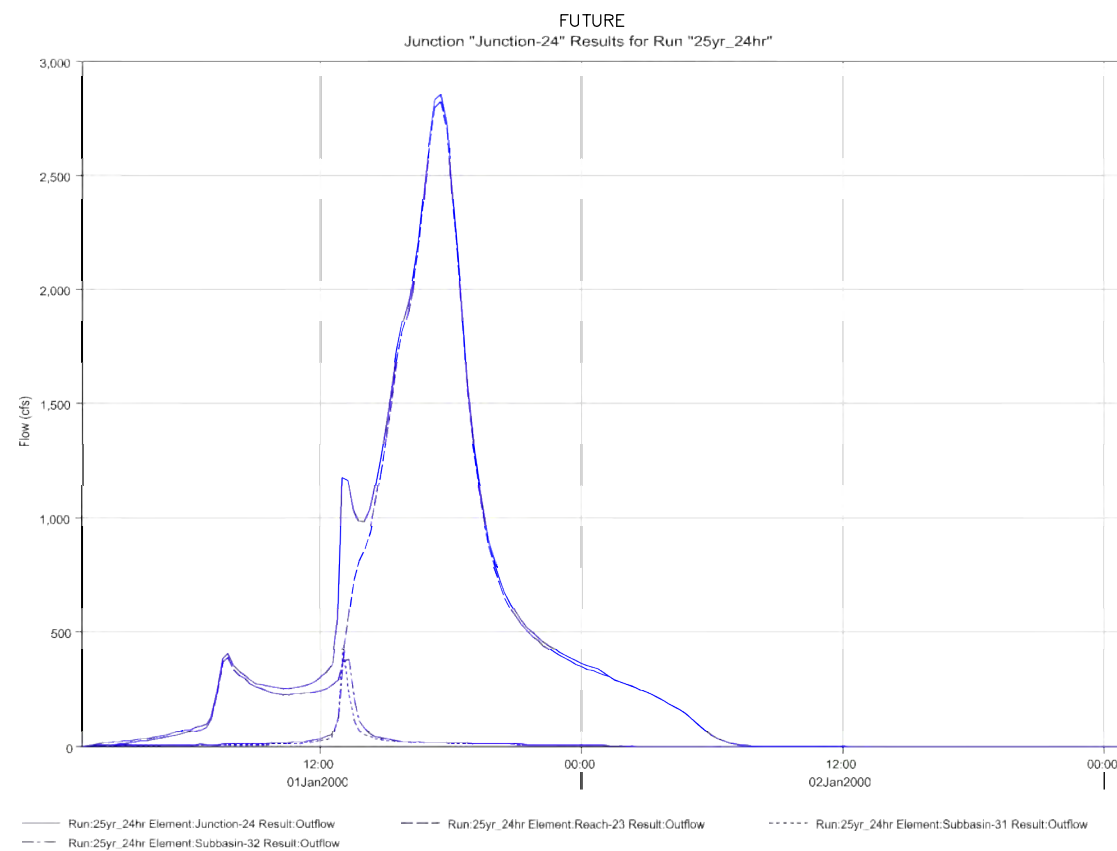

25-YR
24-HR

JUNCTION 24
HWY 83 BRIDGE
FUTURE CONDITIONS HYDROGRAPHS
AT SELECT LOCATIONS
25-YEAR

APPENDIX B – HYDROLOGIC
RESULTS– FUTURE
HYDROGRAPHS 25-YR J-24
KETTLE CREEK DBPS
JOB NO. 25100.00
MAY 2015
B-83



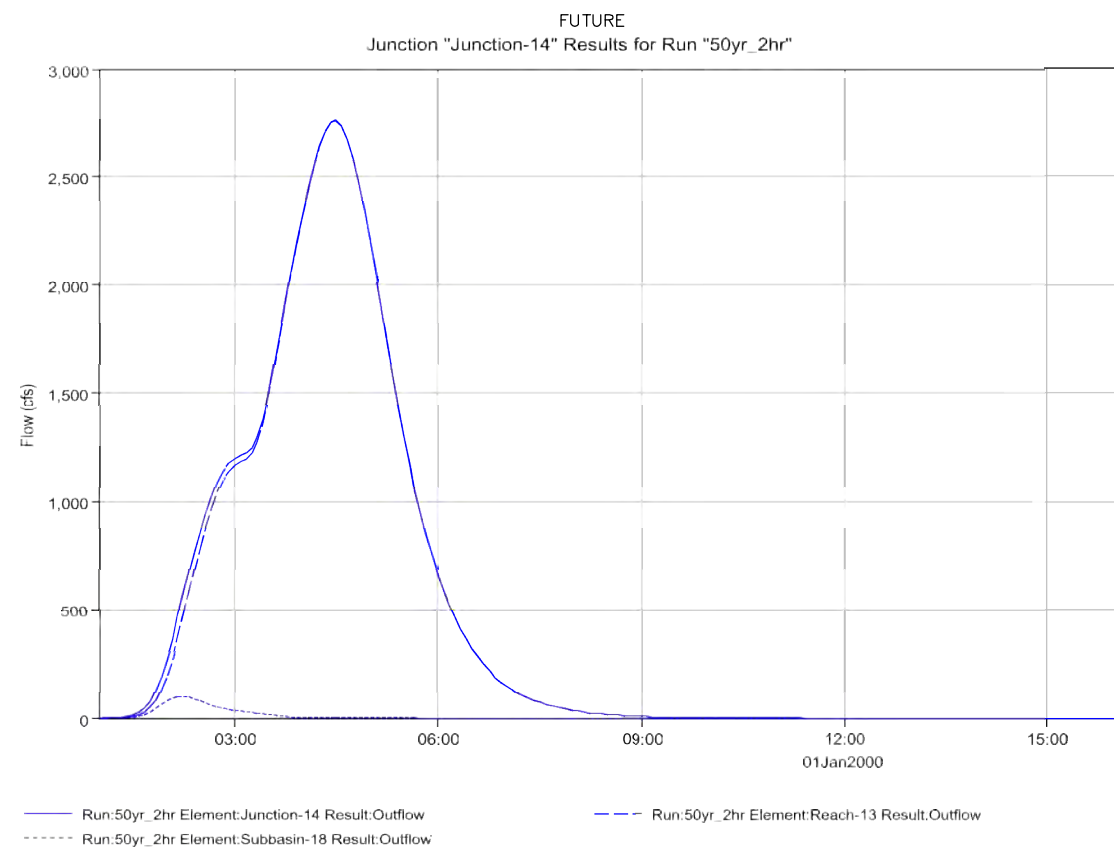

50-YR
2-HR

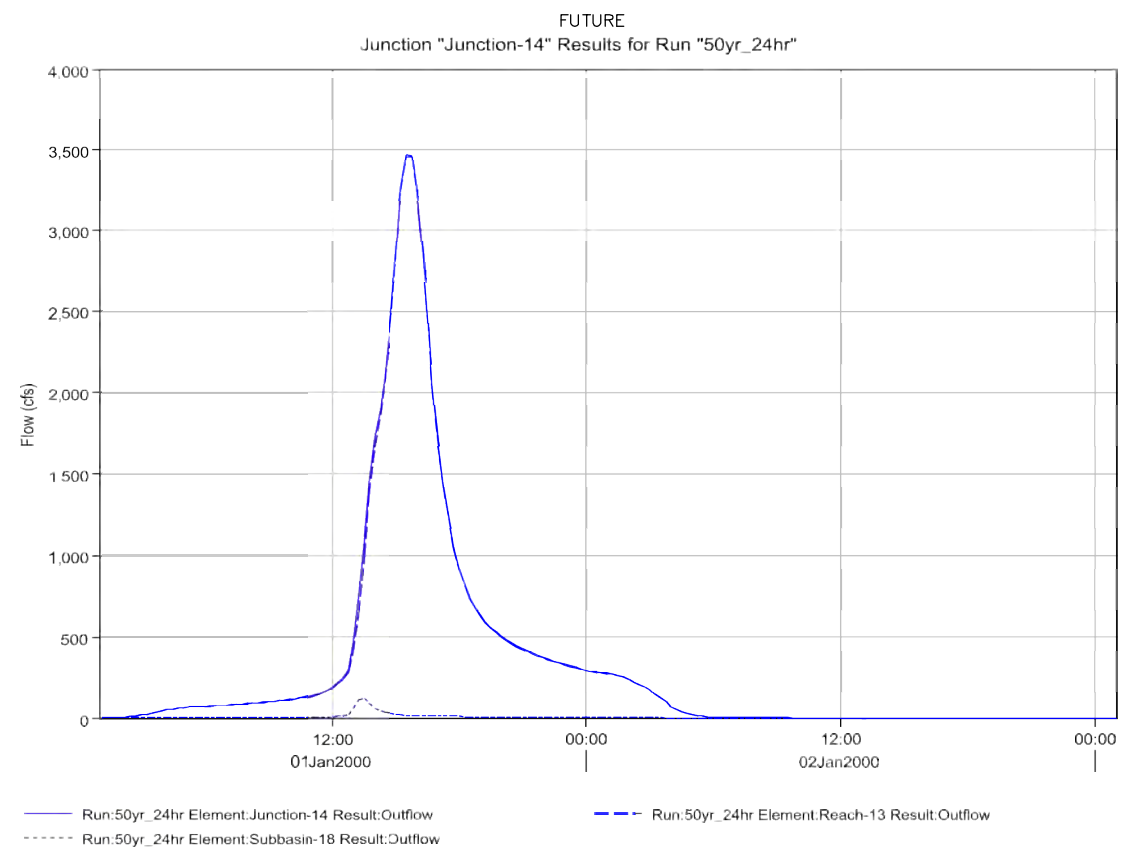

50-YR
24-HR

JUNCTION 14
HOWELLS ROAD (APPROXIMATE)
FUTURE CONDITIONS HYDROGRAPHS
AT SELECT LOCATIONS
50-YEAR

APPENDIX B – HYDROLOGIC
RESULTS– FUTURE
HYDROGRAPHS 50-YR J-14
KETTLE CREEK DBPS
JOB NO. 25100.00
MAY 2015
B-84



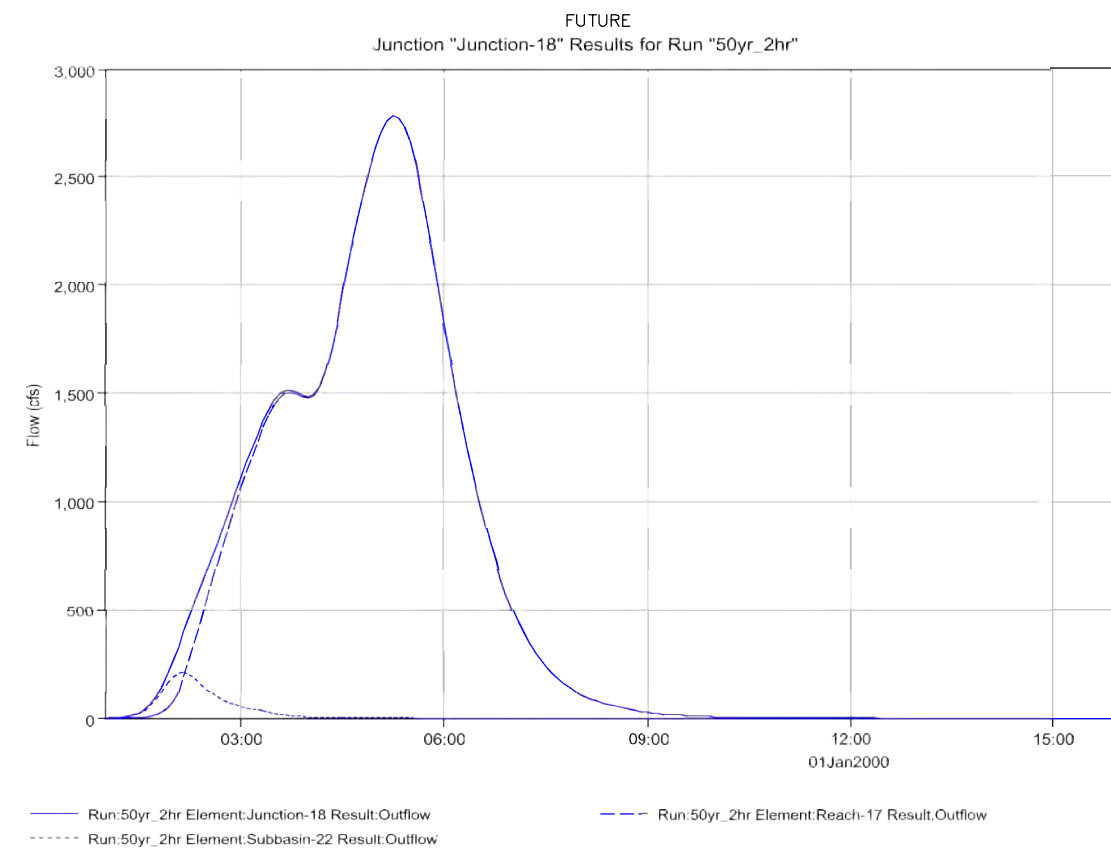

50-YR
2-HR

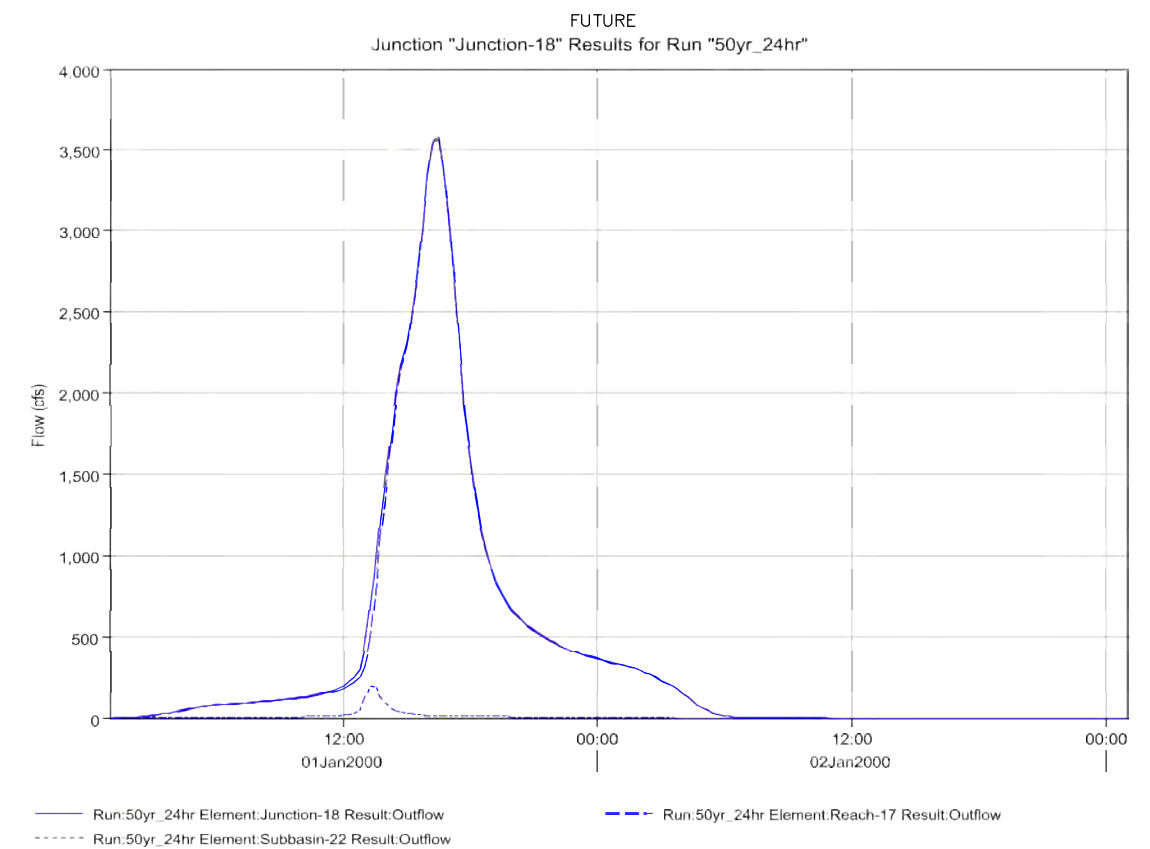

50-YR
24-HR

JUNCTION 18
POWERS BLVD BRIDGE
FUTURE CONDITIONS HYDROGRAPHS
AT SELECT LOCATIONS
50-YEAR

APPENDIX B – HYDROLOGIC
RESULTS– FUTURE
HYDROGRAPHS 50-YR J-18
KETTLE CREEK DBPS
JOB NO. 25100.00
MAY 2015
B-85



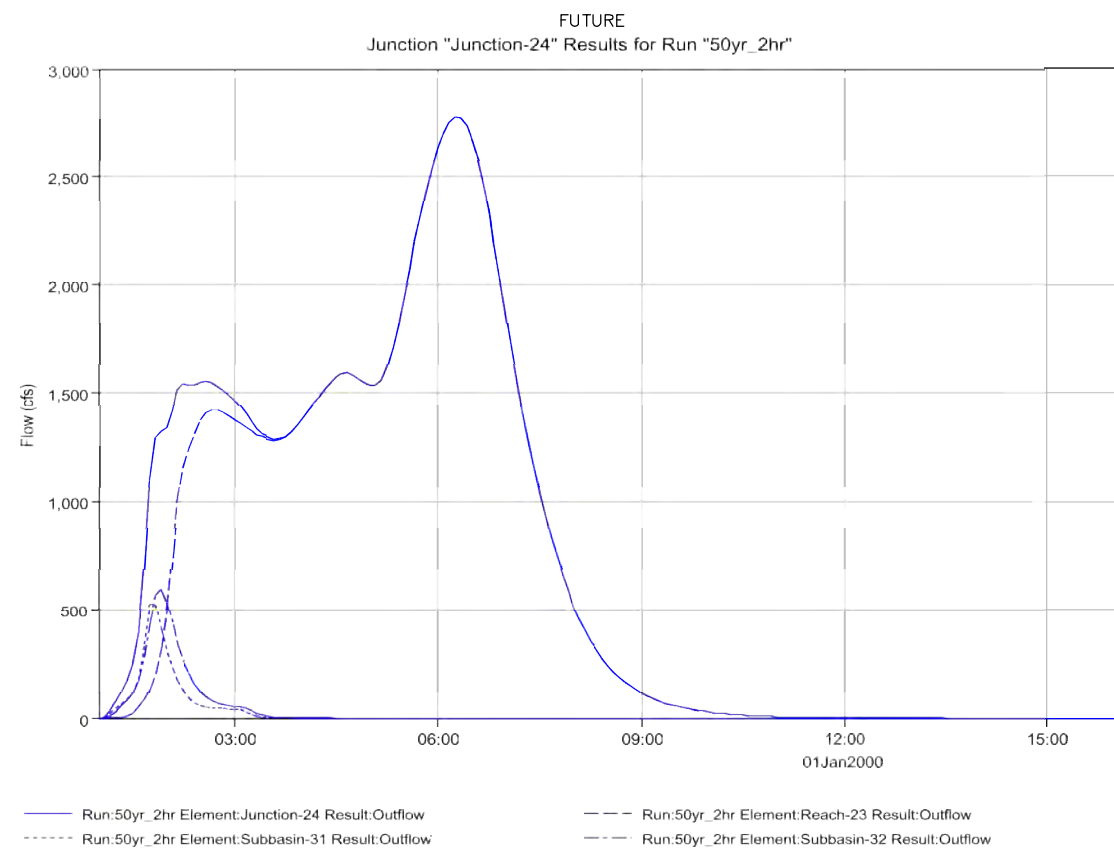

50-YR
2-HR

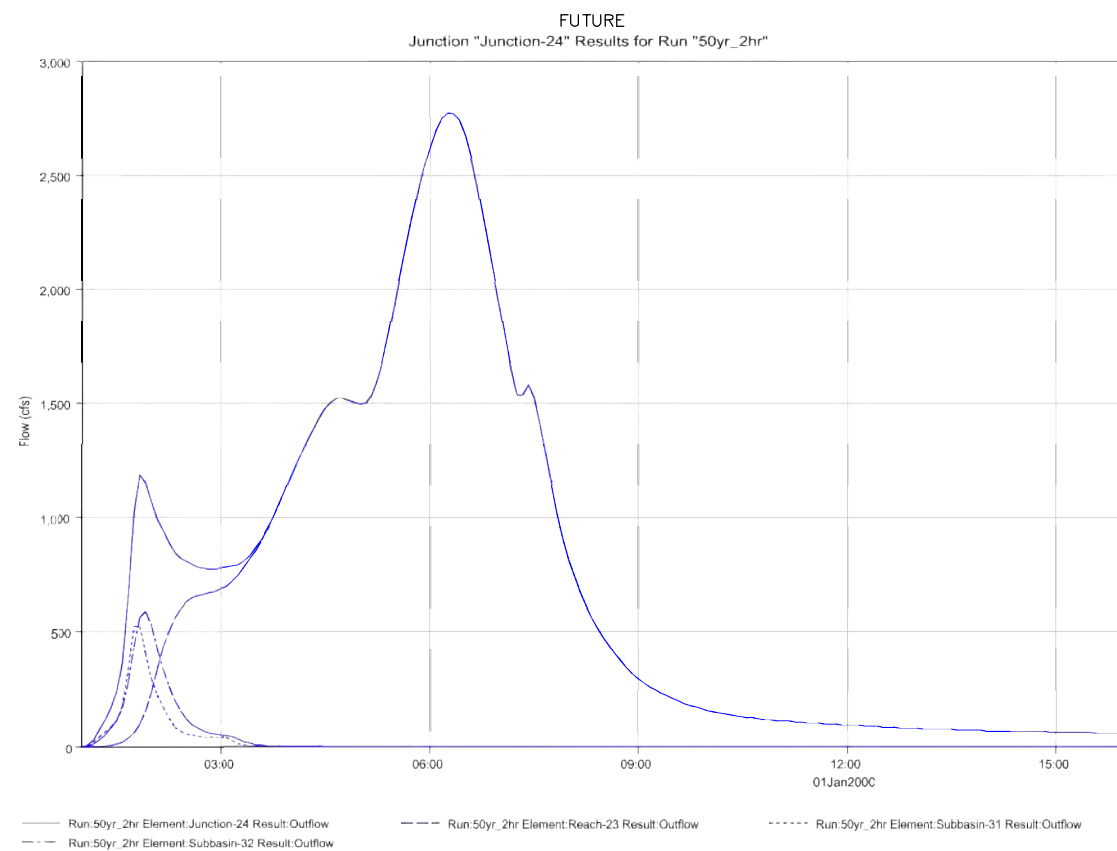

50-YR
24-HR

JUNCTION 24
HWY 83 BRIDGE
FUTURE CONDITIONS HYDROGRAPHS
AT SELECT LOCATIONS
50-YEAR

APPENDIX B – HYDROLOGIC
RESULTS– FUTURE
HYDROGRAPHS 50-YR J-24
KETTLE CREEK DBPS
JOB NO. 25100.00
MAY 2015
B-86



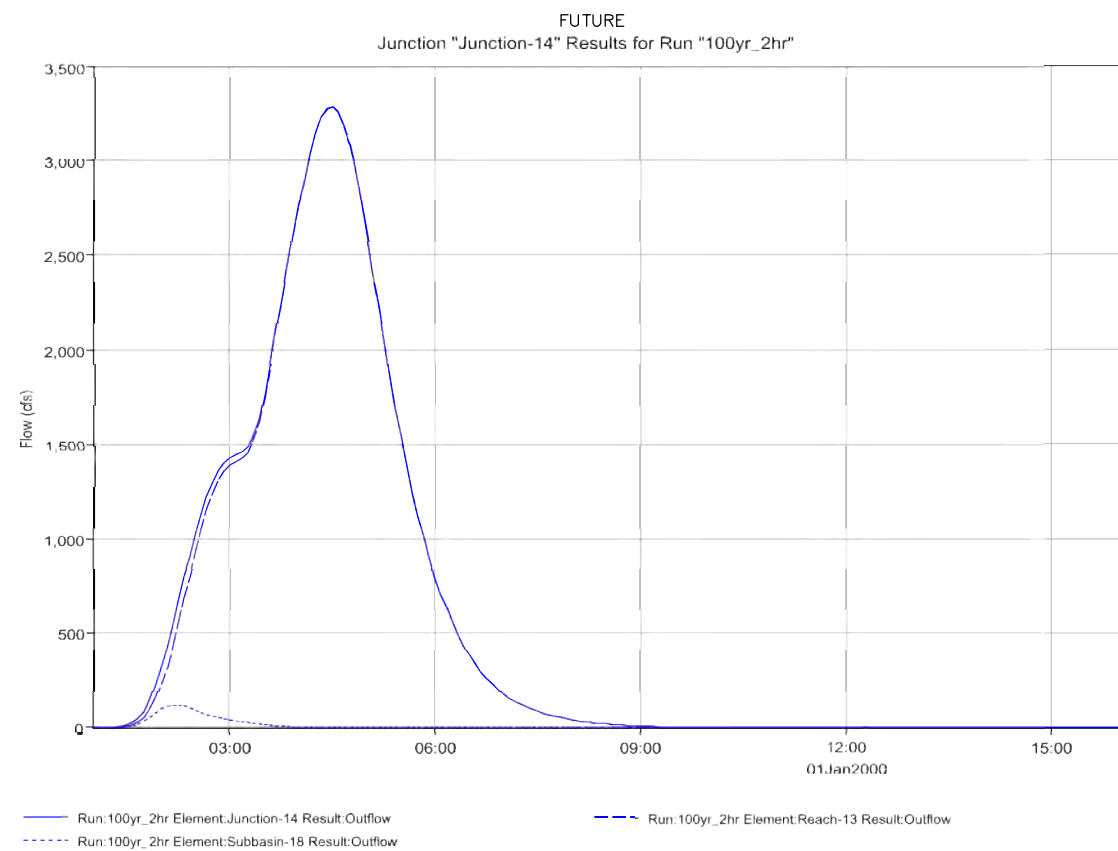

100-YR
2-HR

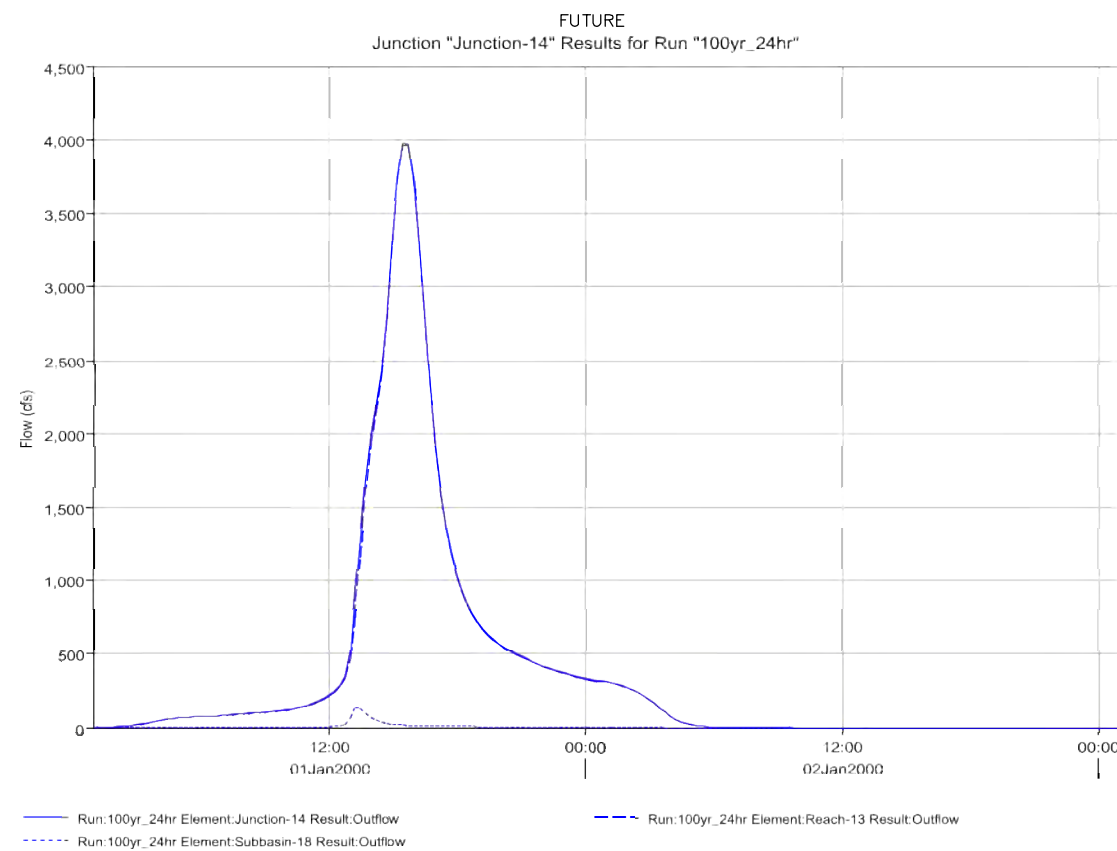

100-YR
24-HR

JUNCTION 14
HOWELLS ROAD (APPROXIMATE)
FUTURE CONDITIONS HYDROGRAPHS
AT SELECT LOCATIONS
100-YEAR

APPENDIX B- HYDROLOGIC
RESULTS- FUTURE
HYDROGRAPHS 100-YR J-14
KETTLE CREEK DBPS
JOB NO. 25100.00
MAY 2015
B-87



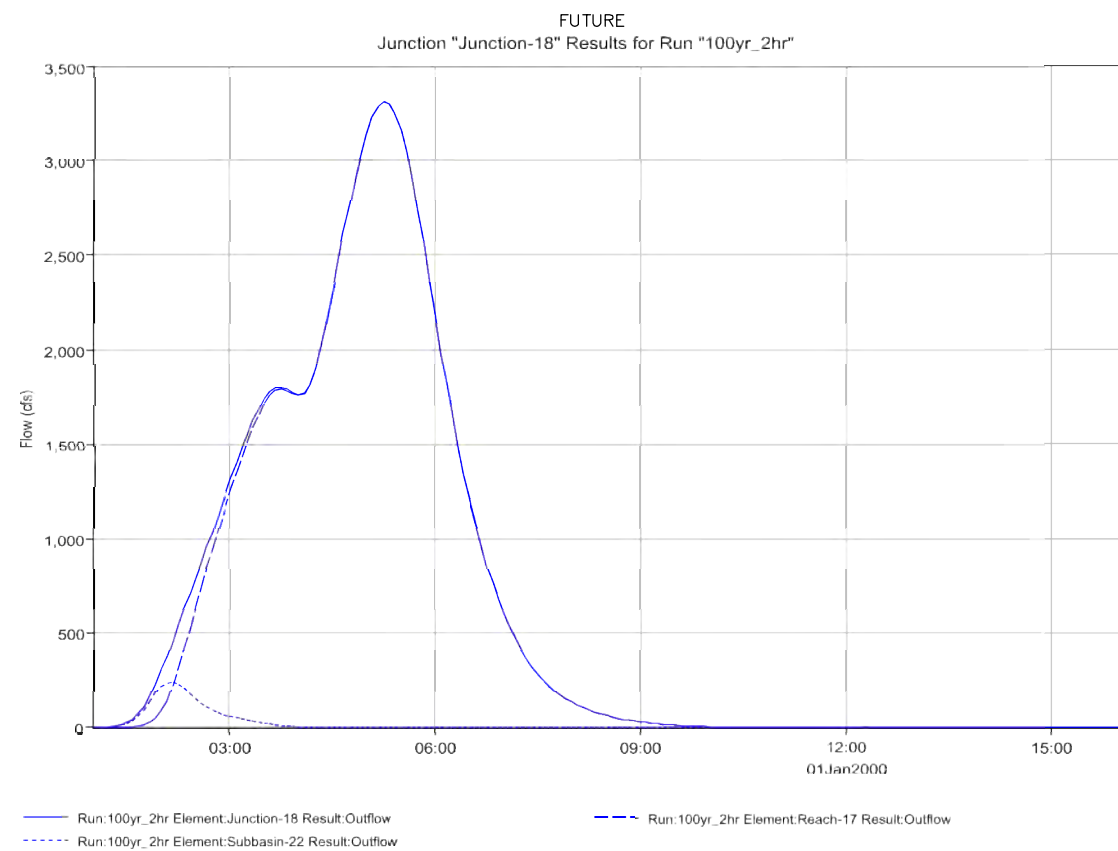

100-YR
2-HR

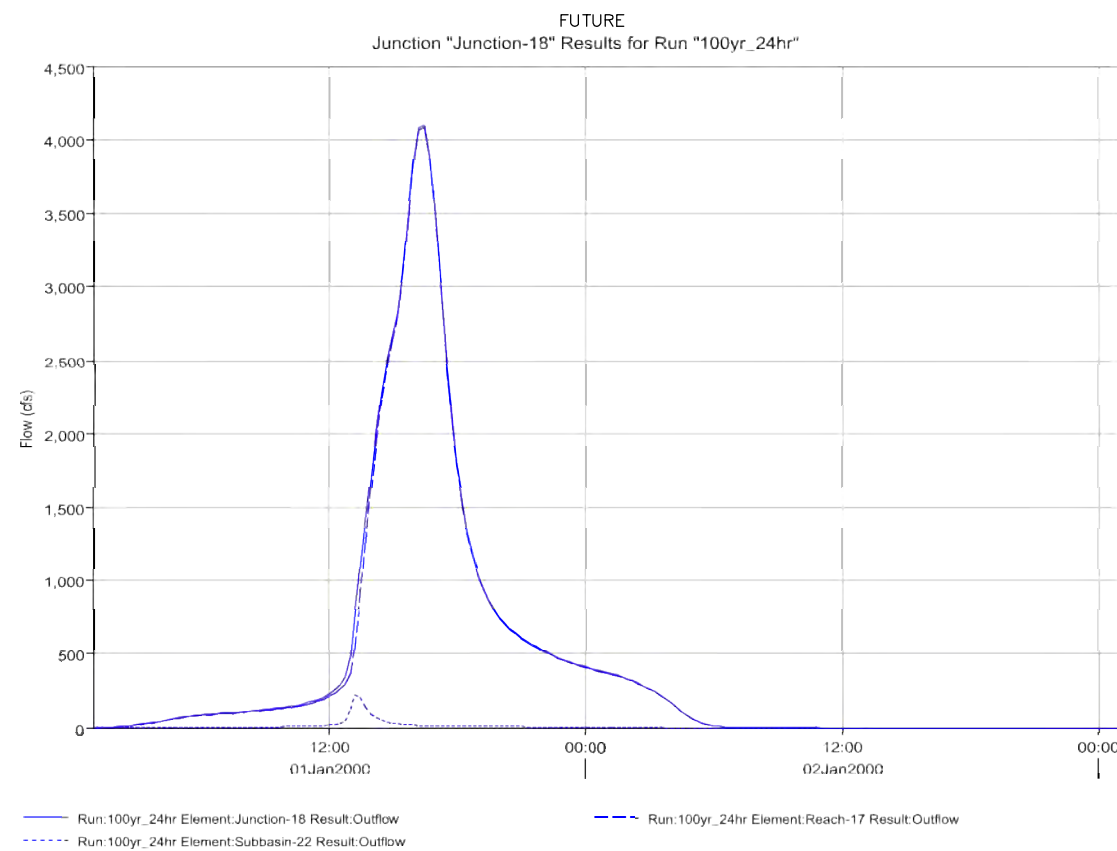

100-YR
24-HR

JUNCTION 18
POWERS BLVD BRIDGE
FUTURE CONDITIONS HYDROGRAPHS
AT SELECT LOCATIONS
100-YEAR

APPENDIX B- HYDROLOGIC
RESULTS- FUTURE
HYDROGRAPHS 100-YR J-18
KETTLE CREEK DBPS
JOB NO. 25100.00
MAY 2015
B-88



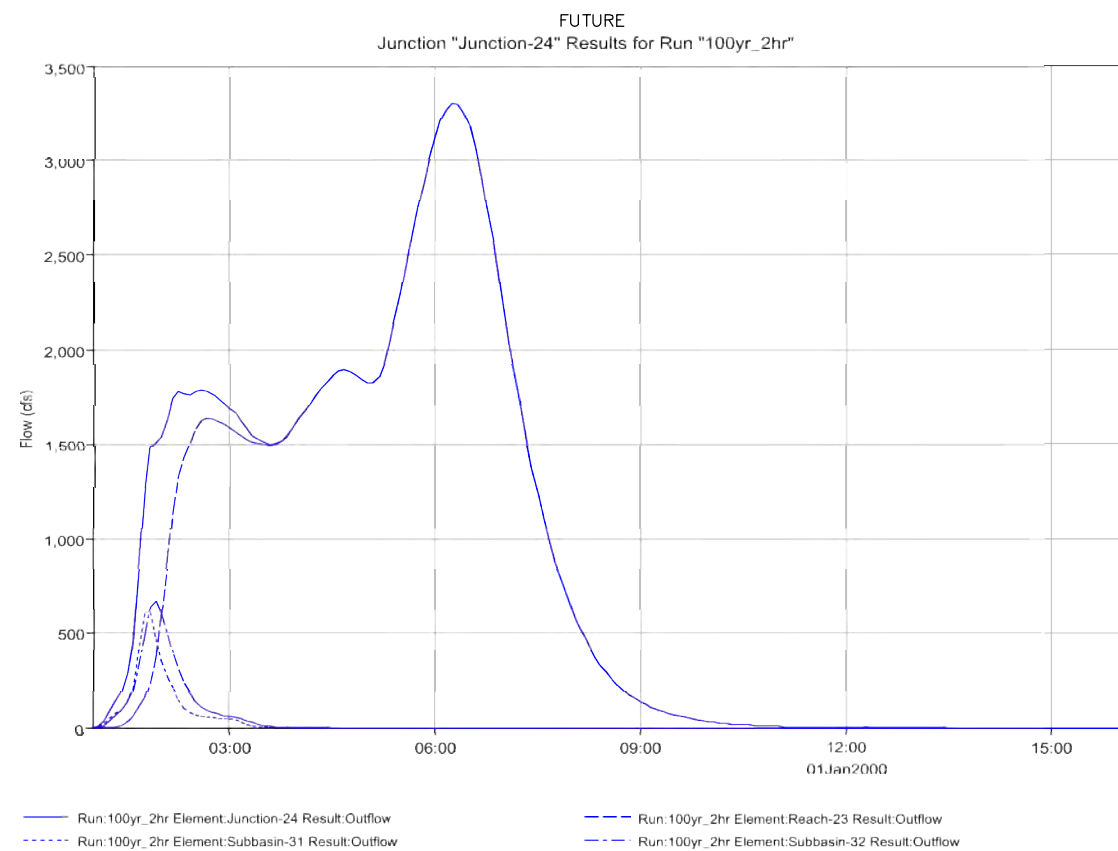

100-YR
2-HR

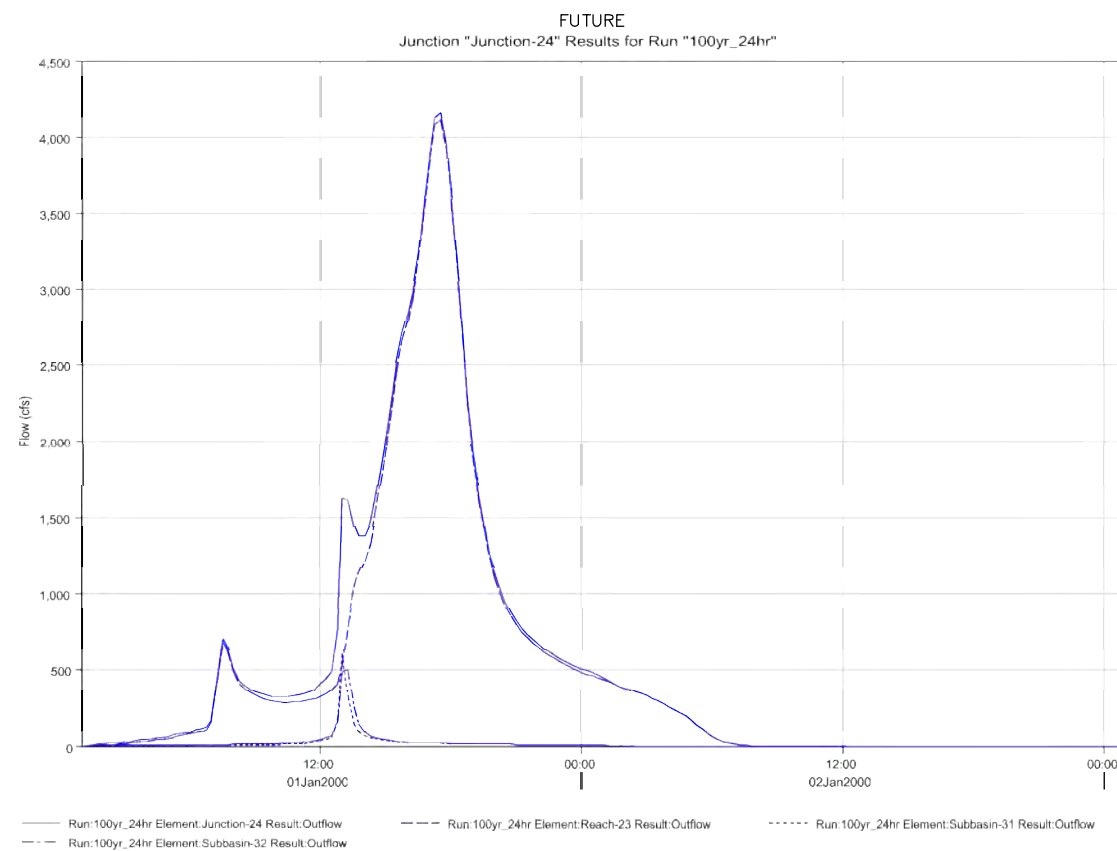

100-YR
24-HR

JUNCTION 24
HWY 83 BRIDGE
FUTURE CONDITIONS HYDROGRAPHS
AT SELECT LOCATIONS
100-YEAR

APPENDIX B- HYDROLOGIC
RESULTS- FUTURE
HYDROGRAPHS 100-YR J-24
KETTLE CREEK DBPS
JOB NO. 25100.00
MAY 2015
B-89



FLOWS COMPARISON
FOR 2 HOUR STORM EVENT
BY RIVER STATION

HEC-HMS Junction	HEC-RAS Cross Section	Historic Flows (cfs)						Existing Flows (cfs)						Future Flows (cfs)					
		2 Year Event	5 Year Event	10 Year Event	25 Year Event	50 Year Event	100 Year Event	2 Year Event	5 Year Event	10 Year Event	25 Year Event	50 Year Event	100 Year Event	2 Year Event	5 Year Event	10 Year Event	25 Year Event	50 Year Event	100 Year Event
Junction-14	253+00	59	101	117	145	193	269	756	1,473	1,831	2,286	2,757	3,281	756	1,473	1,831	2,286	2,757	3,281
Junction-15	237+50	60	102	118	147	197	274	769	1,488	1,850	2,309	2,786	3,314	771	1,490	1,852	2,311	2,788	3,317
Junction-16	217+50	61	102	118	148	197	274	776	1,487	1,849	2,308	2,784	3,313	782	1,490	1,851	2,311	2,788	3,316
Junction-17	203+00	61	102	118	148	197	274	780	1,487	1,849	2,307	2,784	3,312	786	1,489	1,852	2,311	2,787	3,316
Junction-18	169+00	61	102	118	148	197	274	780	1,486	1,847	2,305	2,780	3,308	790	1,488	1,850	2,308	2,784	3,312
Junction-19	120+75	61	102	118	147	197	274	780	1,484	1,845	2,303	2,778	3,305	789	1,487	1,848	2,306	2,782	3,309
Junction-23	106+50	62	102	118	148	197	274	800	1,484	1,845	2,302	2,777	3,305	823	1,487	1,848	2,306	2,782	3,310
Junction-24	87+50	62	101	118	147	197	274	800	1,482	1,842	2,298	2,772	3,298	824	1,486	1,846	2,303	2,777	3,304

FLOWS COMPARISON
FOR 24 HOUR STORM EVENT
BY RIVER STATION

HEC-HMS Junction	HEC-RAS Cross Section	Historic Flows (cfs)						Existing Flows (cfs)						Future Flows (cfs)					
		2 Year Event	5 Year Event	10 Year Event	25 Year Event	50 Year Event	100 Year Event	2 Year Event	5 Year Event	10 Year Event	25 Year Event	50 Year Event	100 Year Event	2 Year Event	5 Year Event	10 Year Event	25 Year Event	50 Year Event	100 Year Event
Junction-14	253+00	308	631	973	1,287	1,813	2,196	1,123	1,711	2,258	2,726	3,471	3,992	1,123	1,711	2,258	2,726	3,471	3,992
Junction-15	237+50	317	641	987	1,307	1,844	2,234	1,144	1,745	2,304	2,781	3,540	4,069	1,146	1,747	2,306	2,784	3,543	4,072
Junction-16	217+50	323	654	1,007	1,330	1,874	2,269	1,154	1,760	2,324	2,806	3,570	4,103	1,161	1,769	2,333	2,816	3,581	4,115
Junction-17	203+00	327	661	1,015	1,339	1,882	2,276	1,149	1,752	2,312	2,793	3,557	4,091	1,157	1,761	2,323	2,805	3,571	4,105
Junction-18	169+00	328	662	1,017	1,341	1,885	2,281	1,151	1,756	2,318	2,798	3,560	4,091	1,162	1,769	2,332	2,813	3,576	4,108
Junction-19	120+75	329	662	1,012	1,333	1,869	2,259	1,145	1,748	2,310	2,791	3,553	4,086	1,157	1,763	2,326	2,807	3,571	4,104
Junction-23	106+50	353	702	1,066	1,399	1,953	2,362	1,185	1,807	2,385	2,880	3,664	4,211	1,213	1,839	2,421	2,917	3,704	4,252
Junction-24	87+50	354	705	1,073	1,410	1,972	2,381	1,186	1,808	2,385	2,877	3,658	4,202	1,219	1,845	2,426	2,921	3,705	4,250

APPENDIX B- HYDROLOGIC
RESULTS COMPARISON
KETTLE CREEK DBPS
JOB NO. 25100.00
MAY 2015
B-90





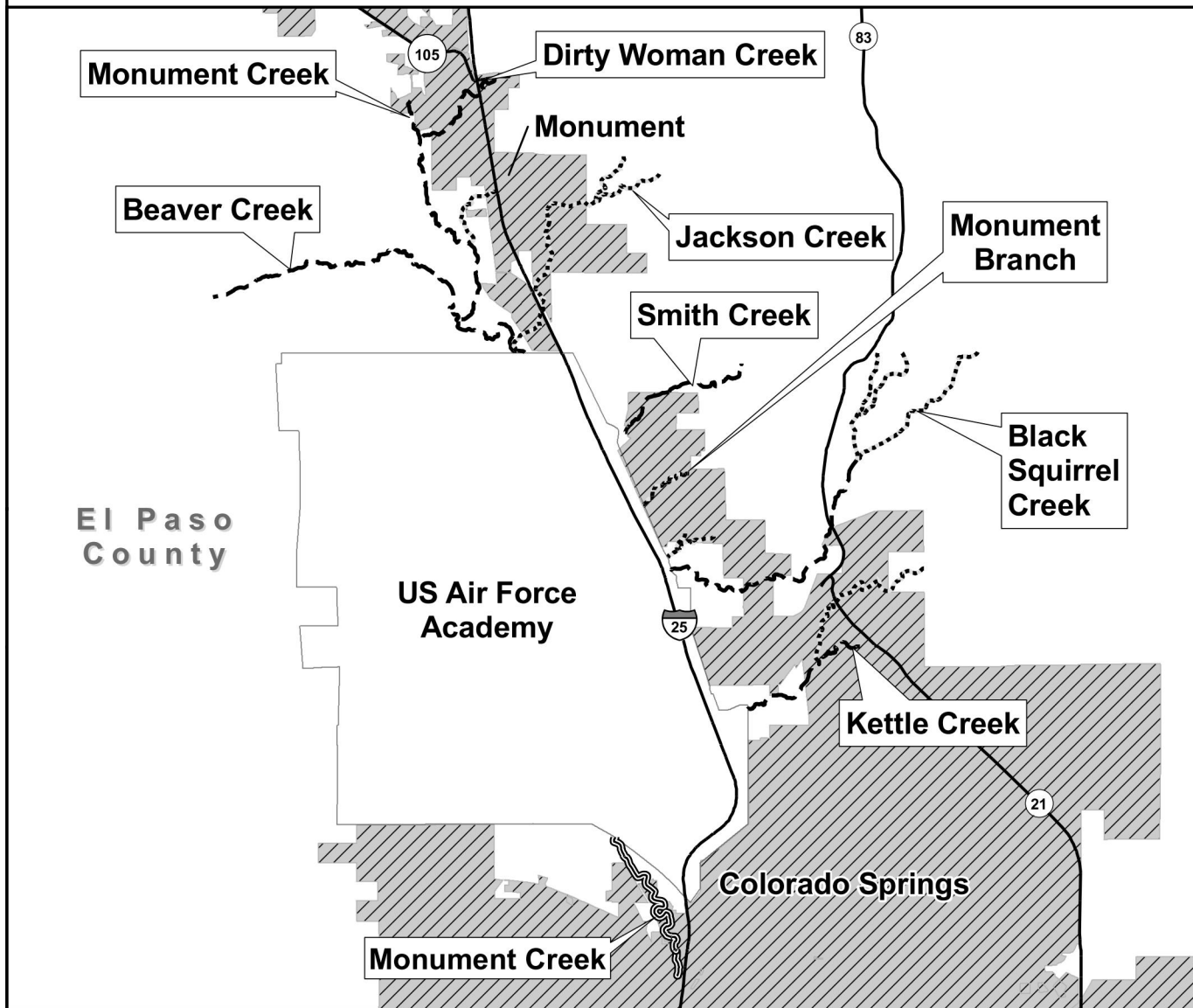

Critical Habitat for the Preble's Meadow Jumping Mouse

Unit 11 - Monument Creek



Critical habitat equals the stream plus the following distance outward on each side.

-  110 meters (361 ft)
-  120 meters (394 ft)
-  140 meters (459 ft)
-  Major Roads
-  Municipal Lands

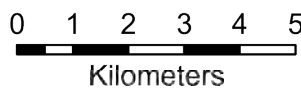
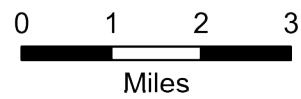
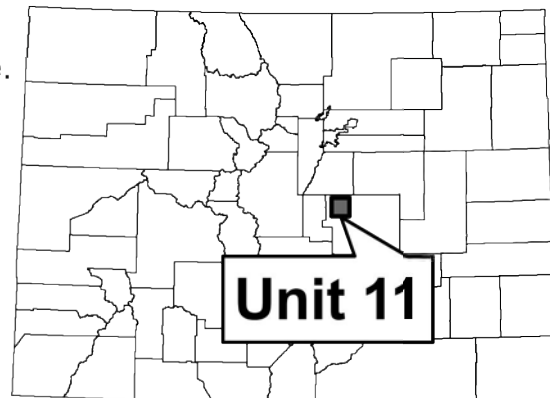

Note: Critical Habitat without name labels are unnamed tributaries.

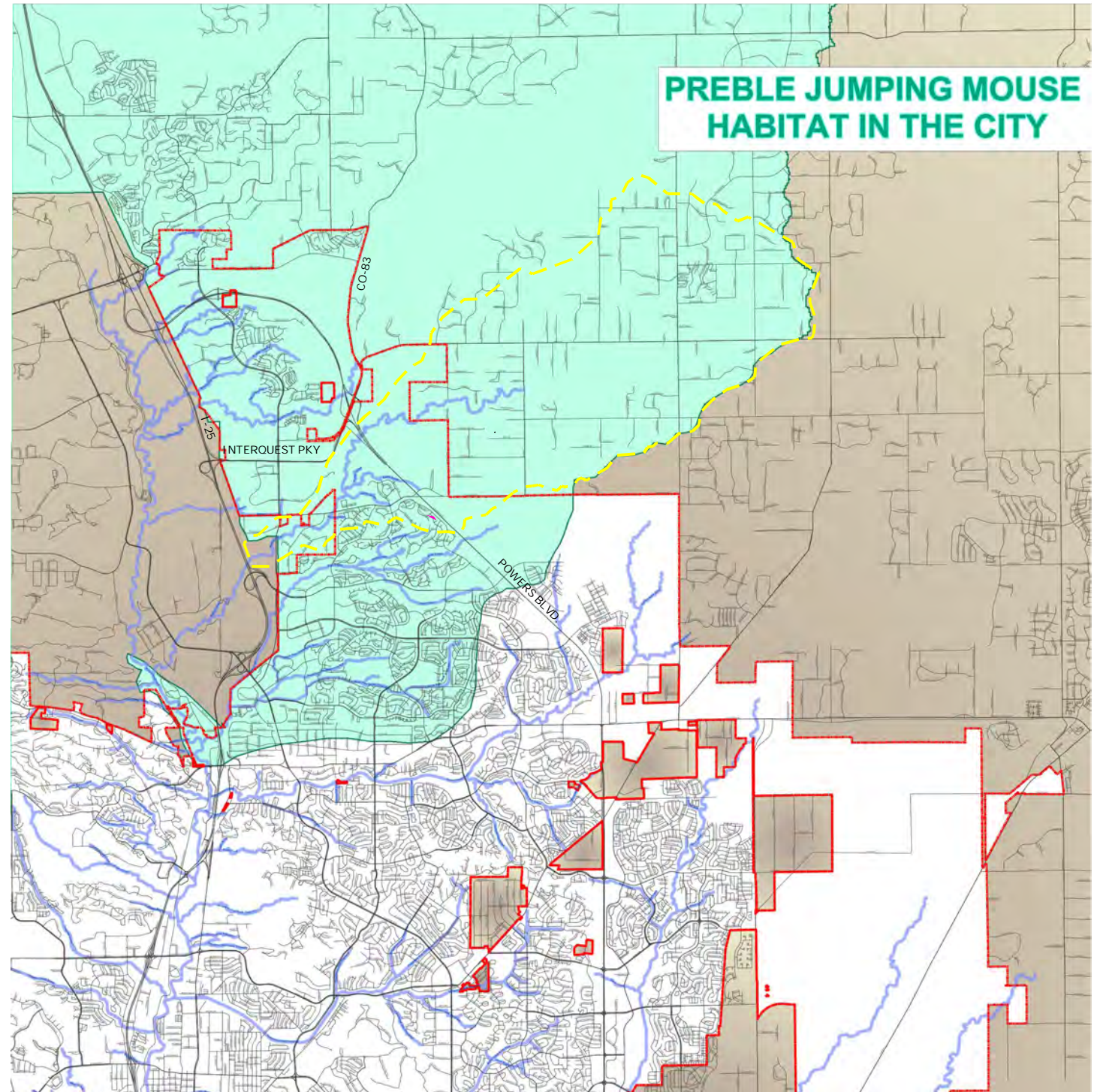

LEGEND

-  CITY LIMITS
-  KETTLE CREEK BASIN
-  MOUSE HABITAT
-  EL PASO COUNTY



APPENDIX B— PREBLE JUMPING MOUSE HABITAT IN THE CITY
 KETTLE CREEK DBPS
 JOB NO. 25100.00
 MAY 2015
 B-91



Centennial 303-740-9393 • Colorado Springs 719-593-2593
 Fort Collins 970-491-9888 • www.jrengineering.com

Kettle Creek Drainage Basin Old Ranch Road Tributary							
Master Development Plan							
2 year Storm data							
Time (hr min)	Flow (CFS)	Time (hr min)	Flow (CFS)	Time (hr min)	Flow (CFS)	Time (hr min)	Flow (CFS)
0	0	915	1	1830	0	2730	11.9
15	0	930	1	1845	0	2745	11.4
30	0.1	945	1.1	1900	0	2800	11.1
45	0.2	1000	1.2	1915	0	2815	10.8
100	0.2	1015	1.2	1930	0	2830	10.7
115	0.3	1030	1.3	1945	0	2845	10.6
130	0.4	1045	1.5	2000	0	2900	10.3
145	0.4	1100	1.7	2015	0	2915	9.9
200	0.4	1115	2	2030	0	2930	9.5
215	0.4	1130	2.3	2045	0	2945	9
230	0.4	1145	5.9	2100	0	3000	8.8
245	0.4	1200	38.1	2115	0	3015	8.5
300	0.4	1215	68	2130	0	3030	8.3
315	0.5	1230	83.2	2145	0	3045	8.2
330	0.5	1245	86.5	2200	0	3100	8.2
345	0.4	1300	82	2215	0	3115	8.2
400	0.5	1315	72	2230	0	3130	8.1
415	0.5	1330	60.2	2245	0	3145	8.2
430	0.5	1345	50.2	2300	0	3200	8.2
445	0.5	1400	42.5	2315	1	3215	8.2
500	0.5	1415	36.3	2330	1	3230	8.3
515	0.5	1430	31.4	2345	1	3245	8.3
530	0.6	1445	27.4	2400	1	3300	7.5
545	0.6	1500	24.3	2415	1	3315	6.2
600	0.6	1515	21.9	2430	1	3330	4.8
615	0.6	1530	20	2445	1	3345	3.5
630	0.7	1545	18.5	2500	1	3400	2.4
645	0.7	1600	17.3	2515	1	3415	1.5
700	0.7	1615	16.5	2530	1	3430	1
715	0.7	1630	15.8	2545	1	3445	0.7
730	0.7	1645	15.2	2600	1	3500	0.4
745	0.7	1700	14.6	2615	1	3515	0.3
800	0.7	1715	14.1	2630	1	3530	0.2
815	0.8	1730	13.6	2645	1	3545	0.1
830	0.8	1745	13.3	2700	1	3600	0.1
845	0.9	1800	12.8	2715	1	3615	0.1
900	0.9	1815	12.4				

APPENDIX B- MDDP 2-YR
FLOW DATA
KETTLE CREEK DBPS
JOB NO. 25100.00
MAY 2015
B-92



2 YR EXISTING AND FUTURE FLOW DATA FOR JUNCTION 22 (MPPD JUNCTION 24)

Kettle Creek Drainage Basin Old Ranch Road Tributary															
Master Development Plan															
5 year Storm data															
Time (hr min)	Flow (CFS)	Time (hr min)	Flow (CFS)	Time (hr min)	Flow (CFS)	Time (hr min)	Flow (CFS)	Time (hr min)	Flow (CFS)	Time (hr min)	Flow (CFS)	Time (hr min)	Flow (CFS)	Time (hr min)	Flow (CFS)
0	0	154	0	345	0	539	1	730	83	924	65	1115	52	1306	43
3	0	157	0	348	0	542	2	733	81	927	65	1118	51	1309	43
6	0	200	0	351	0	545	4	736	80	930	65	1121	51	1312	42
9	0	203	0	354	0	548	8	739	79	933	65	1124	50	1315	42
12	0	206	0	357	0	551	13	742	77	936	65	1127	50	1318	42
15	0	209	0	400	0	554	21	745	76	939	65	1130	50	1321	42
18	0	212	0	403	0	557	29	748	75	942	64	1133	49	1324	42
21	0	215	0	406	0	600	38	751	74	945	64	1136	49	1327	42
24	0	218	0	409	0	603	46	754	74	948	63	1139	48	1330	42
27	0	221	0	412	0	606	48	757	73	951	63	1142	48	1333	42
30	0	224	0	415	0	609	46	800	73	954	62	1145	48	1336	41
33	0	227	0	418	0	612	43	803	72	957	62	1148	47	1339	41
36	0	230	0	421	0	615	41	806	72	1000	61	1151	47	1342	41
39	0	233	0	424	0	618	40	809	71	1003	61	1154	47	1345	41
42	0	236	0	427	0	621	40	812	71	1006	60	1157	46	1348	41
45	0	239	0	430	0	624	60	815	70	1009	60	1200	46	1351	41
48	0	242	0	433	0	627	91	818	69	1012	60	1203	46	1354	41
51	0	245	0	436	0	630	98	821	69	1015	59	1206	45	1357	40
54	0	248	0	439	0	633	104	824	68	1018	59	1209	45	1400	40
57	0	251	0	442	0	636	110	827	67	1021	59	1212	44	1403	40
100	0	254	0	445	0	639	108	830	67	1024	58	1215	44	1406	40
103	0	257	0	448	0	642	111	833	66	1027	58	1218	44	1409	40
106	0	300	0	451	0	645	109	836	65	1030	58	1221	44	1412	40
109	0	303	0	454	0	648	108	839	64	1033	57	1224	44	1415	39
112	0	306	0	457	0	651	107	842	63	1036	57	1227	44	1418	39
115	0	309	0	500	0	654	105	845	62	1039	56	1230	44	1421	39
118	0	312	0	503	0	657	104	848	61	1042	56	1233	44	1424	39
121	0	315	0	506	0	700	101	851	61	1045	56	1236	43	1427	39
124	0	318	0	509	0	703	99	854	60	1048	55	1239	43	1430	38
127	0	321	0	512	0	706	97	857	59	1051	55	1242	43	1433	38
130	0	324	0	515	0	709	95	900	58	1054	54	1245	43	1436	38
133	0	327	0	518	1	712	92	903	59	1057	54	1248	43	1439	38
136	0	330	0	521	1	715	91	906	60	1100	54	1251	43	1442	38
139	0	333	0	524	1	718	89	909	62	1103	53	1254	43	1445	38
142	0	336	0	527	1	721	87	912	63	1106	53	1257	43	1448	37
145	0	339	0	530	1	724	86	915	64	1109	52	1300	43	1451	37
148	0	342	0	533	1	727	84	918	64	1112	52	1303	43	1454	37
151	0			536	1			921	65					1457	37

5 YR EXISTING AND FUTURE FLOW DATA FOR JUNCTION 22 (MPPD JUNCTION 24)

APPENDIX B- MDDP 5-YR
FLOW DATA
KETTLE CREEK DBPS
JOB NO. 25100.00
MAY 2015
B-93



Kettle Creek Drainage Basin Old Ranch Road Tributary															
Master Development Plan															
10 year Storm data															
Time	Flow	Time	Flow	Time	Flow	Time	Flow	Time	Flow	Time	Flow	Time	Flow	Time	Flow
(hr min)	(CFS)	(hr min)	(CFS)	(hr min)	(CFS)	(hr min)	(CFS)	(hr min)	(CFS)	(hr min)	(CFS)	(hr min)	(CFS)	(hr min)	(CFS)
0	0	154	0	345	0	539	1	730	113	924	84	1115	59	1306	47
3	0	157	0	348	0	542	3	733	111	927	83	1118	59	1309	46
6	0	200	0	351	0	545	7	736	109	930	82	1121	59	1312	46
9	0	203	0	354	0	548	13	739	107	933	81	1124	58	1315	46
12	0	206	0	357	0	551	21	742	105	936	80	1127	58	1318	45
15	0	209	0	400	0	554	32	745	103	939	79	1130	58	1321	45
18	0	212	0	403	0	557	42	748	102	942	78	1133	57	1324	45
21	0	215	0	406	0	600	53	751	100	945	77	1136	57	1327	44
24	0	218	0	409	0	603	58	754	99	948	77	1139	56	1330	44
27	0	221	0	412	0	606	58	757	97	951	76	1142	56	1333	44
30	0	224	0	415	0	609	55	800	96	954	76	1145	56	1336	44
33	0	227	0	418	0	612	50	803	95	957	75	1148	55	1339	44
36	0	230	0	421	0	615	48	806	97	1000	75	1151	55	1342	44
39	0	233	0	424	0	618	86	809	99	1003	74	1154	55	1345	44
42	0	236	0	427	0	621	161	812	100	1006	74	1157	54	1348	44
45	0	239	0	430	0	624	177	815	101	1009	73	1200	54	1351	44
48	0	242	0	433	0	627	184	818	101	1012	72	1203	53	1354	43
51	0	245	0	436	0	630	188	821	101	1015	72	1206	53	1357	43
54	0	248	0	439	0	633	186	824	101	1018	71	1209	53	1400	43
57	0	251	0	442	0	636	187	827	101	1021	70	1212	52	1403	43
100	0	254	0	445	0	639	184	830	100	1024	70	1215	52	1406	43
103	0	257	0	448	0	642	182	833	99	1027	69	1218	52	1409	43
106	0	300	0	451	0	645	179	836	99	1030	68	1221	51	1412	43
109	0	303	0	454	0	648	175	839	98	1033	67	1224	51	1415	43
112	0	306	0	457	0	651	171	842	98	1036	67	1227	51	1418	43
115	0	309	0	500	1	654	164	845	97	1039	66	1230	50	1421	43
118	0	312	0	503	1	657	158	848	96	1042	65	1233	50	1424	43
121	0	315	0	506	1	700	152	851	95	1045	64	1236	50	1427	43
124	0	318	0	509	1	703	147	854	94	1048	64	1239	49	1430	42
127	0	321	0	512	1	706	141	857	93	1051	63	1242	49	1433	42
130	0	324	0	515	1	709	137	900	92	1054	62	1245	49	1436	42
133	0	327	0	518	1	712	133	903	91	1057	61	1248	48	1439	42
136	0	330	0	521	1	715	128	906	90	1100	61	1251	48	1442	42
139	0	333	0	524	1	718	125	909	89	1103	61	1254	48	1445	42
142	0	336	0	527	1	721	121	912	88	1106	60	1257	48	1448	42
145	0	339	0	530	1	724	118	915	87	1109	60	1300	47	1451	42
148	0	342	0	533	1	727	115	918	86	1112	60	1303	47	1454	41
151	0			536	1			921	85					1457	41

10 YR EXISTING AND FUTURE FLOW DATA FOR JUNCTION 22 (MPPD JUNCTION 24)

APPENDIX B- MDDP 10-YR
FLOW DATA
KETTLE CREEK DBPS
JOB NO. 25100.00
MAY 2015
B-94



Kettle Creek Drainage Basin Old Ranch Road Tributary															
Master Development Plan															
25 year Storm data															
Time	Flow	Time	Flow	Time	Flow	Time	Flow	Time	Flow	Time	Flow	Time	Flow	Time	Flow
(hr min)	(CFS)	(hr min)	(CFS)	(hr min)	(CFS)	(hr min)	(CFS)	(hr min)	(CFS)	(hr min)	(CFS)	(hr min)	(CFS)	(hr min)	(CFS)
0	0	154	0	345	0	539	2	730	187	924	104	1115	75	1306	58
3	0	157	0	348	0	542	7	733	182	927	103	1118	75	1309	58
6	0	200	0	351	0	545	13	736	177	930	102	1121	74	1312	58
9	0	203	0	354	0	548	23	739	173	933	102	1124	74	1315	57
12	0	206	0	357	0	551	36	742	169	936	101	1127	73	1318	57
15	0	209	0	400	0	554	50	745	165	939	100	1130	73	1321	57
18	0	212	0	403	0	557	61	748	162	942	100	1133	72	1324	56
21	0	215	0	406	0	600	70	751	159	945	99	1136	72	1327	56
24	0	218	0	409	0	603	75	754	156	948	98	1139	71	1330	55
27	0	221	0	412	0	606	74	757	154	951	98	1142	70	1333	55
30	0	224	0	415	0	609	68	800	152	954	97	1145	70	1336	55
33	0	227	0	418	0	612	105	803	151	957	96	1148	69	1339	54
36	0	230	0	421	0	615	234	806	149	1000	95	1151	69	1342	54
39	0	233	0	424	0	618	275	809	147	1003	95	1154	68	1345	54
42	0	236	0	427	0	621	308	812	145	1006	94	1157	68	1348	53
45	0	239	0	430	0	624	348	815	143	1009	93	1200	67	1351	53
48	0	242	0	433	0	627	345	818	141	1012	92	1203	66	1354	53
51	0	245	0	436	0	630	333	821	139	1015	92	1206	66	1357	52
54	0	248	0	439	0	633	324	824	137	1018	91	1209	65	1400	52
57	0	251	0	442	1	636	303	827	135	1021	90	1212	64	1403	52
100	0	254	0	445	1	639	289	830	132	1024	89	1215	64	1406	52
103	0	257	0	448	1	642	273	833	130	1027	88	1218	63	1409	51
106	0	300	0	451	1	645	264	836	128	1030	87	1221	63	1412	51
109	0	303	0	454	1	648	254	839	126	1033	86	1224	62	1415	51
112	0	306	0	457	1	651	242	842	123	1036	85	1227	62	1418	50
115	0	309	0	500	1	654	233	845	121	1039	85	1230	62	1421	50
118	0	312	0	503	1	657	227	848	119	1042	84	1233	61	1424	50
121	0	315	0	506	1	700	221	851	118	1045	83	1236	61	1427	49
124	0	318	0	509	1	703	219	854	116	1048	82	1239	61	1430	49
127	0	321	0	512	1	706	217	857	114	1051	81	1242	61	1433	49
130	0	324	0	515	1	709	215	900	113	1054	80	1245	60	1436	49
133	0	327	0	518	1	712	212	903	111	1057	79	1248	60	1439	48
136	0	330	0	521	1	715	210	906	110	1100	78	1251	60	1442	48
139	0	333	0	524	1	718	207	909	109	1103	77	1254	60	1445	48
142	0	336	0	527	1	721	204	912	107	1106	77	1257	59	1448	47
145	0	339	0	530	1	724	199	915	106	1109	76	1300	59	1451	47
148	0	342	0	533	1	727	192	918	106	1112	76	1303	59	1454	47
151	0			536	1			921	105					1457	47

25 YR EXISTING AND FUTURE FLOW DATA FOR JUNCTION 22 (MPPD JUNCTION 24)

APPENDIX B- MDDP 25-YR
FLOW DATA
KETTLE CREEK DBPS
JOB NO. 25100.00
MAY 2015
B-95



Kettle Creek Drainage Basin Old Ranch Road Tributary															
Master Development Plan															
50 year Storm data															
Time (hr min)	Flow (CFS)	Time (hr min)	Flow (CFS)	Time (hr min)	Flow (CFS)	Time (hr min)	Flow (CFS)	Time (hr min)	Flow (CFS)	Time (hr min)	Flow (CFS)	Time (hr min)	Flow (CFS)	Time (hr min)	Flow (CFS)
0	0	154	0	345	0	539	4	730	222	924	116	1115	89	1306	67
3	0	157	0	348	0	542	9	733	217	927	115	1118	88	1309	67
6	0	200	0	351	0	545	18	736	211	930	114	1121	87	1312	66
9	0	203	0	354	0	548	32	739	204	933	113	1124	86	1315	66
12	0	206	0	357	0	551	47	742	198	936	112	1127	86	1318	65
15	0	209	0	400	0	554	61	745	194	939	111	1130	85	1321	64
18	0	212	0	403	0	557	72	748	188	942	110	1133	84	1324	63
21	0	215	0	406	0	600	81	751	185	945	110	1136	83	1327	63
24	0	218	0	409	0	603	87	754	180	948	109	1139	83	1330	63
27	0	221	0	412	0	606	85	757	177	951	108	1142	82	1333	62
30	0	224	0	415	0	609	113	800	174	954	107	1145	81	1336	62
33	0	227	0	418	0	612	276	803	171	957	107	1148	81	1339	62
36	0	230	0	421	0	615	384	806	168	1000	106	1151	80	1342	62
39	0	233	0	424	0	618	455	809	165	1003	106	1154	79	1345	61
42	0	236	0	427	0	621	501	812	163	1006	105	1157	78	1348	61
45	0	239	0	430	0	624	476	815	160	1009	105	1200	78	1351	61
48	0	242	0	433	0	627	476	818	157	1012	104	1203	77	1354	60
51	0	245	0	436	1	630	459	821	155	1015	103	1206	77	1357	60
54	0	248	0	439	1	633	431	824	153	1018	103	1209	77	1400	60
57	0	251	0	442	1	636	414	827	150	1021	102	1212	76	1403	59
100	0	254	0	445	1	639	380	830	147	1024	101	1215	76	1406	59
103	0	257	0	448	1	642	359	833	145	1027	101	1218	75	1409	59
106	0	300	0	451	1	645	334	836	142	1030	100	1221	75	1412	58
109	0	303	0	454	1	648	317	839	140	1033	99	1224	74	1415	58
112	0	306	0	457	1	651	300	842	138	1036	98	1227	74	1418	58
115	0	309	0	500	1	654	291	845	136	1039	98	1230	73	1421	57
118	0	312	0	503	1	657	282	848	134	1042	97	1233	73	1424	57
121	0	315	0	506	1	700	272	851	132	1045	96	1236	72	1427	57
124	0	318	0	509	1	703	263	854	130	1048	95	1239	72	1430	56
127	0	321	0	512	1	706	256	857	128	1051	95	1242	72	1433	56
130	0	324	0	515	1	709	248	900	126	1054	94	1245	71	1436	56
133	0	327	0	518	1	712	244	903	125	1057	93	1248	71	1439	55
136	0	330	0	521	1	715	241	906	123	1100	92	1251	70	1442	55
139	0	333	0	524	1	718	238	909	122	1103	92	1254	70	1445	55
142	0	336	0	527	1	721	233	912	121	1106	91	1257	69	1448	55
145	0	339	0	530	1	724	230	915	119	1109	90	1300	69	1451	54
148	0	342	0	533	1	727	226	918	118	1112	89	1303	68	1454	54
151	0			536	1			921	117					1457	54

50 YR EXISTING AND FUTURE FLOW DATA FOR JUNCTION 22 (MPPD JUNCTION 24)

APPENDIX B- MDDP 50-YR
FLOW DATA
KETTLE CREEK DBPS
JOB NO. 25100.00
MAY 2015
B-96



Kettle Creek Drainage Basin Old Ranch Road Tributary															
Master Development Plan															
100 year Storm data															
Time	Flow	Time	Flow	Time	Flow	Time	Flow	Time	Flow	Time	Flow	Time	Flow	Time	Flow
(hr min)	(CFS)	(hr min)	(CFS)	(hr min)	(CFS)	(hr min)	(CFS)	(hr min)	(CFS)	(hr min)	(CFS)	(hr min)	(CFS)	(hr min)	(CFS)
0	0	154	0	345	0	539	6	730	243	924	128	1115	100	1306	67
3	0	157	0	348	0	542	13	733	239	927	127	1118	99	1309	78
6	0	200	0	351	0	545	25	736	234	930	126	1121	99	1312	77
9	0	203	0	354	0	548	41	739	230	933	125	1124	98	1315	77
12	0	206	0	357	0	551	59	742	226	936	124	1127	98	1318	77
15	0	209	0	400	0	554	71	745	222	939	124	1130	97	1321	76
18	0	212	0	403	0	557	83	748	216	942	123	1133	97	1324	76
21	0	215	0	406	0	600	94	751	210	945	122	1136	96	1327	75
24	0	218	0	409	0	603	100	754	205	948	121	1139	96	1330	75
27	0	221	0	412	0	606	114	757	201	951	120	1142	95	1333	74
30	0	224	0	415	0	609	297	800	197	954	120	1145	94	1336	73
33	0	227	0	418	0	612	453	803	193	957	119	1148	94	1339	73
36	0	230	0	421	0	615	571	806	189	1000	118	1151	93	1342	72
39	0	233	0	424	0	618	626	809	186	1003	118	1154	93	1345	72
42	0	236	0	427	1	621	612	812	182	1006	117	1157	92	1348	71
45	0	239	0	430	1	624	630	815	179	1009	116	1200	92	1351	71
48	0	242	0	433	1	627	589	818	175	1012	115	1203	91	1354	70
51	0	245	0	436	1	630	576	821	172	1015	115	1206	90	1357	70
54	0	248	0	439	1	633	539	824	168	1018	114	1209	90	1400	69
57	0	251	0	442	1	636	515	827	165	1021	113	1212	89	1403	69
100	0	254	0	445	1	639	485	830	161	1024	112	1215	89	1406	68
103	0	257	0	448	1	642	458	833	158	1027	111	1218	88	1409	67
106	0	300	0	451	1	645	427	836	155	1030	110	1221	87	1412	67
109	0	303	0	454	1	648	395	839	153	1033	109	1224	87	1415	66
112	0	306	0	457	1	651	367	842	151	1036	108	1227	86	1418	65
115	0	309	0	500	1	654	346	845	148	1039	107	1230	85	1421	65
118	0	312	0	503	1	657	327	848	146	1042	107	1233	85	1424	64
121	0	315	0	506	1	700	316	851	144	1045	106	1236	84	1427	63
124	0	318	0	509	1	703	306	854	142	1048	105	1239	84	1430	63
127	0	321	0	512	1	706	295	857	141	1051	105	1242	83	1433	63
130	0	324	0	515	1	709	285	900	139	1054	104	1245	82	1436	63
133	0	327	0	518	1	712	276	903	137	1057	103	1248	82	1439	62
136	0	330	0	521	1	715	268	906	136	1100	103	1251	81	1442	62
139	0	333	0	524	1	718	261	909	134	1103	102	1254	81	1445	62
142	0	336	0	527	1	721	256	912	133	1106	102	1257	80	1448	61
145	0	339	0	530	1	724	252	915	132	1109	101	1300	79	1451	61
148	0	342	0	533	1	727	247	918	131	1112	101	1303	79	1454	61
151	0			536	2			921	129				78	1457	61

100 YR EXISTING AND FUTURE FLOW DATA FOR JUNCTION 22 (MPPD JUNCTION 24)

APPENDIX B- MDDP 100-YR
FLOW DATA
KETTLE CREEK DBPS
JOB NO. 25100.00
MAY 2015
B-97



Appendix C – Hydraulic Calculations and Data

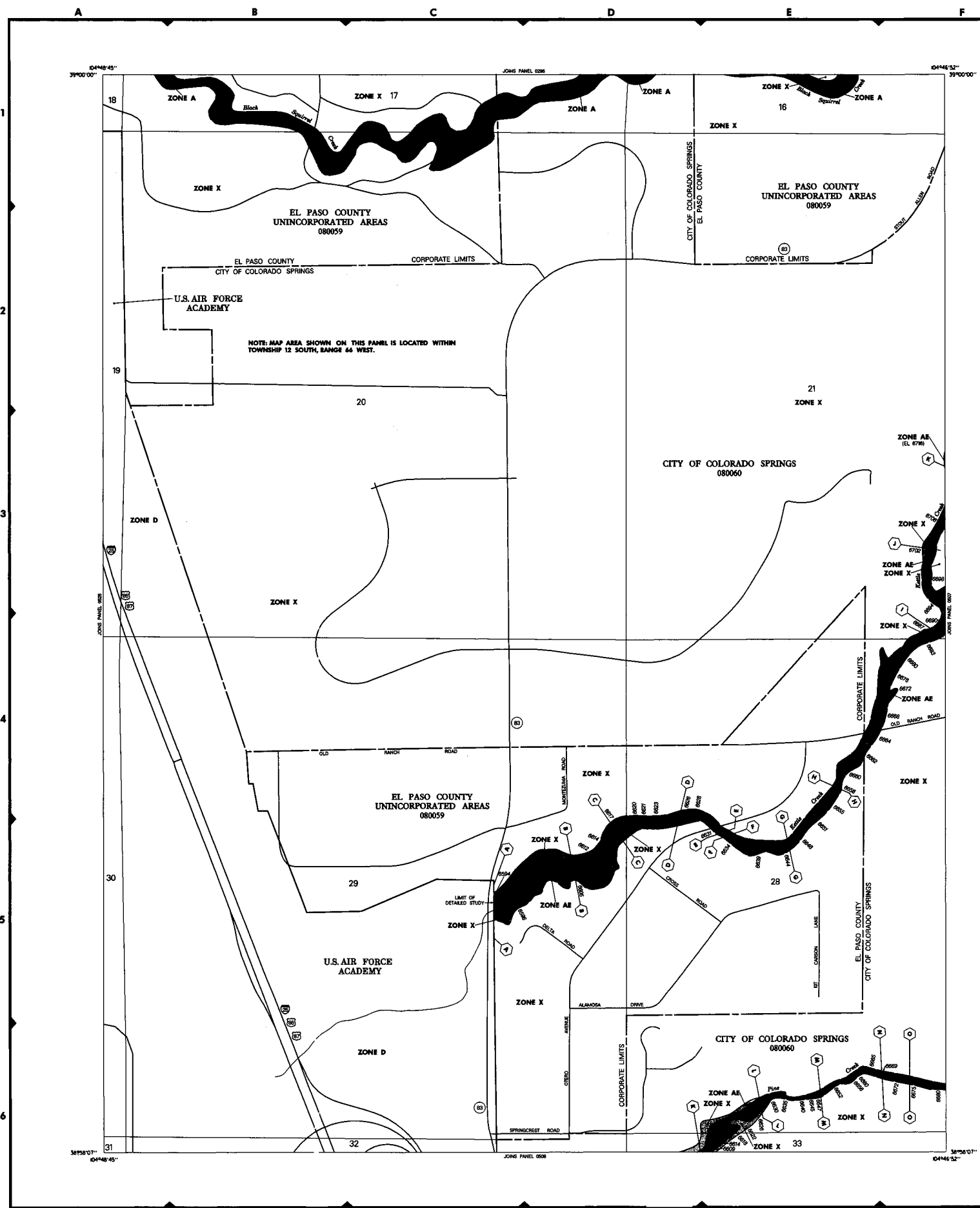

LEGEND

- SPECIAL FLOOD HAZARD AREAS INUNDATED BY 100-YEAR FLOODS**
 - ZONE A**: Base Flood Elevations Determined
 - ZONE AE**: Base Flood Elevations Determined
 - ZONE AH**: Flood depths of 1 to 3 feet usually are of flooding; base flood elevations are determined.
 - ZONE AD**: Flood depths of 1 to 3 feet usually are of flooding; base flood elevations are determined. No areas of shallow flooding.
 - ZONE AV**: Coastal flood with velocity based on wave action; base flood elevations are determined.
 - ZONE VE**: Coastal flood with velocity based on wave action; base flood elevations are determined.
 - FLOODWAY AREAS IN ZONE AE**: Floodway areas in Zone AE.
 - OTHER FLOOD AREAS**
 - ZONE X**: Areas of 500-year flood areas of 100-year flood areas with average depth of less than 1 foot or with drainage areas less than 1 square mile and where protection by levees from 100-year flood.
 - ZONE D**: Areas in which flood hazards are undetermined.
 - UNDEVELOPED COASTAL BARRIERS**
 - Identified**: Coastal barrier areas are normally located within or adjacent to Special Flood Hazard Areas.
 - Unidentified**: Coastal barrier areas are normally located within or adjacent to Special Flood Hazard Areas.
 - OTHER AREAS**
 - ZONE X**: Areas determined to be outside 100-year floodplain.
 - ZONE D**: Areas in which flood hazards are undetermined.

UNDEVELOPED COASTAL BARRIERS

- Identified**: Coastal barrier areas are normally located within or adjacent to Special Flood Hazard Areas.
- Unidentified**: Coastal barrier areas are normally located within or adjacent to Special Flood Hazard Areas.

OTHER AREAS

- ZONE X**: Areas determined to be outside 100-year floodplain.
- ZONE D**: Areas in which flood hazards are undetermined.

BOUNDARIES

- Flood Boundary**
- Floodway Boundary**
- Zone D Boundary**
- Boundary Delineating Special Flood Hazard Zones and Boundaries**
- Channel Area of Channel**
- Channel Flood Elevations**
- Channel Flood**
- Base Flood Elevation Line**
- Elevation in Feet**: See Map Index for Elevation Data.
- Zone Section Line**
- Zone Section Line**
- Zone Section Line**
- Elevation Reference Mark**

MAP SYMBOLS

- RM 7**: Road Mile
- 97°07'30" W, 32°22'30" N**: North American Datum of 1983 (NAD 83)

NOTES

This map is for use in administering the National Flood Insurance Program. It does not necessarily identify all areas subject to flooding, particularly those areas of small size, or all placement features outside Special Flood Hazard Areas.

Coastal zone flood elevations apply only to flooding of 100-year flood and include the effects of wave action. Elevations may differ other applications from those established by the National Weather Service for hurricane protection planning.

Areas of Special Flood Hazard 100-year flood include Zone A, AE, AH, AD, AV, VE, and X.

Certain areas not in Special Flood Hazard Areas may be protected by flood control structures.

Boundaries of the floodways were computed at cross sections and impounded basins area within the floodways were based on hydrologic computations with regard to requirements of the Federal Emergency Management Agency.

Floodway widths in some areas may be 500 feet or more to show its scale. Floodway widths are provided in the Flood Insurance Study Report.

This map may incorporate approximate boundaries of Coastal Barrier Resources System (CBRS) and other flood protection features established under the Coastal Barrier Resources Act of 1982 (PL 97-352).

Corporate limits shown are current as of the date of this map. The user should contact appropriate county or city offices for current corporate limits have changed subsequent to the date of this map.

For community flood insurance rates, see floodway map, or contact the Flood Insurance Study Report.

For additional map panels and base map source see separately printed Map Index.

MAP REPOSITORY

Refer to Repository Listing on Map Index.

EFFECTIVE DATE OF COUNTYWIDE FLOOD INSURANCE RATE MAP:
MARCH 17, 1997

EFFECTIVE DATES OF REVISIONS TO THIS PANEL:

Refer to the FLOOD INSURANCE RATE MAP EFFECTIVE DATE shown on this map to determine when individual rates apply to structures in certain areas or to determine when rates are revised.

To determine if flood insurance is available, contact an insurance agent or call the National Flood Insurance Program at 800-626-8225.

APPROXIMATE SCALE IN FEET

0 200 400

NATIONAL FLOOD INSURANCE PROGRAM

FIRM

FLOOD INSURANCE RATE MAP

EL PASO COUNTY, COLORADO AND INCORPORATED AREAS

PANEL 006 OF 1300

(SEE MAP INDEX FOR PANELS NOT PRINTED)

CONTAINS COORDINATE NUMBER PANEL 23710

COLORADO SPRING CITY OF EL PASO COUNTY UNINCORPORATED AREAS

MAP NUMBER 080410506 F

EFFECTIVE DATE: MARCH 17, 1997

Federal Emergency Management Agency

FLOODING SOURCE		FLOODWAY			BASE FLOOD WATER SURFACE ELEVATION			
CROSS SECTION	DISTANCE ¹	WIDTH (FEET)	SECTION AREA (SQUARE FEET)	MEAN VELOCITY (FEET PER SECOND)	REGULATORY			INCREASE
					WITHOUT FLOODWAY	WITH FLOODWAY	WITH FLOODWAY	
Kettle Creek								
A	0	95	825	11.3	6,593.6	6,593.6	6,593.6	0.0
B	1,120	130	706	13.2	6,604.4	6,604.4	6,604.4	0.0
C	2,000	95	685	13.6	6,616.7	6,616.7	6,616.7	0.0
D	2,720	130	838	11.1	6,625.9	6,625.9	6,626.8	0.9
E	3,120	100	643	14.5	6,631.4	6,631.4	6,631.4	0.0
F	3,150	100	829	11.2	6,633.3	6,633.3	6,633.3	0.0
G	3,930	120	896	10.4	6,644.5	6,644.5	6,644.9	0.4
H	4,780	90	738	12.6	6,657.8	6,657.8	6,657.8	0.0
I	6,740	120	792	9.4	6,687.1	6,687.1	6,687.3	0.2
J	7,860	100	653	11.4	6,702.4	6,702.4	6,702.4	0.0
K	8,790	110	539	12.4	6,712.1	6,712.1	6,712.1	0.0
L	9,490	90	581	11.4	6,723.5	6,723.5	6,724.0	0.5
M	10,460	130	683	9.7	6,735.8	6,735.8	6,735.8	0.0
N	11,290	131	654	10.1	6,747.2	6,747.2	6,747.2	0.0
O	12,440	110	654	10.1	6,764.4	6,764.4	6,764.5	0.1
P	13,590	110	645	10.2	6,780.0	6,780.0	6,780.0	0.0
Q	14,590	100	563	11.7	6,792.8	6,792.8	6,792.9	0.1
R	16,650	140	590	10.1	6,817.5	6,817.5	6,817.6	0.1
S	18,000	140	614	9.7	6,836.1	6,836.1	6,836.1	0.0
T	18,940	142	620	9.6	6,849.4	6,849.4	6,849.4	0.0
U	20,320	136	613	9.7	6,868.5	6,868.5	6,868.5	0.0
V	21,090	80	472	12.6	6,880.8	6,880.8	6,880.8	0.0
W	22,530	99	514	11.6	6,896.7	6,896.7	6,896.8	0.1
X	23,380	160	624	8.7	6,906.5	6,906.5	6,906.5	0.0
Y	25,180	130	586	9.2	6,933.5	6,933.5	6,933.7	0.2
Z	26,880	138	667	8.1	6,954.7	6,954.7	6,954.8	0.1

¹Feet Above State Highway 83

FEDERAL EMERGENCY MANAGEMENT AGENCY

EL PASO COUNTY, CO AND INCORPORATED AREAS

FLOODWAY DATA

KETTLE CREEK

FLOODING SOURCE		FLOODWAY			BASE FLOOD WATER SURFACE ELEVATION			
CROSS SECTION	DISTANCE ¹	WIDTH (FEET)	SECTION AREA (SQUARE FEET)	MEAN VELOCITY (FEET PER SECOND)	REGULATORY			INCREASE
					WITHOUT FLOODWAY	WITH FLOODWAY	WITH FLOODWAY	
Kettle Creek (Cont'd)								
AA	28,200	136	648	8.3	6,971.8	6,971.8	6,971.9	0.1
AB	29,110	88	503	9.2	6,976.1	6,976.1	6,976.1	0.0
AC	29,140	88	526	8.8	6,976.4	6,976.4	6,976.4	0.0
AD	30,630	96	478	9.7	7,007.6	7,007.6	7,007.6	0.0
AE	31,720	78	472	9.9	7,022.1	7,022.1	7,022.6	0.5
AF	32,650	80	428	10.9	7,034.3	7,034.3	7,034.6	0.3
AG	33,350	218	452	9.1	7,043.3	7,043.3	7,043.3	0.0
AH	35,350	131	491	8.3	7,072.8	7,072.8	7,072.8	0.0
AI	36,610	126	440	6.5	7,095.5	7,095.5	7,095.5	0.0
AJ	37,350	120	367	7.9	7,110.1	7,110.1	7,110.1	0.0
AK	38,290	111	310	9.3	7,123.0	7,123.0	7,123.0	0.0
AL	39,930	114	322	8.9	7,150.1	7,150.1	7,150.1	0.0
AM	41,440	96	395	5.4	7,173.5	7,173.5	7,173.5	0.0
AN	41,470	96	400	5.4	7,173.6	7,173.6	7,173.6	0.0
AO	42,490	193	321	6.7	7,200.5	7,200.5	7,200.5	0.0
AP	43,530	101	354	6.0	7,217.6	7,217.6	7,217.6	0.0
AQ	44,580	74	163	8.6	7,237.4	7,237.4	7,237.4	0.0
AR	45,740	53	169	8.3	7,262.8	7,262.8	7,262.8	0.0
AS	46,770	37	137	10.2	7,284.7	7,284.7	7,284.7	0.0
AT	47,240	89	30	3.4	7,319.5	7,319.5	7,319.5	0.0
AU	48,120	41	123	7.6	7,333.4	7,333.4	7,333.4	0.0

¹Feet Above State Highway 83

APPENDIX C — FIRM MAPS

KETTLE CREEK DBPS

JOB NO. 25100.00

MAY 2015

C-1



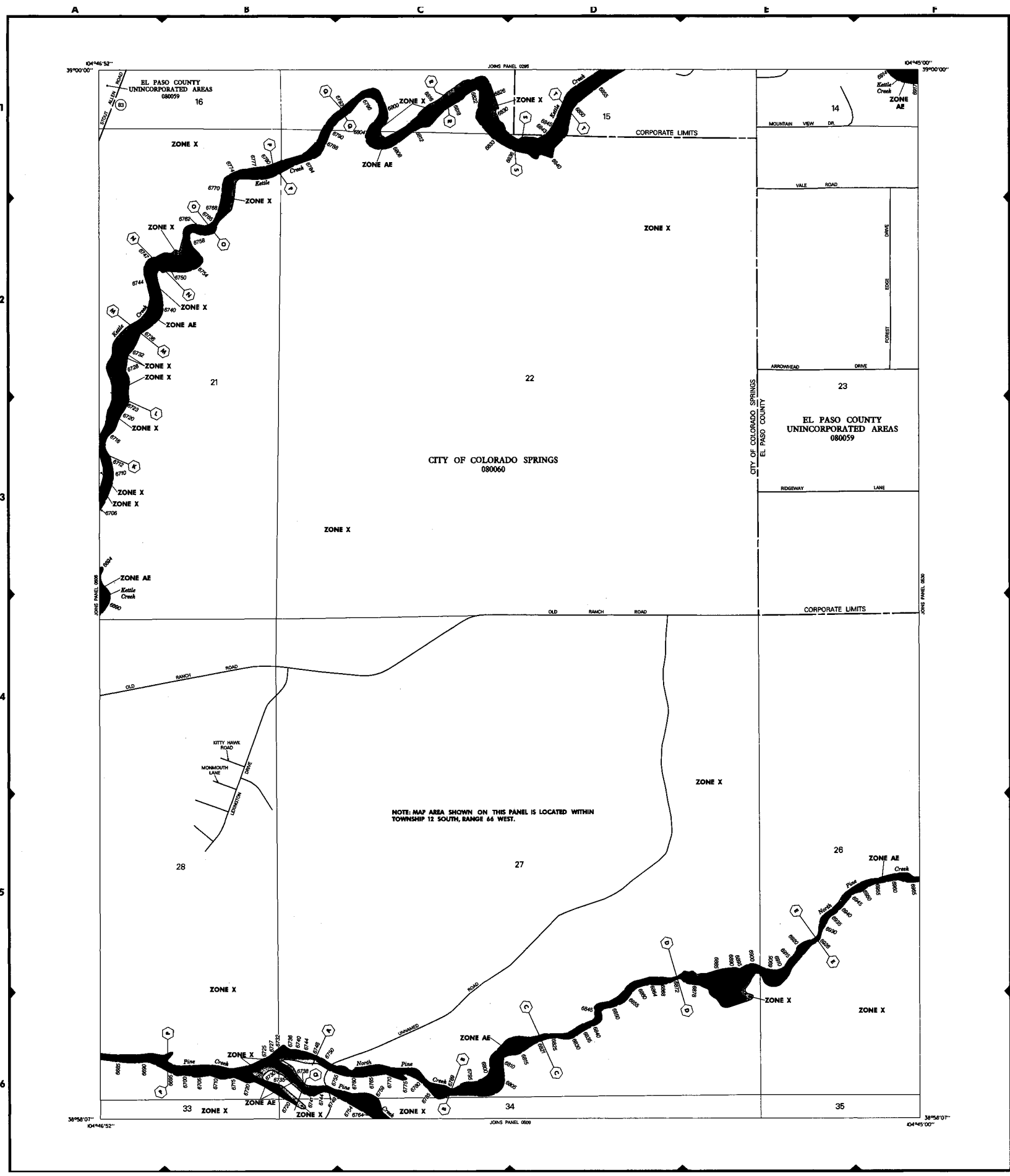

LEGEND

SPECIAL (Hazard) Hazard Areas (Indicated by 300-Year Flood)

ZONE A No base flood elevation determined

ZONE AE Base flood elevation determined

ZONE AH Flood depths of 1 to 3 feet usually areas of parking; base flood elevation determined

ZONE AD Flood depths of 1 to 3 feet usually areas of parking; base flood elevation determined

ZONE APF To be protected from 300-year flood by Federal flood protection system under construction; no base elevation determined

ZONE V Coastal flood with velocity hazard areas within base flood elevation determined

ZONE VE Coastal flood with velocity hazard areas within base flood elevation determined

FLOODWAY AREAS IN ZONE AE

OTHER FLOOD AREAS

ZONE X Areas of 500-year flood areas of 100-year flood with average depths of less than 1 foot or with drainage areas for the 1 square mile and area protected by levees from 100-year flood

OTHER AREAS

ZONE X Areas determined to be outside 500-year floodplain

ZONE D Areas in which flood hazard is indicated

UNDEVELOPED COASTAL BARRIERS

Identified 1975 Coastal barrier areas are normally located within or adjacent to Special Flood Hazard Areas

Identified 1975 Otherwise Protected Areas

Flood Boundary

Floodway Boundary

Zone D Boundary

Boundary Checking Special Flood Hazard Areas of Different Elevation Within Special Flood Hazard Zones

Base Flood Elevation Line Elevation in Feet, See Map Index for Elevation Chart

Cross Section Line

Base Flood Elevation in Feet Where Culture Within in Feet See Map Index for Elevation Diagram

Coastal Barrier Profile

Four Mile

Horizontal Coordinates Based on North Datum of 1983 (NAD 83) Projection

NOTES

This map is for use in determining the National Flood Insurance Program. It does not necessarily identify areas subject to flooding, particularly from flood drainage sources of great size, or all potential features outside Special Flood Hazard Areas.

Coastline flood elevations apply only to landward of U.S. 9042, and include the effects of waves within those elevations and also other significant flood elevations developed by the National Weather Service for hurricane evacuation planning.

Areas of Special Flood Hazard (500-year flood) include Zones A, AE, AH, AD, APF, V, and VE.

Certain areas not in Special Flood Hazard Areas may be protected by flood control structures.

Boundaries of the floodplains were computed at cross sections and extrapolated between cross sections. The floodplains were based on hydraulic considerations with regard to requirements of the Federal Emergency Management Agency.

Floodway widths in some areas may be 500 feet or more to show to scale. Floodway widths are provided in the Flood Insurance Study Report.

This map may incorporate appropriate boundaries of Coastal Barrier Resources System Units and/or Otherwise Protected Areas as determined under the Coastal Barrier Improvement Act of 1982 (CBI-82).

Corporate limits shown are current as of the date of this map. The user should contact appropriate governmental officials to determine if corporate limits have changed subsequent to the issuance of this map.

For community map readers history prior to community mapping see Section 5.0 of the Flood Insurance Study Report.

For mapping map panels and base map source see separately printed Map Index.

MAP REPOSITORY

Refer to Repository Listing on Map Index

EFFECTIVE DATE OF COUNTYWIDE FLOOD INSURANCE RATE MAP:

MARCH 17, 1987

EFFECTIVE DATES OF REVISIONS TO THIS PANEL:

Refer to the FLOOD INSURANCE RATE MAP EFFECTIVE DATE shown on this map to determine when actual rates apply to structures in zones where elevations or depths have been established.

To determine if flood insurance is available contact an insurance agent or call the National Flood Insurance Program at (800) 638-8529.

APPROXIMATE SCALE IN FEET

0 500 1000

NATIONAL FLOOD INSURANCE PROGRAM

FIRM FLOOD INSURANCE RATE MAP

EL PASO COUNTY, COLORADO AND UNINCORPORATED AREAS

PANEL 507 OF 1300
(SEE MAP INDEX FOR PANELS NOT PRINTED)

CONTAINS: COUNTY: NUMBER: PANEL: SHEET:

COLORADO: EL PASO COUNTY: UNINCORPORATED AREAS: 080059: 507: F: 080059: 507: F:

MAP NUMBER 08041C0507 F

EFFECTIVE DATE: MARCH 17, 1987

Federal Emergency Management Agency

Table 3 Summary of Discharges (Cont'd)

Flooding Source and Location	Drainage Area (Square Miles)	Peak Discharges (Cubic Feet Per Second)			
		10-Year	50-Year	100-Year	500-Year
Fisher's Canyon-Above Loomis Avenue At West Meadows Drive	3.59	..1	..1	1,640	..1
Upstream of Fisher's Canyon-South Branch	2.36	..1	..1	440	..1
Fisher's Canyon-South Branch At confluence with Fisher's Canyon	1.23	..1	..1	1,290	..1
Fountain Creek At El Paso-Pueblo County Line	772.0	21,300	64,000	93,000	215,000
Downstream of confluence with Sand Creek	456.0	12,700	38,000	57,000	132,000
Downstream of confluence with Monument Creek	358.0	9,200	28,500	42,200	98,000
Upstream of confluence with Monument Creek	120.0	4,400	14,000	20,500	47,000
Upstream of City of Colorado Springs corporate limits	71.0	3,750	11,800	17,100	40,000
At El Paso-Teller County Line	7.8	2,200	5,800	7,500	14,000
Franceville Tributary to Jimmy Camp Creek At confluence with Jimmy Camp Creek	4.1	1,700	2,800	3,500	4,300
Jimmy Camp Creek At confluence with Fountain Creek	66.4	8,500	12,400	16,000	20,500
Jimmy Camp East Tributary At confluence with Jimmy Camp Creek	9.2	2,800	4,600	5,500	6,900
Jimmy Camp West Tributary At confluence with Jimmy Camp Creek	3.93	1,160	2,280	2,780	4,500
Kettle Creek At State Highway 83	16.3	2,600	6,600	9,300	19,300

¹Data not available

APPENDIX C — FIRM MAPS
KETTLE CREEK DBPS
JOB NO. 25100.00
MAY 2015
C-2



Centennial 303-740-9393 • Colorado Springs 719-593-2593
Fort Collins 970-491-9888 • www.jrengineering.com

HEC-RAS Plan: Historic River: Kettle Creek Reach: Kettle Creek

Reach	River Sta	Profile	Q Total (cfs)	Min Ch El (ft)	W.S. Elev (ft)	Crit W.S. (ft)	E.G. Elev (ft)	E.G. Slope (ft/ft)	Vel Chnl (ft/s)	Flow Area (sq ft)	Top Width (ft)	Froude # Chl
Kettle Creek	24855.28	2-YR	308.10	6868.95	6871.74	6871.00	6871.91	0.018830	3.23	95.51	66.48	0.47
Kettle Creek	24855.28	5-YR	630.50	6868.95	6872.45		6872.74	0.022547	4.30	146.66	76.39	0.55
Kettle Creek	24855.28	10-YR	972.50	6868.95	6872.86		6873.32	0.029283	5.44	178.91	80.16	0.64
Kettle Creek	24855.28	25-YR	1286.50	6868.95	6873.25		6873.83	0.031105	6.10	211.14	83.81	0.67
Kettle Creek	24855.28	50-YR	1812.80	6868.95	6873.91	6873.15	6874.62	0.029451	6.75	268.50	89.98	0.67
Kettle Creek	24855.28	100-YR	2195.90	6868.95	6874.38	6873.52	6875.15	0.026780	7.06	310.82	91.90	0.66
Kettle Creek	23762.63	2-YR	316.60	6855.75	6859.47		6859.53	0.007615	1.78	174.54	112.91	0.25
Kettle Creek	23762.63	5-YR	641.00	6855.75	6860.34		6860.44	0.006747	2.23	275.20	118.68	0.25
Kettle Creek	23762.63	10-YR	987.40	6855.75	6861.15		6861.28	0.005721	2.48	372.90	122.80	0.24
Kettle Creek	23762.63	25-YR	1307.00	6855.75	6861.74		6861.90	0.005489	2.70	445.83	125.94	0.24
Kettle Creek	23762.63	50-YR	1843.70	6855.75	6862.50		6862.73	0.005582	3.07	542.70	129.04	0.25
Kettle Creek	23762.63	100-YR	2234.40	6855.75	6862.93		6863.22	0.005861	3.34	598.52	130.50	0.26
Kettle Creek	22613.19	2-YR	316.60	6839.60	6842.62		6842.94	0.036979	4.56	69.43	33.27	0.56
Kettle Creek	22613.19	5-YR	641.00	6839.60	6843.72		6844.22	0.045594	5.66	113.27	46.17	0.64
Kettle Creek	22613.19	10-YR	987.40	6839.60	6844.19		6845.00	0.076972	7.23	136.63	57.42	0.83
Kettle Creek	22613.19	25-YR	1307.00	6839.60	6844.75	6844.44	6845.62	0.090424	7.47	174.92	79.40	0.89
Kettle Creek	22613.19	50-YR	1843.70	6839.60	6845.52	6845.22	6846.38	0.086852	7.43	248.18	110.76	0.87
Kettle Creek	22613.19	100-YR	2234.40	6839.60	6845.96	6845.63	6846.82	0.073922	7.42	301.50	125.28	0.82
Kettle Creek	21556.31	2-YR	323.20	6825.98	6830.25		6830.32	0.005854	2.00	161.92	68.65	0.23
Kettle Creek	21556.31	5-YR	653.80	6825.98	6831.84		6831.91	0.005205	2.14	306.09	115.04	0.22
Kettle Creek	21556.31	10-YR	1006.50	6825.98	6832.80		6832.89	0.004345	2.37	421.46	123.04	0.21
Kettle Creek	21556.31	25-YR	1330.30	6825.98	6833.46		6833.58	0.004141	2.57	504.71	126.94	0.21
Kettle Creek	21556.31	50-YR	1873.60	6825.98	6834.36		6834.51	0.004095	2.89	620.24	132.37	0.22
Kettle Creek	21556.31	100-YR	2268.90	6825.98	6834.88		6835.06	0.004191	3.11	689.96	135.75	0.23
Kettle Creek	20822.88	2-YR	323.20	6817.21	6821.39		6821.51	0.013524	2.15	141.19	100.61	0.32
Kettle Creek	20822.88	5-YR	653.80	6817.21	6822.06		6822.27	0.020785	2.67	228.99	162.15	0.40
Kettle Creek	20822.88	10-YR	1006.50	6817.21	6822.35		6822.66	0.028506	3.44	275.92	169.82	0.48
Kettle Creek	20822.88	25-YR	1330.30	6817.21	6822.65		6823.01	0.028958	3.85	328.12	172.87	0.49
Kettle Creek	20822.88	50-YR	1873.60	6817.21	6823.23		6823.62	0.024962	4.17	430.48	180.68	0.48
Kettle Creek	20822.88	100-YR	2268.90	6817.21	6823.70		6824.08	0.021155	4.22	516.23	187.76	0.45
Kettle Creek	19882.53	2-YR	326.80	6805.92	6810.22	6808.86	6810.28	0.006672	1.91	170.74	94.30	0.24
Kettle Creek	19882.53	5-YR	661.30	6805.92	6811.63		6811.71	0.003565	1.99	312.29	106.08	0.19
Kettle Creek	19882.53	10-YR	1015.10	6805.92	6812.86		6812.96	0.002426	2.02	447.91	114.13	0.16
Kettle Creek	19882.53	25-YR	1339.20	6805.92	6813.73		6813.86	0.002090	2.10	549.17	119.01	0.16

HYDRAULIC RESULTS –
HISTORIC
KETTLE CREEK DBPS
JOB NO. 25100.00
MAY 2015
C-4

HISTORIC CONDITIONS
MODEL RESULTS



HEC-RAS Plan: Historic River: Kettle Creek Reach: Kettle Creek (Continued)

Reach	River Sta	Profile	Q Total (cfs)	Min Ch El (ft)	W.S. Elev (ft)	Crit W.S. (ft)	E.G. Elev (ft)	E.G. Slope (ft/ft)	Vel Chnl (ft/s)	Flow Area (sq ft)	Top Width (ft)	Froude # Chl
Kettle Creek	19882.53	50-YR	1881.70	6805.92	6814.91		6815.07	0.001856	2.25	693.29	125.40	0.15
Kettle Creek	19882.53	100-YR	2276.20	6805.92	6815.60		6815.79	0.001812	2.37	780.84	129.10	0.15
Kettle Creek	19115.6	2-YR	327.50	6798.52	6801.07		6801.15	0.010962	2.28	142.68	82.89	0.30
Kettle Creek	19115.6	5-YR	662.30	6798.52	6802.72		6802.80	0.004157	2.18	295.69	108.10	0.21
Kettle Creek	19115.6	10-YR	1016.60	6798.52	6804.03		6804.12	0.002468	2.08	449.54	127.91	0.17
Kettle Creek	19115.6	25-YR	1341.40	6798.52	6804.95		6805.04	0.001976	2.10	580.41	157.85	0.16
Kettle Creek	19115.6	50-YR	1885.30	6798.52	6806.14		6806.24	0.001528	2.09	791.49	204.19	0.14
Kettle Creek	19115.6	100-YR	2280.90	6798.52	6806.79		6806.90	0.001302	2.05	927.93	215.92	0.13
Kettle Creek	18505.62	2-YR	327.50	6788.84	6792.13		6792.21	0.006034	2.17	146.94	66.15	0.24
Kettle Creek	18505.62	5-YR	662.30	6788.84	6793.40		6793.56	0.004932	2.56	233.77	70.63	0.23
Kettle Creek	18505.62	10-YR	1016.60	6788.84	6794.36		6794.60	0.004729	2.91	303.57	73.86	0.23
Kettle Creek	18505.62	25-YR	1341.40	6788.84	6795.11		6795.41	0.004615	3.16	359.30	76.07	0.24
Kettle Creek	18505.62	50-YR	1885.30	6788.84	6796.15		6796.56	0.004586	3.53	439.84	79.30	0.24
Kettle Creek	18505.62	100-YR	2280.90	6788.84	6796.81		6797.30	0.004554	3.75	493.69	81.56	0.25
Kettle Creek	17970.84	2-YR	327.50	6783.01	6785.29		6785.48	0.027013	3.53	92.49	58.28	0.47
Kettle Creek	17970.84	5-YR	662.30	6783.01	6786.00		6786.38	0.030500	4.71	136.64	65.58	0.53
Kettle Creek	17970.84	10-YR	1016.60	6783.01	6786.74		6787.25	0.024786	5.06	187.12	71.25	0.50
Kettle Creek	17970.84	25-YR	1341.40	6783.01	6787.27		6787.92	0.022675	5.37	226.19	75.30	0.49
Kettle Creek	17970.84	50-YR	1885.30	6783.01	6788.05		6788.84	0.020495	5.79	287.83	84.29	0.48
Kettle Creek	17970.84	100-YR	2280.90	6783.01	6788.51		6789.46	0.019150	5.97	327.30	86.95	0.47
Kettle Creek	17128.69	2-YR	327.50	6771.75	6775.02		6775.09	0.007009	2.06	158.76	73.23	0.25
Kettle Creek	17128.69	5-YR	662.30	6771.75	6776.21		6776.31	0.006281	2.55	257.23	87.22	0.25
Kettle Creek	17128.69	10-YR	1016.60	6771.75	6776.94		6777.11	0.007047	3.05	322.05	90.46	0.27
Kettle Creek	17128.69	25-YR	1341.40	6771.75	6777.50		6777.72	0.007452	3.42	373.01	93.15	0.29
Kettle Creek	17128.69	50-YR	1885.30	6771.75	6778.28		6778.60	0.007971	3.94	447.05	96.47	0.30
Kettle Creek	17128.69	100-YR	2280.90	6771.75	6778.74		6779.15	0.008423	4.29	492.37	98.53	0.32
Kettle Creek	16326.64	2-YR	327.50	6761.71	6765.20		6765.47	0.024916	4.16	78.87	33.57	0.47
Kettle Creek	16326.64	5-YR	662.30	6761.71	6766.67		6766.93	0.028840	3.99	163.80	85.29	0.50
Kettle Creek	16326.64	10-YR	1016.60	6761.71	6767.39		6767.71	0.023135	4.39	227.16	89.81	0.47
Kettle Creek	16326.64	25-YR	1341.40	6761.71	6767.92		6768.31	0.021173	4.73	275.72	92.98	0.46
Kettle Creek	16326.64	50-YR	1885.30	6761.71	6768.63		6769.09	0.019608	5.18	350.55	109.34	0.46
Kettle Creek	16326.64	100-YR	2280.90	6761.71	6769.07		6769.63	0.018115	5.35	399.77	110.77	0.45
Kettle Creek	15906.34	2-YR	327.50	6753.98	6760.15		6760.24	0.007350	2.47	132.91	51.15	0.26

HYDRAULIC RESULTS –
 HISTORIC
 KETTLE CREEK DBPS
 JOB NO. 25100.00
 MAY 2015
 C-5

HISTORIC CONDITIONS
 MODEL RESULTS (CONT.)



Centennial 303-740-9393 • Colorado Springs 719-593-2593
 Fort Collins 970-491-9888 • www.jrengineering.com

HEC-RAS Plan: Historic River: Kettle Creek Reach: Kettle Creek (Continued)

Reach	River Sta	Profile	Q Total (cfs)	Min Ch El (ft)	W.S. Elev (ft)	Crit W.S. (ft)	E.G. Elev (ft)	E.G. Slope (ft/ft)	Vel Chnl (ft/s)	Flow Area (sq ft)	Top Width (ft)	Froude # Chl
Kettle Creek	19882.53	50-YR	1881.70	6805.92	6814.91		6815.07	0.001856	2.25	693.29	125.40	0.15
Kettle Creek	19882.53	100-YR	2276.20	6805.92	6815.60		6815.79	0.001812	2.37	780.84	129.10	0.15
Kettle Creek	19115.6	2-YR	327.50	6798.52	6801.07		6801.15	0.010962	2.28	142.68	82.89	0.30
Kettle Creek	19115.6	5-YR	662.30	6798.52	6802.72		6802.80	0.004157	2.18	295.69	108.10	0.21
Kettle Creek	19115.6	10-YR	1016.60	6798.52	6804.03		6804.12	0.002468	2.08	449.54	127.91	0.17
Kettle Creek	19115.6	25-YR	1341.40	6798.52	6804.95		6805.04	0.001976	2.10	580.41	157.85	0.16
Kettle Creek	19115.6	50-YR	1885.30	6798.52	6806.14		6806.24	0.001528	2.09	791.49	204.19	0.14
Kettle Creek	19115.6	100-YR	2280.90	6798.52	6806.79		6806.90	0.001302	2.05	927.93	215.92	0.13
Kettle Creek	18505.62	2-YR	327.50	6788.84	6792.13		6792.21	0.006034	2.17	146.94	66.15	0.24
Kettle Creek	18505.62	5-YR	662.30	6788.84	6793.40		6793.56	0.004932	2.56	233.77	70.63	0.23
Kettle Creek	18505.62	10-YR	1016.60	6788.84	6794.36		6794.60	0.004729	2.91	303.57	73.86	0.23
Kettle Creek	18505.62	25-YR	1341.40	6788.84	6795.11		6795.41	0.004615	3.16	359.30	76.07	0.24
Kettle Creek	18505.62	50-YR	1885.30	6788.84	6796.15		6796.56	0.004586	3.53	439.84	79.30	0.24
Kettle Creek	18505.62	100-YR	2280.90	6788.84	6796.81		6797.30	0.004554	3.75	493.69	81.56	0.25
Kettle Creek	17970.84	2-YR	327.50	6783.01	6785.29		6785.48	0.027013	3.53	92.49	58.28	0.47
Kettle Creek	17970.84	5-YR	662.30	6783.01	6786.00		6786.38	0.030500	4.71	136.64	65.58	0.53
Kettle Creek	17970.84	10-YR	1016.60	6783.01	6786.74		6787.25	0.024786	5.06	187.12	71.25	0.50
Kettle Creek	17970.84	25-YR	1341.40	6783.01	6787.27		6787.92	0.022675	5.37	226.19	75.30	0.49
Kettle Creek	17970.84	50-YR	1885.30	6783.01	6788.05		6788.84	0.020495	5.79	287.83	84.29	0.48
Kettle Creek	17970.84	100-YR	2280.90	6783.01	6788.51		6789.46	0.019150	5.97	327.30	86.95	0.47
Kettle Creek	17128.69	2-YR	327.50	6771.75	6775.02		6775.09	0.007009	2.06	158.76	73.23	0.25
Kettle Creek	17128.69	5-YR	662.30	6771.75	6776.21		6776.31	0.006281	2.55	257.23	87.22	0.25
Kettle Creek	17128.69	10-YR	1016.60	6771.75	6776.94		6777.11	0.007047	3.05	322.05	90.46	0.27
Kettle Creek	17128.69	25-YR	1341.40	6771.75	6777.50		6777.72	0.007452	3.42	373.01	93.15	0.29
Kettle Creek	17128.69	50-YR	1885.30	6771.75	6778.28		6778.60	0.007971	3.94	447.05	96.47	0.30
Kettle Creek	17128.69	100-YR	2280.90	6771.75	6778.74		6779.15	0.008423	4.29	492.37	98.53	0.32
Kettle Creek	16326.64	2-YR	327.50	6761.71	6765.20		6765.47	0.024916	4.16	78.87	33.57	0.47
Kettle Creek	16326.64	5-YR	662.30	6761.71	6766.67		6766.93	0.028840	3.99	163.80	85.29	0.50
Kettle Creek	16326.64	10-YR	1016.60	6761.71	6767.39		6767.71	0.023135	4.39	227.16	89.81	0.47
Kettle Creek	16326.64	25-YR	1341.40	6761.71	6767.92		6768.31	0.021173	4.73	275.72	92.98	0.46
Kettle Creek	16326.64	50-YR	1885.30	6761.71	6768.63		6769.09	0.019608	5.18	350.55	109.34	0.46
Kettle Creek	16326.64	100-YR	2280.90	6761.71	6769.07		6769.63	0.018115	5.35	399.77	110.77	0.45
Kettle Creek	15906.34	2-YR	327.50	6753.98	6760.15		6760.24	0.007350	2.47	132.91	51.15	0.26

HYDRAULIC RESULTS –
 HISTORIC
 KETTLE CREEK DBPS
 JOB NO. 25100.00
 MAY 2015
 C-6

HISTORIC CONDITIONS
 MODEL RESULTS (CONT.)



Centennial 303-740-9393 • Colorado Springs 719-593-2593
 Fort Collins 970-491-9888 • www.jrengineering.com

HEC-RAS Plan: Historic River: Kettle Creek Reach: Kettle Creek (Continued)

Reach	River Sta	Profile	Q Total (cfs)	Min Ch El (ft)	W.S. Elev (ft)	Crit W.S. (ft)	E.G. Elev (ft)	E.G. Slope (ft/ft)	Vel Chnl (ft/s)	Flow Area (sq ft)	Top Width (ft)	Froude # Chl
Kettle Creek	13757.33	100-YR	2280.90	6727.92	6735.34		6736.57	0.022250	6.72	282.31	80.42	0.49
Kettle Creek	12367.83	2-YR	327.50	6708.58	6712.16		6712.21	0.003857	1.80	181.55	66.19	0.19
Kettle Creek	12367.83	5-YR	662.30	6708.58	6713.60		6713.69	0.003939	2.36	278.69	69.28	0.20
Kettle Creek	12367.83	10-YR	1016.60	6708.58	6713.70		6713.90	0.008571	3.54	285.63	69.49	0.30
Kettle Creek	12367.83	25-YR	1341.40	6708.58	6714.28		6714.54	0.009806	4.05	328.88	77.18	0.33
Kettle Creek	12367.83	50-YR	1885.30	6708.58	6715.19		6715.54	0.010156	4.63	399.98	79.51	0.34
Kettle Creek	12367.83	100-YR	2280.90	6708.58	6715.78		6716.20	0.010202	4.96	448.09	81.66	0.35
Kettle Creek	11267.11	2-YR	327.50	6695.53	6699.06	6698.91	6699.98	0.116324	7.71	42.49	20.98	0.95
Kettle Creek	11267.11	5-YR	662.30	6695.53	6700.34	6700.34	6701.44	0.104178	8.44	78.83	36.34	0.94
Kettle Creek	11267.11	10-YR	1016.60	6695.53	6702.66		6703.12	0.111298	4.32	203.90	66.60	0.35
Kettle Creek	11267.11	25-YR	1341.40	6695.53	6703.34		6703.92	0.009487	4.32	250.74	71.28	0.33
Kettle Creek	11267.11	50-YR	1885.30	6695.53	6704.12		6704.93	0.009151	4.64	308.54	77.03	0.33
Kettle Creek	11267.11	100-YR	2280.90	6695.53	6704.59		6705.55	0.009161	4.87	345.61	81.11	0.33
Kettle Creek	10087.38	2-YR	328.50	6680.77	6684.95		6685.04	0.002512	1.70	159.07	56.13	0.16
Kettle Creek	10087.38	5-YR	661.50	6680.77	6686.52		6686.66	0.002290	2.09	254.86	69.77	0.16
Kettle Creek	10087.38	10-YR	1012.30	6680.77	6687.64		6687.82	0.002195	2.34	343.59	87.25	0.17
Kettle Creek	10087.38	25-YR	1333.10	6680.77	6688.36		6688.58	0.002116	2.47	406.94	90.09	0.17
Kettle Creek	10087.38	50-YR	1869.30	6680.77	6689.42		6689.71	0.001962	2.61	503.92	92.80	0.16
Kettle Creek	10087.38	100-YR	2258.80	6680.77	6690.11		6690.45	0.001878	2.70	569.13	94.66	0.16
Kettle Creek	9732.32	2-YR	328.50	6676.00	6679.62		6679.78	0.014215	3.12	105.41	44.21	0.36
Kettle Creek	9732.32	5-YR	661.50	6676.00	6680.96		6681.19	0.015232	3.83	172.63	57.27	0.38
Kettle Creek	9732.32	10-YR	1012.30	6676.00	6681.55		6681.92	0.019446	4.86	209.28	67.14	0.45
Kettle Creek	9732.32	25-YR	1333.10	6676.00	6681.82		6682.35	0.025998	5.89	227.43	70.49	0.52
Kettle Creek	9732.32	50-YR	1869.30	6676.00	6682.28		6683.07	0.032827	7.13	261.08	74.66	0.60
Kettle Creek	9732.32	100-YR	2258.80	6676.00	6682.51		6683.54	0.038535	7.99	278.90	76.19	0.65
Kettle Creek	8444.97	2-YR	353.10	6660.69	6664.35		6664.48	0.010189	2.87	123.62	53.24	0.31
Kettle Creek	8444.97	5-YR	701.50	6660.69	6665.42		6665.62	0.009957	3.54	195.76	81.59	0.32
Kettle Creek	8444.97	10-YR	1066.00	6660.69	6666.22		6666.47	0.008287	3.67	269.36	100.58	0.30
Kettle Creek	8444.97	25-YR	1398.50	6660.69	6666.81		6667.14	0.006870	3.63	330.40	104.18	0.28
Kettle Creek	8444.97	50-YR	1953.40	6660.69	6667.60		6668.03	0.006059	3.74	414.16	110.69	0.27
Kettle Creek	8444.97	100-YR	2361.60	6660.69	6668.12		6668.62	0.005609	3.81	473.94	116.54	0.26
Kettle Creek	8350	2-YR	353.10	6660.00	6663.84		6663.91	0.003711	2.04	164.36	65.11	0.19
Kettle Creek	8350	5-YR	701.50	6660.00	6664.85		6665.02	0.004274	2.60	235.14	74.09	0.22

HISTORIC CONDITIONS
MODEL RESULTS (CONT.)

HYDRAULIC RESULTS –
HISTORIC
KETTLE CREEK DBPS
JOB NO. 25100.00
MAY 2015
C-7



HEC-RAS Plan: Historic River: Kettle Creek Reach: Kettle Creek (Continued)

Reach	River Sta	Profile	Q Total (cfs)	Min Ch El (ft)	W.S. Elev (ft)	Crit W.S. (ft)	E.G. Elev (ft)	E.G. Slope (ft/ft)	Vel Chnl (ft/s)	Flow Area (sq ft)	Top Width (ft)	Froude # Chl
Kettle Creek	8350	10-YR	1066.00	6660.00	6665.64		6665.91	0.004490	2.97	296.61	82.32	0.23
Kettle Creek	8350	25-YR	1398.50	6660.00	6666.27		6666.61	0.004560	3.23	352.35	97.72	0.23
Kettle Creek	8350	50-YR	1953.40	6660.00	6667.12		6667.55	0.004276	3.42	438.67	104.63	0.23
Kettle Creek	8350	100-YR	2361.60	6660.00	6667.68		6668.17	0.004090	3.53	498.53	109.43	0.23
Kettle Creek	8251.39	2-YR	353.10	6660.00	6662.16	6662.16	6662.77	0.139520	6.25	56.55	47.96	1.00
Kettle Creek	8251.39	5-YR	701.50	6660.00	6662.98	6662.86	6663.78	0.089996	7.10	98.01	52.88	0.88
Kettle Creek	8251.39	10-YR	1066.00	6660.00	6663.70	6663.45	6664.67	0.067145	7.51	137.80	57.70	0.80
Kettle Creek	8251.39	25-YR	1398.50	6660.00	6664.26		6665.38	0.056623	7.80	170.79	61.78	0.76
Kettle Creek	8251.39	50-YR	1953.40	6660.00	6665.01	6664.69	6666.39	0.047749	8.22	219.99	68.22	0.72
Kettle Creek	8251.39	100-YR	2361.60	6660.00	6665.49	6665.17	6667.04	0.043694	8.47	253.41	72.46	0.70
Kettle Creek	8060.94	2-YR	353.10	6653.57	6656.87	6655.93	6657.22	0.011326	3.29	86.15	37.48	0.33
Kettle Creek	8060.94	5-YR	701.50	6653.57	6657.83	6657.05	6658.50	0.013120	4.27	125.51	43.90	0.38
Kettle Creek	8060.94	10-YR	1066.00	6653.57	6658.53	6657.93	6659.49	0.014608	5.01	157.55	48.51	0.41
Kettle Creek	8060.94	25-YR	1398.50	6653.57	6659.04	6658.62	6660.25	0.015630	5.56	183.29	52.29	0.43
Kettle Creek	8060.94	50-YR	1953.40	6653.57	6659.74	6659.55	6661.33	0.016802	6.28	222.21	57.94	0.46
Kettle Creek	8060.94	100-YR	2361.60	6653.57	6660.17	6660.10	6662.02	0.017487	6.71	247.86	61.29	0.47
Kettle Creek	7863.13	2-YR	353.10	6649.24	6651.10	6651.10	6651.77	0.128027	6.54	54.02	41.06	0.98
Kettle Creek	7863.13	5-YR	701.50	6649.24	6651.94	6651.87	6652.90	0.092227	7.62	90.48	46.02	0.90
Kettle Creek	7863.13	10-YR	1066.00	6649.24	6652.67	6652.53	6653.87	0.071768	8.12	125.51	50.74	0.84
Kettle Creek	7863.13	25-YR	1398.50	6649.24	6653.22	6653.07	6654.65	0.061406	8.43	154.57	54.11	0.80
Kettle Creek	7863.13	50-YR	1953.40	6649.24	6653.99	6653.91	6655.79	0.051887	8.85	198.10	58.45	0.76
Kettle Creek	7863.13	100-YR	2361.60	6649.24	6654.49	6654.49	6656.52	0.047530	9.12	227.90	61.60	0.74
Kettle Creek	7632.03	2-YR	353.10	6641.32	6646.20		6646.31	0.008952	2.75	128.33	45.40	0.29
Kettle Creek	7632.03	5-YR	701.50	6641.32	6647.79		6647.96	0.008705	3.36	208.44	55.76	0.30
Kettle Creek	7632.03	10-YR	1066.00	6641.32	6648.80		6649.04	0.009046	3.96	267.75	61.25	0.32
Kettle Creek	7632.03	25-YR	1398.50	6641.32	6649.49		6649.80	0.009543	4.45	311.28	64.84	0.33
Kettle Creek	7632.03	50-YR	1953.40	6641.32	6650.38		6650.82	0.010474	5.15	371.58	70.06	0.36
Kettle Creek	7632.03	100-YR	2361.60	6641.32	6650.94		6651.46	0.011028	5.59	411.37	74.09	0.37
Kettle Creek	6688.3	2-YR	354.00	6629.79	6633.04		6633.28	0.023936	3.87	91.51	40.83	0.46
Kettle Creek	6688.3	5-YR	704.60	6629.79	6634.52		6634.80	0.025676	4.25	165.73	68.02	0.48
Kettle Creek	6688.3	10-YR	1073.00	6629.79	6635.47		6635.78	0.024632	4.45	240.95	89.79	0.48
Kettle Creek	6688.3	25-YR	1409.70	6629.79	6636.14		6636.47	0.022839	4.60	306.37	103.14	0.47
Kettle Creek	6688.3	50-YR	1972.40	6629.79	6637.06		6637.42	0.020117	4.85	406.97	116.81	0.45
Kettle Creek	6688.3	100-YR	2381.00	6629.79	6637.64		6638.02	0.018858	4.99	476.81	125.69	0.45

HISTORIC CONDITIONS
MODEL RESULTS (CONT.)

HYDRAULIC RESULTS –
HISTORIC
KETTLE CREEK DBPS
JOB NO. 25100.00
MAY 2015
C-8



HEC-RAS Plan: Historic River: Kettle Creek Reach: Kettle Creek (Continued)

Reach	River Sta	Profile	Q Total (cfs)	Min Ch El (ft)	W.S. Elev (ft)	Crit W.S. (ft)	E.G. Elev (ft)	E.G. Slope (ft/ft)	Vel Chnl (ft/s)	Flow Area (sq ft)	Top Width (ft)	Froude # Chl
Kettle Creek	6433.61	2-YR	354.00	6627.42	6631.00		6631.05	0.004341	1.81	195.85	77.32	0.20
Kettle Creek	6433.61	5-YR	704.60	6627.42	6632.27		6632.35	0.004804	2.33	302.53	89.52	0.22
Kettle Creek	6433.61	10-YR	1073.00	6627.42	6633.19		6633.31	0.004951	2.77	387.95	96.32	0.23
Kettle Creek	6433.61	25-YR	1409.70	6627.42	6633.86		6634.01	0.005135	3.10	453.58	100.30	0.24
Kettle Creek	6433.61	50-YR	1972.40	6627.42	6634.80		6635.00	0.005312	3.54	550.18	104.92	0.26
Kettle Creek	6433.61	100-YR	2381.00	6627.42	6635.39		6635.63	0.005402	3.80	613.39	108.34	0.26
Kettle Creek	6305.69	2-YR	354.00	6625.87	6629.15		6629.24	0.010035	2.37	149.39	73.11	0.29
Kettle Creek	6305.69	5-YR	704.60	6625.87	6630.20		6630.34	0.011142	3.02	233.62	86.14	0.32
Kettle Creek	6305.69	10-YR	1073.00	6625.87	6631.14		6631.32	0.010466	3.37	318.99	95.90	0.32
Kettle Creek	6305.69	25-YR	1409.70	6625.87	6631.86		6632.06	0.009444	3.62	390.35	103.34	0.32
Kettle Creek	6305.69	50-YR	1972.40	6625.87	6632.89		6633.13	0.008184	3.92	502.50	113.70	0.31
Kettle Creek	6305.69	100-YR	2381.00	6625.87	6633.55		6633.81	0.007508	4.07	579.41	120.17	0.30
Kettle Creek	6147.73	2-YR	354.00	6623.99	6627.84		6627.91	0.007051	2.06	171.58	90.53	0.25
Kettle Creek	6147.73	5-YR	704.60	6623.99	6629.27		6629.37	0.003841	2.14	306.59	96.98	0.20
Kettle Creek	6147.73	10-YR	1073.00	6623.99	6630.32		6630.45	0.003280	2.35	410.64	101.90	0.19
Kettle Creek	6147.73	25-YR	1409.70	6623.99	6631.09		6631.26	0.003087	2.53	490.56	105.29	0.19
Kettle Creek	6147.73	50-YR	1972.40	6623.99	6632.18		6632.40	0.002932	2.78	607.89	110.61	0.19
Kettle Creek	6147.73	100-YR	2381.00	6623.99	6632.86		6633.12	0.002864	2.94	684.30	113.74	0.19
Kettle Creek	6032.86	2-YR	354.00	6622.67	6626.21		6626.27	0.004310	1.86	182.42	83.84	0.20
Kettle Creek	6032.86	5-YR	704.60	6622.67	6627.31		6627.44	0.003932	2.24	278.07	90.33	0.20
Kettle Creek	6032.86	10-YR	1073.00	6622.67	6628.14		6628.33	0.003912	2.56	355.44	95.50	0.21
Kettle Creek	6032.86	25-YR	1409.70	6622.67	6628.74		6628.99	0.004031	2.82	413.10	98.91	0.22
Kettle Creek	6032.86	50-YR	1972.40	6622.67	6629.62		6629.96	0.004050	3.13	502.76	103.97	0.22
Kettle Creek	6032.86	100-YR	2381.00	6622.67	6630.21		6630.61	0.003981	3.31	564.66	107.03	0.23
Kettle Creek	5983.2	2-YR	354.00	6622.04	6626.06		6626.11	0.002492	1.59	198.91	90.80	0.16
Kettle Creek	5983.2	5-YR	704.60	6622.04	6627.19		6627.29	0.002153	1.81	310.58	106.47	0.15
Kettle Creek	5983.2	10-YR	1073.00	6622.04	6628.04		6628.18	0.002031	1.99	406.65	118.33	0.15
Kettle Creek	5983.2	25-YR	1409.70	6622.04	6628.65		6628.84	0.001923	2.08	479.06	119.70	0.15
Kettle Creek	5983.2	50-YR	1972.40	6622.04	6629.56		6629.81	0.001829	2.24	590.12	124.90	0.15
Kettle Creek	5983.2	100-YR	2381.00	6622.04	6630.16		6630.44	0.001795	2.35	667.83	130.97	0.15
Kettle Creek	5846.46	2-YR	354.00	6620.39	6622.52		6622.96	0.085660	5.32	66.56	48.91	0.80
Kettle Creek	5846.46	5-YR	704.60	6620.39	6623.45		6624.03	0.066162	6.07	116.12	57.50	0.75
Kettle Creek	5846.46	10-YR	1073.00	6620.39	6624.20		6624.89	0.057157	6.65	161.47	63.80	0.73

HYDRAULIC RESULTS –
 HISTORIC
 KETTLE CREEK DBPS
 JOB NO. 25100.00
 MAY 2015
 C-9

HISTORIC CONDITIONS
 MODEL RESULTS (CONT.)



Centennial 303-740-9393 • Colorado Springs 719-593-2593
 Fort Collins 970-491-9888 • www.jrengineering.com

HEC-RAS Plan: Historic River: Kettle Creek Reach: Kettle Creek (Continued)

Reach	River Sta	Profile	Q Total (cfs)	Min Ch El (ft)	W.S. Elev (ft)	Crit W.S. (ft)	E.G. Elev (ft)	E.G. Slope (ft/ft)	Vel Chnl (ft/s)	Flow Area (sq ft)	Top Width (ft)	Froude # Chl
Kettle Creek	5846.46	25-YR	1409.70	6620.39	6624.75		6625.54	0.051331	7.16	197.40	67.93	0.71
Kettle Creek	5846.46	50-YR	1972.40	6620.39	6625.53		6626.48	0.044721	7.76	253.12	73.24	0.69
Kettle Creek	5846.46	100-YR	2381.00	6620.39	6626.03		6627.09	0.041561	8.10	290.28	76.50	0.68
Kettle Creek	5366.46	2-YR	354.00	6612.16	6617.10	6614.99	6617.15	0.004483	1.82	194.57	81.26	0.20
Kettle Creek	5366.46	5-YR	704.60	6612.16	6618.22	6615.79	6618.31	0.004637	2.37	293.22	92.61	0.22
Kettle Creek	5366.46	10-YR	1073.00	6612.16	6619.06	6616.34	6619.20	0.004783	2.77	372.23	95.87	0.23
Kettle Creek	5366.46	25-YR	1409.70	6612.16	6619.70	6616.75	6619.88	0.004881	3.06	433.84	98.08	0.24
Kettle Creek	5366.46	50-YR	1972.40	6612.16	6620.60	6617.35	6620.86	0.005031	3.46	523.66	101.72	0.25
Kettle Creek	5366.46	100-YR	2381.00	6612.16	6621.16	6617.73	6621.48	0.005117	3.70	581.99	103.99	0.25
Kettle Creek	3636.65	2-YR	354.00	6592.57	6594.21	6594.19	6594.63	0.146748	5.20	68.07	77.77	0.98
Kettle Creek	3636.65	5-YR	704.60	6592.57	6594.70	6594.70	6595.37	0.137839	6.57	107.32	82.35	1.01
Kettle Creek	3636.65	10-YR	1073.00	6592.57	6595.15	6595.15	6596.00	0.125751	7.41	144.88	86.50	1.01
Kettle Creek	3636.65	25-YR	1409.70	6592.57	6595.50	6595.50	6596.50	0.118884	8.04	175.35	88.66	1.01
Kettle Creek	3636.65	50-YR	1972.40	6592.57	6596.01	6596.01	6597.24	0.109233	8.91	221.60	91.56	1.00
Kettle Creek	3636.65	100-YR	2381.00	6592.57	6596.34	6596.34	6597.73	0.104607	9.44	252.22	92.88	1.00
Kettle Creek	3115.71	2-YR	354.00	6585.47	6589.02		6589.06	0.003484	1.47	235.63	121.59	0.18
Kettle Creek	3115.71	5-YR	704.60	6585.47	6590.45		6590.50	0.001932	1.53	420.88	137.69	0.14
Kettle Creek	3115.71	10-YR	1073.00	6585.47	6591.69		6591.76	0.001332	1.55	599.41	149.24	0.12
Kettle Creek	3115.71	25-YR	1409.70	6585.47	6592.65		6592.73	0.001084	1.58	747.56	158.05	0.12
Kettle Creek	3115.71	50-YR	1972.40	6585.47	6593.70		6593.80	0.001058	1.74	917.40	167.04	0.12
Kettle Creek	3115.71	100-YR	2381.00	6585.47	6594.34		6594.45	0.001069	1.86	1025.77	174.09	0.12
Kettle Creek	2957.59	2-YR	354.00	6582.74	6586.82		6587.60	0.045479	6.79	50.68	18.96	0.66
Kettle Creek	2957.59	5-YR	704.60	6582.74	6588.24	6587.73	6589.50	0.039862	8.08	80.96	24.34	0.66
Kettle Creek	2957.59	10-YR	1073.00	6582.74	6589.22	6589.00	6590.93	0.037660	8.91	107.60	29.74	0.66
Kettle Creek	2957.59	25-YR	1409.70	6582.74	6590.16	6590.16	6592.00	0.029911	8.79	137.55	34.66	0.60
Kettle Creek	2957.59	50-YR	1972.40	6582.74	6591.52	6591.52	6593.13	0.022892	8.71	201.24	61.95	0.54
Kettle Creek	2957.59	100-YR	2381.00	6582.74	6591.99	6591.99	6593.75	0.021745	8.82	232.06	67.51	0.53
Kettle Creek	2731.34	2-YR	354.00	6579.12	6583.41		6583.59	0.008741	3.21	105.13	39.32	0.30
Kettle Creek	2731.34	5-YR	704.60	6579.12	6584.34		6584.73	0.011926	4.37	146.35	48.54	0.36
Kettle Creek	2731.34	10-YR	1073.00	6579.12	6584.94		6585.61	0.014531	5.24	176.94	52.41	0.41
Kettle Creek	2731.34	25-YR	1409.70	6579.12	6585.39	6584.16	6586.31	0.016387	5.88	200.86	55.38	0.44
Kettle Creek	2731.34	50-YR	1972.40	6579.12	6585.99	6585.20	6587.32	0.019024	6.79	235.85	60.21	0.48
Kettle Creek	2731.34	100-YR	2381.00	6579.12	6586.35	6585.86	6587.99	0.020698	7.35	257.97	63.06	0.51

HISTORIC CONDITIONS
MODEL RESULTS (CONT.)

HYDRAULIC RESULTS –
HISTORIC
KETTLE CREEK DBPS
JOB NO. 25100.00
MAY 2015
C-10



Centennial 303-740-9393 • Colorado Springs 719-593-2593
Fort Collins 970-491-9888 • www.jrengineering.com

HEC-RAS Plan: Historic River: Kettle Creek Reach: Kettle Creek (Continued)

Reach	River Sta	Profile	Q Total (cfs)	Min Ch El (ft)	W.S. Elev (ft)	Crit W.S. (ft)	E.G. Elev (ft)	E.G. Slope (ft/ft)	Vel Chnl (ft/s)	Flow Area (sq ft)	Top Width (ft)	Froude # Chl
Kettle Creek	2597.25	2-YR	354.00	6577.88	6581.02	6580.64	6581.20	0.055461	3.39	104.29	107.64	0.61
Kettle Creek	2597.25	5-YR	704.60	6577.88	6581.62	6581.18	6581.86	0.048160	3.95	178.52	134.67	0.60
Kettle Creek	2597.25	10-YR	1073.00	6577.88	6582.01	6581.53	6582.35	0.046669	4.61	232.45	139.01	0.62
Kettle Creek	2597.25	25-YR	1409.70	6577.88	6582.29	6581.80	6582.71	0.047913	5.16	271.74	140.88	0.64
Kettle Creek	2597.25	50-YR	1972.40	6577.88	6582.69	6582.18	6583.26	0.050104	5.94	327.77	143.50	0.67
Kettle Creek	2597.25	100-YR	2381.00	6577.88	6582.93	6582.42	6583.62	0.052246	6.46	362.15	145.09	0.70
Kettle Creek	2067.56	2-YR	354.00	6572.37	6573.48	6573.27	6573.67	0.006821	0.80	110.53	146.69	0.19
Kettle Creek	2067.56	5-YR	704.60	6572.37	6573.95	6573.70	6574.19	0.007371	0.98	196.15	224.10	0.21
Kettle Creek	2067.56	10-YR	1073.00	6572.37	6574.26	6574.09	6574.53	0.007628	1.27	279.70	286.19	0.23
Kettle Creek	2067.56	25-YR	1409.70	6572.37	6574.43	6574.23	6574.77	0.007727	1.42	328.69	287.15	0.23
Kettle Creek	2067.56	50-YR	1972.40	6572.37	6574.68	6574.47	6575.13	0.007828	1.63	401.36	288.57	0.24
Kettle Creek	2067.56	100-YR	2381.00	6572.37	6574.85	6574.65	6575.37	0.007839	1.76	449.76	289.51	0.25
Kettle Creek	1361.33	2-YR	354.00	6562.11	6564.71		6564.79	0.032083	2.28	155.56	196.41	0.45
Kettle Creek	1361.33	5-YR	704.60	6562.11	6565.18		6565.30	0.027398	2.82	250.24	203.79	0.45
Kettle Creek	1361.33	10-YR	1073.00	6562.11	6565.60		6565.76	0.024637	3.19	336.78	210.32	0.44
Kettle Creek	1361.33	25-YR	1409.70	6562.11	6565.93		6566.12	0.023139	3.45	408.20	215.39	0.44
Kettle Creek	1361.33	50-YR	1972.40	6562.11	6566.44		6566.66	0.021278	3.80	518.80	222.31	0.44
Kettle Creek	1361.33	100-YR	2381.00	6562.11	6566.76		6567.01	0.020307	4.03	591.30	224.27	0.44
Kettle Creek	670.23	2-YR	354.00	6554.40	6557.16	6556.20	6557.20	0.005494	1.44	239.86	174.10	0.21
Kettle Creek	670.23	5-YR	704.60	6554.40	6557.81		6557.88	0.005714	1.87	355.41	183.27	0.22
Kettle Creek	670.23	10-YR	1073.00	6554.40	6558.32		6558.43	0.005904	2.19	450.43	190.11	0.24
Kettle Creek	670.23	25-YR	1409.70	6554.40	6558.70		6558.85	0.006032	2.42	524.49	194.28	0.24
Kettle Creek	670.23	50-YR	1972.40	6554.40	6559.25		6559.45	0.006240	2.74	631.42	199.94	0.26
Kettle Creek	670.23	100-YR	2381.00	6554.40	6559.59		6559.84	0.006379	2.95	700.27	203.50	0.26
Kettle Creek	6.23	2-YR	354.00	6550.00	6550.73	6550.40	6550.79	0.018792	1.63	206.21	297.05	0.34
Kettle Creek	6.23	5-YR	704.60	6550.00	6551.08	6550.63	6551.18	0.018806	2.11	312.90	311.00	0.36
Kettle Creek	6.23	10-YR	1073.00	6550.00	6551.37	6550.83	6551.52	0.018814	2.44	405.23	325.03	0.38
Kettle Creek	6.23	25-YR	1409.70	6550.00	6551.60	6550.99	6551.78	0.018835	2.68	480.15	337.18	0.38
Kettle Creek	6.23	50-YR	1972.40	6550.00	6551.91	6551.23	6552.15	0.018811	3.04	587.01	345.75	0.40
Kettle Creek	6.23	100-YR	2381.00	6550.00	6552.11	6551.40	6552.39	0.018804	3.26	655.86	349.99	0.40

HISTORIC CONDITIONS
MODEL RESULTS

HYDRAULIC RESULTS –
HISTORIC
KETTLE CREEK DBPS
JOB NO. 25100.00
MAY 2015
C-11



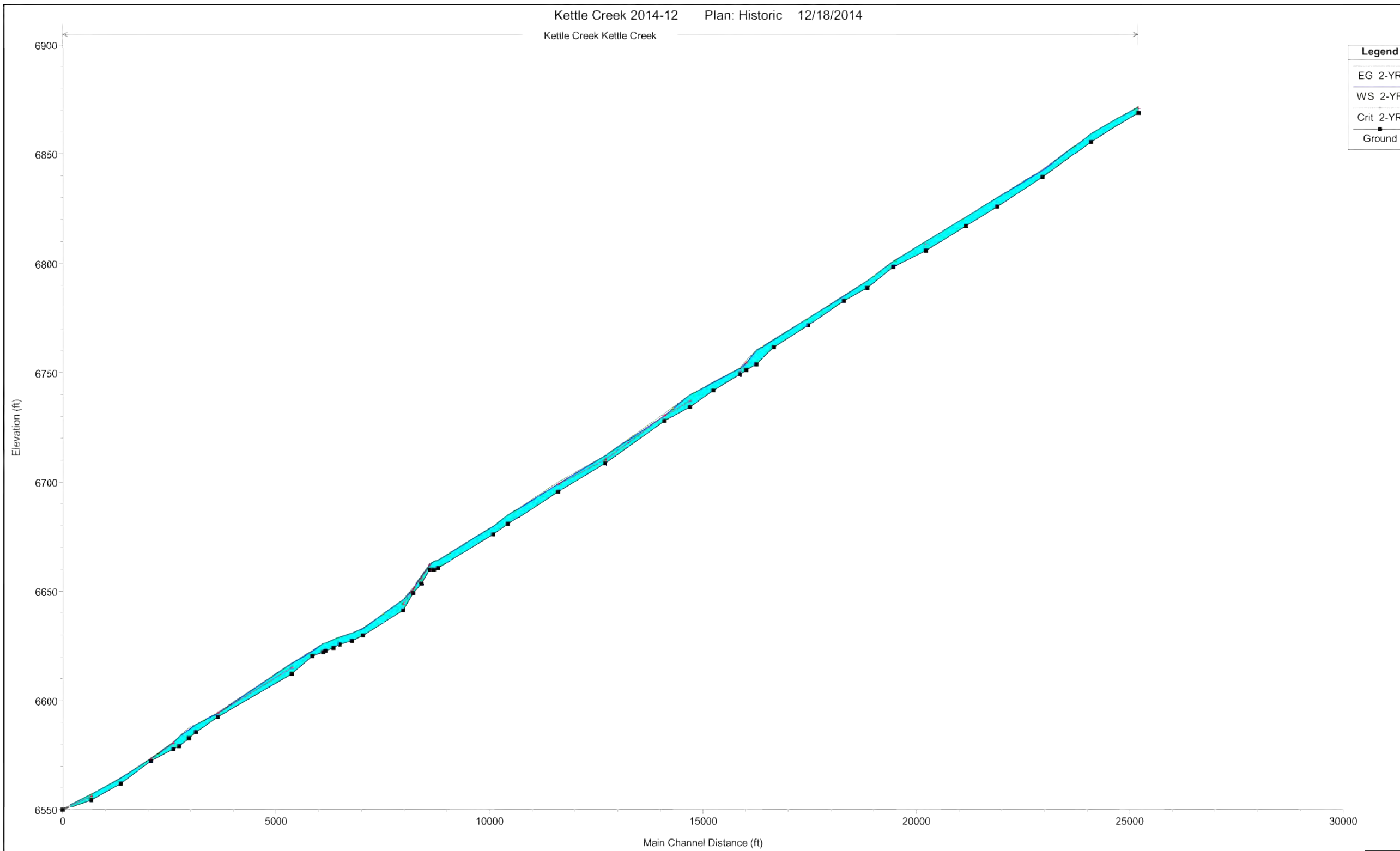

Legend	
EG 2-YR	
WS 2-YR	
Crit 2-YR	
Ground	■

HISTORIC CONDITIONS
MODEL RESULTS
2-YR PROFILE

HYDRAULIC RESULTS –
HISTORIC
KETTLE CREEK DBPS
JOB NO. 25100.00
MAY 2015
C-12



Centennial 303-740-9393 • Colorado Springs 719-593-2593
Fort Collins 970-491-9888 • www.jrengineering.com

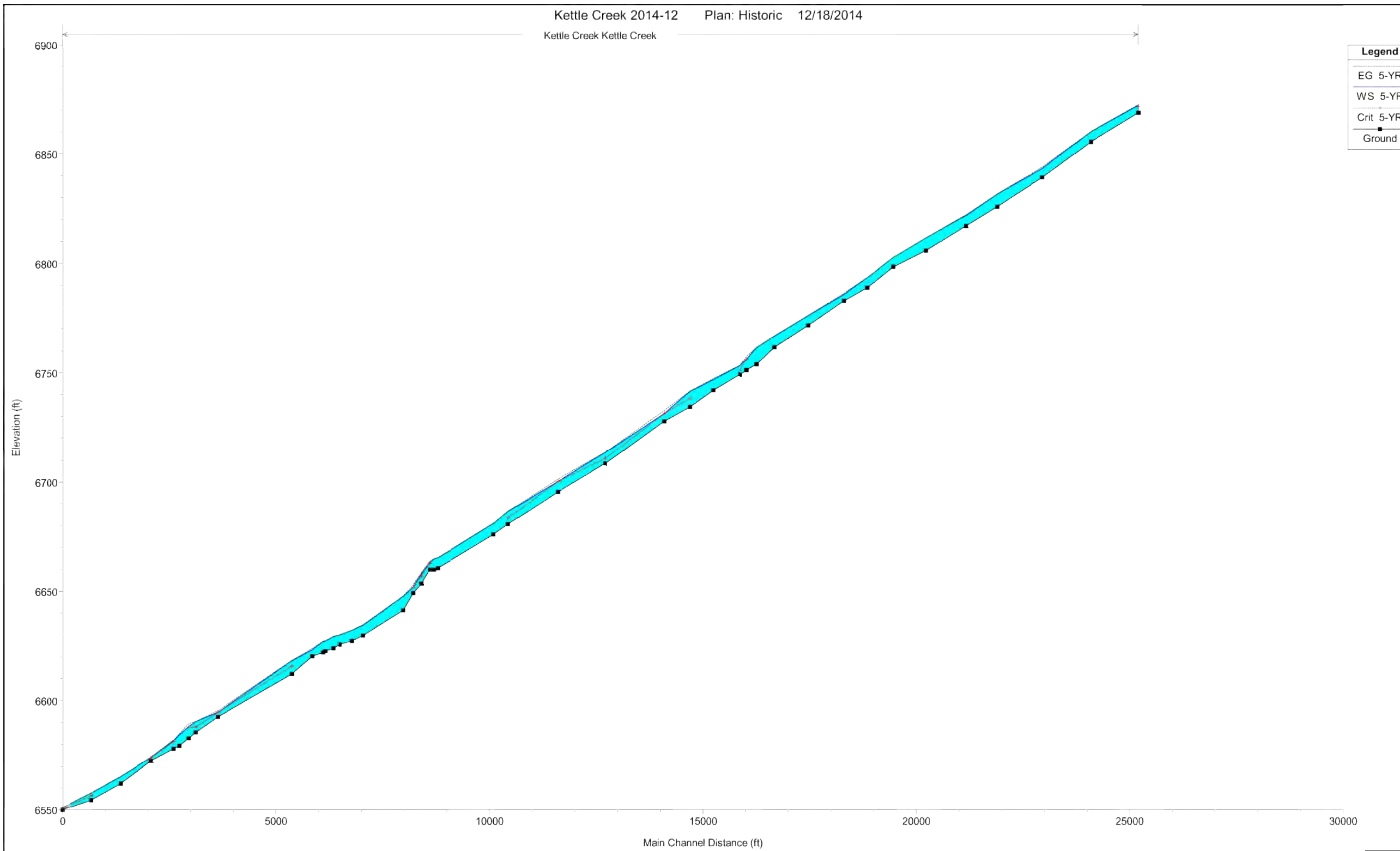

Legend	
EG 5-YR	
WS 5-YR	
Crit 5-YR	
Ground	■

HISTORIC CONDITIONS
MODEL RESULTS
5-YR PROFILE

HYDRAULIC RESULTS –
HISTORIC
KETTLE CREEK DBPS
JOB NO. 25100.00
MAY 2015
C-13



Centennial 303-740-9393 • Colorado Springs 719-593-2593
Fort Collins 970-491-9888 • www.jrengineering.com

Kettle Creek Kettle Creek

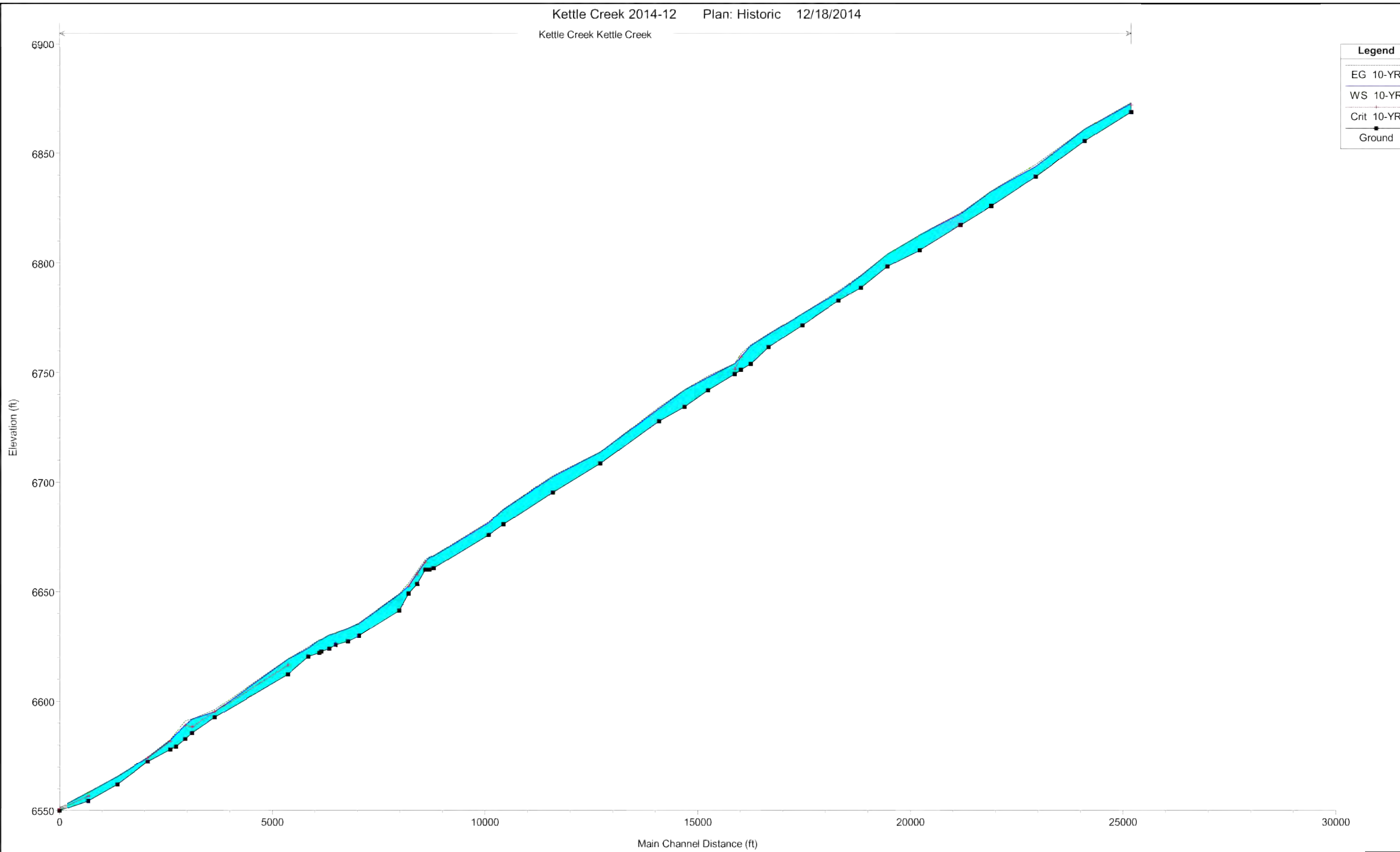

Legend	
EG 10-YR	
WS 10-YR	
Crit 10-YR	
Ground	

HISTORIC CONDITIONS
 MODEL RESULTS
 10-YR PROFILE

HYDRAULIC RESULTS –
 HISTORIC
 KETTLE CREEK DBPS
 JOB NO. 25100.00
 MAY 2015
 C-14



Centennial 303-740-9393 • Colorado Springs 719-593-2593
 Fort Collins 970-491-9888 • www.jrengineering.com

Kettle Creek Kettle Creek

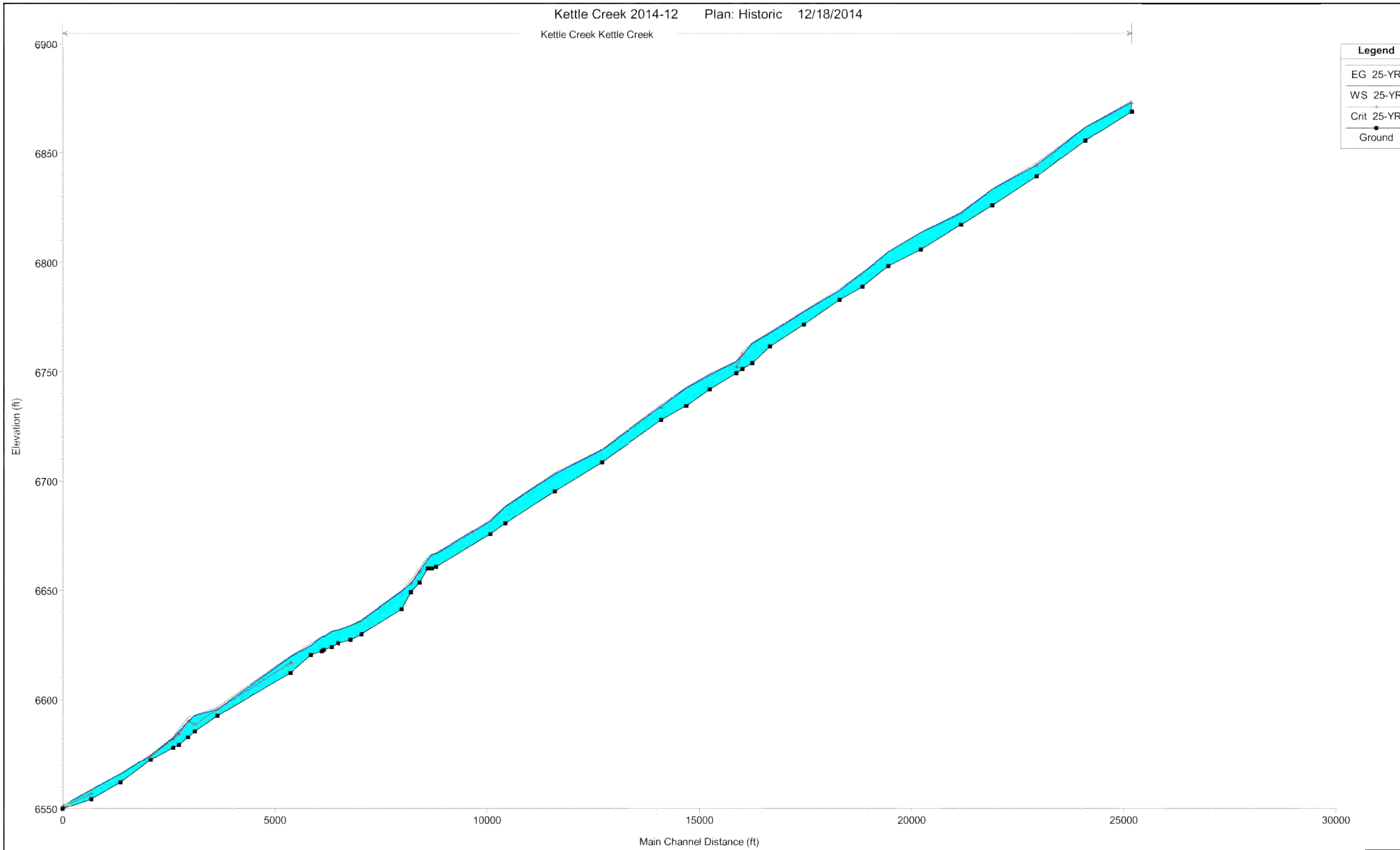

Legend	
EG 25-YR	(Cyan shaded area)
WS 25-YR	(Black line)
Crit 25-YR	(Red line)
Ground	(Black line with dots)

HISTORIC CONDITIONS
MODEL RESULTS
25-YR PROFILE

HYDRAULIC RESULTS –
HISTORIC
KETTLE CREEK DBPS
JOB NO. 25100.00
MAY 2015
C-15



Centennial 303-740-9393 • Colorado Springs 719-593-2593
Fort Collins 970-491-9888 • www.jrengineering.com

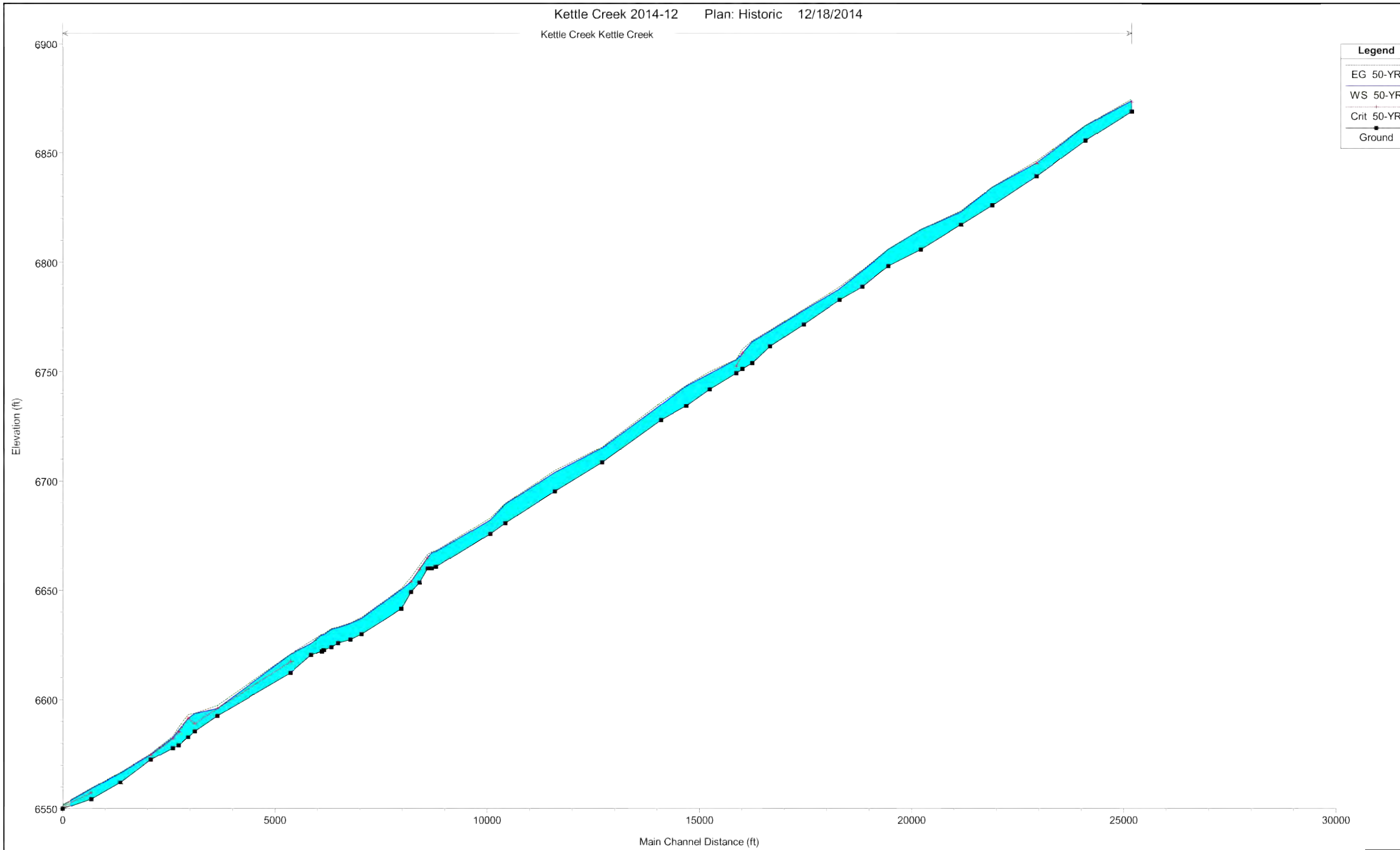

Legend	
EG 50-YR	(Cyan shaded area)
WS 50-YR	(Red line)
Crit 50-YR	(Black line)
Ground	(Black line with dots)

HISTORIC CONDITIONS
MODEL RESULTS
50-YR PROFILE

HYDRAULIC RESULTS –
HISTORIC
KETTLE CREEK DBPS
JOB NO. 25100.00
MAY 2015
C-16



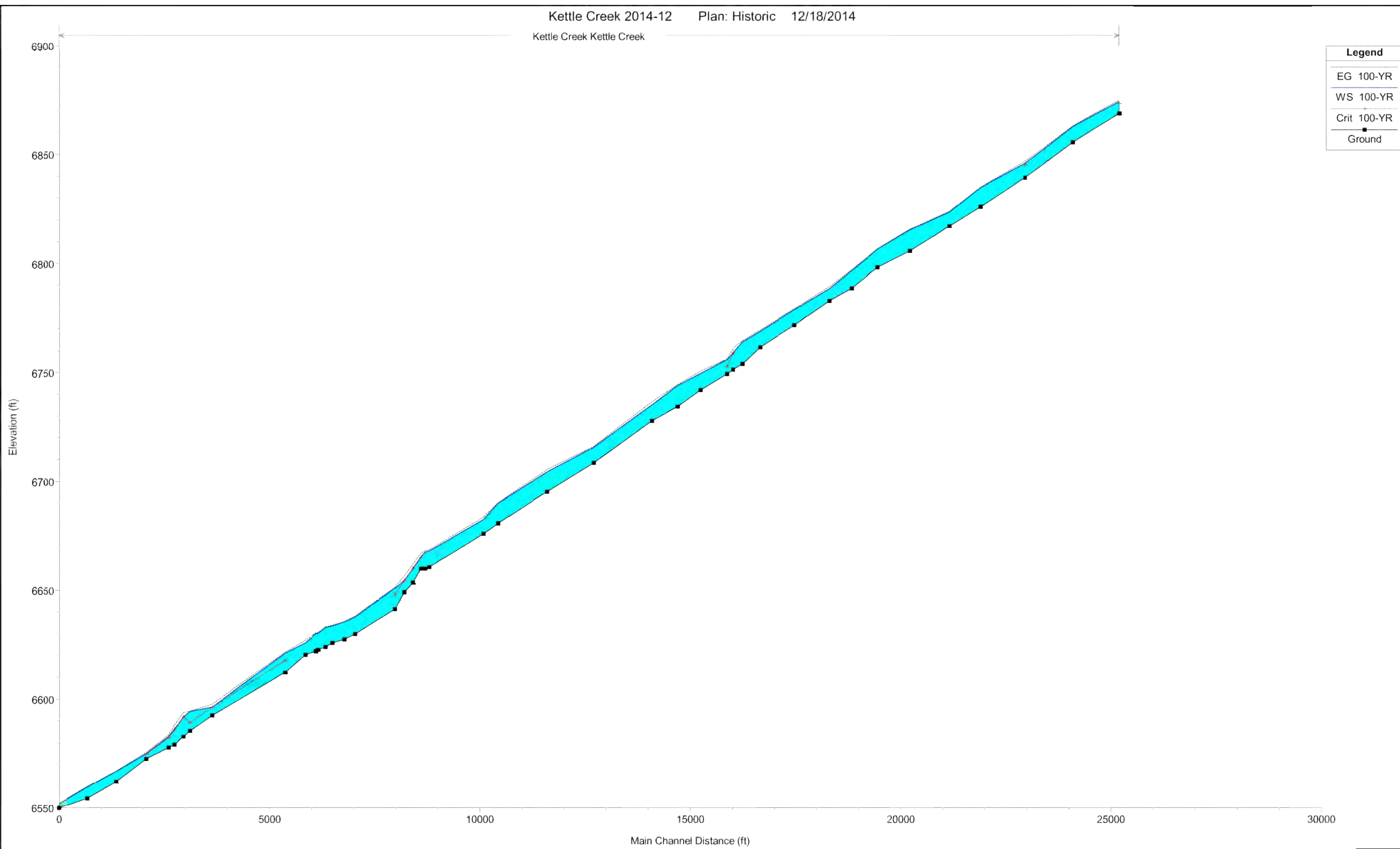

Legend	
EG 100-YR	
WS 100-YR	
Crit 100-YR	■
Ground	■

HISTORIC CONDITIONS
MODEL RESULTS
100-YR PROFILE

HYDRAULIC RESULTS –
HISTORIC
KETTLE CREEK DBPS
JOB NO. 25100.00
MAY 2015
C-17



Centennial 303-740-9393 • Colorado Springs 719-593-2593
Fort Collins 970-491-9888 • www.jrengineering.com

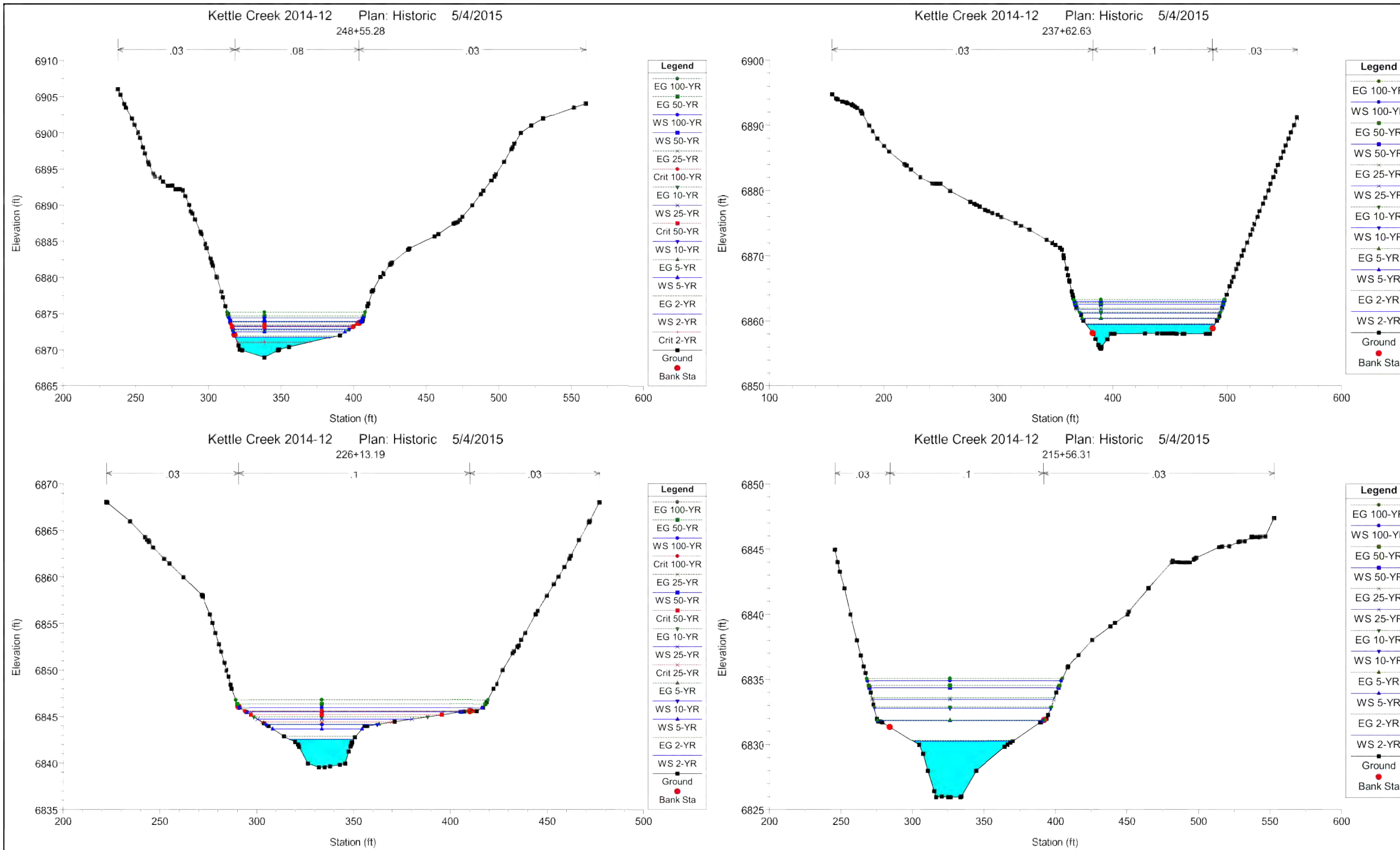

HISTORIC CONDITIONS
MODEL RESULTS

HYDRAULIC RESULTS –
HISTORIC
KETTLE CREEK DBPS
JOB NO. 25100.00
MAY 2015
C-18



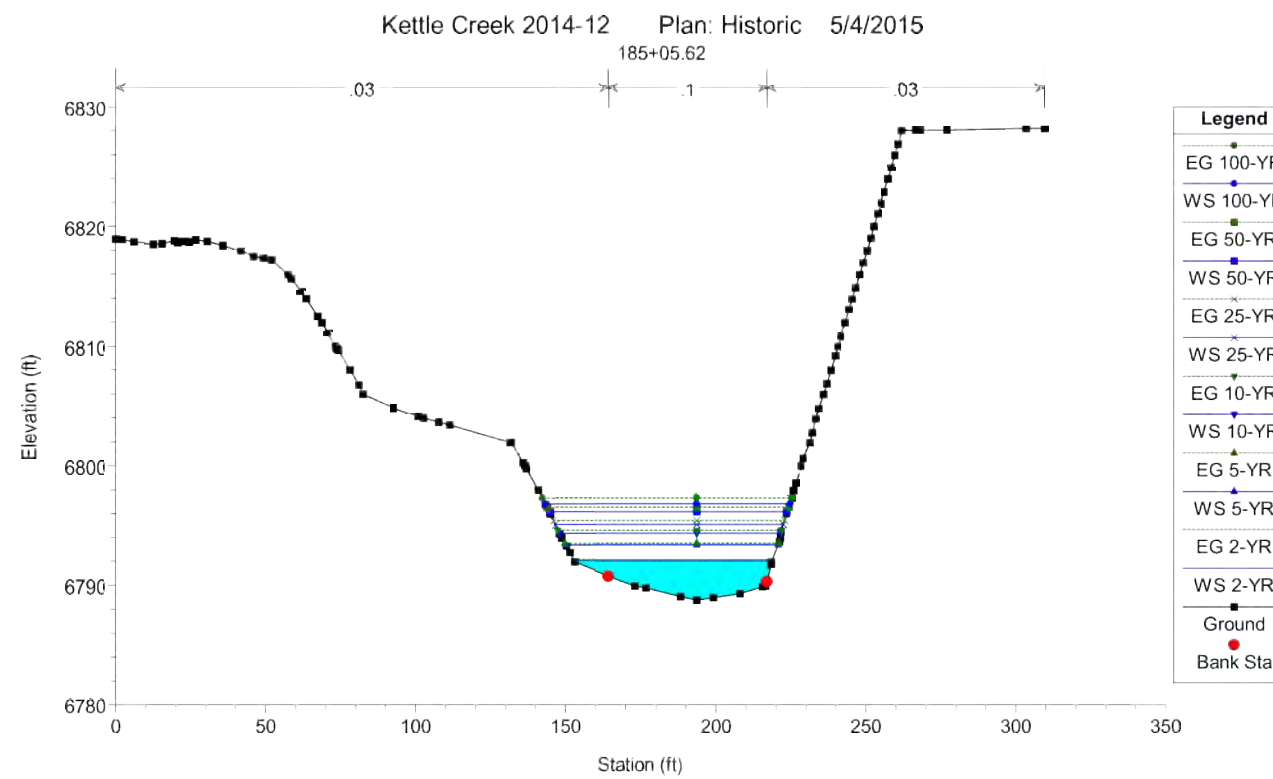
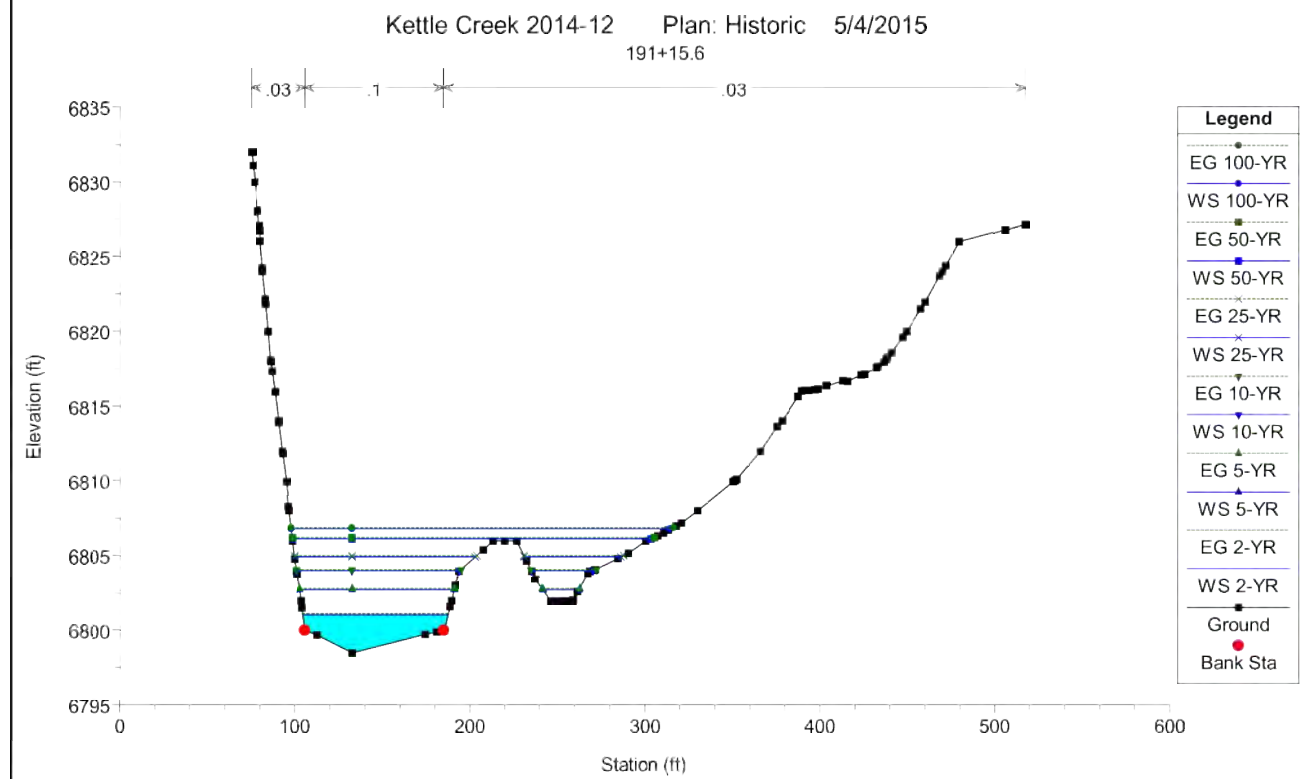
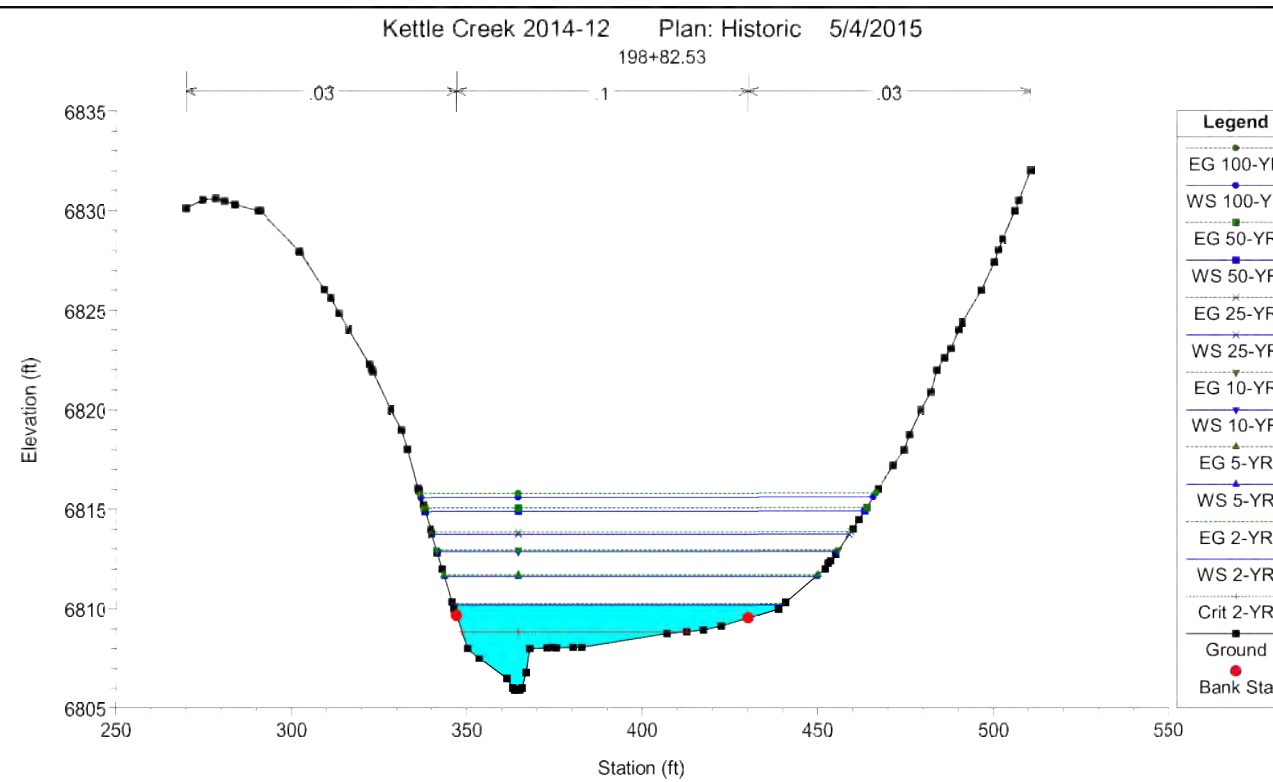
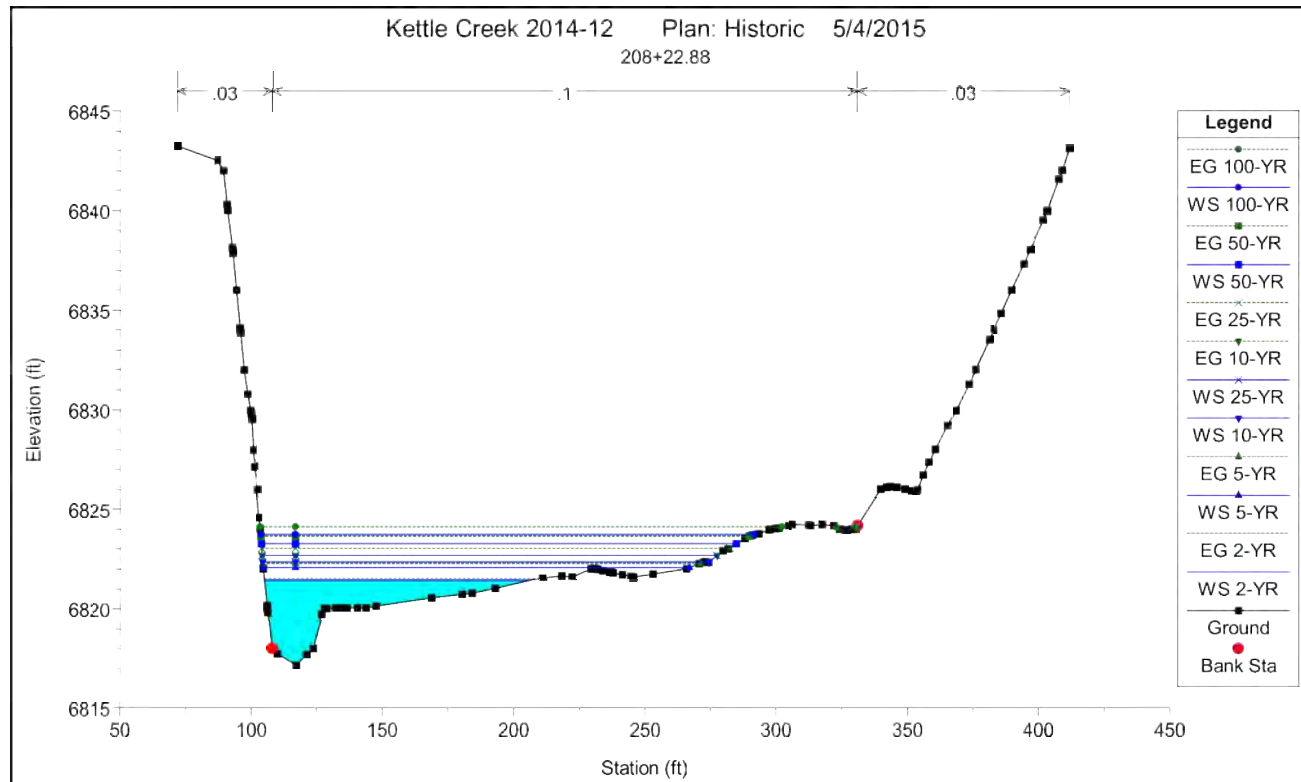

HYDRAULIC RESULTS –
HISTORIC
KETTLE CREEK DBPS
JOB NO. 25100.00
MAY 2015
C-19

HISTORIC CONDITIONS
MODEL RESULTS



Centennial 303-740-9393 • Colorado Springs 719-593-2593
Fort Collins 970-491-9888 • www.jrengineering.com

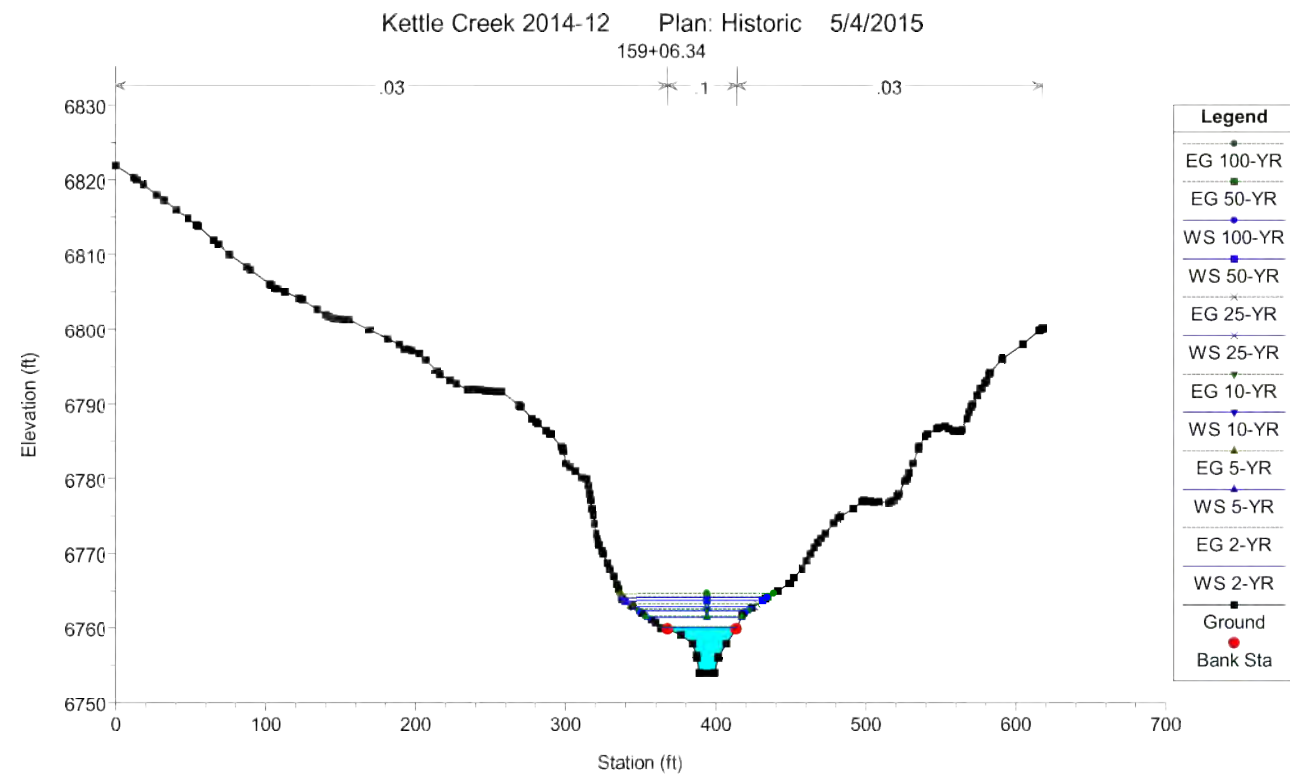
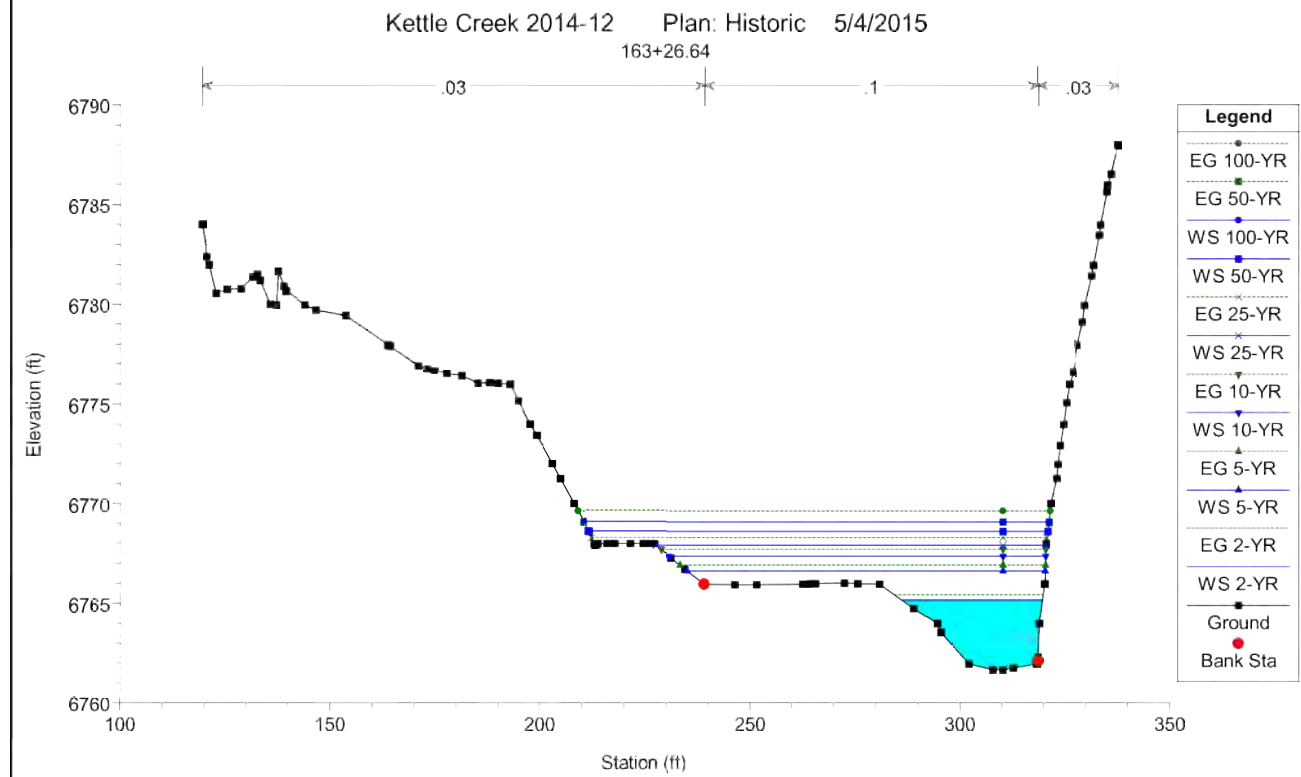
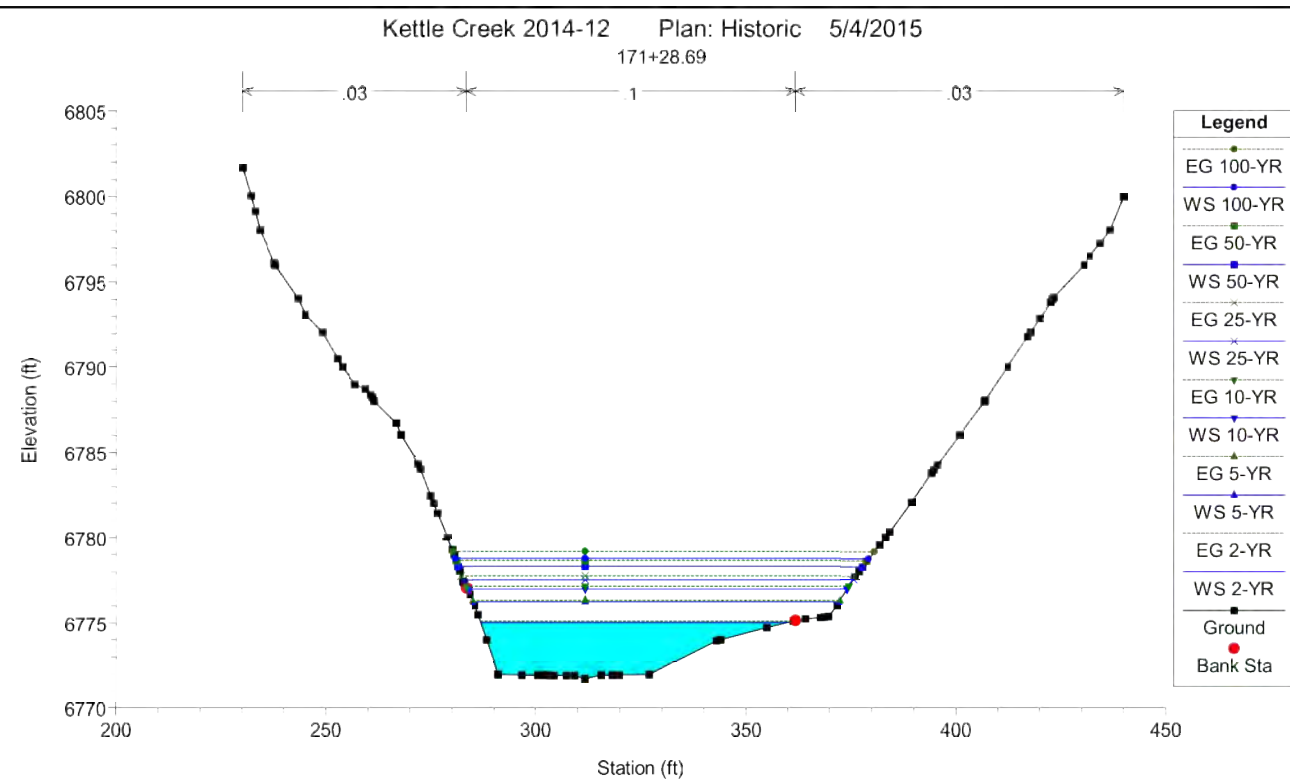
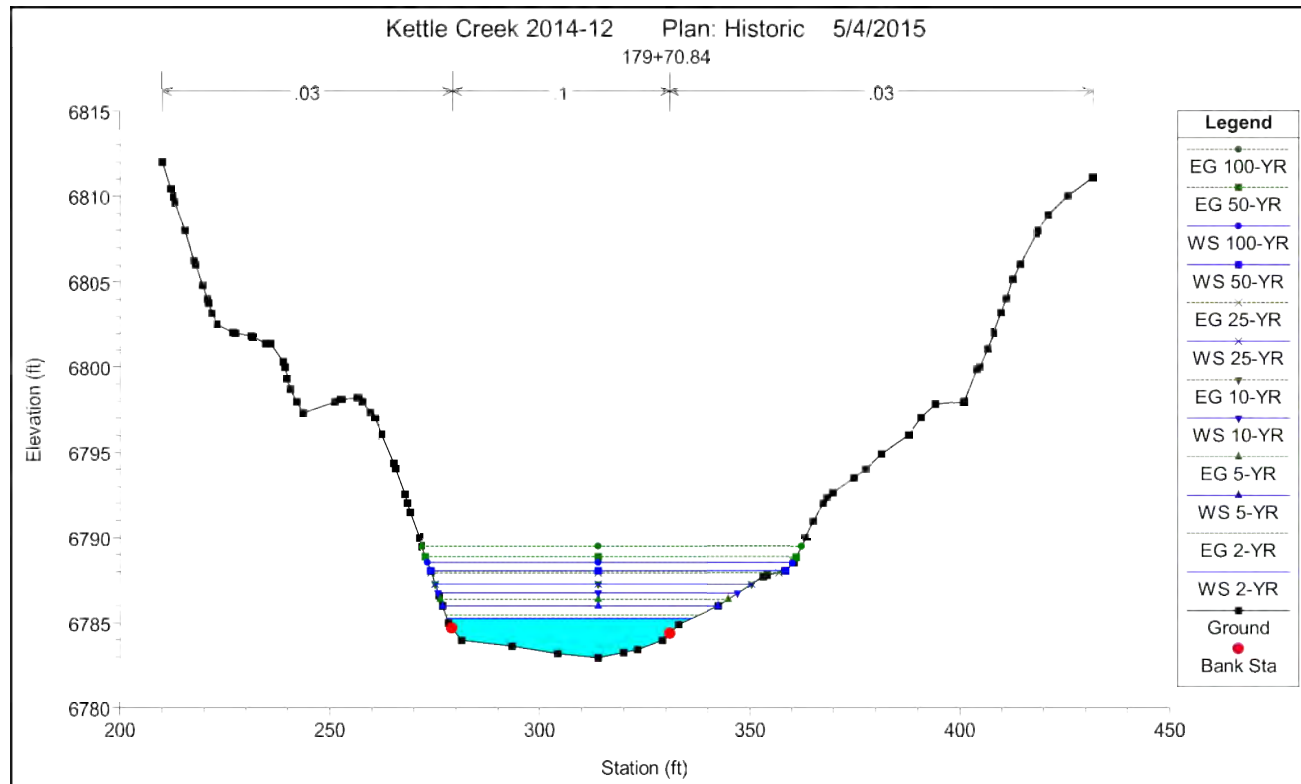

HISTORIC CONDITIONS
MODEL RESULTS

HYDRAULIC RESULTS –
HISTORIC
KETTLE CREEK DBPS
JOB NO. 25100.00
MAY 2015
C-20



Centennial 303-740-9393 • Colorado Springs 719-593-2593
Fort Collins 970-491-9888 • www.jrengineering.com

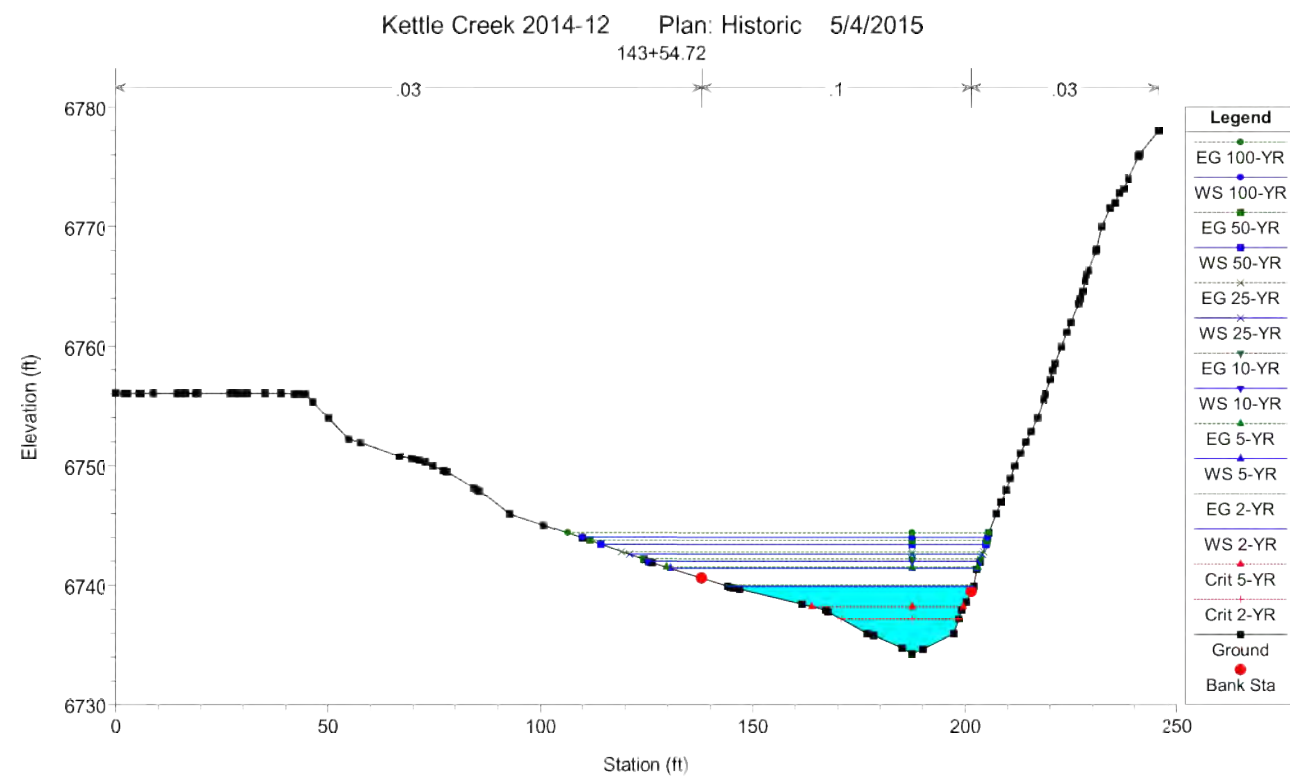
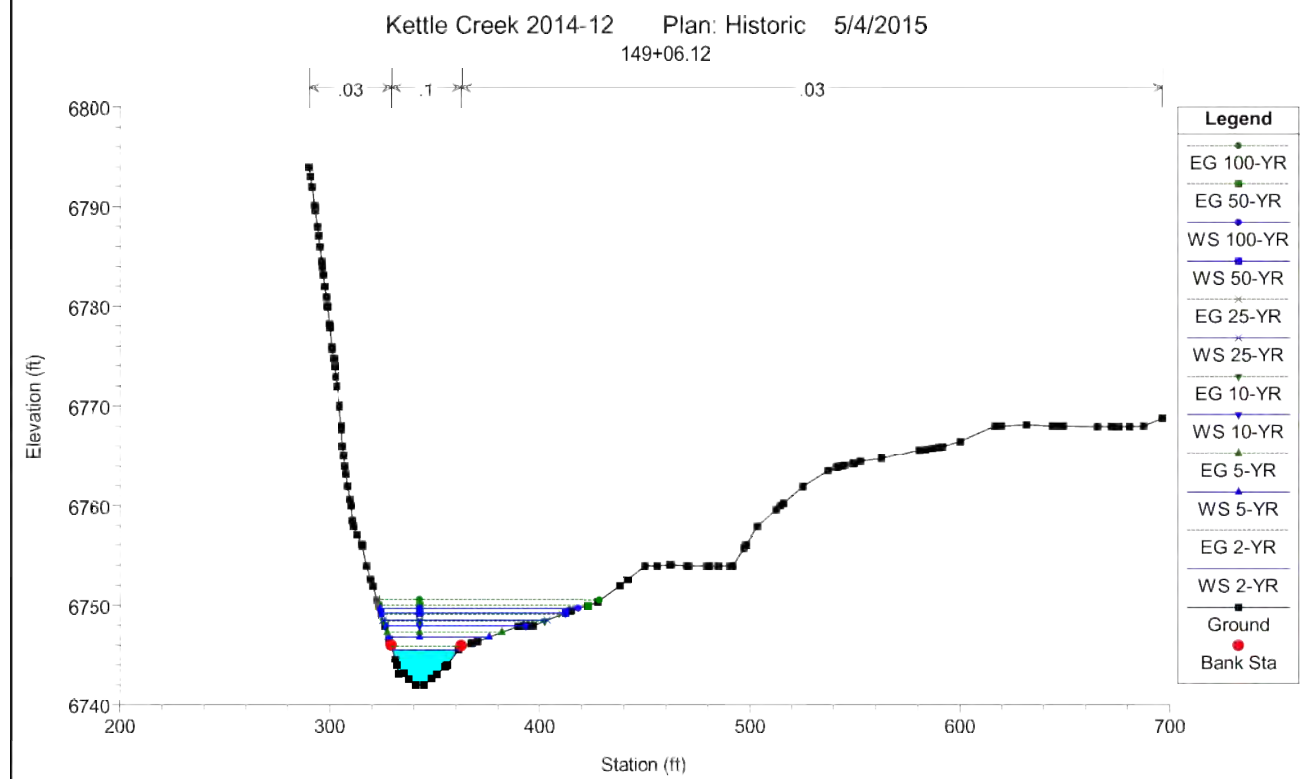
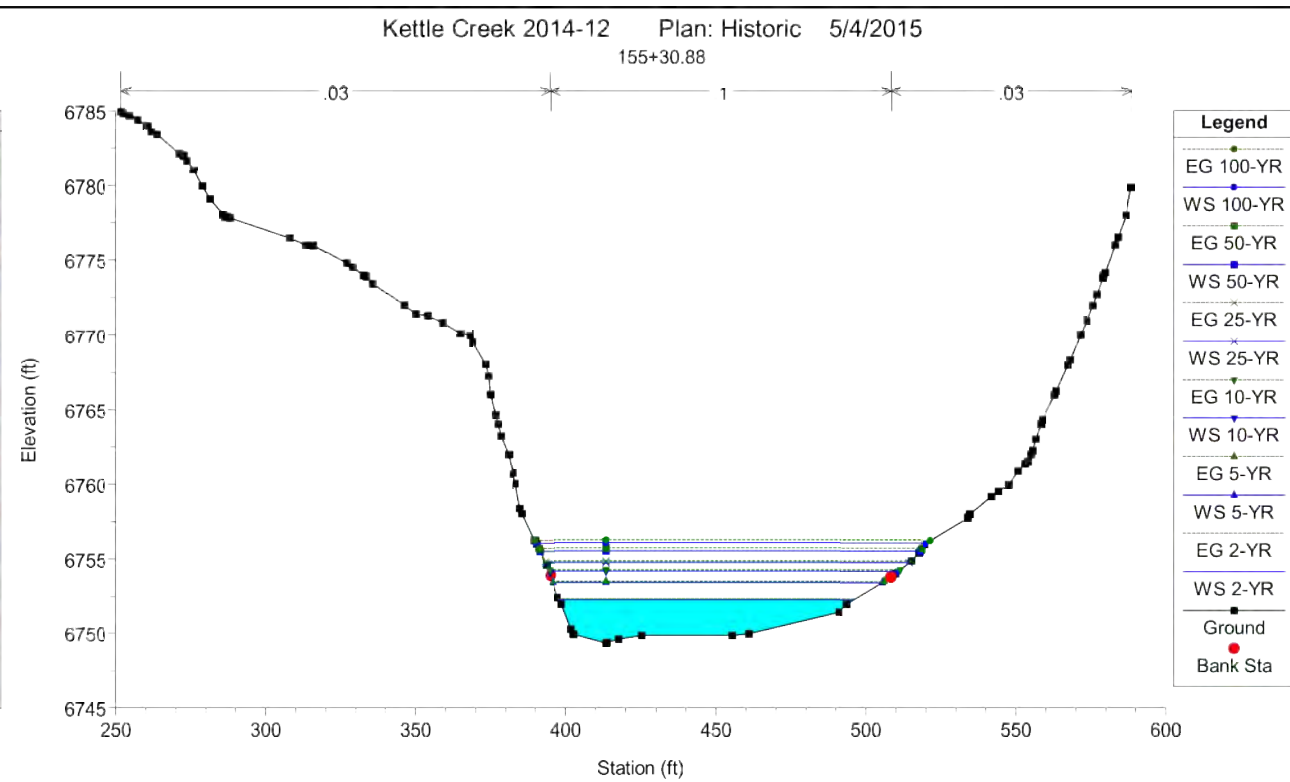
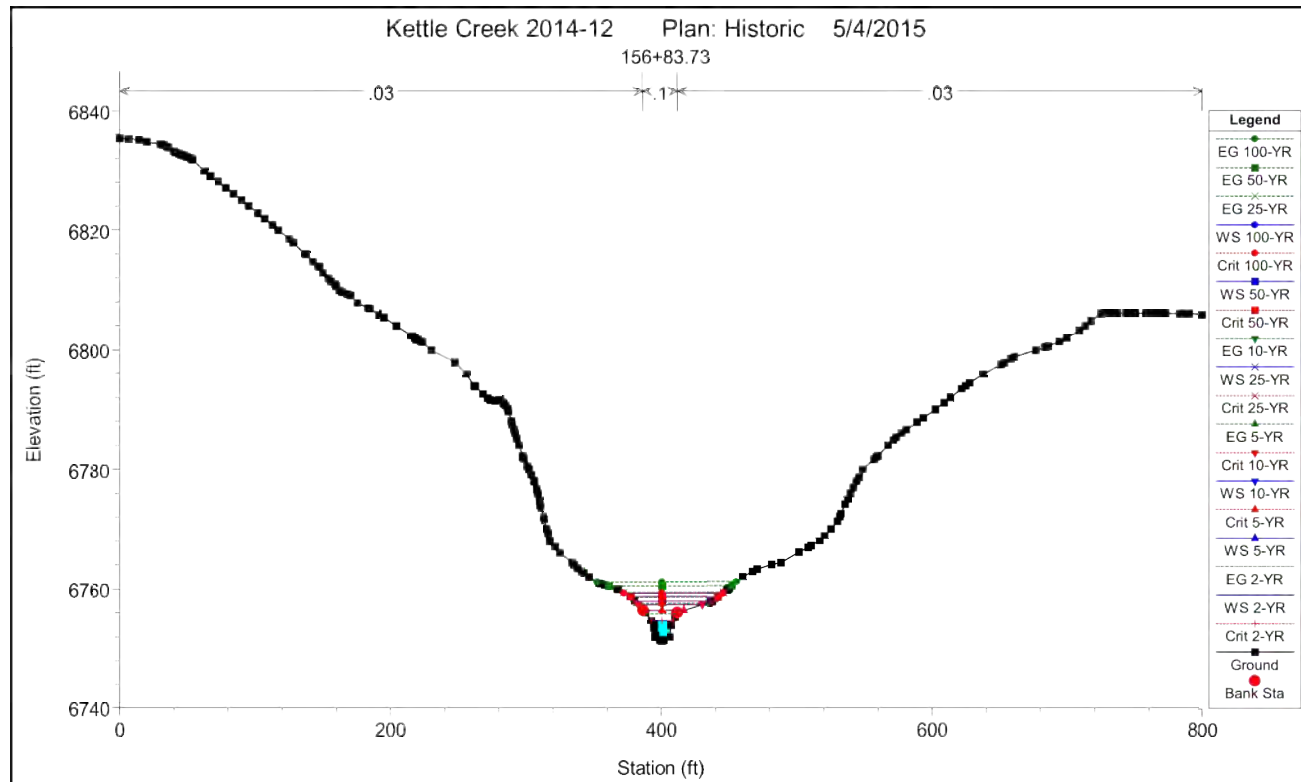

HYDRAULIC RESULTS –
HISTORIC
KETTLE CREEK DBPS
JOB NO. 25100.00
MAY 2015
C-21

HISTORIC CONDITIONS
MODEL RESULTS



Centennial 303-740-9393 • Colorado Springs 719-593-2593
Fort Collins 970-491-9888 • www.jrengineering.com

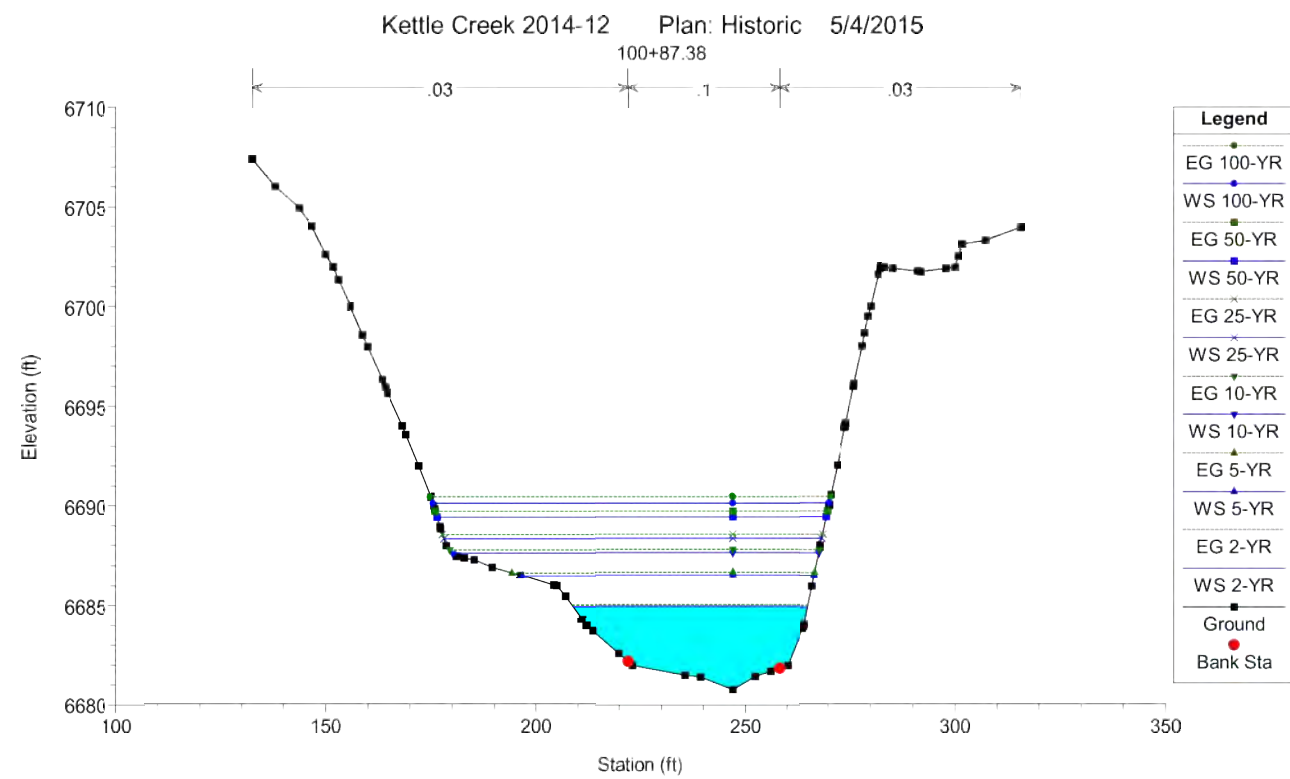
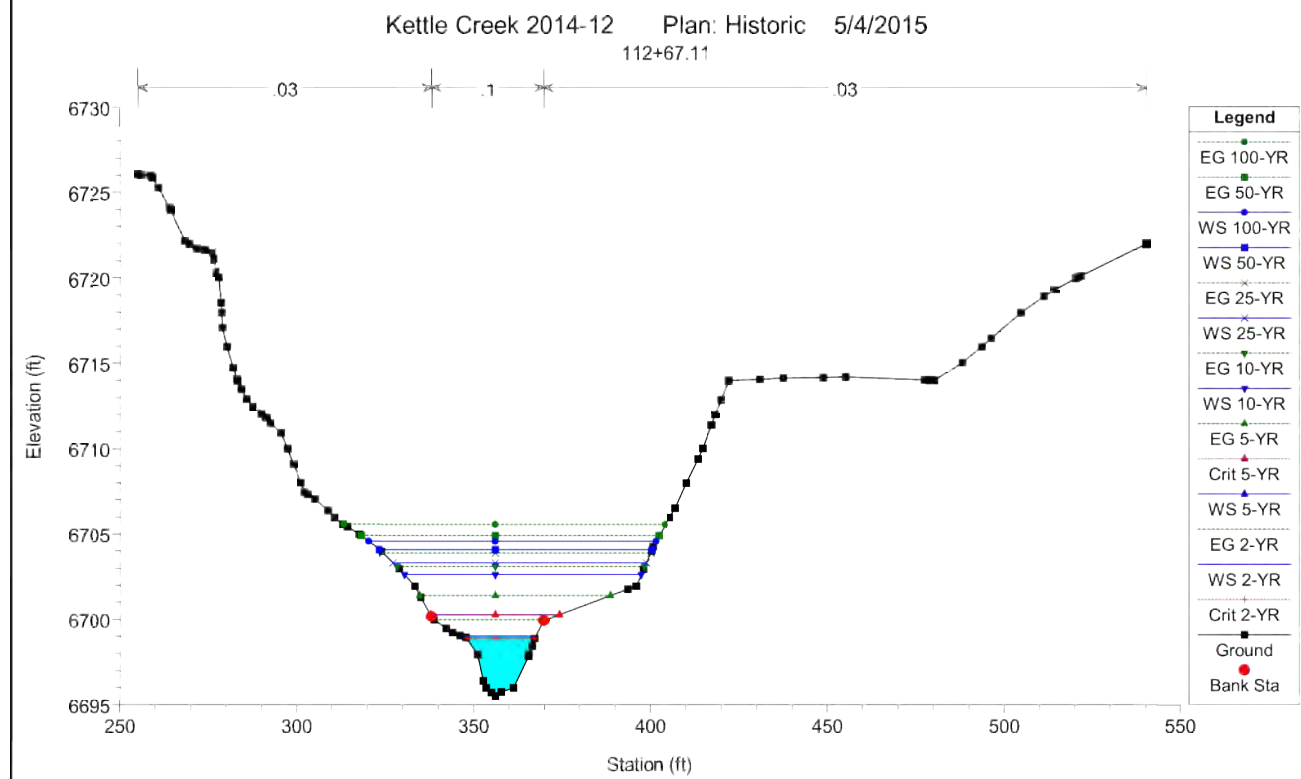
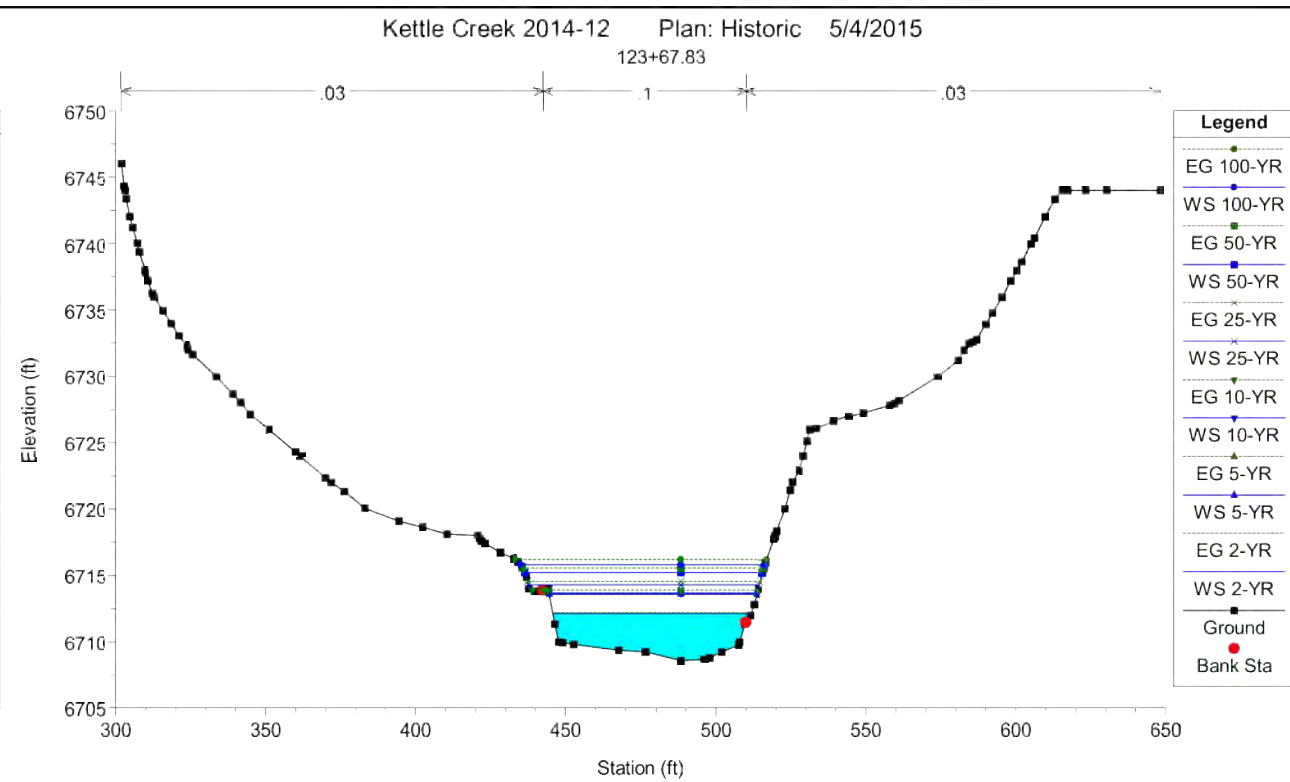
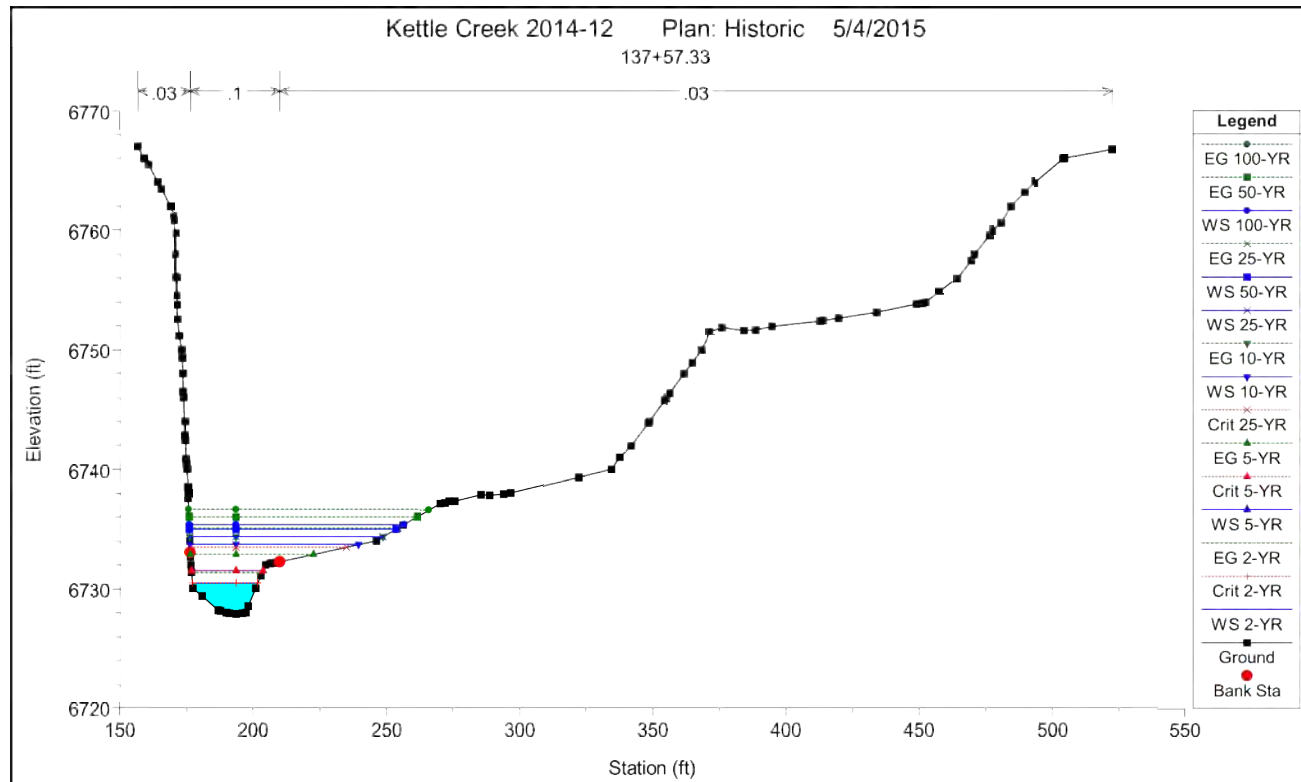

HISTORIC CONDITIONS
MODEL RESULTS

HYDRAULIC RESULTS —
HISTORIC
KETTLE CREEK DBPS
JOB NO. 25100.00
MAY 2015
C-22



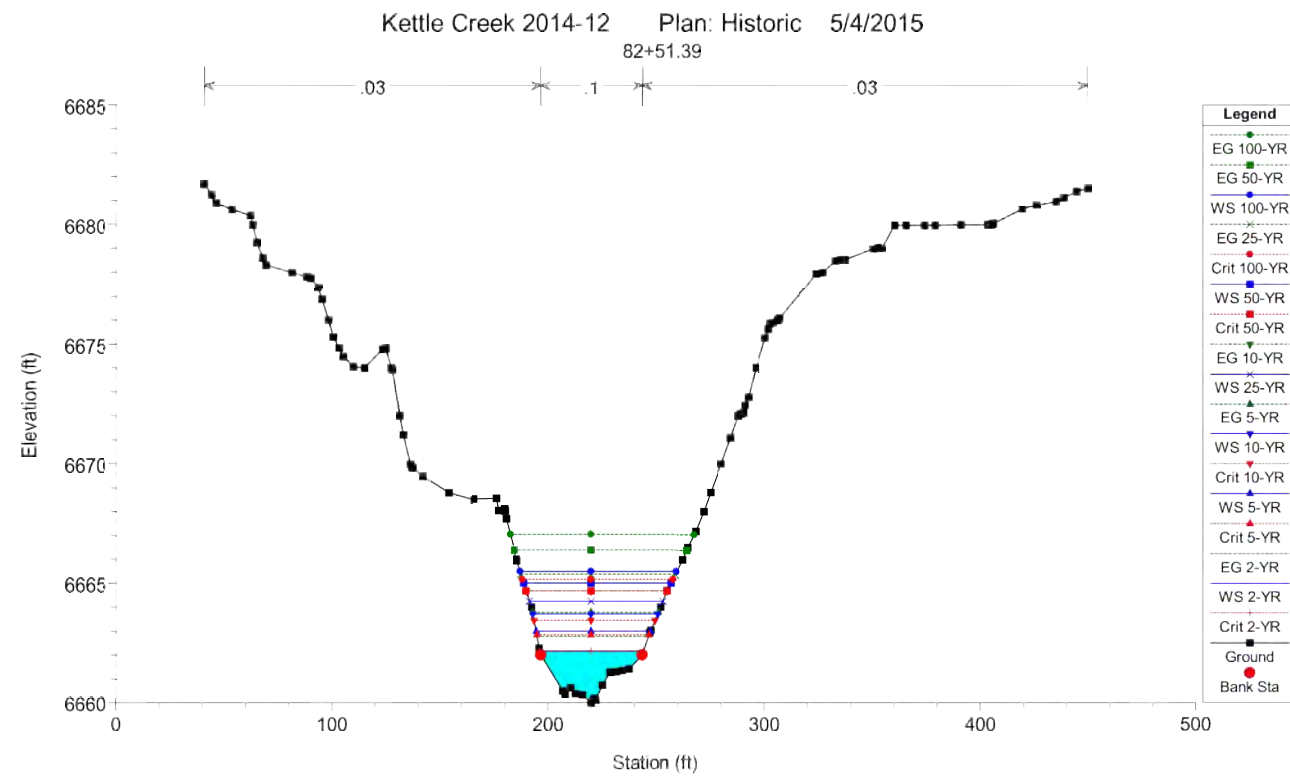
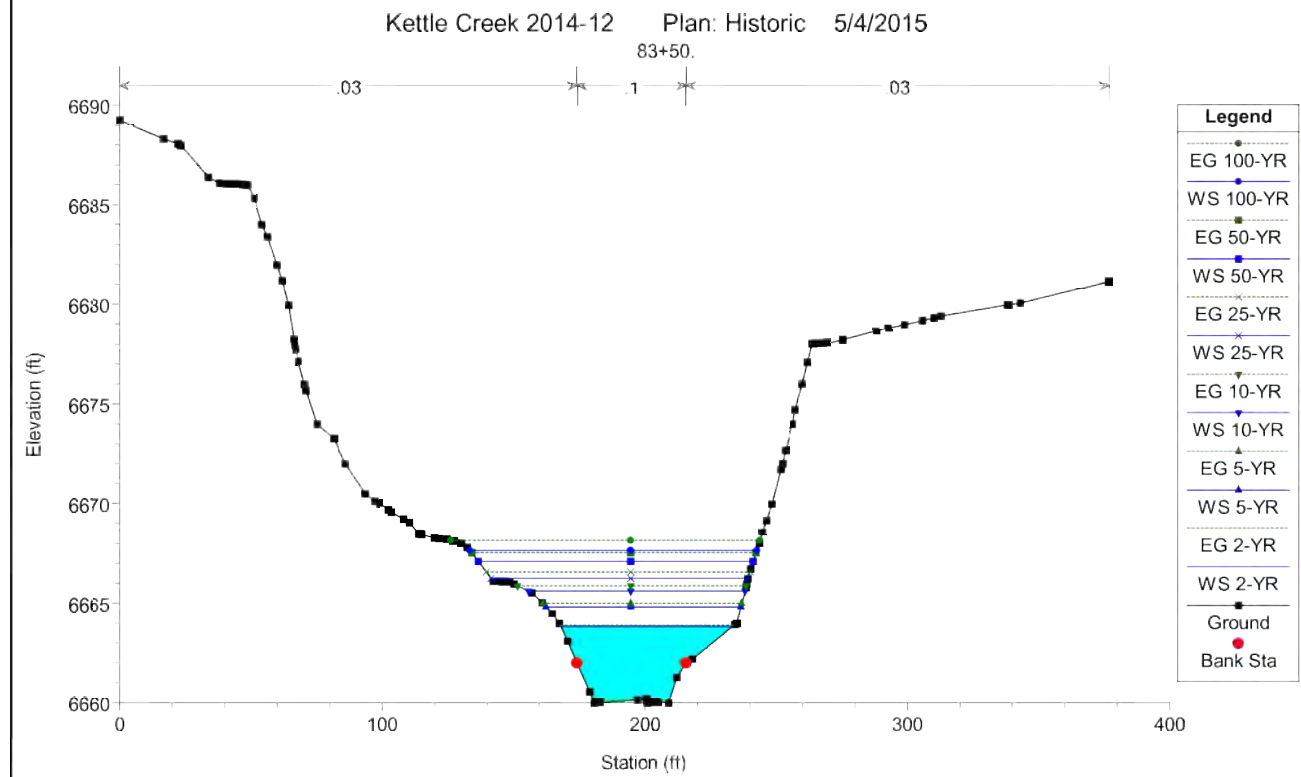
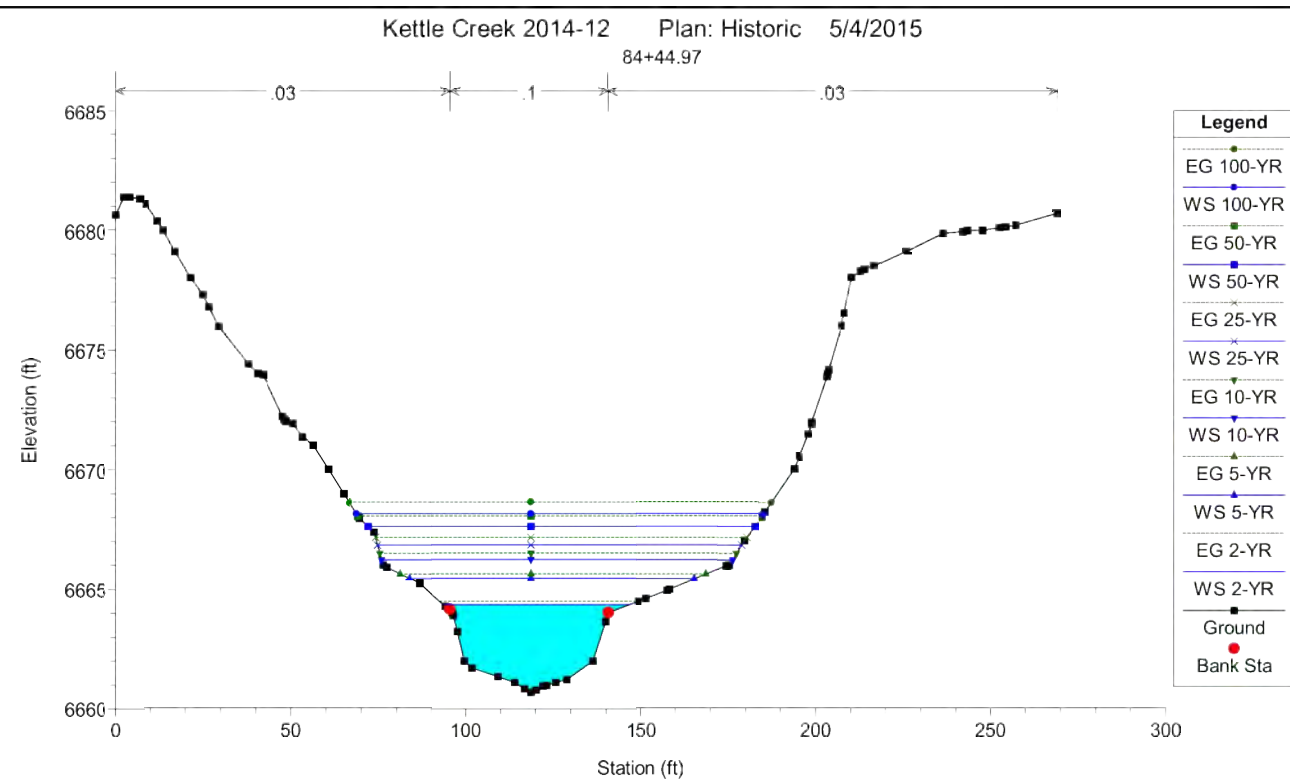
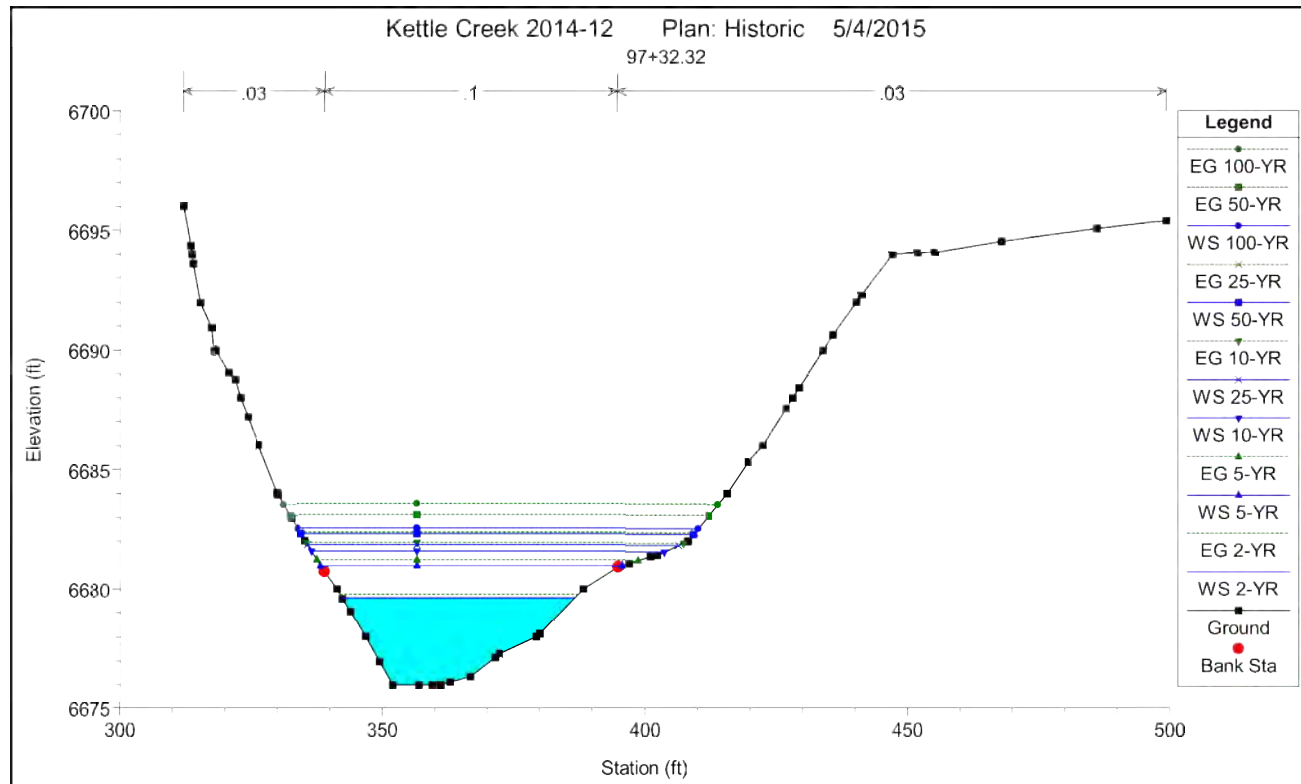

HISTORIC CONDITIONS
MODEL RESULTS

HYDRAULIC RESULTS –
HISTORIC
KETTLE CREEK DBPS
JOB NO. 25100.00
MAY 2015
C-23



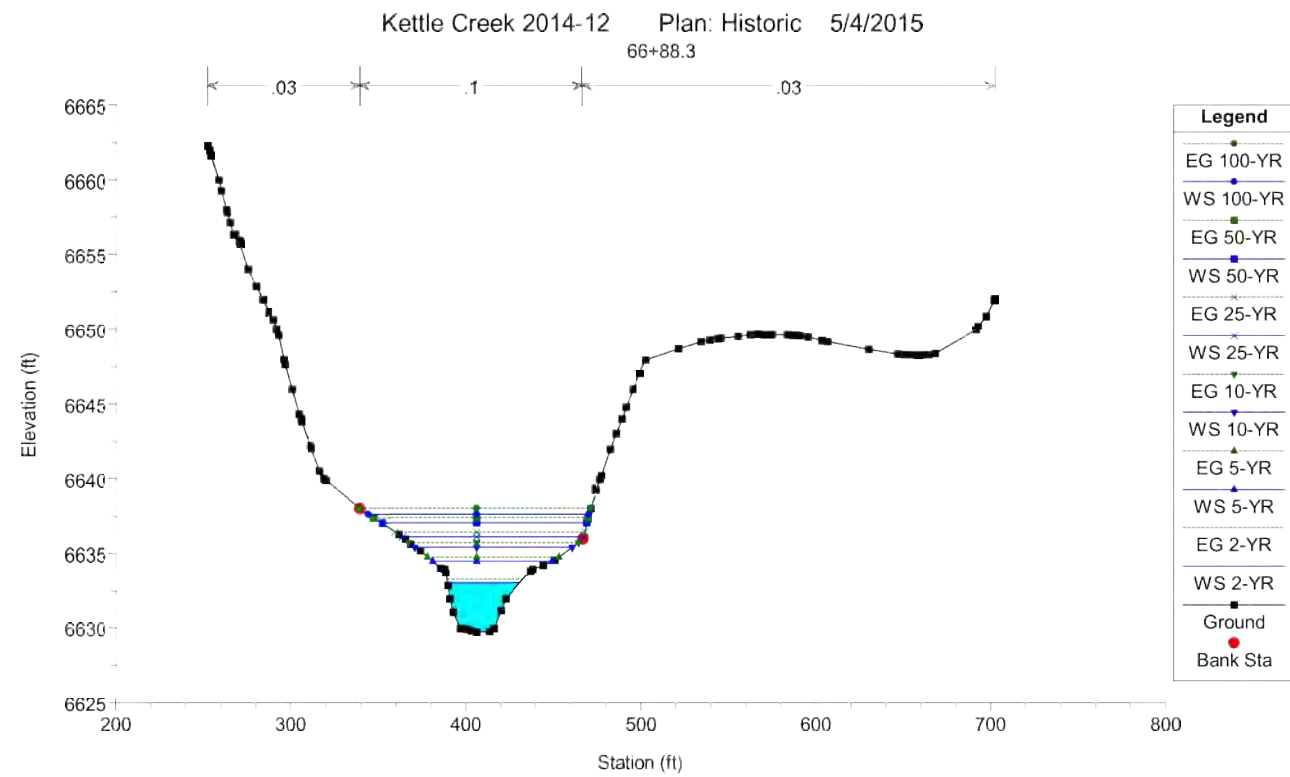
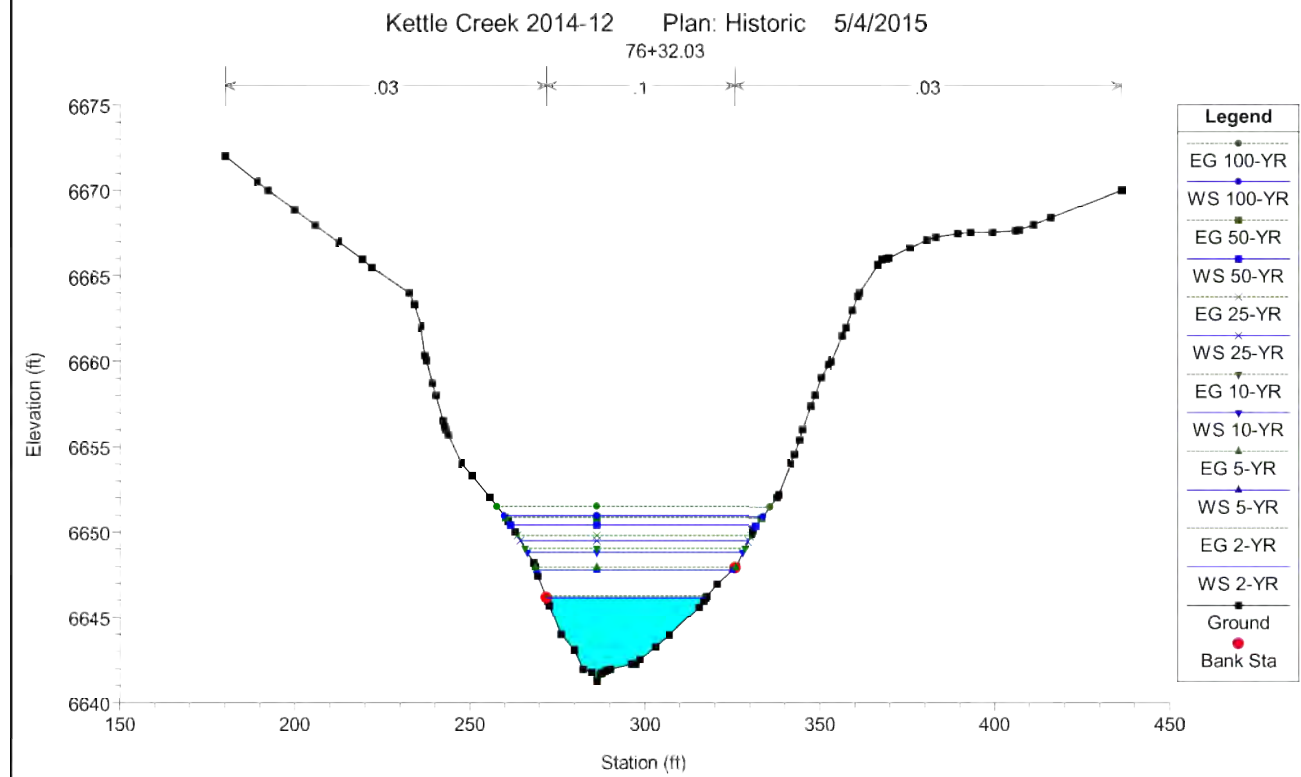
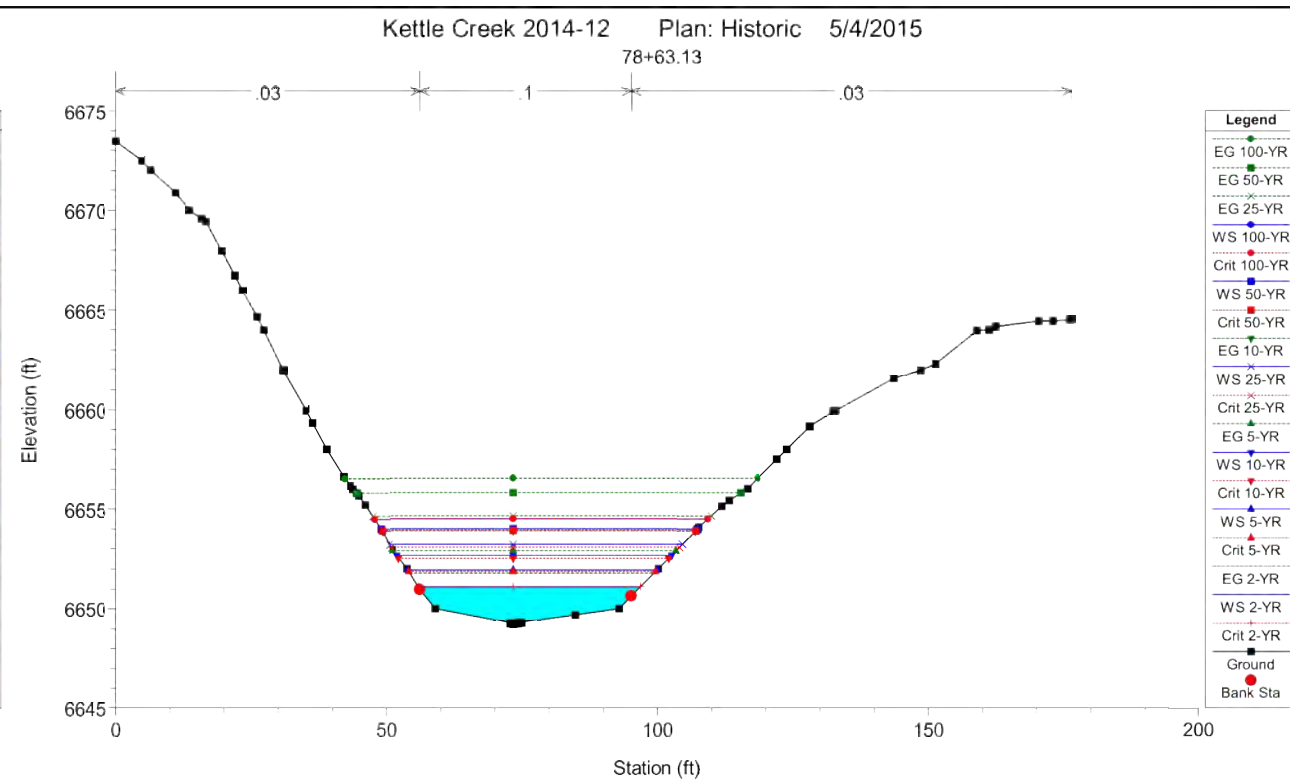
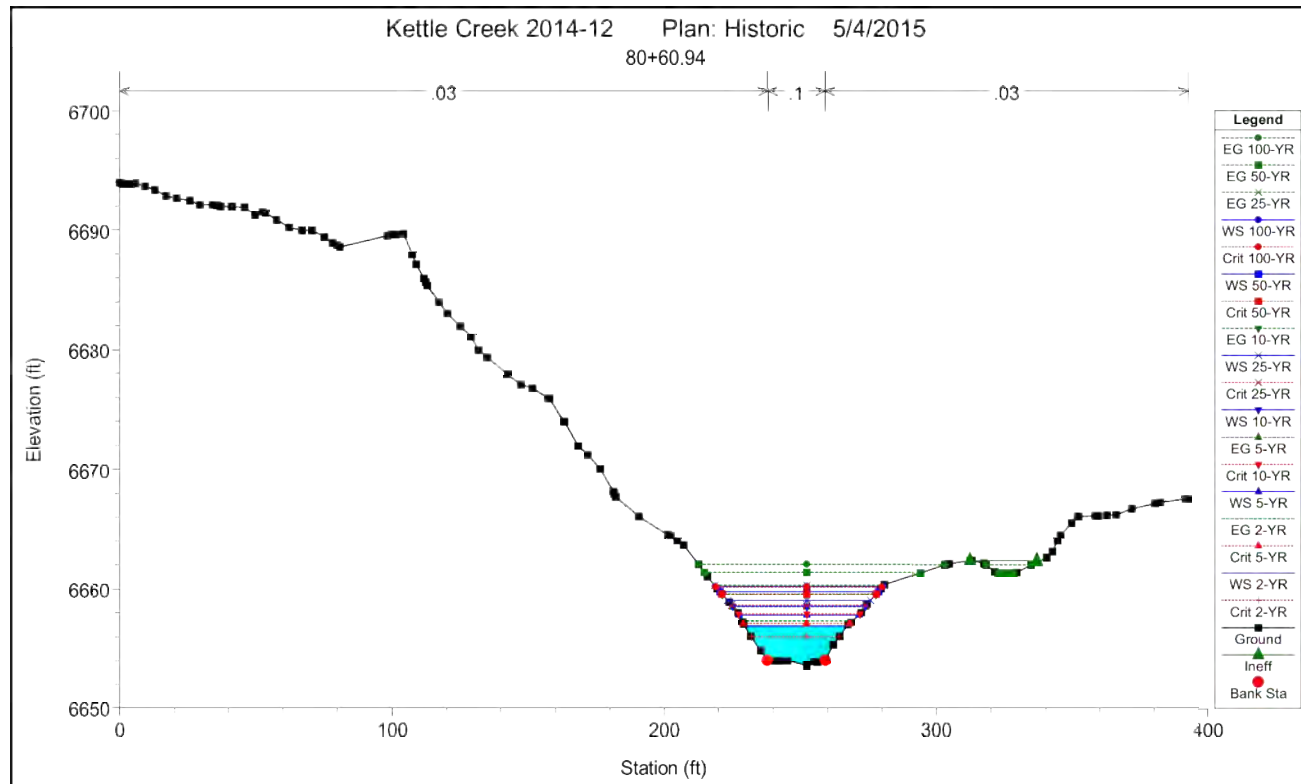

HISTORIC CONDITIONS
MODEL RESULTS

HYDRAULIC RESULTS –
HISTORIC
KETTLE CREEK DBPS
JOB NO. 25100.00
MAY 2015
C-24



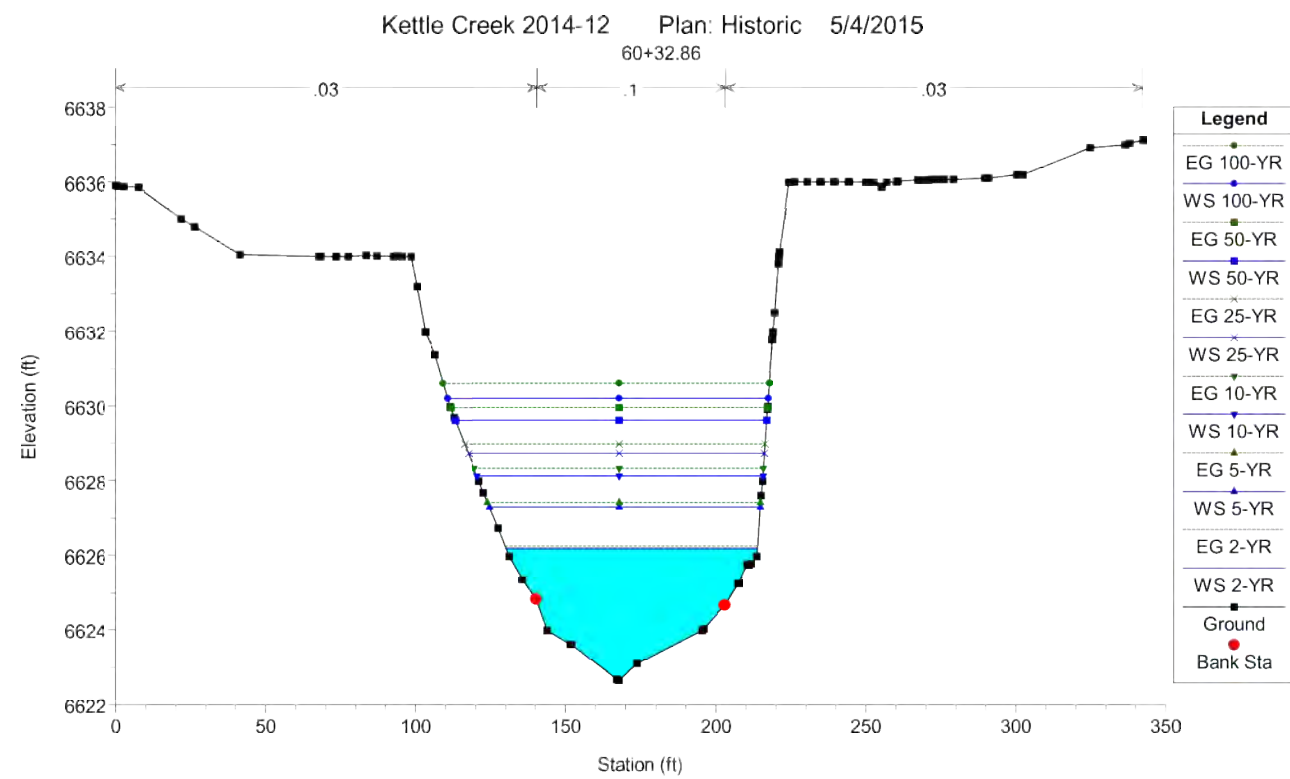
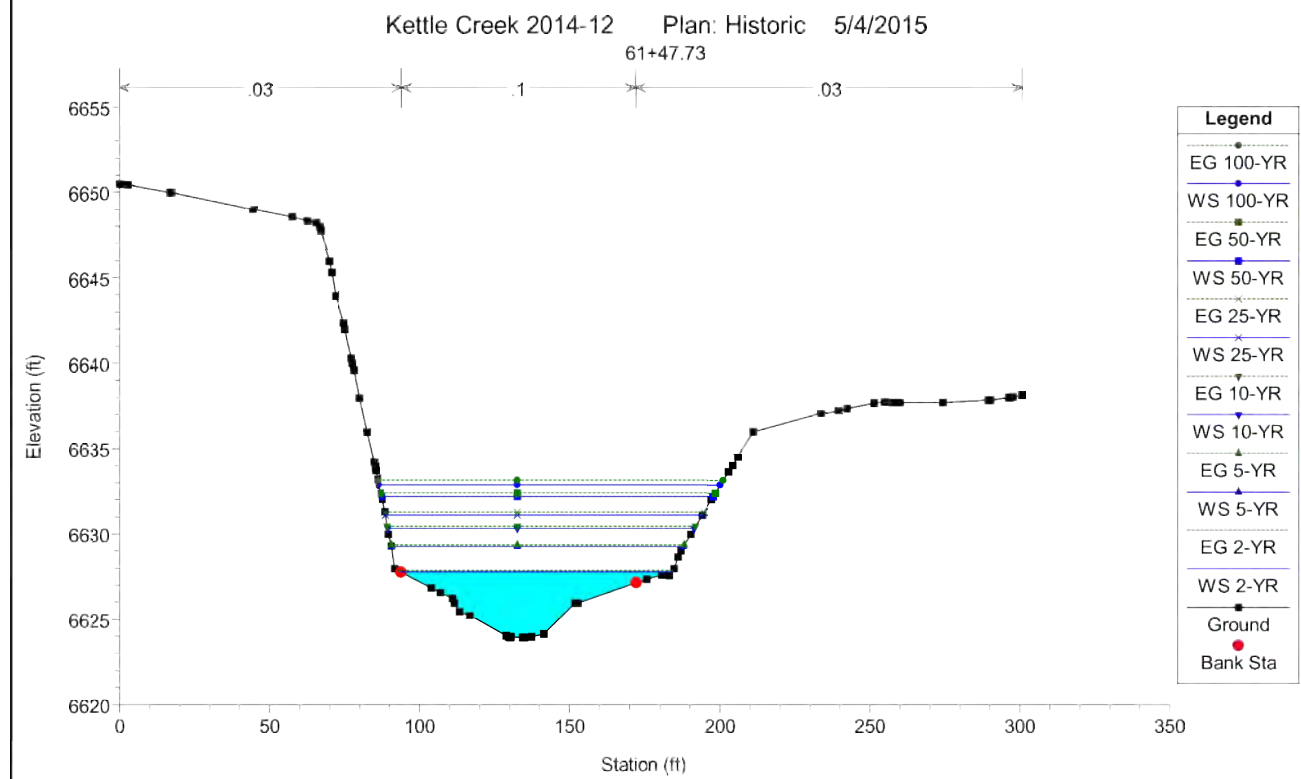
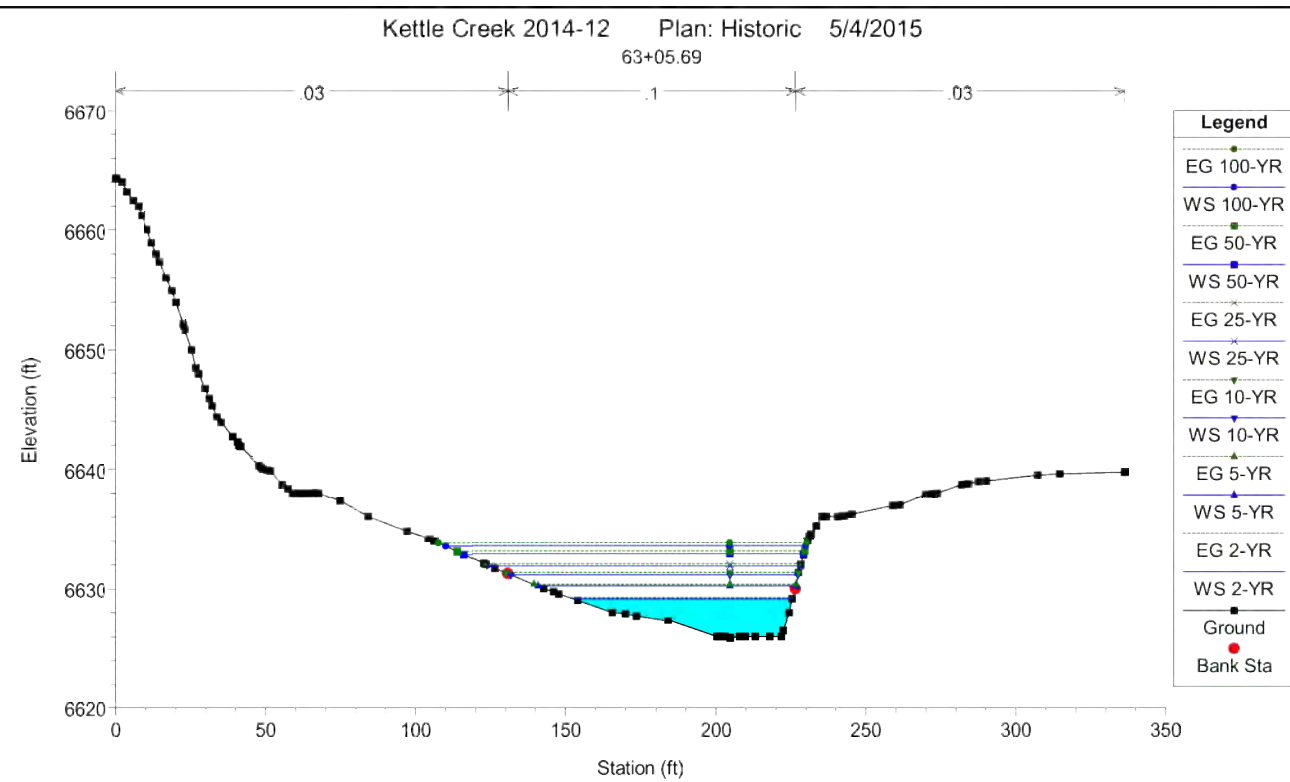
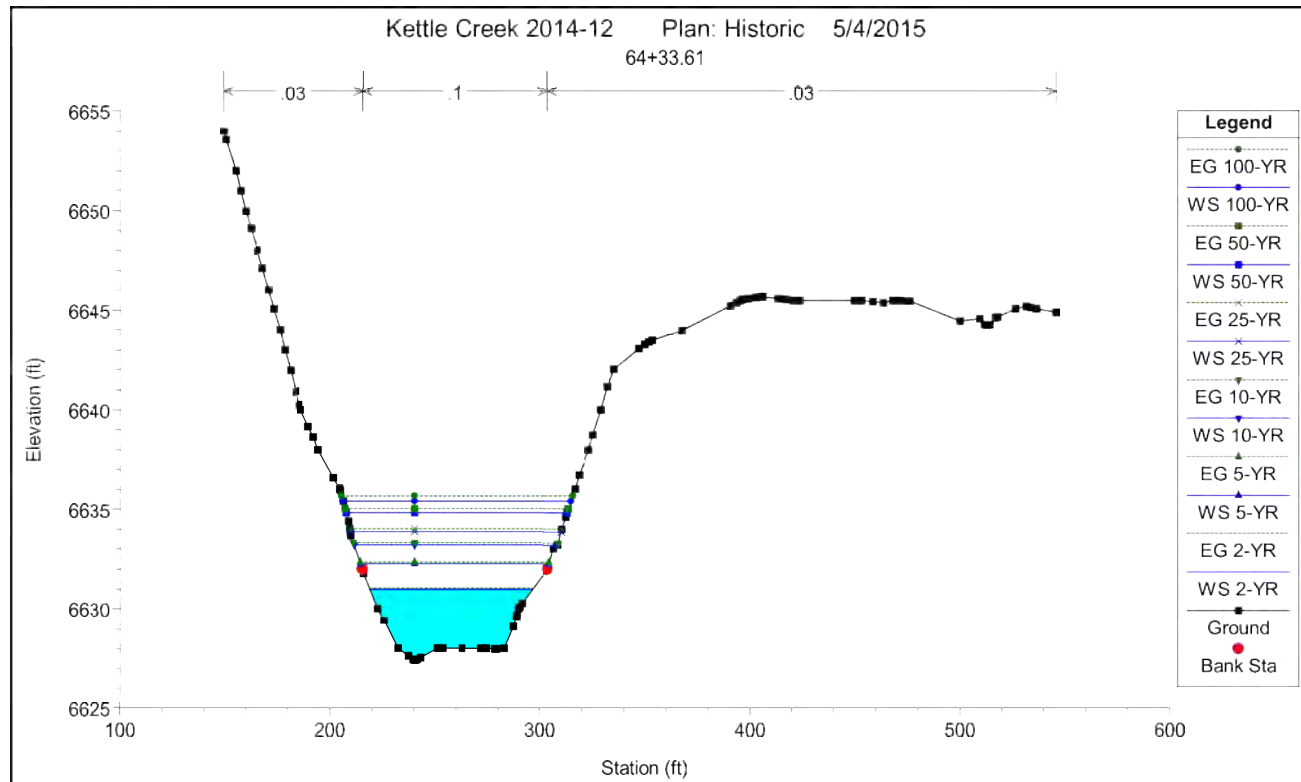

HYDRAULIC RESULTS –
HISTORIC
KETTLE CREEK DBPS
JOB NO. 25100.00
MAY 2015
C-25

HISTORIC CONDITIONS
MODEL RESULTS



Centennial 303-740-9393 • Colorado Springs 719-593-2593
Fort Collins 970-491-9888 • www.jrengineering.com

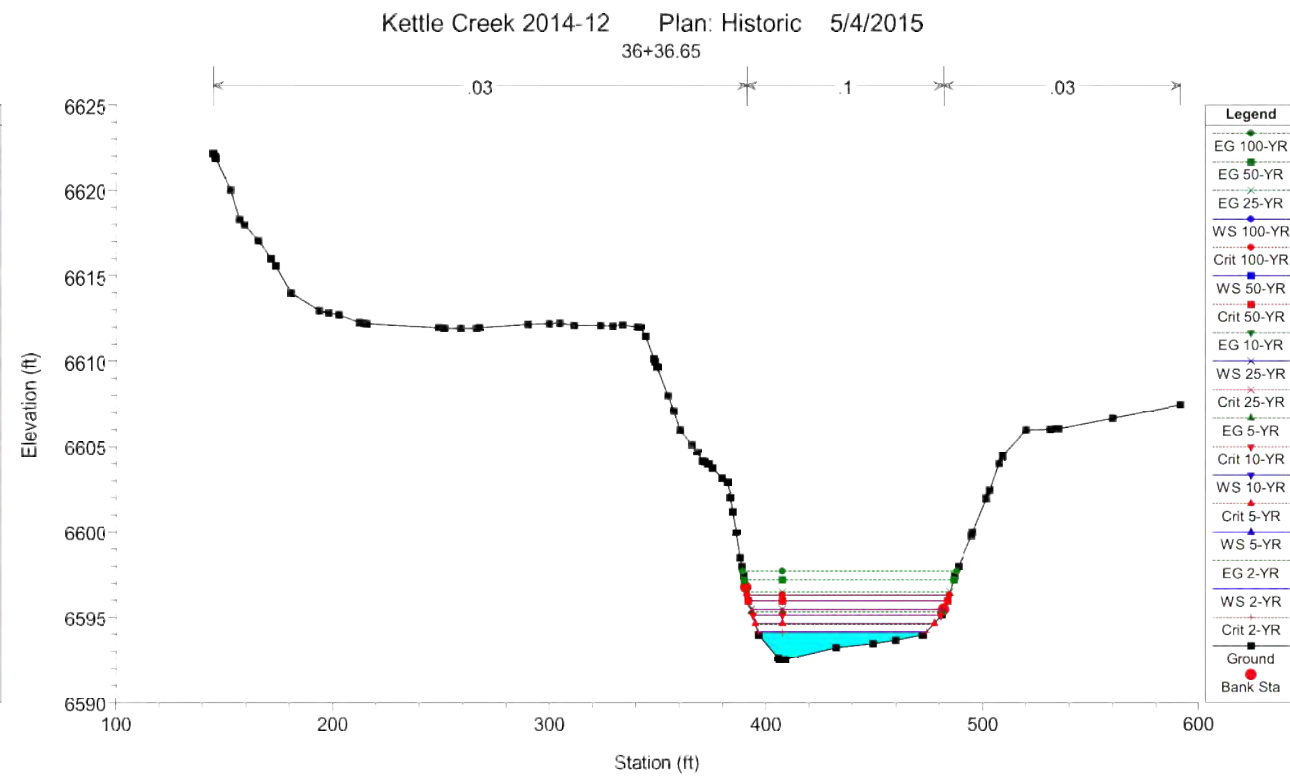
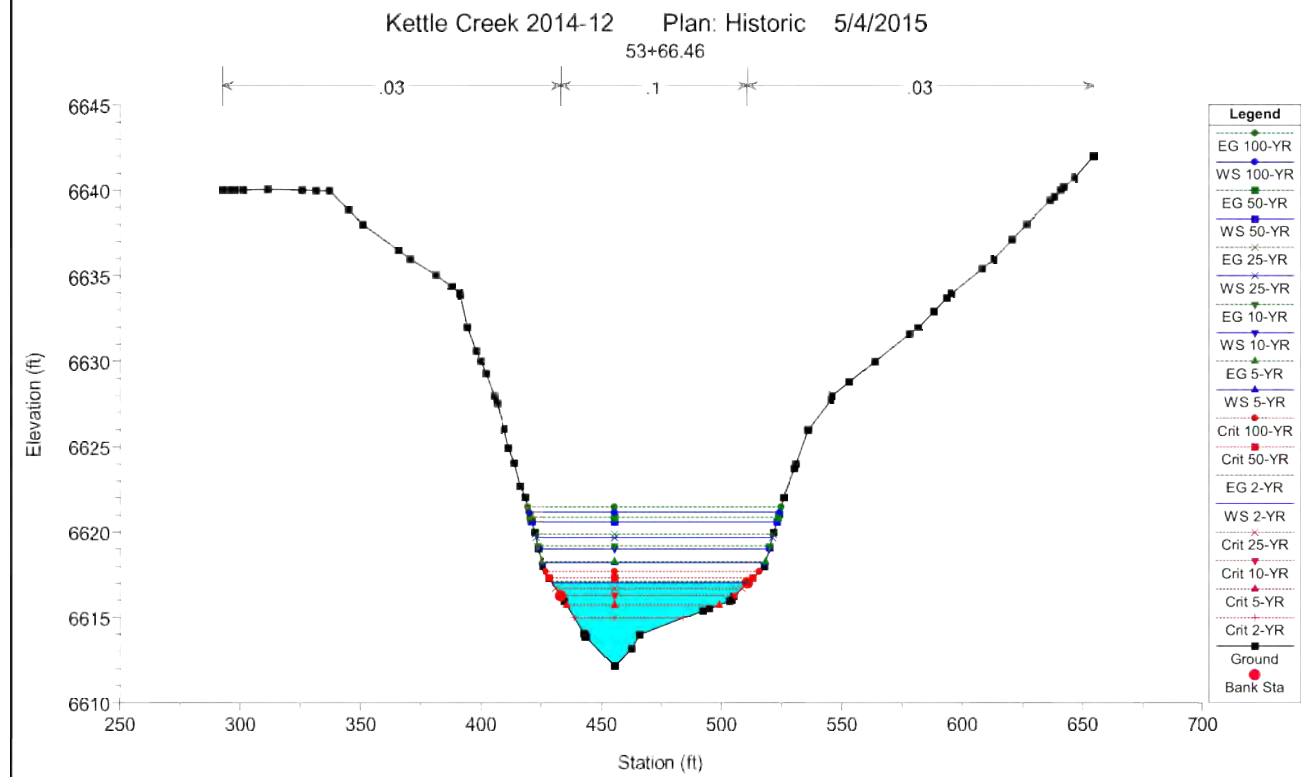
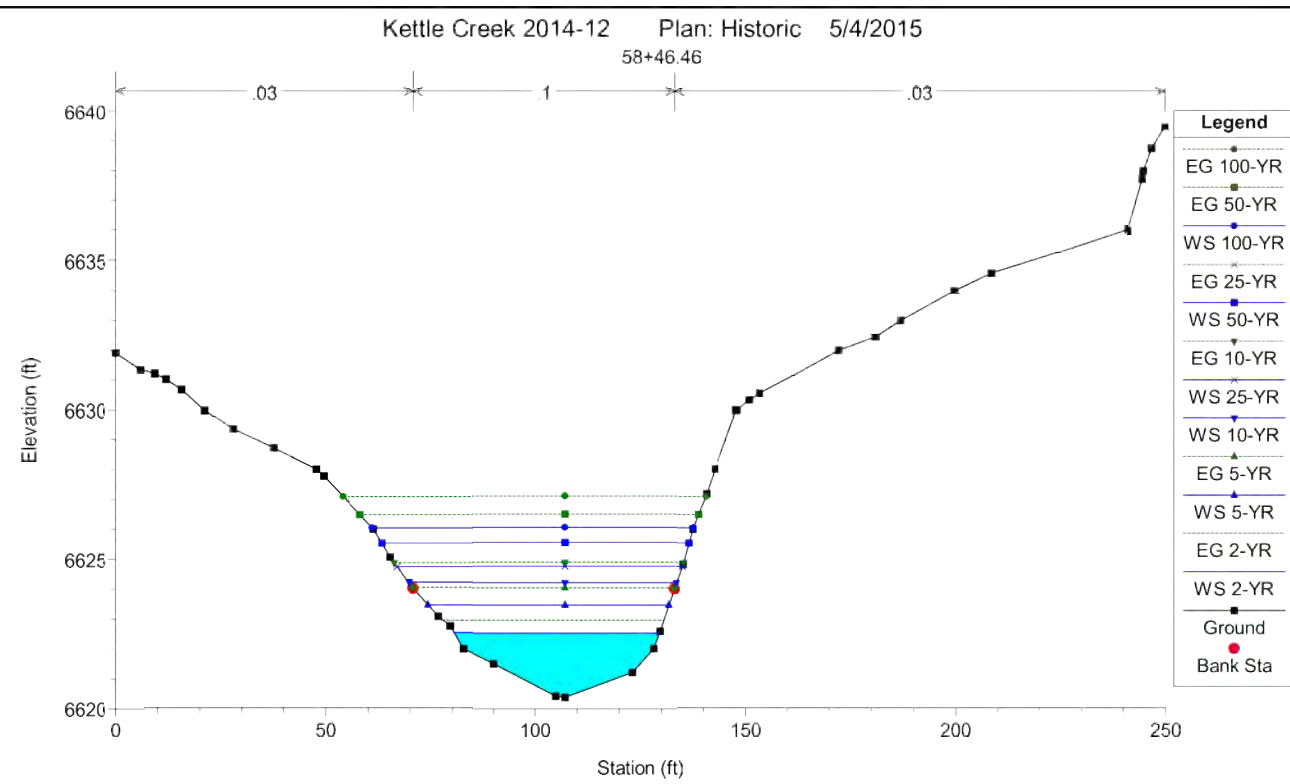
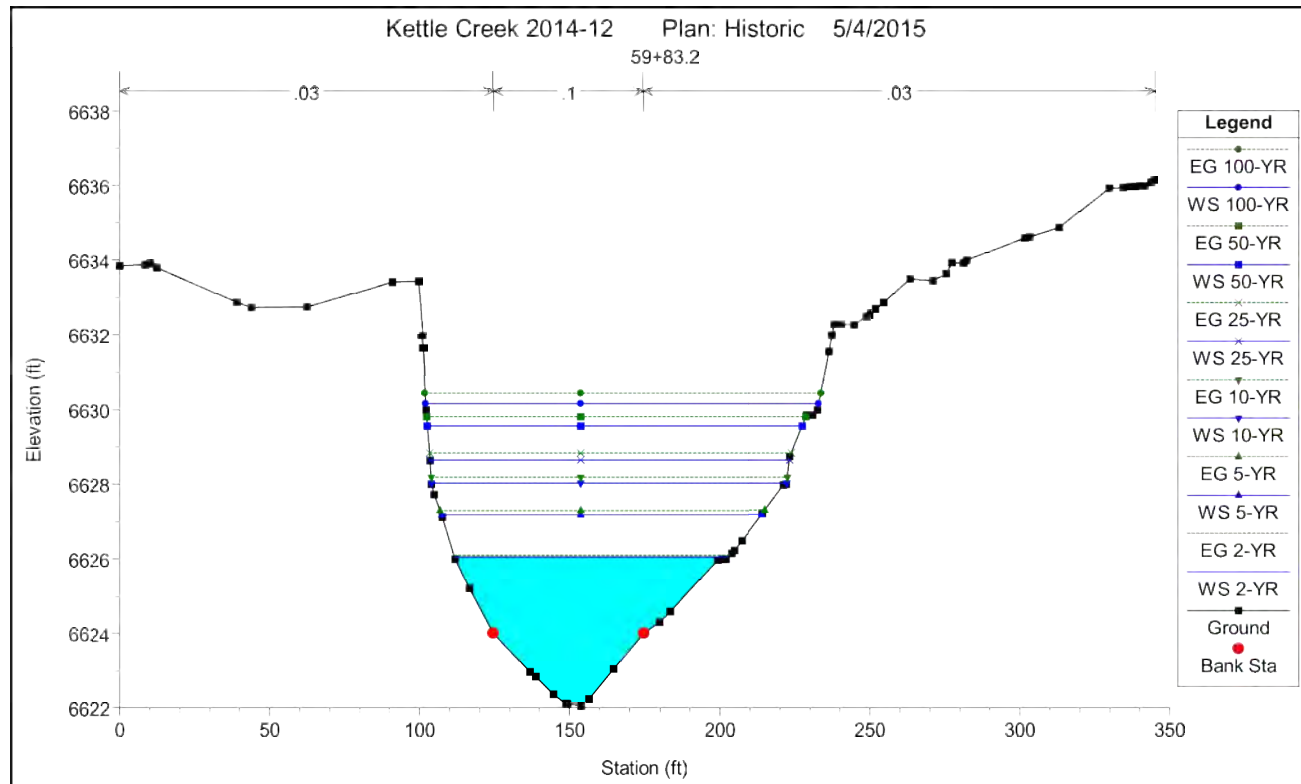

HISTORIC CONDITIONS
MODEL RESULTS

HYDRAULIC RESULTS –
HISTORIC
KETTLE CREEK DBPS
JOB NO. 25100.00
MAY 2015
C-26



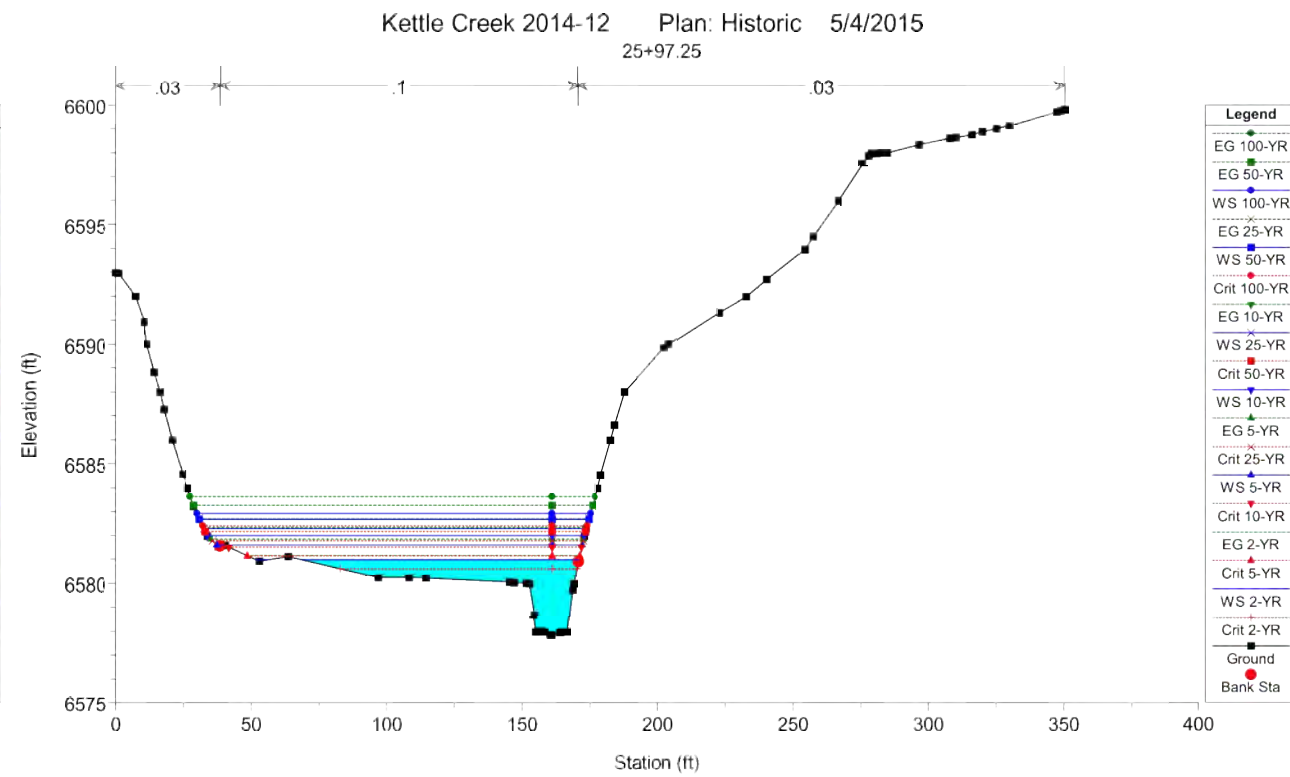
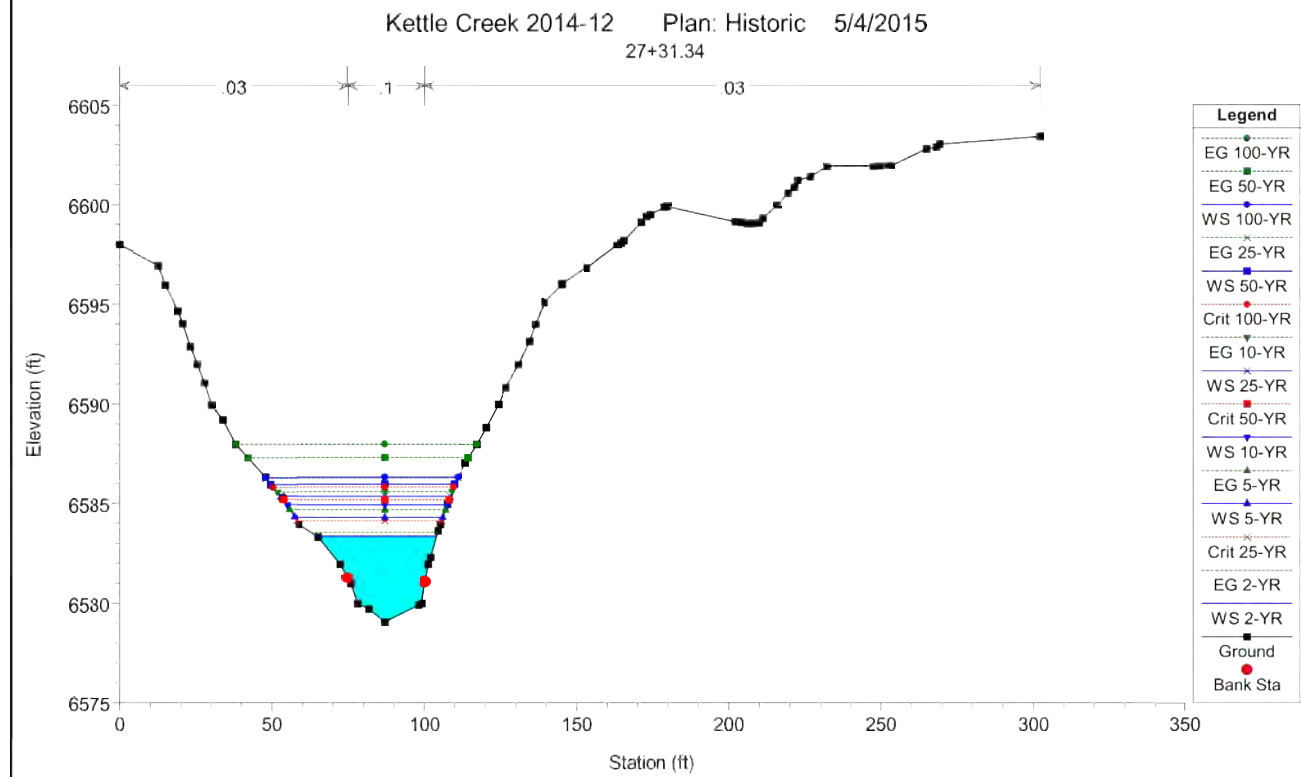
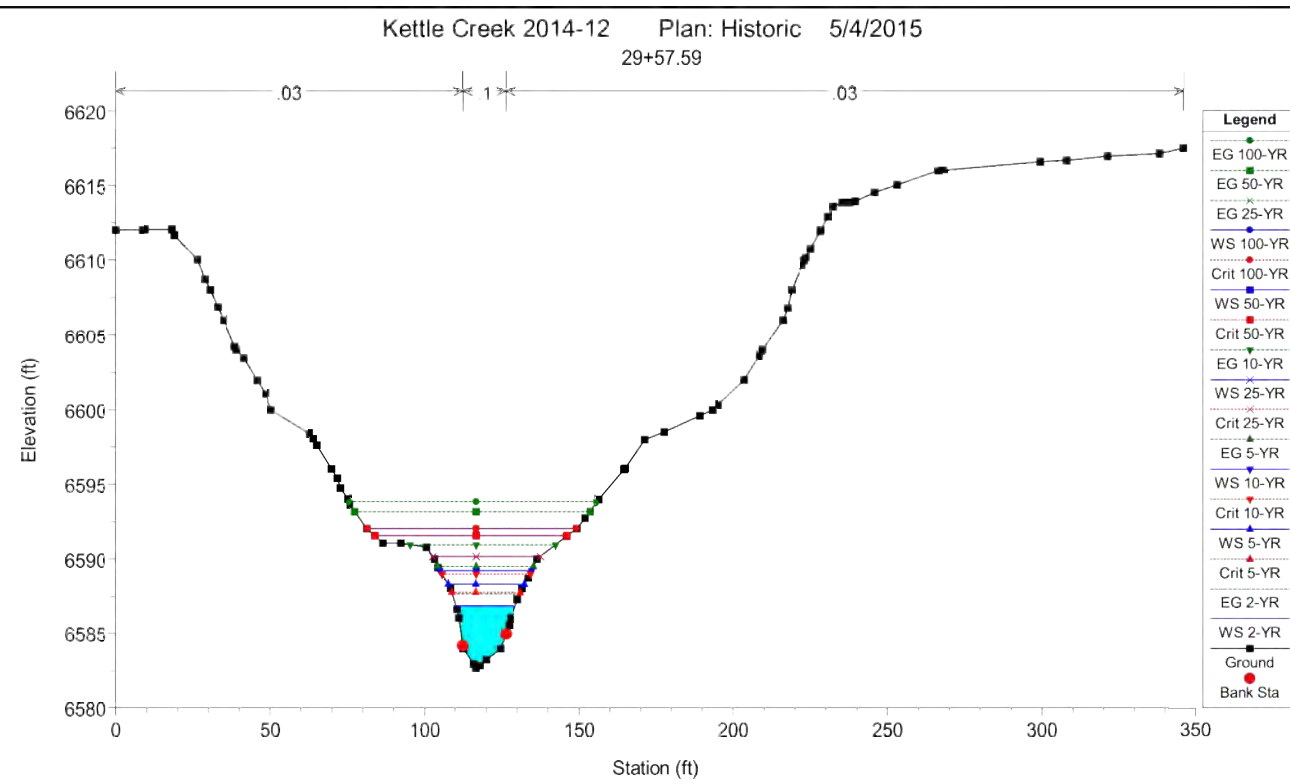
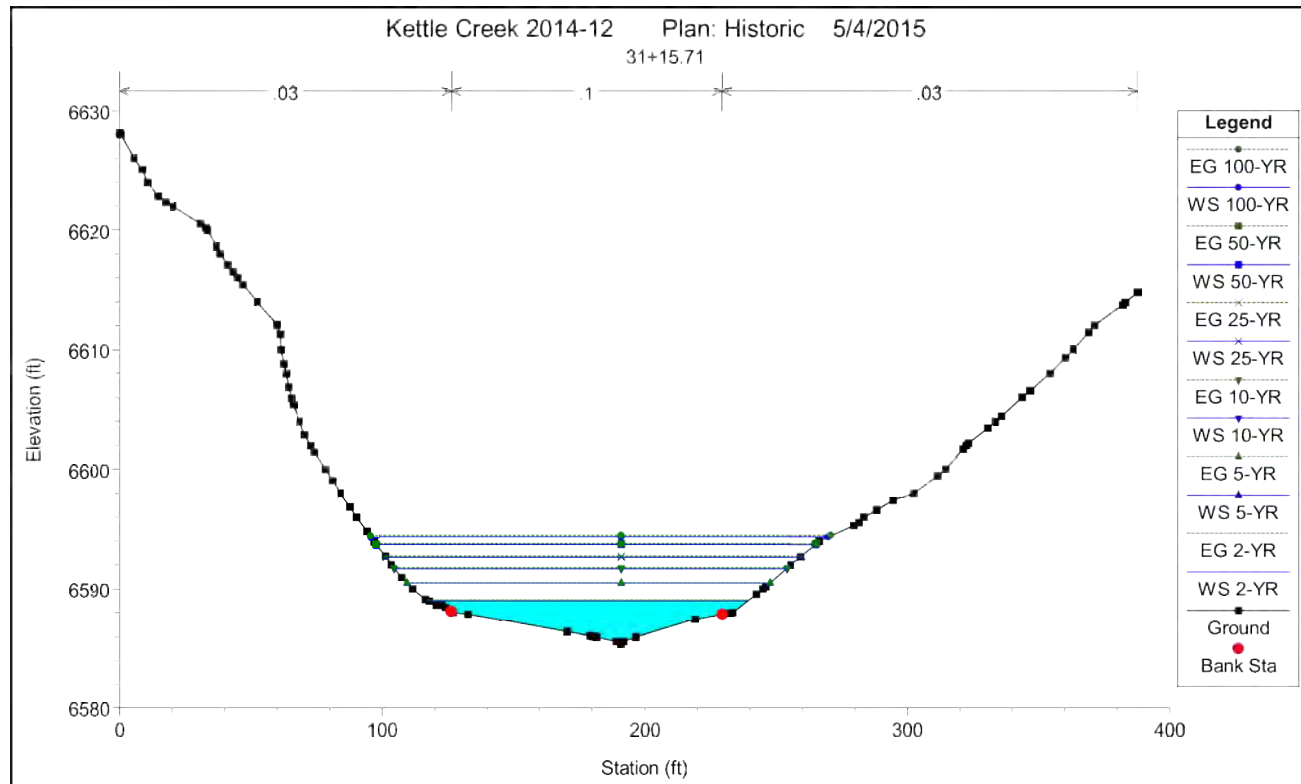

HISTORIC CONDITIONS
MODEL RESULTS

HYDRAULIC RESULTS –
HISTORIC
KETTLE CREEK DBPS
JOB NO. 25100.00
MAY 2015
C-27



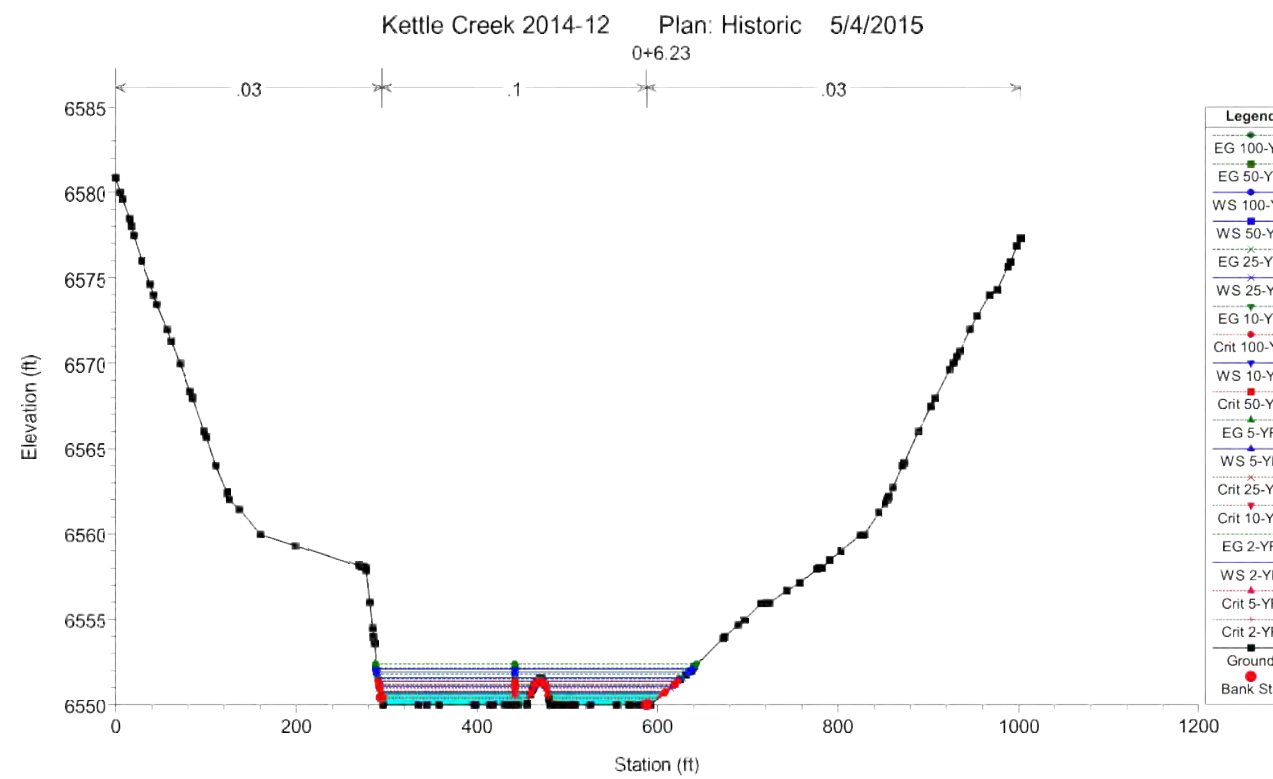
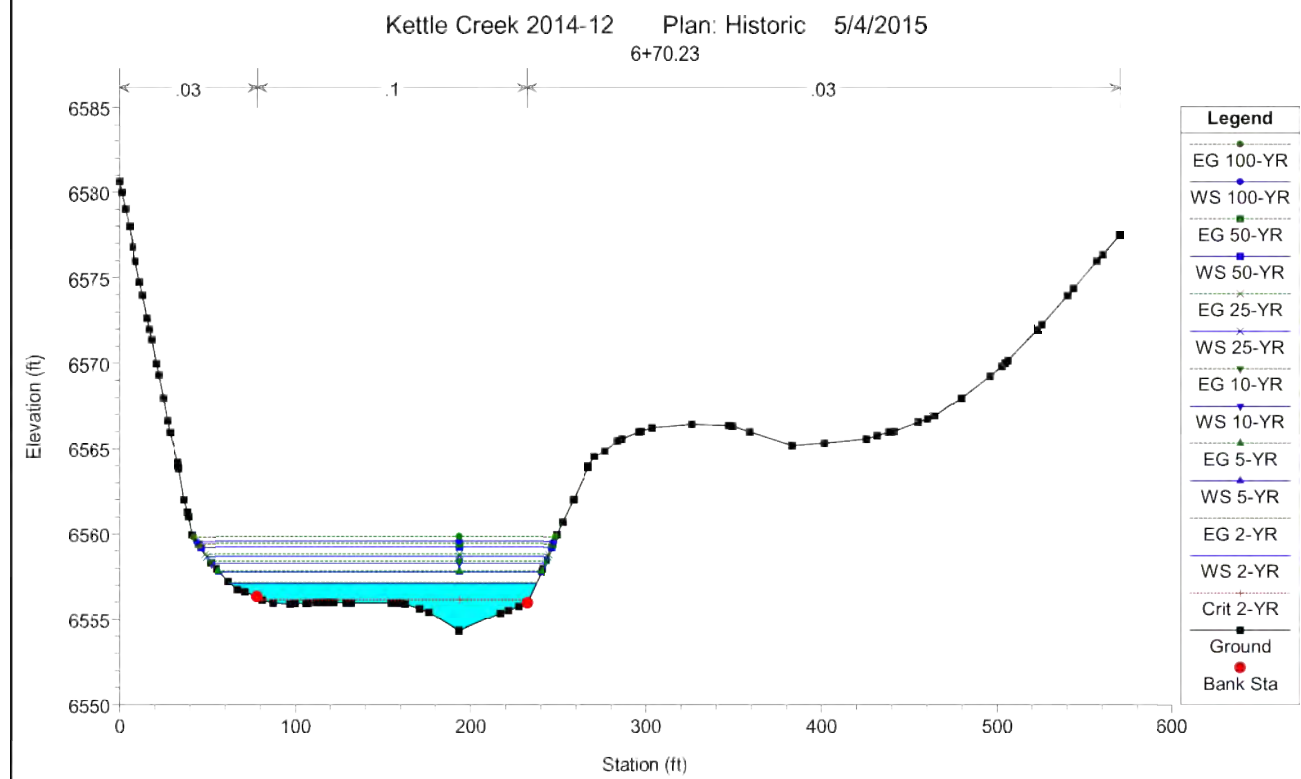
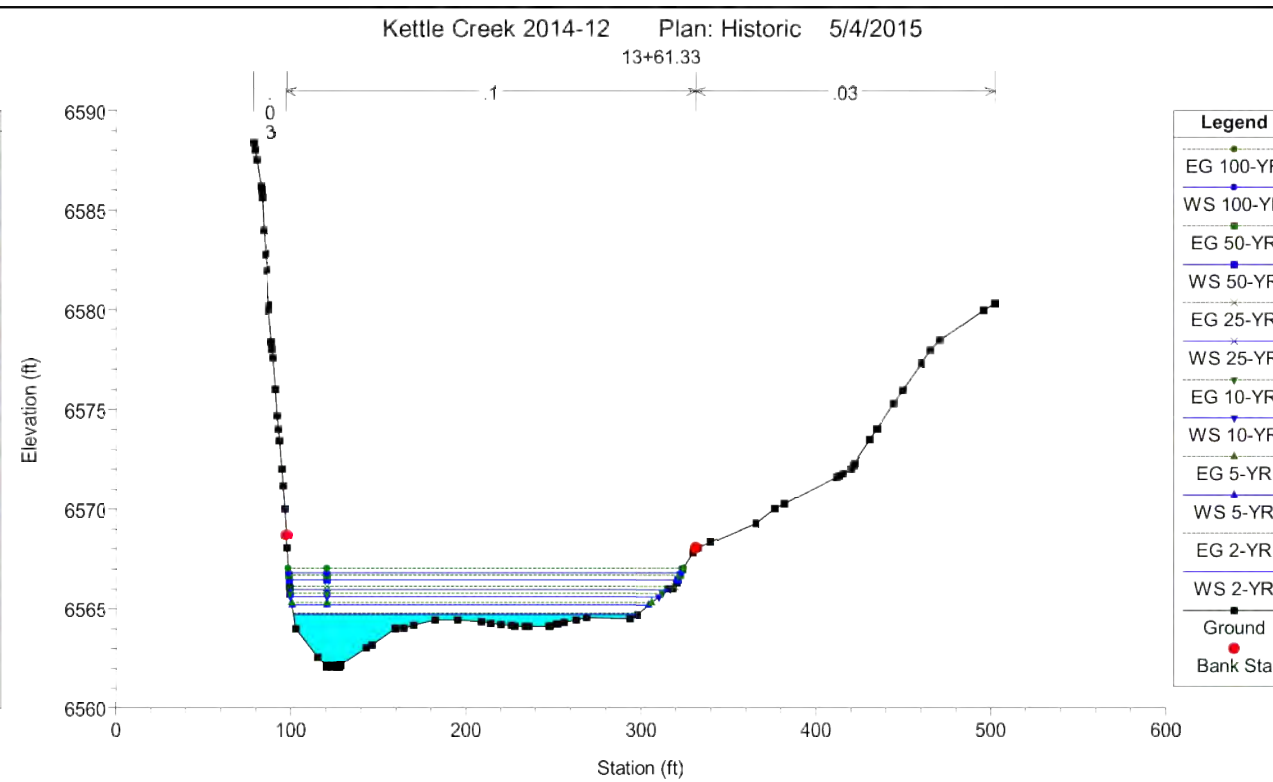
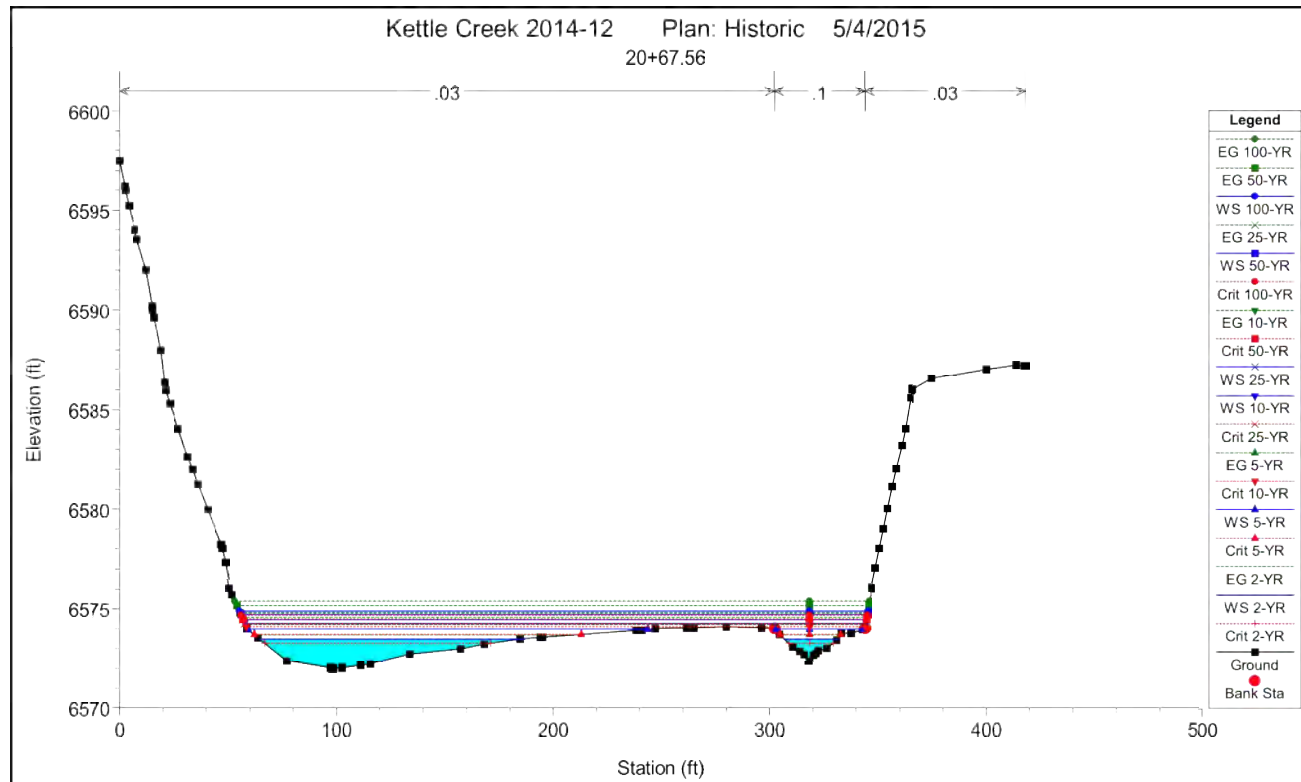

HISTORIC CONDITIONS
MODEL RESULTS

HYDRAULIC RESULTS –
HISTORIC
KETTLE CREEK DBPS
JOB NO. 25100.00
MAY 2015
C-28



Centennial 303-740-9393 • Colorado Springs 719-593-2593
Fort Collins 970-491-9888 • www.jrengineering.com

HEC-RAS Plan: Existing River: Kettle Creek Reach: Kettle Creek

Reach	River Sta	Profile	Q Total (cfs)	Min Ch El (ft)	W.S. Elev (ft)	Crit W.S. (ft)	E.G. Elev (ft)	E.G. Slope (ft/ft)	Vel Chnl (ft/s)	Flow Area (sq ft)	Top Width (ft)	Froude # Chl
Kettle Creek	24855.28	2-YR	1122.90	6868.95	6873.07		6873.58	0.029829	5.75	195.59	82.07	0.65
Kettle Creek	24855.28	5-YR	1711.40	6868.95	6873.81	6873.05	6874.49	0.029547	6.61	258.97	88.97	0.67
Kettle Creek	24855.28	10-YR	2258.20	6868.95	6874.46	6873.58	6875.24	0.026301	7.10	317.92	92.16	0.65
Kettle Creek	24855.28	25-YR	2725.50	6868.95	6874.94	6873.98	6875.82	0.024792	7.49	363.05	93.79	0.65
Kettle Creek	24855.28	50-YR	3471.20	6868.95	6875.75	6874.52	6876.72	0.021327	7.83	440.48	96.58	0.62
Kettle Creek	24855.28	100-YR	3992.10	6868.95	6876.25		6877.29	0.020026	8.09	488.91	98.22	0.61
Kettle Creek	23762.63	2-YR	1144.00	6855.75	6861.44		6861.59	0.005648	2.60	408.50	124.34	0.24
Kettle Creek	23762.63	5-YR	1744.80	6855.75	6862.36		6862.58	0.005592	3.01	525.28	128.58	0.25
Kettle Creek	23762.63	10-YR	2303.50	6855.75	6863.00		6863.30	0.005915	3.39	607.64	130.74	0.26
Kettle Creek	23762.63	25-YR	2781.20	6855.75	6863.49		6863.86	0.006096	3.66	672.98	132.72	0.27
Kettle Creek	23762.63	50-YR	3539.60	6855.75	6864.09		6864.57	0.006744	4.11	752.85	134.98	0.29
Kettle Creek	23762.63	100-YR	4068.60	6855.75	6864.48		6865.04	0.007090	4.39	805.18	136.32	0.30
Kettle Creek	22613.19	2-YR	1144.00	6839.60	6844.57		6845.35	0.079777	7.08	161.52	72.20	0.83
Kettle Creek	22613.19	5-YR	1744.80	6839.60	6845.42	6845.12	6846.26	0.085640	7.34	237.71	106.85	0.87
Kettle Creek	22613.19	10-YR	2303.50	6839.60	6846.03	6845.68	6846.89	0.071601	7.43	310.59	126.15	0.81
Kettle Creek	22613.19	25-YR	2781.20	6839.60	6846.39	6846.05	6847.34	0.066647	7.80	355.83	127.99	0.80
Kettle Creek	22613.19	50-YR	3539.60	6839.60	6847.11		6848.10	0.049388	7.78	449.53	131.24	0.72
Kettle Creek	22613.19	100-YR	4068.60	6839.60	6847.55		6848.59	0.043285	7.85	507.89	133.17	0.68
Kettle Creek	21556.31	2-YR	1154.20	6825.98	6833.10		6833.20	0.004293	2.47	458.98	124.83	0.22
Kettle Creek	21556.31	5-YR	1760.20	6825.98	6834.18		6834.32	0.004117	2.83	596.76	131.21	0.22
Kettle Creek	21556.31	10-YR	2323.80	6825.98	6834.94		6835.14	0.004206	3.14	699.05	136.19	0.23
Kettle Creek	21556.31	25-YR	2805.50	6825.98	6835.55		6835.79	0.004171	3.34	783.46	140.16	0.23
Kettle Creek	21556.31	50-YR	3570.00	6825.98	6836.25		6836.56	0.004526	3.72	883.27	145.82	0.24
Kettle Creek	21556.31	100-YR	4103.10	6825.98	6836.70		6837.05	0.004715	3.95	949.48	150.55	0.25
Kettle Creek	20822.88	2-YR	1154.20	6817.21	6822.51	6822.10	6822.84	0.028017	3.61	302.83	171.40	0.48
Kettle Creek	20822.88	5-YR	1760.20	6817.21	6823.12		6823.50	0.025462	4.10	410.71	179.31	0.48
Kettle Creek	20822.88	10-YR	2323.80	6817.21	6823.77		6824.15	0.020618	4.21	530.55	190.21	0.44
Kettle Creek	20822.88	25-YR	2805.50	6817.21	6824.43		6824.78	0.017689	4.03	668.52	229.08	0.42
Kettle Creek	20822.88	50-YR	3570.00	6817.21	6825.19		6825.52	0.013398	4.09	843.52	233.36	0.38
Kettle Creek	20822.88	100-YR	4103.10	6817.21	6825.70		6826.03	0.011418	4.12	964.25	236.25	0.35
Kettle Creek	19882.53	2-YR	1149.20	6805.92	6813.22		6813.34	0.002287	2.06	489.51	116.16	0.16
Kettle Creek	19882.53	5-YR	1751.90	6805.92	6814.64		6814.79	0.001910	2.22	659.32	123.94	0.15
Kettle Creek	19882.53	10-YR	2312.20	6805.92	6815.65		6815.84	0.001818	2.39	787.27	129.36	0.15
Kettle Creek	19882.53	25-YR	2792.50	6805.92	6816.36		6816.59	0.001811	2.53	881.04	133.12	0.16

HYDRAULIC RESULTS –
EXISTING
KETTLE CREEK DBPS
JOB NO. 25100.00
MAY 2015
C-29

EXISTING CONDITIONS
MODEL RESULTS



HEC-RAS Plan: Existing River: Kettle Creek Reach: Kettle Creek (Continued)

Reach	River Sta	Profile	Q Total (cfs)	Min Ch El (ft)	W.S. Elev (ft)	Crit W.S. (ft)	E.G. Elev (ft)	E.G. Slope (ft/ft)	Vel Chnl (ft/s)	Flow Area (sq ft)	Top Width (ft)	Froude # Chl
Kettle Creek	19882.53	50-YR	3557.00	6805.92	6817.33		6817.62	0.001841	2.75	1012.11	138.06	0.16
Kettle Creek	19882.53	100-YR	4090.50	6805.92	6817.92		6818.24	0.001878	2.90	1094.16	141.30	0.16
Kettle Creek	19115.6	2-YR	1151.10	6798.52	6804.47		6804.55	0.002197	2.08	507.88	142.27	0.16
Kettle Creek	19115.6	5-YR	1755.60	6798.52	6805.89		6805.99	0.001549	2.06	741.52	184.54	0.14
Kettle Creek	19115.6	10-YR	2317.70	6798.52	6806.86		6806.97	0.001273	2.04	942.95	217.14	0.13
Kettle Creek	19115.6	25-YR	2797.90	6798.52	6807.53		6807.65	0.001121	2.03	1091.17	226.86	0.12
Kettle Creek	19115.6	50-YR	3559.70	6798.52	6808.46		6808.60	0.000971	2.03	1307.16	238.12	0.12
Kettle Creek	19115.6	100-YR	4090.90	6798.52	6809.04		6809.20	0.000903	2.04	1448.23	245.02	0.11
Kettle Creek	18505.62	2-YR	1151.10	6788.84	6794.60		6794.88	0.004990	3.09	321.21	74.52	0.24
Kettle Creek	18505.62	5-YR	1755.60	6788.84	6795.81		6796.22	0.004891	3.53	413.73	78.24	0.25
Kettle Creek	18505.62	10-YR	2317.70	6788.84	6796.78		6797.29	0.004790	3.84	490.94	81.45	0.25
Kettle Creek	18505.62	25-YR	2797.90	6788.84	6797.51		6798.11	0.004736	4.07	551.53	83.95	0.25
Kettle Creek	18505.62	50-YR	3559.70	6788.84	6798.55		6799.27	0.004665	4.38	640.51	87.27	0.26
Kettle Creek	18505.62	100-YR	4090.90	6788.84	6799.21		6800.00	0.004631	4.58	698.51	89.51	0.26
Kettle Creek	17970.84	2-YR	1151.10	6783.01	6787.19		6787.69	0.018181	4.74	220.59	74.74	0.44
Kettle Creek	17970.84	5-YR	1755.60	6783.01	6788.14		6788.80	0.016176	5.21	295.68	84.82	0.43
Kettle Creek	17970.84	10-YR	2317.70	6783.01	6788.78		6789.66	0.015429	5.55	350.89	88.00	0.43
Kettle Creek	17970.84	25-YR	2797.90	6783.01	6789.25		6790.32	0.015047	5.81	392.75	89.67	0.43
Kettle Creek	17970.84	50-YR	3559.70	6783.01	6789.91		6791.28	0.014776	6.19	452.33	91.88	0.43
Kettle Creek	17970.84	100-YR	4090.90	6783.01	6790.32		6791.89	0.014671	6.43	490.72	93.30	0.44
Kettle Creek	17128.69	2-YR	1151.10	6771.75	6776.93		6777.14	0.009134	3.47	320.99	90.41	0.31
Kettle Creek	17128.69	5-YR	1755.60	6771.75	6777.76		6778.11	0.010244	4.17	397.94	94.22	0.34
Kettle Creek	17128.69	10-YR	2317.70	6771.75	6778.44		6778.90	0.010715	4.67	462.84	97.19	0.35
Kettle Creek	17128.69	25-YR	2797.90	6771.75	6778.95		6779.52	0.011024	5.03	513.16	99.45	0.36
Kettle Creek	17128.69	50-YR	3559.70	6771.75	6779.70		6780.41	0.011262	5.50	588.34	102.98	0.38
Kettle Creek	17128.69	100-YR	4090.90	6771.75	6780.16		6780.98	0.011382	5.79	637.10	105.28	0.38
Kettle Creek	16326.64	2-YR	1151.10	6761.71	6768.09		6768.34	0.013475	3.90	292.71	107.82	0.37
Kettle Creek	16326.64	5-YR	1755.60	6761.71	6768.97		6769.31	0.011888	4.27	388.32	110.45	0.36
Kettle Creek	16326.64	10-YR	2317.70	6761.71	6769.60		6770.07	0.011460	4.59	459.11	112.42	0.36
Kettle Creek	16326.64	25-YR	2797.90	6761.71	6770.09		6770.66	0.011213	4.83	513.71	113.96	0.37
Kettle Creek	16326.64	50-YR	3559.70	6761.71	6770.75		6771.50	0.011130	5.20	590.02	116.38	0.37
Kettle Creek	16326.64	100-YR	4090.90	6761.71	6771.17		6772.05	0.011084	5.43	639.38	117.92	0.37
Kettle Creek	15906.34	2-YR	1151.10	6753.98	6761.79	6759.97	6762.19	0.016162	4.94	227.34	65.49	0.41

EXISTING CONDITIONS
MODEL RESULTS (CONT.)

HYDRAULIC RESULTS –
EXISTING
KETTLE CREEK DBPS
JOB NO. 25100.00
MAY 2015
C-30



Centennial 303-740-9393 • Colorado Springs 719-593-2593
Fort Collins 970-491-9888 • www.jrengineering.com

HEC-RAS Plan: Existing River: Kettle Creek Reach: Kettle Creek (Continued)

Reach	River Sta	Profile	Q Total (cfs)	Min Ch El (ft)	W.S. Elev (ft)	Crit W.S. (ft)	E.G. Elev (ft)	E.G. Slope (ft/ft)	Vel Chnl (ft/s)	Flow Area (sq ft)	Top Width (ft)	Froude # Chl
Kettle Creek	15906.34	5-YR	1755.60	6753.98	6762.57	6760.94	6763.21	0.018572	5.89	282.60	75.97	0.45
Kettle Creek	15906.34	10-YR	2317.70	6753.98	6763.18	6761.61	6764.02	0.019313	6.46	331.24	84.52	0.47
Kettle Creek	15906.34	25-YR	2797.90	6753.98	6763.60	6762.11	6764.62	0.020024	6.88	368.19	90.84	0.48
Kettle Creek	15906.34	50-YR	3559.70	6753.98	6764.20	6762.95	6765.48	0.020166	7.34	425.15	98.79	0.49
Kettle Creek	15906.34	100-YR	4090.90	6753.98	6764.56	6763.56	6766.05	0.020099	7.57	461.34	102.32	0.49
Kettle Creek	15906		Bridge									
Kettle Creek	15683.73	2-YR	1151.10	6751.41	6757.63	6757.63	6758.94	0.062898	8.85	126.25	51.62	0.77
Kettle Creek	15683.73	5-YR	1755.60	6751.41	6758.45	6758.45	6760.22	0.051347	9.02	173.56	62.60	0.71
Kettle Creek	15683.73	10-YR	2317.70	6751.41	6759.40	6759.40	6761.21	0.030985	7.88	238.24	74.47	0.57
Kettle Creek	15683.73	25-YR	2797.90	6751.41	6759.98	6759.98	6761.90	0.025350	7.59	284.17	82.33	0.52
Kettle Creek	15683.73	50-YR	3559.70	6751.41	6760.93	6760.93	6762.82	0.018071	7.01	370.27	100.69	0.45
Kettle Creek	15683.73	100-YR	4090.90	6751.41	6761.38	6761.38	6763.35	0.016362	6.94	416.57	106.10	0.44
Kettle Creek	15530.88	2-YR	1151.10	6749.40	6754.39		6754.50	0.005703	2.69	428.06	118.46	0.24
Kettle Creek	15530.88	5-YR	1755.60	6749.40	6755.32		6755.48	0.006156	3.24	541.58	125.69	0.26
Kettle Creek	15530.88	10-YR	2317.70	6749.40	6756.05		6756.26	0.006360	3.63	634.79	130.29	0.27
Kettle Creek	15530.88	25-YR	2797.90	6749.40	6756.60		6756.84	0.006511	3.91	707.83	136.27	0.28
Kettle Creek	15530.88	50-YR	3559.70	6749.40	6757.36		6757.66	0.006648	4.29	815.03	144.12	0.29
Kettle Creek	15530.88	100-YR	4090.90	6749.40	6757.84		6758.18	0.006684	4.50	885.30	148.71	0.30
Kettle Creek	14906.12	2-YR	1151.10	6742.04	6748.24		6748.76	0.017659	5.45	201.85	73.53	0.44
Kettle Creek	14906.12	5-YR	1755.60	6742.04	6749.14		6749.85	0.015094	5.64	273.31	85.81	0.42
Kettle Creek	14906.12	10-YR	2317.70	6742.04	6749.77		6750.64	0.014292	5.89	330.11	95.71	0.41
Kettle Creek	14906.12	25-YR	2797.90	6742.04	6750.20		6751.22	0.013939	6.08	373.64	102.33	0.41
Kettle Creek	14906.12	50-YR	3559.70	6742.04	6750.77		6752.04	0.013641	6.35	433.20	107.89	0.41
Kettle Creek	14906.12	100-YR	4090.90	6742.04	6751.12		6752.56	0.013505	6.51	471.08	110.65	0.41
Kettle Creek	14354.72	2-YR	1151.10	6734.36	6742.29		6742.49	0.007728	3.62	316.88	80.15	0.29
Kettle Creek	14354.72	5-YR	1755.60	6734.36	6743.23		6743.54	0.008686	4.33	396.21	88.58	0.32
Kettle Creek	14354.72	10-YR	2317.70	6734.36	6743.99		6744.39	0.008879	4.76	465.89	95.25	0.33
Kettle Creek	14354.72	25-YR	2797.90	6734.36	6744.58		6745.05	0.008790	5.02	524.07	100.95	0.33
Kettle Creek	14354.72	50-YR	3559.70	6734.36	6745.42		6746.00	0.008500	5.32	612.65	109.18	0.33
Kettle Creek	14354.72	100-YR	4090.90	6734.36	6745.95		6746.60	0.008290	5.49	671.39	114.20	0.33
Kettle Creek	13757.33	2-YR	1151.10	6727.92	6733.99	6733.14	6734.63	0.026816	6.18	180.61	69.56	0.51
Kettle Creek	13757.33	5-YR	1755.60	6727.92	6734.90	6734.00	6735.79	0.020945	6.18	247.35	76.93	0.47
Kettle Creek	13757.33	10-YR	2317.70	6727.92	6735.48	6734.50	6736.67	0.020074	6.48	293.46	81.51	0.47

EXISTING CONDITIONS
MODEL RESULTS

HYDRAULIC RESULTS –
EXISTING
KETTLE CREEK DBPS
JOB NO. 25100.00
MAY 2015
C-31



HEC-RAS Plan: Existing River: Kettle Creek Reach: Kettle Creek (Continued)

Reach	River Sta	Profile	Q Total (cfs)	Min Ch El (ft)	W.S. Elev (ft)	Crit W.S. (ft)	E.G. Elev (ft)	E.G. Slope (ft/ft)	Vel Chnl (ft/s)	Flow Area (sq ft)	Top Width (ft)	Froude # Chl
Kettle Creek	13757.33	25-YR	2797.90	6727.92	6735.87	6735.05	6737.32	0.020353	6.81	325.83	84.60	0.48
Kettle Creek	13757.33	50-YR	3559.70	6727.92	6736.38	6735.96	6738.25	0.021302	7.33	369.80	88.59	0.49
Kettle Creek	13757.33	100-YR	4090.90	6727.92	6736.69	6736.50	6738.86	0.021950	7.66	397.69	91.02	0.50
Kettle Creek	12367.83	2-YR	1151.10	6708.58	6713.95		6714.17	0.009200	3.76	303.64	75.16	0.31
Kettle Creek	12367.83	5-YR	1755.60	6708.58	6714.87		6715.22	0.010880	4.61	375.26	78.52	0.35
Kettle Creek	12367.83	10-YR	2317.70	6708.58	6715.69		6716.14	0.011150	5.14	440.38	81.16	0.37
Kettle Creek	12367.83	25-YR	2797.90	6708.58	6716.39		6716.90	0.010864	5.45	498.90	86.32	0.37
Kettle Creek	12367.83	50-YR	3559.70	6708.58	6717.38		6717.98	0.010320	5.81	589.65	96.16	0.37
Kettle Creek	12367.83	100-YR	4090.90	6708.58	6717.97		6718.64	0.010019	6.01	646.95	99.38	0.37
Kettle Creek	11267.11	2-YR	1151.10	6695.53	6702.97		6703.48	0.010294	4.30	224.49	68.56	0.33
Kettle Creek	11267.11	5-YR	1755.60	6695.53	6704.07		6704.78	0.008346	4.40	304.04	76.56	0.31
Kettle Creek	11267.11	10-YR	2317.70	6695.53	6704.79		6705.69	0.008144	4.68	361.71	82.91	0.31
Kettle Creek	11267.11	25-YR	2797.90	6695.53	6705.25		6706.33	0.008516	5.00	400.68	87.41	0.32
Kettle Creek	11267.11	50-YR	3559.70	6695.53	6705.84		6707.21	0.009202	5.47	454.58	93.36	0.34
Kettle Creek	11267.11	100-YR	4090.90	6695.53	6706.21		6707.76	0.009606	5.76	488.97	96.31	0.35
Kettle Creek	10087.38	2-YR	1145.30	6680.77	6687.96		6688.15	0.002153	2.39	371.42	88.96	0.17
Kettle Creek	10087.38	5-YR	1748.30	6680.77	6689.11		6689.39	0.002103	2.64	475.54	92.02	0.17
Kettle Creek	10087.38	10-YR	2310.00	6680.77	6690.07	6686.59	6690.43	0.002011	2.79	565.25	94.54	0.17
Kettle Creek	10087.38	25-YR	2790.50	6680.77	6690.89	6687.11	6691.29	0.001887	2.87	643.04	96.84	0.16
Kettle Creek	10087.38	50-YR	3553.20	6680.77	6692.10	6687.72	6692.58	0.001717	2.97	763.04	100.32	0.16
Kettle Creek	10087.38	100-YR	4085.50	6680.77	6692.90	6688.11	6693.41	0.001624	3.03	843.83	102.58	0.16
Kettle Creek	9732.32	2-YR	1145.30	6676.00	6681.22		6681.80	0.034847	6.11	187.86	61.63	0.59
Kettle Creek	9732.32	5-YR	1748.30	6676.00	6681.56		6682.64	0.057775	8.39	209.55	67.19	0.77
Kettle Creek	9732.32	10-YR	2310.00	6676.00	6681.83	6681.83	6683.42	0.077142	10.17	228.29	70.65	0.90
Kettle Creek	9732.32	25-YR	2790.50	6676.00	6682.24	6682.24	6684.05	0.075615	10.76	258.46	74.43	0.91
Kettle Creek	9732.32	50-YR	3553.20	6676.00	6682.82	6682.82	6685.01	0.072800	11.46	302.38	78.16	0.91
Kettle Creek	9732.32	100-YR	4085.50	6676.00	6683.21	6683.21	6685.65	0.068956	11.75	333.84	80.71	0.90
Kettle Creek	8444.97	2-YR	1184.90	6660.69	6666.67		6666.92	0.005788	3.27	316.02	103.35	0.26
Kettle Creek	8444.97	5-YR	1807.00	6660.69	6667.70		6668.05	0.004719	3.34	425.90	111.97	0.24
Kettle Creek	8444.97	10-YR	2385.10	6660.69	6668.53		6668.96	0.004086	3.39	522.84	120.22	0.23
Kettle Creek	8444.97	25-YR	2879.90	6660.69	6669.18		6669.65	0.003697	3.42	601.93	125.95	0.22
Kettle Creek	8444.97	50-YR	3663.90	6660.69	6670.08		6670.63	0.003291	3.48	719.93	133.88	0.21
Kettle Creek	8444.97	100-YR	4211.20	6660.69	6670.61		6671.21	0.003155	3.55	791.43	137.54	0.21

EXISTING CONDITIONS
MODEL RESULTS

HYDRAULIC RESULTS –
EXISTING
KETTLE CREEK DBPS
JOB NO. 25100.00
MAY 2015
C-32



HEC-RAS Plan: Existing River: Kettle Creek Reach: Kettle Creek (Continued)

Reach	River Sta	Profile	Q Total (cfs)	Min Ch El (ft)	W.S. Elev (ft)	Crit W.S. (ft)	E.G. Elev (ft)	E.G. Slope (ft/ft)	Vel Chnl (ft/s)	Flow Area (sq ft)	Top Width (ft)	Froude # Chl
Kettle Creek	8350	2-YR	1184.90	6660.00	6666.27		6666.52	0.003254	2.73	352.97	97.77	0.20
Kettle Creek	8350	5-YR	1807.00	6660.00	6667.37		6667.69	0.003021	2.94	464.67	106.68	0.20
Kettle Creek	8350	10-YR	2385.10	6660.00	6668.23		6668.62	0.002958	3.15	561.08	121.35	0.20
Kettle Creek	8350	25-YR	2879.90	6660.00	6668.91		6669.34	0.002773	3.22	650.27	134.75	0.19
Kettle Creek	8350	50-YR	3663.90	6660.00	6669.88		6670.34	0.002477	3.27	786.50	148.07	0.19
Kettle Creek	8350	100-YR	4211.20	6660.00	6670.43		6670.92	0.002373	3.33	870.55	154.76	0.18
Kettle Creek	8251.39	2-YR	1184.90	6660.00	6665.53	6663.62	6665.91	0.010606	4.20	256.21	72.80	0.35
Kettle Creek	8251.39	5-YR	1807.00	6660.00	6666.53	6664.46	6667.09	0.010200	4.70	333.81	81.18	0.35
Kettle Creek	8251.39	10-YR	2385.10	6660.00	6667.31	6665.20	6668.00	0.009802	5.02	399.11	87.50	0.35
Kettle Creek	8251.39	25-YR	2879.90	6660.00	6667.92	6665.75	6668.72	0.009244	5.19	454.36	91.94	0.35
Kettle Creek	8251.39	50-YR	3663.90	6660.00	6668.88	6666.52	6669.75	0.008948	5.56	552.96	122.98	0.35
Kettle Creek	8251.39	100-YR	4211.20	6660.00	6669.48	6667.05	6670.37	0.007895	5.49	631.26	135.89	0.33
Kettle Creek	8251		Bridge									
Kettle Creek	8060.94	2-YR	1184.90	6653.57	6658.73	6658.23	6659.78	0.014856	5.20	167.44	49.84	0.42
Kettle Creek	8060.94	5-YR	1807.00	6653.57	6659.58	6659.31	6661.06	0.016409	6.09	212.92	56.64	0.45
Kettle Creek	8060.94	10-YR	2385.10	6653.57	6660.21	6660.13	6662.06	0.017418	6.72	249.75	61.52	0.47
Kettle Creek	8060.94	25-YR	2879.90	6653.57	6660.84	6660.84	6662.75	0.016851	7.04	291.70	71.31	0.47
Kettle Creek	8060.94	50-YR	3663.90	6653.57	6661.63	6661.63	6663.71	0.016094	7.39	353.30	95.52	0.47
Kettle Creek	8060.94	100-YR	4211.20	6653.57	6662.63	6662.63	6664.20	0.011363	6.73	469.57	130.09	0.40
Kettle Creek	7863.13	2-YR	1184.90	6649.24	6652.87	6652.74	6654.16	0.067479	8.24	136.20	52.11	0.82
Kettle Creek	7863.13	5-YR	1807.00	6649.24	6653.81	6653.69	6655.51	0.053491	8.73	187.44	57.41	0.76
Kettle Creek	7863.13	10-YR	2385.10	6649.24	6654.53	6654.53	6656.56	0.046955	9.11	230.10	61.83	0.73
Kettle Creek	7863.13	25-YR	2879.90	6649.24	6655.17	6655.17	6657.35	0.039738	9.11	271.03	65.97	0.69
Kettle Creek	7863.13	50-YR	3663.90	6649.24	6656.00	6656.00	6658.41	0.034690	9.36	328.42	72.80	0.66
Kettle Creek	7863.13	100-YR	4211.20	6649.24	6656.51	6656.51	6659.11	0.031746	9.44	366.77	76.23	0.64
Kettle Creek	7632.03	2-YR	1184.90	6641.32	6649.06		6649.33	0.009212	4.15	284.17	62.63	0.32
Kettle Creek	7632.03	5-YR	1807.00	6641.32	6650.16		6650.57	0.010273	4.99	356.19	68.49	0.35
Kettle Creek	7632.03	10-YR	2385.10	6641.32	6650.96		6651.49	0.011087	5.61	413.22	74.28	0.37
Kettle Creek	7632.03	25-YR	2879.90	6641.32	6651.51		6652.16	0.011854	6.10	454.84	78.34	0.39
Kettle Creek	7632.03	50-YR	3663.90	6641.32	6652.18		6653.03	0.013282	6.84	509.30	83.26	0.42
Kettle Creek	7632.03	100-YR	4211.20	6641.32	6652.57		6653.57	0.014255	7.31	542.28	85.57	0.44
Kettle Creek	6688.3	2-YR	1186.40	6629.79	6635.71		6636.03	0.024177	4.50	263.62	95.43	0.48
Kettle Creek	6688.3	5-YR	1807.50	6629.79	6636.81		6637.16	0.020802	4.79	377.74	112.95	0.46

EXISTING CONDITIONS
MODEL RESULTS

HYDRAULIC RESULTS –
EXISTING
KETTLE CREEK DBPS
JOB NO. 25100.00
MAY 2015
C-33



HEC-RAS Plan: Existing River: Kettle Creek Reach: Kettle Creek (Continued)

Reach	River Sta	Profile	Q Total (cfs)	Min Ch El (ft)	W.S. Elev (ft)	Crit W.S. (ft)	E.G. Elev (ft)	E.G. Slope (ft/ft)	Vel Chnl (ft/s)	Flow Area (sq ft)	Top Width (ft)	Froude # Chl
Kettle Creek	6688.3	10-YR	2384.50	6629.79	6637.64		6638.03	0.018846	4.99	477.42	125.76	0.45
Kettle Creek	6688.3	25-YR	2877.00	6629.79	6638.25		6638.67	0.017332	5.16	556.82	134.66	0.44
Kettle Creek	6688.3	50-YR	3657.80	6629.79	6639.08		6639.54	0.015097	5.41	673.77	145.63	0.42
Kettle Creek	6688.3	100-YR	4201.90	6629.79	6639.61		6640.10	0.013940	5.55	752.55	152.65	0.41
Kettle Creek	6433.61	2-YR	1186.40	6627.42	6633.43		6633.56	0.005007	2.89	411.33	98.04	0.24
Kettle Creek	6433.61	5-YR	1807.50	6627.42	6634.55		6634.73	0.005253	3.42	523.63	103.48	0.25
Kettle Creek	6433.61	10-YR	2384.50	6627.42	6635.41		6635.64	0.005379	3.80	614.71	108.41	0.26
Kettle Creek	6433.61	25-YR	2877.00	6627.42	6636.06		6636.34	0.005440	4.07	686.47	112.67	0.27
Kettle Creek	6433.61	50-YR	3657.80	6627.42	6636.98		6637.32	0.005471	4.42	793.53	120.10	0.27
Kettle Creek	6433.61	100-YR	4201.90	6627.42	6637.56		6637.95	0.005431	4.61	865.62	125.16	0.27
Kettle Creek	6305.69	2-YR	1186.40	6625.87	6631.40		6631.59	0.010044	3.45	344.45	98.60	0.32
Kettle Creek	6305.69	5-YR	1807.50	6625.87	6632.63		6632.85	0.008366	3.83	472.87	111.08	0.31
Kettle Creek	6305.69	10-YR	2384.50	6625.87	6633.59		6633.85	0.007334	4.05	584.12	120.56	0.30
Kettle Creek	6305.69	25-YR	2877.00	6625.87	6634.32		6634.61	0.006664	4.18	675.13	128.74	0.29
Kettle Creek	6305.69	50-YR	3657.80	6625.87	6635.36		6635.68	0.005820	4.31	816.51	143.12	0.28
Kettle Creek	6305.69	100-YR	4201.90	6625.87	6636.03		6636.38	0.005340	4.37	916.05	158.12	0.27
Kettle Creek	6147.73	2-YR	1186.40	6623.99	6630.61		6630.76	0.003154	2.40	440.53	103.18	0.19
Kettle Creek	6147.73	5-YR	1807.50	6623.99	6631.92		6632.12	0.002898	2.69	579.21	109.37	0.19
Kettle Creek	6147.73	10-YR	2384.50	6623.99	6632.92		6633.17	0.002781	2.91	690.92	114.01	0.19
Kettle Creek	6147.73	25-YR	2877.00	6623.99	6633.66		6633.96	0.002724	3.08	777.40	117.54	0.19
Kettle Creek	6147.73	50-YR	3657.80	6623.99	6634.71		6635.08	0.002662	3.31	903.75	122.52	0.19
Kettle Creek	6147.73	100-YR	4201.90	6623.99	6635.40		6635.80	0.002609	3.44	988.82	126.00	0.19
Kettle Creek	6032.86	2-YR	1186.40	6622.67	6628.47	6625.82	6628.68	0.003558	2.55	387.37	97.40	0.20
Kettle Creek	6032.86	5-YR	1807.50	6622.67	6629.56	6626.35	6629.86	0.003538	2.91	496.93	103.65	0.21
Kettle Creek	6032.86	10-YR	2384.50	6622.67	6630.46	6626.93	6630.83	0.003399	3.13	591.99	108.18	0.21
Kettle Creek	6032.86	25-YR	2877.00	6622.67	6631.12	6627.46	6631.55	0.003352	3.30	664.12	111.18	0.21
Kettle Creek	6032.86	50-YR	3657.80	6622.67	6632.08	6628.20	6632.60	0.003269	3.54	774.02	116.50	0.21
Kettle Creek	6032.86	100-YR	4201.90	6622.67	6632.78	6628.68	6633.34	0.003056	3.60	855.85	118.67	0.21
Kettle Creek	6000		Bridge									
Kettle Creek	5983.2	2-YR	1186.40	6622.04	6628.29		6628.44	0.001920	1.99	436.07	118.89	0.15
Kettle Creek	5983.2	5-YR	1807.50	6622.04	6629.35		6629.58	0.001787	2.17	564.57	123.65	0.15
Kettle Creek	5983.2	10-YR	2384.50	6622.04	6630.23		6630.51	0.001717	2.32	676.91	131.18	0.15
Kettle Creek	5983.2	25-YR	2877.00	6622.04	6630.87		6631.19	0.001655	2.40	761.38	133.12	0.15

EXISTING CONDITIONS
MODEL RESULTS

HYDRAULIC RESULTS –
EXISTING
KETTLE CREEK DBPS
JOB NO. 25100.00
MAY 2015
C-34



HEC-RAS Plan: Existing River: Kettle Creek Reach: Kettle Creek (Continued)

Reach	River Sta	Profile	Q Total (cfs)	Min Ch El (ft)	W.S. Elev (ft)	Crit W.S. (ft)	E.G. Elev (ft)	E.G. Slope (ft/ft)	Vel Chnl (ft/s)	Flow Area (sq ft)	Top Width (ft)	Froude # Chl
Kettle Creek	5983.2	50-YR	3657.80	6622.04	6631.80		6632.19	0.001583	2.53	886.53	136.02	0.15
Kettle Creek	5983.2	100-YR	4201.90	6622.04	6632.51		6632.90	0.001608	2.68	985.42	149.06	0.15
Kettle Creek	5846.46	2-YR	1186.40	6620.39	6624.39		6625.12	0.054764	6.83	173.98	65.27	0.72
Kettle Creek	5846.46	5-YR	1807.50	6620.39	6625.32		6626.22	0.046349	7.60	237.36	71.85	0.70
Kettle Creek	5846.46	10-YR	2384.50	6620.39	6626.04		6627.09	0.041528	8.10	290.62	76.54	0.68
Kettle Creek	5846.46	25-YR	2877.00	6620.39	6626.58		6627.76	0.038478	8.43	334.06	81.76	0.67
Kettle Creek	5846.46	50-YR	3657.80	6620.39	6627.34		6628.70	0.034949	8.83	398.47	88.84	0.65
Kettle Creek	5846.46	100-YR	4201.90	6620.39	6627.83		6629.31	0.032396	8.98	443.61	93.39	0.63
Kettle Creek	5366.46	2-YR	1186.40	6612.16	6619.29	6616.48	6619.44	0.004810	2.87	394.04	96.66	0.23
Kettle Creek	5366.46	5-YR	1807.50	6612.16	6620.35	6617.19	6620.59	0.004990	3.35	498.61	100.65	0.25
Kettle Creek	5366.46	10-YR	2384.50	6612.16	6621.17	6617.73	6621.49	0.005120	3.71	582.39	104.00	0.25
Kettle Creek	5366.46	25-YR	2877.00	6612.16	6621.78	6618.08	6622.16	0.005223	3.97	646.28	106.18	0.26
Kettle Creek	5366.46	50-YR	3657.80	6612.16	6622.66	6618.62	6623.14	0.005334	4.34	742.28	110.85	0.27
Kettle Creek	5366.46	100-YR	4201.90	6612.16	6623.15	6618.94	6623.70	0.005553	4.60	796.65	113.16	0.28
Kettle Creek	3636.65	2-YR	1186.40	6592.57	6595.26	6595.26	6596.17	0.124453	7.65	154.98	87.35	1.01
Kettle Creek	3636.65	5-YR	1807.50	6592.57	6595.87	6595.87	6597.03	0.111612	8.67	208.51	90.76	1.00
Kettle Creek	3636.65	10-YR	2384.50	6592.57	6596.35	6596.35	6597.73	0.104123	9.43	252.81	92.90	1.00
Kettle Creek	3636.65	25-YR	2877.00	6592.57	6596.73	6596.73	6598.27	0.098322	9.95	288.94	94.43	0.99
Kettle Creek	3636.65	50-YR	3657.80	6592.57	6597.26	6597.26	6599.07	0.093574	10.75	339.14	96.49	0.99
Kettle Creek	3636.65	100-YR	4201.90	6592.57	6597.74	6597.64	6599.59	0.080575	10.82	385.88	98.53	0.94
Kettle Creek	3115.71	2-YR	1186.40	6585.47	6593.04		6593.08	0.000587	1.21	808.77	161.34	0.09
Kettle Creek	3115.71	5-YR	1807.50	6585.47	6594.35		6594.42	0.000611	1.41	1028.49	174.30	0.09
Kettle Creek	3115.71	10-YR	2384.50	6585.47	6595.36		6595.45	0.000628	1.55	1211.38	187.67	0.09
Kettle Creek	3115.71	25-YR	2877.00	6585.47	6596.11		6596.21	0.000627	1.64	1354.39	194.33	0.09
Kettle Creek	3115.71	50-YR	3657.80	6585.47	6597.16		6597.28	0.000633	1.77	1564.67	206.13	0.10
Kettle Creek	3115.71	100-YR	4201.90	6585.47	6597.82		6597.95	0.000641	1.86	1702.59	215.55	0.10
Kettle Creek	2957.59	2-YR	1186.40	6582.74	6592.42	6589.30	6592.77	0.003681	3.75	261.47	70.77	0.22
Kettle Creek	2957.59	5-YR	1807.50	6582.74	6593.61	6591.30	6594.07	0.003327	3.88	350.43	79.16	0.22
Kettle Creek	2957.59	10-YR	2384.50	6582.74	6594.51	6591.98	6595.07	0.003129	3.98	424.77	85.02	0.21
Kettle Creek	2957.59	25-YR	2877.00	6582.74	6595.19	6592.47	6595.82	0.003019	4.07	483.72	89.32	0.21
Kettle Creek	2957.59	50-YR	3657.80	6582.74	6596.13	6593.21	6596.86	0.002920	4.22	570.82	95.69	0.21
Kettle Creek	2957.59	100-YR	4201.90	6582.74	6596.71	6593.71	6597.51	0.002871	4.31	627.68	99.37	0.21
Kettle Creek	2850		Bridge									

HYDRAULIC RESULTS –
EXISTING
KETTLE CREEK DBPS
JOB NO. 25100.00
MAY 2015
C-35

EXISTING CONDITIONS
MODEL RESULTS



HEC-RAS Plan: Existing River: Kettle Creek Reach: Kettle Creek (Continued)

Reach	River Sta	Profile	Q Total (cfs)	Min Ch El (ft)	W.S. Elev (ft)	Crit W.S. (ft)	E.G. Elev (ft)	E.G. Slope (ft/ft)	Vel Chnl (ft/s)	Flow Area (sq ft)	Top Width (ft)	Froude # Chl
Kettle Creek	2731.34	2-YR	1186.40	6579.12	6584.99		6585.78	0.017018	5.70	179.20	52.69	0.44
Kettle Creek	2731.34	5-YR	1807.50	6579.12	6585.58	6584.88	6586.95	0.022663	7.08	211.80	56.94	0.52
Kettle Creek	2731.34	10-YR	2384.50	6579.12	6586.13	6585.86	6587.95	0.024786	7.86	244.31	61.32	0.55
Kettle Creek	2731.34	25-YR	2877.00	6579.12	6587.10	6586.59	6588.79	0.017325	7.22	307.81	70.05	0.47
Kettle Creek	2731.34	50-YR	3657.80	6579.12	6587.51	6587.51	6589.79	0.021067	8.26	337.30	74.11	0.52
Kettle Creek	2731.34	100-YR	4201.90	6579.12	6588.00	6588.00	6590.44	0.019970	8.38	375.21	79.01	0.52
Kettle Creek	2597.25	2-YR	1186.40	6577.88	6582.41	6581.63	6582.67	0.028079	4.09	287.60	141.63	0.49
Kettle Creek	2597.25	5-YR	1807.50	6577.88	6583.18	6582.07	6583.51	0.021716	4.42	399.13	146.77	0.46
Kettle Creek	2597.25	10-YR	2384.50	6577.88	6583.52	6582.42	6583.99	0.025342	5.14	449.29	148.75	0.50
Kettle Creek	2597.25	25-YR	2877.00	6577.88	6582.67	6582.67	6583.91	0.109793	8.74	324.90	143.37	1.00
Kettle Creek	2597.25	50-YR	3657.80	6577.88	6583.74	6583.10	6584.71	0.047100	7.32	481.74	149.99	0.69
Kettle Creek	2597.25	100-YR	4201.90	6577.88	6584.34	6583.36	6585.29	0.034433	6.97	573.33	153.16	0.61
Kettle Creek	2067.56	2-YR	1186.40	6572.37	6574.23	6574.15	6574.58	0.010365	1.44	270.89	286.02	0.26
Kettle Creek	2067.56	5-YR	1807.50	6572.37	6574.41	6574.41	6574.99	0.013484	1.85	322.80	287.04	0.31
Kettle Creek	2067.56	10-YR	2384.50	6572.37	6574.65	6574.65	6575.33	0.012373	2.02	391.92	288.39	0.31
Kettle Creek	2067.56	25-YR	2877.00	6572.37	6575.34		6575.77	0.004658	1.63	591.22	292.23	0.20
Kettle Creek	2067.56	50-YR	3657.80	6572.37	6575.24	6575.10	6576.02	0.008805	2.17	563.71	291.70	0.27
Kettle Creek	2067.56	100-YR	4201.90	6572.37	6575.28	6575.28	6576.26	0.010960	2.45	573.82	291.89	0.31
Kettle Creek	1361.33	2-YR	1186.40	6562.11	6566.03		6566.15	0.014241	2.77	428.75	219.14	0.35
Kettle Creek	1361.33	5-YR	1807.50	6562.11	6567.55	6565.28	6567.64	0.005012	2.34	771.03	230.13	0.23
Kettle Creek	1361.33	10-YR	2384.50	6562.11	6567.84		6567.97	0.006692	2.84	838.33	232.38	0.26
Kettle Creek	1361.33	25-YR	2877.00	6562.11	6565.80	6565.80	6566.69	0.122082	7.60	378.78	213.39	1.00
Kettle Creek	1361.33	50-YR	3657.80	6562.11	6567.96		6568.24	0.014175	4.22	866.64	233.29	0.39
Kettle Creek	1361.33	100-YR	4201.90	6562.11	6572.62		6572.68	0.000877	1.80	2204.36	330.56	0.11
Kettle Creek	670.23	2-YR	1186.40	6554.40	6558.15	6556.90	6558.30	0.009335	2.63	417.76	187.86	0.29
Kettle Creek	670.23	5-YR	1807.50	6554.40	6557.25	6557.25	6558.08	0.116483	6.88	254.96	175.42	0.96
Kettle Creek	670.23	10-YR	2384.50	6554.40	6558.13		6558.75	0.038510	5.32	415.19	187.68	0.60
Kettle Creek	670.23	25-YR	2877.00	6554.40	6562.37		6562.49	0.001111	1.76	1295.19	223.69	0.12
Kettle Creek	670.23	50-YR	3657.80	6554.40	6567.79		6567.83	0.000154	0.97	2958.07	451.29	0.05
Kettle Creek	670.23	100-YR	4201.90	6554.40	6572.60		6572.61	0.000030	0.53	5287.89	512.72	0.02
Kettle Creek	6.23	2-YR	1186.40	6550.00	6551.80	6550.89	6551.90	0.008487	1.96	549.53	342.68	0.26
Kettle Creek	6.23	5-YR	1807.50	6550.00	6554.80	6551.15	6554.83	0.000460	0.90	1674.92	408.50	0.07
Kettle Creek	6.23	10-YR	2384.50	6550.00	6558.30	6551.40	6558.31	0.000091	0.58	3281.63	527.79	0.04

HYDRAULIC RESULTS –
EXISTING
KETTLE CREEK DBPS
JOB NO. 25100.00
MAY 2015
C-36

EXISTING CONDITIONS
MODEL RESULTS



HEC-RAS Plan: Existing River: Kettle Creek Reach: Kettle Creek (Continued)

Reach	River Sta	Profile	Q Total (cfs)	Min Ch El (ft)	W.S. Elev (ft)	Crit W.S. (ft)	E.G. Elev (ft)	E.G. Slope (ft/ft)	Vel Chnl (ft/s)	Flow Area (sq ft)	Top Width (ft)	Froude # Chl
Kettle Creek	6.23	25-YR	2877.00	6550.00	6562.40	6551.61	6562.41	0.000019	0.34	5987.04	736.04	0.02
Kettle Creek	6.23	50-YR	3657.80	6550.00	6567.80	6551.91	6567.80	0.000005	0.23	10188.80	820.31	0.01
Kettle Creek	6.23	100-YR	4201.90	6550.00	6572.60	6551.98	6572.60	0.000002	0.17	14318.65	901.20	0.01

EXISTING CONDITIONS
MODEL RESULTS (CONT.)

HYDRAULIC RESULTS –
EXISTING
KETTLE CREEK DBPS
JOB NO. 25100.00
MAY 2015
C-37



Centennial 303-740-9393 • Colorado Springs 719-593-2593
Fort Collins 970-491-9888 • www.jrengineering.com

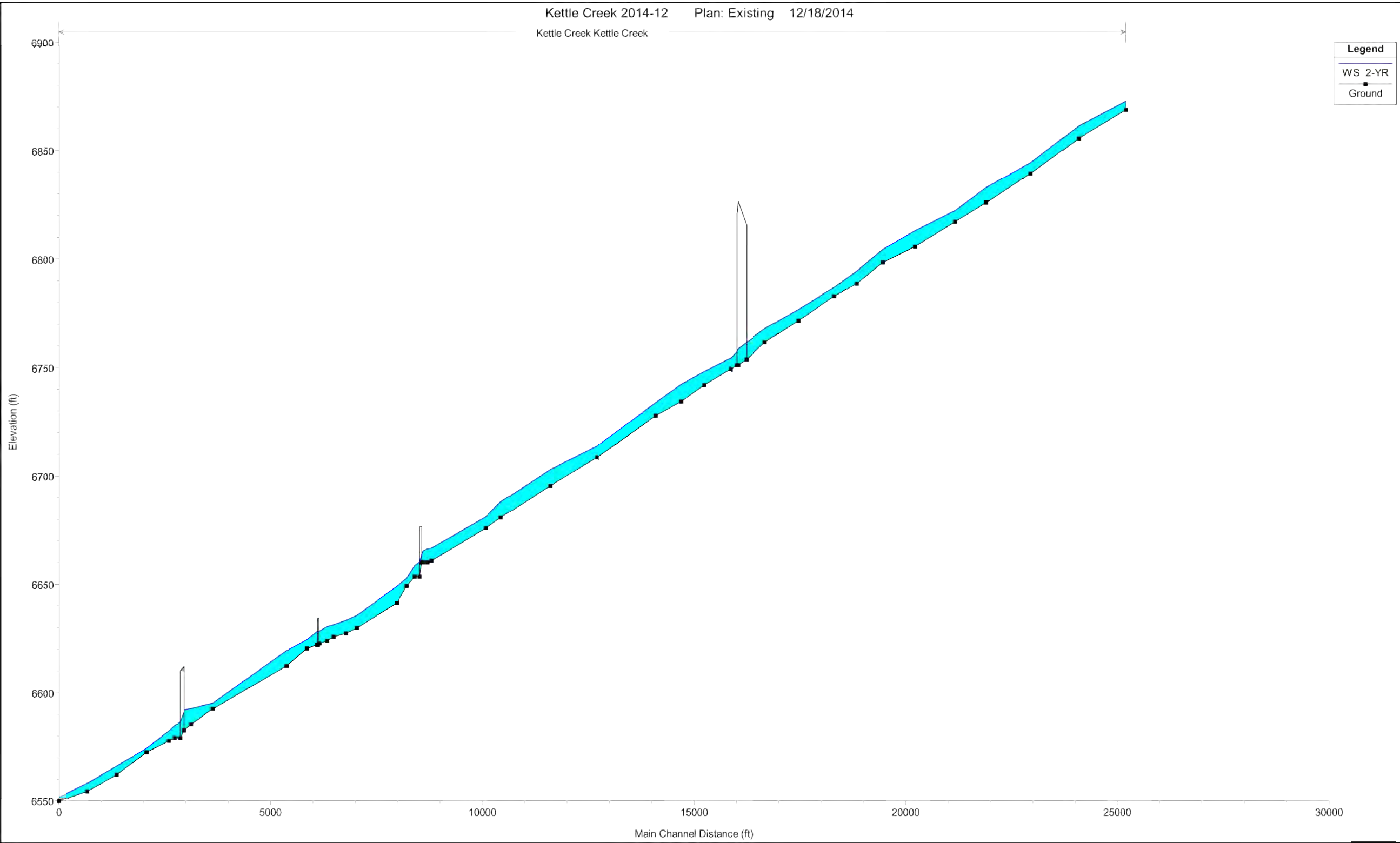

Legend	
WS 2-YR	
Ground	

EXISTING CONDITIONS
MODEL RESULTS.
2 -YR PROFILE

HYDRAULIC RESULTS –
EXISTING
KETTLE CREEK DBPS
JOB NO. 25100.00
MAY 2015
C-38



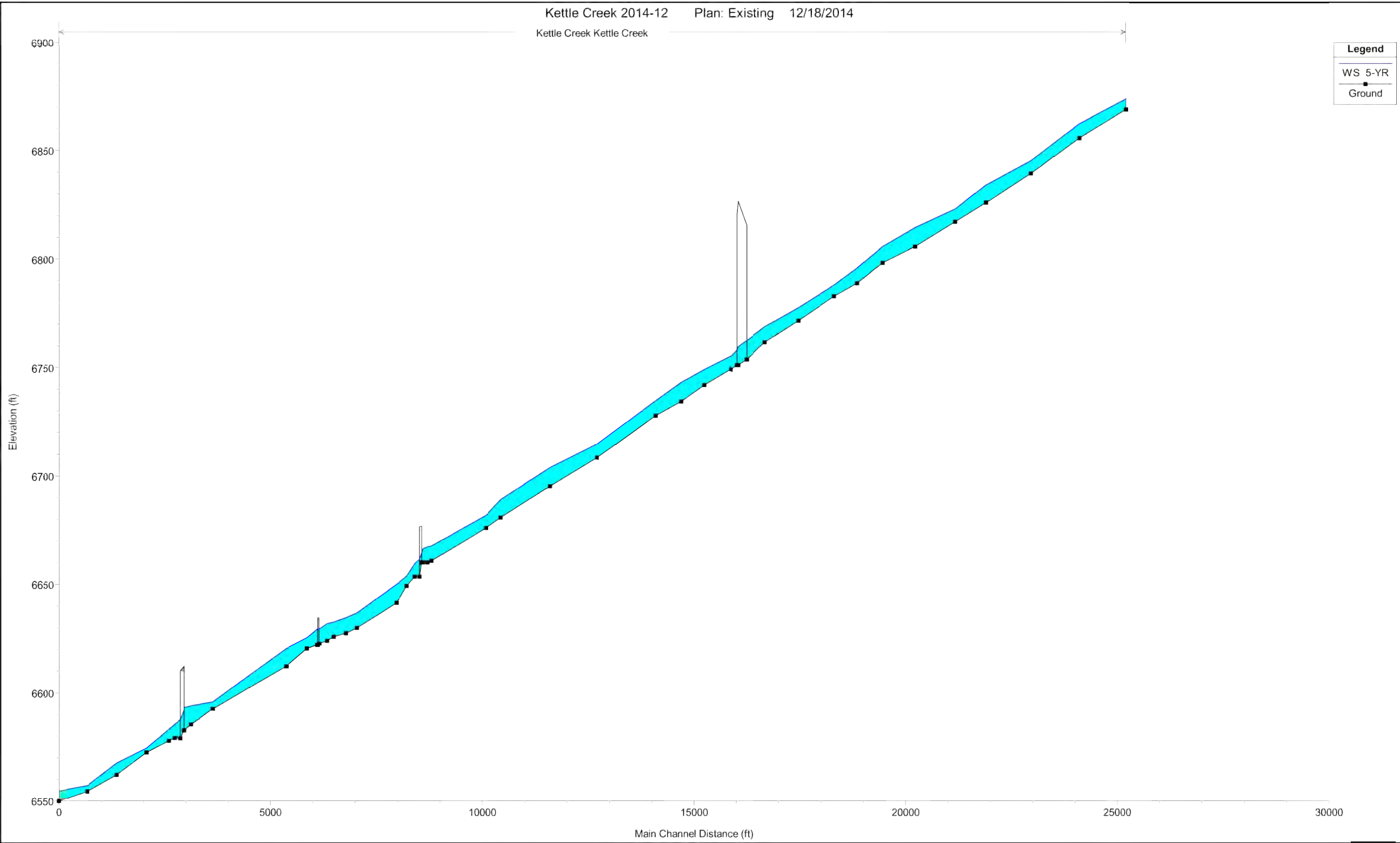

Legend	
WS 5-YR	■
Ground	■

EXISTING CONDITIONS
MODEL RESULTS.
5 -YR PROFILE

HYDRAULIC RESULTS –
EXISTING
KETTLE CREEK DBPS
JOB NO. 25100.00
MAY 2015
C-39



Centennial 303-740-9393 • Colorado Springs 719-593-2593
Fort Collins 970-491-9888 • www.jrengineering.com

Kettle Creek Kettle Creek

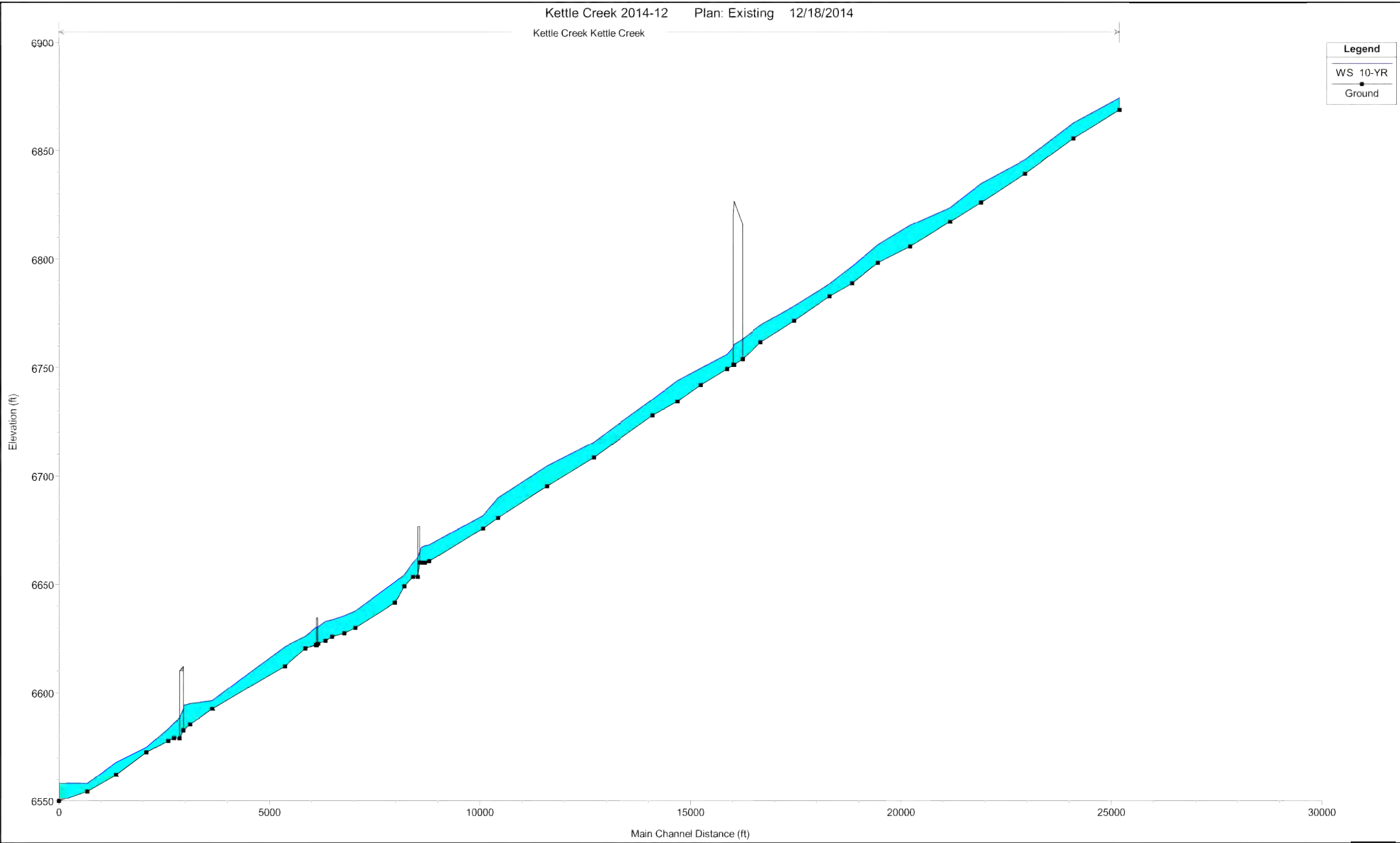

Legend	
WS 10-YR	■
Ground	—

EXISTING CONDITIONS
MODEL RESULTS.
10 -YR PROFILE

HYDRAULIC RESULTS —
EXISTING
KETTLE CREEK DBPS
JOB NO. 25100.00
MAY 2015
C-40



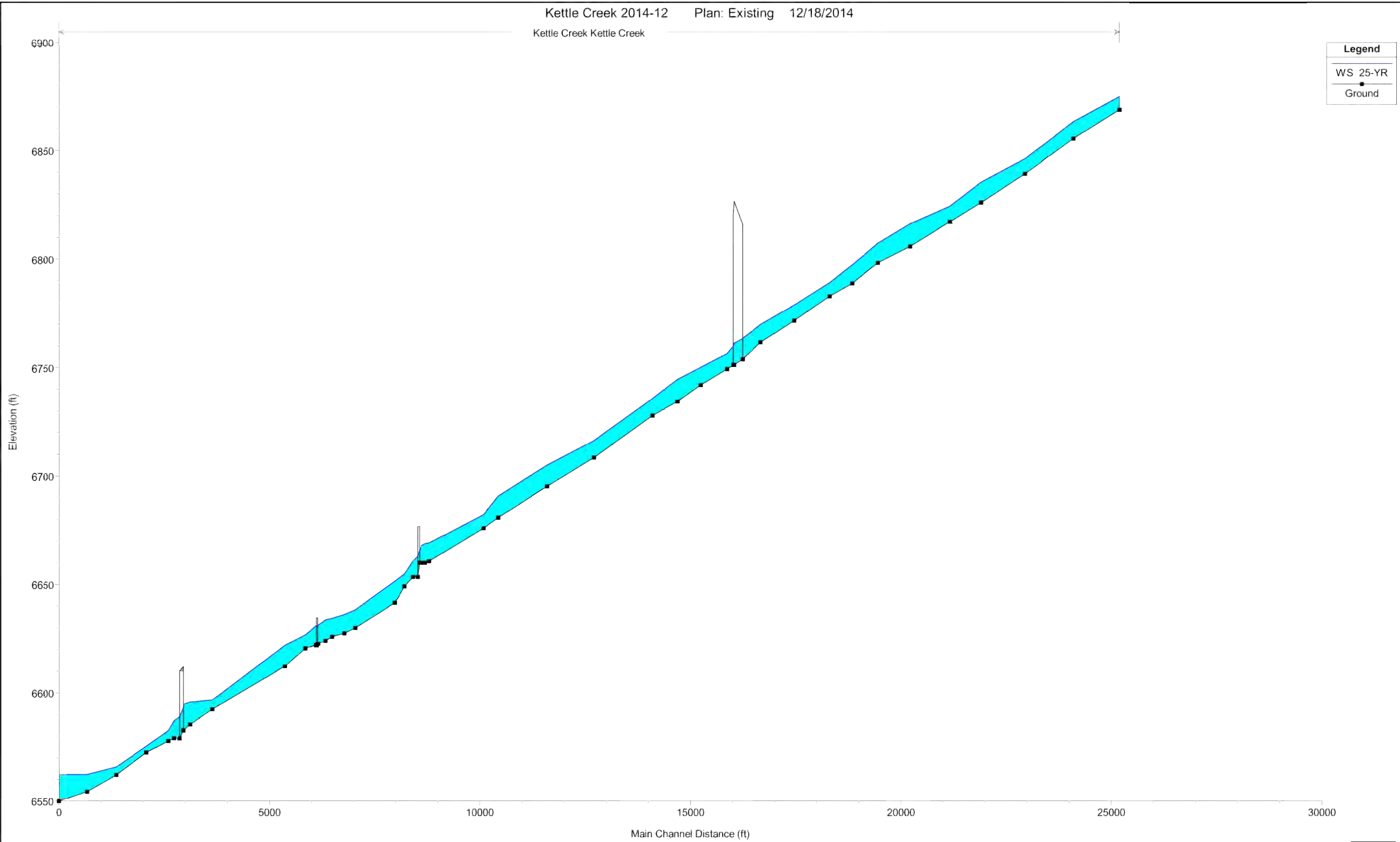

Legend	
WS 25-YR	■
Ground	■

EXISTING CONDITIONS
MODEL RESULTS.
25 -YR PROFILE

HYDRAULIC RESULTS –
EXISTING
KETTLE CREEK DBPS
JOB NO. 25100.00
MAY 2015
C-41



Kettle Creek Kettle Creek

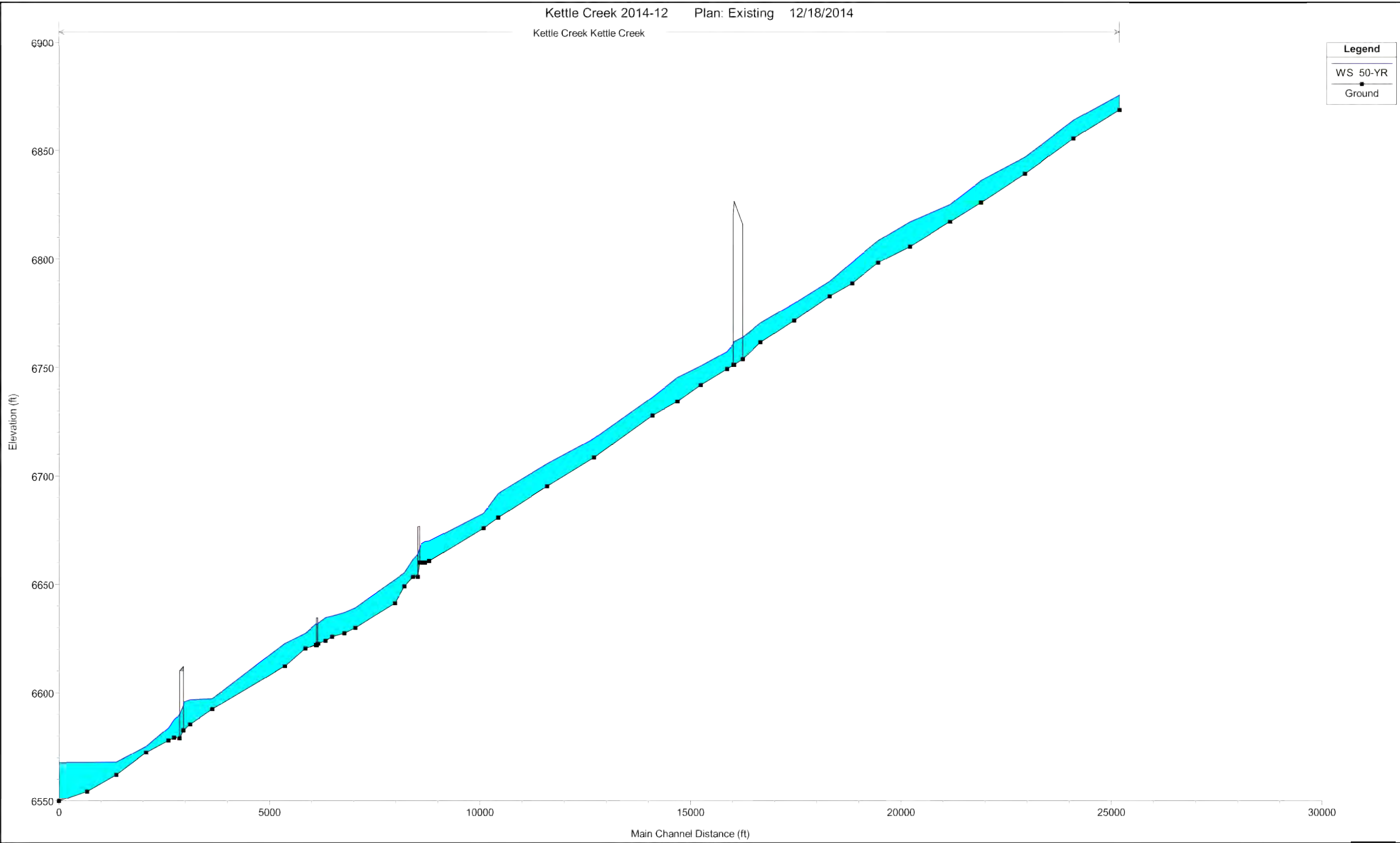

Legend	
WS 50-YR	■
Ground	■

HYDRAULIC RESULTS –
EXISTING
KETTLE CREEK DBPS
JOB NO. 25100.00
MAY 2015
C-42

EXISTING CONDITIONS
MODEL RESULTS.
50 -YR PROFILE



Centennial 303-740-9393 • Colorado Springs 719-593-2593
Fort Collins 970-491-9888 • www.jrengineering.com

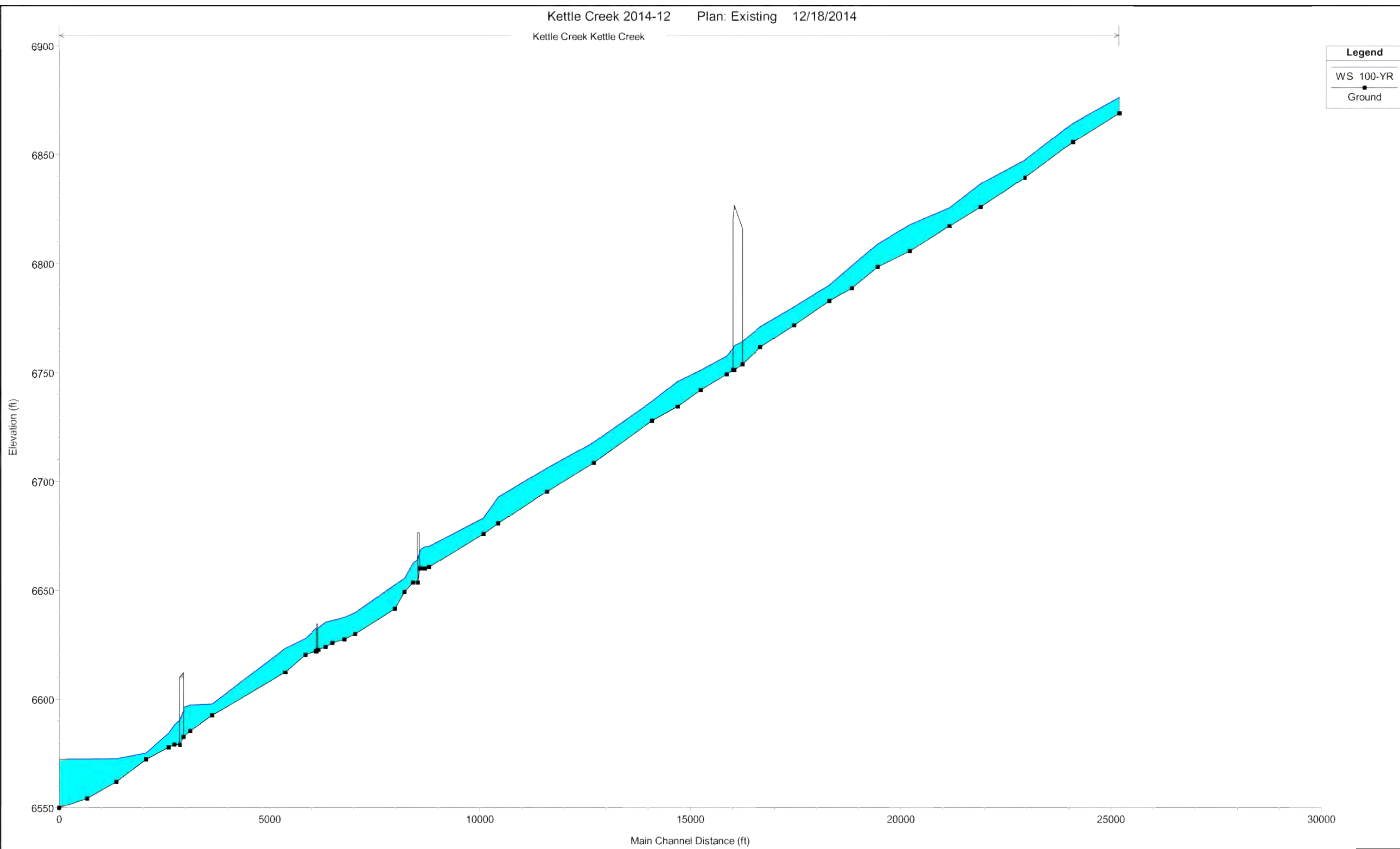

Legend	
WS 100-YR	(Cyan shaded area)
Ground	(Black line)

EXISTING CONDITIONS
MODEL RESULTS.
100 -YR PROFILE

HYDRAULIC RESULTS –
EXISTING
KETTLE CREEK DBPS
JOB NO. 25100.00
MAY 2015
C-43



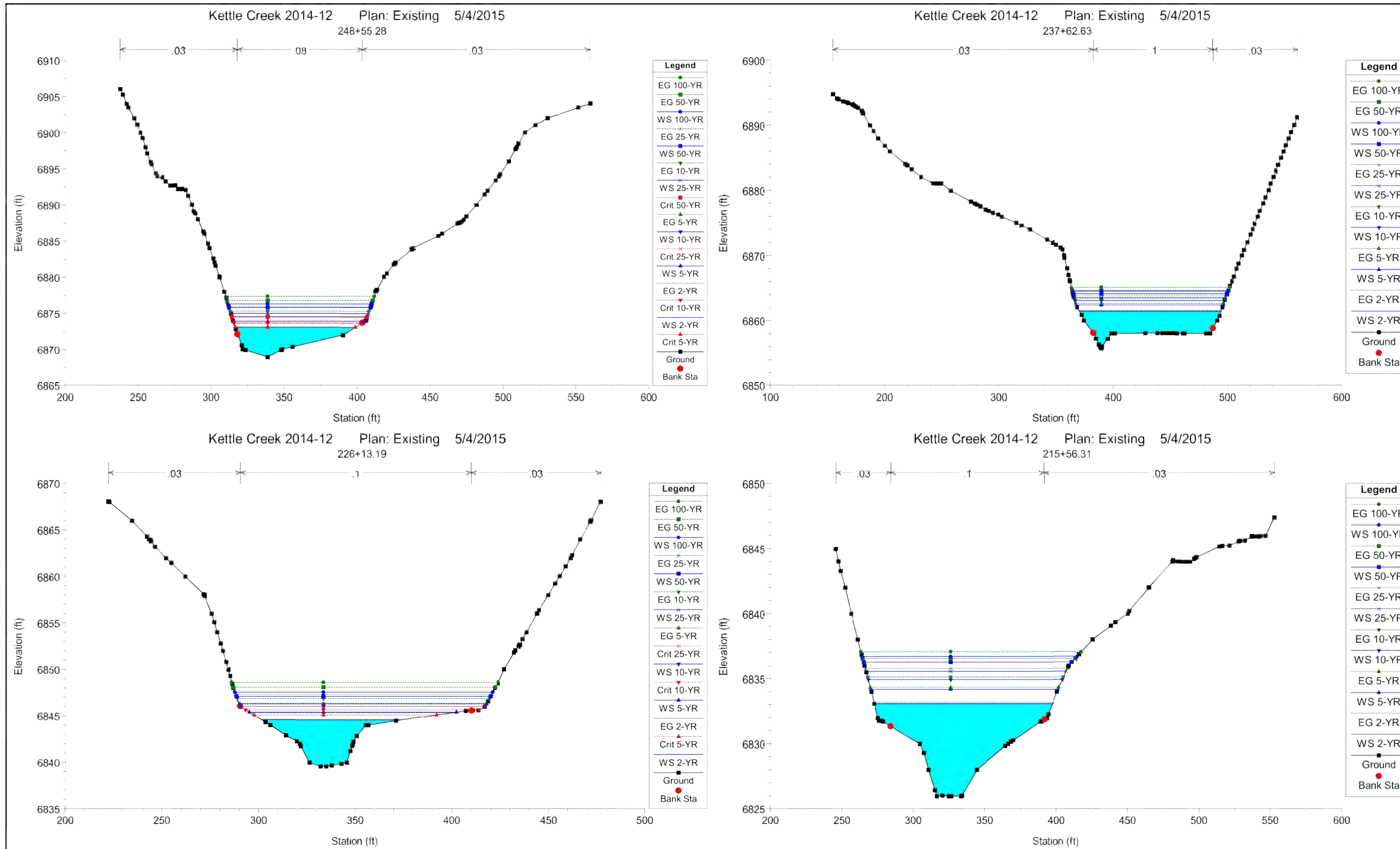

EXISTING CONDITIONS
MODEL RESULTS

HYDRAULIC RESULTS –
EXISTING
KETTLE CREEK DBPS
JOB NO. 25100.00
MAY 2015
C-44



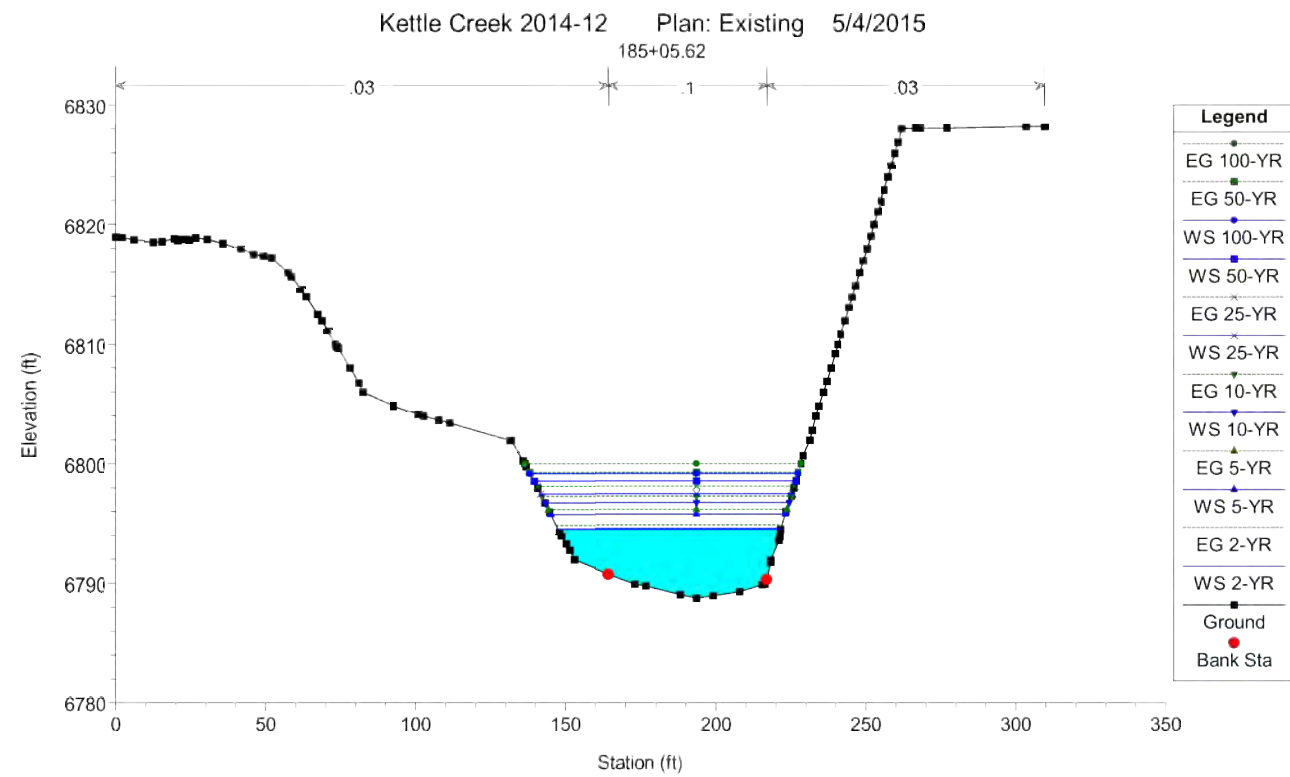
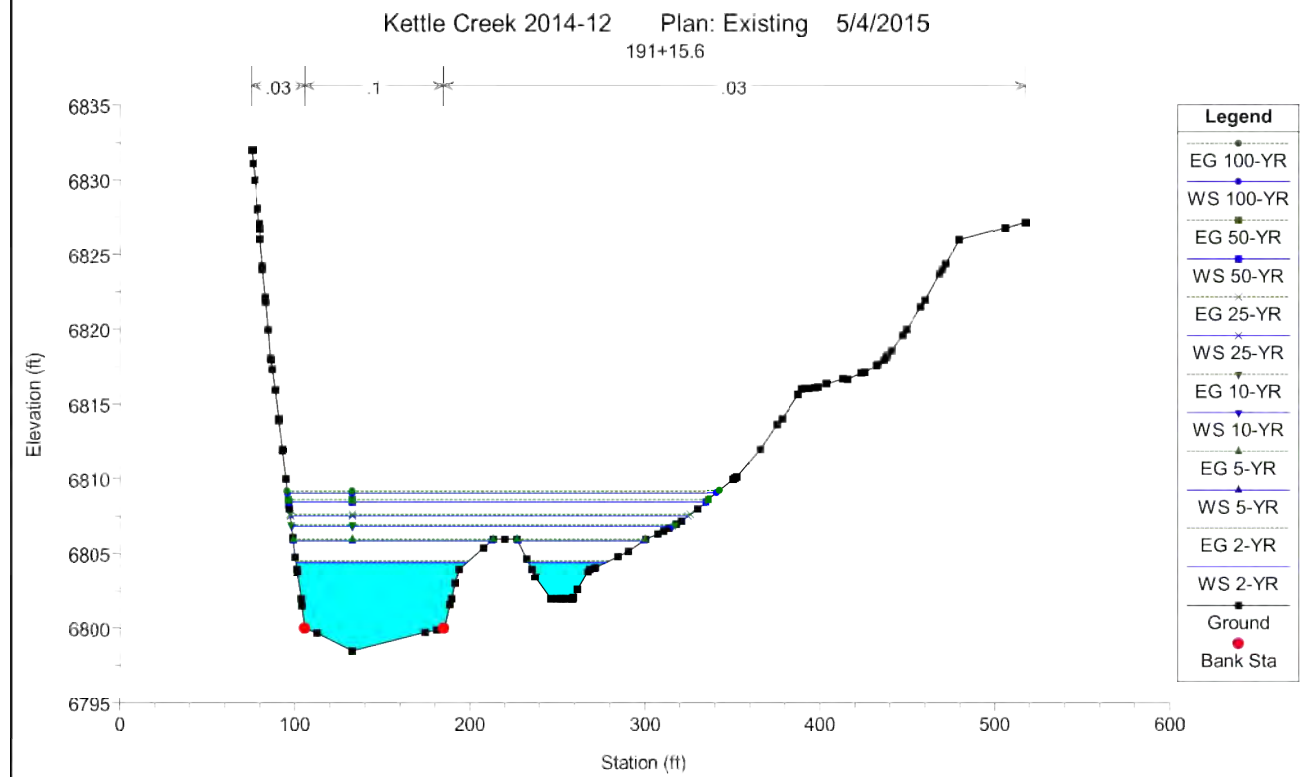
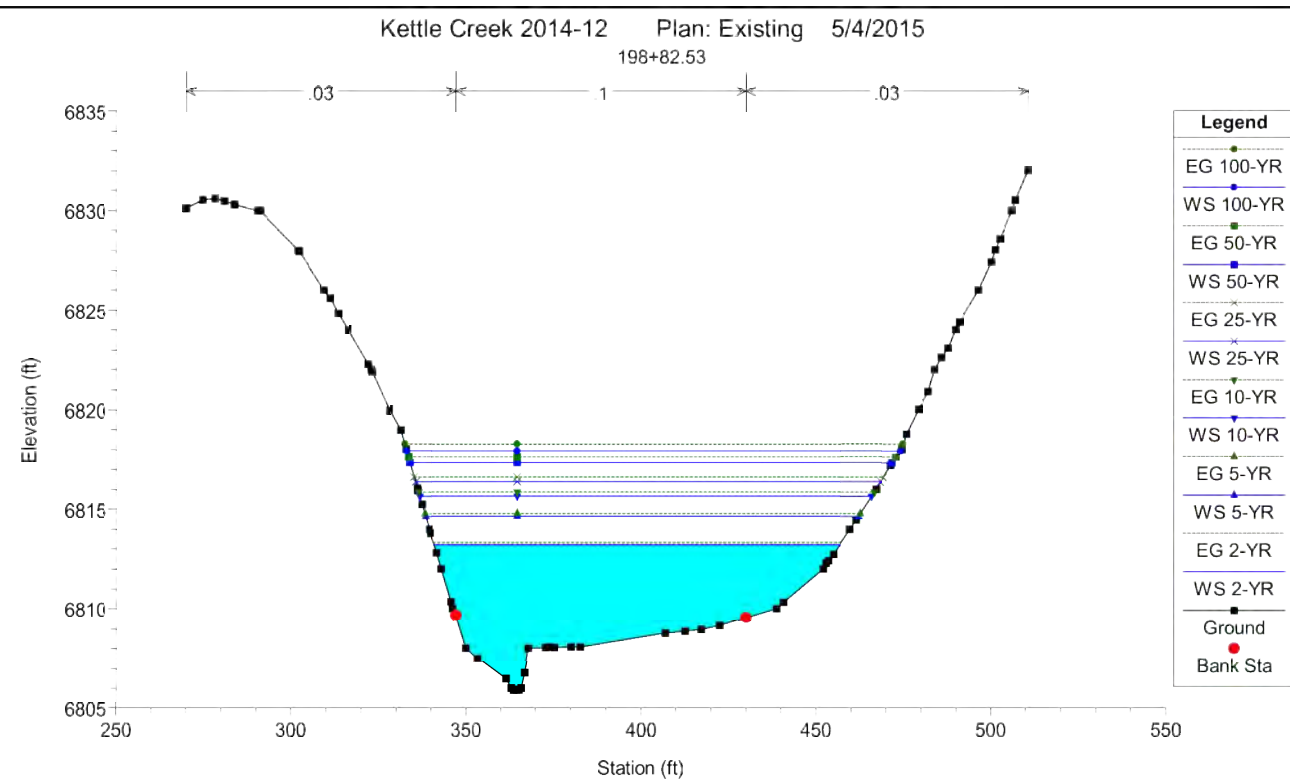
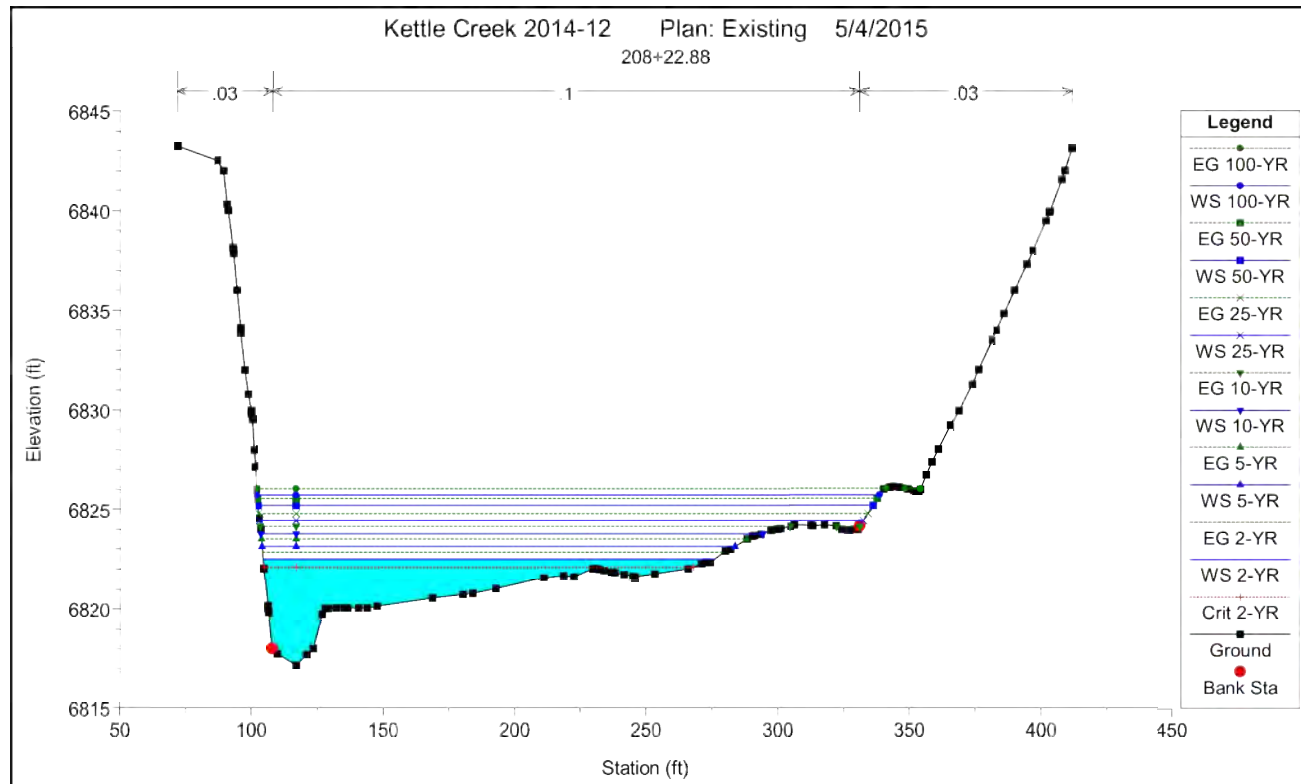

HYDRAULIC RESULTS –
EXISTING
KETTLE CREEK DBPS
JOB NO. 25100.00
MAY 2015
C-45

EXISTING CONDITIONS
MODEL RESULTS



Centennial 303-740-9393 • Colorado Springs 719-593-2593
Fort Collins 970-491-9888 • www.jrengineering.com

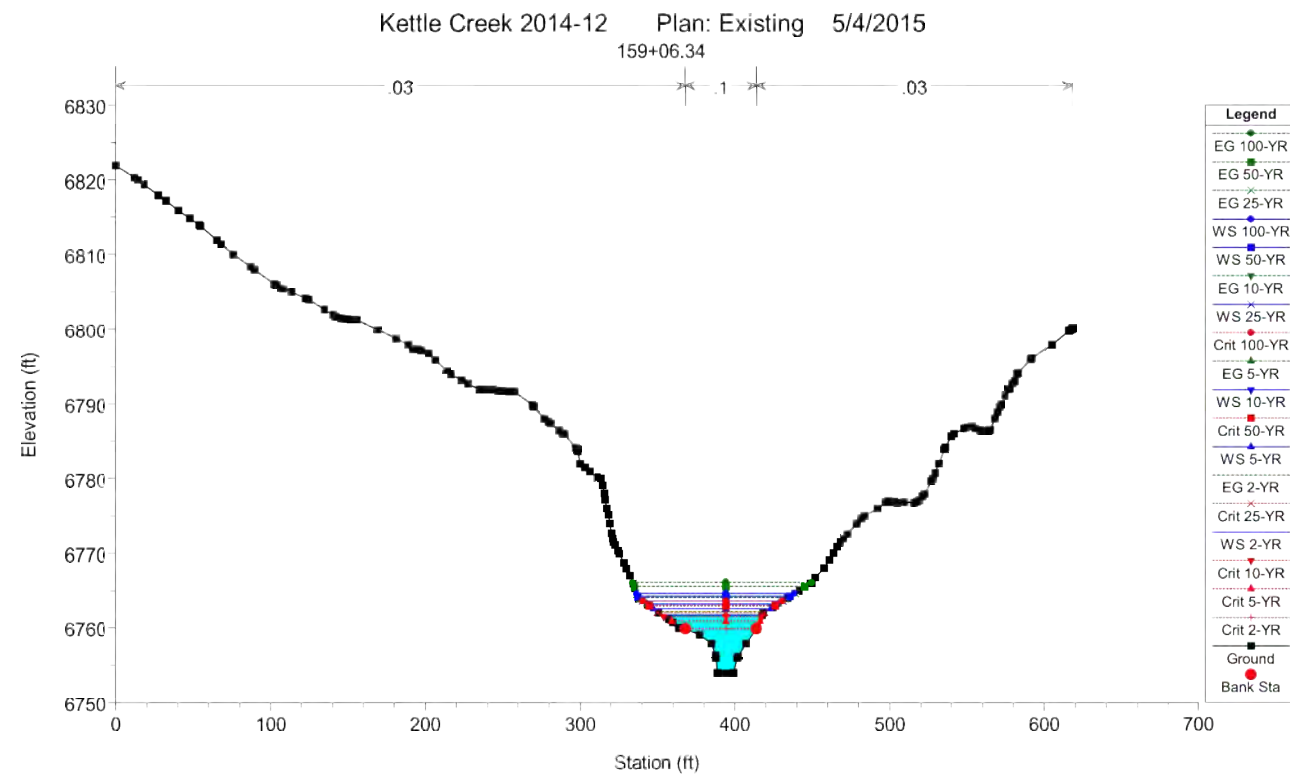
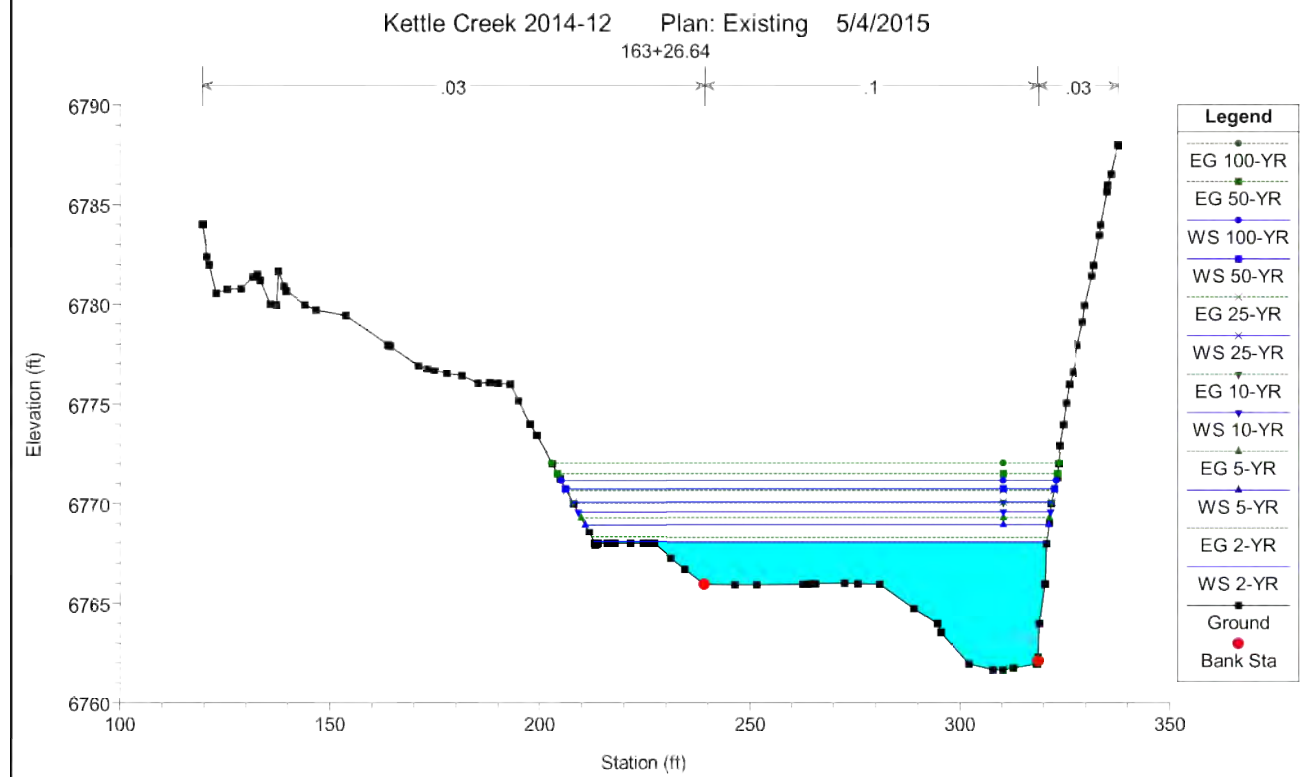
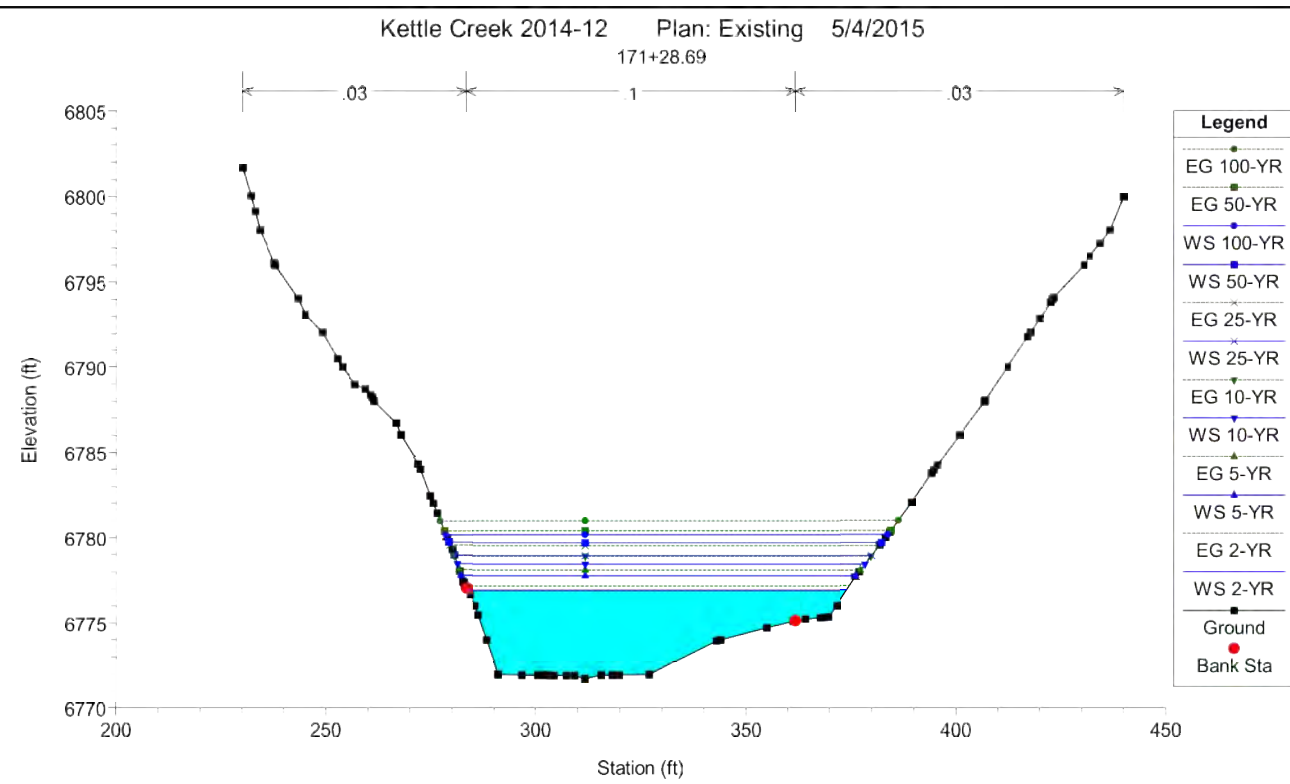
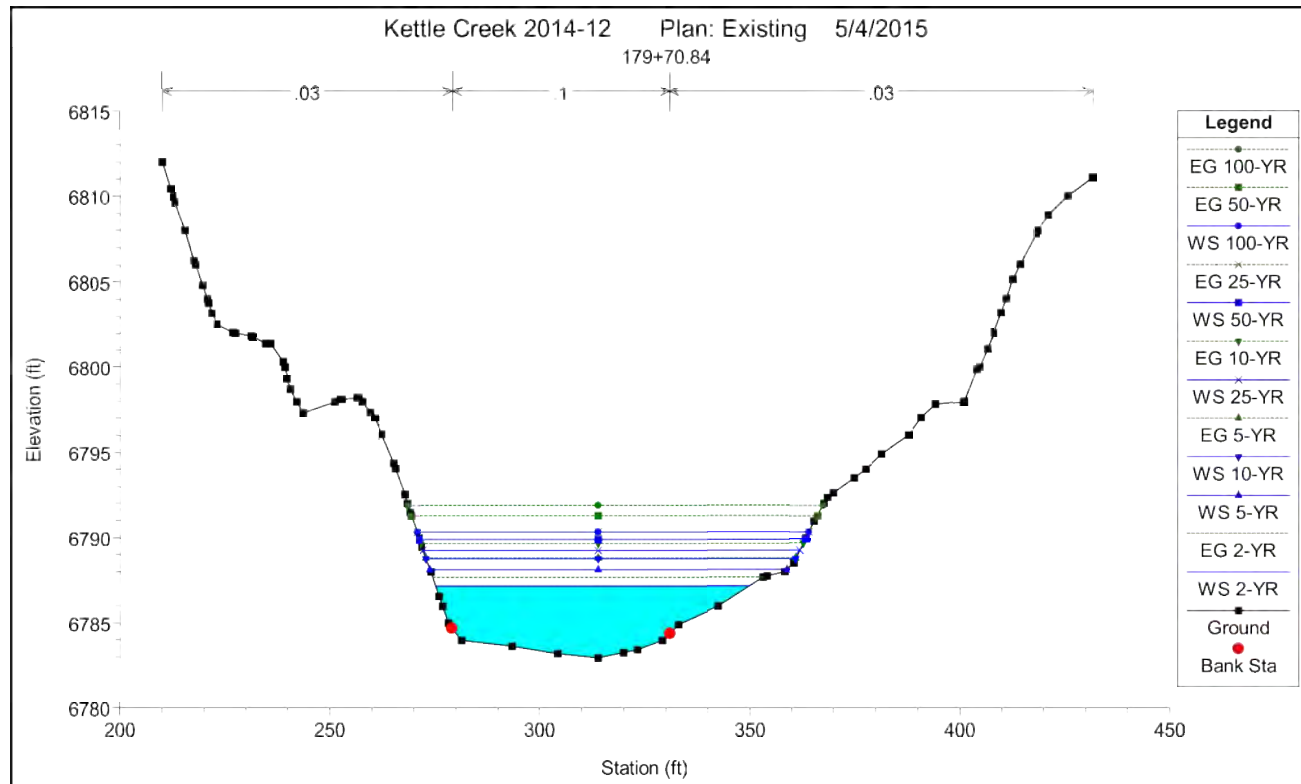

HYDRAULIC RESULTS –
EXISTING
KETTLE CREEK DBPS
JOB NO. 25100.00
MAY 2015
C-46

EXISTING CONDITIONS
MODEL RESULTS



Centennial 303-740-9393 • Colorado Springs 719-593-2593
Fort Collins 970-491-9888 • www.jrengineering.com

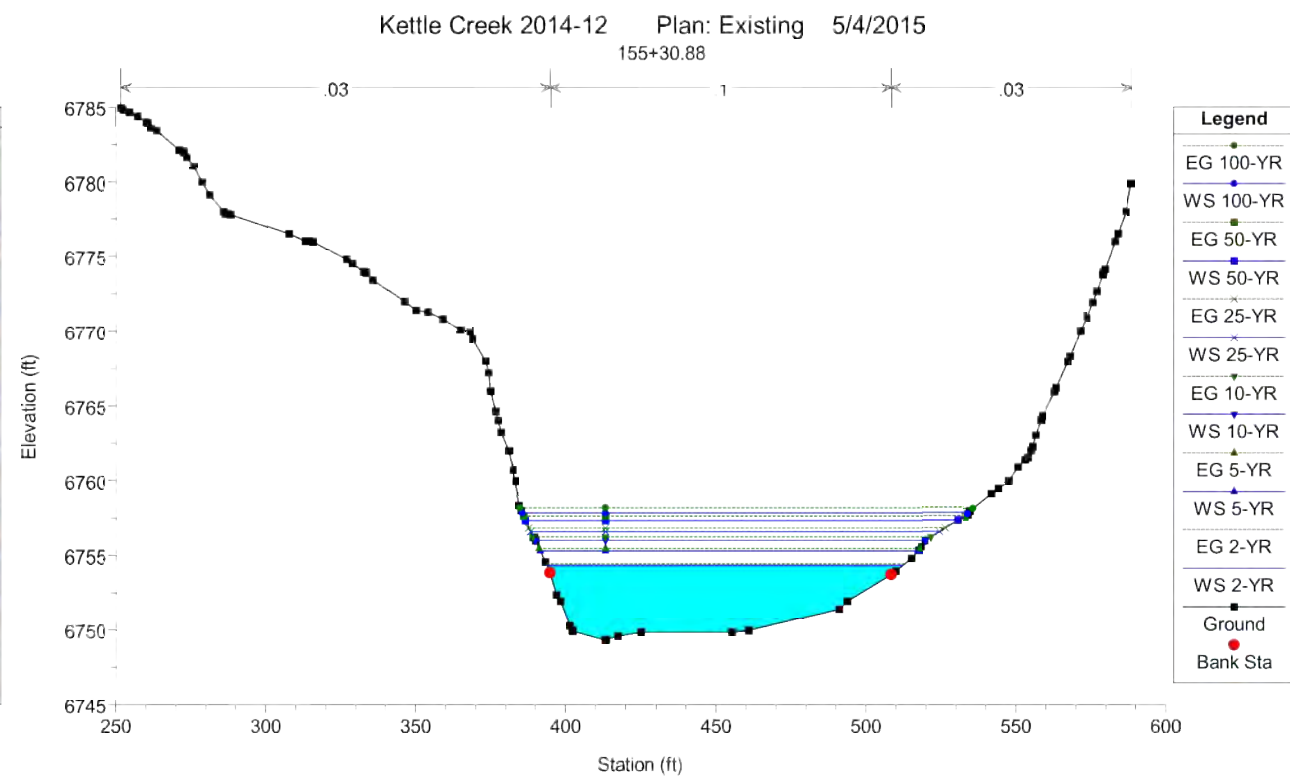
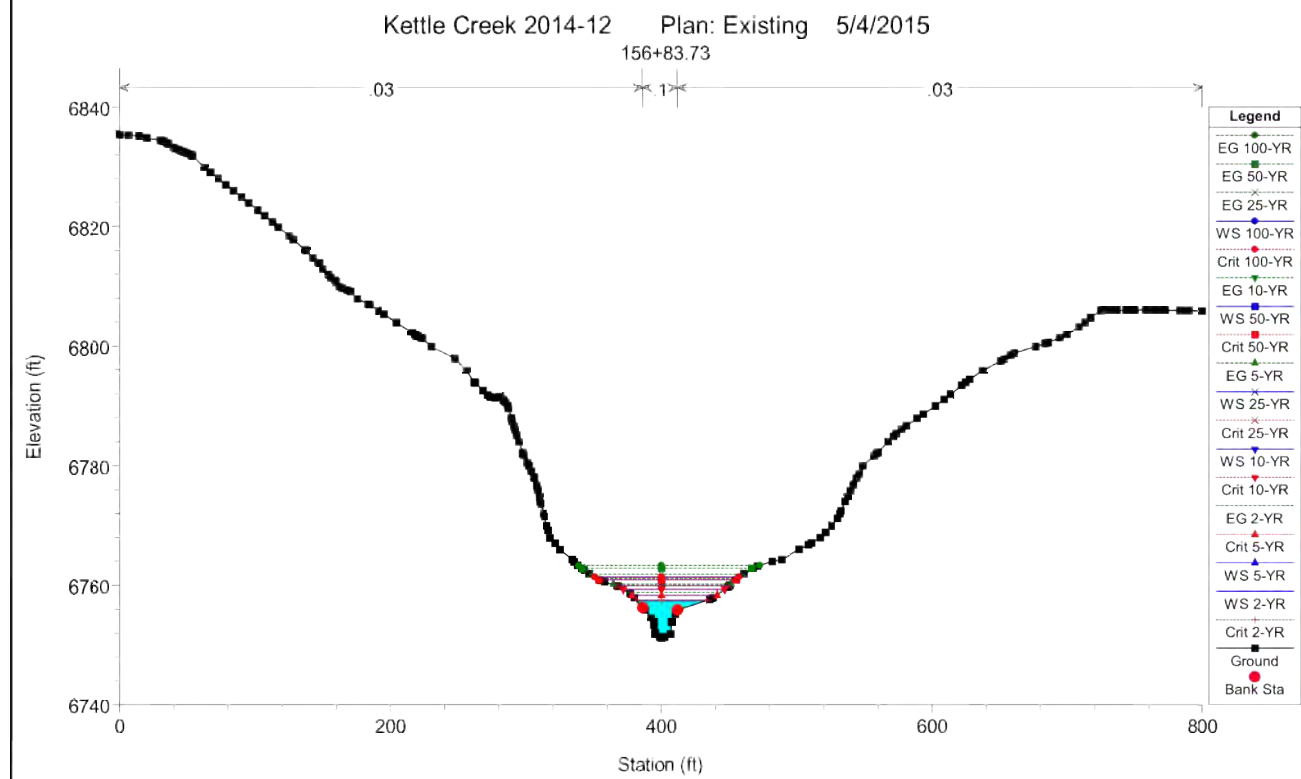
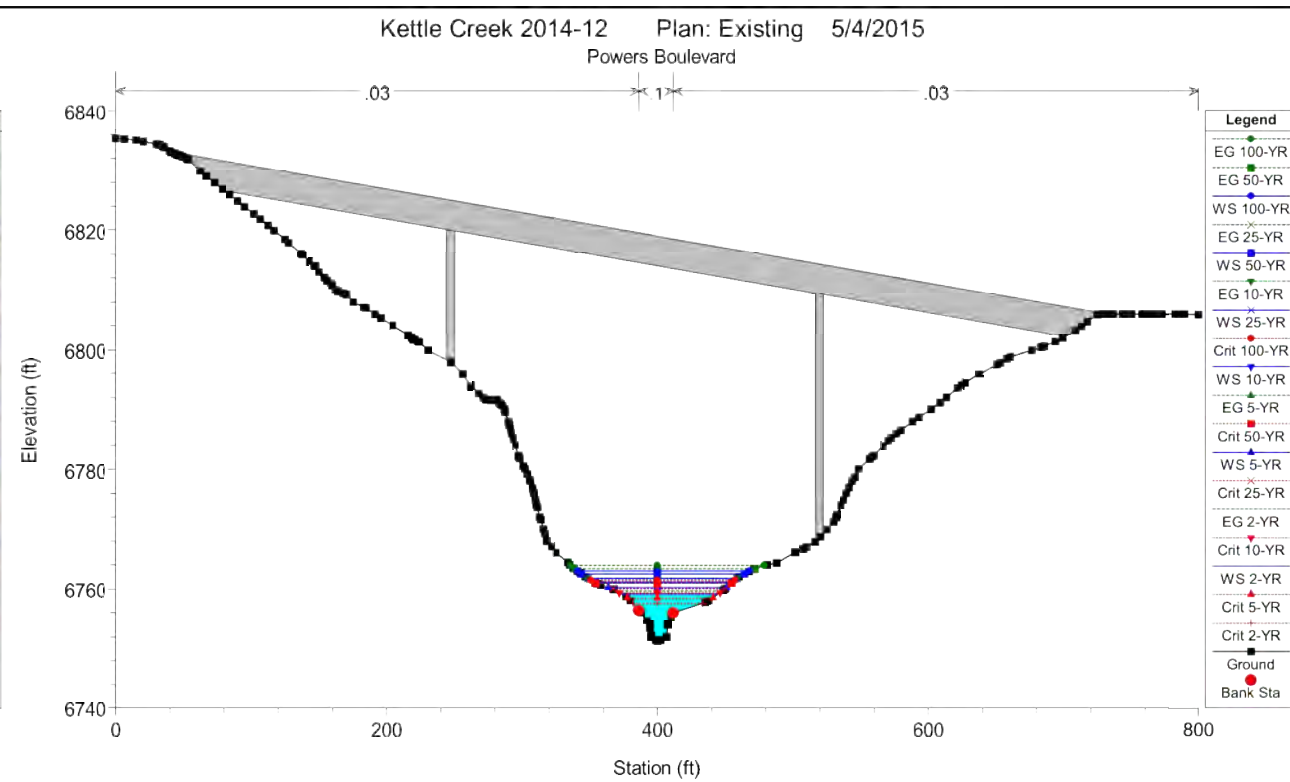
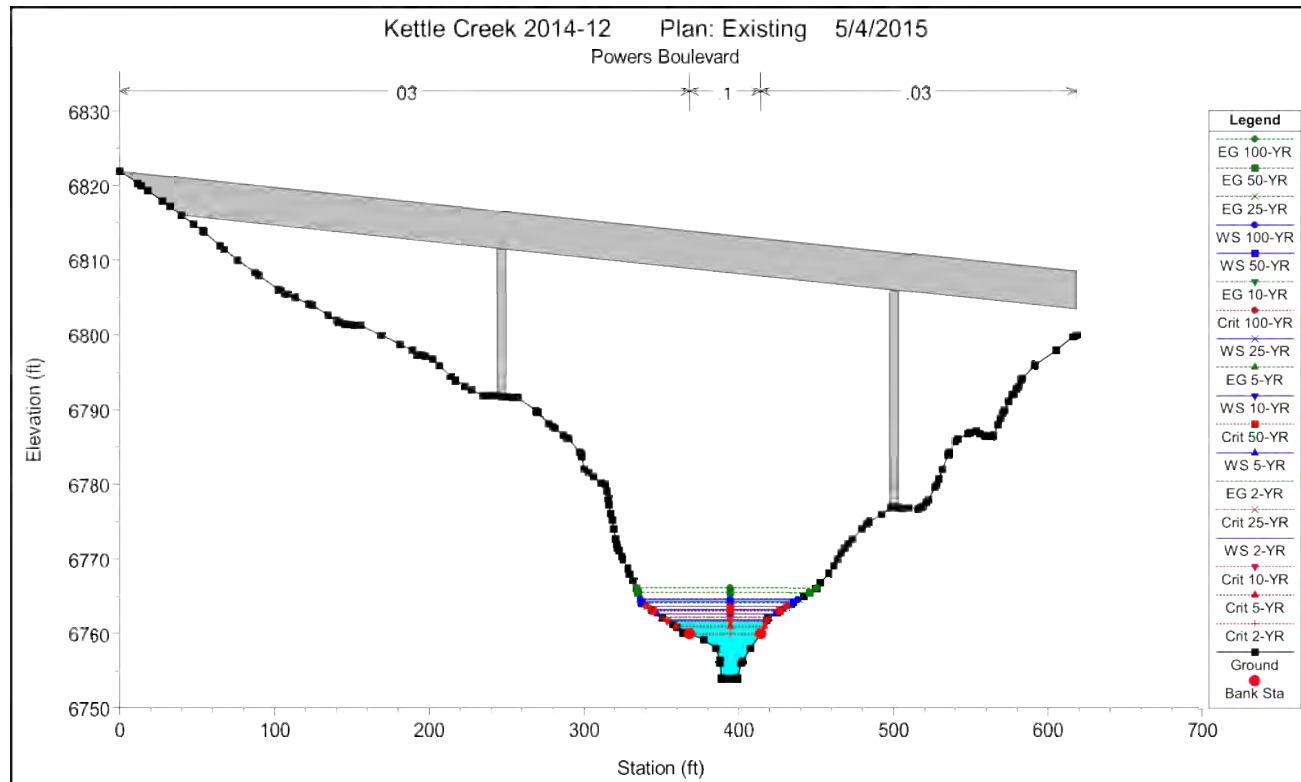

EXISTING CONDITIONS
MODEL RESULTS

HYDRAULIC RESULTS –
EXISTING
KETTLE CREEK DBPS
JOB NO. 25100.00
MAY 2015
C-47



Centennial 303-740-9393 • Colorado Springs 719-593-2593
Fort Collins 970-491-9888 • www.jrengineering.com

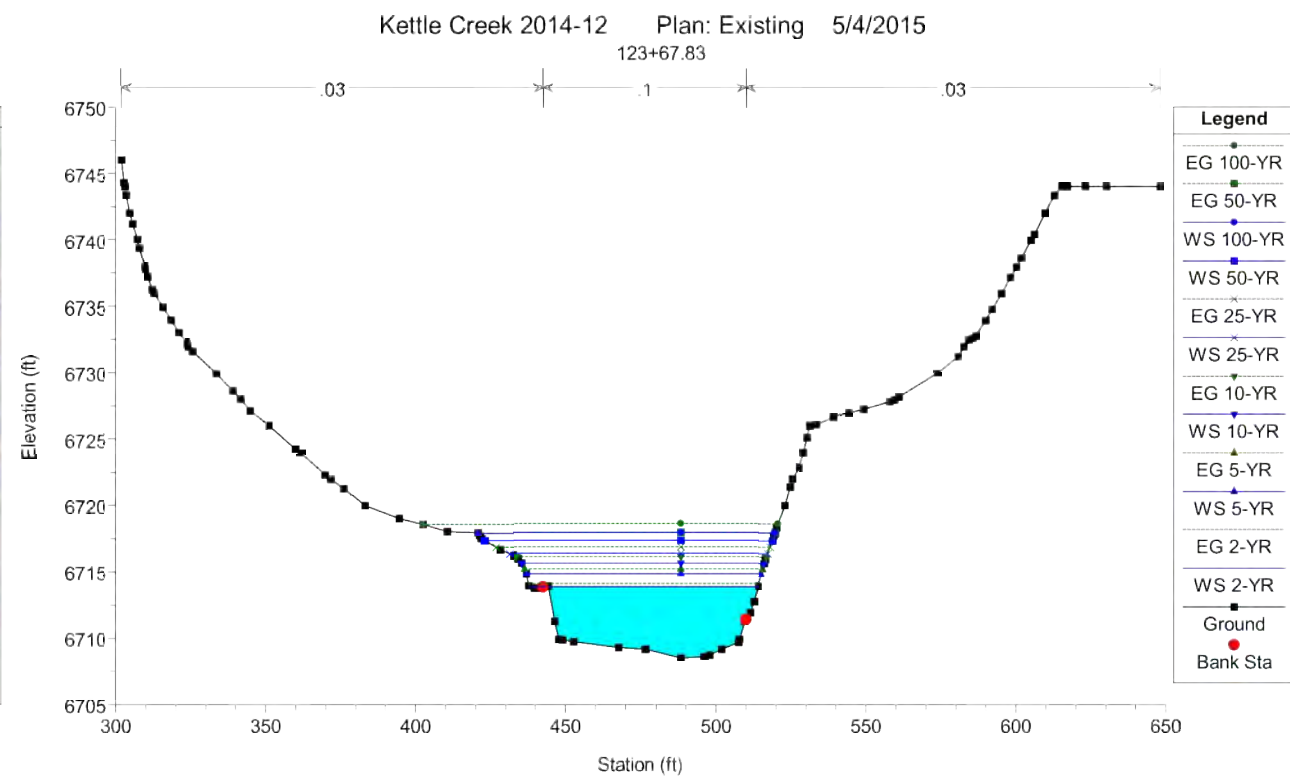
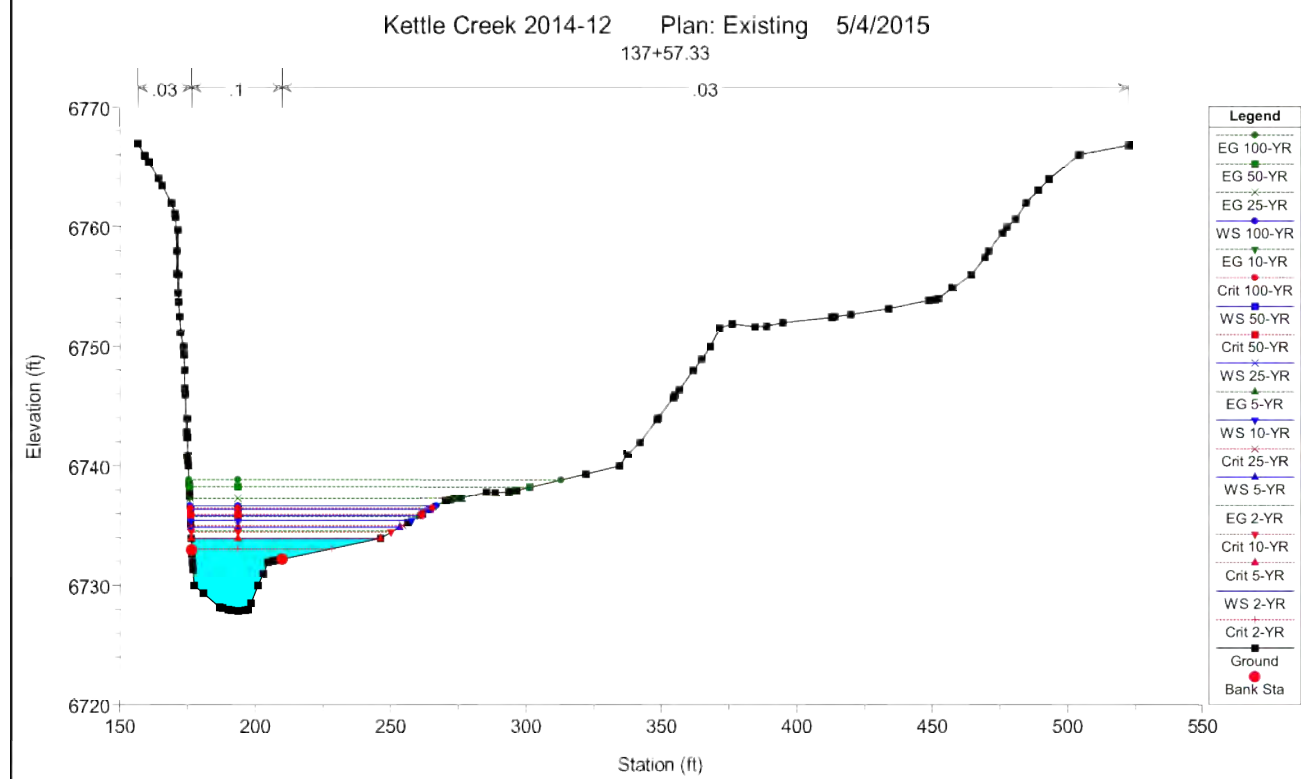
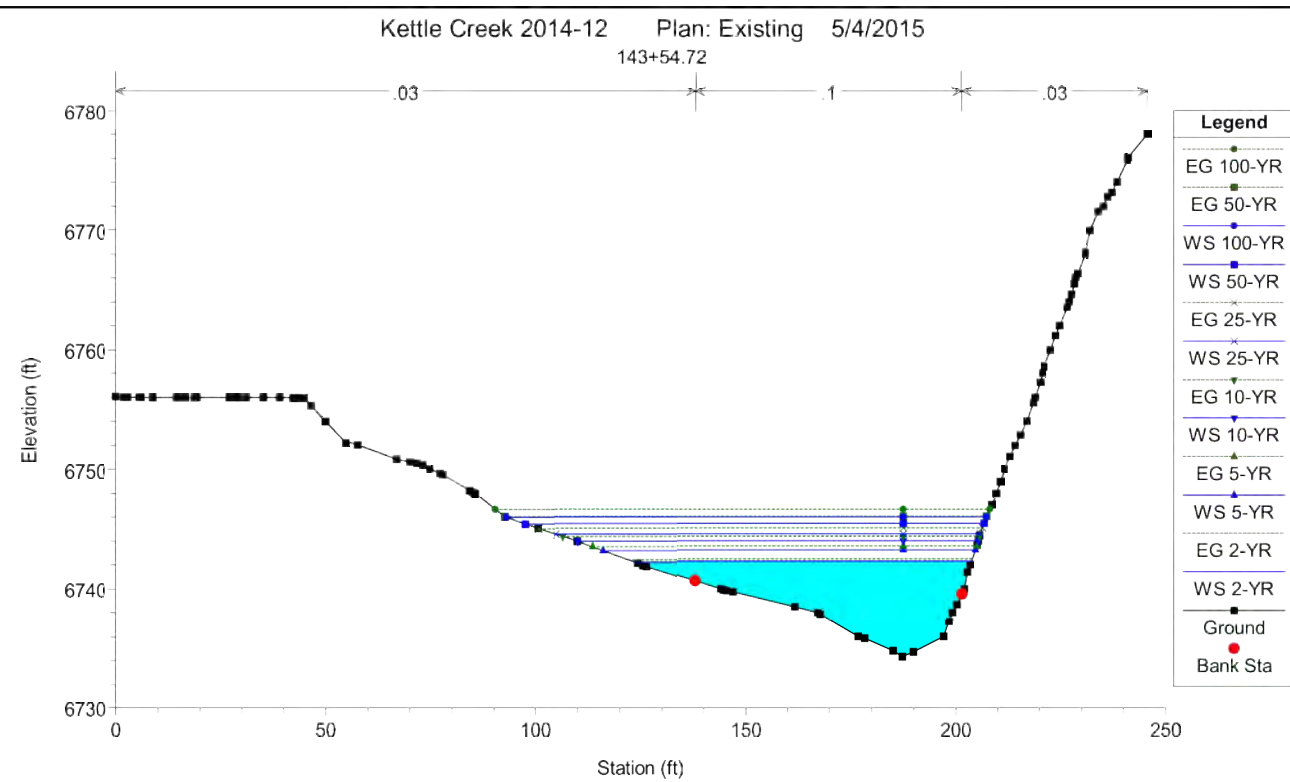
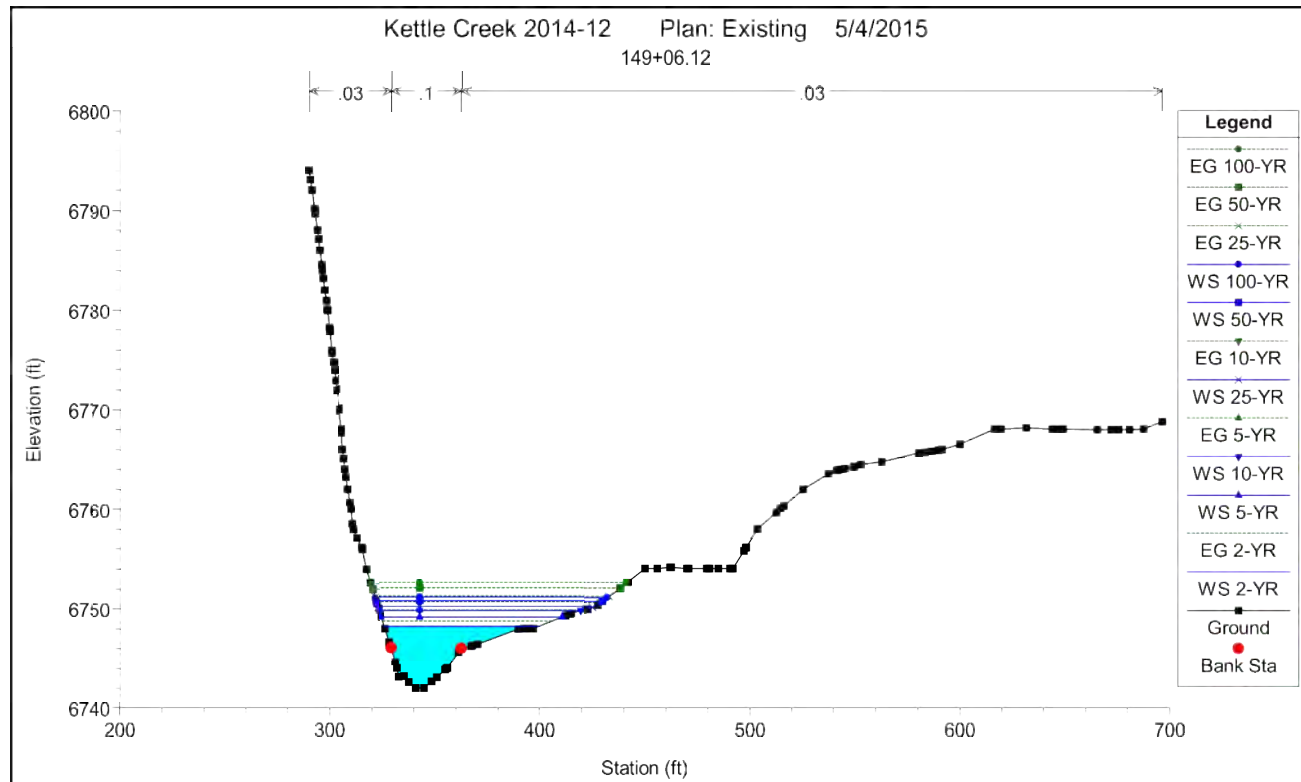

EXISTING CONDITIONS
MODEL RESULTS

HYDRAULIC RESULTS –
EXISTING
KETTLE CREEK DBPS
JOB NO. 25100.00
MAY 2015
C-48



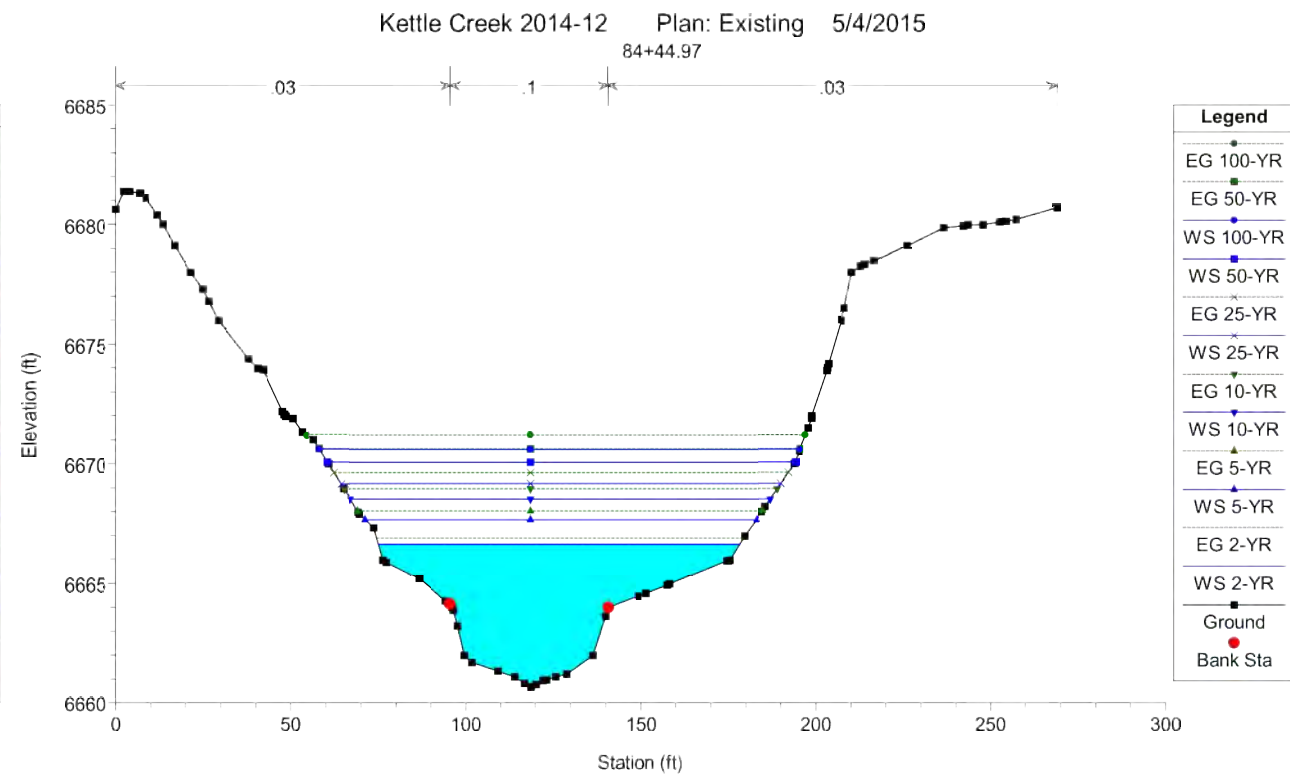
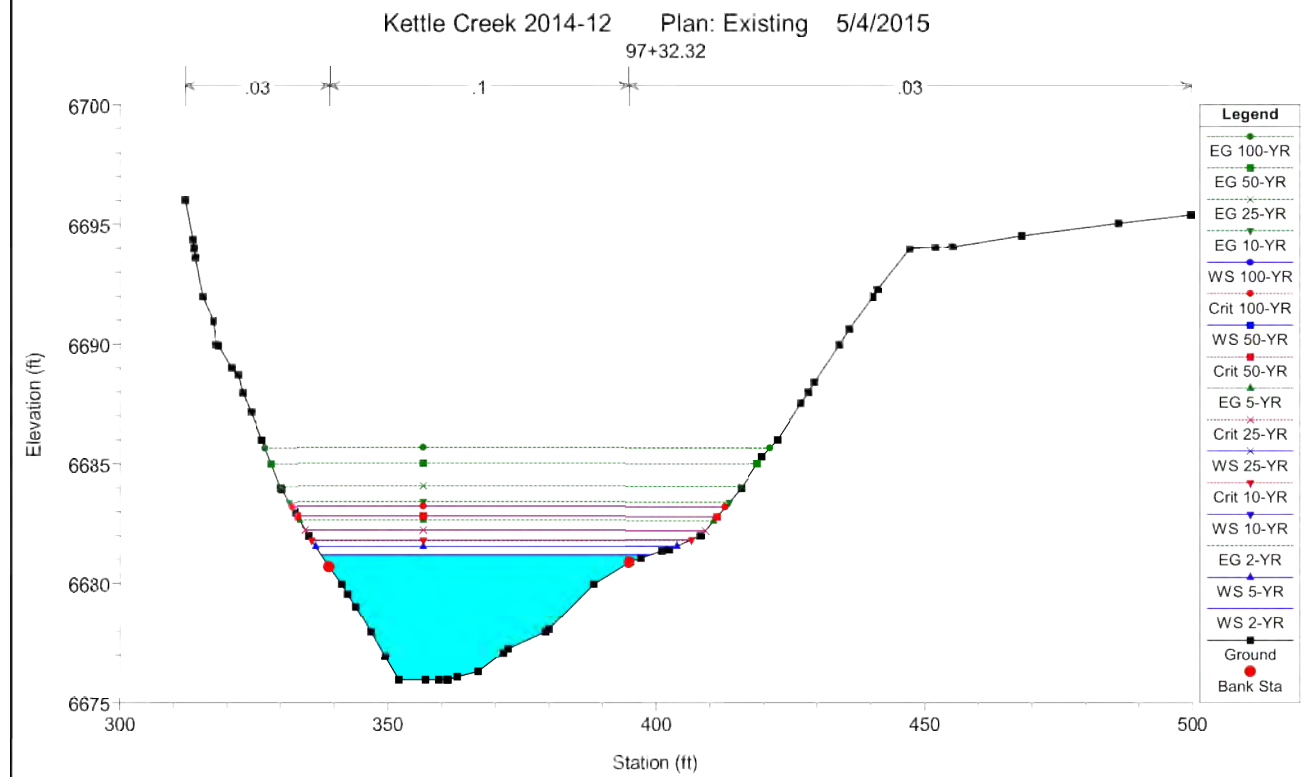
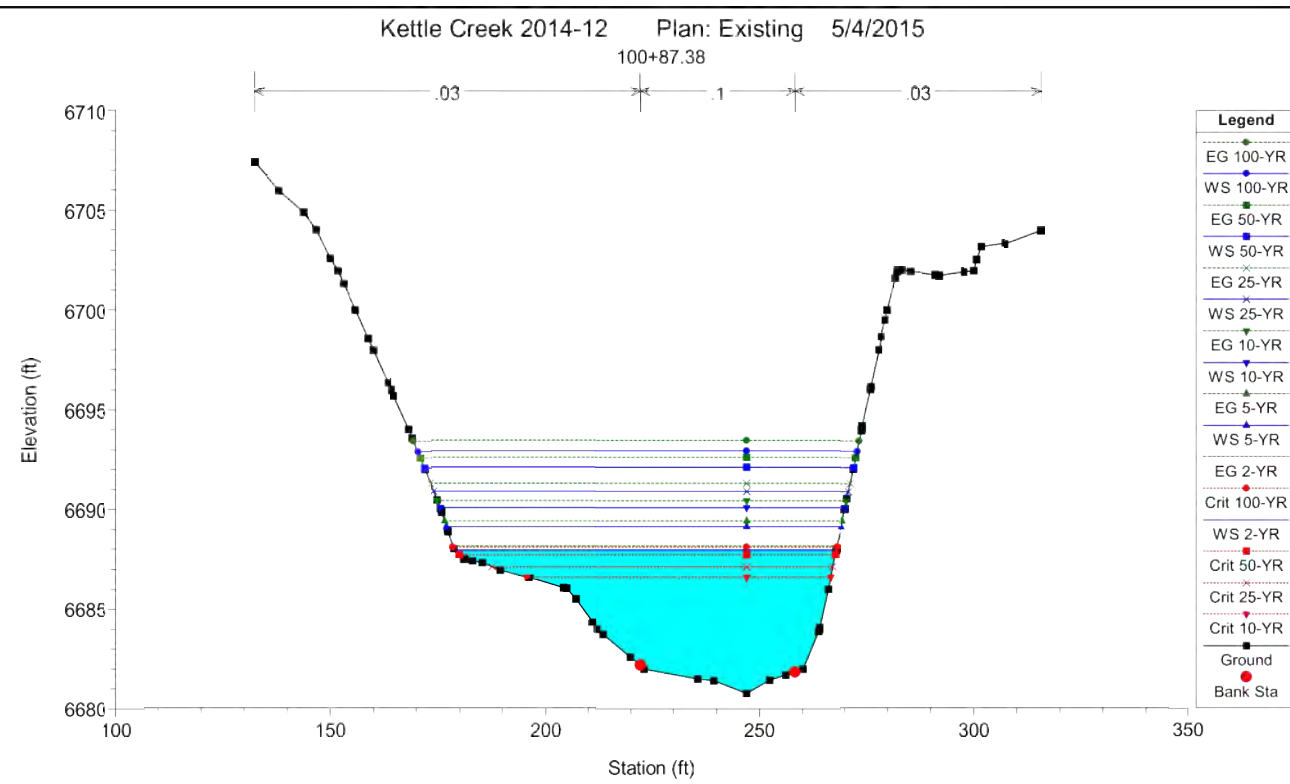
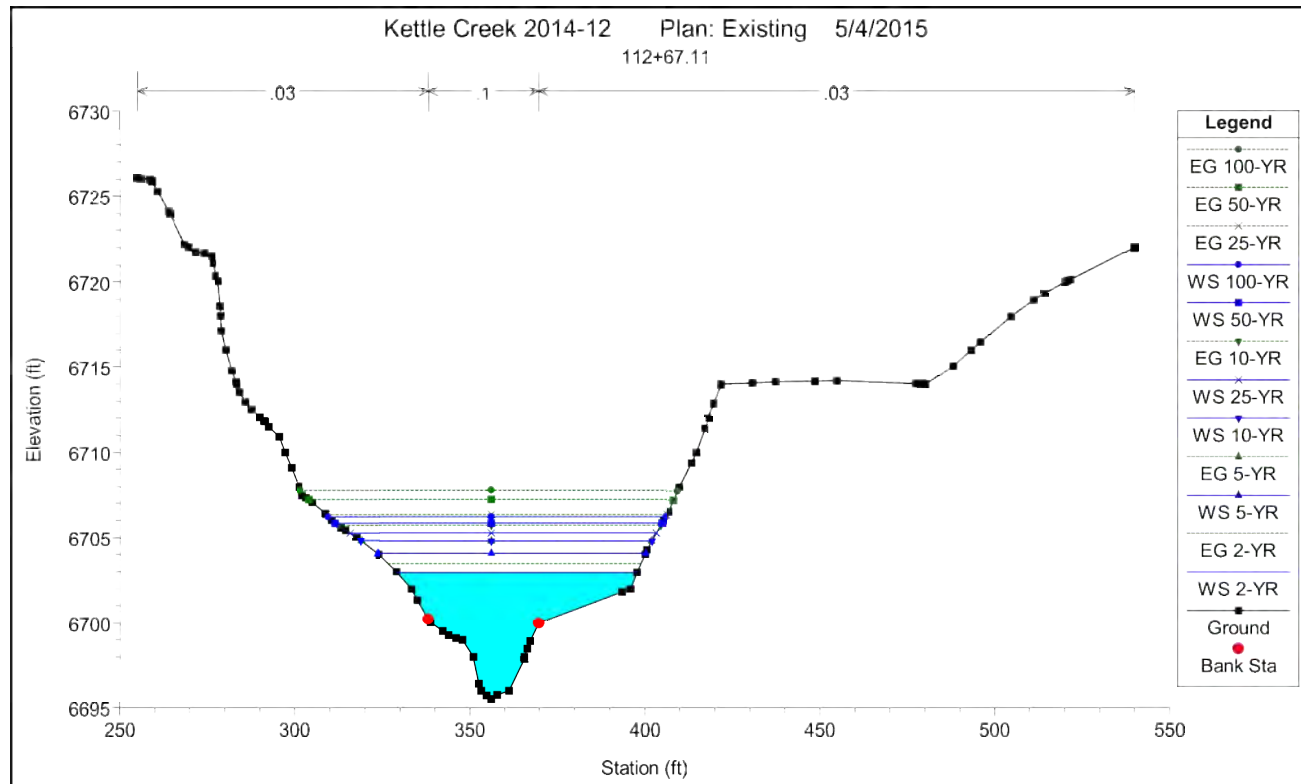

HYDRAULIC RESULTS –
EXISTING
KETTLE CREEK DBPS
JOB NO. 25100.00
MAY 2015
C-49

EXISTING CONDITIONS
MODEL RESULTS



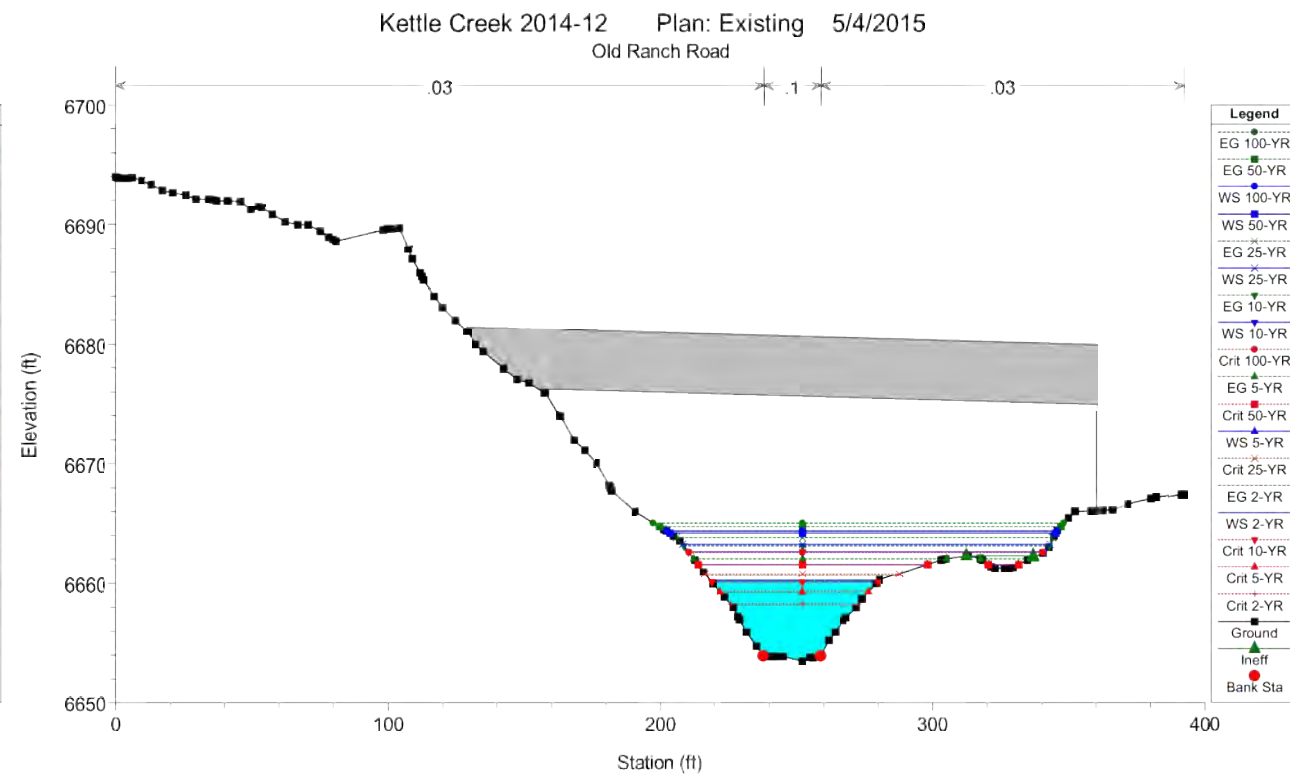
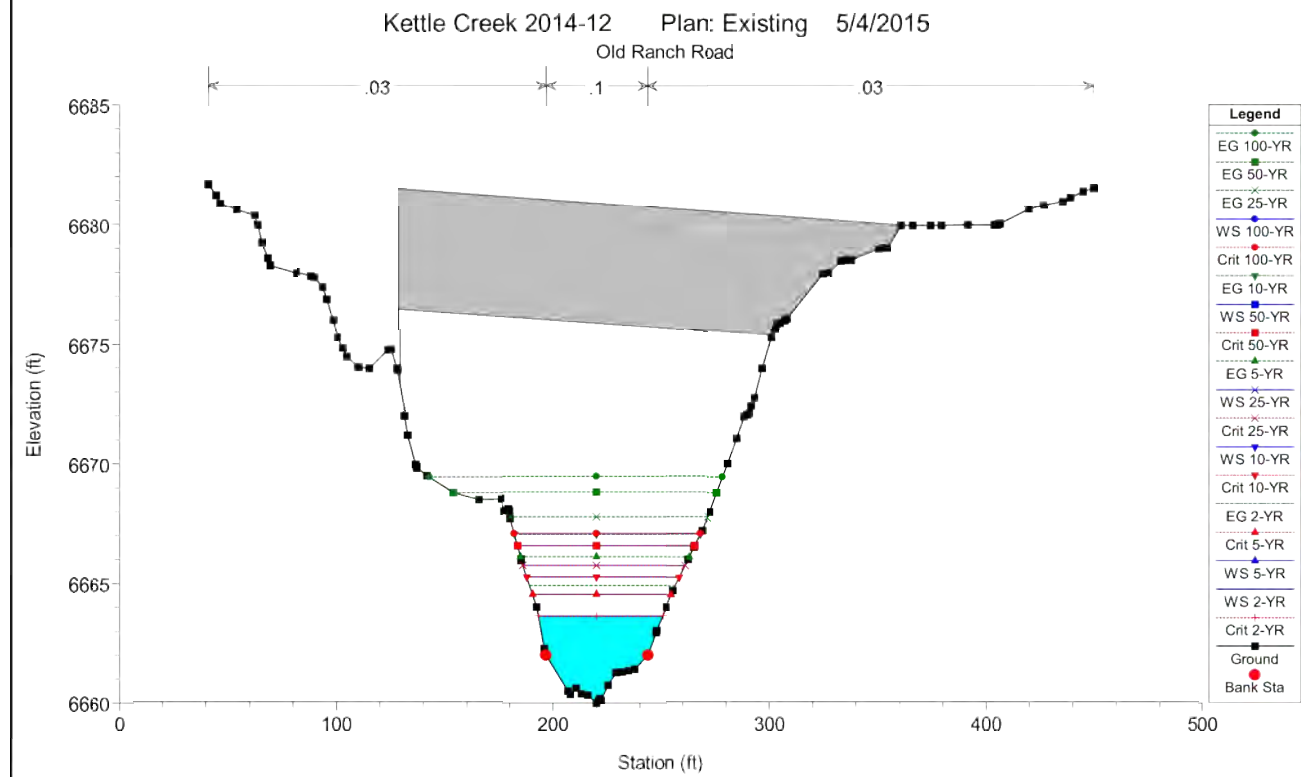
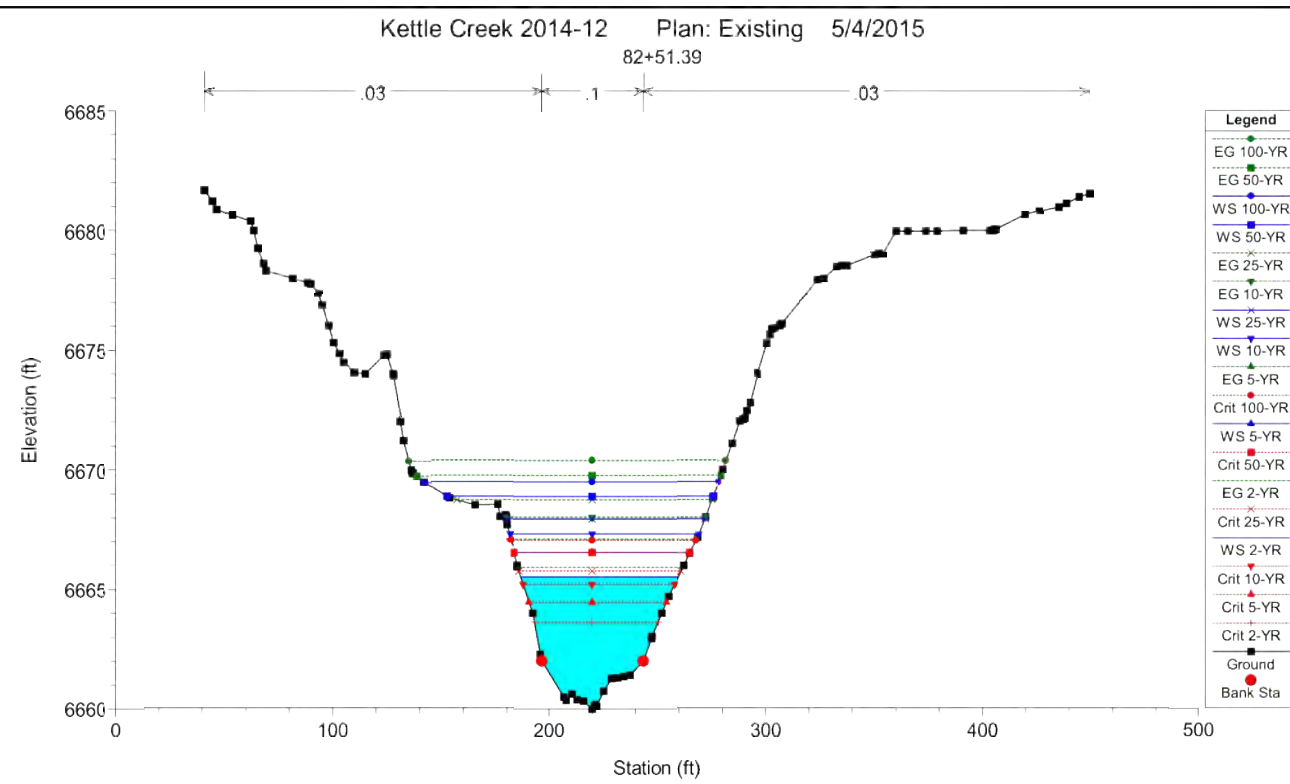
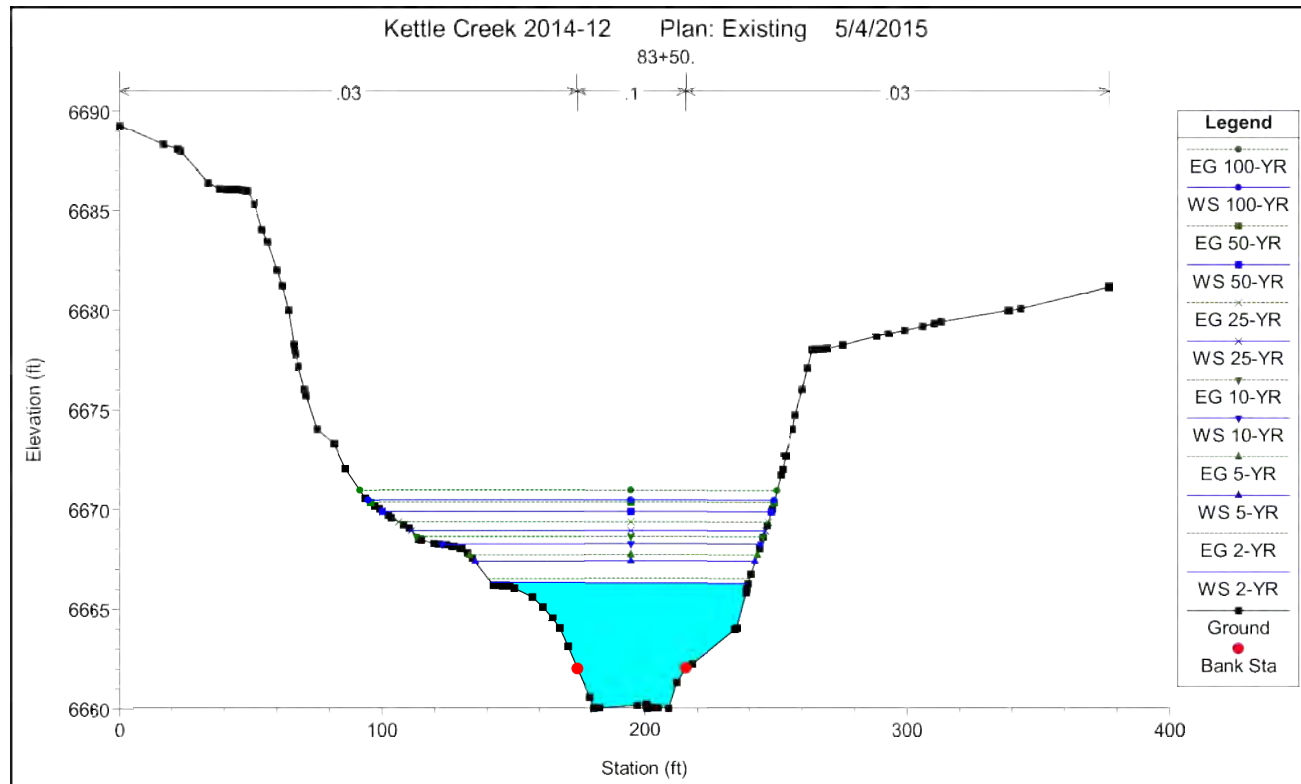

EXISTING CONDITIONS
MODEL RESULTS

HYDRAULIC RESULTS –
EXISTING
KETTLE CREEK DBPS
JOB NO. 25100.00
MAY 2015
C-50



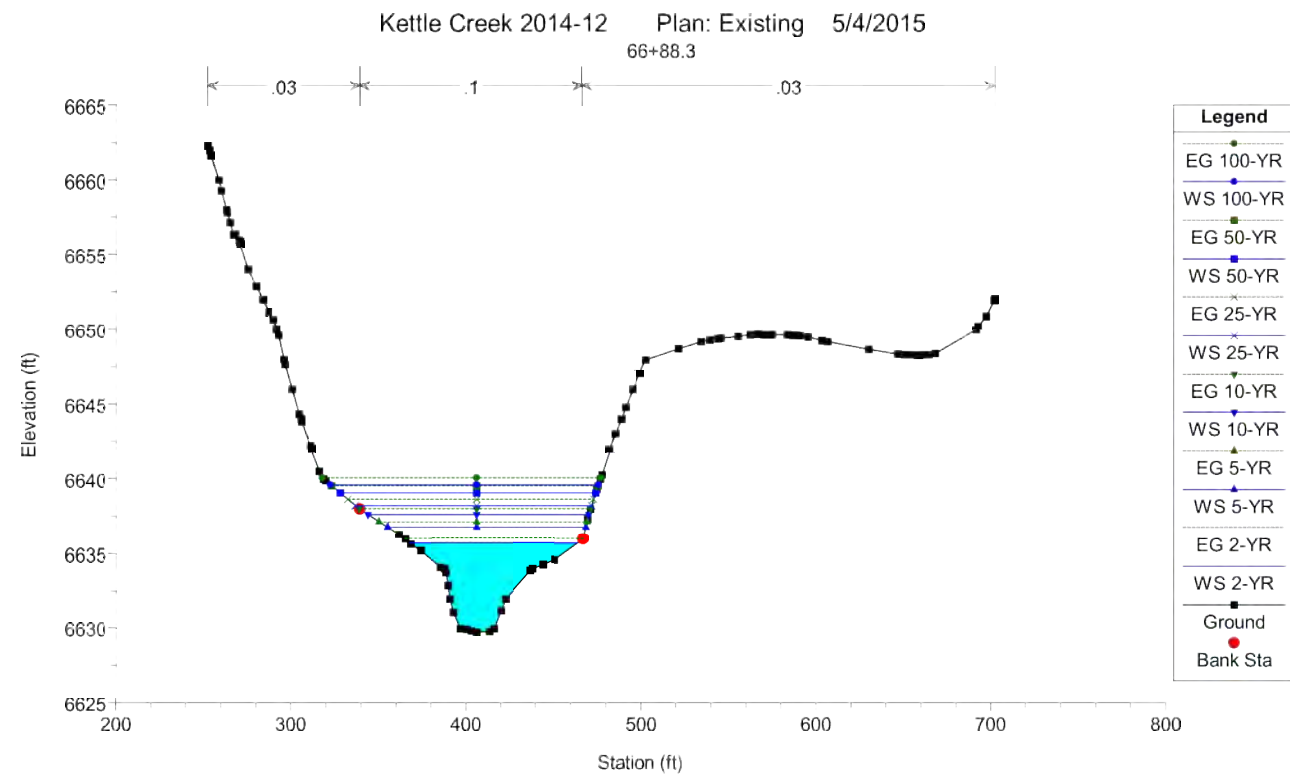
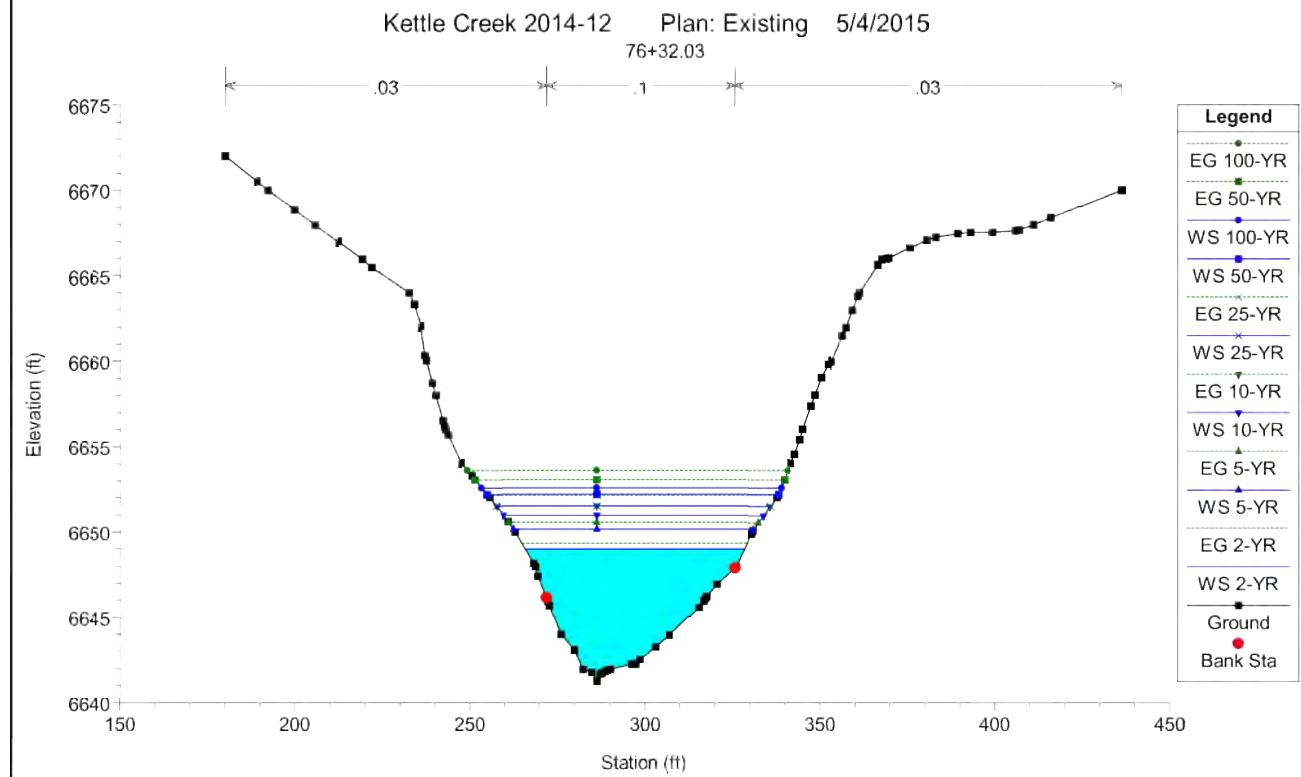
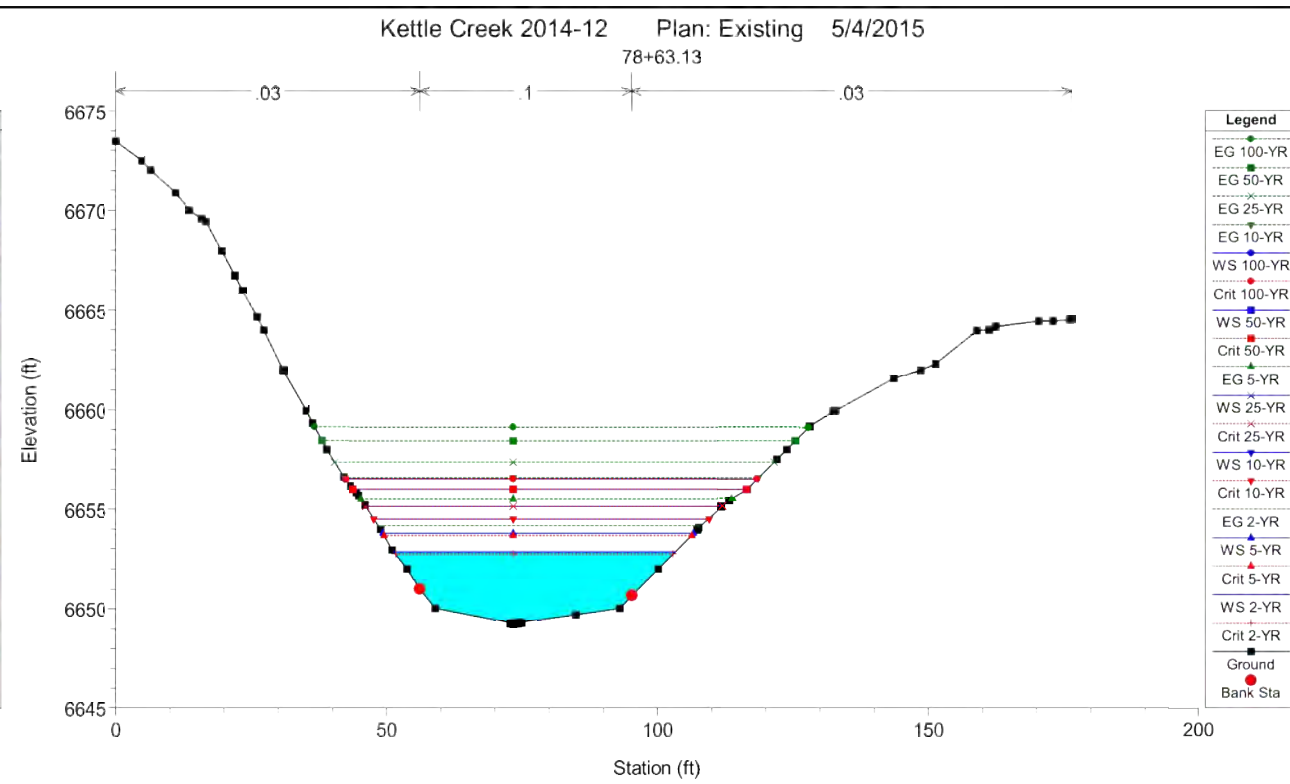
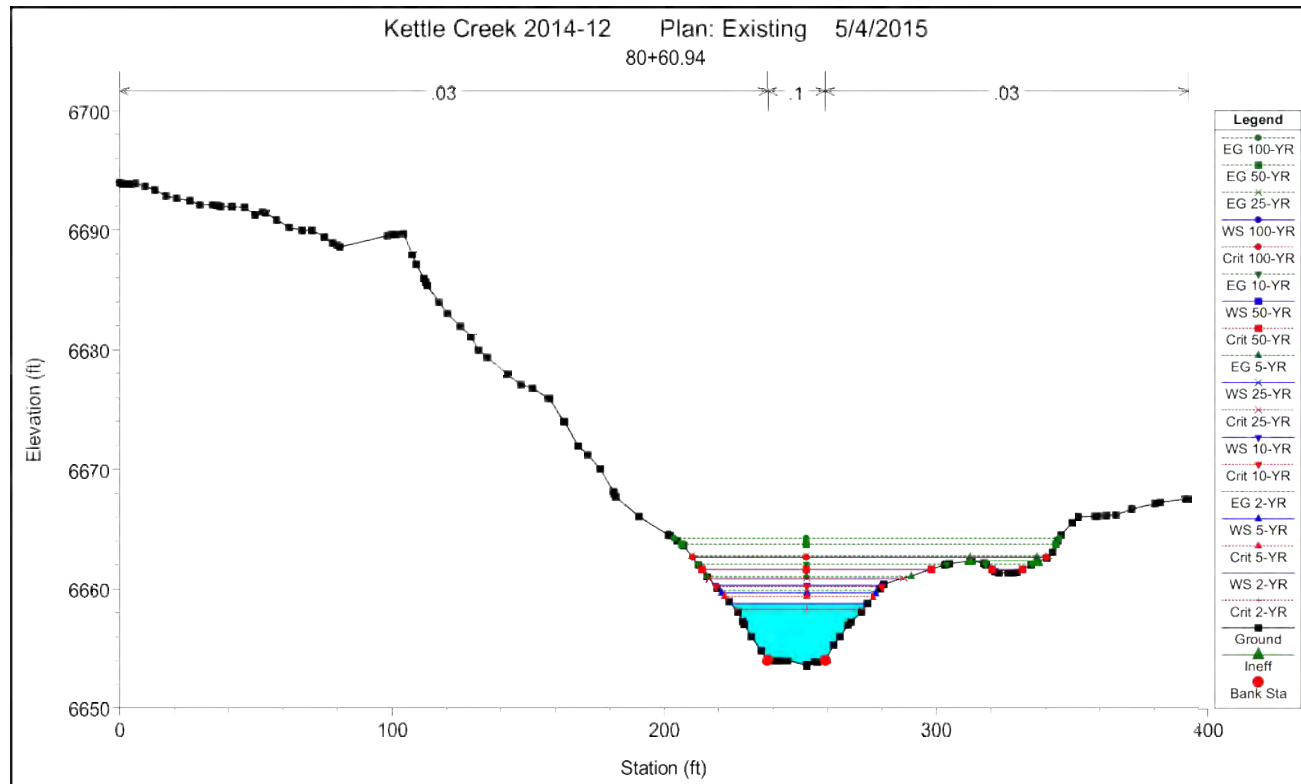

EXISTING CONDITIONS
MODEL RESULTS

HYDRAULIC RESULTS –
EXISTING
KETTLE CREEK DBPS
JOB NO. 25100.00
MAY 2015
C-51



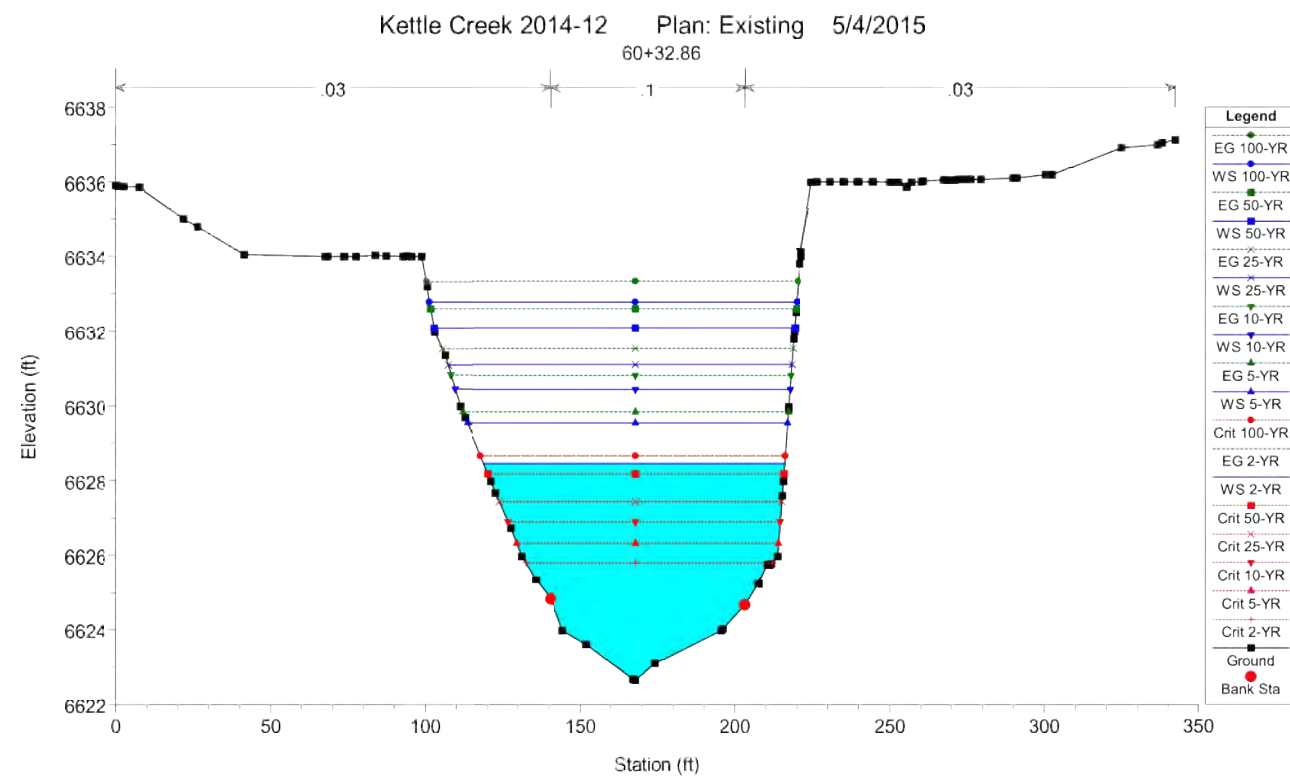
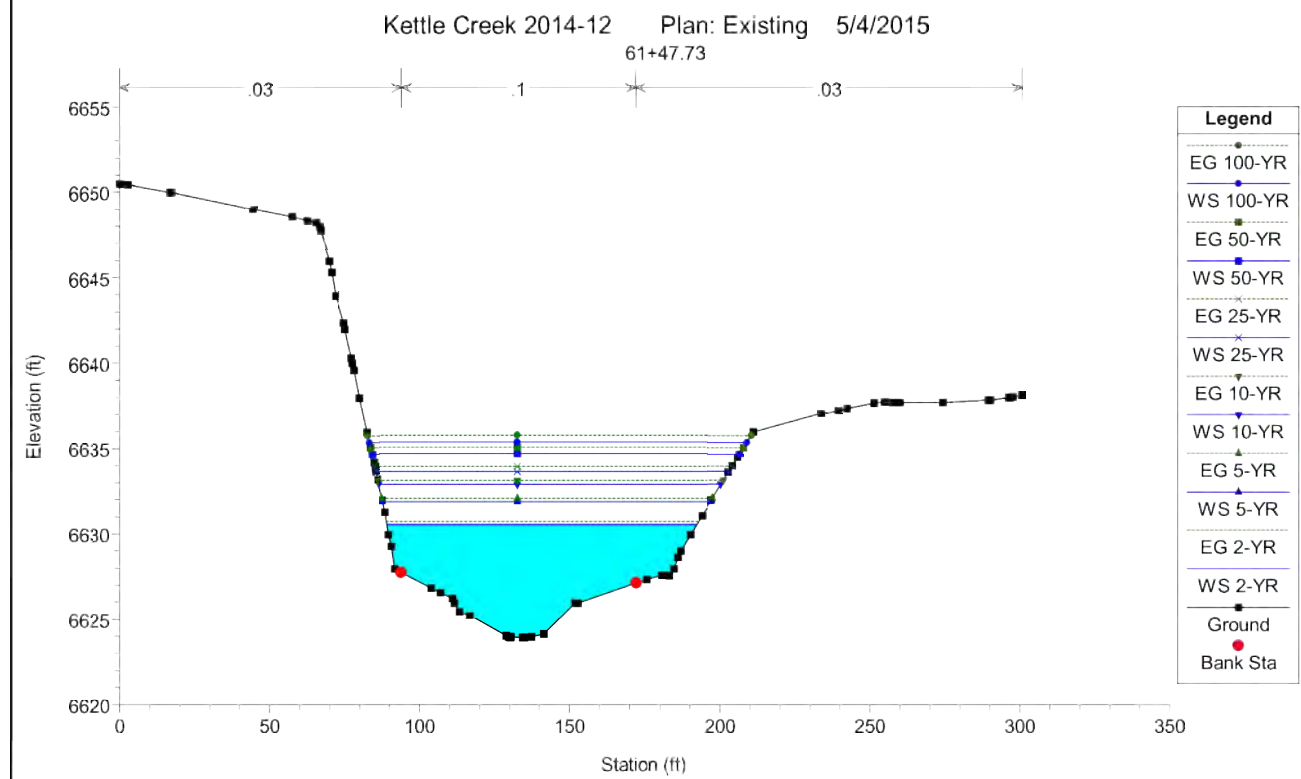
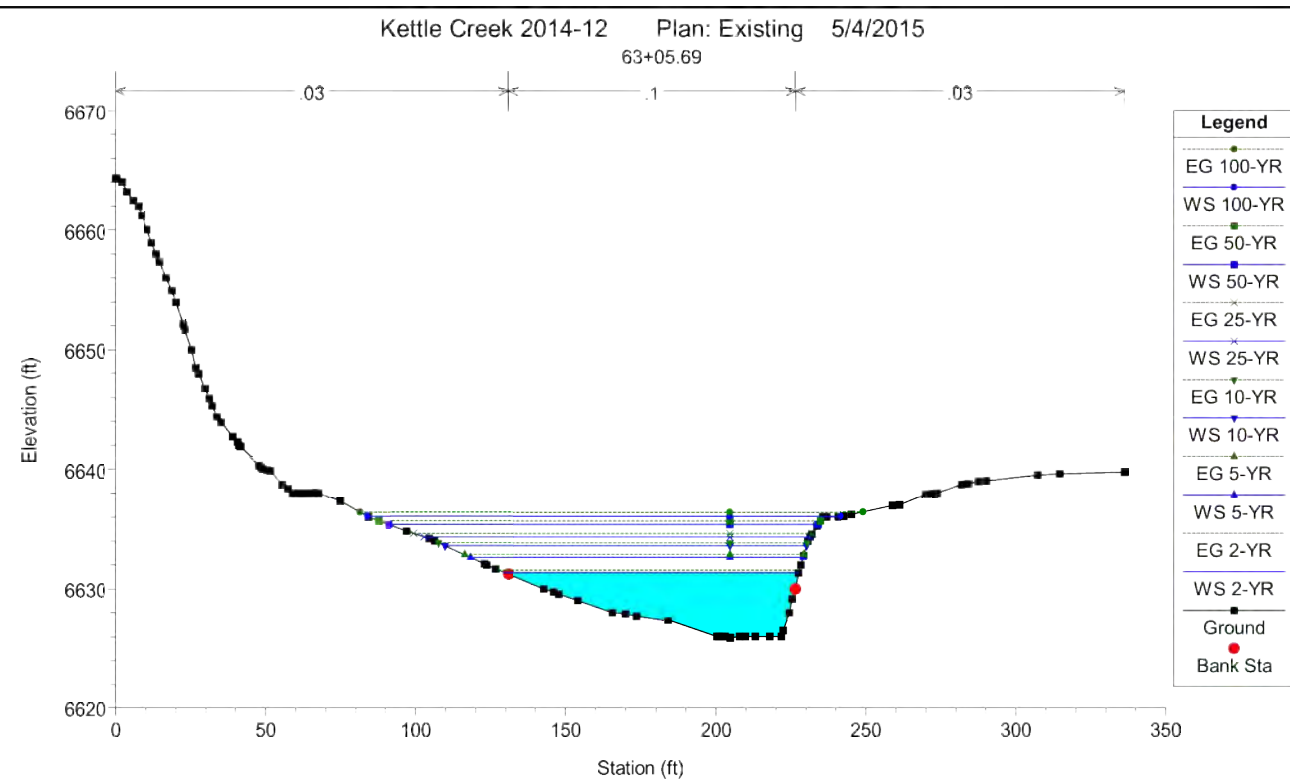
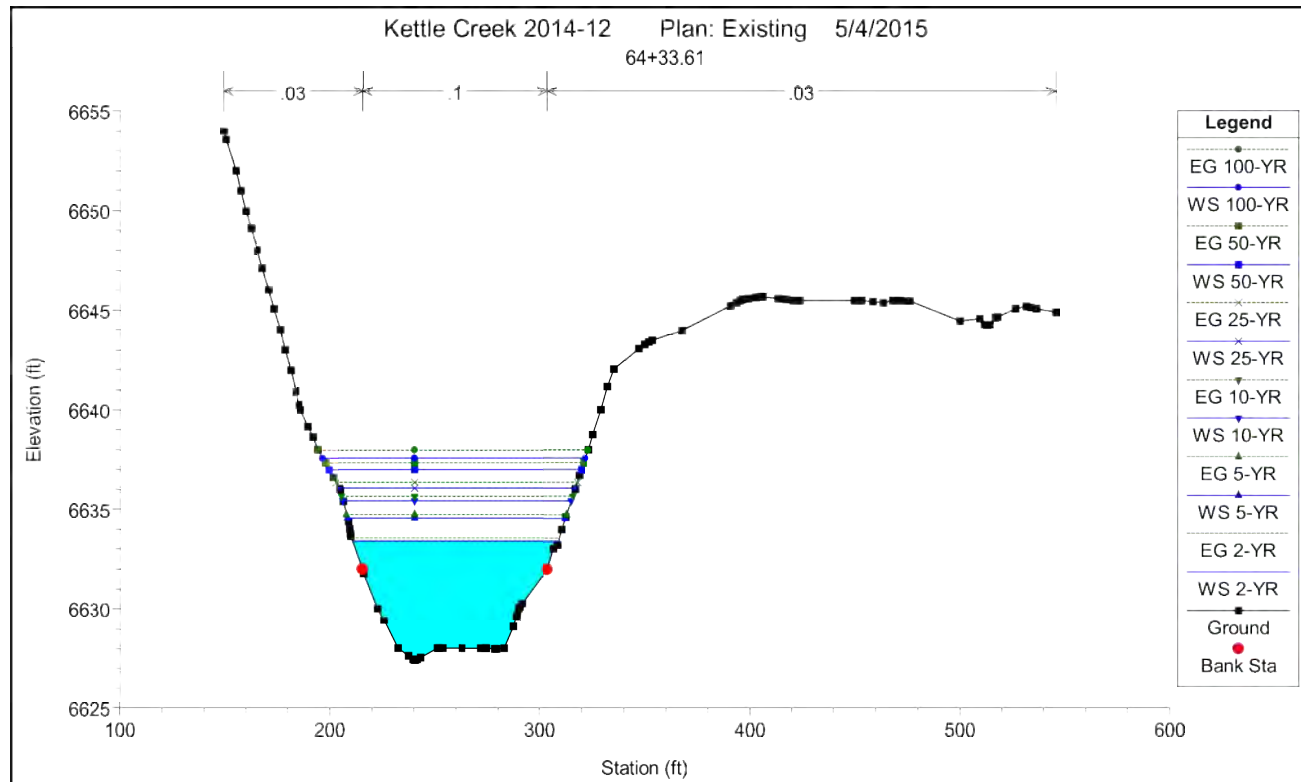

HYDRAULIC RESULTS –
EXISTING
KETTLE CREEK DBPS
JOB NO. 25100.00
MAY 2015
C-52

EXISTING CONDITIONS
MODEL RESULTS



Centennial 303-740-9393 • Colorado Springs 719-593-2593
Fort Collins 970-491-9888 • www.jrengineering.com

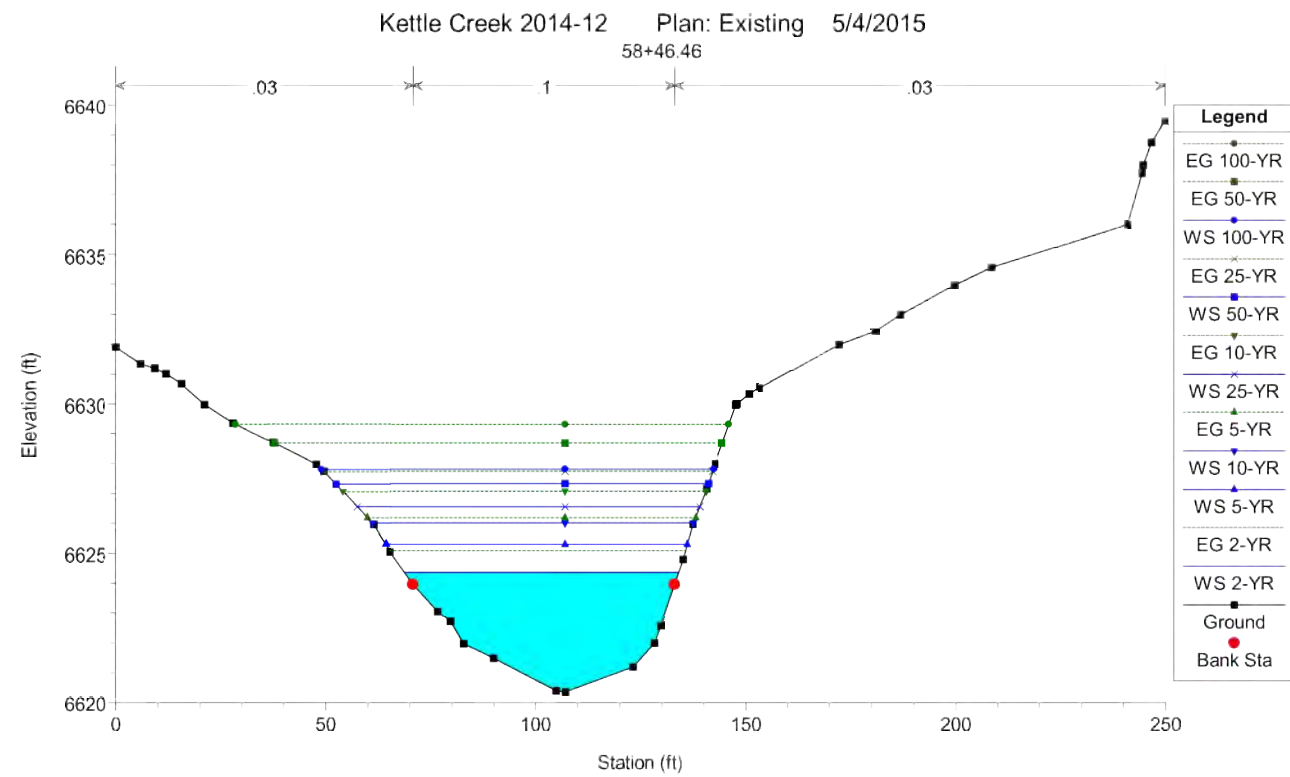
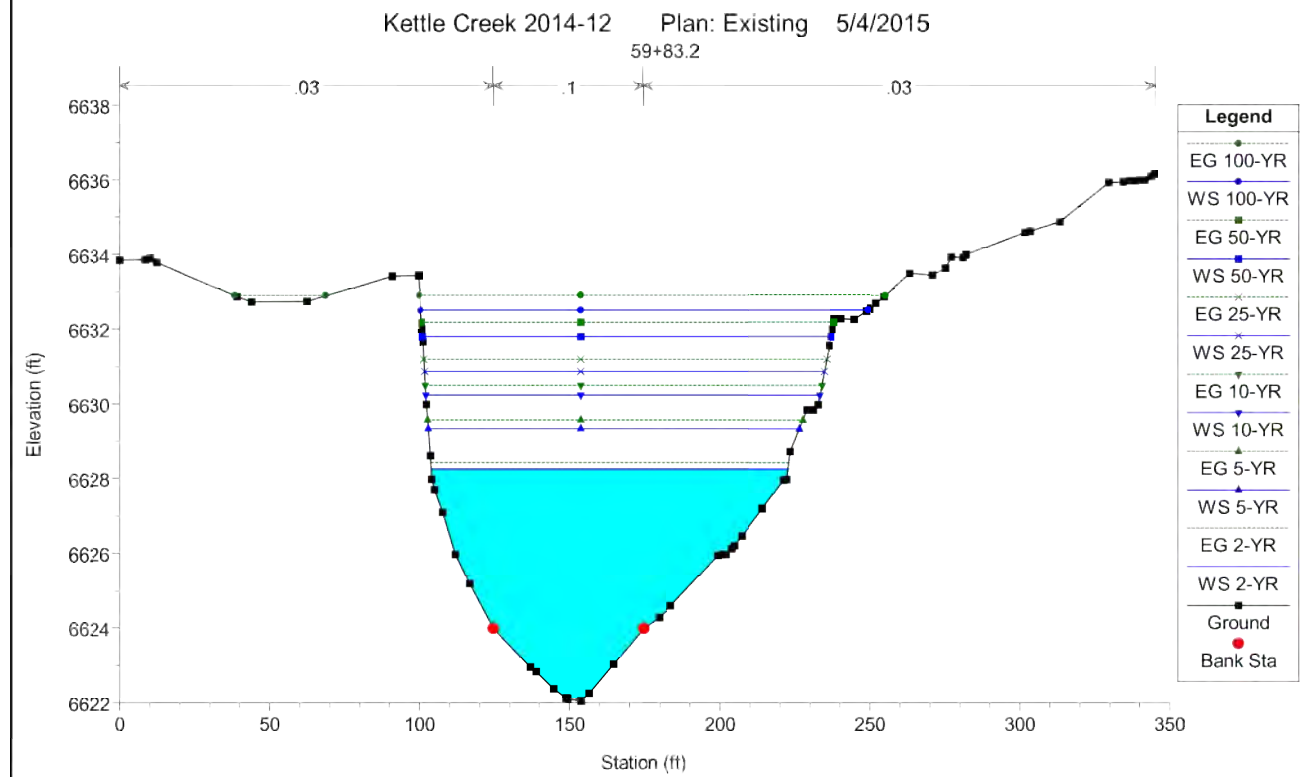
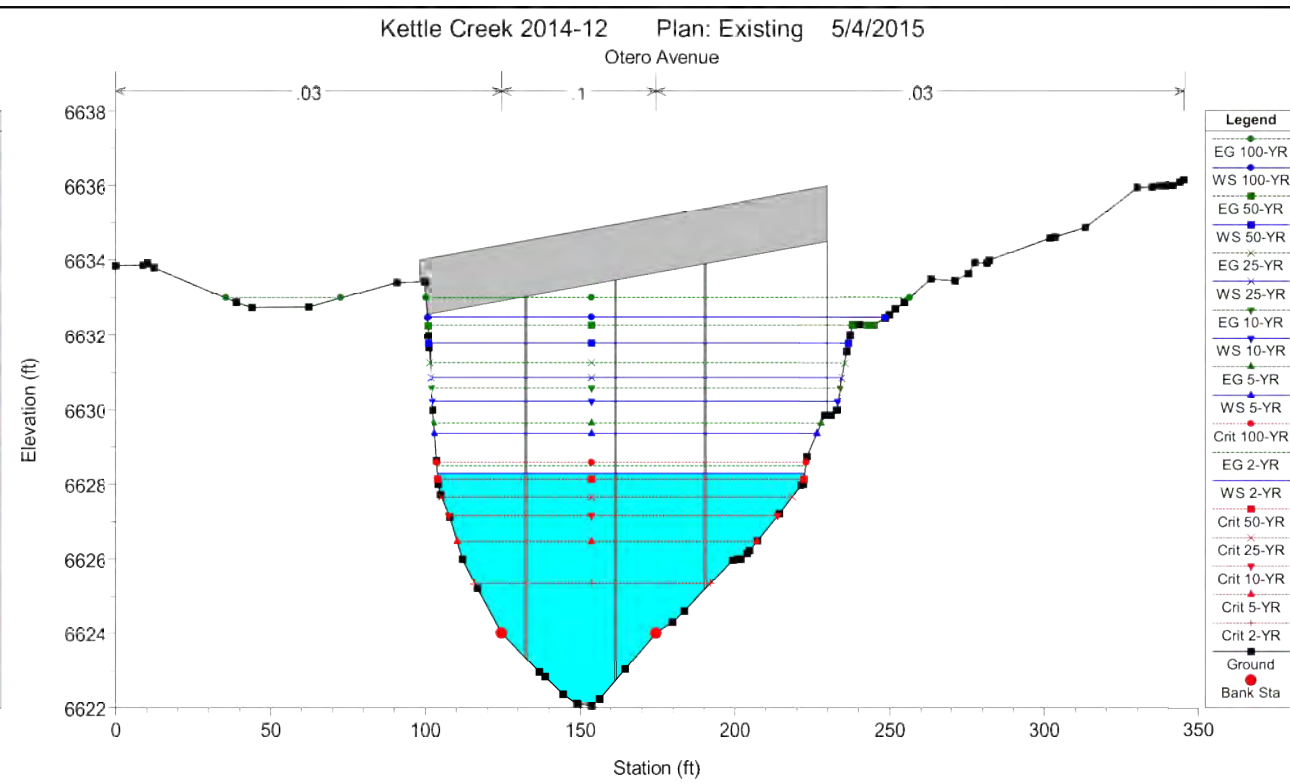
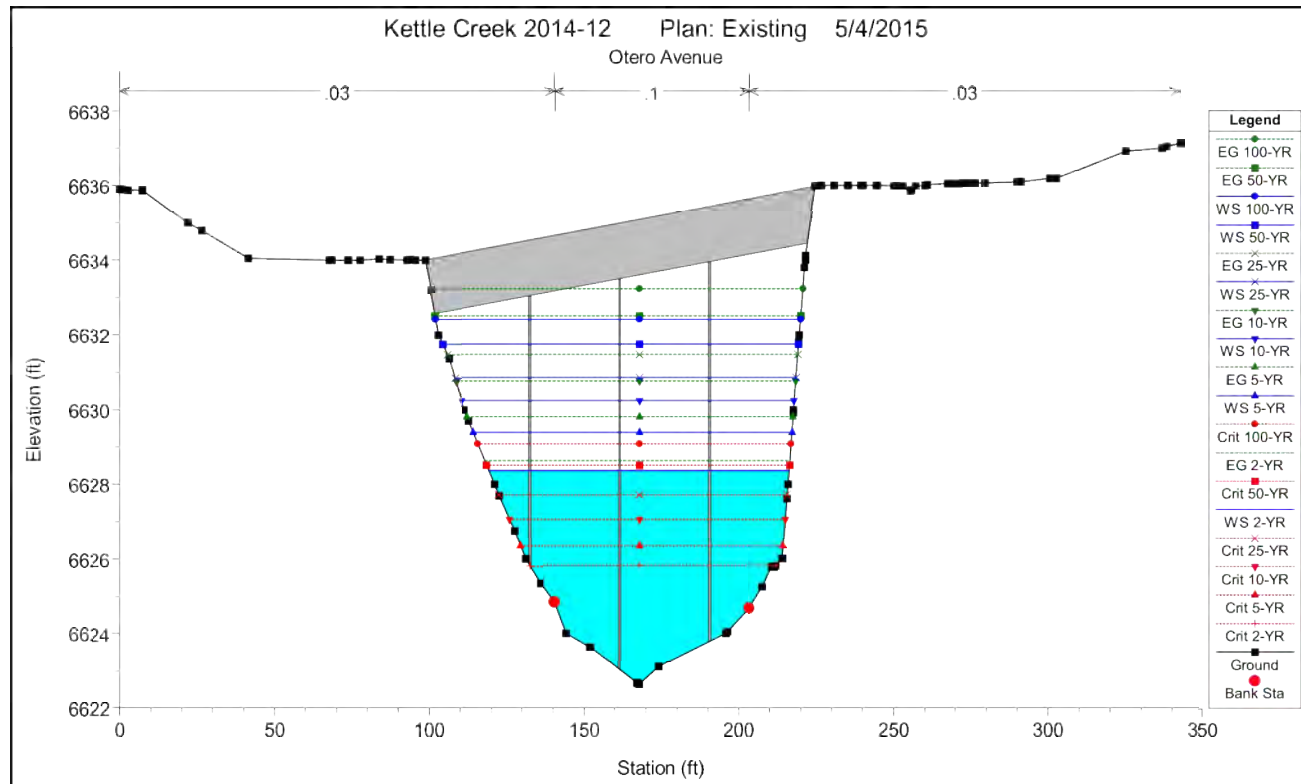

EXISTING CONDITIONS
MODEL RESULTS

HYDRAULIC RESULTS –
EXISTING
KETTLE CREEK DBPS
JOB NO. 25100.00
MAY 2015
C-53



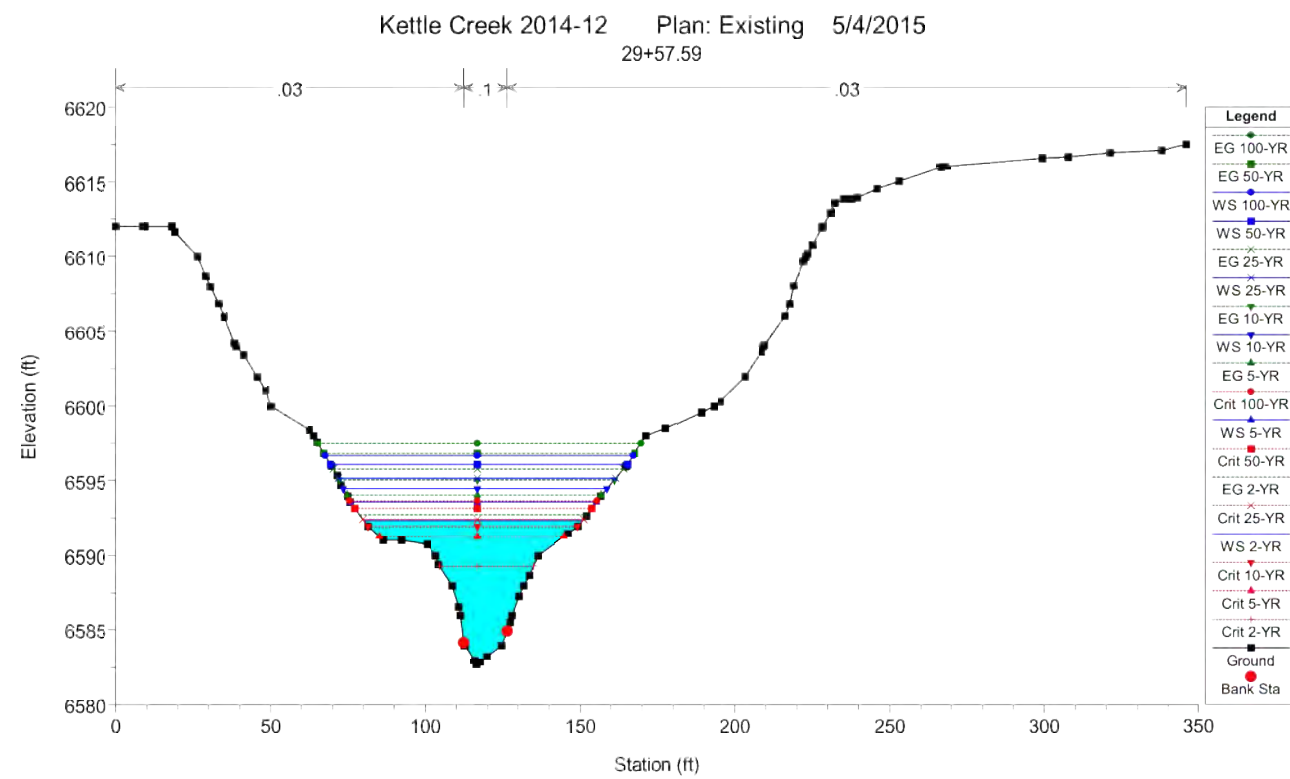
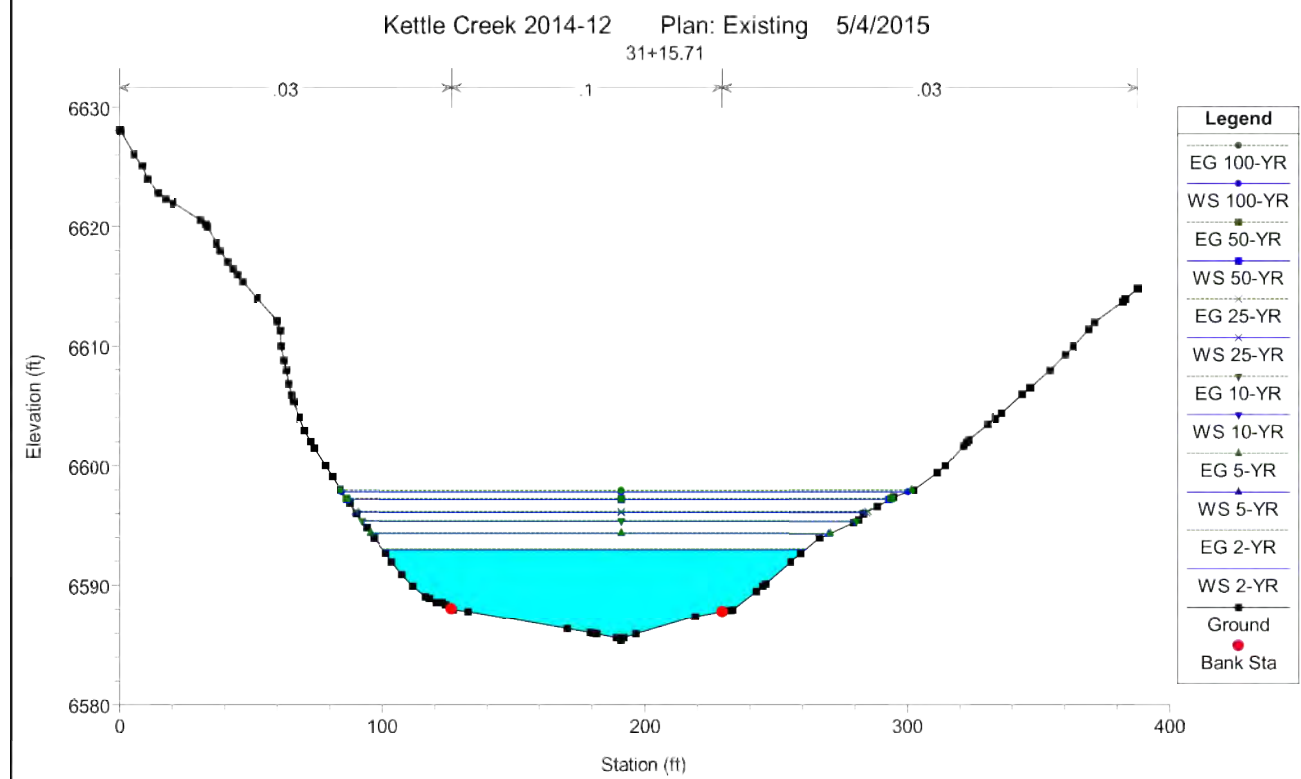
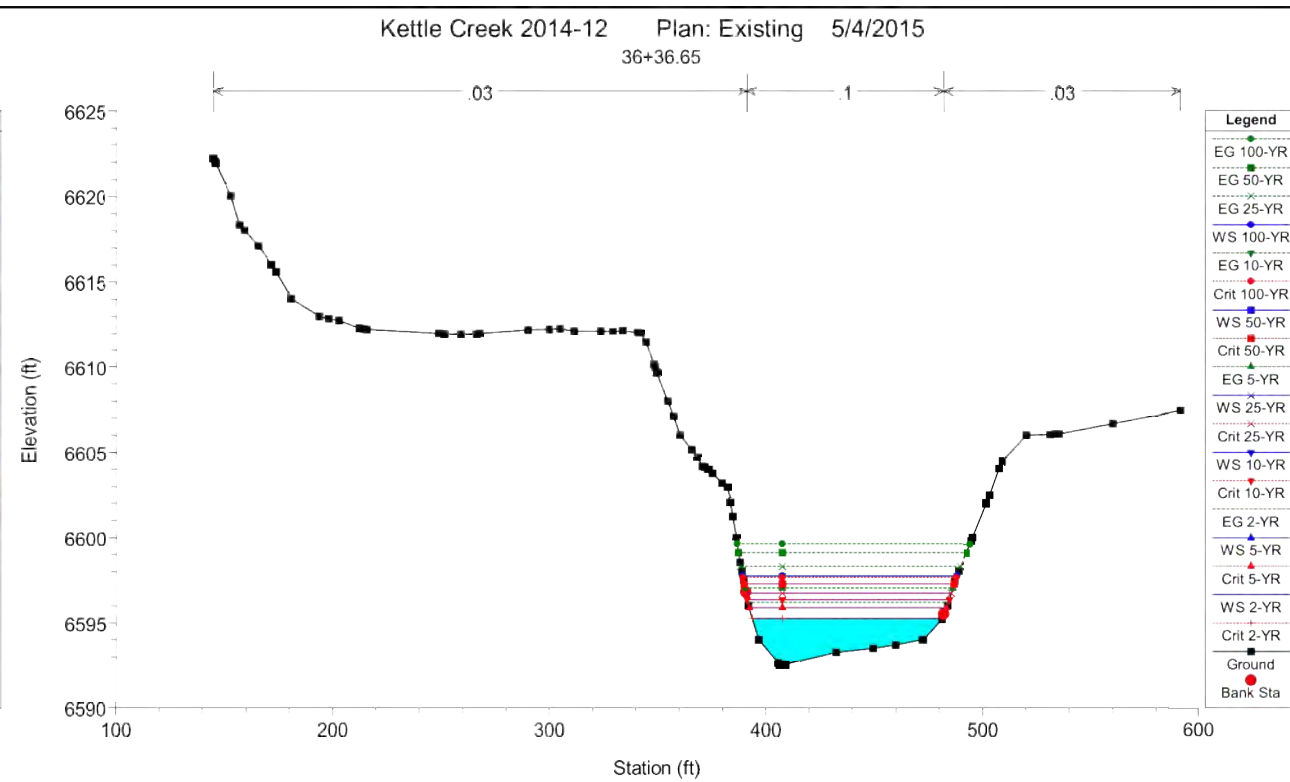
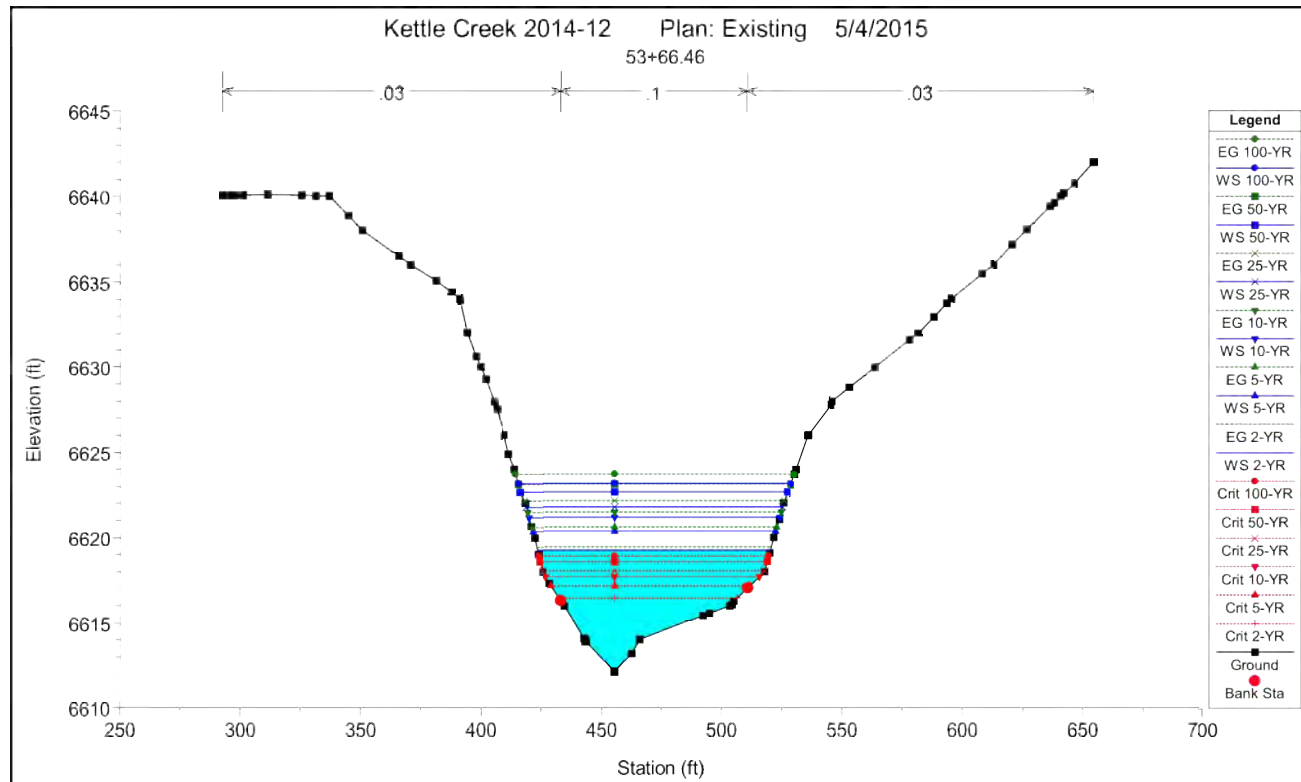

EXISTING CONDITIONS
MODEL RESULTS

HYDRAULIC RESULTS –
EXISTING
KETTLE CREEK DBPS
JOB NO. 25100.00
MAY 2015
C-54



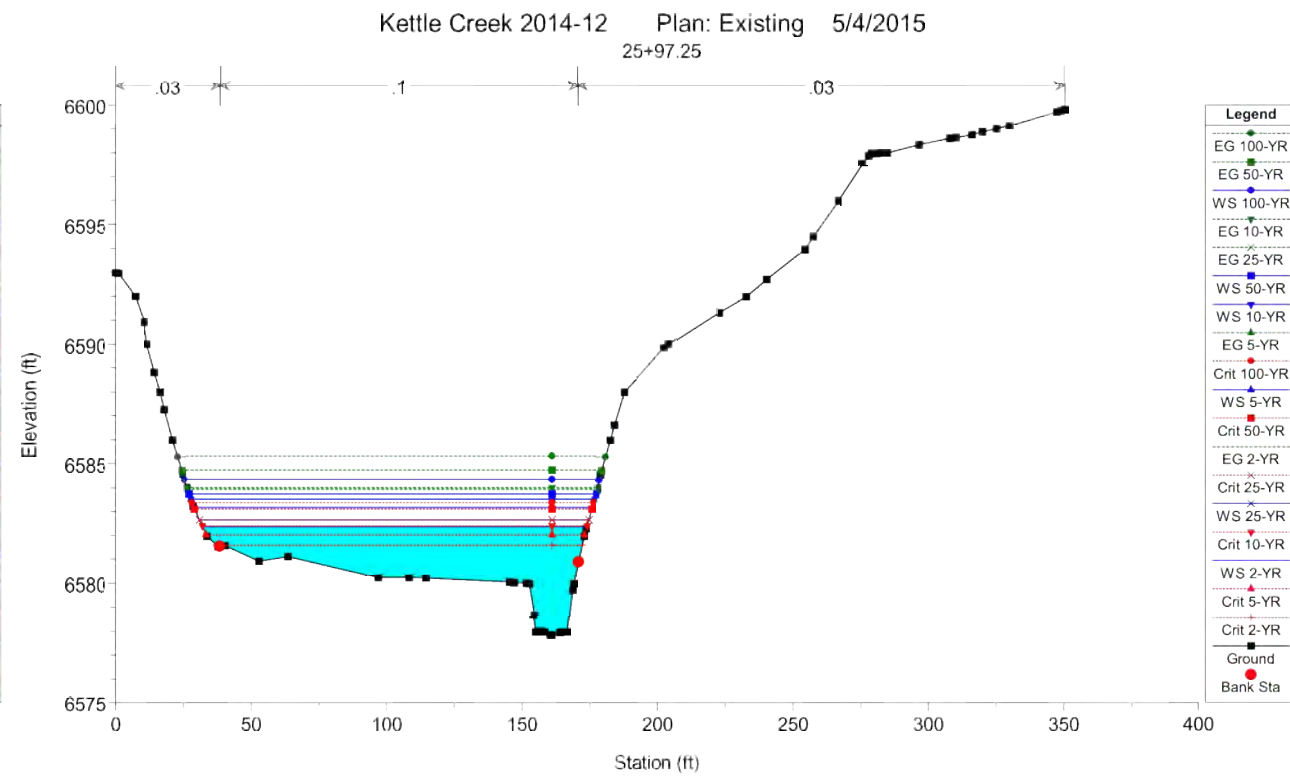
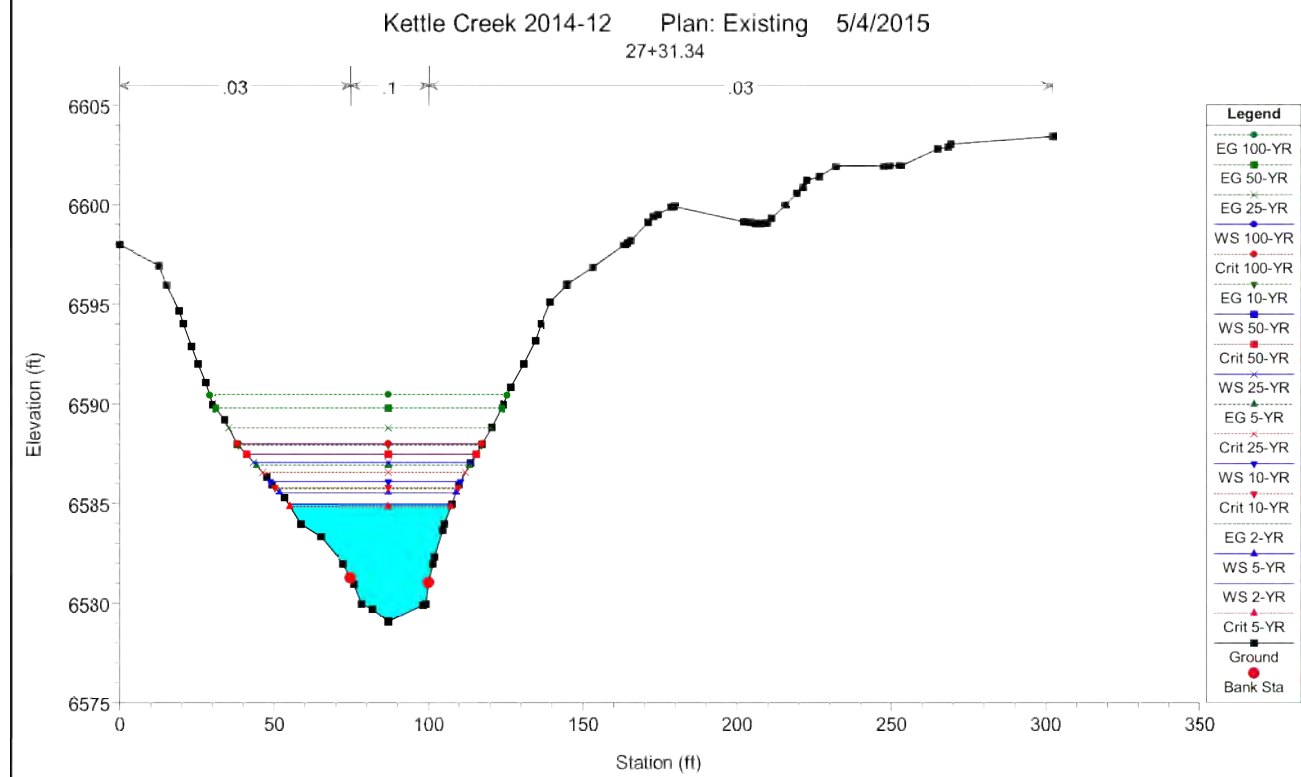
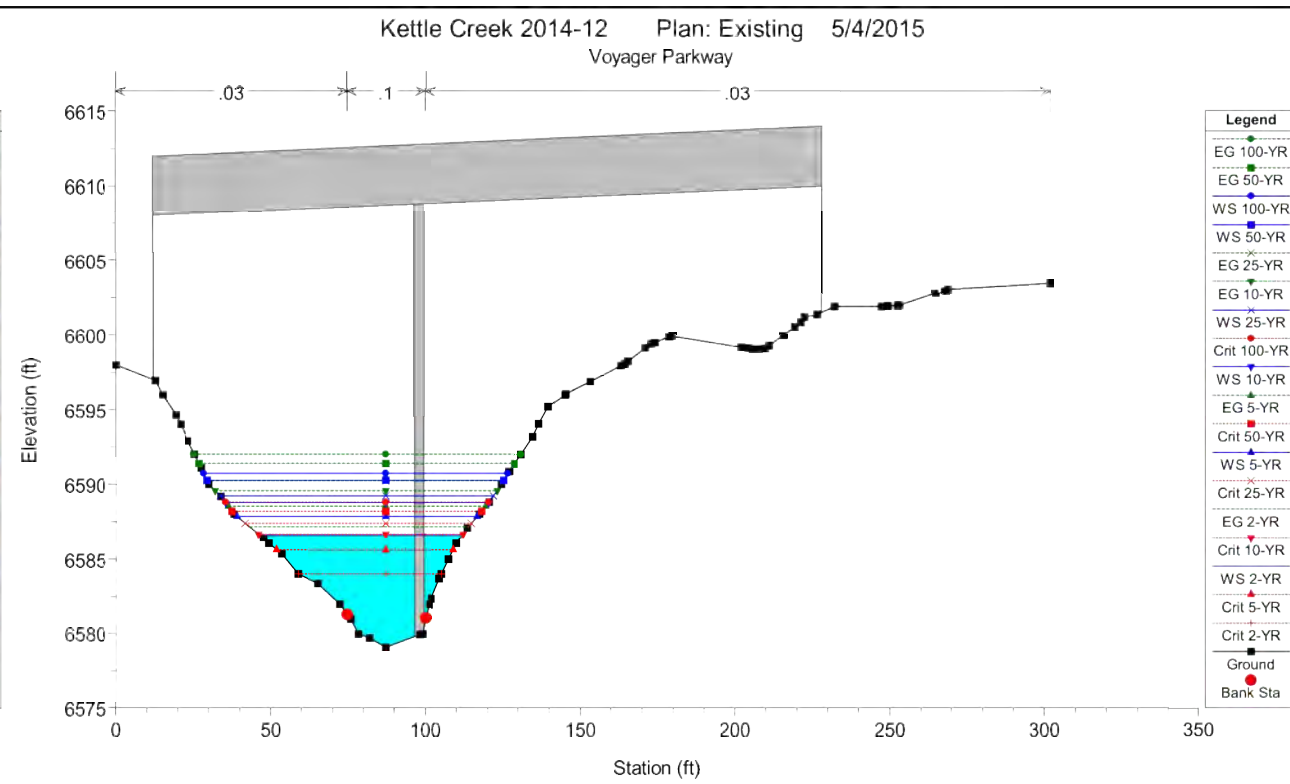
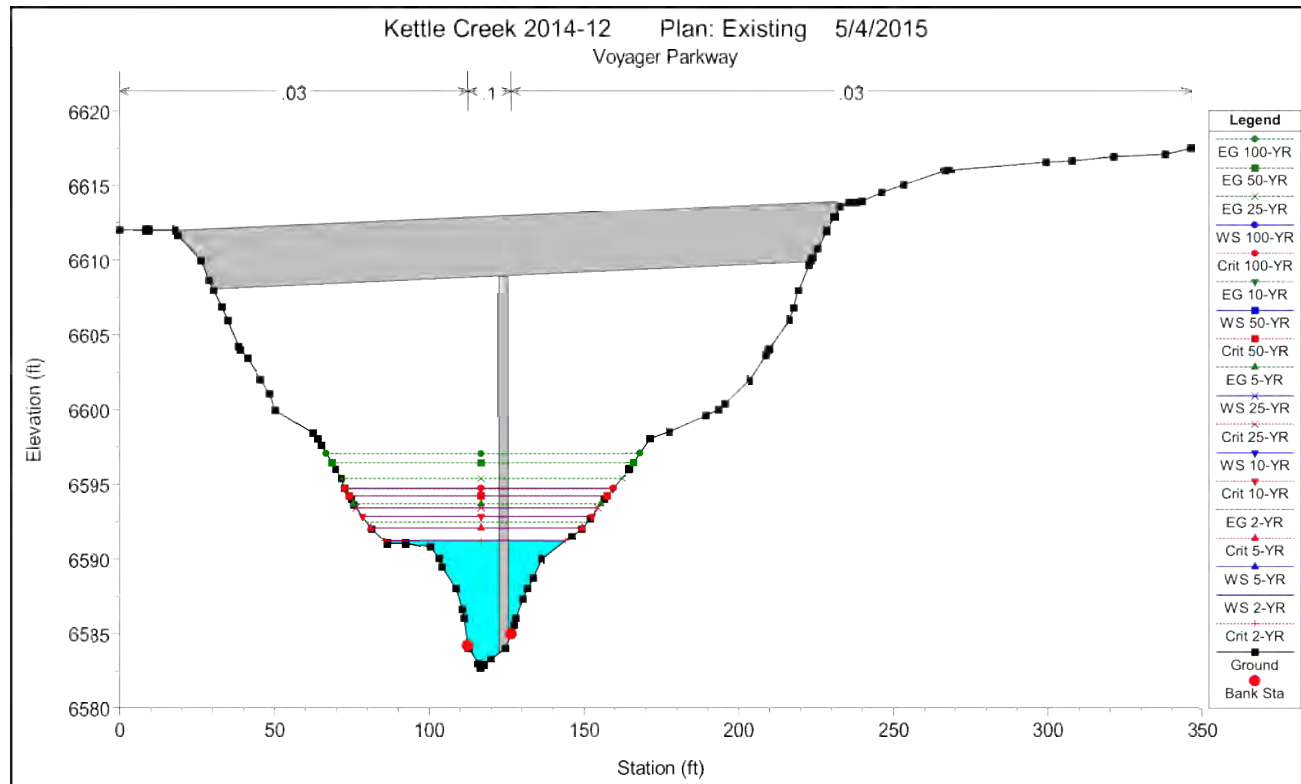

HYDRAULIC RESULTS –
EXISTING
KETTLE CREEK DBPS
JOB NO. 25100.00
MAY 2015
C-55

EXISTING CONDITIONS
MODEL RESULTS



Centennial 303-740-9393 • Colorado Springs 719-593-2593
Fort Collins 970-491-9888 • www.jrengineering.com

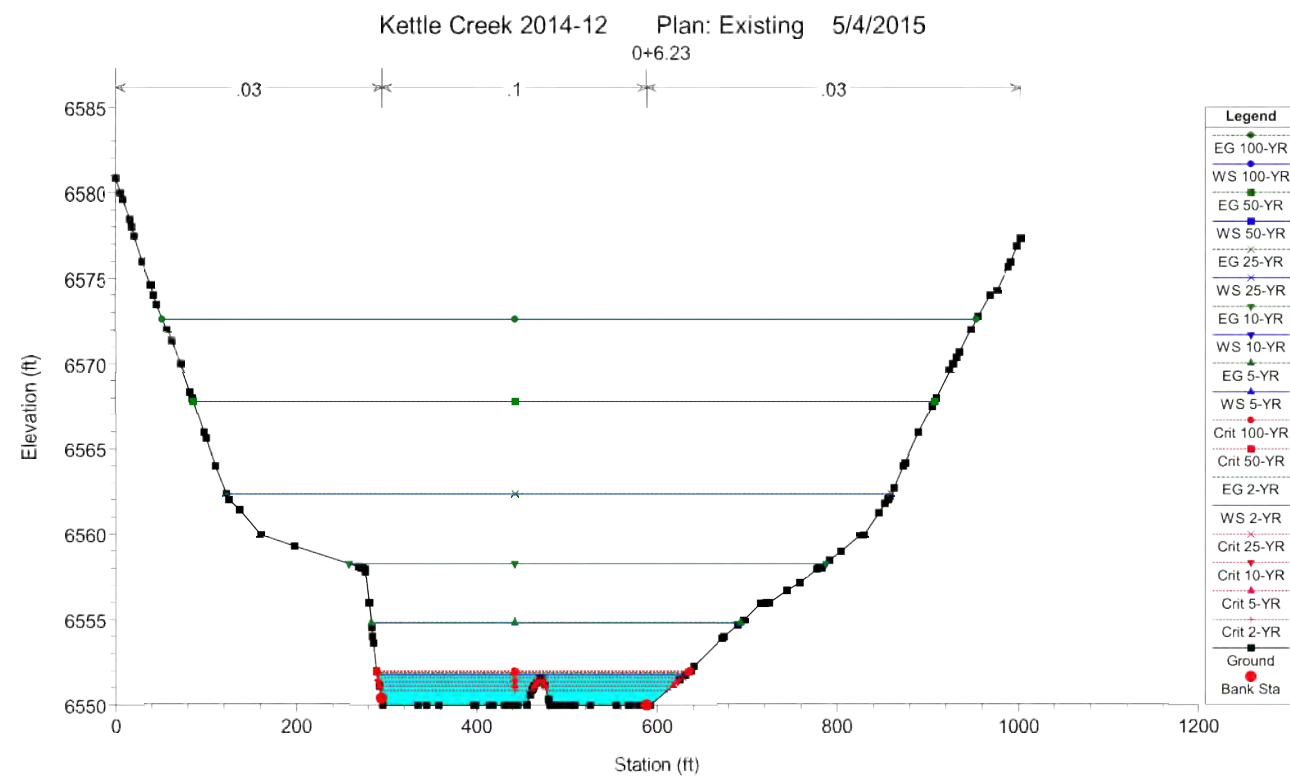
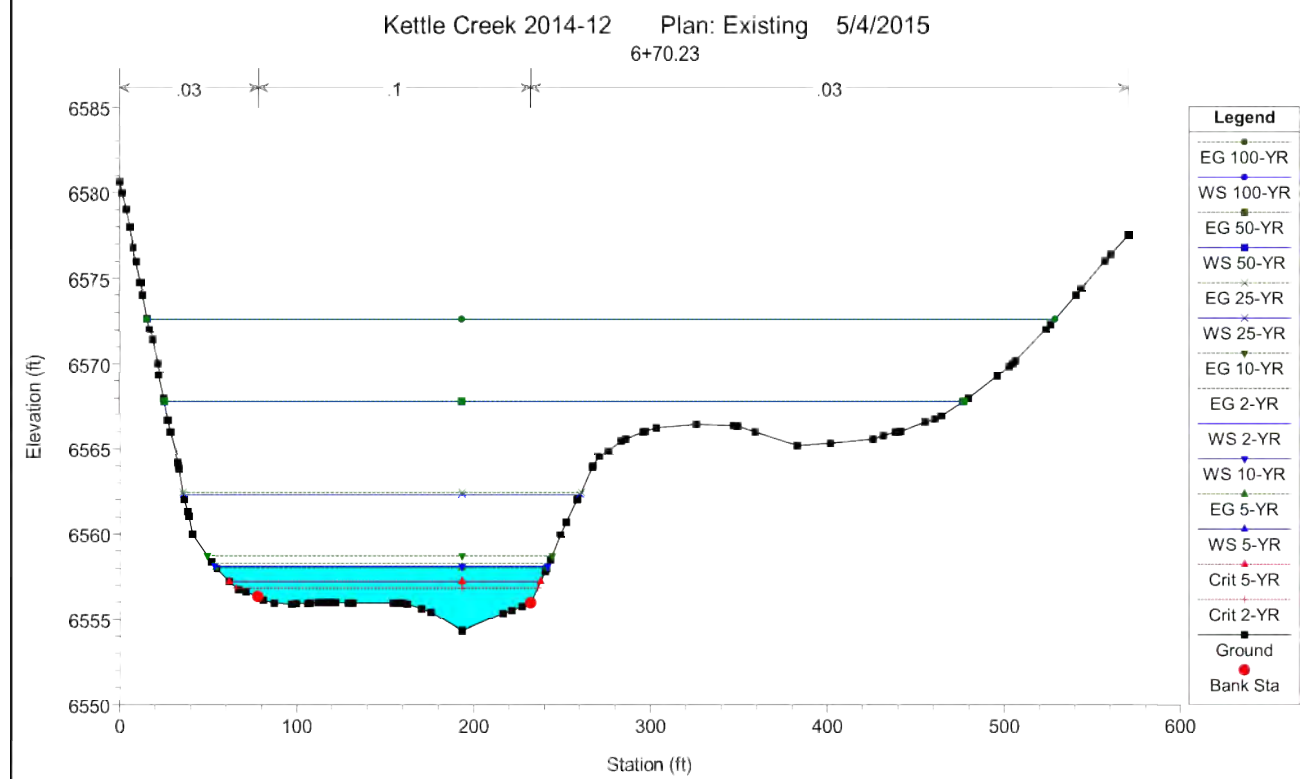
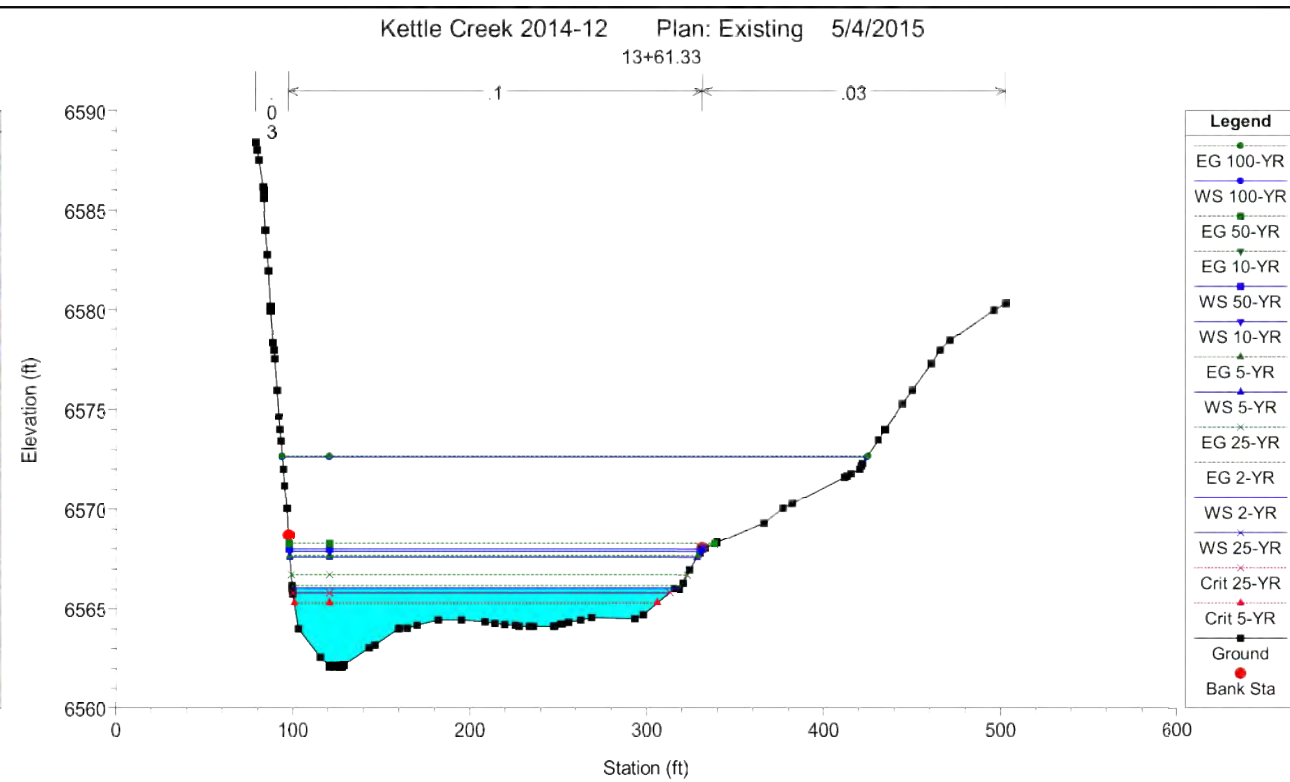
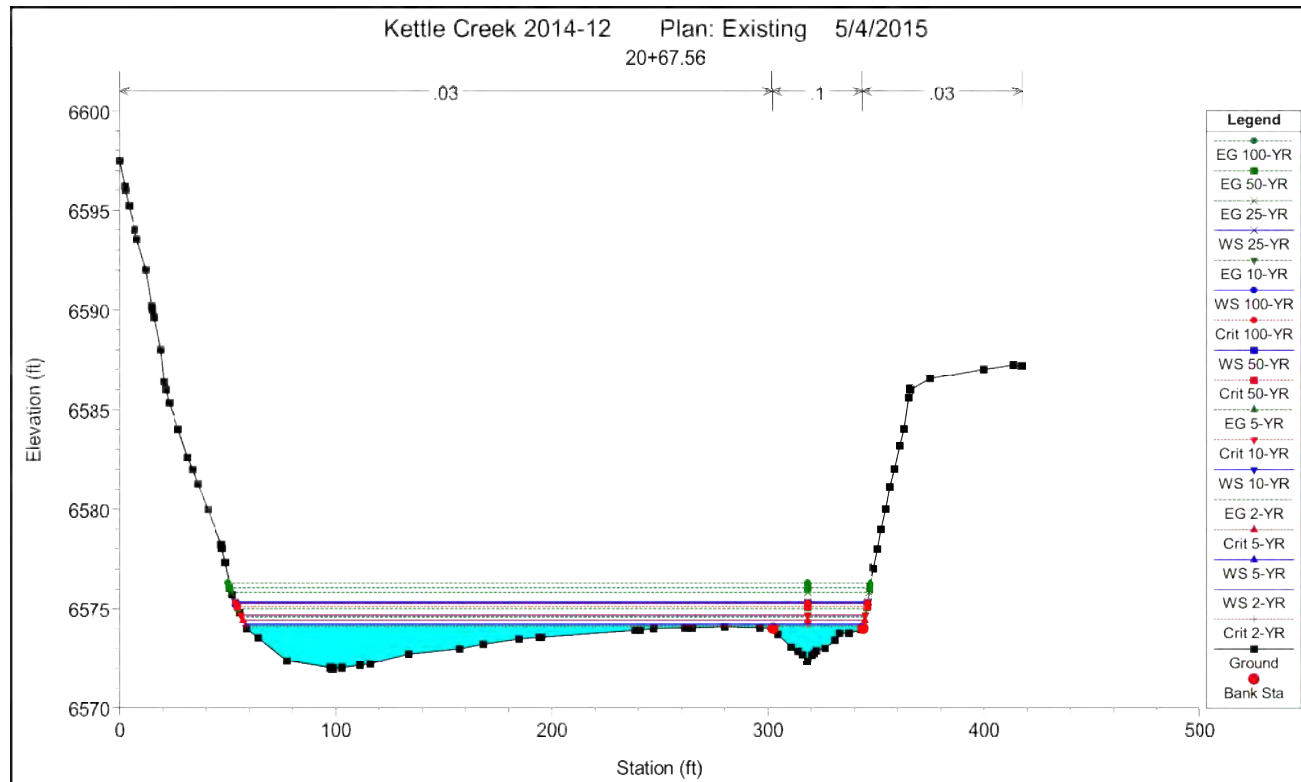

EXISTING CONDITIONS
MODEL RESULTS

HYDRAULIC RESULTS –
EXISTING
KETTLE CREEK DBPS
JOB NO. 25100.00
MAY 2015
C-56



HEC-RAS Plan: Future River: Kettle Creek Reach: Kettle Creek

Reach	River Sta	Profile	Q Total (cfs)	Min Ch El (ft)	W.S. Elev (ft)	Crit W.S. (ft)	E.G. Elev (ft)	E.G. Slope (ft/ft)	Vel Chnl (ft/s)	Flow Area (sq ft)	Top Width (ft)	Froude # Chl
Kettle Creek	24855.28	2-YR	1122.90	6868.95	6873.06		6873.58	0.030051	5.76	195.11	82.02	0.65
Kettle Creek	24855.28	5-YR	1711.40	6868.95	6873.81	6873.05	6874.48	0.029613	6.61	258.80	88.95	0.67
Kettle Creek	24855.28	10-YR	2258.20	6868.95	6874.45	6873.58	6875.24	0.026325	7.10	317.83	92.16	0.66
Kettle Creek	24855.28	25-YR	2725.50	6868.95	6874.94	6873.98	6875.82	0.024772	7.49	363.14	93.79	0.65
Kettle Creek	24855.28	50-YR	3471.20	6868.95	6875.75	6874.52	6876.72	0.021342	7.83	440.39	96.58	0.62
Kettle Creek	24855.28	100-YR	3992.10	6868.95	6876.25		6877.29	0.020000	8.09	489.10	98.23	0.61
Kettle Creek	23762.63	2-YR	1146.00	6855.75	6861.45		6861.60	0.005625	2.60	409.41	124.38	0.24
Kettle Creek	23762.63	5-YR	1747.20	6855.75	6862.37		6862.59	0.005586	3.02	525.84	128.59	0.25
Kettle Creek	23762.63	10-YR	2306.30	6855.75	6863.00		6863.30	0.005915	3.39	608.09	130.75	0.26
Kettle Creek	23762.63	25-YR	2784.30	6855.75	6863.49		6863.86	0.006102	3.66	673.23	132.72	0.27
Kettle Creek	23762.63	50-YR	3543.00	6855.75	6864.09		6864.57	0.006741	4.11	753.38	134.99	0.29
Kettle Creek	23762.63	100-YR	4072.10	6855.75	6864.48		6865.04	0.007096	4.39	805.38	136.33	0.30
Kettle Creek	22613.19	2-YR	1146.00	6839.60	6844.55		6845.35	0.081202	7.16	160.15	71.42	0.84
Kettle Creek	22613.19	5-YR	1747.20	6839.60	6845.42	6845.11	6846.26	0.086001	7.35	237.56	106.79	0.87
Kettle Creek	22613.19	10-YR	2306.30	6839.60	6846.03	6845.68	6846.89	0.071821	7.44	310.53	126.15	0.81
Kettle Creek	22613.19	25-YR	2784.30	6839.60	6846.39	6846.04	6847.34	0.066562	7.80	356.21	128.00	0.80
Kettle Creek	22613.19	50-YR	3543.00	6839.60	6847.12		6848.10	0.049389	7.78	449.79	131.25	0.72
Kettle Creek	22613.19	100-YR	4072.10	6839.60	6847.56		6848.60	0.043173	7.85	508.54	133.19	0.68
Kettle Creek	21556.31	2-YR	1161.30	6825.98	6833.12		6833.22	0.004278	2.48	461.11	124.93	0.22
Kettle Creek	21556.31	5-YR	1768.70	6825.98	6834.19		6834.34	0.004118	2.84	598.42	131.29	0.22
Kettle Creek	21556.31	10-YR	2333.30	6825.98	6834.96		6835.15	0.004204	3.14	700.85	136.27	0.23
Kettle Creek	21556.31	25-YR	2815.70	6825.98	6835.56		6835.80	0.004177	3.34	784.83	140.22	0.23
Kettle Creek	21556.31	50-YR	3581.10	6825.98	6836.26		6836.57	0.004527	3.72	884.84	145.93	0.24
Kettle Creek	21556.31	100-YR	4114.60	6825.98	6836.71		6837.06	0.004721	3.96	950.73	150.63	0.25
Kettle Creek	20822.88	2-YR	1161.30	6817.21	6822.51	6822.11	6822.84	0.028241	3.63	303.24	171.42	0.48
Kettle Creek	20822.88	5-YR	1768.70	6817.21	6823.13		6823.51	0.025390	4.10	412.37	179.43	0.48
Kettle Creek	20822.88	10-YR	2333.30	6817.21	6823.79		6824.16	0.020564	4.21	532.50	190.41	0.44
Kettle Creek	20822.88	25-YR	2815.70	6817.21	6824.44		6824.79	0.017615	4.03	670.86	229.14	0.41
Kettle Creek	20822.88	50-YR	3581.10	6817.21	6825.20		6825.53	0.013351	4.09	846.03	233.42	0.38
Kettle Creek	20822.88	100-YR	4114.60	6817.21	6825.72		6826.04	0.011361	4.12	967.36	236.32	0.35
Kettle Creek	19882.53	2-YR	1156.70	6805.92	6813.25		6813.36	0.002271	2.06	492.35	116.30	0.16
Kettle Creek	19882.53	5-YR	1760.90	6805.92	6814.66		6814.81	0.001906	2.22	661.74	124.04	0.15
Kettle Creek	19882.53	10-YR	2323.10	6805.92	6815.67		6815.86	0.001816	2.39	789.74	129.46	0.15
Kettle Creek	19882.53	25-YR	2805.10	6805.92	6816.38		6816.61	0.001811	2.54	883.45	133.21	0.16

FUTURE CONDITIONS
MODEL RESULTS

HYDRAULIC RESULTS –
FUTURE
KETTLE CREEK DBPS
JOB NO. 25100.00
MAY 2015
C-57



HEC-RAS Plan: Future River: Kettle Creek Reach: Kettle Creek (Continued)

Reach	River Sta	Profile	Q Total (cfs)	Min Ch El (ft)	W.S. Elev (ft)	Crit W.S. (ft)	E.G. Elev (ft)	E.G. Slope (ft/ft)	Vel Chnl (ft/s)	Flow Area (sq ft)	Top Width (ft)	Froude # Chl
Kettle Creek	19882.53	50-YR	3570.80	6805.92	6817.34		6817.63	0.001841	2.75	1014.40	138.15	0.16
Kettle Creek	19882.53	100-YR	4104.90	6805.92	6817.93		6818.26	0.001879	2.90	1096.30	141.38	0.16
Kettle Creek	19115.6	2-YR	1162.10	6798.52	6804.50		6804.58	0.002183	2.08	512.13	143.23	0.16
Kettle Creek	19115.6	5-YR	1768.50	6798.52	6805.91		6806.01	0.001539	2.05	746.39	185.26	0.14
Kettle Creek	19115.6	10-YR	2332.00	6798.52	6806.88		6806.99	0.001267	2.04	947.51	217.51	0.13
Kettle Creek	19115.6	25-YR	2813.20	6798.52	6807.55		6807.67	0.001117	2.03	1095.71	227.11	0.12
Kettle Creek	19115.6	50-YR	3576.10	6798.52	6808.47		6808.62	0.000969	2.03	1311.58	238.34	0.12
Kettle Creek	19115.6	100-YR	4108.00	6798.52	6809.06		6809.22	0.000901	2.04	1452.78	245.24	0.11
Kettle Creek	18505.62	2-YR	1162.10	6788.84	6794.63		6794.90	0.004982	3.09	323.14	74.60	0.24
Kettle Creek	18505.62	5-YR	1768.50	6788.84	6795.84		6796.24	0.004888	3.53	415.61	78.31	0.25
Kettle Creek	18505.62	10-YR	2332.00	6788.84	6796.80		6797.32	0.004790	3.85	492.77	81.52	0.25
Kettle Creek	18505.62	25-YR	2813.20	6788.84	6797.54		6798.13	0.004733	4.08	553.41	84.02	0.25
Kettle Creek	18505.62	50-YR	3576.10	6788.84	6798.57		6799.29	0.004665	4.39	642.26	87.33	0.26
Kettle Creek	18505.62	100-YR	4108.00	6788.84	6799.23		6800.02	0.004631	4.58	700.30	89.57	0.26
Kettle Creek	17970.84	2-YR	1162.10	6783.01	6787.21		6787.71	0.018099	4.75	222.12	74.89	0.44
Kettle Creek	17970.84	5-YR	1768.50	6783.01	6788.16		6788.82	0.016152	5.22	297.05	84.92	0.43
Kettle Creek	17970.84	10-YR	2332.00	6783.01	6788.79		6789.68	0.015410	5.56	352.22	88.06	0.43
Kettle Creek	17970.84	25-YR	2813.20	6783.01	6789.26		6790.34	0.015057	5.82	393.89	89.72	0.43
Kettle Creek	17970.84	50-YR	3576.10	6783.01	6789.92		6791.30	0.014768	6.19	453.59	91.93	0.43
Kettle Creek	17970.84	100-YR	4108.00	6783.01	6790.34		6791.91	0.014651	6.44	492.08	93.36	0.44
Kettle Creek	17128.69	2-YR	1162.10	6771.75	6776.95		6777.16	0.009159	3.48	322.58	90.49	0.31
Kettle Creek	17128.69	5-YR	1768.50	6771.75	6777.78		6778.13	0.010250	4.18	399.60	94.30	0.34
Kettle Creek	17128.69	10-YR	2332.00	6771.75	6778.45		6778.92	0.010739	4.68	464.22	97.26	0.35
Kettle Creek	17128.69	25-YR	2813.20	6771.75	6778.97		6779.53	0.011028	5.04	514.76	99.52	0.36
Kettle Creek	17128.69	50-YR	3576.10	6771.75	6779.71		6780.43	0.011275	5.51	589.75	103.05	0.38
Kettle Creek	17128.69	100-YR	4108.00	6771.75	6780.17		6781.00	0.011409	5.80	638.23	105.33	0.38
Kettle Creek	16326.64	2-YR	1162.10	6761.71	6768.11		6768.35	0.013462	3.91	294.50	107.87	0.37
Kettle Creek	16326.64	5-YR	1768.50	6761.71	6768.98		6769.33	0.011883	4.28	389.99	110.49	0.36
Kettle Creek	16326.64	10-YR	2332.00	6761.71	6769.62		6770.09	0.011431	4.60	461.03	112.47	0.36
Kettle Creek	16326.64	25-YR	2813.20	6761.71	6770.10		6770.68	0.011211	4.84	515.32	114.01	0.37
Kettle Creek	16326.64	50-YR	3576.10	6761.71	6770.76		6771.52	0.011127	5.21	591.61	116.43	0.37
Kettle Creek	16326.64	100-YR	4108.00	6761.71	6771.18		6772.06	0.011089	5.43	640.82	117.96	0.38
Kettle Creek	15906.34	2-YR	1162.10	6753.98	6761.81	6760.00	6762.22	0.016165	4.96	228.66	65.69	0.41

FUTURE CONDITIONS
MODEL RESULTS (CONT.)

HYDRAULIC RESULTS –
FUTURE
KETTLE CREEK DBPS
JOB NO. 25100.00
MAY 2015
C-58



HEC-RAS Plan: Future River: Kettle Creek Reach: Kettle Creek (Continued)

Reach	River Sta	Profile	Q Total (cfs)	Min Ch El (ft)	W.S. Elev (ft)	Crit W.S. (ft)	E.G. Elev (ft)	E.G. Slope (ft/ft)	Vel Chnl (ft/s)	Flow Area (sq ft)	Top Width (ft)	Froude # Chl
Kettle Creek	15906.34	5-YR	1768.50	6753.98	6762.59	6760.95	6763.23	0.018583	5.91	283.83	76.21	0.45
Kettle Creek	15906.34	10-YR	2332.00	6753.98	6763.19	6761.62	6764.04	0.019388	6.48	332.11	84.68	0.47
Kettle Creek	15906.34	25-YR	2813.20	6753.98	6763.61	6762.13	6764.63	0.020032	6.89	369.39	91.04	0.48
Kettle Creek	15906.34	50-YR	3576.10	6753.98	6764.21	6762.98	6765.50	0.020185	7.35	426.16	98.89	0.49
Kettle Creek	15906.34	100-YR	4108.00	6753.98	6764.57	6763.57	6766.07	0.020080	7.58	462.59	102.44	0.49
Kettle Creek	15906	Bridge										
Kettle Creek	15683.73	2-YR	1162.10	6751.41	6757.65	6757.65	6758.97	0.062284	8.84	127.42	52.00	0.76
Kettle Creek	15683.73	5-YR	1768.50	6751.41	6758.47	6758.47	6760.24	0.051052	9.02	174.61	62.77	0.71
Kettle Creek	15683.73	10-YR	2332.00	6751.41	6759.40	6759.40	6761.23	0.031305	7.92	238.38	74.49	0.57
Kettle Creek	15683.73	25-YR	2813.20	6751.41	6760.00	6760.00	6761.92	0.025215	7.58	285.62	82.60	0.52
Kettle Creek	15683.73	50-YR	3576.10	6751.41	6760.95	6760.95	6762.84	0.017924	7.00	372.29	100.95	0.45
Kettle Creek	15683.73	100-YR	4108.00	6751.41	6761.39	6761.39	6763.36	0.016342	6.94	417.81	106.24	0.44
Kettle Creek	15530.88	2-YR	1162.10	6749.40	6754.41		6754.52	0.005714	2.70	430.31	118.62	0.25
Kettle Creek	15530.88	5-YR	1768.50	6749.40	6755.34		6755.50	0.006164	3.25	543.79	125.81	0.26
Kettle Creek	15530.88	10-YR	2332.00	6749.40	6756.06		6756.27	0.006382	3.64	636.51	130.42	0.28
Kettle Creek	15530.88	25-YR	2813.20	6749.40	6756.61		6756.86	0.006514	3.92	710.09	136.44	0.28
Kettle Creek	15530.88	50-YR	3576.10	6749.40	6757.38		6757.68	0.006649	4.29	817.28	144.28	0.29
Kettle Creek	15530.88	100-YR	4108.00	6749.40	6757.85		6758.20	0.006684	4.51	887.48	148.78	0.30
Kettle Creek	14906.12	2-YR	1162.10	6742.04	6748.26		6748.78	0.017584	5.45	203.29	73.80	0.44
Kettle Creek	14906.12	5-YR	1768.50	6742.04	6749.15		6749.87	0.015056	5.65	274.74	86.04	0.42
Kettle Creek	14906.12	10-YR	2332.00	6742.04	6749.78		6750.66	0.014256	5.89	331.66	95.99	0.41
Kettle Creek	14906.12	25-YR	2813.20	6742.04	6750.22		6751.24	0.013937	6.09	374.89	102.48	0.41
Kettle Creek	14906.12	50-YR	3576.10	6742.04	6750.78		6752.06	0.013629	6.35	434.46	107.98	0.41
Kettle Creek	14906.12	100-YR	4108.00	6742.04	6751.13		6752.58	0.013506	6.52	472.21	110.73	0.41
Kettle Creek	14354.72	2-YR	1162.10	6734.36	6742.31		6742.51	0.007755	3.64	318.40	80.32	0.29
Kettle Creek	14354.72	5-YR	1768.50	6734.36	6743.25		6743.56	0.008711	4.34	397.64	88.72	0.32
Kettle Creek	14354.72	10-YR	2332.00	6734.36	6744.00		6744.41	0.008891	4.77	467.43	95.39	0.33
Kettle Creek	14354.72	25-YR	2813.20	6734.36	6744.60		6745.08	0.008780	5.02	525.99	101.14	0.33
Kettle Creek	14354.72	50-YR	3576.10	6734.36	6745.44		6746.02	0.008495	5.33	614.46	109.34	0.33
Kettle Creek	14354.72	100-YR	4108.00	6734.36	6745.96		6746.62	0.008289	5.49	673.11	114.34	0.33
Kettle Creek	13757.33	2-YR	1162.10	6727.92	6734.01	6733.16	6734.65	0.026612	6.18	182.11	69.92	0.51
Kettle Creek	13757.33	5-YR	1768.50	6727.92	6734.91	6734.01	6735.82	0.020840	6.18	248.74	77.07	0.47
Kettle Creek	13757.33	10-YR	2332.00	6727.92	6735.49	6734.51	6736.69	0.020009	6.48	294.78	81.64	0.47

FUTURE CONDITIONS
MODEL RESULTS (CONT.)

HYDRAULIC RESULTS –
FUTURE
KETTLE CREEK DBPS
JOB NO. 25100.00
MAY 2015
C-59



HEC-RAS Plan: Future River: Kettle Creek Reach: Kettle Creek (Continued)

Reach	River Sta	Profile	Q Total (cfs)	Min Ch El (ft)	W.S. Elev (ft)	Crit W.S. (ft)	E.G. Elev (ft)	E.G. Slope (ft/ft)	Vel Chnl (ft/s)	Flow Area (sq ft)	Top Width (ft)	Froude # Chl
Kettle Creek	13757.33	25-YR	2813.20	6727.92	6735.88	6735.07	6737.34	0.020406	6.82	326.61	84.68	0.48
Kettle Creek	13757.33	50-YR	3576.10	6727.92	6736.39	6735.98	6738.27	0.021336	7.34	370.62	88.66	0.49
Kettle Creek	13757.33	100-YR	4108.00	6727.92	6736.70	6736.51	6738.88	0.021941	7.67	398.71	91.11	0.50
Kettle Creek	12367.83	2-YR	1162.10	6708.58	6713.98		6714.21	0.009228	3.77	306.07	76.03	0.31
Kettle Creek	12367.83	5-YR	1768.50	6708.58	6714.89		6715.24	0.010921	4.63	376.48	78.55	0.35
Kettle Creek	12367.83	10-YR	2332.00	6708.58	6715.71		6716.16	0.011163	5.15	441.88	81.26	0.37
Kettle Creek	12367.83	25-YR	2813.20	6708.58	6716.42		6716.93	0.010844	5.46	500.93	86.58	0.37
Kettle Creek	12367.83	50-YR	3576.10	6708.58	6717.40		6718.01	0.010303	5.82	591.62	96.32	0.37
Kettle Creek	12367.83	100-YR	4108.00	6708.58	6717.99		6718.66	0.010011	6.02	648.70	99.45	0.36
Kettle Creek	11267.11	2-YR	1162.10	6695.53	6702.99		6703.50	0.010289	4.31	225.73	68.68	0.34
Kettle Creek	11267.11	5-YR	1768.50	6695.53	6704.09		6704.80	0.008310	4.41	305.72	76.74	0.31
Kettle Creek	11267.11	10-YR	2332.00	6695.53	6704.81		6705.72	0.008140	4.69	363.12	83.07	0.31
Kettle Creek	11267.11	25-YR	2813.20	6695.53	6705.26		6706.35	0.008537	5.01	401.75	87.53	0.32
Kettle Creek	11267.11	50-YR	3576.10	6695.53	6705.85		6707.23	0.009219	5.48	455.63	93.46	0.34
Kettle Creek	11267.11	100-YR	4108.00	6695.53	6706.22		6707.78	0.009624	5.77	489.95	96.39	0.35
Kettle Creek	10087.38	2-YR	1157.20	6680.77	6687.99		6688.18	0.002147	2.40	373.99	89.12	0.17
Kettle Creek	10087.38	5-YR	1762.50	6680.77	6689.13		6689.42	0.002103	2.64	477.70	92.08	0.17
Kettle Creek	10087.38	10-YR	2325.70	6680.77	6690.10	6686.62	6690.46	0.002009	2.79	567.65	94.62	0.17
Kettle Creek	10087.38	25-YR	2807.30	6680.77	6690.91	6687.15	6691.32	0.001883	2.87	645.74	96.92	0.16
Kettle Creek	10087.38	50-YR	3571.30	6680.77	6692.13	6687.76	6692.60	0.001714	2.97	765.78	100.40	0.16
Kettle Creek	10087.38	100-YR	4104.30	6680.77	6692.93	6688.12	6693.44	0.001621	3.03	846.59	102.65	0.16
Kettle Creek	9732.32	2-YR	1157.20	6676.00	6681.18		6681.79	0.036988	6.25	185.55	61.02	0.61
Kettle Creek	9732.32	5-YR	1762.50	6676.00	6681.53		6682.65	0.060140	8.52	207.94	66.89	0.79
Kettle Creek	9732.32	10-YR	2325.70	6676.00	6681.84	6681.84	6683.44	0.077089	10.19	229.33	70.83	0.90
Kettle Creek	9732.32	25-YR	2807.30	6676.00	6682.26	6682.26	6684.08	0.075478	10.77	259.55	74.53	0.91
Kettle Creek	9732.32	50-YR	3571.30	6676.00	6682.83	6682.83	6685.03	0.072678	11.48	303.45	78.25	0.91
Kettle Creek	9732.32	100-YR	4104.30	6676.00	6683.23	6683.23	6685.67	0.068874	11.76	334.86	80.79	0.90
Kettle Creek	8444.97	2-YR	1212.60	6660.69	6666.73		6666.99	0.005652	3.26	322.23	103.71	0.25
Kettle Creek	8444.97	5-YR	1839.30	6660.69	6667.75		6668.11	0.004677	3.34	431.54	112.58	0.24
Kettle Creek	8444.97	10-YR	2420.50	6660.69	6668.59		6669.02	0.004022	3.38	529.84	120.74	0.23
Kettle Creek	8444.97	25-YR	2917.30	6660.69	6669.21		6669.69	0.003708	3.43	606.06	126.24	0.22
Kettle Creek	8444.97	50-YR	3703.70	6660.69	6670.13		6670.67	0.003271	3.48	725.82	134.19	0.21
Kettle Creek	8444.97	100-YR	4252.40	6660.69	6670.65		6671.25	0.003153	3.55	796.20	137.79	0.21

FUTURE CONDITIONS
MODEL RESULTS (CONT.)

HYDRAULIC RESULTS –
FUTURE
KETTLE CREEK DBPS
JOB NO. 25100.00
MAY 2015
C-60



HEC-RAS Plan: Future River: Kettle Creek Reach: Kettle Creek (Continued)

Reach	River Sta	Profile	Q Total (cfs)	Min Ch El (ft)	W.S. Elev (ft)	Crit W.S. (ft)	E.G. Elev (ft)	E.G. Slope (ft/ft)	Vel Chnl (ft/s)	Flow Area (sq ft)	Top Width (ft)	Froude # Chl
Kettle Creek	8350	2-YR	1212.60	6660.00	6666.34		6666.59	0.003197	2.72	359.77	98.32	0.20
Kettle Creek	8350	5-YR	1839.30	6660.00	6667.42		6667.75	0.003009	2.95	470.25	107.11	0.20
Kettle Creek	8350	10-YR	2420.50	6660.00	6668.29		6668.69	0.002973	3.17	568.40	125.14	0.20
Kettle Creek	8350	25-YR	2917.30	6660.00	6668.95		6669.37	0.002784	3.24	654.62	135.05	0.20
Kettle Creek	8350	50-YR	3703.70	6660.00	6669.92		6670.38	0.002461	3.27	793.46	148.64	0.19
Kettle Creek	8350	100-YR	4252.40	6660.00	6670.47		6670.96	0.002371	3.33	876.15	155.16	0.19
Kettle Creek	8251.39	2-YR	1212.60	6660.00	6665.61	6663.66	6665.99	0.010287	4.18	262.21	73.53	0.34
Kettle Creek	8251.39	5-YR	1839.30	6660.00	6666.58	6664.52	6667.14	0.010163	4.72	337.74	81.58	0.35
Kettle Creek	8251.39	10-YR	2420.50	6660.00	6667.37	6665.25	6668.06	0.009665	5.02	404.33	87.96	0.35
Kettle Creek	8251.39	25-YR	2917.30	6660.00	6667.93	6665.79	6668.75	0.009410	5.24	455.44	92.02	0.35
Kettle Creek	8251.39	50-YR	3703.70	6660.00	6668.93	6666.56	6669.80	0.008802	5.54	559.90	124.18	0.35
Kettle Creek	8251.39	100-YR	4252.40	6660.00	6669.52	6667.09	6670.41	0.007862	5.49	636.19	136.64	0.33
Kettle Creek	8251		Bridge									
Kettle Creek	8060.94	2-YR	1212.60	6653.57	6658.77	6658.25	6659.84	0.014912	5.24	169.73	50.19	0.42
Kettle Creek	8060.94	5-YR	1839.30	6653.57	6659.62	6659.37	6661.12	0.016483	6.13	215.06	56.94	0.45
Kettle Creek	8060.94	10-YR	2420.50	6653.57	6660.24	6660.11	6662.11	0.017474	6.75	251.86	61.77	0.47
Kettle Creek	8060.94	25-YR	2917.30	6653.57	6660.89	6660.89	6662.80	0.016738	7.05	295.27	72.14	0.47
Kettle Creek	8060.94	50-YR	3703.70	6653.57	6661.73	6661.73	6663.75	0.015425	7.30	361.45	98.48	0.46
Kettle Creek	8060.94	100-YR	4252.40	6653.57	6662.64	6662.64	6664.23	0.011479	6.77	470.96	130.17	0.40
Kettle Creek	7863.13	2-YR	1212.60	6649.24	6652.92	6652.79	6654.22	0.066748	8.28	138.55	52.40	0.82
Kettle Creek	7863.13	5-YR	1839.30	6649.24	6653.85	6653.74	6655.57	0.053024	8.75	189.91	57.65	0.76
Kettle Creek	7863.13	10-YR	2420.50	6649.24	6654.56	6654.56	6656.62	0.046704	9.14	232.52	62.08	0.73
Kettle Creek	7863.13	25-YR	2917.30	6649.24	6655.23	6655.23	6657.41	0.038665	9.06	275.46	66.44	0.68
Kettle Creek	7863.13	50-YR	3703.70	6649.24	6656.02	6656.02	6658.46	0.034771	9.40	330.34	72.99	0.66
Kettle Creek	7863.13	100-YR	4252.40	6649.24	6656.55	6656.55	6659.16	0.031597	9.45	369.45	76.47	0.64
Kettle Creek	7632.03	2-YR	1212.60	6641.32	6649.12		6649.40	0.009234	4.18	288.04	62.95	0.32
Kettle Creek	7632.03	5-YR	1839.30	6641.32	6650.21		6650.63	0.010320	5.02	359.61	68.84	0.35
Kettle Creek	7632.03	10-YR	2420.50	6641.32	6651.01		6651.55	0.011123	5.65	416.60	74.61	0.37
Kettle Creek	7632.03	25-YR	2917.30	6641.32	6651.54		6652.20	0.011931	6.14	457.56	78.59	0.39
Kettle Creek	7632.03	50-YR	3703.70	6641.32	6652.21		6653.07	0.013350	6.87	511.87	83.46	0.42
Kettle Creek	7632.03	100-YR	4252.40	6641.32	6652.60		6653.61	0.014318	7.34	544.75	85.73	0.44
Kettle Creek	6688.3	2-YR	1218.70	6629.79	6635.78		6636.10	0.024002	4.51	269.96	96.75	0.48
Kettle Creek	6688.3	5-YR	1845.30	6629.79	6636.87		6637.22	0.020600	4.80	384.72	113.89	0.46

FUTURE CONDITIONS
MODEL RESULTS (CONT.)

HYDRAULIC RESULTS –
FUTURE
KETTLE CREEK DBPS
JOB NO. 25100.00
MAY 2015
C-61



Centennial 303-740-9393 • Colorado Springs 719-593-2593
Fort Collins 970-491-9888 • www.jrengineering.com

HEC-RAS Plan: Future River: Kettle Creek Reach: Kettle Creek (Continued)

Reach	River Sta	Profile	Q Total (cfs)	Min Ch El (ft)	W.S. Elev (ft)	Crit W.S. (ft)	E.G. Elev (ft)	E.G. Slope (ft/ft)	Vel Chnl (ft/s)	Flow Area (sq ft)	Top Width (ft)	Froude # Chl
Kettle Creek	6688.3	10-YR	2426.00	6629.79	6637.70		6638.09	0.018731	5.00	484.45	126.63	0.45
Kettle Creek	6688.3	25-YR	2920.90	6629.79	6638.30		6638.72	0.017171	5.17	563.61	135.32	0.44
Kettle Creek	6688.3	50-YR	3704.50	6629.79	6639.13		6639.59	0.014998	5.43	680.47	146.23	0.42
Kettle Creek	6688.3	100-YR	4250.10	6629.79	6639.66		6640.15	0.013840	5.56	759.57	153.27	0.41
Kettle Creek	6433.61	2-YR	1218.70	6627.42	6633.50		6633.63	0.005028	2.92	417.66	98.42	0.24
Kettle Creek	6433.61	5-YR	1845.30	6627.42	6634.61		6634.80	0.005265	3.45	529.85	103.80	0.25
Kettle Creek	6433.61	10-YR	2426.00	6627.42	6635.46		6635.71	0.005386	3.82	620.92	108.75	0.26
Kettle Creek	6433.61	25-YR	2920.90	6627.42	6636.11		6636.40	0.005444	4.09	692.70	113.10	0.27
Kettle Creek	6433.61	50-YR	3704.50	6627.42	6637.03		6637.38	0.005470	4.44	799.75	120.54	0.27
Kettle Creek	6433.61	100-YR	4250.10	6627.42	6637.61		6638.01	0.005426	4.63	871.92	125.59	0.28
Kettle Creek	6305.69	2-YR	1218.70	6625.87	6631.47		6631.66	0.009936	3.47	351.31	99.32	0.32
Kettle Creek	6305.69	5-YR	1845.30	6625.87	6632.70		6632.92	0.008284	3.84	480.43	111.76	0.31
Kettle Creek	6305.69	10-YR	2426.00	6625.87	6633.65		6633.91	0.007272	4.06	591.85	121.19	0.30
Kettle Creek	6305.69	25-YR	2920.90	6625.87	6634.38		6634.67	0.006612	4.19	683.20	129.62	0.29
Kettle Creek	6305.69	50-YR	3704.50	6625.87	6635.42		6635.74	0.005771	4.31	824.99	143.90	0.28
Kettle Creek	6305.69	100-YR	4250.10	6625.87	6636.09		6636.44	0.005302	4.37	925.02	160.54	0.27
Kettle Creek	6147.73	2-YR	1218.70	6623.99	6630.68		6630.84	0.003134	2.42	448.35	103.51	0.19
Kettle Creek	6147.73	5-YR	1845.30	6623.99	6631.99		6632.20	0.002890	2.71	586.91	109.72	0.19
Kettle Creek	6147.73	10-YR	2426.00	6623.99	6632.98		6633.24	0.002775	2.93	698.44	114.31	0.19
Kettle Creek	6147.73	25-YR	2920.90	6623.99	6633.73		6634.03	0.002720	3.09	784.87	117.87	0.19
Kettle Creek	6147.73	50-YR	3704.50	6623.99	6634.77		6635.14	0.002658	3.32	911.12	122.83	0.19
Kettle Creek	6147.73	100-YR	4250.10	6623.99	6635.46		6635.86	0.002605	3.45	996.03	126.29	0.19
Kettle Creek	6032.86	2-YR	1218.70	6622.67	6628.53	6625.86	6628.74	0.003565	2.58	393.28	97.75	0.20
Kettle Creek	6032.86	5-YR	1845.30	6622.67	6629.63	6626.38	6629.93	0.003531	2.93	503.31	104.00	0.21
Kettle Creek	6032.86	10-YR	2426.00	6622.67	6630.52	6626.97	6630.89	0.003392	3.15	598.39	108.45	0.21
Kettle Creek	6032.86	25-YR	2920.90	6622.67	6631.18	6627.51	6631.61	0.003345	3.32	670.54	111.44	0.21
Kettle Creek	6032.86	50-YR	3704.50	6622.67	6632.14	6628.24	6632.65	0.003261	3.55	780.34	116.68	0.21
Kettle Creek	6032.86	100-YR	4250.10	6622.67	6632.83	6628.74	6633.40	0.003047	3.61	862.28	118.83	0.21
Kettle Creek	6000		Bridge									
Kettle Creek	5983.2	2-YR	1218.70	6622.04	6628.35		6628.51	0.001911	2.00	443.10	119.02	0.15
Kettle Creek	5983.2	5-YR	1845.30	6622.04	6629.41		6629.64	0.001781	2.18	572.01	124.02	0.15
Kettle Creek	5983.2	10-YR	2426.00	6622.04	6630.29		6630.57	0.001709	2.32	684.48	131.35	0.15
Kettle Creek	5983.2	25-YR	2920.90	6622.04	6630.93		6631.25	0.001650	2.41	768.79	133.29	0.15

FUTURE CONDITIONS
MODEL RESULTS (CONT.)

HYDRAULIC RESULTS –
FUTURE
KETTLE CREEK DBPS
JOB NO. 25100.00
MAY 2015
C-62



HEC-RAS Plan: Future River: Kettle Creek Reach: Kettle Creek (Continued)

Reach	River Sta	Profile	Q Total (cfs)	Min Ch El (ft)	W.S. Elev (ft)	Crit W.S. (ft)	E.G. Elev (ft)	E.G. Slope (ft/ft)	Vel Chnl (ft/s)	Flow Area (sq ft)	Top Width (ft)	Froude # Chl
Kettle Creek	5983.2	50-YR	3704.50	6622.04	6631.86		6632.24	0.001580	2.54	893.71	136.21	0.15
Kettle Creek	5983.2	100-YR	4250.10	6622.04	6632.56		6632.96	0.001608	2.69	993.52	149.95	0.15
Kettle Creek	5846.46	2-YR	1218.70	6620.39	6624.45		6625.18	0.053734	6.86	177.92	65.73	0.72
Kettle Creek	5846.46	5-YR	1845.30	6620.39	6625.37		6626.28	0.045954	7.64	241.02	72.17	0.69
Kettle Creek	5846.46	10-YR	2426.00	6620.39	6626.08		6627.15	0.041223	8.13	294.40	77.01	0.68
Kettle Creek	5846.46	25-YR	2920.90	6620.39	6626.63		6627.81	0.038242	8.45	337.82	82.20	0.67
Kettle Creek	5846.46	50-YR	3704.50	6620.39	6627.38		6628.76	0.034749	8.84	402.26	89.22	0.65
Kettle Creek	5846.46	100-YR	4250.10	6620.39	6627.88		6629.37	0.032056	8.98	448.18	93.90	0.63
Kettle Creek	5366.46	2-YR	1218.70	6612.16	6619.34	6616.52	6619.50	0.004844	2.90	399.43	96.85	0.23
Kettle Creek	5366.46	5-YR	1845.30	6612.16	6620.41	6617.23	6620.65	0.004999	3.37	504.47	100.90	0.25
Kettle Creek	5366.46	10-YR	2426.00	6612.16	6621.22	6617.77	6621.54	0.005132	3.73	587.88	104.19	0.26
Kettle Creek	5366.46	25-YR	2920.90	6612.16	6621.83	6618.11	6622.22	0.005231	3.99	651.73	106.37	0.26
Kettle Creek	5366.46	50-YR	3704.50	6612.16	6622.71	6618.64	6623.19	0.005346	4.36	747.43	111.08	0.27
Kettle Creek	5366.46	100-YR	4250.10	6612.16	6623.18	6618.97	6623.74	0.005604	4.63	799.91	113.30	0.28
Kettle Creek	3636.65	2-YR	1218.70	6592.57	6595.31	6595.31	6596.22	0.120579	7.65	159.21	87.62	1.00
Kettle Creek	3636.65	5-YR	1845.30	6592.57	6595.90	6595.90	6597.08	0.111442	8.74	211.31	90.94	1.00
Kettle Creek	3636.65	10-YR	2426.00	6592.57	6596.38	6596.38	6597.78	0.103264	9.47	256.17	93.04	0.99
Kettle Creek	3636.65	25-YR	2920.90	6592.57	6596.76	6596.76	6598.32	0.098063	9.99	291.89	94.55	0.99
Kettle Creek	3636.65	50-YR	3704.50	6592.57	6597.29	6597.29	6599.12	0.092906	10.78	342.49	96.63	0.99
Kettle Creek	3636.65	100-YR	4250.10	6592.57	6597.81	6597.65	6599.64	0.077689	10.75	392.87	98.85	0.92
Kettle Creek	3115.71	2-YR	1218.70	6585.47	6593.11		6593.16	0.000588	1.22	821.09	161.99	0.09
Kettle Creek	3115.71	5-YR	1845.30	6585.47	6594.42		6594.49	0.000612	1.42	1041.29	175.28	0.09
Kettle Creek	3115.71	10-YR	2426.00	6585.47	6595.43		6595.51	0.000629	1.56	1223.68	188.39	0.09
Kettle Creek	3115.71	25-YR	2920.90	6585.47	6596.17		6596.27	0.000629	1.65	1366.27	195.03	0.10
Kettle Creek	3115.71	50-YR	3704.50	6585.47	6597.23		6597.35	0.000631	1.78	1578.29	206.86	0.10
Kettle Creek	3115.71	100-YR	4250.10	6585.47	6597.87		6598.01	0.000642	1.86	1715.04	216.47	0.10
Kettle Creek	2957.59	2-YR	1218.70	6582.74	6592.49	6589.37	6592.84	0.003655	3.76	266.46	71.30	0.22
Kettle Creek	2957.59	5-YR	1845.30	6582.74	6593.67	6591.33	6594.14	0.003299	3.88	355.77	79.52	0.21
Kettle Creek	2957.59	10-YR	2426.00	6582.74	6594.57	6591.98	6595.13	0.003125	3.99	429.68	85.44	0.21
Kettle Creek	2957.59	25-YR	2920.90	6582.74	6595.24	6592.53	6595.88	0.003016	4.08	488.52	89.64	0.21
Kettle Creek	2957.59	50-YR	3704.50	6582.74	6596.20	6593.26	6596.93	0.002895	4.21	577.09	96.10	0.21
Kettle Creek	2957.59	100-YR	4250.10	6582.74	6596.77	6593.76	6597.57	0.002863	4.31	632.88	99.70	0.21
Kettle Creek	2850		Bridge									

FUTURE CONDITIONS
MODEL RESULTS (CONT.)

HYDRAULIC RESULTS –
FUTURE
KETTLE CREEK DBPS
JOB NO. 25100.00
MAY 2015
C-63



Centennial 303-740-9393 • Colorado Springs 719-593-2593
Fort Collins 970-491-9888 • www.jrengineering.com

HEC-RAS Plan: Future River: Kettle Creek Reach: Kettle Creek (Continued)

Reach	River Sta	Profile	Q Total (cfs)	Min Ch El (ft)	W.S. Elev (ft)	Crit W.S. (ft)	E.G. Elev (ft)	E.G. Slope (ft/ft)	Vel Chnl (ft/s)	Flow Area (sq ft)	Top Width (ft)	Froude # Chl
Kettle Creek	2731.34	2-YR	1218.70	6579.12	6585.00		6585.83	0.017732	5.83	179.87	52.77	0.45
Kettle Creek	2731.34	5-YR	1845.30	6579.12	6585.63	6584.91	6587.02	0.022646	7.11	214.56	57.32	0.52
Kettle Creek	2731.34	10-YR	2426.00	6579.12	6586.17	6585.92	6588.02	0.024762	7.89	246.98	61.66	0.55
Kettle Creek	2731.34	25-YR	2920.90	6579.12	6587.13	6586.63	6588.85	0.017437	7.27	310.17	70.38	0.47
Kettle Creek	2731.34	50-YR	3704.50	6579.12	6587.57	6587.57	6589.85	0.020784	8.24	341.55	74.67	0.52
Kettle Creek	2731.34	100-YR	4250.10	6579.12	6588.00	6588.00	6590.49	0.020451	8.48	375.09	79.00	0.52
Kettle Creek	2597.25	2-YR	1218.70	6577.88	6582.50	6581.65	6582.76	0.025529	4.01	300.70	142.24	0.47
Kettle Creek	2597.25	5-YR	1845.30	6577.88	6583.19	6582.10	6583.53	0.022457	4.51	400.07	146.81	0.47
Kettle Creek	2597.25	10-YR	2426.00	6577.88	6583.52	6582.44	6584.01	0.026103	5.22	449.94	148.78	0.51
Kettle Creek	2597.25	25-YR	2920.90	6577.88	6582.70	6582.70	6583.95	0.108552	8.76	328.96	143.56	0.99
Kettle Creek	2597.25	50-YR	3704.50	6577.88	6584.15	6583.13	6584.95	0.031990	6.50	544.03	152.22	0.58
Kettle Creek	2597.25	100-YR	4250.10	6577.88	6584.38	6583.38	6585.33	0.034034	6.97	579.17	153.35	0.61
Kettle Creek	2067.56	2-YR	1218.70	6572.37	6574.22	6574.16	6574.60	0.011145	1.49	269.36	285.99	0.27
Kettle Creek	2067.56	5-YR	1845.30	6572.37	6574.43	6574.43	6575.01	0.013128	1.85	329.53	287.17	0.31
Kettle Creek	2067.56	10-YR	2426.00	6572.37	6574.67	6574.65	6575.35	0.012134	2.02	398.40	288.51	0.30
Kettle Creek	2067.56	25-YR	2920.90	6572.37	6575.36		6575.80	0.004652	1.64	596.93	292.33	0.20
Kettle Creek	2067.56	50-YR	3704.50	6572.37	6575.12	6575.12	6576.02	0.011227	2.35	527.57	291.01	0.31
Kettle Creek	2067.56	100-YR	4250.10	6572.37	6575.28	6575.28	6576.29	0.011068	2.47	576.10	291.94	0.31
Kettle Creek	1361.33	2-YR	1218.70	6562.11	6566.13		6566.24	0.012843	2.71	450.19	220.02	0.33
Kettle Creek	1361.33	5-YR	1845.30	6562.11	6567.60	6565.30	6567.68	0.005008	2.36	781.38	230.48	0.23
Kettle Creek	1361.33	10-YR	2426.00	6562.11	6567.46		6567.62	0.009879	3.24	749.49	229.39	0.32
Kettle Creek	1361.33	25-YR	2920.90	6562.11	6565.81	6565.81	6566.72	0.121868	7.63	382.64	213.66	1.01
Kettle Creek	1361.33	50-YR	3704.50	6562.11	6569.09		6569.25	0.005902	3.24	1146.70	263.74	0.26
Kettle Creek	1361.33	100-YR	4250.10	6562.11	6573.91		6573.96	0.000478	1.46	2637.29	341.57	0.08
Kettle Creek	670.23	2-YR	1218.70	6554.40	6558.10	6556.91	6558.27	0.010512	2.76	409.88	187.31	0.31
Kettle Creek	670.23	5-YR	1845.30	6554.40	6557.26	6557.26	6558.11	0.117338	6.95	257.53	175.63	0.97
Kettle Creek	670.23	10-YR	2426.00	6554.40	6558.82		6559.22	0.015452	3.97	547.04	195.49	0.39
Kettle Creek	670.23	25-YR	2920.90	6554.40	6563.07		6563.17	0.000769	1.56	1453.84	227.88	0.10
Kettle Creek	670.23	50-YR	3704.50	6554.40	6568.99		6569.02	0.000090	0.79	3513.16	469.76	0.04
Kettle Creek	670.23	100-YR	4250.10	6554.40	6573.90		6573.91	0.000020	0.46	5963.43	526.34	0.02
Kettle Creek	6.23	2-YR	1218.70	6550.00	6551.90	6550.90	6551.99	0.007307	1.89	583.97	345.51	0.25
Kettle Creek	6.23	5-YR	1845.30	6550.00	6555.20	6551.18	6555.22	0.000350	0.83	1840.45	417.90	0.06
Kettle Creek	6.23	10-YR	2426.00	6550.00	6558.90	6551.43	6558.91	0.000070	0.53	3612.81	576.66	0.03

FUTURE CONDITIONS
MODEL RESULTS (CONT.)

HYDRAULIC RESULTS –
FUTURE
KETTLE CREEK DBPS
JOB NO. 25100.00
MAY 2015
C-64



Centennial 303-740-9393 • Colorado Springs 719-593-2593
Fort Collins 970-491-9888 • www.jrengineering.com

HEC-RAS Plan: Future River: Kettle Creek Reach: Kettle Creek (Continued)

Reach	River Sta	Profile	Q Total (cfs)	Min Ch El (ft)	W.S. Elev (ft)	Crit W.S. (ft)	E.G. Elev (ft)	E.G. Slope (ft/ft)	Vel Chnl (ft/s)	Flow Area (sq ft)	Top Width (ft)	Froude # Chl
Kettle Creek	6.23	25-YR	2920.90	6550.00	6563.10	6551.63	6563.10	0.000015	0.31	6506.39	747.30	0.02
Kettle Creek	6.23	50-YR	3704.50	6550.00	6569.00	6551.92	6569.00	0.000004	0.20	11184.88	840.06	0.01
Kettle Creek	6.23	100-YR	4250.10	6550.00	6573.90	6552.00	6573.90	0.000002	0.16	15505.39	924.54	0.01

FUTURE CONDITIONS
MODEL RESULTS (CONT.)

HYDRAULIC RESULTS –
FUTURE
KETTLE CREEK DBPS
JOB NO. 25100.00
MAY 2015
C-65



Centennial 303-740-9393 • Colorado Springs 719-593-2593
Fort Collins 970-491-9888 • www.jrengineering.com

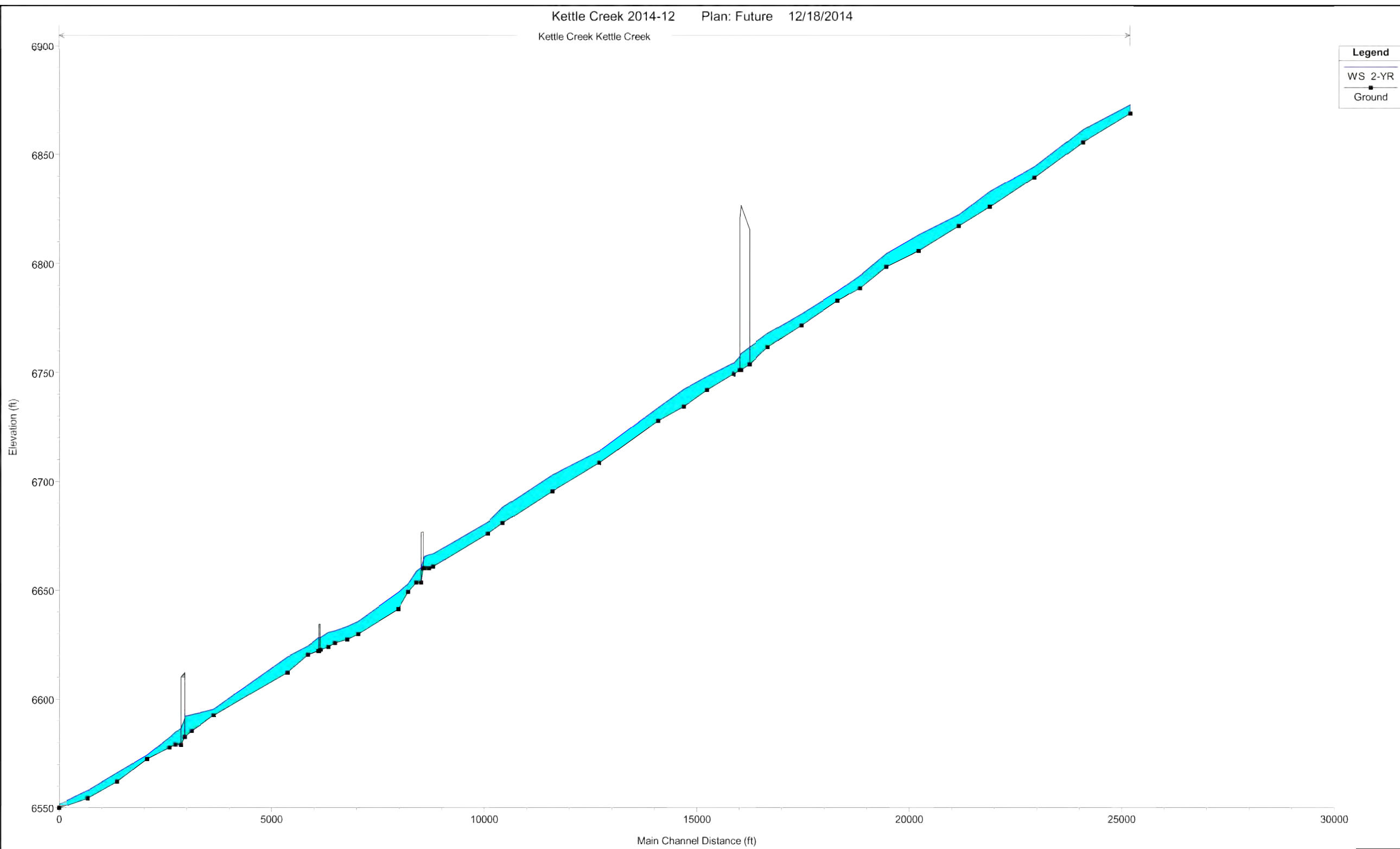

Legend
WS 2-YR
Ground

FUTURE CONDITIONS
MODEL RESULTS
2-YR PROFILE

HYDRAULIC RESULTS –
FUTURE
KETTLE CREEK DBPS
JOB NO. 25100.00
MAY 2015
C-66



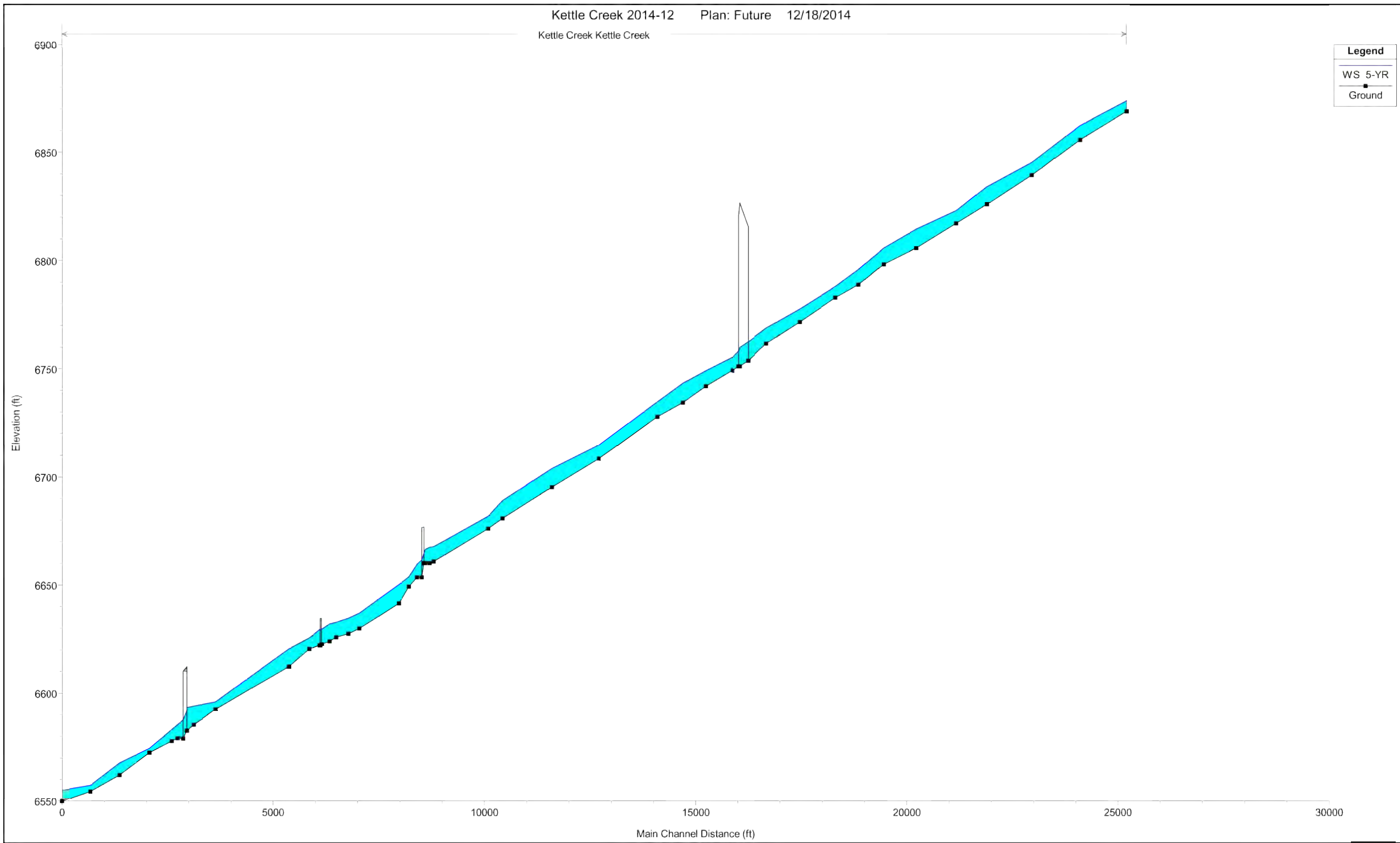

Legend

- WS 5-YR
- Ground

FUTURE CONDITIONS
MODEL RESULTS
5-YR PROFILE

HYDRAULIC RESULTS –
FUTURE
KETTLE CREEK DBPS
JOB NO. 25100.00
MAY 2015
C-67



Centennial 303-740-9393 • Colorado Springs 719-593-2593
Fort Collins 970-491-9888 • www.jrengineering.com

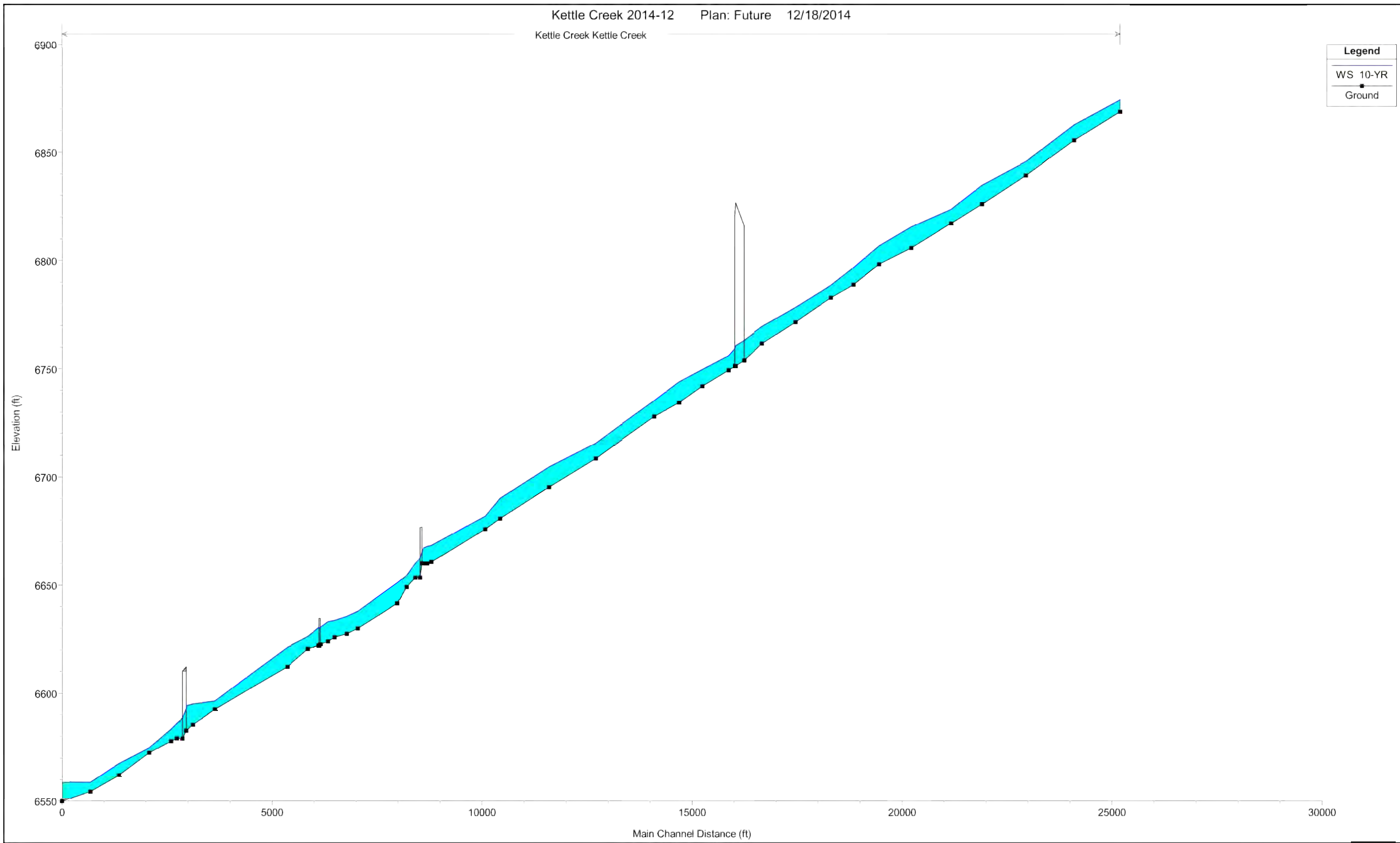

FUTURE CONDITIONS
MODEL RESULTS
10-YR PROFILE

HYDRAULIC RESULTS –
FUTURE
KETTLE CREEK DBPS
JOB NO. 25100.00
MAY 2015
C-68



Centennial 303-740-9393 • Colorado Springs 719-593-2593
Fort Collins 970-491-9888 • www.jrengineering.com

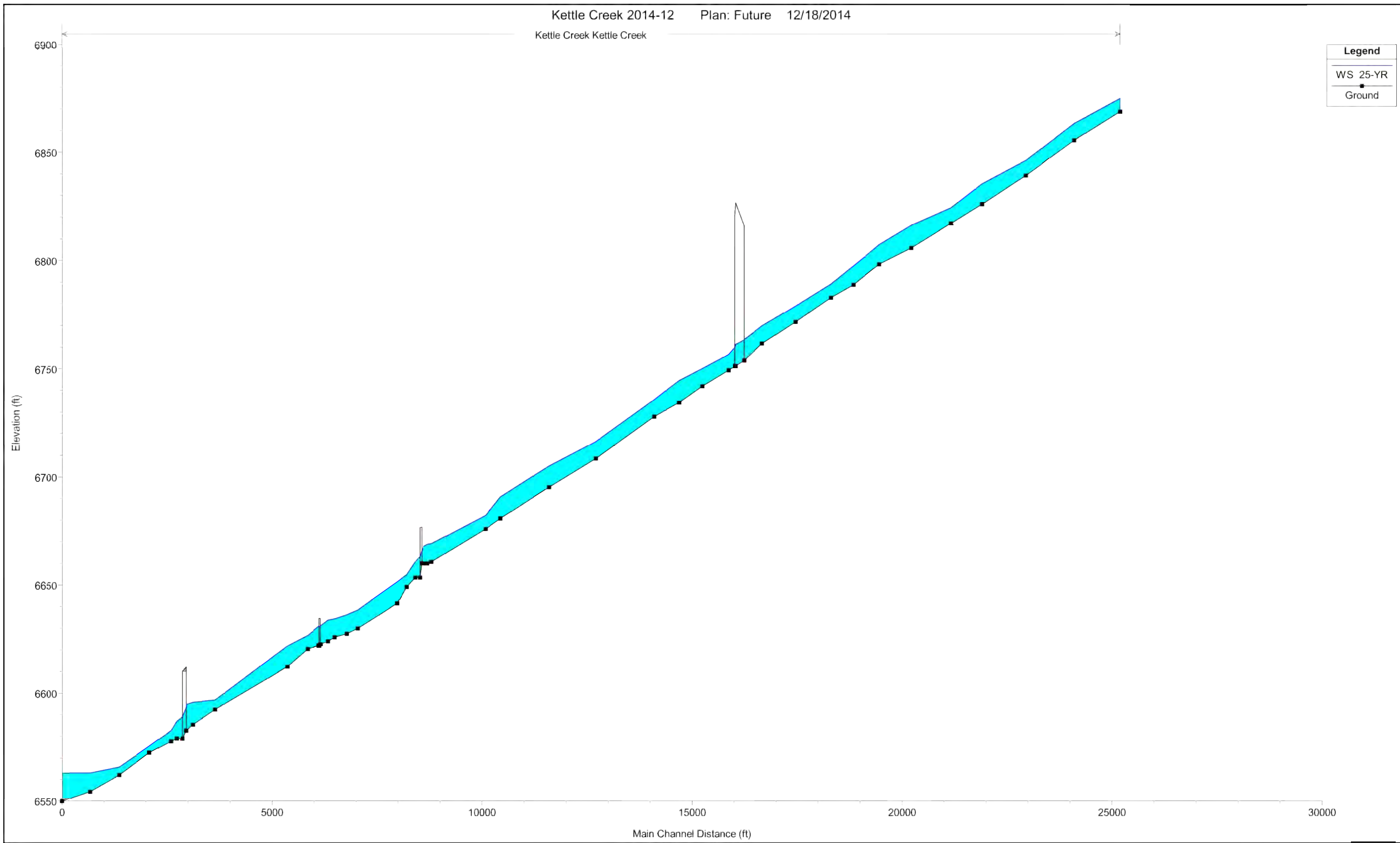

FUTURE CONDITIONS
MODEL RESULTS
25-YR PROFILE

HYDRAULIC RESULTS –
FUTURE
KETTLE CREEK DBPS
JOB NO. 25100.00
MAY 2015
C-69



Centennial 303-740-9393 • Colorado Springs 719-593-2593
Fort Collins 970-491-9888 • www.jrengineering.com

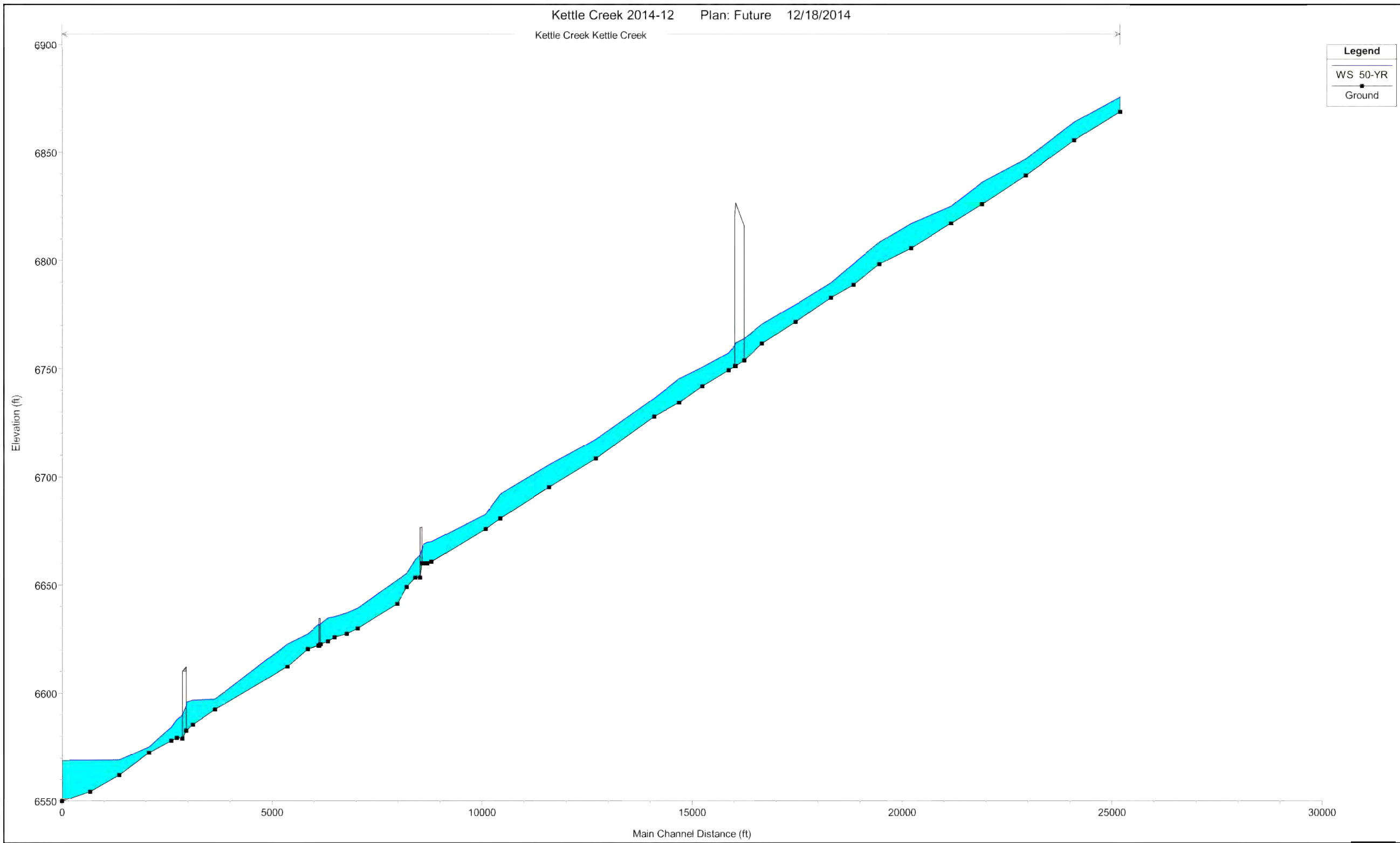

HYDRAULIC RESULTS –
 FUTURE
 KETTLE CREEK DBPS
 JOB NO. 25100.00
 MAY 2015
 C-70

FUTURE CONDITIONS
 MODEL RESULTS
 50-YR PROFILE



Centennial 303-740-9393 • Colorado Springs 719-593-2593
 Fort Collins 970-491-9888 • www.jrengineering.com

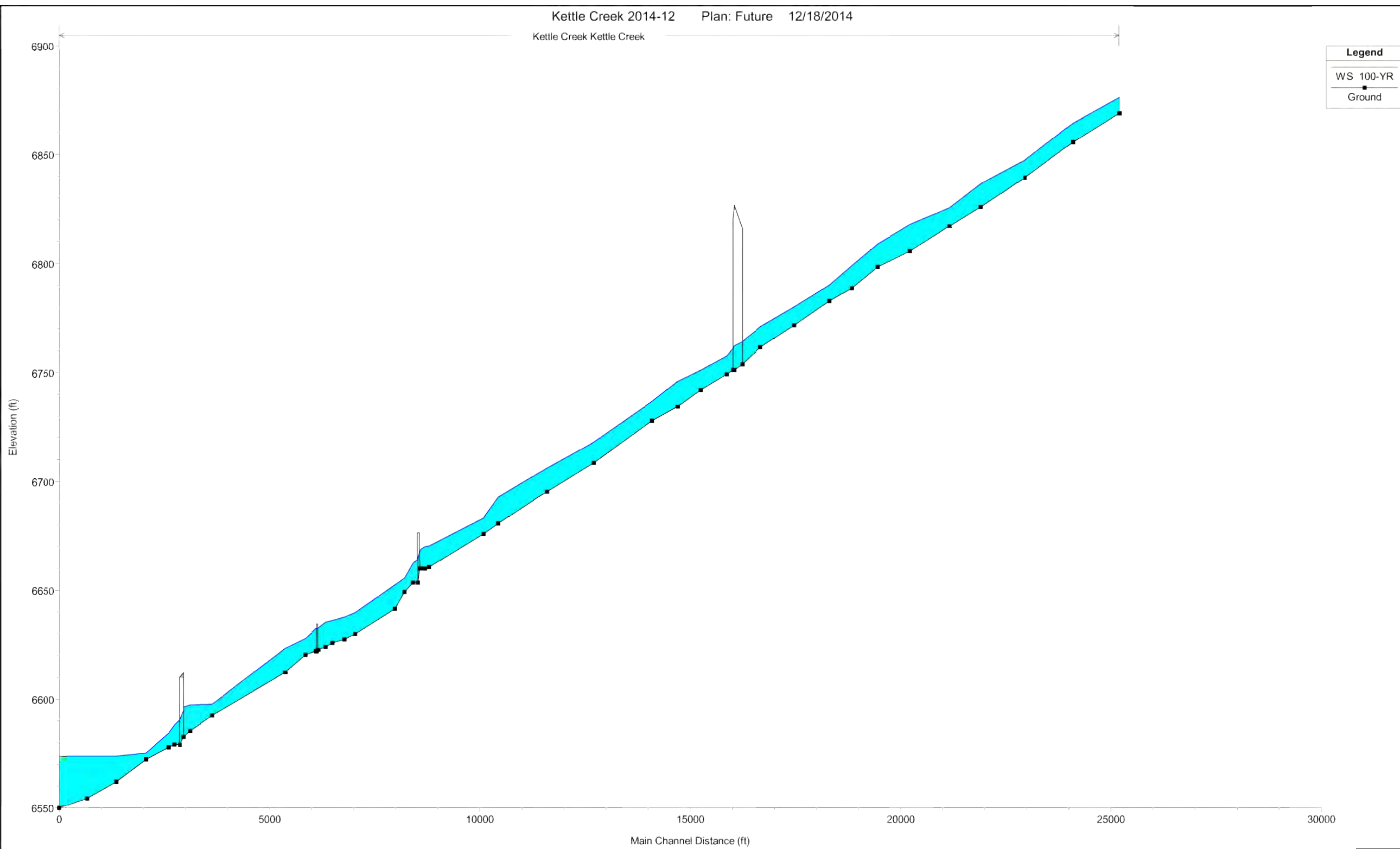

FUTURE CONDITIONS
MODEL RESULTS
100-YR PROFILE

HYDRAULIC RESULTS –
FUTURE
KETTLE CREEK DBPS
JOB NO. 25100.00
MAY 2015
C-71



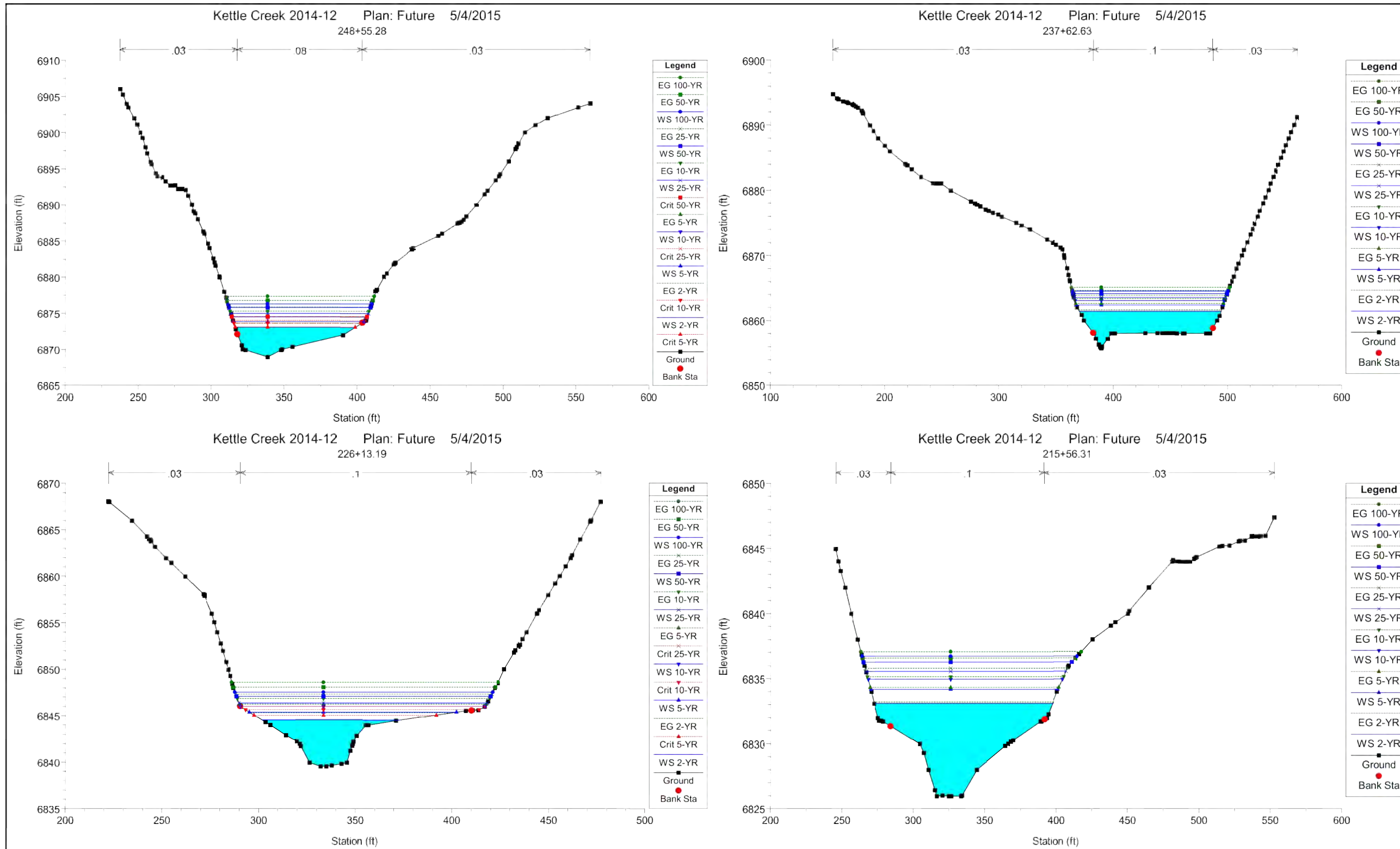

FUTURE CONDITIONS
MODEL RESULTS

HYDRAULIC RESULTS –
FUTURE
KETTLE CREEK DBPS
JOB NO. 25100.00
MAY 2015
C-72



Centennial 303-740-9393 • Colorado Springs 719-593-2593
Fort Collins 970-491-9888 • www.jrengineering.com

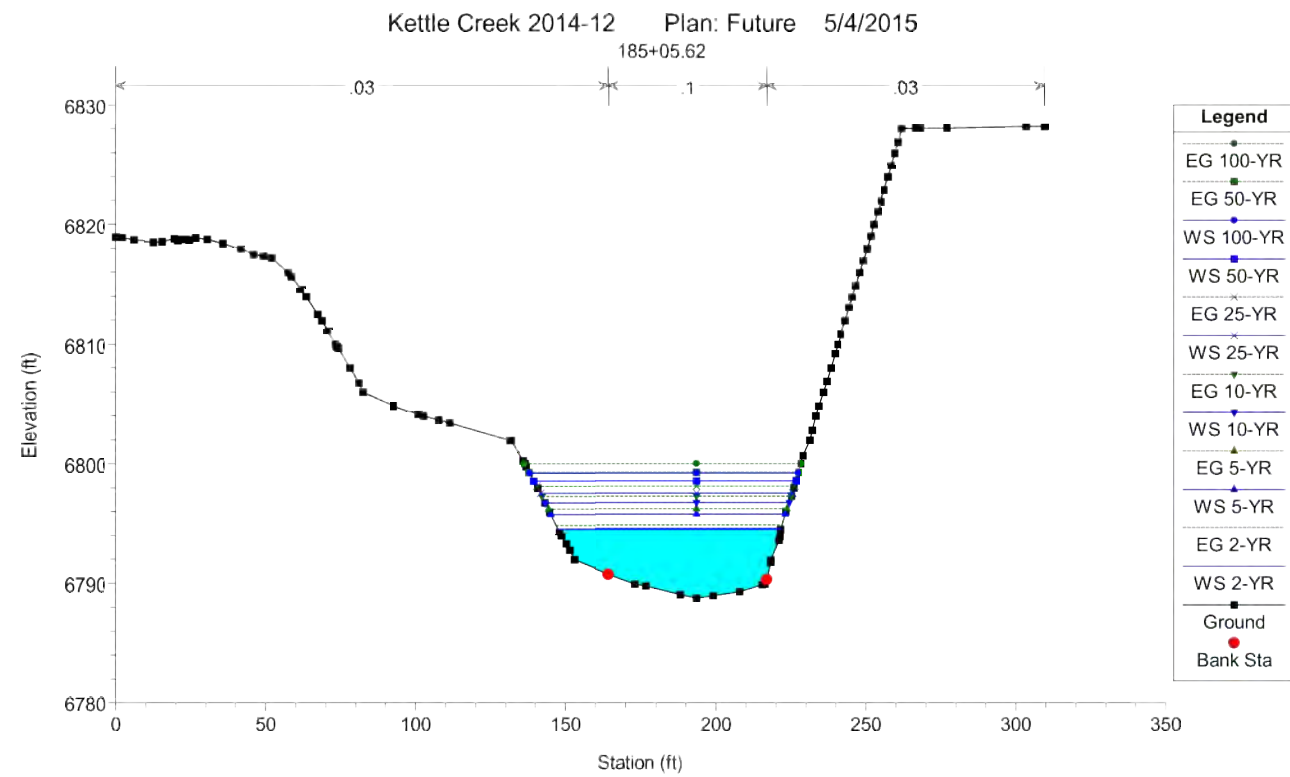
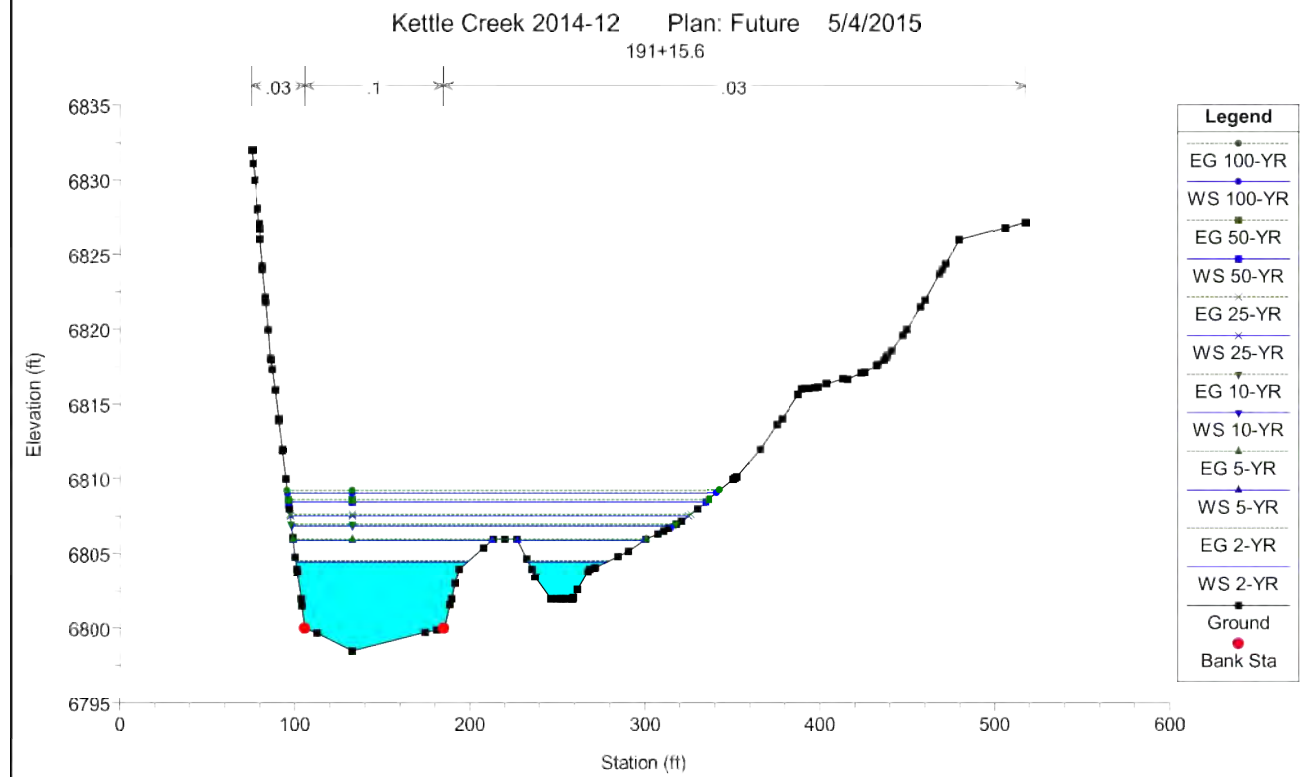
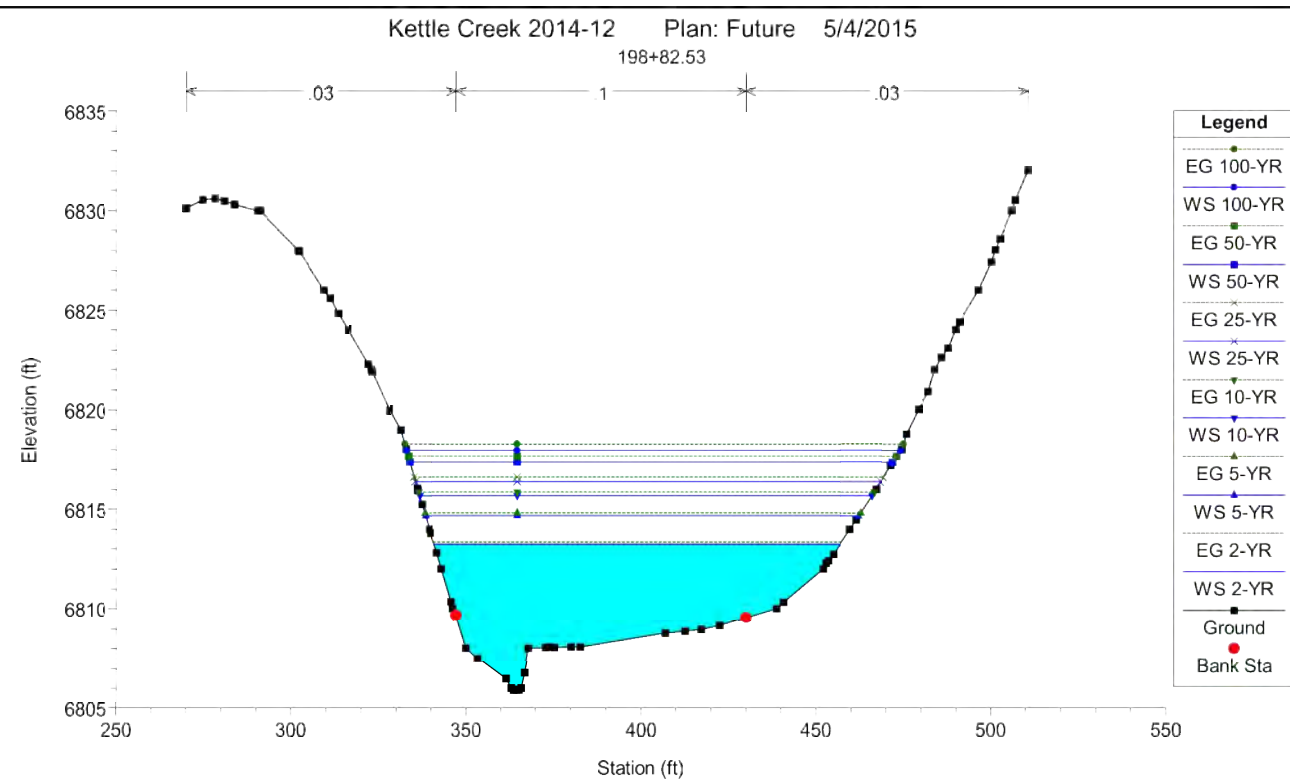
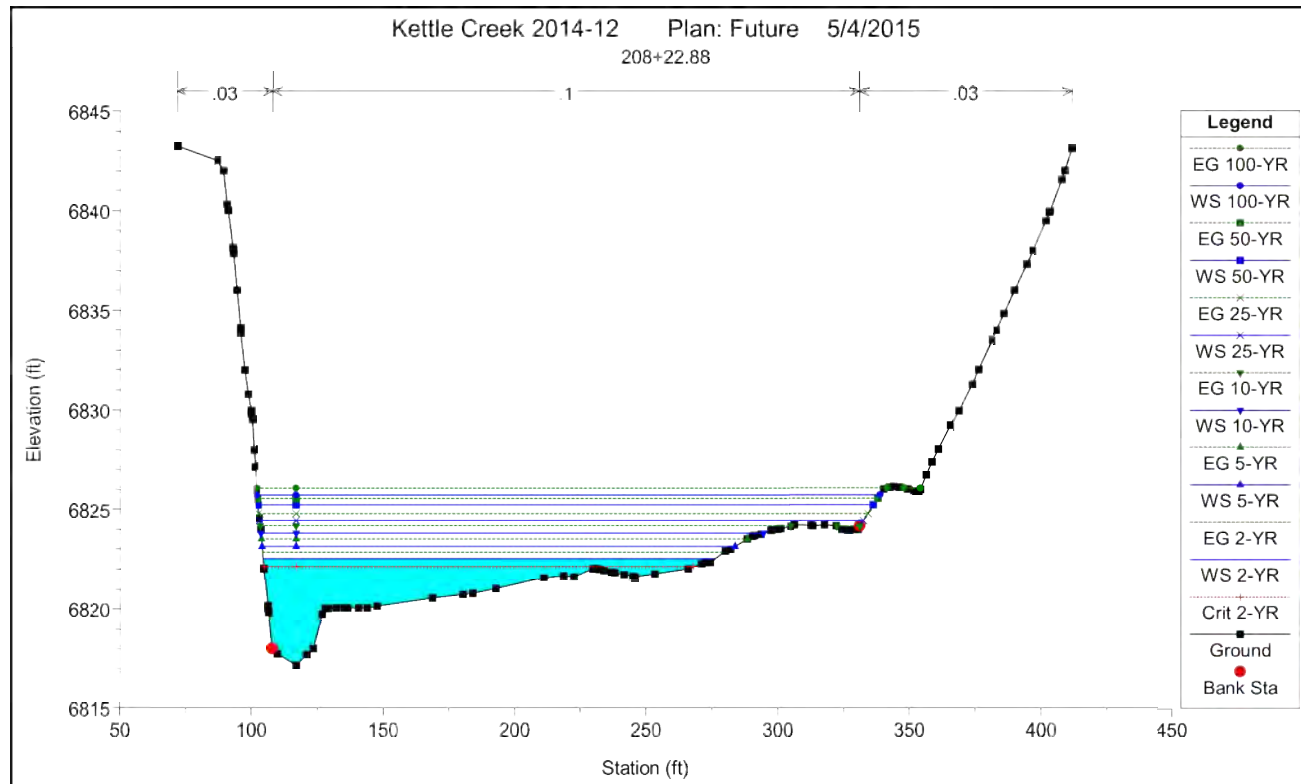

FUTURE CONDITIONS
MODEL RESULTS

HYDRAULIC RESULTS –
FUTURE
KETTLE CREEK DBPS
JOB NO. 25100.00
MAY 2015
C-73



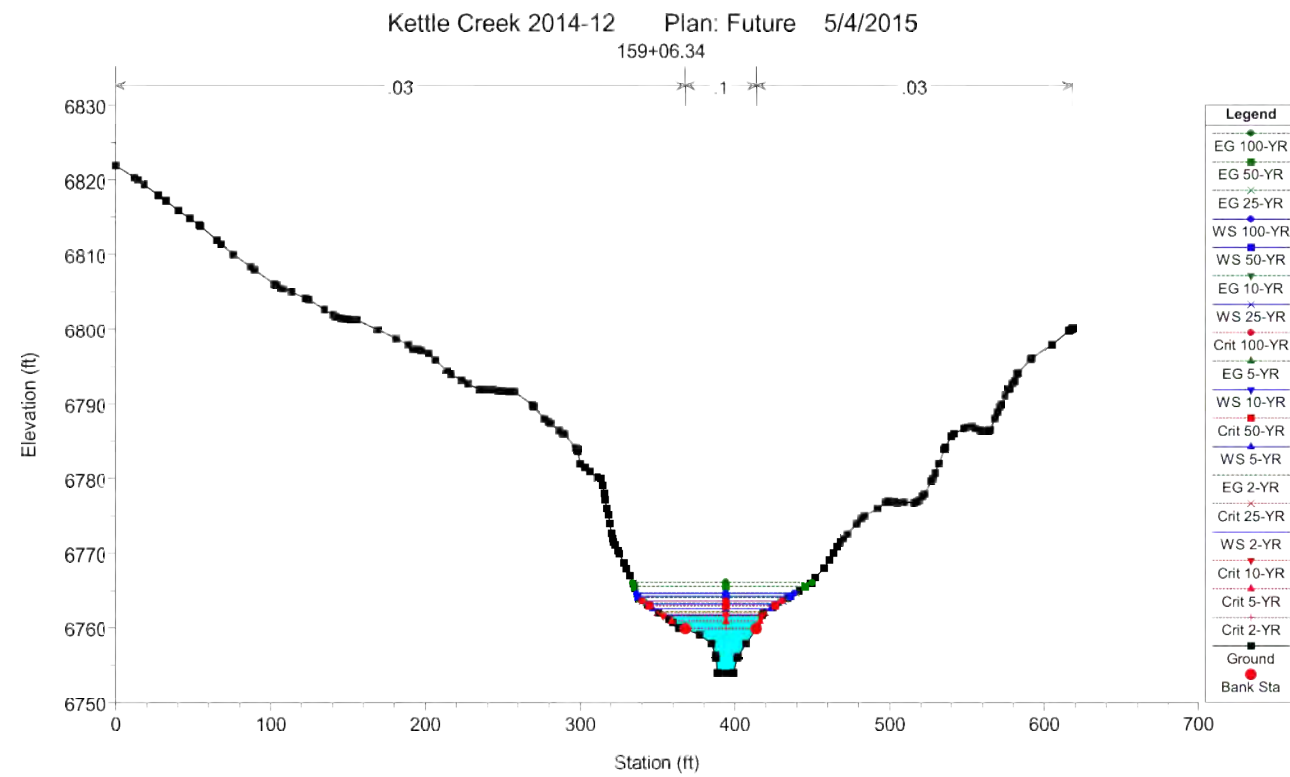
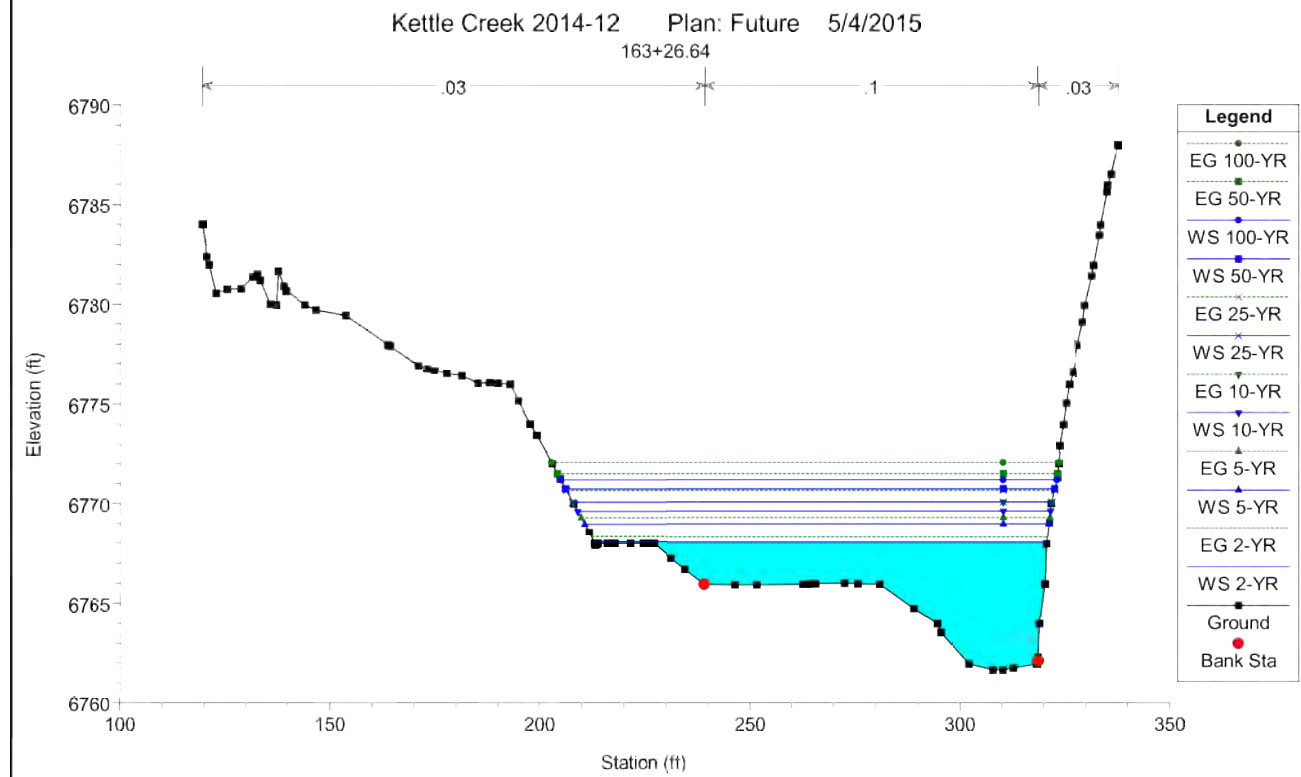
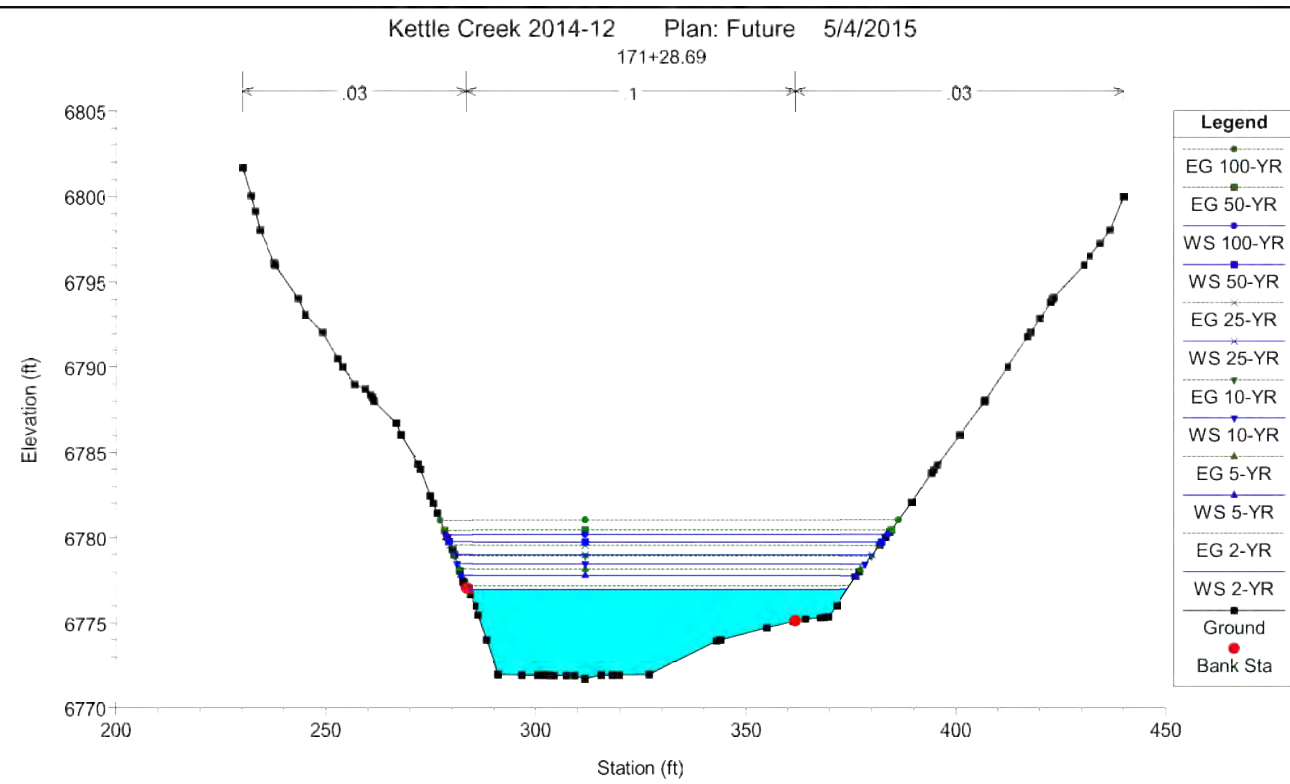
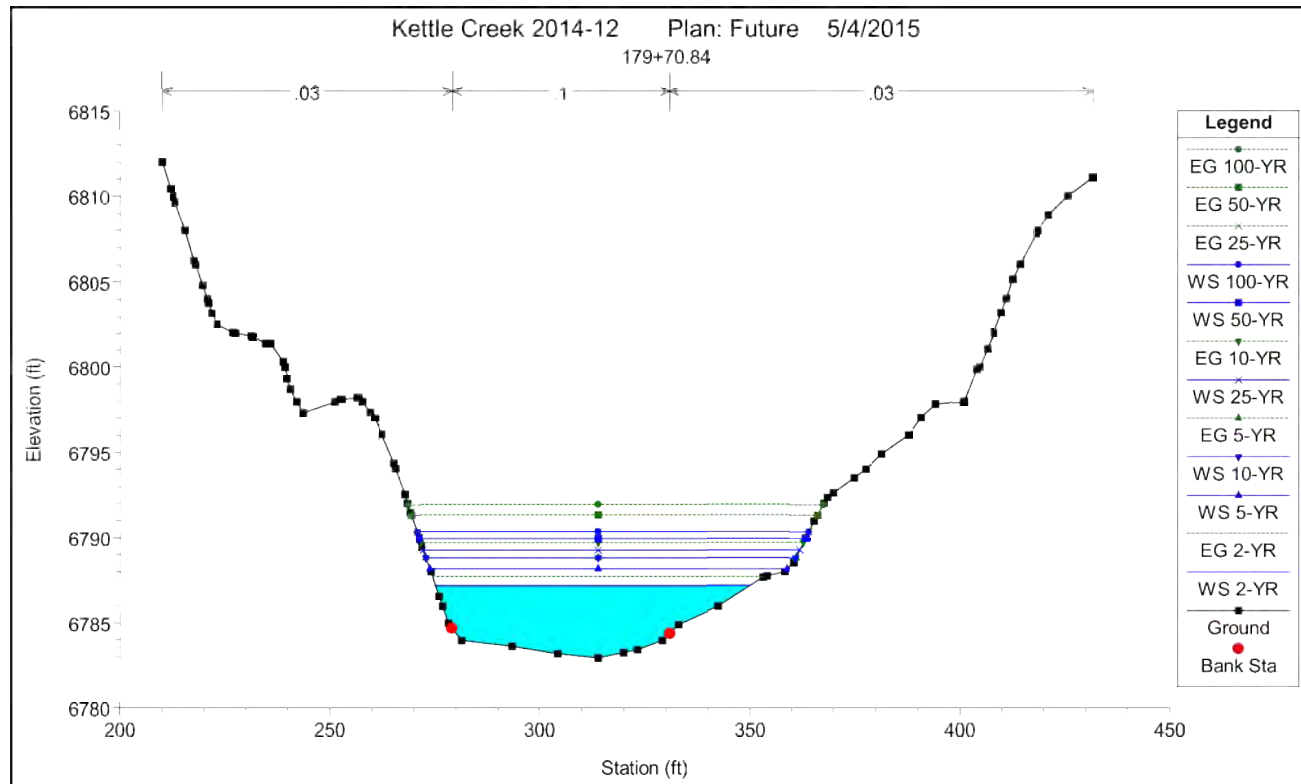

FUTURE CONDITIONS
MODEL RESULTS

HYDRAULIC RESULTS –
FUTURE
KETTLE CREEK DBPS
JOB NO. 25100.00
MAY 2015
C-74



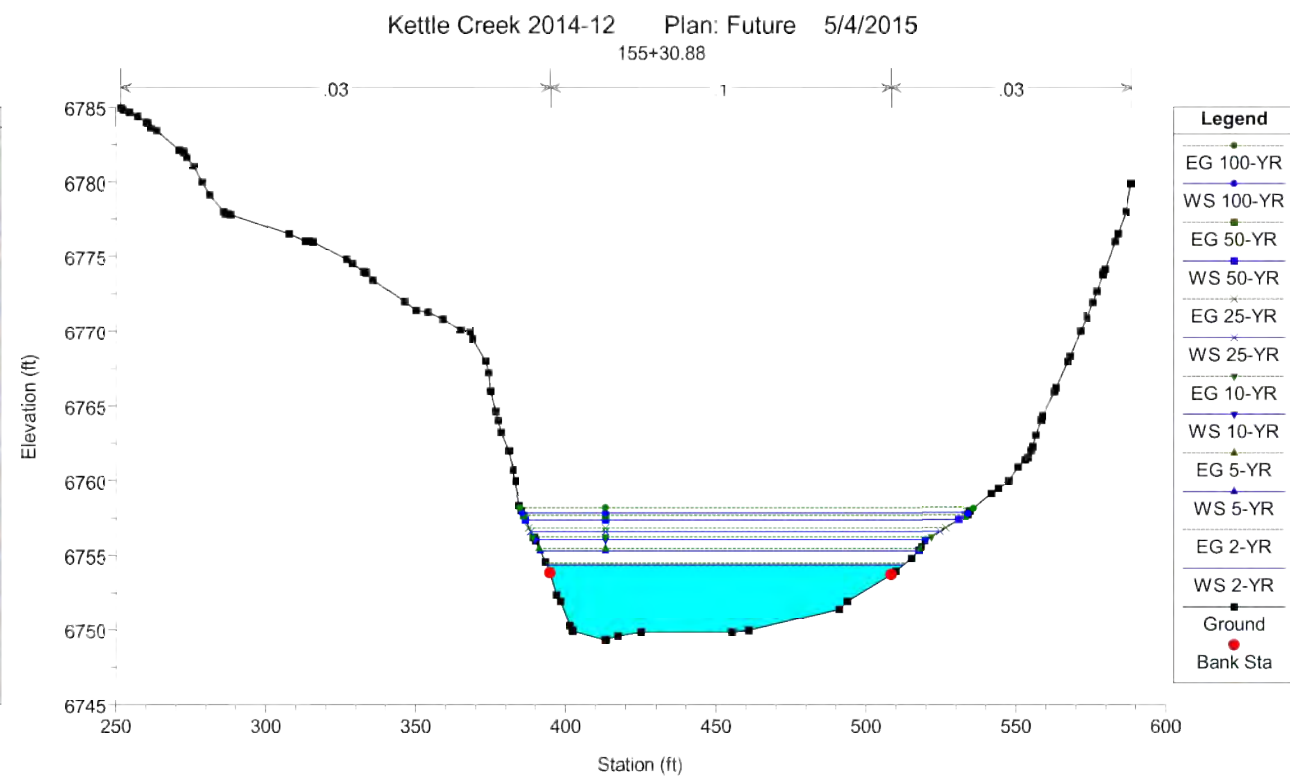
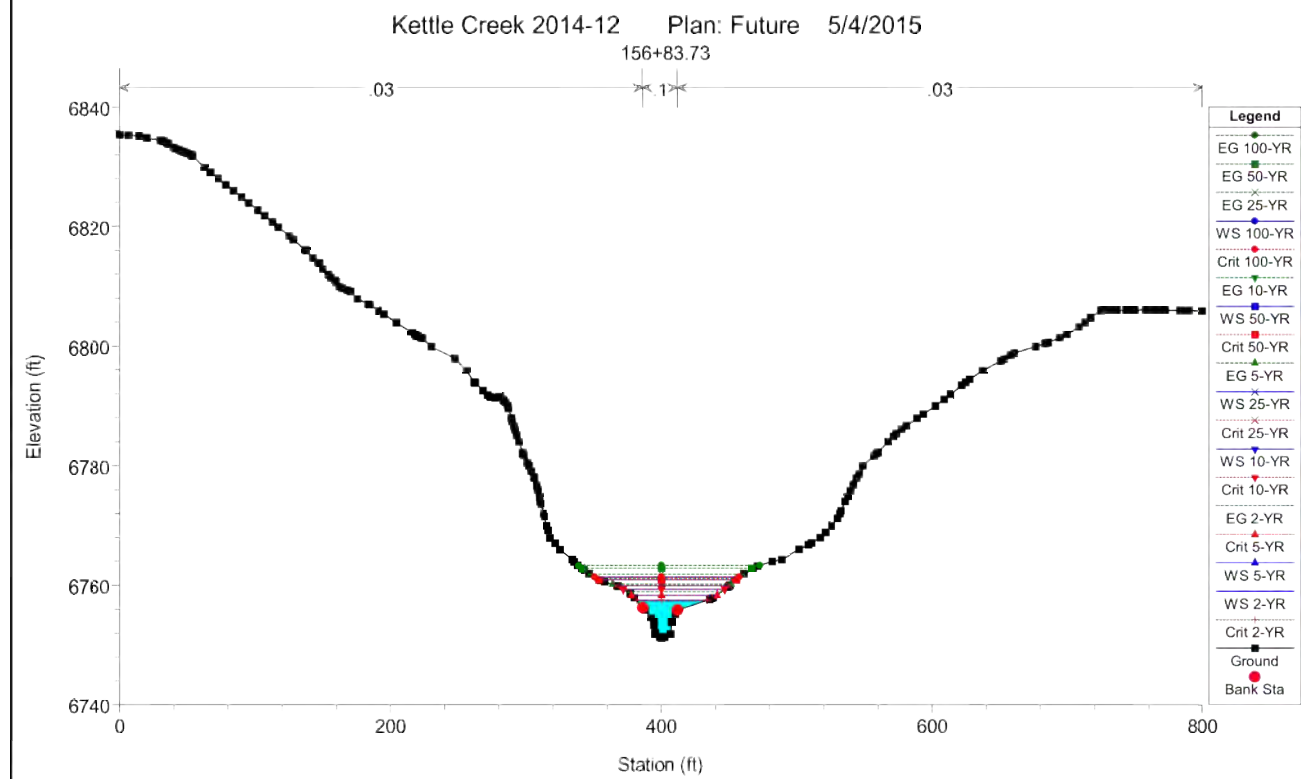
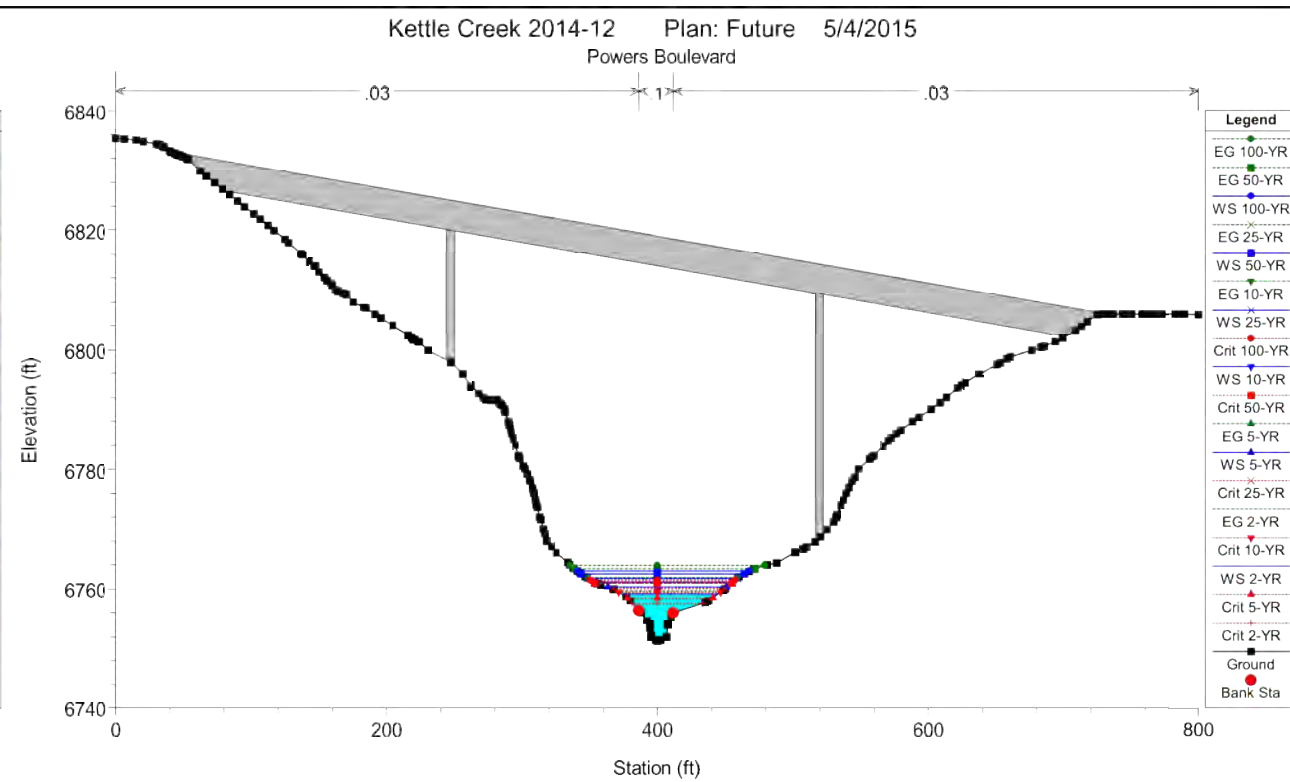
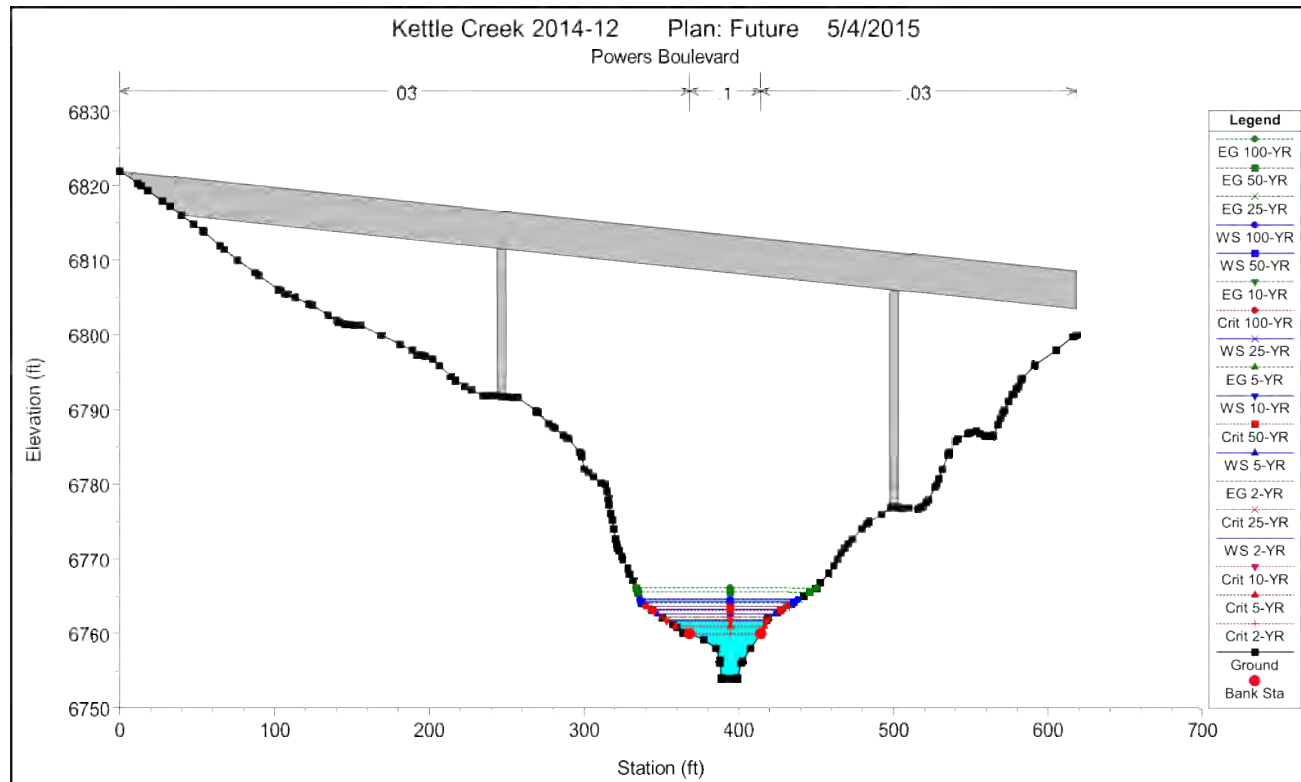

FUTURE CONDITIONS
MODEL RESULTS

HYDRAULIC RESULTS –
FUTURE
KETTLE CREEK DBPS
JOB NO. 25100.00
MAY 2015
C-75



Centennial 303-740-9393 • Colorado Springs 719-593-2593
Fort Collins 970-491-9888 • www.jrengineering.com

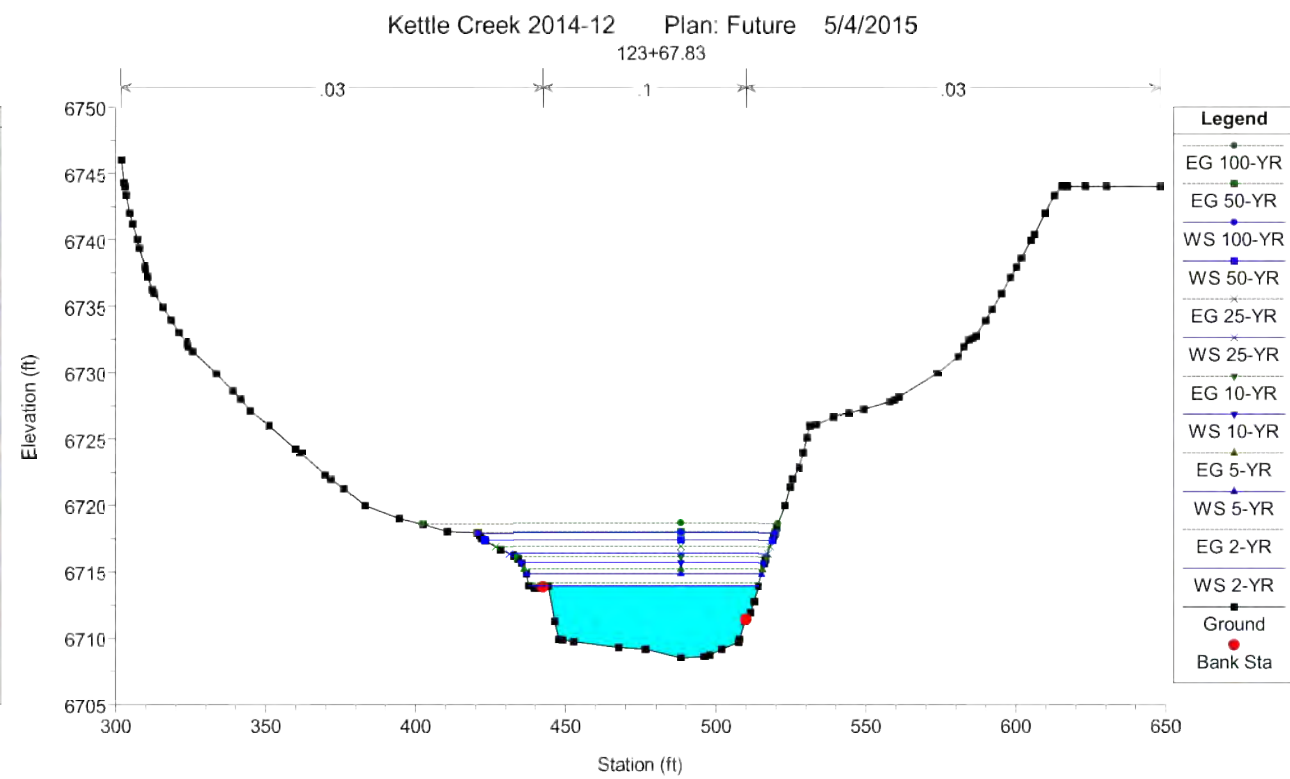
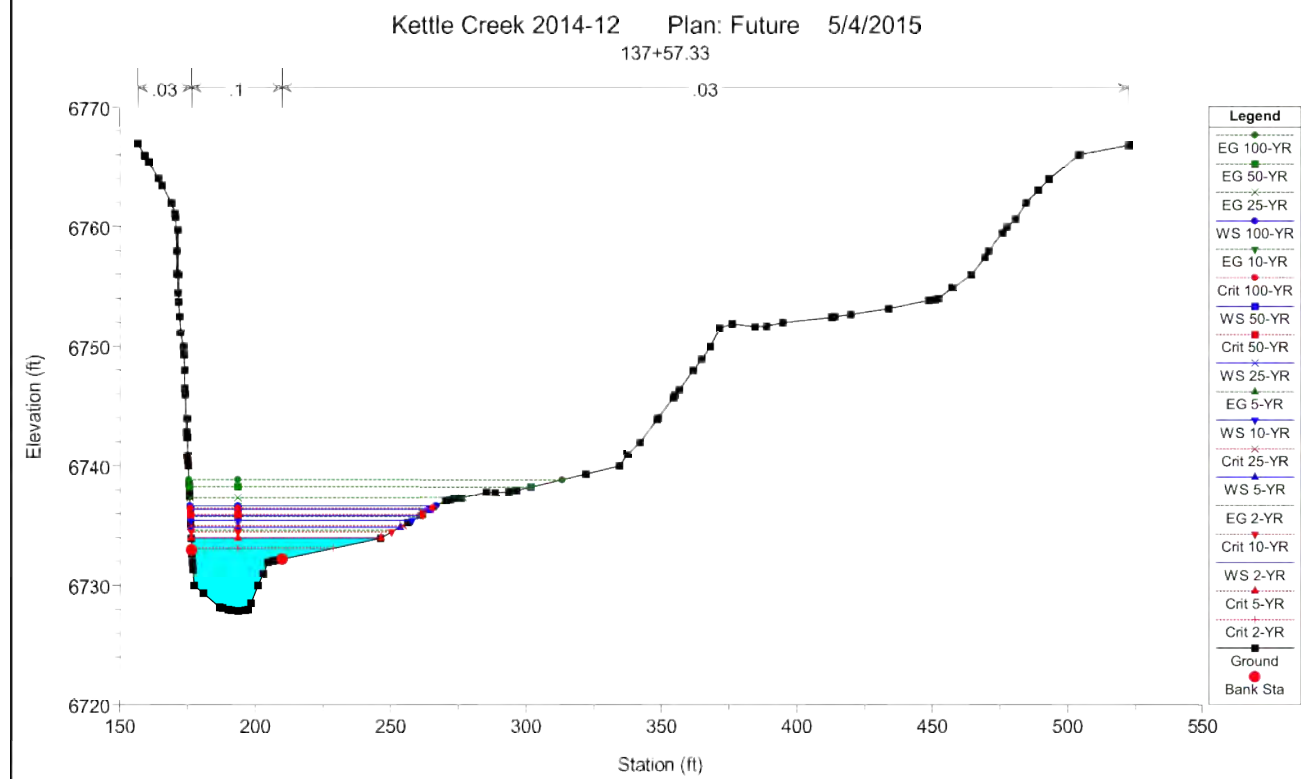
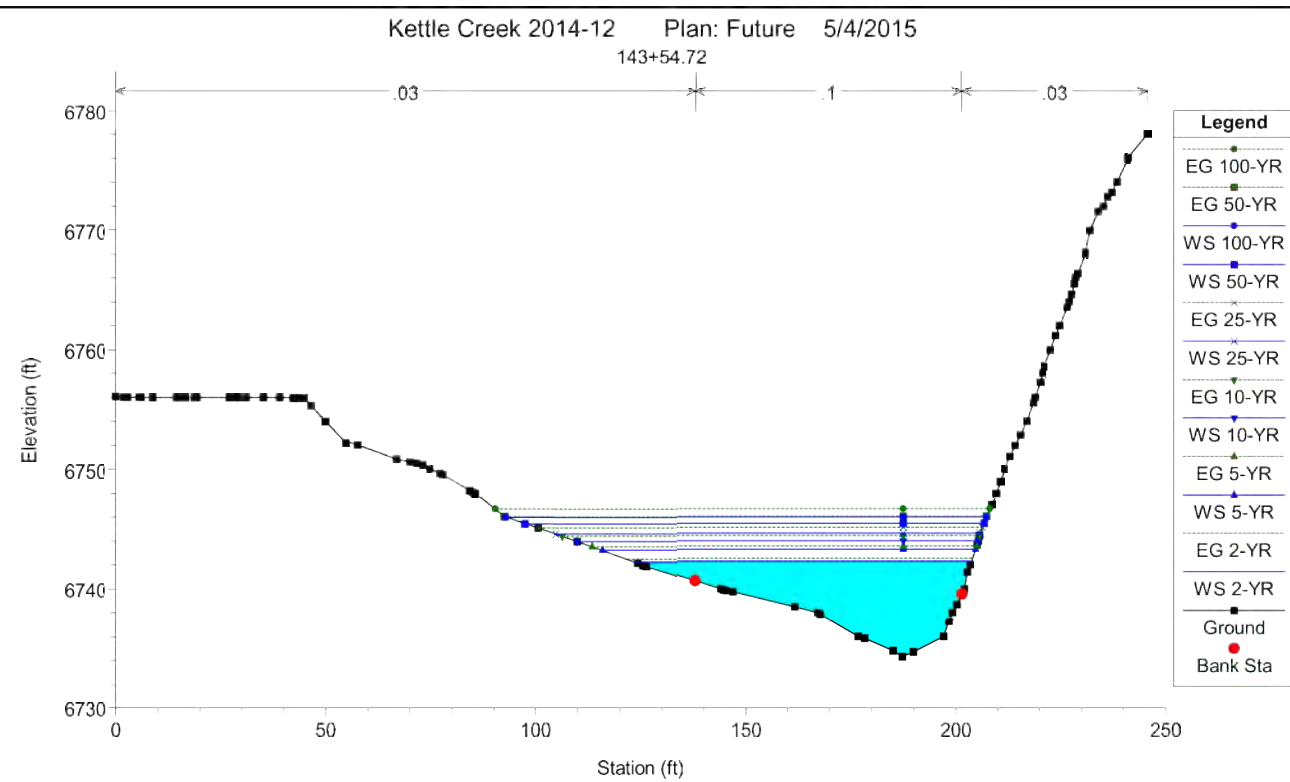
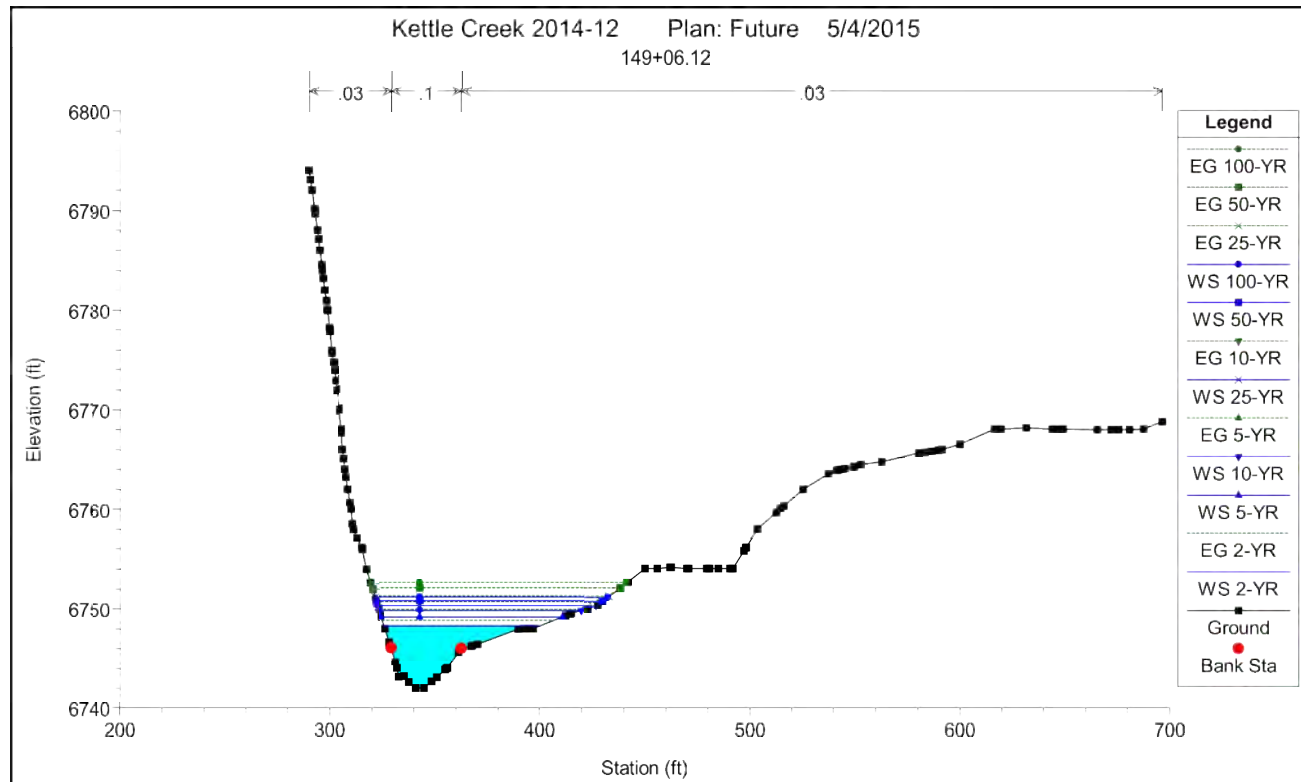

FUTURE CONDITIONS
MODEL RESULTS

HYDRAULIC RESULTS –
FUTURE
KETTLE CREEK DBPS
JOB NO. 25100.00
MAY 2015
C-76



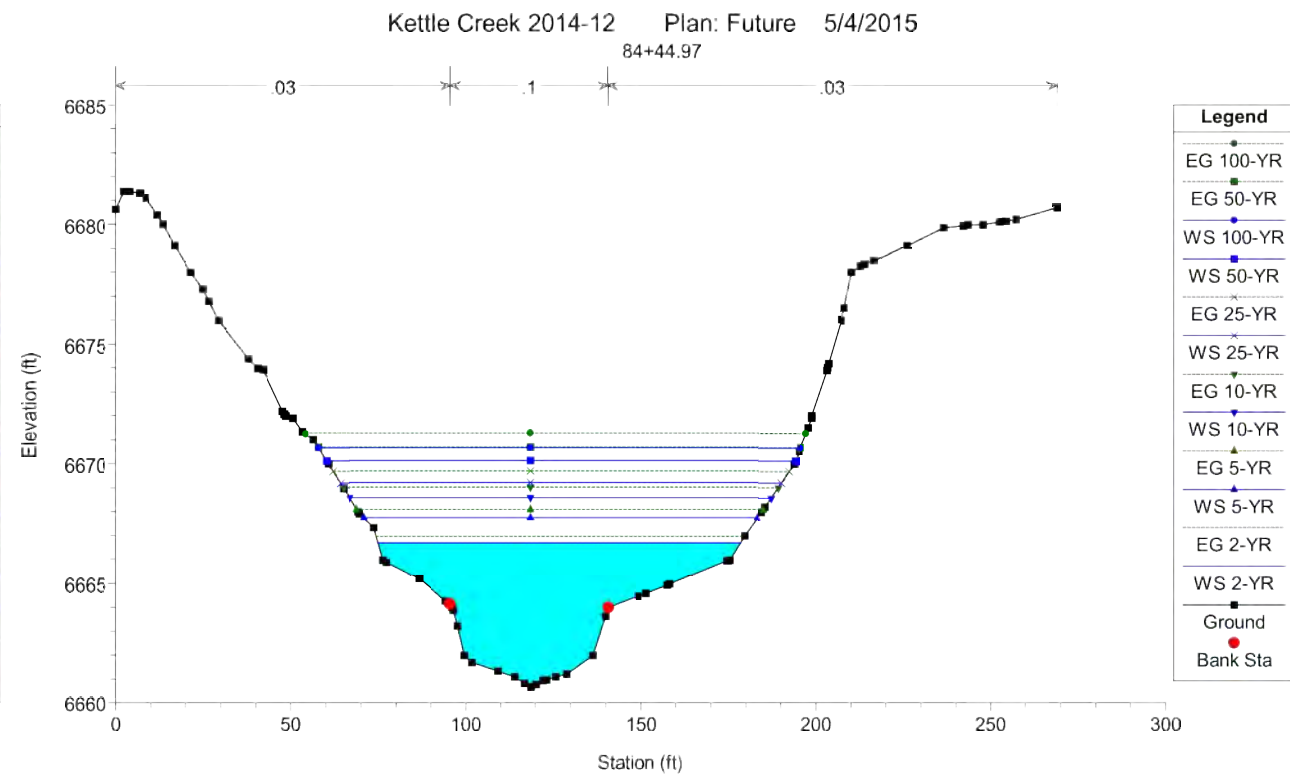
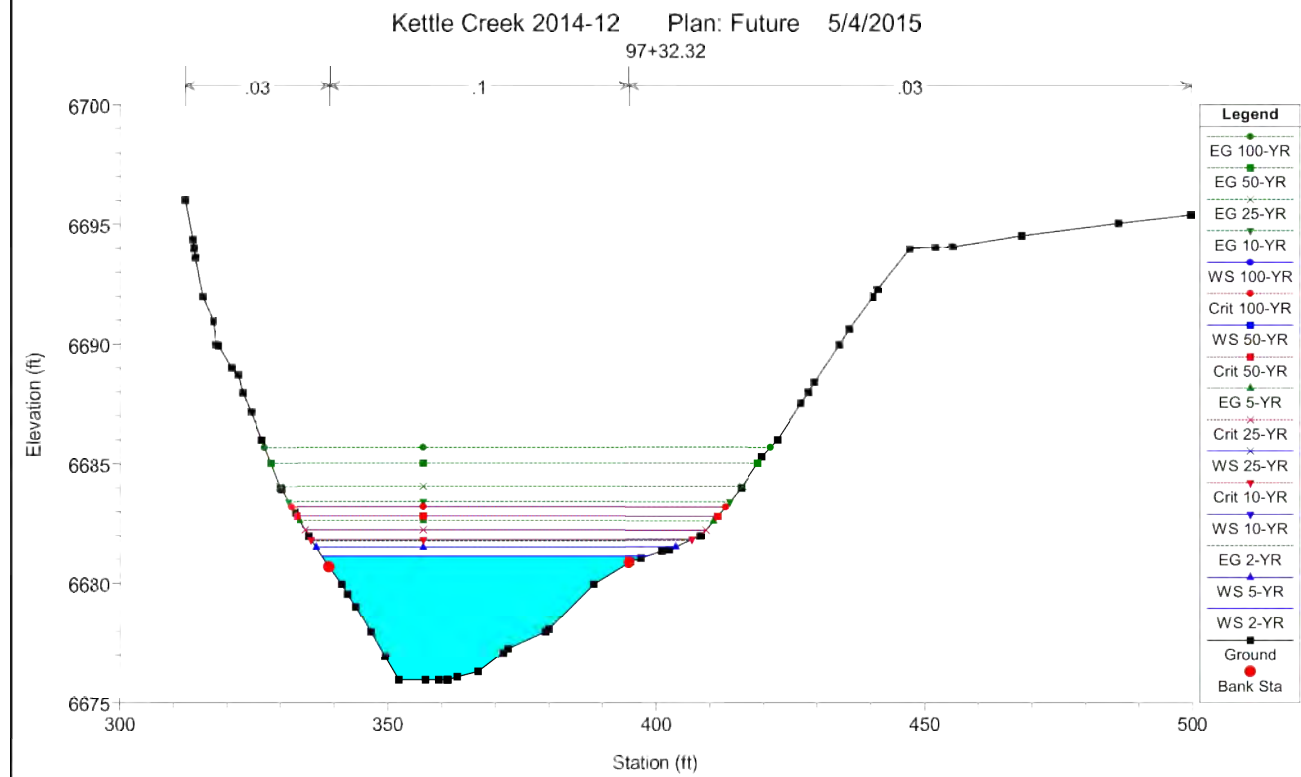
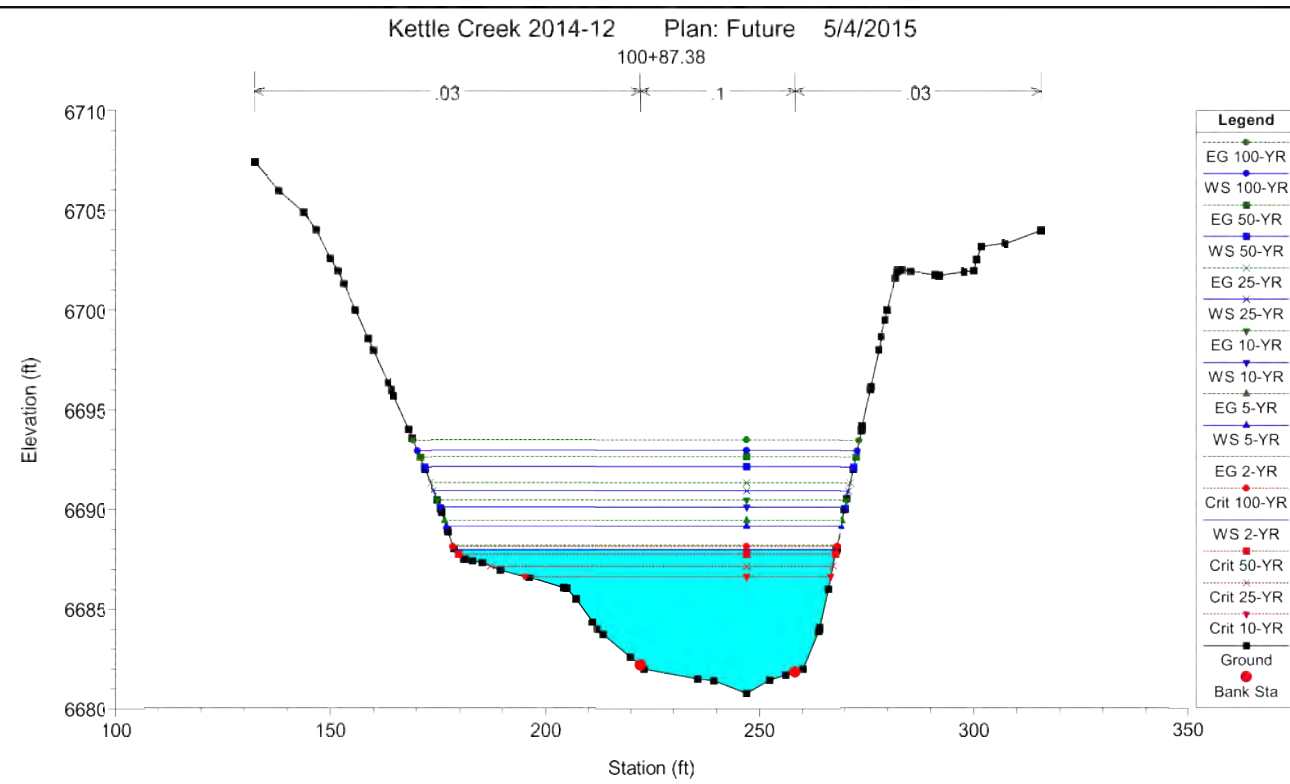
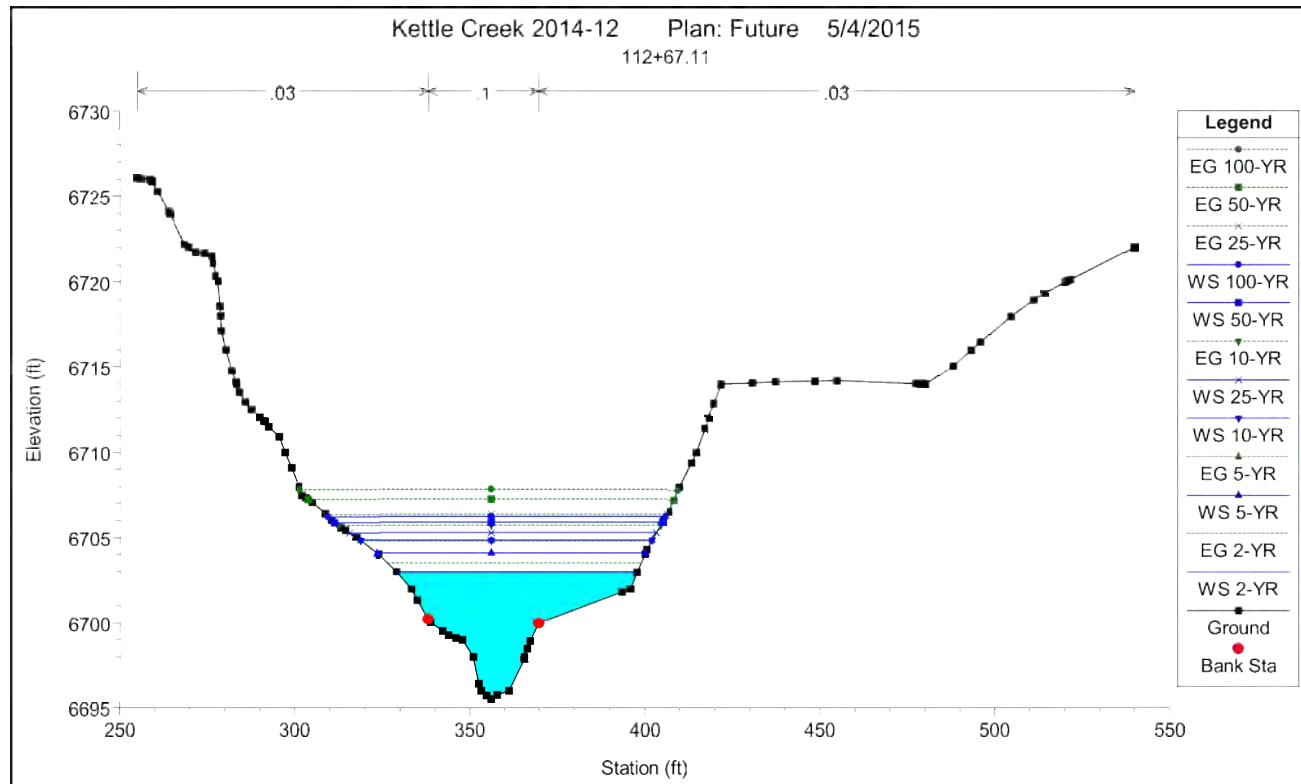

FUTURE CONDITIONS
MODEL RESULTS

HYDRAULIC RESULTS –
FUTURE
KETTLE CREEK DBPS
JOB NO. 25100.00
MAY 2015
C-77



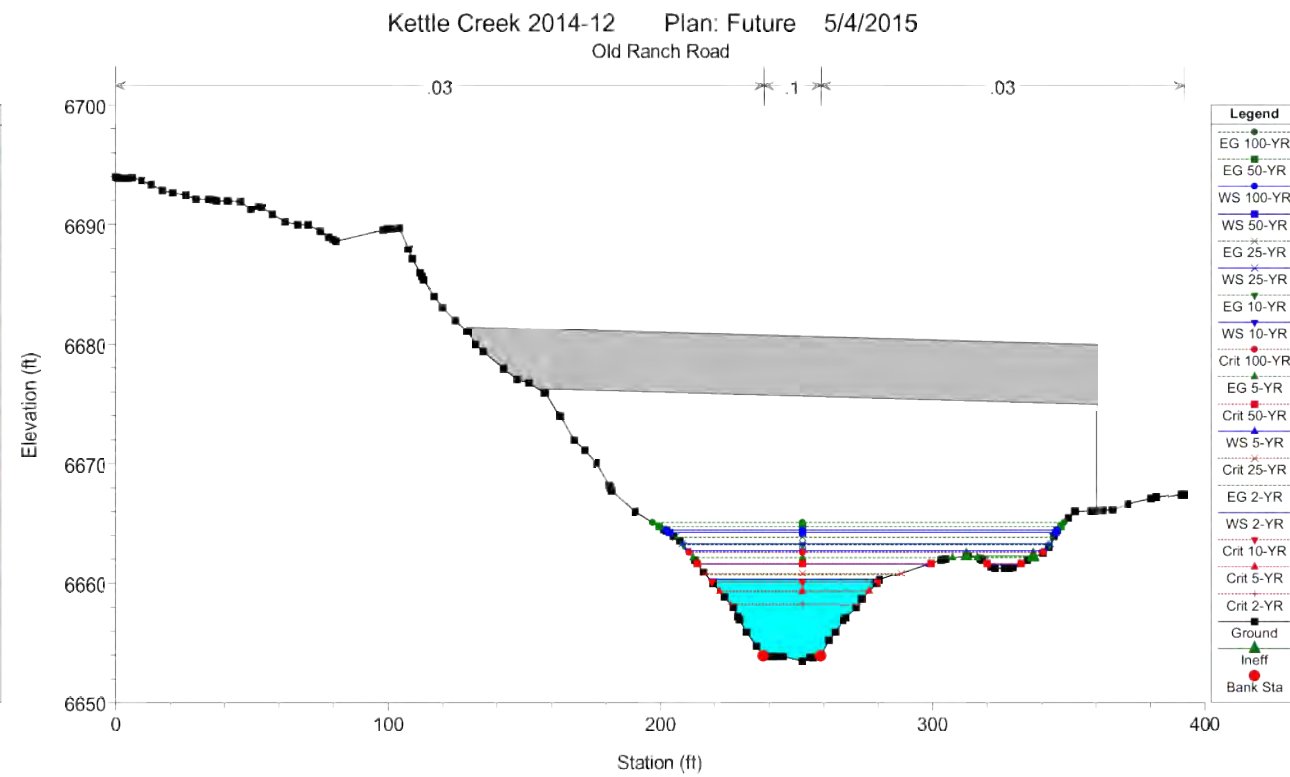
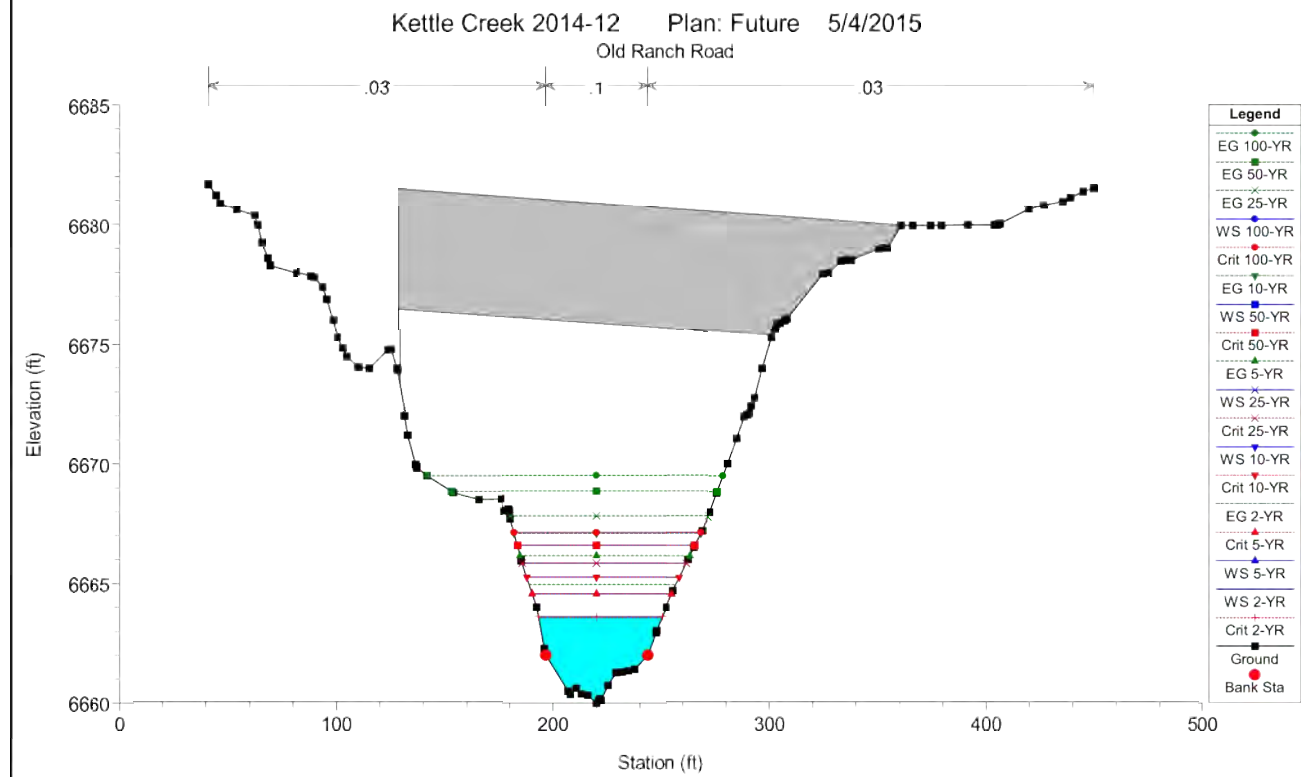
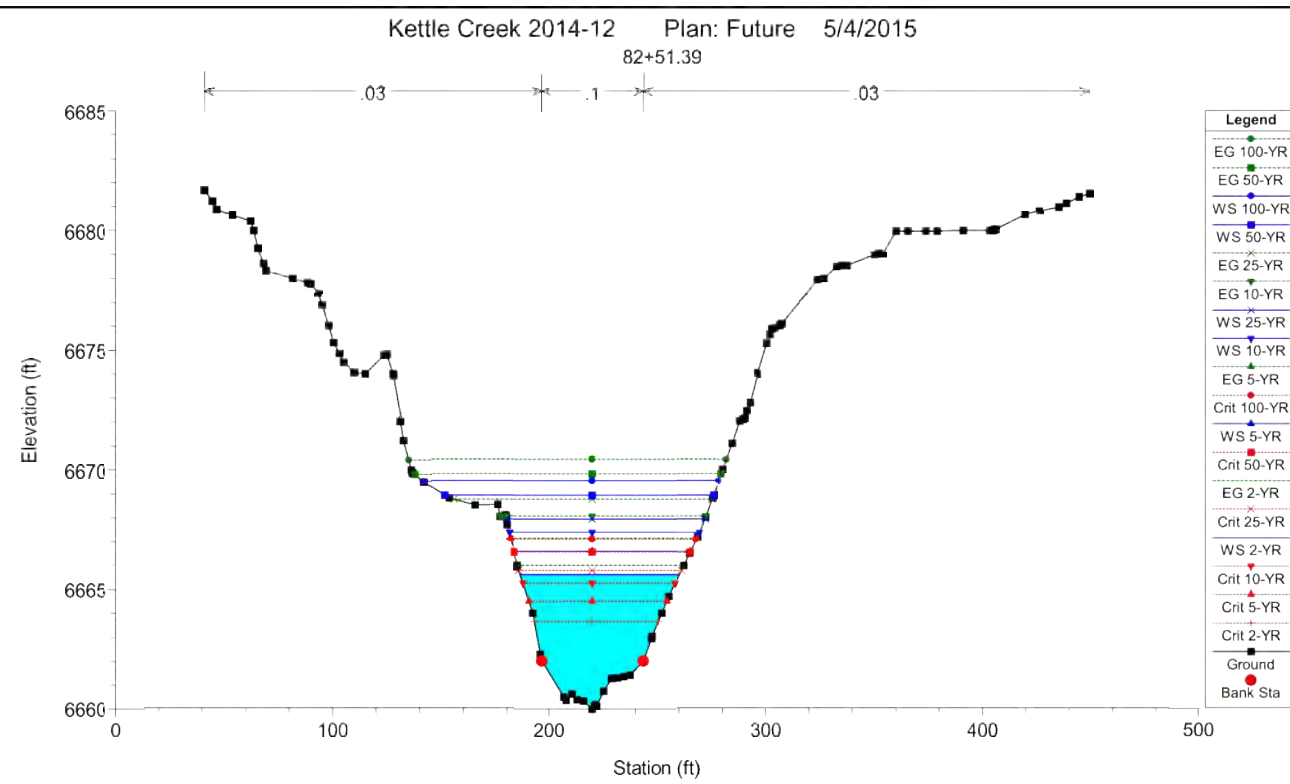
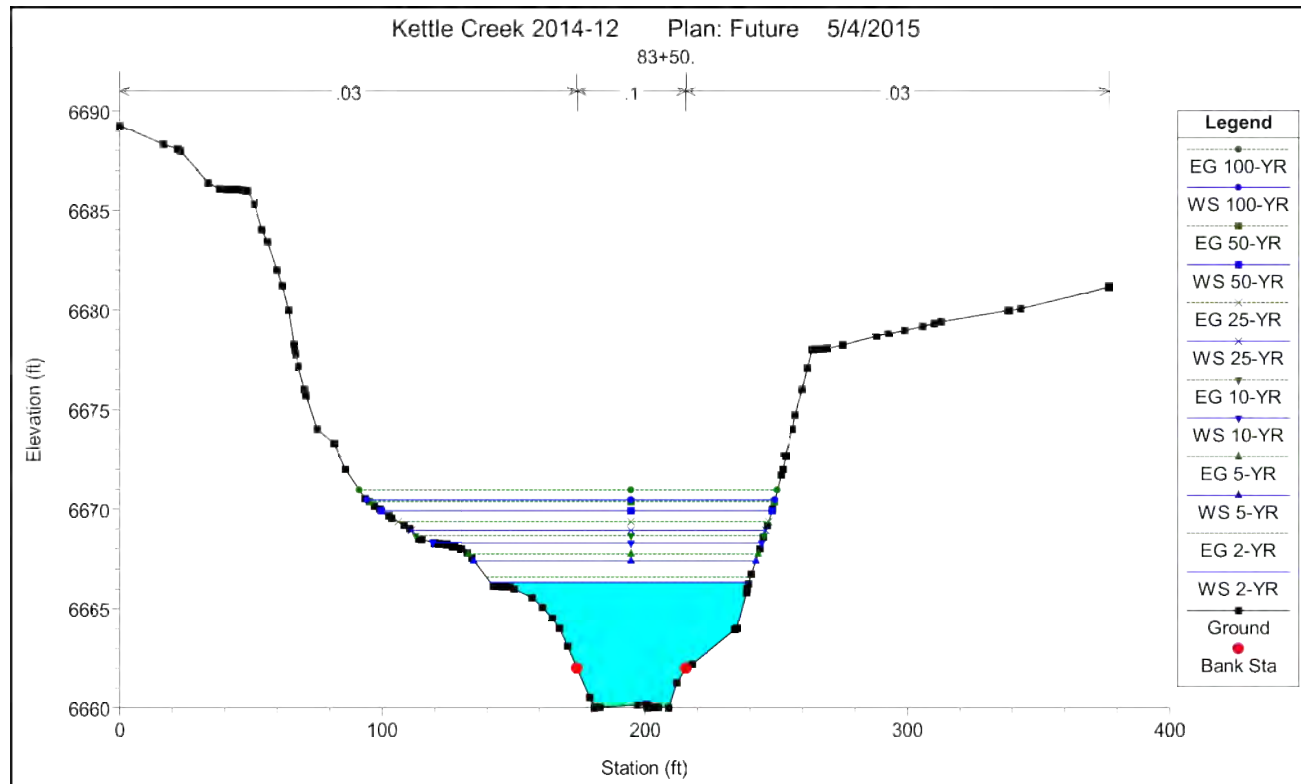

FUTURE CONDITIONS
MODEL RESULTS

HYDRAULIC RESULTS –
FUTURE
KETTLE CREEK DBPS
JOB NO. 25100.00
MAY 2015
C-78



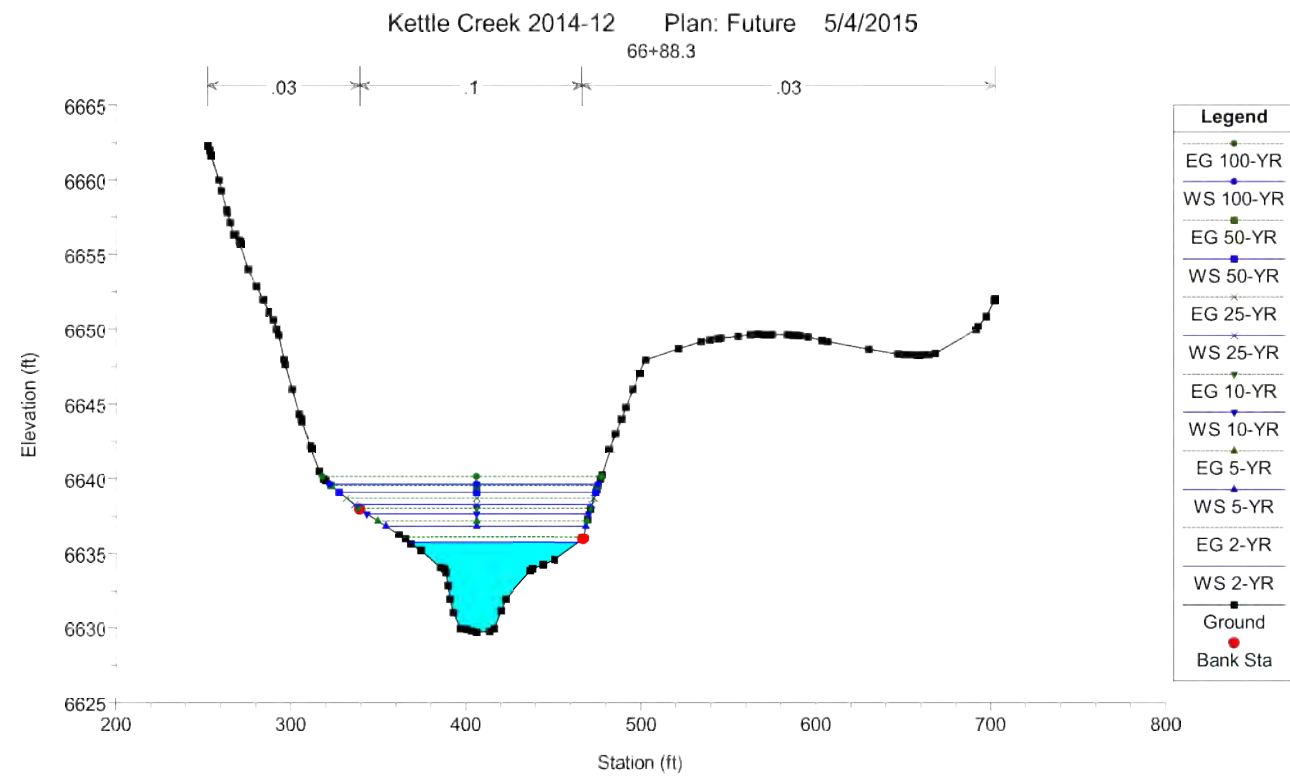
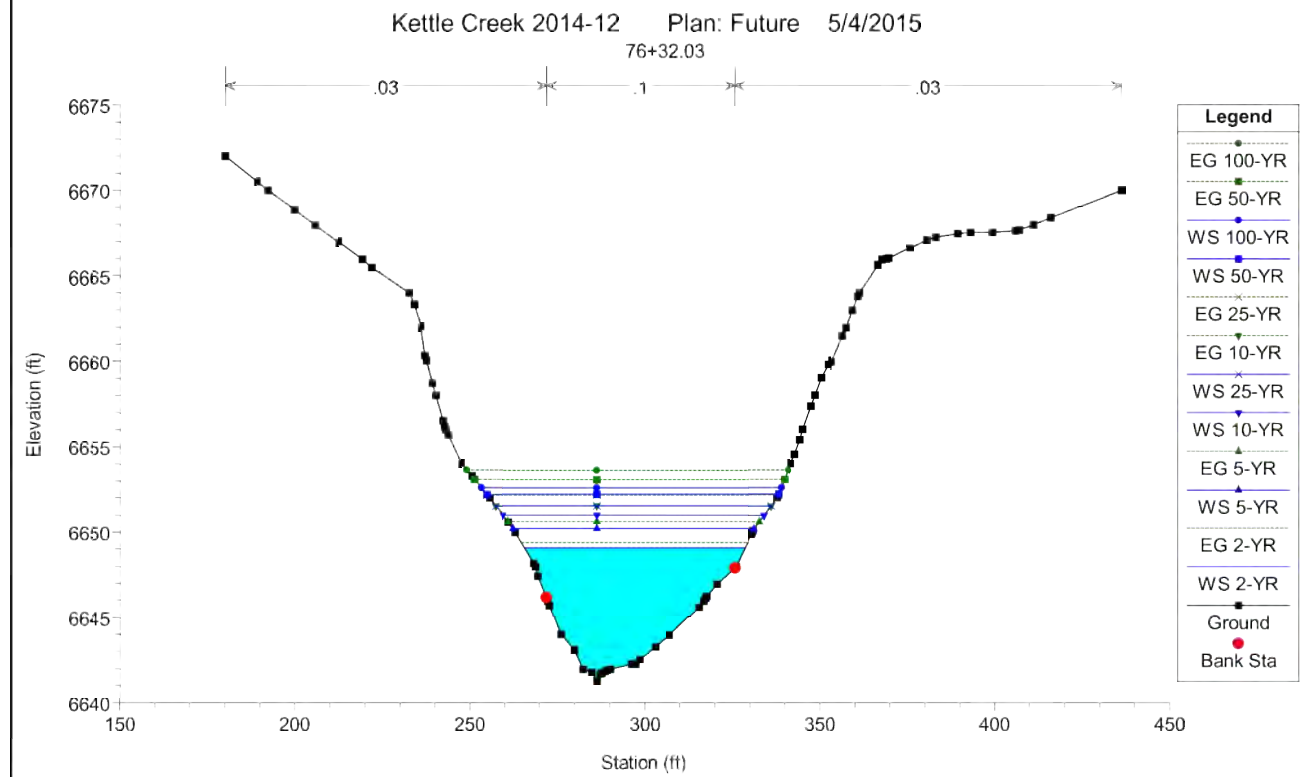
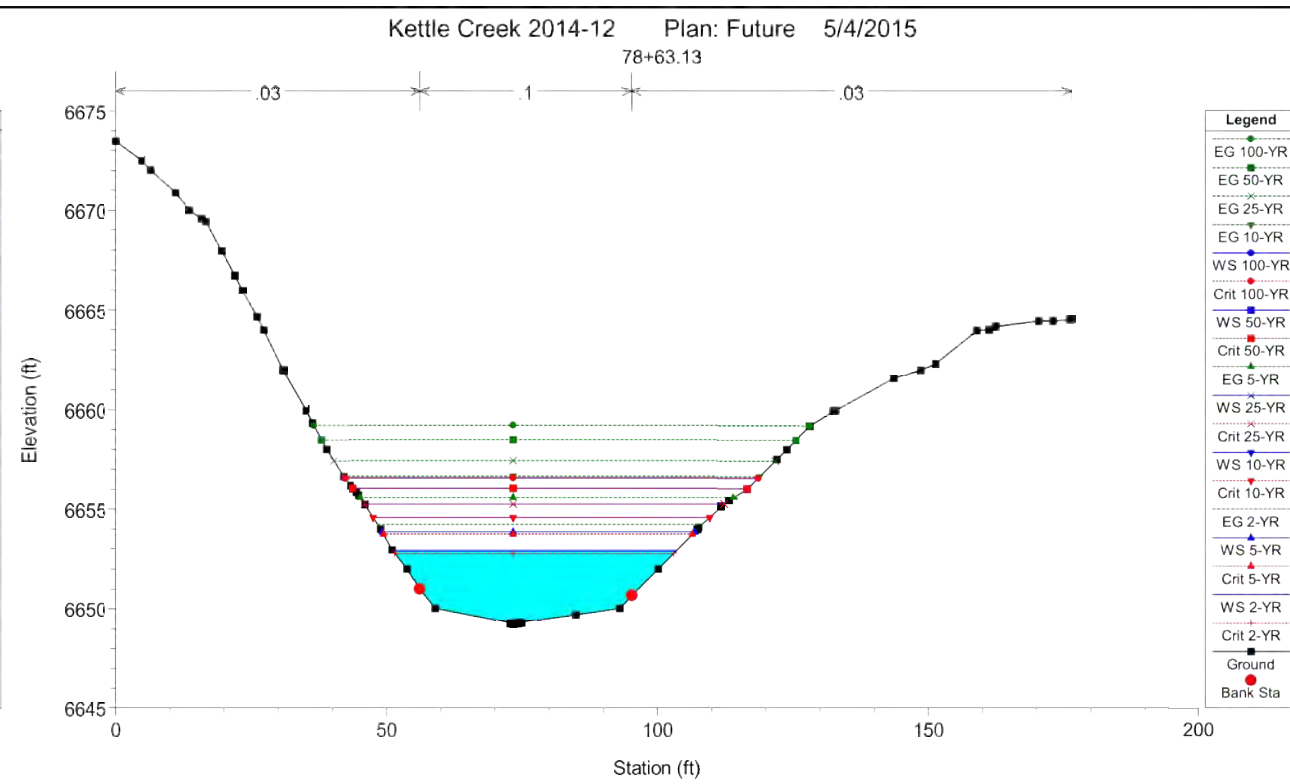
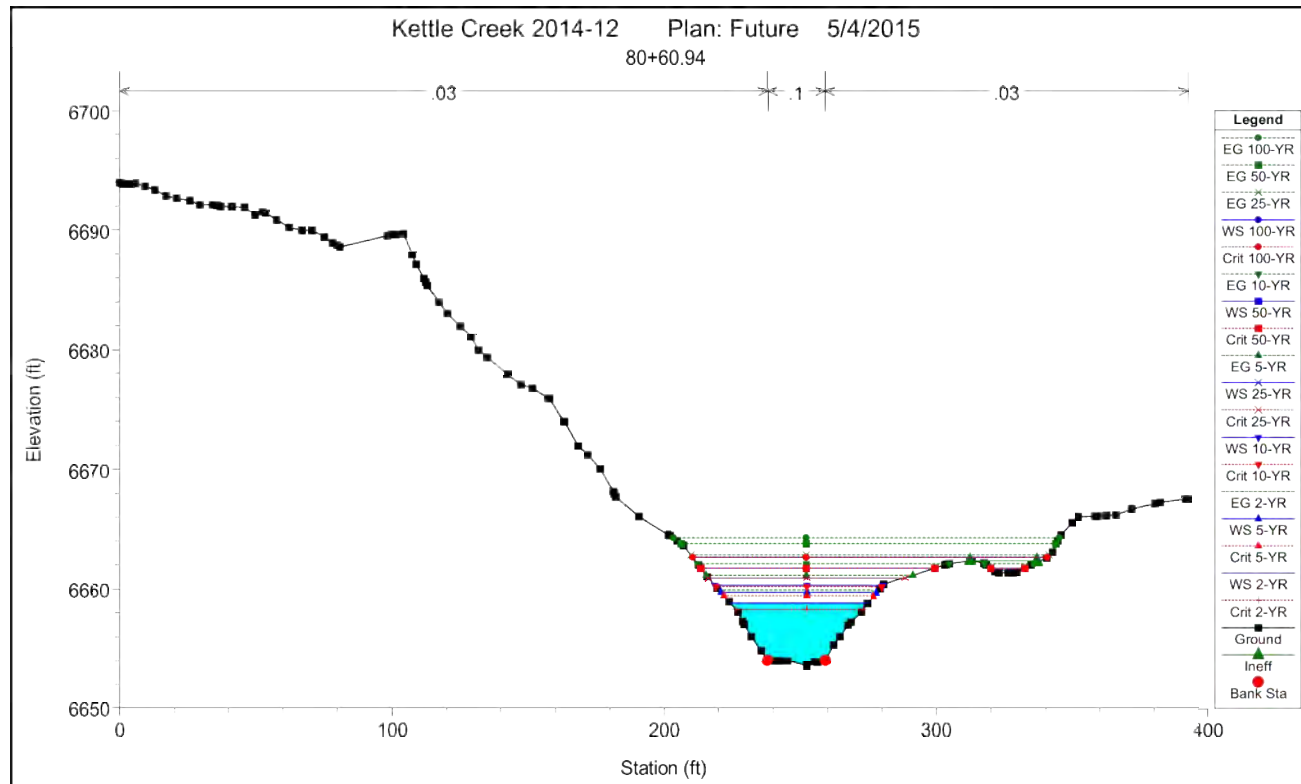

FUTURE CONDITIONS
MODEL RESULTS

HYDRAULIC RESULTS –
FUTURE
KETTLE CREEK DBPS
JOB NO. 25100.00
MAY 2015
C-79



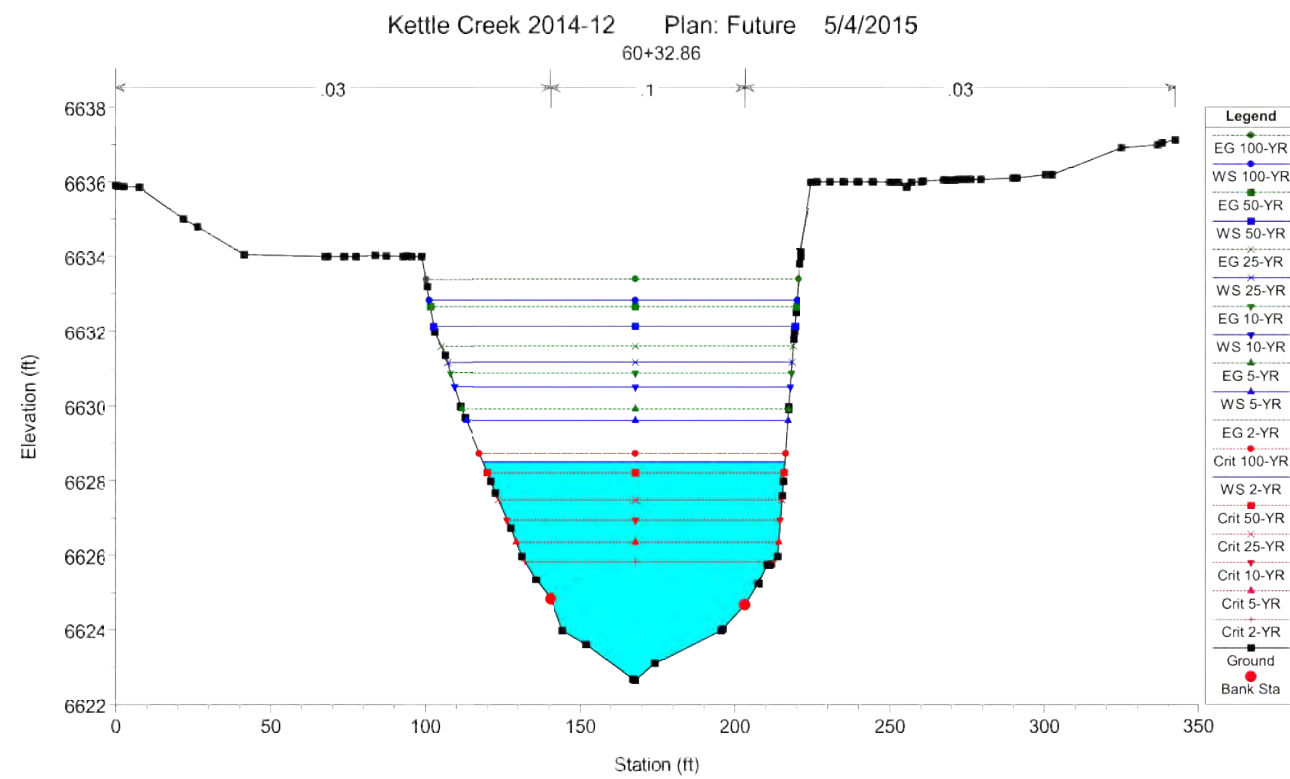
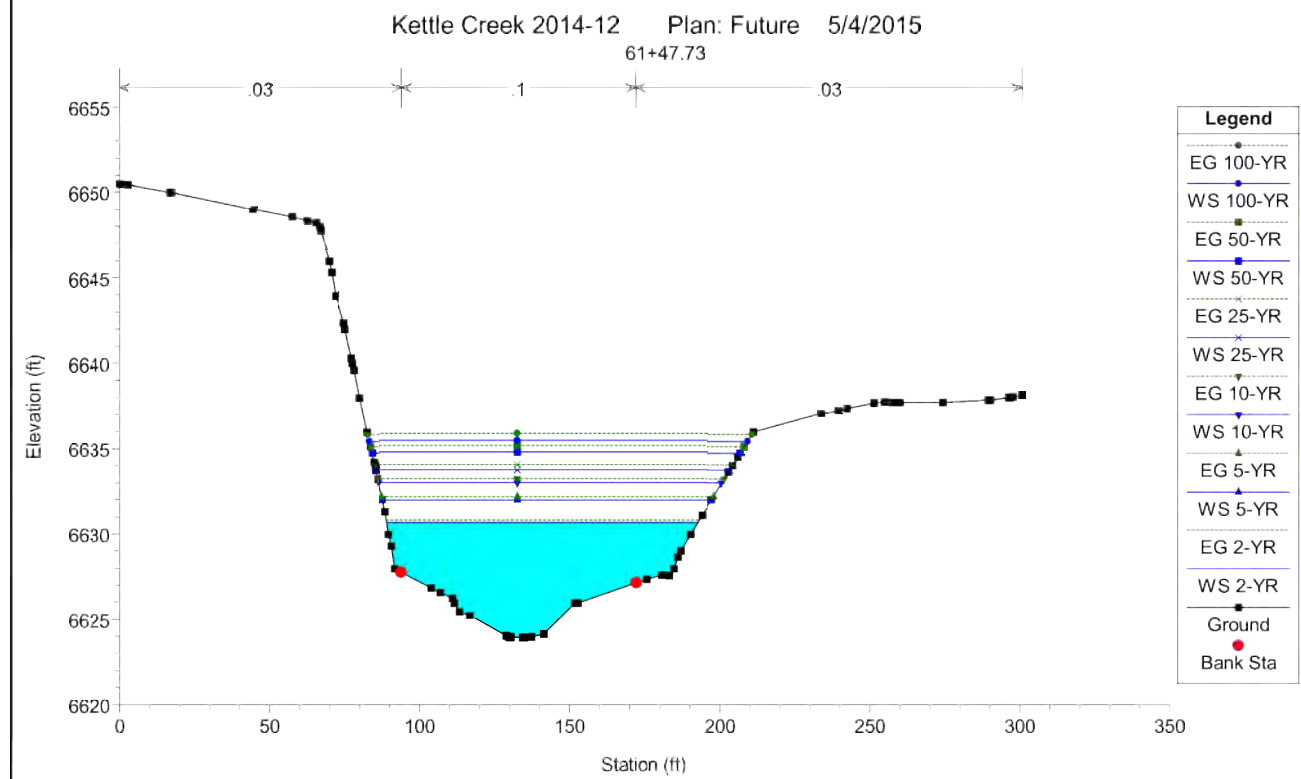
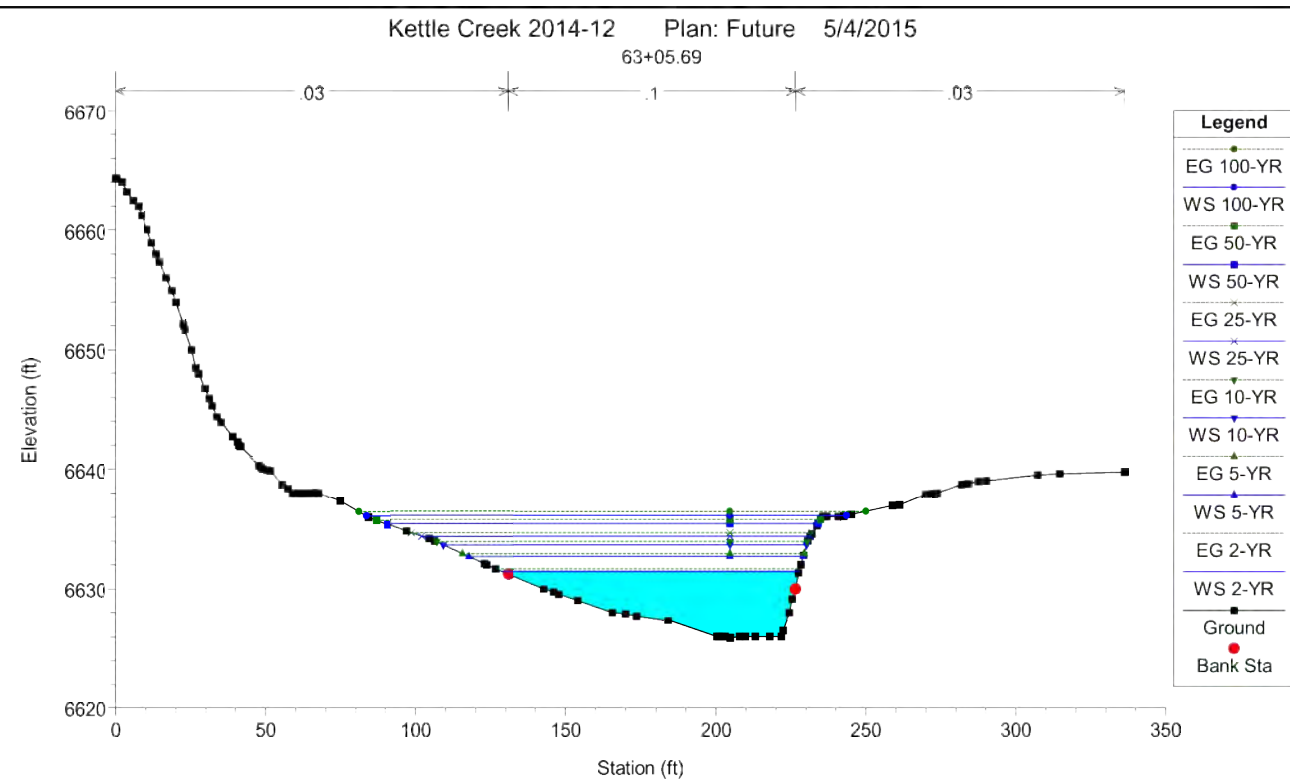
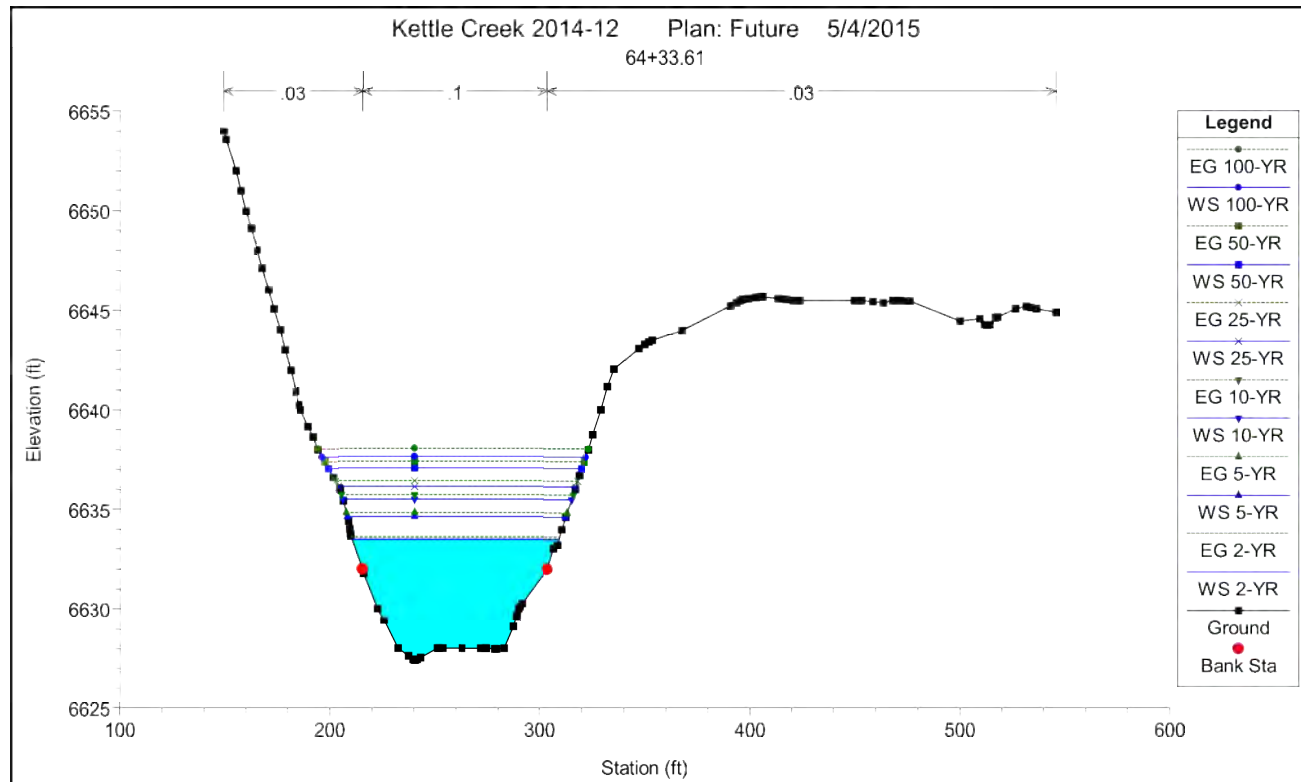

FUTURE CONDITIONS
MODEL RESULTS

HYDRAULIC RESULTS –
FUTURE
KETTLE CREEK DBPS
JOB NO. 25100.00
MAY 2015
C-80



Centennial 303-740-9393 • Colorado Springs 719-593-2593
Fort Collins 970-491-9888 • www.jrengineering.com

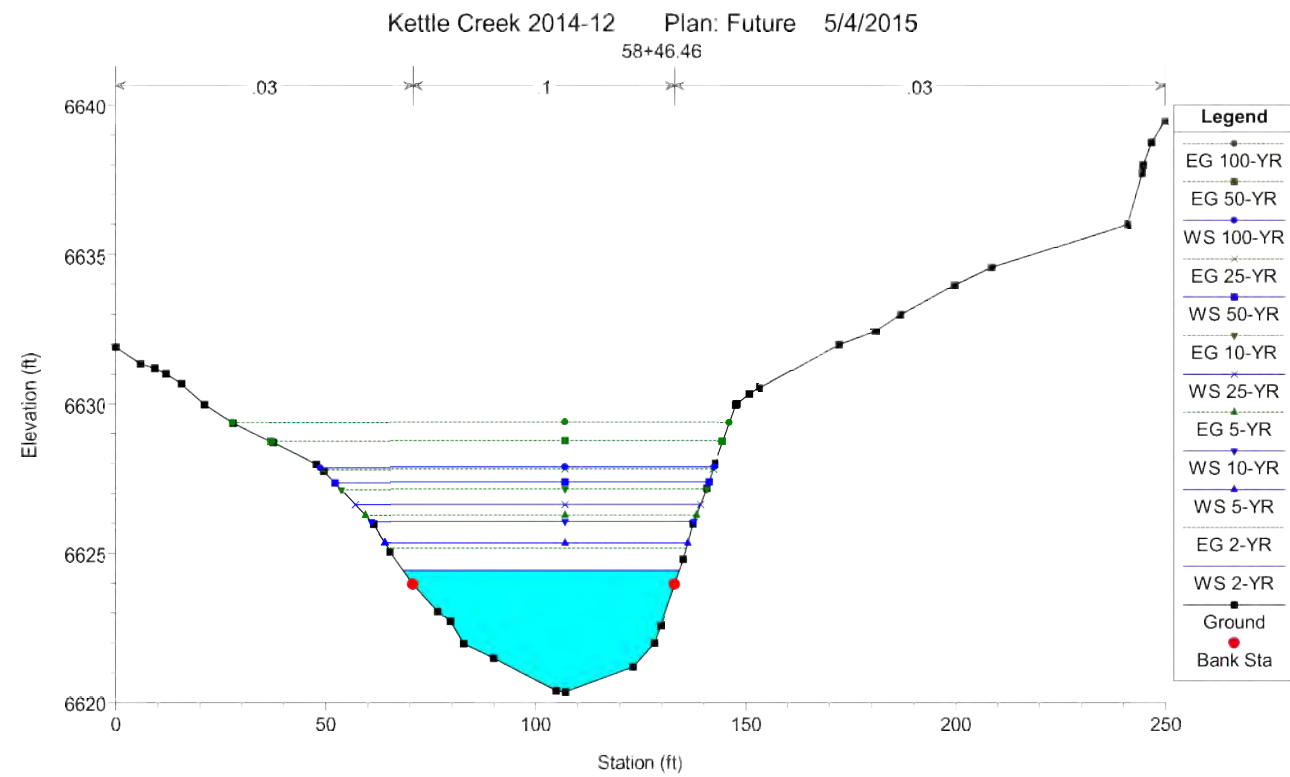
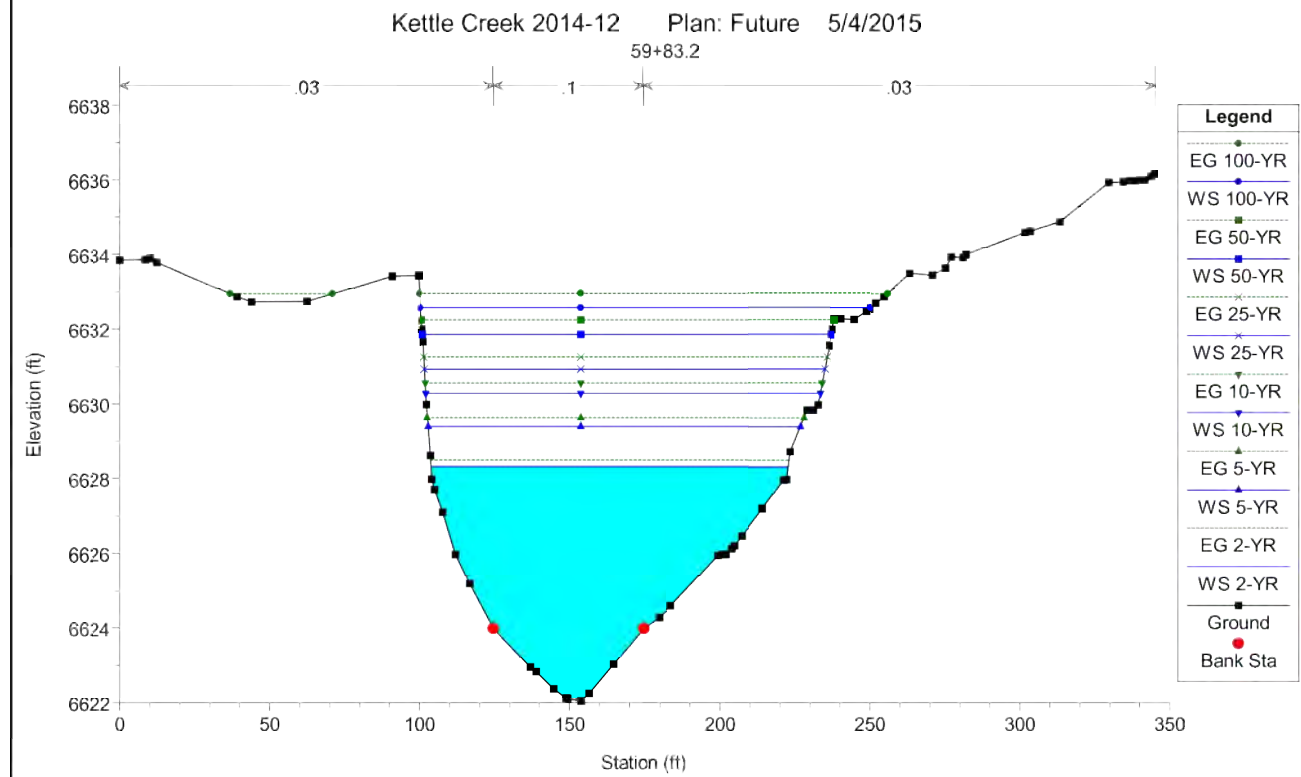
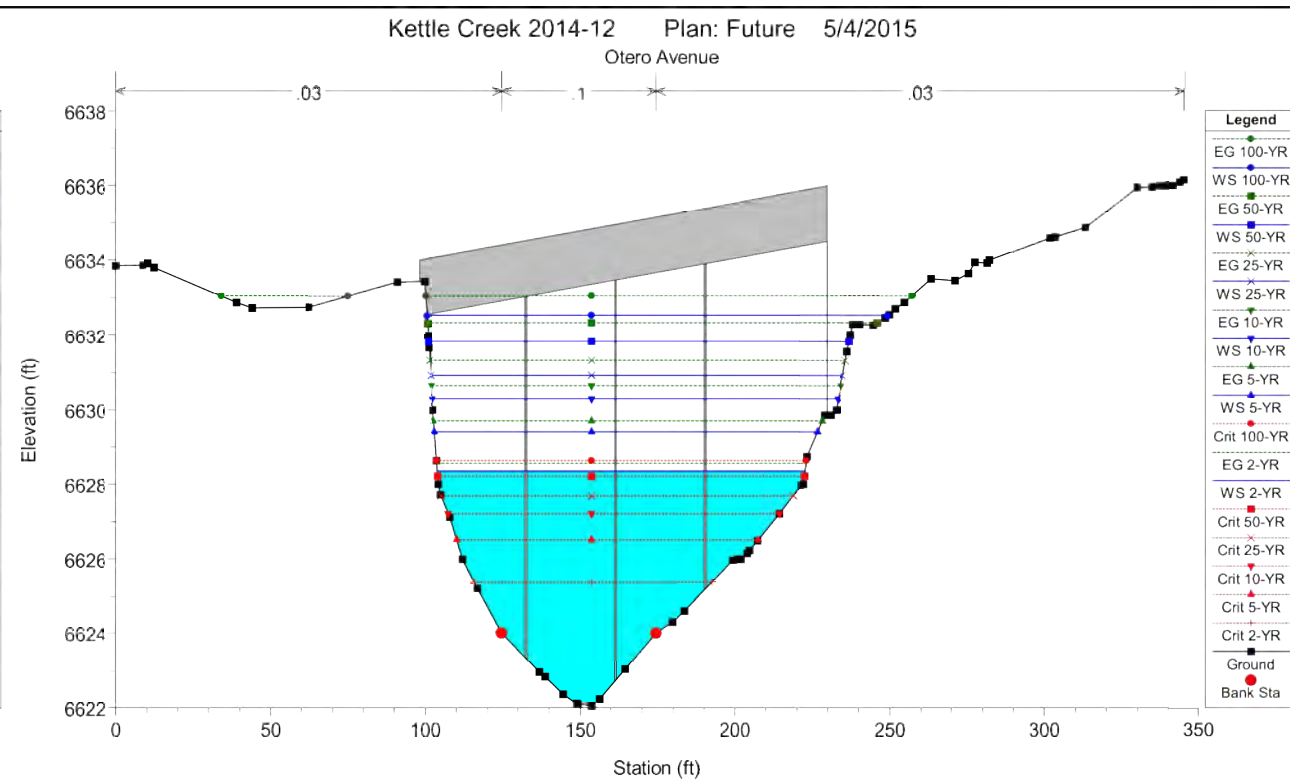
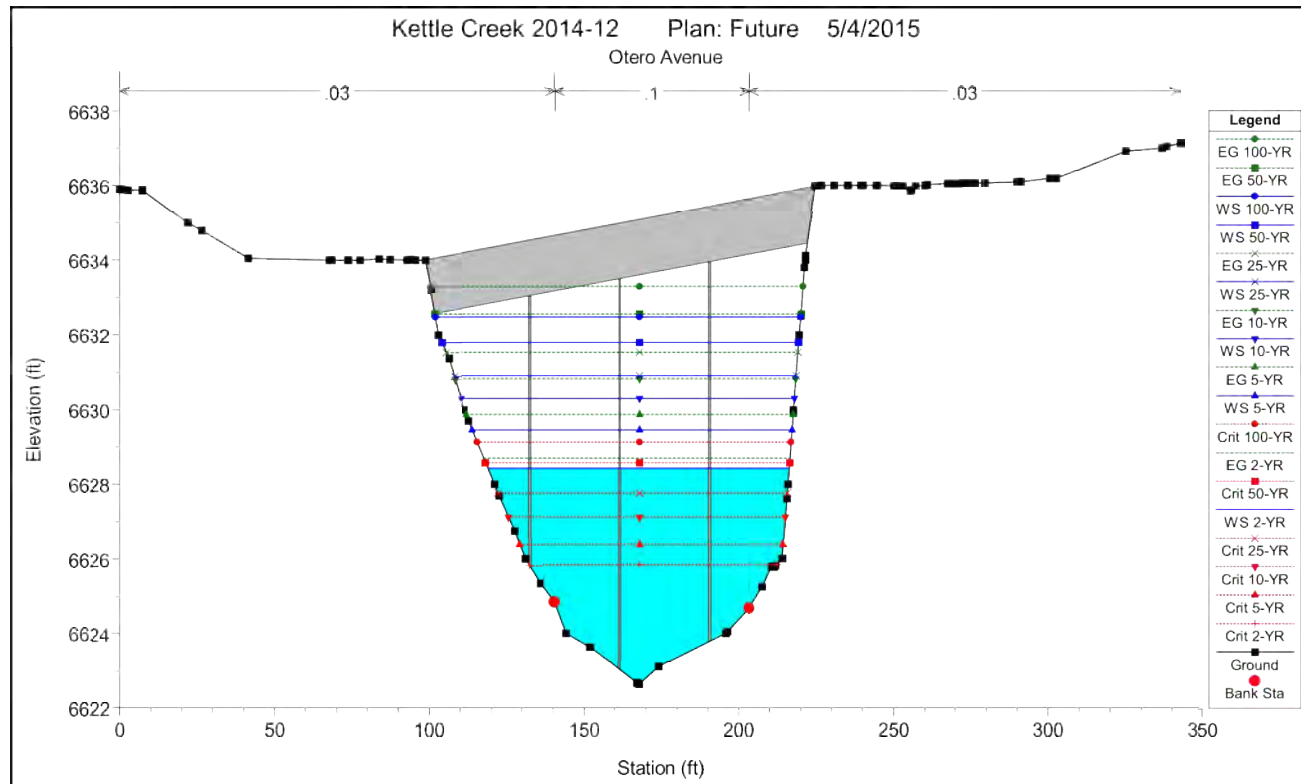

FUTURE CONDITIONS
MODEL RESULTS

HYDRAULIC RESULTS –
FUTURE
KETTLE CREEK DBPS
JOB NO. 25100.00
MAY 2015
C-81



Centennial 303-740-9393 • Colorado Springs 719-593-2593
Fort Collins 970-491-9888 • www.jrengineering.com

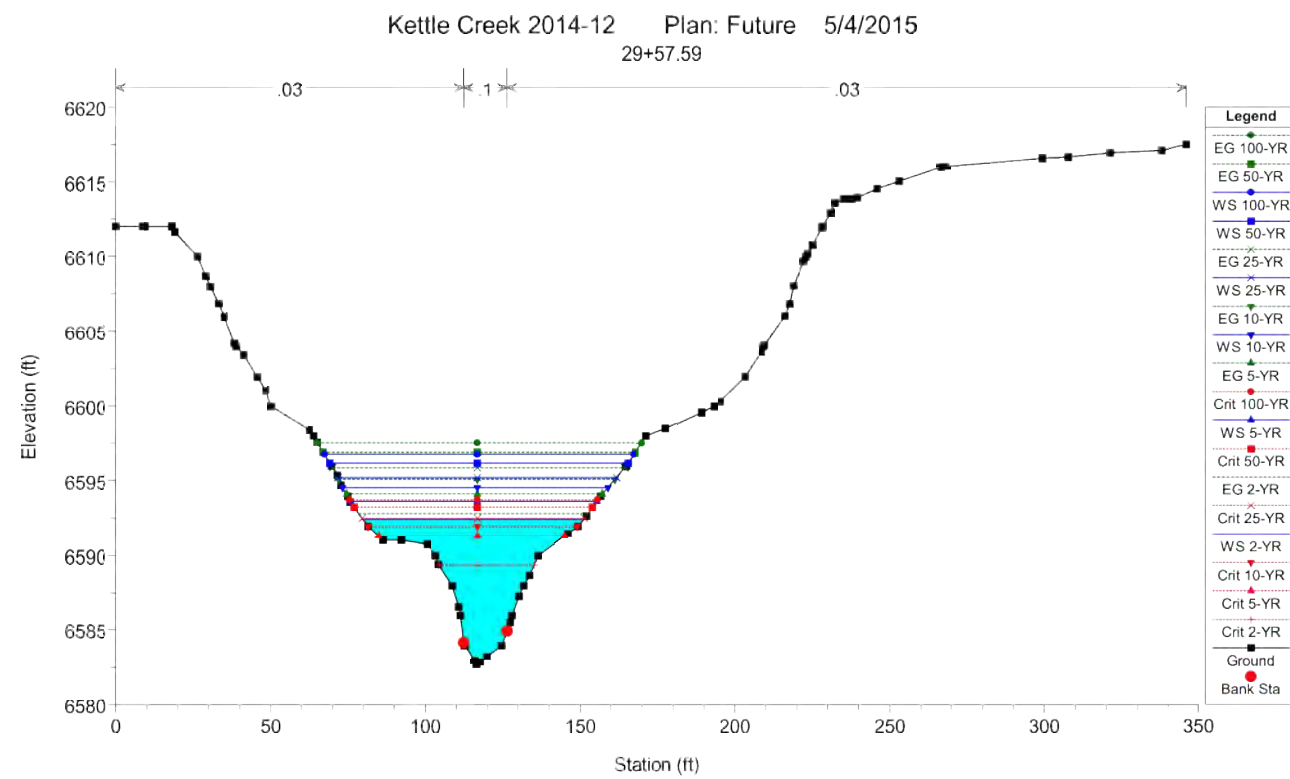
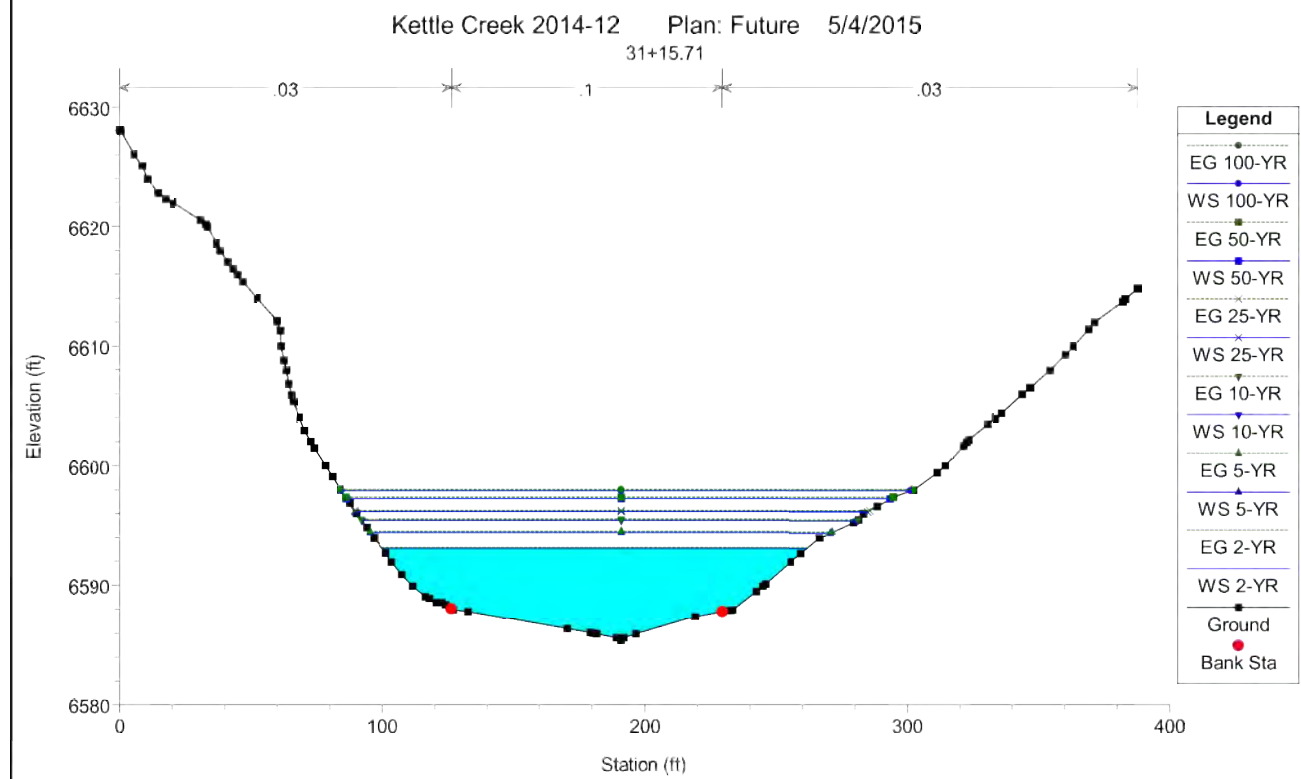
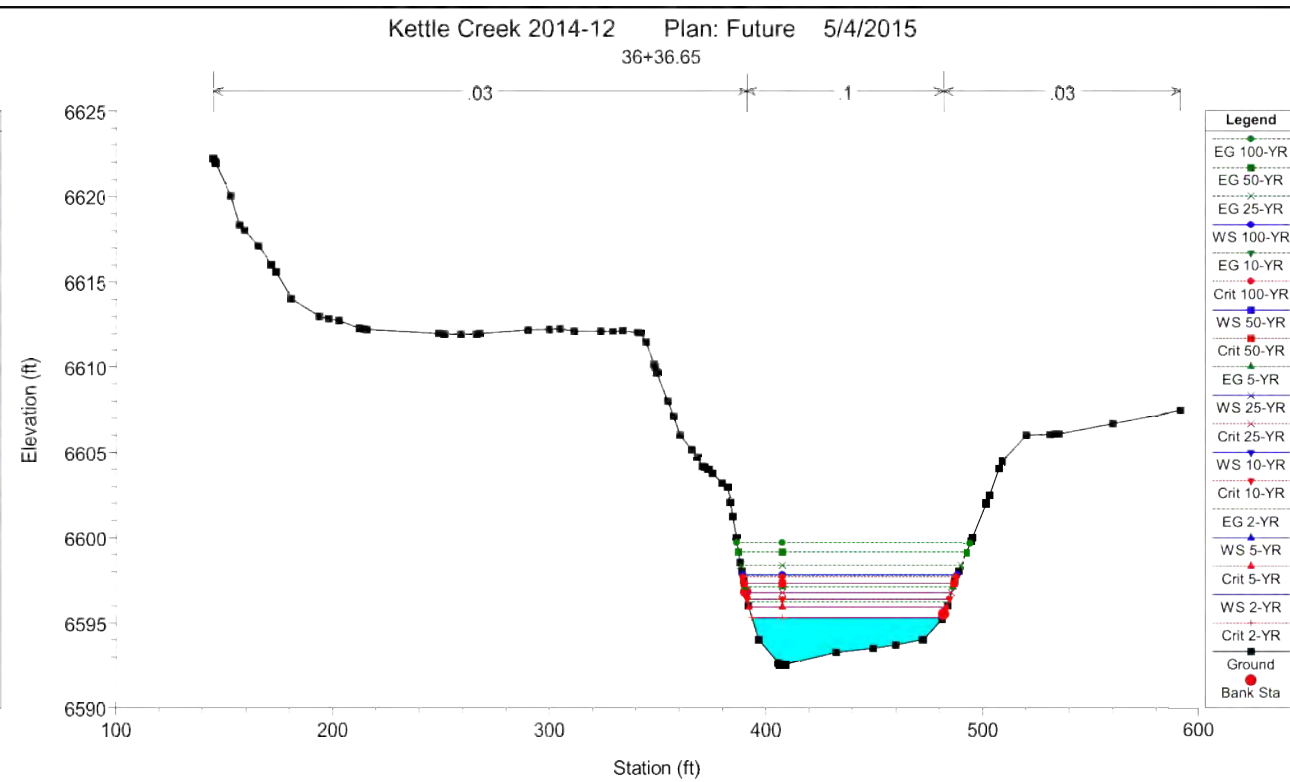
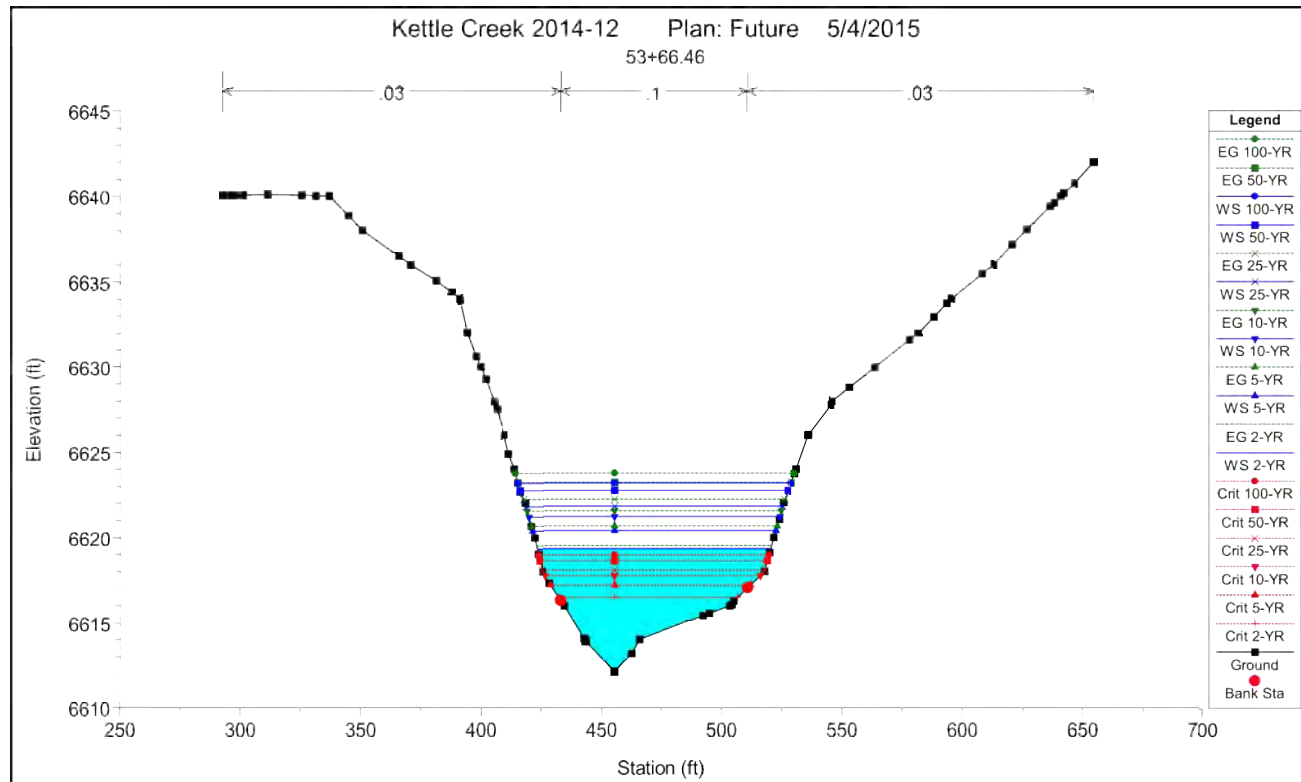

HYDRAULIC RESULTS –
FUTURE
KETTLE CREEK DBPS
JOB NO. 25100.00
MAY 2015
C-82

FUTURE CONDITIONS
MODEL RESULTS



Centennial 303-740-9393 • Colorado Springs 719-593-2593
Fort Collins 970-491-9888 • www.jrengineering.com

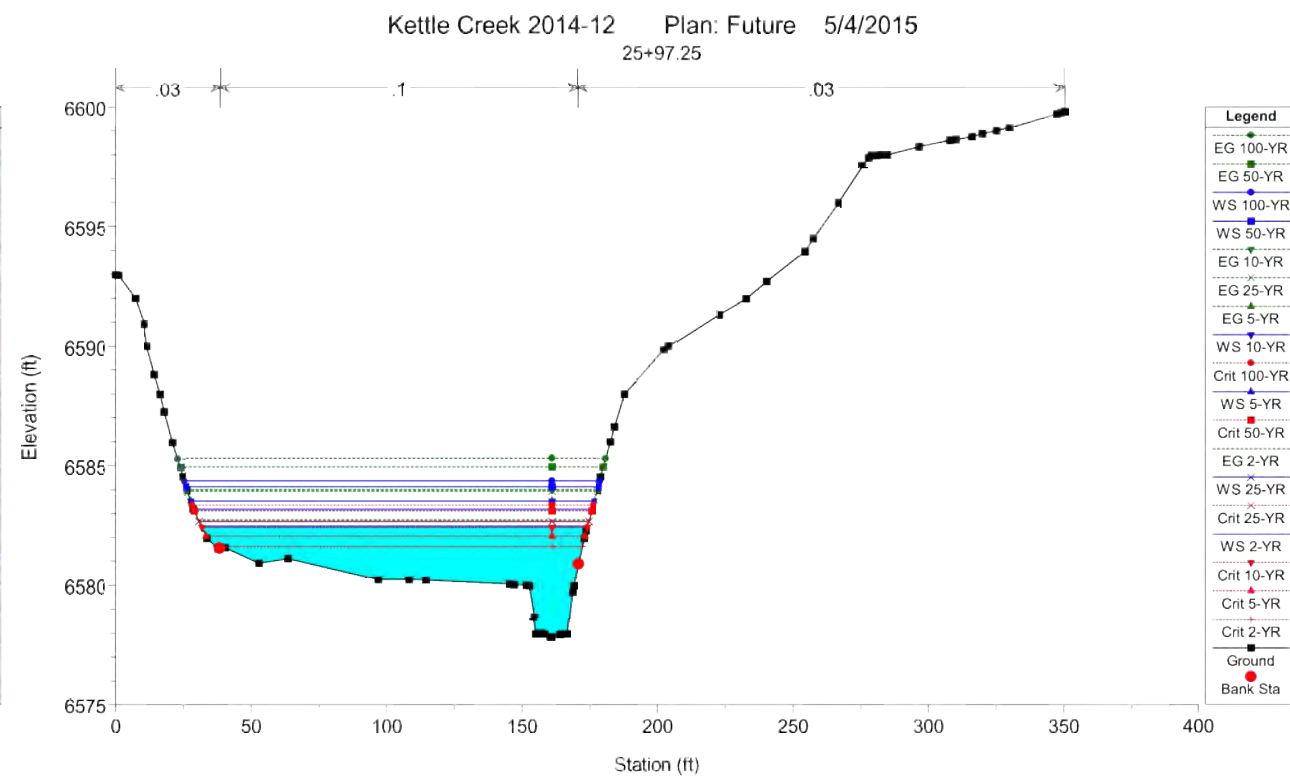
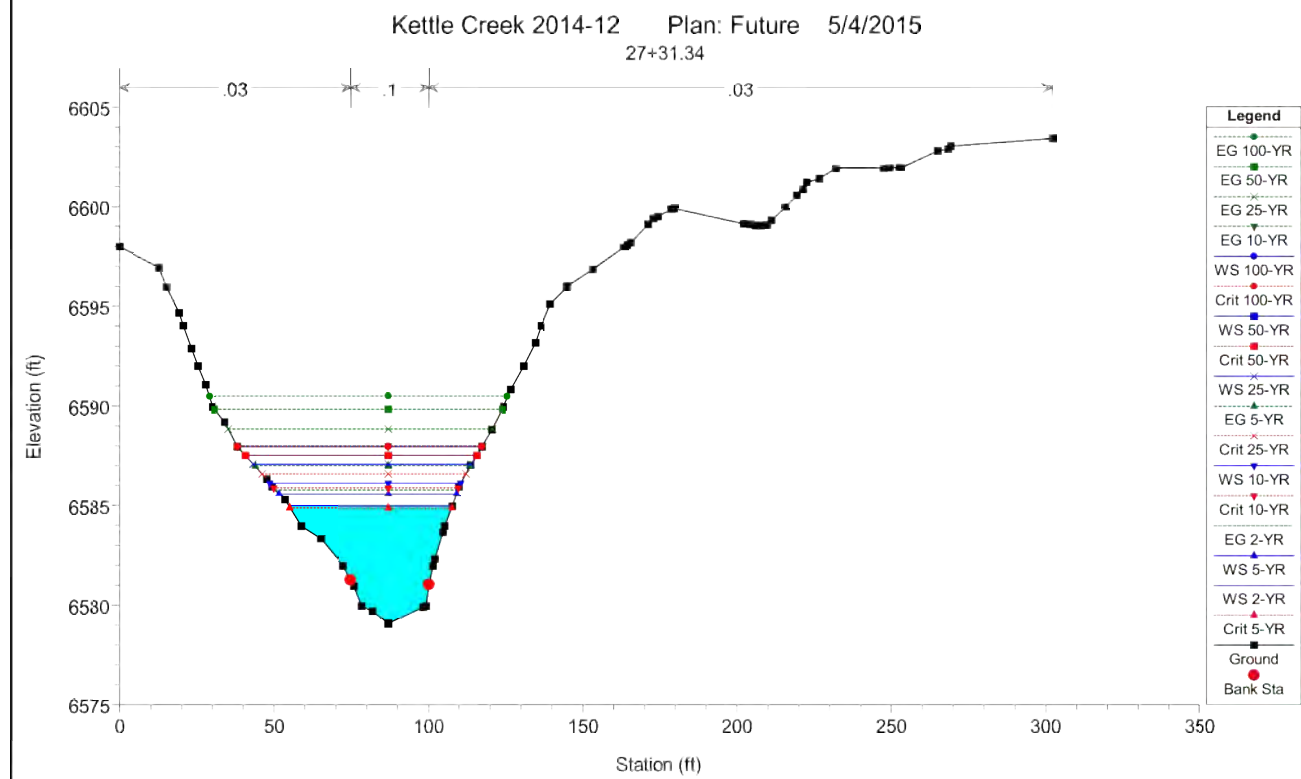
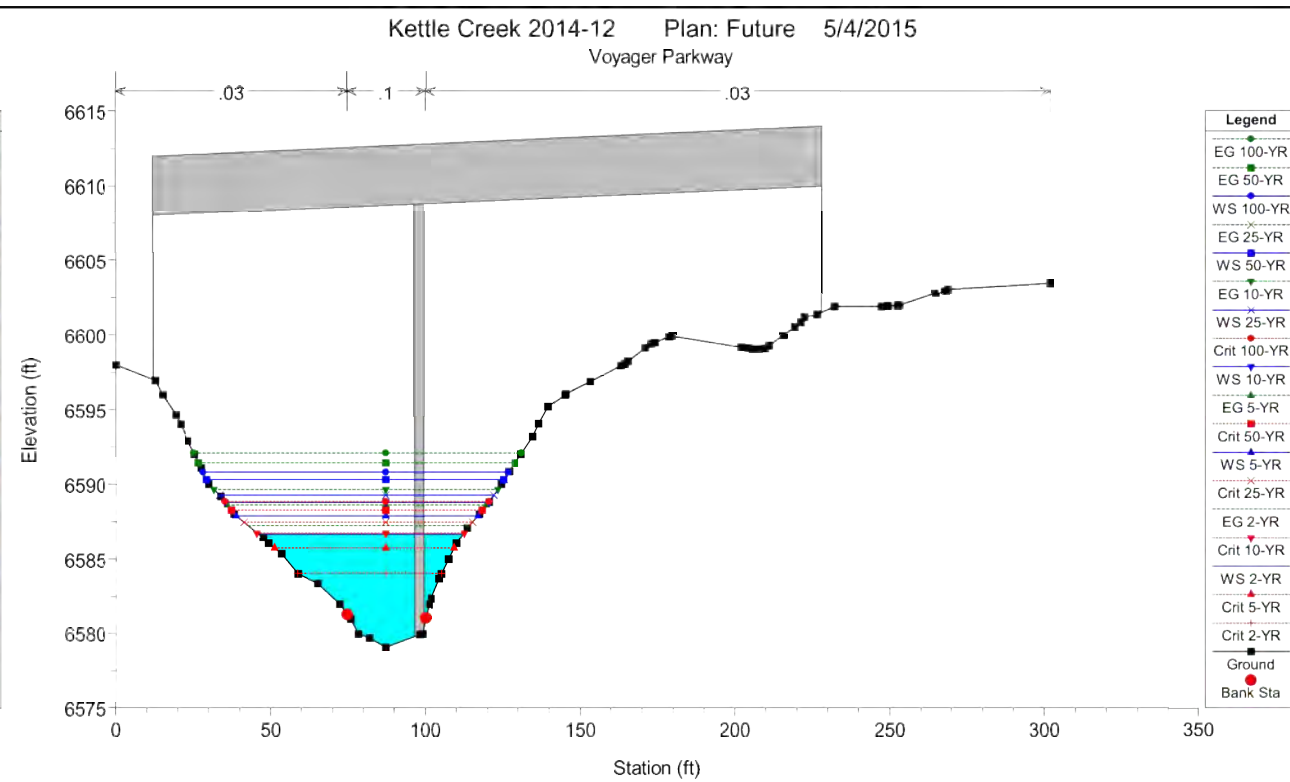
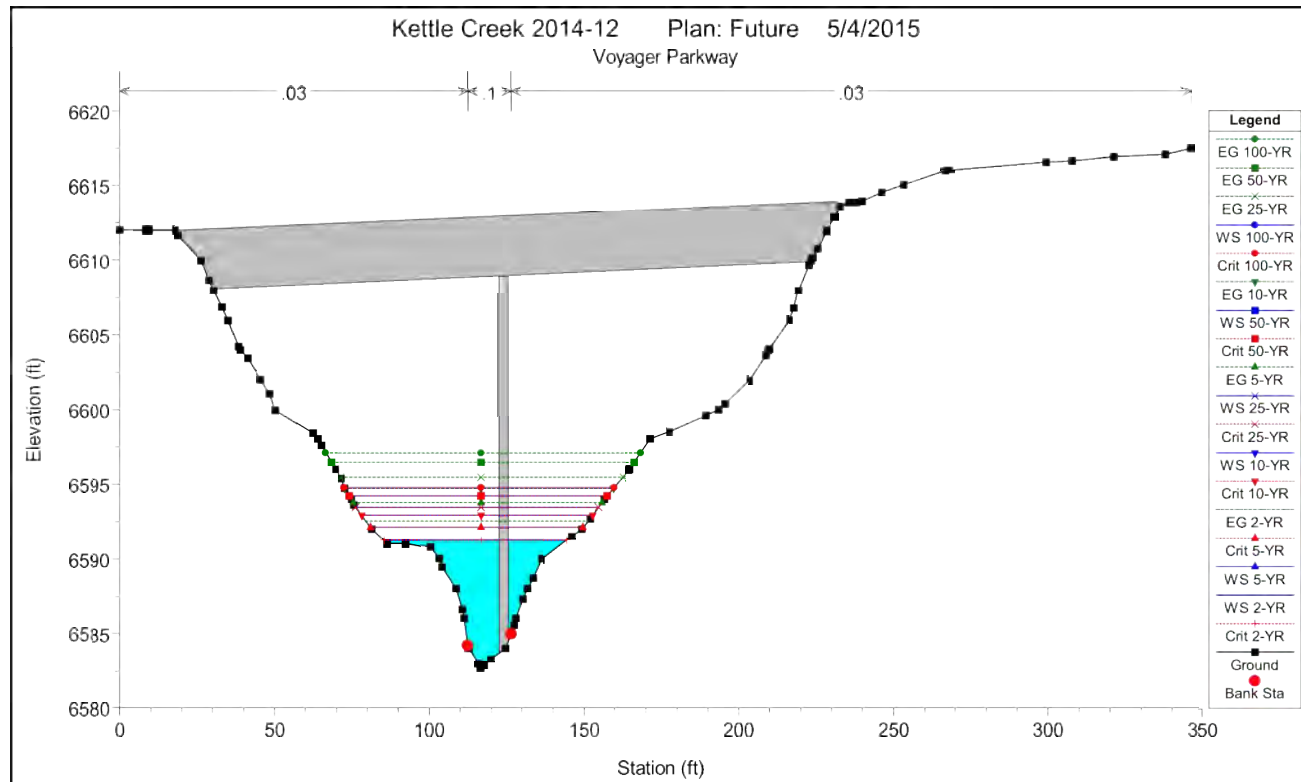

HYDRAULIC RESULTS –
FUTURE
KETTLE CREEK DBPS
JOB NO. 25100.00
MAY 2015
C-83

FUTURE CONDITIONS
MODEL RESULTS



Centennial 303-740-9393 • Colorado Springs 719-593-2593
Fort Collins 970-491-9888 • www.jrengineering.com

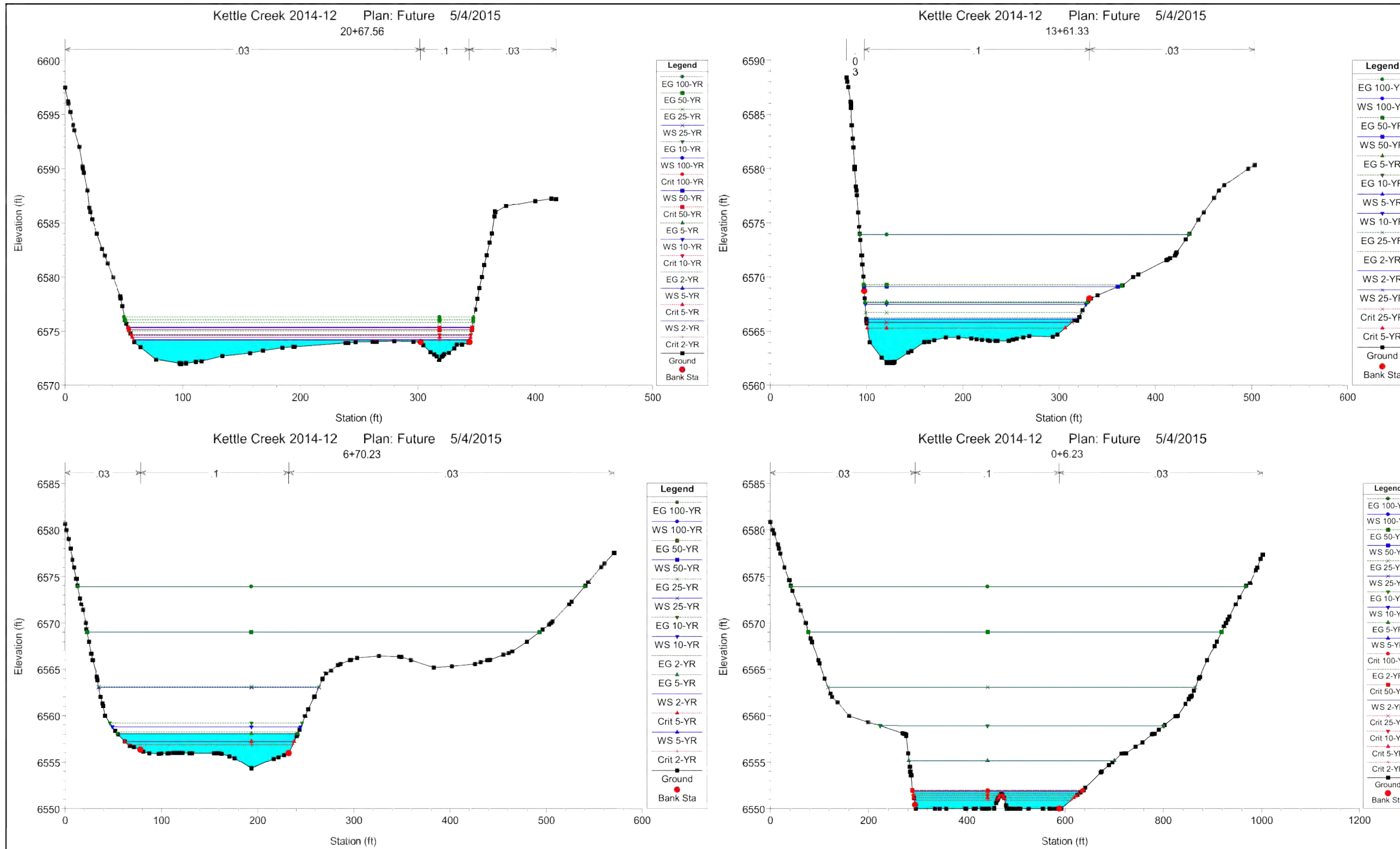

HYDRAULIC RESULTS –
 FUTURE
 KETTLE CREEK DBPS
 JOB NO. 25100.00
 MAY 2015
 C-84

FUTURE CONDITIONS
 MODEL RESULTS



Appendix D – Photo Logs



POWERS BLVD BRIDGE
LOOKING NORTH



POWERS BLVD BRIDGE
LOOKING UPSTREAM



OLD RANCH ROAD BRIDGE
DOWNSTREAM



OLD RANCH ROAD BRIDGE
LOOKING NORTH

APPENDIX D – PHOTOS
KETTLE CREEK DBPS
JOB NO. 25100.00
MAY 2015
D-1



Centennial 303-740-9393 • Colorado Springs 719-593-2593
Fort Collins 970-491-9888 • www.jrengineering.com



OLD RANCH ROAD BRIDGE
LOOKING UPSTREAM



OLD RANCH ROAD BRIDGE
LOOKING UPSTREAM



OTERO AVE BRIDGE
LOOKING UPSTREAM



OTERO AVE BRIDGE
LOOKING UPSTREAM

APPENDIX D – PHOTOS
KETTLE CREEK DBPS
JOB NO. 25100.00
MAY 2015
D-2



Centennial 303-740-9393 • Colorado Springs 719-593-2593
Fort Collins 970-491-9888 • www.jrengineering.com



HWY 83 BRIDGE
LOOKING NORTH



HWY 83 BRIDGE
LOOKING UPSTREAM

APPENDIX D – PHOTOS
KETTLE CREEK DBPS
JOB NO. 25100.00
MAY 2015
D-3



Centennial 303-740-9393 • Colorado Springs 719-593-2593
Fort Collins 970-491-9888 • www.jrengineering.com



CHANNEL CONDITIONS
APPROX. STA 80+00



CHANNEL CONDITIONS
APPROX. STA 165+00



CHANNEL CONDITIONS
APPROX. STA 160+00



CHANNEL CONDITIONS
APPROX. STA 175+00



CHANNEL CONDITIONS
APPROX. STA 169+00



CHANNEL CONDITIONS
APPROX. STA 104+00



CHANNEL CONDITIONS
APPROX. STA 58+00

APPENDIX D – PHOTOS
KETTLE CREEK DBPS
JOB NO. 25100.00
MAY 2015
D-4



Centennial 303-740-9393 • Colorado Springs 719-593-2593
Fort Collins 970-491-9888 • www.jrengineering.com

Appendix E – Unplatted Area Calculations

UNPLATTED AREA WITHIN CITY OF COLORADO SPRINGS CITY LIMITS

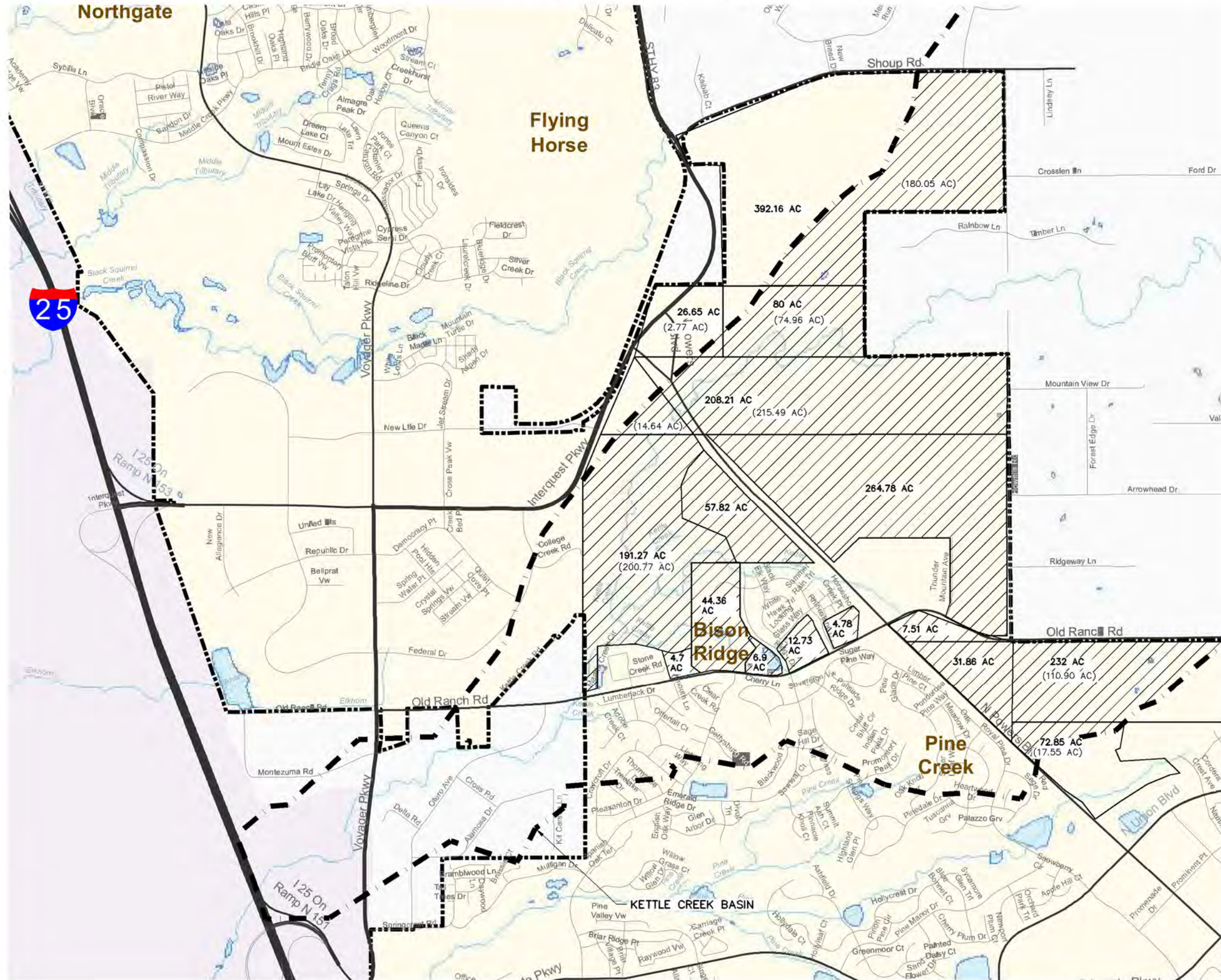

Unplatted Area in the Kettle Creek Basin	
Acreage	
	180.05
	74.96
	2.77
	215.49
	14.64
	200.77
	57.82
	264.78
	44.36
	4.70
	6.90
	12.73
	4.78
	7.51
	31.86
	110.90
	17.55
	1252.57

LEGEND

- KETTLE CREEK BASIN
- UNPLATTED AREA

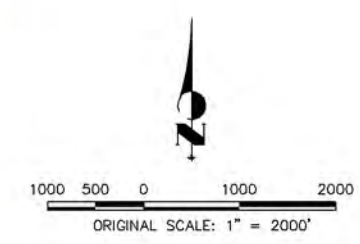

APPENDIX E – UNPLATTED
 AREA CALCULATIONS
 KETTLE CREEK DBPS
 JOB NO. 25100.00
 MAY 2015
 E-1



Centennial 303-740-9893 • Colorado Springs 719-593-2593
 Fort Collins 970-491-9888 • www.jrengineering.com

LEGEND

- JOVENCHI-I LLC
- 260 EB LLC
- HIGH VALLEY LAND COMPANY INC
- KETTLE CREEK LLC & VENEZIA JOHN FAMILY TRUST
- KETTLE CREEK BASIN BOUNDARY

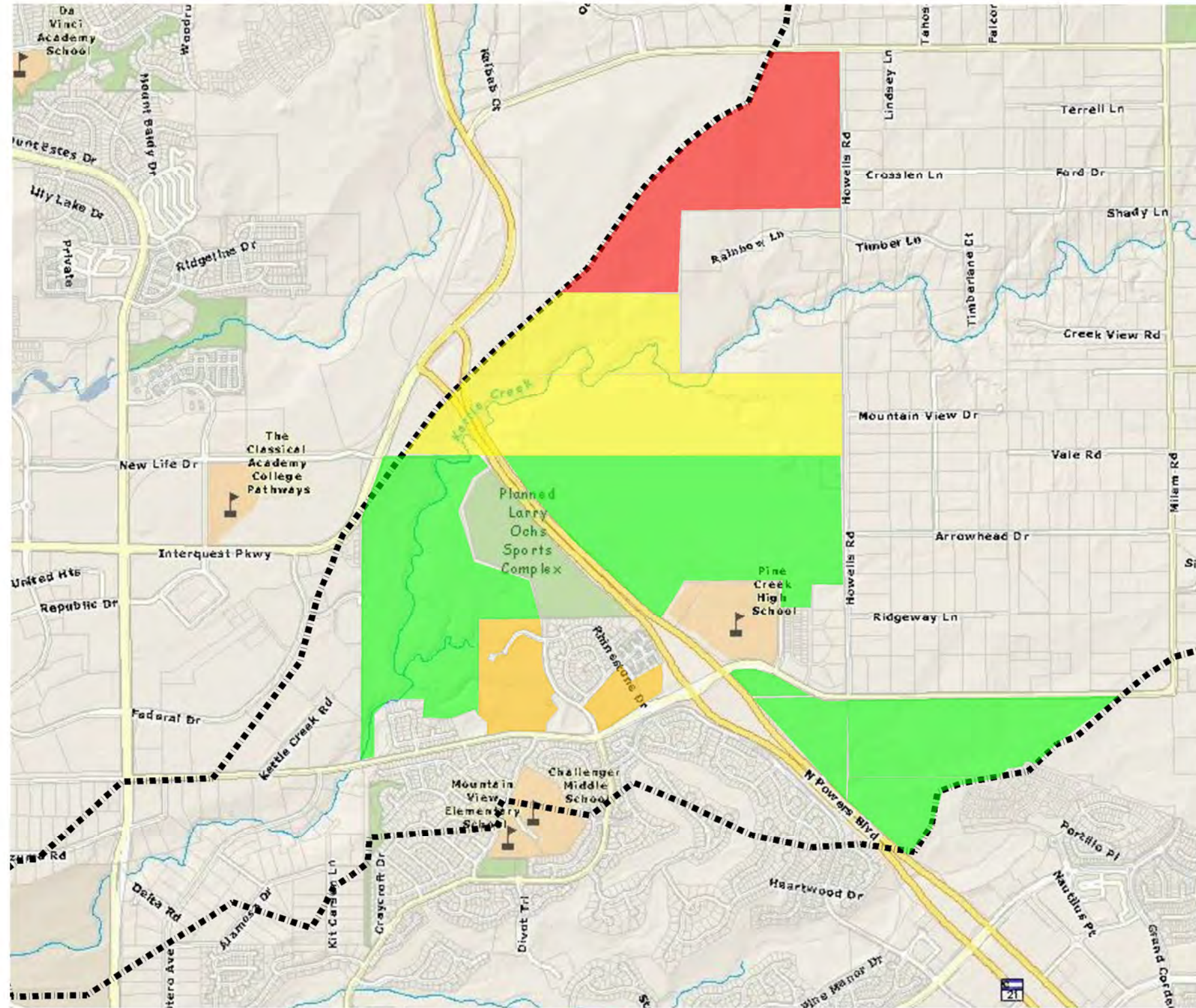

KETTLE CREEK UNDEVELOPED LAND OWNERS		
PROPERTY OWNER	AREA (AC)	PERCENTAGE
JOENCHI-I LLC	307	27.2%
260 EB LLC	180	15.9%
HIGH VALLEY LAND COMPANY	580	51.4%
KETTLE CREEK LLC & VENEZIA JOHN FAMILY TRUST	62	5.5%
Total	1129	100.0%

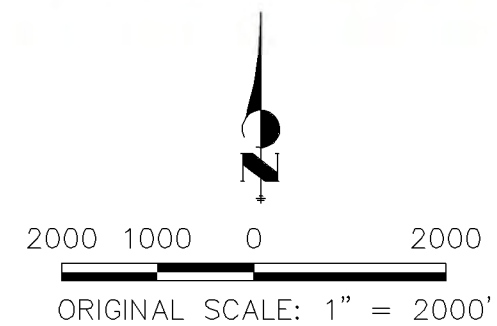

APPENDIX E –
 UNDEVELOPED LAND
 OWNERS
 KETTLE CREEK DBPS
 JOB NO. 25100.00
 MAY 2015
 E-2



Centennial 303-740-9393 • Colorado Springs 719-593-2593
 Fort Collins 970-491-9888 • www.jrengineering.com

Appendix F – Fee Calculations

Channel Report

Hydraflow Express Extension for AutoCAD® Civil 3D® 2012 by Autodesk, Inc.

Wednesday, Jan 21 2015

Conceptual Outfall From 260 EB LLC

Circular
Diameter (ft) = 3.50

Invert Elev (ft) = 10.00
Slope (%) = 0.80
N-Value = 0.013

Calculations
Compute by: Known Q
Known Q (cfs) = 94.50

Highlighted
Depth (ft) = 3.06
Q (cfs) = 94.50
Area (sqft) = 8.93
Velocity (ft/s) = 10.58
Wetted Perim (ft) = 8.47
Crit Depth, Yc (ft) = 3.00
Top Width (ft) = 2.31
EGL (ft) = 4.80

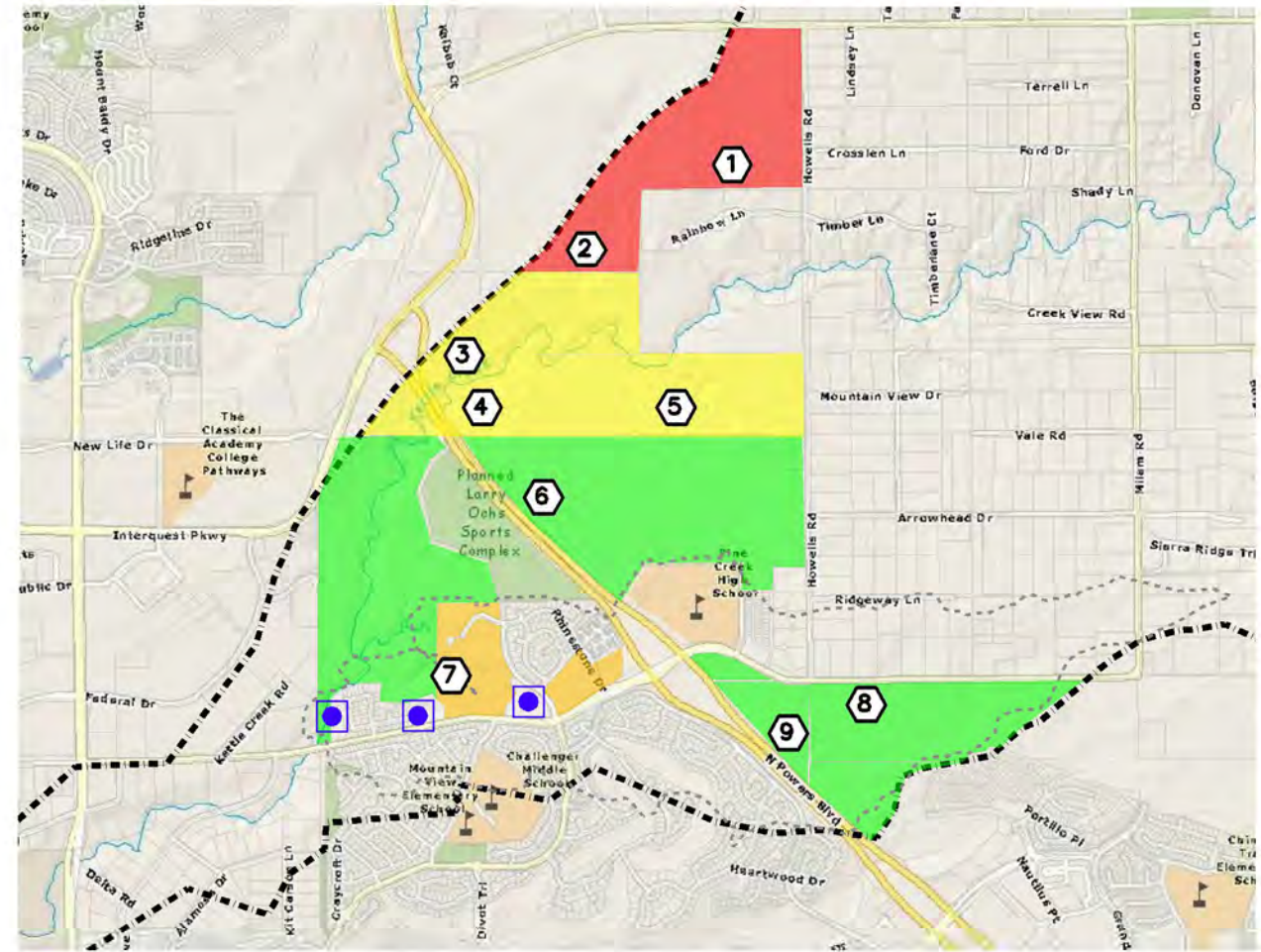
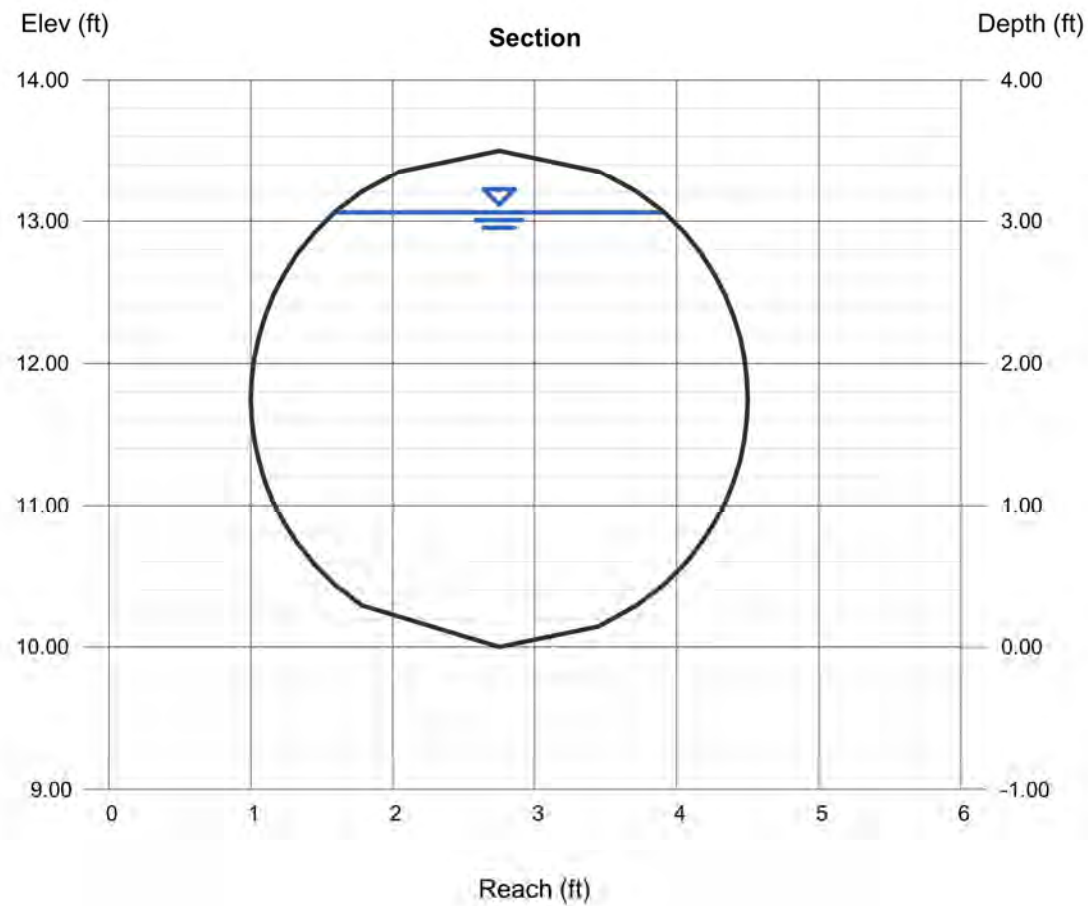

LEGEND

- JOVENCHI-I LLC
- 260 EB LLC
- HIGH VALLEY LAND COMPANY INC
- KETTLE CREEK LLC & VENEZIA JOHN FAMILY TRUST
- ① ESTIMATED LOCATION OF PROPOSED SUBREGIONAL PONDS
- EXISTING LOCATION OF SUBREGIONAL PONDS
- KETTLE CREEK BASIN BOUNDARY
- KETTLE CREEK OLD RANCH TRIBUTARY DRAINAGE BASIN PLANNING STUDY LOCATION

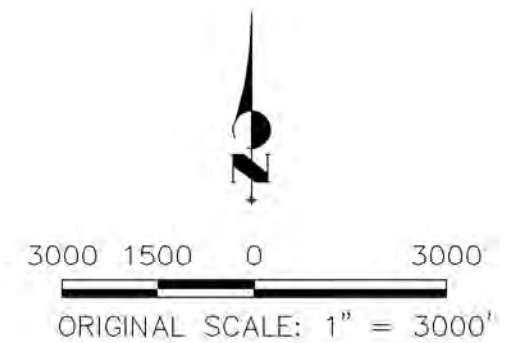

APPENDIX F – BASIN
FEE EXHIBIT
KETTLE CREEK DBPS
JOB NO. 25100.00
MAY 2015
F-1



Centennial 303-740-9898 • Colorado Springs 719-593-2593
Fort Collins 970-491-9888 • www.jrengineering.com

**DRAINAGE CALCULATIONS
FOR FEE DETERMINATION*
FOR 260 EB LLC to Jovenchi-I LLC Property**

Subdivision: 260 EB LLC
Location: Kettle Creek

Project Name: Kettle Creek DBPS
Project No.: 25100.00
Calculated By: Mark Fischer
Checked By: _____
Date: 1/13/15

SUB-BASIN DATA						INITIAL/OVERLAND (T _i)			TRAVEL TIME (T _t)						FLOWS	
BASIN ID	D.A. (AC)	Hydrologic Soils Group	Impervious (%)	C ₁₀₀	C _s	L (FT)	S (%)	T _i (MIN)	L (FT)	S (%)	C _v	VEL. (FPS)	T _t (MIN)	COMP. T _c (MIN)	I ₁₀₀ (IN/HR)	Q (CFS)
260 EB	47.00	B	2.00	0.36	0.08	200	3.0	18.3	3113	4.0	7.0	1.4	37.1	55.4	2.6	44.0
JOVENCHI	54.00	B	2.00	0.36	0.08	100	3.0	13.0	1038	7.0	5.0	1.3	13.1	26.0	4.5	87.5

NOTES:
 $T_i = (0.395 * (1.1 - C_s) * L^{0.5}) / (S^{0.33})$, S in ft/ft
 $T_t = L / 60V$ (Velocity From Fig. 501)
 Velocity $V = C_v * S^{0.5}$, S in ft/ft
 T_c Check = $10 + L / 180$
 $I_{100} = (-2.52 * \ln(T_c)) + 12.735$
 $Q = C_{100} * (D.A.) * I_{100}$

**STANDARD FORM SF-3
STORM DRAINAGE SYSTEM DESIGN
(RATIONAL METHOD PROCEDURE)**

Subdivision: _____
Location: Arapahoe County
Design Storm: 100-Year

Project Name: Kettle Creek DBPS
Project No.: 25100.00
Calculated By: Mark Fischer
Checked By: Tristan Bonser
Date: 1/13/15

STREET	Design Point	DIRECT RUNOFF							TOTAL RUNOFF				STREET		PIPE			TRAVEL TIME			REMARKS
		Basin ID	Area (Ac)	Runoff Coeff.	T _c (min)	C _s (Ac)	I (in/hr)	Q (cfs)	T _c (min)	C _s (Ac)	I (in/hr)	Q (cfs)	Slope (%)	Street Flow (cfs)	Design Flow (cfs)	Slope (%)	Pipe Size (inches)	Length (ft)	Velocity (fps)	T _t (min)	
260 EB LLC		260	47.00	0.36	55.4	16.92	2.60	44.0													
Jovenchi-I LLC		3	54.00	0.36	26.0	19.44	4.50	87.5	55.4	36.36	2.60	94.5									

APPENDIX F – BASIN
FEE FLOW DATA
KETTLE CREEK DBPS
JOB NO. 25100.00
MAY 2015
F-2

*NOTE: NO DRAINAGE FEES IN THE KETTLE CREEK BASIN. CALCULATIONS FOR REFERENCE ONLY.

