

REPORTING REQUIREMENTS

ANTICIPATED STARTING TIME PERIOD OF SITE DISTURBANCE: April, 2023
 COMPLETION TIME PERIOD OF SITE DISTURBANCE: December, 2023
 EXPECTED DATE ON WHICH THE FINAL STABILIZATION WILL BE COMPLETED: June, 2024
 TOTAL AREA OF THE SITE TO BE CLEARED, EXCAVATED OR GRADED: 15.3 acres
 NAME OF RECEIVING WATERS: Cottonwood Creek
 SOILS INFORMATION: Blakeland loamy sand (1-9% slopes)
 Columbine gravelly sandy loam (0-3% slopes)
 Pring coarse sandy loam (3-8% slopes)
 Stapleton-Bernal sandy loams (3-20% slopes)
 [NRCS Soil Survey]

SUBDIVISION NAME: N/A.
 CONTROL MEASURE COST ESTIMATE: See FAE Submitted with Plan
 PROPOSED TOPOGRAPHY: The site will be returned as closely as possible to its pre-construction grade
 LOCATION OF ANY OTHER PROPOSED FEATURES AND STRUCTURES ON THIS SITE: N/A
 LOCATION AND PLANS FOR ALL DRAINAGE FEATURES: N/A
 LOCATION OF PERMANENT SOIL EROSION AND SEDIMENT CONTROL MEASURES: N/A
 LOCATION OF ANY DEDICATED ASPHALT OR CONCRETE BATCH PLANTS: N/A
 EMERGENCY OVERFLOW SWALES: N/A
 FLOW ROUTE - FLOW THROUGH AND OVERFLOW OF PERMANENT CONTROL MEASURES AND TEMPORARY SEDIMENT BASINS: N/A
 DETAIL DRAWINGS OF PERMANENT CONTROL MEASURES: N/A

NOTES:

A designated concrete truck washout is not anticipated for this project.
 Fueling of equipment may occur along the project route; fueling guidelines are included in the SWMP.
 0% of the disturbance area is within the designated 100 year floodplain.

GENERAL NOTES

- Stormwater discharges from construction sites shall not cause or threaten to cause pollution, contamination, or degradation of State Waters. All work and earth disturbance shall be done in a manner that minimizes pollution of any on-site or off-site waters, including wetlands.
- Notwithstanding anything depicted in these plans in words or graphic representation, all design and construction related to roads, storm drainage and erosion control shall conform to the standards and requirements of the most recent version of the relevant adopted El Paso County standards, including the Land Development Code, the Engineering Criteria Manual, the Drainage Criteria Manual, and the Drainage Criteria Manual Volume 2. Any deviations from regulations and standards must be requested, and approved, in writing.
- A separate Stormwater Management Plan (SMWP) for this project shall be completed and an Erosion and Stormwater Quality Control Permit (ESQCP) issued prior to commencing construction. Management of the SWMP during construction is the responsibility of the designated Qualified Stormwater Manager or Certified Erosion Control Inspector. The SWMP shall be located on-site at all times during construction and shall be kept up to date with work progress and changes in the field.
- Once the ESQCP is approved and a "Notice to Proceed" has been issued, the contractor may install the initial stage erosion and sediment control measures as indicated on the approved GEC. A Preconstruction Meeting between the contractor, engineer, and El Paso County will be held prior to any construction. It is the responsibility of the applicant to coordinate the meeting time and place with County staff.
- Control measures must be installed prior to commencement of activities that could contribute pollutants to stormwater. Control measures for all slopes, channels, ditches, and disturbed land areas shall be installed immediately upon completion of the disturbance.
- All temporary sediment and erosion control measures shall be maintained and remain in effective operating condition until permanent soil erosion control measures are implemented and final stabilization is established. All persons engaged in land disturbance activities shall assess the adequacy of control measures at the site and identify if changes to those control measures are needed to ensure the continued effective performance of the control measures. All changes to temporary sediment and erosion control measures must be incorporated into the Stormwater Management Plan.
- Temporary stabilization shall be implemented on disturbed areas and stockpiles where ground disturbing construction activity has permanently ceased or temporarily ceased for longer than 14 days.
- Final stabilization must be implemented at all applicable construction sites. Final stabilization is achieved when all ground disturbing activities are complete and all disturbed areas either have a uniform vegetative cover with individual plant density of 70 percent of pre-disturbance levels established or equivalent permanent alternative stabilization method is implemented. All temporary sediment and erosion control measures shall be removed upon final stabilization and before permit closure.
- All permanent stormwater management facilities shall be installed as designed in the approved plans. Any proposed changes that effect the design or function of permanent stormwater management structures must be approved by the ECM Administrator prior to implementation.
- Earth disturbances shall be conducted in such a manner so as to effectively minimize accelerated soil erosion and resulting sedimentation. All disturbances shall be designed, constructed, and completed so that the exposed area of any disturbed land shall be limited to the shortest practical period of time. Pre-existing vegetation shall be protected and maintained within 50 horizontal feet of a waters of the state unless shown to be infeasible and specifically requested and approved.
- Compaction of soil must be prevented in areas designated for infiltration control measures or where final stabilization will be achieved by vegetative cover. Areas designated for infiltration control measures shall also be protected from sedimentation during construction until final stabilization is achieved. If compaction prevention is not feasible due to site constraints, all areas designated for infiltration and vegetation control measures must be loosened prior to installation of the control measure(s).
- Any temporary or permanent facility designed and constructed for the conveyance of stormwater around, through, or from the earth disturbance area shall be a stabilized conveyance designed to minimize erosion and the discharge of sediment off-site.
- Concrete wash water shall be contained and disposed of in accordance with the SWMP. No wash water shall be discharged to or allowed to enter State Waters, including any surface or subsurface storm drainage system or facilities. Concrete washouts shall not be located in an area where shallow groundwater may be present, or within 50 feet of a surface water body, creek or stream.
- During dewatering operations, uncontaminated groundwater may be discharged on-site, but shall not leave the site in the form of surface runoff unless an approved State dewatering permit is in place.
- Erosion control blanketing or other protective covering shall be used on slopes steeper than 3:1.
- Contractor shall be responsible for the removal of all wastes from the construction site for disposal in accordance with local and State regulatory requirements. No construction debris, tree slash, building material wastes or unused building materials shall be buried, dumped, or discharged at the site.
- Waste materials shall not be temporarily placed or stored in the street, alley, or other public way, unless in accordance with an approved Traffic Control Plan. Control measures may be required by El Paso County Engineering if deemed necessary, based on specific conditions and circumstances.
- Tracking of soils and construction debris off-site shall be minimized. Materials tracked off-site shall be cleaned up and properly disposed of immediately.
- The owner/developer shall be responsible for the removal of all construction debris, dirt, trash, rock, sediment, soil, and sand that may accumulate in roads, storm drains and other drainage conveyance systems and stormwater appurtenances as a result of site development.
- The quantity of materials stored on the project site shall be limited, as much as practical, to that quantity required to perform the work in an orderly sequence. All materials stored on-site shall be stored in a neat, orderly manner, in their original containers, with original manufacturer's labels.
- No chemical(s) having the potential to be released in stormwater are to be stored or used on-site unless permission for the use of such chemical(s) is granted in writing by the ECM Administrator. In granting approval for the use of such chemical(s), special conditions and monitoring may be required.
- Bulk storage of allowed petroleum products or other allowed liquid chemicals in excess of 55 gallons shall require adequate secondary containment protection to contain all spills on-site and to prevent any spilled materials from entering State Waters, any surface or subsurface storm drainage system or other facilities.
- No person shall cause the impediment of stormwater flow in the curb and gutter or ditch except with approved sediment control measures.
- Owner/developer and their agents shall comply with the "Colorado Water Quality Control Act" (Title 25, Article 8, CRS), and the "Clean Water Act" (33 USC 1344), in addition to the requirements of the Land Development Code, DCM Volume II and the ECM Appendix I. All appropriate permits must be obtained by the contractor prior to construction (1041, NPDES, Floodplain, 404, fugitive dust, etc.). In the event of conflicts between these requirements and other laws, rules, or regulations of other Federal, State, local, or County agencies, the most restrictive laws, rules, or regulations shall apply.
- All construction traffic must enter/exit the site only at approved construction access points.
- Prior to construction the permittee shall verify the location of existing utilities.
- A water source shall be available on-site during earthwork operations and shall be utilized as required to minimize dust from earthwork equipment and wind.
- The soils report for this site has been prepared by USDA's Web Soil Survey on October 24, 2022 and shall be considered a part of these plans.
- At least ten (10) days prior to the anticipated start of construction, for projects that will disturb one (1) acre or more, the owner or operator of construction activity shall submit a permit application for stormwater discharge to the Colorado Department of Public Health and Environment, Water Quality Division. The application contains certification of completion of a stormwater management plan (SWMP), of which this Grading and Erosion Control Plan may be a part. For information or application materials contact:

Colorado Department of Public Health and Environment
 Water Quality Control Division
 WQCD - Permits
 4300 Cherry Creek Drive South
 Denver, CO 80246-1530
 Attn: Permits Unit

ENGINEER'S STATEMENT

This Grading and Erosion Control Plan was prepared under my direction and supervision and is correct to the best of my knowledge and belief. Said plan has been prepared according to the criteria established by the County for Grading and Erosion Control Plans. I accept responsibility for any liability, errors or omissions on my part in preparing this Plan.

Joseph Houghton
 Joseph Houghton, PE # 49694

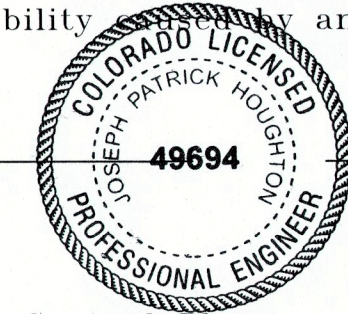

2/19/23
 Date

OWNER'S STATEMENT

The Owner will comply with the requirements of the Grading and Erosion Control Plan.

Joshua Palmer
 Joshua Palmer, P.E.
 County Engineer / ECM Administrator

2/10/23
 Date

EL PASO COUNTY

County plan review is provided only for general conformance with County Design Criteria. The County is not responsible for the accuracy and adequacy of the design, dimensions, and/or elevations which shall be confirmed at the job site. The County through the approval of this document assumes no responsibility for completeness and/or accuracy of this document.

Filed in accordance with the requirements of the El Paso County Land Development Code, Drainage Criteria Manual, Volumes 1 and 2, and Engineering Criteria Manual as amended.

In accordance with ECM Section 1.12, these construction documents will be valid for construction for a period of 2 years from the date signed by the El Paso County Engineer. If construction has not started within those 2 years, the plans will need to be resubmitted for approval, including payment of review fees at the Planning and Community Development Directors discretion.

Joshua Palmer, P.E.
 County Engineer / ECM Administrator

Date



**ENVIRONMENTAL SERVICES
 DEPARTMENT
 TECHNICAL SERVICES SECTION**

P.O. Box 1103, Mail Code 940
 COLORADO SPRINGS, CO 80947
 (719) 668-8426

**TITLE PAGE
 EROSION AND STORMWATER
 QUALITY CONTROL PLAN**

**CSU Gas Line Loch Fyne /
 Marksheffel**

PCD Filing No: CDR-231

Prepared By: RSC

Date: February 2023

**Figure
 1**

Sediment Control Log (SCL) SC-2

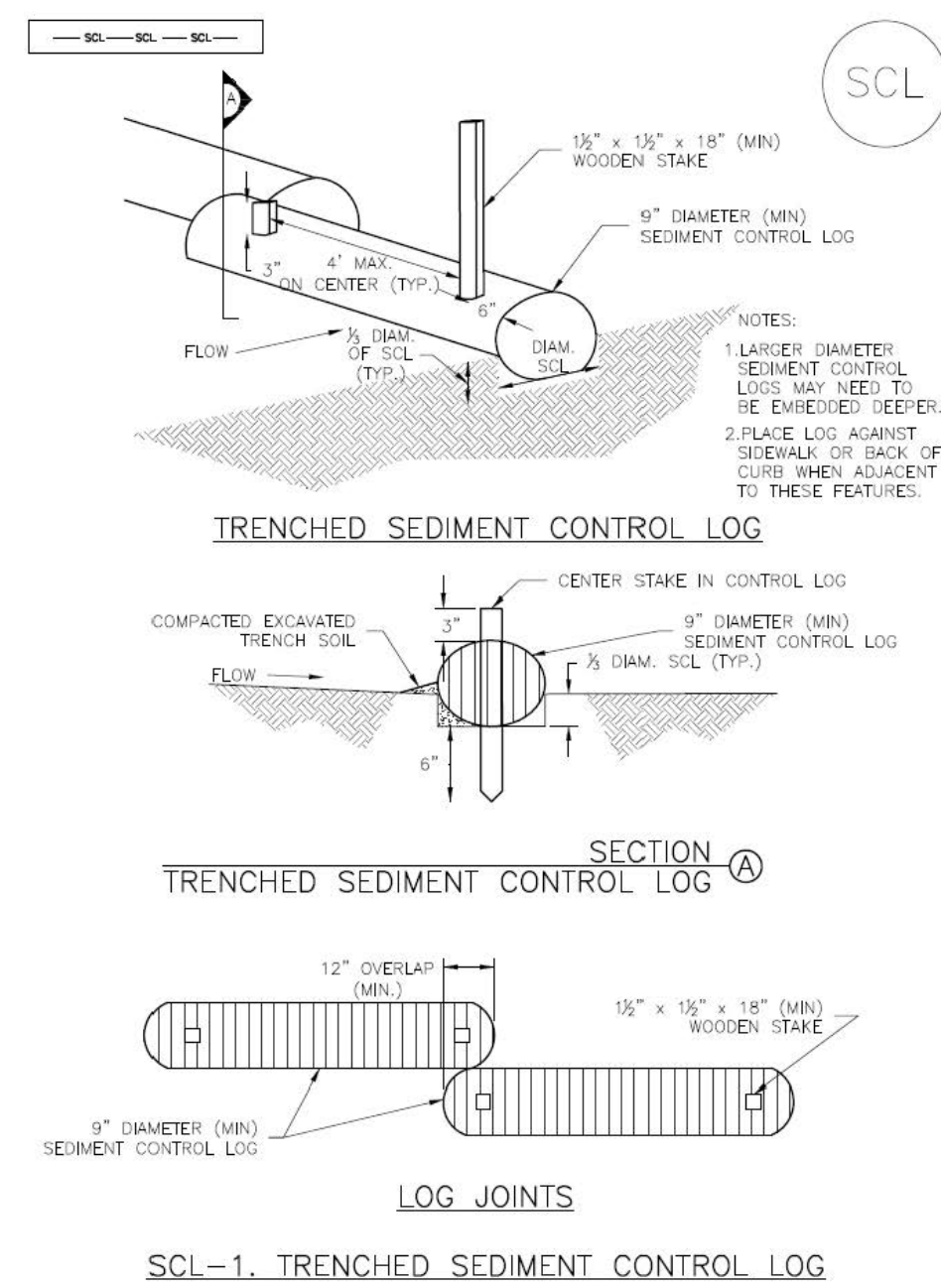

November 2015 Urban Drainage and Flood Control District Urban Storm Drainage Criteria Manual Volume 3 SCL-3

SC-2 Sediment Control Log (SCL)

SEDIMENT CONTROL LOG INSTALLATION NOTES

- SEE PLAN VIEW FOR LOCATION AND LENGTH OF SEDIMENT CONTROL LOGS.
- SEDIMENT CONTROL LOGS THAT ACT AS A PERIMETER CONTROL SHALL BE INSTALLED PRIOR TO ANY UPGRADIENT LAND-DISTURBING ACTIVITIES.
- SEDIMENT CONTROL LOGS SHALL CONSIST OF STRAW, COMPOST, EXCELSIOR OR COCONUT FIBER, AND SHALL BE FREE OF ANY NOXIOUS WEED SEEDS OR DEFECTS INCLUDING RIPS, HOLES AND OBVIOUS WEAR.
- SEDIMENT CONTROL LOGS MAY BE USED AS SMALL CHECK DAMS IN DITCHES AND SWALES. HOWEVER, THEY SHOULD NOT BE USED IN PERENNIAL STREAMS.
- IT IS RECOMMENDED THAT SEDIMENT CONTROL LOGS BE TRENCHED INTO THE GROUND TO A DEPTH OF APPROXIMATELY 1/2 OF THE DIAMETER OF THE LOG. IF TRENCHING TO THIS DEPTH IS NOT FEASIBLE AND/OR DESIRABLE (SHORT TERM INSTALLATION WITH DESIRE NOT TO DAMAGE LANDSCAPE) A LESSER TRENCHING DEPTH MAY BE ACCEPTABLE WITH MORE ROBUST STAKING. COMPOST LOGS THAT ARE 8 LB/FT DO NOT NEED TO BE TRENCHED.
- THE UPHILL SIDE OF THE SEDIMENT CONTROL LOG SHALL BE BACKFILLED WITH SOIL OR FILTER MATERIAL THAT IS FREE OF ROCKS AND DEBRIS. THE SOIL SHALL BE TIGHTLY COMPACTED INTO THE SHAPE OF A RIGHT TRIANGLE USING A SHOVEL OR WEIGHTED LAWN ROLLER OR BLOWN IN PLACE.
- FOLLOW MANUFACTURERS' GUIDANCE FOR STAKING. IF MANUFACTURERS' INSTRUCTIONS DO NOT SPECIFY SPACING, STAKES SHALL BE PLACED ON 4' CENTERS AND EMBEDDED A MINIMUM OF 6" INTO THE GROUND. 3" OF THE STAKE SHALL PROTRUDE FROM THE TOP OF THE LOG. STAKES THAT ARE BROKEN PRIOR TO INSTALLATION SHALL BE REPLACED. COMPOST LOGS SHOULD BE STAKED 10' ON CENTER.

SEDIMENT CONTROL LOG MAINTENANCE NOTES

- INSPECT BMPs EACH WORKDAY, AND MAINTAIN THEM IN EFFECTIVE OPERATING CONDITION. MAINTENANCE OF BMPs SHOULD BE PROACTIVE, NOT REACTIVE. INSPECT BMPs AS SOON AS POSSIBLE (AND ALWAYS WITHIN 24 HOURS) FOLLOWING A STORM THAT CAUSES SURFACE EROSION, AND PERFORM NECESSARY MAINTENANCE.
- FREQUENT OBSERVATIONS AND MAINTENANCE ARE NECESSARY TO MAINTAIN BMPs IN EFFECTIVE OPERATING CONDITION. INSPECTIONS AND CORRECTIVE MEASURES SHOULD BE DOCUMENTED THOROUGHLY.
- WHERE BMPs HAVE FAILED, REPAIR OR REPLACEMENT SHOULD BE INITIATED UPON DISCOVERY OF THE FAILURE.
- SEDIMENT ACCUMULATED UPSTREAM OF SEDIMENT CONTROL LOG SHALL BE REMOVED AS NEEDED TO MAINTAIN FUNCTIONALITY OF THE BMP. TYPICALLY WHEN DEPTH OF ACCUMULATED SEDIMENTS IS APPROXIMATELY 1/2 OF THE HEIGHT OF THE SEDIMENT CONTROL LOG.
- SEDIMENT CONTROL LOG SHALL BE REMOVED AT THE END OF CONSTRUCTION. COMPOST FROM COMPOST LOGS MAY BE LEFT IN PLACE AS LONG AS BAGS ARE REMOVED AND THE AREA SEEDS IF DISTURBED AREAS EXIST AFTER REMOVAL. THEY SHALL BE COVERED WITH TOP SOIL, SEEDS AND MULCHED OR OTHERWISE STABILIZED IN A MANNER APPROVED BY THE LOCAL JURISDICTION.

(DETAILS ADAPTED FROM TOWN OF PARKER, COLORADO, JEFFERSON COUNTY, COLORADO, DOUGLAS COUNTY, COLORADO, AND CITY OF AURORA, COLORADO, NOT AVAILABLE IN AUTOCAD)

NOTE: MANY JURISDICTIONS HAVE BMP DETAILS THAT VARY FROM UDFCD STANDARD DETAILS. CONSULT WITH LOCAL JURISDICTIONS AS TO WHICH DETAIL SHOULD BE USED WHEN DIFFERENCES ARE NOTED.

SCL-6 Urban Drainage and Flood Control District Urban Storm Drainage Criteria Manual Volume 3 November 2015

SC-5 Rock Sock (RS)

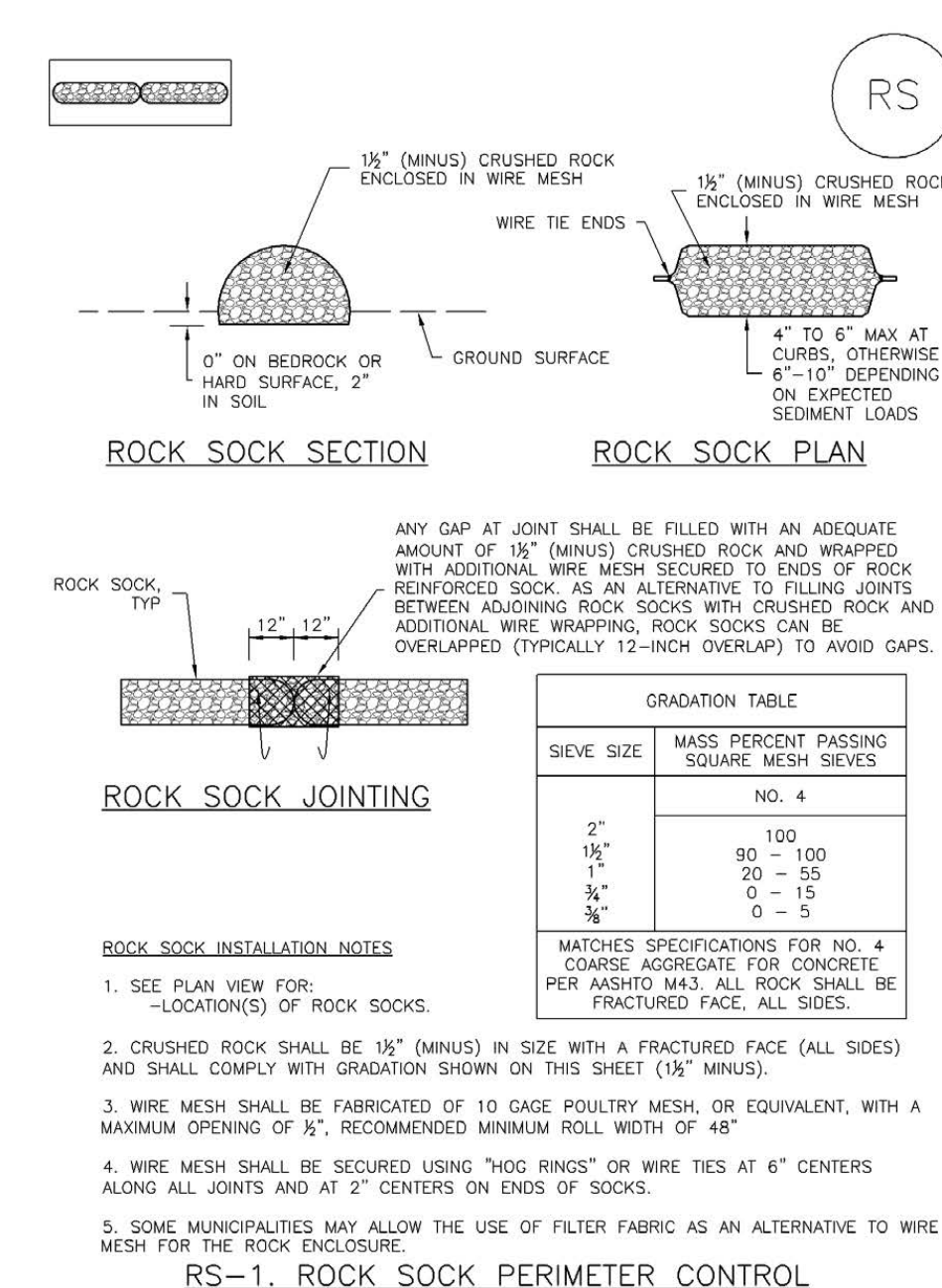

RS-2 Urban Drainage and Flood Control District Urban Storm Drainage Criteria Manual Volume 3 November 2010

Rock Sock (RS) SC-5

ROCK SOCK MAINTENANCE NOTES

- INSPECT BMPs EACH WORKDAY, AND MAINTAIN THEM IN EFFECTIVE OPERATING CONDITION. MAINTENANCE OF BMPs SHOULD BE PROACTIVE, NOT REACTIVE. INSPECT BMPs AS SOON AS POSSIBLE (AND ALWAYS WITHIN 24 HOURS) FOLLOWING A STORM THAT CAUSES SURFACE EROSION, AND PERFORM NECESSARY MAINTENANCE.
- FREQUENT OBSERVATIONS AND MAINTENANCE ARE NECESSARY TO MAINTAIN BMPs IN EFFECTIVE OPERATING CONDITION. INSPECTIONS AND CORRECTIVE MEASURES SHOULD BE DOCUMENTED THOROUGHLY.
- WHERE BMPs HAVE FAILED, REPAIR OR REPLACEMENT SHOULD BE INITIATED UPON DISCOVERY OF THE FAILURE.
- ROCK SOCKS SHALL BE REPLACED IF THEY BECOME HEAVILY SOILED, OR DAMAGED BEYOND REPAIR.
- SEDIMENT ACCUMULATED UPSTREAM OF ROCK SOCKS SHALL BE REMOVED AS NEEDED TO MAINTAIN FUNCTIONALITY OF THE BMP. TYPICALLY WHEN DEPTH OF ACCUMULATED SEDIMENTS IS APPROXIMATELY 1/2 OF THE HEIGHT OF THE ROCK SOCK.
- ROCK SOCKS ARE TO REMAIN IN PLACE UNTIL THE UPSTREAM DISTURBED AREA IS STABILIZED AND APPROVED BY THE LOCAL JURISDICTION.
- WHEN ROCK SOCKS ARE REMOVED, ALL DISTURBED AREAS SHALL BE COVERED WITH TOPSOIL, SEEDS AND MULCHED OR OTHERWISE STABILIZED AS APPROVED BY LOCAL JURISDICTION.

(DETAILS ADAPTED FROM TOWN OF PARKER, COLORADO AND CITY OF AURORA, COLORADO, NOT AVAILABLE IN AUTOCAD)

NOTE: MANY JURISDICTIONS HAVE BMP DETAILS THAT VARY FROM UDFCD STANDARD DETAILS. CONSULT WITH LOCAL JURISDICTIONS AS TO WHICH DETAIL SHOULD BE USED WHEN DIFFERENCES ARE NOTED.

November 2010 Urban Drainage and Flood Control District Urban Storm Drainage Criteria Manual Volume 3 RS-3

Stockpile Management (SP) MM-2

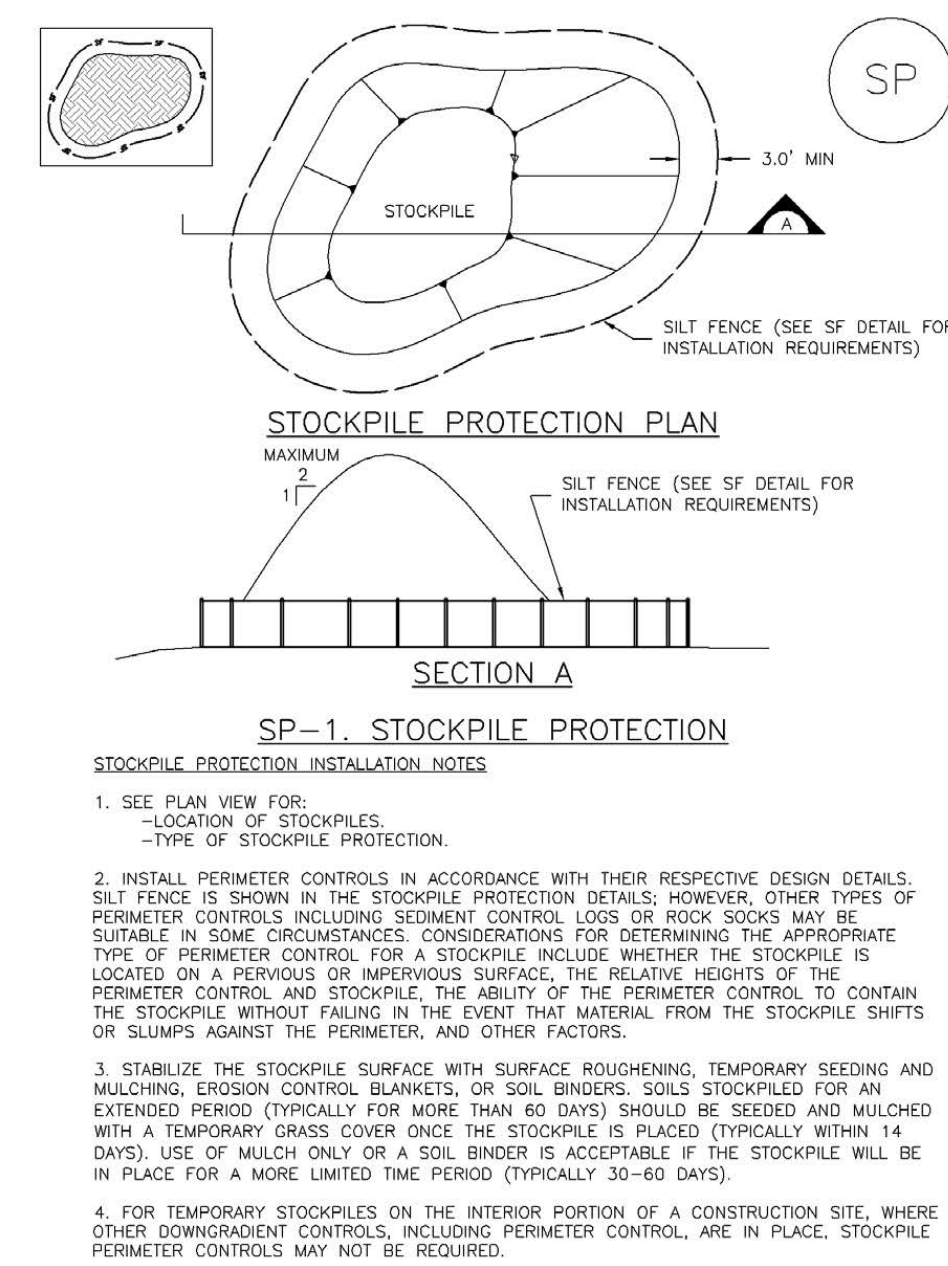

November 2010 Urban Drainage and Flood Control District Urban Storm Drainage Criteria Manual Volume 3 SP-3

MM-2 Stockpile Management (SM)

STOCKPILE PROTECTION MAINTENANCE NOTES

- INSPECT BMPs EACH WORKDAY, AND MAINTAIN THEM IN EFFECTIVE OPERATING CONDITION. MAINTENANCE OF BMPs SHOULD BE PROACTIVE, NOT REACTIVE. INSPECT BMPs AS SOON AS POSSIBLE (AND ALWAYS WITHIN 24 HOURS) FOLLOWING A STORM THAT CAUSES SURFACE EROSION, AND PERFORM NECESSARY MAINTENANCE.
- FREQUENT OBSERVATIONS AND MAINTENANCE ARE NECESSARY TO MAINTAIN BMPs IN EFFECTIVE OPERATING CONDITION. INSPECTIONS AND CORRECTIVE MEASURES SHOULD BE DOCUMENTED THOROUGHLY.
- WHERE BMPs HAVE FAILED, REPAIR OR REPLACEMENT SHOULD BE INITIATED UPON DISCOVERY OF THE FAILURE.
- IF PERIMETER PROTECTION MUST BE MOVED TO ACCESS SOIL STOCKPILE, REPLACE PERIMETER CONTROLS BY THE END OF THE WORKDAY.
- STOCKPILE PERIMETER CONTROLS CAN BE REMOVED ONCE ALL THE MATERIAL FROM THE STOCKPILE HAS BEEN USED.

(DETAILS ADAPTED FROM PARKER, COLORADO, NOT AVAILABLE IN AUTOCAD)

NOTE: MANY JURISDICTIONS HAVE BMP DETAILS THAT VARY FROM UDFCD STANDARD DETAILS. CONSULT WITH LOCAL JURISDICTIONS AS TO WHICH DETAIL SHOULD BE USED WHEN DIFFERENCES ARE NOTED.

SP-4 Urban Drainage and Flood Control District Urban Storm Drainage Criteria Manual Volume 3 November 2010

Vehicle Tracking Control (VTC) SM-4

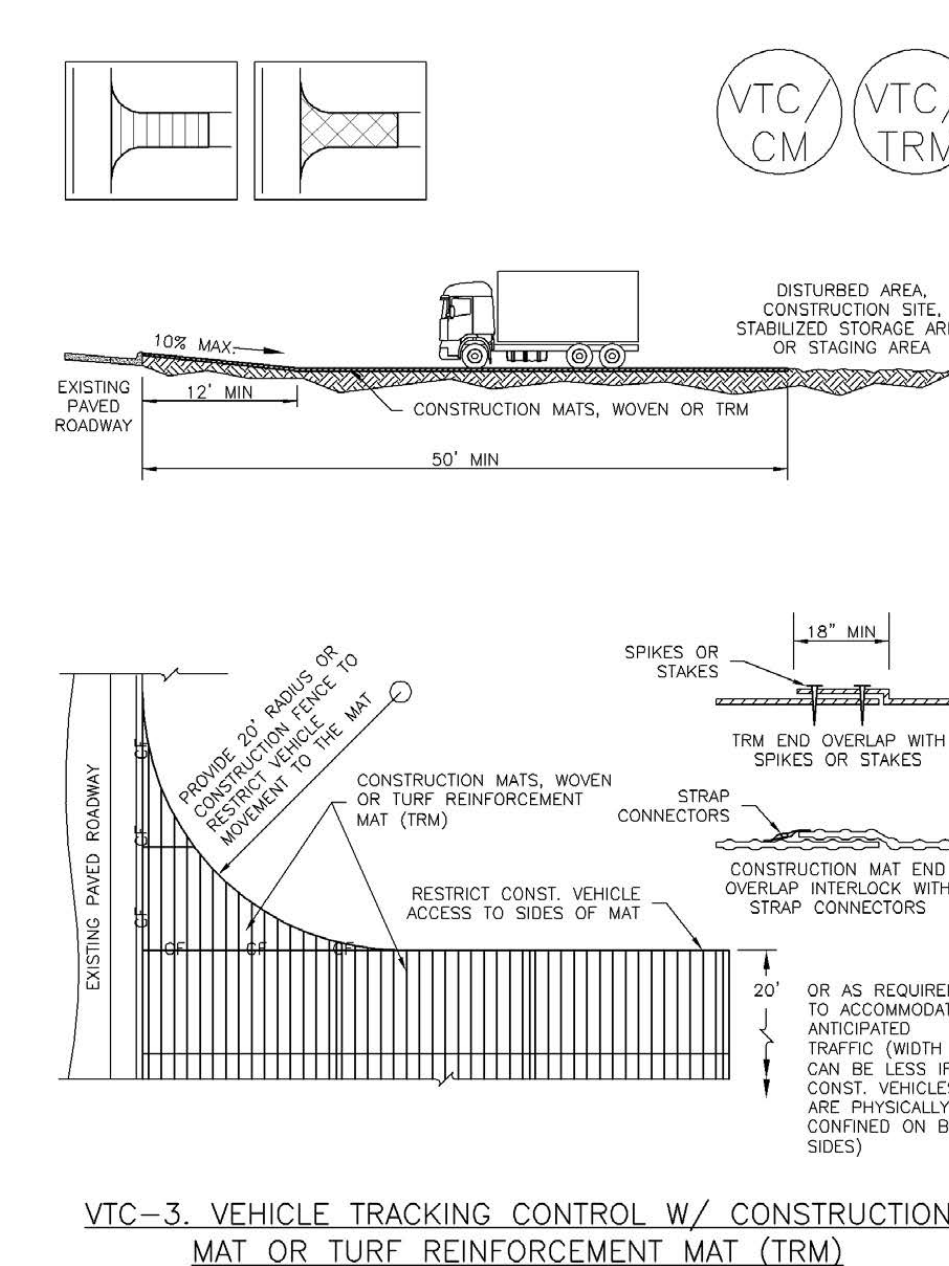

November 2010 Urban Drainage and Flood Control District Urban Storm Drainage Criteria Manual Volume 3 VTC-5

SM-4 Vehicle Tracking Control (VTC)

STABILIZED CONSTRUCTION ENTRANCE/EXIT INSTALLATION NOTES

- SEE PLAN VIEW FOR LOCATION OF CONSTRUCTION ENTRANCE(S)/EXIT(S). TYPE OF CONSTRUCTION ENTRANCE(S)/EXIT(S) (WITH/WITHOUT WHEEL WASH, CONSTRUCTION MAT OR TRM).
- CONSTRUCTION MAT OR TRM STABILIZED CONSTRUCTION ENTRANCES ARE ONLY TO BE USED ON SHORT DURATION PROJECTS (TYPICALLY RANGING FROM A WEEK TO A MONTH) WHERE THERE WILL BE LIMITED VEHICULAR ACCESS.
- A STABILIZED CONSTRUCTION ENTRANCE/EXIT SHALL BE LOCATED AT ALL ACCESS POINTS WHERE VEHICLES ACCESS THE CONSTRUCTION SITE FROM PAVED RIGHT-OF-WAYS.
- STABILIZED CONSTRUCTION ENTRANCE/EXIT SHALL BE INSTALLED PRIOR TO ANY LAND DISTURBING ACTIVITIES.
- A NON-WOVEN GEOTEXTILE FABRIC SHALL BE PLACED UNDER THE STABILIZED CONSTRUCTION ENTRANCE/EXIT PRIOR TO THE PLACEMENT OF ROCK.
- UNLESS OTHERWISE SPECIFIED BY LOCAL JURISDICTION, ROCK SHALL CONSIST OF DOT SECT. #703, ASHTO #3 COARSE AGGREGATE OR 6" (MINUS) ROCK.

STABILIZED CONSTRUCTION ENTRANCE/EXIT MAINTENANCE NOTES

- INSPECT BMPs EACH WORKDAY, AND MAINTAIN THEM IN EFFECTIVE OPERATING CONDITION. MAINTENANCE OF BMPs SHOULD BE PROACTIVE, NOT REACTIVE. INSPECT BMPs AS SOON AS POSSIBLE (AND ALWAYS WITHIN 24 HOURS) FOLLOWING A STORM THAT CAUSES SURFACE EROSION, AND PERFORM NECESSARY MAINTENANCE.
- FREQUENT OBSERVATIONS AND MAINTENANCE ARE NECESSARY TO MAINTAIN BMPs IN EFFECTIVE OPERATING CONDITION. INSPECTIONS AND CORRECTIVE MEASURES SHOULD BE DOCUMENTED THOROUGHLY.
- WHERE BMPs HAVE FAILED, REPAIR OR REPLACEMENT SHOULD BE INITIATED UPON DISCOVERY OF THE FAILURE.
- ROCK SHALL BE REAPPLIED OR REGRADED AS NECESSARY TO THE STABILIZED ENTRANCE/EXIT TO MAINTAIN A CONSISTENT DEPTH.
- SEDIMENT TRACKED ONTO PAVED ROADS IS TO BE REMOVED THROUGHOUT THE DAY AND AT THE END OF THE DAY BY SHOVELING OR SWEEPING. SEDIMENT MAY NOT BE WASHED DOWN STORM SEWER DRAINS.

(DETAILS ADAPTED FROM CITY OF BROOMFIELD, COLORADO, NOT AVAILABLE IN AUTOCAD)

VTC-6 Urban Drainage and Flood Control District Urban Storm Drainage Criteria Manual Volume 3 November 2010

Additional erosion control details on maintenance and installation are located in Attachment 4 to the SWMP/GESQCP Narrative

Temporary and Permanent Seeding (TS/PS) EC-2

Description

Temporary seeding can be used to stabilize disturbed areas that will be inactive for an extended period. Permanent seeding should be used to stabilize areas at final grade that will not be otherwise stabilized. Effective seeding includes preparation of a seedbed, selection of an appropriate seed mixture, proper planting techniques, and protection of the seeded area with mulch, geotextiles, or other appropriate measures.



Photograph TS/PS-1. Equipment used to drill seed. Photo courtesy of Douglas County.

Appropriate Uses

When the soil surface is disturbed and will remain inactive for an extended period (typically, 30 days or longer), proactive stabilization measures should be implemented. If the inactive period is short-lived (on the order of two weeks), techniques such as surface roughening may be appropriate. For longer periods of inactivity, temporary seeding and mulching can provide effective erosion control. Permanent seeding should be used on finished areas that have not been otherwise stabilized.

Typically, local governments have their own seed mixes and timelines for seeding. Check jurisdictional requirements for seeding and temporary stabilization.

Design and Installation

Effective seeding requires proper seedbed preparation, selection of an appropriate seed mixture, use of appropriate seeding equipment to ensure proper coverage and density, and protection with mulch or fabric until plants are established.

The USDCM Volume 2 *Revegetation* Chapter contains detailed seed mix, soil preparations, and seeding and mulching recommendations that may be referenced to supplement this Fact Sheet.

Drill seeding is the preferred seeding method. Hydroseeding is not recommended except in areas where steep slopes prevent use of drill seeding equipment, and even in these instances it is preferable to hand seed and mulch. Some jurisdictions do not allow hydroseeding or hydromulching.

Seedbed Preparation

Prior to seeding, ensure that areas to be revegetated have soil conditions capable of supporting vegetation. Overlot grading can result in loss of topsoil, resulting in poor quality subsoils at the ground surface that have low nutrient value, little organic matter content, few soil microorganisms, rooting restrictions, and conditions less conducive to infiltration of precipitation. As a result, it is typically necessary to provide stockpiled topsoil, compost, or other

Temporary and Permanent Seeding	
Functions	
Erosion Control	Yes
Sediment Control	No
Site/Material Management	No

June 2012 Urban Drainage and Flood Control District Urban Storm Drainage Criteria Manual Volume 3 TS/PS-1

EC-2 Temporary and Permanent Seeding (TS/PS)

soil amendments and rototill them into the soil to a depth of 6 inches or more.

Topsoil should be salvaged during grading operations for use and spread on areas to be revegetated later. Topsoil should be viewed as an important resource to be utilized for vegetation establishment, due to its water-holding capacity, structure, texture, organic matter content, biological activity, and nutrient content. The rooting depth of most native grasses in the semi-arid Denver metropolitan area is 6 to 18 inches. At a minimum, the upper 6 inches of topsoil should be stripped, stockpiled, and ultimately respread across areas that will be revegetated.

Where topsoil is not available, subsoils should be amended to provide an appropriate plant-growth medium. Organic matter, such as well digested compost, can be added to improve soil characteristics conducive to plant growth. Other treatments can be used to adjust soil pH conditions when needed. Soil testing, which is typically inexpensive, should be completed to determine and optimize the types and amounts of amendments that are required.

If the disturbed ground surface is compacted, rip or rototill the surface prior to placing topsoil. If adding compost to the existing soil surface, rototilling is necessary. Surface roughening will assist in placement of a stable topsoil layer on steeper slopes, and allow infiltration and root penetration to greater depth.

Prior to seeding, the soil surface should be rough and the seedbed should be firm, but neither too loose nor compacted. The upper layer of soil should be in a condition suitable for seeding at the proper depth and conducive to plant growth. Seed-to-soil contact is the key to good germination.

Seed Mix for Temporary Vegetation

To provide temporary vegetative cover on disturbed areas which will not be paved, built upon, or fully landscaped or worked for an extended period (typically 30 days or more), plant an annual grass appropriate for the time of planting and mulch the planted areas. Annual grasses suitable for the Denver metropolitan area are listed in Table TS/PS-1. These are to be considered only as general recommendations when specific design guidance for a particular site is not available. Local governments typically specify seed mixes appropriate for their jurisdiction.

Seed Mix for Permanent Revegetation

To provide vegetative cover on disturbed areas that have reached final grade, a perennial grass mix should be established. Permanent seeding should be performed promptly (typically within 14 days) after reaching final grade. Each site will have different characteristics and a landscape professional or the local jurisdiction should be contacted to determine the most suitable seed mix for a specific site. In lieu of a specific recommendation, one of the perennial grass mixes appropriate for site conditions and growth season listed in Table TS/PS-2 can be used. The pure live seed (PLS) rates of application recommended in these tables are considered to be absolute minimum rates for seed applied using proper drill-seeding equipment.

If desired for wildlife habitat or landscape diversity, shrubs such as rubber rabbitbrush (*Chrysothamnus nauseosus*), fourwing saltbush (*Atriplex canescens*) and skunkbrush sumac (*Rhus trilobata*) could be added to the upland seedmixes at 0.25, 0.5 and 1 pound PLS/acre, respectively. In riparian zones, planting root stock of such species as American plum (*Prunus americana*), woods rose (*Rosa woodsii*), plains cottonwood (*Populus sargentii*), and willow (*Populus spp.*) may be considered. On non-topsoiled upland sites, a legume such as Ladak alfalfa at 1 pound PLS/acre can be included as a source of nitrogen for perennial grasses.

TS/PS-2 Urban Drainage and Flood Control District Urban Storm Drainage Criteria Manual Volume 3 June 2012

Temporary and Permanent Seeding (TS/PS) EC-2

Seeding dates for the highest success probability of perennial species along the Front Range are generally in the spring from April through early May and in the fall after the first of September until the ground freezes. If the area is irrigated, seeding may occur in summer months, as well. See Table TS/PS-3 for appropriate seeding dates.

Table TS/PS-1. Minimum Drill Seeding Rates for Various Temporary Annual Grasses

Species* (Common name)	Growth Season	Pounds of Pure Live Seed (PLS)/acre	Planting Depth (inches)
1. Oats	Cool	35 - 50	1 - 2
2. Spring wheat	Cool	25 - 35	1 - 2
3. Spring barley	Cool	25 - 35	1 - 2
4. Annual ryegrass	Cool	10 - 15	½
5. Millet	Warm	3 - 15	½ - ¾
6. Sudangrass	Warm	5 - 10	½ - ¾
7. Sorghum	Warm	5 - 10	½ - ¾
8. Winter wheat	Cool	20 - 35	1 - 2
9. Winter barley	Cool	20 - 35	1 - 2
10. Winter rye	Cool	20 - 35	1 - 2
11. Triticale	Cool	25 - 40	1 - 2

* Successful seeding of annual grass resulting in adequate plant growth will usually produce enough dead-plant residue to provide protection from wind and water erosion for an additional year. This assumes that the cover is not disturbed or mowed closer than 8 inches.

Hydraulic seeding may be substituted for drilling only where slopes are steeper than 3:1 or where access limitations exist. When hydraulic seeding is used, hydraulic mulching should be applied as a separate operation, when practical, to prevent the seeds from being encapsulated in the mulch.

^b See Table TS/PS-3 for seeding dates. Irrigation, if consistently applied, may extend the use of cool season species during the summer months.

^c Seeding rates should be doubled if seed is broadcast, or increased by 50 percent if done using a Brillion Drill or by hydraulic seeding.

June 2012 Urban Drainage and Flood Control District Urban Storm Drainage Criteria Manual Volume 3 TS/PS-3

EC-2 Temporary and Permanent Seeding (TS/PS)

Table TS/PS-2. Minimum Drill Seeding Rates for Perennial Grasses

Common Name	Botanical Name	Growth Season	Growth Form	Seeds/Pound	Pounds of PLS/acre
Alkali Soil Seed Mix					
Alkali seaton	<i>Sporobolus airoides</i>	Cool	Bunch	1,750,000	0.25
Basin wildrye	<i>Elymus cinereus</i>	Cool	Bunch	165,000	2.5
Sodar streambank wheatgrass	<i>Agropyron riparium Sodal'</i>	Cool	Sod	170,000	2.5
Jose tall wheatgrass	<i>Agropyron elongatum Jose'</i>	Cool	Bunch	79,000	7.0
Arriba western wheatgrass	<i>Agropyron smithii Arriba'</i>	Cool	Sod	110,000	5.5
Total					17.75
Fertile Loamy Soil Seed Mix					
Ephraim crested wheatgrass	<i>Agropyron cristatum Ephraim'</i>	Cool	Sod	175,000	2.0
Dural hard fescue	<i>Festuca ovina Duracola'</i>	Cool	Bunch	565,000	1.0
Lincoln smooth brome	<i>Bromus inermis leysii Lincoln'</i>	Cool	Sod	130,000	3.0
Sodar streambank wheatgrass	<i>Agropyron riparium Sodal'</i>	Cool	Sod	170,000	2.5
Arriba western wheatgrass	<i>Agropyron smithii Arriba'</i>	Cool	Sod	110,000	7.0
Total					15.5
High Water Table Soil Seed Mix					
Meadow foxtail	<i>Alopecurus pratensis</i>	Cool	Sod	900,000	0.5
Redtop	<i>Agrostis alba</i>	Warm	Open sod	5,000,000	0.25
Reed canarygrass	<i>Phalaris arundinacea</i>	Cool	Sod	68,000	0.5
Lincoln smooth brome	<i>Bromus inermis leysii Lincoln'</i>	Cool	Sod	130,000	3.0
Pathfinder switchgrass	<i>Panicum virgatum Pathfinder'</i>	Warm	Sod	389,000	1.0
Albar tall wheatgrass	<i>Agropyron elongatum Albar'</i>	Cool	Bunch	79,000	5.5
Total					10.75
Transition Turf Seed Mix^c					
Ruebens Canadian bluegrass	<i>Poa compressa Ruebens'</i>	Cool	Sod	2,500,000	0.5
Dural hard fescue	<i>Festuca ovina Duracola'</i>	Cool	Bunch	565,000	1.0
Citation perennial ryegrass	<i>Lolium perenne Citation'</i>	Cool	Sod	247,000	3.0
Lincoln smooth brome	<i>Bromus inermis leysii Lincoln'</i>	Cool	Sod	130,000	3.0
Total					7.5

TS/PS-4 Urban Drainage and Flood Control District Urban Storm Drainage Criteria Manual Volume 3 June 2012

Temporary and Permanent Seeding (TS/PS) EC-2

Table TS/PS-2. Minimum Drill Seeding Rates for Perennial Grasses (cont.)

Common Name	Botanical Name	Growth Season ^a	Growth Form	Seeds/Pound	Pounds of PLS/acre
Sandy Soil Seed Mix					
Blue grama	<i>Bouteloua gracilis</i>	Warm	Sod-forming bunchgrass	825,000	0.5
Camper little bluestem	<i>Schizachyrium scoparium Camper'</i>	Warm	Bunch	240,000	1.0
Prairie sandreed	<i>Calamovilfa longifolia</i>	Warm	Open sod	274,000	1.0
Sand dropseed	<i>Sporobolus cryptandrus</i>	Cool	Bunch	5,298,000	0.25
Vaughn sideoats grama	<i>Bouteloua curtipendula Vaughn'</i>	Warm	Sod	191,000	2.0
Arriba western wheatgrass	<i>Agropyron smithii Arriba'</i>	Cool	Sod	110,000	5.5
Total					10.25
Heavy Clay, Rocky Foothill Seed Mix					
Ephraim crested wheatgrass ^d	<i>Agropyron cristatum Ephraim'</i>	Cool	Sod	175,000	1.5
Oahe intermediate wheatgrass	<i>Agropyron intermedium Oahe'</i>	Cool	Sod	115,000	5.5
Vaughn sideoats grama ^e	<i>Bouteloua curtipendula Vaughn'</i>	Warm	Sod	191,000	2.0
Lincoln smooth brome	<i>Bromus inermis leysii Lincoln'</i>	Cool	Sod	130,000	3.0
Arriba western wheatgrass	<i>Agropyron smithii Arriba'</i>	Cool	Sod	110,000	5.5
Total					17.5

^a All of the above seeding mixes and rates are based on drill seeding followed by crimped straw mulch. These rates should be doubled if seed is broadcast and should be increased by 50 percent if the seeding is done using a Brillion Drill or is applied through hydraulic seeding. Hydraulic seeding may be substituted for drilling only where slopes are steeper than 3:1. If hydraulic seeding is used, hydraulic mulching should be done as a separate operation.

^b See Table TS/PS-3 for seeding dates.

^c If site is to be irrigated, the transition turf seed rates should be doubled.

^d Crested wheatgrass should not be used on slopes steeper than 6:1 to 1:1.

^e Can substitute 0.5 lbs PLS of blue grama for the 2.0 lbs PLS of Vaughn sideoats grama.

June 2012 Urban Drainage and Flood Control District Urban Storm Drainage Criteria Manual Volume 3 TS/PS-5

EC-2 Temporary and Permanent Seeding (TS/PS)

Table TS/PS-3. Seeding Dates for Annual and Perennial Grasses

Seeding Dates	Annual Grasses (Numbers in table reference species in Table TS/PS-1)		Perennial Grasses	
	Warm	Cool	Warm	Cool
January 1 - March 15			✓	✓
March 16 - April 30	4	1,2,3	✓	✓
May 1 - May 15	4		✓	
May 16 - June 30	4,5,6,7			
July 1 - July 15	5,6,7			
July 16 - August 31				
September 1 - September 30		8,9,10,11		
October 1 - December 31			✓	✓

Mulch

Cover seeded areas with mulch or an appropriate rolled erosion control product to promote establishment of vegetation. Anchor mulch by crimping, netting or use of a non-toxic tackifier. See the Mulching BMP Fact Sheet for additional guidance.

Maintenance and Removal

Monitor and observe seeded areas to identify areas of poor growth or areas that fail to germinate. Reseed and mulch these areas, as needed.

An area that has been permanently seeded should have a good stand of vegetation within one growing season if irrigated and within three growing seasons without irrigation in Colorado. Reseed portions of the site that fail to germinate or remain bare after the first growing season.

Seeded areas may require irrigation, particularly during extended dry periods. Targeted weed control may also be necessary.

Protect seeded areas from construction equipment and vehicle access.

TS/PS-6 Urban Drainage and Flood Control District Urban Storm Drainage Criteria Manual Volume 3 June 2012

Additional erosion control details on maintenance and installation are located in Attachment 4 to the SWMP/GESQCP Narrative



ENVIRONMENTAL SERVICES DEPARTMENT
TECHNICAL SERVICES SECTION

P.O. Box 1103, Mail Code 940
COLORADO SPRINGS, CO 80947
(719) 668-8426

**CONTROL MEASURE DETAILS
EROSION AND STORMWATER
QUALITY CONTROL PLAN**

**CSU Gas Line Loch Fyne /
Marksheffel**

PCD Filing No: CDR-231

Prepared By: JPH

Date: December 2022

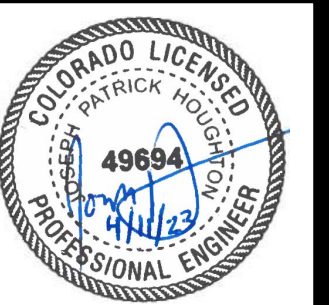

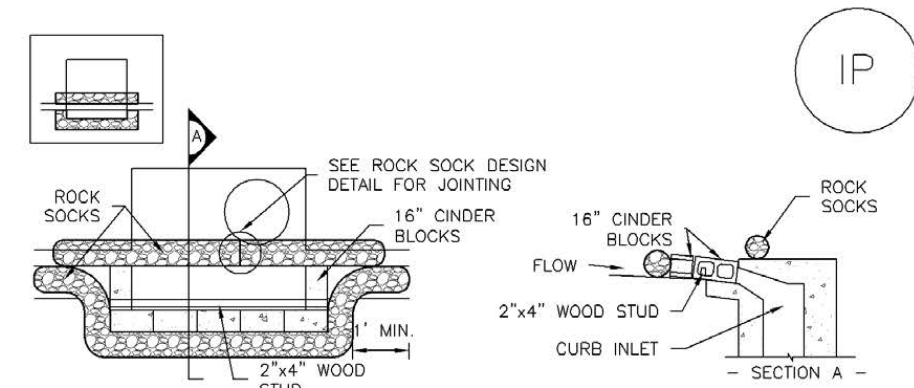

IP-1. BLOCK AND ROCK SOCK SUMP OR ON GRADE INLET PROTECTION

BLOCK AND CURB SOCK INLET PROTECTION INSTALLATION NOTES

1. SEE ROCK SOCK DESIGN DETAIL FOR INSTALLATION REQUIREMENTS.
2. CONCRETE "CINDER" BLOCKS SHALL BE LAID ON THEIR SIDES AROUND THE INLET IN A SINGLE ROW, ABUTTING ONE ANOTHER WITH THE OPEN END FACING AWAY FROM THE CURB.
3. GRAVEL BAGS SHALL BE PLACED AROUND CONCRETE BLOCKS, CLOSELY ABUTTING ONE ANOTHER AND JOINTED TOGETHER IN ACCORDANCE WITH ROCK SOCK DESIGN DETAIL.

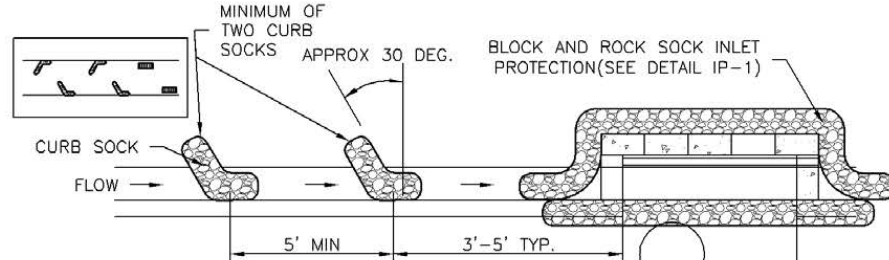

IP-2. CURB ROCK SOCKS UPSTREAM OF INLET PROTECTION

CURB ROCK SOCK INLET PROTECTION INSTALLATION NOTES

1. SEE ROCK SOCK DESIGN DETAIL INSTALLATION REQUIREMENTS.
2. PLACEMENT OF THE SOCK SHALL BE APPROXIMATELY 30 DEGREES FROM PERPENDICULAR IN THE OPPOSITE DIRECTION OF FLOW.
3. SOCKS ARE TO BE FLUSH WITH THE CURB AND SPACED A MINIMUM OF 3 FEET APART.
4. AT LEAST TWO CURB SOCKS IN SERIES ARE REQUIRED UPSTREAM OF ON-GRADE INLETS.

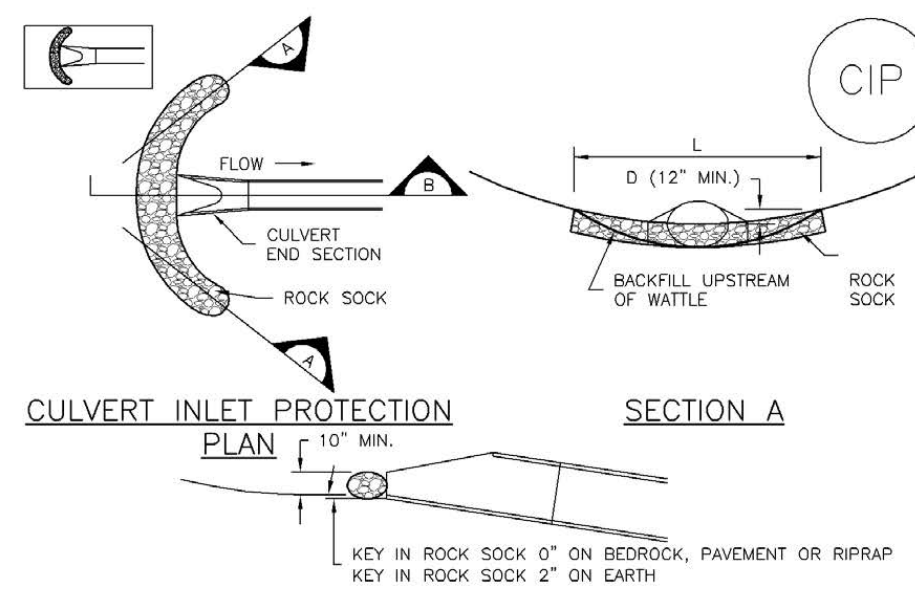

CIP-1. CULVERT INLET PROTECTION

CULVERT INLET PROTECTION INSTALLATION NOTES

1. SEE PLAN VIEW FOR -LOCATION OF CULVERT INLET PROTECTION.
2. SEE ROCK SOCK DESIGN DETAIL FOR ROCK GRADATION REQUIREMENTS AND JOINTING DETAIL.

CULVERT INLET PROTECTION MAINTENANCE NOTES

1. INSPECT BMPs EACH WORKDAY, AND MAINTAIN THEM IN EFFECTIVE OPERATING CONDITION. MAINTENANCE OF BMPs SHOULD BE PROACTIVE, NOT REACTIVE. INSPECT BMPs AS SOON AS POSSIBLE (AND ALWAYS WITHIN 24 HOURS) FOLLOWING A STORM THAT CAUSES SURFACE EROSION, AND PERFORM NECESSARY MAINTENANCE.
2. FREQUENT OBSERVATIONS AND MAINTENANCE ARE NECESSARY TO MAINTAIN BMPs IN EFFECTIVE OPERATING CONDITION. INSPECTIONS AND CORRECTIVE MEASURES SHOULD BE DOCUMENTED THOROUGHLY.
3. WHERE BMPs HAVE FAILED, REPAIR OR REPLACEMENT SHOULD BE INITIATED UPON DISCOVERY OF THE FAILURE.
4. SEDIMENT ACCUMULATED UPSTREAM OF THE CULVERT SHALL BE REMOVED WHEN THE SEDIMENT DEPTH IS 1/2 THE HEIGHT OF THE ROCK SOCK.
5. CULVERT INLET PROTECTION SHALL REMAIN IN PLACE UNTIL THE UPSTREAM DISTURBED AREA IS PERMANENTLY STABILIZED AND APPROVED BY THE LOCAL JURISDICTION.

(DETAILS ADAPTED FROM AURORA, COLORADO, NOT AVAILABLE IN AUTOCAD)
NOTE: MANY JURISDICTIONS HAVE BMP DETAILS THAT VARY FROM UDFCD STANDARD DETAILS. CONSULT WITH LOCAL JURISDICTIONS AS TO WHICH DETAIL SHOULD BE USED WHEN DIFFERENCES ARE NOTED.

GENERAL INLET PROTECTION INSTALLATION NOTES

1. SEE PLAN VIEW FOR -LOCATION OF INLET PROTECTION -TYPE OF INLET PROTECTION (IP.1, IP.2, IP.3, IP.4, IP.5, IP.6)
2. INLET PROTECTION SHALL BE INSTALLED PROMPTLY AFTER INLET CONSTRUCTION OR PAVING IS COMPLETE (TYPICALLY WITHIN 48 HOURS). IF A RAINFALL/RUNOFF EVENT IS FORECAST, INSTALL INLET PROTECTION PRIOR TO ONSET OF EVENT.
3. MANY JURISDICTIONS HAVE BMP DETAILS THAT VARY FROM UDFCD STANDARD DETAILS. CONSULT WITH LOCAL JURISDICTIONS AS TO WHICH DETAIL SHOULD BE USED WHEN DIFFERENCES ARE NOTED.

INLET PROTECTION MAINTENANCE NOTES

1. INSPECT BMPs EACH WORKDAY, AND MAINTAIN THEM IN EFFECTIVE OPERATING CONDITION. MAINTENANCE OF BMPs SHOULD BE PROACTIVE, NOT REACTIVE. INSPECT BMPs AS SOON AS POSSIBLE (AND ALWAYS WITHIN 24 HOURS) FOLLOWING A STORM THAT CAUSES SURFACE EROSION, AND PERFORM NECESSARY MAINTENANCE.
2. FREQUENT OBSERVATIONS AND MAINTENANCE ARE NECESSARY TO MAINTAIN BMPs IN EFFECTIVE OPERATING CONDITION. INSPECTIONS AND CORRECTIVE MEASURES SHOULD BE DOCUMENTED THOROUGHLY.
3. WHERE BMPs HAVE FAILED, REPAIR OR REPLACEMENT SHOULD BE INITIATED UPON DISCOVERY OF THE FAILURE.
4. SEDIMENT ACCUMULATED UPSTREAM OF INLET PROTECTION SHALL BE REMOVED AS NECESSARY TO MAINTAIN BMP EFFECTIVENESS, TYPICALLY WHEN STORAGE VOLUME REACHES 50% OF CAPACITY, A DEPTH OF 6" WHEN SILT FENCE IS USED, OR 1/4 OF THE HEIGHT FOR STRAW BALES.
5. INLET PROTECTION IS TO REMAIN IN PLACE UNTIL THE UPSTREAM DISTURBED AREA IS PERMANENTLY STABILIZED, UNLESS THE LOCAL JURISDICTION APPROVES EARLIER REMOVAL OF INLET PROTECTION IN STREETS.
6. WHEN INLET PROTECTION AT AREA INLETS IS REMOVED, THE DISTURBED AREA SHALL BE COVERED WITH TOP SOIL, SEEDED AND MULCHED, OR OTHERWISE STABILIZED IN A MANNER APPROVED BY THE LOCAL JURISDICTION.

(DETAIL ADAPTED FROM TOWN OF PARKER, COLORADO AND CITY OF AURORA, COLORADO, NOT AVAILABLE IN AUTOCAD)
NOTE: MANY JURISDICTIONS HAVE BMP DETAILS THAT VARY FROM UDFCD STANDARD DETAILS. CONSULT WITH LOCAL JURISDICTIONS AS TO WHICH DETAIL SHOULD BE USED WHEN DIFFERENCES ARE NOTED.

NOTE: THE DETAILS INCLUDED WITH THIS FACT SHEET SHOW COMMONLY USED, CONVENTIONAL METHODS OF INLET PROTECTION IN THE DENVER METROPOLITAN AREA. THERE ARE MANY PROPRIETARY INLET PROTECTION METHODS ON THE MARKET. UDFCD NEITHER ENDORSES NOR DISCOURAGES USE OF PROPRIETARY INLET PROTECTION; HOWEVER, IN THE EVENT PROPRIETARY METHODS ARE USED, THE APPROPRIATE DETAIL FROM THE MANUFACTURER MUST BE INCLUDED IN THE SWMP AND THE BMP MUST BE INSTALLED AND MAINTAINED AS SHOWN IN THE MANUFACTURER'S DETAILS.

NOTE: SOME MUNICIPALITIES DISCOURAGE OR PROHIBIT THE USE OF STRAW BALES FOR INLET PROTECTION. CHECK WITH LOCAL JURISDICTION TO DETERMINE IF STRAW BALE INLET PROTECTION IS ACCEPTABLE.

Additional erosion control details on maintenance and installation are located in Attachment 4 to the SWMP/GESQCP Narrative



ENVIRONMENTAL SERVICES DEPARTMENT
TECHNICAL SERVICES SECTION

P.O. Box 1103, Mail Code 940
COLORADO SPRINGS, CO 80947
(719) 668-8426

CONTROL MEASURE DETAILS
EROSION AND STORMWATER
QUALITY CONTROL PLAN

CSU Gas Line Loch Fyne /
Marksheffel

PCD Filing No: CDR-231

Prepared By: JPH

Date: December 2022





Colorado Springs Utilities

It's how we're all connected

Environmental Services Department
121 South Tejon Street, Fourth Floor
Colorado Springs, Colorado 80903

Legend:

- Streets
- Colorado Springs SW Inlets
- Stormwater Lines
- Stormwater_Outlets
- Water Way
- Construction Project Location
- LOC/LOD
- Construction Project Impervious Areas



Notes:
1. This is a Utilities' project. No grading over any utility will be changed.

GRADING AND EROSION CONTROL PLAN
SITE VICINITY MAP
Loch Fyne Gas Main Installation

Project No: WO# 3704076
Prepared By: R SEBASTIAN-COLEMAN
Date: 24 March, 2023

Figure Number
2

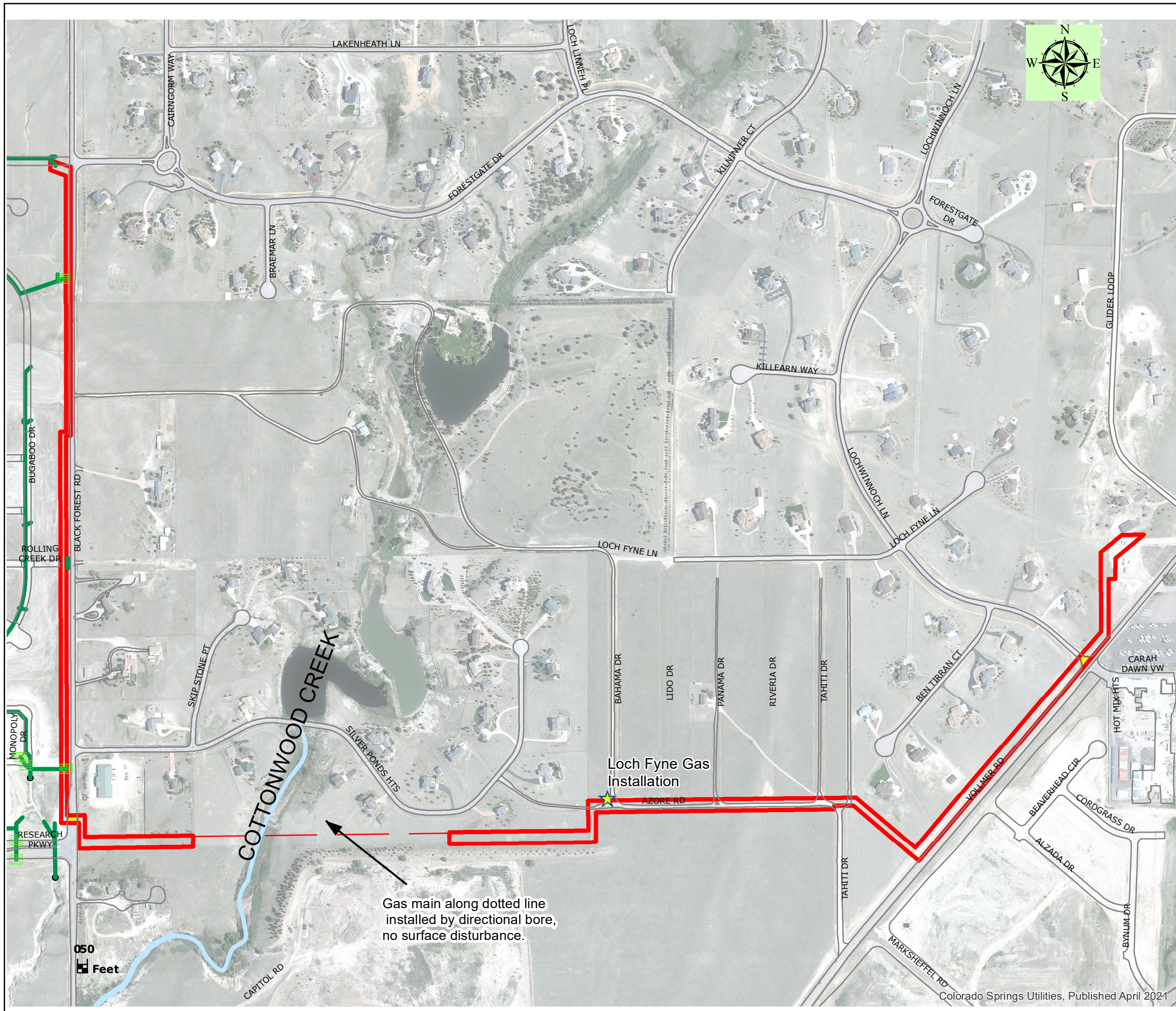

Gas main along dotted line installed by directional bore, no surface disturbance.



Colorado Springs Utilities

It's how we're all connected

Environmental Services Department
121 South Tejon Street, Fourth Floor
Colorado Springs, Colorado 80903

Legend:

- Streets
- Colorado Springs SW Inlets
- Stormwater Lines
- Stormwater_Outlets
- Water Way
- Construction Project Location
- LOC/LOD
- Utility Easements
- Hydrant
- NonPotablePipe
- PotablePipe
- RawPipe
- Existing Water Service Line
- Gas Main
- Electric Line
- 10 Year FEMA Flood Zone
- 100 Year FEMA Flood Zone
- 500 Year FEMA Flood Zone



Notes:

1. This is a Utilities' project. No grading over any utility will be changed.

GRADING AND EROSION CONTROL PLAN EXISTING UTILITIES AND FLOODPLAIN Loch Fyne Gas Main Installation

Project No: WO# 3704076

Prepared By: R SEBASTIAN-COLEMAN

Date: 24 March, 2023

**Figure
Number**
3

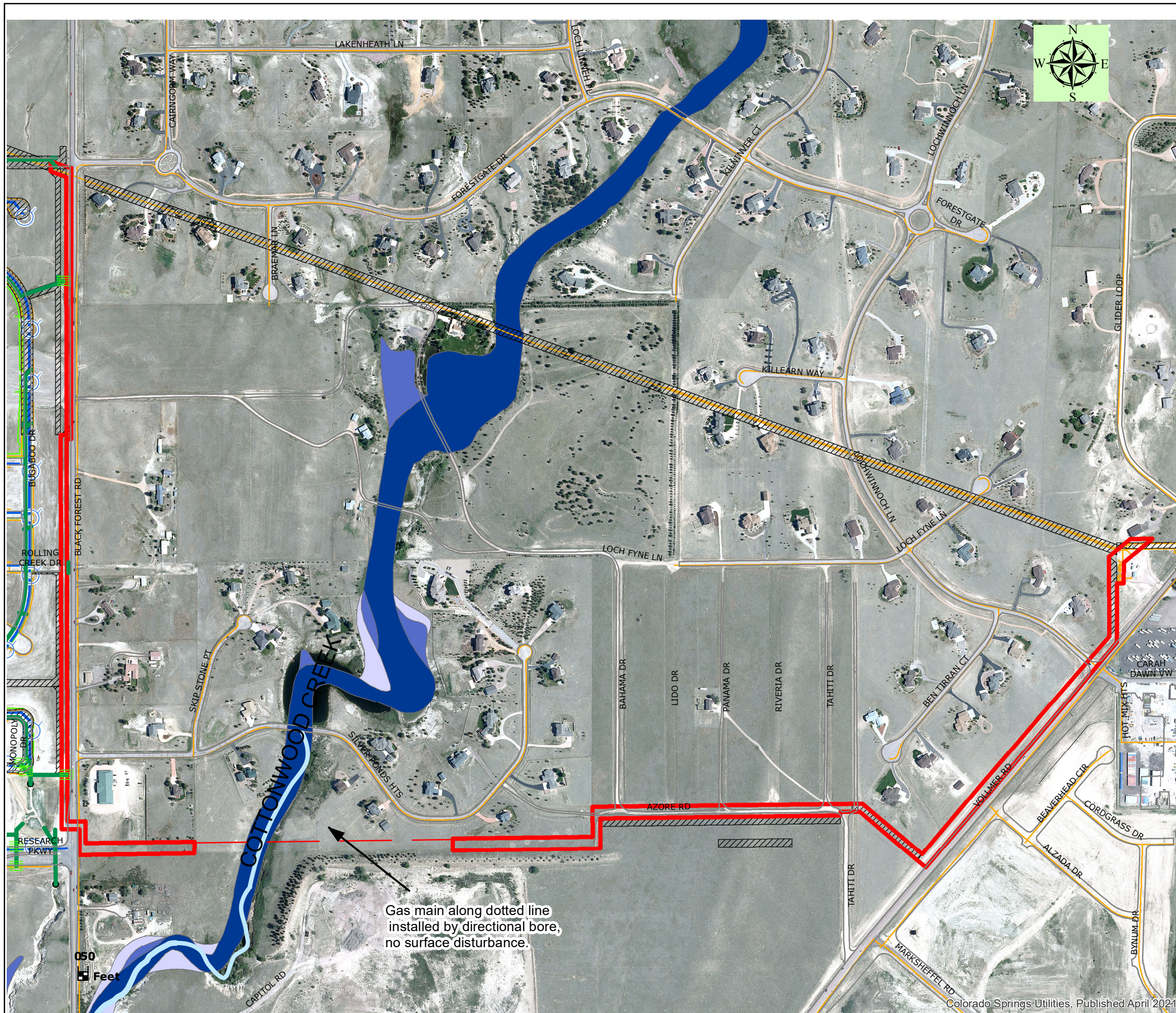

Gas main along dotted line installed by directional bore, no surface disturbance.



Colorado Springs Utilities

It's how we're all connected

Environmental Services Department
121 South Tejon Street, Fourth Floor
Colorado Springs, Colorado 80903

Legend:

- Match Lines
- Streets
- Colorado Springs SW Inlets
- Stormwater Lines
- Stormwater_Outlets
- Water Way
- Construction Project Location
- LOC/LOD
- Construction Project Impervious Areas

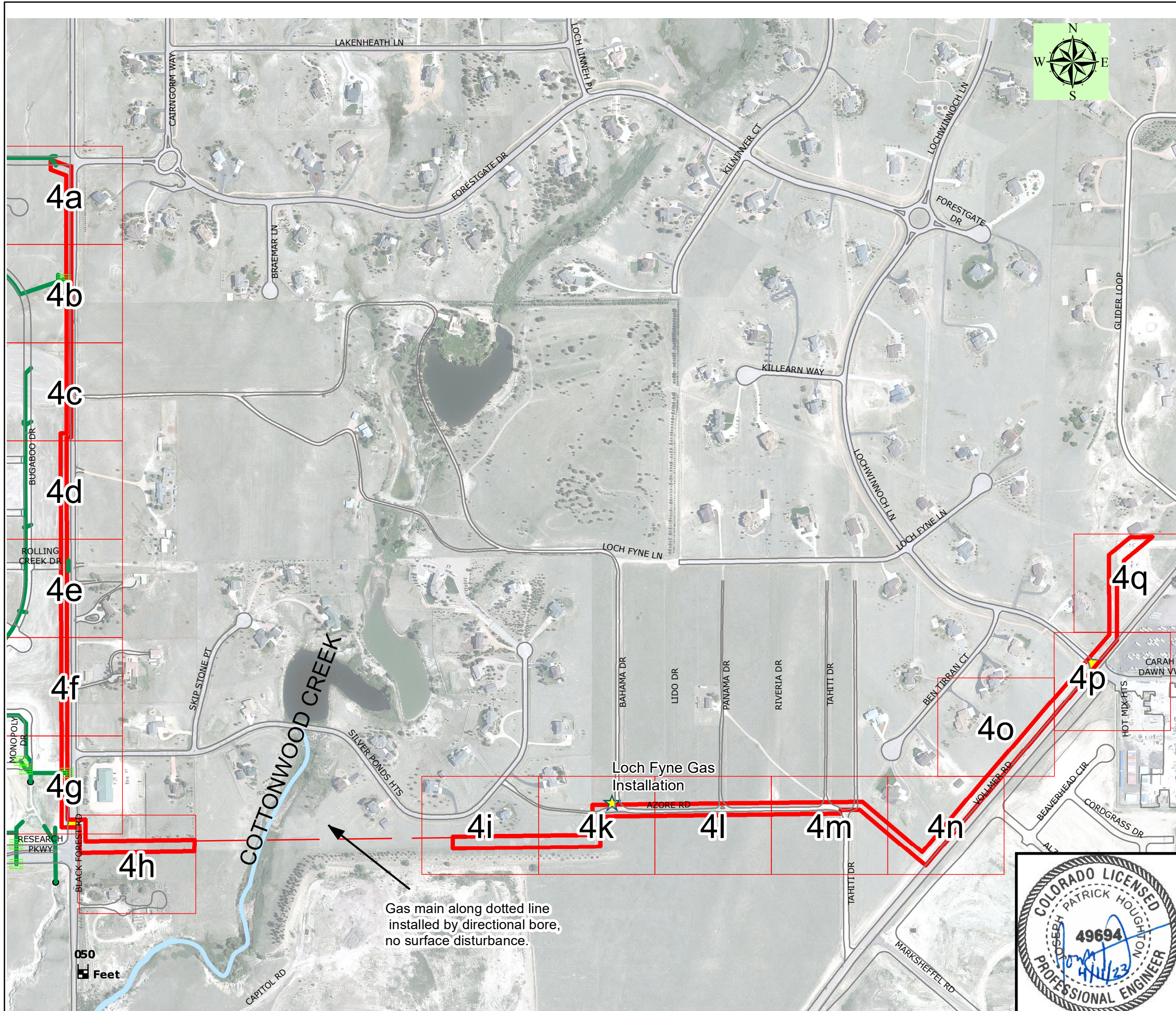

Gas main along dotted line installed by directional bore, no surface disturbance.

Notes:
1. This is a Utilities' project. No grading over any utility will be changed.

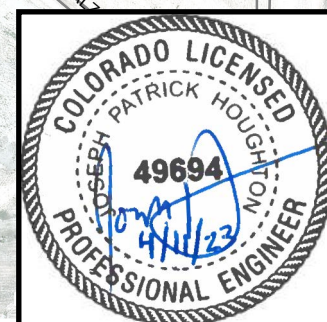

Loch Fyne Gas Main Installation

Project No: WO# 3704076

Prepared By: R SEBASTIAN-COLEMAN

Date: 24 March, 2023

Figure Number
4-Cover



Colorado Springs Utilities

It's how we're all connected

Environmental Services Department
121 South Tejon Street, Fourth Floor
Colorado Springs, Colorado 80903



Legend:

Streets	LOC/LOD - Current Status: Construction
Colorado Springs SW Inlets	Finally Stabilized
Stormwater Lines	Not Started
Stormwater_Outlets	Other
Water Way	Restoration / Stabilization
Control Measures - Is Action Needed?: Install Before Disturbance Begins	ROW
N/A	Utility Easements
No	Existing Hydrant
Yes	Non-Potable Water Distribution Main
Existing/Proposed Contours	Potable Water Distribution Main
Pollutant Source - Present?: No	Raw Water Distribution Main
Yes	Existing Water Service Line
Approximate Surface Flow Direction	Gas Main
	Electric Main (12.5 kV)

Notes:

1. LOC/LOD represents area of disturbance around the trench to account for vehicle traffic, material staging, and spoils piles, estimated to be 40 feet in width. The actual trench is approximately 4 feet in width.
2. Specific locations of staging areas, stockpiles, and any other material storage, including portable toilets will be determined by site crew. These locations, and location of accompanying stockpile protection control measures will be marked and updated on this plan throughout construction. Due to the nature of the project, it is expected that some or all of these items may be located in several areas and may be moved daily.
3. Inlet Protection Control Measures only need to be present while disturbances from main construction are present within each inlet's drainage area.
4. Once construction begins, if additional Control Measures are needed, locations should be identified on the inspection report map updates.
5. Street sweeping will be performed as needed. Areas in need will be marked on this map.
6. All areas within the LOC are expected to be reseeded and mulched after construction is complete, save for those within the roadway, which will simply be repaved to city or county standards depending on jurisdiction."
7. No concrete washout to be performed on site.

GRADING AND EROSION CONTROL PLAN SITE TOPOGRAPHY PLANNED CONTROL MEASURES

Loch Fyne Gas Main Installation

Project No: WO# 3704076

Prepared By: R SEBASTIAN-COLEMAN

Date: 24 March, 2023

Figure Number
4a

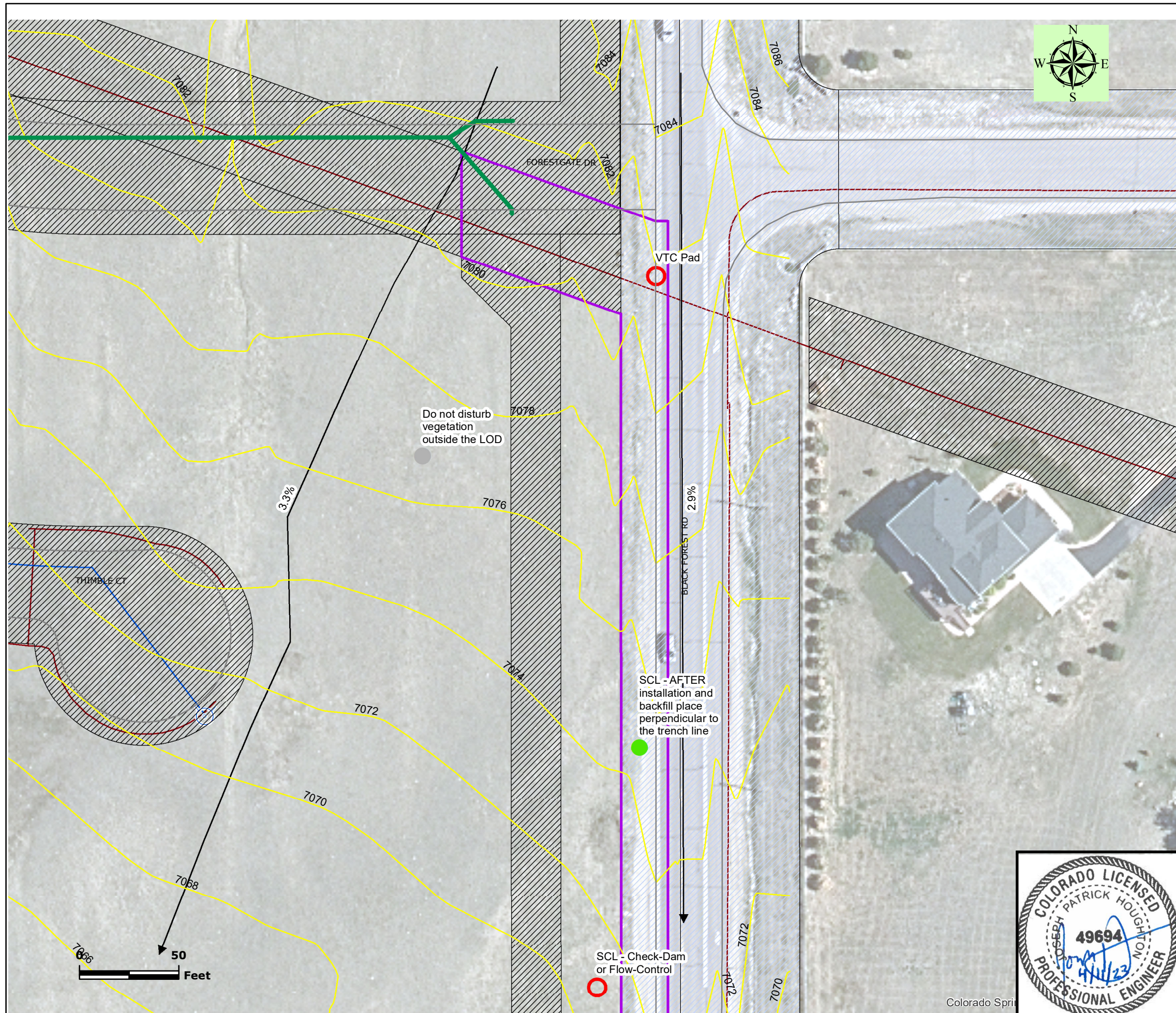
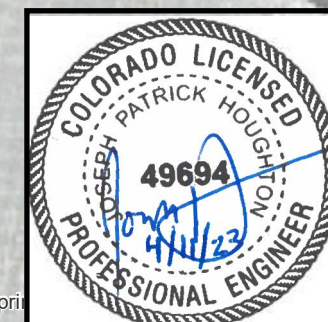

Colorado Springs

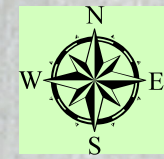
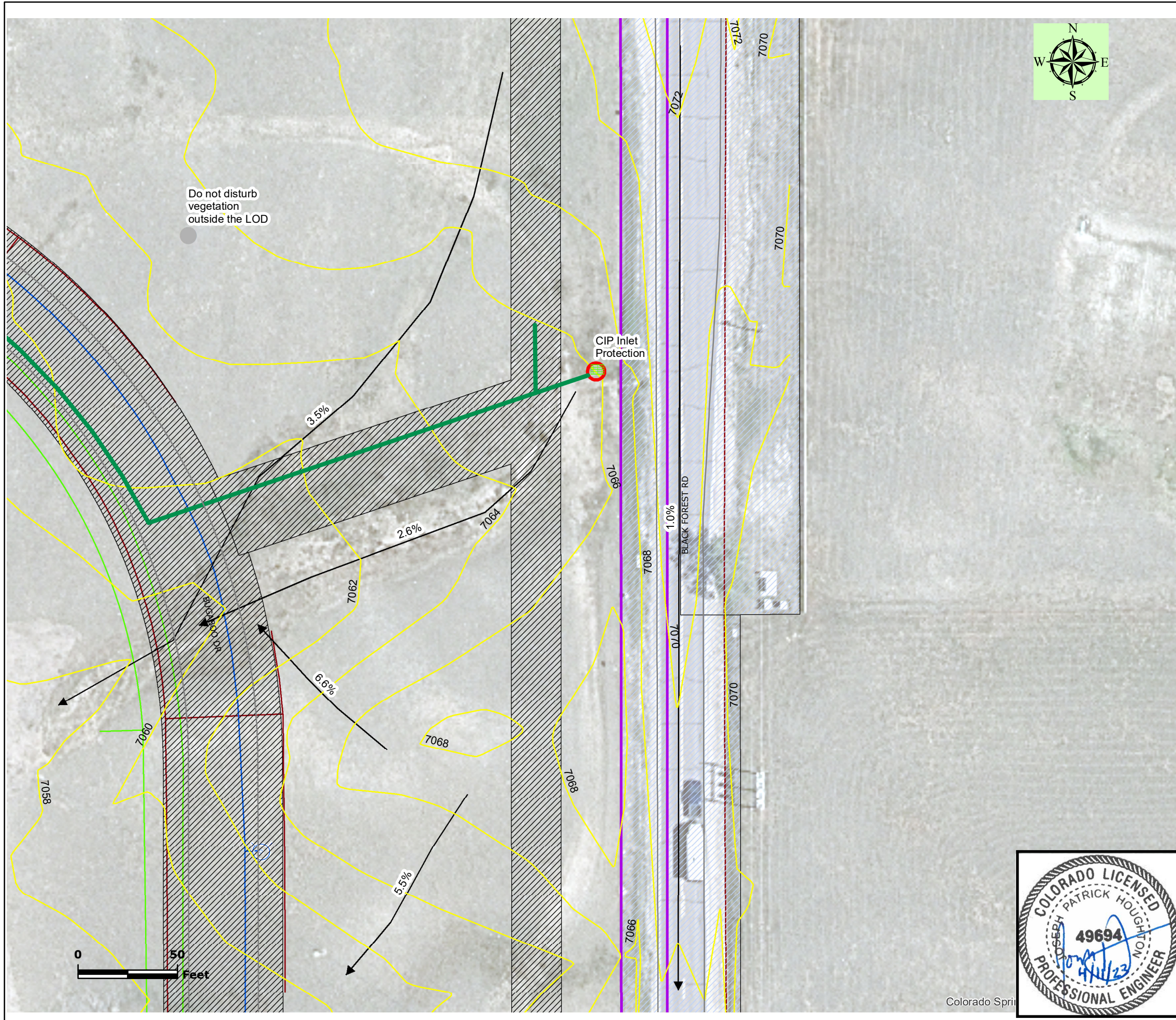

Colorado Springs Utilities

It's how we're all connected

Environmental Services Department
 121 South Tejon Street, Fourth Floor
 Colorado Springs, Colorado 80903

Legend:

—	Streets	—	LOC/LOD - Current Status
■	Colorado Springs SW Inlets	—	Construction
—	Stormwater Lines	—	Finally Stabilized
●	Stormwater_Outlets	—	Not Started
—	Water Way	—	Other
○	Control Measures - Is Action Needed?	—	Restoration / Stabilization
○	Install Before Disturbance Begins	▨	ROW
●	N/A	▨	Utility Easements
●	No	○	Existing Hydrant
●	Yes	—	Non-Potable Water Distribution Main
—	Existing/Proposed Contours	—	Potable Water Distribution Main
■	Pollutant Source - Present?	—	Raw Water Distribution Main
■	No	—	Existing Water Service Line
■	Yes	—	Gas Main
→	Approximate Surface Flow Direction	—	Electric Main (12.5 kV)

Notes:

1. LOC/LOD represents area of disturbance around the trench to account for vehicle traffic, material staging, and spoils piles, estimated to be 40 feet in width. The actual trench is approximately 4 feet in width.
2. Specific locations of staging areas, stockpiles, and any other material storage, including portable toilets will be determined by site crew. These locations, and location of accompanying stockpile protection control measures will be marked and updated on this plan throughout construction. Due to the nature of the project, it is expected that some or all of these items may be located in several areas and may be moved daily.
3. Inlet Protection Control Measures only need to be present while disturbances from main construction are present within each inlet's drainage area.
4. Once construction begins, if additional Control Measures are needed, locations should be identified on the inspection report map updates.
5. Street sweeping will be performed as needed. Areas in need will be marked on this map.
6. All areas within the LOC are expected to be reseeded and mulched after construction is complete, save for those within the roadway, which will simply be repaved to city or county standards depending on jurisdiction."
7. No concrete washout to be performed on site.



GRADING AND EROSION CONTROL PLAN SITE TOPOGRAPHY PLANNED CONTROL MEASURES

Loch Fyne Gas Main Installation

Project No: WO# 3704076	Figure Number 4b
Prepared By: R SEBASTIAN-COLEMAN	
Date: 24 March, 2023	

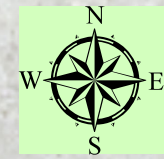
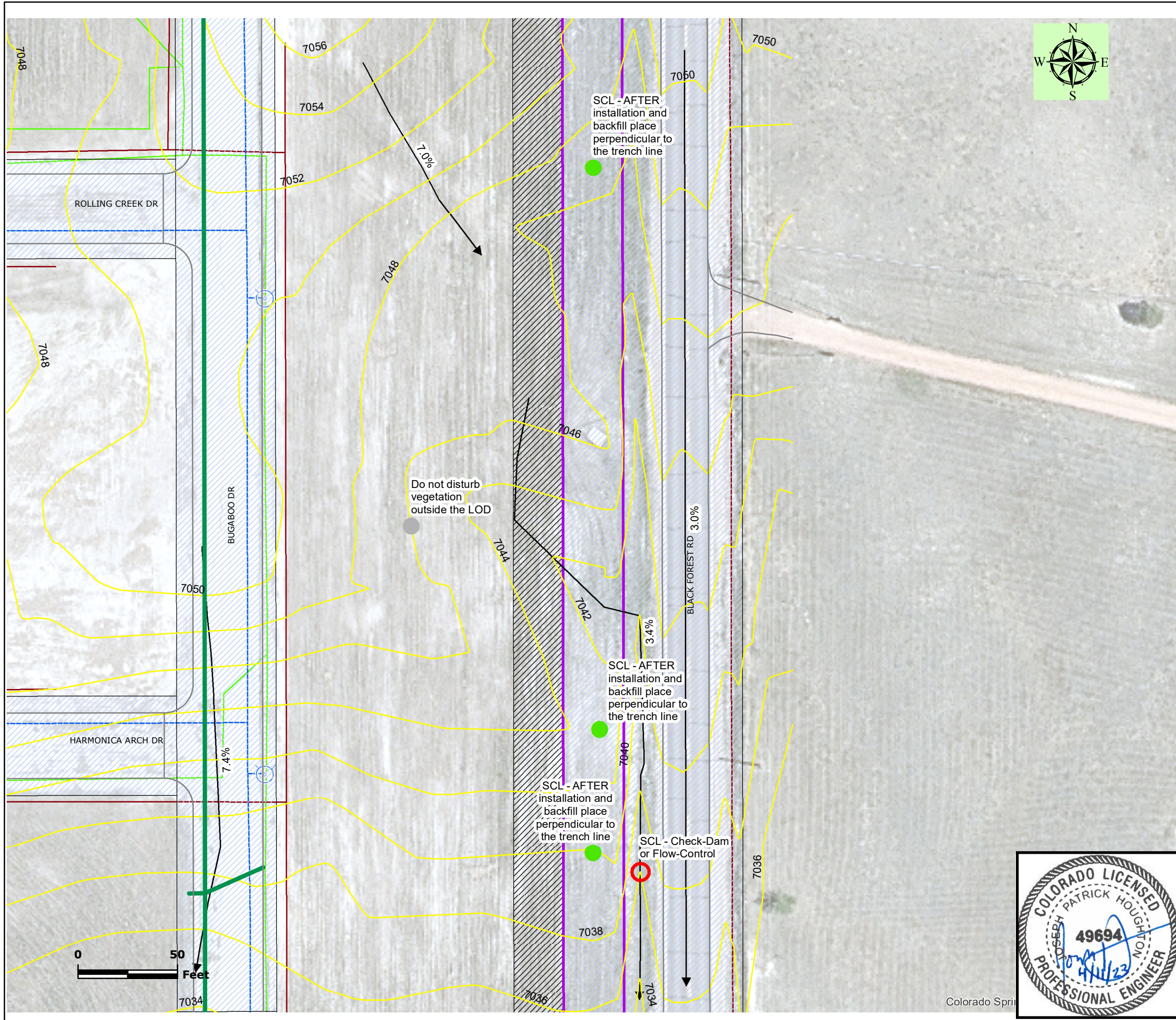

Legend:

— Streets	LOC/LOD - Current Status
Colorado Springs SW Inlets	Construction
Stormwater Lines	Finally Stabilized
Stormwater_Outlets	Not Started
Water Way	Other
Control Measures - Is Action Needed?	Restoration / Stabilization
○ Install Before Disturbance Begins	ROW
● N/A	Existing Hydrant
● No	Non-Potable Water Distribution Main
● Yes	Potable Water Distribution Main
Existing/Proposed Contours	Raw Water Distribution Main
■ No	Existing Water Service Line
■ Yes	Gas Main
→ Approximate Surface Flow Direction	Electric Main (12.5 kV)
	Electric Main (12.5 kV)

- Notes:
1. LOC/LOD represents area of disturbance around the trench to account for vehicle traffic, material staging, and spoils piles, estimated to be 40 feet in width. The actual trench is approximately 4 feet in width.
 2. Specific locations of staging areas, stockpiles, and any other material storage, including portable toilets will be determined by site crew. These locations, and location of accompanying stockpile protection control measures will be marked and updated on this plan throughout construction. Due to the nature of the project, it is expected that some or all of these items may be located in several areas and may be moved daily.
 3. Inlet Protection Control Measures only need to be present while disturbances from main construction are present within each inlet's drainage area.
 4. Once construction begins, if additional Control Measures are needed, locations should be identified on the inspection report map updates.
 5. Street sweeping will be performed as needed. Areas in need will be marked on this map.
 6. All areas within the LOC are expected to be reseeded and mulched after construction is complete, save for those within the roadway, which will simply be repaved to city or county standards depending on jurisdiction."
 7. No concrete washout to be performed on site.



**GRADING AND EROSION CONTROL PLAN
 SITE TOPOGRAPHY
 PLANNED CONTROL MEASURES**

Loch Fyne Gas Main Installation

Project No: WO# 3704076	Figure Number 4d
Prepared By: R SEBASTIAN-COLEMAN	
Date: 24 March, 2023	



Colorado Springs Utilities

It's how we're all connected

Environmental Services Department
121 South Tejon Street, Fourth Floor
Colorado Springs, Colorado 80903

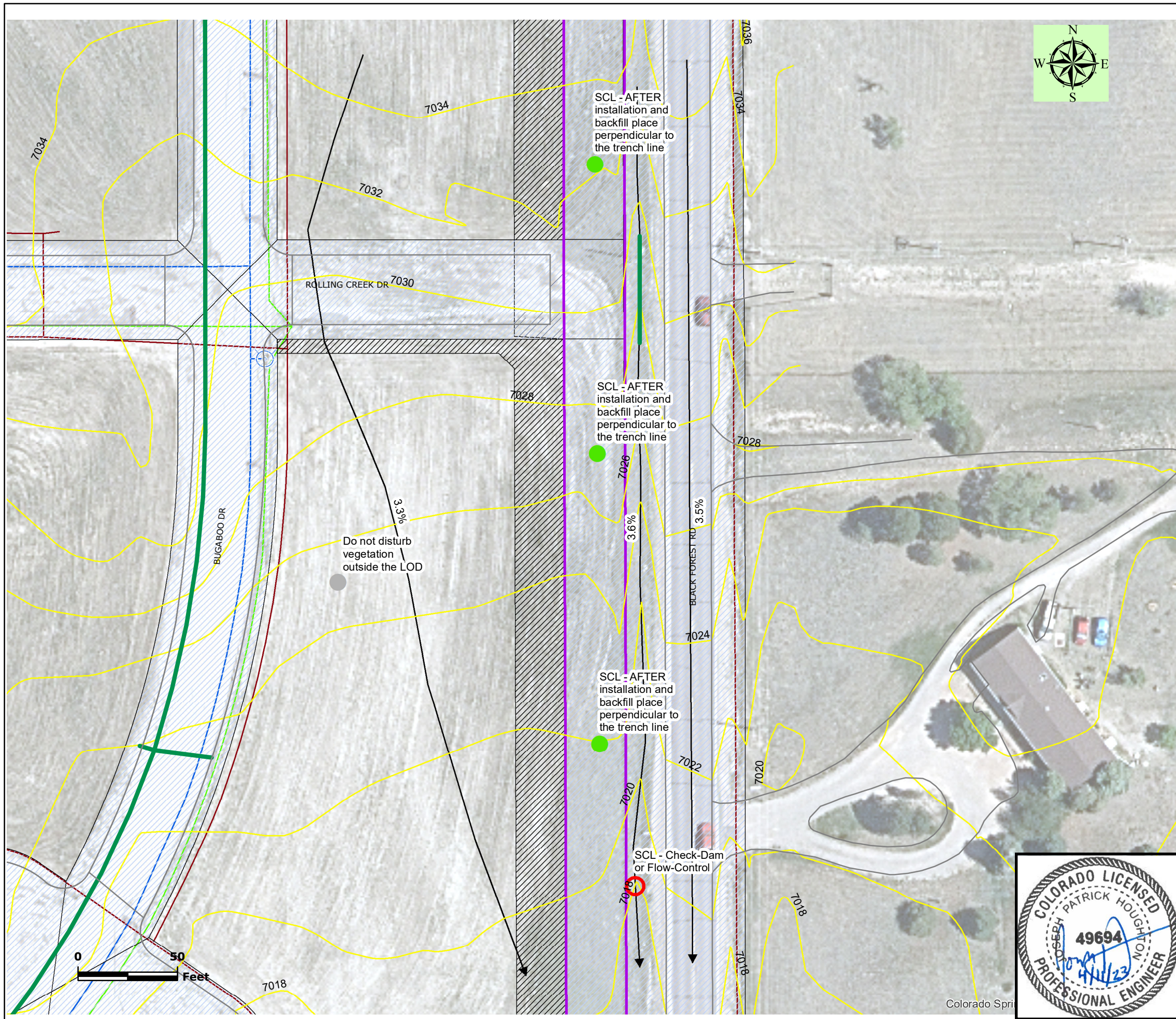

Legend:

Streets	LOC/LOD - Current Status Construction
Colorado Springs SW Inlets	Finally Stabilized
Stormwater Lines	Not Started
Stormwater_Outlets	Other
Water Way	Restoration / Stabilization
Control Measures - Is Action Needed?	ROW
Install Before Disturbance Begins	Utility Easements
N/A	Existing Hydrant
No	Non-Potable Water Distribution Main
Yes	Potable Water Distribution Main
Existing/Proposed Contours	Raw Water Distribution Main
Pollutant Source - Present?	Existing Water Service Line
No	Gas Main
Yes	Electric Main (12.5 kV)
Approximate Surface Flow Direction	

- Notes:
1. LOC/LOD represents area of disturbance around the trench to account for vehicle traffic, material staging, and spoils piles, estimated to be 40 feet in width. The actual trench is approximately 4 feet in width.
 2. Specific locations of staging areas, stockpiles, and any other material storage, including portable toilets will be determined by site crew. These locations, and location of accompanying stockpile protection control measures will be marked and updated on this plan throughout construction. Due to the nature of the project, it is expected that some or all of these items may be located in several areas and may be moved daily.
 3. Inlet Protection Control Measures only need to be present while disturbances from main construction are present within each inlet's drainage area.
 4. Once construction begins, if additional Control Measures are needed, locations should be identified on the inspection report map updates.
 5. Street sweeping will be performed as needed. Areas in need will be marked on this map.
 6. All areas within the LOC are expected to be reseeded and mulched after construction is complete, save for those within the roadway, which will simply be repaved to city or county standards depending on jurisdiction."
 7. No concrete washout to be performed on site.

GRADING AND EROSION CONTROL PLAN SITE TOPOGRAPHY PLANNED CONTROL MEASURES

Loch Fyne Gas Main Installation

Project No: WO# 3704076	Figure Number 4e
Prepared By: R SEBASTIAN-COLEMAN	
Date: 24 March, 2023	





Colorado Springs Utilities

It's how we're all connected

Environmental Services Department
121 South Tejon Street, Fourth Floor
Colorado Springs, Colorado 80903

Legend:

Streets	LOC/LOD - Current Status Construction
Colorado Springs SW Inlets	Finally Stabilized
Stormwater Lines	Not Started
Stormwater_Outlets	Other
Water Way	Restoration / Stabilization
Control Measures - Is Action Needed? Install Before Disturbance Begins	ROW
N/A	Utility Easements
No	Existing Hydrant
Yes	Non-Potable Water Distribution Main
Existing/Proposed Contours	Potable Water Distribution Main
Pollutant Source - Present? No	Raw Water Distribution Main
Yes	Existing Water Service Line
Approximate Surface Flow Direction	Gas Main
	Electric Main (12.5 kV)

Notes:

1. LOC/LOD represents area of disturbance around the trench to account for vehicle traffic, material staging, and spoils piles, estimated to be 40 feet in width. The actual trench is approximately 4 feet in width.
2. Specific locations of staging areas, stockpiles, and any other material storage, including portable toilets will be determined by site crew. These locations, and location of accompanying stockpile protection control measures will be marked and updated on this plan throughout construction. Due to the nature of the project, it is expected that some or all of these items may be located in several areas and may be moved daily.
3. Inlet Protection Control Measures only need to be present while disturbances from main construction are present within each inlet's drainage area.
4. Once construction begins, if additional Control Measures are needed, locations should be identified on the inspection report map updates.
5. Street sweeping will be performed as needed. Areas in need will be marked on this map.
6. All areas within the LOC are expected to be reseeded and mulched after construction is complete, save for those within the roadway, which will simply be repaved to city or county standards depending on jurisdiction."
7. No concrete washout to be performed on site.

GRADING AND EROSION CONTROL PLAN SITE TOPOGRAPHY PLANNED CONTROL MEASURES

Loch Fyne Gas Main Installation

Project No: WO# 3704076

Prepared By: R SEBASTIAN-COLEMAN

Date: 24 March, 2023

Figure Number
4f

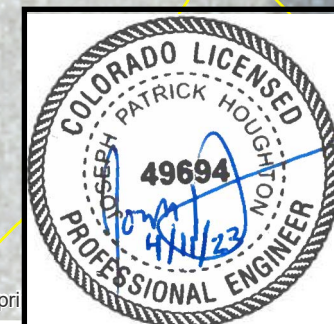
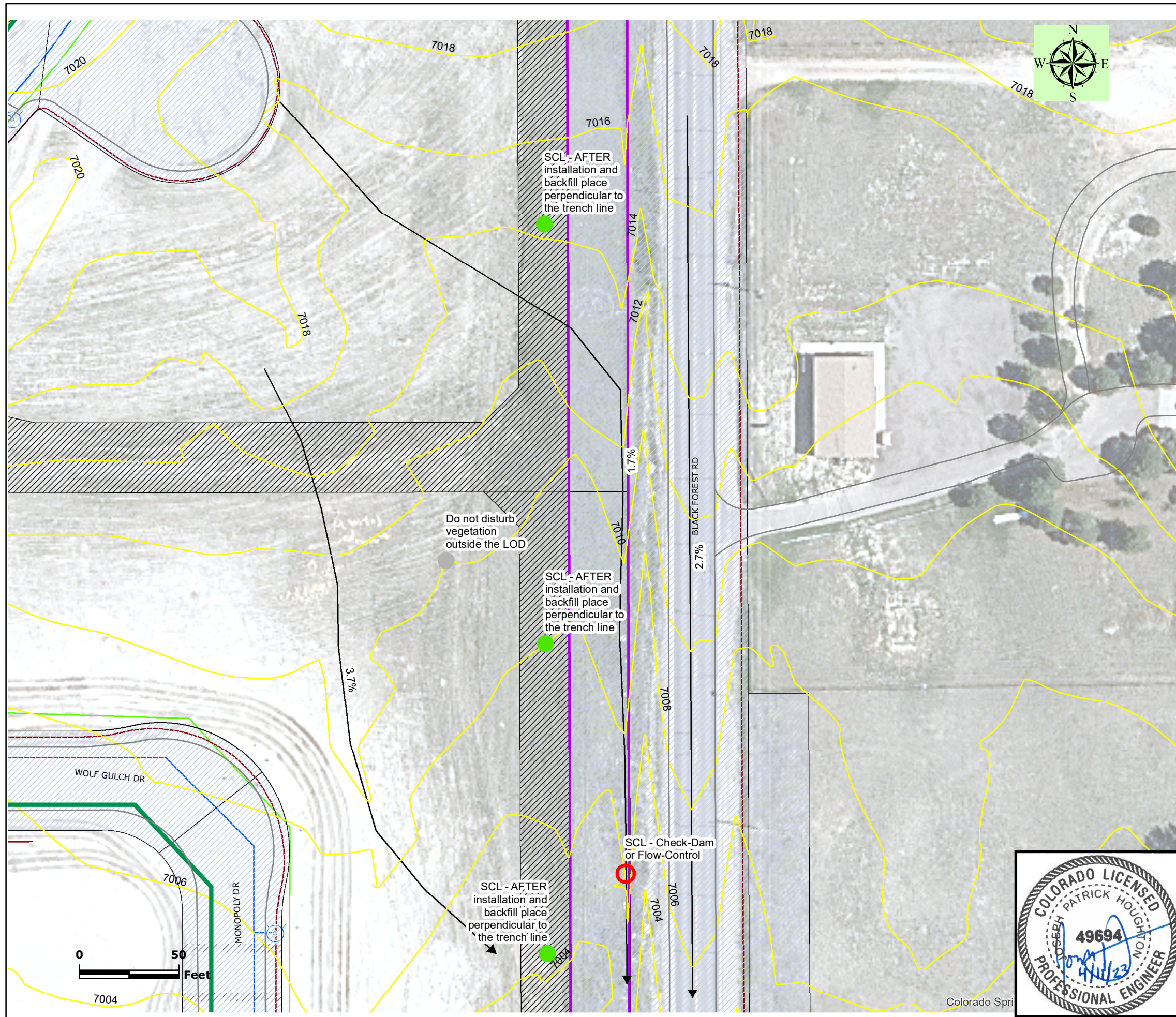



Colorado Springs Utilities

It's how we're all connected

Environmental Services Department
121 South Tejon Street, Fourth Floor
Colorado Springs, Colorado 80903

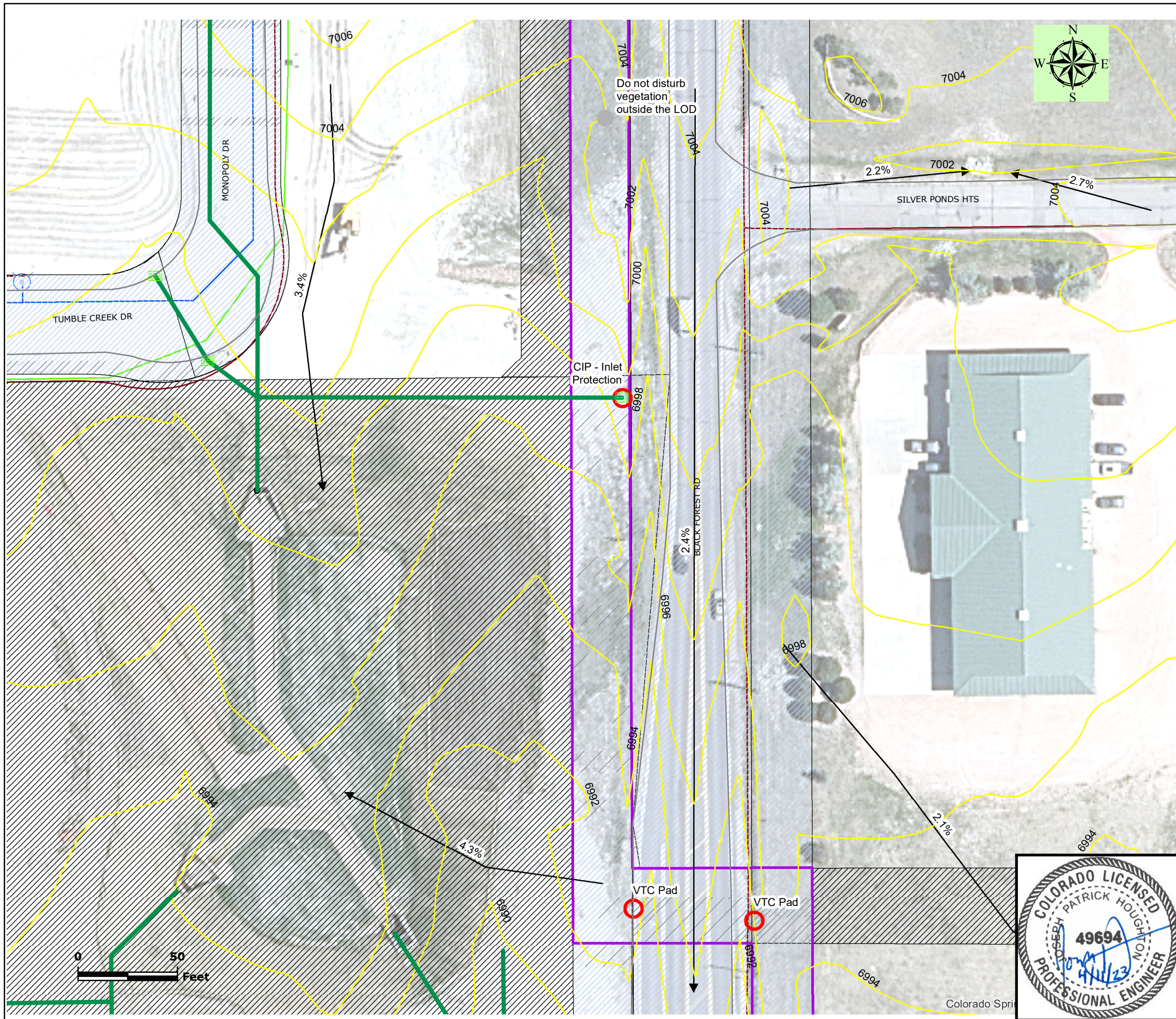

Legend:

Streets	LOC/LOD - Current Status Construction
Colorado Springs SW Inlets	Finally Stabilized
Stormwater Lines	Not Started
Stormwater_Outlets	Other
Water Way	Restoration / Stabilization
Control Measures - Is Action Needed?	ROW
Install Before Disturbance Begins	Utility Easements
N/A	Existing Hydrant
No	Non-Potable Water Distribution Main
Yes	Potable Water Distribution Main
Existing/Proposed Contours	Raw Water Distribution Main
Pollutant Source - Present?	Existing Water Service Line
No	Gas Main
Yes	Electric Main (12.5 kV)
Approximate Surface Flow Direction	

Notes:

1. LOC/LOD represents area of disturbance around the trench to account for vehicle traffic, material staging, and spoils piles, estimated to be 40 feet in width. The actual trench is approximately 4 feet in width.
2. Specific locations of staging areas, stockpiles, and any other material storage, including portable toilets will be determined by site crew. These locations, and location of accompanying stockpile protection control measures will be marked and updated on this plan throughout construction. Due to the nature of the project, it is expected that some or all of these items may be located in several areas and may be moved daily.
3. Inlet Protection Control Measures only need to be present while disturbances from main construction are present within each inlet's drainage area.
4. Once construction begins, if additional Control Measures are needed, locations should be identified on the inspection report map updates.
5. Street sweeping will be performed as needed. Areas in need will be marked on this map.
6. All areas within the LOC are expected to be reseeded and mulched after construction is complete, save for those within the roadway, which will simply be repaved to city or county standards depending on jurisdiction."
7. No concrete washout to be performed on site.

GRADING AND EROSION CONTROL PLAN SITE TOPOGRAPHY PLANNED CONTROL MEASURES

Loch Fyne Gas Main Installation

Project No: WO# 3704076

Prepared By: R SEBASTIAN-COLEMAN

Date: 24 March, 2023

Figure Number
4g

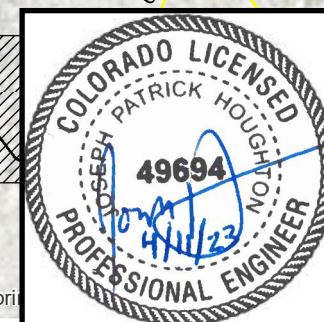



Colorado Springs Utilities

It's how we're all connected

Environmental Services Department
121 South Tejon Street, Fourth Floor
Colorado Springs, Colorado 80903

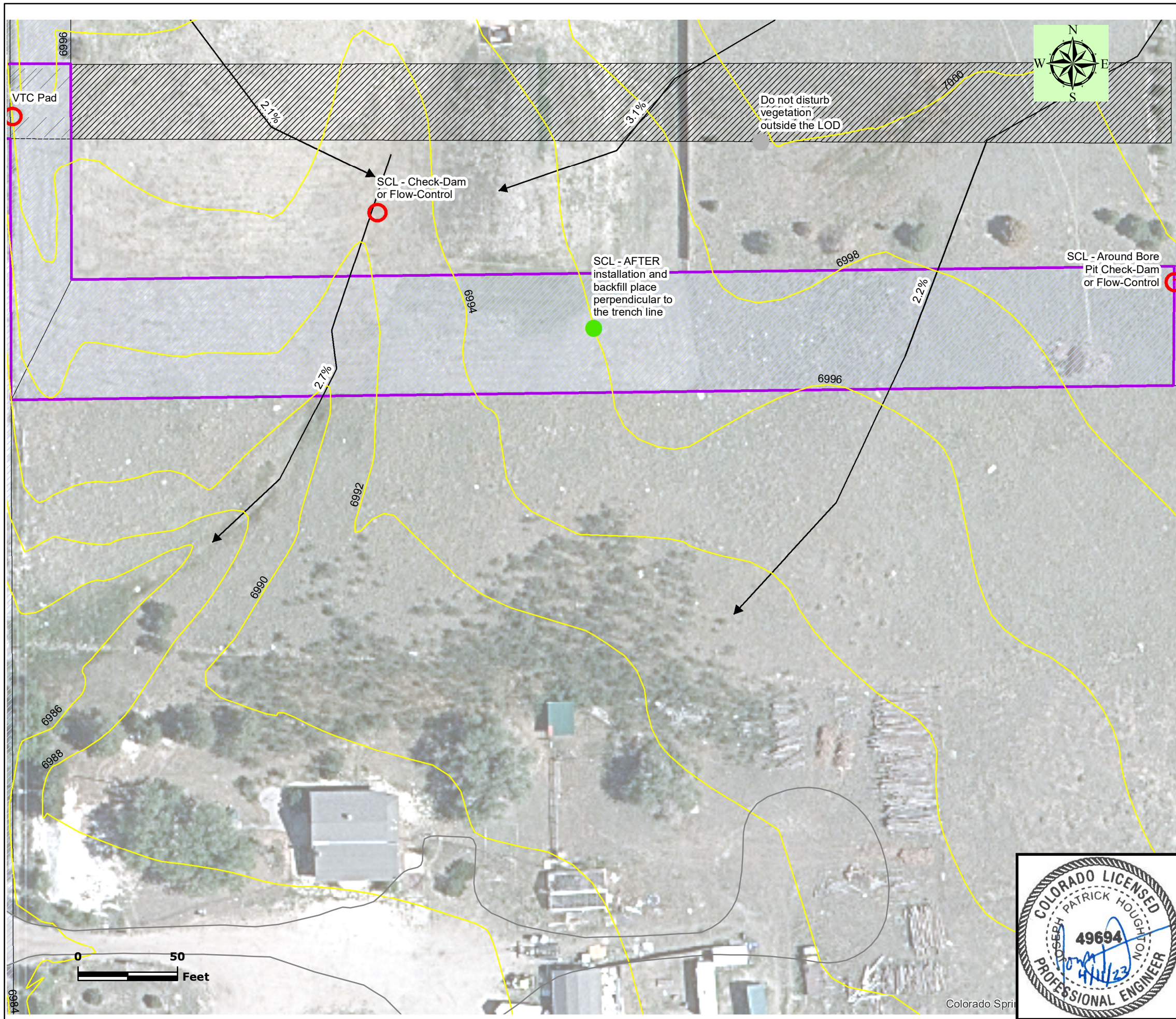

Legend:

Streets	LOC/LOD - Current Status: Construction
Colorado Springs SW Inlets	Finally Stabilized
Stormwater Lines	Not Started
Stormwater_Outlets	Other
Water Way	Restoration / Stabilization
Control Measures - Is Action Needed?: Install Before Disturbance Begins	ROW
N/A	Existing Hydrant
No	Non-Potable Water Distribution Main
Yes	Potable Water Distribution Main
Existing/Proposed Contours	Raw Water Distribution Main
Pollutant Source - Present?: No	Existing Water Service Line
Yes	Electric Main (12.5 kV)
Approximate Surface Flow Direction	

Notes:

1. LOC/LOD represents area of disturbance around the trench to account for vehicle traffic, material staging, and spoils piles, estimated to be 40 feet in width. The actual trench is approximately 4 feet in width.
2. Specific locations of staging areas, stockpiles, and any other material storage, including portable toilets will be determined by site crew. These locations, and location of accompanying stockpile protection control measures will be marked and updated on this plan throughout construction. Due to the nature of the project, it is expected that some or all of these items may be located in several areas and may be moved daily.
3. Inlet Protection Control Measures only need to be present while disturbances from main construction are present within each inlet's drainage area.
4. Once construction begins, if additional Control Measures are needed, locations should be identified on the inspection report map updates.
5. Street sweeping will be performed as needed. Areas in need will be marked on this map.
6. All areas within the LOC are expected to be reseeded and mulched after construction is complete, save for those within the roadway, which will simply be repaved to city or county standards depending on jurisdiction."
7. No concrete washout to be performed on site.

GRADING AND EROSION CONTROL PLAN SITE TOPOGRAPHY PLANNED CONTROL MEASURES

Loch Fyne Gas Main Installation

Project No: WO# 3704076

Prepared By: R SEBASTIAN-COLEMAN

Date: 24 March, 2023

Figure Number
4h

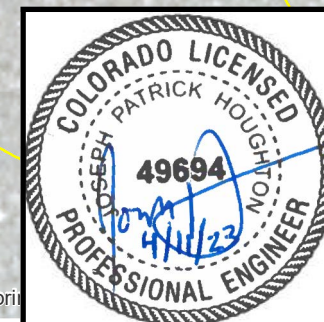



Colorado Springs Utilities

It's how we're all connected

Environmental Services Department
121 South Tejon Street, Fourth Floor
Colorado Springs, Colorado 80903

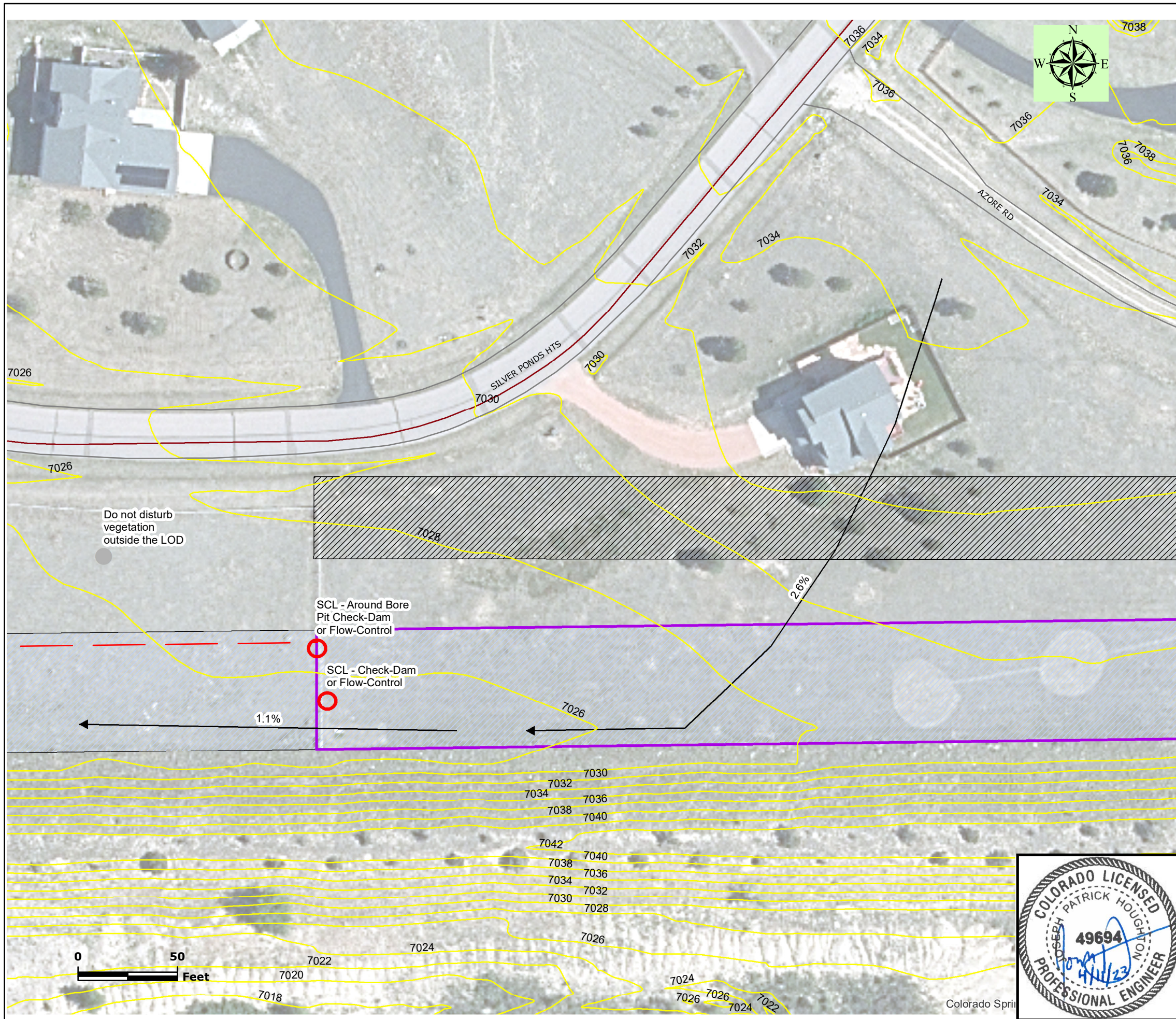

Legend:

Streets	LOC/LOD - Current Status Construction
Colorado Springs SW Inlets	Finally Stabilized
Stormwater Lines	Not Started
Stormwater_Outlets	Other
Water Way	Restoration / Stabilization
Control Measures - Is Action Needed?	ROW
Install Before Disturbance Begins	Existing Hydrant
N/A	Non-Potable Water Distribution Main
No	Potable Water Distribution Main
Yes	Raw Water Distribution Main
Existing/Proposed Contours	Existing Water Service Line
Pollutant Source - Present?	Gas Main
No	Electric Main (12.5 kV)
Yes	Approximate Surface Flow Direction

Notes:

1. LOC/LOD represents area of disturbance around the trench to account for vehicle traffic, material staging, and spoils piles, estimated to be 40 feet in width. The actual trench is approximately 4 feet in width.
2. Specific locations of staging areas, stockpiles, and any other material storage, including portable toilets will be determined by site crew. These locations, and location of accompanying stockpile protection control measures will be marked and updated on this plan throughout construction. Due to the nature of the project, it is expected that some or all of these items may be located in several areas and may be moved daily.
3. Inlet Protection Control Measures only need to be present while disturbances from main construction are present within each inlet's drainage area.
4. Once construction begins, if additional Control Measures are needed, locations should be identified on the inspection report map updates.
5. Street sweeping will be performed as needed. Areas in need will be marked on this map.
6. All areas within the LOC are expected to be reseeded and mulched after construction is complete, save for those within the roadway, which will simply be repaved to city or county standards depending on jurisdiction."
7. No concrete washout to be performed on site.

GRADING AND EROSION CONTROL PLAN SITE TOPOGRAPHY PLANNED CONTROL MEASURES

Loch Fyne Gas Main Installation

Project No: WO# 3704076

Prepared By: R SEBASTIAN-COLEMAN

Date: 24 March, 2023

Figure Number
4i

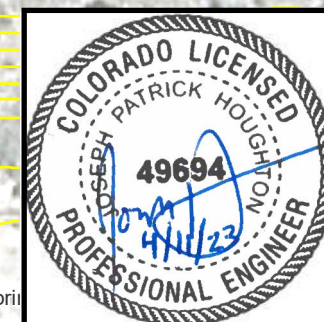



Colorado Springs Utilities

It's how we're all connected

Environmental Services Department
121 South Tejon Street, Fourth Floor
Colorado Springs, Colorado 80903

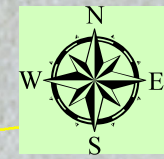
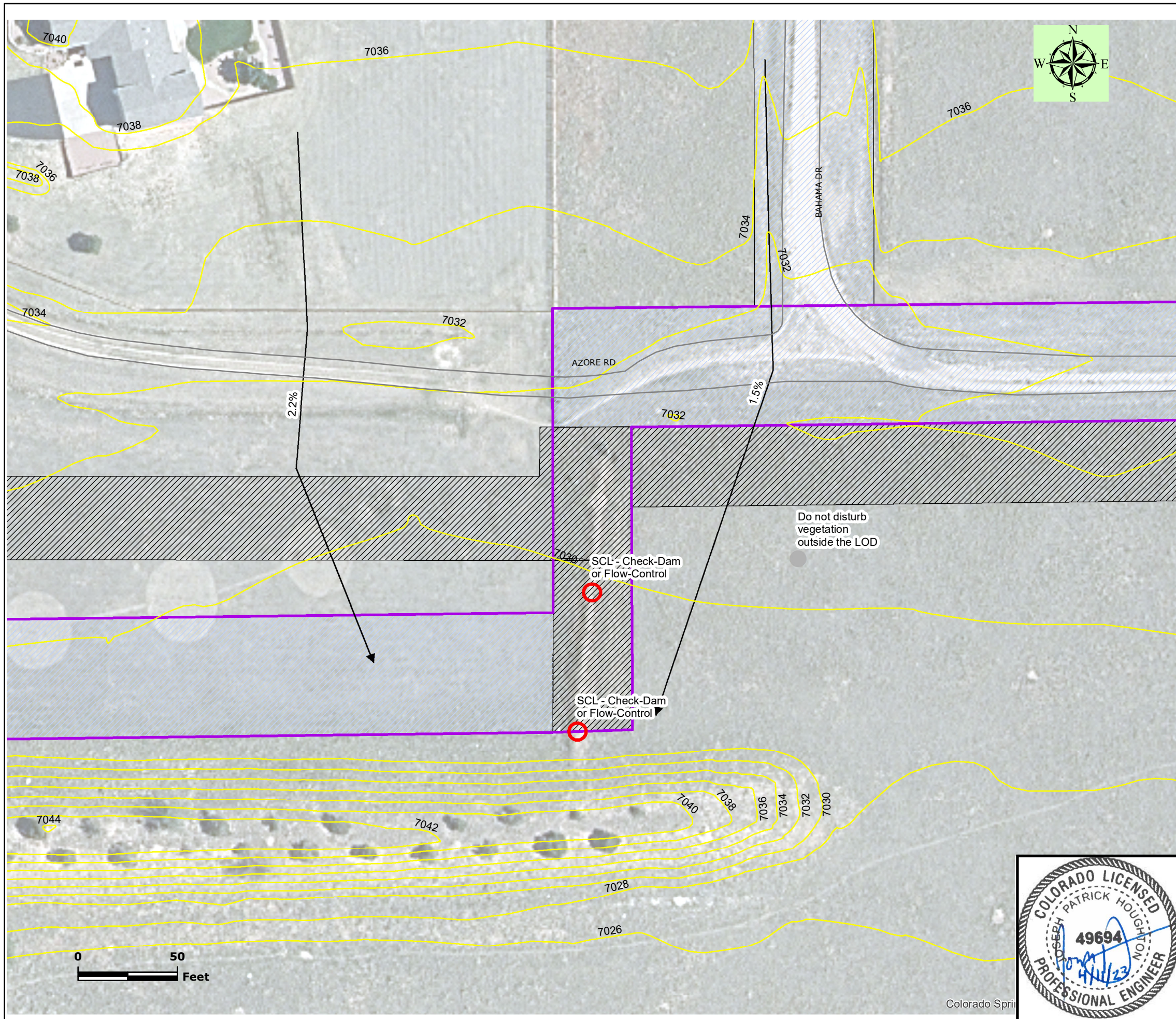

Legend:

Streets	LOC/LOD - Current Status Construction
Colorado Springs SW Inlets	Finally Stabilized
Stormwater Lines	Not Started
Stormwater_Outlets	Other
Water Way	Restoration / Stabilization
Control Measures - Is Action Needed? Install Before Disturbance Begins	ROW
N/A	Utility Easements
No	Existing Hydrant
Yes	Non-Potable Water Distribution Main
Existing/Proposed Contours	Potable Water Distribution Main
Pollutant Source - Present? No	Raw Water Distribution Main
Yes	Existing Water Service Line
Approximate Surface Flow Direction	Electric Main (12.5 kV)

Notes:

1. LOC/LOD represents area of disturbance around the trench to account for vehicle traffic, material staging, and spoils piles, estimated to be 40 feet in width. The actual trench is approximately 4 feet in width.
2. Specific locations of staging areas, stockpiles, and any other material storage, including portable toilets will be determined by site crew. These locations, and location of accompanying stockpile protection control measures will be marked and updated on this plan throughout construction. Due to the nature of the project, it is expected that some or all of these items may be located in several areas and may be moved daily.
3. Inlet Protection Control Measures only need to be present while disturbances from main construction are present within each inlet's drainage area.
4. Once construction begins, if additional Control Measures are needed, locations should be identified on the inspection report map updates.
5. Street sweeping will be performed as needed. Areas in need will be marked on this map.
6. All areas within the LOC are expected to be reseeded and mulched after construction is complete, save for those within the roadway, which will simply be repaved to city or county standards depending on jurisdiction."
7. No concrete washout to be performed on site.

GRADING AND EROSION CONTROL PLAN SITE TOPOGRAPHY PLANNED CONTROL MEASURES

Loch Fyne Gas Main Installation

Project No: WO# 3704076

Prepared By: R SEBASTIAN-COLEMAN

Date: 24 March, 2023

Figure Number
4k

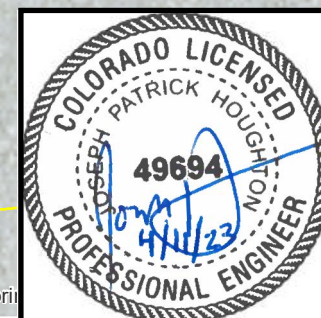

Colorado Springs



Colorado Springs Utilities

It's how we're all connected

Environmental Services Department
121 South Tejon Street, Fourth Floor
Colorado Springs, Colorado 80903

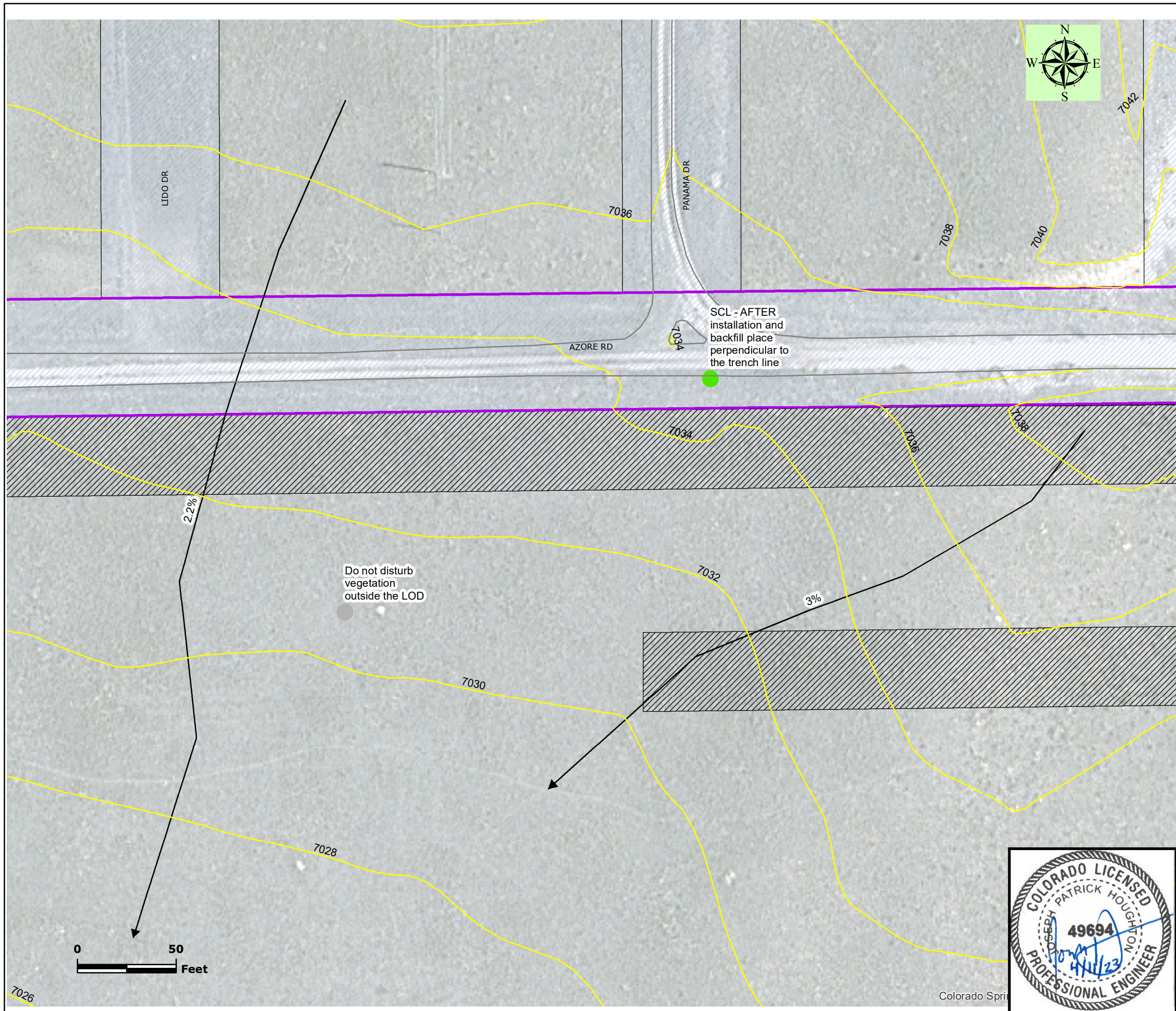

Legend:

Streets	LOC/LOD - Current Status: Construction
Colorado Springs SW Inlets	Finally Stabilized
Stormwater Lines	Not Started
Stormwater_Outlets	Other
Water Way	Restoration / Stabilization
Control Measures - Is Action Needed? Install Before Disturbance Begins	ROW
N/A	Utility Easements
No	Existing Hydrant
Yes	Non-Potable Water Distribution Main
Existing/Proposed Contours	Potable Water Distribution Main
Pollutant Source - Present? No	Raw Water Distribution Main
Yes	Existing Water Service Line
Approximate Surface Flow Direction	Electric Main (12.5 kV)

- Notes:
1. LOC/LOD represents area of disturbance around the trench to account for vehicle traffic, material staging, and spoils piles, estimated to be 40 feet in width. The actual trench is approximately 4 feet in width.
 2. Specific locations of staging areas, stockpiles, and any other material storage, including portable toilets will be determined by site crew. These locations, and location of accompanying stockpile protection control measures will be marked and updated on this plan throughout construction. Due to the nature of the project, it is expected that some or all of these items may be located in several areas and may be moved daily.
 3. Inlet Protection Control Measures only need to be present while disturbances from main construction are present within each inlet's drainage area.
 4. Once construction begins, if additional Control Measures are needed, locations should be identified on the inspection report map updates.
 5. Street sweeping will be performed as needed. Areas in need will be marked on this map.
 6. All areas within the LOC are expected to be reseeded and mulched after construction is complete, save for those within the roadway, which will simply be repaved to city or county standards depending on jurisdiction."
 7. No concrete washout to be performed on site.

GRADING AND EROSION CONTROL PLAN SITE TOPOGRAPHY PLANNED CONTROL MEASURES

Loch Fyne Gas Main Installation

Project No: WO# 3704076	Figure Number 41
Prepared By: R SEBASTIAN-COLEMAN	
Date: 24 March, 2023	

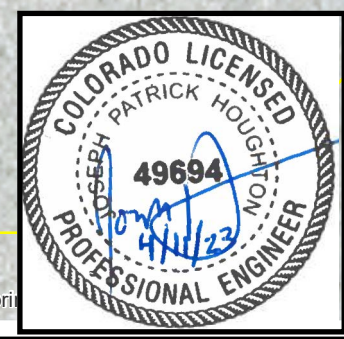



Colorado Springs Utilities

It's how we're all connected

Environmental Services Department
121 South Tejon Street, Fourth Floor
Colorado Springs, Colorado 80903

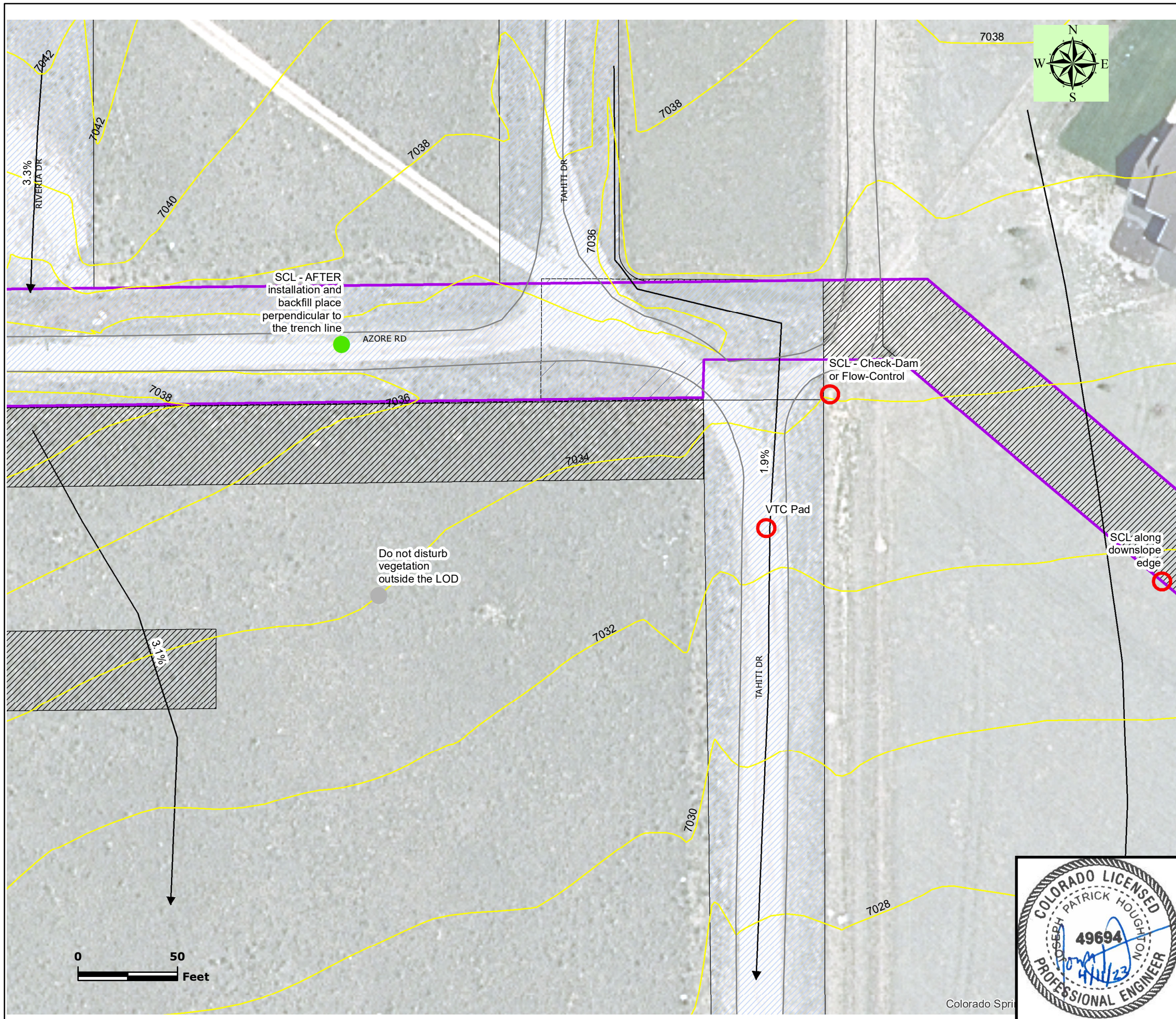

Legend:

Streets	LOC/LOD - Current Status: Construction
Colorado Springs SW Inlets	Finally Stabilized
Stormwater Lines	Not Started
Stormwater_Outlets	Other
Water Way	Restoration / Stabilization
Control Measures - Is Action Needed? Install Before Disturbance Begins	ROW
N/A	Utility Easements
No	Existing Hydrant
Yes	Non-Potable Water Distribution Main
Existing/Proposed Contours	Potable Water Distribution Main
Pollutant Source - Present? No	Raw Water Distribution Main
Yes	Existing Water Service Line
Approximate Surface Flow Direction	Electric Main (12.5 kV)

Notes:

1. LOC/LOD represents area of disturbance around the trench to account for vehicle traffic, material staging, and spoils piles, estimated to be 40 feet in width. The actual trench is approximately 4 feet in width.
2. Specific locations of staging areas, stockpiles, and any other material storage, including portable toilets will be determined by site crew. These locations, and location of accompanying stockpile protection control measures will be marked and updated on this plan throughout construction. Due to the nature of the project, it is expected that some or all of these items may be located in several areas and may be moved daily.
3. Inlet Protection Control Measures only need to be present while disturbances from main construction are present within each inlet's drainage area.
4. Once construction begins, if additional Control Measures are needed, locations should be identified on the inspection report map updates.
5. Street sweeping will be performed as needed. Areas in need will be marked on this map.
6. All areas within the LOC are expected to be reseeded and mulched after construction is complete, save for those within the roadway, which will simply be repaved to city or county standards depending on jurisdiction."
7. No concrete washout to be performed on site.

GRADING AND EROSION CONTROL PLAN SITE TOPOGRAPHY PLANNED CONTROL MEASURES

Loch Fyne Gas Main Installation

Project No: WO# 3704076

Prepared By: R SEBASTIAN-COLEMAN

Date: 24 March, 2023

Figure
Number
4m

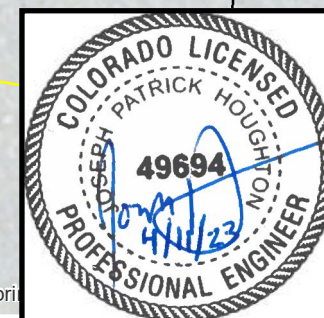

Colorado Springs



Colorado Springs Utilities

It's how we're all connected

Environmental Services Department
121 South Tejon Street, Fourth Floor
Colorado Springs, Colorado 80903

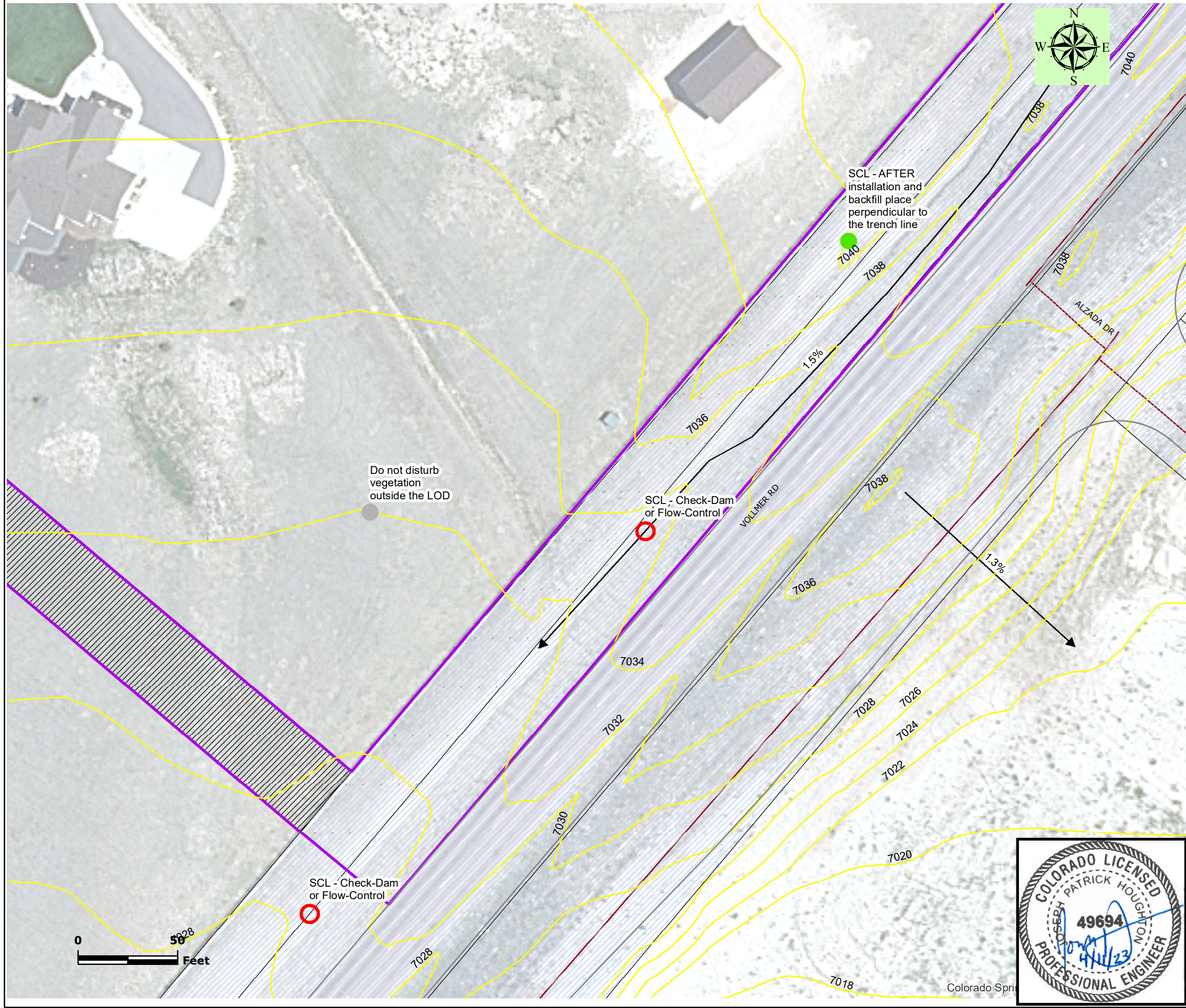

Legend:

Streets	LOC/LOD - Current Status Construction
Colorado Springs SW Inlets	Finally Stabilized
Stormwater Lines	Not Started
Stormwater_Outlets	Other
Water Way	Restoration / Stabilization
Control Measures - Is Action Needed? Install Before Disturbance Begins	ROW
N/A	Utility Easements
No	Existing Hydrant
Yes	Non-Potable Water Distribution Main
Existing/Proposed Contours	Potable Water Distribution Main
Pollutant Source - Present? No	Raw Water Distribution Main
Yes	Existing Water Service Line
Approximate Surface Flow Direction	Gas Main
	Electric Main (12.5 kV)

Notes:

1. LOC/LOD represents area of disturbance around the trench to account for vehicle traffic, material staging, and spoils piles, estimated to be 40 feet in width. The actual trench is approximately 4 feet in width.
2. Specific locations of staging areas, stockpiles, and any other material storage, including portable toilets will be determined by site crew. These locations, and location of accompanying stockpile protection control measures will be marked and updated on this plan throughout construction. Due to the nature of the project, it is expected that some or all of these items may be located in several areas and may be moved daily.
3. Inlet Protection Control Measures only need to be present while disturbances from main construction are present within each inlet's drainage area.
4. Once construction begins, if additional Control Measures are needed, locations should be identified on the inspection report map updates.
5. Street sweeping will be performed as needed. Areas in need will be marked on this map.
6. All areas within the LOC are expected to be reseeded and mulched after construction is complete, save for those within the roadway, which will simply be repaved to city or county standards depending on jurisdiction."
7. No concrete washout to be performed on site.

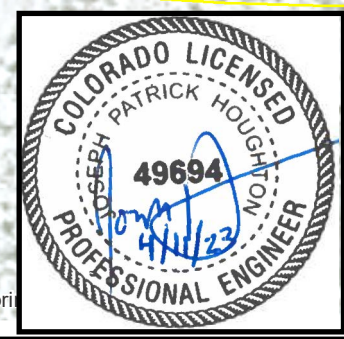

GRADING AND EROSION CONTROL PLAN SITE TOPOGRAPHY PLANNED CONTROL MEASURES

Loch Fyne Gas Main Installation

Project No: WO# 3704076	Figure Number 4n
Prepared By: R SEBASTIAN-COLEMAN	
Date: 24 March, 2023	



Colorado Springs Utilities

It's how we're all connected

Environmental Services Department
121 South Tejon Street, Fourth Floor
Colorado Springs, Colorado 80903

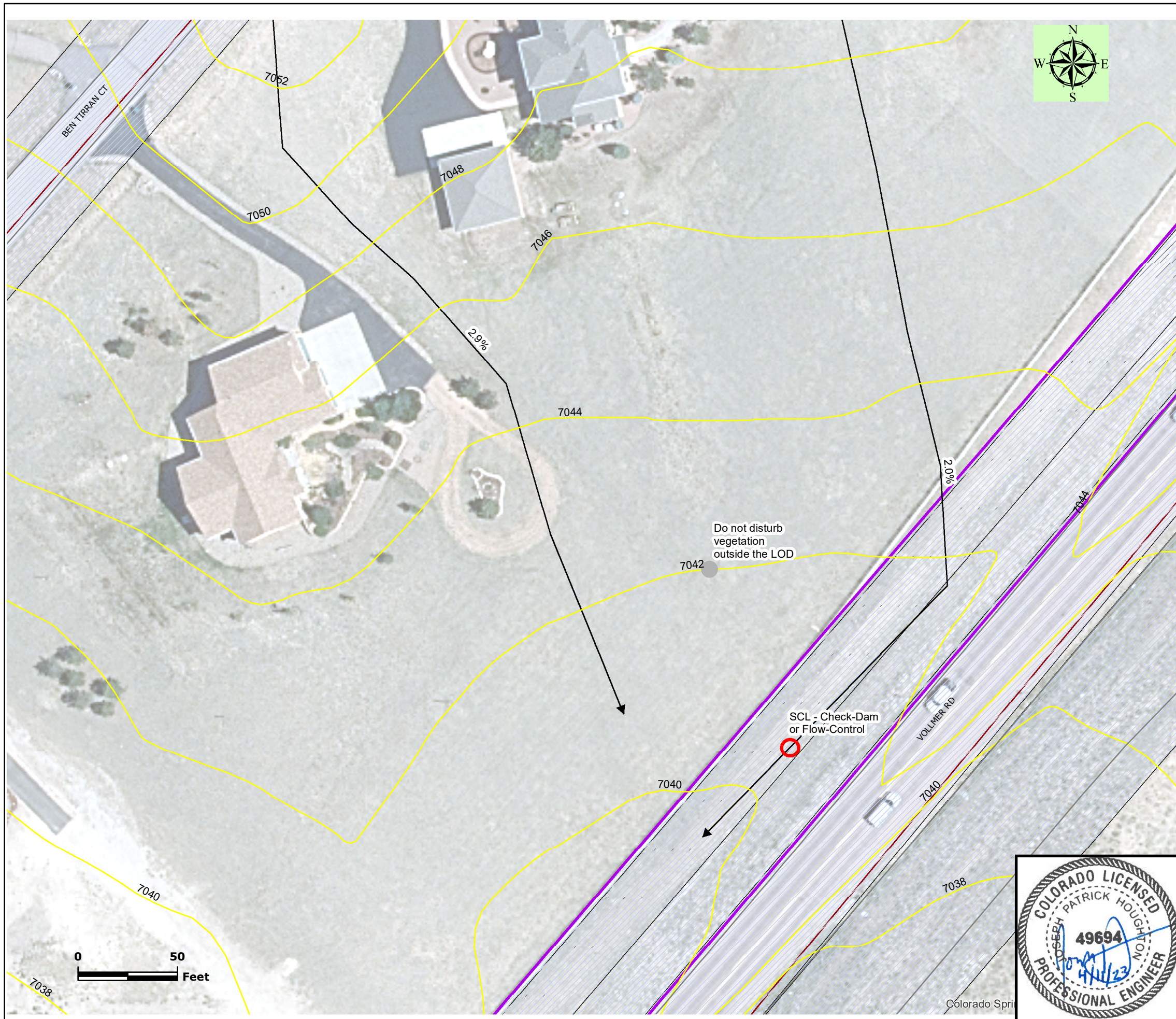
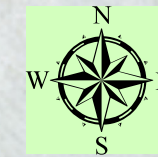

Legend:

Streets	LOC/LOD - Current Status Construction
Colorado Springs SW Inlets	Finally Stabilized
Stormwater Lines	Not Started
Stormwater_Outlets	Other
Water Way	Restoration / Stabilization
Control Measures - Is Action Needed? Install Before Disturbance Begins	ROW
N/A	Existing Hydrant
No	Non-Potable Water Distribution Main
Yes	Potable Water Distribution Main
Existing/Proposed Contours	Raw Water Distribution Main
Pollutant Source - Present? No	Existing Water Service Line
Yes	Gas Main
Approximate Surface Flow Direction	Electric Main (12.5 kV)

Notes:

1. LOC/LOD represents area of disturbance around the trench to account for vehicle traffic, material staging, and spoils piles, estimated to be 40 feet in width. The actual trench is approximately 4 feet in width.
2. Specific locations of staging areas, stockpiles, and any other material storage, including portable toilets will be determined by site crew. These locations, and location of accompanying stockpile protection control measures will be marked and updated on this plan throughout construction. Due to the nature of the project, it is expected that some or all of these items may be located in several areas and may be moved daily.
3. Inlet Protection Control Measures only need to be present while disturbances from main construction are present within each inlet's drainage area.
4. Once construction begins, if additional Control Measures are needed, locations should be identified on the inspection report map updates.
5. Street sweeping will be performed as needed. Areas in need will be marked on this map.
6. All areas within the LOC are expected to be reseeded and mulched after construction is complete, save for those within the roadway, which will simply be repaved to city or county standards depending on jurisdiction."
7. No concrete washout to be performed on site.

GRADING AND EROSION CONTROL PLAN SITE TOPOGRAPHY PLANNED CONTROL MEASURES

Loch Fyne Gas Main Installation

Project No: WO# 3704076

Prepared By: R SEBASTIAN-COLEMAN

Date: 24 March, 2023

Figure Number
40





Colorado Springs Utilities

It's how we're all connected

Environmental Services Department
121 South Tejon Street, Fourth Floor
Colorado Springs, Colorado 80903

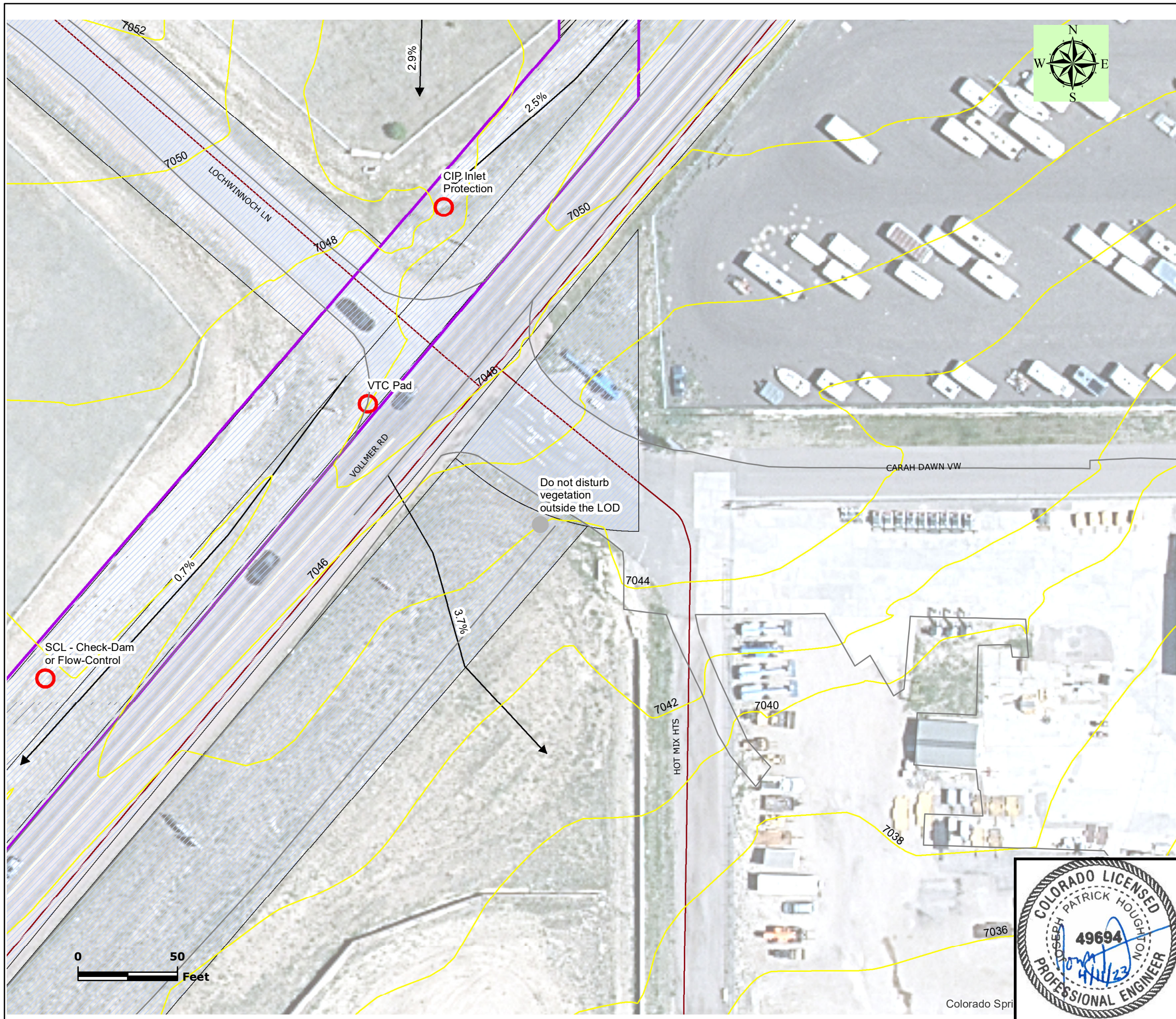

Legend:

Streets	LOC/LOD - Current Status: Construction
Colorado Springs SW Inlets	Finally Stabilized
Stormwater Lines	Not Started
Stormwater_Outlets	Other
Water Way	Restoration / Stabilization
Control Measures - Is Action Needed?	ROW
Install Before Disturbance Begins	Utility Easements
N/A	Existing Hydrant
No	Non-Potable Water Distribution Main
Yes	Potable Water Distribution Main
Existing/Proposed Contours	Raw Water Distribution Main
Pollutant Source - Present?	Existing Water Service Line
No	Gas Main
Yes	Electric Main (12.5 kV)
Approximate Surface Flow Direction	

Notes:

1. LOC/LOD represents area of disturbance around the trench to account for vehicle traffic, material staging, and spoils piles, estimated to be 40 feet in width. The actual trench is approximately 4 feet in width.
2. Specific locations of staging areas, stockpiles, and any other material storage, including portable toilets will be determined by site crew. These locations, and location of accompanying stockpile protection control measures will be marked and updated on this plan throughout construction. Due to the nature of the project, it is expected that some or all of these items may be located in several areas and may be moved daily.
3. Inlet Protection Control Measures only need to be present while disturbances from main construction are present within each inlet's drainage area.
4. Once construction begins, if additional Control Measures are needed, locations should be identified on the inspection report map updates.
5. Street sweeping will be performed as needed. Areas in need will be marked on this map.
6. All areas within the LOC are expected to be reseeded and mulched after construction is complete, save for those within the roadway, which will simply be repaved to city or county standards depending on jurisdiction."
7. No concrete washout to be performed on site.

GRADING AND EROSION CONTROL PLAN SITE TOPOGRAPHY PLANNED CONTROL MEASURES

Loch Fyne Gas Main Installation

Project No: WO# 3704076

Prepared By: R SEBASTIAN-COLEMAN

Date: 24 March, 2023

Figure Number
4p

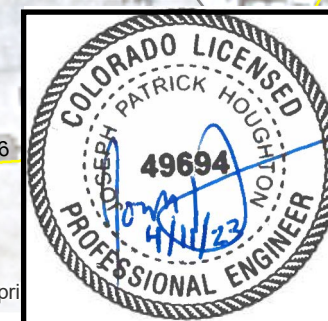

Colorado Springs



Colorado Springs Utilities

It's how we're all connected

Environmental Services Department
121 South Tejon Street, Fourth Floor
Colorado Springs, Colorado 80903

Legend:

Streets	LOC/LOD - Current Status Construction
Colorado Springs SW Inlets	Finally Stabilized
Stormwater Lines	Not Started
Stormwater_Outlets	Other
Water Way	Restoration / Stabilization
Control Measures - Is Action Needed?	ROW
Install Before Disturbance Begins	Utility Easements
N/A	Existing Hydrant
No	Non-Potable Water Distribution Main
Yes	Potable Water Distribution Main
Existing/Proposed Contours	Raw Water Distribution Main
Pollutant Source - Present?	Existing Water Service Line
No	Gas Main
Yes	Electric Main (12.5 kV)
Approximate Surface Flow Direction	

Notes:

1. LOC/LOD represents area of disturbance around the trench to account for vehicle traffic, material staging, and spoils piles, estimated to be 40 feet in width. The actual trench is approximately 4 feet in width.
2. Specific locations of staging areas, stockpiles, and any other material storage, including portable toilets will be determined by site crew. These locations, and location of accompanying stockpile protection control measures will be marked and updated on this plan throughout construction. Due to the nature of the project, it is expected that some or all of these items may be located in several areas and may be moved daily.
3. Inlet Protection Control Measures only need to be present while disturbances from main construction are present within each inlet's drainage area.
4. Once construction begins, if additional Control Measures are needed, locations should be identified on the inspection report map updates.
5. Street sweeping will be performed as needed. Areas in need will be marked on this map.
6. All areas within the LOC are expected to be reseeded and mulched after construction is complete, save for those within the roadway, which will simply be repaved to city or county standards depending on jurisdiction."
7. No concrete washout to be performed on site.

GRADING AND EROSION CONTROL PLAN SITE TOPOGRAPHY PLANNED CONTROL MEASURES

Loch Fyne Gas Main Installation

Project No: WO# 3704076

Prepared By: R SEBASTIAN-COLEMAN

Date: 24 March, 2023

Figure Number
4q

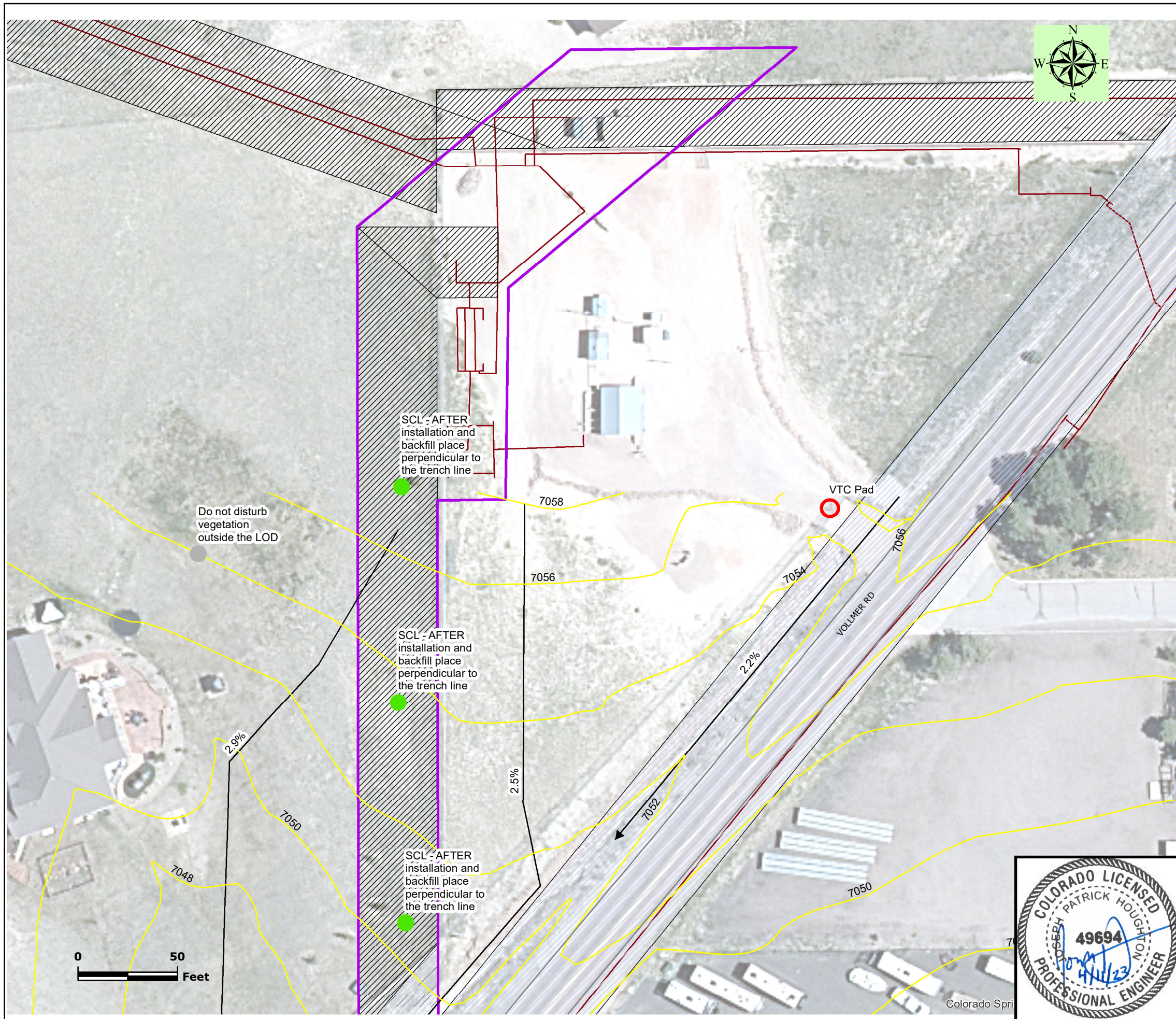
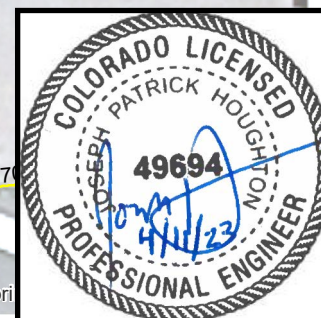



Colorado Springs Utilities

It's how we're all connected

Environmental Services Department
121 South Tejon Street, Fourth Floor
Colorado Springs, Colorado 80903

Legend:

- Streets
- Colorado Springs SW Inlets
- Stormwater Lines
- Stormwater_Outlets
- Water Way
- LOC/LOD
- Property Lines Labeled by Tax Schedule Number

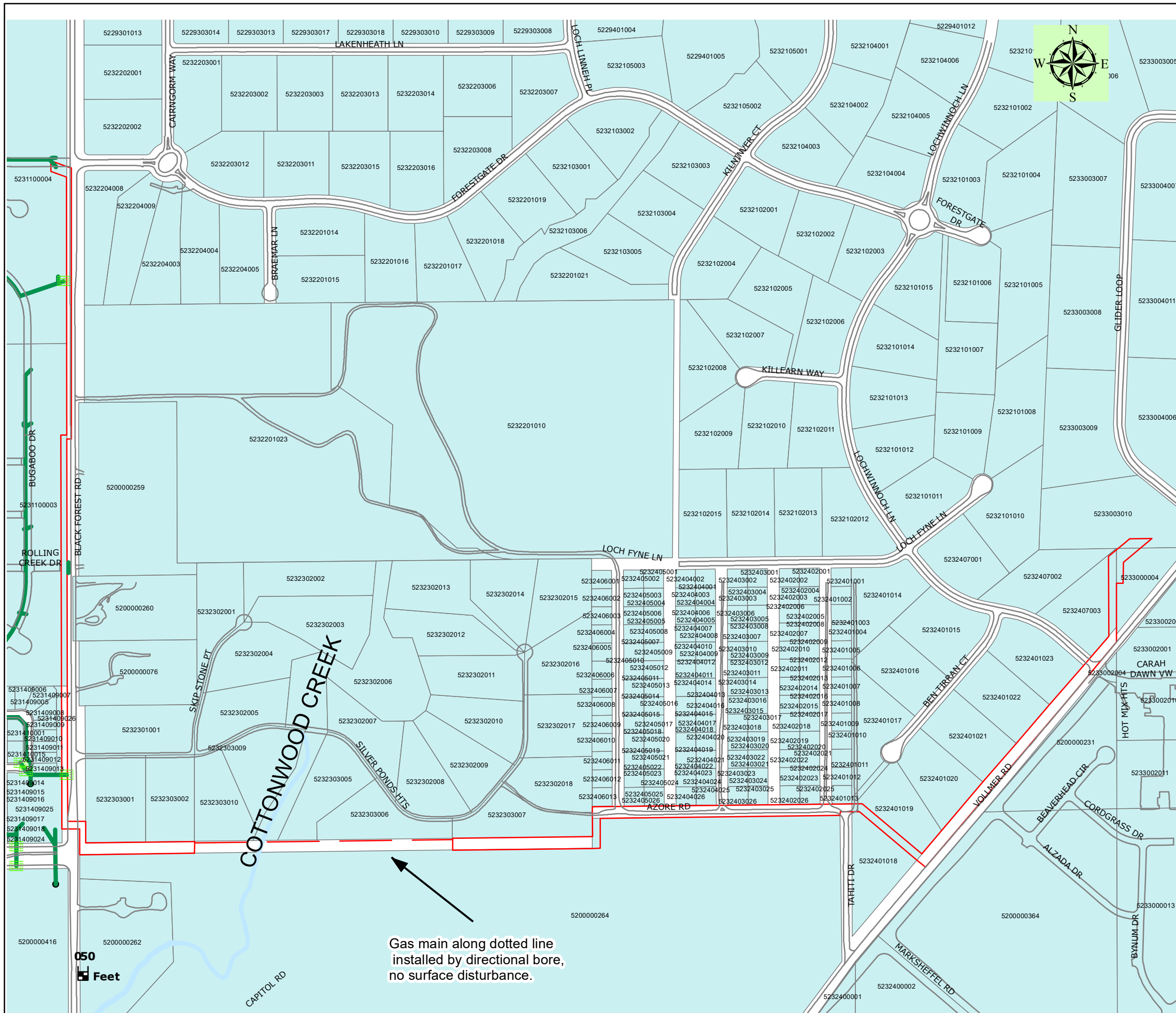

Notes:
1. This is a Utilities' project. No grading over any utility will be changed.

**GRADING AND EROSION CONTROL PLAN
TAX SCHEDULE NUMBER
OF ADJACENT PARCELS
Loch Fyne Gas Main Installation**

Project No: WO# 3704076
Prepared By: R SEBASTIAN-COLEMAN
Date: 24 March, 2023

Figure Number
5

Gas main along dotted line installed by directional bore, no surface disturbance.

050 Feet