



**To:** El Paso County Engineering Division  
**From:** Mike Bramlett, PE  
**Date:** August 27, 2021  
**Subject:** Sand Creek Center Tributary Channel Improvements

---

The purpose of this letter is to provide design information for the existing conditions of the Sand Creek Center Tributary Drainageway, located east of the Solace Apartments site. This letter will also discuss the proposed improvements for the channel, design methodology, and the modeling results. For further information on the previous evaluation of the channel in its existing conditions and conceptual design, see the *Sand Creek – Center Tributary Channel Analyses Report for Solace Apartments* by JR Engineering. For further information concerning drainage for the Solace Apartments Site, see the *Final Drainage Report for Solace Apartments*, by JR Engineering.

### **Project General Discussion**

The Sand Creek Center Tributary Channel is located in Section 7, Township 14 South, Range 65 West of the 6<sup>th</sup> Principal Meridian in El Paso County, Colorado. The site is part of the Solace Apartments project and is located on the eastern edge of the project. As part of the proposed improvements for the Solace Apartments Project, this reach of the Sand Creek Center Tributary will also be improved. The sections upstream and downstream of the site have already undergone improvements, and the channel in its current state shows extensive flooding in a 100 year event. In addition to improvements to the Sand Creek Center Tributary Channel, the channels secondary drainageway located to the west of the channel in Paonia Street will also be improved with an overflow channel that will direct flow present in the secondary drainageway into the main channel and avoid further flooding of the Paonia Street extension into the Solace Apartments site.

### **Channel Flows**

Evaluation of the flows present in the Sand Creek Center Tributary and its secondary drainageway were discussed in detail in the *Sand Creek – Center Tributary Channel Analysis for Solace Apartments* by JR Engineering. Since the initial analysis of the channel took place, JR Engineering was able to acquire the modeling data used by FEMA for determination of flood plain modeling shown in FEMA FIRM 08041C0752G. JR Engineering assumes FEMA's flows to be accurate, and thus utilized these as the basis for our model. The main channel contains 820 cfs of flow and the secondary channel contains 217 cfs. The flow in the main channel then jumps up to 1,037 cfs at the convergence of the secondary drainageway. The convergence of these flows occurs just upstream of the Galley Road crossing, where existing topography directs the secondary drainageway into the main channel. Downstream an existing channel coming from nearby Valley Road (east)

converges with the main channel; we then utilized FEMA's 1,100 cfs to model the remaining portion of the channel.

### **Existing Channel Conditions**

In its existing conditions the Sand Creek Center Tributary Channel along the Solace site consists of a natural channel overgrown with trees and bushes along the sides of the channel with the bottom being relatively clean and free of obstacles. The 1,350 LF reach of the Sand Creek Center Tributary Channel located incorporated with the Solace site is undeveloped, as compared to the majority of channels in the basin which have had some improvement. Downstream and upstream sections of the Sand Creek Center Tributary Channel are concrete lined. The secondary Drainageway located in Paonia Street flows south from Omaha Blvd to the Solace Apartments site where flow splits between an existing concrete channel running east to the main Sand Creek Center Tributary Channel, and a swale flowing south where it eventually rejoins the main channel at the Galley Road crossing. It is anticipated that the concrete channel will divert 42 cfs from the 217cfs present in the secondary drainageway, with 175 cfs flowing south down the existing swale. There is also an existing channel coming from Valley Road to the east. This channel intersects the main channel approximate halfway between the north and south limits of the site, adding 63 cfs to the main channel, as discussed in the Channel Flows section above. In its existing conditions, the Sand Creek Center Tributary Channel FEMA firm panel 08041C0752G, depicts 100 year flooding extending into the adjacent properties to the east and onto Paonia Street improvements to the west. The existing channel currently overtops the Galley Road crossing; primarily due to the capacity of the culverts at the crossing rather than the channel's current conditions.

### **Proposed Channel Improvements**

As determined by the Sand Creek Drainage Basin Planning Study (DBPS) & and JR Engineering Sand Creek – Center Tributary Channel Analysis for Solace Apartments, this section of the Sand Creek Center Tributary will require improvements to ensure adequate capacity in the channel and protection against erosive velocities. In order to be consistent with improvements already made in the surrounding area and to align with the recommendations made by the DBPS, JR Engineering is proposing concrete lining of the channel along the Solace site, along with widening of the existing channel and modification to the channel alignment in this area. JR Engineering is also proposing the addition of a USBR Type III Stilling Basin and 10 foot sloped concrete drop in the channel, in order to force a hydraulic jump in the channel and reduce velocities present in the channel while still matching existing grades for the majority of channel alignment. The design methodology of the sloped drop and USBR Type III Stilling Basin are based on the design procedure for Stilling Basins presented in the Federal Highway Administrations Hydraulic Engineering Circular No. 14, Chapter 8. Calculation for stilling basin and accessories sizing can be found in the Appendix of this letter. The proposed channel section shall be a trapezoidal channel section with a 10' bottom width, with a minimum channel depth of 6.5' and side slopes varying from 3:1 to 2:1 along the channel's alignment. The channel shall be lined with concrete for a depth of 4.5' to protect the channel from the erosive velocities present in the channel, with an average depth of flow in a 100 year event for the proposed channel being approximately 4' this will provide a minimum freeboard of 2' from the top of the channel to the 100 year water surface, adhering to the DCM Volume 1 for minimum freeboard of 1.4'. The concrete section shall typically be a 6" thick concrete apron for the channel, with sections of the section of channel located within the sloped drop and stilling basin being a 12"

---

5475 Tech Center Drive, Ste 235  
Colorado Springs, CO 80909  
303-740-9599 Fax: 303-721-9019  
www.jrengineering.com

Per the profiles provided it appears that the depth is greater than 4.5'. Please revise the narrative and design accordingly. Comments have been provided on the channel construction documents.

---

thick concrete apron. In accordance with the DBPS the channel shall be designed with a stable slope of 1% for the majority of the channel. For further details please see the Channel Improvement Plans included in the Appendix of this letter. In order to reduce the velocities present in the channel and avoid excessively steep slopes for extended portions of the channel's alignment, a 100' long sloped drop structure, with a total vertical drop of 10', will be placed at the upstream end of the channel. At the base of the drop will be a USBR Type III Stilling Basin that will include chute blocks, baffle blocks and a sill wall to decrease the velocity of the water coming down the sloped drop and force a hydraulic jump. This basin will also include a low flow channel through the sill wall located at the end of the stilling basin to allow water movement through the structure at lower flows and prevent ponding of water in the structure. Further detail for the sloped drop and stilling basin can be found in the channel improvement plans shown in the Appendix.

### **Paonia Street Secondary Drainageway Improvements**

Part of the Sand Creek Center Tributary Improvements also includes the addition of a diversion channel that will direct flows present in the Paonia Street Secondary Drainageway into the main channel. This diversion will be known as the Overflow Channel for the remainder of this letter. Just north of the Overflow Channel, the existing Paonia Street is partially supered in existing conditions routing all flows present in the street to the east side. With major flows present in the existing Paonia Street present on the east side of the road, the Overflow channel will act as a large opening weir and divert flows to the main channel. The Overflow Channel shall be a concrete and riprapped lined channel with varying widths and depths that will convey the flows present in Paonia Street into the main channel. The diversion channel shall be concrete from the edge of Paonia to the right-of-way, after which it will become a riprap trapezoidal channel section with a typical bottom width of 20' and a depth of 2'-3'. The channel will run east from Paonia until it intersects with the proposed Sand Creek Center Tributary Channel alignment, where it will outfall just upstream of the proposed sloped drop in the channel. Just south of the diversion channel opening along Paonia Street will be two 15' type R inlets, that will be used to capture nuisance flows in the curb & gutter and also any flow that may bypass the diversion channel. These inlets are a redundant and not intended to capture any flows present in Paonia as the Overflow Channel is sized and designed to capture all flows present in Paonia; each inlet has a total intercept capacity of 17cfs for a total of 34cfs combined. These inlets will directly outfall into the main channel and will not be detained by any of the onsite detention ponds. For further detail on the diversion channel please see the channel improvement plans, and for detail on the type R inlets see the exert of the Solace Construction Drawings, both shown in the Appendix of this letter.

### **Modeling Results**

The proposed conditions of the channel and its second Drainageway were modeled using GeoHecRas to determine the extents of the 100 year floodplain for the site. Flow rates from the model were used based on those discussed in the Channel Flows section and Existing Conditions section of this letter. The model was run with downstream boundary conditions for each reach using critical depths, and the entirety of the model was ran using steady flow conditions. The model was contains four separate reaches, with the main reach modeling the proposed alignment and conditions for the Sand Creek Center Tributary Channel. The other reaches modeling the Paonia Street Overflow Channel, the existing concrete overflow channel at Paonia and an existing channel that runs east to west from Valley Street and intersects the Sand Creek Center Tributary Channel, each reach

intersection were modeled using the energy equation. The model used Manning's values (n) of 0.013 for the concrete lining, 0.033 for the riprap of the overflow channel, and 0.03 for the any location outside of the concrete or riprap extents as they were determined to be most similar to a grassed area with some weeds. The results of the GeoHecRas model show that the proposed improvements to the channel substantially reduce the extents of the flood plain in the channel and contain the 100 year flood plain within the concrete extents of the channel. The results also show a maximum velocity in the channel of 10.32 ft/s in a 100 year event, showing that the concrete lining of the channel will provide sufficient protection from erosive velocities present in the channel. The GeoHecRas model for the proposed conditions also shows overtopping of the channel crossing at Galley Road, which is consistent with the flood data presented by the FEMA FIRM 08041C0752G. Flooding of the roadway is due to the insufficient capacity of the culvert crossing in this area, with the current configuration of three 48" CMP culverts only providing 365 cfs of capacity of the 1,100 cfs flow at the crossing. Flooding of the Galley Road Crossing could be alleviated by upsizing of the culvert(s), these improvements will be necessary when the County deems the historic overtopping of Galley Road to be above acceptable tolerance. *The channel improvements did not result in any change to existing overtopping of Galley Road as this is due to insufficient capacity of the culverts at this crossing, which will ultimately be addressed at a later date.* Further details on the model results can be found in the Appendix.

### Summary

The analysis of the proposed improvements of the Sand Creek Center Tributary Drainageway and its secondary drainageway located in Paonia Street show significant reduction of the flood plain extents, with it now being contained within the channel extents and no longer extensively flooding properties adjacent the proposed Solace Apartment Site. The proposed diversion channel also redirects flow that would otherwise flood the proposed extension of Paonia Street back into the channel, thus alleviating the risk of the roadway flooding in a 100 year event.

Please contact me should you have any questions or concerns regarding this letter at 303-740-9393.

Sincerely,  
**JR ENGINEERING, LLC**



Mike Bramlett, PE  
JR Engineering

S  
P  
R  
I  
N  
G  
S  
C  
R  
I  
P  
T  
E  
D  
B  
Y  
D

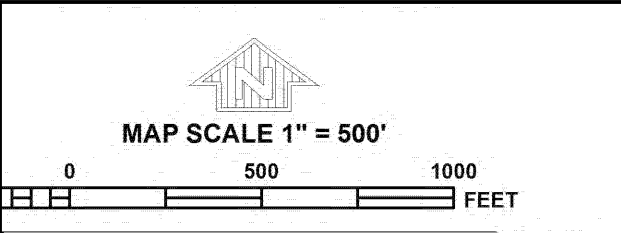
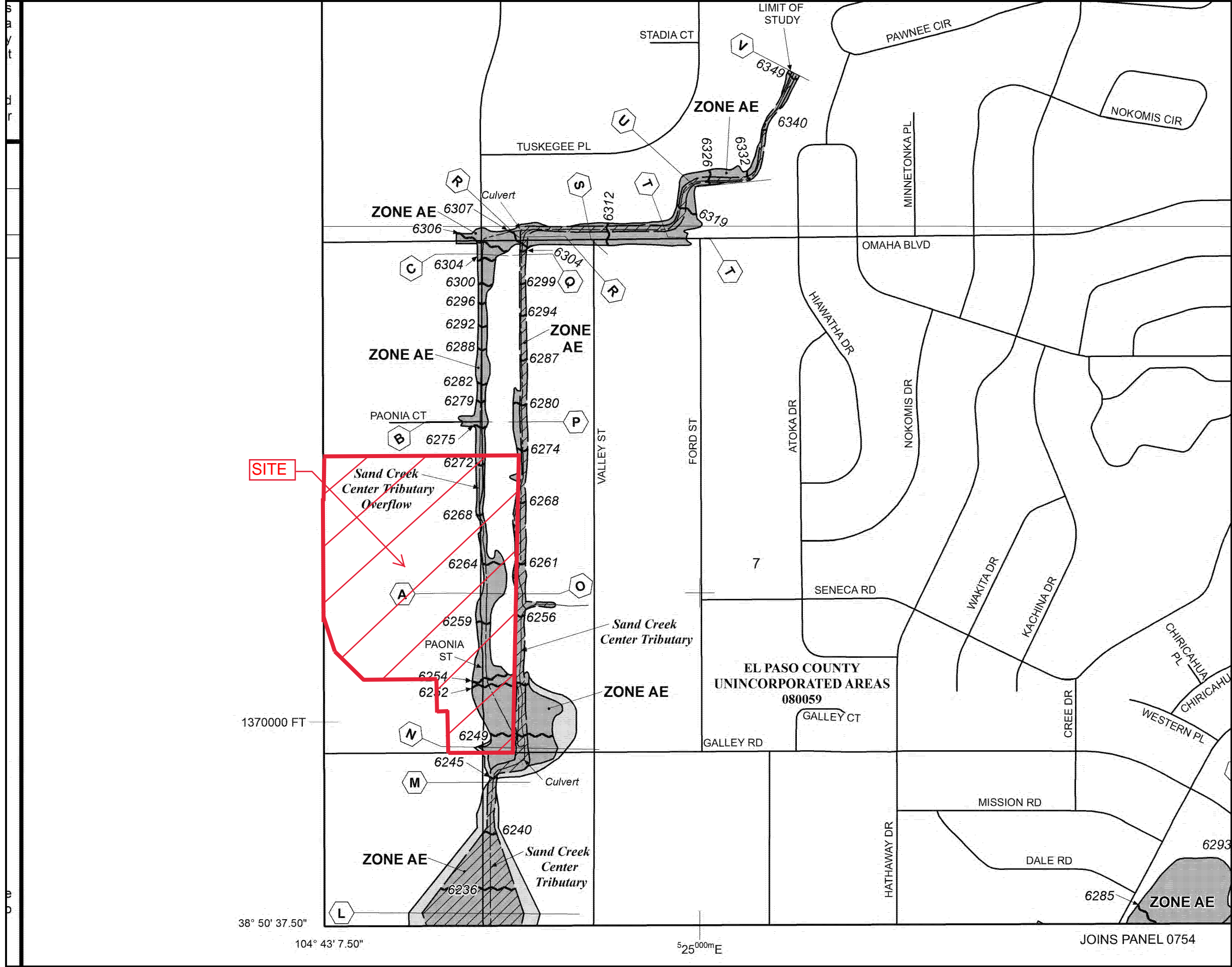

**NFP**

**PANEL 0752G**

**FIRM**  
FLOOD INSURANCE RATE MAP  
EL PASO COUNTY,  
COLORADO  
AND INCORPORATED AREAS

**PANEL 752 OF 1300**  
(SEE MAP INDEX FOR FIRM PANEL LAYOUT)

CONTAINS:

COMMUNITY	NUMBER	PANEL	SUFFIX
COLORADO SPRINGS, CITY OF	080060	0752	G
EL PASO COUNTY	080059	0752	G

Notice to User: The Map Number shown below should be used when placing map orders; the Community Number shown above should be used on insurance applications for the subject community.

**MAP NUMBER**  
08041C0752G

**MAP REVISED**  
DECEMBER 7, 2018

Federal Emergency Management Agency

**NATIONAL FLOOD INSURANCE PROGRAM**

This is an official copy of a portion of the above referenced flood map. It was extracted using F-MIT On-Line. This map does not reflect changes or amendments which may have been made subsequent to the date on the title block. For the latest product information about National Flood Insurance Program flood maps check the FEMA Flood Map Store at [www.msc.fema.gov](http://www.msc.fema.gov)

JOINS PANEL 0754

## USBR Type III Drop and Stilling Basin

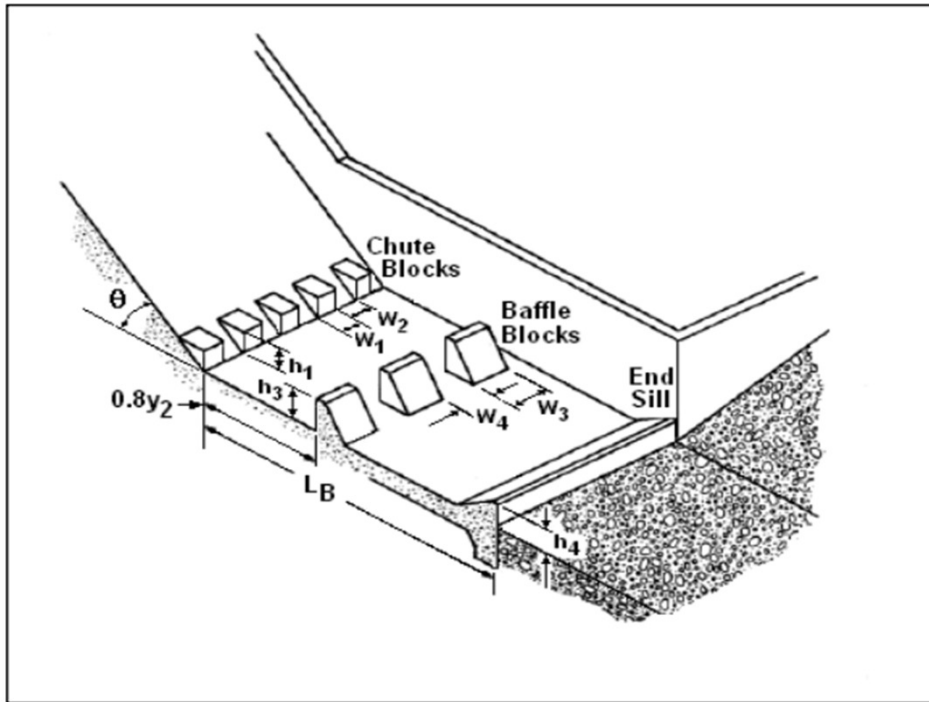
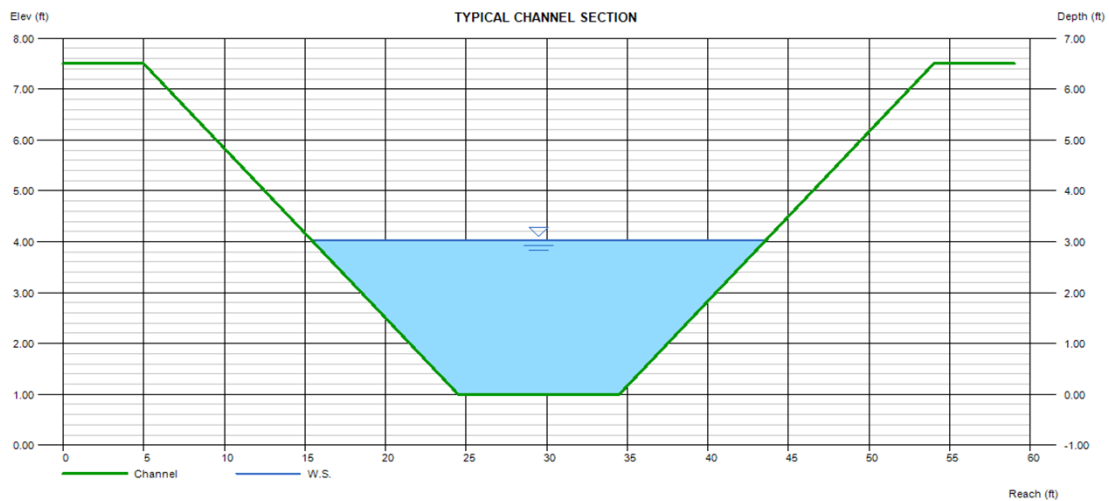

**Figure 8.3. USBR Type III Stilling Basin**

### Design of Energy Dissipators for Culverts and Channels

#### Upstream Channel Parameters

Channel Flow (Q)	1037 cfs
Channel Bottom Width	10 ft
Sill Slopes (Z:1)	1
Channel Total Depth	6.5 ft
Channel Depth (y1)	3.02 ft
Drop Crest Width	35 ft
Upstream Slope	1.00%



## USBR Type III Drop and Stilling Basin (cont...)

### FHWA Criteria Checks

Unit Discharge Over Crest	29.63	cfs/ft	Limit=200 cfs/ft
Transition Slope (St)	10.00%	> as $\theta$	5.71 °
Velocity Entering Basin (V)	41.04	ft/s	Limit=60 ft/s
Channel Depth Entering Basin (d)	1.68	ft	
Transition Length (St)	120	ft	
Basin Width (Wb)	10	ft	

### Basin Parameter Calculations

$$\text{Froude Number entering Basin: } \frac{V}{(gd)^{1/2}} = 5.579879$$

Determine  $L_b/Y_2$  value from FHWA Table 8.2

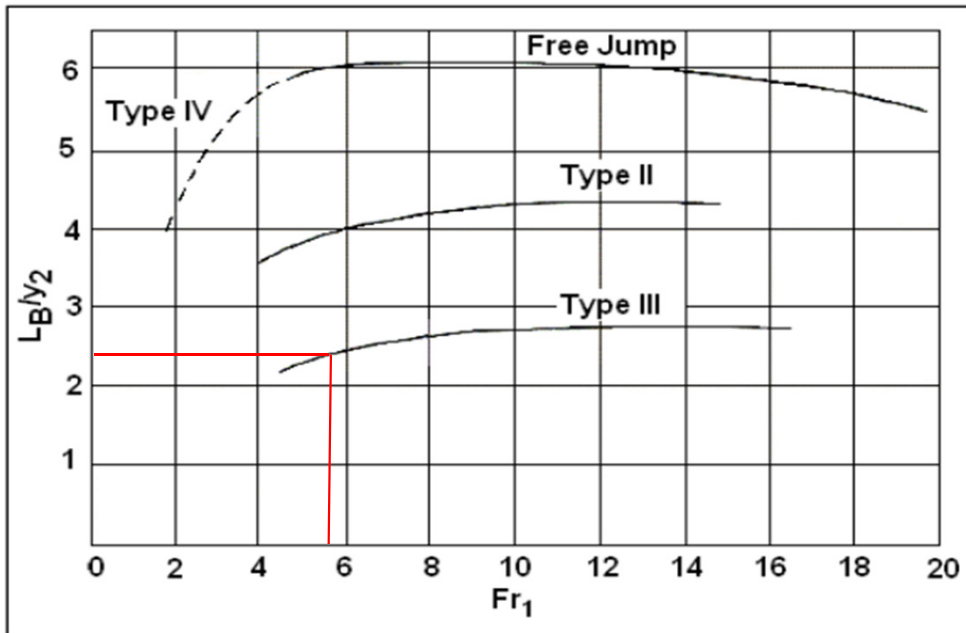

Figure 8.2. Length of Hydraulic Jump on a Horizontal Floor

$L_b/Y_2$ : 2.5      Conservative Approximation

Calculate  $Y_2$

$$Y_2: \frac{C * y_0}{2} (\sqrt{1 + 8Fr} - 1) = 12.4437 \text{ ft}$$

Length of Basin ( $L_b$ ): 31.1092536 ft

$$\text{Length of Basin Floor to Sill Top (Lt): } \frac{L_T(S_T - S_o) - L_b * S_o}{S_s + S_o} = 10.59486 \text{ ft}$$

### USBR Type III Drop and Stilling Basin (cont...)

Basin Element Sizing		
Determine Number of Chute Blocks ( $N_c$ ):	$\frac{W_b}{2y_1} =$	2.98 $\rightarrow$ 3
Chute Block Width and Spacing ( $W_1$ & $W_2$ ):	$\frac{W_b}{2N_c} =$	1.666667
Baffle Block Height ( $h_3$ ):	$y_1(0.168 * Fr + 0.58)$	2.549265 ft
Number of Baffle Blocks ( $N_b$ ):	$\frac{W_b}{1.5h_3} =$	2.615133 $\rightarrow$ 3
Baffle Width and Spacing ( $W_3$ & $W_4$ ):	$\frac{W_b}{2N_b} =$	1.666667
End Sill Height ( $h_4$ ):	$y_1(0.0536 * Fr + 1.04)$	2.249657 ft
$0.8 * Y_2$		9.95496114 ft

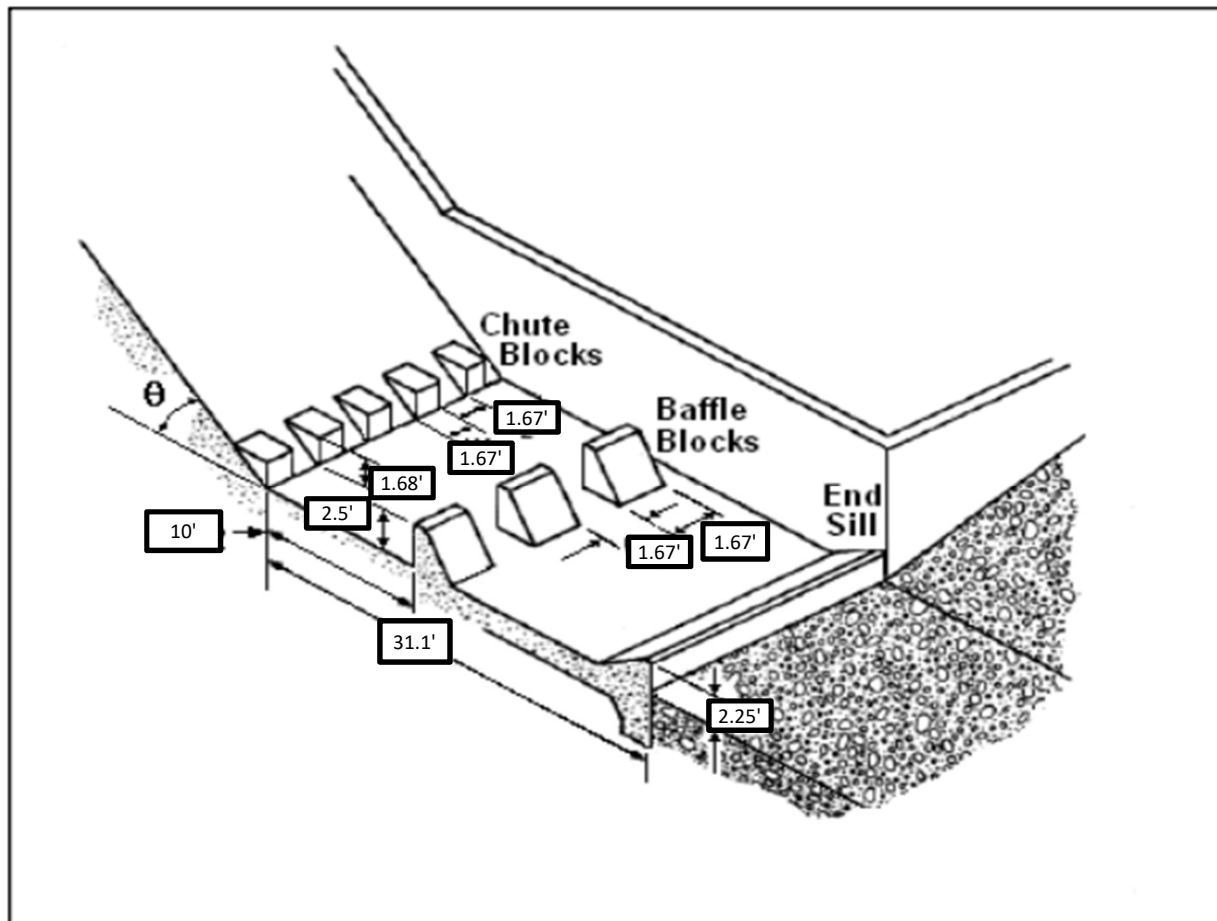

**Figure 8.3. USBR Type III Stilling Basin**



# SAND CREEK CHANNEL GEOHECRAS MODEL OVERLAY

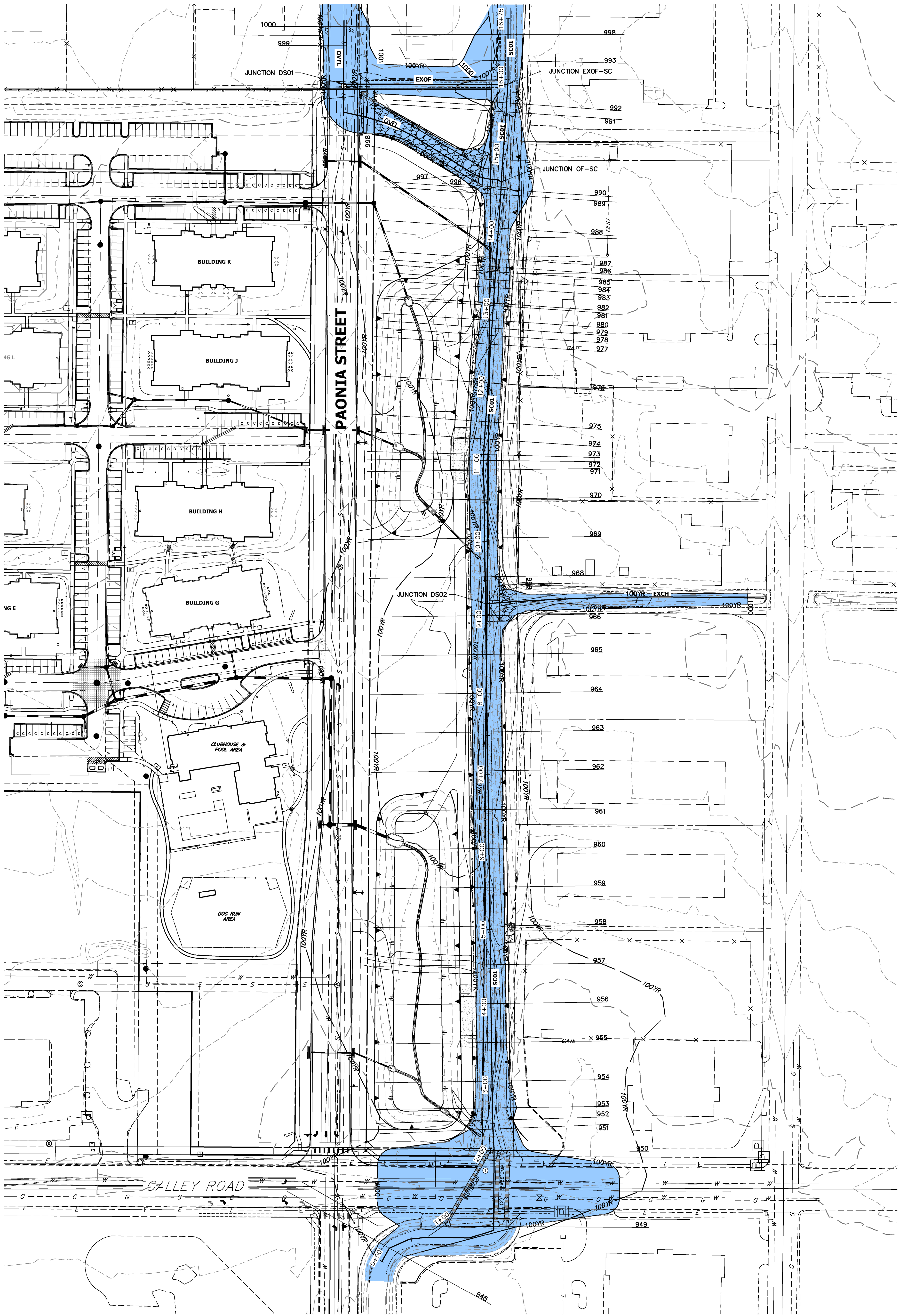

100 50 0 100 200  
ORIGINAL SCALE: 1" = 100'

GEOHECRAS MODEL OVERLAY  
SAND CREEK CHANNEL  
JOB NO. 25174.00  
08/24/21  
SHEET 1 OF 1

**J-R ENGINEERING**  
A Westrian Company

Centennial 303-740-9393 • Colorado Springs 719-593-2593  
Fort Collins 970-491-9888 • www.jrengineering.com

HEC-RAS Model Plan: Default Scenario 8/24/2021  
 River = EXCH Reach = EX CHANNEL RS = 1000

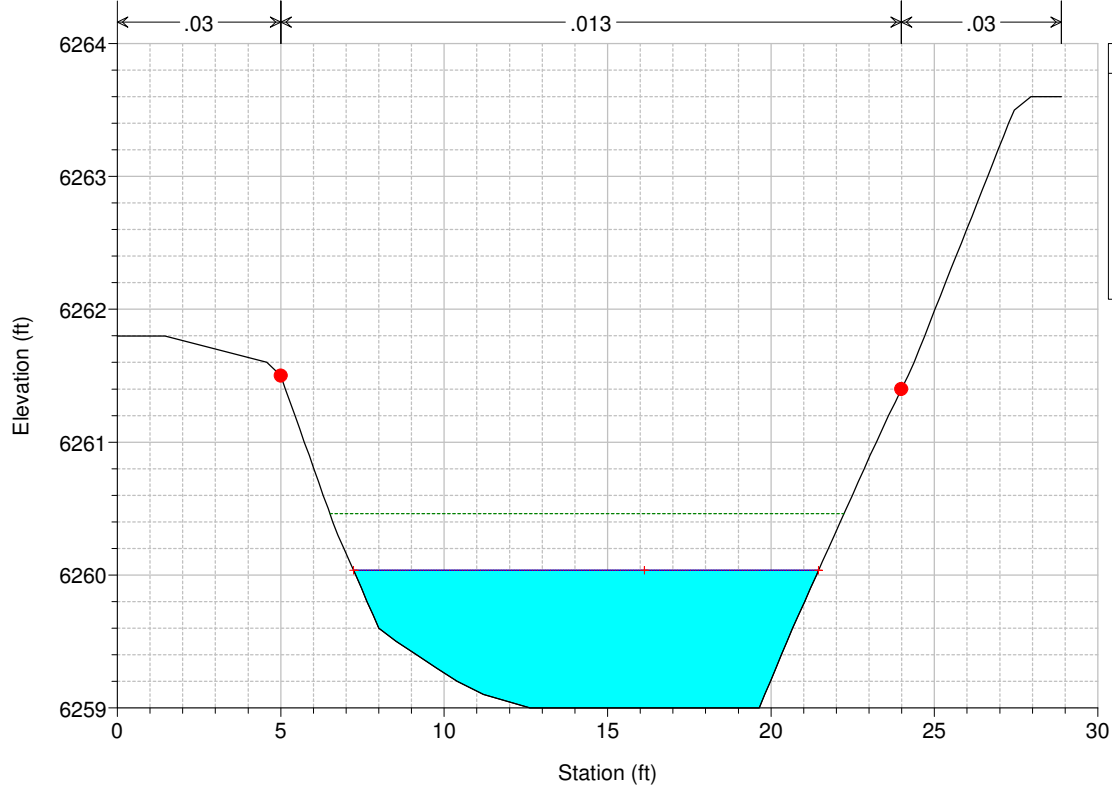

HEC-RAS Model Plan: Default Scenario 8/24/2021  
 River = EXCH Reach = EX CHANNEL RS = 999

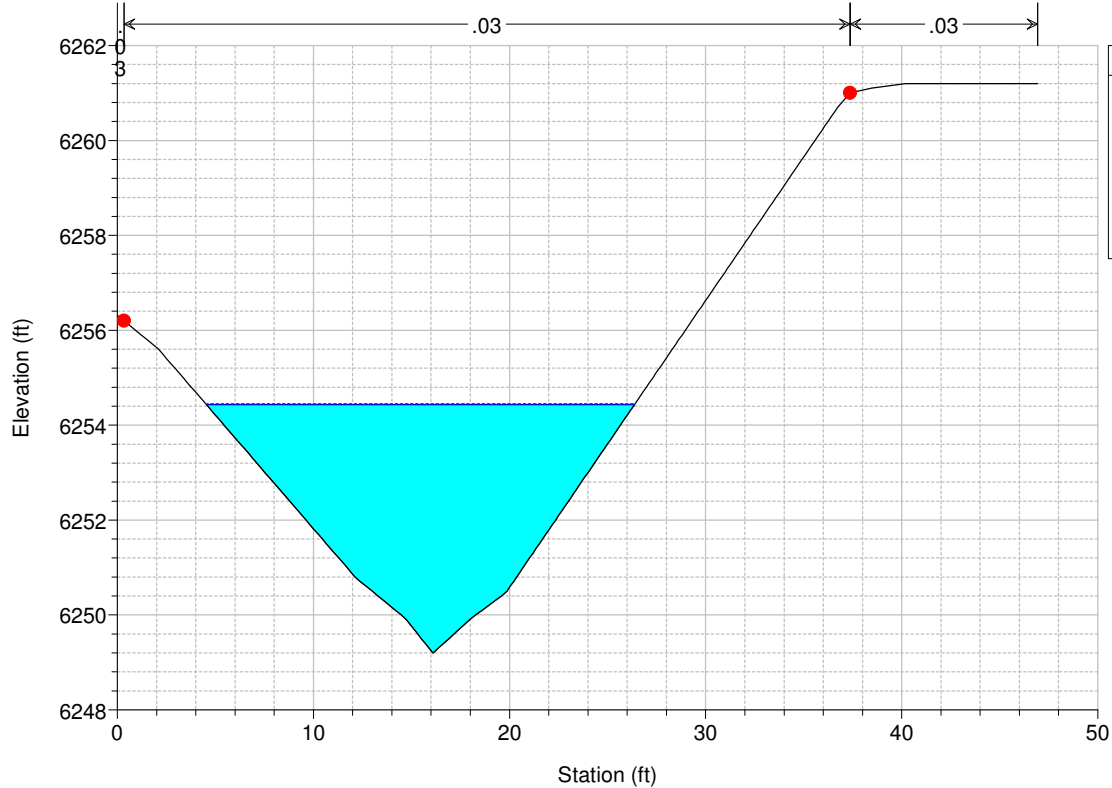

HEC-RAS Model Plan: Default Scenario 8/24/2021  
 River = EXOF Reach = EX OVERFLOW RS = 1001

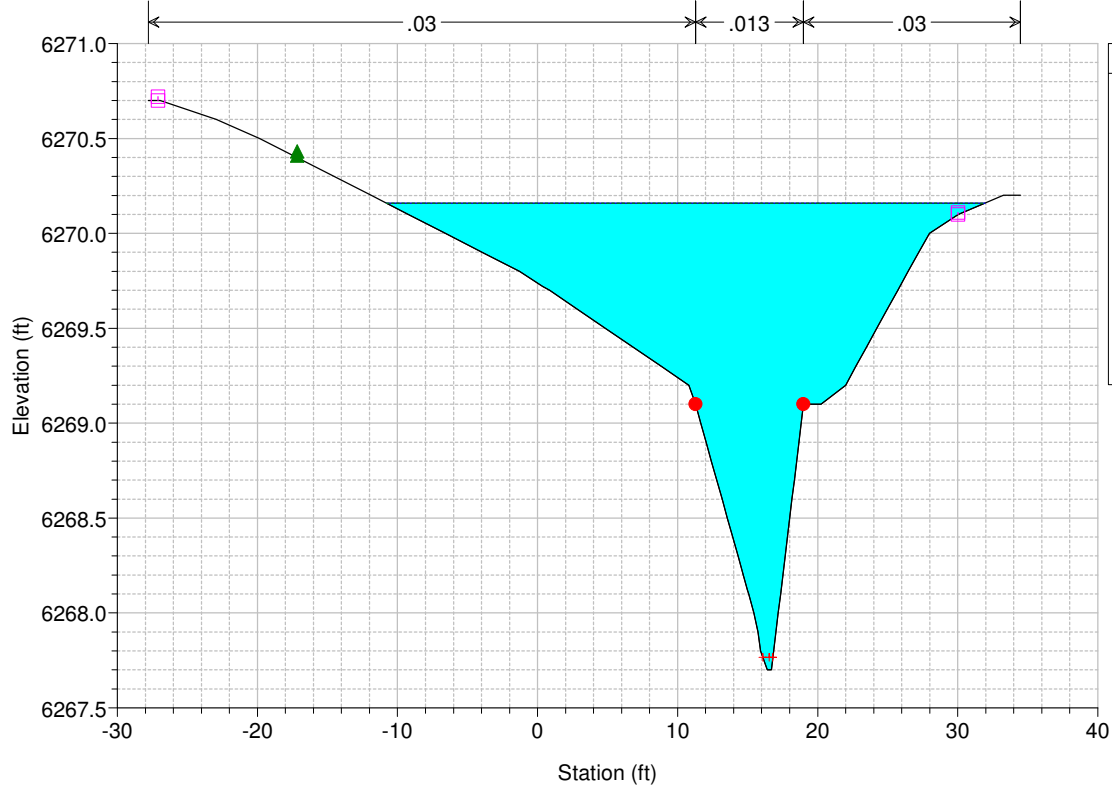

HEC-RAS Model Plan: Default Scenario 8/24/2021  
 River = EXOF Reach = EX OVERFLOW RS = 1000

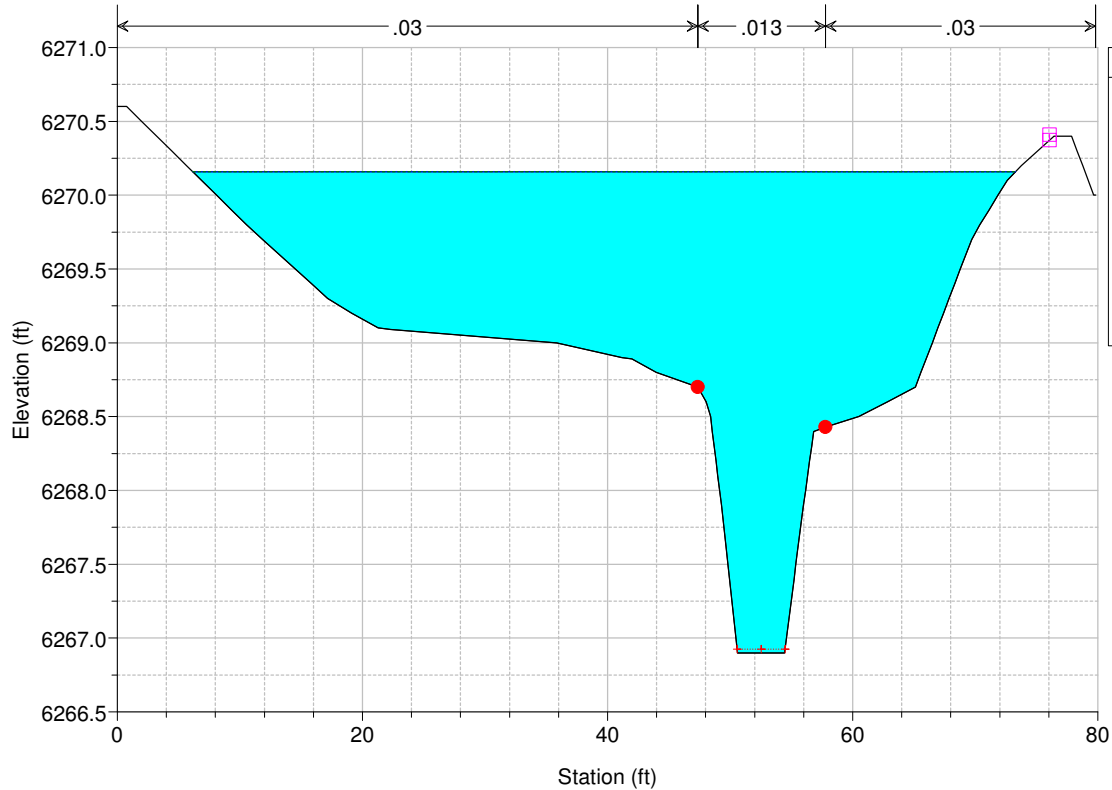

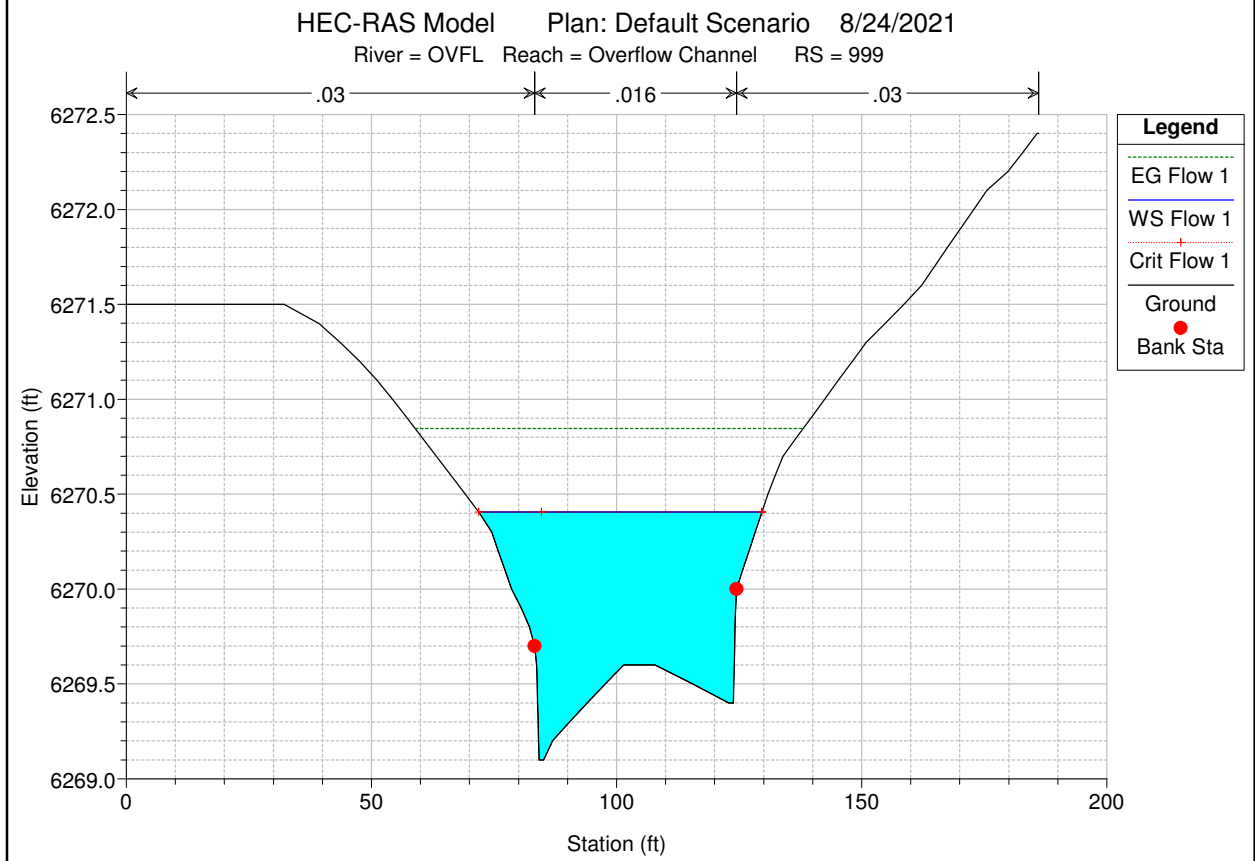
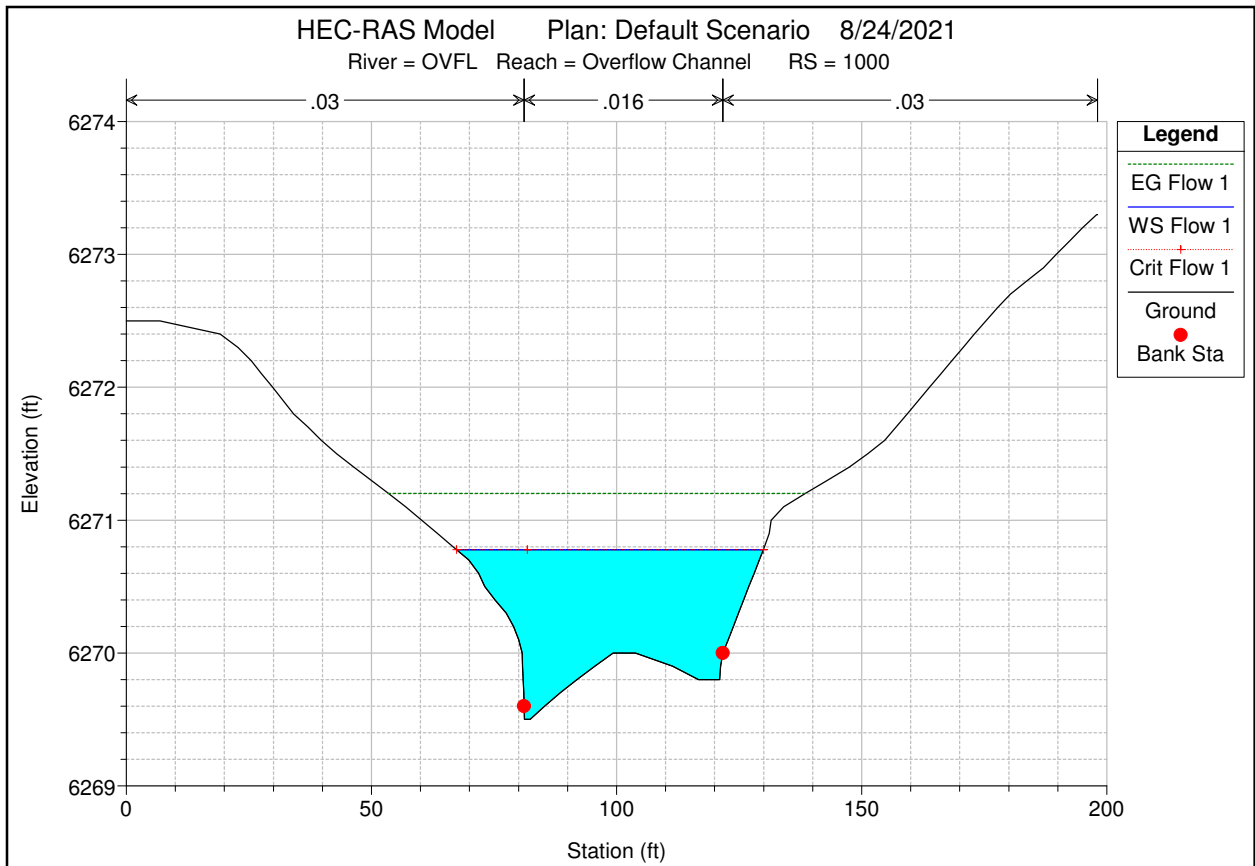

HEC-RAS Model Plan: Default Scenario 8/24/2021  
 River = OVFL Reach = Overflow Ch-DS-0 RS = 998

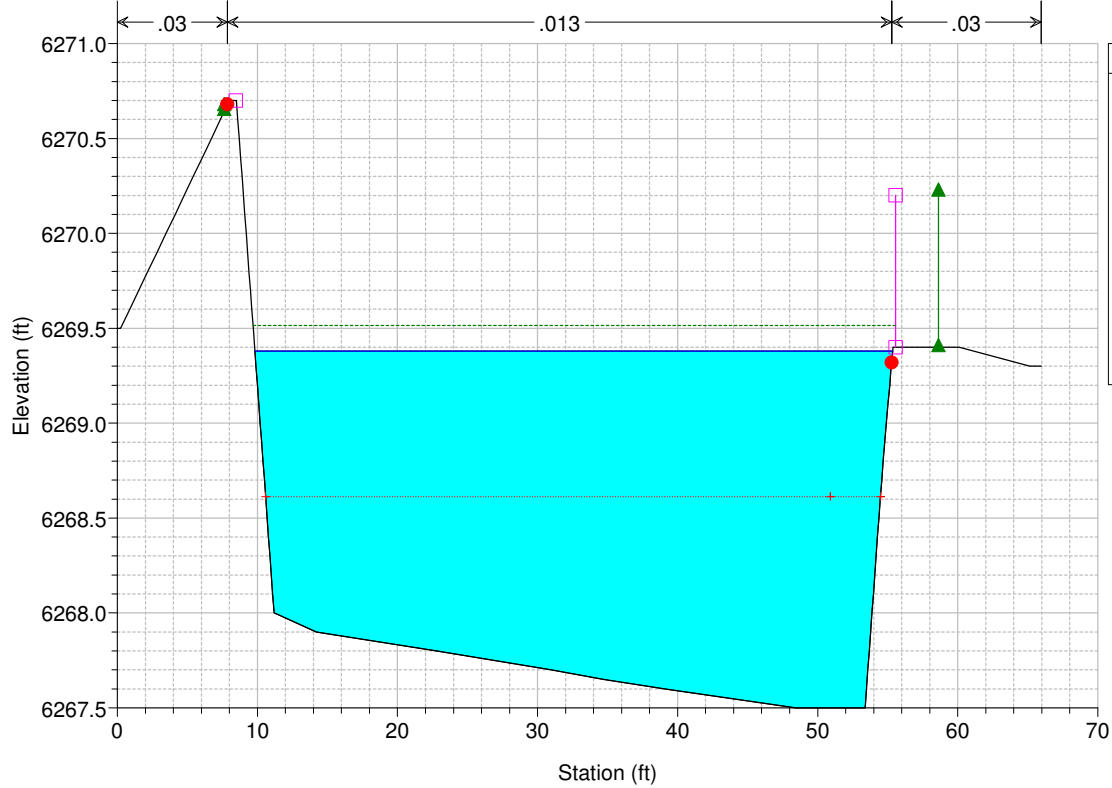

Legend	
EG Flow 1	---
WS Flow 1	---
Crit Flow 1	---
Ground	---
Levee	---
Ineff	▲
Bank Sta	●

HEC-RAS Model Plan: Default Scenario 8/24/2021  
 River = OVFL Reach = Overflow Ch-DS-0 RS = 997

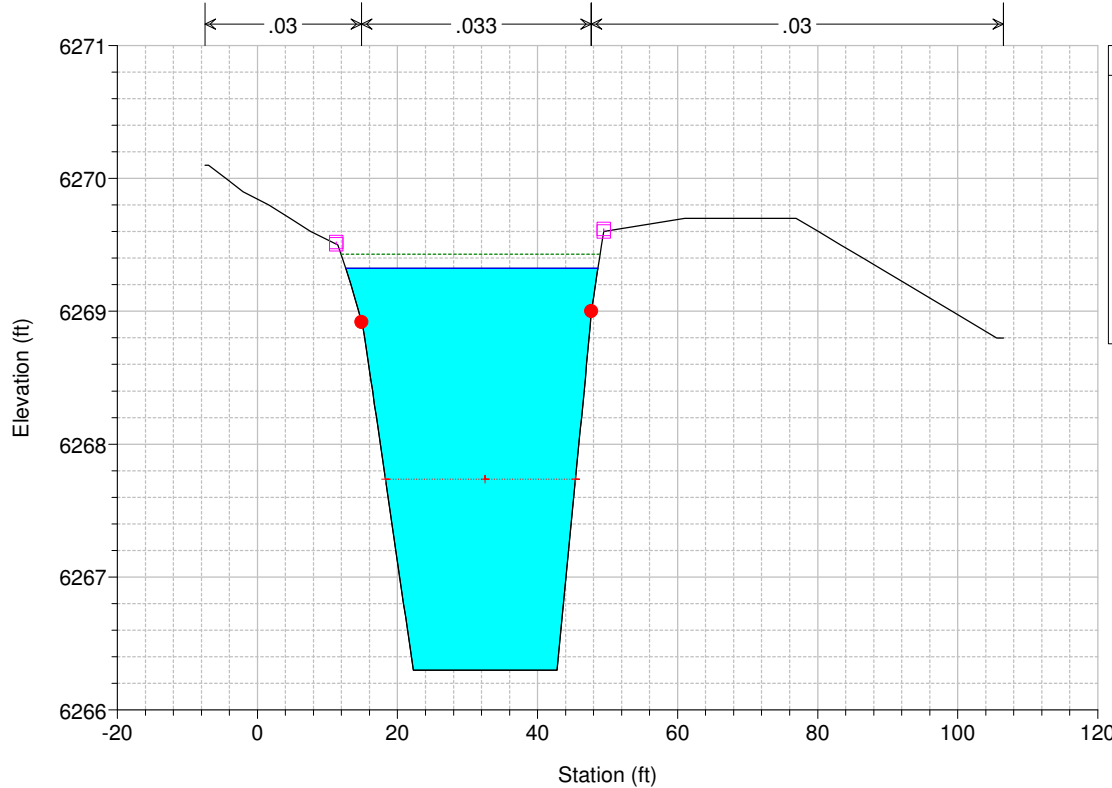

Legend	
EG Flow 1	---
WS Flow 1	---
Crit Flow 1	---
Ground	---
Levee	---
Ineff	▲
Bank Sta	●

HEC-RAS Model Plan: Default Scenario 8/24/2021  
 River = OVFL Reach = Overflow Ch-DS-0 RS = 996

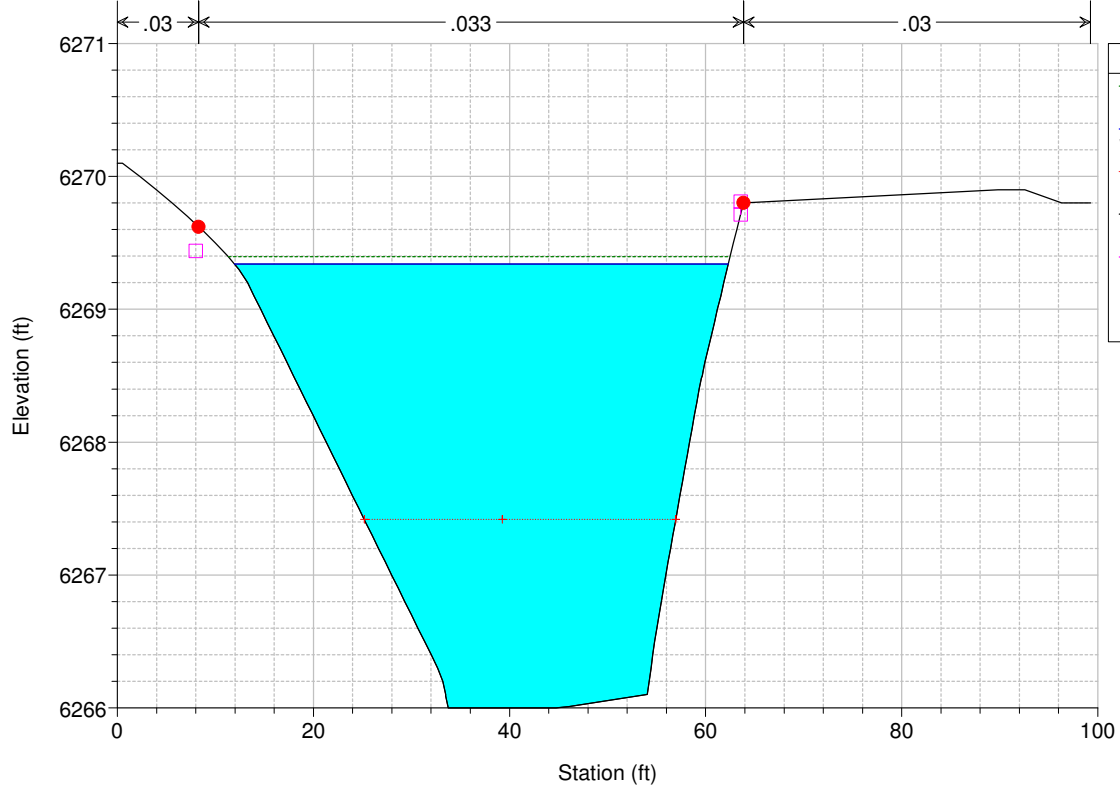

Legend	
EG Flow 1	
WS Flow 1	
Crit Flow 1	
Ground	
Levee	
Bank Sta	

HEC-RAS Model Plan: Default Scenario 8/24/2021  
 River = SC01 Reach = Sand Creek RS = 998

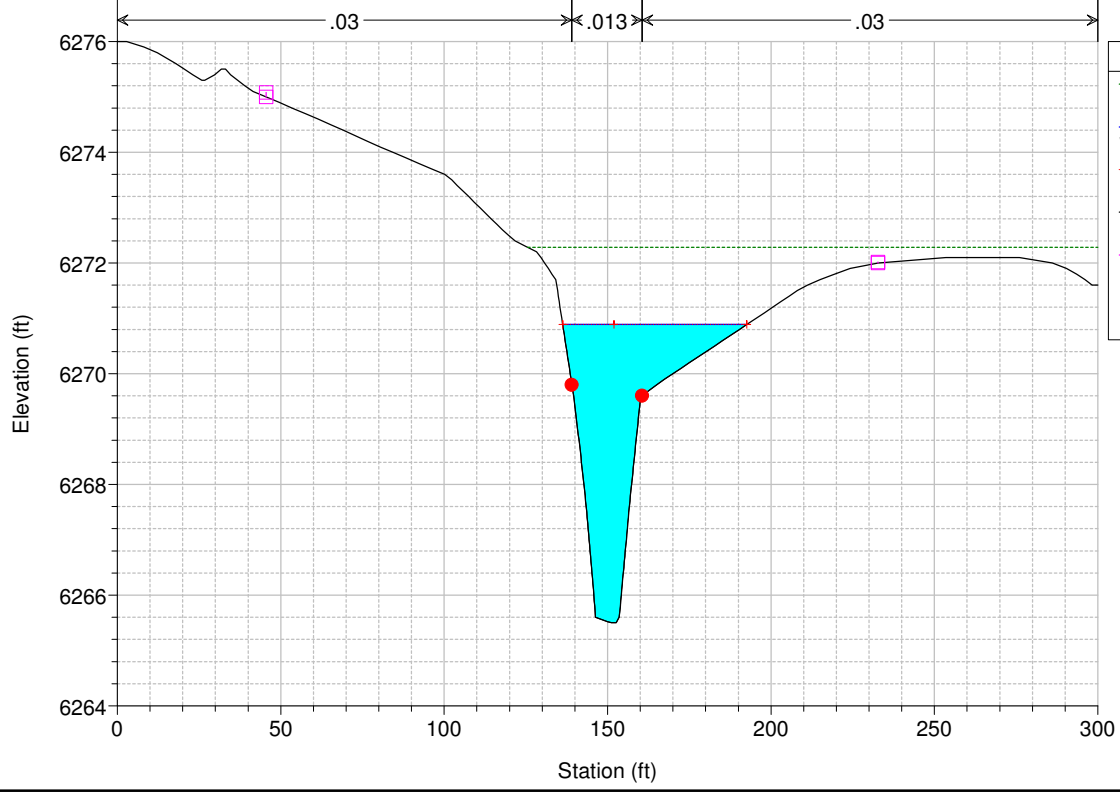

Legend	
EG Flow 1	
WS Flow 1	
Crit Flow 1	
Ground	
Levee	
Bank Sta	

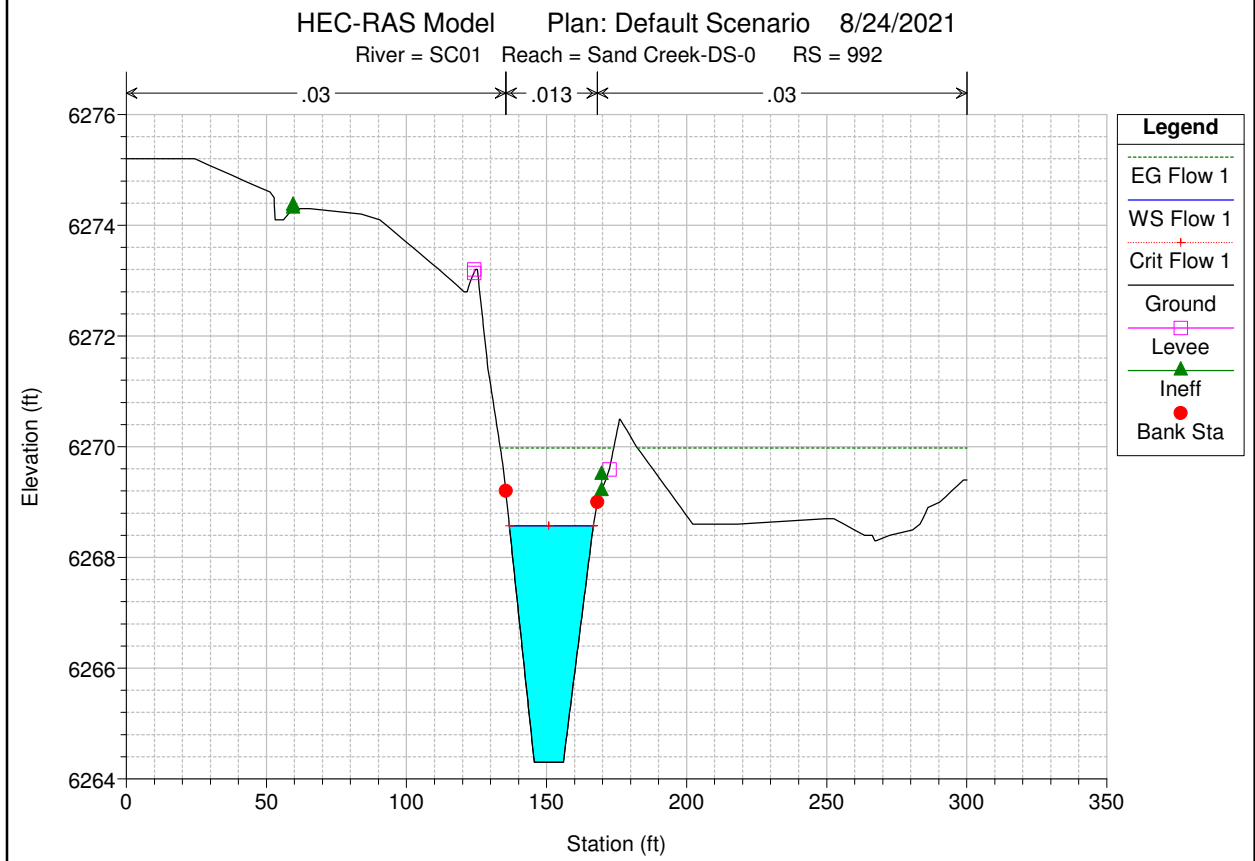
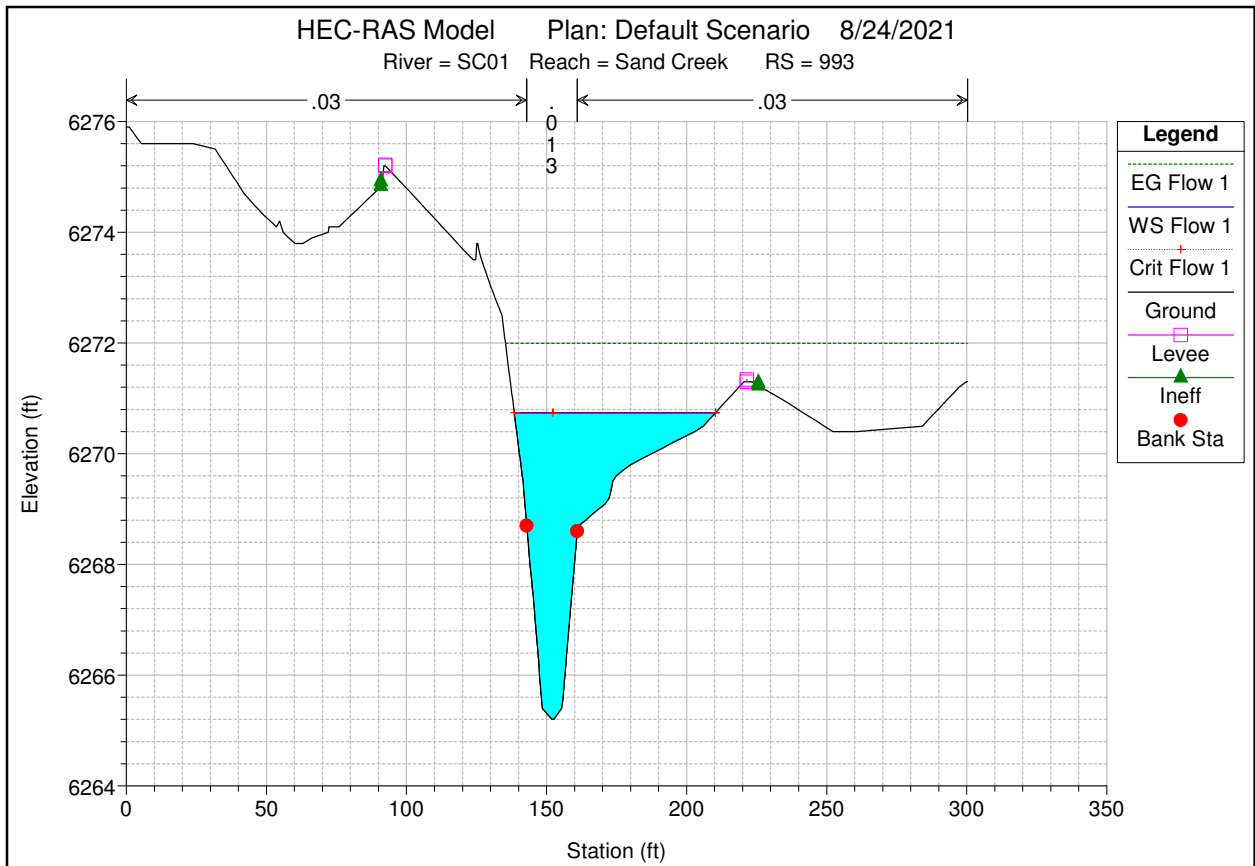

HEC-RAS Model Plan: Default Scenario 8/24/2021  
 River = SC01 Reach = Sand Creek-DS-0 RS = 991

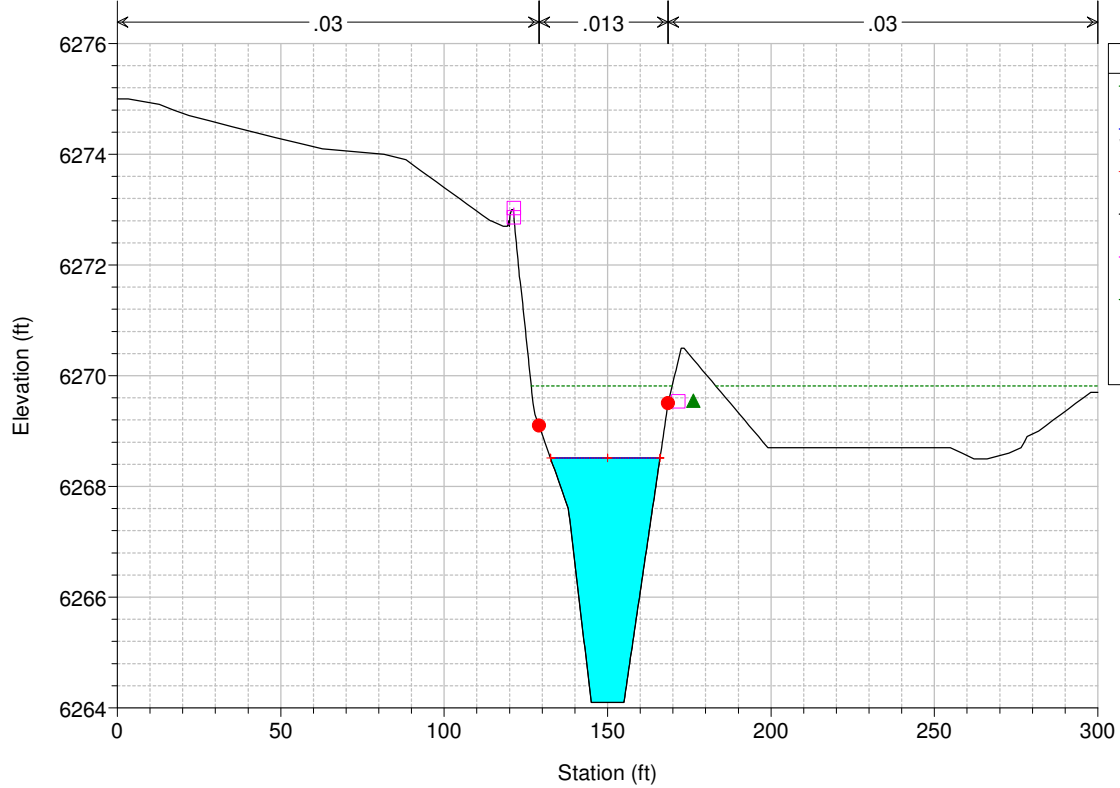

HEC-RAS Model Plan: Default Scenario 8/24/2021  
 River = SC01 Reach = Sand Creek-DS-0- RS = 990

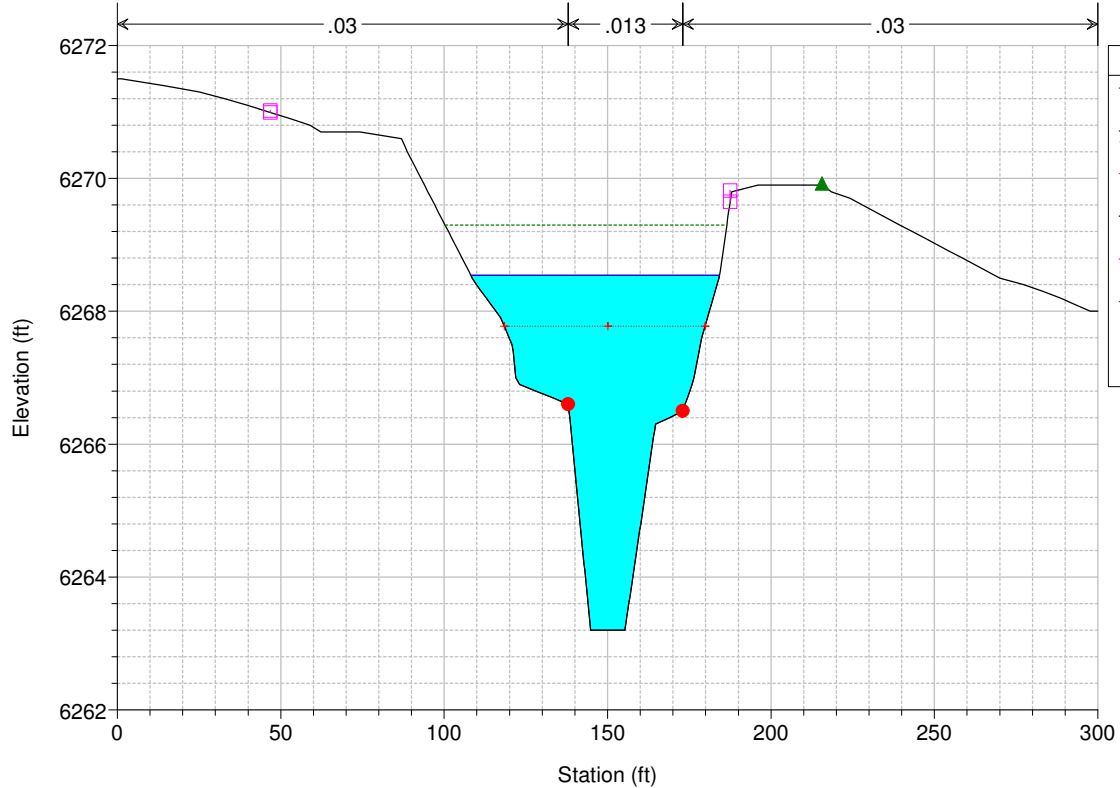



HEC-RAS Model Plan: Default Scenario 8/24/2021  
 River = SC01 Reach = Sand Creek-DS-0- RS = 989

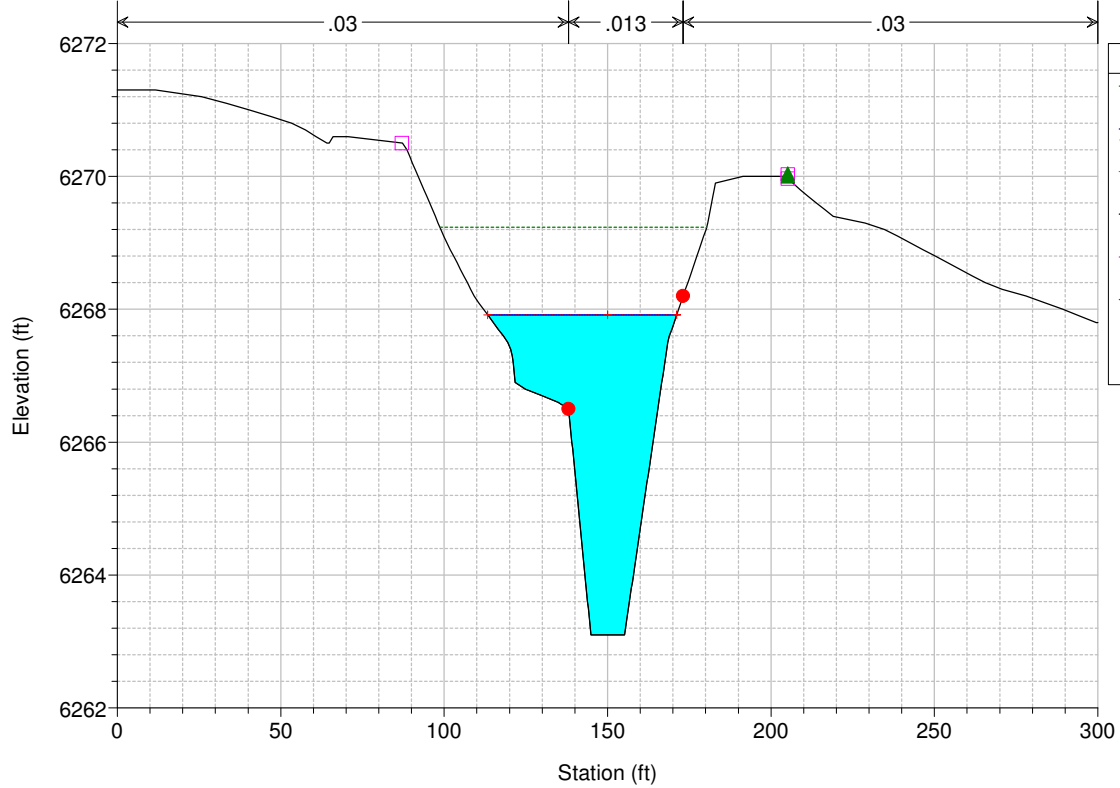

HEC-RAS Model Plan: Default Scenario 8/24/2021  
 River = SC01 Reach = Sand Creek-DS-0- RS = 988

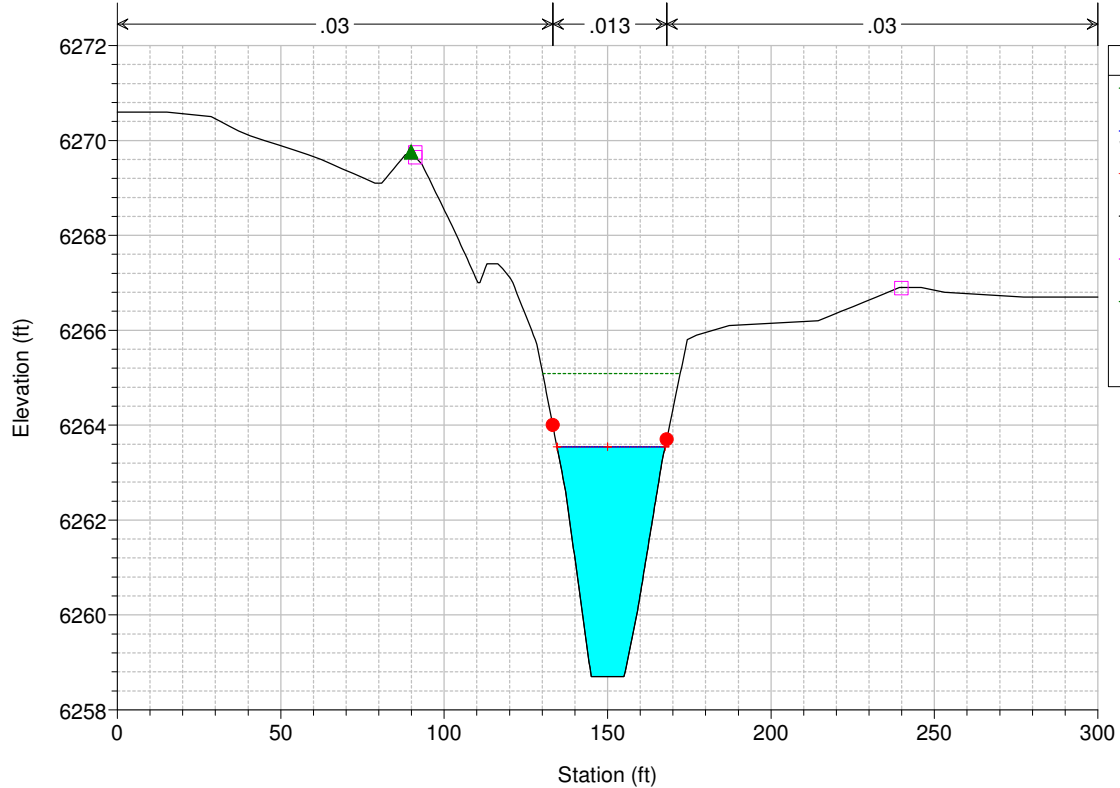

HEC-RAS Model Plan: Default Scenario 8/24/2021  
 River = SC01 Reach = Sand Creek-DS-0- RS = 987

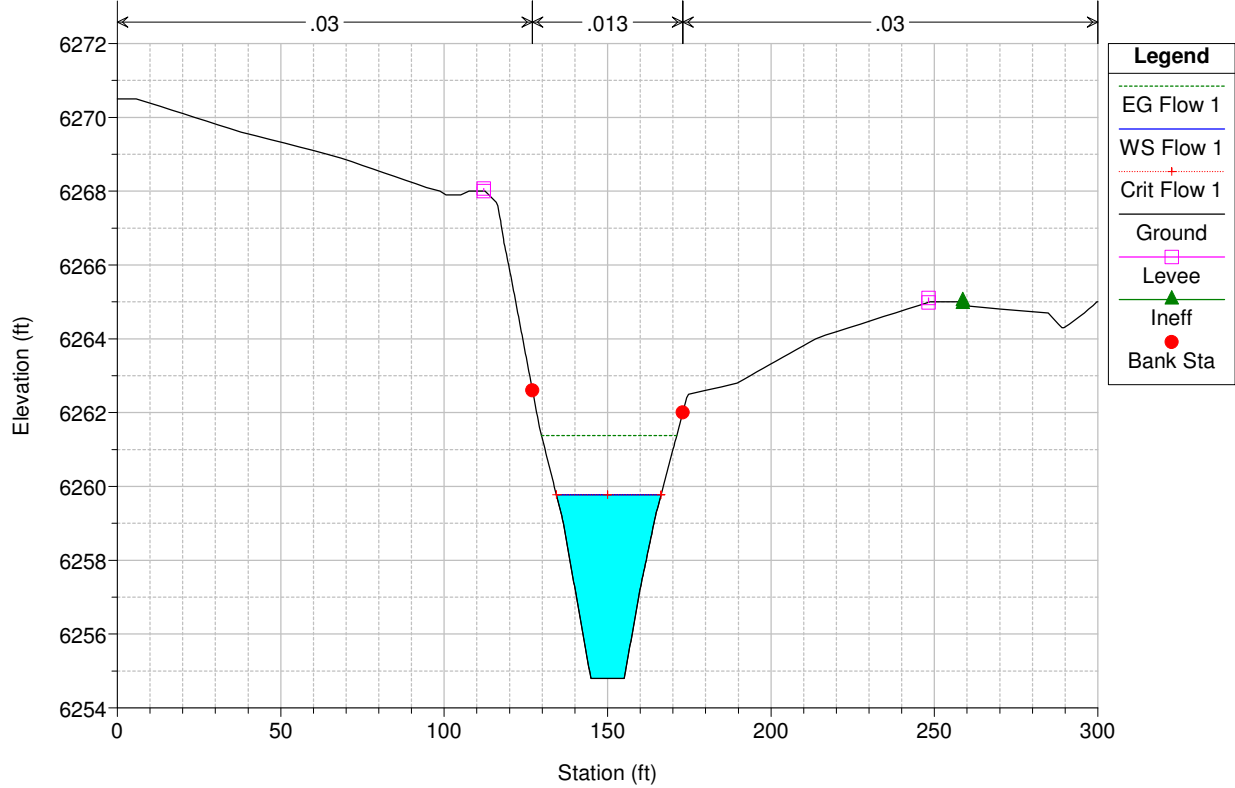

HEC-RAS Model Plan: Default Scenario 8/24/2021  
 River = SC01 Reach = Sand Creek-DS-0- RS = 986

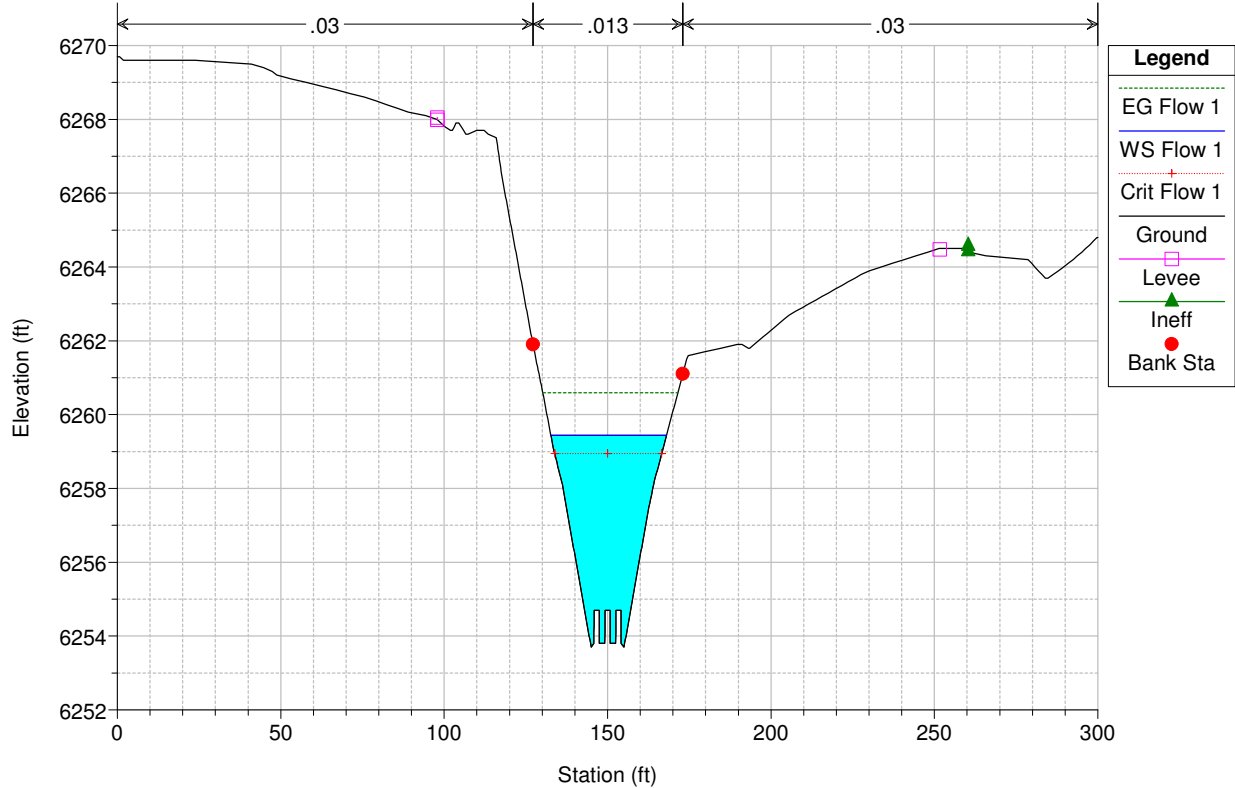

HEC-RAS Model Plan: Default Scenario 8/24/2021  
 River = SC01 Reach = Sand Creek-DS-0- RS = 985

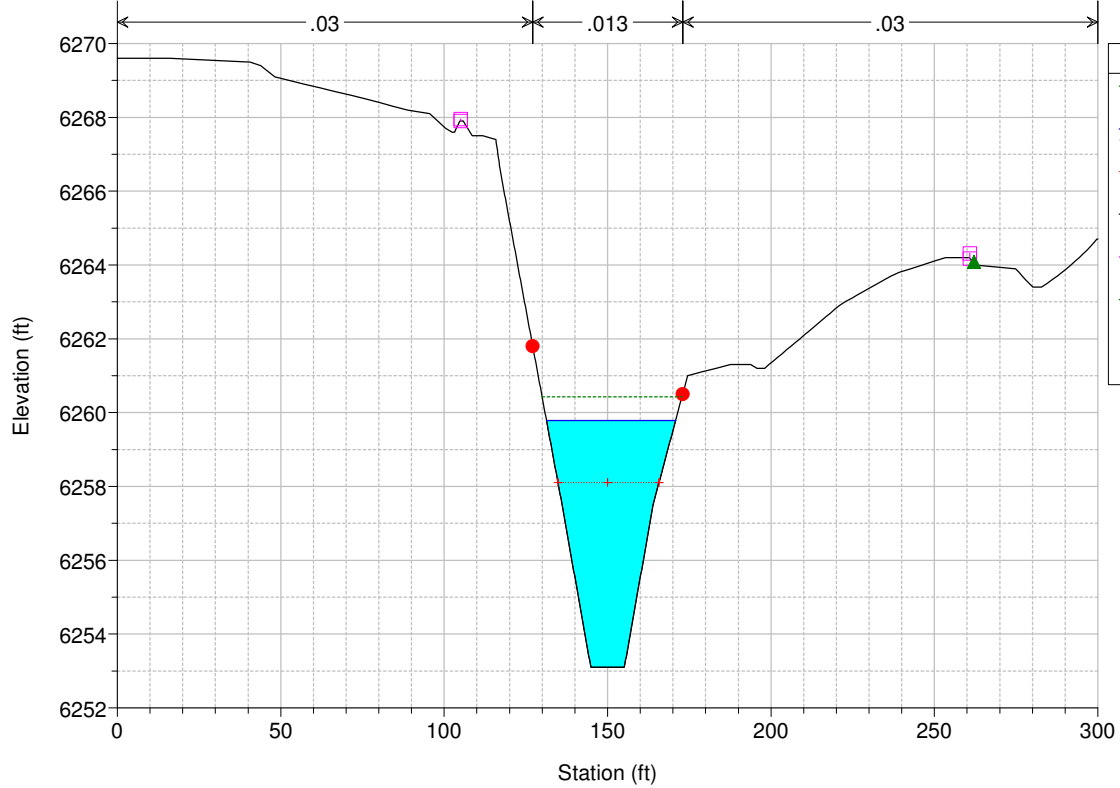

HEC-RAS Model Plan: Default Scenario 8/24/2021  
 River = SC01 Reach = Sand Creek-DS-0- RS = 984

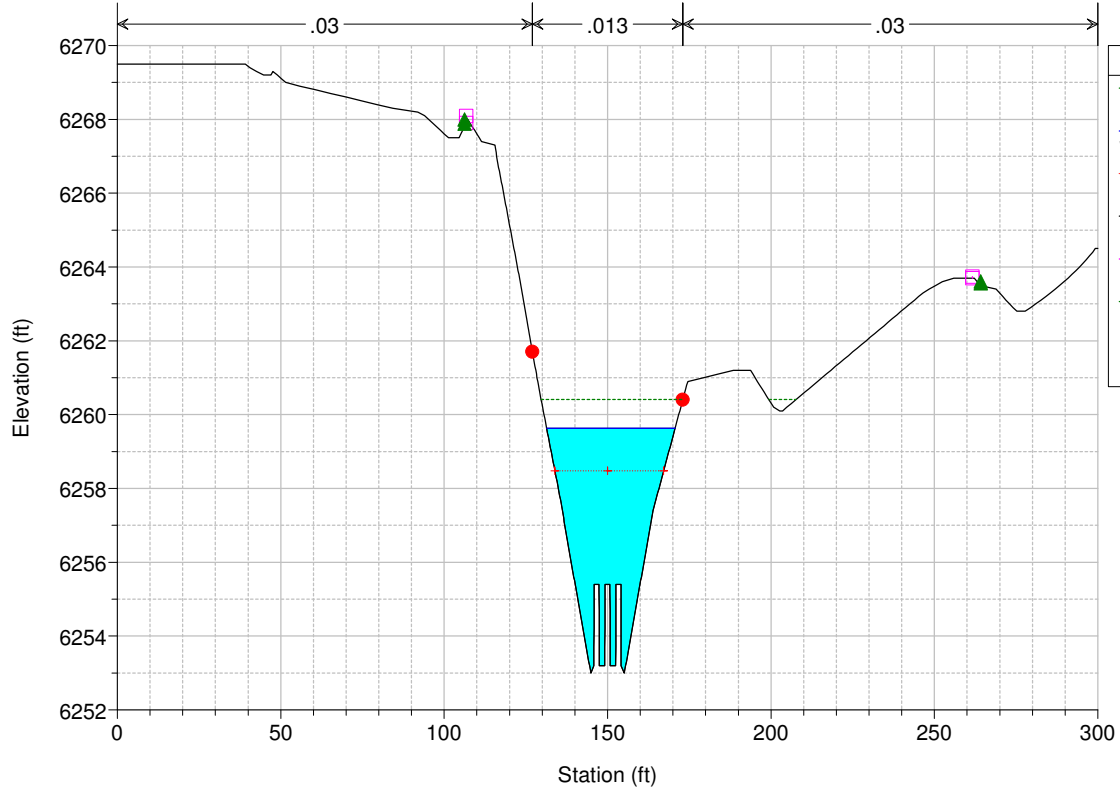

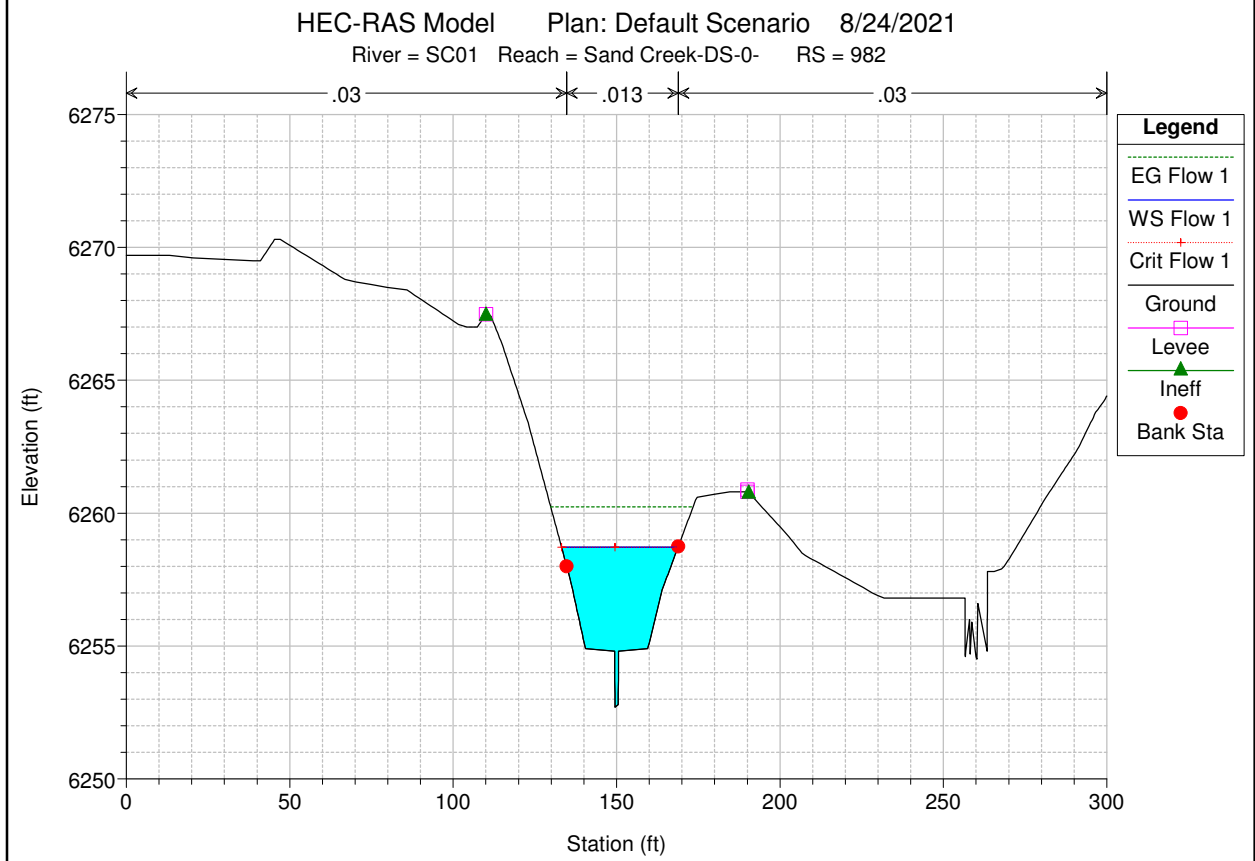
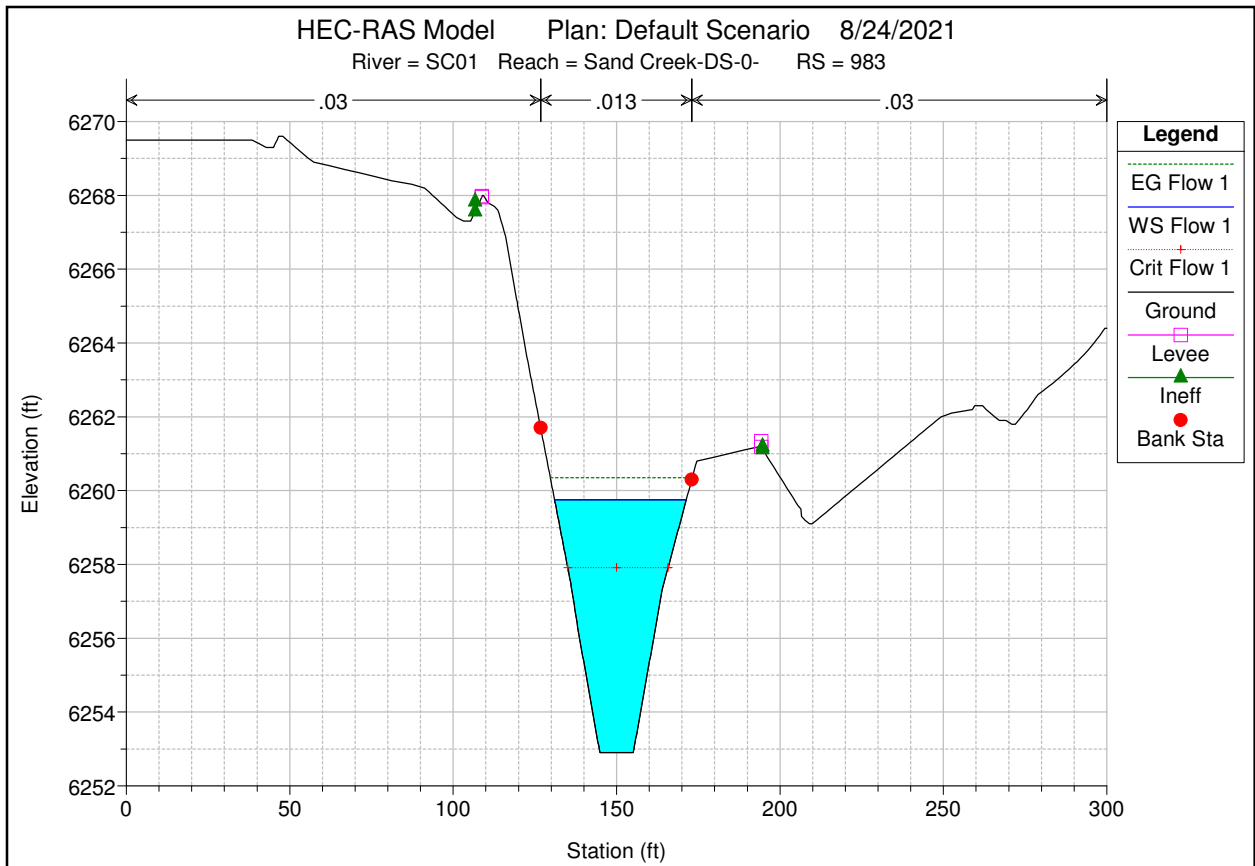

HEC-RAS Model Plan: Default Scenario 8/24/2021  
 River = SC01 Reach = Sand Creek-DS-0- RS = 981

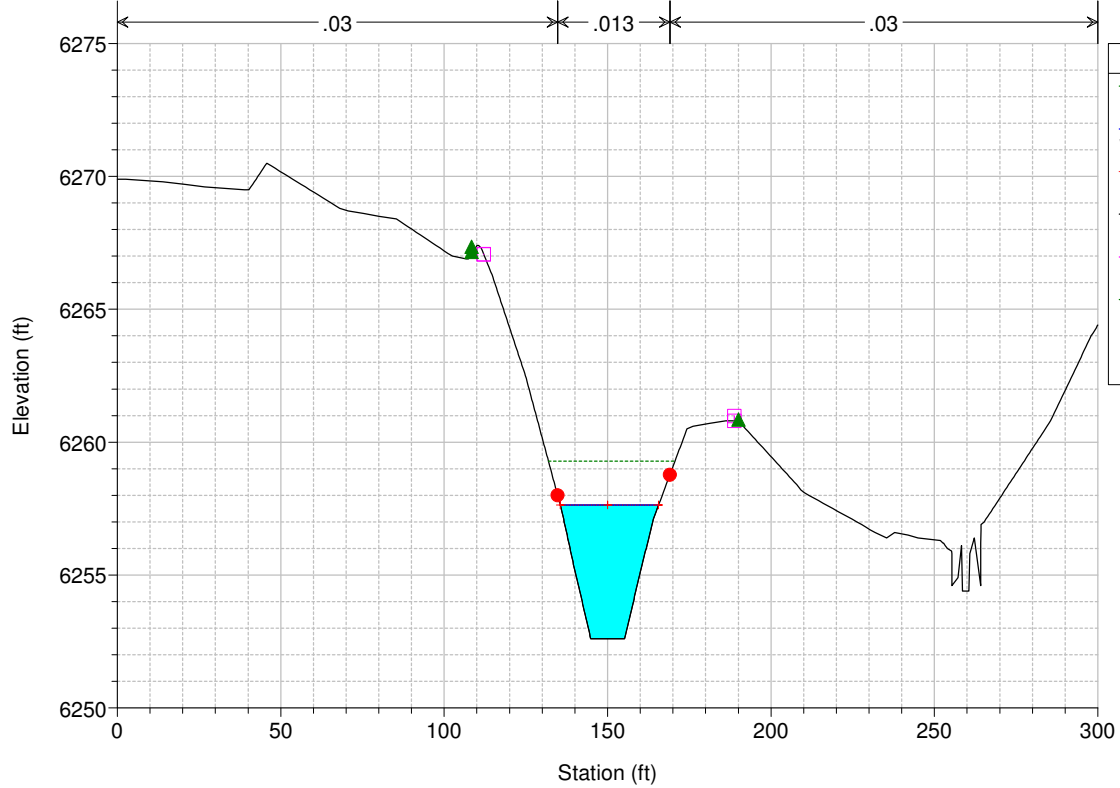

HEC-RAS Model Plan: Default Scenario 8/24/2021  
 River = SC01 Reach = Sand Creek-DS-0- RS = 980

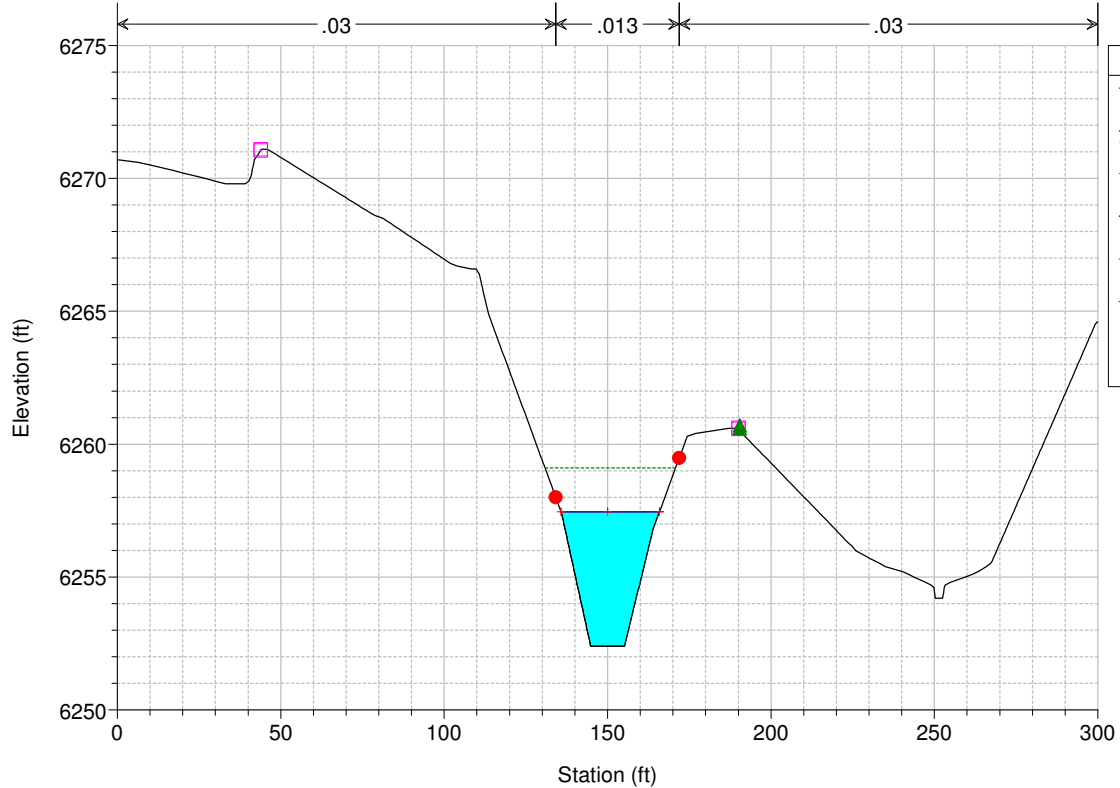

HEC-RAS Model Plan: Default Scenario 8/24/2021  
 River = SC01 Reach = Sand Creek-DS-0- RS = 979

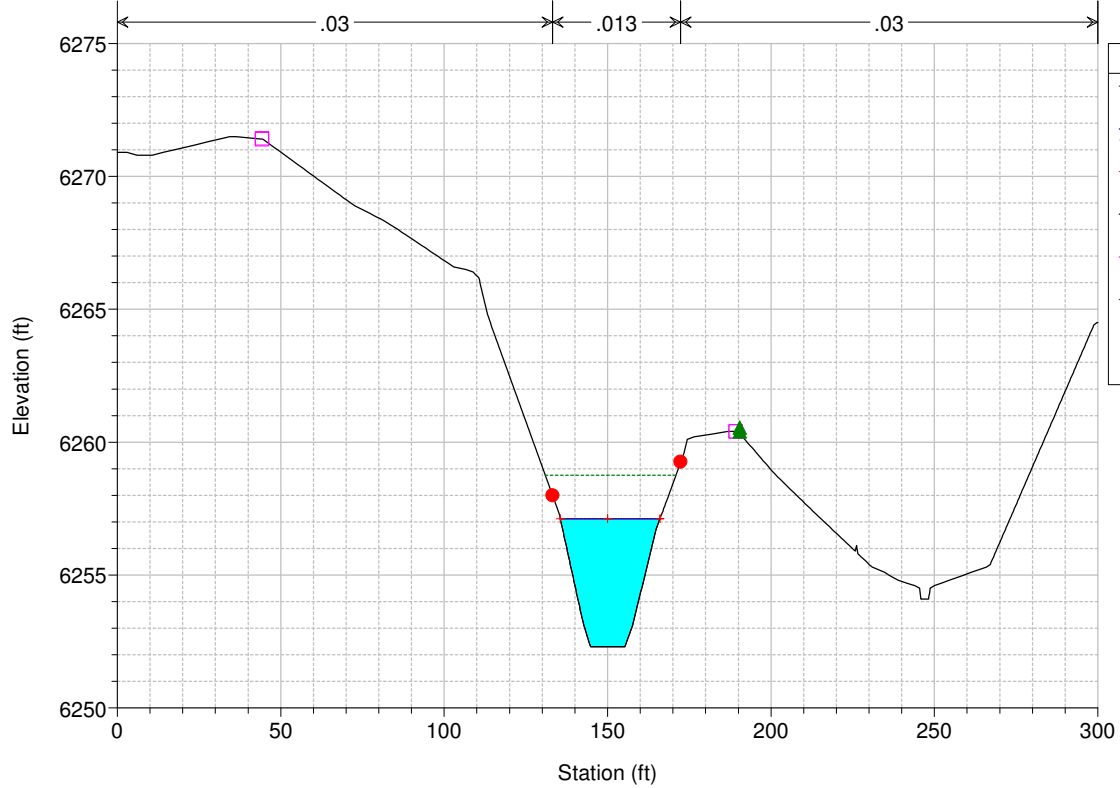

HEC-RAS Model Plan: Default Scenario 8/24/2021  
 River = SC01 Reach = Sand Creek-DS-0- RS = 978

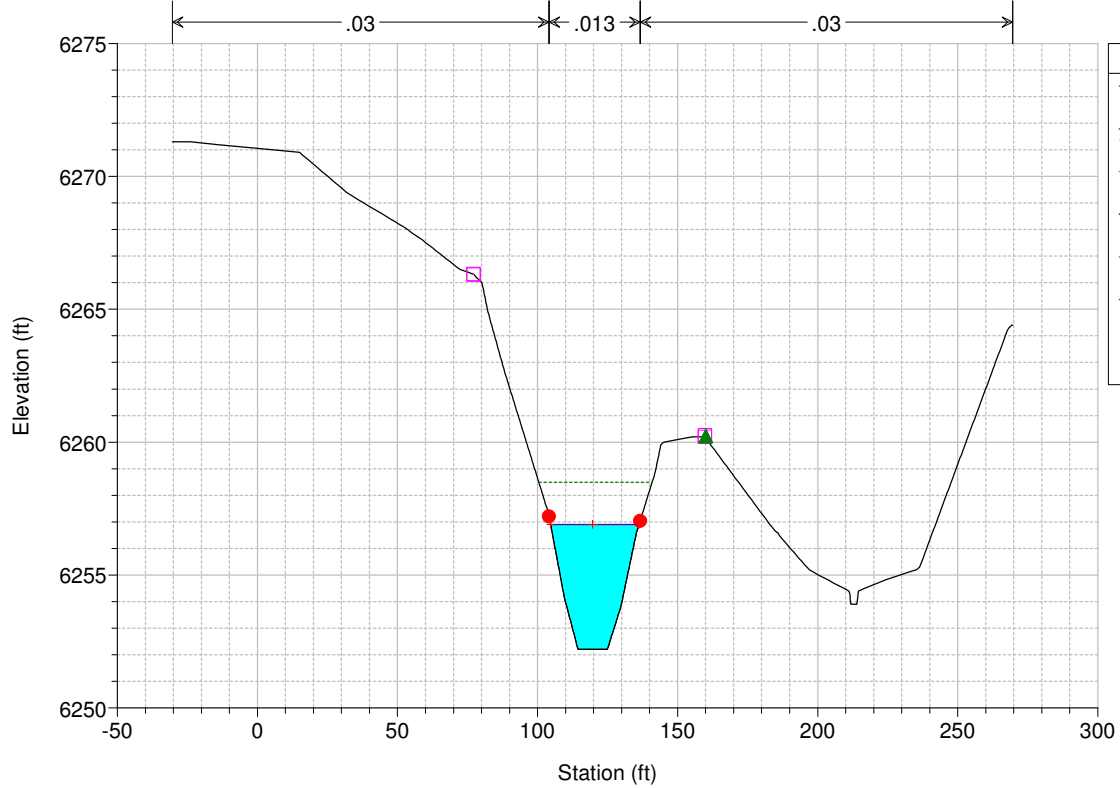

HEC-RAS Model Plan: Default Scenario 8/24/2021  
 River = SC01 Reach = Sand Creek-DS-0- RS = 977

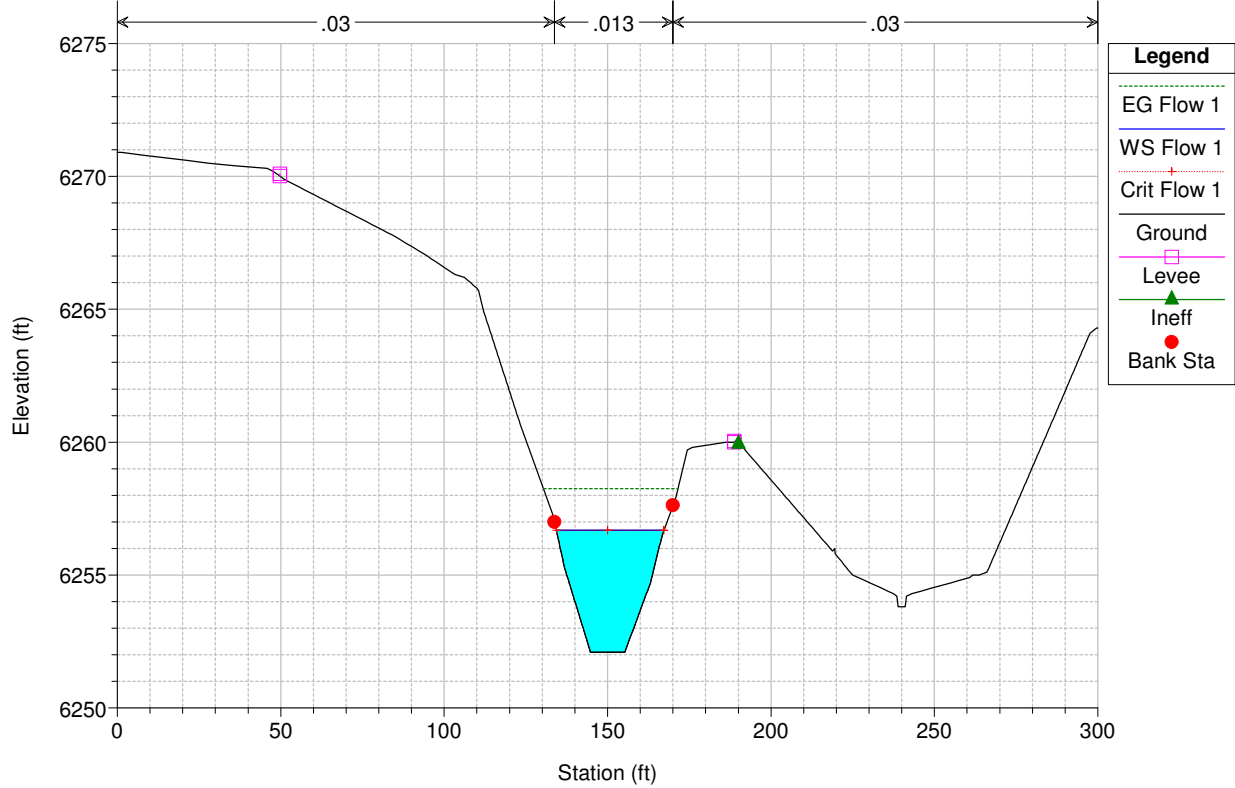

HEC-RAS Model Plan: Default Scenario 8/24/2021  
 River = SC01 Reach = Sand Creek-DS-0- RS = 976

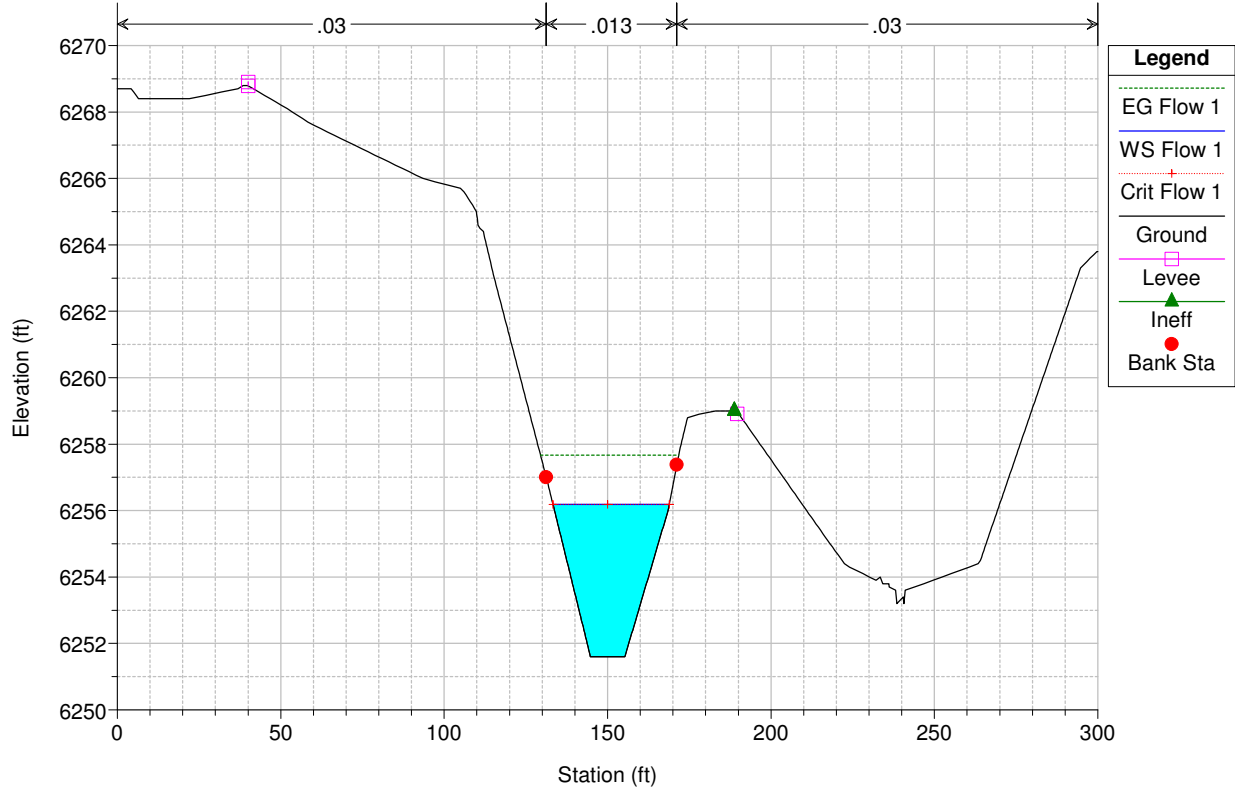

HEC-RAS Model Plan: Default Scenario 8/24/2021  
River = SC01 Reach = Sand Creek-DS-0- RS = 975

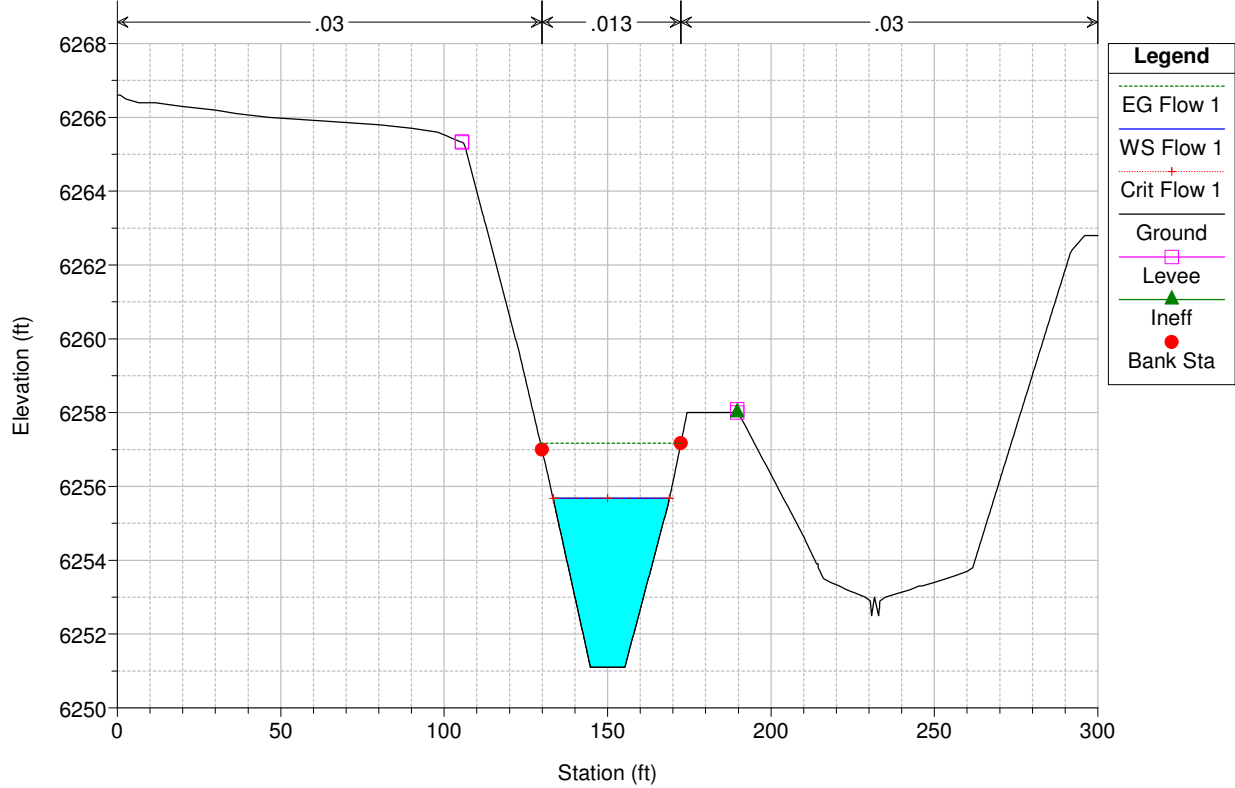

HEC-RAS Model Plan: Default Scenario 8/24/2021  
River = SC01 Reach = Sand Creek-DS-0- RS = 974

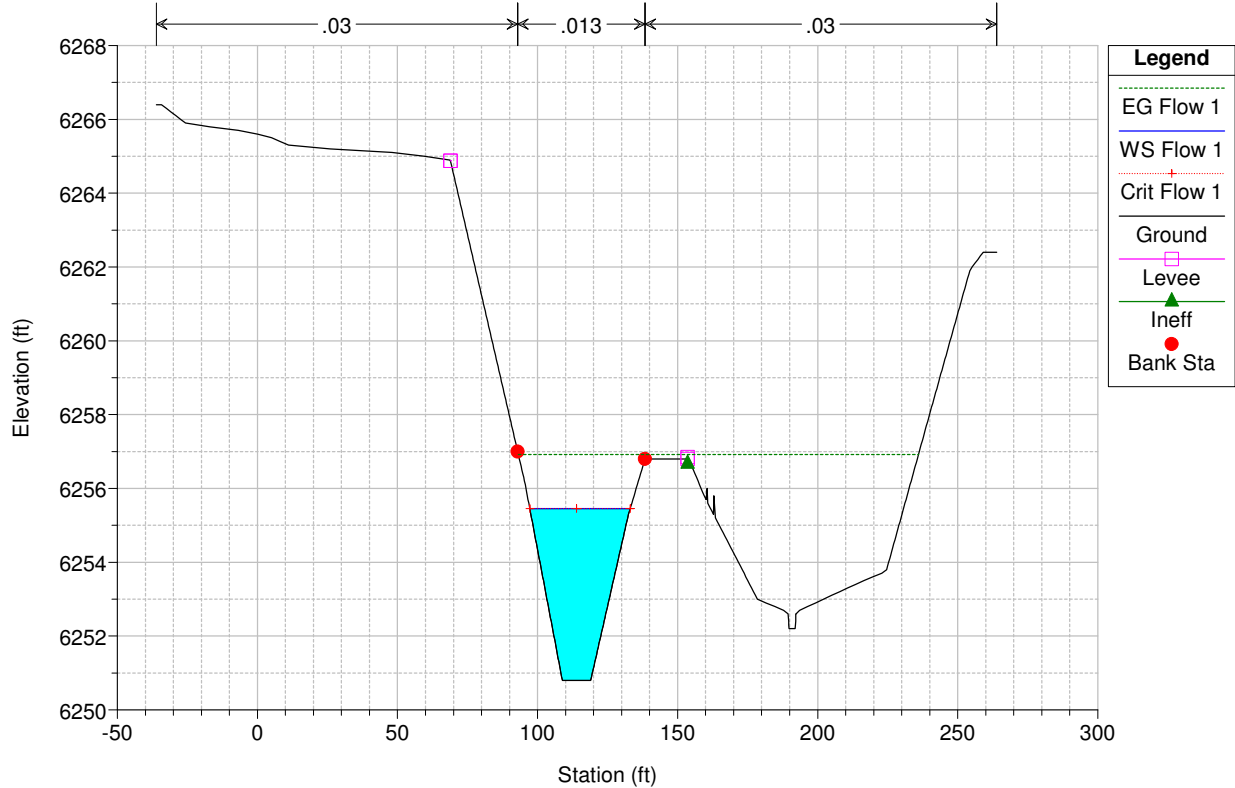



HEC-RAS Model Plan: Default Scenario 8/24/2021  
 River = SC01 Reach = Sand Creek-DS-0- RS = 973

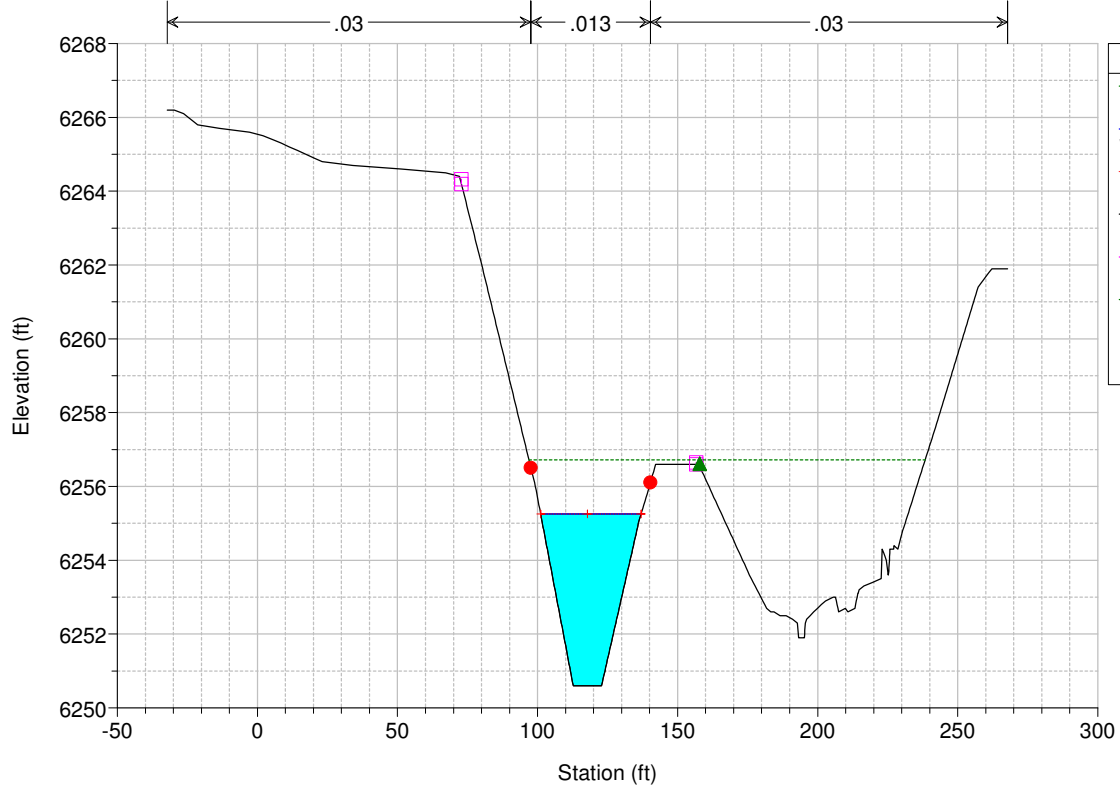

HEC-RAS Model Plan: Default Scenario 8/24/2021  
 River = SC01 Reach = Sand Creek-DS-0- RS = 972

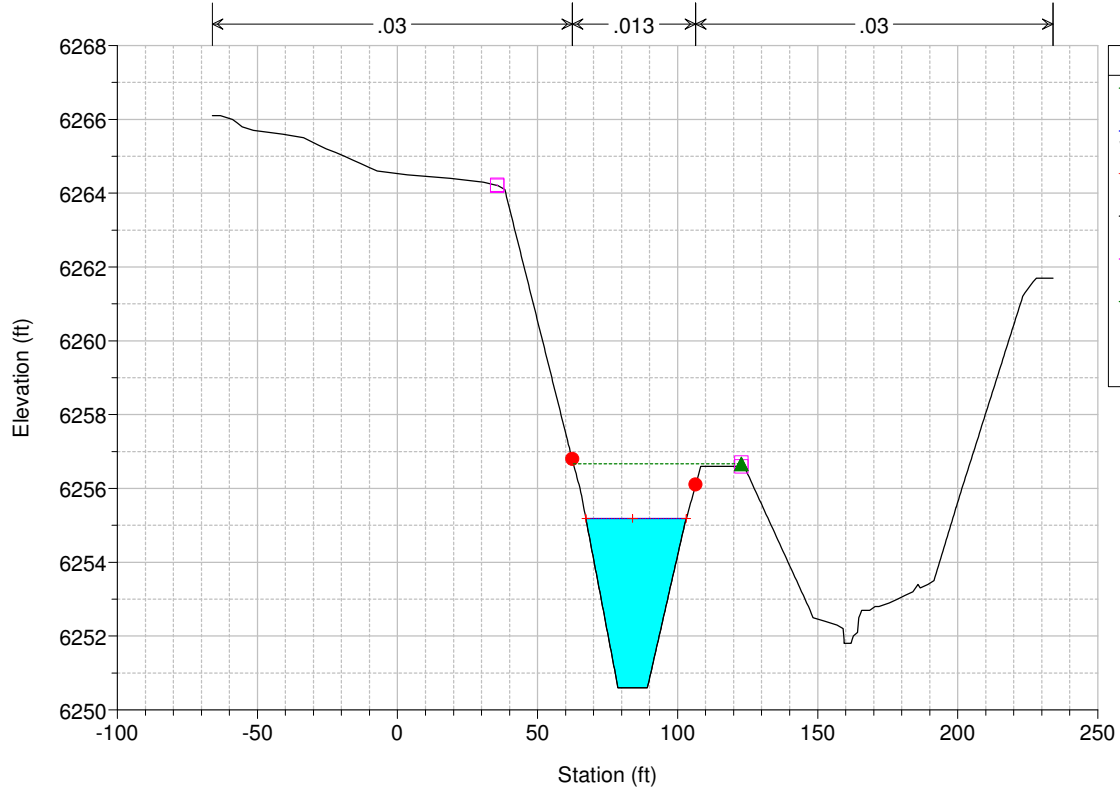

HEC-RAS Model Plan: Default Scenario 8/24/2021  
 River = SC01 Reach = Sand Creek-DS-0- RS = 971

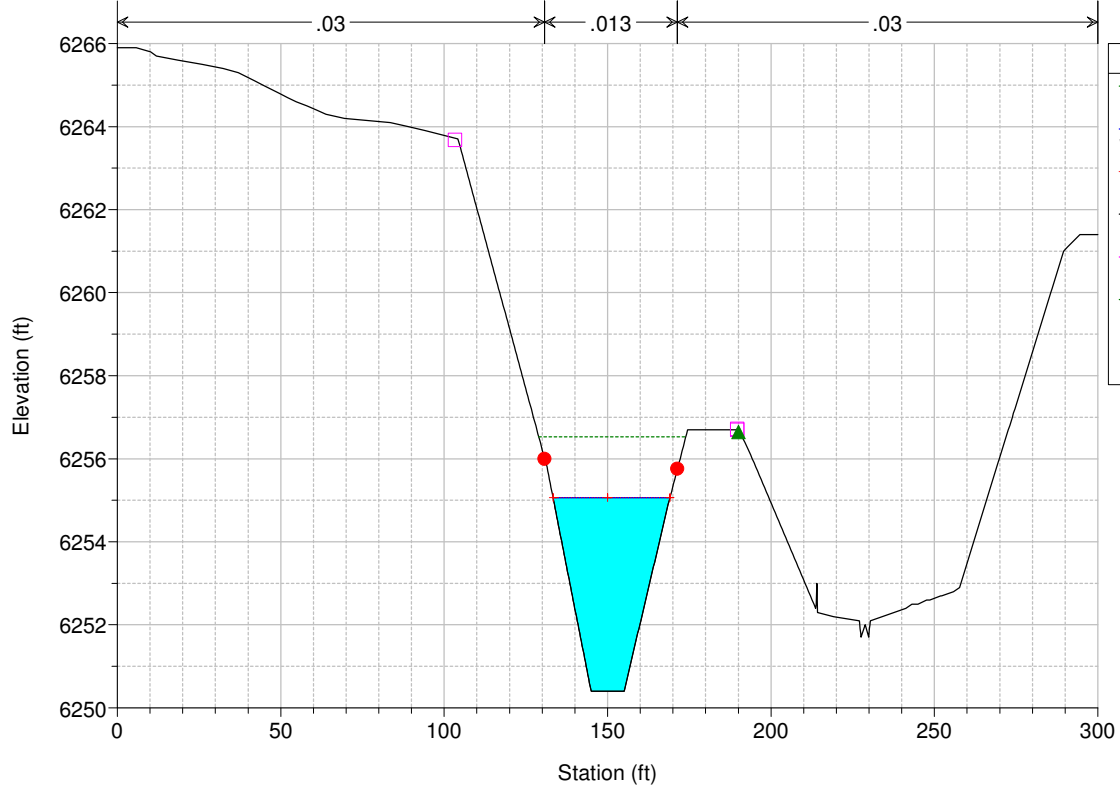

HEC-RAS Model Plan: Default Scenario 8/24/2021  
 River = SC01 Reach = Sand Creek-DS-0- RS = 970

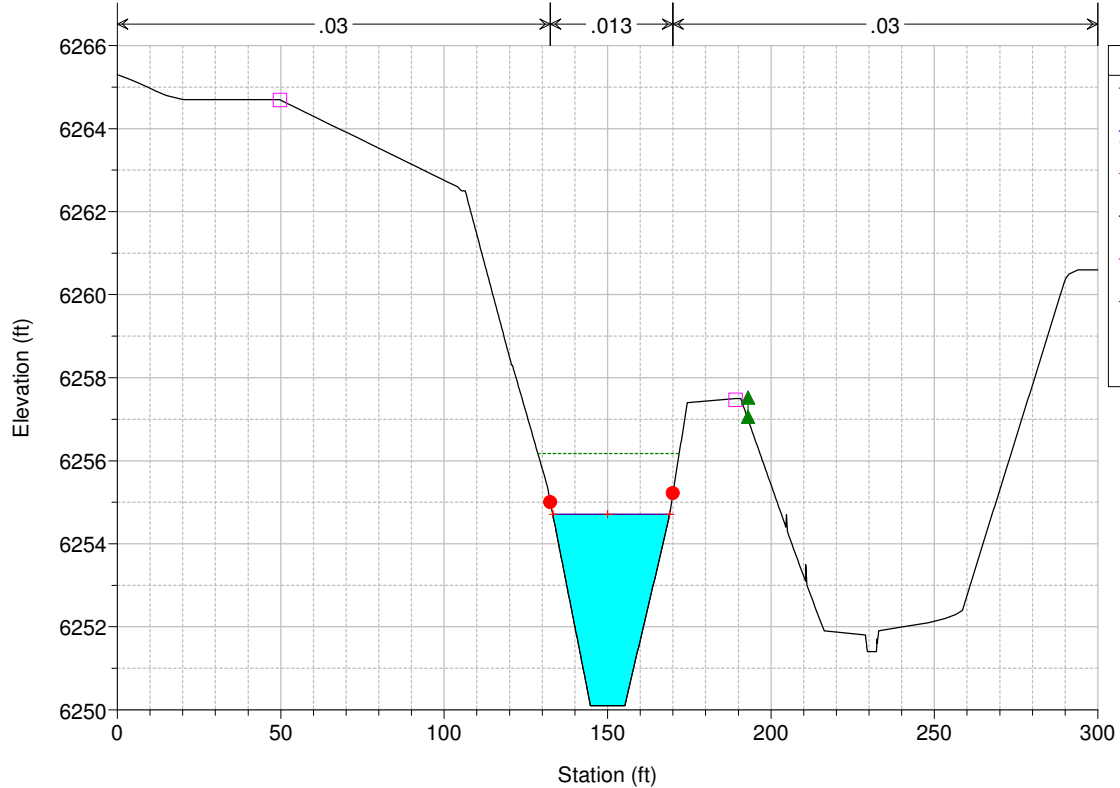

HEC-RAS Model Plan: Default Scenario 8/24/2021  
 River = SC01 Reach = Sand Creek-DS-0- RS = 969

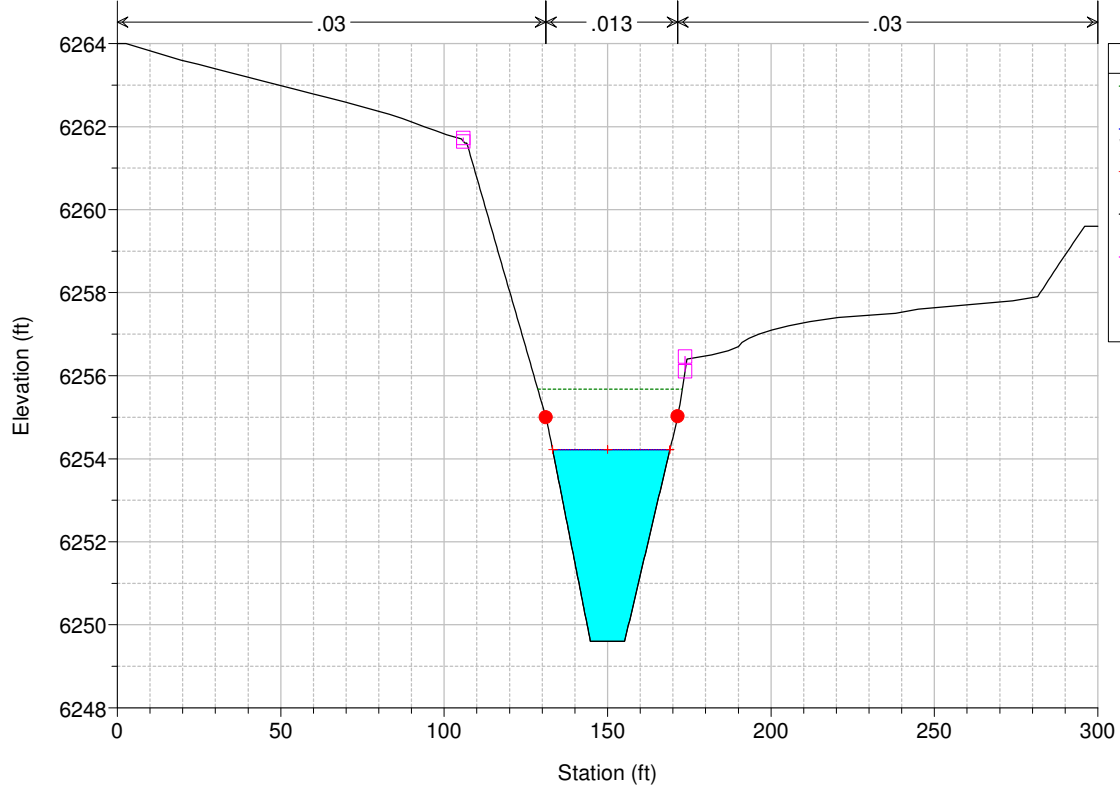

HEC-RAS Model Plan: Default Scenario 8/24/2021  
 River = SC01 Reach = Sand Creek-DS-0- RS = 968

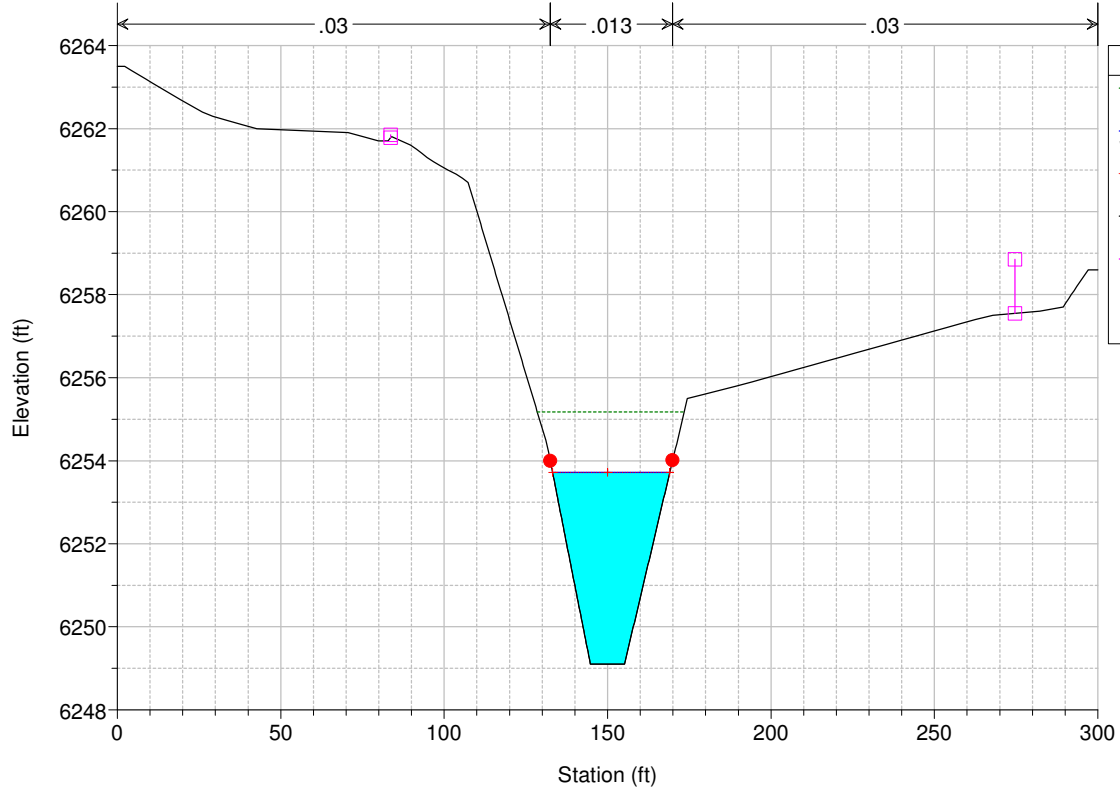

HEC-RAS Model Plan: Default Scenario 8/24/2021  
 River = SC01 Reach = Sand Creek-DS-1 RS = 966

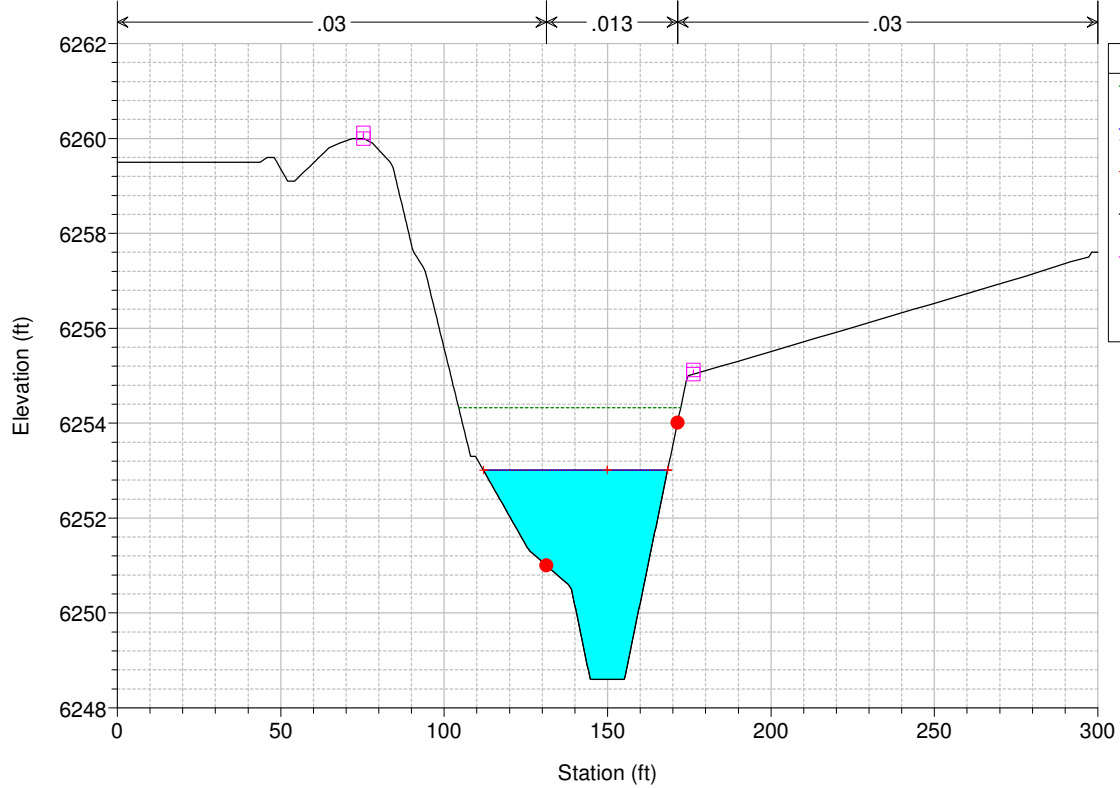

Legend	
EG Flow 1	(Dashed green line)
WS Flow 1	(Solid blue line)
Crit Flow 1	(Red line with '+' marker)
Ground	(Solid black line)
Levee	(Pink square)
Bank Sta	(Red circle)

HEC-RAS Model Plan: Default Scenario 8/24/2021  
 River = SC01 Reach = Sand Creek-DS-1 RS = 965

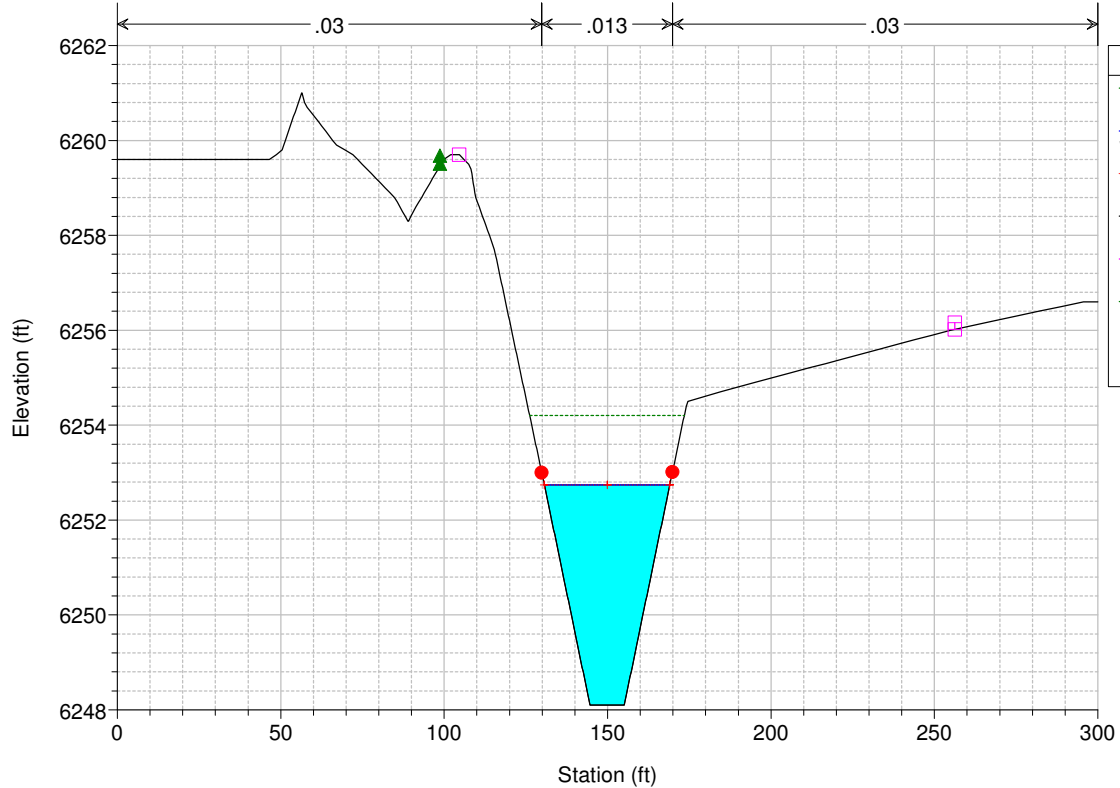

Legend	
EG Flow 1	(Dashed green line)
WS Flow 1	(Solid blue line)
Crit Flow 1	(Red line with '+' marker)
Ground	(Solid black line)
Levee	(Pink square)
Ineff	(Green triangle)
Bank Sta	(Red circle)

HEC-RAS Model Plan: Default Scenario 8/24/2021  
 River = SC01 Reach = Sand Creek-DS-1 RS = 964

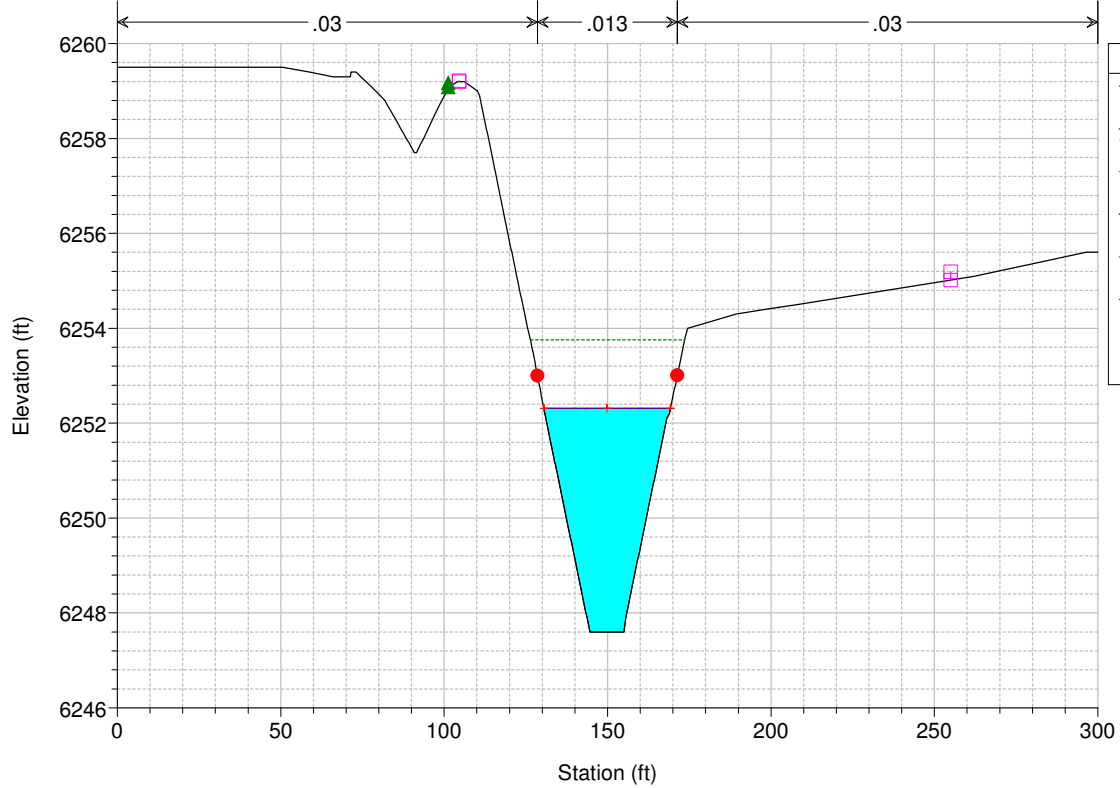

HEC-RAS Model Plan: Default Scenario 8/24/2021  
 River = SC01 Reach = Sand Creek-DS-1 RS = 963

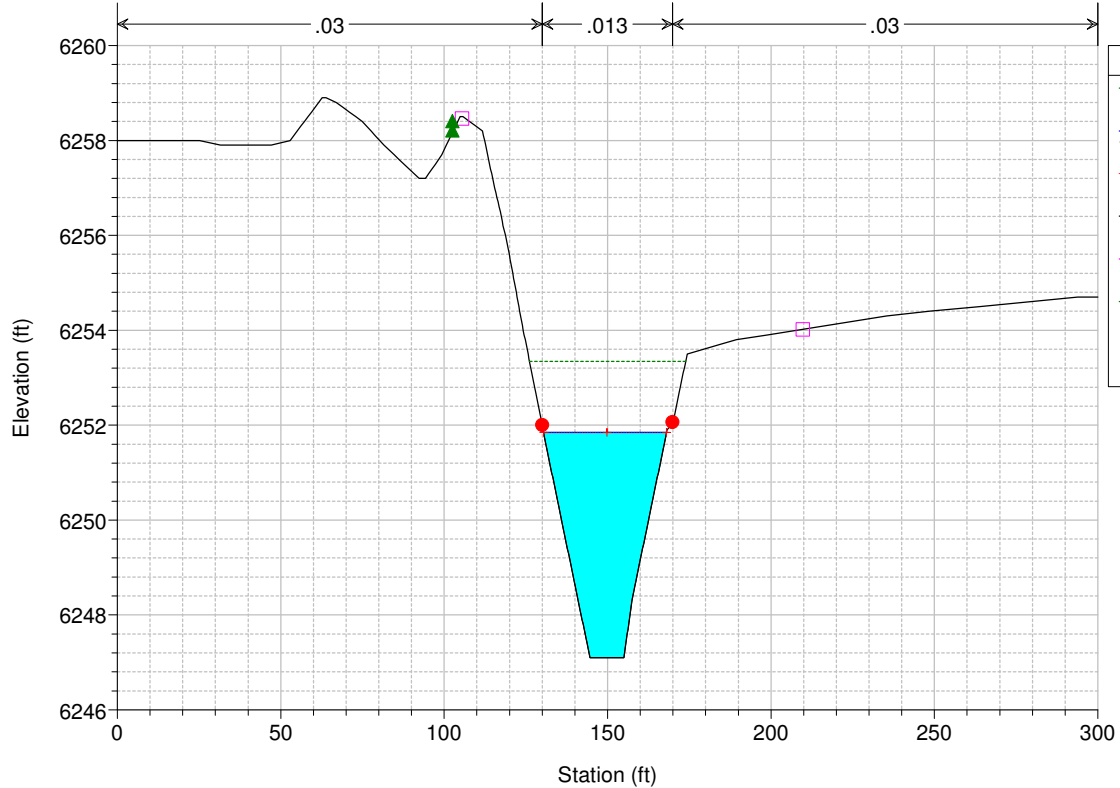

HEC-RAS Model Plan: Default Scenario 8/24/2021  
 River = SC01 Reach = Sand Creek-DS-1 RS = 962

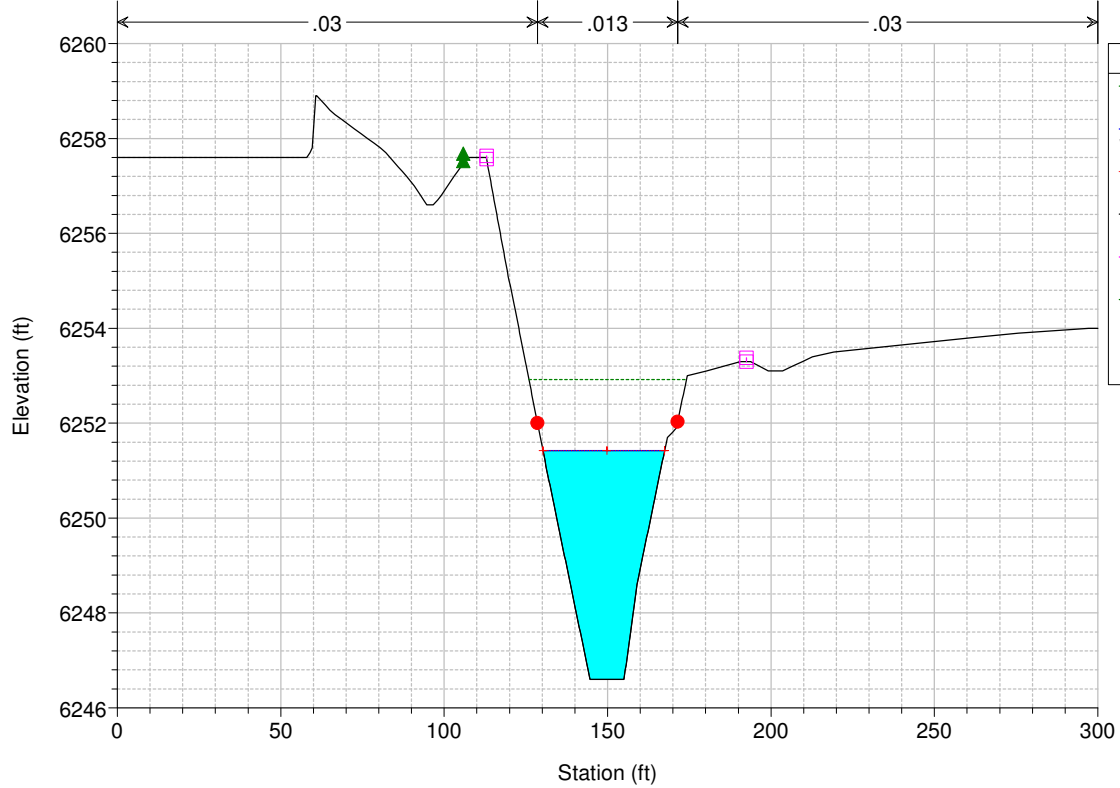

HEC-RAS Model Plan: Default Scenario 8/24/2021  
 River = SC01 Reach = Sand Creek-DS-1 RS = 961

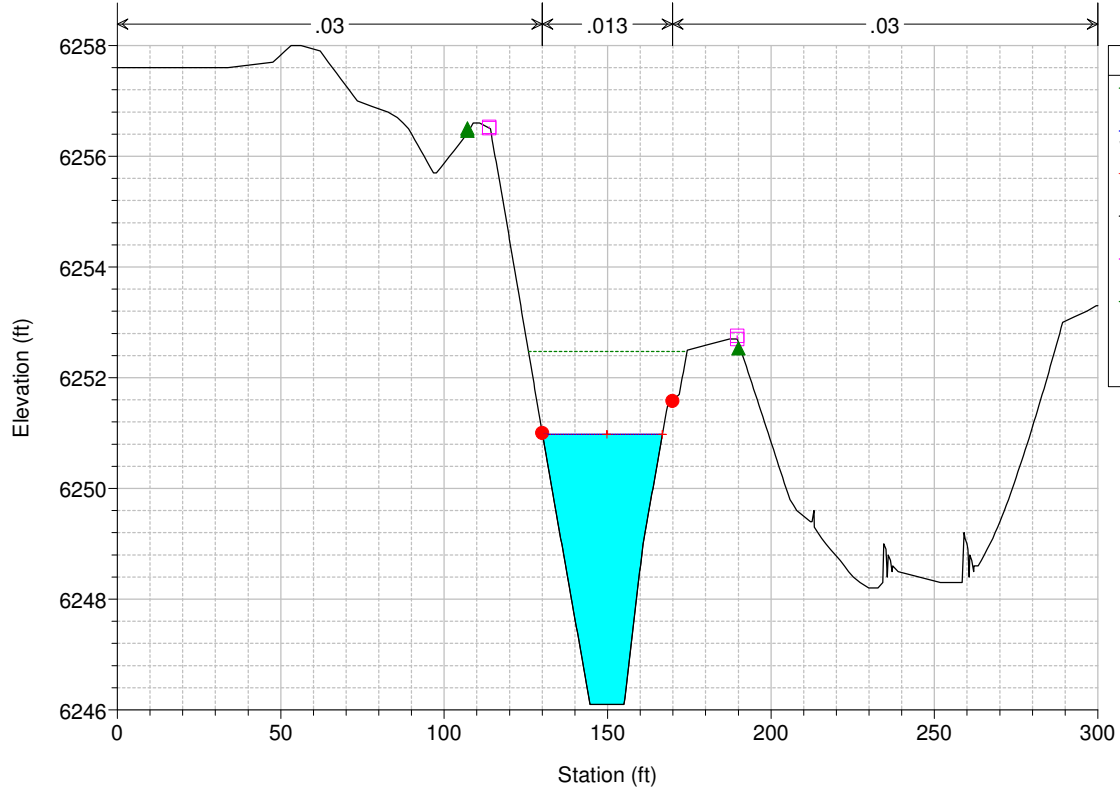

HEC-RAS Model Plan: Default Scenario 8/24/2021  
 River = SC01 Reach = Sand Creek-DS-1 RS = 960

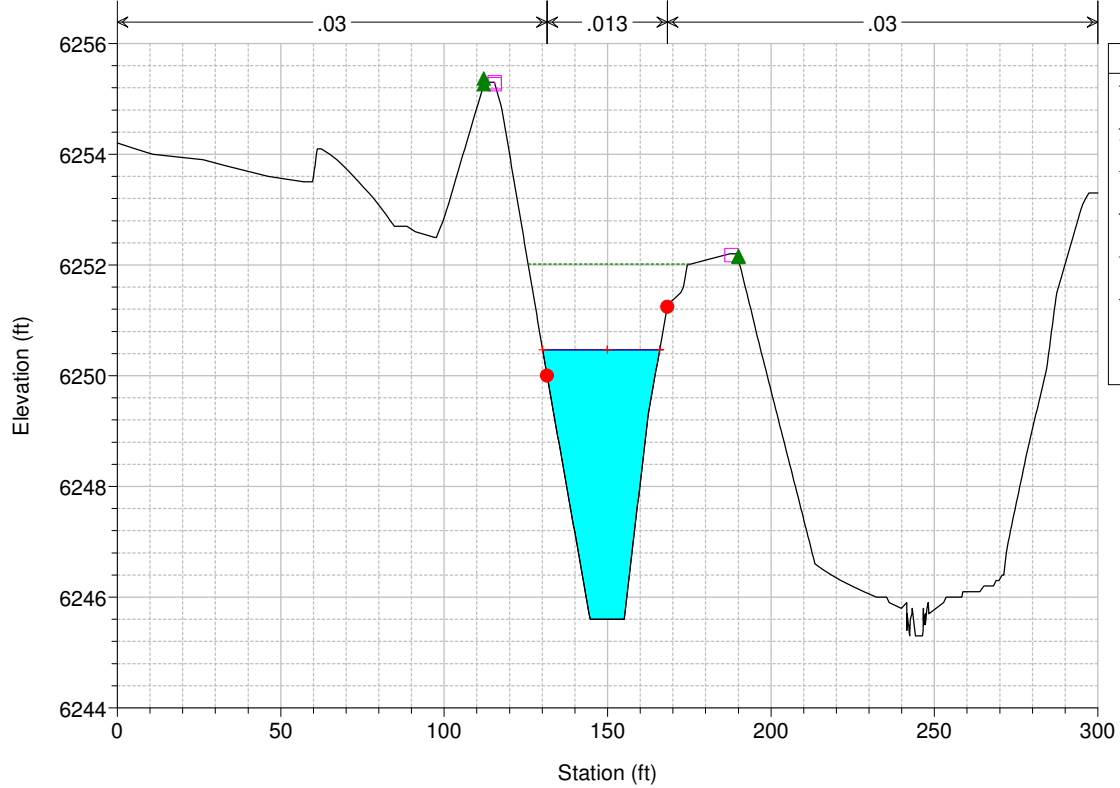

HEC-RAS Model Plan: Default Scenario 8/24/2021  
 River = SC01 Reach = Sand Creek-DS-1 RS = 959

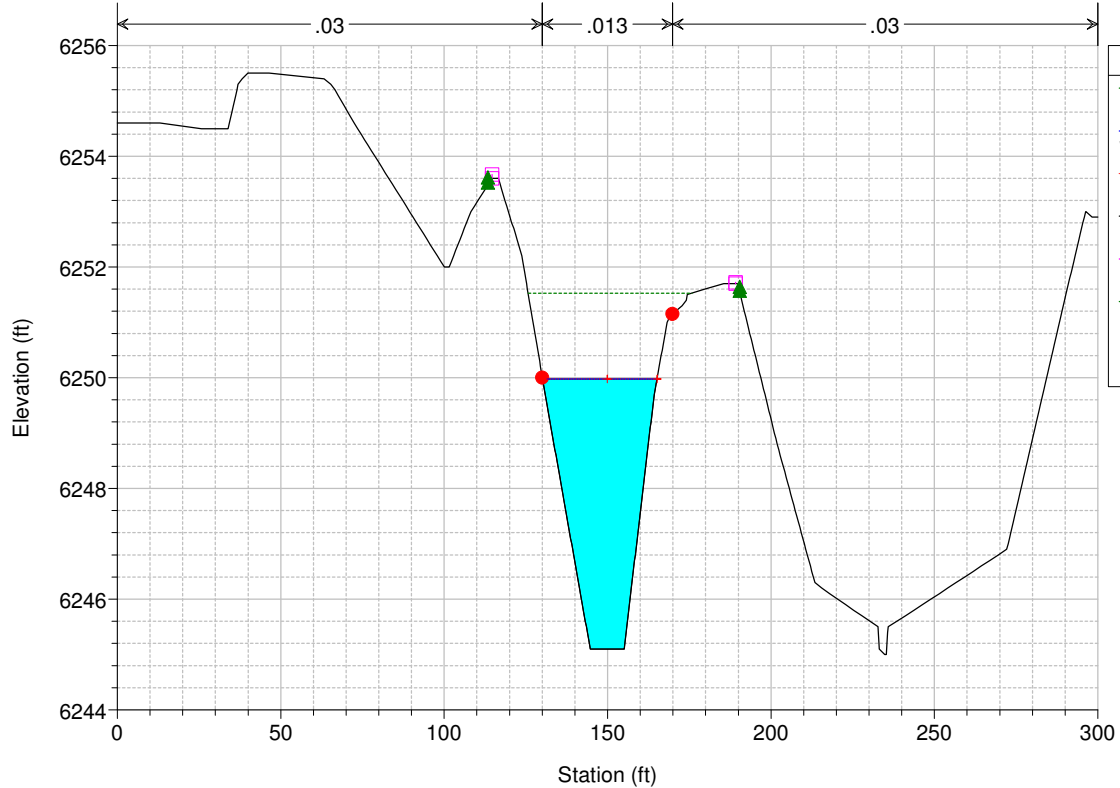

HEC-RAS Model Plan: Default Scenario 8/24/2021  
 River = SC01 Reach = Sand Creek-DS-1 RS = 958

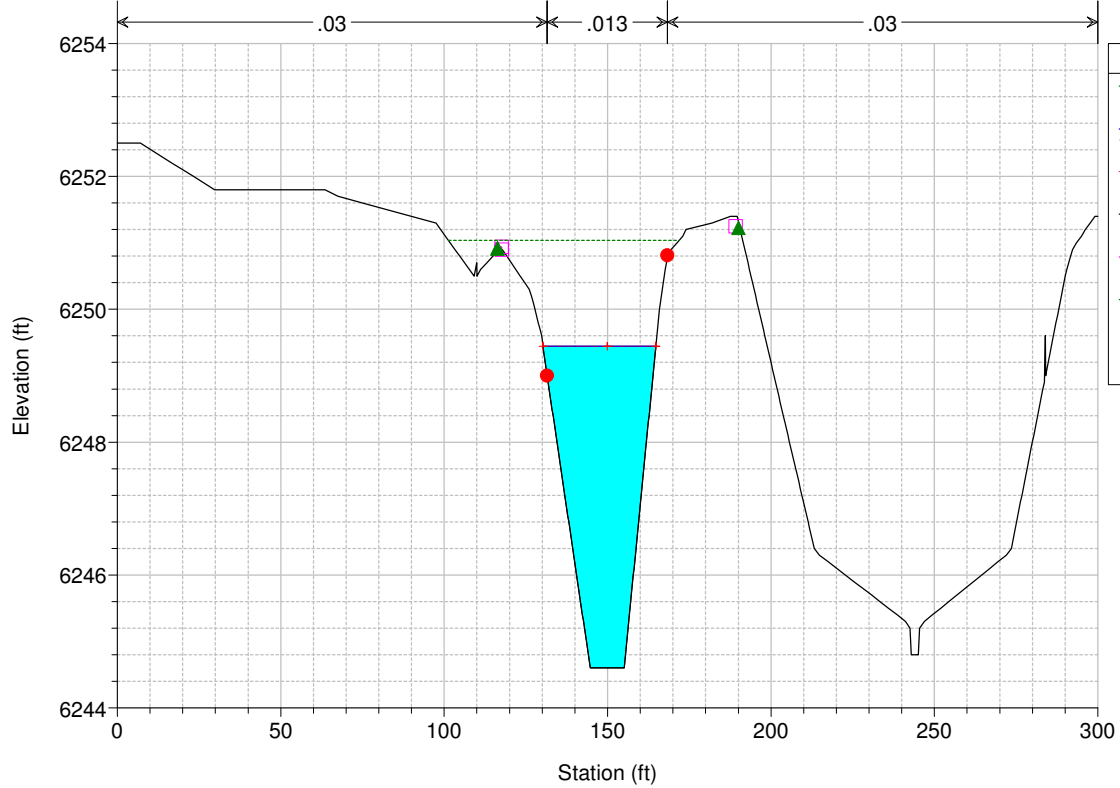

HEC-RAS Model Plan: Default Scenario 8/24/2021  
 River = SC01 Reach = Sand Creek-DS-1 RS = 957

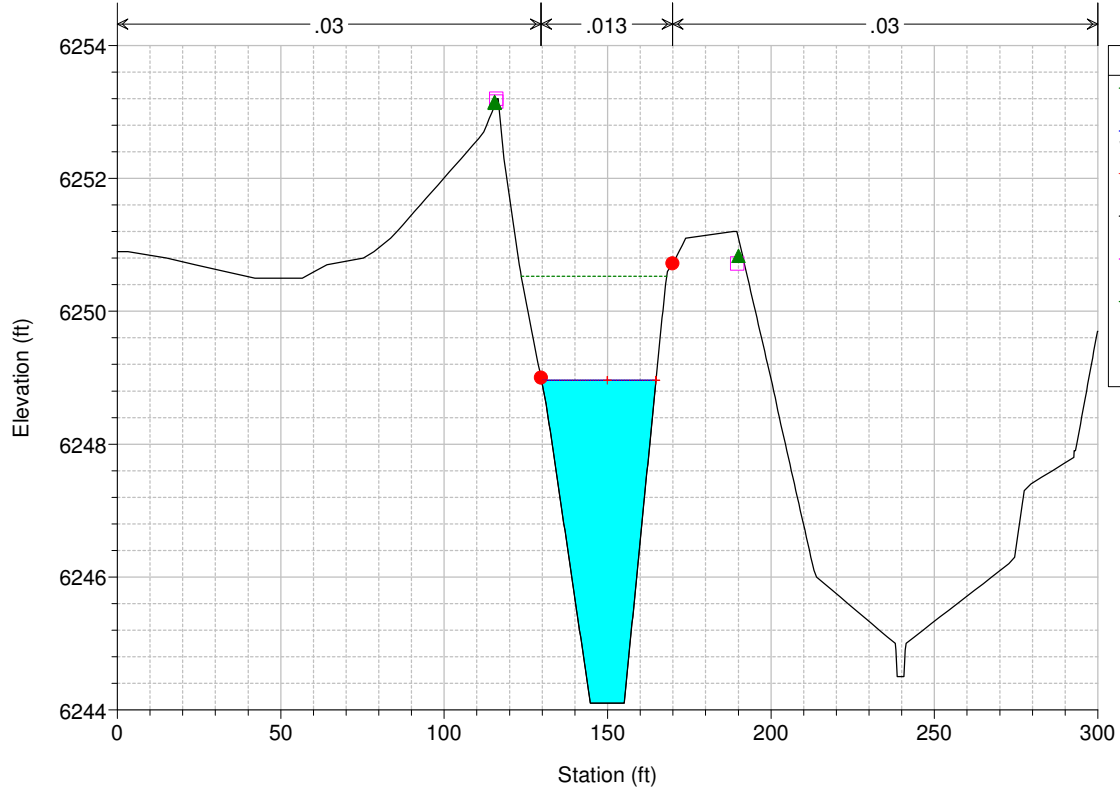



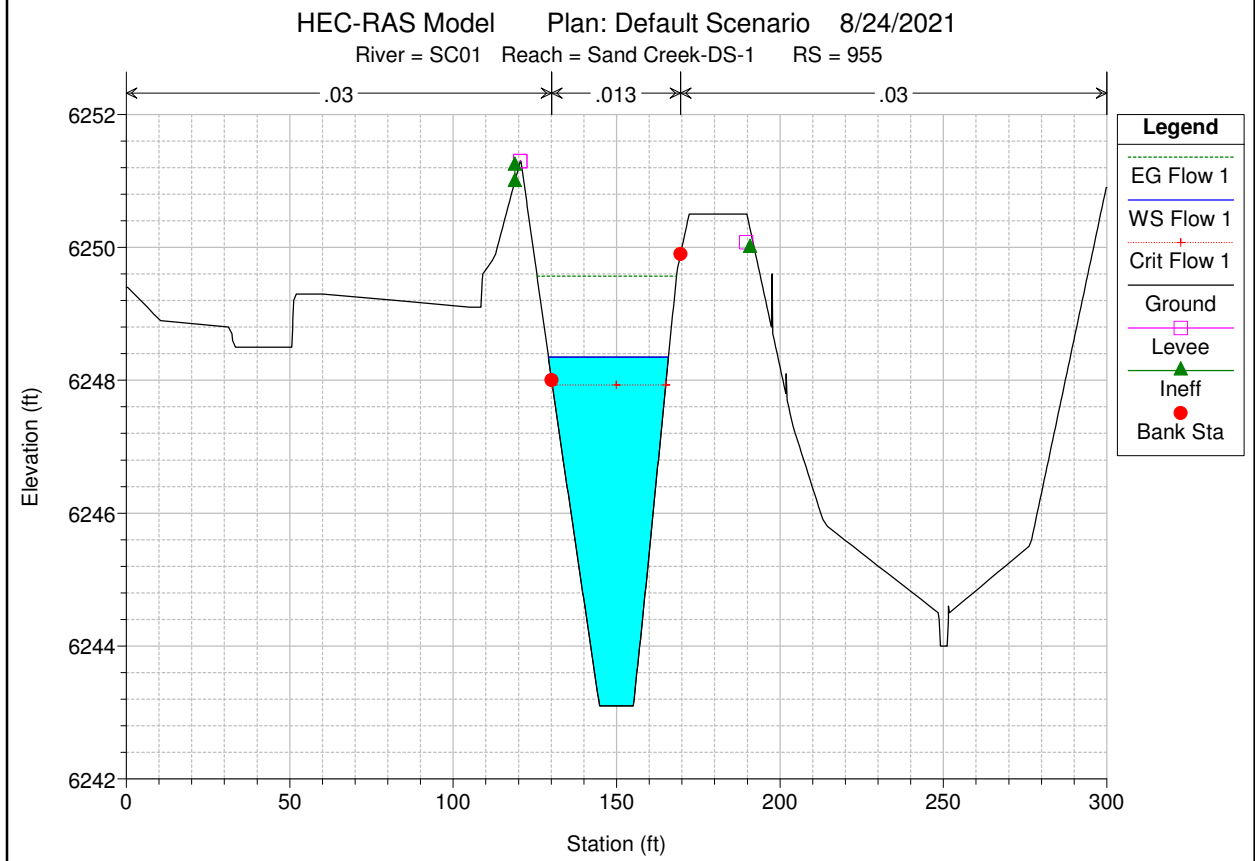
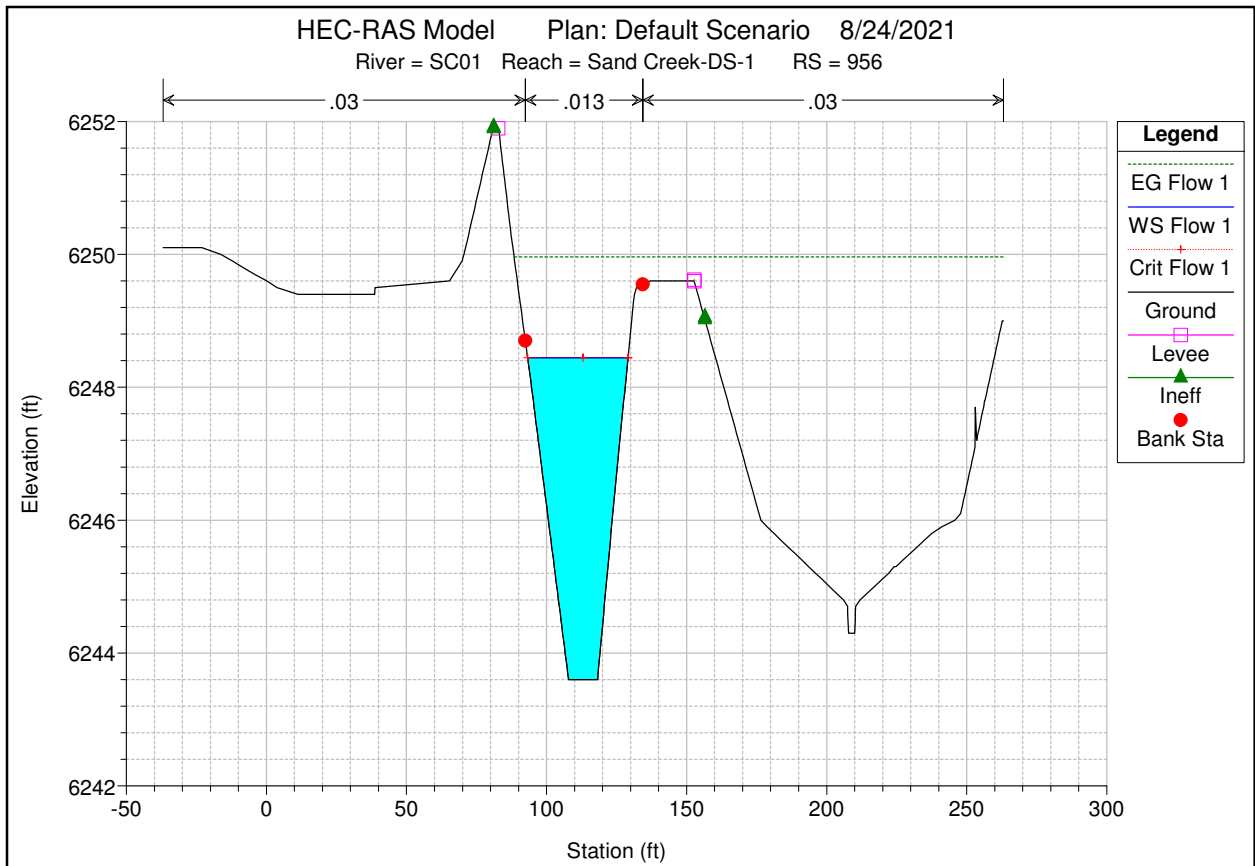

HEC-RAS Model Plan: Default Scenario 8/24/2021  
 River = SC01 Reach = Sand Creek-DS-1 RS = 954

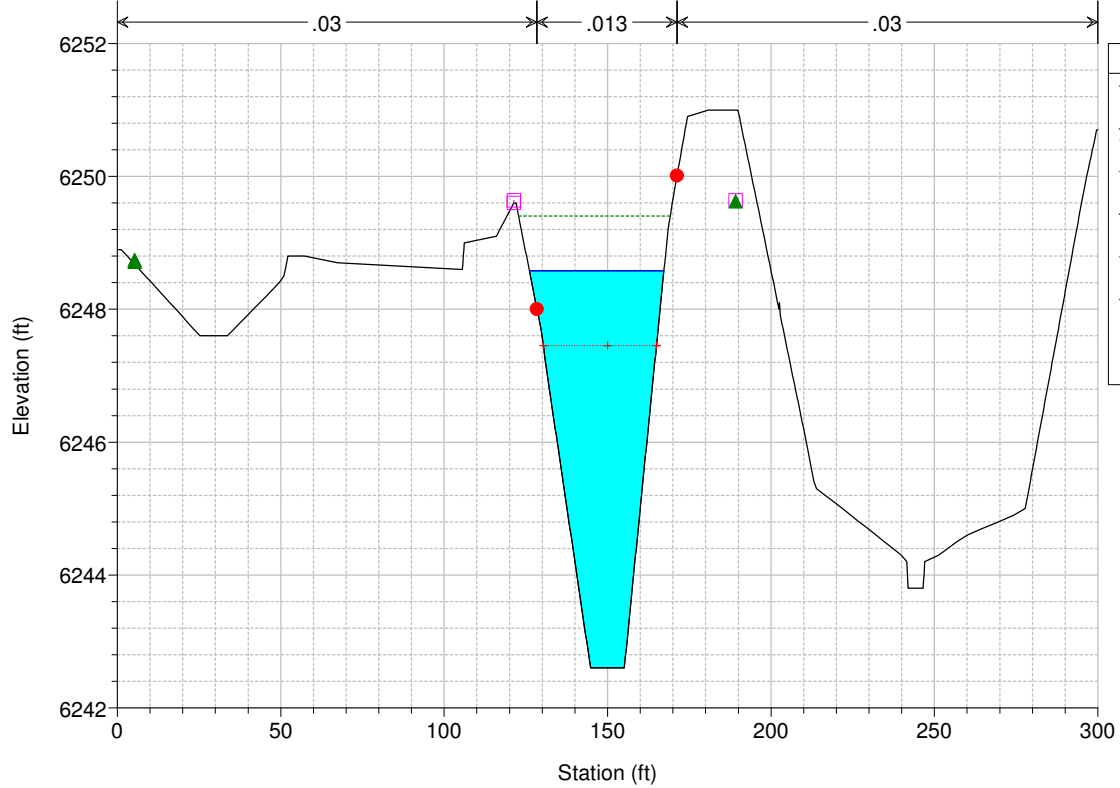

HEC-RAS Model Plan: Default Scenario 8/24/2021  
 River = SC01 Reach = Sand Creek-DS-1 RS = 953

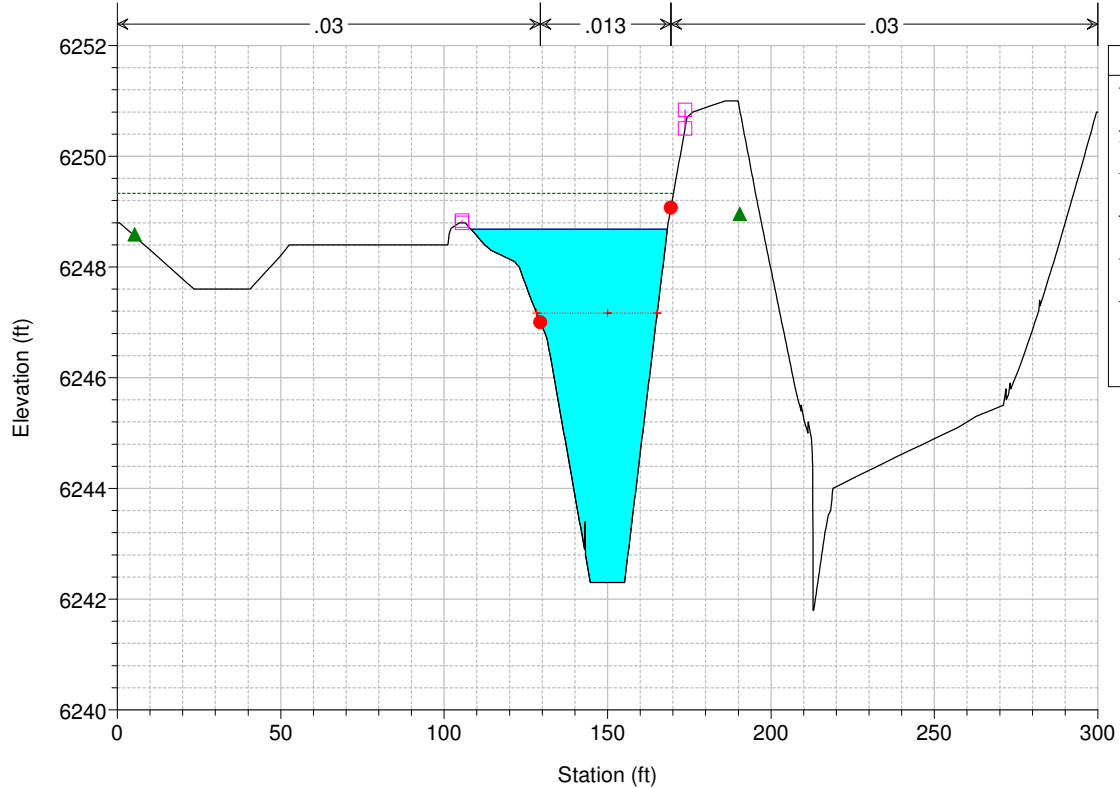

HEC-RAS Model Plan: Default Scenario 8/24/2021  
 River = SC01 Reach = Sand Creek-DS-1 RS = 952

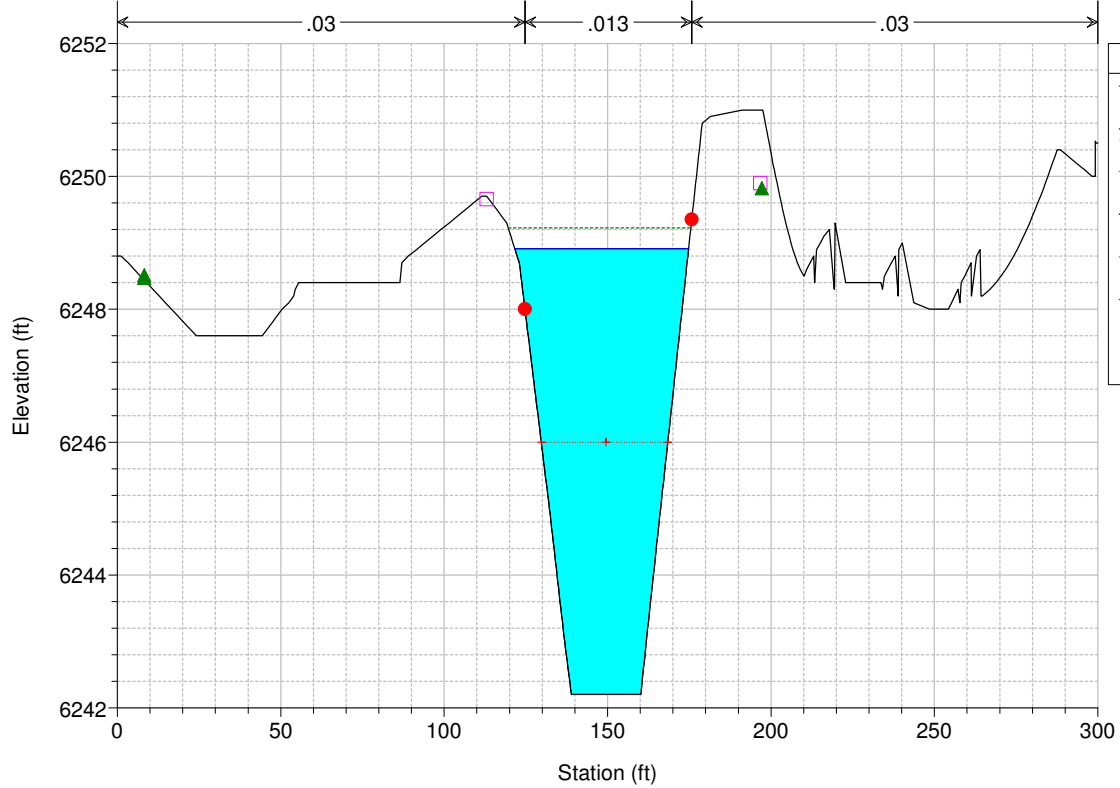

HEC-RAS Model Plan: Default Scenario 8/24/2021  
 River = SC01 Reach = Sand Creek-DS-1 RS = 951

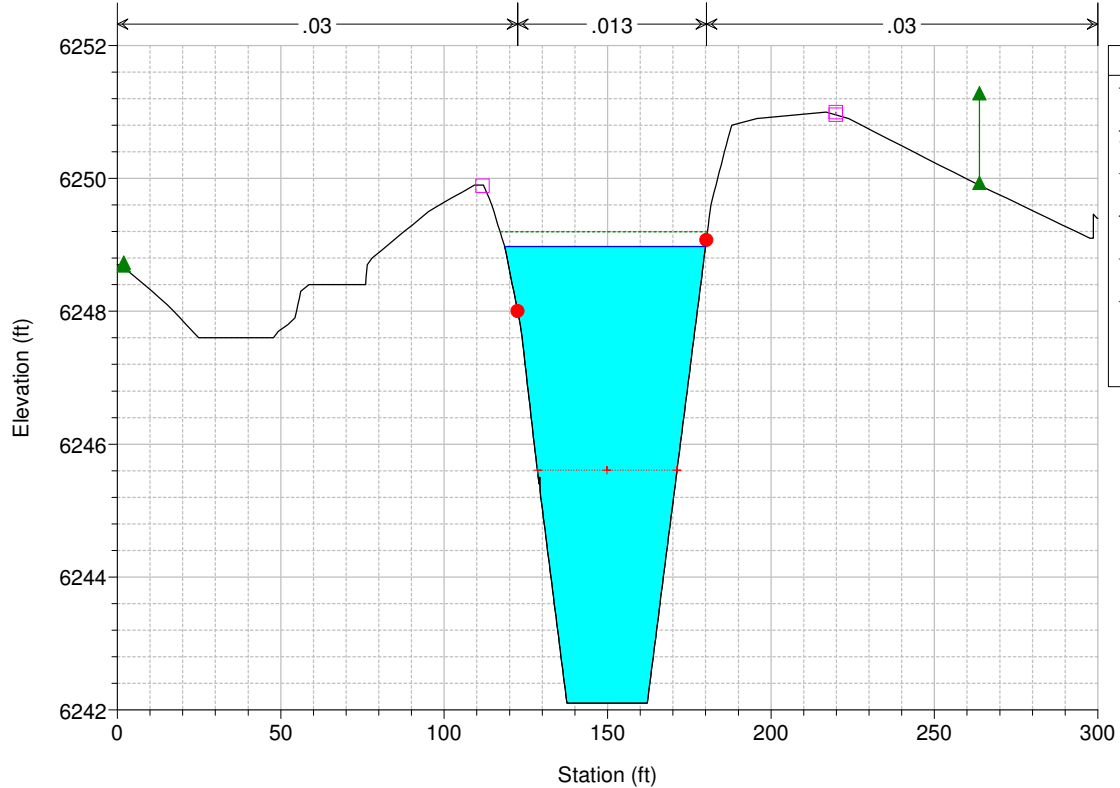

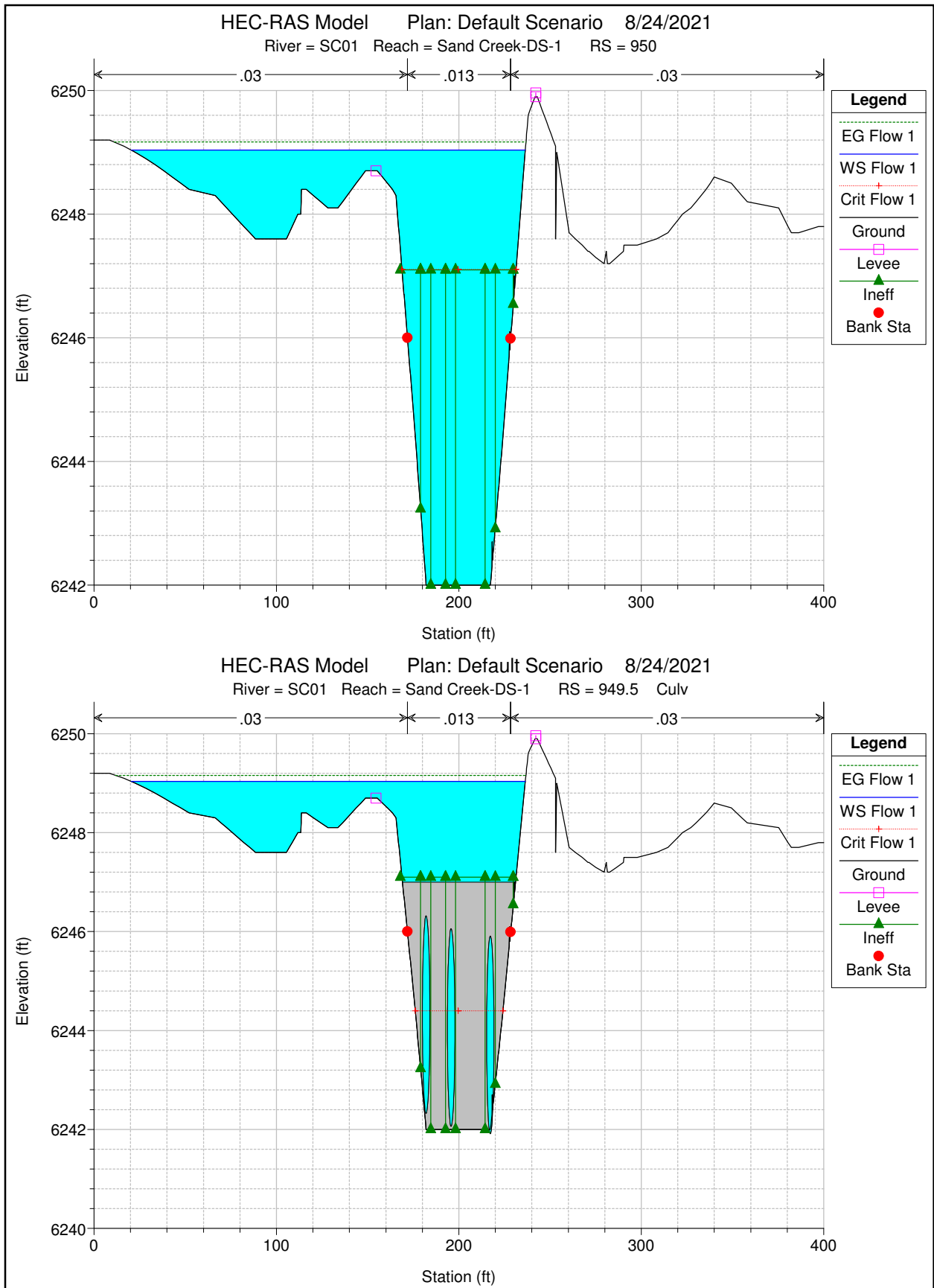

HEC-RAS Model Plan: Default Scenario 8/24/2021

River = SC01 Reach = Sand Creek-DS-1 RS = 949.5 Culv

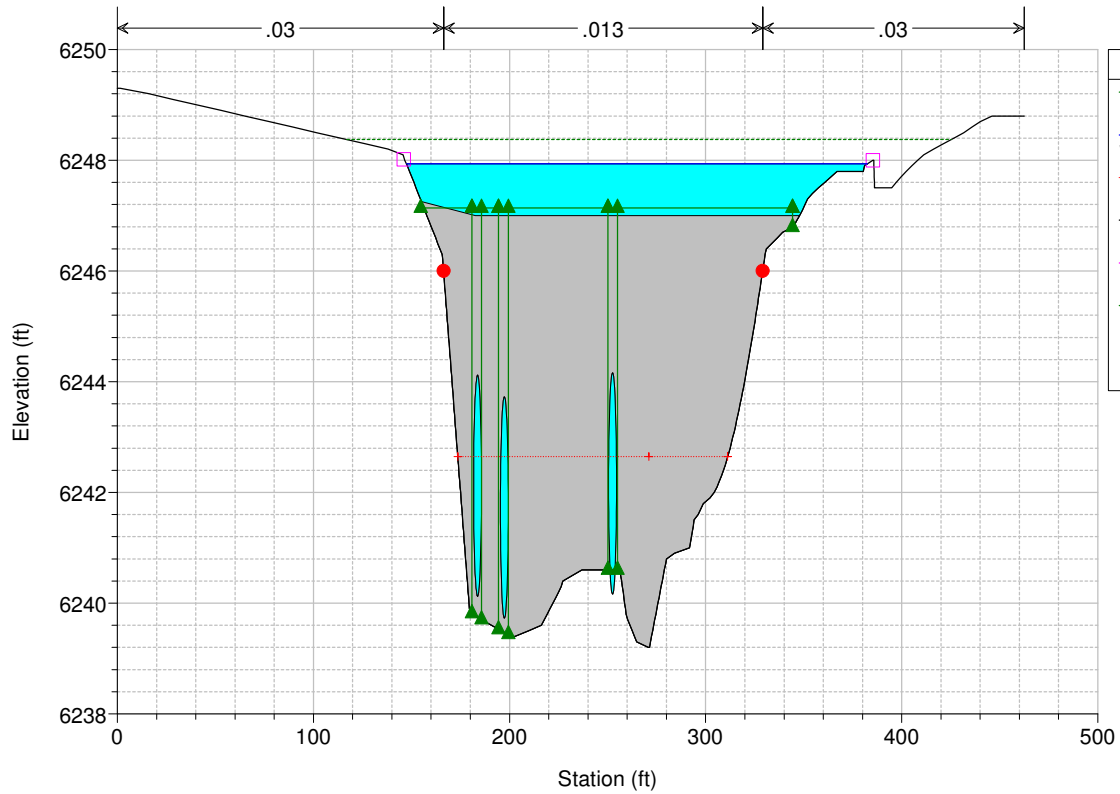

Legend	
EG Flow 1	Green dashed line
WS Flow 1	Solid blue line
Crit Flow 1	Red dashed line with cross
Ground	Grey shaded area
Levee	Pink square
Ineff	Green triangle
Bank Sta	Red circle

HEC-RAS Model Plan: Default Scenario 8/24/2021

River = SC01 Reach = Sand Creek-DS-1 RS = 949

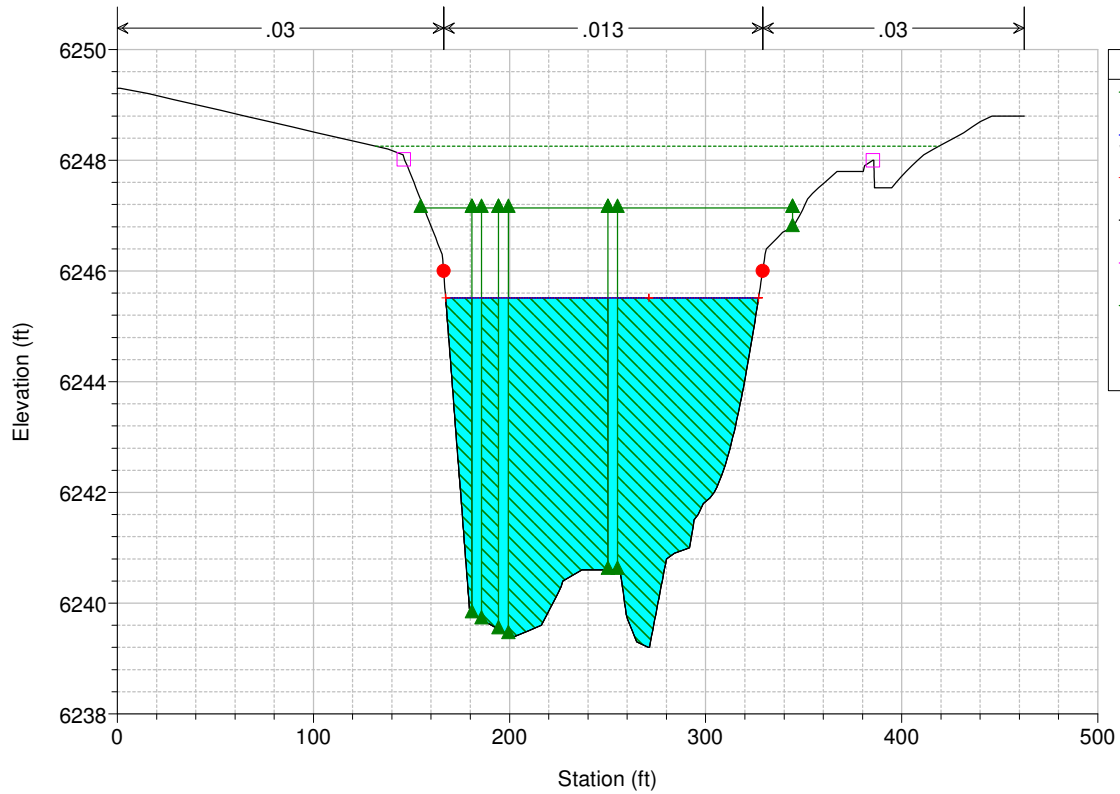

Legend	
EG Flow 1	Green dashed line
WS Flow 1	Solid blue line
Crit Flow 1	Red dashed line with cross
Ground	Grey shaded area
Levee	Pink square
Ineff	Green triangle
Bank Sta	Red circle

HEC-RAS Model Plan: Default Scenario 8/24/2021  
 River = SC01 Reach = Sand Creek-DS-1 RS = 948

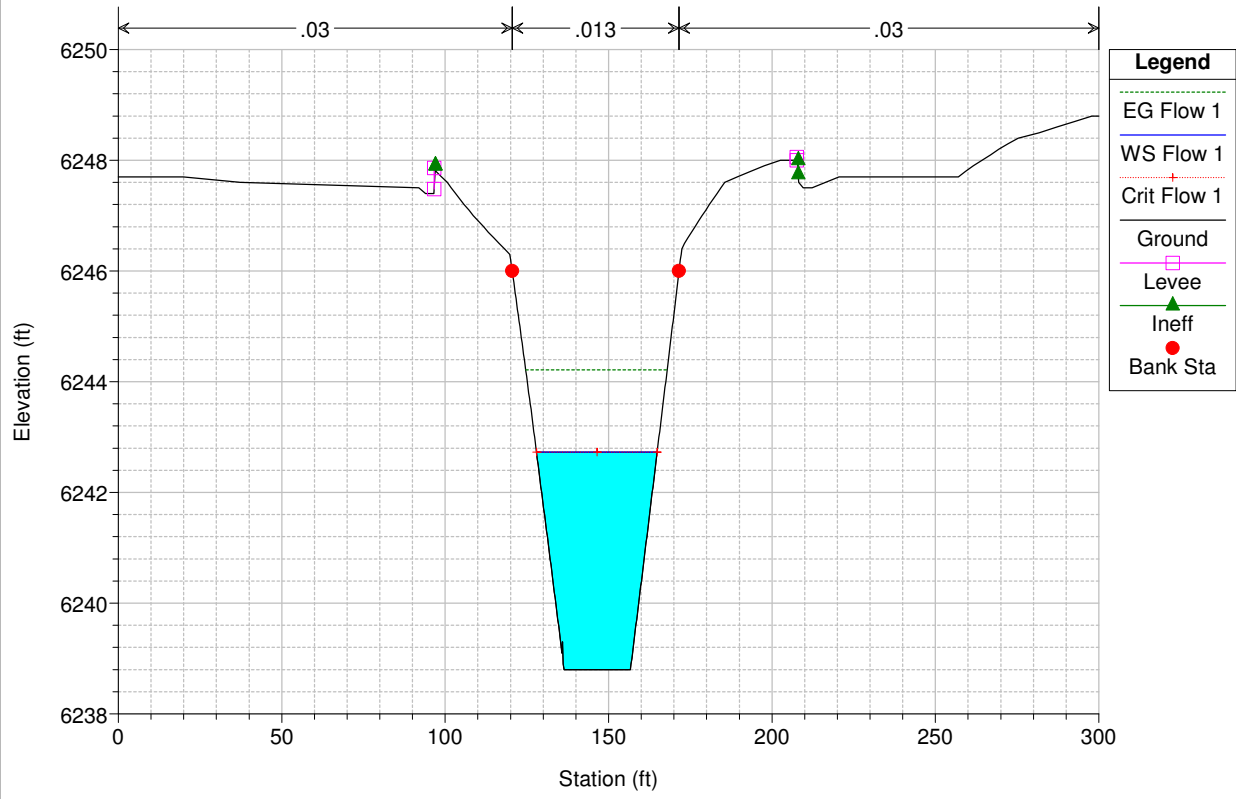

HEC-RAS Model Plan: Default Scenario 8/24/2021

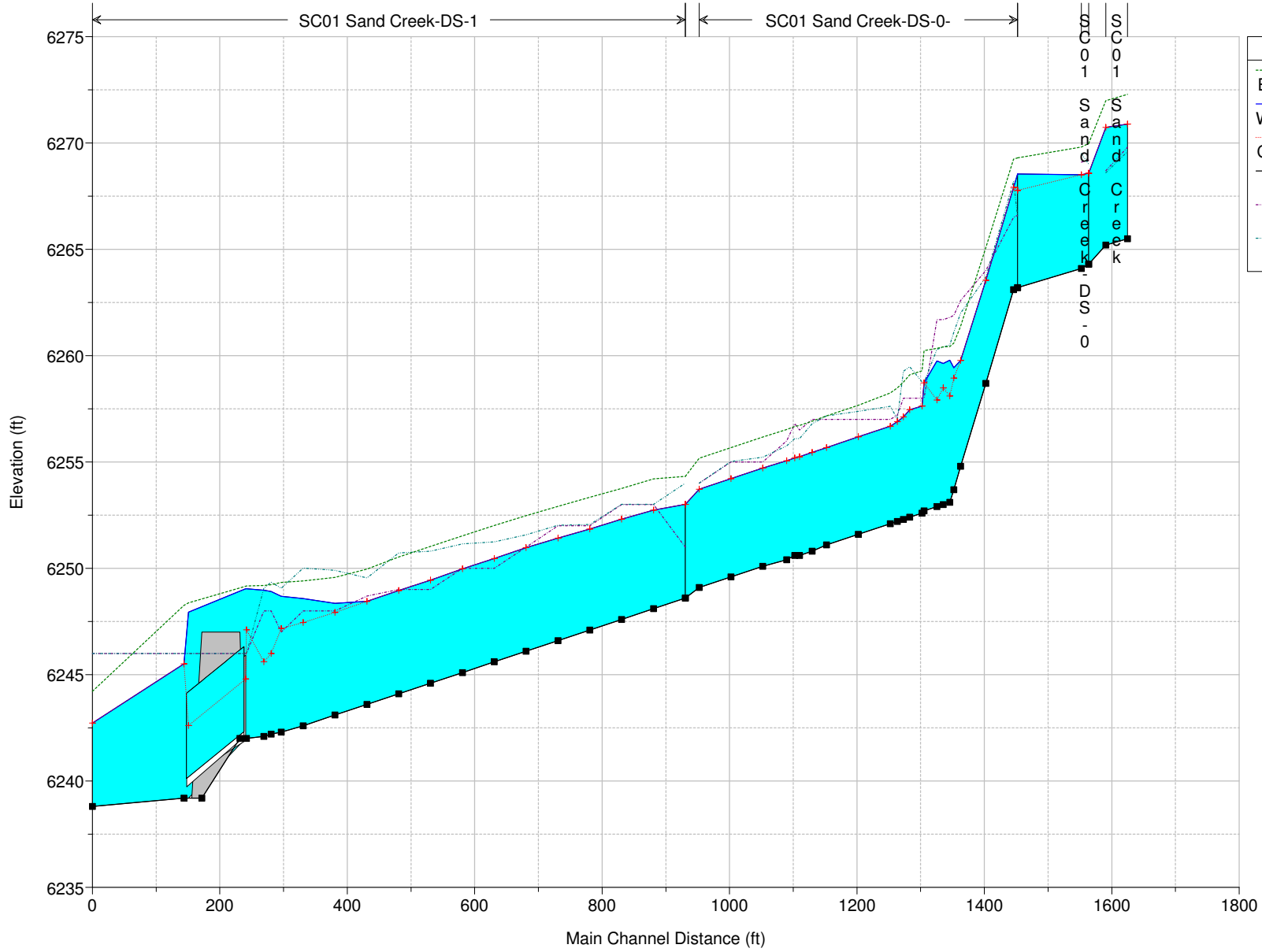

Legend	
EG Flow 1	(Green dashed line)
WS Flow 1	(Blue solid line)
Crit Flow 1	(Red dashed line with '+' markers)
Ground	(Black solid line with square markers)
LOB	(Purple dashed line)
ROB	(Cyan dashed line)

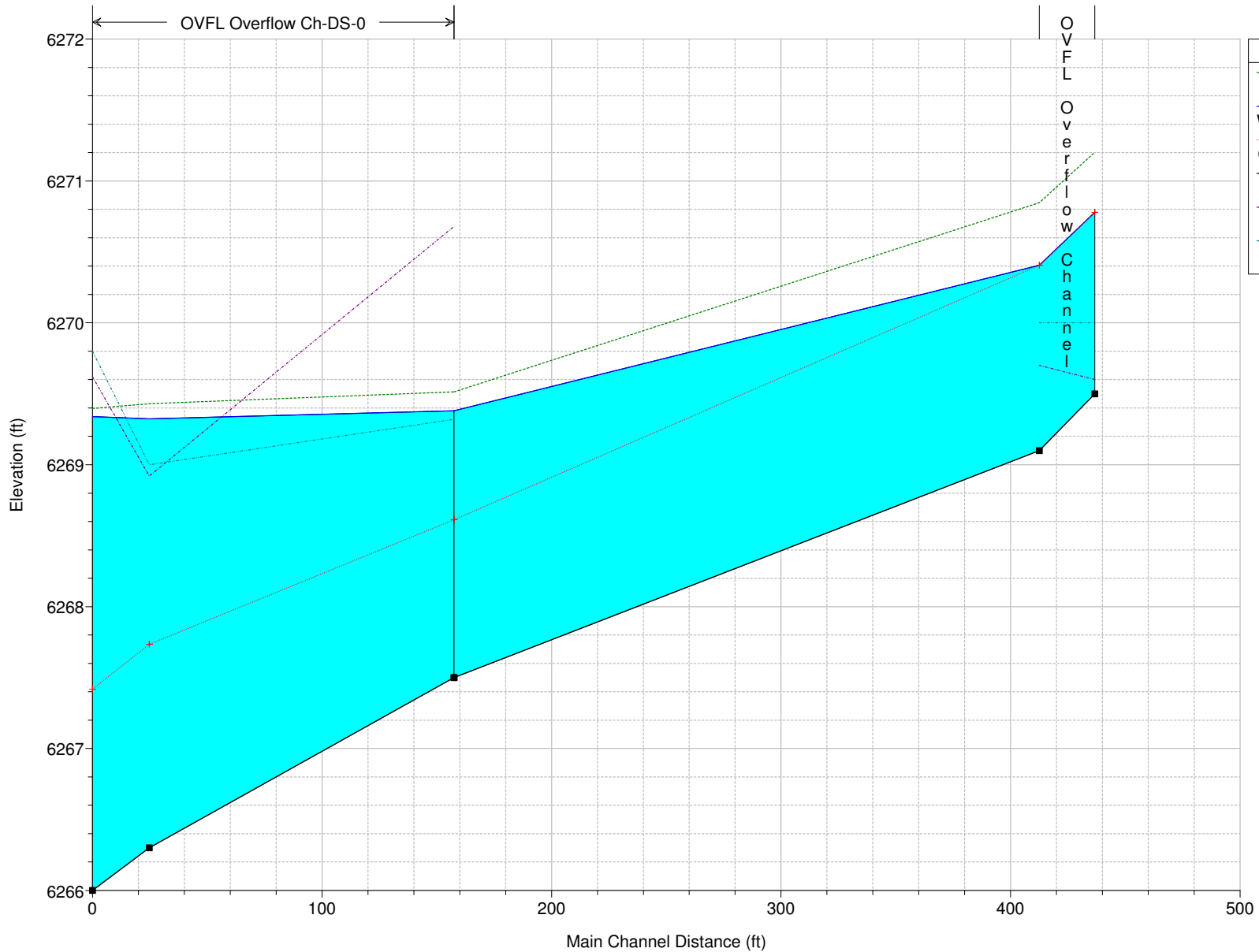

Legend	
EG Flow 1	--- (green dashed line)
WS Flow 1	— (blue solid line)
Crit Flow 1	— (red solid line with markers)
Ground	— (black solid line)
LOB	--- (purple dashed line)
ROB	--- (blue dashed line)



HEC-RAS Plan: Default Scenario Profile: Flow 1

River	Reach	River Sta	Profile	Q Total (cfs)	Min Ch El (ft)	W.S. Elev (ft)	Crit W.S. (ft)	E.G. Elev (ft)	E.G. Slope (ft/ft)	Vel Chnl (ft/s)	Flow Area (sq ft)	Top Width (ft)	Froude # Chl
SC01	Sand Creek	998	Flow 1	820.00	6265.50	6270.89	6270.89	6272.28	0.001362	9.64	103.80	56.32	0.87
SC01	Sand Creek	993	Flow 1	820.00	6265.20	6270.74	6270.74	6272.00	0.001080	9.43	128.24	71.77	0.79
SC01	Sand Creek-DS-0	992	Flow 1	820.02	6264.30	6268.57	6268.57	6269.98	0.001829	9.51	86.27	30.02	0.99
SC01	Sand Creek-DS-0	991	Flow 1	820.02	6264.10	6268.51	6268.51	6269.81	0.001850	9.15	89.57	33.50	0.99
SC01	Sand Creek-DS-0	990	Flow 1	1037.00	6263.20	6268.54	6267.78	6269.30	0.000697	7.21	181.85	76.02	0.65
SC01	Sand Creek-DS-0	989	Flow 1	1037.00	6263.10	6267.92	6267.92	6269.24	0.001524	9.40	128.51	57.84	0.93
SC01	Sand Creek-DS-0	988	Flow 1	1037.00	6258.70	6263.54	6263.54	6265.09	0.001791	9.98	103.92	33.08	0.99
SC01	Sand Creek-DS-0	987	Flow 1	1037.00	6254.80	6259.78	6259.78	6261.38	0.001842	10.16	102.05	32.04	1.00
SC01	Sand Creek-DS-0	986	Flow 1	1037.00	6253.70	6259.44	6258.94	6260.59	0.001447	8.63	120.18	35.39	0.83
SC01	Sand Creek-DS-0	985	Flow 1	1037.00	6253.10	6259.79	6258.11	6260.43	0.000539	6.45	160.82	39.52	0.56
SC01	Sand Creek-DS-0	984	Flow 1	1037.00	6253.00	6259.63	6258.48	6260.41	0.001045	7.09	146.18	39.29	0.65
SC01	Sand Creek-DS-0	983	Flow 1	1037.00	6252.90	6259.75	6257.91	6260.35	0.000491	6.22	166.73	40.29	0.54
SC01	Sand Creek-DS-0	982	Flow 1	1037.00	6252.70	6258.72	6258.72	6260.24	0.002055	9.91	105.15	35.64	1.00
SC01	Sand Creek-DS-0	981	Flow 1	1037.00	6252.60	6257.64	6257.64	6259.29	0.001815	10.32	100.46	30.11	1.00
SC01	Sand Creek-DS-0	980	Flow 1	1037.00	6252.40	6257.46	6257.46	6259.10	0.001807	10.30	100.70	30.18	0.99
SC01	Sand Creek-DS-0	979	Flow 1	1037.00	6252.30	6257.12	6257.12	6258.76	0.001808	10.28	100.87	30.54	1.00
SC01	Sand Creek-DS-0	978	Flow 1	1037.00	6252.20	6256.90	6256.90	6258.49	0.001775	10.13	102.38	31.51	0.99
SC01	Sand Creek-DS-0	977	Flow 1	1037.00	6252.10	6256.69	6256.69	6258.25	0.001800	10.03	103.44	32.94	1.00
SC01	Sand Creek-DS-0	976	Flow 1	1037.00	6251.60	6256.19	6256.19	6257.67	0.001803	9.76	106.20	35.57	1.00
SC01	Sand Creek-DS-0	975	Flow 1	1037.00	6251.10	6255.68	6255.68	6257.17	0.001823	9.79	105.98	35.61	1.00
SC01	Sand Creek-DS-0	974	Flow 1	1037.00	6250.80	6255.45	6255.45	6256.92	0.001804	9.74	106.50	35.84	1.00
SC01	Sand Creek-DS-0	973	Flow 1	1037.00	6250.60	6255.25	6255.25	6256.72	0.001805	9.74	106.46	35.84	1.00
SC01	Sand Creek-DS-0	972	Flow 1	1037.00	6250.60	6255.19	6255.19	6256.67	0.001830	9.78	106.04	35.87	1.00
SC01	Sand Creek-DS-0	971	Flow 1	1037.00	6250.40	6255.06	6255.06	6256.53	0.001786	9.71	106.74	35.77	0.99
SC01	Sand Creek-DS-0	970	Flow 1	1037.00	6250.10	6254.71	6254.71	6256.17	0.001777	9.71	106.85	35.74	0.99
SC01	Sand Creek-DS-0	969	Flow 1	1037.00	6249.60	6254.22	6254.22	6255.68	0.001780	9.69	106.96	35.89	0.99
SC01	Sand Creek-DS-0	968	Flow 1	1037.00	6249.10	6253.72	6253.72	6255.18	0.001784	9.71	106.85	35.86	0.99
SC01	Sand Creek-DS-1	966	Flow 1	1100.00	6248.60	6253.01	6253.01	6254.32	0.001599	9.39	133.91	56.36	0.95
SC01	Sand Creek-DS-1	965	Flow 1	1100.00	6248.10	6252.74	6252.74	6254.20	0.001793	9.71	113.30	38.38	1.00
SC01	Sand Creek-DS-1	964	Flow 1	1100.00	6247.60	6252.31	6252.31	6253.75	0.001776	9.64	114.09	38.73	0.99
SC01	Sand Creek-DS-1	963	Flow 1	1100.00	6247.10	6251.84	6251.84	6253.34	0.001829	9.83	111.93	37.63	1.00
SC01	Sand Creek-DS-1	962	Flow 1	1100.00	6246.60	6251.43	6251.43	6252.92	0.001794	9.80	112.24	37.25	1.00
SC01	Sand Creek-DS-1	961	Flow 1	1100.00	6246.10	6250.98	6250.98	6252.47	0.001774	9.81	112.08	36.70	0.99
SC01	Sand Creek-DS-1	960	Flow 1	1100.00	6245.60	6250.47	6250.47	6252.02	0.001738	9.99	110.37	35.80	0.99
SC01	Sand Creek-DS-1	959	Flow 1	1100.00	6245.10	6249.98	6249.98	6251.53	0.001776	9.98	110.20	35.02	0.99
SC01	Sand Creek-DS-1	958	Flow 1	1100.00	6244.60	6249.44	6249.44	6251.04	0.001742	10.13	108.89	34.53	0.99
SC01	Sand Creek-DS-1	957	Flow 1	1100.00	6244.10	6248.96	6248.96	6250.53	0.001816	10.04	109.52	35.07	1.00
SC01	Sand Creek-DS-1	956	Flow 1	1100.00	6243.60	6248.44	6248.44	6249.96	0.001768	9.89	111.21	35.85	0.99
SC01	Sand Creek-DS-1	955	Flow 1	1100.00	6243.10	6248.35	6247.93	6249.57	0.001227	8.86	124.36	36.74	0.84
SC01	Sand Creek-DS-1	954	Flow 1	1100.00	6242.60	6248.58	6247.46	6249.40	0.000712	7.27	151.93	41.17	0.65
SC01	Sand Creek-DS-1	953	Flow 1	1100.00	6242.30	6248.68	6247.17	6249.33	0.000511	6.51	180.73	60.07	0.55
SC01	Sand Creek-DS-1	952	Flow 1	1100.00	6242.20	6248.91	6246.00	6249.23	0.000197	4.48	246.57	53.19	0.36
SC01	Sand Creek-DS-1	951	Flow 1	1100.00	6242.10	6248.97	6245.61	6249.20	0.000136	3.80	291.11	61.48	0.30
SC01	Sand Creek-DS-1	950	Flow 1	1100.00	6242.00	6249.04	6247.11	6249.17	0.000061	2.96	490.03	216.00	0.21
SC01	Sand Creek-DS-1	949.5		Culvert									
SC01	Sand Creek-DS-1	949	Flow 1	1100.00	6239.20	6245.51	6245.51	6248.25	0.001370	13.29	82.78	159.57	0.99
SC01	Sand Creek-DS-1	948	Flow 1	1100.00	6238.80	6242.73	6242.73	6244.22	0.001785	9.79	112.41	36.93	0.99
OVFL	Overflow Channel	1000	Flow 1	217.00	6269.50	6270.78	6270.78	6271.20	0.003604	5.36	46.17	62.59	0.97
OVFL	Overflow Channel	999	Flow 1	217.00	6269.10	6270.41	6270.41	6270.85	0.003698	5.40	43.73	57.72	0.98
OVFL	Overflow Ch-DS-0	998	Flow 1	216.98	6267.50	6269.38	6268.61	6269.51	0.000357	2.93	73.99	45.53	0.41
OVFL	Overflow Ch-DS-0	997	Flow 1	216.98	6266.30	6269.32	6267.74	6269.43	0.001027	2.62	83.44	36.02	0.29
OVFL	Overflow Ch-DS-0	996	Flow 1	216.98	6266.00	6269.34	6267.42	6269.40	0.000618	1.91	113.85	50.35	0.22
EXOF	EX OVERFLOW	1001	Flow 1	0.04	6267.70	6270.16	6267.77	6270.16	0.000000	0.00	30.50	42.71	0.00
EXOF	EX OVERFLOW	1000	Flow 1	0.04	6266.90	6270.16	6266.92	6270.16	0.000000	0.00	83.82	67.13	0.00
EXCH	EX CHANNEL	1000	Flow 1	63.00	6259.00	6260.04	6260.04	6260.46	0.002746	5.24	12.01	14.23	1.01
EXCH	EX CHANNEL	999	Flow 1	63.00	6249.20	6254.44		6254.45	0.000127	1.03	61.12	21.85	0.11

# SOLACE APARTMENTS - SAND CREEK CENTER TRIBUTARY

A PORTION OF SECTION 7, TOWNSHIP 14 SOUTH, RANGE 65 WEST OF THE 6TH P.M.

EL PASO COUNTY, COLORADO

## CHANNEL IMPROVEMENTS

### ABBREVIATIONS

AC	ACRE	FDP	FINAL DEVELOPMENT PLAN	PL	PROPERTY LINE
AD	ALGEBRAIC DIFFERENCE	FDR	FINAL DRAINAGE REPORT	PR	PROPOSED
AH	AHEAD	FES	FLARED END SECTION	PRC	POINT OF REVERSE CURVATURE
ARCH	ARCHITECT	FG	FINISHED GRADE	PT	POINT OF TANGENCY
ASCE	AMERICAN SOCIETY OF CIVIL ENGINEERS	FH	FIRE HYDRANT	PV	PLUG VALVE
ASSY	ASSEMBLY	FL	FLOWLINE	PVC	POLYVINYL CHLORIDE
AVE	AVENUE	FO	FILING	R	RADIUS
BB	BOX BASE	FO	FIBER OPTIC CABLE	RCP	REINFORCED CONCRETE PIPE
BK	BACK	GB	GRADE BREAK	RD	ROAD
BNDY	BOUNDARY	GE	GAS EASEMENT	ROW	RIGHT OF WAY
BOP	BOTTOM OF PIPE	GIS	GEOGRAPHIC INFORMATION SYSTEM	RT	RIGHT
BOV	BLOW OFF VALVE	GL	GAS LINE	S	SOUTH
BFV	BUTTERFLY VALVE	GPS	GLOBAL POSITIONING SYSTEM	STE	STEEL
BLVD	BOULEVARD	GV	GATE VALVE	SAN	SANITARY SEWER
BW	BOTTOM OF WALL	HC	HANDICAP	SF	SQUARE FEET
C&G	CURB & GUTTER	HDC	HIGH DEFLECTION COUPLING	ST	STREET
CATV	CABLE TELEVISION	HDPE	HIGH DENSITY POLYETHYLENE	STA	STATION
CB	CATCH BASIN	HGL	HYDRAULIC GRADE LINE	STM	STORM SEWER
CBC	CONCRETE BOX CULVERT	HOA	HOME OWNERS ASSOCIATION	SV	SQUARE YARD
CDOT	COLORADO DEPARTMENT OF TRANSPORTATION	HP	HIGH POINT	SY-IN	SQUARE YARD INCH
CDS	CUL-DE-SAC	I	INLET	TB	THRUST BLOCK
CFS	CUBIC FEET PER SECOND	IE	IRRIGATION EASEMENT	TBC	TOP BACK OF CURB
CL	CENTER LINE	INT	INTERSECTION	TBW	TOP BACK OF WALK
CLOMR	CONDITIONAL LETTER OF MAP REVISION	INV	INVERT	TEL	TELEPHONE
CLR	CLEAR	IRR	IRRIGATION	TOA	TOP OF ASPHALT
CMP	CORRUGATED METAL PIPE	KB	KICK (THRUST) BLOCK	TOB	TOP OF BOX
CO	CLEAN OUT	LE	LANDSCAPE EASEMENT	TOC	TOP OF CURB OR CONCRETE
CONC	CONCRETE	LF	LINEAR FEET	TOF	TOP OF FOUNDATION
CR	CIRCLE	LN	LANE	TOP	TOP OF PIPE
CSP	CORRUGATED STEEL PIPE	LOMR	LETTER OF MAP REVISION	TW	TOP OF WALL
CT	COURT	LP	LOW POINT	TYP	TYPICAL
CTRB	CONCRETE THRUST REDUCER BLOCK	LS	LUMP SUM	UDFCD	URBAN DRAINAGE AND FLOOD CONTROL DISTRICT
CY	CUBIC YARD	LT	LEFT	UE	UTILITY EASEMENT
DBPS	DRAINAGE BASIN PLANNING STUDY	MAX	MAXIMUM	U&DE	UTILITY & DRAINAGE EASEMENT
DE	DRAINAGE EASEMENT	MDDP	MASTER DEVELOPMENT DRAINAGE PLAN	UGE	UNDERGROUND ELECTRIC
DIA	DIAMETER	MH	MANHOLE	VCP	VITRIFIED CLAY PIPE
DIP	DUCTILE IRON PIPE	MIN	MINIMUM	VPC	VERTICAL POINT OF CURVATURE
DR	DRIVE	N	NORTH	VPI	VERTICAL POINT OF INTERSECTION
DRC	DESIGN REVIEW COMMITTEE	NRCP	NON-REINFORCED CONCRETE PIPE	VPT	VERTICAL POINT OF TANGENCY
DU	DWELLING UNITS	ODP	OFFICIAL DEVELOPMENT PLAN	VTC	VEHICLE TRACKING CONTROL
E	EAST	OHE	OVERHEAD ELECTRIC	W	WEST
EA	EACH	OHU	OVERHEAD UTILITY	WL	WATER LINE
EGL	ENERGY GRADE LINE	PC	POINT OF CURVATURE	WM	WATER MAIN
EL	ELEVATION	PCC	POINT OF COMPOUND CURVATURE	WRD	WATER RESOURCES DEPARTMENT
ELEC	ELECTRIC	PCR	POINT OF CURB RETURN	WS	WATER SURFACE
EOA	EDGE OF ASPHALT	PDP	PRELIMINARY DEVELOPMENT PLAN	WSE	WATER SURFACE ELEVATION
ESMT	EASEMENT	PE	PROFESSIONAL ENGINEER	WTR	WATER
EST	ESTIMATE	PI	POINT OF INTERSECTION	YR	YEAR
EX	EXISTING	PKWY	PARKWAY		

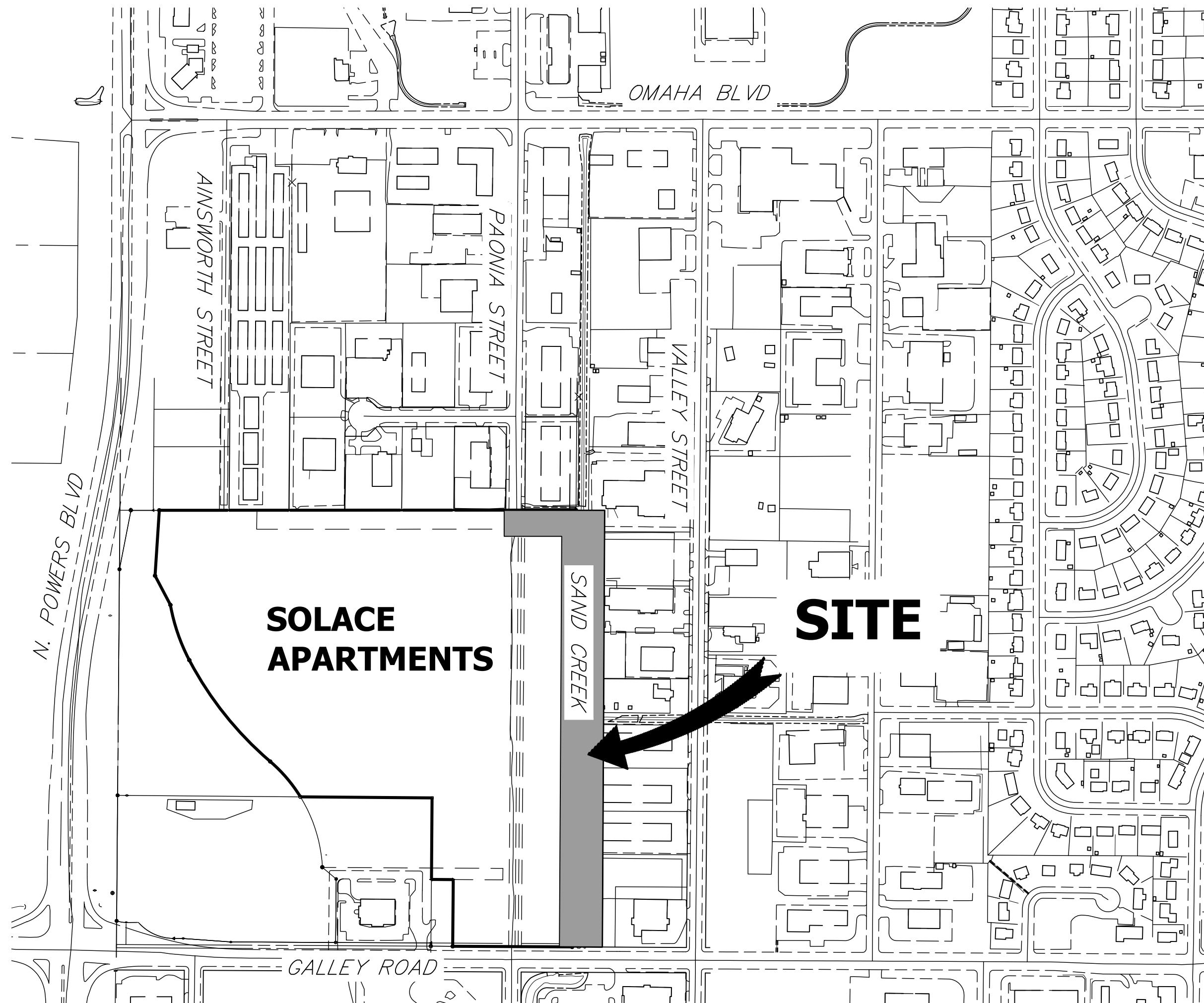

VICINITY MAP  
SCALE: 1" = 300'

### SHEET INDEX

1	COVER SHEET
2	GENERAL NOTES
3	SITE AND DEMO PLAN
4-6	CHANNEL PLAN AND PROFILES
7	CHANNEL DETAILS
8	DROP STRUCTURES PLAN AND PROFILE
9	DROP STRUCTURE DETAIL SHEETS
10	PAONIA STREET OVERFLOW PLAN
TOTAL	10

### BASIS OF BEARINGS

THE EASTERLY LINE OF LOT 2, POWERS & GALLEY PLAZA FILING NO. 1 RECORDED IN PLAT BOOK A-4 AT PAGE 30, SAID LINE BEING MONUMENTED BY A 1-1/4" YELLOW PLASTIC CAP STAMPED "LS 22106" AT THE SOUTH END AND A 1" O.D. PIPE AT THE NORTH END, SAID LINE BEARING N00°27'47"E AS SHOWN ON SAID PLAT.

### BENCHMARK

FIMS MONUMENT FB81, BEING MONUMENTED BY A 3-1/4" ALUMINUM CAP IN RANGE BOX WITH NO TOP, LOCATED 900 FEET EAST OF THE INTERSECTION OF E. PLATTE AVENUE AND VALLEY STREET, APPROXIMATELY 80 FEET NORTH OF THE CENTERLINE OF E PLATTE AVENUE. SAID MONUMENT HAVING A PUBLISHED ELEVATION OF 6275.86 FEET, NAVD88.

THE LOCATIONS OF EXISTING ABOVE GROUND AND UNDERGROUND UTILITIES ARE SHOWN IN AN APPROXIMATE WAY ONLY. THE CONTRACTOR SHALL DETERMINE THE EXACT LOCATION OF ALL EXISTING UTILITIES BEFORE COMMENCING WORK. THE CONTRACTOR SHALL BE FULLY RESPONSIBLE FOR ANY AND ALL DAMAGES WHICH MIGHT BE CAUSED BY HIS FAILURE TO EXACTLY LOCATE AND PRESERVE ANY AND ALL ABOVE GROUND AND UNDERGROUND UTILITIES.

### APPLICANT/OWNER

JACKSON DEARBORN PARTNERS  
404 S. WELLS ST.  
SUITE 400  
CHICAGO, IL 60607  
P~734.216.2577

### CIVIL ENGINEER

JR ENGINEERING  
5475 TECH CENTER DR  
SUITE 235  
COLORADO SPRINGS, CO 80919  
CONTACT: MIKE BRAMLETT  
C~719.659.7679

### PLANNER

N.E.S. INC.  
619 N. CASCADE AVE  
SUITE 200  
COLORADO SPRINGS, CO 80903  
CONTACT: TAMARA BAXTER  
P~719.471.0073

### GEOTECHNICAL ENGINEER

CTL THOMPSON, INC  
5170 MARK DABLING BLVD  
COLORADO SPRINGS, CO 80918  
P~719.528.8300



Know what's below.  
Call before you dig.

### OWNER/DEVELOPER STATEMENT

I, THE OWNER/DEVELOPER HAVE READ AND WILL COMPLY WITH ALL OF THE REQUIREMENTS SPECIFIED IN THESE DETAILED PLANS AND SPECIFICATIONS.

DANE OLMSTEAD

DATE

JACKSON DEARBORN PARTNERS  
404 S. WELLS STREET, SUITE 400  
CHICAGO, IL 60607

### EL PASO COUNTY STATEMENT

COUNTY PLAN REVIEW IS PROVIDED ONLY FOR GENERAL CONFORMANCE WITH COUNTY DESIGN CRITERIA. THE COUNTY IS NOT RESPONSIBLE FOR THE ACCURACY AND ADEQUACY OF THE DESIGN, DIMENSIONS, AND/OR ELEVATIONS WHICH SHALL BE CONFIRMED AT THE JOB SITE. THE COUNTY THROUGH THE APPROVAL OF THIS DOCUMENT ASSUMES NO RESPONSIBILITY FOR COMPLETENESS AND/OR ACCURACY OF THIS DOCUMENT.

FILED IN ACCORDANCE WITH THE REQUIREMENTS OF THE EL PASO COUNTY LAND DEVELOPMENT CODE, DRAINAGE CRITERIA MANUAL VOLUMES 1 AND 2, AND ENGINEERING CRITERIA MANUAL AS AMENDED.

IN ACCORDANCE WITH ECM SECTION 1.12, THESE CONSTRUCTION DOCUMENTS WILL BE VALID FOR CONSTRUCTION FOR A PERIOD OF 2 YEARS FROM THE DATE SIGNED BY THE EL PASO COUNTY ENGINEER. IF CONSTRUCTION HAS NOT STARTED WITHIN THOSE 2 YEARS, THE PLANS WILL NEED TO BE RESUBMITTED FOR APPROVAL, INCLUDING PAYMENT OF REVIEW FEES AT THE PLANNING AND COMMUNITY DEVELOPMENT DIRECTORS DISCRETION.

JENNIFER IRVINE, P.E.

DATE

COUNTY ENGINEER/ECM ADMINISTRATOR

### ENGINEER'S STATEMENT

STANDARD DETAILS SHOWN WERE REVIEWED ONLY AS TO THEIR APPLICATION ON THIS PROJECT

MIKE A. BRAMLETT, P.E.  
COLORADO P.E. 32314  
FOR AND ON BEHALF OF JR ENGINEERING

DATE

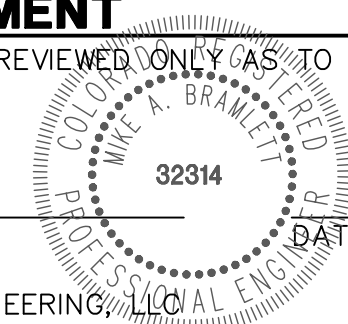

SAND CREEK CENTER TRIBUTARY COVER SHEET	BY	DATE							
	No.	REVISION							
H-SCALE	1"=300'	N/A							
V-SCALE			11/16/20						
DESIGNED BY	JBP								
DRAWN BY	JBP								
CHECKED BY									
SHEET	1	OF	10						
JOB NO.	25174.00								

UNTIL SUCH TIME AS THESE DRAWINGS ARE APPROVED BY THE APPROPRIATE REVIEWING AGENCIES, OR ENGINEERING THEIR USE APPROVES DESIGNATED BY WRITTEN AUTHORIZATION.

PREPARED FOR  
JACKSON DEARBORN PARTNERS  
404 S. WELLS ST.  
SUITE 400  
CHICAGO, ILL 60607  
OFFICE PHONE  
(734) 216-2577

J-R ENGINEERING  
A Westman Company  
Central 303-740-9888 • Colorado Springs 719-588-2683  
Fort Collins 970-491-9888 • www.jrengineering.com





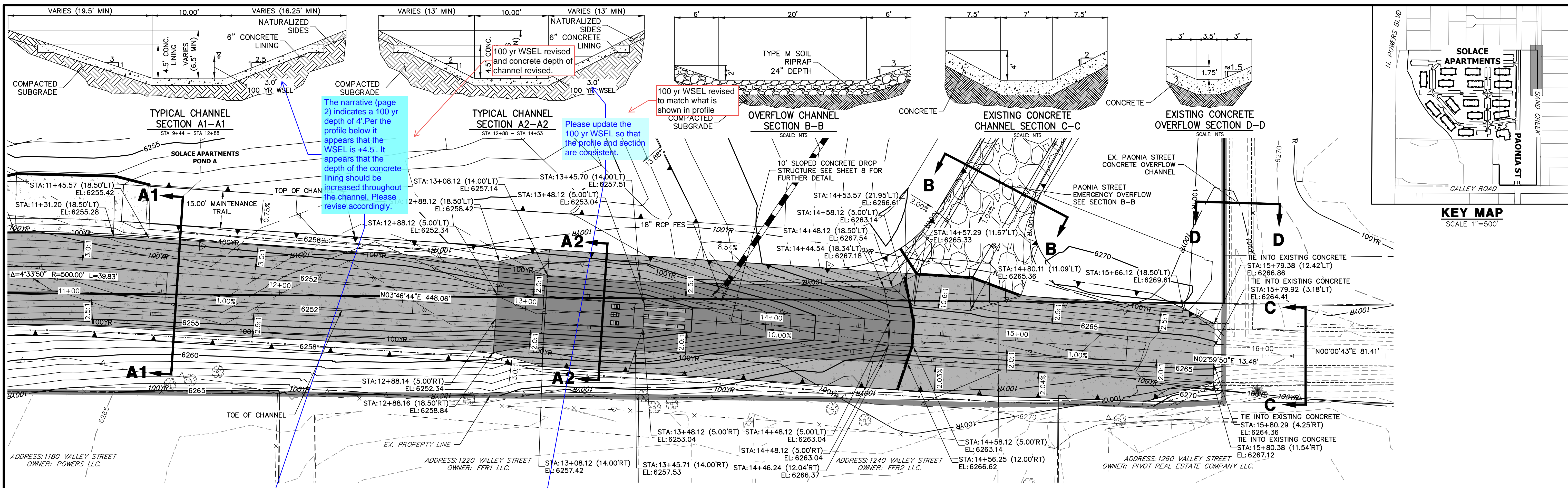

**SAND CREEK-CENTER TRIBUTARY CHANNEL PROFILE (4)  
STA 11+00.00 TO 16+50.00**

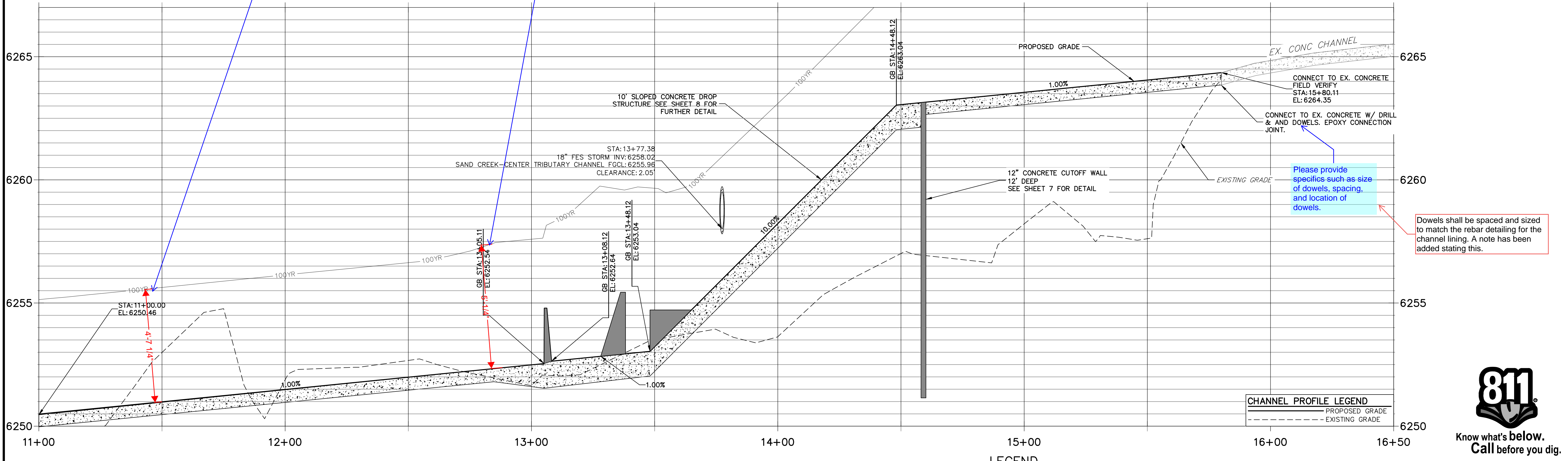

**FENCING NOTES**

- FENCING SHALL BE PROVIDED ALONG THE EXTENTS OF THE CHANNEL, EXCEPT FOR AT LOCATIONS OF MAINTENANCE ACCESS.
- FENCING SHALL CONFORM TO THE LANDSCAPING PLANS FOR SOLACE APARTMENTS, COLORADO SPRINGS SP-20-001, BY NES.

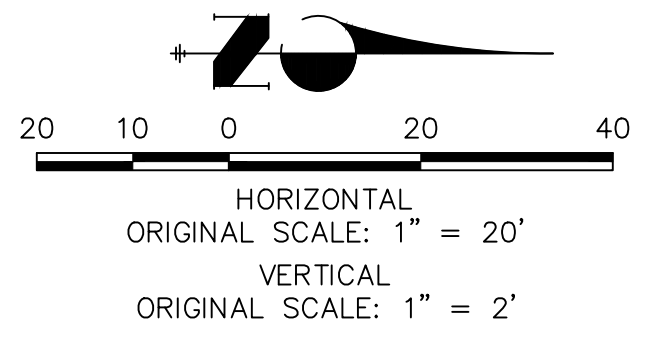

**LEGEND**

- PROPOSED MAJOR CONTOURS (solid line)
- EXISTING MAJOR CONTOUR (dashed line)
- LIMITS OF GRADING (dotted line)
- 6" THICK CONCRETE CHANNEL LINING (stippled pattern)
- 12" THICK CONCRETE CHANNEL LINING (cross-hatched pattern)

**ENGINEER'S STATEMENT**

STANDARD DETAILS SHOWN WERE REVIEWED ONLY AS TO THEIR APPLICATION ON THIS PROJECT

MIKE A. BRAMLETT, P.E.  
COLORADO P.E. 32314  
FOR AND ON BEHALF OF JR ENGINEERING

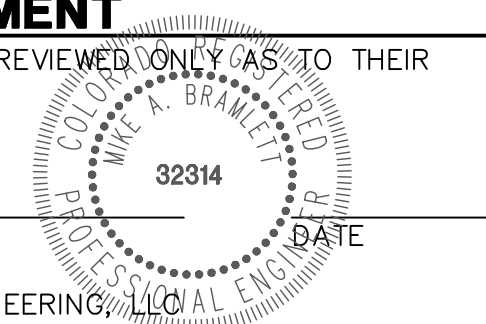

PREPARED FOR  
**JACKSON DEARBORN PARTNERS**  
404 S. WELLS ST.  
SUITE 400  
CHICAGO, ILL. 60607  
OFFICE PHONE (734) 216-2577

**J.R. ENGINEERING**  
A Westman Company  
Central 303-740-9383 • Colorado Springs 719-583-2593  
Fort Collins 970-491-9888 • www.jrengineering.com

BY	DATE	REVISION

H-SCALE 1"=20'  
V-SCALE 1"=2'  
DATE 11/16/20  
DESIGNED BY JBP  
DRAWN BY JBP  
CHECKED BY

**SAND CREEK CENTER TRIBUTARY CHANNEL PLAN AND PROFILES**

SHEET 4 OF 10  
JOB NO. 25174.00

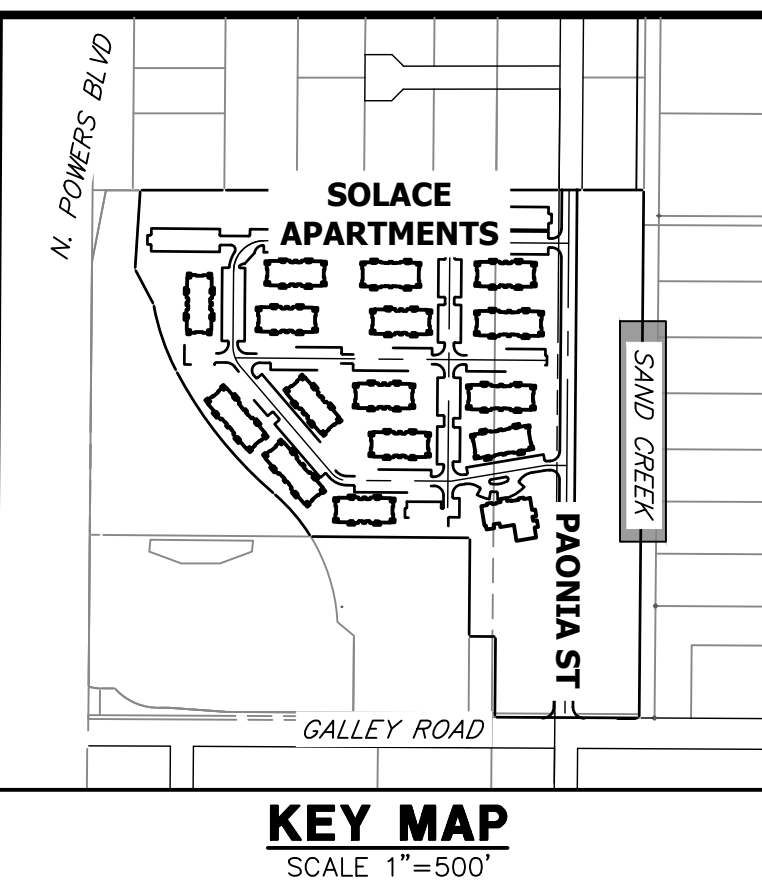
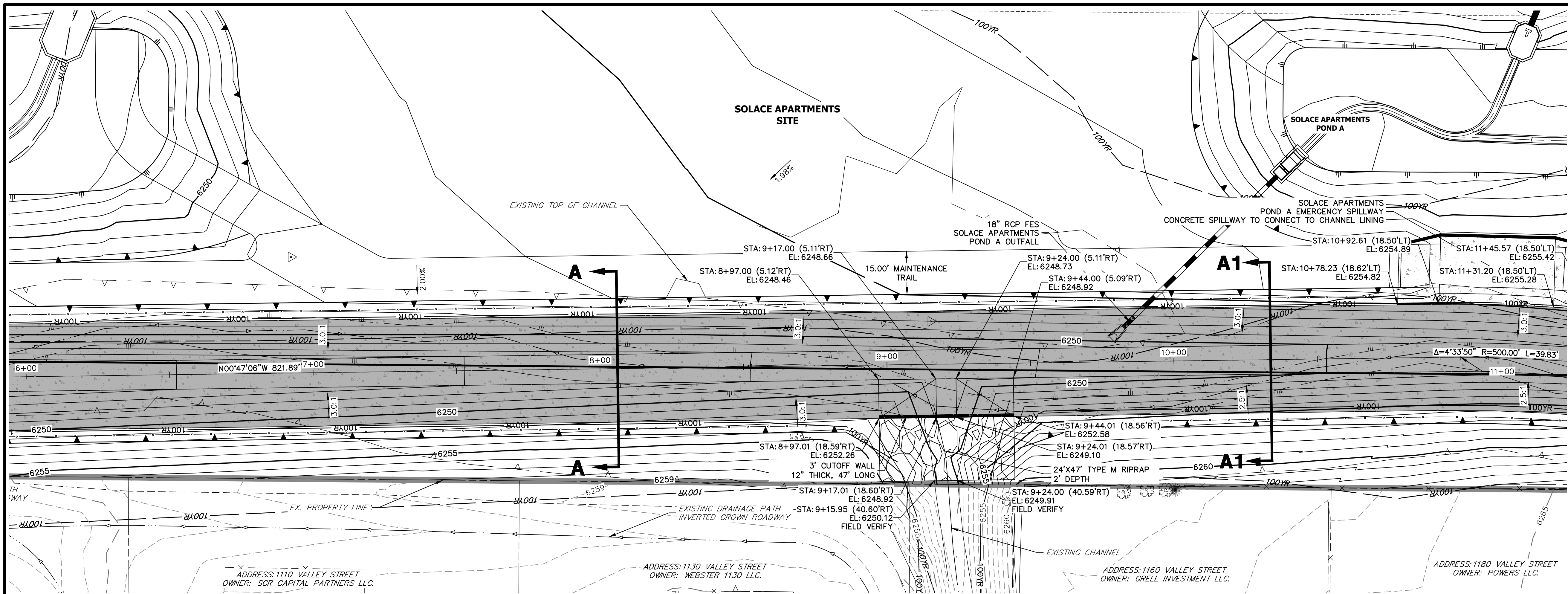

**SAND CREEK-CENTER TRIBUTARY CHANNEL PROFILE (3)  
STA 6+00.00 TO 11+00.00**

**FENCING NOTES**  
 1. FENCING SHALL BE PROVIDED ALONG THE EXTENTS OF THE CHANNEL, EXCEPT FOR AT LOCATIONS OF MAINTENANCE ACCESS.  
 2. FENCING SHALL CONFORM TO THE LANDSCAPING PLANS FOR SOLACE APARTMENTS, COLORADO SPRINGS SP-20-001, BY NES.

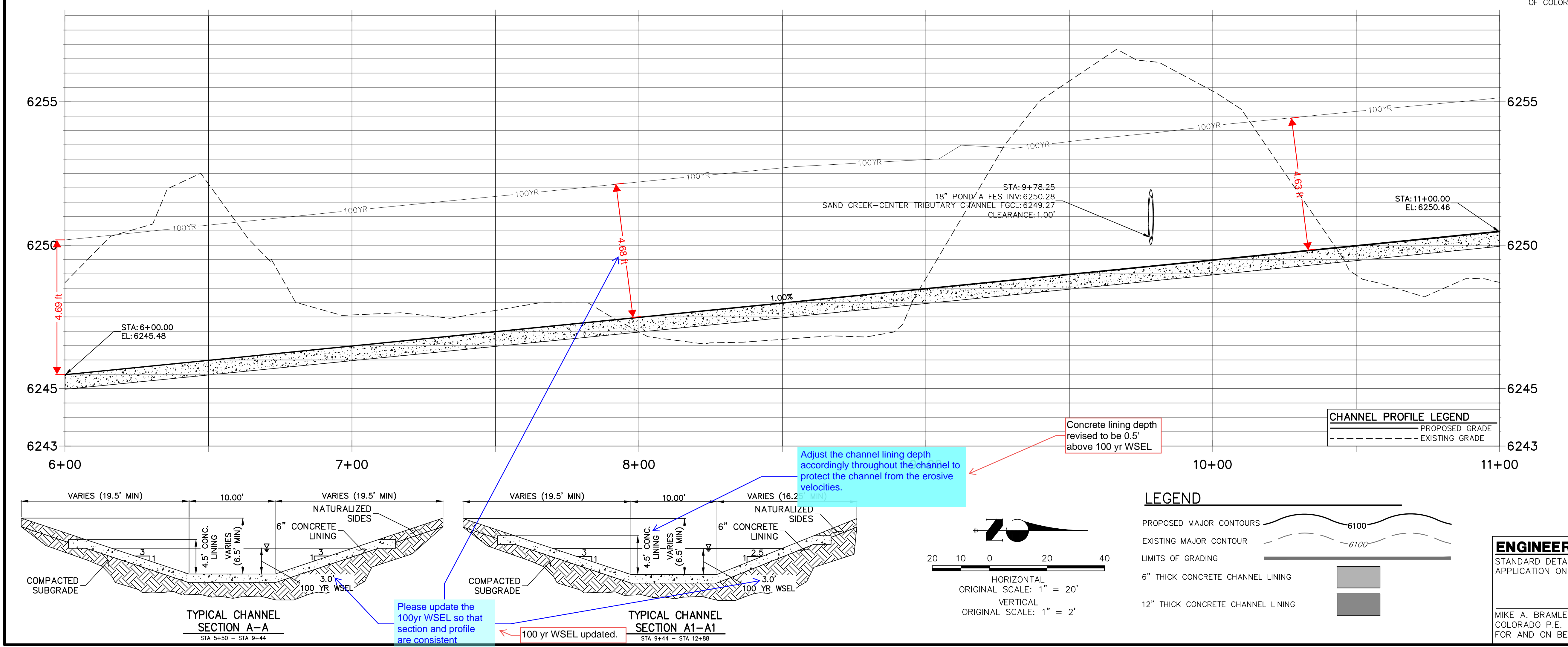

UNTIL SUCH TIME AS THESE DRAWINGS ARE APPROVED BY THE APPROPRIATE REVIEWING AGENCIES, OR ENGINEERING APPROVES THEIR USE, THESE DRAWINGS ARE DESIGNATED BY WRITTEN AUTHORIZATION.

PREPARED FOR  
**JACKSON DEARBORN PARTNERS**  
 404 S. WELLS ST.  
 SUITE 400  
 CHICAGO, ILL. 60607  
 OFFICE PHONE (734) 216-2577

**J.R. ENGINEERING**  
 A Westman Company  
 Centennial 300-740-0888 • Colorado Springs 719-588-2583  
 Fort Collins 970-491-9888 • www.jrengineering.com

BY	DATE	NO.	REVISION

**SAND CREEK CENTER TRIBUTARY CHANNEL PLAN AND PROFILES**

SHEET 5 OF 10  
 JOB NO. 25174.00



**ENGINEER'S STATEMENT**  
 STANDARD DETAILS SHOWN WERE REVIEWED ONLY AS TO THEIR APPLICATION ON THIS PROJECT

MIKE A. BRAMLETT, P.E.  
 COLORADO P.E. 32314  
 FOR AND ON BEHALF OF JR ENGINEERING, LOCAL ENGINEER

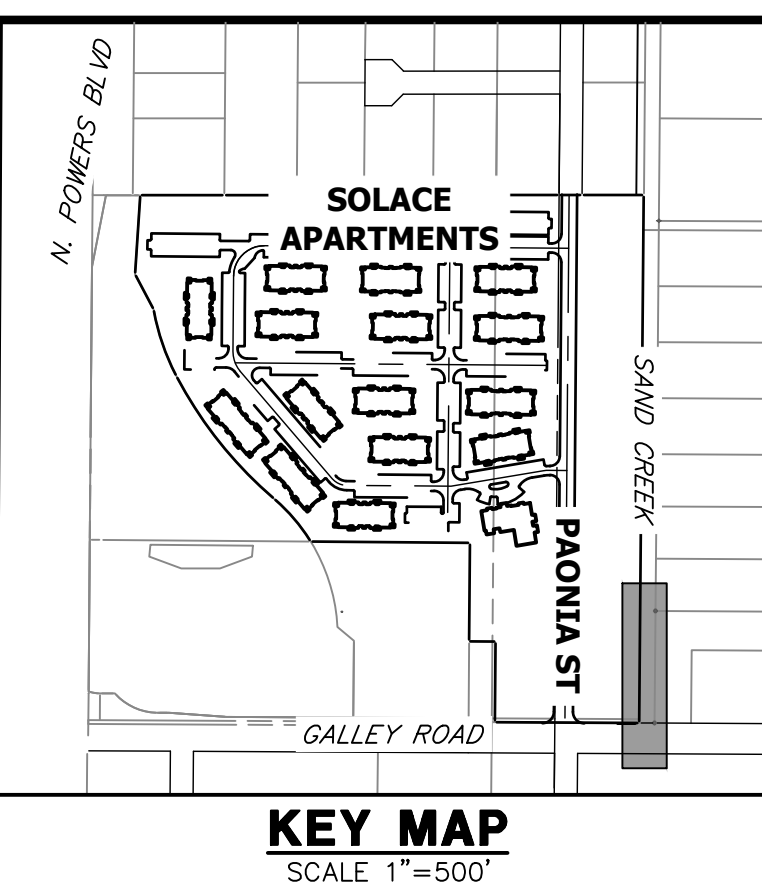
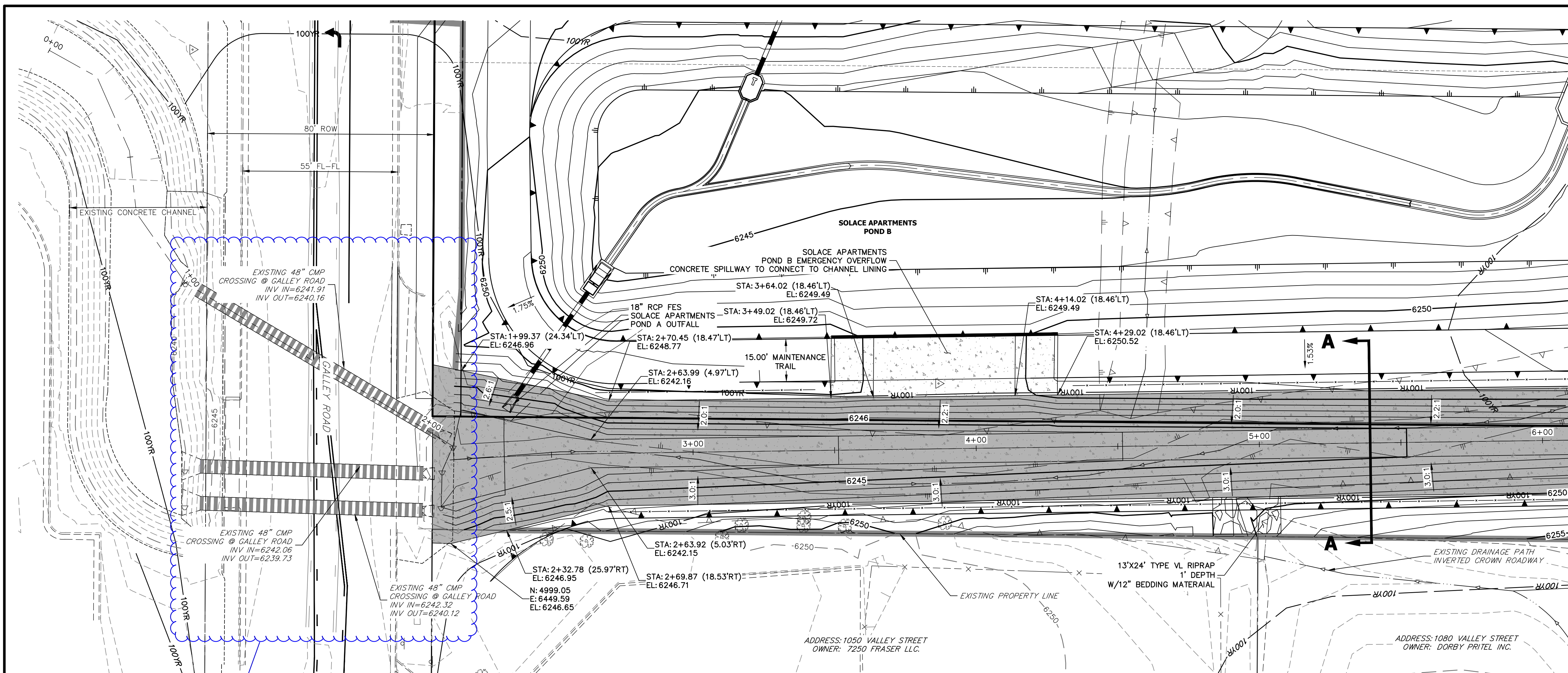

**SAND CREEK-CENTER TRIBUTARY CHANNEL PROFILE  
STA 0+00.00 TO 6+00.00**

Please show the existing size of the culverts. 36x58 shown on the other drawings.

Pipe size updated to match 36x58 shown in other documents.

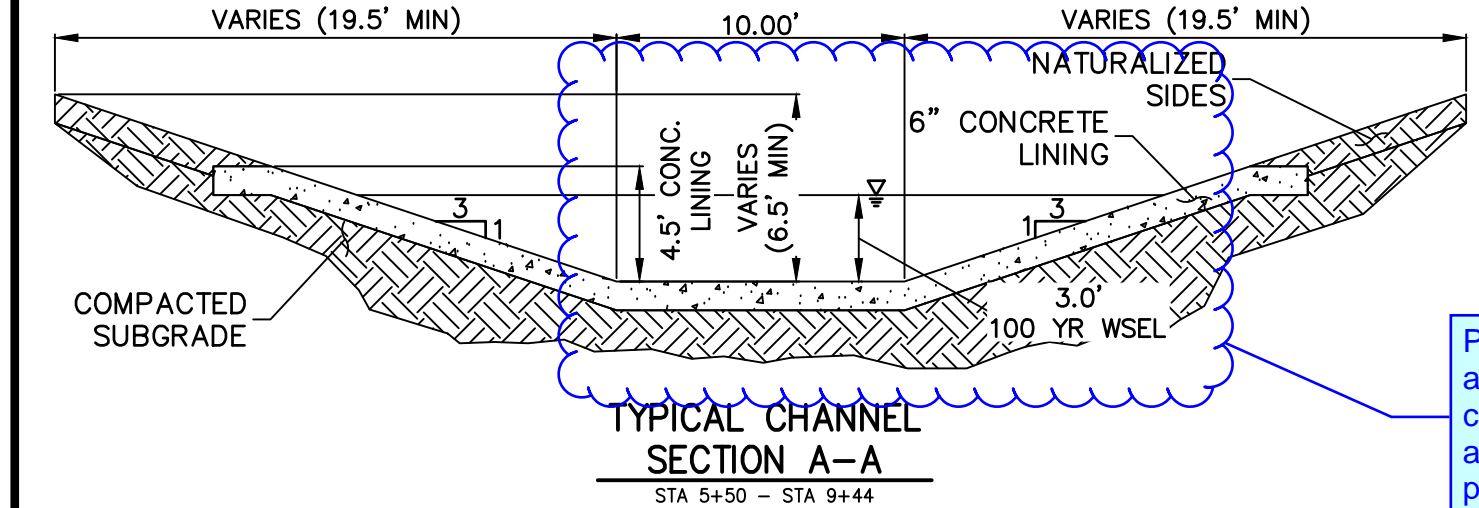
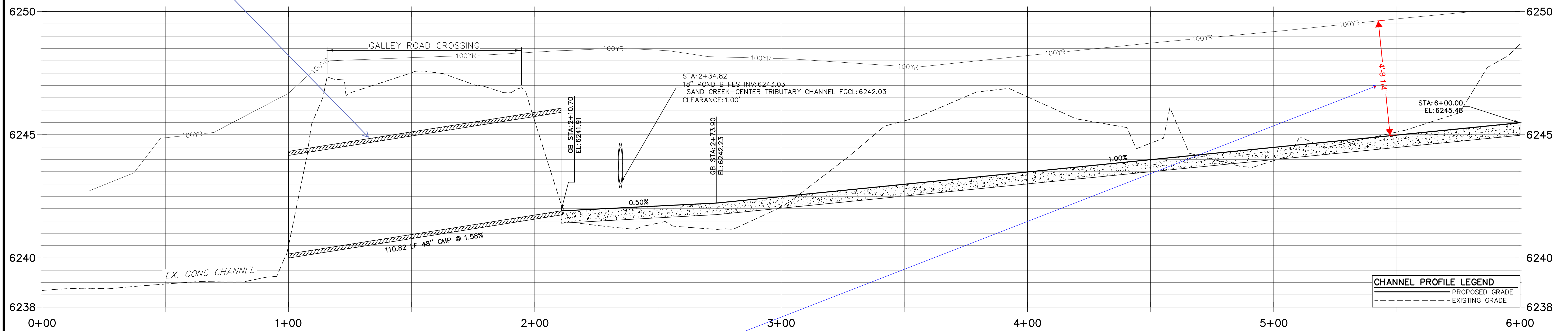

**FENCING NOTES**

- FENCING SHALL BE PROVIDED ALONG THE EXTENTS OF THE CHANNEL, EXCEPT FOR AT LOCATIONS OF MAINTENANCE ACCESS.
- FENCING SHALL CONFORM TO THE LANDSCAPING PLANS FOR SOLACE OF COLORADO SPRINGS SP-20-001, BY NES.

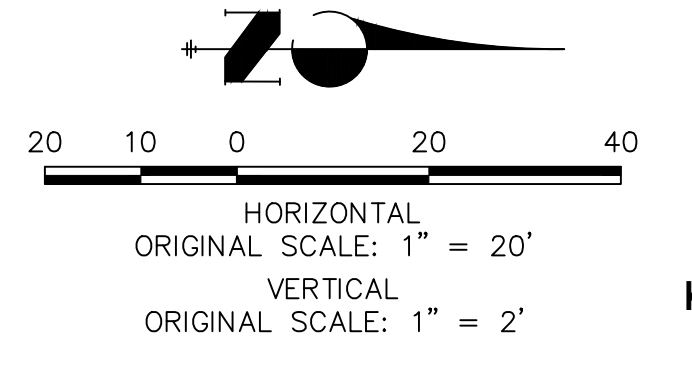
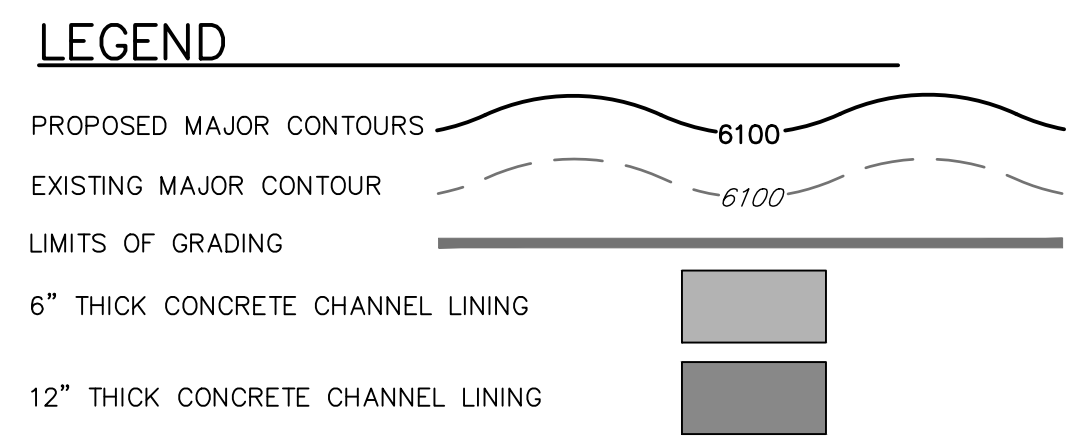

**ENGINEER'S STATEMENT**

STANDARD DETAILS SHOWN WERE REVIEWED ONLY AS TO THEIR APPLICATION ON THIS PROJECT

MIKE A. BRAMLETT, P.E.  
COLORADO P.E. 32314  
FOR AND ON BEHALF OF JR ENGINEERING

PREPARED FOR <b>JACKSON DEARBORN PARTNERS</b> 404 S. WELLS ST. SUITE 400 CHICAGO, ILL. 60607 OFFICE PHONE (734) 216-2577	UNTIL SUCH TIME AS THESE DRAWINGS ARE APPROVED BY THE APPROPRIATE REVIEWING AGENCIES, JR ENGINEERING APPROVES THEIR USE AS DESIGNATED BY WRITTEN AUTHORIZATION.
BY DATE	No. REVISION
H-SCALE 1"=20' V-SCALE 1"=2' DATE 11/16/20 DESIGNED BY JBP DRAWN BY JBP CHECKED BY	SAND CREEK CENTER TRIBUTARY CHANNEL PLAN AND PROFILES
SHEET 6 OF 10 JOB NO. 25174.00	811 Know what's below. Call before you dig.





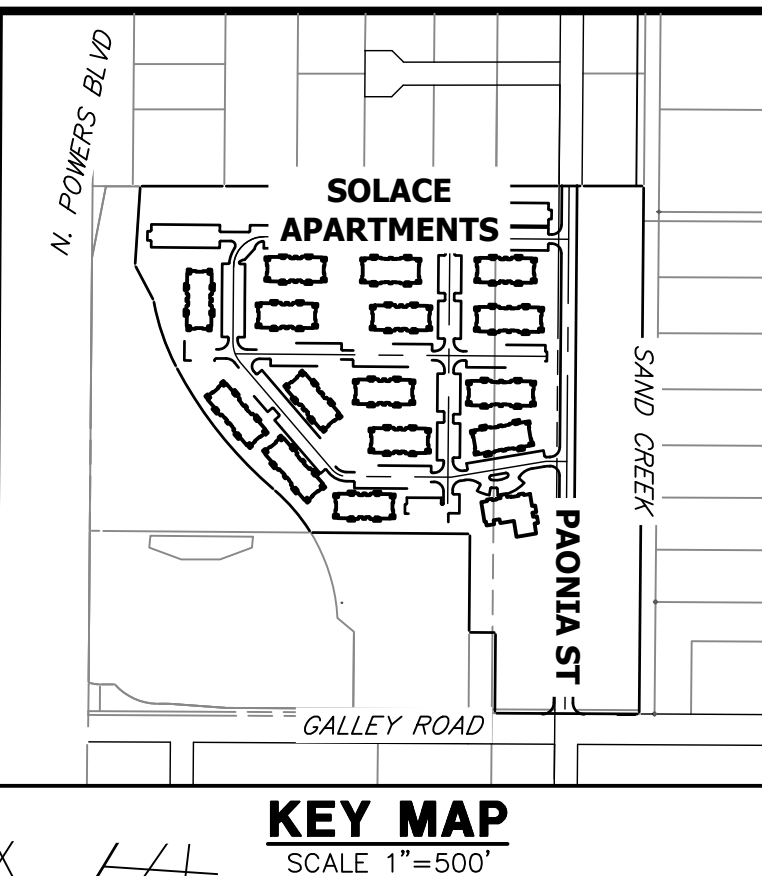
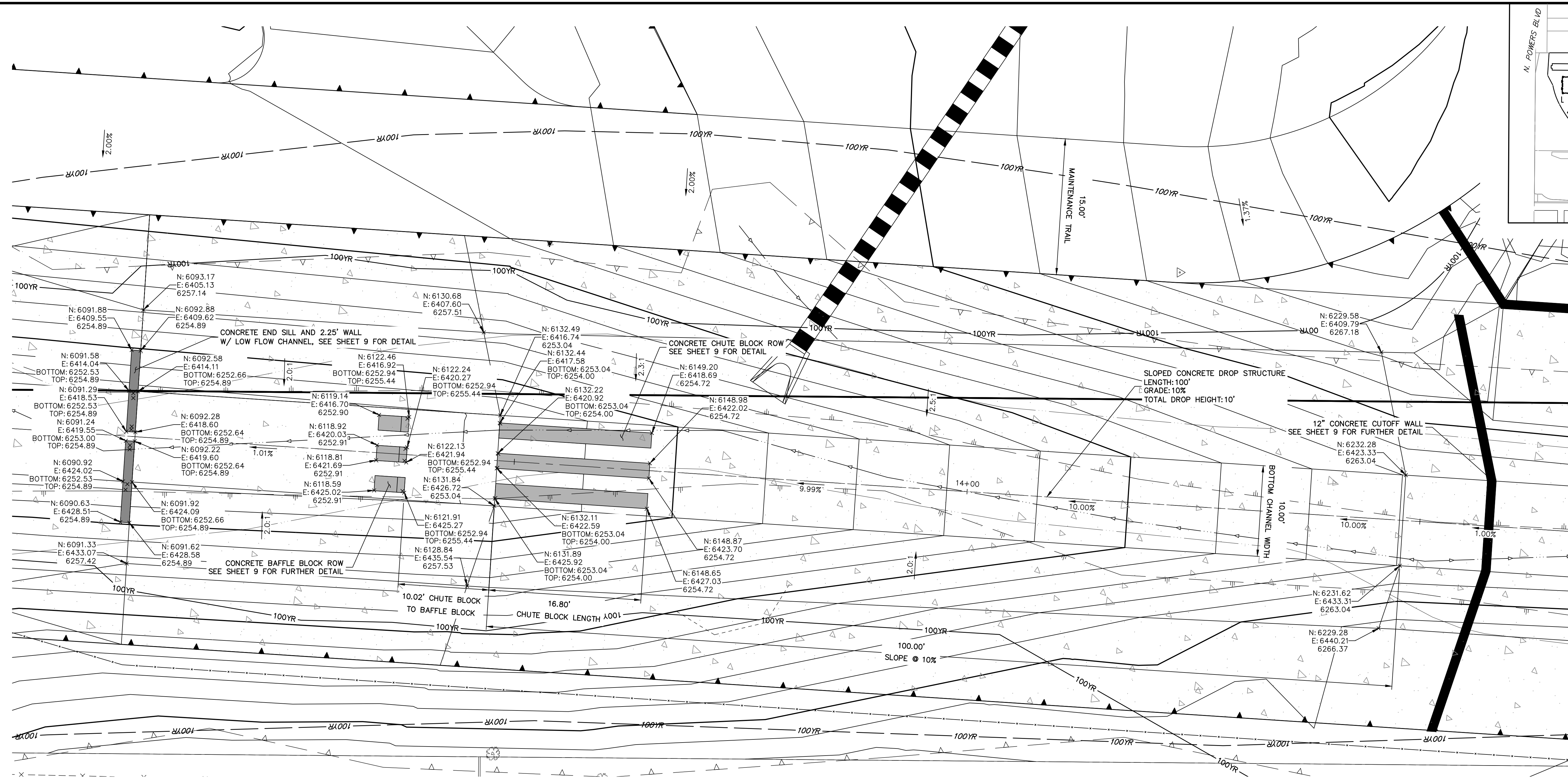

**DROP 1 PROFILE  
STA 13+00.00 TO 14+65.00**

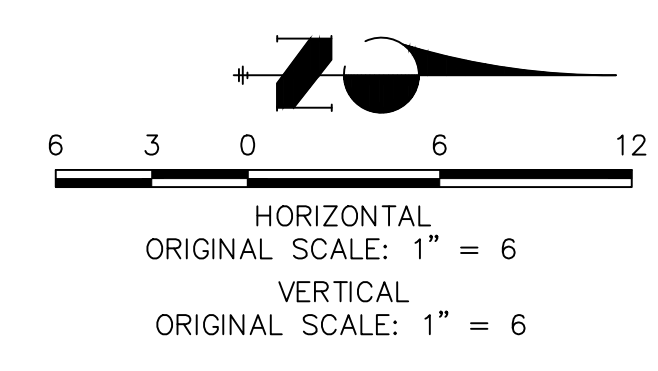
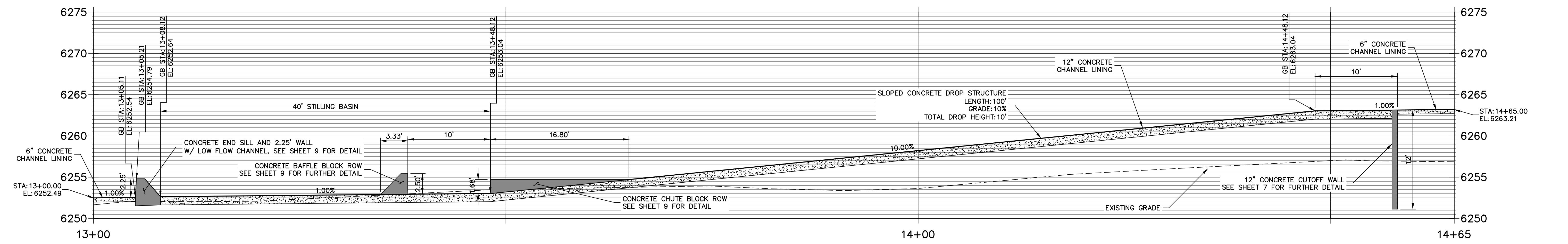

**ENGINEER'S STATEMENT**  
STANDARD DETAILS SHOWN WERE REVIEWED ONLY AS TO THEIR APPLICATION ON THIS PROJECT

MIKE A. BRAMLETT, P.E.  
COLORADO P.E. 32314  
FOR AND ON BEHALF OF JR ENGINEERING, LOCAL ENGINEER

UNLESS SUCH TIME AS THESE DRAWINGS ARE APPROVED BY THE AGENCIES, OR ENGINEERING APPROVES THEIR USE, DESIGNATED BY WRITTEN AUTHORIZATION.

PREPARED FOR  
**JACKSON DEARBORN PARTNERS**  
404 S. WELLS ST.  
SUITE 400  
CHICAGO, ILL. 60607  
OFFICE PHONE (734) 216-2577

**J.R. ENGINEERING**  
A Westman Company

Central 303-740-9888 • Colorado Springs 719-583-2583  
Fort Collins 970-491-9888 • www.jrengineering.com

No.	REVISION	BY	DATE

H-SCALE	V-SCALE	DATE	DESIGNED BY	DRAWN BY	CHECKED BY
1"=6'	1"=6'	11/16/20	JBP	JBP	JBP

**SAND CREEK CENTER TRIBUTARY**  
**DROP STRUCTURES PLAN AND PROFILE**

SHEET 8 OF 10  
JOB NO. 25174.00

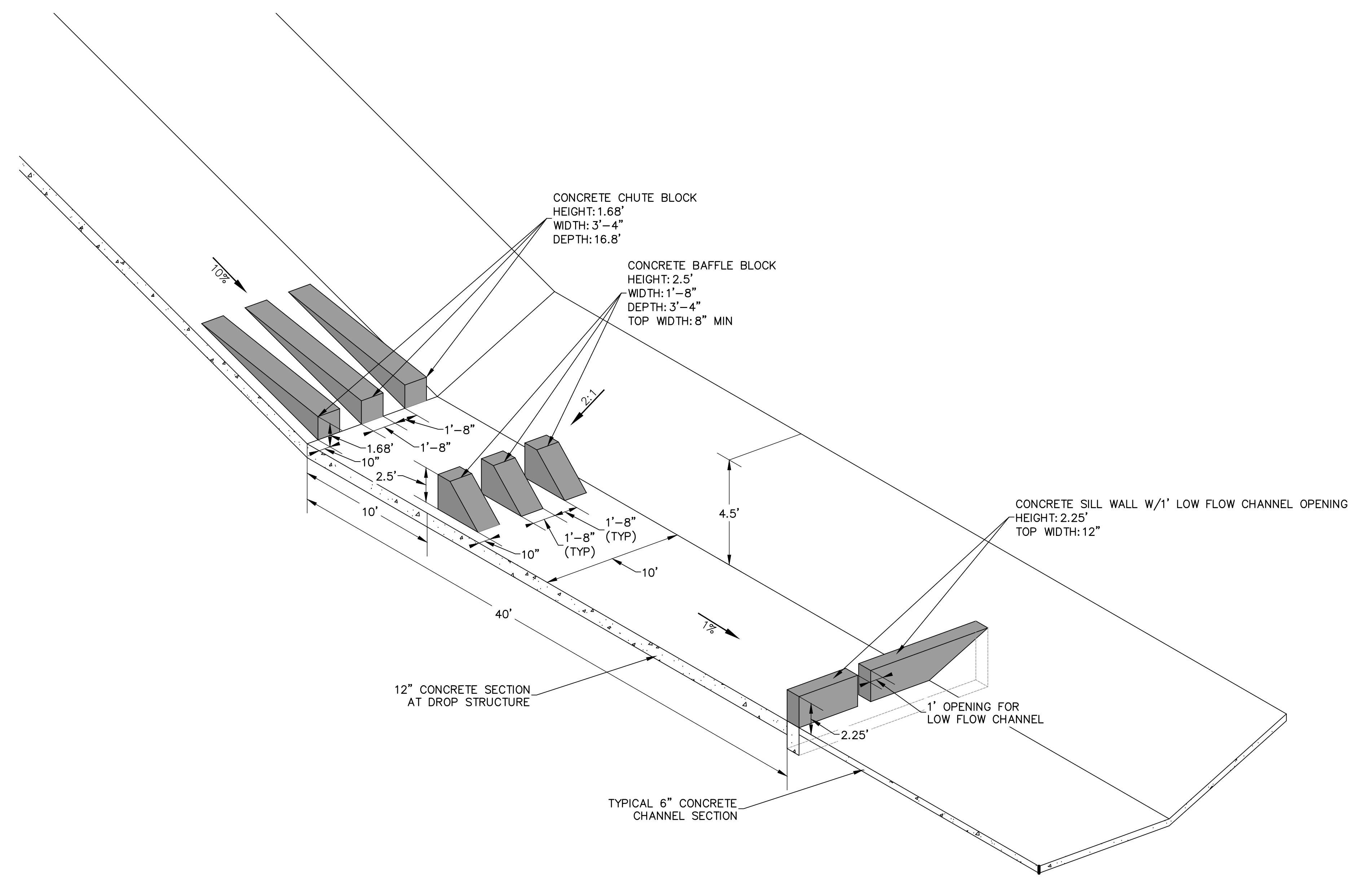

**ENGINEER'S STATEMENT**  
STANDARD DETAILS SHOWN WERE REVIEWED ONLY AS TO THEIR APPLICATION ON THIS PROJECT

MIKE A. BRAMLETT, P.E.  
COLORADO P.E. 32314  
FOR AND ON BEHALF OF JR ENGINEERING, INC.

32314  
DATE

<p>UNTIL SUCH TIME AS THESE DRAWINGS ARE APPROVED BY THE APPROPRIATE REVIEWING AGENCIES, JR ENGINEERING APPROVES THEIR USE AS SHOWN. ANY CHANGES DESIGNATED BY WRITTEN AUTHORIZATION.</p>	
<p>PREPARED FOR <b>JACKSON DEARBORN PARTNERS</b> 404 S. WELLS ST. SUITE 400 CHICAGO, ILL. 60607 OFFICE PHONE (734) 216-2577</p>	
<p><b>J.R. ENGINEERING</b> A Western Company Central 303-740-9888 • Colorado Springs 719-583-2583 Fort Collins 970-491-9888 • www.jrengineering.com</p>	
BY	DATE
No.	REVISION
H-SCALE	N/A
V-SCALE	N/A
DATE	11/16/20
DESIGNED BY	JBP
DRAWN BY	JBP
CHECKED BY	
<p>SAND CREEK CENTER TRIBUTARY DROP STRUCTURE DETAIL SHEETS</p>	
SHEET	9 OF 10
JOB NO.	25174.00

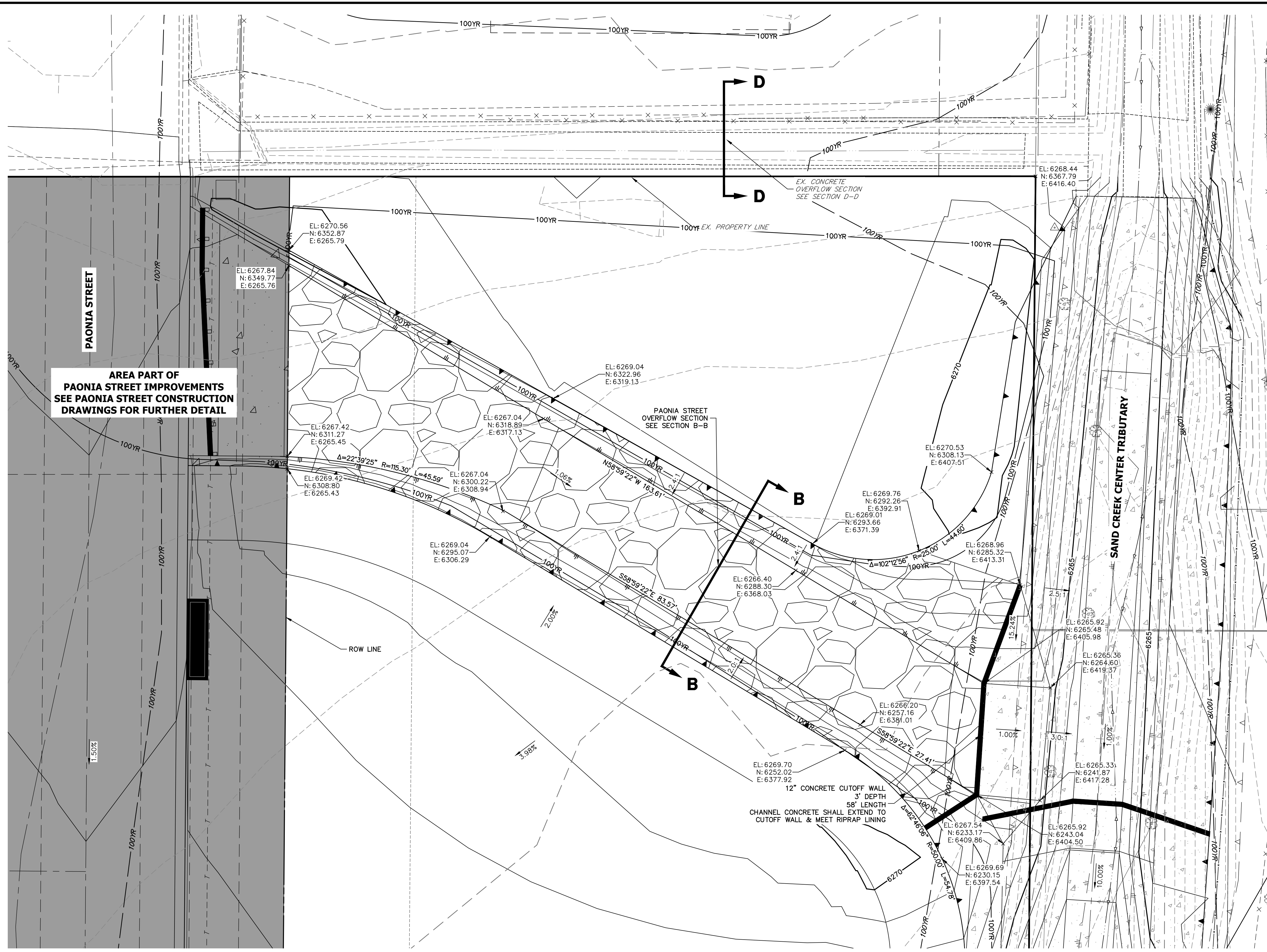

AREA PART OF  
PAONIA STREET IMPROVEMENTS  
SEE PAONIA STREET CONSTRUCTION  
DRAWINGS FOR FURTHER DETAIL

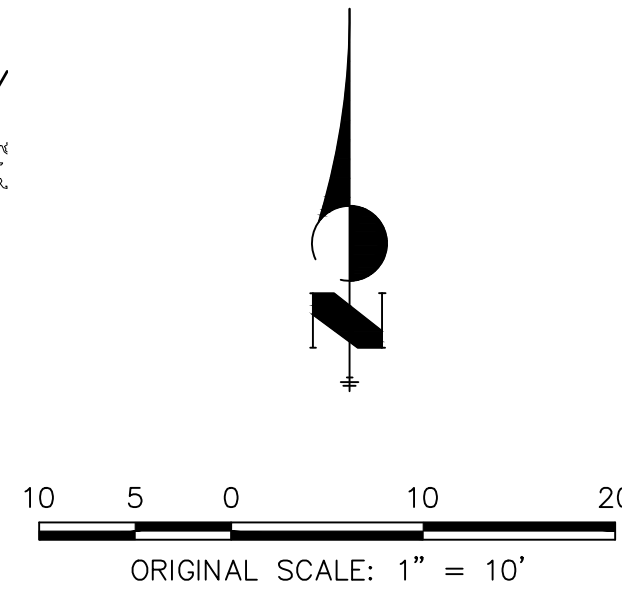
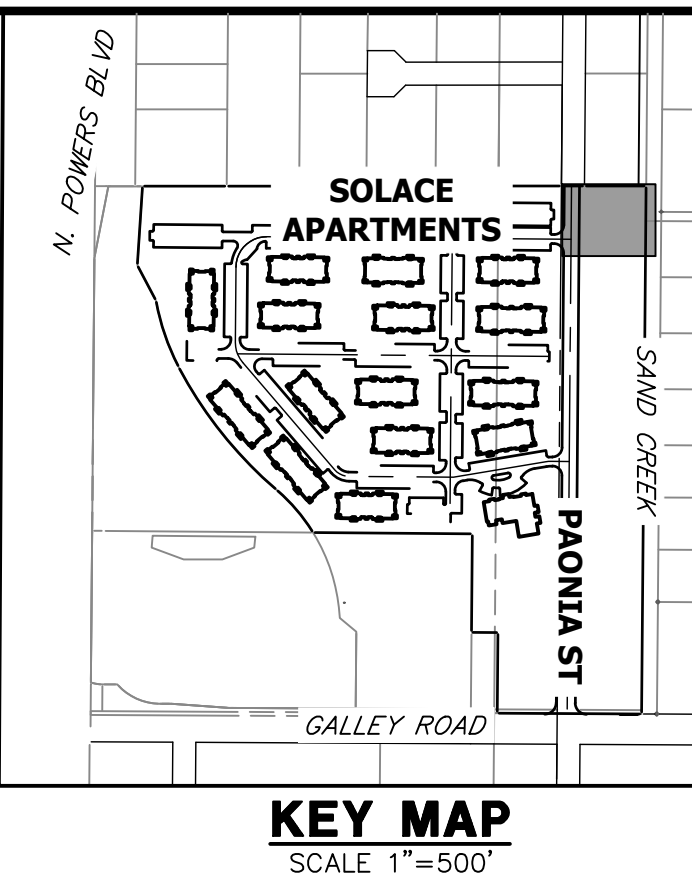
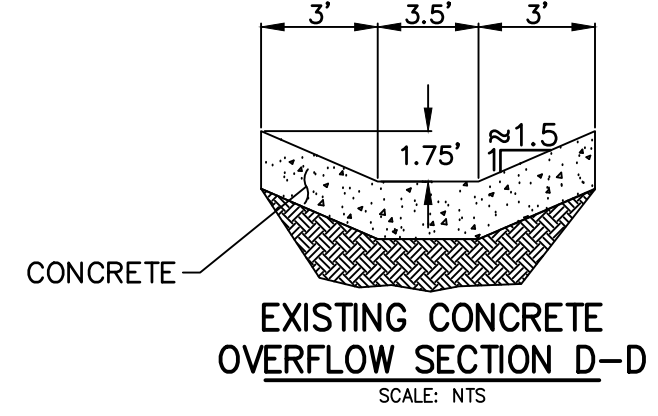
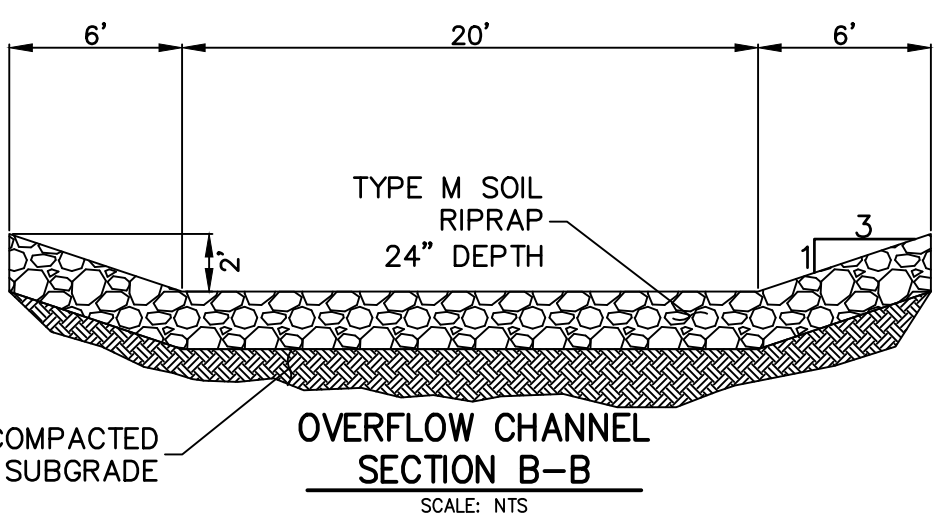

**ENGINEER'S STATEMENT**  
 PREPARED UNDER MY DIRECT SUPERVISION AND ON BEHALF OF JR  
 ENGINEERING  
 Mike Bramlett  
 32314  
 7/14/21  
 DATE  
 MIKE A. BRAMLETT, P.E.  
 COLORADO P.E. 32314  
 FOR AND ON BEHALF OF JR ENGINEERING, A PROFESSIONAL ENGINEERING FIRM

UNTIL SUCH TIME AS THESE DRAWINGS ARE APPROVED BY THE APPROPRIATE REVIEWING AGENCIES, JR ENGINEERING APPROVES THEIR USE DESIGNATED BY WRITTEN AUTHORIZATION.	PREPARED FOR <b>JACKSON DEARBORN PARTNERS</b> 404 S. WELLS ST. SUITE 400 CHICAGO, ILL. 60607 OFFICE PHONE (734) 216-2577
	<b>J.R. ENGINEERING</b> A Westman Company  Centennial 300-740-9888 • Colorado Springs 719-588-2583 Fort Collins 970-491-9888 • www.jrengineering.com
BY DATE	No. REVISION
H-SCALE 1"=10' V-SCALE N/A DATE 11/16/20 DESIGNED BY JBP DRAWN BY JBP CHECKED BY	SHEET 10 OF 10 JOB NO. 25174.00

SAND CREEK CENTER  
 TRIBUTARY  
 PAONIA STREET OVERFLOW  
 PLAN

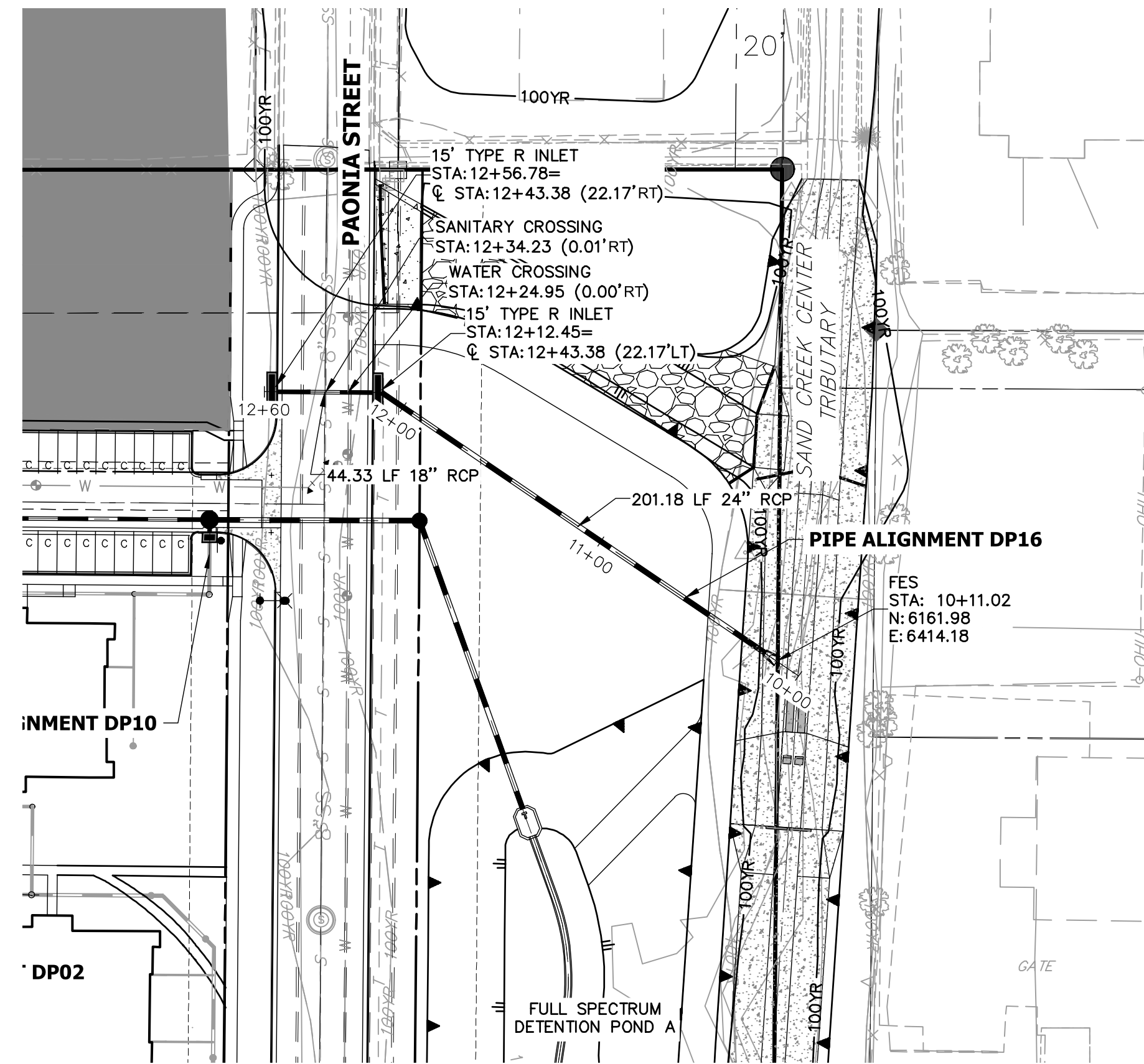
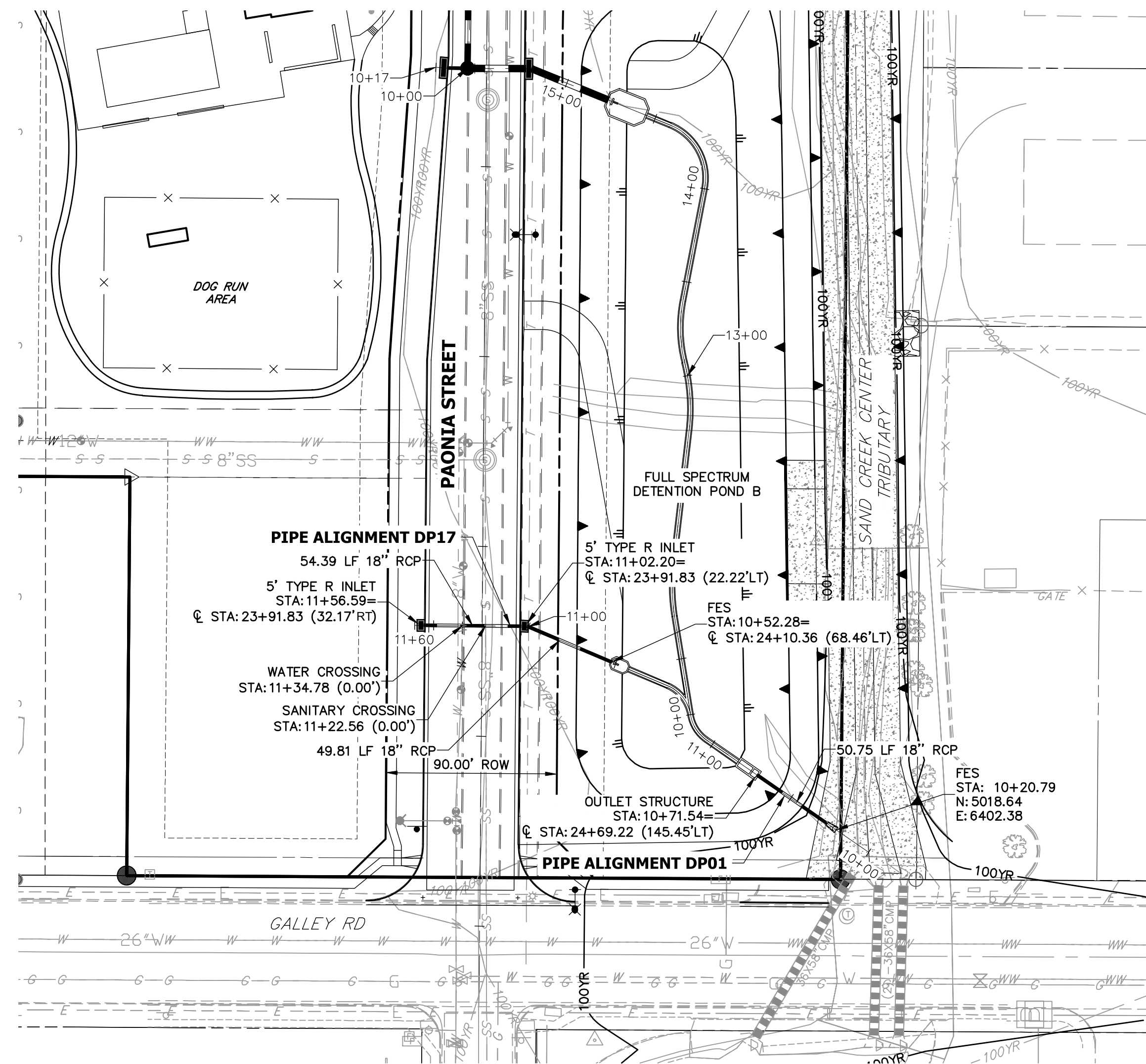

**DP17 PROFILE  
STA 10+00.00 TO 11+60.00**

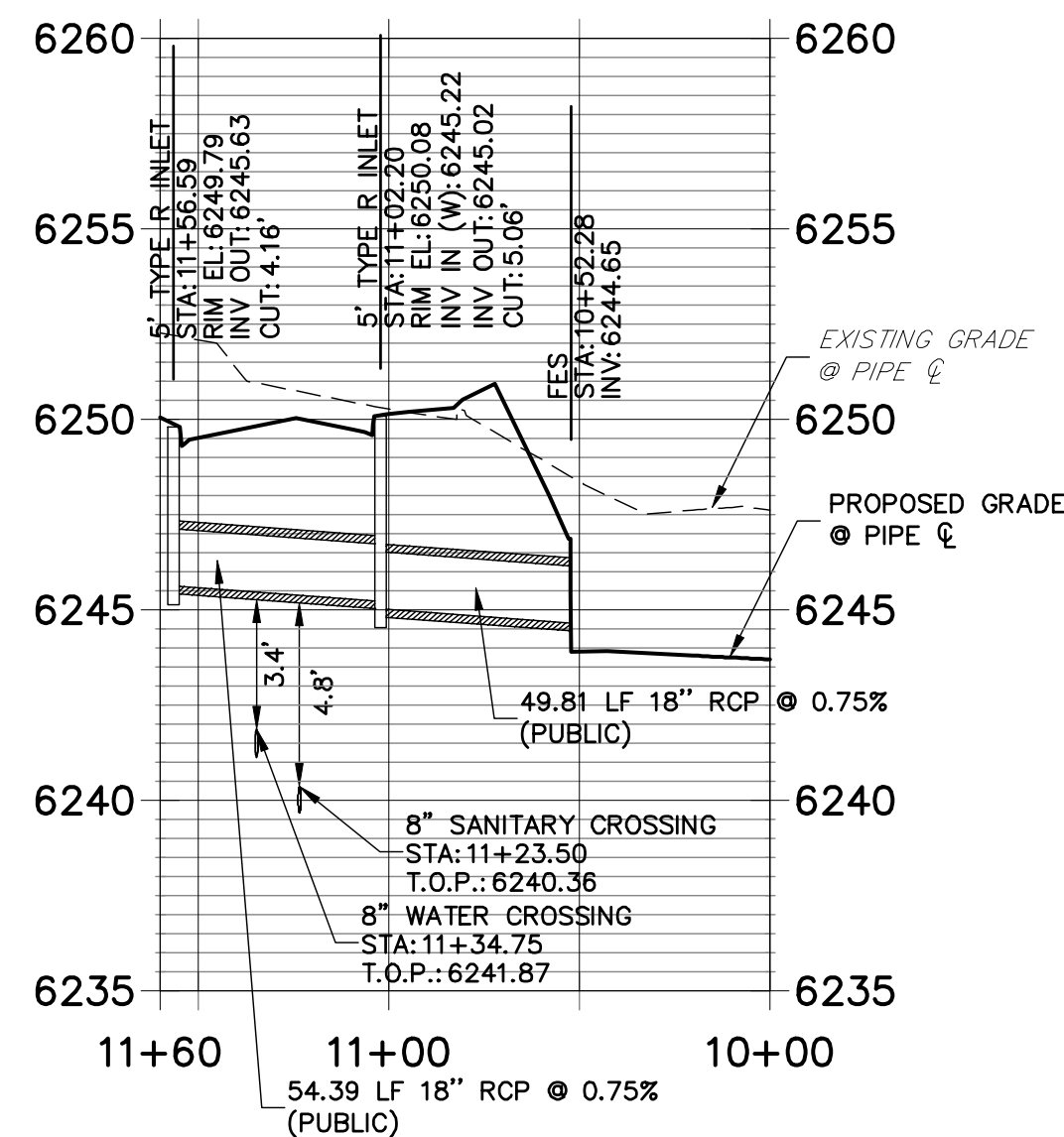

**DP01 PROFILE (1)  
STA 10+00.00 TO 14+50.00**

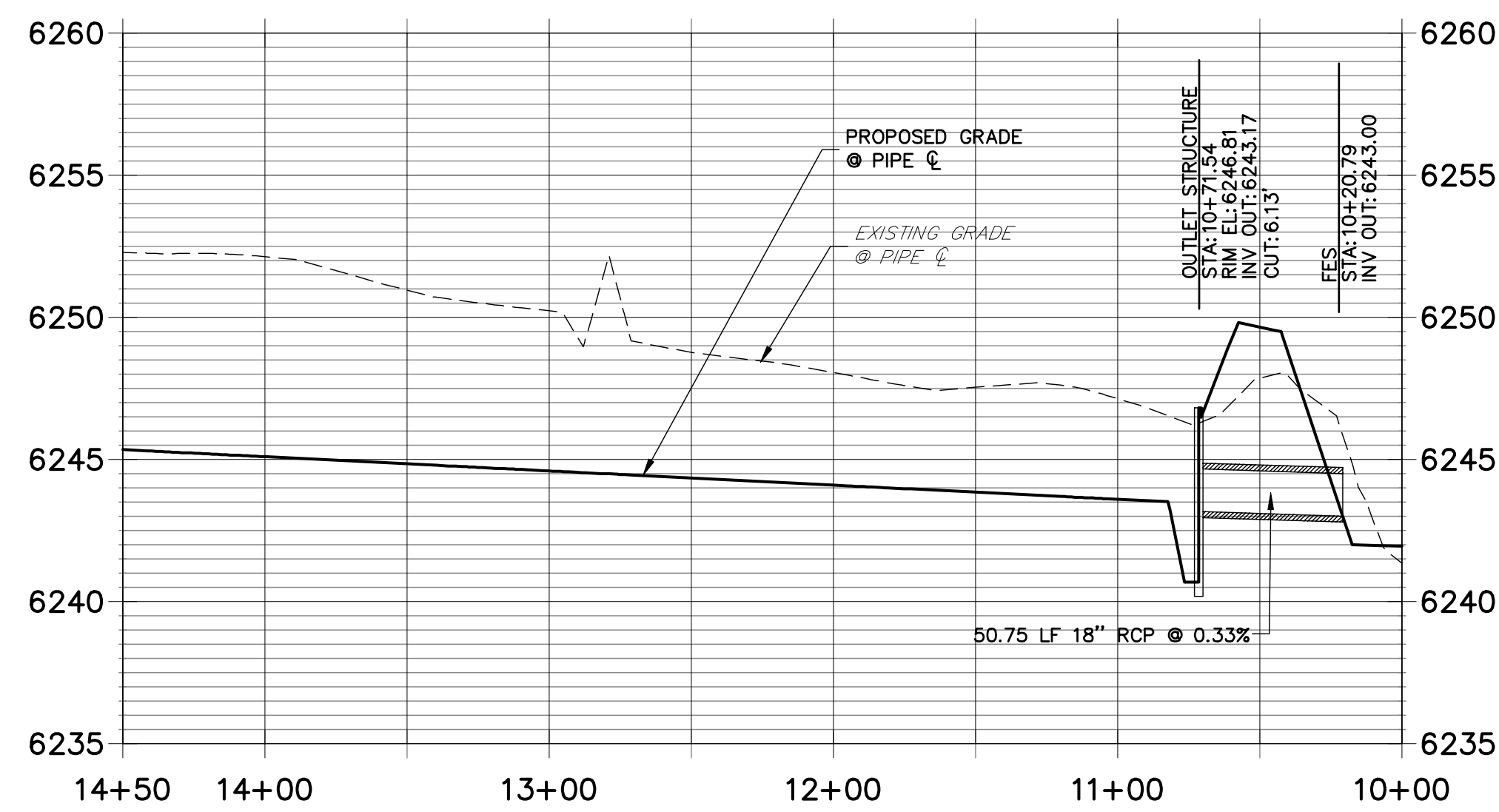

**DP16 PROFILE  
STA 10+00.00 TO 12+60.00**

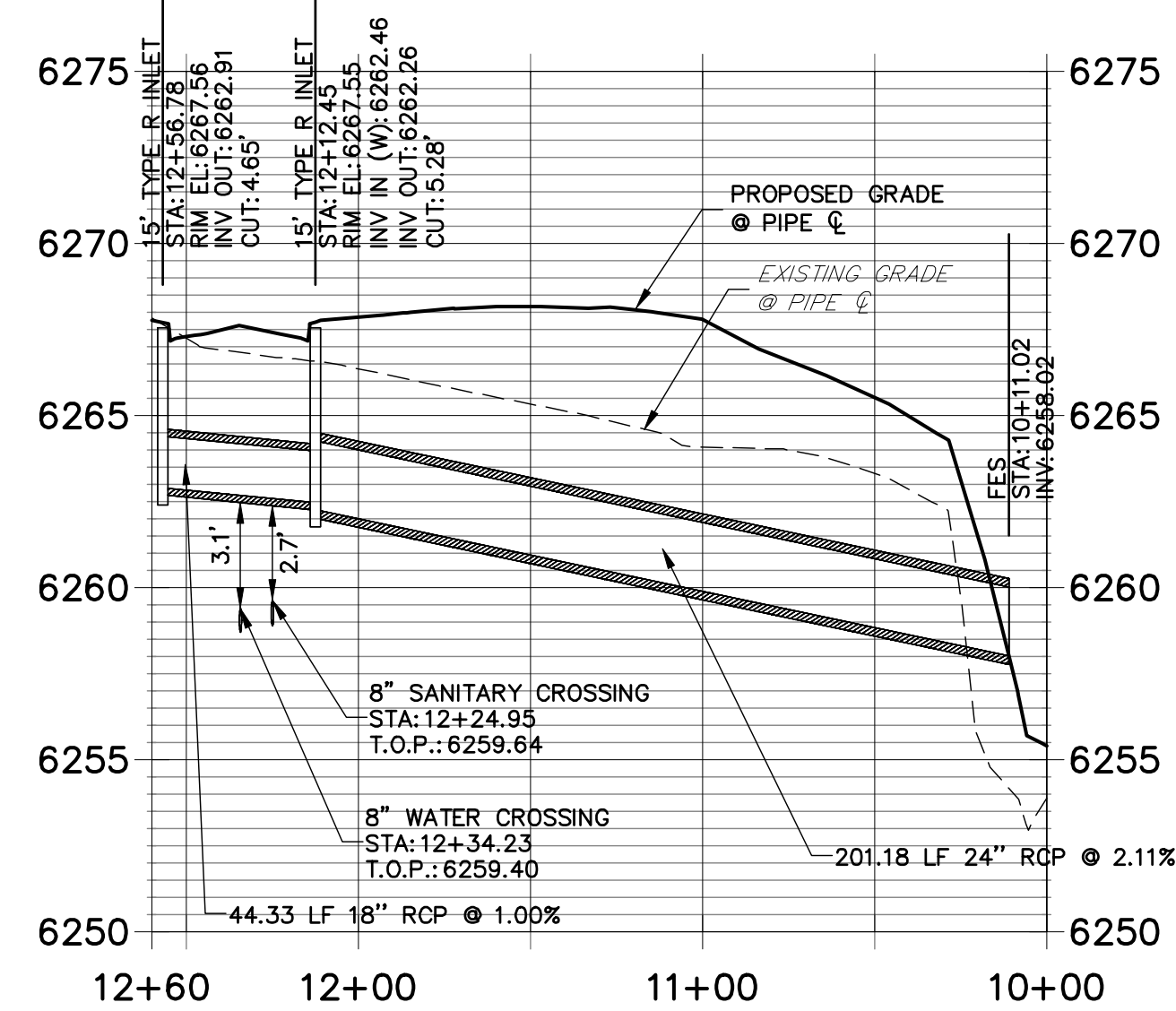

**STORM SEWER NOTES**

- SEE DETAIL SHEET 29 FOR APPLICABLE STORM SEWER DETAILS.
- PIPE LENGTHS MEASURED FROM CENTER OF MANHOLES TO CENTER OF MANHOLES, INSIDE FACE OF INLETS, OUTLET END OF FLARED END SECTIONS AND FACE OF WALLS WHERE APPLICABLE.
- STATIONS & OFFSETS ARE LABELED AT CENTER OF STRUCTURE.
- CONTRACTOR TO FIELD VERIFY EXISTING UTILITY LOCATIONS, PRIOR TO EXTENSION OF MAINS AND SERVICE CONNECTIONS. CONTRACTOR TO COORDINATE CONNECTIONS WITH UTILITY PROVIDER.
- ALL PUBLIC WATER LINES ARE OWNED BY CHEROKEE METROPOLITAN DISTRICT.

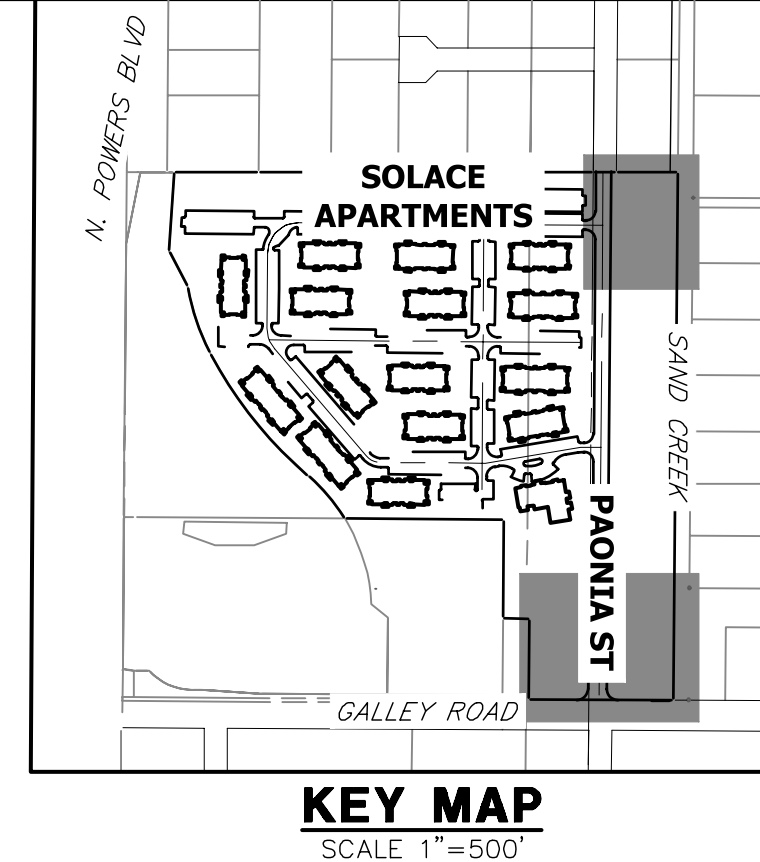

PREPARED FOR  
**JACKSON DEARBORN PARTNERS**  
404 S. WELLS ST.  
SUITE 400  
CHICAGO, ILL. 60607  
OFFICE PHONE (734) 216-2577

**J.R. ENGINEERING**  
A Westman Company  
Central 303-740-9383 • Colorado Springs 719-583-2593  
Fort Collins 970-491-9888 • www.jrengineering.com

BY	DATE	NO.	REVISION

H-SCALE	V-SCALE	DATE	DESIGNED BY	DRAWN BY	CHECKED BY
1"=50'	1"=5'	11/20/20	JRM	JRM	

**SOLACE APARTMENTS -  
FILING NO. 1  
STORM SEWER PLAN AND  
PROFILE**

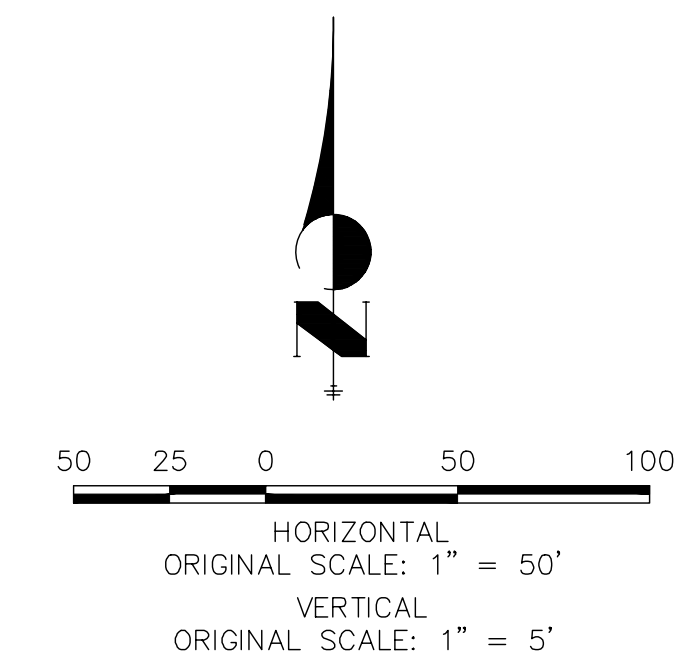

**ENGINEER'S STATEMENT**  
PREPARED UNDER MY SUPERVISION  
DATE  
32314  
FOR AND ON BEHALF OF JR ENGINEERING

HEC-RAS Version 4.1.0 Jan 2010  
 U.S. Army Corps of Engineers  
 Hydrologic Engineering Center  
 609 Second Street  
 Davis, California

```

X   X  XXXXXX   XXXX       XXXX       XX       XXXX
X   X  X         X   X     X   X     X   X   X
X   X  X         X         X   X     X   X   X
XXXXXXXX XXXX   X         XXX XXXX   XXXXXX   XXXX
X   X  X         X         X   X     X   X     X
X   X  X         X   X     X   X     X   X     X
X   X  XXXXXX   XXXX       X   X     X   X   XXXXX
  
```

PROJECT DATA

Project Title: HEC-RAS Model  
 Project File : Updated 08-24-2021 Proposed Model.prj  
 Run Date and Time: 8/24/2021 9:48:33 AM

Project in English units

Project Description:

```

CRS Info=<SpatialReference> <CoordinateSystem WKT="PROJCS["&quot;WGS 84 /
World
Mercator&quot;;GEOGCS["&quot;WGS
84&quot;;DATUM["&quot;WGS_1984&quot;;SPHEROID["&quot;WGS
84&quot;;6378137,298.257223563,AUTHORITY["&quot;EPSG&quot;;&quot;7030&quot;];],A
UT
HORITY["&quot;EPSG&quot;;&quot;6326&quot;];],PRIMEM["&quot;Greenwich&quot;;0,AUTH
OR
ITY["&quot;EPSG&quot;;&quot;8901&quot;];],UNIT["&quot;degree&quot;;0.017453292519
94
33,AUTHORITY["&quot;EPSG&quot;;&quot;9122&quot;];],AUTHORITY["&quot;EPSG&quot;;&quot;4326&quot;];],PROJECTION["&quot;Mercator_1SP&quot;];,PARAMETER["&quot;central_me
ri
dian&quot;;0],PARAMETER["&quot;scale_factor&quot;;1],PARAMETER["&quot;false_east
in
g&quot;;0],PARAMETER["&quot;false_northing&quot;;0],UNIT["&quot;International
Foot&quot;;0.3048],AXIS["&quot;Easting&quot;;EAST],AXIS["&quot;Northing&quot;;N
O
RT
H]]" AcadCode="" /> <Registration OffsetX="0" OffsetY="0" OffsetZ="0"
ScaleX="1" ScaleY="1" ScaleZ="1" /></SpatialReference>
  
```

PLAN DATA

Plan Title: Default Scenario  
 Plan File : X:\2510000.all\2517400\GeoHecRas\Updated 08-24-2021 Proposed Model.p01

Geometry Title: Default Geometry  
 Geometry File : X:\2510000.all\2517400\GeoHecRas\Updated 08-24-2021 Proposed Model.g01

Flow Title : Default Steady Flow  
 Flow File : X:\2510000.all\2517400\GeoHecRas\Updated 08-24-2021 Proposed Model.f01

Plan Description:  
 Default Scenario

Plan Summary Information:

Number of:	Cross Sections =	55	Multiple Openings =	0
	Culverts =	1	Inline Structures =	0
	Bridges =	0	Lateral Structures =	0

Computational Information

Water surface calculation tolerance =	0.01
Critical depth calculation tolerance =	0.01
Maximum number of iterations =	20
Maximum difference tolerance =	0.33
Flow tolerance factor =	0.001

Computation Options

Critical depth computed only where necessary
Conveyance Calculation Method: At breaks in n values only
Friction Slope Method: Average Conveyance
Computational Flow Regime: Subcritical Flow

FLOW DATA

Flow Title: Default Steady Flow  
 Flow File : X:\2510000.all\2517400\GeoHecRas\Updated 08-24-2021 Proposed Model.f01

Flow Data (cfs)

River	Reach	RS	Flow 1
EXCH	EX CHANNEL	1000	63
EXOF	EX OVERFLOW	1001	42
OVFL	Overflow Channel1000		217

OVFL	Overflow Ch-DS-0998	175
SC01	Sand Creek 998	820
SC01	Sand Creek-DS-0 992	862
SC01	Sand Creek-DS-0-990	1037
SC01	Sand Creek-DS-1 966	1100

Boundary Conditions

River	Reach	Profile	Upstream
	Downstream		
SC01	Sand Creek-DS-1 Flow 1 Critical		

GEOMETRY DATA

Geometry Title: Default Geometry  
 Geometry File : X:\2510000.all\2517400\GeoHecRas\Updated 08-24-2021 Proposed Model.g01

Reach Connection Table

River Boundary	Reach	Upstream Boundary	Downstream
EXCH	EX CHANNEL		Junc-DS02
EXOF	EX OVERFLOW	Junc-DS01	EXOF-SC
OVFL	Overflow Channel		Junc-DS01
OVFL	Overflow Ch-DS-0	Junc-DS01	OF-SC
SC01	Sand Creek		EXOF-SC
SC01	Sand Creek-DS-0	EXOF-SC	OF-SC
SC01	Sand Creek-DS-0-	OF-SC	Junc-DS02
SC01	Sand Creek-DS-1	Junc-DS02	

JUNCTION INFORMATION

Name: Junc-DS01  
 Description:  
 Energy computation Method

Length across River	Junction Reach	Tributary River	Reach	Length
Angle OVFL 0	Overflow Channel to	OVFL	Overflow Ch-DS-0	255.09
OVFL 0	Overflow Channel to	EXOF	EX OVERFLOW	209.74

Name: EXOF-SC  
 Description:  
 Energy computation Method

Length across River	Junction Reach	Tributary River	Reach	Length
Angle SC01 0	Sand Creek to	SC01	Sand Creek-DS-0	26.69
EXOF 0	EX OVERFLOW to	SC01	Sand Creek-DS-0	47.45

Name: OF-SC  
 Description:  
 Energy computation Method

Length across River	Junction Reach	Tributary River	Reach	Length
Angle SC01 0	Sand Creek-DS-0 to	SC01	Sand Creek-DS-0-	100.01
OVFL 0	Overflow Ch-DS-0 to	SC01	Sand Creek-DS-0-	41.97

Name: Junc-DS02  
 Description:  
 Energy computation Method

Length across River	Junction Reach	Tributary River	Reach	Length
Angle SC01 0	Sand Creek-DS-0- to	SC01	Sand Creek-DS-1	21.51
EXCH 0	EX CHANNEL to	SC01	Sand Creek-DS-1	0

CROSS SECTION

RIVER: EXCH  
 REACH: EX CHANNEL RS: 1000

INPUT  
 Description:

Station	Elevation	Data	num=	78	Sta	Elev	Sta	Elev	Sta	Elev
6261.5	0	6261.8	1.46	6261.8	3.02	6261.7	4.57	6261.6	5	
6261	5.14	6261.4	5.29	6261.3	5.43	6261.2	5.58	6261.1	5.72	
6260.5	5.87	6260.9	6.01	6260.8	6.16	6260.7	6.3	6260.6	6.45	
6260	6.59	6260.4	6.75	6260.3	6.93	6260.2	7.11	6260.1	7.29	
6259.5	7.47	6259.9	7.64	6259.8	7.82	6259.7	8	6259.6	8.53	
6259	9.15	6259.4	9.77	6259.3	10.4	6259.2	11.2	6259.1	12.62	
6259.4	19.64	6259	19.81	6259.1	19.98	6259.2	20.15	6259.3	20.32	
6259.9	20.49	6259.5	20.66	6259.6	20.85	6259.7	21.03	6259.8	21.21	
6260.4	21.39	6260	21.57	6260.1	21.76	6260.2	21.94	6260.3	22.12	
6260.9	22.3	6260.5	22.49	6260.6	22.67	6260.7	22.85	6260.8	23.03	
6261.4	23.22	6261	23.41	6261.1	23.6	6261.2	23.8	6261.3	23.99	
6261.9	24.19	6261.5	24.38	6261.6	24.54	6261.7	24.7	6261.8	24.86	
6262.4	25.02	6262	25.18	6262.1	25.34	6262.2	25.5	6262.3	25.66	
6262.9	25.83	6262.5	25.99	6262.6	26.15	6262.7	26.31	6262.8	26.47	
6263.4	26.63	6263	26.79	6263.1	26.95	6263.2	27.11	6263.3	27.27	
	27.44	6263.5	27.95	6263.6	28.88	6263.6				

Manning's n	Values	num=	3
Sta	n Val	Sta	n Val
0	.03	5	.013
		23.99	.03

Bank Sta: Left Right Lengths: Left Channel Right Coeff Contr.  
 Expan. 5 23.99 284.89 284.89 284.89 .1  
 .3

CROSS SECTION OUTPUT Profile #Flow 1

Parameter	Value	Element	Left OB
E.G. Elev (ft)	6260.46		
Channel Right OB			
Vel Head (ft)	0.43	Wt. n-Val.	
0.013			
W.S. Elev (ft)	6260.04	Reach Len. (ft)	284.89
284.89 284.89			
Crit W.S. (ft)	6260.04	Flow Area (sq ft)	
12.01			
E.G. Slope (ft/ft)	0.002746	Area (sq ft)	
12.01			
Q Total (cfs)	63.00	Flow (cfs)	
63.00			
Top Width (ft)	14.23	Top Width (ft)	
14.23			
Vel Total (ft/s)	5.24	Avg. Vel. (ft/s)	
5.24			
Max Chl Dpth (ft)	1.04	Hydr. Depth (ft)	
0.84			
Conv. Total (cfs)	1202.3	Conv. (cfs)	
1202.3			
Length Wtd. (ft)	284.89	Wetted Per. (ft)	
14.66			
Min Ch El (ft)	6259.00	Shear (lb/sq ft)	
0.14			
Alpha	1.00	Stream Power (lb/ft s)	28.88
0.00 0.00			
Frctn Loss (ft)	0.10	Cum Volume (acre-ft)	
0.24			
C & E Loss (ft)	0.12	Cum SA (acres)	
0.12			

Warning: The energy equation could not be balanced within the specified number of iterations. The program used critical depth for the water surface and continued on with the calculations.  
 Warning: The conveyance ratio (upstream conveyance divided by downstream conveyance) is less than 0.7 or greater than 1.4. This may indicate the need for additional cross sections.  
 Warning: The energy loss was greater than 1.0 ft (0.3 m) between the current and previous cross section. This may indicate the need for additional cross sections.  
 Warning: During the standard step iterations, when the assumed water surface was set equal to critical depth, the calculated water surface came back below critical depth. This indicates that there is not a valid subcritical answer. The program defaulted to critical depth.

CROSS SECTION

RIVER: EXCH  
 REACH: EX CHANNEL RS: 999





E.G. Slope (ft/ft)	0.000127	Area (sq ft)	
61.12			
Q Total (cfs)	63.00	Flow (cfs)	
63.00			
Top Width (ft)	21.85	Top Width (ft)	
21.85			
Vel Total (ft/s)	1.03	Avg. Vel. (ft/s)	
1.03			
Max Chl Dpth (ft)	5.24	Hydr. Depth (ft)	
2.80			
Conv. Total (cfs)	5597.5	Conv. (cfs)	
5597.5			
Length Wtd. (ft)	0.00	Wetted Per. (ft)	
24.31			
Min Ch El (ft)	6249.20	Shear (lb/sq ft)	
0.02			
Alpha	1.00	Stream Power (lb/ft s)	46.94
0.00			
Frctn Loss (ft)	0.00	Cum Volume (acre-ft)	
C & E Loss (ft)	0.13	Cum SA (acres)	

Warning: The velocity head has changed by more than 0.5 ft (0.15 m). This may indicate the need for additional cross sections.

CROSS SECTION

RIVER: EXOF  
 REACH: EX OVERFLOW RS: 1001

INPUT  
 Description:

Station	Elevation	Data	num=	62					
Sta	Elev	Sta	Elev	Sta	Elev	Sta	Elev	Sta	Elev
Elev									
-27.78	6270.7	-26.94	6270.7	-22.94	6270.6	-19.83	6270.5	-17.18	
6270.4									
-14.53	6270.3	-11.88	6270.2	-9.23	6270.1	-6.58	6270	-3.93	
6269.9									
-1.28	6269.8	.37	6269.72	.87	6269.7	2.83	6269.6	4.83	
6269.5									
6.82	6269.4	8.81	6269.3	10.8	6269.2	11.28	6269.1	11.65	
6269									
12.03	6268.9	12.41	6268.8	12.79	6268.7	13.17	6268.6	13.55	
6268.5									
13.93	6268.4	14.31	6268.3	14.69	6268.2	14.98	6268.12	15.07	
6268.1									
15.45	6268	15.74	6267.9	15.93	6267.8	16.4	6267.7	16.69	
6267.7									

16.85	6267.8	17.02	6267.9	17.18	6268	17.35	6268.1	17.51
6268.2								
17.68	6268.3	17.84	6268.4	18.01	6268.5	18.17	6268.6	18.34
6268.7								
18.5	6268.8	18.67	6268.9	18.82	6269	18.98	6269.1	20.23
6269.1								
21.99	6269.2	22.73	6269.3	23.48	6269.4	24.22	6269.5	24.97
6269.6								
25.71	6269.7	26.46	6269.8	27.2	6269.9	27.98	6270	30.04
6270.1								
33.26	6270.2	34.47	6270.2					
Manning's n Values		num=	3					
Sta	n Val	Sta	n Val	Sta	n Val			
-27.78	.03	11.28	.013	18.98	.03			
Bank Sta: Left	Right	Lengths: Left	Channel	Right	Coeff	Contr.		
Expan.		11.28	18.98	138.8	138.8	138.8	.1	
.3								
Ineffective Flow	num=	1						
Sta L	Sta R	Elev	Permanent					
-27.78	-17.16	6270.42	F					
Left Levee	Station=	-27.1	Elevation=	6270.72				
Right Levee	Station=	30.02	Elevation=	6270.11				

CROSS SECTION OUTPUT Profile #Flow 1

E.G. Elev (ft)	6270.16	Element	Left OB
Channel Right OB			
Vel Head (ft)	0.00	Wt. n-Val.	0.030
0.013	0.030		
W.S. Elev (ft)	6270.16	Reach Len. (ft)	138.80
138.80	138.80		
Crit W.S. (ft)	6267.77	Flow Area (sq ft)	10.11
13.67	6.71		
E.G. Slope (ft/ft)	0.000000	Area (sq ft)	10.11
13.67	6.71		
Q Total (cfs)	0.04	Flow (cfs)	0.00
0.03	0.00		
Top Width (ft)	42.71	Top Width (ft)	22.06
7.70	12.94		
Vel Total (ft/s)	0.00	Avg. Vel. (ft/s)	0.00
0.00	0.00		
Max Chl Dpth (ft)	2.46	Hydr. Depth (ft)	0.46
1.78	0.52		
Conv. Total (cfs)	2693.3	Conv. (cfs)	297.5
2182.1	213.7		
Length Wtd. (ft)	138.80	Wetted Per. (ft)	22.09
8.29	13.03		
Min Ch El (ft)	6267.70	Shear (lb/sq ft)	0.00
0.00	0.00		

Alpha	2.67	Stream Power (lb/ft s)	34.47
-27.10	30.02		
Frctn Loss (ft)	0.00	Cum Volume (acre-ft)	0.10
0.13	0.05		
C & E Loss (ft)	0.00	Cum SA (acres)	0.10
0.03	0.05		

Warning: The conveyance ratio (upstream conveyance divided by downstream conveyance) is less than 0.7 or greater than 1.4.

This may indicate the need for additional cross sections.

Warning: The split flow optimization for the junction failed to converge within the maximum number of iterations. The results from the final iteration were used.

Note: Multiple critical depths were found at this location. The critical depth with the lowest, valid, energy was used.

CROSS SECTION

RIVER: EXOF  
REACH: EX OVERFLOW RS: 1000

INPUT  
Description:  
Station Elevation Data num= 84

Sta	Elev	Sta	Elev	Sta	Elev	Sta	Elev	Sta	Elev
0	6270.6	.76	6270.6	1.98	6270.5	3.2	6270.4	4.43	
6270.3									
5.65	6270.2	6.87	6270.1	8.1	6270	9.32	6269.9	10.55	
6269.8									
11.86	6269.7	13.18	6269.6	14.51	6269.5	15.84	6269.4	17.16	
6269.3									
19.12	6269.2	21.27	6269.1	22.31	6269.09	35.85	6269	41.17	
6268.9									
41.99	6268.89	43.96	6268.8	47.37	6268.7	48.05	6268.6	48.4	
6268.5									
48.55	6268.4	48.69	6268.3	48.84	6268.2	48.99	6268.1	49.14	
6268									
49.29	6267.9	49.43	6267.8	49.56	6267.7	49.69	6267.6	49.82	
6267.5									
49.96	6267.4	50.09	6267.3	50.22	6267.2	50.35	6267.1	50.48	
6267									
50.61	6266.9	54.45	6266.9	54.6	6267	54.75	6267.1	54.9	
6267.2									
55.06	6267.3	55.21	6267.4	55.36	6267.5	55.51	6267.6	55.67	
6267.7									
55.82	6267.8	55.98	6267.9	56.15	6268	56.31	6268.1	56.48	
6268.2									
56.65	6268.3	56.81	6268.4	57.77	6268.43	60.49	6268.5	62.85	
6268.6									

65.12	6268.7	65.57	6268.8	66.03	6268.9	66.49	6269	66.95
6269.1								
67.41	6269.2	67.87	6269.3	68.32	6269.4	68.78	6269.5	69.24
6269.6								
69.7	6269.7	70.36	6269.8	71.11	6269.9	71.85	6270	72.6
6270.1								
73.77	6270.2	75.1	6270.3	76.43	6270.4	77.87	6270.4	78.31
6270.3								
78.76	6270.2	79.21	6270.1	79.65	6270	79.81	6270	

Manning's n Values num= 3

Sta	n Val	Sta	n Val	Sta	n Val
0	.03	47.37	.013	57.77	.03

Bank Sta: Left Right Lengths: Left Channel Right Coeff Contr.  
Expan. 47.37 57.77 0 0 0 .1  
.3  
Right Levee Station= 76.07 Elevation= 6270.41

CROSS SECTION OUTPUT Profile #Flow 1

E.G. Elev (ft)	6270.16	Element	Left OB
Channel Right OB			
Vel Head (ft)	0.00	Wt. n-Val.	0.030
0.013 0.030			
W.S. Elev (ft)	6270.16	Reach Len. (ft)	47.45
47.45 47.45			
Crit W.S. (ft)	6266.92	Flow Area (sq ft)	39.81
27.04 16.97			
E.G. Slope (ft/ft)	0.000000	Area (sq ft)	39.81
27.04 16.97			
Q Total (cfs)	0.04	Flow (cfs)	0.01
0.03 0.00			
Top Width (ft)	67.13	Top Width (ft)	41.21
10.40 15.51			
Vel Total (ft/s)	0.00	Avg. Vel. (ft/s)	0.00
0.00 0.00			
Max Chl Dpth (ft)	3.26	Hydr. Depth (ft)	0.97
2.60 1.09			
Conv. Total (cfs)	8316.8	Conv. (cfs)	1925.4
5504.3 887.1			
Length Wtd. (ft)	47.45	Wetted Per. (ft)	41.26
11.38 15.66			
Min Ch El (ft)	6266.90	Shear (lb/sq ft)	0.00
0.00 0.00			
Alpha	2.87	Stream Power (lb/ft s)	79.81
0.00 76.07			
Frctn Loss (ft)	0.04	Cum Volume (acre-ft)	0.02
0.06 0.01			
C & E Loss (ft)	0.14	Cum SA (acres)	

Warning: The velocity head has changed by more than 0.5 ft (0.15 m). This may indicate the need for additional cross sections.  
 Note: Multiple critical depths were found at this location. The critical depth with the lowest, valid, energy was used.

CROSS SECTION

RIVER: OVFL  
 REACH: Overflow Channel RS: 1000

INPUT  
 Description:

Station	Elevation	Data	num=	78	Sta	Elev	Sta	Elev	Sta	Elev
0	6272.5	6.84	6272.5	19.1	6272.4	22.75	6272.3	25.46		
6272.2										
27.63	6272.1	29.8	6272	31.97	6271.9	34.14	6271.8	37.09		
6271.7										
39.72	6271.6	42.88	6271.5	46.38	6271.4	49.92	6271.3	53.46		
6271.2										
56.99	6271.1	60.28	6271	63.46	6270.9	66.65	6270.8	69.84		
6270.7										
71.87	6270.6	73.1	6270.5	75.2	6270.4	77.48	6270.3	78.97		
6270.2										
80.03	6270.1	80.74	6270	80.84	6269.9	80.94	6269.8	81.04		
6269.7										
81.14	6269.6	81.23	6269.5	82.37	6269.5	85.34	6269.6	88.52		
6269.7										
91.88	6269.8	95.58	6269.9	99.28	6270	103.82	6270	111.4		
6269.9										
116.73	6269.8	121.02	6269.8	121.23	6269.9	121.7	6270	122.76		
6270.1										
123.82	6270.2	124.88	6270.3	125.93	6270.4	126.99	6270.5	128.05		
6270.6										
129.1	6270.7	130.16	6270.8	131.15	6270.9	131.5	6271	134.06		
6271.1										
138.53	6271.2	142.99	6271.3	147.45	6271.4	151.27	6271.5	154.7		
6271.6										
156.98	6271.7	159.26	6271.8	161.54	6271.9	163.82	6272	166.1		
6272.1										
168.39	6272.2	170.67	6272.3	172.95	6272.4	175.35	6272.5	177.75		
6272.6										
180.28	6272.7	183.71	6272.8	187.06	6272.9	189.71	6273	192.36		
6273.1										
195.02	6273.2	197.9	6273.3	198.12	6273.3					

Manning's n Values num= 3  
 Sta n Val Sta n Val Sta n Val

0 .03 81.14 .016 121.7 .03

Bank Sta: Left Right Lengths: Left Channel Right Coeff Contr.  
 Expan. 81.14 121.7 24.16 24.16 24.16 .1  
 .3

CROSS SECTION OUTPUT Profile #Flow 1

Element	Value	Unit
E.G. Elev (ft)	6271.20	
Channel Right OB		
Vel Head (ft)	0.42	Wt. n-Val.
0.016	0.030	0.030
W.S. Elev (ft)	6270.78	Reach Len. (ft)
24.16	24.16	24.16
Crit W.S. (ft)	6270.78	Flow Area (sq ft)
38.30	3.20	4.67
E.G. Slope (ft/ft)	0.003604	Area (sq ft)
38.30	3.20	4.67
Q Total (cfs)	217.00	Flow (cfs)
205.26	5.07	6.67
Top Width (ft)	62.59	Top Width (ft)
40.56	8.23	13.80
Vel Total (ft/s)	4.70	Avg. Vel. (ft/s)
5.36	1.58	1.43
Max Chl Dpth (ft)	1.28	Hydr. Depth (ft)
0.94	0.39	0.34
Conv. Total (cfs)	3614.5	Conv. (cfs)
3419.0	84.4	111.1
Length Wtd. (ft)	24.16	Wetted Per. (ft)
40.65	8.27	13.99
Min Ch El (ft)	6269.50	Shear (lb/sq ft)
0.21	0.09	0.08
Alpha	1.24	Stream Power (lb/ft s)
0.00	0.00	198.12
Frctn Loss (ft)	0.09	Cum Volume (acre-ft)
0.25	0.01	0.02
C & E Loss (ft)	0.00	Cum SA (acres)
0.02	0.00	0.01

Warning: The energy equation could not be balanced within the specified number of iterations. The program used critical depth for the water surface and continued on with the calculations.  
 Warning: During the standard step iterations, when the assumed water surface was set equal to critical depth, the calculated water surface came back below critical depth. This indicates that there is not a valid subcritical answer. The program defaulted to critical depth.

CROSS SECTION

RIVER: OVFL  
 REACH: Overflow Channel RS: 999

INPUT

Description:

Station	Elevation	Data	num=	67	Sta	Elev	Sta	Elev	Sta	Elev
6271.2	0	6271.5	32.18	6271.5	39.29	6271.4	43.62	6271.3	47.59	
6270.7	51.08	6271.1	54.32	6271	57.34	6270.9	60.28	6270.8	63.22	
6270.2	66.16	6270.6	69.11	6270.5	72.05	6270.4	74.52	6270.3	75.88	
6269.7	77.24	6270.1	78.61	6270	80.54	6269.9	82.25	6269.8	83.31	
6269.2	83.7	6269.6	83.8	6269.5	83.9	6269.4	84	6269.3	84.1	
6269.4	84.2	6269.1	85.11	6269.1	86.96	6269.2	90.43	6269.3	94.01	
6269.4	97.72	6269.5	101.43	6269.6	107.82	6269.6	115.44	6269.5	122.9	
6269.4	123.81	6269.4	123.91	6269.5	124	6269.6	124.1	6269.7	124.18	
6270.3	124.25	6269.9	124.47	6270	125.74	6270.1	127.01	6270.2	128.28	
6270.8	129.54	6270.4	130.9	6270.5	132.39	6270.6	133.95	6270.7	136.77	
6271.3	139.6	6270.9	142.43	6271	145.25	6271.1	148.08	6271.2	150.93	
6271.8	154.76	6271.4	158.6	6271.5	162.19	6271.6	164.85	6271.7	167.51	
6272.3	170.17	6271.9	172.83	6272	175.49	6272.1	179.83	6272.2	182.81	
	185.79	6272.4	186.08	6272.4						

Manning's n Values		num=		3	
Sta	n Val	Sta	n Val	Sta	n Val
0	.03	83.31	.016	124.47	.03

Bank Sta:	Left	Right	Lengths:	Left Channel	Right	Coeff	Contr.
Expan.	83.31	124.47		0	0		.1
	.3						

CROSS SECTION OUTPUT Profile #Flow 1

E.G. Elev (ft)	6270.85	Element	Left OB
Channel Right OB			
Vel Head (ft)	0.44	Wt. n-Val.	0.030

0.016	0.030		
W.S. Elev (ft)	6270.41	Reach Len. (ft)	
Crit W.S. (ft)	6270.41	Flow Area (sq ft)	3.71
38.98	1.04	E.G. Slope (ft/ft)	0.003698
38.98	1.04	Area (sq ft)	3.71
Q Total (cfs)	217.00	Flow (cfs)	5.26
210.66	1.08	Top Width (ft)	11.42
41.16	5.14	Avg. Vel. (ft/s)	1.42
5.40	1.04	Hydr. Depth (ft)	0.32
Max Chl Dpth (ft)	1.31	Conv. (cfs)	86.5
0.95	0.20	Wetted Per. (ft)	11.44
Conv. Total (cfs)	3568.5	Shear (lb/sq ft)	0.07
3464.2	17.8	Stream Power (lb/ft s)	186.08
Length Wtd. (ft)		Cum Volume (acre-ft)	0.02
41.64	5.16	Cum SA (acres)	0.09
Min Ch El (ft)	6269.10		
0.22	0.05		
Alpha	1.15		
0.00	0.00		
Frctn Loss (ft)	0.21		
0.23	0.01		
C & E Loss (ft)	0.09		

Warning: The energy equation could not be balanced within the specified number of iterations. The program used critical depth for the water surface and continued on with the calculations.  
 Warning: A flow split was encountered. The program first calculated the momentum of both channels below the junction. An energy balance was performed across the junction from the stream with the highest momentum downstream to the section upstream.  
 Warning: The energy loss was greater than 1.0 ft (0.3 m). between the current and previous cross section. This may indicate the need for additional cross sections.  
 Warning: During the standard step iterations, when the assumed water surface was set equal to critical depth, the calculated water surface came back below critical depth. This indicates that there is not a valid subcritical answer. The program defaulted to critical depth.

CROSS SECTION

RIVER: OVFL  
 REACH: Overflow Ch-DS-0 RS: 998

INPUT  
Description:  
Station Elevation Data num= 73  
Sta Elev Sta Elev Sta Elev Sta Elev Sta Elev

Elev	0	6269.5	.23	6269.5	.88	6269.6	1.53	6269.7	2.18
6269.8	2.83	6269.9	3.48	6270	4.13	6270.1	4.78	6270.2	5.42
6270.3	6.07	6270.4	6.71	6270.5	7.35	6270.6	7.85	6270.68	8.01
6270.7	8.5	6270.7	8.6	6270.6	8.7	6270.5	8.8	6270.4	8.9
6270.3	9	6270.2	9.1	6270.1	9.2	6270	9.3	6269.9	9.4
6269.8	9.5	6269.7	9.6	6269.6	9.7	6269.5	9.8	6269.4	9.9
6269.3	10	6269.2	10.1	6269.1	10.2	6269	10.3	6268.9	10.4
6268.8	10.5	6268.7	10.6	6268.6	10.7	6268.5	10.79	6268.4	10.89
6268.3	10.99	6268.2	11.09	6268.1	11.19	6268	14.2	6267.9	22.78
6267.8	30.95	6267.7	34.7	6267.65	39.11	6267.6	48.43	6267.5	53.38
6267.5	53.48	6267.6	53.58	6267.7	53.68	6267.8	53.78	6267.9	53.88
6268	53.98	6268.1	54.08	6268.2	54.17	6268.3	54.27	6268.4	54.37
6268.5	54.47	6268.6	54.57	6268.7	54.67	6268.8	54.78	6268.9	54.9
6269	55.02	6269.1	55.14	6269.2	55.25	6269.3	55.28	6269.32	55.37
6269.4	60.11	6269.4	65.13	6269.3	65.96	6269.3			

Manning's n Values num= 3  
Sta n Val Sta n Val Sta n Val  
0 .03 7.85 .013 55.28 .03

Bank Sta: Left Right Lengths: Left Channel Right Coeff Contr.  
Expan. 7.85 55.28 132.75 132.75 132.75 .1

.3  
Ineffective Flow num= 2  
Sta L Sta R Elev Permanent  
0 7.62 6270.67 F  
58.63 65.96 6270.22 F  
Left Levee Station= 8.46 Elevation= 6270.7  
Right Levee Station= 55.55 Elevation= 6270.2

CROSS SECTION OUTPUT Profile #Flow 1

E.G. Elev (ft)	6269.51	Element	Left OB
Channel Right OB			
Vel Head (ft)	0.13	Wt. n-Val.	
0.013 0.000			
W.S. Elev (ft)	6269.38	Reach Len. (ft)	132.75
132.75 132.75			
Crit W.S. (ft)	6268.61	Flow Area (sq ft)	
73.99 0.00			
E.G. Slope (ft/ft)	0.000357	Area (sq ft)	
73.99 0.00			
Q Total (cfs)	216.98	Flow (cfs)	
216.98 0.00			
Top Width (ft)	45.53	Top Width (ft)	
45.46 0.07			
Vel Total (ft/s)	2.93	Avg. Vel. (ft/s)	
2.93 0.07			
Max Chl Dpth (ft)	1.88	Hydr. Depth (ft)	
1.63 0.03			
Conv. Total (cfs)	11480.7	Conv. (cfs)	
11480.7 0.0			
Length Wtd. (ft)	132.75	Wetted Per. (ft)	
46.77 0.09			
Min Ch El (ft)	6267.50	Shear (lb/sq ft)	
0.04			
Alpha	1.00	Stream Power (lb/ft s)	65.96
8.46 55.55			
Frctn Loss (ft)	0.08	Cum Volume (acre-ft)	0.02
0.41 0.01			
C & E Loss (ft)	0.01	Cum SA (acres)	0.00
0.14 0.00			

Warning: The conveyance ratio (upstream conveyance divided by downstream conveyance) is less than 0.7 or greater than 1.4.

This may indicate the need for additional cross sections.

Warning: The split flow optimization for the junction failed to converge within the maximum number of iterations. The results from the final iteration were used.

Note: Multiple critical depths were found at this location. The critical depth with the lowest, valid, energy was used.

CROSS SECTION

RIVER: OVFL  
REACH: Overflow Ch-DS-0 RS: 997

INPUT  
Description:  
Station Elevation Data num= 87  
Sta Elev Sta Elev Sta Elev Sta Elev Sta Elev

-7.48	6270.1	-6.96	6270.1	-4.51	6270	-2.05	6269.9	1.62
6269.8								
4.68	6269.7	7.62	6269.6	11.47	6269.5	12.12	6269.4	12.77
6269.3								
13.37	6269.2	13.91	6269.1	14.45	6269	14.88	6268.92	14.99
6268.9								
15.33	6268.8	15.61	6268.7	15.88	6268.6	16.16	6268.5	16.44
6268.4								
16.71	6268.3	16.99	6268.2	17.27	6268.1	17.55	6268	17.82
6267.9								
18.1	6267.8	18.38	6267.7	18.65	6267.6	18.93	6267.5	19.21
6267.4								
19.48	6267.3	19.76	6267.2	20.04	6267.1	20.31	6267	20.59
6266.9								
20.87	6266.8	21.15	6266.7	21.42	6266.6	21.7	6266.5	21.98
6266.4								
22.25	6266.3	42.77	6266.3	42.95	6266.4	43.14	6266.5	43.32
6266.6								
43.5	6266.7	43.69	6266.8	43.87	6266.9	44.06	6267	44.24
6267.1								
44.43	6267.2	44.61	6267.3	44.8	6267.4	44.98	6267.5	45.17
6267.6								
45.35	6267.7	45.54	6267.8	45.72	6267.9	45.91	6268	46.09
6268.1								
46.28	6268.2	46.46	6268.3	46.65	6268.4	46.83	6268.5	47
6268.6								
47.17	6268.7	47.35	6268.8	47.52	6268.9	47.69	6269	47.98
6269.1								
48.27	6269.2	48.56	6269.3	48.85	6269.4	49.14	6269.5	49.43
6269.6								
60.99	6269.7	76.9	6269.7	80.09	6269.6	83.27	6269.5	86.45
6269.4								
89.64	6269.3	92.82	6269.2	96	6269.1	99.18	6269	102.37
6268.9								
105.55	6268.8	106.52	6268.8					

Manning's n Values	num=	3
Sta n Val	Sta n Val	Sta n Val
-7.48 .03 14.88	.033 47.69	.03

Bank Sta: Left	Right	Lengths: Left	Channel	Right	Coeff	Contr.
Expan.	14.88	47.69	24.72	24.72	24.72	.1
.3						
Left Levee	Station=	11.26	Elevation=	6269.52		
Right Levee	Station=	49.45	Elevation=	6269.62		

CROSS SECTION OUTPUT Profile #Flow 1

E.G. Elev (ft)	6269.43	Element	Left OB
Channel Right OB			
Vel Head (ft)	0.11	Wt. n-Val.	0.030

0.033	0.030				
W.S. Elev (ft)	6269.32	Reach Len. (ft)	24.72		
24.72	24.72				
Crit W.S. (ft)	6267.74	Flow Area (sq ft)	0.45		
82.84	0.15				
E.G. Slope (ft/ft)	0.001027	Area (sq ft)	0.45		
82.84	0.15				
Q Total (cfs)	216.98	Flow (cfs)	0.24		
216.67	0.07				
Top Width (ft)	36.02	Top Width (ft)	2.27		
32.81	0.94				
Vel Total (ft/s)	2.60	Avg. Vel. (ft/s)	0.53		
2.62	0.45				
Max Chl Dpth (ft)	3.02	Hydr. Depth (ft)	0.20		
2.52	0.16				
Conv. Total (cfs)	6769.7	Conv. (cfs)	7.4		
6760.2	2.2				
Length Wtd. (ft)	24.72	Wetted Per. (ft)	2.30		
33.96	1.00				
Min Ch El (ft)	6266.30	Shear (lb/sq ft)	0.01		
0.16	0.01				
Alpha	1.01	Stream Power (lb/ft s)	106.52		
11.26	49.45				
Frctn Loss (ft)	0.02	Cum Volume (acre-ft)	0.02		
0.18	0.01				
C & E Loss (ft)	0.01	Cum SA (acres)	0.00		
0.02	0.00				

Note: Multiple critical depths were found at this location. The critical depth with the lowest, valid, energy was used.

CROSS SECTION

RIVER: OVFL  
REACH: Overflow Ch-DS-0 RS: 996

INPUT									
Description:									
Station	Elevation	Data	num=	92					
Sta	Elev	Sta	Elev	Sta	Elev	Sta	Elev	Sta	Elev
Elev									
0	6270.1	.51	6270.1	2.27	6270	3.98	6269.9	5.59	
6269.8									
7.14	6269.7	8.3	6269.62	8.61	6269.6	9.99	6269.5	11.27	
6269.4									
12.41	6269.3	13.29	6269.2	13.95	6269.1	14.62	6269	15.29	
6268.9									
15.96	6268.8	16.63	6268.7	17.29	6268.6	17.96	6268.5	18.63	
6268.4									
19.3	6268.3	19.96	6268.2	20.63	6268.1	21.3	6268	21.97	



107.47	6273.2	109.19	6273.1	110.91	6273	112.64	6272.9	114.36
6272.8								
116.09	6272.7	117.81	6272.6	119.77	6272.5	121.72	6272.4	124.95
6272.3								
128.22	6272.2	129.6	6272.1	130.73	6272	131.86	6271.9	133
6271.8								
134.13	6271.7	134.45	6271.6	134.69	6271.5	134.93	6271.4	135.19
6271.3								
135.45	6271.2	135.7	6271.1	135.96	6271	136.22	6270.9	136.48
6270.8								
136.74	6270.7	137	6270.6	137.26	6270.5	137.52	6270.4	137.78
6270.3								
138.04	6270.2	138.3	6270.1	138.56	6270	138.81	6269.9	139.07
6269.8								
139.33	6269.7	139.59	6269.6	139.81	6269.5	140.01	6269.4	140.22
6269.3								
140.42	6269.2	140.62	6269.1	140.83	6269	141.03	6268.9	141.24
6268.8								
141.44	6268.7	141.65	6268.6	141.83	6268.5	142.01	6268.4	142.19
6268.3								
142.38	6268.2	142.56	6268.1	142.74	6268	142.92	6267.9	143.1
6267.8								
143.29	6267.7	143.47	6267.6	143.62	6267.5	143.77	6267.4	143.92
6267.3								
144.06	6267.2	144.21	6267.1	144.36	6267	144.51	6266.9	144.65
6266.8								
144.8	6266.7	144.95	6266.6	145.09	6266.5	145.24	6266.4	145.39
6266.3								
145.52	6266.2	145.65	6266.1	145.79	6266	145.92	6265.9	146.05
6265.8								
146.19	6265.7	146.32	6265.6	150.01	6265.52	151.21	6265.5	152.65
6265.5								
153.56	6265.6	153.71	6265.7	153.87	6265.8	154.03	6265.9	154.18
6266								
154.34	6266.1	154.5	6266.2	154.65	6266.3	154.81	6266.4	154.97
6266.5								
155.12	6266.6	155.27	6266.7	155.42	6266.8	155.57	6266.9	155.73
6267								
155.88	6267.1	156.03	6267.2	156.18	6267.3	156.33	6267.4	156.48
6267.5								
156.63	6267.6	156.81	6267.7	156.98	6267.8	157.16	6267.9	157.34
6268								
157.51	6268.1	157.69	6268.2	157.86	6268.3	158.04	6268.4	158.21
6268.5								
158.39	6268.6	158.56	6268.7	158.74	6268.8	158.92	6268.9	159.09
6269								
159.27	6269.1	159.44	6269.2	159.62	6269.3	159.79	6269.4	159.97
6269.5								
160.54	6269.6	162.69	6269.7	165.02	6269.8	167.45	6269.9	169.96
6270								
172.48	6270.1	175.02	6270.2	177.57	6270.3	180.12	6270.4	182.67
6270.5								
185.22	6270.6	187.77	6270.7	190.31	6270.8	192.86	6270.9	195.41

6271								
197.96	6271.1	200.49	6271.2	203.01	6271.3	205.54	6271.4	208.06
6271.5								
211.16	6271.6	215.04	6271.7	219.38	6271.8	224.24	6271.9	232.83
6272								
253.5	6272.1	276.06	6272.1	286.06	6272	290.37	6271.9	293.51
6271.8								
296.08	6271.7	298.25	6271.6	300	6271.6			
Manning's n Values			num=	3				
Sta n Val	Sta n Val	Sta n Val						
0	.03	139.07	.013	160.54	.03			
Bank Sta: Left	Right	Lengths: Left	Channel	Right	Coeff	Contr.		
Expan.								
	139.07	160.54	33.99	33.99	33.99	.1		
.3								
Left Levee	Station=	45.54	Elevation=	6275.08				
Right Levee	Station=	232.75	Elevation=	6272.02				
CROSS SECTION OUTPUT	Profile #Flow 1							
E.G. Elev (ft)	6272.28	Element		Left OB				
Channel Right OB								
Vel Head (ft)	1.39	Wt. n-Val.		0.030				
0.013	0.030							
W.S. Elev (ft)	6270.89	Reach Len. (ft)		33.99				
33.99	33.99							
Crit W.S. (ft)	6270.89	Flow Area (sq ft)		1.53				
82.03	20.23							
E.G. Slope (ft/ft)	0.001362	Area (sq ft)		1.53				
82.03	20.23							
Q Total (cfs)	820.00	Flow (cfs)		1.78				
791.01	27.21							
Top Width (ft)	56.32	Top Width (ft)		2.82				
21.47	32.03							
Vel Total (ft/s)	7.90	Avg. Vel. (ft/s)		1.16				
9.64	1.34							
Max Chl Dpth (ft)	5.39	Hydr. Depth (ft)		0.54				
3.82	0.63							
Conv. Total (cfs)	22217.5	Conv. (cfs)		48.2				
21432.0	737.2							
Length Wtd. (ft)	33.99	Wetted Per. (ft)		3.02				
23.74	32.06							
Min Ch El (ft)	6265.50	Shear (lb/sq ft)		0.04				
0.29	0.05							
Alpha	1.44	Stream Power (lb/ft s)		300.00				
45.54	232.75							
Frctn Loss (ft)	0.04	Cum Volume (acre-ft)		0.00				
0.11	0.04							
C & E Loss (ft)	0.04	Cum SA (acres)		0.00				
0.02	0.03							



Warning: The energy equation could not be balanced within the specified number of iterations. The program used critical depth for the water surface and continued on with the calculations.  
 Warning: During the standard step iterations, when the assumed water surface was set equal to critical depth, the calculated water surface came back below critical depth. This indicates that there is not a valid subcritical answer. The program defaulted to critical depth.  
 Note: Multiple critical depths were found at this location. The critical depth with the lowest, valid, energy was used.

CROSS SECTION

RIVER: SC01  
 REACH: Sand Creek RS: 993

INPUT  
 Description:

Station	Elevation	Data	num=	235					
Sta	Elev	Sta	Elev	Sta	Elev	Sta	Elev	Sta	Elev
Elev	0	6275.9	1.05	6275.9	2.47	6275.8	3.9	6275.7	5.33
6275.6	23.88	6275.6	31.7	6275.5	33	6275.4	34.29	6275.3	35.59
6275.2	36.89	6275.1	38.18	6275	39.48	6274.9	40.78	6274.8	42.08
6274.7	43.77	6274.6	45.56	6274.5	47.35	6274.4	49.19	6274.3	51.35
6274.2	53.57	6274.1	54.72	6274.2	56.01	6274	57.87	6273.9	60.22
6273.8	63.01	6273.8	66.37	6273.9	66.49	6273.9	72.12	6274	72.36
6274.1	75.96	6274.1	78.03	6274.2	80.09	6274.3	82.15	6274.4	84.22
6274.5	86.28	6274.6	88.34	6274.7	90.4	6274.8	91.31	6274.9	91.53
6275	91.76	6275.1	91.98	6275.2	92.44	6275.2	94.3	6275.1	96.17
6275	98.04	6274.9	99.9	6274.8	101.77	6274.7	103.63	6274.6	105.48
6274.5	107.29	6274.4	109.11	6274.3	110.92	6274.2	112.74	6274.1	114.55
6274	116.37	6273.9	118.18	6273.8	120	6273.7	121.85	6273.6	123.79
6273.5	124.77	6273.5	124.89	6273.6	125	6273.7	125.11	6273.8	125.42
6273.8	125.81	6273.7	126.19	6273.6	126.74	6273.5	127.44	6273.4	128.15
6273.3									

128.85	6273.2	129.56	6273.1	130.27	6273	130.97	6272.9	131.73	6272.8
132.53	6272.7	133.34	6272.6	134.05	6272.5	134.3	6272.4	134.55	6272.3
134.8	6272.2	135.05	6272.1	135.31	6272	135.56	6271.9	135.81	6271.8
136.06	6271.7	136.31	6271.6	136.56	6271.5	136.81	6271.4	137.06	6271.3
137.32	6271.2	137.57	6271.1	137.82	6271	138.07	6270.9	138.32	6270.8
138.57	6270.7	138.82	6270.6	139.07	6270.5	139.33	6270.4	139.58	6270.3
139.83	6270.2	140.08	6270.1	140.33	6270	140.58	6269.9	140.84	6269.8
141.09	6269.7	141.34	6269.6	141.59	6269.5	141.76	6269.4	141.92	6269.3
142.09	6269.2	142.25	6269.1	142.42	6269	142.59	6268.9	142.75	6268.8
142.92	6268.7	143.09	6268.6	143.25	6268.5	143.42	6268.4	143.58	6268.3
143.75	6268.2	143.92	6268.1	144.08	6268	144.28	6267.9	144.48	6267.8
144.69	6267.7	144.89	6267.6	145.09	6267.5	145.26	6267.4	145.42	6267.3
145.59	6267.2	145.76	6267.1	145.92	6267	146.09	6266.9	146.26	6266.8
146.42	6266.7	146.59	6266.6	146.76	6266.5	146.92	6266.4	147.09	6266.3
147.25	6266.2	147.38	6266.1	147.51	6266	147.64	6265.9	147.81	6265.8
147.97	6265.7	148.14	6265.6	148.31	6265.5	148.47	6265.4	150.16	6265.3
151.95	6265.2	152.65	6265.2	153.99	6265.3	155.38	6265.4	155.71	6265.5
155.88	6265.6	156.05	6265.7	156.22	6265.8	156.39	6265.9	156.57	6266
156.74	6266.1	156.9	6266.2	157.06	6266.3	157.21	6266.4	157.37	6266.5
157.54	6266.6	157.71	6266.7	157.88	6266.8	158.05	6266.9	158.22	6267
158.39	6267.1	158.56	6267.2	158.74	6267.3	158.91	6267.4	159.08	6267.5
159.25	6267.6	159.42	6267.7	159.59	6267.8	159.76	6267.9	159.93	6268
160.1	6268.1	160.27	6268.2	160.44	6268.3	160.61	6268.4	160.79	6268.5
160.96	6268.6	161.13	6268.7	161.55	6268.7	163.9	6268.8	166.25	6268.9
168.6	6269	170.95	6269.1	172.4	6269.2	172.82	6269.3	173.25	6269.4
173.67	6269.5	174.83	6269.6	177.34	6269.7	179.87	6269.8	183.68	6269.9
187.5	6270	191.32	6270.1	195.14	6270.2	198.98	6270.3	202.82	

6270.4  
 205.93 6270.5 207.75 6270.6 209.56 6270.7 211.38 6270.8 213.19  
 6270.9  
 215.01 6271 216.82 6271.1 218.63 6271.2 220.45 6271.3 223.18  
 6271.3  
 226.6 6271.2 230.01 6271.1 233.43 6271 236.64 6270.9 239.76  
 6270.8  
 242.89 6270.7 246.02 6270.6 249.15 6270.5 252.27 6270.4 260.61  
 6270.4  
 284.15 6270.5 286.02 6270.6 287.88 6270.7 289.75 6270.8 291.61  
 6270.9  
 293.48 6271 295.35 6271.1 297.21 6271.2 299.81 6271.3 300.27  
 6271.3

Manning's n Values num= 3  
 Sta n Val Sta n Val Sta n Val  
 0 .03 142.92 .013 160.96 .03

Bank Sta: Left Right Lengths: Left Channel Right Coeff Contr.  
 Expan. 142.92 160.96 40.51 40.51 40.51 .1  
 .3

Ineffective Flow num= 2  
 Sta L Sta R Elev Permanent  
 0 90.77 6274.92 F  
 225.62 300.27 6271.28 F  
 Left Levee Station= 92.44 Elevation= 6275.22  
 Right Levee Station= 221.44 Elevation= 6271.34

CROSS SECTION OUTPUT Profile #Flow 1

E.G. Elev (ft)	6272.00	Element	Left OB
Channel Right OB			
Vel Head (ft)	1.26	Wt. n-Val.	0.030
0.013 0.030			
W.S. Elev (ft)	6270.74	Reach Len. (ft)	26.69
26.69 26.69			
Crit W.S. (ft)	6270.74	Flow Area (sq ft)	4.11
78.94 45.19			
E.G. Slope (ft/ft)	0.001080	Area (sq ft)	4.11
78.94 45.19			
Q Total (cfs)	820.00	Flow (cfs)	5.94
744.73 69.33			
Top Width (ft)	71.77	Top Width (ft)	4.44
18.04 49.29			
Vel Total (ft/s)	6.39	Avg. Vel. (ft/s)	1.45
9.43 1.53			
Max Chl Dpth (ft)	5.54	Hydr. Depth (ft)	0.92
4.38 0.92			
Conv. Total (cfs)	24955.3	Conv. (cfs)	180.7
22664.8 2109.9			
Length Wtd. (ft)	26.69	Wetted Per. (ft)	4.90

19.83 49.39			
Min Ch El (ft)	6265.20	Shear (lb/sq ft)	0.06
0.27 0.06			
Alpha	1.98	Stream Power (lb/ft s)	300.27
92.44 221.44			
Frctn Loss (ft)	0.04	Cum Volume (acre-ft)	0.00
0.05 0.01			
C & E Loss (ft)	0.01	Cum SA (acres)	

Warning: The energy equation could not be balanced within the specified number of iterations. The program used critical depth for the water surface and continued on with the calculations.  
 Warning: The energy loss was greater than 1.0 ft (0.3 m) between the current and previous cross section. This may indicate the need for additional cross sections.  
 Warning: During the standard step iterations, when the assumed water surface was set equal to critical depth, the calculated water surface came back below critical depth. This indicates that there is not a valid subcritical answer. The program defaulted to critical depth.  
 Note: Multiple critical depths were found at this location. The critical depth with the lowest, valid, energy was used.

CROSS SECTION

RIVER: SC01  
 REACH: Sand Creek-DS-0 RS: 992

INPUT  
 Description:  
 Station Elevation Data num= 234  
 Sta Elev Sta Elev Sta Elev Sta Elev Sta  
 Elev 0 6275.2 24.42 6275.2 28.89 6275.1 33.36 6275 37.83  
 6274.9  
 42.3 6274.8 46.77 6274.7 51.24 6274.6 52.72 6274.5 52.82  
 6274.4  
 52.93 6274.3 53.04 6274.2 53.15 6274.1 56.09 6274.1 57.83  
 6274.2  
 59.57 6274.3 65.43 6274.3 83.8 6274.2 90.51 6274.1 92.85  
 6274  
 95.19 6273.9 97.53 6273.8 99.87 6273.7 102.22 6273.6 104.56  
 6273.5  
 106.9 6273.4 109.24 6273.3 111.58 6273.2 113.93 6273.1 116.17  
 6273  
 118.35 6272.9 120.53 6272.8 121.62 6272.8 122.28 6272.9 122.94  
 6273  
 123.75 6273.1 124.66 6273.2 125.3 6273.2 125.51 6273.1 125.72  
 6273

125.93	6272.9	126.14	6272.8	126.36	6272.7	126.57	6272.6	126.78
6272.5								
126.99	6272.4	127.2	6272.3	127.42	6272.2	127.63	6272.1	127.84
6272								
128.05	6271.9	128.26	6271.8	128.48	6271.7	128.69	6271.6	128.9
6271.5								
129.11	6271.4	129.43	6271.3	129.77	6271.2	130.07	6271.1	130.38
6271								
130.68	6270.9	130.99	6270.8	131.29	6270.7	131.6	6270.6	131.9
6270.5								
132.21	6270.4	132.52	6270.3	132.82	6270.2	133.13	6270.1	133.43
6270								
133.74	6269.9	134.04	6269.8	134.31	6269.7	134.59	6269.6	134.8
6269.5								
135.01	6269.4	135.21	6269.3	135.42	6269.2	135.63	6269.1	135.83
6269								
136.04	6268.9	136.25	6268.8	136.45	6268.7	136.66	6268.6	136.87
6268.5								
137.07	6268.4	137.28	6268.3	137.49	6268.2	137.69	6268.1	137.9
6268								
138.11	6267.9	138.31	6267.8	138.52	6267.7	138.73	6267.6	138.93
6267.5								
139.14	6267.4	139.35	6267.3	139.56	6267.2	139.77	6267.1	139.98
6267								
140.19	6266.9	140.39	6266.8	140.6	6266.7	140.81	6266.6	141.02
6266.5								
141.23	6266.4	141.44	6266.3	141.65	6266.2	141.85	6266.1	142.06
6266								
142.27	6265.9	142.48	6265.8	142.69	6265.7	142.9	6265.6	143.11
6265.5								
143.31	6265.4	143.52	6265.3	143.73	6265.2	143.94	6265.1	144.15
6265								
144.36	6264.9	144.57	6264.8	144.77	6264.7	144.98	6264.6	145.19
6264.5								
145.4	6264.4	145.61	6264.3	156	6264.3	156.25	6264.4	156.5
6264.5								
156.75	6264.6	157	6264.7	157.25	6264.8	157.5	6264.9	157.75
6265								
158	6265.1	158.25	6265.2	158.5	6265.3	158.75	6265.4	159
6265.5								
159.25	6265.6	159.5	6265.7	159.75	6265.8	160	6265.9	160.25
6266								
160.5	6266.1	160.75	6266.2	161	6266.3	161.25	6266.4	161.5
6266.5								
161.75	6266.6	162	6266.7	162.25	6266.8	162.5	6266.9	162.75
6267								
163	6267.1	163.25	6267.2	163.5	6267.3	163.75	6267.4	164
6267.5								
164.25	6267.6	164.5	6267.7	164.75	6267.8	165	6267.9	165.25
6268								
165.5	6268.1	165.75	6268.2	166	6268.3	166.25	6268.4	166.5
6268.5								
166.82	6268.6	167.14	6268.7	167.46	6268.8	167.78	6268.9	168.04

6268.97								
168.18	6269	168.9	6269.1	169.62	6269.2	170.35	6269.3	171.07
6269.4								
171.79	6269.5	172.38	6269.59	172.48	6269.6	172.88	6269.7	173.28
6269.8								
173.68	6269.9	174.08	6270	174.48	6270.1	174.88	6270.2	175.28
6270.3								
175.68	6270.4	176.08	6270.5	176.29	6270.5	177.45	6270.4	178.6
6270.3								
179.76	6270.2	180.91	6270.1	182.06	6270	183.61	6269.9	185.04
6269.8								
186.47	6269.7	187.9	6269.6	189.33	6269.5	190.76	6269.4	192.19
6269.3								
193.63	6269.2	195.06	6269.1	196.49	6269	197.92	6268.9	199.35
6268.8								
200.78	6268.7	202.21	6268.6	218.17	6268.6	249.61	6268.7	252.54
6268.7								
256.2	6268.6	259.87	6268.5	263.53	6268.4	266.25	6268.4	267.2
6268.3								
267.59	6268.3	272.49	6268.4	280.68	6268.5	283.34	6268.6	284.27
6268.7								
285.21	6268.8	286.14	6268.9	290.42	6269	290.56	6269.01	292.54
6269.1								
294.65	6269.2	296.76	6269.3	298.88	6269.4	300.03	6269.4	
Manning's n Values	num=	3						
Sta n Val	Sta n Val	Sta n Val						
0 .03	135.42	.013	168.18	.03				
Bank Sta: Left	Right	Lengths: Left	Channel	Right	Coeff	Contr.		
Expan.								
	135.42	168.18		11.58	11.58	11.58		.1
.3								
Ineffective Flow	num=	2						
Sta L	Sta R	Elev	Permanent					
0	59.57	6274.35	F					
169.59	300.03	6269.49	F					
Left Levee	Station=	124.12	Elevation=	6273.2				
Right Levee	Station=	172.46	Elevation=	6269.59				
CROSS SECTION OUTPUT	Profile #Flow 1							
E.G. Elev (ft)	6269.98	Element						Left OB
Channel Right OB								
Vel Head (ft)	1.40	Wt. n-Val.						
0.013								
W.S. Elev (ft)	6268.57	Reach Len. (ft)						11.58
11.58	11.58							
Crit W.S. (ft)	6268.57	Flow Area (sq ft)						
86.27								
E.G. Slope (ft/ft)	0.001829	Area (sq ft)						
86.27								





0	6271.5	1.25	6271.5	14.06	6271.4	25.09	6271.3	32.78
6271.2								
39.93	6271.1	46.38	6271	52.82	6270.9	58.95	6270.8	62.24
6270.7								
74.21	6270.7	86.91	6270.6	87.78	6270.5	88.74	6270.4	89.79
6270.3								
90.83	6270.2	91.88	6270.1	92.92	6270	93.97	6269.9	95.02
6269.8								
96.06	6269.7	97.11	6269.6	98.15	6269.5	99.2	6269.4	100.25
6269.3								
101.29	6269.2	102.34	6269.1	103.39	6269	104.43	6268.9	105.48
6268.8								
106.52	6268.7	107.57	6268.6	108.62	6268.5	109.85	6268.4	111.35
6268.3								
112.85	6268.2	114.35	6268.1	115.86	6268	117.29	6267.9	118.15
6267.8								
119.02	6267.7	119.88	6267.6	120.74	6267.5	121.1	6267.4	121.3
6267.3								
121.51	6267.2	121.71	6267.1	121.89	6267	123.09	6266.9	128.09
6266.8								
133.09	6266.7	138	6266.6	138.2	6266.5	138.4	6266.4	138.6
6266.3								
138.8	6266.2	139	6266.1	139.2	6266	139.4	6265.9	139.6
6265.8								
139.8	6265.7	140	6265.6	140.2	6265.5	140.4	6265.4	140.6
6265.3								
140.8	6265.2	141	6265.1	141.2	6265	141.4	6264.9	141.6
6264.8								
141.8	6264.7	142	6264.6	142.2	6264.5	142.4	6264.4	142.6
6264.3								
142.8	6264.2	143	6264.1	143.2	6264	143.4	6263.9	143.6
6263.8								
143.8	6263.7	144	6263.6	144.2	6263.5	144.4	6263.4	144.6
6263.3								
144.8	6263.2	155.3	6263.2	155.6	6263.3	155.9	6263.4	156.21
6263.5								
156.51	6263.6	156.81	6263.7	157.12	6263.8	157.42	6263.9	157.72
6264								
158.03	6264.1	158.33	6264.2	158.63	6264.3	158.94	6264.4	159.24
6264.5								
159.54	6264.6	159.84	6264.7	160.15	6264.8	160.45	6264.9	160.75
6265								
161.05	6265.1	161.35	6265.2	161.65	6265.3	161.95	6265.4	162.25
6265.5								
162.55	6265.6	162.85	6265.7	163.15	6265.8	163.45	6265.9	163.75
6266								
164.05	6266.1	164.35	6266.2	164.65	6266.3	169	6266.4	173.05
6266.5								
173.74	6266.6	174.44	6266.7	175.14	6266.8	175.84	6266.9	176.48
6267								
176.86	6267.1	177.25	6267.2	177.63	6267.3	178.02	6267.4	178.4
6267.5								
178.79	6267.6	179.37	6267.7	179.96	6267.8	180.54	6267.9	181.12

6268

181.71	6268.1	182.29	6268.2	182.87	6268.3	183.45	6268.4	184.04
6268.5								
184.46	6268.6	184.74	6268.7	185.03	6268.8	185.32	6268.9	185.61
6269								
185.9	6269.1	186.19	6269.2	186.48	6269.3	186.76	6269.4	187.05
6269.5								
187.36	6269.6	187.69	6269.7	188.01	6269.8	195.99	6269.9	215.85
6269.9								
218.42	6269.8	224.13	6269.7	227.95	6269.6	231.78	6269.5	235.6
6269.4								
239.43	6269.3	243.25	6269.2	247.08	6269.1	250.9	6269	254.72
6268.9								
258.55	6268.8	262.37	6268.7	266.2	6268.6	270.02	6268.5	277.32
6268.4								
283.18	6268.3	288.58	6268.2	293.13	6268.1	297.68	6268	300
6268								

Manning's n Values num= 3

Sta	n Val	Sta	n Val	Sta	n Val
0	.03	138	.013	173.05	.03

Bank Sta: Left Right Lengths: Left Channel Right Coeff Contr.

Expan.	138	173.05	6.48	6.48	6.48	.1
--------	-----	--------	------	------	------	----

.3

Ineffective Flow num= 1

Sta L	Sta R	Elev	Permanent
215.58	300	6269.89	F

Left Levee Station= 46.79 Elevation= 6271.02

Right Levee Station= 187.52 Elevation= 6269.82

CROSS SECTION OUTPUT Profile #Flow 1

E.G. Elev (ft)	6269.30	Element	Left OB
Channel Right OB			
Vel Head (ft)	0.76	Wt. n-Val.	0.030
0.013	0.030		
W.S. Elev (ft)	6268.54	Reach Len. (ft)	6.48
6.48	6.48		
Crit W.S. (ft)	6267.78	Flow Area (sq ft)	35.96
134.30	11.59		
E.G. Slope (ft/ft)	0.000697	Area (sq ft)	35.96
134.30	11.59		
Q Total (cfs)	1037.00	Flow (cfs)	53.09
968.53	15.37		
Top Width (ft)	76.02	Top Width (ft)	29.81
35.05	11.16		
Vel Total (ft/s)	5.70	Avg. Vel. (ft/s)	1.48
7.21	1.33		
Max Chl Dpth (ft)	5.34	Hydr. Depth (ft)	1.21
3.83	1.04		

Conv. Total (cfs)	39276.7	Conv. (cfs)	2010.9
36683.5	582.3		
Length Wtd. (ft)	6.48	Wetted Per. (ft)	29.97
36.36	11.35		
Min Ch El (ft)	6263.20	Shear (lb/sq ft)	0.05
0.16	0.04		
Alpha	1.50	Stream Power (lb/ft s)	300.00
46.79	187.52		
Frctn Loss (ft)	0.01	Cum Volume (acre-ft)	0.02
1.31	0.00		
C & E Loss (ft)	0.06	Cum SA (acres)	0.02
0.40	0.00		

Warning: The velocity head has changed by more than 0.5 ft (0.15 m). This may indicate the need for additional cross sections.

Warning: The conveyance ratio (upstream conveyance divided by downstream conveyance) is less than 0.7 or greater than 1.4.

This may indicate the need for additional cross sections.

Warning: The split flow optimization for the junction failed to converge within the maximum number of iterations. The results from the final iteration were used.

Note: Multiple critical depths were found at this location. The critical depth with the lowest, valid, energy was used.

CROSS SECTION

RIVER: SC01

REACH: Sand Creek-DS-0- RS: 989

INPUT

Description:

Station	Elevation	Data	num=	182					
Sta	Elev	Sta	Elev	Sta	Elev	Sta	Elev	Sta	Elev
Elev	0	6271.3	11.68	6271.3	25.78	6271.2	33.47	6271.1	40.5
6271	46.95	6270.9	53.39	6270.8	57.56	6270.7	60.85	6270.6	64.15
6270.5	64.77	6270.5	65.97	6270.6	70.63	6270.6	87.28	6270.5	88.57
6270.4	89.45	6270.3	90.32	6270.2	91.19	6270.1	92.06	6270	92.93
6269.9	93.8	6269.8	94.67	6269.7	95.54	6269.6	96.41	6269.5	97.28
6269.4	98.15	6269.3	99.03	6269.2	99.9	6269.1	100.8	6269	101.85
6268.9	102.89	6268.8	103.94	6268.7	104.99	6268.6	106.03	6268.5	107.08
6268.4	108.12	6268.3	109.17	6268.2	110.55	6268.1	112.05	6268	113.55
6267.9									

115.05	6267.8	116.55	6267.7	118.06	6267.6	119.45	6267.5	120.31
6267.4								
120.87	6267.3	121.08	6267.2	121.28	6267.1	121.49	6267	121.69
6266.9								
124.85	6266.8	129.85	6266.7	134.85	6266.6	138.08	6266.5	138.28
6266.4								
138.48	6266.3	138.68	6266.2	138.88	6266.1	139.08	6266	139.28
6265.9								
139.48	6265.8	139.68	6265.7	139.88	6265.6	140.08	6265.5	140.28
6265.4								
140.48	6265.3	140.68	6265.2	140.88	6265.1	141.08	6265	141.28
6264.9								
141.48	6264.8	141.68	6264.7	141.88	6264.6	142.08	6264.5	142.28
6264.4								
142.48	6264.3	142.68	6264.2	142.88	6264.1	143.08	6264	143.28
6263.9								
143.48	6263.8	143.68	6263.7	143.88	6263.6	144.08	6263.5	144.28
6263.4								
144.48	6263.3	144.68	6263.2	144.88	6263.1	155.19	6263.1	155.49
6263.2								
155.79	6263.3	156.09	6263.4	156.39	6263.5	156.69	6263.6	156.99
6263.7								
157.29	6263.8	157.59	6263.9	157.89	6264	158.19	6264.1	158.49
6264.2								
158.79	6264.3	159.09	6264.4	159.39	6264.5	159.69	6264.6	159.99
6264.7								
160.29	6264.8	160.59	6264.9	160.89	6265	161.19	6265.1	161.49
6265.2								
161.79	6265.3	162.09	6265.4	162.39	6265.5	162.69	6265.6	162.99
6265.7								
163.29	6265.8	163.59	6265.9	163.89	6266	164.19	6266.1	164.49
6266.2								
164.79	6266.3	165.09	6266.4	165.39	6266.5	165.69	6266.6	165.99
6266.7								
166.29	6266.8	166.59	6266.9	166.89	6267	167.19	6267.1	167.49
6267.2								
167.79	6267.3	168.09	6267.4	168.39	6267.5	168.94	6267.6	169.64
6267.7								
170.34	6267.8	171.04	6267.9	171.74	6268	172.43	6268.1	173.13
6268.2								
173.83	6268.3	174.53	6268.4	175.23	6268.5	175.93	6268.6	176.63
6268.7								
177.33	6268.8	178.03	6268.9	178.73	6269	179.42	6269.1	180.12
6269.2								
180.69	6269.3	181.05	6269.4	181.43	6269.5	181.82	6269.6	182.2
6269.7								
182.59	6269.8	182.98	6269.9	191.39	6270	204.28	6270	206.71
6269.9								
208.92	6269.8	211.3	6269.7	213.88	6269.6	216.45	6269.5	219.02
6269.4								
228.83	6269.3	234.72	6269.2	238.8	6269.1	242.62	6269	246.44
6268.9								
250.27	6268.8	254.09	6268.7	257.92	6268.6	261.74	6268.5	265.57





123.3	6266.6	123.89	6266.5	124.47	6266.4	125.05	6266.3	125.63
6266.2								
126.22	6266.1	126.79	6266	127.32	6265.9	127.91	6265.8	128.41
6265.7								
128.69	6265.6	128.98	6265.5	129.26	6265.4	129.54	6265.3	129.83
6265.2								
130.11	6265.1	130.39	6265	130.68	6264.9	130.96	6264.8	131.24
6264.7								
131.52	6264.6	131.81	6264.5	132.09	6264.4	132.37	6264.3	132.66
6264.2								
132.94	6264.1	133.22	6264	133.51	6263.9	133.79	6263.8	134.07
6263.7								
134.36	6263.6	134.64	6263.5	134.92	6263.4	135.21	6263.3	135.49
6263.2								
135.77	6263.1	136.06	6263	136.34	6262.9	136.62	6262.8	136.91
6262.7								
137.17	6262.6	137.37	6262.5	137.57	6262.4	137.77	6262.3	137.97
6262.2								
138.17	6262.1	138.37	6262	138.57	6261.9	138.77	6261.8	138.97
6261.7								
139.17	6261.6	139.37	6261.5	139.57	6261.4	139.77	6261.3	139.97
6261.2								
140.17	6261.1	140.37	6261	140.57	6260.9	140.77	6260.8	140.97
6260.7								
141.17	6260.6	141.37	6260.5	141.57	6260.4	141.77	6260.3	141.97
6260.2								
142.17	6260.1	142.37	6260	142.57	6259.9	142.77	6259.8	142.97
6259.7								
143.17	6259.6	143.37	6259.5	143.57	6259.4	143.77	6259.3	143.97
6259.2								
144.17	6259.1	144.37	6259	144.57	6258.9	144.77	6258.8	144.97
6258.7								
155.04	6258.7	155.34	6258.8	155.64	6258.9	155.94	6259	156.24
6259.1								
156.54	6259.2	156.84	6259.3	157.14	6259.4	157.44	6259.5	157.74
6259.6								
158.04	6259.7	158.34	6259.8	158.64	6259.9	158.94	6260	159.21
6260.1								
159.44	6260.2	159.68	6260.3	159.92	6260.4	160.16	6260.5	160.4
6260.6								
160.63	6260.7	160.87	6260.8	161.11	6260.9	161.35	6261	161.58
6261.1								
161.82	6261.2	162.06	6261.3	162.3	6261.4	162.54	6261.5	162.77
6261.6								
163.01	6261.7	163.25	6261.8	163.49	6261.9	163.72	6262	163.96
6262.1								
164.2	6262.2	164.44	6262.3	164.67	6262.4	164.91	6262.5	165.15
6262.6								
165.39	6262.7	165.63	6262.8	165.86	6262.9	166.1	6263	166.34
6263.1								
166.59	6263.2	166.88	6263.3	167.18	6263.4	167.48	6263.5	167.78
6263.6								
168.08	6263.7	168.38	6263.8	168.68	6263.9	168.98	6264	169.28

6264.1								
169.58	6264.2	169.88	6264.3	170.18	6264.4	170.48	6264.5	170.78
6264.6								
171.07	6264.7	171.37	6264.8	171.67	6264.9	171.97	6265	172.27
6265.1								
172.57	6265.2	172.87	6265.3	173.17	6265.4	173.47	6265.5	173.77
6265.6								
174.07	6265.7	174.37	6265.8	177.25	6265.9	182.25	6266	187.25
6266.1								
214.46	6266.2	218.01	6266.3	221.57	6266.4	225.12	6266.5	228.67
6266.6								
232.22	6266.7	235.77	6266.8	239.33	6266.9	245.92	6266.9	253.13
6266.8								
277.3	6266.7	300	6266.7					
Manning's n Values			num=	3				
Sta n Val	Sta n Val	Sta n Val						
0	.03	133.22	.013	168.08	.03			
Bank Sta: Left	Right	Lengths: Left	Channel	Right	Coeff	Contr.		
Expan.								
	133.22	168.08	39.44	39.44	39.44	.1		
.3								
Ineffective Flow		num=	1					
Sta L	Sta R	Elev	Permanent					
0	89.93	6269.72	F					
Left Levee	Station=	91.19	Elevation=	6269.75				
Right Levee	Station=	239.87	Elevation=	6266.89				
CROSS SECTION OUTPUT	Profile #Flow 1							
E.G. Elev (ft)	6265.09	Element	Left OB					
Channel Right OB								
Vel Head (ft)	1.55	Wt. n-Val.						
0.013								
W.S. Elev (ft)	6263.54	Reach Len. (ft)	39.44					
39.44	39.44							
Crit W.S. (ft)	6263.54	Flow Area (sq ft)						
103.92								
E.G. Slope (ft/ft)	0.001791	Area (sq ft)						
103.92								
Q Total (cfs)	1037.00	Flow (cfs)						
1037.00								
Top Width (ft)	33.08	Top Width (ft)						
33.08								
Vel Total (ft/s)	9.98	Avg. Vel. (ft/s)						
9.98								
Max Chl Dpth (ft)	4.84	Hydr. Depth (ft)						
3.14								
Conv. Total (cfs)	24506.5	Conv. (cfs)						
24506.5								
Length Wtd. (ft)	39.44	Wetted Per. (ft)						

35.07  
 Min Ch El (ft) 6258.70 Shear (lb/sq ft)  
 0.33  
 Alpha 1.00 Stream Power (lb/ft s) 300.00  
 91.19 239.87  
 Frctn Loss (ft) 0.07 Cum Volume (acre-ft) 0.01  
 1.19  
 C & E Loss (ft) 0.01 Cum SA (acres) 0.00  
 0.36

Warning: The energy equation could not be balanced within the specified number of iterations. The program used critical depth for the water surface and continued on with the calculations.  
 Warning: The energy loss was greater than 1.0 ft (0.3 m) between the current and previous cross section. This may indicate the need for additional cross sections.  
 Warning: During the standard step iterations, when the assumed water surface was set equal to critical depth, the calculated water surface came back below critical depth. This indicates that there is not a valid subcritical answer. The program defaulted to critical depth.  
 Note: Multiple critical depths were found at this location. The critical depth with the lowest, valid, energy was used.

CROSS SECTION

RIVER: SC01  
 REACH: Sand Creek-DS-0- RS: 987

INPUT  
 Description:  
 Station Elevation Data num= 283

Sta	Elev	Sta	Elev	Sta	Elev	Sta	Elev	Sta	Elev
Elev	0	6270.5	5.82	6270.5	9.64	6270.4	13.16	6270.3	16.68
6270.2	20.19	6270.1	23.71	6270	27.23	6269.9	30.74	6269.8	34.26
6269.7	37.85	6269.6	42.3	6269.5	46.76	6269.4	51.22	6269.3	55.61
6269.2	59.93	6269.1	64.25	6269	68.45	6268.9	71.72	6268.8	74.99
6268.7	78.26	6268.6	81.53	6268.5	84.8	6268.4	88.08	6268.3	91.35
6268.2	94.62	6268.1	98.74	6268	100.58	6267.9	105.05	6267.9	107.62
6268	112.49	6268	113.63	6267.9	114.77	6267.8	115.91	6267.7	116.45
6267.6	116.65	6267.5	116.85	6267.4	117.05	6267.3	117.25	6267.2	117.43
6267.1									

117.61	6267	117.78	6266.9	117.95	6266.8	118.13	6266.7	118.31
6266.6								
118.55	6266.5	118.78	6266.4	119.02	6266.3	119.25	6266.2	119.48
6266.1								
119.72	6266	119.95	6265.9	120.17	6265.8	120.39	6265.7	120.6
6265.6								
120.81	6265.5	121.03	6265.4	121.24	6265.3	121.46	6265.2	121.67
6265.1								
121.88	6265	122.1	6264.9	122.31	6264.8	122.53	6264.7	122.74
6264.6								
122.96	6264.5	123.17	6264.4	123.38	6264.3	123.6	6264.2	123.81
6264.1								
124.03	6264	124.24	6263.9	124.45	6263.8	124.67	6263.7	124.88
6263.6								
125.1	6263.5	125.31	6263.4	125.52	6263.3	125.74	6263.2	125.95
6263.1								
126.17	6263	126.38	6262.9	126.6	6262.8	126.81	6262.7	127.02
6262.6								
127.24	6262.5	127.45	6262.4	127.67	6262.3	127.88	6262.2	128.09
6262.1								
128.31	6262	128.52	6261.9	128.74	6261.8	128.95	6261.7	129.17
6261.6								
129.44	6261.5	129.73	6261.4	130.01	6261.3	130.29	6261.2	130.58
6261.1								
130.86	6261	131.14	6260.9	131.43	6260.8	131.71	6260.7	131.99
6260.6								
132.28	6260.5	132.56	6260.4	132.84	6260.3	133.13	6260.2	133.41
6260.1								
133.69	6260	133.98	6259.9	134.26	6259.8	134.54	6259.7	134.83
6259.6								
135.11	6259.5	135.39	6259.4	135.68	6259.3	135.96	6259.2	136.24
6259.1								
136.47	6259	136.67	6258.9	136.87	6258.8	137.07	6258.7	137.27
6258.6								
137.47	6258.5	137.67	6258.4	137.87	6258.3	138.07	6258.2	138.27
6258.1								
138.47	6258	138.67	6257.9	138.87	6257.8	139.07	6257.7	139.27
6257.6								
139.47	6257.5	139.67	6257.4	139.87	6257.3	140.07	6257.2	140.27
6257.1								
140.47	6257	140.67	6256.9	140.87	6256.8	141.07	6256.7	141.27
6256.6								
141.47	6256.5	141.67	6256.4	141.87	6256.3	142.07	6256.2	142.27
6256.1								
142.47	6256	142.67	6255.9	142.87	6255.8	143.07	6255.7	143.27
6255.6								
143.47	6255.5	143.67	6255.4	143.87	6255.3	144.07	6255.2	144.27
6255.1								
144.47	6255	144.67	6254.9	144.87	6254.8	155.1	6254.8	155.3
6254.9								
155.5	6255	155.7	6255.1	155.9	6255.2	156.1	6255.3	156.3
6255.4								
156.5	6255.5	156.7	6255.6	156.9	6255.7	157.1	6255.8	157.3

6255.9									
157.5	6256	157.7	6256.1	157.9	6256.2	158.1	6256.3	158.3	
6256.4									
158.5	6256.5	158.7	6256.6	158.9	6256.7	159.1	6256.8	159.3	
6256.9									
159.5	6257	159.7	6257.1	159.9	6257.2	160.14	6257.3	160.37	
6257.4									
160.61	6257.5	160.85	6257.6	161.09	6257.7	161.33	6257.8	161.56	
6257.9									
161.8	6258	162.04	6258.1	162.28	6258.2	162.51	6258.3	162.75	
6258.4									
162.99	6258.5	163.23	6258.6	163.47	6258.7	163.7	6258.8	163.94	
6258.9									
164.18	6259	164.42	6259.1	164.65	6259.2	164.93	6259.3	165.23	
6259.4									
165.53	6259.5	165.83	6259.6	166.13	6259.7	166.42	6259.8	166.72	
6259.9									
167.02	6260	167.32	6260.1	167.62	6260.2	167.92	6260.3	168.22	
6260.4									
168.52	6260.5	168.82	6260.6	169.12	6260.7	169.42	6260.8	169.72	
6260.9									
170.02	6261	170.32	6261.1	170.61	6261.2	170.91	6261.3	171.21	
6261.4									
171.51	6261.5	171.81	6261.6	172.11	6261.7	172.41	6261.8	172.71	
6261.9									
173.01	6262	173.31	6262.1	173.61	6262.2	173.91	6262.3	174.21	
6262.4									
174.82	6262.5	179.82	6262.6	184.82	6262.7	189.62	6262.8	191.62	
6262.9									
193.63	6263	195.63	6263.1	197.63	6263.2	199.64	6263.3	201.64	
6263.4									
203.65	6263.5	205.65	6263.6	207.65	6263.7	209.66	6263.8	211.66	
6263.9									
213.67	6264	216.68	6264.1	220.23	6264.2	223.78	6264.3	227.33	
6264.4									
230.89	6264.5	234.44	6264.6	237.99	6264.7	241.54	6264.8	245.1	
6264.9									
248.65	6265	258.2	6265	259.08	6264.9	270.41	6264.8	284.82	
6264.7									
285.84	6264.6	286.86	6264.5	287.96	6264.4	289.05	6264.3	289.66	
6264.3									
291.32	6264.4	292.9	6264.5	294.42	6264.6	295.85	6264.7	297.2	
6264.8									
298.5	6264.9	299.7	6265	300	6265				

Manning's n Values	num=	3
Sta n Val	Sta n Val	Sta n Val
0 .03 127.02	.013 173.01	.03

Bank Sta: Left	Right	Lengths: Left	Channel	Right	Coeff Contr.	
Expan.	127.02	173.01	10.56	10.56	10.56	.1
.3						

Ineffective Flow	num=	1	
Sta L	Sta R	Elev	Permanent
258.72	300	6265.02	F
Left Levee	Station=	112.13	Elevation= 6268.07
Right Levee	Station=	248.25	Elevation= 6265.11

CROSS SECTION OUTPUT Profile #Flow 1

E.G. Elev (ft)	6261.38	Element	Left OB
Channel Right OB			
Vel Head (ft)	1.60	Wt. n-Val.	
0.013			
W.S. Elev (ft)	6259.78	Reach Len. (ft)	10.56
10.56	10.56		
Crit W.S. (ft)	6259.78	Flow Area (sq ft)	
102.05			
E.G. Slope (ft/ft)	0.001842	Area (sq ft)	
102.05			
Q Total (cfs)	1037.00	Flow (cfs)	
1037.00			
Top Width (ft)	32.04	Top Width (ft)	
32.04			
Vel Total (ft/s)	10.16	Avg. Vel. (ft/s)	
10.16			
Max Chl Dpth (ft)	4.98	Hydr. Depth (ft)	
3.19			
Conv. Total (cfs)	24162.3	Conv. (cfs)	
24162.3			
Length Wtd. (ft)	10.56	Wetted Per. (ft)	
34.23			
Min Ch El (ft)	6254.80	Shear (lb/sq ft)	
0.34			
Alpha	1.00	Stream Power (lb/ft s)	300.00
112.13	248.25		
Frctn Loss (ft)	0.02	Cum Volume (acre-ft)	0.01
1.09			
C & E Loss (ft)	0.13	Cum SA (acres)	0.00
0.33			

Warning: The energy equation could not be balanced within the specified number of iterations. The program used critical depth for the water surface and continued on with the calculations.

Warning: During the standard step iterations, when the assumed water surface was set equal to critical depth, the calculated water surface came back below critical depth. This indicates that there is not a valid subcritical answer. The program defaulted to critical depth.

Note: Multiple critical depths were found at this location. The critical depth with the lowest, valid, energy was used.

CROSS SECTION

RIVER: SC01  
 REACH: Sand Creek-DS-0- RS: 986

INPUT

Description:

Station	Elevation	Data	num=	338					
Sta	Elev	Sta	Elev	Sta	Elev	Sta	Elev	Sta	Elev
0	6269.7	.65	6269.7	1.86	6269.6	23.84	6269.6	41.05	
6269.5									
44.74	6269.4	47.36	6269.3	48.78	6269.2	53.11	6269.1	57.81	
6269									
62.51	6268.9	66.9	6268.8	71.23	6268.7	75.55	6268.6	79.18	
6268.5									
82.45	6268.4	85.72	6268.3	88.99	6268.2	94.38	6268.1	97.79	
6268									
99	6267.9	100.22	6267.8	101.92	6267.7	102.53	6267.7	103.06	
6267.8									
103.58	6267.9	104.51	6267.9	105.21	6267.8	105.91	6267.7	106.61	
6267.6									
107.35	6267.6	109.92	6267.7	112.2	6267.7	113.52	6267.6	115.96	
6267.5									
116.12	6267.4	116.28	6267.3	116.45	6267.2	116.61	6267.1	116.77	
6267									
116.93	6266.9	117.1	6266.8	117.26	6266.7	117.42	6266.6	117.58	
6266.5									
117.77	6266.4	117.98	6266.3	118.19	6266.2	118.4	6266.1	118.61	
6266									
118.81	6265.9	119.02	6265.8	119.23	6265.7	119.44	6265.6	119.65	
6265.5									
119.86	6265.4	120.07	6265.3	120.28	6265.2	120.49	6265.1	120.7	
6265									
120.9	6264.9	121.11	6264.8	121.32	6264.7	121.53	6264.6	121.74	
6264.5									
121.95	6264.4	122.16	6264.3	122.37	6264.2	122.58	6264.1	122.79	
6264									
122.99	6263.9	123.2	6263.8	123.41	6263.7	123.62	6263.6	123.83	
6263.5									
124.04	6263.4	124.25	6263.3	124.46	6263.2	124.67	6263.1	124.87	
6263									
125.08	6262.9	125.29	6262.8	125.5	6262.7	125.71	6262.6	125.92	
6262.5									
126.13	6262.4	126.34	6262.3	126.55	6262.2	126.76	6262.1	126.96	
6262									
127.17	6261.9	127.4	6261.8	127.63	6261.7	127.85	6261.6	128.08	
6261.5									
128.31	6261.4	128.54	6261.3	128.78	6261.2	129.01	6261.1	129.24	
6261									
129.48	6260.9	129.71	6260.8	129.94	6260.7	130.16	6260.6	130.37	
6260.5									

130.59	6260.4	130.8	6260.3	131.01	6260.2	131.23	6260.1	131.44	
6260									
131.66	6259.9	131.87	6259.8	132.08	6259.7	132.3	6259.6	132.51	
6259.5									
132.73	6259.4	132.94	6259.3	133.16	6259.2	133.37	6259.1	133.64	
6259									
133.92	6258.9	134.21	6258.8	134.49	6258.7	134.77	6258.6	135.06	
6258.5									
135.34	6258.4	135.62	6258.3	135.91	6258.2	136.17	6258.1	136.37	
6258									
136.57	6257.9	136.77	6257.8	136.97	6257.7	137.17	6257.6	137.37	
6257.5									
137.57	6257.4	137.77	6257.3	137.97	6257.2	138.17	6257.1	138.37	
6257									
138.57	6256.9	138.77	6256.8	138.97	6256.7	139.17	6256.6	139.37	
6256.5									
139.57	6256.4	139.77	6256.3	139.97	6256.2	140.17	6256.1	140.37	
6256									
140.57	6255.9	140.77	6255.8	140.97	6255.7	141.17	6255.6	141.37	
6255.5									
141.57	6255.4	141.77	6255.3	141.97	6255.2	142.17	6255.1	142.37	
6255									
142.57	6254.9	142.77	6254.8	142.97	6254.7	143.17	6254.6	143.37	
6254.5									
143.57	6254.4	143.77	6254.3	143.97	6254.2	144.17	6254.1	144.37	
6254									
144.57	6253.9	144.77	6253.8	144.97	6253.7	145.17	6253.6	145.37	
6254.1									
145.84	6254.3	145.86	6254.6	145.87	6254.7	147.42	6254.7	147.43	
6254.6									
147.45	6254.3	147.46	6254.1	147.48	6253.8	149.15	6253.8	149.17	
6254.1									
149.18	6254.3	149.2	6254.6	149.21	6254.7	150.76	6254.7	150.77	
6254.6									
150.79	6254.3	150.8	6254.1	150.82	6253.8	152.49	6253.8	152.51	
6254.1									
152.52	6254.3	152.54	6254.6	152.55	6254.7	154.1	6254.7	154.11	
6254.6									
154.13	6254.3	154.14	6254.1	154.16	6253.8	155.03	6253.7	155.23	
6253.8									
155.43	6253.9	155.63	6254	155.83	6254.1	156.03	6254.2	156.23	
6254.3									
156.43	6254.4	156.63	6254.5	156.83	6254.6	157.03	6254.7	157.23	
6254.8									
157.43	6254.9	157.63	6255	157.83	6255.1	158.03	6255.2	158.23	
6255.3									
158.43	6255.4	158.63	6255.5	158.83	6255.6	159.03	6255.7	159.23	
6255.8									
159.43	6255.9	159.63	6256	159.83	6256.1	160.03	6256.2	160.23	
6256.3									
160.43	6256.4	160.63	6256.5	160.83	6256.6	161.03	6256.7	161.23	
6256.8									
161.43	6256.9	161.63	6257	161.83	6257.1	162.03	6257.2	162.23	

6257.3								
162.43	6257.4	162.66	6257.5	162.9	6257.6	163.14	6257.7	163.38
6257.8								
163.61	6257.9	163.85	6258	164.09	6258.1	164.34	6258.2	164.63
6258.3								
164.93	6258.4	165.23	6258.5	165.53	6258.6	165.83	6258.7	166.13
6258.8								
166.43	6258.9	166.73	6259	167.03	6259.1	167.33	6259.2	167.63
6259.3								
167.93	6259.4	168.23	6259.5	168.53	6259.6	168.82	6259.7	169.12
6259.8								
169.42	6259.9	169.72	6260	170.02	6260.1	170.32	6260.2	170.62
6260.3								
170.92	6260.4	171.22	6260.5	171.52	6260.6	171.82	6260.7	172.12
6260.8								
172.42	6260.9	172.71	6261	173.01	6261.1	173.31	6261.2	173.61
6261.3								
173.91	6261.4	174.21	6261.5	174.65	6261.6	179.62	6261.7	184.62
6261.8								
189.66	6261.9	191.12	6261.9	193.08	6261.8	193.46	6261.8	194.8
6261.9								
196.15	6262	197.49	6262.1	198.84	6262.2	200.18	6262.3	201.53
6262.4								
202.87	6262.5	204.22	6262.6	205.6	6262.7	207.6	6262.8	209.61
6262.9								
211.61	6263	213.61	6263.1	215.62	6263.2	217.62	6263.3	219.63
6263.4								
221.63	6263.5	223.63	6263.6	225.64	6263.7	227.64	6263.8	230.14
6263.9								
233.69	6264	237.25	6264.1	240.8	6264.2	244.35	6264.3	247.9
6264.4								
251.46	6264.5	259.74	6264.5	260.62	6264.4	265.71	6264.3	278.7
6264.2								
279.71	6264.1	280.73	6264	281.79	6263.9	282.89	6263.8	283.98
6263.7								
284.71	6263.7	286.37	6263.8	287.98	6263.9	289.53	6264	291
6264.1								
292.43	6264.2	293.78	6264.3	295.1	6264.4	296.32	6264.5	297.52
6264.6								
298.61	6264.7	299.69	6264.8	300	6264.8			

Manning's n Values num= 3

Sta	n Val	Sta	n Val	Sta	n Val
0	.03	127.17	.013	173.01	.03

Bank Sta: Left Right Lengths: Left Channel Right Coeff Contr. Expan.

	127.17	173.01		6.48	6.48	6.48		.1
--	--------	--------	--	------	------	------	--	----

.3 Ineffective Flow num= 1

Sta L	Sta R	Elev	Permanent
260.39	300	6264.57	F

Left Levee Station= 97.89 Elevation= 6268.05

Right Levee Station= 251.6 Elevation= 6264.48

CROSS SECTION OUTPUT Profile #Flow 1

E.G. Elev (ft)	6260.59	Element	Left OB
Channel Right OB			
Vel Head (ft)	1.16	Wt. n-Val.	
0.013			
W.S. Elev (ft)	6259.44	Reach Len. (ft)	6.48
6.48	6.48		
Crit W.S. (ft)	6258.94	Flow Area (sq ft)	
120.18			
E.G. Slope (ft/ft)	0.001447	Area (sq ft)	
120.18			
Q Total (cfs)	1037.00	Flow (cfs)	
1037.00			
Top Width (ft)	35.39	Top Width (ft)	
35.39			
Vel Total (ft/s)	8.63	Avg. Vel. (ft/s)	
8.63			
Max Chl Dpth (ft)	5.74	Hydr. Depth (ft)	
3.40			
Conv. Total (cfs)	27263.1	Conv. (cfs)	
27263.1			
Length Wtd. (ft)	6.48	Wetted Per. (ft)	
42.98			
Min Ch El (ft)	6253.70	Shear (lb/sq ft)	
0.25			
Alpha	1.00	Stream Power (lb/ft s)	300.00
97.89	251.60		
Frctn Loss (ft)	0.01	Cum Volume (acre-ft)	0.01
1.07			
C & E Loss (ft)	0.15	Cum SA (acres)	0.00
0.32			

Warning: The velocity head has changed by more than 0.5 ft (0.15 m). This may indicate the need for additional cross sections.

Warning: The conveyance ratio (upstream conveyance divided by downstream conveyance) is less than 0.7 or greater than 1.4.

This may indicate the need for additional cross sections.

Note: Multiple critical depths were found at this location. The critical depth with the lowest, valid, energy was used.

CROSS SECTION

RIVER: SC01  
REACH: Sand Creek-DS-0- RS: 985

INPUT



174.49	6261	178.82	6261.1	183.23	6261.2	187.64	6261.3	193.76
6261.3								
195.71	6261.2	198.04	6261.2	199.38	6261.3	200.73	6261.4	202.07
6261.5								
203.42	6261.6	204.77	6261.7	206.11	6261.8	207.46	6261.9	208.8
6262								
210.15	6262.1	211.49	6262.2	212.84	6262.3	214.18	6262.4	215.53
6262.5								
216.87	6262.6	218.22	6262.7	219.56	6262.8	220.91	6262.9	222.65
6263								
224.66	6263.1	226.66	6263.2	228.66	6263.3	230.67	6263.4	232.67
6263.5								
234.68	6263.6	236.68	6263.7	239.22	6263.8	242.77	6263.9	246.33
6264								
249.88	6264.1	253.43	6264.2	260.61	6264.2	261.49	6264.1	262.38
6264								
274.85	6263.9	275.87	6263.8	276.88	6263.7	277.91	6263.6	279.01
6263.5								
280.1	6263.4	282.8	6263.4	284.47	6263.5	286.01	6263.6	287.56
6263.7								
289	6263.8	290.43	6263.9	291.77	6264	293.08	6264.1	294.32
6264.2								
295.52	6264.3	296.66	6264.4	297.74	6264.5	298.76	6264.6	299.72
6264.7								
300	6264.7							

Manning's n Values num= 3  
 Sta n Val Sta n Val Sta n Val  
 0 .03 127.09 .013 172.98 .03

Bank Sta: Left Right Lengths: Left Channel Right Coeff Contr.  
 Expan. 127.09 172.98 10.39 10.39 10.39 .1

.3  
 Ineffective Flow num= 1  
 Sta L Sta R Elev Permanent  
 262.07 300 6264.03 F  
 Left Levee Station= 105.01 Elevation= 6267.95  
 Right Levee Station= 260.81 Elevation= 6264.31

CROSS SECTION OUTPUT Profile #Flow 1

E.G. Elev (ft)	6260.43	Element	Left 0B
Channel Right 0B			
Vel Head (ft)	0.65	Wt. n-Val.	
0.013			
W.S. Elev (ft)	6259.79	Reach Len. (ft)	10.39
10.39	10.39		
Crit W.S. (ft)	6258.11	Flow Area (sq ft)	
160.82			
E.G. Slope (ft/ft)	0.000539	Area (sq ft)	
160.82			

Q Total (cfs)	1037.00	Flow (cfs)	
1037.00			
Top Width (ft)	39.52	Top Width (ft)	
39.52			
Vel Total (ft/s)	6.45	Avg. Vel. (ft/s)	
6.45			
Max Chl Dpth (ft)	6.69	Hydr. Depth (ft)	
4.07			
Conv. Total (cfs)	44648.3	Conv. (cfs)	
44648.3			
Length Wtd. (ft)	10.39	Wetted Per. (ft)	
42.49			
Min Ch El (ft)	6253.10	Shear (lb/sq ft)	
0.13			
Alpha	1.00	Stream Power (lb/ft s)	300.00
105.01	260.81		
Frctn Loss (ft)	0.01	Cum Volume (acre-ft)	0.01
1.04			
C & E Loss (ft)	0.01	Cum SA (acres)	0.00
0.32			

Note: Multiple critical depths were found at this location. The critical depth with the lowest, valid, energy was used.

CROSS SECTION

RIVER: SC01  
 REACH: Sand Creek-DS-0- RS: 984

INPUT  
 Description:  
 Station Elevation Data num= 380  
 Sta Elev Sta Elev Sta Elev Sta Elev Sta  
 Elev 0 6269.5 39.13 6269.5 40.55 6269.4 42.6 6269.3 44.71  
 6269.2 47 6269.2 47.54 6269.3 47.6 6269.3 48.91 6269.2 50.23  
 6269.1 51.54 6269 55.82 6268.9 60.57 6268.8 65.32 6268.7 70.07  
 6268.6 74.82 6268.5 79.57 6268.4 84.35 6268.3 91.89 6268.2 94.03  
 6268.1 95.24 6268 96.46 6267.9 97.67 6267.8 98.89 6267.7 100.11  
 6267.6 101.32 6267.5 104.55 6267.5 105.08 6267.6 105.6 6267.7 106.13  
 6267.8 106.66 6267.9 107.18 6268 107.22 6268 107.92 6267.9 108.62  
 6267.8 109.32 6267.7 110.02 6267.6 110.71 6267.5 111.41 6267.4 115.49  
 6267.3

115.69 6267.2 115.88 6267.1 116.07 6267 116.26 6266.9 116.45  
6266.8  
116.63 6266.7 116.86 6266.6 117.11 6266.5 117.32 6266.4 117.53  
6266.3  
117.75 6266.2 117.96 6266.1 118.17 6266 118.38 6265.9 118.6  
6265.8  
118.81 6265.7 119.02 6265.6 119.23 6265.5 119.45 6265.4 119.66  
6265.3  
119.87 6265.2 120.08 6265.1 120.3 6265 120.51 6264.9 120.72  
6264.8  
120.93 6264.7 121.15 6264.6 121.36 6264.5 121.57 6264.4 121.78  
6264.3  
122 6264.2 122.21 6264.1 122.42 6264 122.63 6263.9 122.85  
6263.8  
123.06 6263.7 123.27 6263.6 123.48 6263.5 123.67 6263.4 123.87  
6263.3  
124.07 6263.2 124.27 6263.1 124.46 6263 124.66 6262.9 124.86  
6262.8  
125.06 6262.7 125.25 6262.6 125.45 6262.5 125.65 6262.4 125.85  
6262.3  
126.04 6262.2 126.24 6262.1 126.44 6262 126.64 6261.9 126.83  
6261.8  
127.03 6261.7 127.23 6261.6 127.43 6261.5 127.62 6261.4 127.82  
6261.3  
128.02 6261.2 128.22 6261.1 128.41 6261 128.61 6260.9 128.81  
6260.8  
129.02 6260.7 129.24 6260.6 129.46 6260.5 129.68 6260.4 129.9  
6260.3  
130.11 6260.2 130.33 6260.1 130.55 6260 130.77 6259.9 130.99  
6259.8  
131.21 6259.7 131.43 6259.6 131.64 6259.5 131.86 6259.4 132.08  
6259.3  
132.3 6259.2 132.52 6259.1 132.74 6259 132.96 6258.9 133.17  
6258.8  
133.39 6258.7 133.61 6258.6 133.83 6258.5 134.05 6258.4 134.27  
6258.3  
134.49 6258.2 134.7 6258.1 134.92 6258 135.14 6257.9 135.36  
6257.8  
135.58 6257.7 135.8 6257.6 136.01 6257.5 136.19 6257.4 136.37  
6257.3  
136.55 6257.2 136.72 6257.1 136.9 6257 137.08 6256.9 137.27  
6256.8  
137.47 6256.7 137.67 6256.6 137.87 6256.5 138.07 6256.4 138.27  
6256.3  
138.47 6256.2 138.67 6256.1 138.87 6256 139.07 6255.9 139.27  
6255.8  
139.47 6255.7 139.67 6255.6 139.87 6255.5 140.07 6255.4 140.27  
6255.3  
140.47 6255.2 140.67 6255.1 140.87 6255 141.07 6254.9 141.27  
6254.8  
141.47 6254.7 141.67 6254.6 141.87 6254.5 142.07 6254.4 142.27  
6254.3  
142.47 6254.2 142.67 6254.1 142.87 6254 143.07 6253.9 143.27

6253.8  
143.47 6253.7 143.67 6253.6 143.87 6253.5 144.07 6253.4 144.27  
6253.3  
144.47 6253.2 144.67 6253.1 144.87 6253 145.8 6253.2 145.82  
6253.7  
145.84 6254.2 145.86 6254.7 145.88 6255.2 145.89 6255.4 147.37  
6255.4  
147.39 6255.2 147.41 6254.7 147.43 6254.2 147.45 6253.7 147.47  
6253.2  
149.14 6253.2 149.16 6253.7 149.18 6254.2 149.2 6254.7 149.22  
6255.2  
149.23 6255.4 150.71 6255.4 150.73 6255.2 150.75 6254.7 150.77  
6254.2  
150.79 6253.7 150.81 6253.2 152.49 6253.2 152.51 6253.7 152.53  
6254.2  
152.55 6254.7 152.57 6255.2 152.58 6255.4 154.07 6255.4 154.08  
6255.2  
154.1 6254.7 154.12 6254.2 154.14 6253.7 154.16 6253.2 155.12  
6253  
155.33 6253.1 155.53 6253.2 155.73 6253.3 155.93 6253.4 156.13  
6253.5  
156.33 6253.6 156.53 6253.7 156.73 6253.8 156.93 6253.9 157.13  
6254  
157.33 6254.1 157.53 6254.2 157.73 6254.3 157.93 6254.4 158.13  
6254.5  
158.33 6254.6 158.53 6254.7 158.73 6254.8 158.93 6254.9 159.13  
6255  
159.33 6255.1 159.53 6255.2 159.73 6255.3 159.93 6255.4 160.13  
6255.5  
160.33 6255.6 160.53 6255.7 160.73 6255.8 160.93 6255.9 161.13  
6256  
161.33 6256.1 161.53 6256.2 161.73 6256.3 161.93 6256.4 162.13  
6256.5  
162.33 6256.6 162.53 6256.7 162.73 6256.8 162.93 6256.9 163.13  
6257  
163.33 6257.1 163.53 6257.2 163.73 6257.3 163.93 6257.4 164.2  
6257.5  
164.51 6257.6 164.81 6257.7 165.11 6257.8 165.42 6257.9 165.72  
6258  
166.02 6258.1 166.32 6258.2 166.63 6258.3 166.93 6258.4 167.23  
6258.5  
167.54 6258.6 167.84 6258.7 168.14 6258.8 168.45 6258.9 168.75  
6259  
169.05 6259.1 169.35 6259.2 169.66 6259.3 169.96 6259.4 170.26  
6259.5  
170.57 6259.6 170.87 6259.7 171.17 6259.8 171.48 6259.9 171.78  
6260  
172.08 6260.1 172.38 6260.2 172.69 6260.3 172.99 6260.4 173.29  
6260.5  
173.6 6260.6 173.9 6260.7 174.2 6260.8 174.59 6260.9 179.41  
6261  
184.08 6261.1 188.49 6261.2 193.72 6261.2 194.42 6261.1 195.13  
6261



195.84	6260.9	196.55	6260.8	197.26	6260.7	197.97	6260.6	198.68
6260.5								
199.39	6260.4	200.1	6260.3	200.81	6260.2	202.65	6260.1	203.51
6260.1								
204.86	6260.2	206.2	6260.3	207.55	6260.4	208.89	6260.5	210.24
6260.6								
211.58	6260.7	212.93	6260.8	214.27	6260.9	215.62	6261	216.96
6261.1								
218.31	6261.2	219.65	6261.3	221	6261.4	222.34	6261.5	223.69
6261.6								
225.03	6261.7	226.38	6261.8	227.72	6261.9	229.07	6262	230.42
6262.1								
231.76	6262.2	233.11	6262.3	234.45	6262.4	235.8	6262.5	237.14
6262.6								
238.49	6262.7	239.83	6262.8	241.18	6262.9	242.52	6263	243.87
6263.1								
245.21	6263.2	246.56	6263.3	248.36	6263.4	250.36	6263.5	252.37
6263.6								
255.91	6263.7	262.18	6263.7	263.06	6263.6	263.94	6263.5	268.88
6263.4								
269.9	6263.3	270.92	6263.2	271.93	6263.1	273.01	6263	274.1
6262.9								
275.2	6262.8	277.76	6262.8	279.42	6262.9	281.01	6263	282.56
6263.1								
284.09	6263.2	285.51	6263.3	286.94	6263.4	288.29	6263.5	289.6
6263.6								
290.89	6263.7	292.09	6263.8	293.28	6263.9	294.39	6264	295.47
6264.1								
296.5	6264.2	297.46	6264.3	298.41	6264.4	299.25	6264.5	300
6264.5								

Manning's n Values num= 3

Sta	n Val	Sta	n Val	Sta	n Val
0	.03	127.03	.013	172.99	.03

Bank Sta: Left Right Lengths: Left Channel Right Coeff Contr.

Expan.	127.03	172.99	10	10	10	.1
.3						

Ineffective Flow num= 2

Sta L	Sta R	Elev	Permanent
0	106.27	6267.94	F
264.16	300	6263.55	F

Left Levee Station= 106.69 Elevation= 6268.09  
 Right Levee Station= 261.65 Elevation= 6263.74

CROSS SECTION OUTPUT Profile #Flow 1

E.G. Elev (ft)	6260.41	Element	Left OB
Channel Right OB			
Vel Head (ft)	0.78	Wt. n-Val.	
0.013			

W.S. Elev (ft)	6259.63	Reach Len. (ft)	10.00
10.00	10.00		
Crit W.S. (ft)	6258.48	Flow Area (sq ft)	
146.18			
E.G. Slope (ft/ft)	0.001045	Area (sq ft)	
146.18			
Q Total (cfs)	1037.00	Flow (cfs)	
1037.00			
Top Width (ft)	39.29	Top Width (ft)	
39.29			
Vel Total (ft/s)	7.09	Avg. Vel. (ft/s)	
7.09			
Max Chl Dpth (ft)	6.63	Hydr. Depth (ft)	
3.72			
Conv. Total (cfs)	32086.6	Conv. (cfs)	
32086.6			
Length Wtd. (ft)	10.00	Wetted Per. (ft)	
54.93			
Min Ch El (ft)	6253.00	Shear (lb/sq ft)	
0.17			
Alpha	1.00	Stream Power (lb/ft s)	300.00
106.69	261.65		
Frctn Loss (ft)	0.01	Cum Volume (acre-ft)	0.01
1.01			
C & E Loss (ft)	0.05	Cum SA (acres)	0.00
0.31			

Warning: The conveyance ratio (upstream conveyance divided by downstream conveyance) is less than 0.7 or greater than 1.4.

This may indicate the need for additional cross sections.

Note: Multiple critical depths were found at this location. The critical depth with the lowest, valid, energy was used.

CROSS SECTION

RIVER: SC01  
 REACH: Sand Creek-DS-0- RS: 983

INPUT

Description:

Station	Elevation	Data	num=	366					
Sta	Elev	Sta	Elev	Sta	Elev	Sta	Elev	Sta	Elev
Elev									
0	6269.5	38.52	6269.5	40.63	6269.4	42.74	6269.3	45.02	
6269.3									
45.56	6269.4	46.11	6269.5	46.65	6269.6	47.85	6269.6	49.17	
6269.5									
50.48	6269.4	51.8	6269.3	53.11	6269.2	54.43	6269.1	55.74	
6269									
57.42	6268.9	62.17	6268.8	66.92	6268.7	71.67	6268.6	76.42	

6268.5									
81.17	6268.4	87.35	6268.3	91.3	6268.2	92.52	6268.1	93.73	
6268									
94.95	6267.9	96.17	6267.8	97.38	6267.7	98.6	6267.6	99.81	
6267.5									
101.03	6267.4	103.23	6267.3	105.32	6267.3	105.84	6267.4	106.37	
6267.5									
106.9	6267.6	107.42	6267.7	107.95	6267.8	108.48	6267.9	109.01	
6268									
109.24	6268	109.94	6267.9	110.64	6267.8	112.57	6267.7	113.72	
6267.6									
114.05	6267.5	114.37	6267.4	114.69	6267.3	115.02	6267.2	115.34	
6267.1									
115.66	6267	115.99	6266.9	116.24	6266.8	116.44	6266.7	116.63	
6266.6									
116.83	6266.5	117.03	6266.4	117.23	6266.3	117.42	6266.2	117.62	
6266.1									
117.82	6266	118.02	6265.9	118.21	6265.8	118.41	6265.7	118.61	
6265.6									
118.81	6265.5	119	6265.4	119.2	6265.3	119.4	6265.2	119.6	
6265.1									
119.79	6265	119.99	6264.9	120.19	6264.8	120.39	6264.7	120.58	
6264.6									
120.78	6264.5	120.98	6264.4	121.18	6264.3	121.37	6264.2	121.57	
6264.1									
121.77	6264	121.97	6263.9	122.18	6263.8	122.4	6263.7	122.62	
6263.6									
122.84	6263.5	123.06	6263.4	123.28	6263.3	123.49	6263.2	123.71	
6263.1									
123.93	6263	124.15	6262.9	124.37	6262.8	124.59	6262.7	124.81	
6262.6									
125.02	6262.5	125.24	6262.4	125.46	6262.3	125.68	6262.2	125.9	
6262.1									
126.12	6262	126.34	6261.9	126.55	6261.8	126.77	6261.7	126.99	
6261.6									
127.21	6261.5	127.43	6261.4	127.65	6261.3	127.87	6261.2	128.08	
6261.1									
128.3	6261	128.52	6260.9	128.74	6260.8	128.96	6260.7	129.18	
6260.6									
129.4	6260.5	129.61	6260.4	129.83	6260.3	130.05	6260.2	130.27	
6260.1									
130.49	6260	130.71	6259.9	130.92	6259.8	131.14	6259.7	131.36	
6259.6									
131.58	6259.5	131.8	6259.4	132.02	6259.3	132.24	6259.2	132.45	
6259.1									
132.67	6259	132.89	6258.9	133.11	6258.8	133.33	6258.7	133.55	
6258.6									
133.77	6258.5	133.98	6258.4	134.2	6258.3	134.42	6258.2	134.64	
6258.1									
134.86	6258	135.08	6257.9	135.3	6257.8	135.51	6257.7	135.73	
6257.6									
135.95	6257.5	136.14	6257.4	136.32	6257.3	136.49	6257.2	136.67	
6257.1									

136.85	6257	137.03	6256.9	137.2	6256.8	137.38	6256.7	137.56	
6256.6									
137.74	6256.5	137.91	6256.4	138.09	6256.3	138.27	6256.2	138.47	
6256.1									
138.67	6256	138.87	6255.9	139.07	6255.8	139.27	6255.7	139.47	
6255.6									
139.67	6255.5	139.87	6255.4	140.07	6255.3	140.27	6255.2	140.47	
6255.1									
140.67	6255	140.87	6254.9	141.07	6254.8	141.27	6254.7	141.47	
6254.6									
141.67	6254.5	141.87	6254.4	142.07	6254.3	142.27	6254.2	142.47	
6254.1									
142.67	6254	142.87	6253.9	143.07	6253.8	143.27	6253.7	143.47	
6253.6									
143.67	6253.5	143.87	6253.4	144.07	6253.3	144.27	6253.2	144.47	
6253.1									
144.68	6253	144.88	6252.9	155.11	6252.9	155.31	6253	155.52	
6253.1									
155.72	6253.2	155.92	6253.3	156.12	6253.4	156.32	6253.5	156.53	
6253.6									
156.73	6253.7	156.93	6253.8	157.13	6253.9	157.33	6254	157.53	
6254.1									
157.73	6254.2	157.93	6254.3	158.13	6254.4	158.33	6254.5	158.53	
6254.6									
158.73	6254.7	158.93	6254.8	159.13	6254.9	159.33	6255	159.53	
6255.1									
159.73	6255.2	159.93	6255.3	160.13	6255.4	160.33	6255.5	160.53	
6255.6									
160.73	6255.7	160.93	6255.8	161.13	6255.9	161.33	6256	161.53	
6256.1									
161.73	6256.2	161.93	6256.3	162.13	6256.4	162.33	6256.5	162.53	
6256.6									
162.73	6256.7	162.93	6256.8	163.13	6256.9	163.33	6257	163.53	
6257.1									
163.73	6257.2	163.93	6257.3	164.2	6257.4	164.51	6257.5	164.81	
6257.6									
165.11	6257.7	165.42	6257.8	165.72	6257.9	166.02	6258	166.32	
6258.1									
166.63	6258.2	166.93	6258.3	167.23	6258.4	167.54	6258.5	167.84	
6258.6									
168.14	6258.7	168.45	6258.8	168.75	6258.9	169.05	6259	169.35	
6259.1									
169.66	6259.2	169.96	6259.3	170.26	6259.4	170.57	6259.5	170.87	
6259.6									
171.17	6259.7	171.48	6259.8	171.78	6259.9	172.08	6260	172.38	
6260.1									
172.69	6260.2	172.99	6260.3	173.29	6260.4	173.6	6260.5	173.9	
6260.6									
174.2	6260.7	174.59	6260.8	179.41	6260.9	184.24	6261	189.15	
6261.1									
194.09	6261.2	194.1	6261.2	194.81	6261.1	195.52	6261	196.23	
6260.9									
196.94	6260.8	197.65	6260.7	198.35	6260.6	199.06	6260.5	199.77	

6260.4  
 200.48 6260.3 201.19 6260.2 201.9 6260.1 202.61 6260 203.32  
 6259.9  
 204.03 6259.8 204.74 6259.7 205.45 6259.6 206.41 6259.5 206.5  
 6259.4  
 206.6 6259.3 207.64 6259.2 209.05 6259.1 209.86 6259.1 211.22  
 6259.2  
 212.57 6259.3 213.93 6259.4 215.29 6259.5 216.65 6259.6 218.01  
 6259.7  
 219.37 6259.8 220.73 6259.9 222.09 6260 223.45 6260.1 224.81  
 6260.2  
 226.17 6260.3 227.52 6260.4 228.88 6260.5 230.24 6260.6 231.6  
 6260.7  
 232.96 6260.8 234.32 6260.9 235.68 6261 237.04 6261.1 238.4  
 6261.2  
 239.76 6261.3 241.11 6261.4 242.47 6261.5 243.83 6261.6 245.19  
 6261.7  
 246.55 6261.8 247.91 6261.9 249.27 6262 252.5 6262.1 258.88  
 6262.2  
 259.6 6262.3 262.03 6262.3 263.12 6262.2 264.32 6262.1 265.73  
 6262  
 267.14 6261.9 269.14 6261.9 270.89 6261.8 272.04 6261.8 272.96  
 6261.9  
 273.87 6262 274.78 6262.1 275.68 6262.2 276.48 6262.3 277.27  
 6262.4  
 278.07 6262.5 278.95 6262.6 280.46 6262.7 281.89 6262.8 283.32  
 6262.9  
 284.7 6263 286.01 6263.1 287.32 6263.2 288.56 6263.3 289.76  
 6263.4  
 290.95 6263.5 292.05 6263.6 293.13 6263.7 294.19 6263.8 295.15  
 6263.9  
 296.11 6264 297 6264.1 297.83 6264.2 298.66 6264.3 299.37  
 6264.4  
 300 6264.4

Manning's n Values num= 3  
 Sta n Val Sta n Val Sta n Val  
 0 .03 126.77 .013 172.99 .03

Bank Sta: Left Right Lengths: Left Channel Right Coeff Contr.  
 Expan. 126.77 172.99 20.18 20.18 20.18 .1

.3  
 Ineffective Flow num= 2  
 Sta L Sta R Elev Permanent  
 0 106.69 6267.83 F  
 194.64 300 6261.19 F  
 Left Levee Station= 108.78 Elevation= 6267.98  
 Right Levee Station= 194.22 Elevation= 6261.34

CROSS SECTION OUTPUT Profile #Flow 1

E.G. Elev (ft)	6260.35	Element	Left OB
Channel Right OB			
Vel Head (ft)	0.60	Wt. n-Val.	
0.013			
W.S. Elev (ft)	6259.75	Reach Len. (ft)	20.18
20.18 20.18			
Crit W.S. (ft)	6257.91	Flow Area (sq ft)	
166.73			
E.G. Slope (ft/ft)	0.000491	Area (sq ft)	
166.73			
Q Total (cfs)	1037.00	Flow (cfs)	
1037.00			
Top Width (ft)	40.29	Top Width (ft)	
40.29			
Vel Total (ft/s)	6.22	Avg. Vel. (ft/s)	
6.22			
Max Chl Dpth (ft)	6.85	Hydr. Depth (ft)	
4.14			
Conv. Total (cfs)	46798.2	Conv. (cfs)	
46798.2			
Length Wtd. (ft)	20.18	Wetted Per. (ft)	
43.33			
Min Ch El (ft)	6252.90	Shear (lb/sq ft)	
0.12			
Alpha	1.00	Stream Power (lb/ft s)	300.00
108.78 194.22			
Frctn Loss (ft)	0.02	Cum Volume (acre-ft)	0.01
0.97			
C & E Loss (ft)	0.09	Cum SA (acres)	0.00
0.30			

Warning: The velocity head has changed by more than 0.5 ft (0.15 m). This may indicate the need for additional cross sections.  
 Warning: The conveyance ratio (upstream conveyance divided by downstream conveyance) is less than 0.7 or greater than 1.4.  
 This may indicate the need for additional cross sections.  
 Note: Multiple critical depths were found at this location. The critical depth with the lowest, valid, energy was used.

CROSS SECTION

RIVER: SC01  
 REACH: Sand Creek-DS-0- RS: 982

INPUT  
 Description:  
 Station Elevation Data num= 384  

Sta	Elev	Sta	Elev	Sta	Elev	Sta	Elev	Sta	Elev
Elev									
0	6269.7	13.22	6269.7	20.5	6269.6	38.81	6269.5	41.02	

6269.5  
41.57 6269.6 42.11 6269.7 42.65 6269.8 43.2 6269.9 43.74  
6270  
44.28 6270.1 44.83 6270.2 45.37 6270.3 47.13 6270.3 48.44  
6270.2  
49.75 6270.1 51.07 6270 52.38 6269.9 53.7 6269.8 55.01  
6269.7  
56.33 6269.6 57.64 6269.5 58.96 6269.4 60.27 6269.3 61.59  
6269.2  
62.9 6269.1 64.22 6269 65.53 6268.9 66.84 6268.8 70.15  
6268.7  
74.91 6268.6 79.66 6268.5 85.83 6268.4 87.04 6268.3 88.26  
6268.2  
89.48 6268.1 90.69 6268 91.91 6267.9 93.12 6267.8 94.34  
6267.7  
95.55 6267.6 96.77 6267.5 97.99 6267.4 99.2 6267.3 100.42  
6267.2  
101.63 6267.1 104.2 6267 107.41 6267 107.94 6267.1 108.46  
6267.2  
108.99 6267.3 109.52 6267.4 110.05 6267.5 110.78 6267.5 111.59  
6267.4  
111.92 6267.3 112.24 6267.2 112.56 6267.1 112.89 6267 113.21  
6266.9  
113.53 6266.8 113.86 6266.7 114.18 6266.6 114.51 6266.5 114.83  
6266.4  
115.12 6266.3 115.39 6266.2 115.66 6266.1 115.93 6266 116.2  
6265.9  
116.47 6265.8 116.74 6265.7 117.01 6265.6 117.28 6265.5 117.54  
6265.4  
117.81 6265.3 118.08 6265.2 118.35 6265.1 118.62 6265 118.89  
6264.9  
119.16 6264.8 119.43 6264.7 119.7 6264.6 119.97 6264.5 120.24  
6264.4  
120.51 6264.3 120.78 6264.2 121.05 6264.1 121.31 6264 121.58  
6263.9  
121.85 6263.8 122.12 6263.7 122.39 6263.6 122.66 6263.5 122.93  
6263.4  
123.15 6263.3 123.37 6263.2 123.58 6263.1 123.8 6263 124.02  
6262.9  
124.24 6262.8 124.46 6262.7 124.68 6262.6 124.9 6262.5 125.11  
6262.4  
125.33 6262.3 125.55 6262.2 125.77 6262.1 125.99 6262 126.21  
6261.9  
126.43 6261.8 126.64 6261.7 126.86 6261.6 127.08 6261.5 127.3  
6261.4  
127.52 6261.3 127.74 6261.2 127.95 6261.1 128.17 6261 128.39  
6260.9  
128.61 6260.8 128.83 6260.7 129.05 6260.6 129.27 6260.5 129.48  
6260.4  
129.7 6260.3 129.92 6260.2 130.14 6260.1 130.36 6260 130.58  
6259.9  
130.8 6259.8 131.01 6259.7 131.23 6259.6 131.45 6259.5 131.67  
6259.4

131.89 6259.3 132.11 6259.2 132.33 6259.1 132.54 6259 132.76  
6258.9  
132.98 6258.8 133.2 6258.7 133.42 6258.6 133.64 6258.5 133.86  
6258.4  
134.07 6258.3 134.29 6258.2 134.51 6258.1 134.73 6258 134.95  
6257.9  
135.17 6257.8 135.39 6257.7 135.6 6257.6 135.82 6257.5 136.03  
6257.4  
136.21 6257.3 136.39 6257.2 136.57 6257.1 136.74 6257 136.92  
6256.9  
137.1 6256.8 137.28 6256.7 137.45 6256.6 137.63 6256.5 137.81  
6256.4  
137.99 6256.3 138.17 6256.2 138.34 6256.1 138.52 6256 138.7  
6255.9  
138.88 6255.8 139.05 6255.7 139.23 6255.6 139.41 6255.5 139.59  
6255.4  
139.76 6255.3 139.94 6255.2 140.12 6255.1 140.3 6255 140.48  
6254.9  
149.4 6254.8 149.42 6254.7 149.44 6254.2 149.46 6253.7 149.48  
6253.2  
149.5 6252.7 150 6252.75 150.5 6252.8 150.52 6253.2 150.54  
6253.7  
150.56 6254.2 150.58 6254.7 150.6 6254.8 159.53 6254.9 159.74  
6255  
159.94 6255.1 160.14 6255.2 160.34 6255.3 160.54 6255.4 160.74  
6255.5  
160.94 6255.6 161.14 6255.7 161.34 6255.8 161.54 6255.9 161.74  
6256  
161.94 6256.1 162.14 6256.2 162.34 6256.3 162.54 6256.4 162.74  
6256.5  
162.94 6256.6 163.14 6256.7 163.34 6256.8 163.54 6256.9 163.74  
6257  
163.94 6257.1 164.21 6257.2 164.51 6257.3 164.81 6257.4 165.12  
6257.5  
165.42 6257.6 165.72 6257.7 166.03 6257.8 166.33 6257.9 166.63  
6258  
166.94 6258.1 167.24 6258.2 167.54 6258.3 167.84 6258.4 168.15  
6258.5  
168.45 6258.6 168.75 6258.7 168.88 6258.74 169.06 6258.8 169.36  
6258.9  
169.66 6259 169.97 6259.1 170.27 6259.2 170.57 6259.3 170.88  
6259.4  
171.18 6259.5 171.48 6259.6 171.78 6259.7 172.09 6259.8 172.39  
6259.9  
172.69 6260 173 6260.1 173.3 6260.2 173.6 6260.3 173.91  
6260.4  
174.21 6260.5 174.68 6260.6 179.68 6260.7 184.68 6260.8 190.22  
6260.8  
190.96 6260.7 191.71 6260.6 192.45 6260.5 193.19 6260.4 193.94  
6260.3  
194.68 6260.2 195.43 6260.1 196.17 6260 196.91 6259.9 197.66  
6259.8  
198.4 6259.7 199.15 6259.6 199.89 6259.5 200.63 6259.4 201.38

6259.3									
202.12	6259.2	202.8	6259.1	203.46	6259	204.11	6258.9	204.76	
6258.8									
205.41	6258.7	206.06	6258.6	206.71	6258.5	207.8	6258.4	209.28	
6258.3									
210.76	6258.2	212.24	6258.1	213.71	6258	215.19	6257.9	216.66	
6257.8									
218.13	6257.7	219.59	6257.6	221.06	6257.5	222.52	6257.4	223.99	
6257.3									
225.45	6257.2	226.79	6257.1	228.19	6257	229.86	6256.9	231.89	
6256.8									
256.58	6256.8	256.59	6256.7	256.61	6256.2	256.63	6255.7	256.65	
6255.2									
256.67	6254.7	256.68	6254.6	256.87	6254.8	257.95	6256	258.18	
6254.7									
258.69	6255.9	259.93	6254.6	260.22	6254.5	260.59	6256.6	263.4	
6254.8									
263.41	6255.3	263.43	6255.8	263.45	6256.3	263.46	6256.8	263.48	
6257.3									
263.49	6257.8	265.58	6257.8	267.81	6257.9	268.6	6258	269.15	
6258.1									
269.67	6258.2	270.19	6258.3	270.71	6258.4	271.21	6258.5	271.71	
6258.6									
272.2	6258.7	272.7	6258.8	273.2	6258.9	273.69	6259	274.18	
6259.1									
274.66	6259.2	275.14	6259.3	275.62	6259.4	276.1	6259.5	276.59	
6259.6									
277.07	6259.7	277.55	6259.8	278.03	6259.9	278.52	6260	279	
6260.1									
279.48	6260.2	279.96	6260.3	280.44	6260.4	280.93	6260.5	281.42	
6260.6									
281.95	6260.7	282.49	6260.8	283.02	6260.9	283.56	6261	284.09	
6261.1									
284.62	6261.2	285.16	6261.3	285.69	6261.4	286.23	6261.5	286.76	
6261.6									
287.3	6261.7	287.83	6261.8	288.36	6261.9	288.9	6262	289.43	
6262.1									
289.97	6262.2	290.5	6262.3	291.04	6262.4	291.52	6262.5	291.91	
6262.6									
292.3	6262.7	292.7	6262.8	293.09	6262.9	293.48	6263	293.88	
6263.1									
294.27	6263.2	294.66	6263.3	295.05	6263.4	295.45	6263.5	295.84	
6263.6									
296.23	6263.7	296.62	6263.8	297.22	6263.9	297.86	6264	298.44	
6264.1									
299.01	6264.2	299.49	6264.3	299.92	6264.4	300	6264.4		

Manning's n Values num= 3  
Sta n Val Sta n Val Sta n Val  
0 .03 134.73 .013 168.88 .03

Bank Sta: Left Right Lengths: Left Channel Right Coeff Contr. Expan.

134.73 168.88 2.95 2.95 2.95 .1  
.3  
Ineffective Flow num= 2  
Sta L Sta R Elev Permanent  
0 110.04 6267.43 F  
190.45 300 6260.73 F  
Left Levee Station= 110.04 Elevation= 6267.48  
Right Levee Station= 190.03 Elevation= 6260.89

CROSS SECTION OUTPUT Profile #Flow 1

E.G. Elev (ft)	6260.24	Element	Left OB
Channel Right OB			
Vel Head (ft)	1.52	Wt. n-Val.	0.030
0.013			
W.S. Elev (ft)	6258.72	Reach Len. (ft)	2.95
2.95 2.95			
Crit W.S. (ft)	6258.72	Flow Area (sq ft)	0.56
104.59			
E.G. Slope (ft/ft)	0.002055	Area (sq ft)	0.56
104.59			
Q Total (cfs)	1037.00	Flow (cfs)	0.60
1036.40			
Top Width (ft)	35.64	Top Width (ft)	1.57
34.07			
Vel Total (ft/s)	9.86	Avg. Vel. (ft/s)	1.06
9.91			
Max Chl Dpth (ft)	6.02	Hydr. Depth (ft)	0.36
3.07			
Conv. Total (cfs)	22874.2	Conv. (cfs)	13.2
22861.1			
Length Wtd. (ft)	2.95	Wetted Per. (ft)	1.72
39.55			
Min Ch El (ft)	6252.70	Shear (lb/sq ft)	0.04
0.34			
Alpha	1.01	Stream Power (lb/ft s)	300.00
110.04 190.03			
Frctn Loss (ft)	0.01	Cum Volume (acre-ft)	0.01
0.91			
C & E Loss (ft)	0.01	Cum SA (acres)	0.00
0.28			

Warning: The energy equation could not be balanced within the specified number of iterations. The program used critical depth for the water surface and continued on with the calculations.  
Warning: During the standard step iterations, when the assumed water surface was set equal to critical depth, the calculated water surface came back below critical depth. This indicates that there is not a valid subcritical answer. The program defaulted to critical depth.



159.22	6254.7	159.41	6254.8	159.6	6254.9	159.79	6255	159.98
6255.1								
160.19	6255.2	160.4	6255.3	160.6	6255.4	160.8	6255.5	161
6255.6								
161.2	6255.7	161.4	6255.8	161.6	6255.9	161.8	6256	162
6256.1								
162.2	6256.2	162.4	6256.3	162.6	6256.4	162.8	6256.5	163
6256.6								
163.2	6256.7	163.4	6256.8	163.6	6256.9	163.8	6257	164
6257.1								
164.3	6257.2	164.6	6257.3	164.9	6257.4	165.21	6257.5	165.51
6257.6								
165.81	6257.7	166.12	6257.8	166.42	6257.9	166.72	6258	167.02
6258.1								
167.33	6258.2	167.63	6258.3	167.93	6258.4	168.24	6258.5	168.54
6258.6								
168.84	6258.7	169.05	6258.77	169.15	6258.8	169.45	6258.9	169.75
6259								
170.06	6259.1	170.36	6259.2	170.66	6259.3	170.96	6259.4	171.27
6259.5								
171.57	6259.6	171.87	6259.7	172.18	6259.8	172.48	6259.9	172.78
6260								
173.09	6260.1	173.39	6260.2	173.69	6260.3	173.99	6260.4	174.3
6260.5								
176.15	6260.6	181.15	6260.7	186.15	6260.8	190	6260.8	190.74
6260.7								
191.49	6260.6	192.23	6260.5	192.97	6260.4	193.72	6260.3	194.46
6260.2								
195.21	6260.1	195.95	6260	196.69	6259.9	197.44	6259.8	198.18
6259.7								
198.93	6259.6	199.67	6259.5	200.42	6259.4	201.16	6259.3	201.9
6259.2								
202.65	6259.1	203.39	6259	204.14	6258.9	204.88	6258.8	205.62
6258.7								
206.37	6258.6	207.11	6258.5	207.86	6258.4	208.51	6258.3	209.16
6258.2								
210.14	6258.1	211.62	6258	213.09	6257.9	214.56	6257.8	216.02
6257.7								
217.49	6257.6	218.95	6257.5	220.42	6257.4	221.88	6257.3	223.35
6257.2								
224.81	6257.1	226.27	6257	227.74	6256.9	229.06	6256.8	230.37
6256.7								
231.85	6256.6	233.51	6256.5	235.37	6256.4	237.83	6256.6	241.9
6256.5								
245.02	6256.4	251.83	6256.3	252.65	6256.2	252.76	6256.2	253.34
6256.1								
254.03	6256	255.3	6255.9	255.32	6255.8	255.33	6255.6	255.35
6255.3								
255.36	6255.1	255.39	6254.8	255.4	6254.6	257.21	6254.9	258.32
6256.1								
258.58	6254.4	260.53	6254.4	260.82	6255.8	262.19	6256.4	264.14
6254.6								
264.15	6254.9	264.16	6255.2	264.18	6255.7	264.2	6256.2	264.22

6256.7								
264.23	6256.9	265.25	6257	265.77	6257.1	266.31	6257.2	266.84
6257.3								
267.38	6257.4	267.91	6257.5	268.45	6257.6	268.98	6257.7	269.51
6257.8								
270.05	6257.9	270.58	6258	271.12	6258.1	271.65	6258.2	272.19
6258.3								
272.72	6258.4	273.26	6258.5	273.79	6258.6	274.32	6258.7	274.86
6258.8								
275.39	6258.9	275.93	6259	276.46	6259.1	277	6259.2	277.53
6259.3								
278.07	6259.4	278.6	6259.5	279.13	6259.6	279.67	6259.7	280.2
6259.8								
280.74	6259.9	281.27	6260	281.81	6260.1	282.34	6260.2	282.88
6260.3								
283.41	6260.4	283.94	6260.5	284.48	6260.6	285.01	6260.7	285.5
6260.8								
285.89	6260.9	286.28	6261	286.68	6261.1	287.07	6261.2	287.46
6261.3								
287.85	6261.4	288.25	6261.5	288.64	6261.6	289.03	6261.7	289.42
6261.8								
289.82	6261.9	290.21	6262	290.6	6262.1	291	6262.2	291.39
6262.3								
291.78	6262.4	292.17	6262.5	292.57	6262.6	292.96	6262.7	293.35
6262.8								
293.73	6262.9	294.11	6263	294.49	6263.1	294.87	6263.2	295.25
6263.3								
295.63	6263.4	296.01	6263.5	296.39	6263.6	296.77	6263.7	297.15
6263.8								
297.53	6263.9	297.95	6264	298.53	6264.1	299.03	6264.2	299.47
6264.3								
299.9	6264.4	300	6264.4					
Manning's n Values			num=	3				
Sta n Val	Sta n Val	Sta n Val	Sta n Val	Sta n Val				
0	.03	134.71	.013	169.05	.03			
Bank Sta: Left	Right	Lengths: Left	Channel	Right	Coeff	Contr.		
Expan.		134.71	169.05	19.23	19.23	19.23	.1	
.3								
Ineffective Flow		num=	2					
Sta L	Sta R	Elev	Permanent					
0	108.36	6267.27	F					
190.03	300	6260.77	F					
Left Levee	Station=	112.13	Elevation=	6267.08				
Right Levee	Station=	188.77	Elevation=	6260.98				
CROSS SECTION OUTPUT	Profile #Flow	1						
E.G. Elev (ft)		6259.29	Element				Left OB	
Channel	Right OB							

Vel Head (ft)	1.65	Wt. n-Val.	
0.013			
W.S. Elev (ft)	6257.64	Reach Len. (ft)	19.23
19.23	19.23		
Crit W.S. (ft)	6257.64	Flow Area (sq ft)	
100.46			
E.G. Slope (ft/ft)	0.001815	Area (sq ft)	
100.46			
Q Total (cfs)	1037.00	Flow (cfs)	
1037.00			
Top Width (ft)	30.11	Top Width (ft)	
30.11			
Vel Total (ft/s)	10.32	Avg. Vel. (ft/s)	
10.32			
Max Chl Dpth (ft)	5.03	Hydr. Depth (ft)	
3.34			
Conv. Total (cfs)	24340.3	Conv. (cfs)	
24340.3			
Length Wtd. (ft)	19.23	Wetted Per. (ft)	
32.55			
Min Ch El (ft)	6252.60	Shear (lb/sq ft)	
0.35			
Alpha	1.00	Stream Power (lb/ft s)	300.00
112.13	188.77		
Frctn Loss (ft)	0.03	Cum Volume (acre-ft)	0.01
0.90			
C & E Loss (ft)	0.00	Cum SA (acres)	
0.28			

Warning: The energy equation could not be balanced within the specified number of iterations. The program used critical depth for the water surface and continued on with the calculations.

Warning: During the standard step iterations, when the assumed water surface was set equal to critical depth, the calculated water surface came back below critical depth. This indicates that there is not a valid subcritical answer. The program defaulted to critical depth.

Note: Multiple critical depths were found at this location. The critical depth with the lowest, valid, energy was used.

CROSS SECTION

RIVER: SC01  
 REACH: Sand Creek-DS-0- RS: 980

INPUT  
 Description:  
 Station Elevation Data num= 469  
 Sta Elev Sta Elev Sta Elev Sta Elev Sta  
 Elev

0	6270.7	.15	6270.7	6.35	6270.6	10.35	6270.5	13.74
6270.4								
17.03	6270.3	20.31	6270.2	23.59	6270.1	26.79	6270	29.94
6269.9								
33.08	6269.8	39.05	6269.8	40.29	6269.9	40.63	6270	40.91
6270.1								
41.08	6270.2	41.26	6270.3	41.43	6270.4	41.6	6270.5	41.78
6270.6								
41.95	6270.7	42.5	6270.8	43.04	6270.9	43.58	6271	44.13
6271.1								
45.92	6271.1	47.24	6271	48.55	6270.9	49.87	6270.8	51.18
6270.7								
52.5	6270.6	53.81	6270.5	55.13	6270.4	56.44	6270.3	57.76
6270.2								
59.07	6270.1	60.38	6270	61.7	6269.9	63.01	6269.8	64.33
6269.7								
65.64	6269.6	66.96	6269.5	68.27	6269.4	69.59	6269.3	70.9
6269.2								
72.22	6269.1	73.53	6269	74.85	6268.9	76.16	6268.8	77.48
6268.7								
78.79	6268.6	81.27	6268.5	82.48	6268.4	83.7	6268.3	84.92
6268.2								
86.13	6268.1	87.35	6268	88.56	6267.9	89.78	6267.8	90.99
6267.7								
92.21	6267.6	93.43	6267.5	94.64	6267.4	95.86	6267.3	97.07
6267.2								
98.29	6267.1	99.5	6267	100.72	6266.9	101.94	6266.8	104.03
6266.7								
108.19	6266.6	109.78	6266.6	110.25	6266.5	110.7	6266.4	110.89
6266.3								
111.09	6266.2	111.28	6266.1	111.47	6266	111.67	6265.9	111.86
6265.8								
112.05	6265.7	112.25	6265.6	112.44	6265.5	112.63	6265.4	112.83
6265.3								
113.02	6265.2	113.22	6265.1	113.41	6265	113.6	6264.9	113.85
6264.8								
114.15	6264.7	114.45	6264.6	114.75	6264.5	115.05	6264.4	115.35
6264.3								
115.64	6264.2	115.94	6264.1	116.24	6264	116.54	6263.9	116.84
6263.8								
117.14	6263.7	117.44	6263.6	117.73	6263.5	118.03	6263.4	118.33
6263.3								
118.63	6263.2	118.93	6263.1	119.23	6263	119.53	6262.9	119.82
6262.8								
120.12	6262.7	120.42	6262.6	120.72	6262.5	121.02	6262.4	121.32
6262.3								
121.62	6262.2	121.91	6262.1	122.21	6262	122.51	6261.9	122.81
6261.8								
123.11	6261.7	123.41	6261.6	123.71	6261.5	124	6261.4	124.3
6261.3								
124.6	6261.2	124.9	6261.1	125.2	6261	125.5	6260.9	125.8
6260.8								
126.09	6260.7	126.39	6260.6	126.69	6260.5	126.99	6260.4	127.29



6260.3									
127.59	6260.2	127.89	6260.1	128.18	6260	128.48	6259.9	128.78	
6259.8									
129.08	6259.7	129.38	6259.6	129.68	6259.5	129.98	6259.4	130.27	
6259.3									
130.57	6259.2	130.87	6259.1	131.16	6259	131.46	6258.9	131.75	
6258.8									
132.04	6258.7	132.34	6258.6	132.63	6258.5	132.93	6258.4	133.22	
6258.3									
133.51	6258.2	133.81	6258.1	134.1	6258	134.39	6257.9	134.69	
6257.8									
134.98	6257.7	135.28	6257.6	135.57	6257.5	135.86	6257.4	136.1	
6257.3									
136.27	6257.2	136.45	6257.1	136.63	6257	136.81	6256.9	136.99	
6256.8									
137.17	6256.7	137.34	6256.6	137.52	6256.5	137.7	6256.4	137.88	
6256.3									
138.06	6256.2	138.24	6256.1	138.41	6256	138.59	6255.9	138.77	
6255.8									
138.95	6255.7	139.13	6255.6	139.3	6255.5	139.48	6255.4	139.66	
6255.3									
139.84	6255.2	140.02	6255.1	140.2	6255	140.37	6254.9	140.55	
6254.8									
140.73	6254.7	140.91	6254.6	141.09	6254.5	141.27	6254.4	141.44	
6254.3									
141.62	6254.2	141.8	6254.1	141.98	6254	142.16	6253.9	142.34	
6253.8									
142.51	6253.7	142.69	6253.6	142.87	6253.5	143.05	6253.4	143.23	
6253.3									
143.41	6253.2	143.58	6253.1	143.76	6253	143.94	6252.9	144.12	
6252.8									
144.3	6252.7	144.48	6252.6	144.66	6252.5	144.84	6252.4	155.18	
6252.4									
155.37	6252.5	155.57	6252.6	155.76	6252.7	155.96	6252.8	156.16	
6252.9									
156.35	6253	156.55	6253.1	156.75	6253.2	156.95	6253.3	157.15	
6253.4									
157.35	6253.5	157.55	6253.6	157.75	6253.7	157.95	6253.8	158.15	
6253.9									
158.35	6254	158.55	6254.1	158.75	6254.2	158.95	6254.3	159.15	
6254.4									
159.35	6254.5	159.55	6254.6	159.75	6254.7	159.95	6254.8	160.15	
6254.9									
160.35	6255	160.55	6255.1	160.75	6255.2	160.95	6255.3	161.15	
6255.4									
161.35	6255.5	161.55	6255.6	161.75	6255.7	161.95	6255.8	162.15	
6255.9									
162.35	6256	162.55	6256.1	162.75	6256.2	162.95	6256.3	163.15	
6256.4									
163.35	6256.5	163.55	6256.6	163.75	6256.7	163.95	6256.8	164.22	
6256.9									
164.52	6257	164.82	6257.1	165.11	6257.2	165.41	6257.3	165.71	
6257.4									

166.01	6257.5	166.31	6257.6	166.61	6257.7	166.91	6257.8	167.21	
6257.9									
167.51	6258	167.81	6258.1	168.1	6258.2	168.4	6258.3	168.7	
6258.4									
169	6258.5	169.3	6258.6	169.6	6258.7	169.89	6258.8	170.19	
6258.9									
170.49	6259	170.79	6259.1	171.08	6259.2	171.38	6259.3	171.68	
6259.4									
171.91	6259.48	171.97	6259.5	172.27	6259.6	172.57	6259.7	172.87	
6259.8									
173.16	6259.9	173.46	6260	173.76	6260.1	174.05	6260.2	174.35	
6260.3									
177.03	6260.4	182.12	6260.5	187.24	6260.6	189.81	6260.6	190.51	
6260.5									
191.22	6260.4	192.01	6260.3	192.8	6260.2	193.58	6260.1	194.37	
6260									
195.16	6259.9	195.95	6259.8	196.74	6259.7	197.53	6259.6	198.32	
6259.5									
199.11	6259.4	199.9	6259.3	200.69	6259.2	201.48	6259.1	202.27	
6259									
203.06	6258.9	203.85	6258.8	204.64	6258.7	205.43	6258.6	206.22	
6258.5									
207	6258.4	207.79	6258.3	208.58	6258.2	209.37	6258.1	210.16	
6258									
210.95	6257.9	211.74	6257.8	212.53	6257.7	213.32	6257.6	214.11	
6257.5									
214.9	6257.4	215.69	6257.3	216.48	6257.2	217.27	6257.1	218.06	
6257									
218.85	6256.9	219.64	6256.8	220.43	6256.7	221.21	6256.6	222	
6256.5									
222.79	6256.4	223.58	6256.3	224.42	6256.2	225.15	6256.1	225.88	
6256									
227.21	6255.9	228.75	6255.8	230.3	6255.7	231.84	6255.6	233.39	
6255.5									
234.93	6255.4	237.54	6255.3	240.24	6255.2	241.99	6255.1	243.73	
6255									
245.48	6254.9	247.23	6254.8	248.98	6254.7	249.84	6254.6	249.95	
6254.5									
250.06	6254.4	250.17	6254.3	250.28	6254.2	252.54	6254.2	252.65	
6254.3									
252.76	6254.4	252.87	6254.5	252.98	6254.6	253.27	6254.7	254.92	
6254.8									
257.2	6254.9	259.47	6255	261.75	6255.1	263.39	6255.2	264.64	
6255.3									
265.88	6255.4	267.12	6255.5	267.66	6255.6	268.02	6255.7	268.37	
6255.8									
268.73	6255.9	269.08	6256	269.44	6256.1	269.79	6256.2	270.15	
6256.3									
270.5	6256.4	270.86	6256.5	271.21	6256.6	271.57	6256.7	271.92	
6256.8									
272.28	6256.9	272.63	6257	272.99	6257.1	273.34	6257.2	273.69	
6257.3									
274.05	6257.4	274.4	6257.5	274.76	6257.6	275.11	6257.7	275.47	

6257.8  
 275.82 6257.9 276.18 6258 276.53 6258.1 276.89 6258.2 277.24  
 6258.3  
 277.6 6258.4 277.95 6258.5 278.31 6258.6 278.66 6258.7 279.02  
 6258.8  
 279.37 6258.9 279.72 6259 280.08 6259.1 280.43 6259.2 280.79  
 6259.3  
 281.14 6259.4 281.5 6259.5 281.85 6259.6 282.21 6259.7 282.56  
 6259.8  
 282.92 6259.9 283.27 6260 283.63 6260.1 283.98 6260.2 284.34  
 6260.3  
 284.69 6260.4 285.05 6260.5 285.4 6260.6 285.76 6260.7 286.11  
 6260.8  
 286.46 6260.9 286.82 6261 287.17 6261.1 287.53 6261.2 287.88  
 6261.3  
 288.24 6261.4 288.59 6261.5 288.95 6261.6 289.3 6261.7 289.66  
 6261.8  
 290.01 6261.9 290.36 6262 290.71 6262.1 291.06 6262.2 291.41  
 6262.3  
 291.77 6262.4 292.12 6262.5 292.47 6262.6 292.82 6262.7 293.17  
 6262.8  
 293.52 6262.9 293.88 6263 294.23 6263.1 294.58 6263.2 294.93  
 6263.3  
 295.28 6263.4 295.63 6263.5 295.99 6263.6 296.34 6263.7 296.69  
 6263.8  
 297.04 6263.9 297.39 6264 297.74 6264.1 298.1 6264.2 298.45  
 6264.3  
 298.8 6264.4 299.15 6264.5 299.79 6264.6 300 6264.6

Manning's n Values num= 3  
 Sta n Val Sta n Val Sta n Val  
 0 .03 134.1 .013 171.91 .03

Bank Sta: Left Right Lengths: Left Channel Right Coeff Contr.  
 Expan. 134.1 171.91 10 10 10 .1

.3  
 Ineffective Flow num= 1  
 Sta L Sta R Elev Permanent  
 190.45 300 6260.62 F  
 Left Levee Station= 43.86 Elevation= 6271.1  
 Right Levee Station= 190.03 Elevation= 6260.62

CROSS SECTION OUTPUT Profile #Flow 1

E.G. Elev (ft)	6259.10	Element	Left OB
Channel Right OB			
Vel Head (ft)	1.65	Wt. n-Val.	
0.013			
W.S. Elev (ft)	6257.46	Reach Len. (ft)	10.00
10.00 10.00			
Crit W.S. (ft)	6257.46	Flow Area (sq ft)	

100.70  
 E.G. Slope (ft/ft) 0.001807 Area (sq ft)  
 100.70  
 Q Total (cfs) 1037.00 Flow (cfs)  
 1037.00  
 Top Width (ft) 30.18 Top Width (ft)  
 30.18  
 Vel Total (ft/s) 10.30 Avg. Vel. (ft/s)  
 10.30  
 Max Chl Dpth (ft) 5.06 Hydr. Depth (ft)  
 3.34  
 Conv. Total (cfs) 24396.1 Conv. (cfs)  
 24396.1  
 Length Wtd. (ft) 10.00 Wetted Per. (ft)  
 32.64  
 Min Ch El (ft) 6252.40 Shear (lb/sq ft)  
 0.35  
 Alpha 1.00 Stream Power (lb/ft s) 300.00  
 43.86 190.03  
 Frctn Loss (ft) 0.02 Cum Volume (acre-ft) 0.01  
 0.86  
 C & E Loss (ft) 0.00 Cum SA (acres)  
 0.27

Warning: The energy equation could not be balanced within the specified number of iterations. The program used critical depth for the water surface and continued on with the calculations.  
 Warning: During the standard step iterations, when the assumed water surface was set equal to critical depth, the calculated water surface came back below critical depth. This indicates that there is not a valid subcritical answer. The program defaulted to critical depth.  
 Note: Multiple critical depths were found at this location. The critical depth with the lowest, valid, energy was used.

CROSS SECTION

RIVER: SC01  
 REACH: Sand Creek-DS-0- RS: 979

INPUT  
 Description:  
 Station Elevation Data num= 458  

Sta	Elev	Sta	Elev	Sta	Elev	Sta	Elev	Sta
0	6270.9	2.94	6270.9	6.1	6270.8	10.63	6270.8	14.03
6270.9								
17.42	6271	20.82	6271.1	24.22	6271.2	27.61	6271.3	31.01
6271.4								
34.4	6271.5	36.29	6271.5	44.55	6271.4	45.67	6271.3	46.79

6271.2									
47.9	6271.1	49.02	6271	50.14	6270.9	51.26	6270.8	52.38	
6270.7									
53.49	6270.6	54.61	6270.5	55.73	6270.4	56.85	6270.3	57.96	
6270.2									
59.08	6270.1	60.2	6270	61.32	6269.9	62.44	6269.8	63.55	
6269.7									
64.67	6269.6	65.79	6269.5	66.91	6269.4	68.03	6269.3	69.14	
6269.2									
70.26	6269.1	71.38	6269	72.64	6268.9	74.22	6268.8	75.8	
6268.7									
77.38	6268.6	78.96	6268.5	80.55	6268.4	81.99	6268.3	83.34	
6268.2									
84.62	6268.1	85.84	6268	87.06	6267.9	88.27	6267.8	89.49	
6267.7									
90.7	6267.6	91.92	6267.5	93.13	6267.4	94.35	6267.3	95.57	
6267.2									
96.78	6267.1	98	6267	99.21	6266.9	100.43	6266.8	101.64	
6266.7									
102.86	6266.6	106.65	6266.5	108.91	6266.4	109.6	6266.3	110.55	
6266.2									
110.79	6266.1	110.98	6266	111.17	6265.9	111.36	6265.8	111.55	
6265.7									
111.75	6265.6	111.94	6265.5	112.13	6265.4	112.32	6265.3	112.51	
6265.2									
112.7	6265.1	112.89	6265	113.08	6264.9	113.33	6264.8	113.59	
6264.7									
113.85	6264.6	114.12	6264.5	114.38	6264.4	114.66	6264.3	114.96	
6264.2									
115.25	6264.1	115.55	6264	115.84	6263.9	116.13	6263.8	116.43	
6263.7									
116.72	6263.6	117.01	6263.5	117.31	6263.4	117.6	6263.3	117.9	
6263.2									
118.19	6263.1	118.48	6263	118.78	6262.9	119.07	6262.8	119.36	
6262.7									
119.66	6262.6	119.95	6262.5	120.24	6262.4	120.54	6262.3	120.83	
6262.2									
121.13	6262.1	121.42	6262	121.71	6261.9	122.01	6261.8	122.3	
6261.7									
122.59	6261.6	122.89	6261.5	123.18	6261.4	123.48	6261.3	123.77	
6261.2									
124.06	6261.1	124.36	6261	124.65	6260.9	124.94	6260.8	125.24	
6260.7									
125.53	6260.6	125.83	6260.5	126.12	6260.4	126.41	6260.3	126.71	
6260.2									
127	6260.1	127.29	6260	127.59	6259.9	127.88	6259.8	128.18	
6259.7									
128.47	6259.6	128.76	6259.5	129.06	6259.4	129.35	6259.3	129.64	
6259.2									
129.94	6259.1	130.23	6259	130.53	6258.9	130.82	6258.8	131.11	
6258.7									
131.41	6258.6	131.7	6258.5	131.99	6258.4	132.29	6258.3	132.58	
6258.2									

132.88	6258.1	133.17	6258	133.46	6257.9	133.76	6257.8	134.05	
6257.7									
134.34	6257.6	134.64	6257.5	134.93	6257.4	135.2	6257.3	135.38	
6257.2									
135.55	6257.1	135.73	6257	135.91	6256.9	136.09	6256.8	136.27	
6256.7									
136.45	6256.6	136.62	6256.5	136.8	6256.4	136.98	6256.3	137.16	
6256.2									
137.34	6256.1	137.52	6256	137.69	6255.9	137.87	6255.8	138.05	
6255.7									
138.23	6255.6	138.41	6255.5	138.58	6255.4	138.76	6255.3	138.94	
6255.2									
139.12	6255.1	139.3	6255	139.48	6254.9	139.65	6254.8	139.83	
6254.7									
140.01	6254.6	140.19	6254.5	140.37	6254.4	140.55	6254.3	140.72	
6254.2									
140.9	6254.1	141.08	6254	141.26	6253.9	141.44	6253.8	141.62	
6253.7									
141.79	6253.6	141.97	6253.5	142.15	6253.4	142.33	6253.3	142.52	
6253.2									
142.77	6253.1	143.02	6253	143.27	6252.9	143.52	6252.8	143.77	
6252.7									
144.02	6252.6	144.27	6252.5	144.52	6252.4	144.77	6252.3	155.27	
6252.3									
155.57	6252.4	155.87	6252.5	156.17	6252.6	156.47	6252.7	156.77	
6252.8									
157.07	6252.9	157.37	6253	157.63	6253.1	157.83	6253.2	158.03	
6253.3									
158.23	6253.4	158.43	6253.5	158.63	6253.6	158.83	6253.7	159.03	
6253.8									
159.23	6253.9	159.43	6254	159.63	6254.1	159.83	6254.2	160.03	
6254.3									
160.23	6254.4	160.43	6254.5	160.63	6254.6	160.83	6254.7	161.03	
6254.8									
161.23	6254.9	161.43	6255	161.63	6255.1	161.83	6255.2	162.03	
6255.3									
162.23	6255.4	162.43	6255.5	162.63	6255.6	162.83	6255.7	163.03	
6255.8									
163.23	6255.9	163.43	6256	163.63	6256.1	163.83	6256.2	164.03	
6256.3									
164.23	6256.4	164.43	6256.5	164.63	6256.6	164.83	6256.7	165.11	
6256.8									
165.41	6256.9	165.7	6257	166	6257.1	166.29	6257.2	166.59	
6257.3									
166.89	6257.4	167.18	6257.5	167.48	6257.6	167.77	6257.7	168.07	
6257.8									
168.36	6257.9	168.66	6258	168.95	6258.1	169.25	6258.2	169.54	
6258.3									
169.84	6258.4	170.13	6258.5	170.43	6258.6	170.72	6258.7	171.02	
6258.8									
171.32	6258.9	171.61	6259	171.91	6259.1	172.2	6259.2	172.37	
6259.26									
172.5	6259.3	172.79	6259.4	173.09	6259.5	173.38	6259.6	173.6	



Max Chl Dpth (ft)	4.82	Hydr. Depth (ft)	
3.30			
Conv. Total (cfs)	24386.7	Conv. (cfs)	
24386.7			
Length Wtd. (ft)	9.51	Wetted Per. (ft)	
32.79			
Min Ch El (ft)	6252.30	Shear (lb/sq ft)	
0.35			
Alpha	1.00	Stream Power (lb/ft s)	300.00
44.28	189.19		
Frctn Loss (ft)	0.02	Cum Volume (acre-ft)	0.01
0.83			
C & E Loss (ft)	0.01	Cum SA (acres)	
0.26			

Warning: The energy equation could not be balanced within the specified number of iterations. The program used critical depth for the water surface and continued on with the calculations.

Warning: During the standard step iterations, when the assumed water surface was set equal to critical depth, the calculated water surface came back below critical depth. This indicates that there is not a valid subcritical answer. The program defaulted to critical depth.

Note: Multiple critical depths were found at this location. The critical depth with the lowest, valid, energy was used.

CROSS SECTION

RIVER: SC01  
 REACH: Sand Creek-DS-0- RS: 978

INPUT  
 Description:

Station	Elevation	Data	num=	447					
Sta	Elev	Sta	Elev	Sta	Elev	Sta	Elev	Sta	Elev
Elev									
-30.34	6271.3	-23.86	6271.3	-14.08	6271.2	-4.29	6271.1	5.49	
6271									
15.07	6270.9	16.19	6270.8	17.3	6270.7	18.42	6270.6	19.54	
6270.5									
20.66	6270.4	21.77	6270.3	22.89	6270.2	24.01	6270.1	25.13	
6270									
26.25	6269.9	27.36	6269.8	28.48	6269.7	29.6	6269.6	30.72	
6269.5									
31.84	6269.4	33.25	6269.3	34.83	6269.2	36.41	6269.1	37.99	
6269									
39.57	6268.9	41.15	6268.8	42.73	6268.7	44.32	6268.6	45.9	
6268.5									
47.48	6268.4	49.06	6268.3	50.64	6268.2	52.22	6268.1	53.57	
6268									

54.92	6267.9	56.28	6267.8	57.63	6267.7	58.93	6267.6	60.14	
6267.5									
61.36	6267.4	62.58	6267.3	63.79	6267.2	65.01	6267.1	66.22	
6267									
67.44	6266.9	68.65	6266.8	69.87	6266.7	71.09	6266.6	72.3	
6266.5									
75.05	6266.4	77.42	6266.3	78.21	6266.2	79.15	6266.1	80.09	
6266									
80.38	6265.9	80.57	6265.8	80.76	6265.7	80.95	6265.6	81.14	
6265.5									
81.33	6265.4	81.52	6265.3	81.71	6265.2	81.9	6265.1	82.09	
6265									
82.31	6264.9	82.57	6264.8	82.83	6264.7	83.1	6264.6	83.36	
6264.5									
83.62	6264.4	83.88	6264.3	84.15	6264.2	84.41	6264.1	84.67	
6264									
84.94	6263.9	85.2	6263.8	85.46	6263.7	85.72	6263.6	85.99	
6263.5									
86.25	6263.4	86.51	6263.3	86.77	6263.2	87.04	6263.1	87.3	
6263									
87.56	6262.9	87.83	6262.8	88.09	6262.7	88.38	6262.6	88.67	
6262.5									
88.97	6262.4	89.26	6262.3	89.56	6262.2	89.85	6262.1	90.14	
6262									
90.44	6261.9	90.73	6261.8	91.02	6261.7	91.32	6261.6	91.61	
6261.5									
91.9	6261.4	92.2	6261.3	92.49	6261.2	92.79	6261.1	93.08	
6261									
93.37	6260.9	93.67	6260.8	93.96	6260.7	94.25	6260.6	94.55	
6260.5									
94.84	6260.4	95.14	6260.3	95.43	6260.2	95.72	6260.1	96.02	
6260									
96.31	6259.9	96.6	6259.8	96.9	6259.7	97.19	6259.6	97.49	
6259.5									
97.78	6259.4	98.07	6259.3	98.37	6259.2	98.66	6259.1	98.95	
6259									
99.25	6258.9	99.54	6258.8	99.84	6258.7	100.13	6258.6	100.42	
6258.5									
100.72	6258.4	101.01	6258.3	101.3	6258.2	101.6	6258.1	101.89	
6258									
102.19	6257.9	102.48	6257.8	102.77	6257.7	103.07	6257.6	103.36	
6257.5									
103.65	6257.4	103.95	6257.3	104.13	6257.2	104.31	6257.1	104.49	
6257									
104.67	6256.9	104.84	6256.8	105.02	6256.7	105.2	6256.6	105.38	
6256.5									
105.56	6256.4	105.74	6256.3	105.91	6256.2	106.09	6256.1	106.27	
6256									
106.45	6255.9	106.63	6255.8	106.8	6255.7	106.98	6255.6	107.16	
6255.5									
107.34	6255.4	107.52	6255.3	107.7	6255.2	107.87	6255.1	108.05	
6255									
108.23	6254.9	108.41	6254.8	108.59	6254.7	108.77	6254.6	108.94	

6254.5									
109.12	6254.4	109.3	6254.3	109.48	6254.2	109.7	6254.1	109.95	
6254									
110.2	6253.9	110.45	6253.8	110.7	6253.7	110.95	6253.6	111.2	
6253.5									
111.45	6253.4	111.7	6253.3	111.95	6253.2	112.2	6253.1	112.45	
6253									
112.7	6252.9	112.95	6252.8	113.2	6252.7	113.45	6252.6	113.7	
6252.5									
113.95	6252.4	114.2	6252.3	114.45	6252.2	124.92	6252.2	125.22	
6252.3									
125.52	6252.4	125.82	6252.5	126.12	6252.6	126.42	6252.7	126.72	
6252.8									
127.02	6252.9	127.32	6253	127.62	6253.1	127.92	6253.2	128.22	
6253.3									
128.52	6253.4	128.82	6253.5	129.12	6253.6	129.42	6253.7	129.72	
6253.8									
129.93	6253.9	130.13	6254	130.33	6254.1	130.53	6254.2	130.73	
6254.3									
130.93	6254.4	131.13	6254.5	131.33	6254.6	131.53	6254.7	131.73	
6254.8									
131.93	6254.9	132.13	6255	132.33	6255.1	132.53	6255.2	132.73	
6255.3									
132.93	6255.4	133.13	6255.5	133.33	6255.6	133.53	6255.7	133.73	
6255.8									
133.93	6255.9	134.13	6256	134.33	6256.1	134.53	6256.2	134.73	
6256.3									
134.93	6256.4	135.13	6256.5	135.33	6256.6	135.61	6256.7	135.91	
6256.8									
136.2	6256.9	136.5	6257	136.6	6257.03	136.79	6257.1	137.09	
6257.2									
137.38	6257.3	137.68	6257.4	137.98	6257.5	138.27	6257.6	138.57	
6257.7									
138.86	6257.8	139.16	6257.9	139.45	6258	139.75	6258.1	140.04	
6258.2									
140.34	6258.3	140.63	6258.4	140.93	6258.5	141.22	6258.6	141.52	
6258.7									
141.81	6258.8	142.06	6258.9	142.25	6259	142.45	6259.1	142.64	
6259.2									
142.83	6259.3	143.03	6259.4	143.22	6259.5	143.42	6259.6	143.61	
6259.7									
143.8	6259.8	144	6259.9	145.02	6260	150.2	6260.1	155.32	
6260.2									
159.7	6260.2	160.41	6260.1	161.11	6260	161.82	6259.9	162.52	
6259.8									
163.22	6259.7	163.93	6259.6	164.63	6259.5	165.34	6259.4	166.04	
6259.3									
166.75	6259.2	167.45	6259.1	168.16	6259	168.86	6258.9	169.57	
6258.8									
170.27	6258.7	170.97	6258.6	171.68	6258.5	172.38	6258.4	173.09	
6258.3									
173.79	6258.2	174.5	6258.1	175.2	6258	175.91	6257.9	176.61	
6257.8									

177.32	6257.7	178.02	6257.6	178.72	6257.5	179.43	6257.4	180.13	
6257.3									
180.84	6257.2	181.54	6257.1	182.25	6257	182.95	6256.9	183.75	
6256.8									
184.57	6256.7	185.38	6256.6	185.81	6256.6	186.2	6256.5	187.01	
6256.4									
187.83	6256.3	188.65	6256.2	189.46	6256.1	190.28	6256	191.1	
6255.9									
191.91	6255.8	192.74	6255.7	193.58	6255.6	194.43	6255.5	195.27	
6255.4									
196.11	6255.3	196.95	6255.2	198.52	6255.1	200.31	6255	202.11	
6254.9									
203.9	6254.8	205.7	6254.7	207.5	6254.6	209.3	6254.5	211.1	
6254.4									
211.43	6254.3	211.53	6254.2	211.64	6254.1	211.75	6254	211.85	
6253.9									
213.98	6253.9	214.09	6254	214.19	6254.1	214.3	6254.2	214.41	
6254.3									
214.51	6254.4	216.82	6254.5	219.13	6254.6	221.46	6254.7	223.87	
6254.8									
226.5	6254.9	229.43	6255	232.36	6255.1	235.29	6255.2	236.42	
6255.3									
236.77	6255.4	237.12	6255.5	237.47	6255.6	237.82	6255.7	238.17	
6255.8									
238.52	6255.9	238.88	6256	239.23	6256.1	239.58	6256.2	239.93	
6256.3									
240.28	6256.4	240.63	6256.5	240.98	6256.6	241.33	6256.7	241.69	
6256.8									
242.04	6256.9	242.39	6257	242.74	6257.1	243.09	6257.2	243.44	
6257.3									
243.79	6257.4	244.15	6257.5	244.5	6257.6	244.85	6257.7	245.2	
6257.8									
245.55	6257.9	245.9	6258	246.25	6258.1	246.61	6258.2	246.96	
6258.3									
247.31	6258.4	247.66	6258.5	248.01	6258.6	248.36	6258.7	248.71	
6258.8									
249.07	6258.9	249.42	6259	249.77	6259.1	250.12	6259.2	250.47	
6259.3									
250.82	6259.4	251.17	6259.5	251.52	6259.6	251.88	6259.7	252.23	
6259.8									
252.58	6259.9	252.93	6260	253.28	6260.1	253.63	6260.2	253.98	
6260.3									
254.34	6260.4	254.69	6260.5	255.04	6260.6	255.39	6260.7	255.74	
6260.8									
256.09	6260.9	256.44	6261	256.8	6261.1	257.15	6261.2	257.5	
6261.3									
257.85	6261.4	258.2	6261.5	258.55	6261.6	258.9	6261.7	259.26	
6261.8									
259.61	6261.9	259.96	6262	260.31	6262.1	260.66	6262.2	261.01	
6262.3									
261.36	6262.4	261.71	6262.5	262.07	6262.6	262.42	6262.7	262.77	
6262.8									
263.12	6262.9	263.47	6263	263.82	6263.1	264.17	6263.2	264.53	

6263.3  
 264.88 6263.4 265.22 6263.5 265.57 6263.6 265.92 6263.7 266.27  
 6263.8  
 266.62 6263.9 266.96 6264 267.31 6264.1 267.66 6264.2 268.25  
 6264.3  
 269.24 6264.4 269.66 6264.4

Manning's n Values num= 3  
 Sta n Val Sta n Val Sta n Val  
 -30.34 .03 104.13 .013 136.6 .03

Bank Sta: Left Right Lengths: Left Channel Right Coeff Contr.  
 Expan. 104.13 136.6 11.26 11.26 11.26 .1  
 .3

Ineffective Flow num= 1  
 Sta L Sta R Elev Permanent  
 160.11 269.66 6260.15 F  
 Left Levee Station= 77.18 Elevation= 6266.33  
 Right Levee Station= 159.69 Elevation= 6260.26

CROSS SECTION OUTPUT Profile #Flow 1

E.G. Elev (ft)	6258.49	Element	Left OB
Channel Right OB			
Vel Head (ft)	1.59	Wt. n-Val.	
0.013			
W.S. Elev (ft)	6256.90	Reach Len. (ft)	11.26
11.26 11.26			
Crit W.S. (ft)	6256.90	Flow Area (sq ft)	
102.38			
E.G. Slope (ft/ft)	0.001775	Area (sq ft)	
102.38			
Q Total (cfs)	1037.00	Flow (cfs)	
1037.00			
Top Width (ft)	31.51	Top Width (ft)	
31.51			
Vel Total (ft/s)	10.13	Avg. Vel. (ft/s)	
10.13			
Max Chl Dpth (ft)	4.70	Hydr. Depth (ft)	
3.25			
Conv. Total (cfs)	24611.0	Conv. (cfs)	
24611.0			
Length Wtd. (ft)	11.26	Wetted Per. (ft)	
33.57			
Min Ch El (ft)	6252.20	Shear (lb/sq ft)	
0.34			
Alpha	1.00	Stream Power (lb/ft s)	269.66
77.18 159.69			
Frctn Loss (ft)	0.02	Cum Volume (acre-ft)	0.01
0.81			
C & E Loss (ft)	0.01	Cum SA (acres)	

0.25

Warning: The energy equation could not be balanced within the specified number of iterations. The program used critical depth for the water surface and continued on with the calculations.  
 Warning: During the standard step iterations, when the assumed water surface was set equal to critical depth, the calculated water surface came back below critical depth. This indicates that there is not a valid subcritical answer. The program defaulted to critical depth.  
 Note: Multiple critical depths were found at this location. The critical depth with the lowest, valid, energy was used.

CROSS SECTION

RIVER: SC01  
 REACH: Sand Creek-DS-0- RS: 977

INPUT

Description:  
 Station Elevation Data num= 443  
 Sta Elev Sta Elev Sta Elev Sta Elev Sta Elev  
 Elev  
 0 6270.9 1.28 6270.9 7.94 6270.8 14.61 6270.7 21.27  
 6270.6  
 27.94 6270.5 36.02 6270.4 45.8 6270.3 47.63 6270.2 48.74  
 6270.1  
 49.86 6270 50.98 6269.9 52.45 6269.8 54.03 6269.7 55.61  
 6269.6  
 57.19 6269.5 58.78 6269.4 60.36 6269.3 61.94 6269.2 63.52  
 6269.1  
 65.1 6269 66.68 6268.9 68.26 6268.8 69.84 6268.7 71.42  
 6268.6  
 73.01 6268.5 74.59 6268.4 76.17 6268.3 77.75 6268.2 79.33  
 6268.1  
 80.91 6268 82.49 6267.9 84.07 6267.8 85.44 6267.7 86.79  
 6267.6  
 88.14 6267.5 89.5 6267.4 90.85 6267.3 92.2 6267.2 93.56  
 6267.1  
 94.87 6267 96.08 6266.9 97.3 6266.8 98.51 6266.7 99.73  
 6266.6  
 100.94 6266.5 102.16 6266.4 103.38 6266.3 106.28 6266.2 107.12  
 6266.1  
 108.06 6266 109 6265.9 109.94 6265.8 110.56 6265.7 110.75  
 6265.6  
 110.94 6265.5 111.13 6265.4 111.33 6265.3 111.52 6265.2 111.71  
 6265.1  
 111.9 6265 112.15 6264.9 112.41 6264.8 112.68 6264.7 112.94  
 6264.6  
 113.2 6264.5 113.46 6264.4 113.73 6264.3 113.99 6264.2 114.25

6264.1								
114.52	6264	114.78	6263.9	115.04	6263.8	115.3	6263.7	115.57
6263.6								
115.83	6263.5	116.09	6263.4	116.36	6263.3	116.62	6263.2	116.88
6263.1								
117.14	6263	117.41	6262.9	117.67	6262.8	117.93	6262.7	118.2
6262.6								
118.46	6262.5	118.72	6262.4	118.98	6262.3	119.25	6262.2	119.51
6262.1								
119.77	6262	120.04	6261.9	120.3	6261.8	120.56	6261.7	120.82
6261.6								
121.09	6261.5	121.35	6261.4	121.61	6261.3	121.87	6261.2	122.14
6261.1								
122.4	6261	122.66	6260.9	122.93	6260.8	123.19	6260.7	123.48
6260.6								
123.78	6260.5	124.07	6260.4	124.37	6260.3	124.66	6260.2	124.95
6260.1								
125.25	6260	125.54	6259.9	125.83	6259.8	126.13	6259.7	126.42
6259.6								
126.72	6259.5	127.01	6259.4	127.3	6259.3	127.6	6259.2	127.89
6259.1								
128.18	6259	128.48	6258.9	128.77	6258.8	129.07	6258.7	129.36
6258.6								
129.65	6258.5	129.95	6258.4	130.24	6258.3	130.53	6258.2	130.83
6258.1								
131.12	6258	131.42	6257.9	131.71	6257.8	132	6257.7	132.3
6257.6								
132.59	6257.5	132.88	6257.4	133.18	6257.3	133.4	6257.2	133.58
6257.1								
133.75	6257	133.93	6256.9	134.11	6256.8	134.29	6256.7	134.47
6256.6								
134.65	6256.5	134.82	6256.4	135	6256.3	135.18	6256.2	135.36
6256.1								
135.54	6256	135.72	6255.9	135.89	6255.8	136.07	6255.7	136.25
6255.6								
136.43	6255.5	136.61	6255.4	136.79	6255.3	137.01	6255.2	137.26
6255.1								
137.51	6255	137.76	6254.9	138.01	6254.8	138.26	6254.7	138.51
6254.6								
138.76	6254.5	139.01	6254.4	139.26	6254.3	139.51	6254.2	139.76
6254.1								
140.01	6254	140.26	6253.9	140.51	6253.8	140.76	6253.7	141.01
6253.6								
141.26	6253.5	141.51	6253.4	141.76	6253.3	142.01	6253.2	142.26
6253.1								
142.51	6253	142.76	6252.9	143.01	6252.8	143.26	6252.7	143.51
6252.6								
143.76	6252.5	144.01	6252.4	144.26	6252.3	144.51	6252.2	144.76
6252.1								
155.29	6252.1	155.59	6252.2	155.89	6252.3	156.19	6252.4	156.49
6252.5								
156.79	6252.6	157.09	6252.7	157.39	6252.8	157.69	6252.9	157.99
6253								

158.29	6253.1	158.59	6253.2	158.89	6253.3	159.19	6253.4	159.49
6253.5								
159.79	6253.6	160.09	6253.7	160.39	6253.8	160.69	6253.9	160.99
6254								
161.29	6254.1	161.59	6254.2	161.89	6254.3	162.19	6254.4	162.49
6254.5								
162.79	6254.6	163.09	6254.7	163.31	6254.8	163.51	6254.9	163.71
6255								
163.91	6255.1	164.11	6255.2	164.31	6255.3	164.51	6255.4	164.71
6255.5								
164.91	6255.6	165.11	6255.7	165.31	6255.8	165.51	6255.9	165.71
6256								
165.91	6256.1	166.11	6256.2	166.31	6256.3	166.51	6256.4	166.71
6256.5								
167	6256.6	167.3	6256.7	167.59	6256.8	167.89	6256.9	168.18
6257								
168.48	6257.1	168.77	6257.2	169.07	6257.3	169.37	6257.4	169.66
6257.5								
169.96	6257.6	170.01	6257.62	170.25	6257.7	170.55	6257.8	170.84
6257.9								
171.06	6258	171.26	6258.1	171.45	6258.2	171.65	6258.3	171.84
6258.4								
172.03	6258.5	172.23	6258.6	172.42	6258.7	172.62	6258.8	172.81
6258.9								
173	6259	173.2	6259.1	173.39	6259.2	173.59	6259.3	173.78
6259.4								
173.97	6259.5	174.17	6259.6	174.36	6259.7	175.98	6259.8	181.14
6259.9								
186.14	6260	189.97	6260	190.68	6259.9	191.38	6259.8	192.09
6259.7								
192.79	6259.6	193.5	6259.5	194.2	6259.4	194.91	6259.3	195.61
6259.2								
196.32	6259.1	197.02	6259	197.72	6258.9	198.43	6258.8	199.13
6258.7								
199.84	6258.6	200.54	6258.5	201.25	6258.4	201.95	6258.3	202.66
6258.2								
203.36	6258.1	204.07	6258	204.77	6257.9	205.47	6257.8	206.18
6257.7								
206.88	6257.6	207.59	6257.5	208.29	6257.4	209	6257.3	209.7
6257.2								
210.41	6257.1	211.11	6257	211.82	6256.9	212.52	6256.8	213.22
6256.7								
213.93	6256.6	214.63	6256.5	215.34	6256.4	216.04	6256.3	216.75
6256.2								
217.45	6256.1	218.16	6256	218.86	6255.9	219.54	6256	219.57
6255.8								
220.27	6255.7	220.97	6255.6	221.64	6255.5	222.28	6255.4	222.91
6255.3								
223.55	6255.2	224.18	6255.1	225.03	6255	226.8	6254.9	228.57
6254.8								
230.34	6254.7	232.1	6254.6	233.87	6254.5	235.63	6254.4	237.4
6254.3								
238.51	6254.2	238.61	6254.1	238.71	6254	238.81	6253.9	238.92



6253.8								
241.08	6253.8	241.18	6253.9	241.28	6254	241.39	6254.1	241.49
6254.2								
243.15	6254.3	246.08	6254.4	249.01	6254.5	251.94	6254.6	254.87
6254.7								
257.8	6254.8	260.73	6254.9	261.72	6255	263.66	6255	266.07
6255.1								
266.43	6255.2	266.78	6255.3	267.13	6255.4	267.48	6255.5	267.83
6255.6								
268.18	6255.7	268.53	6255.8	268.89	6255.9	269.24	6256	269.59
6256.1								
269.94	6256.2	270.29	6256.3	270.64	6256.4	270.99	6256.5	271.35
6256.6								
271.7	6256.7	272.05	6256.8	272.4	6256.9	272.75	6257	273.1
6257.1								
273.45	6257.2	273.81	6257.3	274.16	6257.4	274.51	6257.5	274.86
6257.6								
275.21	6257.7	275.56	6257.8	275.91	6257.9	276.26	6258	276.62
6258.1								
276.97	6258.2	277.32	6258.3	277.67	6258.4	278.02	6258.5	278.37
6258.6								
278.72	6258.7	279.08	6258.8	279.43	6258.9	279.78	6259	280.13
6259.1								
280.48	6259.2	280.83	6259.3	281.18	6259.4	281.54	6259.5	281.89
6259.6								
282.24	6259.7	282.59	6259.8	282.94	6259.9	283.29	6260	283.64
6260.1								
284	6260.2	284.35	6260.3	284.7	6260.4	285.05	6260.5	285.4
6260.6								
285.75	6260.7	286.1	6260.8	286.45	6260.9	286.8	6261	287.15
6261.1								
287.5	6261.2	287.85	6261.3	288.19	6261.4	288.54	6261.5	288.89
6261.6								
289.24	6261.7	289.59	6261.8	289.93	6261.9	290.28	6262	290.63
6262.1								
290.98	6262.2	291.33	6262.3	291.67	6262.4	292.02	6262.5	292.37
6262.6								
292.72	6262.7	293.06	6262.8	293.41	6262.9	293.76	6263	294.11
6263.1								
294.46	6263.2	294.8	6263.3	295.15	6263.4	295.5	6263.5	295.85
6263.6								
296.2	6263.7	296.54	6263.8	296.89	6263.9	297.24	6264	297.63
6264.1								
298.62	6264.2	299.62	6264.3	300	6264.3			

Manning's n Values	num=	3
Sta n Val Sta n Val Sta n Val		
0 .03 133.75 .013 170.01 .03		

Bank Sta: Left Right Lengths: Left Channel Right Coeff Contr.						
Expan.	133.75	170.01	50	50	50	.1
.3						

Ineffective Flow	num=	1
Sta L Sta R Elev Permanent		
190.03 300 6259.93 F		
Left Levee Station= 49.73 Elevation= 6270.1		
Right Levee Station= 188.77 Elevation= 6260.04		

CROSS SECTION OUTPUT Profile #Flow 1

E.G. Elev (ft)	6258.25	Element	Left OB
Channel Right OB			
Vel Head (ft)	1.56	Wt. n-Val.	
0.013			
W.S. Elev (ft)	6256.69	Reach Len. (ft)	50.00
50.00 50.00			
Crit W.S. (ft)	6256.69	Flow Area (sq ft)	
103.44			
E.G. Slope (ft/ft)	0.001800	Area (sq ft)	
103.44			
Q Total (cfs)	1037.00	Flow (cfs)	
1037.00			
Top Width (ft)	32.94	Top Width (ft)	
32.94			
Vel Total (ft/s)	10.03	Avg. Vel. (ft/s)	
10.03			
Max Chl Dpth (ft)	4.58	Hydr. Depth (ft)	
3.14			
Conv. Total (cfs)	24445.1	Conv. (cfs)	
24445.1			
Length Wtd. (ft)	50.00	Wetted Per. (ft)	
34.79			
Min Ch El (ft)	6252.10	Shear (lb/sq ft)	
0.33			
Alpha	1.00	Stream Power (lb/ft s)	300.00
49.73 188.77			
Frctn Loss (ft)	0.09	Cum Volume (acre-ft)	0.01
0.79			
C & E Loss (ft)	0.02	Cum SA (acres)	
0.24			

Warning: The energy equation could not be balanced within the specified number of iterations. The program used critical depth for the water surface and continued on with the calculations.

Warning: During the standard step iterations, when the assumed water surface was set equal to critical depth, the calculated water surface came back below critical depth. This indicates that there is not a valid subcritical answer. The program defaulted to critical depth.

Note: Multiple critical depths were found at this location. The critical depth with the lowest, valid, energy was used.

CROSS SECTION

RIVER: SC01  
 REACH: Sand Creek-DS-0- RS: 976

INPUT

Description:

Station	Elevation	Data	num=	429					
Sta	Elev	Sta	Elev	Sta	Elev	Sta	Elev	Sta	Elev
0	6268.7	4.23	6268.7	4.99	6268.6	5.75	6268.5	6.5	
6268.4									
22	6268.4	26.98	6268.5	31.96	6268.6	36.94	6268.7	38.49	
6268.8									
39.86	6268.8	41.59	6268.7	43.32	6268.6	45.05	6268.5	46.78	
6268.4									
48.51	6268.3	50.24	6268.2	51.97	6268.1	53.6	6268	55.16	
6267.9									
56.71	6267.8	58.27	6267.7	60.15	6267.6	62.16	6267.5	64.22	
6267.4									
66.31	6267.3	68.4	6267.2	70.49	6267.1	72.58	6267	74.66	
6266.9									
76.75	6266.8	78.84	6266.7	80.93	6266.6	83.02	6266.5	85.1	
6266.4									
87.19	6266.3	89.28	6266.2	91.37	6266.1	93.46	6266	97.27	
6265.9									
101.1	6265.8	104.94	6265.7	106.06	6265.6	106.71	6265.5	107.35	
6265.4									
108	6265.3	108.64	6265.2	109.27	6265.1	109.86	6265	109.99	
6264.9									
110.11	6264.8	110.24	6264.7	110.37	6264.6	110.98	6264.5	111.97	
6264.4									
112.2	6264.3	112.44	6264.2	112.68	6264.1	112.92	6264	113.16	
6263.9									
113.4	6263.8	113.64	6263.7	113.88	6263.6	114.12	6263.5	114.36	
6263.4									
114.59	6263.3	114.83	6263.2	115.07	6263.1	115.34	6263	115.6	
6262.9									
115.87	6262.8	116.13	6262.7	116.4	6262.6	116.66	6262.5	116.93	
6262.4									
117.19	6262.3	117.46	6262.2	117.72	6262.1	117.99	6262	118.26	
6261.9									
118.52	6261.8	118.79	6261.7	119.05	6261.6	119.32	6261.5	119.58	
6261.4									
119.85	6261.3	120.11	6261.2	120.38	6261.1	120.64	6261	120.91	
6260.9									
121.17	6260.8	121.44	6260.7	121.7	6260.6	121.97	6260.5	122.23	
6260.4									
122.5	6260.3	122.76	6260.2	123.03	6260.1	123.29	6260	123.56	
6259.9									
123.82	6259.8	124.09	6259.7	124.35	6259.6	124.62	6259.5	124.88	
6259.4									

125.15	6259.3	125.41	6259.2	125.68	6259.1	125.94	6259	126.21	
6258.9									
126.47	6258.8	126.74	6258.7	127	6258.6	127.27	6258.5	127.53	
6258.4									
127.8	6258.3	128.06	6258.2	128.33	6258.1	128.6	6258	128.86	
6257.9									
129.13	6257.8	129.39	6257.7	129.66	6257.6	129.92	6257.5	130.19	
6257.4									
130.45	6257.3	130.72	6257.2	130.98	6257.1	131.25	6257	131.51	
6256.9									
131.76	6256.8	132.01	6256.7	132.26	6256.6	132.51	6256.5	132.76	
6256.4									
133.01	6256.3	133.26	6256.2	133.51	6256.1	133.76	6256	134.01	
6255.9									
134.26	6255.8	134.51	6255.7	134.76	6255.6	135.01	6255.5	135.26	
6255.4									
135.51	6255.3	135.76	6255.2	136.01	6255.1	136.26	6255	136.51	
6254.9									
136.76	6254.8	137.01	6254.7	137.26	6254.6	137.51	6254.5	137.76	
6254.4									
138.01	6254.3	138.26	6254.2	138.51	6254.1	138.76	6254	139.01	
6253.9									
139.26	6253.8	139.51	6253.7	139.76	6253.6	140.01	6253.5	140.26	
6253.4									
140.51	6253.3	140.76	6253.2	141.01	6253.1	141.26	6253	141.51	
6252.9									
141.76	6252.8	142.01	6252.7	142.26	6252.6	142.51	6252.5	142.76	
6252.4									
143.01	6252.3	143.26	6252.2	143.51	6252.1	143.76	6252	144.01	
6251.9									
144.26	6251.8	144.51	6251.7	144.76	6251.6	155.29	6251.6	155.59	
6251.7									
155.89	6251.8	156.19	6251.9	156.49	6252	156.79	6252.1	157.09	
6252.2									
157.39	6252.3	157.69	6252.4	157.99	6252.5	158.29	6252.6	158.59	
6252.7									
158.89	6252.8	159.19	6252.9	159.49	6253	159.79	6253.1	160.09	
6253.2									
160.39	6253.3	160.69	6253.4	160.99	6253.5	161.29	6253.6	161.59	
6253.7									
161.89	6253.8	162.19	6253.9	162.49	6254	162.79	6254.1	163.09	
6254.2									
163.39	6254.3	163.69	6254.4	163.99	6254.5	164.29	6254.6	164.59	
6254.7									
164.89	6254.8	165.19	6254.9	165.49	6255	165.79	6255.1	166.09	
6255.2									
166.39	6255.3	166.69	6255.4	166.99	6255.5	167.29	6255.6	167.59	
6255.7									
167.89	6255.8	168.19	6255.9	168.49	6256	168.69	6256.1	168.88	
6256.2									
169.07	6256.3	169.27	6256.4	169.46	6256.5	169.66	6256.6	169.85	
6256.7									
170.04	6256.8	170.24	6256.9	170.43	6257	170.63	6257.1	170.82	

6257.2									
171.01	6257.3	171.18	6257.38	171.21	6257.4	171.4	6257.5	171.6	
6257.6									
171.79	6257.7	172	6257.8	172.24	6257.9	172.49	6258	172.73	
6258.1									
172.97	6258.2	173.21	6258.3	173.46	6258.4	173.7	6258.5	173.94	
6258.6									
174.18	6258.7	174.43	6258.8	177.98	6258.9	182.98	6259	189.51	
6259									
190.22	6258.9	190.94	6258.8	191.65	6258.7	192.36	6258.6	193.08	
6258.5									
193.79	6258.4	194.5	6258.3	195.22	6258.2	195.93	6258.1	196.64	
6258									
197.36	6257.9	198.07	6257.8	198.78	6257.7	199.5	6257.6	200.21	
6257.5									
200.92	6257.4	201.64	6257.3	202.35	6257.2	203.06	6257.1	203.78	
6257									
204.49	6256.9	205.2	6256.8	205.92	6256.7	206.63	6256.6	207.34	
6256.5									
208.06	6256.4	208.77	6256.3	209.48	6256.2	210.2	6256.1	210.91	
6256									
211.62	6255.9	212.34	6255.8	213.05	6255.7	213.76	6255.6	214.48	
6255.5									
215.19	6255.4	215.9	6255.3	216.62	6255.2	217.33	6255.1	218.05	
6255									
218.8	6254.9	219.55	6254.8	220.29	6254.7	221.04	6254.6	221.77	
6254.5									
222.44	6254.4	224.05	6254.3	226.08	6254.2	228.12	6254.1	230.14	
6254									
232.15	6253.9	233.41	6254	234.16	6253.8	236.06	6253.8	236.17	
6253.7									
238.08	6253.6	238.18	6253.5	238.28	6253.4	238.38	6253.3	238.48	
6253.2									
240.5	6253.4	240.67	6253.2	240.77	6253.3	240.87	6253.4	240.97	
6253.5									
241.07	6253.6	243.85	6253.7	246.69	6253.8	249.53	6253.9	252.33	
6254									
255.13	6254.1	257.89	6254.2	260.62	6254.3	263.37	6254.4	264.06	
6254.5									
264.41	6254.6	264.76	6254.7	265.11	6254.8	265.46	6254.9	265.8	
6255									
266.15	6255.1	266.5	6255.2	266.85	6255.3	267.2	6255.4	267.54	
6255.5									
267.89	6255.6	268.24	6255.7	268.59	6255.8	268.94	6255.9	269.28	
6256									
269.63	6256.1	269.98	6256.2	270.33	6256.3	270.68	6256.4	271.02	
6256.5									
271.37	6256.6	271.72	6256.7	272.07	6256.8	272.42	6256.9	272.76	
6257									
273.11	6257.1	273.46	6257.2	273.81	6257.3	274.16	6257.4	274.51	
6257.5									
274.85	6257.6	275.2	6257.7	275.55	6257.8	275.9	6257.9	276.25	
6258									

276.59	6258.1	276.94	6258.2	277.29	6258.3	277.64	6258.4	277.98	
6258.5									
278.33	6258.6	278.68	6258.7	279.03	6258.8	279.38	6258.9	279.72	
6259									
280.07	6259.1	280.42	6259.2	280.77	6259.3	281.12	6259.4	281.46	
6259.5									
281.81	6259.6	282.16	6259.7	282.51	6259.8	282.86	6259.9	283.2	
6260									
283.55	6260.1	283.9	6260.2	284.25	6260.3	284.59	6260.4	284.94	
6260.5									
285.29	6260.6	285.64	6260.7	285.99	6260.8	286.33	6260.9	286.68	
6261									
287.03	6261.1	287.38	6261.2	287.73	6261.3	288.07	6261.4	288.42	
6261.5									
288.77	6261.6	289.12	6261.7	289.46	6261.8	289.81	6261.9	290.16	
6262									
290.51	6262.1	290.86	6262.2	291.2	6262.3	291.55	6262.4	291.9	
6262.5									
292.25	6262.6	292.6	6262.7	292.94	6262.8	293.29	6262.9	293.64	
6263									
293.99	6263.1	294.34	6263.2	294.71	6263.3	295.7	6263.4	296.69	
6263.5									
297.69	6263.6	298.68	6263.7	299.67	6263.8	300	6263.8		

Manning's n Values num= 3  
Sta n Val Sta n Val Sta n Val  
0 .03 131.25 .013 171.18 .03

Bank Sta: Left Right Lengths: Left Channel Right Coeff Contr.  
Expan. 131.25 171.18 50 50 50 .1

.3  
Ineffective Flow num= 1  
Sta L Sta R Elev Permanent  
188.77 300 6259.01 F  
Left Levee Station= 40.09 Elevation= 6268.9  
Right Levee Station= 189.61 Elevation= 6258.91

CROSS SECTION OUTPUT Profile #Flow 1

E.G. Elev (ft)	6257.67	Element	Left OB
Channel Right OB			
Vel Head (ft)	1.48	Wt. n-Val.	
0.013			
W.S. Elev (ft)	6256.19	Reach Len. (ft)	50.00
50.00 50.00			
Crit W.S. (ft)	6256.19	Flow Area (sq ft)	
106.20			
E.G. Slope (ft/ft)	0.001803	Area (sq ft)	
106.20			
Q Total (cfs)	1037.00	Flow (cfs)	
1037.00			

Top Width (ft)	35.57	Top Width (ft)	
35.57			
Vel Total (ft/s)	9.76	Avg. Vel. (ft/s)	
9.76			
Max Chl Dpth (ft)	4.59	Hydr. Depth (ft)	
2.99			
Conv. Total (cfs)	24422.0	Conv. (cfs)	
24422.0			
Length Wtd. (ft)	50.00	Wetted Per. (ft)	
37.21			
Min Ch El (ft)	6251.60	Shear (lb/sq ft)	
0.32			
Alpha	1.00	Stream Power (lb/ft s)	300.00
40.09	189.61		
Frctn Loss (ft)	0.09	Cum Volume (acre-ft)	0.01
0.67			
C & E Loss (ft)	0.00	Cum SA (acres)	
0.21			

Warning: The energy equation could not be balanced within the specified number of iterations. The program used critical depth for the water surface and continued on with the calculations.

Warning: During the standard step iterations, when the assumed water surface was set equal to critical depth, the calculated water surface came back below critical depth. This indicates that there is not a valid subcritical answer. The program defaulted to critical depth.

Note: Multiple critical depths were found at this location. The critical depth with the lowest, valid, energy was used.

CROSS SECTION

RIVER: SC01  
 REACH: Sand Creek-DS-0- RS: 975

INPUT  
 Description:  
 Station Elevation Data num= 394

Sta	Elev	Sta	Elev	Sta	Elev	Sta	Elev	Sta	Elev
Elev									
0	6266.6	.89	6266.6	2.59	6266.5	6.55	6266.4	11.67	
6266.4									
19.4	6266.3	30.05	6266.2	36.51	6266.1	46.74	6266	63.04	
6265.9									
80.29	6265.8	90.31	6265.7	98	6265.6	100.65	6265.5	103.3	
6265.4									
105.96	6265.3	106.45	6265.2	106.74	6265.1	107.04	6265	107.33	
6264.9									
107.63	6264.8	107.92	6264.7	108.22	6264.6	108.51	6264.5	108.81	
6264.4									

109.11	6264.3	109.4	6264.2	109.7	6264.1	109.99	6264	110.29
6263.9								
110.58	6263.8	110.88	6263.7	111.17	6263.6	111.47	6263.5	111.76
6263.4								
112.06	6263.3	112.35	6263.2	112.65	6263.1	112.95	6263	113.24
6262.9								
113.54	6262.8	113.83	6262.7	114.13	6262.6	114.42	6262.5	114.72
6262.4								
115.01	6262.3	115.31	6262.2	115.6	6262.1	115.9	6262	116.2
6261.9								
116.49	6261.8	116.79	6261.7	117.08	6261.6	117.38	6261.5	117.67
6261.4								
117.97	6261.3	118.26	6261.2	118.56	6261.1	118.85	6261	119.15
6260.9								
119.44	6260.8	119.74	6260.7	120.04	6260.6	120.34	6260.5	120.64
6260.4								
120.94	6260.3	121.24	6260.2	121.55	6260.1	121.85	6260	122.15
6259.9								
122.46	6259.8	122.76	6259.7	123.03	6259.6	123.3	6259.5	123.56
6259.4								
123.83	6259.3	124.09	6259.2	124.36	6259.1	124.62	6259	124.89
6258.9								
125.15	6258.8	125.42	6258.7	125.68	6258.6	125.95	6258.5	126.21
6258.4								
126.48	6258.3	126.74	6258.2	127.01	6258.1	127.27	6258	127.54
6257.9								
127.8	6257.8	128.07	6257.7	128.33	6257.6	128.6	6257.5	128.86
6257.4								
129.13	6257.3	129.39	6257.2	129.66	6257.1	129.92	6257	130.19
6256.9								
130.46	6256.8	130.72	6256.7	130.99	6256.6	131.25	6256.5	131.51
6256.4								
131.76	6256.3	132.01	6256.2	132.26	6256.1	132.51	6256	132.76
6255.9								
133.01	6255.8	133.26	6255.7	133.51	6255.6	133.76	6255.5	134.01
6255.4								
134.26	6255.3	134.51	6255.2	134.76	6255.1	135.01	6255	135.26
6254.9								
135.51	6254.8	135.76	6254.7	136.01	6254.6	136.26	6254.5	136.51
6254.4								
136.76	6254.3	137.01	6254.2	137.26	6254.1	137.51	6254	137.76
6253.9								
138.01	6253.8	138.26	6253.7	138.51	6253.6	138.76	6253.5	139.01
6253.4								
139.26	6253.3	139.51	6253.2	139.76	6253.1	140.01	6253	140.26
6252.9								
140.51	6252.8	140.76	6252.7	141.01	6252.6	141.26	6252.5	141.51
6252.4								
141.76	6252.3	142.01	6252.2	142.26	6252.1	142.51	6252	142.76
6251.9								
143.01	6251.8	143.26	6251.7	143.51	6251.6	143.76	6251.5	144.01
6251.4								
144.26	6251.3	144.51	6251.2	144.76	6251.1	155.28	6251.1	155.58

6251.2								
155.88	6251.3	156.18	6251.4	156.48	6251.5	156.78	6251.6	157.08
6251.7								
157.38	6251.8	157.68	6251.9	157.98	6252	158.28	6252.1	158.58
6252.2								
158.88	6252.3	159.18	6252.4	159.48	6252.5	159.78	6252.6	160.08
6252.7								
160.38	6252.8	160.68	6252.9	160.98	6253	161.28	6253.1	161.58
6253.2								
161.88	6253.3	162.18	6253.4	162.48	6253.5	162.78	6253.6	163.08
6253.7								
163.38	6253.8	163.68	6253.9	163.98	6254	164.28	6254.1	164.58
6254.2								
164.88	6254.3	165.18	6254.4	165.48	6254.5	165.78	6254.6	166.08
6254.7								
166.38	6254.8	166.68	6254.9	166.98	6255	167.28	6255.1	167.58
6255.2								
167.88	6255.3	168.18	6255.4	168.48	6255.5	168.73	6255.6	168.97
6255.7								
169.21	6255.8	169.46	6255.9	169.7	6256	169.94	6256.1	170.18
6256.2								
170.42	6256.3	170.65	6256.4	170.88	6256.5	171.11	6256.6	171.34
6256.7								
171.57	6256.8	171.8	6256.9	172.03	6257	172.26	6257.1	172.42
6257.17								
172.49	6257.2	172.71	6257.3	172.94	6257.4	173.17	6257.5	173.4
6257.6								
173.63	6257.7	173.86	6257.8	174.09	6257.9	174.32	6258	189.98
6258								
190.57	6257.9	191.17	6257.8	191.76	6257.7	192.36	6257.6	192.96
6257.5								
193.55	6257.4	194.15	6257.3	194.75	6257.2	195.34	6257.1	195.94
6257								
196.53	6256.9	197.13	6256.8	197.73	6256.7	198.32	6256.6	198.92
6256.5								
199.51	6256.4	200.11	6256.3	200.71	6256.2	201.3	6256.1	201.9
6256								
202.49	6255.9	203.09	6255.8	203.69	6255.7	204.28	6255.6	204.88
6255.5								
205.47	6255.4	206.07	6255.3	206.67	6255.2	207.26	6255.1	207.86
6255								
208.45	6254.9	209.05	6254.8	209.65	6254.7	210.21	6254.6	210.74
6254.5								
211.27	6254.4	211.81	6254.3	212.34	6254.2	212.87	6254.1	213.4
6254								
213.94	6253.9	214.45	6253.9	214.47	6253.8	215	6253.7	215.53
6253.6								
216.07	6253.5	218.27	6253.4	220.85	6253.3	223.17	6253.2	226
6253.1								
228.82	6253	230.37	6252.9	230.48	6252.8	230.58	6252.7	230.68
6252.6								
230.79	6252.5	231.66	6253	232.96	6252.5	233.06	6252.6	233.17
6252.7								

233.2	6252.7	233.27	6252.8	233.37	6252.9	235.03	6253	238.76
6253.1								
242.49	6253.2	245.31	6253.3	246.22	6253.3	249.96	6253.4	253.69
6253.5								
256.95	6253.6	260.02	6253.7	261.71	6253.8	262.06	6253.9	262.41
6254								
262.76	6254.1	263.11	6254.2	263.46	6254.3	263.81	6254.4	264.16
6254.5								
264.51	6254.6	264.86	6254.7	265.21	6254.8	265.56	6254.9	265.91
6255								
266.26	6255.1	266.61	6255.2	266.96	6255.3	267.31	6255.4	267.66
6255.5								
268.01	6255.6	268.36	6255.7	268.71	6255.8	269.06	6255.9	269.41
6256								
269.76	6256.1	270.11	6256.2	270.46	6256.3	270.81	6256.4	271.16
6256.5								
271.51	6256.6	271.86	6256.7	272.21	6256.8	272.56	6256.9	272.91
6257								
273.26	6257.1	273.61	6257.2	273.96	6257.3	274.31	6257.4	274.66
6257.5								
275.01	6257.6	275.36	6257.7	275.71	6257.8	276.06	6257.9	276.41
6258								
276.77	6258.1	277.12	6258.2	277.47	6258.3	277.82	6258.4	278.17
6258.5								
278.52	6258.6	278.87	6258.7	279.22	6258.8	279.57	6258.9	279.92
6259								
280.27	6259.1	280.62	6259.2	280.97	6259.3	281.32	6259.4	281.67
6259.5								
282.02	6259.6	282.38	6259.7	282.73	6259.8	283.08	6259.9	283.43
6260								
283.78	6260.1	284.13	6260.2	284.48	6260.3	284.84	6260.4	285.19
6260.5								
285.54	6260.6	285.89	6260.7	286.24	6260.8	286.59	6260.9	286.94
6261								
287.3	6261.1	287.65	6261.2	288	6261.3	288.35	6261.4	288.7
6261.5								
289.05	6261.6	289.4	6261.7	289.76	6261.8	290.11	6261.9	290.46
6262								
290.81	6262.1	291.16	6262.2	291.51	6262.3	292.03	6262.4	293.02
6262.5								
294.01	6262.6	295	6262.7	295.99	6262.8	300	6262.8	
Manning's n Values			num=	3				
Sta n Val	Sta n Val	Sta n Val						
0	.03	129.92	.013	172.42	.03			
Bank Sta: Left	Right	Lengths: Left	Channel	Right	Coeff	Contr.		
Expan.								
	129.92	172.42		22.55	22.55	22.55		.1
.3								
Ineffective Flow		num=	1					
Sta L	Sta R	Elev	Permanent					
189.61	300	6258	F					

Left Levee Station= 105.43 Elevation= 6265.35  
 Right Levee Station= 189.61 Elevation= 6258.09

CROSS SECTION OUTPUT Profile #Flow 1

E.G. Elev (ft)	6257.17	Element	Left OB
Channel Right OB			
Vel Head (ft)	1.49	Wt. n-Val.	
0.013			
W.S. Elev (ft)	6255.68	Reach Len. (ft)	22.55
22.55			
22.55			
Crit W.S. (ft)	6255.68	Flow Area (sq ft)	
105.88			
E.G. Slope (ft/ft)	0.001823	Area (sq ft)	
105.88			
Q Total (cfs)	1037.00	Flow (cfs)	
1037.00			
Top Width (ft)	35.61	Top Width (ft)	
35.61			
Vel Total (ft/s)	9.79	Avg. Vel. (ft/s)	
9.79			
Max Chl Dpth (ft)	4.58	Hydr. Depth (ft)	
2.97			
Conv. Total (cfs)	24286.3	Conv. (cfs)	
24286.3			
Length Wtd. (ft)	22.55	Wetted Per. (ft)	
37.25			
Min Ch El (ft)	6251.10	Shear (lb/sq ft)	
0.32			
Alpha	1.00	Stream Power (lb/ft s)	300.00
105.43			
189.61			
Frctn Loss (ft)	0.04	Cum Volume (acre-ft)	0.01
0.54			
C & E Loss (ft)	0.01	Cum SA (acres)	
0.16			

Warning: The energy equation could not be balanced within the specified number of iterations. The program used critical depth for the water surface and continued on with the calculations.

Warning: During the standard step iterations, when the assumed water surface was set equal to critical depth, the calculated water surface came back below critical depth. This indicates that there is not a valid subcritical answer. The program defaulted to critical depth.

Note: Multiple critical depths were found at this location. The critical depth with the lowest, valid, energy was used.

CROSS SECTION

RIVER: SC01  
 REACH: Sand Creek-DS-0- RS: 974

INPUT

Description:

Station	Elevation	Data	num=	373				
Sta	Elev	Sta	Elev	Sta	Elev	Sta	Elev	Sta
Elev								
-36.1	6266.4	-34.2	6266.4	-32.49	6266.3	-30.79	6266.2	-29.08
6266.1								
-27.38	6266	-25.67	6265.9	-16.94	6265.8	-6.87	6265.7	.13
6265.6								
5.11	6265.5	8.1	6265.4	11.09	6265.3	25.97	6265.2	47.98
6265.1								
59.67	6265	68.84	6264.9	69.15	6264.8	69.45	6264.7	69.76
6264.6								
70.06	6264.5	70.37	6264.4	70.67	6264.3	70.98	6264.2	71.28
6264.1								
71.59	6264	71.89	6263.9	72.19	6263.8	72.5	6263.7	72.8
6263.6								
73.11	6263.5	73.41	6263.4	73.72	6263.3	74.02	6263.2	74.33
6263.1								
74.63	6263	74.94	6262.9	75.24	6262.8	75.55	6262.7	75.85
6262.6								
76.15	6262.5	76.46	6262.4	76.76	6262.3	77.07	6262.2	77.37
6262.1								
77.68	6262	77.98	6261.9	78.29	6261.8	78.59	6261.7	78.9
6261.6								
79.2	6261.5	79.5	6261.4	79.81	6261.3	80.11	6261.2	80.42
6261.1								
80.72	6261	81.03	6260.9	81.33	6260.8	81.64	6260.7	81.94
6260.6								
82.25	6260.5	82.55	6260.4	82.86	6260.3	83.16	6260.2	83.46
6260.1								
83.77	6260	84.07	6259.9	84.38	6259.8	84.68	6259.7	84.99
6259.6								
85.29	6259.5	85.6	6259.4	85.9	6259.3	86.21	6259.2	86.51
6259.1								
86.81	6259	87.12	6258.9	87.42	6258.8	87.73	6258.7	88.03
6258.6								
88.34	6258.5	88.64	6258.4	88.95	6258.3	89.25	6258.2	89.56
6258.1								
89.86	6258	90.17	6257.9	90.47	6257.8	90.77	6257.7	91.08
6257.6								
91.38	6257.5	91.69	6257.4	91.99	6257.3	92.3	6257.2	92.6
6257.1								
92.91	6257	93.21	6256.9	93.52	6256.8	93.82	6256.7	94.12
6256.6								
94.43	6256.5	94.73	6256.4	95.04	6256.3	95.34	6256.2	95.6
6256.1								
95.85	6256	96.1	6255.9	96.35	6255.8	96.6	6255.7	96.85
6255.6								
97.1	6255.5	97.35	6255.4	97.6	6255.3	97.85	6255.2	98.1

6255.1									
98.35	6255	98.6	6254.9	98.85	6254.8	99.1	6254.7	99.35	
6254.6									
99.6	6254.5	99.85	6254.4	100.1	6254.3	100.35	6254.2	100.6	
6254.1									
100.85	6254	101.1	6253.9	101.35	6253.8	101.6	6253.7	101.85	
6253.6									
102.1	6253.5	102.35	6253.4	102.6	6253.3	102.85	6253.2	103.1	
6253.1									
103.35	6253	103.6	6252.9	103.85	6252.8	104.1	6252.7	104.35	
6252.6									
104.6	6252.5	104.85	6252.4	105.1	6252.3	105.35	6252.2	105.6	
6252.1									
105.85	6252	106.1	6251.9	106.35	6251.8	106.6	6251.7	106.85	
6251.6									
107.1	6251.5	107.35	6251.4	107.6	6251.3	107.85	6251.2	108.1	
6251.1									
108.35	6251	108.6	6250.9	108.85	6250.8	118.96	6250.8	119.26	
6250.9									
119.56	6251	119.86	6251.1	120.16	6251.2	120.46	6251.3	120.76	
6251.4									
121.06	6251.5	121.36	6251.6	121.66	6251.7	121.96	6251.8	122.26	
6251.9									
122.56	6252	122.86	6252.1	123.16	6252.2	123.46	6252.3	123.76	
6252.4									
124.06	6252.5	124.36	6252.6	124.66	6252.7	124.96	6252.8	125.26	
6252.9									
125.56	6253	125.86	6253.1	126.16	6253.2	126.46	6253.3	126.76	
6253.4									
127.06	6253.5	127.36	6253.6	127.66	6253.7	127.96	6253.8	128.26	
6253.9									
128.56	6254	128.86	6254.1	129.16	6254.2	129.46	6254.3	129.76	
6254.4									
130.06	6254.5	130.36	6254.6	130.66	6254.7	130.96	6254.8	131.26	
6254.9									
131.56	6255	131.86	6255.1	132.16	6255.2	132.47	6255.3	132.87	
6255.4									
133.26	6255.5	133.65	6255.6	134.05	6255.7	134.44	6255.8	134.83	
6255.9									
135.22	6256	135.62	6256.1	136.01	6256.2	136.4	6256.3	136.8	
6256.4									
137.19	6256.5	137.58	6256.6	137.97	6256.7	138.37	6256.8	153.49	
6256.8									
154.19	6256.7	154.88	6256.6	155.58	6256.5	156.24	6256.4	156.77	
6256.3									
157.3	6256.2	157.83	6256.1	158.36	6256	158.89	6255.9	159.45	
6255.8									
160.13	6255.7	160.48	6256	160.81	6255.6	161.49	6255.5	162.17	
6255.4									
162.85	6255.3	162.91	6255.8	163.53	6255.2	164.21	6255.1	164.89	
6255									
165.57	6254.9	166.24	6254.8	166.92	6254.7	167.6	6254.6	168.28	
6254.5									

168.96	6254.4	169.64	6254.3	170.32	6254.2	171	6254.1	171.68	
6254									
172.36	6253.9	173.04	6253.8	173.72	6253.7	174.39	6253.6	175.07	
6253.5									
175.75	6253.4	176.43	6253.3	177.11	6253.2	177.79	6253.1	178.47	
6253									
181.55	6252.9	184.72	6252.8	187.88	6252.7	189.4	6252.6	189.5	
6252.5									
189.6	6252.4	189.7	6252.3	189.8	6252.2	191.91	6252.2	192.01	
6252.3									
192.11	6252.4	192.21	6252.5	192.22	6252.6	192.31	6252.6	193.56	
6252.7									
196.41	6252.8	199.27	6252.9	202.13	6253	204.99	6253.1	207.84	
6253.2									
210.7	6253.3	213.58	6253.4	216.46	6253.5	219.49	6253.6	222.87	
6253.7									
224.61	6253.8	224.98	6253.9	225.34	6254	225.71	6254.1	226.07	
6254.2									
226.44	6254.3	226.8	6254.4	227.16	6254.5	227.53	6254.6	227.89	
6254.7									
228.26	6254.8	228.62	6254.9	228.99	6255	229.35	6255.1	229.71	
6255.2									
230.08	6255.3	230.44	6255.4	230.81	6255.5	231.17	6255.6	231.54	
6255.7									
231.9	6255.8	232.27	6255.9	232.63	6256	232.99	6256.1	233.36	
6256.2									
233.72	6256.3	234.09	6256.4	234.45	6256.5	234.82	6256.6	235.18	
6256.7									
235.54	6256.8	235.91	6256.9	236.27	6257	236.64	6257.1	237	
6257.2									
237.37	6257.3	237.73	6257.4	238.09	6257.5	238.46	6257.6	238.82	
6257.7									
239.19	6257.8	239.55	6257.9	239.92	6258	240.28	6258.1	240.65	
6258.2									
241.02	6258.3	241.39	6258.4	241.75	6258.5	242.12	6258.6	242.49	
6258.7									
242.86	6258.8	243.23	6258.9	243.6	6259	243.97	6259.1	244.33	
6259.2									
244.7	6259.3	245.07	6259.4	245.44	6259.5	245.81	6259.6	246.18	
6259.7									
246.54	6259.8	246.91	6259.9	247.28	6260	247.65	6260.1	248.02	
6260.2									
248.39	6260.3	248.75	6260.4	249.12	6260.5	249.49	6260.6	249.86	
6260.7									
250.23	6260.8	250.6	6260.9	250.96	6261	251.33	6261.1	251.7	
6261.2									
252.07	6261.3	252.44	6261.4	252.81	6261.5	253.17	6261.6	253.54	
6261.7									
253.91	6261.8	254.28	6261.9	255.13	6262	256.12	6262.1	257.11	
6262.2									
258.1	6262.3	259.09	6262.4	263.9	6262.4				

Manning's n Values num= 3

Sta n Val Sta n Val Sta n Val  
 -36.1 .03 92.91 .013 138.37 .03

Bank Sta: Left Right Lengths: Left Channel Right Coeff Contr.  
 Expan. 92.91 138.37 19.92 19.92 19.92 .1

.3  
 Ineffective Flow num= 1  
 Sta L Sta R Elev Permanent  
 153.51 263.9 6256.67 F  
 Left Levee Station= 68.91 Elevation= 6264.88  
 Right Levee Station= 153.51 Elevation= 6256.85

CROSS SECTION OUTPUT Profile #Flow 1

E.G. Elev (ft)	6256.92	Element	Left OB
Channel Right OB			
Vel Head (ft)	1.47	Wt. n-Val.	
0.013			
W.S. Elev (ft)	6255.45	Reach Len. (ft)	19.92
19.92 19.92			
Crit W.S. (ft)	6255.45	Flow Area (sq ft)	
106.50			
E.G. Slope (ft/ft)	0.001804	Area (sq ft)	
106.50			
Q Total (cfs)	1037.00	Flow (cfs)	
1037.00			
Top Width (ft)	35.84	Top Width (ft)	
35.84			
Vel Total (ft/s)	9.74	Avg. Vel. (ft/s)	
9.74			
Max Chl Dpth (ft)	4.65	Hydr. Depth (ft)	
2.97			
Conv. Total (cfs)	24417.2	Conv. (cfs)	
24417.2			
Length Wtd. (ft)	19.92	Wetted Per. (ft)	
37.49			
Min Ch El (ft)	6250.80	Shear (lb/sq ft)	
0.32			
Alpha	1.00	Stream Power (lb/ft s)	263.90
68.91 153.51			
Frctn Loss (ft)	0.04	Cum Volume (acre-ft)	0.01
0.49			
C & E Loss (ft)	0.00	Cum SA (acres)	
0.15			

Warning: The energy equation could not be balanced within the specified number of iterations. The program used critical depth for the water surface and continued on with the calculations.  
 Warning: During the standard step iterations, when the assumed water surface

was set equal to critical depth, the calculated water surface came back below critical depth. This indicates that there is not a valid subcritical answer. The program defaulted to critical depth.  
 Note: Multiple critical depths were found at this location. The critical depth with the lowest, valid, energy was used.

CROSS SECTION

RIVER: SC01  
 REACH: Sand Creek-DS-0- RS: 973

INPUT  
 Description:  
 Station Elevation Data num= 390  
 Sta Elev Sta Elev Sta Elev Sta Elev Sta Elev Sta

Elev									
-32.18	6266.2	-29.67	6266.2	-26.39	6266.1	-24.69	6266	-22.99	
6265.9									
-21.29	6265.8	-13.57	6265.7	-2.85	6265.6	1.97	6265.5	5.36	
6265.4									
8.45	6265.3	11.39	6265.2	14.33	6265.1	17.27	6265	20.21	
6264.9									
23.16	6264.8	34.13	6264.7	51.24	6264.6	67.2	6264.5	72.15	
6264.4									
72.48	6264.3	72.81	6264.2	73.14	6264.1	73.47	6264	73.8	
6263.9									
74.13	6263.8	74.46	6263.7	74.79	6263.6	75.12	6263.5	75.45	
6263.4									
75.78	6263.3	76.11	6263.2	76.44	6263.1	76.77	6263	77.1	
6262.9									
77.43	6262.8	77.76	6262.7	78.09	6262.6	78.42	6262.5	78.75	
6262.4									
79.08	6262.3	79.41	6262.2	79.74	6262.1	80.07	6262	80.4	
6261.9									
80.73	6261.8	81.05	6261.7	81.37	6261.6	81.69	6261.5	82.01	
6261.4									
82.32	6261.3	82.64	6261.2	82.96	6261.1	83.28	6261	83.6	
6260.9									
83.92	6260.8	84.24	6260.7	84.56	6260.6	84.87	6260.5	85.19	
6260.4									
85.51	6260.3	85.83	6260.2	86.15	6260.1	86.47	6260	86.79	
6259.9									
87.11	6259.8	87.42	6259.7	87.74	6259.6	88.06	6259.5	88.38	
6259.4									
88.7	6259.3	89.02	6259.2	89.34	6259.1	89.66	6259	89.97	
6258.9									
90.29	6258.8	90.61	6258.7	90.93	6258.6	91.25	6258.5	91.57	
6258.4									
91.89	6258.3	92.21	6258.2	92.52	6258.1	92.84	6258	93.16	
6257.9									
93.48	6257.8	93.8	6257.7	94.12	6257.6	94.44	6257.5	94.76	



6257.4									
95.07	6257.3	95.39	6257.2	95.71	6257.1	96.03	6257	96.35	
6256.9									
96.67	6256.8	96.99	6256.7	97.31	6256.6	97.62	6256.5	97.94	
6256.4									
98.26	6256.3	98.58	6256.2	98.9	6256.1	99.22	6256	99.48	
6255.9									
99.73	6255.8	99.98	6255.7	100.23	6255.6	100.48	6255.5	100.73	
6255.4									
100.98	6255.3	101.23	6255.2	101.48	6255.1	101.73	6255	101.98	
6254.9									
102.23	6254.8	102.48	6254.7	102.73	6254.6	102.98	6254.5	103.23	
6254.4									
103.48	6254.3	103.73	6254.2	103.98	6254.1	104.23	6254	104.48	
6253.9									
104.73	6253.8	104.98	6253.7	105.23	6253.6	105.48	6253.5	105.73	
6253.4									
105.98	6253.3	106.23	6253.2	106.48	6253.1	106.73	6253	106.98	
6252.9									
107.23	6252.8	107.48	6252.7	107.73	6252.6	107.98	6252.5	108.23	
6252.4									
108.48	6252.3	108.73	6252.2	108.98	6252.1	109.23	6252	109.48	
6251.9									
109.73	6251.8	109.98	6251.7	110.23	6251.6	110.48	6251.5	110.73	
6251.4									
110.98	6251.3	111.23	6251.2	111.48	6251.1	111.73	6251	111.98	
6250.9									
112.23	6250.8	112.48	6250.7	112.73	6250.6	122.82	6250.6	123.12	
6250.7									
123.42	6250.8	123.73	6250.9	124.03	6251	124.33	6251.1	124.63	
6251.2									
124.93	6251.3	125.23	6251.4	125.53	6251.5	125.83	6251.6	126.13	
6251.7									
126.43	6251.8	126.73	6251.9	127.03	6252	127.33	6252.1	127.63	
6252.2									
127.94	6252.3	128.24	6252.4	128.54	6252.5	128.84	6252.6	129.14	
6252.7									
129.44	6252.8	129.74	6252.9	130.04	6253	130.34	6253.1	130.64	
6253.2									
130.93	6253.3	131.23	6253.4	131.53	6253.5	131.83	6253.6	132.13	
6253.7									
132.43	6253.8	132.73	6253.9	133.03	6254	133.33	6254.1	133.63	
6254.2									
133.93	6254.3	134.23	6254.4	134.53	6254.5	134.83	6254.6	135.13	
6254.7									
135.42	6254.8	135.72	6254.9	136.02	6255	136.34	6255.1	136.74	
6255.2									
137.14	6255.3	137.53	6255.4	137.93	6255.5	138.33	6255.6	138.73	
6255.7									
139.13	6255.8	139.52	6255.9	139.92	6256	140.3	6256.1	140.67	
6256.2									
141.03	6256.3	141.4	6256.4	141.76	6256.5	142.13	6256.6	157.52	
6256.6									

158.14	6256.5	158.74	6256.4	159.35	6256.3	159.95	6256.2	160.56	
6256.1									
161.16	6256	161.77	6255.9	162.37	6255.8	162.97	6255.7	163.58	
6255.6									
164.18	6255.5	164.79	6255.4	165.39	6255.3	165.99	6255.2	166.6	
6255.1									
167.2	6255	167.81	6254.9	168.41	6254.8	169.01	6254.7	169.62	
6254.6									
170.22	6254.5	170.83	6254.4	171.43	6254.3	172.04	6254.2	172.64	
6254.1									
173.24	6254	173.85	6253.9	174.45	6253.8	175.06	6253.7	175.66	
6253.6									
176.28	6253.5	176.97	6253.4	177.66	6253.3	178.35	6253.2	179.04	
6253.1									
179.73	6253	180.42	6252.9	181.11	6252.8	181.8	6252.7	183.25	
6252.6									
184.35	6252.6	186.62	6252.5	188.78	6252.5	191.04	6252.4	192.75	
6252.3									
192.85	6252.2	192.95	6252.1	193.05	6252	193.15	6251.9	195.22	
6251.9									
195.32	6252	195.42	6252.1	195.52	6252.2	195.62	6252.3	196.1	
6252.4									
197.26	6252.5	198.54	6252.6	199.91	6252.7	201.33	6252.8	202.79	
6252.9									
205.51	6253	206.35	6253	206.64	6252.9	206.93	6252.8	207.22	
6252.7									
207.51	6252.6	209.91	6252.7	210.76	6252.6	213.29	6252.7	213.55	
6252.8									
213.81	6252.9	214.07	6253	214.33	6253.1	214.42	6253.1	214.82	
6253.2									
216.45	6253.3	219.57	6253.4	222.69	6253.5	223.03	6254.3	223.53	
6254.2									
224.03	6254.1	224.51	6254	225.19	6253.6	225.38	6253.7	225.44	
6253.8									
225.51	6253.9	225.58	6254	225.65	6254.1	225.72	6254.2	225.79	
6254.3									
227.13	6254.3	227.25	6254.4	228.62	6254.3	228.97	6254.4	229.32	
6254.5									
229.67	6254.6	230.02	6254.7	230.37	6254.8	230.78	6254.9	231.19	
6255									
231.61	6255.1	232.03	6255.2	232.44	6255.3	232.86	6255.4	233.28	
6255.5									
233.69	6255.6	234.11	6255.7	234.53	6255.8	234.94	6255.9	235.36	
6256									
235.78	6256.1	236.19	6256.2	236.61	6256.3	237.03	6256.4	237.44	
6256.5									
237.86	6256.6	238.28	6256.7	238.69	6256.8	239.11	6256.9	239.53	
6257									
239.94	6257.1	240.36	6257.2	240.78	6257.3	241.19	6257.4	241.61	
6257.5									
242.03	6257.6	242.44	6257.7	242.86	6257.8	243.27	6257.9	243.67	
6258									
244.07	6258.1	244.47	6258.2	244.87	6258.3	245.27	6258.4	245.67	

6258.5  
 246.07 6258.6 246.47 6258.7 246.87 6258.8 247.27 6258.9 247.67  
 6259  
 248.07 6259.1 248.47 6259.2 248.87 6259.3 249.27 6259.4 249.67  
 6259.5  
 250.07 6259.6 250.47 6259.7 250.87 6259.8 251.27 6259.9 251.67  
 6260  
 252.07 6260.1 252.46 6260.2 252.86 6260.3 253.26 6260.4 253.66  
 6260.5  
 254.06 6260.6 254.46 6260.7 254.86 6260.8 255.26 6260.9 255.66  
 6261  
 256.06 6261.1 256.46 6261.2 256.86 6261.3 257.26 6261.4 258.17  
 6261.5  
 259.17 6261.6 260.17 6261.7 261.16 6261.8 262.16 6261.9 267.82  
 6261.9

Manning's n Values num= 3  
 Sta n Val Sta n Val Sta n Val  
 -32.18 .03 97.62 .013 140.3 .03

Bank Sta: Left Right Lengths: Left Channel Right Coeff Contr.  
 Expan. 97.62 140.3 7.53 7.53 7.53 .1  
 .3

Ineffective Flow num= 1  
 Sta L Sta R Elev Permanent  
 157.85 267.82 6256.56 F  
 Left Levee Station= 72.83 Elevation= 6264.32  
 Right Levee Station= 156.59 Elevation= 6256.65

CROSS SECTION OUTPUT Profile #Flow 1

E.G. Elev (ft)	6256.72	Element	Left OB
Channel Right OB			
Vel Head (ft)	1.47	Wt. n-Val.	
0.013			
W.S. Elev (ft)	6255.25	Reach Len. (ft)	7.53
7.53 7.53			
Crit W.S. (ft)	6255.25	Flow Area (sq ft)	
106.46			
E.G. Slope (ft/ft)	0.001805	Area (sq ft)	
106.46			
Q Total (cfs)	1037.00	Flow (cfs)	
1037.00			
Top Width (ft)	35.84	Top Width (ft)	
35.84			
Vel Total (ft/s)	9.74	Avg. Vel. (ft/s)	
9.74			
Max Chl Dpth (ft)	4.65	Hydr. Depth (ft)	
2.97			
Conv. Total (cfs)	24405.7	Conv. (cfs)	
24405.7			

Length Wtd. (ft)	7.53	Wetted Per. (ft)	
37.48			
Min Ch El (ft)	6250.60	Shear (lb/sq ft)	
0.32			
Alpha	1.00	Stream Power (lb/ft s)	267.82
72.83 156.59			
Frctn Loss (ft)	0.01	Cum Volume (acre-ft)	0.01
0.44			
C & E Loss (ft)	0.00	Cum SA (acres)	
0.13			

Warning: The energy equation could not be balanced within the specified number of iterations. The program used critical depth for the water surface and continued on with the calculations.  
 Warning: During the standard step iterations, when the assumed water surface was set equal to critical depth, the calculated water surface came back below critical depth. This indicates that there is not a valid subcritical answer. The program defaulted to critical depth.  
 Note: Multiple critical depths were found at this location. The critical depth with the lowest, valid, energy was used.

CROSS SECTION

RIVER: SC01  
 REACH: Sand Creek-DS-0- RS: 972

INPUT

Description:  
 Station Elevation Data num= 372  
 Sta Elev Sta Elev Sta Elev Sta Elev Sta Elev  
 Elev  
 -66.04 6266.1 -63.22 6266.1 -58.86 6266 -57.17 6265.9 -55.47  
 6265.8  
 -51.5 6265.7 -40.89 6265.6 -33.49 6265.5 -30.79 6265.4 -28.26  
 6265.3  
 -25.41 6265.2 -22.05 6265.1 -18.91 6265 -15.98 6264.9 -13.06  
 6264.8  
 -10.13 6264.7 -7.21 6264.6 3.48 6264.5 18.96 6264.4 30.72  
 6264.3  
 35.96 6264.2 38.29 6264.1 38.62 6264 38.95 6263.9 39.28  
 6263.8  
 39.6 6263.7 39.93 6263.6 40.26 6263.5 40.59 6263.4 40.92  
 6263.3  
 41.25 6263.2 41.58 6263.1 41.91 6263 42.24 6262.9 42.57  
 6262.8  
 42.9 6262.7 43.23 6262.6 43.55 6262.5 43.88 6262.4 44.21  
 6262.3  
 44.54 6262.2 44.87 6262.1 45.2 6262 45.53 6261.9 45.86  
 6261.8

46.19	6261.7	46.52	6261.6	46.85	6261.5	47.17	6261.4	47.5
6261.3								
47.83	6261.2	48.16	6261.1	48.49	6261	48.82	6260.9	49.15
6260.8								
49.48	6260.7	49.81	6260.6	50.14	6260.5	50.47	6260.4	50.8
6260.3								
51.12	6260.2	51.45	6260.1	51.78	6260	52.11	6259.9	52.44
6259.8								
52.77	6259.7	53.1	6259.6	53.43	6259.5	53.76	6259.4	54.09
6259.3								
54.42	6259.2	54.75	6259.1	55.07	6259	55.4	6258.9	55.73
6258.8								
56.06	6258.7	56.39	6258.6	56.72	6258.5	57.05	6258.4	57.38
6258.3								
57.71	6258.2	58.04	6258.1	58.37	6258	58.7	6257.9	59.02
6257.8								
59.35	6257.7	59.68	6257.6	60.01	6257.5	60.34	6257.4	60.67
6257.3								
61	6257.2	61.35	6257.1	61.69	6257	62.03	6256.9	62.38
6256.8								
62.72	6256.7	63.06	6256.6	63.4	6256.5	63.75	6256.4	64.09
6256.3								
64.43	6256.2	64.78	6256.1	65.12	6256	65.45	6255.9	65.7
6255.8								
65.95	6255.7	66.2	6255.6	66.45	6255.5	66.7	6255.4	66.95
6255.3								
67.2	6255.2	67.45	6255.1	67.7	6255	67.95	6254.9	68.2
6254.8								
68.45	6254.7	68.7	6254.6	68.95	6254.5	69.2	6254.4	69.45
6254.3								
69.7	6254.2	69.96	6254.1	70.21	6254	70.46	6253.9	70.71
6253.8								
70.96	6253.7	71.21	6253.6	71.46	6253.5	71.71	6253.4	71.96
6253.3								
72.21	6253.2	72.46	6253.1	72.71	6253	72.96	6252.9	73.21
6252.8								
73.46	6252.7	73.71	6252.6	73.96	6252.5	74.21	6252.4	74.46
6252.3								
74.71	6252.2	74.96	6252.1	75.21	6252	75.46	6251.9	75.71
6251.8								
75.96	6251.7	76.21	6251.6	76.46	6251.5	76.71	6251.4	76.96
6251.3								
77.21	6251.2	77.46	6251.1	77.71	6251	77.96	6250.9	78.21
6250.8								
78.46	6250.7	78.71	6250.6	89.22	6250.6	89.52	6250.7	89.82
6250.8								
90.12	6250.9	90.42	6251	90.72	6251.1	91.02	6251.2	91.32
6251.3								
91.62	6251.4	91.92	6251.5	92.22	6251.6	92.52	6251.7	92.82
6251.8								
93.12	6251.9	93.42	6252	93.72	6252.1	94.03	6252.2	94.33
6252.3								
94.63	6252.4	94.93	6252.5	95.23	6252.6	95.53	6252.7	95.83

6252.8								
96.13	6252.9	96.43	6253	96.73	6253.1	97.03	6253.2	97.33
6253.3								
97.63	6253.4	97.93	6253.5	98.23	6253.6	98.53	6253.7	98.83
6253.8								
99.13	6253.9	99.44	6254	99.74	6254.1	100.04	6254.2	100.34
6254.3								
100.64	6254.4	100.94	6254.5	101.23	6254.6	101.53	6254.7	101.83
6254.8								
102.13	6254.9	102.43	6255	102.81	6255.1	103.17	6255.2	103.54
6255.3								
103.9	6255.4	104.27	6255.5	104.63	6255.6	105	6255.7	105.37
6255.8								
105.73	6255.9	106.1	6256	106.46	6256.1	106.83	6256.2	107.19
6256.3								
107.56	6256.4	107.93	6256.5	108.29	6256.6	123.7	6256.6	124.34
6256.5								
124.94	6256.4	125.55	6256.3	126.15	6256.2	126.76	6256.1	127.36
6256								
127.96	6255.9	128.57	6255.8	129.17	6255.7	129.78	6255.6	130.38
6255.5								
130.98	6255.4	131.59	6255.3	132.19	6255.2	132.8	6255.1	133.4
6255								
134.01	6254.9	134.61	6254.8	135.21	6254.7	135.82	6254.6	136.42
6254.5								
137.03	6254.4	137.63	6254.3	138.23	6254.2	138.84	6254.1	139.44
6254								
140.05	6253.9	140.65	6253.8	141.26	6253.7	141.86	6253.6	142.46
6253.5								
143.07	6253.4	143.67	6253.3	144.28	6253.2	144.88	6253.1	145.48
6253								
146.09	6252.9	146.69	6252.8	147.26	6252.7	147.82	6252.6	148.38
6252.5								
152.55	6252.4	156.94	6252.3	159.06	6252.2	159.16	6252.1	159.26
6252								
159.36	6251.9	159.46	6251.8	161.88	6251.8	162.3	6251.9	162.73
6252								
164.17	6252.1	164.29	6252.2	164.4	6252.3	164.52	6252.4	164.64
6252.5								
165.26	6252.6	165.75	6252.7	168.53	6252.7	170.45	6252.8	171.9
6252.8								
175.53	6252.9	178.46	6253	181.19	6253.1	183.92	6253.2	185.85
6253.4								
186.65	6253.3	189.38	6253.4	191.46	6253.5	191.86	6253.6	192.26
6253.7								
192.66	6253.8	193.06	6253.9	193.46	6254	193.86	6254.1	194.26
6254.2								
194.66	6254.3	195.06	6254.4	195.46	6254.5	195.86	6254.6	196.26
6254.7								
196.66	6254.8	197.06	6254.9	197.46	6255	197.87	6255.1	198.27
6255.2								
198.67	6255.3	199.07	6255.4	199.38	6255.5	199.47	6255.5	199.87
6255.6								



89.24	6264	94.22	6263.9	99.19	6263.8	104.17	6263.7	104.58
6263.6								
104.93	6263.5	105.27	6263.4	105.62	6263.3	105.96	6263.2	106.31
6263.1								
106.65	6263	106.99	6262.9	107.34	6262.8	107.68	6262.7	108.03
6262.6								
108.37	6262.5	108.72	6262.4	109.06	6262.3	109.41	6262.2	109.75
6262.1								
110.1	6262	110.44	6261.9	110.79	6261.8	111.13	6261.7	111.48
6261.6								
111.82	6261.5	112.17	6261.4	112.51	6261.3	112.86	6261.2	113.2
6261.1								
113.54	6261	113.89	6260.9	114.23	6260.8	114.58	6260.7	114.92
6260.6								
115.27	6260.5	115.61	6260.4	115.96	6260.3	116.3	6260.2	116.65
6260.1								
116.99	6260	117.34	6259.9	117.68	6259.8	118.03	6259.7	118.37
6259.6								
118.72	6259.5	119.06	6259.4	119.41	6259.3	119.75	6259.2	120.09
6259.1								
120.44	6259	120.78	6258.9	121.13	6258.8	121.47	6258.7	121.82
6258.6								
122.16	6258.5	122.51	6258.4	122.85	6258.3	123.2	6258.2	123.54
6258.1								
123.89	6258	124.23	6257.9	124.58	6257.8	124.92	6257.7	125.27
6257.6								
125.61	6257.5	125.96	6257.4	126.3	6257.3	126.65	6257.2	126.99
6257.1								
127.33	6257	127.67	6256.9	128.02	6256.8	128.36	6256.7	128.7
6256.6								
129.05	6256.5	129.39	6256.4	129.73	6256.3	130.07	6256.2	130.42
6256.1								
130.76	6256	131.1	6255.9	131.45	6255.8	131.71	6255.7	131.96
6255.6								
132.21	6255.5	132.46	6255.4	132.71	6255.3	132.96	6255.2	133.21
6255.1								
133.46	6255	133.71	6254.9	133.96	6254.8	134.21	6254.7	134.46
6254.6								
134.71	6254.5	134.96	6254.4	135.21	6254.3	135.46	6254.2	135.71
6254.1								
135.96	6254	136.21	6253.9	136.46	6253.8	136.71	6253.7	136.96
6253.6								
137.21	6253.5	137.46	6253.4	137.71	6253.3	137.96	6253.2	138.21
6253.1								
138.46	6253	138.71	6252.9	138.96	6252.8	139.21	6252.7	139.46
6252.6								
139.71	6252.5	139.96	6252.4	140.21	6252.3	140.46	6252.2	140.71
6252.1								
140.96	6252	141.21	6251.9	141.46	6251.8	141.71	6251.7	141.96
6251.6								
142.21	6251.5	142.46	6251.4	142.71	6251.3	142.96	6251.2	143.21
6251.1								
143.46	6251	143.71	6250.9	143.96	6250.8	144.21	6250.7	144.46

6250.6								
144.71	6250.5	144.96	6250.4	155.05	6250.4	155.35	6250.5	155.65
6250.6								
155.95	6250.7	156.25	6250.8	156.55	6250.9	156.85	6251	157.15
6251.1								
157.45	6251.2	157.75	6251.3	158.05	6251.4	158.35	6251.5	158.65
6251.6								
158.95	6251.7	159.25	6251.8	159.55	6251.9	159.85	6252	160.15
6252.1								
160.45	6252.2	160.75	6252.3	161.05	6252.4	161.35	6252.5	161.65
6252.6								
161.95	6252.7	162.25	6252.8	162.55	6252.9	162.85	6253	163.15
6253.1								
163.45	6253.2	163.75	6253.3	164.05	6253.4	164.35	6253.5	164.65
6253.6								
164.95	6253.7	165.25	6253.8	165.55	6253.9	165.85	6254	166.15
6254.1								
166.45	6254.2	166.75	6254.3	167.05	6254.4	167.35	6254.5	167.65
6254.6								
167.95	6254.7	168.25	6254.8	168.55	6254.9	168.88	6255	169.21
6255.1								
169.54	6255.2	169.87	6255.3	170.2	6255.4	170.53	6255.5	170.86
6255.6								
171.19	6255.7	171.39	6255.76	171.52	6255.8	171.85	6255.9	172.18
6256								
172.51	6256.1	172.84	6256.2	173.17	6256.3	173.5	6256.4	173.83
6256.5								
174.16	6256.6	174.49	6256.7	189.94	6256.7	190.64	6256.6	191.34
6256.5								
192.03	6256.4	192.64	6256.3	193.18	6256.2	193.72	6256.1	194.26
6256								
194.8	6255.9	195.34	6255.8	195.88	6255.7	196.42	6255.6	196.96
6255.5								
197.5	6255.4	198.04	6255.3	198.58	6255.2	199.12	6255.1	199.66
6255								
200.19	6254.9	200.73	6254.8	201.27	6254.7	201.81	6254.6	202.35
6254.5								
202.89	6254.4	203.43	6254.3	203.97	6254.2	204.51	6254.1	205.05
6254								
205.59	6253.9	206.13	6253.8	206.67	6253.7	207.21	6253.6	207.75
6253.5								
208.29	6253.4	208.82	6253.3	209.36	6253.2	209.9	6253.1	210.44
6253								
210.98	6252.9	211.52	6252.8	212.06	6252.7	212.6	6252.6	213.14
6252.5								
213.69	6252.4	213.81	6252.5	214.05	6253	214.25	6252.3	219.14
6252.2								
227.09	6252.1	227.2	6252	227.3	6251.9	227.41	6251.8	227.52
6251.7								
228.81	6252	229.91	6251.7	230.02	6251.8	230.14	6251.9	230.25
6252								
230.36	6252.1	233.98	6252.2	237.64	6252.3	241.29	6252.4	243.1
6252.5								

244.95	6252.5	247.6	6252.6	248.61	6252.6	251.9	6252.7	252.26
6252.7								
255.81	6252.8	257.71	6252.9	258.11	6253	258.5	6253.1	258.89
6253.2								
259.28	6253.3	259.68	6253.4	260.07	6253.5	260.46	6253.6	260.85
6253.7								
261.25	6253.8	261.64	6253.9	262.03	6254	262.42	6254.1	262.82
6254.2								
263.21	6254.3	263.6	6254.4	264	6254.5	264.39	6254.6	264.78
6254.7								
265.17	6254.8	265.57	6254.9	265.96	6255	266.35	6255.1	266.74
6255.2								
267.14	6255.3	267.53	6255.4	267.92	6255.5	268.31	6255.6	268.71
6255.7								
269.1	6255.8	269.49	6255.9	269.88	6256	270.28	6256.1	270.67
6256.2								
271.06	6256.3	271.45	6256.4	271.85	6256.5	272.24	6256.6	272.63
6256.7								
273.03	6256.8	273.42	6256.9	273.81	6257	274.2	6257.1	274.6
6257.2								
274.99	6257.3	275.38	6257.4	275.77	6257.5	276.17	6257.6	276.56
6257.7								
276.95	6257.8	277.34	6257.9	277.74	6258	278.13	6258.1	278.52
6258.2								
278.91	6258.3	279.31	6258.4	279.7	6258.5	280.09	6258.6	280.48
6258.7								
280.88	6258.8	281.27	6258.9	281.66	6259	282.05	6259.1	282.45
6259.2								
282.84	6259.3	283.23	6259.4	283.62	6259.5	284.02	6259.6	284.41
6259.7								
284.8	6259.8	285.19	6259.9	285.59	6260	285.98	6260.1	286.37
6260.2								
286.76	6260.3	287.16	6260.4	287.55	6260.5	287.94	6260.6	288.33
6260.7								
288.73	6260.8	289.12	6260.9	289.51	6261	290.7	6261.1	291.97
6261.2								
293.24	6261.3	294.5	6261.4	300	6261.4			

Manning's n Values num= 3  
 Sta n Val Sta n Val Sta n Val  
 0 .03 130.76 .013 171.39 .03

Bank Sta: Left Right Lengths: Left Channel Right Coeff Contr.  
 Expan. 130.76 171.39 37.63 37.63 37.63 .1

.3  
 Ineffective Flow num= 1  
 Sta L Sta R Elev Permanent  
 190.03 300 6256.59 F  
 Left Levee Station= 103.33 Elevation= 6263.68  
 Right Levee Station= 189.61 Elevation= 6256.72

CROSS SECTION OUTPUT Profile #Flow 1

E.G. Elev (ft)	6256.53	Element	Left OB
Channel Right OB			
Vel Head (ft)	1.47	Wt. n-Val.	
0.013			
W.S. Elev (ft)	6255.06	Reach Len. (ft)	37.63
37.63 37.63			
Crit W.S. (ft)	6255.06	Flow Area (sq ft)	
106.74			
E.G. Slope (ft/ft)	0.001786	Area (sq ft)	
106.74			
Q Total (cfs)	1037.00	Flow (cfs)	
1037.00			
Top Width (ft)	35.77	Top Width (ft)	
35.77			
Vel Total (ft/s)	9.71	Avg. Vel. (ft/s)	
9.71			
Max Chl Dpth (ft)	4.66	Hydr. Depth (ft)	
2.98			
Conv. Total (cfs)	24541.1	Conv. (cfs)	
24541.1			
Length Wtd. (ft)	37.63	Wetted Per. (ft)	
37.42			
Min Ch El (ft)	6250.40	Shear (lb/sq ft)	
0.32			
Alpha	1.00	Stream Power (lb/ft s)	300.00
103.33 189.61			
Frctn Loss (ft)	0.06	Cum Volume (acre-ft)	0.01
0.39			
C & E Loss (ft)	0.02	Cum SA (acres)	
0.11			

Warning: The energy equation could not be balanced within the specified number of iterations. The program used critical depth for the water surface and continued on with the calculations.  
 Warning: During the standard step iterations, when the assumed water surface was set equal to critical depth, the calculated water surface came back below critical depth. This indicates that there is not a valid subcritical answer. The program defaulted to critical depth.  
 Note: Multiple critical depths were found at this location. The critical depth with the lowest, valid, energy was used.

CROSS SECTION

RIVER: SC01  
 REACH: Sand Creek-DS-0- RS: 970

INPUT



200.99	6255.2	201.44	6255.1	201.89	6255	202.33	6254.9	202.78
6254.8								
203.23	6254.7	203.68	6254.6	204.12	6254.5	204.57	6254.4	204.7
6254.7								
205.02	6254.3	205.46	6254.2	205.91	6254.1	206.36	6254	206.81
6253.9								
207.28	6253.8	207.75	6253.7	208.22	6253.6	208.69	6253.5	209.16
6253.4								
209.63	6253.3	210.1	6253.2	210.57	6253.1	210.65	6253.5	211.04
6253								
211.51	6252.9	211.98	6252.8	212.45	6252.7	212.92	6252.6	213.39
6252.5								
213.86	6252.4	214.33	6252.3	214.79	6252.2	215.26	6252.1	215.76
6252								
216.26	6251.9	228.9	6251.8	229.04	6251.7	229.18	6251.6	229.32
6251.5								
229.46	6251.4	232.25	6251.4	232.39	6251.5	232.49	6251.7	232.52
6251.6								
232.66	6251.7	232.8	6251.8	232.94	6251.9	240.6	6252	247.97
6252.1								
253.08	6252.2	256.52	6252.3	258.54	6252.4	258.94	6252.5	259.33
6252.6								
259.73	6252.7	260.12	6252.8	260.52	6252.9	260.91	6253	261.31
6253.1								
261.7	6253.2	262.1	6253.3	262.49	6253.4	262.89	6253.5	263.29
6253.6								
263.68	6253.7	264.08	6253.8	264.47	6253.9	264.87	6254	265.26
6254.1								
265.66	6254.2	266.05	6254.3	266.45	6254.4	266.84	6254.5	267.24
6254.6								
267.63	6254.7	268.03	6254.8	268.43	6254.9	268.82	6255	269.22
6255.1								
269.61	6255.2	270.01	6255.3	270.4	6255.4	270.8	6255.5	271.19
6255.6								
271.59	6255.7	271.98	6255.8	272.38	6255.9	272.77	6256	273.17
6256.1								
273.57	6256.2	273.96	6256.3	274.36	6256.4	274.75	6256.5	275.15
6256.6								
275.54	6256.7	275.94	6256.8	276.33	6256.9	276.73	6257	277.12
6257.1								
277.52	6257.2	277.91	6257.3	278.31	6257.4	278.7	6257.5	279.1
6257.6								
279.5	6257.7	279.89	6257.8	280.29	6257.9	280.68	6258	281.08
6258.1								
281.47	6258.2	281.87	6258.3	282.26	6258.4	282.66	6258.5	283.05
6258.6								
283.45	6258.7	283.84	6258.8	284.24	6258.9	284.64	6259	285.03
6259.1								
285.43	6259.2	285.82	6259.3	286.22	6259.4	286.61	6259.5	287.01
6259.6								
287.4	6259.7	287.79	6259.8	288.19	6259.9	288.58	6260	288.97
6260.1								
289.37	6260.2	289.76	6260.3	290.16	6260.4	291.22	6260.5	293.93

6260.6  
300 6260.6

Manning's n Values num= 3  
Sta n Val Sta n Val Sta n Val  
0 .03 132.5 .013 169.98 .03

Bank Sta: Left Right Lengths: Left Channel Right Coeff Contr.  
Expan. 132.5 169.98 50 50 50 .1  
.3

Ineffective Flow num= 1  
Sta L Sta R Elev Permanent  
192.96 300 6257.47 F  
Left Levee Station= 49.73 Elevation= 6264.69  
Right Levee Station= 189.19 Elevation= 6257.47

CROSS SECTION OUTPUT Profile #Flow 1

E.G. Elev (ft)	6256.17	Element	Left OB
Channel Right OB			
Vel Head (ft)	1.46	Wt. n-Val.	
0.013			
W.S. Elev (ft)	6254.71	Reach Len. (ft)	50.00
50.00 50.00			
Crit W.S. (ft)	6254.71	Flow Area (sq ft)	
106.85			
E.G. Slope (ft/ft)	0.001777	Area (sq ft)	
106.85			
Q Total (cfs)	1037.00	Flow (cfs)	
1037.00			
Top Width (ft)	35.74	Top Width (ft)	
35.74			
Vel Total (ft/s)	9.71	Avg. Vel. (ft/s)	
9.71			
Max Chl Dpth (ft)	4.61	Hydr. Depth (ft)	
2.99			
Conv. Total (cfs)	24598.0	Conv. (cfs)	
24598.0			
Length Wtd. (ft)	50.00	Wetted Per. (ft)	
37.38			
Min Ch El (ft)	6250.10	Shear (lb/sq ft)	
0.32			
Alpha	1.00	Stream Power (lb/ft s)	300.00
49.73 189.19			
Frctn Loss (ft)	0.09	Cum Volume (acre-ft)	0.01
0.30			
C & E Loss (ft)	0.00	Cum SA (acres)	
0.08			





172.89	6255.7	173.09	6255.8	173.29	6255.9	173.49	6256	173.69
6256.1								
173.89	6256.2	174.09	6256.3	174.29	6256.4	181.87	6256.5	186.87
6256.6								
190	6256.7	191.15	6256.8	193.28	6256.9	196.33	6257	200.35
6257.1								
205.4	6257.2	211.85	6257.3	220.64	6257.4	238.15	6257.5	245.04
6257.6								
259.5	6257.7	273.95	6257.8	281.58	6257.9	282.39	6258	283.21
6258.1								
284.02	6258.2	284.84	6258.3	285.66	6258.4	286.5	6258.5	287.35
6258.6								
288.2	6258.7	289.06	6258.8	289.94	6258.9	290.75	6259	291.63
6259.1								
292.5	6259.2	293.38	6259.3	294.26	6259.4	295.13	6259.5	295.99
6259.6								
300	6259.6							

Manning's n Values num= 3  
 Sta n Val Sta n Val Sta n Val  
 0 .03 131.11 .013 171.48 .03

Bank Sta: Left Right Lengths: Left Channel Right Coeff Contr.  
 Expan. 131.11 171.48 50 50 50 .1  
 .3  
 Left Levee Station= 105.85 Elevation= 6261.73  
 Right Levee Station= 173.7 Elevation= 6256.46

CROSS SECTION OUTPUT Profile #Flow 1

E.G. Elev (ft)	6255.68	Element	Left OB
Channel Right OB			
Vel Head (ft)	1.46	Wt. n-Val.	
0.013			
W.S. Elev (ft)	6254.22	Reach Len. (ft)	50.00
50.00 50.00			
Crit W.S. (ft)	6254.22	Flow Area (sq ft)	
106.96			
E.G. Slope (ft/ft)	0.001780	Area (sq ft)	
106.96			
Q Total (cfs)	1037.00	Flow (cfs)	
1037.00			
Top Width (ft)	35.89	Top Width (ft)	
35.89			
Vel Total (ft/s)	9.69	Avg. Vel. (ft/s)	
9.69			
Max Chl Dpth (ft)	4.62	Hydr. Depth (ft)	
2.98			
Conv. Total (cfs)	24580.2	Conv. (cfs)	
24580.2			
Length Wtd. (ft)	50.00	Wetted Per. (ft)	

37.52			
Min Ch El (ft)	6249.60	Shear (lb/sq ft)	
0.32			
Alpha	1.00	Stream Power (lb/ft s)	300.00
105.85 173.70			
Frctn Loss (ft)	0.09	Cum Volume (acre-ft)	0.01
0.18			
C & E Loss (ft)	0.00	Cum SA (acres)	
0.04			

Warning: The energy equation could not be balanced within the specified number of iterations. The program used critical depth for the water surface and continued on with the calculations.  
 Warning: During the standard step iterations, when the assumed water surface was set equal to critical depth, the calculated water surface came back below critical depth. This indicates that there is not a valid subcritical answer. The program defaulted to critical depth.

CROSS SECTION

RIVER: SC01  
 REACH: Sand Creek-DS-0- RS: 968

INPUT

Description:  
 Station Elevation Data num= 248  
 Sta Elev Sta Elev Sta Elev Sta Elev Sta Elev  
 Elev 0 6263.5 2.29 6263.5 4.34 6263.4 6.47 6263.3 8.6  
 6263.2  
 10.72 6263.1 12.85 6263 14.98 6262.9 17.11 6262.8 19.26  
 6262.7  
 21.53 6262.6 23.81 6262.5 26.08 6262.4 29.13 6262.3 33.63  
 6262.2  
 38.13 6262.1 42.73 6262 70.63 6261.9 75.25 6261.8 79.86  
 6261.7  
 82.85 6261.7 83.83 6261.8 83.98 6261.8 86.85 6261.7 89.72  
 6261.6  
 91.59 6261.5 93.21 6261.4 94.82 6261.3 96.75 6261.2 98.92  
 6261.1  
 101.1 6261 103.69 6260.9 105.68 6260.8 107.35 6260.7 107.74  
 6260.6  
 108.12 6260.5 108.5 6260.4 108.88 6260.3 109.27 6260.2 109.65  
 6260.1  
 110.03 6260 110.42 6259.9 110.8 6259.8 111.18 6259.7 111.56  
 6259.6  
 111.95 6259.5 112.33 6259.4 112.71 6259.3 113.09 6259.2 113.48  
 6259.1  
 113.86 6259 114.24 6258.9 114.62 6258.8 115.01 6258.7 115.39

6258.6								
115.77	6258.5	116.15	6258.4	116.54	6258.3	116.92	6258.2	117.3
6258.1								
117.69	6258	118.07	6257.9	118.45	6257.8	118.83	6257.7	119.22
6257.6								
119.6	6257.5	119.98	6257.4	120.36	6257.3	120.75	6257.2	121.13
6257.1								
121.51	6257	121.89	6256.9	122.28	6256.8	122.66	6256.7	123.04
6256.6								
123.42	6256.5	123.81	6256.4	124.19	6256.3	124.57	6256.2	124.96
6256.1								
125.34	6256	125.72	6255.9	126.1	6255.8	126.49	6255.7	126.87
6255.6								
127.25	6255.5	127.63	6255.4	128.02	6255.3	128.4	6255.2	128.78
6255.1								
129.16	6255	129.55	6254.9	129.93	6254.8	130.31	6254.7	130.69
6254.6								
131.08	6254.5	131.44	6254.4	131.69	6254.3	131.95	6254.2	132.2
6254.1								
132.45	6254	132.7	6253.9	132.95	6253.8	133.2	6253.7	133.45
6253.6								
133.7	6253.5	133.95	6253.4	134.2	6253.3	134.45	6253.2	134.7
6253.1								
134.95	6253	135.21	6252.9	135.46	6252.8	135.71	6252.7	135.96
6252.6								
136.21	6252.5	136.46	6252.4	136.71	6252.3	136.96	6252.2	137.21
6252.1								
137.46	6252	137.71	6251.9	137.96	6251.8	138.21	6251.7	138.47
6251.6								
138.72	6251.5	138.97	6251.4	139.22	6251.3	139.47	6251.2	139.72
6251.1								
139.97	6251	140.22	6250.9	140.47	6250.8	140.72	6250.7	140.97
6250.6								
141.22	6250.5	141.47	6250.4	141.73	6250.3	141.98	6250.2	142.23
6250.1								
142.48	6250	142.73	6249.9	142.98	6249.8	143.23	6249.7	143.48
6249.6								
143.73	6249.5	143.98	6249.4	144.23	6249.3	144.48	6249.2	144.73
6249.1								
155.18	6249.1	155.48	6249.2	155.78	6249.3	156.08	6249.4	156.38
6249.5								
156.68	6249.6	156.98	6249.7	157.28	6249.8	157.58	6249.9	157.88
6250								
158.18	6250.1	158.48	6250.2	158.78	6250.3	159.08	6250.4	159.38
6250.5								
159.68	6250.6	159.98	6250.7	160.28	6250.8	160.58	6250.9	160.88
6251								
161.18	6251.1	161.48	6251.2	161.78	6251.3	162.08	6251.4	162.38
6251.5								
162.68	6251.6	162.98	6251.7	163.28	6251.8	163.58	6251.9	163.88
6252								
164.18	6252.1	164.48	6252.2	164.78	6252.3	165.08	6252.4	165.38
6252.5								

165.68	6252.6	165.98	6252.7	166.28	6252.8	166.58	6252.9	166.88
6253								
167.18	6253.1	167.48	6253.2	167.78	6253.3	168.08	6253.4	168.38
6253.5								
168.68	6253.6	168.98	6253.7	169.28	6253.8	169.59	6253.9	169.89
6254								
169.91	6254.01	170.19	6254.1	170.5	6254.2	170.8	6254.3	171.1
6254.4								
171.41	6254.5	171.71	6254.6	172.01	6254.7	172.31	6254.8	172.62
6254.9								
172.92	6255	173.22	6255.1	173.53	6255.2	173.83	6255.3	174.13
6255.4								
174.41	6255.5	179.49	6255.6	184.48	6255.7	189.48	6255.8	194.21
6255.9								
198.77	6256	203.33	6256.1	207.89	6256.2	212.44	6256.3	217
6256.4								
221.56	6256.5	226.12	6256.6	230.68	6256.7	235.24	6256.8	239.8
6256.9								
244.36	6257	248.92	6257.1	253.48	6257.2	258.04	6257.3	262.6
6257.4								
267.85	6257.5	282.3	6257.6	289.42	6257.7	290.24	6257.8	291.05
6257.9								
291.88	6258	292.73	6258.1	293.58	6258.2	294.44	6258.3	295.31
6258.4								
296.19	6258.5	297.06	6258.6	300	6258.6			
Manning's n Values			num=	3				
Sta	n Val	Sta	n Val	Sta	n Val			
0	.03	132.45	.013	169.91	.03			
Bank Sta:	Left	Right	Lengths:	Left	Channel	Right		Coeff Contr.
Expan.								
	132.45	169.91		50	50	50		.1
.3								
Left Levee		Station=	83.65		Elevation=	6261.85		
Right Levee		Station=	274.63		Elevation=	6258.85		
CROSS SECTION OUTPUT		Profile #Flow 1						
E.G. Elev (ft)		6255.18		Element				Left OB
Channel Right OB								
Vel Head (ft)		1.46		Wt. n-Val.				
0.013								
W.S. Elev (ft)		6253.72		Reach Len. (ft)				21.51
21.51		21.51						
Crit W.S. (ft)		6253.72		Flow Area (sq ft)				
106.85								
E.G. Slope (ft/ft)		0.001784		Area (sq ft)				
106.85								
Q Total (cfs)		1037.00		Flow (cfs)				
1037.00								
Top Width (ft)		35.86		Top Width (ft)				



162.64	6251.1	162.94	6251.2	163.24	6251.3	163.54	6251.4	163.84
6251.5								
164.14	6251.6	164.44	6251.7	164.74	6251.8	165.04	6251.9	165.34
6252								
165.64	6252.1	165.94	6252.2	166.24	6252.3	166.54	6252.4	166.84
6252.5								
167.14	6252.6	167.44	6252.7	167.74	6252.8	168.04	6252.9	168.34
6253								
168.64	6253.1	168.94	6253.2	169.25	6253.3	169.55	6253.4	169.85
6253.5								
170.16	6253.6	170.46	6253.7	170.76	6253.8	171.07	6253.9	171.37
6254								
171.41	6254.01	171.67	6254.1	171.97	6254.2	172.28	6254.3	172.58
6254.4								
172.88	6254.5	173.19	6254.6	173.49	6254.7	173.79	6254.8	174.1
6254.9								
174.67	6255	179.67	6255.1	184.67	6255.2	189.66	6255.3	194.58
6255.4								
199.5	6255.5	204.41	6255.6	209.33	6255.7	214.24	6255.8	219.16
6255.9								
224.07	6256	228.99	6256.1	233.91	6256.2	238.82	6256.3	243.74
6256.4								
248.65	6256.5	253.57	6256.6	258.48	6256.7	263.4	6256.8	268.32
6256.9								
273.23	6257	277.93	6257.1	282.49	6257.2	287.05	6257.3	291.61
6257.4								
297.27	6257.5	298.12	6257.6	300	6257.6			

Manning's n Values	num=	3
Sta n Val	Sta n Val	Sta n Val
0 .03 131.31	.013 171.41	.03

Bank Sta: Left	Right	Lengths: Left	Channel	Right	Coeff	Contr.
Expan.						
	131.31	171.41	50	50	50	.1
.3						
Left Levee	Station=	75.27	Elevation=	6260.12		
Right Levee	Station=	176.21	Elevation=	6255.12		

CROSS SECTION OUTPUT Profile #Flow 1

E.G. Elev (ft)	6254.32	Element	Left OB
Channel Right OB			
Vel Head (ft)	1.31	Wt. n-Val.	0.030
0.013			
W.S. Elev (ft)	6253.01	Reach Len. (ft)	50.00
50.00	50.00		
Crit W.S. (ft)	6253.01	Flow Area (sq ft)	21.71
112.20			
E.G. Slope (ft/ft)	0.001599	Area (sq ft)	21.71
112.20			
Q Total (cfs)	1100.00	Flow (cfs)	46.33

1053.67			
Top Width (ft)	56.36	Top Width (ft)	19.30
37.06			
Vel Total (ft/s)	8.21	Avg. Vel. (ft/s)	2.13
9.39			
Max Chl Dpth (ft)	4.41	Hydr. Depth (ft)	1.12
3.03			
Conv. Total (cfs)	27510.0	Conv. (cfs)	1158.8
26351.2			
Length Wtd. (ft)	50.00	Wetted Per. (ft)	19.41
38.10			
Min Ch El (ft)	6248.60	Shear (lb/sq ft)	0.11
0.29			
Alpha	1.25	Stream Power (lb/ft s)	300.00
75.27	176.21		
Frctn Loss (ft)	0.08	Cum Volume (acre-ft)	0.06
4.13	0.00		
C & E Loss (ft)	0.01	Cum SA (acres)	0.25
1.16	0.01		

Warning: The energy equation could not be balanced within the specified number of iterations. The program used critical depth for the water surface and continued on with the calculations.  
Warning: During the standard step iterations, when the assumed water surface was set equal to critical depth, the calculated water surface came back below critical depth. This indicates that there is not a valid subcritical answer. The program defaulted to critical depth.  
Note: Multiple critical depths were found at this location. The critical depth with the lowest, valid, energy was used.

CROSS SECTION

RIVER: SC01  
REACH: Sand Creek-DS-1 RS: 965

INPUT									
Description:									
Station	Elevation	Data	num=	264					
Sta	Elev	Sta	Elev	Sta	Elev	Sta	Elev	Sta	Elev
Elev									
0	6259.6	46.46	6259.6	48.64	6259.7	50.38	6259.8	50.88	
6259.9									
51.38	6260	51.89	6260.1	52.39	6260.2	52.89	6260.3	53.39	
6260.4									
53.89	6260.5	54.4	6260.6	54.9	6260.7	55.4	6260.8	55.9	
6260.9									
56.4	6261	56.5	6261	56.88	6260.9	57.26	6260.8	58.11	
6260.7									
59.23	6260.6	60.35	6260.5	61.46	6260.4	62.58	6260.3	63.7	

6260.2									
64.82	6260.1	65.93	6260	67.05	6259.9	69.63	6259.8	72.09	
6259.7									
73.5	6259.6	74.92	6259.5	76.33	6259.4	77.75	6259.3	79.16	
6259.2									
80.58	6259.1	81.99	6259	83.41	6258.9	84.81	6258.8	85.63	
6258.7									
86.46	6258.6	87.28	6258.5	88.1	6258.4	88.93	6258.3	89.08	
6258.3									
89.77	6258.4	90.53	6258.5	91.38	6258.6	92.23	6258.7	93.08	
6258.8									
93.93	6258.9	94.77	6259	95.62	6259.1	96.47	6259.2	97.32	
6259.3									
98.16	6259.4	99.01	6259.5	99.86	6259.6	102.05	6259.7	104.64	
6259.7									
106.06	6259.6	107.49	6259.5	108.22	6259.4	108.45	6259.3	108.68	
6259.2									
108.91	6259.1	109.14	6259	109.36	6258.9	109.67	6258.8	110.19	
6258.7									
110.71	6258.6	111.23	6258.5	111.75	6258.4	112.27	6258.3	112.8	
6258.2									
113.32	6258.1	113.84	6258	114.36	6257.9	114.88	6257.8	115.37	
6257.7									
115.68	6257.6	115.99	6257.5	116.3	6257.4	116.61	6257.3	116.91	
6257.2									
117.22	6257.1	117.53	6257	117.84	6256.9	118.15	6256.8	118.46	
6256.7									
118.76	6256.6	119.07	6256.5	119.38	6256.4	119.69	6256.3	120	
6256.2									
120.3	6256.1	120.61	6256	120.92	6255.9	121.23	6255.8	121.54	
6255.7									
121.84	6255.6	122.15	6255.5	122.46	6255.4	122.77	6255.3	123.08	
6255.2									
123.39	6255.1	123.69	6255	124	6254.9	124.31	6254.8	124.62	
6254.7									
124.93	6254.6	125.23	6254.5	125.54	6254.4	125.85	6254.3	126.16	
6254.2									
126.47	6254.1	126.78	6254	127.08	6253.9	127.39	6253.8	127.7	
6253.7									
128.01	6253.6	128.32	6253.5	128.62	6253.4	128.93	6253.3	129.24	
6253.2									
129.55	6253.1	129.86	6253	130.17	6252.9	130.47	6252.8	130.78	
6252.7									
131.09	6252.6	131.4	6252.5	131.7	6252.4	132	6252.3	132.3	
6252.2									
132.6	6252.1	132.9	6252	133.2	6251.9	133.5	6251.8	133.81	
6251.7									
134.11	6251.6	134.41	6251.5	134.71	6251.4	135.01	6251.3	135.31	
6251.2									
135.61	6251.1	135.91	6251	136.21	6250.9	136.51	6250.8	136.81	
6250.7									
137.11	6250.6	137.41	6250.5	137.71	6250.4	138.01	6250.3	138.31	
6250.2									

138.61	6250.1	138.91	6250	139.21	6249.9	139.51	6249.8	139.81	
6249.7									
140.11	6249.6	140.41	6249.5	140.71	6249.4	141.01	6249.3	141.31	
6249.2									
141.61	6249.1	141.91	6249	142.21	6248.9	142.51	6248.8	142.81	
6248.7									
143.11	6248.6	143.41	6248.5	143.71	6248.4	144.01	6248.3	144.31	
6248.2									
144.61	6248.1	155.1	6248.1	155.4	6248.2	155.7	6248.3	156	
6248.4									
156.3	6248.5	156.6	6248.6	156.9	6248.7	157.2	6248.8	157.5	
6248.9									
157.8	6249	158.1	6249.1	158.4	6249.2	158.7	6249.3	159	
6249.4									
159.9	6249.5	159.6	6249.6	159.9	6249.7	160.2	6249.8	160.5	
6249.3									
160.8	6250	161.1	6250.1	161.4	6250.2	161.7	6250.3	162	
6250.4									
162.3	6250.5	162.6	6250.6	162.9	6250.7	163.2	6250.8	163.5	
6250.9									
163.8	6251	164.1	6251.1	164.4	6251.2	164.7	6251.3	165	
6251.4									
165.3	6251.5	165.6	6251.6	165.9	6251.7	166.2	6251.8	166.5	
6251.9									
166.8	6252	167.1	6252.1	167.4	6252.2	167.7	6252.3	168	
6252.4									
168.3	6252.5	168.6	6252.6	168.91	6252.7	169.21	6252.8	169.51	
6252.9									
169.82	6253	169.84	6253.01	170.12	6253.1	170.42	6253.2	170.73	
6253.3									
171.03	6253.4	171.33	6253.5	171.63	6253.6	171.94	6253.7	172.24	
6253.8									
172.54	6253.9	172.85	6254	173.15	6254.1	173.45	6254.2	173.76	
6254.3									
174.06	6254.4	174.55	6254.5	179.55	6254.6	184.55	6254.7	189.55	
6254.8									
194.99	6254.9	200.43	6255	205.87	6255.1	211.31	6255.2	216.75	
6255.3									
222.2	6255.4	227.64	6255.5	233.08	6255.6	238.52	6255.7	243.96	
6255.8									
249.4	6255.9	254.84	6256	261.61	6256.1	268.4	6256.2	275.19	
6256.3									
281.98	6256.4	288.77	6256.5	295.56	6256.6	300	6256.6		
Manning's n Values			num=	3					
Sta n Val	Sta n Val	Sta n Val							
0 .03	129.86	.013	169.84	.03					
Bank Sta: Left	Right	Lengths: Left	Channel	Right	Coeff	Contr.			
Expan.									
	129.86	169.84		50	50	50		.1	
.3									
Ineffective Flow		num=	1						

Sta L Sta R Elev Permanent  
 0 98.73 6259.63 F  
 Left Levee Station= 104.59 Elevation= 6259.7  
 Right Levee Station= 256.2 Elevation= 6256.16

CROSS SECTION OUTPUT Profile #Flow 1

E.G. Elev (ft)	6254.20	Element	Left OB
Channel Right OB			
Vel Head (ft)	1.46	Wt. n-Val.	
0.013			
W.S. Elev (ft)	6252.74	Reach Len. (ft)	50.00
50.00 50.00			
Crit W.S. (ft)	6252.74	Flow Area (sq ft)	
113.30			
E.G. Slope (ft/ft)	0.001793	Area (sq ft)	
113.30			
Q Total (cfs)	1100.00	Flow (cfs)	
1100.00			
Top Width (ft)	38.38	Top Width (ft)	
38.38			
Vel Total (ft/s)	9.71	Avg. Vel. (ft/s)	
9.71			
Max Chl Dpth (ft)	4.64	Hydr. Depth (ft)	
2.95			
Conv. Total (cfs)	25977.7	Conv. (cfs)	
25977.7			
Length Wtd. (ft)	50.00	Wetted Per. (ft)	
39.88			
Min Ch El (ft)	6248.10	Shear (lb/sq ft)	
0.32			
Alpha	1.00	Stream Power (lb/ft s)	300.00
104.59 256.20			
Frctn Loss (ft)	0.09	Cum Volume (acre-ft)	0.05
4.00 0.00			
C & E Loss (ft)	0.01	Cum SA (acres)	0.24
1.12 0.01			

Warning: The energy equation could not be balanced within the specified number of iterations. The program used critical depth for the water surface and continued on with the calculations.  
 Warning: During the standard step iterations, when the assumed water surface was set equal to critical depth, the calculated water surface came back below critical depth. This indicates that there is not a valid subcritical answer. The program defaulted to critical depth.  
 Note: Multiple critical depths were found at this location. The critical depth with the lowest, valid, energy was used.

CROSS SECTION

RIVER: SC01  
 REACH: Sand Creek-DS-1 RS: 964

INPUT  
 Description:  
 Station Elevation Data num= 240  
 Sta Elev Sta Elev Sta Elev Sta Elev Sta

Elev	0	6259.5	50.51	6259.5	58.79	6259.4	66.02	6259.3	71.28
6259.3									
71.51	6259.4	73.06	6259.4	74.55	6259.3	76.04	6259.2	77.53	
6259.1									
79.02	6259	80.51	6258.9	81.85	6258.8	82.67	6258.7	83.49	
6258.6									
84.32	6258.5	85.14	6258.4	85.96	6258.3	86.79	6258.2	87.61	
6258.1									
88.43	6258	89.26	6257.9	90.08	6257.8	90.91	6257.7	91.57	
6257.7									
92.27	6257.8	92.96	6257.9	93.66	6258	94.36	6258.1	95.05	
6258.2									
95.75	6258.3	96.45	6258.4	97.15	6258.5	97.84	6258.6	98.54	
6258.7									
99.26	6258.8	100.11	6258.9	100.95	6259	101.8	6259.1	104.15	
6259.2									
106.12	6259.2	108.12	6259.1	110.11	6259	110.86	6258.9	111.16	
6258.8									
111.46	6258.7	111.75	6258.6	112.05	6258.5	112.35	6258.4	112.64	
6258.3									
112.94	6258.2	113.24	6258.1	113.53	6258	113.83	6257.9	114.13	
6257.8									
114.42	6257.7	114.72	6257.6	115.02	6257.5	115.31	6257.4	115.61	
6257.3									
115.91	6257.2	116.2	6257.1	116.5	6257	116.8	6256.9	117.09	
6256.8									
117.39	6256.7	117.69	6256.6	117.98	6256.5	118.28	6256.4	118.58	
6256.3									
118.87	6256.2	119.17	6256.1	119.47	6256	119.77	6255.9	120.07	
6255.8									
120.38	6255.7	120.68	6255.6	120.98	6255.5	121.29	6255.4	121.59	
6255.3									
121.89	6255.2	122.2	6255.1	122.5	6255	122.8	6254.9	123.11	
6254.8									
123.41	6254.7	123.72	6254.6	124.03	6254.5	124.33	6254.4	124.64	
6254.3									
124.95	6254.2	125.26	6254.1	125.57	6254	125.87	6253.9	126.22	
6253.8									
126.57	6253.7	126.82	6253.6	127.19	6253.5	127.46	6253.4	127.73	
6253.3									
128	6253.2	128.26	6253.1	128.53	6253	128.8	6252.9	129.1	
6252.8									
129.39	6252.7	129.67	6252.6	129.96	6252.5	130.25	6252.4	130.53	

6252.3								
130.82	6252.2	131.11	6252.1	131.39	6252	131.69	6251.9	131.99
6251.8								
132.29	6251.7	132.59	6251.6	132.89	6251.5	133.19	6251.4	133.49
6251.3								
133.79	6251.2	134.09	6251.1	134.39	6251	134.69	6250.9	134.99
6250.8								
135.29	6250.7	135.59	6250.6	135.89	6250.5	136.19	6250.4	136.49
6250.3								
136.79	6250.2	137.09	6250.1	137.39	6250	137.69	6249.9	137.99
6249.8								
138.29	6249.7	138.59	6249.6	138.89	6249.5	139.19	6249.4	139.49
6249.3								
139.79	6249.2	140.09	6249.1	140.39	6249	140.69	6248.9	140.99
6248.8								
141.29	6248.7	141.59	6248.6	141.89	6248.5	142.19	6248.4	142.49
6248.3								
142.79	6248.2	143.09	6248.1	143.39	6248	143.69	6247.9	143.99
6247.8								
144.29	6247.7	144.59	6247.6	155.01	6247.6	155.21	6247.7	155.41
6247.8								
155.61	6247.9	155.85	6248	156.15	6248.1	156.45	6248.2	156.75
6248.3								
157.05	6248.4	157.35	6248.5	157.65	6248.6	157.95	6248.7	158.25
6248.8								
158.55	6248.9	158.85	6249	159.15	6249.1	159.45	6249.2	159.75
6249.3								
160.05	6249.4	160.35	6249.5	160.65	6249.6	160.95	6249.7	161.25
6249.8								
161.55	6249.9	161.85	6250	162.15	6250.1	162.45	6250.2	162.75
6250.3								
163.05	6250.4	163.35	6250.5	163.65	6250.6	163.95	6250.7	164.25
6250.8								
164.55	6250.9	164.85	6251	165.15	6251.1	165.45	6251.2	165.75
6251.3								
166.05	6251.4	166.35	6251.5	166.65	6251.6	166.95	6251.7	167.25
6251.8								
167.55	6251.9	167.85	6252	168.15	6252.1	168.9	6252.2	169.2
6252.3								
169.5	6252.4	169.81	6252.5	170.11	6252.6	170.41	6252.7	170.71
6252.8								
171.02	6252.9	171.32	6253	171.36	6253.01	171.62	6253.1	171.93
6253.2								
172.23	6253.3	172.53	6253.4	172.84	6253.5	173.14	6253.6	173.44
6253.7								
173.74	6253.8	174.05	6253.9	174.47	6254	179.47	6254.1	184.47
6254.2								
189.47	6254.3	198.65	6254.4	207.85	6254.5	217.05	6254.6	226.25
6254.7								
235.45	6254.8	244.65	6254.9	253.85	6255	262.34	6255.1	269.17
6255.2								
275.99	6255.3	282.82	6255.4	289.65	6255.5	296.48	6255.6	300
6255.6								

Manning's n Values num= 3  
Sta n Val Sta n Val Sta n Val  
0 .03 128.53 .013 171.36 .03

Bank Sta: Left Right Lengths: Left Channel Right Coeff Contr.  
Expan. 128.53 171.36 50 50 50 .1

.3  
Ineffective Flow num= 1  
Sta L Sta R Elev Permanent  
0 101.24 6259.12 F  
Left Levee Station= 104.59 Elevation= 6259.22  
Right Levee Station= 254.95 Elevation= 6255.19

CROSS SECTION OUTPUT Profile #Flow 1

E.G. Elev (ft)	6253.75	Element	Left OB
Channel Right OB			
Vel Head (ft)	1.44	Wt. n-Val.	
0.013			
W.S. Elev (ft)	6252.31	Reach Len. (ft)	50.00
50.00 50.00			
Crit W.S. (ft)	6252.31	Flow Area (sq ft)	
114.09			
E.G. Slope (ft/ft)	0.001776	Area (sq ft)	
114.09			
Q Total (cfs)	1100.00	Flow (cfs)	
1100.00			
Top Width (ft)	38.73	Top Width (ft)	
38.73			
Vel Total (ft/s)	9.64	Avg. Vel. (ft/s)	
9.64			
Max Chl Dpth (ft)	4.71	Hydr. Depth (ft)	
2.95			
Conv. Total (cfs)	26104.4	Conv. (cfs)	
26104.4			
Length Wtd. (ft)	50.00	Wetted Per. (ft)	
40.28			
Min Ch El (ft)	6247.60	Shear (lb/sq ft)	
0.31			
Alpha	1.00	Stream Power (lb/ft s)	300.00
104.59 254.95			
Frctn Loss (ft)	0.09	Cum Volume (acre-ft)	0.05
3.87 0.00			
C & E Loss (ft)	0.01	Cum SA (acres)	0.24
1.08 0.01			

Warning: The energy equation could not be balanced within the specified number of iterations. The program used critical depth





171.03	6252.4	171.33	6252.5	171.63	6252.6	171.94	6252.7	172.24
6252.8								
172.54	6252.9	172.85	6253	173.15	6253.1	173.45	6253.2	173.75
6253.3								
174.06	6253.4	174.41	6253.5	179.41	6253.6	184.41	6253.7	189.41
6253.8								
198.53	6253.9	207.73	6254	216.93	6254.1	226.13	6254.2	235.33
6254.3								
248.64	6254.4	263.69	6254.5	278.74	6254.6	293.79	6254.7	300
6254.7								

Manning's n Values num= 3  
 Sta n Val Sta n Val Sta n Val  
 0 .03 129.98 .013 169.84 .03

Bank Sta: Left Right Lengths: Left Channel Right Coeff Contr.  
 Expan. 129.98 169.84 50 50 50 .1

.3  
 Ineffective Flow num= 1  
 Sta L Sta R Elev Permanent  
 0 102.5 6258.36 F

Left Levee Station= 105.43 Elevation= 6258.46  
 Right Levee Station= 209.72 Elevation= 6254.02

CROSS SECTION OUTPUT Profile #Flow 1

E.G. Elev (ft)	6253.34	Element	Left OB
Channel Right OB			
Vel Head (ft)	1.50	Wt. n-Val.	
0.013			
W.S. Elev (ft)	6251.84	Reach Len. (ft)	50.00
50.00 50.00			
Crit W.S. (ft)	6251.84	Flow Area (sq ft)	
111.93			
E.G. Slope (ft/ft)	0.001829	Area (sq ft)	
111.93			
Q Total (cfs)	1100.00	Flow (cfs)	
1100.00			
Top Width (ft)	37.63	Top Width (ft)	
37.63			
Vel Total (ft/s)	9.83	Avg. Vel. (ft/s)	
9.83			
Max Chl Dpth (ft)	4.74	Hydr. Depth (ft)	
2.97			
Conv. Total (cfs)	25723.4	Conv. (cfs)	
25723.4			
Length Wtd. (ft)	50.00	Wetted Per. (ft)	
39.26			
Min Ch El (ft)	6247.10	Shear (lb/sq ft)	
0.33			
Alpha	1.00	Stream Power (lb/ft s)	300.00

105.43	209.72		
Frctn Loss (ft)	0.09	Cum Volume (acre-ft)	0.05
3.74	0.00		
C & E Loss (ft)	0.00	Cum SA (acres)	0.24
1.03	0.01		

Warning: The energy equation could not be balanced within the specified number of iterations. The program used critical depth for the water surface and continued on with the calculations.  
 Warning: During the standard step iterations, when the assumed water surface was set equal to critical depth, the calculated water surface came back below critical depth. This indicates that there is not a valid subcritical answer. The program defaulted to critical depth.  
 Note: Multiple critical depths were found at this location. The critical depth with the lowest, valid, energy was used.

CROSS SECTION

RIVER: SC01  
 REACH: Sand Creek-DS-1 RS: 962

INPUT  
 Description:  
 Station Elevation Data num= 244  
 Sta Elev Sta Elev Sta Elev Sta Elev Sta Elev Sta Elev

Elev	0	6257.6	58.01	6257.6	58.97	6257.7	59.61	6257.8	59.71
6257.9	59.8	6258	59.9	6258.1	59.99	6258.2	60.09	6258.3	60.19
6258.4	60.28	6258.5	60.38	6258.6	60.47	6258.7	60.57	6258.8	60.67
6258.9	61.02	6258.9	62.36	6258.8	63.7	6258.7	65.05	6258.6	66.62
6258.5	68.61	6258.4	70.59	6258.3	72.58	6258.2	74.56	6258.1	76.55
6258	78.53	6257.9	80.52	6257.8	82.17	6257.7	83.43	6257.6	84.69
6257.5	85.95	6257.4	87.21	6257.3	88.47	6257.2	89.73	6257.1	90.87
6257	91.82	6256.9	92.78	6256.8	93.73	6256.7	94.69	6256.6	96.65
6256.6	97.99	6256.7	99.04	6256.8	100.05	6256.9	101.05	6257	102.05
6257.1	103.05	6257.2	104.06	6257.3	105.06	6257.4	106.06	6257.5	107.06
6257.6	112.88	6257.6	113.15	6257.5	113.41	6257.4	113.68	6257.3	113.95
6257.2	114.22	6257.1	114.49	6257	114.75	6256.9	115.02	6256.8	115.29

6256.7									
115.56	6256.6	115.83	6256.5	116.09	6256.4	116.36	6256.3	116.63	
6256.2									
116.9	6256.1	117.17	6256	117.44	6255.9	117.7	6255.8	117.97	
6255.7									
118.24	6255.6	118.51	6255.5	118.78	6255.4	119.04	6255.3	119.31	
6255.2									
119.58	6255.1	119.85	6255	120.2	6254.9	120.53	6254.8	120.82	
6254.7									
121.11	6254.6	121.4	6254.5	121.68	6254.4	121.97	6254.3	122.26	
6254.2									
122.54	6254.1	122.83	6254	123.12	6253.9	123.4	6253.8	123.69	
6253.7									
123.98	6253.6	124.26	6253.5	124.55	6253.4	124.84	6253.3	125.12	
6253.2									
125.41	6253.1	125.7	6253	125.98	6252.9	126.27	6252.8	126.56	
6252.7									
126.84	6252.6	127.13	6252.5	127.42	6252.4	127.7	6252.3	127.99	
6252.2									
128.28	6252.1	128.56	6252	128.85	6251.9	129.14	6251.8	129.42	
6251.7									
129.71	6251.6	130	6251.5	130.28	6251.4	130.57	6251.3	130.86	
6251.2									
131.14	6251.1	131.43	6251	131.73	6250.9	132.03	6250.8	132.33	
6250.7									
132.63	6250.6	132.93	6250.5	133.23	6250.4	133.53	6250.3	133.83	
6250.2									
134.13	6250.1	134.43	6250	134.73	6249.9	135.03	6249.8	135.33	
6249.7									
135.63	6249.6	135.93	6249.5	136.23	6249.4	136.53	6249.3	136.83	
6249.2									
137.13	6249.1	137.43	6249	137.73	6248.9	138.03	6248.8	138.33	
6248.7									
138.63	6248.6	138.93	6248.5	139.23	6248.4	139.53	6248.3	139.83	
6248.2									
140.13	6248.1	140.43	6248	140.73	6247.9	141.03	6247.8	141.33	
6247.7									
141.63	6247.6	141.93	6247.5	142.23	6247.4	142.53	6247.3	142.83	
6247.2									
143.13	6247.1	143.43	6247	143.73	6246.9	144.03	6246.8	144.33	
6246.7									
144.63	6246.6	155.03	6246.6	155.23	6246.7	155.43	6246.8	155.63	
6246.9									
155.83	6247	156.03	6247.1	156.23	6247.2	156.43	6247.3	156.63	
6247.4									
156.83	6247.5	157.03	6247.6	157.23	6247.7	157.43	6247.8	157.63	
6247.9									
157.83	6248	158.03	6248.1	158.23	6248.2	158.43	6248.3	158.63	
6248.4									
158.83	6248.5	159.03	6248.6	159.29	6248.7	159.59	6248.8	159.89	
6248.9									
160.19	6249	160.49	6249.1	160.79	6249.2	161.09	6249.3	161.39	
6249.4									

161.69	6249.5	161.99	6249.6	162.29	6249.7	162.59	6249.8	162.89	
6249.9									
163.19	6250	163.49	6250.1	163.79	6250.2	164.09	6250.3	164.39	
6250.4									
164.69	6250.5	164.99	6250.6	165.29	6250.7	165.59	6250.8	165.89	
6250.9									
166.19	6251	166.49	6251.1	166.79	6251.2	167.09	6251.3	167.39	
6251.4									
167.69	6251.5	167.99	6251.6	168.29	6251.7	169.79	6251.8	171.04	
6251.9									
171.34	6252	171.44	6252.03	171.64	6252.1	171.95	6252.2	172.25	
6252.3									
172.55	6252.4	172.85	6252.5	173.16	6252.6	173.46	6252.7	173.76	
6252.8									
174.07	6252.9	174.37	6253	180.35	6253.1	185.65	6253.2	190.65	
6253.3									
193.73	6253.3	196.42	6253.2	199.11	6253.1	203.57	6253.1	206.61	
6253.2									
209.66	6253.3	212.7	6253.4	219.21	6253.5	233.34	6253.6	247.47	
6253.7									
261.61	6253.8	275.76	6253.9	297.15	6254	300	6254		

Manning's n Values num= 3

Sta	n Val	Sta	n Val	Sta	n Val
0	.03	128.56	.013	171.44	.03

Bank Sta: Left Right Lengths: Left Channel Right Coeff Contr.

Expan.	128.56	171.44	50	50	50	.1
--------	--------	--------	----	----	----	----

.3

Ineffective Flow num= 1

Sta L	Sta R	Elev	Permanent
0	105.85	6257.63	F

Left Levee Station= 112.97 Elevation= 6257.63

Right Levee Station= 192.54 Elevation= 6253.38

CROSS SECTION OUTPUT Profile #Flow 1

E.G. Elev (ft)	6252.92	Element	Left OB
Channel Right OB			
Vel Head (ft)	1.49	Wt. n-Val.	
0.013			
W.S. Elev (ft)	6251.43	Reach Len. (ft)	50.00
50.00	50.00		
Crit W.S. (ft)	6251.43	Flow Area (sq ft)	
112.24			
E.G. Slope (ft/ft)	0.001794	Area (sq ft)	
112.24			
Q Total (cfs)	1100.00	Flow (cfs)	
1100.00			
Top Width (ft)	37.25	Top Width (ft)	
37.25			

Vel Total (ft/s)	9.80	Avg. Vel. (ft/s)	
9.80			
Max Chl Dpth (ft)	4.82	Hydr. Depth (ft)	
3.01			
Conv. Total (cfs)	25969.3	Conv. (cfs)	
25969.3			
Length Wtd. (ft)	50.00	Wetted Per. (ft)	
38.97			
Min Ch El (ft)	6246.60	Shear (lb/sq ft)	
0.32			
Alpha	1.00	Stream Power (lb/ft s)	300.00
112.97	192.54		
Frctn Loss (ft)	0.09	Cum Volume (acre-ft)	0.05
3.61	0.00		
C & E Loss (ft)	0.00	Cum SA (acres)	0.24
0.99	0.01		

Warning: The energy equation could not be balanced within the specified number of iterations. The program used critical depth for the water surface and continued on with the calculations.

Warning: During the standard step iterations, when the assumed water surface was set equal to critical depth, the calculated water surface came back below critical depth. This indicates that there is not a valid subcritical answer. The program defaulted to critical depth.

Note: Multiple critical depths were found at this location. The critical depth with the lowest, valid, energy was used.

CROSS SECTION

RIVER: SC01

REACH: Sand Creek-DS-1 RS: 961

INPUT

Description:

Station	Elevation	Data	num=	334					
Sta	Elev	Sta	Elev	Sta	Elev	Sta	Elev	Sta	Elev
Elev									
0	6257.6	33.9	6257.6	47.55	6257.7	49.43	6257.8	51.3	
6257.9									
53.17	6258	56.2	6258	62.04	6257.9	63.31	6257.8	64.57	
6257.7									
65.83	6257.6	67.09	6257.5	68.36	6257.4	69.62	6257.3	70.88	
6257.2									
72.14	6257.1	73.41	6257	77.85	6256.9	82.81	6256.8	85.67	
6256.7									
87.46	6256.6	89.08	6256.5	90.04	6256.4	90.99	6256.3	91.95	
6256.2									
92.91	6256.1	93.86	6256	94.82	6255.9	95.77	6255.8	96.73	
6255.7									

97.63	6255.7	98.98	6255.8	100.32	6255.9	101.66	6256	103	
6256.1									
104.34	6256.2	105.68	6256.3	106.87	6256.4	107.88	6256.5	108.88	
6256.6									
110.85	6256.6	114.17	6256.5	114.43	6256.4	114.7	6256.3	114.97	
6256.2									
115.24	6256.1	115.57	6256	115.94	6255.9	116.25	6255.8	116.54	
6255.7									
116.83	6255.6	117.11	6255.5	117.4	6255.4	117.69	6255.3	117.97	
6255.2									
118.26	6255.1	118.55	6255	118.83	6254.9	119.12	6254.8	119.41	
6254.7									
119.7	6254.6	119.98	6254.5	120.27	6254.4	120.56	6254.3	120.84	
6254.2									
121.13	6254.1	121.42	6254	121.7	6253.9	121.99	6253.8	122.28	
6253.7									
122.56	6253.6	122.85	6253.5	123.14	6253.4	123.42	6253.3	123.71	
6253.2									
124	6253.1	124.28	6253	124.57	6252.9	124.86	6252.8	125.14	
6252.7									
125.43	6252.6	125.72	6252.5	126	6252.4	126.29	6252.3	126.58	
6252.2									
126.86	6252.1	127.15	6252	127.44	6251.9	127.72	6251.8	128.01	
6251.7									
128.3	6251.6	128.58	6251.5	128.87	6251.4	129.16	6251.3	129.44	
6251.2									
129.73	6251.1	130.02	6251	130.3	6250.9	130.59	6250.8	130.88	
6250.7									
131.16	6250.6	131.45	6250.5	131.75	6250.4	132.05	6250.3	132.35	
6250.2									
132.65	6250.1	132.95	6250	133.25	6249.9	133.55	6249.8	133.85	
6249.7									
134.15	6249.6	134.45	6249.5	134.75	6249.4	135.05	6249.3	135.35	
6249.2									
135.65	6249.1	135.95	6249	136.25	6248.9	136.55	6248.8	136.85	
6248.7									
137.15	6248.6	137.45	6248.5	137.75	6248.4	138.05	6248.3	138.35	
6248.2									
138.65	6248.1	138.95	6248	139.25	6247.9	139.55	6247.8	139.85	
6247.7									
140.15	6247.6	140.45	6247.5	140.75	6247.4	141.05	6247.3	141.35	
6247.2									
141.65	6247.1	141.95	6247	142.25	6246.9	142.55	6246.8	142.85	
6246.7									
143.15	6246.6	143.45	6246.5	143.75	6246.4	144.05	6246.3	144.35	
6246.2									
144.65	6246.1	155.04	6246.1	155.24	6246.2	155.44	6246.3	155.64	
6246.4									
155.84	6246.5	156.04	6246.6	156.24	6246.7	156.44	6246.8	156.64	
6246.9									
156.84	6247	157.04	6247.1	157.24	6247.2	157.44	6247.3	157.64	
6247.4									
157.84	6247.5	158.04	6247.6	158.24	6247.7	158.44	6247.8	158.64	

6247.9									
158.84	6248	159.04	6248.1	159.24	6248.2	159.44	6248.3	159.64	
6248.4									
159.84	6248.5	160.04	6248.6	160.24	6248.7	160.44	6248.8	160.64	
6248.9									
160.86	6249	161.16	6249.1	161.46	6249.2	161.76	6249.3	162.06	
6249.4									
162.36	6249.5	162.66	6249.6	162.96	6249.7	163.26	6249.8	163.56	
6249.9									
163.86	6250	164.16	6250.1	164.46	6250.2	164.76	6250.3	165.06	
6250.4									
165.36	6250.5	165.66	6250.6	165.96	6250.7	166.26	6250.8	166.56	
6250.9									
166.86	6251	167.16	6251.1	167.46	6251.2	167.76	6251.3	168.06	
6251.4									
168.36	6251.5	169.86	6251.58	170.16	6251.6	171.96	6251.7	172.26	
6251.8									
172.56	6251.9	172.86	6252	173.17	6252.1	173.47	6252.2	173.77	
6252.3									
174.08	6252.4	174.38	6252.5	180.91	6252.6	187.33	6252.7	189.69	
6252.7									
190.24	6252.6	190.8	6252.5	191.35	6252.4	191.9	6252.3	192.46	
6252.2									
193.01	6252.1	193.57	6252	194.12	6251.9	194.67	6251.8	195.23	
6251.7									
195.78	6251.6	196.34	6251.5	196.89	6251.4	197.44	6251.3	198	
6251.2									
198.55	6251.1	199.11	6251	199.66	6250.9	200.21	6250.8	200.77	
6250.7									
201.32	6250.6	201.87	6250.5	202.43	6250.4	202.98	6250.3	203.54	
6250.2									
204.09	6250.1	204.64	6250	205.2	6249.9	205.8	6249.8	206.84	
6249.7									
207.89	6249.6	209.9	6249.5	212.1	6249.4	212.57	6249.4	212.86	
6249.5									
213.15	6249.6	213.25	6249.3	214.35	6249.2	215.53	6249.1	216.81	
6249									
218.15	6248.9	219.67	6248.8	221.17	6248.7	222.43	6248.6	223.69	
6248.5									
225.17	6248.4	227.25	6248.3	229.88	6248.2	232.7	6248.2	234.16	
6248.3									
234.48	6249	235.16	6248.9	235.62	6248.4	235.84	6248.8	236.51	
6248.7									
237.08	6248.5	237.19	6248.6	238.94	6248.5	245.36	6248.4	251.78	
6248.3									
258.45	6248.3	259.03	6249.2	259.35	6249.1	259.91	6249	260.25	
6248.9									
260.66	6248.4	260.86	6248.8	261.47	6248.7	262.05	6248.5	262.08	
6248.6									
263.39	6248.6	264.39	6248.7	265.23	6248.8	266.13	6248.9	267.04	
6249									
267.89	6249.1	268.6	6249.2	269.31	6249.3	270.02	6249.4	270.72	
6249.5									

271.41	6249.6	272.03	6249.7	272.66	6249.8	273.28	6249.9	273.87	
6250									
274.43	6250.1	275	6250.2	275.56	6250.3	276.12	6250.4	276.68	
6250.5									
277.25	6250.6	277.82	6250.7	278.4	6250.8	278.92	6250.9	279.44	
6251									
279.95	6251.1	280.46	6251.2	280.97	6251.3	281.48	6251.4	281.99	
6251.5									
282.5	6251.6	283.01	6251.7	283.52	6251.8	284.02	6251.9	284.5	
6252									
284.98	6252.1	285.46	6252.2	285.93	6252.3	286.41	6252.4	286.88	
6252.5									
287.36	6252.6	287.83	6252.7	288.31	6252.8	288.78	6252.9	289.26	
6253									
292.78	6253.1	296.67	6253.2	299.51	6253.3	300	6253.3		
Manning's n Values	num=	3							
Sta n Val	Sta n Val	Sta n Val							
0	.03	130.02	.013	169.86	.03				
Bank Sta: Left	Right	Lengths: Left	Channel	Right	Coeff	Contr.			
Expan.									
	130.02	169.86		50	50	50		.1	
.3									
Ineffective Flow	num=	2							
Sta L	Sta R	Elev	Permanent						
0	107.1	6256.46	F						
190.03	300	6252.49	F						
Left Levee	Station=	113.81	Elevation=	6256.53					
Right Levee	Station=	189.61	Elevation=	6252.76					
CROSS SECTION OUTPUT	Profile #Flow 1								
E.G. Elev (ft)		6252.47	Element					Left OB	
Channel Right OB									
Vel Head (ft)		1.50	Wt. n-Val.						
0.013									
W.S. Elev (ft)		6250.98	Reach Len. (ft)					50.00	
50.00	50.00								
Crit W.S. (ft)		6250.98	Flow Area (sq ft)						
112.08									
E.G. Slope (ft/ft)		0.001774	Area (sq ft)						
112.08									
Q Total (cfs)		1100.00	Flow (cfs)						
1100.00									
Top Width (ft)		36.70	Top Width (ft)						
36.70									
Vel Total (ft/s)		9.81	Avg. Vel. (ft/s)						
9.81									
Max Chl Dpth (ft)		4.88	Hydr. Depth (ft)						
3.05									
Conv. Total (cfs)		26119.3	Conv. (cfs)						

26119.3  
 Length Wtd. (ft) 50.00 Wetted Per. (ft)  
 38.50  
 Min Ch El (ft) 6246.10 Shear (lb/sq ft)  
 0.32  
 Alpha 1.00 Stream Power (lb/ft s) 300.00  
 113.81 189.61  
 Frctn Loss (ft) 0.09 Cum Volume (acre-ft) 0.05  
 3.48 0.00  
 C & E Loss (ft) 0.01 Cum SA (acres) 0.24  
 0.95 0.01

Warning: The energy equation could not be balanced within the specified number of iterations. The program used critical depth for the water surface and continued on with the calculations.  
 Warning: During the standard step iterations, when the assumed water surface was set equal to critical depth, the calculated water surface came back below critical depth. This indicates that there is not a valid subcritical answer. The program defaulted to critical depth.  
 Note: Multiple critical depths were found at this location. The critical depth with the lowest, valid, energy was used.

CROSS SECTION

RIVER: SC01  
 REACH: Sand Creek-DS-1 RS: 960

INPUT

Description:

Station	Elevation	Data	num=	399	Sta	Elev	Sta	Elev	Sta
Elev									
0	6254.2	.12	6254.2	5.46	6254.1	10.8	6254	26.21	
6253.9	32.83	6253.8	39.45	6253.7	46.07	6253.6	56.98	6253.5	59.77
6253.5	60.01	6253.6	60.24	6253.7	60.47	6253.8	60.71	6253.9	60.94
6254	61.17	6254.1	62.37	6254.1	65.04	6254	67.16	6253.9	69.02
6253.8	70.72	6253.7	72.26	6253.6	73.8	6253.5	75.39	6253.4	76.95
6253.3	78.4	6253.2	79.77	6253.1	81.08	6253	82.34	6252.9	83.56
6252.8	84.75	6252.7	88.6	6252.7	91.19	6252.6	97.11	6252.5	97.66
6252.5	98.33	6252.6	99	6252.7	99.67	6252.8	100.29	6252.9	100.79
6253	101.29	6253.1	101.79	6253.2	102.29	6253.3	102.79	6253.4	103.29

6253.5  
 103.79 6253.6 104.29 6253.7 104.79 6253.8 105.29 6253.9 105.79  
 6254  
 106.29 6254.1 106.79 6254.2 107.29 6254.3 107.79 6254.4 108.3  
 6254.5  
 108.8 6254.6 109.3 6254.7 109.8 6254.8 110.3 6254.9 110.8  
 6255  
 111.3 6255.1 111.8 6255.2 113.03 6255.3 115.32 6255.3 115.8  
 6255.2  
 116.29 6255.1 116.78 6255 117.26 6254.9 117.71 6254.8 117.99  
 6254.7  
 118.28 6254.6 118.57 6254.5 118.85 6254.4 119.14 6254.3 119.43  
 6254.2  
 119.71 6254.1 120 6254 120.29 6253.9 120.57 6253.8 120.86  
 6253.7  
 121.15 6253.6 121.43 6253.5 121.72 6253.4 122.01 6253.3 122.3  
 6253.2  
 122.58 6253.1 122.87 6253 123.16 6252.9 123.44 6252.8 123.73  
 6252.7  
 124.02 6252.6 124.3 6252.5 124.59 6252.4 124.88 6252.3 125.16  
 6252.2  
 125.45 6252.1 125.74 6252 126.02 6251.9 126.31 6251.8 126.6  
 6251.7  
 126.88 6251.6 127.17 6251.5 127.46 6251.4 127.74 6251.3 128.03  
 6251.2  
 128.32 6251.1 128.6 6251 128.89 6250.9 129.18 6250.8 129.46  
 6250.7  
 129.75 6250.6 130.04 6250.5 130.32 6250.4 130.61 6250.3 130.9  
 6250.2  
 131.18 6250.1 131.47 6250 131.77 6249.9 132.07 6249.8 132.37  
 6249.7  
 132.67 6249.6 132.97 6249.5 133.27 6249.4 133.57 6249.3 133.87  
 6249.2  
 134.17 6249.1 134.47 6249 134.77 6248.9 135.07 6248.8 135.37  
 6248.7  
 135.67 6248.6 135.97 6248.5 136.27 6248.4 136.57 6248.3 136.87  
 6248.2  
 137.17 6248.1 137.47 6248 137.77 6247.9 138.07 6247.8 138.37  
 6247.7  
 138.67 6247.6 138.97 6247.5 139.27 6247.4 139.57 6247.3 139.87  
 6247.2  
 140.17 6247.1 140.47 6247 140.77 6246.9 141.07 6246.8 141.37  
 6246.7  
 141.67 6246.6 141.97 6246.5 142.27 6246.4 142.57 6246.3 142.87  
 6246.2  
 143.17 6246.1 143.47 6246 143.77 6245.9 144.07 6245.8 144.37  
 6245.7  
 144.67 6245.6 155.05 6245.6 155.25 6245.7 155.45 6245.8 155.65  
 6245.9  
 155.85 6246 156.05 6246.1 156.25 6246.2 156.45 6246.3 156.65  
 6246.4  
 156.85 6246.5 157.05 6246.6 157.25 6246.7 157.45 6246.8 157.65  
 6246.9

157.85	6247	158.05	6247.1	158.25	6247.2	158.45	6247.3	158.65
6247.4								
158.85	6247.5	159.05	6247.6	159.25	6247.7	159.45	6247.8	159.65
6247.9								
159.85	6248	160.05	6248.1	160.25	6248.2	160.45	6248.3	160.65
6248.4								
160.85	6248.5	161.05	6248.6	161.25	6248.7	161.45	6248.8	161.65
6248.9								
161.85	6249	162.05	6249.1	162.25	6249.2	162.45	6249.3	162.73
6249.4								
163.03	6249.5	163.33	6249.6	163.63	6249.7	163.93	6249.8	164.23
6249.9								
164.53	6250	164.83	6250.1	165.13	6250.2	165.43	6250.3	165.73
6250.4								
166.03	6250.5	166.33	6250.6	166.63	6250.7	166.93	6250.8	167.23
6250.9								
167.53	6251	167.83	6251.1	168.13	6251.2	168.33	6251.24	168.61
6251.3								
170.52	6251.4	172.44	6251.5	173.18	6251.6	173.48	6251.7	173.78
6251.8								
174.09	6251.9	174.39	6252	180.65	6252.1	187.4	6252.2	189.63
6252.2								
190.05	6252.1	190.47	6252	190.89	6251.9	191.31	6251.8	191.72
6251.7								
192.14	6251.6	192.56	6251.5	192.98	6251.4	193.4	6251.3	193.82
6251.2								
194.22	6251.1	194.62	6251	195.03	6250.9	195.45	6250.8	195.87
6250.7								
196.28	6250.6	196.7	6250.5	197.13	6250.4	197.56	6250.3	197.99
6250.2								
198.42	6250.1	198.85	6250	199.28	6249.9	199.71	6249.8	200.14
6249.7								
200.57	6249.6	201	6249.5	201.43	6249.4	201.86	6249.3	202.29
6249.2								
202.72	6249.1	203.15	6249	203.58	6248.9	204.01	6248.8	204.44
6248.7								
204.87	6248.6	205.3	6248.5	205.73	6248.4	206.16	6248.3	206.59
6248.2								
207.02	6248.1	207.45	6248	207.88	6247.9	208.31	6247.8	208.74
6247.7								
209.17	6247.6	209.59	6247.5	210.02	6247.4	210.45	6247.3	210.88
6247.2								
211.31	6247.1	211.74	6247	212.17	6246.9	212.6	6246.8	213.03
6246.7								
213.46	6246.6	215.88	6246.5	218.49	6246.4	221.39	6246.3	224.75
6246.2								
228.4	6246.1	232.21	6246	235.39	6246	236.12	6245.9	239.88
6245.8								
241.55	6245.9	241.59	6245.4	241.64	6245.7	241.82	6245.6	242.01
6245.5								
242.09	6245.5	242.2	6245.4	242.39	6245.3	242.59	6245.6	243.09
6245.7								
243.19	6245.8	244.19	6245.3	246.36	6245.3	246.56	6245.4	246.61

6245.8								
246.67	6245.6	246.77	6245.5	246.98	6245.6	247.19	6245.7	247.24
6245.5								
247.72	6245.8	248.14	6245.9	248.3	6245.7	252.79	6245.9	253.57
6246								
258.34	6246	258.67	6246.1	263.89	6246.1	265.17	6246.2	268.08
6246.2								
268.82	6246.3	269.79	6246.3	270.74	6246.4	271.17	6246.4	271.38
6246.5								
271.6	6246.6	271.82	6246.7	272.04	6246.8	272.25	6246.9	272.58
6247								
272.93	6247.1	273.29	6247.2	273.65	6247.3	274	6247.4	274.36
6247.5								
274.72	6247.6	275.07	6247.7	275.43	6247.8	275.78	6247.9	276.14
6248								
276.5	6248.1	276.85	6248.2	277.21	6248.3	277.57	6248.4	277.92
6248.5								
278.28	6248.6	278.66	6248.7	279.05	6248.8	279.45	6248.9	279.85
6249								
280.25	6249.1	280.65	6249.2	281.05	6249.3	281.45	6249.4	281.85
6249.5								
282.25	6249.6	282.65	6249.7	283.05	6249.8	283.45	6249.9	283.85
6250								
284.25	6250.1	284.5	6250.2	284.73	6250.3	284.95	6250.4	285.17
6250.5								
285.39	6250.6	285.61	6250.7	285.84	6250.8	286.06	6250.9	286.28
6251								
286.5	6251.1	286.72	6251.2	286.95	6251.3	287.17	6251.4	287.47
6251.5								
287.95	6251.6	288.44	6251.7	288.93	6251.8	289.42	6251.9	289.9
6252								
290.39	6252.1	290.88	6252.2	291.37	6252.3	291.85	6252.4	292.34
6252.5								
292.83	6252.6	293.32	6252.7	293.81	6252.8	294.29	6252.9	294.78
6253								
295.36	6253.1	296.3	6253.2	297.25	6253.3	300	6253.3	
Manning's n Values			num=	3				
Sta n Val	Sta n Val	Sta n Val						
0 .03	131.47	.013	168.33	.03				
Bank Sta: Left	Right	Lengths: Left	Channel	Right				
Expan.								
	131.47	168.33		50	50	50		.1
.3								
Ineffective Flow		num=	2					
Sta L	Sta R	Elev	Permanent					
0	112.13	6255.33	F					
190.03	300	6252.12	F					
Left Levee	Station=	115.48	Elevation=	6255.3				
Right Levee	Station=	187.94	Elevation=	6252.18				

CROSS SECTION OUTPUT Profile #Flow 1

E.G. Elev (ft)	6252.02	Element	Left OB
Channel Right OB			
Vel Head (ft)	1.55	Wt. n-Val.	0.030
0.013			
W.S. Elev (ft)	6250.47	Reach Len. (ft)	50.00
50.00			
50.00			
Crit W.S. (ft)	6250.47	Flow Area (sq ft)	0.31
110.06			
E.G. Slope (ft/ft)	0.001738	Area (sq ft)	0.31
110.06			
Q Total (cfs)	1100.00	Flow (cfs)	0.24
1099.76			
Top Width (ft)	35.80	Top Width (ft)	1.34
34.46			
Vel Total (ft/s)	9.97	Avg. Vel. (ft/s)	0.75
9.99			
Max Chl Dpth (ft)	5.17	Hydr. Depth (ft)	0.23
3.19			
Conv. Total (cfs)	26389.4	Conv. (cfs)	5.7
26383.8			
Length Wtd. (ft)	50.00	Wetted Per. (ft)	1.42
36.24			
Min Ch El (ft)	6245.60	Shear (lb/sq ft)	0.02
0.33			
Alpha	1.01	Stream Power (lb/ft s)	300.00
115.48			
187.94			
Frctn Loss (ft)	0.08	Cum Volume (acre-ft)	0.05
3.35			
0.00			
C & E Loss (ft)	0.02	Cum SA (acres)	0.24
0.91			
0.01			

Warning: The energy equation could not be balanced within the specified number of iterations. The program used critical depth for the water surface and continued on with the calculations.

Warning: During the standard step iterations, when the assumed water surface was set equal to critical depth, the calculated water surface came back below critical depth. This indicates that there is not a valid subcritical answer. The program defaulted to critical depth.

Note: Multiple critical depths were found at this location. The critical depth with the lowest, valid, energy was used.

CROSS SECTION

RIVER: SC01  
 REACH: Sand Creek-DS-1 RS: 959

INPUT

Description:									
Station	Elevation	Data	num=	373					
Sta	Elev	Sta	Elev	Sta	Elev	Sta	Elev	Sta	Elev
Elev	0	6254.6	13.02	6254.6	25.77	6254.5	33.92	6254.5	34.3
6254.6									
34.68	6254.7	35.06	6254.8	35.44	6254.9	35.82	6255	36.2	
6255.1									
36.58	6255.2	36.96	6255.3	38.2	6255.4	39.93	6255.5	46.4	
6255.5									
63.21	6255.4	65.32	6255.3	66.61	6255.2	67.58	6255.1	68.55	
6255									
69.52	6254.9	70.49	6254.8	71.46	6254.7	72.44	6254.6	73.5	
6254.5									
74.56	6254.4	75.62	6254.3	76.69	6254.2	77.75	6254.1	78.81	
6254									
79.87	6253.9	80.93	6253.8	82	6253.7	83.06	6253.6	84.12	
6253.5									
85.18	6253.4	86.24	6253.3	87.31	6253.2	88.37	6253.1	89.43	
6253									
90.49	6252.9	91.56	6252.8	92.62	6252.7	93.68	6252.6	94.74	
6252.5									
95.8	6252.4	96.87	6252.3	97.93	6252.2	98.99	6252.1	100.05	
6252									
101.55	6252	102.21	6252.1	102.87	6252.2	103.53	6252.3	104.19	
6252.4									
104.85	6252.5	105.51	6252.6	106.17	6252.7	106.83	6252.8	107.48	
6252.9									
108.17	6253	109.25	6253.1	110.32	6253.2	111.4	6253.3	112.47	
6253.4									
113.55	6253.5	114.62	6253.6	116.58	6253.6	117.09	6253.5	117.59	
6253.4									
118.1	6253.3	118.61	6253.2	119.12	6253.1	119.63	6253	120.14	
6252.9									
120.64	6252.8	121.34	6252.7	121.83	6252.6	122.31	6252.5	122.8	
6252.4									
123.29	6252.3	123.75	6252.2	124.03	6252.1	124.32	6252	124.61	
6251.9									
124.9	6251.8	125.18	6251.7	125.47	6251.6	125.76	6251.5	126.04	
6251.4									
126.33	6251.3	126.62	6251.2	126.9	6251.1	127.19	6251	127.48	
6250.9									
127.76	6250.8	128.05	6250.7	128.34	6250.6	128.62	6250.5	128.91	
6250.4									
129.2	6250.3	129.48	6250.2	129.77	6250.1	130.06	6250	130.34	
6249.9									
130.63	6249.8	130.92	6249.7	131.2	6249.6	131.49	6249.5	131.79	
6249.4									
132.09	6249.3	132.39	6249.2	132.69	6249.1	132.99	6249	133.29	
6248.9									
133.59	6248.8	133.89	6248.7	134.19	6248.6	134.49	6248.5	134.79	
6248.4									
135.09	6248.3	135.39	6248.2	135.69	6248.1	135.99	6248	136.29	



6247.9									
136.59	6247.8	136.89	6247.7	137.19	6247.6	137.49	6247.5	137.79	
6247.4									
138.09	6247.3	138.39	6247.2	138.69	6247.1	138.99	6247	139.29	
6246.9									
139.59	6246.8	139.89	6246.7	140.19	6246.6	140.49	6246.5	140.79	
6246.4									
141.09	6246.3	141.39	6246.2	141.69	6246.1	141.99	6246	142.29	
6245.9									
142.59	6245.8	142.89	6245.7	143.19	6245.6	143.49	6245.5	143.79	
6245.4									
144.09	6245.3	144.39	6245.2	144.69	6245.1	155.06	6245.1	155.26	
6245.2									
155.47	6245.3	155.67	6245.4	155.87	6245.5	156.07	6245.6	156.27	
6245.7									
156.47	6245.8	156.67	6245.9	156.87	6246	157.07	6246.1	157.27	
6246.2									
157.47	6246.3	157.67	6246.4	157.87	6246.5	158.07	6246.6	158.27	
6246.7									
158.47	6246.8	158.67	6246.9	158.87	6247	159.07	6247.1	159.27	
6247.2									
159.47	6247.3	159.67	6247.4	159.87	6247.5	160.07	6247.6	160.27	
6247.7									
160.47	6247.8	160.67	6247.9	160.87	6248	161.07	6248.1	161.27	
6248.2									
161.47	6248.3	161.67	6248.4	161.87	6248.5	162.07	6248.6	162.27	
6248.7									
162.47	6248.8	162.67	6248.9	162.87	6249	163.07	6249.1	163.27	
6249.2									
163.47	6249.3	163.67	6249.4	163.87	6249.5	164.07	6249.6	164.3	
6249.7									
164.6	6249.8	164.9	6249.9	165.2	6250	165.5	6250.1	165.8	
6250.2									
166.1	6250.3	166.4	6250.4	166.7	6250.5	167	6250.6	167.3	
6250.7									
167.6	6250.8	167.9	6250.9	168.2	6251	168.97	6251.1	169.88	
6251.15									
170.89	6251.2	172.81	6251.3	174.1	6251.4	174.4	6251.5	179.79	
6251.6									
185.5	6251.7	189.75	6251.7	190.17	6251.6	190.59	6251.5	191	
6251.4									
191.42	6251.3	191.84	6251.2	192.26	6251.1	192.68	6251	193.1	
6250.9									
193.52	6250.8	193.94	6250.7	194.36	6250.6	194.77	6250.5	195.19	
6250.4									
195.61	6250.3	196.03	6250.2	196.45	6250.1	196.87	6250	197.29	
6249.9									
197.71	6249.8	198.13	6249.7	198.54	6249.6	198.96	6249.5	199.38	
6249.4									
199.8	6249.3	200.22	6249.2	200.64	6249.1	201.06	6249	201.48	
6248.9									
201.9	6248.8	202.35	6248.7	202.81	6248.6	203.27	6248.5	203.73	
6248.4									

204.2	6248.3	204.66	6248.2	205.12	6248.1	205.58	6248	206.04	
6247.9									
206.5	6247.8	206.96	6247.7	207.42	6247.6	207.88	6247.5	208.34	
6247.4									
208.81	6247.3	209.27	6247.2	209.73	6247.1	210.19	6247	210.65	
6246.9									
211.11	6246.8	211.57	6246.7	212.03	6246.6	212.49	6246.5	212.95	
6246.4									
213.42	6246.3	215.5	6246.2	217.96	6246.1	220.41	6246	222.86	
6245.9									
225.33	6245.8	227.82	6245.7	230.31	6245.6	232.76	6245.5	232.86	
6245.4									
232.97	6245.3	233.07	6245.2	233.17	6245.1	234.82	6245	235.32	
6245									
235.42	6245.1	235.52	6245.2	235.62	6245.3	235.72	6245.4	235.87	
6245.5									
238.49	6245.6	241.11	6245.7	243.73	6245.8	246.35	6245.9	248.93	
6246									
251.51	6246.1	254.08	6246.2	256.66	6246.3	259.24	6246.4	261.81	
6246.5									
264.39	6246.6	266.97	6246.7	269.54	6246.8	272.12	6246.9	272.62	
6247									
273.01	6247.1	273.4	6247.2	273.79	6247.3	274.18	6247.4	274.57	
6247.5									
274.96	6247.6	275.35	6247.7	275.74	6247.8	276.13	6247.9	276.52	
6248									
276.91	6248.1	277.3	6248.2	277.68	6248.3	278.07	6248.4	278.46	
6248.5									
278.85	6248.6	279.24	6248.7	279.63	6248.8	280.02	6248.9	280.41	
6249									
280.8	6249.1	281.19	6249.2	281.58	6249.3	281.97	6249.4	282.36	
6249.5									
282.75	6249.6	283.14	6249.7	283.53	6249.8	283.92	6249.9	284.31	
6250									
284.7	6250.1	285.09	6250.2	285.48	6250.3	285.87	6250.4	286.26	
6250.5									
286.65	6250.6	287.03	6250.7	287.43	6250.8	287.83	6250.9	288.23	
6251									
288.63	6251.1	289.03	6251.2	289.43	6251.3	289.83	6251.4	290.23	
6251.5									
290.63	6251.6	291.03	6251.7	291.43	6251.8	291.83	6251.9	292.23	
6252									
292.63	6252.1	293.03	6252.2	293.44	6252.3	293.84	6252.4	294.24	
6252.5									
294.64	6252.6	295.04	6252.7	295.44	6252.8	295.84	6252.9	296.24	
6253									
296.34	6253	298.21	6252.9	300	6252.9				
Manning's	n Values		num=	3					
Sta	n Val	Sta	n Val	Sta	n Val				
0	.03	130.06	.013	169.88	.03				
Bank Sta:	Left	Right	Lengths:	Left Channel	Right	Coeff	Contr.		

Expan. 130.06 169.88 50 50 50 .1

.3  
 Ineffective Flow num= 2  
 Sta L Sta R Elev Permanent  
 0 113.39 6253.58 F  
 190.45 300 6251.6 F  
 Left Levee Station= 114.64 Elevation= 6253.67  
 Right Levee Station= 189.19 Elevation= 6251.72

CROSS SECTION OUTPUT Profile #Flow 1

E.G. Elev (ft)	6251.53	Element	Left OB
Channel Right OB			
Vel Head (ft)	1.55	Wt. n-Val.	
0.013			
W.S. Elev (ft)	6249.98	Reach Len. (ft)	50.00
50.00 50.00			
Crit W.S. (ft)	6249.98	Flow Area (sq ft)	
110.20			
E.G. Slope (ft/ft)	0.001776	Area (sq ft)	
110.20			
Q Total (cfs)	1100.00	Flow (cfs)	
1100.00			
Top Width (ft)	35.02	Top Width (ft)	
35.02			
Vel Total (ft/s)	9.98	Avg. Vel. (ft/s)	
9.98			
Max Chl Dpth (ft)	4.98	Hydr. Depth (ft)	
3.15			
Conv. Total (cfs)	26102.7	Conv. (cfs)	
26102.7			
Length Wtd. (ft)	50.00	Wetted Per. (ft)	
36.94			
Min Ch El (ft)	6245.10	Shear (lb/sq ft)	
0.33			
Alpha	1.00	Stream Power (lb/ft s)	300.00
114.64 189.19			
Frctn Loss (ft)	0.08	Cum Volume (acre-ft)	0.05
3.22 0.00			
C & E Loss (ft)	0.03	Cum SA (acres)	0.24
0.87 0.01			

Warning: The energy equation could not be balanced within the specified number of iterations. The program used critical depth for the water surface and continued on with the calculations.  
 Warning: During the standard step iterations, when the assumed water surface was set equal to critical depth, the calculated water surface came back below critical depth. This indicates that there is not a valid subcritical answer. The program

defaulted to critical depth.  
 Note: Multiple critical depths were found at this location. The critical depth with the lowest, valid, energy was used.

CROSS SECTION

RIVER: SC01  
 REACH: Sand Creek-DS-1 RS: 958

INPUT

Description:  
 Station Elevation Data num= 299  
 Sta Elev Sta Elev Sta Elev Sta Elev Sta Elev  
 Elev 0 6252.5 7.05 6252.5 10.29 6252.4 13.53 6252.3 16.77  
 6252.2  
 20.02 6252.1 23.26 6252 26.5 6251.9 29.74 6251.8 63.58  
 6251.8  
 67.44 6251.7 74.95 6251.6 82.46 6251.5 89.97 6251.4 97.48  
 6251.3  
 98.92 6251.2 100.36 6251.1 101.83 6251 103.29 6250.9 104.76  
 6250.8  
 106.23 6250.7 107.69 6250.6 109.16 6250.5 109.98 6250.7 110.08  
 6250.5  
 111.17 6250.6 113.06 6250.7 114.9 6250.8 116.75 6250.9 117.76  
 6250.9  
 119.13 6250.8 120.5 6250.7 121.88 6250.6 123.25 6250.5 124.62  
 6250.4  
 126 6250.3 126.73 6250.2 127.24 6250.1 127.75 6250 128.26  
 6249.9  
 128.76 6249.8 129.31 6249.7 129.79 6249.6 130.08 6249.5 130.36  
 6249.4  
 130.65 6249.3 130.94 6249.2 131.22 6249.1 131.51 6249 131.81  
 6248.9  
 132.11 6248.8 132.41 6248.7 132.71 6248.6 133.01 6248.5 133.31  
 6248.4  
 133.61 6248.3 133.91 6248.2 134.21 6248.1 134.51 6248 134.81  
 6247.9  
 135.11 6247.8 135.41 6247.7 135.71 6247.6 136.01 6247.5 136.31  
 6247.4  
 136.61 6247.3 136.91 6247.2 137.21 6247.1 137.51 6247 137.81  
 6246.9  
 138.11 6246.8 138.41 6246.7 138.71 6246.6 139.01 6246.5 139.31  
 6246.4  
 139.61 6246.3 139.91 6246.2 140.21 6246.1 140.51 6246 140.81  
 6245.9  
 141.11 6245.8 141.41 6245.7 141.71 6245.6 142.01 6245.5 142.31  
 6245.4  
 142.61 6245.3 142.91 6245.2 143.21 6245.1 143.51 6245 143.81  
 6244.9  
 144.11 6244.8 144.41 6244.7 144.71 6244.6 155.08 6244.6 155.28  
 6244.7

155.48	6244.8	155.68	6244.9	155.88	6245	156.08	6245.1	156.28
6245.2								
156.48	6245.3	156.68	6245.4	156.88	6245.5	157.08	6245.6	157.28
6245.7								
157.48	6245.8	157.68	6245.9	157.88	6246	158.08	6246.1	158.28
6246.2								
158.48	6246.3	158.68	6246.4	158.88	6246.5	159.08	6246.6	159.28
6246.7								
159.48	6246.8	159.68	6246.9	159.88	6247	160.08	6247.1	160.28
6247.2								
160.48	6247.3	160.68	6247.4	160.88	6247.5	161.08	6247.6	161.28
6247.7								
161.48	6247.8	161.68	6247.9	161.88	6248	162.08	6248.1	162.28
6248.2								
162.48	6248.3	162.68	6248.4	162.88	6248.5	163.08	6248.6	163.28
6248.7								
163.48	6248.8	163.68	6248.9	163.88	6249	164.08	6249.1	164.28
6249.2								
164.48	6249.3	164.68	6249.4	164.88	6249.5	165.08	6249.6	165.28
6249.7								
165.48	6249.8	165.68	6249.9	165.88	6250	166.17	6250.1	166.47
6250.2								
166.77	6250.3	167.07	6250.4	167.37	6250.5	167.67	6250.6	167.97
6250.7								
168.27	6250.8	168.35	6250.81	169.34	6250.9	171.25	6251	173
6251.1								
174.02	6251.2	181.94	6251.3	187.63	6251.4	189.65	6251.4	190.12
6251.3								
190.59	6251.2	191.06	6251.1	191.53	6251	192	6250.9	192.47
6250.8								
192.94	6250.7	193.41	6250.6	193.88	6250.5	194.35	6250.4	194.82
6250.3								
195.29	6250.2	195.76	6250.1	196.23	6250	196.7	6249.9	197.17
6249.8								
197.64	6249.7	198.11	6249.6	198.58	6249.5	199.05	6249.4	199.52
6249.3								
199.99	6249.2	200.46	6249.1	200.93	6249	201.4	6248.9	201.87
6248.8								
202.34	6248.7	202.81	6248.6	203.29	6248.5	203.76	6248.4	204.23
6248.3								
204.71	6248.2	205.18	6248.1	205.66	6248	206.13	6247.9	206.61
6247.8								
207.08	6247.7	207.56	6247.6	208.03	6247.5	208.51	6247.4	208.98
6247.3								
209.46	6247.2	209.93	6247.1	210.41	6247	210.88	6246.9	211.36
6246.8								
211.83	6246.7	212.31	6246.6	212.78	6246.5	213.26	6246.4	214.79
6246.3								
217.45	6246.2	220.11	6246.1	222.77	6246	225.42	6245.9	228.08
6245.8								
230.74	6245.7	233.36	6245.6	235.97	6245.5	238.59	6245.4	241.13
6245.3								
242.55	6245.2	242.65	6245.1	242.75	6245	242.85	6244.9	242.95

6244.8									
245.07	6244.8	245.17	6244.9	245.27	6245	245.37	6245.1	245.46	
6245.2									
246.89	6245.3	249.4	6245.4	251.91	6245.5	254.42	6245.6	256.93	
6245.7									
259.45	6245.8	261.96	6245.9	264.47	6246	266.98	6246.1	269.49	
6246.2									
272	6246.3	273.53	6246.4	273.93	6246.5	274.33	6246.6	274.74	
6246.7									
275.14	6246.8	275.54	6246.9	275.95	6247	276.35	6247.1	276.75	
6247.2									
277.15	6247.3	277.56	6247.4	277.96	6247.5	278.36	6247.6	278.76	
6247.7									
279.17	6247.8	279.57	6247.9	279.97	6248	280.38	6248.1	280.78	
6248.2									
281.18	6248.3	281.58	6248.4	281.99	6248.5	282.39	6248.6	282.79	
6248.7									
283.19	6248.8	283.6	6248.9	283.91	6249.6	284	6249	284.4	
6249.1									
284.81	6249.2	285.21	6249.3	285.61	6249.4	286.01	6249.5	286.42	
6249.6									
286.82	6249.7	287.22	6249.8	287.63	6249.9	288.03	6250	288.43	
6250.1									
288.83	6250.2	289.24	6250.3	289.64	6250.4	290.04	6250.5	290.5	
6250.6									
291.1	6250.7	291.69	6250.8	292.29	6250.9	293.45	6251	295.03	
6251.1									
296.22	6251.2	297.69	6251.3	299.16	6251.4	300	6251.4		
Manning's n Values					num=	3			
Sta	n Val	Sta	n Val	Sta	n Val				
0	.03	131.51	.013	168.35	.03				
Bank Sta:	Left	Right	Lengths:	Left	Channel	Right	Coeff	Contr.	
Expan.									
	131.51	168.35		50	50	50		.1	
.3									
Ineffective Flow					num=	2			
Sta L	Sta R	Elev	Permanent						
0	116.32	6250.89	F						
190.03	300	6251.19	F						
Left Levee	Station=	117.57	Elevation=	6250.94					
Right Levee	Station=	189.19	Elevation=	6251.25					
CROSS SECTION OUTPUT		Profile #Flow 1							
E.G. Elev (ft)		6251.04	Element					Left OB	
Channel Right OB									
Vel Head (ft)		1.59	Wt. n-Val.					0.030	
0.013									
W.S. Elev (ft)		6249.44	Reach Len. (ft)					50.00	
50.00	50.00								

Crit W.S. (ft)	6249.44	Flow Area (sq ft)	0.28
108.61			
E.G. Slope (ft/ft)	0.001742	Area (sq ft)	0.28
108.61			
Q Total (cfs)	1100.00	Flow (cfs)	0.21
1099.79			
Top Width (ft)	34.53	Top Width (ft)	1.27
33.26			
Vel Total (ft/s)	10.10	Avg. Vel. (ft/s)	0.73
10.13			
Max Chl Dpth (ft)	4.84	Hydr. Depth (ft)	0.22
3.27			
Conv. Total (cfs)	26356.9	Conv. (cfs)	5.0
26352.0			
Length Wtd. (ft)	50.00	Wetted Per. (ft)	1.35
35.12			
Min Ch El (ft)	6244.60	Shear (lb/sq ft)	0.02
0.34			
Alpha	1.00	Stream Power (lb/ft s)	300.00
117.57	189.19		
Frctn Loss (ft)	0.09	Cum Volume (acre-ft)	0.05
3.10	0.00		
C & E Loss (ft)	0.01	Cum SA (acres)	0.24
0.83	0.01		

Warning: The energy equation could not be balanced within the specified number of iterations. The program used critical depth for the water surface and continued on with the calculations.

Warning: During the standard step iterations, when the assumed water surface was set equal to critical depth, the calculated water surface came back below critical depth. This indicates that there is not a valid subcritical answer. The program defaulted to critical depth.

Note: Multiple critical depths were found at this location. The critical depth with the lowest, valid, energy was used.

CROSS SECTION

RIVER: SC01  
 REACH: Sand Creek-DS-1 RS: 957

INPUT									
Description:									
Station	Elevation	Data	num=	322	Sta	Elev	Sta	Elev	Sta
Elev	Sta	Elev	Sta	Elev	Sta	Elev	Sta	Elev	Sta
0	6250.9	3.24	6250.9	15.11	6250.8	23.82	6250.7	32.94	
6250.6	42.06	6250.5	56.55	6250.5	60.36	6250.6	64.17	6250.7	75.25
6250.8									

78.56	6250.9	81.09	6251	83.61	6251.1	85.53	6251.2	87.32	
6251.3									
89.11	6251.4	90.9	6251.5	92.69	6251.6	94.48	6251.7	96.27	
6251.8									
98.06	6251.9	99.85	6252	101.64	6252.1	103.43	6252.2	105.21	
6252.3									
107	6252.4	108.79	6252.5	110.58	6252.6	112.12	6252.7	112.95	
6252.8									
113.78	6252.9	114.61	6253	115.44	6253.1	116.27	6253.2	116.51	
6253.2									
116.71	6253.1	116.91	6253	117.11	6252.9	117.31	6252.8	117.51	
6252.7									
117.71	6252.6	117.91	6252.5	118.11	6252.4	118.31	6252.3	118.55	
6252.2									
118.85	6252.1	119.15	6252	119.45	6251.9	119.74	6251.8	120.04	
6251.7									
120.34	6251.6	120.64	6251.5	120.93	6251.4	121.23	6251.3	121.53	
6251.2									
121.83	6251.1	122.13	6251	122.42	6250.9	122.72	6250.8	123.02	
6250.7									
123.32	6250.6	123.68	6250.5	124.07	6250.4	124.47	6250.3	124.86	
6250.2									
125.25	6250.1	125.65	6250	126.04	6249.9	126.44	6249.8	126.83	
6249.7									
127.23	6249.6	127.62	6249.5	128.01	6249.4	128.41	6249.3	128.8	
6249.2									
129.2	6249.1	129.59	6249	129.98	6248.9	130.38	6248.8	130.77	
6248.7									
131.17	6248.6	131.53	6248.5	131.83	6248.4	132.13	6248.3	132.43	
6248.2									
132.73	6248.1	133.03	6248	133.33	6247.9	133.63	6247.8	133.93	
6247.7									
134.23	6247.6	134.53	6247.5	134.83	6247.4	135.13	6247.3	135.43	
6247.2									
135.73	6247.1	136.03	6247	136.33	6246.9	136.63	6246.8	136.93	
6246.7									
137.23	6246.6	137.53	6246.5	137.83	6246.4	138.13	6246.3	138.43	
6246.2									
138.73	6246.1	139.03	6246	139.33	6245.9	139.63	6245.8	139.93	
6245.7									
140.23	6245.6	140.53	6245.5	140.83	6245.4	141.13	6245.3	141.43	
6245.2									
141.73	6245.1	142.03	6245	142.33	6244.9	142.63	6244.8	142.93	
6244.7									
143.23	6244.6	143.53	6244.5	143.83	6244.4	144.13	6244.3	144.43	
6244.2									
144.73	6244.1	155.09	6244.1	155.29	6244.2	155.49	6244.3	155.69	
6244.4									
155.89	6244.5	156.09	6244.6	156.29	6244.7	156.49	6244.8	156.69	
6244.9									
156.89	6245	157.09	6245.1	157.29	6245.2	157.49	6245.3	157.69	
6245.4									
157.89	6245.5	158.09	6245.6	158.29	6245.7	158.49	6245.8	158.69	

6245.9  
 158.89 6246 159.09 6246.1 159.29 6246.2 159.49 6246.3 159.69  
 6246.4  
 159.89 6246.5 160.09 6246.6 160.29 6246.7 160.49 6246.8 160.69  
 6246.9  
 160.89 6247 161.09 6247.1 161.29 6247.2 161.49 6247.3 161.69  
 6247.4  
 161.89 6247.5 162.09 6247.6 162.29 6247.7 162.49 6247.8 162.69  
 6247.9  
 162.89 6248 163.09 6248.1 163.29 6248.2 163.49 6248.3 163.69  
 6248.4  
 163.89 6248.5 164.09 6248.6 164.29 6248.7 164.49 6248.8 164.69  
 6248.9  
 164.89 6249 165.09 6249.1 165.29 6249.2 165.49 6249.3 165.69  
 6249.4  
 165.89 6249.5 166.09 6249.6 166.29 6249.7 166.49 6249.8 166.69  
 6249.9  
 166.89 6250 167.09 6250.1 167.29 6250.2 167.49 6250.3 167.74  
 6250.4  
 168.04 6250.5 168.34 6250.6 169.7 6250.7 169.9 6250.72 170.83  
 6250.8  
 171.85 6250.9 172.87 6251 173.89 6251.1 188.46 6251.2 189.59  
 6251.2  
 190.06 6251.1 190.53 6251 191 6250.9 191.47 6250.8 191.93  
 6250.7  
 192.4 6250.6 192.87 6250.5 193.34 6250.4 193.81 6250.3 194.28  
 6250.2  
 194.75 6250.1 195.22 6250 195.69 6249.9 196.16 6249.8 196.63  
 6249.7  
 197.1 6249.6 197.57 6249.5 198.04 6249.4 198.51 6249.3 198.98  
 6249.2  
 199.45 6249.1 199.92 6249 200.39 6248.9 200.86 6248.8 201.31  
 6248.7  
 201.65 6248.6 202.09 6248.5 202.55 6248.4 203.01 6248.3 203.47  
 6248.2  
 203.93 6248.1 204.39 6248 204.85 6247.9 205.31 6247.8 205.77  
 6247.7  
 206.23 6247.6 206.69 6247.5 207.15 6247.4 207.61 6247.3 208.07  
 6247.2  
 208.53 6247.1 208.99 6247 209.45 6246.9 209.91 6246.8 210.37  
 6246.7  
 210.83 6246.6 211.29 6246.5 211.75 6246.4 212.21 6246.3 212.67  
 6246.2  
 213.13 6246.1 213.95 6246 216.35 6245.9 218.75 6245.8 221.16  
 6245.7  
 223.56 6245.6 225.96 6245.5 228.35 6245.4 230.74 6245.3 233.13  
 6245.2  
 235.57 6245.1 238.02 6245 238.26 6244.9 238.35 6244.8 238.45  
 6244.7  
 238.55 6244.6 238.65 6244.5 240.68 6244.5 240.78 6244.6 240.88  
 6244.7  
 240.98 6244.8 241.08 6244.9 241.33 6245 243.92 6245.1 246.51  
 6245.2

249.1 6245.3 251.71 6245.4 254.36 6245.5 257.01 6245.6 259.65  
 6245.7  
 262.28 6245.8 264.91 6245.9 267.54 6246 270.17 6246.1 272.8  
 6246.2  
 274.54 6246.3 274.83 6246.4 275.12 6246.5 275.4 6246.6 275.69  
 6246.7  
 275.98 6246.8 276.27 6246.9 276.58 6247 276.89 6247.1 277.2  
 6247.2  
 277.51 6247.3 279.53 6247.4 282.8 6247.5 286.07 6247.6 289.34  
 6247.7  
 292.61 6247.8 292.72 6247.9 293.18 6247.9 293.55 6248 293.92  
 6248.1  
 294.3 6248.2 294.67 6248.3 295.04 6248.4 295.41 6248.5 295.79  
 6248.6  
 296.16 6248.7 296.53 6248.8 296.9 6248.9 297.28 6249 297.65  
 6249.1  
 298.02 6249.2 298.39 6249.3 298.76 6249.4 299.14 6249.5 299.51  
 6249.6  
 299.88 6249.7 300 6249.7  
  
 Manning's n Values num= 3  
 Sta n Val Sta n Val  
 0 .03 129.59 .013 169.9 .03  
  
 Bank Sta: Left Right Lengths: Left Channel Right Coeff Contr.  
 Expan.  
 129.59 169.9 50 50 50 .1  
 .3  
 Ineffective Flow num= 2  
 Sta L Sta R Elev Permanent  
 0 115.48 6253.12 F  
 190.03 300 6250.8 F  
 Left Levee Station= 115.9 Elevation= 6253.2  
 Right Levee Station= 189.61 Elevation= 6250.72  
  
 CROSS SECTION OUTPUT Profile #Flow 1  
  
 E.G. Elev (ft) 6250.53 Element Left OB  
 Channel Right OB  
 Vel Head (ft) 1.57 Wt. n-Val.  
 0.013  
 W.S. Elev (ft) 6248.96 Reach Len. (ft) 50.00  
 50.00 50.00  
 Crit W.S. (ft) 6248.96 Flow Area (sq ft)  
 109.52  
 E.G. Slope (ft/ft) 0.001816 Area (sq ft)  
 109.52  
 Q Total (cfs) 1100.00 Flow (cfs)  
 1100.00  
 Top Width (ft) 35.07 Top Width (ft)  
 35.07  
 Vel Total (ft/s) 10.04 Avg. Vel. (ft/s)



128.51	6248.2	128.75	6248.3	128.99	6248.4	129.22	6248.5	129.46
6248.6								
129.7	6248.7	129.93	6248.8	130.17	6248.9	130.4	6249	130.64
6249.1								
130.88	6249.2	131.11	6249.3	131.35	6249.4	132.06	6249.5	134.41
6249.55								
137.06	6249.6	152.67	6249.6	153.33	6249.5	153.99	6249.4	154.66
6249.3								
155.32	6249.2	155.98	6249.1	156.65	6249	157.31	6248.9	157.97
6248.8								
158.64	6248.7	159.3	6248.6	159.96	6248.5	160.62	6248.4	161.28
6248.3								
161.94	6248.2	162.6	6248.1	163.27	6248	163.93	6247.9	164.59
6247.8								
165.25	6247.7	165.91	6247.6	166.57	6247.5	167.23	6247.4	167.89
6247.3								
168.56	6247.2	169.22	6247.1	169.88	6247	170.54	6246.9	171.2
6246.8								
171.86	6246.7	172.52	6246.6	173.18	6246.5	173.84	6246.4	174.51
6246.3								
175.17	6246.2	175.83	6246.1	176.49	6246	178.67	6245.9	181.16
6245.8								
183.64	6245.7	186.13	6245.6	188.61	6245.5	191.09	6245.4	193.57
6245.3								
196.05	6245.2	198.53	6245.1	201.01	6245	203.49	6244.9	205.97
6244.8								
207.42	6244.7	207.52	6244.6	207.62	6244.5	207.72	6244.4	207.82
6244.3								
209.96	6244.3	210.06	6244.4	210.16	6244.5	210.26	6244.6	210.36
6244.7								
211.9	6244.8	214.46	6244.9	217.02	6245	219.59	6245.1	222.15
6245.2								
223.99	6245.3	224.71	6245.3	227.27	6245.4	229.82	6245.5	232.37
6245.6								
234.93	6245.7	237.48	6245.8	241.16	6245.9	245.73	6246	247.84
6246.1								
248.35	6246.2	248.86	6246.3	249.37	6246.4	249.88	6246.5	250.39
6246.6								
250.9	6246.7	251.41	6246.8	251.93	6246.9	252.44	6247	252.95
6247.1								
253.01	6247.7	253.46	6247.2	253.97	6247.3	254.48	6247.4	254.99
6247.5								
255.5	6247.6	256.01	6247.7	256.38	6247.8	256.53	6247.8	257.04
6247.9								
257.55	6248	258.06	6248.1	258.57	6248.2	259.08	6248.3	259.59
6248.4								
260.1	6248.5	260.61	6248.6	261.13	6248.7	261.64	6248.8	262.15
6248.9								
262.66	6249	263.1	6249					
Manning's n Values			num=	3				
Sta n Val	Sta n Val	Sta n Val	Sta n Val	Sta n Val				
-36.9 .03	92.43 .013	134.41 .03						

Bank Sta:	Left	Right	Lengths:	Left Channel	Right	Coeff Contr.
Expan.				50	50	.1
	92.43	134.41				
.3						
Ineffective Flow	num=	2				
Sta L	Sta R	Elev	Permanent			
-36.9	81.09	6251.92	F			
156.48	263.1	6249.05	F			
Left Levee	Station=	82.77	Elevation=	6251.9		
Right Levee	Station=	152.71	Elevation=	6249.62		

CROSS SECTION OUTPUT Profile #Flow 1

E.G. Elev (ft)	6249.96	Element	Left OB
Channel Right OB			
Vel Head (ft)	1.52	Wt. n-Val.	
0.013			
W.S. Elev (ft)	6248.44	Reach Len. (ft)	50.00
50.00	50.00		
Crit W.S. (ft)	6248.44	Flow Area (sq ft)	
111.21			
E.G. Slope (ft/ft)	0.001768	Area (sq ft)	
111.21			
Q Total (cfs)	1100.00	Flow (cfs)	
1100.00			
Top Width (ft)	35.85	Top Width (ft)	
35.85			
Vel Total (ft/s)	9.89	Avg. Vel. (ft/s)	
9.89			
Max Chl Dpth (ft)	4.84	Hydr. Depth (ft)	
3.10			
Conv. Total (cfs)	26161.8	Conv. (cfs)	
26161.8			
Length Wtd. (ft)	50.00	Wetted Per. (ft)	
37.66			
Min Ch El (ft)	6243.60	Shear (lb/sq ft)	
0.33			
Alpha	1.00	Stream Power (lb/ft s)	263.10
82.77	152.71		
Frctn Loss (ft)	0.07	Cum Volume (acre-ft)	0.05
2.85	0.00		
C & E Loss (ft)	0.09	Cum SA (acres)	0.24
0.75	0.01		

Warning: The energy equation could not be balanced within the specified number of iterations. The program used critical depth for the water surface and continued on with the calculations.  
Warning: During the standard step iterations, when the assumed water surface was set equal to critical depth, the calculated

water surface came back below critical depth. This indicates that there is not a valid subcritical answer. The program defaulted to critical depth.

Note: Multiple critical depths were found at this location. The critical depth with the lowest, valid, energy was used.

CROSS SECTION

RIVER: SC01  
REACH: Sand Creek-DS-1 RS: 955

INPUT  
Description:

Station	Elevation	Data	num=	344	Elev	Sta	Elev	Sta	Elev	Sta
0	6249.4	.42	6249.4	2.42	6249.3	4.43	6249.2	6.43		
6249.1	8.31	6249	10.46	6248.9	31.24	6248.8	32.32	6248.7	32.47	
6248.6	33.43	6248.5	50.66	6248.5	50.74	6248.6	50.81	6248.7	50.89	
6248.8	50.96	6248.9	51.04	6249	51.11	6249.1	51.19	6249.2	51.99	
6249.3	60.14	6249.3	82.6	6249.2	105.05	6249.1	108.53	6249.1	108.63	
6249.2	108.72	6249.3	108.82	6249.4	108.91	6249.5	109.08	6249.6	110.52	
6249.7	111.95	6249.8	112.97	6249.9	113.51	6250	114.05	6250.1	114.59	
6250.2	115.13	6250.3	115.67	6250.4	116.21	6250.5	116.75	6250.6	117.29	
6250.7	117.83	6250.8	118.37	6250.9	118.91	6251	119.46	6251.1	120	
6251.2	120.54	6251.3	120.73	6251.3	121.01	6251.2	121.3	6251.1	121.58	
6251	121.87	6250.9	122.16	6250.8	122.44	6250.7	122.73	6250.6	123.01	
6250.5	123.3	6250.4	123.58	6250.3	123.87	6250.2	124.15	6250.1	124.44	
6250	124.72	6249.9	125.01	6249.8	125.29	6249.7	125.58	6249.6	125.86	
6249.5	126.15	6249.4	126.43	6249.3	126.72	6249.2	127	6249.1	127.29	
6249	127.57	6248.9	127.86	6248.8	128.14	6248.7	128.43	6248.6	128.72	
6248.5	129	6248.4	129.29	6248.3	129.57	6248.2	129.86	6248.1	130.14	
6248	130.43	6247.9	130.71	6247.8	131	6247.7	131.28	6247.6	131.57	
6247.5	131.87	6247.4	132.17	6247.3	132.47	6247.2	132.77	6247.1	133.07	
6247										

133.37	6246.9	133.67	6246.8	133.97	6246.7	134.27	6246.6	134.57		
6246.5										
134.87	6246.4	135.17	6246.3	135.47	6246.2	135.77	6246.1	136.07		
6246										
136.37	6245.9	136.67	6245.8	136.97	6245.7	137.27	6245.6	137.57		
6245.5										
137.87	6245.4	138.17	6245.3	138.47	6245.2	138.77	6245.1	139.07		
6245										
139.37	6244.9	139.67	6244.8	139.97	6244.7	140.27	6244.6	140.57		
6244.5										
140.87	6244.4	141.17	6244.3	141.47	6244.2	141.77	6244.1	142.07		
6244										
142.37	6243.9	142.67	6243.8	142.97	6243.7	143.27	6243.6	143.57		
6243.5										
143.87	6243.4	144.17	6243.3	144.47	6243.2	144.77	6243.1	155.12		
6243.1										
155.34	6243.2	155.56	6243.3	155.77	6243.4	155.99	6243.5	156.21		
6243.6										
156.43	6243.7	156.64	6243.8	156.86	6243.9	157.08	6244	157.3		
6244.1										
157.51	6244.2	157.71	6244.3	157.92	6244.4	158.13	6244.5	158.33		
6244.6										
158.54	6244.7	158.75	6244.8	158.96	6244.9	159.16	6245	159.37		
6245.1										
159.58	6245.2	159.78	6245.3	159.98	6245.4	160.18	6245.5	160.38		
6245.6										
160.58	6245.7	160.78	6245.8	160.98	6245.9	161.18	6246	161.38		
6246.1										
161.58	6246.2	161.78	6246.3	161.98	6246.4	162.18	6246.5	162.38		
6246.6										
162.58	6246.7	162.78	6246.8	162.98	6246.9	163.18	6247	163.38		
6247.1										
163.58	6247.2	163.78	6247.3	163.98	6247.4	164.18	6247.5	164.38		
6247.6										
164.58	6247.7	164.78	6247.8	164.98	6247.9	165.18	6248	165.38		
6248.1										
165.58	6248.2	165.78	6248.3	165.98	6248.4	166.18	6248.5	166.38		
6248.6										
166.58	6248.7	166.78	6248.8	166.98	6248.9	167.18	6249	167.38		
6249.1										
167.58	6249.2	167.78	6249.3	167.98	6249.4	168.18	6249.5	168.38		
6249.6										
168.71	6249.7	169.15	6249.8	169.58	6249.9	170.02	6250	170.45		
6250.1										
170.89	6250.2	171.32	6250.3	171.76	6250.4	172.19	6250.5	189.87		
6250.5										
190.31	6250.4	190.76	6250.3	191.2	6250.2	191.64	6250.1	192.08		
6250										
192.52	6249.9	192.96	6249.8	193.4	6249.7	193.84	6249.6	194.29		
6249.5										
194.73	6249.4	195.17	6249.3	195.61	6249.2	196.05	6249.1	196.49		
6249										
196.93	6248.9	197.38	6248.8	197.57	6249.6	197.82	6248.7	198.26		



6248.6									
198.7	6248.5	199.14	6248.4	199.58	6248.3	200.02	6248.2	200.46	
6248.1									
200.91	6248	201.35	6247.9	201.79	6247.8	201.9	6248.1	202.23	
6247.7									
202.67	6247.6	203.11	6247.5	203.55	6247.4	204.03	6247.3	204.68	
6247.2									
205.33	6247.1	205.98	6247	206.63	6246.9	207.28	6246.8	207.93	
6246.7									
208.58	6246.6	209.22	6246.5	209.87	6246.4	210.52	6246.3	211.17	
6246.2									
211.82	6246.1	212.47	6246	213.12	6245.9	214.57	6245.8	217.16	
6245.7									
219.75	6245.6	222.35	6245.5	224.94	6245.4	227.53	6245.3	230.14	
6245.2									
232.76	6245.1	235.38	6245	238.01	6244.9	240.63	6244.8	243.21	
6244.7									
245.79	6244.6	248.37	6244.5	248.7	6244.4	248.8	6244.3	248.9	
6244.2									
249	6244.1	249.1	6244	251.15	6244	251.25	6244.1	251.35	
6244.2									
251.45	6244.3	251.55	6244.4	251.57	6244.6	251.84	6244.5	254.27	
6244.6									
256.71	6244.7	259.14	6244.8	261.58	6244.9	264.01	6245	266.45	
6245.1									
268.88	6245.2	271.32	6245.3	273.75	6245.4	276.19	6245.5	276.96	
6245.6									
277.4	6245.7	277.83	6245.8	278.26	6245.9	278.69	6246	279.12	
6246.1									
279.55	6246.2	279.98	6246.3	280.41	6246.4	280.85	6246.5	281.28	
6246.6									
281.71	6246.7	282.14	6246.8	282.57	6246.9	283	6247	283.43	
6247.1									
283.86	6247.2	284.29	6247.3	284.73	6247.4	285.16	6247.5	285.59	
6247.6									
286.02	6247.7	286.45	6247.8	286.88	6247.9	287.31	6248	287.74	
6248.1									
288.17	6248.2	288.61	6248.3	289.04	6248.4	289.47	6248.5	289.9	
6248.6									
290.33	6248.7	290.76	6248.8	291.19	6248.9	291.62	6249	292.06	
6249.1									
292.49	6249.2	292.92	6249.3	293.35	6249.4	293.78	6249.5	294.21	
6249.6									
294.64	6249.7	295.07	6249.8	295.5	6249.9	295.94	6250	296.37	
6250.1									
296.8	6250.2	297.23	6250.3	297.66	6250.4	298.09	6250.5	298.52	
6250.6									
298.95	6250.7	299.38	6250.8	299.82	6250.9	300	6250.9		

Manning's n Values			num=	3		
Sta	n Val	Sta	n Val	Sta	n Val	
0	.03	130.14	.013	169.58	.03	

Bank Sta: Left	Right	Lengths: Left	Channel	Right	Coeff Contr.	
Expan.						
	130.14	169.58	50	50	50	.1
.3						
Ineffective Flow	num=	2				
Sta L	Sta R	Elev	Permanent			
0	118.83	6251.23	F			
190.87	300	6249.99	F			
Left Levee	Station=	120.51	Elevation=	6251.3		
Right Levee	Station=	189.61	Elevation=	6250.08		

CROSS SECTION OUTPUT Profile #Flow 1

E.G. Elev (ft)	6249.57	Element	Left OB
Channel Right OB			
Vel Head (ft)	1.22	Wt. n-Val.	0.030
0.013			
W.S. Elev (ft)	6248.35	Reach Len. (ft)	50.00
50.00	50.00		
Crit W.S. (ft)	6247.93	Flow Area (sq ft)	0.17
124.19			
E.G. Slope (ft/ft)	0.001227	Area (sq ft)	0.17
124.19			
Q Total (cfs)	1100.00	Flow (cfs)	0.09
1099.91			
Top Width (ft)	36.74	Top Width (ft)	1.00
35.74			
Vel Total (ft/s)	8.85	Avg. Vel. (ft/s)	0.52
8.86			
Max Chl Dpth (ft)	5.25	Hydr. Depth (ft)	0.17
3.47			
Conv. Total (cfs)	31397.8	Conv. (cfs)	2.6
31395.2			
Length Wtd. (ft)	50.00	Wetted Per. (ft)	1.06
37.75			
Min Ch El (ft)	6243.10	Shear (lb/sq ft)	0.01
0.25			
Alpha	1.00	Stream Power (lb/ft s)	300.00
120.51	189.61		
Frctn Loss (ft)	0.05	Cum Volume (acre-ft)	0.05
2.71	0.00		
C & E Loss (ft)	0.12	Cum SA (acres)	0.24
0.71	0.01		

Note: Multiple critical depths were found at this location. The critical depth with the lowest, valid, energy was used.

CROSS SECTION



208.74	6246.5	209.16	6246.4	209.57	6246.3	209.99	6246.2	210.41
6246.1								
210.83	6246	211.22	6245.9	211.61	6245.8	212	6245.7	212.39
6245.6								
212.79	6245.5	213.18	6245.4	213.96	6245.3	216.58	6245.2	219.2
6245.1								
221.83	6245	224.41	6244.9	226.98	6244.8	229.56	6244.7	232.14
6244.6								
234.72	6244.5	237.3	6244.4	239.88	6244.3	241.51	6244.2	241.61
6244.1								
241.71	6244	241.81	6243.9	241.91	6243.8	246.55	6243.8	246.68
6243.9								
246.8	6244	246.92	6244.1	247.05	6244.2	251.26	6244.3	254.05
6244.4								
256.85	6244.5	260.06	6244.6	264.8	6244.7	269.54	6244.8	274.28
6244.9								
277.8	6245	278.18	6245.1	278.55	6245.2	278.92	6245.3	279.3
6245.4								
279.67	6245.5	280.05	6245.6	280.42	6245.7	280.8	6245.8	281.17
6245.9								
281.54	6246	281.92	6246.1	282.29	6246.2	282.67	6246.3	283.04
6246.4								
283.42	6246.5	283.79	6246.6	284.17	6246.7	284.54	6246.8	284.91
6246.9								
285.29	6247	285.66	6247.1	286.04	6247.2	286.41	6247.3	286.79
6247.4								
287.16	6247.5	287.53	6247.6	287.91	6247.7	288.28	6247.8	288.66
6247.9								
289.03	6248	289.41	6248.1	289.78	6248.2	290.15	6248.3	290.53
6248.4								
290.9	6248.5	291.28	6248.6	291.65	6248.7	292.03	6248.8	292.4
6248.9								
292.78	6249	293.15	6249.1	293.52	6249.2	293.9	6249.3	294.27
6249.4								
294.65	6249.5	295.02	6249.6	295.4	6249.7	295.77	6249.8	296.17
6249.9								
296.6	6250	297.04	6250.1	297.47	6250.2	297.91	6250.3	298.34
6250.4								
298.78	6250.5	299.21	6250.6	299.65	6250.7	300	6250.7	

Manning's n Values num= 3  
 Sta n Val Sta n Val Sta n Val  
 0 .03 128.41 .013 171.26 .03

Bank Sta: Left Right Lengths: Left Channel Right Coeff Contr.  
 Expan. 128.41 171.26 34.26 34.26 34.26 .1  
 .3

Ineffective Flow num= 2  
 Sta L Sta R Elev Permanent  
 0 5.33 6248.71 F  
 189.19 300 6249.59 F

Left Levee Station= 121.34 Elevation= 6249.64

Right Levee Station= 189.19 Elevation= 6249.64

CROSS SECTION OUTPUT Profile #Flow 1

E.G. Elev (ft)	6249.40	Element	Left OB
Channel Right OB			
Vel Head (ft)	0.82	Wt. n-Val.	0.030
0.013			
W.S. Elev (ft)	6248.58	Reach Len. (ft)	34.26
34.26 34.26			
Crit W.S. (ft)	6247.46	Flow Area (sq ft)	0.68
151.24			
E.G. Slope (ft/ft)	0.000712	Area (sq ft)	0.68
151.24			
Q Total (cfs)	1100.00	Flow (cfs)	0.39
1099.61			
Top Width (ft)	41.17	Top Width (ft)	2.35
38.82			
Vel Total (ft/s)	7.24	Avg. Vel. (ft/s)	0.57
7.27			
Max Chl Dpth (ft)	5.98	Hydr. Depth (ft)	0.29
3.90			
Conv. Total (cfs)	41224.9	Conv. (cfs)	14.6
41210.3			
Length Wtd. (ft)	34.26	Wetted Per. (ft)	2.42
41.09			
Min Ch El (ft)	6242.60	Shear (lb/sq ft)	0.01
0.16			
Alpha	1.01	Stream Power (lb/ft s)	300.00
121.34 189.19			
Frctn Loss (ft)	0.02	Cum Volume (acre-ft)	0.05
2.55 0.00			
C & E Loss (ft)	0.05	Cum SA (acres)	0.23
0.66 0.01			

Note: Multiple critical depths were found at this location. The critical depth with the lowest, valid, energy was used.

CROSS SECTION

RIVER: SC01  
 REACH: Sand Creek-DS-1 RS: 953

INPUT  
 Description:  
 Station Elevation Data num= 354  
 Sta Elev Sta Elev Sta Elev Sta Elev Sta  
 Elev 0 6248.8 .66 6248.8 2.56 6248.7 4.46 6248.6 6.36

6248.5									
8.26	6248.4	10.16	6248.3	12.06	6248.2	13.96	6248.1	15.85	
6248									
17.75	6247.9	19.65	6247.8	21.55	6247.7	23.45	6247.6	40.6	
6247.6									
42.15	6247.7	43.7	6247.8	45.25	6247.9	46.8	6248	48.35	
6248.1									
49.91	6248.2	51.26	6248.3	52.56	6248.4	101.13	6248.4	101.34	
6248.5									
101.58	6248.6	102.1	6248.7	104.64	6248.8	106.39	6248.8	107.91	
6248.7									
109.42	6248.6	110.94	6248.5	112.45	6248.4	114.32	6248.3	117.89	
6248.2									
121.46	6248.1	122.97	6248	123.58	6247.9	124.18	6247.8	124.79	
6247.7									
125.4	6247.6	126.01	6247.5	126.65	6247.4	127.36	6247.3	128.06	
6247.2									
128.76	6247.1	129.46	6247	130.17	6246.9	130.87	6246.8	131.53	
6246.7									
131.83	6246.6	132.13	6246.5	132.43	6246.4	132.73	6246.3	133.03	
6246.2									
133.33	6246.1	133.63	6246	133.93	6245.9	134.23	6245.8	134.53	
6245.7									
134.83	6245.6	135.13	6245.5	135.43	6245.4	135.73	6245.3	136.03	
6245.2									
136.33	6245.1	136.63	6245	136.93	6244.9	137.23	6244.8	137.53	
6244.7									
137.83	6244.6	138.13	6244.5	138.43	6244.4	138.73	6244.3	139.03	
6244.2									
139.33	6244.1	139.63	6244	139.93	6243.9	140.23	6243.8	140.53	
6243.7									
140.83	6243.6	141.13	6243.5	141.43	6243.4	141.73	6243.3	142.03	
6243.2									
142.33	6243.1	142.63	6243	142.93	6242.9	143.18	6243.4	143.23	
6242.8									
143.53	6242.7	143.83	6242.6	144.13	6242.5	144.43	6242.4	144.73	
6242.3									
155.18	6242.3	155.39	6242.4	155.6	6242.5	155.8	6242.6	156.01	
6242.7									
156.21	6242.8	156.42	6242.9	156.62	6243	156.83	6243.1	157.03	
6243.2									
157.24	6243.3	157.44	6243.4	157.65	6243.5	157.85	6243.6	158.06	
6243.7									
158.26	6243.8	158.47	6243.9	158.68	6244	158.88	6244.1	159.09	
6244.2									
159.29	6244.3	159.5	6244.4	159.7	6244.5	159.91	6244.6	160.11	
6244.7									
160.32	6244.8	160.52	6244.9	160.73	6245	160.93	6245.1	161.14	
6245.2									
161.34	6245.3	161.55	6245.4	161.75	6245.5	161.96	6245.6	162.17	
6245.7									
162.37	6245.8	162.58	6245.9	162.78	6246	162.99	6246.1	163.19	
6246.2									

163.4	6246.3	163.6	6246.4	163.81	6246.5	164.01	6246.6	164.22	
6246.7									
164.42	6246.8	164.63	6246.9	164.83	6247	165.04	6247.1	165.24	
6247.2									
165.45	6247.3	165.66	6247.4	165.86	6247.5	166.07	6247.6	166.27	
6247.7									
166.48	6247.8	166.68	6247.9	166.89	6248	167.09	6248.1	167.3	
6248.2									
167.5	6248.3	167.71	6248.4	167.91	6248.5	168.12	6248.6	168.32	
6248.7									
168.54	6248.8	168.85	6248.9	169.15	6249	169.36	6249.07	169.45	
6249.1									
169.75	6249.2	170.06	6249.3	170.36	6249.4	170.66	6249.5	170.96	
6249.6									
171.27	6249.7	171.57	6249.8	171.87	6249.9	172.18	6250	172.48	
6250.1									
172.78	6250.2	173.08	6250.3	173.39	6250.4	173.69	6250.5	173.99	
6250.6									
174.29	6250.7	176.08	6250.8	181.05	6250.9	186.01	6251	189.94	
6251									
190.26	6250.9	190.58	6250.8	190.89	6250.7	191.21	6250.6	191.53	
6250.5									
191.85	6250.4	192.17	6250.3	192.49	6250.2	192.81	6250.1	193.13	
6250									
193.45	6249.9	193.77	6249.8	194.09	6249.7	194.41	6249.6	194.73	
6249.5									
195.05	6249.4	195.37	6249.3	195.69	6249.2	196.02	6249.1	196.37	
6249									
196.71	6248.9	197.06	6248.8	197.41	6248.7	197.76	6248.6	198.1	
6248.5									
198.45	6248.4	198.8	6248.3	199.14	6248.2	199.49	6248.1	199.84	
6248									
200.18	6247.9	200.53	6247.8	200.88	6247.7	201.23	6247.6	201.57	
6247.5									
201.92	6247.4	202.27	6247.3	202.61	6247.2	202.96	6247.1	203.31	
6247									
203.65	6246.9	204	6246.8	204.35	6246.7	204.7	6246.6	205.04	
6246.5									
205.39	6246.4	205.74	6246.3	206.08	6246.2	206.43	6246.1	206.78	
6246									
207.12	6245.9	207.47	6245.8	207.82	6245.7	208.24	6245.6	208.73	
6245.5									
209.24	6245.4	209.25	6245.5	210.25	6245.2	210.76	6245.1	211.26	
6245									
211.33	6245	211.34	6245.1	211.36	6245.2	212.41	6244.9	212.49	
6244.8									
212.56	6244.7	212.64	6244.6	212.71	6244.5	212.77	6244.4	212.78	
6244.2									
212.8	6243.7	212.82	6243.2	212.84	6242.7	212.86	6242.2	212.9	
6241.8									
213.06	6241.8	213.31	6241.9	213.55	6242	213.8	6242.1	214.05	
6242.2									
214.29	6242.3	214.54	6242.4	214.78	6242.5	215.03	6242.6	215.27	

6242.7									
215.52	6242.8	215.77	6242.9	216.01	6243	216.26	6243.1	216.52	
6243.2									
216.83	6243.3	217.44	6243.5	218.25	6243.6	218.42	6243.7	218.59	
6243.8									
218.76	6243.9	218.94	6244	222.21	6244.1	225.65	6244.2	232.55	
6244.4									
235.89	6244.5	239.43	6244.6	242.96	6244.7	246.5	6244.8	250.03	
6244.9									
253.56	6245	257.1	6245.1	260.1	6245.2	262.68	6245.3	266.78	
6245.4									
271.15	6245.5	271.91	6245.8	271.99	6245.6	272.71	6245.7	273.18	
6245.9									
273.4	6245.8	274.09	6245.9	274.78	6246	275.45	6246.1	276.09	
6246.2									
276.69	6246.3	277.28	6246.4	277.87	6246.5	278.46	6246.6	279.05	
6246.7									
279.64	6246.8	280.2	6246.9	280.76	6247	281.31	6247.1	281.85	
6247.2									
282.09	6247.3	282.14	6247.4	282.37	6247.3	282.89	6247.4	283.41	
6247.5									
283.93	6247.6	284.45	6247.7	284.97	6247.8	285.5	6247.9	286.02	
6248									
286.55	6248.1	287.07	6248.2	287.58	6248.3	288.07	6248.4	288.56	
6248.5									
289.06	6248.6	289.55	6248.7	290.04	6248.8	290.53	6248.9	291.02	
6249									
291.51	6249.1	292	6249.2	292.49	6249.3	292.98	6249.4	293.47	
6249.5									
293.95	6249.6	294.43	6249.7	294.91	6249.8	295.38	6249.9	295.85	
6250									
296.31	6250.1	296.78	6250.2	297.25	6250.3	297.72	6250.4	298.19	
6250.5									
298.66	6250.6	299.13	6250.7	299.6	6250.8	300	6250.8		

Manning's n Values num= 3  
 Sta n Val Sta n Val Sta n Val  
 0 .03 129.46 .013 169.36 .03

Bank Sta: Left Right Lengths: Left Channel Right Coeff Contr.  
 Expan. 129.46 169.36 15.74 15.74 15.74 .1

.3  
 Ineffective Flow num= 2  
 Sta L Sta R Elev Permanent  
 0 5.33 6248.55 F  
 190.45 300 6248.92 F  
 Left Levee Station= 105.43 Elevation= 6248.84  
 Right Levee Station= 173.7 Elevation= 6250.84

CROSS SECTION OUTPUT Profile #Flow 1

E.G. Elev (ft)	6249.33	Element	Left OB
Channel Right OB			
Vel Head (ft)	0.65	Wt. n-Val.	0.030
0.013			
W.S. Elev (ft)	6248.68	Reach Len. (ft)	15.74
15.74 15.74			
Crit W.S. (ft)	6247.17	Flow Area (sq ft)	13.36
167.37			
E.G. Slope (ft/ft)	0.000511	Area (sq ft)	13.36
167.37			
Q Total (cfs)	1100.00	Flow (cfs)	10.95
1089.05			
Top Width (ft)	60.07	Top Width (ft)	21.25
38.82			
Vel Total (ft/s)	6.09	Avg. Vel. (ft/s)	0.82
6.51			
Max Chl Dpth (ft)	6.88	Hydr. Depth (ft)	0.63
4.31			
Conv. Total (cfs)	48666.3	Conv. (cfs)	484.5
48181.8			
Length Wtd. (ft)	15.74	Wetted Per. (ft)	21.34
41.87			
Min Ch El (ft)	6242.30	Shear (lb/sq ft)	0.02
0.13			
Alpha	1.13	Stream Power (lb/ft s)	300.00
105.43 173.70			
Frctn Loss (ft)	0.00	Cum Volume (acre-ft)	0.04
2.43 0.00			
C & E Loss (ft)	0.10	Cum SA (acres)	0.22
0.63 0.01			

Warning: The conveyance ratio (upstream conveyance divided by downstream conveyance) is less than 0.7 or greater than 1.4.

This may indicate the need for additional cross sections.  
 Note: Multiple critical depths were found at this location. The critical depth with the lowest, valid, energy was used.

CROSS SECTION

RIVER: SC01  
 REACH: Sand Creek-DS-1 RS: 952

INPUT  
 Description:  
 Station Elevation Data num= 296  
 Sta Elev Sta Elev Sta Elev Sta Elev Sta  
 Elev  
 0 6248.8 1.04 6248.8 3.29 6248.7 5.19 6248.6 7.09  
 6248.5  
 8.99 6248.4 10.89 6248.3 12.79 6248.2 14.69 6248.1 16.59

6248									
18.49	6247.9	20.39	6247.8	22.29	6247.7	24.2	6247.6	44.35	
6247.6									
45.86	6247.7	47.38	6247.8	48.9	6247.9	50.41	6248	52.52	
6248.1									
53.98	6248.2	54.41	6248.3	55.51	6248.4	86.44	6248.4	86.61	
6248.5									
86.8	6248.6	87.03	6248.7	89.03	6248.8	91.53	6248.9	94.03	
6249									
96.53	6249.1	99.03	6249.2	101.52	6249.3	104.02	6249.4	106.52	
6249.5									
109.02	6249.6	111.52	6249.7	113	6249.7	114.54	6249.6	116.09	
6249.5									
117.64	6249.4	119.15	6249.3	119.79	6249.2	120.42	6249.1	121.06	
6249									
121.69	6248.9	122.33	6248.8	122.96	6248.7	123.23	6248.6	123.48	
6248.5									
123.73	6248.4	123.98	6248.3	124.23	6248.2	124.48	6248.1	124.73	
6248									
124.98	6247.9	125.22	6247.8	125.47	6247.7	125.72	6247.6	125.97	
6247.5									
126.22	6247.4	126.47	6247.3	126.72	6247.2	126.97	6247.1	127.22	
6247									
127.46	6246.9	127.71	6246.8	127.96	6246.7	128.21	6246.6	128.46	
6246.5									
128.71	6246.4	128.96	6246.3	129.21	6246.2	129.46	6246.1	129.71	
6246									
129.95	6245.9	130.2	6245.8	130.45	6245.7	130.7	6245.6	130.95	
6245.5									
131.2	6245.4	131.45	6245.3	131.7	6245.2	131.95	6245.1	132.19	
6245									
132.44	6244.9	132.67	6244.8	132.9	6244.7	133.14	6244.6	133.37	
6244.5									
133.6	6244.4	133.83	6244.3	134.07	6244.2	134.3	6244.1	134.53	
6244									
134.76	6243.9	135	6243.8	135.23	6243.7	135.46	6243.6	135.69	
6243.5									
135.93	6243.4	136.16	6243.3	136.39	6243.2	136.62	6243.1	136.86	
6243									
137.11	6242.9	137.36	6242.8	137.62	6242.7	137.88	6242.6	138.14	
6242.5									
138.4	6242.4	138.65	6242.3	138.91	6242.2	160.14	6242.2	160.35	
6242.3									
160.56	6242.4	160.78	6242.5	161	6242.6	161.22	6242.7	161.43	
6242.8									
161.64	6242.9	161.86	6243	162.07	6243.1	162.28	6243.2	162.5	
6243.3									
162.71	6243.4	162.93	6243.5	163.15	6243.6	163.59	6243.8	163.81	
6243.9									
164.03	6244	164.25	6244.1	164.47	6244.2	164.68	6244.3	164.9	
6244.4									
165.12	6244.5	165.34	6244.6	165.56	6244.7	165.78	6244.8	166	
6244.9									

166.22	6245	166.44	6245.1	166.66	6245.2	166.88	6245.3	167.1	
6245.4									
167.32	6245.5	167.54	6245.6	167.76	6245.7	167.97	6245.8	168.19	
6245.9									
168.41	6246	168.63	6246.1	168.85	6246.2	169.07	6246.3	169.29	
6246.4									
169.51	6246.5	169.73	6246.6	169.95	6246.7	170.17	6246.8	170.39	
6246.9									
170.61	6247	170.83	6247.1	171.04	6247.2	171.26	6247.3	171.48	
6247.4									
171.7	6247.5	171.92	6247.6	172.14	6247.7	172.36	6247.8	172.58	
6247.9									
172.8	6248	173.02	6248.1	173.24	6248.2	173.46	6248.3	173.68	
6248.4									
173.9	6248.5	174.11	6248.6	174.33	6248.7	174.55	6248.8	174.77	
6248.9									
174.99	6249	175.21	6249.1	175.43	6249.2	175.65	6249.3	175.77	
6249.35									
175.87	6249.4	176.09	6249.5	176.31	6249.6	176.53	6249.7	176.75	
6249.8									
176.97	6249.9	177.19	6250	177.4	6250.1	177.62	6250.2	177.84	
6250.3									
178.06	6250.4	178.28	6250.5	178.5	6250.6	178.72	6250.7	178.94	
6250.8									
181.43	6250.9	191.11	6251	197.5	6251	197.88	6250.9	198.27	
6250.8									
198.65	6250.7	199.04	6250.6	199.42	6250.5	199.8	6250.4	200.19	
6250.3									
200.57	6250.2	200.99	6250.1	201.42	6250	201.85	6249.9	202.28	
6249.8									
202.72	6249.7	203.15	6249.6	203.58	6249.5	204.03	6249.4	204.55	
6249.3									
205.06	6249.2	205.57	6249.1	206.09	6249	206.73	6248.9	207.37	
6248.8									
208.08	6248.7	208.97	6248.6	210.16	6248.5	210.88	6248.6	211.93	
6248.7									
213.03	6248.8	213.39	6248.4	213.97	6248.9	215.11	6249	216.2	
6249.1									
217.9	6249.2	219.37	6248.3	219.4	6248.3	219.65	6249.3	222.84	
6248.4									
233.6	6248.4	234.07	6248.3	234.69	6248.5	235.79	6248.6	236.88	
6248.7									
237.98	6248.8	238.87	6248.2	239.07	6248.9	240.17	6249	243.68	
6248.1									
248.49	6248	254.25	6248	255.25	6248.1	256.25	6248.2	257.25	
6248.3									
257.76	6248.1	258.24	6248.4	259.24	6248.5	260.24	6248.6	261.24	
6248.7									
261.28	6248.2	262.89	6248.8	264	6248.9	264.28	6248.2	264.65	
6248.2									
267.02	6248.3	268.85	6248.4	270.38	6248.5	271.85	6248.6	273.03	
6248.7									
274.22	6248.8	275.32	6248.9	276.29	6249	277.27	6249.1	278.24	

6249.2  
 279.12 6249.3 279.95 6249.4 280.79 6249.5 281.62 6249.6 282.45  
 6249.7  
 283.22 6249.8 283.95 6249.9 284.68 6250 285.41 6250.1 286.13  
 6250.2  
 286.86 6250.3 287.57 6250.4 288.5 6250.4 290.96 6250.3 293.43  
 6250.2  
 295.89 6250.1 298.2 6250 299.2 6250 299.2 6250.53 299.47  
 6250.5  
 300 6250.5

Manning's n Values num= 3  
 Sta n Val Sta n Val Sta n Val  
 0 .03 124.73 .013 175.77 .03

Bank Sta: Left Right Lengths: Left Channel Right Coeff Contr.  
 Expan. 124.73 175.77 11.7 11.7 11.7 .1

.3  
 Ineffective Flow num= 2  
 Sta L Sta R Elev Permanent  
 0 8.26 6248.48 F  
 197.15 300 6249.79 F  
 Left Levee Station= 112.97 Elevation= 6249.66  
 Right Levee Station= 196.73 Elevation= 6249.9

CROSS SECTION OUTPUT Profile #Flow 1

E.G. Elev (ft)	6249.23	Element	Left OB
Channel Right OB			
Vel Head (ft)	0.31	Wt. n-Val.	0.030
0.013			
W.S. Elev (ft)	6248.91	Reach Len. (ft)	11.70
11.70 11.70			
Crit W.S. (ft)	6246.00	Flow Area (sq ft)	1.13
245.44			
E.G. Slope (ft/ft)	0.000197	Area (sq ft)	1.13
245.44			
Q Total (cfs)	1100.00	Flow (cfs)	0.39
1099.61			
Top Width (ft)	53.19	Top Width (ft)	3.12
50.07			
Vel Total (ft/s)	4.46	Avg. Vel. (ft/s)	0.34
4.48			
Max Chl Dpth (ft)	6.71	Hydr. Depth (ft)	0.36
4.90			
Conv. Total (cfs)	78290.1	Conv. (cfs)	27.7
78262.3			
Length Wtd. (ft)	11.70	Wetted Per. (ft)	3.27
52.67			
Min Ch El (ft)	6242.20	Shear (lb/sq ft)	0.00
0.06			

Alpha	1.01	Stream Power (lb/ft s)	300.00
112.97 196.73			
Frctn Loss (ft)	0.00	Cum Volume (acre-ft)	0.04
2.35 0.00			
C & E Loss (ft)	0.03	Cum SA (acres)	0.22
0.62 0.01			

Note: Multiple critical depths were found at this location. The critical depth with the lowest, valid, energy was used.

CROSS SECTION

RIVER: SC01  
 REACH: Sand Creek-DS-1 RS: 951

INPUT

Description:  
 Station Elevation Data num= 233  
 Sta Elev Sta Elev Sta Elev Sta Elev Sta Elev  
 Elev 0 6248.7 .89 6248.7 3.39 6248.6 5.87 6248.5 8.26  
 6248.4  
 10.65 6248.3 12.94 6248.2 15.24 6248.1 17.28 6248 19.18  
 6247.9  
 21.09 6247.8 22.99 6247.7 24.89 6247.6 47.75 6247.6 49.28  
 6247.7  
 52.19 6247.8 54.36 6247.9 54.8 6248 55.23 6248.1 55.67  
 6248.2  
 56.1 6248.3 58.64 6248.4 75.94 6248.4 76.11 6248.5 76.28  
 6248.6  
 76.47 6248.7 77.9 6248.8 80.37 6248.9 82.84 6249 85.3  
 6249.1  
 87.77 6249.2 90.24 6249.3 92.71 6249.4 95.18 6249.5 98.56  
 6249.6  
 102.14 6249.7 105.72 6249.8 109.31 6249.9 111.97 6249.9 112.89  
 6249.8  
 113.8 6249.7 114.56 6249.6 115.2 6249.5 115.83 6249.4 116.46  
 6249.3  
 117.1 6249.2 117.73 6249.1 118.36 6249 118.84 6248.9 119.25  
 6248.8  
 119.65 6248.7 120.06 6248.6 120.46 6248.5 120.87 6248.4 121.27  
 6248.3  
 121.68 6248.2 122.08 6248.1 122.49 6248 122.89 6247.9 123.3  
 6247.8  
 123.61 6247.7 123.85 6247.6 124.08 6247.5 124.31 6247.4 124.54  
 6247.3  
 124.77 6247.2 125.01 6247.1 125.24 6247 125.47 6246.9 125.7  
 6246.8  
 125.93 6246.7 126.17 6246.6 126.4 6246.5 126.63 6246.4 126.86  
 6246.3

127.09	6246.2	127.33	6246.1	127.56	6246	127.79	6245.9	128.03
6245.8								
128.29	6245.7	128.55	6245.6	128.8	6245.5	129.06	6245.4	129.22
6245.5								
129.32	6245.3	129.58	6245.2	129.83	6245.1	130.09	6245	130.35
6244.9								
130.6	6244.8	130.86	6244.7	131.12	6244.6	131.38	6244.5	131.63
6244.4								
131.89	6244.3	132.15	6244.2	132.4	6244.1	132.66	6244	132.92
6243.9								
133.18	6243.8	133.43	6243.7	133.69	6243.6	133.95	6243.5	134.2
6243.4								
134.46	6243.3	134.72	6243.2	134.98	6243.1	135.23	6243	135.49
6242.9								
135.75	6242.8	136	6242.7	136.26	6242.6	136.52	6242.5	136.78
6242.4								
137.03	6242.3	137.29	6242.2	137.55	6242.1	162.15	6242.1	162.41
6242.2								
162.67	6242.3	162.93	6242.4	163.19	6242.5	163.45	6242.6	163.71
6242.7								
163.97	6242.8	164.23	6242.9	164.49	6243	164.75	6243.1	165.01
6243.2								
165.27	6243.3	165.52	6243.4	165.78	6243.5	166.04	6243.6	166.3
6243.7								
166.56	6243.8	166.82	6243.9	167.08	6244	167.34	6244.1	167.6
6244.2								
167.86	6244.3	168.12	6244.4	168.38	6244.5	168.64	6244.6	168.89
6244.7								
169.15	6244.8	169.41	6244.9	169.67	6245	169.93	6245.1	170.19
6245.2								
170.45	6245.3	170.71	6245.4	170.97	6245.5	171.23	6245.6	171.49
6245.7								
171.75	6245.8	172.01	6245.9	172.27	6246	172.52	6246.1	172.78
6246.2								
173.04	6246.3	173.3	6246.4	173.56	6246.5	173.82	6246.6	174.08
6246.7								
174.34	6246.8	174.6	6246.9	174.86	6247	175.12	6247.1	175.38
6247.2								
175.64	6247.3	175.89	6247.4	176.15	6247.5	176.41	6247.6	176.67
6247.7								
176.93	6247.8	177.19	6247.9	177.45	6248	177.71	6248.1	177.97
6248.2								
178.23	6248.3	178.49	6248.4	178.75	6248.5	179.01	6248.6	179.27
6248.7								
179.52	6248.8	179.78	6248.9	180.04	6249	180.22	6249.07	180.3
6249.1								
180.56	6249.2	180.82	6249.3	181.08	6249.4	181.34	6249.5	181.62
6249.6								
182.14	6249.7	182.65	6249.8	183.17	6249.9	183.68	6250	184.19
6250.1								
184.71	6250.2	185.22	6250.3	185.74	6250.4	186.29	6250.5	186.86
6250.6								
187.43	6250.7	188.01	6250.8	195.73	6250.9	216.8	6251	216.92

6251

223.77	6250.9	227.73	6250.8	231.69	6250.7	235.66	6250.6	239.62
6250.5								
243.59	6250.4	247.55	6250.3	251.52	6250.2	255.54	6250.1	259.58
6250								
263.66	6249.9	267.91	6249.8	272.15	6249.7	276.39	6249.6	280.64
6249.5								
284.88	6249.4	289.12	6249.3	293.37	6249.2	297.6	6249.1	298.61
6249.1								
298.61	6249.46	299.83	6249.4	300	6249.4			

Manning's n Values num= 3

Sta n Val	Sta n Val	Sta n Val	Sta n Val
0	.03	122.49	.013
		180.22	.03

Bank Sta: Left Right Lengths: Left Channel Right Coeff Contr.

Expan.	122.49	180.22	27.44	27.44	27.44	.1
--------	--------	--------	-------	-------	-------	----

.3

Ineffective Flow num= 2

Sta L	Sta R	Elev	Permanent
0	1.98	6248.7	F
263.74	300	6251.25	F

Left Levee Station= 111.71 Elevation= 6249.89

Right Levee Station= 219.77 Elevation= 6251

CROSS SECTION OUTPUT Profile #Flow 1

E.G. Elev (ft)	6249.20	Element	Left OB
Channel Right OB			
Vel Head (ft)	0.22	Wt. n-Val.	0.030
0.013			
W.S. Elev (ft)	6248.97	Reach Len. (ft)	27.44
27.44	27.44		
Crit W.S. (ft)	6245.61	Flow Area (sq ft)	1.92
289.19			
E.G. Slope (ft/ft)	0.000136	Area (sq ft)	1.92
289.19			
Q Total (cfs)	1100.00	Flow (cfs)	0.67
1099.33			
Top Width (ft)	61.48	Top Width (ft)	4.00
57.48			
Vel Total (ft/s)	3.78	Avg. Vel. (ft/s)	0.35
3.80			
Max Chl Dpth (ft)	6.87	Hydr. Depth (ft)	0.48
5.03			
Conv. Total (cfs)	94356.6	Conv. (cfs)	57.2
94299.4			
Length Wtd. (ft)	27.44	Wetted Per. (ft)	4.12
60.02			
Min Ch El (ft)	6242.10	Shear (lb/sq ft)	0.00
0.04			





250.48	6249.3	251.72	6249.2	252.97	6249.1	253.06	6247.6	253.62
6249								
254.14	6248.9	254.67	6248.8	255.19	6248.7	255.72	6248.6	256.24
6248.5								
256.77	6248.4	257.29	6248.3	257.82	6248.2	258.35	6248.1	258.87
6248								
259.4	6247.9	259.92	6247.8	260.45	6247.7	263.86	6247.6	267.59
6247.5								
270.82	6247.4	271.32	6247.4	275.06	6247.3	279.67	6247.2	280.8
6247.4								
281.11	6247.3	281.42	6247.2	282.67	6247.2	286.47	6247.3	290.27
6247.4								
290.42	6247.5	297.84	6247.5	308.3	6247.6	314.67	6247.7	317.29
6247.8								
319.91	6247.9	322.52	6248	327.2	6248.1	330.06	6248.2	332.8
6248.3								
335.49	6248.4	337.85	6248.5	339.94	6248.6	349.29	6248.5	352.22
6248.4								
355.14	6248.3	358.06	6248.2	375.36	6248.1	377.01	6248	378.67
6247.9								
380.43	6247.8	382.22	6247.7	386.33	6247.7	397.18	6247.8	400
6247.8								

Manning's n Values	num=	3
Sta n Val	Sta n Val	Sta n Val
0 .03	171.8	.013 228.36 .03

Bank Sta: Left	Right	Lengths: Left	Channel	Right	Coeff	Contr.
Expan.						
	171.8	228.36	97.99	97.99	97.99	.1

Ineffective Flow	num=	4	
Sta L	Sta R	Elev	Permanent
167.86	179.01	6247.1	F
184.59	192.65	6247.1	F
198.23	214.34	6247.1	F
219.91	229.83	6247.1	F

Left Levee	Station=	154.53	Elevation=	6248.7
Right Levee	Station=	242.21	Elevation=	6249.96

CROSS SECTION OUTPUT Profile #Flow 1

E.G. Elev (ft)	6249.17	Element	Left 0B
Channel Right 0B			
Vel Head (ft)	0.13	Wt. n-Val.	0.030
0.013	0.030		
W.S. Elev (ft)	6249.04	Reach Len. (ft)	97.99
97.99	97.99		
Crit W.S. (ft)	6247.11	Flow Area (sq ft)	122.55
355.21	12.28		
E.G. Slope (ft/ft)	0.000061	Area (sq ft)	122.55
355.21	12.28		

Q Total (cfs)	1100.00	Flow (cfs)	41.23
1052.87	5.90		
Top Width (ft)	216.00	Top Width (ft)	151.36
56.56	8.08		
Vel Total (ft/s)	2.24	Avg. Vel. (ft/s)	0.34
2.96	0.48		
Max Chl Dpth (ft)	7.04	Hydr. Depth (ft)	0.81
6.28	1.52		
Conv. Total (cfs)	140312.1	Conv. (cfs)	5259.0
134300.9	752.2		
Length Wtd. (ft)	97.99	Wetted Per. (ft)	151.97
59.04	8.92		
Min Ch El (ft)	6242.00	Shear (lb/sq ft)	0.00
0.02	0.01		
Alpha	1.67	Stream Power (lb/ft s)	400.00
154.53	242.21		
Frctn Loss (ft)		Cum Volume (acre-ft)	
2.08			
C & E Loss (ft)		Cum SA (acres)	0.17
0.57	0.01		

Note: Multiple critical depths were found at this location. The critical depth with the lowest, valid, water surface was used.

CULVERT

RIVER: SC01  
REACH: Sand Creek-DS-1 RS: 949.5

INPUT

Description:  
Distance from Upstream XS = 10  
Deck/Roadway Width = 60  
Weir Coefficient = 2.6  
Upstream Deck/Roadway Coordinates

num=	10				
Sta Hi Cord	Lo Cord	Sta Hi Cord	Lo Cord	Sta Hi Cord	Lo Cord
5.67	6248	0	5.67	6248	0
33.86	6248	0	33.86	6248	0
114.69	6247	0	174	6247	0
262.89	6247	0	262.89	6247	0
284.97	6247	0	341.67	6247.51	0
347.21	6247.51	0	347.21	6247.51	0
409.46	6247.51	0			

Upstream Bridge Cross Section Data

Station Elevation Data	num=	255			
Sta Elev	Sta Elev	Sta Elev	Sta Elev	Sta Elev	Sta Elev
0	6249.2	8.43	6249.2	16.42	6249.1
22.67	6249	28.22			
6248.9					
33.39	6248.8	38.26	6248.7	42.87	6248.6
47.48	6248.5	52.08			
6248.4					

66.43	6248.3	69.58	6248.2	72.73	6248.1	75.88	6248	79.03
6247.9								
82.18	6247.8	85.33	6247.7	88.48	6247.6	105.48	6247.6	107.05
6247.7								
108.63	6247.8	110.21	6247.9	111.78	6248	113.3	6248	113.41
6248.1								
113.53	6248.2	113.64	6248.3	113.76	6248.4	116.31	6248.4	120.29
6248.3								
124.27	6248.2	128.25	6248.1	133.73	6248.1	136.25	6248.2	138.76
6248.3								
141.27	6248.4	143.78	6248.5	146.3	6248.6	148.85	6248.7	155.27
6248.7								
158.06	6248.6	160.85	6248.5	163.64	6248.4	165.54	6248.3	165.81
6248.2								
166.08	6248.1	166.36	6248	166.63	6247.9	166.9	6247.8	167.17
6247.7								
167.45	6247.6	167.72	6247.5	167.99	6247.4	168.26	6247.3	168.54
6247.2								
168.81	6247.1	169.08	6247	169.35	6246.9	169.63	6246.8	169.9
6246.7								
169.92	6246.7	170.17	6246.6	170.44	6246.5	170.72	6246.4	170.99
6246.3								
171.26	6246.2	171.53	6246.1	171.8	6246	172.08	6245.9	172.35
6245.8								
172.62	6245.7	172.89	6245.6	173.17	6245.5	173.44	6245.4	173.71
6245.3								
173.98	6245.2	174.26	6245.1	174.53	6245	174.8	6244.9	175.07
6244.8								
175.34	6244.7	175.59	6244.6	175.84	6244.5	176.09	6244.4	176.34
6244.3								
176.59	6244.2	176.84	6244.1	177.09	6244	177.34	6243.9	177.59
6243.8								
177.84	6243.7	178.09	6243.6	178.34	6243.5	178.59	6243.4	178.84
6243.3								
179.09	6243.2	179.34	6243.1	179.59	6243	179.84	6242.9	180.09
6242.8								
180.34	6242.7	180.58	6242.6	180.82	6242.5	181.07	6242.4	181.31
6242.3								
181.55	6242.2	181.8	6242.1	182.04	6242	217.25	6242	217.57
6242.1								
217.86	6242.2	218.14	6242.3	218.29	6242.7	218.43	6242.4	218.72
6242.5								
219.01	6242.6	219.3	6242.7	219.59	6242.8	219.76	6243	219.87
6242.9								
220.16	6243	220.45	6243.1	220.74	6243.2	221.03	6243.3	221.31
6243.4								
221.6	6243.5	221.89	6243.6	222.18	6243.7	222.47	6243.8	222.75
6243.9								
223.04	6244	223.33	6244.1	223.61	6244.2	223.88	6244.3	224.14
6244.4								
224.41	6244.5	224.67	6244.6	224.94	6244.7	225.2	6244.8	225.47
6244.9								
225.73	6245	226	6245.1	226.24	6245.2	226.26	6245.2	226.53

6245.3								
226.8	6245.4	227.06	6245.5	227.33	6245.6	227.59	6245.7	227.76
6246.1								
227.86	6245.8	228.12	6245.9	228.36	6245.99	228.39	6246	228.65
6246.1								
228.92	6246.2	229.18	6246.3	229.45	6246.4	229.71	6246.5	229.98
6246.6								
230.24	6246.7	230.43	6247	230.51	6246.8	230.77	6246.9	231.04
6247								
231.31	6247.1	231.57	6247.2	231.84	6247.3	232.1	6247.4	232.37
6247.5								
232.63	6247.6	232.9	6247.7	233.16	6247.8	233.43	6247.9	233.69
6248								
233.96	6248.1	234.22	6248.2	234.49	6248.3	234.75	6248.4	235.02
6248.5								
235.29	6248.6	235.55	6248.7	235.82	6248.8	236.08	6248.9	236.35
6249								
236.61	6249.1	236.88	6249.2	237.14	6249.3	237.41	6249.4	237.67
6249.5								
237.97	6249.6	239.22	6249.7	240.48	6249.8	241.73	6249.9	242.99
6249.9								
244.24	6249.8	245.49	6249.7	246.74	6249.6	247.98	6249.5	249.23
6249.4								
250.48	6249.3	251.72	6249.2	252.97	6249.1	253.06	6247.6	253.62
6249								
254.14	6248.9	254.67	6248.8	255.19	6248.7	255.72	6248.6	256.24
6248.5								
256.77	6248.4	257.29	6248.3	257.82	6248.2	258.35	6248.1	258.87
6248								
259.4	6247.9	259.92	6247.8	260.45	6247.7	263.86	6247.6	267.59
6247.5								
270.82	6247.4	271.32	6247.4	275.06	6247.3	279.67	6247.2	280.8
6247.4								
281.11	6247.3	281.42	6247.2	282.67	6247.2	286.47	6247.3	290.27
6247.4								
290.42	6247.5	297.84	6247.5	308.3	6247.6	314.67	6247.7	317.29
6247.8								
319.91	6247.9	322.52	6248	327.2	6248.1	330.06	6248.2	332.8
6248.3								
335.49	6248.4	337.85	6248.5	339.94	6248.6	349.29	6248.5	352.22
6248.4								
355.14	6248.3	358.06	6248.2	375.36	6248.1	377.01	6248	378.67
6247.9								
380.43	6247.8	382.22	6247.7	386.33	6247.7	397.18	6247.8	400
6247.8								
Manning's n Values			num=	3				
Sta	n Val	Sta	n Val	Sta	n Val			
0	.03	171.8	.013	228.36	.03			
Bank Sta: Left	Right	Coeff	Contr.	Expan.				
171.8	228.36		.1	.3				
Ineffective Flow		num=	4					

Sta L	Sta R	Elev	Permanent
167.86	179.01	6247.1	F
184.59	192.65	6247.1	F
198.23	214.34	6247.1	F
219.91	229.83	6247.1	F
Left Levee	Station=	154.53	Elevation= 6248.7
Right Levee	Station=	242.21	Elevation= 6249.96

Downstream Deck/Roadway Coordinates									
num= 9									
Sta	Hi	Cord	Lo	Cord	Sta	Hi	Cord	Lo	Cord
5.61	6248	0	5.61	6248	0	73.45	6248	0	0
182.55	6247	0	194.99	6247	0	198.01	6247	0	0
220.69	6247	0	347.15	6247	0	409.4	6247	0	0

Downstream Bridge Cross Section Data									
Station Elevation Data num= 241									
Sta	Elev	Sta	Elev	Sta	Elev	Sta	Elev	Sta	Elev
6249	0	6249.3	1.53	6249.3	16.17	6249.2	28.39	6249.1	40.61
6249	52.83	6248.9	65.06	6248.8	77.28	6248.7	89.5	6248.6	101.72
6248.5	113.94	6248.4	126.17	6248.3	138.06	6248.2	145.74	6248.1	146.57
6248	147.91	6247.9	149.01	6247.8	150.1	6247.7	151.21	6247.6	152.31
6247.5	153.42	6247.4	154.53	6247.3	155.63	6247.2	156.74	6247.1	157.85
6247	158.96	6246.9	160.07	6246.8	161.18	6246.7	162.29	6246.6	163.4
6246.5	164.51	6246.4	165.62	6246.3	165.95	6246.2	166.16	6246.1	166.38
6246	166.59	6245.9	166.8	6245.8	167.02	6245.7	167.23	6245.6	167.45
6245.5	167.66	6245.4	167.88	6245.3	168.09	6245.2	168.31	6245.1	168.52
6245	168.74	6244.9	168.95	6244.8	169.17	6244.7	169.38	6244.6	169.6
6244.5	169.81	6244.4	170.03	6244.3	170.24	6244.2	170.46	6244.1	170.67
6244	170.89	6243.9	171.1	6243.8	171.32	6243.7	171.53	6243.6	171.75
6243.5	171.97	6243.4	172.18	6243.3	172.4	6243.2	172.62	6243.1	172.83
6243	173.05	6242.9	173.27	6242.8	173.48	6242.7	173.7	6242.6	173.92
6242.5	174.14	6242.4	174.36	6242.3	174.58	6242.2	174.8	6242.1	175.02
6242	175.24	6241.9	175.45	6241.8	175.67	6241.7	175.88	6241.6	176.1
6241.5	176.32	6241.4	176.53	6241.3	176.75	6241.2	176.97	6241.1	177.18
6241									

177.4	6240.9	177.61	6240.8	177.83	6240.7	178.05	6240.6	178.26	
6240.5									
178.48	6240.4	178.69	6240.3	178.91	6240.2	179.13	6240.1	179.34	
6240									
179.56	6239.9	180.92	6239.8	185.83	6239.7	190.76	6239.6	195.74	
6239.5									
200.03	6239.43	201.64	6239.4	202.69	6239.4	209.86	6239.5	216.25	
6239.6									
217.71	6239.7	219.17	6239.8	220.63	6239.9	222.09	6240	223.55	
6240.1									
225.01	6240.2	226.41	6240.3	227.16	6240.4	231.88	6240.5	236.96	
6240.6									
256.33	6240.6	256.73	6240.5	257.13	6240.4	257.53	6240.3	257.92	
6240.2									
258.32	6240.1	258.72	6240	259.12	6239.9	259.52	6239.8	260.22	
6239.7									
261.38	6239.6	262.54	6239.5	263.7	6239.4	264.86	6239.3	270.67	
6239.2									
271.32	6239.2	271.86	6239.3	272.41	6239.4	272.95	6239.5	273.5	
6239.6									
274.05	6239.7	274.59	6239.8	275.14	6239.9	275.68	6240	276.23	
6240.1									
276.78	6240.2	277.32	6240.3	277.87	6240.4	278.41	6240.5	278.96	
6240.6									
279.51	6240.7	280.05	6240.8	284.18	6240.9	291.75	6241	292.24	
6241.1									
292.72	6241.2	293.19	6241.3	293.67	6241.4	294.14	6241.5	296.25	
6241.6									
297.56	6241.7	298.86	6241.8	302.26	6241.9	304.38	6242	305.8	
6242.1									
307	6242.2	308.11	6242.3	309.12	6242.4	310.01	6242.5	310.89	
6242.6									
311.68	6242.7	312.45	6242.8	313.17	6242.9	313.88	6243	314.55	
6243.1									
315.21	6243.2	315.83	6243.3	316.44	6243.4	317.05	6243.5	317.62	
6243.6									
318.19	6243.7	318.76	6243.8	319.29	6243.9	319.82	6244	320.35	
6244.1									
320.86	6244.2	321.36	6244.3	321.87	6244.4	322.37	6244.5	322.84	
6244.6									
323.31	6244.7	323.79	6244.8	324.27	6244.9	324.71	6245	325.17	
6245.1									
325.62	6245.2	326.07	6245.3	326.51	6245.4	326.94	6245.5	327.38	
6245.6									
327.81	6245.7	328.24	6245.8	328.66	6245.9	329.07	6246	329.49	
6246.1									
329.9	6246.2	330.32	6246.3	330.87	6246.4	333.78	6246.5	336.6	
6246.6									
339.34	6246.7	344.79	6246.8	346.32	6246.9	347.86	6247	349.39	
6247.1									
350.73	6247.2	352.07	6247.3	354.42	6247.4	357.6	6247.5	360.77	
6247.6									
363.85	6247.7	366.98	6247.8	380.36	6247.8	381	6247.9	385.21	

6248  
 385.74 6248 385.82 6247.9 385.9 6247.8 385.98 6247.7 386.06  
 6247.6  
 386.15 6247.5 394.93 6247.5 397.25 6247.6 399.66 6247.7 402.21  
 6247.8  
 405.14 6247.9 408.18 6248 411.21 6248.1 416.26 6248.2 421.39  
 6248.3  
 426.53 6248.4 431.58 6248.5 435.85 6248.6 440.11 6248.7 446.02  
 6248.8  
 462.41 6248.8

Manning's n Values num= 3  
 Sta n Val Sta n Val Sta n Val  
 0 .03 166.38 .013 329.07 .03

Bank Sta: Left Right Coeff Contr. Expan.  
 166.38 329.07 .1 .3

Ineffective Flow num= 4  
 Sta L Sta R Elev Permanent  
 154.72 180.75 6247.14 F  
 185.71 194.38 6247.14 F  
 199.34 250.16 6247.14 F  
 255.11 344.35 6247.14 F

Left Levee Station= 145.97 Elevation= 6248.02  
 Right Levee Station= 385.22 Elevation= 6248

Upstream Embankment side slope = 1 horiz. to 1.0 vertical  
 Downstream Embankment side slope = 2 horiz. to 1.0 vertical  
 Maximum allowable submergence for weir flow = .98  
 Elevation at which weir flow begins =  
 Energy head used in spillway design =  
 Spillway height used in design =  
 Weir crest shape = Broad Crested

Number of Culverts = 3

Culvert Name Shape Rise Span  
 Culvert #1 Circular 4  
 FHWA Chart # 2 - Corrugated Metal Pipe Culvert  
 FHWA Scale # 1 - Headwall  
 Solution Criteria = Highest U.S. EG  
 Culvert Upstrm Dist Length Top n Bottom n Depth Blocked Entrance Loss  
 Coef Exit Loss Coef  
 1 90 .024 .024 0 .5

1  
 Upstream Elevation = 6241.91  
 Centerline Station = 217.23  
 Downstream Elevation = 6240.16  
 Centerline Station = 252.53

Culvert Name Shape Rise Span  
 Culvert #2 Circular 4  
 FHWA Chart # 2 - Corrugated Metal Pipe Culvert

FHWA Scale # 1 - Headwall  
 Solution Criteria = Highest U.S. EG  
 Culvert Upstrm Dist Length Top n Bottom n Depth Blocked Entrance Loss  
 Coef Exit Loss Coef  
 3.64 90 .024 .024 0 .5  
 1  
 Upstream Elevation = 6242.06  
 Centerline Station = 195.75  
 Downstream Elevation = 6239.73  
 Centerline Station = 197.35

Culvert Name Shape Rise Span  
 Culvert #3 Circular 4  
 FHWA Chart # 2 - Corrugated Metal Pipe Culvert  
 FHWA Scale # 1 - Headwall  
 Solution Criteria = Highest U.S. EG  
 Culvert Upstrm Dist Length Top n Bottom n Depth Blocked Entrance Loss  
 Coef Exit Loss Coef  
 3.9 90 .024 .024 0 .5  
 1  
 Upstream Elevation = 6242.32  
 Centerline Station = 182.04  
 Downstream Elevation = 6240.12  
 Centerline Station = 183.71

CULVERT OUTPUT Profile #Flow 1 Culv Group: Culvert #1

Q Culv Group (cfs)	67.74	Culv Full Len (ft)	90.00
# Barrels	1	Culv Vel US (ft/s)	5.39
Q Barrel (cfs)	67.74	Culv Vel DS (ft/s)	5.39
E.G. US. (ft)	6249.16	Culv Inv El Up (ft)	6241.91
W.S. US. (ft)	6249.04	Culv Inv El Dn (ft)	6240.16
E.G. DS (ft)	6248.25	Culv Frctn Ls (ft)	0.68
W.S. DS (ft)	6245.51	Culv Exit Loss (ft)	0.00
Delta EG (ft)	0.90	Culv Entr Loss (ft)	0.23
Delta WS (ft)	3.52	Q Weir (cfs)	897.12
E.G. IC (ft)	6245.64	Weir Sta Lft (ft)	10.85
E.G. OC (ft)	6249.16	Weir Sta Rgt (ft)	236.80
Culvert Control	Outlet	Weir Submrg	0.00
Culv WS Inlet (ft)	6245.91	Weir Max Depth (ft)	2.17
Culv WS Outlet (ft)	6244.16	Weir Avg Depth (ft)	1.23
Culv Nml Depth (ft)		Weir Flow Area (sq ft)	276.92
Culv Crt Depth (ft)	2.49	Min El Weir Flow (ft)	6247.01

CULVERT OUTPUT Profile #Flow 1 Culv Group: Culvert #2

Q Culv Group (cfs)	67.53	Culv Full Len (ft)	90.00
# Barrels	1	Culv Vel US (ft/s)	5.37
Q Barrel (cfs)	67.53	Culv Vel DS (ft/s)	5.37
E.G. US. (ft)	6249.16	Culv Inv El Up (ft)	6242.06
W.S. US. (ft)	6249.04	Culv Inv El Dn (ft)	6239.73
E.G. DS (ft)	6248.25	Culv Frctn Ls (ft)	0.68

W.S. DS (ft)	6245.51	Culv Exit Loss (ft)	0.00
Delta EG (ft)	0.90	Culv Entr Loss (ft)	0.22
Delta WS (ft)	3.52	Q Weir (cfs)	897.12
E.G. IC (ft)	6245.77	Weir Sta Lft (ft)	10.85
E.G. OC (ft)	6249.16	Weir Sta Rgt (ft)	236.80
Culvert Control	Outlet	Weir Submerg	0.00
Culv WS Inlet (ft)	6246.06	Weir Max Depth (ft)	2.17
Culv WS Outlet (ft)	6243.73	Weir Avg Depth (ft)	1.23
Culv Nml Depth (ft)		Weir Flow Area (sq ft)	276.92
Culv Crt Depth (ft)	2.48	Min El Weir Flow (ft)	6247.01

CULVERT OUTPUT Profile #Flow 1 Culv Group: Culvert #3

Q Culv Group (cfs)	67.62	Culv Full Len (ft)	90.00
# Barrels	1	Culv Vel US (ft/s)	5.38
Q Barrel (cfs)	67.62	Culv Vel DS (ft/s)	5.38
E.G. US. (ft)	6249.16	Culv Inv El Up (ft)	6242.32
W.S. US. (ft)	6249.04	Culv Inv El Dn (ft)	6240.12
E.G. DS (ft)	6248.25	Culv Frctn Ls (ft)	0.68
W.S. DS (ft)	6245.51	Culv Exit Loss (ft)	0.00
Delta EG (ft)	0.90	Culv Entr Loss (ft)	0.22
Delta WS (ft)	3.52	Q Weir (cfs)	897.12
E.G. IC (ft)	6246.04	Weir Sta Lft (ft)	10.85
E.G. OC (ft)	6249.16	Weir Sta Rgt (ft)	236.80
Culvert Control	Outlet	Weir Submerg	0.00
Culv WS Inlet (ft)	6246.32	Weir Max Depth (ft)	2.17
Culv WS Outlet (ft)	6244.12	Weir Avg Depth (ft)	1.23
Culv Nml Depth (ft)		Weir Flow Area (sq ft)	276.92
Culv Crt Depth (ft)	2.48	Min El Weir Flow (ft)	6247.01

CROSS SECTION

RIVER: SC01  
 REACH: Sand Creek-DS-1 RS: 949

INPUT  
 Description:  
 Station Elevation Data num= 241

Sta	Elev	Sta	Elev	Sta	Elev	Sta	Elev	Sta	Elev
Elev									
0	6249.3	1.53	6249.3	16.17	6249.2	28.39	6249.1	40.61	
6249									
52.83	6248.9	65.06	6248.8	77.28	6248.7	89.5	6248.6	101.72	
6248.5									
113.94	6248.4	126.17	6248.3	138.06	6248.2	145.74	6248.1	146.57	
6248									
147.91	6247.9	149.01	6247.8	150.1	6247.7	151.21	6247.6	152.31	
6247.5									
153.42	6247.4	154.53	6247.3	155.63	6247.2	156.74	6247.1	157.85	
6247									

158.96	6246.9	160.07	6246.8	161.18	6246.7	162.29	6246.6	163.4	
6246.5									
164.51	6246.4	165.62	6246.3	165.95	6246.2	166.16	6246.1	166.38	
6246									
166.59	6245.9	166.8	6245.8	167.02	6245.7	167.23	6245.6	167.45	
6245.5									
167.66	6245.4	167.88	6245.3	168.09	6245.2	168.31	6245.1	168.52	
6245									
168.74	6244.9	168.95	6244.8	169.17	6244.7	169.38	6244.6	169.6	
6244.5									
169.81	6244.4	170.03	6244.3	170.24	6244.2	170.46	6244.1	170.67	
6244									
170.89	6243.9	171.1	6243.8	171.32	6243.7	171.53	6243.6	171.75	
6243.5									
171.97	6243.4	172.18	6243.3	172.4	6243.2	172.62	6243.1	172.83	
6243									
173.05	6242.9	173.27	6242.8	173.48	6242.7	173.7	6242.6	173.92	
6242.5									
174.14	6242.4	174.36	6242.3	174.58	6242.2	174.8	6242.1	175.02	
6242									
175.24	6241.9	175.45	6241.8	175.67	6241.7	175.88	6241.6	176.1	
6241.5									
176.32	6241.4	176.53	6241.3	176.75	6241.2	176.97	6241.1	177.18	
6241									
177.4	6240.9	177.61	6240.8	177.83	6240.7	178.05	6240.6	178.26	
6240.5									
178.48	6240.4	178.69	6240.3	178.91	6240.2	179.13	6240.1	179.34	
6240									
179.56	6239.9	180.92	6239.8	185.83	6239.7	190.76	6239.6	195.74	
6239.5									
200.03	6239.43	201.64	6239.4	202.69	6239.4	209.86	6239.5	216.25	
6239.6									
217.71	6239.7	219.17	6239.8	220.63	6239.9	222.09	6240	223.55	
6240.1									
225.01	6240.2	226.41	6240.3	227.16	6240.4	231.88	6240.5	236.96	
6240.6									
256.33	6240.6	256.73	6240.5	257.13	6240.4	257.53	6240.3	257.92	
6240.2									
258.32	6240.1	258.72	6240	259.12	6239.9	259.52	6239.8	260.22	
6239.7									
261.38	6239.6	262.54	6239.5	263.7	6239.4	264.86	6239.3	270.67	
6239.2									
271.32	6239.2	271.86	6239.3	272.41	6239.4	272.95	6239.5	273.5	
6239.6									
274.05	6239.7	274.59	6239.8	275.14	6239.9	275.68	6240	276.23	
6240.1									
276.78	6240.2	277.32	6240.3	277.87	6240.4	278.41	6240.5	278.96	
6240.6									
279.51	6240.7	280.05	6240.8	284.18	6240.9	291.75	6241	292.24	
6241.1									
292.72	6241.2	293.19	6241.3	293.67	6241.4	294.14	6241.5	296.25	
6241.6									
297.56	6241.7	298.86	6241.8	302.26	6241.9	304.38	6242	305.8	

6242.1  
 307 6242.2 308.11 6242.3 309.12 6242.4 310.01 6242.5 310.89  
 6242.6  
 311.68 6242.7 312.45 6242.8 313.17 6242.9 313.88 6243 314.55  
 6243.1  
 315.21 6243.2 315.83 6243.3 316.44 6243.4 317.05 6243.5 317.62  
 6243.6  
 318.19 6243.7 318.76 6243.8 319.29 6243.9 319.82 6244 320.35  
 6244.1  
 320.86 6244.2 321.36 6244.3 321.87 6244.4 322.37 6244.5 322.84  
 6244.6  
 323.31 6244.7 323.79 6244.8 324.27 6244.9 324.71 6245 325.17  
 6245.1  
 325.62 6245.2 326.07 6245.3 326.51 6245.4 326.94 6245.5 327.38  
 6245.6  
 327.81 6245.7 328.24 6245.8 328.66 6245.9 329.07 6246 329.49  
 6246.1  
 329.9 6246.2 330.32 6246.3 330.87 6246.4 333.78 6246.5 336.6  
 6246.6  
 339.34 6246.7 344.79 6246.8 346.32 6246.9 347.86 6247 349.39  
 6247.1  
 350.73 6247.2 352.07 6247.3 354.42 6247.4 357.6 6247.5 360.77  
 6247.6  
 363.85 6247.7 366.98 6247.8 380.36 6247.8 381 6247.9 385.21  
 6248  
 385.74 6248 385.82 6247.9 385.9 6247.8 385.98 6247.7 386.06  
 6247.6  
 386.15 6247.5 394.93 6247.5 397.25 6247.6 399.66 6247.7 402.21  
 6247.8  
 405.14 6247.9 408.18 6248 411.21 6248.1 416.26 6248.2 421.39  
 6248.3  
 426.53 6248.4 431.58 6248.5 435.85 6248.6 440.11 6248.7 446.02  
 6248.8  
 462.41 6248.8

Manning's n Values num= 3  
 Sta n Val Sta n Val Sta n Val  
 0 .03 166.38 .013 329.07 .03

Bank Sta: Left Right Lengths: Left Channel Right Coeff Contr.  
 Expan. 166.38 329.07 143.6 143.6 143.6 .1

Ineffective Flow num= 4  
 Sta L Sta R Elev Permanent  
 154.72 180.75 6247.14 F  
 185.71 194.38 6247.14 F  
 199.34 250.16 6247.14 F  
 255.11 344.35 6247.14 F

Left Levee Station= 145.97 Elevation= 6248.02  
 Right Levee Station= 385.22 Elevation= 6248

CROSS SECTION OUTPUT Profile #Flow 1

E.G. Elev (ft) 6248.25 Element Left OB  
 Channel Right OB  
 Vel Head (ft) 2.74 Wt. n-Val.  
 0.013  
 W.S. Elev (ft) 6245.51 Reach Len. (ft) 143.60  
 143.60 143.60  
 Crit W.S. (ft) 6245.51 Flow Area (sq ft)  
 82.78  
 E.G. Slope (ft/ft) 0.001370 Area (sq ft)  
 743.70  
 Q Total (cfs) 1100.00 Flow (cfs)  
 1100.00  
 Top Width (ft) 159.57 Top Width (ft)  
 159.57  
 Vel Total (ft/s) 13.29 Avg. Vel. (ft/s)  
 13.29  
 Max Chl Dpth (ft) 6.31 Hydr. Depth (ft)  
 5.57  
 Conv. Total (cfs) 29717.5 Conv. (cfs)  
 29717.5  
 Length Wtd. (ft) 143.60 Wetted Per. (ft)  
 14.87  
 Min Ch El (ft) 6239.20 Shear (lb/sq ft)  
 0.48  
 Alpha 1.00 Stream Power (lb/ft s) 462.41  
 145.97 385.22  
 Frctn Loss (ft) 0.22 Cum Volume (acre-ft)  
 1.41  
 C & E Loss (ft) 0.38 Cum SA (acres)  
 0.32

Warning: The energy equation could not be balanced within the specified number of iterations. The program used critical depth

for the water surface and continued on with the calculations.

Warning: The velocity head has changed by more than 0.5 ft (0.15 m). This may indicate the need for additional cross sections.

Warning: The energy loss was greater than 1.0 ft (0.3 m) between the current and previous cross section. This may indicate the need for additional cross sections.

Warning: During the standard step iterations, when the assumed water surface was set equal to critical depth, the calculated water surface came back below critical depth. This indicates that there is not a valid subcritical answer. The program defaulted to critical depth.

Note: Multiple critical depths were found at this location. The critical depth with the lowest, valid, water surface was used.

CROSS SECTION

RIVER: SC01  
 REACH: Sand Creek-DS-1 RS: 948

INPUT  
 Description:

Station	Elevation	Data	num=	218					
Sta	Elev	Sta	Elev	Sta	Elev	Sta	Elev	Sta	Elev
Elev									
0	6247.7	19.86	6247.7	37.29	6247.6	91.94	6247.5	94.02	
6247.4									
96.56	6247.4	96.65	6247.5	96.74	6247.6	96.82	6247.7	96.91	
6247.8									
97	6247.9	97.05	6247.9	97.27	6247.8	98.86	6247.7	100.65	
6247.6									
101.78	6247.5	103.19	6247.4	104.44	6247.3	105.78	6247.2	107.35	
6247.1									
108.58	6247	110.16	6246.9	111.78	6246.8	113.16	6246.7	114.83	
6246.6									
116.49	6246.5	118.15	6246.4	119.78	6246.3	120.02	6246.2	120.26	
6246.1									
120.5	6246	120.74	6245.9	120.97	6245.8	121.21	6245.7	121.44	
6245.6									
121.67	6245.5	121.9	6245.4	122.14	6245.3	122.37	6245.2	122.6	
6245.1									
122.84	6245	123.07	6244.9	123.3	6244.8	123.54	6244.7	123.76	
6244.6									
123.99	6244.5	124.21	6244.4	124.43	6244.3	124.66	6244.2	124.89	
6244.1									
125.12	6244	125.35	6243.9	125.57	6243.8	125.8	6243.7	126.03	
6243.6									
126.26	6243.5	126.48	6243.4	126.7	6243.3	126.91	6243.2	127.13	
6243.1									
127.35	6243	127.57	6242.9	127.78	6242.8	128	6242.7	128.21	
6242.6									
128.43	6242.5	128.64	6242.4	128.86	6242.3	129.07	6242.2	129.29	
6242.1									
129.51	6242	129.73	6241.9	129.95	6241.8	130.17	6241.7	130.39	
6241.6									
130.62	6241.5	130.83	6241.4	131.05	6241.3	131.26	6241.2	131.47	
6241.1									
131.69	6241	131.9	6240.9	132.11	6240.8	132.33	6240.7	132.54	
6240.6									
132.75	6240.5	132.97	6240.4	133.18	6240.3	133.39	6240.2	133.6	
6240.1									
133.82	6240	134.03	6239.9	134.25	6239.8	134.47	6239.7	134.68	
6239.6									
134.89	6239.5	135.1	6239.4	135.3	6239.3	135.51	6239.2	135.72	
6239.1									
135.93	6239.3	136.14	6238.9	136.35	6238.8	156.69	6238.8	156.9	
6238.9									
157.11	6239	157.32	6239.1	157.53	6239.2	157.74	6239.3	157.95	
6239.4									

158.16	6239.5	158.37	6239.6	158.58	6239.7	158.79	6239.8	159	
6239.9									
159.21	6240	159.41	6240.1	159.62	6240.2	159.83	6240.3	160.04	
6240.4									
160.25	6240.5	160.46	6240.6	160.66	6240.7	160.87	6240.8	161.08	
6240.9									
161.29	6241	161.5	6241.1	161.71	6241.2	161.92	6241.3	162.12	
6241.4									
162.33	6241.5	162.54	6241.6	162.74	6241.7	162.95	6241.8	163.16	
6241.9									
163.36	6242	163.57	6242.1	163.77	6242.2	163.98	6242.3	164.19	
6242.4									
164.39	6242.5	164.6	6242.6	164.8	6242.7	165.01	6242.8	165.22	
6242.9									
165.42	6243	165.63	6243.1	165.84	6243.2	166.04	6243.3	166.25	
6243.4									
166.46	6243.5	166.66	6243.6	166.87	6243.7	167.07	6243.8	167.28	
6243.9									
167.48	6244	167.69	6244.1	167.89	6244.2	168.09	6244.3	168.3	
6244.4									
168.5	6244.5	168.71	6244.6	168.91	6244.7	169.12	6244.8	169.32	
6244.9									
169.52	6245	169.73	6245.1	169.93	6245.2	170.14	6245.3	170.34	
6245.4									
170.55	6245.5	170.75	6245.6	170.96	6245.7	171.16	6245.8	171.36	
6245.9									
171.57	6246	171.77	6246.1	171.98	6246.2	172.18	6246.3	172.39	
6246.4									
173.2	6246.5	174.29	6246.6	175.38	6246.7	176.47	6246.8	177.56	
6246.9									
178.63	6247	179.73	6247.1	180.89	6247.2	182.05	6247.3	183.21	
6247.4									
184.36	6247.5	185.52	6247.6	189.36	6247.7	193.38	6247.8	197.73	
6247.9									
202.55	6248	207.78	6248	207.88	6247.9	207.98	6247.8	208.09	
6247.7									
208.2	6247.6	209.55	6247.5	212.3	6247.5	216.4	6247.6	220.51	
6247.7									
257.02	6247.7	259.18	6247.8	261.66	6247.9	264.27	6248	266.87	
6248.1									
269.48	6248.2	272.27	6248.3	275.37	6248.4	281.83	6248.5	287.18	
6248.6									
292.54	6248.7	297.89	6248.8	300	6248.8				
Manning's n Values			num=	3					
Sta	n Val	Sta	n Val	Sta	n Val				
0	.03	120.5	.013	171.57	.03				
Bank Sta: Left	Right	Lengths: Left	Channel	Right	Coeff	Contr.			
Expan.		120.5	171.57	0	0	0	.1		
.3									
Ineffective Flow		num=	2						



Sta L	Sta R	Elev	Permanent
0	97.05	6247.91	F
208.04	300	6248	F
Left Levee	Station=	96.63	Elevation= 6247.86
Right Levee	Station=	207.62	Elevation= 6248.06

CROSS SECTION OUTPUT Profile #Flow 1

E.G. Elev (ft)	6244.22	Element	Left OB
Channel Right OB			
Vel Head (ft)	1.49	Wt. n-Val.	
0.013			
W.S. Elev (ft)	6242.73	Reach Len. (ft)	
Crit W.S. (ft)	6242.73	Flow Area (sq ft)	
112.41			
E.G. Slope (ft/ft)	0.001785	Area (sq ft)	
112.41			
Q Total (cfs)	1100.00	Flow (cfs)	
1100.00			
Top Width (ft)	36.93	Top Width (ft)	
36.93			
Vel Total (ft/s)	9.79	Avg. Vel. (ft/s)	
9.79			
Max Chl Dpth (ft)	3.93	Hydr. Depth (ft)	
3.04			
Conv. Total (cfs)	26034.1	Conv. (cfs)	
26034.1			
Length Wtd. (ft)		Wetted Per. (ft)	
38.97			
Min Ch El (ft)	6238.80	Shear (lb/sq ft)	
0.32			
Alpha	1.00	Stream Power (lb/ft s)	300.00
96.63	207.62		
Frctn Loss (ft)		Cum Volume (acre-ft)	
C & E Loss (ft)		Cum SA (acres)	

Note: Multiple critical depths were found at this location. The critical depth with the lowest, valid, energy was used.

SUMMARY OF MANNING'S N VALUES

River:EXCH

Reach	River Sta.	n1	n2	n3
-------	------------	----	----	----

EX CHANNEL	1000	.03	.013	.03
EX CHANNEL	999	.03	.03	.03

River:EXOF

Reach	River Sta.	n1	n2	n3
EX OVERFLOW	1001	.03	.013	.03
EX OVERFLOW	1000	.03	.013	.03

River:OVFL

Reach	River Sta.	n1	n2	n3
Overflow Channel	1000	.03	.016	.03
Overflow Channel	999	.03	.016	.03
Overflow Ch-DS-0	998	.03	.013	.03
Overflow Ch-DS-0	997	.03	.033	.03
Overflow Ch-DS-0	996	.03	.033	.03

River:SC01

Reach	River Sta.	n1	n2	n3
Sand Creek	998	.03	.013	.03
Sand Creek	993	.03	.013	.03
Sand Creek-DS-0	992	.03	.013	.03
Sand Creek-DS-0	991	.03	.013	.03
Sand Creek-DS-0	990	.03	.013	.03
Sand Creek-DS-0	989	.03	.013	.03
Sand Creek-DS-0	988	.03	.013	.03
Sand Creek-DS-0	987	.03	.013	.03
Sand Creek-DS-0	986	.03	.013	.03
Sand Creek-DS-0	985	.03	.013	.03
Sand Creek-DS-0	984	.03	.013	.03
Sand Creek-DS-0	983	.03	.013	.03
Sand Creek-DS-0	982	.03	.013	.03
Sand Creek-DS-0	981	.03	.013	.03
Sand Creek-DS-0	980	.03	.013	.03
Sand Creek-DS-0	979	.03	.013	.03
Sand Creek-DS-0	978	.03	.013	.03
Sand Creek-DS-0	977	.03	.013	.03
Sand Creek-DS-0	976	.03	.013	.03
Sand Creek-DS-0	975	.03	.013	.03
Sand Creek-DS-0	974	.03	.013	.03
Sand Creek-DS-0	973	.03	.013	.03
Sand Creek-DS-0	972	.03	.013	.03
Sand Creek-DS-0	971	.03	.013	.03
Sand Creek-DS-0	970	.03	.013	.03

Sand Creek-DS-0-	969	.03	.013	.03
Sand Creek-DS-0-	968	.03	.013	.03
Sand Creek-DS-1	966	.03	.013	.03
Sand Creek-DS-1	965	.03	.013	.03
Sand Creek-DS-1	964	.03	.013	.03
Sand Creek-DS-1	963	.03	.013	.03
Sand Creek-DS-1	962	.03	.013	.03
Sand Creek-DS-1	961	.03	.013	.03
Sand Creek-DS-1	960	.03	.013	.03
Sand Creek-DS-1	959	.03	.013	.03
Sand Creek-DS-1	958	.03	.013	.03
Sand Creek-DS-1	957	.03	.013	.03
Sand Creek-DS-1	956	.03	.013	.03
Sand Creek-DS-1	955	.03	.013	.03
Sand Creek-DS-1	954	.03	.013	.03
Sand Creek-DS-1	953	.03	.013	.03
Sand Creek-DS-1	952	.03	.013	.03
Sand Creek-DS-1	951	.03	.013	.03
Sand Creek-DS-1	950	.03	.013	.03
Sand Creek-DS-1	949.5	Culvert		
Sand Creek-DS-1	949	.03	.013	.03
Sand Creek-DS-1	948	.03	.013	.03

SUMMARY OF REACH LENGTHS

River: EXCH

Reach	River Sta.	Left	Channel	Right
EX CHANNEL	1000	284.89	284.89	284.89
EX CHANNEL	999	0	0	0

River: EXOF

Reach	River Sta.	Left	Channel	Right
EX OVERFLOW	1001	138.8	138.8	138.8
EX OVERFLOW	1000	0	0	0

River: OVFL

Reach	River Sta.	Left	Channel	Right
Overflow Channel	1000	24.16	24.16	24.16
Overflow Channel	999	0	0	0
Overflow Ch-DS-0	998	132.75	132.75	132.75
Overflow Ch-DS-0	997	24.72	24.72	24.72

Overflow Ch-DS-0	996	0	0	0
------------------	-----	---	---	---

River: SC01

Reach	River Sta.	Left	Channel	Right
Sand Creek	998	33.99	33.99	33.99
Sand Creek	993	40.51	40.51	40.51
Sand Creek-DS-0	992	11.58	11.58	11.58
Sand Creek-DS-0	991	100	100	100
Sand Creek-DS-0-	990	6.48	6.48	6.48
Sand Creek-DS-0-	989	43.52	43.52	43.52
Sand Creek-DS-0-	988	39.44	39.44	39.44
Sand Creek-DS-0-	987	10.56	10.56	10.56
Sand Creek-DS-0-	986	6.48	6.48	6.48
Sand Creek-DS-0-	985	10.39	10.39	10.39
Sand Creek-DS-0-	984	10	10	10
Sand Creek-DS-0-	983	20.18	20.18	20.18
Sand Creek-DS-0-	982	2.95	2.95	2.95
Sand Creek-DS-0-	981	19.23	19.23	19.23
Sand Creek-DS-0-	980	10	10	10
Sand Creek-DS-0-	979	9.51	9.51	9.51
Sand Creek-DS-0-	978	11.26	11.26	11.26
Sand Creek-DS-0-	977	50	50	50
Sand Creek-DS-0-	976	50	50	50
Sand Creek-DS-0-	975	22.55	22.55	22.55
Sand Creek-DS-0-	974	19.92	19.92	19.92
Sand Creek-DS-0-	973	7.53	7.53	7.53
Sand Creek-DS-0-	972	12.38	12.38	12.38
Sand Creek-DS-0-	971	37.63	37.63	37.63
Sand Creek-DS-0-	970	50	50	50
Sand Creek-DS-0-	969	50	50	50
Sand Creek-DS-0-	968	50	50	50
Sand Creek-DS-1	966	50	50	50
Sand Creek-DS-1	965	50	50	50
Sand Creek-DS-1	964	50	50	50
Sand Creek-DS-1	963	50	50	50
Sand Creek-DS-1	962	50	50	50
Sand Creek-DS-1	961	50	50	50
Sand Creek-DS-1	960	50	50	50
Sand Creek-DS-1	959	50	50	50
Sand Creek-DS-1	958	50	50	50
Sand Creek-DS-1	957	50	50	50
Sand Creek-DS-1	956	50	50	50
Sand Creek-DS-1	955	50	50	50
Sand Creek-DS-1	954	34.26	34.26	34.26
Sand Creek-DS-1	953	15.74	15.74	15.74
Sand Creek-DS-1	952	11.7	11.7	11.7
Sand Creek-DS-1	951	27.44	27.44	27.44
Sand Creek-DS-1	950	97.99	97.99	97.99
Sand Creek-DS-1	949.5	Culvert		
Sand Creek-DS-1	949	143.6	143.6	143.6

Sand Creek-DS-1 948 0 0 0

SUMMARY OF CONTRACTION AND EXPANSION COEFFICIENTS  
River: EXCH

Reach	River Sta.	Contr.	Expan.
EX CHANNEL	1000	.1	.3
EX CHANNEL	999	.1	.3

River: EXOF

Reach	River Sta.	Contr.	Expan.
EX OVERFLOW	1001	.1	.3
EX OVERFLOW	1000	.1	.3

River: OVFL

Reach	River Sta.	Contr.	Expan.
Overflow Channel	1000	.1	.3
Overflow Channel	999	.1	.3
Overflow Ch-DS-0	998	.1	.3
Overflow Ch-DS-0	997	.1	.3
Overflow Ch-DS-0	996	.1	.3

River: SC01

Reach	River Sta.	Contr.	Expan.
Sand Creek	998	.1	.3
Sand Creek	993	.1	.3
Sand Creek-DS-0	992	.1	.3
Sand Creek-DS-0	991	.1	.3
Sand Creek-DS-0-	990	.1	.3
Sand Creek-DS-0-	989	.1	.3
Sand Creek-DS-0-	988	.1	.3
Sand Creek-DS-0-	987	.1	.3
Sand Creek-DS-0-	986	.1	.3
Sand Creek-DS-0-	985	.1	.3
Sand Creek-DS-0-	984	.1	.3
Sand Creek-DS-0-	983	.1	.3
Sand Creek-DS-0-	982	.1	.3
Sand Creek-DS-0-	981	.1	.3

Sand Creek-DS-0-	980	.1	.3
Sand Creek-DS-0-	979	.1	.3
Sand Creek-DS-0-	978	.1	.3
Sand Creek-DS-0-	977	.1	.3
Sand Creek-DS-0-	976	.1	.3
Sand Creek-DS-0-	975	.1	.3
Sand Creek-DS-0-	974	.1	.3
Sand Creek-DS-0-	973	.1	.3
Sand Creek-DS-0-	972	.1	.3
Sand Creek-DS-0-	971	.1	.3
Sand Creek-DS-0-	970	.1	.3
Sand Creek-DS-0-	969	.1	.3
Sand Creek-DS-0-	968	.1	.3
Sand Creek-DS-1	966	.1	.3
Sand Creek-DS-1	965	.1	.3
Sand Creek-DS-1	964	.1	.3
Sand Creek-DS-1	963	.1	.3
Sand Creek-DS-1	962	.1	.3
Sand Creek-DS-1	961	.1	.3
Sand Creek-DS-1	960	.1	.3
Sand Creek-DS-1	959	.1	.3
Sand Creek-DS-1	958	.1	.3
Sand Creek-DS-1	957	.1	.3
Sand Creek-DS-1	956	.1	.3
Sand Creek-DS-1	955	.1	.3
Sand Creek-DS-1	954	.1	.3
Sand Creek-DS-1	953	.1	.3
Sand Creek-DS-1	952	.1	.3
Sand Creek-DS-1	951	.1	.3
Sand Creek-DS-1	950	.1	.3
Sand Creek-DS-1	949.5	Culvert	
Sand Creek-DS-1	949	.1	.3
Sand Creek-DS-1	948	.1	.3