

El Paso County MS4 Post Construction Detention / Water Quality Facility Documentation Form

This document **must be completed and submitted** with required attachments to the County for projects requiring a detention and/or a water quality facility. A separate completed form must be submitted for each facility.

Project name: Solace Apartments Filing No. 1 - Pond A

Owner name: CS Powers and Galley, LLC

Location Address:
Tract B Solace Apartments Filing No. 1

Latitude and Longitude:
38°50'56.40" N 104°42'55.97"W

Assessor's Parcel #: 5407200052 Section: 7 Township: 14 S Range: 65 W

Expected Completion date: May 2022

Project acreage: 28.99 Design Ponding Acres: 0.42 Design Storm: 100-YEAR

Design Engineer Email Address: mbramlett@jrengineering.com

To ensure compliance with C.R.S. 37-92-602(8), the completed Stormwater Detention and Infiltration Design Data Sheet **must be attached**. The form can be found here: <https://maperture.digitaldataservices.com/gvh/?viewer=cswdiff#> (click on Download SDI Design Data Sheet)

List all permanent water quality control measure(s) (EDBs, rain gardens, etc):
Pond A is a full spectrum pond, and has been designed in accordance with the full spectrum design criteria set forth by El Paso County.

For all projects for which the constrained redevelopment sites standard is applied, provide an explanation of why it is not practicable to meet the full design standards. Full design standards achieved.

Attach Operations and Maintenance (O&M) Plan describing the operation and maintenance procedures that ensure the long-term observation, maintenance, and operation of control measure(s), including routine inspection frequencies and maintenance activities. If multiple, different water quality control measures are used at the same location, a separate O & M Plan must be provided for each facility.

Attach Private Detention Basin / Stormwater Quality Best Management Practice Maintenance Agreement and Easement addressing maintenance of BMPs that shall be binding on all subsequent owners of the permanent BMPs.

Attachments:
Stormwater Detention and Infiltration Design Data Sheet
O & M Plan
Maintenance and Access Agreement

Review Engineer []
EPC Project File No. SF 2032
PPR2047



El Paso County MS4 Post Construction Detention / Water Quality Facility Documentation Form

This document must be completed and submitted with required attachments to the County for projects requiring a detention and/or a water quality facility. A separate completed form must be submitted for each facility.

Project name: Solace Apartments Filing No. 1 - Pond B

Owner name: CS Powers and Galley, LLC

Location Address: Tract B Solace Apartments Filing No. 1

Latitude and Longitude: 38°50'50.25"N 104°42'56.09"W

Assessor's Parcel #: 5407200052 Section: 7 Township: 14 S Range: 65 W

Expected Completion date: May 2022

Project acreage: 28.99 Design Ponding Acres: 0.82 Design Storm: 100-YEAR

Design Engineer Email Address: mbramlett@jrengineering.com

To ensure compliance with C.R.S. 37-92-602(8), the completed Stormwater Detention and Infiltration Design Data Sheet must be attached. The form can be found here: https://maperture.digitaldataservices.com/gvh/?viewer=cswdiff# (click on Download SDI Design Data Sheet)

List all permanent water quality control measure(s) (EDBs, rain gardens, etc): Pond B is a full spectrum pond, and has been designed in accordance with the full spectrum design criteria set forth by El Paso County.

For all projects for which the constrained redevelopment sites standard is applied, provide an explanation of why it is not practicable to meet the full design standards. Full design standards achieved.

Attach Operations and Maintenance (O&M) Plan describing the operation and maintenance procedures that ensure the long-term observation, maintenance, and operation of control measure(s), including routine inspection frequencies and maintenance activities. If multiple, different water quality control measures are used at the same location, a separate O & M Plan must be provided for each facility.

Attach Private Detention Basin / Stormwater Quality Best Management Practice Maintenance Agreement and Easement addressing maintenance of BMPs that shall be binding on all subsequent owners of the permanent BMPs.

- Attachments: Stormwater Detention and Infiltration Design Data Sheet O & M Plan Maintenance and Access Agreement

Review Engineer [] EPC Project File No. SF 2032 PPR2047

Stormwater Detention and Infiltration Design Data Sheet

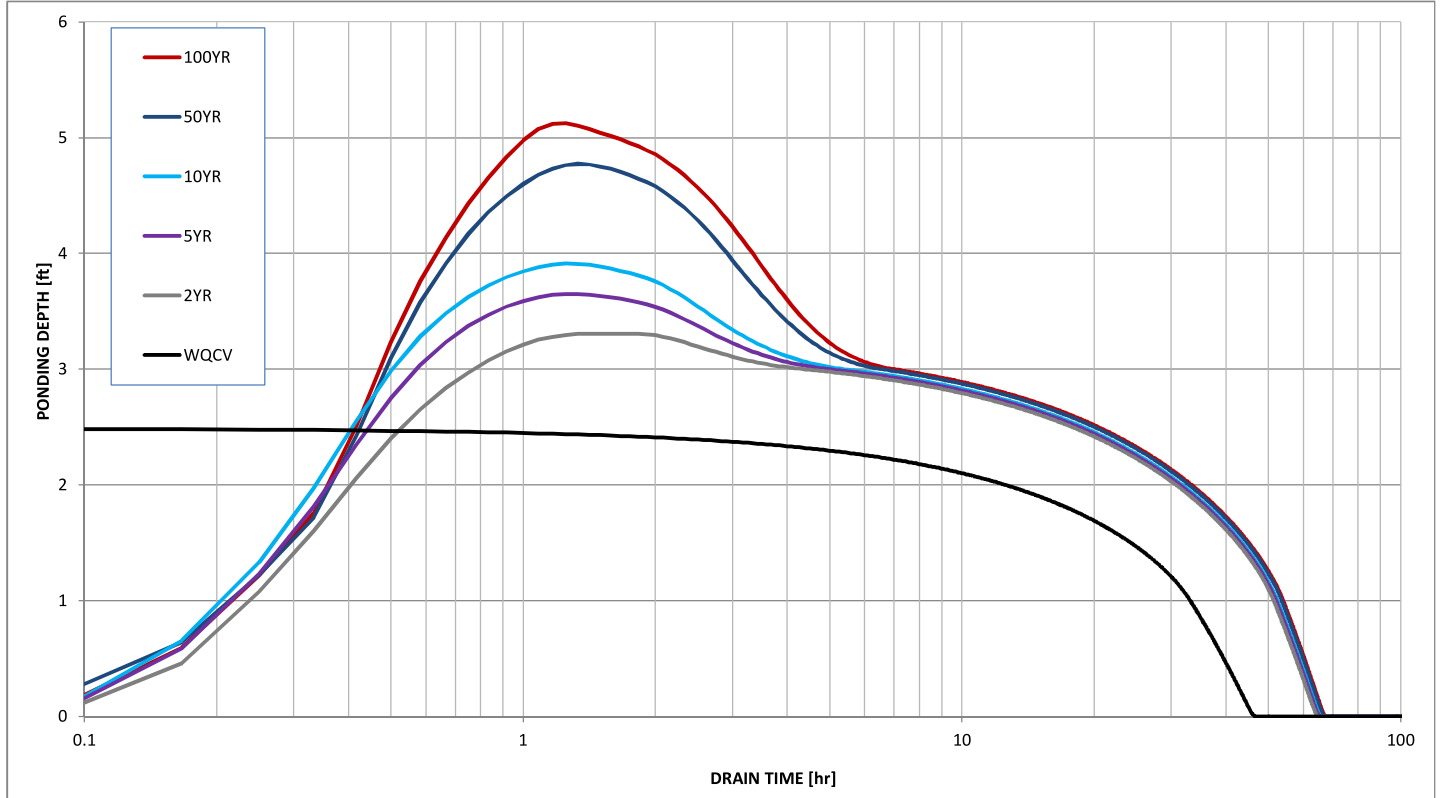
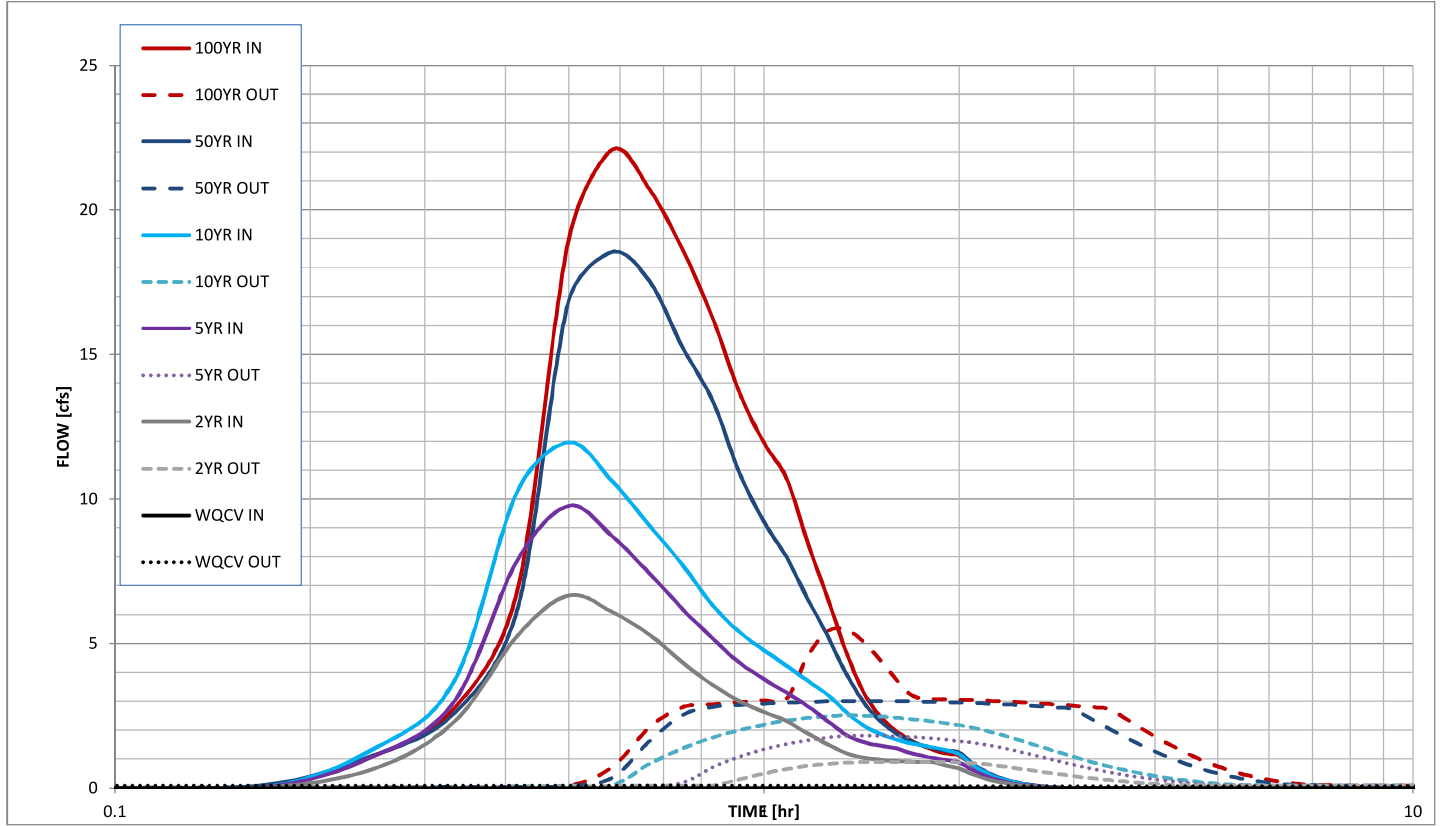

Stormwater Detention and Infiltration Design Data Sheet

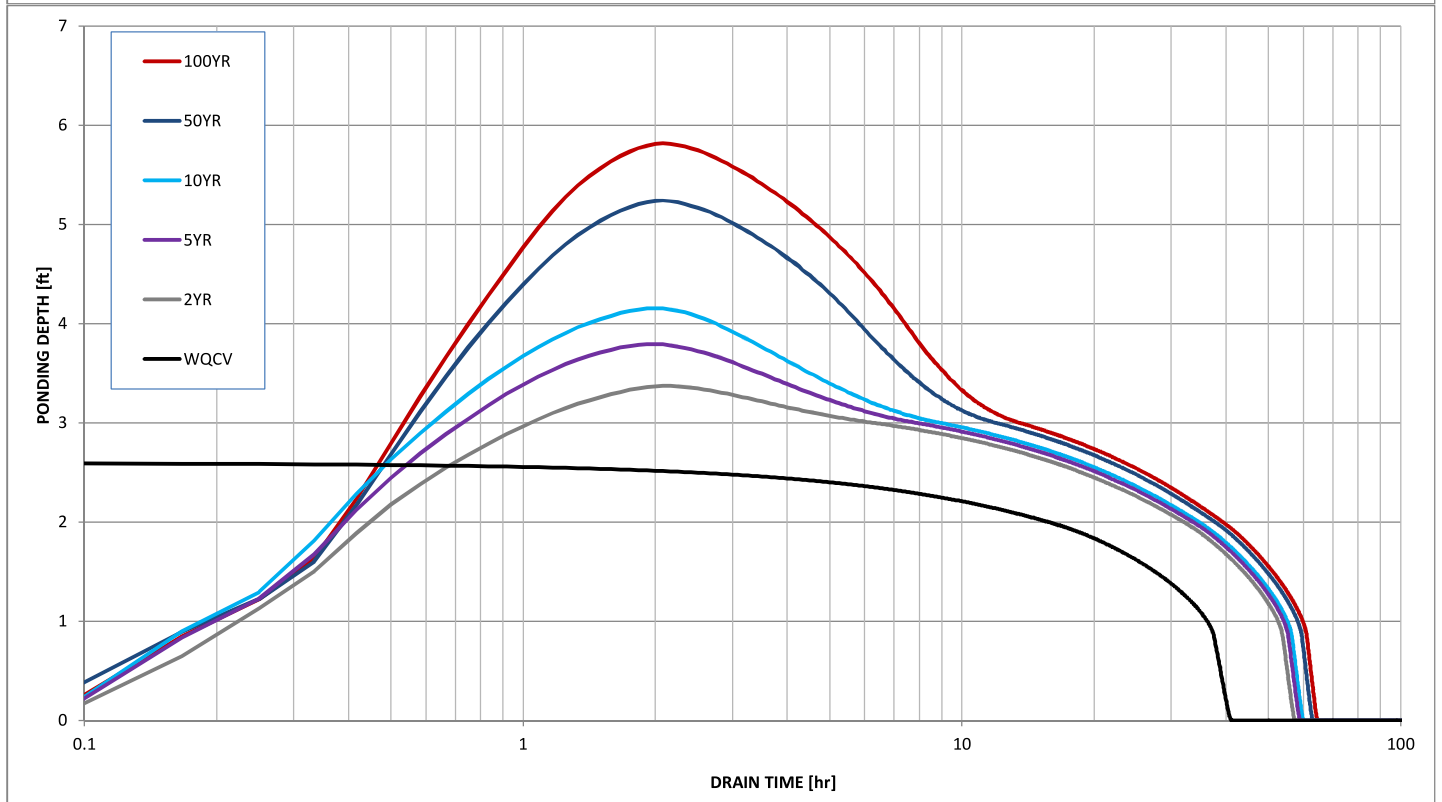
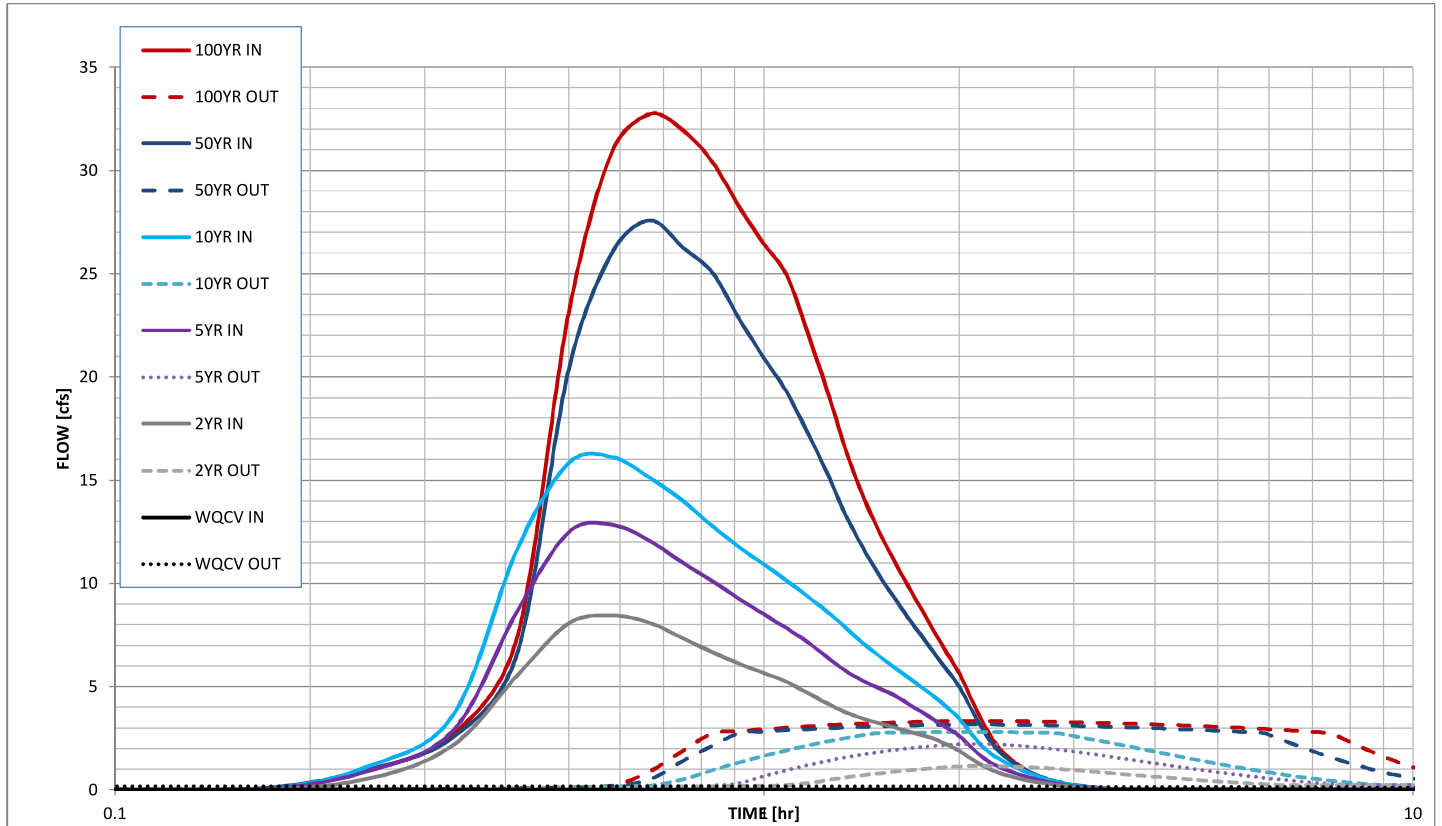



**Stormwater Management Facility
Operation and Maintenance (O&M) Plan**

for:

Solace Apartments Filing No. 1

Located at:

***Northeast Corner of the intersection of
Galley Road and North Powers Boulevard***

Prepared for:

***CS Powers and Galley, LLC
510 S Neil St.
Champaign, IL 61820
(734)216-2577***

Prepared by:

***JR Engineering, LLC
5475 Tech Center Drive
Colorado Springs, CO 80919
(719)593-2593***

11/11/21

PCD File Number: SF-20-032

**Stormwater Management Facility
Inspection and Maintenance (I&M) Plan**

Table of Contents

- I. Compliance with Stormwater Facility Maintenance Requirements**
- II. Inspection & Maintenance- Annual Reporting**
- III. Preventative Measures to Reduce Maintenance Costs**
- IV. Access and Easements**
- V. Safety**
- VI. Field Inspection Equipment**
- VII. Inspecting Stormwater Management Facilities**
 - A. Inspection Procedures
 - B. Inspection Report
 - C. Verification of Inspection and Form Submittal
- VIII. Maintaining Stormwater Management Facilities**
 - A. Maintenance Categories
 - B. Maintenance Personnel
 - C. Maintenance Forms

Appendices

- Appendix A** - Maintenance Agreement(s)
- Appendix B** - Description of Stormwater Management Facilities
- Appendix C** - Standard Operation Procedures (SOP) for Extended Detention Basins; Grass Buffers and Grass Swales
- Appendix D** - Inspection Form(s)
- Appendix E** - Maintenance Form(s)
- Appendix F**- Stormwater Facilities Map; Facility plan and detail sheets

Stormwater Management Facility Inspection and Maintenance (I&M) Plan

I. Compliance with Stormwater Facility Maintenance Requirements

All property owners are responsible for ensuring stormwater facilities installed on their property are properly maintained and function as designed. Jackson Dearborn Partners may elect to assign many of the management and maintenance functions described in this plan to a third party. Jackson Dearborn Partners is aware of their responsibilities regarding stormwater facility maintenance. Maintenance agreement(s) associated with this property are provided in Appendix A.

II. Inspection & Maintenance – Annual Reporting

Requirements for the inspection and maintenance of stormwater facilities, as well as reporting requirements are included in this Stormwater Management Facility Inspection and Maintenance (I&M) Plan.

Verification that the Stormwater facilities have been properly inspected and maintained; submittal of the required Inspection and Maintenance Forms and Inspector qualifications shall be provided to the Owners Representative, and to El Paso County upon request.

Copies of the Inspection and Maintenance forms for each of the stormwater facilities are located in Appendix D and E. A standard annual reporting form is provided in Appendix F. Each form shall be reviewed and submitted by the property owner or property manager to:

El Paso County
Department of Public Works - Stormwater
3275 Akers Drive
Colorado Springs, CO 80922

III. Preventative Measures to Reduce Maintenance Costs

The most effective way to maintain your water quality facility is to prevent the pollutants from entering the facility in the first place. Common pollutants include sediment, trash & debris, chemicals, dog wastes, runoff from stored materials, illicit discharges into the storm drainage system and many others. Jackson Dearborn Partners' maintenance program includes measures to address these potential contaminants. Depending on the storm water quality facilities installed on the site the maintenance program includes:

- Educate property owners/residents to be aware of how their actions affect water quality, and how they can help reduce maintenance costs.
- Keep properties, streets and gutters, and parking lots free of trash, debris, and lawn clippings.
- Ensure the proper disposal of hazardous wastes and chemicals.
- Plan lawn care to minimize the use of chemicals and pesticides.

- Sweep paved surfaces regularly and dispose the sweepings properly.
- Be aware of automobiles leaking fluids. Use absorbents such as cat litter to soak up drippings – dispose of properly.
- Re-vegetate disturbed and bare areas to maintain vegetative stabilization.
- Clean out the upstream components of the storm drainage system, including inlets, storm sewers and outfalls.
- Do not store materials outdoors (including landscaping materials) unless properly protected from runoff.

IV. Access and Easements

Jackson Dearborn Partners shall prepare a drawing showing all stormwater management facilities located on the site including designated access locations as well as required easements. Refer to the Stormwater Facilities Map located in Appendix G for access and easement locations.

V. Safety

Keep safety considerations at the forefront of inspection procedures at all times. Likely hazards should be anticipated and avoided. Jackson Dearborn Partners personnel should never enter a confined space (outlet structure, manhole, etc) without proper training or equipment. A confined space should never be entered without at least one additional person present and without using appropriate personal protection equipment.

If a toxic or flammable substance is discovered, leave the immediate area and call 911.

Vertical drops and fall hazards may be encountered in areas located within and around the facility. Jackson Dearborn Partners shall avoid walking on top of retaining walls or other structures that have a significant vertical drop. If a vertical drop is identified that is greater than 48” in height, make the appropriate note/comment on the maintenance inspection form.

If any hazard is found within the facility area that poses an immediate threat to public safety, call 911.

VI. Field Inspection Equipment

Jackson Dearborn Partners’ inspectors shall have the appropriate equipment to take to the field. This is to ensure the safety of the inspector and allow the inspections to be performed as efficiently as possible. Below is a list of the equipment that may be necessary to perform the inspections of all Stormwater Management Facilities:

- Protective clothing and boots.
- Safety equipment (vest, hard hat, confined space entry equipment).
- Communication equipment.

- Inspection and Maintenance Plan for the site including stormwater management facility location maps.
- Clipboard.
- Stormwater Facility Maintenance Inspection Forms (See Appendix D).
- Manhole Lid Remover
- Shovel.

Some of the items identified above need not be carried by the inspector (manhole lid remover, shovel, and confined space entry equipment). However, this equipment should be available in the vehicle driven to the site.

VII. Inspecting Stormwater Management Facilities

The quality of stormwater entering the waters of the state relies heavily on the proper operation and maintenance of permanent best management practices. Stormwater management facilities shall be periodically inspected to ensure they function as designed. The inspection will determine the appropriate maintenance required for the facility.

A. Inspection Procedures

All stormwater management facilities shall be inspected by a qualified individual at a minimum of once per year. See the *City of Colorado Springs/El Paso County Drainage Criteria Manual* for general guidelines for an inspector. Inspections will follow the inspection guidance found in the SOP for the specific type of facility. (Appendix C of this plan).

B. Inspection Report

Jackson Dearborn Partners' personnel or inspector conducting the inspection activities shall complete the appropriate inspection report for the specific facility. Inspection reports are located in Appendix D.

The following information explains how to fill out the Inspection Forms:

General Information

This section identifies the facility location, person conducting the inspection, the date and time the facility was inspected, and approximate days since the last rainfall. Property classification is identified as single-family residential, multi-family residential, commercial, or other.

The reason for the inspection is also identified on the form depending on the nature of the inspection. All facilities shall be inspected on an annual basis at a minimum. In addition, all facilities shall be inspected after a significant precipitation event to ensure the facility is draining appropriately and to identify any damage that occurred as a result of the increased runoff.

Inspection Scoring

For each inspection item, a score must be given to identify the urgency of required maintenance. The scoring is as follows:

- 0 = No deficiencies identified.
- 1 = Monitor – Although maintenance may not be required at this time, a potential problem exists that will most likely need to be addressed in the future. This can include items like minor erosion, concrete cracks/spalling, or minor sediment accumulation. This item should be revisited at the next inspection.
- 2 = Routine Maintenance Required – Some inspection items can be addressed through the routine maintenance program (See SOP in appendix C). This can include items like vegetation management or debris/trash removal.
- 3 = Immediate Repair Necessary – This item needs immediate attention because failure is imminent or has already occurred. This could include items such as structural failure of a feature (outlet works, forebay, etc), significant erosion, or significant sediment accumulation. This score should be given to an item that can significantly affect the function of the facility.
- N/A This is checked by an item that may not exist in a facility. Not all facilities have all of the features identified on the form (forebay, micro-pool, etc.).

Inspection Summary/Additional Comments

Additional explanations to inspection items, and observations about the facility not covered by the form, are recorded in this section.

Overall Facility Rating

An overall rating must be given for each facility inspected. The overall facility rating should correspond with the highest score (0, 1, 2, 3) given to any feature on the inspection form.

C. Verification of Inspection and Form Submittal

The Stormwater Management Facility Inspection Form provides a record of inspection of the facility. Inspection Forms for each facility type are provided in Appendix D. Verification of the inspection of the stormwater facilities, the facility inspection form(s), and Inspector Qualifications shall be provided to the Owners Representative, and to El Paso County if requested. The verification and the inspection form(s) shall be reviewed and submitted by Jackson Dearborn Partners or their property manager.

Refer to Section II of this Plan regarding the annual reporting of inspections.

VIII. Maintaining Stormwater Management Facilities

Stormwater management facilities shall be properly maintained to ensure they operate correctly and provide the water quality treatment for which they were designed. Routine maintenance performed on a frequently scheduled basis, can help avoid more costly rehabilitative maintenance that results when facilities are not adequately maintained.

A. Maintenance Categories

Stormwater management facility maintenance programs are separated into three broad categories of work. These categories are based largely on the Urban Drainage and Flood Control District's Maintenance Program for regional drainage facilities. The categories are separated based upon the magnitude and type of the maintenance activities performed. A description of each category follows:

Routine Work

The majority of this work consists of scheduled mowings and trash and debris pickups for stormwater management facilities during the growing season. This includes items such as the removal of debris/material that may be clogging the outlet structure well screens and trash racks. It also includes activities such as weed control, mosquito treatment, and algae treatment. These activities normally will be performed numerous times during the year. These items can be completed without any prior correspondence with El Paso County; however, completed inspection and maintenance forms shall be submitted to El Paso County for each inspection and maintenance activity with the annual report.

Restoration Work

This work consists of a variety of isolated or small-scale maintenance and work needed to address operational problems. Most of this work can be completed by a small crew, with minor tools, and small equipment. The Jackson Dearborn Partners shall correspond with El Paso County and submit completed maintenance forms to the owner's representative & El Paso County, if requested, for each maintenance activity.

Rehabilitation Work

This work consists of large-scale maintenance and major improvements needed to address failures within the stormwater management facilities. This work requires consultation with El Paso County and may require an engineering design with construction plans to be prepared for review and approval. This work may also require more specialized maintenance

equipment, surveying, construction permits or assistance through private contractors and consultants. If these items are needed Jackson Dearborn Partners shall correspond with El Paso County and submit completed maintenance forms to El Paso County for each maintenance activity.

B. Maintenance Personnel

Jackson Dearborn Partners' maintenance personnel shall be qualified to properly maintain stormwater management facilities. Inadequately trained personnel can cause additional problems resulting in additional maintenance costs.

C. Maintenance Forms

The Stormwater Management Facility Maintenance Form provides a record of maintenance activities. Maintenance Forms for each facility type are provided in Appendix E. Maintenance Forms shall be completed by the Jackson Dearborn Partners' contractor completing the required maintenance items. The form shall then be reviewed by Jackson Dearborn Partners or an authorized agent of the property owner and submitted to El Paso County, when requested.

Refer to Section II of this Plan regarding the annual reporting of inspections and maintenance activities performed.

A P P E N D I X A

Stormwater Maintenance Agreement Template

**PRIVATE DETENTION BASIN /
STORMWATER QUALITY BEST MANAGEMENT PRACTICE
MAINTENANCE AGREEMENT AND EASEMENT**

This PRIVATE DETENTION BASIN / STORMWATER QUALITY BEST MANAGEMENT PRACTICE MAINTENANCE AGREEMENT AND EASEMENT (Agreement) is made by and between EL PASO COUNTY by and through THE BOARD OF COUNTY COMMISSIONERS OF EL PASO COUNTY, COLORADO (Board or County) and CS POWERS AND GALLEY, LLC, a limited liability company (Owner). The above may occasionally be referred to herein singularly as “Party” and collectively as “Parties.”

Recitals

A. WHEREAS, Owner is the owner of certain real estate (the Property or Subdivision) in El Paso County, Colorado, which Property is legally described in Exhibit A attached hereto and incorporated herein by this reference; and

B. WHEREAS, Owner desires to plat and develop on the Property a subdivision to be known as Solace Apartment; and

C. WHEREAS, the development of this Property will substantially increase the volume of water runoff and will decrease the quality of the stormwater runoff from the Property, and, therefore, it is in the best interest of public health, safety and welfare for the County to condition approval of this subdivision on Owner’s promise to construct adequate drainage, water runoff control facilities, and stormwater quality structural Best Management Practices (“BMPs”) for the subdivision; and

D. WHEREAS, Chapter 8, Section 8.4.5 of the El Paso County Land Development Code, as periodically amended, promulgated pursuant to Section 30-28-133(1), Colorado Revised Statutes (C.R.S.), requires the County to condition approval of all subdivisions on a developer’s promise to so construct adequate drainage, water runoff control facilities, and BMPs in subdivisions; and

E. WHEREAS, the Drainage Criteria Manual, Volume 2, as amended by Appendix I of the El Paso County Engineering Criteria Manual (ECM), as each may be periodically amended, promulgated pursuant to the County’s Colorado Discharge Permit System General Permit (MS4 Permit) as required by Phase II of the National Pollutant Discharge Elimination System (NPDES), which MS4 Permit requires that the County take measures to protect the quality of stormwater from sediment and other contaminants, requires subdividers, developers, landowners, and owners of facilities located in the County’s rights-of-way or easements to provide adequate permanent stormwater quality BMPs with new development or significant redevelopment; and

F. WHEREAS, Section 2.9 of the El Paso County Drainage Criteria Manual provides for a developer’s promise to maintain a subdivision’s drainage facilities in the event the County does not assume such responsibility; and

G. WHEREAS, developers in El Paso County have historically chosen water runoff detention basins as a means to provide adequate drainage and water runoff control in subdivisions,

which basins, while effective, are less expensive for developers to construct than other methods of providing drainage and water runoff control; and

H. WHEREAS, Owner desires to construct for the subdivision two detention basin/stormwater quality BMP(s) (“detention basin/BMP(s)”) as the means for providing adequate drainage and stormwater runoff control and to meet requirements of the County’s MS4 Permit, and to provide for operating, cleaning, maintaining and repairing such detention basin/BMP(s); and

I. WHEREAS, Owner desires to construct the detention basin/BMP(s) on property that is or will be platted as Tract B, and as set forth on Exhibit B attached hereto; and

J. WHEREAS, Owner shall be charged with the duty of constructing the detention basin/BMP(s) and with the duties of operating, maintaining and repairing the detention basin/BMP(s) on the property described in Exhibit B; and

K. WHEREAS, it is the County’s experience that subdivision developers and property owners historically have not properly cleaned and otherwise not properly maintained and repaired these detention basins/BMPs, and that these detention basins/BMPs, when not so properly cleaned, maintained, and repaired, threaten the public health, safety and welfare; and

L. WHEREAS, the County, in order to protect the public health, safety and welfare, has historically expended valuable and limited public resources to so properly clean, maintain, and repair these detention basins/BMPs when developers and property owners have failed in their responsibilities, and therefore, the County desires the means to recover its costs incurred in the event the burden falls on the County to so clean, maintain and repair the detention basin/BMP(s) serving this Subdivision due to the Owner’s failure to meet its obligations to do the same; and

M. WHEREAS, the County conditions approval of this Subdivision on the Owner’s promise to so construct the detention basin/BMP(s), and further conditions approval on the Owner’s promise to reimburse the County in the event the burden falls upon the County to so clean, maintain and/or repair the detention basin/BMP(s) serving this Subdivision; and

N. WHEREAS, the County could condition subdivision approval on the Owner’s promise to construct a different and more expensive drainage, water runoff control system and BMPs than those proposed herein, which more expensive system would not create the possibility of the burden of cleaning, maintenance and repair expenses falling on the County; however, the County is willing to forego such right upon the performance of Owner’s promises contained herein; and

O. WHEREAS, the County, in order to secure performance of the promises contained herein, conditions approval of this Subdivision upon the Owner’s grant herein of a perpetual Easement over a portion of the Property for the purpose of allowing the County to periodically access, inspect, and, when so necessary, to clean, maintain and/or repair the detention basin/BMP(s).

Agreement

NOW, THEREFORE, in consideration of the mutual Promises contained herein, the sufficiency of which are hereby acknowledged, the Parties agree as follows:

1. Incorporation of Recitals: The Parties incorporate the Recitals above into this Agreement.

2. Covenants Running with the Land: Owner agree that this entire Agreement and the performance thereof shall become a covenant running with the land, which land is legally described in Exhibit A attached hereto, and that this entire Agreement and the performance thereof shall be binding upon itself and its successors and assigns.

3. Construction: Owner shall construct on that portion of the Property described in Exhibit B attached hereto and incorporated herein by this reference, two detention basin/BMP(s). Owner shall not commence construction of the detention basin/BMP(s) until the El Paso County Planning and Community Development Department (PCD) has approved in writing the plans and specifications for the detention basin/BMP(s) and this Agreement has been signed by all Parties and returned to the PCD. Owner shall complete construction of the detention basin/BMP(s) in substantial compliance with the County-approved plans and specifications for the detention basin/BMP(s). Failure to meet these requirements shall be a material breach of this Agreement and shall entitle the County to pursue any remedies available to it at law or in equity to enforce the same. Construction of the detention basin/BMP(s) shall be substantially completed within one (1) year (defined as 365 days), which one year period will commence to run on the date the approved plat of this Subdivision is recorded in the records of the El Paso County Clerk and Recorder. Rough grading of the detention basin/BMP(s) must be completed and inspected by the El Paso County Planning and Community Development Department prior to commencing road construction.

In the event construction is not substantially completed within the one (1) year period, then the County may exercise its discretion to complete the project and shall have the right to seek reimbursement from the Owner and its successors and assigns for its actual costs and expenses incurred in the process of completing construction. The term actual costs and expenses shall be liberally construed in favor of the County, and shall include, but shall not be limited to, labor costs, tool and equipment costs, supply costs, and engineering and design costs, regardless of whether the County uses its own personnel, tools, equipment and supplies, etc. to correct the matter. In the event the County initiates any litigation or engages the services of legal counsel in order to enforce the Provisions arising herein, the County shall be entitled to its damages and costs, including reasonable attorney fees, regardless of whether the County contracts with outside legal counsel or utilizes in-house legal counsel for the same.

4. Maintenance: The Owner agrees for itself and its successors and assigns that it will regularly and routinely inspect, clean and maintain the detention basin/BMP(s) and otherwise keep the same in good repair, all at its own cost and expense. No trees or shrubs that will impair the structural integrity of the detention basin/BMP(s) shall be planted or allowed to grow on the detention basin/BMP(s).

5. Creation of Easement: Owner hereby grants the County a non-exclusive perpetual easement upon and across that portion of the Property described in Exhibit B. The purpose of the easement is to allow the County to access, inspect, clean, repair and maintain the detention

basin/BMP(s); however, the creation of the easement does not expressly or implicitly impose on the County a duty to so inspect, clean, repair or maintain the detention basin/BMP(s).

6. County's Rights and Obligations: Any time the County determines, in the sole exercise of its discretion, that the detention basin/BMP(s) is not properly cleaned, maintained and/or otherwise kept in good repair, the County shall give reasonable notice to the Owner and its successors and assigns that the detention basin/BMP(s) needs to be cleaned, maintained and/or otherwise repaired. The notice shall provide a reasonable time to correct the problem(s). Should the responsible parties fail to correct the specified problem(s), the County may enter upon the Property to so correct the specified problem(s). Notice shall be effective to the above by the County's deposit of the same into the regular United States mail, postage pre-paid. Notwithstanding the foregoing, this Agreement does not expressly or implicitly impose on the County a duty to so inspect, clean, repair or maintain the detention basin/BMP(s).

7. Reimbursement of County's Costs: The Owner agrees and covenants, for itself and its successors and assigns, that they will reimburse the County for its costs and expenses incurred in the process of completing construction of, cleaning, maintaining, and/or repairing the detention basin/BMP(s) pursuant to the provisions of this Agreement.

The term "actual costs and expenses" shall be liberally construed in favor of the County, and shall include, but shall not be limited to, labor costs, tools and equipment costs, supply costs, and engineering and design costs, regardless of whether the County uses its own personnel, tools, equipment and supplies, etc. to correct the matter. In the event the County initiates any litigation or engages the services of legal counsel in order to enforce the provisions arising herein, the County shall be entitled to its damages and costs, including reasonable attorney's fees, regardless of whether the County contracts with outside legal counsel or utilizes in-house legal counsel for the same.

8. Contingencies of Subdivision Approval: The Owner's execution of this Agreement is a condition of subdivision approval. Additional conditions of this Agreement include, but are not limited to, the following:

a. [Reserved]

The County shall have the right, in the sole exercise of its discretion, to approve or disapprove any documentation submitted to it under the conditions of this Paragraph, including but not limited to, any separate agreement or amendment, if applicable, identifying any specific maintenance responsibilities not addressed herein. The County's rejection of any documentation submitted hereunder shall mean that the appropriate condition of this Agreement has not been fulfilled.

9. Agreement Monitored by El Paso County Planning and Community Development Department and/or El Paso County Department of Public Works: Any and all actions and decisions to be made hereunder by the County shall be made by the Director of the El Paso County Planning and Community Development Department and/or the Director of the El Paso County Department of Public Works. Accordingly, any and all documents, submissions, plan approvals, inspections, etc. shall be submitted to and shall be made by the Director of the Planning and Community Development Department and/or the Director of the El Paso County Department of Public Works.

10. Indemnification and Hold Harmless: To the extent authorized by law, Owner agrees, for itself and its respective successors and assigns, that they will indemnify, defend, and hold the County

harmless from any and all loss, costs, damage, injury, liability, claim, lien, demand, action and causes of action whatsoever, whether at law or in equity, arising from or related to their respective intentional or negligent acts, errors or omissions or that of their agents, officers, servants, employees, invitees and licensees in the construction, operation, inspection, cleaning (including analyzing and disposing of any solid or hazardous wastes as defined by State and/or Federal environmental laws and regulations), maintenance, and repair of the detention basin/BMP(s), and such obligation arising under this Paragraph shall be joint and several. Nothing in this Paragraph shall be deemed to waive or otherwise limit the defense available to the County pursuant to the Colorado Governmental Immunity Act, Sections 24-10-101, *et seq.* C.R.S., or as otherwise provided by law.

11. Severability: In the event any Court of competent jurisdiction declares any part of this Agreement to be unenforceable, such declaration shall not affect the enforceability of the remaining parts of this Agreement.

12. Third Parties: This Agreement does not and shall not be deemed to confer upon or grant to any third party any right to claim damages or to bring any lawsuit, action or other proceeding against either the County, the Owner, or their respective successors and assigns, because of any breach hereof or because of any terms, covenants, agreements or conditions contained herein.

13. Solid Waste or Hazardous Materials: Should any refuse from the detention basin/BMP(s) be suspected or identified as solid waste or petroleum products, hazardous substances or hazardous materials (collectively referred to herein as “hazardous materials”), the Owner shall take all necessary and proper steps to characterize the solid waste or hazardous materials and properly dispose of it in accordance with applicable State and/or Federal environmental laws and regulations, including, but not limited to, the following: Solid Wastes Disposal Sites and Facilities Acts, §§ 30-20-100.5 – 30-20-119, C.R.S., Colorado Regulations Pertaining to Solid Waste Disposal Sites and Facilities, 6 C.C.R. 1007-2, *et seq.*, Solid Waste Disposal Act, 42 U.S.C. §§ 6901-6992k, and Federal Solid Waste Regulations 40 CFR Ch. I. The County shall not be responsible or liable for identifying, characterizing, cleaning up, or disposing of such solid waste or hazardous materials. Notwithstanding the previous sentence, should any refuse cleaned up and disposed of by the County be determined to be solid waste or hazardous materials, the Owner, but not the County, shall be responsible and liable as the owner, generator, and/or transporter of said solid waste or hazardous materials.

14. Applicable Law and Venue: The laws, rules, and regulations of the State of Colorado and El Paso County shall be applicable in the enforcement, interpretation, and execution of this Agreement, except that Federal law may be applicable regarding solid waste or hazardous materials. Venue shall be in the El Paso County District Court.

IN WITNESS WHEREOF, the Parties affix their signatures below.

Executed this _____ day of _____, 20____, by:

CS Powers and Galley, LLC Owner

By: _____

Ryan Tobias, Managing Member

Attest:

By: _____
Dane Olmstead, Member

The foregoing instrument was acknowledged before me this _____ day of _____, 20____, by Ryan Tobias, Managing Member, and Dane Olmstead, Member, CS Powers Galley, LLC, Owner

Witness my hand and official seal.

My commission expires: _____

Notary Public

Executed this _____ day of _____, 20____, by:

BOARD OF COUNTY COMMISSIONERS
OF EL PASO COUNTY, COLORADO

By: _____
Craig Dossey, Executive Director
Planning and Community Development Department
Authorized signatory pursuant to LDC

The foregoing instrument was acknowledged before me this _____ day of _____, 2021, by _____, Executive Director of El Paso County Planning and Community Development Department.

Witness my hand and official seal.

My commission expires: _____

Notary Public

Approved as to Content and Form:

Assistant County Attorney

Exhibit A

A PARCEL OF LAND LOCATED IN THE SOUTH WEST QUARTER OF THE NORTHWEST QUARTER OF SECTION 7, TOWNSHIP 14 SOUTH, RANGE 65 WEST OF THE 6TH P.M., CITY OF COLORADO SPRINGS, COUNTY OF EL PASO, STATE OF COLORADO, BEING MORE PARTICULARLY DESCRIBED AS FOLLOWS:

BEGINNING AT THE SOUTHEASTERLY CORNER OF LOT 2, POWERS & GALLEY PLAZA FILING NO. 1 RECORDED IN PLAT BOOK A-4 AT PAGE 30 IN THE RECORDS OF THE EL PASO COUNTY CLERK AND RECORDER;

THENCE ON THE EASTERLY LINE OF SAID LOT 2, N00°27'47"E A DISTANCE OF 256.76 FEET, TO THE NORTHEASTERLY CORNER;

THENCE ON THE NORTHERLY LINE OF SAID LOT 2, N89°32'13"W A DISTANCE OF 414.58 FEET, TO A POINT ON THE EASTERLY LINE OF CDOT PARCEL EA-20 PROJECT C R200-142 RECORDED UNDER RECEPTION NO. 210035525, SAID POINT BEING A POINT OF NON-TANGENT CURVE;

THENCE ON SAID EASTERLY LINE, THE FOLLOWING COURSES:

1. ON THE ARC OF A CURVE TO THE LEFT WHOSE CENTER BEARS S58°24'52"W, HAVING A RADIUS OF 470.00 FEET, A CENTRAL ANGLE OF 17°54'45" AND AN ARC LENGTH OF 146.94 FEET, TO A POINT OF REVERSE CURVE;
2. ON THE ARC OF A CURVE TO THE RIGHT HAVING A RADIUS OF 1080.00 FEET, A CENTRAL ANGLE OF 21°47'10" AND AN ARC LENGTH OF 410.66 FEET, TO A POINT OF COMPOUND CURVE;
3. ON THE ARC OF A CURVE TO THE RIGHT, HAVING A RADIUS OF 600.00 FEET, A CENTRAL ANGLE OF 17°38'16" AND AN ARC LENGTH OF 184.70 FEET, TO A POINT OF NON-TANGENT;
4. N27°49'47"W A DISTANCE OF 104.02 FEET;
5. N03°44'19"E A DISTANCE OF 206.36 FEET, TO A POINT ON THE SOUTHERLY LINE OF POWERS POINTE FILING NO. 5 RECORDED UNDER RECEPTION NO. 205094827;

THENCE ON SAID SOUTHERLY LINE AND THE SOUTHERLY LINE OF POWERS POINT FILING NO. 1 RECORDED UNDER RECEPTION NO. 97085192 AND O K SUBDIVISION RECORDED IN PLAT BOOK G-3 AT PAGE 42, SAID LINE BEING THE NORTHERLY LINE SHOWN ON THAT LAND SURVEY PLAT PREPARED BY OLIVER E. WATTS RECORDED UNDER RECEPTION NO. 212900123, N89°58'24"E A DISTANCE OF 1311.67 FEET, TO A POINT ON THE WESTERLY LINE OF CIMMARON INDUSTRIAL NO. 2 RECORDED IN PLAT BOOK Y-2 AT PAGE 22;

THENCE ON SAID WESTERLY LINE AND THE WESTERLY LINE OF CIMMARON-INDUSTRIAL NO. 1 RECORDED IN PLAT BOOK N-2 AT PAGE 6, S00°29'25"W A DISTANCE OF 1375.25 FEET, TO A POINT ON THE NORTHERLY RIGHT-OF-WAY LINE OF GALLEY ROAD;

THENCE ON SAID NORTHERLY RIGHT-OF-WAY LINE, N89°42'00"W A DISTANCE OF 376.01 FEET, TO A POINT ON THE EASTERLY LINE OF THAT PROPERTY RECORDED IN BOOK 5913 AT PAGE 737;

THENCE ON SAID EASTERLY LINE AND THE EASTERLY LINE OF THAT PROPERTY RECORDED UNDER RECEPTION NO. 21538406, N00°27'47"E A DISTANCE OF 210.00 FEET;

THENCE ON THE NORTHERLY LINE OF SAID PROPERTY RECORDED UNDER RECEPTION NO. 215138406, N89°42'00"W A DISTANCE OF 68.61 FEET, TO THE POINT OF BEGINNING;

CONTAINING A CALCULATED AREA OF 1,255,877 SQUARE FEET OR 28.8310 ACRES.

Exhibit B

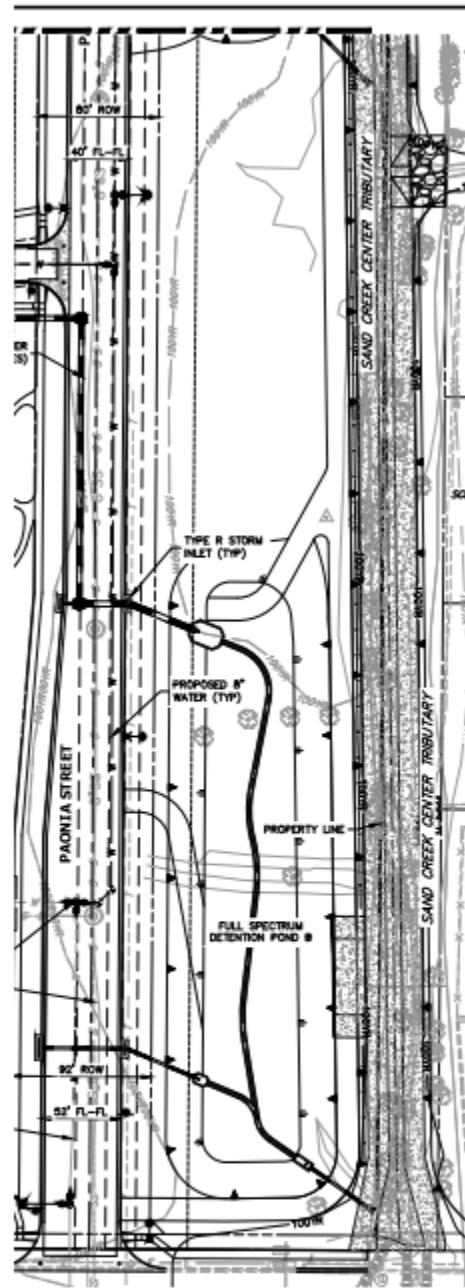
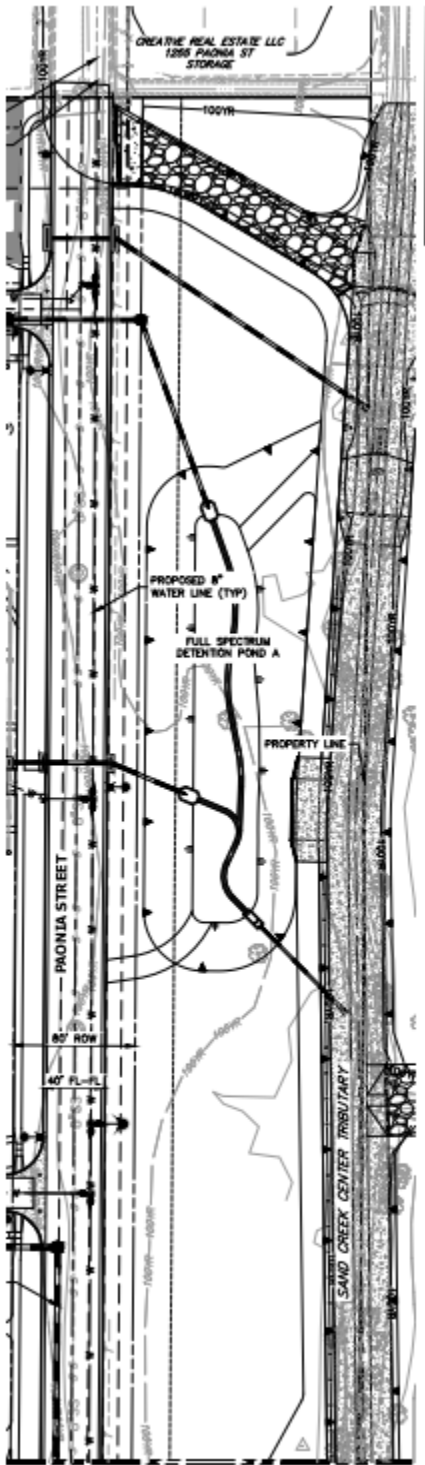

Pond A & B, Stormwater Facilities in Tract B

Solace Apartments Filing No. 1

A P P E N D I X B

General Location and Description of Stormwater Management Facilities

Appendix B

General Location and Description of Stormwater Management Facilities

A. General Site Description

The Solace Apartments Site is a parcel located in Section 7, Township 14 South, Range 65 West of the 6th Principal Meridian. It is an approximately 28.99 acre urban multi family development and is comprised on 16 apartment dwellings with associated infrastructure. The site is currently unoccupied and undeveloped open space, with sparse vegetation cover, in general the site slopes from northwest to southeast.

B. General Stormwater Management Description

All Stormwater is conveyed via curb & gutter and conventional reinforced concrete pipe storm sewers to one of two extended detention basins. After being treated in the extended detention basins, water will outfall to the existing Sand Creek Center Tributary Drainageway running north south along the east portion of the site.

C. Stormwater Facilities Site Plan

Inspection or maintenance personnel may utilize the Stormwater Facilities Map located in Appendix G for locating the stormwater facilities within this development.

D. On-Site Stormwater Management Facilities

Volume Reduction Facilities

Residential Site utilizes Level 0 MDCIA.

Storage Facilities (Detention)

Detention for the site is provided in two full spectrum water quality and detention ponds. See the Facilities Map located in Appendix G for location of ponds.

Water Quality Facilities

Water quality is provided in the two extended detention basins.

Source Control Best Management Practices

Residential Site does not include any nonstructural BMPs.

A P P E N D I X C

Standard Operating Procedures

For:

Extended Detention Basins (EDBs)

Grass Buffers and Grass Swales (GB-GS)

A P P E N D I X C – 1

Extended Detention Basins

Standard Operation Procedures for Inspection and Maintenance

Extended Detention Basins (EDBs)

September 2010

TABLE OF CONTENTS

EDB-1	Background.....	3
EDB-2	INSPECTING EXTENDED DETENTION BASINS (EDBs).....	3
EDB-2.1	Access and Easements	3
EDB-2.2	Stormwater Management Facilities Locations	3
EDB-2.3	Extended Detention Basin (EDB) Features.....	3
EDB-2.3.1	Inflow Points.....	4
EDB-2.3.2	Forebay.....	5
EDB-2.3.3	Trickle Channel (Low-Flow)	6
EDB-2.3.4	Bottom Stage	7
EDB-2.3.5	Micropool	8
EDB-2.3.6	Outlet Works	9
EDB-2.3.7	Emergency Spillway.....	10
EDB-2.3.8	Upper Stage (Dry Storage)	10
EDB-2.3.9	Miscellaneous	12
EDB-2.4	Inspection Forms	13
EDB-3	MAINTAINING EXTENDED DETENTION BASINS (EDBS)	13
EDB-3.1	Maintenance Personnel	13
EDB-3.2	Equipment.....	13
EDB-3.3	Safety.....	14
EDB-3.4	Maintenance Forms	14
EDB-3.5	Maintenance Categories and Activities.....	14
EDB-3.6	Routine Maintenance Activities.....	15
EDB-3.6.1	Mowing.....	15
EDB-3.6.2	Trash/Debris Removal	16
EDB-3.6.3	Outlet Works Cleaning	16
EDB-3.6.4	Weed Control	16
EDB-3.6.5	Mosquito/Algae Treatment.....	16
EDB-3.7	Minor Maintenance Activities	16
EDB-3.7.1	Sediment Removal.....	17
EDB-3.7.2	Erosion Repair	17
EDB-3.7.3	Vegetation Removal/Tree Thinning.....	18
EDB-3.7.4	Clearing Drains/Jet-Vac	18
EDB-3.8	Major Maintenance Activities	18
EDB-3.8.1	Major Sediment Removal.....	19
EDB-3.8.2	Major Erosion Repair	19
EDB-3.8.3	Structural Repair	20

EDB-1 BACKGROUND

Extended Detention Basins (EDBs) are one of the most common types of Stormwater Management Facilities utilized within the Front Range of Colorado. An EDB is a sedimentation basin designed to “extend” the runoff detention time, but to drain completely dry sometime after stormwater runoff ends. The EDB’s drain time for the water quality portion of the facility is typically 40 hours. The basins are considered to be “dry” because the majority of the basin is designed not to have a significant permanent pool of water remaining between runoff events.

EDBs are an adaptation of a detention basin used for flood control, with the primary difference is the addition of forebays, micro-pools and a slow release outlet design. Forebays are shallow concrete “pans” located at the inflow point to the basin and are provided to facilitate sediment removal within a contained area prior to releasing into the pond. These forebays collect and briefly hold stormwater runoff resulting in a process called sedimentation, dropping sediment out of the stormwater. The stormwater is then routed from the forebay into the concrete trickle channel and upper basin, the large grassy portion of the basin. The EDB uses a much smaller outlet that extends the emptying time of the more frequently occurring runoff events to facilitate pollutant removal. An EDB should have a small micro-pool just upstream of the outlet. This micro-pool is designed to hold a small amount of water to keep sediment and floatables from blocking the outlet orifices.

EDB-2 INSPECTING EXTENDED DETENTION BASINS (EDBs)

EDB-2.1 Access and Easements

Inspection or maintenance personnel may utilize the stormwater facility map located in Appendix G containing the location(s) of the access points and maintenance easements of the EDB(s) within this development.

EDB-2.2 Stormwater Management Facilities Locations

Inspection or maintenance personnel may utilize the stormwater facility map located in Appendix G containing the location(s) of the EDB(s) within this development.

EDB-2.3 Extended Detention Basin (EDB) Features

EDBs have a number of features that are designed to serve a particular function. Many times the proper function of one feature depends on another. For example, if a forebay is not properly maintained, it could negatively affect the performance of a feature downstream (trickle channel, micro-pool, etc.). Therefore, it is critical that each feature of the EDB is properly inspected and maintained to ensure the overall facility functions as it was intended. Below is a list and description of the most common features within an EDB and the corresponding maintenance inspection items that can be anticipated:

Table EDB-1
Typical Inspection & Maintenance Requirements Matrix

EDB Features	Sediment Removal	Mowing/ Weed control	Trash & Debris Removal	Erosion	Overgrown Vegetation Removal	Standing Water (mosquito/ algae control)	Structure Repair
Inflow Points (outfalls)	X		X				X
Forebay	X		X				X
Low-flow channel	X		X	X	X		X
Bottom Stage	X	X	X	X	X	X	
Micro-pool	X		X		X	X	X
Outlet Works	X		X				X
Emergency Spillway			X	X	X		X
Upper Stage			X	X			
Embankment		X		X	X		

EDB-2.3.1 Inflow Points

Inflow Points or Outfalls into EDBs are the point source of the stormwater discharge into the facility. An inflow point is commonly a storm sewer pipe with a flared end section that discharges into the EDB. In some instances, an inflow point could be a drainage channel or ditch that flows into the facility.

An energy dissipater (riprap or hard armor protection) is typically immediately downstream of the discharge point into the EDB to protect from erosion. In some cases, the storm sewer outfall can have a toe-wall or cut-off wall immediately below the structure to prevent undercutting of the outfall from erosion.

The typical maintenance items found with inflow points are as follows:

a. Riprap Displaced – Many times, because the repeated impact/force of water, the riprap can shift and settle. If any portion of the riprap apron appears to have settled, soil is present between the riprap, or the riprap has shifted, maintenance may be required to ensure future erosion is prevented. Depending on the nature of the maintenance the use of heavy equipment and proper bedding material may be required to repair the riprap. See Section EDB-3.5 – EDB-3.8.

b. Erosion Present/Outfall Undercut – In some situations, the energy dissipater may not have been sized, constructed, or maintained appropriately and erosion has occurred. Any erosion within the vicinity of the inflow point will require maintenance to prevent damage to the structure(s) and sediment transport within the facility. If there is any

question to whether the original design is inadequate, a qualified engineer should review the situation to avoid chronic maintenance repairs if it is a design issue.

c. Sediment Accumulation – Because of the turbulence in the water created by the energy dissipater, sediment often deposits immediately downstream of the inflow point. To prevent a loss in hydraulic performance of the upstream infrastructure, sediment that accumulates in this area must be removed in a timely manner.

d. Structural Damage – Structural damage can occur at anytime during the life of the facility. Typically, for an inflow, the structural damage occurs to the pipe flared end section (concrete or steel). Structural damage can lead to additional operating problems with the facility, including loss of hydraulic performance.

e. Woody Growth/Weeds Present – Undesirable vegetation can grow in and around the inflow area to an EDB that can significantly affect the performance of the drainage facilities discharging into the facility. This type of vegetation includes trees (typically cottonwoods) and dense areas of shrubs (willows). If woody vegetation is not routinely mowed/removed, the growth can cause debris/sediment to accumulate, resulting in blockage of the discharge. Also, tree roots can cause damage to the structural components of the inflow. Routine maintenance is essential for trees (removing a small tree/sapling is much cheaper and “quieter” than a mature tree). In addition, noxious weeds growing in the facility can result in the loss of desirable native vegetation and impact adjacent open spaces/land.

EDB-2.3.2 Forebay

A forebay is a solid surface (pad), typically constructed of concrete, immediately downstream of the inflow point. The forebay is designed to capture larger particles and trash to prevent them from entering the main portion of the EDB. The solid surface is designed to facilitate mechanical sediment removal (skid steer). The forebay typically includes a small diameter discharge pipe or v-notch weir on the downstream end and designed to drain the forebay in a specified period of time to promote sedimentation. The forebays vary in size and depth depending on the design and site constraints.

The typical maintenance items found with forebays are as follows:

a. Sediment/Debris Accumulation – Because this feature of the EDB is designed to provide the initial sedimentation, debris and sediment frequently accumulate in this area. If the sediment and debris is not removed from the forebay on a regular basis, it can significantly affect the

function of other features within the EDB. Routine sediment removal from the forebay can **significantly** reduce the need for dredging of the main portion of the EDB using specialized equipment (long reach excavators). Routine removal of sediment from the forebay can **substantially** decrease the long-term sediment removal costs of an EDB.

b. Concrete Cracking/Failing – The forebay is primarily constructed of concrete, which cracks, spalls, and settles. Damage to the forebay can result in decreased performance and impact maintenance efforts.

c. Drain Pipe/Weir Clogged – Many times the drainpipe or weir can be clogged with debris, and prevent the forebay from draining properly. If standing water is present in the forebay (and there is not a base flow), the forebay is most likely not draining properly. This can result in a decrease in performance and create potential nuisances with stagnant water (mosquitoes).

d. Weir/Drain Pipe Damaged – Routine maintenance activities, vandalism, or age may cause the weir or drain pipe in the forebay to become damaged. Weirs are typically constructed of concrete, which cracks and spalls. The drainpipe is typically smaller in diameter and constructed with plastic, which can fracture.

EDB-2.3.3 Trickle Channel (Low-Flow)

The trickle channel conveys stormwater from the forebay to the micro-pool of the EDB. The trickle channel is typically made of concrete. However, grass lined (riprap sides protected) is also common and can provide for an additional means of water quality within the EDB. The trickle channel is typically 6-9 inches in depth and can vary in width.

The typical maintenance items found with trickle channels are as follows:

a. Sediment/Debris Accumulation – Trickle channels are typically designed with a relatively flat slope that can promote sedimentation and the collection of debris. Also, if a trickle channel is grass lined it can accumulate sediment and debris at a much quicker rate. Routine removal of accumulated sediment and debris is essential in preventing flows from circumventing the trickle channel and affecting the dry storage portion of the pond.

b. Concrete/Riprap Damage – Concrete can crack, spall, and settle and must be repaired to ensure proper function of the trickle channel. Riprap can also shift over time and must be replaced/repared as necessary.

c. Woody Growth/Weeds Present – Because of the constant moisture in the area surrounding the trickle channel, woody growth (cottonwoods/willows) can become a problem. Trees and dense shrub type vegetation can affect the capacity of the trickle channel and can allow flows to circumvent the feature.

d. Erosion Outside of Channel – In larger precipitation events, the trickle channel capacity will likely be exceeded. This can result in erosion immediately adjacent to the trickle channel and must be repaired to prevent further damage to the structural components of the EDB.

EDB-2.3.4 Bottom Stage

The bottom stage is at least 1.0 to 2.0 feet deeper than the upper stage and is located in front of the outlet works structure. The bottom stage is designed to store the smaller runoff events, assists in keeping the majority of the basin bottom dry resulting in easier maintenance operations, and enhances the facilities pollutant removal capabilities. This area of the EDB may develop wetland vegetation.

The typical maintenance items found with the bottom stage are as follows:

a. Sediment/Debris Accumulation – The bottom stage can frequently accumulate sediment and debris. This material must be removed to maintain pond volume and proper function of the outlet structure.

b. Woody Growth/Weeds Present - Because of the constant moisture in the soil surrounding the micro-pool, woody growth (cottonwoods/willows) can create operational problems for the EDB. If woody vegetation is not routinely mowed/removed, the growth can cause debris/sediment to accumulate outside of the micro-pool (see EDB 2.3.5), which can cause problems with other EDB features. Also, tree roots can cause damage to the structural components of the outlet works. Routine management is essential for trees (removing a small tree/sapling is much cheaper and “quieter” than a mature tree).

c. Bank Erosion – The bottom stage is usually a couple feet deeper than the other areas of the ponds. Erosion can be caused by water dropping into the bottom stage if adequate protection/armor is not present. Erosion in this area must be mitigated to prevent sediment transport and other EDB feature damage.

d. Mosquitoes/Algae Treatment – Nuisance created by stagnant water can result from improper maintenance/treatment of the bottom stage. Mosquito larvae can be laid by adult mosquitoes within the permanent pool. Also, aquatic vegetation that grows in shallow pools of water can decompose causing foul odors. Chemical/mechanical treatment of the

bottom stage may be necessary to reduce these impacts to adjacent homeowners.

e. Petroleum/Chemical Sheen – Many indicators of illicit discharges into the storm sewer systems will be present in the bottom stage area of the EDB. These indicators can include sheens, odors, discolored soil, and dead vegetation. If it is suspected that an illicit discharge has occurred, contact the supervisor immediately. Proper removal/mitigation of contaminated soils and water in the EDB is necessary to minimize any environmental impacts downstream.

EDB-2.3.5 Micro-pool

The micro-pool is a concrete or grouted boulder walled structure directly in front of the outlet works. At a minimum, the micro-pool is 2.5 feet deep and is designed to hold water. The micro-pool is critical in the proper function of the EDB; it allows suspended sediment to be deposited at the bottom of the micro-pool and prevents these sediments from being deposited in front of the outlet works causing clogging of the outlet structure, which results in marshy areas within the top and bottom stages.

The typical maintenance items found with micro-pools are as follows:

a. Sediment/Debris Accumulation – The micro-pool can frequently accumulate sediment and debris. This material must be removed to maintain the micro pool volume, depth, and proper function of the outlet structure.

b. Woody Growth/Weeds Present - Because of the constant moisture in the soil surrounding the micro-pool, woody growth (cottonwoods/willows) can create operational problems for the EDB. If woody vegetation is not routinely mowed/removed, the growth can cause debris/sediment to accumulate outside of the micro-pool, which can cause problems with other EDB features. Also, tree roots can cause damage to the structural components of the outlet works. Routine management is essential for trees (removing a small tree/sapling is much cheaper and “quieter” than a mature tree).

c. Mosquitoes/Algae Treatment – Nuisance created by stagnant water can result from improper maintenance/treatment of the micro-pool. Mosquito larvae can be laid by adult mosquitoes within the permanent pool. If mosquitoes are breeding within the micro-pool this may also be an indication there is significant sediment build-up that is reducing the depth of the micro-pool. Also, aquatic vegetation that grows in shallow pools of water can decompose causing foul odors. Chemical/mechanical treatment of the micro-pool may be necessary to reduce these impacts to adjacent homeowners.

d. Petroleum/Chemical Sheen – Many indicators of illicit discharges into the storm sewer systems will be present in the micro-pool area of the EDB. These indicators can include sheens, odors, discolored soil, and dead vegetation. If it is suspected that an illicit discharge has occurred, contact the supervisor immediately. Proper removal/mitigation of contaminated soils and water in the EDB is necessary to minimize any environmental impacts downstream.

EDB-2.3.6 Outlet Works

The outlet works is the feature that drains the EDB in specified quantities and periods of time. The outlet works is typically constructed of reinforced concrete into the embankment of the EDB. The concrete structure typically has steel orifice plates anchored/embedded into it to control stormwater release rates. The larger openings (flood control) on the outlet structure typically have trash racks over them to prevent clogging. The water quality orifice plate (smaller diameter holes) will typically have a well screen covering it to prevent smaller materials from clogging it. The outlet structure is the single most important feature in the EDB operation. Proper inspection and maintenance of the outlet works is essential in ensuring the long-term operation of the EDB.

The typical maintenance items found with the outlet works are as follows:

a. Trash Rack/Well Screen Clogged – Floatable material entering the EDB will most likely make its way to the outlet structure. This material is trapped against the trash racks and well screens on the outlet structure (which is why they are there). This material must be removed on a routine basis to ensure the outlet structure drains in the specified design period.

b. Structural Damage - The outlet structure is primarily constructed of concrete, which can crack, spall, and settle. The steel trash racks and well screens are also susceptible to damage.

c. Orifice Plate Missing/Not Secure – Many times residents, property owners, or maintenance personnel will remove or loosen orifice plates if they believe the pond is not draining properly. Any modification to the orifice plate(s) will significantly affect the designed discharge rates for water quality and/or flood control. Modification of the orifice plates is not allowed without approval from El Paso County Public Works Department, Engineering Control Division.

d. Manhole Access – Access to the outlet structure is necessary to properly inspect and maintain the facility. If access is difficult or not available to inspect the structure, chances are it will be difficult to maintain as well.

e. *Woody Growth/Weeds Present* - Because of the constant moisture in the soil surrounding the outlet works, woody growth (cottonwoods/willows) can create operational problems for the EDB. If woody vegetation is not routinely mowed/removed, the growth can cause debris/sediment to accumulate around the outlet works, which can cause problems with other EDB features. Also, tree roots can cause damage to the structural components of the outlet works. Routine management is essential for trees (removing a small tree/sapling is much cheaper and “quieter” than a mature tree).

EDB-2.3.7 Emergency Spillway

An emergency spillway is typical of all EDBs and designed to serve as the overflow in the event the volume of the pond is exceeded. The emergency spillway is typically armored with riprap (or other hard armor) and is sometimes buried with soil. The emergency spillway is typically a weir (notch) in the pond embankment. Proper function of the emergency spillway is essential to ensure flooding does not affect adjacent properties.

The typical maintenance items found with emergency spillways are as follows:

a. *Riprap Displaced* – As mentioned before, the emergency spillway is typically armored with riprap to provide erosion protection. Over the life of an EDB, the riprap may shift or dislodge due to flow. Depending on the nature of the maintenance the use of heavy equipment and proper bedding material may be required to repair the riprap. See Section EDB-3.5 – EDB-3.8.

b. *Erosion Present* – Although the spillway is typically armored, stormwater flowing through the spillway can cause erosion damage. Erosion must be repaired to ensure the integrity of the basin embankment, and proper function of the spillway.

c. *Woody Growth/Weeds Present* – Management of woody vegetation is essential in the proper long-term function of the spillway. Larger trees or dense shrubs can capture larger debris entering the EDB and reduce the capacity of the spillway.

d. *Obstruction Debris* – The spillway must be cleared of any obstruction (man-made or natural) to ensure the proper design capacity.

EDB-2.3.8 Upper Stage (Dry Storage)

The upper stage of the EDB provides the majority of the water quality flood detention volume. This area of the EDB is higher than the bottom stage and

typically stays dry, except during storm events. The upper stage is the largest feature/area of the basin. Sometimes, the upper stage can be utilized for park space and other uses in larger EDBs. With proper maintenance of the bottom stage, micro-pool, and forebay(s), the upper stage should not experience much sedimentation; however, bottom elevations should be monitored to ensure adequate volume.

The typical maintenance items found with upper stages are as follows:

a. Vegetation Sparse – The upper basin is the most visible part of the EDB, and therefore aesthetics is important. Adequate and properly maintained vegetation can greatly increase the overall appearance and acceptance of the EDB by the public. In addition, vegetation can reduce the potential for erosion and subsequent sediment transport to the other areas of the pond.

b. Woody Growth/Undesirable Vegetation – Although some trees and woody vegetation may be acceptable in the upper basin, some thinning of cottonwoods and willows may be necessary. Remember, the basin will have to be dredged to ensure volume, and large trees and shrubs will be difficult to protect during that operation.

c. Standing Water/Boggy Areas – Standing water or boggy areas in the upper stage is typically a sign that some other feature in the pond is not functioning properly. Routine maintenance (mowing, trash removal, etc) can be extremely difficult for the upper stage if the ground is saturated. If this inspection item is checked, make sure you have identified the root cause of the problem.

d. Sediment Accumulation – Although other features within the EDB are designed to capture sediment, the upper storage area will collect sediment over time. Excessive amounts of sedimentation will result in a loss of storage volume. It may be more difficult to determine if this area has accumulated sediment without conducting a field survey.

Below is a list of indicators:

1. Ground adjacent to the trickle channel appears to be several inches higher than the concrete/riprap trickle channel.
2. Standing water or boggy areas in upper stage
3. Uneven grades or mounds
4. Bottom Stage, Micro-pool, or Forebay has excessive amounts of sediment

e. Erosion (banks and bottom) – The bottom grades of the dry storage area are typically flat enough that erosion should not occur. However, inadequate vegetative cover may result in erosion of the upper stage. Erosion that occurs in the upper stage can result in increased

dredging/maintenance of the bottom stage/micro-pool.

f. Trash/Debris – Trash and debris can accumulate in the upper area after large events, or from illegal dumping. Over time, this material can accumulate and clog the EDB outlet works.

g. Maintenance Access – Most EDBs typically have a gravel/concrete maintenance access path to either the upper stage or forebay. This access path should be inspected to ensure the surface is still drivable. Some of the smaller EDBs may not have maintenance access paths; however, the inspector should verify that access is available from adjacent properties.

EDB-2.3.9 Miscellaneous

There are a variety of inspection/maintenance issues that may not be attributed to a single feature within the EDB. This category on the inspection form is for maintenance items that are commonly found in the EDB, but may not be attributed to an individual feature.

a. Encroachment in Easement Area – Private lots/property can sometimes be located very close to the EDBs, even though they are required to be located in tracts with drainage easements. Property owners may not place landscaping, trash, fencing, or other items within the easement area that may adversely affect maintenance or the operation of the facility.

b. Graffiti/Vandalism – Damage to the EDB infrastructure can be caused by vandals. If criminal mischief is evident, the inspector should forward this information to the El Paso County Police Department.

c. Public Hazards – Public hazards include items such as vertical drops of greater than 4-feet, containers of unknown/suspicious substances, exposed metal/jagged concrete on structures. **If any hazard is found within the facility area that poses an immediate threat to public safety, call 911 immediately!**

d. Burrowing Animals/Pests – Prairie dogs and other burrowing rodents may cause damage to the EDB features and negatively affect the vegetation within the EDB.

e. Other – Any miscellaneous inspection/maintenance items not contained on the form should be entered here.

EDB-2.4 Inspection Forms

EDB Inspection forms are located in Appendix D. Inspection forms shall be completed by the person(s) conducting the inspection activities. Each form shall be reviewed and submitted by the property owner or property manager to El Paso County per the requirements of the Inspection and Maintenance Plan. These inspection forms shall be kept indefinitely and made available to El Paso County upon request.

EDB-3 MAINTAINING EXTENDED DETENTION BASINS (EDBS)

EDB-3.1 Maintenance Personnel

Maintenance personnel must be qualified to properly maintain EDBs. Inadequately trained personnel can cause additional problems resulting in additional maintenance costs.

EDB-3.2 Equipment

It is imperative the appropriate equipment and tools are taken to the field with the operations crew. The types of equipment/tools will vary depending on the task at hand. Below is a basic list of tools, equipment, and material(s) that may be necessary to perform maintenance on an EDB:

- 1.) Loppers/Tree Trimming Tools
- 2.) Mowing Tractors
- 3.) Trimmers (extra string)
- 4.) Shovels
- 5.) Rakes
- 6.) All Surface Vehicle (ASVs)
- 7.) Skid Steer
- 8.) Back Hoe
- 9.) Track Hoe/Long Reach Excavator
- 10.) Dump Truck
- 11.) Jet-Vac Machine
- 12.) Engineers Level (laser)
- 13.) Riprap (Minimum - Type M, or as shown on the approved civil plans)
- 14.) Filter Fabric
- 15.) Erosion Control Blanket(s)

- 16.) Seed Mix (See seed mix in the *Rules and Regulations Regarding Stormwater (Quality) Discharge for Construction Activities*, Std Det. SM, Seeding & Mulching)
- 17.) Illicit Discharge Cleanup Kits
- 18.) Trash Bags
- 19.) Tools (wrenches, screw drivers, hammers, etc)
- 20.) Chain Saw
- 21.) Confined Space Entry Equipment
- 22.) Approved Stormwater Facility Inspection and Maintenance Plan

Some of the items identified above may not be needed for every maintenance operation. However, this equipment should be available to the maintenance operations crews should the need arise.

EDB-3.3 Safety

Vertical drops may be encountered in areas located within and around the facility. Avoid walking on top of retaining walls or other structures having a significant vertical drop. If a vertical drop within the EDB is identified as greater than 48" in height, make the appropriate note/comment on the maintenance inspection form.

EDB-3.4 Maintenance Forms

The EDB Maintenance Form provides a record of each maintenance operation performed by maintenance contractors. The EDB Maintenance Form shall be filled out in the field after the completion of the maintenance operation. Each form shall be reviewed and submitted by the property owner or property manager to El Paso County per the requirements of the Inspection and Maintenance Plan. The EDB Maintenance form is located in Appendix E.

EDB-3.5 Maintenance Categories and Activities

A typical EDB Maintenance Program will consist of three broad categories of work. Within each category of work, a variety of maintenance activities can be performed on an EDB. A maintenance activity can be specific to each feature within the EDB, or general to the overall facility. This section of the SOP explains each of the categories and briefly describes the typical maintenance activities for an EDB.

A variety of maintenance activities are typical of EDBs. The maintenance activities range in magnitude from routine trash pickup to the reconstruction of drainage infrastructure. Below is a description of each maintenance activity, the objectives, and frequency of actions:

EDB-3.6 Routine Maintenance Activities

The majority of this work consists of regularly scheduled mowing and trash and debris pickups for stormwater management facilities during the growing season. This includes items such as the removal of debris/material that may be clogging the outlet structure well screens and trash racks. It also includes activities such as weed control, mosquito treatment, and algae treatment. These activities normally will be performed numerous times during the year. These items can be completed without any prior correspondence with El Paso County; however, completed inspection and maintenance forms shall be submitted to El Paso County for each inspection and maintenance activity in accordance with the Inspection and Maintenance Plan.

The Maintenance Activities are summarized below, and further described in the following sections.

**TABLE – EDB-2
Summary of Routine Maintenance Activities**

Maintenance Activity	Minimum Frequency	Look for:	Maintenance Action
Mowing	Twice annually	Excessive grass height/aesthetics	Mow grass to a height of 4" to 6"
Trash/Debris Removal	Twice annually	Trash & debris in EDB	Remove and dispose of trash and debris
Outlet Works Cleaning	As needed - after significant rain events – twice annually min.	Clogged outlet structure; ponding water	Remove and dispose of debris/trash/sediment to allow outlet to function properly
Weed control	Minimum twice annually	Noxious weeds; Unwanted vegetation	Treat w/ herbicide or hand pull; Consult the local weed specialist
Mosquito Treatment	As needed	Standing water/mosquito habitat	Treat w/ EPA approved chemicals
Algae Treatment	As needed	Standing water/ Algal growth/green color	Treat w/ EPA approved chemicals

EDB-3.6.1 Mowing

Occasional mowing is necessary to limit unwanted vegetation and to improve the overall appearance of the EDB. Native vegetation should be mowed to a height of 4-to-6 inches tall. Grass clippings should be collected and disposed of properly.

Frequency – Routine - Minimum of twice annually or depending on aesthetics.

EDB-3.6.2 Trash/Debris Removal

Trash and debris must be removed from the entire EDB area to minimize outlet clogging and to improve aesthetics. This activity must be performed prior to mowing operations.

Frequency – Routine – Prior to mowing operations and minimum of twice annually and should be done after significant storm events.

EDB-3.6.3 Outlet Works Cleaning

Debris and other materials can clog the outlet work's well screen, orifice plate(s) and trash rack. This activity must be performed anytime other maintenance activities are conducted to ensure proper operation.

Frequency - Routine – After significant rainfall event or concurrently with other maintenance activities.

EDB-3.6.4 Weed Control

Noxious weeds and other unwanted vegetation must be treated as needed throughout the EDB. This activity can be performed either through mechanical means (mowing/pulling) or with herbicide. Consultation with the local Weed Inspector is highly recommended prior to the use of an herbicide. All herbicide applications should be applied in accordance with the manufacturer's recommendations.

Frequency – Routine – As needed based on inspections.

EDB-3.6.5 Mosquito/Algae Treatment

Treatment of permanent pools is necessary to control mosquitoes and undesirable aquatic vegetation that can create nuisances. Only EPA approved chemicals/materials can be used in areas that are warranted.

Frequency – As needed.

EDB- 3.7 Minor Maintenance Activities

This work consists of a variety of isolated or small-scale maintenance or operational problems. Most of this work can be completed by a small crew, tools, and small equipment. These items require prior correspondence with El Paso County Water Staff and require completed inspection and maintenance forms to be submitted to the El Paso County Water Staff for each inspection and maintenance activity.

**Table – EDB-3
Summary of Minor Maintenance Activities**

Maintenance Activity	Minimum Frequency	Look for:	Maintenance Action
<u>Sediment Removal*</u>	As needed; typically every 1 –2 years	Sediment build-up; decrease in pond volume	Remove and dispose of sediment
Erosion Repair	As needed, based upon inspection	Rills/gullies forming on side slopes, trickle channel, other areas	Repair eroded areas Revegetate; address source of erosion
Vegetation Removal/Tree Thinning	As needed, based upon inspection	Large trees/wood vegetation in lower chamber of pond	Remove vegetation; restore grade and surface
Drain Cleaning/Jet Vac	As needed, based upon inspection	Sediment build-up /non draining system	Clean drains; Jet Vac if needed

*Usually from the forebay, trickle channel, and/or micro-pool

EDB-3.7.1 Sediment Removal

Sediment removal is necessary to maintain the original design volume of the EDB and to ensure proper function of the infrastructure. Regular sediment removal (minor) from the forebay, inflow(s), and trickle channel can significantly reduce the frequency of major sediment removal activities (dredging) in the upper and lower stages. The minor sediment removal activities can typically be addressed with shovels and smaller equipment.

Stormwater sediments removed from EDBs do not meet the criteria of “hazardous waste”. However, these sediments are contaminated with a wide array of organic and inorganic pollutants and handling must be done with care. Sediments from permanent pools must be carefully removed to minimize turbidity, further sedimentation, or other adverse water quality impacts. Sediments should be transported by motor vehicle only after they are dewatered. All sediments must be taken to a landfill for proper disposal. Prompt and thorough cleanup is important should a spill occur during transportation.

Frequency – Nonroutine – As necessary based upon inspections. Sediment removal in the forebay, trickle channel, and micro-pool may be necessary as frequently as every 1-2 years.

EDB-3.7.2 Erosion Repair

The repair of eroded areas is necessary to ensure the proper function of the EDB, minimize sediment transport, and to reduce potential impacts to other features. Erosion can vary in magnitude from minor repairs to trickle channels, energy dissipaters, and rilling to major gullies in the embankments

and spillways. The repair of eroded areas may require the use of excavators, earthmoving equipment, riprap, concrete, erosion control blankets, and turf reinforcement mats. Major erosion repair to the pond embankments, spillways, and adjacent to structures will require consultation with El Paso County Stormwater and Engineering Staff.

Frequency – Nonroutine – As necessary based upon inspections.

EDB-3.7.3 Vegetation Removal/Tree Thinning

Dense stands of woody vegetation (willows, shrubs, etc) or trees can create maintenance problems for the infrastructure within an EDB. Tree roots can damage structures and invade pipes/channels thereby blocking flows. Also, trees growing in the upper and lower stages of the EDB will most likely have to be removed when sediment/dredging operations occur. A small tree is easier to remove than a large tree, therefore, regular removal/thinning is imperative. All trees and woody vegetation that is growing in the bottom of the EDB or near structures (inflows, trickle channels, outlet works, emergency spillways, etc) should be removed. Any trees or woody vegetation in the EDB should be limited to the upper portions of the pond banks.

Frequency – Nonroutine – As necessary based upon inspections.

EDB-3.7.4 Clearing Drains/Jet-Vac

An EDB contains many structures, openings, and pipes that can be frequently clogged with debris. These blockages can result in a decrease of hydraulic capacity and create standing water in areas outside of the micro-pool. Many times the blockage to this infrastructure can be difficult to access and/or clean. Specialized equipment (jet-vac machines) may be necessary to clear debris from these difficult areas.

Frequency – Nonroutine – As necessary based upon inspections.

EDB-3.8 Major Maintenance Activities

This work consists of larger maintenance/operational problems and failures within the stormwater management facilities. All of this work requires consultation with El Paso County to ensure the proper maintenance is performed. This work requires El Paso County Stormwater Staff review the original design before approval of the proposed maintenance. **A ESQCP permit shall be required for all major maintenance activities.** This work may also require more specialized maintenance equipment, design/details, submittal of plans to El Paso County for review and approval, surveying, or assistance through private contractors and consultants.

**Table – EDB-4
Summary of Major Maintenance Activities**

Maintenance Activity	Minimum Frequency	Look for:	Maintenance Action
Major Sediment Removal	As needed – based upon scheduled inspections	Large quantities of sediment; reduced pond capacity	Remove and dispose of sediment. Repair vegetation as needed
Major Erosion Repair	As needed – based upon scheduled inspections	Severe erosion including gullies, excessive soil displacement, areas of settlement, holes	Repair erosion – find cause of problem and address to avoid future erosion
Structural Repair	As needed – based upon scheduled inspections	Deterioration and/or damage to structural components – broken concrete, damaged pipes, outlet works	Structural repair to restore the structure to its original design

EDB-3.8.1 Major Sediment Removal

Major sediment removal consists of removal of large quantities of sediment or removal of sediment from vegetated areas. Care shall be given when removing large quantities of sediment and sediment deposited in vegetated areas. Large quantities of sediment need to be carefully removed, transported and disposed of. Vegetated areas need special care to ensure design volumes and grades are preserved.

Major sediment removal activities will require larger and more specialized equipment. The major sediment activities will also require surveying with an engineer’s level, and consultation with El Paso County Stormwater and Engineering Staff to ensure design volumes/grades are achieved. Pond volume recertification will be required in accordance with El Paso County’s drainage criteria manual.

Frequency – Nonroutine – Repair as needed based upon inspections.

EDB-3.8.2 Major Erosion Repair

Major erosion repair consists of filling and revegetating areas of severe erosion. Determining the cause of the erosion as well as correcting the condition that caused the erosion should also be part of the erosion repair. Care should be given to ensure design grades and volumes are preserved. Any condition/repair affecting design grades or pond volumes requires consultation with El Paso County Stormwater and Engineering Staff.

Frequency – Nonroutine – Repair as needed based upon inspections.
EDB-3.8.3 Structural Repair

An EDB includes a variety of structures that can deteriorate or be damaged during the course of use and routine maintenance. These structures are constructed of steel and concrete that can degrade or be damaged and may need to be repaired or re-constructed from time to time. These structures include items like outlet works, trickle channels, forebays, inflows and other features. In-house operations staff can perform some of the minor structural repairs. Major repairs to structures may require input from a structural engineer and specialized contractors. Consultation with El Paso County and Engineering Staff shall take place prior to all structural repairs.

Frequency – Nonroutine – Repair as needed based upon inspections.

A P P E N D I X C - 2

Grass Buffers and Grass Swales Including Channels

Standard Operation Procedures
for
Inspection and Maintenance

Grass Buffers and Grass Swales
(GB-GS)

September 2010

Table of Contents

GB-GS-1	BACKGROUND	3
GB-GS-2	INSPECTING GRASS BUFFERS AND SWALES (GB-GS)	3
GB-GS-2.1	Access and Easements	3
GB-GS-2.2	Stormwater Management Facilities Locations	3
GB-GS-2.3	Grass Buffer - Grass Swale (GB-GS) Features	3
GB-GS-2.3.1	Grass Swale Bottom and Side Slopes; Grass Buffer Strips	4
GB-GS-2.3.2	Inflow Points	5
GB-GS-2.3.3	Underdrain System	5
GB-GS-2.3.4	Grade Control Level Spreader	6
GB-GS-2.3.5	Irrigation	6
GB-GS-2.3.6	Miscellaneous	7
GB-GS-2.4	Inspection Forms	7
GB-GS-3	MAINTAINING GRASS BUFFERS & GRASS SWALES (GB-GS)	7
GB-GS-3.1	Maintenance Personnel	7
GB-GS-3.2	Equipment	8
GB-GS-3.3	Maintenance Forms	8
GB-GS-3.4	Maintenance Categories and Activities	8
GB-GS-3.5	Routine Maintenance Activities	9
GB-GS-3.5.1	Trash/Debris Removal	9
GB-GS-3.5.2	Mowing	10
GB-GS-3.5.3	Irrigation	10
GB-GS-3.5.4	Weed Control	10
GB-GS-3.5.5	Mosquito Treatment	11
GB-GS-3.5.6	Level Spreader (Grass Buffer only)	11
GB-GS-3.5.7	Rodent Damage	11
GB-GS-3.6	Minor Maintenance Activities	11
GB-GS-3.6.1	Sediment Removal	12
GB-GS-3.6.2	Erosion Repair	12
GB-GS-3.6.3	Vegetation Removal	13
GB-GS-3.6.4	Revegetation	13
GB-GS-3.6.5	Level Spreader	13
GB-GS-3.6.6	Fertilization/Soil Amendment	13
GB-GS-3.6.7	Vehicle Tracks	14
GB-GS-3.7	Major Maintenance Activities	14
GB-GS-3.7.1	Major Sediment/Pollutant Removal	15
GB-GS-3.7.2	Major Erosion Repair	16
GB-GS-3.7.3	Structural Repair	16
GB-GS-3.7.4	GB-GS Rebuild	16

GB-GS-1 BACKGROUND

Grass Buffers and Grass Swales are common types of Stormwater Management Facilities utilized within the Front Range of Colorado. Grass Buffers and Grass Swales promote filtration, infiltration, and settling to reduce runoff volume.

Grass Buffers are uniformly graded and densely vegetated areas of turf grass. They are designed to accommodate sheet flow rather than concentrated or channelized flow. They are typically located adjacent to impervious areas such as parking lots or along roads. Grass Buffers are designed to evenly distribute runoff across the width of the buffer to achieve uniform sheet-flow conditions. A flow spreader may be incorporated for this purpose. In some cases, grass buffers may have underdrain systems.

Grass Swales are densely vegetated drainage ways with low-pitched side slopes that collect and convey runoff. Design of their longitudinal slope and cross section forces the flow to be slow and shallow, thereby facilitating sedimentation while limiting erosion. Berms or check dams may be installed perpendicular to the flow to decrease the slope and slow down the flow. Grass swales are used in open space and landscaped areas to collect and convey overland flows, and can be used as an alternative to curb and gutter (when approved by the County Engineer) to collect and convey street flows. Some grass swales are designed with underdrain systems.

Channels

GB-GS-2 INSPECTING GRASS BUFFERS AND SWALES (GB-GS)

GB-GS-2.1 Access and Easements

Inspection and maintenance personnel may utilize the stormwater facility map located in Appendix G containing the locations of the access points and maintenance easements of the GB-GSs within this development.

GB-GS-2.2 Stormwater Management Facilities Locations

Inspection and maintenance personnel may utilize the stormwater facility map located in Appendix G containing the locations of the GB-GSs within this development.

GB-GS-2.3 Grass Buffer - Grass Swale (GB-GS) Features

GB-GSs are unique stormwater quality facilities, in that they are typically viewed as landscaping or ground cover, and are often overlooked as water quality treatment facilities. GB-GSs have a number of features designed to serve a particular function. It is important for maintenance personnel to understand the function of each of these features. Below is a list of the common features of a Grass Swale or Grass Buffer and the corresponding maintenance inspection items anticipated:

**Table GB-GS-1
Typical Inspection & Maintenance Requirements Matrix**

	Sediment Removal	Mowing Weed control	Trash & Debris Removal	Erosion	Removal/ Replacement	Structural Repair
Swale Bottom	X	X	X	X		
Side Slope		X	X	X		
Buffer Strip	X	X	X	X		
Inflows	X	X	X	X	X	X
Underdrain System*					X	
Grade Control/Level Spreader				X		X
Irrigation System					X	

*If the design and inspection allows, flushing of the system may be all that is needed.

GB-GS-2.3.1 Grass Swale Bottom and Side Slopes; Grass Buffer Strips

Grass Swales and Grass Buffers require general maintenance of the turf grass and repair of any rill or gully development. The bottom and side slopes of grass swales and the area of grass buffer strips should be maintained with dense vegetative cover, and should not be eroded or bare. Inspection over the first few years will help to determine if any problems are developing.

The typical maintenance items required at the side slopes and bottoms of grass swales and within grass buffer areas are as follows:

- a. *Sediment Accumulation* – The purpose of the grass swale or buffer is to slow down flow and allow sedimentation to occur. To prevent a loss in performance of the swale or buffer, sediment that accumulates must be removed on a timely basis.

- b. *Vegetation Sparse* – Grass Swales and Buffers rely on a healthy, dense cover of grass to decrease the flow velocities and promote sedimentation and infiltration. Grasses that are diseased, dying or otherwise damaged should be replaced. All bare areas should be reseeded or patched. Causes which contribute to the damaged grass cover, including lack of adequate irrigation, traces of pedestrian or vehicular traffic, uncontrolled weeds, excessive sedimentation accumulation, etc., should be identified and remedied.

- c. *Erosion Present* – Lack of adequate vegetative cover or excessive flow velocities may result in rill or gully development, and erosion of the swale or buffer strip. Erosion will require maintenance to prevent further damage to the area and to prevent sediment transport.

d. *Standing Water/Boggy Areas* – Grass swales and buffers are generally intended to drain and be dry in between rain events. If areas of standing water are present, the swale or buffer may need to be evaluated for proper grade to ensure drainage or the addition of underdrains. In some cases, where underdrains are used, the underdrains should be inspected to ensure that they are not clogged.

GB-GS-2.3.2 Inflow Points

Inflow points are the points of stormwater discharge into the swale or buffer. Inflow points are typically pipe outfalls, other grass swales or buffers, or curb cuts from upstream impervious areas, such as parking lots. Some form of energy dissipation is typically provided immediately downstream of the inflow point into the grass swale or buffer. Energy dissipation devices may include riprap aprons, or flow spreader devices.

The typical maintenance items required at inflow points are as follows:

a. *Riprap Displaced/Rundown Damaged* – Often, because of the repeated impact/force of water, the riprap can shift and settle. If any portion of the riprap rundown or apron appears to have settled, if soil is present between the riprap, or if the riprap has shifted, maintenance may be required to ensure future erosion is prevented.

b. *Erosion Present/Outfall Undercut* – In some situations, an energy dissipater may have not been provided, or may not have been sized, constructed, or maintained appropriately and erosion has occurred. Any erosion within the vicinity of the inflow point will require maintenance to prevent damage to the structure(s) and sediment transport within the facility.

c. *Sediment Accumulation* – Because of the turbulence in the water created by the energy dissipater, sediment often deposits immediately downstream of the inflow point. To prevent a loss in performance, sediment that accumulates in this area must be removed on a timely basis.

GB-GS-2.3.3 Underdrain System

Some grass swales and buffers that have a flatter slope or soils which do not allow adequate percolation or are in areas with a continuous base flow may have been installed with an underdrain system. Underdrains typically consist of a layer of geotextile fabric, gravel storage area and perforated PVC pipe. The geotextile fabric is utilized to prevent the filter material from entering the underdrain system. The gravel storage area allows for storage of treated stormwater runoff prior to the discharge of the runoff through the perforated PVC pipe.

The typical maintenance activities required for the underdrain system are as follows:

With proper maintenance of the grassed areas, there should be a minimum amount of maintenance required on the underdrain system. Generally the only maintenance performed on the underdrain system is jet-vac cleaning in the event it becomes clogged.

GB-GS-2.3.4 Grade Control Level Spreader

Grass swales installed in areas with steep longitudinal slopes often necessitate the use of grade control checks or drop structures. Grade control structures are typically either concrete walls or rip rap structures that serve to provide a reinforced drop at specific locations in the channel, reducing the longitudinal slope between the control structures.

Level Spreaders are installed on the upstream of grass buffers to evenly distribute flows along the design length. Level spreaders may consist of slotted curbing, modular block porous pavement, level walls or other spreader devices.

The typical maintenance activities required for grade control structures and level spreaders are as follows:

a. Erosion present – Grade control structures and level spreaders are provided to reduce the potential for erosion of the grassed swale or buffer areas. Erosion within the vicinity of the control structure or level spreader indicates the structure is not functioning as intended and requires maintenance to prevent future erosion and damage. Or, review the original design if erosion becomes chronic.

b. Structural damage – Structural damage can occur at anytime along the life of the facility. Typically, structural damage occurs with the deterioration of concrete, including cracking, spalling or settling and the erosion and deterioration of the riprap structures. Level spreaders may settle unevenly creating low areas, which concentrate the flows. Partial or full replacement may be required depending on the extent of the damage.

GB-GS-2.3.5 Irrigation

Grass Buffers and Grass Swales depend on healthy, dense turf grass to function, and therefore require an irrigation system, to provide a consistent water supply. Typically, the condition of the grass cover will provide evidence of the effectiveness and maintenance needs of the irrigation system.

The typical maintenance activities required for irrigation systems are as follows:
Irrigation systems will generally require routine periodic maintenance and

adjustment to ensure proper amounts of water are being applied given the weather conditions, and that they are providing coverage to all areas of the grass to eliminate bare spots.

GB-GS-2.3.6 Miscellaneous

There are a variety of inspection/maintenance issues that may not be attributed to a single feature within the GB-GS. This category on the inspection form is for maintenance items commonly found in the GB-GS, but may not be attributed to an individual feature.

a. Encroachment in Easement Area – The El Paso County requires GB-GS be located in tracts or drainage easements. Property owners may not place landscaping, trash, fencing, or other items within the easement area that may adversely affect maintenance or the operation of the facility.

b. Public Hazards – Public hazards include items such as containers of unknown/suspicious substances, and exposed metal/jagged concrete on structures. **If any unknown/suspicious hazard is found within the facility area that poses an immediate threat to public safety, call 911 immediately.**

c. Burrowing Animals/Pests– Prairie dogs and other burrowing rodents may cause damage to the GB-GS features and negatively affect the vegetation within the GB-GS.

d. Other – Any miscellaneous inspection/maintenance items not contained on the form should be entered here.

GB-GS-2.4 Inspection Forms

GB-GS Inspection forms are located in Appendix D. Inspection forms shall be completed by the person(s) conducting the inspection activities. Each form shall be reviewed and submitted by the property owner or property manager to the El Paso County per the requirements of the Inspection and Maintenance Plan. These inspection forms shall be kept indefinitely and made available to the El Paso County upon request

GB-GS-3 MAINTAINING GRASS BUFFERS & GRASS SWALES (GB-GS)

GB-GS-3.1 Maintenance Personnel

Maintenance personnel must be experienced to properly maintain GB-GSs. Inadequately trained personnel can cause additional problems resulting in additional maintenance costs.

GB-GS-3.2 Equipment

It is imperative the appropriate equipment and tools are taken to the field with the operations crew. The types of equipment/tools will vary depending on the task at hand. Below is a basic list of tools, equipment, and material(s) that may be necessary to perform maintenance on a GB-GS:

- 1.) Mowing Tractors
- 2.) Trimmers (extra string)
- 3.) Shovels
- 4.) Rakes
- 5.) All Surface Vehicle (ASVs)
- 6.) Engineers Level (laser)
- 7.) Erosion Control Blanket(s)
- 8.) Mulch
- 9.) Sod or Seed (See seed mix in the *Rules and Regulations Regarding Stormwater (Quality) Discharge for Construction Activities*, Std Det. SM, Seeding & Mulching)
- 10.) Illicit Discharge Cleanup Kits
- 11.) Trash Bags
- 12.) Jet-Vac Equipment
- 13.) Stormwater Facility Inspection and Maintenance Plan

Some of the items identified above may not be needed for every maintenance operation. However, this equipment should be available to the maintenance operations crews should the need arise.

GB-GS-3.3 Maintenance Forms

The GB-GS Maintenance Form provides a record of each maintenance operation performed by maintenance contractors. The GB-GS Maintenance Form shall be filled out in the field after the completion of the maintenance operation. Each form shall be reviewed and submitted by the property owner or property manager to the El Paso County per the requirements of the Inspection and Maintenance Plan. The GB-GS Maintenance form is located in Appendix E.

GB-GS-3.4 Maintenance Categories and Activities

A typical GB-GS Maintenance Program will consist of three broad categories of work: Routine, Minor and Major. Within each category of work, a variety of maintenance activities can be performed on a GB-GS. A maintenance activity can be specific to each feature within the GB-GS, or general to the overall facility. This section of the SOP explains each of the categories and briefly describes the typical maintenance activities for a GB-GS.

A variety of maintenance activities are typical of GB-GSs. The maintenance activities range in magnitude from routine trash pickup to the reconstruction of the GB-GS or underdrain system. Below is a description of each maintenance activity, the objectives, and frequency of actions.

GB-GS-3.5 Routine Maintenance Activities

The majority of this work consists of scheduled mowing, trash and debris pickups and landscape care for the GB-GS during the growing season. It also includes activities such as weed control. These activities normally will be performed numerous times during the year. These items do not require any prior approval by the El Paso County, however, completed inspection and maintenance forms shall be submitted to the El Paso County for each inspection and maintenance activity in accordance with the Inspection and Maintenance plan.

The Routine Maintenance Activities are summarized below, and further described in the following sections.

**Table GB-GS-2
Summary of Routine Maintenance Activities**

Maintenance Activity	Minimum Frequency	Indication Action is Needed:	Maintenance Action
Trash/Debris Removal	Twice annual and before mowing	Trash & debris in GB-GS	Remove and properly dispose of trash and debris
Mowing	Routine – as necessary to maintain 2” – 4” grass height	Excessive grass height/aesthetics	2”-4” grass height for turf grass; 4” to 6” for native grass
Irrigation (Not Automatic)	As needed to maintain healthy grass	Areas of insufficient or excess watering	Water as needed to maintain healthy grass; (follow watering regulations)
Weed Control	Minimum twice annually	Noxious weeds; Unwanted vegetation	Treat w/herbicide or hand pull; consult a local Weed Inspector
Mosquito Treatment	As needed, based upon inspections	Standing water/ mosquito habitat	Perform maintenance to eliminate standing water*; Treat w/ EPA approved chemicals
Level Spreader (Grass Buffer only)	As needed, based upon inspections	Evidence of uneven flow/localized erosion	Look for cause; repair, fill or revegetate areas of erosion
Rodent Damage	As needed, based upon inspections	Holes, small piles of dirt, raised burrows	Evaluate damage; contact Parks Dept. or Division of Wildlife for guidance

*See Section GB-GS-2.3.1d for further discussion

GB-GS-3.5.1 Trash/Debris Removal

Trash and debris must be removed from the GB-GS area to allow for proper functioning and to improve aesthetics. This activity must be performed prior to mowing operations.

Frequency – Routine – Prior to mowing operations and a minimum of twice annually.

GB-GS-3.5.2 Mowing

Routine mowing of the turf grass embankments is necessary to maintain an appropriate grass height and to improve the overall appearance of the GB-GS. Turf grass should be mowed to a height of 2 to 4- inches (4 – 6- inches for native grass) and shall be bagged to prevent potential contamination of the filter media, especially if there is an underdrain system.

Frequency – Routine – as necessary to maintain grass height.

GB-GS-3.5.3 Irrigation

Irrigation systems should be maintained in proper working order to provide an adequate water supply to support the grass cover. When automatic irrigation systems are not available, alternate methods for providing a water supply during times of drought must be provided.

Automatic irrigation systems should be maintained routinely throughout the growing season to ensure that they are providing the appropriate amounts of water, and are providing complete coverage of the area. Sprinkler heads should be adjusted as necessary, and checked for broken or missing parts.

Frequency - Routine as needed throughout the growing season, plus the following:

 SPRING: Start up the system and test for even coverage and correct timer settings.

 SUMMER: Test for even coverage and correct timer settings.

 FALL: Drain and winterize the system.

GB-GS-3.5.4 Weed Control

Noxious weeds and other unwanted vegetation must be treated as needed throughout the GB-GS. This activity can be performed either through mechanical means (mowing/pulling) or with herbicide. Consultation with a local Weed Inspector is highly recommended prior to the use of herbicide. Herbicides should be utilized sparingly and as a last resort. All herbicide applications should be in accordance with the manufacturer's recommendations.

Frequency – Routine – As needed based upon inspections.

GB-GS-3.5.5 Mosquito Treatment

GB-GS facilities are intended to drain, and should not have areas of standing water which creates mosquito habitat. Causes of the standing water or boggy conditions should be investigated and remediated as necessary to eliminate the standing water. Only EPA approved chemicals should be applied in accordance with the recommendations of the manufacturer. See Section GB-GS-2.3.1d.

Frequency – As needed based upon inspections.

GB-GS-3.5.6 Level Spreader (Grass Buffer only)

Evidence of uneven flow and localized erosion downstream of the level spreader indicates the flow is not evenly distributed along the length of the spreader. Areas of erosion should be repaired, filled and revegetated. Causes for the erosion should be investigated and repaired.

Frequency – As needed based upon inspections.

GB-GS-3.5.7 Rodent Damage

Small holes, piles of dirt, and raised burrows are evidence of rodent damage. Damaged areas should be repaired and revegetated. Consultation with an animal control specialist or the Division of Wildlife may be required for persistent problems.

Frequency – As needed based on inspections.

GB-GS-3.6 Minor Maintenance Activities

This work consists of a variety of isolated or small-scale maintenance/operational problems. Most of this work can be completed by a small crew, hand tools, and small equipment. These items do not require approval by the El Paso County. Completed inspection and maintenance forms shall be submitted to the El Paso County for each inspection and maintenance activity. These minor maintenance activities are to be used for the grass swales, grass buffers, channels, and riprap berms onsite as applicable and deemed necessary by inspection. Maintenance activities for drainage facilities include mowing, trash/debris removal, outlet works cleaning, & weed control. For additional detail on these activities, see table GB-GS-2 above.

**Table GB-GS-3
Summary of Minor Maintenance Activities**

Maintenance Activity	Minimum Frequency	Indication Action is Needed:	Maintenance Action
Sediment Removal	As needed.	Sediment build-up.	Remove and properly dispose of sediment
Erosion Repair	As needed, based upon inspection	Rills and gullies forming on slopes and other areas	Repair eroded areas & revegetate; address cause
Vegetation Removal	As needed, based upon inspection	Trees, willows, shrubs impeding flow	Remove vegetation; restore correct grade and surface
Revegetation	As needed, based upon inspection	Areas without grass	Replace grass by sodding or seeding
Level Spreader (Grass Buffer Only)	As needed, based upon inspection.	Evidence of uneven flow; erosion; or rills/gullies	Repair sections of level spreader and address cause
Fertilization or Soil Amendment	As needed, minimize fertilization	Grass with pale color; areas with poor grass growth not due to irrigation problems	Consult with turf specialist; Test soil
Vehicle Tracks (Along Roadways)	As needed, based upon inspection	Depressions from vehicle tracks; vegetation damage	Repair and fill depressions; sod or seed damaged areas

GB-GS-3.6.1 Sediment Removal

Sediment removal is necessary to ensure proper function of the grass swale or buffer. Care should be taken when removing sediment to prevent damage to the turf grass and surrounding areas. Excessive amounts of sediment are an indication of upstream erosion or lack of adequate BMPs during construction activities. Causes for contributions of excess sediment should be investigated and addressed.

Frequency – As needed based upon inspections.

GB-GS-3.6.2 Erosion Repair

The repair of eroded areas is necessary to ensure the proper functioning of the GB-GS or channel, to minimize sediment transport, and to reduce potential impacts to other features. Erosion can vary in magnitude from minor repairs to vegetation and embankments, to rills and gullies in the embankments and inflow points. The repair of eroded areas may require the use of excavators, riprap, new poured-in-place concrete, and sod. Extreme care should be taken when utilizing motorized or heavy equipment to ensure damage to the underdrain system, if present, does not occur. Major erosion in a GS-GB is generally the result of excessive velocities caused by steep slopes. It may be necessary to

make design improvements to the swale or buffer when erosion becomes a major maintenance item.

Frequency – As necessary, based upon inspections.

GB-GS-3.6.3 Vegetation Removal

Weeds, Shrubs, Willows and other unwanted vegetation that develops in the grass swale or buffer area may impede the flow and cause standing water or back flow problems. It is necessary to remove unwanted vegetation as soon as it appears. Remove the unwanted vegetation, and restore the correct grade. Revegetate with seed or sod. Supplement irrigation as needed until new vegetation is sufficiently established.

Frequency – As necessary, based upon inspections.

GB-GS -3.6.4 Revegetation

Bare areas should be repaired as soon as possible. Repair bare areas with appropriate grass seed or sod. Supplement irrigation as needed until new vegetation is sufficiently established. Causes of the problem, such as inadequate water supply or diseased grasses, should be investigated and resolved.

Frequency – As necessary, based upon inspections.

GB-GS-3.6.5 Level Spreader

Level Spreaders that are no longer level, or have developed damaged areas of cracking or spalling, allow flows to concentrate in these depressed areas instead of being distributed over the length of the structure. Also, build up of grasses along the edge of the spreader may create an uneven flow distribution. Rills, gullies and other erosion that develop downstream of level spreaders should be repaired and reseeded or sodded. Causes of the erosion should be investigated and addressed.

Frequency – As necessary, based upon inspections.

GB-GS-3.6.6 Fertilization/Soil Amendment

Grass Buffers and Swales rely on healthy, dense turf in order to function properly. Grasses that appear to be diseased, dying or unhealthy may require amendments. Fertilizers should be applied in the minimum amounts recommended by the manufacturer. Check for insect infestation also.

Frequency – As necessary, based upon inspections.

GB-GS-3.6.7 Vehicle Tracks

GB-GSs adjacent to roadway sections or drive aisles in parking lots may be damaged by vehicle tracks. Rutted areas should be filled in and revegetated as soon as possible. Frequent problems associated with vehicle traffic (such as around corners) may require a barrier or sign to avoid vehicular traffic within the grassed areas.

Frequency – As necessary, based upon inspections.

GB-GB-3.7 Major Maintenance Activities

This work consists of larger maintenance/operational problems and failures within the stormwater management facilities. All of this work requires consultation with the El Paso County Water Staff to ensure the proper maintenance is performed. This work requires the El Paso County Stormwater and Engineering Staff review the original design and construction drawings to assess the situation before approval of the proposed maintenance. This work may also require more specialized maintenance equipment, design/details, submittal of plans to the El Paso County for review and approval, surveying, or assistance through private contractors and consultants.

**Table GB-GS-4
Summary of Major Maintenance Activities**

Maintenance Activity	Minimum Frequency	Look for:	Maintenance Action
Major Sediment/Pollutant Removal	As needed – based upon scheduled inspections	Large quantities of sediment	Remove and dispose of sediment. Repair vegetation as needed
Major Erosion Repair	As needed – based upon scheduled inspections	Severe erosion including gullies, excessive soil displacement, areas of settlement, holes	Repair erosion – find cause of problem and address to avoid future erosion
Structural Repair	As needed – based upon scheduled inspections	Deterioration and/or damage to structural components – level spreader, grade control structures, irrigation components, and ponding water.	Structural repair to restore the structure to its original design
GB-GS/Channel Rebuild	As needed – due to complete failure of BMP	Removal of filter media and underdrain system	Contact El Paso County Water Staff

GB-GS-3.7.1 Major Sediment/Pollutant Removal

Major sediment removal consists of removal of large quantities of pollutants/sediment /landscaping material. Stormwater sediments removed from GB-GS or channels do not meet the regulatory definition of “hazardous waste”. However, these sediments can be contaminated with a wide array of organic and inorganic pollutants and handling must be done with care to insure proper removal and disposal. Sediments should be transported by motor vehicle only after they are dewatered. All sediments must be taken to a licensed landfill for proper disposal. Should a spill occur during transportation, prompt and thorough cleanup and disposal is imperative. Vegetated areas need special care to ensure design volumes and grades are preserved or may need to be replaced due to the removal activities.

Frequency – Non-routine – Repair as needed, based upon inspections.

GB-GS-3.7.2 Major Erosion Repair

Major erosion repair consists of filling and revegetating areas of severe erosion. Determining the cause of the erosion as well as correcting the condition that caused the erosion should also be part of the erosion repair. Care should be given to ensure design grades and volumes are preserved.

Frequency – Non-routine – Repair as needed, based upon inspections.

GB-GS-3.7.3 Structural Repair

A GB-GS generally includes level spreader and grade control structure that can deteriorate or be damaged during the service life of the facility. These structures are constructed of steel and concrete that can degrade or be damaged and may need to be repaired or re-constructed from time to time. Major repairs to structures may require input from a structural engineer and specialized contractors. Consultation with the El Paso County Water and Engineering Staff shall take place prior to all structural repairs.

Frequency – Non-routine – Repair as needed, based upon inspections.

GB-GS-3.7.4 GB-GS Rebuild

In very rare cases, a GB-GS or channel may need to be rebuilt. Generally, the need for a complete rebuild is a result of improper construction, improper maintenance resulting in structural damage to the underdrain system, if present, or extensive contamination of the GB-GS. Consultation with the El Paso County Water and Engineering Staff shall take place prior to any rebuild project.

Frequency – Non-routine – As needed based upon inspections.

A P P E N D I X D

Inspection Forms



EXTENDED DETENTION BASIN (EDB) INSPECTION FORM

Date: _____

Subdivision/Business Name: _____ Inspector: _____

Subdivision/Business Address: _____

Weather: _____

Date of Last Rainfall: _____ Amount: _____ Inches

Property Classification: Residential Multi Family Commercial Other: _____
(Circle One)

Reason for Inspection: Routine Complaint After Significant Rainfall Event
(Circle One)

INSPECTION SCORING - For each facility inspection item, insert one of the following scores:
 0 = No deficiencies identified 2 = Routine maintenance required
 1 = Monitor (potential for future problem) 3 = Immediate repair necessary
 N/A = Not applicable

FEATURES

1.) Inflow Points

- Riprap Displaced
- Erosion Present/Outfall Undercut
- Sediment Accumulation
- Structural Damage (pipe, end-section, etc.)
- Woody Growth/Weeds Present

2.) Forebay

- Sediment/Debris Accumulation
- Concrete Cracking/Failing
- Drain Pipe/Wier Clogged (not draining)
- Wier/Drain Pipe Damage

3.) Trickle Channel (Low-flow)

- Sediment/Debris Accumulation
- Concrete/Riprap Damage
- Woody Growth/Weeds Present
- Erosion Outside Channel

4.) Bottom Stage (Micro-Pool)

- Sediment/Debris Accumulation
- Woody Growth/Weeds Present
- Bank Erosion
- Mosquitoes/Algae Treatment
- Petroleum/Chemical Sheen

5.) Outlet Works

- Trash Rack/Well Screen Clogged
- Structural Damage (concrete, steel, subgrade)
- Orifice Plate(s) Missing/Not Secure
- Manhole Access (cover, steps, etc.)
- Woody Growth/Weeds Present

6.) Emergency Spillway

- Riprap Displaced
- Erosion Present
- Woody Growth/Weeds Present
- Obstruction/Debris

7.) Upper Stage (Dry Storage)

- Vegetation Sparse
- Woody Growth/Undesirable Vegetation
- Standing Water/Boggy Areas
- Sediment Accumulation
- Erosion (banks and bottom)
- Trash/Debris
- Maintenance Access

8.) Miscellaneous

- Encroachment in Easement Area
- Graffiti/Vandalism
- Public Hazards
- Burrowing Animals/Pests
- Other

Inspection Summary / Additional Comments: _____

OVERALL FACILITY RATING (Circle One)

- 0 = No Deficiencies Identified
- 1 = Monitor (potential for future problem exists)
- 2 = Routine Maintenance Required
- 3 = Immediate Repair Necessary

This inspection form shall be kept indefinitely and made available to the City of Aurora upon request.



GRASS BUFFER-GRASS SWALE INSPECTION FORM

Date: _____

Subdivision/Business Name: _____ Inspector: _____

Subdivision/Business Address: _____

Weather: _____

Date of Last Rainfall: _____ Amount: _____ Inches

Property Classification: Residential Multi Family Commercial Other: _____
(Circle One)

Reason for Inspection: Routine Complaint After Significant Rainfall Event
(Circle One)

INSPECTION SCORING - For each facility inspection item, insert one of the following scores:
0 = No deficiencies identified 2 = Routine maintenance required
1 = Monitor (potential for future problem) 3 = Immediate repair necessary
N/A = Not applicable

FEATURES

1.) Grass Swale Bottom & Side Slopes

- Sediment/Debris Accumulation
- Vegetation Cover
- Erosion Present
- Standing Water/Boggy Areas

2.) Grass Buffer

- Sediment/Debris Accumulation
- Vegetation Cover
- Erosion Present
- Standing Water/Boggy Areas

3.) Inflow Points

- Rip Rap Displaced/Run-down or Pipe Damage
- Erosion Present/Outfall Undercut
- Sediment Accumulation

4.) Underdrain System

- Standing water/Not draining
- Evidence of clogged system

5.) Grade Control

- Erosion Present
- Structural Damage

6.) Level Spreader

- Erosion Present
- Structural Damage
- Unlevel/Uneven Distribution of flow

7.) Irrigation

- General Grass Condition
- Bare Spots
- Broken sprinkler heads

8.) Miscellaneous

- Encroachment in Easement Area
- Public Hazards
- Burrowing Animals/Pests
- Other

Inspection Summary / Additional Comments: _____

OVERALL FACILITY RATING (Circle One)

0 = No Deficiencies Identified 2 = Routine Maintenance Required
1 = Monitor (potential for future problem exists) 3 = Immediate Repair Necessary

This inspection form shall be kept indefinitely and made available to the City of Aurora upon request.

A P P E N D I X E

Maintenance Forms



EXTENDED DETENTION BASIN (EDB) MAINTENANCE FORM

Subdivision/Business Name: _____ Completion Date: _____

Subdivision/Business Address: _____ Contact Name: _____

Maintenance Category: Routine Restoration Rehabilitation
(Circle All That Apply)

MAINTENANCE ACTIVITIES PERFORMED

ROUTINE WORK

- MOWING
- TRASH/DEBRIS REMOVAL
- OUTLET WORKS CLEANING (TRASH RACK/WELL SCREEN)
- WEED CONTROL (HERBICIDE APPLICATION)
- MOSQUITO TREATMENT
- ALGAE TREATMENT

RESTORATION WORK

- SEDIMENT REMOVAL
 - FOREBAY
 - TRICKLE CHANNEL
 - INFLOW
- EROSION REPAIR
 - INFLOW POINT
 - TRICKLE CHANNEL
- VEGETATION REMOVAL/TREE THINNING
 - INFLOW(S)
 - TRICKLE CHANNEL
 - UPPER STAGE
 - BOTTOM STAGE
- REVEGETATION
- JET-VAC/CLEARING DRAINS
 - FOREBAY
 - OUTLET WORKS
 - INFLOWS

REHABILITATION WORK

- SEDIMENT REMOVAL (DREDGING)
 - BOTTOM STAGE
 - UPPER STAGE
- EROSION REPAIR
 - OUTLET WORKS
 - UPPER STAGE
 - BOTTOM STAGE
 - SPILLWAY
- STRUCTURAL REPAIR
 - INFLOW
 - OUTLET WORKS
 - FOREBAY
 - TRICKLE CHANNEL

OTHER _____

ESTIMATED TOTAL MANHOURS: _____

EQUIPMENT/MATERIAL USED: _____

COMMENTS/ADDITIONAL INFO: _____

This Maintenance Activity Form shall be kept indefinitely and made available to the City of Aurora upon request.



**GRASS BUFFERS AND GRASS SWALES
(GB-GS)
MAINTENANCE FORM**

Subdivision/Business Name: _____ Completion Date: _____

Subdivision/Business Address: _____ Contact Name: _____

Maintenance Category: Routine Restoration Rehabilitation
(Circle all that apply)

MAINTENANCE ACTIVITIES PERFORMED

ROUTINE WORK

- MOWING
- TRASH/DEBRIS REMOVAL
- OUTLET WORKS CLEANING (TRASH RACK/WELL SCREEN)
- WEED CONTROL (HERBICIDE APPLICATION)

RESTORATION WORK

- SEDIMENT REMOVAL
 - INFLOW POINT
 - SWALE BOTTOM
 - SIDE SLOPE
 - BUFFER STRIP
- EROSION REPAIR
 - INFLOW POINT
 - SWALE BOTTOM
 - SIDE SLOPE
 - BUFFER STRIP
 - GRADE CONTROL/LEVEL SPREADER
- REVEGETATION
 - SWALE BOTTOM
 - SIDE SLOPE
 - BUFFER STRIP

REHABILITATION WORK

- SEDIMENT REMOVAL (DREDGING)
 - SWALE BOTTOM
 - INFLOW POINT
- EROSION REPAIR
 - INFLOW POINT
 - SWALE BOTTOM
 - SIDE SLOPE
 - BUFFER STRIP
- STRUCTURAL REPAIR
 - INFLOW
 - UNDERDRAIN
 - LEVEL SPREADER

OTHER _____

ESTIMATED TOTAL MANHOURS: _____

EQUIPMENT/MATERIAL USED: _____

COMMENTS/ADDITIONAL INFO: _____

This Maintenance Activity Form shall be kept indefinitely and made available to the City of Aurora upon request.

A P P E N D I X F

Inspection and Maintenance Site Plan(s)

Check Lists

Facilities Map Checklist

EDB Checklist

GB-GS Checklist

**INSPECTION AND MAINTENANCE SITE PLANS
STORMWATER FACILITIES MAP
CHECKLIST FOR REQUIRED ITEMS**

Stormwater facilities map shall include:

- Labels for all streets (includes line work for edge of street and street name)
- Line work for right-of-way lines, lot lines, and tracts
- Line work and labels for all major drainage ways
- Label roadways, developments, etc adjacent to project site
- Labels for all BMPs being constructed on project site including a summary table when multiple BMPs are present
- Legend for identifying features/line types on drawing (optional)

INSPECTION AND MAINTENANCE SITE PLANS EXTENDED DETENTION BASIN (EDB) CHECKLIST FOR REQUIRED ITEMS

PLAN AND PROFILE SHEET

Plan view shall include:

- Location and labels for all major features of EDB (inflow structure(s), forebay, micro-pool, trickle channel, access road, outlet work(s), spillway, maintenance access ramps, embankment, etc.)
- Contours
- Other utilities in vicinity of EDB
- Cross-reference to EDB Operation and Maintenance Details sheet
- Line work for right-of-way lines, lot lines, easements, and tracts
- Hatch indicating permanent water elevation in micro-pool.

Profile view shall include:

- Location and labels for all major features of EDB (inflow structure(s), forebay, micro-pool, trickle channel, access road, outlet work(s), spillway, maintenance access ramps, embankment, etc.)
- Invert elevations at major features of EDB (inflow structure(s), forebay, micro-pool, outlet work(s))
- Permanent pool elevation of micro-pool
- Water quality water surface elevation
- Water surface elevation of all applicable storm events
- Label for upper and bottom stages for EDB

DETAIL SHEET

Detail sheet shall include:

- Volume provided by the EDB forebay and micro-pool, including the WQCV
- WQCV drain time
- Seed mix
- Total mow area including approximate mow boundaries on each side of EDB
- Duplicate the following tables from the "Standard Operation Procedure for Extended Detention Basin Inspection and Maintenance" document:
 - o Inspection and Maintenance Requirements at Specific EDB Features

- Summary of Routine Maintenance Activities for an EDB
 - Summary of Minor Maintenance Activities for an EDB
 - Summary of Major Maintenance Activities for an EDB
- Water quality outlet works detail
- Water quality plate detail
- Maintenance access road detail
- Trickle channel typical section
- Forebay edge detail (or cross section) which includes maximum allowed sediment depth in forebay
- Forebay release structure detail
- Spillway detail(s), including cutoff wall

**INSPECTION AND MAINTENANCE SITE PLANS
GRASS SWALES/GRASS BUFFERS (GS/GB)
CHECKLIST FOR REQUIRED ITEMS**

PLAN SHEET

Plan view shall include:

- Location of grass swale(s) and/or buffer(s)
- Contours
- Line work for right-of-way lines, lot lines, easements, and tracts
- Labels for streets adjacent to grass swale(s)/buffer(s)
- Line work for all storm sewer structures
- Cross-reference to Grass Swale/Buffer Operation and Maintenance Details sheet

DETAIL SHEET

Detail sheet shall include:

- Duplicate the following tables from the “Standard Operation Procedure for Grass Swales/Grass Buffers Inspection and Maintenance” document:
 - Typical Inspection and Maintenance Requirements Matrix
 - Summary of Routine Maintenance Activities
 - Summary of Minor Maintenance Activities
 - Summary of Major Maintenance Activities
- Typical grass swale and/or buffer section including typical horizontal and vertical dimensions, side slopes, subgrade material, and underdrain (if applicable).
- Underdrain details (if applicable) including trench dimensions, perforated PVC dimensions, and trench fill material.

POINT TABULATION				POINT TABULATION				POINT TABULATION				POINT TABULATION				POINT TABULATION				
ID NO.	DESCRIPTION	NORTHING/EASTING	ELEVATION	ID NO.	DESCRIPTION	NORTHING/EASTING	ELEVATION	ID NO.	DESCRIPTION	NORTHING/EASTING	ELEVATION	ID NO.	DESCRIPTION	NORTHING/EASTING	ELEVATION	ID NO.	DESCRIPTION	NORTHING/EASTING	ELEVATION	
A1	ACCESS ROAD/TBC	N: 6309.44 E: 6246.27	6267.94	A21	ACCESS ROAD/ SPILLWAY CREST	N: 5917.45 E: 6367.96	6256.64	A41	ACCESS ROAD/TOP	N: 5967.71 E: 6371.28	6258.45	A61	TOE	N: 5872.32 E: 6341.93	6252.21	A81	TRICKLE CHANNEL	N: 5961.29 E: 6323.89	6252.67	
A2	ACCESS ROAD/TBC	N: 6294.44 E: 6246.15	6267.77	A22	ACCESS ROAD/ SPILLWAY CREST	N: 5917.06 E: 6382.97	6256.70	A42	TOP	N: 5840.20 E: 6366.65	6257.57	A62	TOE	N: 5842.39 E: 6341.66	6251.87	A82	TRICKLE CHANNEL	N: 5996.30 E: 6323.09	6253.12	
A3	ACCESS ROAD	N: 6282.22 E: 6298.56	6269.34	A23	ACCESS ROAD/ SPILLWAY CREST	N: 5877.46 E: 6366.94	6256.64	A43	TOP	N: 5804.97 E: 6351.72	6257.57	A63	TOE	N: 5822.57 E: 6321.50	6252.02	A83	TRICKLE CHANNEL	N: 6014.01 E: 6325.83	6253.35	
A4	ACCESS ROAD	N: 6295.07 E: 6306.29	6269.04	A24	ACCESS ROAD/ SPILLWAY CREST	N: 5872.08 E: 6381.95	6256.64	A44	TOP	N: 5790.61 E: 6316.24	6257.59	A64	TOE	N: 5822.69 E: 6306.50	6252.18	A84	TRICKLE CHANNEL	N: 6062.96 E: 6321.15	6253.98	
A5	ACCESS ROAD	N: 6239.16 E: 6370.19	6270.00	A25	ACCESS ROAD/ SPILLWAY TOP/ CUTOFF WALL	N: 5863.05 E: 6367.14	6258.08	A45	TOP	N: 5790.69 E: 6306.24	6257.58	A65	TOE	N: 5825.08 E: 6300.86	6252.23	A85	FOREBAY	N: 6088.73 E: 6311.93	6254.32	
A6	ACCESS ROAD	N: 6252.02 E: 6377.92	6269.70	A26	ACCESS ROAD/ SPILLWAY TOP	N: 5862.67 E: 6382.14	6258.08	A46	TOP	N: 5802.64 E: 6278.05	6257.35	A66	ACCESS ROAD/TOE	N: 5830.39 E: 6298.57	6252.26	A86	TRICKLE CHANNEL	N: 5896.39 E: 6320.31	6252.44	
A7	ACCESS ROAD	N: 6206.86 E: 6387.08	6267.48	A27	ACCESS ROAD	N: 5791.32 E: 6368.12	6256.70	A47	TOP	N: 5831.01 E: 6266.57	6260.28	A67	TOE	N: 5894.09 E: 6299.08	6253.62	A87	FOREBAY	N: 5903.89 E: 6302.70	6252.87	
A8	ACCESS ROAD	N: 6205.87 E: 6402.05	6267.18	A28	ACCESS ROAD	N: 5791.53 E: 6383.12	6256.53	A48	TOP	N: 5894.35 E: 6267.08	6261.30	A68	TOE	N: 5957.42 E: 6299.59	6253.84	A88	ACCESS ROAD/TBC	N: 5797.94 E: 6241.88	6259.56	
A9	ACCESS ROAD/TOP	N: 6141.31 E: 6382.75	6261.90	A29	CONC CUTOFF WALL	N: 5924.69 E: 6366.62	6257.08	A49	TOP	N: 5957.68 E: 6267.59	6262.56	A69	TOE	N: 6020.76 E: 6300.10	6254.71	A89	ACCESS ROAD/TBC	N: 5782.76 E: 6241.68	6259.26	
A10	ACCESS ROAD	N: 6140.32 E: 6397.72	6261.60	A30	CONC CUTOFF WALL	N: 5917.53 E: 6366.82	6256.18	A50	TOP	N: 6021.01 E: 6268.10	6263.68	A70	TOE	N: 6084.09 E: 6300.61	6255.63	A90	ACCESS ROAD	N: 5800.62 E: 6259.92	6259.90	
A11	TOP	N: 6123.75 E: 6321.23	6262.86	A31	CONC CUTOFF WALL	N: 5877.54 E: 6363.79	6256.18	A51	TOP	N: 6084.35 E: 6268.62	6264.63	A71	TOE	N: 6089.73 E: 6303.00	6255.61	A91	ACCESS ROAD	N: 5785.78 E: 6262.12	6259.52	
A12	TOP	N: 6140.95 E: 6356.46	6263.03	A32	CONC CUTOFF WALL	N: 5870.30 E: 6365.51	6257.14	A52	TOP	N: 6112.54 E: 6280.56	6263.21	A72	TOE	N: 6091.96 E: 6316.26	6255.16	A92	ACCESS ROAD/TOP	N: 5805.60 E: 6275.42	6257.62	
A13	ACCESS ROAD/TOE	N: 6083.63 E: 6329.58	6255.58	A33	SPILLWAY	N: 5862.52 E: 6388.03	6254.82	A53	TOP	N: 6123.99 E: 6310.25	6263.54	A73	TOE	N: 6089.19 E: 6324.83	6255.54	A93	ACCESS ROAD/TOP	N: 5795.40 E: 6287.73	6256.54	
A14	ACCESS ROAD/TOE	N: 6068.02 E: 6335.27	6255.19	A34	SPILLWAY	N: 5876.92 E: 6387.95	6254.89	A54	TOP	N: 6123.57 E: 6316.42	6263.15	A74	OUTLET STRUCTURE	N: 5829.64 E: 6334.38	6251.33	A94	ACCESS ROAD/TOE	N: 5822.65 E: 6311.52	6252.12	
A15	ACCESS ROAD/TOP	N: 6101.17 E: 6380.10	6260.97	A35	SPILLWAY	N: 5916.91 E: 6388.98	6255.28	A55	TOE	N: 6053.91 E: 6339.33	6255.16	A75	TRICKLE CHANNEL	N: 5839.12 E: 6325.05	6251.40	A97	WQCV WSEL 12" CLASS 6 ABC BELOW 8" CLASS 6 ABC ABOVE	N: 5823.36 E: 6294.85	6253.49	
A16	ACCESS ROAD	N: 6100.19 E: 6395.07	6260.67	A36	SPILLWAY	N: 5931.30 E: 6389.57	6255.58	A56	TOE	N: 6012.43 E: 6340.76	6254.59	A76	TRICKLE CHANNEL	N: 5861.60 E: 6321.19	6251.52	A98	WQCV WSEL 12" CLASS 6 ABC BELOW 8" CLASS 6 ABC ABOVE	N: 5812.97 E: 6305.95	6253.49	
A17	ACCESS ROAD	N: 6012.06 E: 6374.21	6259.48	A37	ACCESS ROAD/TOP	N: 6154.20 E: 6383.60	6263.00	A57	TOE	N: 5989.23 E: 6340.05	6254.33	A77	TRICKLE CHANNEL INTERSECTION	N: 5876.29 E: 6328.05	6251.61					
A18	ACCESS ROAD	N: 6011.07 E: 6389.18	6259.22	A38	ACCESS ROAD/TOP	N: 6086.43 E: 6379.13	6260.82	A58	TOE	N: 5965.33 E: 6342.10	6253.91	A78	TRICKLE CHANNEL	N: 5883.34 E: 6329.62	6251.67					
A19	ACCESS ROAD/ SPILLWAY TOP/ CUTOFF WALL	N: 5931.83 E: 6368.92	6258.08	A39	ACCESS ROAD/TOP	N: 6060.71 E: 6377.43	6260.43	A59	TOE	N: 5948.88 E: 6342.83	6253.57	A79	TRICKLE CHANNEL	N: 5912.62 E: 6330.80	6252.04					
A20	ACCESS ROAD/ SPILLWAY TOP	N: 5931.44 E: 6383.92	6258.08	A40	ACCESS ROAD/TOP	N: 6026.71 E: 6375.18	6259.79	A60	TOE	N: 5923.02 E: 6343.05	6253.04	A80	TRICKLE CHANNEL	N: 5936.39 E: 6328.91	6252.35					

POND A
(7.89 TRIBUTARY ACRES,
49.43% COMP. IMPERVIOUSNESS)

DESIGN STORM	STORAGE	STAGE
WQCV (AC-FT)	0.135	6253.49
EURV (AC-FT)	0.417	6254.77
100-YEAR (ACR-FT)	0.732	6255.7

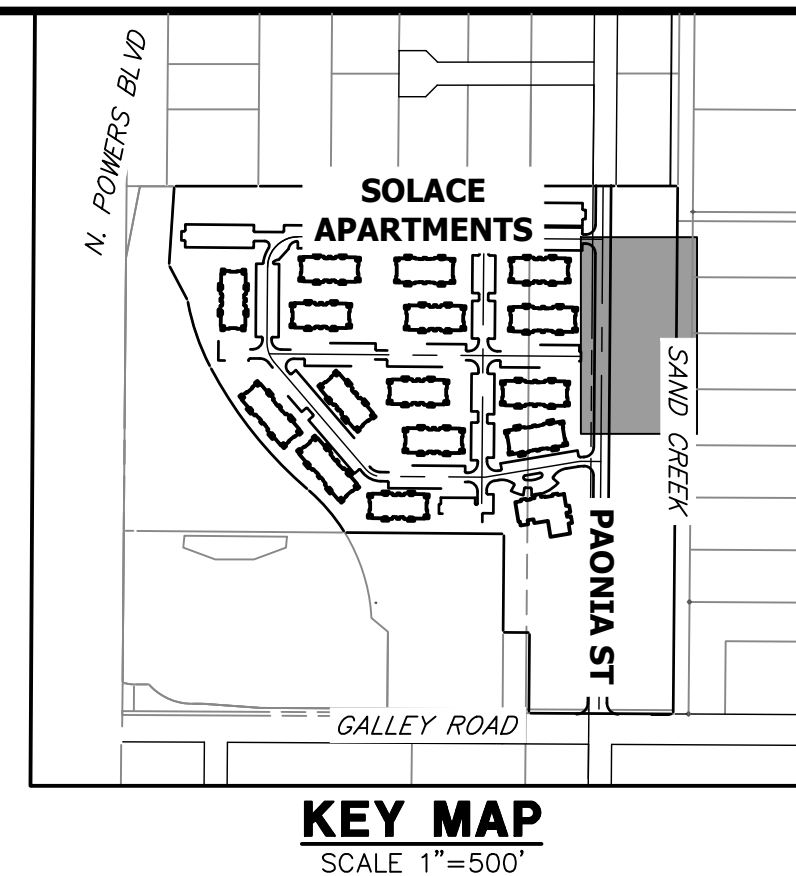

- NOTES**
- ALL PROPOSED POND IMPROVEMENTS ARE PRIVATE UNLESS OTHERWISE NOTED.
 - SEE SHEETS 12-15 FOR PROPOSED STORM SEWER DESIGN.
 - SEE PAONIA STREET IMPROVEMENT PLANS BY JR ENGINEERING FOR PROPOSED PAONIA STREET DESIGN.
 - SEE WATER DISTRIBUTION PLANS AND SANITARY SEWER PLAN AND PROFILE BY JR ENGINEERING FOR PROPOSED DESIGN OF CMD-OWNED WATER AND SANITARY UTILITIES.

LINE TABLE			CURVE TABLE			
LINE	BEARING	DISTANCE	CURVE	DELTA	RADIUS	LENGTH
L1	N44°30'51"W	13.30'	C1	69°32'18"	20.00'	24.27'
L2	N25°01'27"E	15.54'	C2	22°43'37"	20.00'	7.93'
L3	N02°17'50"E	29.31'	C3	13°41'35"	100.00'	23.90'
L4	N11°23'45"W	25.39'	C4	20°10'25"	100.00'	35.21'
L5	N08°46'40"E	17.92'	C5	28°27'59"	100.00'	49.68'
L6	N19°41'19"W	27.37'	C6	92°03'40"	15.00'	24.10'
L7	S67°02'13"E	19.12'				

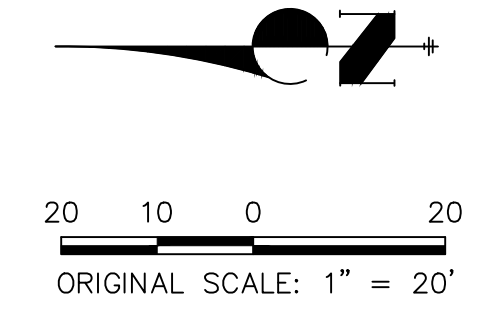
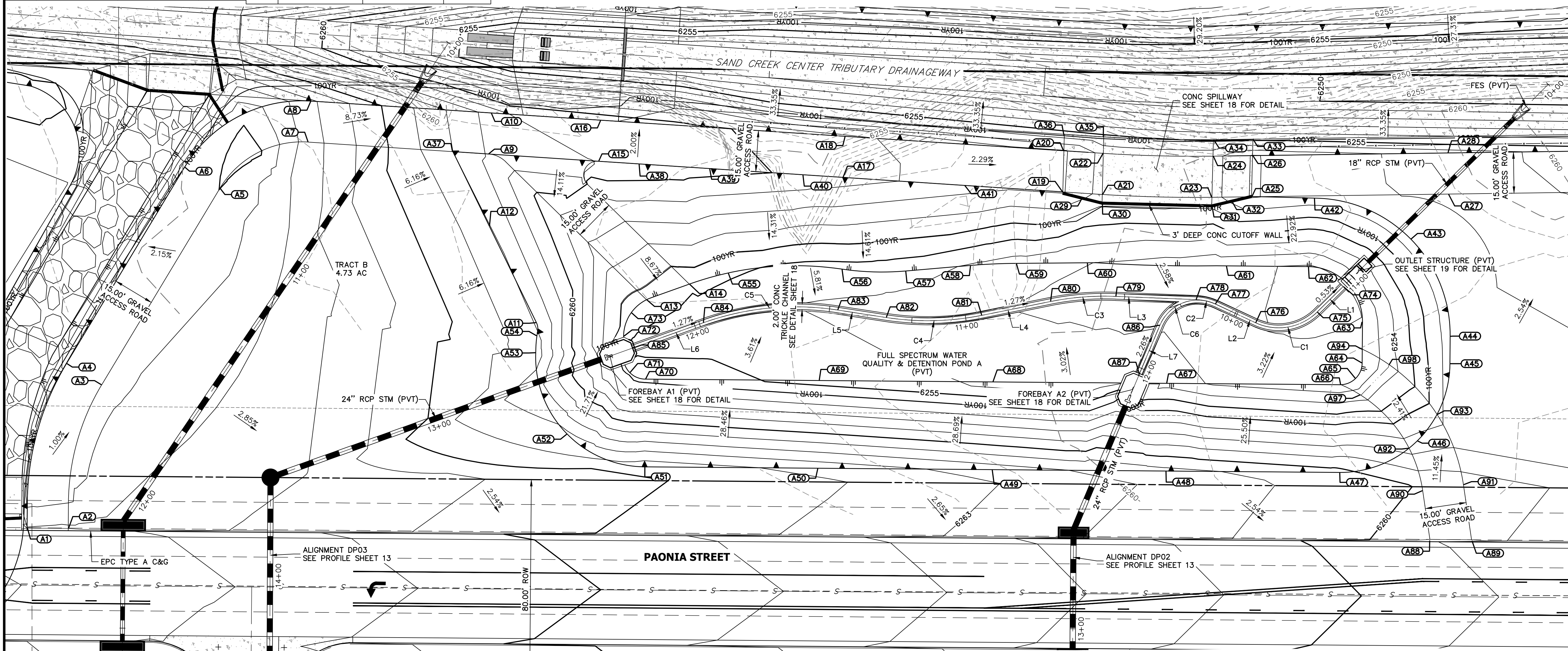

THE LOCATIONS OF EXISTING ABOVE GROUND AND UNDERGROUND UTILITIES ARE SHOWN IN AN APPROXIMATE MANNER ONLY. THE CONTRACTOR SHALL DETERMINE THE EXACT LOCATION OF ALL EXISTING UTILITIES BEFORE COMMENCING WORK. THE CONTRACTOR SHALL BE FULLY RESPONSIBLE FOR ANY AND ALL DAMAGES WHICH MIGHT BE CAUSED BY HIS FAILURE TO EXACTLY LOCATE AND PRESERVE ANY AND ALL ABOVE GROUND AND UNDERGROUND UTILITIES.

ENGINEER'S STATEMENT
PREPARED UNDER MY SUPERVISION
Mike Bramlett
MIKE A. BRAMLETT, P.E.
COLORADO P.E. 32314
FOR AND ON BEHALF OF JR ENGINEERING, LLC
DATE: 6/21/21

UNTIL SUCH TIME AS THESE DRAWINGS ARE APPROVED BY THE AGENCIES, JR ENGINEERING APPROVES THEIR USE DESIGNATED BY WRITTEN AUTHORIZATION.

PREPARED FOR
JACKSON DEARBORN PARTNERS
404 S. WELLS ST.
SUITE 400
CHICAGO, ILL. 60607
OFFICE PHONE (734) 216-2577

J.R. ENGINEERING
A Westman Company
Central 303-740-9888 • Colorado Springs 719-588-2583
Fort Collins 970-491-9888 • www.jrengineering.com

BY	DATE	NO.	REVISION

H-SCALE 1"=20'
V-SCALE N/A
DATE 12/12/20
DESIGNED BY JBP
DRAWN BY RPD
CHECKED BY

SOLACE APARTMENTS - FILING NO. 1
POND A I&M PLANS

SHEET 1 OF 2
JOB NO. 25174.00

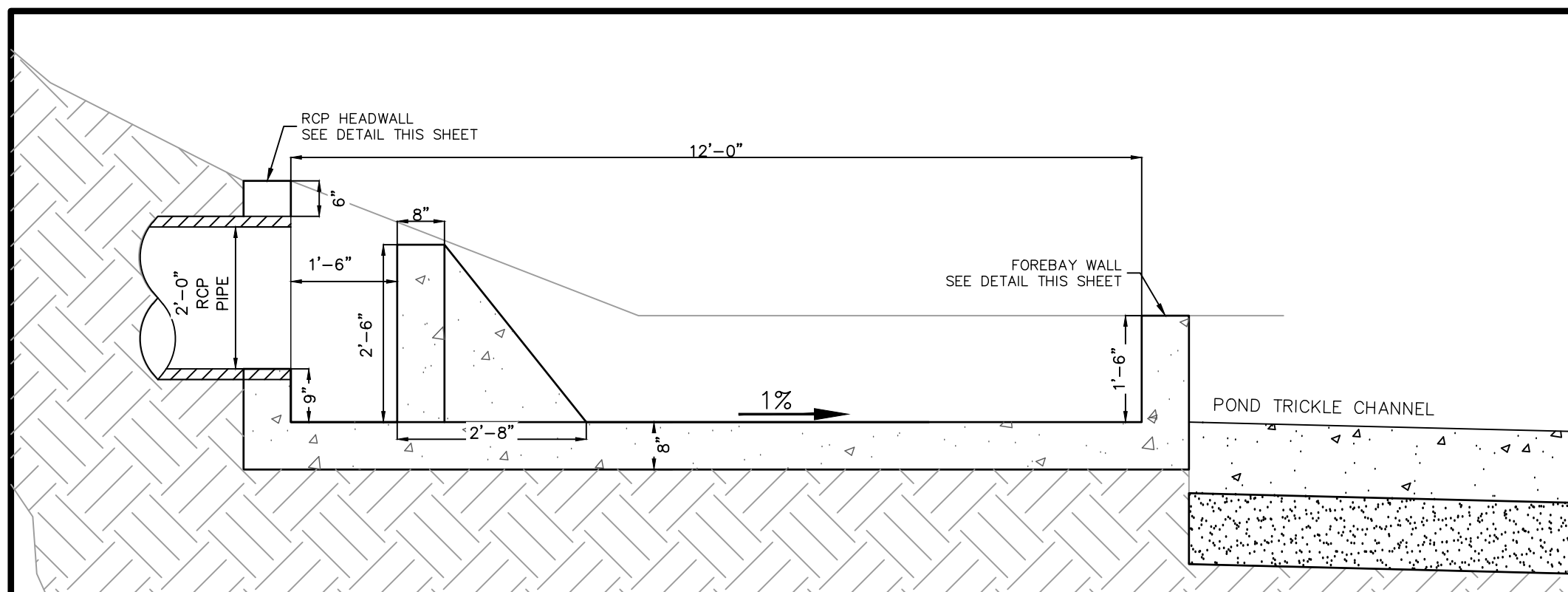

FOREBAY A1 & A2 PROFILE VIEW
SCALE: 1" = 2'

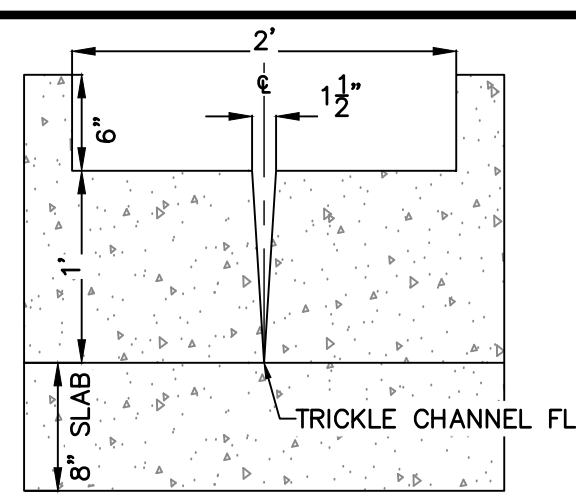

FOREBAY A1 & A2 WALL SECTION
SCALE: 1" = 1'

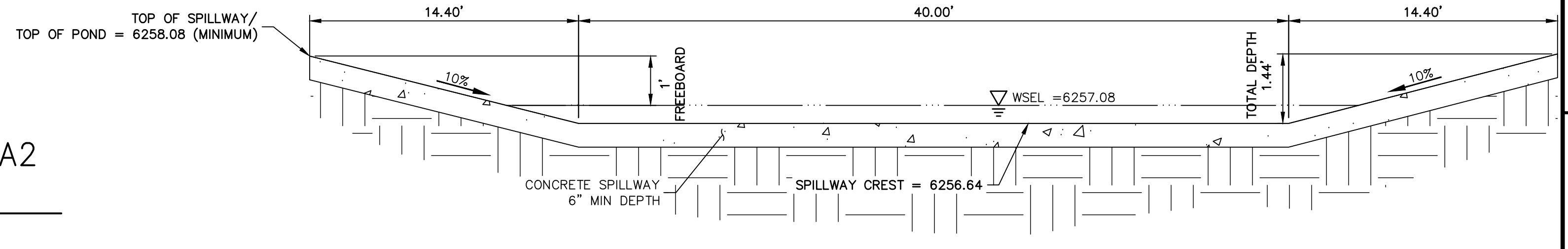

POND A EMERGENCY OVERFLOW SPILLWAY
SCALE: N.T.S.

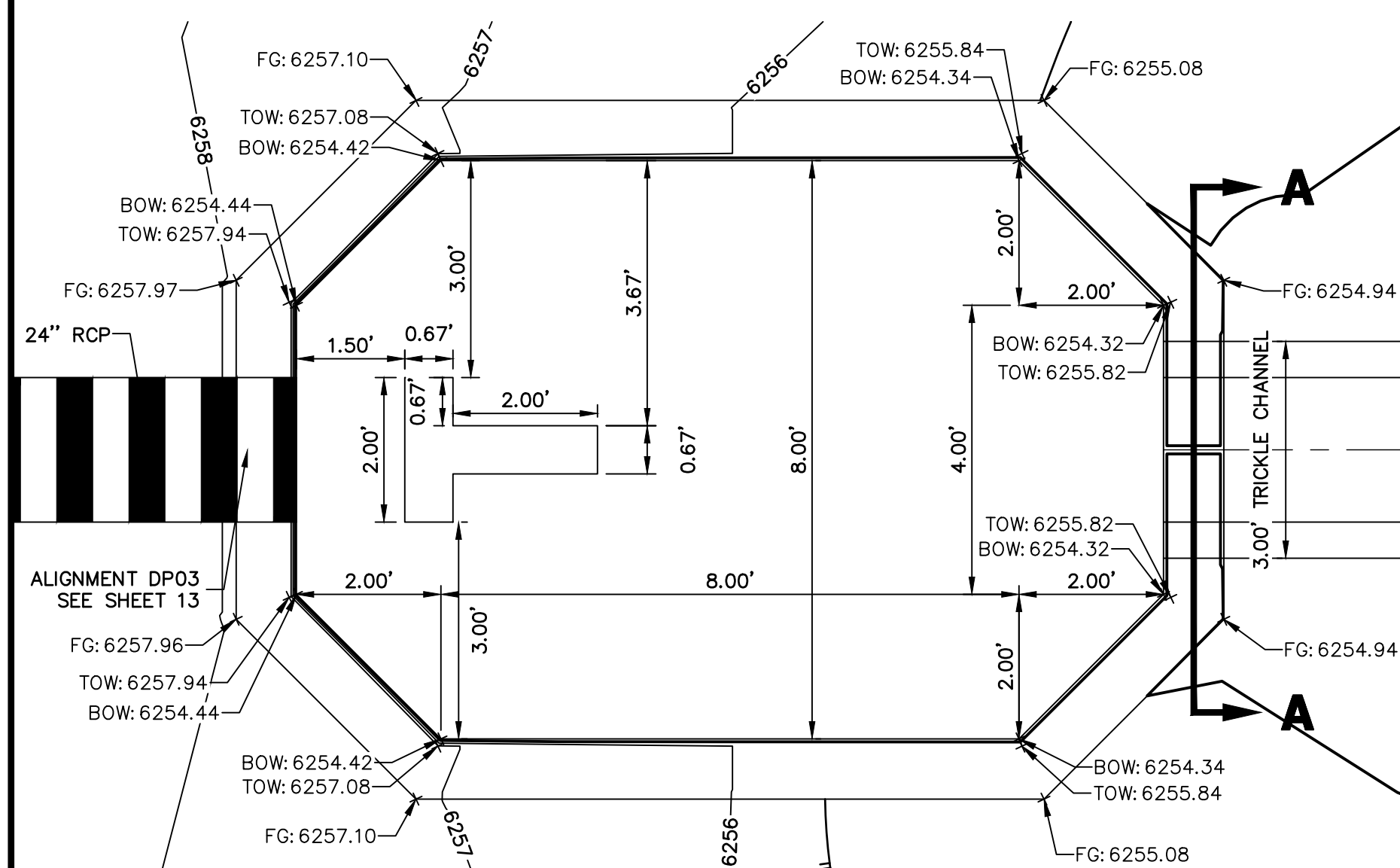

FOREBAY A1 PLAN VIEW
SCALE: 1" = 2'

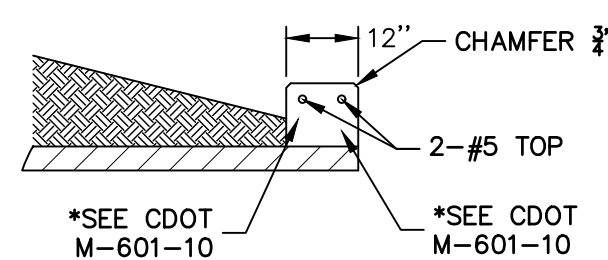

RCP HEADWALL
SCALE: N.T.S.

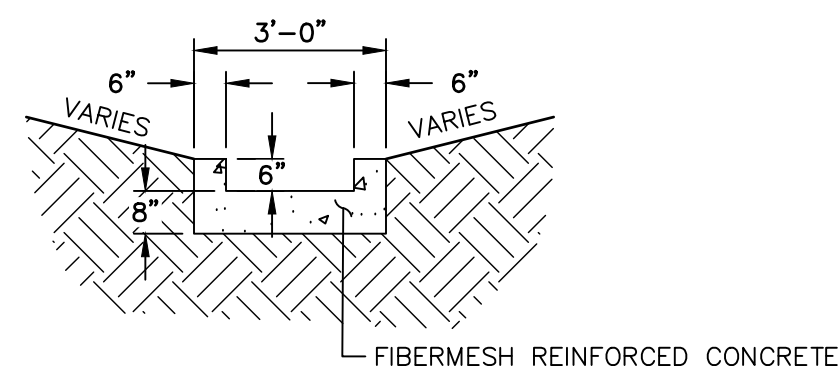

TRICKLE CHANNEL
SCALE: N.T.S.

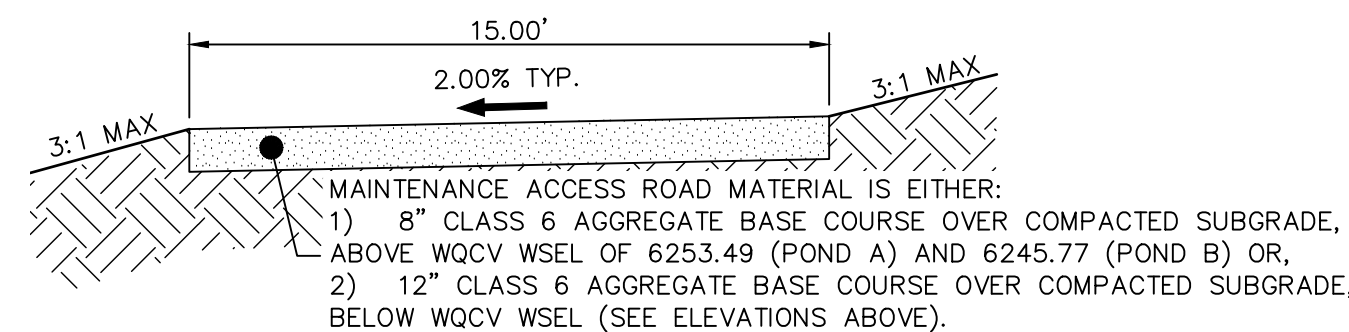

POND MAINTENANCE ACCESS ROAD TYPICAL SECTION
SCALE: N.T.S.

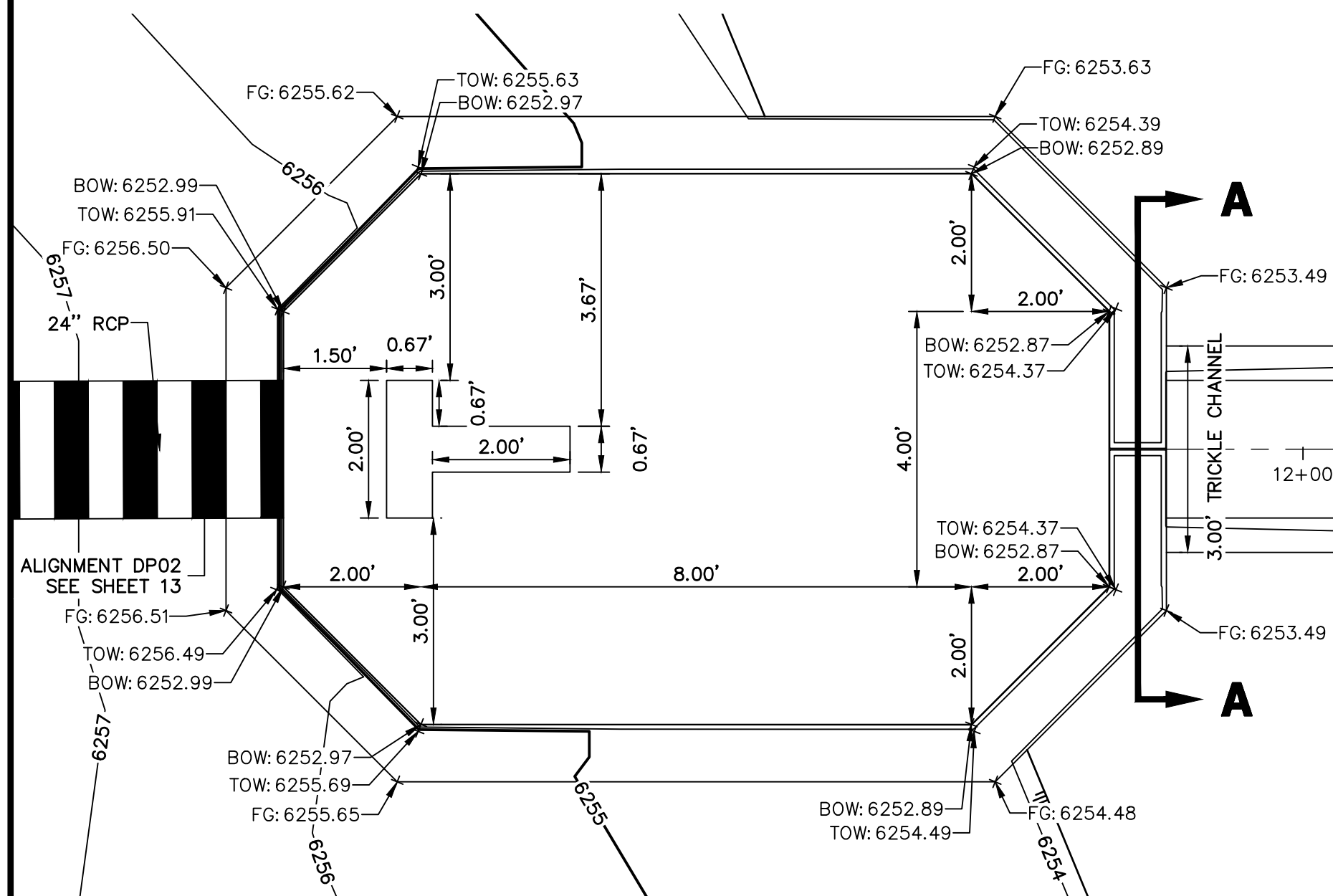

FOREBAY A2 PLAN VIEW
SCALE: 1" = 2'

WALL NOTES:

- HEADWALLS FOR PIPES SHALL BE CONSTRUCTED IN ACCORDANCE WITH CDOT STANDARD PLAN M-601-10.
- WINGWALLS SHALL BE CONSTRUCTED IN ACCORDANCE WITH CDOT STANDARD PLAN M-601-20.

CAST-IN-PLACE STRUCTURAL NOTES:

- ALL CONCRETE SHALL BE CLASS D IN ACCORDANCE WITH CDOT STANDARD SPECIFICATIONS FOR ROAD AND BRIDGE CONSTRUCTION.
- ALL CONSTRUCTION JOINTS SHALL BE THOROUGHLY CLEANED BEFORE FRESH CONCRETE IS POURED.
- ALL CONSTRUCTION JOINTS NOT SHOWN ON THE PLANS SHALL BE APPROVED BY THE ENGINEER.
- THE CONTRACTOR IS RESPONSIBLE FOR THE STABILITY OF THE STRUCTURE DURING CONSTRUCTION.
- STRUCTURE EXCAVATION AND BACKFILL SHALL BE IN ACCORDANCE WITH CDOT STD. M-206-1.
- DO NOT BACKFILL UNTIL CONCRETE HAS REACHED DESIGN STRENGTH, F_c.
- GRADE 60 REINFORCING STEEL AND EPOXY COATED ARE REQUIRED.
- REINFORCING BARS SHALL BE DEFORMED AND SHALL HAVE A MINIMUM OF 2" CLEARANCE.
- ALL EXPOSED CONCRETE CORNERS SHALL BE CHAMFERED 3/4".
- IT SHALL BE THE CONTRACTOR'S RESPONSIBILITY TO VERIFY THE LOCATIONS OF EXISTING STRUCTURES AND EXISTING UTILITIES, PRIOR TO CONSTRUCTION OF THE CAST-IN-PLACE STRUCTURES. FIELD MODIFICATIONS OF PRECAST UNITS TO ACCOMMODATE CAST-IN-PLACE STRUCTURES WILL ONLY BE ACCEPTABLE WITH THE ENGINEER'S APPROVAL.
- CONTRACTOR SHALL SUBMIT STEEL REINFORCING SHOP DRAWINGS FOR ALL CAST-IN-PLACE STRUCTURES FOR ENGINEER'S APPROVAL PRIOR TO CONSTRUCTION.

TABLE EDB-2
SUMMARY OF ROUTINE MAINTENANCE ACTIVITIES

Maintenance Activity	Minimum Frequency	Look for:	Maintenance Action
Mowing	Twice annually	Excessive grass height/aesthetics	Mow grass to a height of 4" to 6"
Trash/Debris Removal	Twice annually	Trash & debris in EDB	Remove and dispose of trash and debris
Outlet Works Cleaning	As needed - after significant rain events - twice annually min.	Clogged outlet structure; ponding water	Remove and dispose of debris/trash/sediment to allow outlet to function properly
Weed control	Minimum twice annually	Noxious weeds; Unwanted vegetation	Treat w/ herbicide or hand pull; Consult the local weed specialist
Mosquito Treatment	As needed	Standing water/mosquito habitat	Treat w/ EPA approved chemicals
Algae Treatment	As needed	Standing water/ Algal growth/green color	Treat w/ EPA approved chemicals

TABLE EDB-3
SUMMARY OF MINOR MAINTENANCE ACTIVITIES

Maintenance Activity	Minimum Frequency	Look for:	Maintenance Action
Sediment Removal*	As needed; typically every 1-2 years	Sediment build-up; decrease in pond volume	Remove and dispose of sediment
Erosion Repair	As needed, based upon inspection	Rills/gullies forming on side slopes, trickle channel, other areas	Repair eroded areas Revegetate; address source of erosion
Vegetation Removal/Tree Thinning	As needed, based upon inspection	Large trees/wood vegetation in lower chamber of pond	Remove vegetation; restore grade and surface
Drain Cleaning/Jet Vac	As needed, based upon inspection	Sediment build-up /non draining system	Clean drains; Jet Vac if needed

*Usually from the forebay, trickle channel, and/or micropool

TABLE EDB-4
SUMMARY OF MAJOR MAINTENANCE ACTIVITIES

Maintenance Activity	Minimum Frequency	Look for:	Maintenance Action
Major Sediment Removal	As needed - based upon scheduled inspections	Large quantities of sediment; reduced pond capacity	Remove and dispose of sediment. Repair vegetation as needed
Major Erosion Repair	As needed - based upon scheduled inspections	Severe erosion including gullies, excessive soil displacement, areas of settlement, holes	Repair erosion - find cause of problem and address to avoid future erosion
Structural Repair	As needed - based upon scheduled inspections	Deterioration and/or damage to structural components - broken concrete, damaged pipes, outlet works	Structural repair to restore the structure to its original design

UNTIL SUCH TIME AS THESE DRAWINGS ARE APPROVED BY THE AGENCIES, OR ENGINEERING APPROVES THEIR USE, THESE DRAWINGS ARE DESIGNATED BY WRITTEN AUTHORIZATION.

PREPARED FOR
JACKSON DEARBORN PARTNERS
404 S. WELLS ST.
SUITE 400
CHICAGO, ILL. 60607
OFFICE PHONE (734) 216-2577

J.R. ENGINEERING
A Westman Company
Central 303-740-9883 • Colorado Springs 719-588-2583
Fort Collins 970-491-9888 • www.jrengineering.com

BY	DATE

No.	REVISION

H-SCALE	V-SCALE	DATE	DESIGNED BY	DRAWN BY	CHECKED BY
VARIES	VARIES	12/12/20	JBP	RPD	

SOLACE APARTMENTS - FILING NO. 1
POND A I&M PLANS

SHEET 2 OF 2
JOB NO. 25174.00



Know what's below.
Call before you dig.

ENGINEER'S STATEMENT

PREPARED UNDER MY SUPERVISION

MIKE A. BRAMLETT, P.E.

COLORADO P.E. 32314

FOR AND ON BEHALF OF JR ENGINEERING

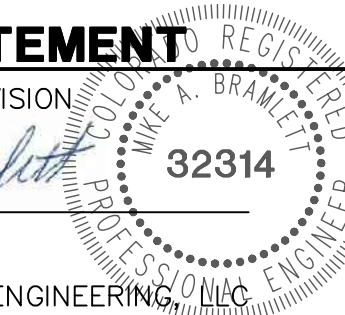

DATE 6/21/21

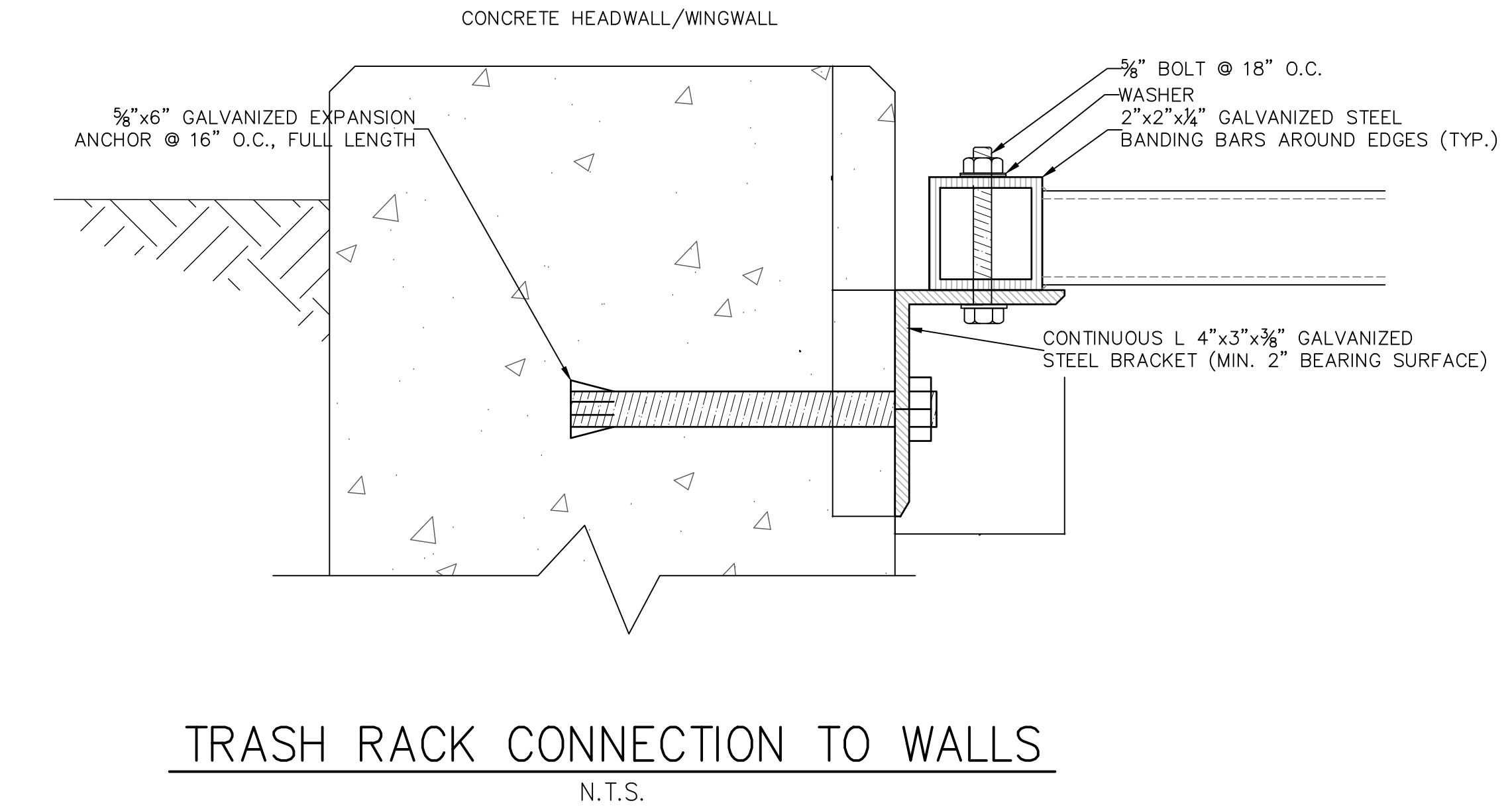
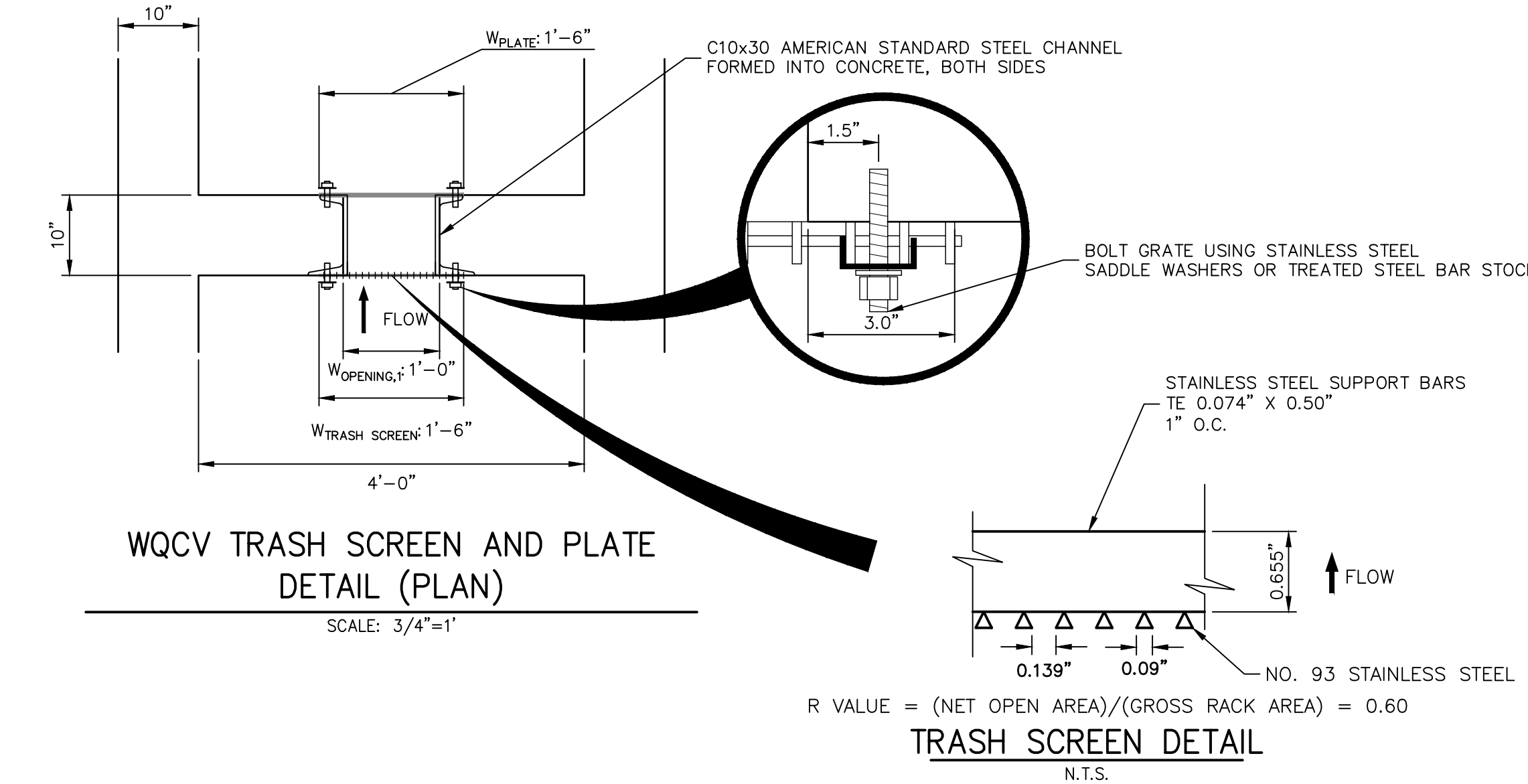
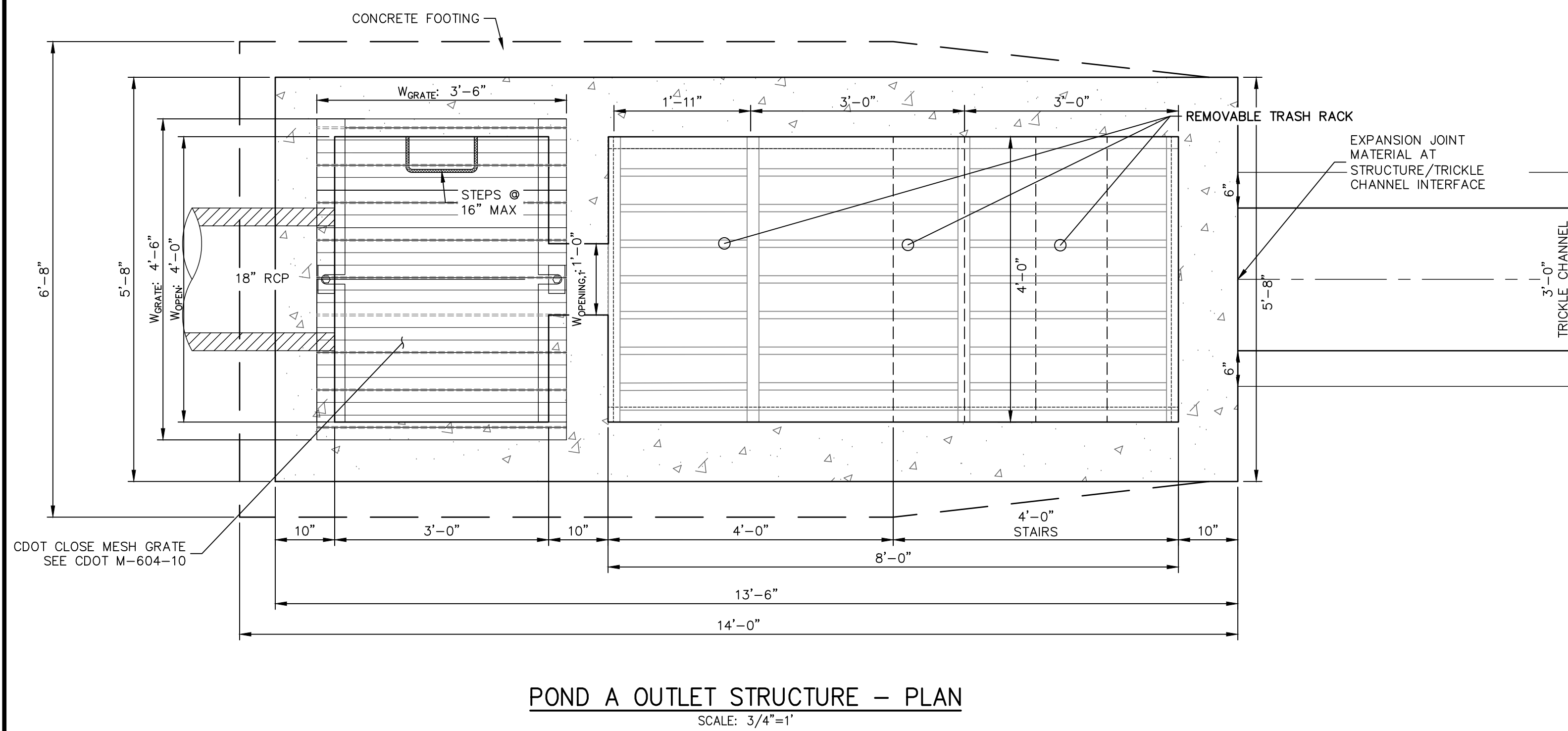
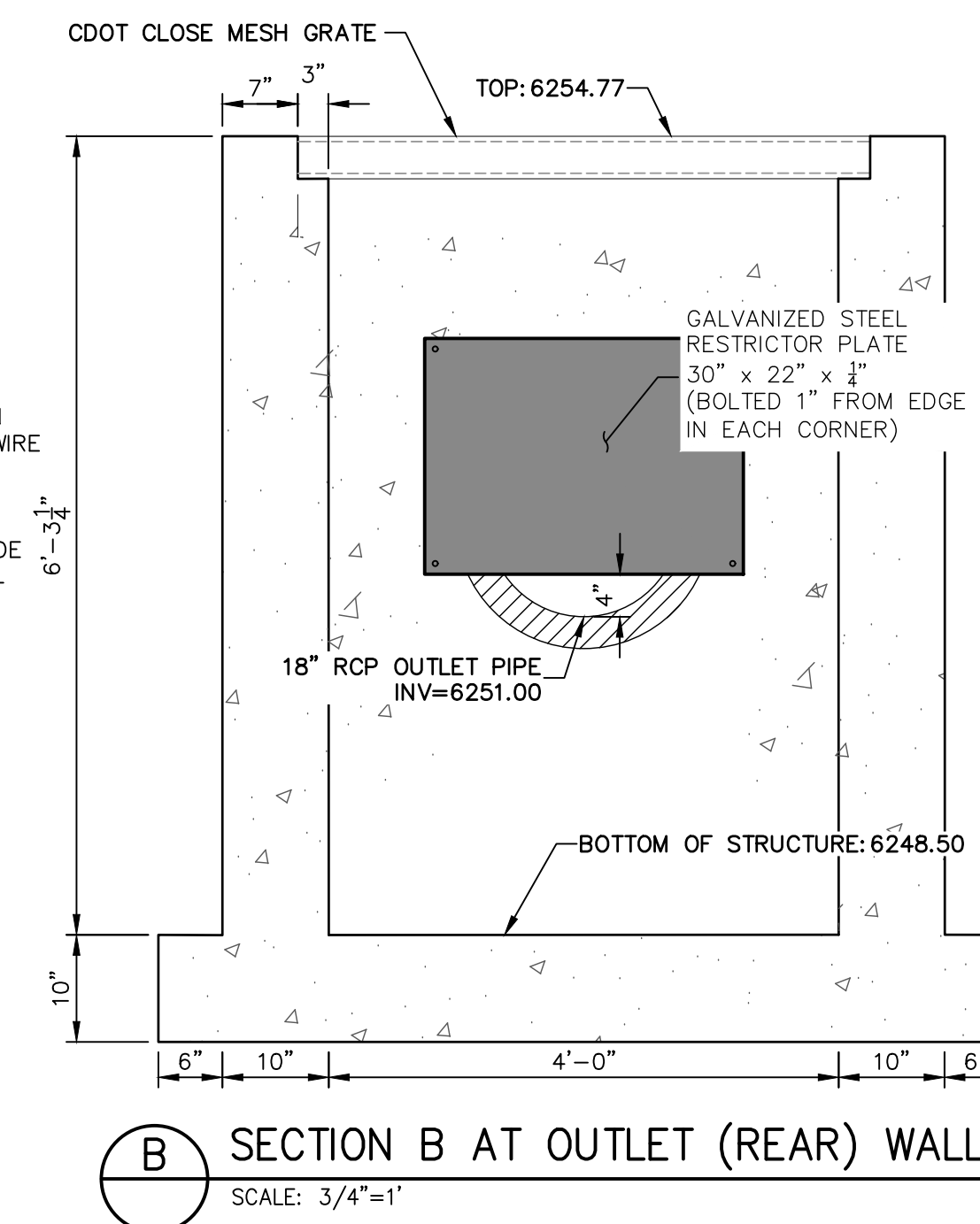
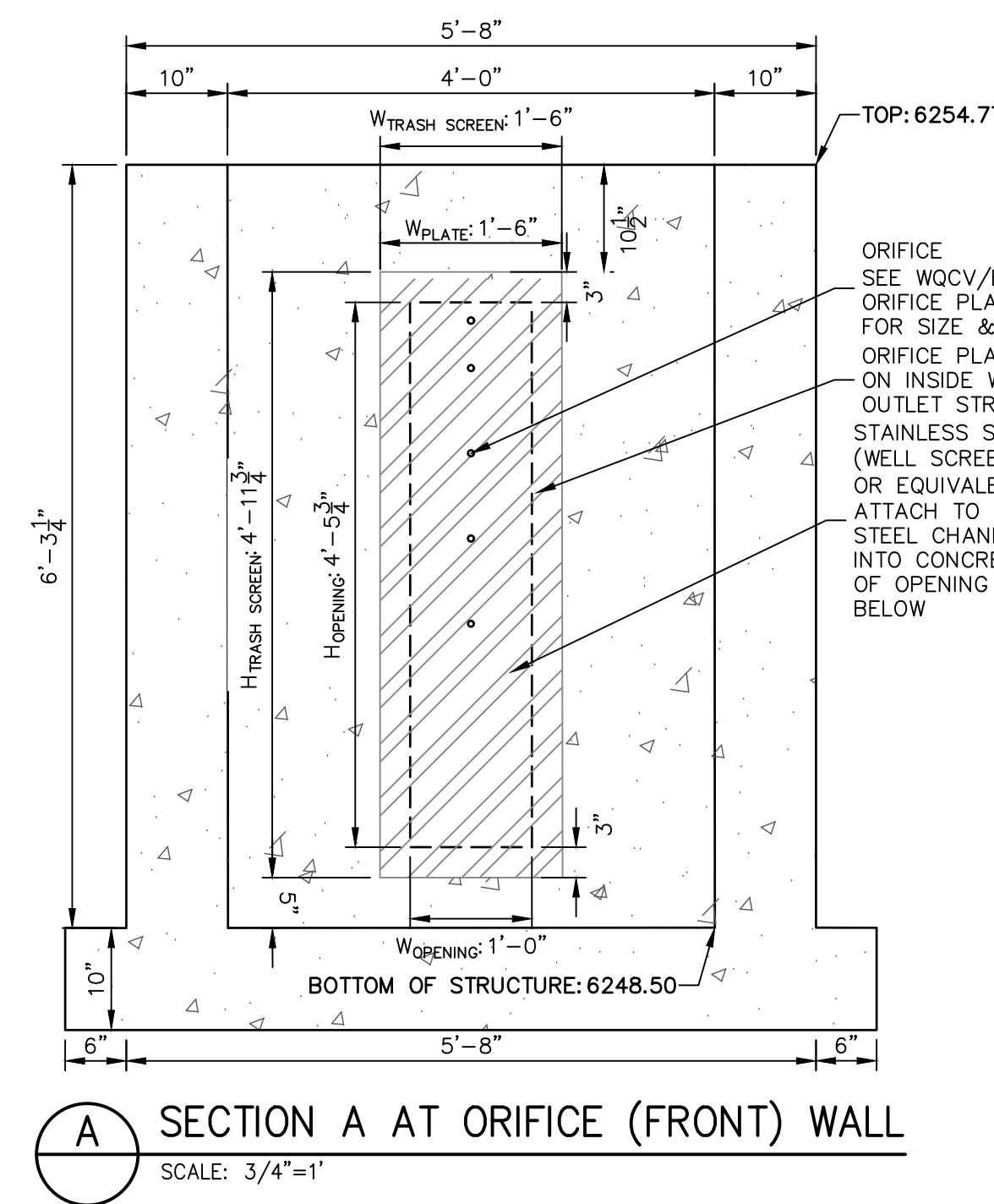
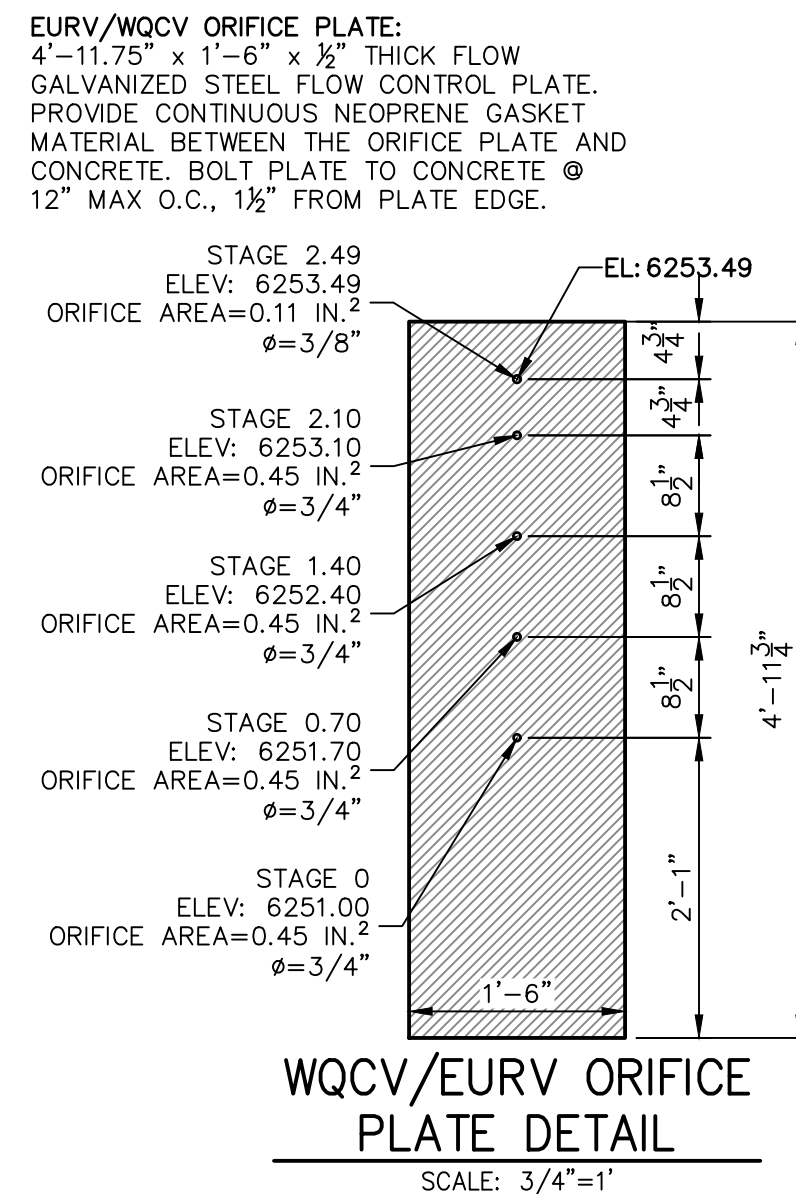
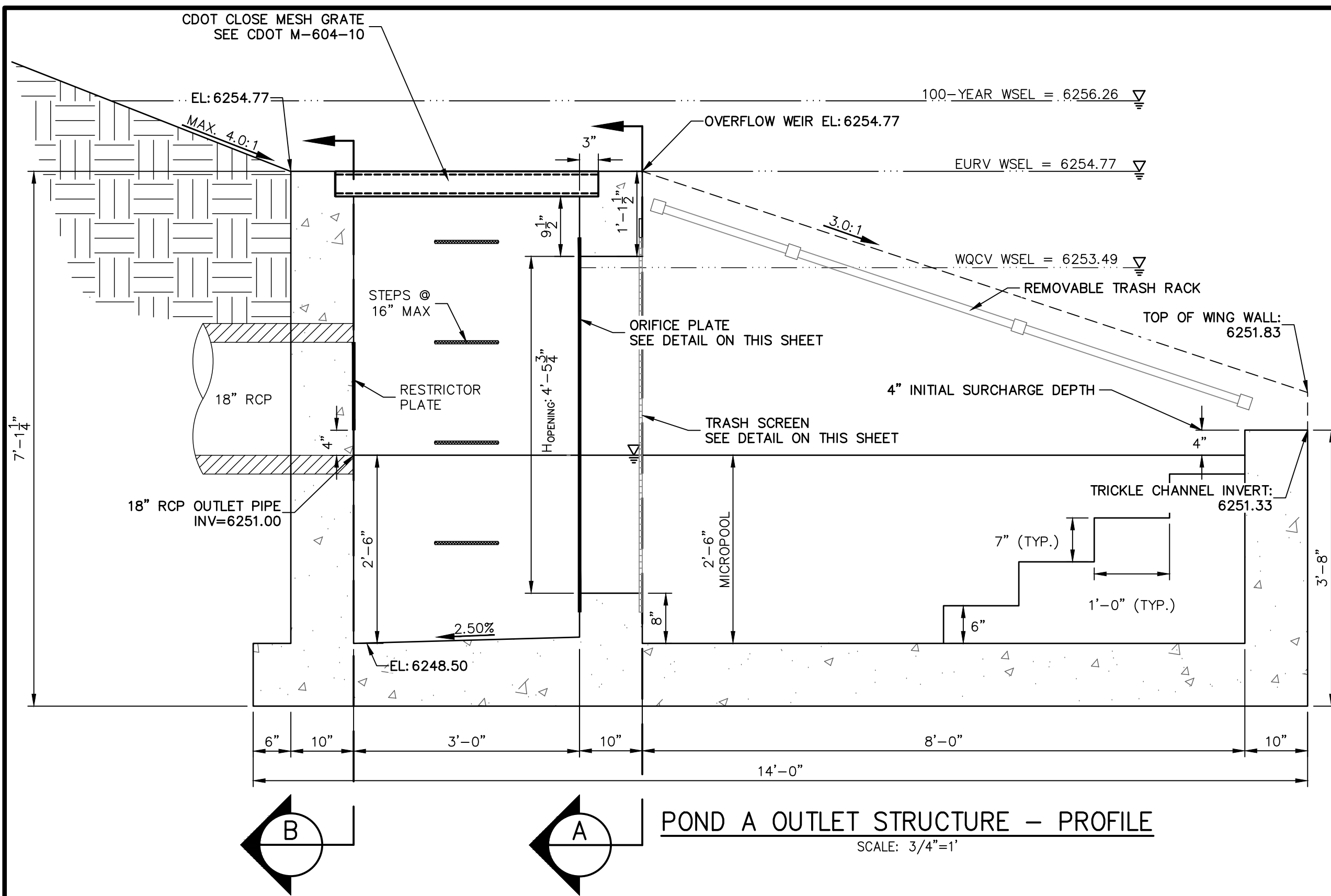

OUTLET STRUCTURE STRUCTURAL NOTES:

- REFER TO CDOT DETAILS M-601-10 AND M-601-20 FOR STRUCTURAL REINFORCEMENT DESIGN.
- ALL CONCRETE SHALL BE CLASS D IN ACCORDANCE WITH CDOT STANDARD SPECIFICATIONS FOR ROAD AND BRIDGE CONSTRUCTION.
- ALL CONSTRUCTION JOINTS SHALL BE THOROUGHLY CLEANED BEFORE FRESH CONCRETE IS POURED.
- ALL CONSTRUCTION JOINTS NOT SHOWN ON THE PLANS SHALL BE APPROVED BY THE ENGINEER.
- THE CONTRACTOR IS RESPONSIBLE FOR THE STABILITY OF THE STRUCTURE DURING CONSTRUCTION.
- STRUCTURE EXCAVATION AND BACKFILL SHALL BE IN ACCORDANCE WITH CDOT STD. M-206-1.
- DO NOT BACKFILL UNTIL CONCRETE HAS REACHED DESIGN STRENGTH, F'c.
- GRADE 60 REINFORCING STEEL AND EPOXY COATED ARE REQUIRED.
- REINFORCING BARS SHALL BE DEFORMED AND SHALL HAVE A MINIMUM OF 2" CLEARANCE.
- ALL EXPOSED CONCRETE CORNERS SHALL BE CHAMFERED 3/4".
- IT SHALL BE THE CONTRACTOR'S RESPONSIBILITY TO VERIFY THE LOCATIONS OF EXISTING STRUCTURES AND EXISTING UTILITIES, PRIOR TO CONSTRUCTION OF THE CAST-IN-PLACE STRUCTURES. FIELD MODIFICATIONS OF PRECAST UNITS TO ACCOMMODATE CAST-IN-PLACE STRUCTURES WILL ONLY BE ACCEPTABLE WITH THE ENGINEER'S APPROVAL.
- CONTRACTOR SHALL SUBMIT STEEL REINFORCING SHOP DRAWINGS FOR ALL CAST-IN-PLACE STRUCTURES FOR ENGINEER'S APPROVAL PRIOR TO CONSTRUCTION.

OUTLET STRUCTURE PLATE AND GRADING NOTES:

- ORIFICE PLATE AND RESTRICTOR PLATE:**
- PROVIDE GASKET MATERIAL BETWEEN THE ORIFICE PLATE AND CONCRETE AND BETWEEN THE RESTRICTOR PLATE AND CONCRETE.
 - BOLT PLATE TO CONCRETE 12" MAX. ON CENTER.
 - ALL HARDWARE, BOLTS, AND FASTENERS SHALL BE STAINLESS STEEL.
 - CONTRACTOR SHALL SUBMIT SHOP DRAWINGS FOR ALL PLATES AND GRATING FOR ENGINEER'S APPROVAL PRIOR TO CONSTRUCTION.
- OVERFLOW GRATE:**
- ALL OVERFLOW GRATES SHALL BE MOUNTED USING STAINLESS STEEL HARDWARE AND PROVIDED WITH HINGED & LOCKABLE OR BOLTABLE ACCESS PANELS AS SHOWN ON THE PLANS.
 - OVERFLOW GRATES SHALL BE HOT DIP GALVANIZED STEEL AND MAY BE HOT POWDER COATED AFTER GALVANIZING.

ENGINEER'S STATEMENT

PREPARED UNDER MY SUPERVISION

 32314
 6/21/21
 COLORADO P.E. 32314
 FOR AND ON BEHALF OF JR ENGINEERING, LLC

UNTIL SUCH TIME AS THESE DRAWINGS ARE APPROVED BY THE AGENCIES, OR ENGINEERING APPROVES THEIR USE, DESIGNATED BY WRITTEN AUTHORIZATION. PREPARED FOR JACKSON DEARBORN PARTNERS 404 S. WELLS ST. SUITE 400 CHICAGO, ILL. 60607 OFFICE PHONE (734) 216-2577	J.R. ENGINEERING A Westman Company Centennial 300-740-8888 • Colorado Springs 719-588-2583 Fort Collins 970-491-9888 • www.jrengineering.com	BY	DATE						
SOLACE AT CIMARRON HILLS - FILLING NO. 1 POND A DETAILS	SHEET 19 OF 32 JOB NO. 25174.00	H-SCALE	3/4" = 1'	No. REVISION					
		V-SCALE	3/4" = 1'						
		DATE	03/12/21	DESIGNED BY	JBP	DRAWN BY	RPD	CHECKED BY	

POINT TABULATION				POINT TABULATION				POINT TABULATION				POINT TABULATION				POINT TABULATION			
ID NO.	DESCRIPTION	NORTHING/EASTING	ELEVATION	ID NO.	DESCRIPTION	NORTHING/EASTING	ELEVATION	ID NO.	DESCRIPTION	NORTHING/EASTING	ELEVATION	ID NO.	DESCRIPTION	NORTHING/EASTING	ELEVATION	ID NO.	DESCRIPTION	NORTHING/EASTING	ELEVATION
B1	TBC/ACCESS ROAD	N: 5025.91 E: 6235.89	6248.51	B21	ACCESS ROAD	N: 5511.78 E: 6371.95	6253.53	B41	TOP	N: 5446.78 E: 6280.21	6253.13	B61	TRICKLE CHANNEL INTERSECTION	N: 5079.32 E: 6325.67	6243.69	B81	ACCESS ROAD	N: 5282.13 E: 6247.84	6251.81
B2	TBC/ACCESS ROAD	N: 5010.91 E: 6235.57	6248.21	B22	ACCESS ROAD	N: 5511.99 E: 6386.95	6253.23	B42	TOP	N: 5458.30 E: 6308.56	6253.40	B62	TRICKLE CHANNEL	N: 5131.15 E: 6317.27	6243.95	B82	ACCESS ROAD/TOP	N: 5291.17 E: 6267.20	6251.36
B3	ACCESS ROAD/TOP	N: 5026.87 E: 6305.94	6250.00	B23	ACCESS ROAD	N: 5541.49 E: 6371.54	6253.83	B43	TOE	N: 5408.79 E: 6348.36	6247.07	B63	TRICKLE CHANNEL	N: 5158.88 E: 6316.67	6244.09	B83	ACCESS ROAD/TOP	N: 5267.23 E: 6267.01	6249.96
B4	ACCESS ROAD	N: 5011.88 E: 6306.15	6249.72	B24	ACCESS ROAD	N: 5541.69 E: 6386.54	6253.53	B44	TOE	N: 5394.18 E: 6349.56	6246.69	B64	TRICKLE CHANNEL	N: 5228.73 E: 6324.92	6244.45	B84	ACCESS ROAD	N: 5268.21 E: 6282.14	6249.46
B5	ACCESS ROAD/TOP	N: 5027.46 E: 6348.58	6251.05	B25	ACCESS ROAD	N: 5469.66 E: 6350.16	6252.52	B45	TOE	N: 5258.63 E: 6351.42	6246.12	B65	TRICKLE CHANNEL	N: 5264.87 E: 6322.59	6244.63	B85	ACCESS ROAD	N: 5265.60 E: 6267.37	6249.76
B6	ACCESS ROAD	N: 5012.46 E: 6348.79	6250.75	B26	ACCESS ROAD/TOP	N: 5462.40 E: 6363.28	6252.82	B46	TOE	N: 5213.09 E: 6352.04	6245.98	B66	TRICKLE CHANNEL	N: 5297.41 E: 6321.68	6244.79	B86	ACCESS ROAD/TOE	N: 5220.07 E: 6290.63	6246.15
B7	ACCESS ROAD/TOP	N: 5036.54 E: 6369.67	6251.06	B27	ACCESS ROAD/TOP	N: 5462.64 E: 6346.27	6251.56	B47	TOE	N: 5133.09 E: 6305.14	6245.80	B67	TRICKLE CHANNEL	N: 5356.40 E: 6333.08	6245.10	B87	ACCESS ROAD/TOE	N: 5137.47 E: 6289.96	6245.52
B8	ACCESS ROAD	N: 5026.08 E: 6380.43	6250.83	B28	ACCESS ROAD/TOE	N: 5433.54 E: 6330.18	6247.58	B48	TOE	N: 5060.84 E: 6354.13	6244.32	B68	TRICKLE CHANNEL	N: 5389.88 E: 6314.94	6245.30	B88	12" WQCV WSEL 12" CLASS 6 ABC BELOW 8" CLASS 6 ABC ABOVE	N: 5159.23 E: 6286.13	6245.77
B9	ACCESS ROAD/TOP	N: 5057.87 E: 6378.17	6251.08	B29	ACCESS ROAD/TOE	N: 5424.86 E: 6342.52	6247.44	B49	TOE	N: 5051.46 E: 6344.88	6244.35	B69	FOREBAY	N: 5395.23 E: 6301.80	6245.37	B89	12" WQCV WSEL 12" CLASS 6 ABC BELOW 8" CLASS 6 ABC ABOVE/TOE	N: 5179.45 E: 6290.30	6245.77
B10	ACCESS ROAD	N: 5058.07 E: 6393.12	6250.78	B30	SPILLWAY	N: 5133.27 E: 6398.16	6249.73	B50	TOE	N: 5050.87 E: 6305.61	6245.32	B70	TRICKLE CHANNEL	N: 5094.53 E: 6313.73	6243.79				
B11	ACCESS ROAD/ SPILLWAY TOP/ CUTOFF WALL	N: 5133.42 E: 6377.13	6251.11	B31	SPILLWAY	N: 5213.27 E: 6397.06	6250.52	B51	TOE	N: 5055.53 E: 6294.11	6245.50	B71	FOREBAY	N: 5103.28 E: 6293.07	6243.90				
B12	ACCESS ROAD/ SPILLWAY TOP/ CUTOFF WALL	N: 5133.31 E: 6392.14	6251.11	B32	TOP	N: 5436.74 E: 6370.45	6252.26	B52	TOE	N: 5067.00 E: 6289.39	6245.69	B72	ACCESS ROAD	N: 5426.42 E: 6323.03	6247.25				
B13	ACCESS ROAD/ SPILLWAY CREST/ CUTOFF WALL	N: 5148.42 E: 6376.93	6249.61	B33	ACCESS ROAD/TOP	N: 5395.32 E: 6373.55	6252.29	B53	TOE	N: 5154.86 E: 6290.10	6245.57	B73	ACCESS ROAD	N: 5413.47 E: 6330.59	6246.83				
B14	ACCESS ROAD/ SPILLWAY CREST	N: 5148.31 E: 6391.93	6249.64	B34	ACCESS ROAD/TOP	N: 5258.96 E: 6375.41	6251.31	B54	TOE	N: 5242.72 E: 6290.81	6246.28	B74	ACCESS ROAD	N: 5423.69 E: 6312.77	6247.05				
B15	ACCESS ROAD/ SPILLWAY CREST/ CUTOFF WALL	N: 5198.41 E: 6376.24	6249.61	B35	TOP	N: 5038.51 E: 6277.19	6250.45	B55	TOE	N: 5330.57 E: 6291.52	6246.82	B75	ACCESS ROAD	N: 5408.69 E: 6312.65	6246.47				
B16	ACCESS ROAD/ SPILLWAY CREST	N: 5198.31 E: 6391.25	6249.62	B36	TOP	N: 5067.19 E: 6265.39	6251.21	B56	TOE	N: 5418.39 E: 6292.23	6246.85	B76	ACCESS ROAD/TOE	N: 5423.85 E: 6293.26	6246.98				
B17	ACCESS ROAD/ SPILLWAY TOP/ CUTOFF WALL	N: 5213.42 E: 6376.04	6251.11	B37	TOP	N: 5155.05 E: 6266.10	6250.20	B57	TOE	N: 5429.67 E: 6297.05	6247.13	B77	ACCESS ROAD/TOE	N: 5408.86 E: 6292.16	6246.63				
B18	ACCESS ROAD/ SPILLWAY TOP	N: 5213.31 E: 6391.04	6251.11	B38	TOP	N: 5242.91 E: 6266.81	6249.42	B58	TOE	N: 5434.30 E: 6308.41	6247.40	B78	ACCESS ROAD/TBC	N: 5297.21 E: 6237.75	6251.81				
B19	ACCESS ROAD	N: 5460.05 E: 6372.66	6252.95	B39	TOP	N: 5330.77 E: 6267.52	6252.95	B59	OUTLET STRUCTURE	N: 5054.56 E: 6350.61	6243.51	B79	ACCESS ROAD/TBC	N: 5282.21 E: 6237.63	6251.66				
B20	ACCESS ROAD	N: 5460.26 E: 6387.66	6252.72	B40	TOP	N: 5418.63 E: 6268.23	6252.85	B60	TRICKLE CHANNEL	N: 5066.08 E: 6334.01	6243.61	B80	ACCESS ROAD	N: 5297.13 E: 6247.96	6251.97				

POND B
(17.50 TRIBUTARY ACRES,
40.55% COMP. IMPERVIOUSNESS)

DESIGN STORM	STORAGE	STAGE
WQCV(AC-FT)	0.264	6245.77
EURV(AC-FT)	0.746	6246.88
100-YEAR(ACR-FT)	1.412	6247.85

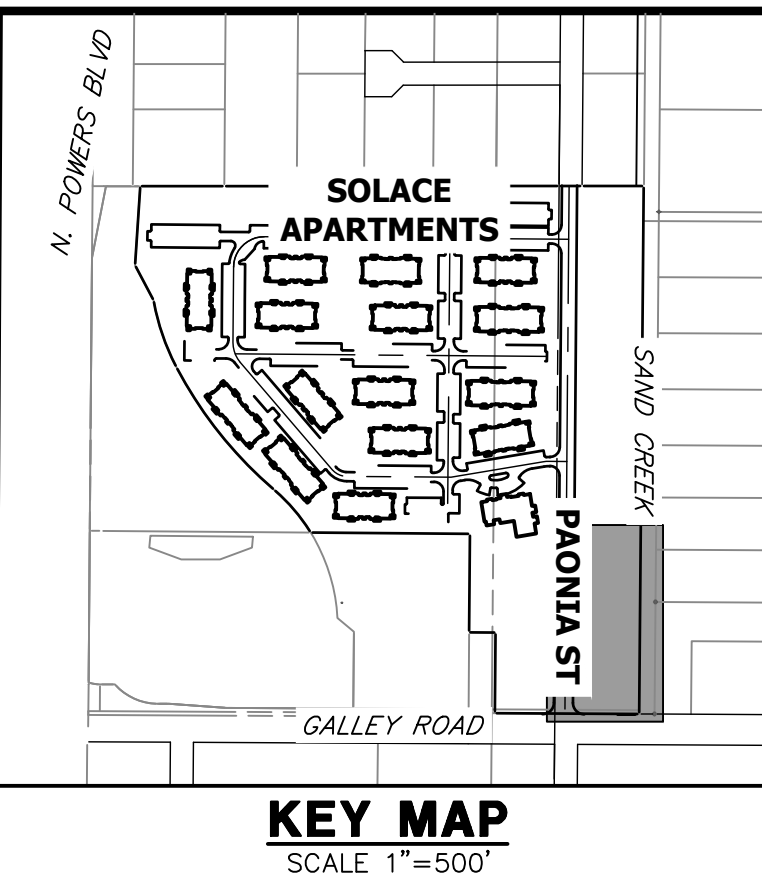

- NOTES**
- ALL PROPOSED POND IMPROVEMENTS ARE PRIVATE UNLESS OTHERWISE NOTED.
 - SEE SHEETS 12-15 FOR PROPOSED STORM SEWER DESIGN.
 - SEE PAONIA STREET IMPROVEMENT PLANS BY JR ENGINEERING FOR PROPOSED PAONIA STREET DESIGN.
 - SEE WATER DISTRIBUTION PLANS AND SANITARY SEWER PLAN AND PROFILE BY JR ENGINEERING FOR PROPOSED DESIGN OF CMD-OWNED WATER AND SANITARY UTILITIES.

LINE TABLE			CURVE TABLE			
LINE	BEARING	DISTANCE	CURVE	DELTA	RADIUS	LENGTH
L8	N55°14'37"W	20.21'	C7	46°02'08"	20.00'	16.07'
L9	N09°12'28"W	52.51'	C8	15°56'41"	100.00'	27.83'
L10	N06°44'13"E	70.34'	C9	20°51'49"	100.00'	36.41'
L11	N10°56'24"E	60.08'	C10	25°04'00"	75.00'	32.81'
L12	N67°51'14"W	14.18'	C11	78°47'38"	30.00'	41.26'
L13	S67°02'13"E	22.43'	C12	57°49'45"	20.00'	20.19'

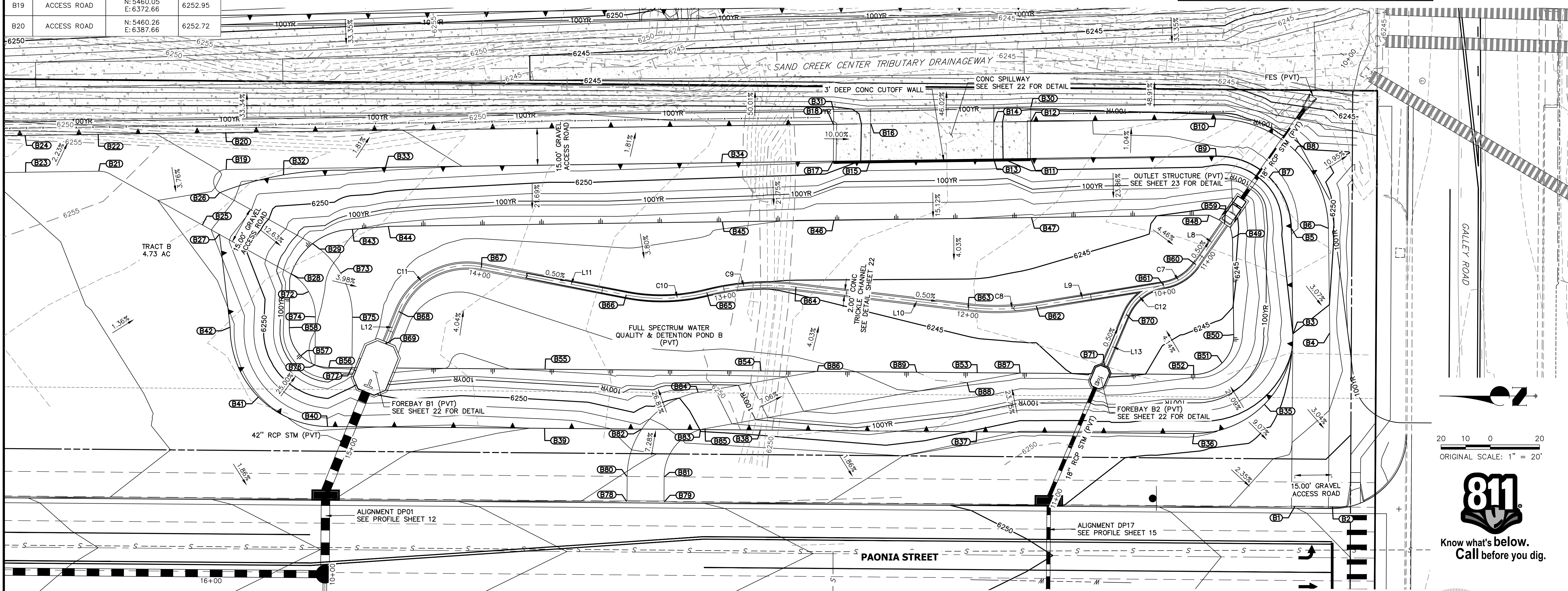

THE LOCATIONS OF EXISTING ABOVE GROUND AND UNDERGROUND UTILITIES ARE SHOWN IN AN APPROXIMATE WAY ONLY. THE CONTRACTOR SHALL DETERMINE THE EXACT LOCATION OF ALL EXISTING UTILITIES BEFORE COMMENCING WORK. THE CONTRACTOR SHALL BE FULLY RESPONSIBLE FOR ANY AND ALL DAMAGES WHICH MIGHT BE CAUSED BY HIS FAILURE TO EXACTLY LOCATE AND PRESERVE ANY AND ALL ABOVE GROUND AND UNDERGROUND UTILITIES.

ENGINEER'S STATEMENT
PREPARED UNDER MY SUPERVISION

Mike Bramlett
32314
6/21/21

MIKE A. BRAMLETT, P.E.
COLORADO P.E. 32314
FOR AND ON BEHALF OF JR ENGINEERING

UNTIL SUCH TIME AS THESE DRAWINGS ARE APPROVED BY THE AGENCIES, JR ENGINEERING APPROVES THEIR USE DESIGNATED BY WRITTEN AUTHORIZATION.

PREPARED FOR
JACKSON DEARBORN PARTNERS
404 S. WELLS ST.
SUITE 400
CHICAGO, ILL. 60607
OFFICE PHONE (734) 216-2577

J.R. ENGINEERING
A Westman Company
Central 303-740-9888 • Colorado Springs 719-588-2583
Fort Collins 970-491-9888 • www.jrengineering.com

NO.	REVISION	BY	DATE

H-SCALE 1"=20'
V-SCALE N/A
DATE 12/12/20
DESIGNED BY JBP
DRAWN BY RPD
CHECKED BY

SOLACE APARTMENTS - FILING NO. 1
POND B I&M PLANS

SHEET 1 OF 2
JOB NO. 25174.00

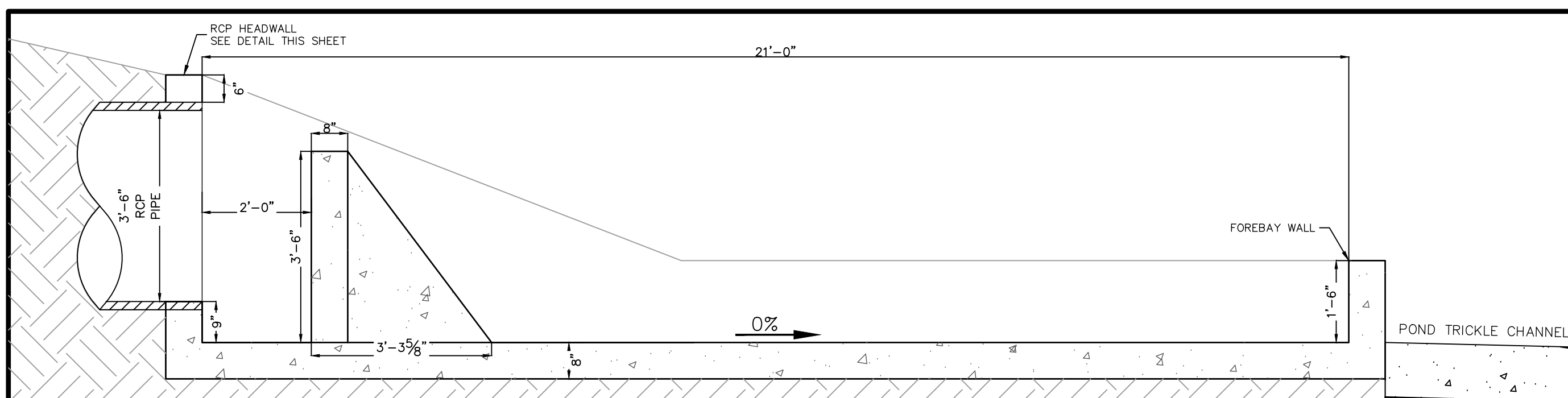

FOREBAY B1 PROFILE VIEW

SCALE: 1" = 2'

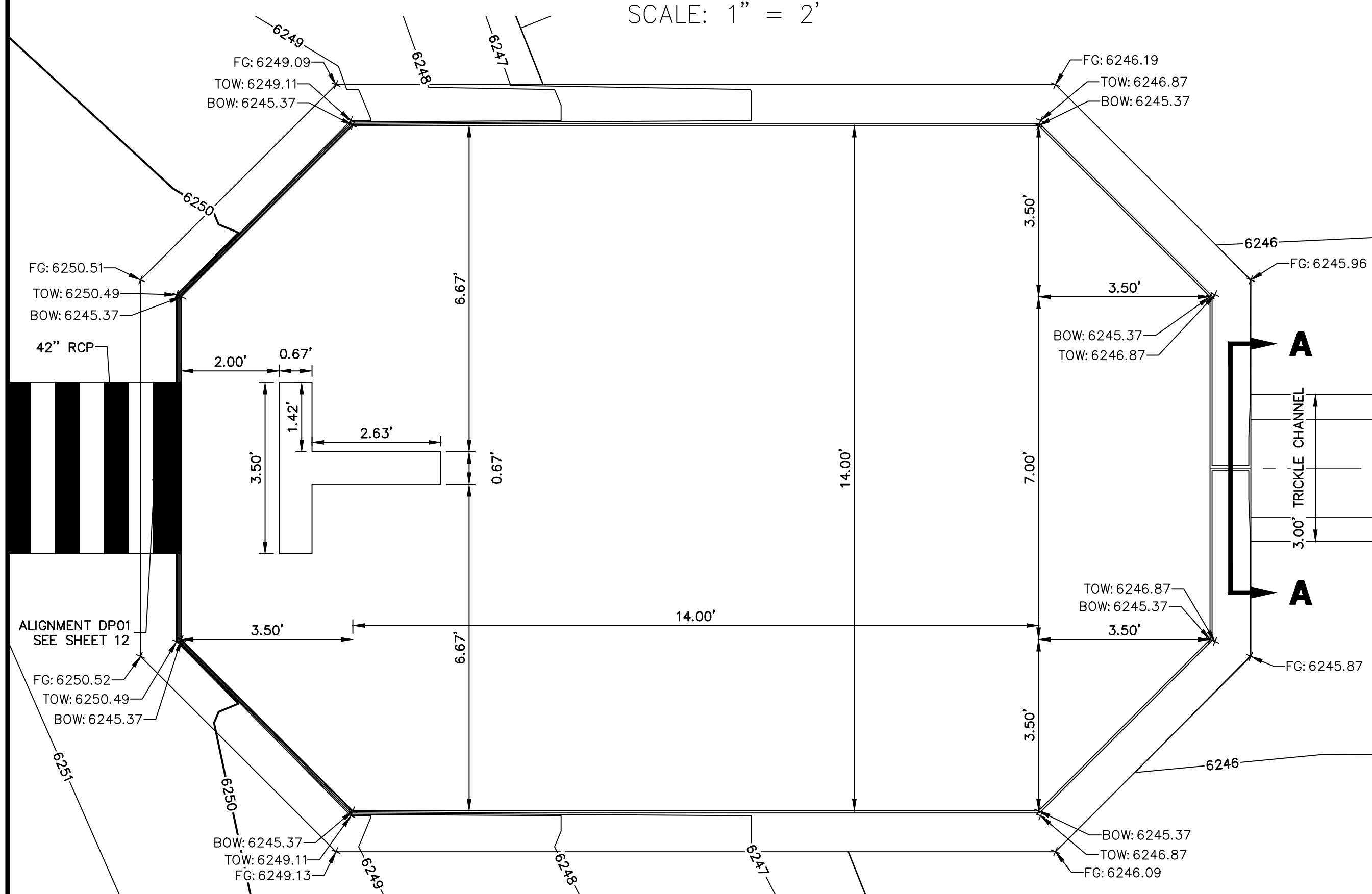

FOREBAY B1 PLAN VIEW

SCALE: 1" = 2'

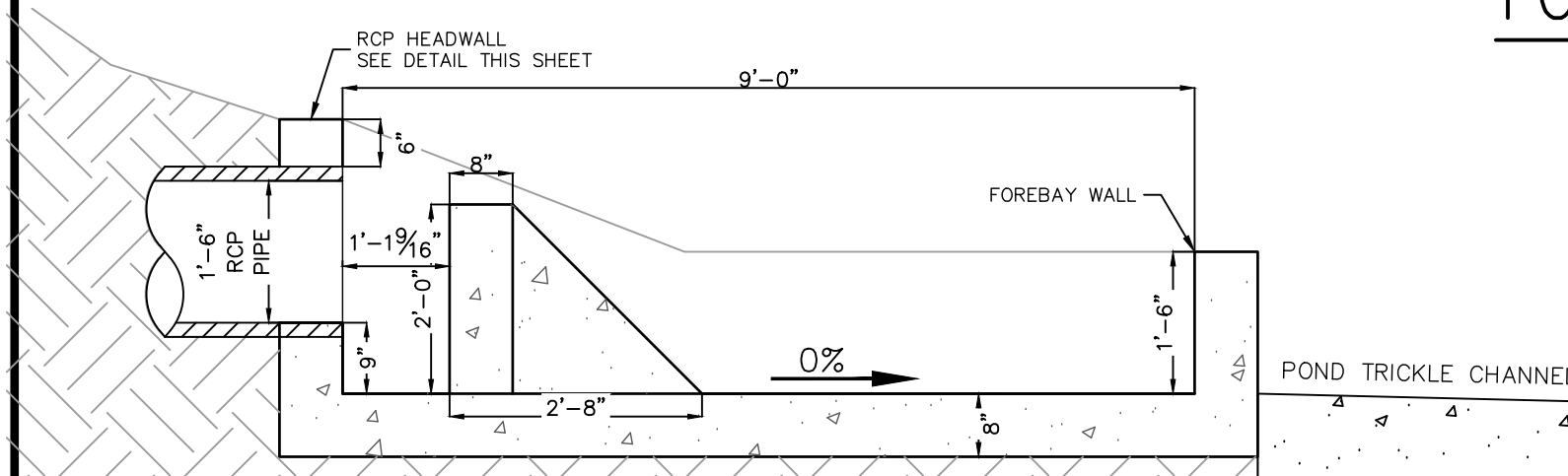

FOREBAY B2 PROFILE VIEW

SCALE: 1" = 2'

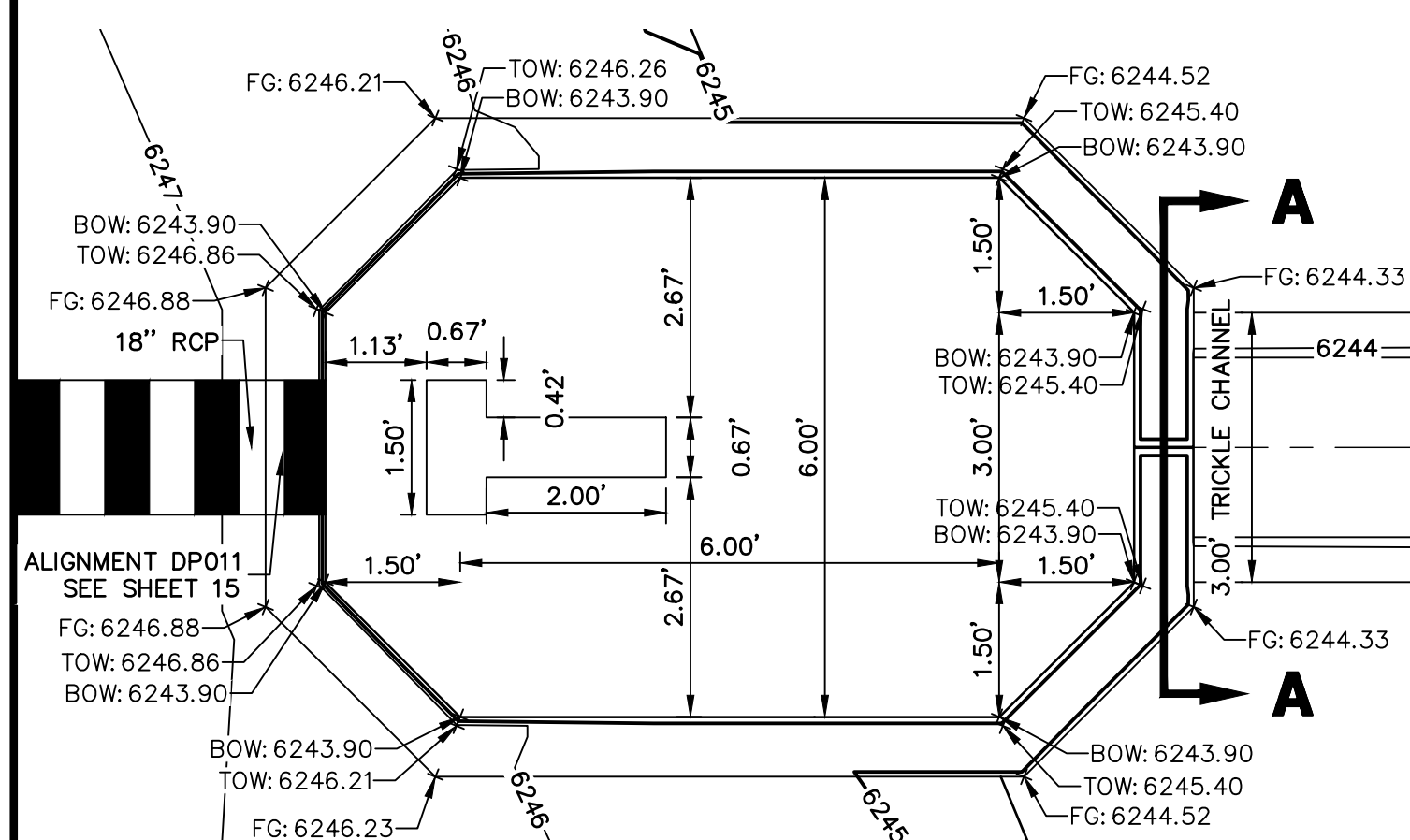

FOREBAY B2 PLAN VIEW

SCALE: 1" = 2'

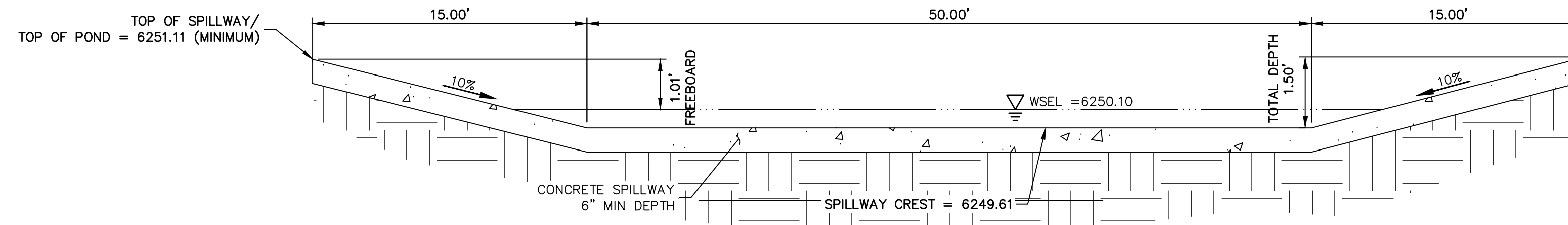

POND B EMERGENCY OVERFLOW SPILLWAY

SCALE: N.T.S.

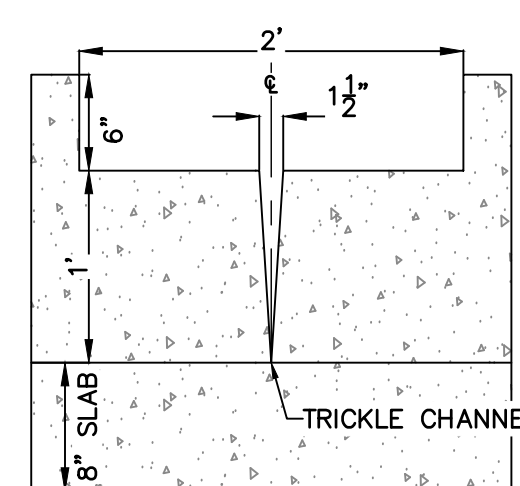

FOREBAY B1 & B2 WALL SECTION

SCALE: 1" = 1'

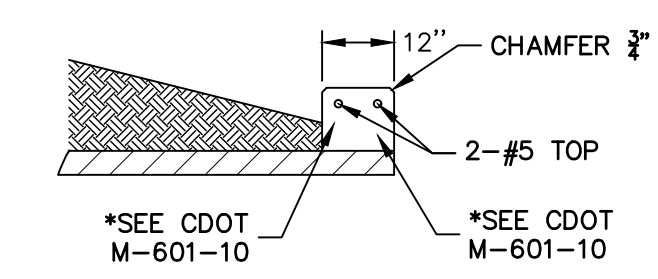

RCP HEADWALL

SCALE: N.T.S.

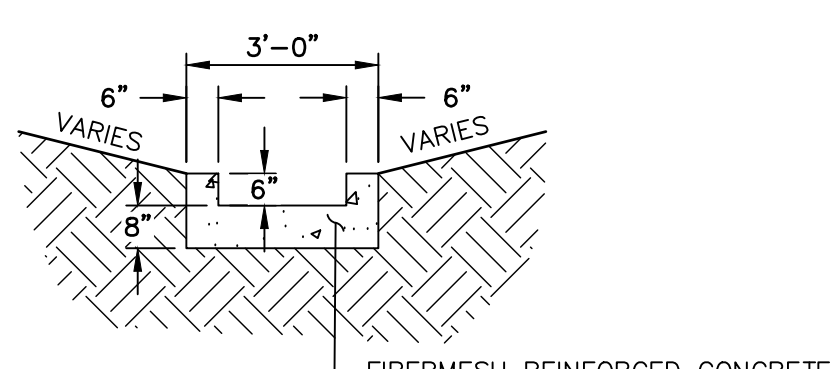

TRICKLE CHANNEL

SCALE: N.T.S.

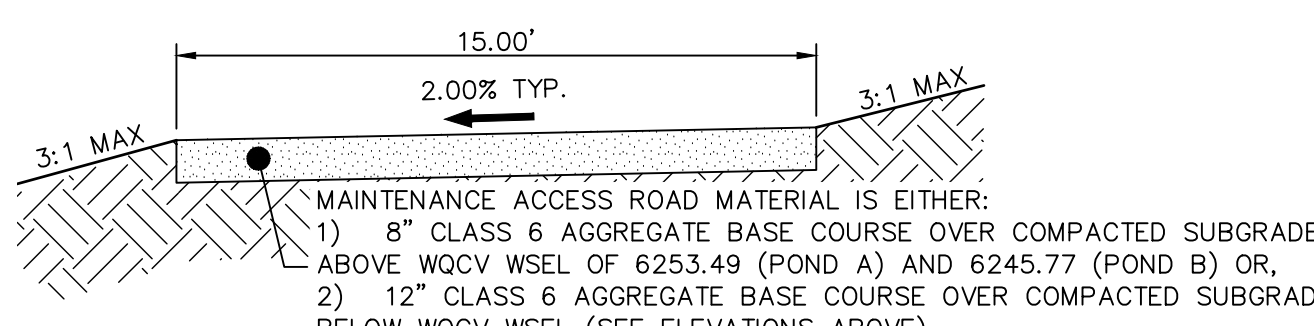

POND MAINTENANCE ACCESS ROAD TYPICAL SECTION

SCALE: N.T.S.

WALL NOTES:

1. HEADWALLS FOR PIPES SHALL BE CONSTRUCTED IN ACCORDANCE WITH CDOT STANDARD PLAN M-601-10.
2. WINGWALLS SHALL BE CONSTRUCTED IN ACCORDANCE WITH CDOT STANDARD PLAN M-601-20.

CAST-IN-PLACE STRUCTURAL NOTES:

1. ALL CONCRETE SHALL BE CLASS D IN ACCORDANCE WITH CDOT STANDARD SPECIFICATIONS FOR ROAD AND BRIDGE CONSTRUCTION.
2. ALL CONSTRUCTION JOINTS SHALL BE THOROUGHLY CLEANED BEFORE FRESH CONCRETE IS POURED.
3. ALL CONSTRUCTION JOINTS NOT SHOWN ON THE PLANS SHALL BE APPROVED BY THE ENGINEER.
4. THE CONTRACTOR IS RESPONSIBLE FOR THE STABILITY OF THE STRUCTURE DURING CONSTRUCTION.
5. STRUCTURE EXCAVATION AND BACKFILL SHALL BE IN ACCORDANCE WITH CDOT STD. M-206-1.
6. DO NOT BACKFILL UNTIL CONCRETE HAS REACHED DESIGN STRENGTH, F_c.
7. GRADE 60 REINFORCING STEEL AND EPOXY COATED ARE REQUIRED.
8. REINFORCING BARS SHALL BE DEFORMED AND SHALL HAVE A MINIMUM OF 2" CLEARANCE.
9. ALL EXPOSED CONCRETE CORNERS SHALL BE CHAMFERED 3/4".
10. IT SHALL BE THE CONTRACTOR'S RESPONSIBILITY TO VERIFY THE LOCATIONS OF EXISTING STRUCTURES AND EXISTING UTILITIES. PRIOR TO CONSTRUCTION OF THE CAST-IN-PLACE STRUCTURES, FIELD MODIFICATIONS OF PRECAST UNITS TO ACCOMMODATE CAST-IN-PLACE STRUCTURES WILL ONLY BE ACCEPTABLE WITH THE ENGINEER'S APPROVAL.
11. CONTRACTOR SHALL SUBMIT STEEL REINFORCING SHOP DRAWINGS FOR ALL CAST-IN-PLACE STRUCTURES FOR ENGINEER'S APPROVAL PRIOR TO CONSTRUCTION.

TABLE EDB-2
SUMMARY OF ROUTINE MAINTENANCE ACTIVITIES

Maintenance Activity	Minimum Frequency	Look for:	Maintenance Action
Mowing	Twice annually	Excessive grass height/aesthetics	Mow grass to a height of 4' to 6"
Trash/Debris Removal	Twice annually	Trash & debris in EDB	Remove and dispose of trash and debris
Outlet Works Cleaning	As needed - after significant rain events - twice annually min.	Clogged outlet structure; ponding water	Remove and dispose of debris/trash/sediment to allow outlet to function properly
Weed control	Minimum twice annually	Noxious weeds; Unwanted vegetation	Treat w/ herbicide or hand pull; Consult the local weed specialist
Mosquito Treatment	As needed	Standing water/mosquito habitat	Treat w/ EPA approved chemicals
Algae Treatment	As needed	Standing water/Algal growth/green color	Treat w/ EPA approved chemicals

TABLE EDB-3
SUMMARY OF MINOR MAINTENANCE ACTIVITIES

Maintenance Activity	Minimum Frequency	Look for:	Maintenance Action
Sediment Removal*	As needed; typically every 1-2 years	Sediment build-up; decrease in pond volume	Remove and dispose of sediment
Erosion Repair	As needed, based upon inspection	Rills/gullies forming on side slopes, trickle channel, other areas	Repair eroded areas Revegetate; address source of erosion
Vegetation Removal/Tree Thinning	As needed, based upon inspection	Large trees/wood vegetation in lower chamber of pond	Remove vegetation; restore grade and surface
Drain Cleaning/Jet Vac	As needed, based upon inspection	Sediment build-up/non draining system	Clean drains; Jet Vac if needed

*Usually from the forebay, trickle channel, and/or micropool

TABLE EDB-4
SUMMARY OF MAJOR MAINTENANCE ACTIVITIES

Maintenance Activity	Minimum Frequency	Look for:	Maintenance Action
Major Sediment Removal	As needed - based upon scheduled inspections	Large quantities of sediment, reduced pond capacity	Remove and dispose of sediment. Repair vegetation as needed
Major Erosion Repair	As needed - based upon scheduled inspections	Severe erosion including gullies, excessive soil displacement, areas of settlement, holes	Repair erosion - find cause of problem and address to avoid future erosion
Structural Repair	As needed - based upon scheduled inspections	Deterioration and/or damage to structural components - broken concrete, damaged pipes, outlet works	Structural repair to restore the structure to its original design

UNTIL SUCH TIME AS THESE DRAWINGS ARE APPROVED BY THE AGENCIES, OR ENGINEERING APPROVES THEIR USE, THESE DRAWINGS ARE DESIGNATED BY WRITTEN AUTHORIZATION.

PREPARED FOR
JACKSON DEARBORN PARTNERS
404 S. WELLS ST.
SUITE 400
CHICAGO, ILL. 60607
OFFICE PHONE (734) 216-2577

J.R. ENGINEERING
A Westman Company
Central 303-740-9888 • Colorado Springs 719-583-2583
Fort Collins 970-491-9888 • www.jrengineering.com

BY	DATE	No.	REVISION

SOLACE APARTMENTS - FILING NO. 1
POND B I&M PLANS

H-SCALE V-SCALE DATE DESIGNED BY DRAWN BY CHECKED BY

DESIGNED BY JBP
DRAWN BY RPD
CHECKED BY

DATE 12/12/20

SHEET 2 OF 2
JOB NO. 25174.00

ENGINEER'S STATEMENT
PREPARED UNDER MY SUPERVISION
MIKE A. BRAMLETT, P.E.
COLORADO P.E. 32314
FOR AND ON BEHALF OF JR ENGINEERING & ARCHITECTURE, P.C.

32314
6/21/21



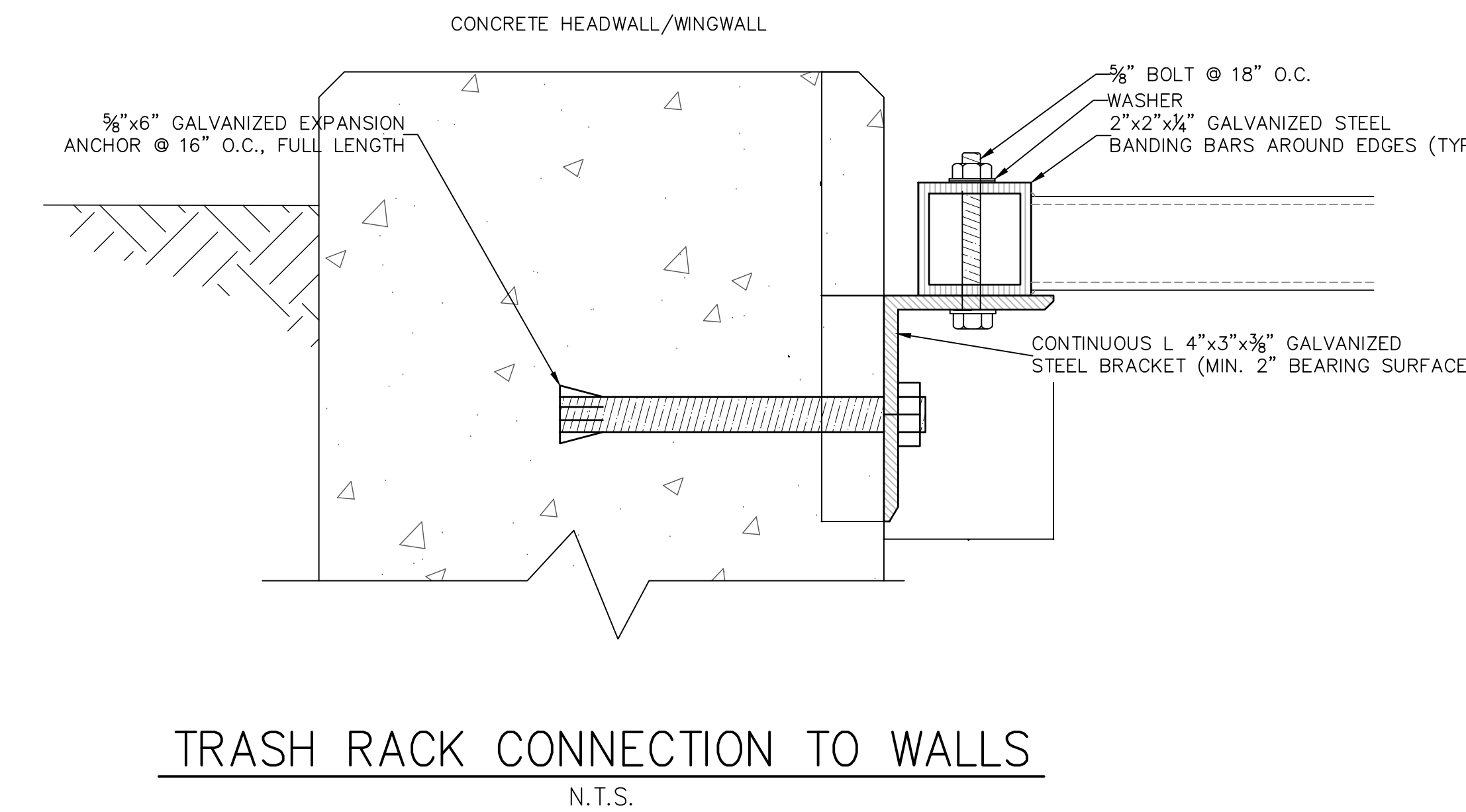
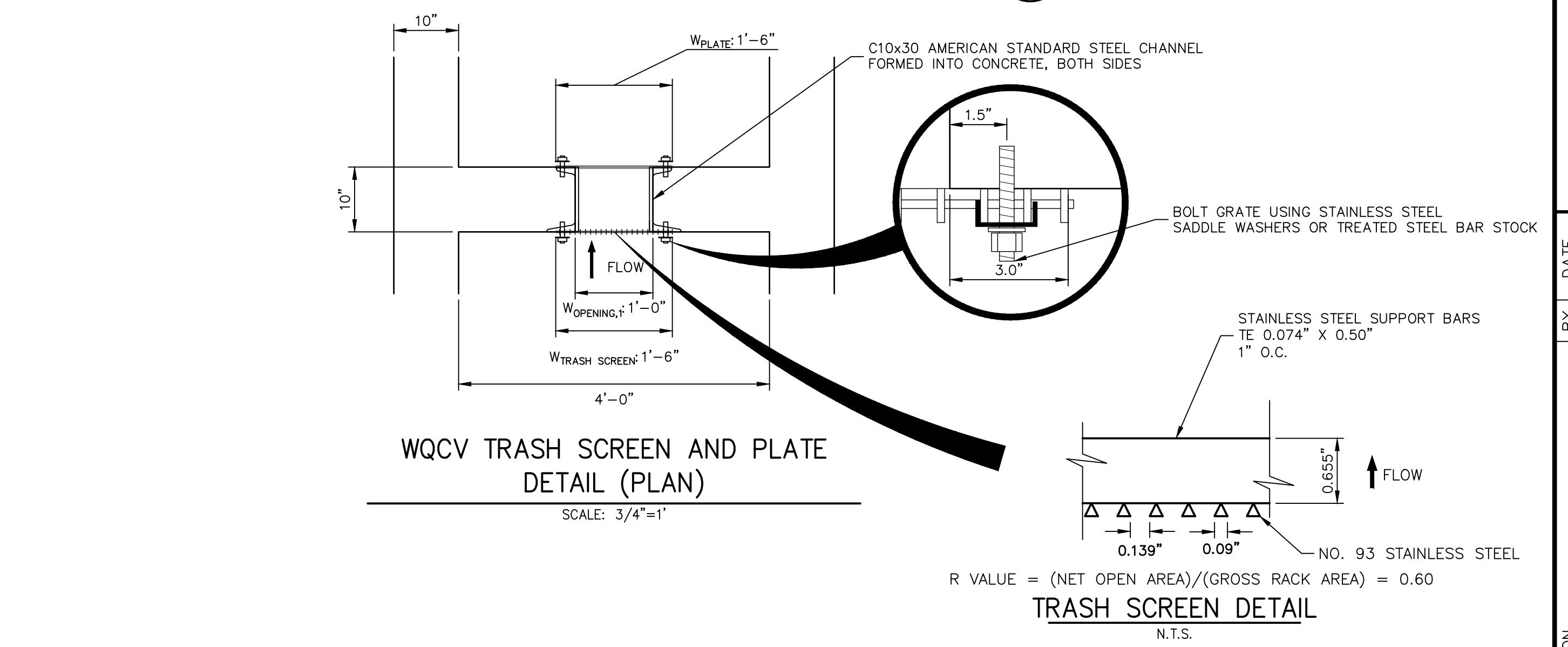
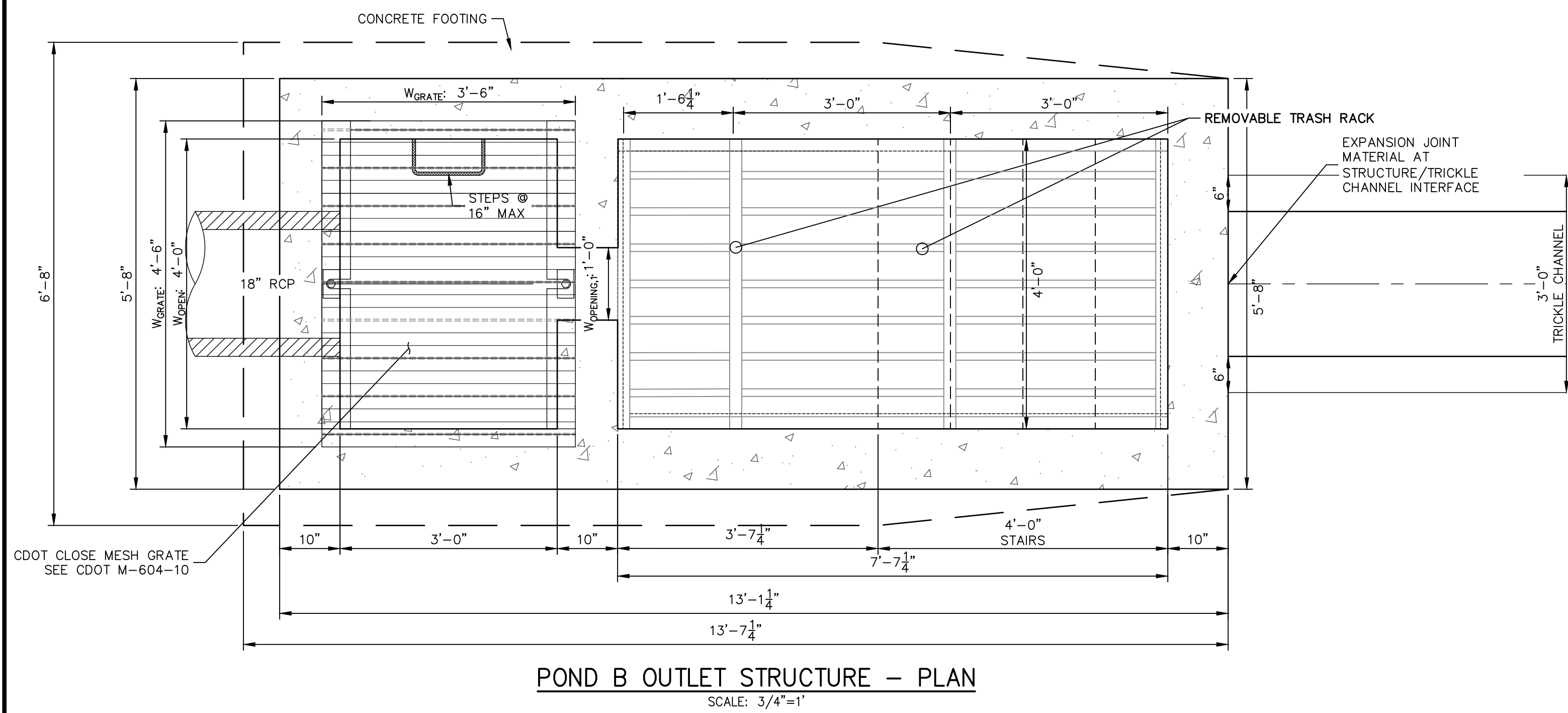
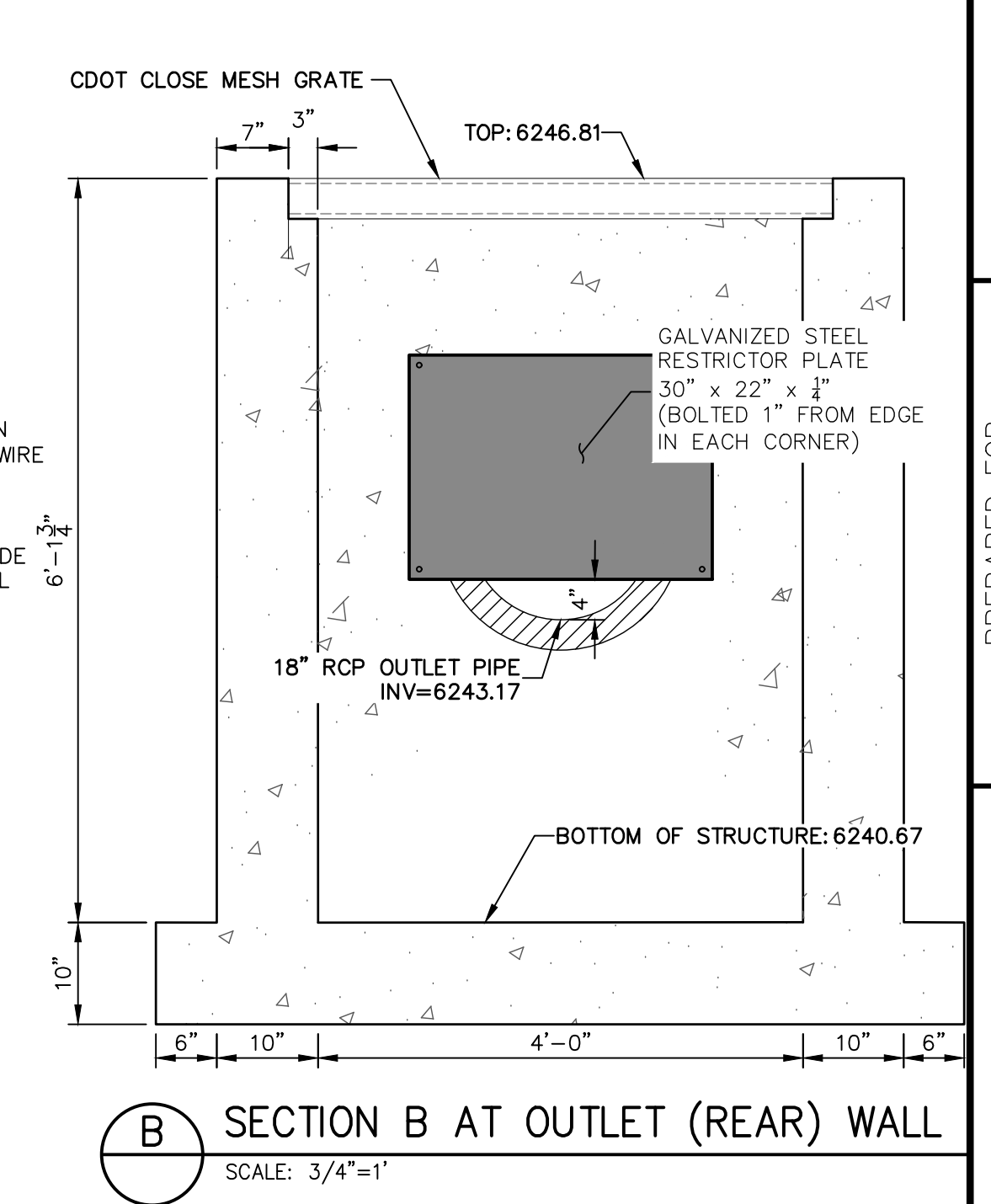
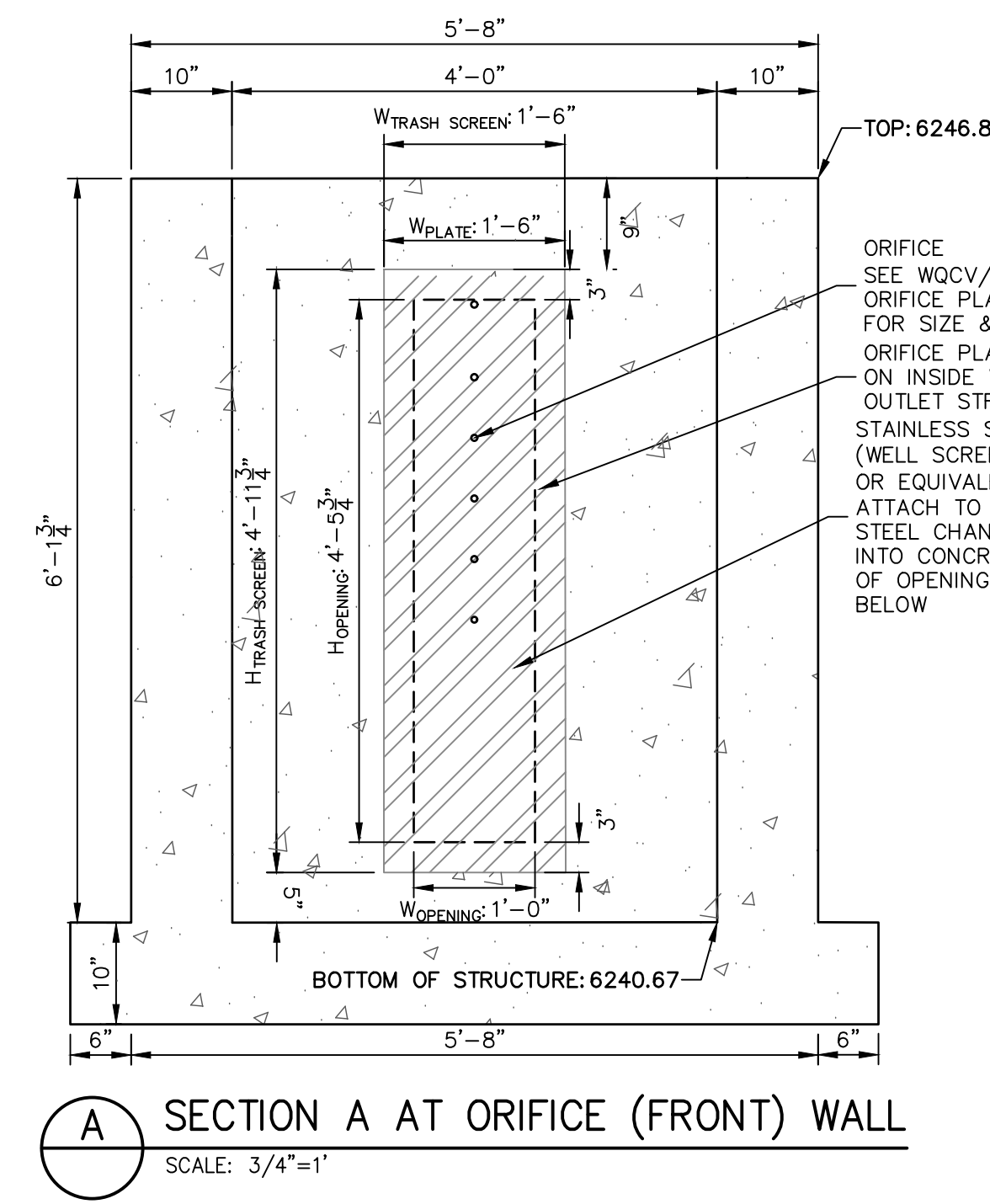
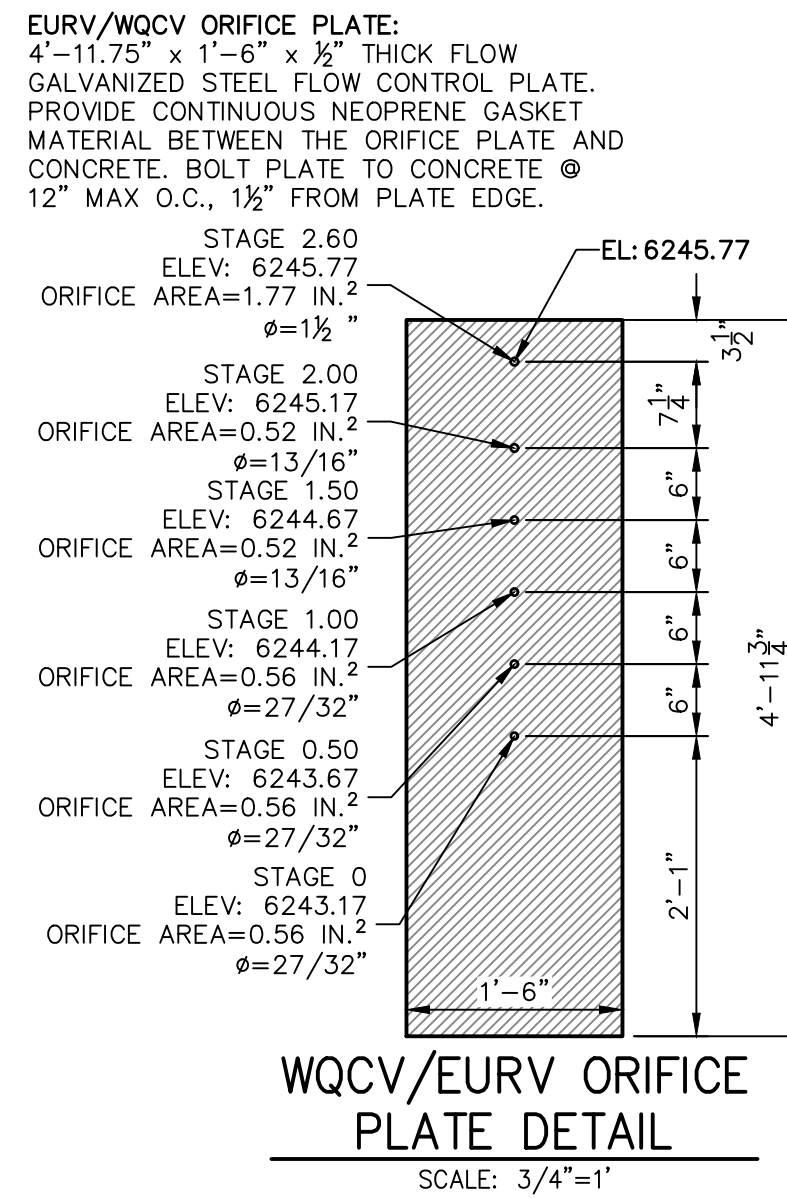
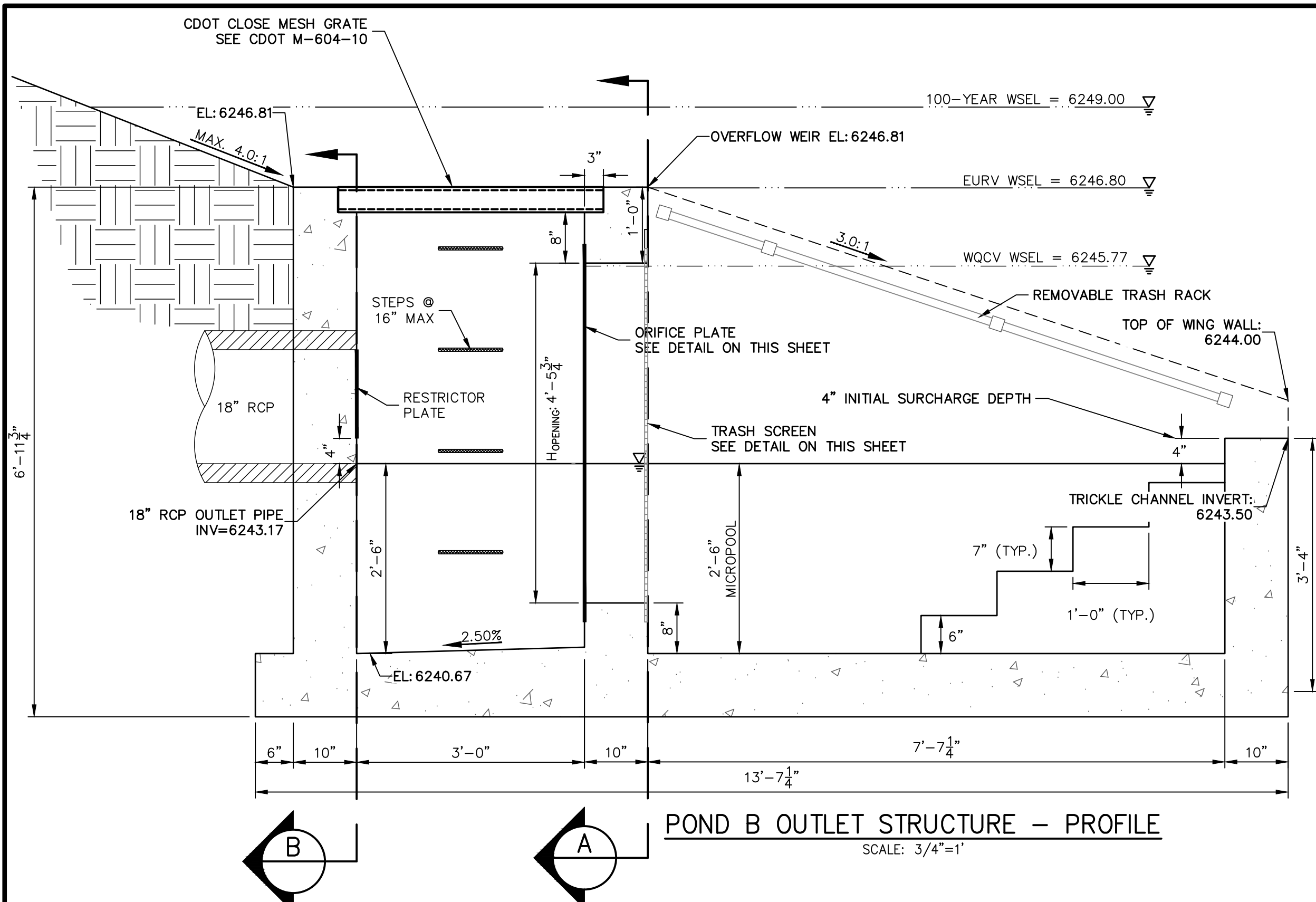

OUTLET STRUCTURE STRUCTURAL NOTES:

- REFER TO CDOT DETAILS M-601-10 AND M-601-20 FOR STRUCTURAL REINFORCEMENT DESIGN.
- ALL CONCRETE SHALL BE CLASS D IN ACCORDANCE WITH CDOT STANDARD SPECIFICATIONS FOR ROAD AND BRIDGE CONSTRUCTION.
- ALL CONSTRUCTION JOINTS SHALL BE THOROUGHLY CLEANED BEFORE FRESH CONCRETE IS POURED.
- ALL CONSTRUCTION JOINTS NOT SHOWN ON THE PLANS SHALL BE APPROVED BY THE ENGINEER.
- THE CONTRACTOR IS RESPONSIBLE FOR THE STABILITY OF THE STRUCTURE DURING CONSTRUCTION.
- STRUCTURE EXCAVATION AND BACKFILL SHALL BE IN ACCORDANCE WITH CDOT STD. M-206-1.
- DO NOT BACKFILL UNTIL CONCRETE HAS REACHED DESIGN STRENGTH, F_c.
- GRADE 60 REINFORCING STEEL AND EPOXY COATED ARE REQUIRED.
- REINFORCING BARS SHALL BE DEFORMED AND SHALL HAVE A MINIMUM OF 2" CLEARANCE.
- ALL EXPOSED CONCRETE CORNERS SHALL BE CHAMFERED 3/4".
- IT SHALL BE THE CONTRACTOR'S RESPONSIBILITY TO VERIFY THE LOCATIONS OF EXISTING STRUCTURES AND EXISTING UTILITIES, PRIOR TO CONSTRUCTION OF THE CAST-IN-PLACE STRUCTURES. FIELD MODIFICATIONS OF PRECAST UNITS TO ACCOMMODATE CAST-IN-PLACE STRUCTURES WILL ONLY BE ACCEPTABLE WITH THE ENGINEER'S APPROVAL.
- CONTRACTOR SHALL SUBMIT STEEL REINFORCING SHOP DRAWINGS FOR ALL CAST-IN-PLACE STRUCTURES FOR ENGINEER'S APPROVAL PRIOR TO CONSTRUCTION.

OUTLET STRUCTURE PLATE AND GRADING NOTES:

- ORIFICE PLATE AND RESTRICTOR PLATE:**
- PROVIDE GASKET MATERIAL BETWEEN THE ORIFICE PLATE AND CONCRETE AND BETWEEN THE RESTRICTOR PLATE AND CONCRETE.
 - BOLT PLATE TO CONCRETE 12" MAX. ON CENTER.
 - ALL HARDWARE, BOLTS, AND FASTENERS SHALL BE STAINLESS STEEL.
 - CONTRACTOR SHALL SUBMIT SHOP DRAWINGS FOR ALL PLATES AND GRATING FOR ENGINEER'S APPROVAL PRIOR TO CONSTRUCTION.
- OVERFLOW GRATE:**
- ALL OVERFLOW GRATES SHALL BE MOUNTED USING STAINLESS STEEL HARDWARE AND PROVIDED WITH HINGED & LOCKABLE OR BOLTABLE ACCESS PANELS AS SHOWN ON THE PLANS.
 - OVERFLOW GRATES SHALL BE HOT DIP GALVANIZED STEEL AND MAY BE HOT POWDER COATED AFTER GALVANIZING.

ENGINEER'S STATEMENT

PREPARED UNDER MY SUPERVISION
 Mike Bramlett 32314 6/21/21
 MIKE A. BRAMLETT, P.E. COLORADO P.E. 32314
 FOR AND ON BEHALF OF JR ENGINEERING, LLC

UNTIL SUCH TIME AS THESE DRAWINGS ARE APPROVED BY THE AGENCIES, JR ENGINEERING APPROVES THEIR USE DESIGNATED BY WRITTEN AUTHORIZATION.

PREPARED FOR
JACKSON DEARBORN PARTNERS
 404 S. WELLS ST.
 SUITE 400
 CHICAGO, ILL. 60607
 OFFICE PHONE (734) 216-2577

J.R. ENGINEERING
 A Westman Company
 Central 303-740-9888 • Colorado Springs 719-583-2583
 Fort Collins 970-491-9888 • www.jrengineering.com

BY	DATE	REVISION

H-SCALE	V-SCALE	DATE	DESIGNED BY	DRAWN BY	CHECKED BY
3/4" = 1'	3/4" = 1'	03/12/21	JBP	RPD	

SOLACE AT CIMARRON HILLS - FILLING NO. 1
POND B DETAILS

SHEET 23 OF 32
 JOB NO. 25174.00