



LSC TRANSPORTATION CONSULTANTS, INC.  
2504 East Pikes Peak Avenue, Suite 304  
Colorado Springs, CO 80909  
(719) 633-2868  
FAX (719) 633-5430  
E-mail: [lsc@lsctrans.com](mailto:lsc@lsctrans.com)  
Website: <http://www.lsctrans.com>

ACCEPTED for FILE  
Engineering Review  
10/17/2022 1:59:30 PM  
dsnjikamp  
EPC Planning & Community  
Development Department

Maltese Point  
Transportation Memorandum  
PCD File No. PPR2124  
(LSC #S214220)  
July 20, 2022

**Traffic Engineer’s Statement**

This traffic report and supporting information were prepared under my responsible charge and they comport with the standard of care. So far as is consistent with the standard of care, said report was prepared in general conformance with the criteria established by the County for traffic reports.

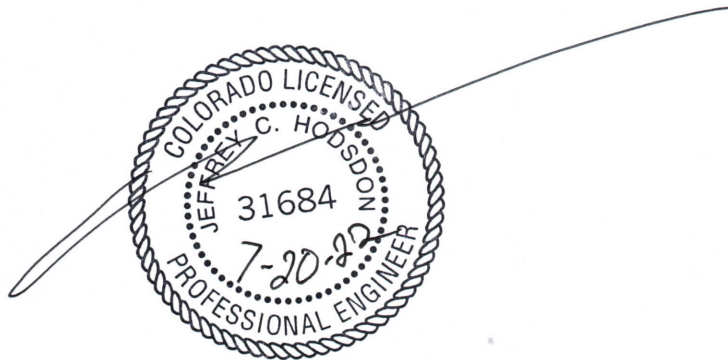

**Developer’s Statement**

I, the Developer, have read and will comply with all commitments made on my behalf within this report.

JEFFREY C. HODSON

7/20/2022  
Date

# Ruckus Development

## Transportation Memorandum

Prepared for:  
Jason Travers  
10276 Evening Vista Drive  
Peyton, CO 80831

JULY 20, 2022

---

LSC Transportation Consultants  
Prepared by: Jeffrey C. Hodsdon, P.E.

LSC #S214220  
PCD File No. PPR2124



CONTENTS

REPORT CONTENTS ..... 1

RECENT TRAFFIC REPORTS ..... 2

PROPOSED LAND USE/SITE ACCESS ..... 2

ROAD AND TRAFFIC CONDITIONS ..... 2

    Traffic Volumes ..... 3

TRIP GENERATION ESTIMATE ..... 3

BACKGROUND TRAFFIC ..... 5

TRIP DISTRIBUTION AND ASSIGNMENT ..... 5

    Trip Directional Distribution ..... 5

    Site-Generated Traffic ..... 6

    Short-Term Total Traffic Volumes ..... 6

    Long-Term Total Traffic Volumes ..... 6

LEVEL OF SERVICE ANALYSIS ..... 6

    Golden Sage Road/Woodmen Road ..... 7

    Firehouse View Intersections ..... 7

AUXILIARY TURN LANES ..... 7

MTCP ROADWAY IMPROVEMENTS ..... 7

PEDESTRIAN AND BICYCLE ACCOMMODATION ..... 7

COUNTY ROAD IMPROVEMENT FEE PROGRAM ..... 8

    Transportation Impact Fees ..... 8

    Reimbursable MTCP Improvements ..... 8

FINDINGS AND CONCLUSIONS ..... 8

    Trip Generation ..... 8

    Recommendations ..... 8

    Roadway Impact Fees ..... 8

Enclosures: ..... 9

    Tables 5-7

    Figures 1-7

    Traffic Counts

    Level of Service Reports



**LSC TRANSPORTATION CONSULTANTS, INC.**  
2504 East Pikes Peak Avenue, Suite 304  
Colorado Springs, CO 80909  
(719) 633-2868  
FAX (719) 633-5430  
E-mail: [lsc@lsctrans.com](mailto:lsc@lsctrans.com)  
Website: <http://www.lsctrans.com>

July 20, 2022

Jason Travers  
Ruckus Investments  
10276 Evening Vista Drive  
Peyton, CO 80831

RE: Maltese Point  
Transportation Memorandum  
El Paso County, CO  
LSC #S214220

Dear Mr. Travers,

LSC Transportation Consultants, Inc. has prepared this transportation memorandum for the proposed office/warehouse development in the Rolling Thunder Business Park located in El Paso County, Colorado. The proposed development will be located on El Paso County parcel 5311101011. The site is northwest of the intersection of Rolling Thunder Way/Firehouse View. Two 10,800 square foot office/warehouse buildings are proposed for a total of 21,600 square feet. This report presents the estimated vehicle-trip generation for the proposed development. This report has been prepared for submittal to El Paso County.

## **REPORT CONTENTS**

The preparation of this report included the following:

- Inventory of the existing adjacent and nearby roadway system. This includes functional classifications, street widths, lane configurations, intersection traffic control, posted speed limits, pavement markings, intersection and access spacing, roadway and intersection alignments, auxiliary left- and right-turn lanes, intersection sight distances, etc.;
- A review of the proposed site land use and access locations;
- Morning and evening peak-hour traffic volumes at the intersections of Firehouse View/Maltese Point, Firehouse View/Rolling Thunder Way, and Golden Sage Road/Woodmen Road;
- Estimates of short- and long-term background traffic volumes and total traffic (site traffic plus background traffic). Forecasts include buildout of adjacent proposed developments;
- Estimates of the daily and peak-hour trip generation for the proposed land use;
- The estimated directional distribution of site-generated vehicle trips on the study-area roadway system;

- Projections of peak-hour site-generated turning-movement traffic volumes at the study-area intersections;
- Level of service (LOS) analysis at the study-area intersections;
- Evaluation of the short-term and long-term projected intersection volumes to determine the potential need for any new auxiliary right-/left-turn lanes and/or the adequacy of existing lanes at the site access-point intersections and the other study-area intersections; and
- Findings and recommendations.

## RECENT TRAFFIC REPORTS

The site was previously studied as part of the *Rolling Thunder Business Park Traffic Impact Analysis*, May 2008, LSC.

The following traffic reports were utilized in the preparation of this report:

- *Rolling Thunder Lots 2-3*, January 2021
- *Falcon Meadows at Bent Grass*, December 2020
- *Black Forest Beverage Company*, May 2020
- *Bent Grass Residential Filing No. 2*, April 2020

## PROPOSED LAND USE/SITE ACCESS

Figure 1 shows the site location relative to the adjacent and nearby roadways. The site is a development of a lot located in the previously approved Rolling Thunder Business Park. The lot is planned to have two 10,800-square-foot office/warehouse buildings for a total of 21,600 square-feet with access onto Maltese Point. From Maltese Point, vehicles can access Rolling Thunder Way via Firehouse View.

Figure 2 shows the site plan and proposed access points. As shown, there are two proposed site access points with one onto Maltese Point and the other onto Firehouse View. Both accesses are full-movement. The intersections of Maltese Point/Firehouse View and Rolling Thunder Way/Firehouse View are also full-movement with two-way stop control.

## ROAD AND TRAFFIC CONDITIONS

Streets adjacent to the site are identified below, followed by a brief description of each:

**Maltese Point** is a private local road. The roadway extends approximately 375 feet to the west from Firehouse View Road and 305 feet to the east, ending in a cul-de-sac on both sides.

**Firehouse View** is a private local road. The roadway extends approximately 275 feet, intersecting Maltese Point to the north and Rolling Thunder Way to the south.

**Rolling Thunder Way** is a two-lane, Urban Non-Residential Collector that runs east/west between Golden Sage Road and Meridian Road. The posted speed limit along this corridor is 35 miles per hour (mph). There is a striped two-way left-turn lane at the intersection with Firehouse View.

**Golden Sage Road** is a two-lane, Urban Non-Residential Collector that runs north/south between Rolling Thunder Way and the frontage road to the north of Woodmen Road. Currently, the roadway turns into Rolling Thunder Way on the south end. When the parcel to the west of Golden Sage Road is developed, Rolling Thunder Way will be extended and this will become an unsignalized T-intersection.

**Woodmen Road** is an east/west Expressway through the northern portion of the City of Colorado Springs and El Paso County. Woodmen Road is a four-lane facility adjacent to the study area. The posted speed limit on Woodmen Road in the vicinity of the site is 55 miles per hour (mph). The intersection with Golden Sage Road is signalized.

### **Traffic Volumes**

The signalized intersection of Golden Sage Road/Woodmen Road was counted in January 2020 and again in December 2020. Traffic counts were conducted in July 2020 at the unsignalized study intersections. The most recent counts at the Golden Sage/Woodmen Road intersection and both unsignalized intersections were conducted during the COVID-19 pandemic, which may have affected traffic volumes. To correct for potentially low traffic volumes, the older count at the Golden Sage Road/Woodmen Road was used for the analysis. Additionally, the through volumes at the Rolling Thunder Way/Firehouse View were increased to balance with traffic volumes at the intersection of Golden Sage Road/Woodmen Road. It is difficult to know if volumes turning into and out of the Rolling Thunder Business Park were also impacted by the pandemic. At the time of the count, the businesses appeared to be open. Therefore, these volumes were left as counted. Figure 3 provides the peak-hour traffic volumes and estimated weekday daily traffic.

### **TRIP GENERATION ESTIMATE**

Estimates of the vehicle trips projected to be generated by the proposed site have been made using the nationally published average trip-generation rates in *Trip Generation, 10<sup>th</sup> Edition, 2017* by the Institute of Transportation Engineers (ITE). The land use code 710 General Office Building was used to calculate site-generated traffic.

Table 1 below presents a summary of the estimated site trip generation for the proposed development. A detailed trip-generation estimate for the site, including ITE rates and building square footage, is presented in Table 5 (attached).

**Table 1: Estimated Site Vehicle-Trip Generation – Office Building**

Analysis Period	Weekday		
	In	Out	Total
Morning peak hour (vehicle trips/hour)	28	4	32
Evening peak hour (vehicle trips/hour)	6	25	31
Weekday – 24-hour total (vehicle trips/day)	105	105	210

Based on the ITE estimate for the proposed development, the site would generate approximately 210 vehicle trips on the average weekday, with half entering and half exiting the site. Approximately 28 entering vehicles and 4 exiting vehicles are projected for the weekday morning peak hour and 6 entering vehicles and 25 exiting vehicles are projected for the weekday evening peak hour.

Traffic counts were completed in July 2020 at the intersection of Firehouse View/Rolling Thunder Way to estimate how much traffic is currently generated by the existing business park. The current counts, along with trip-generation estimates in the *Black Forest Beverage Company Trip Generation Memo* prepared in May 2020, *Rolling Thunder Lots 2-3* prepared in January 2021, and the trip generation forecast for the proposed development were used to develop a trip-generation forecast for the entire business park. Table 2 provides the overall trip-generation estimate for the Rolling Thunder Business Park. The attached Table 6 provides the detailed trip-generation estimate. As shown, with the proposed office/warehouse buildings, the previously proposed shopping center and brewery, and the existing trips generated by the business park, the Rolling Thunder Business Park is projected to generate 88 trips during the morning peak hour and 162 trips during the evening peak hour.

**Table 2: Rolling Thunder Business Park (All Parcels)  
Trip Generation**

Analysis Period	Weekday		
	In	Out	Total
Morning peak hour (vehicle trips/hour)	68	20	88
Evening peak hour (vehicle trips/hour)	62	100	162
Weekday – 24-hour total (vehicle trips/day)	702	702	1,404

The previously-approved use of the business park included 94,500 square feet of business-park land use, which would include a mix of office, retail, light industrial, and warehouse, as well as a 5,000-square-foot shopping center. The attached Table 7 provides a summary of the site-generated traffic volumes that were projected in the previous Rolling Thunder Business Park traffic study that included all parcels within the business park (*Rolling Thunder Business Park Updated Traffic Impact Study*, May 2008).

Table 3 provides a comparison to trip-generation estimates for the previously-approved land use for all parcels within the business park and the current trip-generation estimates for the business park. As

shown, the proposed land use is anticipated to generate less traffic than the previous land use. The business park would generate approximately 286 fewer vehicle trips on the average weekday, with half entering and half exiting the site. Approximately 65 fewer vehicles will enter or exit the site during the morning peak hour and 6 fewer vehicles will enter or exit the site during the evening peak hour.

**Table 3: Rolling Thunder Business Park (All Parcels)  
 Trip Generation Comparison**

Land Use	Daily	Morning Peak		Evening Peak	
		In	Out	In	Out
Proposed Land Use (Table 6)	1,404	68	20	62	100
Previously Estimated Land Use (Table 7)	1,690	123	30	52	116
<b>Difference</b>	<b>-286</b>	<b>-55</b>	<b>-10</b>	<b>10</b>	<b>-16</b>

**BACKGROUND TRAFFIC**

Background traffic includes growth that is projected to occur on the study roadways, due to future development in the area. Background volumes do not include projected traffic to be generated by the proposed development. Long-term volumes were estimated by LSC, based on previous work completed in the area by LSC, including *Falcon Meadows at Bent Grass*, *Bent Grass Meadows*, and *Falcon Marketplace*. The 2040 background traffic volumes assume buildout of the area north of Woodmen Road and west of Meridian Road. Figure 4 provides the calculated long-term background traffic volumes.

It is anticipated that, by the year 2040, the west leg of the intersection of Golden Sage Road/Rolling Thunder Way would likely be constructed and carry traffic. However, this was not included in this analysis. It is expected that the development to the west would need to submit a traffic impact study to address impacts to the study intersections, including Golden Sage Road/Rolling Thunder Way.

**TRIP DISTRIBUTION AND ASSIGNMENT**

**Trip Directional Distribution**

Estimation of the directional distribution of site-generated vehicle trips to the study-area roads and intersections is a necessary component in determining the site’s traffic impacts. Figure 5 shows the directional distribution estimates for the proposed development. Estimates were based on the following factors: existing traffic counts, existing area development, and the area roadway system. As shown, it has been assumed that 80 percent of site-generated traffic would travel to/from Woodmen Road.



**Site-Generated Traffic**

Site-generated traffic volumes at the study intersections have been calculated by applying the directional-distribution percentages estimated by LSC to the trip-generation estimates (from Table 5). Figure 5 provides the site-generated traffic for the site.

**Short-Term Total Traffic Volumes**

Figure 6 shows the sum of the existing traffic volumes (from Figure 3) and the site-generated peak-hour traffic volumes for the development (shown in Figure 5). As mentioned previously, the through volumes at the intersection of Rolling Thunder Way/Firehouse View were increased to balance with volumes at Golden Sage Road/Woodmen Road. This was done to try to correct for the traffic impacts of the COVID-19 pandemic. The resulting volumes represent the projected short-term total traffic following construction of development.

**Long-Term Total Traffic Volumes**

Figure 7 shows the projected 2040 total traffic volumes, which are the sum of 2040 background traffic volumes (from Figure 4) plus the site-generated traffic volumes (from Figure 5).

**LEVEL OF SERVICE ANALYSIS**

Level of service (LOS) is a quantitative measure of the level of congestion or delay at an intersection and is indicated on a scale from “A” to “F.” LOS A is indicative of little congestion or delay. LOS F indicates a high level of congestion or delay. Table 4 shows the level of service delay ranges for signalized and unsignalized intersections.

**Table 4: Intersection Levels of Service Delay Ranges**

Level of Service	Signalized Intersections	Unsignalized Intersections
	Average Control Delay (seconds per vehicle)	Average Control Delay (seconds per vehicle) <sup>(1)</sup>
A	10.0 sec or less	10.0 sec or less
B	10.1-20.0 sec	10.1-15.0 sec
C	20.1-35.0 sec	15.1-25.0 sec
D	35.1-55.0 sec	25.1-35.0 sec
E	55.1-80.0 sec	35.1-50.0 sec
F	80.1 sec or more	50.1 sec or more

(1) For unsignalized intersections if V/C ratio is greater than 1.0 the level of service is LOS F regardless of the projected average control delay per vehicle.

The study intersections have been analyzed to determine the projected control delay and corresponding levels of service for turning movements. Figure 3 provides the existing levels of service. Figure 4 provides the background levels of service for the long-term scenarios. Figure 6 and Figure 7 provide the levels of service for the short-term and long-term total traffic scenarios, respectively.

### **Golden Sage Road/Woodmen Road**

The signalized intersection of Golden Sage Road/Woodmen Road currently operates at LOS B during the peak hours, with all movements operating at LOS D or better. In the short-term total, the levels of service experienced at the intersection are expected to remain unchanged with the addition of the site-generated traffic.

In the long-term background, this intersection is projected to operate at LOS C during the morning and evening peak hours. All movements are expected to operate at LOS D or better. With the addition of the site-generated traffic, the level of service experienced at the intersection is expected to remain unchanged.

### **Firehouse View Intersections**

All yielding turning movements at the unsignalized study intersections are projected to operate at LOS C or better during both peak hours in all existing and future scenarios.

### **AUXILIARY TURN LANES**

No additional auxiliary lanes are necessary with this proposed development.

### **MTCP ROADWAY IMPROVEMENTS**

The *2016 El Paso County Major Transportation Corridor Plan* does not show any planned improvements in the study area.

### **PEDESTRIAN AND BICYCLE ACCOMMODATION**

There is currently no sidewalk along Maltese Point or Firehouse View. There is an incomplete segment of sidewalk along the east side of Golden Sage Road, but no sidewalk on the west side. In the *2016 El Paso County Major Transportation Corridor Plan* (MTCP), Woodmen Road is shown as a non-motorized priority corridor with proposed bicycle routes.

## **COUNTY ROAD IMPROVEMENT FEE PROGRAM**

### **Transportation Impact Fees**

Transportation impact fees are not required to be paid to El Paso County. Rather, applicable fees will need to be paid to the Woodmen Road District pursuant to the agreement between El Paso County and the Woodmen Road District.

### **Reimbursable MTCP Improvements**

There are no apparent reimbursable improvements programmed in the MTCP in the general vicinity of this site.

## **FINDINGS AND CONCLUSIONS**

### **Trip Generation**

- The development is expected to generate approximately 210 vehicle trips on the average weekday with approximately 32 trips occurring during the morning peak hour and 31 trips during the evening peak hour.

### **Recommendations**

- No additional auxiliary lanes or other improvements are required for the proposed development.

### **Roadway Impact Fees**

Road Impact fees are paid to County and the County will transfer to Woodmen Road Metro per Resolution 13-041 IAW post 12/31/20 process.

\* \* \* \* \*

Please contact me if you have any questions.

Respectfully Submitted,

LSC TRANSPORTATION CONSULTANTS, INC.

By: Jeffrey C. Hodsdon, P.E.  
Principal

JCH:jas

Enclosures: Tables 5-7  
Figures 1-7  
Traffic Counts  
Level of Service Reports

# Tables

---



**Table 5: Detailed Trip Generation – Proposed Site**

Land Use Code	Land Use Description	Trip Generation Units	Trip Generation Rates <sup>(1)</sup>					Total Trips Generated				
			Average Weekday Traffic <sup>(3)</sup>	Morning Peak Hour		Afternoon Peak Hour		Average Weekday Traffic	Morning Peak Hour		Afternoon Peak Hour	
				In	Out	In	Out		In	Out	In	Out
710	General Office Building	21.6 KSF <sup>(2)</sup>	9.74	1.29	0.18	0.26	1.16	210	28	4	6	25
<p>Notes:</p> <p>(1) Source: "Trip Generation, 10th Edition, 2017" by the Institute of Transportation Engineers (ITE)</p> <p>(2) KSF = 1,000 Square Feet</p> <p>Source: LSC Transportation Consultants, Inc.</p>												

**Table 6: Detailed Trip Generation – Rolling Thunder Business Park (All Parcels)**

Land Use Code	Land Use Description	Trip Generation Units	Trip Generation Rates <sup>(1)</sup>				Total Trips Generated					
			Average Weekday Traffic <sup>(3)</sup>	Morning Peak Hour		Afternoon Peak Hour		Average Weekday Traffic	Morning Peak Hour		Afternoon Peak Hour	
				In	Out	In	Out		In	Out	In	Out
<b>Proposed Land Use</b>												
710	General Office Building	21.6 KSF <sup>(2)</sup>	9.74	1.29	0.18	0.26	1.16	210	28	4	6	25
<b>Other Proposed Land Uses Within Rolling Thunder <sup>(3)</sup></b>												
820	Shopping Center	7.5 KSF	37.75	1.62	1.38	2.11	2.11	283	12	10	16	16
925	Drinking Place	1.383 KSF	56.09	0.00	0.00	7.50	3.86	78	0	0	10	5
140	Manufacturing	2.27 KSF	3.93	0.48	0.14	0.21	0.46	9	1	0	0	1
492	Health/Fitness Club	1.15 KSF	28.82	0.67	0.64	1.97	1.48	33	1	1	2	2
<b>Subtotal</b>								<b>403</b>	<b>14</b>	<b>11</b>	<b>29</b>	<b>24</b>
<b>Existing Land Use <sup>(4)</sup></b>												
Count Data		- -	-	-	-	-	-	790 <sup>(5)</sup>	26	5	28	51
<b>Total</b>								<b>1,403</b>	<b>68</b>	<b>20</b>	<b>62</b>	<b>100</b>
Notes:												
(1) Source: "Trip Generation, 10th Edition, 2017" by the Institute of Transportation Engineers (ITE)												
(2) KSF = 1,000 Square Feet												
(3) From Rolling Thunder Lots 2-3, LSC, January 2021												
(4) Based on peak hour counts collected in July 2020 at Firehouse View/Rolling Thunder Way												
(5) Estimated based on peak hour traffic counts												
Source: LSC Transportation Consultants, Inc.												

**Table 7: Rolling Thunder Business Park  
Previously Approved Site Generated Traffic (All Parcels)**

Analysis Period	Weekday		Total
	In	Out	
Morning peak hour (vehicle trips/hour)	123	30	153
Evening peak hour (vehicle trips/hour)	52	116	168
Weekday – 24-hour total (vehicle trips/day)	845	845	1,690



# Figures

---





Not to scale

Figure 1  
**Vicinity**

Ruckus Development (LSC #S214220)

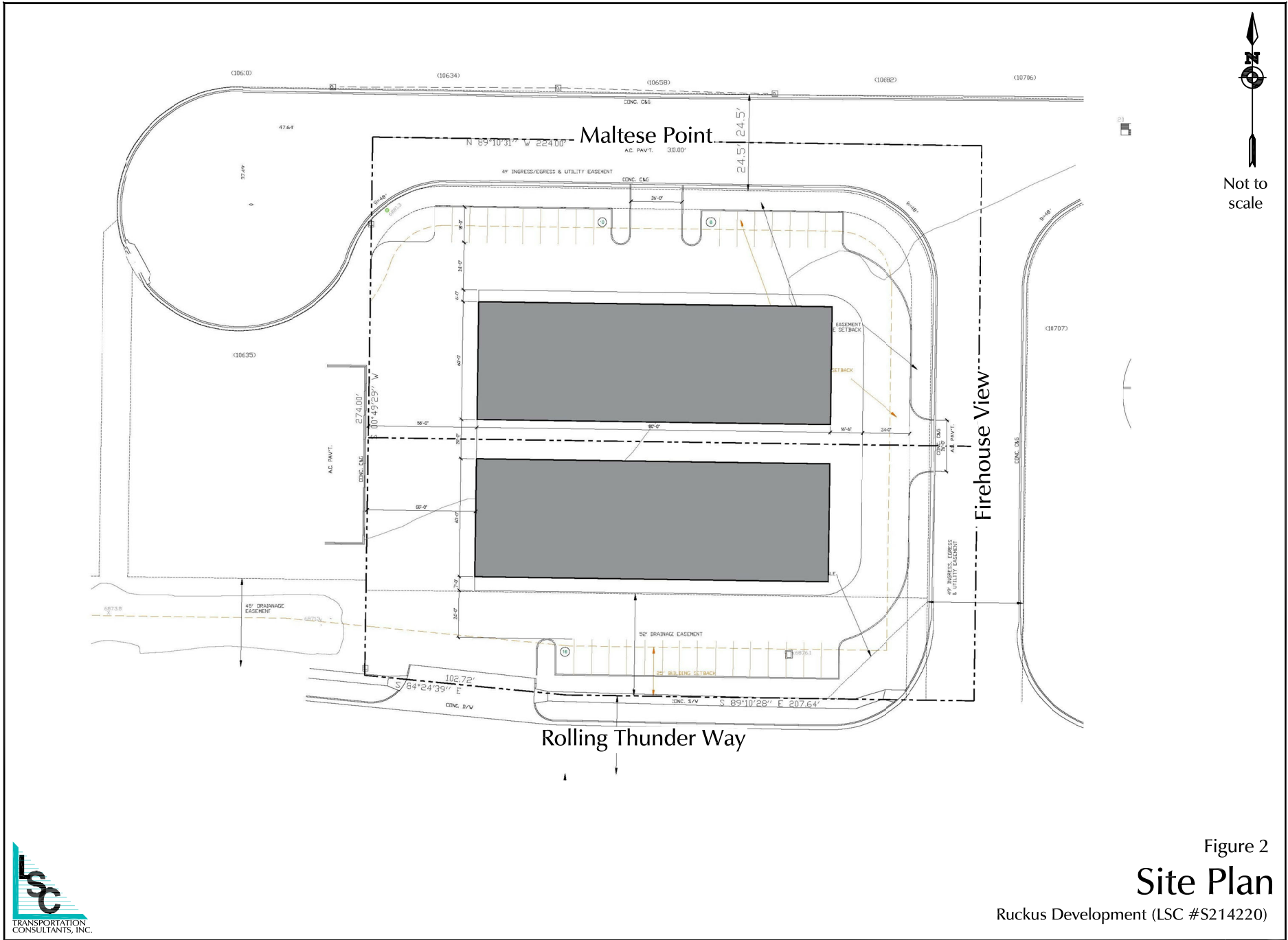

Not to scale

Figure 2  
**Site Plan**

Ruckus Development (LSC #S214220)



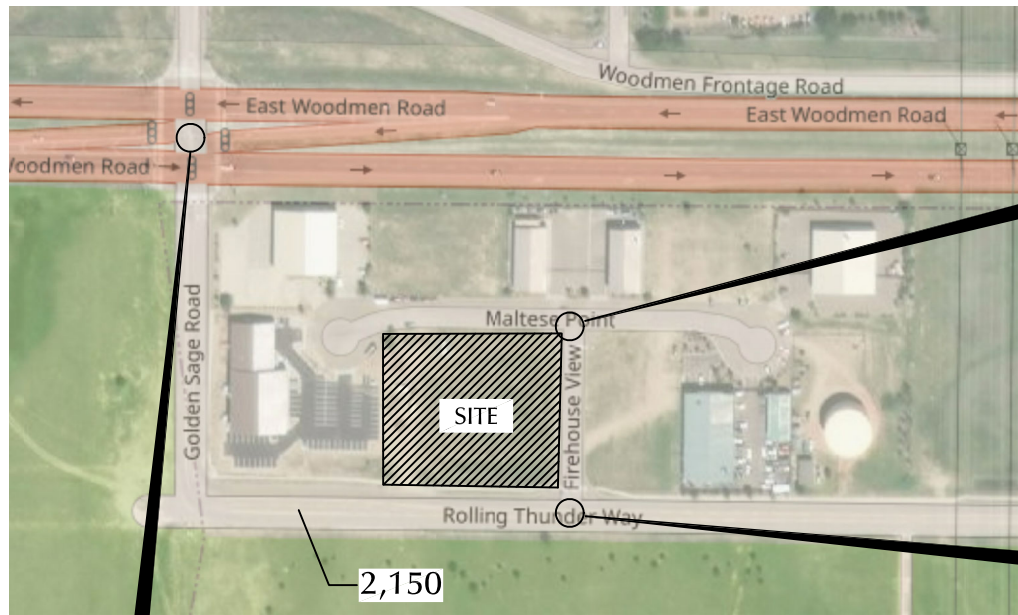

2,150

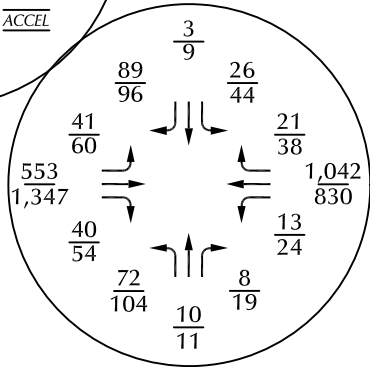
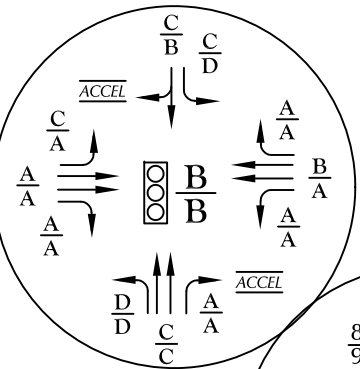
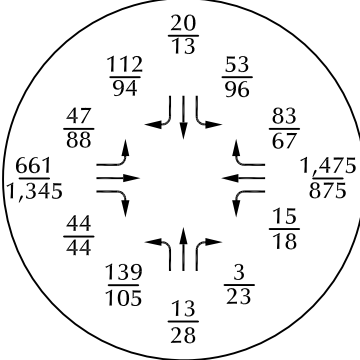
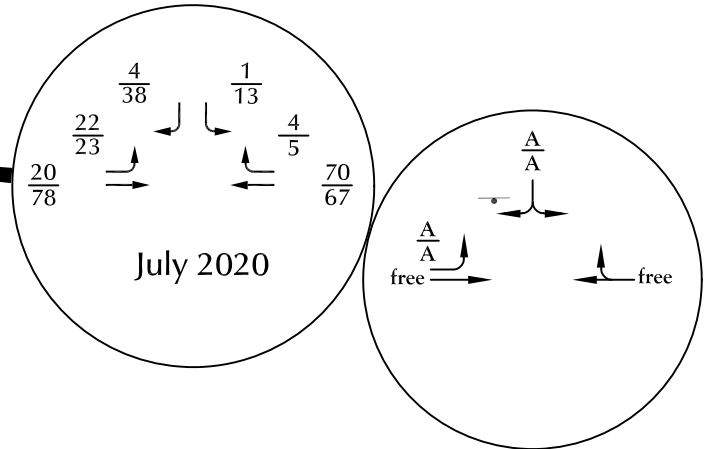
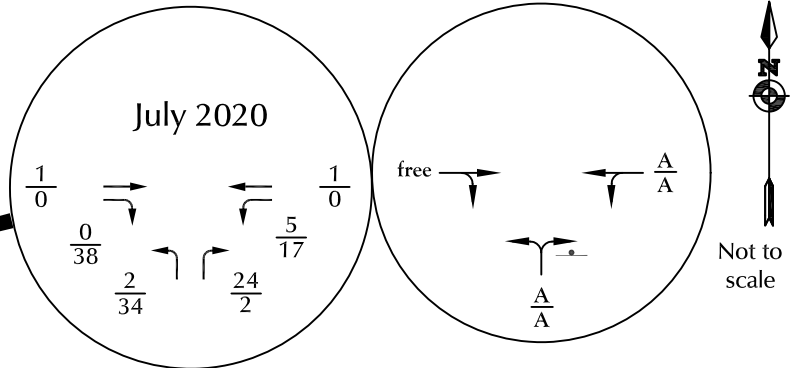

\*December 2020 counts were lower than the January 2020 counts due to the impact of the COVID-19 pandemic on traffic. The January 2020 counts were used for the analysis to be conservative.

LEGEND:

$\frac{XX}{XX}$  = AM Peak-Hour Traffic (veh/hr)  
 PM Peak-Hour Traffic (veh/hr)

XXX = Average Weekday Daily Traffic (vehicles per day)

$\frac{A}{B}$  = AM Individual Movement Peak-Hour Level of Service  
 PM Individual Movement Peak-Hour Level of Service

$\frac{C}{D}$  = AM Entire Intersection Peak-Hour Level of Service  
 PM Entire Intersection Peak-Hour Level of Service

⊥ = Stop Sign

Figure 3  
**Existing Traffic Conditions**  
 Ruckus Development (LSC #S214220)



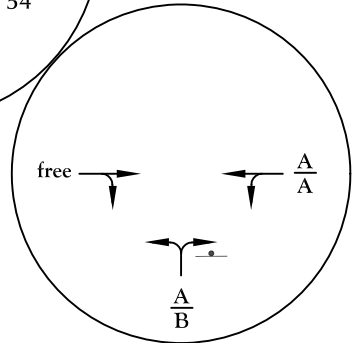
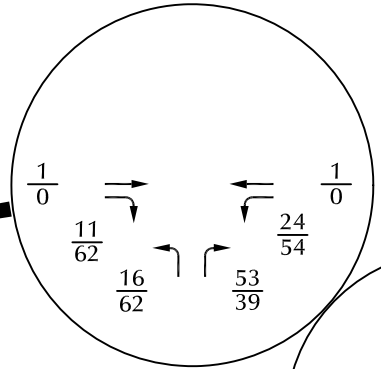
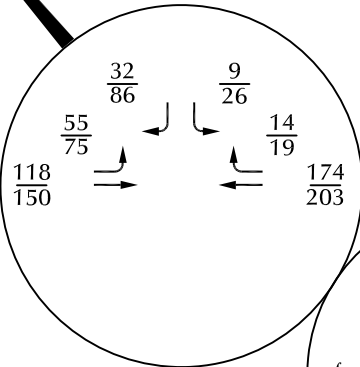
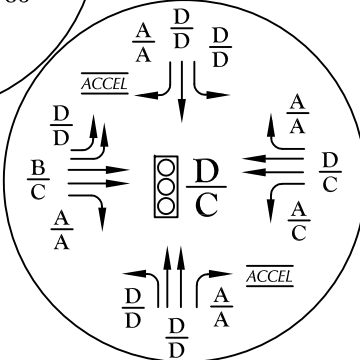
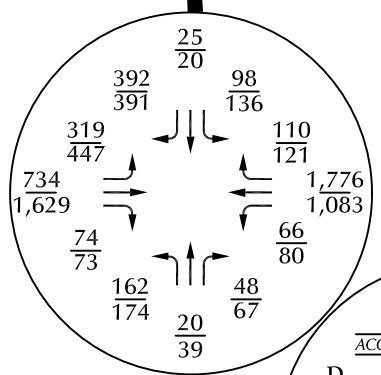
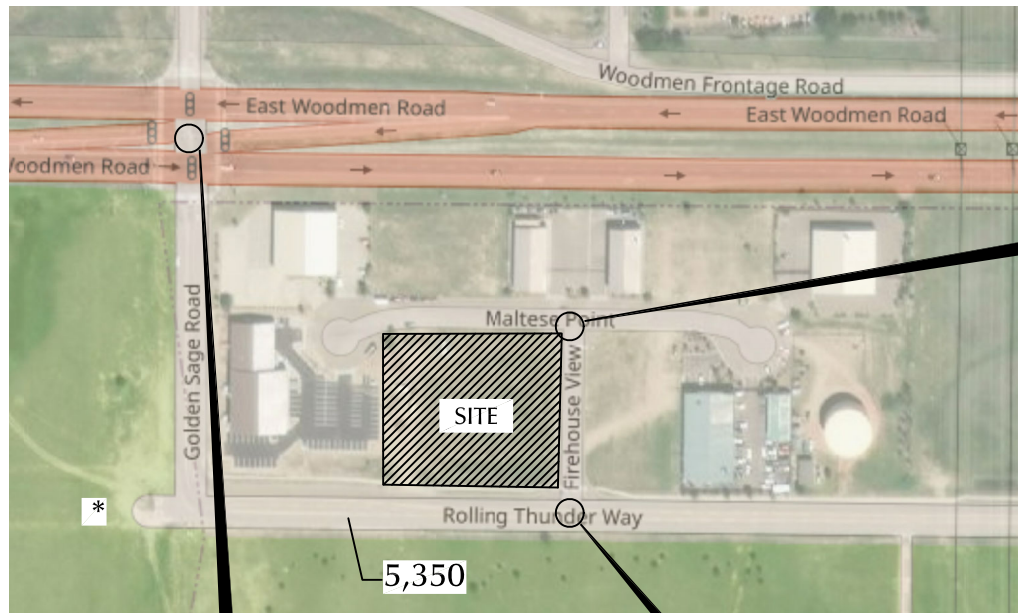

LEGEND:

$\frac{XX}{XX}$  = AM Peak-Hour Traffic (veh/hr)  
 $\frac{XX}{XX}$  = PM Peak-Hour Traffic (veh/hr)

XXX = Average Weekday Daily Traffic (vehicles per day)

$\frac{A}{B}$  = AM Individual Movement Peak-Hour Level of Service  
 $\frac{A}{B}$  = PM Individual Movement Peak-Hour Level of Service

⊥ = Stop Sign

\*Future traffic by 2040 is likely on this leg – however not included in this analysis. The development to the west would likely need to submit a TIS report to address impacts to the study area intersections.

Figure 4  
 Long-Term Background Traffic Conditions

Ruckus Development (LSC #S214220)



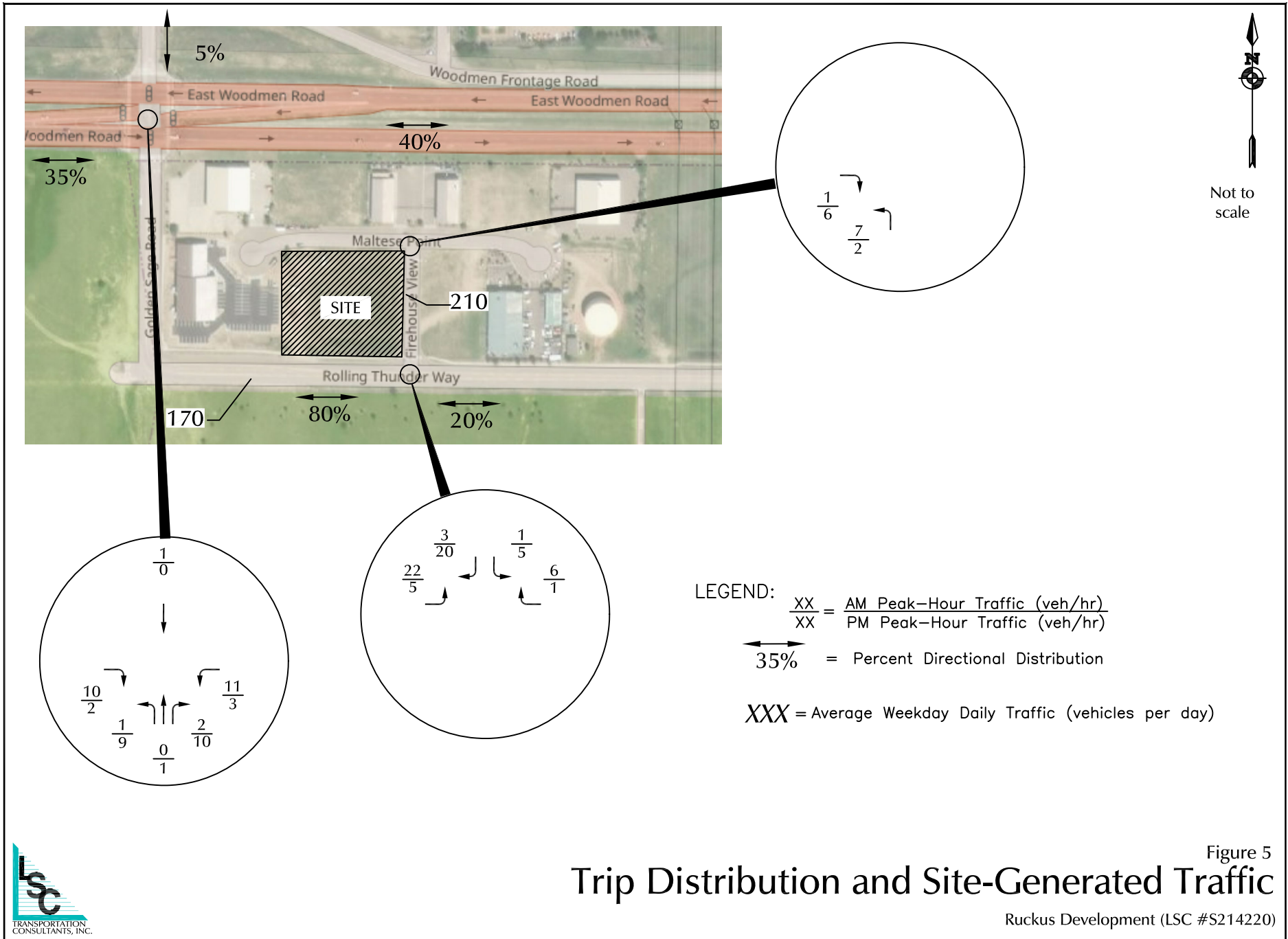
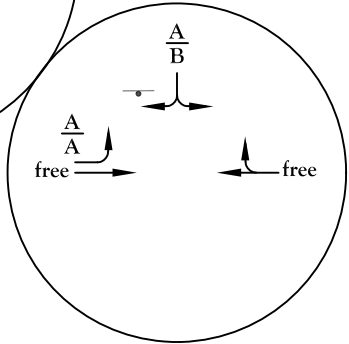
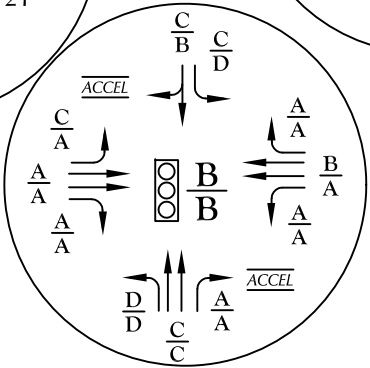
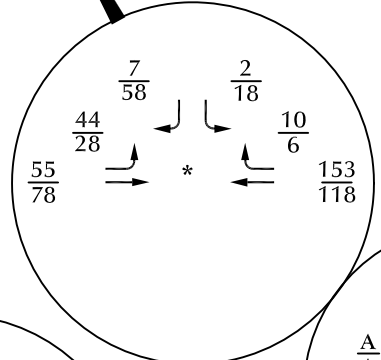
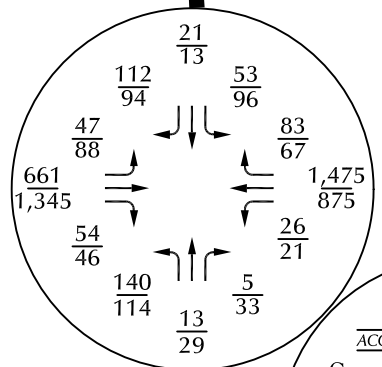
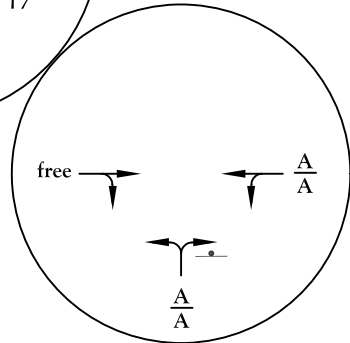
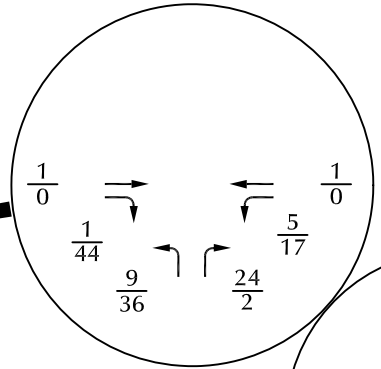
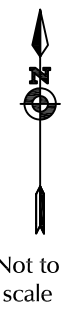
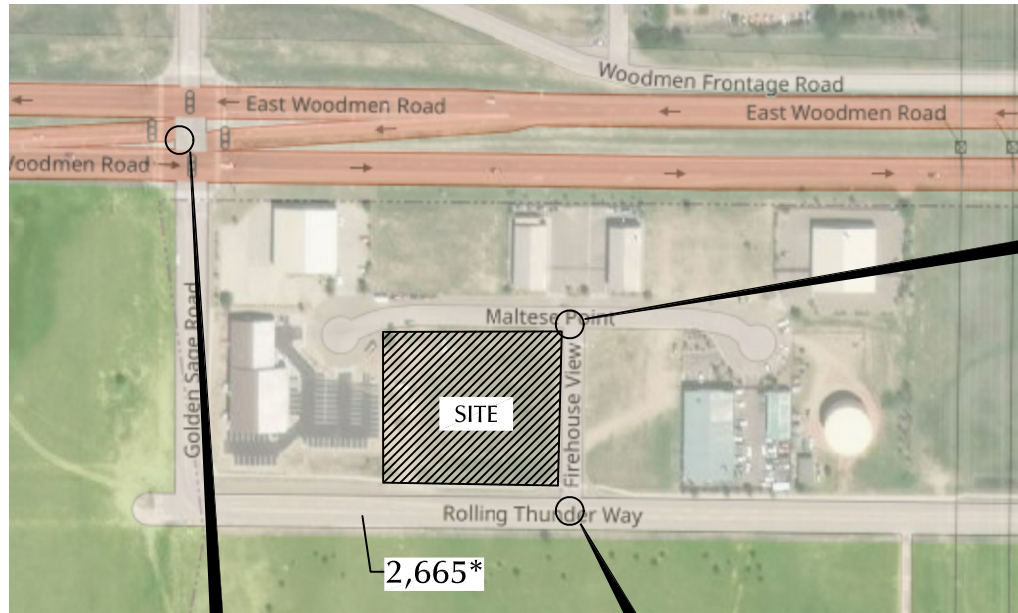

Figure 5  
 Trip Distribution and Site-Generated Traffic

Ruckus Development (LSC #S214220)



LEGEND:

$\frac{XX}{XX}$  = AM Peak-Hour Traffic (veh/hr)  
 $\frac{XX}{XX}$  = PM Peak-Hour Traffic (veh/hr)

XXX = Average Weekday Daily Traffic (vehicles per day)

$\frac{A}{B}$  =  $\frac{\text{AM Individual Movement Peak-Hour Level of Service}}{\text{PM Individual Movement Peak-Hour Level of Service}}$

⊥ = Stop Sign

\*Through volumes have been adjusted to account for lower traffic volumes during the COVID-19 pandemic.



Figure 6  
**Short-Term Total Traffic Conditions**

Ruckus Development (LSC #S214220)

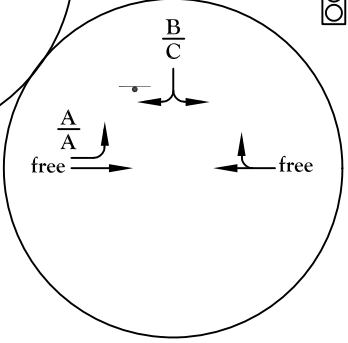
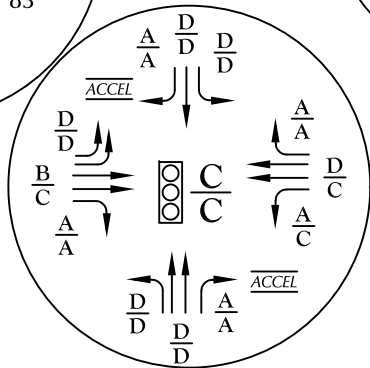
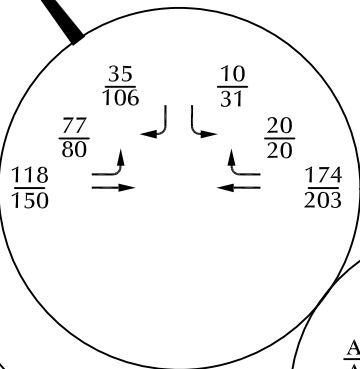
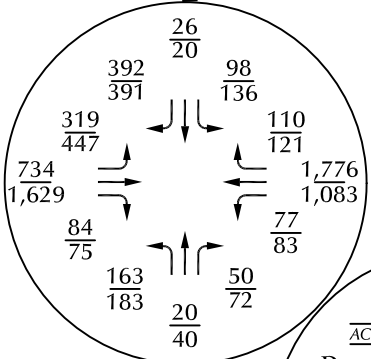
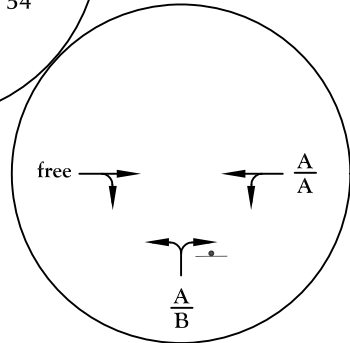
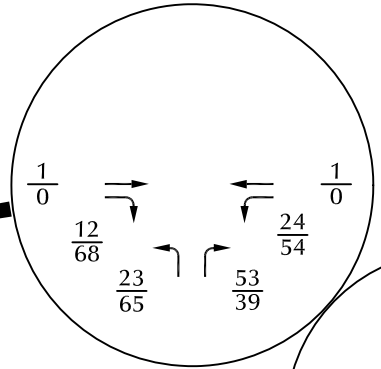
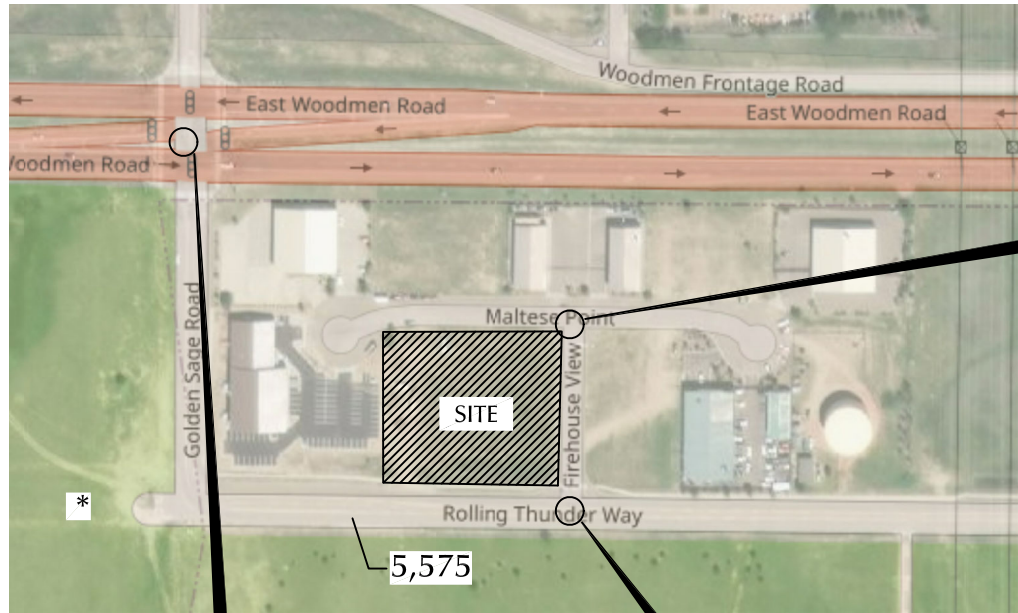

LEGEND:

$\frac{XX}{XX}$  = AM Peak-Hour Traffic (veh/hr)  
 $\frac{XX}{XX}$  = PM Peak-Hour Traffic (veh/hr)

XXX = Average Weekday Daily Traffic (vehicles per day)

$\frac{A}{B}$  = AM Individual Movement Peak-Hour Level of Service  
 $\frac{A}{B}$  = PM Individual Movement Peak-Hour Level of Service

= Traffic Signal | = Stop Sign

\*Future traffic by 2040 is likely on this leg – however not included in this analysis. The development to the west would likely need to submit a TIS report to address impacts to the study area intersections.

Figure 7  
**Long-Term Total Traffic Conditions**  
 Ruckus Development (LSC #S214220)





# Traffic Counts

---



# LSC Transportation Consultants, Inc.

545 E Pikes Peak Ave, Suite 210  
 Colorado Springs, CO 80905  
 719-633-2868

File Name : Firehouse View - Maltese Pt AM  
 Site Code : 00204440  
 Start Date : 7/1/2020  
 Page No : 1

### Groups Printed- Bank 1

Start Time	Southbound					Maltese Pt Westbound					Firehouse View Northbound					Maltese Pt Eastbound					Int. Total
	L	T	R	U	App. Total	L	T	R	U	App. Total	L	T	R	U	App. Total	L	T	R	U	App. Total	
06:30 AM	0	0	0	0	0	0	0	0	0	0	0	0	1	0	1	0	0	0	0	0	1
06:45 AM	0	0	0	0	0	0	0	0	0	0	0	0	1	0	1	0	0	0	0	0	1
Total	0	0	0	0	0	0	0	0	0	0	0	0	2	0	2	0	0	0	0	0	2
07:00 AM	0	0	0	0	0	0	1	0	0	1	1	0	7	0	8	0	1	0	0	1	10
07:15 AM	0	0	0	0	0	2	0	0	0	2	0	0	4	0	4	0	0	0	0	0	6
07:30 AM	0	0	0	0	0	2	0	0	0	2	1	0	7	0	8	0	0	0	0	0	10
07:45 AM	0	0	0	0	0	1	0	0	0	1	0	0	6	0	6	0	0	0	0	0	7
Total	0	0	0	0	0	5	1	0	0	6	2	0	24	0	26	0	1	0	0	1	33
08:00 AM	0	0	0	0	0	0	1	0	0	1	0	0	0	0	0	0	0	1	0	1	2
08:15 AM	0	0	0	0	0	2	0	0	0	2	3	0	2	0	5	0	0	1	0	1	8
Grand Total	0	0	0	0	0	7	2	0	0	9	5	0	28	0	33	0	1	2	0	3	45
Apprch %	0	0	0	0	0	77.8	22.2	0	0		15.2	0	84.8	0		0	33.3	66.7	0		
Total %	0	0	0	0	0	15.6	4.4	0	0	20	11.1	0	62.2	0	73.3	0	2.2	4.4	0	6.7	

# LSC Transportation Consultants, Inc.

545 E Pikes Peak Ave, Suite 210  
 Colorado Springs, CO 80905  
 719-633-2868

File Name : Firehouse View - Maltese Pt AM  
 Site Code : 00204440  
 Start Date : 7/1/2020  
 Page No : 2

Start Time	Southbound					Maltese Pt Westbound					Firehouse View Northbound					Maltese Pt Eastbound					Int. Total
	L	T	R	U	App. Total	L	T	R	U	App. Total	L	T	R	U	App. Total	L	T	R	U	App. Total	
<b>Peak Hour Analysis From 6:30:00 AM to 8:15:00 AM - Peak 1 of 1</b>																					
Peak Hour for Entire Intersection Begins at 7:00:00 AM																					
7:00:00 AM	0	0	0	0	0	0	1	0	0	1	1	0	7	0	8	0	1	0	0	1	10
7:15:00 AM	0	0	0	0	0	2	0	0	0	2	0	0	4	0	4	0	0	0	0	0	6
7:30:00 AM	0	0	0	0	0	2	0	0	0	2	1	0	7	0	8	0	0	0	0	0	10
7:45:00 AM	0	0	0	0	0	1	0	0	0	1	0	0	6	0	6	0	0	0	0	0	7
Total Volume	0	0	0	0	0	5	1	0	0	6	2	0	24	0	26	0	1	0	0	1	33
% App. Total	0	0	0	0	0	83.3	16.7	0	0		7.7	0	92.3	0		0	100	0	0		
PHF	.000	.000	.000	.000	.000	.625	.250	.000	.000	.750	.500	.000	.857	.000	.813	.000	.250	.000	.000	.250	.825

# LSC Transportation Consultants, Inc.

545 E Pikes Peak Ave, Suite 210  
 Colorado Springs, CO 80905  
 719-633-2868

File Name : Firehouse View - Maltese Pt AM  
 Site Code : 00204440  
 Start Date : 7/1/2020  
 Page No : 3

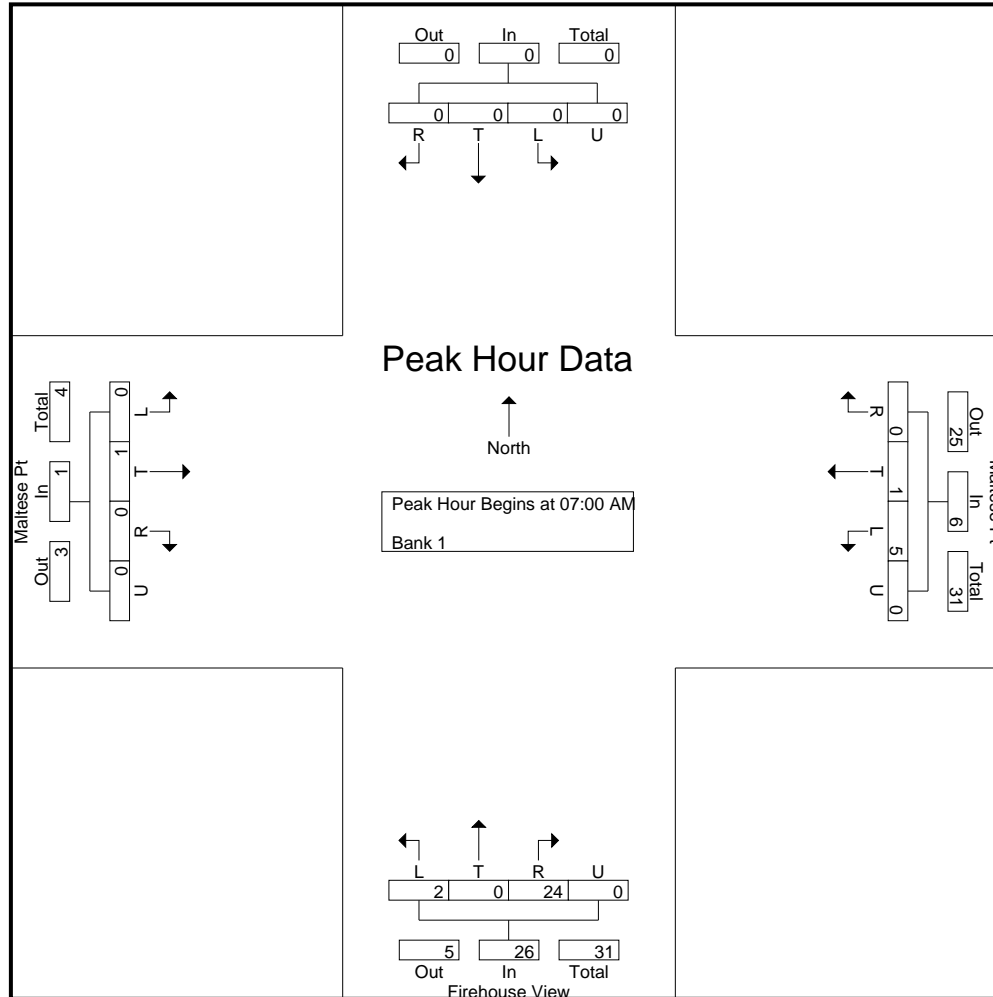

# LSC Transportation Consultants, Inc.

545 E Pikes Peak Ave, Suite 210  
 Colorado Springs, CO 80905  
 719-633-2868

File Name : Firehouse View - Maltese Pt AM  
 Site Code : 00204440  
 Start Date : 7/1/2020  
 Page No : 4

Start Time	Southbound					Maltese Pt Westbound					Firehouse View Northbound					Maltese Pt Eastbound					Int. Total
	L	T	R	U	App. Total	L	T	R	U	App. Total	L	T	R	U	App. Total	L	T	R	U	App. Total	
<b>Peak Hour Analysis From 6:30:00 AM to 8:15:00 AM - Peak 1 of 1</b>																					
Peak Hour for Each Approach Begins at:																					
	6:30:00 AM					7:00:00 AM					7:00:00 AM					7:30:00 AM					
+0 mins.	0	0	0	0	0	0	1	0	0	1	1	0	7	0	8	0	0	0	0	0	0
+5 mins.	0	0	0	0	0	2	0	0	0	2	0	0	4	0	4	0	0	0	0	0	0
+10 mins.	0	0	0	0	0	2	0	0	0	2	1	0	7	0	8	0	0	1	0	1	1
+15 mins.	0	0	0	0	0	1	0	0	0	1	0	0	6	0	6	0	0	1	0	1	1
Total Volume	0	0	0	0	0	5	1	0	0	6	2	0	24	0	26	0	0	2	0	2	2
% App. Total	0	0	0	0	0	83.3	16.7	0	0		7.7	0	92.3	0		0	0	100	0		
PHF	.000	.000	.000	.000	.000	.625	.250	.000	.000	.750	.500	.000	.857	.000	.813	.000	.000	.500	.000	.500	

# LSC Transportation Consultants, Inc.

545 E Pikes Peak Ave, Suite 210  
Colorado Springs, CO 80905  
719-633-2868

File Name : Firehouse View - Maltese Pt AM  
Site Code : 00204440  
Start Date : 7/1/2020  
Page No : 5

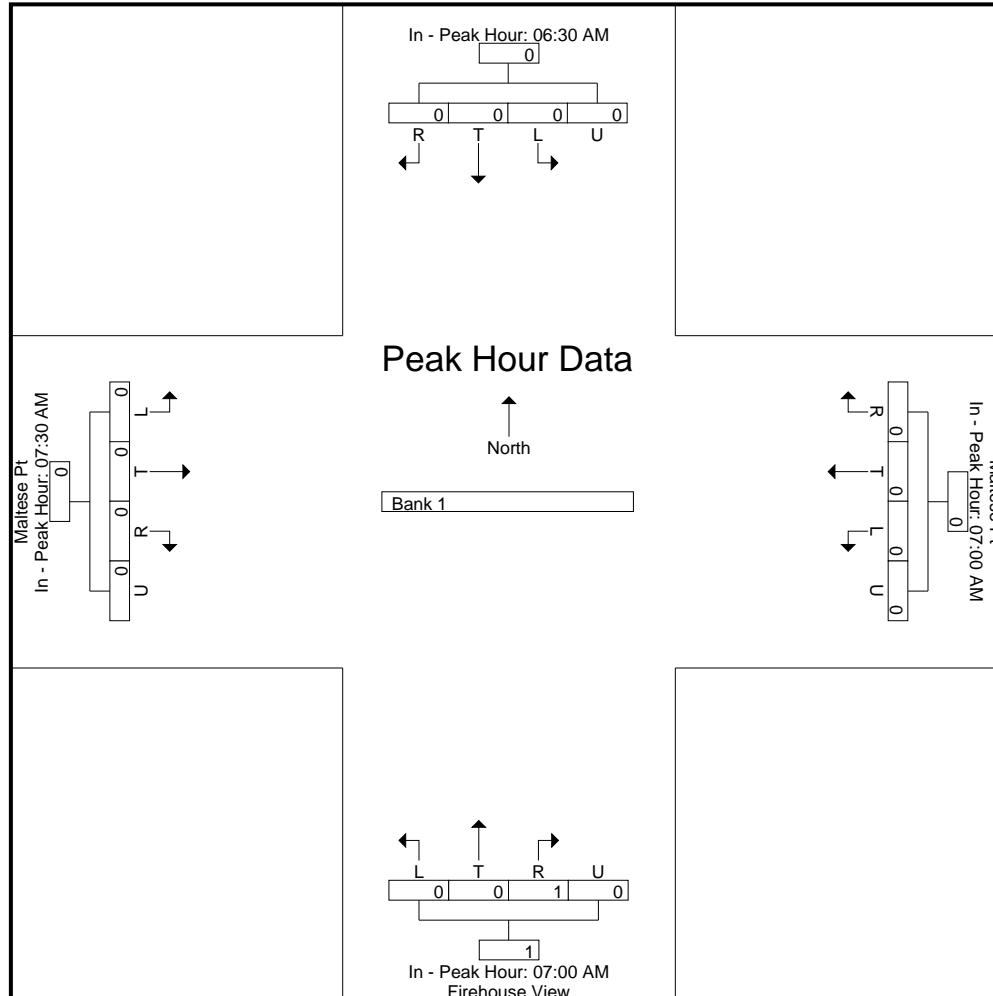

# LSC Transportation Consultants, Inc.

545 E Pikes Peak Ave, Suite 210  
 Colorado Springs, CO 80905  
 719-633-2868

File Name : Firehouse View - Maltese Pt PM  
 Site Code : 00204440  
 Start Date : 7/1/2020  
 Page No : 1

### Groups Printed- Bank 1

Start Time	Southbound					Maltese Pt Westbound					Firehouse View Northbound					Maltese Pt Eastbound					Int. Total
	L	T	R	U	App. Total	L	T	R	U	App. Total	L	T	R	U	App. Total	L	T	R	U	App. Total	
04:00 PM	0	0	0	0	0	4	0	0	0	4	6	0	3	0	9	0	0	8	0	8	21
04:15 PM	0	0	0	0	0	3	0	0	0	3	2	0	2	0	4	0	0	1	0	1	8
04:30 PM	0	0	0	0	0	4	0	0	0	4	4	0	0	0	4	0	0	2	0	2	10
04:45 PM	0	0	0	0	0	2	0	0	0	2	9	0	1	0	10	0	0	3	0	3	15
<b>Total</b>	0	0	0	0	0	13	0	0	0	13	21	0	6	0	27	0	0	14	0	14	54
05:00 PM	0	0	0	0	0	5	0	0	0	5	18	0	0	0	18	0	0	25	0	25	48
05:15 PM	0	0	0	0	0	1	0	0	0	1	4	0	1	0	5	0	0	9	0	9	15
05:30 PM	0	0	0	0	0	9	0	0	0	9	3	0	0	0	3	0	0	1	0	1	13
05:45 PM	0	0	0	0	0	2	0	0	0	2	3	0	0	0	3	0	0	0	0	0	5
<b>Total</b>	0	0	0	0	0	17	0	0	0	17	28	0	1	0	29	0	0	35	0	35	81
<b>Grand Total</b>	0	0	0	0	0	30	0	0	0	30	49	0	7	0	56	0	0	49	0	49	135
Apprch %	0	0	0	0	0	100	0	0	0	100	87.5	0	12.5	0	87.5	0	0	100	0	100	
Total %	0	0	0	0	0	22.2	0	0	0	22.2	36.3	0	5.2	0	41.5	0	0	36.3	0	36.3	

# LSC Transportation Consultants, Inc.

545 E Pikes Peak Ave, Suite 210  
 Colorado Springs, CO 80905  
 719-633-2868

File Name : Firehouse View - Maltese Pt PM  
 Site Code : 00204440  
 Start Date : 7/1/2020  
 Page No : 2

Start Time	Southbound					Maltese Pt Westbound					Firehouse View Northbound					Maltese Pt Eastbound					Int. Total
	L	T	R	U	App. Total	L	T	R	U	App. Total	L	T	R	U	App. Total	L	T	R	U	App. Total	
<b>Peak Hour Analysis From 4:00:00 PM to 5:45:00 PM - Peak 1 of 1</b>																					
Peak Hour for Entire Intersection Begins at 4:45:00 PM																					
4:45:00 PM	0	0	0	0	0	2	0	0	0	2	9	0	1	0	10	0	0	3	0	3	15
5:00:00 PM	0	0	0	0	0	5	0	0	0	5	18	0	0	0	18	0	0	25	0	25	48
5:15:00 PM	0	0	0	0	0	1	0	0	0	1	4	0	1	0	5	0	0	9	0	9	15
5:30:00 PM	0	0	0	0	0	9	0	0	0	9	3	0	0	0	3	0	0	1	0	1	13
Total Volume	0	0	0	0	0	17	0	0	0	17	34	0	2	0	36	0	0	38	0	38	91
% App. Total	0	0	0	0	0	100	0	0	0	100	94.4	0	5.6	0	100	0	0	100	0	100	91
PHF	.000	.000	.000	.000	.000	.472	.000	.000	.000	.472	.472	.000	.500	.000	.500	.000	.000	.380	.000	.380	.474



# LSC Transportation Consultants, Inc.

545 E Pikes Peak Ave, Suite 210  
 Colorado Springs, CO 80905  
 719-633-2868

File Name : Firehouse View - Maltese Pt PM  
 Site Code : 00204440  
 Start Date : 7/1/2020  
 Page No : 3

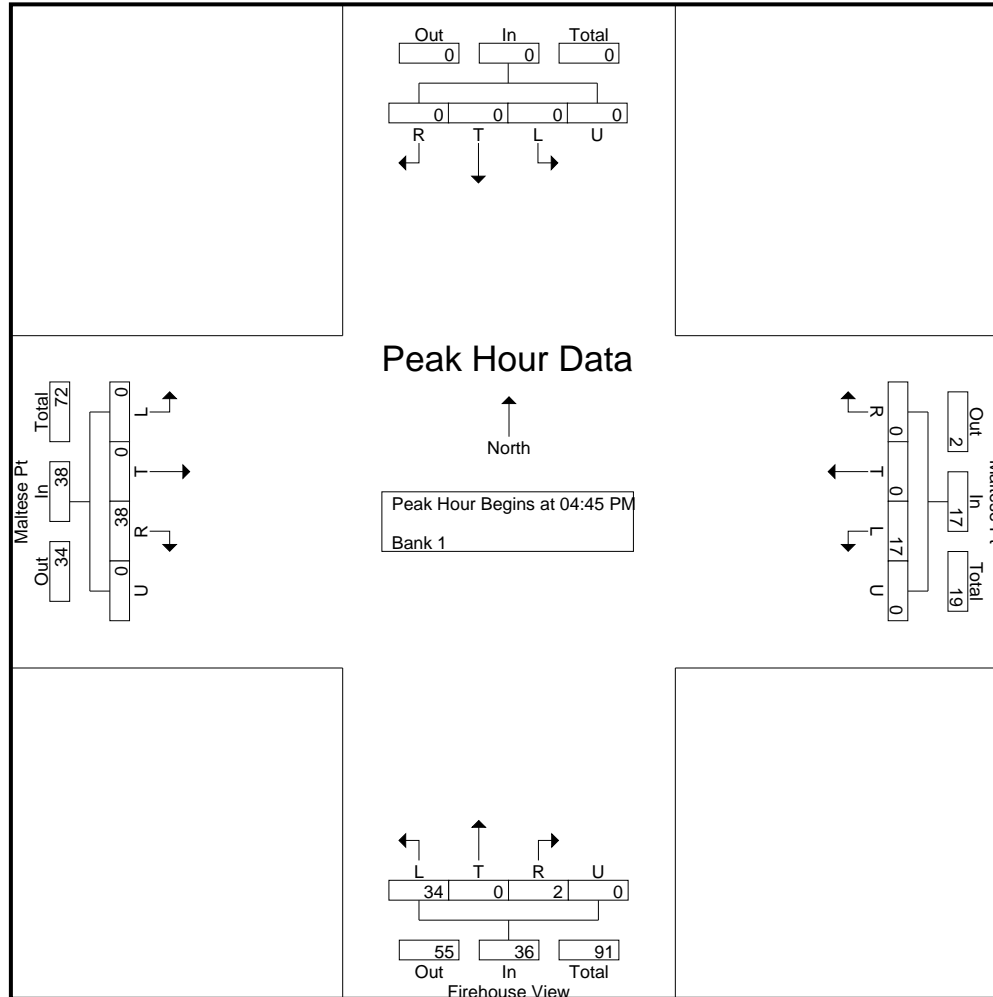

# LSC Transportation Consultants, Inc.

545 E Pikes Peak Ave, Suite 210  
 Colorado Springs, CO 80905  
 719-633-2868

File Name : Firehouse View - Maltese Pt PM  
 Site Code : 00204440  
 Start Date : 7/1/2020  
 Page No : 4

Start Time	Southbound					Maltese Pt Westbound					Firehouse View Northbound					Maltese Pt Eastbound					Int. Total
	L	T	R	U	App. Total	L	T	R	U	App. Total	L	T	R	U	App. Total	L	T	R	U	App. Total	
<b>Peak Hour Analysis From 4:00:00 PM to 5:45:00 PM - Peak 1 of 1</b>																					
Peak Hour for Each Approach Begins at:																					
	4:00:00 PM					4:45:00 PM					4:30:00 PM					4:30:00 PM					
+0 mins.	0	0	0	0	0	2	0	0	0	2	4	0	0	0	4	0	0	2	0	2	
+5 mins.	0	0	0	0	0	5	0	0	0	5	9	0	1	0	10	0	0	3	0	3	
+10 mins.	0	0	0	0	0	1	0	0	0	1	18	0	0	0	18	0	0	25	0	25	
+15 mins.	0	0	0	0	0	9	0	0	0	9	4	0	1	0	5	0	0	9	0	9	
Total Volume	0	0	0	0	0	17	0	0	0	17	35	0	2	0	37	0	0	39	0	39	
% App. Total	0	0	0	0	0	100	0	0	0	100	94.6	0	5.4	0	94.6	0	0	100	0	100	
PHF	.000	.000	.000	.000	.000	.472	.000	.000	.000	.472	.486	.000	.500	.000	.514	.000	.000	.390	.000	.390	

# LSC Transportation Consultants, Inc.

545 E Pikes Peak Ave, Suite 210  
 Colorado Springs, CO 80905  
 719-633-2868

File Name : Firehouse View - Maltese Pt PM  
 Site Code : 00204440  
 Start Date : 7/1/2020  
 Page No : 5

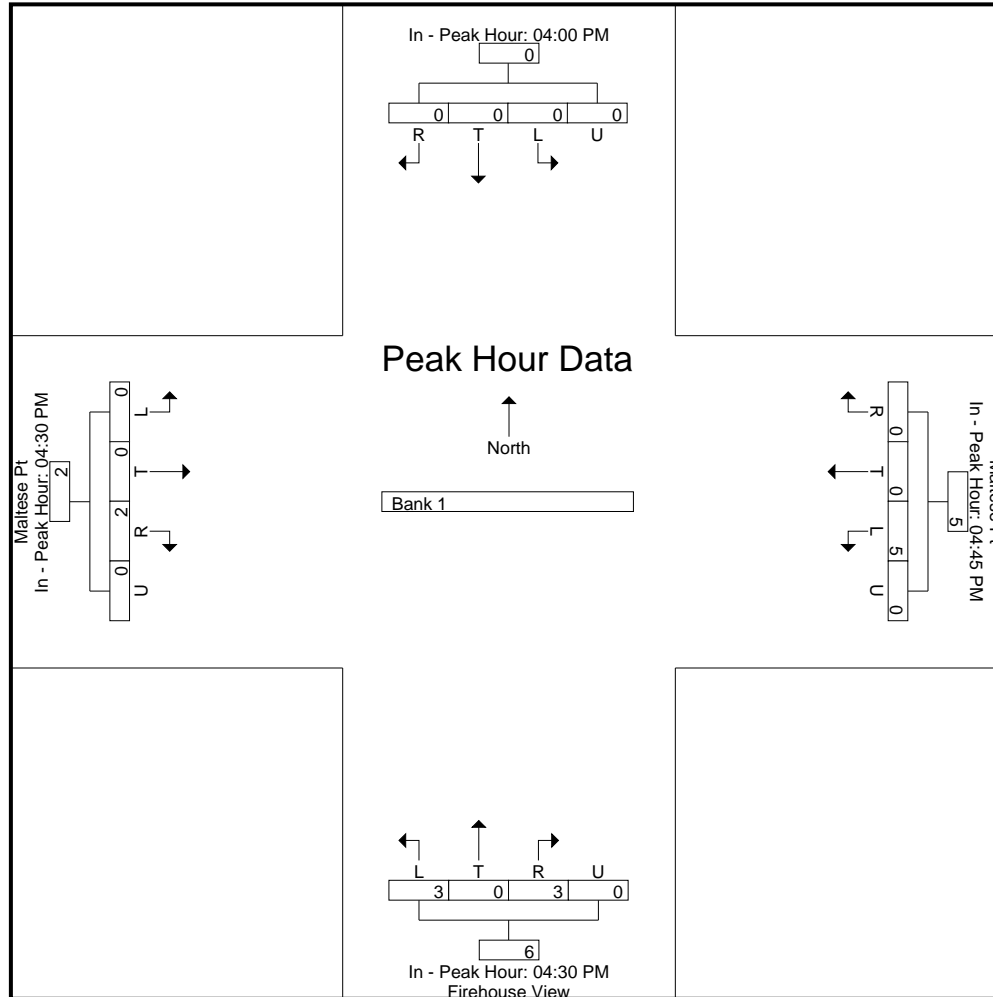

# LSC Transportation Consultants, Inc.

545 E Pikes Peak Ave, Suite 210  
 Colorado Springs, CO 80905  
 719-633-2868

File Name : Firehouse View - Rolling Thunder Wy AM  
 Site Code : 00204440  
 Start Date : 7/1/2020  
 Page No : 1

### Groups Printed- Unshifted

Start Time	Firehouse View Southbound					Rolling Thunder Wy Westbound					Northbound					Rolling Thunder Wy Eastbound					Int. Total
	L	T	R	U	App. Total	L	T	R	U	App. Total	L	T	R	U	App. Total	L	T	R	U	App. Total	
06:30 AM	0	0	0	0	0	0	19	0	0	19	0	0	0	0	0	1	4	0	0	5	24
06:45 AM	0	0	0	0	0	0	12	1	0	13	0	0	0	0	0	0	1	0	0	1	14
Total	0	0	0	0	0	0	31	1	0	32	0	0	0	0	0	1	5	0	0	6	38
07:00 AM	0	0	0	0	0	0	21	3	0	24	0	0	0	0	0	5	3	0	0	8	32
07:15 AM	1	0	1	0	2	0	18	0	0	18	0	0	0	0	0	4	8	0	0	12	32
07:30 AM	0	0	2	0	2	0	19	0	0	19	0	0	0	0	0	8	3	0	1	12	33
07:45 AM	0	0	1	0	1	0	12	1	0	13	0	0	0	0	0	5	6	0	0	11	25
Total	1	0	4	0	5	0	70	4	0	74	0	0	0	0	0	22	20	0	1	43	122
08:00 AM	1	0	0	0	1	0	5	0	0	5	0	0	0	0	0	0	1	0	0	1	7
08:15 AM	0	0	3	0	3	0	18	1	0	19	0	0	0	0	0	4	10	0	0	14	36
Grand Total	2	0	7	0	9	0	124	6	0	130	0	0	0	0	0	27	36	0	1	64	203
Apprch %	22.2	0	77.8	0		0	95.4	4.6	0		0	0	0	0		42.2	56.2	0	1.6		
Total %	1	0	3.4	0	4.4	0	61.1	3	0	64	0	0	0	0	0	13.3	17.7	0	0.5	31.5	

# LSC Transportation Consultants, Inc.

545 E Pikes Peak Ave, Suite 210  
 Colorado Springs, CO 80905  
 719-633-2868

File Name : Firehouse View - Rolling Thunder Wy AM  
 Site Code : 00204440  
 Start Date : 7/1/2020  
 Page No : 2

Start Time	Firehouse View Southbound					Rolling Thunder Wy Westbound					Northbound					Rolling Thunder Wy Eastbound					Int. Total
	L	T	R	U	App. Total	L	T	R	U	App. Total	L	T	R	U	App. Total	L	T	R	U	App. Total	
<b>Peak Hour Analysis From 6:30:00 AM to 8:15:00 AM - Peak 1 of 1</b>																					
Peak Hour for Entire Intersection Begins at 7:00:00 AM																					
7:00:00 AM	0	0	0	0	0	0	21	3	0	24	0	0	0	0	0	5	3	0	0	8	32
7:15:00 AM	1	0	1	0	2	0	18	0	0	18	0	0	0	0	0	4	8	0	0	12	32
7:30:00 AM	0	0	2	0	2	0	19	0	0	19	0	0	0	0	0	8	3	0	1	12	33
7:45:00 AM	0	0	1	0	1	0	12	1	0	13	0	0	0	0	0	5	6	0	0	11	25
Total Volume	1	0	4	0	5	0	70	4	0	74	0	0	0	0	0	22	20	0	1	43	122
% App. Total	20	0	80	0		0	94.6	5.4	0		0	0	0	0		51.2	46.5	0	2.3		
PHF	.250	.000	.500	.000	.625	.000	.833	.333	.000	.771	.000	.000	.000	.000	.000	.688	.625	.000	.250	.896	.924

# LSC Transportation Consultants, Inc.

545 E Pikes Peak Ave, Suite 210  
 Colorado Springs, CO 80905  
 719-633-2868

File Name : Firehouse View - Rolling Thunder Wy AM  
 Site Code : 00204440  
 Start Date : 7/1/2020  
 Page No : 3

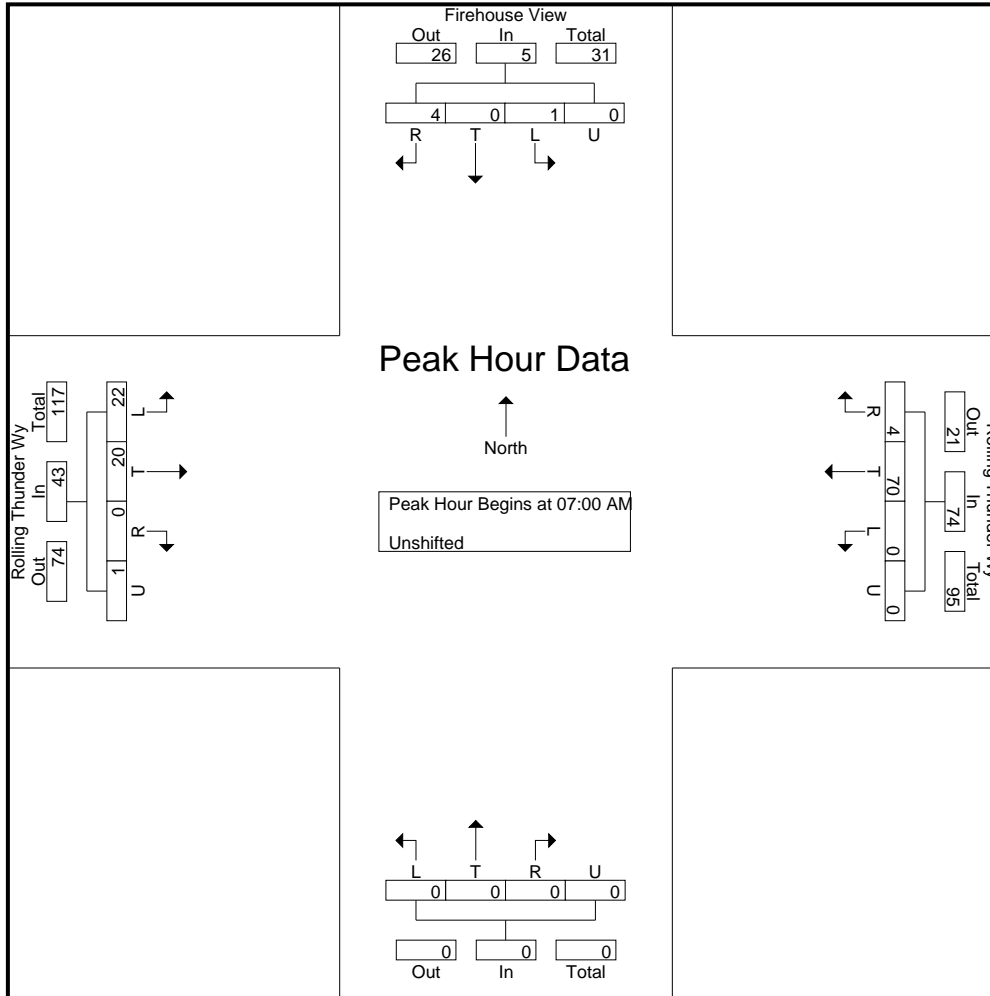

# LSC Transportation Consultants, Inc.

545 E Pikes Peak Ave, Suite 210  
 Colorado Springs, CO 80905  
 719-633-2868

File Name : Firehouse View - Rolling Thunder Wy AM  
 Site Code : 00204440  
 Start Date : 7/1/2020  
 Page No : 4

Start Time	Firehouse View Southbound					Rolling Thunder Wy Westbound					Northbound					Rolling Thunder Wy Eastbound					Int. Total
	L	T	R	U	App. Total	L	T	R	U	App. Total	L	T	R	U	App. Total	L	T	R	U	App. Total	
<b>Peak Hour Analysis From 6:30:00 AM to 8:15:00 AM - Peak 1 of 1</b>																					
Peak Hour for Each Approach Begins at:																					
	7:30:00 AM					6:30:00 AM					6:30:00 AM					7:00:00 AM					
+0 mins.	0	0	2	0	2	0	19	0	0	19	0	0	0	0	0	5	3	0	0	8	
+5 mins.	0	0	1	0	1	0	12	1	0	13	0	0	0	0	0	4	8	0	0	12	
+10 mins.	1	0	0	0	1	0	21	3	0	24	0	0	0	0	0	8	3	0	1	12	
+15 mins.	0	0	3	0	3	0	18	0	0	18	0	0	0	0	0	5	6	0	0	11	
Total Volume	1	0	6	0	7	0	70	4	0	74	0	0	0	0	0	22	20	0	1	43	
% App. Total	14.3	0	85.7	0		0	94.6	5.4	0		0	0	0	0		51.2	46.5	0	2.3		
PHF	.250	.000	.500	.000	.583	.000	.833	.333	.000	.771	.000	.000	.000	.000	.000	.688	.625	.000	.250	.896	

# LSC Transportation Consultants, Inc.

545 E Pikes Peak Ave, Suite 210  
 Colorado Springs, CO 80905  
 719-633-2868

File Name : Firehouse View - Rolling Thunder Wy AM  
 Site Code : 00204440  
 Start Date : 7/1/2020  
 Page No : 5

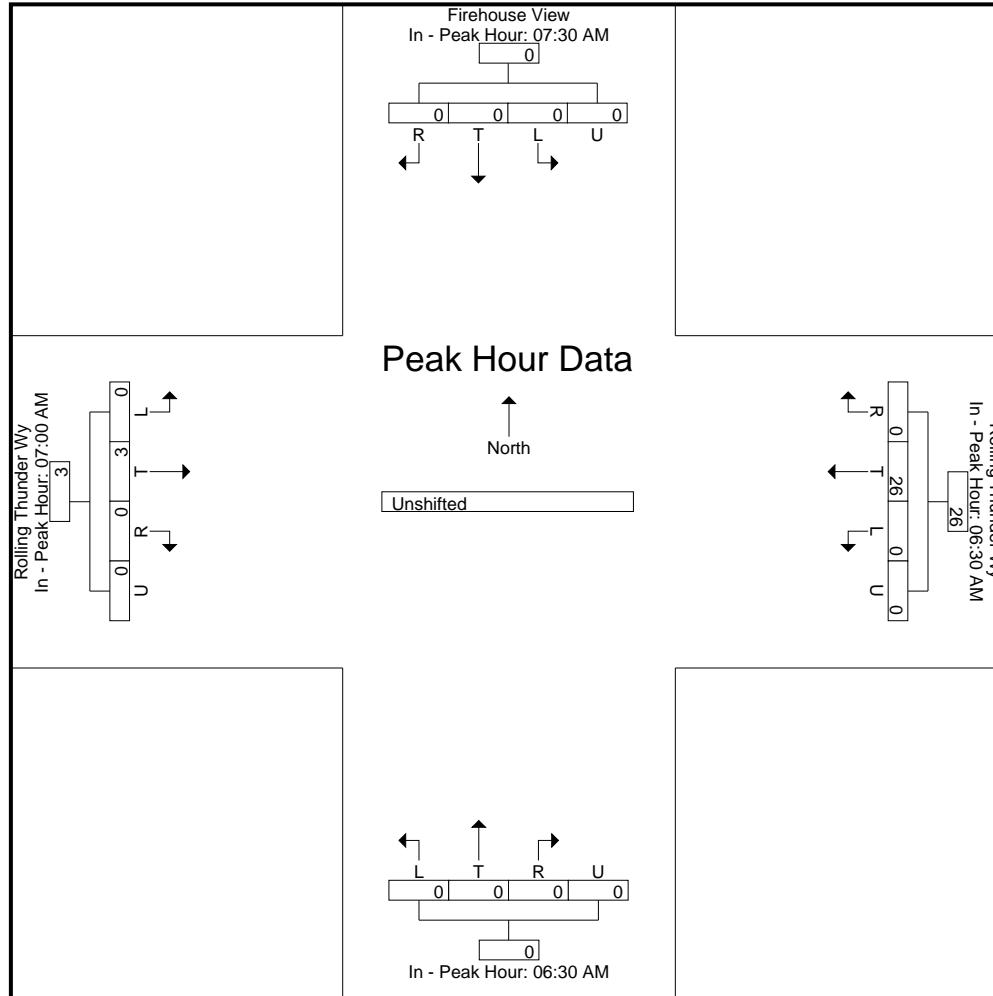



# LSC Transportation Consultants, Inc.

545 E Pikes Peak Ave, Suite 210  
 Colorado Springs, CO 80905  
 719-633-2868

File Name : Firehouse View - Rolling Thunder Wy PM  
 Site Code : 00204440  
 Start Date : 7/1/2020  
 Page No : 1

### Groups Printed- Unshifted

Start Time	Firehouse View Southbound					Rolling Thunder Wy Westbound					Northbound					Rolling Thunder Wy Eastbound					Int. Total
	L	T	R	U	App. Total	L	T	R	U	App. Total	L	T	R	U	App. Total	L	T	R	U	App. Total	
04:00 PM	4	0	10	0	14	0	19	4	0	23	0	0	0	0	0	3	12	1	0	16	53
04:15 PM	0	0	4	0	4	0	9	3	0	12	0	0	0	0	0	2	16	0	0	18	34
04:30 PM	1	0	4	0	5	0	13	1	0	14	0	0	0	0	0	3	15	0	0	18	37
04:45 PM	1	0	5	0	6	0	9	3	0	12	0	0	0	0	0	8	12	0	0	20	38
Total	6	0	23	0	29	0	50	11	0	61	0	0	0	0	0	16	55	1	0	72	162
05:00 PM	7	0	23	0	30	0	15	5	0	20	0	0	0	0	0	12	27	0	0	39	89
05:15 PM	4	0	6	0	10	0	14	0	0	14	0	0	0	0	0	6	17	0	0	23	47
05:30 PM	0	0	8	0	8	0	24	0	0	24	0	0	0	0	0	2	15	0	0	17	49
05:45 PM	2	0	1	0	3	0	14	0	0	14	0	0	0	0	0	3	19	0	0	22	39
Total	13	0	38	0	51	0	67	5	0	72	0	0	0	0	0	23	78	0	0	101	224
Grand Total	19	0	61	0	80	0	117	16	0	133	0	0	0	0	0	39	133	1	0	173	386
Apprch %	23.8	0	76.2	0		0	88	12	0		0	0	0	0		22.5	76.9	0.6	0		
Total %	4.9	0	15.8	0	20.7	0	30.3	4.1	0	34.5	0	0	0	0	0	10.1	34.5	0.3	0	44.8	

# LSC Transportation Consultants, Inc.

545 E Pikes Peak Ave, Suite 210  
 Colorado Springs, CO 80905  
 719-633-2868

File Name : Firehouse View - Rolling Thunder Wy PM  
 Site Code : 00204440  
 Start Date : 7/1/2020  
 Page No : 2

Start Time	Firehouse View Southbound					Rolling Thunder Wy Westbound					Northbound					Rolling Thunder Wy Eastbound					Int. Total
	L	T	R	U	App. Total	L	T	R	U	App. Total	L	T	R	U	App. Total	L	T	R	U	App. Total	
<b>Peak Hour Analysis From 4:00:00 PM to 5:45:00 PM - Peak 1 of 1</b>																					
Peak Hour for Entire Intersection Begins at 5:00:00 PM																					
5:00:00 PM	7	0	23	0	30	0	15	5	0	20	0	0	0	0	0	12	27	0	0	39	89
5:15:00 PM	4	0	6	0	10	0	14	0	0	14	0	0	0	0	0	6	17	0	0	23	47
5:30:00 PM	0	0	8	0	8	0	24	0	0	24	0	0	0	0	0	2	15	0	0	17	49
5:45:00 PM	2	0	1	0	3	0	14	0	0	14	0	0	0	0	0	3	19	0	0	22	39
Total Volume	13	0	38	0	51	0	67	5	0	72	0	0	0	0	0	23	78	0	0	101	224
% App. Total	25.5	0	74.5	0		0	93.1	6.9	0		0	0	0	0		22.8	77.2	0	0		
PHF	.464	.000	.413	.000	.425	.000	.698	.250	.000	.750	.000	.000	.000	.000	.000	.479	.722	.000	.000	.647	.629

# LSC Transportation Consultants, Inc.

545 E Pikes Peak Ave, Suite 210  
 Colorado Springs, CO 80905  
 719-633-2868

File Name : Firehouse View - Rolling Thunder Wy PM  
 Site Code : 00204440  
 Start Date : 7/1/2020  
 Page No : 3

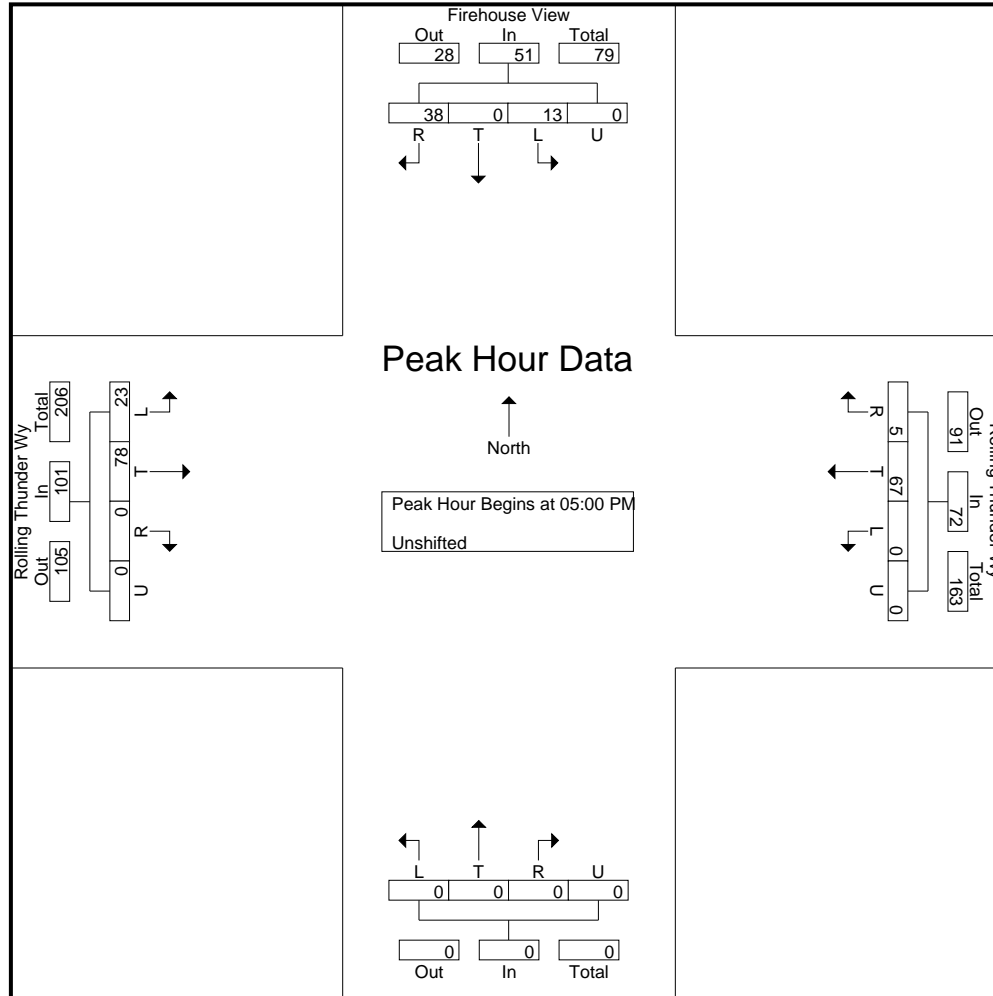

# LSC Transportation Consultants, Inc.

545 E Pikes Peak Ave, Suite 210  
 Colorado Springs, CO 80905  
 719-633-2868

File Name : Firehouse View - Rolling Thunder Wy PM  
 Site Code : 00204440  
 Start Date : 7/1/2020  
 Page No : 4

Start Time	Firehouse View Southbound					Rolling Thunder Wy Westbound					Northbound					Rolling Thunder Wy Eastbound					Int. Total
	L	T	R	U	App. Total	L	T	R	U	App. Total	L	T	R	U	App. Total	L	T	R	U	App. Total	
<b>Peak Hour Analysis From 4:00:00 PM to 5:45:00 PM - Peak 1 of 1</b>																					
Peak Hour for Each Approach Begins at:																					
	4:45:00 PM					5:00:00 PM					4:00:00 PM					5:00:00 PM					
+0 mins.	1	0	5	0	6	0	15	5	0	20	0	0	0	0	0	12	27	0	0	39	
+5 mins.	7	0	23	0	30	0	14	0	0	14	0	0	0	0	0	6	17	0	0	23	
+10 mins.	4	0	6	0	10	0	24	0	0	24	0	0	0	0	0	2	15	0	0	17	
+15 mins.	0	0	8	0	8	0	14	0	0	14	0	0	0	0	0	3	19	0	0	22	
Total Volume	12	0	42	0	54	0	67	5	0	72	0	0	0	0	0	23	78	0	0	101	
% App. Total	22.2	0	77.8	0		0	93.1	6.9	0		0	0	0	0		22.8	77.2	0	0		
PHF	.429	.000	.457	.000	.450	.000	.698	.250	.000	.750	.000	.000	.000	.000	.000	.479	.722	.000	.000	.647	

# LSC Transportation Consultants, Inc.

545 E Pikes Peak Ave, Suite 210  
 Colorado Springs, CO 80905  
 719-633-2868

File Name : Firehouse View - Rolling Thunder Wy PM  
 Site Code : 00204440  
 Start Date : 7/1/2020  
 Page No : 5

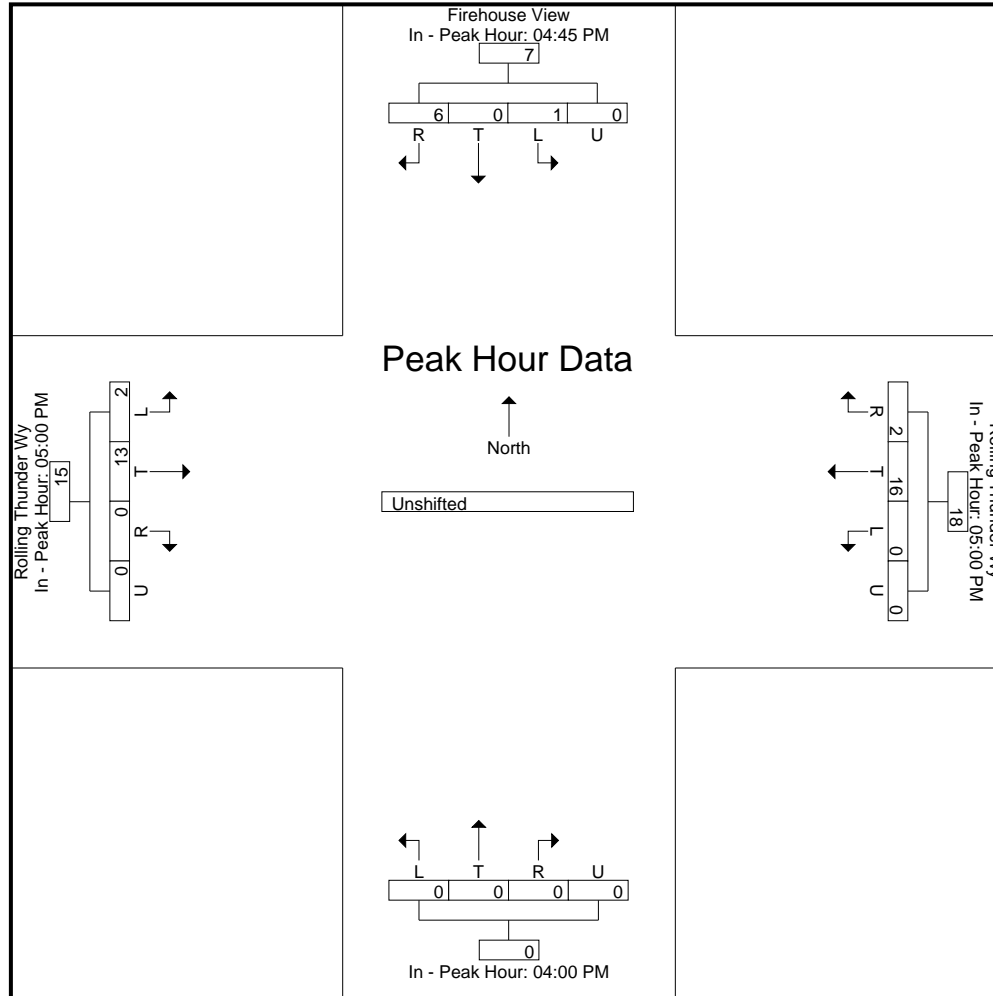

# LSC Transportation Consultants, Inc.

545 E Pikes Peak Ave, Suite 210

Colorado Springs, CO 80905

719-633-2868

File Name : Golden Sage Rd - Woodmen Rd AM 1-20

Site Code : 00194460

Start Date : 1/21/2020

Page No : 1

## Groups Printed- Unshifted

Start Time	Golden Sage Rd Southbound					Woodmen Rd Westbound					Golden Sage Rd Northbound					Woodmen Rd Eastbound					Int. Total
	Left	Through	Right	Peds	App. Total	Left	Through	Right	Peds	App. Total	Left	Through	Right	Peds	App. Total	Left	Through	Right	Peds	App. Total	
06:30 AM	5	1	25	0	31	0	195	48	1	244	20	2	0	0	22	10	107	0	0	117	414
06:45 AM	12	5	28	0	45	4	355	30	0	389	24	4	0	0	28	14	151	9	0	174	636
Total	17	6	53	0	76	4	550	78	1	633	44	6	0	0	50	24	258	9	0	291	1050
07:00 AM	17	7	29	0	53	2	340	25	0	367	42	2	1	0	45	13	158	13	0	184	649
07:15 AM	8	4	30	0	42	3	424	16	0	443	44	3	1	0	48	12	171	11	0	194	727
07:30 AM	16	4	25	1	46	6	356	12	0	374	29	4	1	0	34	8	181	11	0	200	654
07:45 AM	7	1	7	0	15	2	293	17	0	312	13	5	0	0	18	16	209	20	0	245	590
Total	48	16	91	1	156	13	1413	70	0	1496	128	14	3	0	145	49	719	55	0	823	2620
08:00 AM	9	1	14	0	24	3	239	12	1	255	18	0	0	0	18	16	165	13	1	195	492
08:15 AM	13	2	12	0	27	2	267	19	1	289	18	3	2	0	23	28	142	6	1	177	516
Grand Total	87	25	170	1	283	22	2469	179	3	2673	208	23	5	0	236	117	1284	83	2	1486	4678
Apprch %	30.7	8.8	60.1	0.4		0.8	92.4	6.7	0.1		88.1	9.7	2.1	0		7.9	86.4	5.6	0.1		
Total %	1.9	0.5	3.6	0	6	0.5	52.8	3.8	0.1	57.1	4.4	0.5	0.1	5		2.5	27.4	1.8	0	31.8	

# LSC Transportation Consultants, Inc.

545 E Pikes Peak Ave, Suite 210  
 Colorado Springs, CO 80905  
 719-633-2868

File Name : Golden Sage Rd - Woodmen Rd AM 1-20  
 Site Code : 00194460  
 Start Date : 1/21/2020  
 Page No : 2

Start Time	Golden Sage Rd Southbound					Woodmen Rd Westbound					Golden Sage Rd Northbound					Woodmen Rd Eastbound					Int. Total
	Left	Through	Right	Peds	App. Total	Left	Through	Right	Peds	App. Total	Left	Through	Right	Peds	App. Total	Left	Through	Right	Peds	App. Total	
<b>Peak Hour Analysis From 6:30:00 AM to 8:15:00 AM - Peak 1 of 1</b>																					
Peak Hour for Entire Intersection Begins at 6:45:00 AM																					
6:45:00 AM	12	5	28	0	45	4	355	30	0	389	24	4	0	0	28	14	151	9	0	174	636
7:00:00 AM	17	7	29	0	53	2	340	25	0	367	42	2	1	0	45	13	158	13	0	184	649
7:15:00 AM	8	4	30	0	42	3	424	16	0	443	44	3	1	0	48	12	171	11	0	194	727
7:30:00 AM	16	4	25	1	46	6	356	12	0	374	29	4	1	0	34	8	181	11	0	200	654
Total Volume	53	20	112	1	186	15	1475	83	0	1573	139	13	3	0	155	47	661	44	0	752	2666
% App. Total	28.5	10.8	60.2	0.5		1	93.8	5.3	0		89.7	8.4	1.9	0		6.2	87.9	5.9	0		
PHF	.779	.714	.933	.250	.877	.625	.870	.692	.000	.888	.790	.813	.750	.000	.807	.839	.913	.846	.000	.940	.917

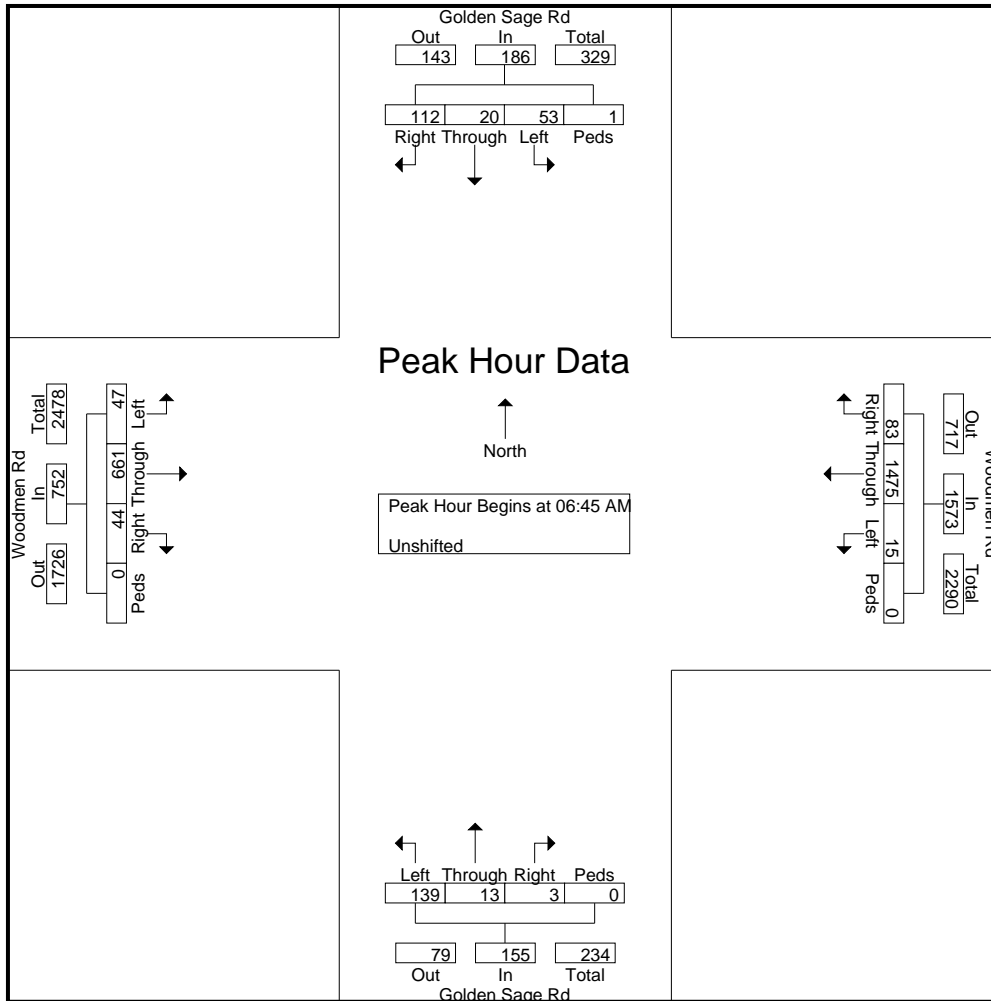

# LSC Transportation Consultants, Inc.

545 E Pikes Peak Ave, Suite 210  
 Colorado Springs, CO 80905  
 719-633-2868

File Name : Golden Sage Rd - Woodmen Rd AM 1-20  
 Site Code : 00194460  
 Start Date : 1/21/2020  
 Page No : 3

Start Time	Golden Sage Rd Southbound					Woodmen Rd Westbound					Golden Sage Rd Northbound					Woodmen Rd Eastbound					Int. Total
	Left	Through	Right	Peds	App. Total	Left	Through	Right	Peds	App. Total	Left	Through	Right	Peds	App. Total	Left	Through	Right	Peds	App. Total	
<b>Peak Hour Analysis From 6:30:00 AM to 8:15:00 AM - Peak 1 of 1</b>																					
Peak Hour for Each Approach Begins at:																					
	6:45:00 AM					6:45:00 AM					6:45:00 AM					7:15:00 AM					
+0 mins.	12	5	28	0	45	4	355	<b>30</b>	0	389	24	<b>4</b>	0	0	28	12	171	11	0	194	
+5 mins.	<b>17</b>	<b>7</b>	29	0	<b>53</b>	2	340	25	0	367	42	2	<b>1</b>	0	45	8	181	11	0	200	
+10 mins.	8	4	<b>30</b>	0	42	3	<b>424</b>	16	0	<b>443</b>	<b>44</b>	3	1	0	<b>48</b>	<b>16</b>	<b>209</b>	<b>20</b>	0	<b>245</b>	
+15 mins.	16	4	25	<b>1</b>	46	<b>6</b>	356	12	0	374	29	4	1	0	34	16	165	13	<b>1</b>	195	
Total Volume	53	20	112	1	186	15	1475	83	0	1573	139	13	3	0	155	52	726	55	1	834	
% App. Total	28.5	10.8	60.2	0.5		1	93.8	5.3	0		89.7	8.4	1.9	0		6.2	87.1	6.6	0.1		
PHF	.779	.714	.933	.250	.877	.625	.870	.692	.000	.888	.790	.813	.750	.000	.807	.813	.868	.688	.250	.851	

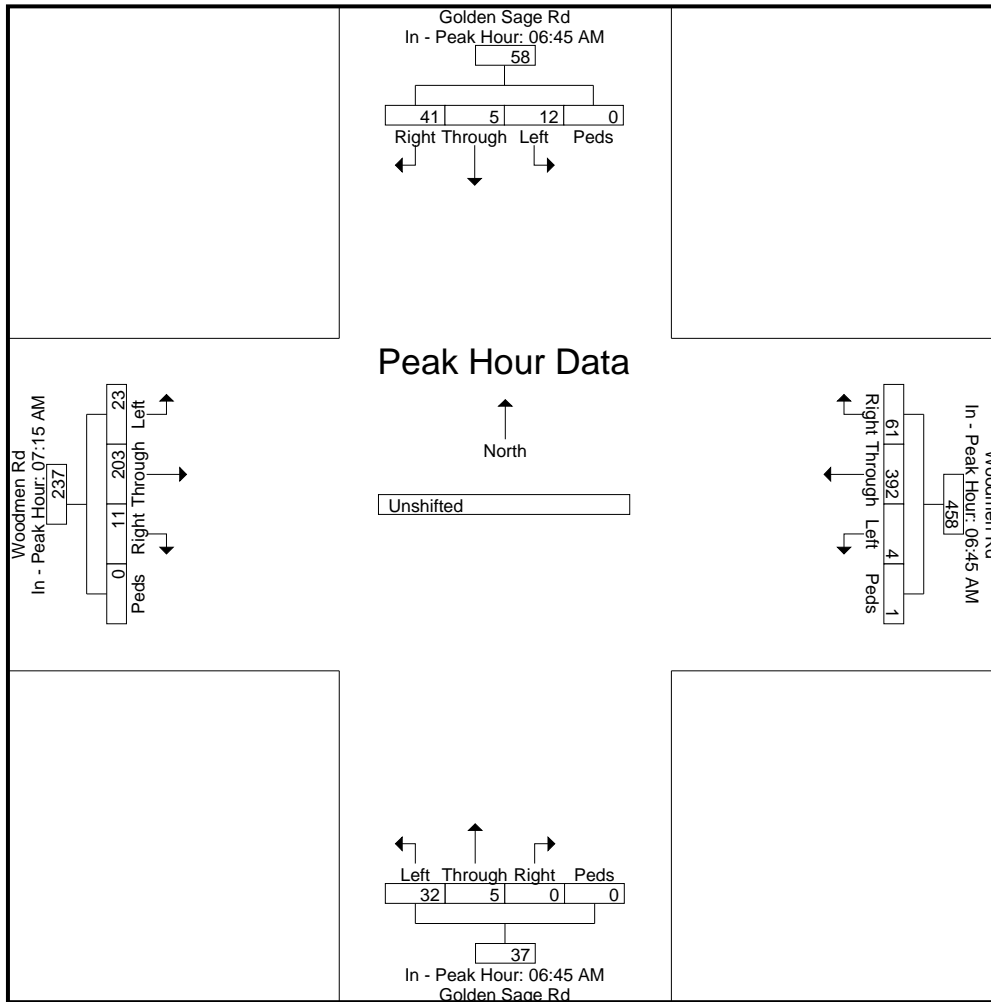



# LSC Transportation Consultants, Inc.

545 E Pikes Peak Ave, Suite 210

Colorado Springs, CO 80905

719-633-2868

File Name : Golden Sage Rd - Woodmen Rd PM 1-20

Site Code : 00194460

Start Date : 1/21/2020

Page No : 1

## Groups Printed- Unshifted

Start Time	Golden Sage Rd Southbound					Woodmen Rd Westbound					Golden Sage Rd Northbound					Woodmen Rd Eastbound					Int. Total
	Left	Through	Right	Peds	App. Total	Left	Through	Right	Peds	App. Total	Left	Through	Right	Peds	App. Total	Left	Through	Right	Peds	App. Total	
04:00 PM	17	2	26	0	45	7	205	16	0	228	23	9	5	0	37	21	272	23	2	318	628
04:15 PM	7	1	22	0	30	5	241	26	0	272	26	5	6	0	37	28	325	12	1	366	705
04:30 PM	21	4	24	0	49	1	241	20	1	263	26	8	4	0	38	24	313	3	1	341	691
04:45 PM	29	3	19	2	53	1	202	24	0	227	16	4	0	0	20	18	341	10	1	370	670
Total	74	10	91	2	177	14	889	86	1	990	91	26	15	0	132	91	1251	48	5	1395	2694
05:00 PM	18	1	27	0	46	2	254	11	2	269	27	7	1	0	35	19	328	11	0	358	708
05:15 PM	7	2	6	0	15	8	192	9	1	210	32	10	12	0	54	23	340	17	0	380	659
05:30 PM	42	7	42	1	92	7	227	23	0	257	30	7	10	0	47	28	336	6	0	370	766
05:45 PM	21	1	18	0	40	1	180	12	1	194	19	5	5	0	29	18	326	9	0	353	616
Total	88	11	93	1	193	18	853	55	4	930	108	29	28	0	165	88	1330	43	0	1461	2749
Grand Total	162	21	184	3	370	32	1742	141	5	1920	199	55	43	0	297	179	2581	91	5	2856	5443
Apprch %	43.8	5.7	49.7	0.8		1.7	90.7	7.3	0.3		67	18.5	14.5	0		6.3	90.4	3.2	0.2		
Total %	3	0.4	3.4	0.1	6.8	0.6	32	2.6	0.1	35.3	3.7	1	0.8	0	5.5	3.3	47.4	1.7	0.1	52.5	

# LSC Transportation Consultants, Inc.

545 E Pikes Peak Ave, Suite 210  
 Colorado Springs, CO 80905  
 719-633-2868

File Name : Golden Sage Rd - Woodmen Rd PM 1-20  
 Site Code : 00194460  
 Start Date : 1/21/2020  
 Page No : 2

Start Time	Golden Sage Rd Southbound					Woodmen Rd Westbound					Golden Sage Rd Northbound					Woodmen Rd Eastbound					Int. Total
	Left	Through	Right	Peds	App. Total	Left	Through	Right	Peds	App. Total	Left	Through	Right	Peds	App. Total	Left	Through	Right	Peds	App. Total	
<b>Peak Hour Analysis From 4:00:00 PM to 5:45:00 PM - Peak 1 of 1</b>																					
Peak Hour for Entire Intersection Begins at 4:45:00 PM																					
4:45:00 PM	29	3	19	2	53	1	202	24	0	227	16	4	0	0	20	18	341	10	1	370	670
5:00:00 PM	18	1	27	0	46	2	254	11	2	269	27	7	1	0	35	19	328	11	0	358	708
5:15:00 PM	7	2	6	0	15	8	192	9	1	210	32	10	12	0	54	23	340	17	0	380	659
5:30:00 PM	42	7	42	1	92	7	227	23	0	257	30	7	10	0	47	28	336	6	0	370	766
Total Volume	96	13	94	3	206	18	875	67	3	963	105	28	23	0	156	88	1345	44	1	1478	2803
% App. Total	46.6	6.3	45.6	1.5		1.9	90.9	7	0.3		67.3	17.9	14.7	0		6	91	3	0.1		
PHF	.571	.464	.560	.375	.560	.563	.861	.698	.375	.895	.820	.700	.479	.000	.722	.786	.986	.647	.250	.972	.915

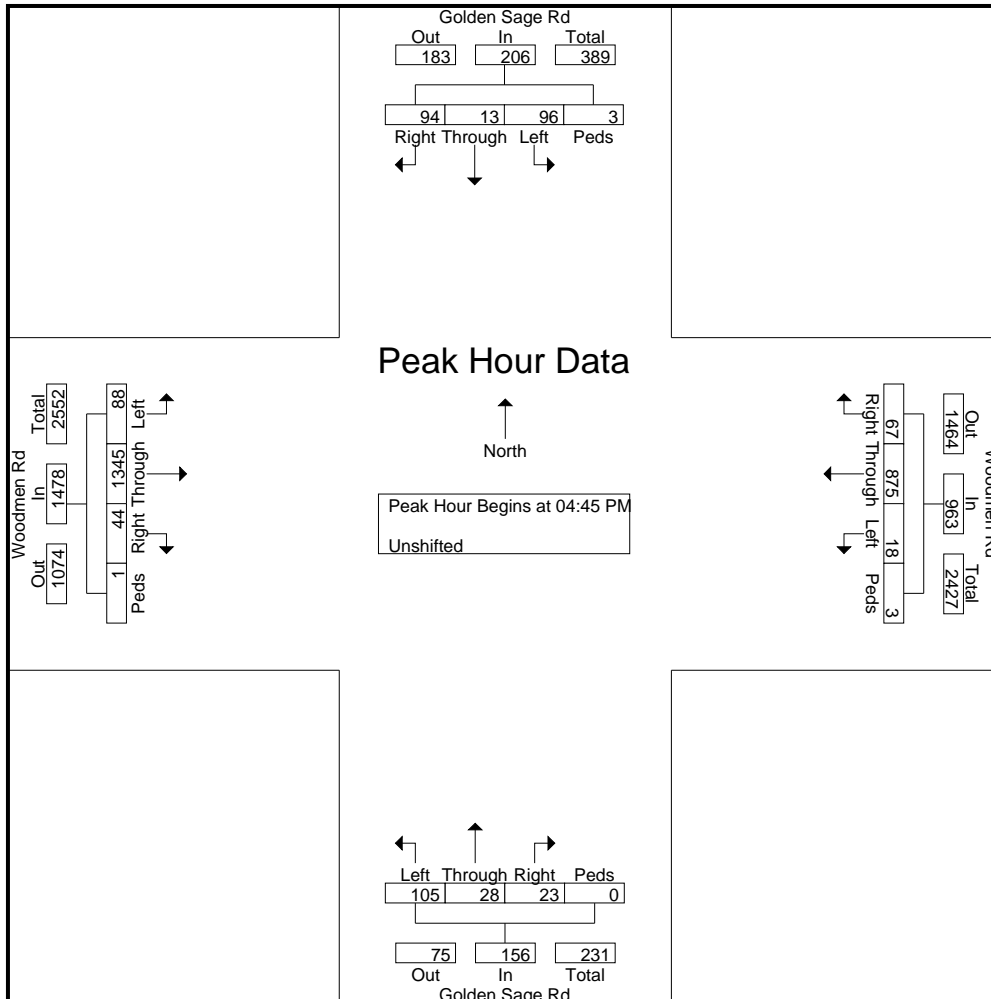

# LSC Transportation Consultants, Inc.

545 E Pikes Peak Ave, Suite 210  
 Colorado Springs, CO 80905  
 719-633-2868

File Name : Golden Sage Rd - Woodmen Rd PM 1-20  
 Site Code : 00194460  
 Start Date : 1/21/2020  
 Page No : 3

Start Time	Golden Sage Rd Southbound					Woodmen Rd Westbound					Golden Sage Rd Northbound					Woodmen Rd Eastbound					Int. Total
	Left	Through	Right	Peds	App. Total	Left	Through	Right	Peds	App. Total	Left	Through	Right	Peds	App. Total	Left	Through	Right	Peds	App. Total	
<b>Peak Hour Analysis From 4:00:00 PM to 5:45:00 PM - Peak 1 of 1</b>																					
Peak Hour for Each Approach Begins at:																					
	4:45:00 PM					4:15:00 PM					5:00:00 PM					4:45:00 PM					
+0 mins.	29	3	19	2	53	5	241	26	0	272	27	7	1	0	35	18	341	10	1	370	
+5 mins.	18	1	27	0	46	1	241	20	1	263	32	10	12	0	54	19	328	11	0	358	
+10 mins.	7	2	6	0	15	1	202	24	0	227	30	7	10	0	47	23	340	17	0	380	
+15 mins.	42	7	42	1	92	2	254	11	2	269	19	5	5	0	29	28	336	6	0	370	
Total Volume	96	13	94	3	206	9	938	81	3	1031	108	29	28	0	165	88	1345	44	1	1478	
% App. Total	46.6	6.3	45.6	1.5		0.9	91	7.9	0.3		65.5	17.6	17	0		6	91	3	0.1		
PHF	.571	.464	.560	.375	.560	.450	.923	.779	.375	.948	.844	.725	.583	.000	.764	.786	.986	.647	.250	.972	

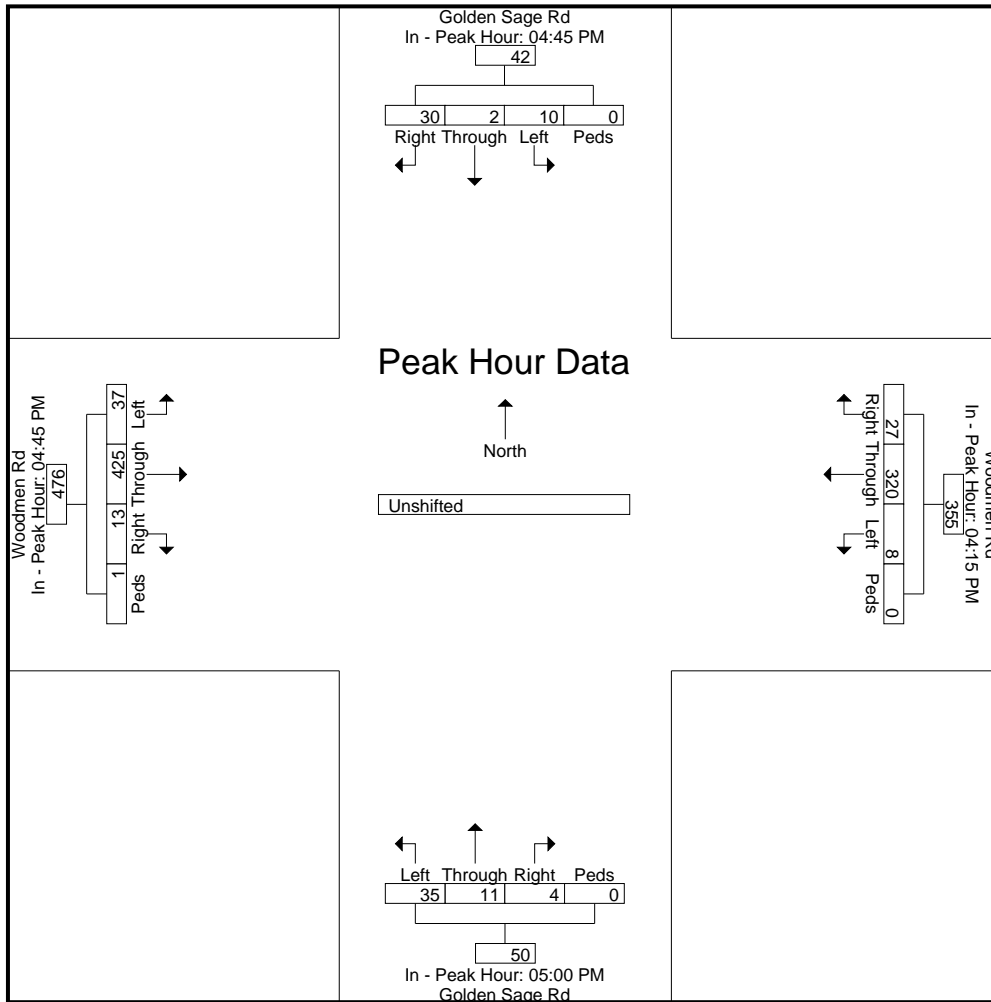

# Levels of Service

---



HCM 6th TWSC  
1: Firehouse View & Maltese Point

Existing  
AM Peak Hour

Intersection						
Int Delay, s/veh	7.3					
Movement	EBT	EBR	WBL	WBT	NBL	NBR
Lane Configurations	↔			↔	↔	
Traffic Vol, veh/h	1	0	5	1	2	24
Future Vol, veh/h	1	0	5	1	2	24
Conflicting Peds, #/hr	0	0	0	0	0	0
Sign Control	Free	Free	Free	Free	Stop	Stop
RT Channelized	-	None	-	None	-	None
Storage Length	-	-	-	-	0	-
Veh in Median Storage, #	0	-	-	0	0	-
Grade, %	0	-	-	0	0	-
Peak Hour Factor	25	25	75	75	81	81
Heavy Vehicles, %	2	2	2	2	2	2
Mvmt Flow	4	0	7	1	2	30

Major/Minor	Major1	Major2	Minor1		
Conflicting Flow All	0	0	4	0	19
Stage 1	-	-	-	-	4
Stage 2	-	-	-	-	15
Critical Hdwy	-	-	4.12	-	6.42
Critical Hdwy Stg 1	-	-	-	-	5.42
Critical Hdwy Stg 2	-	-	-	-	5.42
Follow-up Hdwy	-	-	2.218	-	3.518
Pot Cap-1 Maneuver	-	-	1618	-	998
Stage 1	-	-	-	-	1019
Stage 2	-	-	-	-	1008
Platoon blocked, %	-	-	-	-	-
Mov Cap-1 Maneuver	-	-	1618	-	994
Mov Cap-2 Maneuver	-	-	-	-	994
Stage 1	-	-	-	-	1019
Stage 2	-	-	-	-	1004

Approach	EB	WB	NB
HCM Control Delay, s	0	6	8.5
HCM LOS			A

Minor Lane/Major Mvmt	NBLn1	EBT	EBR	WBL	WBT
Capacity (veh/h)	1073	-	-	1618	-
HCM Lane V/C Ratio	0.03	-	-	0.004	-
HCM Control Delay (s)	8.5	-	-	7.2	0
HCM Lane LOS	A	-	-	A	A
HCM 95th %tile Q(veh)	0.1	-	-	0	-

HCM 6th TWSC  
2: Rolling Thunder & Firehouse View

Existing  
AM Peak Hour

Intersection						
Int Delay, s/veh	1.7					
Movement	EBL	EBT	WBT	WBR	SBL	SBR
Lane Configurations	↘	↑	↔		↘	
Traffic Vol, veh/h	22	20	70	4	1	4
Future Vol, veh/h	22	20	70	4	1	4
Conflicting Peds, #/hr	0	0	0	0	0	0
Sign Control	Free	Free	Free	Free	Stop	Stop
RT Channelized	-	None	-	None	-	None
Storage Length	0	-	-	-	0	-
Veh in Median Storage, #	-	0	0	-	0	-
Grade, %	-	0	0	-	0	-
Peak Hour Factor	90	90	77	77	62	62
Heavy Vehicles, %	2	2	2	2	2	2
Mvmt Flow	24	22	91	5	2	6

Major/Minor	Major1	Major2	Minor2		
Conflicting Flow All	96	0	-	0	164 94
Stage 1	-	-	-	-	94 -
Stage 2	-	-	-	-	70 -
Critical Hdwy	4.12	-	-	-	6.42 6.22
Critical Hdwy Stg 1	-	-	-	-	5.42 -
Critical Hdwy Stg 2	-	-	-	-	5.42 -
Follow-up Hdwy	2.218	-	-	-	3.518 3.318
Pot Cap-1 Maneuver	1498	-	-	-	827 963
Stage 1	-	-	-	-	930 -
Stage 2	-	-	-	-	953 -
Platoon blocked, %		-	-	-	
Mov Cap-1 Maneuver	1498	-	-	-	814 963
Mov Cap-2 Maneuver	-	-	-	-	814 -
Stage 1	-	-	-	-	915 -
Stage 2	-	-	-	-	953 -

Approach	EB	WB	SB
HCM Control Delay, s	3.9	0	8.9
HCM LOS			A

Minor Lane/Major Mvmt	EBL	EBT	WBT	WBR	SBLn1
Capacity (veh/h)	1498	-	-	-	929
HCM Lane V/C Ratio	0.016	-	-	-	0.009
HCM Control Delay (s)	7.4	-	-	-	8.9
HCM Lane LOS	A	-	-	-	A
HCM 95th %tile Q(veh)	0.1	-	-	-	0

HCM 6th TWSC  
1: Firehouse View & Maltese Point

Existing  
PM Peak Hour

Intersection						
Int Delay, s/veh	4.6					
Movement	EBT	EBR	WBL	WBT	NBL	NBR
Lane Configurations	↔			↔	↔	
Traffic Vol, veh/h	0	38	17	0	34	2
Future Vol, veh/h	0	38	17	0	34	2
Conflicting Peds, #/hr	0	0	0	0	0	0
Sign Control	Free	Free	Free	Free	Stop	Stop
RT Channelized	-	None	-	None	-	None
Storage Length	-	-	-	-	0	-
Veh in Median Storage, #	0	-	-	0	0	-
Grade, %	0	-	-	0	0	-
Peak Hour Factor	38	38	47	47	50	50
Heavy Vehicles, %	2	2	2	2	2	2
Mvmt Flow	0	100	36	0	68	4

Major/Minor	Major1	Major2	Minor1		
Conflicting Flow All	0	0	100	0	122 50
Stage 1	-	-	-	-	50 -
Stage 2	-	-	-	-	72 -
Critical Hdwy	-	-	4.12	-	6.42 6.22
Critical Hdwy Stg 1	-	-	-	-	5.42 -
Critical Hdwy Stg 2	-	-	-	-	5.42 -
Follow-up Hdwy	-	-	2.218	-	3.518 3.318
Pot Cap-1 Maneuver	-	-	1493	-	873 1018
Stage 1	-	-	-	-	972 -
Stage 2	-	-	-	-	951 -
Platoon blocked, %	-	-	-	-	-
Mov Cap-1 Maneuver	-	-	1493	-	852 1018
Mov Cap-2 Maneuver	-	-	-	-	852 -
Stage 1	-	-	-	-	972 -
Stage 2	-	-	-	-	928 -

Approach	EB	WB	NB
HCM Control Delay, s	0	7.5	9.6
HCM LOS			A

Minor Lane/Major Mvmt	NBLn1	EBT	EBR	WBL	WBT
Capacity (veh/h)	860	-	-	1493	-
HCM Lane V/C Ratio	0.084	-	-	0.024	-
HCM Control Delay (s)	9.6	-	-	7.5	0
HCM Lane LOS	A	-	-	A	A
HCM 95th %tile Q(veh)	0.3	-	-	0.1	-

HCM 6th TWSC  
2: Rolling Thunder & Firehouse View

Existing  
PM Peak Hour

Intersection						
Int Delay, s/veh	3.9					
Movement	EBL	EBT	WBT	WBR	SBL	SBR
Lane Configurations	↘	↑	↗		↘	
Traffic Vol, veh/h	23	78	67	5	13	38
Future Vol, veh/h	23	78	67	5	13	38
Conflicting Peds, #/hr	0	0	0	0	0	0
Sign Control	Free	Free	Free	Free	Stop	Stop
RT Channelized	-	None	-	None	-	None
Storage Length	0	-	-	-	0	-
Veh in Median Storage, #	-	0	0	-	0	-
Grade, %	-	0	0	-	0	-
Peak Hour Factor	65	65	75	75	42	42
Heavy Vehicles, %	2	2	2	2	2	2
Mvmt Flow	35	120	89	7	31	90

Major/Minor	Major1	Major2	Minor2		
Conflicting Flow All	96	0	-	0	283 93
Stage 1	-	-	-	-	93 -
Stage 2	-	-	-	-	190 -
Critical Hdwy	4.12	-	-	-	6.42 6.22
Critical Hdwy Stg 1	-	-	-	-	5.42 -
Critical Hdwy Stg 2	-	-	-	-	5.42 -
Follow-up Hdwy	2.218	-	-	-	3.518 3.318
Pot Cap-1 Maneuver	1498	-	-	-	707 964
Stage 1	-	-	-	-	931 -
Stage 2	-	-	-	-	842 -
Platoon blocked, %		-	-	-	
Mov Cap-1 Maneuver	1498	-	-	-	691 964
Mov Cap-2 Maneuver	-	-	-	-	691 -
Stage 1	-	-	-	-	910 -
Stage 2	-	-	-	-	842 -

Approach	EB	WB	SB
HCM Control Delay, s	1.7	0	9.8
HCM LOS			A

Minor Lane/Major Mvmt	EBL	EBT	WBT	WBR	SBLn1
Capacity (veh/h)	1498	-	-	-	876
HCM Lane V/C Ratio	0.024	-	-	-	0.139
HCM Control Delay (s)	7.5	-	-	-	9.8
HCM Lane LOS	A	-	-	-	A
HCM 95th %tile Q(veh)	0.1	-	-	-	0.5



Timings  
25: Golden Sage & Woodmen

Existing Traffic  
AM Peak Hour

Lane Group	EBL	EBT	EBR	WBL	WBT	WBR	NBL	NBT	NBR	SBL	SBT
Lane Configurations											
Traffic Volume (vph)	47	661	44	15	1475	83	134	13	3	53	20
Future Volume (vph)	47	661	44	15	1475	83	134	13	3	53	20
Turn Type	Perm	NA	Perm	Perm	NA	Perm	Perm	NA	Perm	Perm	NA
Protected Phases		2			6			8			4
Permitted Phases	2		2	6		6	8		8	4	
Detector Phase	2	2	2	6	6	6	8	8	8	4	4
Switch Phase											
Minimum Initial (s)	4.0	4.0	4.0	4.0	4.0	4.0	4.0	4.0	4.0	4.0	4.0
Minimum Split (s)	11.0	11.0	11.0	11.0	11.0	11.0	21.5	21.5	21.5	21.5	21.5
Total Split (s)	63.0	63.0	63.0	63.0	63.0	63.0	27.0	27.0	27.0	27.0	27.0
Total Split (%)	70.0%	70.0%	70.0%	70.0%	70.0%	70.0%	30.0%	30.0%	30.0%	30.0%	30.0%
Yellow Time (s)	5.0	5.0	5.0	5.0	5.0	5.0	3.5	3.5	3.5	3.5	3.5
All-Red Time (s)	2.0	2.0	2.0	2.0	2.0	2.0	2.0	2.0	2.0	2.0	2.0
Lost Time Adjust (s)	0.0	0.0	0.0	0.0	0.0	0.0	0.0	0.0	0.0	0.0	0.0
Total Lost Time (s)	7.0	7.0	7.0	7.0	7.0	7.0	5.5	5.5	5.5	5.5	5.5
Lead/Lag											
Lead-Lag Optimize?											
Recall Mode	Max	Max	Max	Max	Max	Max	None	None	None	None	None
Act Effct Green (s)	56.2	56.2	56.2	56.2	56.2	56.2	16.4	16.4	16.4	16.4	16.4
Actuated g/C Ratio	0.66	0.66	0.66	0.66	0.66	0.66	0.19	0.19	0.19	0.19	0.19
v/c Ratio	0.44	0.31	0.05	0.04	0.71	0.09	0.76	0.04	0.01	0.24	0.47
Control Delay	23.6	7.1	2.2	6.6	12.2	1.8	54.1	27.1	0.0	30.7	28.9
Queue Delay	0.0	0.0	0.0	0.0	0.0	0.0	0.0	0.0	0.0	0.0	0.0
Total Delay	23.6	7.1	2.2	6.6	12.2	1.8	54.1	27.1	0.0	30.7	28.9
LOS	C	A	A	A	B	A	D	C	A	C	C
Approach Delay		7.9			11.6			50.6			29.4
Approach LOS		A			B			D			C

Intersection Summary

Cycle Length: 90  
 Actuated Cycle Length: 85.1  
 Natural Cycle: 60  
 Control Type: Semi Act-Uncoord  
 Maximum v/c Ratio: 0.76  
 Intersection Signal Delay: 14.3  
 Intersection Capacity Utilization 71.2%  
 Analysis Period (min) 15  
 Intersection LOS: B  
 ICU Level of Service C

Splits and Phases: 25: Golden Sage & Woodmen



Timings  
25: Golden Sage & Woodmen

Existing Traffic  
PM Peak Hour

Lane Group	EBL	EBT	EBR	WBL	WBT	WBR	NBL	NBT	NBR	SBL	SBT
Lane Configurations											
Traffic Volume (vph)	88	1345	44	18	875	67	105	28	23	96	13
Future Volume (vph)	88	1345	44	18	875	67	105	28	23	96	13
Turn Type	Perm	NA	Perm	Perm	NA	Perm	Perm	NA	Perm	Perm	NA
Protected Phases		2			6			8			4
Permitted Phases	2		2	6		6	8		8	4	
Detector Phase	2	2	2	6	6	6	8	8	8	4	4
Switch Phase											
Minimum Initial (s)	4.0	4.0	4.0	4.0	4.0	4.0	4.0	4.0	4.0	4.0	4.0
Minimum Split (s)	11.0	11.0	11.0	11.0	11.0	11.0	21.5	21.5	21.5	21.5	21.5
Total Split (s)	65.0	65.0	65.0	65.0	65.0	65.0	25.0	25.0	25.0	25.0	25.0
Total Split (%)	72.2%	72.2%	72.2%	72.2%	72.2%	72.2%	27.8%	27.8%	27.8%	27.8%	27.8%
Yellow Time (s)	5.0	5.0	5.0	5.0	5.0	5.0	3.5	3.5	3.5	3.5	3.5
All-Red Time (s)	2.0	2.0	2.0	2.0	2.0	2.0	2.0	2.0	2.0	2.0	2.0
Lost Time Adjust (s)	0.0	-3.0	-3.0	-1.0	-3.0	-3.0	-1.0	0.0	0.0	0.0	0.0
Total Lost Time (s)	7.0	4.0	4.0	6.0	4.0	4.0	4.5	5.5	5.5	5.5	5.5
Lead/Lag											
Lead-Lag Optimize?											
Recall Mode	Max	Max	Max	Max	Max	Max	None	None	None	None	None
Act Effct Green (s)	58.1	61.1	61.1	59.1	61.1	61.1	16.2	15.2	15.2	15.2	15.2
Actuated g/C Ratio	0.68	0.71	0.71	0.69	0.71	0.71	0.19	0.18	0.18	0.18	0.18
v/c Ratio	0.25	0.58	0.04	0.11	0.37	0.06	0.69	0.10	0.09	0.71	0.45
Control Delay	8.5	7.7	1.6	7.3	5.8	1.4	52.4	29.6	4.7	49.6	10.6
Queue Delay	0.0	0.0	0.0	0.0	0.0	0.0	0.0	0.0	0.0	0.0	0.0
Total Delay	8.5	7.7	1.6	7.3	5.8	1.4	52.4	29.6	4.7	49.6	10.6
LOS	A	A	A	A	A	A	D	C	A	D	B
Approach Delay		7.6			5.5			41.2			29.0
Approach LOS		A			A			D			C

Intersection Summary

Cycle Length: 90  
 Actuated Cycle Length: 85.8  
 Natural Cycle: 55  
 Control Type: Semi Act-Uncoord  
 Maximum v/c Ratio: 0.71  
 Intersection Signal Delay: 11.3  
 Intersection Capacity Utilization 65.9%  
 Analysis Period (min) 15  
 Intersection LOS: B  
 ICU Level of Service C

Splits and Phases: 25: Golden Sage & Woodmen



Intersection						
Int Delay, s/veh	6					
Movement	EBT	EBR	WBL	WBT	NBL	NBR
Lane Configurations						
Traffic Vol, veh/h	1	11	24	1	16	53
Future Vol, veh/h	1	11	24	1	16	53
Conflicting Peds, #/hr	0	0	0	0	0	0
Sign Control	Free	Free	Free	Free	Stop	Stop
RT Channelized	-	None	-	None	-	None
Storage Length	-	-	-	-	0	-
Veh in Median Storage, #	0	-	-	0	0	-
Grade, %	0	-	-	0	0	-
Peak Hour Factor	25	25	75	75	81	81
Heavy Vehicles, %	2	2	2	2	2	2
Mvmt Flow	4	44	32	1	20	65

Major/Minor	Major1	Major2	Minor1	Minor2	Minor3
Conflicting Flow All	0	0	48	0	91
Stage 1	-	-	-	-	26
Stage 2	-	-	-	-	65
Critical Hdwy	-	-	4.12	-	6.42
Critical Hdwy Stg 1	-	-	-	-	5.42
Critical Hdwy Stg 2	-	-	-	-	5.42
Follow-up Hdwy	-	-	2.218	-	3.518
Pot Cap-1 Maneuver	-	-	1559	-	909
Stage 1	-	-	-	-	997
Stage 2	-	-	-	-	958
Platoon blocked, %	-	-	-	-	-
Mov Cap-1 Maneuver	-	-	1559	-	890
Mov Cap-2 Maneuver	-	-	-	-	890
Stage 1	-	-	-	-	997
Stage 2	-	-	-	-	938

Approach	EB	WB	NB
HCM Control Delay, s	0	7.1	8.9
HCM LOS			A

Minor Lane/Major Mvmt	NBLn1	EBT	EBR	WBL	WBT
Capacity (veh/h)	1008	-	-	1559	-
HCM Lane V/C Ratio	0.085	-	-	0.021	-
HCM Control Delay (s)	8.9	-	-	7.4	0
HCM Lane LOS	A	-	-	A	A
HCM 95th %tile Q(veh)	0.3	-	-	0.1	-

Intersection						
Int Delay, s/veh	2.3					
Movement	EBL	EBT	WBT	WBR	SBL	SBR
Lane Configurations						
Traffic Vol, veh/h	55	118	174	14	9	32
Future Vol, veh/h	55	118	174	14	9	32
Conflicting Peds, #/hr	0	0	0	0	0	0
Sign Control	Free	Free	Free	Free	Stop	Stop
RT Channelized	-	None	-	None	-	None
Storage Length	0	-	-	-	0	-
Veh in Median Storage, #	-	0	0	-	0	-
Grade, %	-	0	0	-	0	-
Peak Hour Factor	90	90	77	77	62	62
Heavy Vehicles, %	2	2	2	2	2	2
Mvmt Flow	61	131	226	18	15	52

Major/Minor	Major1	Major2	Minor2		
Conflicting Flow All	244	0	-	0	488 235
Stage 1	-	-	-	-	235 -
Stage 2	-	-	-	-	253 -
Critical Hdwy	4.12	-	-	-	6.42 6.22
Critical Hdwy Stg 1	-	-	-	-	5.42 -
Critical Hdwy Stg 2	-	-	-	-	5.42 -
Follow-up Hdwy	2.218	-	-	-	3.518 3.318
Pot Cap-1 Maneuver	1322	-	-	-	539 804
Stage 1	-	-	-	-	804 -
Stage 2	-	-	-	-	789 -
Platoon blocked, %		-	-	-	
Mov Cap-1 Maneuver	1322	-	-	-	514 804
Mov Cap-2 Maneuver	-	-	-	-	514 -
Stage 1	-	-	-	-	767 -
Stage 2	-	-	-	-	789 -

Approach	EB	WB	SB
HCM Control Delay, s	2.5	0	10.5
HCM LOS			B

Minor Lane/Major Mvmt	EBL	EBT	WBT	WBR	SBLn1
Capacity (veh/h)	1322	-	-	-	715
HCM Lane V/C Ratio	0.046	-	-	-	0.092
HCM Control Delay (s)	7.9	-	-	-	10.5
HCM Lane LOS	A	-	-	-	B
HCM 95th %tile Q(veh)	0.1	-	-	-	0.3

Lanes, Volumes, Timings  
25: Golden Sage Rd & Woodmen Rd

Long Term Background  
AM Peak Hour

Lane Group	EBL	EBT	EBR	WBL	WBT	WBR	NBL	NBT	NBR	SBL	SBT	SBR
Lane Configurations												
Traffic Volume (vph)	319	734	74	66	1776	110	162	20	48	98	25	392
Future Volume (vph)	319	734	74	66	1776	110	162	20	48	98	25	392
Satd. Flow (prot)	3433	3539	1583	1770	3539	1583	1770	1863	1583	1770	1863	1583
Flt Permitted	0.950			0.367			0.429			0.744		
Satd. Flow (perm)	3433	3539	1583	684	3539	1583	799	1863	1583	1386	1863	1583
Satd. Flow (RTOR)			109			155			173			281
Peak Hour Factor	0.95	0.98	0.95	0.95	0.98	0.95	0.95	0.95	0.95	0.95	0.95	0.95
Shared Lane Traffic (%)												
Lane Group Flow (vph)	336	749	78	69	1812	116	171	21	51	103	26	413
Turn Type	Prot	NA	Perm	pm+pt	NA	Perm	pm+pt	NA	Perm	pm+pt	NA	Free
Protected Phases	5	2		1	6		3	8		7	4	
Permitted Phases			2	6		6	8		8	4		Free
Detector Phase	5	2	2	1	6	6	3	8	8	7	4	
Switch Phase												
Minimum Initial (s)	5.0	5.0	5.0	5.0	5.0	5.0	5.0	5.0	5.0	5.0	5.0	5.0
Minimum Split (s)	10.0	12.0	12.0	10.0	12.0	12.0	10.0	10.0	10.0	10.0	10.0	10.0
Total Split (s)	21.0	71.0	71.0	10.0	60.0	60.0	24.0	15.0	15.0	24.0	15.0	
Total Split (%)	17.5%	59.2%	59.2%	8.3%	50.0%	50.0%	20.0%	12.5%	12.5%	20.0%	12.5%	
Yellow Time (s)	3.0	5.0	5.0	3.0	5.0	5.0	3.0	3.0	3.0	3.0	3.0	3.0
All-Red Time (s)	2.0	2.0	2.0	2.0	2.0	2.0	2.0	2.0	2.0	2.0	2.0	2.0
Lost Time Adjust (s)	-1.0	-1.0	-1.0	-1.0	-1.0	-1.0	-1.0	-1.0	-1.0	-1.0	-1.0	-1.0
Total Lost Time (s)	4.0	6.0	6.0	4.0	6.0	6.0	4.0	4.0	4.0	4.0	4.0	4.0
Lead/Lag	Lead	Lag	Lag	Lead	Lag	Lag	Lead	Lag	Lag	Lead	Lag	
Lead-Lag Optimize?	Yes	Yes	Yes	Yes	Yes	Yes	Yes	Yes	Yes	Yes	Yes	Yes
Recall Mode	None	Min	Min	None	Min	Min	None	None	None	None	None	None
Act Effct Green (s)	15.4	66.3	66.3	62.6	54.5	54.5	24.2	10.4	10.4	17.4	8.1	108.4
Actuated g/C Ratio	0.14	0.61	0.61	0.58	0.50	0.50	0.22	0.10	0.10	0.16	0.07	1.00
v/c Ratio	0.69	0.35	0.08	0.15	1.02	0.13	0.52	0.12	0.17	0.39	0.19	0.26
Control Delay	53.3	12.7	1.2	8.5	54.7	1.5	41.3	47.9	1.1	39.8	53.3	0.4
Queue Delay	0.0	0.0	0.0	0.0	0.0	0.0	0.0	0.0	0.0	0.0	0.0	0.0
Total Delay	53.3	12.7	1.2	8.5	54.7	1.5	41.3	47.9	1.1	39.8	53.3	0.4
LOS	D	B	A	A	D	A	D	D	A	D	D	A
Approach Delay		23.7			50.1			33.4			10.4	
Approach LOS		C			D			C			B	

Intersection Summary

Cycle Length: 120  
 Actuated Cycle Length: 108.4  
 Natural Cycle: 80  
 Control Type: Semi Act-Uncoord  
 Maximum v/c Ratio: 1.02  
 Intersection Signal Delay: 35.8  
 Intersection LOS: D  
 Intersection Capacity Utilization 85.5%  
 ICU Level of Service E  
 Analysis Period (min) 15

Splits and Phases: 25: Golden Sage Rd & Woodmen Rd



Intersection						
Int Delay, s/veh	6.9					
Movement	EBT	EBR	WBL	WBT	NBL	NBR
Lane Configurations						
Traffic Vol, veh/h	0	62	54	0	63	39
Future Vol, veh/h	0	62	54	0	63	39
Conflicting Peds, #/hr	0	0	0	0	0	0
Sign Control	Free	Free	Free	Free	Stop	Stop
RT Channelized	-	None	-	None	-	None
Storage Length	-	-	-	-	0	-
Veh in Median Storage, #	0	-	-	0	0	-
Grade, %	0	-	-	0	0	-
Peak Hour Factor	38	38	47	47	50	50
Heavy Vehicles, %	2	2	2	2	2	2
Mvmt Flow	0	163	115	0	126	78

Major/Minor	Major1	Major2	Minor1			
Conflicting Flow All	0	0	163	0	312	82
Stage 1	-	-	-	-	82	-
Stage 2	-	-	-	-	230	-
Critical Hdwy	-	-	4.12	-	6.42	6.22
Critical Hdwy Stg 1	-	-	-	-	5.42	-
Critical Hdwy Stg 2	-	-	-	-	5.42	-
Follow-up Hdwy	-	-	2.218	-	3.518	3.318
Pot Cap-1 Maneuver	-	-	1416	-	681	978
Stage 1	-	-	-	-	941	-
Stage 2	-	-	-	-	808	-
Platoon blocked, %	-	-	-	-	-	-
Mov Cap-1 Maneuver	-	-	1416	-	626	978
Mov Cap-2 Maneuver	-	-	-	-	626	-
Stage 1	-	-	-	-	941	-
Stage 2	-	-	-	-	743	-

Approach	EB	WB	NB
HCM Control Delay, s	0	7.8	11.9
HCM LOS			B

Minor Lane/Major Mvmt	NBLn1	EBT	EBR	WBL	WBT
Capacity (veh/h)	726	-	-	1416	-
HCM Lane V/C Ratio	0.281	-	-	0.081	-
HCM Control Delay (s)	11.9	-	-	7.8	0
HCM Lane LOS	B	-	-	A	A
HCM 95th %tile Q(veh)	1.2	-	-	0.3	-

Intersection						
Int Delay, s/veh	5.7					
Movement	EBL	EBT	WBT	WBR	SBL	SBR
Lane Configurations						
Traffic Vol, veh/h	75	150	203	19	26	86
Future Vol, veh/h	75	150	203	19	26	86
Conflicting Peds, #/hr	0	0	0	0	0	0
Sign Control	Free	Free	Free	Free	Stop	Stop
RT Channelized	-	None	-	None	-	None
Storage Length	0	-	-	-	0	-
Veh in Median Storage, #	-	0	0	-	0	-
Grade, %	-	0	0	-	0	-
Peak Hour Factor	65	65	75	75	42	42
Heavy Vehicles, %	2	2	2	2	2	2
Mvmt Flow	115	231	271	25	62	205

Major/Minor	Major1	Major2	Minor2		
Conflicting Flow All	296	0	-	0	745 284
Stage 1	-	-	-	-	284 -
Stage 2	-	-	-	-	461 -
Critical Hdwy	4.12	-	-	-	6.42 6.22
Critical Hdwy Stg 1	-	-	-	-	5.42 -
Critical Hdwy Stg 2	-	-	-	-	5.42 -
Follow-up Hdwy	2.218	-	-	-	3.518 3.318
Pot Cap-1 Maneuver	1265	-	-	-	382 755
Stage 1	-	-	-	-	764 -
Stage 2	-	-	-	-	635 -
Platoon blocked, %		-	-	-	
Mov Cap-1 Maneuver	1265	-	-	-	347 755
Mov Cap-2 Maneuver	-	-	-	-	347 -
Stage 1	-	-	-	-	694 -
Stage 2	-	-	-	-	635 -

Approach	EB	WB	SB
HCM Control Delay, s	2.7	0	15.9
HCM LOS			C

Minor Lane/Major Mvmt	EBL	EBT	WBT	WBR	SBLn1
Capacity (veh/h)	1265	-	-	-	593
HCM Lane V/C Ratio	0.091	-	-	-	0.45
HCM Control Delay (s)	8.1	-	-	-	15.9
HCM Lane LOS	A	-	-	-	C
HCM 95th %tile Q(veh)	0.3	-	-	-	2.3

Lanes, Volumes, Timings  
25: Golden Sage Rd & Woodmen Rd

Long Term Background  
PM Peak Hour

Lane Group	EBL	EBT	EBR	WBL	WBT	WBR	NBL	NBT	NBR	SBL	SBT	SBR
Lane Configurations												
Traffic Volume (vph)	447	1629	73	80	1083	121	174	39	67	136	20	391
Future Volume (vph)	447	1629	73	80	1083	121	174	39	67	136	20	391
Satd. Flow (prot)	3433	3539	1583	1770	3539	1583	1770	1863	1583	1770	1863	1583
Flt Permitted	0.950			0.095			0.513					
Satd. Flow (perm)	3433	3539	1583	177	3539	1583	956	1863	1583	1863	1863	1583
Satd. Flow (RTOR)			109			155			173			365
Peak Hour Factor	0.95	0.98	0.95	0.95	0.98	0.95	0.95	0.95	0.95	0.95	0.95	0.95
Shared Lane Traffic (%)												
Lane Group Flow (vph)	471	1662	77	84	1105	127	183	41	71	143	21	412
Turn Type	Prot	NA	Perm	pm+pt	NA	Perm	pm+pt	NA	Perm	pm+pt	NA	Free
Protected Phases	5	2		1	6		3	8		7	4	
Permitted Phases			2	6		6	8		8	4		Free
Detector Phase	5	2	2	1	6	6	3	8	8	7	4	
Switch Phase												
Minimum Initial (s)	5.0	5.0	5.0	5.0	5.0	5.0	5.0	5.0	5.0	5.0	5.0	5.0
Minimum Split (s)	10.0	12.0	12.0	10.0	12.0	12.0	10.0	10.0	10.0	10.0	10.0	10.0
Total Split (s)	23.0	64.0	64.0	10.0	51.0	51.0	31.0	15.0	15.0	31.0	15.0	
Total Split (%)	19.2%	53.3%	53.3%	8.3%	42.5%	42.5%	25.8%	12.5%	12.5%	25.8%	12.5%	
Yellow Time (s)	3.0	5.0	5.0	3.0	5.0	5.0	3.0	3.0	3.0	3.0	3.0	3.0
All-Red Time (s)	2.0	2.0	2.0	2.0	2.0	2.0	2.0	2.0	2.0	2.0	2.0	2.0
Lost Time Adjust (s)	-1.0	-1.0	-1.0	-1.0	-1.0	-1.0	-1.0	-1.0	-1.0	-1.0	-1.0	-1.0
Total Lost Time (s)	4.0	6.0	6.0	4.0	6.0	6.0	4.0	4.0	4.0	4.0	4.0	4.0
Lead/Lag	Lead	Lag	Lag	Lead	Lag	Lag	Lead	Lag	Lag	Lead	Lag	Lag
Lead-Lag Optimize?	Yes	Yes	Yes	Yes	Yes	Yes	Yes	Yes	Yes	Yes	Yes	Yes
Recall Mode	None	Min	Min	None	Min	Min	None	None	None	None	None	None
Act Effct Green (s)	18.3	55.7	55.7	48.9	40.5	40.5	24.1	9.4	9.4	17.5	8.0	98.0
Actuated g/C Ratio	0.19	0.57	0.57	0.50	0.41	0.41	0.25	0.10	0.10	0.18	0.08	1.00
v/c Ratio	0.73	0.83	0.08	0.44	0.76	0.17	0.46	0.23	0.23	0.45	0.14	0.26
Control Delay	47.9	24.2	1.3	20.2	29.4	2.6	35.4	48.6	1.7	39.5	49.2	0.4
Queue Delay	0.0	0.0	0.0	0.0	0.0	0.0	0.0	0.0	0.0	0.0	0.0	0.0
Total Delay	47.9	24.2	1.3	20.2	29.4	2.6	35.4	48.6	1.7	39.5	49.2	0.4
LOS	D	C	A	C	C	A	D	D	A	D	D	A
Approach Delay		28.5			26.2			29.1			11.9	
Approach LOS		C			C			C			B	

Intersection Summary

Cycle Length: 120  
 Actuated Cycle Length: 98  
 Natural Cycle: 70  
 Control Type: Semi Act-Uncoord  
 Maximum v/c Ratio: 0.83  
 Intersection Signal Delay: 25.7  
 Intersection Capacity Utilization 77.4%  
 Analysis Period (min) 15  
 Intersection LOS: C  
 ICU Level of Service D

Splits and Phases: 25: Golden Sage Rd & Woodmen Rd

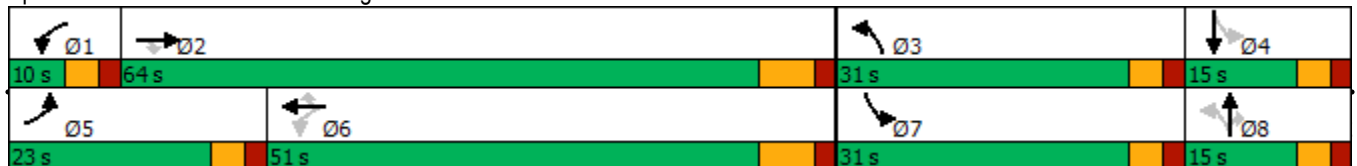



HCM 6th TWSC  
1: Firehouse View & Maltese Point

Short Term Total  
AM Peak Hour

Intersection						
Int Delay, s/veh	7					
Movement	EBT	EBR	WBL	WBT	NBL	NBR
Lane Configurations	↔			↔	↔	
Traffic Vol, veh/h	1	1	5	1	9	24
Future Vol, veh/h	1	1	5	1	9	24
Conflicting Peds, #/hr	0	0	0	0	0	0
Sign Control	Free	Free	Free	Free	Stop	Stop
RT Channelized	-	None	-	None	-	None
Storage Length	-	-	-	-	0	-
Veh in Median Storage, #	0	-	-	0	0	-
Grade, %	0	-	-	0	0	-
Peak Hour Factor	25	25	75	75	81	81
Heavy Vehicles, %	2	2	2	2	2	2
Mvmt Flow	4	4	7	1	11	30

Major/Minor	Major1	Major2	Minor1	Minor2	Minor3
Conflicting Flow All	0	0	8	0	21
Stage 1	-	-	-	-	6
Stage 2	-	-	-	-	15
Critical Hdwy	-	-	4.12	-	6.42
Critical Hdwy Stg 1	-	-	-	-	5.42
Critical Hdwy Stg 2	-	-	-	-	5.42
Follow-up Hdwy	-	-	2.218	-	3.518
Pot Cap-1 Maneuver	-	-	1612	-	996
Stage 1	-	-	-	-	1017
Stage 2	-	-	-	-	1008
Platoon blocked, %	-	-	-	-	-
Mov Cap-1 Maneuver	-	-	1612	-	992
Mov Cap-2 Maneuver	-	-	-	-	992
Stage 1	-	-	-	-	1017
Stage 2	-	-	-	-	1004

Approach	EB	WB	NB
HCM Control Delay, s	0	6	8.6
HCM LOS			A

Minor Lane/Major Mvmt	NBLn1	EBT	EBR	WBL	WBT
Capacity (veh/h)	1052	-	-	1612	-
HCM Lane V/C Ratio	0.039	-	-	0.004	-
HCM Control Delay (s)	8.6	-	-	7.2	0
HCM Lane LOS	A	-	-	A	A
HCM 95th %tile Q(veh)	0.1	-	-	0	-

HCM 6th TWSC  
2: Rolling Thunder & Firehouse View

Short Term Total  
AM Peak Hour

Intersection						
Int Delay, s/veh	1.5					
Movement	EBL	EBT	WBT	WBR	SBL	SBR
Lane Configurations						
Traffic Vol, veh/h	44	55	153	10	2	7
Future Vol, veh/h	44	55	153	10	2	7
Conflicting Peds, #/hr	0	0	0	0	0	0
Sign Control	Free	Free	Free	Free	Stop	Stop
RT Channelized	-	None	-	None	-	None
Storage Length	0	-	-	-	0	-
Veh in Median Storage, #	-	0	0	-	0	-
Grade, %	-	0	0	-	0	-
Peak Hour Factor	90	90	77	77	62	62
Heavy Vehicles, %	2	2	2	2	2	2
Mvmt Flow	49	61	199	13	3	11

Major/Minor	Major1	Major2	Minor2		
Conflicting Flow All	212	0	-	0	365 206
Stage 1	-	-	-	-	206 -
Stage 2	-	-	-	-	159 -
Critical Hdwy	4.12	-	-	-	6.42 6.22
Critical Hdwy Stg 1	-	-	-	-	5.42 -
Critical Hdwy Stg 2	-	-	-	-	5.42 -
Follow-up Hdwy	2.218	-	-	-	3.518 3.318
Pot Cap-1 Maneuver	1358	-	-	-	635 835
Stage 1	-	-	-	-	829 -
Stage 2	-	-	-	-	870 -
Platoon blocked, %		-	-	-	
Mov Cap-1 Maneuver	1358	-	-	-	612 835
Mov Cap-2 Maneuver	-	-	-	-	612 -
Stage 1	-	-	-	-	799 -
Stage 2	-	-	-	-	870 -

Approach	EB	WB	SB
HCM Control Delay, s	3.4	0	9.8
HCM LOS			A

Minor Lane/Major Mvmt	EBL	EBT	WBT	WBR	SBLn1
Capacity (veh/h)	1358	-	-	-	772
HCM Lane V/C Ratio	0.036	-	-	-	0.019
HCM Control Delay (s)	7.8	-	-	-	9.8
HCM Lane LOS	A	-	-	-	A
HCM 95th %tile Q(veh)	0.1	-	-	-	0.1

Lanes, Volumes, Timings  
25: Golden Sage & Woodmen

Short Term Total  
AM Peak Hour

Lane Group	EBL	EBT	EBR	WBL	WBT	WBR	NBL	NBT	NBR	SBL	SBT	SBR
Lane Configurations												
Traffic Volume (vph)	47	661	54	26	1475	83	140	13	5	53	21	112
Future Volume (vph)	47	661	54	26	1475	83	140	13	5	53	21	112
Satd. Flow (prot)	1770	3539	1583	1770	3539	1583	1770	1863	1583	1770	1626	0
Flt Permitted	0.093			0.373			0.613			0.747		
Satd. Flow (perm)	173	3539	1583	695	3539	1583	1142	1863	1583	1391	1626	0
Satd. Flow (RTOR)			59			93			48		28	
Peak Hour Factor	0.92	0.92	0.92	0.89	0.89	0.89	0.81	0.81	0.81	0.83	0.83	0.83
Shared Lane Traffic (%)												
Lane Group Flow (vph)	51	718	59	29	1657	93	173	16	6	64	160	0
Turn Type	Perm	NA	Perm	Perm	NA	Perm	Perm	NA	Perm	Perm	NA	
Protected Phases		2			6			8				4
Permitted Phases	2		2	6		6	8		8	4		
Detector Phase	2	2	2	6	6	6	8	8	8	4	4	
Switch Phase												
Minimum Initial (s)	4.0	4.0	4.0	4.0	4.0	4.0	4.0	4.0	4.0	4.0	4.0	4.0
Minimum Split (s)	11.0	11.0	11.0	11.0	11.0	11.0	21.5	21.5	21.5	21.5	21.5	21.5
Total Split (s)	62.0	62.0	62.0	62.0	62.0	62.0	28.0	28.0	28.0	28.0	28.0	28.0
Total Split (%)	68.9%	68.9%	68.9%	68.9%	68.9%	68.9%	31.1%	31.1%	31.1%	31.1%	31.1%	31.1%
Yellow Time (s)	5.0	5.0	5.0	5.0	5.0	5.0	3.5	3.5	3.5	3.5	3.5	3.5
All-Red Time (s)	2.0	2.0	2.0	2.0	2.0	2.0	2.0	2.0	2.0	2.0	2.0	2.0
Lost Time Adjust (s)	0.0	0.0	0.0	0.0	0.0	0.0	0.0	0.0	0.0	0.0	0.0	0.0
Total Lost Time (s)	7.0	7.0	7.0	7.0	7.0	7.0	5.5	5.5	5.5	5.5	5.5	5.5
Lead/Lag												
Lead-Lag Optimize?												
Recall Mode	Max	Max	Max	Max	Max	Max	None	None	None	None	None	None
Act Effct Green (s)	55.2	55.2	55.2	55.2	55.2	55.2	16.9	16.9	16.9	16.9	16.9	16.9
Actuated g/C Ratio	0.65	0.65	0.65	0.65	0.65	0.65	0.20	0.20	0.20	0.20	0.20	0.20
v/c Ratio	0.46	0.31	0.06	0.06	0.72	0.09	0.76	0.04	0.02	0.23	0.46	0.46
Control Delay	25.9	7.4	2.1	7.1	12.8	1.9	53.1	26.4	0.0	29.8	28.5	28.5
Queue Delay	0.0	0.0	0.0	0.0	0.0	0.0	0.0	0.0	0.0	0.0	0.0	0.0
Total Delay	25.9	7.4	2.1	7.1	12.8	1.9	53.1	26.4	0.0	29.8	28.5	28.5
LOS	C	A	A	A	B	A	D	C	A	C	C	C
Approach Delay		8.2			12.1			49.3			28.8	
Approach LOS		A			B			D			C	

Intersection Summary

Cycle Length: 90  
 Actuated Cycle Length: 84.6  
 Natural Cycle: 60  
 Control Type: Semi Act-Uncoord  
 Maximum v/c Ratio: 0.76  
 Intersection Signal Delay: 14.7  
 Intersection Capacity Utilization 71.5%  
 Analysis Period (min) 15

Intersection LOS: B  
 ICU Level of Service C

Splits and Phases: 25: Golden Sage & Woodmen

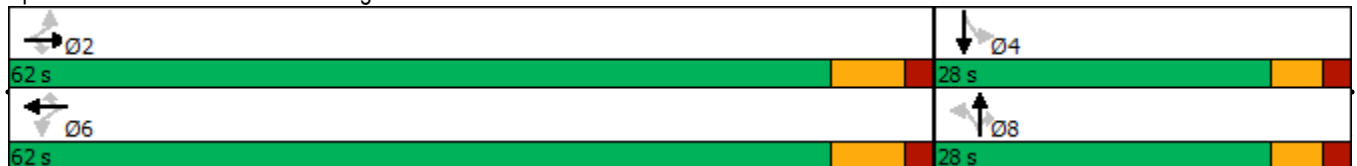

HCM 6th TWSC  
1: Firehouse View & Maltese Point

Short Term Total  
PM Peak Hour

Intersection						
Int Delay, s/veh	4.4					
Movement	EBT	EBR	WBL	WBT	NBL	NBR
Lane Configurations	↔			↔	↔	
Traffic Vol, veh/h	0	44	17	0	36	2
Future Vol, veh/h	0	44	17	0	36	2
Conflicting Peds, #/hr	0	0	0	0	0	0
Sign Control	Free	Free	Free	Free	Stop	Stop
RT Channelized	-	None	-	None	-	None
Storage Length	-	-	-	-	0	-
Veh in Median Storage, #	0	-	-	0	0	-
Grade, %	0	-	-	0	0	-
Peak Hour Factor	38	38	47	47	50	50
Heavy Vehicles, %	2	2	2	2	2	2
Mvmt Flow	0	116	36	0	72	4

Major/Minor	Major1	Major2	Minor1	Minor2	Minor3
Conflicting Flow All	0	0	116	0	130
Stage 1	-	-	-	-	58
Stage 2	-	-	-	-	72
Critical Hdwy	-	-	4.12	-	6.42
Critical Hdwy Stg 1	-	-	-	-	5.42
Critical Hdwy Stg 2	-	-	-	-	5.42
Follow-up Hdwy	-	-	2.218	-	3.518
Pot Cap-1 Maneuver	-	-	1473	-	864
Stage 1	-	-	-	-	965
Stage 2	-	-	-	-	951
Platoon blocked, %	-	-	-	-	-
Mov Cap-1 Maneuver	-	-	1473	-	843
Mov Cap-2 Maneuver	-	-	-	-	843
Stage 1	-	-	-	-	965
Stage 2	-	-	-	-	928

Approach	EB	WB	NB
HCM Control Delay, s	0	7.5	9.7
HCM LOS			A

Minor Lane/Major Mvmt	NBLn1	EBT	EBR	WBL	WBT
Capacity (veh/h)	850	-	-	1473	-
HCM Lane V/C Ratio	0.089	-	-	0.025	-
HCM Control Delay (s)	9.7	-	-	7.5	0
HCM Lane LOS	A	-	-	A	A
HCM 95th %tile Q(veh)	0.3	-	-	0.1	-

Intersection						
Int Delay, s/veh	4.5					
Movement	EBL	EBT	WBT	WBR	SBL	SBR
Lane Configurations	↘	↑	↗		↘	
Traffic Vol, veh/h	28	78	118	6	18	58
Future Vol, veh/h	28	78	118	6	18	58
Conflicting Peds, #/hr	0	0	0	0	0	0
Sign Control	Free	Free	Free	Free	Stop	Stop
RT Channelized	-	None	-	None	-	None
Storage Length	0	-	-	-	0	-
Veh in Median Storage, #	-	0	0	-	0	-
Grade, %	-	0	0	-	0	-
Peak Hour Factor	65	65	75	75	42	42
Heavy Vehicles, %	2	2	2	2	2	2
Mvmt Flow	43	120	157	8	43	138

Major/Minor	Major1	Major2	Minor2		
Conflicting Flow All	165	0	-	0	367
Stage 1	-	-	-	-	161
Stage 2	-	-	-	-	206
Critical Hdwy	4.12	-	-	-	6.42
Critical Hdwy Stg 1	-	-	-	-	5.42
Critical Hdwy Stg 2	-	-	-	-	5.42
Follow-up Hdwy	2.218	-	-	-	3.518
Pot Cap-1 Maneuver	1413	-	-	-	633
Stage 1	-	-	-	-	868
Stage 2	-	-	-	-	829
Platoon blocked, %		-	-	-	
Mov Cap-1 Maneuver	1413	-	-	-	614
Mov Cap-2 Maneuver	-	-	-	-	614
Stage 1	-	-	-	-	842
Stage 2	-	-	-	-	829

Approach	EB	WB	SB
HCM Control Delay, s	2	0	10.8
HCM LOS			B

Minor Lane/Major Mvmt	EBL	EBT	WBT	WBR	SBLn1
Capacity (veh/h)	1413	-	-	-	801
HCM Lane V/C Ratio	0.03	-	-	-	0.226
HCM Control Delay (s)	7.6	-	-	-	10.8
HCM Lane LOS	A	-	-	-	B
HCM 95th %tile Q(veh)	0.1	-	-	-	0.9

Lanes, Volumes, Timings  
25: Golden Sage & Woodmen

Short Term Total  
PM Peak Hour

Lane Group	EBL	EBT	EBR	WBL	WBT	WBR	NBL	NBT	NBR	SBL	SBT	SBR
Lane Configurations												
Traffic Volume (vph)	88	1345	46	21	875	67	114	29	33	96	13	94
Future Volume (vph)	88	1345	46	21	875	67	114	29	33	96	13	94
Satd. Flow (prot)	1770	3539	1583	1770	3539	1583	1770	1863	1583	1770	1617	0
Flt Permitted	0.274			0.134			0.532			0.734		
Satd. Flow (perm)	510	3539	1583	250	3539	1583	991	1863	1583	1367	1617	0
Satd. Flow (RTOR)			50			72			48		168	
Peak Hour Factor	0.92	0.92	0.92	0.93	0.93	0.93	0.83	0.83	0.83	0.56	0.56	0.56
Growth Factor	90%	100%	100%	100%	100%	100%	100%	100%	100%	100%	100%	100%
Shared Lane Traffic (%)												
Lane Group Flow (vph)	86	1462	50	23	941	72	137	35	40	171	191	0
Turn Type	Perm	NA	Perm	Perm	NA	Perm	Perm	NA	Perm	Perm	NA	
Protected Phases		2			6			8				4
Permitted Phases	2		2	6		6	8		8	4		
Detector Phase	2	2	2	6	6	6	8	8	8	4	4	
Switch Phase												
Minimum Initial (s)	4.0	4.0	4.0	4.0	4.0	4.0	4.0	4.0	4.0	4.0	4.0	4.0
Minimum Split (s)	11.0	11.0	11.0	11.0	11.0	11.0	21.5	21.5	21.5	21.5	21.5	21.5
Total Split (s)	64.0	64.0	64.0	64.0	64.0	64.0	26.0	26.0	26.0	26.0	26.0	26.0
Total Split (%)	71.1%	71.1%	71.1%	71.1%	71.1%	71.1%	28.9%	28.9%	28.9%	28.9%	28.9%	28.9%
Yellow Time (s)	5.0	5.0	5.0	5.0	5.0	5.0	3.5	3.5	3.5	3.5	3.5	3.5
All-Red Time (s)	2.0	2.0	2.0	2.0	2.0	2.0	2.0	2.0	2.0	2.0	2.0	2.0
Lost Time Adjust (s)	0.0	-3.0	-3.0	-1.0	-3.0	-3.0	-1.0	0.0	0.0	0.0	0.0	0.0
Total Lost Time (s)	7.0	4.0	4.0	6.0	4.0	4.0	4.5	5.5	5.5	5.5	5.5	
Lead/Lag												
Lead-Lag Optimize?												
Recall Mode	Max	Max	Max	Max	Max	Max	None	None	None	None	None	None
Act Effct Green (s)	57.2	60.2	60.2	58.2	60.2	60.2	16.7	15.7	15.7	15.7	15.7	15.7
Actuated g/C Ratio	0.67	0.70	0.70	0.68	0.70	0.70	0.20	0.18	0.18	0.18	0.18	0.18
v/c Ratio	0.25	0.59	0.04	0.14	0.38	0.06	0.71	0.10	0.12	0.68	0.44	
Control Delay	9.1	8.1	1.7	8.3	6.1	1.5	52.2	28.8	8.1	46.6	10.2	
Queue Delay	0.0	0.0	0.0	0.0	0.0	0.0	0.0	0.0	0.0	0.0	0.0	0.0
Total Delay	9.1	8.1	1.7	8.3	6.1	1.5	52.2	28.8	8.1	46.6	10.2	
LOS	A	A	A	A	A	A	D	C	A	D	B	
Approach Delay		8.0			5.8			40.0			27.4	
Approach LOS		A			A			D			C	

Intersection Summary

Cycle Length: 90  
 Actuated Cycle Length: 85.4  
 Natural Cycle: 55  
 Control Type: Semi Act-Uncoord  
 Maximum v/c Ratio: 0.71  
 Intersection Signal Delay: 11.6  
 Intersection Capacity Utilization 66.4%  
 Analysis Period (min) 15

Intersection LOS: B  
 ICU Level of Service C

Splits and Phases: 25: Golden Sage & Woodmen



HCM 6th TWSC  
1: Firehouse View & Maltese Point

Long Term Total  
AM Peak Hour

Intersection						
Int Delay, s/veh	6					
Movement	EBT	EBR	WBL	WBT	NBL	NBR
Lane Configurations	↔			↔	↔	
Traffic Vol, veh/h	1	12	24	1	23	53
Future Vol, veh/h	1	12	24	1	23	53
Conflicting Peds, #/hr	0	0	0	0	0	0
Sign Control	Free	Free	Free	Free	Stop	Stop
RT Channelized	-	None	-	None	-	None
Storage Length	-	-	-	-	0	-
Veh in Median Storage, #	0	-	-	0	0	-
Grade, %	0	-	-	0	0	-
Peak Hour Factor	25	25	75	75	81	81
Heavy Vehicles, %	2	2	2	2	2	2
Mvmt Flow	4	48	32	1	28	65

Major/Minor	Major1	Major2	Minor1	Minor2	Minor3
Conflicting Flow All	0	0	52	0	93
Stage 1	-	-	-	-	28
Stage 2	-	-	-	-	65
Critical Hdwy	-	-	4.12	-	6.42
Critical Hdwy Stg 1	-	-	-	-	5.42
Critical Hdwy Stg 2	-	-	-	-	5.42
Follow-up Hdwy	-	-	2.218	-	3.518
Pot Cap-1 Maneuver	-	-	1554	-	907
Stage 1	-	-	-	-	995
Stage 2	-	-	-	-	958
Platoon blocked, %	-	-	-	-	-
Mov Cap-1 Maneuver	-	-	1554	-	888
Mov Cap-2 Maneuver	-	-	-	-	888
Stage 1	-	-	-	-	995
Stage 2	-	-	-	-	938

Approach	EB	WB	NB
HCM Control Delay, s	0	7.1	9
HCM LOS			A

Minor Lane/Major Mvmt	NBLn1	EBT	EBR	WBL	WBT
Capacity (veh/h)	993	-	-	1554	-
HCM Lane V/C Ratio	0.094	-	-	0.021	-
HCM Control Delay (s)	9	-	-	7.4	0
HCM Lane LOS	A	-	-	A	A
HCM 95th %tile Q(veh)	0.3	-	-	0.1	-

HCM 6th TWSC  
2: Rolling Thunder & Firehouse View

Long Term Total  
AM Peak Hour

Intersection						
Int Delay, s/veh	2.7					
Movement	EBL	EBT	WBT	WBR	SBL	SBR
Lane Configurations						
Traffic Vol, veh/h	77	118	174	20	10	35
Future Vol, veh/h	77	118	174	20	10	35
Conflicting Peds, #/hr	0	0	0	0	0	0
Sign Control	Free	Free	Free	Free	Stop	Stop
RT Channelized	-	None	-	None	-	None
Storage Length	0	-	-	-	0	-
Veh in Median Storage, #	-	0	0	-	0	-
Grade, %	-	0	0	-	0	-
Peak Hour Factor	90	90	77	77	62	62
Heavy Vehicles, %	2	2	2	2	2	2
Mvmt Flow	86	131	226	26	16	56

Major/Minor	Major1	Major2	Minor2		
Conflicting Flow All	252	0	-	0	542 239
Stage 1	-	-	-	-	239 -
Stage 2	-	-	-	-	303 -
Critical Hdwy	4.12	-	-	-	6.42 6.22
Critical Hdwy Stg 1	-	-	-	-	5.42 -
Critical Hdwy Stg 2	-	-	-	-	5.42 -
Follow-up Hdwy	2.218	-	-	-	3.518 3.318
Pot Cap-1 Maneuver	1313	-	-	-	501 800
Stage 1	-	-	-	-	801 -
Stage 2	-	-	-	-	749 -
Platoon blocked, %		-	-	-	
Mov Cap-1 Maneuver	1313	-	-	-	468 800
Mov Cap-2 Maneuver	-	-	-	-	468 -
Stage 1	-	-	-	-	749 -
Stage 2	-	-	-	-	749 -

Approach	EB	WB	SB
HCM Control Delay, s	3.1	0	10.8
HCM LOS			B

Minor Lane/Major Mvmt	EBL	EBT	WBT	WBR	SBLn1
Capacity (veh/h)	1313	-	-	-	691
HCM Lane V/C Ratio	0.065	-	-	-	0.105
HCM Control Delay (s)	7.9	-	-	-	10.8
HCM Lane LOS	A	-	-	-	B
HCM 95th %tile Q(veh)	0.2	-	-	-	0.4



Lanes, Volumes, Timings  
25: Golden Sage Rd & Woodmen Rd

Long Term Total  
AM Peak Hour

Lane Group	EBL	EBT	EBR	WBL	WBT	WBR	NBL	NBT	NBR	SBL	SBT	SBR
Lane Configurations												
Traffic Volume (vph)	319	734	84	77	1776	110	163	20	50	98	26	392
Future Volume (vph)	319	734	84	77	1776	110	163	20	50	98	26	392
Satd. Flow (prot)	3433	3539	1583	1770	3539	1583	1770	1863	1583	1770	1863	1583
Flt Permitted	0.950			0.367			0.431			0.744		
Satd. Flow (perm)	3433	3539	1583	684	3539	1583	803	1863	1583	1386	1863	1583
Satd. Flow (RTOR)			109			155			173			272
Peak Hour Factor	0.95	0.98	0.95	0.95	0.98	0.95	0.95	0.95	0.95	0.95	0.95	0.95
Shared Lane Traffic (%)												
Lane Group Flow (vph)	336	749	88	81	1812	116	172	21	53	103	27	413
Turn Type	Prot	NA	Perm	pm+pt	NA	Perm	pm+pt	NA	Perm	pm+pt	NA	Free
Protected Phases	5	2		1	6		3	8		7	4	
Permitted Phases			2	6		6	8		8	4		Free
Detector Phase	5	2	2	1	6	6	3	8	8	7	4	
Switch Phase												
Minimum Initial (s)	5.0	5.0	5.0	5.0	5.0	5.0	5.0	5.0	5.0	5.0	5.0	5.0
Minimum Split (s)	10.0	12.0	12.0	10.0	12.0	12.0	10.0	10.0	10.0	10.0	10.0	10.0
Total Split (s)	21.0	72.0	72.0	10.0	61.0	61.0	23.0	15.0	15.0	23.0	15.0	
Total Split (%)	17.5%	60.0%	60.0%	8.3%	50.8%	50.8%	19.2%	12.5%	12.5%	19.2%	12.5%	
Yellow Time (s)	3.0	5.0	5.0	3.0	5.0	5.0	3.0	3.0	3.0	3.0	3.0	3.0
All-Red Time (s)	2.0	2.0	2.0	2.0	2.0	2.0	2.0	2.0	2.0	2.0	2.0	2.0
Lost Time Adjust (s)	-1.0	-1.0	-1.0	-1.0	-1.0	-1.0	-1.0	-1.0	-1.0	-1.0	-1.0	-1.0
Total Lost Time (s)	4.0	6.0	6.0	4.0	6.0	6.0	4.0	4.0	4.0	4.0	4.0	4.0
Lead/Lag	Lead	Lag	Lag	Lead	Lag	Lag	Lead	Lag	Lag	Lead	Lag	
Lead-Lag Optimize?	Yes	Yes	Yes	Yes	Yes	Yes	Yes	Yes	Yes	Yes	Yes	Yes
Recall Mode	None	Min	Min	None	Min	Min	None	None	None	None	None	None
Act Effct Green (s)	15.5	67.3	67.3	63.6	55.5	55.5	24.1	10.3	10.3	17.6	8.2	109.4
Actuated g/C Ratio	0.14	0.62	0.62	0.58	0.51	0.51	0.22	0.09	0.09	0.16	0.07	1.00
v/c Ratio	0.69	0.34	0.09	0.18	1.01	0.13	0.53	0.12	0.17	0.39	0.19	0.26
Control Delay	54.0	12.6	1.6	8.5	52.4	1.5	42.2	48.6	1.2	40.3	53.7	0.4
Queue Delay	0.0	0.0	0.0	0.0	0.0	0.0	0.0	0.0	0.0	0.0	0.0	0.0
Total Delay	54.0	12.6	1.6	8.5	52.4	1.5	42.2	48.6	1.2	40.3	53.7	0.4
LOS	D	B	A	A	D	A	D	D	A	D	D	A
Approach Delay		23.6			47.7			33.9			10.6	
Approach LOS		C			D			C			B	

Intersection Summary

Cycle Length: 120  
 Actuated Cycle Length: 109.4  
 Natural Cycle: 80  
 Control Type: Semi Act-Uncoord  
 Maximum v/c Ratio: 1.01  
 Intersection Signal Delay: 34.6  
 Intersection Capacity Utilization 85.6%  
 Analysis Period (min) 15

Intersection LOS: C  
 ICU Level of Service E

Splits and Phases: 25: Golden Sage Rd & Woodmen Rd



HCM 6th TWSC  
1: Firehouse View & Maltese Point

Long Term Total  
PM Peak Hour

Intersection						
Int Delay, s/veh	6.8					
Movement	EBT	EBR	WBL	WBT	NBL	NBR
Lane Configurations						
Traffic Vol, veh/h	0	68	54	0	65	39
Future Vol, veh/h	0	68	54	0	65	39
Conflicting Peds, #/hr	0	0	0	0	0	0
Sign Control	Free	Free	Free	Free	Stop	Stop
RT Channelized	-	None	-	None	-	None
Storage Length	-	-	-	-	0	-
Veh in Median Storage, #	0	-	-	0	0	-
Grade, %	0	-	-	0	0	-
Peak Hour Factor	38	38	47	47	50	50
Heavy Vehicles, %	2	2	2	2	2	2
Mvmt Flow	0	179	115	0	130	78

Major/Minor	Major1	Major2	Minor1	Minor2	Minor3
Conflicting Flow All	0	0	179	0	320
Stage 1	-	-	-	-	90
Stage 2	-	-	-	-	230
Critical Hdwy	-	-	4.12	-	6.42
Critical Hdwy Stg 1	-	-	-	-	5.42
Critical Hdwy Stg 2	-	-	-	-	5.42
Follow-up Hdwy	-	-	2.218	-	3.518
Pot Cap-1 Maneuver	-	-	1397	-	673
Stage 1	-	-	-	-	934
Stage 2	-	-	-	-	808
Platoon blocked, %	-	-	-	-	-
Mov Cap-1 Maneuver	-	-	1397	-	618
Mov Cap-2 Maneuver	-	-	-	-	618
Stage 1	-	-	-	-	934
Stage 2	-	-	-	-	742

Approach	EB	WB	NB
HCM Control Delay, s	0	7.8	12.1
HCM LOS			B

Minor Lane/Major Mvmt	NBLn1	EBT	EBR	WBL	WBT
Capacity (veh/h)	715	-	-	1397	-
HCM Lane V/C Ratio	0.291	-	-	0.082	-
HCM Control Delay (s)	12.1	-	-	7.8	0
HCM Lane LOS	B	-	-	A	A
HCM 95th %tile Q(veh)	1.2	-	-	0.3	-

Intersection						
Int Delay, s/veh	7.2					
Movement	EBL	EBT	WBT	WBR	SBL	SBR
Lane Configurations						
Traffic Vol, veh/h	80	150	203	20	31	106
Future Vol, veh/h	80	150	203	20	31	106
Conflicting Peds, #/hr	0	0	0	0	0	0
Sign Control	Free	Free	Free	Free	Stop	Stop
RT Channelized	-	None	-	None	-	None
Storage Length	0	-	-	-	0	-
Veh in Median Storage, #	-	0	0	-	0	-
Grade, %	-	0	0	-	0	-
Peak Hour Factor	65	65	75	75	42	42
Heavy Vehicles, %	2	2	2	2	2	2
Mvmt Flow	123	231	271	27	74	252

Major/Minor	Major1	Major2	Minor2		
Conflicting Flow All	298	0	-	0	762 285
Stage 1	-	-	-	-	285 -
Stage 2	-	-	-	-	477 -
Critical Hdwy	4.12	-	-	-	6.42 6.22
Critical Hdwy Stg 1	-	-	-	-	5.42 -
Critical Hdwy Stg 2	-	-	-	-	5.42 -
Follow-up Hdwy	2.218	-	-	-	3.518 3.318
Pot Cap-1 Maneuver	1263	-	-	-	373 754
Stage 1	-	-	-	-	763 -
Stage 2	-	-	-	-	624 -
Platoon blocked, %		-	-	-	
Mov Cap-1 Maneuver	1263	-	-	-	337 754
Mov Cap-2 Maneuver	-	-	-	-	337 -
Stage 1	-	-	-	-	689 -
Stage 2	-	-	-	-	624 -

Approach	EB	WB	SB
HCM Control Delay, s	2.8	0	18.4
HCM LOS			C

Minor Lane/Major Mvmt	EBL	EBT	WBT	WBR	SBLn1
Capacity (veh/h)	1263	-	-	-	589
HCM Lane V/C Ratio	0.097	-	-	-	0.554
HCM Control Delay (s)	8.2	-	-	-	18.4
HCM Lane LOS	A	-	-	-	C
HCM 95th %tile Q(veh)	0.3	-	-	-	3.4

Lanes, Volumes, Timings  
25: Golden Sage Rd & Woodmen Rd

Long Term Total  
PM Peak Hour

Lane Group	EBL	EBT	EBR	WBL	WBT	WBR	NBL	NBT	NBR	SBL	SBT	SBR
Lane Configurations												
Traffic Volume (vph)	447	1629	75	83	1083	121	183	40	77	136	21	391
Future Volume (vph)	447	1629	75	83	1083	121	183	40	77	136	21	391
Satd. Flow (prot)	3433	3539	1583	1770	3539	1583	1770	1863	1583	1770	1863	1583
Flt Permitted	0.950			0.095			0.506					
Satd. Flow (perm)	3433	3539	1583	177	3539	1583	943	1863	1583	1863	1863	1583
Satd. Flow (RTOR)			109			155			173			357
Peak Hour Factor	0.95	0.98	0.95	0.95	0.98	0.95	0.95	0.95	0.95	0.95	0.95	0.95
Shared Lane Traffic (%)												
Lane Group Flow (vph)	471	1662	79	87	1105	127	193	42	81	143	22	412
Turn Type	Prot	NA	Perm	pm+pt	NA	Perm	pm+pt	NA	Perm	pm+pt	NA	Free
Protected Phases	5	2		1	6		3	8		7	4	
Permitted Phases			2	6		6	8		8	4		Free
Detector Phase	5	2	2	1	6	6	3	8	8	7	4	
Switch Phase												
Minimum Initial (s)	5.0	5.0	5.0	5.0	5.0	5.0	5.0	5.0	5.0	5.0	5.0	5.0
Minimum Split (s)	10.0	12.0	12.0	10.0	12.0	12.0	10.0	10.0	10.0	10.0	10.0	10.0
Total Split (s)	23.0	64.0	64.0	10.0	51.0	51.0	31.0	15.0	15.0	31.0	15.0	
Total Split (%)	19.2%	53.3%	53.3%	8.3%	42.5%	42.5%	25.8%	12.5%	12.5%	25.8%	12.5%	
Yellow Time (s)	3.0	5.0	5.0	3.0	5.0	5.0	3.0	3.0	3.0	3.0	3.0	3.0
All-Red Time (s)	2.0	2.0	2.0	2.0	2.0	2.0	2.0	2.0	2.0	2.0	2.0	2.0
Lost Time Adjust (s)	-1.0	-1.0	-1.0	-1.0	-1.0	-1.0	-1.0	-1.0	-1.0	-1.0	-1.0	-1.0
Total Lost Time (s)	4.0	6.0	6.0	4.0	6.0	6.0	4.0	4.0	4.0	4.0	4.0	4.0
Lead/Lag	Lead	Lag	Lag	Lead	Lag	Lag	Lead	Lag	Lag	Lead	Lag	
Lead-Lag Optimize?	Yes	Yes	Yes	Yes	Yes	Yes	Yes	Yes	Yes	Yes	Yes	Yes
Recall Mode	None	Min	Min	None	Min	Min	None	None	None	None	None	None
Act Effct Green (s)	18.6	55.9	55.9	48.9	40.5	40.5	24.9	9.6	9.6	17.7	8.0	98.8
Actuated g/C Ratio	0.19	0.57	0.57	0.49	0.41	0.41	0.25	0.10	0.10	0.18	0.08	1.00
v/c Ratio	0.73	0.83	0.08	0.46	0.76	0.17	0.47	0.23	0.26	0.45	0.15	0.26
Control Delay	47.9	24.6	1.4	21.5	29.9	2.6	35.6	48.5	2.1	39.3	49.7	0.4
Queue Delay	0.0	0.0	0.0	0.0	0.0	0.0	0.0	0.0	0.0	0.0	0.0	0.0
Total Delay	47.9	24.6	1.4	21.5	29.9	2.6	35.6	48.5	2.1	39.3	49.7	0.4
LOS	D	C	A	C	C	A	D	D	A	D	D	A
Approach Delay		28.7			26.7			28.7			11.9	
Approach LOS		C			C			C			B	

Intersection Summary

Cycle Length: 120  
 Actuated Cycle Length: 98.8  
 Natural Cycle: 70  
 Control Type: Semi Act-Uncoord  
 Maximum v/c Ratio: 0.83  
 Intersection Signal Delay: 25.9  
 Intersection Capacity Utilization 78.1%  
 Analysis Period (min) 15  
 Intersection LOS: C  
 ICU Level of Service D

Splits and Phases: 25: Golden Sage Rd & Woodmen Rd

