



STORMWATER MANAGEMENT PLAN FOR LEWIS PALMER TRAIL

Prepared For (Applicant):

Lewis Palmer School District 38
146 N. Jefferson Street
Monument, CO 80132
(719) 757-1430
Contact: Ricky Vestal

Prepared By:

JR Engineering, LLC
5475 Tech Center Drive, Suite 235
Colorado Springs, Colorado 80919
(303) 267-6241
Contact: Glenn Ellis

Qualified Stormwater Manager:

To Be Determined

Contractor:

To Be Determined

November, 2022

El Paso County PCD File No.:
PPR2240

ENGINEER OF RECORD:

The Stormwater Management Plan was prepared under my direction and supervision and is correct to the best of my knowledge and belief. Said Plan has been prepared according to the criteria established by the County and State for Stormwater Management Plans.

Glenn Ellis, P.E. Date
Registered Professional Engineer
State of Colorado No. 38861
For and on behalf of JR Engineering, LLC.

REVIEW ENGINEER:

The Stormwater Management Plan was reviewed and found to meet the checklist requirements except where otherwise noted or allowed by an approved deviation request.

Review Engineer Date

TABLE OF CONTENTS

| | | |
|----|---|---|
| 1. | Applicant / Contact Information | 1 |
| 2. | Site Description and Location..... | 1 |
| 3. | Proposed Sequence of Major Activities..... | 4 |
| 4. | BMPs for Stormwater Pollution Prevention | 4 |
| 5. | Final Stabilization and Long-Term Stormwater Management | 7 |
| 6. | Inspection and Maintenance | 8 |

Appendices

A. Vicinity Map

B. Soils Map

C. GEC (Construction Documents) Plans and Details

D. SWMP Report and GEC Plan Checklists

E. Inspection Report Template

1. Applicant / Contact Information

Owner/Developer: Lewis Palmer School District 38
Attn: Ricky Vestal
146 N. Jefferson Street
Monument, CO 80132
(719) 757-1430

Engineer: JR Engineering, LLC
5475 Tech Center Drive, Suite 235
Colorado Springs, CO 80919
Attn: Glenn Ellis (303) 267-6241
gellis@jrengineering.com

SWMP Administrator: To Be Determined

Contractor: To Be Determined

2. Site Description and Location

The site is located in Monument, CO and the proposed development is comprised of a 4 foot wide trail approximately 2.5 miles long. The trail will be installed along Woodmoor Drive, Willow Park Way, below Lake Woodmoor on maintenance access paths, Lake Woodmoor Drive, through open tracts owned by the Woodmoor Improvement Association, and along Deer Creek Drive, within School District, Woodmoor Improvement Association property, or on properties where easements have been obtained. See Appendix A for a vicinity map.

The existing site is comprised of both developed and undeveloped nearly bare ground. The development of the proposed site will include implementation of BMPs, site grading, trail installation, and removal of temporary BMPs. Refer to GEC (Construction) plans in Appendix C.

Site details:

- a. Estimated area to undergo disturbance: 1.34 acres
 - i. No off-site grading is proposed.
- b. Soil Types: Soil characteristics are comprised of various soils throughout the project limits of the trail. Soils are comprised of Pring coarse sandy loam (Group B)(31.9% of trail), Tomah-Crowfoot loamy sands (Group B)(29.7% of trail), Kettle gravelly loamy sand (Group B)(20.4% of trail), and Alamosa loam (Group D)(18.0% of trail). Group B soils exhibit a moderate infiltration rate when thoroughly wet and consist chiefly of moderately deep or deep, moderately well drained or well drained soils that have moderately fine texture to moderately coarse texture. These soils have a moderate rate of water transmission. Group D soils

exhibit a very slow infiltration rate when thoroughly wet and consist chiefly of clays that have a high shrink-swell potential, have a high water table, have a claypan or clay layer at or near the surface, and soils that are shallow over nearly impervious material. These soils have a very slow rate of water transmission. Refer to the soil survey mapping in Appendix B. BMP's will be installed and maintained to mitigate adverse impacts due to soil erosion.

- c. Soil erosion potential and potential impacts upon discharge:
 - i. Conduct land-disturbing activities in a manner that effectively reduces accelerated soil erosion and reduces sediment movement and deposition off site.
 - ii. Schedule construction activities to minimize the total amount of soil exposed at any given time.
 - iii. Establish temporary or permanent cover on areas that have been disturbed as soon as practical after grading is completed.
 - iv. Design and construct temporary or permanent facilities to limit the flow of water to non-erosive velocities for the conveyance of water around, through or from the disturbed area.
 - v. Remove sediment caused by accelerated soil erosion from surface runoff water before it leaves the site.
 - vi. Stabilize disturbed areas with permanent vegetative cover and provide permanent storm water quality control measures for the post-construction condition.
- d. Existing vegetation: Native meadow grasses (approximately 70% coverage), determined using aerial inspection.
- e. Location and description of potential pollution sources: Potential sources of pollution include: Onsite waste management, portable toilets, onsite vehicle fueling, and outdoor storage, vehicle tracking pads, dust management, and temporary stock pile. The locations of these sources are will be determined by the contractor.
 - i. Non-industrial waste sources such as worker trash and portable toilets – Clean up litter and debris from the construction site daily and worker trash receptacles will be located by entrance/exit for easy removal/replacement access. All portable toilets should be kept a minimum of 50 feet from a storm drain inlet or drainage course and secured to the ground. Toilets will be cleaned regularly and inspected daily for any spills or leaks. Waste disposal bins will be reasonably maintained at regular intervals to check for leaks and overflow capacity, and will be emptied routinely to prevent overflow.
 - ii. Routine maintenance activities involving fertilizers, pesticides, detergents, fuels, solvents, oils, etc. – oil, grease, coolants, etc. that leak onto the soil or impervious surface should be cleaned up as soon as possible and on-site personnel notified.
 - iii. Vehicle, equipment maintenance, and fueling – all designated fueling and maintenance areas shall be located a minimum of 100 feet from any drainage course whenever possible. If the fueling area is located on a pervious surface, the area shall be covered with a non-pervious lining so as to prevent soil contamination by way of infiltration. Any spillage shall

- be cleaned up immediately.
- iv. Raw materials, intermediate products, byproducts, process residuals, Finished products, containers, and materials storage areas can be sources of pollutants such as metals, oils and grease, sediment and other contaminants. Where practical, conduct operations indoors. Where impractical, select an appropriate temporary or permanent covering to reduce exposure of materials to rainfall and runoff.
 - v. Vehicle tracking controls (VTC) provide stabilized construction site access where vehicles exit the site onto paved public roads. An effective vehicle tracking control helps remove sediment (mud or dirt) from vehicles, reducing tracking onto the paved surface. With aggregate vehicle tracking controls, ensure rock and debris from this area do not enter the public right-of-way. Inspect the VTC for degradation and replace aggregate or material used for a stabilized entrance/exit as needed.
 - vi. Wind erosion and dust control BMPs help to keep soil particles from entering the air as a result of land disturbing construction activities. Dust control measures should be used on any site where dust poses a problem to air quality. Dust control is important to control for the health of construction workers and surrounding waterbodies.
 - vii. Stockpile management should be used when soils or other erodible materials are stored at the construction site. Special attention should be given to stockpiles in close proximity to natural or manmade storm systems. Soils stockpiled for an extended period (typically for more than 30 days) mulched with a temporary grass cover once the stockpile is placed (typically within 21 days). An area that will remain in an interim state for over 60 days must also be seeded. Use of mulch only or a soil binder is acceptable if the stockpile will be in place for a more limited time period (typically 30-60 days). Refer to DCM Vol 2 – Section 3.2- General principles - Basic Grading, Erosion and Stormwater Quality Requirements and General Prohibitions #16 for more information.
 - f. Spill prevention and pollution controls for dedicated batch plants: Not applicable for this site since there will be no dedicated batch plants.
 - g. Street sweeping or vacuuming should be conducted when there is noticeable sediment accumulation on roadways adjacent to the construction site. Typically, this will be concentrated at the entrance/exit to the construction site. Well-maintained stabilized construction entrances and vehicle tracking controls can help reduce the necessary frequency of street sweeping and vacuuming.
 - h. Location and description of anticipated non-stormwater components of discharge: There will be a concrete washout area (CWA) where the cleaning of concrete trucks could produce a non-stormwater discharge. Proper installation and maintenance of the CWA will not allow runoff from this area. Another potential source of non-stormwater discharge could be the irrigation of permanent seeding (PS). Irrigation will be kept at a rate so as to not create runoff.
 - i. Existing basin drainage patterns are generally from north to south and east to west by way of sheet flow.
 - j. Receiving water: Runoff from the project will be limited using the GEC BMPs.

Runoff from the site will follow the historic paths within the major basins they are in. include the name(s) of ultimate receiving waters.

- k. There are no streams that cross the project site.

3. Proposed Sequence of Major Activities

The project will follow standard construction sequences for construction, i.e., clearing and grubbing, over excavation, overlot grading, utility installation, and street paving. The contractor will be responsible for implementing and maintaining the erosion and sediment control measures described in this document and the accompanying design drawings. The contractor may designate these tasks to certain subcontractors as they see fit, but the ultimate responsibility for implementing these controls and their proposed function at each phase of the project remains with the contractor. The order of major activities (with estimated completion dates) will be as follows:

1. Install VTC and other perimeter soil erosion control measures (Spring 2023).
2. Clear and rough grade for improvements (Spring 2023).
3. Install proposed trail (Spring 2023).
4. Place Seed and Mulch (Summer 2023).
5. Clean up and final stabilization (Summer 2023).

4. BMPs for Stormwater Pollution Prevention

See GEC (Construction) plans in Appendix C for BMP locations and detail sheets.

- a. Erosion and Sediment Controls

- i. Structural BMPs:

remove BMPs that are not to be used at the Site.

1. Sediment basins (SB) to collect runoff before it enters receiving waters (initial, interim)
2. Silt fence (SF) along downstream limits of disturbed areas to filter sediment from runoff (initial, interim)
3. Stabilized staging area (SSA) near site entrance to consolidate construction equipment in a stabilized location (initial, interim)
4. Construction fence (CF) to identify limits of construction (LOC) where silt fence is not needed (initial, interim)
5. Vehicle tracking control (VTC) at site entrance to prevent sediment from leaving the site via vehicle tires (initial, interim)
6. Rough Cut Street Control (RCS) is material placed after a road has been cut and before base has been installed for paving (initial)
7. Erosion Control Blanket (ECB) is used on slopes greater than a 3:1 slope (interim)
8. Temporary stock pile (TSP) to consolidate materials such as topsoil in a controlled area bounded by silt fence (interim)
9. Inlet protection (IP) around culvert entrances (interim, final)
10. Outlet protection (OP) at culvert outlets (interim, final)
11. Concrete washout area (CWA) to allow a controlled area for concrete

- trucks to be washed (initial, interim)
- 12. Temporary Swale (TSW) to Convey runoff to sediment basins (initial, interim)
- 13. Straw Bale Barrier (STB) to be used as check dams in swales to slow and filter sediment from runoff (initial, interim)
- 14. Sediment Control Logs (SCL) to slow and filter sediment from runoff, to be placed behind sidewalks (initial, interim)
- ii. Non-structural BMPs:
 - 1. Mulching (MU) to stabilize soils and promote seed growth (final)
 - 2. Permanent seeding (PS) to stabilize disturbed areas (final)
- b. Materials Handling and Spill Prevention
 - i. General Materials Handling Practices:
 - 1. Potential pollutants shall be stored and used in a manner consistent with the manufacturer's instructions in a secure location. To the extent practical, material storage areas should not be located near storm drain inlets and should be equipped with covers, roofs, or secondary containment as required to prevent storm water from contacting stored materials. Chemicals that are not compatible shall be stored in segregated areas so that spilled materials cannot combine and react.
 - 2. Disposal of materials shall be in accordance with the manufacturer's instructions and applicable local, state, and federal regulations.
 - 3. Materials no longer required for construction shall be removed from the site as soon as possible.
 - 4. Adequate garbage, construction waste, and sanitary waste handling and disposal facilities shall be provided as necessary to keep the site clear of obstruction and BMPs clear and functional.
 - ii. Specific Materials Handling Practices
 - 1. All pollutants, including waste materials and demolition debris, that occur onsite during construction shall be handled in a way that does not contaminate storm water.
 - 2. All chemicals including liquid products, petroleum products, water treatment chemicals, and wastes stored onsite shall be covered and protected from vandalism.
 - 3. Maintenance, fueling, and repair of all equipment and vehicles involving oil changes, hydraulic system drain down, degreasing operations, fuel tank drain down and removal, and other activities which may result in the accidental release of contaminants, shall be conducted under cover during wet weather and on an impervious surface to prevent release of contaminants onto the ground. Materials spilled during maintenance operations shall be cleaned up immediately and properly disposed of.
 - 4. Wheel wash water shall be settled and discharged onsite by infiltration.
 - 5. Application of agricultural chemicals, including fertilizers and pesticides, shall be conducted in a manner and at application rates that

will not result in loss of chemical to storm water runoff. Follow manufacturer's recommendations for application rates and procedures.

6. pH-modifying sources shall be managed to prevent contamination of runoff and storm water collected onsite. The most common sources of pH-modifying materials are bulk cement, cement kiln dust (CKD), fly ash, new concrete washing and curing waters, waste streams generated from concrete grinding and sawing, exposed aggregate processes, and concrete pumping and mixer washout waters.
- iii. Spill Prevention and Response Procedures
1. The primary objective in responding to a spill is to quickly contain the material(s) and prevent or minimize their migration into storm water runoff and conveyance systems. If the release has impacted onsite storm water, it is critical to contain the released materials onsite and prevent their release into receiving waters.
 2. Spill Response Procedures:
 - a. Notify site superintendent immediately when a spill, or the threat of a spill, is observed. The superintendent shall assess the situation and determine the appropriate response.
 - b. If spills represent an imminent threat of escaping onsite facilities and entering the receiving waters, site personnel shall respond immediately to contain the release and notify the superintendent after the situation has stabilized.
 - c. The site superintendent, or his/her designee, shall be responsible for completing a spill reporting form and for reporting the spill to the appropriate agency.
 - d. Spill response equipment shall be inspected and maintained as necessary to replace any materials used in spill response activities.
 3. Spill kits shall be on-hand at all fueling sites. Spill kit location(s) shall be reported to the SWMP administrator.
 4. Absorbent materials shall be on-hand at all fueling areas for use in containing inadvertent spills. Containers shall be on-hand at all fueling sites for disposal of used absorbents.
 5. Recommended components of spill kits include the following:
 - a. Oil absorbent pads (one bale)
 - b. Oil absorbent booms (40 feet)
 - c. 55-gallon drums (2)
 - d. 9-mil plastic bags (10)
 - e. Personal protective equipment including gloves and goggles
 6. Concrete wash water: unless confined in a pre-defined, bermed containment area, the cleaning of concrete truck delivery chutes is prohibited at the job site.
 7. Notification procedures:
 - a. In the event of an accident or spill, the SWMP administrator shall be notified.

- b. Depending on the nature of the spill material involved, the Colorado Department of Public Health and Environment (24-hour spill reporting line: 887-518-5608), downstream water users, or other agencies may also need to be notified.
- c. Any spill of oil which 1) violates water quality standards, 2) produces a “sheen” on a surface water, or 3) causes a sludge or emulsion, or any hazardous substance release, or hazardous waste release which exceeds the reportable quantity, must be reported immediately by telephone to the National Response Center Hotline at (800) 424-8802.

5. Final Stabilization and Long-Term Stormwater Management

- a. Permanent seeding will be provided to achieve long-term stabilization of the site.
- b. Seed Mix: Sand dropseed, or approved equal.
- c. Seeding Application Rate: Drill seed 0.25” to 0.5” into the soil. In small areas not accessible to a drill, hand broadcast at double the rate and rake 0.25” to 0.5” into the soil. Apply seed at the following rates:
 - i. Dryland: 20-25 lbs/acre
 - ii. Irrigated: 40 lbs/acre
- d. Soil stabilization Practices:
 - i. Mulching Application: Apply 1-1/2 tons of certified weed free hay per acre mechanically crimped into the soil in combination with an organic mulch tackifier. On slopes and ditches requiring a blanket, the blanket shall be placed in lieu of much and mulch tackifier.
- e. Soil Conditioning and Fertilization Requirements:
 - i. Soil conditioner, organic amendment shall be applied to all seeded areas at 3 CY / 1000 SF.
 - ii. Fertilizer shall consist of 90% fungal biomass (mycelium) and 10% potassium-magnesia with a grade of 6-1-3 or approved equal. Fertilizer shall be applied as recommended by seed supplier.
- f. Final stabilization is reached when all soil-disturbing activities at the site have been completed, and uniform vegetative cover has been established with an individual plan density of at least 70 percent of pre-disturbance levels, or equivalent permanent, physical erosion reduction methods have been employed.
 - i. The overall project does not solely rely on another entity or control measures for final stabilization or permanent water quality or detention.
- g. Final Stabilization and Long-term Stormwater Quality:
 - i. After final stabilization occurs, Stormwater Quality of the site will be maintained via the use of GEC BMPs.
 - ii. Onsite flows will also be treated via grass swales that route flows present in open spaces to the storm sewer system which eventually outfalls to the full-spectrum pond.

update. there is no long term water quality proposed at the site.

6. Inspection and Maintenance

- a. Inspection Schedules:
 - i. The contractor shall inspect BMPs once every 14 days at a minimum, and immediately (within 24 hours) after any precipitation or snowmelt event that causes surface erosion (i.e. that results in storm water running across the ground), to ensure that BMPs are maintained in effective operating condition.
 - ii. The contractor will be responsible for any re-excavation of sediment and debris that collects in the basin depression required to ensure that the basin meets the design grades following construction. The storm lines shall also be cleaned and free of sediment once the site becomes stabilized.
- b. Inspection Procedures:
 - i. Site Inspection / Observation Items:
 - 1. Construction site perimeter and discharge points
 - 2. All disturbed areas
 - 3. Areas used for material / waste storage that are exposed to precipitation
 - 4. Other areas having a significant potential for storm water pollution, such as demolition areas or concrete washout areas, or locations where vehicles enter or leave the site
 - 5. Erosion and sediment control measures identified in the SWMP
 - 6. Any other structural BMPs that may require maintenance, such as secondary containment around fuel tanks, or the conditions of spill response kits.
 - ii. Inspection Requirements:
 - 1. Determine if there is any evidence of, or potential for, pollutants entering the receiving waters.
 - 2. Review BMPs to determine if they still meet design and operational criteria in the SWMP, and if they continue to adequately control pollutants at the site.
 - 3. Upgrade and/or revise any BMPs not operating in accordance with the SWMP and update the SWMP to reflect any revisions.
 - 4. The SWMP should be viewed as a “living document” that is continuously being reviewed and modified as a part of the overall process of evaluating and managing storm water quality issues at the site.
 - 5. The QSM will be sufficiently qualified for the required duties per the ECM Appendix I.5.2.A.
 - 6. The Qualified Storm water Manager shall amend the SWMP when there is a change in design, construction, operation or maintenance of the site which would require the implementation of new or revised BMPs or if the SWMP proves to be ineffective in achieving the general objectives of controlling pollutants in storm water discharges associated with construction activity or when BMPs are no longer necessary and are removed.

- iii. BMP Maintenance / Replacement and Failed BMPs:
 - 1. The contractor shall remove sediment that has been collected by perimeter controls, such as silt fence and inlet protection, on a regular basis to prevent failure of BMPs, and remove potential of sediment from being discharged from the site in the event of BMP failure.
 - 2. Removed sediment must be moved to an appropriate location where it will not become an additional pollutant source, and should never be placed in ditches or streams.
 - 3. The contractor shall update the GEC as required with any new BMPs added during the construction period.
 - 4. The SWMP should be viewed as a “living document” that is continuously being reviewed and modified as a part of the overall process of evaluating and managing storm water quality issues at the site.
 - 5. The Qualified Storm water Manager shall amend the SWMP when there is a change in design, construction, operation or maintenance of the site which would require the implementation of new or revised BMPs or if the SWMP proves to be ineffective in achieving the general objectives of controlling pollutants in storm water discharges associated with construction activity or when BMPs are no longer necessary and are removed.
 - 6. The contractor shall address BMPs that have failed or have the potential to fail without maintenance or modifications, as soon as possible, immediately in most cases, to prevent discharge of pollutants.
- iv. Record Keeping and Documenting Inspections:
 - 1. The contractor shall maintain records of all inspection reports, including signed inspection logs, at the project site.
 - 2. The permittee shall document inspection results and maintain a record of the results for a period of 3 years following expiration or inactivation of permit coverage.
 - 3. Site inspection records shall include the following:
 - a. Inspection date
 - b. Name and title of personnel making the inspection
 - c. Location of discharges of sediment or other pollutants from the site
 - d. Location(s) of BMPs in need of maintenance
 - e. Location(s) of BMPs that failed to operate as designed or proved inadequate for a particular location
 - f. Location(s) where additional BMPs are needed that were not in place at the time of inspection
 - g. Deviations from the minimum inspection schedule

APPENDIX A – VICINITY MAP

X:\2520000_01\2520300\Drawings\Blocks\2520300_VicMap.dwg, 8.5x11 Portrait, 11/23/2022 10:57:22 AM, CS

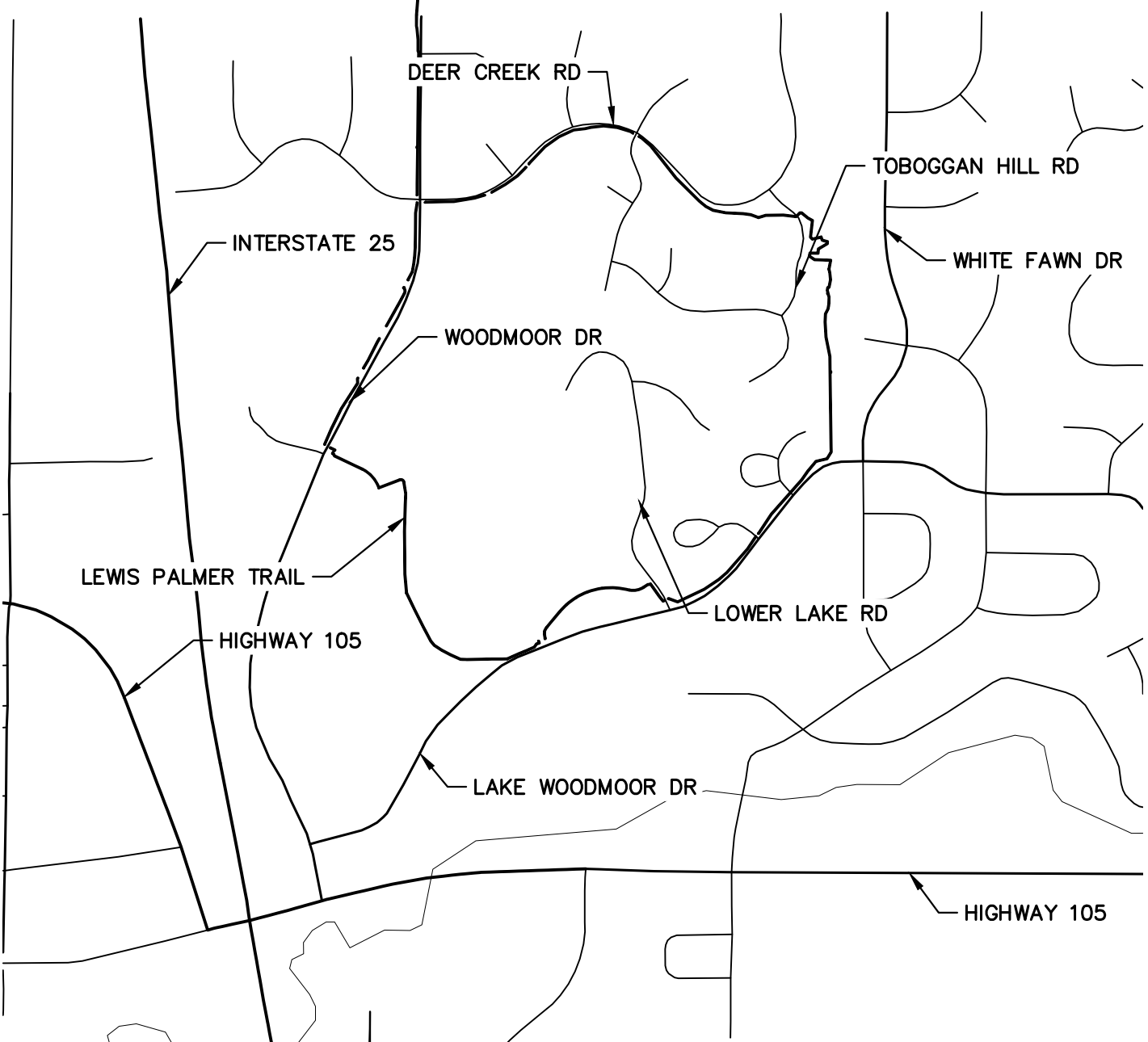

LEWIS PALMER TRAIL

INTERSTATE 25

DEER CREEK RD

WOODMOOR DR

TOBOGGAN HILL RD

WHITE FAWN DR

LOWER LAKE RD

HIGHWAY 105

LAKE WOODMOOR DR

HIGHWAY 105

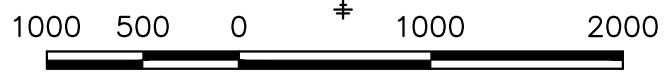

ORIGINAL SCALE: 1" = 1000'

VICINITY MAP
 LEWIS PALMER TRAIL
 JOB NO. 25203.00
 11/23/22
 SHEET 1 OF 1



Centennial 303-740-9393 • Colorado Springs 719-593-2593
 Fort Collins 970-491-9888 • www.jrengineering.com







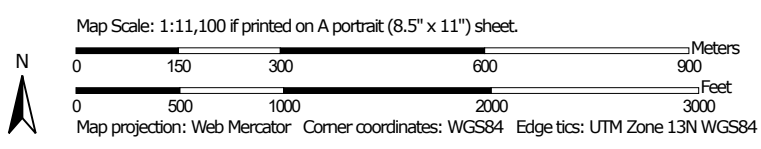
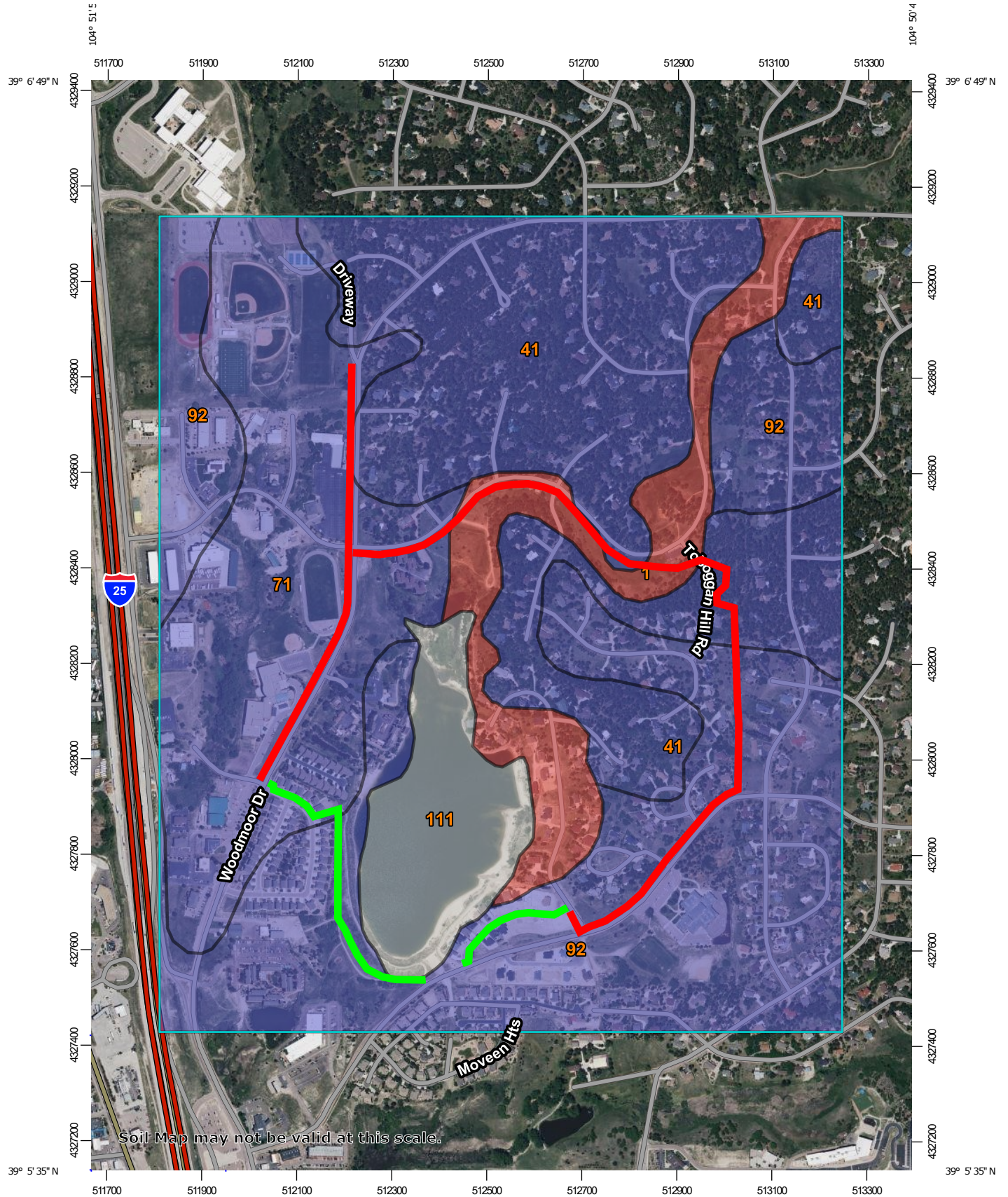

























APPENDIX B – SOILS MAP

TRAIL DISTURBANCE

TRAIL ON EXISTING CONCRETE OR MAINTENANCE ACCESS ROAD (NO DISTURBANCE)



MAP LEGEND

- Area of Interest (AOI)**
 -  Area of Interest (AOI)
- Soils**
 - Soil Rating Polygons**
 -  A
 -  A/D
 -  B
 -  B/D
 -  C
 -  C/D
 -  D
 -  Not rated or not available
 - Soil Rating Lines**
 -  A
 -  A/D
 -  B
 -  B/D
 -  C
 -  C/D
 -  D
 -  Not rated or not available
 - Soil Rating Points**
 -  A
 -  A/D
 -  B
 -  B/D
- Water Features**
 -  Streams and Canals
- Transportation**
 -  Rails
 -  Interstate Highways
 -  US Routes
 -  Major Roads
 -  Local Roads
- Background**
 -  Aerial Photography
- Other**
 -  C
 -  C/D
 -  D
 -  Not rated or not available

MAP INFORMATION

The soil surveys that comprise your AOI were mapped at 1:24,000.

Warning: Soil Map may not be valid at this scale.
 Enlargement of maps beyond the scale of mapping can cause misunderstanding of the detail of mapping and accuracy of soil line placement. The maps do not show the small areas of contrasting soils that could have been shown at a more detailed scale.

Please rely on the bar scale on each map sheet for map measurements.

Source of Map: Natural Resources Conservation Service
 Web Soil Survey URL:
 Coordinate System: Web Mercator (EPSG:3857)

Maps from the Web Soil Survey are based on the Web Mercator projection, which preserves direction and shape but distorts distance and area. A projection that preserves area, such as the Albers equal-area conic projection, should be used if more accurate calculations of distance or area are required.

This product is generated from the USDA-NRCS certified data as of the version date(s) listed below.

Soil Survey Area: El Paso County Area, Colorado
 Survey Area Data: Version 20, Sep 2, 2022

Soil map units are labeled (as space allows) for map scales 1:50,000 or larger.

Date(s) aerial images were photographed: Jun 9, 2021—Jun 12, 2021

The orthophoto or other base map on which the soil lines were compiled and digitized probably differs from the background imagery displayed on these maps. As a result, some minor shifting of map unit boundaries may be evident.

Hydrologic Soil Group

| Map unit symbol | Map unit name | Rating | Acres in AOI | Percent of AOI |
|------------------------------------|--|--------|--------------|----------------|
| 1 | Alamosa loam, 1 to 3 percent slopes | D | 49.5 | 8.1% |
| 41 | Kettle gravelly loamy sand, 8 to 40 percent slopes | B | 172.3 | 28.3% |
| 71 | Pring coarse sandy loam, 3 to 8 percent slopes | B | 130.6 | 21.5% |
| 92 | Tomah-Crowfoot loamy sands, 3 to 8 percent slopes | B | 216.4 | 35.5% |
| 111 | Water | | 40.0 | 6.6% |
| Totals for Area of Interest | | | 608.9 | 100.0% |

Description

Hydrologic soil groups are based on estimates of runoff potential. Soils are assigned to one of four groups according to the rate of water infiltration when the soils are not protected by vegetation, are thoroughly wet, and receive precipitation from long-duration storms.

The soils in the United States are assigned to four groups (A, B, C, and D) and three dual classes (A/D, B/D, and C/D). The groups are defined as follows:

Group A. Soils having a high infiltration rate (low runoff potential) when thoroughly wet. These consist mainly of deep, well drained to excessively drained sands or gravelly sands. These soils have a high rate of water transmission.

Group B. Soils having a moderate infiltration rate when thoroughly wet. These consist chiefly of moderately deep or deep, moderately well drained or well drained soils that have moderately fine texture to moderately coarse texture. These soils have a moderate rate of water transmission.

Group C. Soils having a slow infiltration rate when thoroughly wet. These consist chiefly of soils having a layer that impedes the downward movement of water or soils of moderately fine texture or fine texture. These soils have a slow rate of water transmission.

Group D. Soils having a very slow infiltration rate (high runoff potential) when thoroughly wet. These consist chiefly of clays that have a high shrink-swell potential, soils that have a high water table, soils that have a claypan or clay layer at or near the surface, and soils that are shallow over nearly impervious material. These soils have a very slow rate of water transmission.

If a soil is assigned to a dual hydrologic group (A/D, B/D, or C/D), the first letter is for drained areas and the second is for undrained areas. Only the soils that in their natural condition are in group D are assigned to dual classes.

Rating Options

Aggregation Method: Dominant Condition

Component Percent Cutoff: None Specified

Tie-break Rule: Higher

APPENDIX C – GEC (CONSTRUCTION) PLANS AND DETAILS

| | |
|--------------------------------------|--|
| PoDI / NHS | |
| PROJECT OF DIVISION INTEREST (PoDI)? | <input type="checkbox"/> NO <input type="checkbox"/> YES |
| NATIONAL HIGHWAY SYSTEM? | <input type="checkbox"/> NO <input type="checkbox"/> YES |

DEPARTMENT OF TRANSPORTATION STATE OF COLORADO

CONSTRUCTION BID PLANS OF PROPOSED FEDERAL AID PROJECT NO. SAR M915-009 LEWIS PALMER TRAIL LEWIS PALMER SCHOOL DISTRICT 38

| |
|---|
| RELATED PROJECT: |
| P.E. UNDER PROJECT: PROJECT NUMBER: PROJECT CODE: |
| R.O.W. PROJECT: |
| TBD |

TABULATION OF LENGTH & DESIGN DATA

| STATION | PATH LENGTH (FT) |
|---|------------------|
| WOODMOOR DRIVE BEGIN PATH 0+00.00 END PATH 30+99.13 | 3099.13 |
| WILLOW PARK WAY & LAKE ACCESS ROAD BEGIN PATH 30+99.13 END PATH 52+84.41 | 2185.28 |
| LAKE WOODMOOR DRIVE BEGIN PATH 52+84.41 END PATH 55+32.09 | 247.68 |
| CORONADO BEACH DR BEGIN PATH 55+32.09 END PATH 64+33.46 | 901.37 |
| LOWER LAKE ROAD BEGIN PATH 64+33.46 END PATH 66+69.77 | 236.31 |
| LAKE WOODMOOR DRIVE BEGIN PATH 66+69.77 END PATH 80+76.62 | 1406.85 |
| WOODMOOR IMPROVEMENT (ASSOCIATION- OPEN SPACE) BEGIN PATH 80+76.62 END PATH 103+00.00 | 2223.38 |
| DEER CREEK ROAD BEGIN PATH 103+00.00 END PATH 127+63.00 | 2463.00 |

TOWN OF MONUMENT, EL PASO COUNTY, COLORADO

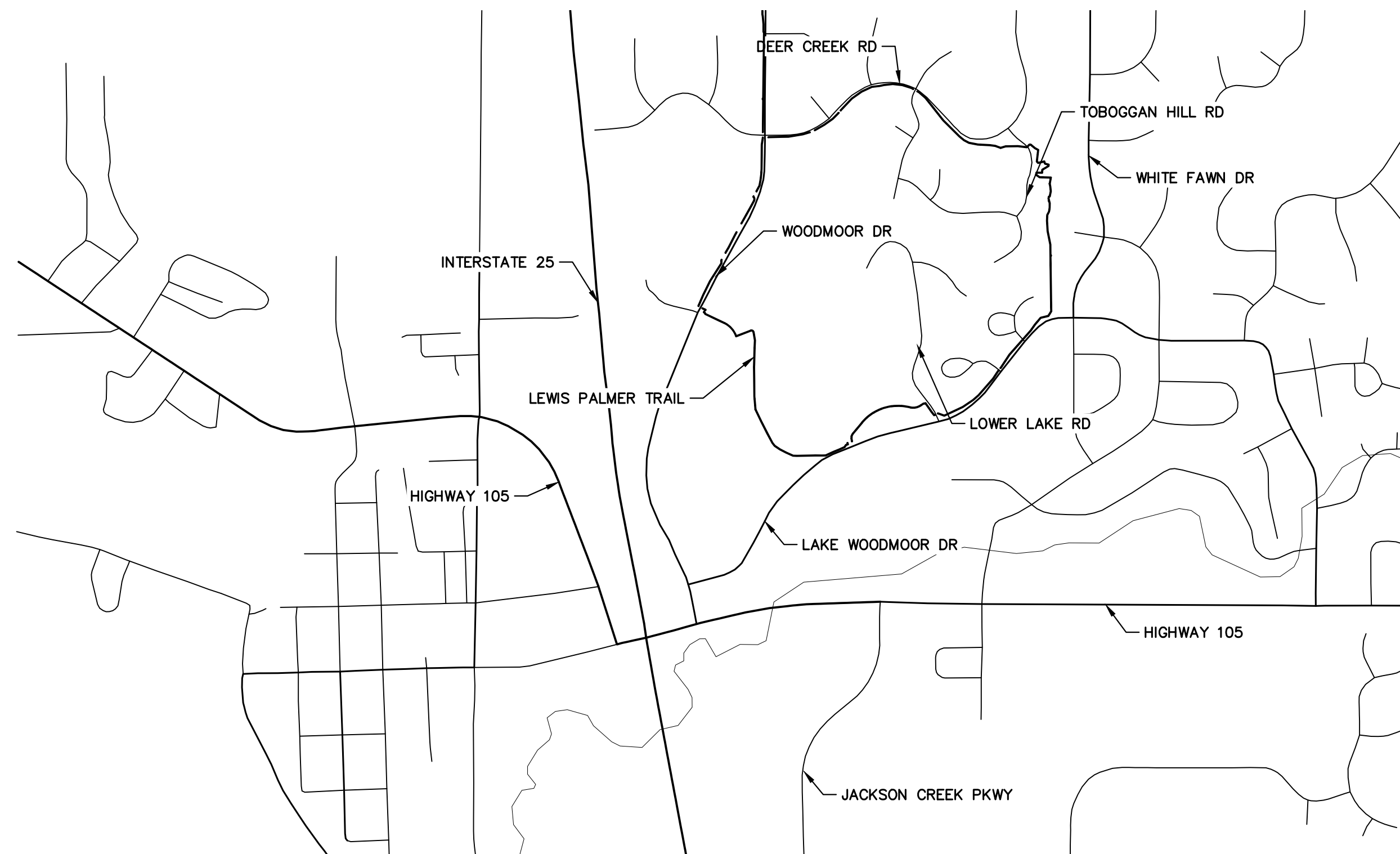

VICINITY MAP
SCALE: 1"=1000'

DESIGN DATA

| | |
|---------------|------------------------|
| WIDTH | 4' |
| CROSS-SLOPE | 5% MAX |
| MAXIMUM SLOPE | 12.5% |
| PASSING ZONE | 5'x5' MAX 1,000' APART |
| RESTING ZONES | 5% MAX SLOPE |

SHEET INDEX

- 1 - COVER SHEET
- 2 - STANDARDS PLAN LIST
- 3 - LEGEND
- 4 - TYPICAL SECTIONS
- 5-6 - RAMP DETAILS
- 7 - GEC DETAILS
- 8 - NOTES
- 9 - SUMMARY OF APPROXIMATE QUANTITIES
- 10 - SURVEY TABULATIONS
- 11-13 - HORIZONTAL CONTROL PLANS
- 14-29 - TRAIL PLAN AND PROFILE
- 30-42 - CROSS SECTION

CONTACTS:

| | |
|--------------------------|--|
| OWNER | LEWIS PALMER SCHOOL DISTRICT 38 146 N JEFFERSON STREET MONUMENT, CO 80132 ATTN: RICKY VESTAL P~(719) 757-1430 |
| PROJECT PARTNER | WOODMOOR IMPROVEMENT ASSOCIATION 1691 WOODMOOR DR. MONUMENT, CO 80132 ATTN: P~(719) 488-2693 |
| PROJECT PARTNER | WOODMOOR WATER AND SANITATION DISTRICT PO BOX 1407 MONUMENT, CO 80132 ATTN: P~() - |
| ENGINEER/SURVEYOR | JR ENGINEERING, LLC ATTN: GLENN ELLIS 5475 TECH CENTER DRIVE, SUITE 235 COLORADO SPRINGS, CO 80919 P~(303) 267-6241 |
| CDOT (REGION 2) | COLORADO DEPARTMENT OF TRANSPORTATION 5615 WILLS BOULEVARD PUEBLO, CO 81008 CONTACT: JUNIOR RODRIGUEZ P~(719) 251-6980 |

ENGINEER'S STATEMENT

PREPARED UNDER MY SUPERVISION

GLENN D. ELLIS, P.E.
COLORADO P.E. 38861
FOR AND ON BEHALF OF JR ENGINEERING, LLC

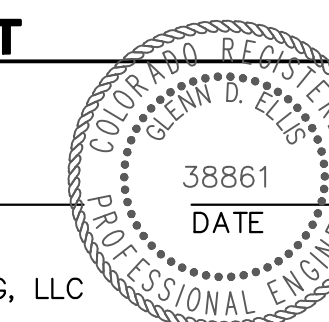

Print Date: 11/23/2022

File Name: _____

Horiz. Scale: N/A Vert. Scale: N/A

Unit name: _____ Unit leader: _____

J-R ENGINEERING
A Westrian Company
Centennial 303-740-9393 • Colorado Springs 719-583-2583
Fort Collins 970-491-9888 • www.jrengineering.com

| Sheet Revisions | | |
|-----------------|----------|-------|
| Date: | Comments | Init. |
| | | |
| | | |
| | | |
| | | |

Colorado Department of Transportation

CDOT
Region 2

5615 WILL BLVD.
Pueblo, CO 81008
Phone: 719-546-5750

LP
Lewis Palmer School District 38

| | | | |
|----------------|---|-------------------|----------------------|
| As Constructed | LEWIS PALMER TRAIL COVER SHEET | | Project No./Code |
| No Revisions: | | | M915-009/22585 |
| Revised: | Designer: GG | Structure Numbers | 2520300 |
| Void: | Detailer: GG | Sheet Subset: | Sheet Number 1 OF 42 |
| | Sheet Subset: | Subset Sheets: OF | |

X:\2022\0000\Drawings\Sheet\Drawings\20220000\01.dwg, C:\01_11232022 7:54:16 AM, CS

| PLAN NUMBER | M STANDARD TITLE | PAGE NUMBER |
|---|--|-------------|
| <input type="checkbox"/> M-100-1 | STANDARD SYMBOLS (3 SHEETS) | 1-3 |
| <input type="checkbox"/> M-100-2 | ACRONYMS AND ABBREVIATIONS (4 SHEETS) | 4-7 |
| <input type="checkbox"/> M-203-1 | APPROACH ROADS | 8 |
| <input type="checkbox"/> M-203-2 | DITCH TYPES | 9 |
| <input type="checkbox"/> M-203-11 | SUPERELEVATION CROWNED AND DIVIDED HIGHWAYS (3 SHEETS) | 10-12 |
| <input type="checkbox"/> M-203-12 | SUPERELEVATION STREETS (2 SHEETS) | 13-14 |
| <input type="checkbox"/> M-206-1 | EXCAVATION AND BACKFILL FOR STRUCTURES (2 SHEETS) | 15-16 |
| <input type="checkbox"/> M-206-2 | EXCAVATION AND BACKFILL FOR BRIDGES (2 SHEETS) | 17-18 |
| <input checked="" type="checkbox"/> M-208-1 | TEMPORARY EROSION CONTROL (11 SHEETS) | 19-29 |
| <input type="checkbox"/> M-210-1 | MAILBOX SUPPORTS (2 SHEETS) | 30-31 |
| <input type="checkbox"/> M-214-1 | NURSERY STOCK DETAILS | 32 |
| <input type="checkbox"/> M-216-1 | SOIL RETENTION COVERING (2 SHEETS) | 33-34 |
| <input type="checkbox"/> M-412-1 | CONCRETE PAVEMENT JOINTS (9 SHEETS) <i>(REVISED ON JANUARY 31, 2022)</i> | 35-39 |
| <input type="checkbox"/> M-412-2 | CONCRETE PAVEMENT CRACK REPAIR (4 SHEETS) <i>(NEW, ISSUED ON OCTOBER 7, 2019)</i> | |
| <input type="checkbox"/> M-510-1 | STRUCTURAL PLATE PIPE H-20 LOADING | 40 |
| <input type="checkbox"/> M-601-1 | SINGLE CONCRETE BOX CULVERT (CAST-IN-PLACE) (2 SHEETS) | 41-42 |
| <input type="checkbox"/> M-601-2 | DOUBLE CONCRETE BOX CULVERT (CAST-IN-PLACE) (2 SHEETS) | 43-44 |
| <input type="checkbox"/> M-601-3 | TRIPLE CONCRETE BOX CULVERT (CAST-IN-PLACE) (2 SHEETS) | 45-46 |
| <input type="checkbox"/> M-601-10 | HEADWALL FOR PIPES | 47 |
| <input type="checkbox"/> M-601-11 | TYPE "S" SADDLE HEADWALLS FOR PIPE | 48 |
| <input type="checkbox"/> M-601-12 | HEADWALLS AND PIPE OUTLET PAVING | 49 |
| <input type="checkbox"/> M-601-20 | WINGWALLS FOR PIPE OR BOX CULVERTS (2 SHEETS) | 50-51 |
| <input type="checkbox"/> M-603-1 | METAL PIPE (4 SHEETS) | 52-55 |
| <input type="checkbox"/> M-603-2 | REINFORCED CONCRETE PIPE | 56 |
| <input type="checkbox"/> M-603-3 | PRECAST CONCRETE BOX CULVERT <i>(REVISED ON SEPTEMBER 10, 2020)</i> | 57 |
| <input type="checkbox"/> M-603-4 | CORRUGATED POLYETHYLENE PIPE (AASHTO M294) AND CORRUGATED POLYPROPYLENE PIPE (AASHTO M330) (2 sheets) <i>(REVISED ON MARCH 7, 2022)</i> | 58 |
| <input type="checkbox"/> M-603-5 | POLYVINYL CHLORIDE (PVC) PIPE (AASHTO M304) | 59 |
| <input type="checkbox"/> M-603-6 | STEEL REINFORCED POLYETHYLENE RIBBED PIPE (AASHTO MP 20) | 60 |
| <input type="checkbox"/> M-603-10 | CONCRETE AND METAL END SECTIONS | 61 |
| <input type="checkbox"/> M-603-12 | TRAVERSABLE END SECTIONS AND SAFETY GRATES (3 SHEETS) | 62-64 |
| <input type="checkbox"/> M-604-10 | INLET, TYPE C | 65 |
| <input type="checkbox"/> M-604-11 | INLET, TYPE D | 66 |
| <input type="checkbox"/> M-604-12 | CURB INLET TYPE R (2 SHEETS) | 67-68 |
| <input type="checkbox"/> M-604-13 | CONCRETE INLET TYPE 13 | 69 |
| <input type="checkbox"/> M-604-20 | MANHOLES (3 SHEETS) | 70-72 |
| <input type="checkbox"/> M-604-25 | VANE GRATE INLET (5 SHEETS) | 73-77 |
| <input type="checkbox"/> M-605-1 | SUBSURFACE DRAINS | 78 |

| PLAN NUMBER | M STANDARD TITLE | PAGE NUMBER |
|---|---|-------------|
| <input type="checkbox"/> M-606-1 | MIDWEST GUARDRAIL SYSTEM TYPE 3 W-BEAM 31 INCHES (19 SHEETS) <i>(REVISED ON MARCH 5, 2020)</i> | 79-97 |
| <input type="checkbox"/> M-606-13 | GUARDRAIL TYPE 7 F-SHAPE BARRIER (4 SHEETS) | 98-101 |
| <input type="checkbox"/> M-606-14 | PRECAST TYPE 7 CONCRETE BARRIER (4 SHEETS) <i>(REVISED ON AUGUST 21, 2020)</i> | 102-104 |
| <input type="checkbox"/> M-606-15 | GUARDRAIL TYPE 9 SINGLE SLOPE BARRIER (11 SHEETS) <i>(REVISED ON MARCH 5, 2020)</i> | 105-115 |
| <input type="checkbox"/> M-607-1 | WIRE FENCES AND GATES (3 SHEETS) | 116-118 |
| <input type="checkbox"/> M-607-2 | CHAIN LINK FENCE (3 SHEETS) | 119-121 |
| <input type="checkbox"/> M-607-3 | BARRIER FENCE | 122 |
| <input type="checkbox"/> M-607-4 | DEER FENCE, GATES, AND GAME RAMPS (7 SHEETS) <i>(REVISED ON JULY 13, 2020)</i> | 123-127 |
| <input type="checkbox"/> M-607-10 | PICKET SNOW FENCE | 128 |
| <input type="checkbox"/> M-607-15 | ROAD CLOSURE GATE (9 SHEETS) | 129-137 |
| <input checked="" type="checkbox"/> M-608-1 | CURB RAMPS (10 SHEETS) | 138-147 |
| <input type="checkbox"/> M-609-1 | CURBS, GUTTERS, AND SIDEWALKS (4 SHEETS) | 148-151 |
| <input type="checkbox"/> M-611-1 | CATTLE GUARD (2 SHEETS) | 152-153 |
| <input type="checkbox"/> M-611-2 | DEER GUARD (2 SHEETS) | 154-155 |
| <input type="checkbox"/> M-614-1 | RUMBLE STRIPS (3 SHEETS) | 156-158 |
| <input type="checkbox"/> M-614-2 | SAND BARREL ARRAYS (2 SHEETS) | 159-160 |
| <input type="checkbox"/> M-615-1 | EMBANKMENT PROTECTOR TYPE 3 | 161 |
| <input type="checkbox"/> M-615-2 | EMBANKMENT PROTECTOR TYPE 5 | 162 |
| <input type="checkbox"/> M-616-1 | INVERTED SIPHON | 163 |
| <input type="checkbox"/> M-620-1 | FIELD LABORATORY CLASS 1 | 164 |
| <input type="checkbox"/> M-620-2 | FIELD LABORATORY CLASS 2 (2 SHEETS) | 165-166 |
| <input type="checkbox"/> M-620-11 | FIELD OFFICE CLASS 1 | 167 |
| <input type="checkbox"/> M-620-12 | FIELD OFFICE CLASS 2 | 168 |
| <input type="checkbox"/> M-629-1 | SURVEY MONUMENTS (2 SHEETS) | 169-170 |

| PLAN NUMBER | S STANDARD TITLE | PAGE NUMBER |
|---|--|--------------------|
| <input type="checkbox"/> S-612-1 | DELINEATOR INSTALLATIONS (8 SHEETS) | 171-178 |
| <input type="checkbox"/> S-613-1 | ROADWAY LIGHTING (6 SHEETS) <i>(REVISED ON SEPTEMBER 30, 2020)</i> | 179-186 |
| <input checked="" type="checkbox"/> S-613-2 | ALTERNATIVE ROADWAY LIGHTING (4 SHEETS) <i>(NEW, ISSUED ON SEPTEMBER 30, 2020)</i> | |
| <input type="checkbox"/> S-614-1 | GROUND SIGN PLACEMENT (2 SHEETS) | 187-188 |
| <input type="checkbox"/> S-614-2 | CLASS I SIGNS | 189 |
| <input type="checkbox"/> S-614-3 | CLASS II SIGNS | 190 |
| <input type="checkbox"/> S-614-4 | CLASS III SIGNS (3 SHEETS) | 191-193 |
| <input type="checkbox"/> S-614-5 | BREAK-AWAY SIGN SUPPORT DETAILS FOR CLASS III SIGNS (2 SHEETS) | 194-195 |
| <input type="checkbox"/> S-614-6 | CONCRETE FOOTINGS AND SIGN ISLANDS FOR CLASS III SIGNS (2 SHEETS) | 196-197 |
| <input type="checkbox"/> S-614-8 | TUBULAR STEEL SIGN SUPPORT DETAILS (7 SHEETS) <i>(REVISED ON DECEMBER 31, 2020)</i> | 198-204 |
| S-614-9 | PEDESTRIAN PUSH BUTTON POST ASSEMBLY (2 SHEETS) <i>(SUPERSEDED ON JANUARY 23, 2020 BY S-614-45)</i> | 205-206 |
| <input type="checkbox"/> S-614-10 | MARKER ASSEMBLY INSTALLATIONS | 207 |
| <input type="checkbox"/> S-614-11 | MILEPOST SIGN DETAIL FOR HIGH SNOW AREAS | 208 |
| <input type="checkbox"/> S-614-12 | STRUCTURE NUMBER INSTALLATION (2 SHEETS) | 209-210 |
| <input type="checkbox"/> S-614-14 | FLASHING BEACON AND SIGN INSTALLATIONS (4 SHEETS) | 211-214 |
| <input type="checkbox"/> S-614-20 | TYPICAL POLE MOUNT SIGN INSTALLATIONS | 215 |
| <input type="checkbox"/> S-614-21 | CONCRETE BARRIER SIGN POST INSTALLATIONS (2 SHEETS) <i>(REVISED ON SEPTEMBER 21, 2020)</i> | 216-217 |
| <input type="checkbox"/> S-614-22 | TYPICAL MULTI-SIGN INSTALLATIONS | 218 |
| <input type="checkbox"/> S-614-40 | TYPICAL TRAFFIC SIGNAL 30'-75' DOUBLE MAST ARMS 65'-75' SINGLE MAST ARMS (5 SHEETS) <i>(REVISED ON JULY 22, 2022)</i> | 219-223 |
| <input type="checkbox"/> S-614-40A | ALTERNATIVE TRAFFIC SIGNAL 25'-55' SINGLE MAST ARMS (4 SHEETS) <i>(REVISED ON JULY 22, 2022)</i> | 224-227 |
| <input type="checkbox"/> S-614-41 | TEMPORARY SPAN WIRE SIGNALS (13 SHEETS) | 228-240 |
| <input type="checkbox"/> S-614-42 | CABINET FOUNDATION DETAIL (4 SHEETS) | 241-244 |
| <input type="checkbox"/> S-614-43 | TRAFFIC LOOP AND MISCELLANEOUS SIGNAL DETAILS (8 SHEETS) | 245-252 |
| <input type="checkbox"/> S-614-44 | PEDESTAL POLE SIGNALS (2 SHEETS) | 253-254 |
| <input type="checkbox"/> S-614-45 | PEDESTRIAN PUSH BUTTON POST ASSEMBLY DETAILS (6 SHEETS) <i>(REVISED ON DECEMBER 3, 2020)</i> | |
| <input type="checkbox"/> S-614-50 | STATIC SIGN MONOTUBE STRUCTURES (12 SHEETS) | 255-266 |
| <input type="checkbox"/> S-614-60 | DYNAMIC SIGN MONOTUBE STRUCTURES (14 SHEETS) | 267-280 |
| <input type="checkbox"/> S-627-1 | PAVEMENT MARKINGS (9 SHEETS) <i>(REVISED ON JULY 22, 2022)</i> | 281-289 |
| <input type="checkbox"/> S-630-1 | TRAFFIC CONTROLS FOR HIGHWAY CONSTRUCTION (24 SHEETS) | 290-313 |
| <input type="checkbox"/> S-630-2 | BARRICADES, DRUMS, CONCRETE BARRIERS (TEMP.) AND VERTICAL PANELS | 314 |
| <input type="checkbox"/> S-630-3 | FLASHING BEACON (PORTABLE) DETAILS | 315 |
| <input type="checkbox"/> S-630-4 | STEEL SIGN SUPPORT (TEMPORARY) INSTALLATION DETAILS (2 SHEETS) | 316-317 |
| <input type="checkbox"/> S-630-5 | PORTABLE RUMBLE STRIPS (TEMPORARY) (2 SHEETS) | 318-319 |
| <input type="checkbox"/> S-630-6 | EMERGENCY PULL-OFF AREA (TEMPORARY) | 320 |
| <input type="checkbox"/> S-630-7 | ROLLING ROADBLOCKS FOR TRAFFIC CONTROL (3 SHEETS) | 321-323 |

COLORADO
 DEPARTMENT OF TRANSPORTATION
M&S STANDARDS PLANS LIST
 July 31, 2019
 Revised on September 6, 2022

ALL OF THE M&S STANDARD PLANS, AS SUPPLEMENTED AND REVISED, APPLY TO THIS PROJECT WHEN USED BY DESIGNATED PAY ITEM OR SUBSIDIARY ITEM.

THE M&S STANDARD PLANS USED TO DESIGN THIS PROJECT ARE INDICATED BY A MARKED BOX AND WILL BE ATTACHED TO THE PLANS. ALL THE OTHER M&S STANDARD PLANS ARE STILL ELIGIBLE FOR CONSTRUCTION IF APPROVED BY AN APPROPRIATE CDOT ENGINEER.

| | | | | | | | | | | | | | | | | |
|--|--|-----------------|----------|-------|--|--|---------------------------------|--|--|--|---|------------------|--|--|----------------------|--|
| Print Date: 11/23/2022 | | Sheet Revisions | | | Colorado Department of Transportation | | As Constructed | | LEWIS PALMER TRAIL STANDARDS PLAN LIST | | | Project No./Code | | | | |
| File Name: | | Date: | Comments | Init. | 5615 WILL BLVD. Pueblo, CO 81008 Phone: 719-546-5750 Region 2 | | Lewis Palmer School District 38 | | No Revisions: Revised: Void: | | Designer: GG Detailer: GG Sheet Subset: | | Structure Numbers Subset Sheets: OF | | M915-009/22585 | |
| Horiz. Scale: N/A | | | | | | | | | | | | | | | 2520300 | |
| Unit name | | | | | | | | | | | | | | | Sheet Number 2 OF 42 | |
| Unit leader | | | | | | | | | | | | | | | | |
| J-R ENGINEERING A Westrian Company Centennial 303-740-9393 • Colorado Springs 719-593-2583 Fort Collins 970-491-9888 • www.jrengineering.com | | | | | | | | | | | | | | | | |

X:\25203000\Drawings\Sheet\Drawings\25203000\CDOT.dwg, STANDARD PLAN LIST, 11/23/2022 7:54:35 AM, C:\S

LAYER LINETYPE LEGEND

| | EXISTING | PROPOSED |
|--------------------------|----------|----------|
| PHASE LINE | --- | --- |
| MATCH LINE | --- | --- |
| SECTION LINE | --- | --- |
| BOUNDARY LINE | --- | --- |
| PROPERTY LINE | --- | --- |
| EASEMENT LINE | --- | --- |
| RIGHT OF WAY | --- | --- |
| R.O.W. A LINE | --- | --- |
| CENTERLINE | --- | --- |
| CITY LIMITS | --- | --- |
| WIRE FENCE | --- | --- |
| CHAIN LINK FENCE | --- | --- |
| WOOD FENCE | --- | --- |
| MASONRY FENCE | --- | --- |
| GUARDRAIL | --- | --- |
| CONC. BARRIER | --- | --- |
| CABLE TV | --- | --- |
| ELECTRIC | --- | --- |
| FIBER OPTIC | --- | --- |
| GAS MAIN | --- | --- |
| IRRIGATION MAIN | --- | --- |
| OIL/PETRO. MAIN | --- | --- |
| OVERHEAD UTILITY | --- | --- |
| SANITARY SEWER | --- | --- |
| STORM DRAIN | --- | --- |
| TELEPHONE | --- | --- |
| WATER MAIN | --- | --- |
| RAW WATER LINE | --- | --- |
| SWALE/WATERWAY FLOWLINE | --- | --- |
| DIVERSION DITCH | --- | --- |
| DIVERSION CHANNEL | --- | --- |
| MAJOR DRAINAGE BASIN | --- | --- |
| MINOR DRAINAGE BASIN | --- | --- |
| TOP OF SLOPE | --- | --- |
| TOE OF SLOPE | --- | --- |
| EDGE OF WATER | --- | --- |
| INDEX CONTOUR | --- | --- |
| INTERMEDIATE CONTOUR | --- | --- |
| DEPRESSION CONT. (INDEX) | --- | --- |
| DEPRESSION CONT. (INTER) | --- | --- |
| TOP OF CUTS | --- | --- |
| TOE OF FILLS | --- | --- |
| CUT AND FILL LINE | --- | --- |
| SILT FENCE | --- | --- |
| 100 YEAR FLOODPLAIN | --- | --- |
| 500 YEAR FLOODPLAIN | --- | --- |
| FLOODWAY | --- | --- |
| BASE FLOOD ELEVATION | --- | --- |
| EDGE OF WETLANDS | --- | --- |
| STONE WALL | --- | --- |
| GRAVEL TRAIL | --- | --- |

UTILITIES LEGEND

| | EXISTING | PROPOSED |
|-----------------------------------|----------------------|----------|
| STORM SEWER | | |
| MANHOLE | ⊙ | ● |
| STORM INLET | ⊕ | ⊕ |
| AREA INLET - SQUARE | □ | ■ |
| AREA INLET - ROUND | ○ | ● |
| FLARED END SECTION | ▷ | ▷ |
| RIPRAP | ▨ | ▨ |
| SANITARY SEWER | | |
| LINE MARKER | Mkr San ^o | |
| SERVICE MARKER | △ | |
| CLEAN-OUT | ○ | ● |
| MANHOLE W/ DIRECTIONAL FLOW ARROW | ⊙ | ● |
| WATER LINE | | |
| LINE MARKER | Mkr W ^o | |
| SERVICE MARKER | △ | |
| FIRE HYDRANT | ⊕ | ⊕ |
| FIRE CONNECTION | ⊕ | ⊕ |
| MANHOLE | ⊙ | ● |
| BEND | ⊕ | ⊕ |
| BLOW-OFF VALVE | ⊕ | ⊕ |
| WELL | ⊙ | ● |
| METER | ⊕ | ⊕ |
| VALVE | ⊕ | ⊕ |
| REDUCER | ⊕ | ⊕ |
| THRUST BLOCK | ⊕ | ⊕ |
| CROSS | ⊕ | ⊕ |
| PLUG W/ THRUST BLOCK | ⊕ | ⊕ |
| TEE | ⊕ | ⊕ |
| REVERSE ANCHOR | ⊕ | ⊕ |
| ANODE | ⊕ | ⊕ |
| AIR & VACUUM VALVE ASSEMBLY | ⊕ | ⊕ |
| TRANSMISSION BLOW-OFF ASSEMBLY | ⊕ | ⊕ |
| GAS LINE | | |
| MARKER | Mkr G ^o | |
| SERVICE MARKER | △ | |
| METER | ⊕ | ⊕ |
| VALVE | ⊕ | ⊕ |
| DRY UTILITIES | | |
| CABLE TV MARKER | Mkr TV ^o | |
| CABLE TELEVISION PEDESTAL | ⊕ | |
| ELECTRIC MARKER | Mkr E ^o | |
| ELECTRIC SERVICE MARKER | △ | |
| ELECTRICAL PEDESTAL | ⊕ | |
| ELECTRICAL METER | ⊕ | |
| ELECTRICAL MANHOLE | ⊕ | |
| FIBER-OPTIC MARKER | Mkr FO ^o | |
| IRRIGATION PEDESTAL | ⊕ | |
| TELEPHONE MARKER | Mkr T ^o | |
| TELEPHONE PEDESTAL | ⊕ | |

MONUMENTATION LEGEND

| | |
|--------------------------------|----------------|
| ALUMINUM CAP - FOUND | ●AC |
| BRASS CAP - FOUND | ●BC |
| BENCHMARK - FOUND | ⊕ |
| CROSS - FOUND | ⊕ |
| MONUMENT - SET | ○ |
| MONUMENT - FOUND (DEFAULT) | ● |
| MONUMENT - FOUND (ALTERNATE 1) | ■ |
| MONUMENT - FOUND (ALTERNATE 2) | ⊕ |
| MONUMENT - FOUND (ALTERNATE 3) | ▲ |
| MONUMENT - FOUND (ALTERNATE 4) | ▲ |
| MONUMENT - FOUND (ALTERNATE 5) | ● |
| MONUMENT - FOUND (ALTERNATE 6) | ● |
| MONUMENT - FOUND (ALTERNATE 7) | ● |
| NAIL & WASHER - FOUND | ●NAIL & WASHER |
| PANEL - FOUND | ⊕ |
| PK NAIL - FOUND | ●PK NAIL |
| ROW MONUMENT - FOUND | ⊕ |
| ROW MARKER - FOUND | ⊕ |
| SECTION CORNER - FOUND | ⊕ |
| SECTION CORNER - SET | ⊕ |
| QUARTER-SECTION CORNER - FOUND | ⊕ |
| QUARTER-SECTION CORNER - SET | ⊕ |
| SECTION CENTER - FOUND | ⊕ |
| SECTION CENTER - FOUND | ⊕ |
| CONTROL/TRVERSE POINT - SET | △ |

STORM WATER MANAGEMENT

| KEY | SYMBOL |
|--|--------|
| CHECK DAM | ⊕ |
| CONSTRUCTION ROAD STABILIZATION | ⊕ |
| CURB SOCK INLET PROTECTION | ⊕ |
| CONCRETE WASHOUT AREA | ⊕ |
| DIVERSION DITCH AND DIKE, TEMPORARY | ⊕ |
| DIVERSION CHANNEL, TEMPORARY | ⊕ |
| DEWATERING | ⊕ |
| EROSION CONTROL BLANKET | ⊕ |
| INLET FILTER | ⊕ |
| INLET PROTECTION | ⊕ |
| MULCHING | ⊕ |
| OUTLET PROTECTION | ⊕ |
| PAVED FLUME | ⊕ |
| PERMENENT SEEDING | ⊕ |
| REINFORCED CONCRETE DAM | ⊕ |
| ROUGH CUT STREET CONTROL | ⊕ |
| SEDIMENT BASIN | ⊕ |
| SEDIMENT CONTROL LOG | ⊕ |
| SILT FENCE | ⊕ |
| SURFACE ROUGHENING | ⊕ |
| STABILIZED STAGING AREA | ⊕ |
| SEDIMENT TRAP | ⊕ |
| STRAW BALE BARRIER | ⊕ |
| TERRACING | ⊕ |
| TEMPORARY SEEDING | ⊕ |
| TEMPORARY STREAM CROSSING CULVERT/BRIDGE | ⊕ |
| TEMPORARY STREAM CROSSING FORD TYPE | ⊕ |
| TEMPORARY SLOPE DRAIN | ⊕ |
| VEHICLE TRACKING CONTROL | ⊕ |
| VEHICLE TRACKING CONTROL WITH WASH RACK | ⊕ |

LANDSCAPE LEGEND

| | EXISTING | PROPOSED |
|----------------------|----------|----------|
| TREE - CONIFEROUS | ⊕ | ⊕ |
| TREE - DECIDUOUS | ⊕ | ⊕ |
| SHRUB/BUSH | ⊕ | ⊕ |
| SHRUBS AND BUSHES | ⊕ | ⊕ |
| IRRIGATION BOX | ⊕ | |
| IRRIGATION SPRINKLER | ⊕ | |
| IRRIGATION VALVE | ⊕ | |
| BOLLARD | ⊕ | |
| FLAGPOLE | ⊕ | |

ENGINEER'S STATEMENT

PREPARED UNDER MY SUPERVISION

GLENN D. ELLIS, P.E.
 COLORADO P.E. 38861
 FOR AND ON BEHALF OF JR ENGINEERING, LLC

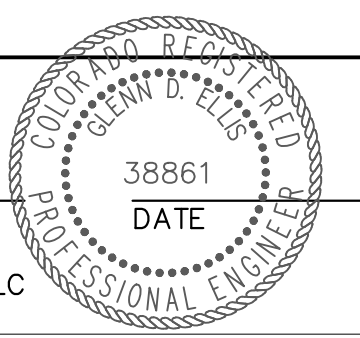

Print Date: 11/23/2022
 File Name:
 Horiz. Scale: N/A Vert. Scale: N/A
 Unit name Unit leader
J-R ENGINEERING
 A Westrian Company
 Centennial 303-740-9393 • Colorado Springs 719-593-2583
 Fort Collins 970-491-9888 • www.jrengineering.com

| Sheet Revisions | | |
|-----------------|----------|-------|
| Date: | Comments | Init. |
| | | |
| | | |
| | | |
| | | |

Colorado Department of Transportation

 5615 WILL BLVD.
 Pueblo, CO 81008
 Phone: 719-546-5750
 Region 2

 Lewis Palmer School District 38

| As Constructed | LEWIS PALMER TRAIL LEGEND | | Project No./Code |
|----------------|---------------------------|----------------|----------------------|
| No Revisions: | Designer: | GG | M915-009/22585 |
| Revised: | Detailer: | GG | 2520300 |
| Void: | Sheet Subset: | Subset Sheets: | Sheet Number 3 OF 42 |

X:\2020\000\Drawings\Sheet\Drawings\2020\000\001.dwg, LEGEND, 11/23/2022, 7:54:31 AM, CS

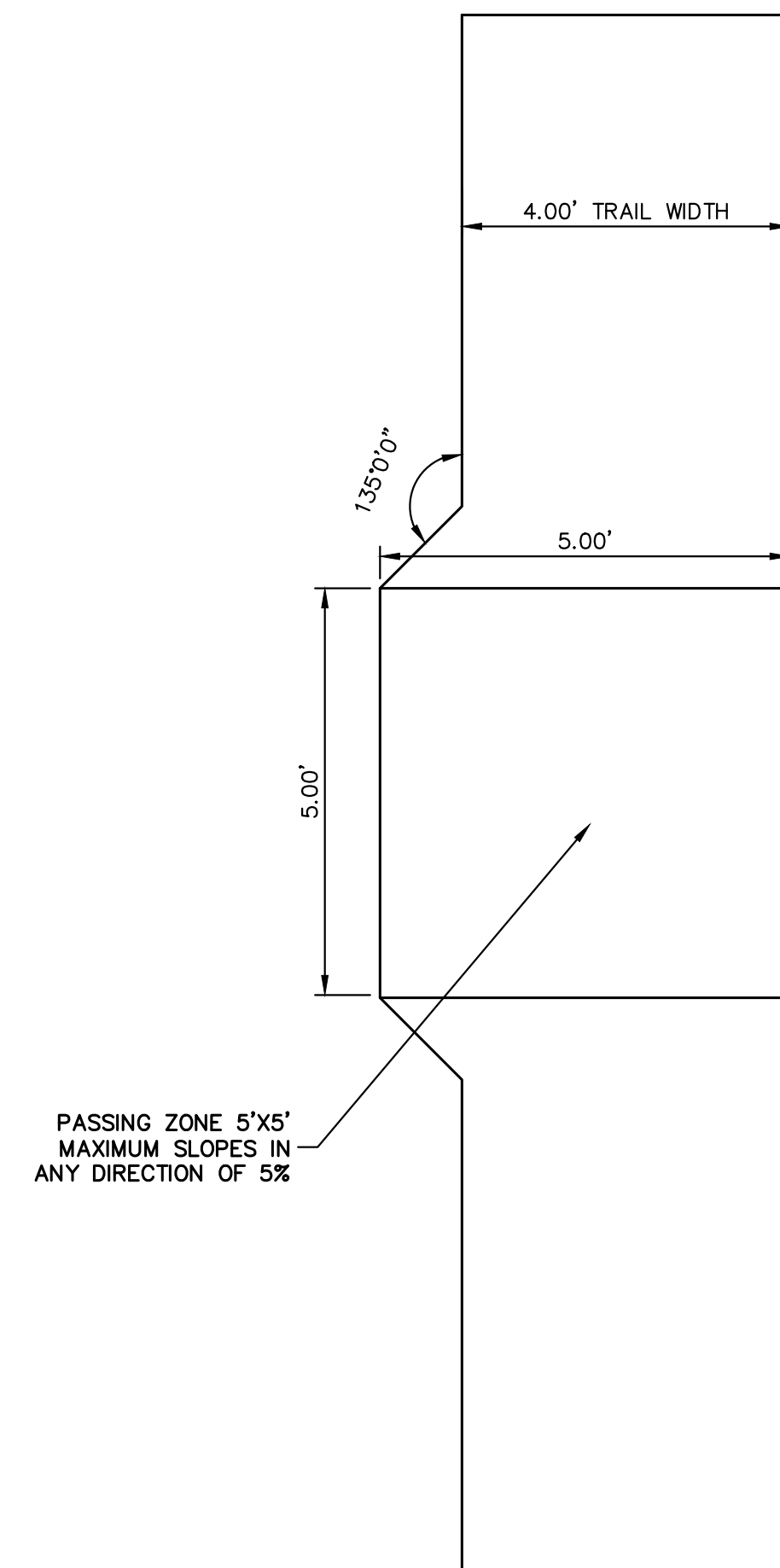

PASSING ZONE
SCALE: N.T.S.

NOTE:
PLACE SILT FENCE AT THE BASE OF THE DOWN HILL SIDE OF THE DISTURBED AREA. REFER TO COUNTY DETAILS ON SHEET 7.

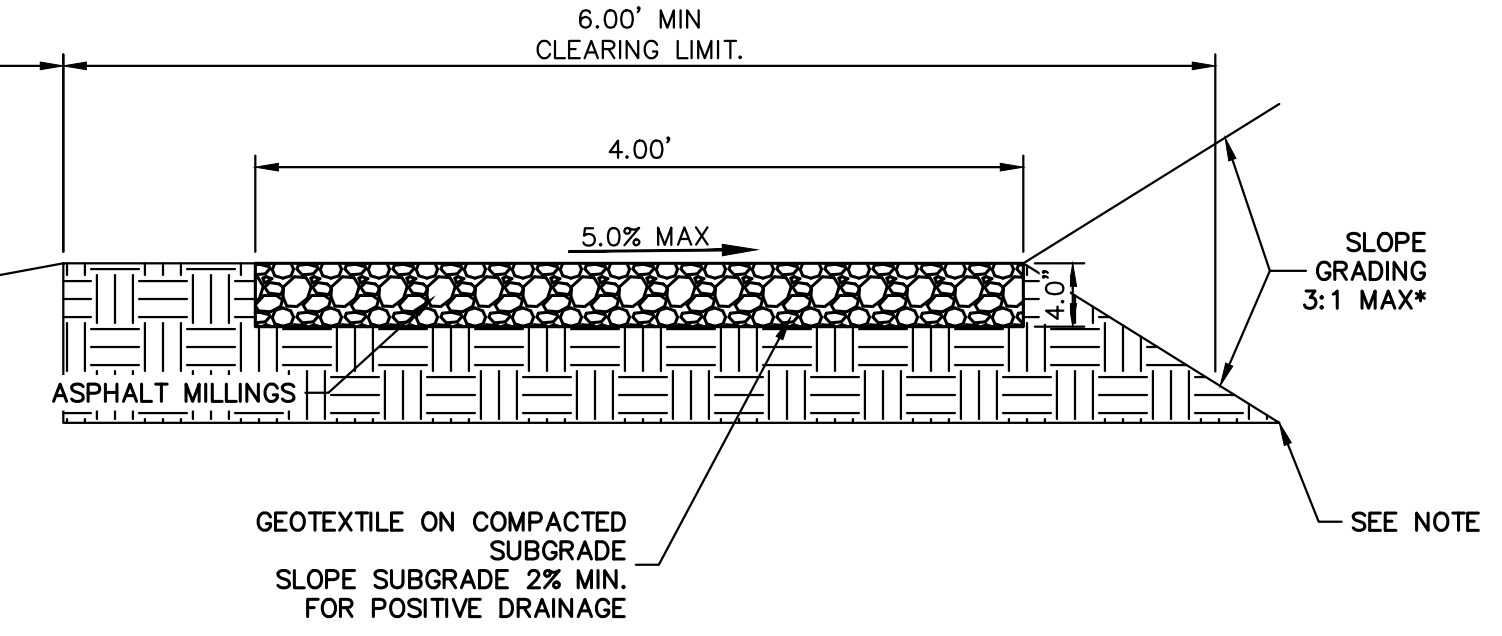
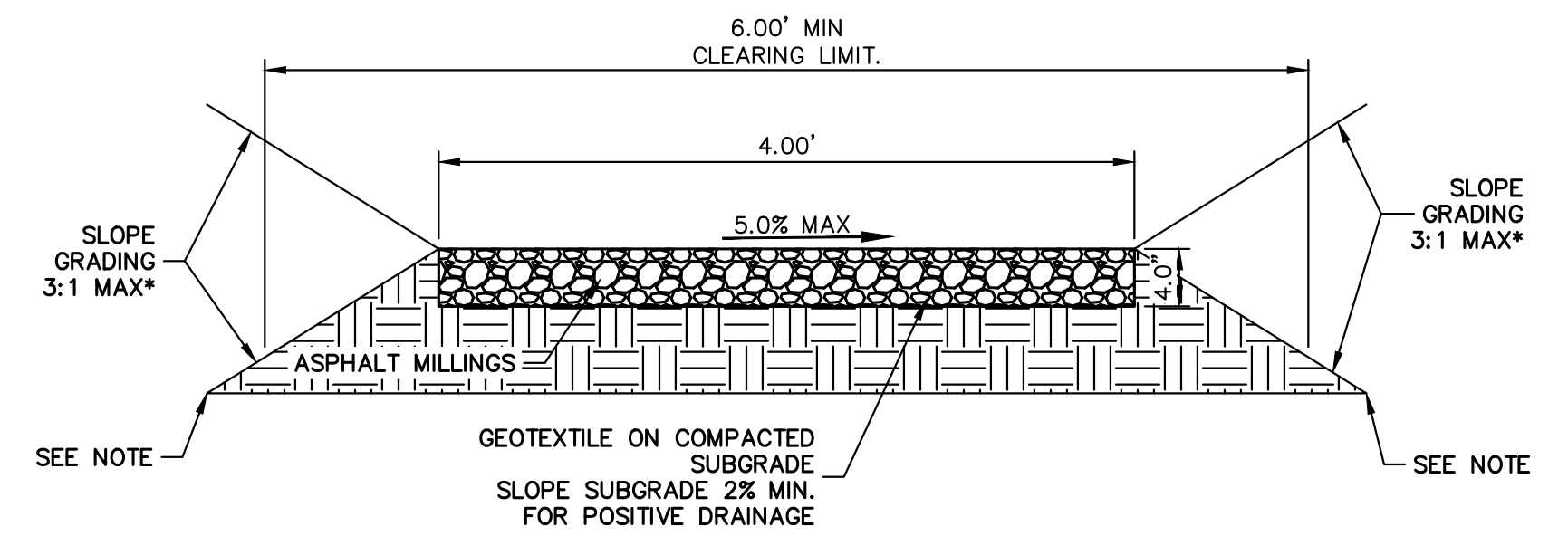
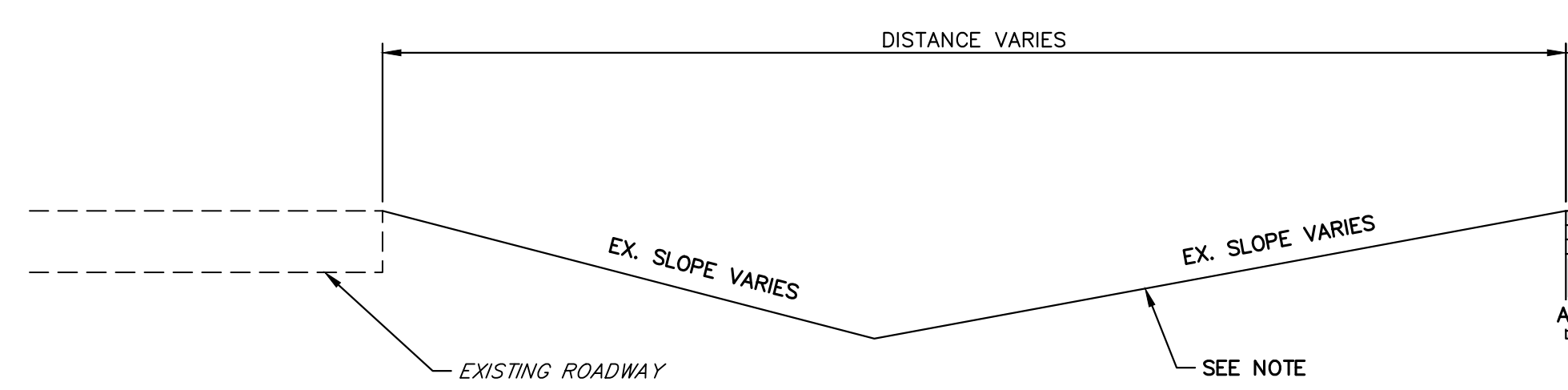

* - UNLESS STATED OTHERWISE IN THE PLANS OR CROSS-SECTIONS

PROPOSED TRAIL TYPICAL SECTION
SCALE: N.T.S.



ENGINEER'S STATEMENT
PREPARED UNDER MY SUPERVISION

GLENN D. ELLIS, P.E.
COLORADO P.E. 38861
FOR AND ON BEHALF OF JR ENGINEERING, LLC

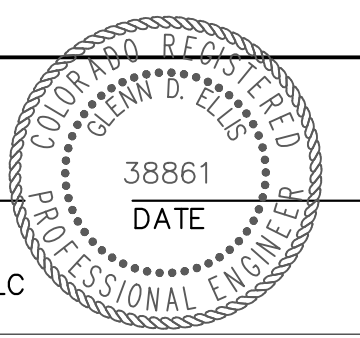

Print Date: 11/23/2022
File Name:
Horiz. Scale: N.T.S. Vert. Scale:
Unit name Unit leader
J-R ENGINEERING
A Westrian Company
Centennial 303-740-9393 • Colorado Springs 719-593-2583
Fort Collins 970-491-9888 • www.jrengineering.com

| Sheet Revisions | | |
|-----------------|----------|-------|
| Date: | Comments | Init. |
| | | |
| | | |
| | | |
| | | |

Colorado Department of Transportation
CDOT
Region 2
5615 WILL BLVD.
Pueblo, CO 81008
Phone: 719-546-5750
LP
Lewis Palmer School District 38

| |
|----------------|
| As Constructed |
| No Revisions: |
| Revised: |
| Void: |

| LEWIS PALMER TRAIL TYPICAL SECTIONS | | | |
|-------------------------------------|----|-------------------|----|
| Designer: | GG | Structure Numbers | |
| Detailer: | GG | | |
| Sheet Subset: | | Subset Sheets: | OF |

| | |
|------------------|----------------|
| Project No./Code | M915-009/22585 |
| | 2520300 |
| Sheet Number | 4 OF 42 |

X:\25203000\Drawings\Sheet\Drawings\25203000_X-Section.dwg, X-Section, 11/23/2022 7:54:35 AM, CS

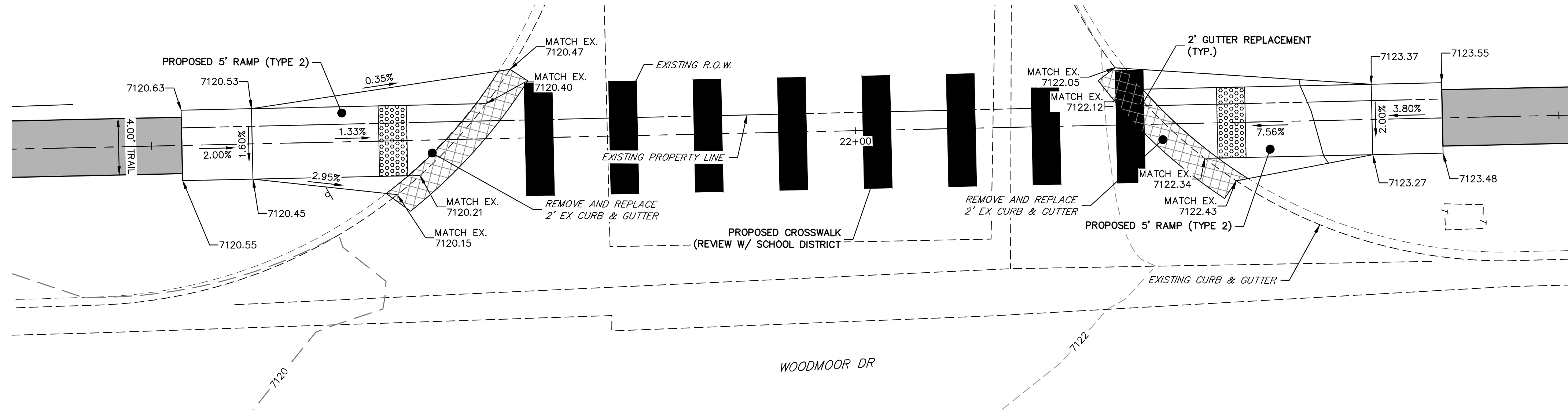

RAMP DETAIL
STA: 21+48.48 TO 22+59.95

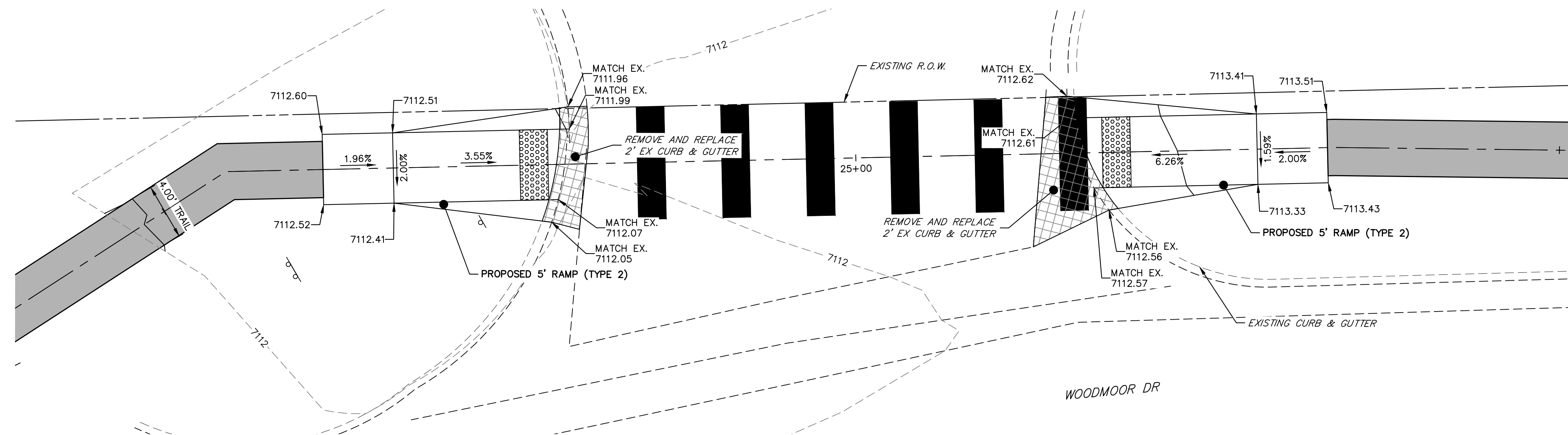

RAMP DETAIL
STA: 24+48.28 TO 25+62.62

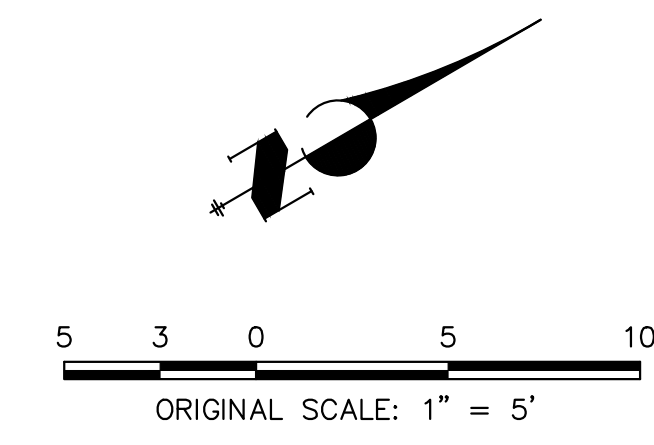

ENGINEER'S STATEMENT

PREPARED UNDER MY SUPERVISION

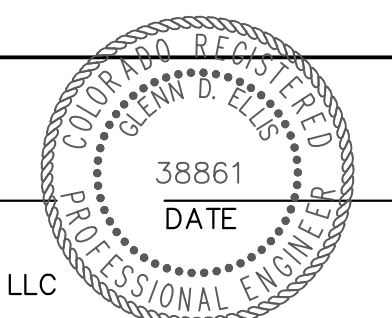

38861
DATE
GLENN D. ELLIS, P.E.
COLORADO P.E. 38861
FOR AND ON BEHALF OF JR ENGINEERING, LLC

Print Date: 11/23/2022

File Name:

Horiz. Scale: 1"=5' Vert. Scale: N/A

Unit name Unit leader

J-R ENGINEERING
A Westrian Company
Centennial 303-740-9393 • Colorado Springs 719-593-2583
Fort Collins 970-491-9888 • www.jrengineering.com

| Sheet Revisions | | |
|-----------------|----------|-------|
| Date: | Comments | Init. |
| | | |
| | | |
| | | |
| | | |

Colorado Department of Transportation

5615 WILL BLVD.
Pueblo, CO 81008
Phone: 719-546-5750

Region 2 Lewis Palmer School District 38

As Constructed

No Revisions:

Revised:

Void:

| LEWIS PALMER TRAIL RAMP DETAILS | | | |
|------------------------------------|----|----------------|----|
| Designer: | GG | Structure | |
| Detailer: | GG | Numbers | |
| Sheet Subset: | | Subset Sheets: | OF |

| Project No./Code |
|----------------------|
| M915-009/22585 |
| 2520300 |
| Sheet Number 5 OF 42 |

X:\2020\000\Drawings\Sheet\Drawings\2020000_Ramp_Details.dwg - Ramp Details - 11/23/2022 7:55:40 AM, CS

CURB RAMP GENERAL NOTES:

- 1 IN NEW CONSTRUCTION OR FULL-DEPTH RECONSTRUCTION, PROVIDE A SEPARATE CURB RAMP FOR EACH MARKED OR UNMARKED PEDESTRIAN STREET CROSSING. CURB RAMP SHALL BE CONTAINED WHOLLY WITHIN THE WIDTH OF THE PEDESTRIAN STREET CROSSING OR CROSSWALK THEY SERVE, OR AS SHOWN ON THE CONTRACT PLANS.
- 2 ALTERATIONS ARE DEFINED AS CHANGES TO AN EXISTING HIGHWAY THAT AFFECT PEDESTRIAN ACCESS, CIRCULATION, OR USE. ALTERATIONS INCLUDE, BUT ARE NOT LIMITED TO, RESURFACING, REHABILITATION, RECONSTRUCTION, CURB RAMP RETROFITS, HISTORIC RESTORATION, OR CHANGES OR REARRANGEMENT TO STRUCTURAL PARTS OR ELEMENTS OF A PEDESTRIAN FACILITY.
- 3 A WALKABLE SURFACE IS DEFINED AS A PAVED SURFACE ADJACENT TO A CURB RAMP OR TURNING SPACE, WITHOUT RAISED OBSTACLES, THAT COULD BE MISTAKENLY TRAVERSED BY A USER WHO IS VISUALLY IMPAIRED.
- 4 IN ALTERATIONS, WHERE AN EXISTING PHYSICAL CONSTRAINT PREVENTS PROVIDING A SEPARATE CURB RAMP FOR EACH PEDESTRIAN STREET CROSSING, A SINGLE DIAGONAL RAMP (ON THE APEX) SHALL BE PERMITTED TO SERVE BOTH PEDESTRIAN STREET CROSSINGS. THE USE OF A SINGLE DIAGONAL RAMP SHALL BE APPROVED BY THE ENGINEER PRIOR TO CONSTRUCTION. DIAGONAL RAMP IS NOT ACCEPTABLE IN NEW CONSTRUCTION OR FULL-DEPTH RECONSTRUCTION.
- 5 DETECTABLE WARNING SURFACES (DWS) ARE INTENDED TO INDICATE THE BOUNDARY BETWEEN A PEDESTRIAN ROUTE AND VEHICULAR ROUTE WHERE THERE IS A FLUSH RATHER THAN CURBED CONNECTION. DWS ARE NOT INTENDED TO PROVIDE WAYFINDING. DWS SHALL BE PROVIDED AT THE FOLLOWING LOCATIONS:
 1. CURB RAMPS, BLENDED TRANSITIONS, AND DEPRESSED CORNERS AT PEDESTRIAN STREET CROSSINGS;
 2. PEDESTRIAN REFUGE ISLANDS (6 FEET IN WIDTH OR GREATER);
 3. BOARDING PLATFORMS AT TRANSIT STOPS WHERE THE EDGE OF THE PLATFORM IS NOT PROTECTED TO PEDESTRIAN CROSS TRAFFIC; AND
 4. BOARDING AREAS AT SIDEWALK OR STREET LEVEL TRANSIT STOPS WHERE THE AREA IS NOT PROTECTED TO PEDESTRIAN CROSS TRAFFIC.
- 6 DETECTABLE WARNING SURFACES SHALL CONTRAST VISUALLY WITH THE ADJACENT GUTTER, HIGHWAY, OR PEDESTRIAN ACCESS ROUTE SURFACE. EITHER LIGHT-ON-DARK OR DARK-ON-LIGHT. FEDERAL YELLOW COLOR IS PREFERRED, HOWEVER, OTHER COLORS MAY BE USED IF APPROVED BY THE ENGINEER.
- 7 IN ALTERATIONS, TO AVOID CHANGING GRADE INDEFINITELY ON STEEP ROADWAYS, A CURB RAMP LENGTH IS NOT REQUIRED TO EXCEED 15 FEET REGARDLESS OF THE RESULTING RAMP RUNNING SLOPE.
- 8 ALL SLOPES ARE MEASURED WITH RESPECT TO A LEVEL PLANE.
- 9 DRAINAGE STRUCTURES, TRAFFIC SIGNAL EQUIPMENT, OR OTHER OBSTRUCTIONS SHALL NOT BE INSTALLED ON THE CURB RAMP, OR TURNING SPACE AREAS.
- 10 IN NEW CONSTRUCTION, PULL BOXES, METER BOXES, MAINTENANCE HOLE COVERS, VAULT LIDS, OR SIMILAR, SHALL NOT BE CONSTRUCTED WITHIN ANY PART OF CURB RAMP OR TURNING SPACE. IN ALTERATIONS, WHERE THESE ITEMS CANNOT BE RELOCATED OUTSIDE OF THE CURB RAMP OR TURNING SPACE, THEY MUST NOT CREATE A VERTICAL DISCONTINUITY GREATER THAN 1/2 INCH. ANY VERTICAL DISCONTINUITY BETWEEN 1/4 INCH AND 1/2 INCH SHALL BE BEVELED WITH A SLOPE NOT STEEPER THAN 1V:2H. THE BEVEL SHALL BE APPLIED ACROSS THE ENTIRE SURFACE DISCONTINUITY.
- 11 CONSTRUCTION OF ANY REQUIRED PEDESTRIAN CURB SHALL BE INCLUDED IN THE BID PRICE OF THE CONCRETE CURB RAMP AND WILL NOT BE PAID FOR SEPARATELY.
- 12 ALL CURB RAMP JOINTS AND GRADE BREAKS SHALL BE FLUSH (0"-1/8"). THE JOINT BETWEEN THE ROADWAY SURFACE AND THE GUTTER PAN SHALL BE FLUSH.
- 13 THE CONTRACTOR SHALL VERIFY REMOVAL LIMITS ARE SUFFICIENT TO PROVIDE POSITIVE DRAINAGE, MAINTAIN EXISTING DRAINAGE PATTERNS, AND AVOID PONDING IN THE FINAL CONFIGURATION.
- 14 FLARED SIDE SLOPES MAY EXCEED 10.0% ONLY WHERE THEY ADJUT A NON-WALKABLE SURFACE, OR WHERE THE ADJACENT RAMP SURFACE IS BLOCKED TO PEDESTRIAN TRAFFIC.
- 15 THE CHANGE IN GRADE AT THE BOTTOM OF THE CURB RAMP SHALL NOT EXCEED AN ALGEBRAIC DIFFERENCE OF 13.33%. THE COUNTER SLOPE OF THE GUTTER AT THE FOOT OF A RAMP, TURNING SPACE, OR BLENDED TRANSITION SHALL NOT EXCEED 5.0%.
- 16 GRADE BREAKS AT THE TOP AND BOTTOM OF RAMP RUNS SHALL BE PERPENDICULAR TO THE DIRECTION OF THE RAMP RUN. GRADE BREAKS SHALL NOT BE PERMITTED ON THE SURFACE OF THE RAMP RUN OR TURNING SPACE. SURFACE SLOPES THAT MEET AT GRADE BREAKS SHALL BE FLUSH.
- 17 A BROOM FINISH, WITH SWEEPS PERPENDICULAR TO THE DIRECTION OF PEDESTRIAN TRAFFIC, SHALL BE APPLIED TO ALL RAMP AND TURNING SPACE SURFACES.
- 18 IN ALTERATIONS, WHERE A RAMP OR TURNING SPACE MUST TIE INTO AN EXISTING GRADE THAT CANNOT BE ALTERED, THE RAMP OR TURNING SPACE MAY BE WARPED TO TRANSITION TO THE REQUIRED CROSS SLOPE. THE TRANSITION TO THE REQUIRED CROSS SLOPE SHALL BE SPREAD EVENLY OVER THE LENGTH OF THE RAMP OR TURNING SPACE TO MINIMIZE THE DEGREE OF WARPING. THE RATE OF CHANGE ON A RAMP OR TURNING SPACE SHALL NOT EXCEED 3% PER LINEAR FOOT.
- 19 DESIGN AND CONSTRUCT CURB RAMPS, TURNING SPACES, AND FLARE SLOPES WITH THE FLATTEST SLOPES POSSIBLE. THE SLOPES INDICATED IN THESE DETAILS SHOW THE MAXIMUM SLOPES ALLOWABLE. PREFERRED VALUES TO BE USED DURING DESIGN, LAYOUT, AND CONSTRUCTION ARE:
 - RAMP RUNNING SLOPE 7.5%
 - RAMP CROSS SLOPE 1.5%
 - TURNING SPACE RUNNING SLOPE 1.5%
 - TURNING SPACE CROSS SLOPE 1.5%
 - FLARE SLOPE 8:10-9:10

- 20 WHERE SNOW REMOVAL EQUIPMENT WILL BE USED TO CLEAR THE PEDESTRIAN ACCESS ROUTE, CONSULT THE ENGINEER PRIOR TO CONSTRUCTION TO ENSURE THE WIDTH AND THICKNESS OF CURB RAMPS IS SUFFICIENT TO ACCOMMODATE SUCH EQUIPMENT.
- 21 PROVIDE EXPANSION JOINT MATERIAL 1/2" THICK WHERE CURB RAMPS ADJOIN ANY RIGID PAVEMENT, OR STRUCTURE. THE TOP OF THE JOINT FILLER MATERIAL SHALL BE FLUSH WITH ADJOINING CONCRETE SURFACES. THE EXPANSION JOINT MATERIAL SHALL EXTEND FOR THE FULL DEPTH OF THE CONCRETE SURFACE.
- 22 PROVIDE TIE BAR REINFORCING BETWEEN INDEPENDENTLY POURED CONCRETE CURB RAMPS OR TURNING SPACES AND CURB AND GUTTER. DRILL AND GROUT NO. 4 12 INCH LONG REINFORCEMENT BARS (EPOXY COATED) AT 18 INCHES CENTER TO CENTER MINIMUM.

CURB RAMP PAY AREAS

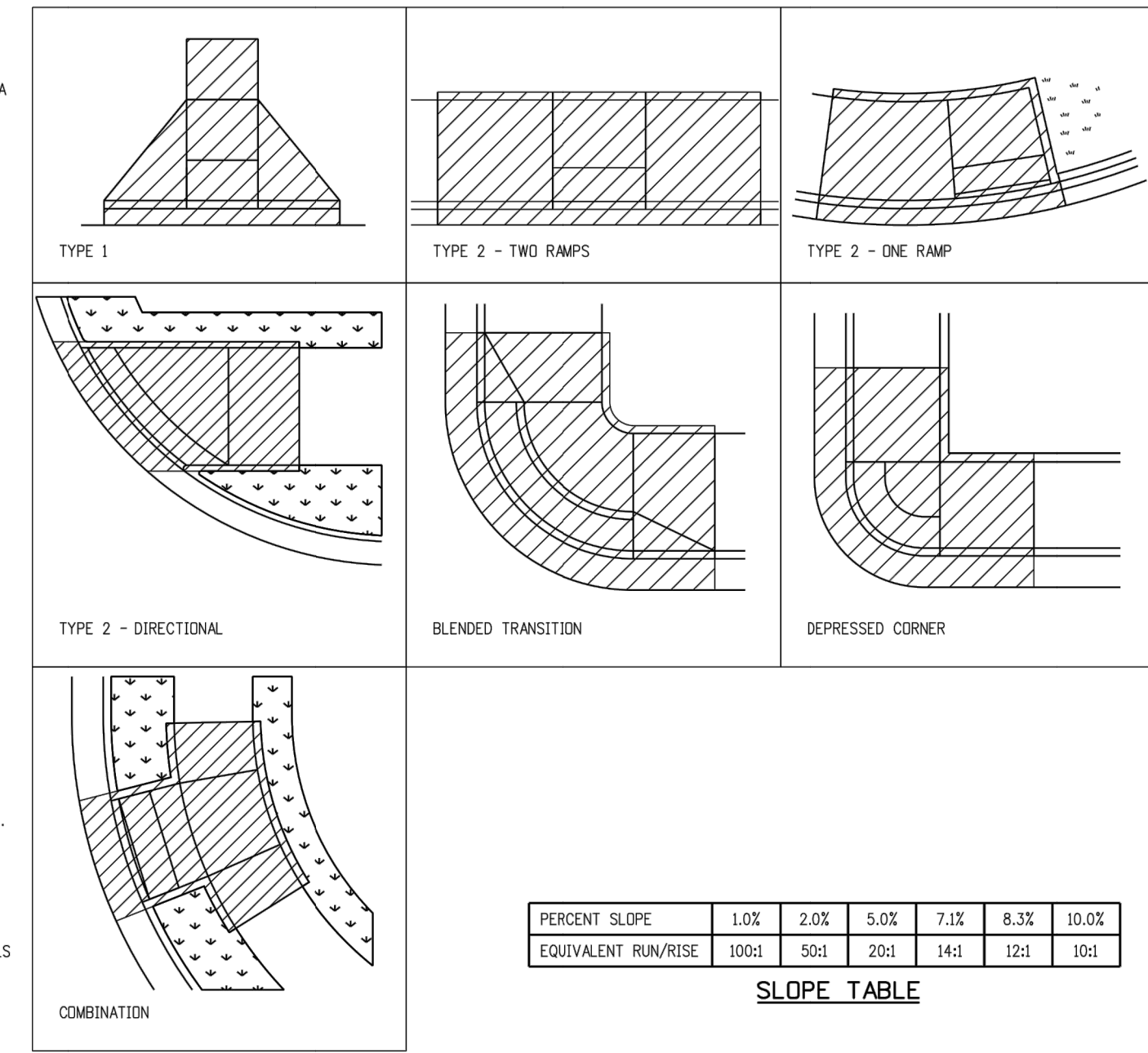

GENERAL NOTES & PAY AREAS

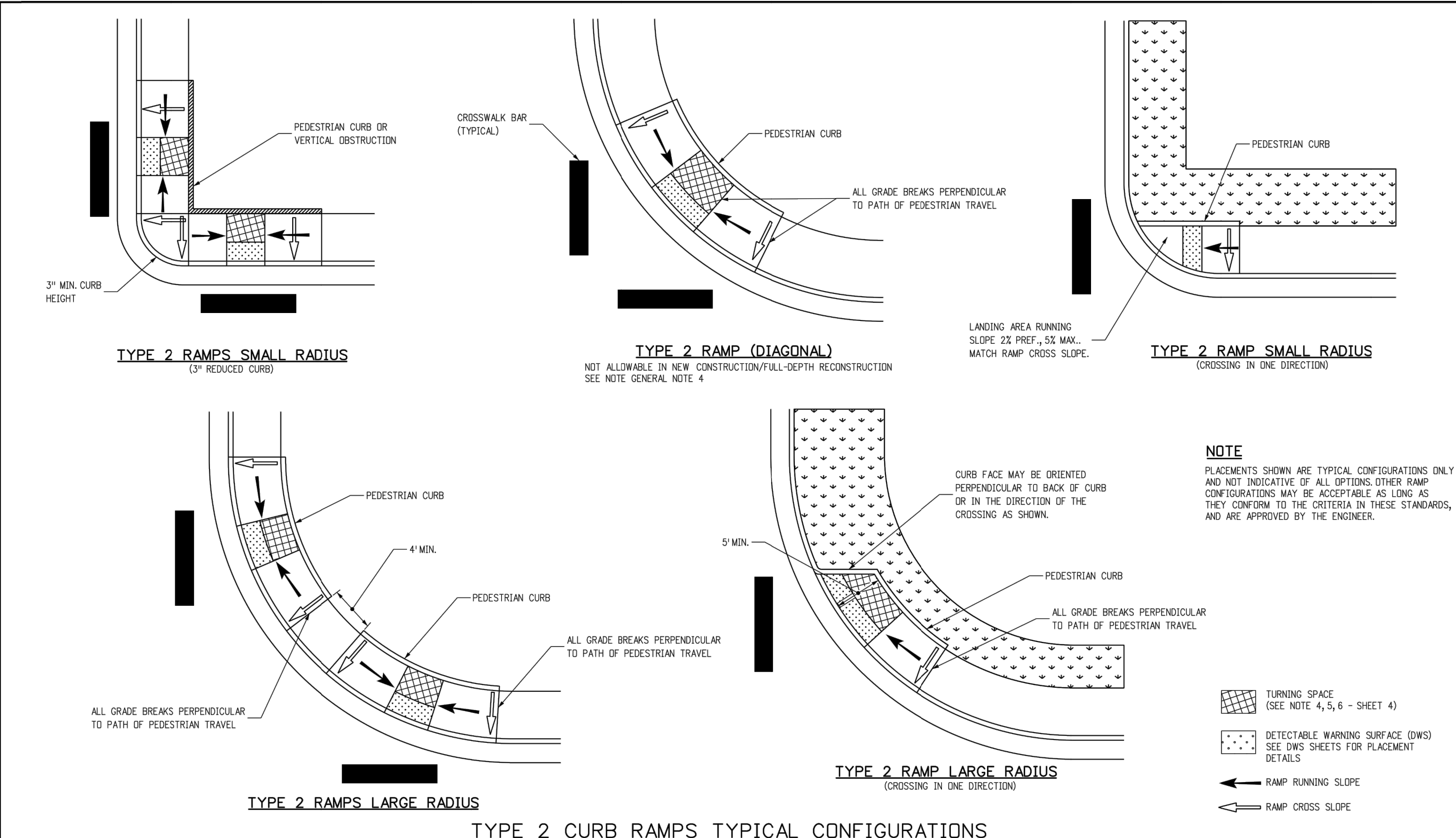

| | | | | | | | |
|---|---|--|--|---|---|--|--|
| Computer File Information Creation Date: 07/31/19 Designer Initials: JBK Last Modification Date: 07/31/19 Detailer Initials: LTA CAD Ver.: MicroStation V8 Scale: Not to Scale Units: English | Sheet Revisions Date: _____ Comments: _____ Date: _____ Comments: _____ Date: _____ Comments: _____ | Colorado Department of Transportation 2829 West Howard Place CDOT HQ, 3rd Floor Denver, CO 80204 Phone: 303-757-9021 FAX: 303-757-9868 Project Development Branch | STANDARD PLAN NO. M-608-1 Standard Sheet No. 1 of 10 Project Sheet Number: _____ | Computer File Information Creation Date: 07/31/19 Designer Initials: JBK Last Modification Date: 07/31/19 Detailer Initials: LTA CAD Ver.: MicroStation V8 Scale: Not to Scale Units: English | Sheet Revisions Date: _____ Comments: _____ Date: _____ Comments: _____ Date: _____ Comments: _____ | Colorado Department of Transportation 2829 West Howard Place CDOT HQ, 3rd Floor Denver, CO 80204 Phone: 303-757-9021 FAX: 303-757-9868 Project Development Branch | STANDARD PLAN NO. M-608-1 Standard Sheet No. 5 of 10 Project Sheet Number: _____ |
|---|---|--|--|---|---|--|--|

Print Date: 11/23/2022
 File Name: _____
 Horiz. Scale: N/A Vert. Scale: N/A
 Unit name: _____ Unit leader: _____

J-R ENGINEERING
 A Westrian Company
 Centennial 303-740-9393 • Colorado Springs 719-583-2583
 Fort Collins 970-491-9888 • www.jrengineering.com

| Date: | Comments | Init. |
|-------|----------|-------|
| | | |
| | | |
| | | |
| | | |

Colorado Department of Transportation
 5615 WILL BLVD.
 Pueblo, CO 81008
 Phone: 719-546-5750

Region 2

Lewis Palmer School District 38

As Constructed
 No Revisions:
 Revised:
 Void:

LEWIS PALMER TRAIL
 RAMP DETAILS

Project No./Code
 M915-009/22585

2520300

Sheet Number 6 OF 42

Designer: GG Structure Numbers
 Detailer: GG
 Sheet Subset: _____ Subset Sheets: OF

811
 Know what's below.
 Call before you dig.

ENGINEER'S STATEMENT
 PREPARED UNDER MY SUPERVISION

GLENN D. ELLIS, P.E.
 COLORADO P.E. 38861
 FOR AND ON BEHALF OF JR ENGINEERING, LLC

38861
 DATE

X:\25203000\Drawings\Sheet\Drawings\25203000_Ramp_Details.dwg Details: 11/23/2022 7:56:46 AM CS

Concrete Washout Area (CWA) MM-1

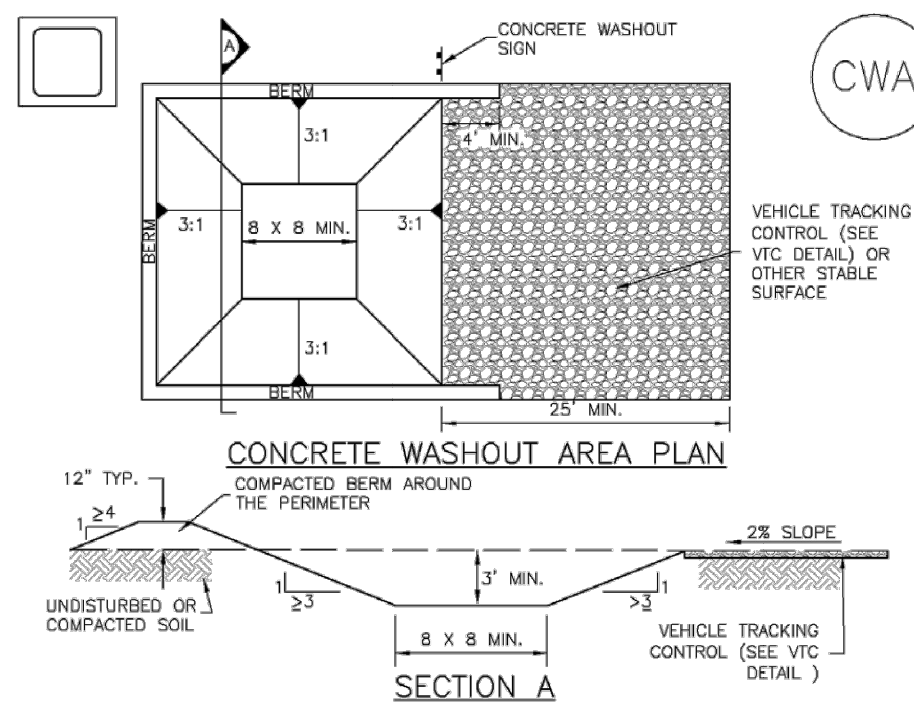

CWA-1. CONCRETE WASHOUT AREA

- CWA INSTALLATION NOTES**
- SEE PLAN VIEW FOR -CWA INSTALLATION LOCATION.
 - DO NOT LOCATE AN UNLINED CWA WITHIN 400' OF ANY NATURAL DRAINAGE PATHWAY OR WATERBODY. DO NOT LOCATE WITHIN 1,000' OF ANY WELLS OR DRINKING WATER SOURCES. IF SITE CONSTRAINTS MAKE THIS INFEASIBLE, OR IF HIGHLY PERMEABLE SOILS EXIST ON SITE, THE CWA MUST BE INSTALLED WITH AN IMPERMEABLE LINER (18 MIL MIN. THICKNESS) OR SURFACE STORAGE ALTERNATIVES USING PREFABRICATED CONCRETE WASHOUT DEVICES OR A LINER ABOVE GROUND STORAGE ARE SHOULD BE USED.
 - THE CWA SHALL BE INSTALLED PRIOR TO CONCRETE PLACEMENT ON SITE.
 - CWA SHALL INCLUDE A FLAT SUBSURFACE PIT THAT IS AT LEAST 3' BY 6' SLOPES LEADING OUT OF THE SUBSURFACE PIT SHALL BE 3:1 OR FLATTER. THE PIT SHALL BE AT LEAST 3" DEEP.
 - BERM SURROUNDING SIDES AND BACK OF THE CWA SHALL HAVE MINIMUM HEIGHT OF 12".
 - VEHICLE TRACKING PAD SHALL BE SLOPED 2% TOWARDS THE CWA.
 - SIGNS SHALL BE PLACED AT THE CONSTRUCTION ENTRANCE, AT THE CWA, AND ELSEWHERE AS NECESSARY TO CLEARLY INDICATE THE LOCATION OF THE CWA TO OPERATORS OF CONCRETE TRUCKS AND PUMP TRUCKS.
 - USE EXCAVATED MATERIAL FOR PERIMETER BERM CONSTRUCTION.

November 2010 Urban Drainage and Flood Control District CWA-3
Urban Storm Drainage Criteria Manual Volume 3

Concrete Washout Area (CWA) MM-1

- CWA MAINTENANCE NOTES**
- INSPECT BMPs EACH WORKDAY, AND MAINTAIN THEM IN EFFECTIVE OPERATING CONDITION. MAINTENANCE OF BMPs SHOULD BE PROACTIVE, NOT REACTIVE. INSPECT BMPs AS SOON AS POSSIBLE (AND ALWAYS WITHIN 24 HOURS) FOLLOWING A STORM THAT CAUSES SURFACE EROSION, AND PERFORM NECESSARY MAINTENANCE.
 - FREQUENT OBSERVATIONS AND MAINTENANCE ARE NECESSARY TO MAINTAIN BMPs IN EFFECTIVE OPERATING CONDITION. INSPECTIONS AND CORRECTIVE MEASURES SHOULD BE DOCUMENTED THOROUGHLY.
 - WHERE BMPs HAVE FAILED, REPAIR OR REPLACEMENT SHOULD BE INITIATED UPON DISCOVERY OF THE FAILURE.
 - THE CWA SHALL BE REPAIRED, CLEANED, OR ENLARGED AS NECESSARY TO MAINTAIN CAPACITY FOR CONCRETE WASTE. CONCRETE MATERIALS, ACCUMULATED IN PIT, SHALL BE REMOVED ONCE THE MATERIALS HAVE REACHED A DEPTH OF 2'.
 - CONCRETE WASHOUT WATER, WASTED PIECES OF CONCRETE AND ALL OTHER DEBRIS IN THE SUBSURFACE PIT SHALL BE TRANSPORTED FROM THE JOB SITE IN A WATER-TIGHT CONTAINER AND DISPOSED OF PROPERLY.
 - THE CWA SHALL REMAIN IN PLACE UNTIL ALL CONCRETE FOR THE PROJECT IS PLACED.
 - WHEN THE CWA IS REMOVED, COVER THE DISTURBED AREA WITH TOP SOIL, SEED AND MULCH OR OTHERWISE STABILIZED IN A MANNER APPROVED BY THE LOCAL JURISDICTION.
- NOTE: MANY JURISDICTIONS HAVE BMP DETAILS THAT VARY FROM UDFCD STANDARD DETAILS. CONSULT WITH LOCAL JURISDICTIONS AS TO WHICH DETAIL SHOULD BE USED WHEN DIFFERENCES ARE NOTED.
- (DETAIL ADAPTED FROM DOUGLAS COUNTY, COLORADO AND THE CITY OF PARKER, COLORADO, NOT AVAILABLE IN AUTOCAD)

CWA-4 Urban Drainage and Flood Control District November 2010
Urban Storm Drainage Criteria Manual Volume 3

Silt Fence (SF) SC-1

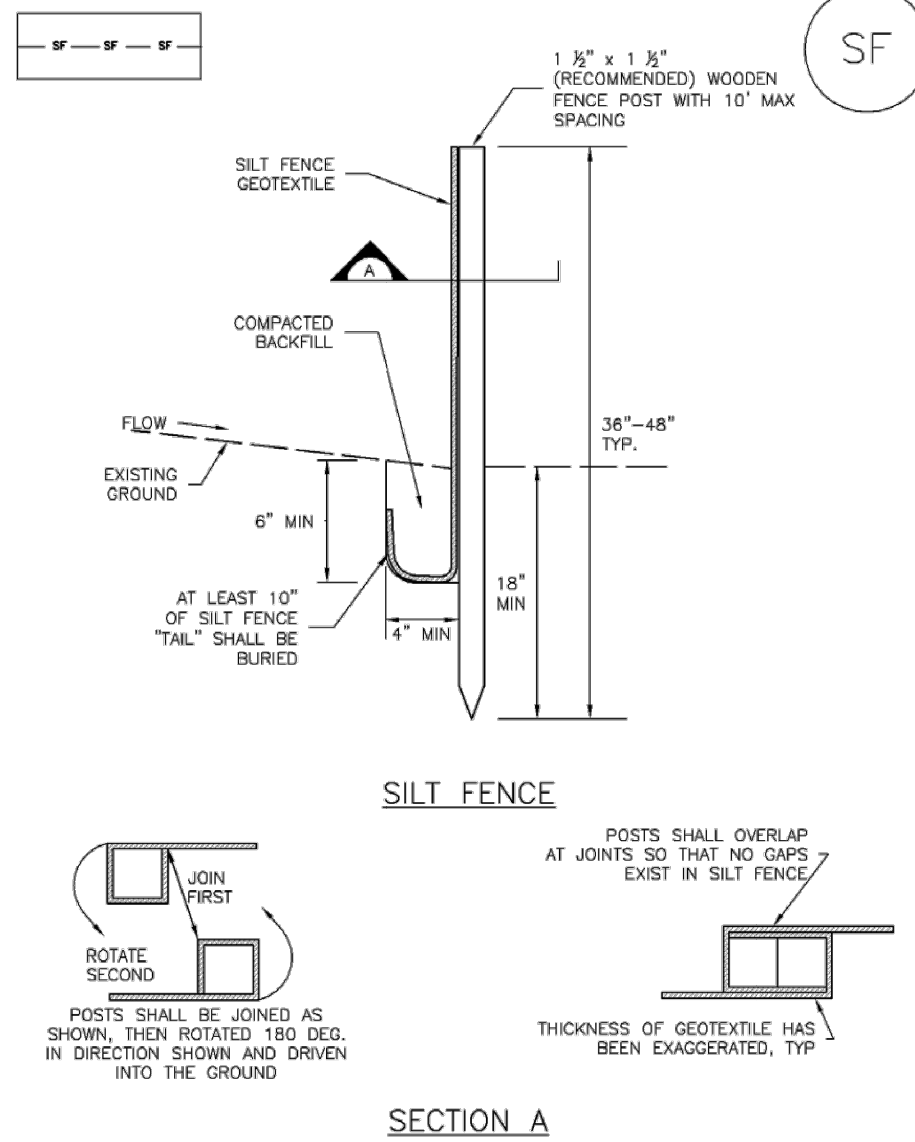

SF-1. SILT FENCE

- SILT FENCE INSTALLATION NOTES**
- SILT FENCE MUST BE PLACED AWAY FROM THE TOE OF THE SLOPE TO ALLOW FOR WATER PONDING. SILT FENCE AT THE TOE OF A SLOPE SHOULD BE INSTALLED IN A FLAT LOCATION AT LEAST SEVERAL FEET (2-3 FT) FROM THE TOE OF THE SLOPE TO ALLOW ROOM FOR PONDING AND DEPOSITION.
 - A UNIFORM 6" X 4" ANCHOR TRENCH SHALL BE EXCAVATED USING TRENCHER OR SILT FENCE INSTALLATION DEVICE. NO ROAD GRADERS, BACKHOES, OR SIMILAR EQUIPMENT SHALL BE USED.
 - COMPACT ANCHOR TRENCH BY HAND WITH A "JUMPING JACK" OR BY WHEEL ROLLING. COMPACTION SHALL BE SUCH THAT SILT FENCE RESISTS BEING PULLED OUT OF ANCHOR TRENCH BY HAND.
 - SILT FENCE SHALL BE PULLED TIGHT AS IT IS ANCHORED TO THE STAKES. THERE SHOULD BE NO NOTICEABLE SAG BETWEEN STAKES AFTER IT HAS BEEN ANCHORED TO THE STAKES.
 - SILT FENCE FABRIC SHALL BE ANCHORED TO THE STAKES USING 1" HEAVY DUTY STAPLES OR NAILS WITH 1" HEADS. STAPLES AND NAILS SHOULD BE PLACED 3" ALONG THE FABRIC DOWN THE STAKE.
 - AT THE END OF A RUN OF SILT FENCE ALONG A CONTOUR, THE SILT FENCE SHOULD BE TURNED PERPENDICULAR TO THE CONTOUR TO CREATE A "J-HOOK." THE "J-HOOK" EXTENDING PERPENDICULAR TO THE CONTOUR SHOULD BE OF SUFFICIENT LENGTH TO KEEP RUNOFF FROM FLOWING AROUND THE END OF THE SILT FENCE (TYPICALLY 10' - 20').
 - SILT FENCE SHALL BE INSTALLED PRIOR TO ANY LAND DISTURBING ACTIVITIES.

- SILT FENCE MAINTENANCE NOTES**
- INSPECT BMPs EACH WORKDAY, AND MAINTAIN THEM IN EFFECTIVE OPERATING CONDITION. MAINTENANCE OF BMPs SHOULD BE PROACTIVE, NOT REACTIVE. INSPECT BMPs AS SOON AS POSSIBLE (AND ALWAYS WITHIN 24 HOURS) FOLLOWING A STORM THAT CAUSES SURFACE EROSION, AND PERFORM NECESSARY MAINTENANCE.
 - FREQUENT OBSERVATIONS AND MAINTENANCE ARE NECESSARY TO MAINTAIN BMPs IN EFFECTIVE OPERATING CONDITION. INSPECTIONS AND CORRECTIVE MEASURES SHOULD BE DOCUMENTED THOROUGHLY.
 - WHERE BMPs HAVE FAILED, REPAIR OR REPLACEMENT SHOULD BE INITIATED UPON DISCOVERY OF THE FAILURE.
 - SEDIMENT ACCUMULATED UPSTREAM OF THE SILT FENCE SHALL BE REMOVED AS NEEDED TO MAINTAIN THE FUNCTIONALITY OF THE BMP, TYPICALLY WHEN DEPTH OF ACCUMULATED SEDIMENTS IS APPROXIMATELY 6".
 - REPAIR OR REPLACE SILT FENCE WHEN THERE ARE SIGNS OF WEAR, SUCH AS SAGGING, TEARING, OR COLLAPSE.
 - SILT FENCE IS TO REMAIN IN PLACE UNTIL THE UPSTREAM DISTURBED AREA IS STABILIZED AND APPROVED BY THE LOCAL JURISDICTION, OR IS REPLACED BY AN EQUIVALENT PERIMETER SEDIMENT CONTROL BMP.
 - WHEN SILT FENCE IS REMOVED, ALL DISTURBED AREAS SHALL BE COVERED WITH TOPSOIL, SEEDED AND MULCHED OR OTHERWISE STABILIZED AS APPROVED BY LOCAL JURISDICTION.
- (DETAIL ADAPTED FROM TOWN OF PARKER, COLORADO AND CITY OF AURORA, NOT AVAILABLE IN AUTOCAD)
- NOTE: MANY JURISDICTIONS HAVE BMP DETAILS THAT VARY FROM UDFCD STANDARD DETAILS. CONSULT WITH LOCAL JURISDICTIONS AS TO WHICH DETAIL SHOULD BE USED WHEN DIFFERENCES ARE NOTED.

November 2010 Urban Drainage and Flood Control District SF-3
Urban Storm Drainage Criteria Manual Volume 3

Silt Fence (SF) SC-1

GEC NOTES:

- LOCATIONS OF CONCRETE WASHOUT AREAS, SILT FENCE, STABILIZED STAGING AREAS, AND VEHICLE TRACKING CONTROL SHALL BE REVIEWED AND APPROVED BY THE SCHOOL DISTRICT PRIOR TO INSTALLATION.

Stabilized Staging Area (SSA) SM-6

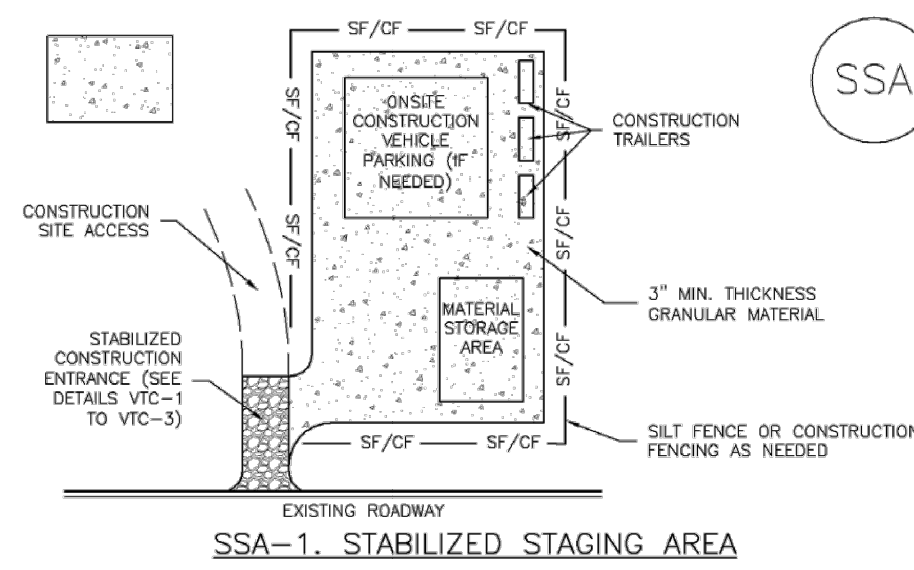

SSA-1. STABILIZED STAGING AREA

- STABILIZED STAGING AREA INSTALLATION NOTES**
- SEE PLAN VIEW FOR -LOCATION OF STAGING AREA(S). -CONTRACTOR MAY ADJUST LOCATION AND SIZE OF STAGING AREA WITH APPROVAL FROM THE LOCAL JURISDICTION.
 - STABILIZED STAGING AREA SHOULD BE APPROPRIATE FOR THE NEEDS OF THE SITE. OVERSIZING RESULTS IN A LARGER AREA TO STABILIZE FOLLOWING CONSTRUCTION.
 - STAGING AREA SHALL BE STABILIZED PRIOR TO OTHER OPERATIONS ON THE SITE.
 - THE STABILIZED STAGING AREA SHALL CONSIST OF A MINIMUM 3" THICK GRANULAR MATERIAL.
 - UNLESS OTHERWISE SPECIFIED BY LOCAL JURISDICTION, ROCK SHALL CONSIST OF DOT SECT. #703, AASHTO #3 COARSE AGGREGATE OR 6" (MINUS) ROCK.
 - ADDITIONAL PERIMETER BMPs MAY BE REQUIRED INCLUDING BUT NOT LIMITED TO SILT FENCE AND CONSTRUCTION FENCING.
- STABILIZED STAGING AREA MAINTENANCE NOTES**
- INSPECT BMPs EACH WORKDAY, AND MAINTAIN THEM IN EFFECTIVE OPERATING CONDITION. MAINTENANCE OF BMPs SHOULD BE PROACTIVE, NOT REACTIVE. INSPECT BMPs AS SOON AS POSSIBLE (AND ALWAYS WITHIN 24 HOURS) FOLLOWING A STORM THAT CAUSES SURFACE EROSION, AND PERFORM NECESSARY MAINTENANCE.
 - FREQUENT OBSERVATIONS AND MAINTENANCE ARE NECESSARY TO MAINTAIN BMPs IN EFFECTIVE OPERATING CONDITION. INSPECTIONS AND CORRECTIVE MEASURES SHOULD BE DOCUMENTED THOROUGHLY.
 - WHERE BMPs HAVE FAILED, REPAIR OR REPLACEMENT SHOULD BE INITIATED UPON DISCOVERY OF THE FAILURE.
 - ROCK SHALL BE REAPPLIED OR REGRADDED AS NECESSARY IF RUTTING OCCURS OR UNDERLYING SUBGRADE BECOMES EXPOSED.

November 2010 Urban Drainage and Flood Control District SSA-3
Urban Storm Drainage Criteria Manual Volume 3

Stabilized Staging Area (SSA) SM-6

- STABILIZED STAGING AREA MAINTENANCE NOTES**
- STABILIZED STAGING AREA SHALL BE ENLARGED IF NECESSARY TO CONTAIN PARKING, STORAGE, AND UNLOADING/LOADING OPERATIONS.
 - THE STABILIZED STAGING AREA SHALL BE REMOVED AT THE END OF CONSTRUCTION THE GRANULAR MATERIAL SHALL BE REMOVED OR, IF APPROVED BY THE LOCAL JURISDICTION, USED ON SITE, AND THE AREA COVERED WITH TOPSOIL, SEEDED AND MULCHED OR OTHERWISE STABILIZED IN A MANNER APPROVED BY LOCAL JURISDICTION.
- NOTE: MANY MUNICIPALITIES PROHIBIT THE USE OF RECYCLED CONCRETE AS GRANULAR MATERIAL FOR STABILIZED STAGING AREAS DUE TO DIFFICULTIES WITH RE-ESTABLISHMENT OF VEGETATION IN AREAS WHERE RECYCLED CONCRETE WAS PLACED.
- NOTE: MANY JURISDICTIONS HAVE BMP DETAILS THAT VARY FROM UDFCD STANDARD DETAILS. CONSULT WITH LOCAL JURISDICTIONS AS TO WHICH DETAIL SHOULD BE USED WHEN DIFFERENCES ARE NOTED.
- (DETAILS ADAPTED FROM DOUGLAS COUNTY, COLORADO, NOT AVAILABLE IN AUTOCAD)

SSA-4 Urban Drainage and Flood Control District November 2010
Urban Storm Drainage Criteria Manual Volume 3

Vehicle Tracking Control (VTC) SM-4

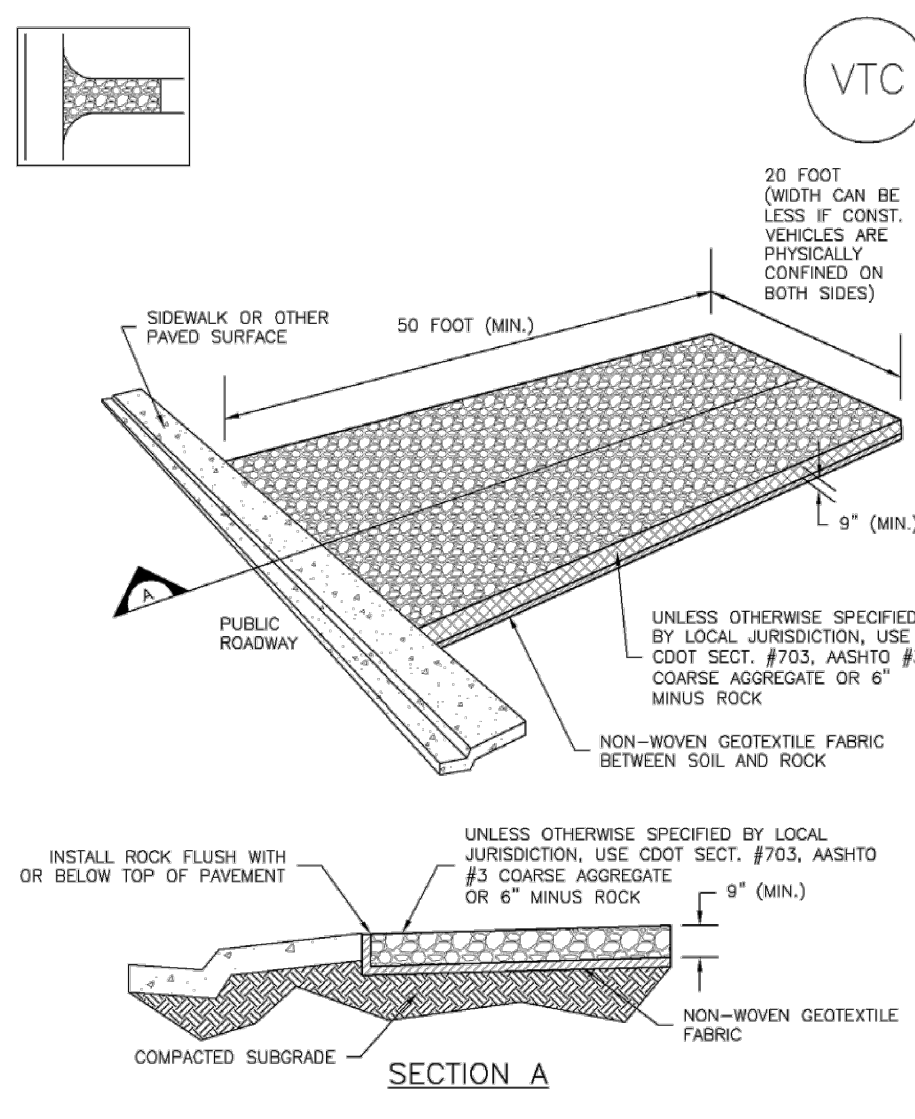

VTC-1. AGGREGATE VEHICLE TRACKING CONTROL

November 2010 Urban Drainage and Flood Control District VTC-3
Urban Storm Drainage Criteria Manual Volume 3

ENGINEER'S STATEMENT

PREPARED UNDER MY SUPERVISION

GLENN D. ELLIS, P.E.
COLORADO P.E. 38861
FOR AND ON BEHALF OF JR ENGINEERING, LLC



Know what's below.
Call before you dig.

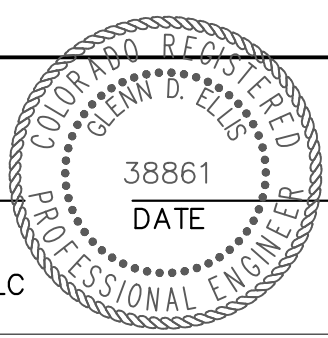

Print Date: 11/23/2022
File Name:
Horiz. Scale: N/A Vert. Scale: N/A
Unit name Unit leader
J-R ENGINEERING
A Westrian Company
Central 303-740-9393 • Colorado Springs 719-583-2583
Fort Collins 970-491-9888 • www.jrengineering.com

| Sheet Revisions | | |
|-----------------|----------|-------|
| Date: | Comments | Init. |
| | | |
| | | |
| | | |
| | | |

Colorado Department of Transportation
5615 WILL BLVD.
Pueblo, CO 81008
Phone: 719-546-5750
Region 2
Lewis Palmer School District 38

| |
|----------------|
| As Constructed |
| No Revisions: |
| Revised: |
| Void: |

| | | | |
|-----------------------------------|----|----------------|----|
| LEWIS PALMER TRAIL GEC DETAILS | | | |
| Designer: | GG | Structure | |
| Detailer: | GG | Numbers | |
| Sheet Subset: | | Subset Sheets: | OF |

| | |
|------------------|----------------|
| Project No./Code | M915-009/22585 |
| | 2520300 |
| Sheet Number | 7 OF 42 |

CONSTRUCTION:

- ALL CONSTRUCTION SHALL BE IN ACCORDANCE WITH THE COLORADO DEPARTMENT OF TRANSPORTATION, STANDARD SPECIFICATIONS FOR ROAD AND BRIDGE CONSTRUCTION, DATED 2019, AND AS SUBSEQUENTLY REVISED. THE STANDARD PLANS DATED JULY 2019 AND AS SUBSEQUENTLY REVISED, AND IN ACCORDANCE WITH THE PLANS AND SPECIFICATIONS INCLUDED HEREIN.
- THE EXISTING CONDITIONS INDICATED ON THESE PLANS ARE BASED ON THE BEST AVAILABLE INFORMATION. THE CONTRACTOR IS RESPONSIBLE FOR VERIFYING EXISTING CONDITIONS AND FOR THE FIT OF ALL NEW CONSTRUCTION.
- THE CONTRACTOR SHALL PROTECT ALL WORK AREAS AND FACILITIES FROM WATER AT ALL TIMES, AREAS AND FACILITIES SUBJECTED TO FLOODING, REGARDLESS OF THE SOURCE OF WATER SHALL BE PROMPTLY DEWATERED AND RESTORED AT NO COST TO THE OWNER. THIS SHALL INCLUDE REMOVAL OF ANY DEBRIS CAUSED BY FLOODING.
- LIMITS OF CONSTRUCTION SHALL BE CONFINED TO PUBLIC PROPERTY, RIGHT-OF-WAY, AND EASEMENTS.
- REPAIR OF ANY DAMAGE TO EXISTING IMPROVEMENTS, IRRIGATION, OR LANDSCAPING IS THE RESPONSIBILITY OF THE CONTRACTOR. ALL ASSOCIATED COSTS FOR IMPROVEMENTS REPAIR SHALL BE PAID FOR BY THE CONTRACTOR, AT NO EXPENSE TO THE SCHOOL DISTRICT.
- THE CONTRACTOR SHALL NOTIFY THE OWNER 2 WEEKS PRIOR TO THE START OF CONSTRUCTION. A PRECONSTRUCTION MEETING SHALL BE HELD PRIOR TO THE START ON CONSTRUCTION.
- THE CONTRACTOR SHALL HAVE: ONE (1) COPY OF THE PLANS, ONE (1) COPY OF THE CONSTRUCTION SPECIFICATIONS, ONE (1) COPY OF THE STORMWATER MANAGEMENT PLAN FOR THE PROJECT, AND ONE (1) COPY OF THE CDOT SPECIFICATIONS (2019) AT THE JOB SITE AT ALL TIMES.
- THE CONTRACTOR SHALL LIMIT CONSTRUCTION ACTIVITIES TO THOSE AREAS WITHIN THE LIMITS OF DISTURBANCE AND/OR TOES OF SLOPES AS SHOWN ON THE PLANS AND CROSS-SECTIONS. ANY DISTURBANCE BEYOND THESE LIMITS SHALL BE RESTORED TO ORIGINAL BY THE CONTRACTOR AT THE CONTRACTOR'S EXPENSE. CONSTRUCTION ACTIVITIES IN ADDITION TO NORMAL CONSTRUCTION PROCEDURES SHALL INCLUDE THE PARKING OF VEHICLES OR EQUIPMENT, DISPOSAL OF LITTER, AND ANY OTHER ACTIONS WHICH WOULD ALTER EXISTING CONDITIONS. THE CONTRACTOR SHALL NOT CONDUCT ANY OPERATIONS OR STAGING OUTSIDE THE CONSTRUCTION LIMITS SHOWN ON THE PLANS OR THAT NOTED ABOVE.
- THE CONTRACTOR SHALL COORDINATE CONSTRUCTION ACTIVITIES WITH IMPACTED UTILITIES TO ASSURE THE TIMELY OPERATION OF THEIR FACILITIES. THIS COORDINATION SHALL INCLUDE ANTICIPATED UTILITIES AND UNFORESEEN UTILITIES.
- HOT WEATHER AND COLD WEATHER CONCRETE OPERATION SHALL BE PERFORMED IN ACCORDANCE WITH CDOT "STANDARD SPECIFICATION FOR ROAD AND BRIDGE CONSTRUCTION" SECTION 601. THIS COST SHALL BE INCLUDED IN THE WORK.
- THE SEVERITY OF CONCRETE EXPOSURE SHALL BE CLASS 1.
- THE CONTRACTOR SHALL NOT PARK VEHICLES OR STORE MATERIALS IN THE CLEAR ZONE.
- REMOVAL OF CONCRETE PAVEMENT ON THIS PROJECT SHALL BE SAWCUT PERPENDICULAR TO THE NEAREST JOINT TO A NEAT LINE AND REMOVED. COST OF SAWING TO BE INCLUDED IN THE WORK.

EARTHWORK:

- WATER SHALL BE USED AS A DUST PALLIATIVE WHERE REQUIRED.
- PRIOR TO MOISTURE DENSITY CONTROL, THE CONTRACTOR SHALL REMOVE ALL TOPSOIL AND SOFT OR DISTURBED SOILS. DEPTH OF MOISTURE – DENSITY CONTROL FOR THIS PROJECT SHALL BE AS FOLLOWS: BASES OF CUTS AND FILLS – 6 INCHES.
- EXCAVATION REQUIRED FOR COMPACTION OF BASES OF CUTS AND FILLS WILL BE CONSIDERED AS SUBSIDIARY TO THAT OPERATION AND WILL NOT BE PAID FOR SEPARATELY.
- COMPACTION OF SOILS, AGGREGATE BASES, AND STRUCTURAL BACKFILL SHALL BE DETERMINED BY CDOT STANDARD SPECIAL PROVISION REVISION TO 203, 206, 304, & 612 COMPACTION AND SHALL BE INCLUDED IN COST OF THE WORK.
- DEPTH OF TOPSOIL REMOVAL SHALL BE AS DIRECTED BY THE ENGINEER. A MINIMUM OF FOUR (4) INCHES OF TOPSOIL SHALL BE PLACED ON ALL DISTURBED AREAS NOT SURFACED. TOPSOIL TO BE USED IS SUBJECT TO REVIEW AND APPROVAL BY THE ENGINEER.
- ALL BORROW MATERIAL IMPORTED FOR USE ON THIS PROJECT SHALL HAVE A MINIMUM R VALUE OF 40 FOR EMBANKMENT WHEN TESTED BY THE HVEM STABILOMETER, AND IS SUBJECT TO REVIEW AND APPROVAL BY THE ENGINEER PRIOR TO ITS INCORPORATION INTO THE PROJECT. ALL BORROW MATERIAL IMPORTED TO THE SITE SHALL MEET THE RESILIENT MODULUS CRITERIA IN ITS NATURAL STATE – NO MIXING SHALL BE ALLOWED.

DRAINAGE/STORM SEWER NOTES:

- THE CONTRACTOR IS REQUIRED TO KEEP EXISTING DRAINAGE STRUCTURES FUNCTIONAL AND MAINTAIN DRAINAGE TO THOSE STRUCTURES AT ALL TIMES DURING CONSTRUCTION.

BUY AMERICA:

ALL STEEL AND IRON PRODUCTS MUST MEET BUY AMERICA REQUIREMENT PER CDOT SPECIFICATIONS SECTION 106.11. BUY AMERICA CERTIFICATIONS SHALL BE PROVIDED TO THE PROJECT ENGINEER WHEN PRODUCTS ARE DELIVERED TO THE SITE.

PERMITS:

STORMWATER CONSTRUCTION PERMIT

IT IS ANTICIPATED THAT A CDPS STORMWATER CONSTRUCTION PERMIT (SCP) WILL BE REQUIRED FOR THIS PROJECT. THE CONTRACTOR SHALL COMPLY WITH ALL REQUIREMENTS OF SECTIONS 101, 107, AND 208 OF THE 2019 STANDARD SPECIFICATIONS FOR ROAD AND BRIDGE CONSTRUCTION.

EL PASO COUNTY RIGHT OF WAY PERMIT

THE CONTRACTOR SHALL OBTAIN A WORK IN RIGHT OF WAY PERMIT FROM EL PASO COUNTY PUBLIC WORKS PRIOR TO CONSTRUCTION.

GRADING AND EROSION CONTROL STANDARD NOTES

- STORMWATER DISCHARGES FROM CONSTRUCTION SITES SHALL NOT CAUSE OR THREATEN TO CAUSE POLLUTION, CONTAMINATION, OR DEGRADATION OF STATE WATERS. ALL WORK AND EARTH DISTURBANCE SHALL BE DONE IN A MANNER THAT MINIMIZES POLLUTION OF ANY ON-SITE OR OFF-SITE WATERS, INCLUDING WETLANDS.
- NOTWITHSTANDING ANYTHING DEPICTED IN THESE PLANS IN WORDS OR GRAPHIC REPRESENTATION, ALL DESIGN AND CONSTRUCTION RELATED TO ROADS, STORM DRAINAGE AND EROSION CONTROL SHALL CONFORM TO THE STANDARDS AND REQUIREMENTS OF THE MOST RECENT VERSION OF THE RELEVANT ADOPTED EL PASO COUNTY STANDARDS, INCLUDING THE LAND DEVELOPMENT CODE, THE ENGINEERING CRITERIA MANUAL, THE DRAINAGE CRITERIA MANUAL, AND THE DRAINAGE CRITERIA MANUAL VOLUME 2. ANY DEVIATIONS FROM REGULATIONS AND STANDARDS MUST BE REQUESTED, AND APPROVED, IN WRITING.
- A SEPARATE STORMWATER MANAGEMENT PLAN (SMWP) FOR THIS PROJECT SHALL BE COMPLETED AND AN EROSION AND STORMWATER QUALITY CONTROL PERMIT (ESQCP) ISSUED PRIOR TO COMMENCING CONSTRUCTION. MANAGEMENT OF THE SWMP DURING CONSTRUCTION IS THE RESPONSIBILITY OF THE DESIGNATED QUALIFIED STORMWATER MANAGER OR CERTIFIED EROSION CONTROL INSPECTOR. THE SWMP SHALL BE LOCATED ON SITE AT ALL TIMES DURING CONSTRUCTION AND SHALL BE KEPT UP TO DATE WITH WORK PROGRESS AND CHANGES IN THE FIELD.
- ONCE THE ESQCP IS APPROVED AND A NOTICE TO PROCEED HAS BEEN ISSUED, THE CONTRACTOR MAY INSTALL THE INITIAL STAGE EROSION AND SEDIMENT CONTROL MEASURES AS INDICATED ON THE APPROVED GEC. A PRECONSTRUCTION MEETING BETWEEN THE CONTRACTOR, ENGINEER, AND EL PASO COUNTY WILL BE HELD PRIOR TO ANY CONSTRUCTION. IT IS THE RESPONSIBILITY OF THE APPLICANT TO COORDINATE THE MEETING TIME AND PLACE WITH COUNTY STAFF.
- CONTROL MEASURES MUST BE INSTALLED PRIOR TO COMMENCEMENT OF ACTIVITIES THAT COULD CONTRIBUTE POLLUTANTS TO STORMWATER. CONTROL MEASURES FOR ALL SLOPES, CHANNELS, DITCHES, AND DISTURBED LAND AREAS SHALL BE INSTALLED IMMEDIATELY UPON COMPLETION OF THE DISTURBANCE.
- ALL TEMPORARY SEDIMENT AND EROSION CONTROL MEASURES SHALL BE MAINTAINED AND REMAIN IN EFFECTIVE OPERATING CONDITION UNTIL PERMANENT SOIL EROSION CONTROL MEASURES ARE IMPLEMENTED AND FINAL STABILIZATION IS ESTABLISHED. ALL PERSONS ENGAGED IN LAND DISTURBANCE ACTIVITIES SHALL ASSESS THE ADEQUACY OF CONTROL MEASURES AT THE SITE AND IDENTIFY IF CHANGES TO THOSE CONTROL MEASURES ARE NEEDED TO ENSURE THE CONTINUED EFFECTIVE PERFORMANCE OF THE CONTROL MEASURES. ALL CHANGES TO TEMPORARY SEDIMENT AND EROSION CONTROL MEASURES MUST BE INCORPORATED INTO THE STORMWATER MANAGEMENT PLAN.
- TEMPORARY STABILIZATION SHALL BE IMPLEMENTED ON DISTURBED AREAS AND STOCKPILES WHERE GROUND DISTURBING CONSTRUCTION ACTIVITY HAS PERMANENTLY CEASED OR TEMPORARILY CEASED FOR LONGER THAN 14 DAYS.
- FINAL STABILIZATION MUST BE IMPLEMENTED AT ALL APPLICABLE CONSTRUCTION SITES. FINAL STABILIZATION IS ACHIEVED WHEN ALL GROUND DISTURBING ACTIVITIES ARE COMPLETE AND ALL DISTURBED AREAS EITHER HAVE A UNIFORM VEGETATIVE COVER WITH INDIVIDUAL PLANT DENSITY OF 70 PERCENT OF PRE-DISTURBANCE LEVELS ESTABLISHED OR EQUIVALENT PERMANENT ALTERNATIVE STABILIZATION METHOD IS IMPLEMENTED. ALL TEMPORARY SEDIMENT AND EROSION CONTROL MEASURES SHALL BE REMOVED UPON FINAL STABILIZATION AND BEFORE PERMIT CLOSURE.
- ALL PERMANENT STORMWATER MANAGEMENT FACILITIES SHALL BE INSTALLED AS DESIGNED IN THE APPROVED PLANS. ANY PROPOSED CHANGES THAT AFFECT THE DESIGN OR FUNCTION OF PERMANENT STORMWATER MANAGEMENT STRUCTURES MUST BE APPROVED BY THE ECM ADMINISTRATOR PRIOR TO IMPLEMENTATION.
- EARTH DISTURBANCES SHALL BE CONDUCTED IN SUCH A MANNER SO AS TO EFFECTIVELY MINIMIZE ACCELERATED SOIL EROSION AND RESULTING SEDIMENTATION. ALL DISTURBANCES SHALL BE DESIGNED, CONSTRUCTED, AND COMPLETED SO THAT THE EXPOSED AREA OF ANY DISTURBED LAND SHALL BE LIMITED TO THE SHORTEST PRACTICAL PERIOD OF TIME. PRE-EXISTING VEGETATION SHALL BE PROTECTED AND MAINTAINED WITHIN 50 HORIZONTAL FEET OF A WATERS OF THE STATE UNLESS SHOWN TO BE INFEASIBLE AND SPECIFICALLY REQUESTED AND APPROVED.
- COMPACTION OF SOIL MUST BE PREVENTED IN AREAS DESIGNATED FOR INFILTRATION CONTROL MEASURES OR WHERE FINAL STABILIZATION WILL BE ACHIEVED BY VEGETATIVE COVER. AREAS DESIGNATED FOR INFILTRATION CONTROL MEASURES SHALL ALSO BE PROTECTED FROM SEDIMENTATION DURING CONSTRUCTION UNTIL FINAL STABILIZATION IS ACHIEVED. IF COMPACTION PREVENTION IS NOT FEASIBLE DUE TO SITE CONSTRAINTS, ALL AREAS DESIGNATED FOR INFILTRATION AND VEGETATION CONTROL MEASURES MUST BE LOOSENEED PRIOR TO INSTALLATION OF THE CONTROL MEASURE(S).
- ANY TEMPORARY OR PERMANENT FACILITY DESIGNED AND CONSTRUCTED FOR THE CONVEYANCE OF STORMWATER AROUND, THROUGH, OR FROM THE EARTH DISTURBANCE AREA SHALL BE A STABILIZED CONVEYANCE DESIGNED TO MINIMIZE EROSION AND THE DISCHARGE OF SEDIMENT OFF SITE.
- CONCRETE WASH WATER SHALL BE CONTAINED AND DISPOSED OF IN ACCORDANCE WITH THE SWMP. NO WASH WATER SHALL BE DISCHARGED TO OR ALLOWED TO ENTER STATE WATERS, INCLUDING ANY SURFACE OR SUBSURFACE STORM DRAINAGE SYSTEM OR FACILITIES. CONCRETE WASHOUTS SHALL NOT BE LOCATED IN AN AREA WHERE SHALLOW GROUNDWATER MAY BE PRESENT, OR WITHIN 50 FEET OF A SURFACE WATER BODY, CREEK OR STREAM.
- DURING DEWATERING OPERATIONS OF UNCONTAMINATED GROUND WATER MAY BE DISCHARGED ON SITE, BUT SHALL NOT LEAVE THE SITE IN THE FORM OF SURFACE RUNOFF UNLESS AN APPROVED STATE DEWATERING PERMIT IS IN PLACE.
- EROSION CONTROL BLANKETING OR OTHER PROTECTIVE COVERING SHALL BE USED ON SLOPES STEEPER THAN 3:1.
- CONTRACTOR SHALL BE RESPONSIBLE FOR THE REMOVAL OF ALL WASTES FROM THE CONSTRUCTION SITE FOR DISPOSAL IN ACCORDANCE WITH LOCAL AND STATE REGULATORY REQUIREMENTS. NO CONSTRUCTION DEBRIS, TREE SLASH, BUILDING MATERIAL WASTES OR UNUSED BUILDING MATERIALS SHALL BE BURIED, DUMPED, OR DISCHARGED AT THE SITE.
- WASTE MATERIALS SHALL NOT BE TEMPORARILY PLACED OR STORED IN THE STREET, ALLEY, OR OTHER PUBLIC WAY, UNLESS IN ACCORDANCE WITH AN APPROVED TRAFFIC CONTROL PLAN. CONTROL MEASURES MAY BE REQUIRED BY EL PASO COUNTY ENGINEERING IF DEEMED NECESSARY, BASED ON SPECIFIC CONDITIONS AND CIRCUMSTANCES.
- TRACKING OF SOILS AND CONSTRUCTION DEBRIS OFF-SITE SHALL BE MINIMIZED. MATERIALS TRACKED OFF-SITE SHALL BE CLEANED UP AND PROPERLY DISPOSED OF IMMEDIATELY.
- THE OWNER/DEVELOPER SHALL BE RESPONSIBLE FOR THE REMOVAL OF ALL CONSTRUCTION DEBRIS, DIRT, TRASH, ROCK, SEDIMENT, SOIL, AND SAND THAT MAY ACCUMULATE IN ROADS, STORM DRAINS AND OTHER DRAINAGE CONVEYANCE SYSTEMS AND STORMWATER APPURTENANCES AS A RESULT OF SITE DEVELOPMENT.
- THE QUANTITY OF MATERIALS STORED ON THE PROJECT SITE SHALL BE LIMITED, AS MUCH AS PRACTICAL, TO THAT QUANTITY REQUIRED TO PERFORM THE WORK IN AN ORDERLY SEQUENCE. ALL MATERIALS STORED ON-SITE SHALL BE STORED IN A NEAT, ORDERLY MANNER, IN THEIR ORIGINAL CONTAINERS, WITH ORIGINAL MANUFACTURER'S LABELS.
- NO CHEMICAL(S) HAVING THE POTENTIAL TO BE RELEASED IN STORMWATER ARE TO BE STORED OR USED ONSITE UNLESS PERMISSION FOR THE USE OF SUCH CHEMICAL(S) IS GRANTED IN WRITING BY THE ECM ADMINISTRATOR. IN GRANTING APPROVAL FOR THE USE OF SUCH CHEMICAL(S), SPECIAL CONDITIONS AND MONITORING MAY BE REQUIRED.
- BULK STORAGE OF ALLOWED PETROLEUM PRODUCTS OR OTHER ALLOWED LIQUID CHEMICALS IN EXCESS OF 55 GALLONS SHALL REQUIRE ADEQUATE SECONDARY CONTAINMENT PROTECTION TO CONTAIN ALL SPILLS ONSITE AND TO PREVENT ANY SPILLED MATERIALS FROM ENTERING STATE WATERS, ANY SURFACE OR SUBSURFACE STORM DRAINAGE SYSTEM OR OTHER FACILITIES.
- NO PERSON SHALL CAUSE THE IMPEDIMENT OF STORMWATER FLOW IN THE CURB AND GUTTER OR DITCH EXCEPT WITH APPROVED SEDIMENT CONTROL MEASURES.
- OWNER/DEVELOPER AND THEIR AGENTS SHALL COMPLY WITH THE "COLORADO WATER QUALITY CONTROL ACT" (TITLE 25, ARTICLE 8, CRS), AND THE "CLEAN WATER ACT" (33 USC 1344), IN ADDITION TO THE REQUIREMENTS OF THE LAND DEVELOPMENT CODE, DCM VOLUME II AND THE ECM APPENDIX I. ALL APPROPRIATE PERMITS MUST BE OBTAINED BY THE CONTRACTOR PRIOR TO CONSTRUCTION (1041, NPDES, FLOODPLAIN, 404, FUGITIVE DUST, ETC.). IN THE EVENT OF CONFLICTS BETWEEN THESE REQUIREMENTS AND OTHER LAWS, RULES, OR REGULATIONS OF OTHER FEDERAL, STATE, LOCAL, OR COUNTY AGENCIES, THE MOST RESTRICTIVE LAWS, RULES, OR REGULATIONS SHALL APPLY.
- ALL CONSTRUCTION TRAFFIC MUST ENTER/EXIT THE SITE ONLY AT APPROVED CONSTRUCTION ACCESS POINTS.
- PRIOR TO CONSTRUCTION THE PERMITTEE SHALL VERIFY THE LOCATION OF EXISTING UTILITIES.
- A WATER SOURCE SHALL BE AVAILABLE ON SITE DURING EARTHWORK OPERATIONS AND SHALL BE UTILIZED AS REQUIRED TO MINIMIZE DUST FROM EARTHWORK EQUIPMENT AND WIND.
- NO SOILS REPORT HAS BEEN PROVIDED FOR THIS SITE.
- AT LEAST TEN (10) DAYS PRIOR TO THE ANTICIPATED START OF CONSTRUCTION, FOR PROJECTS THAT WILL DISTURB ONE (1) ACRE OR MORE, THE OWNER OR OPERATOR OF CONSTRUCTION ACTIVITY SHALL SUBMIT A PERMIT APPLICATION FOR STORMWATER DISCHARGE TO THE COLORADO DEPARTMENT OF PUBLIC HEALTH AND ENVIRONMENT, WATER QUALITY DIVISION. THE APPLICATION CONTAINS CERTIFICATION OF COMPLETION OF A STORMWATER MANAGEMENT PLAN (SWMP), OF WHICH THIS GRADING AND EROSION CONTROL PLAN MAY BE A PART. FOR INFORMATION OR APPLICATION MATERIALS CONTACT:

COLORADO DEPARTMENT OF PUBLIC HEALTH AND ENVIRONMENT
WATER QUALITY CONTROL DIVISION
WQCD – PERMITS
4300 CHERRY CREEK DRIVE SOUTH
DENVER, CO 80246-1530
ATTN: PERMITS UNIT

UTILITIES:

- UTILITIES AS SHOWN ON THE PLAN SHEETS ARE PLOTTED FROM SURVEY SHOTS OF SURFACE FEATURES. THE CONTRACTOR'S ATTENTION IS DIRECTED TO PARAGRAPH 105.11 OF THE STANDARD SPECIFICATION CONCERNING UTILITIES. FOR UTILITY LOCATES, THE CONTRACTOR SHALL CALL THE UTILITY NOTIFICATION CENTER OF COLORADO (UNCC) AT 811 OR 1-800-922-1987 AT LEAST TWO (2) WORKING DAYS (NOT INCLUDING THE INITIAL DAY OF CONTACT) PRIOR TO DIGGING, GRADING OR EXCAVATING.
- THE LOCATION OF EXISTING UTILITIES SHOWN ON THE DRAWINGS HAVE BEEN PLOTTED FROM SURVEY SHOTS OF SURFACE FEATURES. IT IS HOWEVER THE CONTRACTOR'S RESPONSIBILITY TO FIELD VERIFY HORIZONTAL AND VERTICAL LOCATIONS OF ALL UTILITIES PRIOR TO COMMENCING CONSTRUCTION AND TO NOTIFY THE ENGINEER OF ANY DISCREPANCY. ALL CONFLICTING UTILITIES SHALL BE EXPOSED BY THE CONTRACTOR PRIOR TO CONSTRUCTION AND INSPECTION BY THE ENGINEER TO VERIFY CONFORMANCE WITH THE PLANS. RELOCATION OF EXISTING UTILITIES IS NOT A PART OF THIS CONTRACT EXCEPT AS SHOWN ON THESE DRAWINGS. THE CONTRACTOR IS RESPONSIBLE FOR COORDINATION OF UTILITY RELOCATION BY UTILITY COMPANIES. THE CONTRACTOR SHALL BE RESPONSIBLE FOR PROTECTING UTILITIES DURING CONSTRUCTION AND SHALL HOLD THE SCHOOL DISTRICT HARMLESS FOR DAMAGES ARISING FROM CONTRACTOR'S FAILURE TO ADEQUATELY PROTECT EXISTING UTILITIES.
- THE CONTRACTOR SHALL REFERENCE THE PROJECT TECHNICAL SPECIFICATIONS FOR ADDITIONAL ITEMS THE CONTRACTOR SHALL ADHERE TO IN COOPERATION WITH UTILITIES.

SIGNING, STRIPING, TRAFFIC CONTROL NOTES:

- CONSTRUCTION TRAFFIC CONTROL SHALL CONFORM TO THE 2009 MANUAL ON UNIFORM TRAFFIC CONTROL DEVICES (MUTCD) AND CDOT STANDARD S-630-1. THE CONTRACTOR WILL BE REQUIRED TO SUBMIT A METHOD OF HANDLING TRAFFIC (MHT) TO THE ENGINEER FOR APPROVAL FOR EACH APPLICABLE PHASE OF WORK. ALL COST FOR CONTROLLING TRAFFIC DURING CONSTRUCTION SHALL BE INCLUDED IN ITEM 630 – CONSTRUCTION TRAFFIC CONTROL (LS).
- THE CONTRACTOR IS RESPONSIBLE FOR SECURING AND DELINEATING THE SITE DURING CONSTRUCTION.
- THE CONTRACTOR IS RESPONSIBLE TO, AT HIS OWN EXPENSE, REPLACE ANY SIGNS THAT ARE DAMAGED OR LOST DURING CONSTRUCTION.
- THE CONTRACTOR SHALL BE RESPONSIBLE FOR ALL WORK ZONE TRAFFIC CONTROL, INCLUDING PEDESTRIAN TRAFFIC CONTROL, BICYCLE TRAFFIC, PARK USERS AND ON STREET PARKING. TRAFFIC CONTROL SHALL BE IN ACCORDANCE WITH THE LATEST VERSION OF THE MUTCD AND ANY CDOT STANDARDS. ALL TRAFFIC CONTROL IS TO BE APPROVED BY THE SCHOOL DISTRICT PRIOR TO INSTALLATION. COST SHALL BE INCLUDED IN PAY ITEM 630-TRAFFIC CONTROL. CONTRACTOR TO PROVIDE TRAFFIC CONTROL PLANS TO CDOT FOR APPROVAL 2 DAYS PRIOR TO CONSTRUCTION.
- SIGNS MUST MEET CURRENT MUTCD STANDARDS FOR ROADS, AND BE HIGH INTENSITY PRISMATIC SHEETING.
- POST AND MOUNTS – POST AND MOUNTS SHALL BE NCHRP 350 COMPLIANT.
- POST – 12 GAUGE 1-3/4" 12' TALL PERFORATED SQUARE POSTS.



Know what's below.
Call before you dig.

ENGINEER'S STATEMENT

PREPARED UNDER MY SUPERVISION

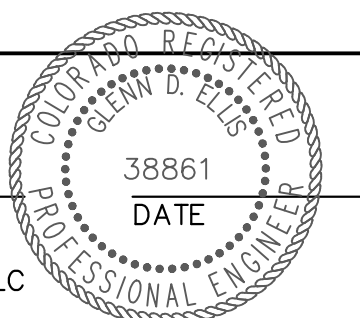

GLENN D. ELLIS, P.E.
COLORADO P.E. 38861
FOR AND ON BEHALF OF JR ENGINEERING, LLC

| | | | | | | | | | |
|--|------------------|----------|-------|--|---------------------------------|--------------------|-------|----------------|----------------------|
| Print Date: 11/23/2022 | Sheet Revisions | | | Colorado Department of Transportation | As Constructed | LEWIS PALMER TRAIL | | | Project No./Code |
| File Name: | Date: | Comments | Init. | | | No Revisions: | NOTES | | |
| Horiz. Scale: N/A | Vert. Scale: N/A | | | | Revised: | Designer: | GG | Structure | 2520300 |
| Unit name | Unit leader | | | | Void: | Detailer: | GG | Numbers | Sheet Number 8 OF 42 |
| J-R ENGINEERING A Westrian Company Centennial 303-740-9393 • Colorado Springs 719-593-2583 Fort Collins 970-491-9888 • www.jrengineering.com | | | | 5615 WILL BLVD. Pueblo, CO 81008 Phone: 719-546-5750 Region 2 | Lewis Palmer School District 38 | Sheet Subset: | | Subset Sheets: | OF |

X:\25203000\Drawings\Sheet\DWG\25203000_Notes.dwg, Notes, 11/23/2022, 1:33:08 PM, CS

| CDOT ITEM NO. | DESCRIPTION | UNIT | QUANTITY | |
|---------------|---|------|----------|-----------|
| | | | PLAN | AS CONST. |
| 201-00000 | Clearing and Grubbing | LS | 1 | |
| 202-00203 | Removal of Curb and Gutter | LF | 50 | |
| 203-00060 | Embankment Material (Complete In Place) | CY | 110 | |
| 208-00000-SPC | Erosion Control | LS | 1 | |
| 208-00046 | Pre-fabricated Concrete Washout Structure | EACH | 1 | |
| 208-00070 | Vehicle Tracking Pad | EACH | 6 | |
| 210-01000 | Reset Fence | LF | 70 | |
| 212-00006 | Seeding (Native) | ACRE | 0.6 | |
| 213-00000 | Mulching | ACRE | 0.6 | |
| 213-00061 | Mulch Tackifier | LB | 300 | |
| 306-01000 | Reconditioning | SY | 4,150 | |
| 608-00000 | Concrete Sidewalk | SY | 100 | |
| 608-00010 | Concrete Curb Ramp | SY | 75 | |
| 608-00015 | Detectable Warnings | SF | 65 | |
| 608-01550 | Place Asphalt Millings | SY | 4,150 | |
| 614-00011 | Sign Panel (Class I) | SF | 50 | |
| 614-00214 | Steel Sign Post (1.75x1.75 Inch Tubing) | LF | 75 | |
| 620-00020 | Sanitary Facility | EACH | 1 | |
| 625-00000 | Construction Surveying | LS | 1 | |
| 626-00000 | Mobilization | LS | 1 | |
| 627-00002 | Thermoplastic Pavement Marking | SF | 1,650 | |
| 630-10005 | Traffic Control | LS | 1 | |
| 700-70010 | F/A Minor Contract Revisions | FA | 1 | |



Know what's below.
Call before you dig.

ENGINEER'S STATEMENT

PREPARED UNDER MY SUPERVISION

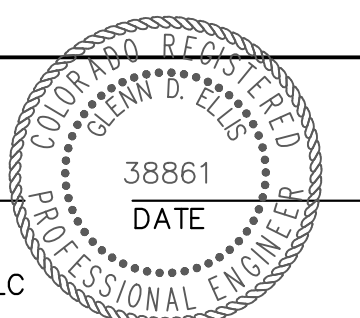

GLENN D. ELLIS, P.E.
COLORADO P.E. 38861
FOR AND ON BEHALF OF JR ENGINEERING, LLC

Print Date: 11/23/2022

File Name:

Horiz. Scale: N/A Vert. Scale: N/A

Unit name Unit leader

J-R ENGINEERING
A Westrian Company
Centennial 303-740-9393 • Colorado Springs 719-583-2583
Fort Collins 970-491-9888 • www.jrengineering.com

| Sheet Revisions | | |
|-----------------|----------|-------|
| Date: | Comments | Init. |
| | | |
| | | |
| | | |
| | | |

Colorado Department of Transportation

5615 WILL BLVD.
Pueblo, CO 81008
Phone: 719-546-5750

Region 2 Lewis Palmer School District 38

| | | | |
|----------------|-----------------------------------|-------------------|----------------------|
| As Constructed | LEWIS PALMER TRAIL | | Project No./Code |
| No Revisions: | SUMMARY OF APPROXIMATE QUANTITIES | | M915-009/22585 |
| Revised: | Designer: GG | Structure Numbers | 2520300 |
| Void: | Detailer: GG | Sheet Subset: | Sheet Number 9 OF 42 |
| | | Subset Sheets: OF | |

X:\25203000\Drawings\Sheet\Drawings\25203000_Quantities.dwg, Quantities.dwg, 11/23/2022 7:56:59 AM, CS

TO ESTABLISH GEOMETRIC CONTROL FOR THE CONSTRUCTION OF THIS PROJECT, THE DEPARTMENT HAS PROVIDED THE FOLLOWING INFORMATION:

- Format *
- 3D Design Modeling Electronic Files _____
 - Horizontal Control PLAN SHEET
 - Vertical Control PLAN SHEET
 - Roadway Alignment DWG
 - Original Terrain Data _____
 - Other: _____

* Specify the information format, ie., plan sheet, computer disk, computer printout, or other. The information marked is either contained on the plans or is available from the Engineer.

TYPE OF PROJECT

- Landscaping
- Signalization
- Safety Improvement
- Asphalt Overlay
- Concrete Overlay
- Minor Widening
- Major Reconstruction
- New Roadway Construction
- Bridge Replacement
- Bridge Widening
- New Bridge
- Other: PEDESTRIAN IMPROVEMENT

SURVEY WORK TO BE PERFORMED BY OTHERS: _____

WORK PERFORMED BY THE CONTRACTOR'S SURVEYOR UNDER SECTION 625:

- A complete passing Base Line report (completed within 6 months prior to the start of the project)
- An instrument calibration Certification (completed within 6 months prior to the start of the project)
- Establish and Maintain Project Centerline or Engineer Approved Offset Line(s)
- Verification and Maintenance of Horizontal and Vertical Control
- Verify or Determine existing grades and alignments
- Verify or Determine existing topography
- Clearing and Grubbing Limits (Section 201)
- Removal Limits (Section 202)
- Reset Items (Section 210)
- Excavation and Embankment (Section 203)

- Excavation**
- Unclassified
 - Stripping
 - Muck
 - Rock
 - Borrow
 - Other: _____
 - Potholing

- Embankment**
- Site Grading
 - Erosion Control (Perm)
 - Other: _____

As Staked Earthwork Quantities (See General Notes)

- Landscaping
- Top Soil (Section 207)
- Seeding (Section 212)
- Mulching (Section 213)
- Planting (Section 214)
- Herbicide (Section 217)
- Other: _____

- Erosion Control (Section 208)
- Seeding (Temp)
- Silt Fence
- Erosion Bales
- Erosion Logs
- Riprap (Temp)
- Other: _____

- Roadway Bases
- Untreated Subgrade
- Treated Subgrade
- Aggregate Base Course (Section 304)
- Reconditioning
- PMBB - Plant Mix Bituminous Base
- Other: _____

| | Slope Staking (Y/N) | Grid (Y/N) | Grade (Y/N) | Special Interval |
|------------|---------------------|------------|-------------|------------------|
| Excavation | Y | N | Y | N |
| | - | N | Y | N |
| | - | - | - | - |
| | - | - | - | - |

| | Slope Staking (Y/N) | Grid (Y/N) | Grade (Y/N) | Special Interval |
|------------|---------------------|------------|-------------|------------------|
| Embankment | - | - | - | - |
| | - | - | - | - |
| | - | - | - | - |
| | - | - | - | - |

| | Grid (Y/N) | Grade (Y/N) | Special Interval | Special Offset |
|---------------|------------|-------------|------------------|----------------|
| Roadway Bases | - | - | - | - |
| | - | - | - | - |
| | N | Y | N | N |
| | - | - | - | - |

- Pavements
- HMA - Hot Mix Asphalt (Section 403)
- Concrete (Section 412)
- Heating & Scarifying Treatment
- Prime Coat, Tack Coat & Rejuvenating Agent (Section 407)
- Seal Coat or Chip Seal (Section 409)
- Other: ASPHALT MILLINGS

| | Grid (Y/N) | Special Interval | Special Offset |
|-----------|------------|------------------|----------------|
| Pavements | - | - | - |
| | - | - | - |
| | - | - | - |
| | N | N | N |

- Roadway Elements
- Curb and Gutter (Section 609)
- Drop inlets - alignment and grades (Section 604)
- Retaining Walls
- Guard Rail (Section 606)
- Sidewalk (Section 608)
- Overlay Stationing
- Other: _____

| | Tangent Interval | Curve Interval | Special Offset |
|---------------|------------------|----------------|----------------|
| Curb & Gutter | - | - | - |
| | - | - | - |
| | - | - | - |
| | - | - | - |

- Riprap (Perm) (Section 506)
- Slope and Ditch Paving (Section 507)
- Minor Structures

- Structure Excavation Limits (Section 206)
- Culverts (Section 603)
- Culverts w/ Headwalls and Wingwalls (Section 601)
- Concrete Box Culverts w/ Headwalls and Wingwalls
- Pipes (Section 603)
- Sanitary Sewer
- Storm Sewer
- Water
- Irrigation
- Miscellaneous
- Manholes (Section 604)
- Inlets (Section 604)
- Permanent Water Quality BMP (Section 208)
- Other: _____

- Major Structures - Overhead Signs (Section 614), Concrete Box Culverts, Bridges - and all other structures assigned a structure number
- Structure Excavation Limits (Section 206)
- Concrete Box Culverts (Section 603) w/ Headwalls and Wingwalls (Section 601)
- Piling locations and cut off elevations (Section 502)
- Caisson locations and elevations (Section 503)
- Footing locations, alignment, and elevations
- Abutment/Pier locations, alignment, and elevations
- Wingwall skew angles/offsets
- Structural concrete form locations
- Substructure As-constructed survey required for Bridges (Subsection 601 .12) and Overhead signs (S-614-50)
- Bridge expansion joint(s) alignment and grade (longitudinal and transverse)
- Deck grades at Girder 10th or 'n' th point locations and elevations
- Slope and Ditch Paving (Section 507)
- Other: _____

- Fencing (Section 607)
- Temporary
- Permanent
- Sound Barrier
- Other: _____

- Delineators (Section 612)
- Temporary
- Permanent

- Lighting (Section 613) and Traffic Control Devices (Permanent) (Section 614)
- Signal pole locations and elevations
- Light pole locations and elevations
- Sign locations
- Field verify sign post locations, elevations, and lengths before fabrication.
- Other: _____

| | Left Interval | Center Interval | Right Interval |
|------------|---------------|-----------------|----------------|
| Stationing | - | - | - |
| | - | - | - |
| | - | - | - |
| | - | - | - |

- Pavement Marking (Section 627)
- Striping (Temp)
- Striping (Perm)
- Symbols
- Other: _____
- Temporary Lighting and Construction Traffic Control Devices (Section 630)
- Signal pole locations and elevations (Temp)
- Light pole locations and elevations (Temp)
- Sign Locations (Temp)
- Other: _____
- All Easements (Temp Staking by P.L.S. Only)
- Right of Way (Temp Staking by P.L.S. Only)

WORK PERFORMED BY THE CONTRACTOR'S SURVEYOR UNDER SECTION 629:

- Monumentation (Section 629)
- Control
- Right of Way
- Land corners, Aliquot corners
- Easements
- Reference the specified existing monuments: _____
- Replace the specified existing monuments: _____
- Locate monuments. It is estimated _____ hours are required.

NOTE: All 629 items shall include adequate research, calculations, and evaluations of evidence for monuments to be set.



** A Tabulation of Survey Monuments may be provided on the plans.

GENERAL NOTES:

- Unless indicated otherwise on this Survey Tabulation Sheet, all survey work and staking intervals shall be done in accordance with the latest edition of the CDOT Survey Manual.
- Adequate information for establishing lines, grades, and locations for all work items have been specified on the plans. Any additional information required to stake the item or element shall be generated by the Contractor's surveyor.
- The Contractor's surveyor shall provide an estimate of the man-hours necessary to complete the work items indicated on this sheet. A copy of this sheet, with the estimated man-hours written on the blank line to the left of the specified items, shall be submitted with the Survey Schedule to the Engineer 5 days prior to the Presurvey Conference - Construction Survey.
- Stakes and Monuments which are damaged or destroyed by the progress of construction shall be replaced by the Contractor at no additional cost to the Department.
- The Contractor shall furnish an As Staked (or 3D Design Modeling Electronic Files) Earthwork Quantity report to the Engineer prior to completion of twenty percent (20%) of the planned earthwork in any phase as per the CDOT Survey Manual. A printed copy of the As Staked (or 3D Design Modeling Electronic Files) Earthwork data report and a computer disk with that information on it, in the specified format shall be submitted to the Engineer. The Contractor shall field verify original ground cross sections at a maximum 500 feet intervals.
- Prior to beginning work on any subsequent operation, such as placing base course or paving, the Contractor shall certify in writing to the Engineer that the final grade is within specified tolerance.
- The Contractor's surveyor shall perform all field surveying and calculations necessary to tie plan grades into field grades.
- The Contractor shall coordinate construction staking on the project with any utility work.
- Fieldbooks shall contain daily records of points set and or measurements observed. The information recorded shall contain: date, crew members' names, point no., description, staking information, and sketches. If the survey information is collected electronically, information recorded shall be provided to the Project Engineer in a hard copy format that is intuitive, clear and related to the supplemental information recorded in the field books. All linear surveys, such as slope stakes and blue tops, shall have the station and offset information related to the measured information. Non-linear surveys such as structures staking shall have sketches relating electronic information, such as point numbers, to the sketch.
- The Contractor's surveyor shall submit the following fieldbooks to the Engineer:
 - Horizontal Control (Primary & Secondary)
 - Vertical Control (i.e. Benchmarks)
 - Property Pin Ties
 - Horizontal Alignment
 - Grading
 - Slope Staking
 - Minor Structures
 - Major Structures
 - One fieldbook for each work category shown on this sheet
 - Other Fieldbook(s): _____
- The Contractor's surveyor shall submit the following (prior to surveying on the project) to the Engineer:
 - All required Instrument Calibrations

Print Date: 11/23/2022
 File Name: _____
 Horiz. Scale: 1"=XX' Vert. Scale: _____
 Unit name Unit leader
 **J-R ENGINEERING**
 A Westrian Company Centennial 303-740-9393 • Colorado Springs 719-593-2583
 Fort Collins 970-491-9888 • www.jrengineering.com

| Sheet Revisions | | | |
|-----------------|----------|-------|--|
| Date: | Comments | Init. | |
| | | | |
| | | | |
| | | | |

Colorado Department of Transportation
 **CDOT**
 5615 WILL BLVD.
 Pueblo, CO 81008
 Phone: 719-546-5750
 **LP**
 Lewis Palmer School District 38
 Region 2

| As Constructed | LEWIS PALMER TRAIL SURVEY TABULATIONS | | | | Project No./Code |
|----------------|---------------------------------------|----|----------------|----|-----------------------|
| No Revisions: | | | | | M915-009/22585 |
| Revised: | Designer: | GG | Structure | | 2520300 |
| Void: | Detailer: | GG | Numbers | | |
| | Sheet Subset: | | Subset Sheets: | OF | Sheet Number 10 OF 42 |

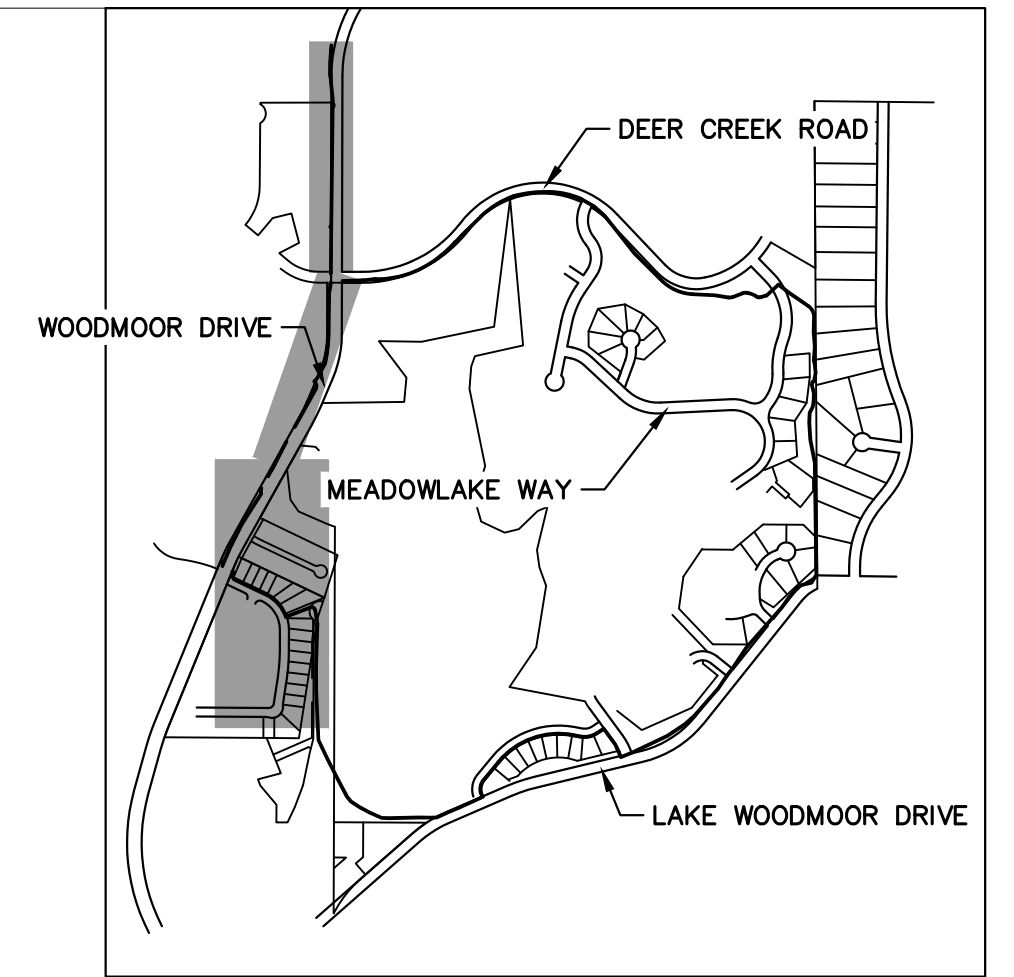

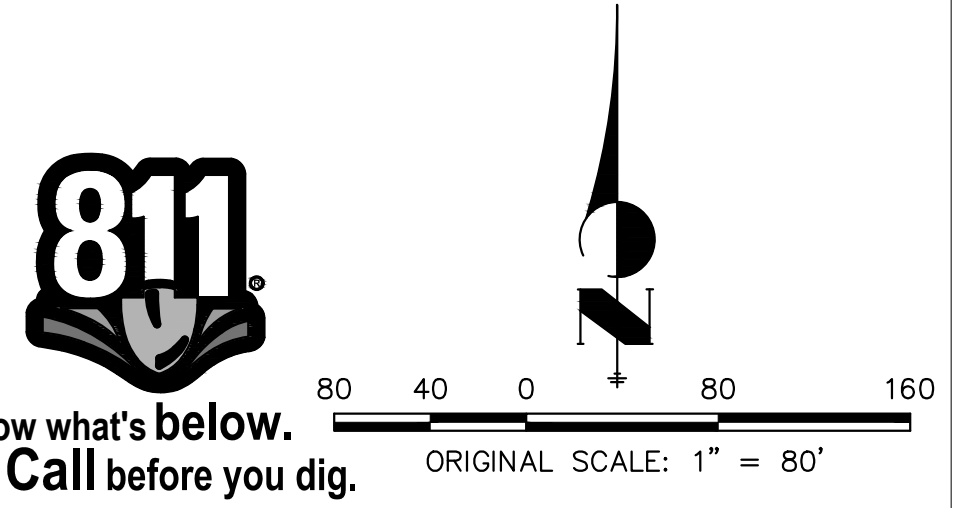
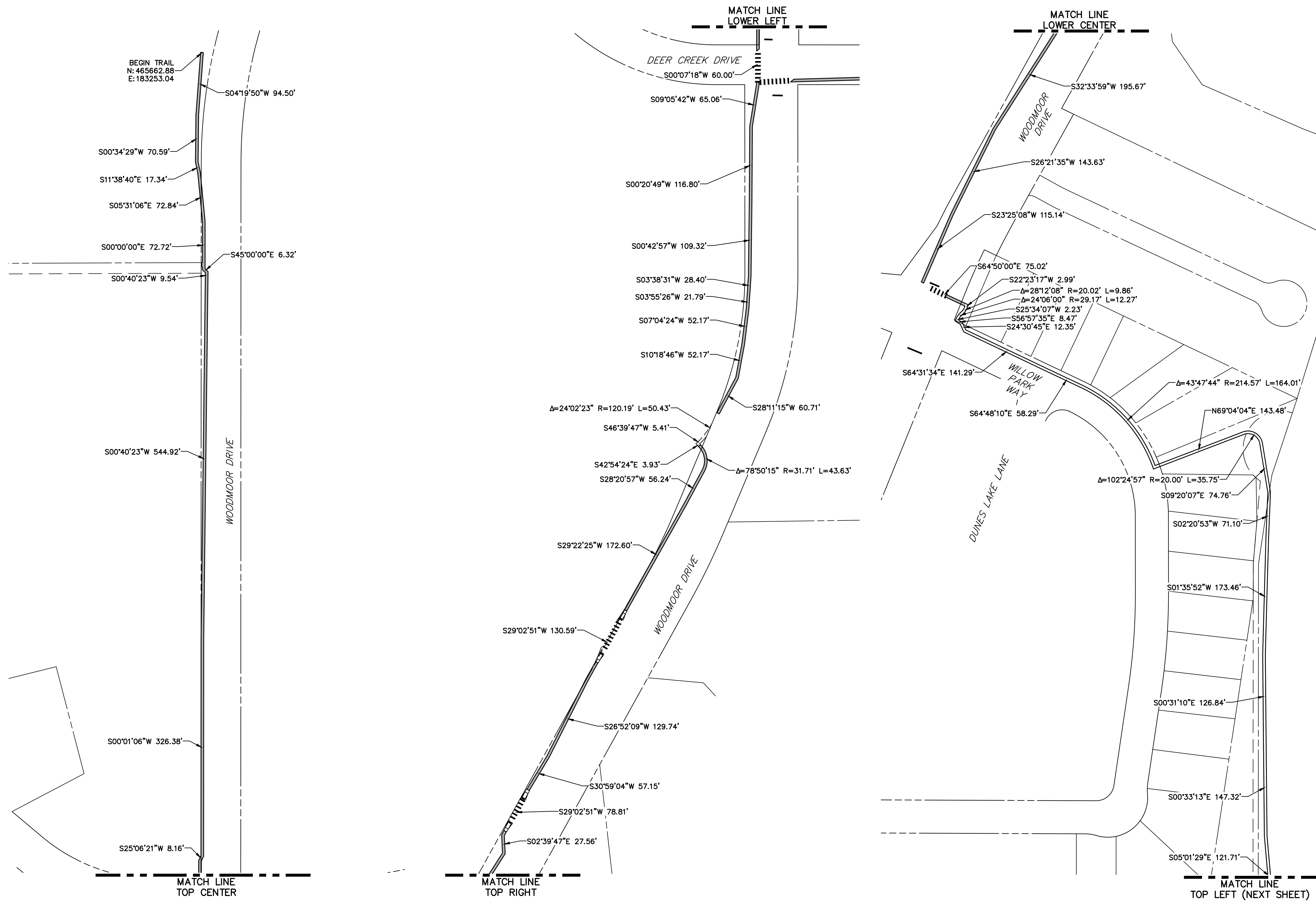

KEY MAP
SCALE: NOT TO SCALE



811
Know what's below.
Call before you dig.

Print Date: 11/23/2022
 File Name:
 Horiz. Scale: 1"=80' Vert. Scale: N/A
 Unit name Unit leader
 **J-R ENGINEERING**
 A Westrian Company Centennial 303-740-9393 • Colorado Springs 719-583-2583
 Fort Collins 970-491-9888 • www.jrengineering.com

| Sheet Revisions | | |
|-----------------|----------|-------|
| Date: | Comments | Init. |
| | | |
| | | |
| | | |

Colorado Department of Transportation
 5615 WILL BLVD.
 Pueblo, CO 81008
 Phone: 719-546-5750
 Region 2
 Lewis Palmer School District 38

As Constructed
 No Revisions:
 Revised:
 Void:

LEWIS PALMER TRAIL
 HORIZONTAL CONTROL
 Designer: GG Structure Numbers
 Detailer: GG
 Sheet Subset: Subset Sheets: OF

Project No./Code
 M915-009/22585
 2520300
 Sheet Number 11 OF 42

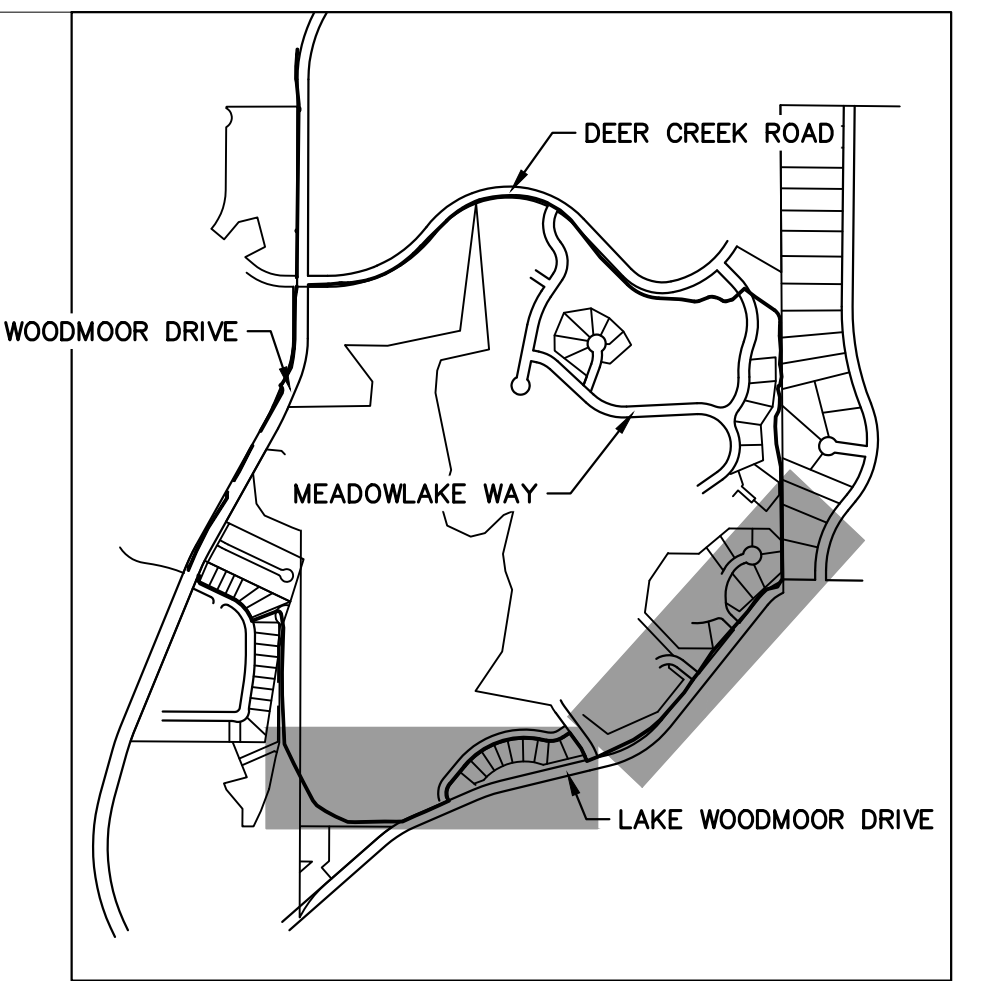
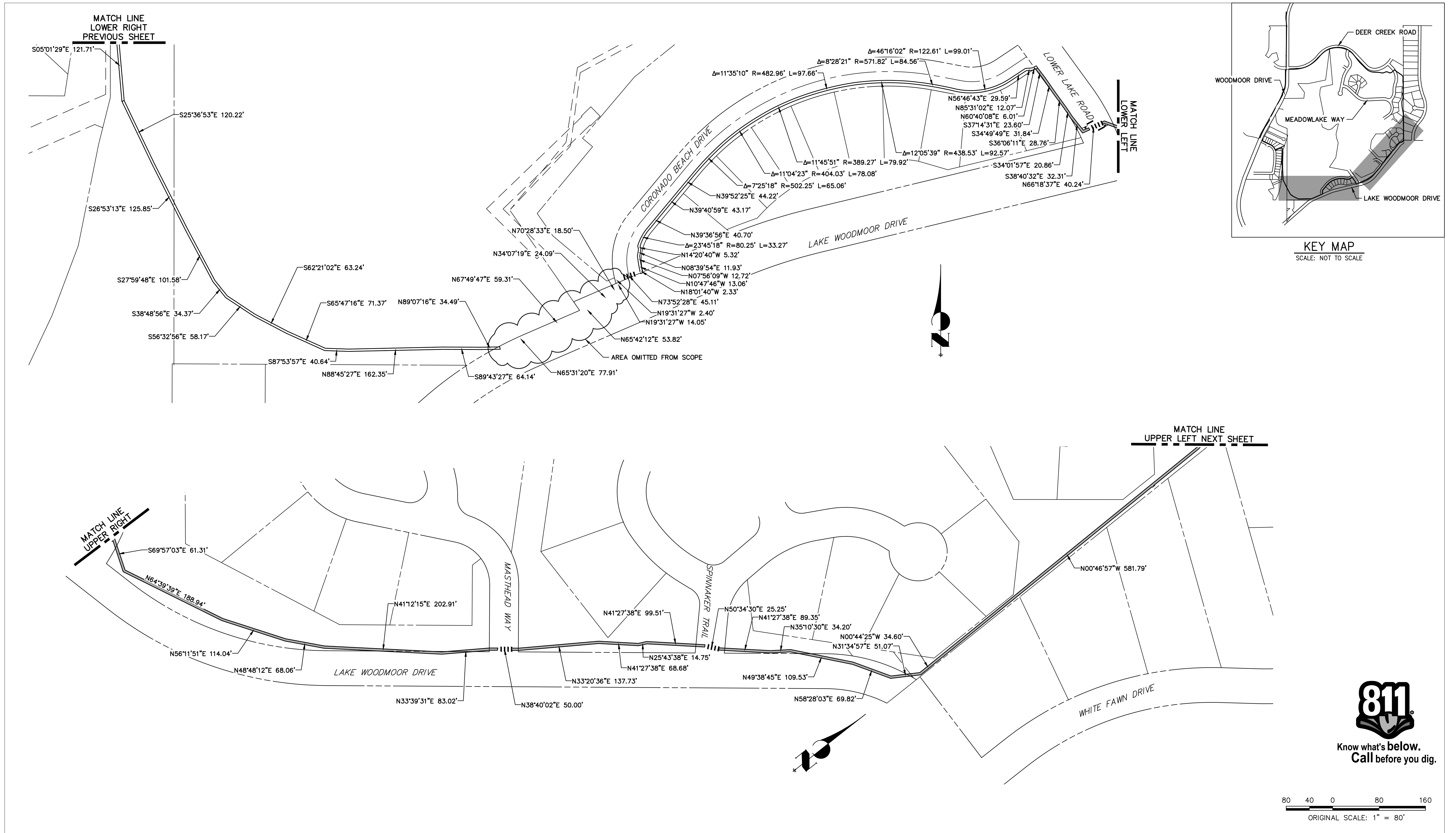

KEY MAP
SCALE: NOT TO SCALE

| | |
|--|------------------|
| Print Date: 11/23/2022 | |
| File Name: | |
| Horiz. Scale: 1"=80' | Vert. Scale: N/A |
| Unit name | Unit leader |
| A Westrian Company Centennial 303-740-9393 • Colorado Springs 719-593-2583 Fort Collins 970-491-9888 • www.jrengineering.com | |

| Sheet Revisions | | |
|-----------------|----------|-------|
| Date: | Comments | Init. |
| | | |
| | | |
| | | |
| | | |

Colorado Department of Transportation

5615 WILL BLVD.
Pueblo, CO 81008
Phone: 719-546-5750

Lewis Palmer School District 38

| |
|----------------|
| As Constructed |
| No Revisions: |
| Revised: |
| Void: |

| | | | |
|--|----|----------------|----|
| LEWIS PALMER TRAIL HORIZONTAL CONTROL | | | |
| Designer: | GG | Structure | |
| Detailer: | GG | Numbers | |
| Sheet Subset: | | Subset Sheets: | OF |

| |
|-----------------------|
| Project No./Code |
| M915-009/22585 |
| 2520300 |
| Sheet Number 12 OF 42 |

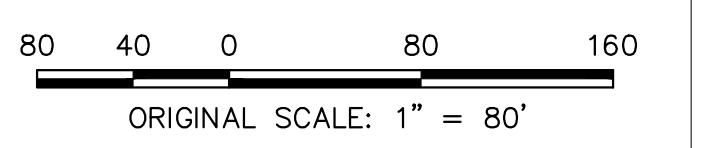
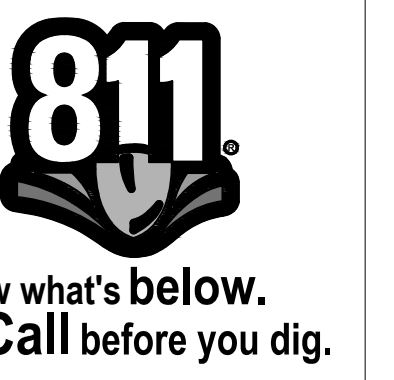

X:\25203000\Drawings\Sheet\Drawings\Horizontal Control.dwg, Horizontal 2, 11/23/2022 7:57:32 AM, CS

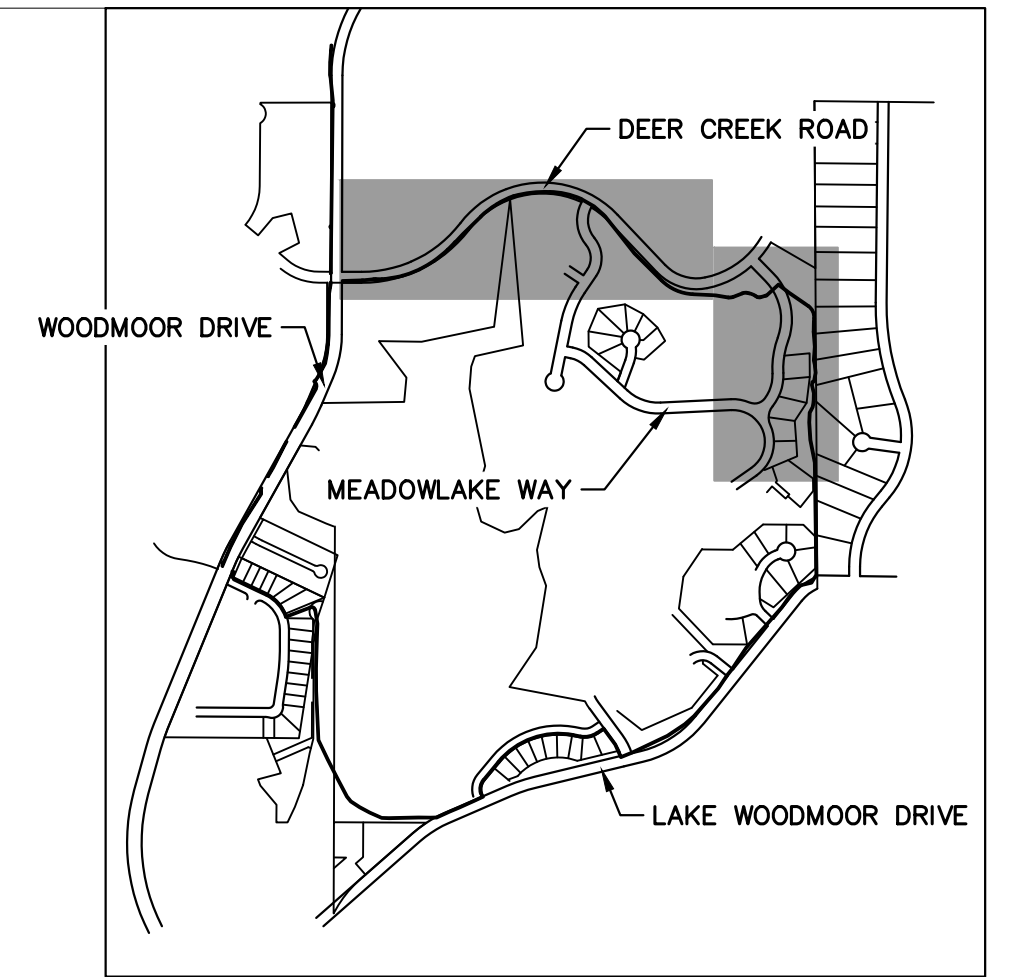

KEY MAP
SCALE: NOT TO SCALE

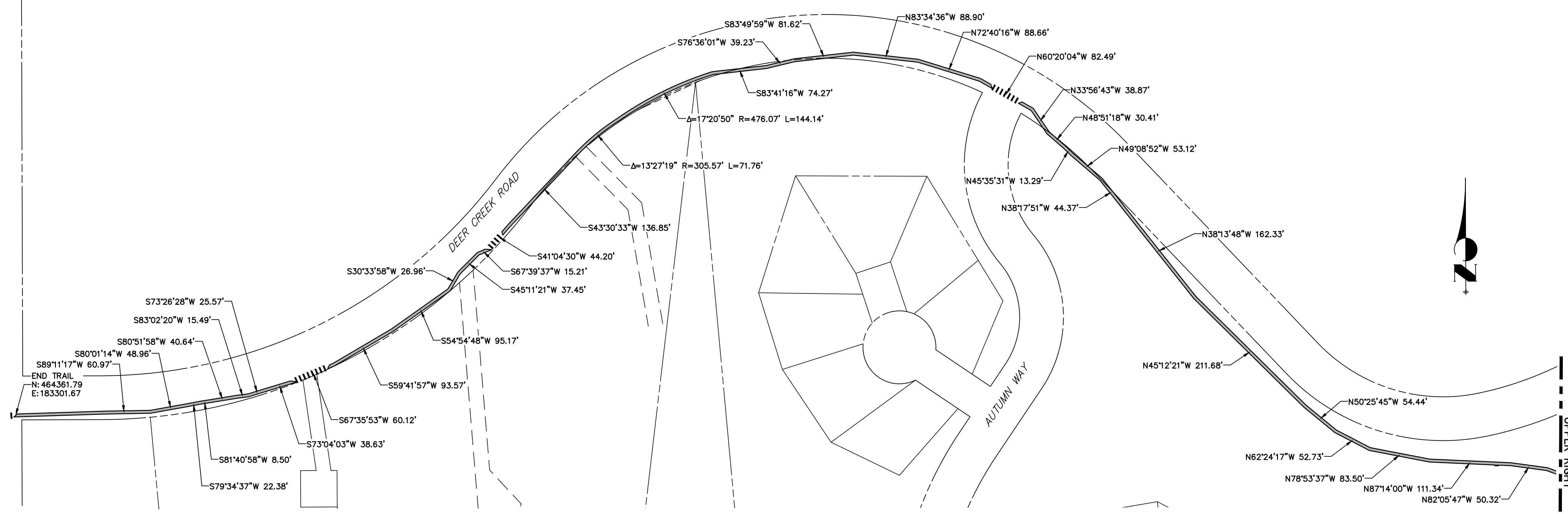
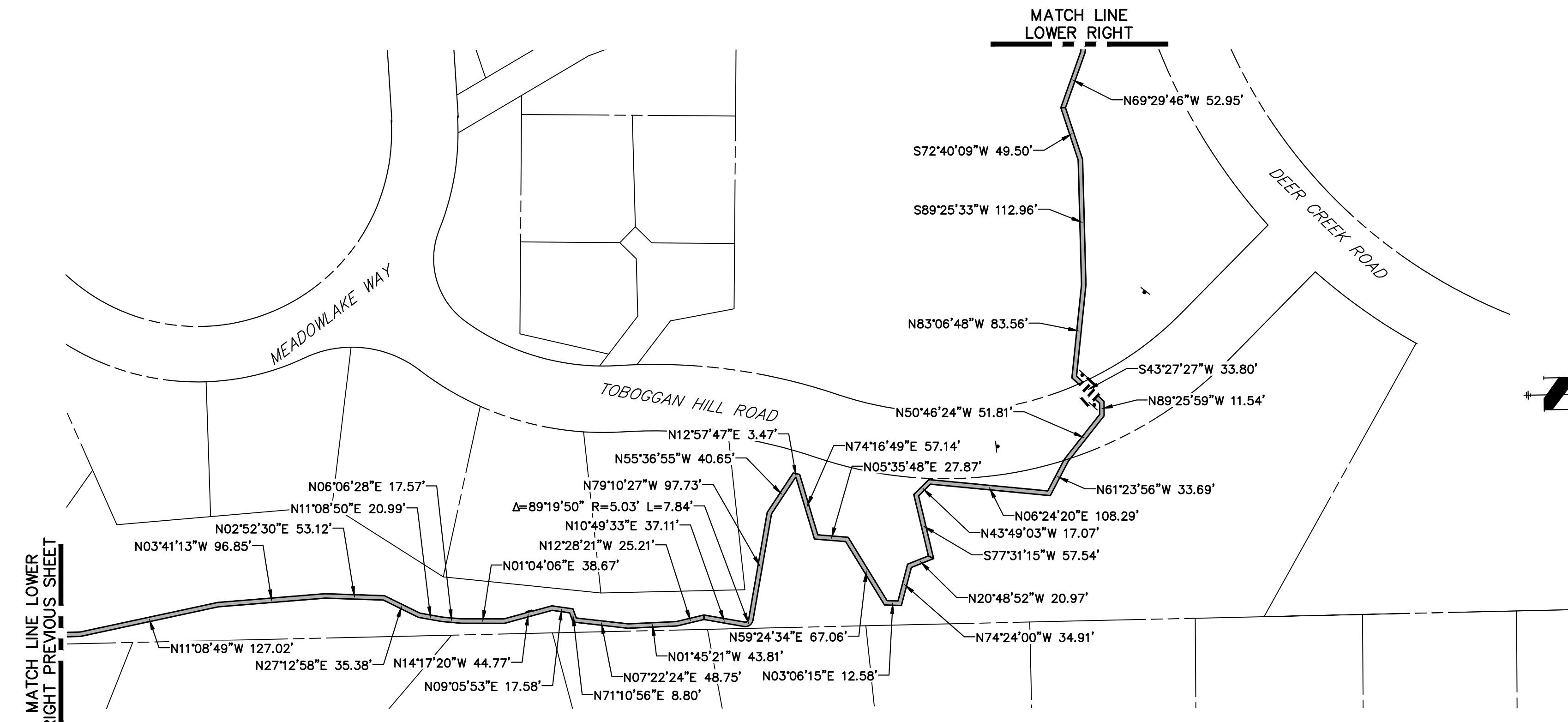

Know what's below.
Call before you dig.

Print Date: 11/23/2022

File Name:

Horiz. Scale: 1"=80' Vert. Scale: N/A

Unit name Unit leader

J-R ENGINEERING
A Westrian Company
Centennial 303-740-9393 • Colorado Springs 719-593-2583
Fort Collins 970-491-9888 • www.jrengineering.com

| Sheet Revisions | | |
|-----------------|----------|-------|
| Date: | Comments | Init. |
| | | |
| | | |
| | | |

Colorado Department of Transportation

5615 WILL BLVD.
Pueblo, CO 81008
Phone: 719-546-5750

Lewis Palmer School District 38

| |
|----------------|
| As Constructed |
| No Revisions: |
| Revised: |
| Void: |

| | | | |
|--|----|----------------|----|
| LEWIS PALMER TRAIL HORIZONTAL CONTROL | | | |
| Designer: | GG | Structure | |
| Detailer: | GG | Numbers | |
| Sheet Subset: | | Subset Sheets: | OF |

| | |
|------------------|----------------|
| Project No./Code | M915-009/22585 |
| | 2520300 |
| Sheet Number | 13 OF 42 |

X:\25203000\Drawings\Sheet\Drawings\Horizontal Control.dwg, Horizontal Control.dwg, 11/23/2022 7:57:37 AM, C:\

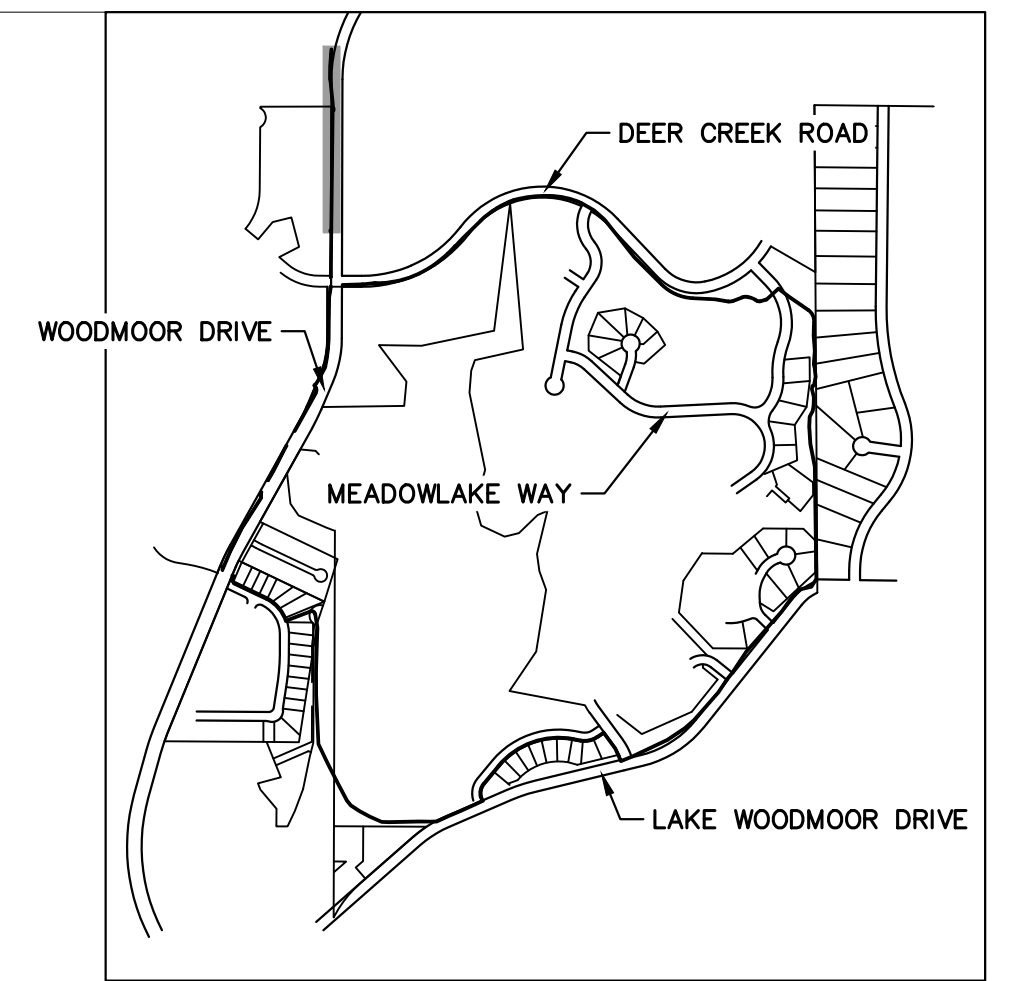
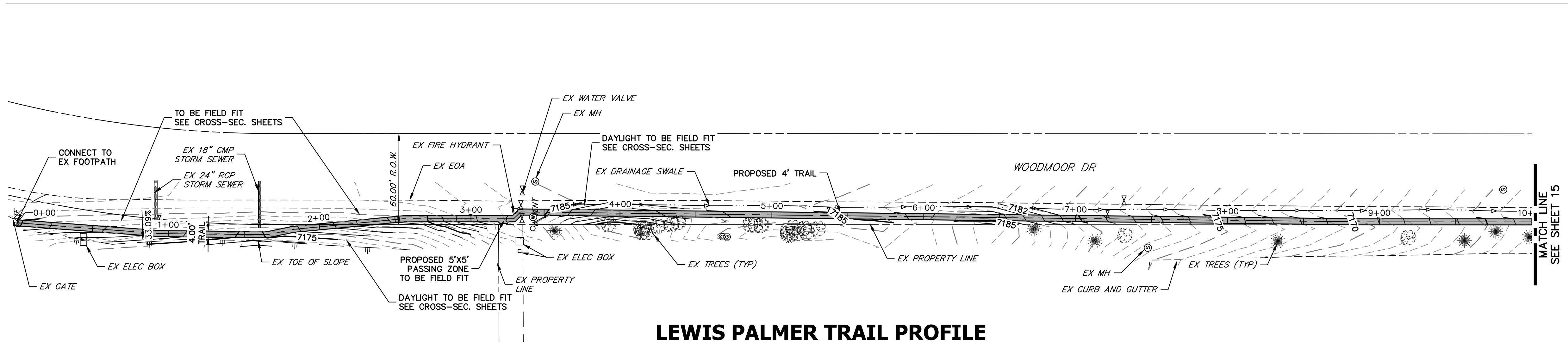

KEY MAP
SCALE: NOT TO SCALE

LEWIS PALMER TRAIL PROFILE
STA 0+00.00 TO 10+00.00

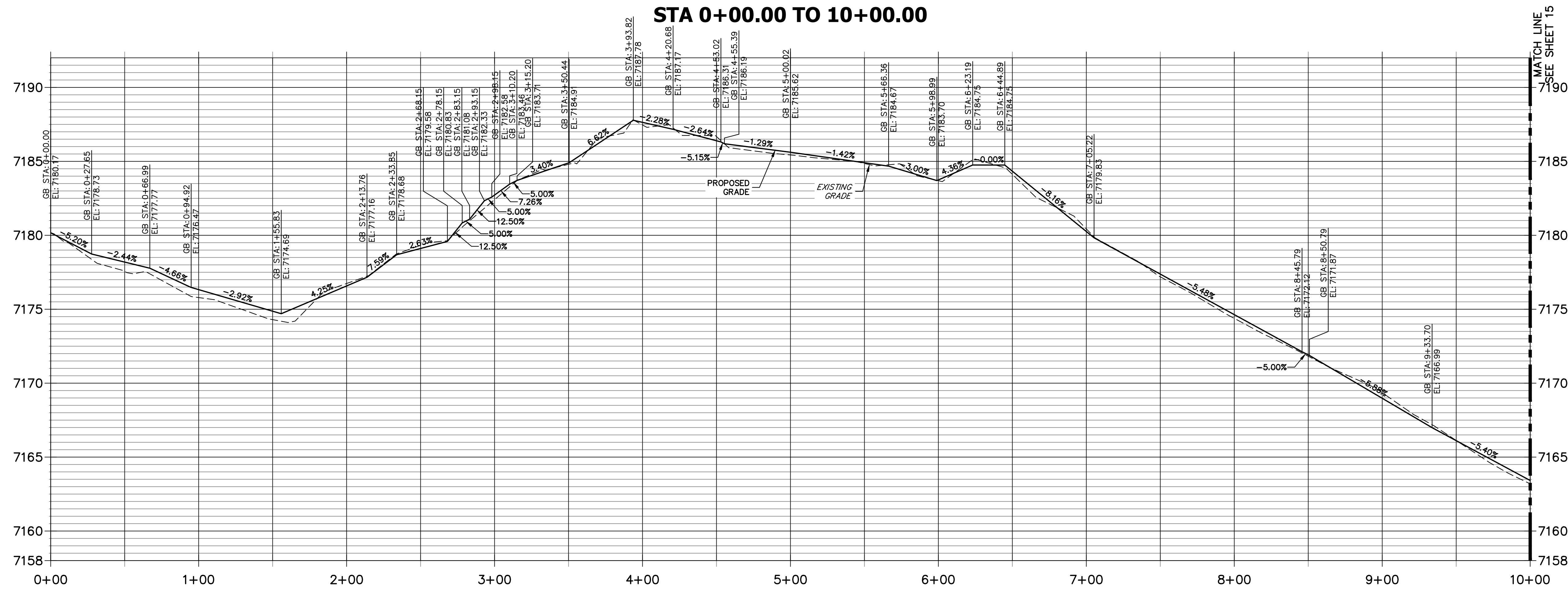

- NOTES:
1. THE SURVEY OF EXISTING CONDITIONS WAS COMPLETED IN APRIL 2021. THERE ARE A NUMBER OF LOCATIONS ALONG THE CORRIDOR THAT HAVE BEEN MODIFIED BY OTHER WORK SINCE THEN (I.E. UTILITY AND GRADING) THAT ARE NOT REPRESENTED IN THESE PLANS. THE CONTRACTOR IS RESPONSIBLE FOR REVIEWING THE TRAIL ALIGNMENT AND BECOMING FAMILIAR WITH THESE LOCATIONS. IF THE CONTRACTOR DETERMINES THAT CHANGES HAVE BEEN MADE THAT IMPACT THE TRAIL DESIGN, THE SCHOOL DISTRICT AND ENGINEER SHALL BE NOTIFIED PRIOR TO CONSTRUCTION OF THE SEGMENT OF TRAIL POTENTIALLY IMPACTED. THIS PLAN DOES NOT TAKE INTO ACCOUNT EXISTING DRAINAGE PATHS. THE CONTRACTOR SHALL WORK WITH THE SCHOOL DISTRICT AND THE ENGINEER IN DETERMINING AREAS WHERE CULVERTS MAY BE REQUIRED.
 - 2.

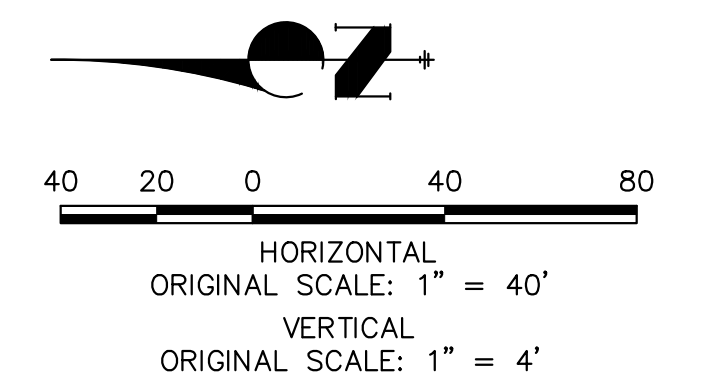

Know what's below.
Call before you dig.

ENGINEER'S STATEMENT

PREPARED UNDER MY SUPERVISION

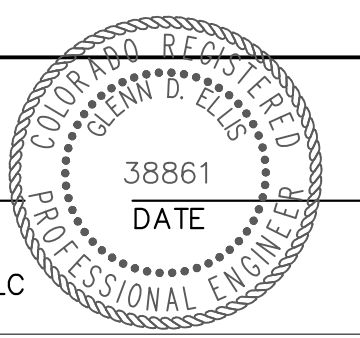

GLENN D. ELLIS, P.E.
COLORADO P.E. 38861
FOR AND ON BEHALF OF JR ENGINEERING, LLC

Print Date: 11/23/2022
File Name:
Horiz. Scale: 1"=40' Vert. Scale: 1"=4'
Unit name Unit leader
J-R ENGINEERING
A Westrian Company Centennial 303-740-9393 • Colorado Springs 719-583-2583
Fort Collins 970-491-9888 • www.jrengineering.com

| Sheet Revisions | | |
|-----------------|----------|-------|
| Date: | Comments | Init. |
| | | |
| | | |
| | | |

Colorado Department of Transportation
CDOT
Region 2
5615 WILL BLVD.
Pueblo, CO 81008
Phone: 719-546-5750
LP
Lewis Palmer School District 38

| |
|----------------|
| As Constructed |
| No Revisions: |
| Revised: |
| Void: |

| | | | |
|---|----|-------------------|----|
| LEWIS PALMER TRAIL TRAIL PLAN AND PROFILE | | | |
| Designer: | GG | Structure Numbers | |
| Detailer: | GG | | |
| Sheet Subset: | | Subset Sheets: | OF |

| | |
|------------------|----------------|
| Project No./Code | M915-009/22585 |
| | 2520300 |
| Sheet Number | 14 OF 42 |

X:\2020000\Drawings\Sheet\Drawings\2020000\Trail Plan&Profile.dwg, 11/23/2022, 1:32:06 AM, CS

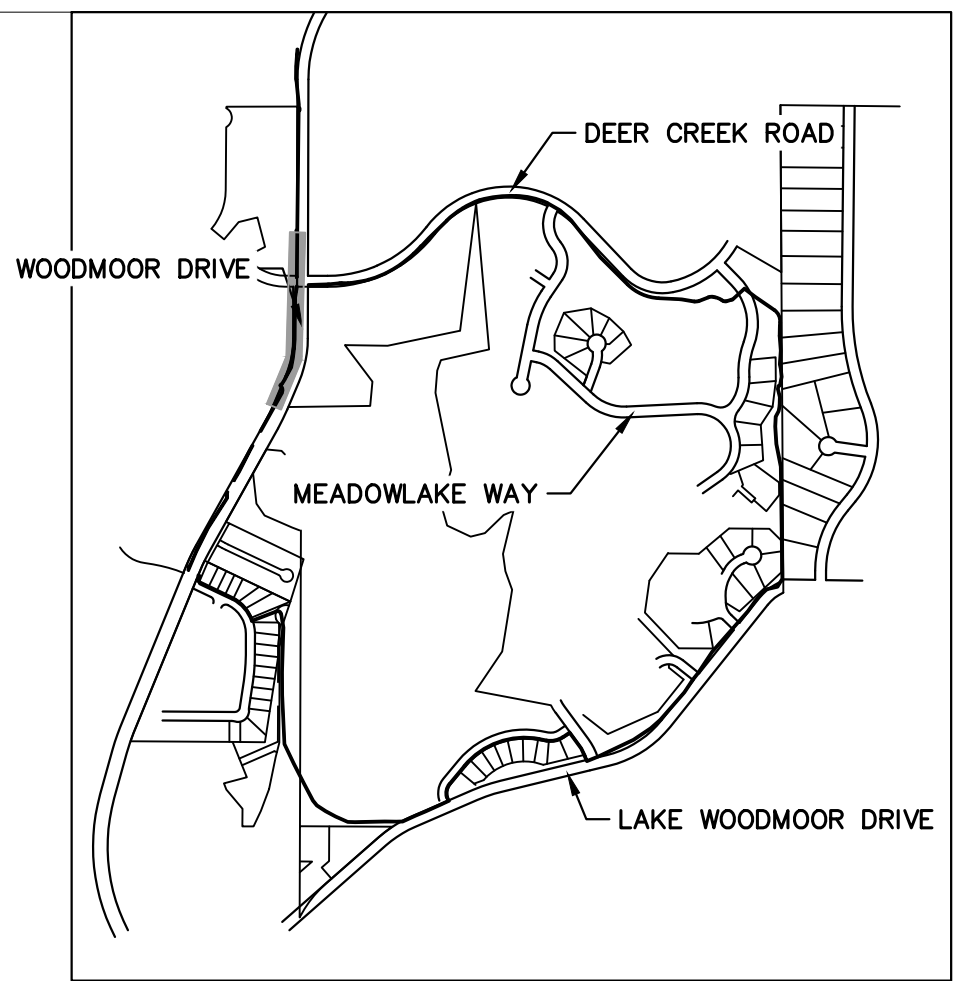
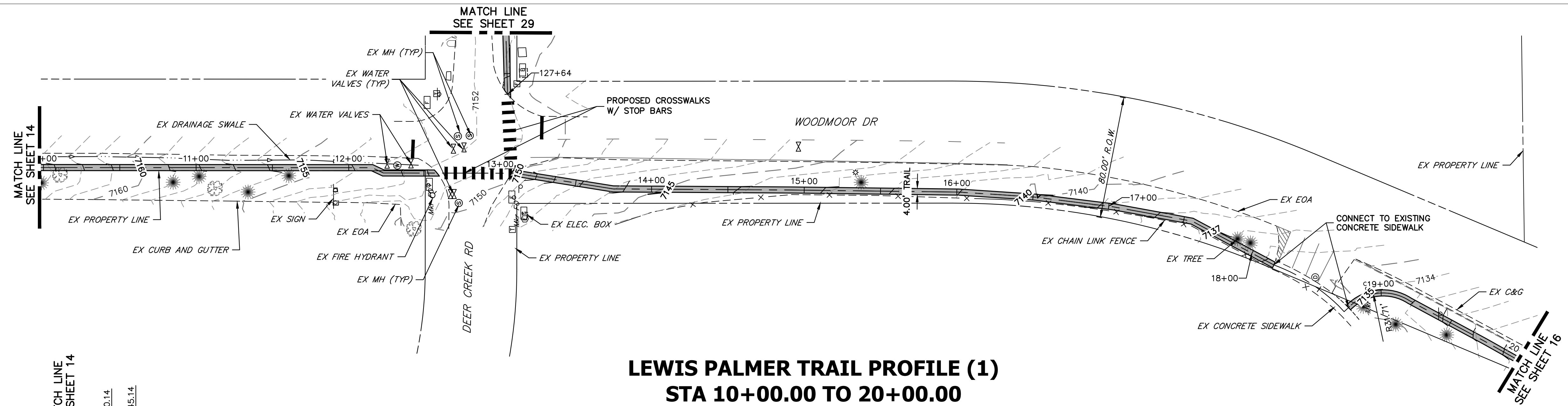

KEY MAP
SCALE: NOT TO SCALE

LEWIS PALMER TRAIL PROFILE (1)
STA 10+00.00 TO 20+00.00

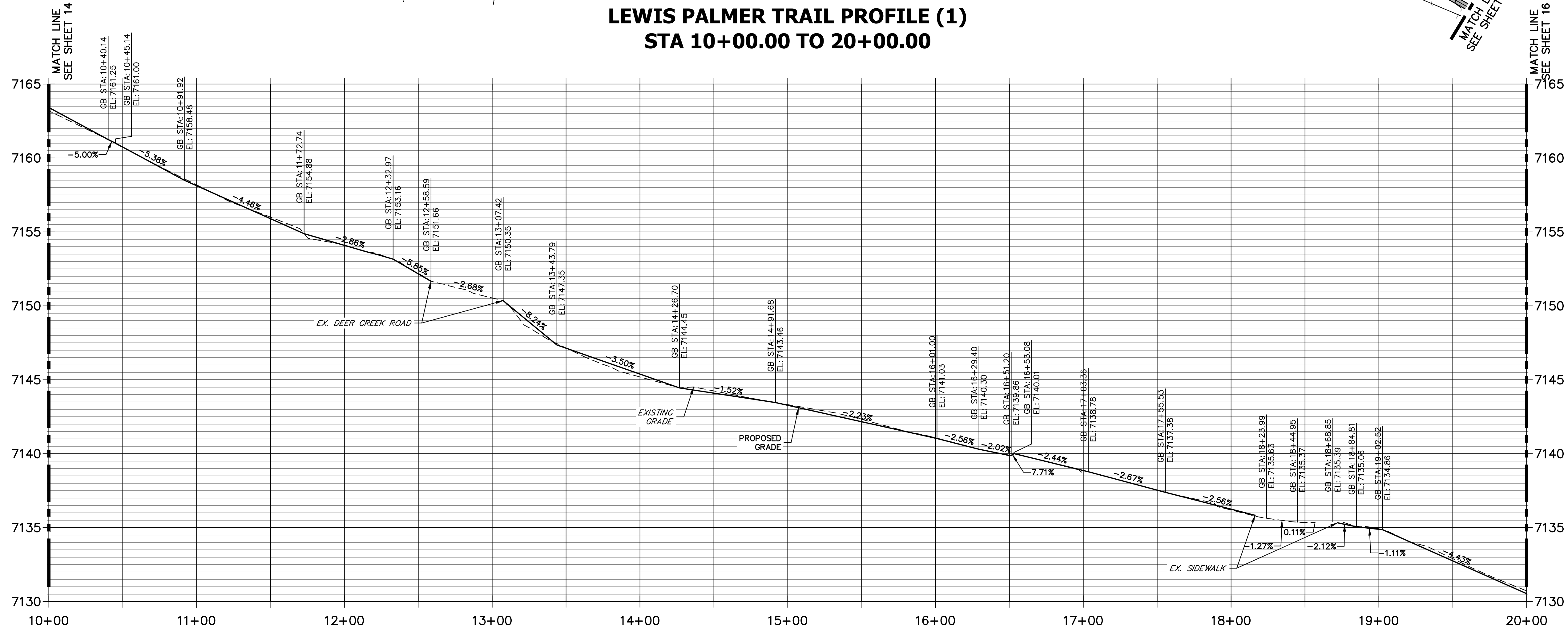

- NOTES:
1. THE SURVEY OF EXISTING CONDITIONS WAS COMPLETED IN APRIL 2021. THERE ARE A NUMBER OF LOCATIONS ALONG THE CORRIDOR THAT HAVE BEEN MODIFIED BY OTHER WORK SINCE THEN (I.E. UTILITY AND GRADING) THAT ARE NOT REPRESENTED IN THESE PLANS. THE CONTRACTOR IS RESPONSIBLE FOR REVIEWING THE TRAIL ALIGNMENT AND BECOMING FAMILIAR WITH THESE LOCATIONS. IF THE CONTRACTOR DETERMINES THAT CHANGES HAVE BEEN MADE THAT IMPACT THE TRAIL DESIGN, THE SCHOOL DISTRICT AND ENGINEER SHALL BE NOTIFIED PRIOR TO CONSTRUCTION OF THE SEGMENT OF TRAIL POTENTIALLY IMPACTED.
 2. THIS PLAN DOES NOT TAKE INTO ACCOUNT EXISTING DRAINAGE PATHS. THE CONTRACTOR SHALL WORK WITH THE SCHOOL DISTRICT AND THE ENGINEER IN DETERMINING AREAS WHERE CULVERTS MAY BE REQUIRED.

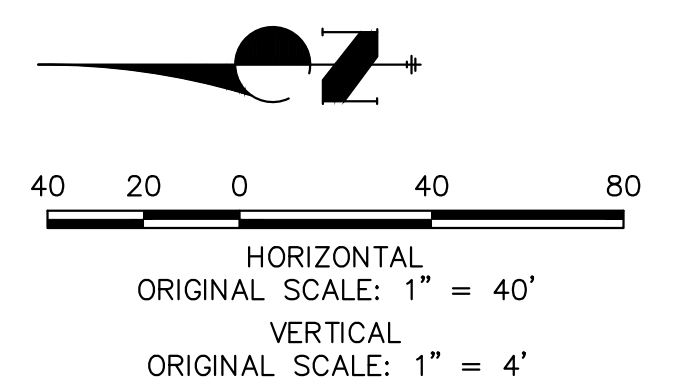

Know what's below.
Call before you dig.

ENGINEER'S STATEMENT
PREPARED UNDER MY SUPERVISION

GLENN D. ELLIS, P.E.
COLORADO P.E. 38861
FOR AND ON BEHALF OF JR ENGINEERING, LLC

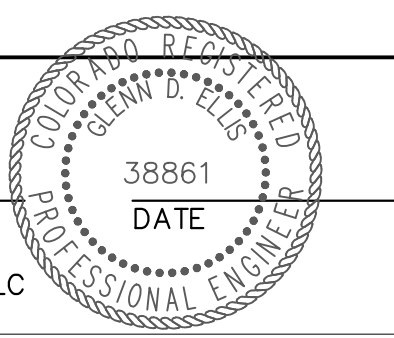

Print Date: 11/23/2022
File Name:
Horiz. Scale: 1"=40' Vert. Scale: 1"=4'
Unit name Unit leader
J-R ENGINEERING
A Westrian Company Centennial 303-740-9393 • Colorado Springs 719-593-2583
Fort Collins 970-491-9888 • www.jrengineering.com

| Sheet Revisions | | |
|-----------------|----------|-------|
| Date: | Comments | Init. |
| | | |
| | | |
| | | |

Colorado Department of Transportation
Region 2
5615 WILL BLVD.
Pueblo, CO 81008
Phone: 719-546-5750
Lewis Palmer School District 38

As Constructed
No Revisions:
Revised:
Void:

| LEWIS PALMER TRAIL TRAIL PLAN AND PROFILE | | | |
|--|----|-------------------|--|
| Designer: | GG | Structure Numbers | |
| Detailer: | GG | Sheet Subset: | |
| Subst Sheets: | | OF | |

| Project No./Code |
|-----------------------|
| M915-009/22585 |
| 2520300 |
| Sheet Number 15 OF 42 |

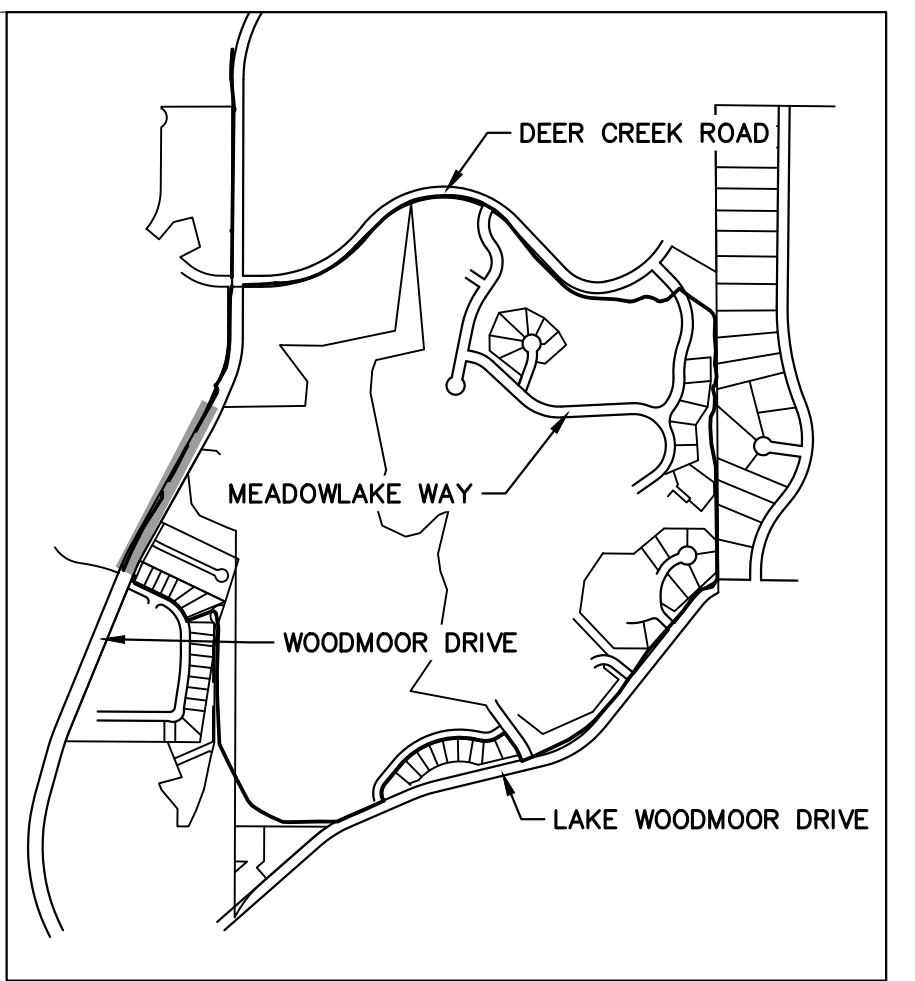
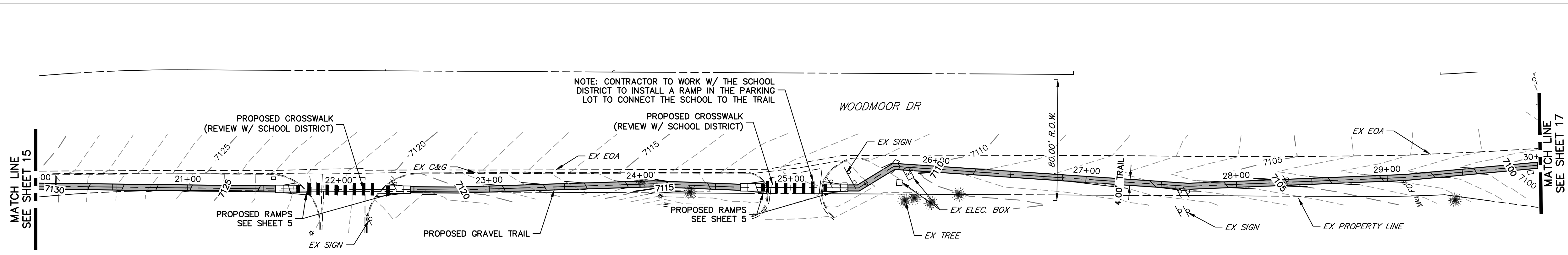

KEY MAP
SCALE: NOT TO SCALE

LEWIS PALMER TRAIL PROFILE (2)
STA 20+00.00 TO 30+00.00

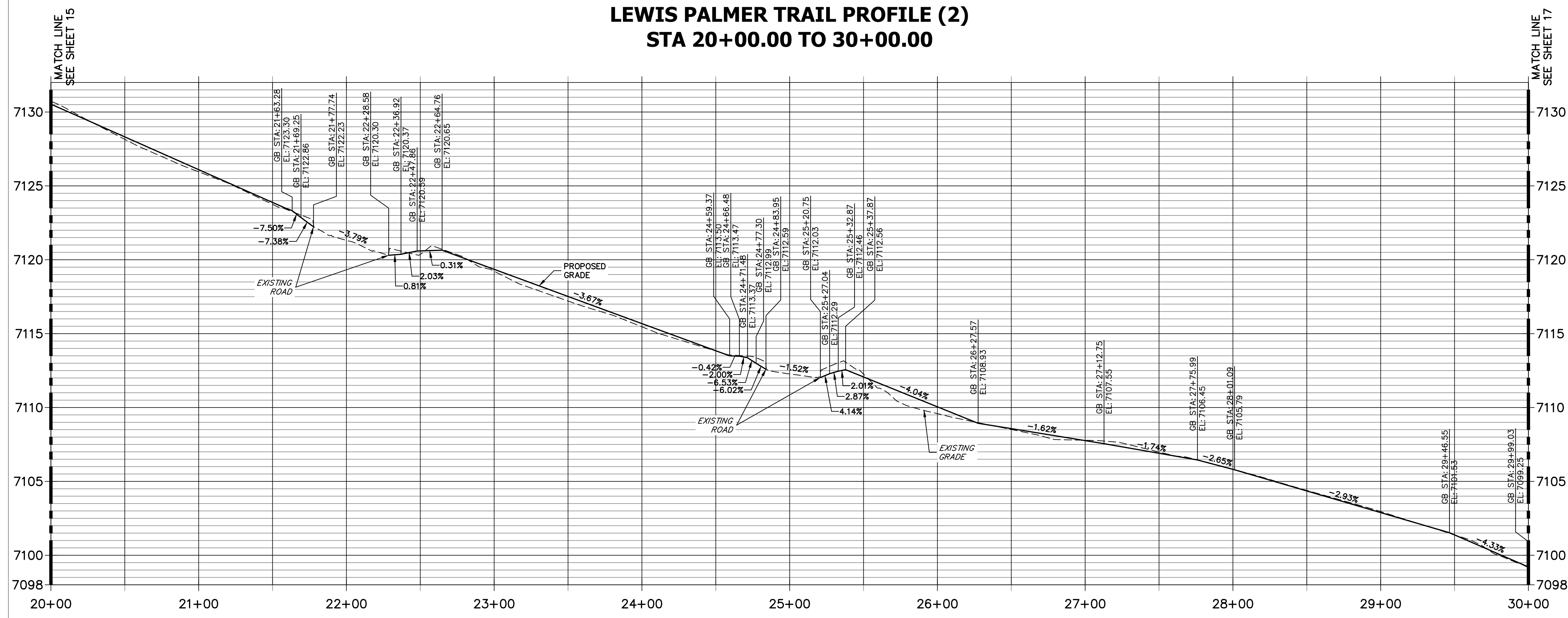

- NOTES:
1. THE SURVEY OF EXISTING CONDITIONS WAS COMPLETED IN APRIL 2021. THERE ARE A NUMBER OF LOCATIONS ALONG THE CORRIDOR THAT HAVE BEEN MODIFIED BY OTHER WORK SINCE THEN (I.E. UTILITY AND GRADING) THAT ARE NOT REPRESENTED IN THESE PLANS. THE CONTRACTOR IS RESPONSIBLE FOR REVIEWING THE TRAIL ALIGNMENT AND BECOMING FAMILIAR WITH THESE LOCATIONS. IF THE CONTRACTOR DETERMINES THAT CHANGES HAVE BEEN MADE THAT IMPACT THE TRAIL DESIGN, THE SCHOOL DISTRICT AND ENGINEER SHALL BE NOTIFIED PRIOR TO CONSTRUCTION OF THE SEGMENT OF TRAIL POTENTIALLY IMPACTED. THIS PLAN DOES NOT TAKE INTO ACCOUNT EXISTING DRAINAGE PATHS. THE CONTRACTOR SHALL WORK WITH THE SCHOOL DISTRICT AND THE ENGINEER IN DETERMINING AREAS WHERE CULVERTS MAY BE REQUIRED.
 - 2.

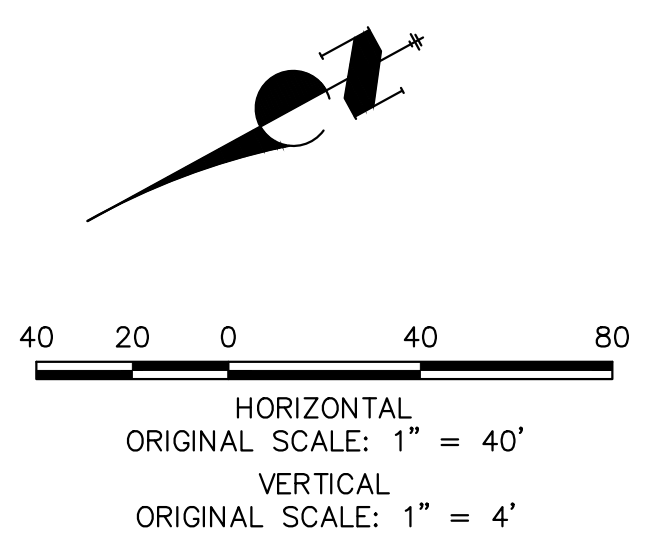

ENGINEER'S STATEMENT
PREPARED UNDER MY SUPERVISION

GLENN D. ELLIS, P.E.
COLORADO P.E. 38861
FOR AND ON BEHALF OF JR ENGINEERING, LLC

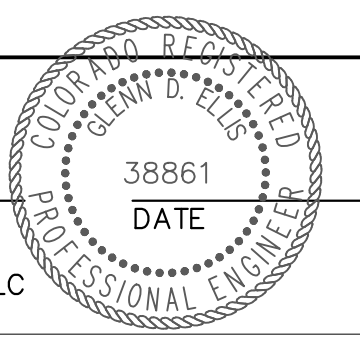

Print Date: 11/23/2022
File Name:
Horiz. Scale: 1"=40' Vert. Scale: 1"=4'
Unit name Unit leader
J-R ENGINEERING
A Westrian Company Centennial 303-740-9393 • Colorado Springs 719-593-2583
Fort Collins 970-491-9888 • www.jrengineering.com

| Sheet Revisions | | |
|-----------------|----------|-------|
| Date: | Comments | Init. |
| | | |
| | | |
| | | |

Colorado Department of Transportation
CDOT
Region 2
5615 WILL BLVD.
Pueblo, CO 81008
Phone: 719-546-5750
LP
Lewis Palmer School District 38

| |
|----------------|
| As Constructed |
| No Revisions: |
| Revised: |
| Void: |

| | | | |
|---|----|-------------------|----|
| LEWIS PALMER TRAIL TRAIL PLAN AND PROFILE | | | |
| Designer: | GG | Structure Numbers | |
| Detailer: | GG | | |
| Sheet Subset: | | Subset Sheets: | OF |

| | |
|------------------|----------------|
| Project No./Code | M915-009/22585 |
| | 2520300 |
| Sheet Number | 16 OF 42 |

X:\20220000\Drawings\Sheet\Drawings\20220000\Trail Plan and Profile.dwg, 3, 11/23/2022, 1:32:30 AM, CS

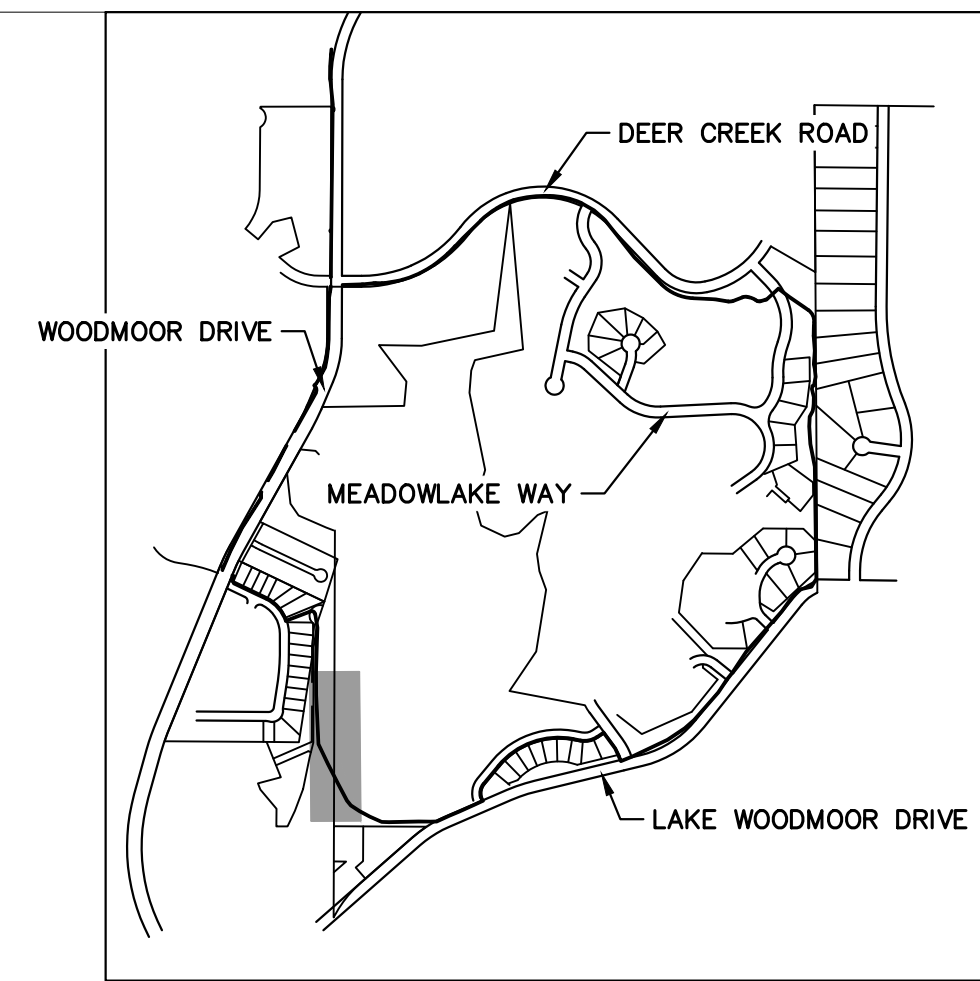
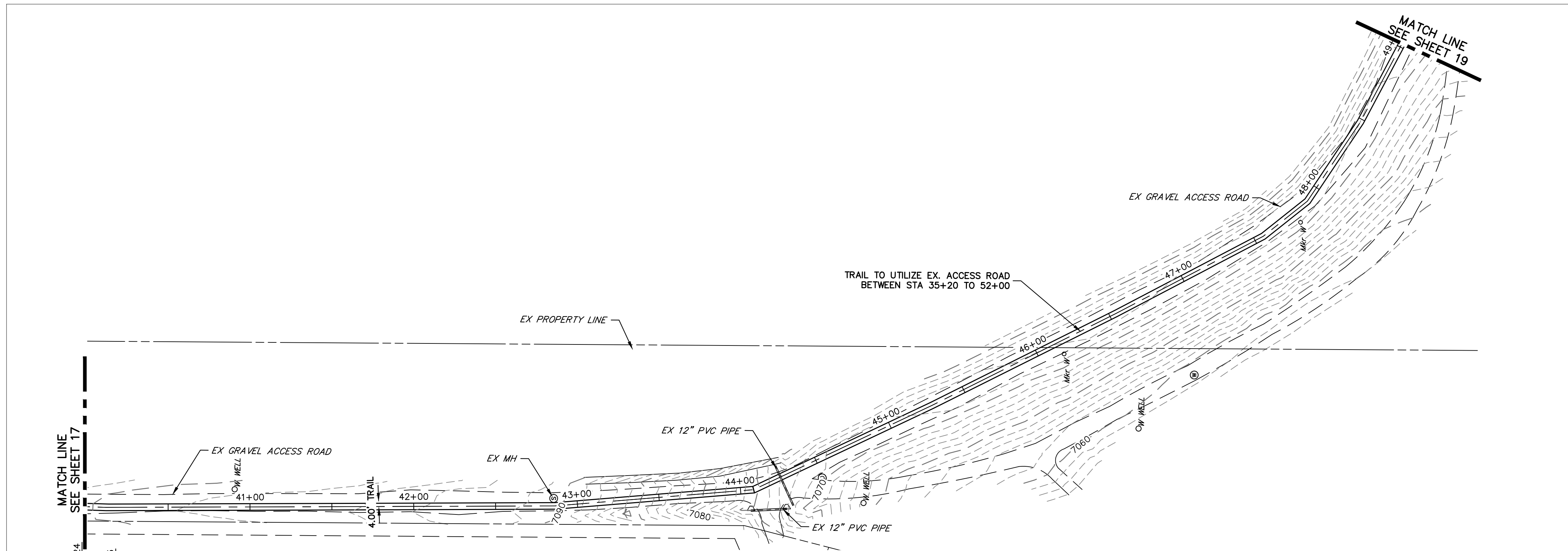

KEY MAP
SCALE: NOT TO SCALE

- NOTES:
1. THE SURVEY OF EXISTING CONDITIONS WAS COMPLETED IN APRIL 2021. THERE ARE A NUMBER OF LOCATIONS ALONG THE CORRIDOR THAT HAVE BEEN MODIFIED BY OTHER WORK SINCE THEN (I.E. UTILITY AND GRADING) THAT ARE NOT REPRESENTED IN THESE PLANS. THE CONTRACTOR IS RESPONSIBLE FOR REVIEWING THE TRAIL ALIGNMENT AND BECOMING FAMILIAR WITH THESE LOCATIONS. IF THE CONTRACTOR DETERMINES THAT CHANGES HAVE BEEN MADE THAT IMPACT THE TRAIL DESIGN, THE SCHOOL DISTRICT AND ENGINEER SHALL BE NOTIFIED PRIOR TO CONSTRUCTION OF THE SEGMENT OF TRAIL POTENTIALLY IMPACTED. THIS PLAN DOES NOT TAKE INTO ACCOUNT EXISTING DRAINAGE PATHS. THE CONTRACTOR SHALL WORK WITH THE SCHOOL DISTRICT AND THE ENGINEER IN DETERMINING AREAS WHERE CULVERTS MAY BE REQUIRED.
 - 2.

**LEWIS PALMER TRAIL PROFILE (4)
STA 40+00.00 TO 49+00.00**

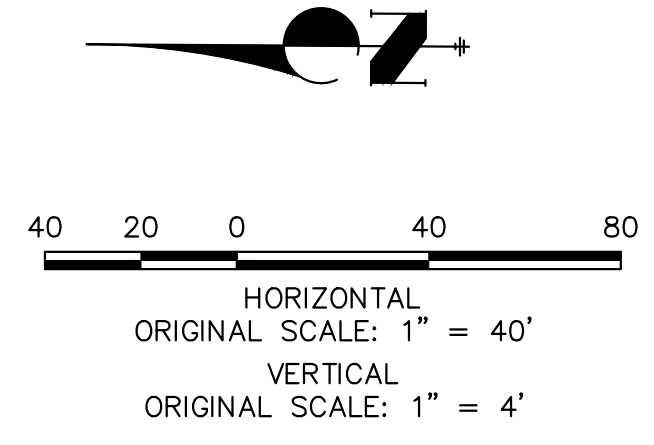
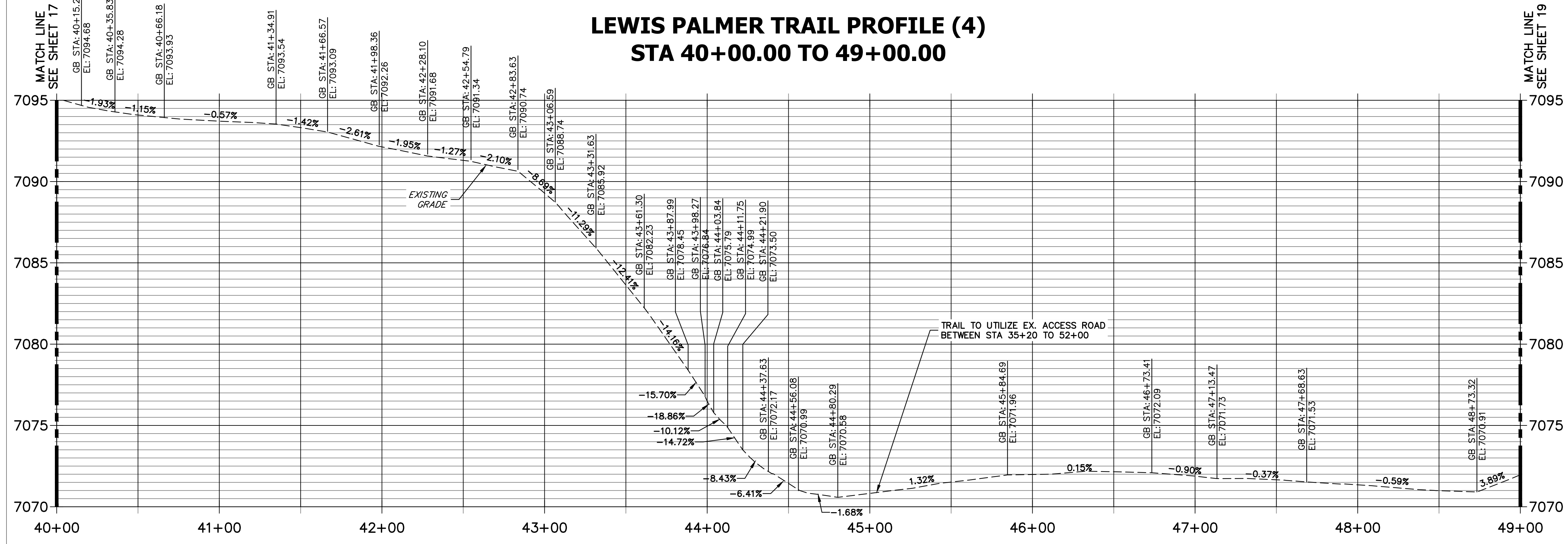

ENGINEER'S STATEMENT
PREPARED UNDER MY SUPERVISION

GLENN D. ELLIS, P.E.
COLORADO P.E. 38861
FOR AND ON BEHALF OF JR ENGINEERING, LLC

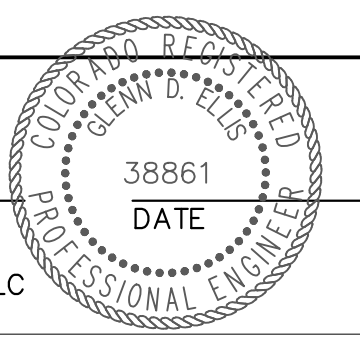

| | |
|--|--------------------|
| Print Date: 11/23/2022 | |
| File Name: | |
| Horiz. Scale: 1"=40' | Vert. Scale: 1"=4' |
| Unit name | Unit leader |
| J-R ENGINEERING A Westrian Company Centennial 303-740-9393 • Colorado Springs 719-593-2583 Fort Collins 970-491-9888 • www.jrengineering.com | |

| Sheet Revisions | | |
|-----------------|----------|-------|
| Date: | Comments | Init. |
| | | |
| | | |
| | | |

Colorado Department of Transportation

5615 WILL BLVD.
Pueblo, CO 81008
Phone: 719-546-5750

Lewis Palmer School District 38

| |
|----------------|
| As Constructed |
| No Revisions: |
| Revised: |
| Void: |

| | | | |
|--|----|----------------|----|
| LEWIS PALMER TRAIL TRAIL PLAN AND PROFILE | | | |
| Designer: | GG | Structure | |
| Detailer: | GG | Numbers | |
| Sheet Subset: | | Subset Sheets: | OF |

| | |
|------------------|----------------|
| Project No./Code | M915-009/22585 |
| | 2520300 |
| Sheet Number | 18 OF 42 |

X:\25203000\Drawings\Sheet\Drawings\25203000\Trail Plan\Profile.dwg, 5, 11/23/2022, 1:32:51 AM, CS

LEWIS PALMER TRAIL PROFILE (5) STA 49+00.00 TO 59+00.00

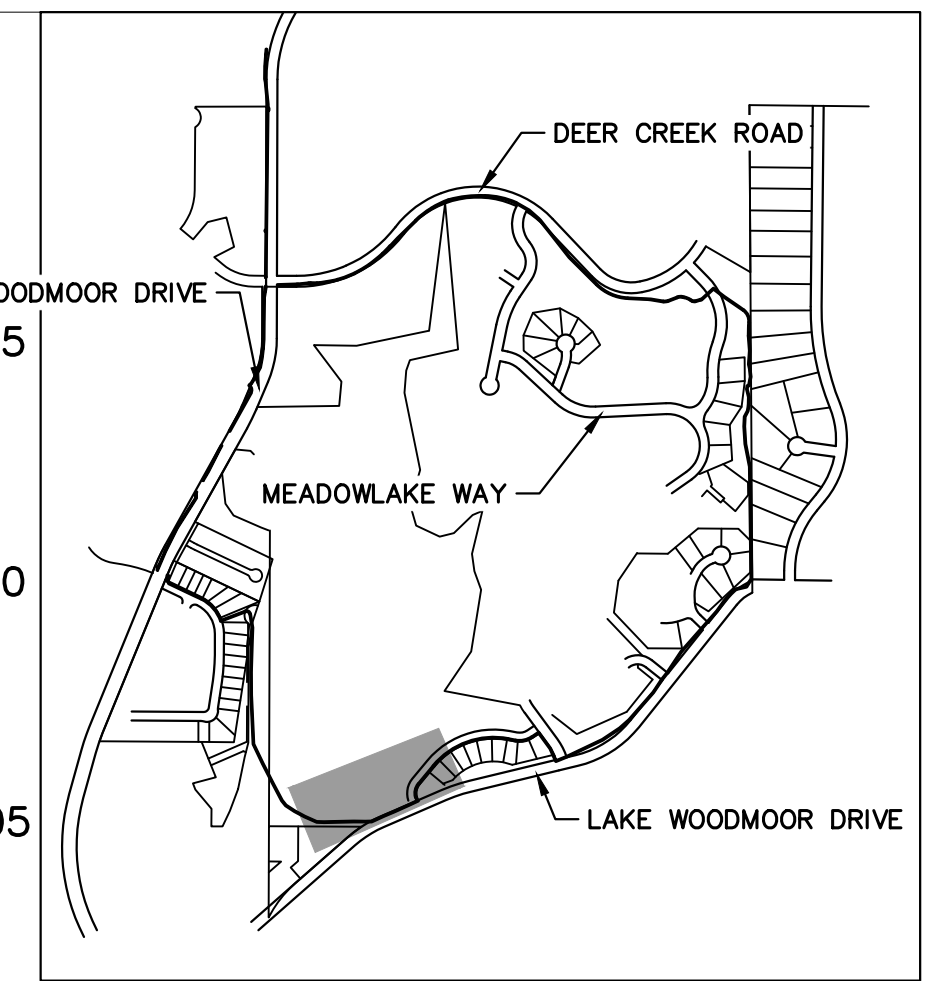
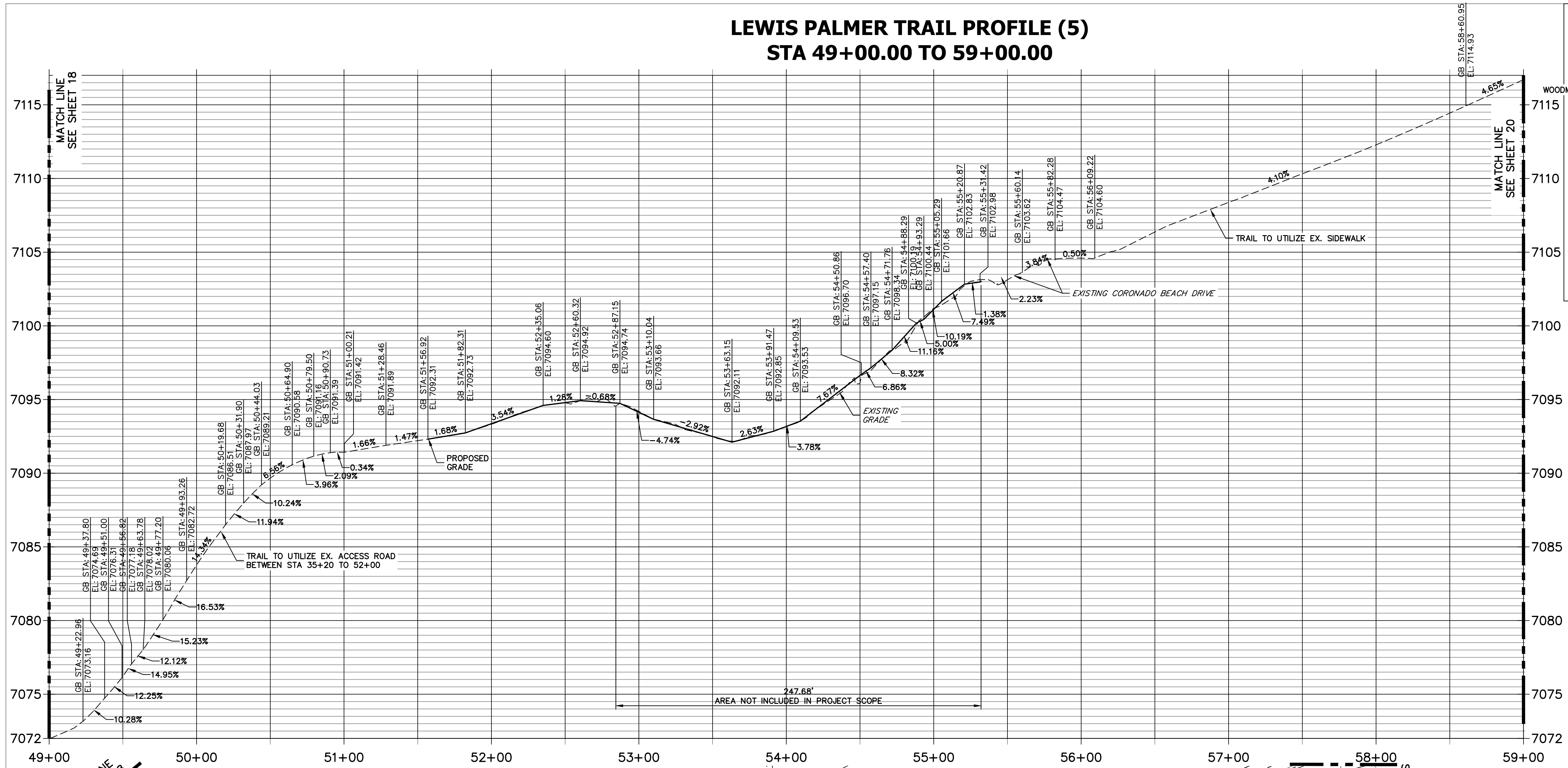

KEY MAP
SCALE: NOT TO SCALE

- NOTES:
1. THE SURVEY OF EXISTING CONDITIONS WAS COMPLETED IN APRIL 2021. THERE ARE A NUMBER OF LOCATIONS ALONG THE CORRIDOR THAT HAVE BEEN MODIFIED BY OTHER WORK SINCE THEN (I.E. UTILITY AND GRADING) THAT ARE NOT REPRESENTED IN THESE PLANS. THE CONTRACTOR IS RESPONSIBLE FOR REVIEWING THE TRAIL ALIGNMENT AND BECOMING FAMILIAR WITH THESE LOCATIONS. IF THE CONTRACTOR DETERMINES THAT CHANGES HAVE BEEN MADE THAT IMPACT THE TRAIL DESIGN, THE SCHOOL DISTRICT AND ENGINEER SHALL BE NOTIFIED PRIOR TO CONSTRUCTION OF THE SEGMENT OF TRAIL POTENTIALLY IMPACTED. THIS PLAN DOES NOT TAKE INTO ACCOUNT EXISTING DRAINAGE PATHS. THE CONTRACTOR SHALL WORK WITH THE SCHOOL DISTRICT AND THE ENGINEER IN DETERMINING AREAS WHERE CULVERTS MAY BE REQUIRED.
 - 2.

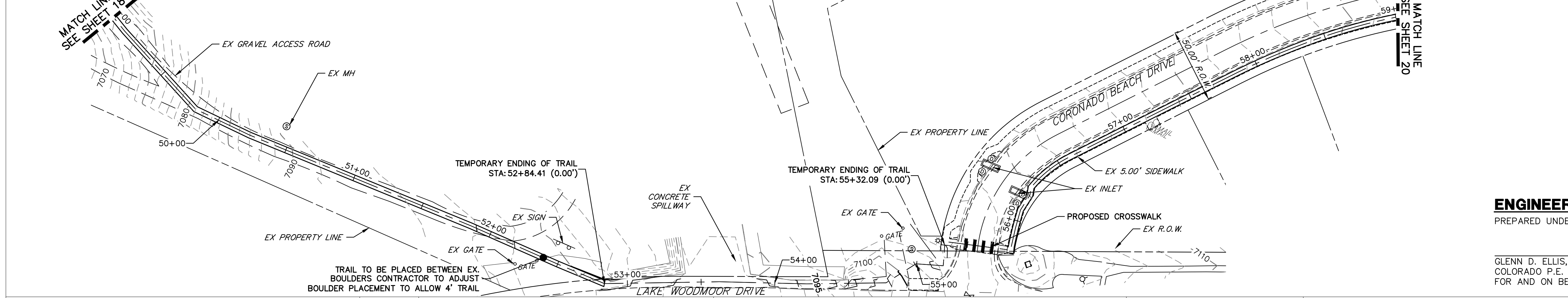
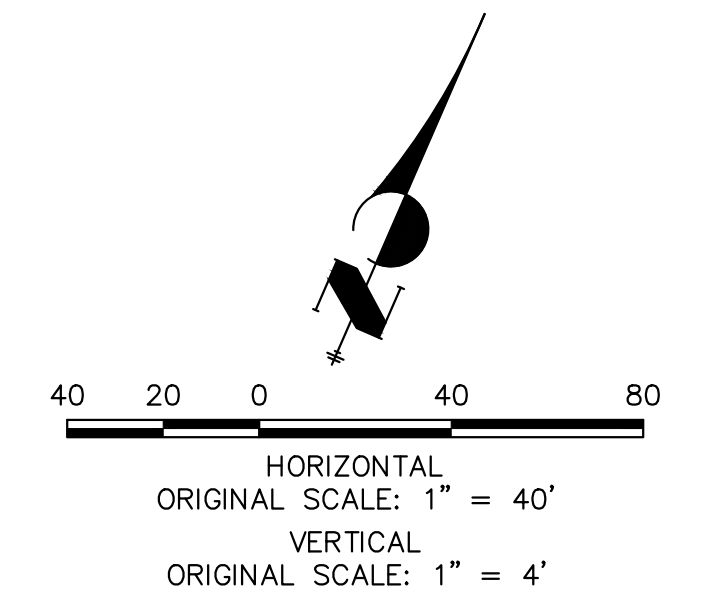

ENGINEER'S STATEMENT

PREPARED UNDER MY SUPERVISION

GLENN D. ELLIS, P.E.
COLORADO P.E. 38861
FOR AND ON BEHALF OF JR ENGINEERING, LLC

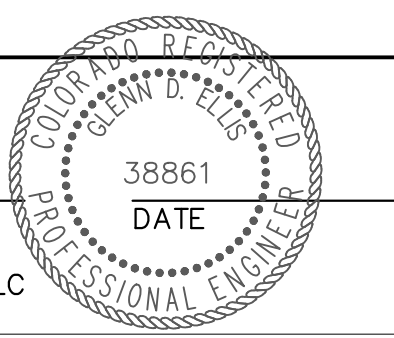

Print Date: 11/23/2022

File Name:

Horiz. Scale: 1"=40' Vert. Scale: 1"=4'

Unit name Unit leader

A Westrian Company Centennial 303-740-9393 • Colorado Springs 719-593-2583
Fort Collins 970-491-9888 • www.jrengineering.com

| Sheet Revisions | | |
|-----------------|----------|-------|
| Date: | Comments | Init. |
| | | |
| | | |
| | | |

Colorado Department of Transportation

5615 WILL BLVD.
Pueblo, CO 81008
Phone: 719-546-5750

Lewis Palmer School District 38

| |
|----------------|
| As Constructed |
| No Revisions: |
| Revised: |
| Void: |

| | | | |
|---|----|-------------------|--|
| LEWIS PALMER TRAIL TRAIL PLAN AND PROFILE | | | |
| Designer: | GG | Structure Numbers | |
| Detailer: | GG | Subset Sheets: | |
| Sheet Subset: | | OF | |

| | |
|------------------|----------------|
| Project No./Code | M915-009/22585 |
| | 2520300 |
| Sheet Number | 19 OF 42 |

X:\25203000\Drawings\Sheet\Drawings\25203000\Trail Plan and Profile.dwg, 6, 11/23/2022, 1:33:02 AM, CS

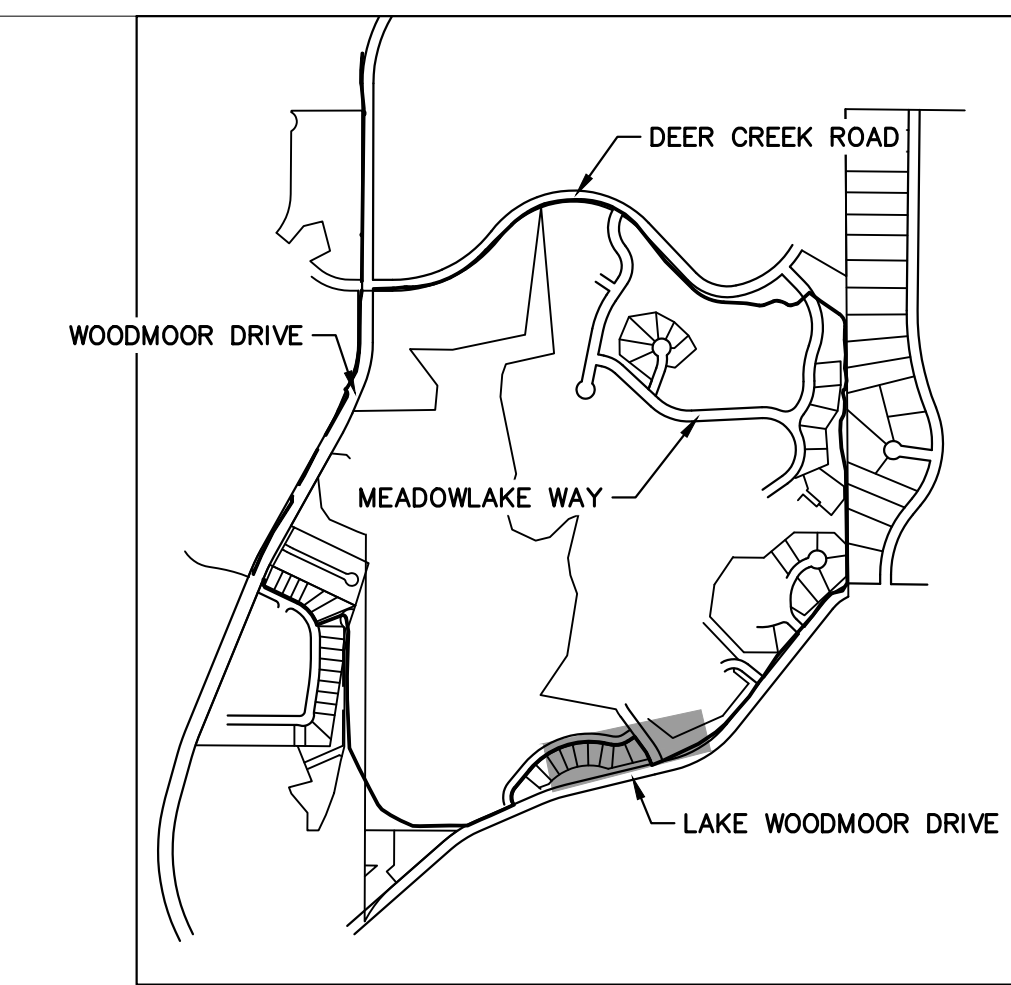
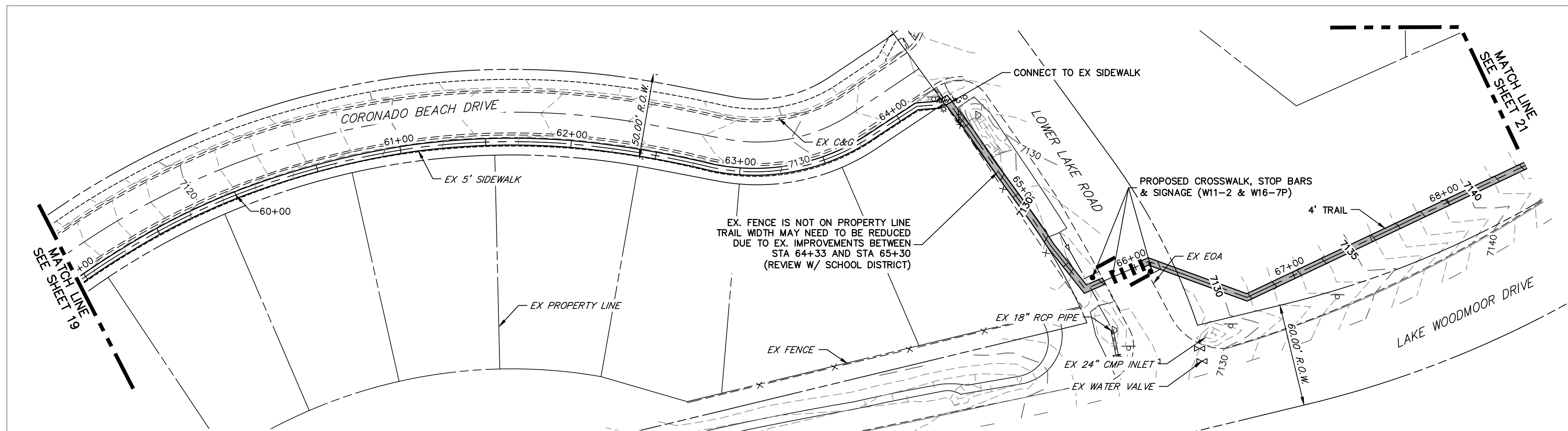

LEWIS PALMER TRAIL PROFILE (6)
STA 59+00.00 TO 68+50.00

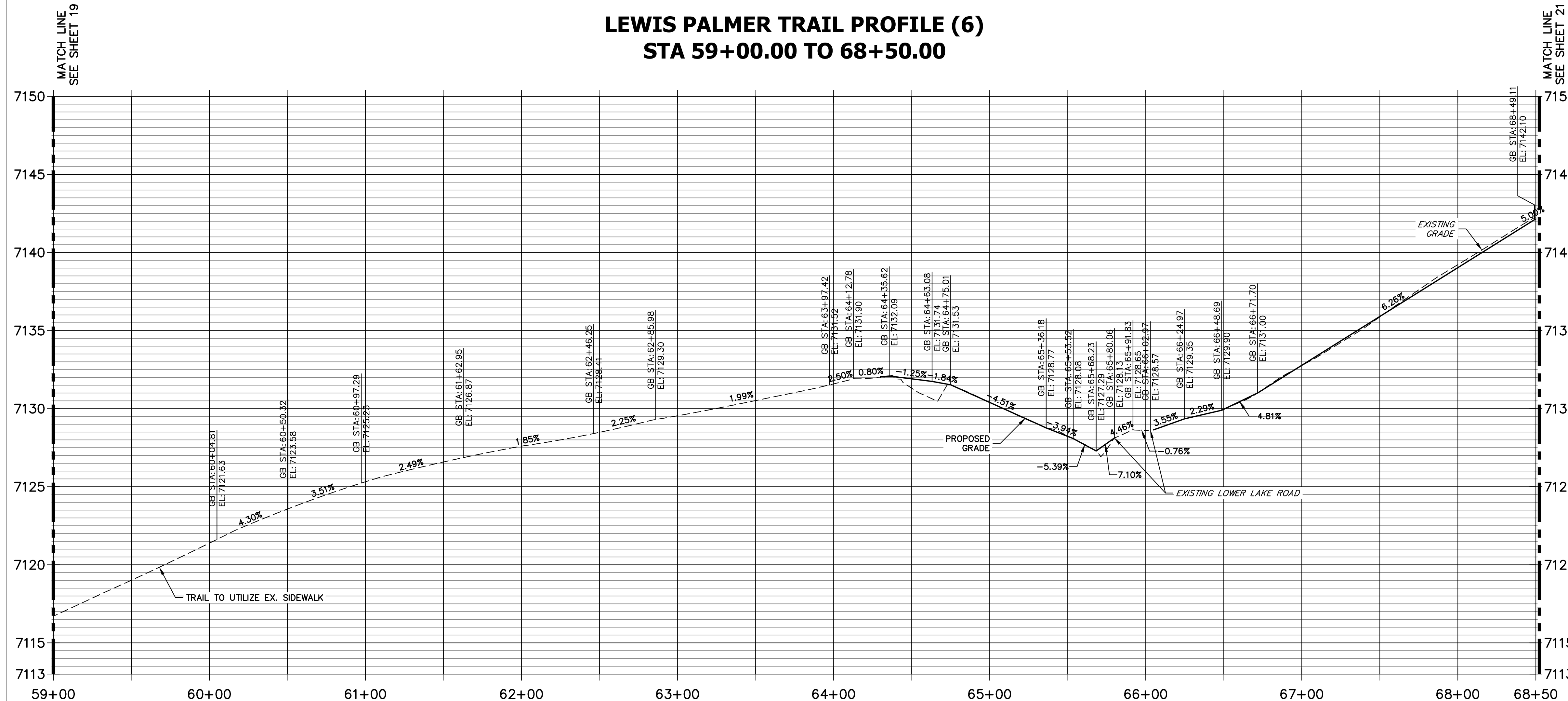

- NOTES:
1. THE SURVEY OF EXISTING CONDITIONS WAS COMPLETED IN APRIL 2021. THERE ARE A NUMBER OF LOCATIONS ALONG THE CORRIDOR THAT HAVE BEEN MODIFIED BY OTHER WORK SINCE THEN (I.E. UTILITY AND GRADING) THAT ARE NOT REPRESENTED IN THESE PLANS. THE CONTRACTOR IS RESPONSIBLE FOR REVIEWING THE TRAIL ALIGNMENT AND BECOMING FAMILIAR WITH THESE LOCATIONS. IF THE CONTRACTOR DETERMINES THAT CHANGES HAVE BEEN MADE THAT IMPACT THE TRAIL DESIGN, THE SCHOOL DISTRICT AND ENGINEER SHALL BE NOTIFIED PRIOR TO CONSTRUCTION OF THE SEGMENT OF TRAIL POTENTIALLY IMPACTED.
 2. THIS PLAN DOES NOT TAKE INTO ACCOUNT EXISTING DRAINAGE PATHS. THE CONTRACTOR SHALL WORK WITH THE SCHOOL DISTRICT AND THE ENGINEER IN DETERMINING AREAS WHERE CULVERTS MAY BE REQUIRED.

ENGINEER'S STATEMENT
 PREPARED UNDER MY SUPERVISION

GLENN D. ELLIS, P.E.
 COLORADO P.E. 38861
 FOR AND ON BEHALF OF JR ENGINEERING, LLC

Print Date: 11/23/2022
 File Name:
 Horiz. Scale: 1"=40' Vert. Scale: 1"=4'
 Unit name Unit leader

| Sheet Revisions | | |
|-----------------|----------|-------|
| Date: | Comments | Init. |
| | | |
| | | |
| | | |

Colorado Department of Transportation

5615 WILL BLVD.
 Pueblo, CO 81008
 Phone: 719-546-5750

Lewis Palmer School District 38

| |
|----------------|
| As Constructed |
| No Revisions: |
| Revised: |
| Void: |

| | | | |
|---|----|-------------------|----|
| LEWIS PALMER TRAIL TRAIL PLAN AND PROFILE | | | |
| Designer: | GG | Structure Numbers | |
| Detailer: | GG | | |
| Sheet Subset: | | Subset Sheets: | OF |

| | |
|------------------|----------------|
| Project No./Code | M915-009/22585 |
| | 2520300 |
| Sheet Number | 20 OF 42 |

X:\2020000\Drawings\Sheet\Drawings\2020000\Trail Plan and Profile.dwg, 11/23/2022, 11:33:13 AM, CS

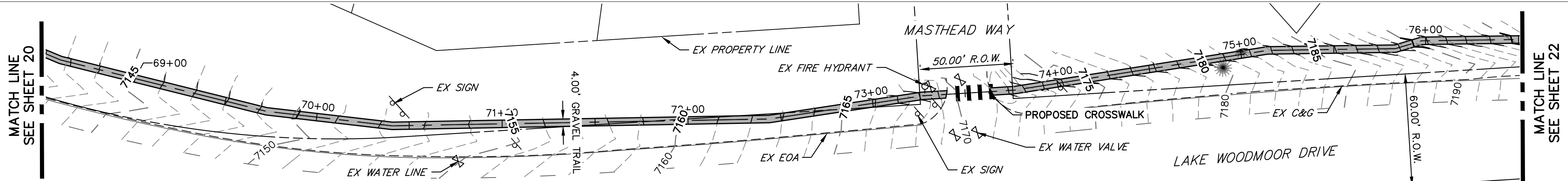

**LEWIS PALMER TRAIL PROFILE (7)
STA 68+50.00 TO 76+50.00**

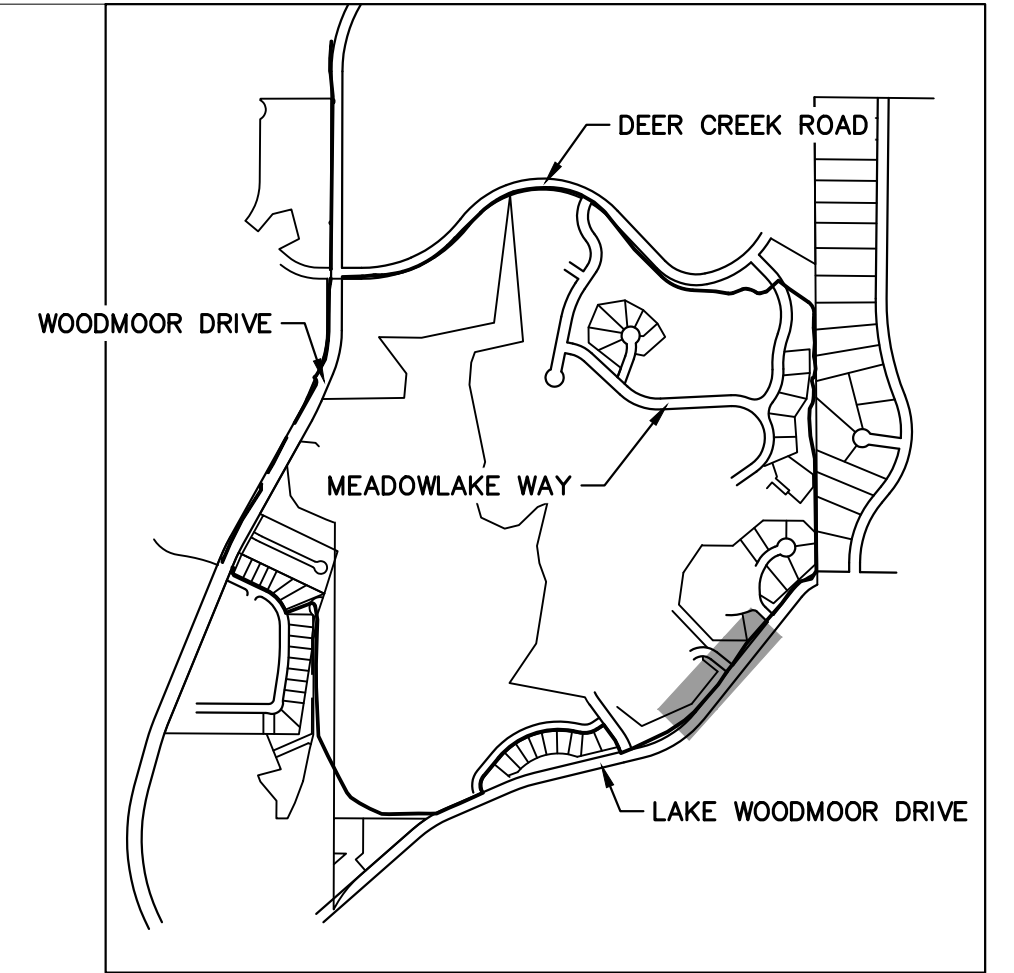

KEY MAP
SCALE: NOT TO SCALE

- NOTES:
1. THE SURVEY OF EXISTING CONDITIONS WAS COMPLETED IN APRIL 2021. THERE ARE A NUMBER OF LOCATIONS ALONG THE CORRIDOR THAT HAVE BEEN MODIFIED BY OTHER WORK SINCE THEN (I.E. UTILITY AND GRADING) THAT ARE NOT REPRESENTED IN THESE PLANS. THE CONTRACTOR IS RESPONSIBLE FOR REVIEWING THE TRAIL ALIGNMENT AND BECOMING FAMILIAR WITH THESE LOCATIONS. IF THE CONTRACTOR DETERMINES THAT CHANGES HAVE BEEN MADE THAT IMPACT THE TRAIL DESIGN, THE SCHOOL DISTRICT AND ENGINEER SHALL BE NOTIFIED PRIOR TO CONSTRUCTION OF THE SEGMENT OF TRAIL POTENTIALLY IMPACTED.
 2. THIS PLAN DOES NOT TAKE INTO ACCOUNT EXISTING DRAINAGE PATHS. THE CONTRACTOR SHALL WORK WITH THE SCHOOL DISTRICT AND THE ENGINEER IN DETERMINING AREAS WHERE CULVERTS MAY BE REQUIRED.

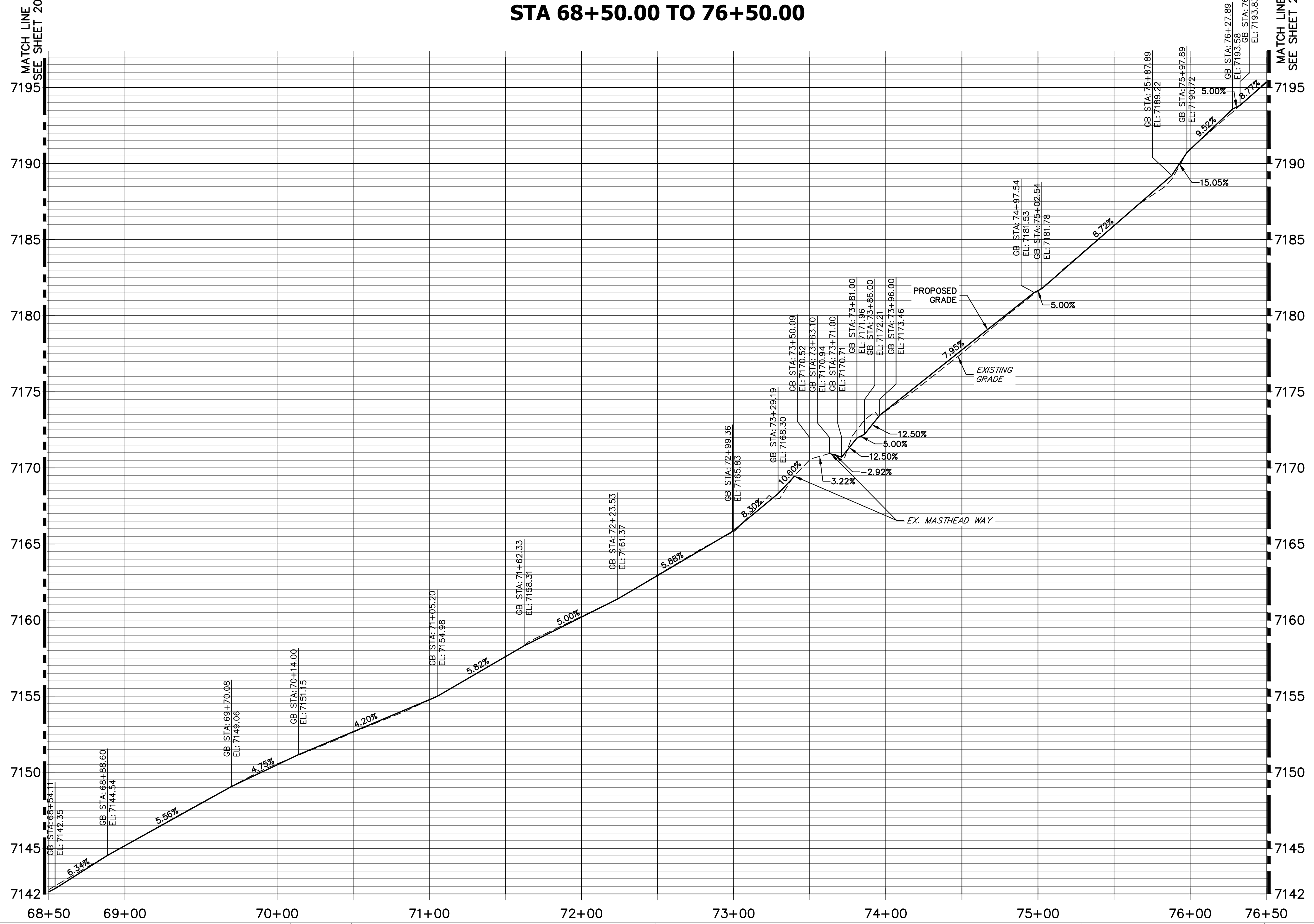

811
Know what's below.
Call before you dig.

HORIZONTAL ORIGINAL SCALE: 1" = 40'
VERTICAL ORIGINAL SCALE: 1" = 4'

ENGINEER'S STATEMENT

PREPARED UNDER MY SUPERVISION

GLENN D. ELLIS, P.E.
COLORADO P.E. 38861
FOR AND ON BEHALF OF JR ENGINEERING, LLC

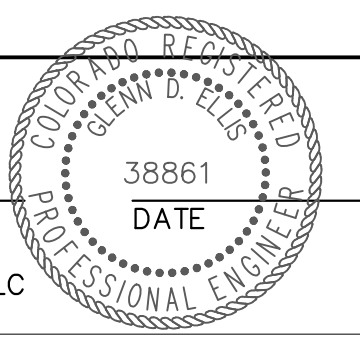

Print Date: 11/23/2022

File Name: _____

Horiz. Scale: 1"=40' Vert. Scale: 1"=4'

Unit name: _____ Unit leader: _____

J-R ENGINEERING
A Westrian Company
Centennial 303-740-9393 • Colorado Springs 719-593-2583
Fort Collins 970-491-9888 • www.jrengineering.com

| Sheet Revisions | | |
|-----------------|----------|-------|
| Date: | Comments | Init. |
| | | |
| | | |
| | | |

Colorado Department of Transportation

5615 WILL BLVD.
Pueblo, CO 81008
Phone: 719-546-5750

Lewis Palmer School District 38

| |
|----------------|
| As Constructed |
| No Revisions: |
| Revised: |
| Void: |

| | | | |
|---|----|-------------------|----|
| LEWIS PALMER TRAIL TRAIL PLAN AND PROFILE | | | |
| Designer: | GG | Structure Numbers | |
| Detailer: | GG | | |
| Sheet Subset: | | Subset Sheets: | OF |

| | |
|------------------|----------------|
| Project No./Code | M915-009/22585 |
| | 2520300 |
| Sheet Number | 21 OF 42 |

X:\25203000\Drawings\Sheet\Drawings\25203000\Trail Plan & Profile.dwg, 8/11/2022 11:33:22 AM, CS

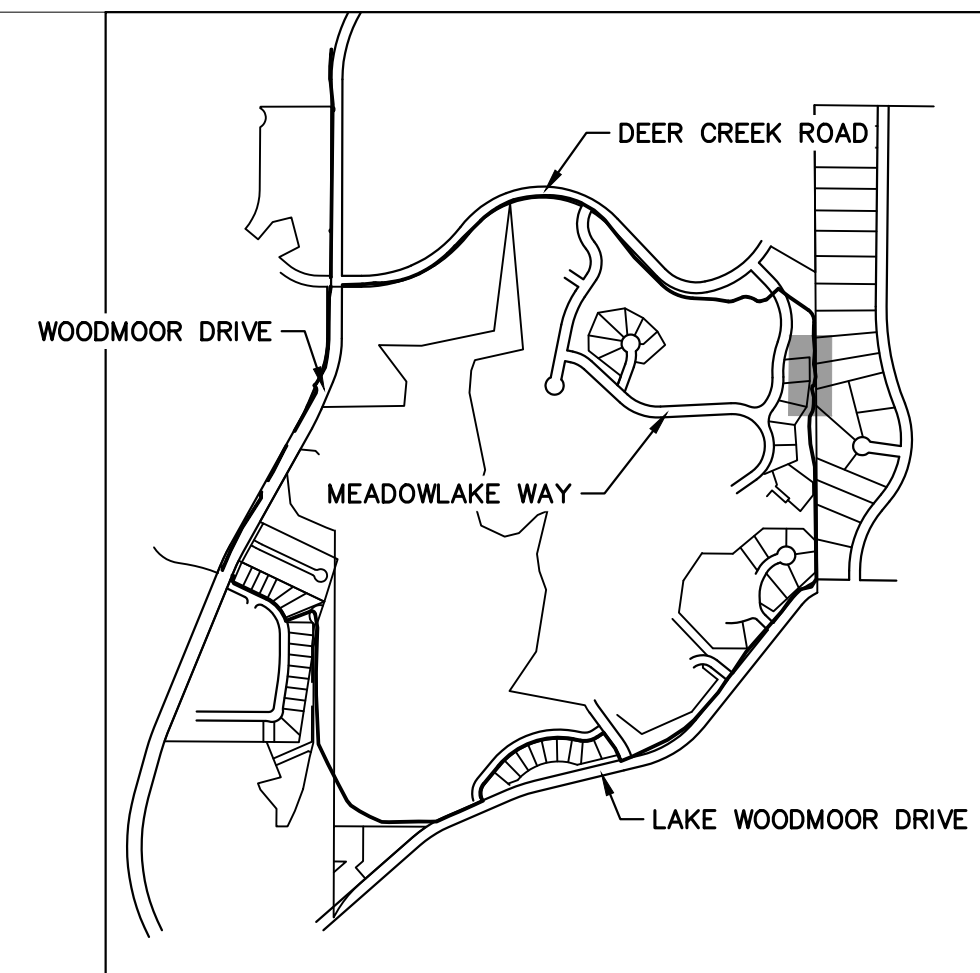
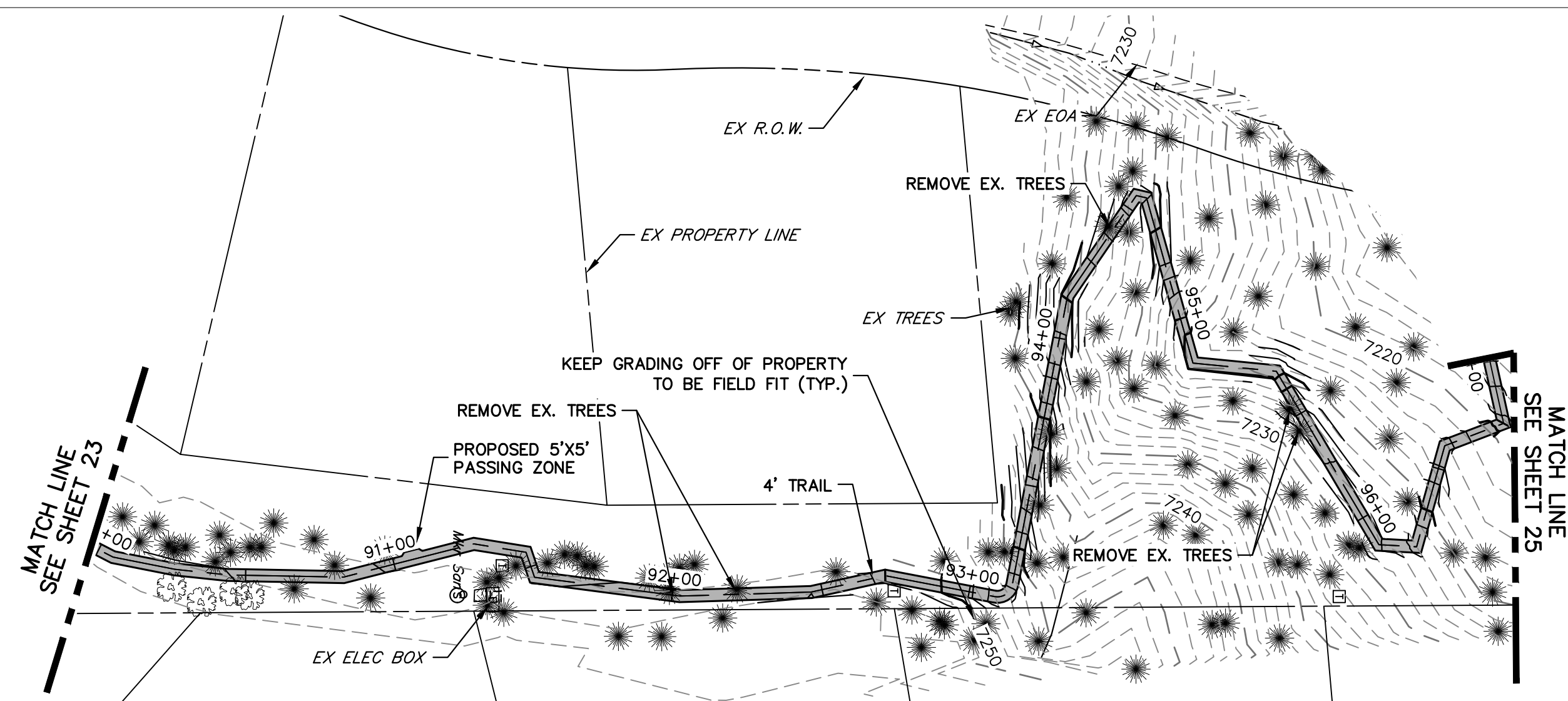

LEWIS PALMER TRAIL PROFILE (11)
STA 90+00.00 TO 97+00.00

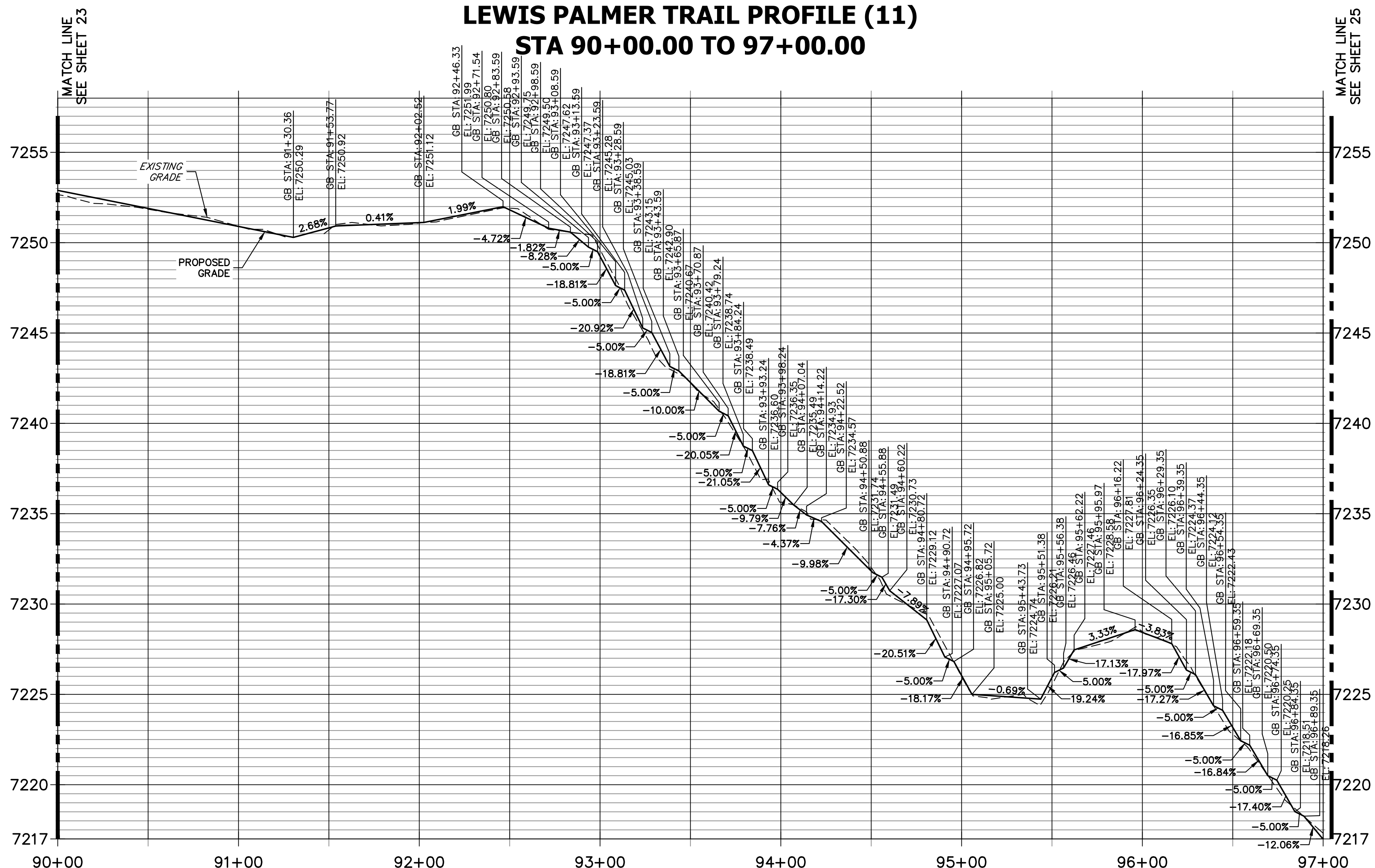

- NOTES:
1. THE SURVEY OF EXISTING CONDITIONS WAS COMPLETED IN APRIL 2021. THERE ARE A NUMBER OF LOCATIONS ALONG THE CORRIDOR THAT HAVE BEEN MODIFIED BY OTHER WORK SINCE THEN (I.E. UTILITY AND GRADING) THAT ARE NOT REPRESENTED IN THESE PLANS. THE CONTRACTOR IS RESPONSIBLE FOR REVIEWING THE TRAIL ALIGNMENT AND BECOMING FAMILIAR WITH THESE LOCATIONS. IF THE CONTRACTOR DETERMINES THAT CHANGES HAVE BEEN MADE THAT IMPACT THE TRAIL DESIGN, THE SCHOOL DISTRICT AND ENGINEER SHALL BE NOTIFIED PRIOR TO CONSTRUCTION OF THE SEGMENT OF TRAIL POTENTIALLY IMPACTED.
 2. THIS PLAN DOES NOT TAKE INTO ACCOUNT EXISTING DRAINAGE PATHS. THE CONTRACTOR SHALL WORK WITH THE SCHOOL DISTRICT AND THE ENGINEER IN DETERMINING AREAS WHERE CULVERTS MAY BE REQUIRED.

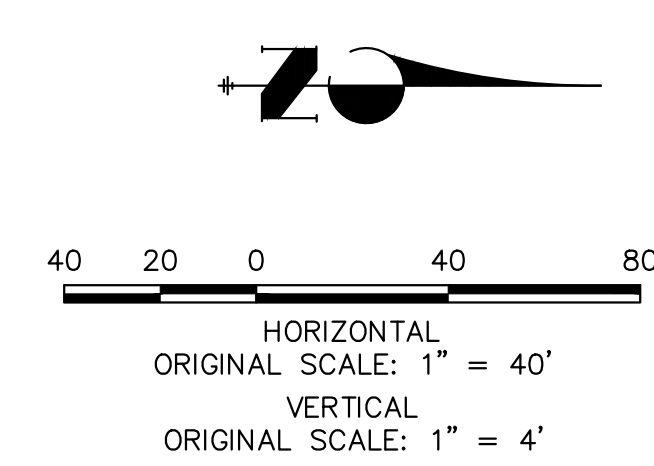

811
 Know what's below.
 Call before you dig.

ENGINEER'S STATEMENT
 PREPARED UNDER MY SUPERVISION

GLENN D. ELLIS, P.E.
 COLORADO P.E. 38861
 FOR AND ON BEHALF OF JR ENGINEERING, LLC

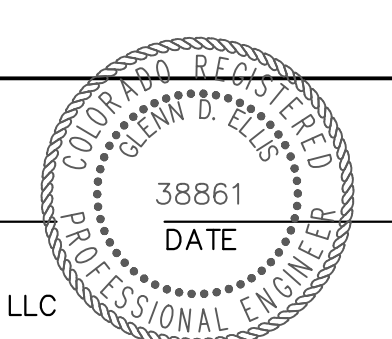

Print Date: 11/23/2022
 File Name:
 Horiz. Scale: 1"=40' Vert. Scale: 1"=4'
 Unit name Unit leader

J-R ENGINEERING
 A Westrian Company
 Centennial 303-740-9393 • Colorado Springs 719-583-2583
 Fort Collins 970-491-9888 • www.jrengineering.com

| Sheet Revisions | | |
|-----------------|----------|-------|
| Date: | Comments | Init. |
| | | |
| | | |
| | | |

Colorado Department of Transportation

CDOT **LP**
 Region 2 Lewis Palmer School District 38

5615 WILL BLVD.
 Pueblo, CO 81008
 Phone: 719-546-5750

| |
|----------------|
| As Constructed |
| No Revisions: |
| Revised: |
| Void: |

| | | | |
|---|----|----------------|----|
| LEWIS PALMER TRAIL TRAIL PLAN AND PROFILE | | | |
| Designer: | GG | Structure | |
| Detailer: | GG | Numbers | |
| Sheet Subset: | | Subset Sheets: | OF |

| | |
|------------------|----------------|
| Project No./Code | M915-009/22585 |
| | 2520300 |
| Sheet Number | 24 OF 42 |

X:\25203000\Drawings\Sheet\Drawings\25203000\Trail Plan and Profile.dwg, 11/23/2022 11:33:52 AM, CS

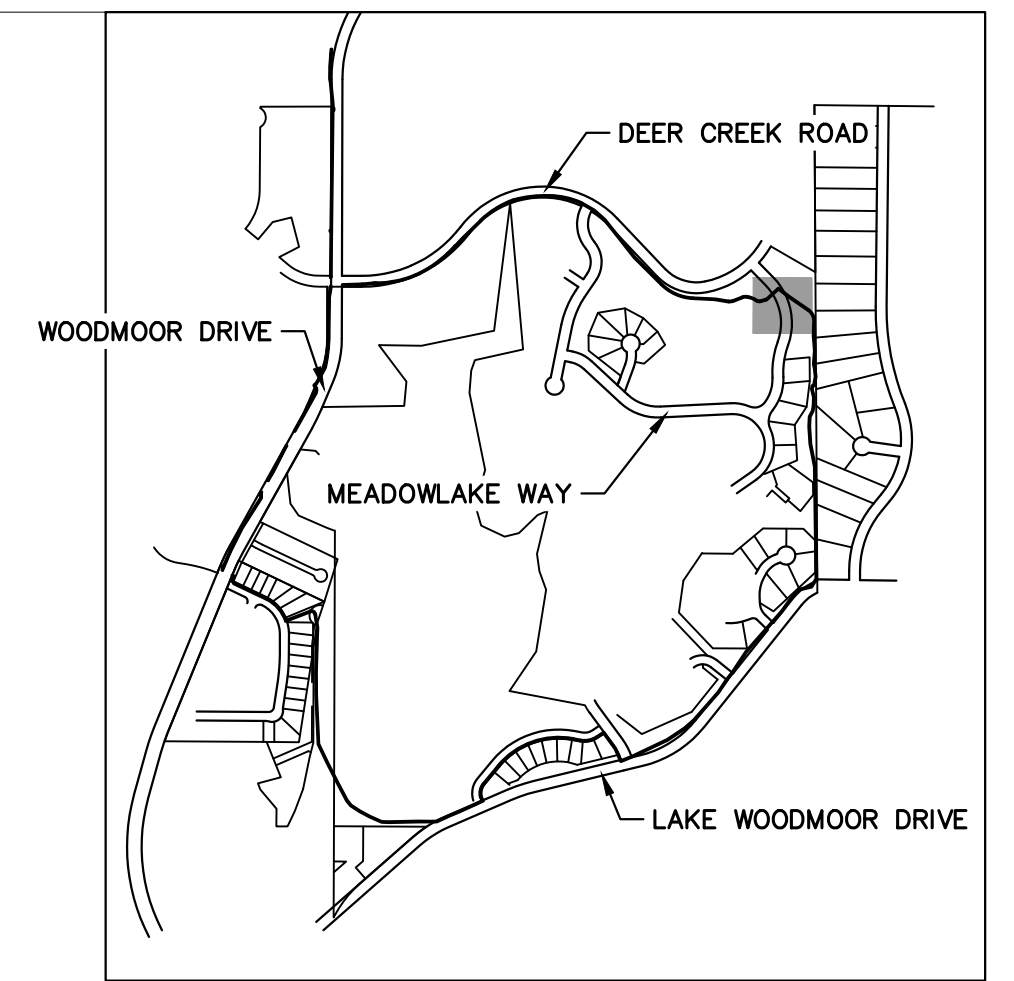

KEY MAP
SCALE: NOT TO SCALE

- NOTES:
1. THE SURVEY OF EXISTING CONDITIONS WAS COMPLETED IN APRIL 2021. THERE ARE A NUMBER OF LOCATIONS ALONG THE CORRIDOR THAT HAVE BEEN MODIFIED BY OTHER WORK SINCE THEN (I.E. UTILITY AND GRADING) THAT ARE NOT REPRESENTED IN THESE PLANS. THE CONTRACTOR IS RESPONSIBLE FOR REVIEWING THE TRAIL ALIGNMENT AND BECOMING FAMILIAR WITH THESE LOCATIONS. IF THE CONTRACTOR DETERMINES THAT CHANGES HAVE BEEN MADE THAT IMPACT THE TRAIL DESIGN, THE SCHOOL DISTRICT AND ENGINEER SHALL BE NOTIFIED PRIOR TO CONSTRUCTION OF THE SEGMENT OF TRAIL POTENTIALLY IMPACTED.
 2. THIS PLAN DOES NOT TAKE INTO ACCOUNT EXISTING DRAINAGE PATHS. THE CONTRACTOR SHALL WORK WITH THE SCHOOL DISTRICT AND THE ENGINEER IN DETERMINING AREAS WHERE CULVERTS MAY BE REQUIRED.

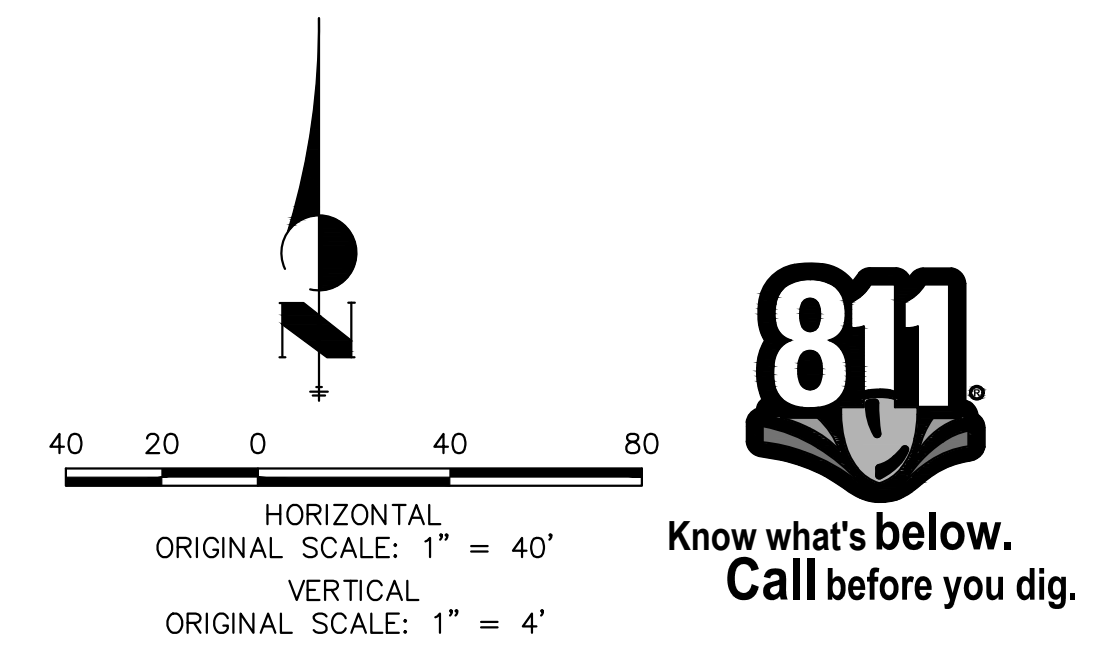

ENGINEER'S STATEMENT
PREPARED UNDER MY SUPERVISION

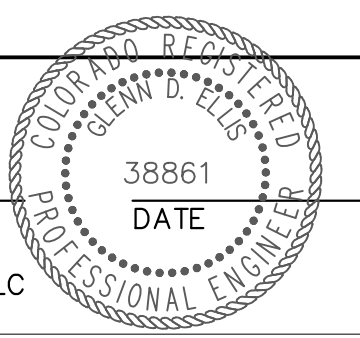

GLENN D. ELLIS, P.E.
COLORADO P.E. 38861
FOR AND ON BEHALF OF JR ENGINEERING, LLC

LEWIS PALMER TRAIL PROFILE (12)
STA 97+00.00 TO 102+00.00

(NOTE: PROFILE IS REVERSED DUE TO TRAIL DIRECTION CHANGE)

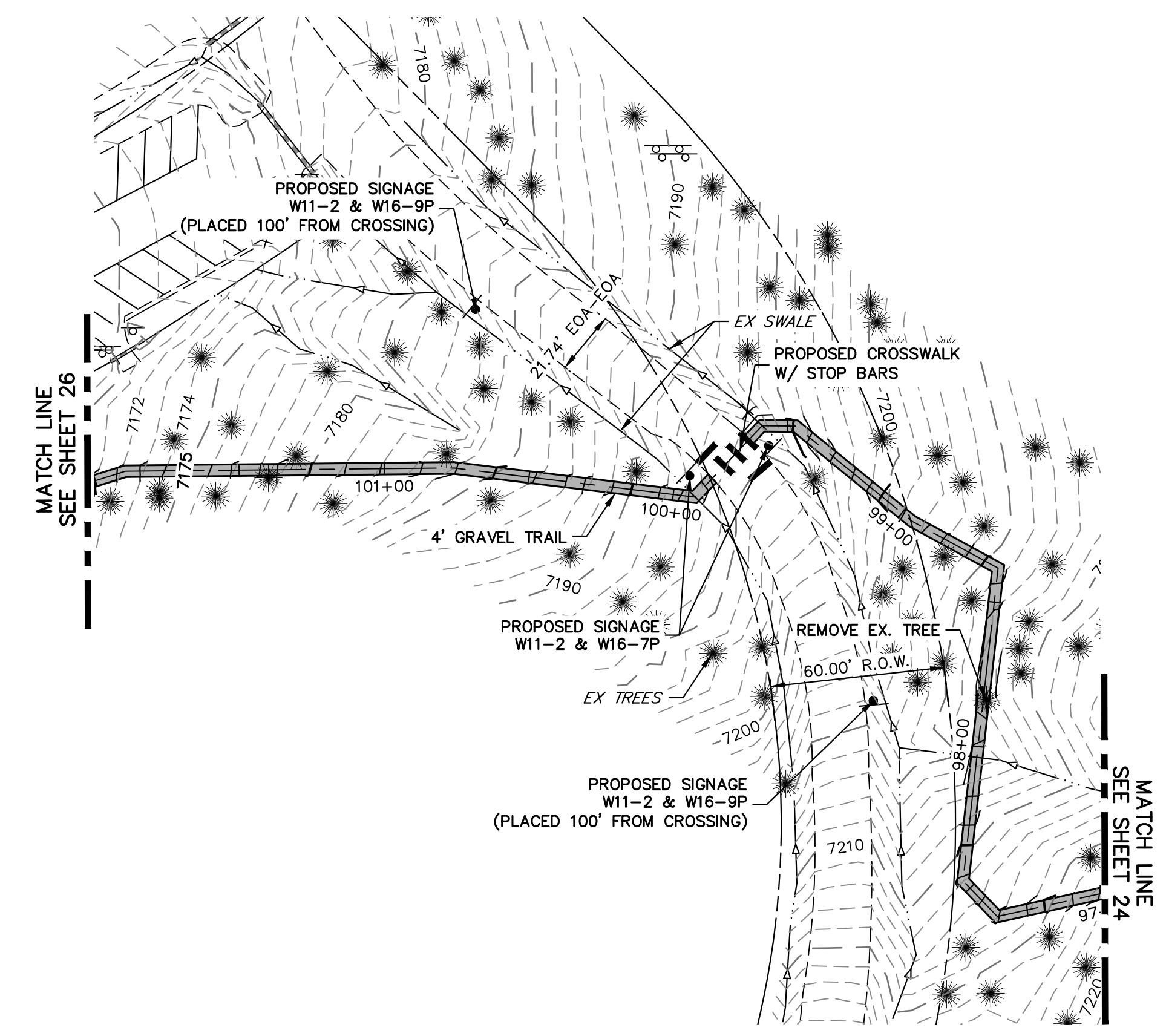
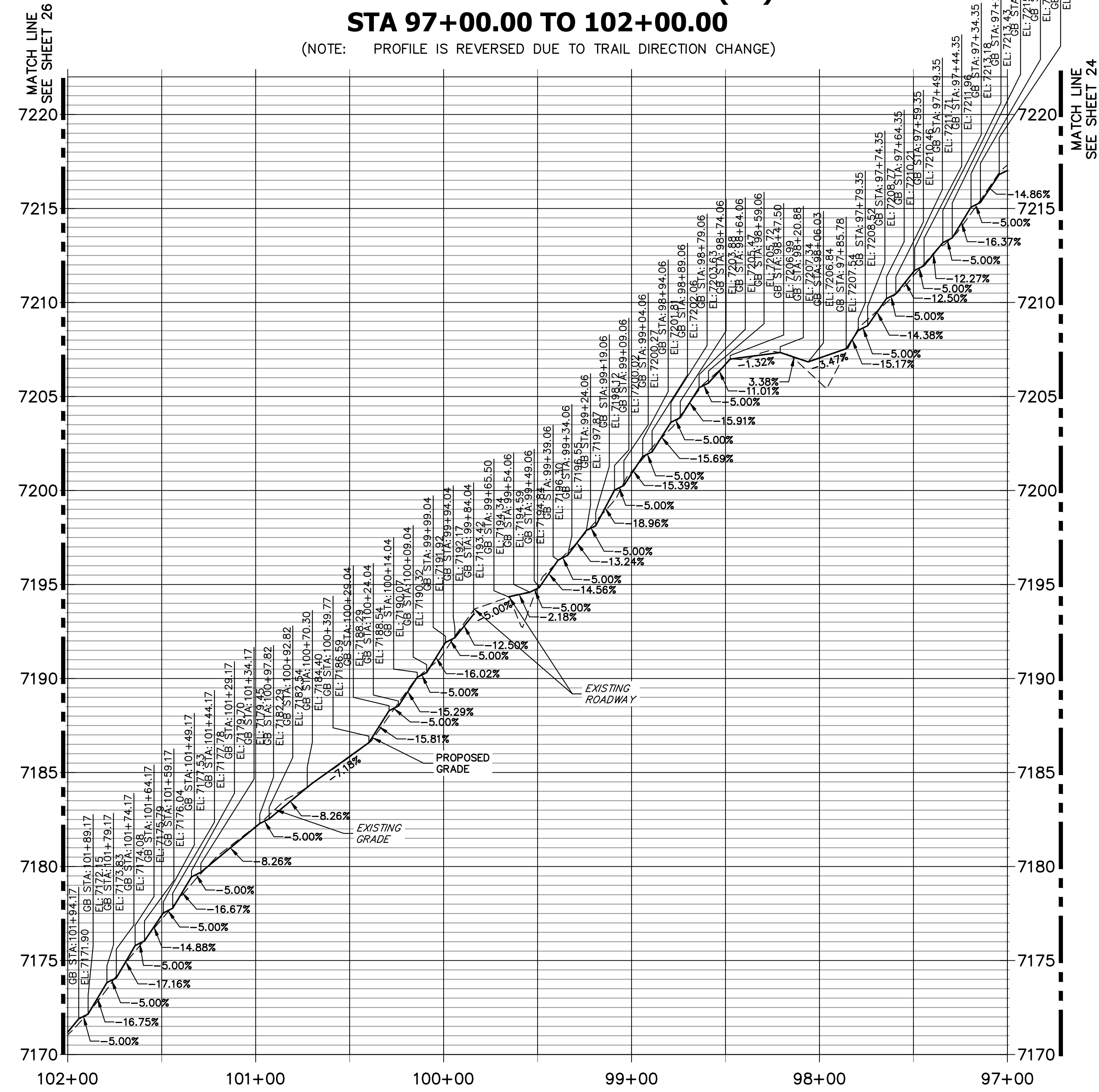

| | |
|--|--------------------|
| Print Date: 11/23/2022 | |
| File Name: | |
| Horiz. Scale: 1"=40' | Vert. Scale: 1"=4' |
| Unit name | Unit leader |
| J-R ENGINEERING A Westrian Company Centennial 303-740-9393 • Colorado Springs 719-583-2583 Fort Collins 970-491-9888 • www.jrengineering.com | |

| Sheet Revisions | | |
|-----------------|----------|-------|
| Date: | Comments | Init. |
| | | |
| | | |
| | | |

Colorado Department of Transportation

5615 WILL BLVD.
Pueblo, CO 81008
Phone: 719-546-5750

Lewis Palmer School District 38

| |
|----------------|
| As Constructed |
| No Revisions: |
| Revised: |
| Void: |

| | | | |
|---|----|-------------------|----|
| LEWIS PALMER TRAIL TRAIL PLAN AND PROFILE | | | |
| Designer: | GG | Structure Numbers | |
| Detailer: | GG | Subset Sheets: | OF |
| Sheet Subset: | | | |

| | |
|------------------|----------------|
| Project No./Code | M915-009/22585 |
| Sheet Number | 25 OF 42 |

X:\2520300_Drawings\Sheet\Drawings\252030001\Trail Plan and Profile.dwg, 12, 11/23/2022, 11:34:01 AM, CS

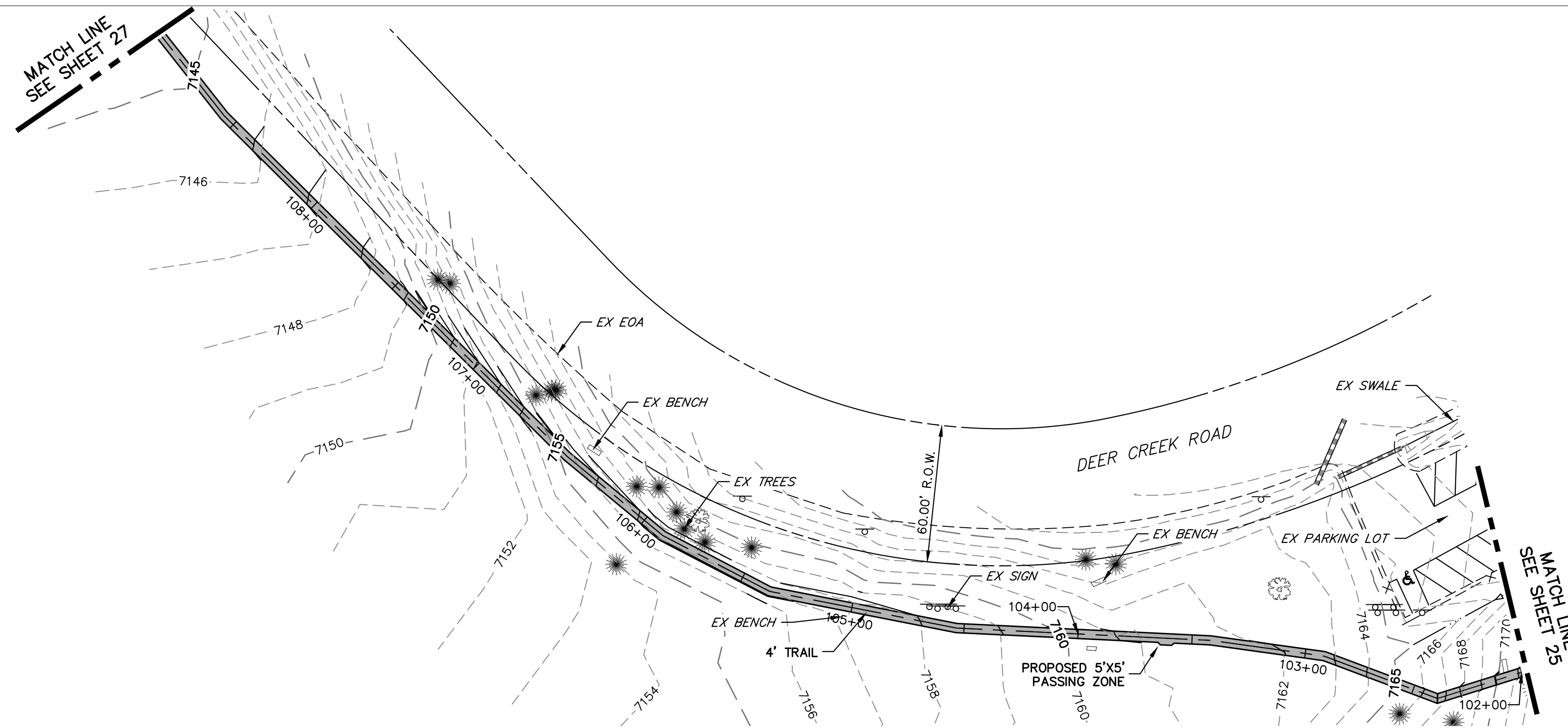

LEWIS PALMER TRAIL PROFILE (13)
STA 102+00.00 TO 109+00.00

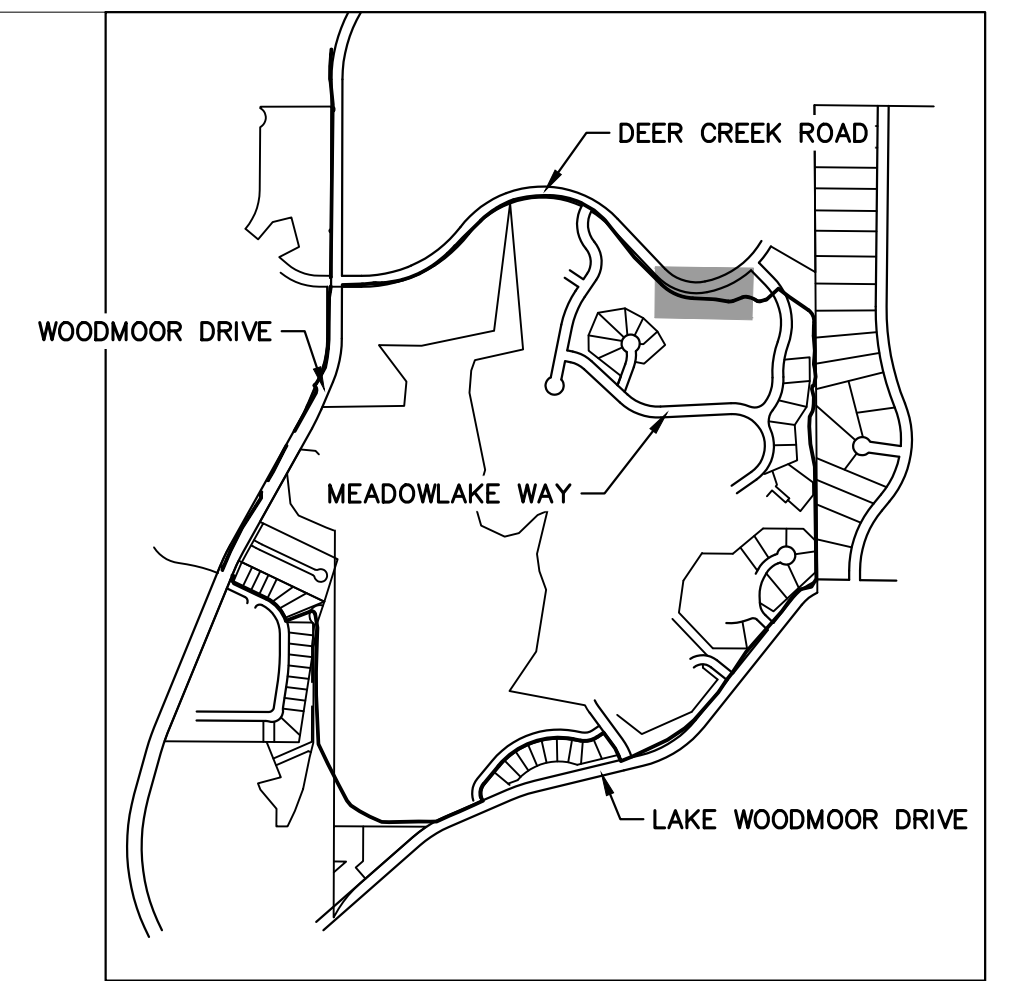
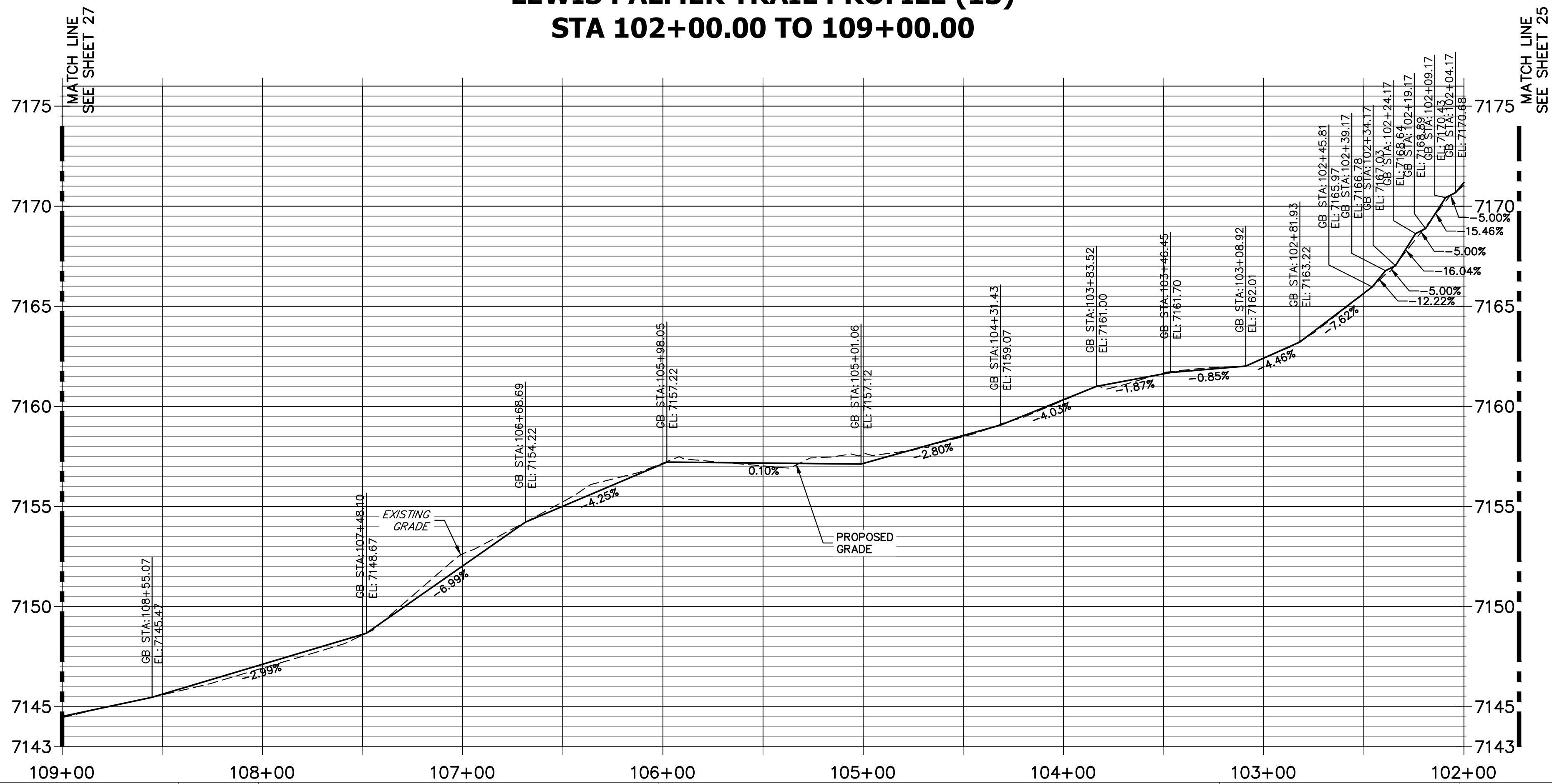

KEY MAP
 SCALE: NOT TO SCALE

- NOTES:**
1. THE SURVEY OF EXISTING CONDITIONS WAS COMPLETED IN APRIL 2021. THERE ARE A NUMBER OF LOCATIONS ALONG THE CORRIDOR THAT HAVE BEEN MODIFIED BY OTHER WORK SINCE THEN (I.E. UTILITY AND GRADING) THAT ARE NOT REPRESENTED IN THESE PLANS. THE CONTRACTOR IS RESPONSIBLE FOR REVIEWING THE TRAIL ALIGNMENT AND BECOMING FAMILIAR WITH THESE LOCATIONS. IF THE CONTRACTOR DETERMINES THAT CHANGES HAVE BEEN MADE THAT IMPACT THE TRAIL DESIGN, THE SCHOOL DISTRICT AND ENGINEER SHALL BE NOTIFIED PRIOR TO CONSTRUCTION OF THE SEGMENT OF TRAIL POTENTIALLY IMPACTED.
 2. THIS PLAN DOES NOT TAKE INTO ACCOUNT EXISTING DRAINAGE PATHS. THE CONTRACTOR SHALL WORK WITH THE SCHOOL DISTRICT AND THE ENGINEER IN DETERMINING AREAS WHERE CULVERTS MAY BE REQUIRED.

HORIZONTAL
 ORIGINAL SCALE: 1" = 40'
 VERTICAL
 ORIGINAL SCALE: 1" = 4'

Know what's below.
Call before you dig.

ENGINEER'S STATEMENT

PREPARED UNDER MY SUPERVISION

GLENN D. ELLIS, P.E.
 COLORADO P.E. 38861
 FOR AND ON BEHALF OF JR ENGINEERING, LLC

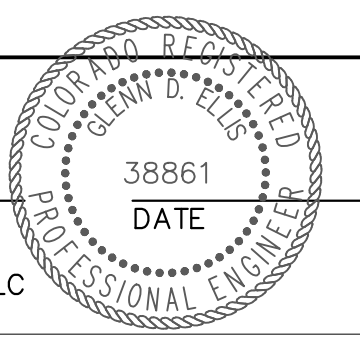

Print Date: 11/23/2022

File Name: _____

Horiz. Scale: 1"=40' Vert. Scale: 1"=4'

Unit name: _____ Unit leader: _____



J-R ENGINEERING
 A Westrian Company
 Centennial 303-740-9393 • Colorado Springs 719-583-2583
 Fort Collins 970-491-9888 • www.jrengineering.com

| Sheet Revisions | | |
|-----------------|----------|-------|
| Date: | Comments | Init. |
| | | |
| | | |
| | | |

Colorado Department
of Transportation



5615 WILL BLVD.
 Pueblo, CO 81008
 Phone: 719-546-5750



Lewis Palmer
School District 38

| |
|----------------|
| As Constructed |
| No Revisions: |
| Revised: |
| Void: |

| | | | |
|--|----|----------------|----|
| LEWIS PALMER TRAIL TRAIL PLAN AND PROFILE | | | |
| Designer: | GG | Structure | |
| Detailer: | GG | Numbers | |
| Sheet Subset: | | Subset Sheets: | OF |

| | |
|------------------|----------------|
| Project No./Code | M915-009/22585 |
| | 2520300 |
| Sheet Number | 26 OF 42 |

X:\25203000\Drawings\Sheet\Drawings\25203000\Trail Plan & Profile.dwg, 13, 11/23/2022, 11:34:10 AM, CS

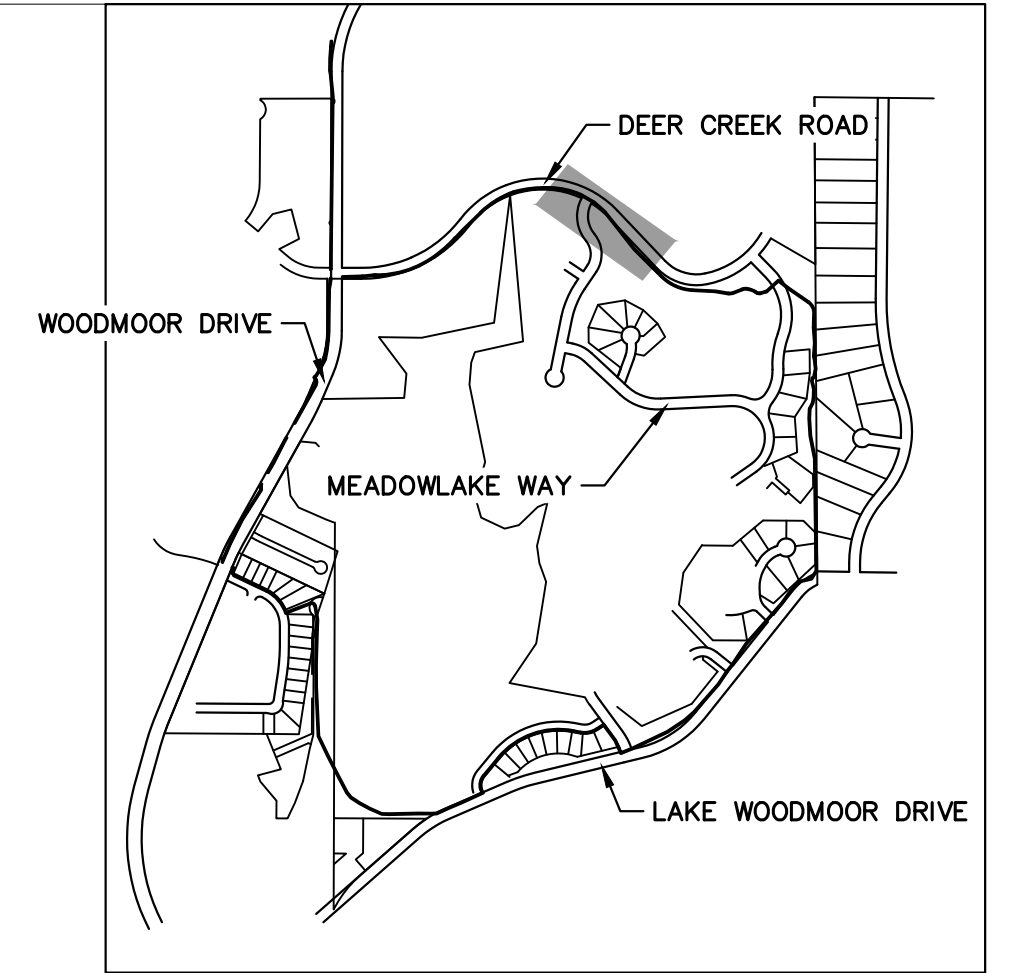
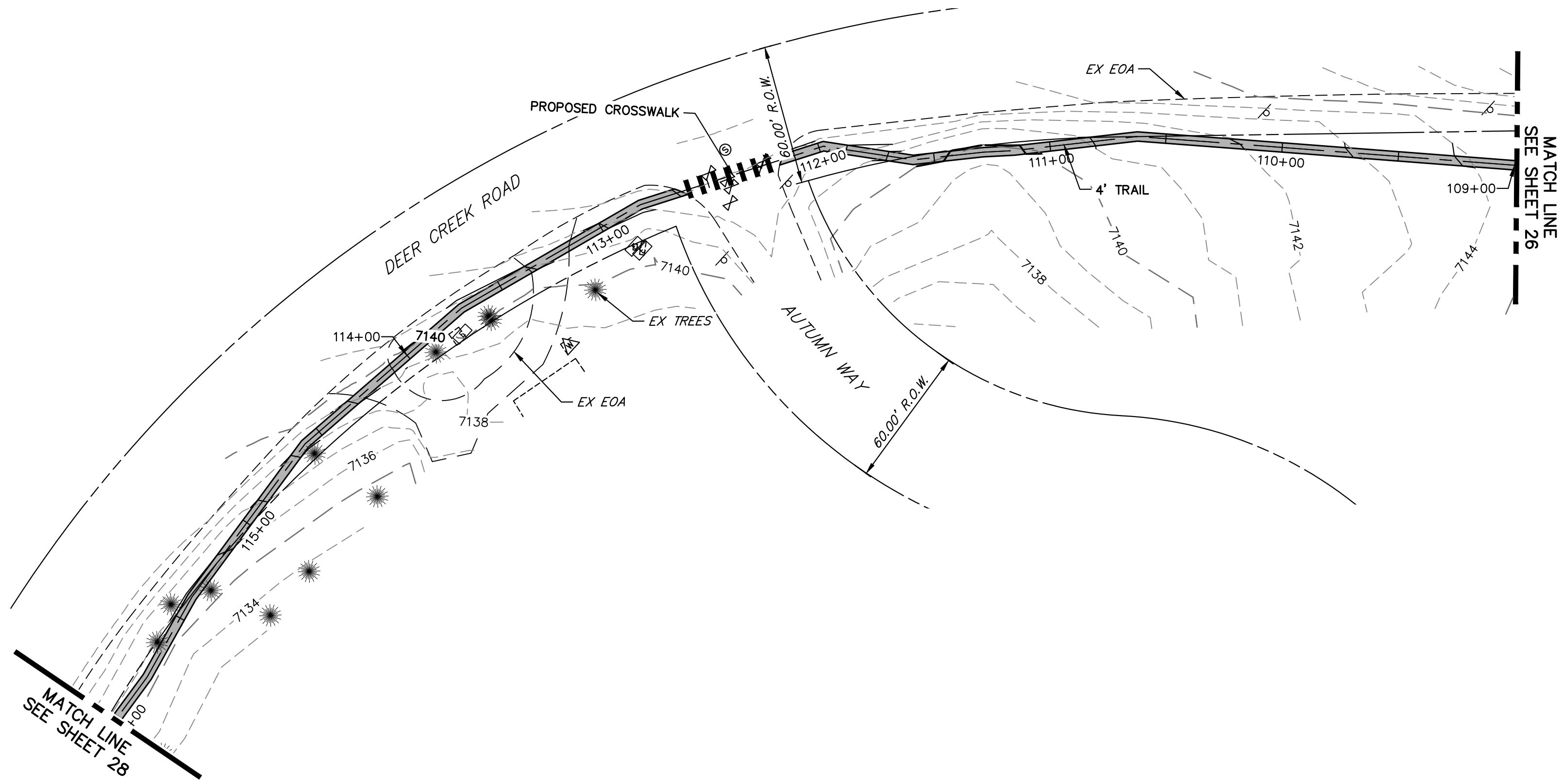

KEY MAP
SCALE: NOT TO SCALE

- NOTES:
1. THE SURVEY OF EXISTING CONDITIONS WAS COMPLETED IN APRIL 2021. THERE ARE A NUMBER OF LOCATIONS ALONG THE CORRIDOR THAT HAVE BEEN MODIFIED BY OTHER WORK SINCE THEN (I.E. UTILITY AND GRADING) THAT ARE NOT REPRESENTED IN THESE PLANS. THE CONTRACTOR IS RESPONSIBLE FOR REVIEWING THE TRAIL ALIGNMENT AND BECOMING FAMILIAR WITH THESE LOCATIONS. IF THE CONTRACTOR DETERMINES THAT CHANGES HAVE BEEN MADE THAT IMPACT THE TRAIL DESIGN, THE SCHOOL DISTRICT AND ENGINEER SHALL BE NOTIFIED PRIOR TO CONSTRUCTION OF THE SEGMENT OF TRAIL POTENTIALLY IMPACTED.
 2. THIS PLAN DOES NOT TAKE INTO ACCOUNT EXISTING DRAINAGE PATHS. THE CONTRACTOR SHALL WORK WITH THE SCHOOL DISTRICT AND THE ENGINEER IN DETERMINING AREAS WHERE CULVERTS MAY BE REQUIRED.

**LEWIS PALMER TRAIL PROFILE (14)
STA 109+00.00 TO 116+00.00**

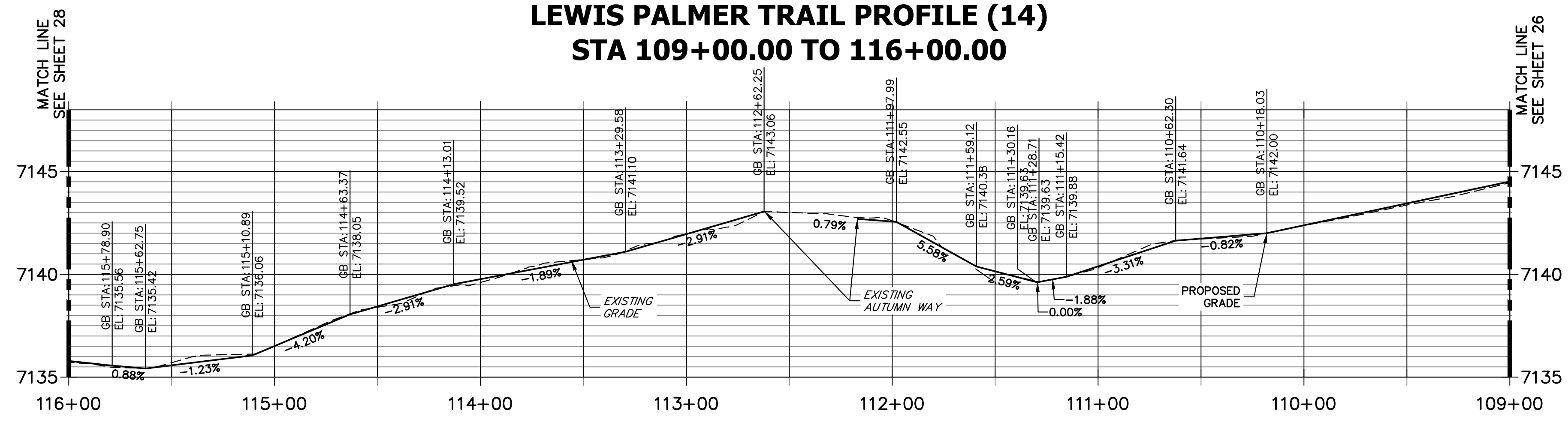

HORIZONTAL ORIGINAL SCALE: 1" = 40'
VERTICAL ORIGINAL SCALE: 1" = 4'

ENGINEER'S STATEMENT
PREPARED UNDER MY SUPERVISION

GLENN D. ELLIS, P.E.
COLORADO P.E. 38861
FOR AND ON BEHALF OF JR ENGINEERING, LLC

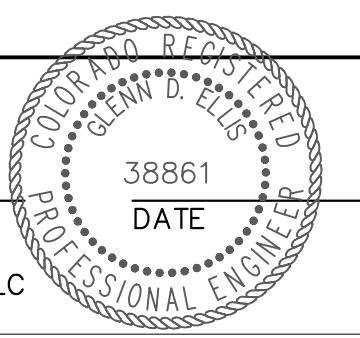

Print Date: 11/23/2022

File Name:

Horiz. Scale: 1"=40' Vert. Scale: 1"=4'

Unit name Unit leader

J-R ENGINEERING
A Westrian Company
Centennial 303-740-9393 • Colorado Springs 719-583-2583
Fort Collins 970-431-9888 • www.jrengineering.com

| Sheet Revisions | | |
|-----------------|----------|-------|
| Date: | Comments | Init. |
| | | |
| | | |
| | | |

Colorado Department of Transportation

5615 WILL BLVD.
Pueblo, CO 81008
Phone: 719-546-5750

Lewis Palmer School District 38

| |
|----------------|
| As Constructed |
| No Revisions: |
| Revised: |
| Void: |

| | | | |
|---|----|-------------------|----|
| LEWIS PALMER TRAIL TRAIL PLAN AND PROFILE | | | |
| Designer: | GG | Structure Numbers | |
| Detailer: | GG | | |
| Sheet Subset: | | Subset Sheets: | OF |

| | |
|------------------|----------------|
| Project No./Code | M915-009/22585 |
| | 2520300 |
| Sheet Number | 27 OF 42 |

X:\25203000\Drawings\Sheet\Drawings\25203000\Trail Plan and Profile.dwg, 14, 11/23/2022, 11:34:20 AM, CS

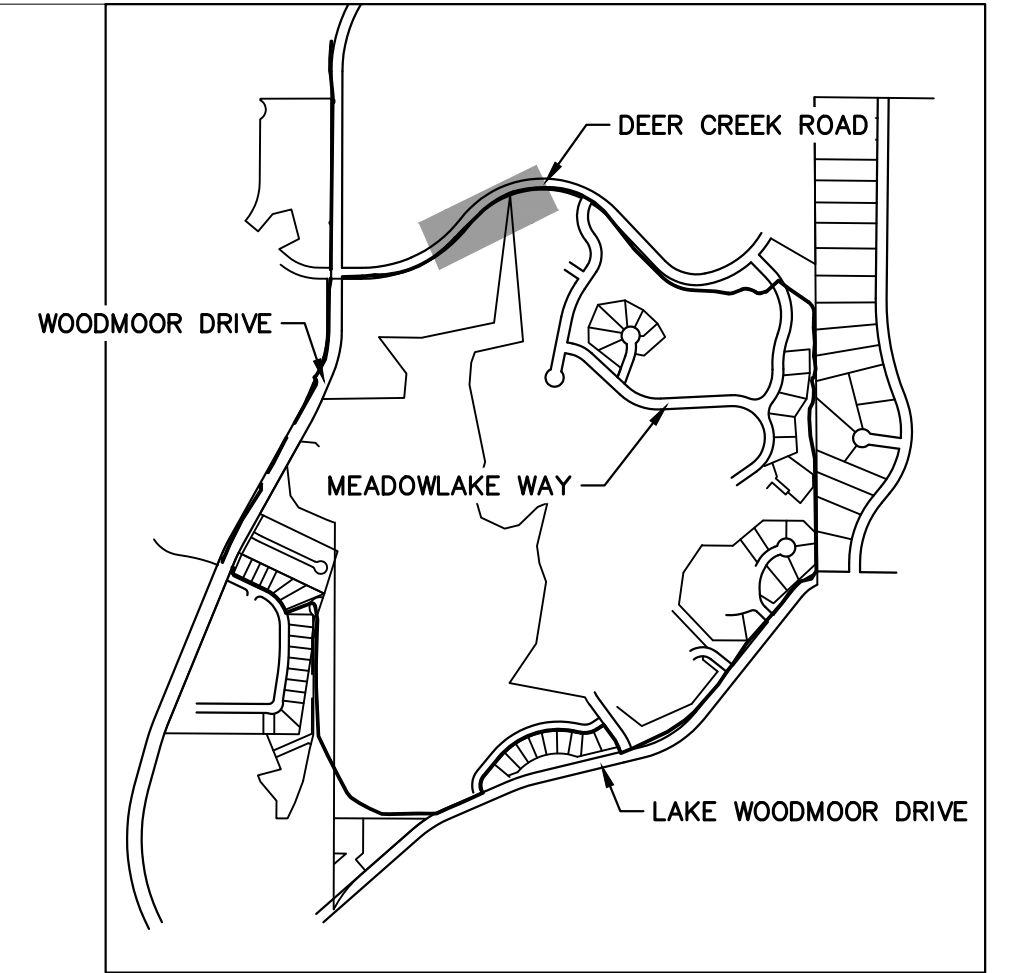
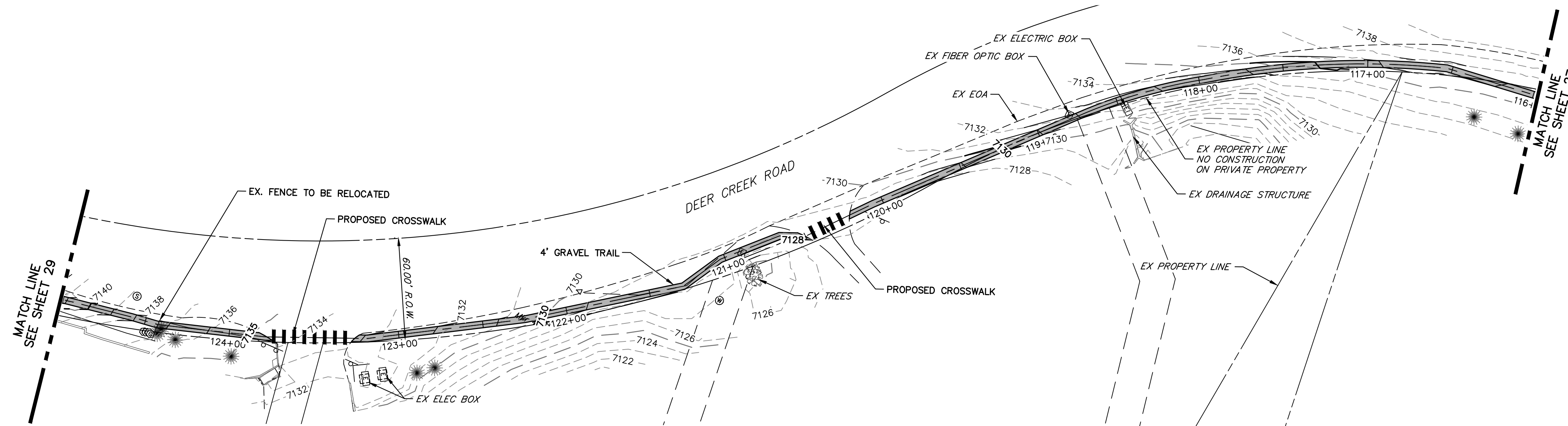

**LEWIS PALMER TRAIL PROFILE (15)
STA 116+00.00 TO 125+00.00**

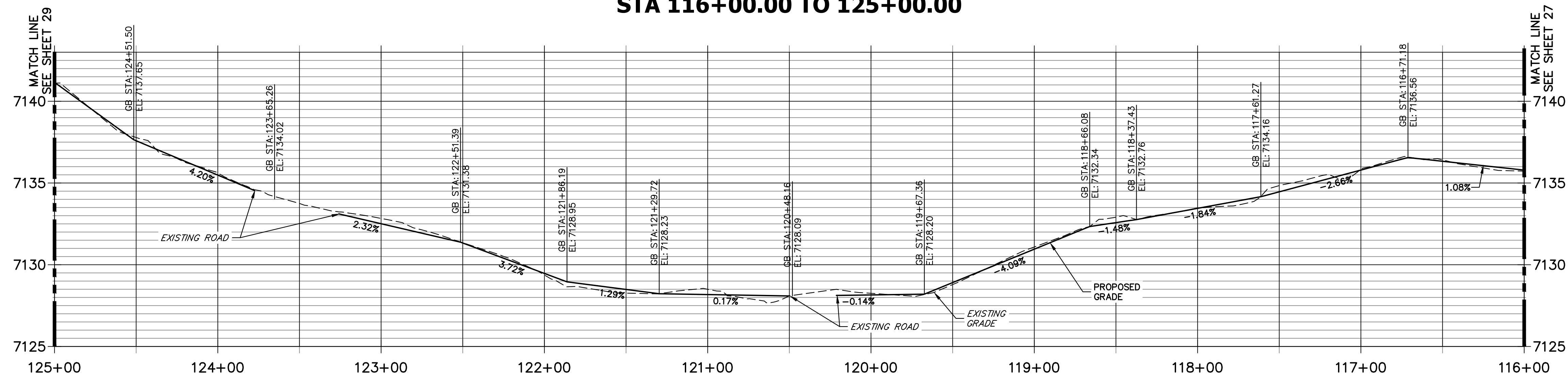

- NOTES:
1. THE SURVEY OF EXISTING CONDITIONS WAS COMPLETED IN APRIL 2021. THERE ARE A NUMBER OF LOCATIONS ALONG THE CORRIDOR THAT HAVE BEEN MODIFIED BY OTHER WORK SINCE THEN (I.E. UTILITY AND GRADING) THAT ARE NOT REPRESENTED IN THESE PLANS. THE CONTRACTOR IS RESPONSIBLE FOR REVIEWING THE TRAIL ALIGNMENT AND BECOMING FAMILIAR WITH THESE LOCATIONS. IF THE CONTRACTOR DETERMINES THAT CHANGES HAVE BEEN MADE THAT IMPACT THE TRAIL DESIGN, THE SCHOOL DISTRICT AND ENGINEER SHALL BE NOTIFIED PRIOR TO CONSTRUCTION OF THE SEGMENT OF TRAIL POTENTIALLY IMPACTED.
 2. THIS PLAN DOES NOT TAKE INTO ACCOUNT EXISTING DRAINAGE PATHS. THE CONTRACTOR SHALL WORK WITH THE SCHOOL DISTRICT AND THE ENGINEER IN DETERMINING AREAS WHERE CULVERTS MAY BE REQUIRED.

HORIZONTAL ORIGINAL SCALE: 1" = 40'
VERTICAL ORIGINAL SCALE: 1" = 4'

ENGINEER'S STATEMENT

PREPARED UNDER MY SUPERVISION

GLENN D. ELLIS, P.E.
COLORADO P.E. 38861
FOR AND ON BEHALF OF JR ENGINEERING, LLC

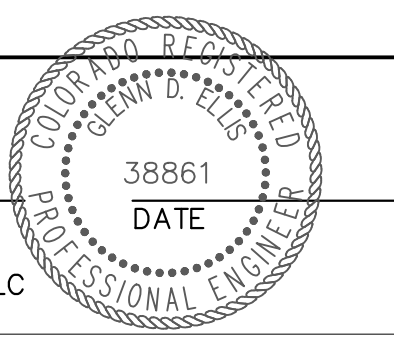

Print Date: 11/23/2022
File Name:
Horiz. Scale: 1"=40' Vert. Scale: 1"=4'
Unit name Unit leader

J-R ENGINEERING
A Westrian Company
Centennial 303-740-9393 • Colorado Springs 719-583-2583
Fort Collins 970-491-9888 • www.jrengineering.com

| Sheet Revisions | | |
|-----------------|----------|-------|
| Date: | Comments | Init. |
| | | |
| | | |
| | | |

Colorado Department of Transportation

5615 WILL BLVD.
Pueblo, CO 81008
Phone: 719-546-5750

Lewis Palmer School District 38

| | | | |
|----------------|---|-------------------|-----------------------|
| As Constructed | LEWIS PALMER TRAIL TRAIL PLAN AND PROFILE | | Project No./Code |
| No Revisions: | Designer: GG Structure: GG | | M915-009/22585 |
| Revised: | Detailer: GG Numbers: | | 2520300 |
| Void: | Sheet Subset: | Subset Sheets: OF | Sheet Number 28 OF 42 |

X:\25203000\Drawings\Sheet\Drawings\25203000\Trail\Plan&Profile.dwg, 15, 11/23/2022, 11:34:30 AM, CS

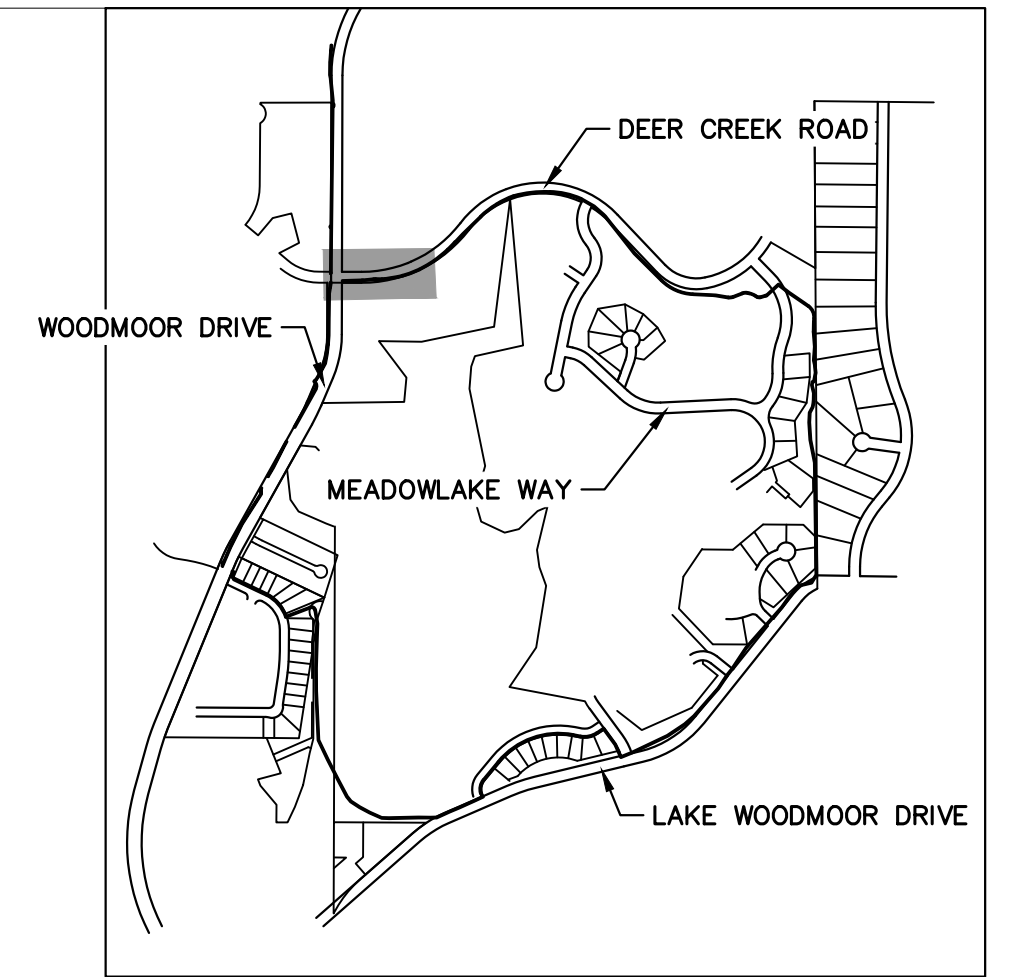
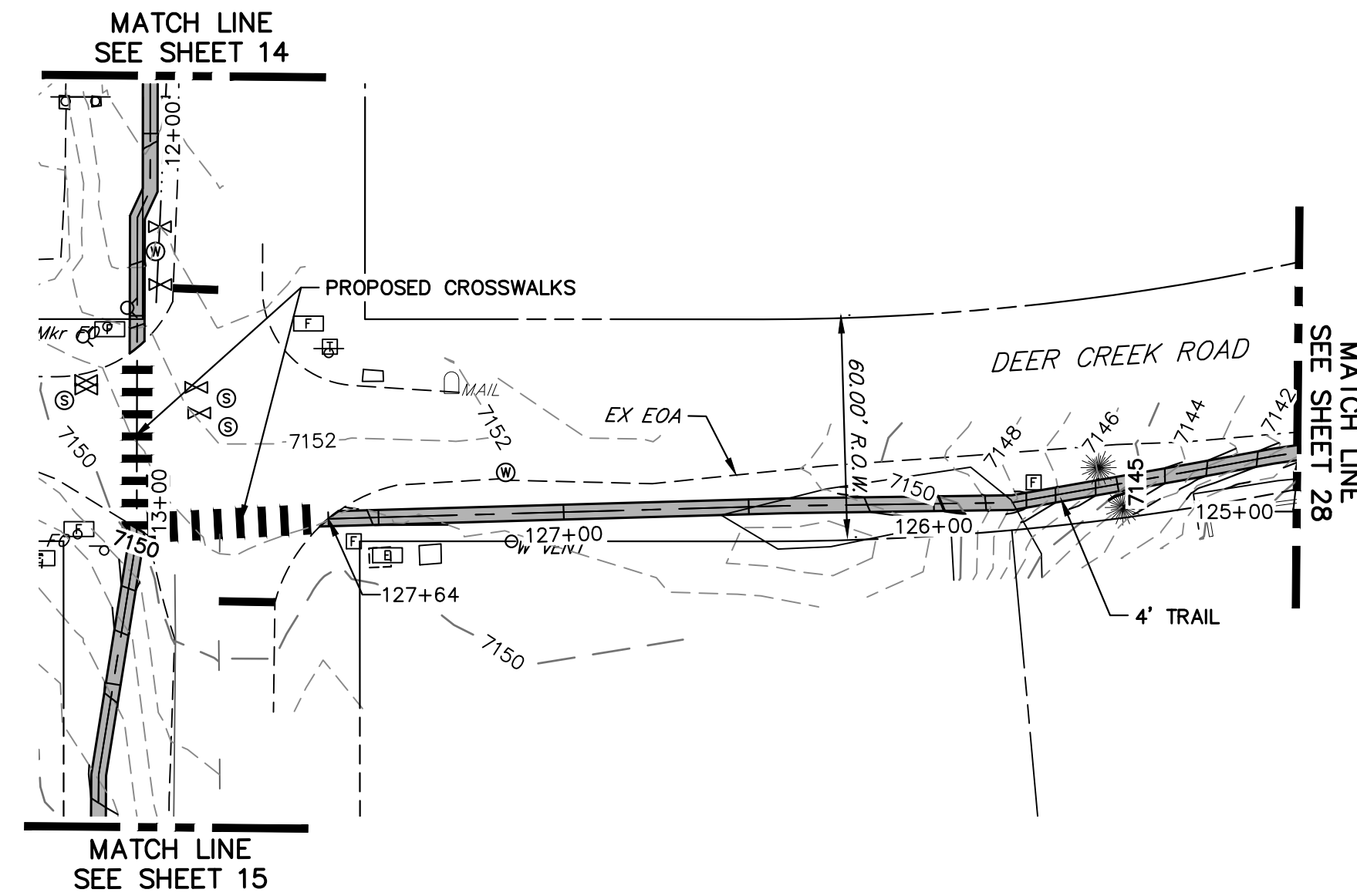

KEY MAP
SCALE: NOT TO SCALE

- NOTES:
1. THE SURVEY OF EXISTING CONDITIONS WAS COMPLETED IN APRIL 2021. THERE ARE A NUMBER OF LOCATIONS ALONG THE CORRIDOR THAT HAVE BEEN MODIFIED BY OTHER WORK SINCE THEN (I.E. UTILITY AND GRADING) THAT ARE NOT REPRESENTED IN THESE PLANS. THE CONTRACTOR IS RESPONSIBLE FOR REVIEWING THE TRAIL ALIGNMENT AND BECOMING FAMILIAR WITH THESE LOCATIONS. IF THE CONTRACTOR DETERMINES THAT CHANGES HAVE BEEN MADE THAT IMPACT THE TRAIL DESIGN, THE SCHOOL DISTRICT AND ENGINEER SHALL BE NOTIFIED PRIOR TO CONSTRUCTION OF THE SEGMENT OF TRAIL POTENTIALLY IMPACTED.
 2. THIS PLAN DOES NOT TAKE INTO ACCOUNT EXISTING DRAINAGE PATHS. THE CONTRACTOR SHALL WORK WITH THE SCHOOL DISTRICT AND THE ENGINEER IN DETERMINING AREAS WHERE CULVERTS MAY BE REQUIRED.

**LEWIS PALMER TRAIL PROFILE (16)
STA 125+00.00 TO 128+25.00**

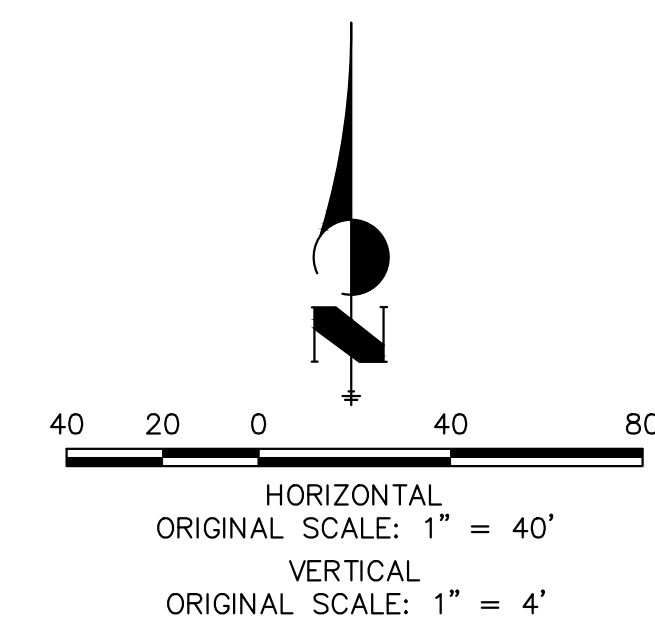
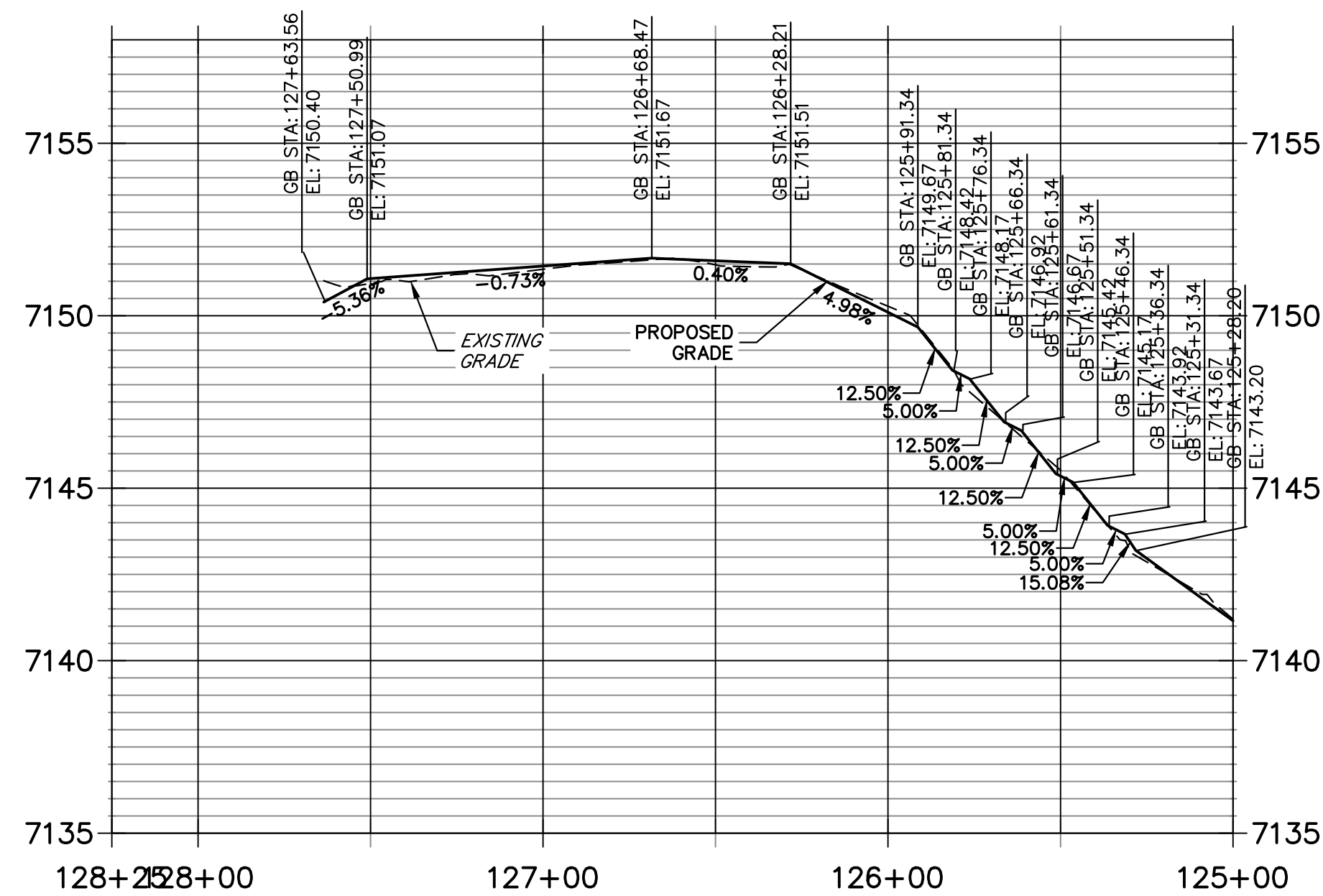

Know what's below.
Call before you dig.

ENGINEER'S STATEMENT
PREPARED UNDER MY SUPERVISION

GLENN D. ELLIS, P.E.
COLORADO P.E. 38861
FOR AND ON BEHALF OF JR ENGINEERING, LLC

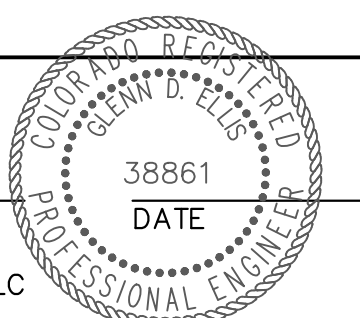

Print Date: 11/23/2022
File Name:
Horiz. Scale: 1"=40' Vert. Scale: 1"=4'
Unit name Unit leader
J-R ENGINEERING
A Westrian Company Centennial 303-740-9393 • Colorado Springs 719-583-2583
Fort Collins 970-431-9888 • www.jrengineering.com

| Sheet Revisions | | |
|-----------------|----------|-------|
| Date: | Comments | Init. |
| | | |
| | | |
| | | |

Colorado Department of Transportation
CDOT
Region 2
5615 WILL BLVD.
Pueblo, CO 81008
Phone: 719-546-5750
LP
Lewis Palmer School District 38

| | | | |
|----------------|---|-------------------|-----------------------|
| As Constructed | LEWIS PALMER TRAIL TRAIL PLAN AND PROFILE | | Project No./Code |
| No Revisions: | | | M915-009/22585 |
| Revised: | Designer: GG | Structure Numbers | 2520300 |
| Void: | Detailer: GG | Sheet Subset: | Sheet Number 29 OF 42 |
| | | Subset Sheets: OF | |

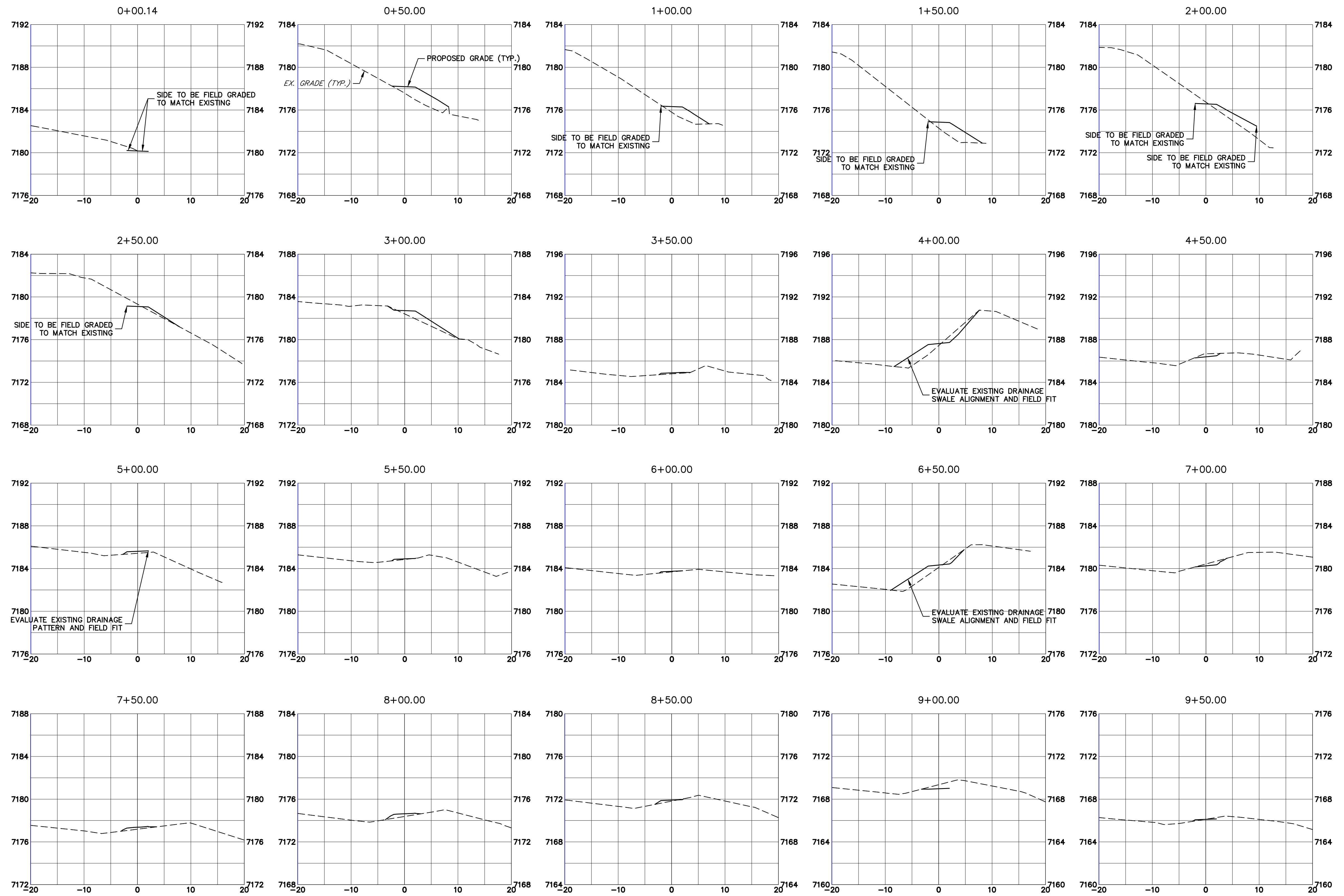

Know what's below.
Call before you dig.

Print Date: 11/23/2022
 File Name:
 Horiz. Scale: 1"=10' Vert. Scale: 1"=5'
 Unit name Unit leader
J-R ENGINEERING
 A Westrian Company Centennial 303-740-9393 • Colorado Springs 719-593-2583
 Fort Collins 970-491-9888 • www.jrengineering.com

| Sheet Revisions | | |
|-----------------|----------|-------|
| Date: | Comments | Init. |
| | | |
| | | |
| | | |
| | | |

Colorado Department of Transportation
 5615 WILL BLVD.
 Pueblo, CO 81008
 Phone: 719-546-5750
 Lewis Palmer School District 38
 Region 2

As Constructed
 No Revisions:
 Revised:
 Void:

LEWIS PALMER TRAIL
 CROSS SECTION
 Designer: GG Structure
 Detailer: GG Numbers
 Sheet Subset: Subset Sheets: OF

Project No./Code
 M915-009/22585
 2520300
 Sheet Number 30 OF 42

X:\25203000\Drawings\Sheet\Drawings\25203000_Cross Section.dwg, 1:11/23/2022 8:01:38 AM, CS

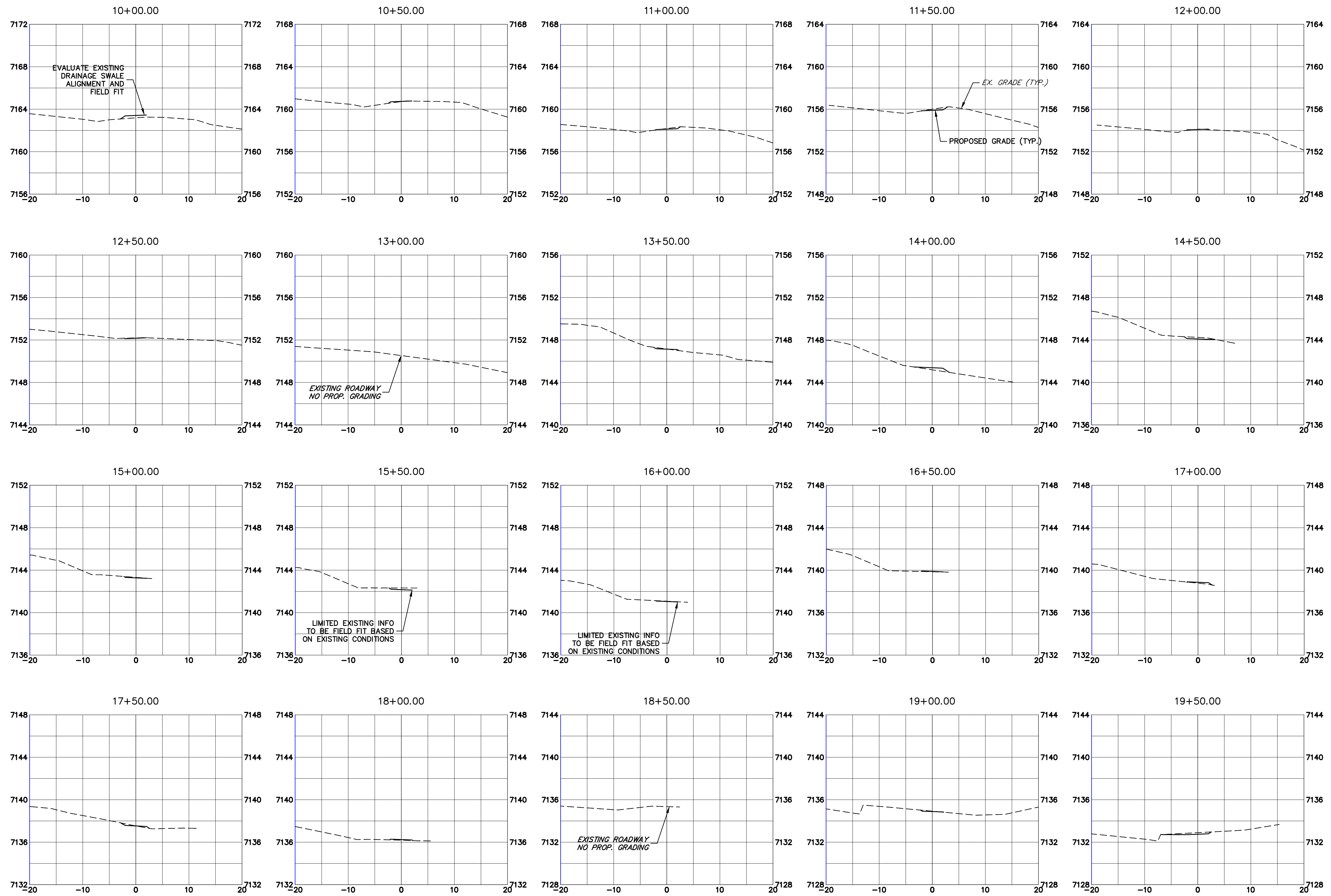

Know what's below.
Call before you dig.

Print Date: 11/23/2022
 File Name:
 Horiz. Scale: 1"=10' Vert. Scale: 1"=5'
 Unit name Unit leader
J-R ENGINEERING
 A Westrian Company
 Centennial 303-740-9393 • Colorado Springs 719-593-2593
 Fort Collins 970-491-9888 • www.jrengineering.com

| Sheet Revisions | | |
|-----------------|----------|-------|
| Date: | Comments | Init. |
| | | |
| | | |
| | | |

Colorado Department of Transportation



5615 WILL BLVD.
 Pueblo, CO 81008
 Phone: 719-546-5750



Lewis Palmer School District 38

As Constructed
 No Revisions:
 Revised:
 Void:

LEWIS PALMER TRAIL
 CROSS SECTION

Designer: GG Structure
 Detailer: GG Numbers
 Sheet Subset: Subset Sheets: OF

Project No./Code
 M915-009/22585
 2520300
 Sheet Number 31 OF 42

X:\25203000\Drawings\Sheet\Drawings\25203000_Cross Section.dwg, 2:11/23/2022 8:01:43 AM, CS

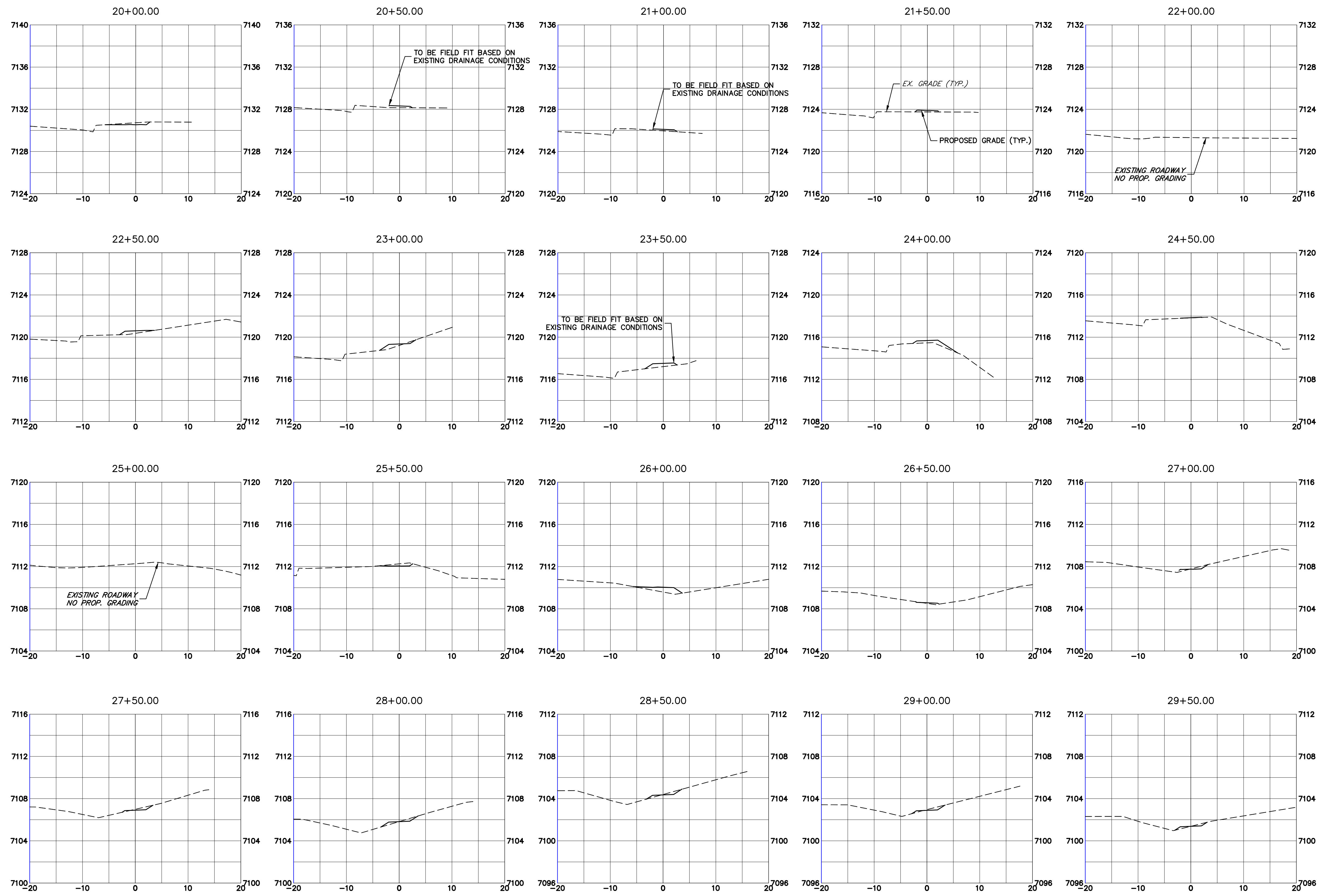

Know what's below.
Call before you dig.

Print Date: 11/23/2022

File Name:

Horiz. Scale: 1"=10' Vert. Scale: 1"=5'

Unit name Unit leader

J-R ENGINEERING
A Westrian Company
Centennial 303-740-9393 • Colorado Springs 719-593-2583
Fort Collins 970-491-9888 • www.jrengineering.com

| Sheet Revisions | | |
|-----------------|----------|-------|
| Date: | Comments | Init. |
| | | |
| | | |
| | | |

Colorado Department of Transportation

CDOT

5615 WILL BLVD.
Pueblo, CO 81008
Phone: 719-546-5750

LP
Lewis Palmer School District 38

Region 2

| |
|----------------|
| As Constructed |
| No Revisions: |
| Revised: |
| Void: |

| | | | |
|-------------------------------------|----|----------------|----|
| LEWIS PALMER TRAIL CROSS SECTION | | | |
| Designer: | GG | Structure | |
| Detailer: | GG | Numbers | |
| Sheet Subset: | | Subset Sheets: | OF |

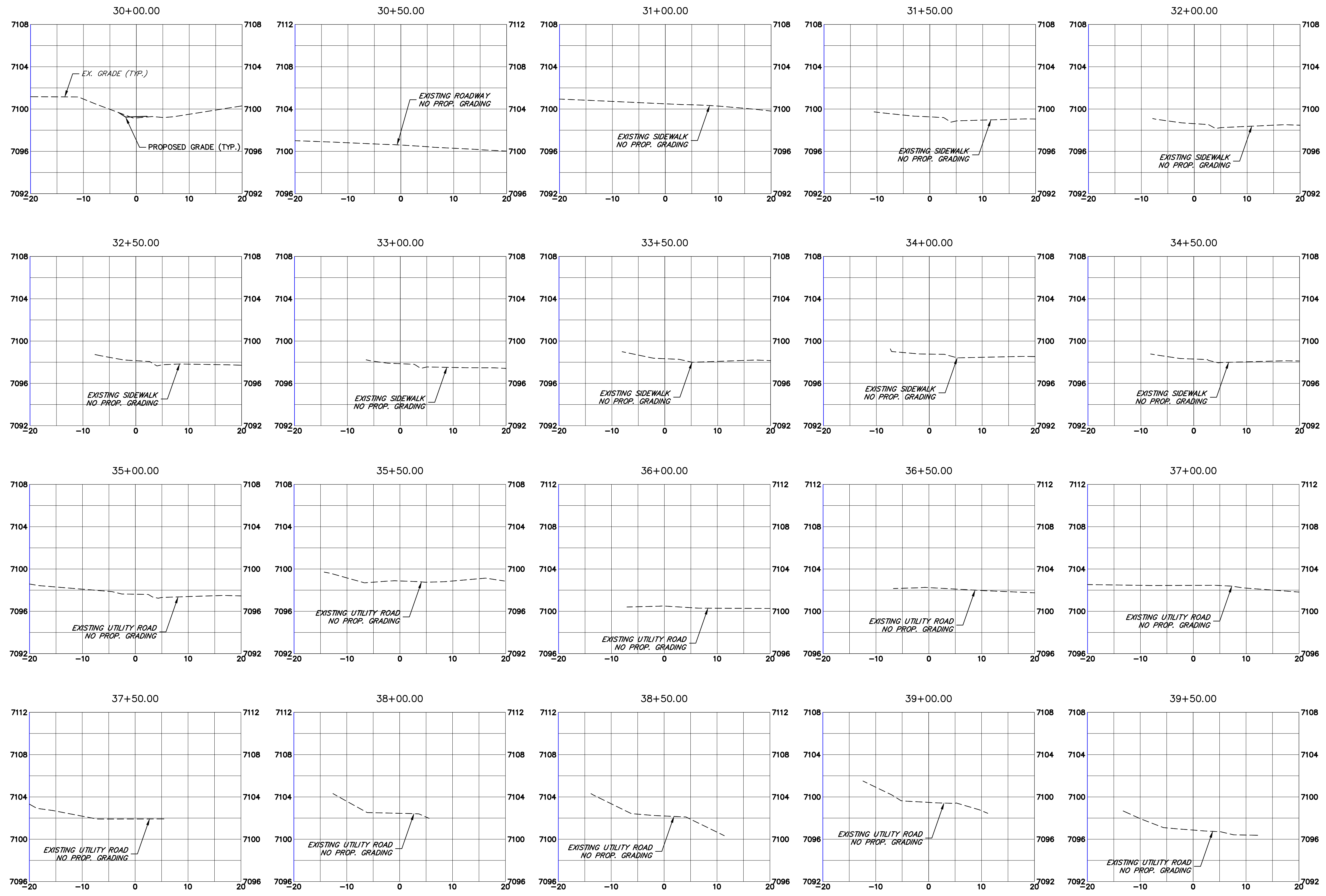

| | |
|------------------|----------------|
| Project No./Code | M915-009/22585 |
| | 2520300 |
| Sheet Number | 32 OF 42 |

X:\25203000\Drawings\Sheet\Drawings\25203000_Cross Section.dwg, 3, 11/23/2022 8:01:48 AM, CS



Print Date: 11/23/2022
 File Name:
 Horiz. Scale: 1"=10' Vert. Scale: 1"=5'
 Unit name Unit leader
 **J-R ENGINEERING**
 A Westrian Company Centennial 303-740-9393 • Colorado Springs 719-593-2583
 Fort Collins 970-491-9888 • www.jrengineering.com

| Sheet Revisions | | |
|-----------------|----------|-------|
| Date: | Comments | Init. |
| | | |
| | | |
| | | |

Colorado Department of Transportation
 5615 WILL BLVD.
 Pueblo, CO 81008
 Phone: 719-546-5750
 Lewis Palmer School District 38
 Region 2

As Constructed
 No Revisions:
 Revised:
 Void:

LEWIS PALMER TRAIL
 CROSS SECTION
 Designer: GG Structure
 Detailer: GG Numbers
 Sheet Subset: Subset Sheets: OF

Project No./Code
 M915-009/22585
 2520300
 Sheet Number 33 OF 42

X:\25203000\Drawings\Sheet\Drawings\25203000_Cross Section.dwg, 4, 11/23/2022 8:01:53 AM, CS

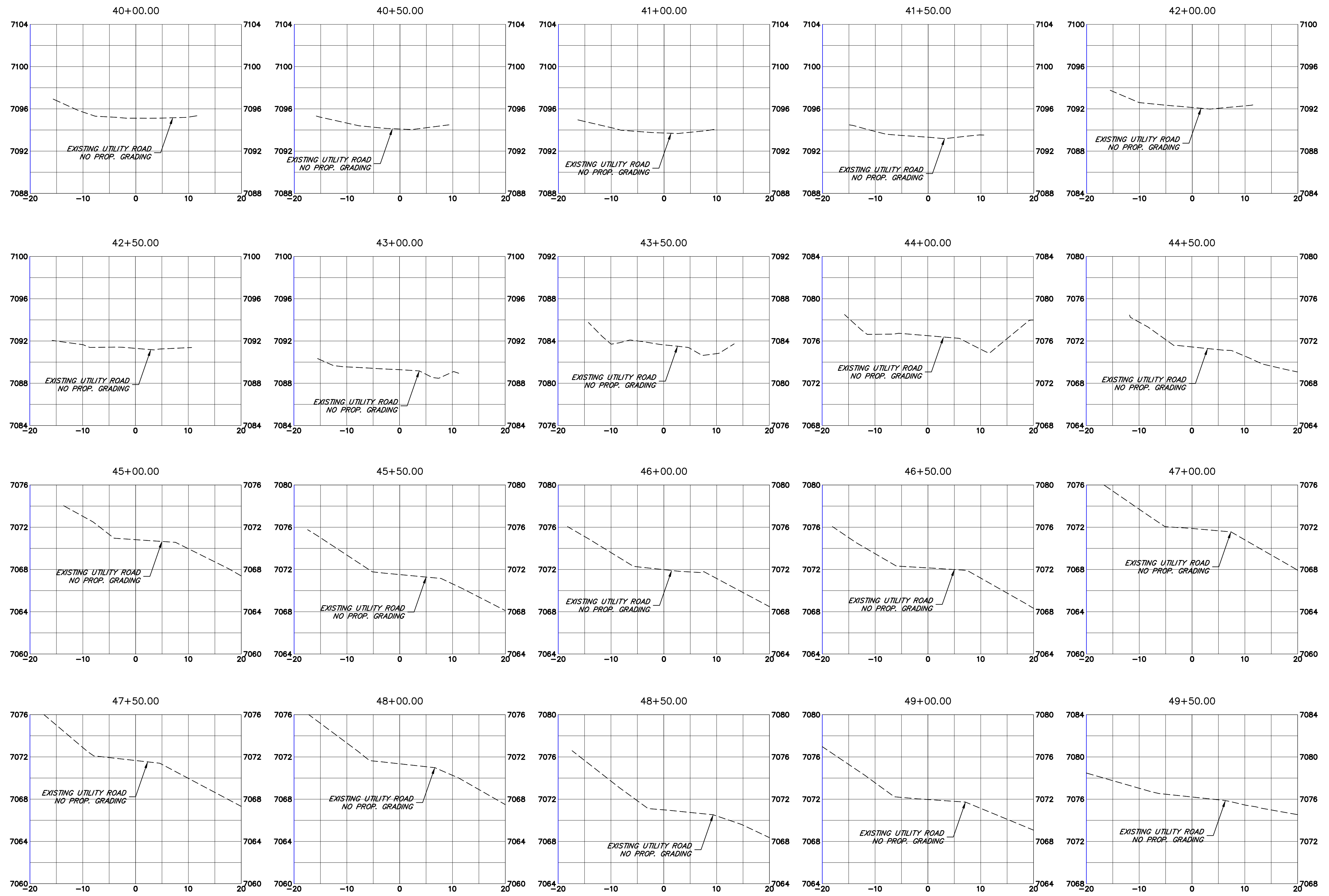

Know what's below.
Call before you dig.

Print Date: 11/23/2022
 File Name:
 Horiz. Scale: 1"=10' Vert. Scale: 1"=5'
 Unit name Unit leader
J-R ENGINEERING
 A Westrian Company Centennial 303-740-9393 • Colorado Springs 719-593-2583
 Fort Collins 970-491-9888 • www.jrengineering.com

| Sheet Revisions | | |
|-----------------|----------|-------|
| Date: | Comments | Init. |
| | | |
| | | |
| | | |
| | | |

Colorado Department of Transportation

 5615 WILL BLVD.
 Pueblo, CO 81008
 Phone: 719-546-5750
 Region 2

As Constructed
 No Revisions:
 Revised:
 Void:

LEWIS PALMER TRAIL
 CROSS SECTION
 Designer: GG Structure
 Detailer: GG Numbers
 Sheet Subset: Subset Sheets: OF

Project No./Code
 M915-009/22585
 2520300
 Sheet Number 34 OF 42

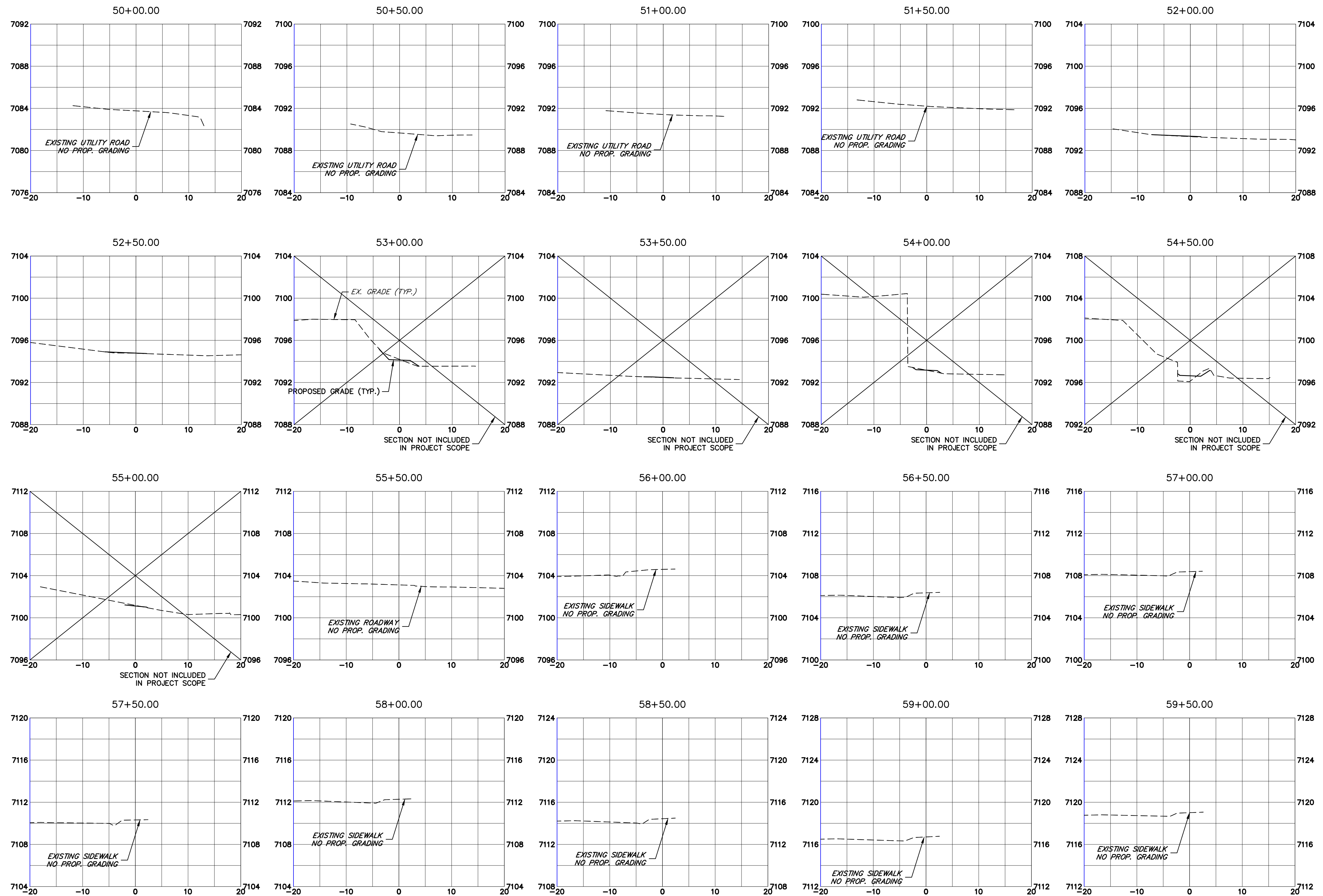

Know what's below.
Call before you dig.

Print Date: 11/23/2022
 File Name:
 Horiz. Scale: 1"=10' Vert. Scale: 1"=5'
 Unit name Unit leader
J-R ENGINEERING
 A Westrian Company Centennial 303-740-9393 • Colorado Springs 719-593-2583
 Fort Collins 970-491-9888 • www.jrengineering.com

| Sheet Revisions | | |
|-----------------|----------|-------|
| Date: | Comments | Init. |
| | | |
| | | |
| | | |
| | | |

Colorado Department of Transportation

 5615 WILL BLVD.
 Pueblo, CO 81008
 Phone: 719-546-5750
 Region 2

As Constructed
 No Revisions:
 Revised:
 Void:

LEWIS PALMER TRAIL
 CROSS SECTION
 Designer: GG Structure
 Detailer: GG Numbers
 Sheet Subset: Subset Sheets: OF

Project No./Code
 M915-009/22585
 2520300
 Sheet Number 35 OF 42

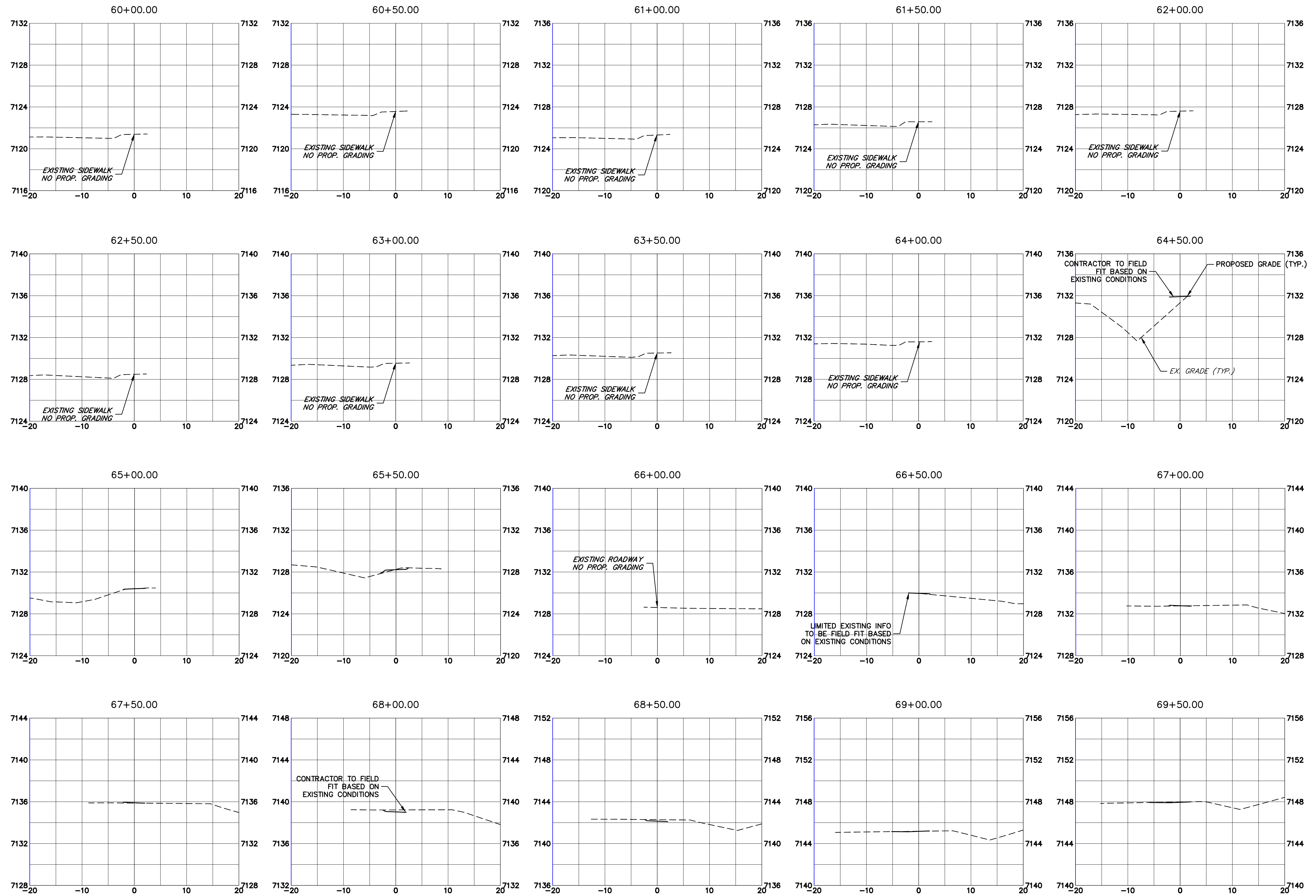

Know what's below.
Call before you dig.

Print Date: 11/23/2022
 File Name:
 Horiz. Scale: 1"=10' Vert. Scale: 1"=5"
 Unit name Unit leader
 **J-R ENGINEERING**
 A Westrian Company Centennial 303-740-9393 • Colorado Springs 719-593-2583
 Fort Collins 970-491-9888 • www.jrengineering.com

| Sheet Revisions | | |
|-----------------|----------|-------|
| Date: | Comments | Init. |
| | | |
| | | |
| | | |

Colorado Department of Transportation
 **CDOT**
 Region 2

5615 WILL BLVD.
 Pueblo, CO 81008
 Phone: 719-546-5750

 **LP**
 Lewis Palmer School District 38

As Constructed
 No Revisions:
 Revised:
 Void:

**LEWIS PALMER TRAIL
 CROSS SECTION**
 Designer: GG Structure Numbers
 Detailer: GG
 Sheet Subset: Subset Sheets: OF

Project No./Code
 M915-009/22585
 2520300
 Sheet Number 36 OF 42

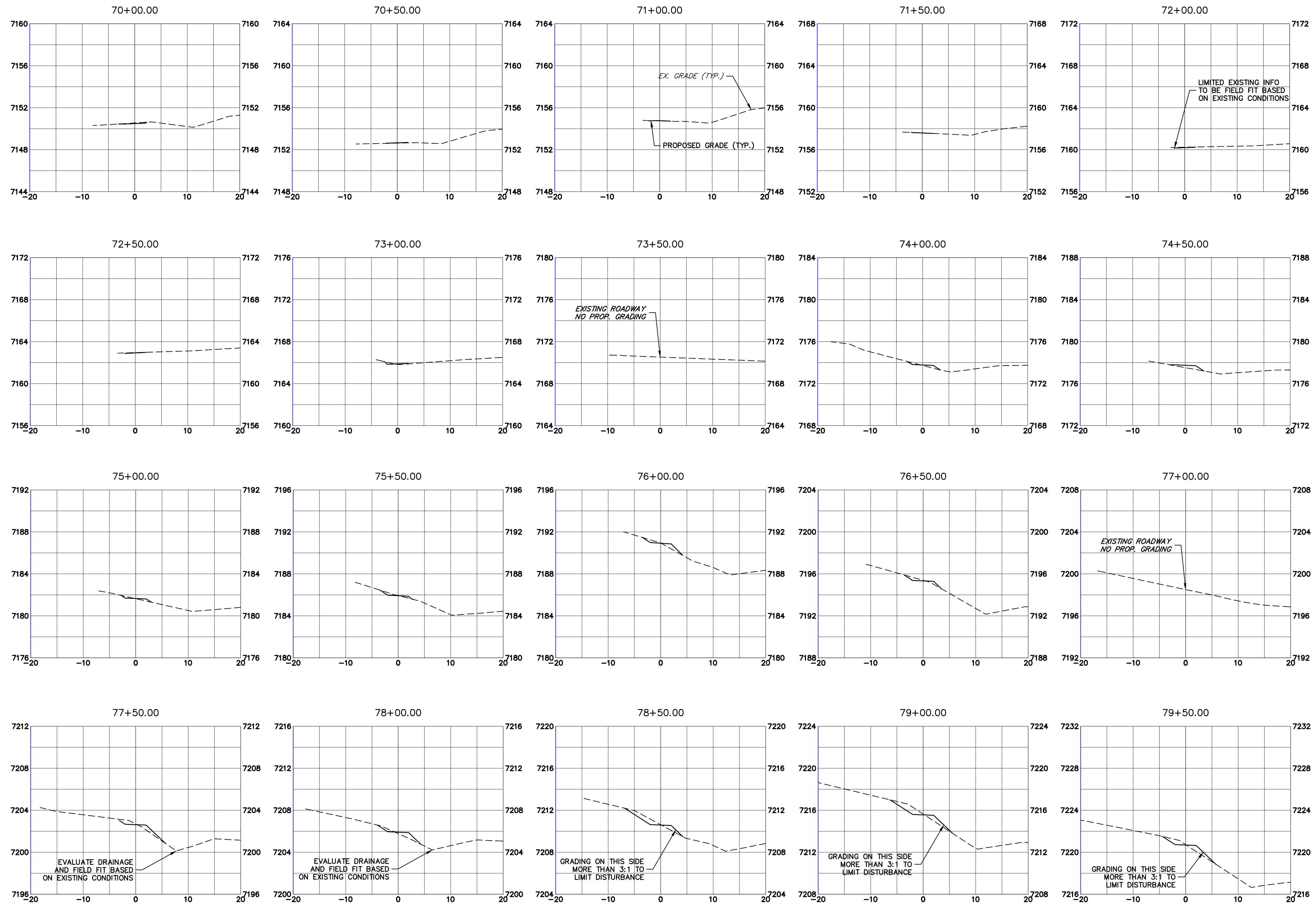

Print Date: 11/23/2022
 File Name:
 Horiz. Scale: 1"=10' Vert. Scale: 1"=5'
 Unit name Unit leader
J-R ENGINEERING
 A Westrian Company Centennial 303-740-9393 • Colorado Springs 719-593-2583
 Fort Collins 970-491-9888 • www.jrengineering.com

| Sheet Revisions | | |
|-----------------|----------|-------|
| Date: | Comments | Init. |
| | | |
| | | |
| | | |

Colorado Department of Transportation
 5615 WILL BLVD. Pueblo, CO 81008 Phone: 719-546-5750
 Lewis Palmer School District 38
 Region 2

As Constructed
 No Revisions:
 Revised:
 Void:

LEWIS PALMER TRAIL
 CROSS SECTION
 Designer: GG Structure Numbers
 Detailer: GG
 Sheet Subset: Subset Sheets: OF

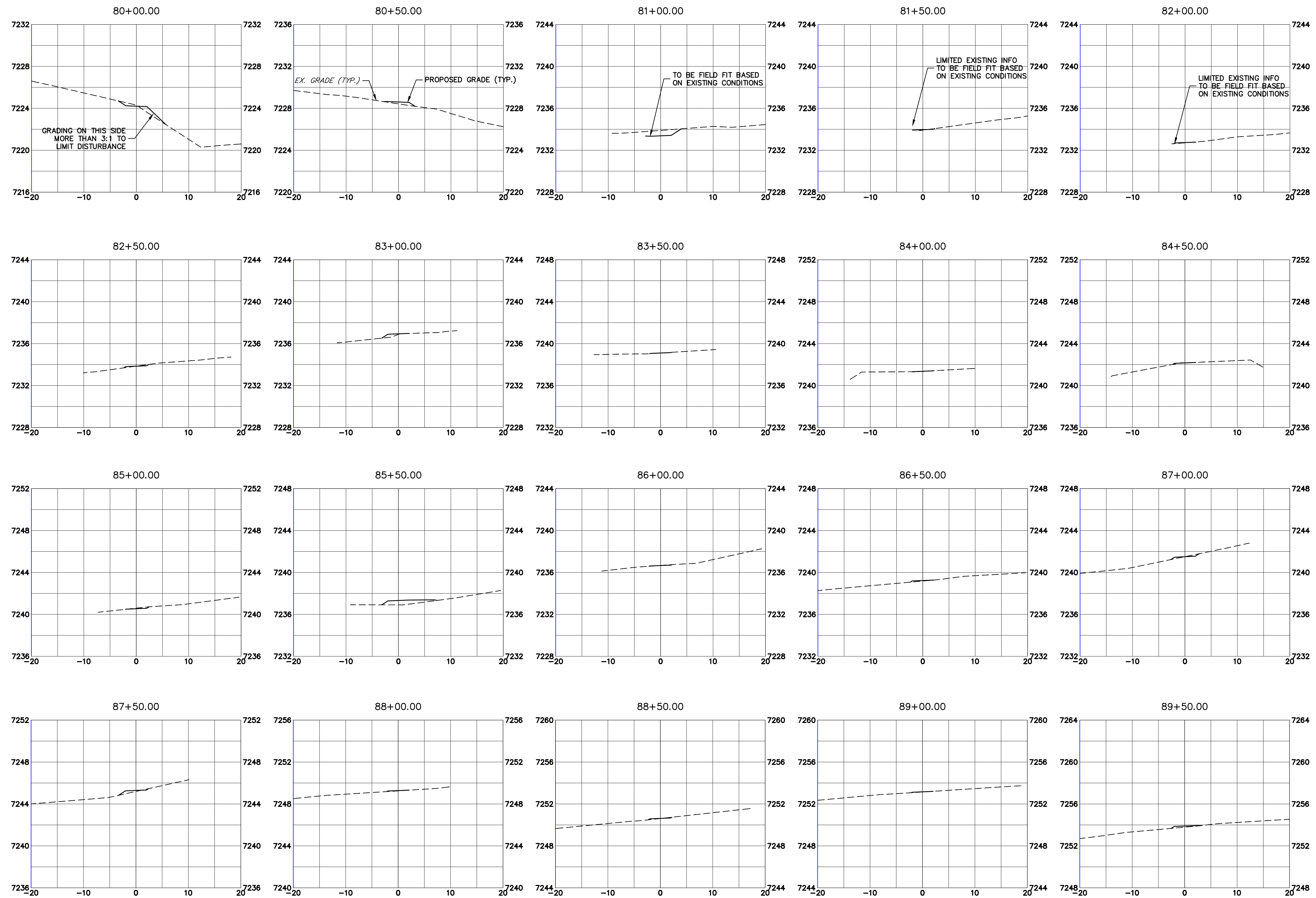

Project No./Code
 M915-009/22585
 2520300
 Sheet Number 37 OF 42

X:\25203000\Drawings\Sheet\Drawings\25203000_Cross Section.dwg, 8/11/2022 8:02:13 AM, CS



Print Date: 11/23/2022
 File Name:
 Horiz. Scale: 1"=10' Vert. Scale: 1"=5'
 Unit name Unit leader
 **J-R ENGINEERING**
 A Westrian Company Centennial 303-740-9393 • Colorado Springs 719-593-2593
 Fort Collins 970-491-9888 • www.jrengineering.com

| Sheet Revisions | | |
|-----------------|----------|-------|
| Date: | Comments | Init. |
| | | |
| | | |
| | | |

Colorado Department of Transportation
 5615 WILL BLVD.
 Pueblo, CO 81008
 Phone: 719-546-5750
 Lewis Palmer School District 38
 Region 2

As Constructed
 No Revisions:
 Revised:
 Void:

LEWIS PALMER TRAIL
 CROSS SECTION
 Designer: GG Structure Numbers
 Detailer: GG
 Sheet Subset: Subset Sheets: OF

Project No./Code
 M915-009/22585
 2520300
 Sheet Number 38 OF 42

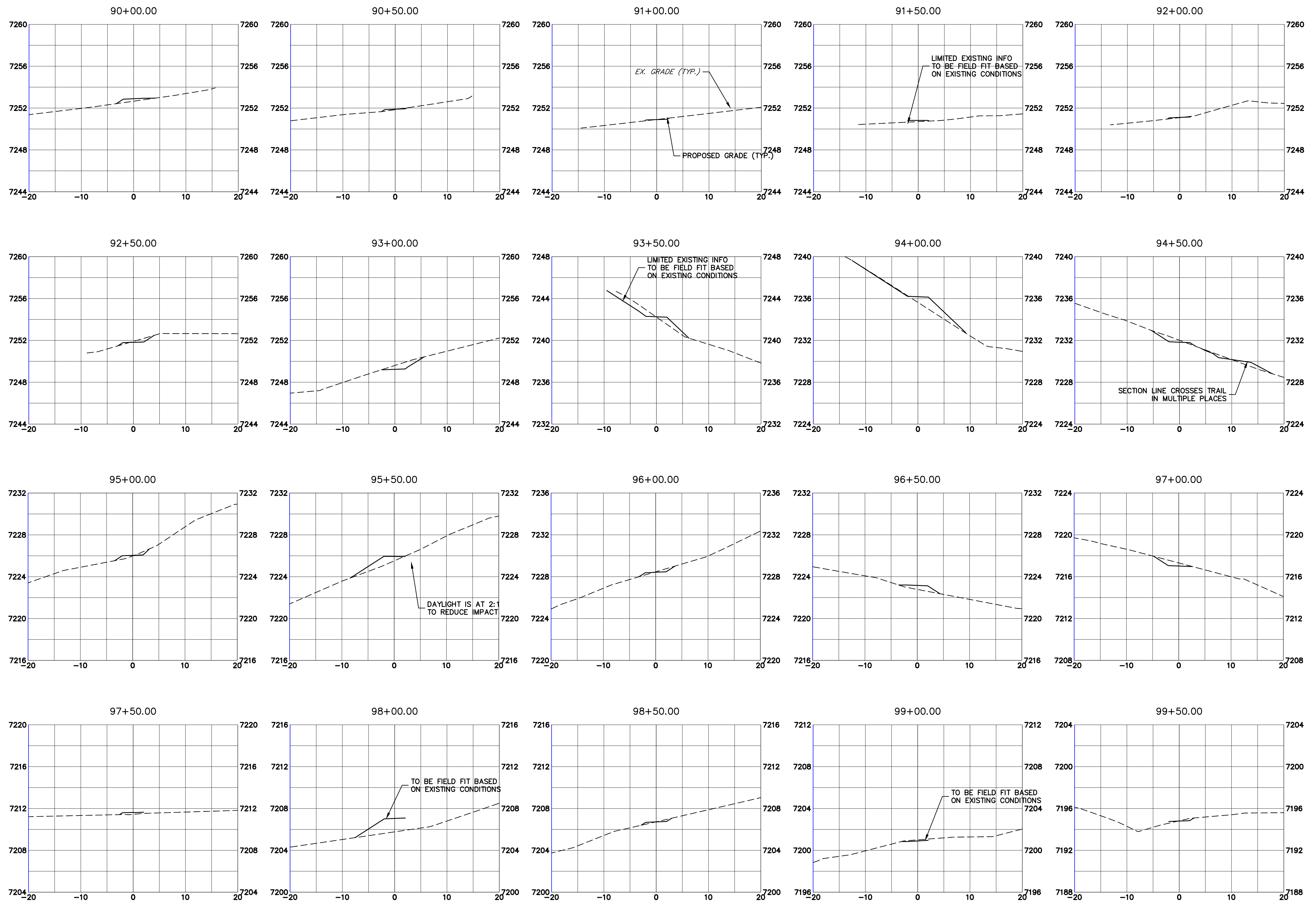

Know what's below.
Call before you dig.

Print Date: 11/23/2022
 File Name:
 Horiz. Scale: 1"=10' Vert. Scale: 1"=5'
 Unit name Unit leader
J-R ENGINEERING
 A Westrian Company
 Centennial 303-740-9393 • Colorado Springs 719-593-2583
 Fort Collins 970-491-9888 • www.jrengineering.com

| Sheet Revisions | | |
|-----------------|----------|-------|
| Date: | Comments | Init. |
| | | |
| | | |
| | | |

Colorado Department of Transportation

 5615 WILL BLVD.
 Pueblo, CO 81008
 Phone: 719-546-5750
 Region 2 Lewis Palmer School District 38

As Constructed
 No Revisions:
 Revised:
 Void:

LEWIS PALMER TRAIL
 CROSS SECTION
 Designer: GG Structure
 Detailer: GG Numbers
 Sheet Subset: Subset Sheets: OF

Project No./Code
 M915-009/22585
 2520300
 Sheet Number 39 OF 42

X:\25203000\Drawings\Sheet\Drawings\25203000_Cross Section.dwg, 10/11/2022 8:02:23 AM, CS

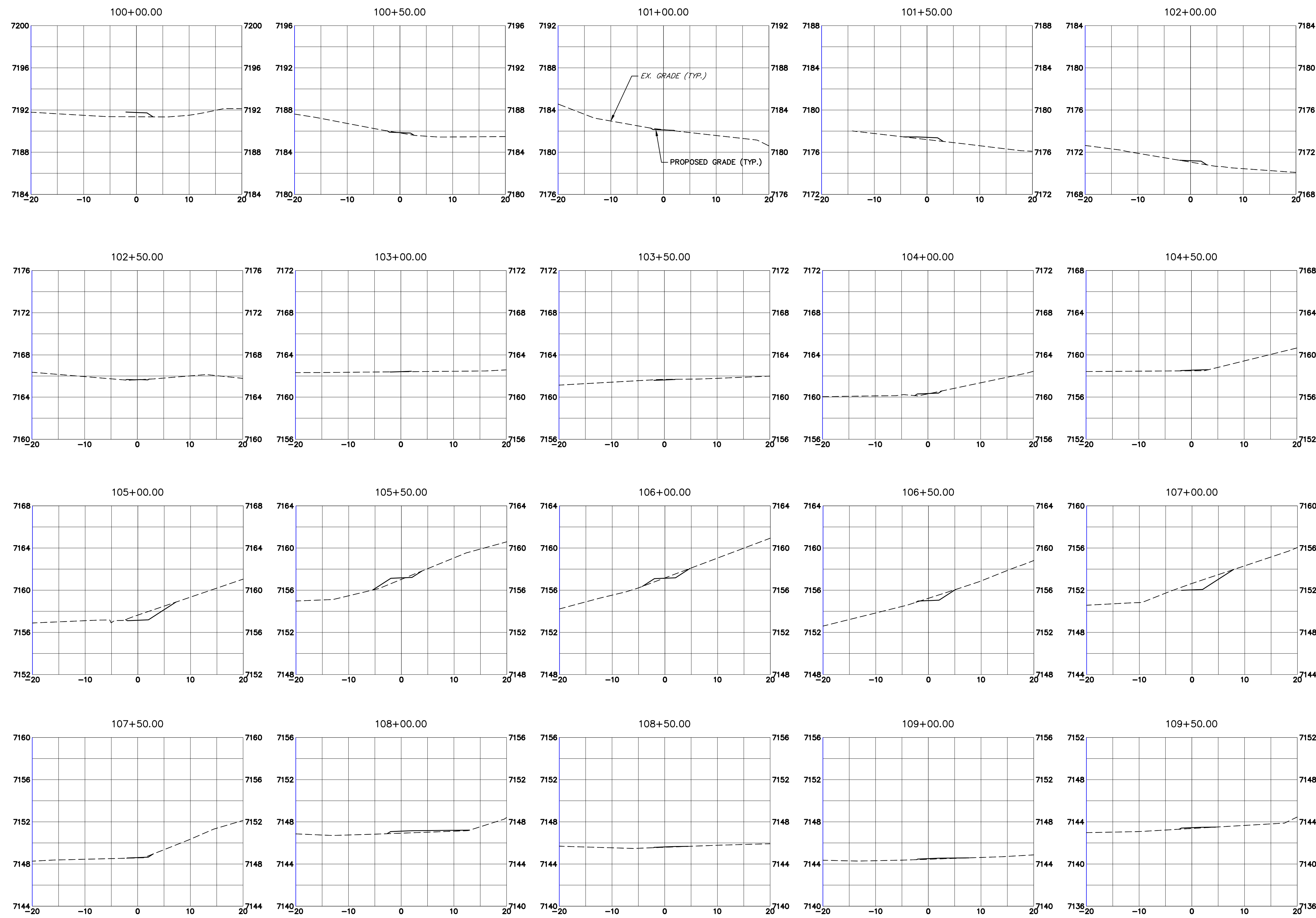

Print Date: 11/23/2022
 File Name:
 Horiz. Scale: 1"=10' Vert. Scale: 1"=5'
 Unit name Unit leader
 **J-R ENGINEERING**
 A Westrian Company Centennial 303-740-9393 • Colorado Springs 719-583-2583
 Fort Collins 970-431-9888 • www.jrengineering.com

| Sheet Revisions | | |
|-----------------|----------|-------|
| Date: | Comments | Init. |
| | | |
| | | |
| | | |
| | | |

Colorado Department of Transportation
 5615 WILL BLVD.
 Pueblo, CO 81008
 Phone: 719-546-5750
 Lewis Palmer School District 38
 Region 2

As Constructed
 No Revisions:
 Revised:
 Void:

LEWIS PALMER TRAIL
 CROSS SECTION
 Designer: GG Structure
 Detailer: GG Numbers
 Sheet Subset: Subset Sheets: OF

Project No./Code
 M915-009/22585
 2520300
 Sheet Number 40 OF 42

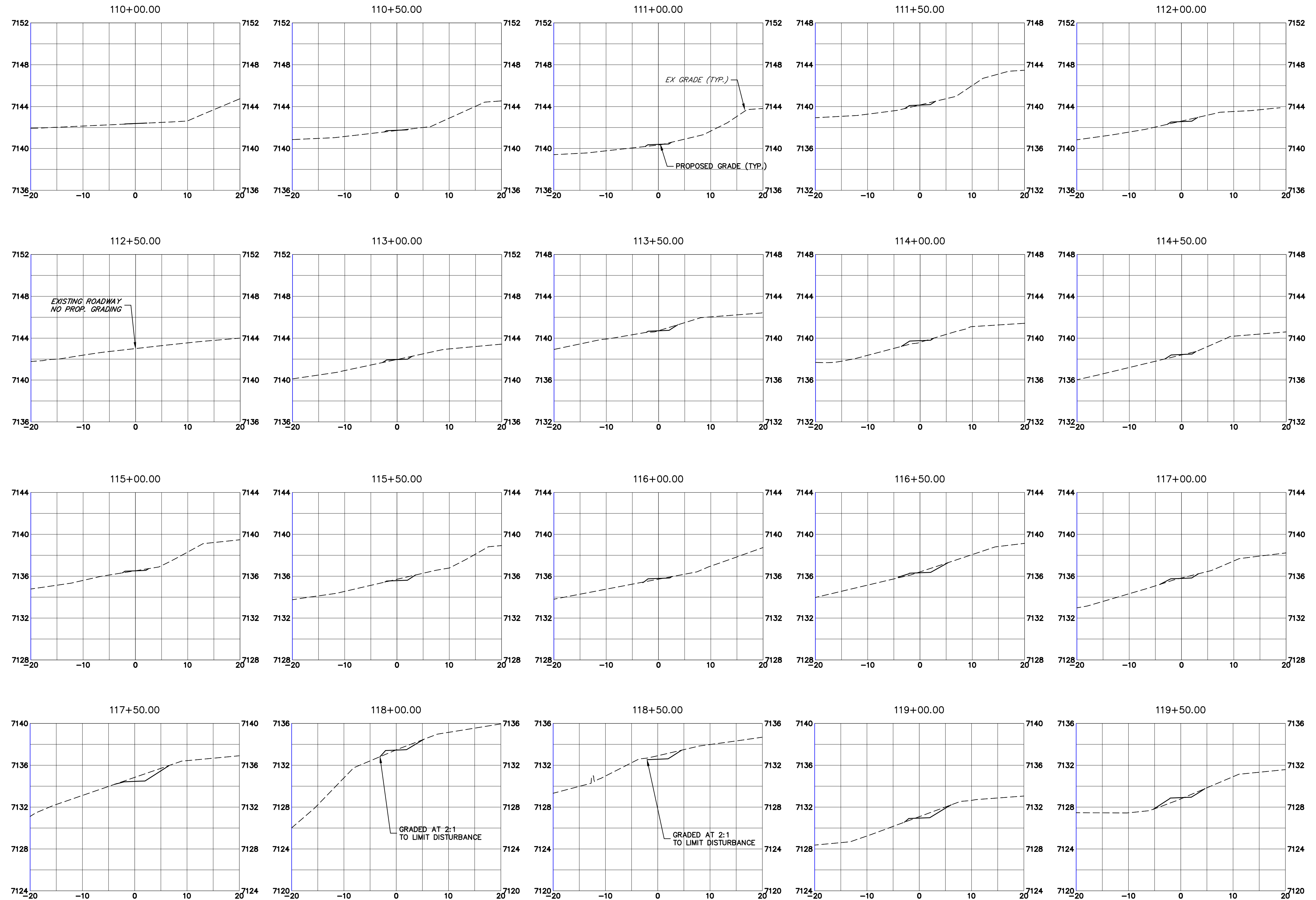

Print Date: 11/23/2022
 File Name:
 Horiz. Scale: 1"=10' Vert. Scale: 1"=5'
 Unit name Unit leader
 **J-R ENGINEERING**
 A Westrian Company Centennial 303-740-9393 • Colorado Springs 719-593-2583
 Fort Collins 970-491-9888 • www.jrengineering.com

| Sheet Revisions | | |
|-----------------|----------|-------|
| Date: | Comments | Init. |
| | | |
| | | |
| | | |

Colorado Department of Transportation
 5615 WILL BLVD.
 Pueblo, CO 81008
 Phone: 719-546-5750
 Region 2

As Constructed
 No Revisions:
 Revised:
 Void:

LEWIS PALMER TRAIL
 CROSS SECTION
 Designer: GG Structure
 Detailer: GG Numbers
 Sheet Subset: Subset Sheets: OF

Project No./Code
 M915-009/22585
 2520300
 Sheet Number 41 OF 42

X:\25203000\Drawings\Sheet\Drawings\25203000_Cross Section.dwg, 12/11/2022 8:02:33 AM, CS

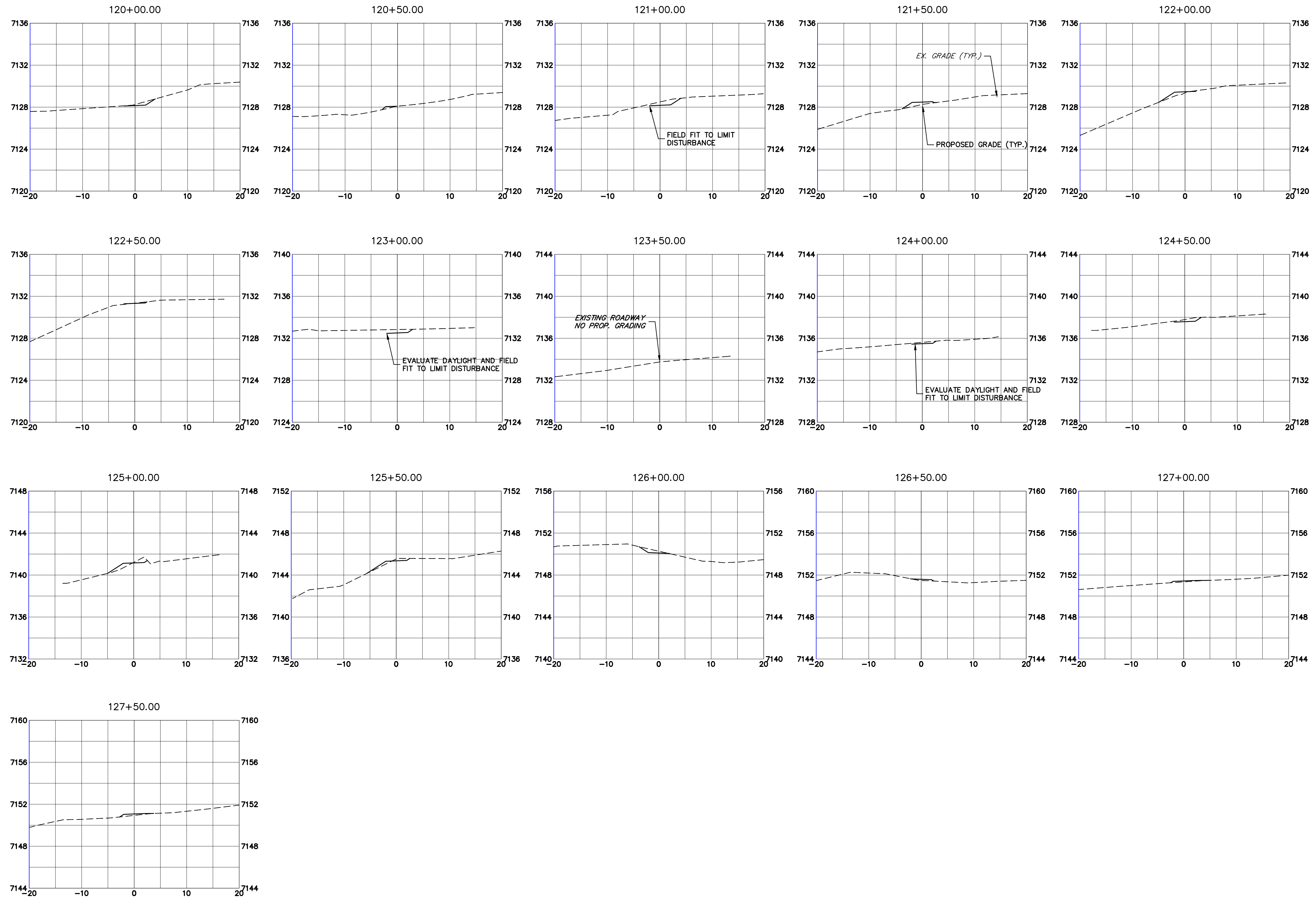

Know what's below.
Call before you dig.

Print Date: 11/23/2022

File Name:

Horiz. Scale: 1"=10' Vert. Scale: 1"=5'

Unit name Unit leader

J-R ENGINEERING
A Westrian Company
Centennial 303-740-9393 • Colorado Springs 719-593-2583
Fort Collins 970-491-9888 • www.jrengineering.com

| Sheet Revisions | | |
|-----------------|----------|-------|
| Date: | Comments | Init. |
| | | |
| | | |
| | | |

Colorado Department of Transportation

CDOT

5615 WILL BLVD.
Pueblo, CO 81008
Phone: 719-546-5750

LP
Lewis Palmer School District 38

Region 2

| |
|----------------|
| As Constructed |
| No Revisions: |
| Revised: |
| Void: |

| | | | |
|-------------------------------------|----|----------------|----|
| LEWIS PALMER TRAIL CROSS SECTION | | | |
| Designer: | GG | Structure | |
| Detailer: | GG | Numbers | |
| Sheet Subset: | | Subset Sheets: | OF |

| |
|-----------------------|
| Project No./Code |
| M915-009/22585 |
| 2520300 |
| Sheet Number 42 OF 42 |

X:\25203000\Drawings\Sheet\Drawings\25203000_Cross Section.dwg, 13, 11/23/2022 8:02:38 AM, CS

APPENDIX D – SWMP REPORT & GEC PLAN CHECKLIST



3275 Akers Drive
 Colorado Springs, CO 80922
 Phone 719-520-6460
 Fax 719-520-6879
 www.elpasoco.com

EL PASO COUNTY STORMWATER MANAGEMENT PLAN CHECKLIST

EPC Project Number:

Revised: October 2021

| | | Applicant | EPC |
|--|--|-----------|-----|
| 1. STORMWATER MANAGEMENT PLAN (in the "Applicant" column specify the page number for each item) | | | |
| 1 | Applicant (owner/designated operator), SWMP Preparer, Qualified Stormwater Manager, and Contractor Information. (On cover/title sheet) | | |
| 2 | Table of Contents | | |
| 3 | Site description and location to include: vicinity map with nearest street/crossroads description | | |
| 4 | Narrative description of construction activities proposed (e.g., may include clearing and grubbing, temporary stabilization, road grading, utility / storm installation, final grading, final stabilization, and removal of temporary control measures) | | |
| 5 | Phasing plan – may require separate drawings indicating initial, interim, and final site phases for larger projects. Provide "living maps" that can be revised in the field as conditions dictate | | |
| 6 | Proposed sequence for major activities: Provide a construction schedule of anticipated starting and completion dates for each stage of land-disturbing activity depicting conservation measures anticipated, including the expected date on which the final stabilization will be completed | | |
| 7 | Estimates of the total site area and area to undergo disturbance; current area of disturbance must be updated on the SWMP as changes occur | | |
| 8 | Soil erosion potential and impacts on discharge that includes a summary of the data used to determine soil erosion potential | | |
| 9 | A description of existing vegetation at the site and percent ground cover and method used to determine ground cover | | |
| 10 | Location and description of all potential pollution sources including but not limited to: disturbed and stored soils; vehicle tracking; management of contaminated soils; loading and unloading operations; outdoor storage of materials; vehicle and equipment maintenance and fueling; significant dust generating process; routine maintenance activities involving fertilizers, pesticides, herbicides, detergents, fuels, solvents, oils, etc.; on-site waste management; concrete truck/equipment washing; dedicated asphalt, concrete batch plants and masonry mixing stations; non-industrial waste such as trash and portable toilets | | |
| 11 | Material handling to include spill prevention and response plan and procedures | | |
| 12 | Spill prevention and pollution controls for dedicated batch plants | | |
| 13 | Other SW pollutant control measures to include waste disposal and off-site soil tracking | | |
| 14 | Location and description of any anticipated allowable non-stormwater discharge (ground water, springs, irrigation, discharge covered by CDPHE Low Risk Guidance, etc.) | | |
| 15 | Name(s) of ultimate receiving waters; size, type and location of stormwater outfall or storm sewer system discharge | | |
| 16 | Description of all stream crossings located within the project area or statement that no streams cross the project area | | |



3275 Akers Drive
 Colorado Springs, CO 80922
 Phone 719-520-6460
 Fax 719-520-6879
 www.elpasoco.com

EL PASO COUNTY STORMWATER MANAGEMENT PLAN CHECKLIST

EPC Project Number:

Revised: October 2021

| | | Applicant | EPC |
|---|---|-----------|-----|
| 17 | SWMP Map to include: | | |
| 17a | construction site boundaries | | |
| 17b | flow arrows to depict stormwater flow directions | | |
| 17c | all areas of disturbance | | |
| 17d | areas of cut and fill | | |
| 17e | areas used for storage of building materials, soils (stockpiles) or wastes | | |
| 17f | location of any dedicated asphalt / concrete batch plants | | |
| 17g | location of all structural control measures | | |
| 17h | location of all non-structural control measures | | |
| 17i | springs, streams, wetlands and other surface waters, including areas that require maintenance of pre-existing vegetation within 50 feet of a receiving water | | |
| 18 | Narrative description of all structural control measures to be used. Modifications to EPC standard control measures must meet or exceed County-approved details | | |
| 19 | Description of all non-structural control measures to be used including seeding, mulching, protection of existing vegetation, site watering, sod placement, etc. | | |
| 20 | Technical drawing details for all control measure installation and maintenance; custom or other jurisdiction's details used must meet or exceed EPC standards | | |
| 21 | Procedure describing how the SWMP is to be revised | | |
| 22 | Description of Final Stabilization and Long-term Stormwater Quality (describe nonstructural and structural measures to control SW pollutants after construction operations have been completed, including detention, water quality control measure etc.) | | |
| 23 | Specification that final vegetative cover density is to be 70% of pre-disturbed levels | | |
| 24 | Outline of permit holder inspection procedures to install, maintain, and effectively operate control measures to manage erosion and sediment | | |
| 25 | Record keeping procedures identified to include signature on inspection logs and location of SWMP records on-site | | |
| 26 | If this project relies on control measures owned or operated by another entity, a documented agreement must be included in the SWMP that identifies location, installation and design specifications, and maintenance requirements and responsibility of the control measure(s) | | |
| Please note: all items above must be addressed. If not applicable, explain why, simply identifying "not applicable" will not satisfy CDPHE requirement of explanation. | | | |
| 2. ADDITIONAL REPORTS/PERMITS/DOCUMENTS | | | |
| a | Grading and Erosion Control Plan (signed) | | |
| b | Erosion and Stormwater Quality Control Permit (ESQCP) (signed) | | |



3275 Akers Drive
 Colorado Springs, CO 80922
 Phone 719-520-6460
 Fax 719-520-6879
 www.elpasoco.com

EL PASO COUNTY STORMWATER MANAGEMENT PLAN CHECKLIST

EPC Project Number:

Revised: October 2021

| | | Applicant | EPC |
|---|--|-----------|-----|
| 3. APPLICANT COMMENTS | | | |
| a | | | |
| b | | | |
| c | | | |
| 4. CHECKLIST REVIEW CERTIFICATIONS | | | |
| a | <p>Applicant: The Stormwater Management Plan was prepared under my direction and supervision and is correct to the best of my knowledge and belief. Said Plan has been prepared according to the criteria established by the County and State for Stormwater Management Plans.</p> <p>_____ Date</p> <p>Engineer of Record and/or Qualified Stormwater Manager Signature</p> | | |
| b | <p>Review Engineer: The Stormwater Management Plan was reviewed and found to meet the checklist requirements except where otherwise noted or allowed by an approved deviation request.</p> <p>_____ Date</p> <p>Review Engineer</p> | | |



3275 Akers Drive
 Colorado Springs, CO 80922
 Phone 719-520-6460
 Fax 719-520-6879
 www.elpasoco.com

EL PASO COUNTY GRADING AND EROSION CONTROL PLAN CHECKLIST

EPC Project Number:

Revised: October 2021

| | | Applicant | EPC |
|--|--|-----------|-----|
| 1. GRADING AND EROSION CONTROL PLAN (complete form using Y, N, N/A in the "Applicant" column) | | | |
| a | Vicinity map | | |
| b | Adjacent city/town/jurisdictional boundaries, subdivision names, and property parcel numbers labeled | | |
| c | North arrow and acceptable scale (1"=20' to 1"=100') | | |
| d | Legend for all symbols used in the plan | | |
| e | Existing and proposed property lines. Proposed subdivision boundary for subdivision projects | | |
| f | All existing structures | | |
| g | All existing utilities | | |
| h | Construction site boundaries | | |
| i | Existing vegetation (notes are acceptable in cases where there is no notable vegetation, only grasses/weeds, or site has already been stripped) | | |
| j | FEMA 100-yr floodplain | | |
| k | Existing and proposed water courses including springs, streams, wetlands, detention ponds, stormwater quality structures, roadside ditches, irrigation ditches and other water surfaces. Show maintenance of pre-existing vegetation within 50 feet of a receiving water | | |
| l | Existing and proposed contours 2 feet or less (except for hillside) | | |
| m | Limits of disturbance delineating all anticipated areas of soil disturbance | | |
| n | Identify and protect areas outside of the construction site boundary with existing fencing, construction fencing or other methods as appropriate | | |
| o | Off-site grading clearly shown and called out | | |
| p | Areas of cut and fill identified | | |
| q | Conclusions from soils/geotechnical report and geologic hazards report incorporated in grading design (slopes, embankments, materials, mitigation, etc.) | | |
| r | Proposed slopes steeper than 3:1 with top and toe of slope delineated. Erosion control blanketing or other protective covering required | | |
| s | Stormwater flow direction arrows | | |
| t | Location of any dedicated asphalt / concrete batch plants | | |
| u | Areas used for staging, storage of building materials, soils (stockpiles) or wastes. The use of construction office trailers requires PCD permitting | | |
| v | All proposed temporary construction control measures, structural and non-structural. Temporary construction control measures shall be identified by phase of implementation to include "initial," "interim," and "final" or shown on separate phased maps identifying each phase | | |
| w | Vehicle tracking provided at all construction entrances/exits. Construction fencing, barricades, and/or signage provided at access points not to be used for construction | | |
| x | Temporary sediment ponds provided for disturbed drainage areas greater than 1 acre | | |



3275 Akers Drive
 Colorado Springs, CO 80922
 Phone 719-520-6460
 Fax 719-520-6879
 www.elpasoco.com

EL PASO COUNTY GRADING AND EROSION CONTROL PLAN CHECKLIST

EPC Project Number:

Revised: October 2021

| | | Applicant | EPC |
|----|--|-----------|-----|
| y | Dewatering operations to include locations of diversion, pump and discharge(s) as anticipated at time of design | | |
| z | All proposed temporary construction control measure details. Custom or other jurisdiction's details used must meet or exceed EPC standards | | |
| aa | Any off-site stormwater control measure proposed for use by the project and not under the direct control or ownership of the Owner or Operator | | |
| bb | Existing and proposed permanent storm water management facilities, including areas proposed for stormwater infiltration or subsurface detention | | |
| cc | Existing and proposed easements (permanent and construction) including required off-site easements | | |
| dd | Retaining walls shall not to be located in County ROW unless approved via license agreement. A building permit from Regional Building Department is required for walls greater than or equal to 4 feet in height, series of walls, or walls supporting a surcharge and must be design by P.E. | | |
| ee | Plan certified by a Colorado Registered P.E., with EPC standard signature blocks for Engineer, Owner and EPC | | |
| ff | <p>Engineer's Statement (for standalone GEC Plan): This Grading and Erosion Control Plan was prepared under my direction and supervision and is correct to the best of my knowledge and belief. Said Plan has been prepared according to the criteria established by the County for Grading and Erosion Control Plans. I accept responsibility for any liability caused by any negligent acts, errors or omissions on my part in preparing this plan.</p> <p>_____ Date</p> <p>Engineer of Record Signature</p> | | |
| gg | <p>Engineer's Statement (for GEC Plan within Construction Drawing set): These detailed plans and specifications were prepared under my direction and supervision. Said plans and specifications have been prepared according to the criteria established by the County for detailed roadway, drainage, grading and erosion control plans and specifications, and said plans and specifications are in conformity with applicable master drainage plans and master transportation plans. Said plans and specifications meet the purposes for which the particular roadway and drainage facilities are designed and are correct to the best of my knowledge and belief. I accept responsibility for any liability caused by any negligent acts, errors or omissions on my part in preparation of these detailed plans and specifications.</p> <p>_____ Date</p> <p>Engineer of Record Signature</p> | | |
| hh | <p>Owner's Statement (for standalone GEC Plan): I, the owner/developer have read and will comply with the requirements of the Grading and Erosion Control Plan.</p> <p>_____ Date</p> <p>Owner Signature</p> | | |
| ii | <p>Owner's Statement (for GEC Plan within Construction Drawing set): I, the owner/developer have read and will comply with the requirements of the grading and erosion control plan and all of the requirements specified in these detailed plans and specifications.</p> <p>_____ Date</p> <p>Owner Signature</p> | | |



3275 Akers Drive
 Colorado Springs, CO 80922
 Phone 719-520-6460
 Fax 719-520-6879
 www.elpasoco.com

EL PASO COUNTY GRADING AND EROSION CONTROL PLAN CHECKLIST

EPC Project Number:

Revised: October 2021

| | | Applicant | EPC |
|--|--|-----------|-----|
| jj | <p>El Paso County: County plan review is provided only for general conformance with County Design Criteria. The County is not responsible for the accuracy and adequacy of the design, dimensions, and/ or elevations which shall be confirmed at the job site. The County through the approval of this document assumes no responsibility for completeness and/ or accuracy of this document.</p> <p>Filed in accordance with the requirements of the El Paso County Land Development Code, Drainage Criteria Manual Volumes 1 and 2, and Engineering Criteria Manual, as amended.</p> <p>In accordance with ECM Section 1.12, these construction documents will be valid for construction for a period of 2 years from the date signed by the El Paso County Engineer. If construction has not started within those 2 years, the plans will need to be resubmitted for approval, including payment of review fees at the Planning and Community Development Director's discretion.</p> <p>_____ Date County Engineer/ECM Administrator</p> | | |
| 2. ADDITIONAL REPORTS/PERMITS/DOCUMENTS | | | |
| a | Soils report / geotechnical investigation as appropriate for grading/utilities/drainage/road construction. | | |
| b | Use Agreement/easement between the Owner or Operator and other third party for use of all off-site grading or stormwater control measures, used by the owner or operator but not under their direct control or ownership. | | |
| c | Floodplain Development Permit | | |
| d | USACE 404/wetlands permit/mitigation plan | | |
| e | FEMA CLOMR | | |
| f | State Engineer's permit/Notice Of Intent to Construct | | |
| g | Stormwater Management Plan (SWMP) | | |
| h | Financial Assurance Estimate (FAE) (signed) | | |
| i | Erosion and Stormwater Quality Control Permit (ESQCP) (signed) | | |
| j | Pre-Development Site Grading Acknowledgement & Right of Access Form (signed) | | |
| k | Conditions of Approval met? | | |



3275 Akers Drive
 Colorado Springs, CO 80922
 Phone 719-520-6460
 Fax 719-520-6879
 www.elpasoco.com

EL PASO COUNTY GRADING AND EROSION CONTROL PLAN CHECKLIST

EPC Project Number:

Revised: October 2021

| | | Applicant | EPC |
|---|---|-----------|-----|
| 3. STANDARD NOTES FOR EL PASO COUNTY GRADING AND EROSION CONTROL PLANS | | | |
| 1 | Stormwater discharges from construction sites shall not cause or threaten to cause pollution, contamination, or degradation of State Waters. All work and earth disturbance shall be done in a manner that minimizes pollution of any on-site or off-site waters, including wetlands. | | |
| 2 | Notwithstanding anything depicted in these plans in words or graphic representation, all design and construction related to roads, storm drainage and erosion control shall conform to the standards and requirements of the most recent version of the relevant adopted El Paso County standards, including the Land Development Code, the Engineering Criteria Manual, the Drainage Criteria Manual, and the Drainage Criteria Manual Volume 2. Any deviations from regulations and standards must be requested, and approved, in writing. | | |
| 3 | A separate Stormwater Management Plan (SMWP) for this project shall be completed and an Erosion and Stormwater Quality Control Permit (ESQCP) issued prior to commencing construction. Management of the SWMP during construction is the responsibility of the designated Qualified Stormwater Manager or Certified Erosion Control Inspector. The SWMP shall be located on-site at all times during construction and shall be kept up to date with work progress and changes in the field. | | |
| 4 | Once the ESQCP is approved and a "Notice to Proceed" has been issued, the contractor may install the initial stage erosion and sediment control measures as indicated on the approved GEC. A Preconstruction Meeting between the contractor, engineer, and El Paso County will be held prior to any construction. It is the responsibility of the applicant to coordinate the meeting time and place with County staff. | | |
| 5 | Control measures must be installed prior to commencement of activities that could contribute pollutants to stormwater. Control measures for all slopes, channels, ditches, and disturbed land areas shall be installed immediately upon completion of the disturbance. | | |
| 6 | All temporary sediment and erosion control measures shall be maintained and remain in effective operating condition until permanent soil erosion control measures are implemented and final stabilization is established. All persons engaged in land disturbance activities shall assess the adequacy of control measures at the site and identify if changes to those control measures are needed to ensure the continued effective performance of the control measures. All changes to temporary sediment and erosion control measures must be incorporated into the Stormwater Management Plan. | | |
| 7 | Temporary stabilization shall be implemented on disturbed areas and stockpiles where ground disturbing construction activity has permanently ceased or temporarily ceased for longer than 14 days. | | |
| 8 | Final stabilization must be implemented at all applicable construction sites. Final stabilization is achieved when all ground disturbing activities are complete and all disturbed areas either have a uniform vegetative cover with individual plant density of 70 percent of pre-disturbance levels established or equivalent permanent alternative stabilization method is implemented. All temporary sediment and erosion control measures shall be removed upon final stabilization and before permit closure. | | |
| 9 | All permanent stormwater management facilities shall be installed as designed in the approved plans. Any proposed changes that effect the design or function of permanent stormwater management structures must be approved by the ECM Administrator prior to implementation. | | |



3275 Akers Drive
 Colorado Springs, CO 80922
 Phone 719-520-6460
 Fax 719-520-6879
 www.elpasoco.com

EL PASO COUNTY GRADING AND EROSION CONTROL PLAN CHECKLIST

EPC Project Number:

Revised: October 2021

| | | Applicant | EPC |
|----|--|-----------|-----|
| 10 | Earth disturbances shall be conducted in such a manner so as to effectively minimize accelerated soil erosion and resulting sedimentation. All disturbances shall be designed, constructed, and completed so that the exposed area of any disturbed land shall be limited to the shortest practical period of time. Pre-existing vegetation shall be protected and maintained within 50 horizontal feet of a waters of the state unless shown to be infeasible and specifically requested and approved. | | |
| 11 | Compaction of soil must be prevented in areas designated for infiltration control measures or where final stabilization will be achieved by vegetative cover. Areas designated for infiltration control measures shall also be protected from sedimentation during construction until final stabilization is achieved. If compaction prevention is not feasible due to site constraints, all areas designated for infiltration and vegetation control measures must be loosened prior to installation of the control measure(s). | | |
| 12 | Any temporary or permanent facility designed and constructed for the conveyance of stormwater around, through, or from the earth disturbance area shall be a stabilized conveyance designed to minimize erosion and the discharge of sediment off-site. | | |
| 13 | Concrete wash water shall be contained and disposed of in accordance with the SWMP. No wash water shall be discharged to or allowed to enter State Waters, including any surface or subsurface storm drainage system or facilities. Concrete washouts shall not be located in an area where shallow groundwater may be present, or within 50 feet of a surface water body, creek or stream. | | |
| 14 | During dewatering operations, uncontaminated groundwater may be discharged on-site, but shall not leave the site in the form of surface runoff unless an approved State dewatering permit is in place. | | |
| 15 | Erosion control blanketing or other protective covering shall be used on slopes steeper than 3:1. | | |
| 16 | Contractor shall be responsible for the removal of all wastes from the construction site for disposal in accordance with local and State regulatory requirements. No construction debris, tree slash, building material wastes or unused building materials shall be buried, dumped, or discharged at the site. | | |
| 17 | Waste materials shall not be temporarily placed or stored in the street, alley, or other public way, unless in accordance with an approved Traffic Control Plan. Control measures may be required by El Paso County Engineering if deemed necessary, based on specific conditions and circumstances. | | |
| 18 | Tracking of soils and construction debris off-site shall be minimized. Materials tracked off-site shall be cleaned up and properly disposed of immediately. | | |
| 19 | The owner/developer shall be responsible for the removal of all construction debris, dirt, trash, rock, sediment, soil, and sand that may accumulate in roads, storm drains and other drainage conveyance systems and stormwater appurtenances as a result of site development. | | |
| 20 | The quantity of materials stored on the project site shall be limited, as much as practical, to that quantity required to perform the work in an orderly sequence. All materials stored on-site shall be stored in a neat, orderly manner, in their original containers, with original manufacturer's labels. | | |
| 21 | No chemical(s) having the potential to be released in stormwater are to be stored or used on-site unless permission for the use of such chemical(s) is granted in writing by the ECM Administrator. In granting approval for the use of such chemical(s), special conditions and monitoring may be required. | | |
| 22 | Bulk storage of allowed petroleum products or other allowed liquid chemicals in excess of 55 gallons shall require adequate secondary containment protection to contain all spills on-site and to prevent any spilled materials from entering State Waters, any surface or subsurface storm drainage system or other facilities. | | |



3275 Akers Drive
 Colorado Springs, CO 80922
 Phone 719-520-6460
 Fax 719-520-6879
 www.elpasoco.com

EL PASO COUNTY GRADING AND EROSION CONTROL PLAN CHECKLIST

EPC Project Number:

Revised: October 2021

| | | Applicant | EPC |
|------------------------------|---|-----------|-----|
| 23 | No person shall cause the impediment of stormwater flow in the curb and gutter or ditch except with approved sediment control measures. | | |
| 24 | Owner/developer and their agents shall comply with the "Colorado Water Quality Control Act" (Title 25, Article 8, CRS), and the "Clean Water Act" (33 USC 1344), in addition to the requirements of the Land Development Code, DCM Volume II and the ECM Appendix I. All appropriate permits must be obtained by the contractor prior to construction (1041, NPDES, Floodplain, 404, fugitive dust, etc.). In the event of conflicts between these requirements and other laws, rules, or regulations of other Federal, State, local, or County agencies, the most restrictive laws, rules, or regulations shall apply. | | |
| 25 | All construction traffic must enter/exit the site only at approved construction access points. | | |
| 26 | Prior to construction the permittee shall verify the location of existing utilities. | | |
| 27 | A water source shall be available on-site during earthwork operations and shall be utilized as required to minimize dust from earthwork equipment and wind. | | |
| 28 | The soils report for this site has been prepared by [Company Name, Date of Report] and shall be considered a part of these plans. | | |
| 29 | At least ten (10) days prior to the anticipated start of construction, for projects that will disturb one (1) acre or more, the owner or operator of construction activity shall submit a permit application for stormwater discharge to the Colorado Department of Public Health and Environment, Water Quality Division. The application contains certification of completion of a stormwater management plan (SWMP), of which this Grading and Erosion Control Plan may be a part. For information or application materials contact: Colorado Department of Public Health and Environment Water Quality Control Division WQCD – Permits 4300 Cherry Creek Drive South Denver, CO 80246-1530 Attn: Permits Unit | | |
| 4. APPLICANT COMMENTS | | | |
| a | | | |
| b | | | |
| c | | | |



3275 Akers Drive
 Colorado Springs, CO 80922
 Phone 719-520-6460
 Fax 719-520-6879
 www.elpasoco.com

EL PASO COUNTY GRADING AND EROSION CONTROL PLAN CHECKLIST

EPC Project Number:

Revised: October 2021

| | |
|-----------|-----|
| Applicant | EPC |
|-----------|-----|

| 5. CHECKLIST REVIEW CERTIFICATIONS | | | |
|---|---|--|--|
| a | <p>Engineer of Record: The Grading and Erosion Control Plan was prepared under my direction and supervision and is complete and correct to the best of my knowledge and belief. Said Plan has been prepared according to the criteria established by the County for Grading and Erosion Control Plans.</p> <hr style="border: 0; border-top: 1px solid black; margin: 10px 0;"/> <p style="display: flex; justify-content: space-between;"> Engineer of Record Signature Date </p> | | |
| b | <p>Review Engineer: The Grading and Erosion Control Plan was reviewed and found to meet the checklist requirements except where otherwise noted or allowed by an approved deviation request.</p> <hr style="border: 0; border-top: 1px solid black; margin: 10px 0;"/> <p style="display: flex; justify-content: space-between;"> Review Engineer Date </p> | | |

APPENDIX E – INSPECTION REPORT TEMPLATE

CONSTRUCTION STORMWATER SITE INSPECTION REPORT

| | | | | | | | |
|--|--------------------------|--------------------|--|-----|----|--------------------------|--------------------------|
| Facility Name | | Permittee | | | | | |
| Date of Inspection | | Weather Conditions | | | | | |
| Permit Certification # | | Disturbed Acreage | | | | | |
| Phase of Construction | | Inspector Title | | | | | |
| Inspector Name | | | | | | | |
| Is the above inspector a qualified stormwater manager? (permittee is responsible for ensuring that the inspector is a qualified stormwater manager) | | | <table border="1" style="width: 100%; border-collapse: collapse;"> <tr> <td style="width: 50%; text-align: center;">YES</td> <td style="width: 50%; text-align: center;">NO</td> </tr> <tr> <td style="text-align: center;"><input type="checkbox"/></td> <td style="text-align: center;"><input type="checkbox"/></td> </tr> </table> | YES | NO | <input type="checkbox"/> | <input type="checkbox"/> |
| YES | NO | | | | | | |
| <input type="checkbox"/> | <input type="checkbox"/> | | | | | | |

| INSPECTION FREQUENCY | | | | | |
|---|--|-----|----|--------------------------|--------------------------|
| Check the box that describes the minimum inspection frequency utilized when conducting each inspection | | | | | |
| At least one inspection every 7 calendar days | <input type="checkbox"/> | | | | |
| At least one inspection every 14 calendar days, with post-storm event inspections conducted within 24 hours after the end of any precipitation or snowmelt event that causes surface erosions | <input type="checkbox"/> | | | | |
| <ul style="list-style-type: none"> • This is this a post-storm event inspection. Event Date: _____ | <input type="checkbox"/> | | | | |
| Reduced inspection frequency - Include site conditions that warrant reduced inspection frequency | <input type="checkbox"/> | | | | |
| <ul style="list-style-type: none"> • Post-storm inspections at temporarily idle sites | <input type="checkbox"/> | | | | |
| <ul style="list-style-type: none"> • Inspections at completed sites/area | <input type="checkbox"/> | | | | |
| <ul style="list-style-type: none"> • Winter conditions exclusion | <input type="checkbox"/> | | | | |
| Have there been any deviations from the minimum inspection schedule? If yes, describe below. | <table border="1" style="width: 100%; border-collapse: collapse;"> <tr> <td style="width: 50%; text-align: center;">YES</td> <td style="width: 50%; text-align: center;">NO</td> </tr> <tr> <td style="text-align: center;"><input type="checkbox"/></td> <td style="text-align: center;"><input type="checkbox"/></td> </tr> </table> | YES | NO | <input type="checkbox"/> | <input type="checkbox"/> |
| YES | NO | | | | |
| <input type="checkbox"/> | <input type="checkbox"/> | | | | |
| | | | | | |

| INSPECTION REQUIREMENTS* |
|---|
| i. Visually verify all implemented control measures are in effective operational condition and are working as designed in the specifications |
| ii. Determine if there are new potential sources of pollutants |
| iii. Assess the adequacy of control measures at the site to identify areas requiring new or modified control measures to minimize pollutant discharges |
| iv. Identify all areas of non-compliance with the permit requirements, and if necessary, implement corrective action |
| *Use the attached Control Measures Requiring Routine Maintenance and Inadequate Control Measures Requiring Corrective Action forms to document results of this assessment that trigger either maintenance or corrective actions |

| AREAS TO BE INSPECTED | | | |
|---|--------------------------|--------------------------|--|
| Is there evidence of, or the potential for, pollutants leaving the construction site boundaries, entering the stormwater drainage system or discharging to state waters at the following locations? | | | |
| | NO | YES | If "YES" describe discharge or potential for discharge below. Document related maintenance, inadequate control measures and corrective actions Inadequate Control Measures Requiring Corrective Action form |
| Construction site perimeter | <input type="checkbox"/> | <input type="checkbox"/> | |
| All disturbed areas | <input type="checkbox"/> | <input type="checkbox"/> | |
| Designated haul routes | <input type="checkbox"/> | <input type="checkbox"/> | |
| Material and waste storage areas exposed to precipitation | <input type="checkbox"/> | <input type="checkbox"/> | |
| Locations where stormwater has the potential to discharge offsite | <input type="checkbox"/> | <input type="checkbox"/> | |
| Locations where vehicles exit the site | <input type="checkbox"/> | <input type="checkbox"/> | |
| Other: _____ | <input type="checkbox"/> | <input type="checkbox"/> | |

REPORTING REQUIREMENTS

The permittee shall report the following circumstances orally within twenty-four (24) hours from the time the permittee becomes aware of the circumstances, and shall mail to the division a written report containing the information requested within five (5) working days after becoming aware of the following circumstances. The division may waive the written report required if the oral report has been received within 24 hours.

| | | |
|---|--|--|
| All Noncompliance Requiring 24-Hour Notification per Part II.L.6 of the Permit | | |
| a. Endangerment to Health or the Environment Circumstances leading to any noncompliance which may endanger health or the environment regardless of the cause of the incident (See Part II.L.6.a of the Permit) <i>This category would primarily result from the discharge of pollutants in violation of the permit</i> | | |
| b. Numeric Effluent Limit Violations <ul style="list-style-type: none"> o Circumstances leading to any unanticipated bypass which exceeds any effluent limitations (See Part II.L.6.b of the Permit) o Circumstances leading to any upset which causes an exceedance of any effluent limitation (See Part II.L.6.c of the Permit) o Daily maximum violations (See Part II.L.6.d of the Permit) <i>Numeric effluent limits are very uncommon in certifications under the COR400000 general permit. This category of noncompliance only applies if numeric effluent limits are included in a permit certification.</i> | | |

| | | | |
|---|--------------------------|--------------------------|-------------------------|
| Has there been an incident of noncompliance requiring 24-hour notification? | NO | YES | |
| | <input type="checkbox"/> | <input type="checkbox"/> | If "YES" document below |

| Date and Time of Incident | Location | Description of Noncompliance | Description of Corrective Action | Date and Time of 24 Hour Oral Notification | Date of 5 Day Written Notification * |
|---------------------------|----------|------------------------------|----------------------------------|--|--------------------------------------|
| | | | | | |
| | | | | | |

*Attach copy of 5 day written notification to report. Indicate if written notification was waived, including the name of the division personnel who granted waiver.

After adequate corrective action(s) and maintenance have been taken, or where a report does not identify any incidents requiring corrective action or maintenance, the individual(s) designated as the Qualified Stormwater Manager, shall sign and certify the below statement:

"I verify that, to the best of my knowledge and belief, all corrective action and maintenance items identified during the inspection are complete, and the site is currently in compliance with the permit."

Name of Qualified Stormwater Manager

Title of Qualified Stormwater Manager

Signature of Qualified Stormwater Manager

Date

Notes/Comments