



# **STORMWATER MANAGEMENT PLAN (SWMP)**

FOR

## **MAYBERRY – TRACT K APARTMENTS MAYBERRY, COLORADO SPRINGS**

PREPARED FOR:

**COLORADO SPRINGS MAYBERRY, LLC  
3296 DEVINE HEIGHTS #208  
COLORADO SPRINGS, CO 80922**

PREPARED BY:

**R & R ENGINEERS - SURVEYORS, INC.  
1635 W. 13<sup>TH</sup> AVE, SUITE 310  
DENVER, CO 80204  
CONTACT: CLIF DAYTON, P.E.  
(303) 753-6730**

**R&R JOB #MC22068  
EPC PROJECT No. #####**

**ORIGINAL SUBMITTAL: MARCH 2023**

**TABLE OF CONTENTS**

	<u>PAGE</u>
1. APPLICANT/CONTACT INFORMATION.....	1
2. SITE DESCRIPTION.....	1
3. SITE MAP.....	2
4. BMP'S FOR STORMWATER POLLUTION PREVENTION.....	2
5. FINAL STABILIZATION AND LONG-TERM STORMWATER MANAGEMENT.....	5
6. OTHER CONTROLS.....	6
7. INSPECTION AND MAINTENANCE.....	6

**APPENDICES**

<u>APPENDIX A</u>	SITE MAP
<u>APPENDIX B</u>	SOILS MAP
<u>APPENDIX C</u>	SITE GRADING & EROSION CONTROL PLAN
<u>APPENDIX D</u>	EROSION CONTROL NOTES & DETAILS

**MAYBERRY – TRACT K APARTMENTS  
SWMP REPORT**

## **1. APPLICANT/CONTACT INFORMATION**

**Developer:** Colorado Springs Mayberry, LLC  
3296 Devine Heights #208  
Colorado Springs, CO 80922

**Engineer:** R & R Engineers - Surveyors, Inc.  
1635 W. 13<sup>th</sup> Ave, Suite 310  
Denver, CO 80204

**Contractor:** Raw Land Detailing  
10475 Accipiter Dr.  
Peyton, CO 80831  
Attn: Larry Lee (719)-495-7770

## **2. SITE DESCRIPTION**

- a. The site is located in a portion of the Northwest Quarter Section 14, Township 14 South, Range 63 West of the Principal Median. The proposed improvements are located southeast of State Highway 94 and New Log Road intersection. The site is located within the Mayberry Master Development which contains the Ellicott Town Center, a proposed subdivision located west of Ellicott, Colorado in El Paso County. The development is located on the south side of State Highway 94, approximately 1-1/2 miles west of Ellicott Highway. The approved Ellicott Town Center PUD includes a total of 1,048 single-family dwelling units and 32 acres of commercial space.
- b. There are no stream crossings in the project area.
- c. The proposed will consist of an apartment complex and townhomes. The apartment complex will include 4 apartment buildings, an asphalt parking lot, multiple garage structures, private driveways, a clubhouse, and two outdoor amenity areas. Although the final layout and design of this project area was not complete during the master drainage plan of the Mayberry Subdivision, it was determined this area would serve as a commercial space when determining runoff values and storm drain sizes. The site development activities will include site grading, pavement, curb and gutter, and related site improvements.
- d. Proposed sequence of major activities:
  - Mobilization/implementation of BMP's
  - Clearing and grubbing
  - Rough grading
  - Roadway grading/paving

**MAYBERRY – TRACT K APARTMENTS  
SWMP REPORT**

- e. Total site area = 8.31 acres (Mayberry Tract K Apartments); Proposed disturbed area = 9.09 acres (includes development of sidewalks located in the surrounding right-of-way)
- f. Historic runoff coefficient, C = 0.35  
Developed runoff coefficient, C = 0.88
- g. Existing vegetation on site on site: existing gravel, native meadow grasses (approx. 10% coverage).
- h. Potential pollution sources: vehicle emissions.
- i. Non-stormwater components of discharge: none anticipated.
- j. Receiving water: Surface drainage from this site will flow southeasterly to existing natural drainage swales flowing to the West Fork of Black Squirrel Creek located east of this parcel between the site and Ellicott Highway. Black Squirrel Creek ultimately outfalls into the Arkansas River.
- k. Erosion potential and potential impacts upon discharge: According to the Web Soil Survey by the Natural Resources Conservation Service, on-site soils are comprised primarily of Truckton-Bresser complex, eroded and Blakeland loamy sand which are both classified as soil Group A. Group A soils have a high infiltration rate with a moderate rate of water transmission. The erosion factor K for these soils are 0.24 and 0.10 respectively. Uncontrolled soil erosion may adversely affect downstream drainageways; on-site BMP's will be provided and maintained to mitigate impacts. See soils map in appendices.

**3. SITE MAP**

See Site Map in appendices.

**4. BMP'S FOR STORMWATER POLLUTION PREVENTION**

<u>Phase</u>	<u>BMP</u>
Clearing and grubbing necessary for perimeter controls	VTC's
Initiation of perimeter controls	SCL
Remaining clearing and grubbing	
Site grading	RS/SCL
Stabilization	SM
Removal of erosion control measures	

A. Erosion and Sediment Controls

1) Structural Practices:

- Vehicle Tracking Control (VTC) pad at construction entry. This will be located near the intersection of Cattlemen Run & Market Place Drive construction entrance.
- Sediment Control Logs (SCL) at toe of slope along downstream limits of disturbance.

**MAYBERRY – TRACT K APARTMENTS**  
**SWMP REPORT**

- Inlet protection (IP) to be located on the southeast corner of the site on the corner of Market Place Drive and Village Main Street. This will remain until the completion of improvements on this site and Filing No.1

2) Non-Structural Practices:

- Preserve existing vegetation beyond limits of work
- Temporary seeding of areas to remain disturbed for significant periods of time.
- Permanent seeding/mulching (SM) upon completion of rough grading.

**B. Materials Handling and Spill Prevention**

- **General Materials Handling Practices:**
  - Potential pollutants shall be stored and used in a manner consistent with the manufacturer's instructions in a secure location. To the extent practical, material storage areas should not be located near storm drain inlets and should be equipped with covers, roofs, or secondary containment as required to prevent storm water from contacting stored materials. Chemicals that are not compatible shall be stored and segregated areas so that spilled materials cannot combine and react.
  - Disposal of materials shall be in accordance with the manufacturer's instructions and applicable local, state, and federal regulations.
  - Materials no longer required for construction shall be removed from the site as soon as possible.
- Adequate garbage, construction waste, and sanitary waste handling and disposal facilities shall be provided as necessary to keep the site clear of obstruction and BMPs clear and functional.
- **Specific Materials Handling Practices:**
  - All pollutants, including waste materials and demolition debris, that occur on-site during construction shall be handled in a way that does not contaminate storm water.
  - All chemicals including liquid products, petroleum products, water treatment chemicals, and wastes stored on site shall be covered and contained and protected from vandalism.
  - Maintenance and repair of all equipment and vehicles involving oil changes, hydraulic system drain down, de-greasing operations, fuel tank drain down and removal, and other activities which may result in the accidental release of contaminants, shall be conducted under cover during wet weather and on an impervious surface to prevent release of contaminants onto the ground.

**MAYBERRY – TRACT K APARTMENTS**  
**SWMP REPORT**

Materials spilled during maintenance operations shall be cleaned up immediately and properly disposed of.

- Wheel wash water shall be settled and discharged on site by infiltration. Wheel wash water shall not be discharged to the storm water system.
- Application of agricultural chemicals, including fertilizers and pesticides, shall be conducted in a manner and at application rates that will not result in loss of chemical to storm water runoff. Follow manufacturer's recommendations for application rates and procedures.
- pH-modifying sources shall be managed to prevent contamination of runoff and storm water collected on site. The most common sources of pH-modifying materials are bulk cement, cement kiln dust (CKD), fly ash, new concrete washing and curing waters, waste streams generated from concrete grinding and sawing, exposed aggregate processes, and concrete pumping and mixer washout waters.
- Equipment maintenance and fueling: Contractor shall implement appropriate spill prevention and response procedures
- Spill Prevention and Response Procedures:
  - The primary objective in responding to a spill is to quickly contain the material(s) and prevent or minimize their migration into storm water runoff and conveyance systems. If the release has impacted on-site storm water, it is critical to contain the released materials on site and prevent their release into receiving waters.
  - Spill Response Procedures:
    - Notify site superintendent immediately when a spill, or the threat of a spill, is observed. The superintendent shall assess the situation and determine the appropriate response.
    - If spills represent an imminent threat of escaping on-site facilities and entering the receiving waters, site personnel shall respond immediately to contain the release and notify the superintendent after the situation has stabilized.
    - The site superintendent, or his designee, shall be responsible for completing a spill reporting form and for reporting the spill to the appropriate agency.
    - Spill response equipment shall be inspected and maintained as necessary to replace any materials used in spill response activities.
  - Spill kits shall be on-hand at all fueling sites. Spill kit location(s) shall be reported to the SWMP Administrator.
  - Absorbent materials shall be on-hand at all fueling areas for use in containing inadvertent spills. Containers shall be on-hand at all fueling sites for disposal of used absorbents.
  - Recommended components of spill kits include the following:
    - Oil absorbent pads (one bale)

**MAYBERRY – TRACT K APARTMENTS  
SWMP REPORT**

- Oil absorbent booms (40 feet)
- 55-gallon drums (2)
- 9-mil plastic bags (10)
- Personal protective equipment including gloves and goggles
- Concrete Wash Water: Unless confined in a pre-defined, bermed containment area, the cleaning of concrete truck delivery chutes is prohibited at the job site. The discharge of water containing waste cement to the storm drainage system is prohibited.
- Concrete Batch Plant: This project will not have an on-site dedicated batch plant.
- Notification Procedures:
  - In the event of an accident or spill, the SWMP Administrator shall be notified as a minimum.
  - Depending on the nature of the spill material involved, the Colorado Department of Public Health and Environment (24-hour spill reporting line: 877-518-5608), downstream water users, or other agencies may also need to be notified.
  - Any spill of oil which 1) violates water quality standards, 2) produces a “sheen” on a surface water, or 3) causes a sludge or emulsion, or any hazardous substance release, or hazardous waste release which exceeds the reportable quantity, must be reported immediately by telephone to the National Response Center Hotline at (800)-424-8802.

**5. FINAL STABILIZATION AND LONG-TERM STORMWATER MANAGEMENT**

- Permanent seeding will be provided to achieve long-term stabilization of the site.
- Seed Mix: “Foothills Mix” or approved equal:
- Seeding Application Rate: Drill seed 0.25” to 0.5” into the soil. In small areas not accessible to a drill, hand broadcast at double the rate and rake 0.25” to 0.5” into the soil. Apply seed at the following rates:
  - Dryland: 20-25 lbs/acre
  - Irrigated: 40 lbs/acre
- Soil Stabilization Practices:
  - Mulching Application: Apply 1-1/2 tons of certified weed free hay per acre mechanically crimped into the soil in combination with an organic mulch tackifier. On slopes and ditches requiring a blanket, the blanket shall be placed in lieu of much and mulch tackifier.
- Soil Conditioning and Fertilizer Requirements:
  - Soil conditioner, organic amendment shall be applied to all seeded areas at 3 CY / 1000 SF.
  - Fertilizer shall consist of 90% fungal biomass (mycelium) and 10% potassium-magnesia with a grade of 6-1-3 or approved equal. Fertilizer shall be applied as recommended by seed supplier.

**MAYBERRY – TRACT K APARTMENTS**  
**SWMP REPORT**

- Final stabilization is reached when all soil-disturbing activities at the site have been completed, and uniform vegetative cover has been established with an individual plant density of at least 70 percent of pre-disturbance levels, or equivalent permanent, physical erosion reduction methods have been employed.

**6. OTHER CONTROLS**

- Contractor shall dispose of all waste materials at a permitted off-site disposal site.
- Vehicle tracking pads from Mayberry Filing No. 3 BMP's will remain in place to limit off-site soil tracking.

**7. INSPECTION AND MAINTENANCE**

A. Inspection Schedules:

- Contractor shall inspect BMPs bi-weekly as a minimum, and immediately (within 24 hours) after any precipitation or snowmelt event that causes surface erosion (i.e. that results in stormwater running across the ground), to ensure that BMPs are maintained in effective operating condition.

B. Inspection Procedures:

1. Site Inspection / Observation Items:

- Construction site perimeter and discharge points (including discharges into a storm sewer system)
- All disturbed areas
- Areas used for material / waste storage that are exposed to precipitation
- Other areas having a significant potential for stormwater pollution, such as demolition areas or concrete washout locations, or locations where vehicles enter or leave the site
- Erosion and sediment control measures identified in the SWMP
- Any other structural BMPs that may require maintenance, such as secondary containment around fuel tanks, or the condition of spill response kits.

2. Inspection requirements:

- Determine if there is any evidence of, or potential for, pollutants entering the drainage system.
- Review BMPs to determine if they still meet design and operational criteria in the SWMP, and if they continue to adequately control pollutants at the site.
- Upgrade and/or revise any BMPs not operating in accordance with the SWMP and update the SWMP to reflect any revisions.

C. BMP Maintenance / Replacement and Failed BMPs:



**MAYBERRY – TRACT K APARTMENTS**  
**SWMP REPORT**

- Contractor shall remove sediment that has been collected by perimeter controls, such as silt fence and inlet protection, on a regular basis to prevent failure of BMPs, and remove potential of sediment from being discharged from the site in the event of BMP failure.
  - Removed sediment must be moved to an appropriate location where it will not become an additional pollutant source, and should never be placed in ditches or streams.
  - Contractor shall update Erosion Control Plans as required with any new BMPs added during the construction period.
  - Contractor shall address BMPs that have failed or have the potential to fail without maintenance or modifications, as soon as possible, immediately in most cases, to prevent discharge of pollutants.
- D. Record Keeping and Documenting Inspections:
- Contractor shall maintain records of all inspection reports, including signed inspection logs, at the project site.
  - Permittee shall document inspection results and maintain a record of the results for a period of 3 years following expiration or inactivation of permit coverage.
  - Site inspection records shall include the following:
    - Inspection date
    - Name and title of personnel making the inspection
    - Location of discharges of sediment or other pollutants from the site
    - Location(s) of BMPs that need to be maintained
    - Location(s) of BMPs that failed to operate as designed or proved inadequate for a particular location
    - Location(s) where additional BMPs are needed that were not in place at the time of inspection
    - Deviations from the minimum inspection schedule

## **APPENDIX A – SITE MAP**



**VICINITY MAP**  
SCALE 1" = 5,000'

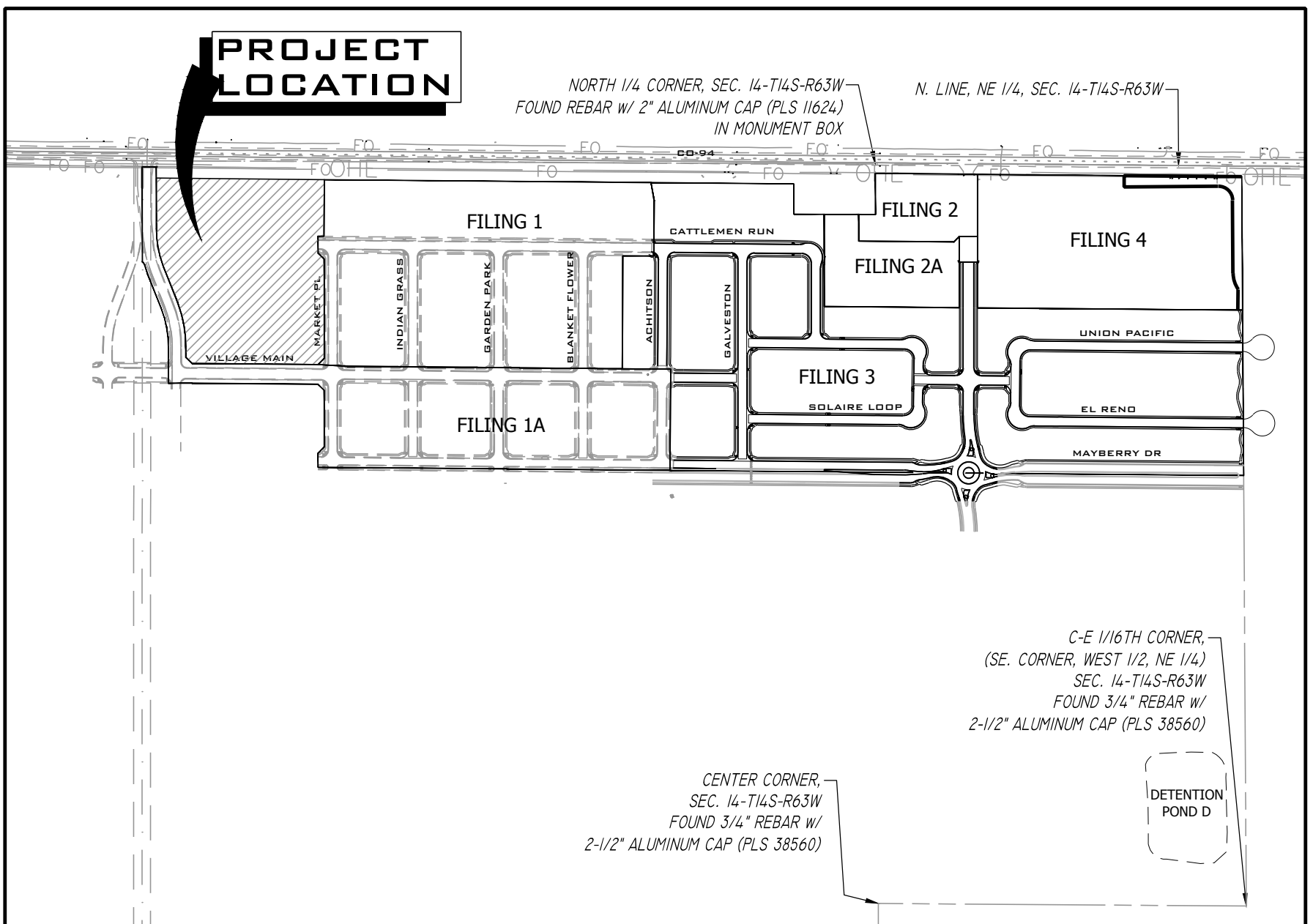

**SITE MAP**  
SCALE 1" = 500'

PATH: P:\MC22068 MAYBERRY APARTMENTS (SEC. HWY. 94 & NEW LOG RD)\ENGINEERING\4 DRAWINGS\PLANS\CDS - COVER & NOTES\MC22068 - CVR - CD.DWG, PLOT DATE: 3/6/2023 4:07:15 PM, BY: CARLOS BARRIENTOS

<b>REVISIONS</b>  R&R ENGINEERS SURVEYORS INC. WWW.RRENGINEERS.COM	

**SITE MAP**

**MAYBERRY APARTMENTS**

3296 DEVINE HEIGHTS #208  
COLORADO SPRINGS, CO 80922

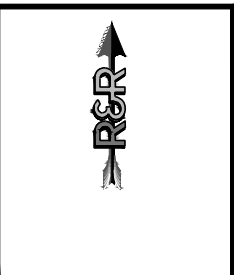

JOB NO.	MC22068
DATE	3-6-2023
DRN	CJB   CHK   CD
EXHIBIT NAME	SITE MAP
SHEET NO.	1 OF 1

## **APPENDIX B – SOILS MAP**

Hydrologic Soil Group—El Paso County Area, Colorado  
(Mayberry Apartments)

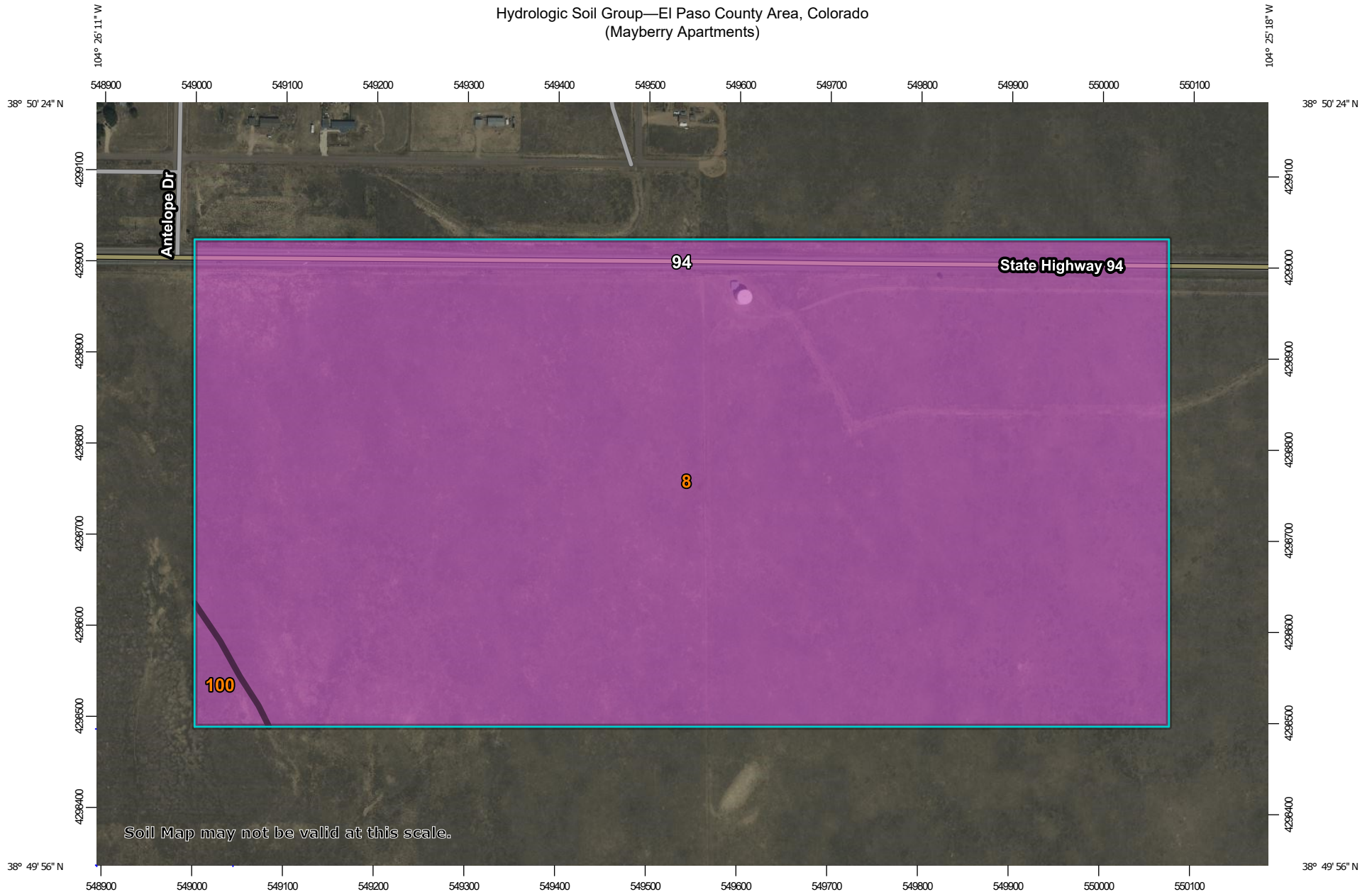

Soil Map may not be valid at this scale.

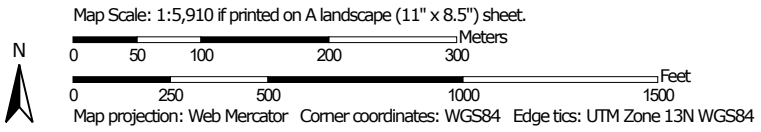

Hydrologic Soil Group—El Paso County Area, Colorado  
(Mayberry Apartments)

### MAP LEGEND

**Area of Interest (AOI)**









 Area of Interest (AOI)

**Soils**

**Soil Rating Polygons**





-  A
-  A/D
-  B
-  B/D
-  C
-  C/D
-  D
-  Not rated or not available

**Soil Rating Lines**

-  A
-  A/D
-  B
-  B/D
-  C
-  C/D
-  D
-  Not rated or not available

**Soil Rating Points**





-  A
-  A/D
-  B
-  B/D

-  C
-  C/D
-  D
-  Not rated or not available

**Water Features**

 Streams and Canals

**Transportation**

-  Rails
-  Interstate Highways
-  US Routes
-  Major Roads
-  Local Roads

**Background**

 Aerial Photography

### MAP INFORMATION

The soil surveys that comprise your AOI were mapped at 1:24,000.

Warning: Soil Map may not be valid at this scale.

Enlargement of maps beyond the scale of mapping can cause misunderstanding of the detail of mapping and accuracy of soil line placement. The maps do not show the small areas of contrasting soils that could have been shown at a more detailed scale.

Please rely on the bar scale on each map sheet for map measurements.

Source of Map: Natural Resources Conservation Service  
Web Soil Survey URL:  
Coordinate System: Web Mercator (EPSG:3857)

Maps from the Web Soil Survey are based on the Web Mercator projection, which preserves direction and shape but distorts distance and area. A projection that preserves area, such as the Albers equal-area conic projection, should be used if more accurate calculations of distance or area are required.

This product is generated from the USDA-NRCS certified data as of the version date(s) listed below.

Soil Survey Area: El Paso County Area, Colorado  
Survey Area Data: Version 19, Aug 31, 2021

Soil map units are labeled (as space allows) for map scales 1:50,000 or larger.

Date(s) aerial images were photographed: Sep 11, 2018—Oct 20, 2018

The orthophoto or other base map on which the soil lines were compiled and digitized probably differs from the background imagery displayed on these maps. As a result, some minor shifting of map unit boundaries may be evident.

## Hydrologic Soil Group

Map unit symbol	Map unit name	Rating	Acres in AOI	Percent of AOI
8	Blakeland loamy sand, 1 to 9 percent slopes	A	141.2	99.0%
100	Truckton-Bresser complex, eroded	A	1.4	1.0%
<b>Totals for Area of Interest</b>			<b>142.6</b>	<b>100.0%</b>

### Description

Hydrologic soil groups are based on estimates of runoff potential. Soils are assigned to one of four groups according to the rate of water infiltration when the soils are not protected by vegetation, are thoroughly wet, and receive precipitation from long-duration storms.

The soils in the United States are assigned to four groups (A, B, C, and D) and three dual classes (A/D, B/D, and C/D). The groups are defined as follows:

Group A. Soils having a high infiltration rate (low runoff potential) when thoroughly wet. These consist mainly of deep, well drained to excessively drained sands or gravelly sands. These soils have a high rate of water transmission.

Group B. Soils having a moderate infiltration rate when thoroughly wet. These consist chiefly of moderately deep or deep, moderately well drained or well drained soils that have moderately fine texture to moderately coarse texture. These soils have a moderate rate of water transmission.

Group C. Soils having a slow infiltration rate when thoroughly wet. These consist chiefly of soils having a layer that impedes the downward movement of water or soils of moderately fine texture or fine texture. These soils have a slow rate of water transmission.

Group D. Soils having a very slow infiltration rate (high runoff potential) when thoroughly wet. These consist chiefly of clays that have a high shrink-swell potential, soils that have a high water table, soils that have a claypan or clay layer at or near the surface, and soils that are shallow over nearly impervious material. These soils have a very slow rate of water transmission.

If a soil is assigned to a dual hydrologic group (A/D, B/D, or C/D), the first letter is for drained areas and the second is for undrained areas. Only the soils that in their natural condition are in group D are assigned to dual classes.

### Rating Options

*Aggregation Method:* Dominant Condition

*Component Percent Cutoff: None Specified*

*Tie-break Rule: Higher*



K Factor, Whole Soil—El Paso County Area, Colorado  
(Mayberry Apartments)

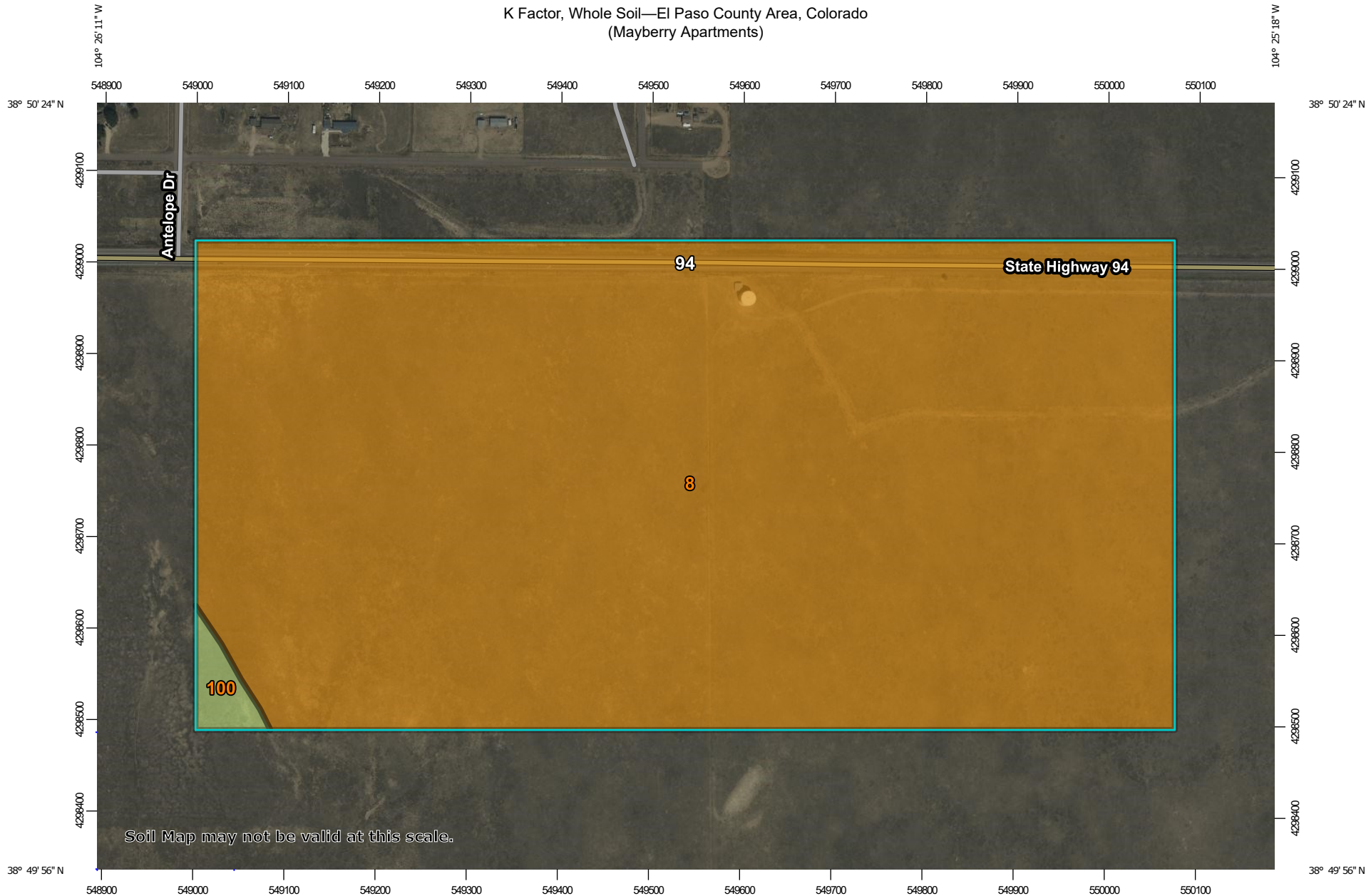

Soil Map may not be valid at this scale.

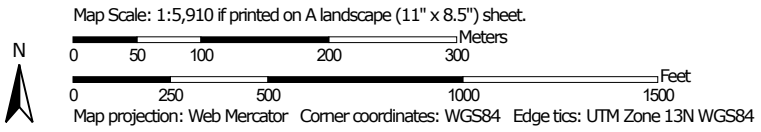

K Factor, Whole Soil—El Paso County Area, Colorado  
(Mayberry Apartments)















### MAP LEGEND

**Area of Interest (AOI)**







 Area of Interest (AOI)









**Soils**

**Soil Rating Polygons**















-  .02
-  .05
-  .10
-  .15
-  .17
-  .20
-  .24
-  .28
-  .32
-  .37
-  .43
-  .49
-  .55
-  .64
-  Not rated or not available

**Soil Rating Lines**







-  .02
-  .05
-  .10
-  .15
-  .17
-  .20

-  .24
-  .28
-  .32
-  .37
-  .43
-  .49
-  .55
-  .64
-  Not rated or not available

**Soil Rating Points**

-  .02
-  .05
-  .10
-  .15
-  .17
-  .20
-  .24
-  .28
-  .32
-  .37
-  .43
-  .49
-  .55
-  .64
-  Not rated or not available

**Water Features**

-  Streams and Canals
- Transportation**
-  Rails
-  Interstate Highways
-  US Routes
-  Major Roads
-  Local Roads
- Background**
-  Aerial Photography

### MAP INFORMATION

The soil surveys that comprise your AOI were mapped at 1:24,000.

**Warning:** Soil Map may not be valid at this scale.  
Enlargement of maps beyond the scale of mapping can cause misunderstanding of the detail of mapping and accuracy of soil line placement. The maps do not show the small areas of contrasting soils that could have been shown at a more detailed scale.

Please rely on the bar scale on each map sheet for map measurements.

Source of Map: Natural Resources Conservation Service  
Web Soil Survey URL:  
Coordinate System: Web Mercator (EPSG:3857)

Maps from the Web Soil Survey are based on the Web Mercator projection, which preserves direction and shape but distorts distance and area. A projection that preserves area, such as the Albers equal-area conic projection, should be used if more accurate calculations of distance or area are required.

This product is generated from the USDA-NRCS certified data as of the version date(s) listed below.

Soil Survey Area: El Paso County Area, Colorado  
Survey Area Data: Version 19, Aug 31, 2021

Soil map units are labeled (as space allows) for map scales 1:50,000 or larger.

Date(s) aerial images were photographed: Sep 11, 2018—Oct 20, 2018

The orthophoto or other base map on which the soil lines were compiled and digitized probably differs from the background imagery displayed on these maps. As a result, some minor shifting of map unit boundaries may be evident.

## K Factor, Whole Soil

Map unit symbol	Map unit name	Rating	Acres in AOI	Percent of AOI
8	Blakeland loamy sand, 1 to 9 percent slopes	.10	141.2	99.0%
100	Truckton-Bresser complex, eroded	.24	1.4	1.0%
<b>Totals for Area of Interest</b>			<b>142.6</b>	<b>100.0%</b>

### Description

Erosion factor K indicates the susceptibility of a soil to sheet and rill erosion by water. Factor K is one of six factors used in the Universal Soil Loss Equation (USLE) and the Revised Universal Soil Loss Equation (RUSLE) to predict the average annual rate of soil loss by sheet and rill erosion in tons per acre per year. The estimates are based primarily on percentage of silt, sand, and organic matter and on soil structure and saturated hydraulic conductivity (Ksat). Values of K range from 0.02 to 0.69. Other factors being equal, the higher the value, the more susceptible the soil is to sheet and rill erosion by water.

"Erosion factor Kw (whole soil)" indicates the erodibility of the whole soil. The estimates are modified by the presence of rock fragments.

Factor K does not apply to organic horizons and is not reported for those layers.

### Rating Options

*Aggregation Method:* Dominant Condition

*Component Percent Cutoff:* None Specified

*Tie-break Rule:* Higher

*Layer Options (Horizon Aggregation Method):* Surface Layer (Not applicable)

## **APPENDIX C – EROSION CONTROL PLAN**

PATH: P:\MC22068 MAYBERRY APARTMENTS (SEC HWY 94 & NEW LOG RD)\ENGINEERING\DRAWINGS\PLANS\CDS - GESC - E&S INITIAL.DWG. PLOT DATE: 3/14/2023 2:32:29 PM BY: LNN GRADY

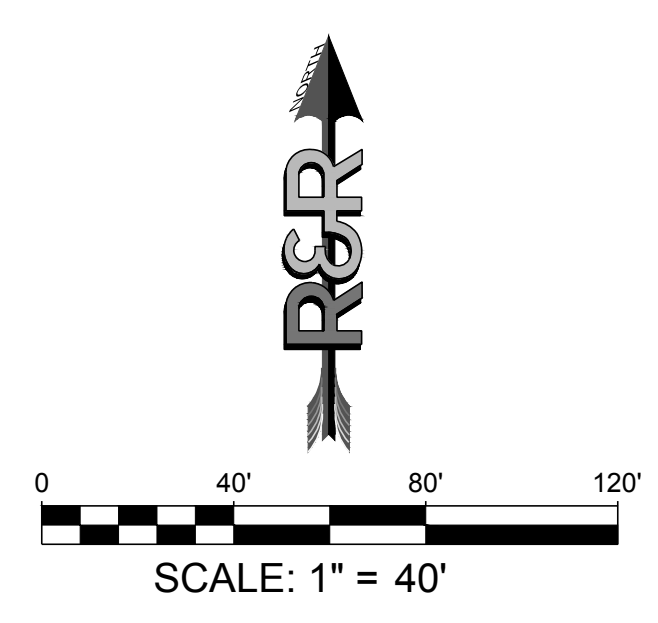
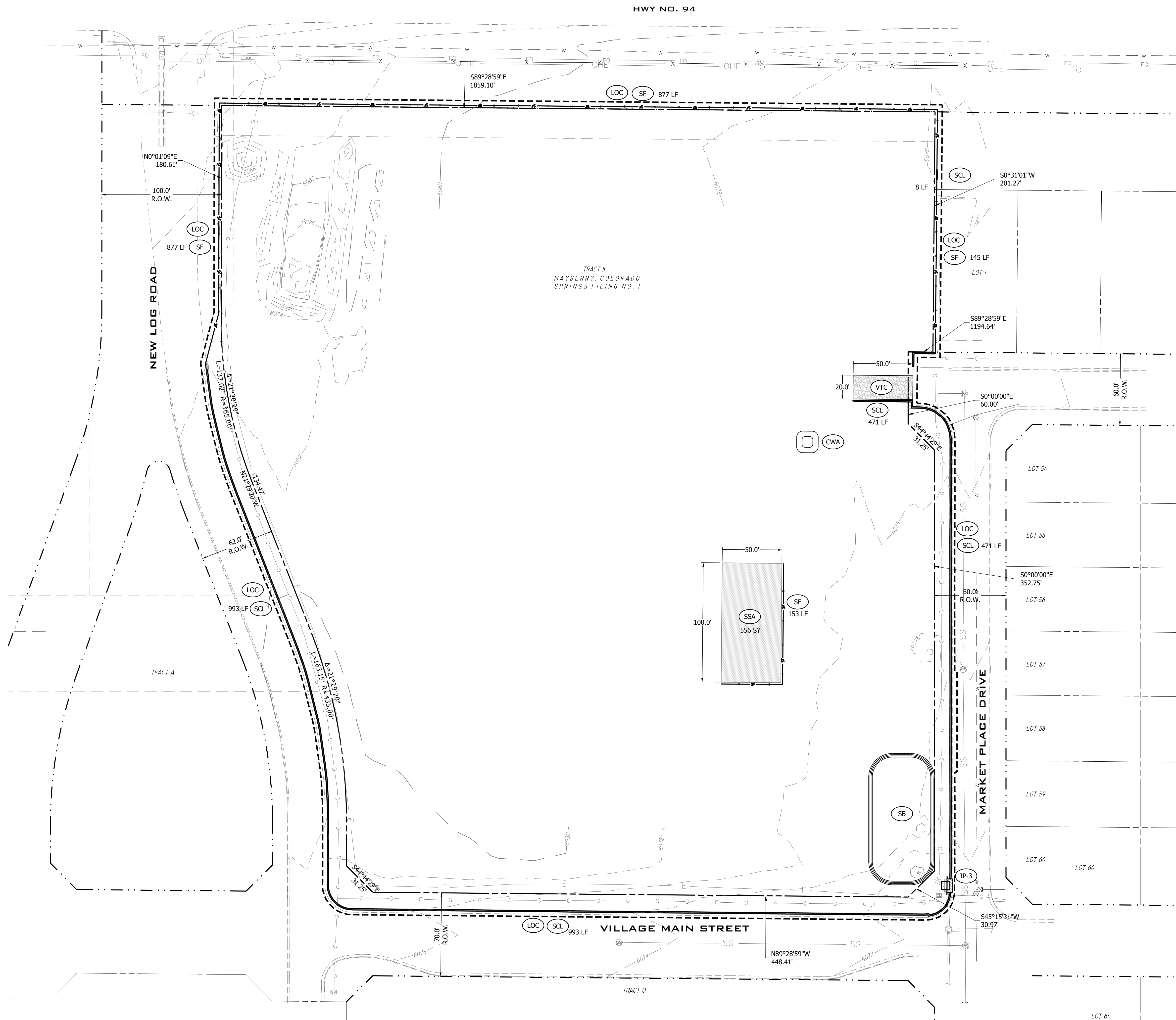

NO.	REVISION	BY	DATE

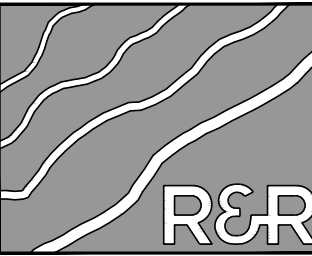
  
**R&R ENGINEERS-SURVEYORS, INC.**  
 1635 WEST 13TH AVENUE, SUITE 310  
 DENVER, COLORADO 80204  
 PHONE: 303-753-6730

WWW.RRENGINEERS.COM

**MAYBERRY - TRACT K APARTMENTS**  
 SITE ADDRESS: SEC OF HIGHWAY 94 & NEW LOG ROAD  
 EL PASO COUNTY, COLORADO  
 PREPARED FOR: MAYBERRY COMMUNITIES, LLC  
 3296 DIVINE HEIGHTS, #207  
 COLORADO SPRINGS, CO 80922

GESC PLANS	
JOB NO.	MC22068
ORG. SUBM. DATE	03/21/2023
DWN.	LAO
CHKD.	CJD
NAME	
EROSION & SEDIMENT CONTROL PLAN - INITIAL	
NO.	8.2

PATH: P:\MC22068 MAYBERRY APARTMENTS (SEC HWY 94 & NEW LOG ROAD) ENGINEERING & DRAWINGS\PLANS.CDS - GESC - E&S INTERIM.DWG - PLOT DATE: 3/14/2023 2:33:32 PM BY: LNN O'GRADY

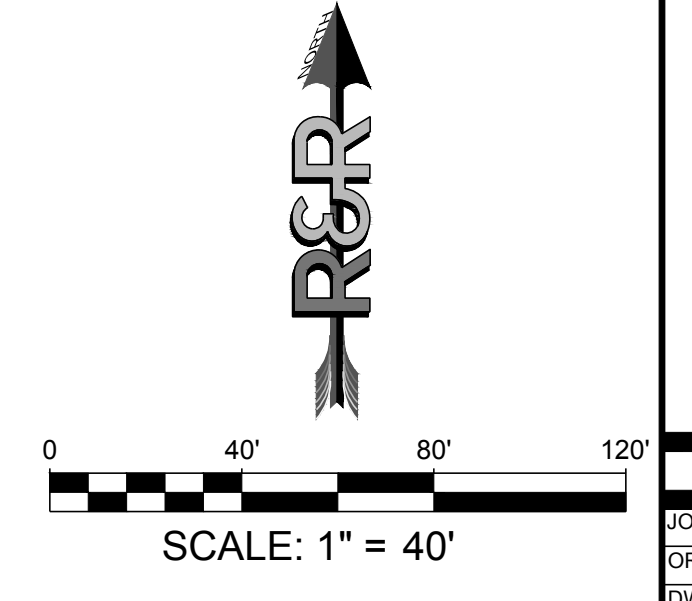
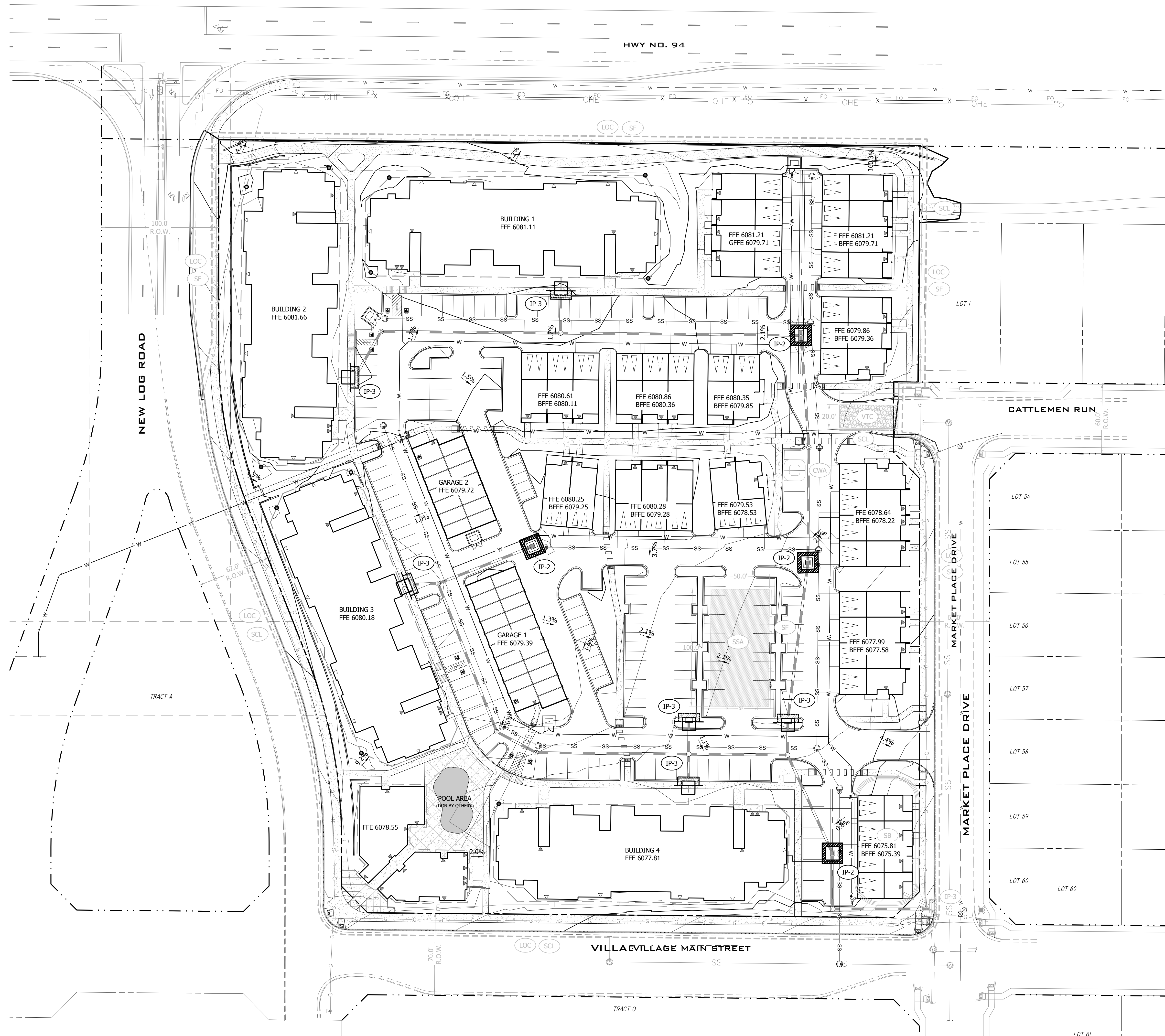

NO.	REVISION	BY	DATE

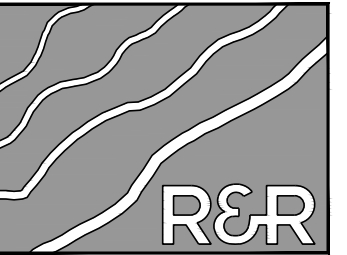
  
**R&R ENGINEERS-SURVEYORS, INC.**  
 1635 WEST 13TH AVENUE, SUITE 310  
 DENVER, COLORADO 80204  
 PHONE: 303-753-6730

WWW.RRENGINEERS.COM

MAYBERRY - TRACT K APARTMENTS  
 SITE ADDRESS: SEC OF HIGHWAY 94 & NEW LOG ROAD  
 EL PASO COUNTY, COLORADO  
 PREPARED FOR: MAYBERRY COMMUNITIES, LLC  
 3296 DIVINE HEIGHTS, #207  
 COLORADO SPRINGS, CO 80922

GESC PLANS  
 JOB NO. MC22068  
 ORG. SUBM. DATE 03/21/2023  
 DWN: LAO CHKD: CJJ  
 NAME

EROSION & SOIL CONTROL PLAN - INTERIM  
 NO.

8.3

PATH: P:\MC22068 MAYBERRY APARTMENTS (SEC HWY 94 & NEW LOG RD)\ENGINEERING & DRAWINGS\PLANS\GSC - GESC PLANS\MC22068 - GESC - FINAL.DWG. PLOT DATE: 3/14/2023 2:13:42 PM. BY: LANN GRADY

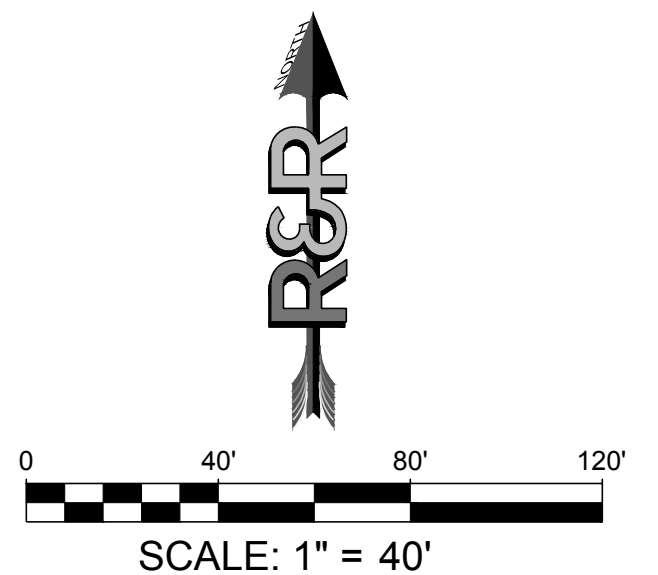
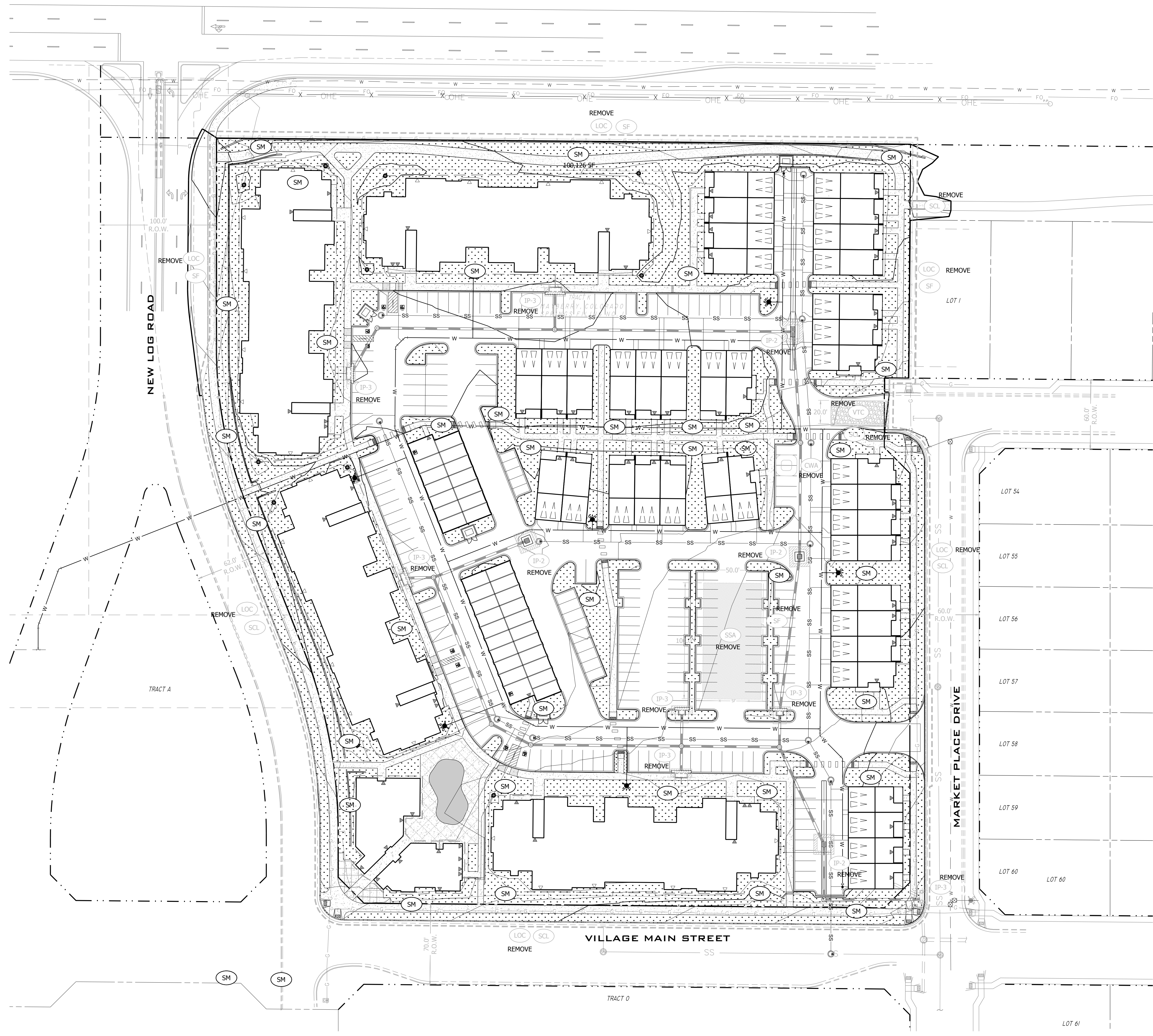

NO.	REVISION	BY	DATE

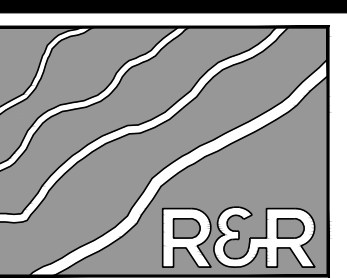

ENGINEERS  
SURVEYORS

**R&R ENGINEERS-SURVEYORS, INC.**  
1635 WEST 13TH AVENUE, SUITE 310  
DENVER, COLORADO 80204  
PHONE: 303-753-6730

WWW.RRENGINEERS.COM

MAYBERRY - TRACT K APARTMENTS  
SITE ADDRESS: SEC OF HIGHWAY 94 & NEW LOG ROAD  
EL PASO COUNTY, COLORADO  
PREPARED FOR: MAYBERRY COMMUNITIES, LLC  
3296 DIVINE HEIGHTS, #207  
COLORADO SPRINGS, CO 80922

GESC PLANS  
JOB NO: MC22068  
ORG. SUBM. DATE: 03/21/2023  
DWN: LAO CHKD: CJJ  
NAME

EROSION & SEDIMENT  
CONTROL PLAN -  
FINAL

NO. **C8.4**



Know what's below.  
Call before you dig.

## **APPENDIX D – BMP DETAILS**





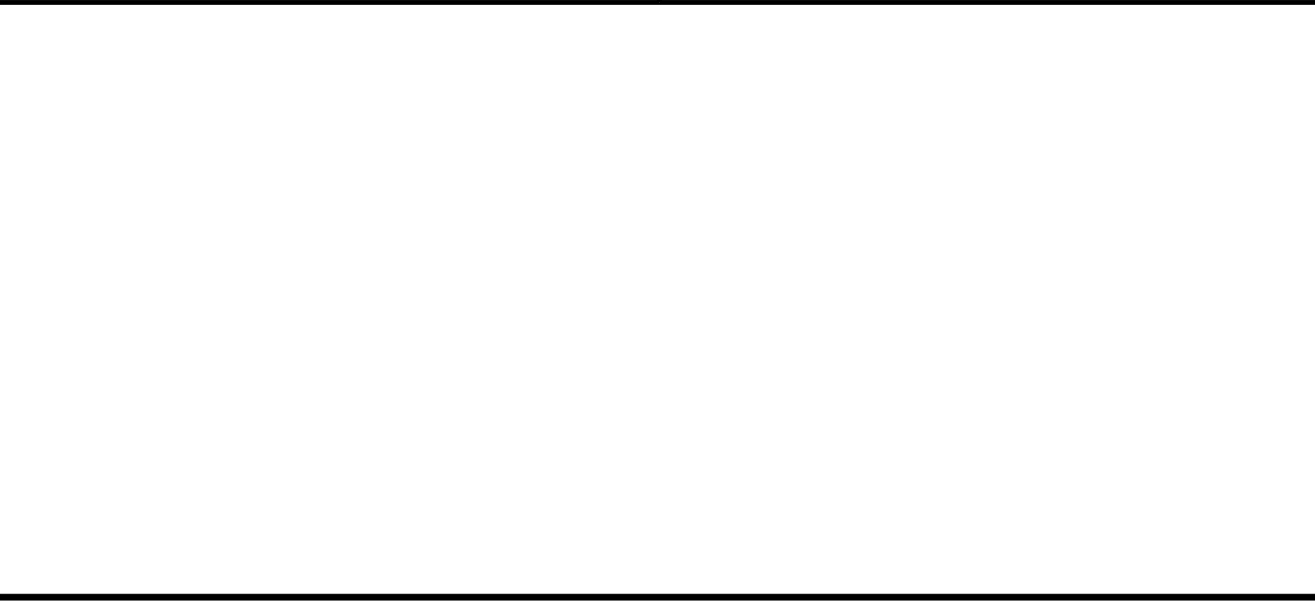
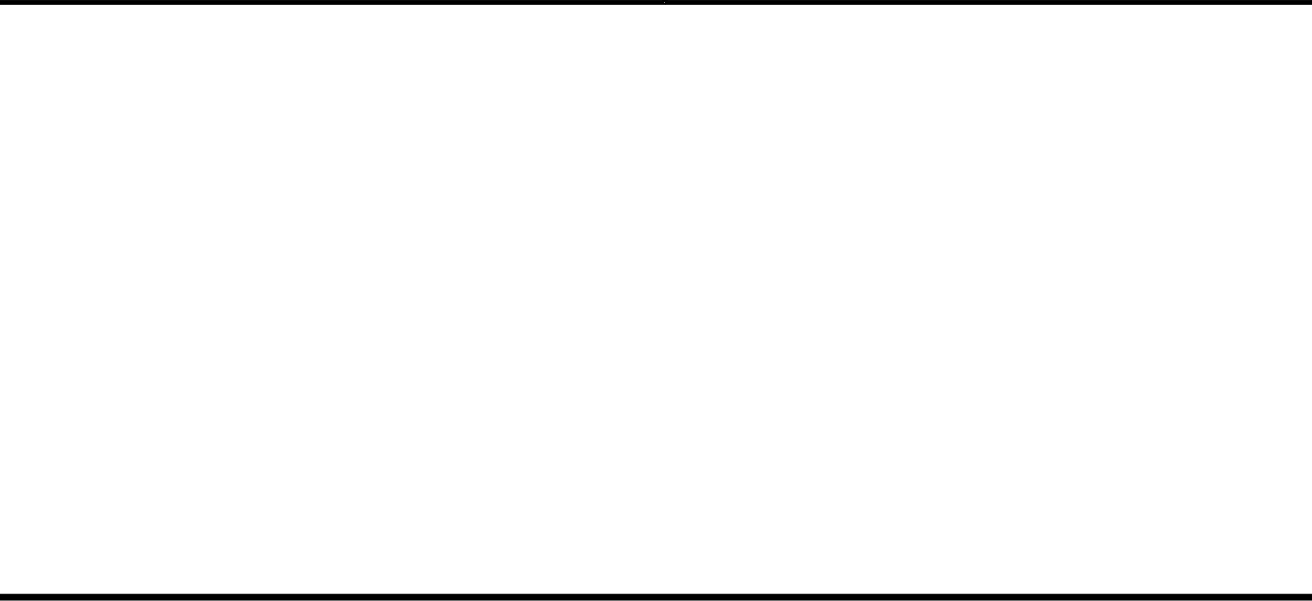
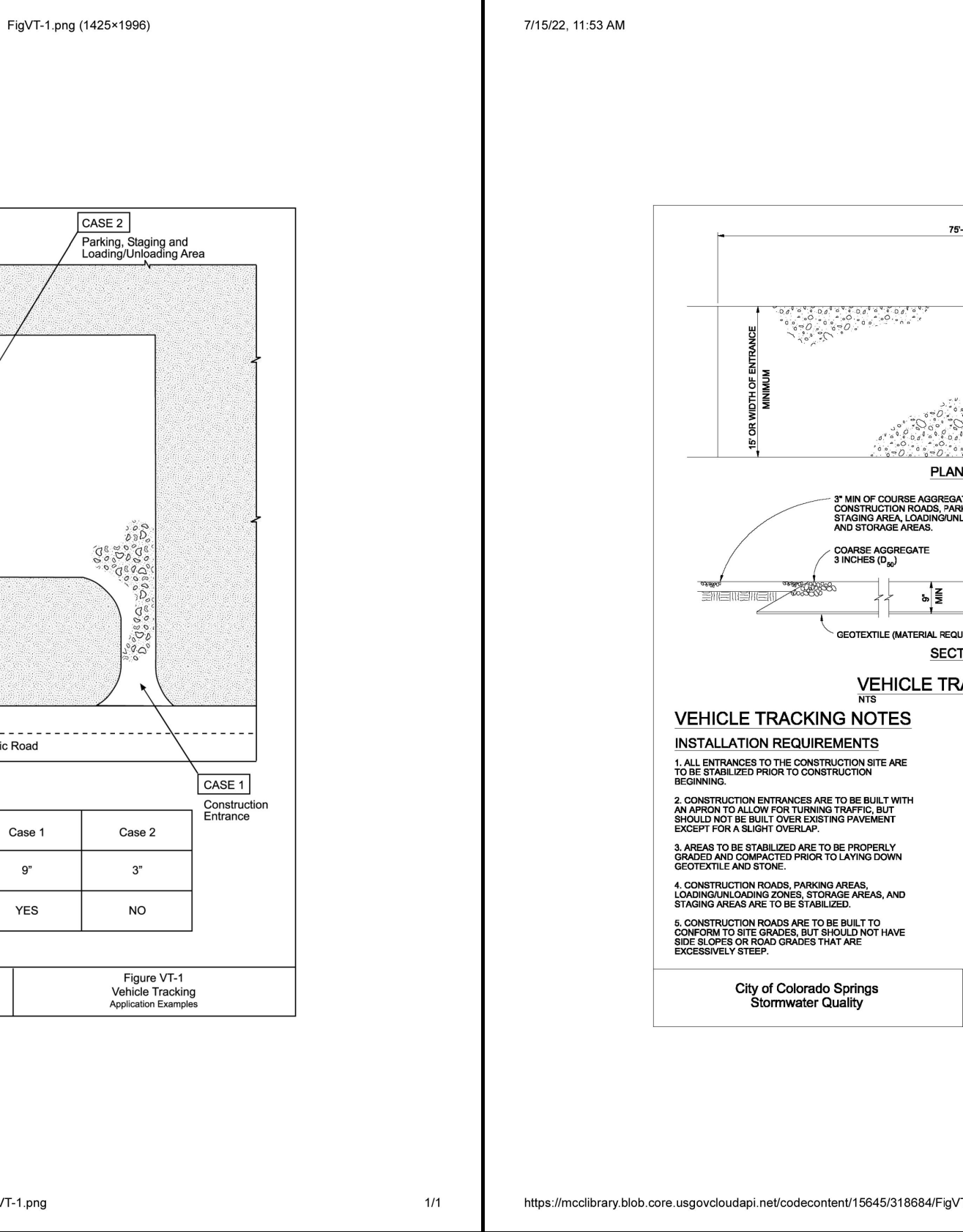
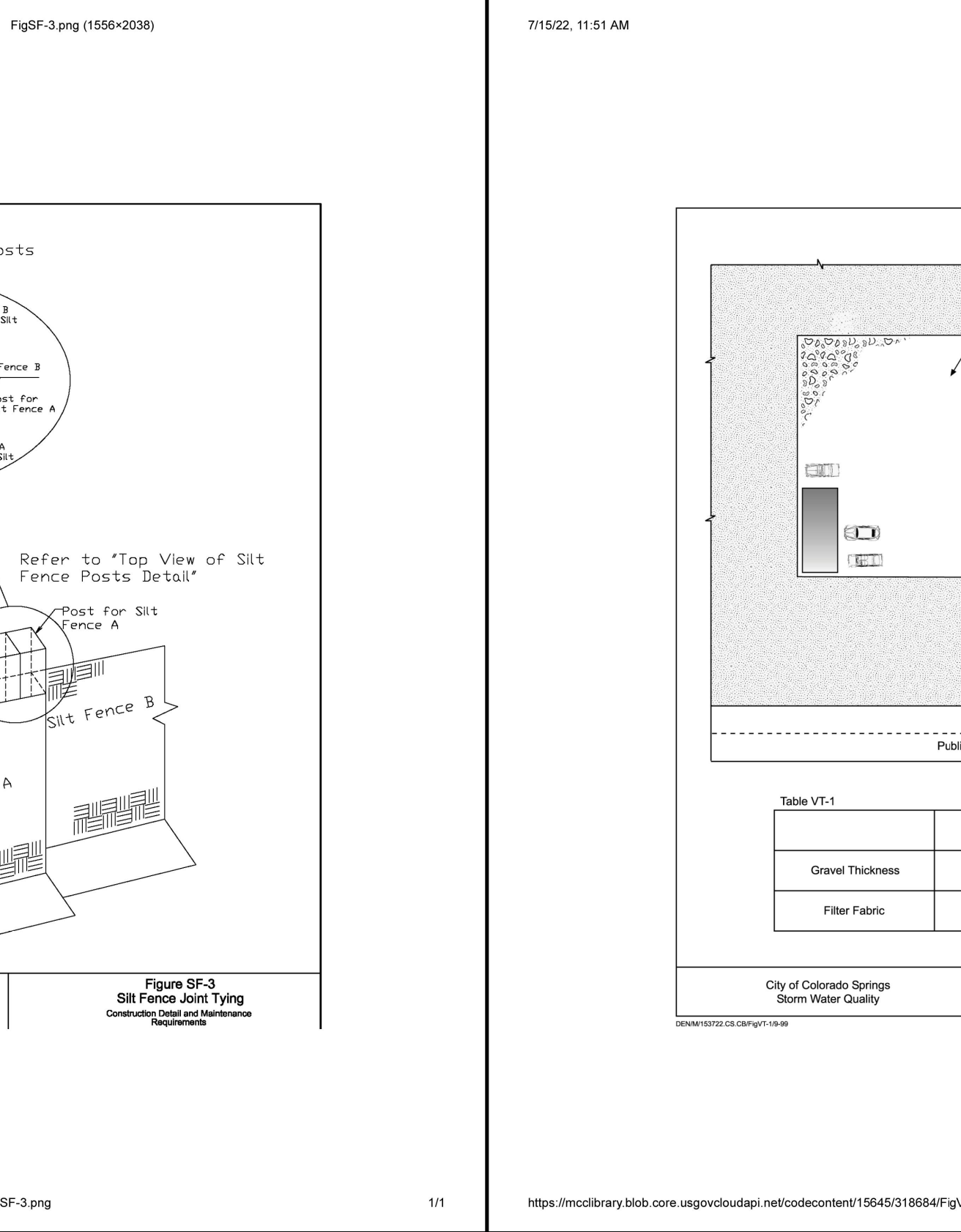
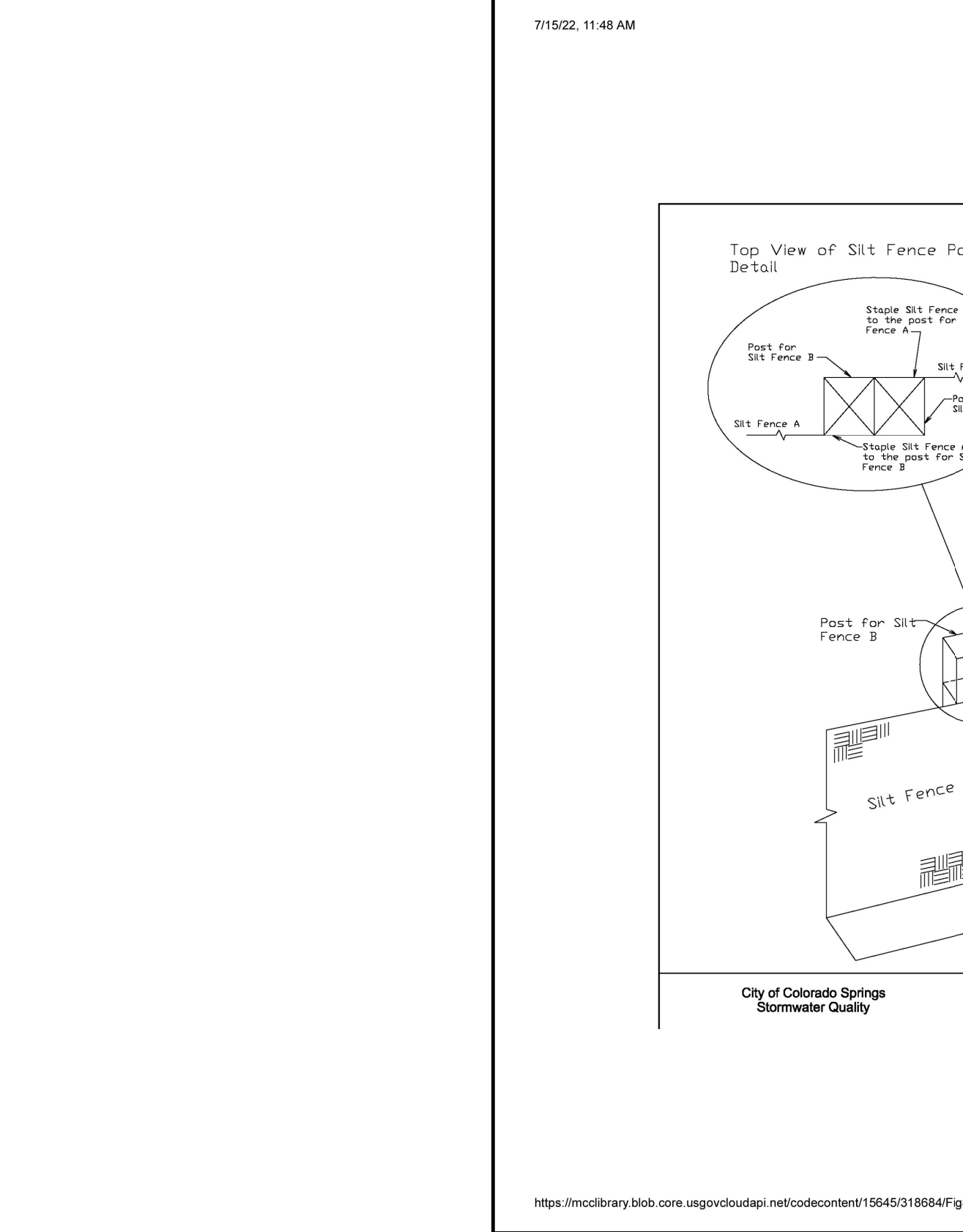
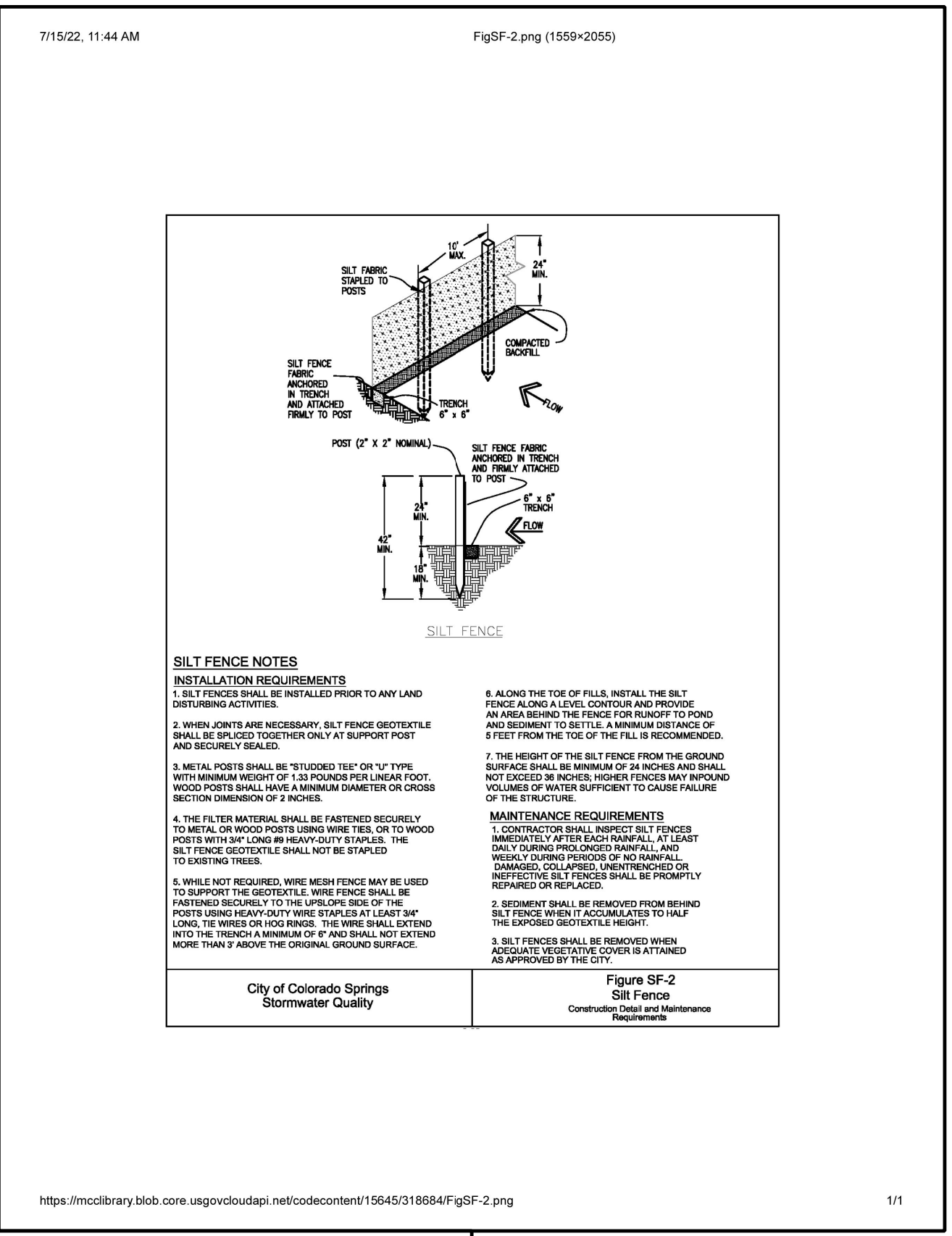
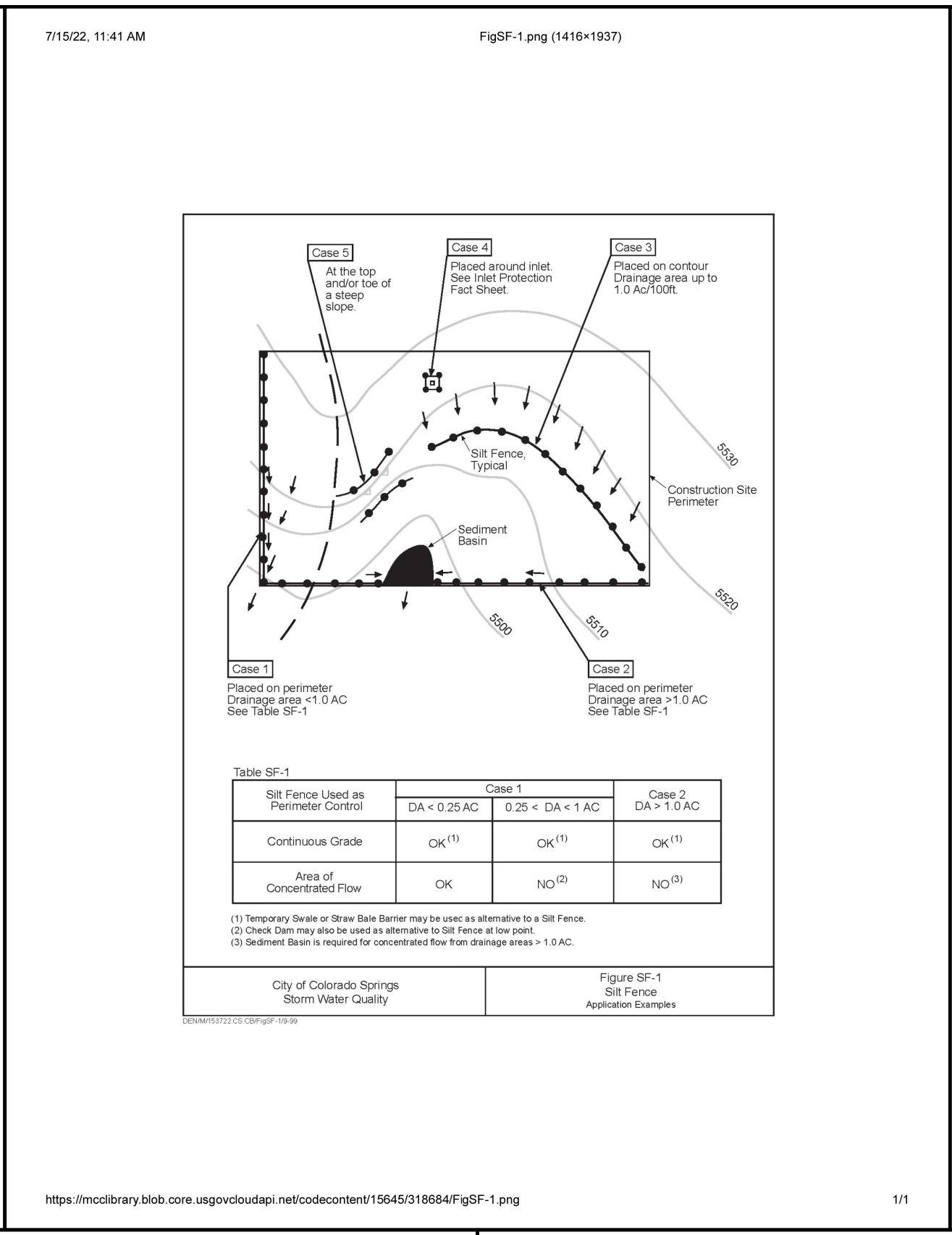
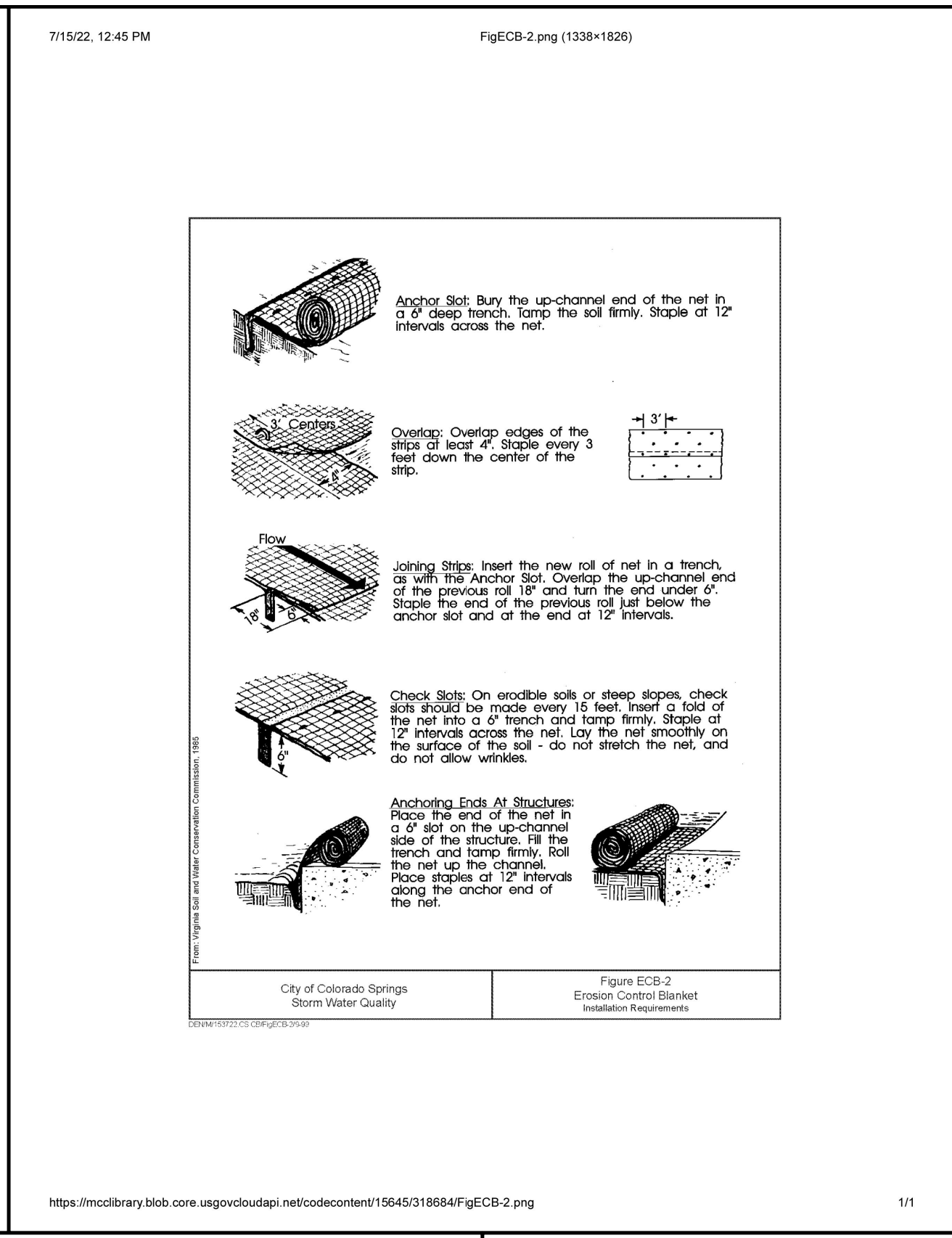
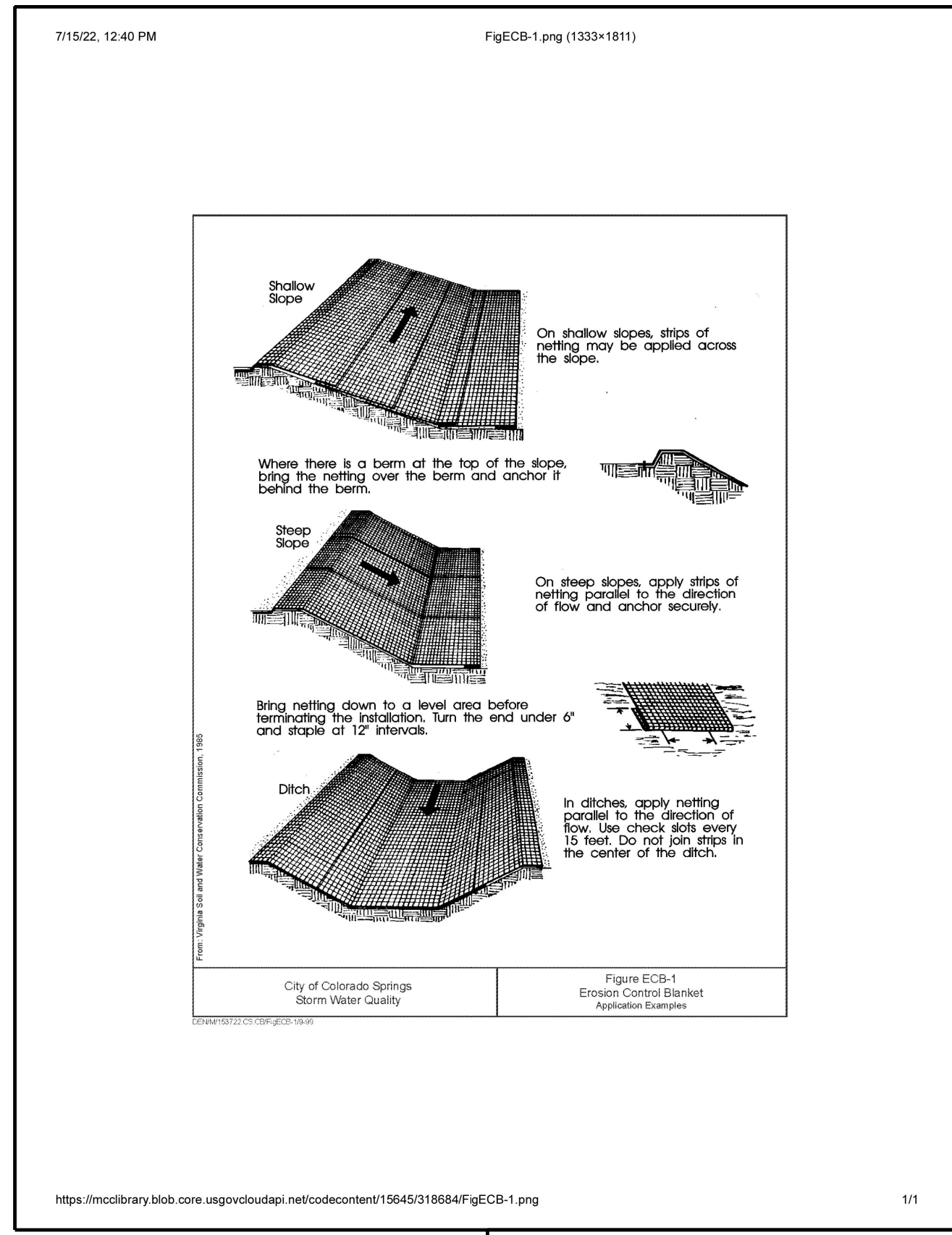

NO.	REVISION	BY	DATE

**R&R ENGINEERS-SURVEYORS, INC.**  
1635 WEST 13TH AVENUE, SUITE 310  
DENVER, COLORADO 80204  
PHONE: 303-753-6730

WWW.RRENGINEERS.COM

MAYBERRY - TRACT K APARTEMENTS  
SITE ADDRESS: SEC OF HIGHWAY 94 & NEW LOG ROAD  
EL PASO COUNTY, COLORADO

PREPARED FOR: MAYBERRY COMMUNITIES, LLC  
3296 DIVINE HEIGHTS, #207  
COLORADO SPRINGS, CO 80922

GESC PLANS  
JOB NO. MC22068  
ORG. SUBM. DATE 03/21/2023  
DWN: LAO CHKD: CJJ  
NAME  
BMP DETAILS  
NO. C8.7

