

**TRACT L FLYING HORSE
NORTH FILING NO. 1
RECORDED UNDER RECEPTION NO.
218714238
GOLF COURSE
84.66 ACRES**

**LOT 29 FLYING HORSE
NORTH FILING NO. 1
5555 OLD STAGECOACH RD.
RECEPTION NO. 6136003001
RESIDENTIAL
3.56 ACRES**

PARKING

use	Maintenance Building
bdg area	10,800 sf
ratio	1 parking space per anticipated employee
required	11 required (including 1 accessible spaces 1 being van accessible)
provided	11 provided (1 accessible including 1 van accessible space)

The parties responsible for this plan have familiarized themselves with all current accessibility criteria and specifications and the proposed plan reflects all site elements required by the applicable ADA design standards and guidelines as published by the United States Department of Justice. Approval of this plan by El Paso County does not assure compliance with the ADA or any regulations or guidelines enacted or promulgated under or with respect to such laws.

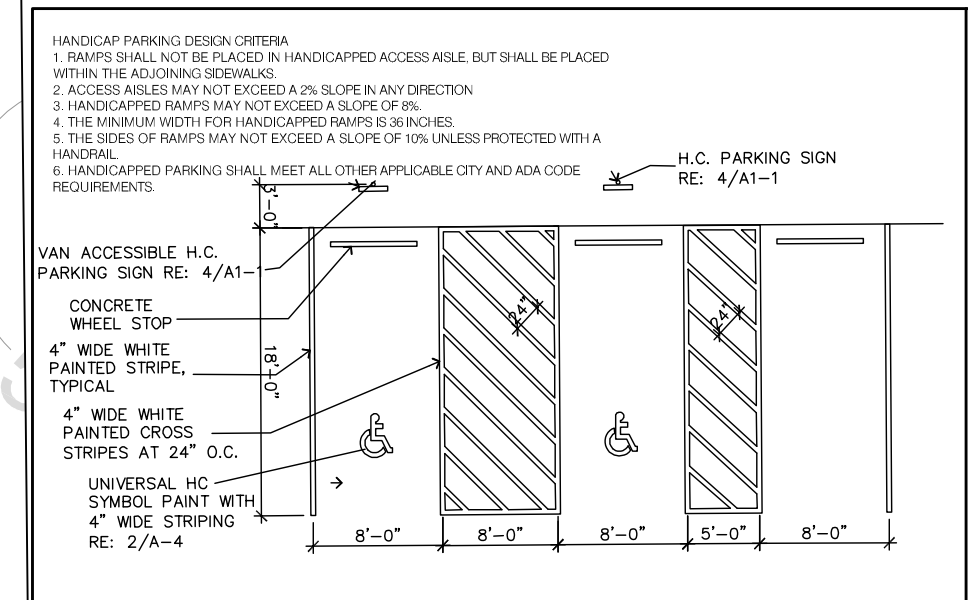

FLYING HORSE NORTH MAINTENANCE

LOT	USE	LOT SIZE	BUILDING SIZE
TRACT L	MAINTENANCE	84.66 Acres	10,800 SF / 875 SF

**LEGAL DESCRIPTION: TRACT L
FLYING HORSE NORTH FILING NO. 1
84.66 ACRES**

SITE DATA

tax schedule no.:	6136003004
area	84.66 acres
ex use	Vacant
proposed use	Golf course maintenance

OWNER INFO

company name	PRI #2 LLC
address	6385 Corporate Drive, Suite 200
city/state	Colorado Springs CO, 80919
phone no	

PCD city file no: PPR1934

YOW Architects PC
Architecture & Planning
115 S. Weber Colorado Springs, Colorado 719-475-8133

GOLF MAINTENANCE FACILITY
5770 & 5772 Old Stagecoach Road
El Paso County, Colorado

Project Number
18.209
Date
7/22/19
Revisions

Drawn By
DBN
Checked By

SD1.0
Site Development
Plan
Scale
1" = 20'-0"

