

PROJECT TEAM:

OWNER:
SECURITY CORNER, LLC
A COLORADO LIMITED LIABILITY COMPANY
2201 FRANCISCO DR. #140-277
EL DORADO HILLS, CA 95762
CONTACT: ROBERTS PEDRICK
PH: (415) 722-2222
E: ROB@PEDHOLD.COM

APPLICANT:
KUM & GO L.C.
1459 GRAND AVE
DES MOINES, IA 50309
CONTACT: DAN GARNEAU
PH: (515) 457-6392
E: DAN.GARNEAU@KUMANDGO.COM

ARCHITECT:
BRR ARCHITECTURE
8131 METCALF AVE., SUITE 300
OVERLAND PARK, KS 66204
CONTACT: ASHLEY WEBER
PH: (913) 236-3325
E: ASHLEY.WEBER@BRRARCH.COM

ENGINEER:
ENTITLEMENT & ENGINEERING SOLUTIONS, INC.
3801 E. FLORIDA AVE., SUITE 425
DENVER, CO 80210
CONTACT: KRYSTA HOUTCHENS, PE
PH: (970) 380-7054
E: KRYSTA.HOUTCHENS@EES.US.COM

LANDSCAPE ARCHITECT:
VALERIAN LLC
907 YUMA ST. SUITE 130
DENVER, CO 80204
CONTACT: NATHANIEL RONEY
PH: (303) 347-1200
E: NATHANIEL@VALERIANLLC.COM

SURVEYOR:
FORESIGHT WEST SURVEYING, INC.
1285 W. BYERS PL., UNIT A
DENVER, CO 80223
CONTACT: LESTER J. LUDEMAN
PH: (303) 504-4440
E: LLUDEMAN@FORESIGHTWEST.COM

SEWER AND WATER:
SECURITY WATER AND SANITATION DISTRICTS
231 SECURITY BLVD.
COLORADO SPRINGS, CO 80911
CONTACT: BRANDON BERNARD
OPERATIONS MANAGER OF WATER AND WASTEWATER
PH: (719) 464-2051 (CELL)
E: B.BERNARD@SECURITYWSD.COM

KUM & GO GAS & C-STORE

PART OF THE SOUTHEAST 1/4 OF SECTION 11, TOWNSHIP 15 SOUTH, RANGE 66
WEST OF THE SIXTH PRINCIPAL MERIDIAN,
COUNTY OF EL PASO, STATE OF COLORADO

MAJOR SITE DEVELOPMENT PLAN



WHERE & MEANS MORE!

SITE DETAILS:

PROPERTY ADDRESS:
675 SECURITY BLVD.
COLORADO SPRINGS, CO 80911
EL PASO COUNTY, STATE OF COLORADO

PROPERTY SIZE:
±56,190 S.F. / ±1.29 ACRES

PROPERTY TAX SCHEDULE NO.:
6511415042

LOT AREA COVERAGE CALCULATION:
TOTAL LOT AREA = 56,190 S.F. / TOTAL LOT COVERAGE = 42,691 S.F.
TOTAL LOT COVERAGE PERCENTAGE = 76.0 PERCENT

EXISTING / PROPOSED LAND USE AND ZONING:
EXISTING / PROPOSED LAND USE: VACANT COMMERCIAL LOT / COMMERCIAL
ZONING: CC CAD-O

TOTAL GROSS BUILDING SQUARE FOOTAGE:
3,962 SQ. FT.

OPEN SPACE PERCENTAGE:
N/A

LANDSCAPING PERCENTAGE:
17.6 PERCENT

IMPERMEABLE SURFACE PERCENTAGE:
72.4 PERCENT

IMPERMEABLE SURFACE AND LANDSCAPING PERCENTAGE:
90.0 PERCENT

LEGAL DESCRIPTION:
DESCRIPTION PER TITLE COMMITMENT:

PARCEL A:
LOT 2, PEDRICK-ECKERD FILING NO 3, COUNTY OF EL PASO, STATE OF COLORADO.

PARCEL B:
THOSE EASEMENT RIGHTS CREATED BY DECLARATION OF RESTRICTIONS AND GRANT OF EASEMENTS RECORDED JULY 1, 1983 IN BOOK 3750 AT PAGE 909, FIRST AMENDMENT TO SAID DECLARATION RECORDED DECEMBER 2, 1994 IN BOOK 6571 AT PAGE 1245 AND SECOND AMENDMENT TO SAID DECLARATION RECORDED JANUARY 29, 2004 UNDER RECEPTION NO. 204016205 AND THIRD AMENDMENT TO SAID DECLARATION RECORDED FEBRUARY 19, 2013 UNDER RECEPTION NO. 213022221, AND COMMON AREA MAINTENANCE AGREEMENT RECORDED JULY 1, 1983 IN BOOK 3750 AT PAGE 929, FIRST AMENDMENT TO SAID AGREEMENT RECORDED DECEMBER 2, 1994 IN BOOK 6571 AT PAGE 1251 AND SECOND AMENDMENT TO SAID AGREEMENT RECORDED JANUARY 29, 2004 UNDER RECEPTION NO. 204016204, AND ASSIGNMENT AND ASSUMPTION OF RECIPROCAL EASEMENT AGREEMENT RECORDED SEPTEMBER 5, 2007 UNDER RECEPTION NO. 207115485.

BASIS OF BEARING:
BEARINGS ARE BASED UPON THE SOUTHEASTERLY LINE OF PEDRICK - ECKERD FILING NO. 3 AS BEARING NORTH 28° 41' 44" EAST, PER SAID PLAT.

BENCHMARK:
ELEVATIONS ARE BASED UPON COLORADO SPRINGS UTILITIES FIMS CONTROL MONUMENT SE09, BEING A 2-INCH DIAMETER ALUMINUM CAP STAMPED "CSU FIMS CONTROL SE09" ON THE EAST CORNER OF THE CONCRETE BASE OF A TELEPHONE RELAY BOX AT THE EAST CORNER OF 226 MAIN STREET, ABOUT 3 FEET NORTHWEST OF THE NORTHWEST CURB OF MAIN STREET, AND ABOUT 205 FEET SOUTHWEST OF THE SOUTHWEST CURB LINE OF SECURITY BOULEVARD. CITY ELEVATION: 5726.76 (NGVD 29)

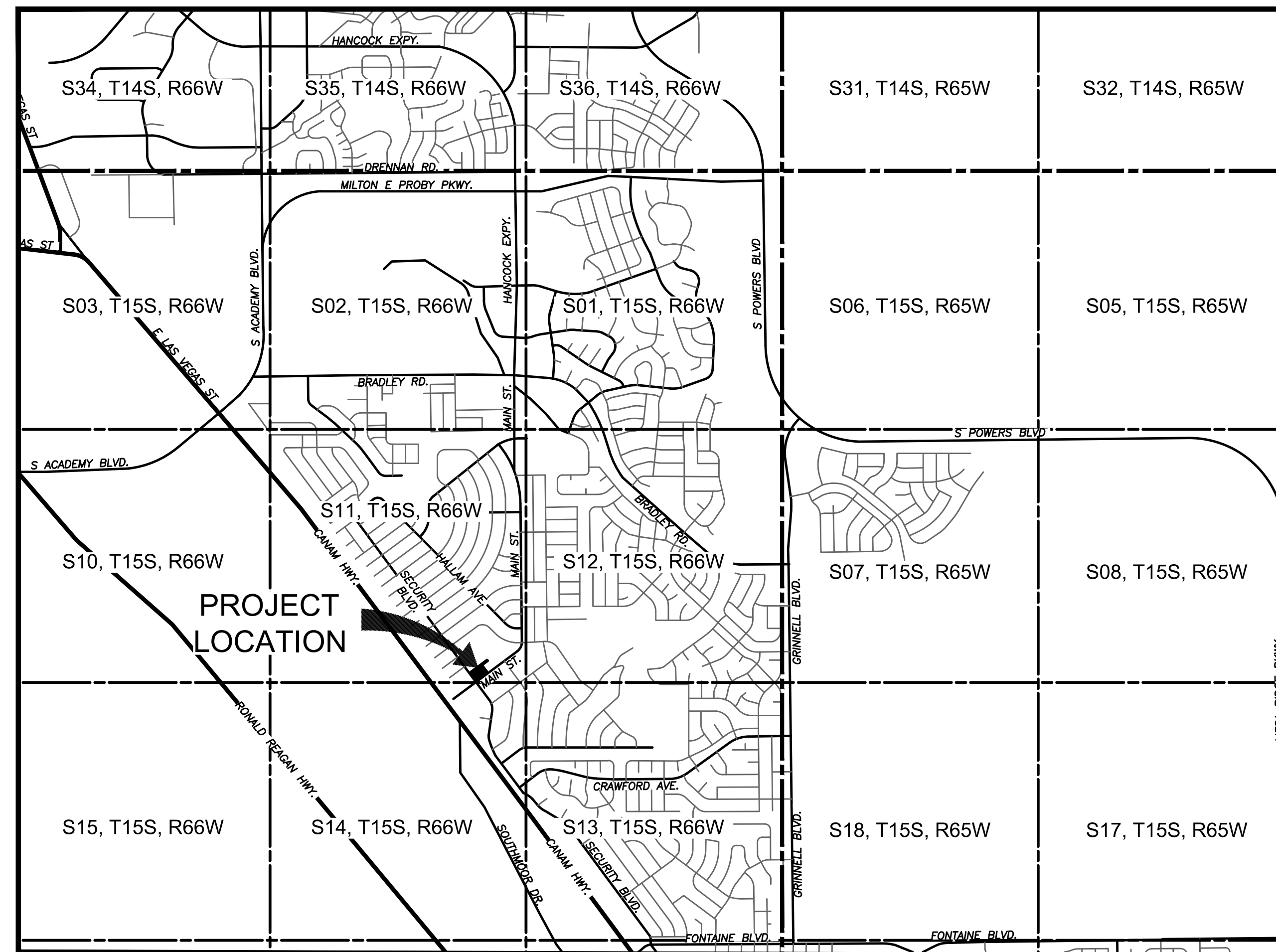

VICINITY MAP
SCALE: 1" = 2000'

REV	SHEET LIST	
1	COVER SHEET	C0.0
2	GENERAL NOTES	C0.1
3	EXISTING CONDITIONS AND DEMOLITION PLAN	C1.0
4	SITE PLAN	C1.1
5	HORIZONTAL CONTROL, PAVING AND SIGNAGE PLAN	C1.2
6	GRADING PLAN	C2.1
7	DETAILED GRADING PLAN - SOUTH	C2.2
8	DETAILED GRADING PLAN - NORTH	C2.3
9	EROSION AND STORMWATER CONTROL PLAN - INITIAL	C3.1
10	EROSION AND STORMWATER CONTROL PLAN - INTERIM	C3.2
11	EROSION AND STORMWATER CONTROL PLAN - FINAL	C3.3
12	EROSION AND STORMWATER CONTROL DETAILS	C3.4
13	EROSION AND STORMWATER CONTROL DETAILS	C3.5
14	EROSION AND STORMWATER CONTROL DETAILS	C3.6
15	EROSION AND STORMWATER CONTROL DETAILS	C3.7
16	EROSION AND STORMWATER CONTROL DETAILS	C3.8
17	STORM SEWER PLAN	C4.1
18	ADS SYSTEM DETAILS	C4.2
19	ADS SYSTEM DETAILS	C4.3
20	ADS SYSTEM DETAILS	C4.4
21	ADS SYSTEM DETAILS	C4.2
22	ADS SYSTEM DETAILS	C4.3
23	ADS SYSTEM DETAILS	C4.4
24	ADS SYSTEM DETAILS	C4.5
25	UTILITY PLAN	C5.1
26	UTILITY PROFILES	C5.2
27	UTILITY DETAILS	C5.3
28	UTILITY DETAILS	C5.4
29	UTILITY NOTES	C5.5
30	CIVIL DETAILS	C6.1
31	CIVIL DETAILS	C6.2
32	CIVIL DETAILS	C6.3
33	LANDSCAPE PLAN	C7.1
34	LANDSCAPE NOTES AND DETAILS	C7.2
35	IRRIGATION PLAN	C7.3
36	IRRIGATION NOTES	C7.4
37	IRRIGATION DETAILS	C7.5
38	EXTERIOR ELEVATIONS	C8.1
39	CANOPY ELEVATIONS	C8.2
40	TRASH ENCLOSURE ELEVATIONS	C8.3
41	FLOOR PLAN	C8.4
42	ROOF PLAN	C8.5
43	PHOTOMETRIC PLAN	C9.1

PARKING COMPUTATIONS		
REQUIRED PARKING	STANDARD	22
	ADA	1
	TOTAL	23
PARKING RATIO = 3 PER FUELING BAY + 1 PER EMPLOYEE MAX SHIFT		
PROPOSED PARKING	STANDARD	22
	ADA	1
	TOTAL	23
PARKING RATIO = PARKING RATIO = 3 PER FUELING BAY + 1 PER EMPLOYEE MAX SHIFT		

PLANNING AND COMMUNITY
DEVELOPMENT DIRECTOR
SIGNATURE BLOCK



1459 Grand Ave
Des Moines, IA 50309
P: 888-458-6646

2232 - EL PASO, COLORADO
SECURITY BLVD. AND MAIN ST.
COVER SHEET

KG PROJECT TEAM:
RDM:
SDM:
CPM:

REVISIONS	DATE	REVISION DESCRIPTION
1	08/19/22	1ST REVIEW COMMENTS
2	01/06/23	2ND REVIEW COMMENTS
3	04/05/23	3RD REVIEW COMMENTS
4	05/11/23	4TH REVIEW COMMENTS

DATE: 05-11-2023

SHEET NUMBER:
C0.0
1 OF 43

PCD FILE NO. PPR-2225



GENERAL NOTES

- 1. ALL WORK AND CONSTRUCTION OF THIS PROJECT ON PRIVATE PROPERTY SHALL CONFORM TO KUM & GO STANDARD SPECIFICATIONS...
2. ALL WORK AND CONSTRUCTION WITHIN PUBLIC RIGHT OF WAY AND EASEMENTS SHALL CONFORM TO THE TECHNICAL SPECIFICATIONS...
3. IN CASE OF A CONFLICT BETWEEN VARYING SPECIFICATIONS, THE MOST STRINGENT SHALL APPLY...
4. THE CONTRACTOR SHALL OBTAIN A COPY OF THE LATEST STANDARD SPECIFICATIONS AND DETAILS OF ALL AGENCIES EXERCISING JURISDICTION OVER THIS PROJECT...
5. THE CONTRACTOR SHALL HAVE IN HIS POSSESSION AT ALL TIMES ONE (1) SIGNED COPY OF THE PLANS, STANDARDS, AND SPECIFICATIONS AS APPROVED BY THE APPROPRIATE GOVERNING AGENCY AND OWNER...
6. ALL WORK SHALL CONFORM TO ALL LOCAL, STATE, AND FEDERAL APPLICABLE LAWS AND REGULATIONS...
7. THE CONTRACTOR SHALL BE RESPONSIBLE FOR ALL JOB SITE SAFETY ON THE PROJECT...
8. THE CONTRACTOR SHALL CONTACT ONE CALL AT #811 A MINIMUM OF 72 HOURS (EXCLUDING WEEKENDS AND HOLIDAYS) IN ADVANCE OF ANY EXCAVATION...
9. THE LOCATIONS OF EXISTING UTILITIES AND STRUCTURES SHOWN ON THE PLANS ARE APPROXIMATE AND HAVE BEEN SHOWN FROM AVAILABLE SURVEYS AND/OR RECORDS...
10. ALL MATERIALS SHALL BE NEW UNLESS OTHERWISE INDICATED IN THE PLANS, AND SHALL BE SUBJECT TO INSPECTION AND APPROVAL BY THE OWNER OR THE OWNER'S REPRESENTATIVE...
11. LOCATIONS AND ELEVATIONS OF EXISTING IMPROVEMENTS TO BE MET (OR AVOIDED) BY THE PROPOSED WORK SHALL BE CONFIRMED BY THE CONTRACTOR THROUGH FIELD EXPLORATIONS PRIOR TO CONSTRUCTION...
12. THE CONTRACTOR SHALL CONTACT THE OWNER IMMEDIATELY UPON DISCOVERY OF ANY ERRORS OR INCONSISTENCIES SHOWN IN THE PLANS AND/OR SPECIFICATIONS...
13. ALL ESTIMATES OF QUANTITIES ARE FOR INFORMATIONAL PURPOSES ONLY...
14. CONTRACTOR SHALL PROTECT ALL EXISTING IMPROVEMENTS NOT DESIGNATED FOR REMOVAL AND THOSE IMPROVEMENTS THAT ARE OUTSIDE THE LIMITS OF THE PROPOSED CONSTRUCTION...
15. ALL GRADING AND CONSTRUCTION ACTIVITIES SHALL BE CONFINED TO THE OWNER'S PROPERTY, PUBLIC RIGHT-OF-WAY, PERMANENT EASEMENTS, AND TEMPORARY CONSTRUCTION EASEMENTS...
16. THE CONTRACTOR SHALL BE RESPONSIBLE FOR OBTAINING ALL PERMITS NOT OBTAINED BY THE OWNER OR OWNER'S REPRESENTATIVES...
17. THE CONTRACTOR SHALL BE RESPONSIBLE FOR NOTIFYING THE APPROPRIATE GOVERNING AGENCIES AND LOCAL FIRE DEPARTMENT OF ALL STREET CLOSURES AND EXISTING FIRE HYDRANTS/FIRE SUPPRESSION TAKEN OUT OF SERVICE AT LEAST 48 HOURS PRIOR TO CONSTRUCTION...
18. THE CONTRACTOR IS RESPONSIBLE FOR ALL SITE SECURITY AND SHALL PROPERLY PROTECT AND BARRICADE THE CONSTRUCTION SITE UNTIL CONSTRUCTION IS COMPLETE...
19. PRIOR TO BEGINNING THE WORK, THE CONTRACTOR SHALL OBTAIN ANY WRITTEN AGREEMENTS FOR INGRESS AND EGRESS TO THE WORK FROM ADJACENT PRIVATE PROPERTY OWNERS...
20. FOR ANY CHANGES OR DEVIATIONS FROM THESE PLANS PROPOSED BY THE CONTRACTOR, SHOP DRAWINGS AND MATERIAL SPECIFICATIONS SHALL BE SUBMITTED TO OWNER FOR REVIEW AND APPROVAL PRIOR TO PLACEMENT OF MATERIAL...
21. CONTRACTOR MUST COORDINATE ALL CONSTRUCTION WITH THE DESIGNATED KUM & GO CONSTRUCTION PROJECT MANAGER...
22. CONTRACTOR SHALL PROTECT AND PRESERVE ALL SURVEY CONTROL AND PROPERTY MONUMENTATION...
23. PRIOR TO MOVING OFF THE JOB SITE THE CONTRACTOR SHALL NOTIFY THE OWNER OR THE OWNER'S REPRESENTATIVE TO PERFORM THE FINAL WALK-THROUGH OF THE CONSTRUCTION SITE...
24. TEMPORARY POWER, TELEPHONE, AND WATER FOR THE SITE IS THE CONTRACTOR'S RESPONSIBILITY UNLESS OTHERWISE SPECIFIED...
25. CONTRACTOR SHALL REFER TO OTHER DRAWINGS ISSUED BY ARCHITECT, STRUCTURAL, ELECTRICAL, AND MECHANICAL ENGINEERS...
26. NO BELOW GRADE WORK SHALL BE BACKFILLED (INCLUDING BEDDING MATERIAL ABOVE THE SPRING LINE OF THE PIPE) UNTIL THE CONSTRUCTION HAS BEEN INSPECTED AND APPROVED FOR BACKFILLING BY THE APPROPRIATE GOVERNING AGENCY, OWNER AND/OR OWNER'S REPRESENTATIVE.

- 27. THE CONTRACTOR SHALL PROVIDE ALL TRAFFIC CONTROL NECESSARY TO COMPLETE THE WORK...
28. IF UNANTICIPATED HAZARDOUS MATERIALS OF ANY KIND ARE ENCOUNTERED IN THE WORK, THE CONTRACTOR SHALL IMMEDIATELY CEASE ALL CONSTRUCTION OPERATIONS...
29. ALL DEBRIS RESULTING FROM CONSTRUCTION AND DEMOLITION SHALL BE HAULED OFF SITE AND DISPOSED OF PROPERLY AND LEGALLY...
30. GENERAL CONTRACTOR SHALL COORDINATE WITH POSTMASTER TO DETERMINE MAILBOX LOCATION.

SITE PLAN NOTES

- 1. DIMENSIONS SHOWN ON THE SITE PLAN ARE TO FACE OF CURB LINE IN CURBED AREAS AND EXTERIOR FACE OF BUILDING, UNLESS OTHERWISE SPECIFIED...
2. A SEPARATE SIGN APPLICATION TO THE CITY OF COLORADO SPRINGS IS REQUIRED FOR ALL SIGNS.

DEMOLITION PLAN NOTES

- 1. PRIOR TO BIDDING, CONTRACTOR SHALL VISIT THE SITE TO BECOME FAMILIAR WITH THE EXISTING CONDITIONS OF THE PROJECT AREA AND ANTICIPATED DEMOLITION REQUIREMENTS...
2. CONTRACTOR TO PROTECT ALL UTILITY, PAVING, BUILDINGS, ETC. OUTSIDE OF LIMITS OF PROPOSED CONSTRUCTION DURING DEMOLITION OPERATIONS...
3. ALL EXISTING PAVEMENT ONSITE SHALL BE REMOVED UNLESS OTHERWISE NOTED...
4. CONTRACTOR SHALL REFER TO PAVING PLAN FOR DETAILS ON LIMITS OF PAVING DEMOLITION, AND EROSION CONTROL PLAN FOR PERIMETER CONTROL...
5. ALL DEMOLITION WORK ON THIS CONSTRUCTION SITE SHALL BE IN CONFORMANCE WITH LOCAL STANDARDS AND GUIDELINES...
6. THIS DEMOLITION PLAN DEPICTS THE ANTICIPATED REMOVALS NECESSARY FOR CONSTRUCTION OF THE PROJECT...
7. CONTRACTOR SHALL COORDINATE DEMOLITION AND/OR RELOCATION OF EXISTING UTILITIES WITH THE APPROPRIATE UTILITY OWNER...
8. THE SITE MAY CONTAIN EXISTING FOOTINGS OR OTHER UNDERGROUND STRUCTURES THAT ARE NOT DEPICTED ON THIS PLAN...
9. CONTRACTOR TO COMPLETELY REMOVE TREES DESIGNATED TO BE REMOVED, STUMPS, AND ROOT SYSTEMS...
10. PRIOR TO DEMOLITION WORK, EROSION CONTROL DEVICES ARE TO BE INSTALLED...
11. ALL EXISTING UNUSED SERVICE LINES FOR WATER AND WASTEWATER SHALL BE REMOVED PER LOCAL UTILITY COMPANY STANDARDS...
12. THE CONTRACTOR IS RESPONSIBLE FOR DEMOLITION, REMOVAL, AND DISPOSING IN A MANNER APPROVED BY ALL GOVERNING AUTHORITIES...
13. DURING DEMOLITION OPERATIONS, THE CONTRACTOR MUST PROTECT THE PUBLIC AT ALL TIMES USING MEANS OF THEIR CHOICE...
14. CONTRACTOR SHALL PRESERVE ALL LANDSCAPING NOT TO BE REMOVED FOR CONSTRUCTION...
15. SAWCUTS SHALL BE TO FULL DEPTH OF EXISTING PAVEMENT.

GRADING PLAN NOTES

- 1. PRIOR TO ANY GRADING OPERATIONS, ALL EROSION AND SEDIMENT CONTROL DEVICES SHALL BE ADEQUATELY IN PLACE...
2. THE CONTOUR LINES, SPOT ELEVATIONS AND BUILDING FLOOR ELEVATIONS SHOWN ARE TO FINISH GRADE FOR SURFACE OF PAVEMENT...
3. ALL TOP OF CURB AND SIDEWALK ELEVATIONS SHALL BE 0.5' ABOVE GUTTER ELEVATIONS UNLESS OTHERWISE NOTED...
4. THE CONTRACTOR SHALL FINISH GRADE SLOPES AS SHOWN NO STEEPER THAN ONE FOOT VERTICAL IN THREE FEET HORIZONTAL...
5. CONTRACTOR SHALL GRADE LANDSCAPED AREAS TO PROVIDE POSITIVE DRAINAGE AWAY FROM BUILDINGS AND SIDEWALKS...
6. SITE AND BUILDING PAD PREPARATION, GRADING AND EXCAVATION PROCEDURES SHALL CONFORM TO THE RECOMMENDATIONS OUTLINED IN THE GEOTECHNICAL REPORT...
7. IN CASE OF ANY DISCREPANCIES REGARDING EARTHWORK BETWEEN THE GEOTECHNICAL REPORT AND THE SPECIFICATIONS SHOWN IN THESE PLANS...
8. ALL HERBACEOUS VEGETATION AND TOPSOIL SHALL BE STRIPPED TO A MINIMUM DEPTH OF 3 INCHES PER GEOTECHNICAL REPORT AND REMOVED FROM SITE OR STOCKPILED FOR LATER USE IN LANDSCAPED AREAS.

- 9. ALL EXISTING PAVEMENT, UTILITIES, BURIED DEBRIS, RUBBLE, AND/OR STRUCTURES/FOUNDATIONS ENCOUNTERED WITHIN AREAS OF DISTURBANCE SHALL BE COMPLETELY REMOVED PRIOR TO OR DURING EARTHWORK OPERATIONS...
10. THE UPPER 24" OF ALL UTILITY TRENCHES IN UNPAVED AREAS SHALL BE BACKFILLED WITH COMPACTED COHESIVE SOILS...
11. FINAL PAVEMENT SUBGRADES SHALL BE PROOFROLLED IMMEDIATELY PRIOR TO THE PLACEMENT OF THE PAVEMENT TO DETECT LOCALIZED AREAS OF INSTABILITY...
12. SUITABLE FILL MATERIALS SHALL BE PLACED IN THIN LIFTS OF 4 TO 8 INCHES LOOSE MEASUREMENT...
13. IF REQUIRED, THE CONTRACTOR SHALL OBTAIN ALL LOCAL AND STATE PERMITS AND AUTHORIZATION TO DISCHARGE FROM DEWATERING ACTIVITIES...
14. THE CONTRACTOR SHALL DEWATER ALL EXCAVATIONS AND TRENCHES AS NEEDED FOR THE CONSTRUCTION OF THE PROJECT USING MEANS/METHODS OF HIS CHOICE...
15. ALL EXCAVATIONS AND TRENCHES SHALL BE SLOPED/SHORED/BRACED FOR PROTECTION OF PERSONNEL IN ACCORDANCE WITH OSHA REGULATIONS AND AT THE CONTRACTOR'S FULL DISCRETION BASED ON THE SITE CONDITIONS.

STORMWATER MANAGEMENT AND EROSION/SEDIMENT CONTROL NOTES

- 1. THIS PROJECT REQUIRES A PERMIT FOR STORMWATER DISCHARGE ASSOCIATED WITH CONSTRUCTION ACTIVITY FROM THE STATE'S GOVERNING AUTHORITY...
2. THE CONTRACTOR SHALL CONTINUOUSLY PROVIDE ADEQUATE STORMWATER MANAGEMENT IN ACCORDANCE WITH THE APPROVED GRADING, EROSION AND SEDIMENT CONTROL REPORT...
3. THE CONTRACTOR SHALL BE RESPONSIBLE FOR KEEPING THE PUBLIC STREETS, ACCESS ROUTES, AND WATERWAYS IN THE VICINITY OF THE JOB SITE CLEAN AND FREE OF ROCKS, SOIL AND DEBRIS...
4. THE CONTRACTOR SHALL INSTALL EROSION AND SEDIMENTATION CONTROL "BEST MANAGEMENT PRACTICES" (BMPs) PRIOR TO ANY SITE PREPARATION WORK...
5. THE PLACEMENT OF EROSION AND SEDIMENT BMPs SHALL BE IN ACCORDANCE WITH THE EROSION AND SEDIMENT CONTROL PLAN PREPARED FOR THE PROJECT...
6. A GROUNDWATER DISCHARGE PERMIT MAY BE REQUIRED FROM THE STATE GOVERNING AUTHORITY PRIOR TO DISCHARGE...
7. GROUNDWATER SHALL BE SAMPLED AND SENT TO AN APPROVED LABORATORY FOR TESTING PRIOR TO BEING DISCHARGED...
8. APPROVED EROSION AND SEDIMENT CONTROL BMPs SHALL BE MAINTAINED AND KEPT IN GOOD REPAIR FOR THE DURATION OF THIS PROJECT...
9. TOPSOIL AND SUITABLE EARTHEN MATERIALS SHALL BE SEGREGATED AND STOCKPILED WITHIN THE LIMITS OF CONSTRUCTION FOR USE ON AREAS TO BE FILLED AND RE-VEGETATED...
10. SOILS THAT WILL BE STOCKPILED FOR MORE THAN THIRTY (30) DAYS SHALL BE MULCHED AND SEEDED WITH A TEMPORARY OR PERMANENT GRASS COVER WITHIN FOURTEEN (14) DAYS OF STOCKPILE CONSTRUCTION...
11. ANY SETTLEMENT OR SOIL ACCUMULATIONS BEYOND THE LIMITS OF CONSTRUCTION DUE TO GRADING OR EROSION SHALL BE REPAIRED IMMEDIATELY...
12. A WATER SOURCE MUST BE AVAILABLE ON SITE DURING EARTHWORK OPERATIONS AND UTILIZED AS REQUIRED TO MINIMIZE DUST FROM EARTHWORK EQUIPMENT AND WIND...
13. THE CONTRACTOR MUST KEEP ALL POLLUTANTS, INCLUDING SEDIMENT, CONSTRUCTION DEBRIS, AND TRENCH BACKFILL MATERIALS FROM ENTERING THE STORM SEWER SYSTEM...
14. ALL SPILLS INCLUDING, BUT NOT LIMITED TO, PETROLEUM PRODUCTS, SOLVENTS, AND CEMENT SHALL BE CLEANED UP IMMEDIATELY...
15. THE CONTRACTOR SHALL ENSURE THAT ALL LOADS OF CUT AND FILL MATERIAL IMPORTED TO OR EXPORTED FROM THE SITE SHALL BE PROPERLY COVERED TO PREVENT LOSS OF THE MATERIAL DURING TRANSPORT...
16. THE USE OF REBAR, STEEL STAKES OR STEEL FENCE POSTS FOR STAKING DOWN STRAW OR HAY BALES, OR TO SUPPORT SILT FENCING USED AS AN EROSION CONTROL MEASURE, IS PROHIBITED...
17. THE CLEANING OF CONCRETE DELIVERY TRUCK CHUTES IS RESTRICTED TO APPROVED LOCATIONS ON THE JOB SITE...
18. CONTRACTOR SHALL PROVIDE A COMPLETED "NOTICE OF TERMINATION" TO OWNER, FOR OWNERS SUBMITTAL TO THE STATE'S GOVERNING AUTHORITY ONCE THE PROJECT IS COMPLETE.

- 19. THE CONTRACTOR SHALL CLEAN OUT ALL EXISTING AND PROPOSED INLETS, PIPES AND MANHOLES OF DEBRIS AND SEDIMENTATION AT COMPLETION OF SITEWORK...
CONSTRUCTION DEBRIS OR MUD DROPPED INTO MANHOLES, INLETS, PIPES OR TRACKED ONTO EXISTING ROADWAYS SHALL BE REMOVED IMMEDIATELY BY THE CONTRACTOR.

PAVING NOTES

- 1. ALL PAVING WORK AND SUBGRADE PREPARATION/STABILIZATION SHALL CONFORM TO THE RECOMMENDATIONS OF THE GEOTECHNICAL REPORT...
2. UNLESS PROVIDED FOR IN THE PLANS, CONTRACTOR SHALL DEVELOP A CONCRETE PAVEMENT JOINTING PLAN USING THE PROPOSED PAVING PLAN AND SITE CONDITIONS...
3. ALL CONCRETE PAVEMENT AND CONSTRUCTION SHALL MEET THE CITY OF COLORADO SPRINGS AND EL PASO COUNTY STANDARDS...
4. PAVEMENT MUST HAVE A SOLAR REFLECTANCE INDEX (SRI) OF 29 OR HIGHER...
5. ALL RADIUS DIMENSIONS SHOWN ON THE PAVING PLAN ARE TO BACK OF CURB UNLESS OTHERWISE NOTED...
6. ALL PAVEMENT MARKINGS FOR PARKING STALLS SHALL BE 4" WIDE YELLOW MARKINGS, CONFORMING TO ASHTO M248 READY MIXED YELLOW TRAFFIC PAINT...
7. THE CONTRACTOR IS RESPONSIBLE FOR ENSURING THAT ALL ACCESSIBLE AREAS AND ROUTES ARE BUILT IN ACCORDANCE WITH THE PLANS AND THE "2010 ADA STANDARDS FOR ACCESSIBLE DESIGN"...
8. ADA ACCESSIBLE PARKING STALLS AND AISLES SHALL BE CONSTRUCTED WITH A MAXIMUM SLOPE OF 2.00% IN ANY DIRECTION...
9. (UNLESS RAMPS AND LANDINGS ARE PROVIDED PER ADA STANDARDS), CURB RAMPS SHALL HAVE A MAXIMUM LONGITUDINAL SLOPE OF 8.33% (12:1).

UTILITY NOTES

- 1. CONTRACTOR SHALL FIELD VERIFY ALL EXISTING UTILITIES AT PROPOSED POINTS OF CONNECTION AND CONFIRM EXACT LOCATIONS/SIZES OF ALL UTILITY SERVICE LINE HOOKUPS TO THE BUILDING (PER MEP PLANS) PRIOR TO UTILITIES CONSTRUCTION...
2. THE CONTRACTOR SHALL BE RESPONSIBLE FOR ARRANGING ONSITE MEETINGS WITH THE CITY, GOVERNING AGENCIES, AND UTILITY OWNERS PRIOR TO THE START OF ANY CONSTRUCTION OR INSTALLATION OF UTILITIES...
3. THE CONTRACTOR SHALL CONSTRUCT ALL WATER AND SANITARY SEWER SERVICE LINES AND CONNECTIONS IN ACCORDANCE WITH THE APPLICABLE STANDARDS AND SPECIFICATIONS OF THE CITY OR LOCAL UTILITY PROVIDER...
4. THE CONTRACTOR IS RESPONSIBLE FOR COORDINATING UTILITY SERVICE CONNECTIONS WITH THE APPROPRIATE UTILITY COMPANY/OWNER...
5. UTILITY TRENCHES AND STRUCTURE EXCAVATIONS ARE TO BE SLOPED OR BRACED AND SHEETED AS NECESSARY FOR THE SAFETY OF THE WORKMEN...
6. UNLESS OTHERWISE NOTED, CONTRACTOR SHALL PROVIDE TRENCHING FOR ALL UTILITY SERVICE LINES...
7. CONTRACTOR TO SET AND ADJUST ALL PROPOSED UTILITY STRUCTURES, CLEANOUTS, VALVES, METER PITS, ETC. TO FINISH GRADE...
8. THE CONTRACTOR SHALL COORDINATE WATER MAIN WORK WITH THE FIRE DEPARTMENT TO ENSURE ADEQUATE FIRE PROTECTION IS CONSTANTLY AVAILABLE TO THE SITE AND ADJACENT PROPERTIES.

STORM SEWER NOTES

- 1. STORM SEWER PIPE MATERIALS SHALL MEET THE KUM & GO STANDARD SPECIFICATIONS, UNLESS OTHERWISE SPECIFIED IN THE PLANS...
2. STORM SEWER PIPE SHALL BE BEDDED, INSTALLED, AND BACKFILLED IN ACCORDANCE WITH THE DETAILS INCLUDED IN THE PLANS...
3. ALL CAST-IN-PLACE CONCRETE DRAINAGE STRUCTURES SHALL HAVE A MINIMUM 28 DAY COMPRESSIVE STRENGTH OF 4,000 PSI...
4. SMALL DIAMETER STORM SEWER CONNECTIONS (12 INCH DIAMETER AND LESS) SHALL BE MADE WITH REDUCING WYE'S, 45 DEGREE BENDS, AND REDUCING COUPLERS...
5. ALL CAST-IN-PLACE AND PRE-FABRICATED DRAINAGE STRUCTURES WITHIN PAVED AREAS MUST BE INSTALLED TO MEET (AT A MINIMUM) ASHTO H-20/HS-20 LOAD RATING.

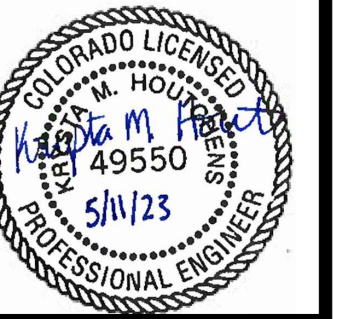

1459 Grand Ave
Des Moines, IA 50309
P: 888-458-6646

2232 - EL PASO, COLORADO
SECURITY BLVD. AND MAIN ST.
GENERAL NOTES

KG PROJECT TEAM:
RDM:
SDM:
CPM:

Table with 4 columns: REVISIONS, DATE, REVISION DESCRIPTION, and COMMENTS. Contains 4 revision entries.

DATE: 05-11-2023

SHEET NUMBER:

C0.1
2 OF 43

PCD FILE NO. PPR-2225

KUM & GO GAS & C-STORE

PART OF THE SOUTHEAST 1/4 OF SECTION 11, TOWNSHIP 15 SOUTH, RANGE 66
WEST OF THE SIXTH PRINCIPAL MERIDIAN,
COUNTY OF EL PASO, STATE OF COLORADO

MAJOR SITE DEVELOPMENT PLAN

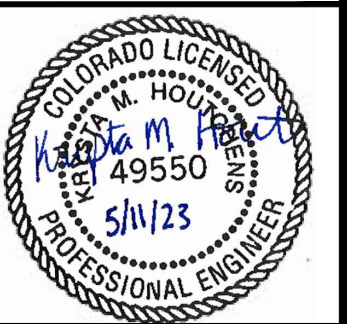
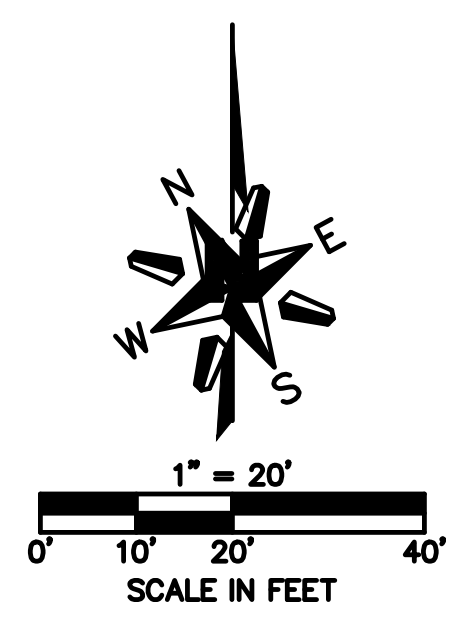

1459 Grand Ave
Des Moines, IA 50309
P: 888-458-6646

2232 - EL PASO, COLORADO
SECURITY BLVD. AND MAIN ST.
EXISTING CONDITIONS AND DEMOLITION PLAN

KG PROJECT TEAM:
RDM:
SDM:
CPM:

REVISIONS	DATE	REVISION DESCRIPTION
1	08/19/22	1ST REVIEW COMMENTS
2	01/06/23	2ND REVIEW COMMENTS
3	04/05/23	3RD REVIEW COMMENTS
4	05/11/23	4TH REVIEW COMMENTS

DATE: 05-11-2023

SHEET NUMBER:

C1.0
3 OF 43

CRITERIA PLAN 04/20/20

MATCHLINE SEE PLAN RIGHT

MATCHLINE SEE PLAN LEFT

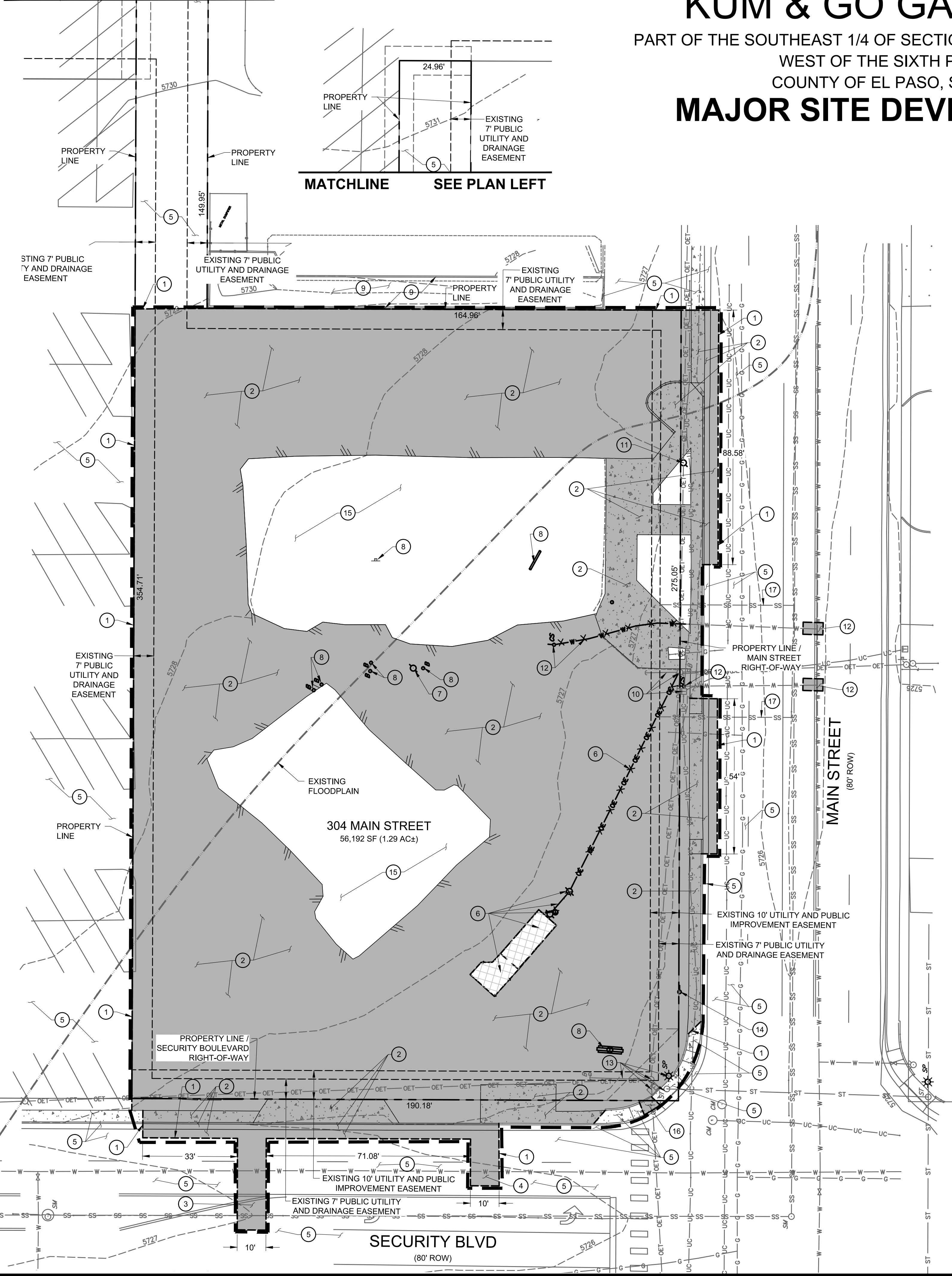

EXISTING CONDITIONS AND DEMOLITION LEGEND

	PROPOSED PROPERTY BOUNDARY
	CONSTRUCTION / DISTURBANCE LIMITS
	PROPOSED SAWCUT LINE
	EXISTING CURB AND GUTTER
	EXISTING CONCRETE SIDEWALK
	EXISTING UTILITY TO BE ABANDONED. EXISTING UTILITY TO BE REMOVED IF UNDER PROPOSED STRUCTURE, CONFLICTS WITH PROPOSED IMPROVEMENTS, OR REMOVAL IS REQUIRED BY GOVERNING JURISDICTION.
	EXISTING WATER LINE
	EXISTING SANITARY SEWER
	EXISTING STORM SEWER
	EXISTING GAS LINE
	EXISTING BURIED ELECTRIC
	EXISTING BURIED COMMUNICATION
	EX. PAVEMENT AND CURB & GUTTER TO BE REMOVED AND REPLACED PER PROPOSED SITE PLAN
	EX. STRUCTURE AND FOUNDATION TO BE REMOVED
	EXISTING UTILITY POLE
	EXISTING SANITARY MANHOLE
	EXISTING STORM INLET/MANHOLE
	EXISTING SIGN

DEMOLITION NOTES

- BUILDING PERMIT SET PREPARED UNDER SEPARATE COVER.
- ALL INITIAL BMP'S TO BE INSTALLED PRIOR TO DEMOLITION. SEE GESC PLANS UNDER SEPARATE COVER FOR BMP'S.
- CONTRACTOR TO VERIFY CONDITION OF EXISTING INFRASTRUCTURE INTENDED FOR PROPOSED C-STORE USE INCLUDING, BUT NOT LIMITED TO, STORM SEWER INFRASTRUCTURE, SANITARY SERVICE, RETAINING WALLS, AND PAVEMENT.
- CONTRACTOR TO CLEAN AND FLUSH OUT INLETS FULL OF DEBRIS.
- CONTRACTOR TO NOTIFY ENGINEER OF RECORD OF INFRASTRUCTURE REQUIRING REMOVAL OR REPAIR NOT IDENTIFIED IN THESE PLANS PRIOR TO START OF WORK.
- ALL DEMOLITION TO BE IN ACCORDANCE WITH STATE, LOCAL AND FEDERAL REQUIREMENTS.
- CONTRACTOR SHALL FOLLOW THE SECURITY WATER AND SANITATION DISTRICT RULES AND REGULATIONS (WATER SYSTEM) FOR ABANDONMENT, AND METER REMOVAL.
- ANY ABANDONED DOMESTIC OR FIRE PROTECTION SERVICE SHALL BE CUT, CAPPED, AND INSPECTED AT THE WATER DISTRICT'S DISCRETION.
- WHEN A BUILDING IS TO BECOME VACANT OR DEMOLISHED, THE WATER METER MUST BE REMOVED BY THE WATER DISTRICT. THE CUSTOMER OR OWNER WILL BE BILLED FOR ALL LOST OR DAMAGED METERS, DRAINING OF THE PLUMBING AND METER TO PREVENT DAMAGE IS NOT THE RESPONSIBILITY OF THE WATER SYSTEM.
- CONTRACTOR TO VERIFY ALL UTILITY SERVICE LOCATIONS AND EXISTING SITE CONDITIONS PRIOR TO PROCEEDING. ANY SITE CONDITIONS THAT ARE NOT AS SHOWN MUST BE REPORTED TO THE OWNER REPRESENTATIVE PRIOR TO COMMENCEMENT OF CONSTRUCTION.
- CONTRACTOR TO REMOVE OR RELOCATE EXISTING UTILITIES PER UTILITY COMPANY REQUIREMENTS. CONTRACTOR SHALL COORDINATE REMOVALS AND RELOCATIONS DIRECTLY WITH UTILITY COMPANIES PRIOR TO ANY WORK BEING PERFORMED.
- CONTRACTOR TO ERECT BARRIERS, FENCES, GUARDRAILS, ENCLOSURES, ETC. TO PROTECT THE SITE. THE PROTECTION PLAN MUST BE REVIEWED BY THE OWNER REPRESENTATIVE PRIOR TO PROCEEDING.
- OWNER REPRESENTATIVE WILL DETERMINE WHEN CONDITIONS ARE SUITABLE TO COMMENCE WORK. CONTRACTOR TO VERIFY AREAS TO BE DEMOLISHED ARE UNOCCUPIED AND NOT IN USE.
- ALL STRUCTURES, SLABS, PAVEMENT TO REMAIN UNLESS OTHERWISE NOTED.
- DISPOSE OF AND TRANSPORT DEBRIS TO AREA OBTAINED BY CONTRACTOR. DO NOT STORE OR BURN MATERIALS ON SITE.
- ALL UNDERGROUND STORM SEWER, WATER AND SANITARY SEWER MAIN LOCATIONS ARE BASED ON MAPS PROVIDED BY THE APPROPRIATE UTILITY COMPANY AND FIELD SURFACE EVIDENCE AT THE TIME OF SURVEY AND IS TO BE CONSIDERED AN APPROXIMATE LOCATION ONLY.
- ALL UNDERGROUND GAS AND ELECTRIC UTILITY INFORMATION SHOWN IS BASED ON MAPS PROVIDED BY UTILITY COMPANY AND ARE CONSIDERED AS AN APPROXIMATE LOCATION ONLY BASED ON SAID MAPS.
- CONTRACTOR TO OBTAIN ALL PERMITS AND LICENSES REQUIRED FOR DEMOLITION OF WORK SHOWN. THIS SHALL INCLUDE, BUT NOT LIMITED TO, CITY OF COLORADO SPRINGS, EL PASO COUNTY AND APPROVAL FROM ADJACENT LAND OWNERS AS NECESSARY.
- ALL UTILITIES ARE TO REMAIN UNLESS SPECIFICALLY CALLED OUT TO BE REMOVED.
- ALL CURB AND GUTTER THAT IS BEING REMOVED SHALL BE REMOVED TO A JOINT.
- ALL SITE ITEMS, UTILITIES, PAVEMENT, STRUCTURES, TREES, ETC. TO REMAIN UNLESS SPECIFIED TO BE REMOVED. PROTECT FROM DAMAGE. CONTRACTOR SHALL REPLACE DAMAGED ITEMS AT THEIR EXPENSE.
- REMOVE ALL PAVEMENT STRIPING AND RE-STRIPE IN LOCATIONS IDENTIFIED ON THE SITE PLAN.

DEMOLITION SCHEDULE:

- SAWCUT ASPHALT / CONCRETE TO FORM A CLEAN SMOOTH EDGE.
- REMOVE EXISTING ASPHALT, CONCRETE CURB & GUTTER, SIDEWALK, DRIVEWAY APRONS AND ADA RAMP. CONTRACTOR SHALL LEGALLY DISPOSE OF ALL MATERIALS OFF-SITE.
- NEW SANITARY SEWER SERVICE UTILITY TRENCH PER SECURITY WATER AND SANITATION DISTRICT. SEE UTILITY PLAN ON SHEET C5.1 FOR MORE INFORMATION.
- NEW DOMESTIC WATER SERVICE UTILITY TRENCH PER SECURITY WATER AND SANITATION DISTRICT. SEE UTILITY PLAN ON SHEET C5.1 FOR MORE INFORMATION.
- EXISTING ASPHALT, CONCRETE SIDEWALK AND CURB & GUTTER TO REMAIN AND BE PROTECTED DURING CONSTRUCTION.
- REMOVE EXISTING COFFEE SHACK, FOUNDATION, FENCE, UTILITY POLE, POWER METER, AND OVERHEAD ELECTRICAL SERVICE. CONTRACTOR SHALL COORDINATE WITH THE UTILITY PROVIDER FOR SHUT OFF OF SERVICE AND REMOVAL OF UTILITY POLE, POWER METER AND OVERHEAD POWER LINES. CONTRACTOR SHALL LEGALLY DISPOSE OF ALL MATERIALS OFF-SITE.
- REMOVE EXISTING ABANDONED UTILITY POLE. CONTRACTOR SHALL LEGALLY DISPOSE OF ALL MATERIALS OFF-SITE.
- REMOVE EXISTING SIGN AND/OR BOLLARD. CONTRACTOR SHALL LEGALLY DISPOSE OF ALL MATERIALS OFF-SITE.
- EXISTING CURB AND DRAINAGE SWALE TO REMAIN AND BE PROTECTED DURING CONSTRUCTION.
- EXISTING UTILITY POLE, GUY WIRE AND TELEPHONE VAULT TO REMAIN AND BE PROTECTED DURING CONSTRUCTION.
- EXISTING UTILITY POLE TO BE REMOVED / RELOCATED. CONTRACTOR SHALL COORDINATE WITH THE UTILITY PROVIDER FOR SCHEDULING WORK AND PAYMENT OF FEES.
- REMOVE EXISTING CURB STOPS AND WATER SERVICE LINES TO BEHIND BACK OF EXISTING CURB AND GUTTER PER SECURITY WATER AND SANITATION DISTRICT STANDARDS. THE EXISTING CORPORATION STOPS ON THE WATER MAIN WILL NEED TO BE EXCAVATED, SHUT OFF AND CAPPED. CUT THE WATER SERVICE LINES 3-FT BACK FROM THE WATER MAIN. CONTRACTOR SHALL COORDINATE WORK PERFORMED FOR WORK PERFORMED IN MAIN STREET AND SHUT DOWN OF EXISTING WATER MAIN WITH SECURITY WATER AND SANITATION DISTRICT.
- EXISTING UTILITY POLE, GUY WIRE, STREET LIGHT POLE, ELECTRICAL VAULT AND STORM SEWER INLET TO REMAIN AND BE PROTECTED DURING CONSTRUCTION.
- REMOVE SIGN AND LEGALLY DISPOSE OF OFF-SITE.
- EXISTING GRAVEL TO BE REMOVED.
- REMOVE EAST WING OF EXISTING ADA RAMP AND CURB AT BACK OF EXISTING RAMP FOR THE LENGTH OF RAMP. CONTRACTOR SHALL REPLACE IN-KIND.
- EXISTING SANITARY SEWER SERVICES TO BE ABANDONED TO SECURITY SANITATION DISTRICT SPECIFICATIONS.

NOTE:
A WORK-IN-ROW PERMIT IS REQUIRED FOR WORK BEING PERFORMED WITHIN BOTH MAIN STREET AND SECURITY BOULEVARD RIGHT-OF-WAY. 5 BUSINESS DAYS REQUIRED FOR EL PASO COUNTY PUBLIC WORKS PROCESSING.

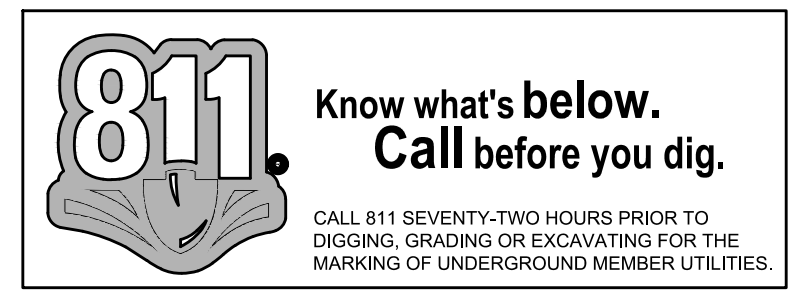

P:\KUM & GO\CO. EL PASO COUNTY - 2232 MAIN AND SECURITY\08 CAD\SDP\2225 - 03 - EXIST-DEMOL.DWG

PCD FILE NO. PPR-2225

MATCHLINE SEE PLAN RIGHT

KUM & GO GAS & C-STORE

PART OF THE SOUTHEAST 1/4 OF SECTION 11, TOWNSHIP 15 SOUTH, RANGE 66
WEST OF THE SIXTH PRINCIPAL MERIDIAN,
COUNTY OF EL PASO, STATE OF COLORADO

MAJOR SITE DEVELOPMENT PLAN

NOTE:
A WORK-IN-ROW PERMIT IS REQUIRED FOR WORK BEING PERFORMED WITHIN BOTH MAIN STREET AND SECURITY BOULEVARD RIGHT-OF-WAY. 5 BUSINESS DAYS REQUIRED FOR EL PASO COUNTY PUBLIC WORKS PROCESSING.

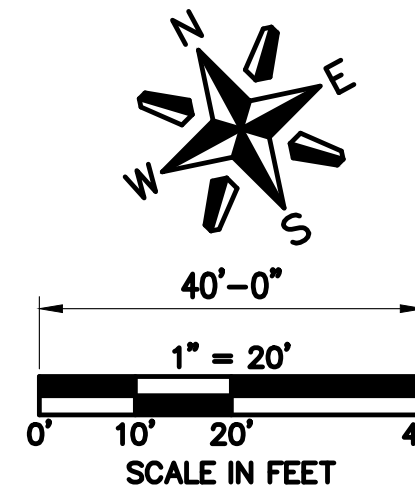

SITE PLAN LEGEND

- OET --- OET --- OET --- OET --- OET --- EXISTING OVERHEAD ELECTRICAL AND TELECOMMUNICATIONS
- - - - - PROPERTY BOUNDARY
- - - - - EXISTING EASEMENT
- - - - - CONSTRUCTION / DISTURBANCE LIMITS
- - - - - EXISTING FLOODPLAIN
- - - - - EXISTING CURB & GUTTER
- - - - - PROPOSED INTEGRAL CURB
- - - - - PROPOSED CURB & GUTTER
- - - - - PROPOSED CONCRETE SIDEWALK
- - - - - PROPOSED BUILDING
- - - - - PROPOSED RETAINING WALL
- - - - - PROPOSED ADA ROUTE
- ⊙ EXISTING STORM SEWER MANHOLE/INLET
- ⊙ PROPOSED STORM SEWER MANHOLE/INLET
- ☀ EXISTING STREET LIGHTING
- ☀ EXISTING FIRE HYDRANT
- ☀ EXISTING SIGNAGE
- ☀ PROPOSED SITE LIGHTING
- ⬢ PROPOSED PARKING COUNT

GENERAL NOTES:

1. ALL ITEMS IN SCHEDULE ARE PROPOSED UNLESS NOTED OTHERWISE.
2. CONTRACTOR TO COORDINATE WITH CENTURY LINK PRIOR TO AND DURING CONSTRUCTION.
3. AMERICANS WITH DISABILITIES ACT (ADA) SITE ACCESSIBILITY (EL PASO LAND DEVELOPMENT CODE 6.1.3)
 - (A) COMPLIANCE WITH THE ADA AND OTHER FEDERAL AND STATE ACCESSIBILITY LAWS IS THE SOLE RESPONSIBILITY OF THE PROPERTY OWNER. THEREFORE, COMPLIANCE WITH THIS CODE DOES NOT ASSURE COMPLIANCE WITH ADA OR ANY OTHER FEDERAL OR STATE ACCESSIBILITY LAWS OR ANY OTHER REGULATIONS OR GUIDELINES ENACTED OR PROMULGATED UNDER OR WITH RESPECT TO SUCH LAWS. EL PASO COUNTY IS NOT RESPONSIBLE FOR ENFORCEMENT OF THE ADA OR ANY OTHER FEDERAL OR STATE ACCESSIBILITY LAWS. (B) NOTES ON SITE DEVELOPMENT PLAN OR NON-RESIDENTIAL SITE PLAN. THE FOLLOWING NOTE SHOULD BE ADDED TO ALL SITE DEVELOPMENT PLANS OR NON-RESIDENTIAL SITE PLANS, AS APPLICABLE, PRIOR TO PCD APPROVAL:
 - (B) THE PARTIES RESPONSIBLE FOR THIS PLAN HAVE FAMILIARIZED THEMSELVES WITH ALL CURRENT ACCESSIBILITY CRITERIA AND SPECIFICATIONS AND THE PROPOSED PLAN REFLECTS ALL SITE ELEMENTS REQUIRED BY THE APPLICABLE ADA DESIGN STANDARDS AND GUIDELINES AS PUBLISHED BY THE UNITED STATES DEPARTMENT OF JUSTICE. APPROVAL OF THIS PLAN BY EL PASO COUNTY DOES NOT ASSURE COMPLIANCE WITH THE ADA OR ANY REGULATIONS OR GUIDELINES ENACTED OR PROMULGATED UNDER OR WITH RESPECT TO SUCH LAWS.
 - (C) ILLUSTRATED ON SITE DEVELOPMENT PLAN OR NON-RESIDENTIAL SITE PLAN. EACH SITE DEVELOPMENT PLAN OR NON-RESIDENTIAL SITE PLAN SUBMITTED TO EL PASO COUNTY SHALL CLEARLY ILLUSTRATE AND IDENTIFY THE PROVISION OF ADA ACCESSIBLE EXTERIOR ROUTES IN ACCORDANCE WITH THE APPLICABLE ADA DESIGN STANDARDS AND GUIDELINES AS PUBLISHED BY THE UNITED STATES DEPARTMENT OF JUSTICE.

SITE SCHEDULE:

- 1 BUILDING ENTRY, REFER TO ARCHITECTURAL PLANS.
- 2 PROPANE CAGE (9' X 9', 4" CONCRETE PAD, 1.5% SLOPE AWAY FROM SIDE WALL OF BUILDING).
- 3 MISCELLANEOUS MERCHANDISE.
- 4 FIREWOOD.
- 5 NOT USED.
- 6 ICE MERCHANDISER.
- 7 8" CONCRETE PAN.
- 8 SINGLE WAVE/U-SHAPED BIKE RACK ON 5.0' x 6.5' x 4" THICK CONCRETE PAD (5 BIKE SPACES PROVIDED). REFER TO DETAIL ON SHEET C6.1 FOR MORE INFORMATION.
- 9 FUELING CANOPY. SEE PETROLEUM PLANS FOR MORE INFORMATION.
- 10A 4" CONCRETE SITE SIDEWALK. (REFERENCE ARCHITECTURAL DRAWINGS FOR CONTROL JOINT PLAN).
- 10B 4" CONCRETE SITE SIDEWALK, 1.5% MAX. CROSS SLOPE. (REFERENCE ARCHITECTURAL DRAWINGS FOR CONTROL JOINT PLAN).
- 10C BUILDING CONCRETE SIDEWALK, 1.5% MAX. CROSS SLOPE. (REFERENCE ARCHITECTURAL DRAWINGS FOR CONTROL JOINT PLAN).
- 10D BUILDING CONCRETE SIDEWALK ADJACENT TO LANDSCAPE, 1.5% MAX. CROSS SLOPE. (REFERENCE ARCHITECTURAL DRAWINGS FOR CONTROL JOINT PLAN).
- 11 STANDARD DUTY CONCRETE PAVEMENT. (REFERENCE GEOTECHNICAL ENGINEERING REPORT)
- 12 4" WIDE WHITE PAVEMENT MARKING, TYP.
- 13 1" WIDE X 6" MAX. HEIGHT CONCRETE RETAINING WALL WITH HAND RAILING CENTERED ON WALL. REFER TO STRUCTURAL PLANS UNDER SEPARATE COVER.
- 14 BOLLARD MOUNTED ADA VAN PARKING SIGN. REFER TO DETAIL ON SHEET C6.1 FOR MORE INFORMATION.
- 15 ACCESSIBLE PARKING SPACE. REFER TO DETAIL ON SHEET C6.2 FOR MORE INFORMATION.
- 16 PEDESTRIAN CURB RAMP PER EL PASO COUNTY DEPARTMENT OF PUBLIC WORKS STANDARD DETAIL ON SHEET C6.3.
- 17 AIR MACHINE LOCATION, 4'X4' CONCRETE PAD. KEEP AT LEAST 80" AWAY FROM DISPENSERS AND TANK FULL PORTS. REFER TO DETAIL ON SHEET C6.1 FOR MORE INFORMATION.
- 18 20' TALL MONUMENT SIGN. REFER TO SEPARATE SIGNAGE PERMIT UNDER SEPARATE COVER.
- 19 EXISTING 100-YR FLOODPLAIN.
- 20 STOP SIGN. REFER TO DETAIL ON SHEET C6.1 FOR MORE INFORMATION
- 21 14'-8" X24'-8" TRASH ENCLOSURE. (REFER TO ARCHITECTURAL PLANS).
- 22 55'X25' MINIMUM GARBAGE TRUCK CLEAR SPACE
- 23 UNDERGROUND FUEL STORAGE TANKS. (REFER TO PETROLEUM PLANS).
- 24 TANK OVERDIG LIMITS, WITH APPROVED BACKFILL.
- 25 ADA ROUTE. SEE GRADING PLAN ON SHEET C2.1 FOR MORE INFORMATION.
- 26 12'X60' LOADING ZONE, 45' CROSS HATCH, 2' O.C. STRIPING.
- 27 INTEGRAL CONCRETE CURB. REFER TO DETAIL ON SHEET C6.2 FOR MORE INFORMATION.
- 28 4" DIAMETER BOLLARDS @ 5' O.C. REFER TO DETAIL ON SHEET C6.1 FOR MORE INFORMATION.
- 29 BROOM FINISH COLORED CONCRETE PAVEMENT. REFER TO DETAIL ON SHEET C6.3 FOR MORE INFORMATION.
- 30 ELECTRICAL TRANSFORMER LOCATION.
- 31 PAINT CURB ALONG FRONT OF TANKS YELLOW.
- 32 DRIVEWAY ENTRANCE PAVEMENT MARKINGS. REFER TO DETAIL ON SHEET C6.2 FOR MORE INFORMATION.
- 33 NOT USED.
- 34 CONCRETE CURB AND GUTTER PER EL PASO COUNTY PUBLIC WORKS STANDARD DETAIL ON SHEET C6.1.
- 35 APPROXIMATE LOCATION OF SITE LIGHTING. REFER TO PHOTOMETRICS SHEET FOR LOCATION AND DETAILS.
- 36 EXISTING CURB AND GUTTER TO REMAIN.
- 37 EXISTING SIDEWALK TO REMAIN.
- 38 EXISTING ADA RAMP TO REMAIN.
- 39 EXISTING STREET LIGHT TO REMAIN.
- 40 EXISTING STORM INLET TO REMAIN.
- 41 EXISTING FIRE HYDRANT TO REMAIN.
- 42 EXISTING WATER VALVE TO REMAIN.
- 43 EXISTING SEWER MANHOLE TO REMAIN.
- 44 EXISTING OVERHEAD UTILITIES AND POLES TO REMAIN.
- 45 EXISTING ROAD STRIPING TO REMAIN.
- 46 EXISTING DRIVEWAY TO REMAIN.
- 47 EXISTING ASPHALT TO REMAIN.
- 48 EXISTING PARKING STRIPING TO REMAIN.
- 49 PATCH BACK SECURITY BOULEVARD AND MAIN STREET ASPHALT ROAD SECTION TO MATCH EXISTING SECTION PER EL PASO COUNTY STANDARDS.
- 50 SITE ENTRANCE CROSS PAN LAYOUT PER EL PASO COUNTY DEPARTMENT OF TRANSPORTATION DETAIL ON SHEET C6.3.
- 51 RAMP AND HANDRAIL. REFER TO DETAIL ON SHEET C6.2 FOR MORE INFORMATION.
- 52 CONCRETE CURB ISLAND (REFERENCE ARCHITECTURAL DRAWINGS FOR CONTROL JOINT PLAN).

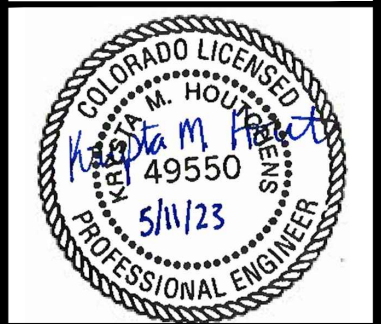
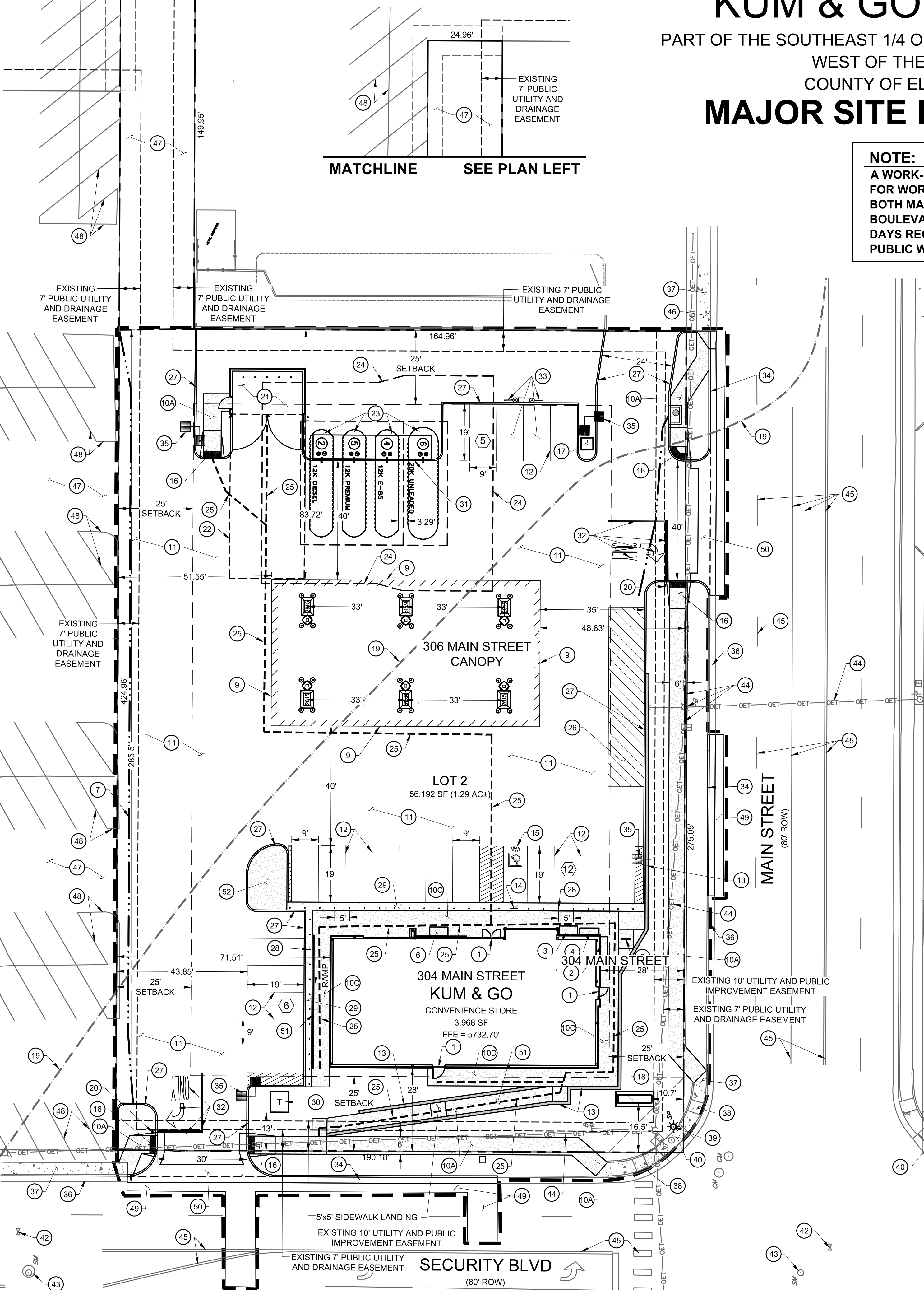

1459 Grand Ave
Des Moines, IA 50309
P: 888-458-6646

2232 - EL PASO, COLORADO
SECURITY BLVD. AND MAIN ST.
SITE PLAN

KG PROJECT TEAM:
RDM:
SDM:
CPM:

REVISION	DATE	REVISION DESCRIPTION
1	08/18/22	1ST REVIEW COMMENTS
2	01/06/23	2ND REVIEW COMMENTS
3	04/05/23	3RD REVIEW COMMENTS
4	05/11/23	4TH REVIEW COMMENTS

DATE: 05-11-2023

SHEET NUMBER:

PCD FILE NO. PPR-2225

C1.1
4 OF 43

P:\KUM & GO\CO. EL PASO COUNTY - 2232 MAIN AND SECURITY\08 CAD\SPR\2225-04 - SITE PLAN.DWG

MATCHLINE SEE PLAN RIGHT

KUM & GO GAS & C-STORE

PART OF THE SOUTHEAST 1/4 OF SECTION 11, TOWNSHIP 15 SOUTH, RANGE 66
WEST OF THE SIXTH PRINCIPAL MERIDIAN,
COUNTY OF EL PASO, STATE OF COLORADO

MAJOR SITE DEVELOPMENT PLAN

MATCHLINE SEE PLAN LEFT

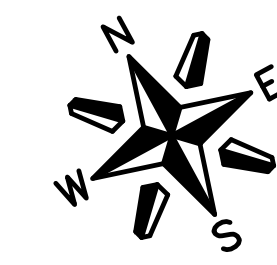
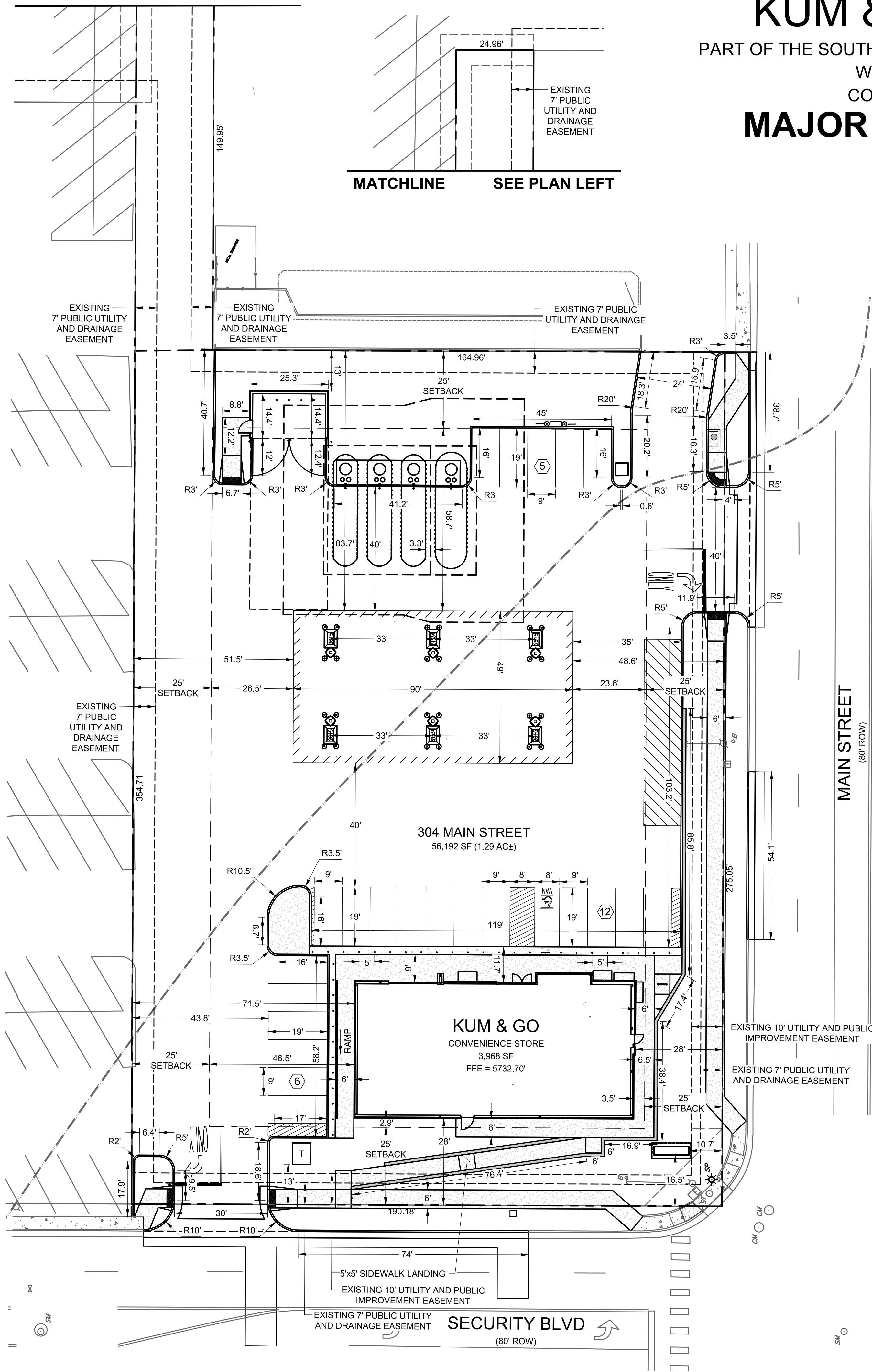

1" = 20'
SCALE IN FEET

SITE PLAN LEGEND

- PROPERTY BOUNDARY
- EXISTING EASEMENT
- EXISTING CURB & GUTTER
- EXISTING FLOODPLAIN
- PROPOSED INTEGRAL CURB
- PROPOSED CURB & GUTTER
- PROPOSED BUILDING
- PROPOSED TRASH ENCLOSURE, PARKING AREA AND DRIVE AISLES
STANDARD CONCRETE PAVEMENT (SEE DETAIL SHEET)
- PROPOSED CONCRETE SIDEWALK

HORIZONTAL CONTROL NOTES:

1. ALL DIMENSIONS ARE TO FLOWLINE UNLESS OTHERWISE NOTED.
2. THE CONTRACTOR SHALL OBTAIN THE LATEST CAD FILE OF SITE IMPROVEMENTS FROM THE ENGINEER OF RECORD FOR HORIZONTAL AND VERTICAL SURVEY CONTROL PRIOR TO CONSTRUCTION. CONTRACTOR TO VERIFY WITH ENGINEER OF RECORD ANY DISCREPANCIES BETWEEN THE CAD FILES AND CONSTRUCTION PLANS PRIOR TO INSTALLATION OF PLAN IMPROVEMENTS.
3. SEE ARCHITECTURAL PLANS FOR BUILDING DIMENSIONS.

TRASH ENCLOSURE AND PAVEMENT SECTIONS:

SITE PARKING AND DRIVE AREAS - STANDARD DUTY CONCRETE PAVEMENT
A = 6" CONCRETE PAVEMENT
B = 4" AGGREGATE BASE
C = 12" PREPARED SUBGRADE

NOTE:

PAVEMENT SECTIONS PER GEOTECHNICAL ENGINEERING SERVICES REPORT, PREPARED BY OLSSON, PROJECT NO. 021-05598, DATED 12-07-2021 AND ANY ADDENDUMS.

SOIL PREPARATION NOTE:

SOIL PREPARATION SHALL BE PER RECOMMENDATIONS FROM A GEOTECHNICAL ENGINEERING REPORT PREPARED FOR THIS SITE AS FOLLOWS

GEOTECHNICAL ENGINEER: OLSSON
REPORT NO. 021-05598

THE CONTRACTOR MUST FULLY REVIEW THIS REPORT PRIOR TO CONSTRUCTION INFORMATION IN THE GEOTECHNICAL REPORT SUPERSEDES ANY CONFLICTING INFORMATION CONTAINED IN THE CONSTRUCTION PLANS AND SPECIFICATIONS.

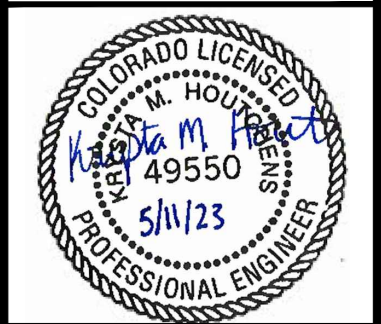

1459 Grand Ave
Des Moines, IA 50309
P: 888-458-6646

2232 - EL PASO, COLORADO
SECURITY BLVD. AND MAIN ST.
HORIZONTAL CONTROL, PAVING
AND SIGNAGE PLAN

KG PROJECT TEAM:
RDM:
SDM:
CPM:

NO.	DATE	REVISION DESCRIPTION
1	08/18/22	1ST REVIEW COMMENTS
2	01/06/23	2ND REVIEW COMMENTS
3	04/05/23	3RD REVIEW COMMENTS
4	05/11/23	4TH REVIEW COMMENTS

DATE: 05-11-2023

SHEET NUMBER:

C1.2
5 OF 43

PCD FILE NO. PPR-2225

PKUM & GO/CO. EL PASO COUNTY. 2232 MAIN AND SECURITY/08 CAD/SDP/2225 - 05 - HORIZONTAL CONTROL PLAN.DWG

GRADING NOTES:

1. NO WORK IS TO BEGIN UNTIL ALL PERMITS HAVE BEEN OBTAINED.
2. FINAL GRADES ARE SUBJECT TO MINOR CHANGE BY CONTRACTOR. NO GRADE CHANGES IN EXCESS OF 0.05' WITHOUT ENGINEER APPROVAL.
3. ANY FILL MATERIAL REQUIRED TO BRING THE SITE TO GRADE SHALL BE CLEAN FILL APPROVED BY GEOTECHNICAL ENGINEER. SEE "SOIL PREPARATION NOTE" THIS SHEET.
4. GENERAL CONTRACTOR SHALL BE RESPONSIBLE FOR MINIMIZING DEPOSITION OF ONSITE SEDIMENTS ONTO SURROUNDING PUBLIC STREETS DURING CONSTRUCTION.
5. SEE THE SITE SURVEY FOR SURVEY INFORMATION.
6. GRADES SHOWN ARE FLOWLINE UNLESS OTHERWISE NOTED.
7. GUTTER GRADES SHALL BE A MINIMUM 0.50%.
8. CONTRACTOR TO ENSURE SMOOTH TRANSITION BETWEEN PRIVATE DRIVE AND TRASH ENCLOSURE.
9. RETAINING WALL HEIGHTS AND GRADES SHOWN ARE FROM FINISHED GRADE AT TOP OF WALL TO FINISHED GRADE AT BOTTOM OF WALL AND DO NOT INCORPORATE FOOTING DEPTH OR WALL HEIGHT ABOVE FINISHED GRADE. REFER TO STRUCTURAL PLANS UNDER SEPARATE COVER.

KUM & GO GAS & C-STORE

PART OF THE SOUTHEAST 1/4 OF SECTION 11, TOWNSHIP 15 SOUTH, RANGE 66
WEST OF THE SIXTH PRINCIPAL MERIDIAN,
COUNTY OF EL PASO, STATE OF COLORADO

MAJOR SITE DEVELOPMENT PLAN

STANDARD NOTES FOR EL PASO COUNTY CONSTRUCTION PLANS

1. ALL DRAINAGE AND ROADWAY CONSTRUCTION SHALL MEET THE STANDARDS AND SPECIFICATIONS OF THE CITY OF COLORADO SPRINGS/EL PASO COUNTY DRAINAGE CRITERIA MANUAL, VOLUMES 1 AND 2, AND THE EL PASO COUNTY ENGINEERING CRITERIA MANUAL.
2. CONTRACTOR SHALL BE RESPONSIBLE FOR THE NOTIFICATION AND FIELD NOTIFICATION OF ALL EXISTING UTILITIES, WHETHER SHOWN ON THE PLANS OR NOT, BEFORE BEGINNING CONSTRUCTION. LOCATION OF EXISTING UTILITIES SHALL BE VERIFIED BY THE CONTRACTOR PRIOR TO CONSTRUCTION. CALL 811 TO CONTACT THE UTILITY NOTIFICATION CENTER OF COLORADO (UNCC).
3. CONTRACTOR SHALL KEEP A COPY OF THESE APPROVED PLANS, THE GRADING AND EROSION CONTROL PLAN, THE STORMWATER MANAGEMENT PLAN (SWMP), THE SOILS AND GEOTECHNICAL REPORT, AND THE APPROPRIATE DESIGN AND CONSTRUCTION STANDARDS AND SPECIFICATIONS AT THE JOB SITE AT ALL TIMES, INCLUDING THE FOLLOWING:
 - a. EL PASO COUNTY ENGINEERING CRITERIA MANUAL (ECM)
 - b. CITY OF COLORADO SPRINGS/EL PASO COUNTY DRAINAGE CRITERIA MANUAL, VOLUMES 1 AND 2
 - c. COLORADO DEPARTMENT OF TRANSPORTATION (CDOT) STANDARD SPECIFICATIONS FOR ROAD AND BRIDGE CONSTRUCTION
 - d. CDOT M & S STANDARDS
4. NOTWITHSTANDING ANYTHING DEPICTED IN THESE PLANS IN WORDS OR GRAPHIC REPRESENTATION, ALL DESIGN AND CONSTRUCTION RELATED TO ROADS, STORM DRAINAGE AND EROSION CONTROL SHALL CONFORM TO THE STANDARDS AND REQUIREMENTS OF THE MOST RECENT VERSION OF THE RELEVANT ADOPTED EL PASO COUNTY STANDARDS, INCLUDING THE LAND DEVELOPMENT CODE, THE ENGINEERING CRITERIA MANUAL, THE DRAINAGE CRITERIA MANUAL, AND THE DRAINAGE CRITERIA MANUAL VOLUME 2. ANY DEVIATIONS FROM REGULATIONS AND STANDARDS MUST BE REQUESTED, AND APPROVED, IN WRITING. ANY MODIFICATIONS NECESSARY TO MEET CRITERIA AFTER-FACT WILL BE ENTIRELY THE DEVELOPER'S RESPONSIBILITY TO RECTIFY.
5. IT IS THE DESIGN ENGINEER'S RESPONSIBILITY TO ACCURATELY SHOW EXISTING CONDITIONS, BOTH ONSITE AND OFFSITE, ON THE CONSTRUCTION PLANS. ANY MODIFICATIONS NECESSARY DUE TO CONFLICTS, OMISSIONS, OR CHANGED CONDITIONS WILL BE ENTIRELY THE DEVELOPER'S RESPONSIBILITY TO RECTIFY.
6. CONTRACTOR SHALL SCHEDULE A PRE-CONSTRUCTION MEETING WITH EL PASO COUNTY PLANNING AND COMMUNITY DEVELOPMENT (PCD) - INSPECTIONS, PRIOR TO STARTING CONSTRUCTION.
7. IT IS THE CONTRACTOR'S RESPONSIBILITY TO UNDERSTAND THE REQUIREMENTS OF ALL JURISDICTIONAL AGENCIES AND TO OBTAIN ALL REQUIRED PERMITS, INCLUDING BUT NOT LIMITED TO EL PASO COUNTY EROSION AND STORMWATER QUALITY CONTROL PERMIT (ESQCP), REGIONAL BUILDING FLOODPLAIN DEVELOPMENT PERMIT, U.S. ARMY CORPS OF ENGINEERS-ISSUED 401 AND/OR 404 PERMITS, AND COUNTY AND STATE FUGITIVE DUST PERMITS.
8. CONTRACTOR SHALL NOT DEVIATE FROM THE PLANS WITHOUT FIRST OBTAINING WRITTEN APPROVAL FROM THE DESIGN ENGINEER AND PCD. CONTRACTOR SHALL NOTIFY THE DESIGN ENGINEER IMMEDIATELY UPON DISCOVERY OF ANY ERRORS OR INCONSISTENCIES.
9. ALL STORM DRAIN PIPE SHALL BE CLASS III RCP UNLESS OTHERWISE NOTED AND APPROVED BY PCD.
10. CONTRACTOR SHALL COORDINATE GEOTECHNICAL TESTING PER ECM STANDARDS. PAVEMENT DESIGN SHALL BE APPROVED BY EL PASO COUNTY PCD PRIOR TO PLACEMENT OF CURB AND GUTTER AND PAVEMENT.
11. ALL CONSTRUCTION TRAFFIC MUST ENTER/EXIT THE SITE AT APPROVED CONSTRUCTION ACCESS POINTS.
12. SIGHT VISIBILITY TRIANGLES AS IDENTIFIED IN THE PLANS SHALL BE PROVIDED AT ALL INTERSECTIONS. OBSTRUCTIONS GREATER THAN 18 INCHES ABOVE FLOWLINE ARE NOT ALLOWED WITHIN SIGHT TRIANGLES.
13. SIGNING AND STRIPING SHALL COMPLY WITH EL PASO COUNTY DOT AND MUTCD CRITERIA. [IF APPLICABLE, ADDITIONAL SIGNING AND STRIPING NOTES WILL BE PROVIDED.]
14. CONTRACTOR SHALL OBTAIN ANY PERMITS REQUIRED BY EL PASO COUNTY DOT, INCLUDING WORK WITHIN THE RIGHT-OF-WAY AND SPECIAL TRANSPORT PERMITS.
15. THE LIMITS OF CONSTRUCTION SHALL REMAIN WITHIN THE PROPERTY LINE UNLESS OTHERWISE NOTED. THE OWNER/DEVELOPER SHALL OBTAIN WRITTEN PERMISSION AND EASEMENTS, WHERE REQUIRED, FROM ADJOINING PROPERTY OWNER(S) PRIOR TO ANY OFF-SITE DISTURBANCE, GRADING, OR CONSTRUCTION.

BENCHMARK:

ELEVATIONS ARE BASED UPON COLORADO SPRINGS UTILITIES FIMS CONTROL MONUMENT SE09, BEING A 2-INCH DIAMETER ALUMINUM CAP STAMPED "CSU FIMS CONTROL SE09" ON THE EAST CORNER OF THE CONCRETE BASE OF A TELEPHONE RELAY BOX AT THE EAST CORNER OF 226 MAIN STREET, ABOUT 3 FEET NORTHWEST OF THE NORTHWEST CURB OF MAIN STREET, AND ABOUT 205 FEET SOUTHWEST OF THE SOUTHWEST CURB LINE OF SECURITY BOULEVARD. CITY ELEVATION: 5726.76 (NGVD 29)

SOIL PREPARATION NOTE:

SOIL PREPARATION SHALL BE PER RECOMMENDATIONS FROM A GEOTECHNICAL ENGINEERING REPORT PREPARED FOR THIS SITE AS FOLLOWS

GEOTECHNICAL ENGINEER: OLSSON
REPORT NO. 021-05598

THE CONTRACTOR MUST FULLY REVIEW THIS REPORT PRIOR TO CONSTRUCTION INFORMATION IN THE GEOTECHNICAL REPORT SUPERSEDES ANY CONFLICTING INFORMATION CONTAINED IN THE CONSTRUCTION PLANS AND SPECIFICATIONS.

GRADING QUANTITIES	
CUT*	77 CY
FILL*	4,035 CY
NET*	4,035 CY (FILL)

*QUANTITIES ARE RAW VALUES FROM EXISTING GRADE TO FINISHED GRADE AND DO NOT ACCOMMODATE ANY PAVEMENT SECTIONS, OVEREXCAVATION OR UTILITY TRENCHING.

GRADING PLAN LEGEND

— G — G — G — G — G — G —	EXISTING GAS	— · · · · · —	PROPOSED SURFACE FLOW LINE
— SS — SS — SS — SS — SS —	EXISTING SANITARY SEWER	— — — — —	PROPOSED ADA ROUTE
— OET — OET — OET — OET — OET —	EXISTING OVERHEAD ELECTRICAL AND TELECOMMUNICATIONS	— — — — —	PROPOSED RETAINING WALL
— UC — UC — UC — UC — UC —	EXISTING UNDERGROUND TELECOMMUNICATIONS	— — — — —	PROPOSED STORM SEWER
— W — W — W — W — W — W —	EXISTING WATER	⊙ ⊙	EXISTING STORM SEWER MANHOLE/INLET
— — — — —	CONSTRUCTION / DISTURBANCE LIMITS	⊙ ⊙	PROPOSED STORM SEWER MANHOLE/INLET
— — — — —	PROPERTY BOUNDARY	☀	EXISTING STREET LIGHTING
— — — — —	EXISTING EASEMENT	⊕	EXISTING FIRE HYDRANT
— — — — —	EXISTING FLOODPLAIN	⊕	EXISTING SIGNAGE
— — — — —	EXISTING CURB & GUTTER	— — — — —	PROPOSED SITE LIGHTING
— — — — —	EXISTING MAJOR CONTOUR	— — — — —	PROPOSED SURFACE FLOW DIRECTION ARROW
— — — — —	EXISTING MINOR CONTOUR	4727.21 →	PROPOSED ELEVATION AT FLOW LINE
— — — — —	PROPOSED MAJOR CONTOUR	4727.21 SW →	PROPOSED EXTERIOR GRADE AT FOUNDATION
— — — — —	PROPOSED MINOR CONTOUR	4727.21 ME →	PROPOSED SIDEWALK ELEVATION
— — — — —	PROPOSED INTEGRAL CURB	4727.21 FG →	PROPOSED GRADE TO MATCH EXISTING
— — — — —	PROPOSED CURB & GUTTER	4727.21 TW →	PROPOSED FINISHED GRADE
— — — — —	PROPOSED BUILDING	4727.21 BW →	PROPOSED TOP OF WALL GRADE
			PROPOSED FINISHED GRADE AT BOTTOM OF WALL

NOTE:

A WORK-IN-ROW PERMIT IS REQUIRED FOR WORK BEING PERFORMED WITHIN MAIN STREET AND SECURITY BOULEVARD RIGHT-OF-WAY. 5 BUSINESS DAYS REQUIRED FOR EL PASO COUNTY PUBLIC WORKS PROCESSING.

STORM SEWER NOTE:

SEE SHEET C4.1 FOR ALL STORM SEWER PIPING AND STRUCTURE DESIGN INFORMATION.

VEGETATION NOTE:

NO NOTABLE VEGETATION ON-SITE. SITE CONSISTS OF MOSTLY ASPHALT, CONCRETE, CURB & GUTTER AND DIRT AREAS.

811 Know what's below. Call before you dig.
CALL 811 SEVENTY-TWO HOURS PRIOR TO DIGGING, GRADING OR EXCAVATING FOR THE MARKING OF UNDERGROUND MEMBER UTILITIES.

EES ENGINEERING AND ENVIRONMENTAL SOLUTIONS, INC.
3901 E. Florida Avenue, Suite 425
Denver, CO 80210
303.572.1997 www.ees.us.com

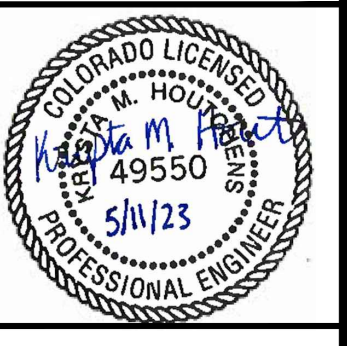

1459 Grand Ave
Des Moines, IA 50309
P: 888-458-6646

2232 - EL PASO, COLORADO
SECURITY BLVD. AND MAIN ST.
GRADING PLAN

KG PROJECT TEAM:
RDM:
SDM:
CPM:

REVISIONS	REVISION DESCRIPTION	DATE
1	1ST REVIEW COMMENTS	08/19/22
2	2ND REVIEW COMMENTS	01/06/23
3	3RD REVIEW COMMENTS	04/05/23
4	4TH REVIEW COMMENTS	05/11/23

DATE: 05-11-2023
SHEET NUMBER: C2.1 OF 43

PCD FILE NO. PPR-2225

KUM & GO GAS & C-STORE

PART OF THE SOUTHEAST 1/4 OF SECTION 11, TOWNSHIP 15 SOUTH, RANGE 66
WEST OF THE SIXTH PRINCIPAL MERIDIAN,
COUNTY OF EL PASO, STATE OF COLORADO

MAJOR SITE DEVELOPMENT PLAN

SEE SHEET 8

SEE SHEET 8

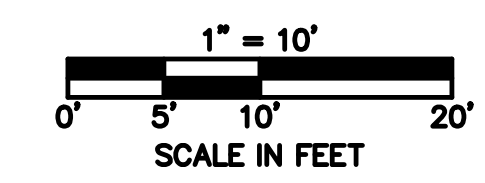
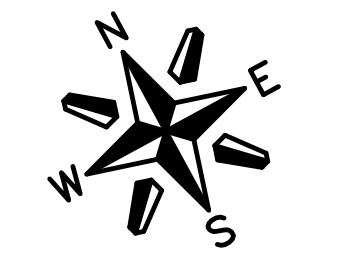
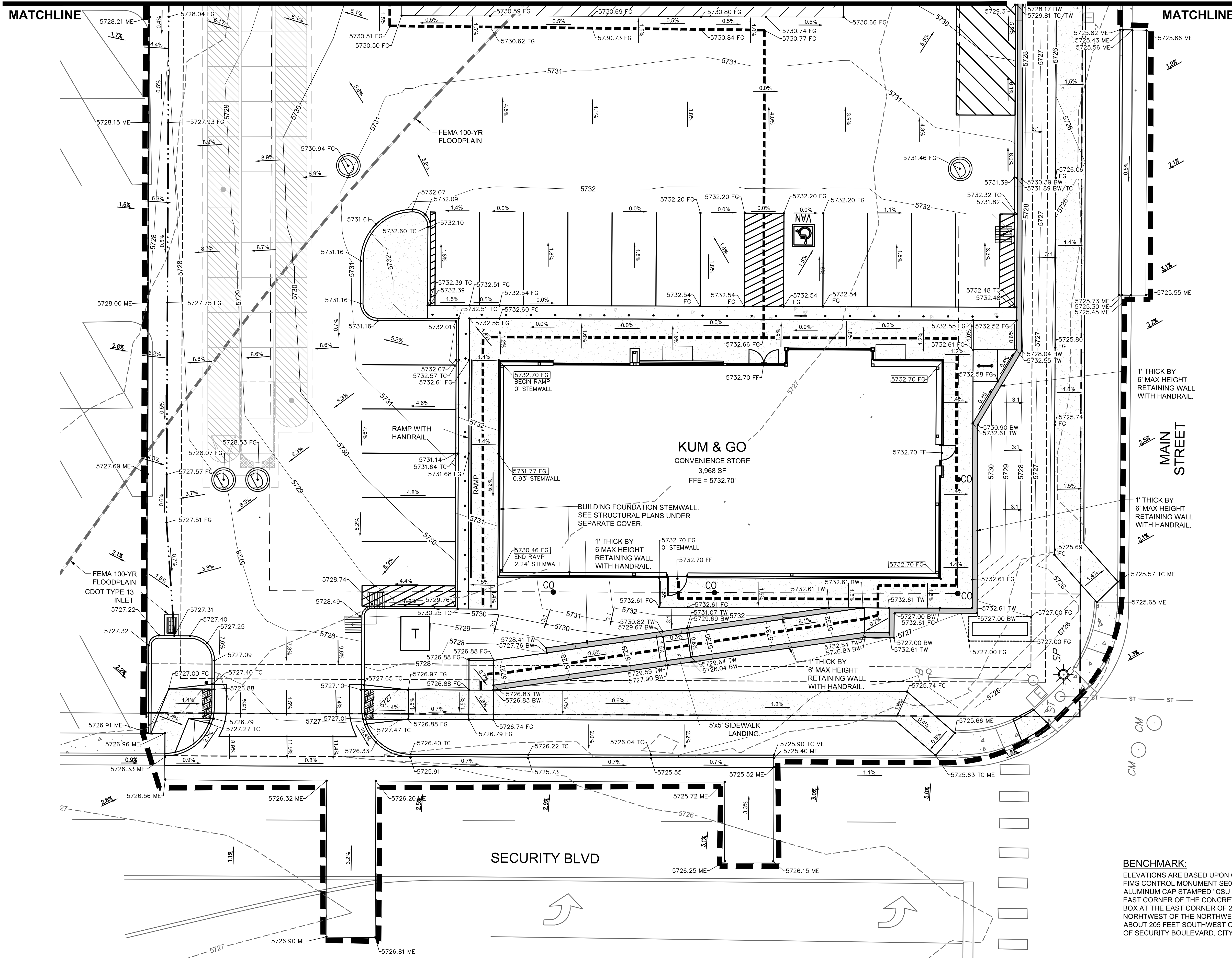

GRADING PLAN LEGEND

	PROPOSED PROPERTY BOUNDARY
	PROPOSED EASEMENT
	CONSTRUCTION / DISTURBANCE LIMITS
	EXISTING FLOODPLAIN
	EXISTING MAJOR CONTOUR
	EXISTING MINOR CONTOUR
	PROPOSED MAJOR CONTOUR
	PROPOSED MINOR CONTOUR
	PROPOSED BUILDING OUTLINE
	PROPOSED INTEGRAL CURB
	PROPOSED CURB AND GUTTER
	PROPOSED RETAINING WALL
	PROPOSED ACCESSIBLE ROUTE
	PROPOSED SURFACE FLOW LINE
	PROPOSED / EXISTING STORM MANHOLE
	PROPOSED / EXISTING STORM INLET
	EXISTING STREET LIGHTING
	EXISTING FIRE HYDRANT
	EXISTING SIGNAGE
	PROPOSED SITE LIGHTING
	PROPOSED FLOWLINE ELEVATION
	PROPOSED EXTERIOR GRADE AT FOUNDATION
	PROPOSED SIDEWALK ELEVATION
	PROPOSED GRADE TO MATCH EXISTING
	PROPOSED FINISHED GRADE
	PROPOSED HIGHPOINT ELEVATION
	PROPOSED TOP OF WALL
	PROPOSED BOTTOM OF WALL
	PROPOSED TOP OF CURB
	PROPOSED TOP OF CURB
	FLOW ARROW AND GRADE

GRADING NOTES:

- NO WORK IS TO BEGIN UNTIL ALL PERMITS HAVE BEEN OBTAINED.
- FINAL GRADES ARE SUBJECT TO MINOR CHANGE BY CONTRACTOR. NO GRADE CHANGES IN EXCESS OF 0.05' WITHOUT ENGINEER APPROVAL.
- ANY FILL MATERIAL REQUIRED TO BRING THE SITE TO GRADE SHALL BE CLEAN FILL APPROVED BY GEOTECHNICAL ENGINEER. SEE "SOIL PREPARATION NOTE" THIS SHEET.
- GENERAL CONTRACTOR SHALL BE RESPONSIBLE FOR MINIMIZING DEPOSITION OF ONSITE SEDIMENTS ONTO SURROUNDING PUBLIC STREETS DURING CONSTRUCTION.
- SEE THE SITE SURVEY FOR SURVEY INFORMATION.
- GRADES SHOWN ARE FLOWLINE UNLESS OTHERWISE NOTED.
- GUTTER GRADES SHALL BE A MINIMUM 0.50%.
- CONTRACTOR TO ENSURE SMOOTH TRANSITION BETWEEN PRIVATE DRIVE AND TRASH ENCLOSURE.
- RETAINING WALL HEIGHTS AND GRADES SHOWN ARE FROM FINISHED GRADE AT TOP OF WALL TO FINISHED GRADE AT BOTTOM OF WALL AND DO NOT INCORPORATE FOOTING DEPTH OR WALL HEIGHT ABOVE FINISHED GRADE. REFER TO STRUCTURAL PLANS UNDER SEPARATE COVER.

BENCHMARK:

ELEVATIONS ARE BASED UPON COLORADO SPRINGS UTILITIES FIMS CONTROL MONUMENT SE09, BEING A 2-INCH DIAMETER ALUMINUM CAP STAMPED "CSU FIMS CONTROL SE09" ON THE EAST CORNER OF THE CONCRETE BASE OF A TELEPHONE RELAY BOX AT THE EAST CORNER OF 226 MAIN STREET, ABOUT 3 FEET NORTHWEST OF THE NORTHWEST CURB OF MAIN STREET, AND ABOUT 205 FEET SOUTHWEST OF THE SOUTHWEST CURB LINE OF SECURITY BOULEVARD. CITY ELEVATION: 5726.76 (NGVD 29)

811 Know what's below. Call before you dig.
CALL 811 SEVENTY-TWO HOURS PRIOR TO DIGGING, GRADING OR EXCAVATING FOR THE MARKING OF UNDERGROUND MEMBER UTILITIES.

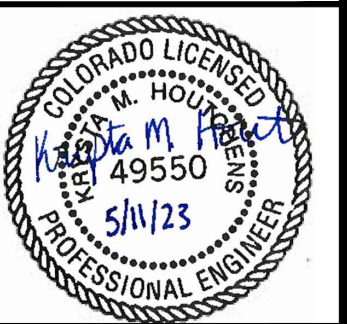

1459 Grand Ave
Des Moines, IA 50309
P: 888-458-6646

2232 - EL PASO, COLORADO
SECURITY BLVD. AND MAIN ST.
DETAILED GRADING PLAN - SOUTH

KG PROJECT TEAM:
RDM:
SDM:
CPM:

REVISION DESCRIPTION	DATE
1ST REVIEW COMMENTS	08/19/22
2ND REVIEW COMMENTS	01/06/23
3RD REVIEW COMMENTS	04/05/23
4TH REVIEW COMMENTS	05/11/23

DATE: 05-11-2023
SHEET NUMBER: 7 OF 43

PCD FILE NO. PPR-2225

KUM & GO GAS & C-STORE

PART OF THE SOUTHEAST 1/4 OF SECTION 11, TOWNSHIP 15 SOUTH, RANGE 66
WEST OF THE SIXTH PRINCIPAL MERIDIAN,
COUNTY OF EL PASO, STATE OF COLORADO
MAJOR SITE DEVELOPMENT PLAN

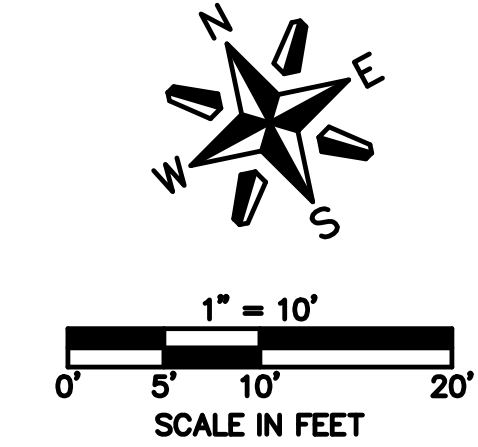

EES
ENTITLEMENT AND
ENGINEERING
SOLUTIONS, INC.
3801 E. Florida Avenue, Suite 425
Denver, CO 80210
303-572-1997 www.ees.us.com

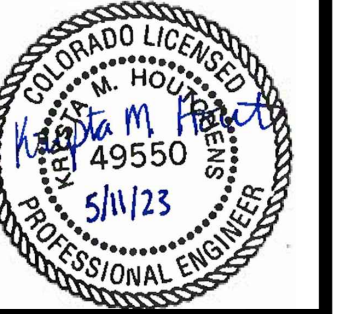

1459 Grand Ave
Des Moines, IA 50309
P: 888-458-6646

2232 - EL PASO, COLORADO
SECURITY BLVD. AND MAIN ST.
DETAILED GRADING PLAN - NORTH

KG PROJECT TEAM:
RDM:
SDM:
CPM:

REVISION DESCRIPTION	DATE
1ST REVIEW COMMENTS	08/19/22
2ND REVIEW COMMENTS	01/06/23
3RD REVIEW COMMENTS	04/05/23
4TH REVIEW COMMENTS	05/11/23

DATE: 05-11-2023
SHEET NUMBER:

C2.3
8 OF 43

CRITERIA PLAN 04/2020

GRADING PLAN LEGEND

	PROPOSED PROPERTY BOUNDARY
	PROPOSED EASEMENT
	CONSTRUCTION / DISTURBANCE LIMITS
	EXISTING FLOODPLAIN
	EXISTING MAJOR CONTOUR
	EXISTING MINOR CONTOUR
	PROPOSED MAJOR CONTOUR
	PROPOSED MINOR CONTOUR
	PROPOSED BUILDING OUTLINE
	PROPOSED INTEGRAL CURB
	PROPOSED CURB AND GUTTER
	PROPOSED RETAINING WALL
	PROPOSED ACCESSIBLE ROUTE
	PROPOSED SURFACE FLOW LINE
	PROPOSED / EXISTING STORM MANHOLE
	PROPOSED / EXISTING STORM INLET
	EXISTING STREET LIGHTING
	EXISTING FIRE HYDRANT
	EXISTING SIGNAGE
	PROPOSED SITE LIGHTING
	PROPOSED FLOWLINE ELEVATION
	PROPOSED EXTERIOR GRADE AT FOUNDATION
	PROPOSED SIDEWALK ELEVATION
	PROPOSED GRADE TO MATCH EXISTING
	PROPOSED FINISHED GRADE
	PROPOSED HIGHPOINT ELEVATION
	PROPOSED TOP OF WALL
	PROPOSED BOTTOM OF WALL
	PROPOSED TOP OF CURB
	FLOW ARROW AND GRADE

GRADING NOTES:

- NO WORK IS TO BEGIN UNTIL ALL PERMITS HAVE BEEN OBTAINED.
- FINAL GRADES ARE SUBJECT TO MINOR CHANGE BY CONTRACTOR. NO GRADE CHANGES IN EXCESS OF 0.05' WITHOUT ENGINEER APPROVAL.
- ANY FILL MATERIAL REQUIRED TO BRING THE SITE TO GRADE SHALL BE CLEAN FILL APPROVED BY GEOTECHNICAL ENGINEER. SEE "SOIL PREPARATION NOTE" THIS SHEET.
- GENERAL CONTRACTOR SHALL BE RESPONSIBLE FOR MINIMIZING DEPOSITION OF ONSITE SEDIMENTS ONTO SURROUNDING PUBLIC STREETS DURING CONSTRUCTION.
- SEE THE SITE SURVEY FOR SURVEY INFORMATION.
- GRADES SHOWN ARE FLOWLINE UNLESS OTHERWISE NOTED.
- GUTTER GRADES SHALL BE A MINIMUM 0.50%.
- CONTRACTOR TO ENSURE SMOOTH TRANSITION BETWEEN PRIVATE DRIVE AND TRASH ENCLOSURE.
- RETAINING WALL HEIGHTS AND GRADES SHOWN ARE FROM FINISHED GRADE AT TOP OF WALL TO FINISHED GRADE AT BOTTOM OF WALL AND DO NOT INCORPORATE FOOTING DEPTH OR WALL HEIGHT ABOVE FINISHED GRADE. REFER TO STRUCTURAL PLANS UNDER SEPARATE COVER.

BENCHMARK:

ELEVATIONS ARE BASED UPON COLORADO SPRINGS UTILITIES FIMS CONTROL MONUMENT SE09, BEING A 2-INCH DIAMETER ALUMINUM CAP STAMPED "CSU FIMS CONTROL SE09" ON THE EAST CORNER OF THE CONCRETE BASE OF A TELEPHONE RELAY BOX AT THE EAST CORNER OF 228 MAIN STREET, ABOUT 3 FEET NORTHWEST OF THE NORTHWEST CURB OF MAIN STREET, AND ABOUT 205 FEET SOUTHWEST OF THE SOUTHWEST CURB LINE OF SECURITY BOULEVARD. CITY ELEVATION: 5726.76 (NGVD 29)

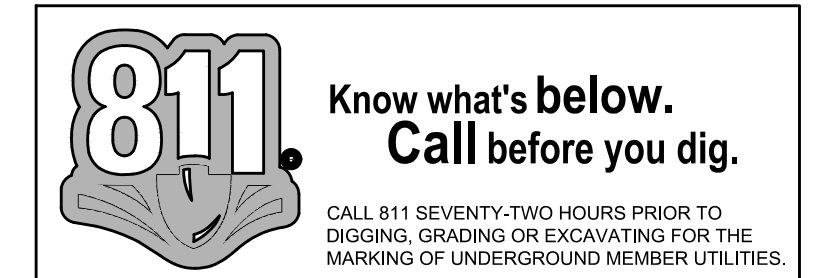

PCD FILE NO. PPR-2225

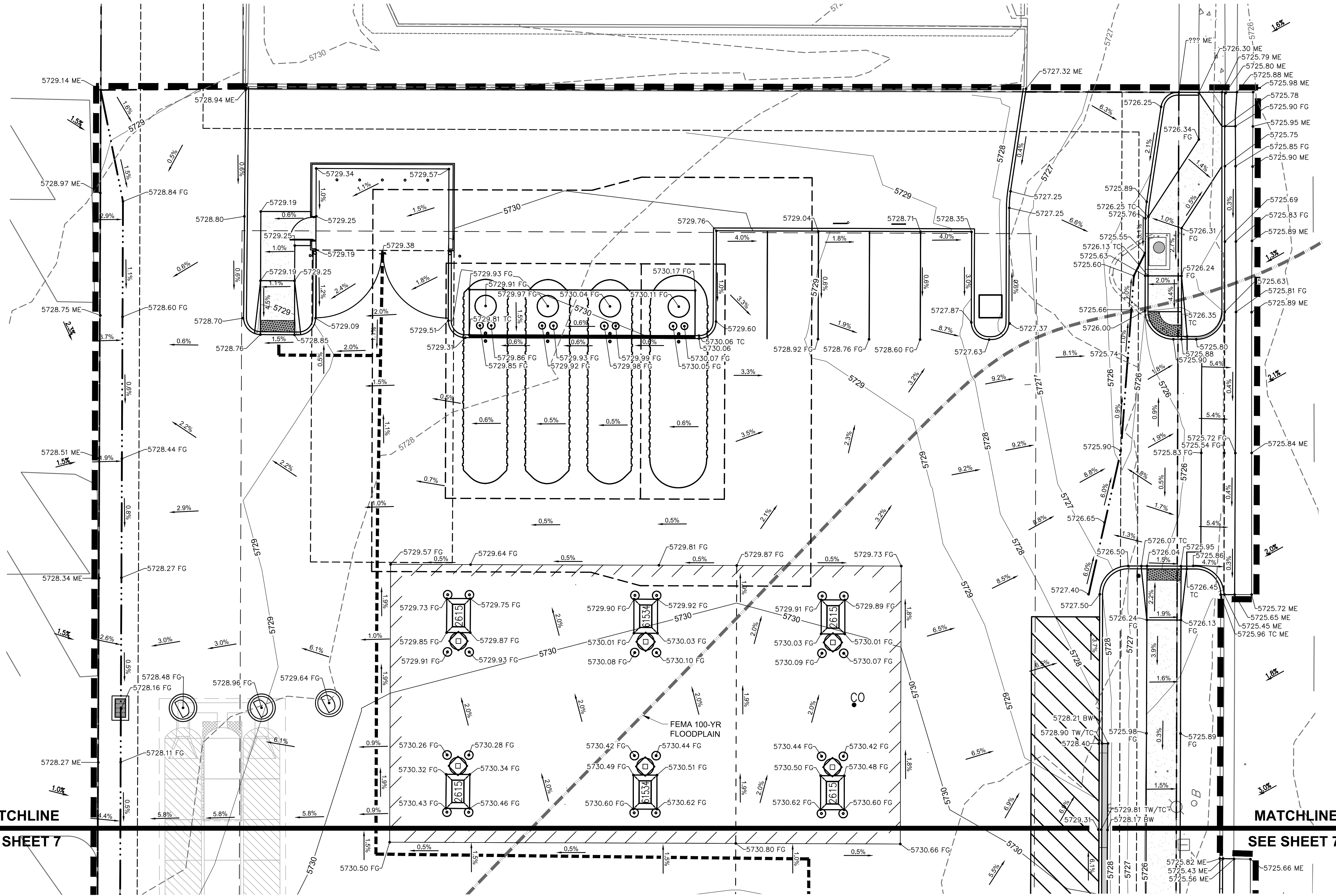

MATCHLINE
SEE SHEET 7

MATCHLINE
SEE SHEET 7

P:\KUM & GO\CO. EL PASO COUNTY - 2232 MAIN AND SECURITY\08 CAD\GESC2232 - 08 - GRADING 10SC-NORTH.DWG

MATCHLINE SEE PLAN RIGHT

MATCHLINE SEE PLAN LEFT

KUM & GO GAS & C-STORE

PART OF THE SOUTHEAST 1/4 OF SECTION 11, TOWNSHIP 15 SOUTH, RANGE 66
WEST OF THE SIXTH PRINCIPAL MERIDIAN,
COUNTY OF EL PASO, STATE OF COLORADO

MAJOR SITE DEVELOPMENT PLAN

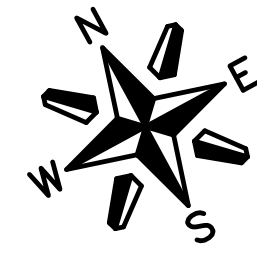
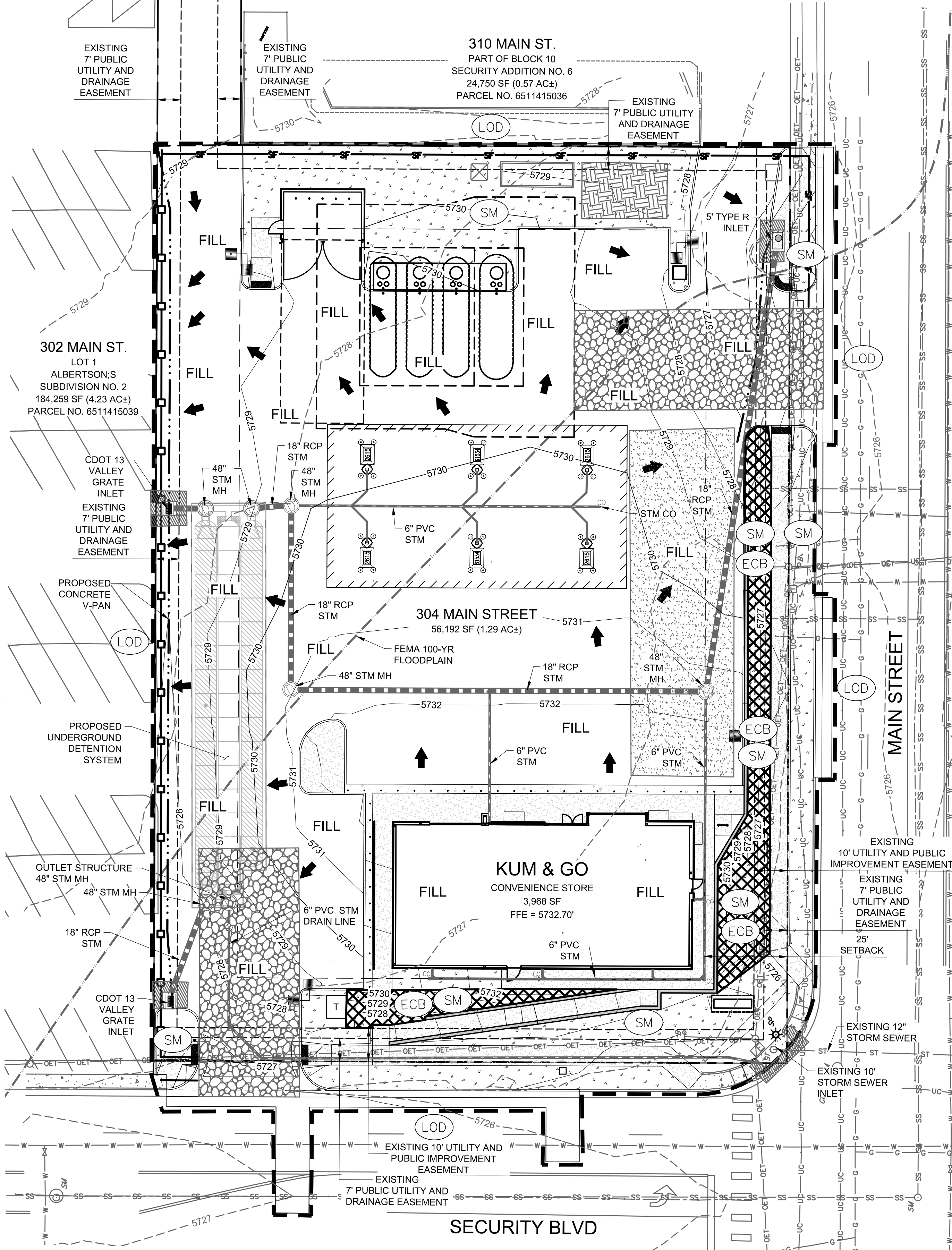

1" = 20'
SCALE IN FEET

	EXISTING GAS
	EXISTING SANITARY SEWER
	EXISTING OVERHEAD ELECTRICAL AND TELECOMMUNICATIONS
	EXISTING UNDERGROUND TELECOMMUNICATIONS
	EXISTING WATER
	PROPERTY BOUNDARY
	EXISTING EASEMENT
	CONSTRUCTION / DISTURBANCE LIMITS
	EXISTING FLOODPLAIN
	EXISTING CURB & GUTTER
	EXISTING MAJOR CONTOUR
	EXISTING MINOR CONTOUR
	PROPOSED MAJOR CONTOUR
	PROPOSED MINOR CONTOUR
	PROPOSED CURB & GUTTER
	PROPOSED BUILDING
	PROPOSED RETAINING WALL
	PROPOSED SURFACE FLOW LINE
	PROPOSED STORM SEWER
	EXISTING STORM SEWER MANHOLE/INLET
	PROPOSED STORM SEWER MANHOLE/INLET
	EXISTING STREET LIGHTING
	EXISTING FIRE HYDRANT
	EXISTING SIGNAGE
	PROPOSED SURFACE FLOW DIRECTION ARROW
	PROPOSED SITE LIGHTING

NOTE:
A WORK-IN-ROW PERMIT IS REQUIRED FOR WORK BEING PERFORMED WITHIN SECURITY BOULEVARD RIGHT-OF-WAY. 5 BUSINESS DAYS REQUIRED FOR EL PASO COUNTY PUBLIC WORKS PROCESSING.

STORM SEWER NOTE:
SEE SHEET 12 FOR ALL STORM SEWER PIPING AND STRUCTURE DESIGN INFORMATION.

VEGETATION NOTE:
NO NOTABLE VEGETATION ON-SITE. SITE CONSISTS OF MOSTLY ASPHALT, CONCRETE, CURB & GUTTER AND DIRT AREAS.

SOIL PREPARATION NOTE:
SOIL PREPARATION SHALL BE PER RECOMMENDATIONS FROM A GEOTECHNICAL ENGINEERING REPORT PREPARED FOR THIS SITE AS FOLLOWS

GEOTECHNICAL ENGINEER: OLSSON
REPORT NO. 021-05598

THE CONTRACTOR MUST FULLY REVIEW THIS REPORT PRIOR TO CONSTRUCTION INFORMATION IN THE GEOTECHNICAL REPORT SUPERSEDES ANY CONFLICTING INFORMATION CONTAINED IN THE CONSTRUCTION PLANS AND SPECIFICATIONS.

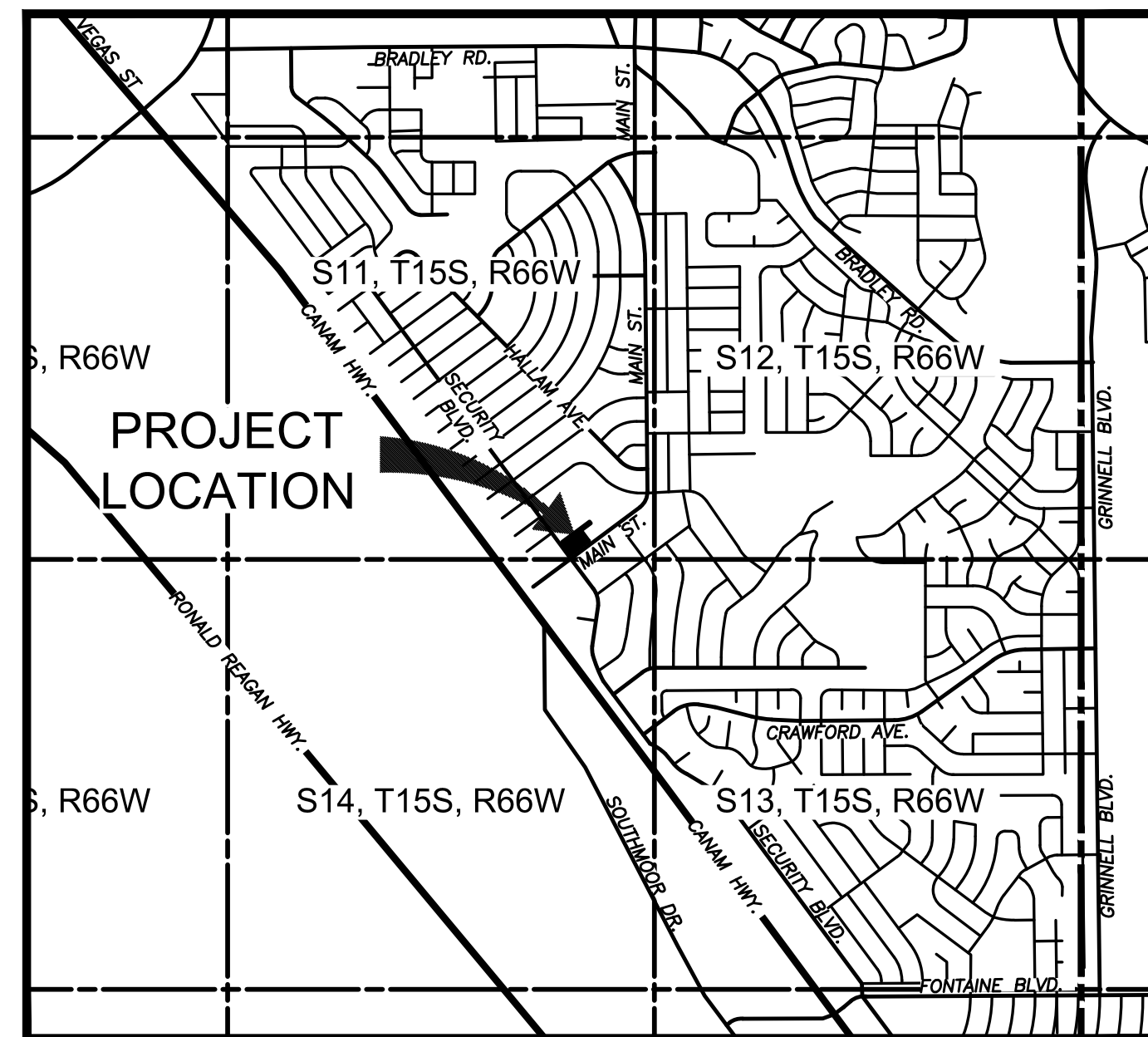

VICINITY MAP
SCALE: 1" = 2000'

BMP LEGEND

	(CWA)	CONCRETE WASHOUT AREA
	(CF)	CONSTRUCTION FENCE
	(IP)	INLET PROTECTION
	(SCL)	SEDIMENT CONTROL LOG
	(SM)	SEEDING AND MULCHING
	(SF)	SILT FENCE
	(SP)	STOCKPILE AREA
	(SSA)	STABILIZED STAGING AREA
	(VTC)	VEHICLE TRACKING CONTROL
	(LOD)	LIMITS OF CONSTRUCTION / DISTURBANCE
	(CS)	CURB SOCK
	(ST)	SEDIMENT TRAP
	(SS)	STREET SWEEPING
	(ECB)	EROSION CONTROL BLANKET

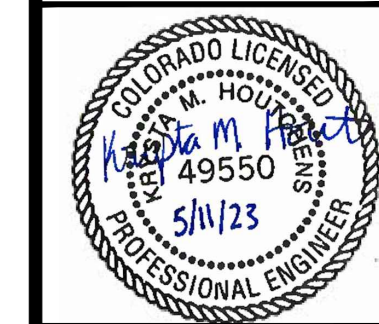

1459 Grand Ave
Des Moines, IA 50309
P: 888-458-6646

2232 - EL PASO, COLORADO
SECURITY BLVD. AND MAIN ST.
EROSION AND STORMWATER CONTROL PLAN - FINAL

KG PROJECT TEAM:
RDM:
SDM:
CPM:

REVISIONS	DATE	REVISION DESCRIPTION
1	08/19/22	1ST REVIEW COMMENTS
2	01/06/23	2ND REVIEW COMMENTS
3	04/05/23	3RD REVIEW COMMENTS
4	05/11/23	4TH REVIEW COMMENTS

DATE: 05-11-2023

SHEET NUMBER: C3.3
11 OF 43

PCD FILE NO. PPR-2225

GENERAL NOTES:

- STORMWATER DISCHARGES FROM CONSTRUCTION SITES SHALL NOT CAUSE OR THREATEN TO CAUSE POLLUTION, CONTAMINATION, OR DEGRADATION OF STATE WATERS. ALL WORK AND EARTH DISTURBANCE SHALL BE DONE IN A MANNER THAT MINIMIZES POLLUTION OF ANY ON-SITE OR OFF-SITE WATERS, INCLUDING WETLANDS.
- NOTWITHSTANDING ANYTHING DEPICTED IN THESE PLANS IN WORDS OR GRAPHIC REPRESENTATION, ALL DESIGN AND CONSTRUCTION RELATED TO ROADS, STORM DRAINAGE AND EROSION CONTROL SHALL CONFORM TO THE STANDARDS AND REQUIREMENTS OF THE MOST RECENT VERSION OF THE RELEVANT ADOPTED EL PASO COUNTY STANDARDS, INCLUDING THE LAND DEVELOPMENT CODE, THE ENGINEERING CRITERIA MANUAL, THE DRAINAGE CRITERIA MANUAL, AND THE DRAINAGE CRITERIA MANUAL VOLUME 2. ANY DEVIATIONS FROM REGULATIONS AND STANDARDS MUST BE REQUESTED, AND APPROVED, IN WRITING.
- A SEPARATE STORMWATER MANAGEMENT PLAN (SMWP) FOR THIS PROJECT SHALL BE COMPLETED AND AN EROSION AND STORMWATER QUALITY CONTROL PERMIT (ESQCP) ISSUED PRIOR TO COMMENCING CONSTRUCTION. MANAGEMENT OF THE SMWP DURING CONSTRUCTION IS THE RESPONSIBILITY OF THE DESIGNATED QUALIFIED STORMWATER MANAGER OR CERTIFIED EROSION CONTROL INSPECTOR. THE SMWP SHALL BE LOCATED ON-SITE AT ALL TIMES DURING CONSTRUCTION AND SHALL BE KEPT UP TO DATE WITH WORK PROGRESS AND CHANGES IN THE FIELD.
- ONCE THE ESQCP IS APPROVED AND A "NOTICE TO PROCEED" HAS BEEN ISSUED, THE CONTRACTOR MAY INSTALL THE INITIAL STAGE EROSION AND SEDIMENT CONTROL MEASURES AS INDICATED ON THE APPROVED GEC. A PRECONSTRUCTION MEETING BETWEEN THE CONTRACTOR, ENGINEER, AND EL PASO COUNTY WILL BE HELD PRIOR TO ANY CONSTRUCTION. IT IS THE RESPONSIBILITY OF THE APPLICANT TO COORDINATE THE MEETING TIME AND PLACE WITH COUNTY STAFF.
- CONTROL MEASURES MUST BE INSTALLED PRIOR TO COMMENCEMENT OF ACTIVITIES THAT COULD CONTRIBUTE POLLUTANTS TO STORMWATER. CONTROL MEASURES FOR ALL SLOPES, CHANNELS, DITCHES, AND DISTURBED LAND AREAS SHALL BE INSTALLED IMMEDIATELY UPON COMPLETION OF THE DISTURBANCE.
- ALL TEMPORARY SEDIMENT AND EROSION CONTROL MEASURES SHALL BE MAINTAINED AND REMAIN IN EFFECTIVE OPERATING CONDITION UNTIL PERMANENT SOIL EROSION CONTROL MEASURES ARE IMPLEMENTED AND FINAL STABILIZATION IS ESTABLISHED. ALL PERSONS ENGAGED IN LAND DISTURBANCE ACTIVITIES SHALL ASSESS THE ADEQUACY OF CONTROL MEASURES AT THE SITE AND IDENTIFY IF CHANGES TO THOSE CONTROL MEASURES ARE NEEDED TO ENSURE THE CONTINUED EFFECTIVE PERFORMANCE OF THE CONTROL MEASURES. ALL CHANGES TO TEMPORARY SEDIMENT AND EROSION CONTROL MEASURES MUST BE INCORPORATED INTO THE STORMWATER MANAGEMENT PLAN.
- TEMPORARY STABILIZATION SHALL BE IMPLEMENTED ON DISTURBED AREAS AND STOCKPILES WHERE GROUND DISTURBING CONSTRUCTION ACTIVITY HAS PERMANENTLY CEASED OR TEMPORARILY CEASED FOR LONGER THAN 14 DAYS.
- FINAL STABILIZATION MUST BE IMPLEMENTED AT ALL APPLICABLE CONSTRUCTION SITES. FINAL STABILIZATION IS ACHIEVED WHEN ALL GROUND DISTURBING ACTIVITIES ARE COMPLETE AND ALL DISTURBED AREAS EITHER HAVE A UNIFORM VEGETATIVE COVER WITH INDIVIDUAL PLANT DENSITY OF 70 PERCENT OF PRE-DISTURBANCE LEVELS ESTABLISHED OR EQUIVALENT PERMANENT ALTERNATIVE STABILIZATION METHOD IS IMPLEMENTED. ALL TEMPORARY SEDIMENT AND EROSION CONTROL MEASURES SHALL BE REMOVED UPON FINAL STABILIZATION AND BEFORE PERMIT CLOSURE.
- ALL PERMANENT STORMWATER MANAGEMENT FACILITIES SHALL BE INSTALLED AS DESIGNED IN THE APPROVED PLANS. ANY PROPOSED CHANGES THAT AFFECT THE DESIGN OR FUNCTION OF PERMANENT STORMWATER MANAGEMENT STRUCTURES MUST BE APPROVED BY THE ECM ADMINISTRATOR PRIOR TO IMPLEMENTATION.
- EARTH DISTURBANCES SHALL BE CONDUCTED IN SUCH A MANNER SO AS TO EFFECTIVELY MINIMIZE ACCELERATED SOIL EROSION AND RESULTING SEDIMENTATION. ALL DISTURBANCES SHALL BE DESIGNED, CONSTRUCTED, AND COMPLETED SO THAT THE EXPOSED AREA OF ANY DISTURBED LAND SHALL BE LIMITED TO THE SHORTEST PRACTICAL PERIOD OF TIME. PRE-EXISTING VEGETATION SHALL BE PROTECTED AND MAINTAINED WITHIN 50 HORIZONTAL FEET OF A WATERS OF THE STATE UNLESS SHOWN TO BE INFEASIBLE AND SPECIFICALLY REQUESTED AND APPROVED.
- COMPACTION OF SOIL MUST BE PREVENTED IN AREAS DESIGNATED FOR INFILTRATION CONTROL MEASURES OR WHERE FINAL STABILIZATION WILL BE ACHIEVED BY VEGETATIVE COVER. AREAS DESIGNATED FOR INFILTRATION CONTROL MEASURES SHALL ALSO BE PROTECTED FROM SEDIMENTATION DURING CONSTRUCTION UNTIL FINAL STABILIZATION IS ACHIEVED. IF COMPACTION PREVENTION IS NOT FEASIBLE DUE TO SITE CONSTRAINTS, ALL AREAS DESIGNATED FOR INFILTRATION AND VEGETATION CONTROL MEASURES MUST BE LOOSENEED PRIOR TO INSTALLATION OF THE CONTROL MEASURE(S).
- ANY TEMPORARY OR PERMANENT FACILITY DESIGNED AND CONSTRUCTED FOR THE CONVEYANCE OF STORMWATER AROUND, THROUGH, OR FROM THE EARTH DISTURBANCE AREA SHALL BE A STABILIZED CONVEYANCE DESIGNED TO MINIMIZE EROSION AND THE DISCHARGE OF SEDIMENT OFF-SITE.
- CONCRETE WASH WATER SHALL BE CONTAINED AND DISPOSED OF IN ACCORDANCE WITH THE SMWP. NO WASH WATER SHALL BE DISCHARGED TO OR ALLOWED TO ENTER STATE WATERS, INCLUDING ANY SURFACE OR SUBSURFACE STORM DRAINAGE SYSTEM OR FACILITIES. CONCRETE WASHOUTS SHALL NOT BE LOCATED IN AN AREA WHERE SHALLOW GROUNDWATER MAY BE PRESENT, OR WITHIN 50 FEET OF A SURFACE WATER BODY, CREEK OR STREAM.
- DURING DEWATERING OPERATIONS, UNCONTAMINATED GROUNDWATER MAY BE DISCHARGED ON-SITE, BUT SHALL NOT LEAVE THE SITE IN THE FORM OF SURFACE RUNOFF UNLESS AN APPROVED STATE DEWATERING PERMIT IS IN PLACE.
- EROSION CONTROL BLANKETING OR OTHER PROTECTIVE COVERING SHALL BE USED ON SLOPES STEEPER THAN 3:1.
- CONTRACTOR SHALL BE RESPONSIBLE FOR THE REMOVAL OF ALL WASTES FROM THE CONSTRUCTION SITE FOR DISPOSAL IN ACCORDANCE WITH LOCAL AND STATE REGULATORY REQUIREMENTS. NO CONSTRUCTION DEBRIS, TREE SLASH, BUILDING MATERIAL WASTES OR UNUSED BUILDING MATERIALS SHALL BE BURIED, DUMPED, OR DISCHARGED AT THE SITE.
- WASTE MATERIALS SHALL NOT BE TEMPORARILY PLACED OR STORED IN THE STREET, ALLEY, OR OTHER PUBLIC WAY, UNLESS IN ACCORDANCE WITH AN APPROVED TRAFFIC CONTROL PLAN. CONTROL MEASURES MAY BE REQUIRED BY EL PASO COUNTY ENGINEERING IF DEEMED NECESSARY, BASED ON SPECIFIC CONDITIONS AND CIRCUMSTANCES.
- TRACKING OF SOILS AND CONSTRUCTION DEBRIS OFF-SITE SHALL BE MINIMIZED. MATERIALS TRACKED OFF-SITE SHALL BE CLEANED UP AND PROPERLY DISPOSED OF IMMEDIATELY.
- THE OWNER/DEVELOPER SHALL BE RESPONSIBLE FOR THE REMOVAL OF ALL CONSTRUCTION DEBRIS, DIRT, TRASH, ROCK, SEDIMENT, SOIL, AND SAND THAT MAY ACCUMULATE IN ROADS, STORM DRAINS AND OTHER DRAINAGE CONVEYANCE SYSTEMS AND STORMWATER APPURTENANCES AS A RESULT OF SITE DEVELOPMENT.
- THE QUANTITY OF MATERIALS STORED ON THE PROJECT SITE SHALL BE LIMITED, AS MUCH AS PRACTICAL, TO THAT QUANTITY REQUIRED TO PERFORM THE WORK IN AN ORDERLY SEQUENCE. ALL MATERIALS STORED ON-SITE SHALL BE STORED IN A NEAT, ORDERLY MANNER, IN THEIR ORIGINAL CONTAINERS, WITH ORIGINAL MANUFACTURER'S LABELS.
- NO CHEMICAL(S) HAVING THE POTENTIAL TO BE RELEASED IN STORMWATER ARE TO BE STORED OR USED ON-SITE UNLESS PERMISSION FOR THE USE OF SUCH CHEMICAL(S) IS GRANTED IN WRITING BY THE ECM ADMINISTRATOR. IN GRANTING APPROVAL FOR THE USE OF SUCH CHEMICAL(S), SPECIAL CONDITIONS AND MONITORING MAY BE REQUIRED.
- BULK STORAGE OF ALLOWED PETROLEUM PRODUCTS OR OTHER ALLOWED LIQUID CHEMICALS IN EXCESS OF 55 GALLONS SHALL REQUIRE ADEQUATE SECONDARY CONTAINMENT PROTECTION TO CONTAIN ALL SPILLS ON-SITE AND TO PREVENT ANY SPILLED MATERIALS FROM ENTERING STATE WATERS, ANY SURFACE OR SUBSURFACE STORM DRAINAGE SYSTEM OR OTHER FACILITIES.
- NO PERSON SHALL CAUSE THE IMPEDIMENT OF STORMWATER FLOW IN THE CURB AND GUTTER OR DITCH EXCEPT WITH APPROVED SEDIMENT CONTROL MEASURES.
- OWNER/DEVELOPER AND THEIR AGENTS SHALL COMPLY WITH THE "COLORADO WATER QUALITY CONTROL ACT" (TITLE 25, ARTICLE 8, CRS) AND THE "CLEAN WATER ACT" (33 USC 1344), IN ADDITION TO THE REQUIREMENTS OF THE LAND DEVELOPMENT CODE, DCM VOLUME II AND THE ECM APPENDIX I. ALL APPROPRIATE PERMITS MUST BE OBTAINED BY THE CONTRACTOR PRIOR TO CONSTRUCTION (1041, NPDES, FLOODPLAIN, 404, FUGITIVE DUST, ETC.), IN THE EVENT OF CONFLICTS BETWEEN THESE REQUIREMENTS AND OTHER LAWS, RULES, OR REGULATIONS OF OTHER FEDERAL, STATE, LOCAL, OR COUNTY AGENCIES, THE MOST RESTRICTIVE LAWS, RULE, OR REGULATIONS SHALL APPLY.
- ALL CONSTRUCTION TRAFFIC MUST ENTER/EXIT THE SITE ONLY AT APPROVED CONSTRUCTION ACCESS POINTS.
- PRIOR TO CONSTRUCTION THE PERMITTEE SHALL VERIFY THE LOCATION OF EXISTING UTILITIES.
- A WATER SOURCE SHALL BE AVAILABLE ON-SITE DURING EARTHWORK OPERATIONS AND SHALL BE UTILIZED AS REQUIRED TO MINIMIZE DUST FROM EARTHWORK EQUIPMENT AND WIND.
- THE SOILS REPORT FOR THIS SITE HAS BEEN PREPARED BY OLSSON ON DECEMBER 21ST, 2021 AND SHALL BE CONSIDERED A PART OF THESE PLANS.
- AT LEAST (10) DAYS PRIOR TO THE ANTICIPATED START OF CONSTRUCTION, FOR PROJECTS THAT WILL DISTURB ONE (1) ACRE OR MORE, THE OWNER OR OPERATOR OF CONSTRUCTION ACTIVITY SHALL SUBMIT A PERMIT APPLICATION FOR STORMWATER DISCHARGE TO THE COLORADO DEPARTMENT OF PUBLIC HEALTH AND ENVIRONMENT, WATER QUALITY DIVISION. THE APPLICATION CONTAINS CERTIFICATION OF COMPLETION OF A STORMWATER MANAGEMENT PLAN (SMWP), OF WHICH THIS GRADING AND EROSION CONTROL PLAN MAY BE A PART. FOR INFORMATION OR APPLICATION MATERIALS CONTACT:

COLORADO DEPARTMENT OF PUBLIC HEALTH AND ENVIRONMENT
 WATER QUALITY CONTROL DIVISION
 WQCD - PERMITS
 4300 CHERRY CREEK DRIVE SOUTH
 DENVER, CO 80246-1530
 ATTN: PERMITS UNIT

KUM & GO GAS & C-STORE

PART OF THE SOUTHEAST 1/4 OF SECTION 11, TOWNSHIP 15 SOUTH, RANGE 66
 WEST OF THE SIXTH PRINCIPAL MERIDIAN,
 COUNTY OF EL PASO, STATE OF COLORADO

MAJOR SITE DEVELOPMENT PLAN

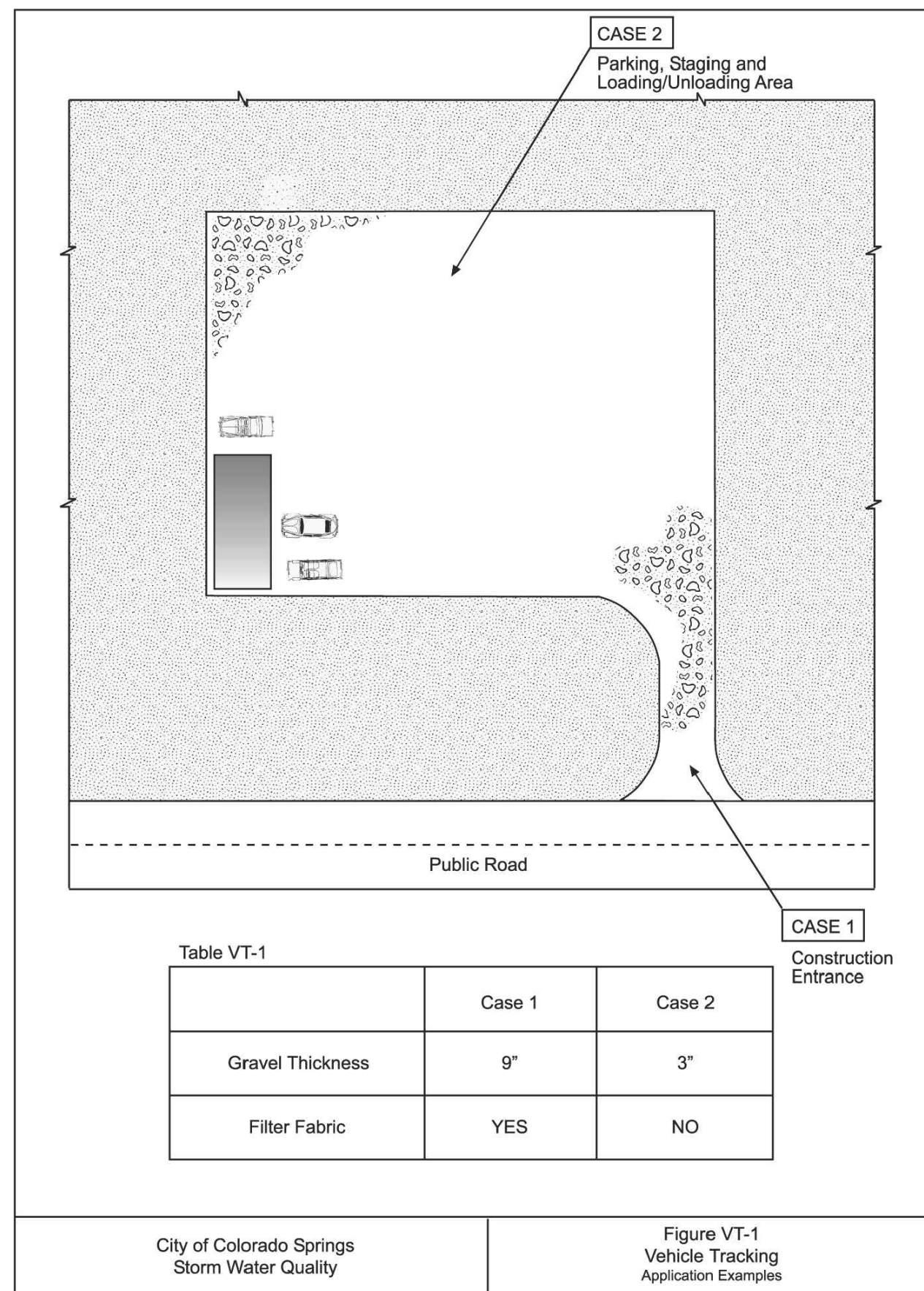

EC-4 Mulching (MU)

- Clean, weed-free and seed-free cereal grain straw should be applied evenly at a rate of 2 tons per acre and must be tacked or fastened by a method suitable for the condition of the site. Straw mulch must be anchored (and not merely placed) on the surface. This can be accomplished mechanically by crimping or with the aid of tackifiers or nets. Anchoring with a crimping implement is preferred, and is the recommended method for areas flatter than 3:1. Mechanical crimpers must be capable of tucking the long mulch fibers into the soil to a depth of 3 inches without cutting them. An agricultural disk, while not an ideal substitute, may work if the disk blades are dull or blunted and set vertically; however, the frame may have to be weighted to afford proper soil penetration.
- Grass hay may be used in place of straw; however, because hay is comprised of the entire plant including seed, mulching with hay may seed the site with non-native grass species which might in turn out-compete the native seed. Alternatively, native species of grass hay may be purchased, but can be difficult to find and are more expensive than straw. Purchasing and utilizing a certified weed-free straw is an easier and less costly mulching method. When using grass hay, follow the same guidelines as for straw (provided above).
- On small areas sheltered from the wind and heavy runoff, spraying a tackifier on the mulch is satisfactory for holding it in place. For steep slopes and special situations where greater control is needed, erosion control blankets anchored with stakes should be used instead of mulch.
- Hydraulic mulching consists of wood cellulose fibers mixed with water and a tackifying agent and should be applied at a rate of no less than 1,500 pounds per acre (1,425 lbs of fibers mixed with at least 75 lbs of tackifier) with a hydraulic mulcher. For steeper slopes, up to 2000 pounds per acre may be required for effective hydrosedding. Hydromulch typically requires up to 24 hours to dry; therefore, it should not be applied immediately prior to inclement weather. Application to roads, waterways and existing vegetation should be avoided.
- Erosion control mats, blankets, or nets are recommended to help stabilize steep slopes (generally 3:1 and steeper) and waterways. Depending on the product, these may be used alone or in conjunction with grass or straw mulch. Normally, use of these products will be restricted to relatively small areas. Biodegradable mats made of straw and jute, straw-coconut, coconut fiber, or excelsior can be used instead of mulch. (See the ECM/TRM BMP for more information.)
- Some tackifiers or binders may be used to anchor mulch. Check with the local jurisdiction for allowed tackifiers. Manufacturer's recommendations should be followed at all times. (See the Soil Binder BMP for more information on general types of tackifiers.)
- Rock can also be used as mulch. It provides protection of exposed soils to wind and water erosion and allows infiltration of precipitation. An aggregate base course can be spread on disturbed areas for temporary or permanent stabilization. The rock mulch layer should be thick enough to provide full coverage of exposed soil on the area it is applied.

Maintenance and Removal

After mulching, the bare ground surface should not be more than 10 percent exposed. Reapply mulch, as needed, to cover bare areas.

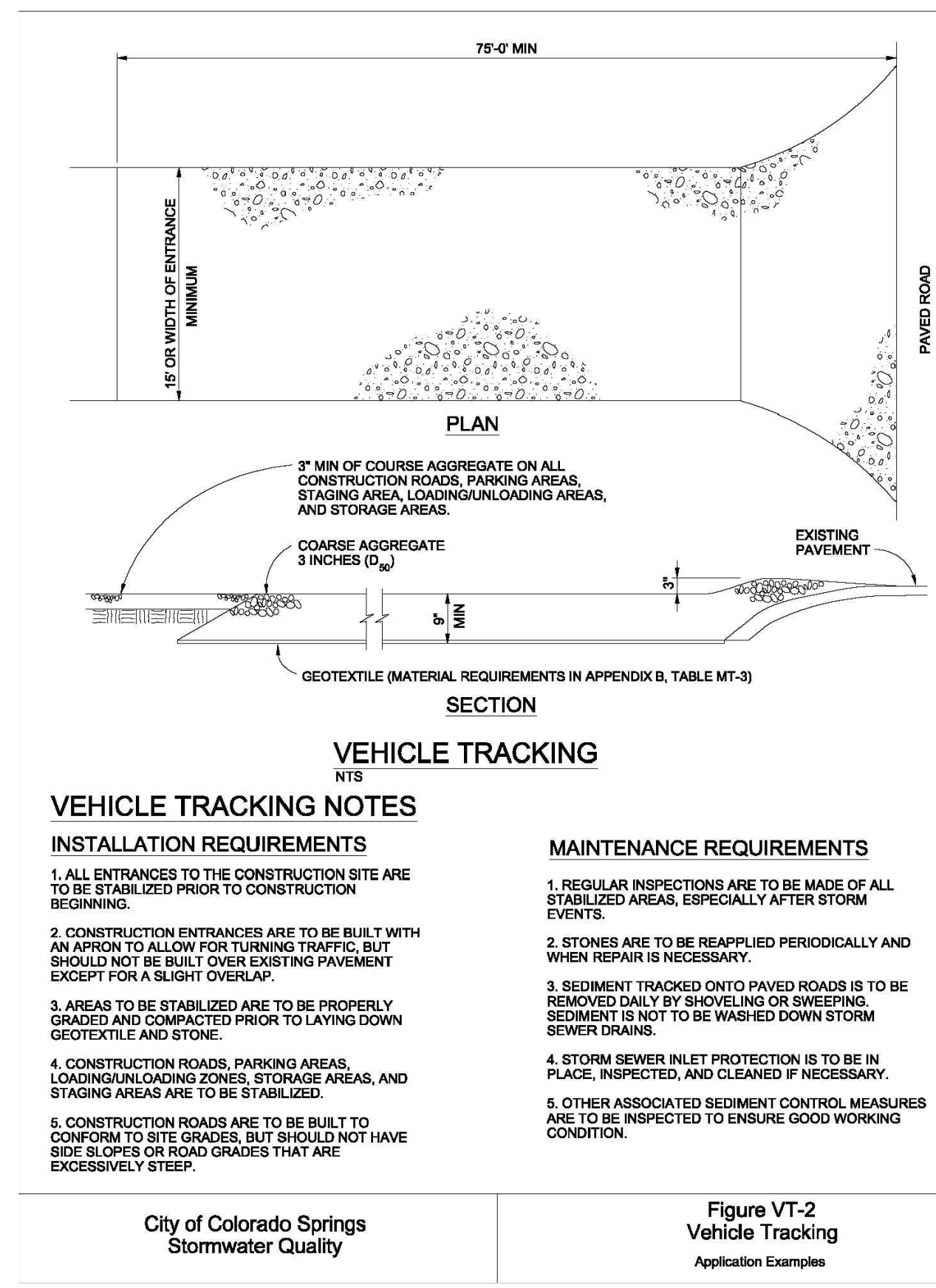

SM-4 Vehicle Tracking Control (VTC)

STABILIZED CONSTRUCTION ENTRANCE/EXIT INSTALLATION NOTES

- SEE PLAN VIEW FOR
 - LOCATION OF CONSTRUCTION ENTRANCE(S)/EXIT(S).
 - TYPE OF CONSTRUCTION ENTRANCE(S)/EXIT(S) (WITH/WITHOUT WHEEL WASH, CONSTRUCTION MAT OR TRM).
- CONSTRUCTION MAT OR TRM STABILIZED CONSTRUCTION ENTRANCES ARE ONLY TO BE USED ON SHORT DURATION PROJECTS (TYPICALLY RANGING FROM A WEEK TO A MONTH) WHERE THERE WILL BE LIMITED VEHICULAR ACCESS.
- A STABILIZED CONSTRUCTION ENTRANCE/EXIT SHALL BE LOCATED AT ALL ACCESS POINTS WHERE VEHICLES ACCESS THE CONSTRUCTION SITE FROM PAVED RIGHT-OF-WAYS.
- STABILIZED CONSTRUCTION ENTRANCE/EXIT SHALL BE INSTALLED PRIOR TO ANY LAND DISTURBING ACTIVITIES.
- A NON-WOVEN GEOTEXTILE FABRIC SHALL BE PLACED UNDER THE STABILIZED CONSTRUCTION ENTRANCE/EXIT PRIOR TO THE PLACEMENT OF ROCK.
- UNLESS OTHERWISE SPECIFIED BY LOCAL JURISDICTION, ROCK SHALL CONSIST OF DOT SECT. #703, AASHTO #3 COARSE AGGREGATE OR 6" (MINUS) ROCK.

STABILIZED CONSTRUCTION ENTRANCE/EXIT MAINTENANCE NOTES

- INSPECT BMPs EACH WORKDAY, AND MAINTAIN THEM IN EFFECTIVE OPERATING CONDITION. MAINTENANCE OF BMPs SHOULD BE PROACTIVE, NOT REACTIVE. INSPECT BMPs AS SOON AS POSSIBLE (AND ALWAYS WITHIN 24 HOURS) FOLLOWING A STORM THAT CAUSES SURFACE EROSION, AND PERFORM NECESSARY MAINTENANCE.
 - FREQUENT OBSERVATIONS AND MAINTENANCE ARE NECESSARY TO MAINTAIN BMPs IN EFFECTIVE OPERATING CONDITION. INSPECTIONS AND CORRECTIVE MEASURES SHOULD BE DOCUMENTED THOROUGHLY.
 - WHERE BMPs HAVE FAILED, REPAIR OR REPLACEMENT SHOULD BE INITIATED UPON DISCOVERY OF THE FAILURE.
 - ROCK SHALL BE REAPPLIED OR REGRADED AS NECESSARY TO THE STABILIZED ENTRANCE/EXIT TO MAINTAIN A CONSISTENT DEPTH.
 - SEDIMENT TRACKED ONTO PAVED ROADS IS TO BE REMOVED THROUGHOUT THE DAY AND AT THE END OF THE DAY BY SHOVELING OR SWEEPING. SEDIMENT MAY NOT BE WASHED DOWN STORM SEWER DRAINS.
- NOTE: MANY JURISDICTIONS HAVE BMP DETAILS THAT VARY FROM UDFCD STANDARD DETAILS. CONSULT WITH LOCAL JURISDICTIONS AS TO WHICH DETAIL SHOULD BE USED WHEN DIFFERENCES ARE NOTED.

(DETAILS ADAPTED FROM CITY OF BROOMFIELD, COLORADO, NOT AVAILABLE IN AUTOCAD)

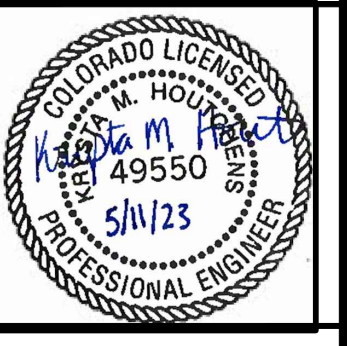

1459 Grand Ave
 Des Moines, IA 50309
 P: 888-458-6646

2232 - EL PASO, COLORADO
 SECURITY BLVD. AND MAIN ST.
 EROSION AND STORMWATER CONTROL DETAILS

KG PROJECT TEAM:
 RDM:
 SDM:
 CPM:

REVISION DESCRIPTION	DATE
1 1ST REVIEW COMMENTS	08/19/22
2 2ND REVIEW COMMENTS	01/06/23
3 3RD REVIEW COMMENTS	04/05/23
4 4TH REVIEW COMMENTS	05/11/23

DATE: 05-11-2023

SHEET NUMBER:
C3.4
 12 OF 43

P:\KUM & GO\CO. EL PASO COUNTY - 2232 MAIN AND SECURITY\08 CAD\GEC02232 - 12 - GEC02.DWG

KUM & GO GAS & C-STORE

PART OF THE SOUTHEAST 1/4 OF SECTION 11, TOWNSHIP 15 SOUTH, RANGE 66
WEST OF THE SIXTH PRINCIPAL MERIDIAN,
COUNTY OF EL PASO, STATE OF COLORADO
MAJOR SITE DEVELOPMENT PLAN



1459 Grand Ave
Des Moines, IA 50309
P: 888-458-6646

2232 - EL PASO, COLORADO
SECURITY BLVD. AND MAIN ST.
EROSION AND STORMWATER CONTROL DETAILS

KG PROJECT TEAM:
RDM:
SDM:
CPM:

REVISION	DATE	REVISION DESCRIPTION
1	08/19/22	1ST REVIEW COMMENTS
2	01/06/23	2ND REVIEW COMMENTS
3	04/05/23	3RD REVIEW COMMENTS
4	05/11/23	4TH REVIEW COMMENTS

DATE: 05-11-2023

SHEET NUMBER:
C3.5
13 OF 43

CRITERIA PLAN 04/2020

Concrete Washout Area (CWA) MM-1

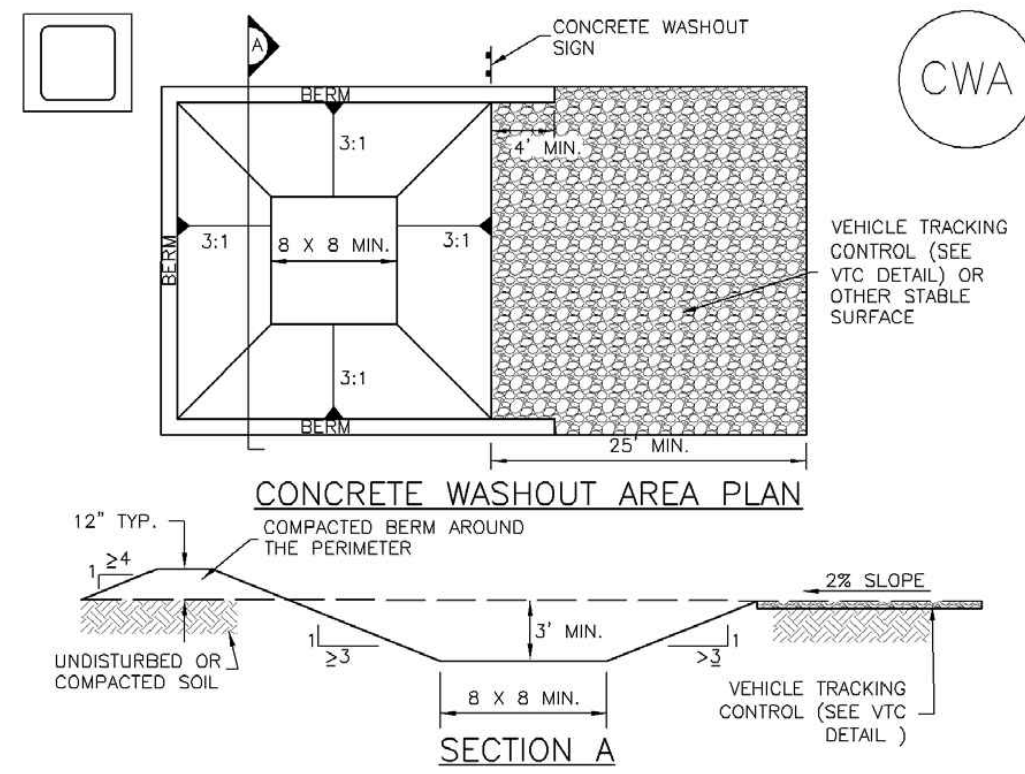

- CWA-1. CONCRETE WASHOUT AREA**
- CWA INSTALLATION NOTES**
- SEE PLAN VIEW FOR CWA INSTALLATION LOCATION.
 - DO NOT LOCATE AN UNLINED CWA WITHIN 400' OF ANY NATURAL DRAINAGE PATHWAY OR WATERBODY. DO NOT LOCATE WITHIN 1,000' OF ANY WELLS OR DRINKING WATER SOURCES. IF SITE CONSTRAINTS MAKE THIS INFEASIBLE, OR IF HIGHLY PERMEABLE SOILS EXIST ON SITE, THE CWA MUST BE INSTALLED WITH AN IMPERMEABLE LINER (15 MIL MIN. THICKNESS) OR SURFACE STORAGE ALTERNATIVES USING PREFABRICATED CONCRETE WASHOUT DEVICES OR A LINED ABOVE GROUND STORAGE ARE SHOULD BE USED.
 - THE CWA SHALL BE INSTALLED PRIOR TO CONCRETE PLACEMENT ON SITE.
 - CWA SHALL INCLUDE A FLAT SUBSURFACE PIT THAT IS AT LEAST 8' BY 8' SLOPES LEADING OUT OF THE SUBSURFACE PIT SHALL BE 3:1 OR FLATTER. THE PIT SHALL BE AT LEAST 3' DEEP.
 - BERM SURROUNDING SIDES AND BACK OF THE CWA SHALL HAVE MINIMUM HEIGHT OF 1'.
 - VEHICLE TRACKING PAD SHALL BE SLOPED 2% TOWARDS THE CWA.
 - SIGNS SHALL BE PLACED AT THE CONSTRUCTION ENTRANCE, AT THE CWA, AND ELSEWHERE AS NECESSARY TO CLEARLY INDICATE THE LOCATION OF THE CWA TO OPERATORS OF CONCRETE TRUCKS AND PUMP RIGS.
 - USE EXCAVATED MATERIAL FOR PERIMETER BERM CONSTRUCTION.

November 2010 Urban Drainage and Flood Control District Urban Storm Drainage Criteria Manual Volume 3 CWA-3

Concrete Washout Area (CWA) MM-1

- CWA MAINTENANCE NOTES**
- INSPECT BMPs EACH WORKDAY, AND MAINTAIN THEM IN EFFECTIVE OPERATING CONDITION. MAINTENANCE OF BMPs SHOULD BE PROMPTIVE, NOT REACTIVE. INSPECT BMPs AS SOON AS POSSIBLE (AND ALWAYS WITHIN 24 HOURS) FOLLOWING A STORM THAT CAUSES SURFACE EROSION, AND PERFORM NECESSARY MAINTENANCE.
 - FREQUENT OBSERVATIONS AND MAINTENANCE ARE NECESSARY TO MAINTAIN BMPs IN EFFECTIVE OPERATING CONDITION. INSPECTIONS AND CORRECTIVE MEASURES SHOULD BE DOCUMENTED THOROUGHLY.
 - WHERE BMPs HAVE FAILED, REPAIR OR REPLACEMENT SHOULD BE INITIATED UPON DISCOVERY OF THE FAILURE.
 - THE CWA SHALL BE REPAIRED, CLEANED, OR ENLARGED AS NECESSARY TO MAINTAIN CAPACITY FOR CONCRETE WASTE. CONCRETE MATERIALS ACCUMULATED IN PIT, SHALL BE REMOVED ONCE THE MATERIALS HAVE REACHED A DEPTH OF 2'.
 - CONCRETE WASHOUT WATER, WASTED PIECES OF CONCRETE AND ALL OTHER DEBRIS IN THE SUBSURFACE PIT SHALL BE TRANSPORTED FROM THE JOB SITE IN A WATER-TIGHT CONTAINER AND DISPOSED OF PROPERLY.
 - THE CWA SHALL REMAIN IN PLACE UNTIL ALL CONCRETE FOR THE PROJECT IS PLACED.
 - WHEN THE CWA IS REMOVED, COVER THE DISTURBED AREA WITH TOP SOIL, SEED AND MULCH OR OTHERWISE STABILIZED IN A MANNER APPROVED BY THE LOCAL JURISDICTION. (DETAIL ADAPTED FROM TOWN OF DENVER, COLORADO AND THE CITY OF PUEBLO, COLORADO, NOT AVAILABLE IN AUTOCAD)
- NOTE: MANY JURISDICTIONS HAVE BMP DETAILS THAT VARY FROM UDFCD STANDARD DETAILS. CONSULT WITH LOCAL JURISDICTIONS AS TO WHICH DETAIL SHOULD BE USED WHEN DIFFERENCES ARE NOTED.

CWA-4 Urban Drainage and Flood Control District Urban Storm Drainage Criteria Manual Volume 3 November 2010

Inlet Protection (IP) SC-6

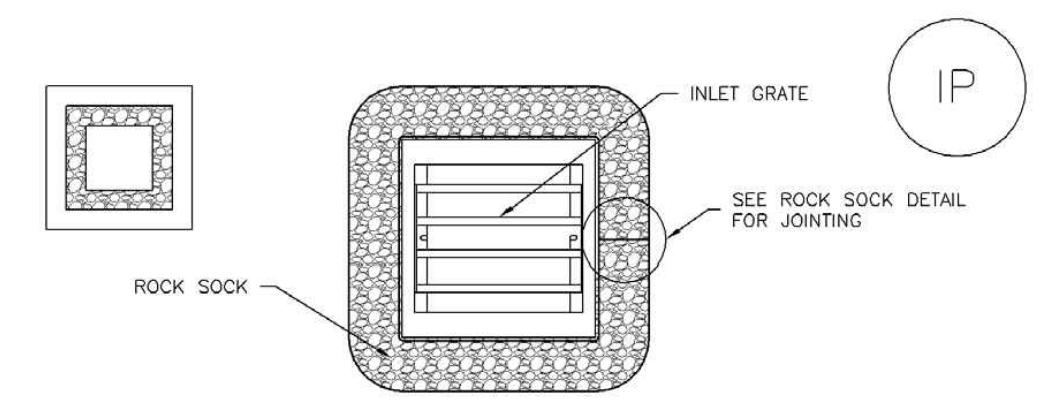

IP-3. ROCK SOCK SUMP/AREA INLET PROTECTION

- ROCK SOCK SUMP/AREA INLET PROTECTION INSTALLATION NOTES**
- SEE ROCK SOCK DESIGN DETAIL FOR INSTALLATION REQUIREMENTS.
 - STRAW WATTLES/SEDIMENT CONTROL LOGS MAY BE USED IN PLACE OF ROCK SOCKS FOR INLETS IN PERVIOUS AREAS. INSTALL PER SEDIMENT CONTROL LOG DETAIL.

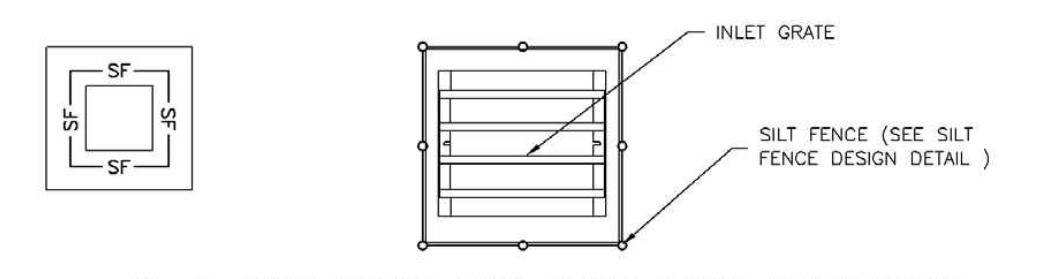

IP-4. SILT FENCE FOR SUMP INLET PROTECTION

- SILT FENCE INLET PROTECTION INSTALLATION NOTES**
- SEE SILT FENCE DESIGN DETAIL FOR INSTALLATION REQUIREMENTS.
 - POSTS SHALL BE PLACED AT EACH CORNER OF THE INLET AND AROUND THE EDGES AT A MAXIMUM SPACING OF 3 FEET.
 - STRAW WATTLES/SEDIMENT CONTROL LOGS MAY BE USED IN PLACE OF SILT FENCE FOR INLETS IN PERVIOUS AREAS. INSTALL PER SEDIMENT CONTROL LOG DETAIL.

August 2013 Urban Drainage and Flood Control District Urban Storm Drainage Criteria Manual Volume 3 IP-5

Inlet Protection (IP) SC-6

- GENERAL INLET PROTECTION INSTALLATION NOTES**
- SEE PLAN VIEW FOR LOCATION OF INLET PROTECTION. -TYPE OF INLET PROTECTION (IP-1, IP-2, IP-3, IP-4, IP-5, IP-6)
 - INLET PROTECTION SHALL BE INSTALLED PROMPTLY AFTER INLET CONSTRUCTION OR PAVING IS COMPLETE (TYPICALLY WITHIN 48 HOURS). IF A RAINFALL/RUNOFF EVENT IS FORECAST, INSTALL INLET PROTECTION PRIOR TO ONSET OF EVENT.
 - MANY JURISDICTIONS HAVE BMP DETAILS THAT VARY FROM UDFCD STANDARD DETAILS. CONSULT WITH LOCAL JURISDICTIONS AS TO WHICH DETAIL SHOULD BE USED WHEN DIFFERENCES ARE NOTED.
- INLET PROTECTION MAINTENANCE NOTES**
- INSPECT BMPs EACH WORKDAY, AND MAINTAIN THEM IN EFFECTIVE OPERATING CONDITION. MAINTENANCE OF BMPs SHOULD BE PROMPTIVE, NOT REACTIVE. INSPECT BMPs AS SOON AS POSSIBLE (AND ALWAYS WITHIN 24 HOURS) FOLLOWING A STORM THAT CAUSES SURFACE EROSION, AND PERFORM NECESSARY MAINTENANCE.
 - FREQUENT OBSERVATIONS AND MAINTENANCE ARE NECESSARY TO MAINTAIN BMPs IN EFFECTIVE OPERATING CONDITION. INSPECTIONS AND CORRECTIVE MEASURES SHOULD BE DOCUMENTED THOROUGHLY.
 - WHERE BMPs HAVE FAILED, REPAIR OR REPLACEMENT SHOULD BE INITIATED UPON DISCOVERY OF THE FAILURE.
 - SEDIMENT ACCUMULATED UPSTREAM OF INLET PROTECTION SHALL BE REMOVED AS NECESSARY TO MAINTAIN BMP EFFECTIVENESS. TYPICALLY WHEN STORAGE VOLUME REACHES 50% OF CAPACITY, A DEPTH OF 6" WHEN SILT FENCE IS USED, OR 1/4 OF THE HEIGHT FOR STRAW BALES.
 - INLET PROTECTION IS TO REMAIN IN PLACE UNTIL THE UPSTREAM DISTURBED AREA IS PERMANENTLY STABILIZED. UNLESS THE LOCAL JURISDICTION APPROVES EARLIER REMOVAL OF INLET PROTECTION IN STREETS.
 - WHEN INLET PROTECTION AT AREA INLETS IS REMOVED, THE DISTURBED AREA SHALL BE COVERED WITH TOP SOIL, SEED AND MULCHED, OR OTHERWISE STABILIZED IN A MANNER APPROVED BY THE LOCAL JURISDICTION.
- (DETAIL ADAPTED FROM TOWN OF PUEBLO, COLORADO AND CITY OF AURORA, COLORADO, NOT AVAILABLE IN AUTOCAD)
- NOTE: MANY JURISDICTIONS HAVE BMP DETAILS THAT VARY FROM UDFCD STANDARD DETAILS. CONSULT WITH LOCAL JURISDICTIONS AS TO WHICH DETAIL SHOULD BE USED WHEN DIFFERENCES ARE NOTED.
- NOTE: THE DETAILS INCLUDED WITH THIS FACT SHEET SHOW COMMONLY USED, CONVENTIONAL METHODS OF INLET PROTECTION IN THE DENVER METROPOLITAN AREA. THERE ARE MANY PROPRIETARY INLET PROTECTION METHODS ON THE MARKET. UDFCD NEITHER ENDORSES NOR DISCOURAGES USE OF PROPRIETARY INLET PROTECTION; HOWEVER, IN THE EVENT PROPRIETARY METHODS ARE USED, THE APPROPRIATE DETAIL FROM THE MANUFACTURER MUST BE INCLUDED IN THE SWMP AND THE BMP MUST BE INSTALLED AND MAINTAINED AS SHOWN IN THE MANUFACTURER'S DETAILS.
- NOTE: SOME MUNICIPALITIES DISCOURAGE OR PROHIBIT THE USE OF STRAW BALES FOR INLET PROTECTION. CHECK WITH LOCAL JURISDICTION TO DETERMINE IF STRAW BALE INLET PROTECTION IS ACCEPTABLE.

IP-8 Urban Drainage and Flood Control District Urban Storm Drainage Criteria Manual Volume 3 August 2013

Silt Fence (SF) SC-1

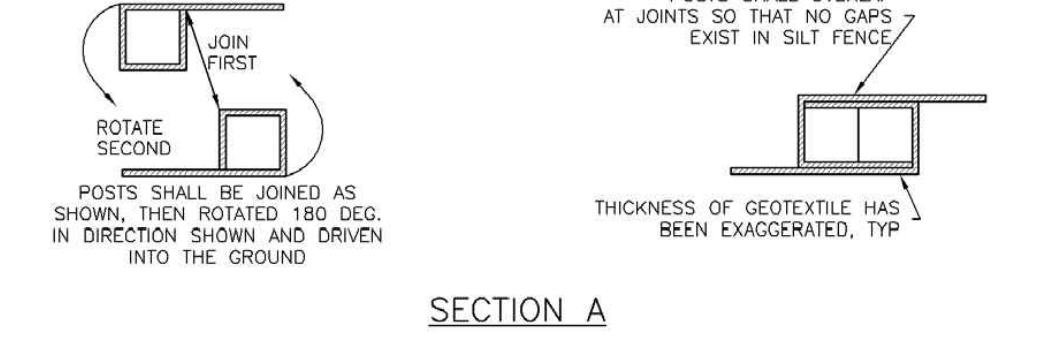
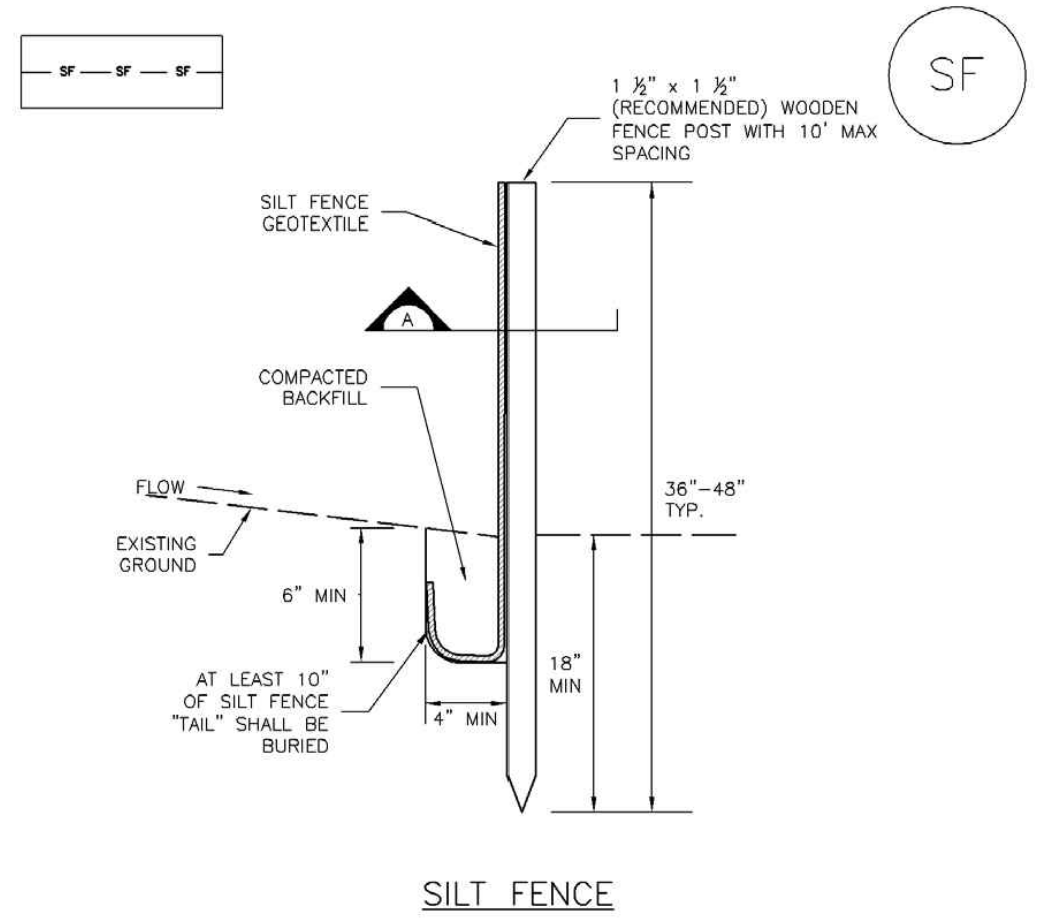

SF-1. SILT FENCE

November 2010 Urban Drainage and Flood Control District Urban Storm Drainage Criteria Manual Volume 3 SF-3

Silt Fence (SF) SC-1

- SILT FENCE INSTALLATION NOTES**
- SILT FENCE MUST BE PLACED AWAY FROM THE TOE OF THE SLOPE TO ALLOW FOR WATER PONDING. SILT FENCE AT THE TOE OF A SLOPE SHOULD BE INSTALLED IN A FLAT LOCATION AT LEAST SEVERAL FEET (2-5 FT) FROM THE TOE OF THE SLOPE TO ALLOW ROOM FOR PONDING AND DEPOSITION.
 - A UNIFORM 6\"/>
- SILT FENCE MAINTENANCE NOTES**
- INSPECT BMPs EACH WORKDAY, AND MAINTAIN THEM IN EFFECTIVE OPERATING CONDITION. MAINTENANCE OF BMPs SHOULD BE PROMPTIVE, NOT REACTIVE. INSPECT BMPs AS SOON AS POSSIBLE (AND ALWAYS WITHIN 24 HOURS) FOLLOWING A STORM THAT CAUSES SURFACE EROSION, AND PERFORM NECESSARY MAINTENANCE.
 - FREQUENT OBSERVATIONS AND MAINTENANCE ARE NECESSARY TO MAINTAIN BMPs IN EFFECTIVE OPERATING CONDITION. INSPECTIONS AND CORRECTIVE MEASURES SHOULD BE DOCUMENTED THOROUGHLY.
 - WHERE BMPs HAVE FAILED, REPAIR OR REPLACEMENT SHOULD BE INITIATED UPON DISCOVERY OF THE FAILURE.
 - SEDIMENT ACCUMULATED UPSTREAM OF THE SILT FENCE SHALL BE REMOVED AS NEEDED TO MAINTAIN THE FUNCTIONALITY OF THE BMP. TYPICALLY WHEN DEPTH OF ACCUMULATED SEDIMENTS IS APPROXIMATELY 6\"/>
- (DETAIL ADAPTED FROM TOWN OF PUEBLO, COLORADO AND CITY OF AURORA, NOT AVAILABLE IN AUTOCAD)
- NOTE: MANY JURISDICTIONS HAVE BMP DETAILS THAT VARY FROM UDFCD STANDARD DETAILS. CONSULT WITH LOCAL JURISDICTIONS AS TO WHICH DETAIL SHOULD BE USED WHEN DIFFERENCES ARE NOTED.

November 2010 Urban Drainage and Flood Control District Urban Storm Drainage Criteria Manual Volume 3 SF-4

P:\KUM & GO\CO. EL PASO COUNTY - 2232 - MAIN AND SECURITY\08 CAD\GES02232 - 13 - GESC DETAILS.dwg

KUM & GO GAS & C-STORE

PART OF THE SOUTHEAST 1/4 OF SECTION 11, TOWNSHIP 15 SOUTH, RANGE 66
WEST OF THE SIXTH PRINCIPAL MERIDIAN,
COUNTY OF EL PASO, STATE OF COLORADO

MAJOR SITE DEVELOPMENT PLAN

EC-2 Temporary and Permanent Seeding (TS/PS)

have low nutrient value, little organic matter content, few soil microorganisms, rooting restrictions, and conditions less conducive to infiltration of precipitation. As a result, it is typically necessary to provide stockpiled topsoil, compost, or other soil amendments and rototill them into the soil to a depth of 6 inches or more.

Topsoil should be salvaged during grading operations for use and spread on areas to be revegetated later. Topsoil should be viewed as an important resource to be utilized for vegetation establishment, due to its water-holding capacity, structure, texture, organic matter content, biological activity, and nutrient content. The rooting depth of most native grasses in the semi-arid Denver metropolitan area is 6 to 18 inches. If present, at a minimum of the upper 6 inches of topsoil should be stripped, stockpiled, and ultimately respread across areas that will be revegetated.

Where topsoil is not available, subsoils should be amended to provide an appropriate plant-growth medium. Organic matter, such as well digested compost, can be added to improve soil characteristics conducive to plant growth. Other treatments can be used to adjust soil pH conditions when needed. Soil testing, which is typically inexpensive, should be completed to determine and optimize the types and amounts of amendments that are required.

If the disturbed ground surface is compacted, rip or rototill the upper 12 inches of the surface prior to placing topsoil. If adding compost to the existing soil surface, rototilling is necessary. Surface roughening will assist in placing a stable topsoil layer on steeper slopes, and allow infiltration and root penetration to greater depth. Topsoil should not be placed when either the salvaged topsoil or receiving ground are frozen or snow covered.

Prior to seeding, the soil surface should be rough and the seedbed should be firm, but neither too loose nor compacted. The upper layer of soil should be in a condition suitable for seeding at the proper depth and conducive to plant growth. Seed-to-soil contact is the key to good germination.

Refer to MHPD's Topsoil Management Guidance for detailed information on topsoil assessment, design, and construction.

Temporary Vegetation

To provide temporary vegetative cover on disturbed areas which will not be paved, built upon, or fully landscaped or worked for an extended period (typically 30 days or more), plant an annual grass appropriate for the time of planting and mulch the planted areas. Temporary grain seed mixes suitable for the Denver metropolitan area are listed in Table TS/PS-1. Native temporary seed mixes are provided in USDCM Volume 2, Chapter 13, Appendix A. These are to be considered only as general recommendations when specific design guidance for a particular site is not available. Local governments typically specify seed mixes appropriate for their jurisdiction.

Permanent Revegetation

To provide vegetative cover on disturbed areas that have reached final grade, a perennial grass mix should be established. Permanent seeding should be performed promptly (typically within 14 days) after reaching final grade. Each site will have different characteristics and a landscape professional or the local jurisdiction should be contacted to determine the most suitable seed mix for a specific site. In lieu of a specific recommendation, one of the perennial grass mixes appropriate for site conditions and growth season listed in seed mix tables in the USDCM Volume 2 *Revegetation* Chapter can be used. The pure live seed (PLS) rates of application recommended in these tables are considered to be absolute minimum rates for seed applied using proper drill-seeding equipment. These are to be considered only as general

TS/PS-2	Urban Drainage and Flood Control District Urban Storm Drainage Criteria Manual Volume 3	January 2021
---------	--	--------------

EC-10 Earth Dikes and Drainage Swales (ED/DS)

Unlined dikes or swales should only be used for intercepting sheet flow runoff and are not intended for diversion of concentrated flows.

Details with notes are provided for several design variations, including:

- ED-1. Unlined Earth Dike formed by Berm
- DS-1. Unlined Excavated Swale
- DS-2. Unlined Swale Formed by Cut and Fill
- DS-3. ECB-lined Swale
- DS-4. Synthetic-lined Swale
- DS-5. Riprap-lined Swale

The details also include guidance on permissible velocities for cohesive channels if unlined approaches will be used.

Maintenance and Removal

Inspect earth dikes for stability, compaction, and signs of erosion and repair. Inspect side slopes for erosion and damage to erosion control fabric. Stabilize slopes and repair fabric as necessary. If there is recurring extensive damage, consider installing rock check dams or lining the channel with riprap.

If drainage swales are not permanent, remove dikes and fill channels when the upstream area is stabilized. Stabilize the fill or disturbed area immediately following removal by revegetation or other permanent stabilization method approved by the local jurisdiction.

ED/DS-2	Urban Drainage and Flood Control District Urban Storm Drainage Criteria Manual Volume 3	November 2010
---------	--	---------------

Temporary and Permanent Seeding (TS/PS) EC-2

recommendations when specific design guidance for a particular site is not available. Local governments typically specify seed mixes appropriate for their jurisdiction.

If desired for wildlife habitat or landscape diversity, shrubs such as rubber rabbitbrush (*Chrysothamnus nauseosus*), fourwing saltbush (*Atriplex canescens*) and skunkbrush sumac (*Rhus trilobata*) could be added to the upland seed mixes at 0.25, 0.5 and 1 pound PLS/acre, respectively. In riparian zones, planting root stock of such species as American plum (*Prunus americana*), woods rose (*Rosa woodsii*), plains cottonwood (*Populus sargentii*), and willow (*Salix spp.*) may be considered. On non-topsoiled upland sites, a legume such as Ladak alfalfa at 1 pound PLS/acre can be included as a source of nitrogen for perennial grasses.

Timing of seeding is an important aspect of the revegetation process. For upland and riparian areas on the Colorado Front Range, the suitable timing for seeding is from October through May. The most favorable time to plant non-irrigated areas is during the fall, so that seed can take advantage of winter and spring moisture. Seed should not be planted if the soil is frozen, snow covered, or wet.

Seeding dates for the highest success probability of perennial species along the Front Range are generally in the spring from April through early May and in the fall after the first of September until the ground freezes. If the area is irrigated, seeding may occur in summer months, as well. See Table TS/PS-2 for appropriate seeding dates.

January 2021	Urban Drainage and Flood Control District Urban Storm Drainage Criteria Manual Volume 3	TS/PS-3
--------------	--	---------

Earth Dikes and Drainage Swales (ED/DS) EC-10



ED-1. COMPACTED UNLINED EARTH DIKE FORMED BY BERM

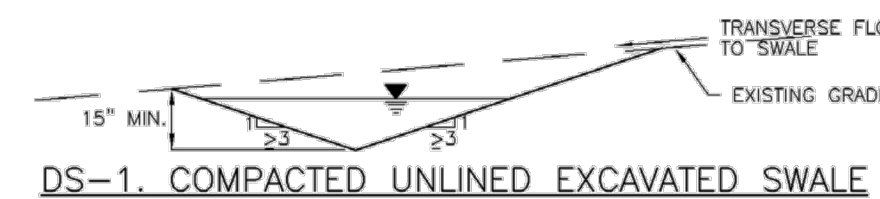

DS-1. COMPACTED UNLINED EXCAVATED SWALE

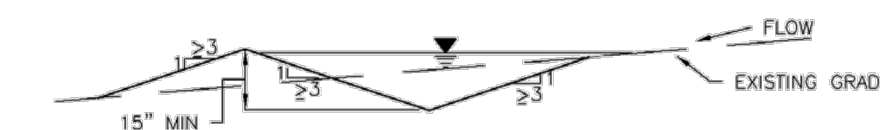

DS-2. COMPACTED UNLINED SWALE FORMED BY CUT AND FILL

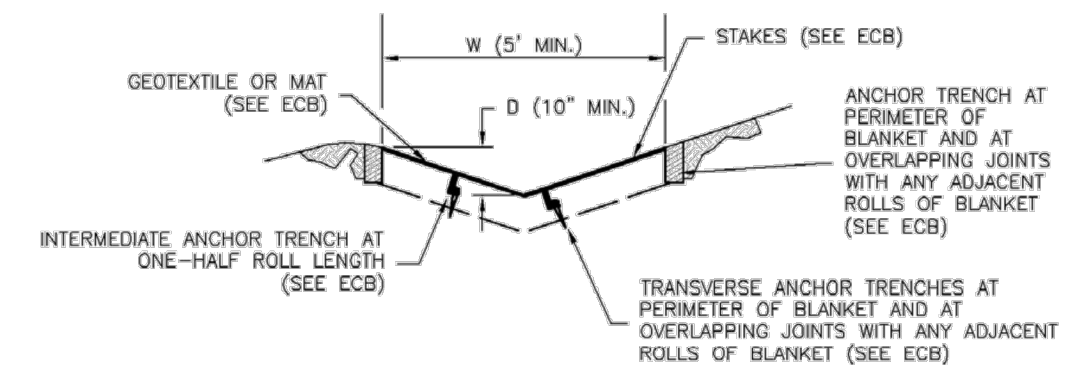

DS-3. ECB LINED SWALE (CUT AND FILL OR BERM)

November 2010	Urban Drainage and Flood Control District Urban Storm Drainage Criteria Manual Volume 3	ED/DS-3
---------------	--	---------

EC-2 Temporary and Permanent Seeding (TS/PS)

Table TS/PS-1. Minimum Drill Seeding Rates for Various Temporary Annual Grasses

Species* (Common name)	Growth Season*	Pounds of Pure Live Seed (PLS)/acre*	Planting Depth (inches)
1. Oats	Cool	35 - 50	1 - 2
2. Spring wheat	Cool	25 - 35	1 - 2
3. Spring barley	Cool	25 - 35	1 - 2
4. Annual ryegrass	Cool	10 - 15	½
5. Millet	Warm	3 - 15	½ - ¾
6. Winter wheat	Cool	20-35	1 - 2
7. Winter barley	Cool	20-35	1 - 2
8. Winter rye	Cool	20-35	1 - 2
9. Triticale	Cool	25-40	1 - 2

* Successful seeding of annual grass resulting in adequate plant growth will usually produce enough dead-plant residue to provide protection from wind and water erosion for an additional year. This assumes that the cover is not disturbed or mowed closer than 8 inches.

Hydraulic seeding may be substituted for drilling only where slopes are steeper than 3:1 or where access limitations exist. When hydraulic seeding is used, hydraulic mulching should be applied as a separate operation, when practical, to prevent the seeds from being encapsulated in the mulch.

† See Table TS/PS-2 for seeding dates. Irrigation, if consistently applied, may extend the use of cool season species during the summer months.

‡ Seeding rates should be doubled if seed is broadcast, or increased by 50 percent if done using a Brillion Drill or by hydraulic seeding.

TS/PS-4	Urban Drainage and Flood Control District Urban Storm Drainage Criteria Manual Volume 3	January 2021
---------	--	--------------

EC-10 Earth Dikes and Drainage Swales (ED/DS)

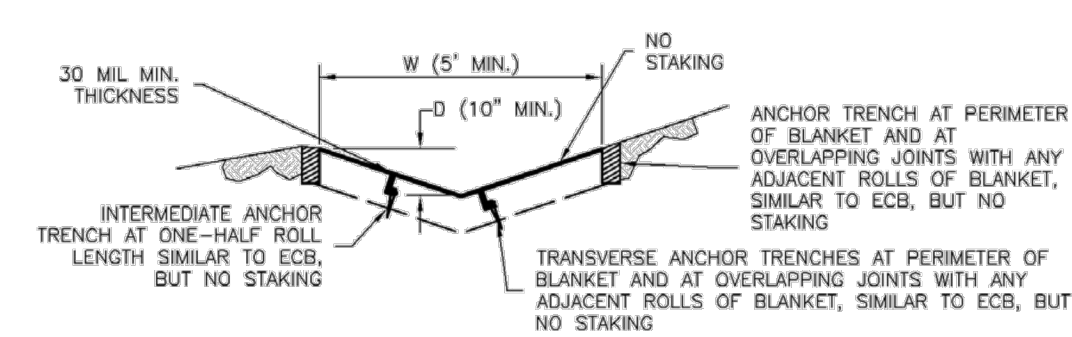

DS-4. SYNTHETIC LINED SWALE

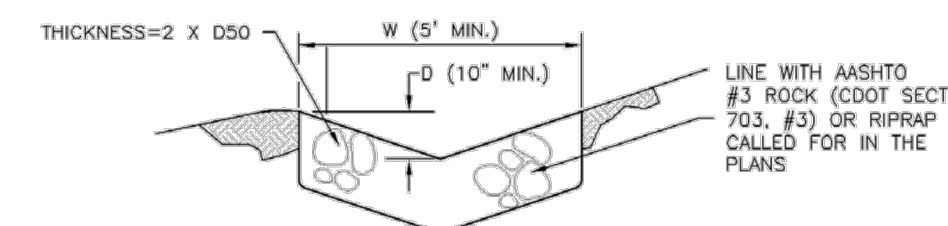

DS-5. RIPRAP LINED SWALE

EARTH DIKE AND DRAINAGE SWALE INSTALLATION NOTES

- SEE SITE PLAN FOR:
 - LOCATION OF DIVERSION SWALE
 - TYPE OF SWALE (UNLINED, COMPACTED AND/OR LINED).
 - LENGTH OF EACH SWALE.
 - DEPTH, D, AND WIDTH, W DIMENSIONS.
 - FOR ECB/TRM LINED DITCH, SEE ECB DETAIL.
 - FOR RIPRAP LINED DITCH, SIZE OF RIPRAP, D50.
- SEE DRAINAGE PLANS FOR DETAILS OF PERMANENT CONVEYANCE FACILITIES AND/OR DIVERSION SWALES EXCEEDING 2-YEAR FLOW RATE OR 10 CFS.
- EARTH DIKES AND SWALES INDICATED ON SWMP PLAN SHALL BE INSTALLED PRIOR TO LAND-DISTURBING ACTIVITIES IN PROXIMITY.
- EMBANKMENT IS TO BE COMPACTED TO 90% OF MAXIMUM DENSITY AND WITHIN 2% OF OPTIMUM MOISTURE CONTENT ACCORDING TO ASTM D1558.
- SWALES ARE TO DRAIN TO A SEDIMENT CONTROL BMP.
- FOR LINED DITCHES, INSTALLATION OF ECB/TRM SHALL CONFORM TO THE REQUIREMENTS OF THE ECB DETAIL.
- WHEN CONSTRUCTION TRAFFIC MUST CROSS A DIVERSION SWALE, INSTALL A TEMPORARY CULVERT WITH A MINIMUM DIAMETER OF 12 INCHES.

ED/DS-4	Urban Drainage and Flood Control District Urban Storm Drainage Criteria Manual Volume 3	November 2010
---------	--	---------------

Temporary and Permanent Seeding (TS/PS) EC-2

Table TS/PS-2. Seeding Dates for Annual and Perennial Grasses

Seeding Dates	Annual Grasses (Numbers in table reference species in Table TS/PS-1)		Perennial Grasses	
	Warm	Cool	Warm	Cool
January 1-March 15			✓	✓
March 16-April 30		1,2,3	✓	✓
May 1-May 15			✓	
May 16-June 30	5			
July 1-July 15	5			
July 16-August 31				
September 1-September 30		6, 7, 8, 9		
October 1-December 31			✓	✓

Mulch

Cover seeded areas with mulch or an appropriate rolled erosion control product to promote establishment of vegetation. Anchor mulch by crimping, netting or use of a non-toxic tackifier. See the USDCM Volume 2 *Revegetation* Chapter and Volume 3 *Mulching BMP Fact Sheet (EC-04)* for additional guidance.

Maintenance and Removal

Monitor and observe seeded areas to identify areas of poor growth or areas that fail to germinate. Reseed and mulch these areas, as needed.

If a temporary annual seed was planted, the area should be reseeded with the desired perennial mix when there will be no further work in the area. To minimize competition between annual and perennial species, the annual mix needs time to mature and die before seeding the perennial mix. To increase success of the perennial mix, it should be seeded during the appropriate seeding dates the second year after the temporary annual mix was seeded. Alternatively, if this timeline is not feasible, the annual mix seed heads should be removed and then the area seeded with the perennial mix.

An area that has been permanently seeded should have a good stand of vegetation within one growing season if irrigated and within three growing seasons without irrigation in Colorado. Reseed portions of the site that fail to germinate or remain bare after the first growing season.

Seeded areas may require irrigation, particularly during extended dry periods. Targeted weed control may also be necessary.

Protect seeded areas from construction equipment and vehicle access.

January 2021	Urban Drainage and Flood Control District Urban Storm Drainage Criteria Manual Volume 3	TS/PS-5
--------------	--	---------

Earth Dikes and Drainage Swales (ED/DS) EC-10

EARTH DIKE AND DRAINAGE SWALE MAINTENANCE NOTES

- INSPECT BMPs EACH WORKDAY, AND MAINTAIN THEM IN EFFECTIVE OPERATING CONDITION. MAINTENANCE OF BMPs SHOULD BE PROACTIVE, NOT REACTIVE. INSPECT BMPs AS SOON AS POSSIBLE (AND ALWAYS WITHIN 24 HOURS) FOLLOWING A STORM THAT CAUSES SURFACE EROSION, AND PERFORM NECESSARY MAINTENANCE.
- FREQUENT OBSERVATIONS AND MAINTENANCE ARE NECESSARY TO MAINTAIN BMPs IN EFFECTIVE OPERATING CONDITION. INSPECTIONS AND CORRECTIVE MEASURES SHOULD BE DOCUMENTED THOROUGHLY.
- WHERE BMPs HAVE FAILED, REPAIR OR REPLACEMENT SHOULD BE INITIATED UPON DISCOVERY OF THE FAILURE.
- SWALES SHALL REMAIN IN PLACE UNTIL THE END OF CONSTRUCTION; IF APPROVED BY LOCAL JURISDICTION, SWALES MAY BE LEFT IN PLACE.
- WHEN A SWALE IS REMOVED, THE DISTURBED AREA SHALL BE COVERED WITH TOPSOIL, SEEDED AND MULCHED OR OTHERWISE STABILIZED IN A MANNER APPROVED BY LOCAL JURISDICTION.

(DETAIL ADAPTED FROM DOUGLAS COUNTY, COLORADO AND THE CITY OF COLORADO SPRINGS, COLORADO, NOT AVAILABLE IN AUTOCAD)

NOTE: MANY JURISDICTIONS HAVE BMP DETAILS THAT VARY FROM USDFCD STANDARD DETAILS. CONSULT WITH LOCAL JURISDICTIONS AS TO WHICH DETAIL SHOULD BE USED WHEN DIFFERENCES ARE NOTED.

November 2010	Urban Drainage and Flood Control District Urban Storm Drainage Criteria Manual Volume 3	ED/DS-5
---------------	--	---------

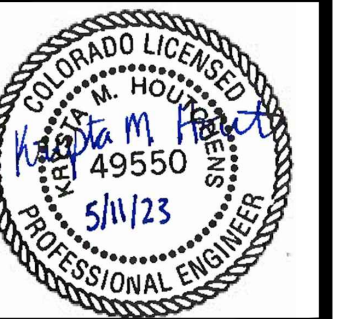

1459 Grand Ave
Des Moines, IA 50309
P: 888-458-6646

2232 - EL PASO, COLORADO
SECURITY BLVD. AND MAIN ST.
EROSION AND STORMWATER CONTROL DETAILS

KG PROJECT TEAM:
RDM:
SDM:
CPM:

REVISIONS	DATE	REVISION DESCRIPTION
1	08/19/22	1ST REVIEW COMMENTS
2	01/06/23	2ND REVIEW COMMENTS
3	04/05/23	3RD REVIEW COMMENTS
4	05/11/23	4TH REVIEW COMMENTS

DATE: 05-11-2023

SHEET NUMBER: C3.6
14 OF 43

PCD FILE NO. PPR-2225

KUM & GO GAS & C-STORE

PART OF THE SOUTHEAST 1/4 OF SECTION 11, TOWNSHIP 15 SOUTH, RANGE 66
WEST OF THE SIXTH PRINCIPAL MERIDIAN,
COUNTY OF EL PASO, STATE OF COLORADO

MAJOR SITE DEVELOPMENT PLAN

SC-8

Sediment Trap (ST)

SC-5 Rock Sock (RS)

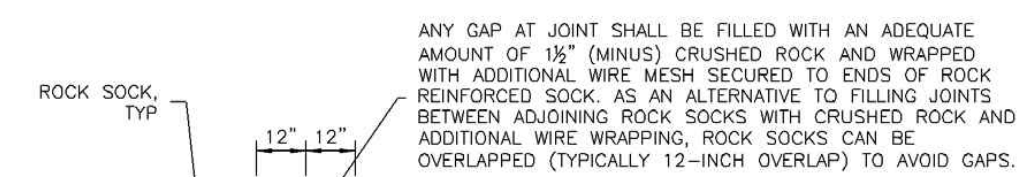
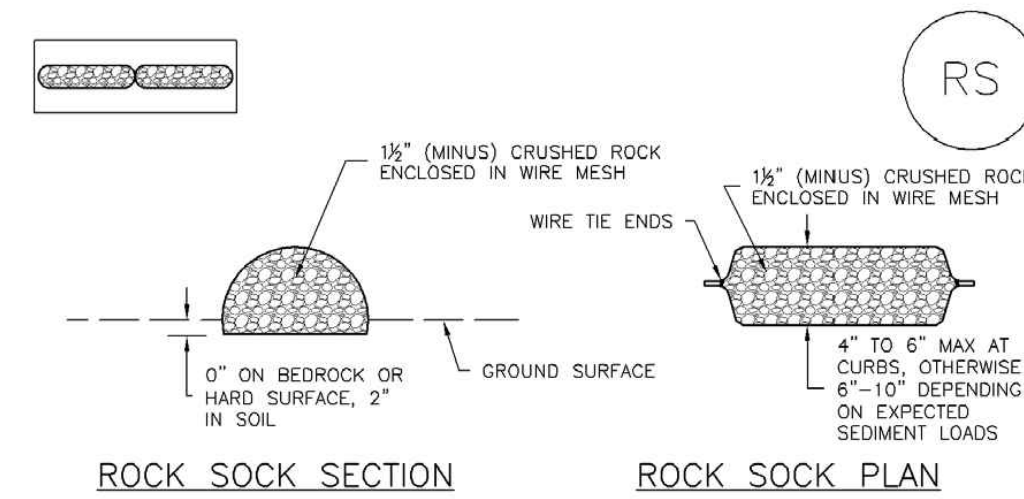

GRADATION TABLE	
SIEVE SIZE	MASS PERCENT PASSING SQUARE MESH SIEVES
NO. 4	
2"	100
1 1/2"	90 - 100
1"	20 - 55
3/4"	0 - 15
3/8"	0 - 5

ROCK SOCK INSTALLATION NOTES

- SEE PLAN VIEW FOR: -LOCATION(S) OF ROCK SOCKS.
- CRUSHED ROCK SHALL BE 1 1/2" (MINUS) IN SIZE WITH A FRACTURED FACE (ALL SIDES) AND SHALL COMPLY WITH GRADATION SHOWN ON THIS SHEET (1 1/2" MINUS).
- WIRE MESH SHALL BE FABRICATED OF 10 GAGE POULTRY MESH, OR EQUIVALENT, WITH A MAXIMUM OPENING OF 1/2". RECOMMENDED MINIMUM ROLL WIDTH OF 48".
- WIRE MESH SHALL BE SECURED USING "HOG RINGS" OR WIRE TIES AT 6" CENTERS ALONG ALL JOINTS AND AT 2" CENTERS ON ENDS OF SOCKS.
- SOME MUNICIPALITIES MAY ALLOW THE USE OF FILTER FABRIC AS AN ALTERNATIVE TO WIRE MESH FOR THE ROCK ENCLOSURE.

RS-1. ROCK SOCK PERIMETER CONTROL

RS-2 Urban Drainage and Flood Control District
Urban Storm Drainage Criteria Manual Volume 3 November 2010

Rock Sock (RS) SC-5

ROCK SOCK MAINTENANCE NOTES

- INSPECT BMPs EACH WORKDAY, AND MAINTAIN THEM IN EFFECTIVE OPERATING CONDITION. MAINTENANCE OF BMPs SHOULD BE PROACTIVE, NOT REACTIVE. INSPECT BMPs AS SOON AS POSSIBLE (AND ALWAYS WITHIN 24 HOURS) FOLLOWING A STORM THAT CAUSES SURFACE EROSION, AND PERFORM NECESSARY MAINTENANCE.
- FREQUENT OBSERVATIONS AND MAINTENANCE ARE NECESSARY TO MAINTAIN BMPs IN EFFECTIVE OPERATING CONDITION. INSPECTIONS AND CORRECTIVE MEASURES SHOULD BE DOCUMENTED THOROUGHLY.
- WHERE BMPs HAVE FAILED, REPAIR OR REPLACEMENT SHOULD BE INITIATED UPON DISCOVERY OF THE FAILURE.
- ROCK SOCKS SHALL BE REPLACED IF THEY BECOME HEAVILY SOILED, OR DAMAGED BEYOND REPAIR.
- SEDIMENT ACCUMULATED UPSTREAM OF ROCK SOCKS SHALL BE REMOVED AS NEEDED TO MAINTAIN FUNCTIONALITY OF THE BMP. TYPICALLY WHEN DEPTH OF ACCUMULATED SEDIMENTS IS APPROXIMATELY 1/2 OF THE HEIGHT OF THE ROCK SOCK.
- ROCK SOCKS ARE TO REMAIN IN PLACE UNTIL THE UPSTREAM DISTURBED AREA IS STABILIZED AND APPROVED BY THE LOCAL JURISDICTION.
- WHEN ROCK SOCKS ARE REMOVED, ALL DISTURBED AREAS SHALL BE COVERED WITH TOPSOIL, SEEDED AND MULCHED OR OTHERWISE STABILIZED AS APPROVED BY LOCAL JURISDICTION.

(DETAILS ADAPTED FROM TOWN OF PARKER, COLORADO AND CITY OF AURORA, COLORADO, NOT AVAILABLE IN AUTOCAD)
NOTE: MANY JURISDICTIONS HAVE BMP DETAILS THAT VARY FROM UDFCD STANDARD DETAILS. CONSULT WITH LOCAL JURISDICTIONS AS TO WHICH DETAIL SHOULD BE USED WHEN DIFFERENCES ARE NOTED.

NOTE: THE DETAILS INCLUDED WITH THIS FACT SHEET SHOW COMMONLY USED, CONVENTIONAL METHODS OF ROCK SOCK INSTALLATION IN THE DENVER METROPOLITAN AREA. THERE ARE MANY OTHER SIMILAR PROPRIETARY PRODUCTS ON THE MARKET. UDFCD NEITHER ENDORSES NOR DISCOURAGES USE OF PROPRIETARY PROTECTION PRODUCTS; HOWEVER, IN THE EVENT PROPRIETARY METHODS ARE USED, THE APPROPRIATE DETAIL FROM THE MANUFACTURER MUST BE INCLUDED IN THE SWMP AND THE BMP MUST BE INSTALLED AND MAINTAINED AS SHOWN IN THE MANUFACTURER'S DETAILS.

November 2010 Urban Drainage and Flood Control District RS-3
Urban Storm Drainage Criteria Manual Volume 3

SM-3 Construction Fence (CF)

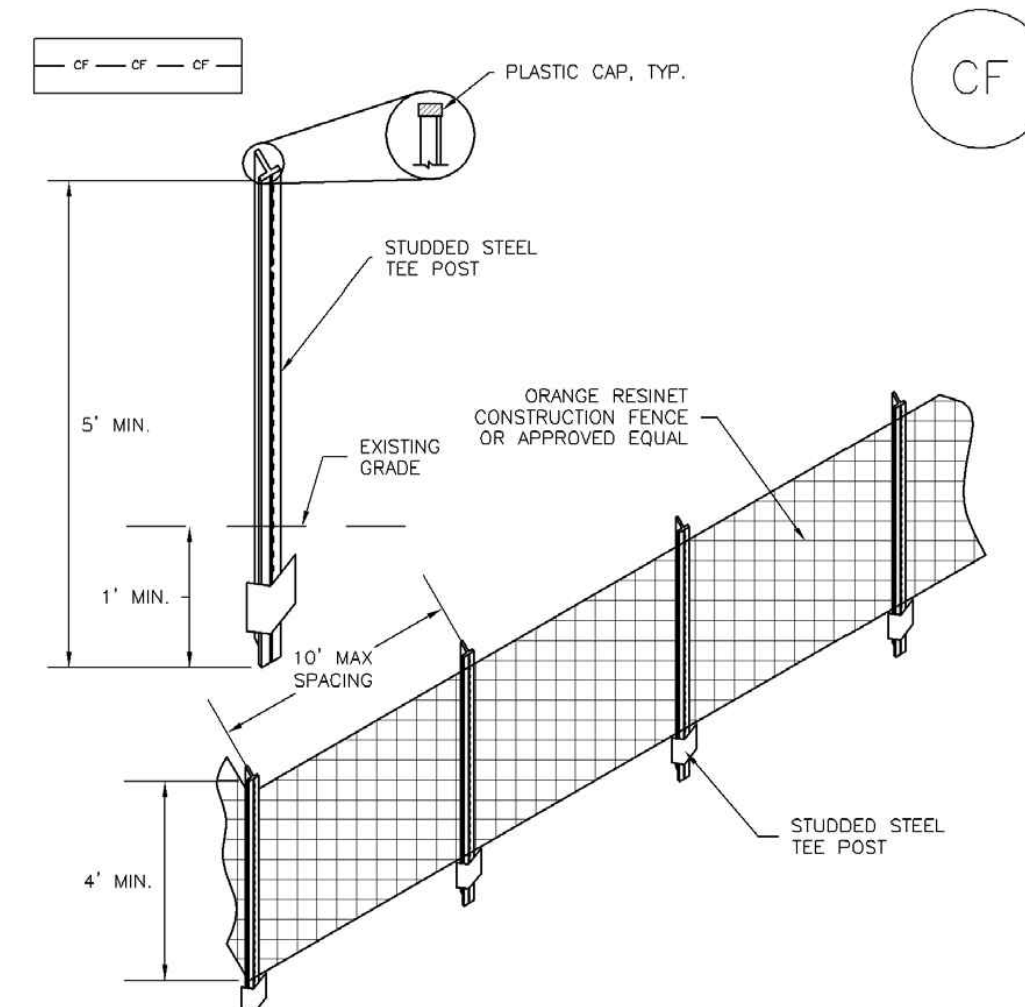

CF-1. PLASTIC MESH CONSTRUCTION FENCE

CONSTRUCTION FENCE INSTALLATION NOTES

- SEE PLAN VIEW FOR: -LOCATION OF CONSTRUCTION FENCE.
- CONSTRUCTION FENCE SHOWN SHALL BE INSTALLED PRIOR TO ANY LAND DISTURBING ACTIVITIES.
- CONSTRUCTION FENCE SHALL BE COMPOSED OF ORANGE, CONTRACTOR-GRADE MATERIAL THAT IS AT LEAST 4" HIGH. METAL POSTS SHOULD HAVE A PLASTIC CAP FOR SAFETY.
- STUDDED STEEL TEE POSTS SHALL BE UTILIZED TO SUPPORT THE CONSTRUCTION FENCE. MAXIMUM SPACING FOR STEEL TEE POSTS SHALL BE 10'.
- CONSTRUCTION FENCE SHALL BE SECURELY FASTENED TO THE TOP, MIDDLE, AND BOTTOM OF EACH POST.

CONSTRUCTION FENCE MAINTENANCE NOTES

- INSPECT BMPs EACH WORKDAY, AND MAINTAIN THEM IN EFFECTIVE OPERATING CONDITION. MAINTENANCE OF BMPs SHOULD BE PROACTIVE, NOT REACTIVE. INSPECT BMPs AS SOON AS POSSIBLE (AND ALWAYS WITHIN 24 HOURS) FOLLOWING A STORM THAT CAUSES SURFACE EROSION, AND PERFORM NECESSARY MAINTENANCE.
- FREQUENT OBSERVATIONS AND MAINTENANCE ARE NECESSARY TO MAINTAIN BMPs IN EFFECTIVE OPERATING CONDITION. INSPECTIONS AND CORRECTIVE MEASURES SHOULD BE DOCUMENTED THOROUGHLY.
- WHERE BMPs HAVE FAILED, REPAIR OR REPLACEMENT SHOULD BE INITIATED UPON DISCOVERY OF THE FAILURE.
- CONSTRUCTION FENCE SHALL BE REPAIRED OR REPLACED WHEN THERE ARE SIGNS OF DAMAGE SUCH AS RIPS OR SAGS. CONSTRUCTION FENCE IS TO REMAIN IN PLACE UNTIL THE UPSTREAM DISTURBED AREA IS STABILIZED AND APPROVED BY THE LOCAL JURISDICTION.
- WHEN CONSTRUCTION FENCES ARE REMOVED, ALL DISTURBED AREAS ASSOCIATED WITH THE INSTALLATION, MAINTENANCE, AND/OR REMOVAL OF THE FENCE SHALL BE COVERED WITH TOPSOIL, SEEDED AND MULCHED, OR OTHERWISE STABILIZED AS APPROVED BY LOCAL JURISDICTION.

(DETAILS ADAPTED FROM TOWN OF PARKER, COLORADO, NOT AVAILABLE IN AUTOCAD)
NOTE: MANY JURISDICTIONS HAVE BMP DETAILS THAT VARY FROM UDFCD STANDARD DETAILS. CONSULT WITH LOCAL JURISDICTIONS AS TO WHICH DETAIL SHOULD BE USED WHEN DIFFERENCES ARE NOTED.

November 2010 Urban Drainage and Flood Control District CF-3
Urban Storm Drainage Criteria Manual Volume 3

Stabilized Staging Area (SSA) SM-6

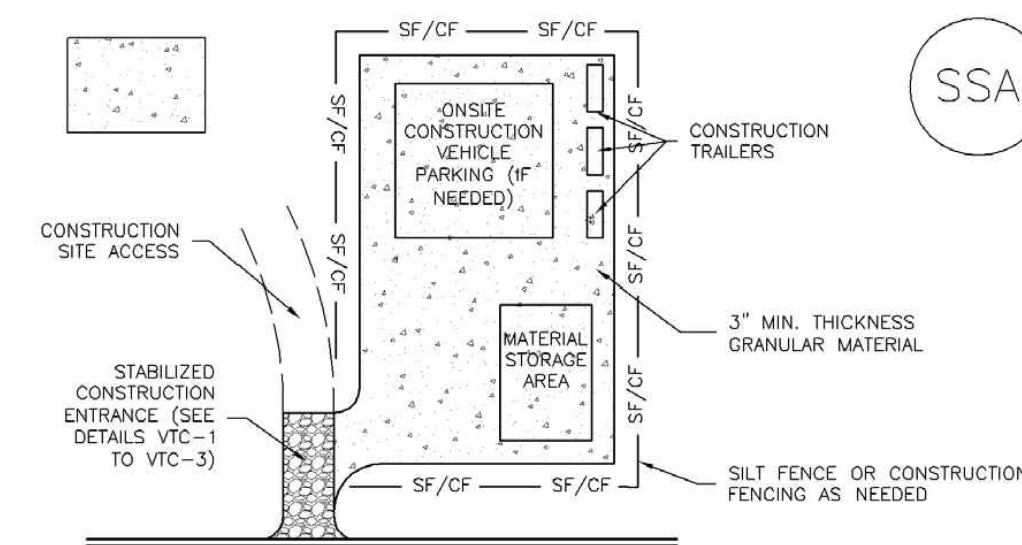

SSA-1. STABILIZED STAGING AREA

STABILIZED STAGING AREA INSTALLATION NOTES

- SEE PLAN VIEW FOR: -LOCATION OF STAGING AREA(S). -CONTRACTOR MAY ADJUST LOCATION AND SIZE OF STAGING AREA WITH APPROVAL FROM THE LOCAL JURISDICTION.
- STABILIZED STAGING AREA SHOULD BE APPROPRIATE FOR THE NEEDS OF THE SITE. OVERSIZING RESULTS IN A LARGER AREA TO STABILIZE FOLLOWING CONSTRUCTION.
- STAGING AREA SHALL BE STABILIZED PRIOR TO OTHER OPERATIONS ON THE SITE.
- THE STABILIZED STAGING AREA SHALL CONSIST OF A MINIMUM 3" THICK GRANULAR MATERIAL.
- UNLESS OTHERWISE SPECIFIED BY LOCAL JURISDICTION, ROCK SHALL CONSIST OF DOT SECT. #703, AASHTO #3 COARSE AGGREGATE OR 6" (MINUS) ROCK.
- ADDITIONAL PERIMETER BMPs MAY BE REQUIRED INCLUDING BUT NOT LIMITED TO SILT FENCE AND CONSTRUCTION FENCING.

STABILIZED STAGING AREA MAINTENANCE NOTES

- INSPECT BMPs EACH WORKDAY, AND MAINTAIN THEM IN EFFECTIVE OPERATING CONDITION. MAINTENANCE OF BMPs SHOULD BE PROACTIVE, NOT REACTIVE. INSPECT BMPs AS SOON AS POSSIBLE (AND ALWAYS WITHIN 24 HOURS) FOLLOWING A STORM THAT CAUSES SURFACE EROSION, AND PERFORM NECESSARY MAINTENANCE.
- FREQUENT OBSERVATIONS AND MAINTENANCE ARE NECESSARY TO MAINTAIN BMPs IN EFFECTIVE OPERATING CONDITION. INSPECTIONS AND CORRECTIVE MEASURES SHOULD BE DOCUMENTED THOROUGHLY.
- WHERE BMPs HAVE FAILED, REPAIR OR REPLACEMENT SHOULD BE INITIATED UPON DISCOVERY OF THE FAILURE.
- ROCK SHALL BE REAPPLIED OR REGRADED AS NECESSARY IF RUTTING OCCURS OR UNDERLYING SUBGRADE BECOMES EXPOSED.

November 2010 Urban Drainage and Flood Control District SSA-3
Urban Storm Drainage Criteria Manual Volume 3

Stabilized Staging Area (SSA) SM-6

STABILIZED STAGING AREA MAINTENANCE NOTES

- STABILIZED STAGING AREA SHALL BE ENLARGED IF NECESSARY TO CONTAIN PARKING, STORAGE, AND UNLOADING/LOADING OPERATIONS.
 - THE STABILIZED STAGING AREA SHALL BE REMOVED AT THE END OF CONSTRUCTION THE GRANULAR MATERIAL SHALL BE REMOVED OR, IF APPROVED BY THE LOCAL JURISDICTION, USED ON SITE, AND THE AREA COVERED WITH TOPSOIL, SEEDED AND MULCHED OR OTHERWISE STABILIZED IN A MANNER APPROVED BY LOCAL JURISDICTION.
- NOTE: MANY MUNICIPALITIES PROHIBIT THE USE OF RECYCLED CONCRETE AS GRANULAR MATERIAL FOR STABILIZED STAGING AREAS DUE TO DIFFICULTIES WITH RE-ESTABLISHMENT OF VEGETATION IN AREAS WHERE RECYCLED CONCRETE WAS PLACED.
- NOTE: MANY JURISDICTIONS HAVE BMP DETAILS THAT VARY FROM UDFCD STANDARD DETAILS. CONSULT WITH LOCAL JURISDICTIONS AS TO WHICH DETAIL SHOULD BE USED WHEN DIFFERENCES ARE NOTED.

(DETAILS ADAPTED FROM DOUGLAS COUNTY, COLORADO, NOT AVAILABLE IN AUTOCAD)

November 2010 Urban Drainage and Flood Control District SSA-4
Urban Storm Drainage Criteria Manual Volume 3

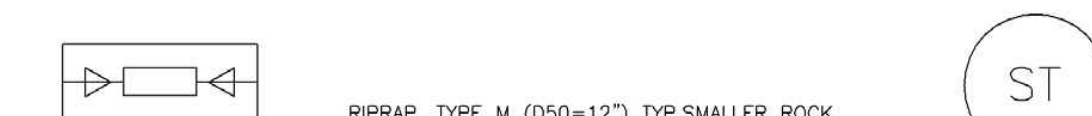

SEDIMENT TRAP PLAN

SECTION A

SECTION B

ST-1. SEDIMENT TRAP

ST-2 Urban Drainage and Flood Control District
Urban Storm Drainage Criteria Manual Volume 3 November 2010

Sediment Trap (ST) SC-8

SEDIMENT TRAP INSTALLATION NOTES

- SEE PLAN VIEW FOR: -LOCATION, LENGTH AND WIDTH OF SEDIMENT TRAP.
- ONLY USE FOR DRAINAGE AREAS LESS THAN 1 ACRE.
- SEDIMENT TRAPS SHALL BE INSTALLED PRIOR TO ANY UPGRADED LAND-DISTURBING ACTIVITIES.
- SEDIMENT TRAP BERM SHALL BE CONSTRUCTED FROM MATERIAL FROM EXCAVATION. THE BERM SHALL BE COMPACTED TO 95% OF THE MAXIMUM DENSITY IN ACCORDANCE WITH ASTM D698.
- SEDIMENT TRAP OUTLET TO BE CONSTRUCTED OF RIPRAP, TYPE M (0.50-1.2") TYP. SMALLER ROCK SIZE MAY BE ALLOWABLE FOR SMALLER TRAPS IF APPROVED BY LOCAL JURISDICTION.
- THE TOP OF THE EARTHEN BERM SHALL BE A MINIMUM OF 6" HIGHER THAN THE TOP OF THE RIPRAP OUTLET STRUCTURE.
- THE ENDS OF THE RIPRAP OUTLET STRUCTURE SHALL BE A MINIMUM OF 6" HIGHER THAN THE CENTER OF THE OUTLET STRUCTURE.

SEDIMENT TRAP MAINTENANCE NOTES

- INSPECT BMPs EACH WORKDAY, AND MAINTAIN THEM IN EFFECTIVE OPERATING CONDITION. MAINTENANCE OF BMPs SHOULD BE PROACTIVE, NOT REACTIVE. INSPECT BMPs AS SOON AS POSSIBLE (AND ALWAYS WITHIN 24 HOURS) FOLLOWING A STORM THAT CAUSES SURFACE EROSION, AND PERFORM NECESSARY MAINTENANCE.
- FREQUENT OBSERVATIONS AND MAINTENANCE ARE NECESSARY TO MAINTAIN BMPs IN EFFECTIVE OPERATING CONDITION. INSPECTIONS AND CORRECTIVE MEASURES SHOULD BE DOCUMENTED THOROUGHLY.
- WHERE BMPs HAVE FAILED, REPAIR OR REPLACEMENT SHOULD BE INITIATED UPON DISCOVERY OF THE FAILURE.
- REMOVE SEDIMENT ACCUMULATED IN TRAP AS NEEDED TO MAINTAIN THE FUNCTIONALITY OF THE BMP. TYPICALLY WHEN THE SEDIMENT DEPTH REACHES 1/2 THE HEIGHT OF THE RIPRAP OUTLET.
- SEDIMENT TRAPS SHALL REMAIN IN PLACE UNTIL THE UPSTREAM DISTURBED AREA IS STABILIZED AND APPROVED BY THE LOCAL JURISDICTION.
- WHEN SEDIMENT TRAPS ARE REMOVED, THE DISTURBED AREA SHALL BE COVERED WITH TOPSOIL, SEEDED AND MULCHED OR OTHERWISE STABILIZED IN A MANNER APPROVED BY THE LOCAL JURISDICTION.

(DETAILS ADAPTED FROM DOUGLAS COUNTY, COLORADO, NOT AVAILABLE IN AUTOCAD)
NOTE: MANY JURISDICTIONS HAVE BMP DETAILS THAT VARY FROM UDFCD STANDARD DETAILS. CONSULT WITH LOCAL JURISDICTIONS AS TO WHICH DETAIL SHOULD BE USED WHEN DIFFERENCES ARE NOTED.

November 2010 Urban Drainage and Flood Control District ST-3
Urban Storm Drainage Criteria Manual Volume 3

EES
ENTITLEMENT AND
ENGINEERING
SOLUTIONS, INC.
3801 E. Florida Avenue, Suite 425
Denver, CO 80210
303-572-1997 www.ees.us.com

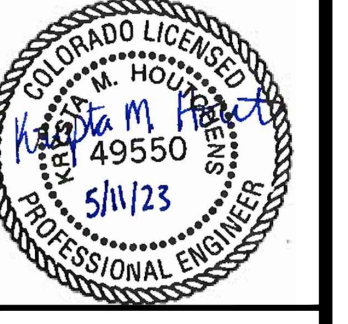

1459 Grand Ave
Des Moines, IA 50309
P: 888-458-6646

2232 - EL PASO, COLORADO
SECURITY BLVD. AND MAIN ST.
EROSION AND STORMWATER CONTROL DETAILS

KG PROJECT TEAM:
RDM:
SDM:
CPM:

REVISION	DATE	REVISION DESCRIPTION
1	08/19/22	1ST REVIEW COMMENTS
2	01/06/23	2ND REVIEW COMMENTS
3	04/05/23	3RD REVIEW COMMENTS
4	05/11/23	4TH REVIEW COMMENTS

DATE: 05-11-2023

SHEET NUMBER:
C3.7
15 OF 43

PCD FILE NO. PPR-2225

KUM & GO GAS & C-STORE

PART OF THE SOUTHEAST 1/4 OF SECTION 11, TOWNSHIP 15 SOUTH, RANGE 66
WEST OF THE SIXTH PRINCIPAL MERIDIAN,
COUNTY OF EL PASO, STATE OF COLORADO

MAJOR SITE DEVELOPMENT PLAN

MM-2 Stockpile Management (SM)

When the stockpile is no longer needed, properly dispose of excess materials and revegetate or otherwise stabilize the ground surface where the stockpile was located.

Stockpile Management (SP)

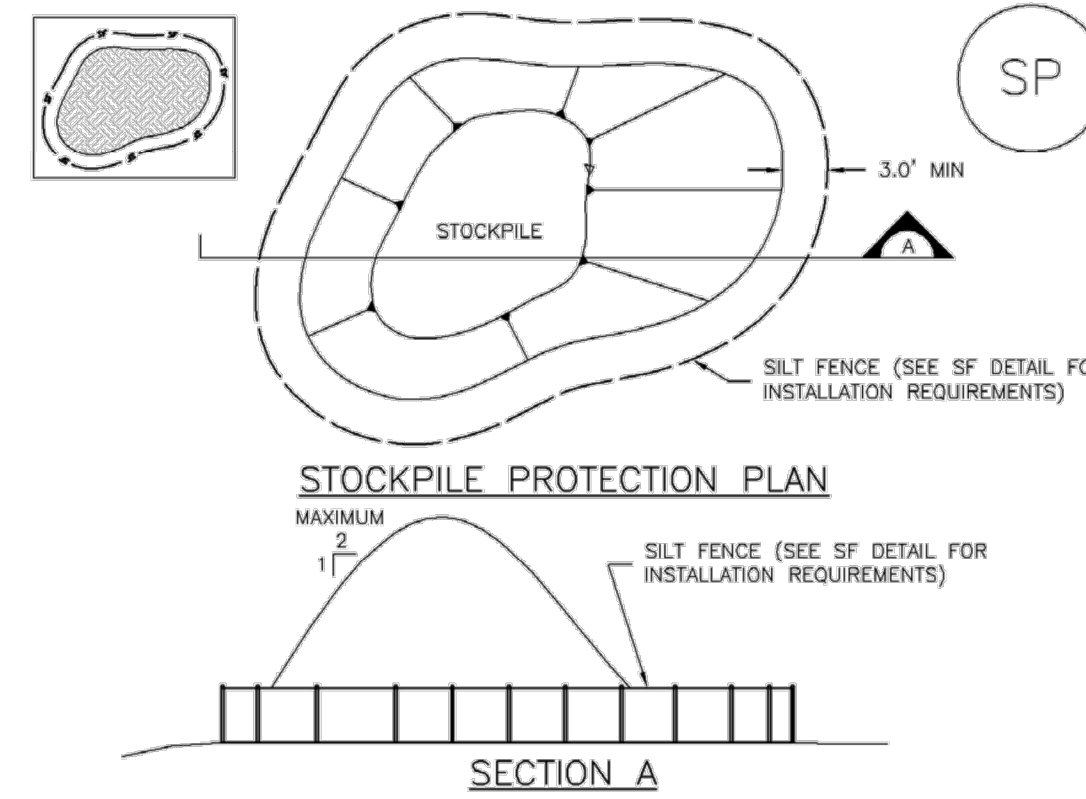

SP-1. STOCKPILE PROTECTION

STOCKPILE PROTECTION INSTALLATION NOTES

- SEE PLAN VIEW FOR:
 - LOCATION OF STOCKPILES.
 - TYPE OF STOCKPILE PROTECTION.
- INSTALL PERIMETER CONTROLS IN ACCORDANCE WITH THEIR RESPECTIVE DESIGN DETAILS. SILT FENCE IS SHOWN IN THE STOCKPILE PROTECTION DETAILS; HOWEVER, OTHER TYPES OF PERIMETER CONTROLS INCLUDING SEDIMENT CONTROL LOGS OR ROCK SOCKS MAY BE SUITABLE IN SOME CIRCUMSTANCES. CONSIDERATIONS FOR DETERMINING THE APPROPRIATE TYPE OF PERIMETER CONTROL FOR A STOCKPILE INCLUDE WHETHER THE STOCKPILE IS LOCATED ON A PERVIOUS OR IMPVIOUS SURFACE, THE RELATIVE HEIGHTS OF THE PERIMETER CONTROL AND STOCKPILE, THE ABILITY OF THE PERIMETER CONTROL TO CONTAIN THE STOCKPILE WITHOUT FAILING IN THE EVENT THAT MATERIAL FROM THE STOCKPILE SHIFTS OR SLUMPS AGAINST THE PERIMETER, AND OTHER FACTORS.
- STABILIZE THE STOCKPILE SURFACE WITH SURFACE ROUGHENING, TEMPORARY SEEDING AND MULCHING, EROSION CONTROL BLANKETS, OR SOIL BINDERS. SOILS STOCKPILED FOR AN EXTENDED PERIOD (TYPICALLY FOR MORE THAN 60 DAYS) SHOULD BE SEEDED AND MULCHED WITH A TEMPORARY GRASS COVER ONCE THE STOCKPILE IS PLACED (TYPICALLY WITHIN 14 DAYS). USE OF MULCH ONLY OR A SOIL BINDER IS ACCEPTABLE IF THE STOCKPILE WILL BE IN PLACE FOR A MORE LIMITED TIME PERIOD (TYPICALLY 30-60 DAYS).
- FOR TEMPORARY STOCKPILES ON THE INTERIOR PORTION OF A CONSTRUCTION SITE, WHERE OTHER DOWNGRADE CONTROLS, INCLUDING PERIMETER CONTROL, ARE IN PLACE, STOCKPILE PERIMETER CONTROLS MAY NOT BE REQUIRED.

STOCKPILE PROTECTION MAINTENANCE NOTES

- INSPECT BMPs EACH WORKDAY, AND MAINTAIN THEM IN EFFECTIVE OPERATING CONDITION. MAINTENANCE OF BMPs SHOULD BE PROACTIVE, NOT REACTIVE. INSPECT BMPs AS SOON AS POSSIBLE (AND ALWAYS WITHIN 24 HOURS) FOLLOWING A STORM THAT CAUSES SURFACE EROSION, AND PERFORM NECESSARY MAINTENANCE.
- FREQUENT OBSERVATIONS AND MAINTENANCE ARE NECESSARY TO MAINTAIN BMPs IN EFFECTIVE OPERATING CONDITION. INSPECTIONS AND CORRECTIVE MEASURES SHOULD BE DOCUMENTED THOROUGHLY.
- WHERE BMPs HAVE FAILED, REPAIR OR REPLACEMENT SHOULD BE INITIATED UPON DISCOVERY OF THE FAILURE.

STOCKPILE PROTECTION MAINTENANCE NOTES

- IF PERIMETER PROTECTION MUST BE MOVED TO ACCESS SOIL STOCKPILE, REPLACE PERIMETER CONTROLS BY THE END OF THE WORKDAY.
- STOCKPILE PERIMETER CONTROLS CAN BE REMOVED ONCE ALL THE MATERIAL FROM THE STOCKPILE HAS BEEN USED.

(DETAILS ADAPTED FROM PARKER, COLORADO, NOT AVAILABLE IN AUTOCAD)

NOTE: MANY JURISDICTIONS HAVE BMP DETAILS THAT VARY FROM UDPCD STANDARD DETAILS. CONSULT WITH LOCAL JURISDICTIONS AS TO WHICH DETAIL SHOULD BE USED WHEN DIFFERENCES ARE NOTED.

SP-2 Urban Drainage and Flood Control District
Urban Storm Drainage Criteria Manual Volume 3 November 2010

November 2010 Urban Drainage and Flood Control District
Urban Storm Drainage Criteria Manual Volume 3

SP-4 Urban Drainage and Flood Control District
Urban Storm Drainage Criteria Manual Volume 3 November 2010

Stockpile Management (SP)

MM-2

MM-2

Stockpile Management (SM)

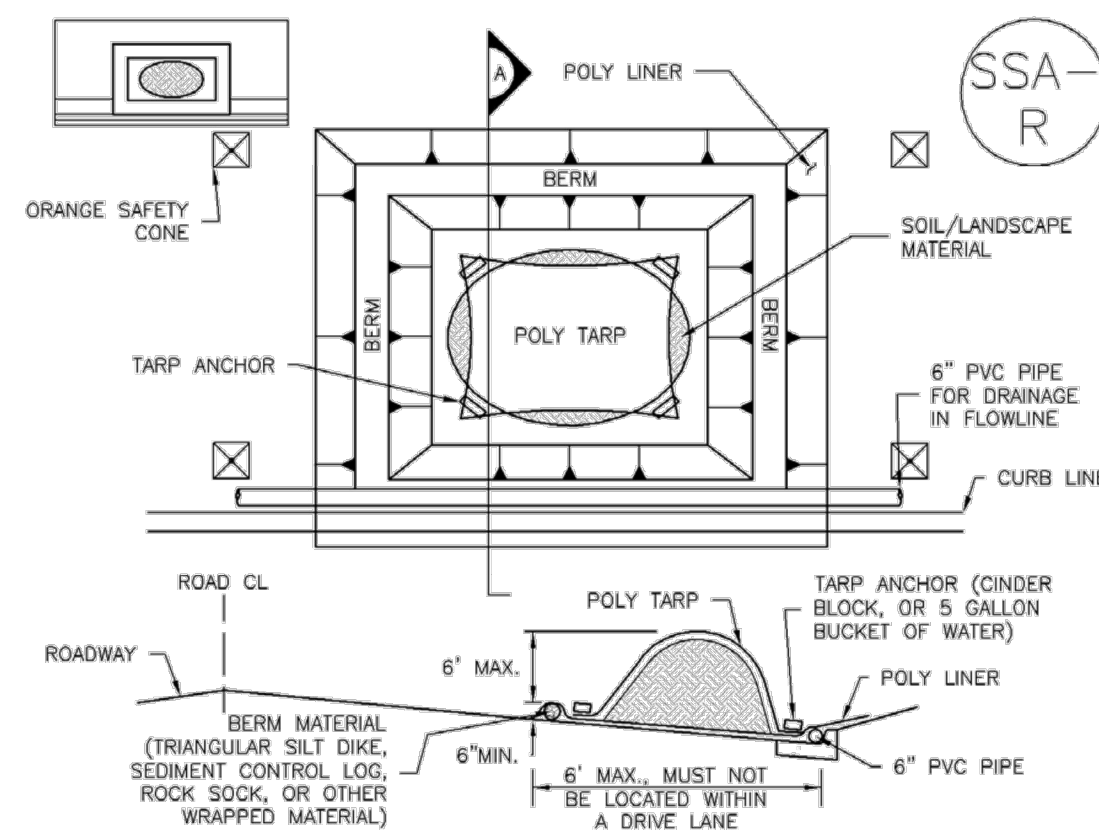

SP-2. MATERIALS STAGING IN ROADWAY

MATERIALS STAGING IN ROADWAYS INSTALLATION NOTES

- SEE PLAN VIEW FOR:
 - LOCATION OF MATERIAL STAGING AREA(S).
 - CONTRACTOR MAY ADJUST LOCATION AND SIZE OF STAGING AREA WITH APPROVAL FROM THE LOCAL JURISDICTION.
- FEATURE MUST BE INSTALLED PRIOR TO EXCAVATION, EARTHWORK OR DELIVERY OF MATERIALS.
- MATERIALS MUST BE STATIONED ON THE POLY LINER. ANY INCIDENTAL MATERIALS DEPOSITED ON PAVED SECTION OR ALONG CURB LINE MUST BE CLEANED UP PROMPTLY.
- POLY LINER AND TARP COVER SHOULD BE OF SIGNIFICANT THICKNESS TO PREVENT DAMAGE OR LOSS OF INTEGRITY.
- SAND BAGS MAY BE SUBSTITUTED TO ANCHOR THE COVER TARP OR PROVIDE BERMING UNDER THE BASE LINER.
- FEATURE IS NOT INTENDED FOR USE WITH WET MATERIAL THAT WILL BE DRAINING AND/OR SPREADING OUT ON THE POLY LINER OR FOR DEMOLITION MATERIALS.
- THIS FEATURE CAN BE USED FOR:
 - UTILITY REPAIRS.
 - WHEN OTHER STAGING LOCATIONS AND OPTIONS ARE LIMITED.
 - OTHER LIMITED APPLICATION AND SHORT DURATION STAGING.

MATERIALS STAGING IN ROADWAY MAINTENANCE NOTES

- INSPECT BMPs EACH WORKDAY, AND MAINTAIN THEM IN EFFECTIVE OPERATING CONDITION. MAINTENANCE OF BMPs SHOULD BE PROACTIVE, NOT REACTIVE. INSPECT BMPs AS SOON AS POSSIBLE (AND ALWAYS WITHIN 24 HOURS) FOLLOWING A STORM THAT CAUSES SURFACE EROSION, AND PERFORM NECESSARY MAINTENANCE.
- FREQUENT OBSERVATIONS AND MAINTENANCE ARE NECESSARY TO MAINTAIN BMPs IN EFFECTIVE OPERATING CONDITION. INSPECTIONS AND CORRECTIVE MEASURES SHOULD BE DOCUMENTED THOROUGHLY.
- WHERE BMPs HAVE FAILED, REPAIR OR REPLACEMENT SHOULD BE INITIATED UPON DISCOVERY OF THE FAILURE.
- INSPECT PVC PIPE ALONG CURB LINE FOR CLOGGING AND DEBRIS. REMOVE OBSTRUCTIONS PROMPTLY.
- CLEAN MATERIAL FROM PAVED SURFACES BY SWEEPING OR VACUUMING.

NOTE: MANY JURISDICTIONS HAVE BMP DETAILS THAT VARY FROM UDPCD STANDARD DETAILS. CONSULT WITH LOCAL JURISDICTIONS AS TO WHICH DETAIL SHOULD BE USED WHEN DIFFERENCES ARE NOTED.

(DETAILS ADAPTED FROM AURORA, COLORADO)

November 2010 Urban Drainage and Flood Control District
Urban Storm Drainage Criteria Manual Volume 3 SP-5

SP-6 Urban Drainage and Flood Control District
Urban Storm Drainage Criteria Manual Volume 3 November 2010

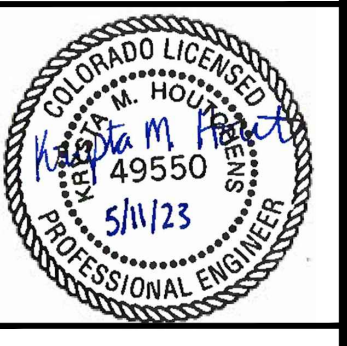

1459 Grand Ave
Des Moines, IA 50309
P: 888-458-6646

2232 - EL PASO, COLORADO
SECURITY BLVD. AND MAIN ST.
EROSION AND STORMWATER CONTROL DETAILS

KG PROJECT TEAM:
RDM:
SDM:
CPM:

REVISION	DATE	REVISION DESCRIPTION
1	08/19/22	1ST REVIEW COMMENTS
2	01/06/23	2ND REVIEW COMMENTS
3	04/05/23	3RD REVIEW COMMENTS
4	05/11/23	4TH REVIEW COMMENTS

DATE: 05-11-2023

SHEET NUMBER: C3.8

16 OF 43

PCD FILE NO. PPR-2225

P:\KUM & GO\CO. EL PASO COUNTY_ 2232_MAIN AND SECURITY\08 CAD\GESC02232_16 - GESC DETAILS.dwg

KUM & GO GAS & C-STORE

PART OF THE SOUTHEAST 1/4 OF SECTION 11, TOWNSHIP 15 SOUTH, RANGE 66
 WEST OF THE SIXTH PRINCIPAL MERIDIAN,
 COUNTY OF EL PASO, STATE OF COLORADO
MAJOR SITE DEVELOPMENT PLAN

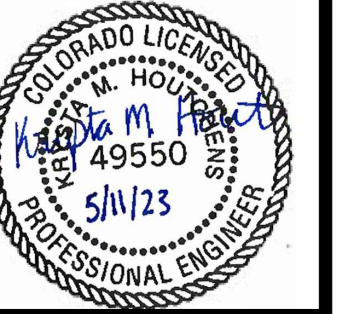

1459 Grand Ave
 Des Moines, IA 50309
 P: 888-458-6646

2232 - EL PASO, COLORADO
 SECURITY BLVD. AND MAIN ST.
STORM SEWER PLAN

KG PROJECT TEAM:
 RDM:
 SDM:
 CPM:

REVISION	DATE	DESCRIPTION
1	08/19/22	1ST REVIEW COMMENTS
2	01/09/23	2ND REVIEW COMMENTS
3	04/05/23	3RD REVIEW COMMENTS
4	05/11/23	4TH REVIEW COMMENTS

DATE: 05-11-2023
 SHEET NUMBER:

C4.1
 17 OF 43

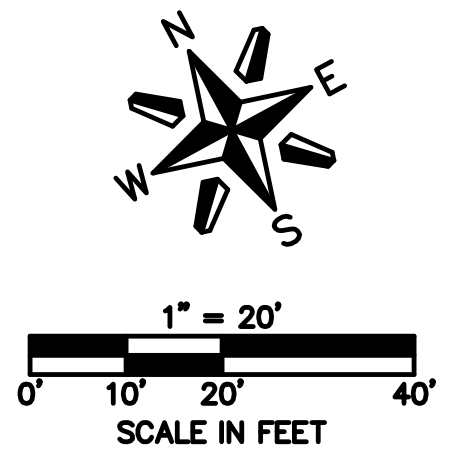
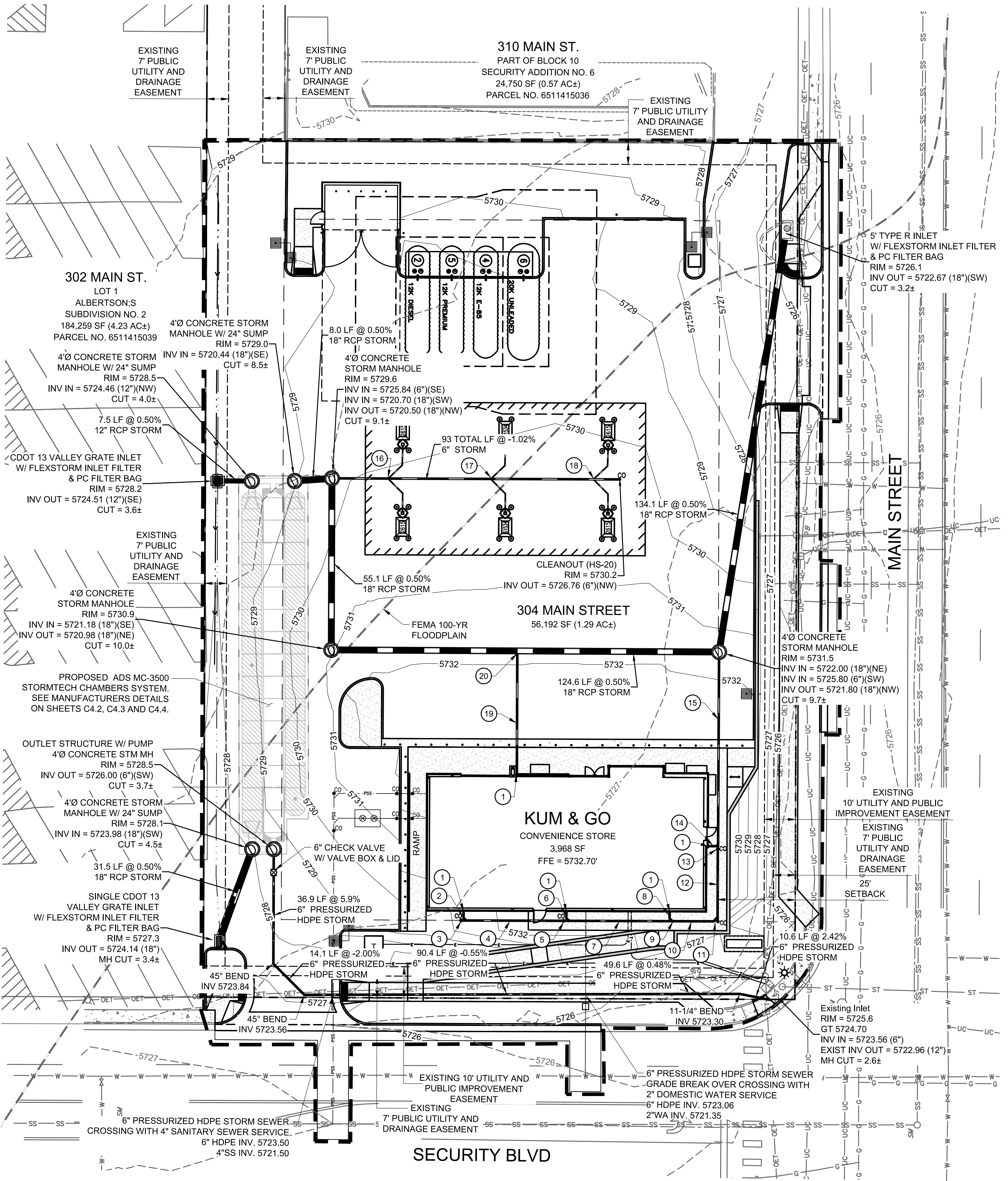

STORM SEWER PLAN LEGEND

— G — G — G — G — G — G —	EXISTING GAS
— SS — SS — SS — SS — SS —	EXISTING SANITARY SEWER
— ST — ST — ST — ST — ST —	EXISTING STORM SEWER
— OET — OET — OET — OET — OET —	EXISTING OVERHEAD ELECTRICAL AND TELECOMMUNICATIONS
— UC — UC — UC — UC — UC —	EXISTING UNDERGROUND TELECOMMUNICATIONS
— W — W — W — W — W — W —	EXISTING WATER
— — — — —	CONSTRUCTION / DISTURBANCE LIMITS
— — — — —	PROPERTY BOUNDARY
— — — — —	EXISTING EASEMENT
— — — — —	EXISTING FLOODPLAIN
— — — — —	EXISTING CURB & GUTTER
— — — — —	EXISTING MAJOR CONTOUR
— — — — —	EXISTING MINOR CONTOUR
— — — — —	PROPOSED MAJOR CONTOUR
— — — — —	PROPOSED MINOR CONTOUR
— — — — —	PROPOSED CURB & GUTTER
— — — — —	PROPOSED BUILDING
— — — — —	PROPOSED SURFACE FLOW LINE
— — — — —	PROPOSED STORM SEWER
⊙	EXISTING STORM SEWER MANHOLE/INLET
⊙	PROPOSED STORM SEWER MANHOLE/INLET
☀	EXISTING STREET LIGHTING
⊕	EXISTING FIRE HYDRANT
⊕	EXISTING SIGNAGE
⊕	PROPOSED SITE LIGHTING

BENCHMARK:

ELEVATIONS ARE BASED UPON COLORADO SPRINGS UTILITIES FIRMS CONTROL MONUMENT SE09, BEING A 2-INCH DIAMETER ALUMINUM CAP STAMPED "CSU FIRMS CONTROL SE09" ON THE EAST CORNER OF THE CONCRETE BASE OF A TELEPHONE RELAY BOX AT THE EAST CORNER OF 226 MAIN STREET, ABOUT 3 FEET NORTHWEST OF THE NORTHWEST CURB OF MAIN STREET, AND ABOUT 205 FEET SOUTHWEST OF THE SOUTHWEST CURB LINE OF SECURITY BOULEVARD. CITY ELEVATION: 5726.76 (NGVD 29)

PRIVATE ROOF DRAIN APPURTENANCES NOTES:

- PROPOSED 6" ROOF DRAIN DOWN SPOUT BUILDING CONNECTION. REFER TO ARCHITECTURAL PLANS FOR DETAILS AND INFORMATION REGARDING POINT OF CONNECTION / CONTINUATION AT THE BUILDING. 6" INV.=5729.20
- PROPOSED 6" ASTM 3034 SDR-35 PVC ROOF DRAIN 2.5 LF @ 2.0%
- PROPOSED 6" STORM CLEANOUT WITH WYE CONNECTION (E) RIM EL.=5831.20 INV.=5729.16
- PROPOSED 6" ASTM 3034 SDR-35 PVC ROOF DRAIN 31.2 LF @ 2.0%
- PROPOSED 6" STORM CLEANOUT WITH WYE CONNECTION (E) RIM EL.=5732.65 INV.=5728.51
- PROPOSED 6" ASTM 3034 SDR-35 PVC ROOF DRAIN 2.5 LF @ 21.0%
- PROPOSED 6" ASTM 3034 SDR-35 PVC ROOF DRAIN 33.2 LF @ 2.0%
- PROPOSED 6" ASTM 3034 SDR-35 PVC ROOF DRAIN 2.5 LF @ 40.0%
- PROPOSED 6" WYE CONNECTION INV.=5727.81
- PROPOSED 6" ASTM 3034 SDR-35 PVC ROOF DRAIN 13.1 LF @ 2.0%
- PROPOSED 6" STORM CLEANOUT WITH WYE CONNECTION (N) RIM EL.=5832.63 INV.=5727.54
- PROPOSED 6" ASTM 3034 SDR-35 PVC ROOF DRAIN 21.8 LF @ 2.0%
- PROPOSED 6" STORM CLEANOUT WITH WYE CONNECTION (N) RIM EL.=5832.65 INV.=5727.04
- PROPOSED 6" ASTM 3034 SDR-35 PVC ROOF DRAIN 2.5 LF @ 69.0%
- PROPOSED 6" ASTM 3034 SDR-35 PVC ROOF DRAIN 62.1 LF @ 2.0%
- 6" CANOPY DRAINAGE CONNECTION, EAST AND WEST. INV.=5726.06
- 6" CANOPY DRAINAGE CONNECTION, EAST AND WEST. INV.=5726.45
- 6" CANOPY DRAINAGE CONNECTION, EAST AND WEST. INV.=5726.85
- PROPOSED 6" ASTM 3034 SDR-35 PVC ROOF DRAIN 39.2 LF @ 20.1%
- PROPOSED 18"x6" INSERT-A-TEE 18" INV.=5721.45

811 Know what's below. Call before you dig.
 CALL 811 SEVENTY-TWO HOURS PRIOR TO DIGGING, GRADING OR EXCAVATING FOR THE MARKING OF UNDERGROUND MEMBER UTILITIES.

PCD FILE NO. PPR-2225

KUM & GO GAS & C-STORE

PART OF THE SOUTHEAST 1/4 OF SECTION 11, TOWNSHIP 15 SOUTH, RANGE 66
WEST OF THE SIXTH PRINCIPAL MERIDIAN,
COUNTY OF EL PASO, STATE OF COLORADO
MAJOR SITE DEVELOPMENT PLAN

PROJECT INFORMATION	
ENGINEERED PRODUCT MANAGER	JEROME MAGSINO 303-349-7555 JEROME.MAGSINO@ADSPIPE.COM
ADS SALES REP	AARON ZEE 303-548-3479 AARON.ZEE@ADS-PIPE.COM
PROJECT NO.	S314443



KUM & GO 2232 EL PASO COUNTY, CO, USA

MC-3500 STORMTECH CHAMBER SPECIFICATIONS

- CHAMBERS SHALL BE STORMTECH MC-3500.
- CHAMBERS SHALL BE ARCH-SHAPED AND SHALL BE MANUFACTURED FROM VIRGIN, IMPACT-MODIFIED POLYPROPYLENE COPOLYMERS.
- CHAMBERS SHALL MEET THE REQUIREMENTS OF ASTM F2418, "STANDARD SPECIFICATION FOR POLYPROPYLENE (PP) CORRUGATED WALL STORMWATER COLLECTION CHAMBERS" CHAMBER CLASSIFICATION 45x76 DESIGNATION SS.
- CHAMBER ROWS SHALL PROVIDE CONTINUOUS, UNOBSTRUCTED INTERNAL SPACE WITH NO INTERNAL SUPPORTS THAT WOULD IMPEDE FLOW OR LIMIT ACCESS FOR INSPECTION.
- THE STRUCTURAL DESIGN OF THE CHAMBERS, THE STRUCTURAL BACKFILL, AND THE INSTALLATION REQUIREMENTS SHALL ENSURE THAT THE LOAD FACTORS SPECIFIED IN THE AASHTO LRFD BRIDGE DESIGN SPECIFICATIONS, SECTION 12.12, ARE MET FOR: 1) LONG-DURATION DEAD LOADS AND 2) SHORT-DURATION LIVE LOADS, BASED ON THE AASHTO DESIGN TRUCK WITH CONSIDERATION FOR IMPACT AND MULTIPLE VEHICLE PRESENCES.
- CHAMBERS SHALL BE DESIGNED, TESTED AND ALLOWABLE LOAD CONFIGURATIONS DETERMINED IN ACCORDANCE WITH ASTM F2787, "STANDARD PRACTICE FOR STRUCTURAL DESIGN OF THERMOPLASTIC CORRUGATED WALL STORMWATER COLLECTION CHAMBERS". LOAD CONFIGURATIONS SHALL INCLUDE: 1) INSTANTANEOUS (<1 MIN) AASHTO DESIGN TRUCK LIVE LOAD ON MINIMUM COVER 2) MAXIMUM PERMANENT (75-YR) COVER LOAD AND 3) ALLOWABLE COVER WITH PARKED (1-WEEK) AASHTO DESIGN TRUCK.
- REQUIREMENTS FOR HANDLING AND INSTALLATION:
 - TO MAINTAIN THE WIDTH OF CHAMBERS DURING SHIPPING AND HANDLING, CHAMBERS SHALL HAVE INTEGRAL, INTERLOCKING STACKING LUGS.
 - TO ENSURE A SECURE JOINT DURING INSTALLATION AND BACKFILL, THE HEIGHT OF THE CHAMBER JOINT SHALL NOT BE LESS THAN 3".
 - TO ENSURE THE INTEGRITY OF THE ARCH SHAPE DURING INSTALLATION, a) THE ARCH STIFFNESS CONSTANT SHALL BE GREATER THAN OR EQUAL TO 450 LBS/FT³. THE ASC IS DEFINED IN SECTION 6.2.8 OF ASTM F2418. AND b) TO RESIST CHAMBER DEFORMATION DURING INSTALLATION AT ELEVATED TEMPERATURES (ABOVE 73° F / 23° C), CHAMBERS SHALL BE PRODUCED FROM REFLECTIVE GOLD OR YELLOW COLORS.
- ONLY CHAMBERS THAT ARE APPROVED BY THE SITE DESIGN ENGINEER WILL BE ALLOWED. UPON REQUEST BY THE SITE DESIGN ENGINEER OR OWNER, THE CHAMBER MANUFACTURER SHALL SUBMIT A STRUCTURAL EVALUATION FOR APPROVAL BEFORE DELIVERING CHAMBERS TO THE PROJECT SITE AS FOLLOWS:
 - THE STRUCTURAL EVALUATION SHALL BE SEALED BY A REGISTERED PROFESSIONAL ENGINEER.
 - THE STRUCTURAL EVALUATION SHALL DEMONSTRATE THAT THE SAFETY FACTORS ARE GREATER THAN OR EQUAL TO 1.95 FOR DEAD LOAD AND 1.75 FOR LIVE LOAD, THE MINIMUM REQUIRED BY ASTM F2787 AND BY SECTIONS 3 AND 12.12 OF THE AASHTO LRFD BRIDGE DESIGN SPECIFICATIONS FOR THERMOPLASTIC PIPE.
 - THE TEST DERIVED CREEP MODULUS AS SPECIFIED IN ASTM F2418 SHALL BE USED FOR PERMANENT DEAD LOAD DESIGN EXCEPT THAT IT SHALL BE THE 75-YEAR MODULUS USED FOR DESIGN.
- CHAMBERS AND END CAPS SHALL BE PRODUCED AT AN ISO 9001 CERTIFIED MANUFACTURING FACILITY.

IMPORTANT - NOTES FOR THE BIDDING AND INSTALLATION OF MC-3500 CHAMBER SYSTEM

- STORMTECH MC-3500 CHAMBERS SHALL NOT BE INSTALLED UNTIL THE MANUFACTURER'S REPRESENTATIVE HAS COMPLETED A PRE-CONSTRUCTION MEETING WITH THE INSTALLERS.
- STORMTECH MC-3500 CHAMBERS SHALL BE INSTALLED IN ACCORDANCE WITH THE "STORMTECH MC-3500/MC-4500 CONSTRUCTION GUIDE".
- CHAMBERS ARE NOT TO BE BACKFILLED WITH A DOZER OR AN EXCAVATOR SITUATED OVER THE CHAMBERS. STORMTECH RECOMMENDS 3 BACKFILL METHODS:
 - STONESHOOTER LOCATED OFF THE CHAMBER BED.
 - BACKFILL AS ROWS ARE BUILT USING AN EXCAVATOR ON THE FOUNDATION STONE OR SUBGRADE.
 - BACKFILL FROM OUTSIDE THE EXCAVATION USING A LONG BOOM HOE OR EXCAVATOR.
- THE FOUNDATION STONE SHALL BE LEVELED AND COMPACTED PRIOR TO PLACING CHAMBERS.
- JOINTS BETWEEN CHAMBERS SHALL BE PROPERLY SEATED PRIOR TO PLACING STONE.
- MAINTAIN MINIMUM - 6" (150 mm) SPACING BETWEEN THE CHAMBER ROWS.
- INLET AND OUTLET MANIFOLDS MUST BE INSERTED A MINIMUM OF 12" (300 mm) INTO CHAMBER END CAPS.
- EMBEDMENT STONE SURROUNDING CHAMBERS MUST BE A CLEAN, CRUSHED, ANGULAR STONE MEETING THE AASHTO M43 DESIGNATION OF #3 OR #4.
- STONE MUST BE PLACED ON THE TOP CENTER OF THE CHAMBER TO ANCHOR THE CHAMBERS IN PLACE AND PRESERVE ROW SPACING.
- THE CONTRACTOR MUST REPORT ANY DISCREPANCIES WITH CHAMBER FOUNDATION MATERIALS BEARING CAPACITIES TO THE SITE DESIGN ENGINEER.
- ADS RECOMMENDS THE USE OF "FLEXSTORM CATCH IT" INSERTS DURING CONSTRUCTION FOR ALL INLETS TO PROTECT THE SUBSURFACE STORMWATER MANAGEMENT SYSTEM FROM CONSTRUCTION SITE RUNOFF.

NOTES FOR CONSTRUCTION EQUIPMENT

- STORMTECH MC-3500 CHAMBERS SHALL BE INSTALLED IN ACCORDANCE WITH THE "STORMTECH MC-3500/MC-4500 CONSTRUCTION GUIDE".
- THE USE OF EQUIPMENT OVER MC-3500 CHAMBERS IS LIMITED:
 - NO EQUIPMENT IS ALLOWED ON BARE CHAMBERS.
 - NO RUBBER Tired LOADER, DUMP TRUCK, OR EXCAVATORS ARE ALLOWED UNTIL PROPER FILL DEPTHS ARE REACHED IN ACCORDANCE WITH THE "STORMTECH MC-3500/MC-4500 CONSTRUCTION GUIDE".
 - WEIGHT LIMITS FOR CONSTRUCTION EQUIPMENT CAN BE FOUND IN THE "STORMTECH MC-3500/MC-4500 CONSTRUCTION GUIDE".
- FULL 36" (900 mm) OF STABILIZED COVER MATERIALS OVER THE CHAMBERS IS REQUIRED FOR DUMP TRUCK TRAVEL OR DUMPING.

USE OF A DOZER TO PUSH EMBEDMENT STONE BETWEEN THE ROWS OF CHAMBERS MAY CAUSE DAMAGE TO CHAMBERS AND IS NOT AN ACCEPTABLE BACKFILL METHOD. ANY CHAMBERS DAMAGED BY USING THE "DUMP AND PUSH" METHOD ARE NOT COVERED UNDER THE STORMTECH STANDARD WARRANTY.

CONTACT STORMTECH AT 1-888-892-2694 WITH ANY QUESTIONS ON INSTALLATION REQUIREMENTS OR WEIGHT LIMITS FOR CONSTRUCTION EQUIPMENT.



1459 Grand Ave
Des Moines, IA 50309
P: 888-458-6646

2232 - EL PASO, COLORADO
SECURITY BLVD. AND MAIN ST.

ADS SYSTEM DETAILS

KG PROJECT TEAM:
RDM:
SDM:
CPM:

DATE	REVISION DESCRIPTION
08/19/22	1ST REVIEW COMMENTS
01/06/23	2ND REVIEW COMMENTS
04/05/23	3RD REVIEW COMMENTS
05/11/23	4TH REVIEW COMMENTS

DATE: 05-11-2023

SHEET NUMBER:

C4.2
18 OF 43



PCD FILE NO. PPR-2225

KUM & GO GAS & C-STORE

PART OF THE SOUTHEAST 1/4 OF SECTION 11, TOWNSHIP 15 SOUTH, RANGE 66
WEST OF THE SIXTH PRINCIPAL MERIDIAN,
COUNTY OF EL PASO, STATE OF COLORADO

MAJOR SITE DEVELOPMENT PLAN

PROPOSED LAYOUT		PROPOSED ELEVATIONS		*INVERT ABOVE BASE OF CHAMBER	
44	STORMTECH MC-3500 CHAMBERS	5732.50	MAXIMUM ALLOWABLE GRADE (TOP OF PAVEMENT/UNPAVED)		
6	STORMTECH MC-3500 END CAPS	5726.50	MINIMUM ALLOWABLE GRADE (UNPAVED WITH TRAFFIC)		
12	STONE ABOVE (in)	5726.00	MINIMUM ALLOWABLE GRADE (UNPAVED NO TRAFFIC)		
9	STONE BELOW (in)	5726.00	MINIMUM ALLOWABLE GRADE (BASE OF FLEXIBLE PAVEMENT)		
40	% STONE VOID	5726.00	MINIMUM ALLOWABLE GRADE (TOP OF RIGID PAVEMENT)		
8,901	INSTALLED SYSTEM VOLUME (CF) (PERIMETER STONE INCLUDED)	5725.50	TOP OF STONE		
		5724.50	TOP OF MC-3500 CHAMBER		
2,702	SYSTEM AREA (ft ²)	5722.42	18" TOP MANIFOLD INVERT		
289	SYSTEM PERIMETER (ft)	5720.92	24" ISOLATOR ROW PLUS CONNECTION INVERT		
		5720.90	18" BOTTOM MANIFOLD INVERT		
		5720.75	BOTTOM OF MC-3500 CHAMBER		
		5720.00	UNDERDRAIN INVERT		
		5720.00	BOTTOM OF STONE		

PART TYPE	ITEM ON LAYOUT	DESCRIPTION	INVERT	MAX FLOW
PREFABRICATED END CAP	A	24" BOTTOM CORED END CAP, PART#: MC3500IEPP24BC / TYP OF ALL 24" BOTTOM CONNECTIONS AND ISOLATOR PLUS ROWS	2.06"	
PREFABRICATED END CAP	B	18" TOP CORED END CAP, PART#: MC3500IEPP18TC / TYP OF ALL 18" TOP CONNECTIONS	20.03"	
FLAMP	C	INSTALL FLAMP ON 24" ACCESS PIPE / PART#: MC350024RAMP (TYP 3 PLACES)		
MANIFOLD	D	18" x 18" TOP MANIFOLD, ADS N-12	20.03"	
MANIFOLD	E	18" x 18" TOP MANIFOLD, ADS N-12	20.03"	
CONCRETE STRUCTURE	F	(DESIGN BY ENGINEER / PROVIDED BY OTHERS)		11.0 CFS IN
CONCRETE STRUCTURE	G	(DESIGN BY ENGINEER / PROVIDED BY OTHERS)		
CONCRETE STRUCTURE	H	(DESIGN BY ENGINEER / PROVIDED BY OTHERS)		5.5 CFS IN
CONCRETE STRUCTURE	I	OUTLET CONTROL STRUCTURE (DESIGN BY ENGINEER / PROVIDED BY OTHERS)		4.0 CFS OUT
INSPECTION PORT	J	4" SEE DETAIL		

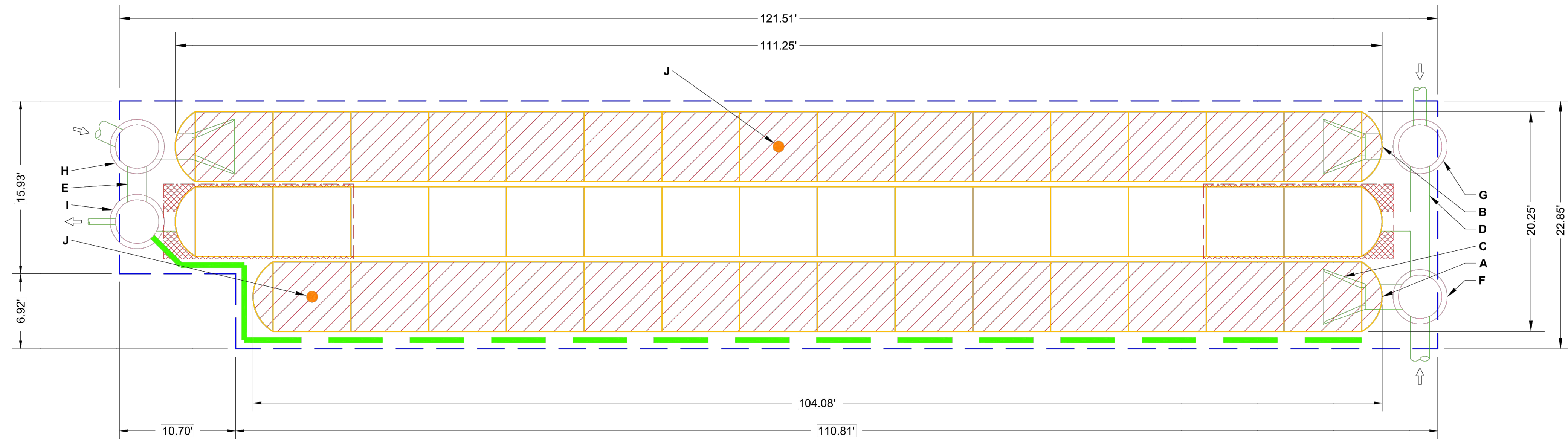

ISOLATOR ROW PLUS
(SEE DETAIL/TYP 2 PLACES)

PLACE MINIMUM 17.50' OF ADSPLUS175 WOVEN GEOTEXTILE OVER BEDDING STONE AND UNDERNEATH CHAMBER FEET FOR SCOUR PROTECTION AT ALL CHAMBER INLET ROWS

BED LIMITS

NOTES

- DUE TO THE ADAPTATION OF THIS CHAMBER SYSTEM TO SPECIFIC SITE AND DESIGN CONSTRAINTS, IT MAY BE NECESSARY TO CUT AND COUPLE ADDITIONAL PIPE TO STANDARD MANIFOLD COMPONENTS IN THE FIELD.
- THE SITE DESIGN ENGINEER MUST REVIEW ELEVATIONS AND IF NECESSARY ADJUST GRADING TO ENSURE THE CHAMBER COVER REQUIREMENTS ARE MET.
- THIS CHAMBER SYSTEM WAS DESIGNED WITHOUT SITE-SPECIFIC INFORMATION ON SOIL CONDITIONS OR BEARING CAPACITY. THE SITE DESIGN ENGINEER IS RESPONSIBLE FOR DETERMINING THE SUITABILITY OF THE SOIL AND PROVIDING THE BEARING CAPACITY OF THE INSITU SOILS. THE BASE STONE DEPTH MAY BE INCREASED OR DECREASED ONCE THIS INFORMATION IS PROVIDED.
- **NOT FOR CONSTRUCTION:** THIS LAYOUT IS FOR DIMENSIONAL PURPOSES ONLY TO PROVE CONCEPT & THE REQUIRED STORAGE VOLUME CAN BE ACHIEVED ON SITE.

StormTech®
Chamber System
888-892-2894 | WWW.STORMTECH.COM

4640 TRUEMAN BLVD
HILLIARD, OH 43026
1-800-733-7473

ADS

SHEET
2 OF 5

660/23 CTS LOWER BASE STONE TO 5720.00
03/04/23 AGC I AGC REV. PER MARKUP, UPDATED ELEV.
03/04/23 AGC I DRW I CHK DATE DESCRIPTION

KUM & GO 2232
EL PASO COUNTY, CO. USA
DATE: 01/13/23 DRAWN: DDW
PROJECT #: S311443 CHECKED: N/A

THIS DRAWING HAS BEEN PREPARED BASED ON INFORMATION PROVIDED TO ADS UNDER THE DIRECTION OF THE SITE DESIGN ENGINEER OR OTHER PROJECT REPRESENTATIVE. THE SITE DESIGN ENGINEER SHALL REVIEW THIS DRAWING PRIOR TO CONSTRUCTION. IT IS THE ULTIMATE RESPONSIBILITY OF THE SITE DESIGN ENGINEER TO ENSURE THAT THE PRODUCTS SHOWN AND ALL ASSOCIATED DETAILS MEET ALL APPLICABLE LAWS, REGULATIONS, AND PROJECT REQUIREMENTS.

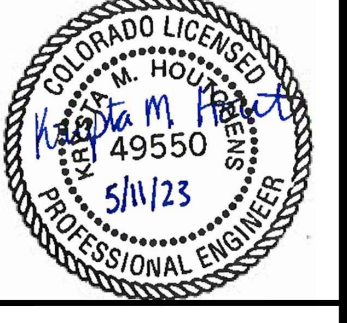

1459 Grand Ave
Des Moines, IA 50309
P: 888-458-6646

2232 - EL PASO, COLORADO
SECURITY BLVD. AND MAIN ST.
ADS SYSTEM DETAILS

KG PROJECT TEAM:
RDM:
SDM:
CPM:

REVISION	DATE	DESCRIPTION
1	08/19/22	1ST REVIEW COMMENTS
2	01/06/23	2ND REVIEW COMMENTS
3	04/05/23	3RD REVIEW COMMENTS
4	05/11/23	4TH REVIEW COMMENTS

DATE: 05-11-2023

SHEET NUMBER:
C4.3
19 OF 43

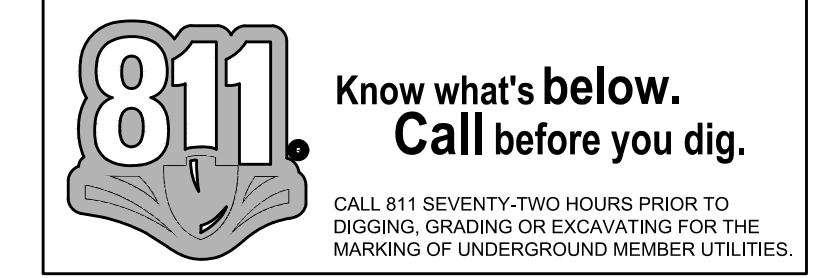

PCD FILE NO. PPR-2225

KUM & GO GAS & C-STORE

PART OF THE SOUTHEAST 1/4 OF SECTION 11, TOWNSHIP 15 SOUTH, RANGE 66
WEST OF THE SIXTH PRINCIPAL MERIDIAN,
COUNTY OF EL PASO, STATE OF COLORADO
MAJOR SITE DEVELOPMENT PLAN

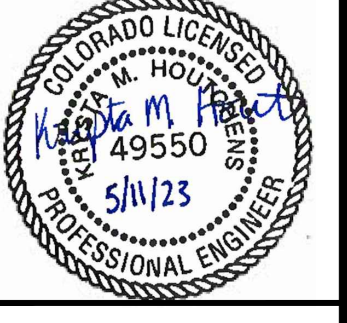
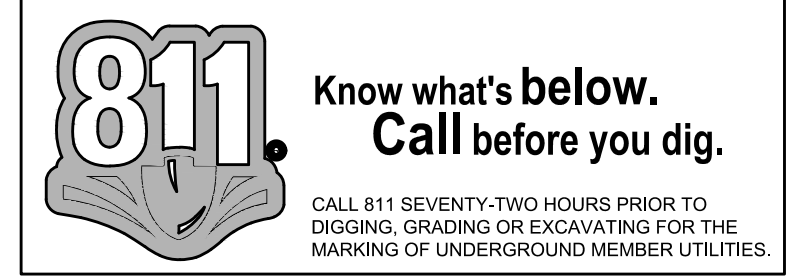

1459 Grand Ave
Des Moines, IA 50309
P: 888-458-6646

2232 - EL PASO, COLORADO
SECURITY BLVD. AND MAIN ST.
ADS SYSTEM DETAILS

KG PROJECT TEAM:
RDM:
SDM:
CPM:

DATE	REVISION DESCRIPTION
08/19/22	1ST REVIEW COMMENTS
01/06/23	2ND REVIEW COMMENTS
04/05/23	3RD REVIEW COMMENTS
05/11/23	4TH REVIEW COMMENTS

DATE: 05-11-2023

SHEET NUMBER: C4.4
20 OF 43

ACCEPTABLE FILL MATERIALS: STORMTECH MC-3500 CHAMBER SYSTEMS

MATERIAL LOCATION	DESCRIPTION	AASHTO MATERIAL CLASSIFICATIONS	COMPACTION / DENSITY REQUIREMENT
D	FINAL FILL: FILL MATERIAL FOR LAYER 'D' STARTS FROM THE TOP OF THE 'C' LAYER TO THE BOTTOM OF FLEXIBLE PAVEMENT OR UNPAVED FINISHED GRADE ABOVE. NOTE THAT PAVEMENT SUBBASE MAY BE PART OF THE 'D' LAYER	N/A	PREPARE PER SITE DESIGN ENGINEER'S PLANS. PAVED INSTALLATIONS MAY HAVE STRINGENT MATERIAL AND PREPARATION REQUIREMENTS.
C	INITIAL FILL: FILL MATERIAL FOR LAYER 'C' STARTS FROM THE TOP OF THE EMBEDMENT STONE ('B' LAYER) TO 24" (600 mm) ABOVE THE TOP OF THE CHAMBER. NOTE THAT PAVEMENT SUBBASE MAY BE A PART OF THE 'C' LAYER.	AASHTO M145' A-1, A-2-4, A-3 OR AASHTO M43' 3, 357, 4, 467, 5, 56, 57, 6, 67, 68, 7, 78, 8, 89, 9, 10	BEGIN COMPACTIONS AFTER 24" (600 mm) OF MATERIAL OVER THE CHAMBERS IS REACHED. COMPACT ADDITIONAL LAYERS IN 12" (300 mm) MAX LIFTS TO A MIN. 95% PROCTOR DENSITY FOR WELL GRADED MATERIAL AND 95% RELATIVE DENSITY FOR PROCESSED AGGREGATE MATERIALS.
B	EMBEDMENT STONE: FILL SURROUNDING THE CHAMBERS FROM THE FOUNDATION STONE ('A' LAYER) TO THE 'C' LAYER ABOVE.	AASHTO M43' 3, 4	NO COMPACTION REQUIRED.
A	FOUNDATION STONE: FILL BELOW CHAMBERS FROM THE SUBGRADE UP TO THE FOOT (BOTTOM) OF THE CHAMBER.	AASHTO M43' 3, 4	PLATE COMPACT OR ROLL TO ACHIEVE A FLAT SURFACE. ^{2,3}

PLEASE NOTE:

- THE LISTED AASHTO DESIGNATIONS ARE FOR GRADATIONS ONLY. THE STONE MUST ALSO BE CLEAN, CRUSHED, ANGULAR. FOR EXAMPLE, A SPECIFICATION FOR #4 STONE WOULD STATE: "CLEAN, CRUSHED, ANGULAR NO. 4 (AASHTO M43) STONE".
- STORMTECH COMPACTION REQUIREMENTS ARE MET FOR 'A' LOCATION MATERIALS WHEN PLACED AND COMPACTED IN 9" (230 mm) (MAX) LIFTS USING TWO FULL COVERAGES WITH A VIBRATORY COMPACTOR.
- WHERE INFILTRATION SURFACES MAY BE COMPROMISED BY COMPACTION, FOR STANDARD DESIGN LOAD CONDITIONS, A FLAT SURFACE MAY BE ACHIEVED BY RAKING OR DRAGGING WITHOUT COMPACTION EQUIPMENT. FOR SPECIAL LOAD DESIGNS, CONTACT STORMTECH FOR COMPACTION REQUIREMENTS.
- ONCE LAYER 'C' IS PLACED, ANY SOIL/MATERIAL CAN BE PLACED IN LAYER 'D' UP TO THE FINISHED GRADE. MOST PAVEMENT SUBBASE SOILS CAN BE USED TO REPLACE THE MATERIAL REQUIREMENTS OF LAYER 'C' OR 'D' AT THE SITE DESIGN ENGINEER'S DISCRETION.

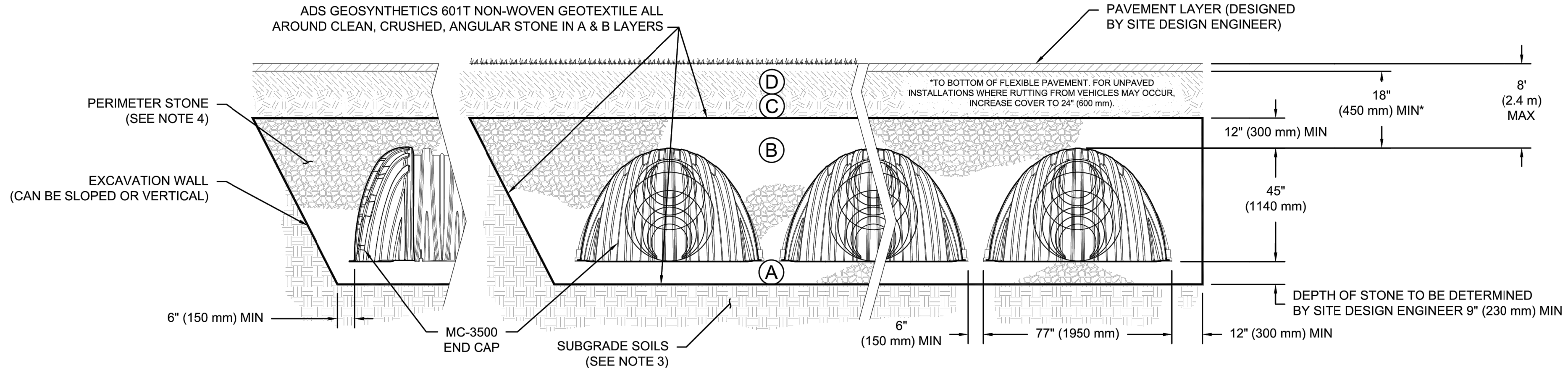

NOTES:

- CHAMBERS SHALL MEET THE REQUIREMENTS OF ASTM F2418, "STANDARD SPECIFICATION FOR POLYPROPYLENE (PP) CORRUGATED WALL STORMWATER COLLECTION CHAMBERS" CHAMBER CLASSIFICATION 45x76 DESIGNATION SS.
- MC-3500 CHAMBERS SHALL BE DESIGNED IN ACCORDANCE WITH ASTM F2787 "STANDARD PRACTICE FOR STRUCTURAL DESIGN OF THERMOPLASTIC CORRUGATED WALL STORMWATER COLLECTION CHAMBERS".
- THE SITE DESIGN ENGINEER IS RESPONSIBLE FOR ASSESSING THE BEARING RESISTANCE (ALLOWABLE BEARING CAPACITY) OF THE SUBGRADE SOILS AND THE DEPTH OF FOUNDATION STONE WITH CONSIDERATION FOR THE RANGE OF EXPECTED SOIL MOISTURE CONDITIONS.
- PERIMETER STONE MUST BE EXTENDED HORIZONTALLY TO THE EXCAVATION WALL FOR BOTH VERTICAL AND SLOPED EXCAVATION WALLS.
- REQUIREMENTS FOR HANDLING AND INSTALLATION:
 - TO MAINTAIN THE WIDTH OF CHAMBERS DURING SHIPPING AND HANDLING, CHAMBERS SHALL HAVE INTEGRAL, INTERLOCKING STACKING LUGS.
 - TO ENSURE A SECURE JOINT DURING INSTALLATION AND BACKFILL, THE HEIGHT OF THE CHAMBER JOINT SHALL NOT BE LESS THAN 3".
 - TO ENSURE THE INTEGRITY OF THE ARCH SHAPE DURING INSTALLATION, a) THE ARCH STIFFNESS CONSTANT SHALL BE GREATER THAN OR EQUAL TO 450 LBS/FT². THE ASC IS DEFINED IN SECTION 6.2.8 OF ASTM F2418. AND b) TO RESIST CHAMBER DEFORMATION DURING INSTALLATION AT ELEVATED TEMPERATURES (ABOVE 73° F / 23° C), CHAMBERS SHALL BE PRODUCED FROM REFLECTIVE GOLD OR YELLOW COLORS.

StormTech® Chamber System
888-892-2684 | WWW.STORMTECH.COM

4640 TRUEMAN BLVD
HILLIARD, OH 43026
1-800-733-7473

ADS

THIS DRAWING HAS BEEN PREPARED BASED ON INFORMATION PROVIDED TO ADS UNDER THE DIRECTION OF THE SITE DESIGN ENGINEER OR OTHER PROJECT REPRESENTATIVE. THE SITE DESIGN ENGINEER SHALL REVIEW THIS DRAWING PRIOR TO CONSTRUCTION. IT IS THE ULTIMATE RESPONSIBILITY OF THE SITE DESIGN ENGINEER TO ENSURE THAT THE PRODUCT(S) DEPICTED AND ALL ASSOCIATED DETAILS MEET ALL APPLICABLE LAWS, REGULATIONS, AND PROJECT REQUIREMENTS.

EL PASO COUNTY, CO, USA
DATE: 01/13/23
PROJECT #: S311443
CHECKED: N/A

LOWER BASE STONE TO 5720.00
REV. PER MARKUP, UPDATED ELEV.
DATE: 03/08/23
AGC
DATE: 03/04/23
DRW: CHK

SHEET
3 OF 5

PCD FILE NO. PPR-2225

KUM & GO GAS & C-STORE

PART OF THE SOUTHEAST 1/4 OF SECTION 11, TOWNSHIP 15 SOUTH, RANGE 66
 WEST OF THE SIXTH PRINCIPAL MERIDIAN,
 COUNTY OF EL PASO, STATE OF COLORADO
MAJOR SITE DEVELOPMENT PLAN



1459 Grand Ave
 Des Moines, IA 50309
 P: 888-458-6646

2232 - EL PASO, COLORADO
SECURITY BLVD. AND MAIN ST.
 ADS SYSTEM DETAILS

KG PROJECT TEAM:
 RDM:
 SDM:
 CPM:

REVISION DESCRIPTION	DATE
1ST REVIEW COMMENTS	08/19/22
2ND REVIEW COMMENTS	01/06/23
3RD REVIEW COMMENTS	04/05/23
4TH REVIEW COMMENTS	05/11/23

DATE: 05-11-2023

SHEET NUMBER:
C4.5
 21 OF 43

P:\KUM & GO\CO. EL PASO COUNTY_ 2232_MAIN AND SECURITY\08 CAD\GEGS02232_21 - ADS SYSTEM DETAILS.DWG

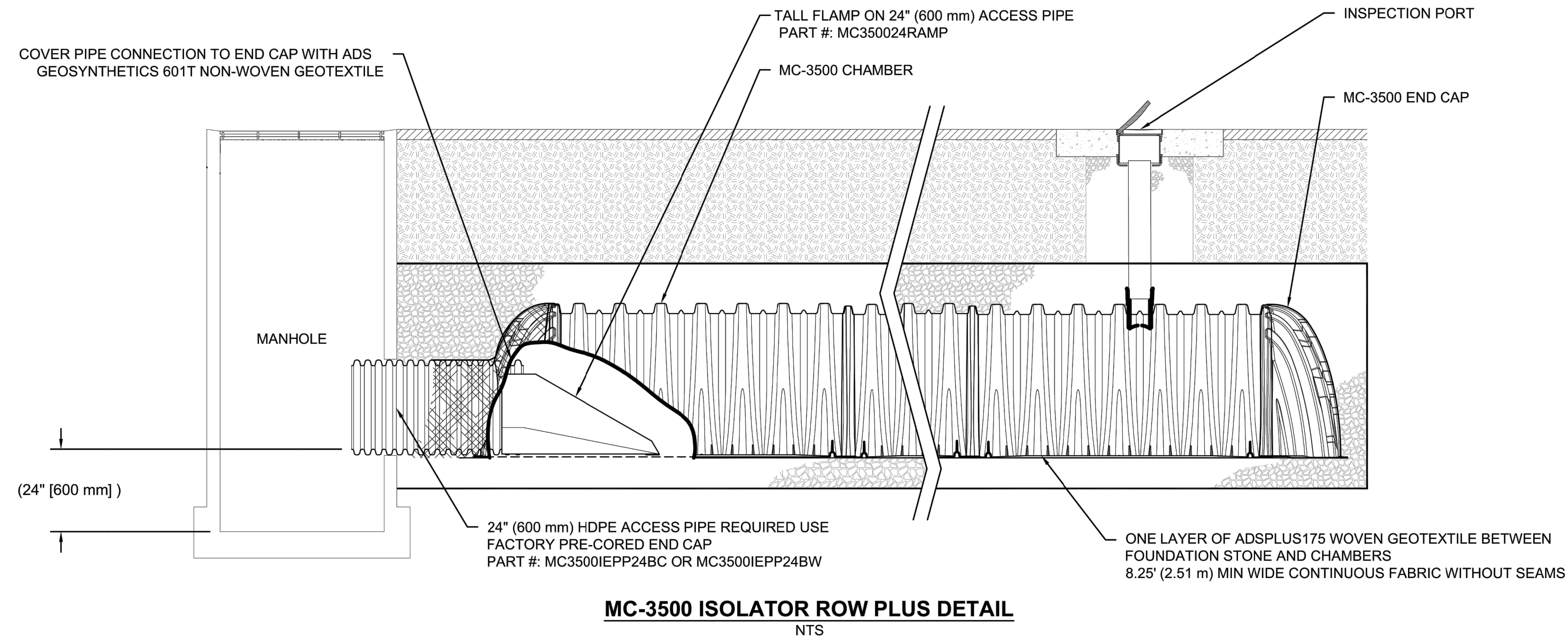

INSPECTION & MAINTENANCE

- STEP 1) INSPECT ISOLATOR ROW PLUS FOR SEDIMENT
- A. INSPECTION PORTS (IF PRESENT)
 - A.1. REMOVE/OPEN LID ON NYLOPLAST INLINE DRAIN
 - A.2. REMOVE AND CLEAN FLEXSTORM FILTER IF INSTALLED
 - A.3. USING A FLASHLIGHT AND STADIA ROD, MEASURE DEPTH OF SEDIMENT AND RECORD ON MAINTENANCE LOG
 - A.4. LOWER A CAMERA INTO ISOLATOR ROW PLUS FOR VISUAL INSPECTION OF SEDIMENT LEVELS (OPTIONAL)
 - A.5. IF SEDIMENT IS AT, OR ABOVE, 3" (80 mm) PROCEED TO STEP 2. IF NOT, PROCEED TO STEP 3.
 - B. ALL ISOLATOR PLUS ROWS
 - B.1. REMOVE COVER FROM STRUCTURE AT UPSTREAM END OF ISOLATOR ROW PLUS
 - B.2. USING A FLASHLIGHT, INSPECT DOWN THE ISOLATOR ROW PLUS THROUGH OUTLET PIPE
 - i) MIRRORS ON POLES OR CAMERAS MAY BE USED TO AVOID A CONFINED SPACE ENTRY
 - ii) FOLLOW OSHA REGULATIONS FOR CONFINED SPACE ENTRY IF ENTERING MANHOLE
 - B.3. IF SEDIMENT IS AT, OR ABOVE, 3" (80 mm) PROCEED TO STEP 2. IF NOT, PROCEED TO STEP 3.
- STEP 2) CLEAN OUT ISOLATOR ROW PLUS USING THE JETVAC PROCESS
- A. A FIXED CULVERT CLEANING NOZZLE WITH REAR FACING SPREAD OF 45° (1.1 m) OR MORE IS PREFERRED
 - B. APPLY MULTIPLE PASSES OF JETVAC UNTIL BACKFLUSH WATER IS CLEAN
 - C. VACUUM STRUCTURE SUMP AS REQUIRED
- STEP 3) REPLACE ALL COVERS, GRATES, FILTERS, AND LIDS; RECORD OBSERVATIONS AND ACTIONS.
- STEP 4) INSPECT AND CLEAN BASINS AND MANHOLES UPSTREAM OF THE STORMTECH SYSTEM.

NOTES

1. INSPECT EVERY 6 MONTHS DURING THE FIRST YEAR OF OPERATION. ADJUST THE INSPECTION INTERVAL BASED ON PREVIOUS OBSERVATIONS OF SEDIMENT ACCUMULATION AND HIGH WATER ELEVATIONS.
2. CONDUCT JETTING AND VACTORING ANNUALLY OR WHEN INSPECTION SHOWS THAT MAINTENANCE IS NECESSARY.

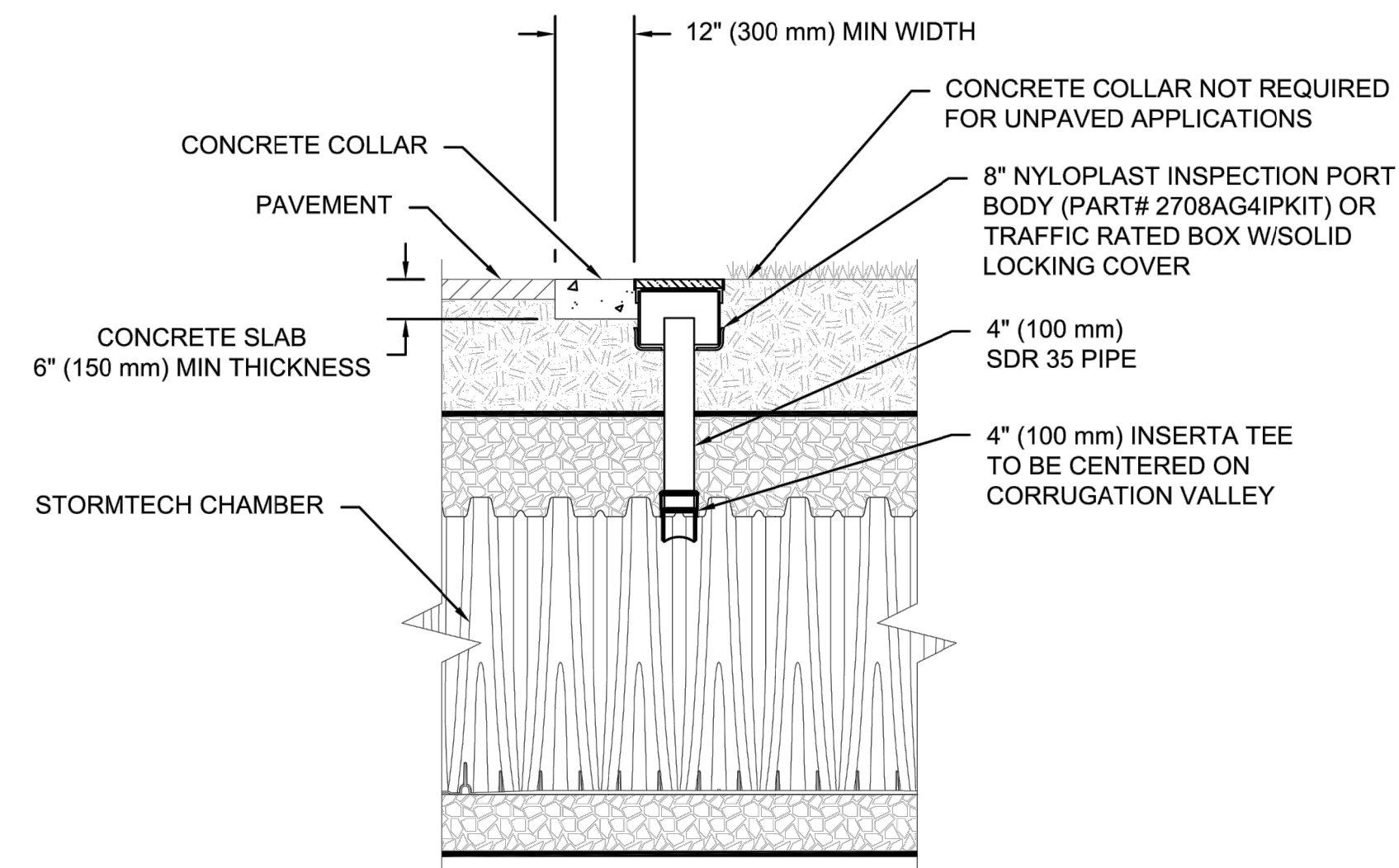

4" PVC INSPECTION PORT DETAIL
(MC SERIES CHAMBER)
 NTS

KUM & GO 2232
 EL PASO COUNTY, CO, USA

03/08/23	CTS	LOWER BASE STONE TO 5720.00
03/04/23	AGC	REV. PER MARKUP, UPDATED ELEV.
DATE	DRW	CHK
01/13/23	DDW	N/A
PROJECT #	S311443	CHECKED: N/A

StormTech®
 Chamber System
 888-892-2684 | WWW.STORMTECH.COM

4840 TRUENAN BLVD
 HILLIARD, OH 43026
 1-800-733-7473

ADS

THIS DRAWING HAS BEEN PREPARED BASED ON INFORMATION PROVIDED TO ADS. ADS DOES NOT ASSUME THE RESPONSIBILITY OF THE SITE DESIGN ENGINEER TO ENSURE THAT THE PRODUCT(S) DESCRIBED AND ALL ASSOCIATED DETAILS MEET ALL APPLICABLE LAWS, REGULATIONS, AND PROJECT REQUIREMENTS.

DESIGN ENGINEER SHALL REVIEW THIS DRAWING PRIOR TO CONSTRUCTION. IT IS THE ULTIMATE RESPONSIBILITY OF THE DESIGN ENGINEER TO ENSURE THAT THE PRODUCT(S) DESCRIBED AND ALL ASSOCIATED DETAILS MEET ALL APPLICABLE LAWS, REGULATIONS, AND PROJECT REQUIREMENTS.

SHEET
4 OF 5

811 Know what's below.
 Call before you dig.

CALL 811 SEVENTY-TWO HOURS PRIOR TO DIGGING, GRADING OR EXCAVATING FOR THE MARKING OF UNDERGROUND MEMBER UTILITIES.

PCD FILE NO. PPR-2225

KUM & GO GAS & C-STORE

PART OF THE SOUTHEAST 1/4 OF SECTION 11, TOWNSHIP 15 SOUTH, RANGE 66
 WEST OF THE SIXTH PRINCIPAL MERIDIAN,
 COUNTY OF EL PASO, STATE OF COLORADO
MAJOR SITE DEVELOPMENT PLAN



1459 Grand Ave
 Des Moines, IA 50309
 P: 888-458-6646

2232 - EL PASO, COLORADO
 SECURITY BLVD. AND MAIN ST.
 ADS SYSTEM DETAILS

KG PROJECT TEAM:
 RDM:
 SDM:
 CPM:

REVISION	DATE	REVISION DESCRIPTION
1	08/19/22	1ST REVIEW COMMENTS
2	01/06/23	2ND REVIEW COMMENTS
3	04/05/23	3RD REVIEW COMMENTS
4	05/11/23	4TH REVIEW COMMENTS

DATE: 05-11-2023

SHEET NUMBER: C4.6

22 OF 43

CRITERIA PLAN 04/2020

P:\KUM & GO\CO. EL PASO COUNTY - 2232 MAIN AND SECURITY\08 CAD\GSC02232 - 22 - ADS SYSTEM DETAILS.DWG

MC-SERIES END CAP INSERTION DETAIL

NTS

NOTE: MANIFOLD STUB MUST BE LAID HORIZONTAL FOR A PROPER FIT IN END CAP OPENING.

MC-3500 TECHNICAL SPECIFICATION

NTS

NOMINAL CHAMBER SPECIFICATIONS
 SIZE (W X H X INSTALLED LENGTH) 77.0" X 45.0" X 86.0" (1956 mm X 1143 mm X 2184 mm)
 CHAMBER STORAGE 109.9 CUBIC FEET (3.11 m³)
 MINIMUM INSTALLED STORAGE* 175.0 CUBIC FEET (4.96 m³)
 WEIGHT 134 lbs. (60.8 kg)

NOMINAL END CAP SPECIFICATIONS
 SIZE (W X H X INSTALLED LENGTH) 75.0" X 45.0" X 22.2" (1905 mm X 1143 mm X 564 mm)
 END CAP STORAGE 14.9 CUBIC FEET (0.42 m³)
 MINIMUM INSTALLED STORAGE* 45.1 CUBIC FEET (1.28 m³)
 WEIGHT 49 lbs. (22.2 kg)

*ASSUMES 12" (305 mm) STONE ABOVE, 9" (229 mm) STONE FOUNDATION, 6" SPACING BETWEEN CHAMBERS, 6" (152 mm) STONE PERIMETER IN FRONT OF END CAPS AND 40% STONE POROSITY

STUBS AT BOTTOM OF END CAP FOR PART NUMBERS ENDING WITH "B"
 STUBS AT TOP OF END CAP FOR PART NUMBERS ENDING WITH "T"
 END CAPS WITH A WELDED CROWN PLATE END WITH "C"
 END CAPS WITH A PREFABRICATED WELDED STUB END WITH "W"

PART #	STUB	B	C
MC3500IEPP06T	6" (150 mm)	33.21" (844 mm)	---
MC3500IEPP06B	---	---	0.66" (17 mm)
MC3500IEPP08T	8" (200 mm)	31.16" (791 mm)	---
MC3500IEPP08B	---	---	0.81" (21 mm)
MC3500IEPP10T	10" (250 mm)	29.04" (738 mm)	---
MC3500IEPP10B	---	---	0.93" (24 mm)
MC3500IEPP12T	12" (300 mm)	26.36" (670 mm)	---
MC3500IEPP12B	---	---	1.35" (34 mm)
MC3500IEPP15T	15" (375 mm)	23.39" (594 mm)	---
MC3500IEPP15B	---	---	1.50" (38 mm)
MC3500IEPP18TC	18" (450 mm)	20.03" (509 mm)	---
MC3500IEPP18TW	---	---	---
MC3500IEPP18BC	---	---	1.77" (45 mm)
MC3500IEPP18BW	---	---	---
MC3500IEPP24TC	24" (600 mm)	14.48" (368 mm)	---
MC3500IEPP24TW	---	---	---
MC3500IEPP24BC	---	---	2.06" (52 mm)
MC3500IEPP24BW	---	---	---
MC3500IEPP30BC	30" (750 mm)	---	2.75" (70 mm)

NOTE: ALL DIMENSIONS ARE NOMINAL

StormTech® Chamber System

888-892-2694 | WWW.STORMTECH.COM

4640 TREUMANN BLVD
 HILLIARD, OH 43026
 1-800-733-7473

THIS DRAWING HAS BEEN PREPARED BASED ON INFORMATION PROVIDED TO ADS UNDER THE DIRECTION OF THE SITE DESIGN ENGINEER OR OTHER PROJECT REPRESENTATIVE. THE SITE DESIGN ENGINEER SHALL REVIEW THIS DRAWING PRIOR TO CONSTRUCTION. IT IS THE ULTIMATE RESPONSIBILITY OF THE SITE DESIGN ENGINEER TO ENSURE THAT THE PROJECT IS DESIGNED AND ALL ASSOCIATED DETAILS MEET ALL APPLICABLE LAWS, REGULATIONS, AND PROJECT REQUIREMENTS.

SHEET 5 OF 5

CALL 811 SEVENTY-TWO HOURS PRIOR TO DIGGING, GRADING OR EXCAVATING FOR THE MARKING OF UNDERGROUND MEMBER UTILITIES.

PCD FILE NO. PPR-2225

KUM & GO GAS & C-STORE

PART OF THE SOUTHEAST 1/4 OF SECTION 11, TOWNSHIP 15 SOUTH, RANGE 66
WEST OF THE SIXTH PRINCIPAL MERIDIAN,
COUNTY OF EL PASO, STATE OF COLORADO

MAJOR SITE DEVELOPMENT PLAN



1459 Grand Ave
Des Moines, IA 50309
P: 888-458-6646

2232 - EL PASO, COLORADO
SECURITY BLVD. AND MAIN ST.
ADS SYSTEM DETAILS

KG PROJECT TEAM:
RDM:
SDM:
CPM:

REVISION	DATE	DESCRIPTION
1	08/19/22	1ST REVIEW COMMENTS
2	01/06/23	2ND REVIEW COMMENTS
3	04/05/23	3RD REVIEW COMMENTS
4	05/11/23	4TH REVIEW COMMENTS

DATE: 05-11-2023
SHEET NUMBER: C4.8
24 OF 43

FLEXSTORM P/Ns 62SHDFX & 62SHDFXP HD4 INLET TYPE: SQUARE/RECT PRECAST OPENING WITH 4 SEAT GRATE SUPPORT

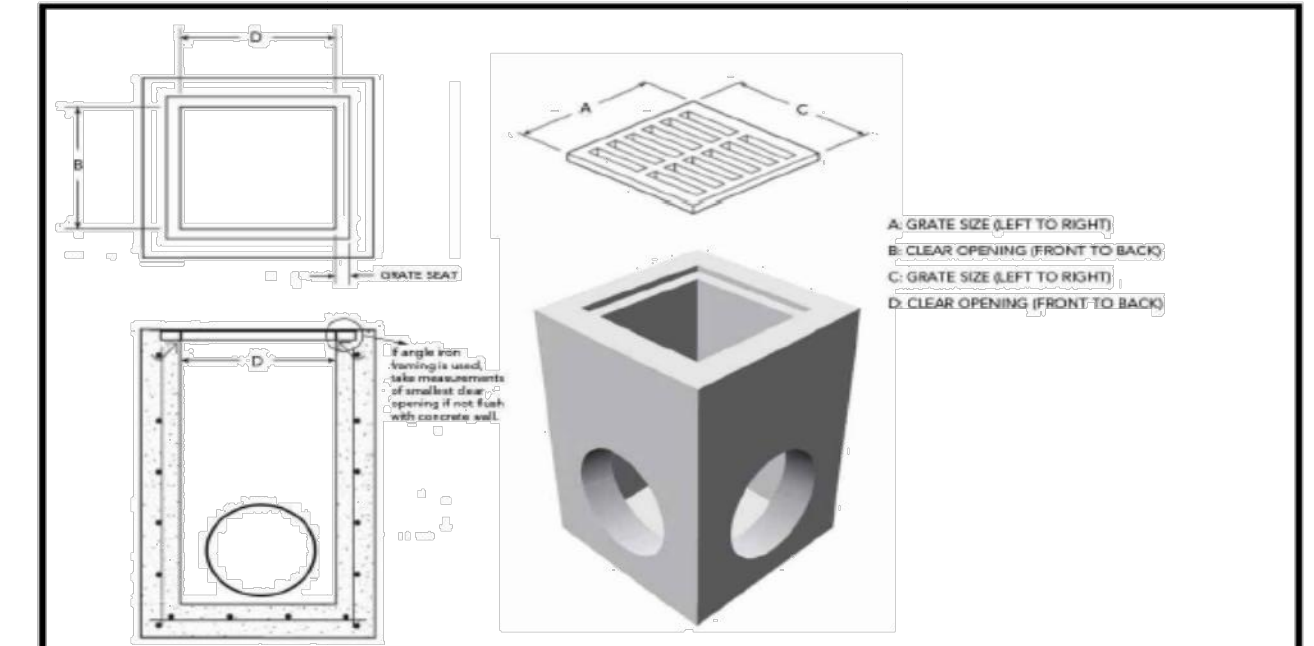

A. GRATE SIZE (LEFT TO RIGHT)
B. CLEAR OPENING (FRONT TO BACK)
C. GRATE SIZE (LEFT TO RIGHT)
D. CLEAR OPENING (FRONT TO BACK)

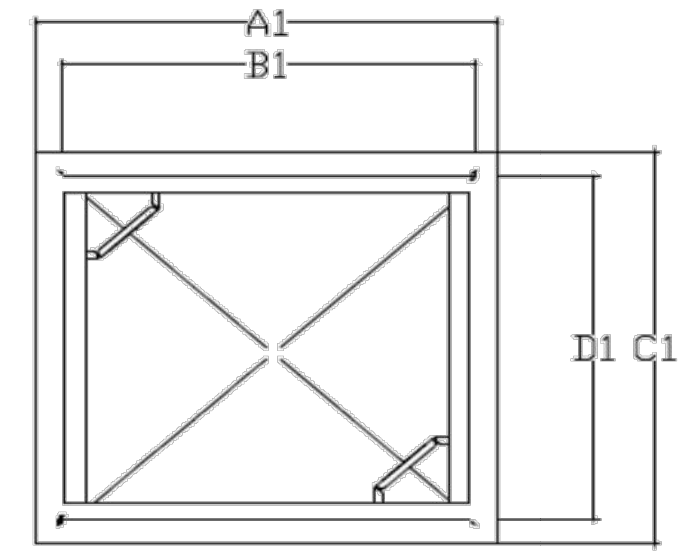

ADS PIN	Flexstorm Item Code	Field Inlet Dimensions		Flexstorm Framing Dims				Flexstorm Ratings (Flow at 50% Max)				Pure Frame with FX Bag	
		Grate Size (A x C)	Clear Opening (B x D)	B1	D1	A1	C1	Bag Capacity (ft³)	PC/PC+ Flow Rate (CFS)	Bypass (CFS)	ADS PIN	Flexstorm Item Code	
62SHDFX	F4HD-95-95-80-80-FX	9 1/2 X 9 1/2	8 X 8	6.0	5.0	9.5	9.3	0.2	0.5	1.2	62SHDFXP	F4HD-95-95-80-80-FXP	
62SHDFX	F4HD-115-115-105-105-FX	11.5 X 11.5	10.5 X 10.5	8.0	7.5	11.5	11.3	0.4	0.7	1.7	62SHDFXP	F4HD-115-115-105-105-FXP	
62SHDFX	F4HD-135-135-105-105-FX	13.5 X 13.5	12.5 X 12.5	10.0	9.5	13.5	13.3	0.6	1.0	2.3	62SHDFXP	F4HD-135-135-105-105-FXP	
62SHDFX	F4HD-155-155-110-110-FX	15.5 X 15.5	14.5 X 14.5	12.0	11.5	15.5	15.3	0.8	1.3	3.1	62SHDFXP	F4HD-155-155-110-110-FXP	
62SHDFX	F4HD-175-175-110-110-FX	17.5 X 17.5	16.5 X 16.5	14.0	13.5	17.5	17.3	1.0	1.6	4.1	62SHDFXP	F4HD-175-175-110-110-FXP	

- NOTES:
- RATINGS SHOWN ARE FOR STANDARD 22" BAG DEPTH; *SHORT* 12" DEPTH BAGS ARE AVAILABLE WITH -S SUFFIX; RATINGS REDUCED BY ~50%.
 - THE FOLLOWING REQUIRES ADDITIONAL REVIEW
-GRATES WITH EXTENDED BOTTOMS
-ANY OBSTRUCTED INLET OPENINGS

Standard	Inlet Type	Krazer Equivalent	Grate Size	Clear Opening Size	Bag Cap. (ft³)	Flow Ratings (CFS)			PRICE			
						FX/FX+	PC/PC+	Bypass	FX	FX+	PC	PC+
36" Open Throat Inlet	Open Throat (WM)	FGP-36CI	N/A	36	2.5	1.9	1.4	N/A	62HDWM8FX	62HDWM8FXP	62HDWM8PC	62HDWM8PCP
42" Open Throat Inlet	Open Throat (WM)	FGP-42CI	N/A	42	3.0	2.5	1.7	N/A	62HDWM1FX	62HDWM1FXP	62HDWM1PC	62HDWM1PCP
48" Open Throat Inlet	Open Throat (WM)	FGP-48CI	N/A	48	3.3	2.8	2.2	N/A	62HDWM8FX	62HDWM8FXP	62HDWM8PC	62HDWM8PCP
60" Open Throat Inlet (2 piece)	Open Throat (WM)	FGP-60CI	N/A	60	4.2	3.6	2.6	N/A	62HDWM8FX	62HDWM8FXP	62HDWM8PC	62HDWM8PCP
84" Open Throat Inlet (2 piece)	Open Throat (WM)	FGP-84CI	N/A	84	5.8	5.0	3.4	N/A	62HDWM8FX	62HDWM8FXP	62HDWM8PC	62HDWM8PCP
96" Open Throat Inlet (2 piece)	Open Throat (WM)	FGP-96CI	N/A	96	6.6	5.6	4.4	N/A	62HDWM8FX	62HDWM8FXP	62HDWM8PC	62HDWM8PCP
48" Open Throat with Side Wings	Open Throat (WM)	N/A	N/A	48 Winged	5.1	2.7	1.7	N/A	62HDWM818FX	62HDWM818FXP	62HDWM818PC	62HDWM818PCP

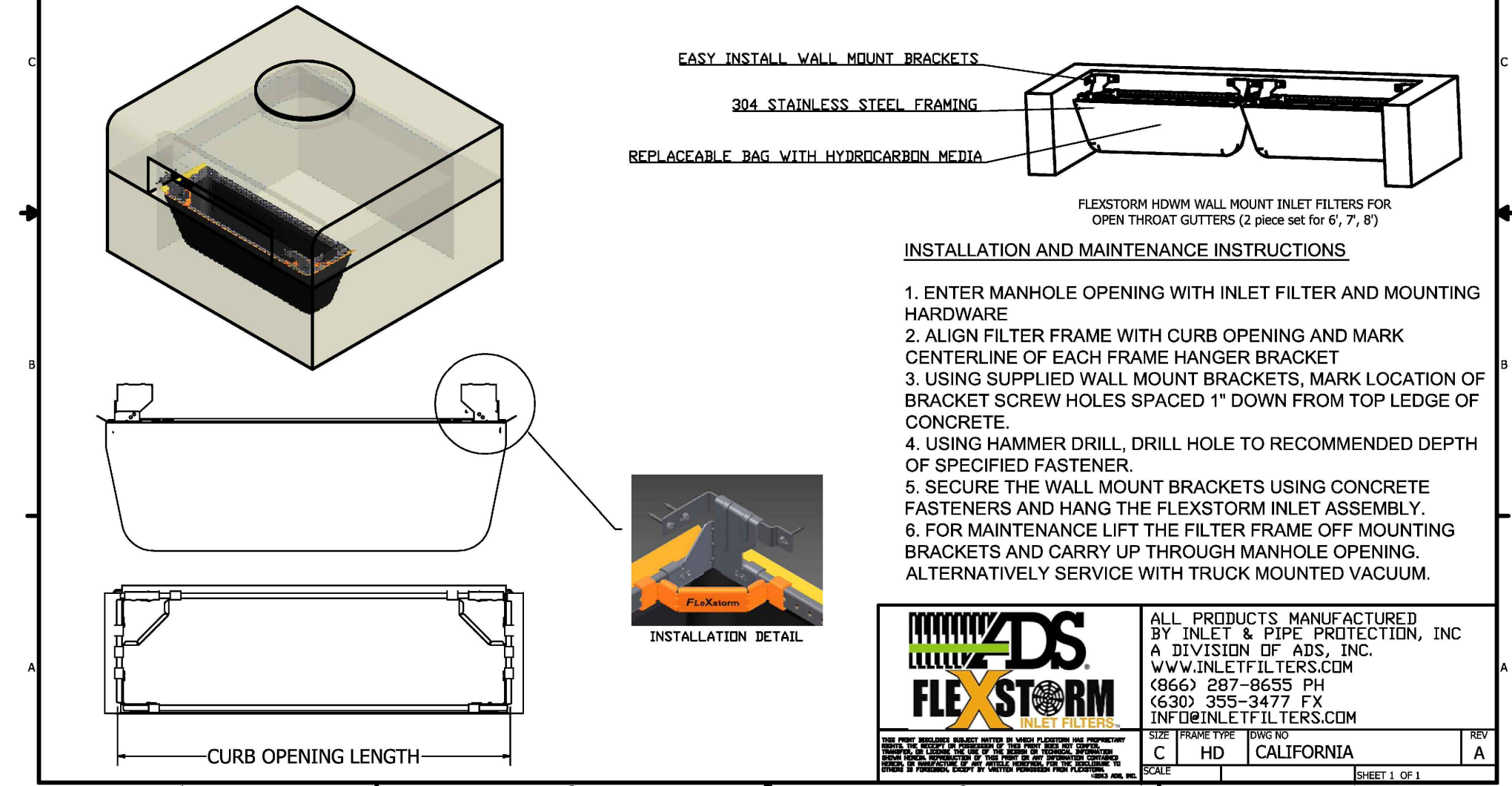

JOB NAME: KUM & GO 2232 DATE: 5/15/2023

SUMP PUMP SCHEDULE

ITEM	TYPE	SERVICE	SINGLE / DUPLEX STAGED	GPM	HEAD	HP	RPM	V-FPH	AMPS	MANUFACTURER & MODEL #	NOTES	CONTROLS
SP1	SUBMERSIBLE	SUMP PUMP	DUPLEX STAGED SEQUENTIAL	90	5.2	1/2	3450	208V / 3PH	6.4	ALDERON	1, 2, 3, 4, 5	ALDERON CUSTOM CONTROL PANEL
SP2	SUBMERSIBLE	SUMP PUMP	DUPLEX STAGED SEQUENTIAL	295	8.4	1 1/2	1750	208V / 3PH	5.9	ALDERON	1, 2, 3, 5, 6, 7	ALDERON CUSTOM CONTROL PANEL
TOTAL COMBINED FLOW				318								

NOTES:

- PROVIDE ZOELLER NEMA4 PRIMARY/SECONDARY ALTERNATING CONTROL PANEL WITH ALARMS, BECON, HOA SWITCHES AND DRY CONTACTS FOR REMOTE ALARM MONITORING. (ZOELLER 13404-0001)
- PROVIDE FOUR FLOAT SWITCHES WITH WEIGHTS (ALDERON 200181) AND FOUR POSITION FLOAT SWITCH BRACKET (ALDERON 7902)
- PROVIDE PUMP WITH 2" VERTICAL THREADED OUTLET, 2" COMBINATION CHECK VALVE AND BALL VALVE WITH UNION END (ZOELLER #30-0248) FOR EACH PUMP
- PROVIDE 2" VERTICAL THREADED RAIL SYSTEM (ZOELLER #39-0129) AND STAINLESS STEEL LIFTING CABLE FOR EACH PUMP
- PROVIDE 1 1/2" VERTICAL THREADED INLET WITH 2" VERTICAL THREADED OUTLET RAIL SYSTEM (ZOELLER #39-0131) AND STAINLESS STEEL LIFTING CABLE FOR EACH PUMP
- PROVIDE PUMP WITH 4" HORIZONTAL FLANGED OUTLET, 4" CHECK VALVE (ZOELLER #600-0030) AND PLUG VALVE (ZOELLER #600-0086) FOR EACH PUMP
- PROVIDE 4" HORIZONTAL FLANGED RAIL SYSTEM (ZOELLER #39-0154) AND STAINLESS STEEL LIFTING CABLE FOR EACH PUMP
- SP1 TO HAVE TRIMMED IMPELLER TO PERFORM AT 27 GPM @ 4.5 TDH
- SP2 TO HAVE TRIMMED IMPELLER TO PERFORM AT 295 GPM @ 8.4 TDH

WE RECOMMENDED OUR SMALLEST COMMERCIAL GRADE 208V/3PH PUMP FOR THE LOW FLOW RATE. WE DO NOT HAVE A PUMP FOR A 9 GPM FLOW RATE.

The employees of Rocky Mountain Sales have extensive experience in applications and selections of pumps and pump system components. However, we are NOT professional engineers or licensed contractors. This proposed specification and/or illustration are not intended to be construction documents, and are offered ONLY for your professional consideration.

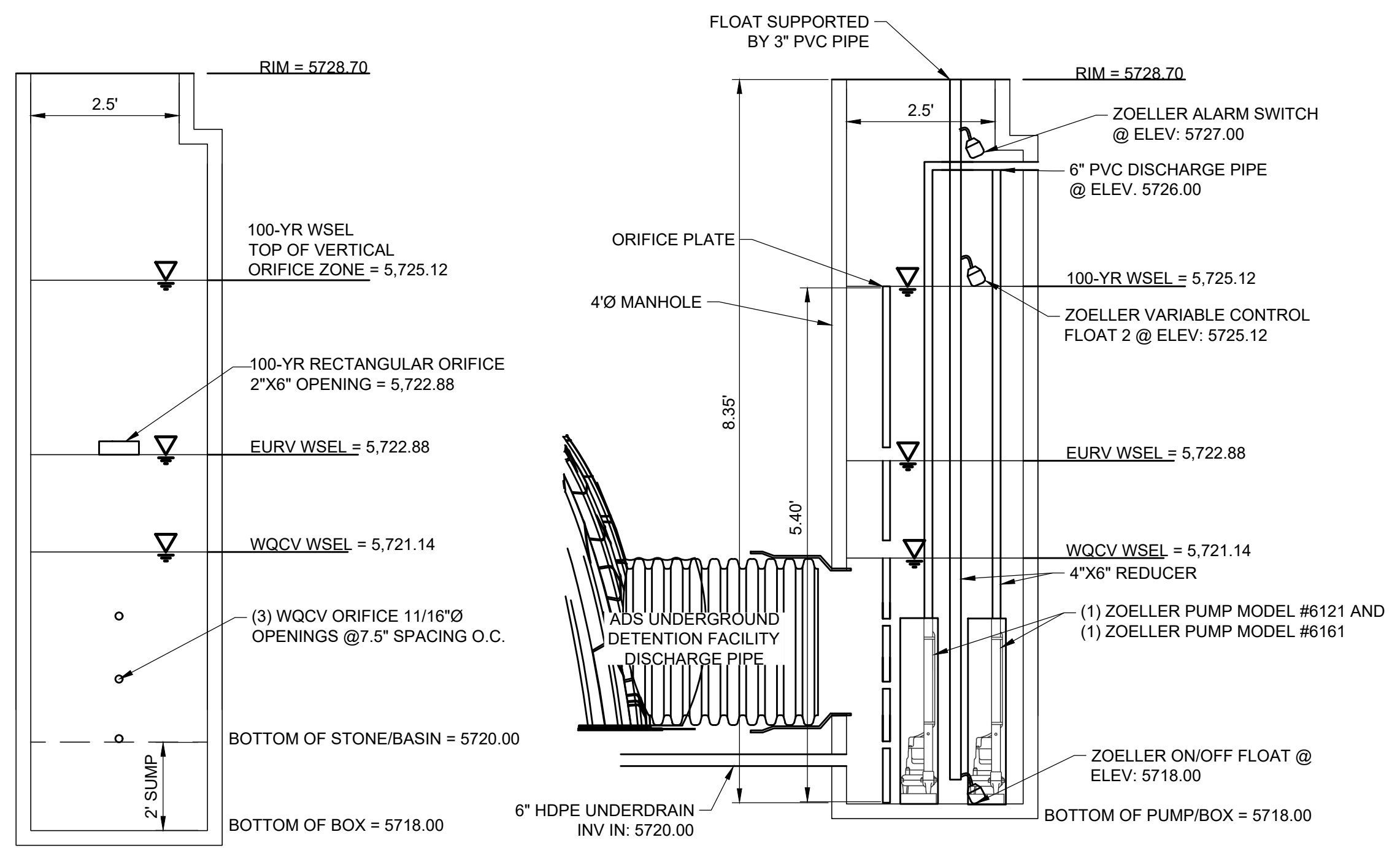

PCD FILE NO. PPR-2225

P:\KUM & GO\CO. EL PASO COUNTY - 2232 MAIN AND SECURITY\08 CAD\GSC02232 - 24 - ADS SYSTEM DETAILS.DWG

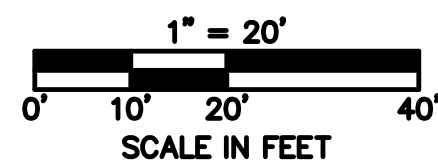
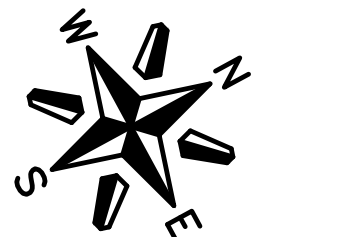

KUM & GO GAS & C-STORE

PART OF THE SOUTHEAST 1/4 OF SECTION 11, TOWNSHIP 15 SOUTH, RANGE 66
WEST OF THE SIXTH PRINCIPAL MERIDIAN,
COUNTY OF EL PASO, STATE OF COLORADO

MAJOR SITE DEVELOPMENT PLAN

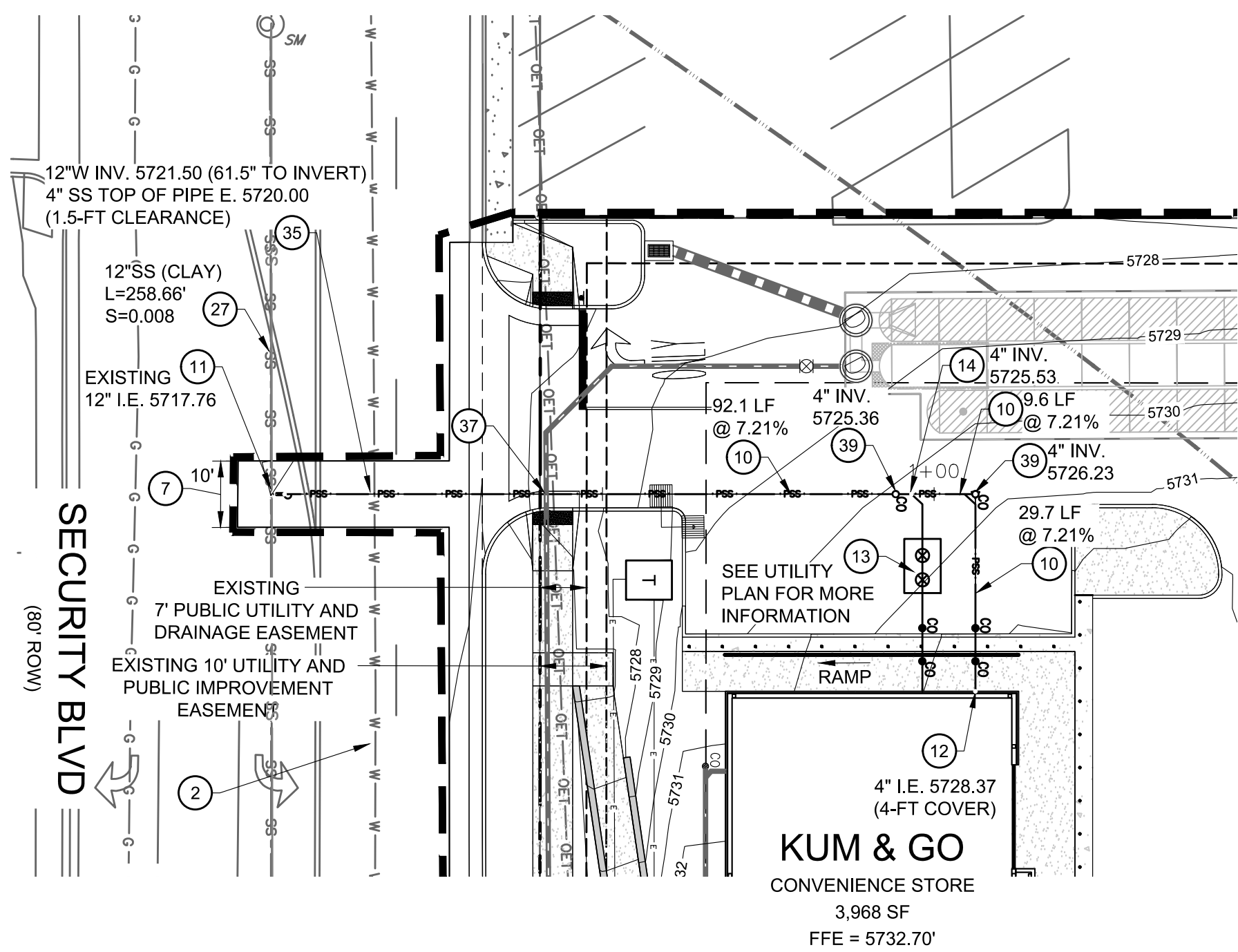

SITE AND UTILITY PLAN LEGEND

— G — G — G — G — G — G —	EXISTING GAS
— SS — SS — SS — SS — SS —	EXISTING SANITARY SEWER
— ST — ST — ST — ST — ST —	EXISTING STORM SEWER
— OET — OET — OET — OET — OET —	EXISTING OVERHEAD ELECTRICAL AND TELECOMMUNICATIONS
— UC — UC — UC — UC — UC —	EXISTING UNDERGROUND TELECOMMUNICATIONS
— W — W — W — W — W — W —	EXISTING WATER
— — — — —	CONSTRUCTION / DISTURBANCE LIMITS
— — — — —	PROPERTY BOUNDARY
— — — — —	EXISTING EASEMENT
— — — — —	PROPOSED RETAINING WALL
— PSS — PSS — PSS — PSS — PSS —	PROPOSED SANITARY SEWER
— — — — —	PROPOSED WATER
— — — — —	PROPOSED STORM SEWER
— — — — —	PROPOSED UNDERGROUND ELECTRIC
— — — — —	PROPOSED COMMUNICATION LINE
— — — — —	PROPOSED STORM INLET AND MANHOLE
— — — — —	PROPOSED DRAINAGE FLOW ARROWS
☀	EXISTING STREET LIGHT
⊕	EXISTING FIRE HYDRANT
— — — — —	PROPOSED SITE LIGHT

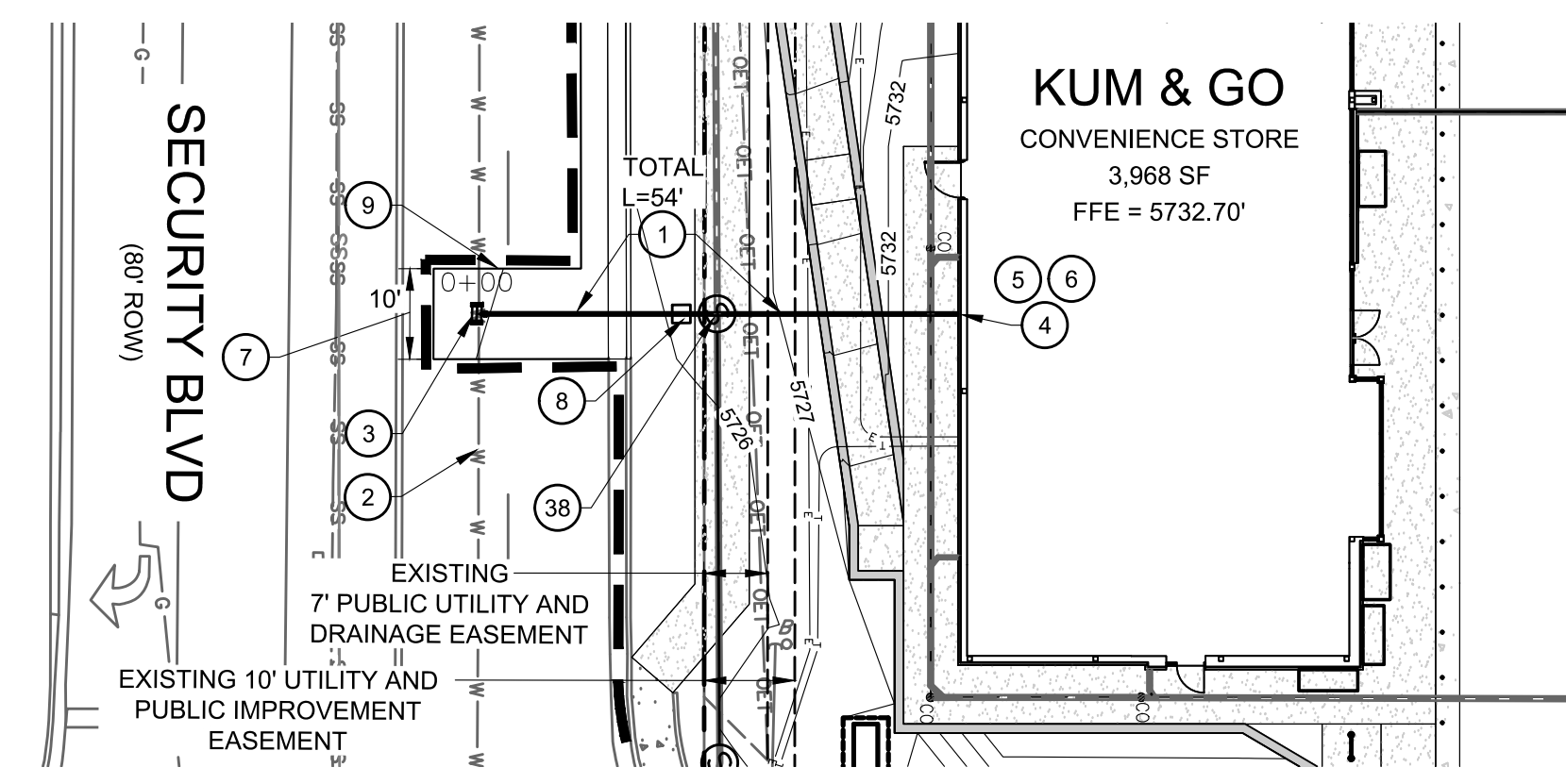
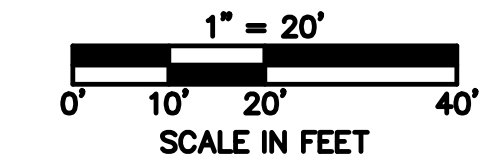
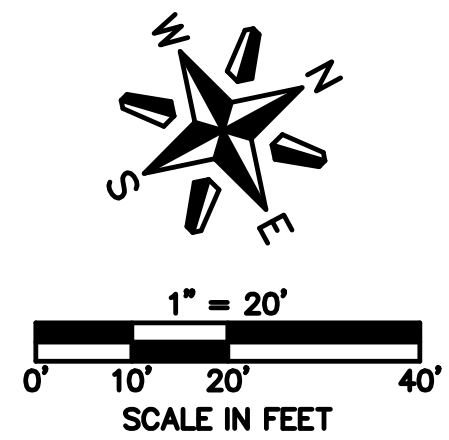

UTILITY SCHEDULE:

- 1 PROPOSED 2" WATER SERVICE (HDPE PE 4710 IPS, SDR7, SDR7) WITH FORD BRASS FITTINGS, SOLID NO. 6 AWG (BARE COPPER) TRACER WIRE AND 5.0 FEET MINIMUM DEPTH BELOW GRADE IN ACCORDANCE WITH SECURITY WATER AND SANITATION DISTRICT STANDARDS AND SPECIFICATIONS. SEE DETAILS ON SHEET C5.3. CONTRACTOR TO COORDINATE INSTALLATION OF ALL APPURTENANCES NECESSARY FOR CONSTRUCTION WITH SECURITY WATER AND SANITATION DISTRICT STANDARDS. PERFORM REQUIRED WORK, AND CONFIRM PROPOSED SERVICE SIZE WITH ARCHITECT AND MECHANICAL PLANS PRIOR TO CONSTRUCTION.
- 2 EXISTING WATER MAIN TO REMAIN AND BE PROTECTED DURING CONSTRUCTION. SECURITY BLVD IS 12" CAST IRON PIPE AND MAIN IS 10" CAST IRON PIPE.
- 3 PROPOSED 2" DOMESTIC WATER SERVICE POINT OF CONNECTION WITH EXISTING 12" WATER MAIN. INSTALL 2" WATER SERVICE TAP PER SECURITY WATER AND SANITATION DISTRICT STANDARDS. SEE DETAIL ON SHEET C5.3.
- 4 PROPOSED 2" DOMESTIC WATER SERVICE ENTRY. PROVIDE 6-FT OF COVER AT BUILDING CONNECTION TO PROVIDE 1.5-FT CLEARANCE UNDER 6" ROOF DRAIN. CONTRACTOR SHALL VERIFY HORIZONTAL AND VERTICAL LOCATION. COORDINATE WITH ARCHITECTURAL AND MECHANICAL PLANS FOR WATER METER PLACEMENT (INSIDE THE BUILDING).
- 5 PROPOSED IRRIGATION TAP TO BE INSTALLED INSIDE THE BUILDING IN MECHANICAL ROOM OFF DOMESTIC WATER SERVICE LINE. IRRIGATION TAP/METER LOCATION SHALL BE BETWEEN INTERIOR WALL AND DOMESTIC WATER METER. SEE MECHANICAL PLANS FOR CONTINUATION.
- 6 PROPOSED 2" WATER METER LOCATED INSIDE THE BUILDING MECHANICAL ROOM. CONTRACTOR SHALL INSTALL 2" WATER METER. COORDINATE WITH THE SECURITY WATER AND SANITATION DISTRICT FOR APPROVAL OF WATER METER LOCATION PRIOR TO INSTALLATION. SEE MECHANICAL PLANS FOR CONTINUATION.
- 7 PROPOSED 10-FT WIDE UTILITY TRENCH PER SECURITY WATER AND SEWER DISTRICT STANDARDS. SAWCUT ASPHALT TO FORM A CLEAN SMOOTH EDGE AND REPLACE ROAD SECTION IN-KIND.
- 8 PROPOSED CURB STOP AND BOX TO BE INSTALLED 6" FROM THE INSIDE EDGE OF THE SIDEWALK IN ACCORDANCE WITH SECURITY WATER AND SANITATION DISTRICT STANDARDS. CONTRACTOR SHALL COORDINATE INSTALLATION OF ALL APPURTENANCES NECESSARY FOR CONSTRUCTION WITH SECURITY WATER AND SANITATION DISTRICT. SEE DETAIL ON SHEET C5.3.
- 9 SAWCUT ASPHALT / CONCRETE TO FORM A CLEAN, SMOOTH EDGE.
- 10 PROPOSED 4" ASTM 3034 SDR-35 PVC SANITARY SEWER SERVICE. INSTALL AT 2.0% MINIMUM SLOPE. REFER TO ARCHITECTURAL PLANS FOR DETAILS AND INFORMATION REGARDING POINT OF CONNECTION/CONTINUATION AT THE BUILDING. SEE DETAILS ON SHEET C5.4.
- 11 PROPOSED 4" SS SERVICE POINT OF CONNECTION WITH EXISTING 12" SS MAIN LINE. INSTALL PVC TAP SADDLE CONNECTION WITH STAINLESS STEEL BANDS PER SECURITY WATER AND SANITATION DISTRICT STANDARD DETAIL WW-9. SEE DETAIL ON SHEET C5.4.
- 12 SANITARY SEWER SERVICE ENTRY. CONTRACTOR SHALL VERIFY HORIZONTAL AND VERTICAL LOCATION AND CONTINUATION WITH ARCHITECTURAL AND MECHANICAL PLANS.
- 13 PROPOSED 1,000 GALLON GREASE INTERCEPTOR WITH SAMPLE PORT PER SECURITY WATER AND SANITATION DISTRICT STANDARDS. SEE DETAIL ON SHEET C5.4 AND UTILITY PLAN FOR MORE INFORMATION.
- 14 4" WYE CONNECTION. SEE PLAN FOR INVERT ELEVATION.
- 27 EXISTING SEWER MANHOLE / SEWER MAIN LINE TO REMAIN AND BE PROTECTED DURING CONSTRUCTION.
- 35 PROPOSED 4" SANITARY SEWER CROSSING WITH EXISTING 12" CIP WATER MAIN PER SECURITY WATER AND SANITATION DISTRICT STANDARDS. SEE PLAN FOR UTILITY CROSSING ELEVATIONS.
- 37 PROPOSED 6" PRESSURIZED HDPE STORM SEWER CROSSING WITH 4" SANITARY SEWER SERVICE. SEE PROFILE FOR UTILITY CROSSING ELEVATIONS.
- 38 PROPOSED 6" PRESSURIZED HDPE STORM SEWER CROSSING WITH 2" DOMESTIC WATER SERVICE. SEE PROFILE FOR UTILITY CROSSING ELEVATIONS.
- 39 PROPOSED 4" SANITARY SEWER CLEANOUT PER SECURITY WATER AND SANITATION DISTRICT STANDARDS. REFER TO DETAIL ON SHEET C5.4. SEE PROFILE FOR INVERT ELEVATION.

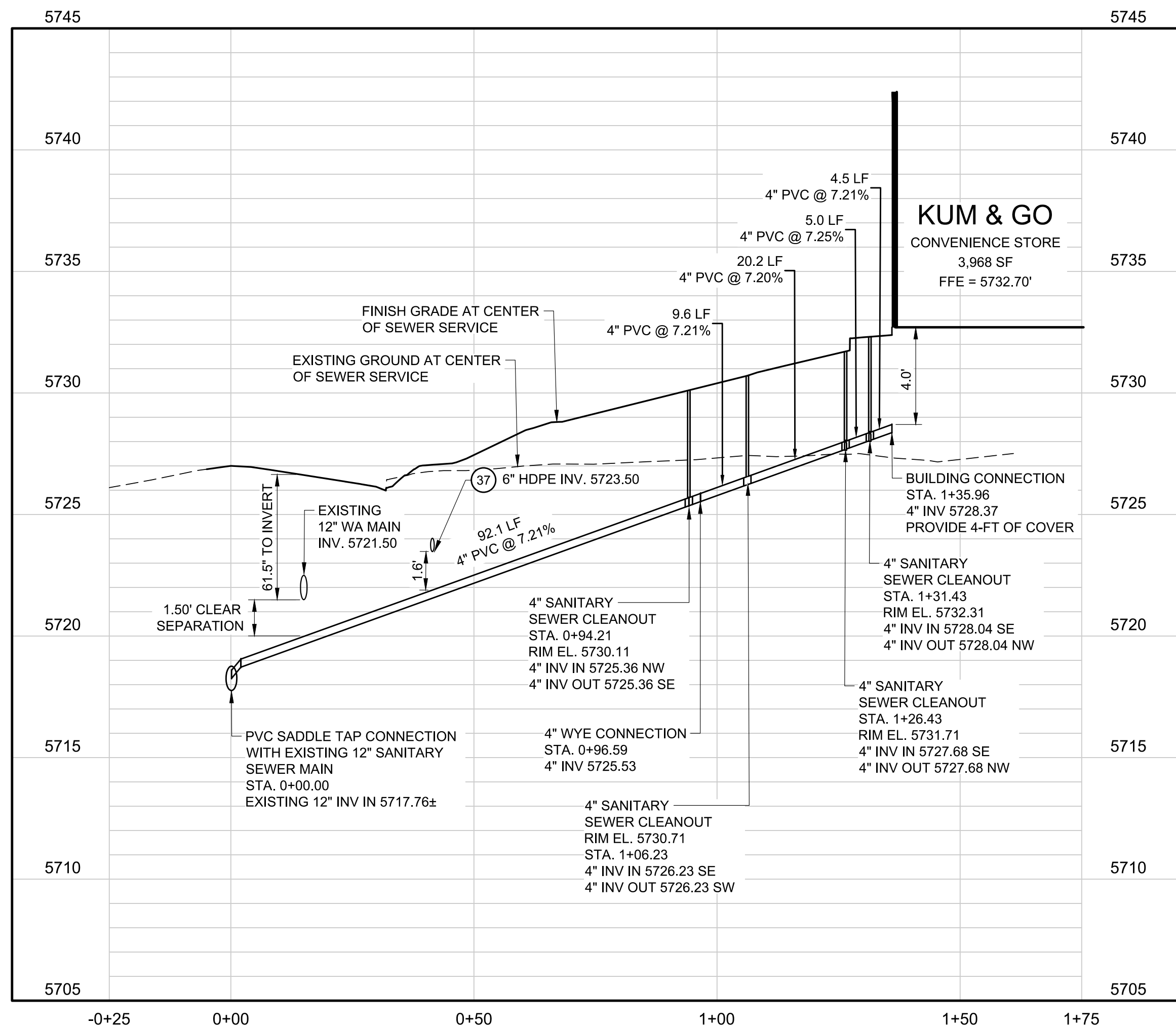

PROFILE SANITARY SEWER SERVICE (STA: -0+25 TO 1+75)

SCALES: 1"=20' HORIZONTAL, 1"=4' VERTICAL

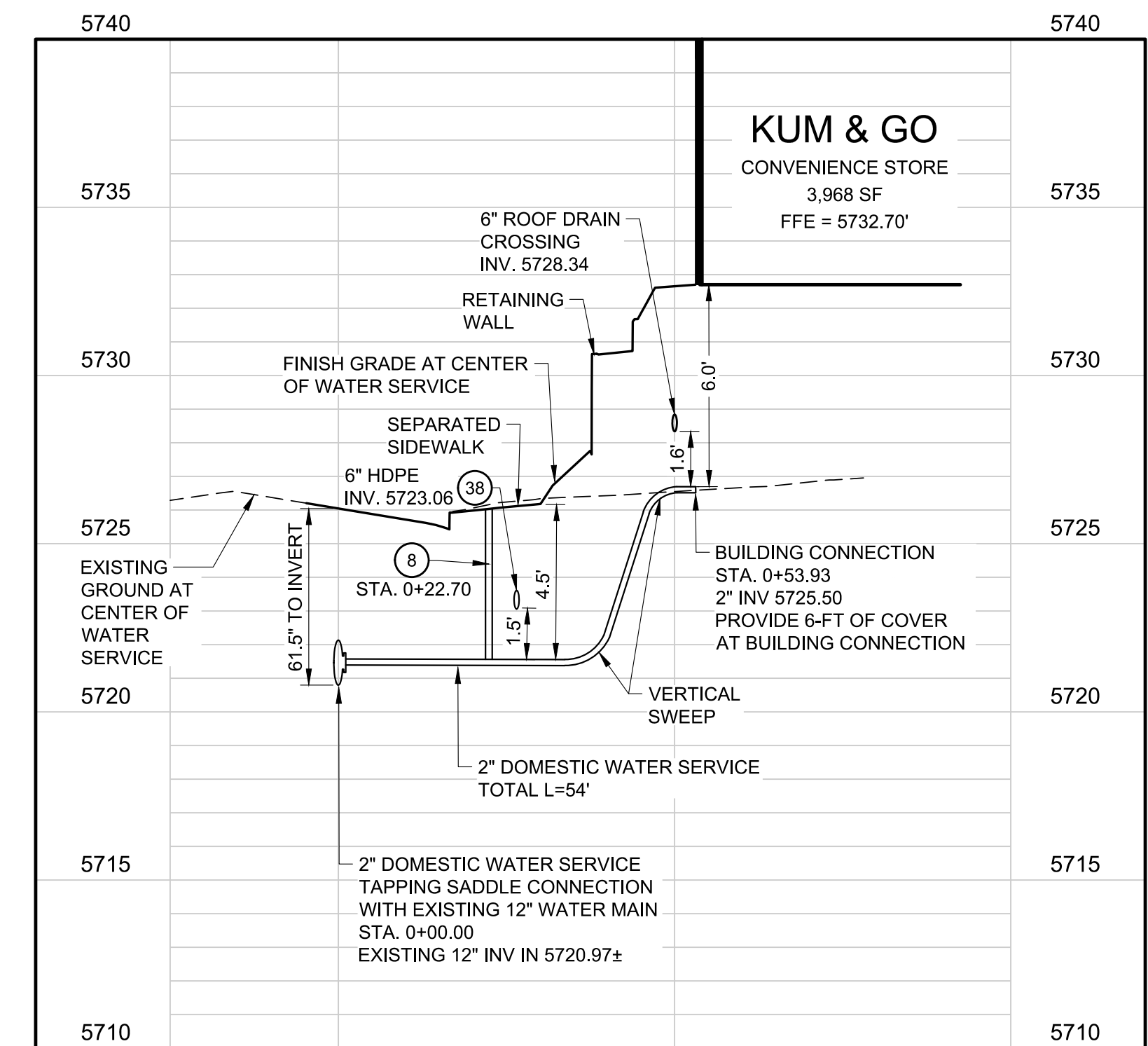

PROFILE DOMESTIC WATER SERVICE (STA: -0+25 TO 1+00)

SCALES: 1"=20' HORIZONTAL, 1"=4' VERTICAL

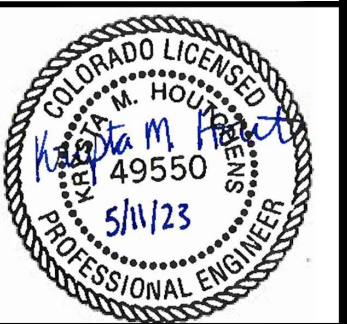

1459 Grand Ave
Des Moines, IA 50309
P: 888-458-6646

2232 - EL PASO, COLORADO
SECURITY BLVD. AND MAIN ST.
UTILITY PROFILES

KG PROJECT TEAM:
RDM:
SDM:
CPM:

REVISIONS	DATE	REVISION DESCRIPTION
1	08/19/22	1ST REVIEW COMMENTS
2	01/06/23	2ND REVIEW COMMENTS
3	04/05/23	3RD REVIEW COMMENTS
4	05/11/23	4TH REVIEW COMMENTS

DATE: 05-11-2023

SHEET NUMBER:

PCD FILE NO. PPR-2225

C5.2
26 OF 43

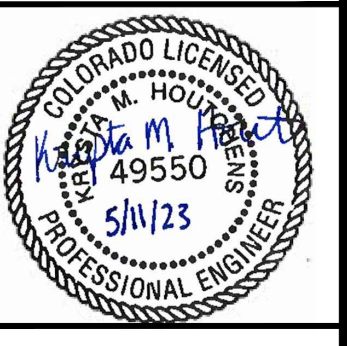
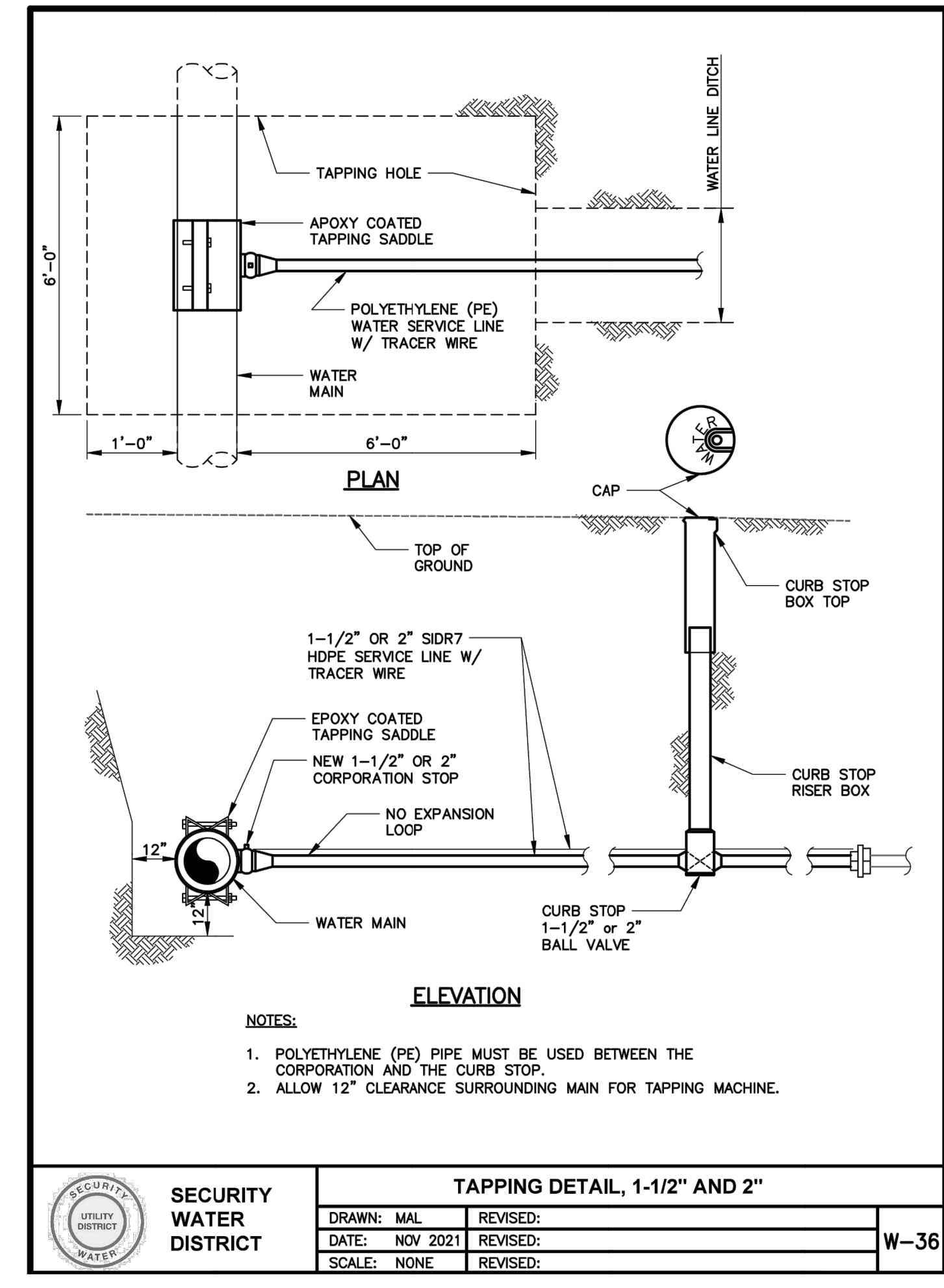
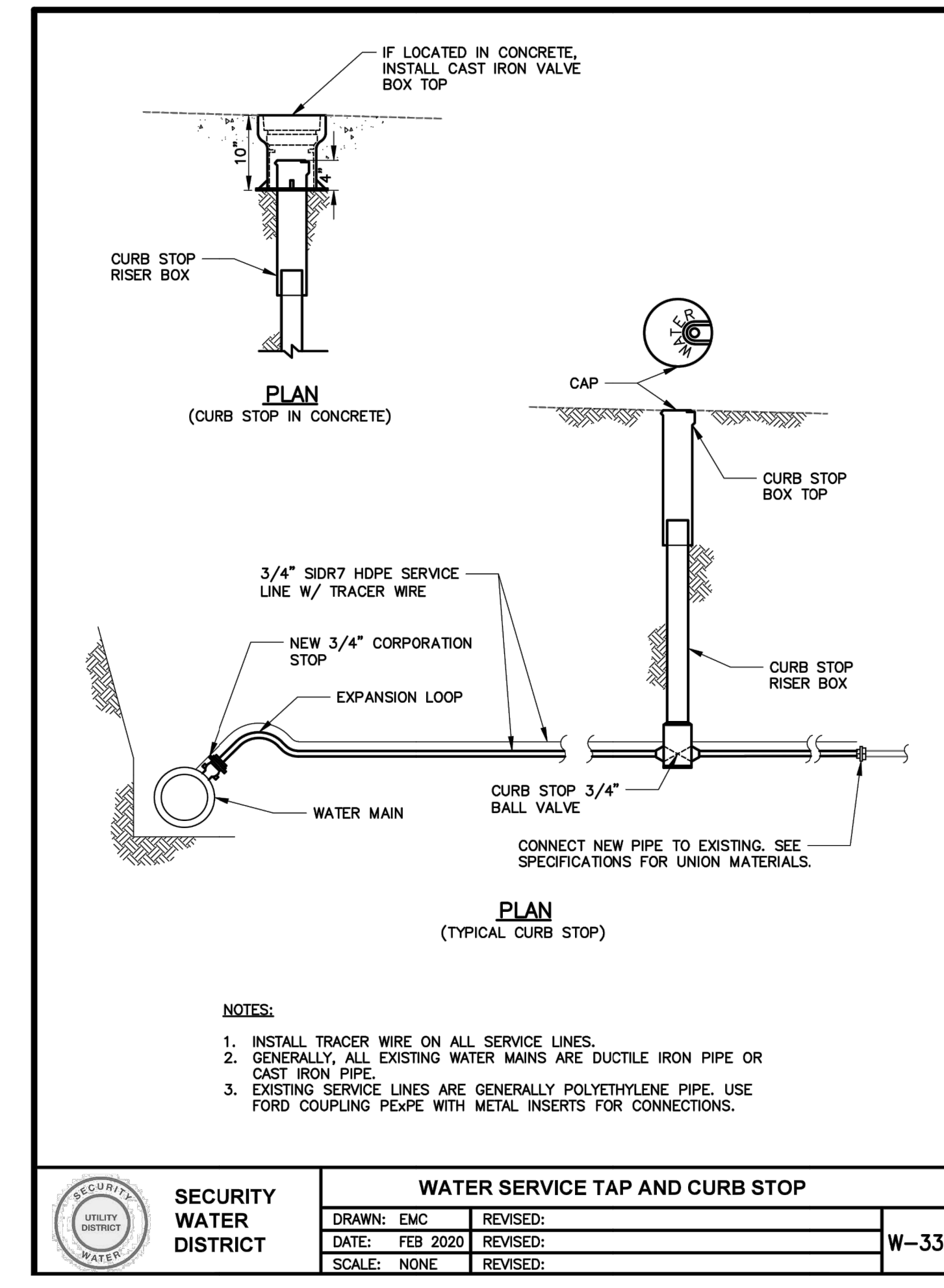
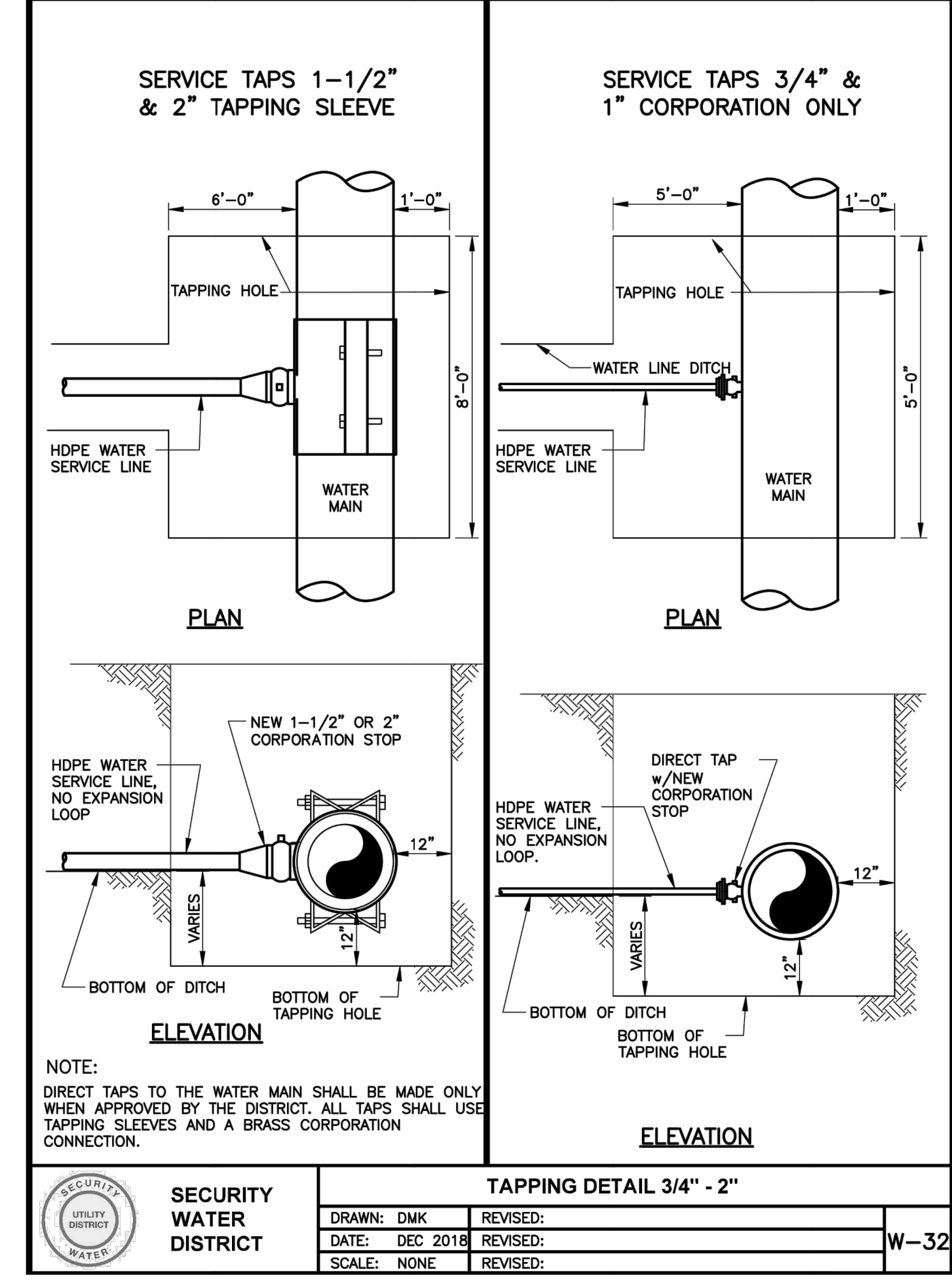
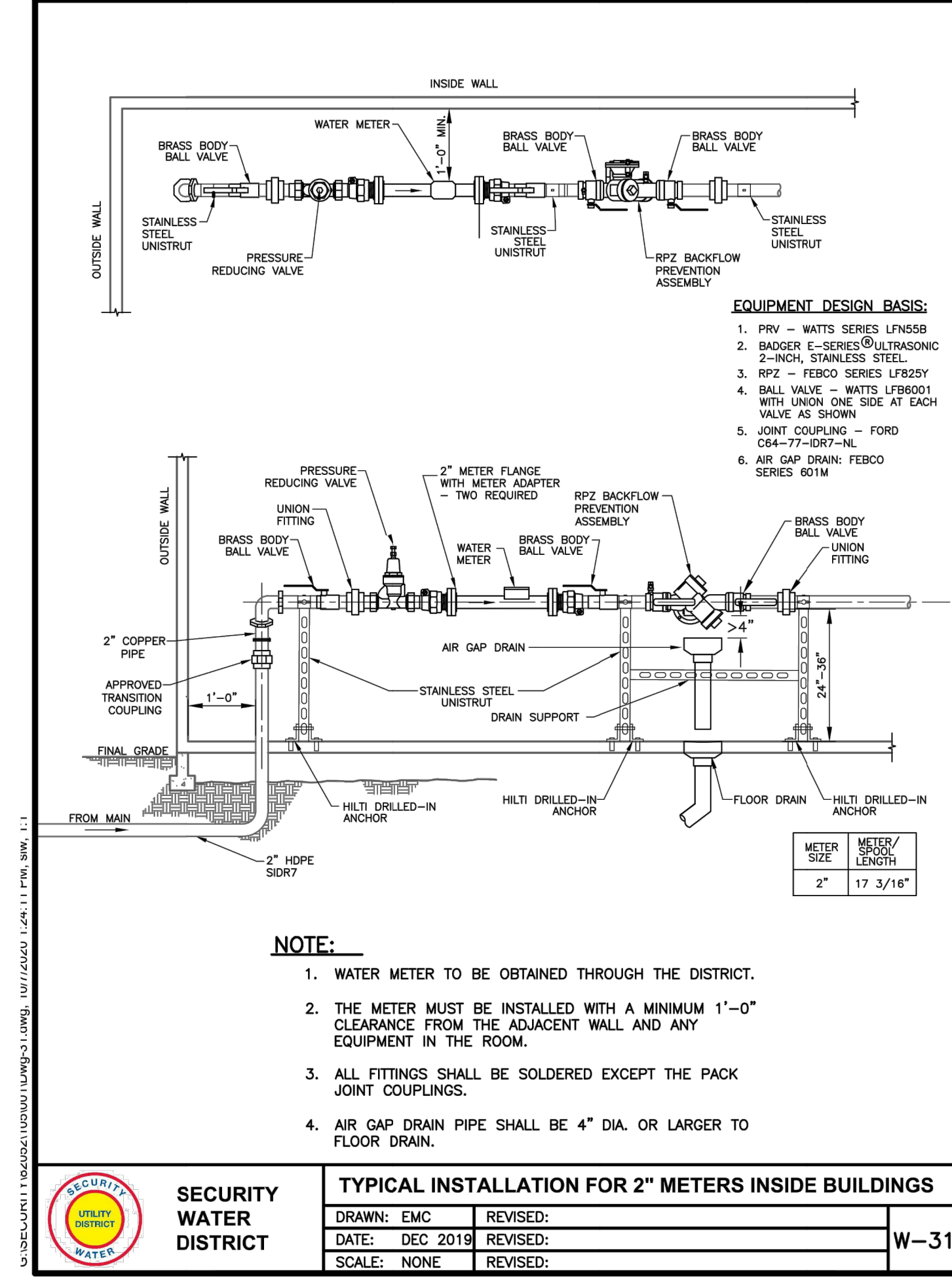
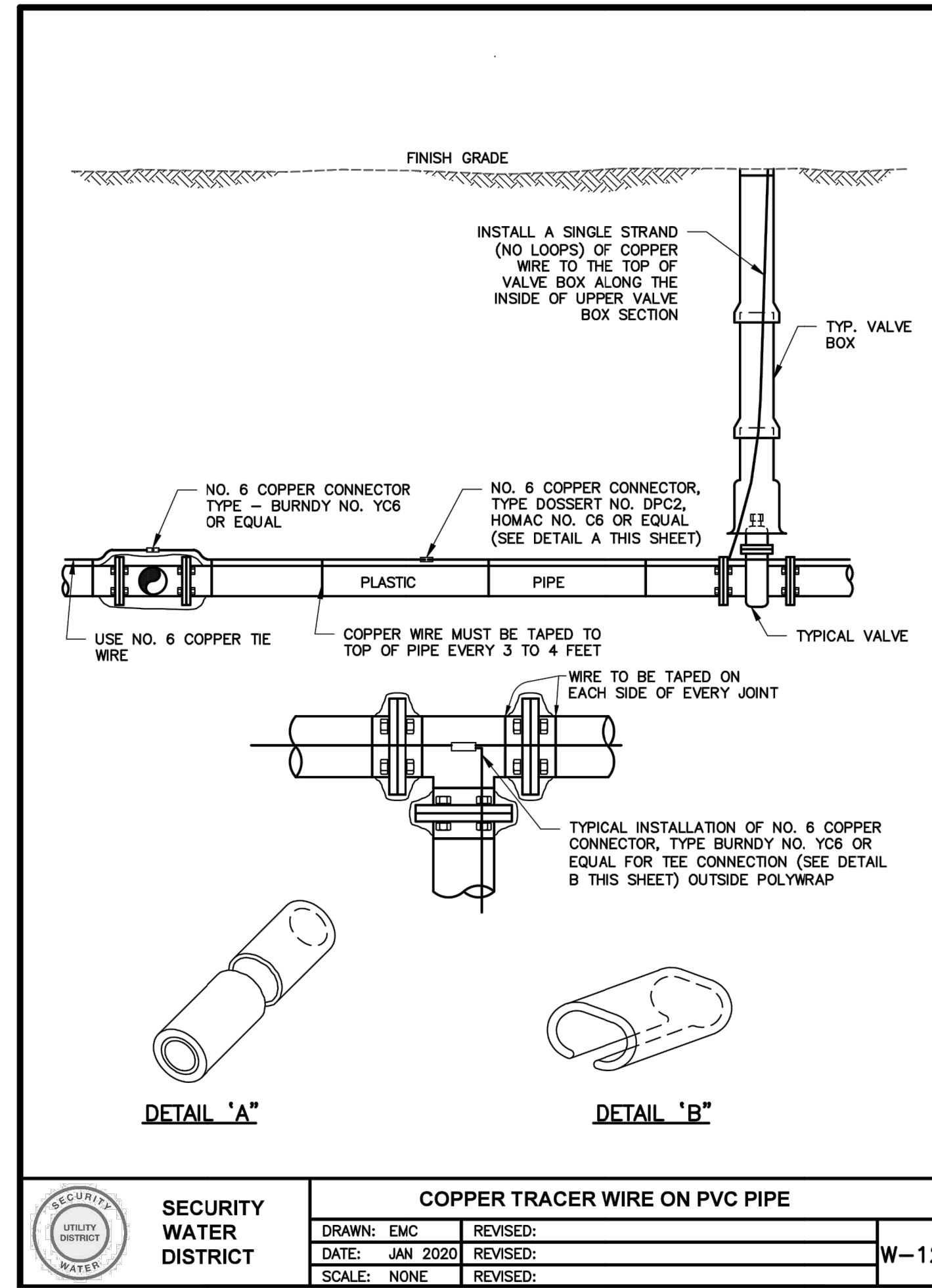

1459 Grand Ave
Des Moines, IA 50309
P: 888-458-6646

2232 - EL PASO, COLORADO
SECURITY BLVD. AND MAIN ST.
UTILITY DETAILS

KG PROJECT TEAM:
RDM:
SDM:
CPM:

REVISION DESCRIPTION	DATE
1ST REVIEW COMMENTS	08/18/22
2ND REVIEW COMMENTS	01/06/23
3RD REVIEW COMMENTS	04/05/23
4TH REVIEW COMMENTS	05/11/23

DATE: 05-11-2023

SHEET NUMBER:
C5.3
27 OF 43

PCD FILE NO. PPR-2225

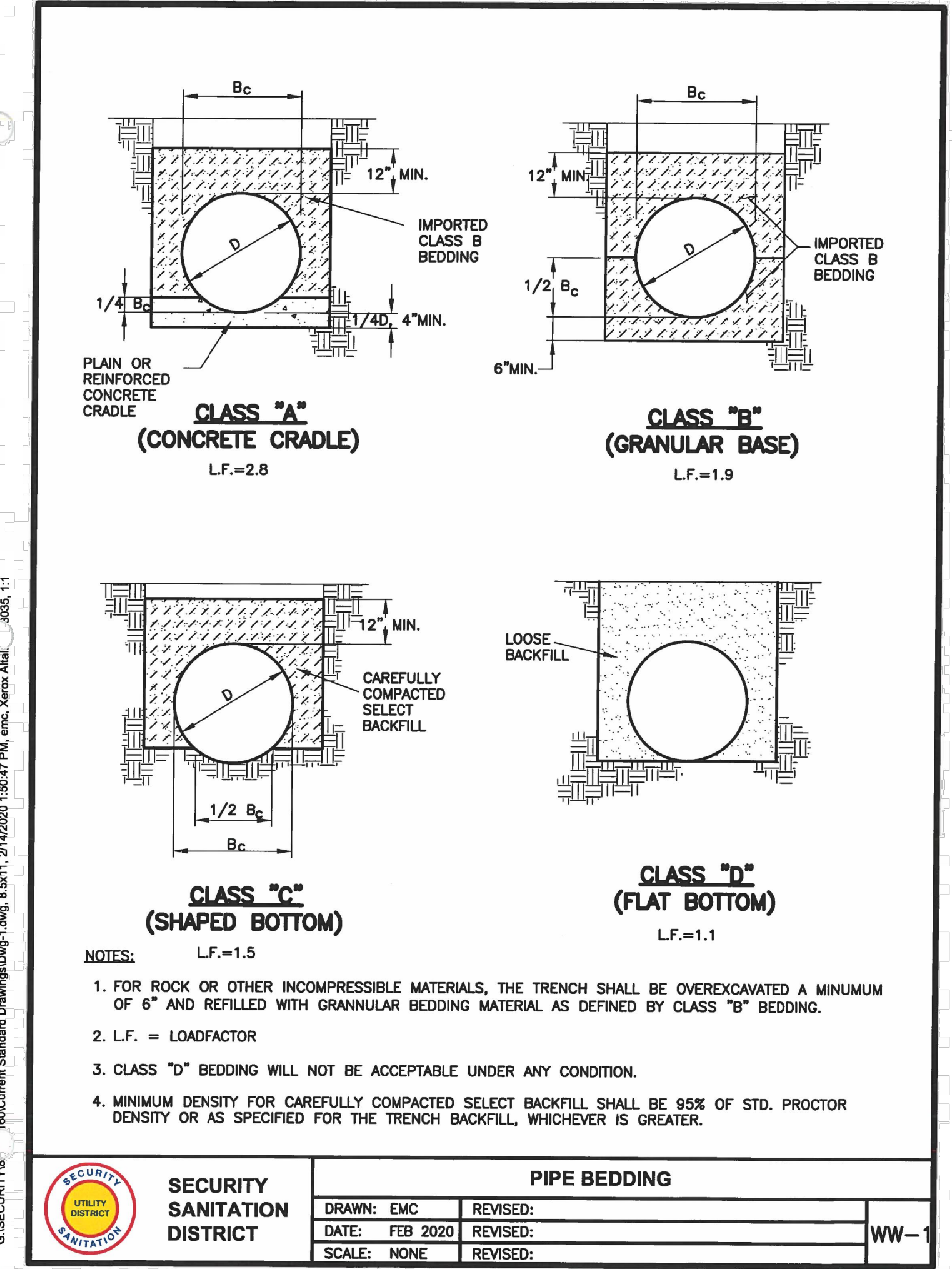

SECURITY UTILITY DISTRICT SANITATION	SECURITY SANITATION DISTRICT		PIPE BEDDING	DRAWN: EMC DATE: FEB 2020 SCALE: NONE	REVISED: REVISED: REVISED:	WW-1
	SECURITY SANITATION DISTRICT					
	SECURITY SANITATION DISTRICT					
	SECURITY SANITATION DISTRICT					

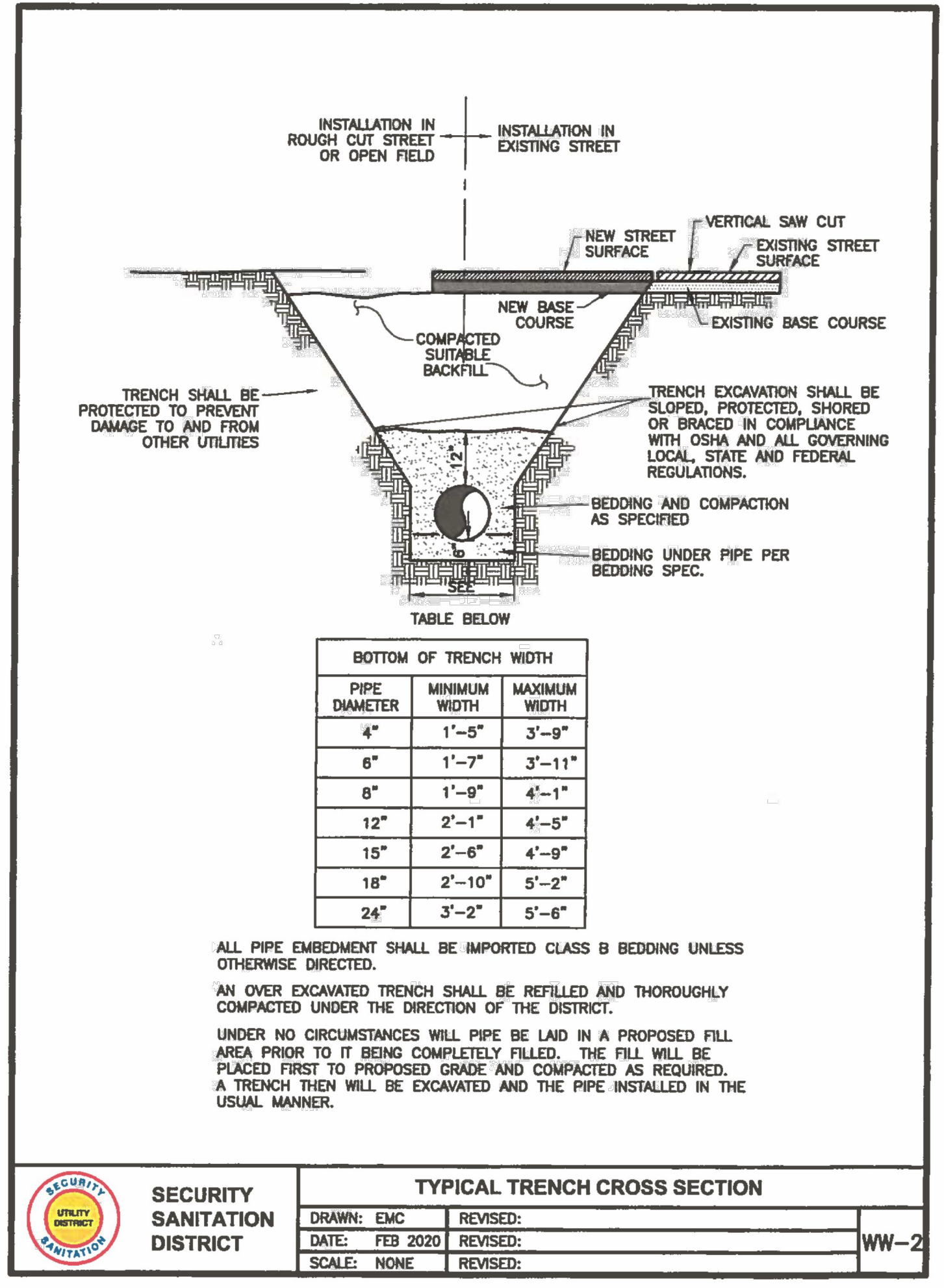

SECURITY UTILITY DISTRICT SANITATION	SECURITY SANITATION DISTRICT		TYPICAL TRENCH CROSS SECTION	DRAWN: EMC DATE: FEB 2020 SCALE: NONE	REVISED: REVISED: REVISED:	WW-2
	SECURITY SANITATION DISTRICT					
	SECURITY SANITATION DISTRICT					
	SECURITY SANITATION DISTRICT					

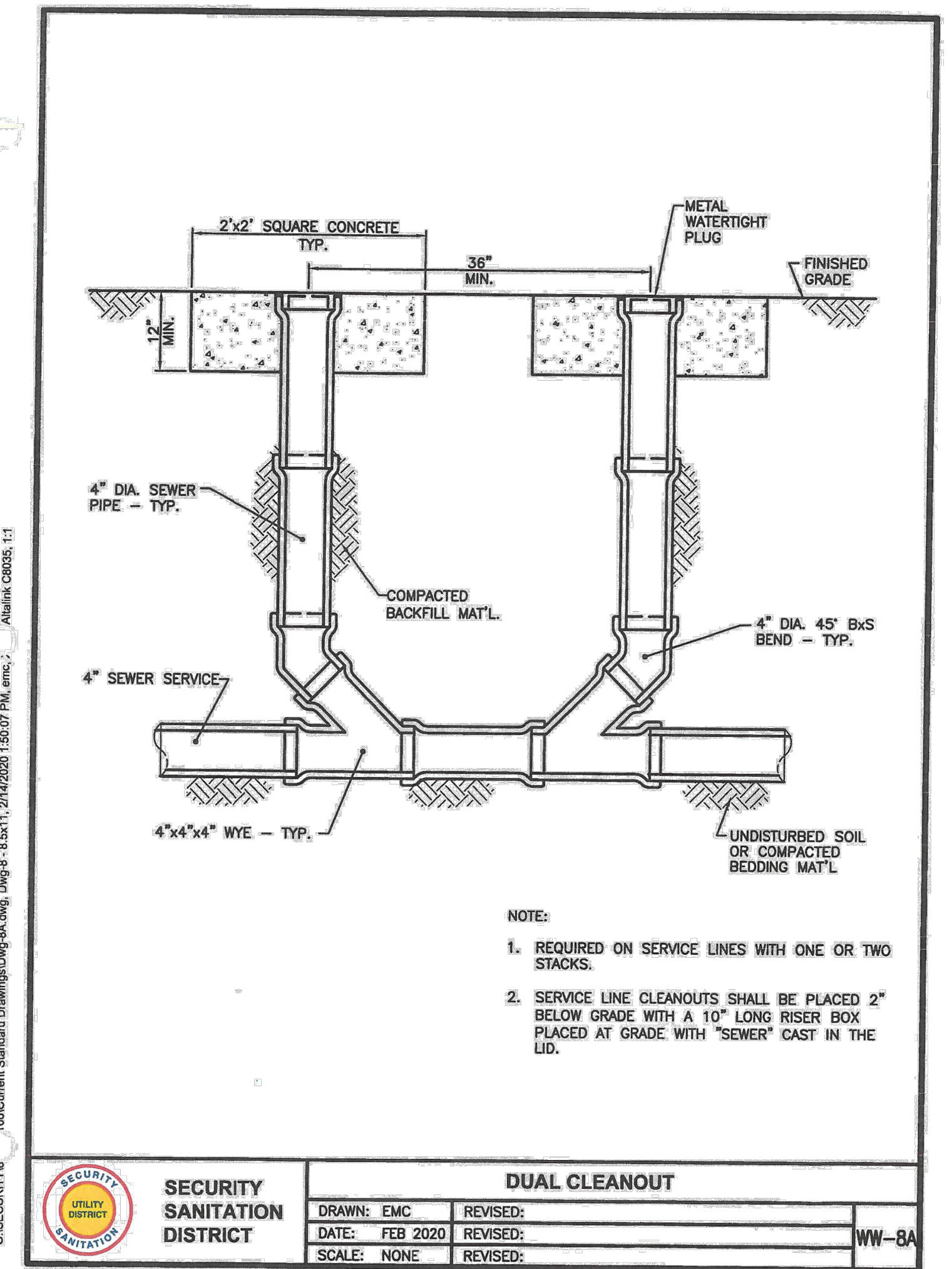

SECURITY UTILITY DISTRICT SANITATION	SECURITY SANITATION DISTRICT		DUAL CLEANOUT	DRAWN: EMC DATE: FEB 2020 SCALE: NONE	REVISED: REVISED: REVISED:	WW-8A
	SECURITY SANITATION DISTRICT					
	SECURITY SANITATION DISTRICT					
	SECURITY SANITATION DISTRICT					

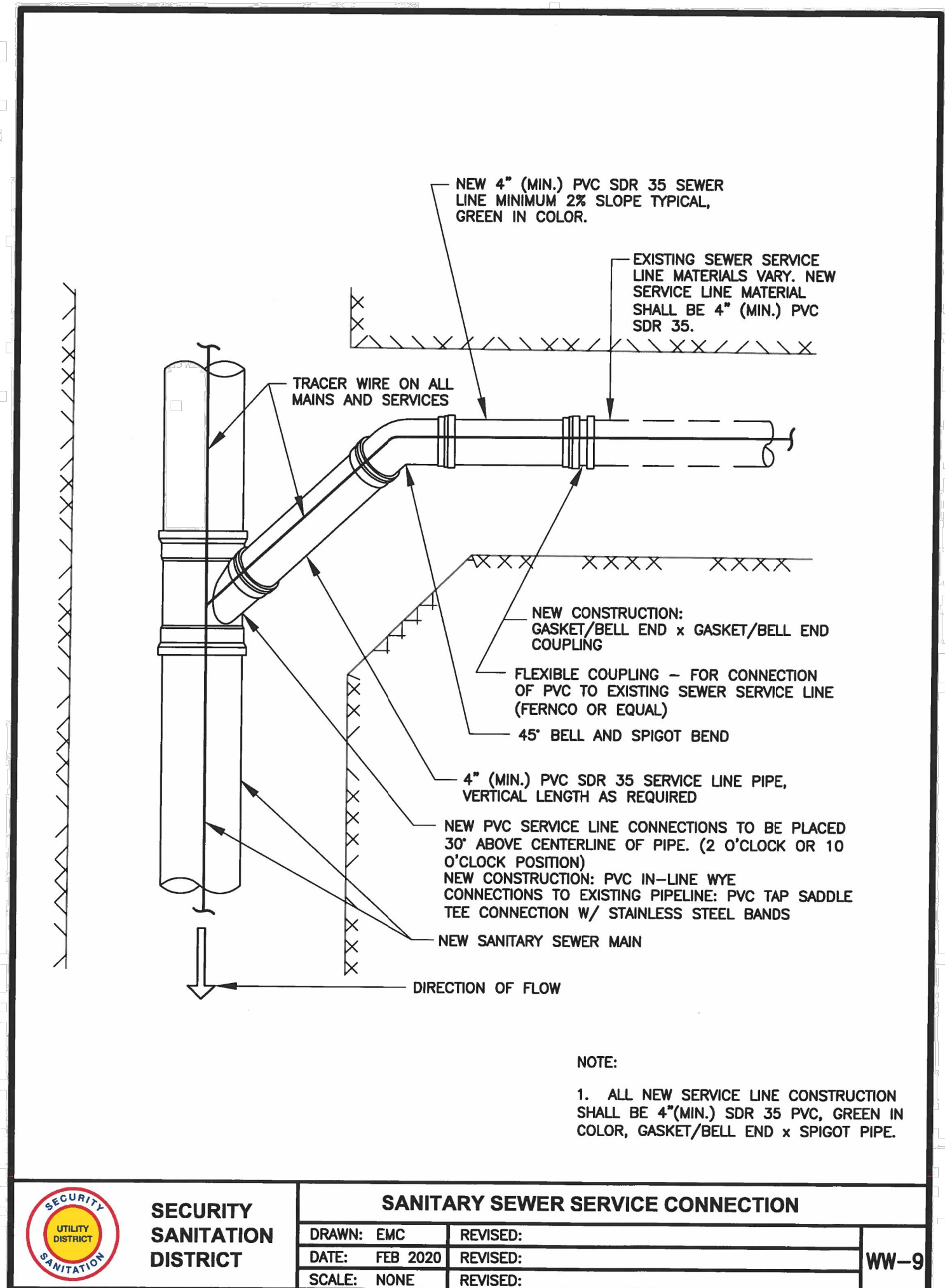

SECURITY UTILITY DISTRICT SANITATION	SECURITY SANITATION DISTRICT		SANITARY SEWER SERVICE CONNECTION	DRAWN: EMC DATE: FEB 2020 SCALE: NONE	REVISED: REVISED: REVISED:	WW-9
	SECURITY SANITATION DISTRICT					
	SECURITY SANITATION DISTRICT					
	SECURITY SANITATION DISTRICT					

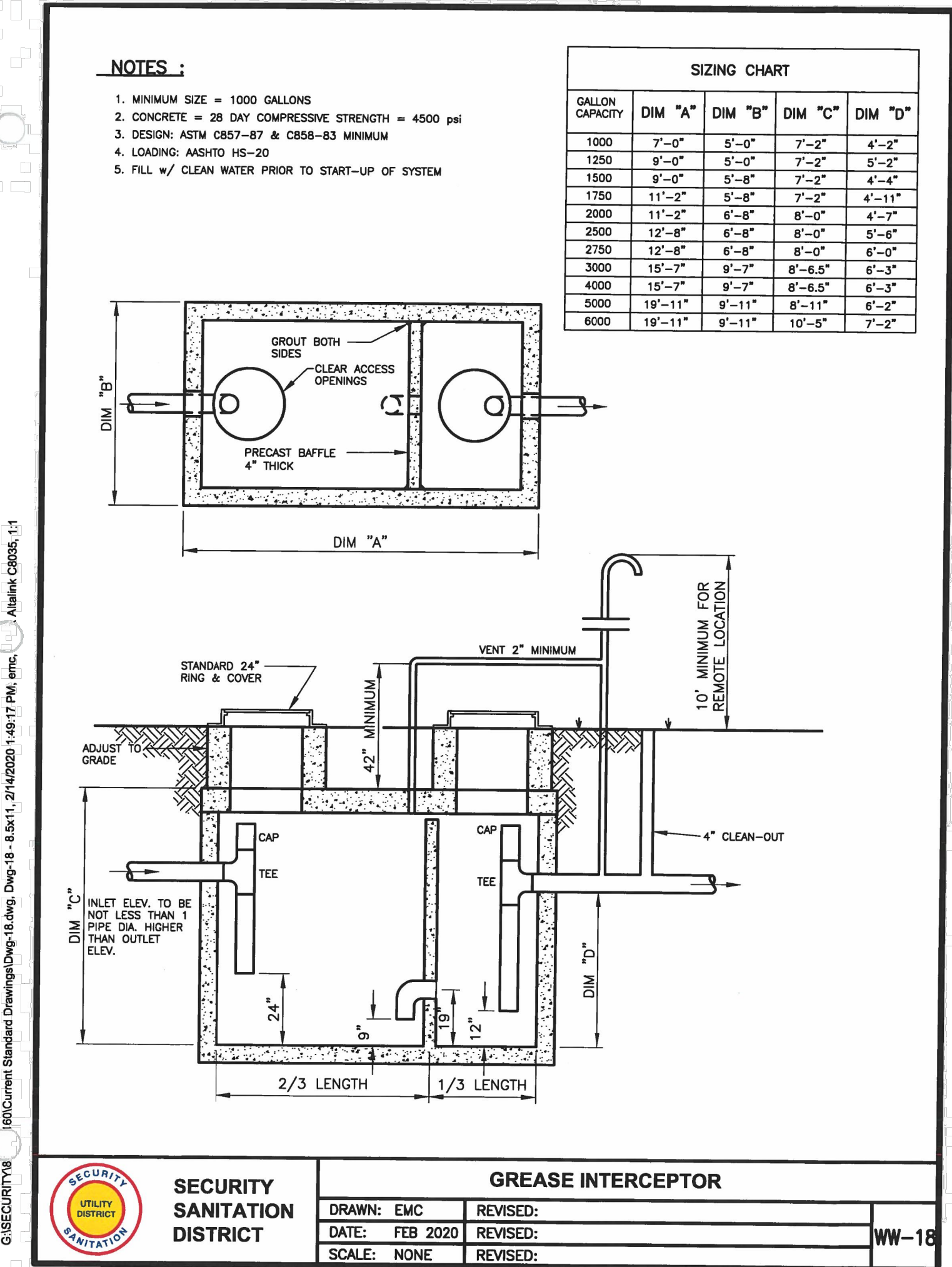

SECURITY UTILITY DISTRICT SANITATION	SECURITY SANITATION DISTRICT		GREASE INTERCEPTOR	DRAWN: EMC DATE: FEB 2020 SCALE: NONE	REVISED: REVISED: REVISED:	WW-18
	SECURITY SANITATION DISTRICT					
	SECURITY SANITATION DISTRICT					
	SECURITY SANITATION DISTRICT					



1459 Grand Ave
Des Moines, IA 50309
P: 888-458-6646

2232 - EL PASO, COLORADO
SECURITY BLVD. AND MAIN ST.
UTILITY DETAILS

KG PROJECT TEAM:
RDM:
SDM:
CPM:

DATE	REVISION DESCRIPTION
08/19/22	1ST REVIEW COMMENTS
01/06/23	2ND REVIEW COMMENTS
04/05/23	3RD REVIEW COMMENTS
05/11/23	4TH REVIEW COMMENTS

DATE: 05-11-2023

SHEET NUMBER:

C5.4
28 OF 43

SECURITY WATER DISTRICT GENERAL NOTES FOR WATER DISTRIBUTION SYSTEM CONSTRUCTION

A. GENERAL

- "DISTRICT MAINS" AS DEFINED IN SECTION 2.01 (A) OF THE SECURITY WATER DISTRICT DESIGN CRITERIA AND STANDARD SPECIFICATIONS WILL BE LOCATED WITHIN PUBLIC RIGHT-OF-WAY AND/OR EASEMENTS AS DETERMINED BY THE SECURITY WATER DISTRICT. PUBLIC RIGHT-OF-WAYS MUST BE APPROVED BY THE LOCAL LAND USE AUTHORITY IN THE SUBDIVISION PLAT OR OTHERWISE BY DEDICATION AND ACCEPTANCE.
- THE SECURITY WATER DISTRICT MUST RECEIVE SIGNED AND RECORDED COPIES OF ALL EASEMENT AGREEMENTS PRIOR TO THE START OF CONSTRUCTION.
- ALL WORK SHALL BE IN ACCORDANCE WITH THE SECURITY WATER DISTRICT DESIGN CRITERIA AND STANDARD SPECIFICATIONS AND THE SECURITY WATER DISTRICT POLICIES, PROCEDURES AND AGREEMENTS PERTAINING TO THIS PROJECT.
- THE CONTRACTOR SHALL COORDINATE AND PROVIDE FOR DETERMINING THE LOCATION AND PROVIDING FOR PROTECTION OF EXISTING UTILITIES AND DRAINAGE STRUCTURES. THE UTILITY NOTIFICATION CENTER OF COLORADO SHALL BE CONTACTED BY DIALING 811 OR 1-800-922-1987.

ALL PLANS FOR WATER SYSTEM ADDITIONS OR IMPROVEMENTS TO BE CONSTRUCTED WITHIN THE DISTRICT'S SYSTEM SHALL COMPLY WITH THE COLORADO SUBSURFACE UTILITY LAW: SENATE BILL 18-167, CRS 9-1.5-101 THROUGH 9-1.5-108. AS MAY BE AMENDED FROM TIME TO TIME, INCLUDING, BUT NOT LIMITED TO, PREPARATION AND SUBMITTAL OF SUBSURFACE UTILITY ENGINEERING PLANS, DOCUMENTS AND CERTIFICATIONS AS SPECIFIED.

- SUFFICIENT CLEARANCE SHALL BE MAINTAINED BETWEEN THE EXCAVATION FOR THE NEW WATER FACILITIES AND ANY POWER OR TELEPHONE POLE OR GUY WIRE. IN CASES WHERE FAILURE OF A POLE IS POSSIBLE, THE CONTRACTOR SHALL CONTACT THE APPROPRIATE UTILITY FOR ASSISTANCE TO TEMPORARILY BRACE OR SUPPORT THE POLE AS REQUIRED. IN THE CASE WHERE A GUY WIRE OR ITS ANCHOR IS IN DIRECT CONFLICT WITH THE WORK PROPOSED, THE CONTRACTOR SHALL COORDINATE WITH THE APPROPRIATE UTILITY FOR THE REMOVAL AND REINSTALLATION OF THE CONFLICTING GUY WIRE OR ANCHOR AS REQUIRED.
- NO EXCAVATED MATERIAL SHALL BE PLACED UNDER OVERHEAD ELECTRIC CONDUCTORS OR AROUND POLES OR TEMPORARILY STORED UNDER LINES WITHOUT FIRST CONSULTING WITH THE ELECTRIC UTILITY TO DETERMINE IF ADEQUATE CLEARANCES WILL BE MAINTAINED. NO PERSON, TOOL OR EQUIPMENT SHALL OPERATE CLOSER THAN 10 FEET TO ANY PORTION OF ANY ENERGIZED LINE WITHOUT FIRST COMPLYING WITH THE PROVISIONS OF COLORADO REVISED STATUTES 1973, SECTION 1, TITLE 9, ARTICLE 2.5, 102 AND 103.
- THE CONTRACTOR SHALL NOT DISTURB ANY EXISTING UTILITIES UNLESS OTHERWISE NOTED ON THE DRAWINGS. ALL UTILITIES SHALL REMAIN IN SERVICE AT ALL TIMES DURING CONSTRUCTION UNLESS OTHER ARRANGEMENTS, ACCEPTABLE TO THE UTILITY OWNER, ARE MADE BETWEEN THE CONTRACTOR, THE RESPECTIVE UTILITY DEPARTMENT AND WHERE APPROPRIATE, THE PRIVATE PROPERTY OWNER(S).
- THE CONTRACTOR IS RESPONSIBLE TO ENSURE THAT ALL WORK IS PERFORMED IN ACCORDANCE WITH APPLICABLE STANDARDS AND REGULATIONS AS SET FORTH BY THE OCCUPATIONAL SAFETY AND HEALTH ADMINISTRATION (OSHA).

B. EARTHWORK

- ALL EXCAVATION, PIPE EMBEDMENT AND TRENCH BACKFILL SHALL BE IN ACCORDANCE WITH THE SECURITY WATER DISTRICT DESIGN CRITERIA AND STANDARD SPECIFICATIONS AND SHALL CONFORM TO THE REQUIREMENTS OF THE LOCAL AUTHORITY GOVERNING WORK IN AND USE OF PUBLIC RIGHT-OF-WAYS.
- IN THOSE AREAS WHERE CONSTRUCTION ACTIVITY ALTERS EXISTING DRAINAGE CONFIGURATIONS, DRAINAGE PATTERNS SHALL BE RESTORED TO AS GOOD AS OR BETTER CONDITIONS THAN THOSE THAT EXISTED PRIOR TO THE CONSTRUCTION ACTIVITY.
- COMPACTION SHALL BE IN COMPLIANCE WITH THE SECURITY WATER DISTRICT DESIGN CRITERIA AND STANDARD SPECIFICATIONS. IN THOSE AREAS WHERE EXCAVATION PERMITS ARE ISSUED BY AN OUTSIDE AUTHORITY OR IN CASE OF CONFLICT IN THE REFERENCED STANDARDS, COMPLY WITH THE MORE STRINGENT SPECIFICATION.
- ANY MATERIAL NOT SUITABLE FOR INCORPORATION INTO TRENCH BACKFILL OR STREET SUBGRADE SHALL BE REMOVED FROM THE SITE.
- ANY SOIL THAT IS DISTURBED BELOW THE DESIGNATED SUBGRADE ELEVATIONS BY CONSTRUCTION ACTIVITIES SHALL BE REPLACED IN ACCORDANCE WITH THE SECURITY WATER DISTRICT DESIGN CRITERIA AND STANDARD SPECIFICATIONS.

C. TRAFFIC CONTROL AND STREET SURFACE RESTORATION

- ALL STREET SURFACE RESTORATION SHALL BE IN ACCORDANCE WITH THE REQUIREMENTS OF THE APPLICABLE AGENCY HAVING JURISDICTION OVER THE ROADWAY, SUBJECT TO THE ACCEPTANCE BY THE SECURITY WATER DISTRICT.

D. WATER MAINS & APPURTENANCES

- POTHOLES OR EXCAVATION FOR WATER MAINS CROSSING EXISTING UTILITIES OR OBSTRUCTIONS SHALL BE PERFORMED IN THE DESIGN STAGE OF THE PLAN PREPARATION. THE LOCATION OF CONNECTION OF NEW WATER MAINS TO THE EXISTING DISTRIBUTION SYSTEM FACILITIES SHALL BE EXCAVATED AND HORIZONTAL AND VERTICAL LOCATION OF EXISTING FACILITIES DETERMINED BY PRECISE SURVEY. THE POTHOLE AND SURVEY DATA SHALL BE SHOWN ON THE FINAL APPROVED WATER MAIN PLANS AND/OR DRAWINGS.
- THE CONTRACTOR IS REQUIRED TO NOTIFY THE SECURITY WATER DISTRICT INSPECTOR OFFICE TWO WORKING DAYS PRIOR TO BEGINNING CONSTRUCTION. THE SECURITY WATER DISTRICT WILL BE NOTIFIED FIVE WORKING DAYS PRIOR TO ANY SHUT DOWN OF EXISTING SERVICE DUE TO CONSTRUCTION.
- REUSE OF ANY MATERIALS OR REJECTION OF ANY NEW MATERIALS SHALL BE AT THE SOLE DISCRETION OF THE SECURITY WATER DISTRICT'S INSPECTOR. THE SECURITY WATER DISTRICT'S DECISION SHALL BE FINAL.
- ALL STREET VALVE BOXES SHALL BE TYLER/UNION SLIP TYPE (684-A, 26T+36B IS REFERENCE TO LEVEL ONE ASSEMBLY, LESS LID WHICH IS A 5-1/4" DROP LID MARKED "WATER"). STREET VALVE BOXES SHALL BE SET 0" - 1/4" BELOW FINAL PAVEMENT SURFACE ELEVATION. FINAL SURFACE ELEVATION SHALL BE CONSTRUCTED AS ASSEMBLY IS DESIGNED (TOP SECTION FLANGE WILL BEAR APPLIED LOADING. DROP-IN RISERS SHALL NOT BE USED).
- DO NOT DROP PIPE AND FITTINGS WHEN OFF-LOADING. DO NOT STORE PIPE AND ASSOCIATED MATERIALS DIRECTLY ON THE GROUND.
- ALL WATER MAINS AND APPURTENANCES DELIVERED TO THE SITE FOR INSTALLATION SHALL BE KEPT CLEAN. THE ENDS OF PIPES AND FITTINGS SHALL BE COVERED UNDER PROTECTIVE COVERINGS AT THE TIME OF DELIVERY TO PROTECT THE INNER SURFACES FROM COMING INTO CONTACT WITH MOISTURE, DIRT, DUST, DEBRIS AND ANIMALS AND SHALL REMAIN PROTECTED UNTIL INSTALLATION IS COMPLETE.

E. WATER SERVICE LINES

- SERVICE LINES SHALL BE INSTALLED WITH WET TAPS FOR CORPORATION STOPS. LINES ONE (1) INCH AND SMALLER DIAMETER SHALL BE DIRECT TAPPED (CC THREADED), TAPS ONE AND A HALF (1-1/2) INCH AND LARGER REQUIRE A TWELVE (12) INCH LONG, CC THREADED, FUSION EPOXY COATED, STEEL TAPPING SLEEVE OR CUT IN TEE.
- EACH BUSINESS, EACH RESIDENCE, AND EACH UNIT OF A DUPLEX HAVING SEPARATE WATER FACILITIES SHALL HAVE A SEPARATE METER AND WATER SERVICE LINE FROM THE MAIN TO THE METER ASSEMBLY.
- EXISTING BUSINESSES OR RESIDENCES THAT MODIFY, EXPAND OR SPLIT SPACE THAT NOW HAVE ONE SERVICE LINE, SHALL INSTALL A NEW SERVICE LINE CONNECTED TO THE DISTRIBUTION SYSTEM AND METER ASSEMBLY IF THERE IS TO BE A SEPARATE BUSINESS OR RESIDENCE.
- TAPPING PERMITS MUST BE APPLIED FOR AT THE SECURITY WATER DISTRICT OFFICE LOCATED AT 231 SECURITY BOULEVARD, PHONE 719-392-3475, AND PAID FOR AT LEAST 24 HOURS PRIOR TO TAPPING.
- ALL SERVICE TAPS ON WATER MAINS WITHIN THE SECURITY WATER DISTRICT DISTRIBUTION SYSTEM SHALL BE ACCOMPLISHED BY THE CONTRACTOR, WHO SHALL NOTIFY THE SECURITY WATER DISTRICT 24 HOURS PRIOR TO TAPPING. PROPERTY CORNERS SHALL BE CLEARLY MARKED BY CONTRACTOR OR OWNER PRIOR TO TAPPING.
- SERVICE LINE MATERIAL SHALL BE DRISCOPELEX® 5100 ULTRA-LINE® POLYETHYLENE (PE) PIPING, SIDR-7, OR OTHER SECURITY WATER DISTRICT APPROVED MATERIAL, ACCOMPANIED BY A #6 BARE COPPER LOCATION WIRE. CURB STOPS AND CORPORATION STOPS SHALL BE FORD METER BOX CO. BRASS AS SPECIFIED. CURB STOP BOXES SHALL BE TYLER, BOTTOM SLIP JOINT AND TOP SCREW JOINT.
- SERVICE LINES SHALL ENTER THE LOT AS CLOSE AS POSSIBLE TO 90-DEGREES TO THE FRONT PROPERTY LINE. SERVICE LINES SHALL HAVE NO LESS THAN 10-FEET OF SEPARATION FROM SEWER SERVICES AND NO LESS THAN 6-FEET OF SEPARATION FROM ALL OTHER UTILITIES. BENCHING OF WATER SERVICE LINES ABOVE SEWER SERVICES IN A COMMON DITCH IS NOT PERMITTED. CURB STOPS SHALL BE SET AT A DEPTH OF 4-FEET TO FINAL GRADE OR AT SIDEWALK ELEVATION. CURB STOPS SHALL NOT BE LOCATED IN SIDEWALKS OR DRIVEWAYS.
- DRAWINGS FOR NON-RESIDENTIAL SERVICE INSTALLATIONS SHALL HAVE A DETAIL OF THE UTILITY ROOM SHOWING METER(S), PRV, BACKFLOW DEVICE, ISOLATION VALVES, FLOOR DRAINS, AND OTHER REQUIRED APPURTENANCES. BACKFLOW DEVICES SHALL BE TESTED BY A CERTIFIED BACKFLOW TECHNICIAN PRIOR TO INITIAL ACCEPTANCE BY THE SECURITY WATER DISTRICT. THE SECURITY WATER DISTRICT SHALL RECEIVE COPIES OF TEST RESULTS ON SECURITY WATER DISTRICT TEST FORMS AVAILABLE AT THE SECURITY WATER DISTRICT OFFICE.

F. GENERAL CONSTRUCTION NOTES

- SHOP DRAWING SUBMITTALS SHALL BE MADE TO THE SECURITY WATER DISTRICT FOR ALL MATERIALS TO BE INCORPORATED INTO THIS PROJECT.
- ALL WATER MAINS AND SERVICE LINE WORK SHALL BE UNDERTAKEN UTILIZING CLASS "B" BEDDING. REFER TO THE SECURITY WATER DISTRICT DESIGN CRITERIA AND STANDARD SPECIFICATIONS FOR THE REQUIRED PIPELINE EMBEDMENT.
- ANY SIGNS, DELINEATOR POSTS, MAILBOXES, NEWSPAPER BOXES AND OTHER APPURTENANCES REMOVED DURING CONSTRUCTION SHALL BE REINSTALLED IN THE SAME LOCATION AND IN AN ACCEPTABLE CONDITION.
- IN THOSE AREAS WHERE NEW PIPELINE CONSTRUCTION IMPACTS EXISTING FENCING, THE CONTRACTOR SHALL REMOVE THE FENCING AS NECESSARY. ALL FENCING REMOVED DURING CONSTRUCTION SHALL BE REINSTALLED IN A CONDITION AS GOOD AS OR BETTER THAN ORIGINALLY FOUND.
- EXISTING PROPERTY CORNERS AND SECTION MONUMENTATION SHALL NOT BE DISTURBED. IN THE EVENT ANY EXISTING PROPERTY MONUMENTATION IS DISTURBED DURING THE COURSE OF CONSTRUCTION, IT SHALL BE REPLACED BY A SURVEYOR LICENSED IN THE STATE OF COLORADO.
- THE CONTRACTOR SHALL SET ALL VALVE RISER BOXES OUTSIDE OF PAVED ROADWAYS OR HARDCAPED AREAS 2-INCHES ABOVE THE FINISH GRADE AND INSTALL A CARSONITE MARKER POST AT EACH VALVE. CONTRACTOR SHALL COORDINATE WITH THE SECURITY WATER DISTRICT FOR THE PLACEMENT OF THE CARSONITE MARKERS AT ALL LOCATIONS.
- NEW MATERIALS SHALL BE USED FOR ALL WORK UNLESS NOTED OTHERWISE ON THE DRAWINGS.
- POSITIVE DRAINAGE SHALL BE PROVIDED AWAY FROM ALL STRUCTURES. FINAL GRADING IS SUBJECT TO REVIEW AND APPROVAL.
- THE SUBGRADE UNDERNEATH ALL STRUCTURES SHALL BE ADEQUATELY STABILIZED IN ACCORDANCE WITH THE SECURITY WATER DISTRICT DESIGN CRITERIA AND STANDARD SPECIFICATIONS.
- ALL WATER MAINS ARE SUBJECT TO PRESSURE TESTING IN ACCORDANCE WITH THE SECURITY WATER DISTRICT DESIGN CRITERIA AND STANDARD SPECIFICATIONS. PRIOR TO FINAL ACCEPTANCE BY THE SECURITY WATER DISTRICT, ALL WATER MAINS MUST BE PRESSURE TESTED, DISINFECTED, AND AN ACCEPTABLE BACTERIOLOGICAL TEST RECEIVED AND PROVIDED TO THE SECURITY WATER DISTRICT FOR ACCEPTANCE.
- THE PIPELINE INSTALLATION SHALL GENERALLY BE ACCOMPLISHED BY PUSHING SPIGOT ENDS INTO BELL ENDS OF THE PIPE.
- ALL WATER MAINS INSTALLED WITHIN THE SECURITY WATER DISTRICT SHALL BE DUCTILE IRON PIPE (DIP) IN ACCORDANCE WITH THE SECURITY WATER DISTRICT DESIGN CRITERIA AND STANDARD SPECIFICATIONS.
- WHERE THE NEW WATER MAIN IS LESS THAN 18 VERTICAL INCHES OVER A SANITARY SEWER MAIN, THE WATER LINE SHALL BE INSTALLED IN ACCORDANCE WITH THE REQUIREMENTS OF THE COLORADO DEPARTMENT OF PUBLIC HEALTH AND ENVIRONMENT REQUIREMENTS.
- ALL DUCTILE IRON PIPING UTILIZED WITHIN THE SECURITY WATER DISTRICT DISTRIBUTION SYSTEM SHALL HAVE AN EXTERIOR COATING AND AN INTERIOR LINING IN ACCORDANCE WITH THE REQUIREMENTS OF THE SECURITY WATER DISTRICT DESIGN CRITERIA AND STANDARD SPECIFICATIONS.
- THE WATER MAIN PIPELINE SHALL BE INSTALLED IN STRAIGHT ALIGNMENTS UNLESS OTHERWISE APPROVED BY THE SECURITY WATER DISTRICT.
- THE CONTRACTOR IS RESPONSIBLE FOR ANY DAMAGE TO THE EXISTING WATER DISTRIBUTION SYSTEM PIPELINES AS A RESULT OF THEIR CONSTRUCTION ACTIVITY.
- ALL PIPELINES SHALL BE "AS BUILT" SURVEYED AND "AS BUILT" DRAWINGS SUBMITTED TO THE SECURITY WATER DISTRICT FOR REVIEW AND ACCEPTANCE. PAPER OR "HARD COPY" DRAWINGS AND ELECTRONIC AUTOCAD FILES ARE REQUIRED. REFER TO THE SECURITY WATER DISTRICT DESIGN CRITERIA AND STANDARD SPECIFICATIONS FOR THE REQUIRED ELECTRONIC FILE FORMAT, HORIZONTAL COORDINATE SYSTEM AND VERTICAL DATUM.
- THE CONTRACTOR SHALL PROCURE AND BE FAMILIAR WITH THE SECURITY WATER DISTRICT DESIGN CRITERIA AND STANDARD SPECIFICATIONS AND THE SECURITY WATER DISTRICT POLICIES, PROCEDURES AND AGREEMENTS PERTAINING TO THIS PROJECT PRIOR TO COMMENCING CONSTRUCTION. A COPY OF THE SECURITY WATER DISTRICTS' DESIGN CRITERIA AND STANDARD SPECIFICATIONS SHALL BE ON-SITE ANY TIME CONSTRUCTION IS BEING ACCOMPLISHED.
- THE WARRANTY FOR COMPLETED WORK SHALL EXTEND FOR A TWO-YEAR PERIOD FROM THE DATE OF THE PRELIMINARY ACCEPTANCE OF THE PROJECT BY THE SECURITY WATER DISTRICT.

SECURITY SANITATION DISTRICT GENERAL NOTES FOR WASTEWATER COLLECTION SYSTEM CONSTRUCTION

GENERAL

- ALL WORK SHALL BE IN ACCORDANCE WITH THE SECURITY SANITATION DISTRICT (SSD) SEWER USE REGULATIONS (SUR), THE SECURITY SANITATION DISTRICT DESIGN CRITERIA AND STANDARD SPECIFICATIONS AND THE SSD POLICIES, PROCEDURES AND AGREEMENTS PERTAINING TO THIS PROJECT.
- THE CONTRACTOR SHALL COORDINATE AND PROVIDE FOR DETERMINING THE LOCATION AND PROVIDING FOR PROTECTION OF EXISTING UTILITIES AND DRAINAGE STRUCTURES. THE UTILITY NOTIFICATION CENTER OF COLORADO SHALL BE CONTACTED BY DIALING 811 OR 1-800-922-1987.
- SUFFICIENT CLEARANCE SHALL BE MAINTAINED BETWEEN THE EXCAVATION FOR THE NEW WASTEWATER FACILITIES AND ANY POWER OR TELEPHONE POLE OR GUY WIRE. IN CASES WHERE FAILURE OF A POLE IS POSSIBLE, THE CONTRACTOR SHALL CONTACT THE APPROPRIATE UTILITY FOR ASSISTANCE TO TEMPORARILY BRACE OR SUPPORT THE POLE AS REQUIRED. IN THE CASE WHERE A GUY WIRE OR ITS ANCHOR IS IN DIRECT CONFLICT WITH THE WORK PROPOSED, THE CONTRACTOR SHALL COORDINATE WITH THE APPROPRIATE UTILITY FOR THE REMOVAL AND REINSTALLATION OF THE CONFLICTING GUY WIRE OR ANCHOR AS REQUIRED.
- NO EXCAVATED MATERIAL SHALL BE PLACED UNDER OVERHEAD ELECTRIC CONDUCTORS OR AROUND POLES OR TEMPORARILY STORED UNDER LINES WITHOUT FIRST CONSULTING WITH THE ELECTRIC UTILITY TO DETERMINE IF ADEQUATE CLEARANCES WILL BE MAINTAINED. NO PERSON, TOOL OR EQUIPMENT SHALL OPERATE CLOSER THAN 10 FEET TO ANY PORTION OF ANY ENERGIZED LINE WITHOUT FIRST COMPLYING WITH THE PROVISIONS OF COLORADO REVISED STATUTES 1973, SECTION 1, TITLE 9, ARTICLE 2.5, 102 AND 103.
- THE CONTRACTOR SHALL NOT DISTURB ANY EXISTING UTILITIES UNLESS OTHERWISE NOTED ON THE DRAWINGS. ALL UTILITIES SHALL REMAIN IN SERVICE AT ALL TIMES DURING CONSTRUCTION UNLESS OTHER ARRANGEMENTS, ACCEPTABLE TO THE UTILITY OWNER, ARE MADE BETWEEN THE CONTRACTOR, THE RESPECTIVE UTILITY DEPARTMENT AND WHERE APPROPRIATE, THE PRIVATE PROPERTY OWNER(S).
- THE CONTRACTOR IS RESPONSIBLE TO INSURE THAT ALL WORK IS PERFORMED IN ACCORDANCE WITH APPLICABLE STANDARDS AND REGULATIONS AS SET FORTH BY THE OCCUPATIONAL SAFETY AND HEALTH ADMINISTRATION (OSHA).

EARTHWORK

- ALL EXCAVATION, PIPE EMBEDMENT AND TRENCH BACKFILL SHALL BE IN ACCORDANCE WITH THE SECURITY SANITATION DISTRICT SEWER USE REGULATIONS AND THE DISTRICT DESIGN CRITERIA AND STANDARD SPECIFICATIONS AND SHALL CONFORM TO THE REQUIREMENTS OF THE LOCAL AUTHORITY GOVERNING WORK IN AND USE OF PUBLIC RIGHT-OF-WAYS.
- IN THOSE AREAS WHERE CONSTRUCTION ACTIVITY ALTERS EXISTING DRAINAGE CONFIGURATIONS, DRAINAGE PATTERNS SHALL BE RESTORED TO AS GOOD AS OR BETTER CONDITIONS THAN THOSE THAT EXISTED PRIOR TO THE CONSTRUCTION ACTIVITY.
- COMPACTION SHALL BE IN COMPLIANCE WITH THE SECURITY SANITATION DISTRICT SEWER USE REGULATIONS. IN THOSE AREAS WHERE CUT PERMITS ARE ISSUED BY AN OUTSIDE AUTHORITY OR IN CASE OF CONFLICT IN THE REFERENCED STANDARDS, COMPLY WITH THE MORE STRINGENT SPECIFICATION.
- ANY MATERIAL NOT SUITABLE FOR INCORPORATION INTO TRENCH BACKFILL OR STREET SUBGRADE SHALL BE REMOVED FROM THE SITE.
- ANY SOIL THAT IS DISTURBED BELOW THE DESIGNATED SUBGRADE ELEVATIONS BY CONSTRUCTION ACTIVITIES SHALL BE REPLACED IN ACCORDANCE WITH THE SECURITY SANITATION DISTRICT DESIGN CRITERIA AND STANDARD SPECIFICATIONS.

TRAFFIC CONTROL AND STREET SURFACE RESTORATION

- ALL STREET SURFACE RESTORATION SHALL BE IN ACCORDANCE WITH THE REQUIREMENTS OF THE APPLICABLE AGENCY HAVING JURISDICTION OVER THE ROADWAY, SUBJECT TO THE ACCEPTANCE BY THE SECURITY SANITATION DISTRICT.

SANITARY SEWER SERVICE LINES

- SANITARY SEWER SERVICE LINES MUST BE INSTALLED IN ACCORDANCE WITH THE REQUIREMENTS OF THE SECURITY SANITATION DISTRICT SEWER USE REGULATIONS AND THE SECURITY SANITATION DISTRICT DESIGN CRITERIA AND STANDARD SPECIFICATIONS.
- SANITARY SEWER SERVICE CONNECTIONS USING IN-LINE TEES OR SADDLE TAP TEES SHALL BE INSTALLED NO LESS THAN 5-FEET FROM ANY MANHOLE AND NO LESS THAN 3-FEET FROM AN ADJACENT SEWER SERVICE CONNECTION OR TAP.
- THE CONTRACTOR SHALL NOTIFY THE SECURITY SANITATION DISTRICT 48-HOURS PRIOR TO COMMENCING EXCAVATION FOR A SANITARY SEWER SERVICE LINE AND COORDINATE THE REQUIRED INSPECTIONS.
- CLEANOUTS SHALL BE INSTALLED WHERE HORIZONTAL DEFLECTIONS IN ALIGNMENT OCCUR IN ACCORDANCE WITH THE SECURITY SANITATION DISTRICT DESIGN CRITERIA AND STANDARD SPECIFICATIONS.
- ALL SERVICE LINE INSTALLATIONS SHALL BE INSPECTED BY THE SECURITY SANITATION DISTRICT PRIOR TO BACKFILLING.
- SANITARY SEWER SERVICE LINES SHALL BE INSTALLED WITH AN ABSOLUTE MINIMUM SLOPE OF 2% UNLESS SPECIFICALLY AUTHORIZED BY THE SECURITY SANITATION DISTRICT IN WRITING.

GENERAL CONSTRUCTION NOTES

- SHOP DRAWING SUBMITTALS SHALL BE MADE TO THE SECURITY SANITATION DISTRICT FOR ALL MATERIALS TO BE INCORPORATED INTO THIS PROJECT.
- ALL SEWER MAIN AND SERVICE LINE WORK SHALL BE UNDERTAKEN UTILIZING CLASS "B" BEDDING. REFER TO THE SECURITY SANITATION DISTRICT DESIGN CRITERIA AND STANDARD SPECIFICATIONS FOR THE REQUIRED PIPELINE EMBEDMENT.
- ANY SIGNS, DELINEATOR POSTS, MAILBOXES, NEWSPAPER BOXES AND OTHER APPURTENANCES REMOVED DURING CONSTRUCTION SHALL BE REINSTALLED IN THE SAME LOCATION AND IN AN ACCEPTABLE CONDITION.
- IN THOSE AREAS WHERE NEW PIPELINE CONSTRUCTION IMPACTS EXISTING FENCING, THE CONTRACTOR SHALL REMOVE THE FENCING AS NECESSARY. ALL FENCING REMOVED DURING CONSTRUCTION SHALL BE REINSTALLED IN A CONDITION AS GOOD AS OR BETTER THAN ORIGINALLY FOUND.

GENERAL CONSTRUCTION NOTES (CONTINUED)

- EXISTING PROPERTY CORNERS AND SECTION MONUMENTATION SHALL NOT BE DISTURBED. IN THE EVENT ANY EXISTING PROPERTY MONUMENTATION IS DISTURBED DURING THE COURSE OF CONSTRUCTION, IT SHALL BE REPLACED BY A SURVEYOR LICENSED IN THE STATE OF COLORADO.
- THE CONTRACTOR SHALL SET ALL MANHOLE RINGS AND COVERS OUTSIDE OF PAVED ROADWAYS OR HARDCAPED AREAS 2-INCHES ABOVE THE FINISH GRADE AND INSTALL A CARSONITE MARKER POST AT EACH MANHOLE. THE CONTRACTOR SHALL COORDINATE WITH THE SECURITY SANITATION DISTRICT FOR THE PLACEMENT OF THE CARSONITE MARKERS AT ALL OFF-ROAD MANHOLE LOCATIONS.
- IN PAVED ROADS OR HARDCAPPED SURFACES, MANHOLE RINGS SHALL BE SET 1/4-INCH BELOW FINISH GRADE. CARE SHALL BE TAKEN IN FINAL GRADING TO PRECLUDE PONDING OF SURFACE WATER OVER MANHOLE RINGS AND COVERS.
- THE CONTRACTOR SHALL REVIEW THE DETAILS IN THE SECURITY SANITATION DISTRICT SEWER USE REGULATIONS AND STANDARD DRAWINGS FOR MANHOLE WALL THICKNESS, BASE DIAMETER AND THICKNESS, STEEL REQUIREMENTS AND WATERPROOFING REQUIREMENTS. MANHOLE BASES SHALL BE PRECAST UNITS UNLESS APPROVED IN ADVANCE BY THE SECURITY SANITATION DISTRICT.
- THE CONTRACTOR SHALL COORDINATE THE INSTALLATION OF CONCRETE/GROUT FILLETS IN THE MANHOLES WITH THE SECURITY SANITATION DISTRICT TO ENSURE PROPER PERFORMANCE AND ACHIEVEMENT OF DESIGN INTENT. FULL DEPTH, EQUAL TO THE PIPE DIAMETER, FLOW CHANNELS ARE REQUIRED.
- THE CONTRACTOR IS TO UNDERTAKE HIS WORK IN ACCORDANCE WITH OSHA'S CONFINED SPACE ENTRY REQUIREMENTS.
- NEW MATERIALS SHALL BE USED FOR ALL WORK UNLESS NOTED OTHERWISE ON THE DRAWINGS.
- POSITIVE DRAINAGE SHALL BE PROVIDED AWAY FROM ALL STRUCTURES. FINAL GRADING IS SUBJECT TO REVIEW AND APPROVAL.
- THE SUBGRADE UNDERNEATH ALL STRUCTURES SHALL BE ADEQUATELY STABILIZED IN ACCORDANCE WITH THE SECURITY SANITATION DISTRICT SEWER USE REGULATIONS.
- ALL SANITARY SEWER COLLECTION SYSTEM COMPONENTS ARE SUBJECT TO PRESSURE TESTING IN ACCORDANCE WITH THE SECURITY SANITATION DISTRICT DESIGN CRITERIA AND STANDARD SPECIFICATIONS. PRIOR TO FINAL ACCEPTANCE BY THE DISTRICT, ALL SANITARY SEWER LINES SHALL BE PROFESSIONALLY CLEANED, INSPECTED BY INTERNAL VIDEO CAMERA AND WRITTEN RECORDS AND DIGITAL VIDEO DISK (DVD) RECORDINGS FURNISHED TO THE SECURITY SANITATION DISTRICT FOR REVIEW AND APPROVAL.
- THE PIPELINE INSTALLATION SHALL GENERALLY BE ACCOMPLISHED FROM THE LOWEST PORTION OF THE PROJECT PROCEEDING UPHILL.
- FLAT TOP LIDS ON PRECAST CONCRETE MANHOLES ARE REQUIRED FOR ALL MANHOLES 5.0 FEET AND LESS IN DEPTH. ECCENTRIC CONES ARE TO BE INSTALLED ON ALL MANHOLES WITH DEPTHS GREATER THAN 5.0 FEET.
- THE CONTRACTOR SHALL THICKEN FILLETS IN MANHOLES AT THE DIRECTION OF THE SECURITY SANITATION DISTRICT WHERE THE UPSTREAM LINES HAVE EXCESSIVE GRADES.
- ALL POLYVINYLCHLORIDE (PVC) PIPE SHALL BE IN CONFORMANCE WITH ASTM D3034 (GREEN IN COLOR) AND INSTALLED PER ASTM D321. PIPE STANDARD DIMENSION RATIO (SDR) OR PIPE STIFFNESS (PS) MAY VARY AND SHALL BE SHOWN ON THE CONSTRUCTION DRAWINGS.
- WHERE THE NEW SANITARY SEWER MAIN IS LESS THAN 18 VERTICAL INCHES UNDER A WATER MAIN, THE CONTRACTOR SHALL INSTALL A 20-FOOT LONG SEGMENT OF DUCTILE IRON PIPE (DIP) IN THE SANITARY SEWER MAIN CENTERED ON THE WATER MAIN CROSSING. THE DIP SHALL BE CONNECTED TO THE PVC SANITARY SEWER MAIN WITH WATERTIGHT FERRO TYPE COUPLINGS ENCASED IN REINFORCED CONCRETE 12- INCHES LONG, 6-INCHES THICK. MATCH INVERTS OF THE DIP AND PVC PIPE.
- ALL DUCTILE IRON PIPING UTILIZED WITHIN THE SECURITY SANITATION DISTRICT SHALL HAVE AN INTERIOR COATING OR LINING IN ACCORDANCE WITH THE REQUIREMENTS OF THE SECURITY SANITATION DISTRICT DESIGN CRITERIA AND STANDARD SPECIFICATIONS SPECIFICALLY DESIGN, APPLIED AND INSTALLED FOR CORROSION CONTROL.
- THE SANITARY SEWER PIPELINE SHALL BE INSTALLED IN STRAIGHT ALIGNMENTS BETWEEN MANHOLES UNLESS OTHERWISE APPROVED BY THE SECURITY SANITATION DISTRICT.
- THE CONTRACTOR IS RESPONSIBLE FOR ANY DAMAGE TO THE EXISTING WASTEWATER PIPELINES OR MANHOLES AS A RESULT OF THEIR CONSTRUCTION ACTIVITY.
- ALL PIPELINES SHALL BE "AS BUILT" SURVEYED AND "AS BUILT" DRAWINGS SUBMITTED TO THE SECURITY SANITATION DISTRICT FOR REVIEW AND ACCEPTANCE. PAPER OR "HARD COPY" DRAWINGS AND ELECTRONIC AUTOCAD FILES ARE REQUIRED. REFER TO THE SECURITY SANITATION DISTRICT DESIGN CRITERIA AND STANDARD SPECIFICATIONS FOR THE REQUIRED ELECTRONIC FILE FORMAT, HORIZONTAL COORDINATE SYSTEM AND VERTICAL DATUM.
- THE CONTRACTOR SHALL PROCURE AND FAMILIARIZE HIMSELF WITH THE SECURITY SANITATION DISTRICT (SSD) SEWER USE REGULATIONS (SURS), THE SECURITY SANITATION DISTRICT DESIGN CRITERIA AND STANDARD SPECIFICATIONS AND THE SSD POLICIES, PROCEDURES AND AGREEMENTS PERTAINING TO THIS PROJECT PRIOR TO COMMENCING CONSTRUCTION. A COPY OF THE DISTRICT'S SEWER USE REGULATIONS AND DESIGN CRITERIA AND STANDARD SPECIFICATIONS SHALL BE ON-SITE ANY TIME CONSTRUCTION IS BEING ACCOMPLISHED.
- MANHOLE ENTRY PERMIT: THE SECURITY SANITATION DISTRICT WILL AUTHORIZE THE CONTRACTOR TO ENTER DISTRICT-OWNED MANHOLES; HOWEVER, THE DISTRICT WILL NOT ISSUE AN ENTRY PERMIT TO THE CONTRACTOR FOR ANY CONFINED SPACE. PRIOR TO ANY ENTRY, THE CONTRACTOR SHALL PROVIDE HIS OWN PERSONNEL CAPABLE AND QUALIFIED TO ISSUE AN ENTRY PERMIT AND SHALL BE EQUIPPED FOR ENTRY INTO CONFINED SPACES. THE SECURITY SANITATION DISTRICT WILL ASSUME NO RESPONSIBILITY FOR THE CONTRACTOR'S ENTRY INTO DISTRICT-OWNED MANHOLES.
- ALL MANHOLES SHALL HAVE A FOUR (4) FOOT INSIDE DIAMETER UNLESS OTHERWISE SHOWN ON THE CONSTRUCTION DRAWINGS.
- THE WARRANTY FOR COMPLETED WORK SHALL EXTEND FOR A TWO-YEAR PERIOD FROM THE DATE OF ACCEPTANCE OF THE PROJECT BY THE DISTRICT.

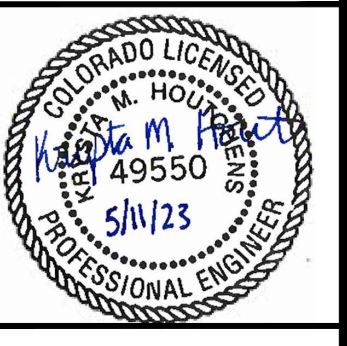

1459 Grand Ave.
Des Moines, IA 50309
P: 888-458-6646

2232 - EL PASO, COLORADO
SECURITY BLVD. AND MAIN ST.

UTILITY NOTES

KG PROJECT TEAM:
RDM:
SDM:
CPM:

DATE	REVISION DESCRIPTION
08/19/22	1ST REVIEW COMMENTS
01/09/23	2ND REVIEW COMMENTS
04/05/23	3RD REVIEW COMMENTS
05/11/23	4TH REVIEW COMMENTS

DATE: 05-11-2023

SHEET NUMBER:

C5.5
29 OF 43

PCD FILE NO. PPR-2225

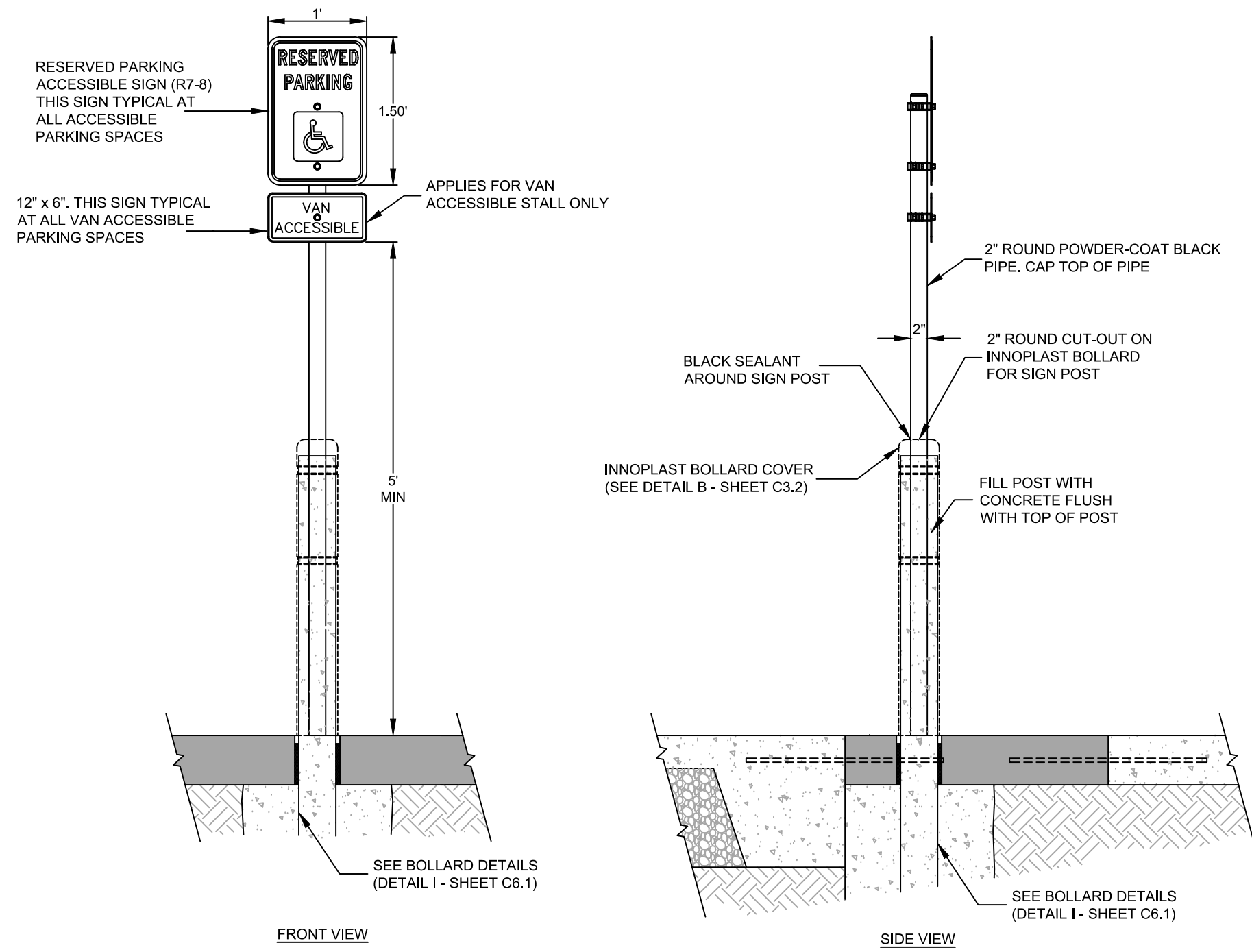

A BOLLARD-MOUNTED ADA SIGN
NOT TO SCALE

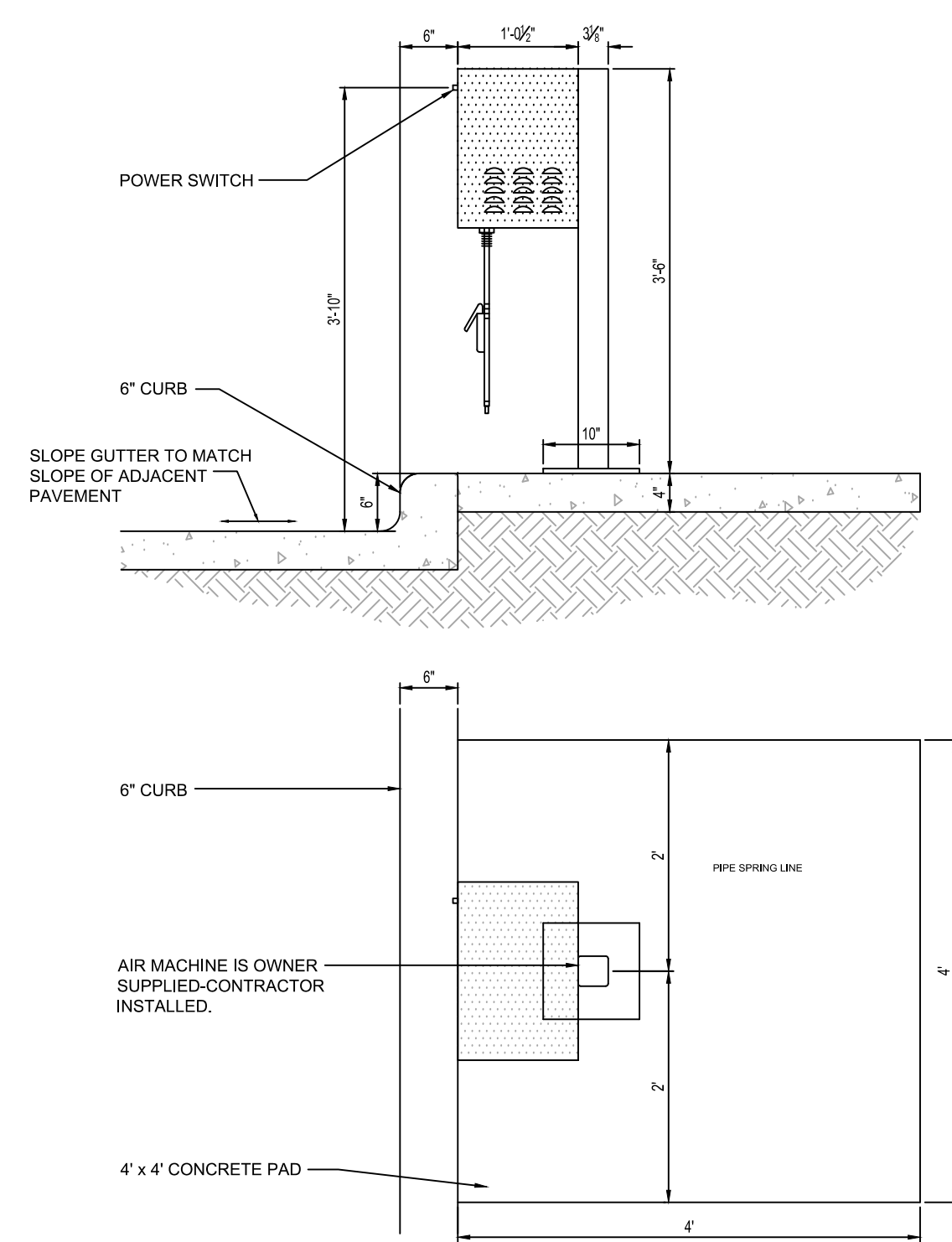

D AIR MACHINE
NOT TO SCALE

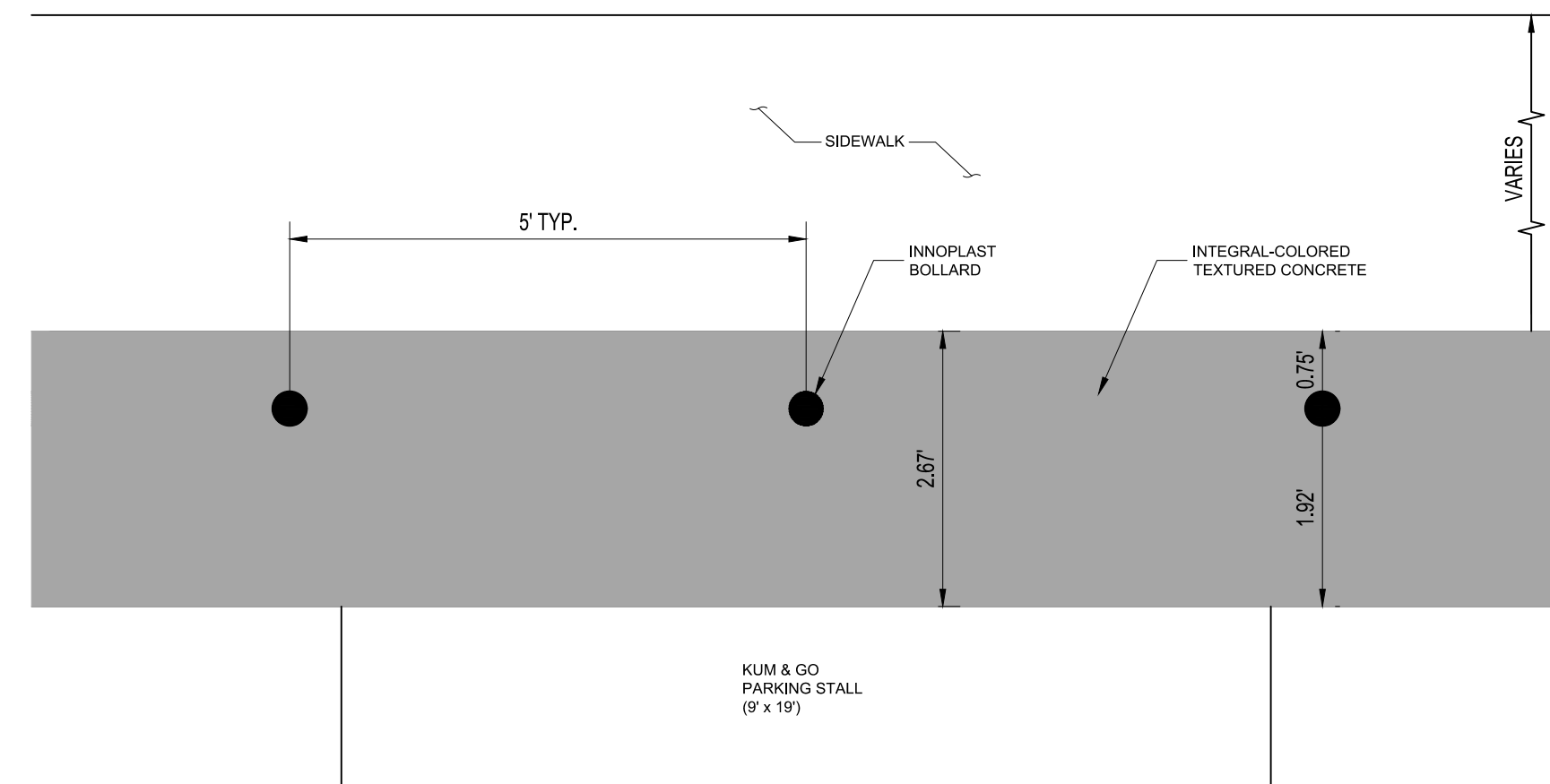

H BOLLARD DETAIL (PLAN VIEW)
NOT TO SCALE

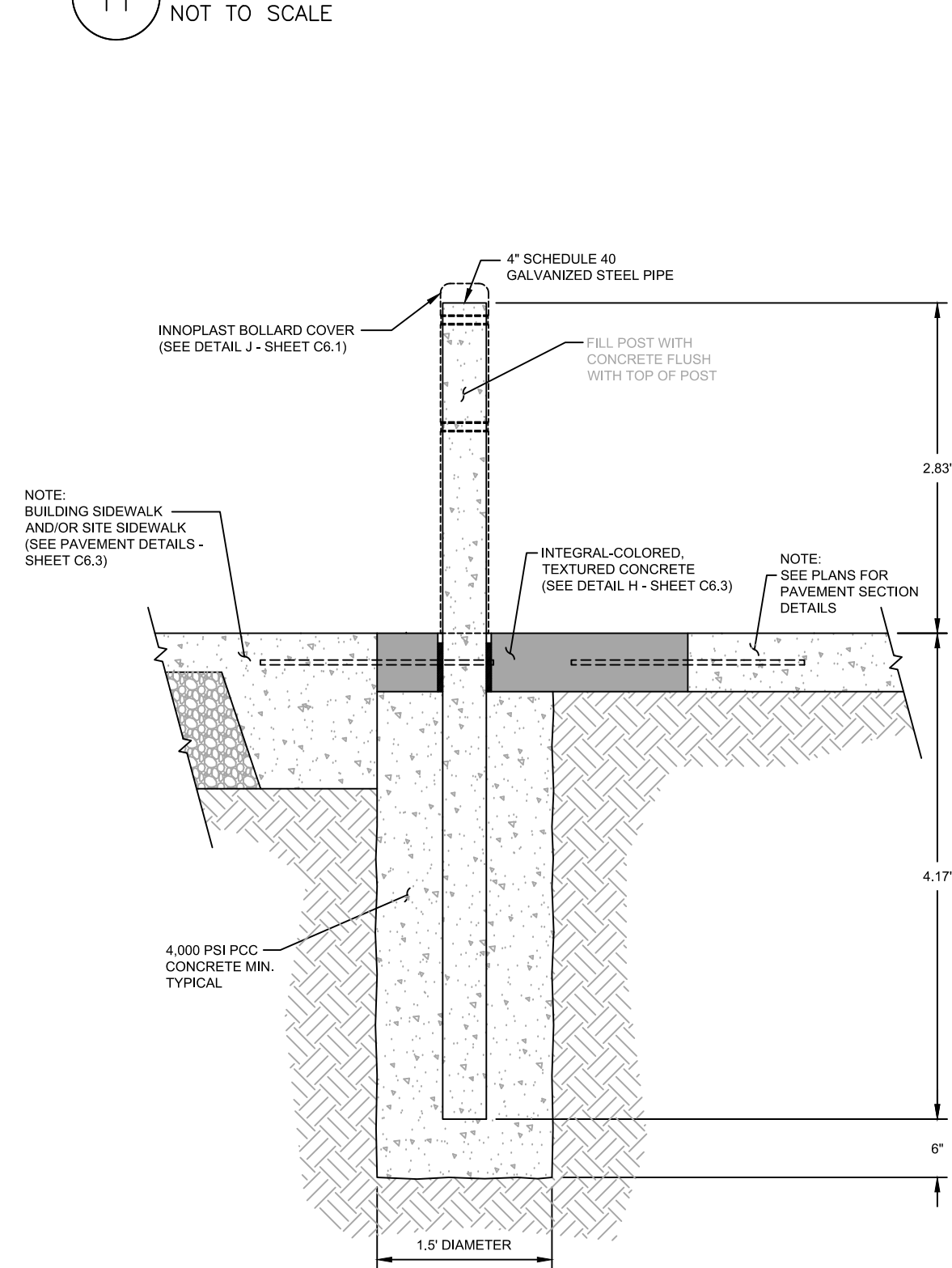

I BOLLARD DETAIL (TYP.)
NOT TO SCALE

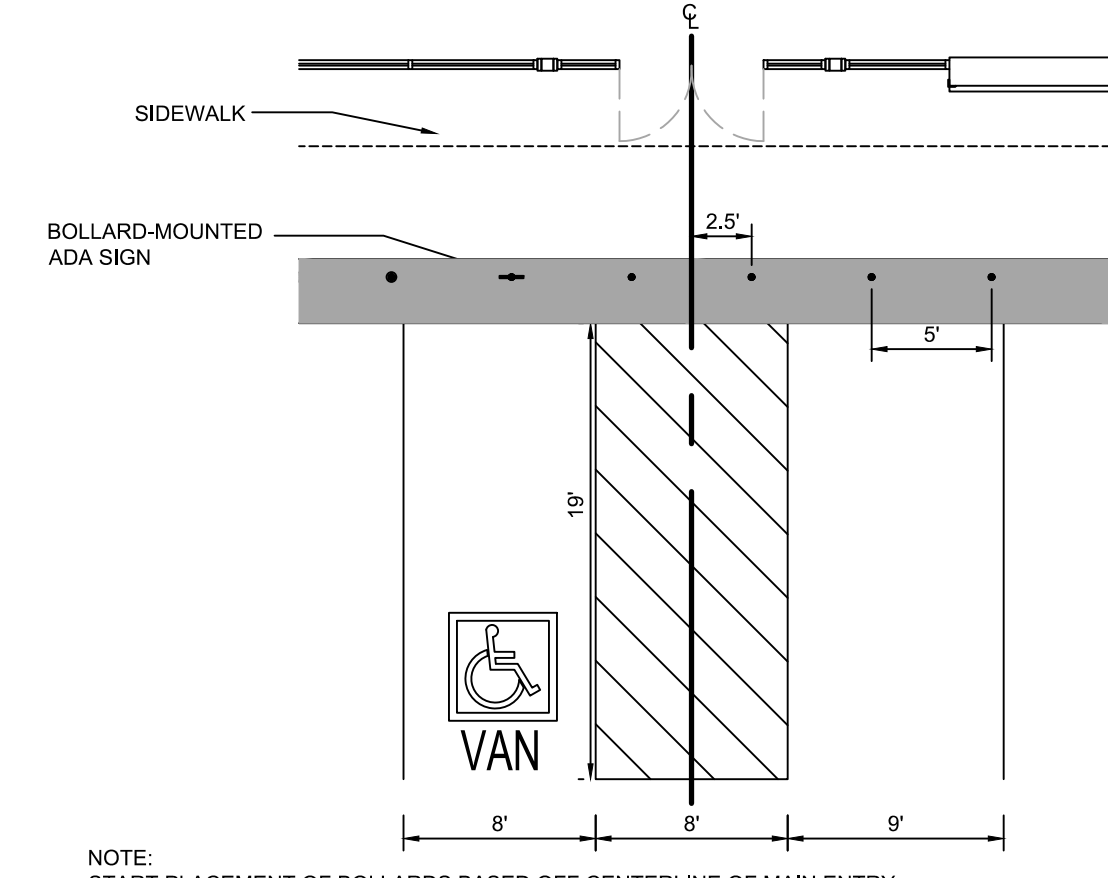

K BOLLARD PLACEMENT DETAILS
NOT TO SCALE

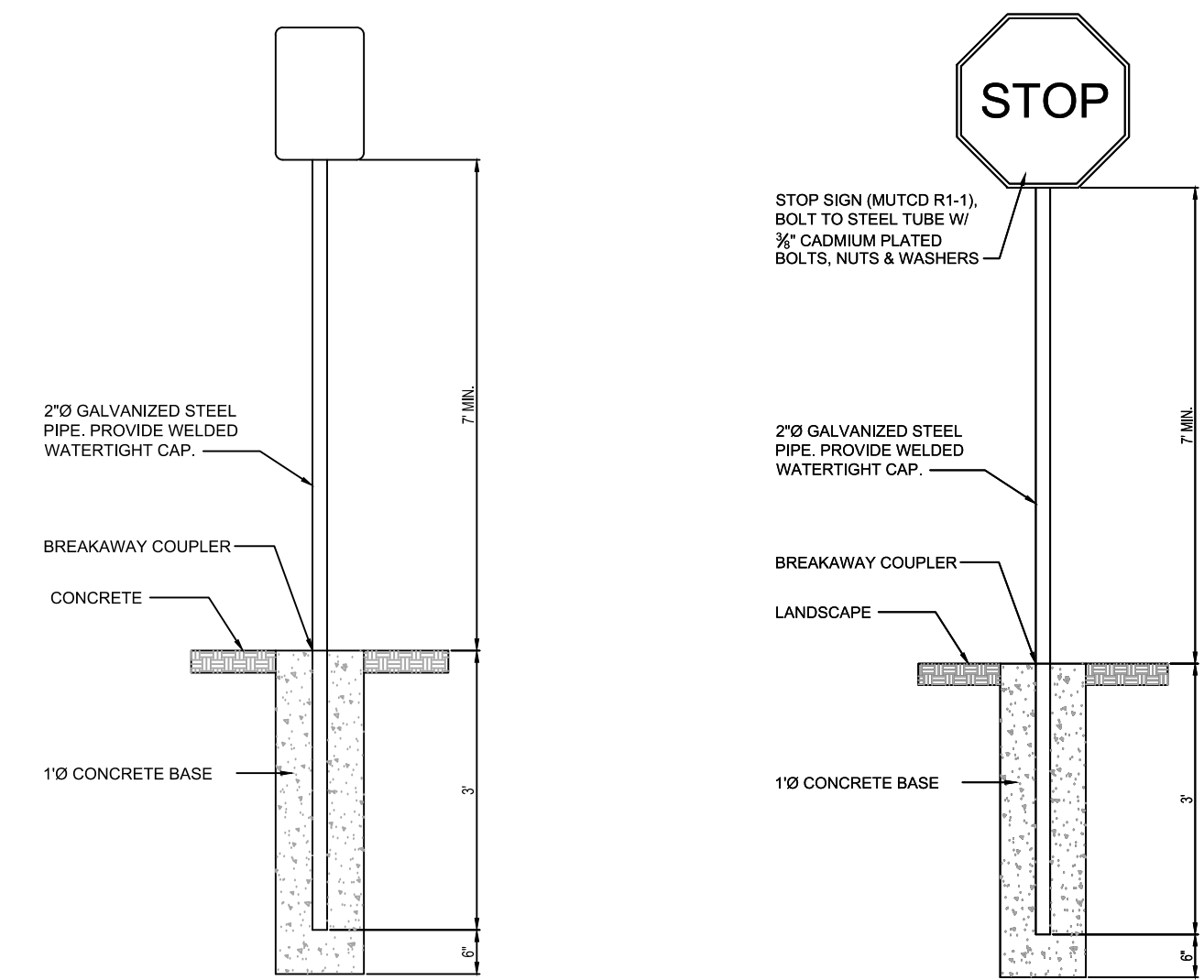

B SIGN IN CONCRETE
NOT TO SCALE

C SIGN IN LANDSCAPE
NOT TO SCALE

F NOT USED

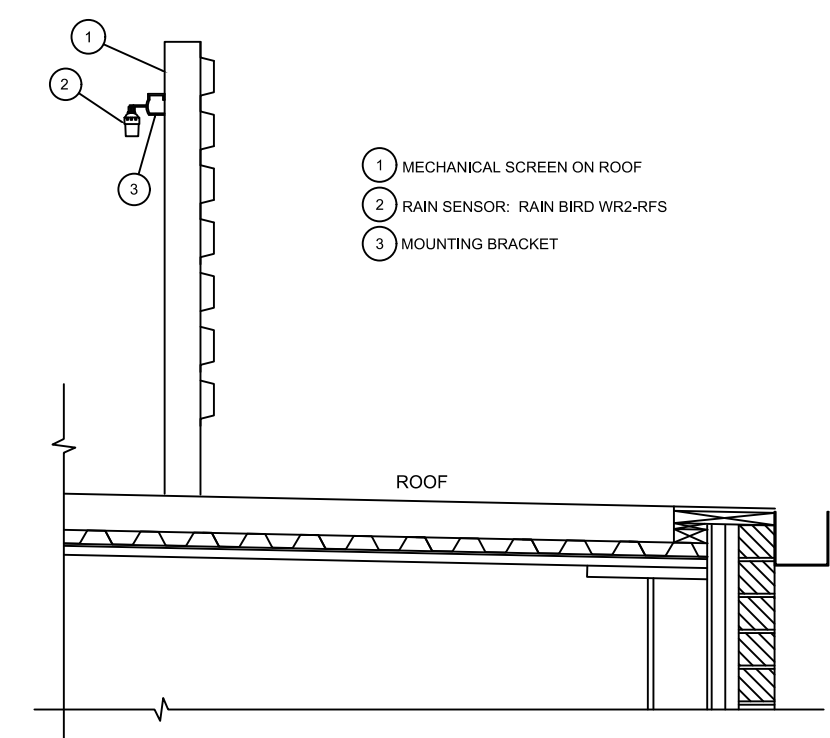

E RAIN SENSOR
NOT TO SCALE

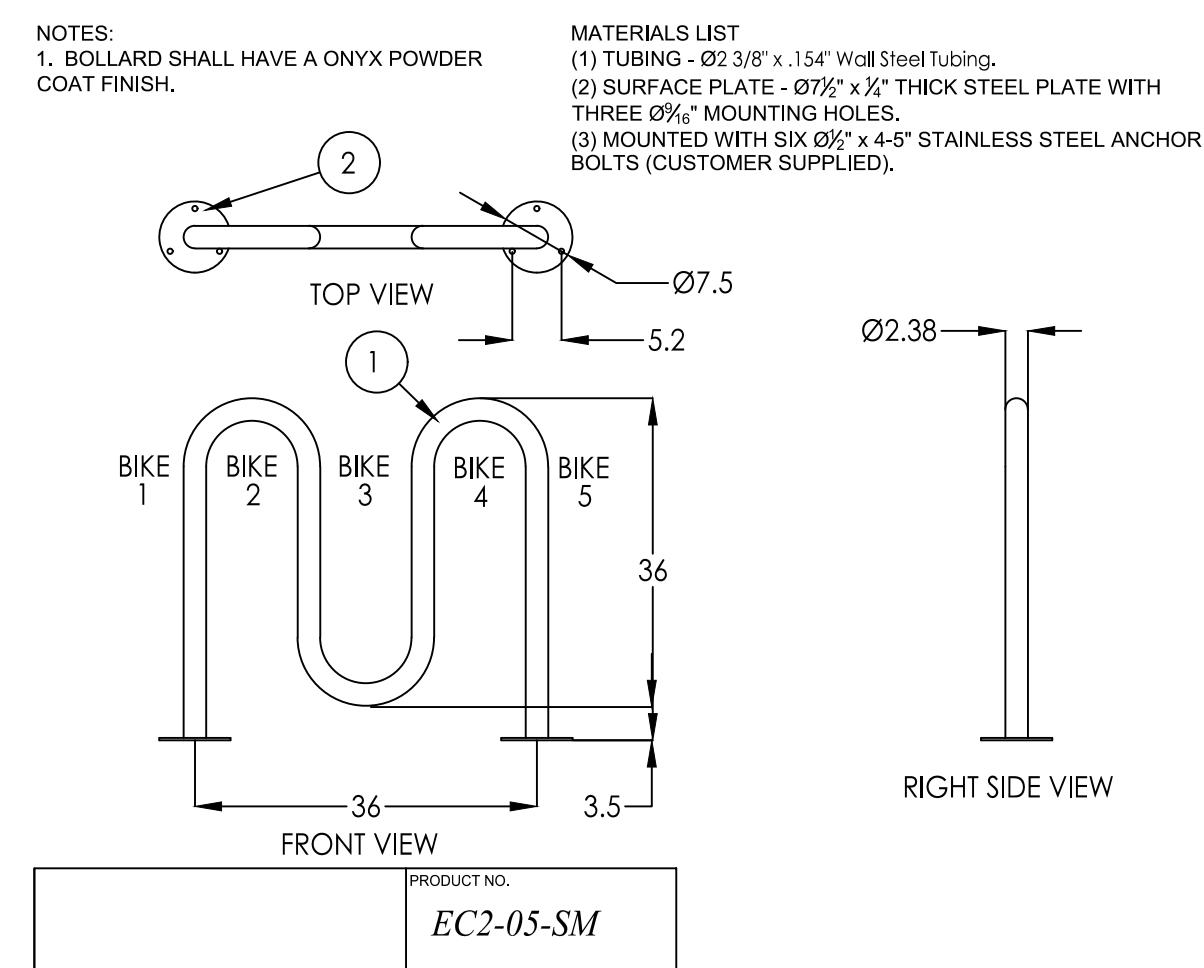

G BOLLARD BIKE RACK DETAIL
NOT TO SCALE

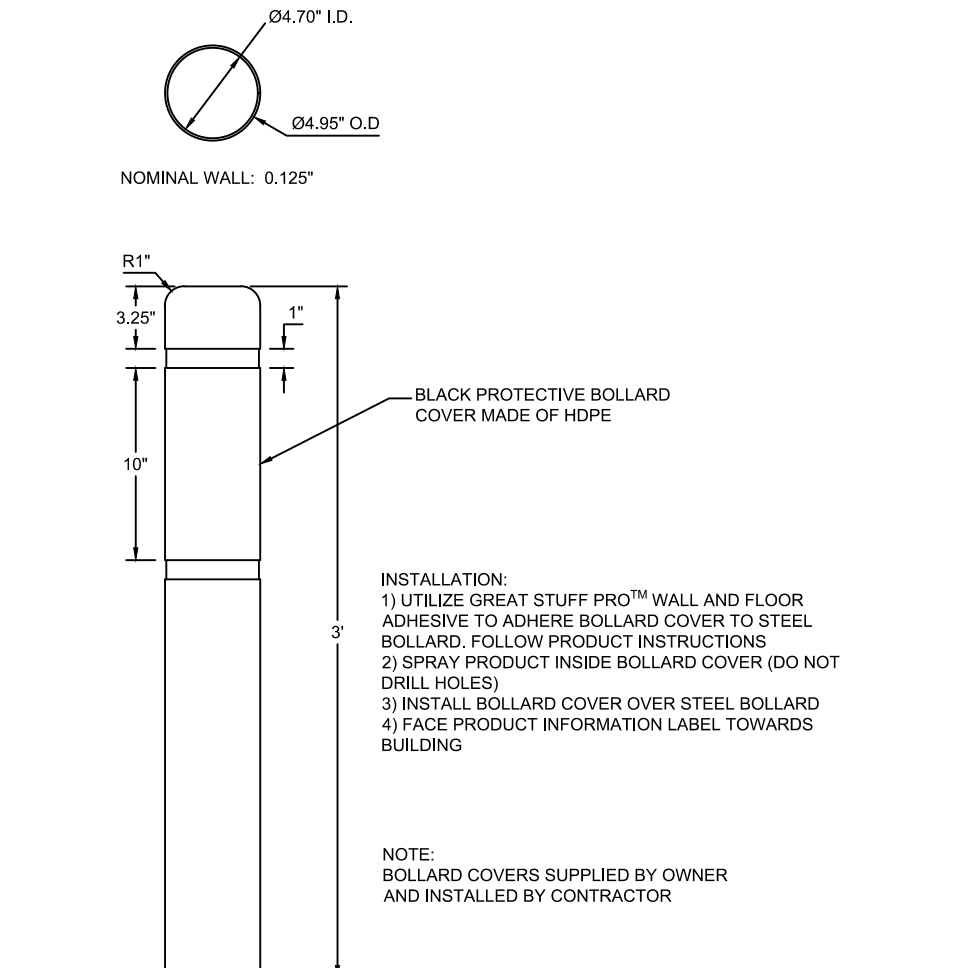

J INNOPLAST BOLLARD COVER
NOT TO SCALE

REVISION	DATE	REVISION DESCRIPTION
1	08/19/22	1ST REVIEW COMMENTS
2	01/06/23	2ND REVIEW COMMENTS
3	04/05/23	3RD REVIEW COMMENTS
4	05/11/23	4TH REVIEW COMMENTS

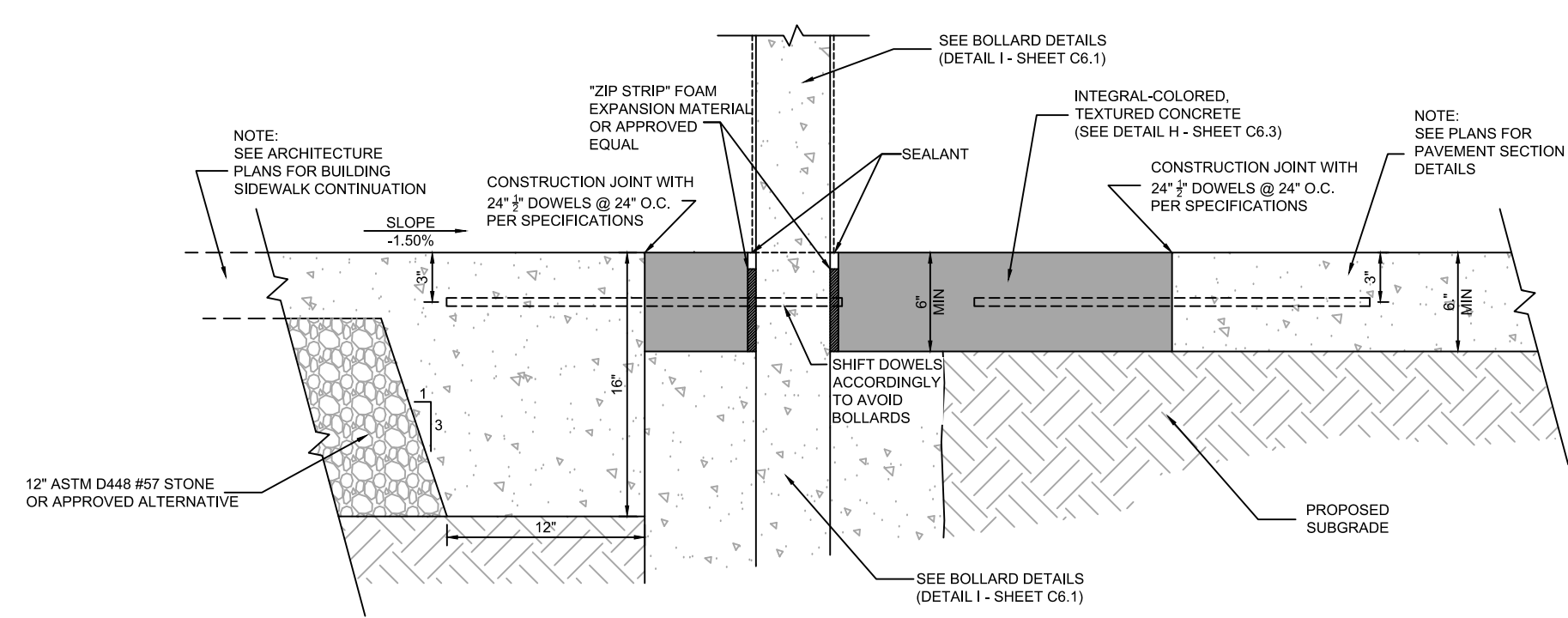

A BUILDING SIDEWALK AT BOLLARD DETAIL
NOT TO SCALE

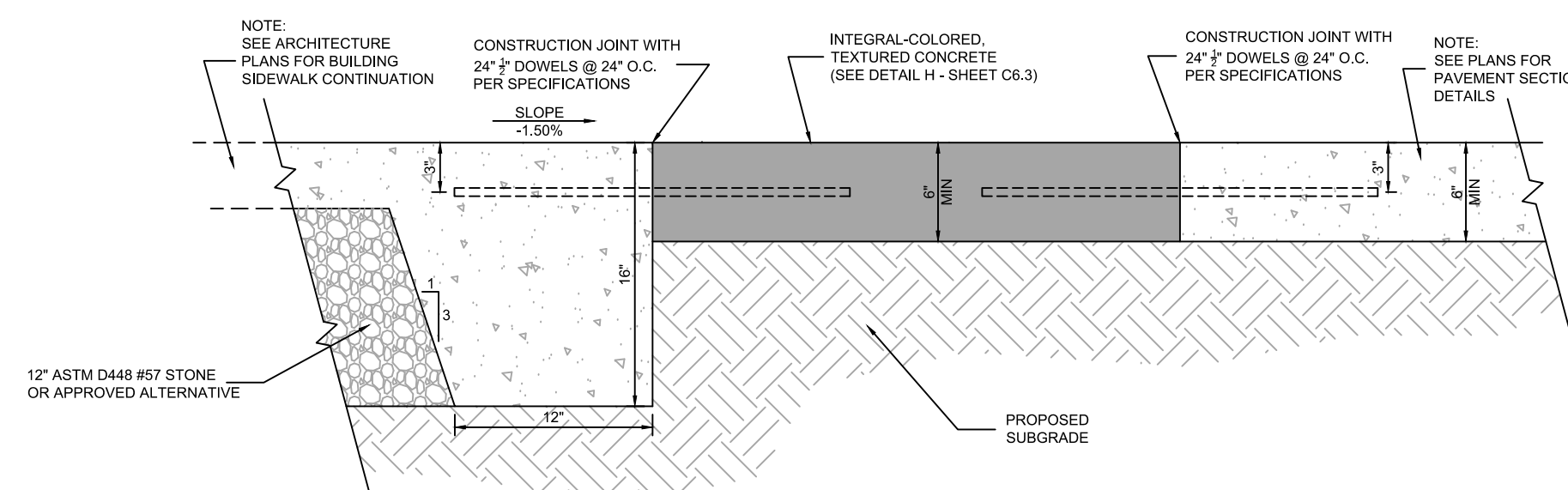

B BUILDING SIDEWALK TO PAVEMENT DETAIL
NOT TO SCALE

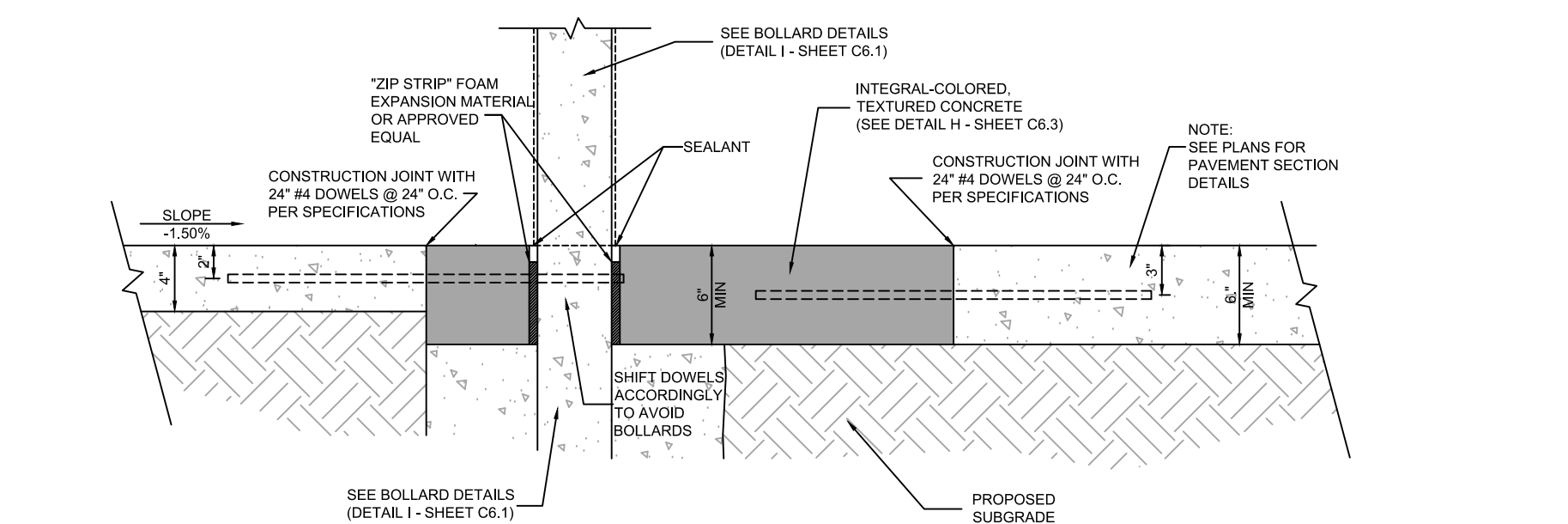

C SITE SIDEWALK AT BOLLARD DETAIL
NOT TO SCALE

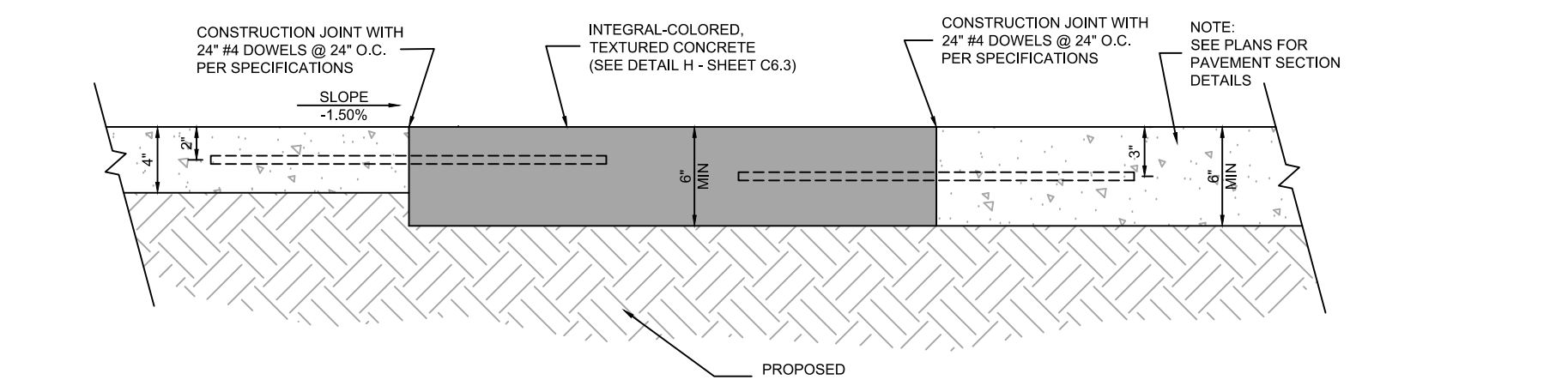

D SITE SIDEWALK TO PAVEMENT DETAIL
NOT TO SCALE

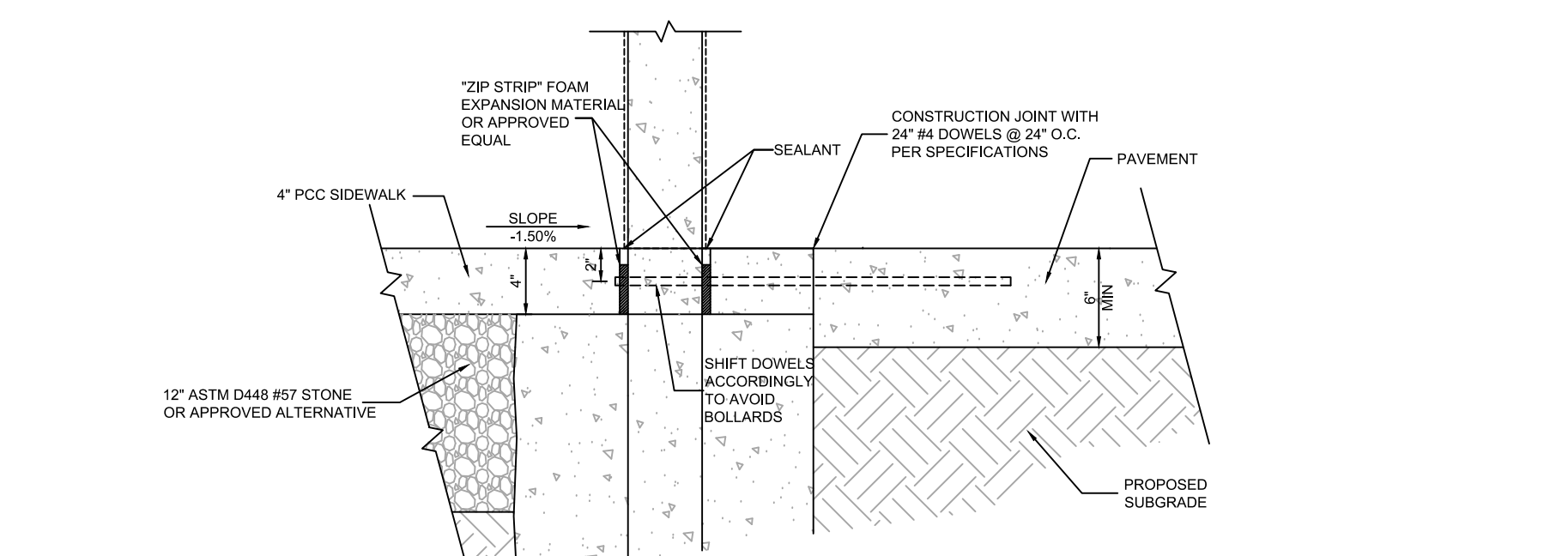

E SITE SIDEWALK AT BOLLARD - NO COLORED CONCRETE
NOT TO SCALE

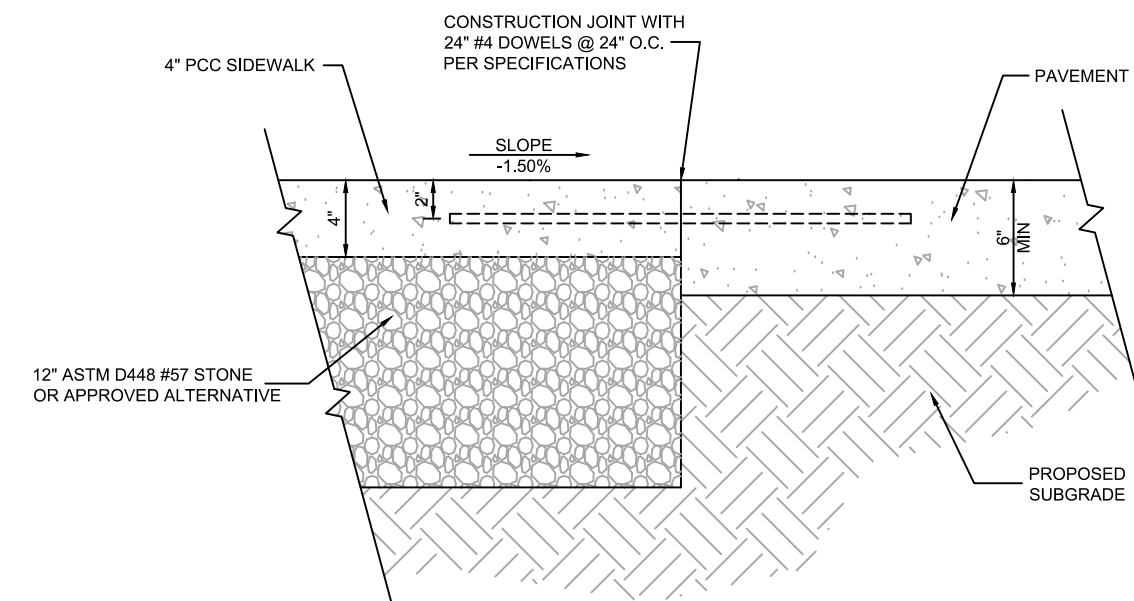

F BUILDING SIDEWALK TO PAVEMENT - NO COLORED CONCRETE
NOT TO SCALE

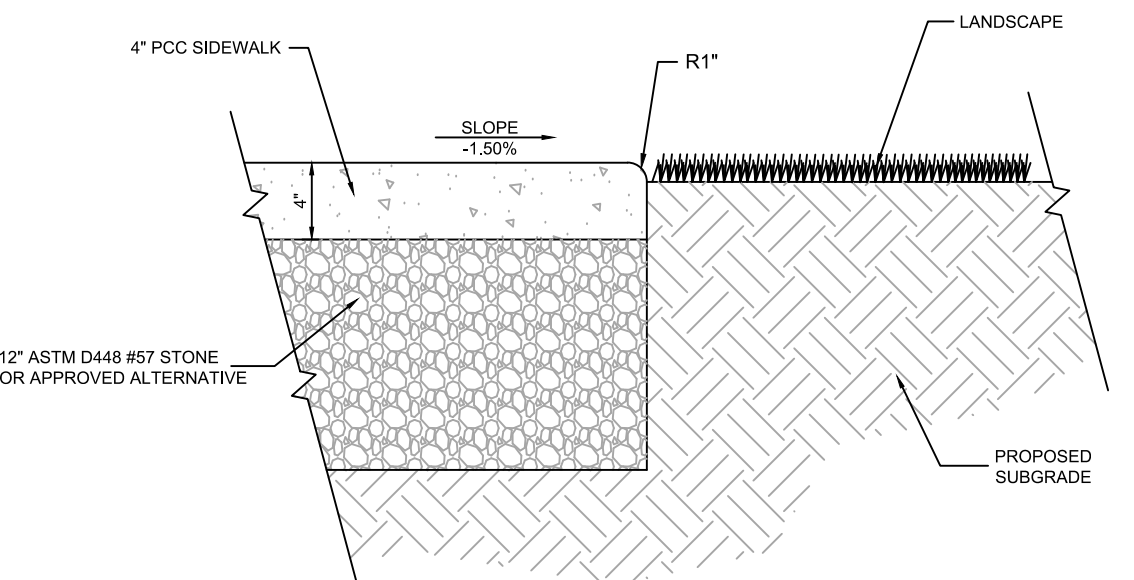

G BUILDING SIDEWALK TO LANDSCAPE
NOT TO SCALE

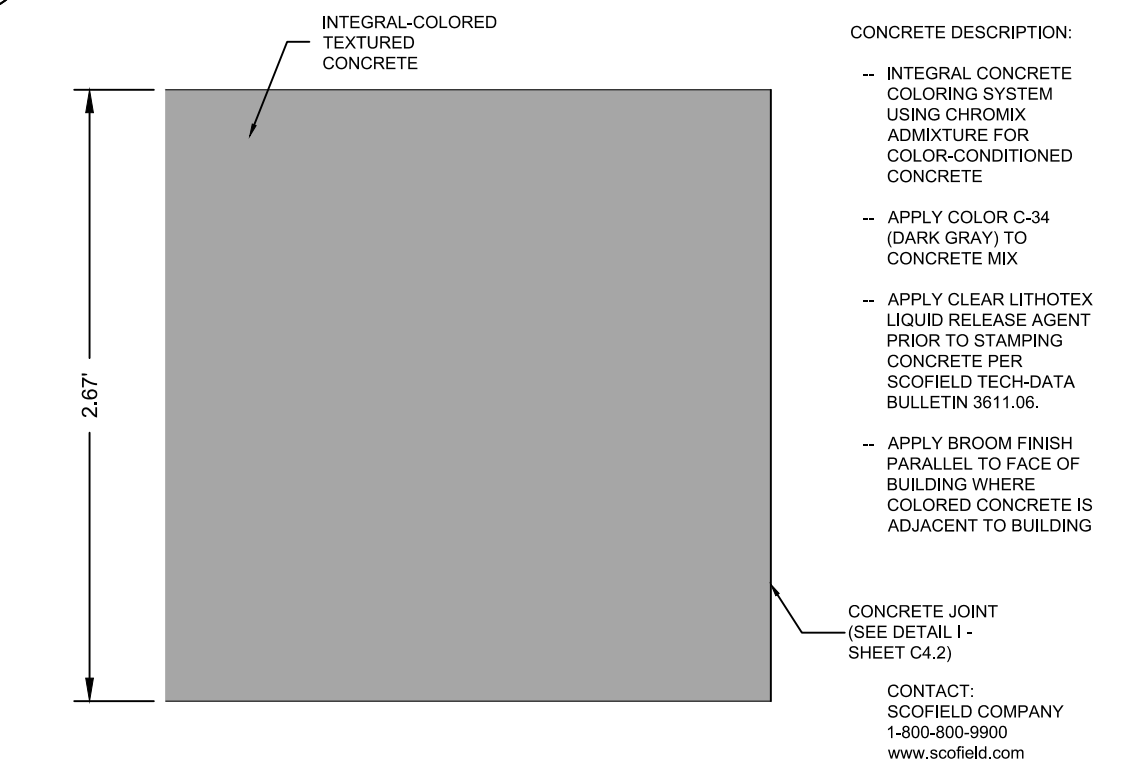

H COLORED CONCRETE DETAIL
NOT TO SCALE

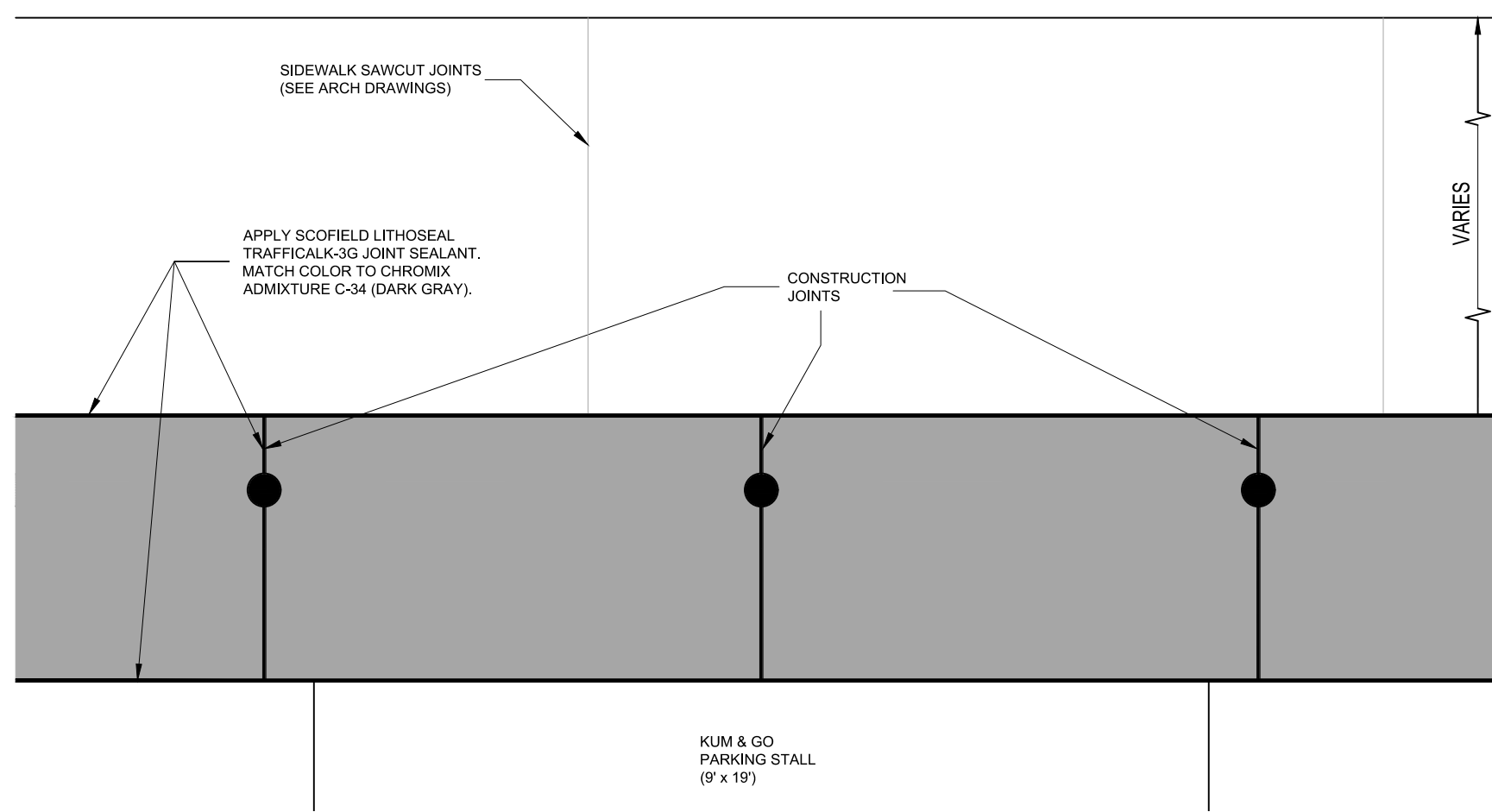

I COLORED CONCRETE CONSTRUCTION JOINTS
NOT TO SCALE

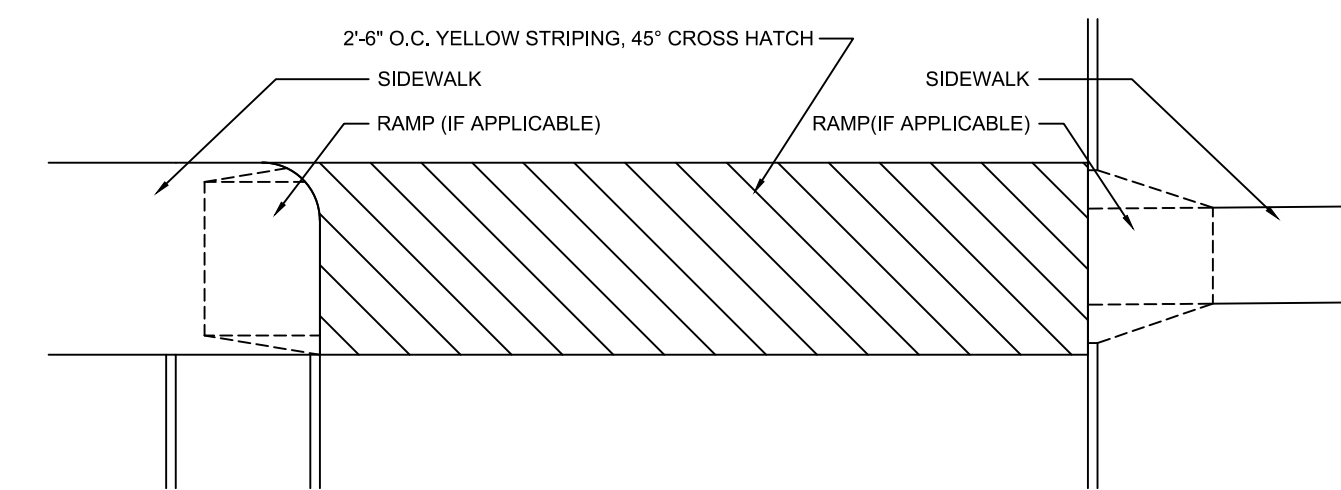

J CROSSWALK
NOT TO SCALE

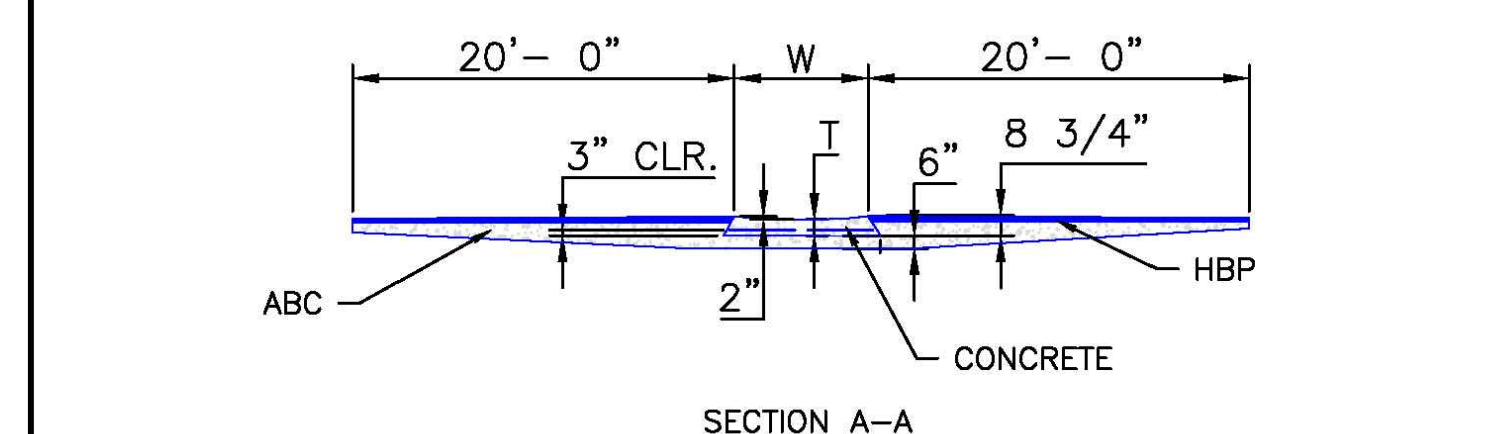
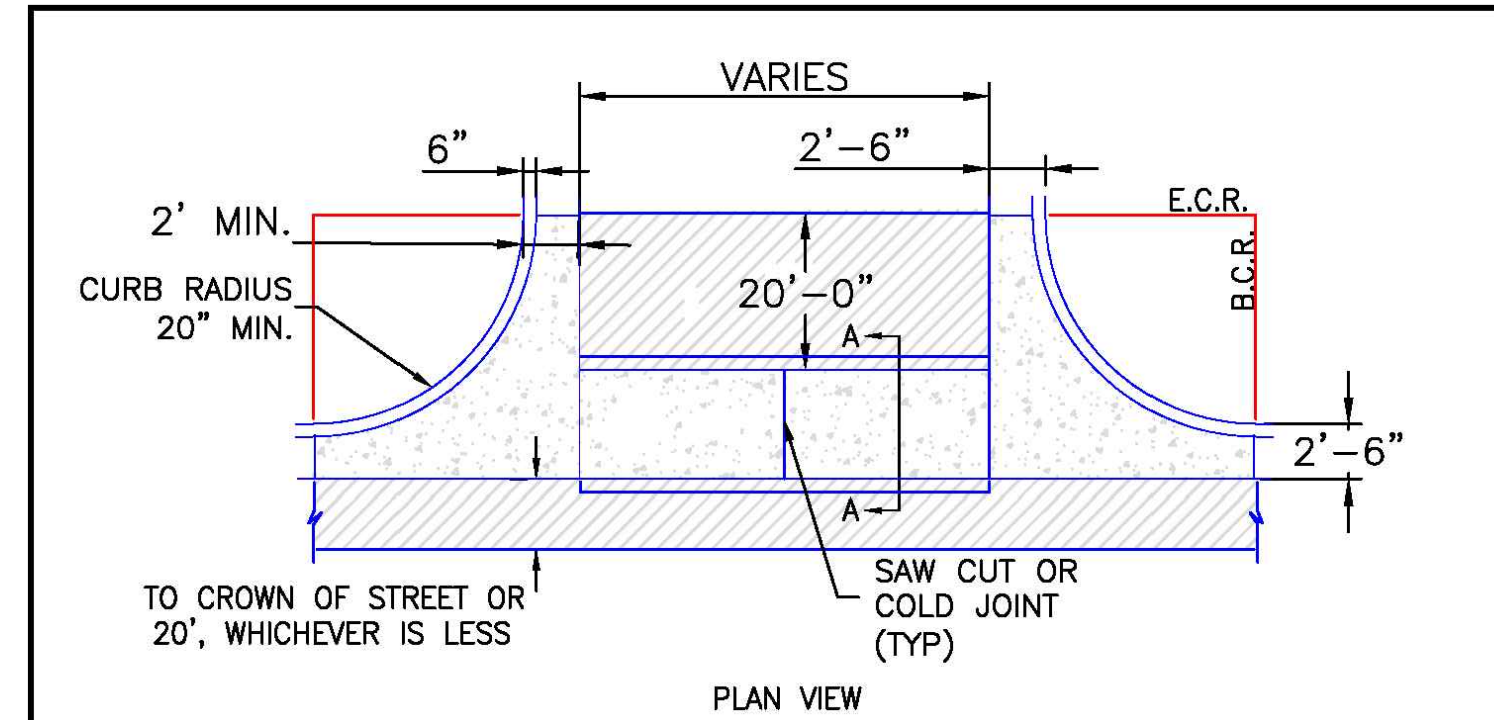

- NOTES
- W - WIDTH SHALL BE 6' FOR LOCAL, 8' FOR COLLECTORS, AND 10' FOR ARTERIAL ROADS.
 - T - SQUARED-OFF RETURN TO BE POURED MONOLITHICALLY, 8" PCC FOR LOCAL ROADS, 9" FOR COLLECTORS WITH 6x6 - 4.4 W.W.F. OR #4 REINFORCING BAR @ 18" EACH WAY.
 - 3" = 3" MINIMUM ASPHALT DEPTH (2 LIFTS).
 - DESIGN TO SPECIFY ELEVATIONS AT PI AND PCR.
- SCALE: NOT TO SCALE

DATE APPROVED: 8/11/11	Typical Cross Plan Layout Detail Standard Drawing	EL PASO COUNTY DEPARTMENT OF TRANSPORTATION
APPROVED: André P. Brackin	REVISION DATE: 12/8/15	FILE NAME: SD_2-26

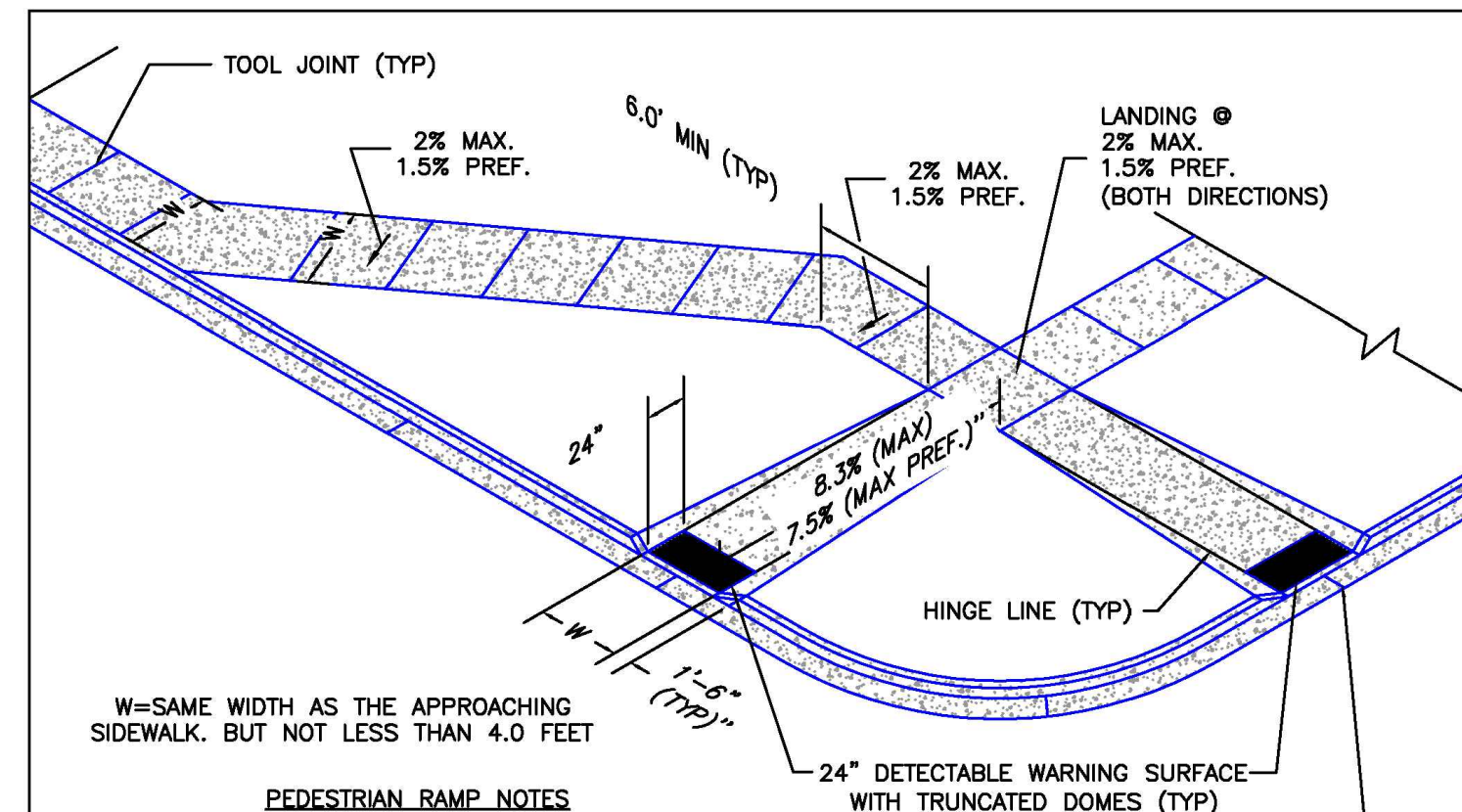

- PEDESTRIAN RAMP NOTES**
- ALL WORK SHALL BE DONE IN ACCORDANCE WITH THE CURRENT ENGINEERING CRITERIA MANUAL AND ADA REQUIREMENTS.
 - CONTRACTOR TO NOTIFY ENGINEERING DIVISION INSPECTION STAFF 48 HOURS PRIOR TO CONCRETE PLACEMENT.
 - PEDESTRIAN CURB RAMP CONSTRUCTION SHALL BE A MINIMUM 4,500 PSI CONCRETE, MINIMUM 4" THICK, NON-COLORED, NON-SCORED, COARSE BROOM FINISH.
 - PEDESTRIAN CURB RAMP LOCATION AND LENGTH MAY REQUIRE MODIFICATION TO MAINTAIN THE 8.3% MAXIMUM RUNNING RAMP SLOPE DUE TO STREET INTERSECTION GRADES AND/OR ALIGNMENTS. SEE ECM SECTION 6.3.8 FOR PEDESTRIAN PUSHBUTTON LOCATION REQUIREMENTS.
 - DETECTABLE WARNING SURFACE SHALL START A MINIMUM OF 6" BUT NOT MORE THAN 8" FROM THE FLOWLINE OF THE CURB AT ANY POINT.
 - DETECTABLE WARNING SURFACE SHALL BE PREFABRICATED, CAST IRON (PATINA NATURAL FINISH) AND IN ACCORDANCE WITH ECM CHAPTER 6 AND SD-2-42. THERMOPLASTIC TRUNCATED DOMES AND PAVERS WILL NOT BE ACCEPTED.
 - THE DETECTABLE WARNING SURFACE SHALL BE 24" IN LENGTH AND THE FULL WIDTH OF THE RAMP.
 - PEDESTRIAN CURB RAMP WIDTH REQUIRED IS SAME AS APPROACHING SIDEWALK; 4' MINIMUM.
 - ALL PEDESTRIAN CURB RAMPS WILL BE PERPENDICULAR TO TRAFFIC WITH THE EXCEPTION OF MID-BLOCK OR TERMINAL RAMPS WHICH MAY BE PARALLEL SUBJECT TO APPROVAL.
 - DRAINAGE STRUCTURES, TRAFFIC SIGNAL/SIGNAGE, UTILITIES/JUNCTION BOXES, OR OTHER OBSTRUCTIONS WITHIN PROPOSED PEDESTRIAN CURB RAMP AREAS AND LANDINGS ARE PROHIBITED.
 - THE COUNTER SLOPE OF THE GUTTER OR ROAD AT THE FOOT OF A RAMP SHALL NOT EXCEED 3%.
- GENERAL NOTES**
- WHERE THE 1'-6" FLARED SIDES OF A PERPENDICULAR CURB RAMP IS HARD CONTIGUOUS WITH A PEDESTRIAN OR HARD SURFACE AREA (PEDESTRIAN CIRCULATION PATH), THE MAXIMUM FLARE SLOPE SHALL NOT EXCEED 10:1.
 - PEDESTRIAN WALKWAY (PEDESTRIAN ACCESS ROUTE) AND/OR LOCATION OF EXISTING OR FUTURE PEDESTRIAN RAMPS ON OPPOSITE CORNERS SHALL BE REVIEWED BEFORE CONSTRUCTING NEW RAMPS.
 - AT MARKED PEDESTRIAN CROSSINGS, THE BOTTOM OF THE RAMPS, EXCLUSIVE OF THE FLARE SIDES, SHALL BE TOTALLY CONTAINED WITHIN THE MARKINGS.

DATE APPROVED: 6/23/20	Pedestrian Curb Ramp Detail Standard Drawing	DEPARTMENT OF PUBLIC WORKS
APPROVED: Jennifer E. Irvine	REVISION DATE: 6/23/20	FILE NAME: SD_2-41

DATE: 05-11-2023	SHEET NUMBER: C6.3 32 OF 43
------------------	-----------------------------

PCD FILE NO. PPR-2225

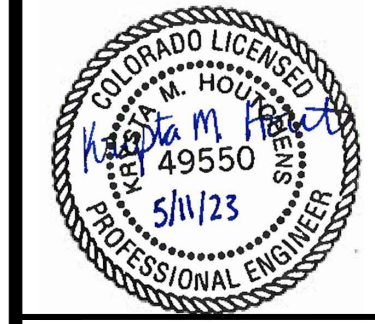

1459 Grand Ave
Des Moines, IA 50309
P: 888-458-6646

2232 - EL PASO, COLORADO
SECURITY BLVD. AND MAIN ST.
CIVIL DETAILS

KG PROJECT TEAM:
RDM:
SDM:
CPM:

REVISION DESCRIPTION	DATE
1ST REVIEW COMMENTS	08/19/22
2ND REVIEW COMMENTS	01/06/23
3RD REVIEW COMMENTS	04/05/23
4TH REVIEW COMMENTS	05/11/23

DATE: 05-11-2023	SHEET NUMBER: C6.3 32 OF 43
------------------	-----------------------------

PCD FILE NO. PPR-2225

GENERAL NOTES:

1. VERIFY ALL EXISTING CONDITIONS PRIOR TO BEGINNING WORK. BE AWARE OF ANY UNDERGROUND UTILITIES. PROTECT ALL EXISTING SITE FEATURES TO REMAIN FROM POTENTIAL DAMAGE BY SITE CONSTRUCTION OPERATIONS. AVOID ANY WORK BEYOND SCOPE OF PROJECT AREA.
2. COORDINATE ALL DISCIPLINES AND SITE CONSTRUCTION THAT WILL BE NEEDED TO COMPLETE THE PROJECT IN THE TIME FRAME GIVEN AND WITHIN BUDGET. ALL ACCESS TO SITE, USE OF UTILITIES, STORAGE, AND OTHER REQUIREMENTS SHALL BE COORDINATED PRIOR TO BEGINNING WORK.
3. CONTRACTOR IS RESPONSIBLE TO INSPECT AND CONFIRM SITE CONDITIONS PRIOR TO BEGINNING WORK. COMMENCEMENT OF WORK SHALL SIGNIFY ALL CONDITIONS ARE ACCEPTABLE AND NO ALLOWANCE WILL BE MADE FOR UNRECOGNIZED CONDITIONS AFTER START OF WORK.
4. NOTIFY OWNER/LANDSCAPE ARCHITECT IMMEDIATELY UPON DISCOVERY OF UNFORESEEN SITE CONDITIONS OR PLAN DISCREPANCIES. NO CHANGE TO SPECIFIED WORK SHALL BE COMPLETED WITHOUT VERIFICATION OF EXISTING CONDITIONS AND WRITTEN APPROVAL OF MODIFICATION BY THE LANDSCAPE ARCHITECT.

CLEARING & GRADING:

1. ALL CONSTRUCTION MUST BE IN ACCORDANCE WITH ALL APPLICABLE MUNICIPAL CODES AND DEVELOPMENT STANDARDS; UNIFORM BUILDING CODES; PERMIT CONDITIONS; AND ALL OTHER APPLICABLE CODES, ORDINANCES, STANDARDS, AND POLICIES.
2. A COPY OF THE APPROVED PLANS MUST BE ON-SITE WHENEVER CONSTRUCTION IS IN PROGRESS.
3. THE CONTRACTOR IS RESPONSIBLE FOR OBTAINING ANY OTHER RELATED OR REQUIRED PERMITS PRIOR TO BEGINNING CONSTRUCTION.
4. ALL LOCATIONS OF EXISTING UTILITIES HAVE BEEN ESTABLISHED BY FIELD SURVEY OR OBTAINED FROM AVAILABLE RECORDS AND SHOULD, THEREFORE, BE CONSIDERED APPROXIMATE ONLY AND NOT NECESSARILY COMPLETE. IT IS THE SOLE RESPONSIBILITY OF THE CONTRACTOR (1) TO INDEPENDENTLY VERIFY THE ACCURACY OF ALL UTILITY LOCATIONS AND (2) TO DISCOVER AND AVOID ANY OTHER UTILITIES NOT SHOWN WHICH MAY BE AFFECTED BY THE IMPLEMENTATION OF THIS PLAN.

SOIL SPECIFICATIONS:

1. ANY PLANTING AREA THAT DOES NOT MEET THE FOLLOWING SOIL PREPARATION REQUIREMENTS ARE SUBJECT TO REJECTION AT OWNER/OWNERS REPRESENTATIVES DISCRETION.
2. LANDSCAPE CONTRACTOR IS REQUIRED TO NOTIFY OWNER/OWNERS REPRESENTATIVE A MINIMUM OF 24 HOURS PRIOR TO BEGINNING SOIL PREP WORK. SOIL PREP NOT INSPECTED BY OWNER/OWNERS REPRESENTATIVE IS SUBJECT TO REJECTION AT ANYTIME PRIOR TO INITIAL ACCEPTANCE.
3. LANDSCAPE CONTRACTOR SHALL SUBMIT DELIVERY (TRIP) TICKETS TO OWNER/OWNERS REPRESENTATIVE FOR ALL ORGANIC SOIL AMENDMENTS WITHIN 24 HOURS AFTER DELIVERY.
4. IMPORTED TOPSOIL SHALL BE FERTILE, FRIABLE, SANDY LOAM FROM THE 'A' HORIZON AND SHALL BE FREE OF STONES OVER .75" IN DIAMETER, REFUSE, PLANTS OR THEIR ROOTS, STICKS, NOXIOUS WEEDS, SALTS, SOIL STERILANTS, OR OTHER MATERIAL WHICH WOULD BE DETRIMENTAL TO PLANT GROWTH.
5. ORGANIC SOIL AMENDMENT SHALL CONSIST OF DRY, WELL-ROTTED, PULVERIZED, AGED MINIMUM ONE YEAR ORGANIC COMPOST CLASS 1 TYPE SUCH AS AVAILABLE FROM A-1 COMPOST, JENSEN SALES. PULVERIZED HORSE, SHEEP OR DAIRY COW MANURE **NOT ACCEPTABLE**. SUBMIT DATED RECENT MATERIAL ANALYSIS TO OWNER/OWNERS REPRESENTATIVE TO GUARANTEE PRODUCT CONDITION AND PROOF NO LIVE WEED SEEDS AND CHEMICAL ADDITIVES ARE PRESENT.
6. SOIL PREPARATION FOR AREAS TO BE SODDED SHALL INCLUDE TOPSOIL AND ORGANIC MATTER ADDED AT A RATE OF FIVE CUBIC YARDS PER ONE THOUSAND SQUARE FEET AND TILLED EIGHT (8) INCHES INTO THE SOIL.
7. PREPARED BACKFILL FOR TREE/SHRUB PLANTING SHALL BE A MIX OF 2/3 IMPORTED/ SALVAGED TOPSOIL AND 1/3 ORGANIC SOIL AMENDMENT. WHERE TREES AND SHRUBS ARE LOCATED IN LARGE BEDS PROVIDE SOIL AMENDMENT AT A RATE OF FIVE CUBIC YARDS PER ONE THOUSAND SQUARE FEET AND TILL EIGHT INCHES INTO THE SOIL THROUGHOUT THE ENTIRE PLANTING BED, NOT JUST IN EXCAVATED PLANTING HOLES.

EDGING:

1. ALL EDGING SHALL BE 1/8" X 4" GREEN PAINTED "RYERSON TYPE" METAL EDGING W/ MILLED EDGE AND ANCHOR STAKES PER MANUFACTURE'S SPECIFICATIONS OR EQUAL.

MULCH

1. PLANTING BEDS (AS SPECIFIED) SHALL CONTAIN 2"-4" RIVER ROCK COBBLE MULCH OVER FABRIC AT A MINIMUM DEPTH OF 3" WITH A DOUBLE SHREDDED CEDAR MULCH RING AROUND EACH TREE, SHRUB, GRASS, AND PERENNIAL. WOOD MULCH RING SHALL BE 1.5X THE CONTAINER SIZE OF THE SHRUB, GRASS OR PERENNIAL. TREE MULCH RING SHALL BE GREEN INDUSTRY STANDARD SIZE.
2. PLANTING BEDS (AS SPECIFIED) SHALL CONTAIN 1" GRAY CHIPPED GRANITE MULCH AT A MINIMUM DEPTH OF 3", DEPRESSED 2" BELOW SURROUNDING CURBS AND WALKS. PLACE WITH TIGHT JOINTS.
3. GEOTEXTILE FABRIC (FILTER FABRIC) UNDERLAYMENT SHALL BE MIRAFI, MIRASCAP, DUPONT TYPAR 3301 OR APPROVED EQUAL (SUBMIT SAMPLE).

PLANTING NOTES:

1. LANDSCAPE CONTRACTOR SHALL LOCATE ALL TREES, SHRUBS AND PLANTING BEDS ACCORDING TO LOCATIONS SHOWN ON DRAWINGS. ALL PLANTING LOCATIONS SHALL BE SUBJECT TO REVIEW AND APPROVAL BY LANDSCAPE ARCHITECT PRIOR TO THE START OF PLANTING OPERATIONS. LANDSCAPE CONTRACTOR SHALL MAKE MODIFICATIONS IN LOCATIONS AS DIRECTED BY LANDSCAPE ARCHITECT.
2. THE PLANT SCHEDULE IS FOR CONTRACTOR'S CONVENIENCE ONLY. THE CONTRACTOR SHALL BE RESPONSIBLE FOR VERIFYING EXISTING CONDITIONS AND REPORTING IN WRITING TO THE LANDSCAPE ARCHITECT ANY CONFLICTS RELATIVE TO IMPLEMENTATION OF THE LANDSCAPE CONSTRUCTION DOCUMENTS. VALERIAN LLC SHALL NOT ASSUME ANY ERRORS OR OMISSIONS IN THE PLANT SCHEDULE LISTED HEREIN. THE PLANT SYMBOLS SHOWN ON THE LANDSCAPE PLAN SHALL PREVAIL SHOULD THERE BE ANY DISCREPANCIES IN QUANTITIES BETWEEN THE PLAN AND PLANT SCHEDULE.
3. LANDSCAPE CONTRACTOR SHALL PROVIDE PLANT PROTECTION AND MAINTENANCE THROUGHOUT INSTALLATION AND UNTIL FINAL ACCEPTANCE OF LANDSCAPE INSTALLATION AS FOLLOWS:
 - A) ALL PLANT MATERIAL SHALL BE PROTECTED FROM TIME OF DIGGING TO TIME OF FINAL ACCEPTANCE, FROM INJURY, EXCESSIVE DRYING FROM WINDS, IMPROPER VENTILATION, OVER-WATERING, FREEZING, HIGH TEMPERATURES, OR ANY OTHER CONDITION DAMAGING TO PLANTS.
 - B) PLANT MATERIAL SHALL BE PLANTED ON THE DAY OF DELIVERY IF POSSIBLE. ALL PLANTS NOT PLANTED ON THE DAY OF DELIVERY SHALL BE PLACED IN A TEMPORARY NURSERY AND KEPT MOIST, SHADED, AND PROTECTED FROM THE SUN AND WIND. EACH ROOTBALL SHALL BE COVERED ENTIRELY WITH MULCH. ALL PLANT MATERIALS SHALL BE INSTALLED PER THE PLAN DRAWINGS AND SPECIFICATIONS.
 - C) LANDSCAPE CONTRACTOR SHALL PROVIDE PLANT MATERIALS THAT COMPLY WITH THE REQUIREMENTS OF THE MOST RECENT ANSI Z 60.1 "STANDARDS FOR NURSERY STOCK" UNLESS OTHERWISE SPECIFIED. CALIPER OF B&B TREES SHALL BE TAKEN 6 INCHES ABOVE THE GROUND UP TO AND INCLUDING 4 INCH CALIPER SIZE, AND 12 INCHES ABOVE THE GROUND FOR LARGER SIZES.
 - D) PLANTING MAINTENANCE SHALL INCLUDE WATERING, WEEDING, CULTIVATING, RESETTLING PLANTS TO PROPER GRADES OR POSITION, REESTABLISHING SETTLED GRADES. HERBICIDE IS NOT RECOMMENDED FOR ONE YEAR FOLLOWING LANDSCAPE INSTALLATION.
 - E) PLANT MAINTENANCE SHALL INCLUDE THOSE OPERATIONS NECESSARY TO PROPER GROWTH AND SURVIVAL OF ALL PLANT MATERIALS. CONTRACTOR SHALL PROVIDE THIS WORK IN ADDITION TO SPECIFIC WARRANTY/GUARANTEES.
4. CONTRACTOR SHALL VERIFY AND MAINTAIN ALL SETBACKS, CLEAR ZONES AND SIGHT TRIANGLES REQUIRED BY ALL LOCAL AND MUNICIPAL CODES WHERE APPLICABLE.
5. LANDSCAPE CONTRACTOR SHALL ENSURE THAT THE LANDSCAPE INSTALLATION IS COORDINATED WITH THE PLANS PREPARED BY OTHER CONSULTANTS SO THAT THE PROPOSED GRADING, STORM DRAINAGE OR OTHER PROPOSED CONSTRUCTION DOES NOT CONFLICT WITH NOR PRECLUDE INSTALLATION AND MAINTENANCE OF LANDSCAPE ELEMENTS AS DESIGNATED ON THIS PLAN.
6. ALL LANDSCAPE AREAS SHALL BE IRRIGATED BY AN AUTOMATIC UNDERGROUND IRRIGATION SYSTEM. THE SYSTEM SHALL BE PROPERLY ZONED TO SEPARATE PLANT MATERIAL BY WATER REQUIREMENT. ALL SHRUB BEDS AND TREES IN NATIVE SEED AREAS SHALL BE IRRIGATED BY USING LOW WATER/DRIP TECHNIQUES. ALL TURF AREAS SHALL BE IRRIGATED USING POP-UP SPRAY OR ROTOR APPLICATION.

NOTES:

1. DO NOT REMOVE OR CUT LEADER.
2. PRUNE ALL DAMAGED OR DEAD WOOD AFTER PLANTING, STAKING AND MULCHING.
3. DO NOT REMOVE LOWER LIMBS AND SPROUTS FOR AT LEAST TWO GROWING SEASONS.
4. KEEP PLANTS MOIST AND SHADED UNTIL PLANTING.
5. REMOVE ALL PLANTING LABELS AFTER FINAL ACCEPTANCE BY LANDSCAPE ARCHITECT.

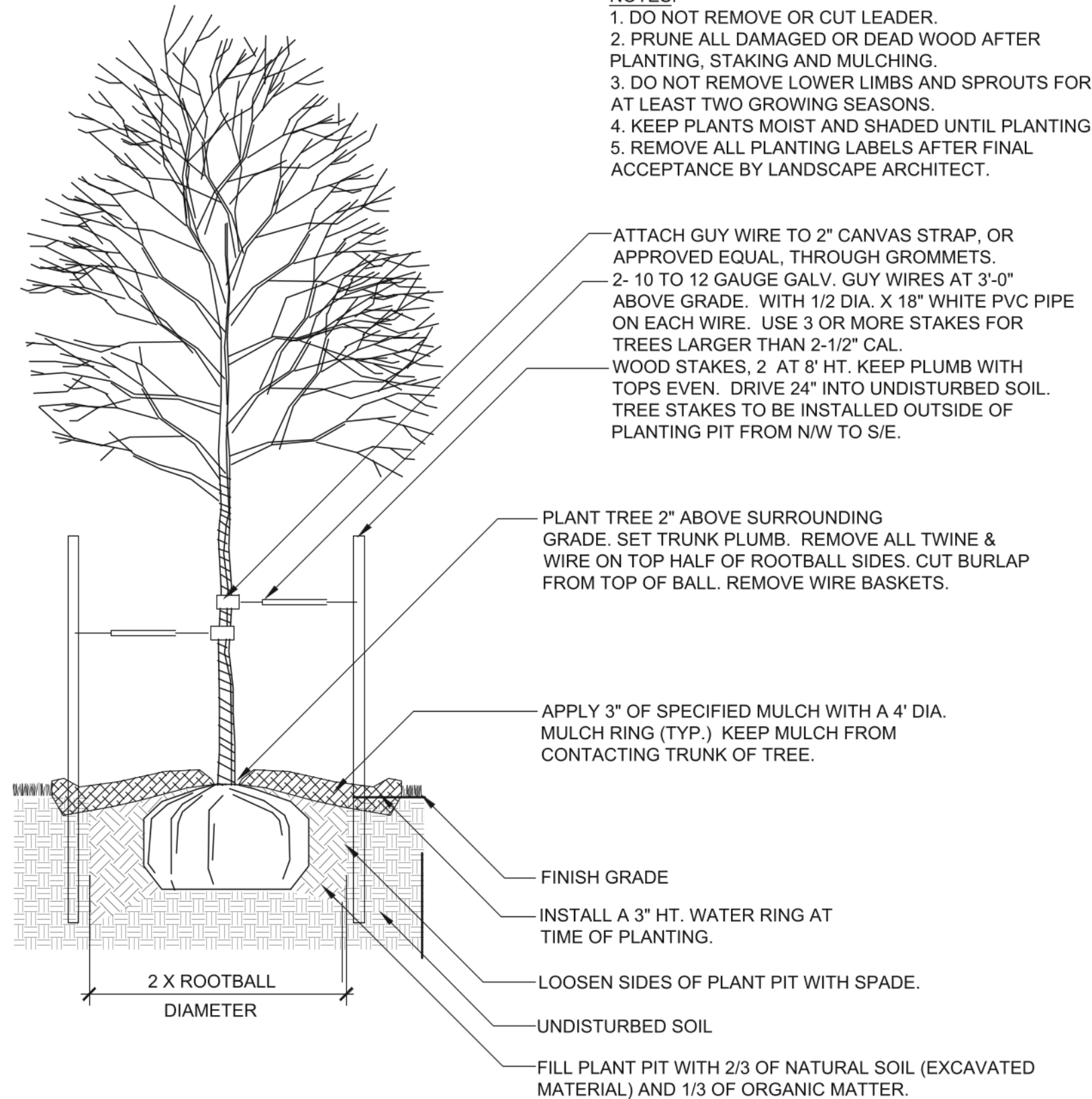

NOTE: ALL TREES LOCATED WITHIN SIGHT TRIANGLES OR WITHIN 100' APPROACHING A STOP SIGN ARE TO BE LIMBED TO 8' AT ONSET OF WINTER FOR THE FIRST YEAR OF INSTALLATION. WRAP ENTIRE SURFACE OF TRUNK UP TO BRANCHES. SECURE AT TOP AND BOTTOM WITH DUCT TAPE. AT ONSET OF SPRING REMOVE ALL WRAPPING.

1 DECIDUOUS TREE PLANTING

1" = 1'-0"

BLCC-03

NOTES:

1. DO NOT REMOVE OR CUT LEADER.
2. PRUNE ALL DAMAGED OR DEAD WOOD AFTER PLANTING, STAKING AND MULCHING.
3. DO NOT REMOVE LOWER LIMBS AND SPROUTS FOR AT LEAST TWO GROWING SEASONS.
4. KEEP PLANTS MOIST AND SHADED UNTIL PLANTING.
5. REMOVE ALL PLANTING LABELS AFTER FINAL ACCEPTANCE BY LANDSCAPE ARCHITECT.

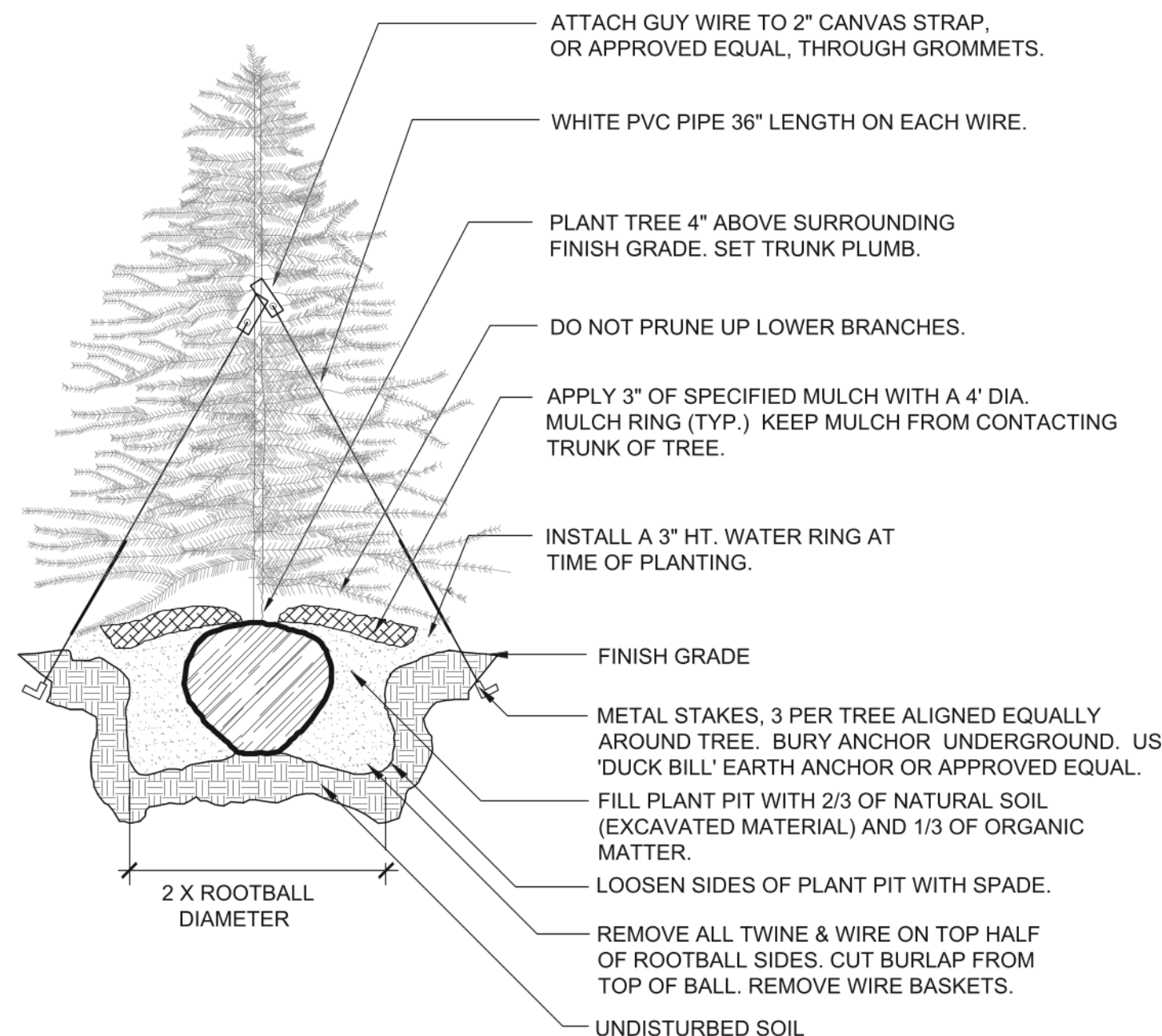

2 EVERGREEN TREE PLANTING

1" = 1'-0"

BLCC-04

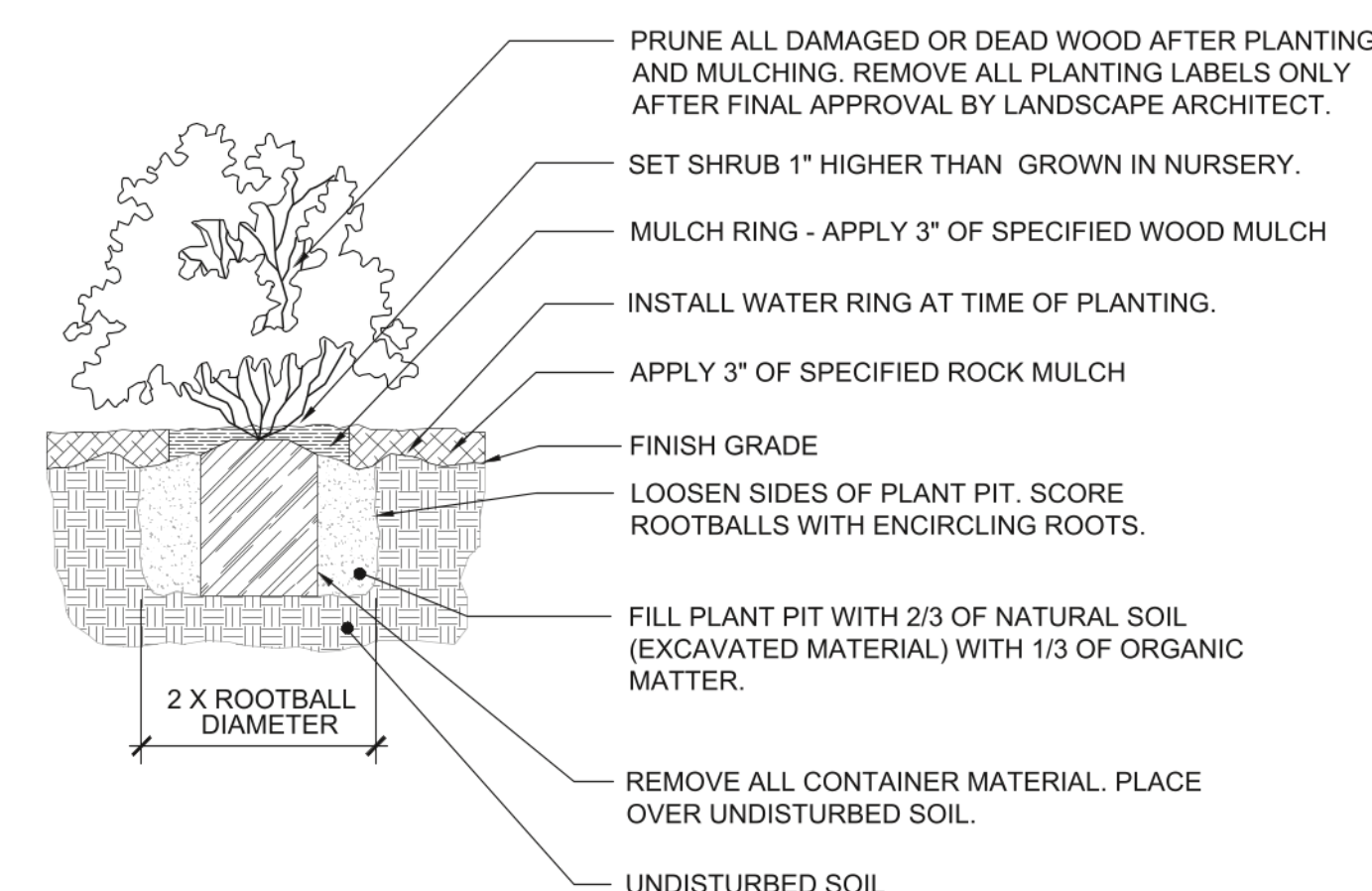

NOTE: ANY PLANT NOT IN ACCORDANCE WITH COLORADO NURSERY ACT REQUIREMENTS WILL BE REJECTED. HOLD MULCH GRADE 1" BELOW EDGE OF WALK, EDGING AND CURB. JUNIPER PLANTS SHALL BE PLANTED WITH TOP OF ROOTBALL AT FINISH GRADE OF MULCH LAYER.

3 SHRUB / ORNAMENTAL GRASS PLANTING WITH MULCH RING

1" = 1'-0"

32 9333.13-11

X:\DROPOX\VALERIAN\TEAM FOLDER\PROJECTS\21-074 EES\EL PASO MAIN STREET K&G 22202-WORKING\2022-04-07 - SUBMITTAL_4TH02-1974_12_LANDSCAPE DETAILS & NOTES.DWG

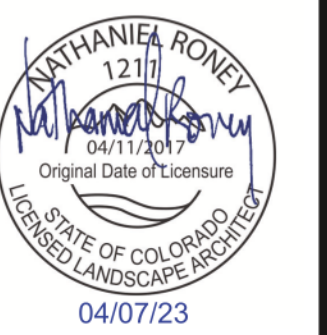

1459 Grand Ave
Des Moines, IA 50309
P: 888-458-6646

2232 - EL PASO, COLORADO
SECURITY BLVD. AND MAIN ST.
LANDSCAPE NOTES & DETAILS

KG PROJECT TEAM:
RDM:
SDM:
CPM:

REVISION DESCRIPTION	DATE	REVISIONS PER COMMENTS	REVISIONS PER COMMENTS	REVISIONS PER COMMENTS
1	8/19/22			
2	12/20/22			
3	04/07/23			

DATE: 04-26-2022

SHEET NUMBER:

C7.2
34 of 43

X:\DROPOX (VALERIAN)\VALERIAN TEAM FOLDER\PROJECTS\21-074 EES-EL PASO MAIN STREET K&G 22322-WORKING\2022-04-07_SUBMITTAL_4TH\21-074_13_IRRIGATION PLAN.DWG

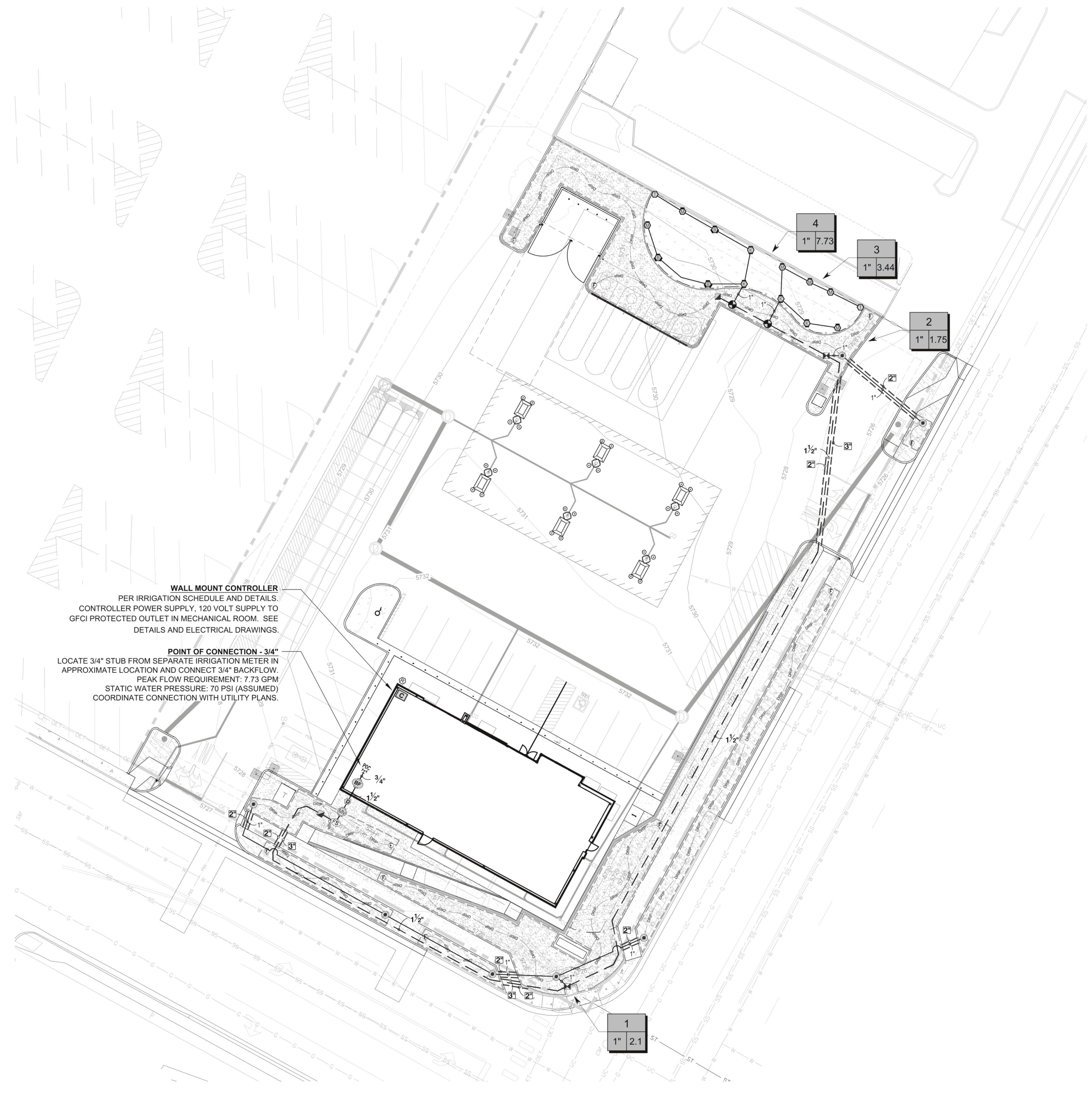

WALL MOUNT CONTROLLER
PER IRRIGATION SCHEDULE AND DETAILS.
CONTROLLER POWER SUPPLY, 120 VOLT SUPPLY TO
GFCI PROTECTED OUTLET IN MECHANICAL ROOM. SEE
DETAILS AND ELECTRICAL DRAWINGS.

POINT OF CONNECTION - 3/4"
LOCATE 3/4" STUB FROM SEPARATE IRRIGATION METER IN
APPROXIMATE LOCATION AND CONNECT 3/4" BACKFLOW.
PEAK FLOW REQUIREMENT: 7.73 GPM
STATIC WATER PRESSURE: 70 PSI (ASSUMED)
COORDINATE CONNECTION WITH UTILITY PLANS.

1 IRRIGATION PLAN

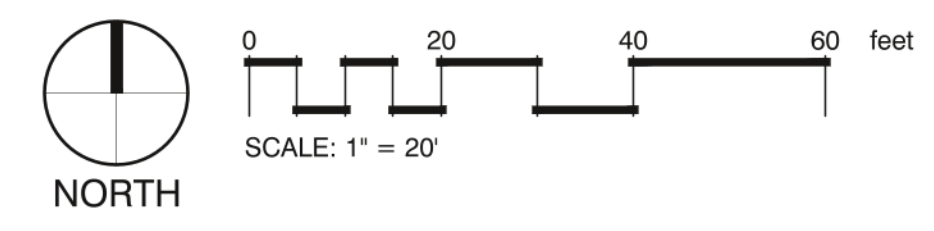

1459 Grand Ave
Des Moines, IA 50309
P: 888-458-6646

2232 - EL PASO, COLORADO
SECURITY BLVD. AND MAIN ST.
IRRIGATION PLAN

KG PROJECT TEAM:
RDM:
SDM:
CPM:

DATE	REVISION DESCRIPTION
10/20/22	IRRIGATION PLANS
04/07/23	REVISIONS PER COMMENTS

DATE: 04-26-2022

SHEET NUMBER:
C7.3
35 of 43

GENERAL NOTES:

- PRIOR TO BEGINNING WORK VERIFY THE CONTRACT DRAWINGS AGAINST ALL APPLICABLE EXISTING CONDITIONS, NOTIFY THE DESIGNER IMMEDIATELY UPON DISCOVERY OF UNFORESEEN SITE CONDITIONS OR PLAN DISCREPANCIES.
- CONTRACTOR IS RESPONSIBLE TO INSPECT AND CONFIRM SITE CONDITIONS PRIOR TO BEGINNING WORK.
- VERIFY LOCATION OF ALL ABOVE AND BELOW GRADE MECHANICAL, PLUMBING, ELECTRICAL/UTILITY LINES AND EQUIPMENT AND ADHERE TO ALL FEDERAL, MUNICIPAL, UTILITY PURVEYOR REQUIRED EASEMENTS, MINIMUM OFFSETS AND SETBACKS.
- ALL ACCESS TO SITE, USE OF UTILITIES, STORAGE, AND OTHER REQUIREMENTS SHALL BE COORDINATED PRIOR TO BEGINNING WORK.

IRRIGATION NOTES:

- THE CONTRACTOR IS TO INSTALL AN AUTOMATIC IRRIGATION SYSTEM THAT WILL PROVIDE COVERAGE FOR ALL LANDSCAPED AREAS AS SHOWN ON CONTRACT DRAWINGS.
- REFER TO DETAILS FOR INSTALLATION INSTRUCTIONS.
- ALL WORK SHALL BE DONE IN ACCORDANCE WITH ALL APPLICABLE LOCAL AND MUNICIPAL CODES FOR WORK NECESSARY IN IRRIGATION SYSTEM INSTALLATION.
- POINT OF CONNECTION SHOWN ON THE IRRIGATION PLANS ARE PER THE CIVIL DOCUMENTS. REPORT ANY DISCREPANCIES IN THE LOCATION TO THE DESIGNER FOR CLARIFICATION OR REVISION.
- CONTRACTOR IS TO PROVIDE ALL NECESSARY PIPE, VALVES, ETC. DOWNSTREAM FROM POINT OF CONNECTION NOT INSTALLED BY OTHER DISCIPLINES.
- WORK SHALL BE DONE IN FULL ACCORDANCE WITH THE RULES AND REGULATIONS OF THE 2009 INTERNATIONAL PLUMBING CODE (IPC) AND ALL OTHER STATE OR LOCAL MUNICIPAL REGULATIONS CURRENT UPON THE SIGNING OF THIS CONTRACT.
- CONTRACT DRAWINGS ARE GENERALLY DIAGRAMMATIC AND INDICATIVE OF THE WORK TO BE INSTALLED. IT IS THE INTENT OF THIS DESIGN THAT ALL IRRIGATION EQUIPMENT BE INSTALLED IN LANDSCAPED AREAS WHEREVER POSSIBLE AND WITHIN THE PROPERTY LIMITS. ANY EQUIPMENT SHOWN OUTSIDE OF THESE LIMITS IS SHOWN IN THAT LOCATION FOR GRAPHICAL CLARITY ONLY.
- LATERAL AND MAINLINE PIPE, CONTROL WIRES AND SLEEVES ARE SHOWN ON CONTRACT DRAWINGS SPACED HORIZONTALLY ON PLAN FOR GRAPHIC CLARITY ONLY. CONTRACTOR SHALL CONSOLIDATE IRRIGATION LATERALS, MAINLINES AND COMPONENTS WHEREVER POSSIBLE. IRRIGATION PIPING SHALL BE INSTALLED WITH A MINIMUM OF 4 INCHES CLEAR ON ALL SIDES.
- CONTRACTOR SHALL MAINTAIN THE MINIMUM DEPTHS DETAILED AND SPECIFIED FOR ALL IRRIGATION EQUIPMENT.
- CONTRACTOR IS TO VERIFY AVAILABLE PRESSURE AND FLOW AT POINT OF CONNECTION PRIOR TO INSTALLATION OF IRRIGATION SYSTEM EQUIPMENT.
- CONTRACTOR TO COORDINATE INSTALLATION OF SLEEVING WITH OVERALL SITE CONSTRUCTION AND INSTALLATION OF PAVING AND SIDEWALKS. ALL SLEEVING UNDER PAVED SURFACES SHOWN ON CONTRACT DRAWINGS IS BY CONTRACTOR UNLESS OTHERWISE NOTED. ALL MAINLINES, LATERAL LINES, DRIP LINES AND CONTROL WIRES UNDER PAVED SURFACES ARE TO BE INSTALLED IN SLEEVING. INSTALL SLEEVING AS PER DETAIL, NOTES, SCHEDULES AND SPECIFICATIONS.
- ALL PIPING, PVC ELECTRICAL SLEEVES, ETC. UNDER PAVING SHALL BE INSTALLED PRIOR TO PAVING WORK. NO TEES, ELLS OR OTHER TURNS IN PIPING SHALL BE LOCATED UNDER PAVING. CAP ALL ENDS HAND TIGHT PRIOR TO BACKFILL.
- EACH MAINLINE SLEEVE REPRESENTED IN THE DRAWINGS SHALL CONSIST OF TWO SLEEVES: ONE FOR MAINLINE PIPING AND ONE FOR FIELD WIRING.
- CONTRACTOR IS TO PROVIDE ELECTRICAL POWER TO THE AUTOMATIC CONTROLLER, SEE ELECTRICAL DRAWINGS.
- INSTALL ALL MATERIALS AND EQUIPMENT AS SHOWN IN DETAILS. USE TEFLON TAPE OR TEFLON PIPE DOPE ON ALL MALE PIPE THREADS ON ALL IRRIGATION SWING JOINT AND VALVE ASSEMBLIES.
- BACKFILLING SHALL BE DONE IN LIFTS AND COMPACTED.
- MAINTENANCE AND OPERATION REQUIREMENTS: A SEASONAL MAINTENANCE SCHEDULE BEGINNING ON APRIL 1 THROUGH OCTOBER 1 SHALL ESTABLISH PROCEDURES FOR OPTIMUM IRRIGATION EFFICIENCY AND PREVENTIVE MAINTENANCE PRACTICES THAT WILL CONSERVE WATER RESOURCES. THE MAINTENANCE SCHEDULE SHOULD INCLUDE THE FOLLOWING ITEMS:
 - VERIFY COVERAGE OF HEADS (BI-MONTHLY)*
 - CHECK FOR BROKEN HEADS OR LEAKAGE (BI-MONTHLY)*
 - REPROGRAM CONTROLLERS ACCORDING TO THE SEASONAL NEEDS (MONTHLY)*
 - VERIFY WATER SUPPLY AND PRESSURE (UPON SYSTEM STARTUP, THEN TWO ADDITIONAL TIMES)
 - INSPECT THE BACKFLOW PREVENTER DEVICE (UPON SYSTEM STARTUP)
 - VERIFY SENSOR FUNCTIONALITY (BI-MONTHLY)*

*ALL ITEMS SHALL BE PERFORMED UPON SYSTEM START UP AND THEN AT A MINIMUM OF THE PERIOD STATED, INSPECTIONS SHALL BE PERFORMED MORE FREQUENTLY AS REQUIRED.

POINT OF CONNECTION (P.O.C.) NOTES:

P.O.C. '1' - CONNECT TO 3/4" STUB LOCATED IN THE MECHANICAL ROOM, EXTEND AND CONNECT 3/4" TYPE-K COPPER LINE TO 3/4" BACKFLOW DEVICE. REFER TO CIVIL PLANS FOR CONNECTION LOCATION.

AVAILABLE WATER PRESSURE: THE ASSUMED AVAILABLE PSI AT THE POINT OF CONNECTION IS - **70 PSI**. CONTRACTOR SHALL TEST PRIOR TO INSTALLATION.

ASSUMED DESIGN PRESSURE: 70 PSI

DESIGN FLOW : 7.73 GPM MAX. (SINGLE VALVE OPERATION)

- THE IRRIGATION SYSTEMS ARE DESIGNED WITHIN A WATER WINDOW AND SIZED TO ACCOMMODATE SINGLE VALVE STARTS NOT TO EXCEED DESIGN FLOW LISTED. CONTRACTOR TO PROGRAM CONTROLLER ACCORDINGLY.
- CONTRACTOR TO INSTALL ALL REQUIRED EQUIPMENT IN ACCORDANCE WITH ALL LOCAL WATER PURVEYORS REQUIREMENTS.
- CONTRACTOR TO FIELD LOCATE REQUIRED IRRIGATION EQUIPMENT DOWNSTREAM FROM METER FOR APPROVAL PRIOR TO INSTALLATION. ALL ATTEMPTS SHALL BE MADE TO INSTALL EQUIPMENT IN LANDSCAPE BEDS.
- ALL ENCLOSURES SHALL BE SECURELY MOUNTED AND LOCKABLE TO PREVENT VANDALISM, DAMAGE AND/OR THEFT. TURN KEYS OVER TO OWNERS REPRESENTATIVE AT COMPLETION OF WORK AS PER SPECIFICATIONS.
- CONTRACTOR TO COORDINATE CONTROLLER LOCATIONS WITH OWNERS REPRESENTATIVE PRIOR TO INSTALLATION.
- RAIN SENSOR, MOUNT WIRELESS RAIN SENSOR WITHIN OPTIMAL RANGE FROM CONTROLLER, PER MANUFACTURERS RECOMMENDATIONS. INSTALL SENSOR ON LIGHT/UTILITY POLE A MINIMUM OF 10' ABOVE GRADE TO MINIMIZE DAMAGE/VANDALISM, CLEARLY NOTE LOCATION AND PROVIDE INFORMATION TO OWNERS REPRESENTATIVE.
- IRRIGATION ZONES HAVE BEEN CREATED TO PROPERLY HYDROZONE THE SITE BASED ON SITE CONDITIONS AND MICROCLIMATES. IF FIELD ADJUSTMENTS ARE TO BE MADE IRRIGATION EQUIPMENT IRRIGATING A NORTH AND EAST EXPOSURE SHOULD NOT BE INSTALLED ON THE SAME ZONE AS IRRIGATION EQUIPMENT ON THE SOUTH AND WEST EXPOSURES TO ALLOW FOR MICROCLIMATE ADJUSTMENTS IN THE CONTROLLER PROGRAMMING.

IRRIGATION SCHEDULE

SYMBOL	MANUFACTURER/MODEL/DESCRIPTION	QTY	PSI
	TURF ROTARY - 1000 HUNTER MP1000 PROS-06-PRS40-CV 6" POP-UP WITH CHECK VALVE, PRESSURE REGULATED TO 40 PSI, MP ROTATOR NOZZLE ON PRS40 BODY. M=MAROON ADJ ARC 90 TO 210, L=LIGHT BLUE 210 TO 270 ARC, O=OLIVE 360 ARC.	6	40
	TURF ROTARY - 2000 HUNTER MP2000 PROS-06-PRS40-CV 6" POP-UP WITH FACTORY INSTALLED CHECK VALVE, PRESSURE REGULATED TO 40 PSI, MP ROTATOR NOZZLE ON PRS40 BODY. K=BLACK ADJ ARC 90-210, G=GREEN ADJ ARC 210-270, R=RED 360 ARC.	4	40
	TURF ROTARY - 3000 HUNTER MP3000 PROS-06-PRS40-CV 6" POP-UP WITH FACTORY INSTALLED CHECK VALVE, PRESSURE REGULATED TO 40 PSI, MP ROTATOR NOZZLE ON PRS40 BODY. B=BLUE ADJ ARC 90-210, Y=YELLOW ADJ ARC 210-270, A=GRAY 360 ARC.	3	40
	TURF ROTARY - CORNER HUNTER MP CORNER PROS-06-PRS40-CV 6" POP-UP WITH FACTORY INSTALLED CHECK VALVE, PRESSURE REGULATED TO 40 PSI, MP ROTATOR NOZZLE ON PRS40 BODY. T=TURQUOISE ADJ ARC 45-105.	2	40

SYMBOL	MANUFACTURER/MODEL/DESCRIPTION	QTY
	DRIP CONTROL VALVE ASSEMBLY - MED. FLOW HUNTER ICZ-101-40 1" ICV GLOBE VALVE WITH 1" HY100 FILTER SYSTEM, PRESSURE REGULATION: 40PSI, FLOW RANGE: 2 GPM TO 20 GPM. 150 MESH STAINLESS STEEL SCREEN.	2
	PIPE TRANSITION POINT PIPE TRANSITION FROM PVC LATERAL TO DRIP TUBING WITH RISER IN 6" DRIP BOX.	7
	FLUSH VALVE 3/4" PVC BALL VALVE IN 10" VALVE BOX.	10
	AREA TO RECEIVE DRIP EMITTERS AREA FOR DRIP EMITTERS RAIN BIRD XB-PC SINGLE OUTLET, PRESSURE COMPENSATING DRIP EMITTERS. FLOW RATES OF 0.5GPH=BLUE, 1.0GPH=BLACK, AND 2.0GPH=RED. COMES WITH A SELF-PIERCING BARB INLET X BARB OUTLET. Emitter Notes: 0.5 GPH emitters (1 assigned to each #1 plant) 1.0 GPH emitters (1 assigned to each #5 plant) 2.0 GPH emitters (4 assigned to each B & B, 2" Cal plant) 2.0 GPH emitters (6 assigned to each B & B, 6" HT plant)	6,063 S.F.

SYMBOL	MANUFACTURER/MODEL/DESCRIPTION	QTY
	CONTROL VALVE HUNTER ICV-G PLASTIC ELECTRIC REMOTE CONTROL VALVE, GLOBE CONFIGURATION, WITH NPT THREADED INLET/OUTLET.	2
	QUICK COUPLER VALVE RAIN BIRD 44-RC 1" BRASS QUICK-COUPPLING VALVE, WITH CORROSION-RESISTANT STAINLESS STEEL SPRING, THERMOPLASTIC RUBBER COVER, AND 2-PIECE BODY.	2
	MASTER VALVE - NORMALLY CLOSED 1" RAIN BIRD EFB-CP BRASS MASTER VALVE, THAT IS CONTAMINATION PROOF W/SELF-FLUSHING FILTER SCREEN AND FD-101TURF DECODER. GLOBE CONFIGURATION, RECLAIMED WATER COMPATIBLE.	1
	MANUAL DRAIN VALVE MUELLER ORISEAL #H-10283, WITH BRASS SWING JOINT ASSEMBLY. INSTALL PER INSTALLATION DETAIL.	1
	BACKFLOW PREVENTER - INDOOR 3/4" FEBCO 825Y REDUCED PRESSURE BACKFLOW PREVENTER	1
	HUNTER PHC-1200 WIFI ENABLED, FULL-FUNCTIONING CONTROLLER WITH TOUCHSCREEN, 12-STATION FIXED CONTROLLER, 120 VAC, OUTDOOR MODEL.	1
	HUNTER WSS WIRELESS SOLAR, RAIN FREEZE SENSOR WITH OUTDOOR INTERFACE, CONNECTS TO HUNTER PCC, PRO-C, AND I-CORE CONTROLLERS, INSTALL AS NOTED. INCLUDES 10 YEAR LITHIUM BATTERY AND RUBBER MODULE COVER, AND GUTTER MOUNT BRACKET.	1
	FLOW SENSOR -1" RAINBIRD MJ100B - 1" FLOW SENSOR FOR USE WITH RAIN BIRD ESP-ME.	1
	POINT OF CONNECTION 3/4"	1

	IRRIGATION LATERAL LINE: PVC CLASS 200 SDR 21	419.2 L.F.
	IRRIGATION MAINLINE: PVC CLASS 200 SDR 21	483.3 L.F.
	IRRIGATION MAINLINE: TYPE K COPPER PIPE	5.4 L.F.
	PIPE SLEEVE: PVC CLASS 160 SDR 26	122.1 L.F.

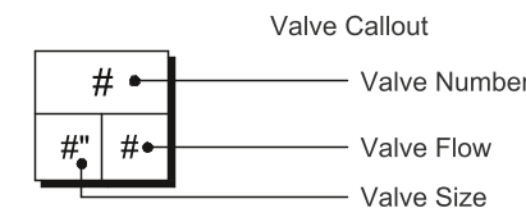

1459 Grand Ave
Des Moines, IA 50309
P: 888-458-6646

2232 - EL PASO, COLORADO
SECURITY BLVD. AND MAIN ST.

IRRIGATION NOTES

KG PROJECT TEAM:
RDM:
SDM:
CPM:

REVISION DESCRIPTION	DATE	IRRIATION PLANS	REVISIONS PER COMMENTS
1	10/20/22		
2	04/07/23		

DATE: 04-26-2022

SHEET NUMBER:
C7.4
36 of 43

NOTES:
 ENSURE PRESENCE OF A FLOOR DRAIN IN MECHANICAL ROOM. EXTEND DRAIN PIPE FROM BACKFLOW LOCATION TO DRAIN.

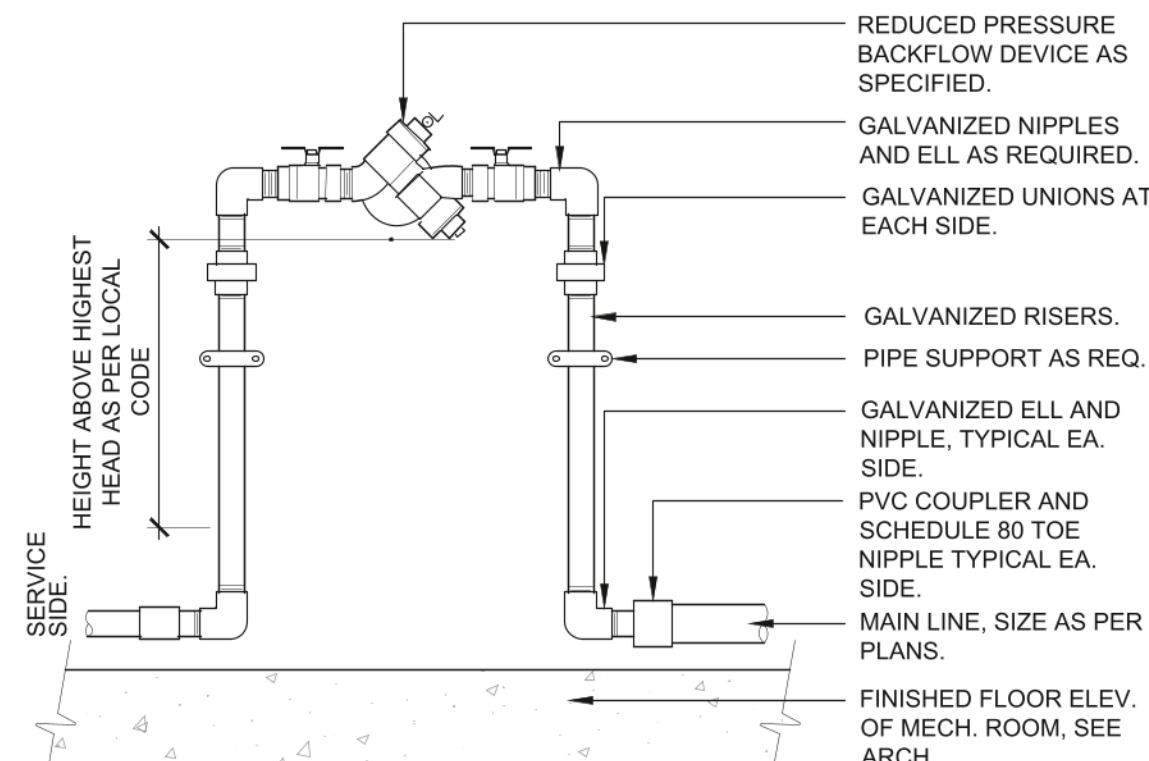

1 RP BACKFLOW DEVICE IN MECH. ROOM
 1" = 1'-0" 328409.43-12

NOTE:
 1. BRAND (DV) INTO VALVE BOX LID WITH 2" HIGH LETTERS MIN.
 2. EXTEND VERTICAL DISCHARGE NIPPLE INTO DRAIN SUMP A MINIMUM OF 3".
 3. SET TOP OF VALVE BOX LID LEVEL WITH FINISHED GRADE OF ADJACENT UNDISTURBED TURF GRASS AREAS.

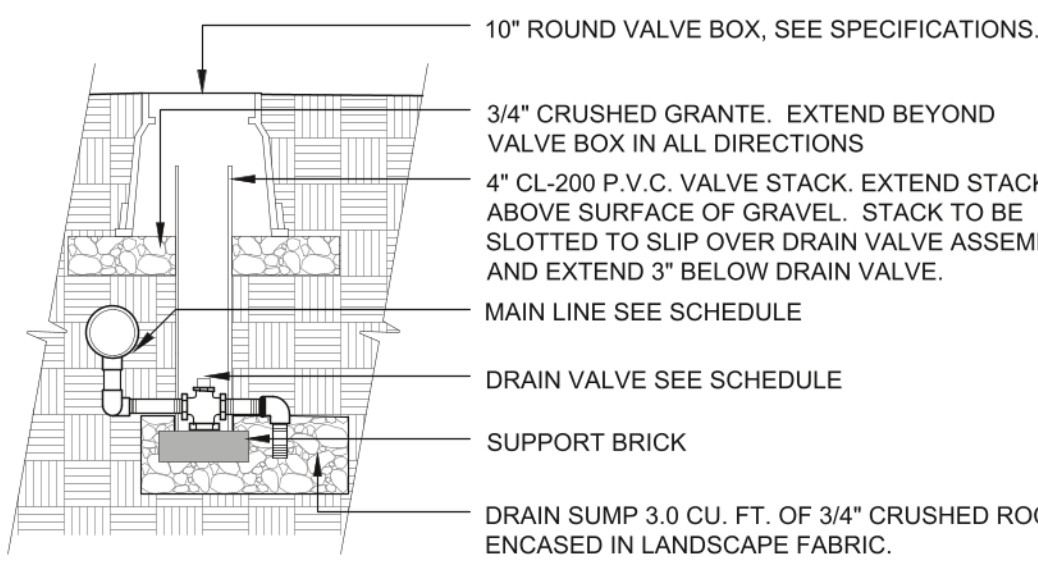

2 MANUAL DRAIN VALVE
 1/2" = 1'-0" 328409.86-13

NOTE:
 1. BRAND (MV) INTO VALVE BOX LID WITH 2" HIGH LETTERS MINIMUM.

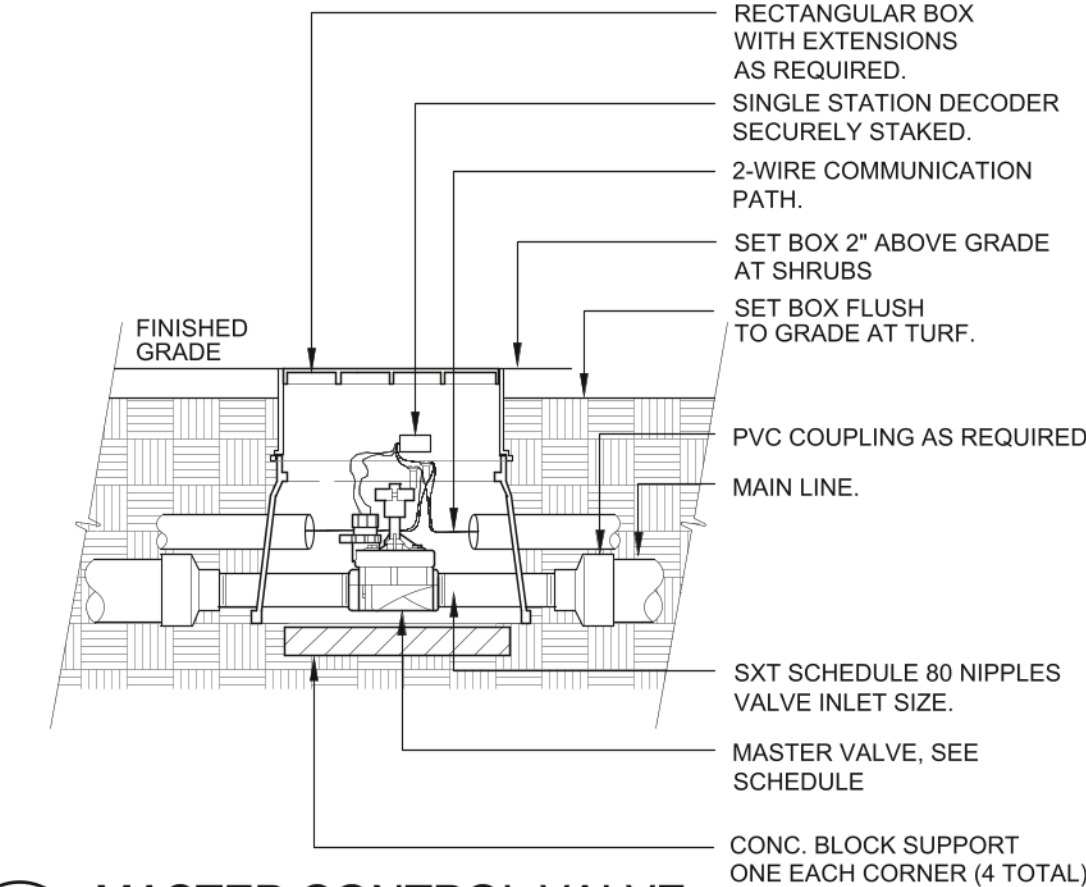

3 MASTER CONTROL VALVE
 1 1/2" = 1'-0" 328406.23-12

NOTE:
 1. HEAT BRAND (FS) ON VALVE BOX LID IN 2" HIGH LETTERS MINIMUM

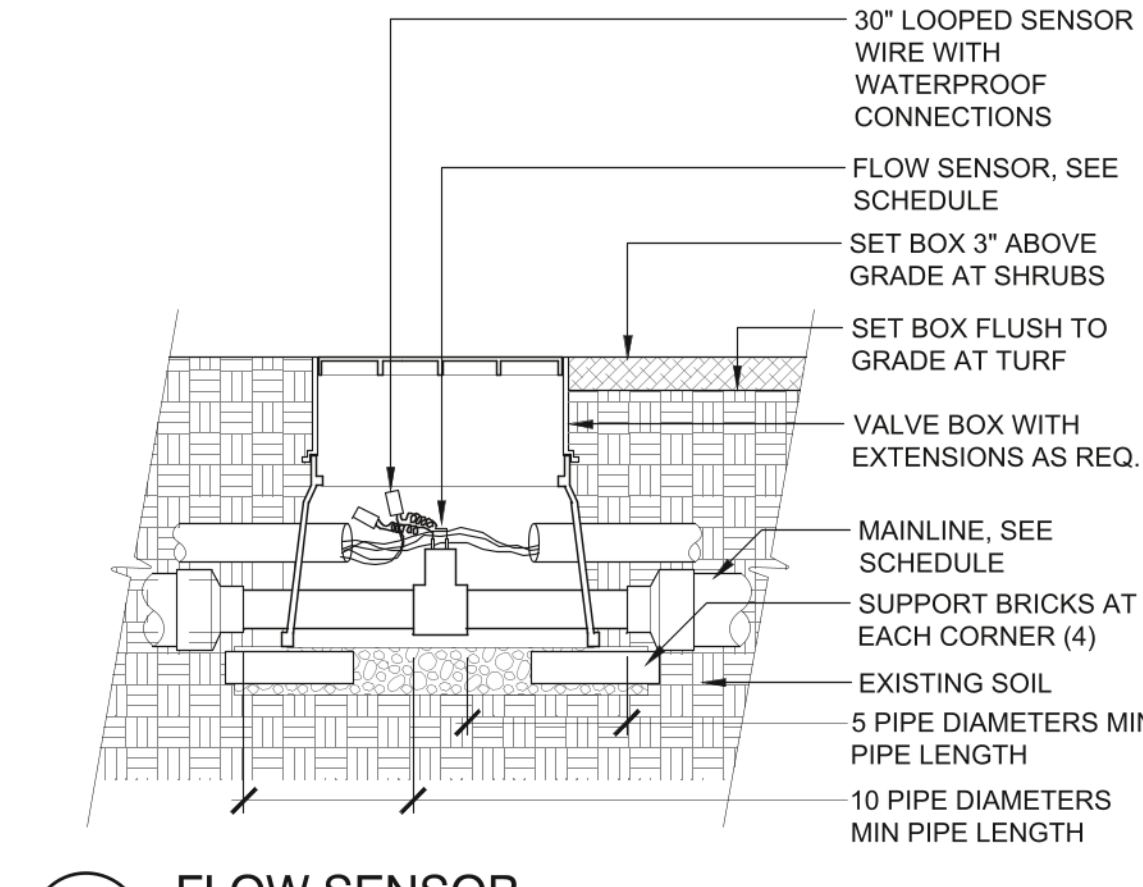

4 FLOW SENSOR
 1" = 1'-0" 328413.46-13

NOTE:
 1. 10" DIAMETER VALVE BOX. HEAT BRAND 'QC' ON LID WITH 2" HIGH CHARACTERS.

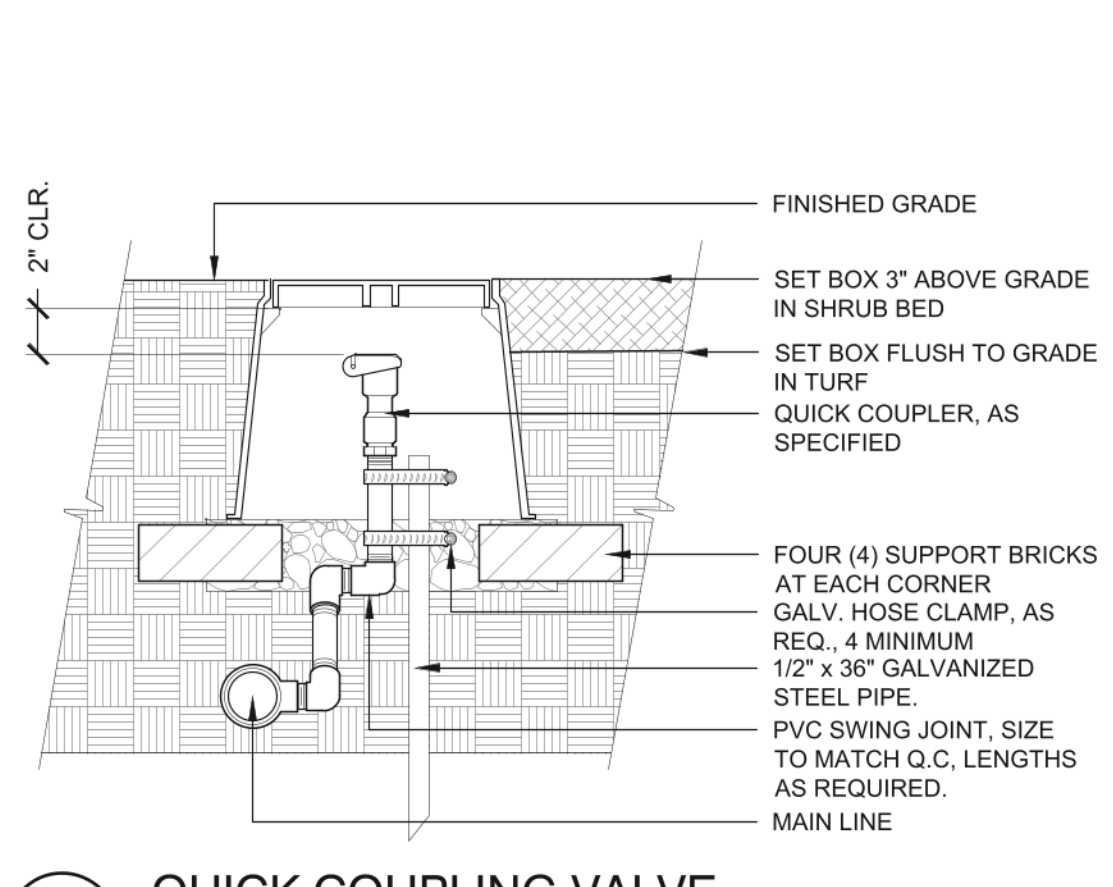

5 QUICK COUPLING VALVE
 1 1/2" = 1'-0" 328413.46-13

NOTE:
 1. HEAT BRAND VALVE AND CONTROLLER NUMBER (EX. A-#) ON LID WITH 2" HIGH LETTERS MINIMUM.

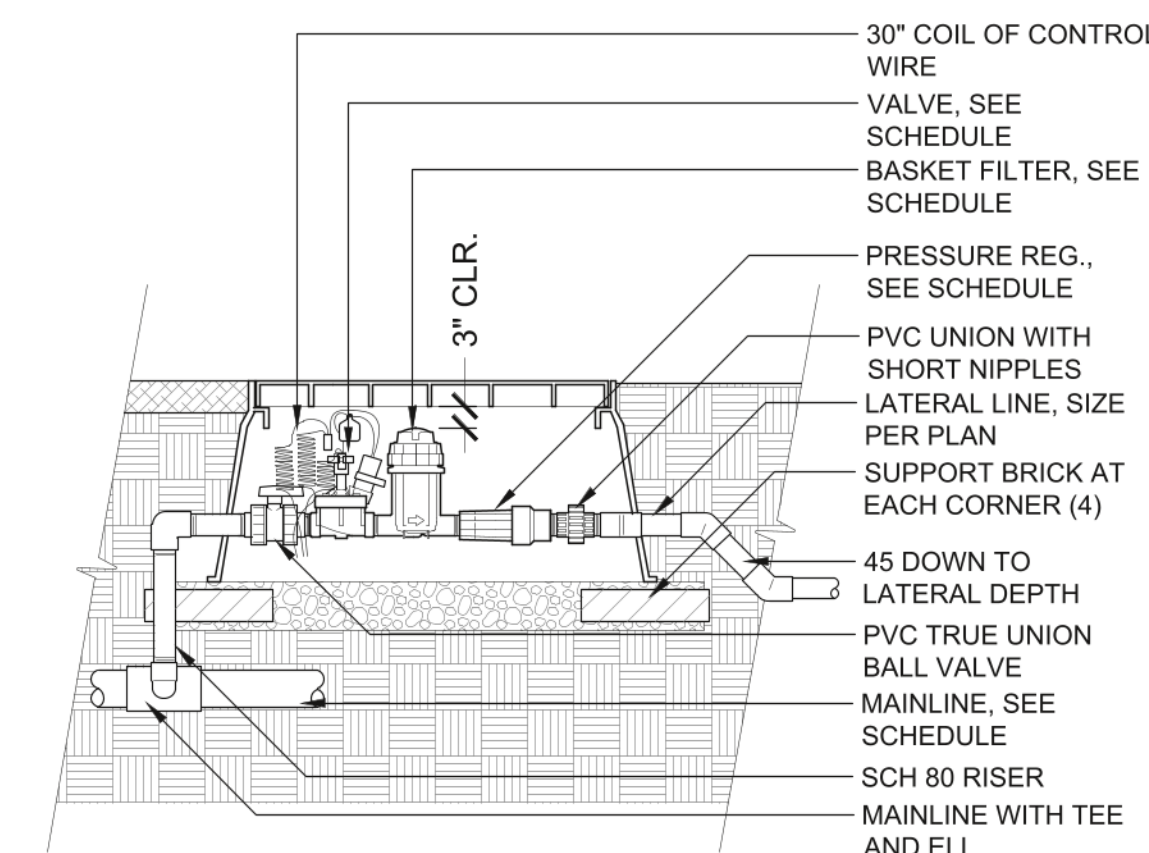

6 1" DRIP VALVE W/ BASKET FILTER
 1" = 1'-0" 328413.46-13

NOTE:
 HEAT BRAND 'ZC' ON LID WITH 2" HIGH CHARACTERS.

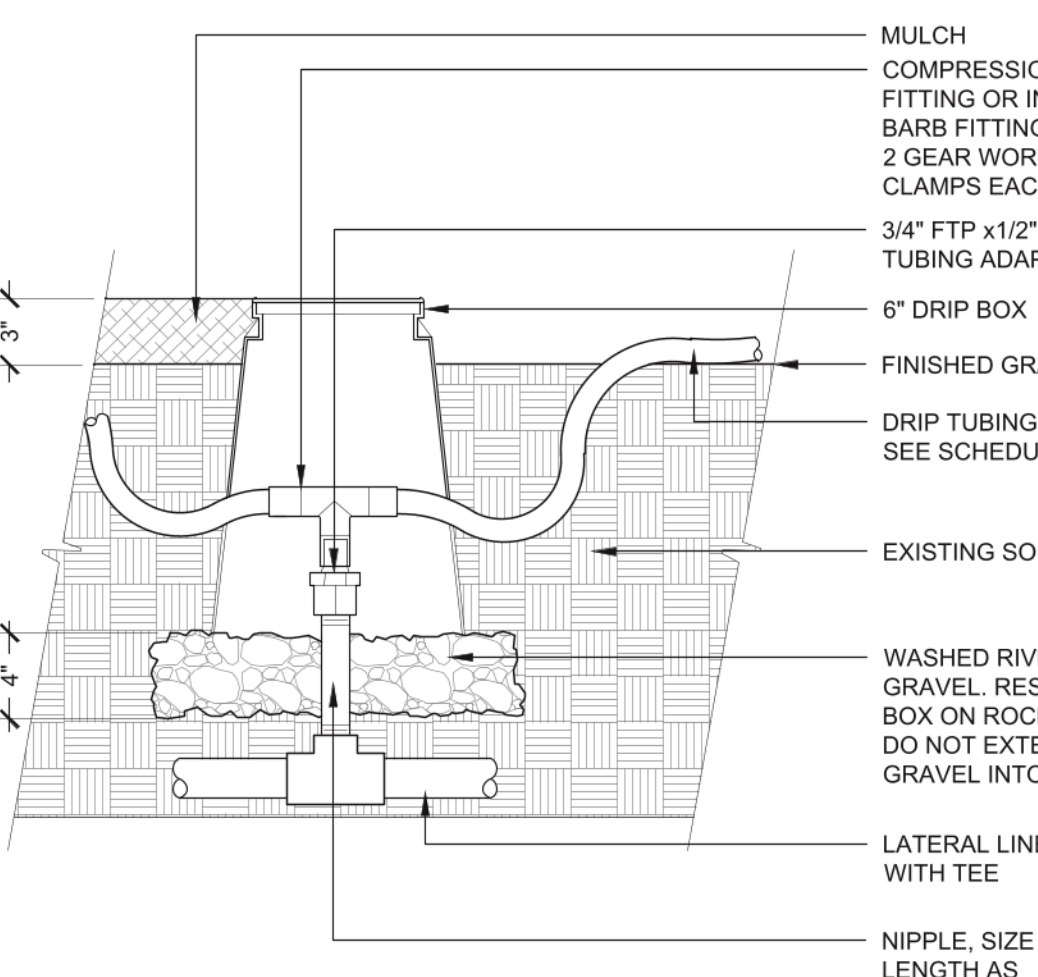

7 DRIPLINE ZONE CONTROL
 1 1/2" = 1'-0" 328413.46-13

NOTE:
 HEAT BRAND 'FV' ON LID WITH 2" HIGH CHARACTERS.

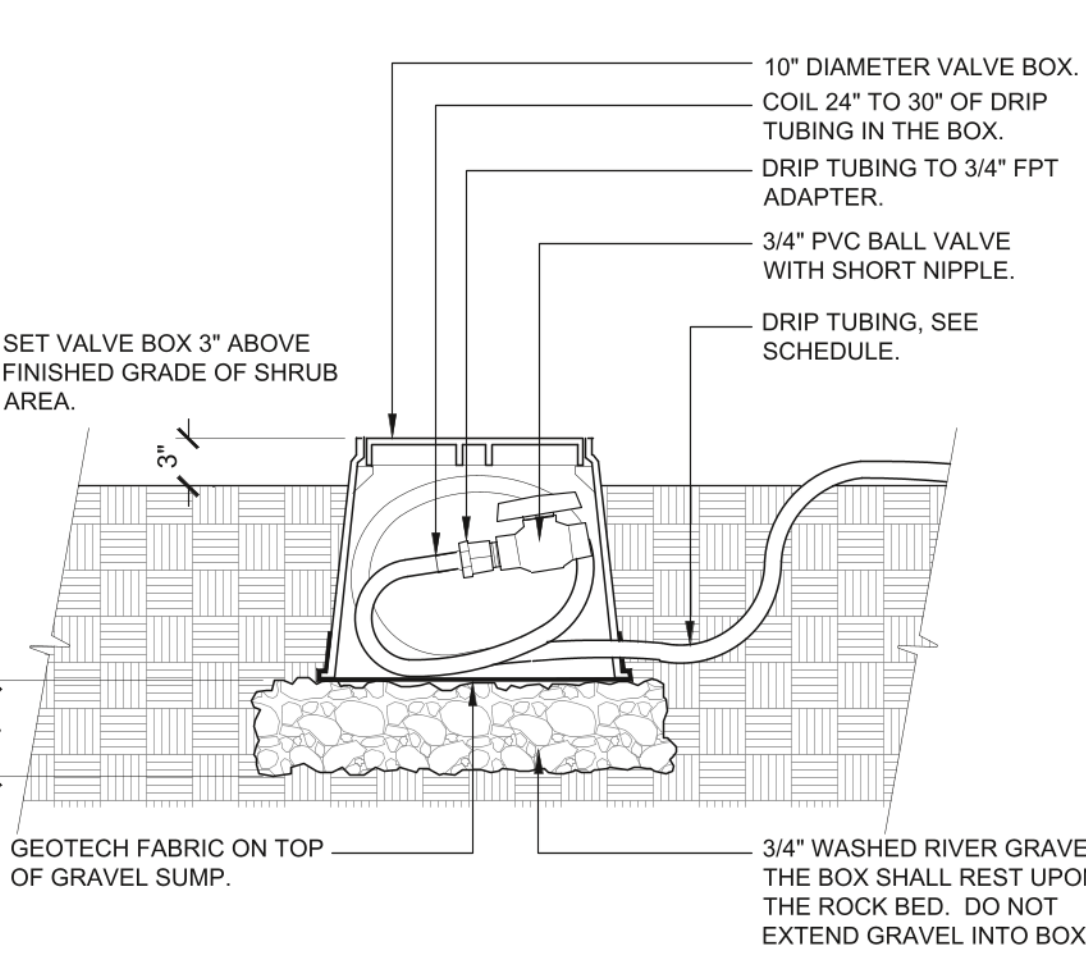

8 DRIP FLUSH VALVE
 1 1/2" = 1'-0" 328413.49-98

NOTE:
 1. PLACE EMITTERS 3/4 BETWEEN THE TRUNK AND OUTER DRIPLENE.
 2. EVENLY SPACE EMITTERS AROUND PLANT.
 3. STAKE THE DRIP TUBING AT EACH TEE, ELL, COUPLER, AT EACH EMITTER OR TRANSFER, AND AT 6'-0" MAX O.C.
 4. ALL INSERT BARB FITTINGS SHALL HAVE 2 STAINLESS STEEL WORM GEAR CLAMPS PER CONNECTION.

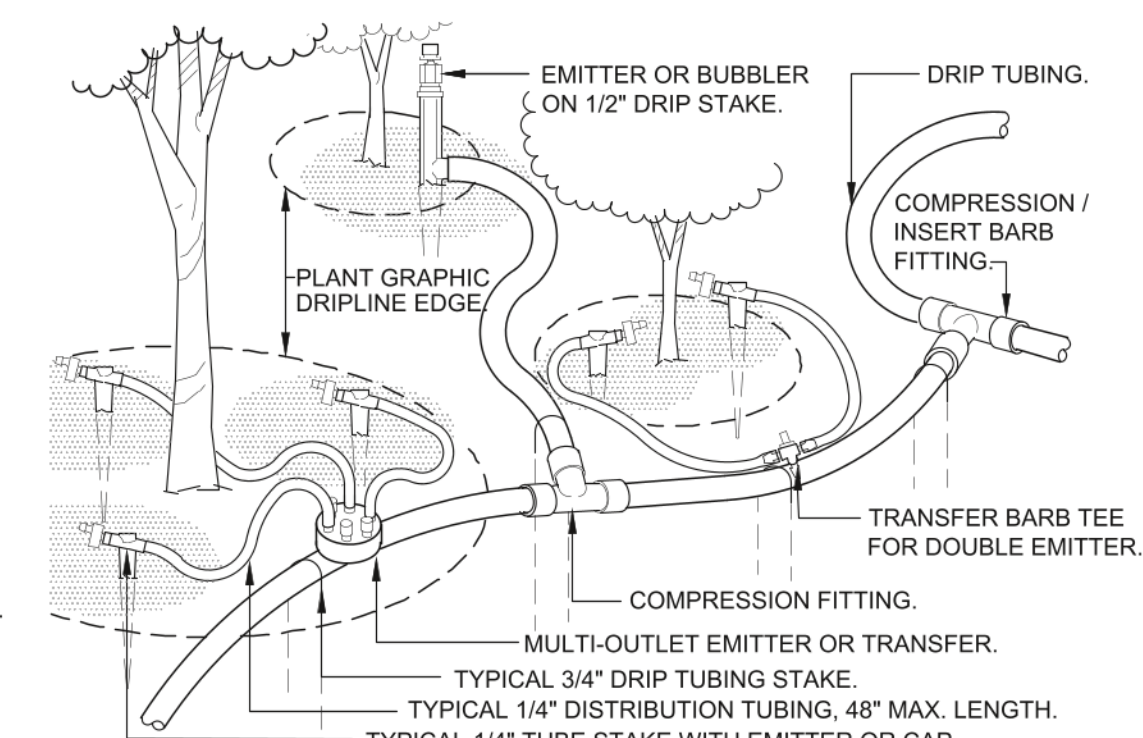

9 TYPICAL DRIP TUBING
 1 1/2" = 1'-0" 328413.43-02

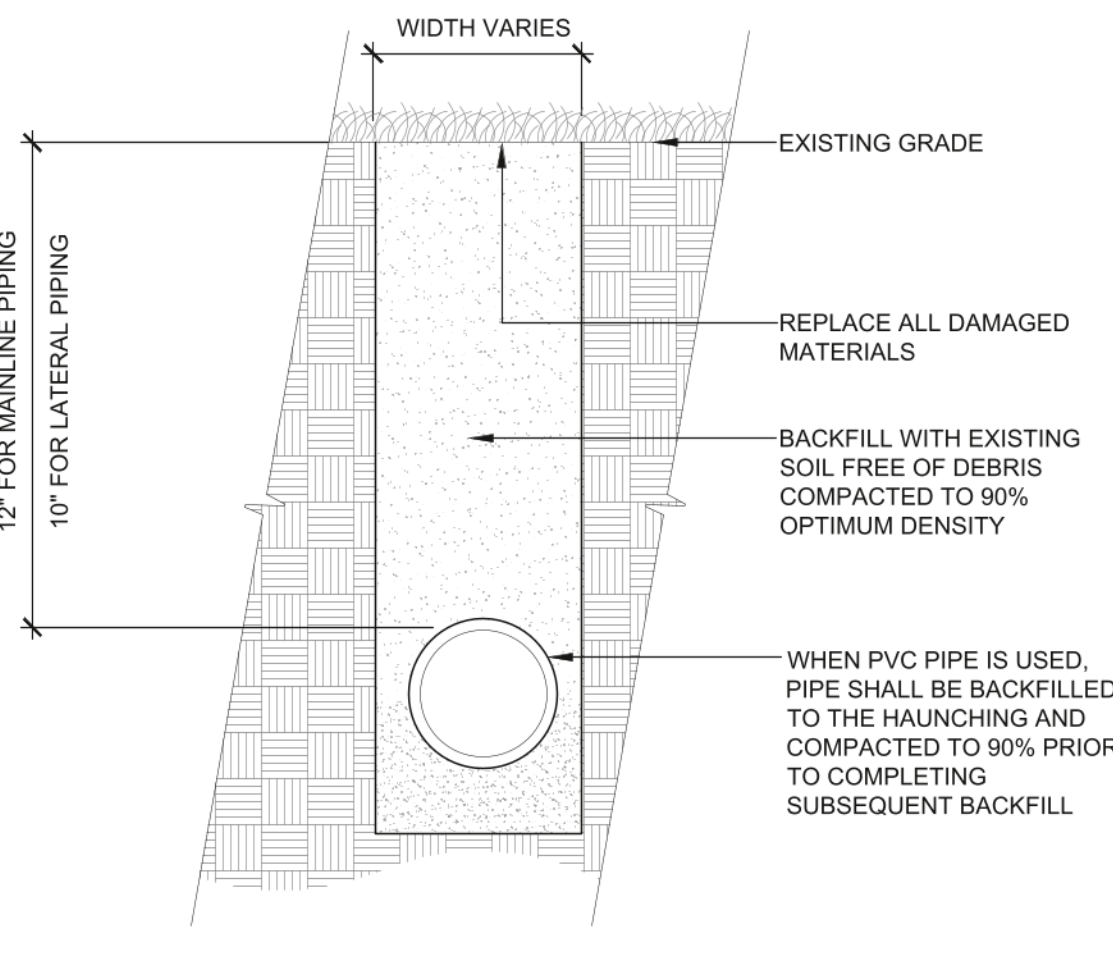

10 TRENCH DETAIL
 1 1/2" = 1'-0" 328409.76-95

NOTE:
 1. ALL JOINTS TO BE SOLVENT WELDED AND WATERTIGHT.
 2. MECHANICALLY TAMP TO 95% PROCTOR DENSITY.

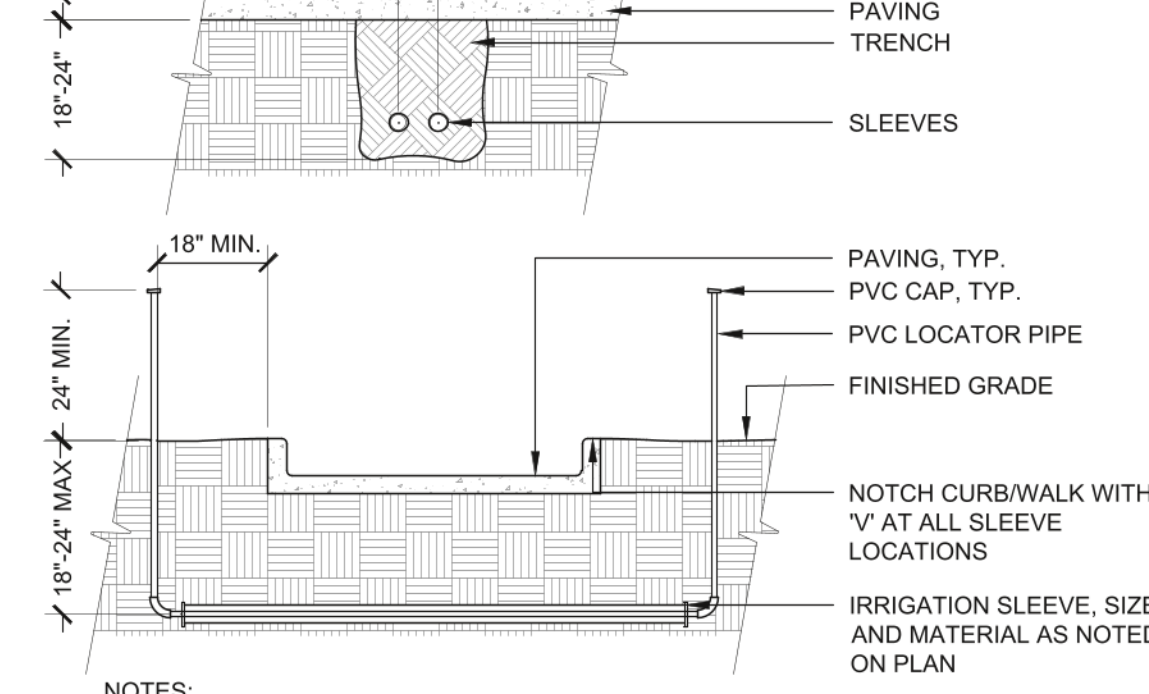

11 SLEEVING
 3/8" = 1'-0" 328409.76-07

NOTE:
 1. CONTRACTOR TO COORDINATE WITH OWNER/OWNERS REPRESENTATIVE ON FINAL LOCATION OF CONTROLLER AND ALL BUILDING FLOOR OR WALL PERFORATIONS TO ROUTE CONTROL WIRES.

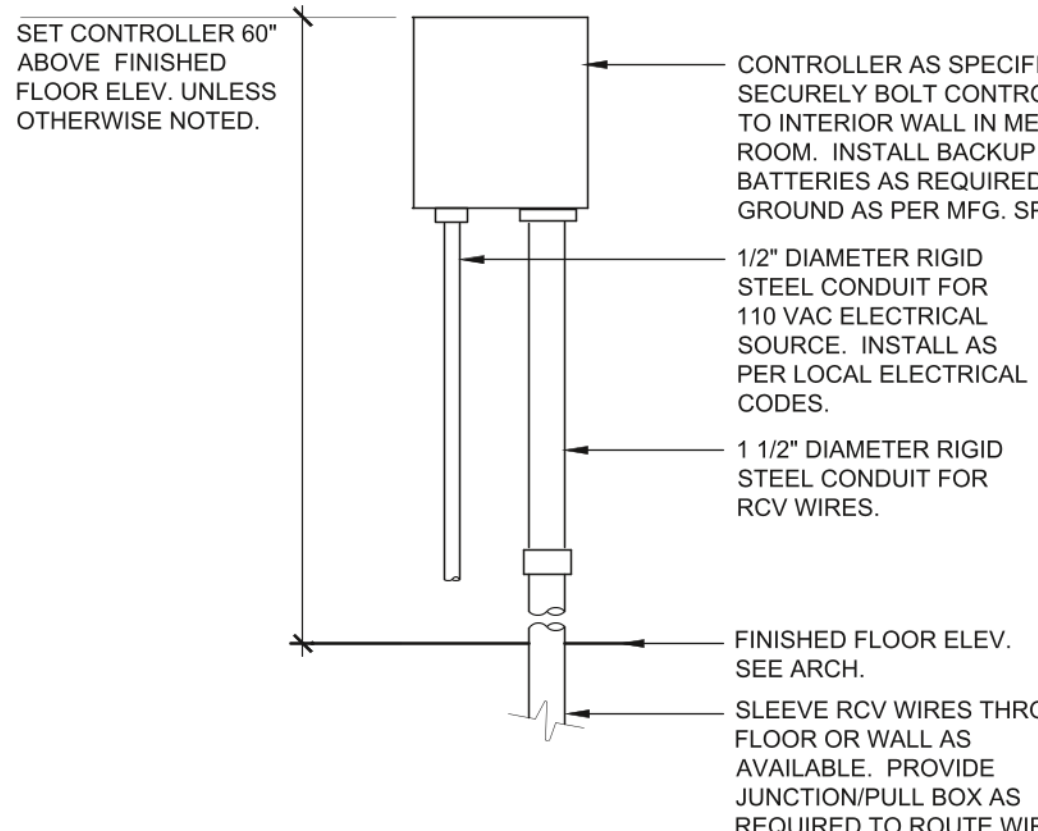

12 WALL MOUNT CONTROLLER
 1" = 1'-0" 328409.19-11

NOTE:
 1. BUILDING FACADE, UTILITY POLE OR AS SHOWN ON PLANS. OWNER/OWNER'S REPRESENTATIVE TO APPROVE LOCATION.

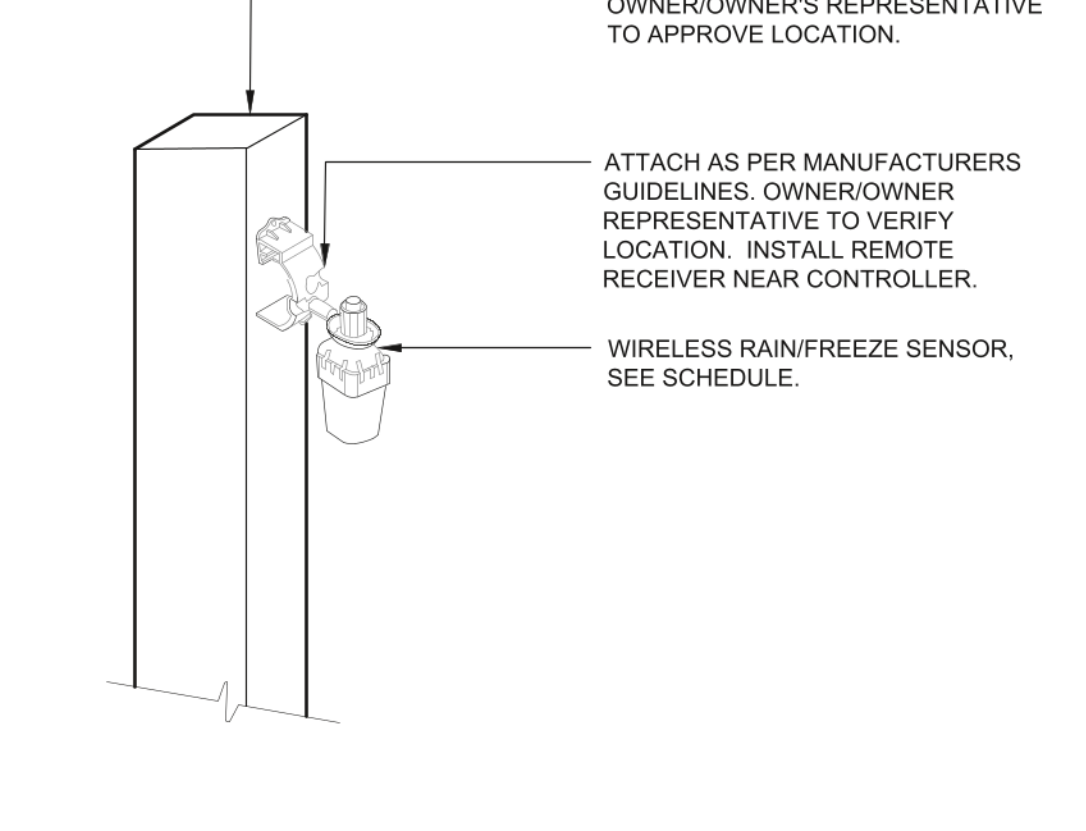

13 WIRELESS RAIN/FREEZE SENSOR
 3/4" = 1'-0" 328409.66-13

REVISION DESCRIPTION	DATE
IRRIGATION PLANS	10/20/22
REVISIONS PER COMMENTS	04/07/23

X:\DROPOBOX\VALERIAN\TEAM FOLDER\PROJECTS\2021-07-4 EES_EL_PASO MAIN STREET K&G 2232-2232-WORKING\04-07-SUBMITTALS\41102-074-15-IRRIGATION-DETAILS.DWG

Proposed Building Signage

Location	Sign	Size	Area
North Elevation	"Kum & Go" Sign	6' x 12'	72 SF
	"Go Fresh Market" Sign	5' x 9'	45 SF
East Elevation	"Kum & Go" Sign	6' x 12'	72 SF
South Elevation	No Signage	---	0 SF
West Elevation	No Signage	---	0 SF
Total			189 SF

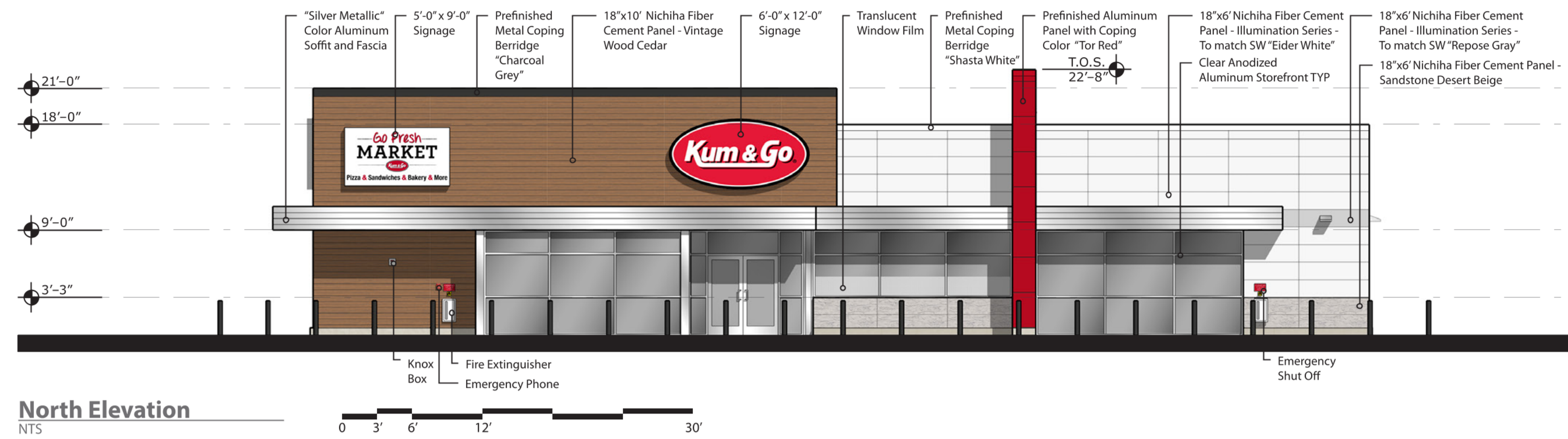

North Elevation
NTS

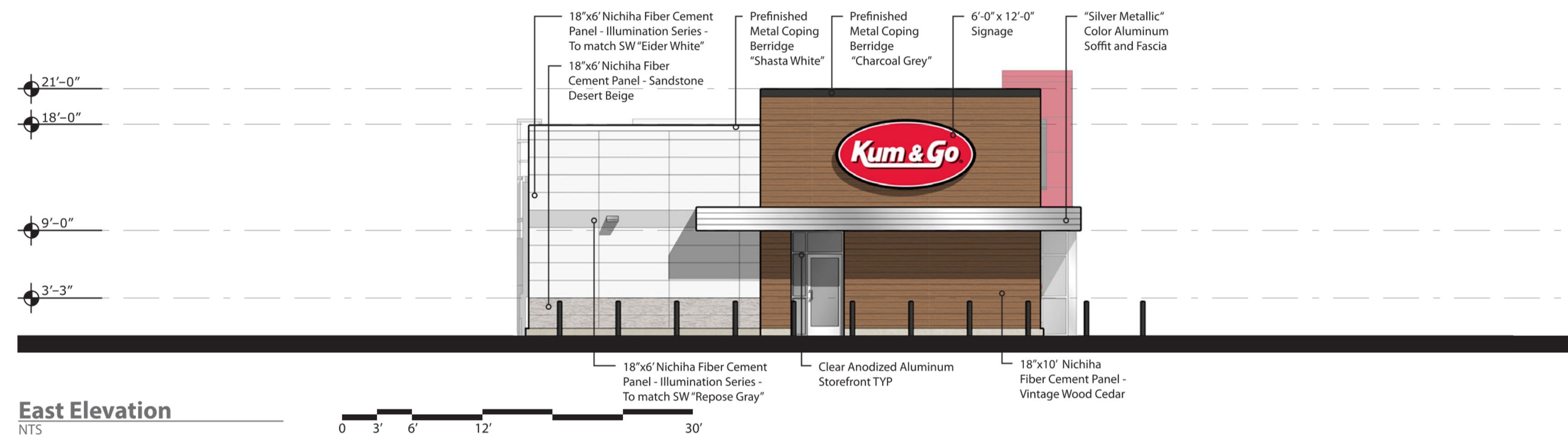

East Elevation
NTS

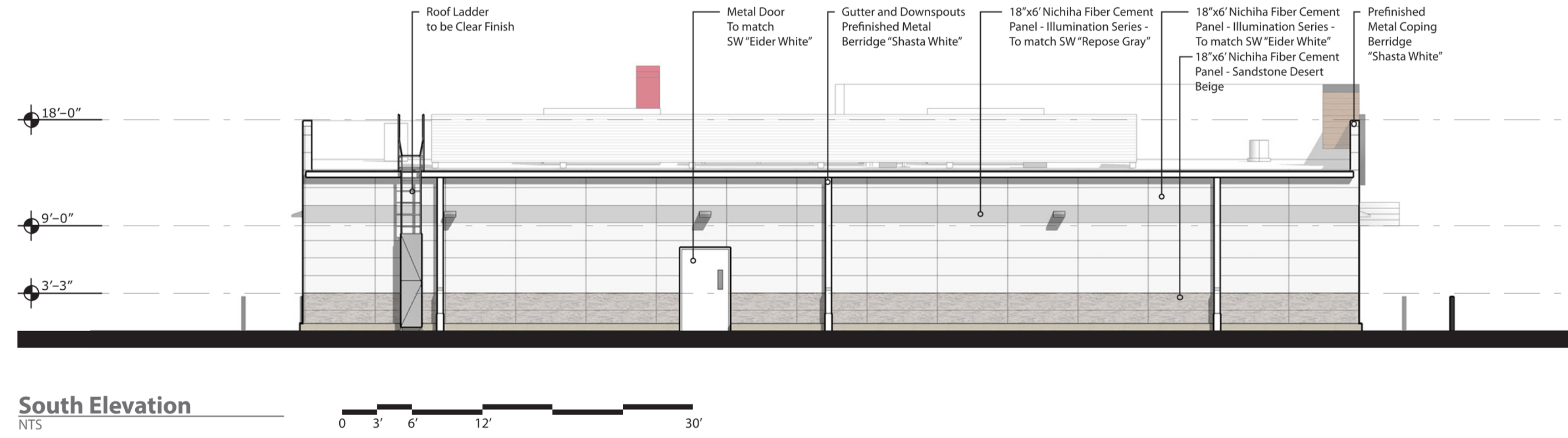

South Elevation
NTS

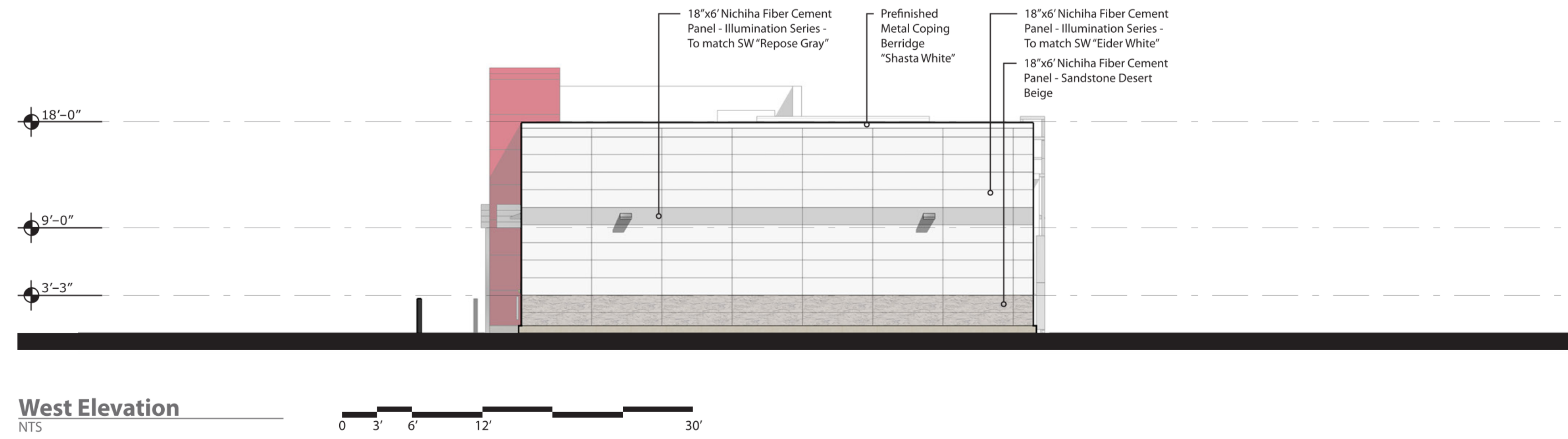

West Elevation
NTS

brr
ARCHITECT OF RECORD:
BRR ARCHITECTURE, INC
813 METCALF AVENUE
SUITE 300
OVERLAND PARK, KS 66204
www.brrarch.com
TEL: 913-262-9095
FAX: 913-262-9044

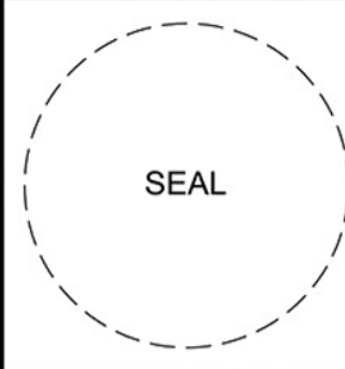

1459 Grand Avenue
Des Moines, Iowa
50309
P:515-457-6247

EL PASO COUNTY, CO
MAIN ST. AND SECURITY BLVD.
EXTERIOR ELEVATIONS

KG PROJECT TEAM:
RDM:
SDM:
CPM:

REVISION DESCRIPTION	DATE	REVISIONS

DATE: 01/06/2023

SHEET NUMBER:
C8.1
38 OF 43

Proposed Canopy Signage

Location	Sign	Size	Area
North Elevation	"Kum & Go" Sign	3' x 6'	18 SF
South Elevation	No Signage	---	0 SF
East Elevation	"Kum & Go" Sign	3' x 6'	18 SF
West Elevation	"Kum & Go" Sign	3' x 6'	18 SF
Total			54 SF

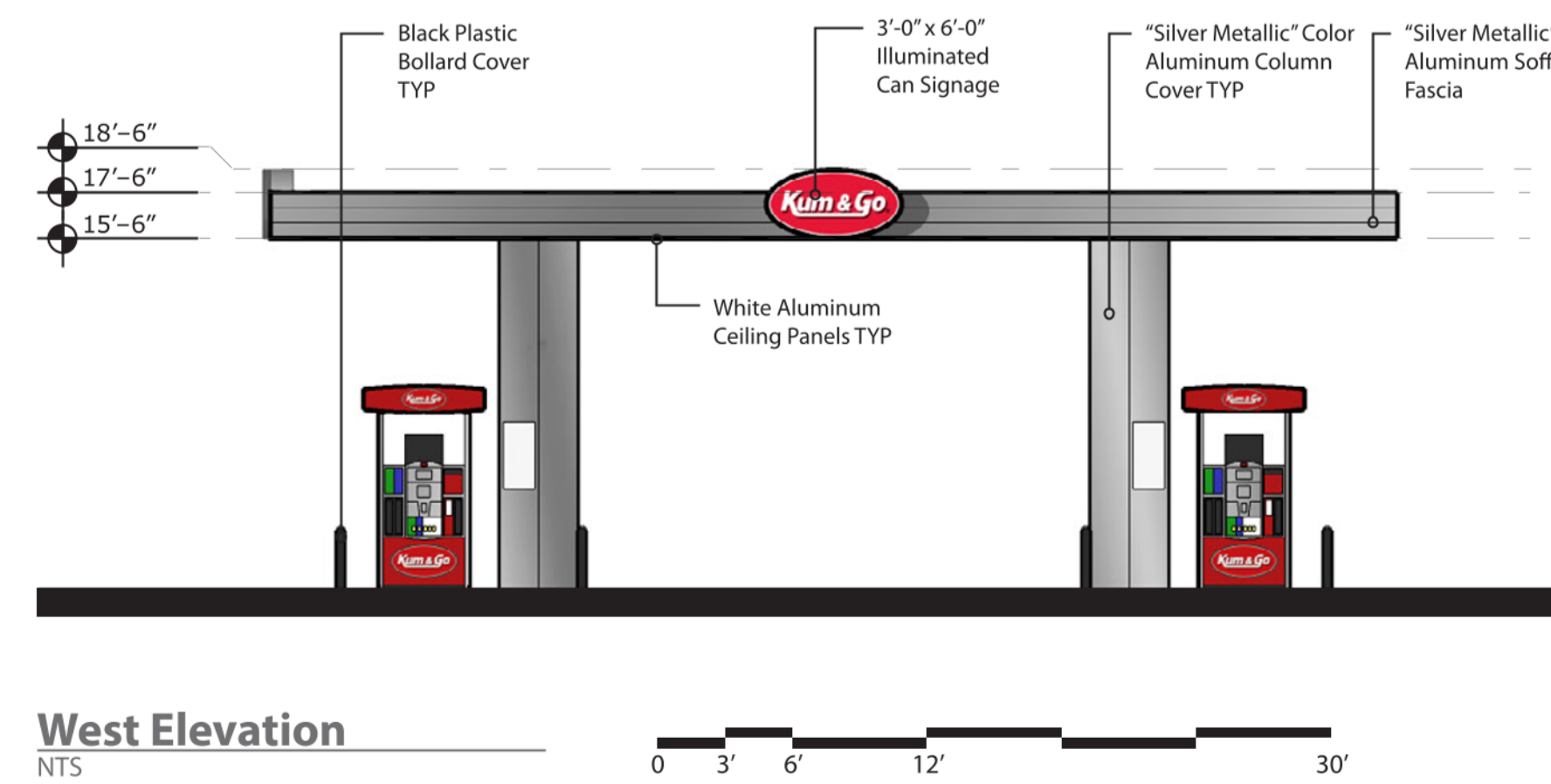
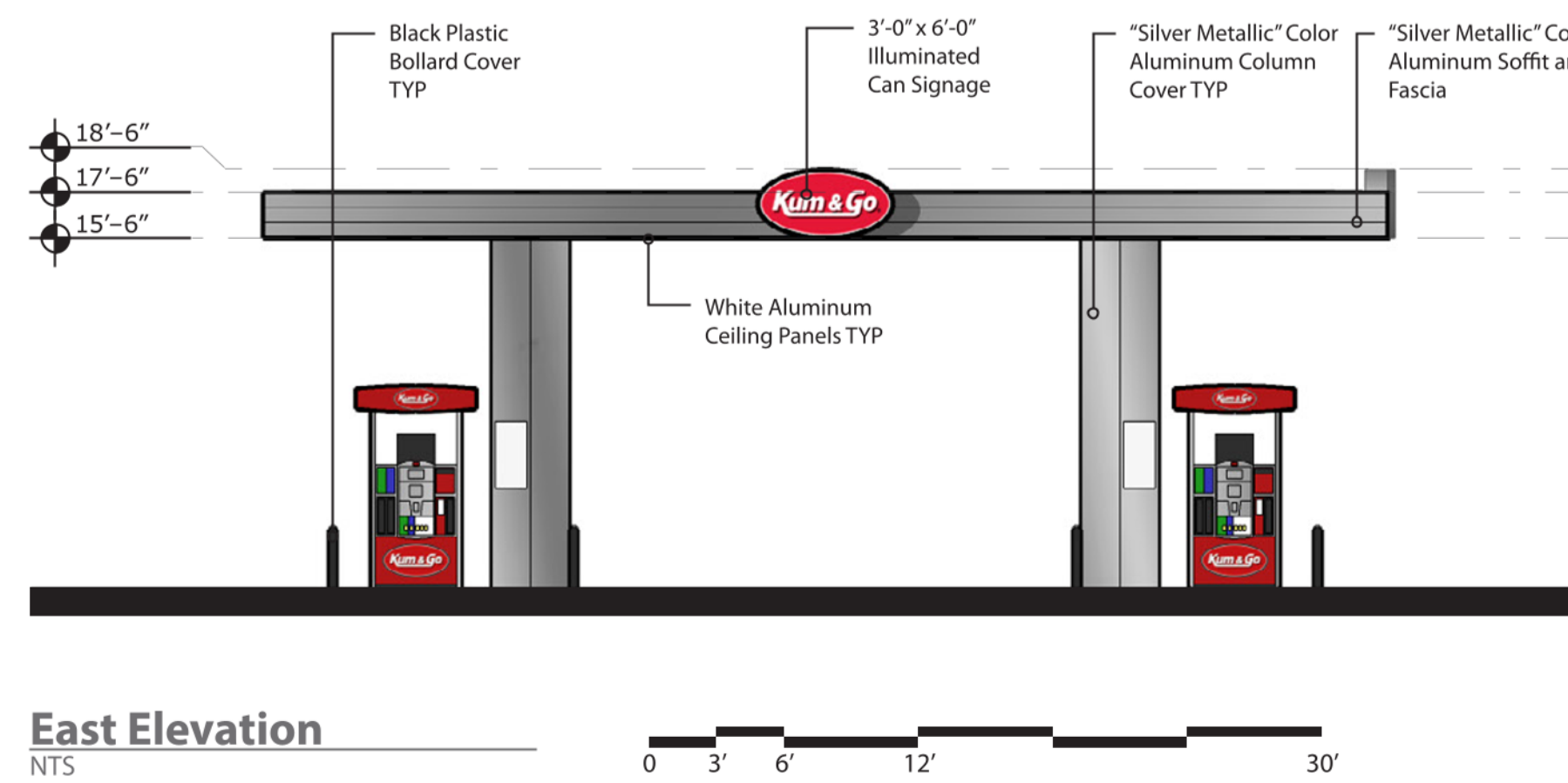
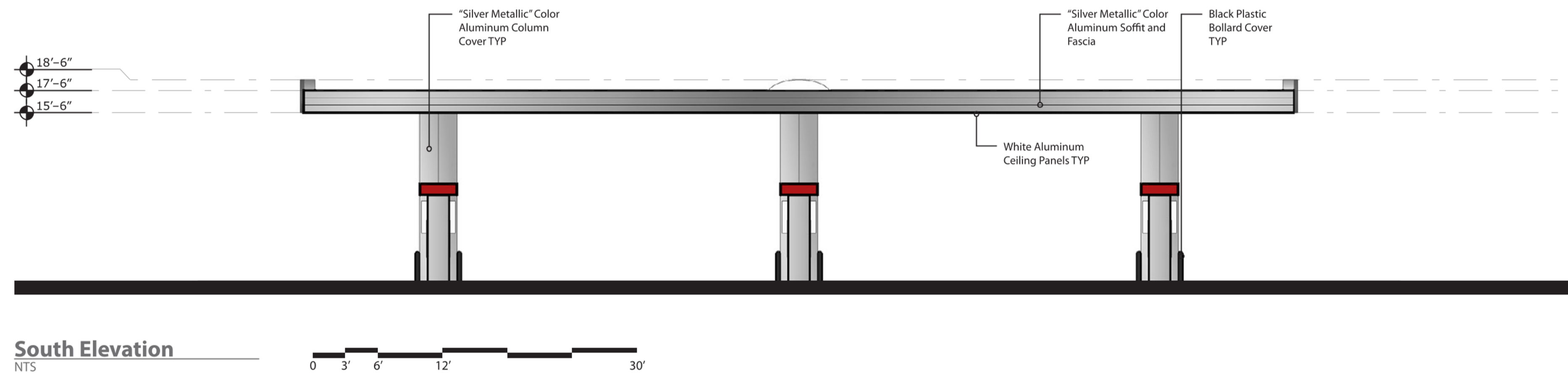
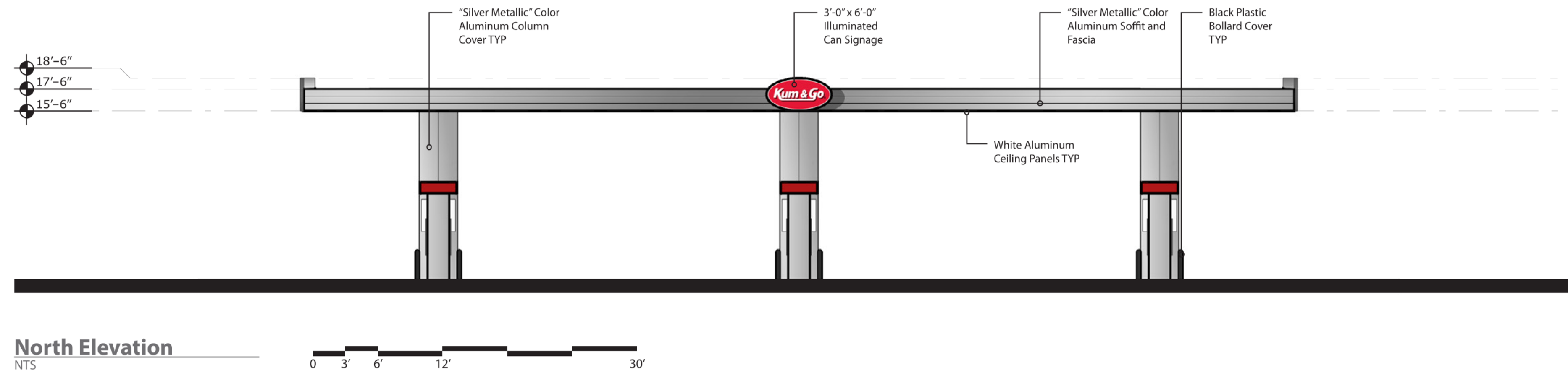

brr

ARCHITECT OF RECORD:
BRR ARCHITECTURE, INC
813 METCALF AVENUE
SUITE 300
OVERLAND PARK, KS 66204
www.brrarch.com
TEL: 913-262-9095
FAX: 913-262-9044



1459 Grand Avenue
Des Moines, Iowa
50309
P:515-457-6247

EL PASO COUNTY, CO
MAIN ST. AND SECURITY BLVD.
CANOPY ELEVATIONS

KG PROJECT TEAM:
RDM:
SDM:
CPM:

REVISION DESCRIPTION	DATE	BY

DATE: 01/06/2023

SHEET NUMBER:

C8.2
39 OF 43

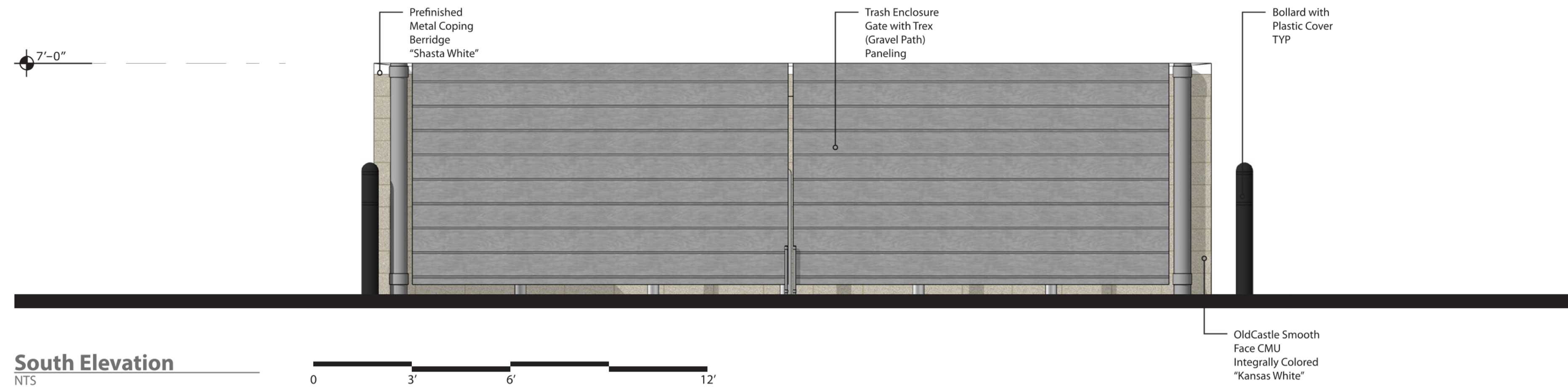

South Elevation
NTS

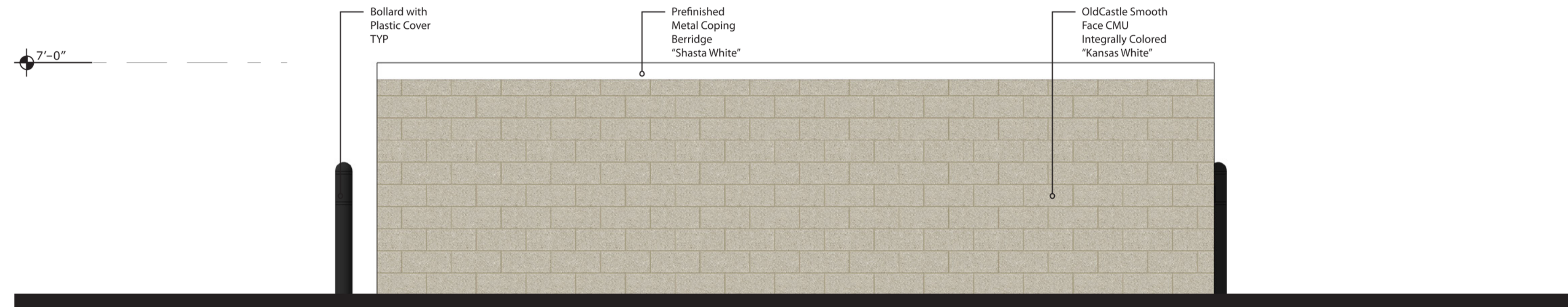

North Elevation
NTS

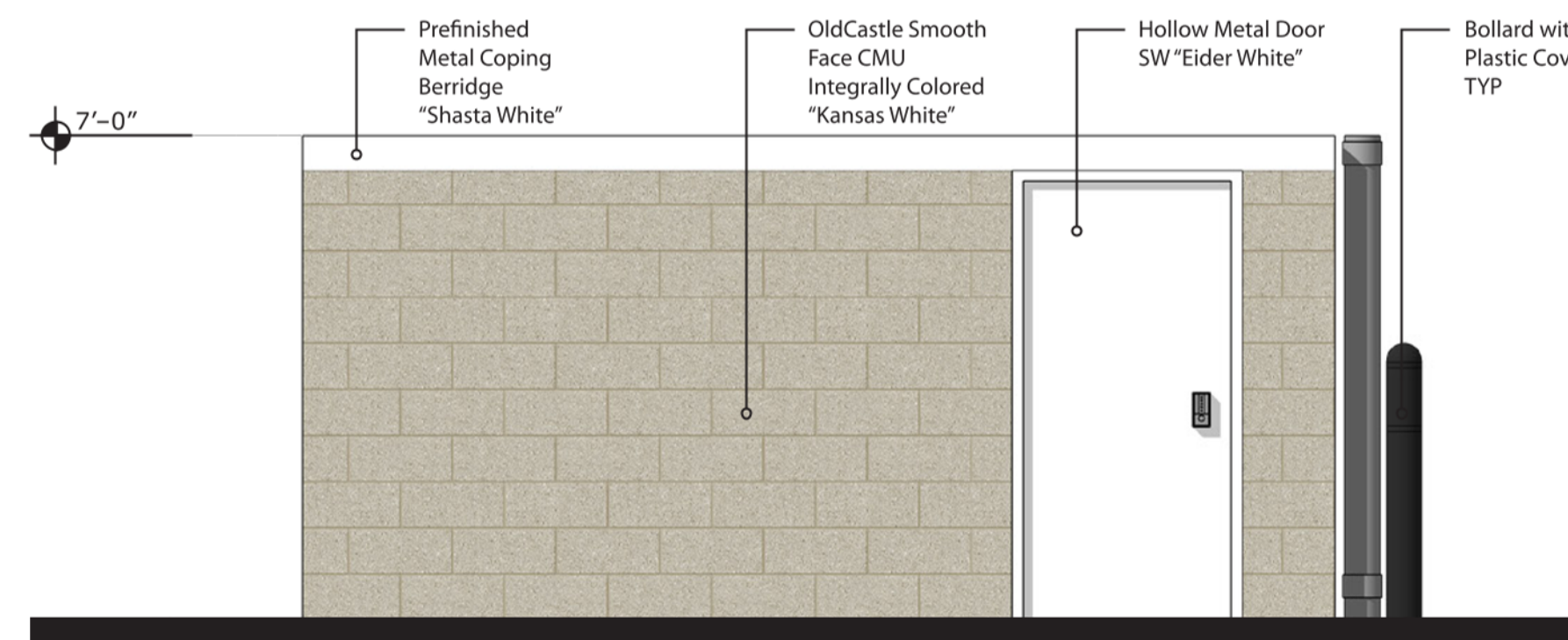

West Elevation
NTS

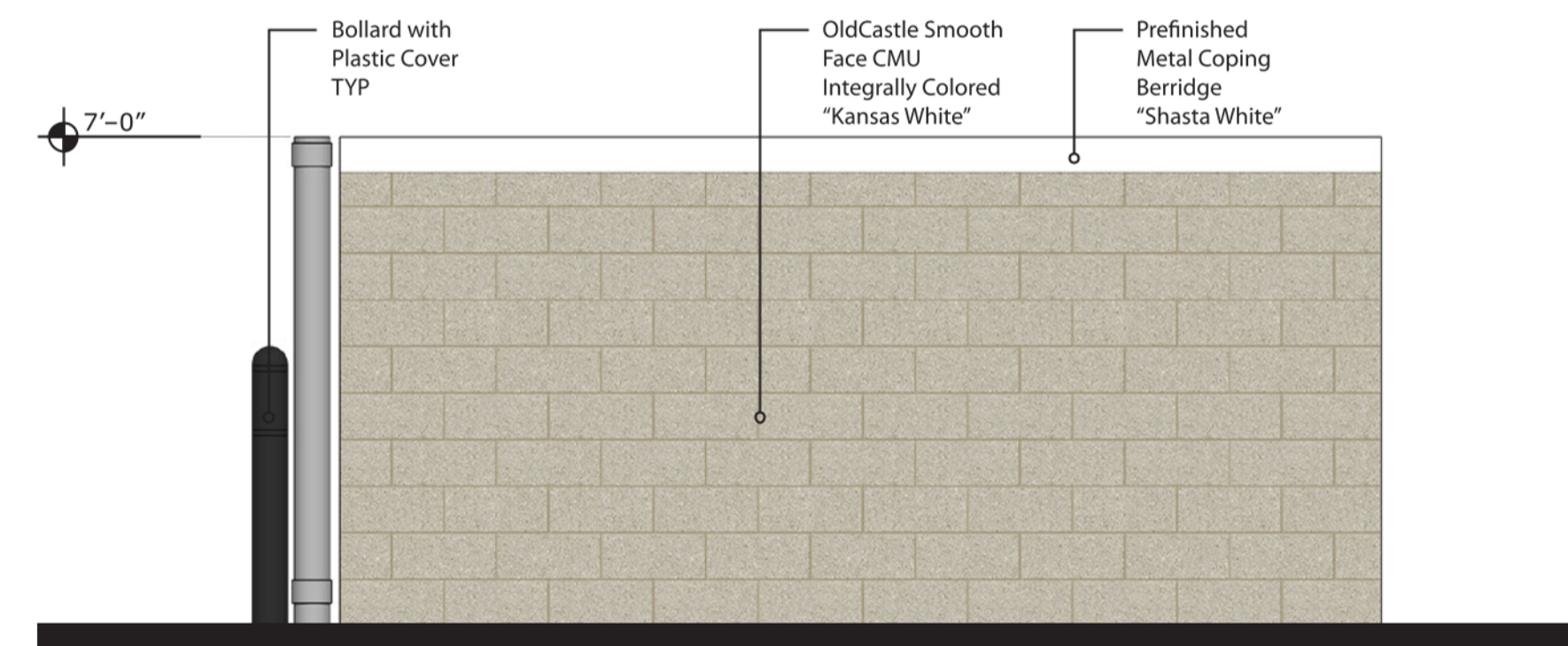

East Elevation
NTS

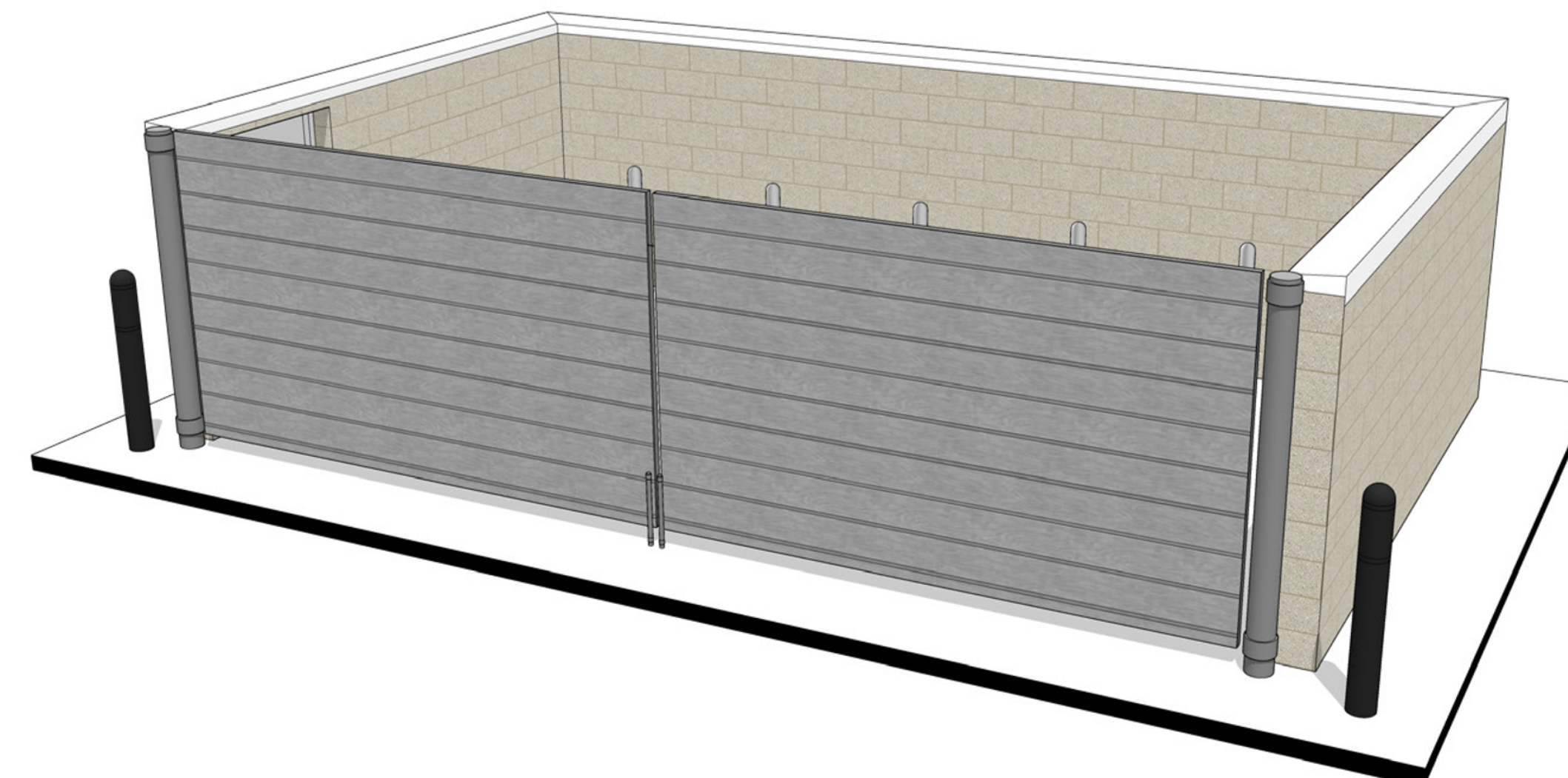

Perspective
NTS

brr

ARCHITECT OF RECORD:
BRR ARCHITECTURE, INC
813 METCALF AVENUE
SUITE 300
OVERLAND PARK, KS 66204
www.brrarch.com
TEL: 913-262-9095
FAX: 913-262-9044

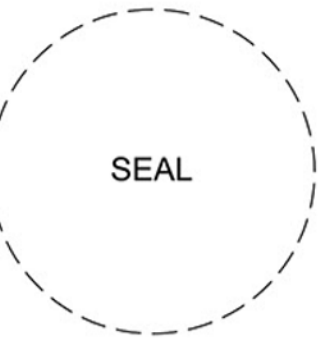

1459 Grand Avenue
Des Moines, Iowa
50309
P:515-457-6247

EL PASO COUNTY, CO
MAIN ST. AND SECURITY BLVD.
TRASH ENCLOSURE ELEVATIONS

KG PROJECT TEAM:
RDM:
SDM:
CPM:

REVISION DESCRIPTION	DATE

DATE: 09/08/2022

SHEET NUMBER:
C8.3
40 OF 43

REVISIONS

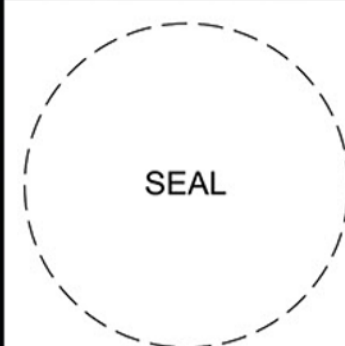

1459 Grand Avenue
 Des Moines, Iowa
 50309
 P:515-457-6247

EL PASO COUNTY, CO
 MAIN ST. AND SECURITY BLVD.
 FIXTURE PLAN

KG PROJECT TEAM:
 RDM:
 SDM:
 CPM:

REVISION DESCRIPTION	DATE

DATE: 01/06/2023

SHEET NUMBER:
 C8.4
 41 OF 43

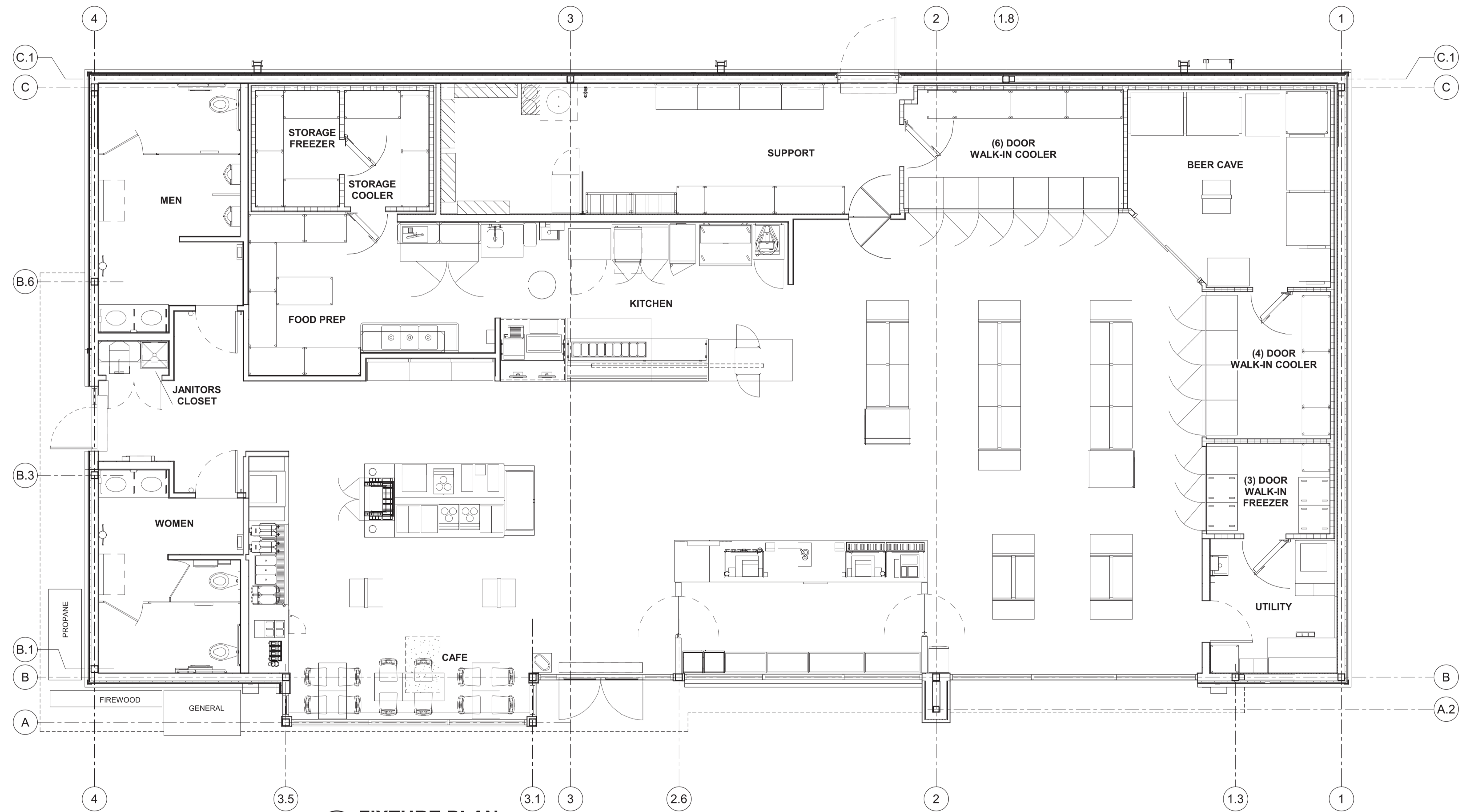

1 FIXTURE PLAN
 1/4" = 1'-0"

REVISIONS



ARCHITECT OF RECORD:
 BRR ARCHITECTURE, INC
 813 METCALF AVENUE
 SUITE 300
 OVERLAND PARK, KS 66204
 www.brrarch.com
 TEL: 913-262-9095
 FAX: 913-262-9044

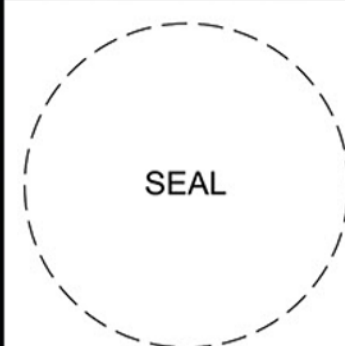

1459 Grand Avenue
 Des Moines, Iowa
 50309
 P:515-457-6247

EL PASO COUNTY, CO
 MAIN ST. AND SECURITY BLVD.
 ROOF PLAN

KG PROJECT TEAM:
 RDM:
 SDM:
 CPM:

REVISION DESCRIPTION	DATE

DATE: 01/06/2023

SHEET NUMBER:
 C8.5
 42 OF 43

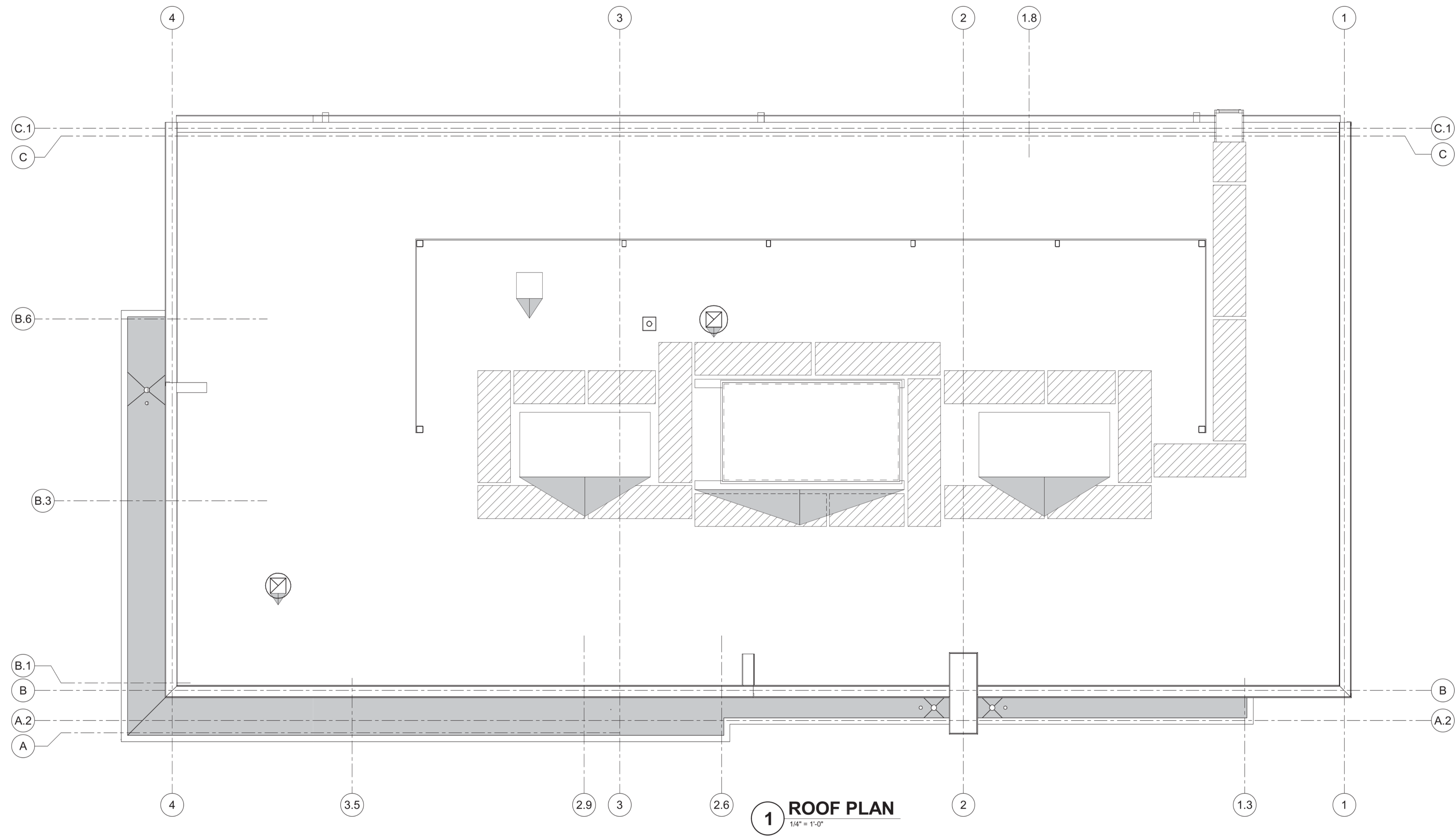

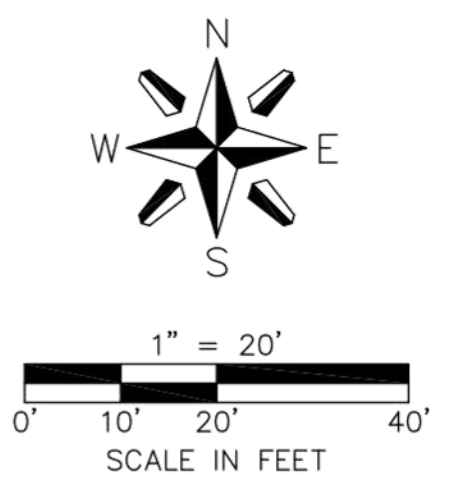
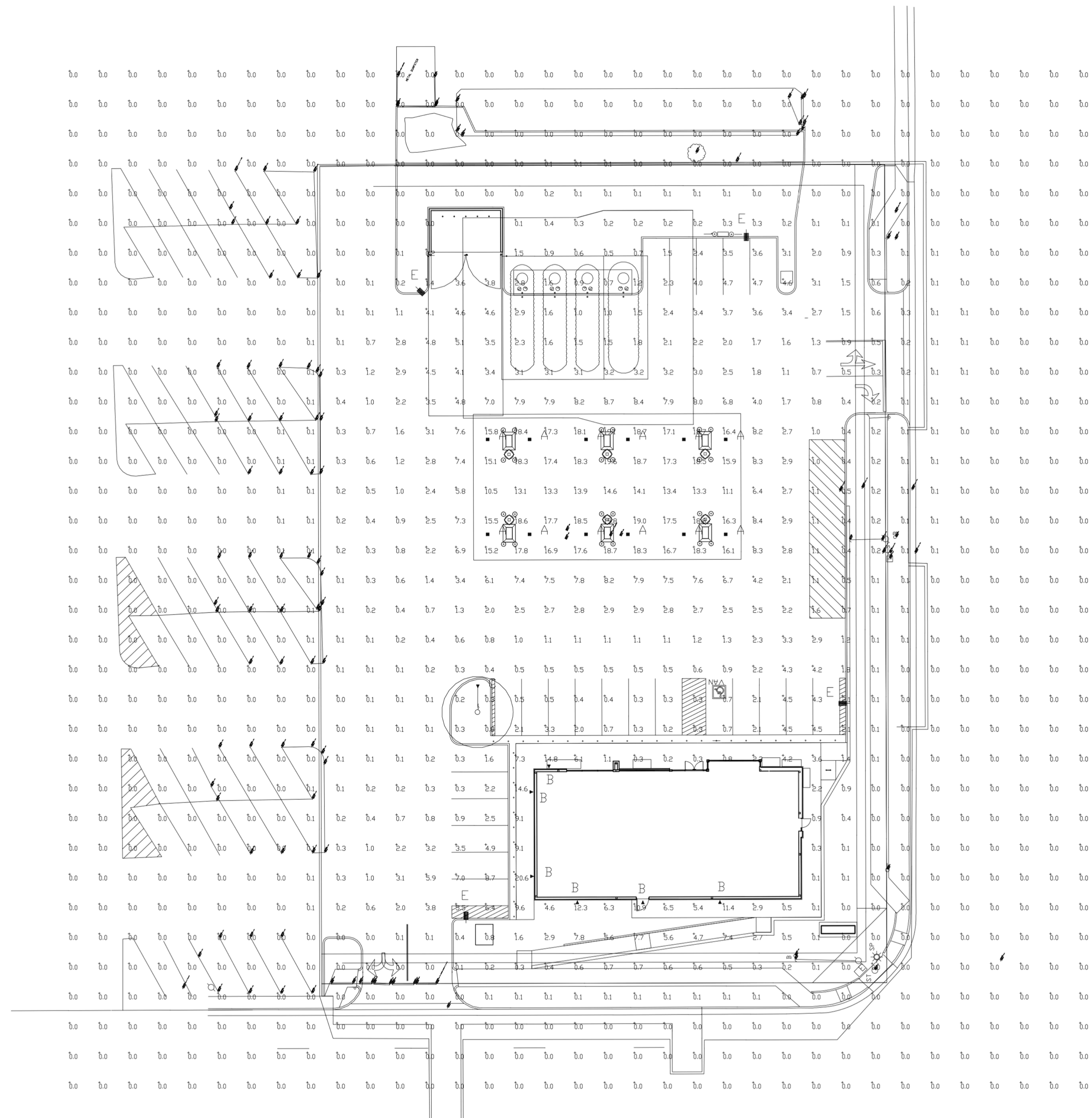

CRUS



TLFL



SLM



6400 Westown Parkway
West Des Moines, Iowa
50266
P: 515-226-0128
F: 515-223-9873

#2232 - EL PASO COUNTY
MAIN & SECURITY

LO-155702-1 - PHOTOMETRIC PLAN

KG PROJECT TEAM:
RDR:
SDM:
CPM:

REVISION DESCRIPTION	DATE

DATE: 01/06/2023

SHEET NUMBER
C9.1
43 OF 43

**PHOTOMETRIC EVALUATION
NOT FOR CONSTRUCTION**

Based on the information provided, all dimensions and luminaire locations shown represent recommended positions. The engineer and/or architect must determine the applicability of the layout to existing or future field conditions.

This lighting plan represents illumination levels calculated from laboratory data taken under controlled conditions in accordance with The Illuminating Engineering Society (IES) approved methods. Actual performance of any manufacturer's luminaires may vary due to changes in electrical voltage, tolerance in lamps/LED's and other variable field conditions. Calculations do not include obstructions such as buildings, curbs, landscaping, or any other architectural elements unless noted. Fixture nomenclature noted does not include mounting hardware or poles. This drawing is for photometric evaluation purposes only and should not be used as a construction document or as a final document for ordering product.

Luminaire Schedule									
Symbol	Qty	Label	Arrangement	Description	LLD	LDD	LLF	Arr. Lum. Lumens	Arr. Watts
■	12	A	SINGLE	CRUS-SC-VLW-50MTD @ 15.5' DIMMED 10%	1.000	1.000	0.900	9364	60
▲	6	B	SINGLE	WST LED P2 40K VW MVOLT - 11' MH - FIXTURE BY LITHONIA LIGHTING	1.000	1.000	1.000	3512	25
▶	1	C	SINGLE	TLFL-LED-20L- 4' MH	1.000	1.000	1.000	18768	187.91
■	4	E	SINGLE	SLM-LED-12L-SIL-FT-50-70CRI-IL-SINGLE-16'POLE+2.5'BASE	1.000	1.000	1.000	8193	85

Calculation Summary							
Label	CalcType	Units	Avg	Max	Min	Avg/Min	Max/Min
ALL CALCS @ GRADE	Illuminance	Fc	1.40	20.6	0.0	N.A.	N.A.
CANDPY	Illuminance	Fc	16.74	19.8	10.5	1.59	1.89
INSIDE CURB	Illuminance	Fc	2.15	8.7	0.0	N.A.	N.A.