

Stormwater Management Facility Operation and Maintenance (O&M) Manual Underground Detention & Water Quality

for:

**Lot 2, Pedrick-Eckerd Filing No. 3
Subdivision
304 Main Street
Kum & Go #2232**

Prepared for:

**Kum & Go LC
1459 Grand Ave
Des Moines, IA 50309**

Prepared by:

**Entitlement & Engineering Solutions, Inc
3801 E. Florida Ave., Ste 425
Denver, CO 80210**



EDARP File Number: PPR2225

**Stormwater Management Facility Operation
and Maintenance (O&M) Manual Underground
Detention & Water Quality**

Table of Contents

- I. Compliance with Stormwater Facility Maintenance Requirements**
- II. Inspection & Maintenance- Annual Reporting**
- III. Preventative Measures to Reduce Maintenance Costs**
- IV. Access and Easements**
- V. Safety**
- VI. Field Inspection Equipment**
- VII. Inspecting Stormwater Management Facilities**
 - A. Inspection Procedures
 - B. Inspection Report
 - C. Verification of Inspection and Form Submittal
- VIII. Maintaining Stormwater Management Facilities**
 - A. Maintenance Categories
 - B. Maintenance Personnel
 - C. Maintenance Forms

Appendices

- Appendix A** - Maintenance Agreement(s)
- Appendix B** - Description of Stormwater Management Facilities
- Appendix C** - Standard Operation Procedures (SOP) for each facility type
- Appendix D** - Inspection Form(s)
- Appendix E** - Maintenance Form(s)
- Appendix F** - Annual Inspection and Maintenance Submittal form
- Appendix G** - Stormwater Facilities Map; Facility plan and detail sheets

Stormwater Management Facility Operation and Maintenance (O&M) Manual

I. Compliance with Stormwater Facility Maintenance Requirements

All property owners are responsible for ensuring that stormwater facilities installed on their property are properly maintained and that they function as designed. In some cases, this maintenance responsibility may be assigned to others through special agreements. The maintenance responsibility for a stormwater facility may be designated on the subdivision plat, the site development plan, and/or within a maintenance agreement for the property. Property owners should be aware of their responsibilities regarding stormwater facility maintenance. Maintenance agreement(s) associated with this property are provided in Appendix A.

II. Inspection & Maintenance – Annual Reporting

Requirements for the inspection and maintenance of stormwater facilities, as well as reporting requirements are included in this Stormwater Management Facility Operation and Maintenance (O&M) Manual.

Verification that the Stormwater facilities have been properly inspected and maintained; submittal of the required Inspection and Maintenance Forms and Inspector qualifications shall be provided to EPC on an annual basis. The annual reporting form shall be provided to EPC prior to May 31st of each year.

Copies of the Inspection and Maintenance forms for each of the stormwater facilities are located in Appendix D and E. A standard annual reporting form is provided in Appendix F. Each form shall be reviewed and submitted by the property owner or property manager to EPC.

III. Preventative Measures to Reduce Maintenance Costs

The most effective way to maintain your water quality facility is to prevent the pollutants from entering the facility in the first place. Common pollutants include sediment, trash & debris, chemicals, dog wastes, runoff from stored materials, illicit discharges into the storm drainage system and many others. A thoughtful maintenance program will include measures to address these

potential contaminants, and will save money and time in the long run. Key points to consider in your maintenance program include:

- Educate property owners/residents to be aware of how their actions affect water quality, and how they can help reduce maintenance costs.
- Keep properties, streets and gutters, and parking lots free of trash, debris, and lawn clippings.
- Ensure the proper disposal of hazardous wastes and chemicals.
- Plan lawn care to minimize the use of chemicals and pesticides.
- Sweep paved surfaces and put the sweepings back on the lawn.
- Be aware of automobiles leaking fluids. Use absorbents such as cat litter to soak up drippings – dispose of properly.
- Re-vegetate disturbed and bare areas to maintain vegetative stabilization.
- Clean out the upstream components of the storm drainage system, including inlets, storm sewers and outfalls.
- Do not store materials outdoors (including landscaping materials) unless properly protected from runoff.

IV. Access and Easements

All stormwater management facilities located on the site have both a designated access location as well as a maintenance easement. Refer to the Stormwater Facilities Map located in Appendix G for access and easement locations.

V. Safety

Keep safety considerations at the forefront of inspection procedures at all times. Likely hazards should be anticipated and avoided. Never enter a confined space (outlet structure, manhole, etc) without proper training or equipment. A confined space should never be entered without at least one additional person present.

If a toxic or flammable substance is discovered, leave the immediate area and contact the local Sheriff at 911.

Potentially dangerous (e.g., fuel, chemicals, hazardous materials) substances found in the areas must be referred to the local Sheriff's Office immediately for response by the Hazardous Materials Unit. The emergency contact number is 911.

Vertical drops may be encountered in areas located within and around the facility. Avoid walking on top of retaining walls or other structures that have a significant vertical drop. If a vertical drop is identified within the pond that is greater than 48" in height, make the appropriate note/comment on the maintenance inspection form.

If any hazard is found within the facility area that poses an immediate threat to public safety, contact the local Sheriff's Office immediately.

VI. Field Inspection Equipment

It is imperative that the appropriate equipment is taken to the field with the inspector(s). This is to ensure the safety of the inspector and allow the inspections to be performed as efficiently as possible. Below is a list of the equipment that may be necessary to perform the inspections of all Stormwater Management Facilities:

- Protective clothing and boots
- Safety equipment (vest, hard hat, confined space entry equipment).
- Communication equipment
- Operation and Maintenance Manual for the site including stormwater management facility location maps
- Clipboard
- Stormwater Facility Maintenance Inspection Forms (See Appendix D).
- Manhole Lid Remover
- Shovel.
- Sediment Probe
- Measuring Tape

Some of the items identified above need not be carried by the inspector (manhole lid remover, shovel, and confined space entry equipment). However, this equipment should be available in the vehicle driven to the site.

VII. Inspecting Stormwater Management Facilities

The quality of stormwater entering the waters of the state relies heavily on the proper operation and maintenance of permanent best management practices. Stormwater management facilities must be periodically inspected to ensure that they function as designed. The inspection will determine the appropriate maintenance that is required for the facility.

A. Inspection Procedures

All stormwater management facilities are required to be inspected by a qualified individual at a minimum of once per year. Inspections should follow the inspection guidance found in the SOP for the specific type of facility. (Appendix C of this manual).

B. Inspection Report

The person(s) conducting the inspection activities shall complete the appropriate inspection report for the specific facility. Inspection reports are located in Appendix D.

The following information explains how to fill out the Inspection Forms:

General Information

This section identifies the facility location, person conducting the inspection, the date and time the facility was inspected, and approximate days since the last rainfall. Property classification is identified as single-family residential, multi-family residential, commercial, or other.

The reason for the inspection is also identified on the form depending on the nature of the inspection. All facilities should be inspected on an annual basis at a minimum. In addition, all facilities should be inspected after a significant precipitation event to ensure the facility is draining appropriately and to identify any damage that occurred as a result of the increased runoff.

Inspection Scoring

For each inspection item, a score must be given to identify the urgency of required maintenance. The scoring is as follows:

- 0 = No deficiencies identified.
- 1 = Monitor – Although maintenance may not be required at this time, a potential problem exists that will most likely need to be addressed in the future. This can include items like minor erosion, concrete cracks/spalling, or minor sediment accumulation. This item should be revisited at the next inspection.
- 2 = Routine Maintenance Required – Some inspection items can be addressed through the routine maintenance program (See SOP in appendix A). This can include items like vegetation management or debris/trash removal.
- 3 = Immediate Repair Necessary – This item needs immediate attention because failure is imminent or has already occurred. This could include items such as structural failure of a feature (outlet works, forebay, etc), significant erosion, or significant sediment accumulation. This score should be given to an item that can significantly affect the function of the facility.
- N/A This is checked by an item that may not exist in a facility. Not all facilities have all of the features identified on the form (forebay, micro-pool, etc.).

Inspection Summary/Additional Comments

Additional explanations to inspection items, and observations about the facility not covered by the form, are recorded in this section.

Overall Facility Rating

An overall rating must be given for each facility inspected. The overall facility rating should correspond with the highest score (0, 1, 2, 3) given to any feature on the inspection form.

C. Verification of Inspection and Form Submittal

The Stormwater Management Facility Inspection Form provides a record of inspection of the facility. Inspection Forms for each facility type are provided in Appendix D. Verification of the inspection of the stormwater facilities, the facility inspection form(s), and Inspector Qualifications shall be provided to EPC on an annual basis. The verification and the inspection form(s) shall be reviewed and submitted by the property owner or property manager.

Refer to Section II of this Manual regarding the annual reporting of inspections.

VIII. Maintaining Stormwater Management Facilities

Stormwater management facilities must be properly maintained to ensure that they operate correctly and provide the water quality treatment for which they were designed. Routine maintenance performed on a frequently scheduled basis, can help avoid more costly rehabilitative maintenance that results when facilities are not adequately maintained.

A. Maintenance Categories

Stormwater management facility maintenance programs are separated into three broad categories of work. These categories are based largely on the Urban Drainage and Flood Control District's Maintenance Program for regional drainage facilities. The categories are separated based upon the magnitude and type of the maintenance activities performed. A description of each category follows:

Routine Work

The majority of this work consists of scheduled mowings and trash and debris pickups for stormwater management facilities during the growing season. This includes items such as the removal of debris/material that may be clogging the outlet structure orifice plan and pump screens. It also includes activities such as weed control, mosquito treatment, and algae treatment. These activities normally will be performed numerous times during the year. These items can be completed without any prior

correspondence with EPC; however, completed inspection and maintenance forms shall be submitted to EPC for each inspection and maintenance activity.

Restoration Work

This work consists of a variety of isolated or small-scale maintenance and work needed to address operational problems. Most of this work can be completed by a small crew, with minor tools, and small equipment. These items require prior correspondence with EPC and require that completed maintenance forms be submitted to EPC for each maintenance activity.

Rehabilitation Work

This work consists of large-scale maintenance and major improvements needed to address failures within the stormwater management facilities. This work requires consultation with EPC and may require an engineering design with construction plans to be prepared for review and approval. This work may also require more specialized maintenance equipment, surveying, construction permits or assistance through private contractors and consultants. These items require prior correspondence with EPC and require that completed maintenance forms be submitted to EPC for each maintenance activity.

B. Maintenance Personnel

Maintenance personnel must be qualified to properly maintain stormwater management facilities. Inadequately trained personnel can cause additional problems resulting in additional maintenance costs.

C. Maintenance Forms

The Stormwater Management Facility Maintenance Form provides a record of maintenance activities. Maintenance Forms for each facility type are provided in Appendix E. Maintenance Forms shall be completed by the contractor completing the required maintenance items. The form shall then be reviewed by the property owner or an authorized agent of the property owner and submitted on an annual basis to the Southeast Metro Stormwater Authority.

Refer to Section II of this Manual regarding the annual reporting of inspections and maintenance activities performed.

Appendix A

**PRIVATE DETENTION BASIN / STORMWATER
QUALITY BEST MANAGEMENT PRACTICE
MAINTENANCE AGREEMENT AND EASEMENT**

This PRIVATE DETENTION BASIN / STORMWATER QUALITY BEST MANAGEMENT PRACTICE MAINTENANCE AGREEMENT AND EASEMENT (Agreement) is made by and between EL PASO COUNTY by and through THE BOARD OF COUNTY COMMISSIONERS OF EL PASO COUNTY, COLORADO (Board or County) and KG Store 2232 LLC (Developer). The above may occasionally be referred to herein singularly as “Party” and collectively as “Parties.”

Recitals

A. WHEREAS, Developer is the owner of certain real estate (the Property) in El Paso County, Colorado, which Property is legally described in Exhibit A attached hereto and incorporated herein by this reference; and

B. WHEREAS, Developer desires to develop on the Property a land use to be known as Kum & Go at Security Blvd & Main St; and

C. WHEREAS, the development of this Property will substantially increase the volume of water runoff and will decrease the quality of the stormwater runoff from the Property, and, therefore, it is in the best interest of public health, safety and welfare for the County to condition approval of this land use on Developer’s promise to construct adequate drainage, water runoff control facilities, and stormwater quality structural Best Management Practices (“BMPs”) for the land use; and

D. WHEREAS, Chapter 8, Section 8.4.5 of the El Paso County Land Development Code, as periodically amended, promulgated pursuant to Section 30-28-133(1), Colorado Revised Statutes (C.R.S.), requires the County to condition approval of all subdivisions on a developer’s promise to so construct adequate drainage, water runoff control facilities, and BMPs in subdivisions; and

E. WHEREAS, the Drainage Criteria Manual, Volume 2, as amended by Appendix I of the El Paso County Engineering Criteria Manual (ECM), as each may be periodically amended, promulgated pursuant to the County’s Colorado Discharge Permit System General Permit (MS4 Permit) as required by Phase II of the National Pollutant Discharge Elimination System (NPDES), which MS4 Permit requires that the County take measures to protect the quality of stormwater from sediment and other contaminants, requires subdividers, developers, landowners, and owners of facilities located in the County’s rights-of-way or easements to provide adequate permanent stormwater quality BMPs with new development or significant redevelopment; and

F. WHEREAS, Section 2.9 of the El Paso County Drainage Criteria Manual provides for a developer’s promise to maintain a subdivision’s drainage facilities in the event the County does not assume such responsibility; and

G. WHEREAS, developers in El Paso County have historically chosen water runoff detention basins as a means to provide adequate drainage and water runoff control in subdivisions,

which basins, while effective, are less expensive for developers to construct than other methods of providing drainage and water runoff control; and

H. WHEREAS, Developer desires to construct for the land use one (1) detention basin/stormwater quality BMP(s) (“detention basin/BMP(s)”) as the means for providing adequate drainage and stormwater runoff control and to meet requirements of the County’s MS4 Permit, and to operate, clean, maintain and repair such detention basin/BMP(s); and

I. WHEREAS, Developer desires to construct the detention basin/BMP(s) on the Property legally described in Exhibit A;

J. WHEREAS, Developer shall be charged with the duties of constructing, operating, maintaining and repairing the detention basin/BMP(s) on the Property; and

K. WHEREAS, it is the County’s experience that subdivision developers and property owners historically have not properly cleaned and otherwise not properly maintained and repaired these detention basins/BMPs, and that these detention basins/BMPs, when not so properly cleaned, maintained, and repaired, threaten the public health, safety and welfare; and

L. WHEREAS, the County, in order to protect the public health, safety and welfare, has historically expended valuable and limited public resources to so properly clean, maintain, and repair these detention basins/BMPs when developers and property owners have failed in their responsibilities, and therefore, the County desires the means to recover its costs incurred in the event the burden falls on the County to so clean, maintain and repair the detention basin/BMP(s) serving this land use due to the Developer’s failure to meet its obligations to do the same; and

M. WHEREAS, the County conditions approval of this land use on the Developer’s promise to so construct the detention basin/BMP(s), and conditions approval on the Developer’s promise to reimburse the County in the event the burden falls upon the County to so clean, maintain and/or repair the detention basin/BMP(s) serving this Subdivision; and

N. WHEREAS, the County could condition land use approval on the Developer’s promise to construct a different and more expensive drainage, water runoff control system and BMPs than those proposed herein, which more expensive system would not create the possibility of the burden of cleaning, maintenance and repair expenses falling on the County; however, the County is willing to forego such right upon the performance of Developer’s promises contained herein; and

O. WHEREAS, the County, in order to secure performance of the promises contained herein, conditions approval of this land use upon the Developer’s grant herein of a perpetual Easement over the Property for the purpose of allowing the County to periodically access, inspect, and, when so necessary, to clean, maintain and/or repair the detention basin/BMP(s); and

Agreement

NOW, THEREFORE, in consideration of the mutual Promises contained herein, the sufficiency of which are hereby acknowledged, the Parties agree as follows:

1. **Incorporation of Recitals:** The Parties incorporate the Recitals above into this Agreement.
2. **Covenants Running with the Land:** Developer agrees that this entire Agreement and the performance thereof shall become a covenant running with the land, which land is legally described in Exhibit A attached hereto, and that this entire Agreement and the performance thereof shall be binding upon itself, its successors and assigns.
3. **Construction:** Developer shall construct on the Property described in Exhibit A attached hereto and incorporated herein by this reference, one (1) detention basin/BMP(s). Developer shall not commence construction of the detention basin/BMP(s) until the El Paso County Planning and Community Development Department (PCD) has approved in writing the plans and specifications for the detention basin/BMP(s) and this Agreement has been signed by all Parties and returned to the PCD. Developer shall complete construction of the detention basin/BMP(s) in substantial compliance with the County-approved plans and specifications for the detention basin/BMP(s). Failure to meet these requirements shall be a material breach of this Agreement and shall entitle the County to pursue any remedies available to it at law or in equity to enforce the same. Construction of the detention basin/BMP(s) shall be substantially completed within one (1) year (defined as 365 days), which one-year period will commence to run on the date the approved plat of this Subdivision is recorded in the records of the El Paso County Clerk and Recorder. In cases where a subdivision is not required, the one-year period will commence to run on the date the Erosion and Stormwater Quality Control Permit (ESQCP) is issued. Rough grading of the detention basin/BMP(s) must be completed and inspected by the El Paso County Planning and Community Development Department prior to commencing road construction.

In the event construction is not substantially completed within the one (1) year period, then the County may exercise its discretion to complete the project and shall have the right to seek reimbursement from the Developer and its successors and assigns, for its actual costs and expenses incurred in the process of completing construction. The term actual costs and expenses shall be liberally construed in favor of the County, and shall include, but shall not be limited to, labor costs, tool and equipment costs, supply costs, and engineering and design costs, regardless of whether the County uses its own personnel, tools, equipment, and supplies, etc. to correct the matter. In the event the County initiates any litigation or engages the services of legal counsel in order to enforce the Provisions arising herein, the County shall be entitled to its damages and costs, including reasonable attorney fees, regardless of whether the County contracts with outside legal counsel or utilizes in-house legal counsel for the same.

4. **Maintenance:** The Developer agrees for itself and its successors and assigns that it will regularly and routinely inspect, clean, and maintain the detention basin/BMP(s) and otherwise keep the same in good repair, all at its own cost and expense. No trees or shrubs that will impair the structural integrity of the detention basin/BMP(s) shall be planted or allowed to grow on the detention basin/BMP(s).
5. **Creation of Easement:** Developer hereby grants the County a non-exclusive perpetual easement upon and across the Property described in Exhibit A. The purpose of the easement is to allow the County to access, inspect, clean, repair and maintain the detention basin/BMP(s); however, the creation of the easement does not expressly or implicitly impose on the County a duty to so inspect, clean, repair or maintain the detention basin/BMP(s).

6. **County's Rights and Obligations:** Any time the County determines, in the sole exercise of its discretion, that the detention basin/BMP(s) is not properly cleaned, maintained and/or otherwise kept in good repair, the County shall give reasonable notice to the Developer and its successors and assigns

that the detention basin/BMP(s) needs to be cleaned, maintained and/or otherwise repaired. The notice shall provide a reasonable time to correct the problem(s). Should the responsible parties fail to correct the specified problem(s), the County may enter upon the Property to so correct the specified problem(s). Notice shall be effective to the above by the County's deposit of the same into the regular United States mail, postage pre-paid. Notwithstanding the foregoing, this Agreement does not expressly or implicitly impose on the County a duty to so inspect, clean, repair or maintain the detention basin/BMP(s).

7. Reimbursement of County's Costs / Covenant Running With the Land: The Developer agrees and covenants, for itself and its successors and assigns, that it will reimburse the County for its costs and expenses incurred in the process of completing construction of, cleaning, maintaining, and/or repairing the detention basin/BMP(s) pursuant to the provisions of this Agreement.

The term "actual costs and expenses" shall be liberally construed in favor of the County, and shall include, but shall not be limited to, labor costs, tools and equipment costs, supply costs, and engineering and design costs, regardless of whether the County uses its own personnel, tools, equipment, and supplies, etc. to correct the matter. In the event the County initiates any litigation or engages the services of legal counsel in order to enforce the provisions arising herein, the County shall be entitled to its damages and costs, including reasonable attorney's fees, regardless of whether the County contracts with outside legal counsel or utilizes in-house legal counsel for the same.

8. Contingencies of Land Use/Land Disturbance Approval: Developer's execution of this Agreement is a condition of land use/land disturbance approval.

The County shall have the right, in the sole exercise of its discretion, to approve or disapprove any documentation submitted to it under the conditions of this Paragraph, including but not limited to, any separate agreement or amendment, if applicable, identifying any specific maintenance responsibilities not addressed herein. The County's rejection of any documentation submitted hereunder shall mean that the appropriate condition of this Agreement has not been fulfilled.

9. Agreement Monitored by El Paso County Planning and Community Development Department and/or El Paso County Department of Public Works: Any and all actions and decisions to be made hereunder by the County shall be made by the Director of the El Paso County Planning and Community Development Department and/or the Director of the El Paso County Department of Public Works. Accordingly, any and all documents, submissions, plan approvals, inspections, etc. shall be submitted to and shall be made by the Director of the Planning and Community Development Department and/or the Director of the El Paso County Department of Public Works.

10. Indemnification and Hold Harmless: To the extent authorized by law, Developer agrees, for itself, its successors and assigns, that it will indemnify, defend, and hold the County harmless from any and all loss, costs, damage, injury, liability, claim, lien, demand, action and causes of action whatsoever, whether at law or in equity, arising from or related to its intentional or negligent acts, errors or omissions or that of its agents, officers, servants, employees, invitees and licensees in the construction, operation, inspection, cleaning (including analyzing and disposing of any solid or hazardous wastes as defined by State and/or Federal environmental laws and regulations), maintenance, and repair of the detention basin/BMP(s), and such obligation arising under this Paragraph shall be joint and several. Nothing in this Paragraph shall be deemed to waive or otherwise limit the defense available to the County pursuant to the Colorado Governmental Immunity Act, Sections 24-10-101, *et seq.* C.R.S., or as otherwise provided by law.

11. Severability: In the event any Court of competent jurisdiction declares any part of this Agreement to be unenforceable, such declaration shall not affect the enforceability of the remaining parts of this Agreement.

12. Third Parties: This Agreement does not and shall not be deemed to confer upon or grant to any third party any right to claim damages or to bring any lawsuit, action or other proceeding against either the County, the Developer, or their respective successors and assigns, because of any breach hereof or because of any terms, covenants, agreements or conditions contained herein.

13. Solid Waste or Hazardous Materials: Should any refuse from the detention basin/BMP(s) be suspected or identified as solid waste or petroleum products, hazardous substances or hazardous materials (collectively referred to herein as “hazardous materials”), the Developer shall take all necessary and proper steps to characterize the solid waste or hazardous materials and properly dispose of it in accordance with applicable State and/or Federal environmental laws and regulations, including, but not limited to, the following: Solid Wastes Disposal Sites and Facilities Acts, §§ 30-20-100.5 – 30-20- 119, C.R.S., Colorado Regulations Pertaining to Solid Waste Disposal Sites and Facilities, 6 C.C.R. 1007-2, *et seq.*, Solid Waste Disposal Act, 42 U.S.C. §§ 6901-6992k, and Federal Solid Waste Regulations 40 CFR Ch. I. The County shall not be responsible or liable for identifying, characterizing, cleaning up, or disposing of such solid waste or hazardous materials. Notwithstanding the previous sentence, should any refuse cleaned up and disposed of by the County be determined to be solid waste or hazardous materials, the Developer, but not the County, shall be responsible and liable as the owner, generator, and/or transporter of said solid waste or hazardous materials.

14. Applicable Law and Venue: The laws, rules, and regulations of the State of Colorado and El Paso County shall be applicable in the enforcement, interpretation, and execution of this Agreement, except that Federal law may be applicable regarding solid waste or hazardous materials. Venue shall be in the El Paso County District Court.

[Signature page to follow]

IN WITNESS WHEREOF, the Parties affix their signatures below.

Executed this 8 day of March, 2023, by:

KG Store 2232 LLC

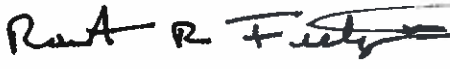
By: 
Robert Fiebig III, Real Estate Development Manager

The foregoing instrument was acknowledged before me this 8 day of March, 2023, by Robert Fiebig III, Real Estate Development Manager, KG Store 2232 LLC.

Witness my hand and official seal.

My commission expires: February 13, 2026



Notary Public

Executed this _____ day of _____, 20____, by:

BOARD OF COUNTY COMMISSIONERS
OF EL PASO COUNTY, COLORADO

By: _____
Meggan Herington, Executive Director
Planning and Community Development Department
Authorized signatory pursuant to LDC

The foregoing instrument was acknowledged before me this _____ day of _____, 2023, by _____, Executive Director of the El Paso County Planning and Community Development Department.

Witness my hand and official seal.

My commission expires: _____

Notary Public

Approved as to Content and Form:

County Attorney's Office

Exhibit A

LEGAL DESCRIPTION:

Description per Title

Commitment: PARCEL

A:

LOT 2, PEDRICK—ECKERD FILING NO 3, COUNTY OF EL PASO, STATE OF

COLORADO. PARCEL 8:

THOSE EASEMENT RIGHTS CREATED BY DECLARATION OF RESTRICTIONS AND GRANT OF EASEMENTS RECORDED JULY 1, 1983 IN BOOK 3750 AT PAGE 909, FIRST AMENDMENT TO SAID DECLARATION RECORDED DECEMBER 2, 1994 IN BOOK 6571 AT PAGE 1245 AND SECOND AMENDMENT TO SAID DECLARATION RECORDED JANUARY 29, 2004 UNDER RECEPTION NO.

204016205 AND THIRD AMENDMENT TO SAID DECLARATION RECORDED FEBRUARY 19, 2013 UNDER RECEPTION NO. 213022221, AND COMMON AREA MAINTENANCE AGREEMENT RECORDED JULY 1, 1983 IN BOOK 3750 AT PAGE 929, FIRST AMENDMENT TO SAID AGREEMENT RECORDED DECEMBER 2, 1994 IN BOOK 6571 AT PAGE 125J AND SECOND AMENDMENT TO SAID AGREEMENT RECORDED JANUARY 29, 2004 UNDER RECEPTION NO. 204016204, AND ASSIGNMENT AND ASSUMPTION OF RECIPROCAL EASEMENT AGREEMENT RECORDED SEPTEMBER 5, 2007 UNDER RECEPTION NO. 207115485.

Appendix B

Appendix B

General Location and Description of Stormwater Management Facilities Underground Detention & Water Quality

A. General Site Description

The subject site is located at 304 Main Street in the southeastern quarter of Section 11, Township 15 South, Range 66 West of the 6th P.M. in El Paso County, Colorado. The 1.29 Acre site currently consists of asphalt parking area and a recently removed drive-thru coffee stand. The site is bounded by existing commercial developments consisting of Ross Dress for Less, Security Discount Liquor, H&R Block, Comfort Dental, Hair Therapy Hair Dresser, First Cash Pawn, Tobacco Shop, Laundromat, and Sonic Drive-In to the north and east, Main Street to the south, and Security Boulevard to the west.

The proposed site is will be developed into an approximately 3,968 sf Kum & Go convenience store with six (6) MPD fueling canopy and associated drives, sidewalks and landscaping. This plan addresses operation and maintenance of public detention / water quality facilities (Underground Stormwater Detention and Water Quality Facility) constructed as part of the Kum & Go #2232 development project at the north corner of the existing Security Boulevard and Main Street intersection in Colorado Springs, El Paso County, State of Colorado (EPC PCD projects number(s): EA File No. 21-146 and PPR2225 Kum and Go. The existing plat number of Kum and Go Gas and C-Store is 204016203

B. General Stormwater Management Description

The (Underground Stormwater Detention and Water Quality Facility) is located in lot 2 of the Pedrick– Eckerd Filing No. 3 Subdivision. Site Accesses are located off both Main Street and Security Boulevard. An Existing 7-ft Utility and Drainage Easement exists along both Main Street and Security Boulevard. The subject sites surface drainage is detained and treated in an underground stormwater detainment and treatment facility. Detained runoff is released and controlled by designed orifices to release at water quality and design storm events. This runoff is released into a manhole that will have a pump designed to conveyed the flow to an existing inlet located at the intersection of Main Street and Security Blvd.

Onsite runoff is conveyed to the underground detention facility by on site private storm inlets, roof drains and storm sewer. Captured runoff is conveyed first to the an inlet structure with a 2' sump that will provide initial water quality and then into the isolation row of the ADS system. The isolation row will provide the water quality for they system by the fabric material surrounding the chambers treating and preventing debris from entering the remainder of the system. The ADS system will include a 9" rock base with 40% voids and underdrain pipe that will convey and drain the system at the design rate. Inspection ports are provided with in the isolation row to provide access to inspect system and determine when maintenance is necessary.

Due to existing condition constraints, the pond release will be conveyed to an existing inlet located at the north corner of the intersection of Main Street and Security Boulevard by a pump system. In the event of runoff overtopping, the emergency spillway will be at the proposed site access onto Security Boulevard as the site currently drains today in the existing condition.

C. Stormwater Facilities Site Plan

Inspection or maintenance personnel may utilize the Stormwater Facilities Map located in Appendix G for locating the stormwater facilities within this development.

D. On-Site Stormwater Management Facilities

Volume Reduction Facilities

The detention pond submitted for Kum & Go #2232- contains a private underground detention and water quality facility (UGD) which will reduce the 100-yr peak post-development flow from 9.81 cfs peak inflow to 0.71 peak outflow compared to 2.1 cfs pre-development peak outflow.

Storage Facilities (Detention)

The detention pond submitted for Kum & Go #2232- contains a private underground detention and water quality facility (UGD) which will store the 100 year volume of 0.193 ac-ft.

Water Quality Facilities

Pond 1 submitted for Kum & Go #2232- Underground Detention Facility contains an Underground Detention Basin (UGD) for water quality which utilizes the Isolation Rows as a means of water quality as well as the required water quality volume. Pond 1 has been designed and shall be constructed as follows.

| | |
|------------------------|-------------|
| WQCV Provided= | 0.037 ac-ft |
| Q100 Volume Provided= | 0.193 ac-ft |
| WQCV Release Proposed= | 0.02 cfs |
| Q100 Release Proposed= | 0.71 cfs |

Flows from the UGD pond are routed via a proposed 6" PVC pipe to discharge by pump to an existing inlet at the intersection of Main Street and Security Blvd.

Additional means of water quality is being provided by Stormflex Inlet Filters and PC Filter Bags to be placed within each of the proposed inlet structures to provide initial flush of water quality.

Source Control Best Management Practices

Proposed construction BMP's (silt fence, vehicle tracking, straw bale barriers, erosion control fabric and temporary sediment facility) will capture any sedimentation caused by construction before it can make it into the existing downstream tributaries. The water quality method meets the intent of treating impervious areas, based on the guidelines as set forth in the City of Colorado Springs/El Paso County Drainage Criteria Manual – Volume II.

Appendix C

Standard Operation Procedures
for
Inspection and Maintenance

Underground Detention Basin
(UGD)

TABLE OF CONTENTS

| | |
|--|----------|
| UGD-1 BACKGROUND | 3 |
| UGD-2 INSPECTING UNDERGROUND DETENTION BASIN (UGD) | 3 |
| UGD-2.1 ACCESS AND EASEMENTS..... | 3 |
| UGD-2.2 STORMWATER MANAGEMENT FACILITIES LOCATIONS..... | 3 |
| UGD-2.3 UNDERGROUND DETENTION BASIN (UGD) FEATURES..... | 3 |
| UGD-2.3.1 Inflow Points..... | 4 |
| UGD-2.3.2 Forebay..... | 5 |
| UGD-2.3.3 Trickle Channel (Low-Flow)..... | 5 |
| UGD-2.3.4 Bottom Stage..... | 6 |
| UGD-2.3.5 Micropool..... | 6 |
| UGD-2.3.6 Outlet Works..... | 6 |
| UGD-2.3.7 Emergency Spillway..... | 7 |
| UGD-2.3.8 Upper Stage (Dry Storage)..... | 7 |
| UGD-2.3.9 Miscellaneous..... | 7 |
| UGD-2.4 INSPECTION FORMS..... | 8 |
| UGD-3 MAINTAINING UNDERGROUND DETENTION BASIN (UGD) | 8 |
| UGD-3.1 MAINTENANCE PERSONNEL..... | 8 |
| UGD-3.2 EQUIPMENT..... | 8 |
| UGD-3.3 SAFETY..... | 9 |
| UGD-3.4 MAINTENANCE FORMS..... | 9 |
| UGD-3.5 MAINTENANCE CATEGORIES AND ACTIVITIES..... | 9 |
| UGD-3.6 ROUTINE MAINTENANCE ACTIVITIES..... | 11 |
| UGD-3.6.1 Mowing..... | 12 |
| UGD-3.6.2 Trash/Debris Removal..... | 12 |
| UGD-3.6.3 Outlet Works Cleaning..... | 12 |
| UGD-3.6.4 Weed Control..... | 12 |
| UGD-3.6.5 Mosquito/Algae Treatment..... | 12 |
| UGD-3.7 MINOR MAINTENANCE ACTIVITIES..... | 13 |
| UGD-3.7.1 Sediment Removal..... | 13 |
| UGD-3.7.2 Erosion Repair..... | 14 |
| UGD-3.7.3 Vegetation Removal/Tree Thinning..... | 14 |
| UGD-3.7.4 Clearing Drains/Jet-Vac..... | 15 |
| UGD-3.8 MAJOR MAINTENANCE ACTIVITIES..... | 15 |
| UGD-3.8.1 Major Sediment Removal..... | 16 |
| UGD-3.8.2 Major Erosion Repair..... | 16 |
| UGD-3.8.3 Structural Repair..... | 16 |

UGD-1 BACKGROUND

Underground Detention Basins (UGD) are one of the least common types of Stormwater Management Facilities utilized within the Front Range of Colorado. An UGD is a sedimentation basin designed to “extend” the runoff detention time, but to drain completely dry sometime after stormwater runoff ends. The UGD’s drain time for the water quality portion of the facility is typically 40 hours. The chambers are considered to be “dry” because the majority of the chambers are designed not to have a significant permanent pool of water remaining between runoff events.

UGDs are an adaptation of an extended detention basin used for flood control, with the primary difference is the addition of additional manufactured treatment devices (MTDs) but they also include a slow release outlet design. Forebays are replaced by the MTDs, located at the inflow point to the system (Stormflex Inlet Filters and PC Filter Bags at storm inlets) and are provided to facilitate sediment removal within a contained area prior to releasing into the pond (underground chambers). The MTDs collect and filter stormwater runoff resulting in a process called sedimentation, capturing sediment out of the stormwater. The stormwater is then routed from the MTD through storm sewer and into the Isolator row. The isolator row holds the sediment in one or more underground chambers for easier maintenance (removal of sediment & pollutants). The UGD also uses smaller outlet (manifold pipes (18” diameter) rather than EDB open flow that extends the emptying time of the more frequently occurring runoff events to facilitate pollutant removal. An UGD does not have a small micropool just upstream of the outlet like an EDB. The micropool is not necessary to hold a small amount of water to keep sediment and floatables from blocking the outlet orifices because this occurs in the isolator row(s).

UGD-2 INSPECTING UNDERGROUND DETENTION BASINS (UGD)

UGD-2.1 Access and Easements

Inspection or maintenance personnel may utilize the stormwater facility map located in Appendix G containing the location(s) of the access points and maintenance easements of the UGD(s) within this development.

UGD-2.2 Stormwater Management Facilities Locations

Inspection or maintenance personnel may utilize the stormwater facility map located in Appendix G containing the location(s) of the UGD(s) within this development.

UGD-2.3 Underground Detention Basin (UGD) Features

UGDs have a number of features that are designed to serve a particular function. Many times the proper function of one feature depends on another. For

example, if a MTD is not properly maintained, it could negatively affect the performance of a feature downstream (isolator row, outlet structure, etc.). Therefore, it is critical that each feature of the UGD is properly inspected and maintained to ensure that the overall facility functions as it was intended. Below is a list and description of the most common features within an UGD and the corresponding maintenance inspection items that can be anticipated:

**Table UGD-1
Typical Inspection & Maintenance Requirements Matrix**

| UGD Features | Sediment Removal | Mowing/ Weed control | Trash & Debris Removal | Erosion | Overgrown Vegetation Removal | Standing Water (mosquito/ algae control) | Structure Repair |
|--|------------------|----------------------|------------------------|---------|------------------------------|--|------------------|
| Inflow Points (MTDs) | X | | X | | | | X |
| Isolation Rows | X | | X | | | | X |
| Stormflex Inlet Filters and PC Filter Bags | X | | X | | | | X |
| Outlet Works/Pump | X | | X | | | | X |

UGD-2.3.1 Inflow Points

Inflow Points or Outfalls into EDBs are the point source of the stormwater discharge into the facility. An inflow point is commonly a storm sewer pipe with a flared end section that discharges into an EDB. However, an Inflow Point for a UGD must first pass through a MTD.

An energy dissipation occurs with flows through the MTD.

The typical maintenance items that are found with inflow points are as follows:

a. Sediment Accumulation – Because of the turbulence in the water created by the energy dissipater, sediment often deposits immediately downstream of the inflow point. To prevent a loss in hydraulic performance of the upstream infrastructure, sediment that accumulates in this area must be removed in a timely manner.

b. Structural Damage – Structural damage can occur at anytime during the life of the facility. Typically, for an inflow, the structural damage occurs to the concrete inflow manhole structure end section. Structural damage can lead to additional operating problems with the facility, including loss of hydraulic performance.

c. Woody Growth/Weeds Present – Undesirable vegetation can grow in and

around the inflow area to an UGD that can significantly affect the performance of the drainage facilities discharging into the facility. This type of vegetation includes trees (typically cottonwoods) and dense areas of shrubs (willows). If woody vegetation is not routinely mowed/removed, the growth can cause debris/sediment to accumulate, resulting in blockage of the discharge. Also, tree roots can cause damage to the structural components of the inflow. Routine maintenance is essential for trees (removing a small tree/sapling is much cheaper and “quieter” than a mature tree). In addition, noxious weeds growing in the facility can result in the loss of desirable native vegetation and impact adjacent open spaces/land. However, since the inflow point is below ground, the presence of these natural materials will be less common.

UGD-2.3.2 Forebay (MTD)

Manufactured Treatment Devices (MTDs) include many different types of proprietary devices that use various treatment processes and designs to remove targeted pollutants. For example, some MTDs are suitable for pretreatment and gross solid removal, whereas others incorporate advanced designs targeting specific metals, nutrients and other pollutants in stormwater runoff. MTD’s included with this development are the Stormflex Inlet Filters with PC Filter Bags and ADS Isolation Rows within the UGD.

The typical maintenance items that are found with MTDs are as follows:

a. Sediment/Debris Accumulation – Because this feature of the UGD is designed to provide the initial sedimentation, debris and sediment frequently accumulate in this area. If the sediment and debris is not removed from the MTD’s on a regular basis, it can significantly affect the function of other features within the UGD. Routine sediment removal from the MTD’s can **significantly** reduce the need for dredging of the main portion of the UGD isolator row using specialized equipment (jet vacuums). Routine removal of sediment from the MTD can **substantially** decrease the long-term sediment removal costs of an UGD. Maintenance specifics can be found in section UGD-3 of this manual.

b. Structural Damage – Structural damage can occur at anytime during the life of the facility. Typically, for an inflow, the structural damage occurs to the concrete inflow manhole structure end section. Structural damage can lead to additional operating problems with the facility, including loss of hydraulic performance.

UGD-2.3.3 Trickle Channel (Low-Flow)

The trickle channels are not necessary in an UGD. Therefore, no maintenance is necessary.

GD-2.3.4 Bottom Stage

The bottom stage is not necessary in an UGD since the facility is underground. Therefore, no maintenance is necessary.

UGD-2.3.5 Micro-pool

The micro-pool is not necessary in an UGD since the facility is underground. Therefore, no maintenance is necessary.

UGD-2.3.6 Outlet Works

The outlet works is the feature that drains the UGD in specified quantities and periods of time. The outlet works is a 4' diameter manhole constructed of reinforced concrete at the end of the UGD. The concrete structure has steel orifice plates anchored/embedded into it to control stormwater release rates. No well screening is required on this project due to the MTDs provided at the beginning of the system. The outlet structure also includes a manhole with pumps system that will release the runoff after it has passed through the UGD and designed orifices. The outlet structure is the single most important feature in the UGD operation. Proper inspection and maintenance of the outlet works is essential in ensuring the long-term operation of the UGD.

The typical maintenance items that are found with the outlet works are as follows:

a. Trash Rack/Well Screen Clogged – Floatable material that enters the UGD will not make their way to the outlet structure. The isolation row within the UGD is surrounded by filter material that will not allow floatable material to enter the system. In addition pumps are designed to convey trash and debris that may make its way towards the outlet of the system. There is no proposed trash rack/well screen.

b. Structural Damage - The outlet structure is primarily constructed of concrete, which can crack, spall, and settle.

c. Orifice Plate Missing/Not Secure – Many times residents, property owners, or maintenance personnel will remove or loosen orifice plates if they believe the pond is not draining properly. Any modification to the orifice plate(s) will significantly affect the designed discharge rates for water quality and/or flood control. Modification of the orifice plates is not allowed without approval from EPC.

d. Manhole Access – Access to the outlet structure is necessary to properly inspect and maintain the facility. If access is difficult or not available to inspect the structure, chances are it will be difficult to maintain as well.

e. Woody Growth/Weeds Present - Because of the constant moisture in the soil surrounding the outlet works, woody growth (cottonwoods/willows) can create operational problems for the UGD. If woody vegetation is not routinely mowed/removed, the growth can cause debris/sediment to accumulate around the outlet works, which can cause problems with other UGD features. Also, tree roots can cause damage to the structural components of the outlet works. Routine management is essential for trees (removing a small tree/sapling is much cheaper and “quieter” than a mature tree). However, since the outflow point is below ground, the presence of these natural materials will be less common.

f. Pump Damage/Clogging – Access to the pump system is through an access manhole at the outlet structure. The pump is needed to be properly inspected and maintained. The pump system is designed to convey trash and debris that may make its way towards the outlet of the system.

The system will pump the detained stormwater and discharge into the existing inlet at the northwest corner of Security Boulevard and Main Street. There are alarms for the pump system that are wired to the convenience store building electrical panel. Wiring to the building will allow for notification to be sent directly to the building in the event of a malfunction. The pump control panels include a top mounted globe light that flashes, and an alarm buzzer on the side. The alarm turns on if the high-water float switch in the vault raises. The alarm will also turn on if one of the float switches in the vault raises in the wrong order or if the power supply to the pump circuit or the control circuit is interrupted. The alarm can be reset by holding down a toggle switch on the side of the panel for five seconds. If the condition that caused the alarm still exists, the alarm will turn on again. The audible alarm can be easily silenced by holding down the toggle switch for two seconds. If the alarm continues to sound the owner should investigate the cause of the alarm condition. Replacement and or maintenance by a pump company may be required in the event that pump is not working properly after investigation.

UGD-2.3.7 Emergency Spillway

An emergency spillway is not a component of an UGD, therefore no maintenance is necessary. In the event of clogging, the runoff would pond out of the proposed inlet and the emergency overflow path would follow the proposed access drive on the north side of the site and into the Security Boulevard right-of-way as it does in the existing condition. This area shall remain clear from permanent structures and be inspected for damage after an overflow event.

UGD-2.3.8 Upper Stage (Dry Storage)

There is no upper stage in an UGD, therefore no maintenance is necessary.

UGD-2.3.9 Miscellaneous

There are a variety of inspection/maintenance issues that may not be attributed to a single feature within the UGD. This category on the inspection form is for maintenance items that are commonly found in the UGD, but may not be attributed to an individual feature.

a. Encroachment in Easement Area – Private lots/property can sometimes be located very close to the UGDs, even though they are required to be located in tracts with drainage easements. Property owners may place landscaping, trash, fencing, or other items within the easement area that may affect maintenance or the operation of the facility.

b. Graffiti/Vandalism – Damage to the UGD infrastructure can be caused by vandals. If criminal mischief is evident, the inspector should forward this information to the local Sheriff's Office. The UGD is mostly underground and un-visible. Therefore, vandalism would be an uncommon problem.

c. Public Hazards – Public hazards include items such as vertical drops of greater than 4-feet, containers of unknown/suspicious substances, exposed metal/jagged concrete on structures. **If any hazard is found within the facility area that poses an immediate threat to public safety, contact the local Sheriff at 911 immediately!**

d. Burrowing Animals/Pests – Prairie dogs and other burrowing rodents may cause damage to the UGD features and negatively affect the components within the UGD.

e. Other – Any miscellaneous inspection/maintenance items not contained on the form should be entered here.

UGD-2.4 Inspection Forms

UGD Inspection forms are located in Appendix D. Inspection forms shall be completed by the person(s) conducting the inspection activities. Each form shall be reviewed and submitted by the property owner or property manager to the El Paso County per the requirements of the Operations and Maintenance Manual. These inspection forms shall be kept indefinitely and made available to the El Paso County upon request. Inspections involving measurements of the sediment depth should be done at least 5 days after the last storm even to allow all water to drainage from the system.

UGD-3 MAINTAINING UNDERGROUND DETENTION BASINS (UGD)

UGD-3.1 Maintenance Personnel

Maintenance personnel must be qualified to properly maintain UGDs. Inadequately trained personnel can cause additional problems resulting in additional maintenance costs. Maintenance for the UGD will be completed by a third party company hired by the site owner. The third party sewer and pipe maintenance company should utilize a Vac Truck and there are not required certifications or trainings required. It is recommended that they have experience cleaning storm drains. The Vac Truck should be able to handle cleaning and pulling sediment 150-200 feet from the back of the isolator row. It is recommended to use a “sled” based nozzle shack as a Keg Floor Clearer for the Vac Truck hose. Inspections should be completed by the operator and third party company hired by the site owner.

UGD-3.2 Equipment

It is imperative that the appropriate equipment and tools are taken to the field with the operations crew. The types of equipment/tools will vary depending on the task at hand. Below is a list of tools, equipment, and material(s) that may be necessary to perform maintenance on an UGD:

- 1.) All Surface Vehicle (ASVs) – Required to access UGD and MTD during maintenance.
- 2.) Dump Truck – Truck to haul sediment and/or debris collected during maintenance of UGD and MTD.
 - Vehicle size dependent on amount of visible sediment.
- 3.) Jet-Vac Machine – To be used during maintenance of the UGD isolation row and MTD. Jet-Vac requirements and recommendations listed below. Jet-Vac should only be used on the isolation rows that have ADS Plus Fabric (not to be used on detention rows).
 - “Sled” based nozzle such as Keg Floor Cleaner recommended.
 - Maximum nozzle pressure of 2000 psi.
 - Hose lengths recommended to be 200’
 - Standard hose sizes less than 12” diameter are acceptable
- 4.) Confined Space Entry Equipment – Required for maintenance and inspection of the UGD and MTD. Used to inspect UGD isolations row, detention rows, maintain inlets and maintain outlet rows. In the event that the detention row acquires sediments, entry into the system would be required to clean detention row with buckets and shovel.
- 5.) Approved Stormwater Facility Operation and Maintenance Manual
- 6.) Mirror on pole, camera, flashlight – Utilized to inspect sediment levels within the isolation rows and detention row of the UGD.
- 7.) Stadia Rod, Sediment Probe - Utilized to inspect sediment levels within the isolation rows and detention row of the UGD as well as the MTD.
- 8.) Tape Measure- Utilized to inspect and measure sediment levels within the isolation rows and detention row of the UGD as well as the MTD.

- 9.) Maintenance Log – Utilized to track maintenance efforts on the UGD and MTD.
- 10.) Shovel – Utilized to clean sediment within the MTD and UGD. The Jet-vac should not be used for detention row of UGD and shovel should be used if sediment accumulates.
- 11.) Buckets to remove sediment and/or trash debris– Utilized to clean sediment within the MTD and UGD. The Jet-vac should not be used for detention row of UGD and shovel should be used if sediment accumulates.

Some of the items identified above may not be needed for every maintenance operation. However, this equipment should be available to the maintenance operations crews should the need arise.

UGD-3.3 Safety

Vertical drops may be encountered in areas located within and around the facility. Avoid walking on top of retaining walls or other structures that have a significant vertical drop. If a vertical drop is identified within the UGD that is greater than 48” in height, make the appropriate note/comment on the maintenance inspection form.

UGD-3.4 Maintenance Forms

The UGD Maintenance Form provides a record of each maintenance operation performed by maintenance contractors. The UGD Maintenance Form shall be filled out in the field after the completion of the maintenance operation. Each form shall be reviewed and submitted by the property owner or property manager to the El Paso County per the requirements of the Operations and Maintenance Manual. The UGD Maintenance form is located in Appendix E.

UGD-3.5 Maintenance Categories and Activities

A typical UGD Maintenance Program will consist of three broad categories of work. Within each category of work, a variety of maintenance activities can be performed on an UGD. A maintenance activity can be specific to each feature within the UGD, or general to the overall facility. This section of the SOP explains each of the categories and briefly describes the typical maintenance activities for an UGD.

A variety of maintenance activities are typical of UGDs. The maintenance activities range in magnitude from routine trash pickup to the reconstruction of drainage infrastructure. Below is a description of each maintenance activity, the objectives, and frequency of actions:

The Isolator Row PLUS was designed to reduce the cost of periodic maintenance. By “isolating” sediments to just one row, costs are dramatically reduced by eliminating the need to clean out each row of the entire storage bed. If inspection indicates the potential need for maintenance, access is provided via a manhole(s) located on the end(s) of the row for cleanout. If entry into the manhole is required, please follow local and OSHA rules for a confined space entries. Maintenance is accomplished with the JetVac process. The

JetVac process utilizes a high pressure water nozzle to propel itself down the Isolator Row PLUS while scouring and suspending sediments. As the nozzle is retrieved, the captured pollutants are flushed back into the manhole for vacuuming. Most sewer and pipe maintenance companies have vacuum/JetVac combination vehicles. Selection of an appropriate JetVac nozzle will improve maintenance efficiency. Fixed nozzles designed for culverts or large diameter pipe cleaning are preferable. Rear facing jets with an effective spread of at least 45" are best. StormTech recommends a maximum nozzle pressure of 2000 psi be utilized during cleaning. Most JetVac reels have 400 feet of hose allowing maintenance of an Isolator Row PLUS up to 50 chambers long. The JetVac process shall only be performed on StormTech Isolator Row PLUS that have ADS PLUS Fabric (as specified by StormTech) over their angular base stone.

ISOLATOR ROW PLUS STEP BY STEP MAINTENANCE PROCEDURES STEP 1

Inspect Isolator Row PLUS for sediment.

- A) Inspection ports
 - i. Remove lid from from box frame
 - ii. Remove cap from inspection riser
 - iii. Using a flashlight and stadia rod, measure depth of sediment and record results on maintenance log.
 - iv. If sediment is at or above 3 inch depth, proceed to Step 2. If not, proceed to Step 3.

- B) All Isolator Row PLUS
 - i. Remove cover from manhole at upstream end of Isolator Row PLUS
 - ii. Using a flashlight, inspect down Isolator Row PLUS through outlet pipe
 - 1. Mirrors on poles or cameras may be used to avoid a confined space entry
 - 2. Follow OSHA regulations for confined space entry if entering manhole
 - iii. If sediment is at or above the lower row of sidewall holes (approximately 3 inches), proceed to Step 2. If not, proceed to Step 3.

STEP 2

Clean out Isolator Row PLUS using the JetVac process.

- A) A fixed floor cleaning nozzle with rear facing nozzle spread of 45 inches or more is preferable
- B) Apply multiple passes of JetVac until backflush water is clean
- C) Vacuum manhole sump as required

STEP 3

Replace all caps, lids and covers, record observations and actions.

STEP 4

Inspect & clean catch basins and manholes upstream of the StormTech system.

DETENTION ROW STEP BY STEP MAINTENANCE PROCEDURES STEP 1

Inspect Detention Row for sediment.

C) Inlet Structure

- i. Remove lid from concrete structure
- ii. Using a flashlight and stadia rod, measure depth of sediment and record results on maintenance log. This may require entering inlet structure to get better access visibility to detention row.
- iii. If sediment is at or above 3 inch depth, proceed to Step 2. If not, proceed to Step 3.

D) Detention Row

- i. Remove cover from manhole at upstream end of detention ROW
- ii. Using a flashlight, inspect down Isolator Row PLUS through outlet pipe
 - 1. Mirrors on poles or cameras may be used to avoid a confined space entry
 - 2. Follow OSHA regulations for confined space entry if entering manhole
- iii. If sediment is at or above the lower row of sidewall holes (approximately 3 inches), proceed to Step 2. If not, proceed to Step 3.

STEP 2

Clean out Detention Row using shovel and bucket.

STEP 3

Replace all caps, lids and covers, record observations and actions.

STEP 4

Inspect & clean catch basins and manholes upstream of the StormTech system.

UGD-3.6 Routine Maintenance Activities

The majority of this work consists of regularly scheduled mowing and trash and debris pickups for stormwater management facilities during the growing season **upstream** of the UDG. This includes items such as the removal of debris/material that may be clogging the upstream stormwater inlets. These activities normally will be performed numerous times during the year. These items can be completed without any prior correspondence with the El Paso County; however, completed inspection and maintenance forms shall be submitted to the EPC for each inspection and maintenance activity.

The Maintenance Activities are summarized below, and further described in the following sections.

**TABLE – UGD-2
Summary of Routine Maintenance Activities**

| MAINTENANCE ACTIVITY | MINIMUM FREQUENCY | LOOK FOR: | MAINTENANCE ACTION |
|----------------------|-------------------|-----------------------------------|--|
| Mowing | Twice annually | Excessive grass height/aesthetics | Mow grass to a height of 4" to 6" |
| Trash/Debris Removal | Twice annually | Trash & debris in UGD | Remove and dispose of trash and debris |

| | | | |
|---|---|--|--|
| Outlet Works Cleaning | As needed - after significant rain events – twice annually min. | Clogged outlet structure; ponding water | Remove and dispose of debris/trash/sediment to allow outlet to function properly |
| Inlet Structure with Stormflex Inlet Filters & PC Filter Bag Cleaning | As needed - after significant rain events – twice annually min. | Clogged inlet structure; ponding water | Remove and dispose of debris/trash/sediment to allow outlet to function properly |
| Weed control | Minimum twice annually | Noxious weeds; Unwanted vegetation | Treat w/ herbicide or hand pull; Consult the local weed specialist |
| Mosquito Treatment | As needed | Standing water/mosquito habitat | Treat w/ EPA approved chemicals |
| Algae Treatment | As needed | Standing water/ Algal growth/green color | Treat w/ EPA approved chemicals |

UGD-3.6.1 Mowing

Mowing is necessary to limit **upstream** unwanted vegetation and to remove the overall pollutants allowed to enter the UGD. Native vegetation should be mowed to a height of 4-to-6 inches tall. Grass clippings should be collected and disposed of properly.

Frequency – Routine - Minimum of twice annually or depending on aesthetics.

UGD-3.6.2 Trash/Debris Removal

Trash and debris must be removed from the MTDs and entire UGD area to minimize inlet/outlet clogging and to improve aesthetics. This activity must be performed prior to mowing operations.

Frequency – Routine – Prior to mowing operations and minimum of twice annually.

UGD-3.6.3 Outlet Works Cleaning

Debris and other materials can clog the outlet work's well screen, orifice plate(s) and pump system. This activity must be performed anytime other maintenance activities are conducted to ensure proper operation.

Frequency - Routine – After significant rainfall event or concurrently with other maintenance activities.

UGD-3.6.4 Weed Control

Upstream Noxious weeds and other unwanted vegetation must be treated as needed prior to reaching the UGD. This activity can be performed either through mechanical means (mowing/pulling) or with herbicide. Consultation with the local Weed Inspector is highly recommended prior to the use of herbicide.

Frequency – Routine – As needed based on inspections.

UGD-3.6.5 Mosquito/Algae Treatment

Treatment of permanent pools **upstream** to the UGD is necessary to control mosquitoes and undesirable aquatic vegetation that can create nuisances. Only EPA approved chemicals/materials can be used in areas that are warranted.

Frequency – As needed.

UGD- 3.7 Minor Maintenance Activities

This work consists of a variety of isolated or small-scale maintenance or operational problems. Most of this work can be completed by a small crew, tools, and small equipment. These items require prior correspondence with EPC and require completed inspection and maintenance forms to be submitted to EPC for each inspection and maintenance activity.

**Table – UGD-3
Summary of Minor Maintenance Activities**

| MAINTENANCE ACTIVITY | MINIMUM FREQUENCY | LOOK FOR: | MAINTENANCE ACTION |
|---|---------------------------------------|--|--|
| Sediment Removal | As needed; typically every 1 –2 years | Sediment build-up; decrease in pond Volume and clogging of Inlets at MTD | Remove and dispose of sediment |
| Erosion Repair | As needed, based upon inspection | Rills/gullies forming on side slopes, trickle channel, other areas | Repair eroded areas Revegetate; address source of erosion |
| Vegetation Removal/Tree Thinning | As needed, based upon inspection | Large trees/wood vegetation in lower chamber of pond | Remove vegetation; restore grade and surface |
| Drain Cleaning/Jet Vac | As needed, based upon inspection | Sediment build-up /non draining system | Clean drains; Jet Vac if needed |
| PC Filter Bag Replacement | As needed; typically every 1 –2 years | Oil skimmer pouches solidify and darken indicating saturation | Replace filter with new PC filter bag |

UGD-3.7.1 Sediment Removal

Sediment removal is necessary to maintain the original design volume of the UGD and to ensure proper function of the infrastructure. Regular sediment removal (minor) from the MTD(s), and inflow(s), can significantly reduce the frequency of major sediment removal activities (dredging) in the isolator row. The minor sediment removal activities can typically be addressed with shovels or smaller equipment, including a vac truck as needed at the inlets and UGD inlet structures. Major sediment removal activities will require larger and more specialized equipment as outlined in section UGD-3.2.

Stormwater sediments removed from UGDs do not meet the criteria of “hazardous waste”. However, these sediments are contaminated with a wide array of organic and inorganic pollutants and handling must be done with care. Sediments from isolator row must be carefully removed to minimize further sedimentation or other adverse water quality impacts. Sediments

should be transported by motor vehicle only after they are dewatered. All sediments must be taken to a landfill for proper disposal. Prompt and thorough cleanup is important should a spill occur during transportation.

Frequency – Nonroutine – As necessary based upon inspections. Sediment removal in the forebay and trickle channel may be necessary as frequently as every 1-2 years.

UGD-3.7.2 Erosion Repair

The repair of eroded areas upstream of the UGD is necessary to minimize eroded material from reaching the UGD, minimize sediment transport, and to reduce potential impacts to other features. Erosion can vary in magnitude from minor repairs or major repairs on developments upstream of the UGD. The repair of eroded areas may require the use of excavators, earthmoving equipment, riprap, concrete, erosion control blankets, and turf reinforcement mats. Major erosion repair to the pond embankments, spillways, and adjacent to structures will require consultation with EPC engineering staff.

Frequency – Nonroutine – As necessary based upon inspections.

UGD-3.7.3 Vegetation Removal/Tree Thinning

Dense stands of woody vegetation (willows, shrubs, etc) or trees can create maintenance problems for the infrastructure within an UGD. Tree roots can damage structures and invade pipes/channels thereby blocking flows. There are no trees planted near the UGD and should be avoided in the future. In the event a tree is planted, a small tree is easier to remove than a large tree, therefore, regular removal/thinning is imperative. All trees and woody vegetation that is growing on top of the UGD or near structures (inflows, outlet works, etc) should be removed. Any trees or woody vegetation within 30 feet of the UGD should be monitored for root growth.

Frequency – Nonroutine – As necessary based upon inspections.

UGD-3.7.4 Clearing Drains/Jet-Vac

An UGD contains many structures, openings, vaults and pipes that can be frequently clogged with debris. These blockages can result in a decrease of hydraulic capacity. Many times the blockage to this infrastructure can be difficult to access and/or clean. Specialized equipment (jet-vac machines) may be necessary to clear debris from these difficult areas.

Frequency – Nonroutine – As necessary based upon inspections.

UGD-3.8 Major Maintenance Activities

This work consists of larger maintenance/operational problems and failures within the

stormwater management facilities. All of this work requires consultation with EPC to ensure the proper maintenance is performed. This work requires that the engineering staff review the original design and construction drawings to assess the situation and assign the necessary maintenance. A Public Improvements Permit shall be required for all major maintenance activities. A public improvement permit requires an application, traffic control plan (as necessary), site map, construction plans of proposed work/maintenance, certificate of liability insurance, construction/permit bond. The county should be contact to confirm if any requirements have been modified since this report has been published. This work may also require more specialized maintenance equipment, design/details, surveying, or assistance through private contractors and consultants.

**Table – UGD-4
Summary of Major Maintenance Activities**

| MAINTENANCE ACTIVITY | MINIMUM FREQUENCY | LOOK FOR: | MAINTENANCE ACTION |
|-----------------------------|--|---|--|
| Major Sediment Removal | As needed – based upon scheduled inspections | Large quantities of sediment; reduced pond capacity | Remove and dispose of sediment. Repair vegetation as needed |
| Major Erosion Repair | As needed – based upon scheduled inspections | Severe erosion including gullies, excessive soil displacement, areas of settlement, holes | Repair erosion – find cause of problem and address to avoid future erosion |
| Structural Repair | As needed – based upon scheduled inspections | Deterioration and/or damage to structural components – broken concrete, damaged pipes, outlet works | Structural repair to restore the structure to its original design |

UGD-3.8.1 Major Sediment Removal

Major sediment removal consists of removal of large quantities of sediment or removal of sediment from vegetated areas. Care shall be given when removing large quantities of sediment and sediment deposited in vegetated areas. Large quantities of sediment need to be carefully removed, transported and disposed of. Vegetated areas need special care to ensure design volumes and grades are preserved.

Similar to the procedure for the isolator rows if >3” of sediment (per ADS O&M) is measured in the inspection port of the detention row, sediment will be removed from all detention row. Maintenance procedure for sediment in the detention row are as follows.

Frequency – Nonroutine – Repair as needed based upon inspections.

UGD-3.8.2 Major Erosion Repair

Major erosion repair consists of filling and revegetating areas of severe erosion. Determining the cause of the erosion as well as correcting the condition that caused the erosion should also be part of the erosion repair. Care should be given to ensure design grades and volumes are preserved.

Frequency – Nonroutine – Repair as needed based upon inspections.

UGD-3.8.3 Structural Repair

An UGD includes a variety of structures that can deteriorate or be damaged during the course of routine maintenance. These structures are constructed of steel and concrete that can degrade or be damaged and may need to be repaired or re-constructed from time to time. These structures include items like outlet works, forebays, inflows and other features. In-house operations staff can perform some of the minor structural repairs. Major repairs to structures may require input from a structural engineer and specialized contractors. Consultation with EPC Engineering Staff should take place prior to all structural repairs.

Frequency – Nonroutine – Repair as needed based upon inspections.

Appendix D

UNDERGROUND DETENTION (UGD)

INSPECTION FORM

Date: _____

Subdivision/Business Name: Kum & Go #2232

Inspector: _____

Business Address: 304 Main Street

Weather: _____

Date of Last Rainfall: _____ Amount: _____ Inches

Property Classification: Residential Multi Family Commercial Other: _____
(Circle One)

Reason for Inspection: Routine Complaint After Significant Rainfall Event
(Circle One)

INSPECTION SCORING - For each facility inspection item, insert one of the following scores:
0 = No deficiencies identified 2 = Routine maintenance required
1 = Monitor (potential for future problem) 3 = Immediate repair necessary
N/A = Not applicable

FEATURES

1.) Inflow Points

- Sediment/Debris Accumulation
- Access Manhole Condition
- Drain Pipe/Wier Clogged (not draining)
- Structural Damage (pipe, end-section, etc.)
- Oil Accumulation

2.) Inlet Filter & Filter Bags at Inlets

- Sediment/Debris Accumulation
- Structural Damage (pipe, end-section, etc.)
- Drain Pipe/Wier Clogged (not draining)
- Oil Accumulation

3.) Isolation Row

- Sediment/Debris Accumulation
- Access Manhole Condition
- Drain Pipe/Wier Clogged (not draining)
- Structural Damage (pipe, end-section, etc.)
- Oil Accumulation

4.) Outlet Works

- Sediment/Debris Accumulation
- Access Manhole Condition
- Drain Pipe/Orifice Clogged (not draining)
- Structural Damage (pipe, end-section, etc.)
- Oil Accumulation
- Pump Condition/Function

5.) Emergency Spillway

- Obstruction/Debris
- Structural Damage (concrete, condition)
- Orifice Plate(s) Missing/Not Secure
- Manhole Access (cover, steps, etc.)

6.) Miscellaneous

- Encroachment in Easement Area
- Graffiti/Vandalism
- Public Hazards
- Other

Inspection Summary / Additional Comments: _____

OVERALL FACILITY RATING (Circle One)

0 = No Deficiencies Identified 2 = Routine Maintenance Required
1 = Monitor (potential for future problem exists) 3 = Immediate Repair Necessary

This inspection form shall be kept indefinitely and made available to the El Paso County upon request.

Appendix E

**UNDERGROUND DETENTION (UGD)
MAINTENANCE FORM**

Subdivision/Business Name: Kum & Go #2232
Subdivision/Business Address: 304 Main Street

Completion Date: _____
Contact Name: _____

Maintenance Category: Routine Restoration Rehabilitation
(Circle All That Apply)

MAINTENANCE ACTIVITIES PERFORMED

ROUTINE WORK

- ___ TRASH/DEBRIS REMOVAL
- ___ INLET FILTER BAG CLEANING
- ___ INLET WORKS CLEANING (STRUCTURE PIPES/WEIR)
- ___ OUTLET WORKS CLEANING (ORIFICE PLATE/PUMP STRUCTURE)

RESTORATION WORK

- ___ SEDIMENT REMOVAL
 - ___ INLET FILTER & FILTER BAG
 - ___ INFLOW POINT
 - ___ OUTLET WORKS
 - ___ DETENTION ROW
- ___ EROSION REPAIR
 - ___ INLET FILTER & FILTER BAG
 - ___ INFLOW POINT
 - ___ OUTLET WORKS
 - ___ DETENTION ROW

- ___ JET-VAC/CLEARING DRAINS
 - ___ ISOLATION ROW
 - ___ OUTLET WORKS
 - ___ INFLOWS

REHABILITATION WORK

- ___ SEDIMENT REMOVAL (JETVAC)
 - ___ ISOLATION ROW
 - ___ INFLOW POINT
 - ___ OUTLET WORKS
- ___ EROSION REPAIR
 - ___ ISOLATION ROW
 - ___ UPPER STAGE
- ___ STRUCTURAL REPAIR
 - ___ INFLOW
 - ___ OUTLET WORKS
 - ___ INLET FILTER & FILTER BAG

OTHER _____

ESTIMATED TOTAL MANHOURS: _____

EQUIPMENT/MATERIAL USED: _____

COMMENTS/ADDITIONAL INFO: _____

Appendix F

Annual Inspection and Maintenance Reporting Form
for
Stormwater Facilities

(This form to be submitted to EPC prior to May 31 of each year)

Date: _____

**To: El Paso County Department of Public Works
Attn: Stormwater Facility Operations and Maintenance Program
2880 International Circle, Suite 7437 South Fairplay Street
Colorado Springs, CO 80922**

Re: Certification of Inspection and Maintenance; Submittal of forms

Property/Subdivision Name: Kum & Go #2232 – Lot 2, Pedrick-Echerd Filing No. 3

Property Address: 304 Main Street

Contact Name: _____

I verify that the required stormwater facility inspections and required maintenance have been completed in accordance with the Stormwater Facilities Maintenance Agreement and the Operations and Maintenance Manual associated with the above referenced property.

The required Stormwater Facility Inspection and Maintenance forms are hereby provided.

Name of Party Responsible for Inspection
& Maintenance

Property Owner

Authorized Signature

Signature

Items to be included with submittal:

- Completed Annual Maintenance Form
- Record of Inspection completed
- Record of Maintenance Completed

Appendix G

KUM & GO GAS & C-STORE

PART OF THE SOUTHEAST 1/4 OF SECTION 11, TOWNSHIP 15 SOUTH, RANGE 66
 WEST OF THE SIXTH PRINCIPAL MERIDIAN,
 COUNTY OF EL PASO, STATE OF COLORADO
MAJOR SITE DEVELOPMENT PLAN



1459 Grand Ave
 Des Moines, IA 50309
 P: 888-458-6646

2232 - EL PASO, COLORADO
 SECURITY BLVD. AND MAIN ST.
STORM SEWER PLAN

KG PROJECT TEAM:
 RDM:
 SDM:
 CPM:

| REVISION | DATE | DESCRIPTION |
|----------|----------|---------------------|
| 1 | 08/19/22 | 1ST REVIEW COMMENTS |
| 2 | 01/06/23 | 2ND REVIEW COMMENTS |
| 3 | 04/05/23 | 3RD REVIEW COMMENTS |
| 4 | 05/11/23 | 4TH REVIEW COMMENTS |

DATE: 05-11-2023
 SHEET NUMBER: C4.1
 17 OF 43

PCD FILE NO. PPR-2225

CRITERIA PLAN 04/2020

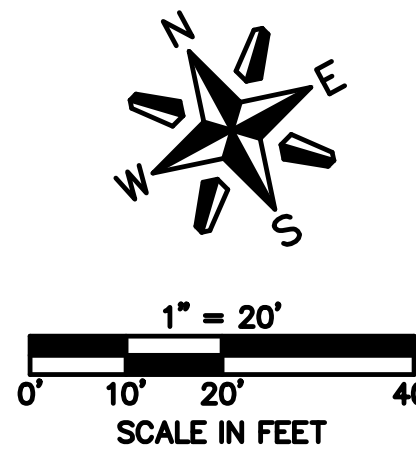
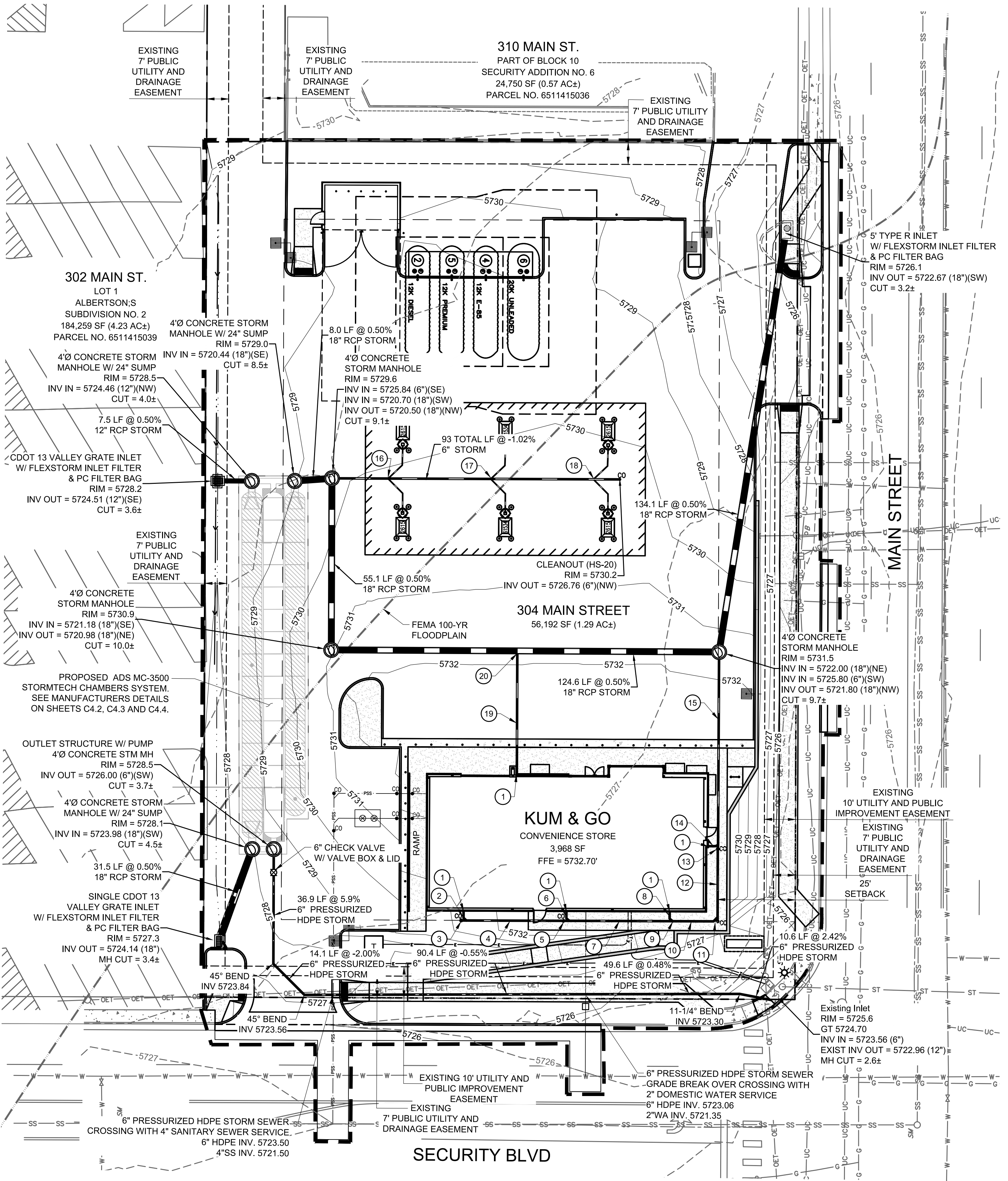

STORM SEWER PLAN LEGEND

| | |
|---------------------------------|---|
| — G — G — G — G — G — G — | EXISTING GAS |
| — SS — SS — SS — SS — SS — | EXISTING SANITARY SEWER |
| — ST — ST — ST — ST — ST — | EXISTING STORM SEWER |
| — OET — OET — OET — OET — OET — | EXISTING OVERHEAD ELECTRICAL AND TELECOMMUNICATIONS |
| — UC — UC — UC — UC — UC — | EXISTING UNDERGROUND TELECOMMUNICATIONS |
| — W — W — W — W — W — W — | EXISTING WATER |
| — — — — — | CONSTRUCTION / DISTURBANCE LIMITS |
| — — — — — | PROPERTY BOUNDARY |
| — — — — — | EXISTING EASEMENT |
| — — — — — | EXISTING FLOODPLAIN |
| — — — — — | EXISTING CURB & GUTTER |
| — — — — — | EXISTING MAJOR CONTOUR |
| — — — — — | EXISTING MINOR CONTOUR |
| — — — — — | PROPOSED MAJOR CONTOUR |
| — — — — — | PROPOSED MINOR CONTOUR |
| — — — — — | PROPOSED CURB & GUTTER |
| — — — — — | PROPOSED BUILDING |
| — — — — — | PROPOSED SURFACE FLOW LINE |
| — — — — — | PROPOSED STORM SEWER |
| ⊙ | EXISTING STORM SEWER MANHOLE/INLET |
| ⊙ | PROPOSED STORM SEWER MANHOLE/INLET |
| ⊙ | EXISTING STREET LIGHTING |
| ⊙ | EXISTING FIRE HYDRANT |
| ⊙ | EXISTING SIGNAGE |
| ⊙ | PROPOSED SITE LIGHTING |

BENCHMARK:

ELEVATIONS ARE BASED UPON COLORADO SPRINGS UTILITIES FIRMS CONTROL MONUMENT SE09, BEING A 2-INCH DIAMETER ALUMINUM CAP STAMPED "CSU FIRMS CONTROL SE09" ON THE EAST CORNER OF THE CONCRETE BASE OF A TELEPHONE RELAY BOX AT THE EAST CORNER OF 226 MAIN STREET, ABOUT 3 FEET NORTHWEST OF THE NORTHWEST CURB OF MAIN STREET, AND ABOUT 205 FEET SOUTHWEST OF THE SOUTHWEST CURB LINE OF SECURITY BOULEVARD. CITY ELEVATION: 5726.76 (NGVD 29)



P:\KUM & GO\CO. EL PASO COUNTY - 2232 MAIN AND SECURITY\08 CAD\GSC2232 - 17 - STORM SEWER PLAN.DWG

KUM & GO GAS & C-STORE

PART OF THE SOUTHEAST 1/4 OF SECTION 11, TOWNSHIP 15 SOUTH, RANGE 66
WEST OF THE SIXTH PRINCIPAL MERIDIAN,
COUNTY OF EL PASO, STATE OF COLORADO
MAJOR SITE DEVELOPMENT PLAN

| PROJECT INFORMATION | |
|----------------------------|--|
| ENGINEERED PRODUCT MANAGER | JEROME MAGSINO 303-349-7555 JEROME.MAGSINO@ADSPIPE.COM |
| ADS SALES REP | AARON ZEE 303-548-3479 AARON.ZEE@ADS-PIPE.COM |
| PROJECT NO. | S314443 |



KUM & GO 2232 EL PASO COUNTY, CO, USA

MC-3500 STORMTECH CHAMBER SPECIFICATIONS

- CHAMBERS SHALL BE STORMTECH MC-3500.
- CHAMBERS SHALL BE ARCH-SHAPED AND SHALL BE MANUFACTURED FROM VIRGIN, IMPACT-MODIFIED POLYPROPYLENE COPOLYMERS.
- CHAMBERS SHALL MEET THE REQUIREMENTS OF ASTM F2418, "STANDARD SPECIFICATION FOR POLYPROPYLENE (PP) CORRUGATED WALL STORMWATER COLLECTION CHAMBERS" CHAMBER CLASSIFICATION 45x76 DESIGNATION SS.
- CHAMBER ROWS SHALL PROVIDE CONTINUOUS, UNOBSTRUCTED INTERNAL SPACE WITH NO INTERNAL SUPPORTS THAT WOULD IMPEDE FLOW OR LIMIT ACCESS FOR INSPECTION.
- THE STRUCTURAL DESIGN OF THE CHAMBERS, THE STRUCTURAL BACKFILL, AND THE INSTALLATION REQUIREMENTS SHALL ENSURE THAT THE LOAD FACTORS SPECIFIED IN THE AASHTO LRFD BRIDGE DESIGN SPECIFICATIONS, SECTION 12.12, ARE MET FOR: 1) LONG-DURATION DEAD LOADS AND 2) SHORT-DURATION LIVE LOADS, BASED ON THE AASHTO DESIGN TRUCK WITH CONSIDERATION FOR IMPACT AND MULTIPLE VEHICLE PRESENCES.
- CHAMBERS SHALL BE DESIGNED, TESTED AND ALLOWABLE LOAD CONFIGURATIONS DETERMINED IN ACCORDANCE WITH ASTM F2787, "STANDARD PRACTICE FOR STRUCTURAL DESIGN OF THERMOPLASTIC CORRUGATED WALL STORMWATER COLLECTION CHAMBERS". LOAD CONFIGURATIONS SHALL INCLUDE: 1) INSTANTANEOUS (<1 MIN) AASHTO DESIGN TRUCK LIVE LOAD ON MINIMUM COVER 2) MAXIMUM PERMANENT (75-YR) COVER LOAD AND 3) ALLOWABLE COVER WITH PARKED (1-WEEK) AASHTO DESIGN TRUCK.
- REQUIREMENTS FOR HANDLING AND INSTALLATION:
 - TO MAINTAIN THE WIDTH OF CHAMBERS DURING SHIPPING AND HANDLING, CHAMBERS SHALL HAVE INTEGRAL, INTERLOCKING STACKING LUGS.
 - TO ENSURE A SECURE JOINT DURING INSTALLATION AND BACKFILL, THE HEIGHT OF THE CHAMBER JOINT SHALL NOT BE LESS THAN 3".
 - TO ENSURE THE INTEGRITY OF THE ARCH SHAPE DURING INSTALLATION, a) THE ARCH STIFFNESS CONSTANT SHALL BE GREATER THAN OR EQUAL TO 450 LBS/FT³. THE ASC IS DEFINED IN SECTION 6.2.8 OF ASTM F2418. AND b) TO RESIST CHAMBER DEFORMATION DURING INSTALLATION AT ELEVATED TEMPERATURES (ABOVE 73° F / 23° C), CHAMBERS SHALL BE PRODUCED FROM REFLECTIVE GOLD OR YELLOW COLORS.
- ONLY CHAMBERS THAT ARE APPROVED BY THE SITE DESIGN ENGINEER WILL BE ALLOWED. UPON REQUEST BY THE SITE DESIGN ENGINEER OR OWNER, THE CHAMBER MANUFACTURER SHALL SUBMIT A STRUCTURAL EVALUATION FOR APPROVAL BEFORE DELIVERING CHAMBERS TO THE PROJECT SITE AS FOLLOWS:
 - THE STRUCTURAL EVALUATION SHALL BE SEALED BY A REGISTERED PROFESSIONAL ENGINEER.
 - THE STRUCTURAL EVALUATION SHALL DEMONSTRATE THAT THE SAFETY FACTORS ARE GREATER THAN OR EQUAL TO 1.95 FOR DEAD LOAD AND 1.75 FOR LIVE LOAD, THE MINIMUM REQUIRED BY ASTM F2787 AND BY SECTIONS 3 AND 12.12 OF THE AASHTO LRFD BRIDGE DESIGN SPECIFICATIONS FOR THERMOPLASTIC PIPE.
 - THE TEST DERIVED CREEP MODULUS AS SPECIFIED IN ASTM F2418 SHALL BE USED FOR PERMANENT DEAD LOAD DESIGN EXCEPT THAT IT SHALL BE THE 75-YEAR MODULUS USED FOR DESIGN.
- CHAMBERS AND END CAPS SHALL BE PRODUCED AT AN ISO 9001 CERTIFIED MANUFACTURING FACILITY.

IMPORTANT - NOTES FOR THE BIDDING AND INSTALLATION OF MC-3500 CHAMBER SYSTEM

- STORMTECH MC-3500 CHAMBERS SHALL NOT BE INSTALLED UNTIL THE MANUFACTURER'S REPRESENTATIVE HAS COMPLETED A PRE-CONSTRUCTION MEETING WITH THE INSTALLERS.
- STORMTECH MC-3500 CHAMBERS SHALL BE INSTALLED IN ACCORDANCE WITH THE "STORMTECH MC-3500/MC-4500 CONSTRUCTION GUIDE".
- CHAMBERS ARE NOT TO BE BACKFILLED WITH A DOZER OR AN EXCAVATOR SITUATED OVER THE CHAMBERS. STORMTECH RECOMMENDS 3 BACKFILL METHODS:
 - STONESHOOTER LOCATED OFF THE CHAMBER BED.
 - BACKFILL AS ROWS ARE BUILT USING AN EXCAVATOR ON THE FOUNDATION STONE OR SUBGRADE.
 - BACKFILL FROM OUTSIDE THE EXCAVATION USING A LONG BOOM HOE OR EXCAVATOR.
- THE FOUNDATION STONE SHALL BE LEVELED AND COMPACTED PRIOR TO PLACING CHAMBERS.
- JOINTS BETWEEN CHAMBERS SHALL BE PROPERLY SEATED PRIOR TO PLACING STONE.
- MAINTAIN MINIMUM - 6" (150 mm) SPACING BETWEEN THE CHAMBER ROWS.
- INLET AND OUTLET MANIFOLDS MUST BE INSERTED A MINIMUM OF 12" (300 mm) INTO CHAMBER END CAPS.
- EMBEDMENT STONE SURROUNDING CHAMBERS MUST BE A CLEAN, CRUSHED, ANGULAR STONE MEETING THE AASHTO M43 DESIGNATION OF #3 OR #4.
- STONE MUST BE PLACED ON THE TOP CENTER OF THE CHAMBER TO ANCHOR THE CHAMBERS IN PLACE AND PRESERVE ROW SPACING.
- THE CONTRACTOR MUST REPORT ANY DISCREPANCIES WITH CHAMBER FOUNDATION MATERIALS BEARING CAPACITIES TO THE SITE DESIGN ENGINEER.
- ADS RECOMMENDS THE USE OF "FLEXSTORM CATCH IT" INSERTS DURING CONSTRUCTION FOR ALL INLETS TO PROTECT THE SUBSURFACE STORMWATER MANAGEMENT SYSTEM FROM CONSTRUCTION SITE RUNOFF.

NOTES FOR CONSTRUCTION EQUIPMENT

- STORMTECH MC-3500 CHAMBERS SHALL BE INSTALLED IN ACCORDANCE WITH THE "STORMTECH MC-3500/MC-4500 CONSTRUCTION GUIDE".
- THE USE OF EQUIPMENT OVER MC-3500 CHAMBERS IS LIMITED:
 - NO EQUIPMENT IS ALLOWED ON BARE CHAMBERS.
 - NO RUBBER Tired LOADER, DUMP TRUCK, OR EXCAVATORS ARE ALLOWED UNTIL PROPER FILL DEPTHS ARE REACHED IN ACCORDANCE WITH THE "STORMTECH MC-3500/MC-4500 CONSTRUCTION GUIDE".
 - WEIGHT LIMITS FOR CONSTRUCTION EQUIPMENT CAN BE FOUND IN THE "STORMTECH MC-3500/MC-4500 CONSTRUCTION GUIDE".
- FULL 36" (900 mm) OF STABILIZED COVER MATERIALS OVER THE CHAMBERS IS REQUIRED FOR DUMP TRUCK TRAVEL OR DUMPING.

USE OF A DOZER TO PUSH EMBEDMENT STONE BETWEEN THE ROWS OF CHAMBERS MAY CAUSE DAMAGE TO CHAMBERS AND IS NOT AN ACCEPTABLE BACKFILL METHOD. ANY CHAMBERS DAMAGED BY USING THE "DUMP AND PUSH" METHOD ARE NOT COVERED UNDER THE STORMTECH STANDARD WARRANTY.

CONTACT STORMTECH AT 1-888-892-2694 WITH ANY QUESTIONS ON INSTALLATION REQUIREMENTS OR WEIGHT LIMITS FOR CONSTRUCTION EQUIPMENT.



1459 Grand Ave
Des Moines, IA 50309
P: 888-458-6646

2232 - EL PASO, COLORADO
SECURITY BLVD. AND MAIN ST.

ADS SYSTEM DETAILS

KG PROJECT TEAM:
RDM:
SDM:
CPM:

| DATE | REVISION DESCRIPTION |
|----------|----------------------|
| 08/19/22 | 1ST REVIEW COMMENTS |
| 01/06/23 | 2ND REVIEW COMMENTS |
| 04/05/23 | 3RD REVIEW COMMENTS |
| 05/11/23 | 4TH REVIEW COMMENTS |

DATE: 05-11-2023

SHEET NUMBER:

C4.2
18 OF 43



PCD FILE NO. PPR-2225

KUM & GO GAS & C-STORE

PART OF THE SOUTHEAST 1/4 OF SECTION 11, TOWNSHIP 15 SOUTH, RANGE 66
WEST OF THE SIXTH PRINCIPAL MERIDIAN,
COUNTY OF EL PASO, STATE OF COLORADO

MAJOR SITE DEVELOPMENT PLAN

| PROPOSED LAYOUT | | PROPOSED ELEVATIONS | | *INVERT ABOVE BASE OF CHAMBER | | | | |
|-----------------|--|---------------------|---|-------------------------------|----------------|--|--------|-------------|
| 44 | STORMTECH MC-3500 CHAMBERS | 5732.50 | MAXIMUM ALLOWABLE GRADE (TOP OF PAVEMENT/UNPAVED) | PART TYPE | ITEM ON LAYOUT | DESCRIPTION | INVERT | MAX FLOW |
| 6 | STORMTECH MC-3500 END CAPS | 5726.50 | MINIMUM ALLOWABLE GRADE (UNPAVED WITH TRAFFIC) | PREFABRICATED END CAP | A | 24" BOTTOM CORED END CAP, PART#: MC3500IEPP24BC / TYP OF ALL 24" BOTTOM CONNECTIONS AND ISOLATOR PLUS ROWS | 2.06" | |
| 12 | STONE ABOVE (in) | 5726.00 | MINIMUM ALLOWABLE GRADE (UNPAVED NO TRAFFIC) | PREFABRICATED END CAP | B | 18" TOP CORED END CAP, PART#: MC3500IEPP18TC / TYP OF ALL 18" TOP CONNECTIONS | 20.03" | |
| 9 | STONE BELOW (in) | 5726.00 | MINIMUM ALLOWABLE GRADE (BASE OF FLEXIBLE PAVEMENT) | FLAMP | C | INSTALL FLAMP ON 24" ACCESS PIPE / PART#: MC350024RAMP (TYP 3 PLACES) | | |
| 40 | % STONE VOID | 5726.00 | MINIMUM ALLOWABLE GRADE (TOP OF RIGID PAVEMENT) | MANIFOLD | D | 18" x 18" TOP MANIFOLD, ADS N-12 | 20.03" | |
| 8,901 | INSTALLED SYSTEM VOLUME (CF) (PERIMETER STONE INCLUDED) | 5725.50 | TOP OF STONE | MANIFOLD | E | 18" x 18" TOP MANIFOLD, ADS N-12 | 20.03" | |
| 2,702 | SYSTEM AREA (ft ²) | 5724.50 | TOP OF MC-3500 CHAMBER | CONCRETE STRUCTURE | F | (DESIGN BY ENGINEER / PROVIDED BY OTHERS) | | 11.0 CFS IN |
| 289 | SYSTEM PERIMETER (ft) | 5720.92 | 18" TOP MANIFOLD INVERT | CONCRETE STRUCTURE | G | (DESIGN BY ENGINEER / PROVIDED BY OTHERS) | | |
| | | 5720.90 | 24" ISOLATOR ROW PLUS CONNECTION INVERT | CONCRETE STRUCTURE | H | (DESIGN BY ENGINEER / PROVIDED BY OTHERS) | | 5.5 CFS IN |
| | | 5720.75 | 18" BOTTOM MANIFOLD INVERT | CONCRETE STRUCTURE | I | (DESIGN BY ENGINEER / PROVIDED BY OTHERS) | | 4.0 CFS OUT |
| | | 5720.00 | BOTTOM OF MC-3500 CHAMBER | CONCRETE STRUCTURE | J | OUTLET CONTROL STRUCTURE (DESIGN BY ENGINEER / PROVIDED BY OTHERS) | | |
| | | 5720.00 | UNDERDRAIN INVERT | INSPECTION PORT | | 4" SEE DETAIL | | |
| | | 5720.00 | BOTTOM OF STONE | | | | | |

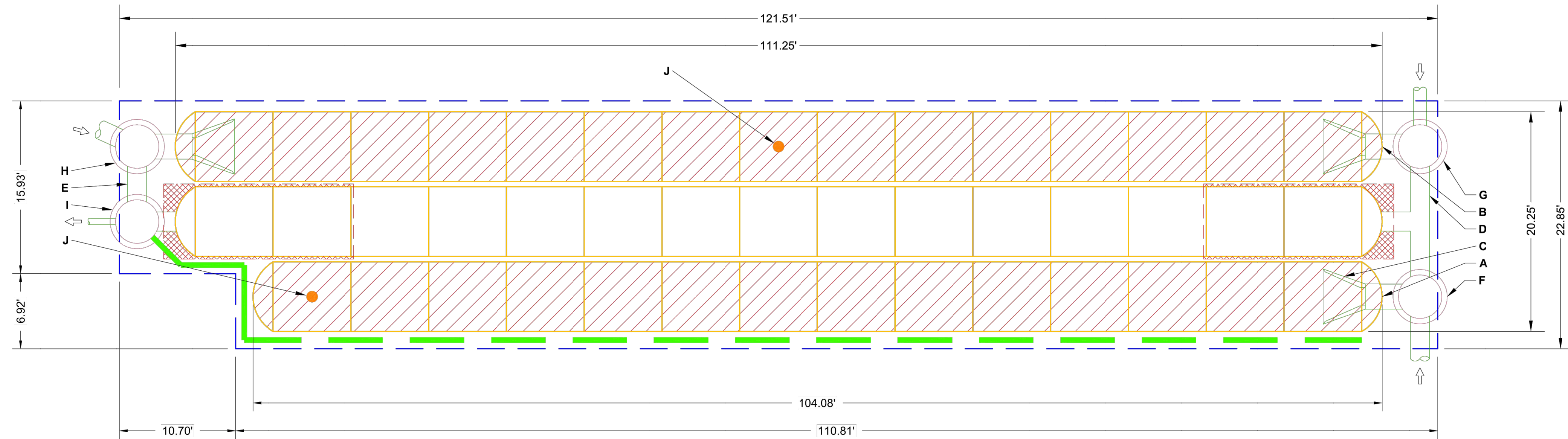

ISOLATOR ROW PLUS
(SEE DETAIL/TYP 2 PLACES)

PLACE MINIMUM 17.50' OF ADSPLUS175 WOVEN GEOTEXTILE OVER BEDDING STONE AND UNDERNEATH CHAMBER FEET FOR SCOUR PROTECTION AT ALL CHAMBER INLET ROWS

BED LIMITS

NOTES

- DUE TO THE ADAPTATION OF THIS CHAMBER SYSTEM TO SPECIFIC SITE AND DESIGN CONSTRAINTS, IT MAY BE NECESSARY TO CUT AND COUPLE ADDITIONAL PIPE TO STANDARD MANIFOLD COMPONENTS IN THE FIELD.
- THE SITE DESIGN ENGINEER MUST REVIEW ELEVATIONS AND IF NECESSARY ADJUST GRADING TO ENSURE THE CHAMBER COVER REQUIREMENTS ARE MET.
- THIS CHAMBER SYSTEM WAS DESIGNED WITHOUT SITE-SPECIFIC INFORMATION ON SOIL CONDITIONS OR BEARING CAPACITY. THE SITE DESIGN ENGINEER IS RESPONSIBLE FOR DETERMINING THE SUITABILITY OF THE SOIL AND PROVIDING THE BEARING CAPACITY OF THE INSITU SOILS. THE BASE STONE DEPTH MAY BE INCREASED OR DECREASED ONCE THIS INFORMATION IS PROVIDED.
- **NOT FOR CONSTRUCTION:** THIS LAYOUT IS FOR DIMENSIONAL PURPOSES ONLY TO PROVE CONCEPT & THE REQUIRED STORAGE VOLUME CAN BE ACHIEVED ON SITE.

StormTech®
Chamber System
888-892-2894 | WWW.STORMTECH.COM

4640 TRUEMAN BLVD
HILLIARD, OH 43026
1-800-753-7473

60/0/23 CTS LOWER BASE STONE TO 5720.00
03/04/23 AGC I AGC REV. PER MARKUP, UPDATED ELEV.
03/04/23 AGC I AGC REV. PER MARKUP, UPDATED ELEV.

DATE: 01/13/23 DRAWN: DDW
PROJECT #: S311443 CHECKED: N/A

THIS DRAWING HAS BEEN PREPARED BASED ON INFORMATION PROVIDED TO ADS UNDER THE DIRECTION OF THE SITE DESIGN ENGINEER OR OTHER PROJECT REPRESENTATIVE. THE SITE DESIGN ENGINEER SHALL REVIEW THIS DRAWING PRIOR TO CONSTRUCTION. IT IS THE ULTIMATE RESPONSIBILITY OF THE SITE DESIGN ENGINEER TO ENSURE THAT THE PRODUCTS SHOWN AND ALL ASSOCIATED DETAILS MEET ALL APPLICABLE LAWS, REGULATIONS, AND PROJECT REQUIREMENTS.

20
10
0

SHEET
2 OF 5



1459 Grand Ave
Des Moines, IA 50309
P: 888-458-6646

2232 - EL PASO, COLORADO
SECURITY BLVD. AND MAIN ST.
ADS SYSTEM DETAILS

KG PROJECT TEAM:
RDM:
SDM:
CPM:

| REVISION | DATE | DESCRIPTION |
|----------|----------|---------------------|
| 1 | 08/19/22 | 1ST REVIEW COMMENTS |
| 2 | 01/06/23 | 2ND REVIEW COMMENTS |
| 3 | 04/05/23 | 3RD REVIEW COMMENTS |
| 4 | 05/11/23 | 4TH REVIEW COMMENTS |

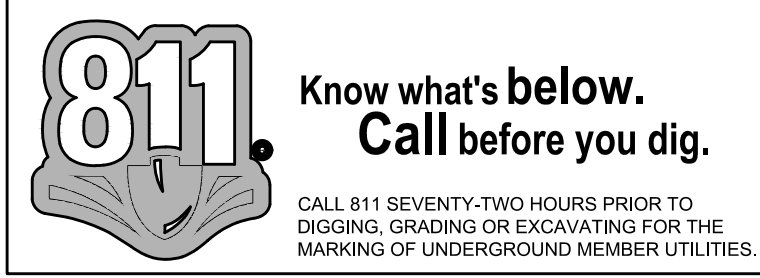

PCD FILE NO. PPR-2225

DATE: 05-11-2023
SHEET NUMBER:
C4.3
19 OF 43

KUM & GO GAS & C-STORE

PART OF THE SOUTHEAST 1/4 OF SECTION 11, TOWNSHIP 15 SOUTH, RANGE 66
WEST OF THE SIXTH PRINCIPAL MERIDIAN,
COUNTY OF EL PASO, STATE OF COLORADO
MAJOR SITE DEVELOPMENT PLAN

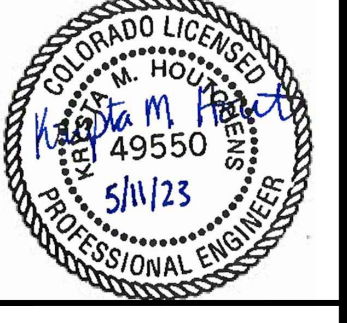
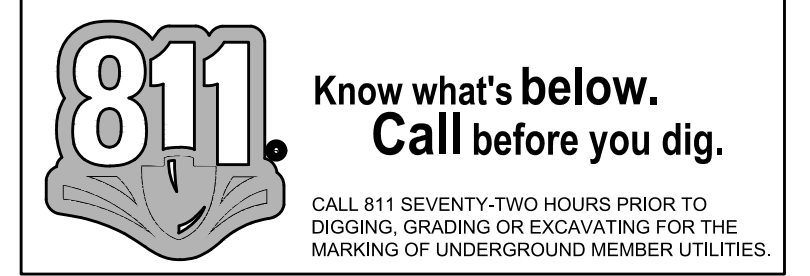

1459 Grand Ave
Des Moines, IA 50309
P: 888-458-6646

2232 - EL PASO, COLORADO
SECURITY BLVD. AND MAIN ST.
ADS SYSTEM DETAILS

KG PROJECT TEAM:
RDM:
SDM:
CPM:

| DATE | REVISION DESCRIPTION |
|----------|----------------------|
| 08/19/22 | 1ST REVIEW COMMENTS |
| 01/06/23 | 2ND REVIEW COMMENTS |
| 04/05/23 | 3RD REVIEW COMMENTS |
| 05/11/23 | 4TH REVIEW COMMENTS |

DATE: 05-11-2023

SHEET NUMBER: C4.4
20 OF 43

ACCEPTABLE FILL MATERIALS: STORMTECH MC-3500 CHAMBER SYSTEMS

| MATERIAL LOCATION | DESCRIPTION | AASHTO MATERIAL CLASSIFICATIONS | COMPACTION / DENSITY REQUIREMENT |
|-------------------|--|---|---|
| D | FINAL FILL: FILL MATERIAL FOR LAYER 'D' STARTS FROM THE TOP OF THE 'C' LAYER TO THE BOTTOM OF FLEXIBLE PAVEMENT OR UNPAVED FINISHED GRADE ABOVE. NOTE THAT PAVEMENT SUBBASE MAY BE PART OF THE 'D' LAYER | N/A | PREPARE PER SITE DESIGN ENGINEER'S PLANS. PAVED INSTALLATIONS MAY HAVE STRINGENT MATERIAL AND PREPARATION REQUIREMENTS. |
| C | INITIAL FILL: FILL MATERIAL FOR LAYER 'C' STARTS FROM THE TOP OF THE EMBEDMENT STONE ('B' LAYER) TO 24" (600 mm) ABOVE THE TOP OF THE CHAMBER. NOTE THAT PAVEMENT SUBBASE MAY BE A PART OF THE 'C' LAYER. | AASHTO M145 ¹ A-1, A-2-4, A-3 OR AASHTO M43 ¹ 3, 357, 4, 467, 5, 56, 57, 6, 67, 68, 7, 78, 8, 89, 9, 10 | BEGIN COMPACTIONS AFTER 24" (600 mm) OF MATERIAL OVER THE CHAMBERS IS REACHED. COMPACT ADDITIONAL LAYERS IN 12" (300 mm) MAX LIFTS TO A MIN. 95% PROCTOR DENSITY FOR WELL GRADED MATERIAL AND 95% RELATIVE DENSITY FOR PROCESSED AGGREGATE MATERIALS. |
| B | EMBEDMENT STONE: FILL SURROUNDING THE CHAMBERS FROM THE FOUNDATION STONE ('A' LAYER) TO THE 'C' LAYER ABOVE. | AASHTO M43 ¹ 3, 4 | NO COMPACTION REQUIRED. |
| A | FOUNDATION STONE: FILL BELOW CHAMBERS FROM THE SUBGRADE UP TO THE FOOT (BOTTOM) OF THE CHAMBER. | AASHTO M43 ¹ 3, 4 | PLATE COMPACT OR ROLL TO ACHIEVE A FLAT SURFACE. ^{2,3} |

PLEASE NOTE:

- THE LISTED AASHTO DESIGNATIONS ARE FOR GRADATIONS ONLY. THE STONE MUST ALSO BE CLEAN, CRUSHED, ANGULAR. FOR EXAMPLE, A SPECIFICATION FOR #4 STONE WOULD STATE: "CLEAN, CRUSHED, ANGULAR NO. 4 (AASHTO M43) STONE".
- STORMTECH COMPACTION REQUIREMENTS ARE MET FOR 'A' LOCATION MATERIALS WHEN PLACED AND COMPACTED IN 9" (230 mm) (MAX) LIFTS USING TWO FULL COVERAGES WITH A VIBRATORY COMPACTOR.
- WHERE INFILTRATION SURFACES MAY BE COMPROMISED BY COMPACTION, FOR STANDARD DESIGN LOAD CONDITIONS, A FLAT SURFACE MAY BE ACHIEVED BY RAKING OR DRAGGING WITHOUT COMPACTION EQUIPMENT. FOR SPECIAL LOAD DESIGNS, CONTACT STORMTECH FOR COMPACTION REQUIREMENTS.
- ONCE LAYER 'C' IS PLACED, ANY SOIL/MATERIAL CAN BE PLACED IN LAYER 'D' UP TO THE FINISHED GRADE. MOST PAVEMENT SUBBASE SOILS CAN BE USED TO REPLACE THE MATERIAL REQUIREMENTS OF LAYER 'C' OR 'D' AT THE SITE DESIGN ENGINEER'S DISCRETION.

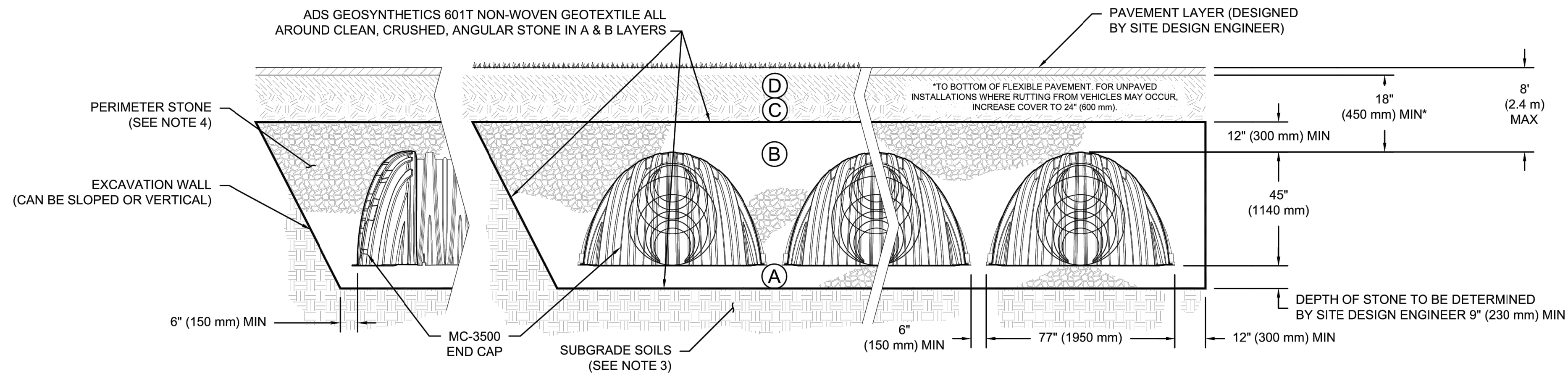

NOTES:

- CHAMBERS SHALL MEET THE REQUIREMENTS OF ASTM F2418, "STANDARD SPECIFICATION FOR POLYPROPYLENE (PP) CORRUGATED WALL STORMWATER COLLECTION CHAMBERS" CHAMBER CLASSIFICATION 45x76 DESIGNATION SS.
- MC-3500 CHAMBERS SHALL BE DESIGNED IN ACCORDANCE WITH ASTM F2787 "STANDARD PRACTICE FOR STRUCTURAL DESIGN OF THERMOPLASTIC CORRUGATED WALL STORMWATER COLLECTION CHAMBERS".
- THE SITE DESIGN ENGINEER IS RESPONSIBLE FOR ASSESSING THE BEARING RESISTANCE (ALLOWABLE BEARING CAPACITY) OF THE SUBGRADE SOILS AND THE DEPTH OF FOUNDATION STONE WITH CONSIDERATION FOR THE RANGE OF EXPECTED SOIL MOISTURE CONDITIONS.
- PERIMETER STONE MUST BE EXTENDED HORIZONTALLY TO THE EXCAVATION WALL FOR BOTH VERTICAL AND SLOPED EXCAVATION WALLS.
- REQUIREMENTS FOR HANDLING AND INSTALLATION:
 - TO MAINTAIN THE WIDTH OF CHAMBERS DURING SHIPPING AND HANDLING, CHAMBERS SHALL HAVE INTEGRAL, INTERLOCKING STACKING LUGS.
 - TO ENSURE A SECURE JOINT DURING INSTALLATION AND BACKFILL, THE HEIGHT OF THE CHAMBER JOINT SHALL NOT BE LESS THAN 3".
 - TO ENSURE THE INTEGRITY OF THE ARCH SHAPE DURING INSTALLATION, a) THE ARCH STIFFNESS CONSTANT SHALL BE GREATER THAN OR EQUAL TO 450 LBS/FT². THE ASC IS DEFINED IN SECTION 6.2.8 OF ASTM F2418. AND b) TO RESIST CHAMBER DEFORMATION DURING INSTALLATION AT ELEVATED TEMPERATURES (ABOVE 73° F / 23° C), CHAMBERS SHALL BE PRODUCED FROM REFLECTIVE GOLD OR YELLOW COLORS.

StormTech® Chamber System
888-892-2684 | WWW.STORMTECH.COM

4640 TRUEMAN BLVD
HILLIARD, OH 43026
1-800-733-7473

ADS

EL PASO COUNTY, CO, USA
DATE: 01/13/23
PROJECT #: S311443
CHECKED: N/A

LOWER BASE STONE TO 5720.00
REV. PER MARKUP, UPDATED ELEV.
DATE: 03/08/23
AGC
DATE: 03/04/23
DRW: CHK

THIS DRAWING HAS BEEN PREPARED BASED ON INFORMATION PROVIDED TO ADS UNDER THE DIRECTION OF THE SITE DESIGN ENGINEER. ADS ACCEPTS NO LIABILITY FOR THE ACCURACY OF THE INFORMATION PROVIDED OR FOR THE DESIGN OF THE PROJECT. THE SITE DESIGN ENGINEER SHALL REVIEW THIS DRAWING PRIOR TO CONSTRUCTION. IT IS THE ULTIMATE RESPONSIBILITY OF THE SITE DESIGN ENGINEER TO ENSURE THAT THE PRODUCTS (DETAILED) AND ALL ASSOCIATED DETAILS MEET ALL APPLICABLE LAWS, REGULATIONS, AND PROJECT REQUIREMENTS.

SHEET
3 OF 5

PCD FILE NO. PPR-2225

KUM & GO GAS & C-STORE

PART OF THE SOUTHEAST 1/4 OF SECTION 11, TOWNSHIP 15 SOUTH, RANGE 66
 WEST OF THE SIXTH PRINCIPAL MERIDIAN,
 COUNTY OF EL PASO, STATE OF COLORADO
MAJOR SITE DEVELOPMENT PLAN



1459 Grand Ave
 Des Moines, IA 50309
 P: 888-458-6646

2232 - EL PASO, COLORADO
SECURITY BLVD. AND MAIN ST.
 ADS SYSTEM DETAILS

KG PROJECT TEAM:
 RDM:
 SDM:
 CPM:

| REVISION DESCRIPTION | DATE |
|----------------------|----------|
| 1ST REVIEW COMMENTS | 08/19/22 |
| 2ND REVIEW COMMENTS | 01/06/23 |
| 3RD REVIEW COMMENTS | 04/05/23 |
| 4TH REVIEW COMMENTS | 05/11/23 |

DATE: 05-11-2023

SHEET NUMBER:
C4.5
 21 OF 43

MC-3500 ISOLATOR ROW PLUS DETAIL
NTS

| | |
|--------------------------------|--------------|
| KUM & GO 2232 | |
| EL PASO COUNTY, CO. USA | |
| DATE: 01/13/23 | DRAWN: DDW |
| PROJECT # S311443 | CHECKED: N/A |
| DESCRIPTION | DESIGNER |
| LOWER BASE STONE TO 5720.00 | CTS |
| REV. PER MARKUP, UPDATED ELEV. | AGC |
| DATE | CHK |
| 03/08/23 | DRW |
| 03/04/23 | AGC |

4\"/>

INSPECTION & MAINTENANCE

STEP 1) INSPECT ISOLATOR ROW PLUS FOR SEDIMENT

A. INSPECTION PORTS (IF PRESENT)

A.1. REMOVE/OPEN LID ON NYLOPLAST INLINE DRAIN

A.2. REMOVE AND CLEAN FLEXSTORM FILTER IF INSTALLED

A.3. USING A FLASHLIGHT AND STADIA ROD, MEASURE DEPTH OF SEDIMENT AND RECORD ON MAINTENANCE LOG

A.4. LOWER A CAMERA INTO ISOLATOR ROW PLUS FOR VISUAL INSPECTION OF SEDIMENT LEVELS (OPTIONAL)

A.5. IF SEDIMENT IS AT, OR ABOVE, 3\"/>

NOTES

1. INSPECT EVERY 6 MONTHS DURING THE FIRST YEAR OF OPERATION. ADJUST THE INSPECTION INTERVAL BASED ON PREVIOUS OBSERVATIONS OF SEDIMENT ACCUMULATION AND HIGH WATER ELEVATIONS.

2. CONDUCT JETTING AND VACTORING ANNUALLY OR WHEN INSPECTION SHOWS THAT MAINTENANCE IS NECESSARY.

P:\KUM & GO\CO. EL PASO COUNTY_ 2232_MAIN AND SECURITY\08 CAD\GEGS02232_21 - ADS SYSTEM DETAILS.DWG

PCD FILE NO. PPR-2225

KUM & GO GAS & C-STORE

PART OF THE SOUTHEAST 1/4 OF SECTION 11, TOWNSHIP 15 SOUTH, RANGE 66
 WEST OF THE SIXTH PRINCIPAL MERIDIAN,
 COUNTY OF EL PASO, STATE OF COLORADO
MAJOR SITE DEVELOPMENT PLAN



1459 Grand Ave
 Des Moines, IA 50309
 P: 888-458-6646

2232 - EL PASO, COLORADO
 SECURITY BLVD. AND MAIN ST.
 ADS SYSTEM DETAILS

KG PROJECT TEAM:
 RDM:
 SDM:
 CPM:

| DATE | REVISION DESCRIPTION |
|----------|----------------------|
| 08/19/22 | 1ST REVIEW COMMENTS |
| 01/06/23 | 2ND REVIEW COMMENTS |
| 04/05/23 | 3RD REVIEW COMMENTS |
| 05/11/23 | 4TH REVIEW COMMENTS |

DATE: 05-11-2023

SHEET NUMBER: C4.6

22 OF 43

CRITERIA PLAN 04/2020

MC-3500 TECHNICAL SPECIFICATION

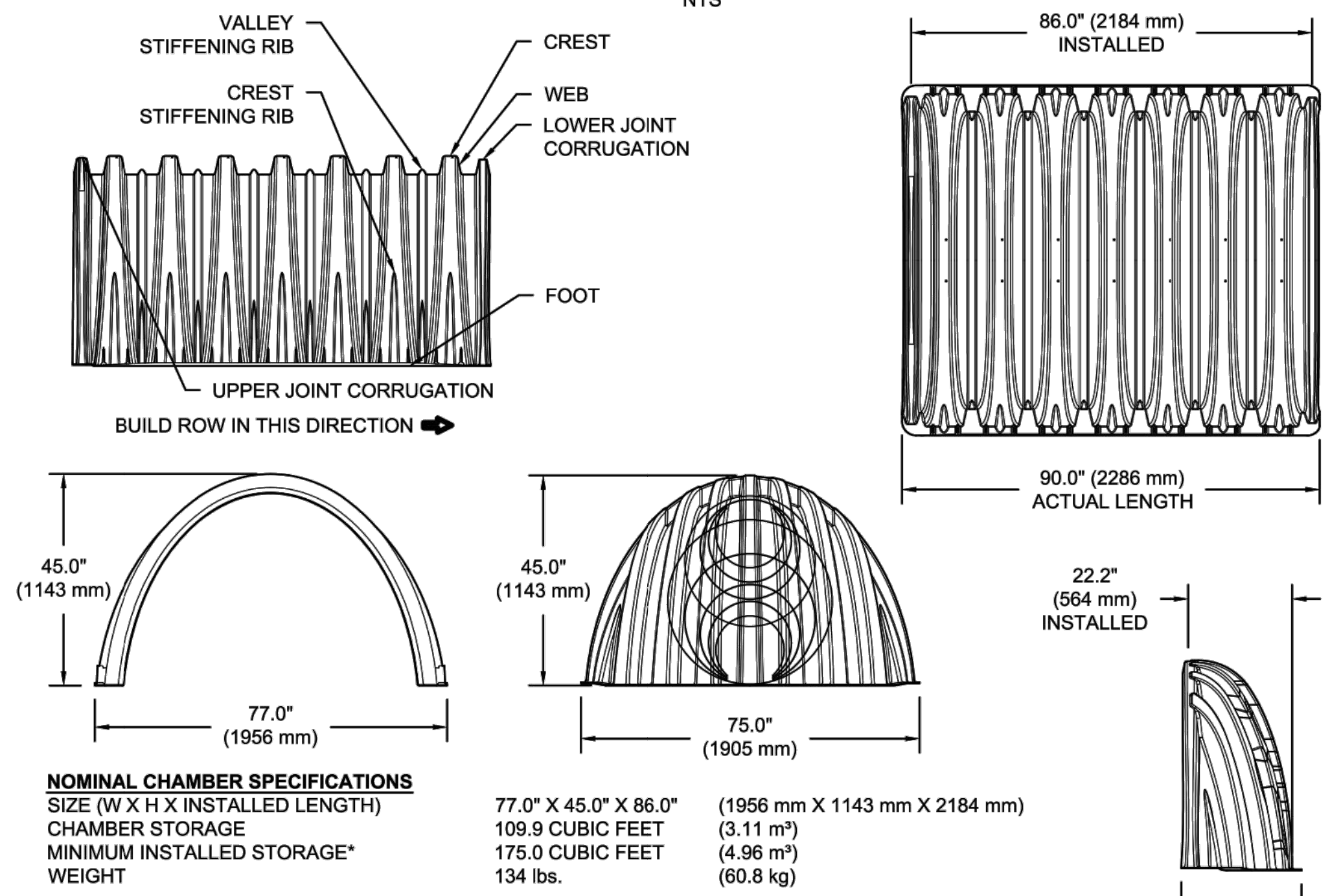

NOMINAL CHAMBER SPECIFICATIONS

| SIZE (W X H X INSTALLED LENGTH) | 77.0" X 45.0" X 86.0" | (1956 mm X 1143 mm X 2184 mm) |
|---------------------------------|-----------------------|-------------------------------|
| CHAMBER STORAGE | 109.9 CUBIC FEET | (3.11 m ³) |
| MINIMUM INSTALLED STORAGE* | 175.0 CUBIC FEET | (4.96 m ³) |
| WEIGHT | 134 lbs. | (60.8 kg) |

NOMINAL END CAP SPECIFICATIONS

| SIZE (W X H X INSTALLED LENGTH) | 75.0" X 45.0" X 22.2" | (1905 mm X 1143 mm X 564 mm) |
|---------------------------------|-----------------------|------------------------------|
| END CAP STORAGE | 14.9 CUBIC FEET | (0.42 m ³) |
| MINIMUM INSTALLED STORAGE* | 45.1 CUBIC FEET | (1.28 m ³) |
| WEIGHT | 49 lbs. | (22.2 kg) |

*ASSUMES 12" (305 mm) STONE ABOVE, 9" (229 mm) STONE FOUNDATION, 6" SPACING BETWEEN CHAMBERS, 6" (152 mm) STONE PERIMETER IN FRONT OF END CAPS AND 40% STONE POROSITY

STUBS AT BOTTOM OF END CAP FOR PART NUMBERS ENDING WITH "B"
 STUBS AT TOP OF END CAP FOR PART NUMBERS ENDING WITH "T"
 END CAPS WITH A WELDED CROWN PLATE END WITH "C"
 END CAPS WITH A PREFABRICATED WELDED STUB END WITH "W"

| PART # | STUB | B | C |
|----------------|--------------|-----------------|---------------|
| MC3500IEPP06T | | 33.21" (844 mm) | --- |
| MC3500IEPP06B | 6" (150 mm) | --- | 0.66" (17 mm) |
| MC3500IEPP08T | | 31.16" (791 mm) | --- |
| MC3500IEPP08B | 8" (200 mm) | --- | 0.81" (21 mm) |
| MC3500IEPP10T | | 29.04" (738 mm) | --- |
| MC3500IEPP10B | 10" (250 mm) | --- | 0.93" (24 mm) |
| MC3500IEPP12T | | 26.36" (670 mm) | --- |
| MC3500IEPP12B | 12" (300 mm) | --- | 1.35" (34 mm) |
| MC3500IEPP15T | | 23.39" (594 mm) | --- |
| MC3500IEPP15B | 15" (375 mm) | --- | 1.50" (38 mm) |
| MC3500IEPP18TC | | 20.03" (509 mm) | --- |
| MC3500IEPP18TW | | --- | --- |
| MC3500IEPP18BC | 18" (450 mm) | --- | 1.77" (45 mm) |
| MC3500IEPP18BW | | --- | --- |
| MC3500IEPP24TC | | 14.48" (368 mm) | --- |
| MC3500IEPP24TW | | --- | --- |
| MC3500IEPP24BC | 24" (600 mm) | --- | 2.06" (52 mm) |
| MC3500IEPP24BW | | --- | --- |
| MC3500IEPP30BC | 30" (750 mm) | --- | 2.75" (70 mm) |

CUSTOM PRECURED INVERTS ARE AVAILABLE UPON REQUEST. INVENTORIED MANIFOLDS INCLUDE 12-24" (300-600 mm) SIZE ON SIZE AND 15-48" (375-1200 mm) ECCENTRIC MANIFOLDS. CUSTOM INVERT LOCATIONS ON THE MC-3500 END CAP CUT IN THE FIELD ARE NOT RECOMMENDED FOR PIPE SIZES GREATER THAN 10" (250 mm). THE INVERT LOCATION IN COLUMN 'B' ARE THE HIGHEST POSSIBLE FOR THE PIPE SIZE.

MC-SERIES END CAP INSERTION DETAIL

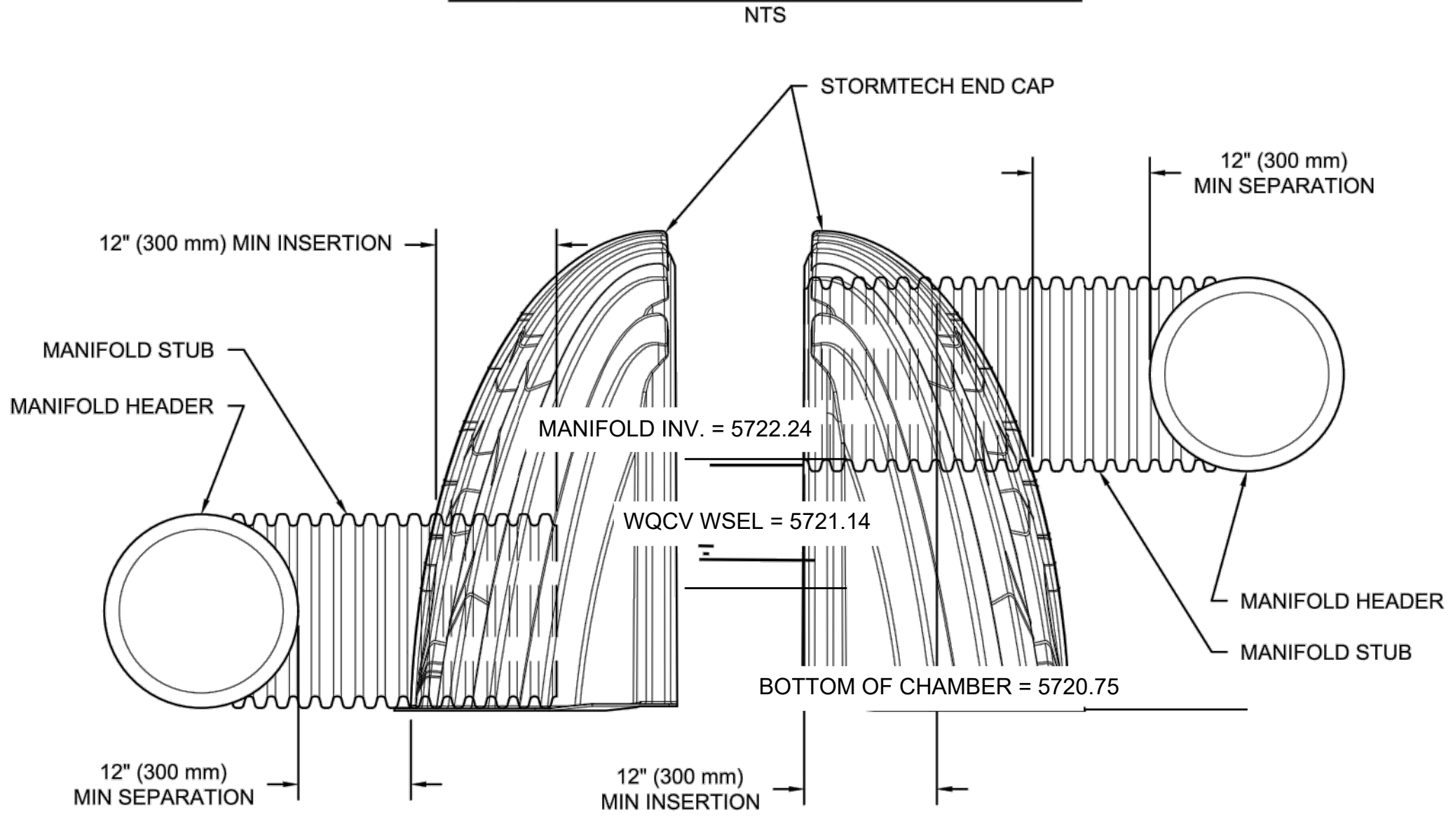

NOTE: MANIFOLD STUB MUST BE LAID HORIZONTAL FOR A PROPER FIT IN END CAP OPENING.

NOTE: ALL DIMENSIONS ARE NOMINAL

KUM & GO 2232
 EL PASO COUNTY, CO, USA
 DATE: 01/13/23 DRAWN: DDW
 PROJECT #: S311443 CHECKED: N/A

03/08/23 CTS LOWER BASE STONE TO 5720.00
 03/04/23 AGC AGC REV. PER MARKUP, UPDATED ELEV.
 DATE DRW CHK DESCRIPTION

StormTech®
 Chamber System
 888-892-2894 | WWW.STORMTECH.COM

4640 TREEMAN BLVD
 HILLIARD, OH 43026
 1-800-733-7473

SHEET
5 OF 5

811 Know what's below.
 Call before you dig.
 CALL 811 SEVENTY-TWO HOURS PRIOR TO DIGGING, GRADING OR EXCAVATING FOR THE MARKING OF UNDERGROUND MEMBER UTILITIES.

PCD FILE NO. PPR-2225

P:\KUM & GO\CO. EL PASO COUNTY - 2232 - MAIN AND SECURITY\08 CAD\GSC02232 - 22 - ADS SYSTEM DETAILS.DWG

KUM & GO GAS & C-STORE

PART OF THE SOUTHEAST 1/4 OF SECTION 11, TOWNSHIP 15 SOUTH, RANGE 66
WEST OF THE SIXTH PRINCIPAL MERIDIAN,
COUNTY OF EL PASO, STATE OF COLORADO

MAJOR SITE DEVELOPMENT PLAN

EES
ENTITLEMENT AND
ENGINEERING
SOLUTIONS, INC.
3901 E. Florida Avenue, Suite 425
Denver, CO 80210
303-572-1997 www.ees.us.com

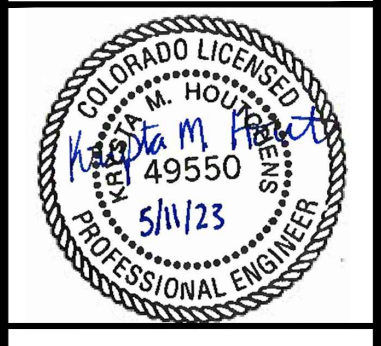

1459 Grand Ave
Des Moines, IA 50309
P: 888-458-6646

2232 - EL PASO, COLORADO
SECURITY BLVD. AND MAIN ST.
ADS SYSTEM DETAILS

KG PROJECT TEAM:
RDM:
SDM:
CPM:

| REVISION DESCRIPTION | DATE |
|----------------------|----------|
| 1ST REVIEW COMMENTS | 08/19/22 |
| 2ND REVIEW COMMENTS | 01/06/23 |
| 3RD REVIEW COMMENTS | 04/05/23 |
| 4TH REVIEW COMMENTS | 05/11/23 |

REVISIONS

SHEET NUMBER:
C4.8
24 OF 43

FLEXSTORM P/Ns 62SHDFX & 62SHDFXP HD4 INLET TYPE: SQUARE/RECT PRECAST OPENING WITH 4 SEAT GRATE SUPPORT

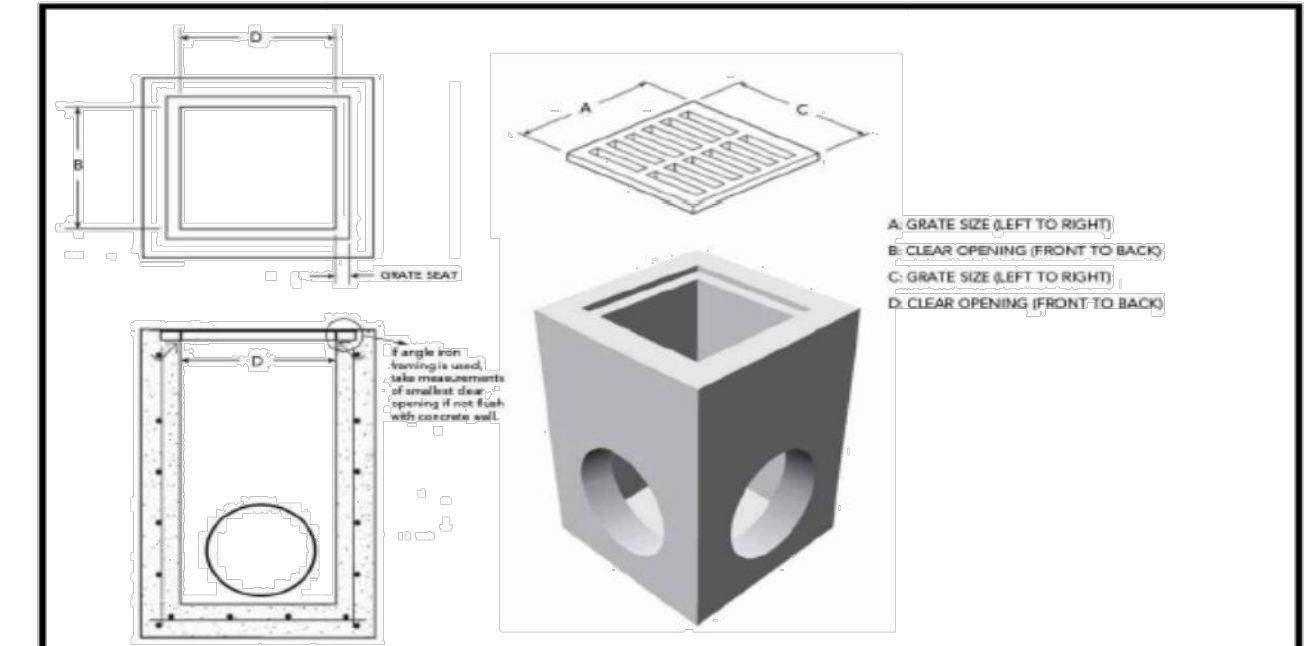

A. GRATE SIZE LEFT TO RIGHT
B. CLEAR OPENING FRONT TO BACK
C. GRATE SIZE LEFT TO RIGHT
D. CLEAR OPENING FRONT TO BACK

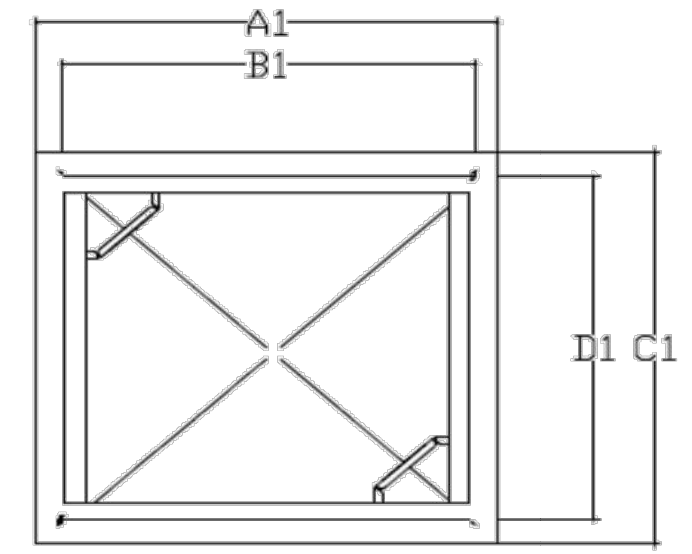

| ADS PIN | Flexstorm Item Code | Field Inlet Dimensions | | Flexstorm Framing Dims | | | | Flexstorm Ratings (Flow at 50% Max) | | | | Pure Frame with FX Bag | |
|----------|-------------------------|------------------------|-----------------------|------------------------|------|------|------|-------------------------------------|------------------------|-------------------|----------|--------------------------|--|
| | | Grate Size (A x C) | Clear Opening (B x D) | B1 | D1 | A1 | C1 | Bag Capacity (ft³) | PC/PC+ Flow Rate (CFS) | Bypass Rate (CFS) | ADS PIN | Flexstorm Item Code | |
| 62SHDFXP | F4HD-95-95-80-80-FX | 9 1/2 X 9 1/2 | 8 X 8 | 6.0 | 5.0 | 9.5 | 9.3 | 0.2 | 0.5 | 1.2 | 62SHDFXP | F4HD-95-95-80-80-FXP | |
| 62SHDFX | F4HD-115-115-105-105-FX | 11.5 X 11.5 | 10.5 X 10.5 | 8.0 | 7.5 | 11.5 | 11.3 | 0.4 | 0.7 | 1.7 | 62SHDFXP | F4HD-115-115-105-105-FXP | |
| 62SHDFXP | F4HD-118-118-105-105-FX | 11.75 X 11.75 | 10.5 X 10.5 | 8.0 | 7.5 | 11.5 | 11.5 | 0.4 | 0.7 | 1.7 | 62SHDFXP | F4HD-118-118-105-105-FXP | |
| 62SHDFX | F4HD-120-120-105-105-FX | 12 X 12 | 10.5 X 10.5 | 8.5 | 7.5 | 12.0 | 11.8 | 0.4 | 0.7 | 1.7 | 62SHDFXP | F4HD-120-120-105-105-FXP | |
| 62SHDFX | F4HD-134-134-110-110-FX | 13.375 X 13.375 | 11.5 X 11.5 | 9.5 | 8.5 | 13.0 | 13.1 | 0.5 | 0.8 | 1.9 | 62SHDFXP | F4HD-134-134-110-110-FXP | |
| 62SHDFX | F4HD-130-130-120-120-FX | 13 X 13 | 12 X 12 | 9.5 | 9.0 | 13.0 | 12.8 | 0.5 | 0.8 | 2.0 | 62SHDFXP | F4HD-130-130-120-120-FXP | |
| 62SHDFX | F4HD-144-144-133-133-FX | 14.375 X 14.375 | 13.25 X 13.25 | 10.5 | 10.5 | 14.0 | 14.1 | 0.7 | 0.9 | 2.3 | 62SHDFXP | F4HD-144-144-133-133-FXP | |
| 62SHDFX | F4HD-145-145-133-133-FX | 14.5 X 14.5 | 13.25 X 13.25 | 11.0 | 10.5 | 14.5 | 14.3 | 0.7 | 0.9 | 2.3 | 62SHDFXP | F4HD-145-145-133-133-FXP | |
| 62SHDFX | F4HD-159-159-143-143-FX | 15.87 X 15.87 | 14.25 X 14.25 | 12.0 | 11.5 | 15.5 | 15.6 | 0.9 | 1.0 | 2.5 | 62SHDFXP | F4HD-159-159-143-143-FXP | |
| 62SHDFX | F4HD-178-178-160-160-FX | 17.75 X 17.75 | 16 X 16 | 14.0 | 13.0 | 17.5 | 17.5 | 1.2 | 1.1 | 2.9 | 62SHDFXP | F4HD-178-178-160-160-FXP | |

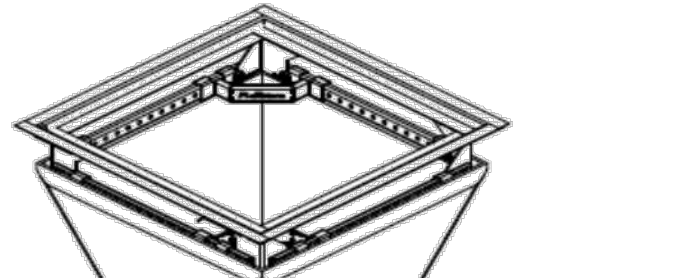
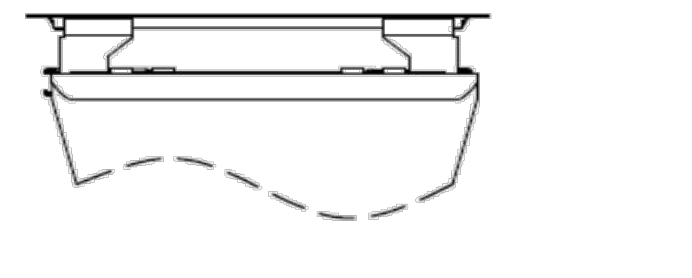

- NOTES:**
- RATINGS SHOWN ARE FOR STANDARD 22" BAG DEPTH; *SHORT* 12" DEPTH BAGS ARE AVAILABLE WITH -S SUFFIX; RATINGS REDUCED BY ~50%.
 - THE FOLLOWING REQUIRES ADDITIONAL REVIEW
-GRATES WITH EXTENDED BOTTOMS
-ANY OBSTRUCTED INLET OPENINGS

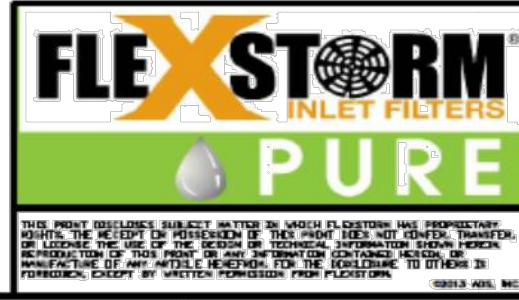

ALL PRODUCTS MANUFACTURED BY INLET & PIPE PROTECTION, INC A DIVISION OF ADS, INC. WWW.INLETFILTERS.COM (630) 287-8655 PH (630) 355-3477 FX INFO@INLETFILTERS.COM

| Standard | Inlet Type | Kraier Equivalent | Grate Size | Clear Opening Size | Bag Cap. (ft³) | Flow Ratings (CFS) | | | PRICE | | | |
|---------------------------------|------------------|-------------------|------------|--------------------|----------------|--------------------|--------|--------|-------------|--------------|-------------|--------------|
| | | | | | | FX/FX+ | PC/PC+ | Bypass | FX | FX+ | PC | PC+ |
| 36" Open Throat Inlet | Open Throat (WM) | FGP-36CI | N/A | 36 | 2.5 | 1.9 | 1.4 | N/A | 62HDWM8FX | 62HDWM8FXP | 62HDWM8PC | 62HDWM8PCP |
| 42" Open Throat Inlet | Open Throat (WM) | FGP-42CI | N/A | 42 | 3.0 | 2.5 | 1.7 | N/A | 62HDWM1FX | 62HDWM1FXP | 62HDWM1PC | 62HDWM1PCP |
| 48" Open Throat Inlet | Open Throat (WM) | FGP-48CI | N/A | 48 | 3.3 | 2.8 | 2.2 | N/A | 62HDWM8FX | 62HDWM8FXP | 62HDWM8PC | 62HDWM8PCP |
| 60" Open Throat Inlet (2 piece) | Open Throat (WM) | FGP-60CI | N/A | 60 | 4.2 | 3.6 | 2.6 | N/A | 62HDWM8FX | 62HDWM8FXP | 62HDWM8PC | 62HDWM8PCP |
| 84" Open Throat Inlet (2 piece) | Open Throat (WM) | FGP-84CI | N/A | 84 | 5.8 | 5.0 | 3.4 | N/A | 62HDWM8FX | 62HDWM8FXP | 62HDWM8PC | 62HDWM8PCP |
| 96" Open Throat Inlet (2 piece) | Open Throat (WM) | FGP-96CI | N/A | 96 | 6.6 | 5.6 | 4.4 | N/A | 62HDWM8FX | 62HDWM8FXP | 62HDWM8PC | 62HDWM8PCP |
| 48" Open Throat with Side Wings | Open Throat (WM) | N/A | N/A | 48 Winged | 5.1 | 2.7 | 1.7 | N/A | 62HDWM818FX | 62HDWM818FXP | 62HDWM818PC | 62HDWM818PCP |

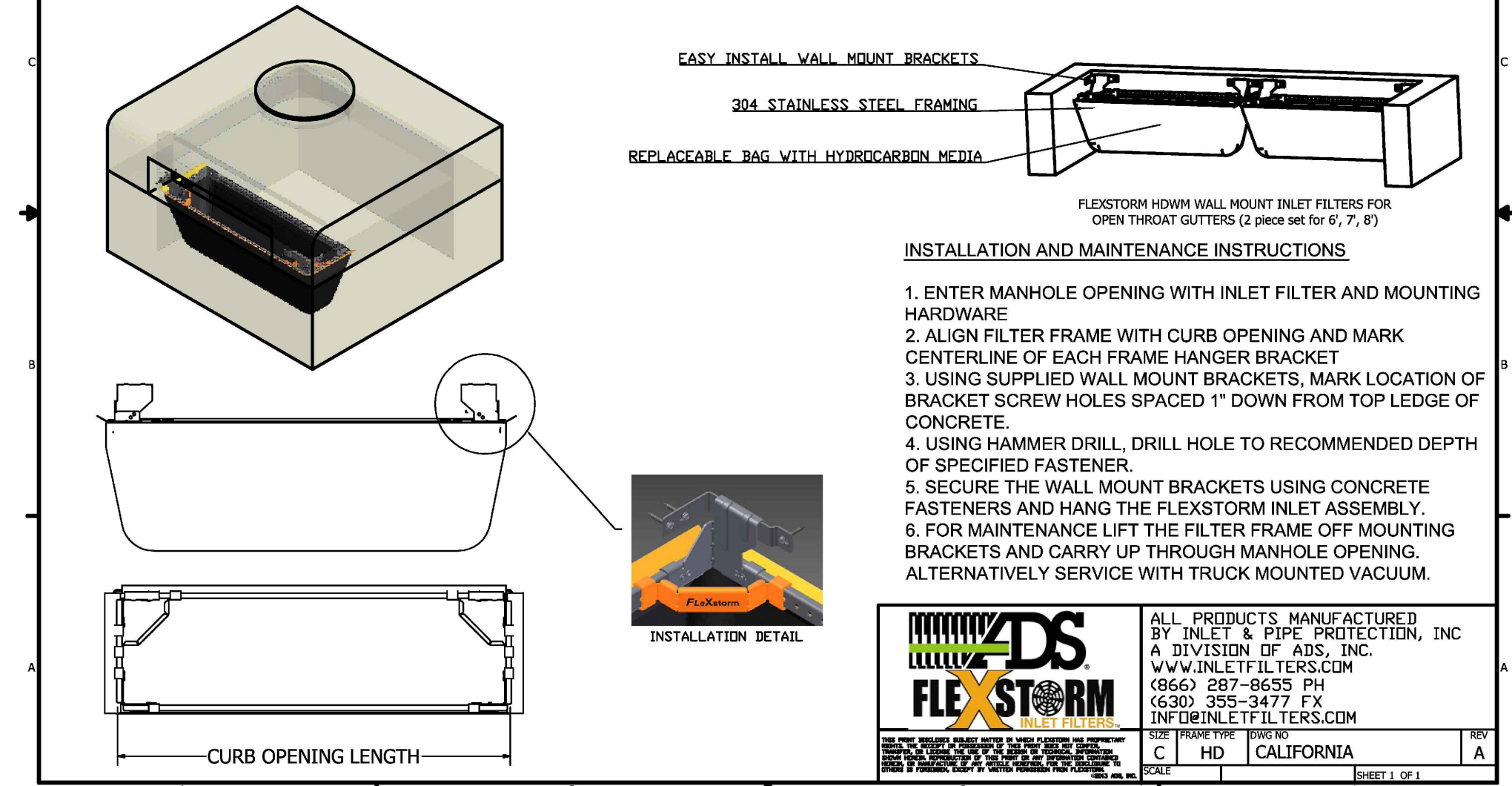

JOB NAME: KUM & GO 2232 DATE: 5/15/2023

SUMP PUMP SCHEDULE

| ITEM | TYPE | SERVICE | SINGLE / DUPLEX STAGED | GPM | HEAD | HP | RPM | V-FPH | AMPS | MANUFACTURER & MODEL # | NOTES | CONTROLS |
|---------------------|-------------|-----------|--------------------------|-----|------|-------|------|------------|------|------------------------|------------------|------------------------------|
| SP1 | SUBMERSIBLE | SUMP PUMP | DUPLEX STAGED SEQUENTIAL | 90 | 5.2 | 1/2 | 3450 | 208V / 3PH | 6.4 | RS151 | 1, 2, 3, 4, 5 | ALDERON CUSTOM CONTROL PANEL |
| SP2 | SUBMERSIBLE | SUMP PUMP | DUPLEX STAGED SEQUENTIAL | 295 | 8.4 | 1 1/2 | 1750 | 208V / 3PH | 5.9 | RS121 | 1, 2, 3, 5, 6, 7 | ALDERON CUSTOM CONTROL PANEL |
| TOTAL COMBINED FLOW | | | | 318 | | | | | | | | |

NOTES:

- PROVIDE ZOELLER NEMA4 PRIMARY/SECONDARY ALTERNATING CONTROL PANEL WITH ALARMA, BECON, HOA SWITCHES AND DRY CONTACTS FOR REMOTE ALARM MONITORING (ZOELLER 13404-0001)
- PROVIDE FOUR FLOAT SWITCHES WITH WEIGHTS (ALDERON 200181) AND FOUR POSITION FLOAT SWITCH BRACKET (ALDERON 7802)
- PROVIDE PUMP WITH 2" VERTICAL THREADED OUTLET, 2" COMBINATION CHECK VALVE AND BALL VALVE WITH UNION END (ZOELLER #30-048) FOR EACH PUMP
- PROVIDE 2" VERTICAL THREADED RAIL SYSTEM (ZOELLER #39-0129) AND STAINLESS STEEL LIFTING CABLE FOR EACH PUMP
- PROVIDE 1 1/2" VERTICAL THREADED INLET WITH 2" VERTICAL THREADED OUTLET RAIL SYSTEM (ZOELLER #39-0131) AND STAINLESS STEEL LIFTING CABLE FOR EACH PUMP
- PROVIDE PUMP WITH 4" HORIZONTAL FLANGED OUTLET, 4" CHECK VALVE (ZOELLER #600-0030) AND PLUG VALVE (ZOELLER #600-0086) FOR EACH PUMP
- PROVIDE 4" HORIZONTAL FLANGED RAIL SYSTEM (ZOELLER #39-0154) AND STAINLESS STEEL LIFTING CABLE FOR EACH PUMP
- SP1 TO HAVE TRIMMED IMPELLER TO PERFORM AT 27 GPM @ 4.5 TDH
- SP2 TO HAVE TRIMMED IMPELLER TO PERFORM AT 295 GPM @ 8.4 TDH

NET STATIC HEAD

| TDH | 5725.5 | 5725.75 | 5725.8 | 5725.83 |
|-------------|-------------|-------------|-----------|-----------|
| DESCRIPTION | 100-YR WSEL | 100-YR WSEL | EURV WSEL | WQCV WSEL |
| VALUE | 5725.5 | 5725.75 | 5725.8 | 5725.83 |

WE RECOMMENDED OUR SMALLEST COMMERCIAL GRADE 208V/3PH PUMP FOR THE LOW FLOW RATE. WE DO NOT HAVE A PUMP FOR A 9 GPM FLOW RATE.

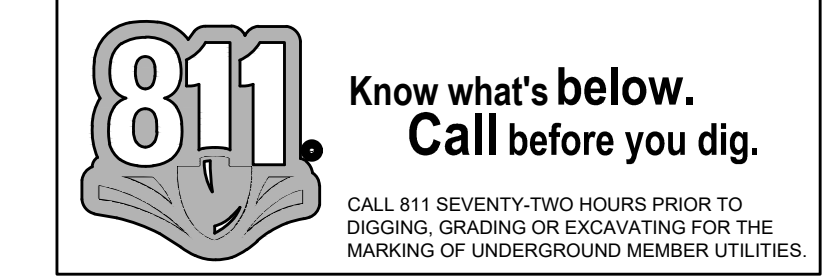
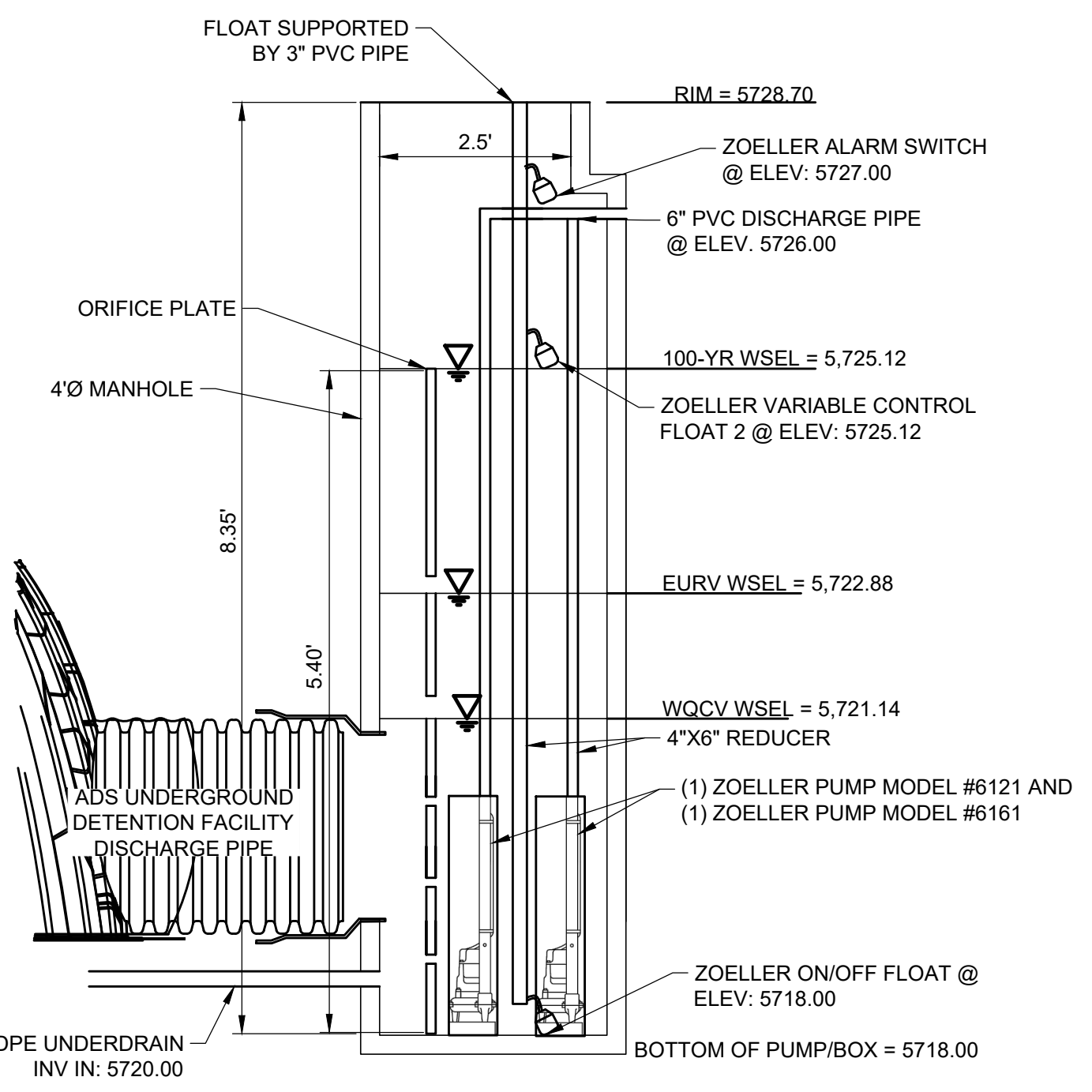
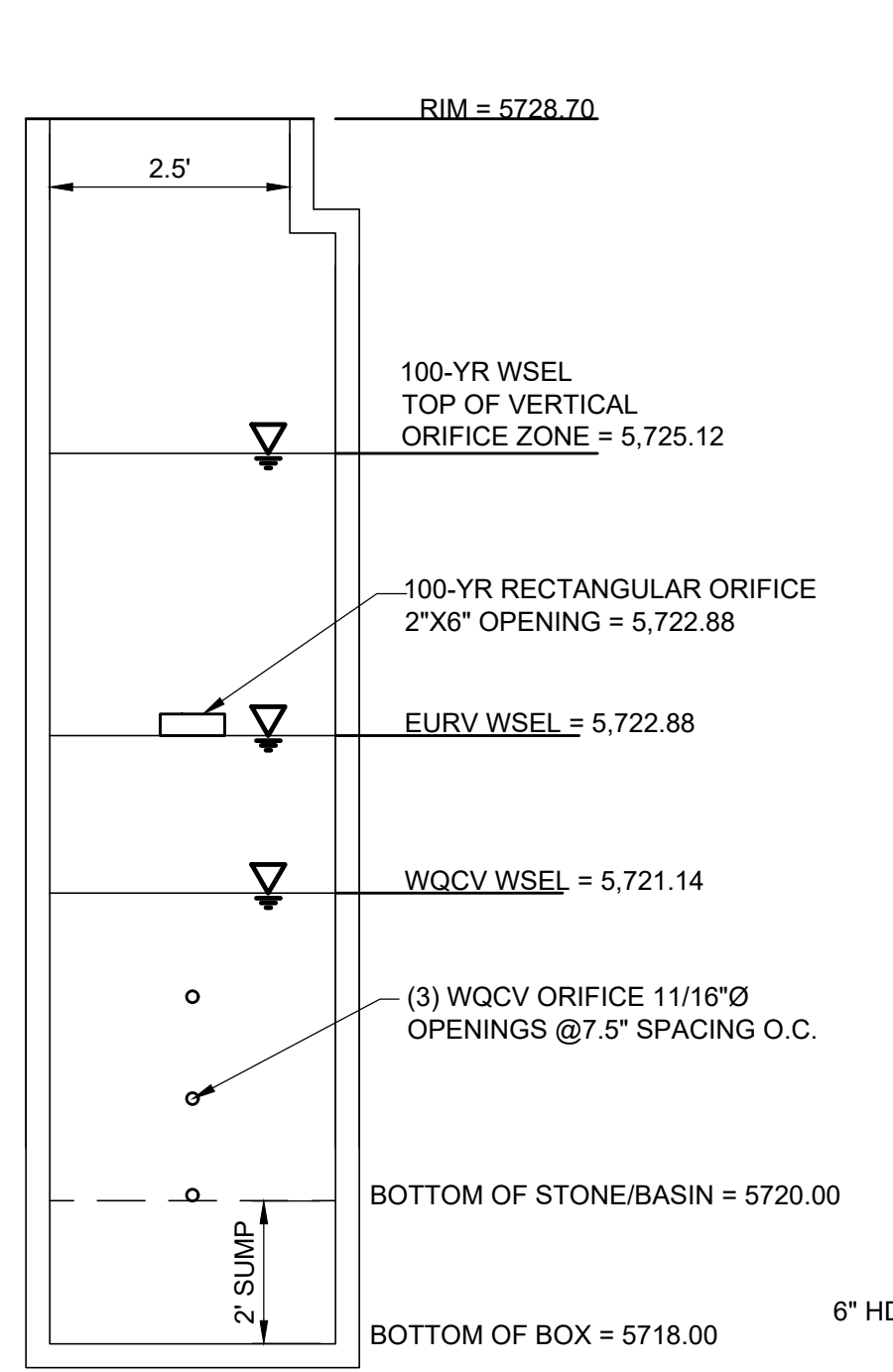

PCD FILE NO. PPR-2225

P:\KUM & GO\CO. EL PASO COUNTY - 2232 - MAIN AND SECURITY\08 CAD\GSC02232 - 24 - ADS SYSTEM DETAILS.DWG