

---

## FOREST LAKES PHASE 2

### *FIRE PROTECTION REPORT*

**DECEMBER 2018**

**OWNER:**

Forest Lakes Residential  
Development #2 LLC  
111 Main Street, Suite 1600  
Kansas City, MO 64105

**DEVELOPER/APPLICANT:**

Classic Homes  
6385 Corporate Drive  
Colorado Springs, CO 80919

**CONSULTANT:**

N.E.S. Inc.  
619 North Cascade Ave  
Colorado Springs, CO 80903

---

Forest Lakes Phase 2 is within the Tri-Lakes Monument Fire Protection District (TLMFPD). The TLMFPD is located in North-Western El-Paso County. The boundaries are Baptist Road to the South, Black Forest Road to the East, and County Line Road to the North. The fire district includes roughly 68 square miles and a mean elevation of 7100 feet above sea level, and serves approximately 30,000 residents.

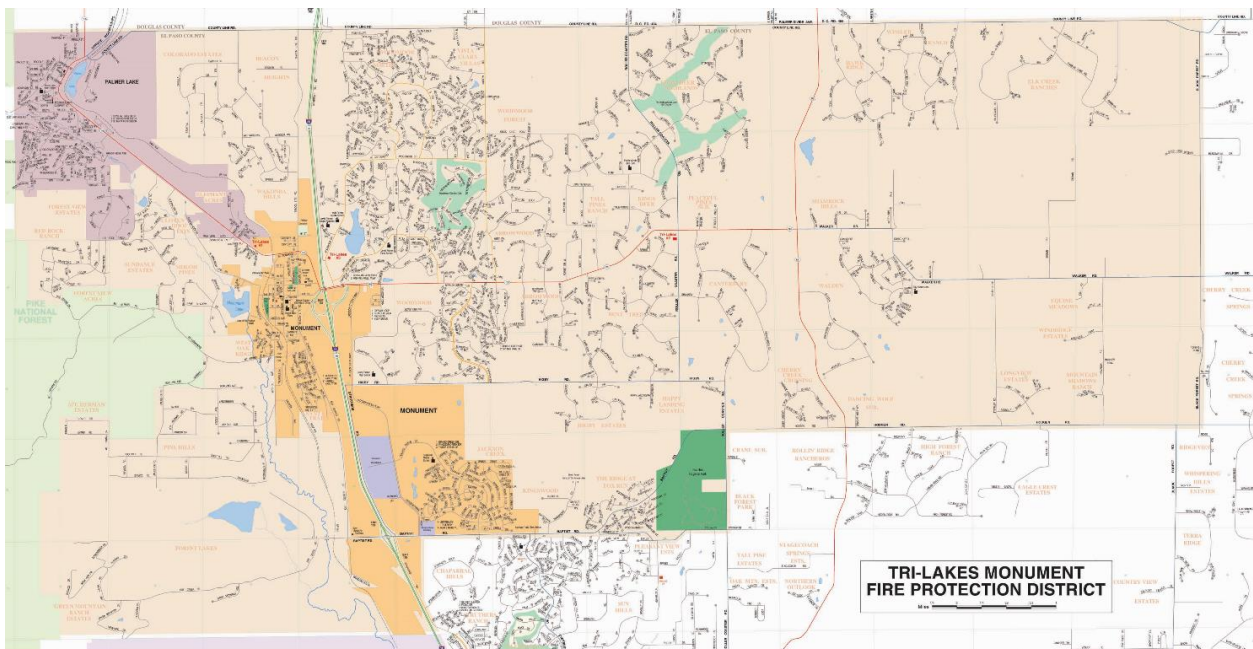

The fire stations are located on Highway 105, just west of the Burlington Northern railroad tracks, on Woodmoor Drive, just north of Highway 105, and on the southwest corner of Highway 105 and Roller Coaster Road. The administrative offices for the district are located at 15455 Gleneagle Drive, Suite 230, Colorado Springs, CO 80921.

---



The TLMFPD is a mostly career department and has approximately 50 full-time firefighters, EMTs, and Paramedics in three fire stations with service provided 24 hours a day, 7 days a week. Tri-Lakes/Monument is a member of a mutual-aid group that has been established for Northern El Paso County, called the North Group. This allows Tri-Lakes to request resources from neighboring fire districts and vice-versa.

#### FACILITIES

**Headquarters:** 15455 Gleneagle Dr, Ste 230

**Station 1:** 18650 Highway 105, Monument, CO 80132



**Station 2:** 18460 Roller Coaster Road, Monument, CO  
80132



**Station 3:** 1855 Woodmoor Drive, Monument, CO 80132



### EQUIPMENT

The District operates 3 engines, 1 tower ladder, 3 ambulances, 3 brush trucks, 4 command vehicles, 1 Snowcat and 1 ATV.



## **PROPOSED DEVELOPMENT**

TLMFPD has reviewed and approved the proposed layout for Forest Lakes Phase 2 subject to stipulations regarding construction materials, the width of the lanes in the proposed median-separated section of road and required median breaks, provision of fuel breaks and that the proposed water tank be operational before certificates of occupancy are issued for homes in Phase 2.

TLMFPD has also reviewed and approved the proposed emergency access road subject to the provision of a Fire District Knox Lock.

These requirements are either addressed on the revised plans or will be addressed with building permits and covenants.

See attached letters from the Fire Department.

**TRI-LAKES MONUMENT FIRE PROTECTION DISTRICT**

16055 Old Forest Point, Suite 103

Monument, CO 80132

Bus: (719) 484-0911 Fax (719) 481-3456



Jamey Bumgarner, Fire Marshal

To: Jim Bolton, Classic Homes, Vice President/Project Manager

From: Jamey Bumgarner, Fire Marshal

Subject: Forest Lakes Proposed Phase 2

Date: October 30, 2018

Please accept the following discussion as the comments from the Tri Lakes Monument Fire Protection District (TLMFPD) reference the proposed Phase 2 for the Forest Lakes Subdivision.

After careful review and consultation from many sources including current codes, professional research, and other discussions with fire service professionals TLMFPD would like to provide the following comments.

Based upon alterations to the original proposed plan for Phase 2 you plan to reduce the two roads originally proposed down to one road with a divided median (that is wide enough to accommodate four lanes during an emergency) over the culvert. Furthermore, you plan to construct an additional 180 homes within Phase 2 which are located behind the already existing 200 homes.

The Wildfire Hazard & Mitigation Report (January 18, 2003) prepared by Stephan J. Spaulding states very clearly that the area and acreage within the Forest Lakes Subdivision is frequented by fire events as recently as the 2002 Spaatz Fire that started on the ranch and consumed over 67 acres while taxing the response of local resources even with a rapid 4-minute response. The Berry Fire (1989) and the Beaver Creek Fire (2011) both burned on the adjacent property and required a heavy commitment of local, state, and federal resources to contain the fire and provide structure protection. All these fires occurred with just a few structures (located in the meadow areas) present on the ranch and no resources or very few were required for structure protection. The report also states that the 990-acre subdivision has a low rating for wildfire in the meadow areas and severe rating for wildfire in the brush which is where most of the homes are being constructed in Phase 2. The entire Forest Lakes subdivision lies within the El Paso County hazard map for wildland fires and is considered a Wildland Urban Interface Subdivision per the International Code Council's Wildland Urban Interface code.

By adding an additional 180 homes to the wildfire prone area where most will be built within the severe hazard rated areas, proper actions must be taken. We must ensure that fire resistant construction, mitigation, and design elements are incorporated and adhered to, so we minimize fire danger to the residents, first responders, and create a community that is prepared for wildfire. The community will experience wildfire again as has been demonstrated numerous times over the last 20 plus years.

**TRI-LAKES MONUMENT FIRE PROTECTION DISTRICT**

16055 Old Forest Point, Suite 103

Monument, CO 80132

Bus: (719) 484-0911 Fax (719) 481-3456



Jamey Bumgarner, Fire Marshal

TLMFPD requires the following actions be taken and adhered to fully therefore creating an environment that will protect the safety of responders and residents.

1. Construction: All structures and property within Phase 2 be constructed to comply with the Colorado Springs Fire Department Ignition Resistant and Construction Design manual.
2. Access: The roadways widths be increased to 24 feet each direction with medians being constructed to allow for fire apparatus and responders to drive over them and a minimum of 3 crossovers, location to be determined by the developer and fire district, for responders to access both sides of the roadways. If parking is to be permitted on roadways there should be 9 feet additional added to allow fire apparatus to flow freely alongside parked cars for a total of 33 feet plus medians.
3. Mitigation/Access: All lots will be mitigated to the CSFD Ignition Resistant and Construction Design manual before the construction of the home is completed or a certificate of occupancy issued. This includes creating sufficient fuel breaks to prevent fire impingement to roadways that would inhibit the ability of responders to access the subdivision and the resident's ability to evacuate the subdivision. As stated within the wildfire mitigation report you can never remove wildfire from the property however, removing fuel can reduce the risk.
4. Water Supply: Based upon the calculations provided by JDS Hydro Consultants, Inc it appears that sufficient water pressure and flow exist to support fire protection. The fire district would require that the newly constructed water tank and piping be operational before the homes in Phase 2 are issued a certificate of occupancy.

The entire subdivision of Forest Lakes lies within the Wildland Urban Interface and therefore should be treated as such. Once the completion or build out occurs it will be the responsibility of the HOA's and its residents to ensure that proper mitigation is maintained to prevent catastrophic losses from occurring due to the eventual wildfire.

**TRI-LAKES MONUMENT FIRE PROTECTION DISTRICT**

16055 Old Forest Point, Suite 103

Monument, CO 80132

Bus: (719) 484-0911 Fax (719) 481-3456



Jamey Bumgarner, Fire Marshal

To: Matt Larson, Classic Consulting  
From: J.C. Bumgarner Jr., Fire Marshal  
Subject: Forest Lakes Emergency Access Road  
Date: November 7, 2018

I am writing to confirm that the Tri Lakes Monument Fire Protection District is aware of the emergency access road being required for Forest Lakes Phase 2. We also understand that the road standards (base road layers) being used do not support large fire apparatus. That being stated we believe this road will however serve the district in the capacity of fire breaks and access for smaller brush units and other apparatus in the event of wildfire if needed.

We are requesting that a Fire District Knox Lock be installed on whatever the final detriment is for blocking the access, whether it be bollard or chain. Who will be responsible for opening the access will also need to be addressed in the event evacuation would need to occur via this route.

These comments are all in addition to our previously provided comments dated October 30, 2018 and in no way are intended to remove or supersede all other comments.

Respectfully,

Jamey Bumgarner

Fire Marshal

# Ignition Resistant Construction Design Manual

A guide to smart construction and wildfire mitigation in the  
wildland/urban interface



Published by the City of Colorado Springs Fire Department

Division of the Fire Marshal



*Sharing the Responsibility!*



Ignition Resistant Construction Design Manual  
Published by the Colorado Springs Fire Department  
City of Colorado Springs, Colorado

Third Printing  
October 21, 2016

## Table of Contents

Purpose .....	5
Scope.....	5
Introduction .....	6
Colorado Springs Wildfire History.....	7
Waldo Canyon Findings.....	7
Fire Brands/Embers.....	8
Vegetation Exposure .....	9
Structural Exposure.....	9
Fire Front/Direct Flame Contact .....	10
Ignition Resistant Construction Features.....	11
Class A Roofing.....	11
Protection of, Overhangs and Structural Projections .....	13
Exterior Doors .....	14
Windows .....	14
Attic Vents.....	15
Gutters .....	18
Decks.....	20
Base of Walls.....	22
Alternative Methods and Materials.....	23
Construction Permit Review Requirements.....	24
Fuels Management .....	25
Plant Selection .....	25
Safety Zone .....	26
Ground Cover.....	27
Bushes.....	28
Trees.....	28
Clearance to Main Structure.....	30
Pruning of Limbs .....	31
Clearance of Tree Branches to Structures or Appurtenances .....	32
Additional Tips to Reduce Your Wildfire Risk .....	34

Summary ..... 35  
Glossary of Terms..... 36  
Annex A – Examples of Decking Materials..... 38  
Annex B – FireWise Plant Materials..... 39  
Annex C – Hillside Overlay Map ..... 44  
Referenced Documents ..... 45

# Hillside Wildfire Mitigation Design Manual

## Purpose

---

This manual is to be used in conjunction with Appendix K of the 2009 International Fire Code, as adopted by the City of Colorado Springs, which together serve to provide all users with both legal requirements, as well as recommended guidance for optimal ignition resistant construction features. All requirements found in Appendix K supersede or override less-restrictive HOA and Neighborhood Covenants and shall apply to all new building construction or reconstruction in the Hillside Overlay Zone, regardless of development plan or initial construction plan approval date. This design manual does not cover fire protection system requirements such as monitored residential fire alarm or residential fire sprinkler systems already covered through the original Hillside Ordinance.

## Scope

---

The Waldo Canyon Fire has and will continue to be examined for lessons learned, not only by local residents but also by distant neighborhoods, cities, states, government agencies, students of fire science, and more. As such, all users of this manual need to understand that concerted effort was made by the contributors of this document (listed in the back of this manual) to achieve a balance between common sense ignition resistant construction and landscaping, common construction methods, and homeowner desires.

The material found in this manual is intended to follow the provisions of the Ignition Resistant Construction Ordinance and provide the reader with a clear understanding as to why the ordinance was created. In addition, this document will provide the reader with information they can use in preparing their home against the threat of wildfire. The two primary sections of this document include Ignition Resistant Construction and Landscaping/Vegetation Management.

It is important to note and understand that **ALL** of the provisions included in this manual are intended to function as a system or design package. Eliminating just one element or feature from the system approach may increase a home's vulnerability to a wildfire or urban conflagration event. For example, a home could be constructed with ignition resistant materials, but if vegetation is allowed to grow under decks or tress branches extend over the roof, then the construction materials may not be enough to protect the home from wildfire. Likewise, if a home has good defensible space but has combustible construction materials, then the home is still subject to ignition from fire embers and brands from open space or adjacent properties. In any case, the provisions outlined in this document do not guarantee that every home will survive a wildfire event. Wildfire will always be a dynamic and unpredictable event, influenced by several factors including fire weather, fuels, topography, and human activity.

Each of the provisions listed in this manual apply to all new or reconstructed residential structures within the Hillside Overlay Zone of the City of Colorado Springs. These provisions do not apply to small detached accessory structures such as storage sheds, dog houses, and children's playhouses.

## Introduction

---

The City of Colorado Springs is a wonderfully diverse community in terms of landscape, architecture and topography. This diversity and the majestic mountains are a few of the things that entice people to call this community home. Many people enjoy the opportunity to reside within the hillside areas of this community as a way to embrace the beauty of nature and wildlife, while still having the convenience of city living. However, what most people don't realize when they move into the hillside areas of this community, is that they have chosen to reside in one of the largest wildland/urban interface zones in the entire country. In fact, 36,485 homes or addresses have been identified as at-risk of wildfire in Colorado Springs.

Residing within a wildland/urban interface comes with some unique risks not generally found in other parts of this community. One such risk is the ever present threat of wildfire. Wildfire is an event nature uses to improve the overall health of our forests. Fire removes dead, diseased, and overgrown vegetation, which in return provides nutrients for new growth and improved wildlife habitat. It is impossible to prevent wildfires from impacting communities in the wildland/urban interface; as such, homeowners need to learn to live within that ever changing environment without increasing the risk or subjecting their homes to an increased level of threat.

As a result of the Waldo Canyon Fire and the disastrous outcomes that were experienced, the Colorado Springs Fire Department, in partnership with the Colorado Springs Housing and Building Association, collaborated to address some critical issues in house design and construction. The result of the collaborated effort was the modification of City Code language to more safely and reasonably protect those residents who are rebuilding homes in the Waldo Canyon Fire Burn Area, or building new homes in any portion of the City's Hillside Overlay.

The Colorado Springs Fire Department has written this manual with the goal of reasonable design that will improve the odds of a home surviving a wildfire event with little or no fire fighter intervention. In Colorado Springs, thirteen fire fighters respond on the initial dispatch of every reported house fire. Additional resources are brought in as needed based upon the severity of the fire. During a wildfire event, there are not enough resources available to protect each home as we would for a single house fire. Fire fighters must make difficult decisions as to how best deploy resources to provide the most effective fire attack. A home constructed with ignition resistant materials and adequate defensible space requires fewer resources to defend than a home that is more vulnerable to wildfire. It is everyone's duty to *Share the Responsibility* in protecting this community.

## Colorado Springs Wildfire History

---

Our region is no stranger to the natural and sometimes human caused wildfires. Some significant fires the Pikes Peak Region has experienced over the years are:

- The Big Burn, 1854
- Camp Carson Fire, 1950
- Hayman Fire, 2002
- Westwood Fire, 2005
- Manitou Incline Fire, 2007
- Turkey Creek Fire, 2008
- Waldo Canyon Fire, 2012

The Colorado Springs Fire Department has been actively involved in wildfire mitigation efforts since 1993 when the City passed the Hillside Fire Mitigation Ordinance. This ordinance was primarily intended to protect homes against geological hazards such as landslides, and to protect natural vegetation from unnecessary disturbance, it also included some fire prevention features as well.

In 2000, a Tri-Data Consulting study identified wildfire risk as one of the greatest threats to the City of Colorado Springs. The wildland/urban interface covers 28,800 acres and includes 24% of the City's population. Currently, the Colorado Springs Wildfire Mitigation program works in stewardship with 92 homeowner associations and neighborhoods. As part of a cohesive strategy, wildfire mitigation includes a wildfire risk model that identifies 25 weighted values to determine risk ratings at the lot level. Each individual lot in the wildland-urban interface and the associated wildfire risk rating can be viewed at <http://csfd.springsgov.com>. In addition to identifying wildfire risk, the program has grown to include education and outreach, planning, fuels management, contracting, development review process, grant administration and volunteer program management.

The information and design provisions provided in this design manual are the result of many years of research, observations, and studies of actual fire events, to include the Waldo Canyon Fire, which forever changed the landscape of Colorado Springs on June 26, 2012. In order to understand fire's impacts on building construction, we must first have an understanding on basic fire behavior. During a wildfire event, fire propagates through direct flame contact, radiant heat transfer from structure to structure, radiant heat transfer from vegetation to structure, and fire brands and embers that ignite vegetation and structures. However, the most prominent method of initial ignition is through fire brands and embers. The industry term for fire embers is "an ember storm," which can be compared to a snow storm with blizzard like conditions.

### Waldo Canyon Findings

The driving force behind the Ignition Resistant Construction and Fuels Management Ordinance was the lessons learned over the past decade and the local evidence from the Waldo Canyon Fire. The findings from the Waldo Canyon Fire highlighted the need for additional effort in reducing the effects and impacts of future fires that will someday again threaten this community.

On June 23, 2012, a wildfire was reported burning in Waldo Canyon to the west of the City of Colorado Springs. After three long days of hard work to keep the fire outside of the city limits and in the National Forest, the Waldo Canyon Fire took a turn for the worse. There was a wind shift, driven by thunderstorm activity over

Woodland Park, which caused significant down slope winds. On the afternoon of June 26, the weather front pushed the fire into the Mountain Shadows neighborhood, ultimately destroying 346 homes and significantly damaging 45 others.

Colorado Springs Fire Investigators reported the following summary of structural ignition sources.

Ignition Source	Percentage of Burned Structures*
Fire Brands/Embers	54%
Vegetation Exposure	22%
Structural Exposure	16%
Fire Front / Direct Flame Contact	8%

\*The percentage reported in this table are estimated based upon investigation findings. This table does not include home counts from the Parkside Neighborhood, Courtney Drive or Yankton Place. The homes lost in these two neighborhoods were the result of primary ignition of homes from brands/embers, which led to conflagration of the entire neighborhoods through vegetation and structure exposure.

### Fire Brands/Embers

Based upon the investigation findings, structural ignition from fire brands/embers accounted for more than half of all homes burned in the non-conflagration areas (see Figure 1 below for an example of a roof ignited by brands/embers). As fires burn, they produce fire brands/embers that are pushed by the winds generated by the fire. It is not uncommon to have fire brands/embers igniting spot fires as much as one-half mile or more ahead of the fire front. Some studies have reported spotting fire as much as ten miles ahead of the fire front. The brands/embers can carry enough heat energy to ignite combustible structures as they blow against or land upon the combustible surfaces of a home. The findings support and stress the importance of ignition resistant construction. Specifically, features such as screened attic vents, composite decking and Class A roofing provide significant defense against brand/ember initiated ignition of homes.



Figure 1

### **Vegetation Exposure**

The next highest source of initial ignition to homes was burning vegetation in close proximity to structures as represented in Figure 2. Trees such as dense conifers and similar vegetation tend to catch fire embers/brands, and when located adjacent to, or in close proximity of the homes, can be a significant fire exposure to the structure. The Fuels Management Features portion of this manual provides specific and reasonable steps a homeowner can take to reduce the likelihood that burning vegetation will ignite their home. The fuels management features work in concert with ignition resistant siding and similar construction features to improve the odds of a home surviving a wildfire event without firefighter intervention.



Figure 2

### **Structural Exposure**

Similar to the vegetation exposure, home to home ignition is a common event in wildland/urban interface fires. During the Waldo Canyon Fire, the two neighborhoods that experienced the most loss were a result of home to home ignition. The single greatest thing a homeowner can do is to ensure adequate distance between their home and their neighbor's house. That said, most homeowners don't have the luxury of adequate clearance to their neighbor's home due to lot sizes. However, the same features used to protect a home against a vegetation exposure fire are also effective against a structural exposure fire. Figure 3 shows the density of structure in the Parkside Neighborhood prior to the Waldo Canyon Fire, this is one of the neighborhoods hit the hardest during the fire.





Figure 3 - Photo courtesy of Bing maps.

### **Fire Front/Direct Flame Contact**

The smallest percentage of home ignitions was due to direct flame contact or impact from the forest fire front. Typically, in these cases, the fire front approaches from open space or forest land. A fast moving crown fire through a forested area burns with intense radiant heat that pre-heats everything within its path. As the fire front approaches the houses on the perimeter of the neighborhood, they can be very vulnerable to easy ignition (Figure 4). Good forest health goes a long way in keeping forest fires small and preventing crown fires. Unfortunately, this type of fire is the hardest to mitigate, and in most urban environments is beyond the capability of a homeowner to mitigate.



Figure 4 - Ignition of homes along the northern fire front. Photo courtesy of the Denver Post.

During the fire, and in the days following, there were many examples of successful wildfire mitigation work. Fire crews were able to defend structures because homeowners had taken time to create defensible space. Some neighborhoods or portions thereof, sustained little to no fire damage because of mitigation work prior to the fire in open spaces adjacent to the threatened neighborhoods.

It is the professional opinion of the Colorado Springs Fire Department that the loss of structures would have been less had the provisions in this document been implemented prior to the Waldo Canyon Fire.

## Ignition Resistant Construction Features

This section of the design manual specifically addresses the construction materials and finishes used to reduce the likelihood of ignition of a home from an exposure fire.

### Class A Roofing

#### Ordinance Section K105.1 (1)

*A Class A roof covering (excluding solid wood materials) shall be installed on all Residential Occupancies and a minimum Class B roof coverings shall be installed on remaining occupancies, unless otherwise permitted.*

In 2002, the fire department convened a working committee to study a ban on wood shake roofs and require Class A roofing installations for all residential properties. There was representation on this committee from the Council of Neighbors and Organizations (CONO), local builders, roofing contractors, Housing and Building Association (HBA), and various regulatory agencies. City Council passed the Class A roofing ordinance prohibiting wood shake roofs from being installed on residential occupancies in this community. Since then, more than 69,000 roofs have been replaced and/or upgraded to Class A materials throughout the city.

A Class A roof is not just the roof covering itself, but is an overall assembly required to achieve a Class A rating. Roofing products are tested by submitting a roofing mock up to a testing lab where they subject the roofing assembly to a fire brand test. This test involves placing a burning fire brand upon the roof. Figure 5 shows the three sizes of fire test brands – the largest is Class A (12"x12"), Class B (6"x6"), Class C (1"x1"). During the test, the fire cannot penetrate the roof or cause the roof structure/underlayment to ignite before the brand is consumed and burns out.



Figure 5

Combustible roofing materials, to include wood, fiberglass, etc. are subject to ignition from fire embers and brands. Many homes that ignite in wildland/urban interface fires burn from the top down, this is a result of ignition of the roofing materials or the combustible roof decking.

There are many types and architectural styles of Class A roofing materials available on the market today. The variety of styles allow for flexibility in achieving the desired look of the home and complying with HOA architectural design standards while providing for fire resistive properties that are so important in the wildland/urban interface.

Typical Class A roofing products include, but are not limited to the following types:

- Asphalt Shingles
- Metal / Stone-coated Metal
- Concrete (standard weight and lightweight)
- Clay Tile
- Synthetic
- Slate
- Hybrid Composite

## Exterior Cladding & Siding, Eaves and soffits

### Ordinance Section K105.1 (2)

*Exterior cladding, eaves and soffits shall be constructed of ignition-resistant materials approved by CSFD. Approved materials include, but are not limited to: fiber-cement board, stucco, masonry/brick, manufactured stone, and similar materials. Natural wood/cedar siding, hardboard, vinyl, and similar combustible materials are not allowed.*

**Exception:** *Natural wood or plastic products used for fascia, trim board materials and trim accents, such as corbels, false rafter tails, faux trusses, shutters and decorative vents material are allowed when painted or as approved.*

The home's siding is the largest overall surface of the home. The materials, in which the exterior of the home are wrapped, play a significant role of preventing home to home, or vegetation to home ignition. In exposure fires, the siding of a home is subject to extremely high radiant heat, which can ultimately ignite the home. This is the same problem experienced throughout history in terms of conflagrations such as the Great London Fire and Great Chicago Fire that consumed entire cities.

Ignition resistant siding helps prevent house to house ignition, thereby slowing the fire's progress and giving the fire department an opportunity to contain a fire to the original structure of origin.

There are many different exterior cladding and siding products available to satisfy a variety of architectural styles. The most common, as shown in Figure 6 below, are natural or fabricated stone/rock, stucco, and cement board.



Figure 6

As indicated in the ordinance exception, decorative construction features such as fascia, trim board materials and trim accents, corbels, false rafter tails (Figure 7), faux trusses, and shutters are not required to be ignition resistant. These features can be constructed of wood, vinyl, composite materials, or non-combustible products. CSFD strongly encourages the use of non-combustible products when they are available. Vinyl decorative features can be used when installed on ignition resistant surface. When wood products are used they must be

painted or sealed to protect the wood from drying out and cracking or splitting. The cracks or splits in wood create a void for embers to attach to and propagate ignition.



Figure 7

### Protection of, Overhangs and Structural Projections

#### Ordinance Section K105.1 (3)

*For any portion of the attached structure with projections or overhangs, the area below the structure shall have all horizontal under-floor areas enclosed with ignition resistive materials such as those allowed in the exterior cladding and siding section above.*

**Exception:** *Heavy timber or dimensional log construction is allowed.*

Projections of homes are areas that are vulnerable to heat and embers collection. While not common in this area, the undersides of some building projections are left open to expose the structural members. The exposed structural members are generally combustible and can act as a heat collection and ignition point on the home.

Enclosing the underside of projections with ignition resistant products will help to reduce the likelihood of fire starting in these areas. See Figure 8 below for examples on how to properly protect the underside of the projections. In the example photos, the horizontal surface is constructed with cement board as would commonly be used for soffit and fascia material.

horizontal surface is constructed with cement board as would commonly be used for soffit and fascia material.



Figure 8

## Exterior Doors

### Ordinance Section K105.1 (4)

*Exterior doors shall be non-combustible or solid core not less than 1 ¾-inches thick. Windows within doors and glazed doors shall be tempered safety glass or multi-layered glazed panels.*

**Exception:** *Decorative single pane glazing in front entry doors is allowed.*

As with any entry point into a home, exterior doors can leave the house vulnerable to fire intrusion. The International Residential Code requires that exterior doors meet or exceed specific industry testing standards in terms of deflection caused by wind. A solid core door not only provides the best protection against deflection by wind, but it also provides protection against radiant heat as compared to a lighter weight hollow core door. Doors should be constructed of non-combustible products such as metal or composites. Wooden doors are acceptable when they are solid core construction.

Sliding glass doors or decorative front doors with glass panels shall have tempered glass that are designed to withstand impact and meet the design standards required by building codes (Figure 9). In an effort not to restrict architectural design and curb appeal, the exception to this section allows for entry doors with decorative glass, which may or may not be tempered.



Figure 9

## Windows

### Ordinance Section K105.1 (5)

*Exterior windows shall be a minimum double pane. Tempered panes are preferable but not required.*

There are two main components of windows that are vulnerable to fire: the first is the frame construction, and the second is the glazing (or glass surface). While not specifically addressed by the Ignition Resistant Construction Ordinance, if vinyl windows are used, they should contain an aluminum sub-frame to help the window frame retain its shape when exposed to increased heat. Melting or distortion of the frame can cause the glass panes to shift or fall out.

The primary area of concern addressed by the ordinance related to windows is the glass surface. Today's windows are constructed to be very energy efficient in terms of insulation properties and UV reflection. As such, most modern windows perform extremely well during a wildfire. Dual pane windows can successfully withstand a flame front as it moves quickly into or through a community by reflecting the radiant heat energy.

Just like placing a hot glass in cold water, the extreme temperature fluctuation in a wildfire will cause the glazing in a window to crack. The insulating factor of a dual pane window will help protect against the temperature differences. Single pane windows do not perform as well and are vulnerable to cracking and breaking due to the intense heat of a wildfire.

Most homes built today already include dual pane windows as an energy conservation and efficiency feature. Similar to the section on doors above, windows must meet or exceed rigorous testing to national standards to be approved for use in a home.

## Attic Vents

### **Ordinance Section K105.1 (6)**

*All attic vents shall be screened with wire mesh or hardware cloth having openings no larger than 1/8-inch unless an alternative design or product is allowed by the Fire Code Official. Soffit vents are allowed. Gable vents may be allowed but only as approved by the Fire Code Official.*

Ember intrusion is a very significant factor in determining whether or not a home will survive a wildfire event. Attic venting is critical in preventing excessive temperatures and moisture in attics; however, the venting also leaves homes very vulnerable to ember intrusion. Using vents with 1/8" screening is important in restricting the size and overall number of embers able to enter the attic (Figure 10). This screening will not stop all embers, but generally speaking, embers less than 1/8" do not have the heat energy needed to ignite combustible framing or insulation within the attic space.

Consider a camp fire; as the fire pops and cracks, small embers fly out of the fire. The small embers will generally burn out before falling to the ground. The small embers do not have enough heat energy to continue to burn. Now, think of the larger embers or brands that pop from a campfire and land on the ground. Many of the larger embers will still be glowing, if not flaming, when they land. These larger embers or brands are the ones that need to be kept out of attic spaces as they have enough heat energy to ignite combustible structural members. Even with the smaller vent screens, potentially hundreds of smaller embers will enter the attic. The primary goal is to prevent thousands of larger/hotter embers and brands from entering the home, as there will be a much higher risk of ignition.

As an added safety measure, homeowners should not use attics for the storage of combustible materials as they may ignite from embers as well.

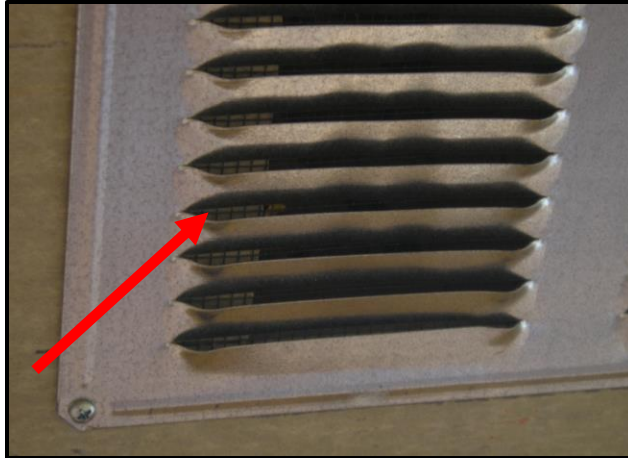

Figure 10. The 1/8" screening can be seen where it contrasts with the wood on the left side of the vent.

There are several different types of vents commonly used for attics, which include soffit (Figure 11), roof (Figure 12), ridge (Figure 13), and gable (Figure 14) vents. Each of these vents types are required to include 1/8" screening.



Figure 11



Figure 12

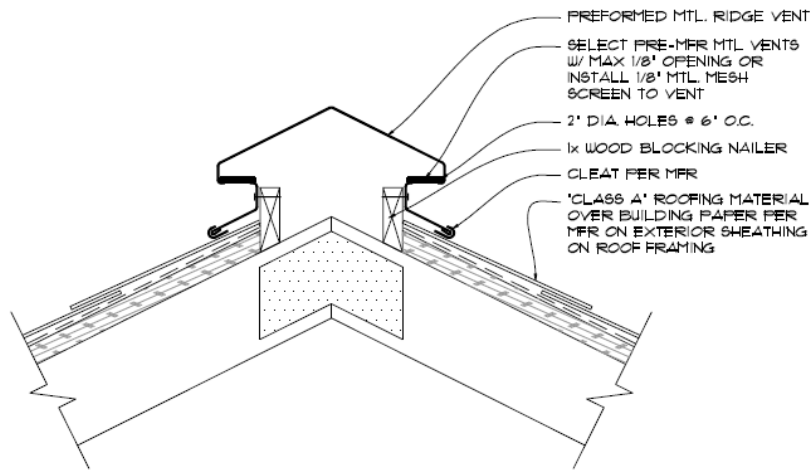

Figure 13

Gable vents (Figure 14) are highly discouraged as they are more susceptible to ember intrusion and should only be considered on sides of homes that do not face steep slopes or typical prevailing winds. Figure 15 is an example of a faux gable vent and is for decorative purposes only. The decorative vent does not penetrate the attic and therefore does not require screening.



Figure 14



Figure 15

While not specifically addressed in the ordinance, other types of vents, such as those for crawlspaces are also vulnerable to ember intrusion. The same screening practices for these would be a wise choice.



## Gutters

### Ordinance Section K105.1 (7)

*Gutters and downspouts that are of non-combustible construction shall be installed such that the leading edge of the roof is finished with a metal drip edge so that no wood sheathing is exposed. The drip edge shall extend into the gutter. Vinyl gutters may be allowed, but must have a non-combustible landing area below the roof line, that is a minimum 5 foot distance from the side of the structure or foundation. NOTE: gutter caps are highly encouraged as a home-owner maintenance item to prevent combustible debris from collecting in the trough.*

Studies have been conducted to evaluate the performance of both metal and vinyl gutters during wildfires. While the gutter material certainly has an impact, of greater concern is the combustible debris (leaves, pine needles, etc) that can accumulate in gutters and ignite during a fire.

Metal gutters will not burn, and they tend to stay in place during a fire. Any debris within the gutter that ignites will burn and expose the roof decking and fascia to heat and direct flame contact. Vinyl gutters tend to ignite when exposed to significant heat or fire, but they will melt away from the structure, thus limiting the amount of heat or flame exposure to the roof decking or fascia. From a fire safety standpoint, it is more important to prevent the accumulation of combustible debris in the gutter than to be concerned with the actual material of the gutter itself. If gutter caps are not used to prevent accumulation of foreign combustible debris (Figure 16), then homeowners must be vigilant to ensure the gutters are cleaned out on a regular basis.



Figure 16

Standard practice is to install a piece of metal flashing, otherwise known as a drip edge along the exposed face of the roof decking. This design is common from the moisture prevention aspect, but it is also found to be very effective in preventing flame exposure or ember intrusion along the exposed edge of the roof decking under the shingles of roofing material. This drip edge shall cover the edge of the roof deck, extend into the gutter, and shall be installed tightly against the gutter material (Figure 17). In cases of a very long roof line, additional flashing may need to be installed behind the gutter and drip edge to prevent exposure of the fascia.

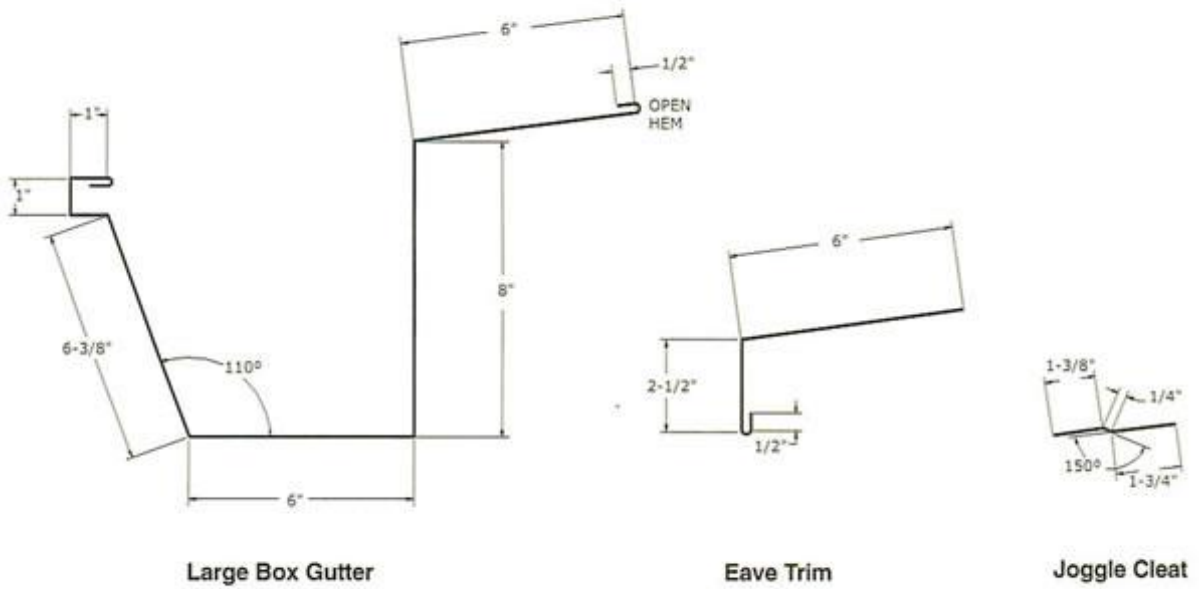

Large Box Gutter

Eave Trim

Joggle Cleat

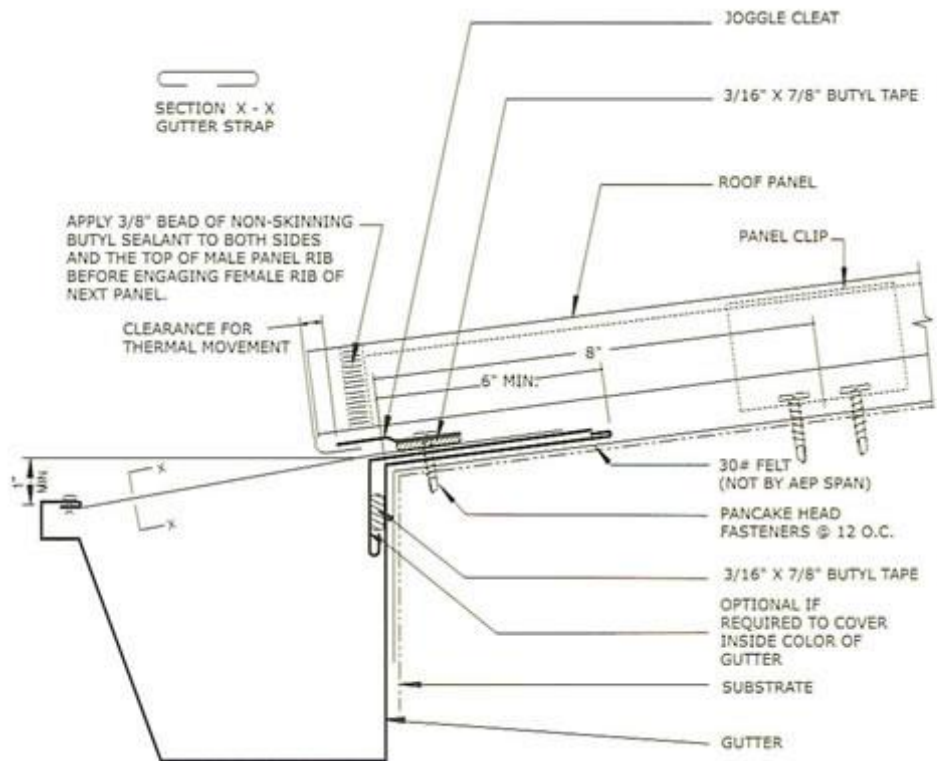

Figure 17

## Decks

### **Ordinance Section K105.1 (8)**

*Decks and other habitable spaces shall be of ignition resistant or non-combustible decking materials, such as composite or metal decking. Wood is not permitted to be used for the decking surface, but can be used for all large structural components and railings.*

Decks and outdoor living spaces are an important aspect of Colorado living. Many homes throughout this community utilize decks and other outdoor living spaces to take full advantage of the beautiful views and climate our community has to offer. As such, residents desire to retain decks as an important aspect of hillside homes. When choosing decking material it is important to understand that deck safety is not just about the decking material, but is a package design to include smart storage and landscaping practices. Decks are most vulnerable to ignition from direct flame impingement from adjacent combustible material such as firewood, bushes, trees, etc., and from fire brands or embers landing on the horizontal surfaces of the deck. The point at which the deck connects to the home should have adequate metal flashing to provide additional protection against ignition where there is potential for an increased accumulation of embers and brands.

When choosing decking surfaces there are two primary material types on the market: wood and composite or PVC. Wood is the most common product found in the construction of decks. Wood is generally fairly easy to work with; however, it does require significant maintenance to keep it from drying out and splitting. The dry and split wood is very susceptible to capturing embers and igniting. Composite decking on the other hand is relatively maintenance free and does not rot or split, making it a much better product in terms of fire safety.

Like roofing materials, building products are tested for the surface burning characteristics and given a rating classification depending upon how well they resist ignition and spread of flame across the surface. The classification has three levels; Class A, Class B and Class C, with Class A having the best performance at resisting flame spread. Many natural wood products inherently have a Class C rating, with the exception of some exotic hardwoods or other products not typically selected for decking materials. Many of the composite or PVC decking materials are available with a Class B rating – some even have a Class A rating (Figure 18).



Figure 18

During the Waldo Canyon Fire, many of the decks that ignited or burned were due to direct flame contact from ignition of combustible storage under the deck or adjacent trees and bushes. In this case, both wood and composite decks burned. Where decks were subject to embers and fire brands, wooden deck surfaces were

more easily ignited than the composite decks, which tended to melt but not ignite. Figure 19 shows a composite deck that was attached to a home completely destroyed by fire. The deck did receive damage, but for the most part was intact as the composite deck itself did not burn. In contrast, Figure 20 shows a combustible deck that was ignited due to embers/brands. Fire fighter intervention prevented further damage to the deck and structure.



Figure 19



Figure 20

Examples of composite or ignition resistant decking products may be found in Annex A in the back of this document.

The ordinance itself does not regulate the structural components of the deck. While standard lumber is common, many builders and home owners are utilizing alternative materials for the construction of their decks. Figure 21 show a deck built with metal framing member in lieu of wood. Although not shown in the photo, this deck also has a concrete decking surface. In addition, they chose to wrap the support columns in stucco rather than leaving them exposed. Like the base of walls, it is also important to enclose the base of any exterior columns as discussed in the next section. These areas are vulnerable to debris and ember collection inside the base of the column.



Figure 21

## Base of Walls

### Ordinance Section K105.1 (9)

*The base of exterior walls, posts or columns shall be protected on the bottom side with provisions such as fire resistant foam or wire mesh having openings no larger than 1/8-inch to protect them from ember intrusion and still allow for weeping and moisture control.*

Traditional building construction methods have the tendency to leave gaps under the lower edge of siding at the base of walls, posts, columns, etc. Figure 22 shows a close up view, looking up from the bottom of the wall, which reveals vulnerable gaps at the base of walls. In the picture on the left you can see the exposed combustible sheathing (green) and foam board insulation (blue). In the picture on the right you can see the combustible wood sheathing (brown). This gap, while typically not noticeable, provides an entry point for embers and flames to enter the exterior walls of the home. As winds and embers blow up against the foundation of the home, the gap left between the siding and foundation can leave the stud wall cavity exposed. The gap provides for a point of ember intrusion into the combustible wall cavities and concealed spaces of the home. Fire can burn undetected and unimpeded in the concealed spaces for long periods of time before venting to the exterior where it is discovered. This gap needs to be protected with screening or sealed off with caulking, fire resistive foam, mortar, or similar product.

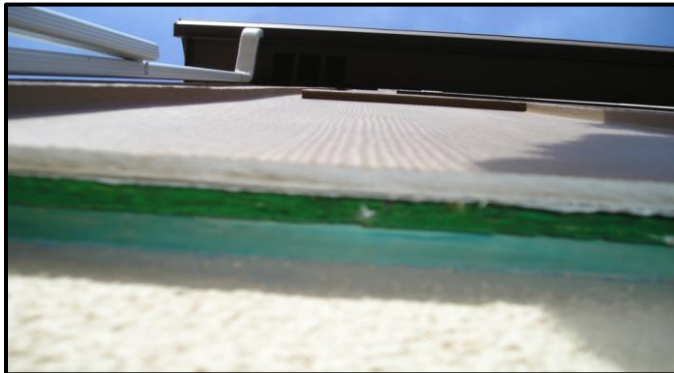

Figure 22

In Figure 23, the builder utilized metal flashing and stucco to seal the exposure where the wall connects to the foundation. Be advised that there may be a need or desire to provide provisions for a weep or drainage to prevent moisture and condensation collection within the wall. Make sure these drains or weeps are not closed off when sealing the bottom side of the walls if moisture control is needed.



Figure 23

## Chimneys

### Ordinance Section K105.1 (10)

*Chimneys serving fireplaces, as well as other heating appliances in which solid or liquid fuels are used, shall have an approved spark arrester or cap.*

Spark arresters are required to be installed in accordance with the mechanical and building codes for all new installations of solid fuel and wood burning appliances. We highly recommend them to be installed on existing chimneys. While spark arresters are important from a wildfire prevention standpoint, they are different for the other provisions in this guidebook. These are not for protecting your home from wildfire, but preventing a wildfire from starting due to embers from your wood burning appliances.

Spark arresters are design to catch embers and brands that are produced during normal operation of a fireplace or wood burning appliance. Prevention of embers and brands from exiting a chimney reduces the risk of ignition outside of the home and potentially causing a wildfire event. Code compliant spark arresters shall be constructed of woven or welded wire screening of 12 USA standard wire gauge having openings not exceeding  $\frac{1}{2}$  inch (Figure 24).



Figure 24

## Alternative Methods and Materials

The Colorado Springs Fire Department recognizes that there are many different construction methods and materials available in the construction of a home. As with everything else, technology continues to improve and new products and construction methods are frequently introduced into the home building markets. As such, we are open to discussion and evaluation of methods or materials not specifically addressed within this document. Our goal is smart construction with ignition-resistant design that will increase a home's ability to stand alone with limited or no fire fighter intervention during a wildfire event. Nothing in this design manual is intended to prevent the use of products that have been tested and proven to provide equivalent or greater levels of protection and design than what have been called out in this manual. Consideration of alternative building

products will generally require manufacturer's literature and independent product testing reports describing the flame spread characteristics of the proposed materials.

For additional information and updated lists of potentially acceptable construction materials, please visit the California Office of the State Fire Marshal, California Department of Forestry and Fire Protection web site at [http://osfm.fire.ca.gov/licensinglistings/licenselisting\\_bml\\_searchcotest.php](http://osfm.fire.ca.gov/licensinglistings/licenselisting_bml_searchcotest.php). This site will include many of the product suggestions listed in this document, as well as any additional products that may have been added since the publication of this document. The City of Colorado Springs does not endorse any specific product or material, but rather looks subjectively at each product for compliance with code and documented testing performance when considering its use in a local application.

### **Construction Permit Review Requirements**

All requirements must be reviewed and approved by the Colorado Springs Fire Department Construction Services prior to building permit issuance. Hillside homes are reviewed through the plot plan/site plan process through City Planning. After Planning completes their review of the plot, the plan will be routed to Fire Construction Services for review. Information regarding the building materials, compliance with applicable development plan conditions associated with the specific lot, and compliance with ignition resistant construction and fuels management practices shall be indicated on the plot plan at the time of submittal.

Two inspections are required during the construction process. A preliminary inspection around the time of the framing inspection is important to allow the inspector to look at roof vents and construction materials such as soffits/fascia material before they are concealed. In addition, the preliminary inspection allows us to provide feedback on the existing landscaping and native vegetation. A final fire department inspection to verify compliance with all the provisions of the Ignition Resistant Construction Ordinance, to include any vegetation and landscaping, will be required prior to issuance of the Certificate of Occupancy.

## Fuels Management

---

This section of the design manual specifically addresses landscaping and natural vegetation surrounding houses, and how to apply smart landscaping design to reduce the likelihood of ignition of a home from an exposure fire. Fuels management includes selecting plant materials that have a greater resistance to wildfire in terms of susceptibility to ignition and providing adequate clearance to homes.

### Plant Selection

Proper selection of plants and trees is critical when creating a defensible space around your home. However, it's not just how you landscape, but the selection of plants and materials is of equal importance. Colorado Springs is a semi-arid climate and prone to drought conditions. Selection of plants that are drought resistant and tend to maintain greater fuel moisture is a good start. Deciduous plants are a great choice because they generally have higher moisture content, and can shed their leaves when they go dormant due to drought or during the winter months. The shedding of leaves allows the structure of the plant or tree to retain higher moisture content.

Other attributes and considerations for fire resistant landscaping include:

- Avoid plants with volatile oils and resins like pine and juniper
- Choose plants that are native to the area and are drought tolerant for our climate
- Choose plants with a naturally higher moisture content
- Consider mature size and spacing
- Select a diversity of species (as different plants are more susceptible to burning at various times of the year)

For additional information on FireWise Plant Materials, refer to Annex B in the back of this manual.



## Safety Zone

### Ordinance Section K102.1.1

*Brush patches or clusters such as Gambel oak, Mountain mahogany, Rocky Mountain maple, chokecherry, etc. may be left, or planted, or allowed to grow in the safety zone, but shall be separated by clear areas of ten feet (10') or more of noncombustible materials or grass mowed to not more than four inches (4") in height.*

The safety zone (or home ignition zone) is defined as the first 30' immediately surrounding a structure including roofline and decks. Contrary to false impression, this area does not have to be clear cut. Fuels management is about making smart choices in selecting the plants within the safety zone, and maintaining the existing healthy vegetation using the techniques covered in this section. There are three primary fuel layers of vegetation to be considered when evaluating the safety zones. These layers include ground cover, bushes, and trees. Figure 25 illustrates an overgrown lot. This image is typical of an unmitigated property. The adjacent image, Figure 26, provides an example of a well mitigated lot with plenty of clearance within the safety zone.

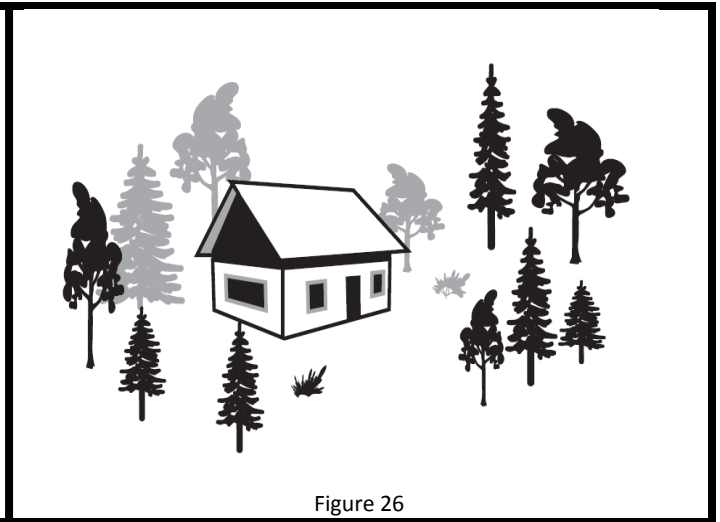
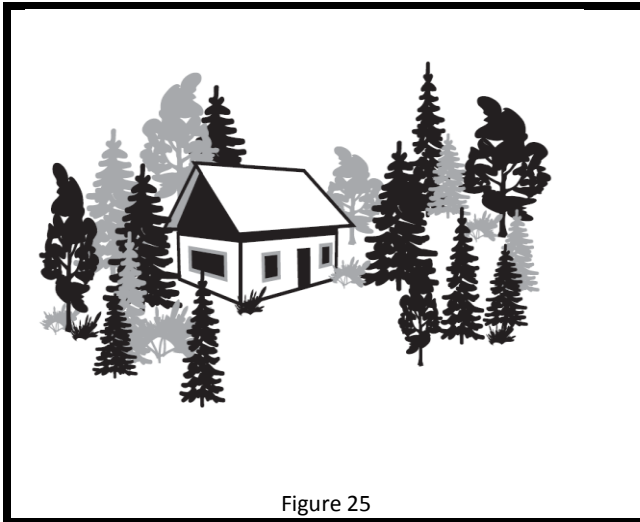

Figure 27 is a good example of the various layers of vegetation within the safety zone. Note the separation of fuels and the use of features such as rock walls and planting beds to create defined fuel breaks.



Figure 27

### **Ground Cover**

Ground cover includes any materials or surfaces at grade. Native or planted grasses are the most common type of ground cover. Considerations regarding ground cover include height of the materials, clearance to structures, and fuel moisture. Ground cover is predominantly considered to be light, flashy fuels. These fuels generally don't have very high heat energy, but they do provide for very rapid fire spread when the fuel moisture is low. Keeping grasses mowed to a height of less than 4" and well irrigated within close proximity to the home will reduce the rate of spread as well as the intensity.

Also, of significant consideration in terms of the safety zone is ground cover mulch. While mulch might not seem like a big deal, combustible mulch near homes can be receptive to embers and fire brands. Avoid mulches that tend to be light weight. Denser bark or even rock and stone are a much better choice for mulch around the perimeter of the home. Rock or stone mulch should always be used when vinyl gutters are present on the home as discussed in the gutters section on page 16.

## **Bushes**

Bushes and other low level vegetation are those intermediate level plants that generally grow in the two to six foot high range. The intermediate plants, also known as ladder fuels, become a conduit for flame transfer from ground cover to larger plants and trees. Bushes are an important consideration when evaluating the overall safety zone of the home. Care should be taken to select plants for the FireWise Plant Materials list from Annex B of this document.

Maintenance of bushes includes removing debris and dead branches from the base (understory) of the plant and limiting the size of clusters of multiple plants to no more than one hundred (100) square feet. Gambel oak, or scrub oak, grows in clumps and share root systems. Limiting the size of and separating the clumps from other vegetation is intended to break up the continuity of brush leading up to structures. By removing the debris and dead branches from the brush, the likelihood of ignition from a ground cover fire is reduced.

## **Trees**

Trees are obviously the largest and often times most sought after vegetation within the safety zone. Strong, healthy trees provide many benefits to homeowners, including curb appeal, shade, wildlife habitat, and soil stabilization.

There are several factors to consider when selecting trees to plant or maintain around a home. First and foremost, select types and species of trees that are found on the FireWise Plant Materials list in Annex B of this document. Care should be taken to avoid trees such as conifers or evergreens, including pines, firs, spruces and junipers in the safety zone. These trees have characteristics that make them prone to fire including resin and oil content, low hanging limbs, needles, thin bark, and low fuel moisture. Some pines, like Ponderosas, have thicker bark and higher limbs that make it the better choice for selecting an evergreen. Deciduous trees are always a much better choice in the safety zone.

The next thing to consider is the maturity and health of existing trees. A certified arborist can be a great resource in determining the overall health of trees around a home. However, some indicators of stressed or unhealthy trees include obvious sign of disease such as mistletoe as shown in Figure 28, or pest infestation such as pine beetle as indicated by the sap in Figure 29.



Figure 28



Figure 29

The biggest consideration in terms of trees within the safety zone is to provide plenty of clearance between trees, other vegetation, and structures. In the previous section, bushes are described as ladder fuels because they can be a conduit for flame transfer from ground cover to larger plants and trees. The most dangerous and rapid fire spread during a wildfire is known as a crown fire, which allows fire to jump from bush to bush or tree top to tree top, covering large areas of land in very short timeframes. Trees can also be a method of fire spread to structures and homes when adequate clearance is not provided as described in the following sections.

## Clearance to Main Structure

### Ordinance Section K102.1.2

*No combustible brush, trees or shrubs such as Gambel oak, conifers, junipers and yews shall be allowed to be left, or planted, or allowed to grow within fifteen feet (15') of the main structure or significant accessory structure such as sheds, decks, and pergolas. The trunks of deciduous trees may be allowed to be planted up to 10 foot (10') from structures when approved by the Fire Code Official.*

**Exception:** *When approved by the Fire Code Official, small brush patches such as Gambel oak, Mountain mahogany, Rocky Mountain maple, chokecherry, etc. not exceeding one hundred (100) square feet in size or trees, no larger than fifteen (15) linear feet in any direction, may be allowed to encroach into this zone. Vegetation must be maintained in accord with the applicable Colorado Springs Community Wildfire Protection Plan.*

The intent of the 15' clearance of trees or brush is to provide spacing between the tree limbs in relation to the eaves, roofline or deck. Figure 30 shows illustration that compares and contrast adequate clearance to the home. The 15' clearance also accounts for several tree characteristics including mature height, shape, leaf type, moisture content, resins, and additional plant characteristics that make trees less ignition resistant. In some instances based on property lines, the 15' clearance is not possible. In certain circumstances, tree, brush and plant species identified as Firewise plants by Colorado State Forest Service are allowed within 15'. See Annex B in the back of this manual or visit <http://www.ext.colostate.edu/pubs/natres/06305.html> for more information on FireWise plant materials.



Figure 30

Figure 31 shows two examples where the 15' clearance to the main structure is not provided. In both of the examples provided, the homes are at significant risk of vegetation to structure ignition in the event of a wildfire.



Figure 31

## Pruning of Limbs

**Ordinance Section K102.1.3** *Large trees shall not be allowed to have limbs overlap smaller trees or brush which creates ladder fuels, and shall be pruned of limbs to a height of up to ten feet (10') above the ground while maintaining a minimum of 70% of the crown. Certain tree clusters may be allowed if sufficient clear area is provided and approved by the Fire Code Official.*

Pruning up to 10' in height is intended to remove ladder fuels and prevent fire spread from the ground into the crowns of the trees and brush. Both live and dead limbs can act as ladder fuels. The 10' limit for pruning is intended to leave enough foliage on the tree to make enough food to survive. It is also intended to provide a limit that residents can safely prune up to, without climbing the tree or cutting over head. While pruning is limited to 10' the recommendation is always to maintain at least 70% of the crown to ensure good health of the tree.

Figure 32 shows an actual example of a home site before fuels mitigation. This lot is overgrown and creates a significant fire risk. Figure 33 is the same lot after fuels mitigation. This lot is now safer for the property owner and is esthetically pleasing and no longer overgrown.



Figure 32

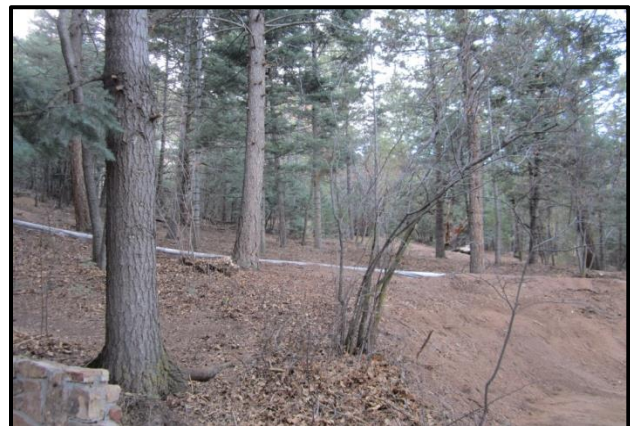

Figure 33

Figure 34 provides a great example of how good clearance to the structure and pruning of limbs successfully protected a home from ignition. The arrow in the photo identifies where the fire burned along the ground but stopped short of the home. The scrub oak was properly pruned and limbed up to prevent the ground cover from extending into the taller plants.



Figure 34

### Clearance of Tree Branches to Structures or Appurtenances

**Ordinance Section K102.1.4**

*Character tree branches shall not extend over or under the roof or eaves, and the canopy or drip-line shall not be within fifteen feet (15') of a deck or similar combustible projection, wood burning appliance or chimney unless approved by the Fire Code Official. Character trees shall be defined as existing, mature overstory trees that are unique to the site; i.e. species specific or large diameter (>12 inches) or wildlife essential (nesting habitat)*

While house plans and landscape plans note the relation of vegetation to the structure, it again does not address the size, shape, or future growth of the tree. Figure 35 represents how dense vegetation and landscaping create a means of continuity for a ground fire to spread to bushes and trees. In contrast, Figure 36 shows how good fuels management is design to limit the spread of fire, thus keeping the fire small and manageable. Regardless of the planting location, no limbs should reach on, over, or under rooflines, decks, eaves or chimney (Figure 37).



Figure 35



Figure 36



Figure 37

Like building construction, good fuels management practices include a systems approach within the safety zone. Overall clearance to the main structure is essential in providing a buffer or fire break between combustible vegetation and the home. Pruning of limbs helps to reduce the ladder fuels, which prevents ground cover fires from moving to the crowns of trees where the fire can spread much more freely. Keeping tree branches from touching or being in close proximity to a home will provide protection from a crown fire and reduce the likely ignition of the home. Overlooking just one piece of the fuels management model will reduce the overall protection of the home.



## Additional Tips to Reduce Your Wildfire Risk

---

1. Create defensible space around your home. Colorado Springs Fire Department recommends thinning out 30 feet or to your property line, whichever comes first.
2. Keep rain gutters clear of leaves and pine needles.
3. Do not store combustibles on or under decks, including fire wood.
4. Rake up pine needles and leaves within 30 feet of any structure.
5. Select plant species with fire resistant characteristics.
6. Keep grasses mowed to a maximum height of 4 inches.
7. Incorporate landscaping designs to break up fuel continuity (i.e. paths, rock walls, gravel mulch.
8. Keep addresses clearly marked and visible from both directions of traffic. (Fire fighter can't help you if they can't find you.)
9. Prune lower branches. Removing ladder fuels will help keep the fire from getting into the crowns of the trees. Remove dead or diseased trees and brush.
10. When making home improvements or repairs, consider wildfire safety. Refer to this manual and incorporate ignition resistant design whenever possible.
11. Maintenance! You have worked hard to protect your investment, make sure you continue those efforts through regular maintenance.
12. Get involved with your HOA and participate in neighborhood chipping programs.
13. Work with your neighbors and encourage them to participate in wildfire mitigation efforts as well.
14. Contact the CSFD Wildfire Mitigation office at 385-7342 to request a free on-site consultation regarding specific wildfire threats on your property.

## Summary

---

The Colorado Springs Fire Department is here to support and encourage the citizens of our city to do their part in keeping our community safe against the ever present threat of wildfire. Wildfire safety and prevention is *EVERYONE'S* responsibility and it is up to each and every homeowner to take the necessary steps to prepare their home against wildfire.

The information provided within this design manual is an overview, and by no means all encompassing in terms of the methods and materials available for ignition resistant construction and smart landscaping practices. We encourage you to contact the Colorado Springs Fire Department if you have any questions or would like us to visit with you regarding your wildfire risk.

- For Ignition Resistant Construction questions, please contact the Fire Construction Services office at (719) 385-5982, Ext. 2.
- For Wildfire Mitigation and landscaping questions, please contact the Wildfire Mitigation office at (719) 385-7342.
- For additional fire safety tips and information, please visit our website at <http://www.springsgov.com/fire>

## Glossary of Terms

---

**Brands:** A burning piece of wood or other burning material generally distributed by wind currents. A brand is differentiated from an ember by its larger size and higher heat energy.

**Character Tree:** Character trees shall be defined as existing, mature over story trees that are unique to the site: ie. species specific or large diameter (>12 inches) or wildlife essential (nesting habitat).

**Conflagration:** A large, out of control and destructive fire, generally categorized by the loss of many continuous structures within a defined fire area.

**Clusters:** Clumps of trees and/or brush no more than one hundred (100) square feet in size and no more than fifteen (15) linear feet in any direction, separated by clear areas of ten (10) feet or more of non combustible materials or grass mowed to not more than four (4) inches in height.

**Crown Fire:** A rapidly moving fire burning in the tops or crowns of trees, which is able to cover a significant area in a short amount of time.

**Defensible Space:** An area either natural or man-made, where material capable of allowing a fire to spread unchecked has been treated, cleared, or modified to slow the rate and intensity of an advancing wildfire and to create an area for fire suppression operations to occur.

**Embers:** A small piece of wood or other burning material generally distributed by wind currents. An ember is differentiated from a brand by its smaller size and lower heat energy

**Exposure Fire:** A direct flame contact or radiant heat energy substantial enough to ignite vegetation and/or the adjacent structures.

**Fuels Management:** The act or practice of controlling flammability and reducing resistance to control of wildland fuels through mechanical, chemical, biological, or manual means.

**Fuel Moisture:** The amount of moisture found in dead or living organic fuels (vegetation).

**Hillside Overlay:** An overlay zone characterized by ridgelines, bluffs, view corridors, foothills, mountain backdrop, excessive slope, unique vegetation, natural drainage, rock outcroppings, geologic conditions, wildlife habitats, and other physical hazards that are significant natural features worthy of preservation. A map of the Hillside Overlay Area can be found in Appendix D of this manual.

**Ignition Resistant Construction:** The use of materials and systems in the design and construction of a building or structure to safeguard or provide reasonable protection against the ignition and/or spread of fire to or from buildings or structures.

**Ladder Fuels:** Natural vegetation or other combustible materials that provide a conduit through direct contact or close proximity to allow for a fire in smaller plants to progress vertically into taller plants and trees.

**Mitigation:** The intentional act of reducing the threat or severity of a fire through ignition resistant construction, creation of defensible space, and the use of FireWise plant materials.

**Patches:** See “Clusters” above.

**Safety Zone:** The first thirty (30) feet immediately surrounding a structure including roofline and decks.

**Wildfire:** An uncontrolled fire spreading through vegetative fuels, exposing and possibly consuming structures.

**Wildland/Urban Interface:** A geographical area where structures and other human development meets or intermingles with wildland or vegetative fuels. For the sake of this manual the wildland/urban interface includes, but is not limited to, the Hillside Overlay Zone.

## Annex A – Examples of Decking Materials

This list of products below is simply a representation of products that would be acceptable for use as decking material. The CSFD does not promote or endorse any specific product. New products are continually being developed. Homeowners and contractors should do their research to find the appropriate type of materials that will work but for their particular situation. One such resource is the State of California Building Materials Listing, which can be found at: [http://www.osfm.fire.ca.gov/licensinglistings/licenselisting\\_bml\\_searchcotest.php](http://www.osfm.fire.ca.gov/licensinglistings/licenselisting_bml_searchcotest.php)

### Advanced Enviromental Recycling Technologies, Inc.

- “ChoiceDek® FR” composite wood plastic deck board - Class C Flame Spread
- “MoistureShield® FR” composite wood plastic deck board - Class C Flame Spread

### Tamko Building Products, Inc.

- “EverGrain” composite deck board - Class C Flame Spread
- “Elements Dockboard” composite deck board, 1.4” thick x 5.25” width - Class C Flame Spread
- Model Envision composite decking board - Class C Flame Spread

### Fiber Composites, LLC

- “Fiberon” composite deck board - Class B Flame Spread
- “Portico” composite deck board - Class B Flame Spread
- “Veranda” composite deck board - Class B Flame Spread
- “WeatherBest™” composite deck board, - Class B Flame Spread
- “Sensibuilt™” cellular PVC composite deck board - Class A Flame Spread
- Veranda ArmorGuard/Fiberon ProTect composite deck board - SFM 12-7A-4A

### Gossen Corporation

- “Passport” Cellular PVC deck board - Class B Flame Spread.
- “Weather Ready” Cellular PVC deck board - Class B Flame Spread

### Interplast World-Pak

- “TUF DECK™” extruded PVC composite square edge deck board - Class A Flame Spread

### TimberTech Ltd.

- “DockSider™ Plank” wood plastic composite (WPC) deck board - Class B Flame Spread
- “ReliaBoard™” HDPE composite deck board - Class B Flame Spread
- “TwinFinish™ Plank” wood plastic composite (WPC) deck board - Class B Flame Spread
- “TimberTech XLM™” plastic composite deck board - Class B Flame Spread

### Enduris Extrusion Inc.

- “Endeck” Cellular PVC deck board - Class A Flame Spread

## Annex B – FireWise Plant Materials

Key:	Water needs: VL = very low L = low M = medium H = high
	Sun/Shade: S = Sun PS = part sun Sh = shade

Scientific Name	Common Name	Approx. Water Needs	Sun/Shade Preference	Approx. Mature Height	Approx. Bloom Month
<b>Flowers and Ground Covers</b>					
<i>Achillea lanulosa</i> <sup>a</sup>	Native yarrow	L-H	S/PS	1.5-2'	Jul
<i>Achillea tomentosa</i> <sup>b</sup>	Woolly yarrow	M-H	S/PS	.5'	Jul
<i>Aconitum</i> spp. <sup>c</sup>	Monkshood	M-H	S	2'	Jun-Jul
<i>Aconitum columbianum</i> <sup>ac</sup>	Columbian monkshood	M-H	S	2'	Jun-Jul
<i>Ajuga reptans</i> <sup>b</sup>	Bugleweed	H	Sh	< .5'	Jun-Jul
<i>Alchemilla</i> sp.	Ladys mantle	M-H	PS/Sh	1'	Jun-Jul
<i>Allium cernuum</i> <sup>ac</sup>	Nodding onion	L-H	S/PS	1'	Jun
<i>Allium geeyer</i> <sup>ac</sup>	Geyer onion	L-H	S/PS	1'	Jun
<i>Anaphalis margaritacea</i> <sup>a</sup>	Pearly everlasting	L-H	S	1.5 - 2.5'	Aug
<i>Anemone blanda</i>	Windflower	M-H	S/PS	1'	Apr-May
<i>Antennaria parvifolia</i> <sup>ab</sup>	Small-leaf pussytoes	M	S/PS	<.5'	Jun
<i>Antennaria rosea</i> <sup>ab</sup>	Rosy pussytoes	M	S/PS	<.5'	Jun
<i>Aquilegia</i> spp.	Columbine	M-H	S/PS	1 - 2'	Jun-Jul
<i>Aquilegia coerulea</i> <sup>a</sup>	Colorado blue columbine	M-H	S/PS	1 - 2'	Jun-Jul
<i>Aquilegia chrysantha</i> <sup>a</sup>	Yellow columbine	M-H	S/PS	1 - 2'	Jun-Aug
<i>Arabis</i> sp. <sup>b</sup>	Rockcress	L-H	S	< 1'	May-Jun
<i>Armeria maritima</i>	Sea thrift	L-H	S/PS	.5'	Apr-Jun
<i>Artemisia caucasica</i>	Caucasian sage	L-M	S/PS	1- 2'	n/a
<i>Artemisia frigida</i> <sup>ac</sup>	Fringed sage	L-M	S	1 - 1.5'	n/a
<i>Artemisia ludoviciana</i> <sup>a</sup>	Prairie sage	L-M	S	1 - 1.5'	n/a
<i>Aster laevis</i> <sup>a</sup>	Smooth aster	L-H	S/PS	1 - 3'	Aug-Sep
<i>Aster porter</i> <sup>a</sup>	Porter aster	L-M	S	1'	Aug-Sep
<i>Aubrieta</i> sp. <sup>b</sup>	False rockcress	M	S	1'	Apr-May
<i>Aurinia</i> sp. <sup>b</sup>	Basket of gold	M	S/PS	1'	Apr-May
<i>Calochortus gunnisoni</i> <sup>f</sup>	Mariposa lily	M-H	S	.5 - 2'	Jul-Aug
<i>Campanula rotundifolia</i> <sup>a</sup>	Common harebell	M-H	S	.5 - 1'	May-Oct
<i>Centranthus ruber</i>	Jupiters beard	L-H	S/Sh	2 - 2.5'	May-Oct
<i>Cerastium strictum</i> <sup>ab</sup>	Mouse ear chickweed	M	S/PS	1'	May-Jun
<i>Cerastium tomentosum</i> <sup>b</sup>	Snow-in-summer	L-M	S/PS	1'	May-Jun
<i>Claytonia lanceolata</i> <sup>a</sup>	Spring beauty	M	Sh	.5 - 1.5'	Mar-Apr
<i>Convallaria majalis</i> <sup>bc</sup>	Lily-of-the-valley	H	Sh	< 1'	May-Jun
<i>Delosperma nubigenum</i> <sup>b</sup>	Hardy yellow iceplant	M-H	S	.5'	Jun
<i>Delphinium</i> spp. <sup>c</sup>	Delphinium	M-H	S/PS	.5 - 3'+	Jun-Jul
<i>Dianthus</i> spp.	Pinks	L-H	S	<.5' - 2'	May-Aug
<i>Doronicum</i> sp.	Leopards bane	H	S/PS	2 - 3'	Jul-Aug
<p><sup>a</sup> Native species.</p> <p><sup>b</sup> Ground cover plant.</p> <p><sup>c</sup> This species, or some species in this genus, may be poisonous to livestock, pets, wildlife and/or people under some conditions. Before planting, check with Colorado State University Extension, Colorado State Forest Service, or other knowledgeable personnel.</p> <p><sup>d</sup> Several species of symphoricarpos are native.</p>					

Key:	Water needs: VL = very low L = low M = medium H = high
	Sun/Shade: S = Sun PS = part sun Sh = shade

Scientific Name	Common Name	Approx. Water Needs	Sun/Shade Preference	Approx. Mature Height	Approx. Bloom Month
<i>Echinacea purpurea</i>	Purple coneflower	M	S	2 - 3'	Jul-Aug
<i>Epilobium angustifolium</i>	Fireweed	H	S/PS	3'	Jul-Aug
<i>Erigeron flagellaris</i> <sup>a</sup>	Whiplash daisy, trailing fleabane	L-M	S	< 1'	Jun-Jul
<i>Eriogonum umbellatum</i> <sup>a</sup>	Sulphur flower	M	S/PS	<.5'	Jun-Jul
<i>Erysimum asperum</i> <sup>a</sup>	Western wallflower	M	S/PS	1'+	Jun-Jul
<i>Gaillardia aristata</i> <sup>a</sup>	Blanket flower	L-M	S	1 - 1.5'	Jul-Sep
<i>Galium boreale</i> <sup>ab</sup>	Northern bedstraw	M-H	Sh	<1'	May-Jun
<i>Geranium</i> spp.	Hardy geraniums	M	Sh/PS	2'	May-Oct
<i>Geranium caespitosum</i> <sup>a</sup>	Wild geranium	M	Sh/PS	2'	May-Oct
<i>Geum triflorum</i>	Prairie smoke	M-H	S/PS	1.5'	Jun
<i>Helianthella quinquenervis</i> <sup>a</sup>	Aspen sunflower	M	S	1'	?
<i>Helianthemum nummularium</i>	Rockrose	M-H	S	< 1'	May-Jun
<i>Helianthus pumilus</i> <sup>a</sup>	Small sunflower	M	S	1 - 2'	Jun-Jul
<i>Heuchera</i> spp.	Coral bells	M-H	PS/Sh	1 - 2'	Jun-Aug
<i>Ipomopsis aggregata</i> <sup>a</sup>	Scarlet gilia	M	S/PS	1 - 2'	Jun-Aug
<i>Iris germanica</i>	Bearded iris	L-M	S	1 - 3'	May-Jun
<i>Iris missouriensis</i> <sup>ac</sup>	Missouri or Native iris	M-H	S	1 - 2'	May
<i>Lamium</i> sp. <sup>b</sup>	Dead nettle	M-H	Sh	< 1'	May-Jun
<i>Lavandula</i> spp.	Lavender	L-M	S	1 - 2'	Jun-Nov
<i>Leucocrinum montanum</i> <sup>a</sup>	Sand lily	L-M	S	< 1'	May
<i>Liatris punctata</i> <sup>a</sup>	Dotted gayfeather	VL-L	S	1 - 2'	Aug-Oct
<i>Linum lewisii</i> <sup>ac</sup>	Wild blue flax	L-H	S/PS	1 - 2'	May-Sep
<i>Lupinus argenteus</i> <sup>ac</sup>	Silver lupine	M	Sh/PS	1 - 3'	Jun-Jul
<i>Mertensia lanceolata</i> <sup>a</sup>	Narrow-leaved chiming bells	M-H	Sh/PS	1 - 2'	May-Jun
<i>Mimulus guttatus</i> <sup>a</sup>	Yellow monkey-flower	H	Sh	1'	?
<i>Monarda fistulosa</i> <sup>a</sup>	Native beebalm	M-H	S/PS	1 - 2'	Jul-Oct
<i>Oenothera caespitosa</i> <sup>a</sup>	White stemless evening primrose	L-M	S	1 - 2'	Jun-Aug
<i>Papaver orientale</i>	Oriental poppy	H	S/Sh	2 - 3'	May-Jun
<i>Penstemon caespitosus</i> <sup>ab</sup>	Mat penstemon	L-M	S	< .5'	Jun

<sup>a</sup> Native species.

<sup>b</sup> Ground cover plant.

<sup>c</sup> This species, or some species in this genus, may be poisonous to livestock, pets, wildlife and/or people under some conditions. Before planting, check with Colorado State University Extension, Colorado State Forest Service, or other knowledgeable personnel.

<sup>d</sup> Several species of symphoricarpos are native.

Key:	Water needs: VL = very low L = low M = medium H = high
	Sun/Shade: S = Sun PS = part sun Sh = shade

Scientific Name	Common Name	Approx. Water Needs	Sun/Shade Preference	Approx. Mature Height	Approx. Bloom Month
<i>Penstemon secundiflorus</i>	Sidebells	L-M	S	1 - 2'	May-Jun
<i>Penstemon teucrioides</i> <sup>a</sup>	Germander penstemon	L-M	S	.5'	Jun-Jul
<i>Penstemon virens</i> <sup>a,c</sup>	Blue mist penstemon	M	S/PS	.5'	May-Jun
<i>Phlox subulata</i>	Moss phlox	M	S	< .5'	May
<i>Polemonium</i> sp.	Jacobs ladder	H	S/PS	1 - 2'	May-Aug
<i>Potentilla fissa</i> <sup>a</sup>	Leafy potentilla	M-H	PS	1'	?
<i>Potentilla verna</i> <sup>b</sup>	Spring potentilla	M-H	PS	< .5'	Mar-May
<i>Pulsatilla patens</i> <sup>a</sup>	Pasque flower	M	S/PS	1'	Mar-May
<i>Ratibida columnifera</i> <sup>a</sup>	Prairie coneflower	L-M	S	2'	Jul-Sep
<i>Rudbeckia hirta</i> <sup>a</sup>	Black-eyed Susan	M-H	S	2 - 3'	Jul-Sep
<i>Salvia officinalis</i>	Cooking sage	L-M	S/PS	2'	Jun
<i>Saxifraga hirsuta</i>	Saxifrage	H	S/PS	.5'+	May-Jun
<i>Scutellaria brittonii</i> <sup>a</sup>	Skullcap	M	S/PS	.5 - 1'	Aug-Sep
<i>Sedum</i> spp. <sup>b</sup>	Stonewall	M	S/PS	1 - 1.5'	Jul-Aug
<i>Sedum lanceolatum</i> <sup>a</sup>	Yellow stonewall	M	S/PS	.5'	Jul-Aug
<i>Sempervivum</i> sp.	Hens and chicks	L-M	S/PS	.5'	n/a
<i>Senecio spartioides</i> <sup>a,c</sup>	Broom groundsel	VL-L	S	2 - 3'	Sep-Oct
<i>Solidago missouriensis</i> <sup>a</sup>	Smooth goldenrod	L-M	S	1 - 2'	Jul-Aug
<i>Thalictrum fendleri</i> <sup>a</sup>	Fendler meadowrue	H	S/PS	2 - 3'	Jul-Aug
<i>Thermopsis divaricarpa</i> <sup>a</sup>	Spreading golden banner	M-H	S/PS	2'	May
<i>Tradescantia occidentalis</i> <sup>a</sup>	Western spiderwort	M	S/PS	1.5'	Jun-Aug
<i>Thymus</i> spp. <sup>b</sup>	Thyme	L-M	S	< .5'	Jun-Jul
<i>Veronica pectinata</i>	Speedwell	L-M	S	< .5'	Apr-Jul
<i>Vinca minor</i> <sup>p</sup>	Periwinkle, myrtle	H	Sh	< 1'	Apr-Jun
<i>Waldsteinia</i> sp. <sup>b</sup>	Barren strawberry	M-H	Sh/PS	< 1'	May-Jun
<b>Shrubs</b>					
<i>Arctostaphylos nevadensis</i> <sup>a,b</sup>	Pinemat manzanita	M	S/PS	1 - 2'	n/a
<i>Arctostaphylos patula</i> <sup>a</sup>	Greenleaf manzanita	M	S/PS	3 - 4'	n/a
<i>Arctostaphylos uva-ursi</i> <sup>a,b</sup>	Kinnikinnick, bearberry	M	S/Sh	1'	n/a
<i>Betula glandulosa</i> <sup>a</sup>	Bog birch	H	S/PS	6 - 8'	n/a
<i>Calluna</i> sp.	Heather	H	S/PS	2'	Jul-Aug

<sup>a</sup> Native species.

<sup>b</sup> Ground cover plant.

<sup>c</sup> This species, or some species in this genus, may be poisonous to livestock, pets, wildlife and/or people under some conditions. Before planting, check with Colorado State University Extension, Colorado State Forest Service, or other knowledgeable personnel.

<sup>d</sup> Several species of symphoricarpos are native.



Key:	Water needs:	VL = very low	L = low	M = medium	H = high
	Sun/Shade:	S = Sun	PS = part sun	Sh = shade	

Scientific Name	Common Name	Approx. Water Needs	Sun/Shade Preference	Approx. Mature Height	Approx. Bloom Month
<i>Ceanothus fendleri</i> <sup>a</sup>	Buckbrush, mountain lilac	M	S	2'	Jul
<i>Cercocarpus intricatus</i>	Little-leaf mountain mahogany	VL-L	S	4 - 6'	n/a
<i>Cercocarpus montanus</i> <sup>ac</sup>	True mountain mahogany	L-M	S	4 - 6'	n/a
<i>Chrysothamnusspp.</i> <sup>a</sup>	Rabbitbrush	VL-L	S	2 - 6'	Jul-Aug
<i>Cornus stolonifera</i> <sup>a</sup>	Redtwig dogwood	H	S/Sh	4 - 6'	n/a
<i>Cotoneaster horizontalis</i>	Spreading cotoneaster	M	S/PS	2 - 3'	May-Jun
<i>Daphne burkwoodii</i>	Burkwood daphne	M	S/PS	2 - 3'	Apr-Jun
<i>Erica sp.</i>	Heath	H	S/PS	1'	Jan-Mar
<i>Euonymus alatus</i>	Burning bush euonymus	M	S/Sh	1 - 6'	n/a
<i>Fallugia paradoxa</i> <sup>a</sup>	Apache plume	VL-L	S	2 - 4'	Jun-Oct
<i>Holodiscus dumosus</i> <sup>a</sup>	Ocean spray, cliff/rock spirea	L-M	S/PS	4'	Jun
<i>Jamesia americana</i> <sup>a</sup>	Wax flower	M-H	S/Sh	2 - 6'	Jun
<i>Lonicera tatarica</i>	Tatarian honeysuckle	M	S/PS	4 - 6'	May-Jun
<i>Mahonia aquifolium</i>	Oregon grape holly	M-H	S/Sh	4 - 6'	May-Jun
<i>Mahonia repens</i> <sup>ab</sup>	Creeping grape holly	L-H	S/Sh	1 - 2'	Mar-May
<i>Philadelphus microphyllus</i> <sup>a</sup>	Little-leaf mockorange	M	S	2 - 3'	Jun
<i>Physocarpus monogynus</i> <sup>a</sup>	Mountain ninebark	M	S/Sh	2 - 4'	Jun
<i>Potentilla fruticosa</i> <sup>a</sup>	Shrubby cinquefoil	M	S/PS	2 - 3'	May-Sep
<i>Prunus besseyi</i> <sup>a</sup>	Western sand cherry	L-M	S	1 - 3'	May
<i>Purshia tridentata</i> <sup>a</sup>	Antelope bitterbrush	L-M	S	1 - 2'	Jun-Aug
<i>Ribes aureum</i> <sup>a</sup>	Golden currant	M	S/PS	2 - 3'	Apr-May
<i>Rosa woodsii</i> <sup>a</sup>	Woods' or native wild rose	M	S/PS	2 - 3'	Jun-Jul
<i>Shepherdia canadensis</i> <sup>a</sup>	Russet buffaloberry	M-H	S	5 - 6'	n/a
<i>Shepherdia canadensis</i> <sup>a</sup>	Russet buffaloberry	M-H	S	5 - 6'	n/a
<i>Symphoricarpossp.</i> <sup>d</sup>	Snowberry, coralberry	M	S/PS	2 - 3'	n/a
<i>Viburnum edule</i> <sup>a</sup>	Highbush cranberry	H	S	6 - 8'	May-Jun
<i>Yucca baccata</i> <sup>a</sup>	Banana or broad-leaf yucca	VL-L	S/PS	2 - 3'	Jun
<i>Yucca filamentosa</i>	Adams needle	M	S/PS	2 - 3'	Jun
<i>Yucca glauca</i> <sup>a</sup>	Spanish bayonet, small soapweed, Great Plains yucca	VL-L	S/PS	2 - 3'	Jun

<sup>a</sup> Native species.

<sup>b</sup> Ground cover plant.

<sup>c</sup> This species, or some species in this genus, may be poisonous to livestock, pets, wildlife and/or people under some conditions. Before planting, check with Colorado State University Extension, Colorado State Forest Service, or other knowledgeable personnel.

<sup>d</sup> Several species of symphoricarpos are native.

Key: Water needs: VL = very low L = low M = medium H = high

Sun/Shade: S = Sun PS = part sun Sh = shade

Scientific Name	Common Name	Approx. Water Needs	Sun/Shade Preference	Approx. Mature Height	Approx Bloom Month
<b>Large Shrubs and Trees</b>					
<i>Acer ginnala</i>	Ginnala maple	M-H	S	6 - 10'	n/a
<i>Acer glabrum</i> <sup>a</sup>	Rocky Mountain maple	M-H	S/Sh	6 - 10'	n/a
<i>Acer grandidentatum</i> <sup>a</sup>	Wasatch maple	M	S/PS	10 - 20'	n/a
<i>Alnus tenuifolia</i> <sup>a</sup>	Thinleaf alder	H	S/PS	6 - 8'	Apr
<i>Amelanchier alnifolia</i> <sup>ac</sup>	Saskatoon alder-leaf serviceberry	M	S/PS	6 - 8'	Apr-May
<i>Amelanchier utahensis</i> <sup>a</sup>	Utah serviceberry	VL-M	S	4 - 6'	May
<i>Betula fontinalis</i> <sup>a</sup>	River birch	H	S/PS	6 - 8'	n/a
<i>Cercocarpus ledifolius</i> <sup>a</sup>	Mountain mahogany	VL-L	S	6 - 15'	n/a
<i>Corylus cornuta</i> <sup>a</sup>	Filbert, beaked hazelnut	H	S/Sh	5 - 6'	n/a
<i>Crataegus</i> spp. <sup>a</sup>	Hawthorn (several native)	M	S	6 - 8'	May
<i>Fraxinus pennsylvanica</i>	Green ash	M-H	S	20 - 25'	n/a
<i>Gleditsia triacanthos</i>	Honeylocust	M-H	S	60 - 70'	May
<i>Malus</i> sp.	Crabapple	M	S	10 - 15'	Apr-May
<i>Physocarpus opulifolius</i> <sup>a</sup>	Tall ninebark	M	S/PS	4 - 6'	May
<i>Populus tremuloides</i> <sup>a</sup>	Aspen	M	S	8 - 25'	n/a
<i>Prunus americana</i> <sup>a</sup>	American wild plum	M	S/PS	4 - 6'	Apr
<i>Prunus cerasifera</i>	Flowering plum	M	S/PS	8 - 10'	Apr
<i>Prunus pennsylvanica</i> <sup>a</sup>	Pin/fire/wild/red cherry	M	S/PS	6 - 8'	May
<i>Prunus virginiana melanocarpa</i> <sup>ac</sup>	Western chokecherry	M-H	S/PS	6 - 8'	Apr-May
<i>Rubus deliciosus</i> <sup>a</sup>	Boulder raspberry, thimbleberry	M	S/Sh	4 - 6'	Apr-May
<i>Salix amygdaloides</i> <sup>a</sup>	Peachleaf willow	H	S/PS	20 - 30'	n/a
<i>Shepherdia argentea</i> <sup>a</sup>	Silver buffaloberry	M	S/PS	4 - 6'	Apr
<i>Sorbus scopulina</i> <sup>a</sup>	Western mountain ash	M-H	S/Sh	6 - 8'	May
<i>Syringa vulgaris</i>	Common lilac	M	S	6 - 8'	May

<sup>a</sup> Native species.

<sup>b</sup> Ground cover plant.

<sup>c</sup> This species, or some species in this genus, may be poisonous to livestock, pets, wildlife and/or people under some conditions. Before planting, check with Colorado State University Extension, Colorado State Forest Service, or other knowledgeable personnel.

<sup>d</sup> Several species of symphoricarpos are native.

\* Staff Forester (retired), Colorado State Forest Service. 10/99. Revised 1/12.

Colorado State University, U.S. Department of Agriculture and Colorado counties cooperating. CSU Extension programs are available to all without discrimination.

No endorsement of products mentioned is intended nor is criticism implied of products not mentioned.

# Annex C – Hillside Overlay Map

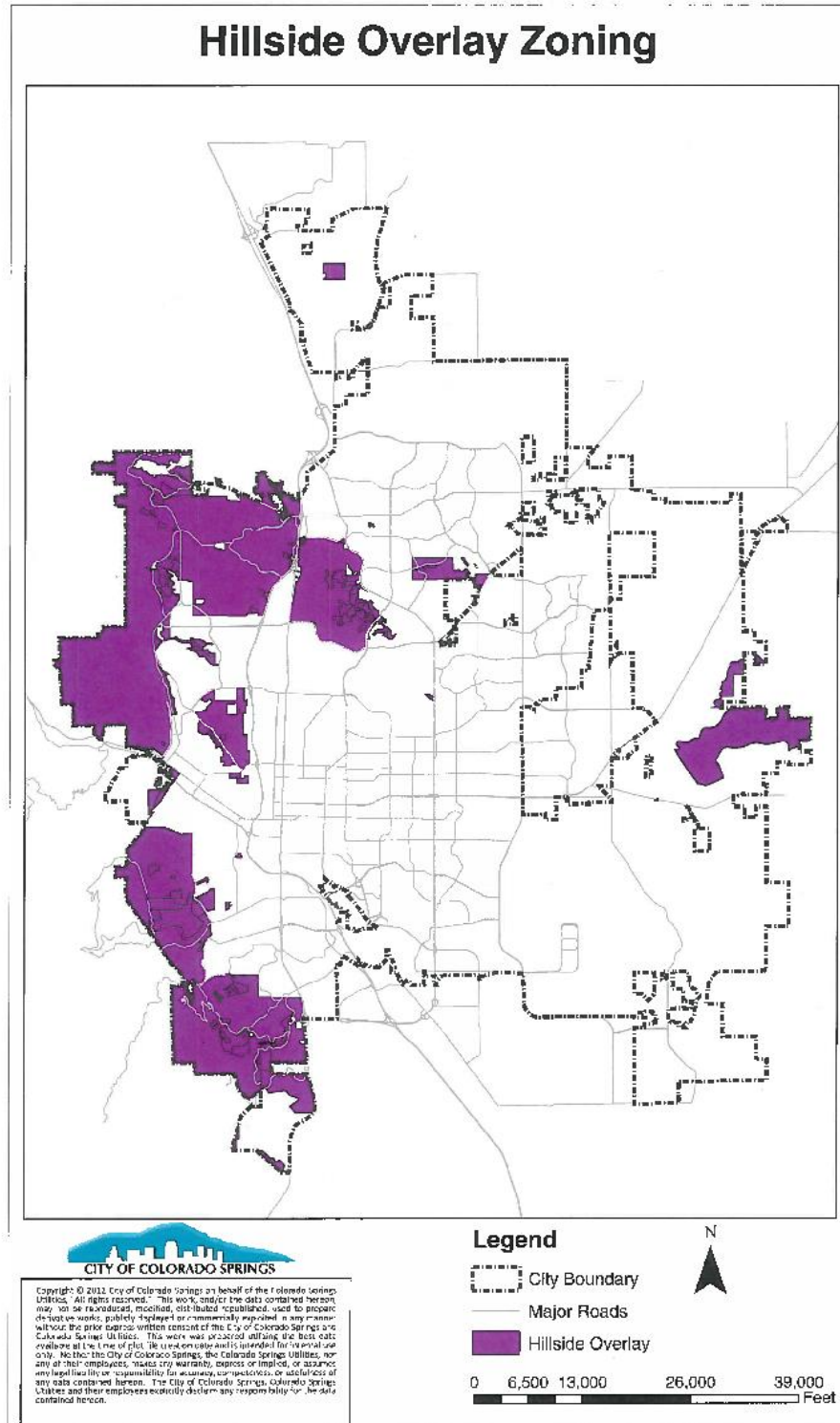

## Referenced Documents

---

### International Code Council (ICC)

International Residential Code, 2009 Edition

International Wildland-Urban Interface Code, 2009 Edition

International Mechanical Code, 2009 Edition

International Building Code, 2009 Edition

NFPA Publications. National Fire Protection Association, 1 Batterymarch Park, Quincy, MA 02169-7471

NFPA 1144 – Reducing Structure Ignition Hazards from Wildland Fire

### Insurance Institute for Business & Home Safety

Wildfire Home Assessment & Checklist

Protect Your Property from Wildfire – Rocky Mountain Edition

Lessons Learned from Waldo Canyon – Fire Adapted Communities, Mitigation Assessment Team findings

### California Office of the State Fire Marshal

Website: <http://osfm.fire.ca.gov/>

### Colorado State University

FireWise Plant Materials, Fact Sheet No. 6.305, National Resource Series – Forestry

### City of Colorado Springs Fire Department

Waldo Canyon Fire Investigations Summary memo, Nancy Gosch-Schanel, Fire Investigator

**Special thanks to the following partners that made this design manual possible**

The Colorado Springs Housing and Building Association

The Colorado South Chapter of the American Institute of Architects

**Design Manual Review Committee Members:**

Chuck Fowler

Christy Riggs

Adam Thesing

Teresa Ward

Marc Sabin

Greg Ralphe

Mark Bussone

Mike Mallon

Josh Peterson