



ANTLER RANGE FILING NO. 1

FINAL DRAINAGE REPORT

EL PASO COUNTY PROJECT NO: SF264

ALL TERRAIN ENGINEERING PROJECT NO: 24031

APRIL 2026

PREPARED FOR:

ANTLER RANGE LLC

CONTACT: GRANT LANGDON

PO BOX 38939

COLORADO SPRINGS, CO 80937

PREPARED BY:

ALL TERRAIN ENGINEERING LLC

CONTACT: RYAN BURNS

RBURNS@ALLTERRAINENG.COM

(203) 577-8656

ENGINEER'S STATEMENT

The attached drainage plan and report were prepared under my direction and supervision and are correct to the best of my knowledge and belief. Said drainage report has been prepared according to the criteria established by the County for drainage reports and said report is in conformity with the applicable master plan of the drainage basin. I accept responsibility for any liability caused by any negligent acts, errors or omissions on my part in preparing this report.

Ryan Burns, PE

Date

State of Colorado No. 54412

For and on behalf of All Terrain Engineering LLC

DEVELOPER'S STATEMENT

I, the owner/developer, have read and will comply with all of the requirements specified in this drainage report and plan.

Grant Langdon

Date

Antler Range LLC

PO Box 38939, Colorado Springs, CO 80937

EL PASO COUNTY ONLY

Filed in accordance with the requirements of the Drainage Criteria Manual, Volumes 1 and 2, El Paso County Engineering Criteria Manual and Land Development Code as amended.

Joshua J. Palmer, PE

Date

County Engineer/ECM Administrator

Conditions:



Table of Contents

I. General Purpose, Location & Description	2
II. Drainage Basins	3
III. Drainage Design Criteria	5
IV. Drainage Facility Design.....	6
V. Summary.....	10
VI. References	10

Appendices

- A. Vicinity Map, FEMA Map, NRCS Soil Survey & NOAA Atlas 14
- B. Hydrologic Analysis
- C. Hydraulic Analysis
- D. Water Quality & Detention
- E. Reference Material
- F. Drainage Maps

I. General Purpose, Location & Description

a. Purpose & Project Description

The purpose of the Final Drainage Report (FDR) for the ANTLER RANGE FILING NO. 1 project is to describe the site's onsite and offsite drainage patterns, existing and proposed storm infrastructure, and to safely route developed stormwater to adequate outfalls.

b. Location

ANTLER RANGE FILING NO. 1, referred to as 'the site' herein, is in a portion of the northwest quarter of Section 18, Township 12 South, Range 64 West of the 6th P.M., El Paso County, Colorado. The site is bound by unplatted land to the north, Meridian Road to the west, unplatted land (remaining area of existing parcel being platted with this project) to the east & The Trails Filing 2 to the east of that, and Ayer Road to the south & Antler Ridge Eastates to the South of that. Surrounding platted developments include Latigo Country Estates Filing 1, The Trail Filing 2, Camelot Subdivision and Antlers Ridge Estates. A vicinity map is presented in Appendix A.

c. Description of Property

The site (Filing No. 1) is approximately 26.05 acres of the existing 244.50 acre parcel and is largely undeveloped, with the exception of half of Ayer Road and existing electric, gas, and tele-communication utilities, lie within a portion of the site that is proposed to be dedicated as public R.O.W. Existing vegetation consists of prairie grasses and sparse forest. The site is unplatted and zoned A-35. The project will be rezoned to RR-2.5 and platted. The site will be platted with nine (9) 2.5+ acre lots. The total disturbed area associated with the proposed development is approximately 3.6 acres.

In general, the site slopes northeasterly. Onsite elevations range from 7248' - 7290' with slopes ranging 1 – 15%. Per an NRCS soil survey, the site is made up of Type B soils including Kettle gravelly loam, Pring coarse sandy loam and Tomah-Crowfoot loamy sands.

Existing, onsite utilities include overhead electric along the northern property line and existing storm sewer culverts that discharge on to the site along the southern border. The existing culverts are detailed in the 'Existing Basin Description' section. Black Squirrel Creek is located approximately 1,400' north of the site and is the ultimate outfall for the site's stormwater. Unnamed tributaries of Black Squirrel Creek traverse the site from south to north. An existing drainage map is presented in Appendix F.

d. Floodplain Statement

Based on FEMA Firm map 08041C0340G dated December 7, 2018, the site is Zone X. Zone X are areas determined to be outside the 0.2% annual chance flood. Site development will occur within Zone X areas.

II. Drainage Basins

a. Major Basin Description

The site is located within the Upper Black Squirrel Drainage Basin. Upper Black Squirrel is an unstudied drainage basin and an approved DBPS is not available. The site and surrounding areas were studied in the previous drainage reports:

1. "Preliminary/Final Drainage Report for Antler Ridge Estates" by Merrick and Company, approved July 2006.
2. "Final Drainage Report for Camelot Subdivision" by Classic Consulting Engineers and Surveyors, approved March 2002.
3. "Black Squirrel Creek and Snipe Creek Letter of Map Revision" by Kiowa Engineering Corporation, April 2006.

Antler Ridge Estates is located south of the site across Ayer Road. Pond UBS-2 from Antler Ridge Estates discharges under Ayer Road and into Existing Tributary A2. The pond outfall will be maintained with the development of Antler Range subdivision. See Basin B/A5 description for additional information.

Camelot Subdivision is located on the southwest corner of the Ayer Road and Meridian Road intersection. Pond DP-6 from Camelot Subdivision discharges onto the site, under Ayer and Meridian Road, into Existing Tributary A. See Basin A/A3 description for additional information.

The "Black Squirrel Creek and Snipe Creek Letter of Map Revision" analyzed a portion of Black Squirrel Creek that is located approximately 1,400' north of the site boundary. The LOMR was approved December 11, 2006 and revised the limits of Zone A.

b. Black Squirrel Creek

Black Squirrel Creek lies approximately 1,400' north of the site along the western property boundary. This reach of Black Squirrel Creek is included in the Colorado Water Conservation Board Base Level Engineering Study by AECOM (CWCB BLE) that aimed to revise Zone A floodplain limits, establish Base Flood Elevations (BFEs) and update Flood Insurance Rate Maps (FIRMs). While the results have not been formally adopted by FEMA, they have undergone FEMA review and are considered the best available information at this time and the County/Floodplain Manager has indicated that the CWCB model may be utilized for evaluating stability within Black Squirrel Creek. The channel will be fully analyzed and improved as necessary with future filings and will be part of the future filing FDR's or Channel Design Report/s.

A preliminary analysis of Black Squirrel Creek was provided with the PDR under EDARP File No. SP251. See the 'Major Drainageway' section later in this report regarding the stability analysis of Black Squirrel Creek.

c. Existing Subbasin Description

The existing site's drainage patterns are generally to the northeast. Unnamed tributaries convey onsite and offsite stormwater through the site. The site is divided into 2 existing drainage basins. See below for existing basin descriptions.

Basin A is 11.86 acres of onsite undeveloped area and portions of Meridian and Ayer Road. The Camelot Subdivision Pond (Camelot DP-6) discharges through an existing public 30" CMP culvert into the southwest

corner of Basin A. Camelot DP6 discharges ($Q_5 = 11$ cfs $Q_{100} = 22$ cfs) into Existing Tributary A and combines with Basin A flows ($Q_5 = 3.4$ cfs $Q_{100} = 18.1$ cfs). The combined stormwater is conveyed in Existing Tributary A to DP1 ($Q_5 = 11.8$ cfs $Q_{100} = 32.9$ cfs). DP1 stormwater continues offsite in ex Tributary A and continues to Black Squirrel Creek per historic patterns.

Basin B is 14.84 acres of onsite undeveloped area and a portion of Ayer Road. The Antler's Ridge Estates Pond (UBS-2 Pond) discharges through an existing 42" culvert under Ayer Road and into Existing Tributary A2 within Basin B. UBS-2 discharges ($Q_5 = 32.9$ cfs $Q_{100} = 69.2$ cfs) into Existing Tributary A2 and combines with Basin B ($Q_5 = 3.7$ cfs $Q_{100} = 20.4$ cfs) and Basin OS-B flows at DP2 ($Q_5 = 2.9$ cfs $Q_{100} = 77.4$ cfs). The combined flow continues off-site in Existing Tributary A2 to Black Squirrel Creek per historic drainage patterns.

d. Proposed Subbasin Description

In the proposed condition, the site will be subdivided into nine (9) 2.5+ acre lots with public, rural local roadways. Lots will not be developed at this time. However, to account for future home building, proposed lot areas are analyzed for their future condition. A 7% impervious is applied to the portion of lots that are not restricted by plat and developable in the future, while the remaining lot area is analyzed as undeveloped and typically includes drainage easements that will remain impervious.

In general, developed stormwater will be conveyed overland to existing and proposed grass lined swales that will carry stormwater towards the sites outfall/s. Roadway runoff and portions of lots tributary to road side swales will be routed to a private, full-spectrum detention and water quality pond, Pond A. Developed lots that do not drain towards the roadway or proposed Pond A will utilize the EPC DCM Appendix I.7.1.B – Large Lot Single Family Sites water quality exclusion. Where required, culverts will be utilized to pass stormwater under roadways or access roads.

Basin A:

Basin A1 is 4.71 acres of large lot residential, roadway and undeveloped area. Basin A1 stormwater ($Q_5 = 2.1$ cfs $Q_{100} = 8.3$ cfs) sheet flows towards proposed Road A and enters the roadside ditch and continues north to DP1 ($Q_5 = 2.1$ cfs $Q_{100} = 8.3$ cfs). Flows enter the proposed, public 18" RCP culvert and continue to DP2 where they combine with Basin A2 flows in Pond A. Water quality and detention for Basin A1 is provided in Pond A. Swale, culvert and riprap sizing calculations are included in Appendix C.

Basin A2 is 0.91 acres of large lot residential, roadway, full-spectrum detention Pond A, and undeveloped area. Basin A2 stormwater ($Q_5 = 0.9$ cfs $Q_{100} = 1.5$ cfs) sheet flows north and east and enters the roadside ditch, which conveys flows to DP2 ($Q_5 = 2.7$ cfs $Q_{100} = 10.1$ cfs). Flows at DP2 discharge into a proposed concrete bottom forebay, sized per the tributary area. Water quality and detention for Basin A2 is provided in Pond A. Pond A releases treated flows through a full-spectrum outlet at or below historic rates to DP2.1 ($Q_5 = 1.5$ cfs, $Q_{100} = 8.7$ cfs) and are piped to DP3, where they combined with flows from Basin A3 and A4. Flows at DP3 continue off-site in existing Tributary A and continue to Black Squirrel Creek per historic patterns. Swale, pipe/culvert and riprap sizing calculations are included in Appendix C. Detention and Water quality calculations are included in Appendix D.

Basin A3 is 4.70 acres of large lot residential and undeveloped areas, portions of Meridian Road and a small portion of Ayer Road. Basin A3 stormwater ($Q_5 = 1.5$ cfs $Q_{100} = 7.0$ cfs) sheet flows towards proposed Drainage A Swale. Flows continue in the swale north and east to DP3 ($Q_5 = 11.7$ cfs $Q_{100} = 33.9$ cfs) where they combine with flows from Basin A4 & DP2.1 controlled release. Basin A3 is excluded from water quality treatment per EPC DCM Appendix I.7.1.B – Large Lot Single Family Sites. A table is provided in the ‘Water Quality and Detention’ section that details the negligible increase in 100-year flow resulting from undetained, large lot residential areas. Flows at DP3 continue off-site in existing Tributary A and continue to Black Squirrel Creek per historic patterns. Swale, pipe/culvert and riprap sizing calculations are included in Appendix C.

Basin A4 is 2.08 acres of large lot residential and undeveloped area. Basin A4 stormwater ($Q_5 = 0.6$ cfs $Q_{100} = 3.5$ cfs) sheet flows to DP3 ($Q_5 = 11.7$ cfs $Q_{100} = 33.9$ cfs). and combines with the Pond A discharge Basin A3 flows. Flows at DP3 continue off-site in existing Tributary A and continue to Black Squirrel Creek per historic patterns. Basin A4 is excluded from water quality treatment per EPC DCM Appendix I.7.1.B – Large Lot Single Family Sites. A table is provided in the ‘Water Quality and Detention’ section that details the negligible increase in 100-year flow resulting from undetained, large lot residential areas. Swale, pipe/culvert and riprap sizing calculations are included in Appendix C.

Basin A5 is 14.28 acres of large lot residential areas, a portion of Ayer Road, and undeveloped area. Basin A5 stormwater ($Q_5 = 4.5$ cfs $Q_{100} = 22.6$ cfs) sheet flows towards Proposed Swale A2 and are conveyed to DP5 ($Q_5 = 34.3$ cfs $Q_{100} = 81.0$ cfs). where they combine with flows from Antler Ridge UBS-2 ($Q_5 = 32.9$ cfs $Q_{100} = 69.2$ cfs). Flows at DP5 continue off-site in the existing drainage A2 and to Black Squirrel Creek per historic patterns. Basin A5 is excluded from water quality treatment per EPC DCM Appendix I.7.1.B – Large Lot Single Family Sites. A table is provided in the ‘Water Quality and Detention’ section that details the negligible increase in 100-year flow resulting from undetained, large lot residential areas. Swale, pipe/culvert and riprap sizing calculations are included in Appendix C.

III. Drainage Design Criteria

a. Development Criteria Reference

The drainage analysis follows the criteria from the “Drainage Criteria Manual County of El Paso, Colorado” Volumes 1 and 2,” as amended.

b. Hydrologic Criteria

Onsite drainage analysis included the 5-year storm (minor event) and 100-year storm (major event) using the Rational Method per EPCDCM Chapter 5 – Storm Runoff Method of Analysis.

d. Hydraulic Criteria

Hydraulic criteria for channel analysis are obtained from EPCDCM Chapter 9 – Culvert Design & Chapter 10 - Open Channels and Structures.

e. **Detention/Water Quality Criteria**

Detention and Water Quality criteria for Pond analysis are obtained from EPCDCM V1 Chapter 11 – Detention Storage, from EPCDCM V2 Chapter 2 – Stormwater Quality Management & Chapter 4 – New Development Stormwater Management.

IV. Drainage Facility Design

a. **General Concept**

In the proposed condition, the site will be subdivided into nine (9) 2.5+ acre lots with public, rural local roadways. Lots will not be developed at this time. However, to account for future home building, proposed lot areas are analyzed for their future condition. Roadway flow and tributary portions of lot area are captured in roadside swales and conveyed to private full spectrum water quality and detention pond, Pond A. Where grade allows, roadside ditches discharge directly into FSD ponds down a riprap armored rundown and into a concrete bottom forebay. Pond A provides water quality treatment and detention for the applicable portions of the site and will be maintained by the entity assigned with a detention maintenance agreement. The pond is contained within a permanent easement. Portions of lots that do not drain towards proposed roadways will follow historic drainage patterns to the drainageway tributaries and are excluded from water quality treatment per EPC DCM Appendix I.7.1.B – Large Lot Single Family Sites. Existing natural drainage tributaries on site will be analyzed for stability and capacity, and where deficient, improved to accommodate the 100-yr flows. See ‘Water Quality & Detention’ section below for additional information.

b. **Water Quality & Detention**

Historically, undeveloped site area drains directly to the onsite drainageways and Black Squirrel Creek. In the proposed condition, road profiles are designed to direct developed lot area towards roadside ditches. Due to the size and variability of existing grade on the proposed lots, not all lot area drains towards the proposed roadways. In this scenario, those lot areas will utilize the EPC DCM Appendix I.7.1.B – Large Lot Single Family Sites water quality exclusion. However, the exclusion does not relinquish detention requirements for developed area. Based upon proposed condition Rational Method calculations, the development of the site has a marginal increase on peak flows in the 100-year scenario. The table below compares the flows leaving the site at each design point between the existing condition and the proposed fully developed condition.

The marginal increase in flows will not adversely affect downstream drainageways and associated facilities. For specific design point comparisons, please see the drainage maps and included summary tables in Appendix F. All outfall points will be designed to be stable up to and including the 100-yr event.

EXISTING V. PROPOSED FLOW (INDIVIDUAL DESIGN POINTS)							
DP#		Q _{5-YR}			Q _{100-YR}		
EX	PROP	EX	PROP	Δ	EX	PROP	Δ
1	3	12.9	11.7	-9%	34.3	33.9	-1%
2	5	34.3	34.3	0%	77.4	81.0	5%
TOTAL		47.3	46.1	-3%	111.7	114.9	3%

All flows leaving the site have remained consistent with the historic/existing conditions, with the exception of a small increase at DP5 in the proposed condition. This increase is considered negligible, however, please see the Drainage A2 calculations included in Appendix C, showing the drainageway downstream of this design point will remain stable and has adequate capacity to convey the proposed flow.

Pond A: Pond A is located at the northern end of Road A. Pond A provides water quality and detention for Basin A1 and A2, a total of 5.63 acres at 18.5% impervious. The WQCV is 0.053 ac-ft, the EURV is 0.051 ac-ft, and the 100-year volume is 0.180 ac-ft. The WQCV, EURV and 100-year storms are released in 40, 66 and 68 hours, respectively through a full-spectrum outlet structure and associated 18" RCP pipe with restrictor plate. A concrete bottom forebay is provided at the proposed swale outfall into the pond. A riprap trickle channel conveys flow towards the outlet structure and is 9" deep and has greater than twice the capacity of the forebay release rate. A 10' maintenance road is provided to the bottom of the pond to facilitate future maintenance of the pond facilities. A 10' buried soil riprap emergency overflow spillway conveys the developed, peak 100-yr flow rate with 1.0' or greater of freeboard towards Proposed Swale A. An emergency condition swale will direct any flows from the spillway to Swale A. Final calculations for detention/wq and outlet structure design, forebay, trickle channel, riprap and spillway sizing are included in appendix D.

c. Major Drainageways

There are not major drainage ways located on the Site. Black Squirrel Creek is located approximately 1,400' north of the site. Full channel analysis and improvements, as required, will be designed with future filings. Preliminary analysis was included in the PDR, under EDARP files no. SP251.

Two grass lined swales, swale A1 and A2 are proposed to convey stormwater through the site. They will be vegetated with the seed mix per "Table 5-1. El Paso County Conservation District All-Purpose Mix for Upland, Transition and Permanent Control Measure Areas". In the interim condition, before vegetation is established, "erosion log check dams" per EPC SD-3-85 are proposed to help slow and infiltrate runoff within the swale. Swales should be inspected during the vegetation establishment period, especially after wet weather events to ensure the seed is germinating and hasn't been washed away. Reseeding during this period may be necessary.

Existing Tributary A & Proposed Swale A1: In the existing condition, Existing Tributary A conveys offsite and onsite flow northerly through the site and to Black Squirrel Creek. At the upstream limit Camelot Subdivision DP-6 Pond discharges into the tributary. To accommodate the proposed subdivision lot boundaries, the tributary is routed around the western and northern limits of Basin A3 as Proposed Swale A. Proposed Swale A will continue to bypass the existing discharge from the Camelot Subdivision DP-6 Pond, in addition to the discharge from on-site Pond A. Proposed swale A is a V swale, with grass lining per the "Table 5-1. El Paso County Conservation District All-Purpose Mix for Upland, Transition and Permanent Control Measure Areas", 6:1 side slopes, a 2.33' total depth, and is located per the Rural Major Arterial County Cross section. Where the tributary crosses offsite along the northern boundary of Basin A3, the proposed swale will tie into the existing tributary for the offsite portion. Portions of the existing Tributary are proposed to be filled in.

For the purposes of hydraulic calculations, the swale has been broken into four segments of differing design slopes, ranging from 0.62% slope to 3%. A "Proposed Conditions – Drainage Summary Table" has been

included below and shows that the swale is expected to be stable while conveying all design storms up to and including the 100-yr event. Although the swale is expected to remain stable once vegetation is established, two sections of the swale will be armored with Turf Reinforcement Mat (TRM) Vmax SC250 or approved equal to help ensure stability and vegetation establishment. The first spot is along the outside bank of the swale from PC to PT where it makes a 90-degree corner within segment A1-3 adjacent to the northwestern site boundary and the second is where the swale turns north and flows off-site at the end of segment A1-3 along the site northern boundary. The entire transition area and turn will be armored with TRM per the GEC plans. The Cross-sectional output tables and hydraulic calcs for Proposed Swale A are presented in Appendix C.

Existing Tributary & Proposed Swale A2: In the existing condition, Existing Tributary A2 conveys offsite and onsite flow northerly through the site and to Black Squirrel Creek. At the upstream limit, Antler Ridge Estates DP UBS-2 Pond discharges into the tributary under Ayer Road via an existing 42” RCP culvert. To accommodate the proposed subdivision lot boundaries, the tributary is routed around the western limits of the Filing No. 1 site in proposed Swale A2. Swale A2 will continue to bypass the existing discharge from the Antler Ridge Estates DP UBS-2 Pond, in addition to the discharge from on-site area. Swale A2 will be grass lined, with the seed mix per “Table 5-1. El Paso County Conservation District All-Purpose Mix for Upland, Transition and Permanent Control Measure Areas”. At the end of the proposed swale A2 grading, a type L riprap pad is proposed to armor the transition between the engineered swale section and the existing natural swale that continues offsite to the east and north. The swale grading and riprap is proposed to terminate prior to existing wetland vegetation in order to preserve its ecological and hydraulic value, as the existing swale is stable in its present day condition. It is anticipated that in the future, swale section A2 will be extended to the north along the western boundary of the existing site’s parcel and portions of the existing natural swale will be filled in as necessary. Cross sectional output tables and hydraulic calcs for Proposed Swale A2 and Existing Tributary A2 are presented in Appendix C.

Proposed Conditions - Drainageway/Swale Summary Table											
Channel Section	Section Slope, ft/ft	5-year Depth, ft	5-year Velocity, ft/s	5-year Hydraulic Radius, ft	100-year Depth, ft	100-year Velocity, ft/s	100-year Hydraulic Radius, ft	Froude, 5-yr	Froude, 100-yr	Shear Stress, 5-yr	Shear Stress, 100-yr
A1-1	0.0136	0.83	2.66	0.41	1.07	3.2	0.53	0.51	0.55	0.3	0.4
A1-2	0.0062	0.96	1.99	0.47	1.24	2.38	0.61	0.36	0.38	0.2	0.2
A1-3	0.0300	0.71	3.64	0.35	0.92	4.33	0.45	0.76	0.80	0.7	0.8
A1-4	0.0180	0.80	3.84	0.39	1.19	3.99	0.59	0.76	0.64	0.4	0.7
A2-1	0.0192	0.67	3.49	0.56	1.09	4.54	0.85	0.75	0.77	0.7	1.0
EX-A2	0.0257	0.63	2.87	0.34	0.88	3.75	0.51	0.64	0.70	0.5	0.8
DP1 RS	0.0250	0.49	2.5	0.24	0.82	3.53	0.39	0.63	0.69	0.4	0.6

d. Operations & Maintenance

An Operations and Maintenance Manual has been provided with this project to detail maintenance intervals and required actions to maintain the stormwater facilities. The district is assumed to take on maintenance responsibilities and DMA will be recorded with this project. The maintenance of Ponds and Stormwater facilities will be assigned through a detention maintenance agreement with this project. A cost estimate for the Pond A construction items is included below.

ANTLERS RANGE FILING NO. 1				
POND A - ENGINEER'S OPINION OF PROBABLE COSTS				
Item*	Quantity	Units	Unit Cost	Total
Rip Rap, d50 size from 6" to 24" (Forebay, Trickle Channel, Spillway, Inlet/Outlet Protection)	126.33	TONS	\$ 102.00	\$12,885.28
Aggregate Base Course (135 lbs/cf) - Maint. Road	35.26	CY	\$ 81.00	\$ 2,856.00
Concrete Paving (4" thick w/ Fibermesh) - Forebay	7.22	SY	\$ 69.00	\$ 498.33
Concrete Weir Wall Forebay	1	EA	\$ 1,750.00	\$ 1,750.00
Outlet Structure & Appurtenances	1	EA	\$12,500.00	\$12,500.00
18" RCP	95	LF	\$ 111.00	\$10,545.00
18" RCP FES	1	EA	\$ 600.00	\$ 600.00
TOTAL				\$41,634.61
*All items include labor costs				

e. **Grading & Erosion Control Plan**

A Grading and Erosion Control plan is provided with this project.

f. **Four Step Method**

Step 1 – Reducing Runoff Volumes: Roof drains should route across landscape areas whenever possible to promote infiltration. In addition, grass lined swales will capture and convey developed roadway and lot flows to the FSD Pond A. Furthermore, existing, vegetated drainageways convey stormwater, that cannot be captured in roadside ditches, to the historic outfalls at site boundary. Lot imperviousness is limited to 7% with this FDR, which is below the County allowable thresholds.

Step 2 – Treat and slowly release the WQCV: Water quality for the site is provided in FSD Pond A. The pond provides water quality treatment and detention for proposed roadways and developed lot areas that drain towards roadside ditches. Portions of developed lots that do not drain towards the roadside ditches will be excluded from water quality treatment, per EPC DCM Appendix I.7.1.B – Large Lot Single Family Sites.

Step 3 – Stabilize stream channels: All new and re-development projects are required to construct or participate in the funding of channel stabilization measures. Drainage basin fees will be paid at the time of platting, and go towards channel stabilization with the drainage basin. However, the site is within the Upper Black Squirrel Drainage Basin which does not have established basin or bridge fees.

Instead, channel stability analysis and improvements, as required will be performed/provided for Black Squirrel Creek and the existing, onsite tributaries with future phases of development, adjacent to the Creek. See the PDR included with EDARP file no. SP251 for preliminary analysis and recommended improvements.

Step 4 – Consider the need for source controls: No industrial or commercial uses are proposed within this development and therefore no source controls are proposed.

g. **Drainage Basin & Bridge Fees**

The site is within the Upper Black Squirrel Drainage Basin which does not have established basin or bridge fees. Therefore, no drainage fees are required at the time of platting.

V. Summary

ANTLER RANGE FILING NO. 1 remains consistent with pre-development drainage conditions. The proposed condition routes stormwater to suitable outfalls. The proposed development will not adversely affect downstream stormwater infrastructure or surrounding developments. This report is in accordance with the latest El Paso County Drainage criteria.

VI. References

1. El Paso County – Drainage Criteria Manual, current revisions.
2. Urban Storm Drainage Criteria Manual, Mile High Flood District, March 2024.
3. Federal Emergency Management Agency, Flood Map Service Center - <https://msc.fema.gov/portal/home>, September 2024.
4. Web Soil Survey, Natural Resources Conservation Service - <https://websoilsurvey.nrcs.usda.gov/app/>, September 2024.
5. Preliminary/Final Drainage Report for Antler Ridge Estates by Merrick and Company, approved July 2006.
6. Final Drainage Report for Camelot Subdivision by Classic Consulting Engineers and Surveyors, approved March 2002.
7. Black Squirrel Creek and Snipe Creek Letter of Map Revision by Kiowa Engineering Corporation, April 2006.
8. Hydraulic Analysis Technical Support Data Notebook (TSDN) for El Paso County, Colorado by AECOM, submitted January 17th, 2025



APPENDIX A – VICINITY MAP, FEMA MAP, NRCS WEB SOIL SURVEY

ANTLERS RANGE SUBDIVISION

VICINITY MAP

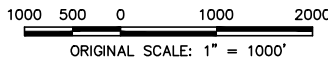
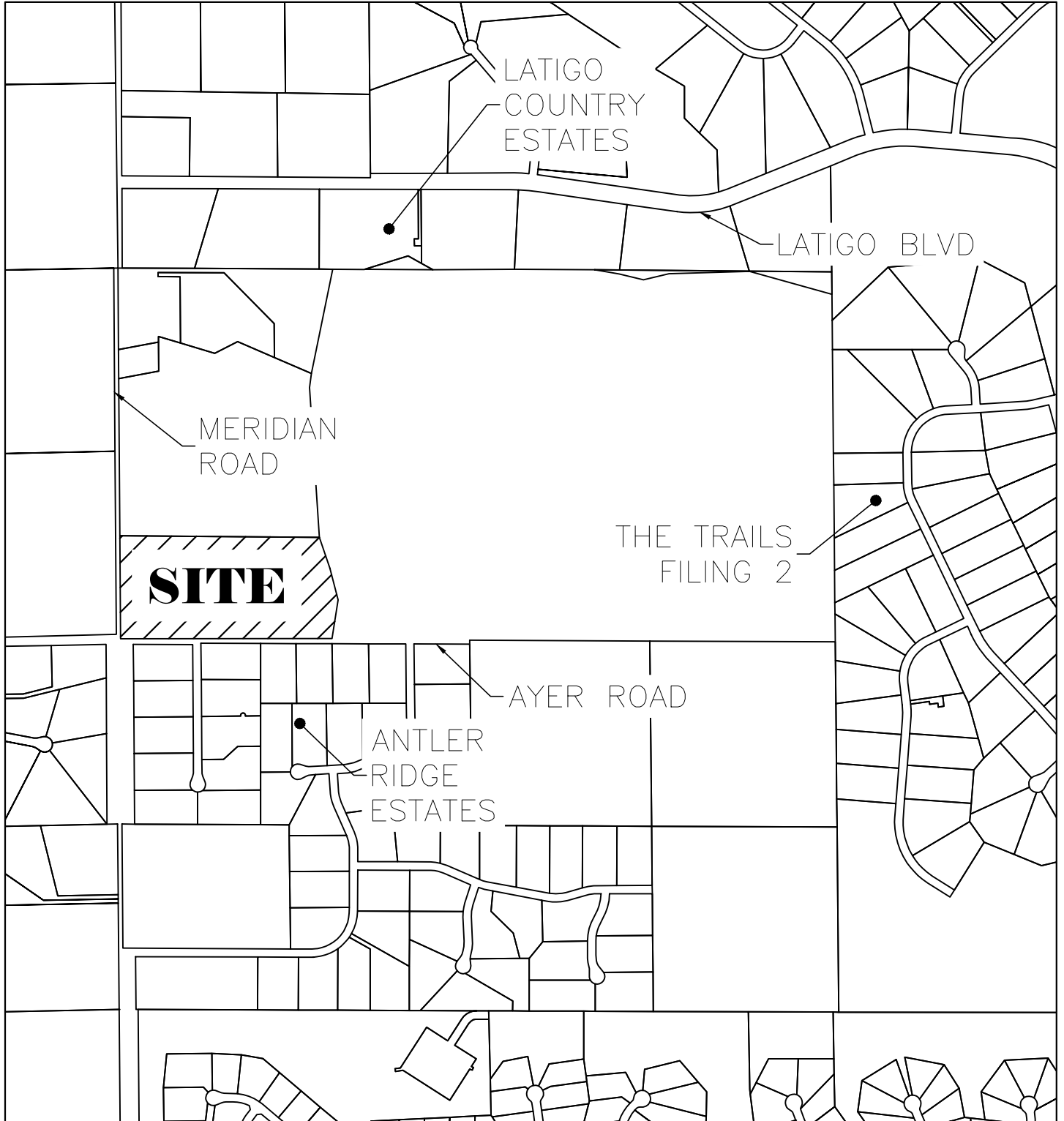

VICINITY MAP

ANTLERS RANGE SUB.

JOB NO. 24031

LOCATION: EPC

02/14/2026

SHEET: 1

SHEET



1004 WEST VAN BUREN STREET
COLORADO SPRINGS, CO 80907



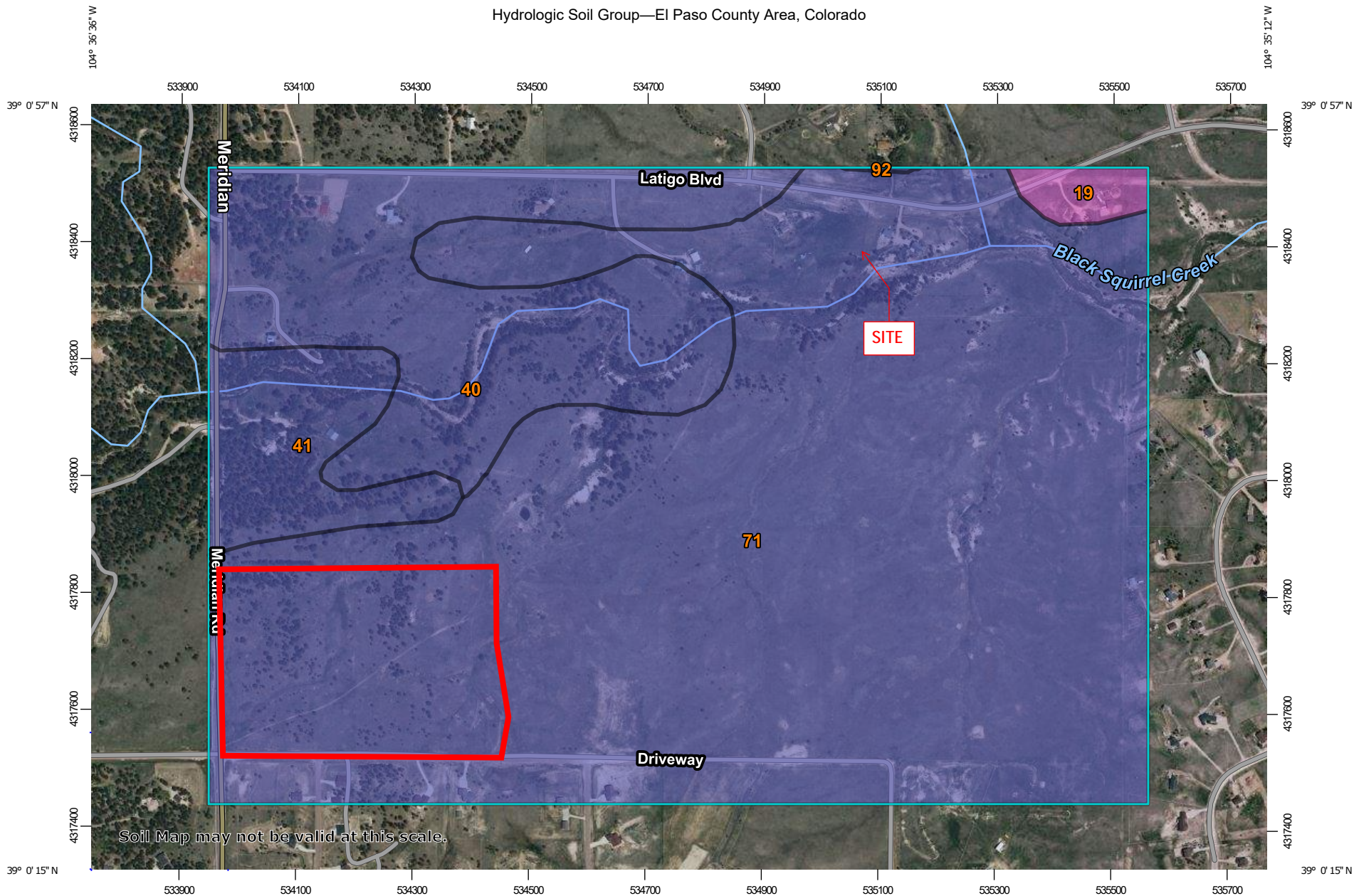



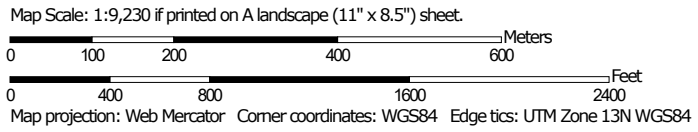

























Hydrologic Soil Group—El Paso County Area, Colorado



Soil Map may not be valid at this scale.



MAP LEGEND

- Area of Interest (AOI)**
 -  Area of Interest (AOI)
- Soils**
 - Soil Rating Polygons**
 -  A
 -  A/D
 -  B
 -  B/D
 -  C
 -  C/D
 -  D
 -  Not rated or not available
 - Soil Rating Lines**
 -  A
 -  A/D
 -  B
 -  B/D
 -  C
 -  C/D
 -  D
 -  Not rated or not available
 - Soil Rating Points**
 -  A
 -  A/D
 -  B
 -  B/D
- Water Features**
 -  Streams and Canals
- Transportation**
 -  Rails
 -  Interstate Highways
 -  US Routes
 -  Major Roads
 -  Local Roads
- Background**
 -  Aerial Photography
- Other**
 -  C
 -  C/D
 -  D
 -  Not rated or not available

MAP INFORMATION

The soil surveys that comprise your AOI were mapped at 1:24,000.

Warning: Soil Map may not be valid at this scale.
 Enlargement of maps beyond the scale of mapping can cause misunderstanding of the detail of mapping and accuracy of soil line placement. The maps do not show the small areas of contrasting soils that could have been shown at a more detailed scale.

Please rely on the bar scale on each map sheet for map measurements.

Source of Map: Natural Resources Conservation Service
 Web Soil Survey URL:
 Coordinate System: Web Mercator (EPSG:3857)

Maps from the Web Soil Survey are based on the Web Mercator projection, which preserves direction and shape but distorts distance and area. A projection that preserves area, such as the Albers equal-area conic projection, should be used if more accurate calculations of distance or area are required.

This product is generated from the USDA-NRCS certified data as of the version date(s) listed below.

Soil Survey Area: El Paso County Area, Colorado
 Survey Area Data: Version 22, Sep 3, 2024

Soil map units are labeled (as space allows) for map scales 1:50,000 or larger.

Date(s) aerial images were photographed: Jun 9, 2021—Jun 12, 2021

The orthophoto or other base map on which the soil lines were compiled and digitized probably differs from the background imagery displayed on these maps. As a result, some minor shifting of map unit boundaries may be evident.

Hydrologic Soil Group

Map unit symbol	Map unit name	Rating	Acres in AOI	Percent of AOI
19	Columbine gravelly sandy loam, 0 to 3 percent slopes	A	4.8	1.1%
40	Kettle gravelly loamy sand, 3 to 8 percent slopes	B	81.6	18.7%
41	Kettle gravelly loamy sand, 8 to 40 percent slopes	B	24.9	5.7%
71	Pring coarse sandy loam, 3 to 8 percent slopes	B	324.5	74.4%
92	Tomah-Crowfoot loamy sands, 3 to 8 percent slopes	B	0.2	0.0%
Totals for Area of Interest			436.0	100.0%



APPENDIX B – HYDROLOGIC CALCULATIONS

Subdivision: Antlers Range Filing No. 1
Location: El Paso County
Project Name: Antlers Range Filing No. 1
Project Number: 24031
Calculated By: REB
Checked By:
Date: 4/13/2026

EXISTING CONDITIONS - BASIN SUMMARY TABLE							
Sub-basin	Area (ac)	Impervious	C _s	C ₁₀₀	t _c (min)	Q _{5-YR} (cfs)	Q _{100-YR} (cfs)
A	11.86	6%	0.12	0.38	32.2	3.4	18.1
B	14.84	5%	0.12	0.39	38.8	3.7	20.4

EXISTING CONDITIONS - DESIGN POINT SUMMARY TABLE		
DP#	Q _{5-YR}	Q _{100-YR}
Camelot DP-6*	11.0	22.0
1	12.9	34.3
2	34.3	77.4
Antlers Ridge* Estates UBS-2	32.9	69.2

*FROM A DIFFERENT APPROVED DRAINAGE REPORT

EXISTING V. PROPOSED FLOW (INDIVIDUAL DESIGN POINTS)							
DP#		Q _{5-YR}			Q _{100-YR}		
EX	PROP	EX	PROP	Δ	EX	PROP	Δ
1	3	12.9	11.7	-9%	34.3	33.9	-1%
2	5	34.3	34.3	0%	77.4	81.0	5%
TOTAL		47.3	46.1	-3%	111.7	114.9	3%

COMPOSITE % IMPERVIOUS CALCULATIONS - EXISTING CONDITIONS

Subdivision: Antlers Range Filing No. 1
 Location: El Paso County

Project Name: Antlers Range Filing No. 1
 Project No.: 24031.00
 Calculated By: REB
 Checked By:
 Date: 2/19/26

Basin ID	Total Area (ac)	Gravel Drives				Paved				Large Residential Lots(7%)				Undeveloped/Argriculture				Weighted C _s & C ₁₀₀		Basins Total Weighted % Imp.	
		C _s	C ₁₀₀	Area (ac)	% Imp.	C _s	C ₁₀₀	Area (ac)	% Imp.	C _s	C ₁₀₀	Area (ac)	% Imp.	C _s	C ₁₀₀	Area (ac)	% Imp.	C _s	C ₁₀₀		
		A	11.86	0.59	0.70	0.04	80.0%	0.90	0.96	0.44	100.0%	0.12	0.39	0.00	7.0%	0.09	0.36	11.37	2.0%		0.12
B	14.84	0.59	0.70	0.06	80.0%	0.90	0.96	0.45	100.0%	0.12	0.39	0.00	7.0%	0.09	0.36	14.79	2.0%	0.12	0.39	5.3%	
Total	26.70																				5.6%

Table 6-6. Runoff Coefficients for Rational Method
 (Source: UDFCD 2001)

Land Use or Surface Characteristics	Percent Impervious	Runoff Coefficients																					
		2-year		5-year		10-year		25-year		50-year		100-year											
		HSG A&B	HSG C&D	HSG A&B	HSG C&D	HSG A&B	HSG C&D	HSG A&B	HSG C&D	HSG A&B	HSG C&D	HSG A&B	HSG C&D										
Business																							
Commercial Areas	95	0.79	0.80	0.81	0.82	0.83	0.84	0.85	0.87	0.87	0.88	0.88	0.89										
Neighborhood Areas	70	0.45	0.49	0.49	0.53	0.53	0.57	0.58	0.62	0.60	0.65	0.62	0.68										
Residential																							
1/8 Acre or less	65	0.41	0.45	0.45	0.49	0.49	0.54	0.54	0.59	0.57	0.62	0.59	0.65										
1/4 Acre	40	0.23	0.28	0.30	0.35	0.36	0.42	0.42	0.50	0.46	0.54	0.50	0.58										
1/3 Acre	30	0.18	0.22	0.25	0.30	0.32	0.38	0.39	0.47	0.43	0.52	0.47	0.57										
1/2 Acre	25	0.15	0.20	0.22	0.28	0.30	0.36	0.37	0.46	0.41	0.51	0.46	0.56										
1 Acre	20	0.12	0.17	0.20	0.26	0.27	0.34	0.35	0.44	0.40	0.50	0.44	0.55										
Industrial																							
Light Areas	80	0.57	0.60	0.59	0.63	0.63	0.66	0.66	0.70	0.68	0.72	0.70	0.74										
Heavy Areas	90	0.71	0.73	0.73	0.75	0.75	0.77	0.78	0.80	0.80	0.82	0.81	0.83										
Parks and Cemeteries																							
Parks and Cemeteries	7	0.05	0.09	0.12	0.19	0.20	0.29	0.30	0.40	0.34	0.46	0.39	0.52										
Playgrounds	13	0.07	0.13	0.16	0.23	0.24	0.31	0.32	0.42	0.37	0.48	0.41	0.54										
Railroad Yard Areas	40	0.23	0.28	0.30	0.35	0.36	0.42	0.42	0.50	0.46	0.54	0.50	0.58										
Undeveloped Areas																							
Historic Flow Analysis--Greenbelts, Agriculture	2	0.03	0.05	0.09	0.16	0.17	0.26	0.26	0.38	0.31	0.45	0.36	0.51										
Pasture/Meadow	0	0.02	0.04	0.08	0.15	0.15	0.25	0.25	0.37	0.30	0.44	0.35	0.50										
Forest	0	0.02	0.04	0.08	0.15	0.15	0.25	0.25	0.37	0.30	0.44	0.35	0.50										
Exposed Rock	100	0.89	0.89	0.90	0.90	0.92	0.92	0.94	0.94	0.95	0.95	0.96	0.96										
Offsite Flow Analysis (when landuse is undefined)	45	0.26	0.31	0.32	0.37	0.38	0.44	0.44	0.51	0.48	0.55	0.51	0.59										
Streets																							
Paved	100	0.89	0.89	0.90	0.90	0.92	0.92	0.94	0.94	0.95	0.95	0.96	0.96										
Gravel	80	0.57	0.60	0.59	0.63	0.63	0.66	0.66	0.70	0.68	0.72	0.70	0.74										
Drive and Walks																							
Drive and Walks	100	0.89	0.89	0.90	0.90	0.92	0.92	0.94	0.94	0.95	0.95	0.96	0.96										
Roofs	90	0.71	0.73	0.73	0.75	0.75	0.77	0.78	0.80	0.80	0.82	0.81	0.83										
Lawns	0	0.02	0.04	0.08	0.15	0.15	0.25	0.25	0.37	0.30	0.44	0.35	0.50										

STANDARD FORM SF-2 - EXISTING CONDITIONS TIME OF CONCENTRATION

Subdivision: Antlers Range Filing No. 1
Location: El Paso County

Project Name: Antlers Range Filing No. 1
Project No.: 24031.00
Calculated By: REB
Checked By:
Date: 2/19/26

SUB-BASIN DATA						INITIAL/OVERLAND (T _i)			TRAVEL TIME (T _t)					t _c CHECK (URBANIZED BASINS)			FINAL
BASIN ID	D.A. (ac)	Hydrologic Soils Group	Weighted C ₅	Weighted C ₁₀₀	Impervious (%)	L (ft)	S _o (%)	t _i (min)	L _t (ft)	S _t (%)	K	VEL. (ft/s)	t _t (min)	COMP. t _c (min)	TOTAL LENGTH (ft)	Urbanized t _c (min)	t _c (min)
A	11.86	B	0.12	0.38	5.9%	50	2.0%	9.9	1055	2.5%	5.0	0.8	22.2	32.2	1105.0	36.3	32.2
B	14.84	B	0.12	0.39	5.3%	263	3.6%	18.8	1293	2.6%	5.0	0.8	26.7	45.5	1556.0	38.8	38.8

NOTES:

$$t_c = t_i + t_t$$

Where:

t_c = computed time of concentration (minutes)

t_i = overland (initial) flow time (minutes)

t_t = channelized flow time (minutes).

$$t_t = \frac{L_t}{60K\sqrt{S_o}} = \frac{L_t}{60V_t}$$

Where:

t_t = channelized flow time (travel time, min)

L_t = waterway length (ft)

S_o = waterway slope (ft/ft)

V_t = travel time velocity (ft/sec) = K√S_o

K = NRCS conveyance factor (see Table 6-2).

$$\text{Eq } t_i = \frac{0.395(1.1 - C_5)\sqrt{L_i}}{S_o^{0.33}}$$

Where:

t_i = overland (initial) flow time (minutes)

C₅ = runoff coefficient for 5-year frequency (from Table 6-4)

L_i = length of overland flow (ft)

S_o = average slope along the overland flow path (ft/ft).

$$\text{Equation 6-4 } 6 - 17t_i + \frac{L_t}{60(1.4t_i + 9)\sqrt{S_t}}$$

t_c = minimum time of concentration for first design point when less than t_c from Equation 6-1.

L_t = length of channelized flow path (ft)

t = imperviousness (expressed as a decimal)

S_t = slope of the channelized flow path (ft/ft).

Table 6-2. NRCS Conveyance factors, K

Equation 6-3

Type of Land Surface	Conveyance Factor, K
Heavy meadow	2.5
Tillage/field	5
Short pasture and lawns	7
Nearly bare ground	10
Grassed waterway	15
Paved areas and shallow paved swales	20

Equation 6-5

Use a minimum t_c value of 5 minutes for urbanized areas and a minimum t_c value of 10 minutes for areas that are not considered urban. Use minimum values even when calculations result in a lesser time of concentration.

STANDARD FORM SF-3 - EXISTING CONDITIONS
STORM DRAINAGE SYSTEM DESIGN
(RATIONAL METHOD PROCEDURE)

Subdivision: Antlers Range Filing No. 1
Location: El Paso County
Design Storm: 5-Year

Project Name: Antlers Range Filing No. 1
Project No.: 24031.00
Calculated By: REB
Checked By:
Date: 2/19/26

DESCRIPTION	Design Point	DIRECT RUNOFF							TOTAL RUNOFF				STREET			PIPE				TRAVEL TIME			REMARKS
		Basin ID	Area (Ac)	Runoff Coeff.	t_c (min)	C*A (Ac)	I (in/hr)	Q (cfs)	t_c (min)	C*A (ac)	I (in/hr)	Q (cfs)	Q _{street} (cfs)	C*A (ac)	Slope (%)	Q _{pipe} (cfs)	C*A (ac)	Slope (%)	Pipe Size (inches)	Length (ft)	Velocity (fps)	t_t (min)	
Camelot DP-6					36.7	5.05	2.18	11.0												475	1.6	4.9	Offsite Flows from Camelot Subdivision, DP-6, 11 cfs controlled release, combines w/ Basin A flows @ DP-1
	1	A	11.86	0.12	32.2	1.45	2.38	3.4	41.6	6.49	1.99	12.9							188	0.8	4.0	Runoff sheet flows NE, enters semi-defined flow path where flows combine @ DP-1 with controlled release from ex 30" culvert from Camelot DP-6, flows continue offsite per historic patterns top BSC	
Antlers Ridge Estates UBS-2					57.6	21.89	1.50	32.9											456	3.8	2.0	Offsite Flows from Antlers Ridge Estates, DP UBS-2, 32.9 cfs controlled release, combines w/ Basin B flows @ DP-	
	2	B	14.84	0.12	38.8	1.77	2.10	3.7	59.6	23.66	1.45	34.3										Runoff sheet flows to NE, enter loosely defined drainage, combines w/ upstream flows from Antlers Ridghe UBS-2 (controlled release) @ DP-2	

Notes:
Street and Pipe C*A values are determined by Q/i using the catchment's intensity value.

STANDARD FORM SF-3 - EXISTING CONDITIONS
STORM DRAINAGE SYSTEM DESIGN
(RATIONAL METHOD PROCEDURE)

Subdivision: Antlers Range Filing No. 1
Location: El Paso County
Design Storm: 100-Year

Project Name: Antlers Range Filing No. 1
Project No.: 24031.00
Calculated By: REB
Checked By:
Date: 11/5/25

STREET	Design Point	DIRECT RUNOFF							TOTAL RUNOFF				STREET			PIPE			TRAVEL TIME			REMARKS	
		Basin ID	Area (ac)	Runoff Coeff.	t _c (min)	C*A (ac)	I (in/hr)	Q (cfs)	t _c (min)	C*A (ac)	I (in/hr)	Q (cfs)	Q _{street} (cfs)	C*A (ac)	Slope (%)	Q _{pipe} (cfs)	C*A (ac)	Slope (%)	Pipe Size (inches)	Length (ft)	Velocity (fps)		t _r (min)
Camelot DP-6					36.7	6.02	3.66	22.0												475	0.8	9.8	Offsite Flows from Camelot Subdivision, DP-6, 11 cfs controlled release, combines w/ Basin A flows @ DP-1
	1	A	11.86	0.38	32.2	4.55	3.99	18.1	46.5	10.57	3.06	32.3							188	0.8	4.0	Runoff sheet flows NE, enters semi-defined flow path where flows combine @ DP-1 with controlled release from ex 30" culvert from Camelot DP-6, flows continue offsite per historic patterns top BSC	
Antlers Ridge Estates UBS-2					57.6	27.46	2.52	69.2											456	1.7	4.6	Offsite Flows from Antlers Ridge Estates, DP UBS-2, 32.9 cfs controlled release, combines w/ Basin B flows @ DP-	
	2	B	14.84	0.39	38.8	5.80	3.52	20.4	62.2	33.26	2.33	77.4									2	Runoff sheet flows to NE, enter loosely defined drainage, combines w/ upstream flows from Antlers Ridghe UBS-2 (controlled release) @ DP-2	

Notes:
Street and Pipe C*A values are determined by Q/I using the catchment's intensity value.

Subdivision: Antlers Subdivision Proposed
Location: El Paso County
Project Name: Antlers Subdivision Proposed
Project Number: 24031
Calculated By: REB
Checked By:
Date: 2/15/2026

PROPOSED DRAINAGE CALCS - BASIN SUMMARY TABLE							
Tributary Sub-basin	Area (acres)	Percent Impervious	C ₅	C ₁₀₀	t _c (min)	Q ₅ (cfs)	Q ₁₀₀ (cfs)
A1	4.71	16%	0.19	0.44	32.39	2.1	8.3
A2	0.91	33%	0.32	0.54	20.68	0.9	1.5
A3	4.70	12%	0.15	0.42	38.81	1.5	7.0
A4	2.08	7%	0.12	0.39	27.90	0.6	3.5
A5	14.28	9%	0.14	0.40	33.09	4.5	22.6

DESIGN POINT SUMMARY TABLE		
DP#	Q _{5-YR}	Q _{100-YR}
Camelot DP-6	11	22
1	2.1	8.3
2	2.7	10.1
2.1	1.5	8.7
3	11.7	33.9
Antlers Ridge Estates UBS-2	32.9	69.2
5	34.3	81.0

Gold shaded cells indicate a controlled release from an off-site pond, flow rates from a previous report.

Color shaded cells indicate that basin & or design point is tributary to a PCM (Full Spectrum EDB or Infiltration Pond)

Gray shaded basins utilize "large lot residential" sites, exempt from water quality per ECM Appendix I.7.1.B.5 or are off-site and undeveloped

COMPOSITE % IMPERVIOUS CALCULATIONS - PROPOSED CONDITIONS

Subdivision: Antlers Subdivision Proposed
 Location: El Paso County

Project Name: Antlers Subdivision Proposed
 Project No.: 24031.00
 Calculated By: REB
 Checked By: _____
 Date: 2/15/26

Basin ID ¹	Total Area (ac)	Gravel Drives				Paved				LARGE RESIDENTIAL LOTS (7%)				Lawns/undeveloped ²				Weighted C ₅ & C ₁₀₀		Basins Total Weighted % Imp.
		C ₅	C ₁₀₀	Area (ac)	% Imp.	C ₅	C ₁₀₀	Area (ac)	% Imp.	C ₅	C ₁₀₀	Area (ac)	% Imp.	C ₅	C ₁₀₀	Area (ac)	% Imp.	C ₅	C ₁₀₀	
A1	4.71	0.59	0.70	0.06	80.0%	0.90	0.96	0.42	100.0%	0.12	0.39	3.76	7.0%	0.02	0.35	0.47	0.0%	0.19	0.44	15.6%
A2	0.91	0.59	0.70	0.06	80.0%	0.90	0.96	0.23	100.0%	0.12	0.39	0.41	7.0%	0.02	0.35	0.22	0.0%	0.32	0.54	33.3%
Subtotal Pond A	5.63																			18.5%
A3	4.70	0.59	0.70	0.03	80.0%	0.90	0.96	0.34	100.0%	0.12	0.39	3.03	7.0%	0.02	0.35	1.30	0.0%	0.15	0.42	12.3%
A4	2.08	0.59	0.70	0.00	80.0%	0.90	0.96	0.00	100.0%	0.12	0.39	2.08	7.0%	0.02	0.35	0.00	0.0%	0.12	0.39	7.0%
A5	14.28	0.59	0.70	0.05	80.0%	0.90	0.96	0.38	100.0%	0.12	0.39	12.84	7.0%	0.02	0.35	1.02	0.0%	0.14	0.40	9.2%
Total	26.70																			11.5%

1A. shaded basins are tributary/included in the Pond/PCM area and imperviousness subtotals shown for that color/PCM

1B. Gray shaded basins utilize "large lot residential" sites, exempt from water quality per ECM Appendix I.7.1.B.5 or are off-site and undeveloped

2. Lawns/Undeveloped areas include roadside ditches and/or drainage easements that will remain impervious

STANDARD FORM SF-2 - PROPOSED CONDITIONS TIME OF CONCENTRATION

Subdivision: Antlers Subdivision Proposed
Location: El Paso County

Project Name: Antlers Subdivision Proposed
Project No.: 24031.00
Calculated By: REB
Checked By:
Date: 2/15/26

SUB-BASIN						INITIAL/OVERLAND			TRAVEL TIME					t _c CHECK			FINAL
DATA						(T _i)			(T _t)					(URBANIZED BASINS)			
BASIN ID	D.A. (ac)	Hydrologic Soils Group	Weighted C _s	Weighted C ₁₀₀	Impervious (%)	L (ft)	S _o (%)	t _i (min)	L _t (ft)	S _t (%)	K	VEL. (ft/s)	t _t (min)	COMP. t _c (min)	TOTAL LENGTH (ft)	Urbanized t _c (min)	
A1	4.71	B	0.19	0.44	15.6%	50	2.0%	9.3	930	1.8%	5.0	0.7	23.1	32.4	980.0	33.7	32.4
A2	0.91	B	0.32	0.54	33.3%	50	2.0%	7.9	500	1.7%	5.0	0.7	12.8	20.7	550.0	25.0	20.7
A3	4.70	B	0.15	0.42	12.3%	60	2.0%	10.5	1286	1.8%	5.0	0.7	32.0	42.5	1346.0	38.8	38.8
A4	2.08	B	0.12	0.39	7.0%	215	2.1%	20.3	360	2.5%	5.0	0.8	7.6	27.9	575.0	28.6	27.9
A5	14.28	B	0.14	0.40	9.2%	222	2.8%	18.5	1040	2.2%	8.0	1.2	14.6	33.1	1262.0	35.8	33.1

NOTES:

$$t_c = t_i + t_t$$

Eq
$$t_i = \frac{0.395(1 - C_s)\sqrt{L_i}}{S_o^{0.33}}$$

Equation 6-3 **Table 6-2. NRCS Conveyance factors, K**

Type of Land Surface	Conveyance Factor, K
Heavy meadow	2.5
Tillage/field	5
Short pasture and lawns	7
Nearly bare ground	10
Grassed waterway	15
Paved areas and shallow paved swales	20

Where:

t_c = computed time of concentration (minutes)

t_i = overland (initial) flow time (minutes)

t_t = channelized flow time (minutes).

Where:

t_i = overland (initial) flow time (minutes)
C_s = runoff coefficient for 5-year frequency (from Table 6-4)
L_i = length of overland flow (ft)
S_o = average slope along the overland flow path (ft/ft).

$$t_t = \frac{L_t}{60K\sqrt{S_o}} = \frac{L_t}{60V_t}$$

Equation 6-4
$$t_c = 6 - 17i + \frac{L_t}{60(14i + 9)\sqrt{S_t}}$$

Equation 6-5

Where:

t_t = channelized flow time (travel time, min)
L_t = waterway length (ft)
S_o = waterway slope (ft/ft)
V_t = travel time velocity (ft/sec) = K√S_o
K = NRCS conveyance factor (see Table 6-2).

∴

t_c = minimum time of concentration for first design point when less than t_c from Equation 6-1.
L_t = length of channelized flow path (ft)
i = imperviousness (expressed as a decimal)
S_t = slope of the channelized flow path (ft/ft).

Use a minimum t_c value of 5 minutes for urbanized areas and a minimum t_c value of 10 minutes for areas that are not considered urban. Use minimum values even when calculations result in a lesser time of concentration.

STANDARD FORM SF-3 - PROPOSED CONDITIONS

STORM DRAINAGE SYSTEM DESIGN

(RATIONAL METHOD PROCEDURE)

Subdivision: Antlers Subdivision Proposed
 Location: El Paso County
 Design Storm: 5-Year

Project Name: Antlers Subdivision Proposed
 Project No.: 24031.00
 Calculated By: REB
 Checked By:
 Date: 2/15/26

DESCRIPTION	Design Point	DIRECT RUNOFF							TOTAL RUNOFF				STREET			PIPE				TRAVEL TIME			REMARKS
		Basin ID	Area (Ac)	Runoff Coeff.	t_c (min)	C*A (Ac)	I (in/hr)	Q (cfs)	t_c (min)	C*A (ac)	I (in/hr)	Q (cfs)	Q_{street} (cfs)	C*A (ac)	Slope (%)	Q_{pipe} (cfs)	C*A (ac)	Slope (%)	Pipe Size (inches)	Length (ft)	Velocity (fps)	t_r (min)	
Camelot DP-6					36.7	5.05	2.18	11.0												1325	2.32	9.5	Offsite Flows from Camelot Subdivision, DP-6, 11 cfs controlled release, combines w/ Basin A3 flows @ DP-3
	1	A1	4.71	0.19	32.4	0.88	2.37	2.1												60	1.5	0.6	Runoff sheet flows NE, enters roadside ditch and continues north to DP1
	2	A2	0.91	0.32	20.7	0.29	3.04	0.9	33.0	1.17	2.34	2.7											Runoff sheet flows NW, enters roadside ditch and continues north to proposed FSEDB Pond A @ DP2. combines w/ DP1 flows in Pond A.
	2.1								50.0	1.71	1.5				1.5	0.87	2.0	18	101	5.2	0.3	Controlled release from FSEDB Pond A, continues to DP3	
	3	A3	4.70	0.15	38.8	0.71	2.09	1.5															Runoff sheet flows NE, enters Swale A and continues to DP3, combines with flows from Basin A4, and DP2.1
	3	A4	2.08	0.12	27.9	0.25	2.59	0.6															Runoff sheet flows NW, enters ex natural drainage A, continues to DP3 and combines with flows from Basin A3 and DP2.1
	3								50.3	6.89	1.71	11.7											Total flow at DP3, continues offsite NE along existing semi-defined drainage of Basin OA1 to DP6
Antlers Ridge Estates UBS-2					57.6	21.89	1.50	32.9												545	3.75	2.4	Offsite Flows from Antlers Ridge Estates, DP UBS-2, 32.9 cfs controlled release, combines w/ Basin A5 in swale A2 @ DP5
	5	A5	14.28	0.14	33.1	1.93	2.33	4.5															Runoff sheet flows NW, enters proposed Drainage A2 swale, continues north to DP5 where it combines with flow from DP4 & Antlers Range UBS-2
	5								60.0	23.82	1.44	34.3											Total flow @ DP5 in swale A2, continues in swale to DP7

Notes:

Pond releases, Street, and Pipe C*A values are determined by Q/i using the catchment's intensity value.

Gold shaded cells indicate a controlled release from an off-site pond, flows taken from previous report/s.

Color shaded cells indicate that basin & or design point is tributary to a PCM (Full Spectrum EDB or Infiltration Pond)

1B. Gray shaded basins utilize "large lot residential" sites, exempt from water quality per ECM Appendix I.7.1.B.5 or are off-site and undeveloped

STANDARD FORM SF-3 - PROPOSED CONDITIONS
STORM DRAINAGE SYSTEM DESIGN
(RATIONAL METHOD PROCEDURE)

Subdivision: Antlers Subdivision Proposed
Location: El Paso County
Design Storm: 100-Year

Project Name: Antlers Subdivision Proposed
Project No.: 24031.00
Calculated By: REB
Checked By:
Date: 2/15/26

STREET	Design Point	DIRECT RUNOFF							TOTAL RUNOFF				STREET			PIPE				TRAVEL TIME			REMARKS
		Basin ID	Area (ac)	Runoff Coeff.	t _c (min)	C*A (ac)	I (in/hr)	Q (cfs)	t _c (min)	C*A (ac)	I (in/hr)	Q (cfs)	Q _{street} (cfs)	C*A (ac)	Slope (%)	Q _{pipe} (cfs)	C*A (ac)	Slope (%)	Pipe Size (inches)	Length (ft)	Velocity (fps)	t _c (min)	
Camelot DP-6					36.7	6.02	3.66	22.0												1325	4.4	5.0	Offsite Flows from Camelot Subdivision, DP-6, 22 cfs controlled release, combines w/ Basin A3 flows @ DP-3
	1	A1	4.71	0.44	32.4	2.08	3.97	8.3												60	1.9	0.5	Runoff sheet flows NE, enters roadside ditch and continues north to DP1
	2	A2	0.91	0.54	20.7	0.50	3.04	1.5	32.9	2.57	3.93	10.1											Runoff sheet flows NE, enters roadside ditch and continues north to proposed FSEDB Pond A @ DP2. combines w/ DP1 flows in Pond A.
	2.1								50.0		2.88	8.7			8.7	3.02	2.0	18	101	8.7	0.2	Controlled release from FSEDB Pond A, continues to DP3	
	3	A3	4.70	0.42	38.8	1.98	3.51	7.0															Runoff sheet flows NE, enters Swale A and continues to DP3, combines with flows from Basin A4, and DP2.1
	3	A4	2.08	0.39	27.9	0.81	4.35	3.5															Runoff sheet flows NE, enters proposed drainage A swale, continues to DP3 and combines with flows from Basin A4 and DP2.1
	3								50.2	11.84	2.87	33.9											Total flow at DP3, continues offsite NE along existing semi-defined drainage of Basin OA1 to DP6
Antlers Ridge Estates UBS-2					57.6	27.46	2.52	69.2												545	4.8	1.9	Offsite Flows from Antlers Ridge Estates, DP UBS-2, 32.9 cfs controlled release, combines w/ Basin A5 in swale A2 @ DP5
	5	A5	14.28	0.40	33.1	5.76	3.92	22.6															Runoff sheet flows NW, enters proposed Drainage A2 swale, continues north to DP5 where it combines with flow from DP4 & Antlers Range UBS-2
	5								59.5	33.22	2.44	81.0											Total flow @ DP5 in swale A2, continues in swale to DP7

Notes:
Pond releases, Street, and Pipe C*A values are determined by Q/i using the catchment's intensity value.
Gold shaded cells indicate a controlled release from an off-site pond, flows taken from previous report/s.
Color shaded cells indicate that basin & or design point is tributary to a PCM (Full Spectrum EDB or Infiltration Pond)
1B. Gray shaded basins utilize "large lot residential" sites, exempt from water quality per ECM Appendix I.7.1.B.5 or are off-site and undeveloped



APPENDIX C – HYDRAULIC CALCULATIONS

Subdivision: ANTLER RANGE F1
Location: El Paso County
Project Name: ANTLER RANGE F1
Project Number: 24031
Calculated By: NQJ
Checked By: REB
Date: 4/13/2026

Proposed Conditions - Drainageway/Swale Summary Table											
Channel Section	Section Slope, ft/ft	5-year Depth, ft	5-year Velocity, ft/s	5-year Hydraulic Radius, ft	100-year Depth, ft	100-year Velocity, ft/s	100-year Hydraulic Radius, ft	Froude, 5-yr	Froude, 100-yr	Shear Stress, 5-yr	Shear Stress, 100-yr
A1-1	0.0136	0.83	2.66	0.41	1.07	3.2	0.53	0.51	0.55	0.3	0.4
A1-2	0.0062	0.96	1.99	0.47	1.24	2.38	0.61	0.36	0.38	0.2	0.2
A1-3	0.0300	0.71	3.64	0.35	0.92	4.33	0.45	0.76	0.80	0.7	0.8
A1-4	0.0180	0.80	3.84	0.39	1.19	3.99	0.59	0.76	0.64	0.4	0.7
A2-1	0.0192	0.67	3.49	0.56	1.09	4.54	0.85	0.75	0.77	0.7	1.0
EX-A2	0.0257	0.63	2.87	0.34	0.88	3.75	0.51	0.64	0.70	0.5	0.8
DP1 RS	0.0250	0.49	2.5	0.24	0.82	3.53	0.39	0.63	0.69	0.4	0.6

Channel Report

DP1 - Roadside Swale Q5 (2.1 CFS)

Triangular

Side Slopes (z:1) = 4.00, 3.00

Total Depth (ft) = 2.50

Invert Elev (ft) = 1.00

Slope (%) = 2.50

N-Value = 0.035

Calculations

Compute by: Known Q

Known Q (cfs) = 2.10

Highlighted

Depth (ft) = 0.49

Q (cfs) = 2.100

Area (sqft) = 0.84

Velocity (ft/s) = 2.50

Wetted Perim (ft) = 3.57

Crit Depth, Yc (ft) = 0.47

Top Width (ft) = 3.43

EGL (ft) = 0.59

SEE 1ST PAGE OF APPENDIX C FOR FROUDE # AND ADDITIONAL CALCULATIONS

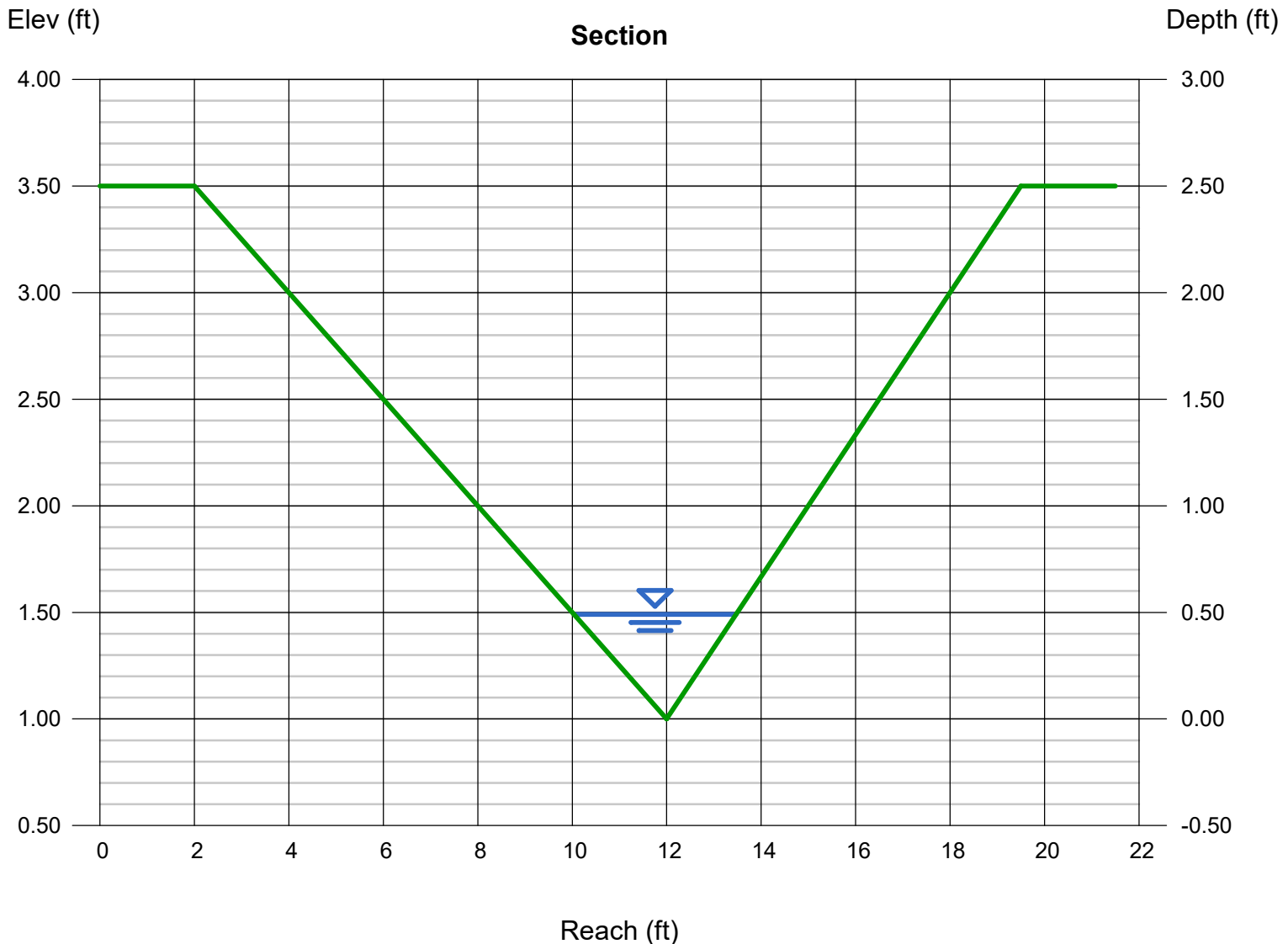

Channel Report

DP1 - Roadside Swale Q100 (8.3 CFS) Velocity

Triangular

Side Slopes (z:1) = 4.00, 3.00

Total Depth (ft) = 2.50

Invert Elev (ft) = 1.00

Slope (%) = 2.50

N-Value = 0.035

Calculations

Compute by: Known Q

Known Q (cfs) = 8.30

Highlighted

Depth (ft) = 0.82

Q (cfs) = 8.300

Area (sqft) = 2.35

Velocity (ft/s) = 3.53

Wetted Perim (ft) = 5.97

Crit Depth, Yc (ft) = 0.82

Top Width (ft) = 5.74

EGL (ft) = 1.01

SEE 1ST PAGE OF APPENDIX C FOR FROUDE # AND ADDITIONAL CALCULATIONS

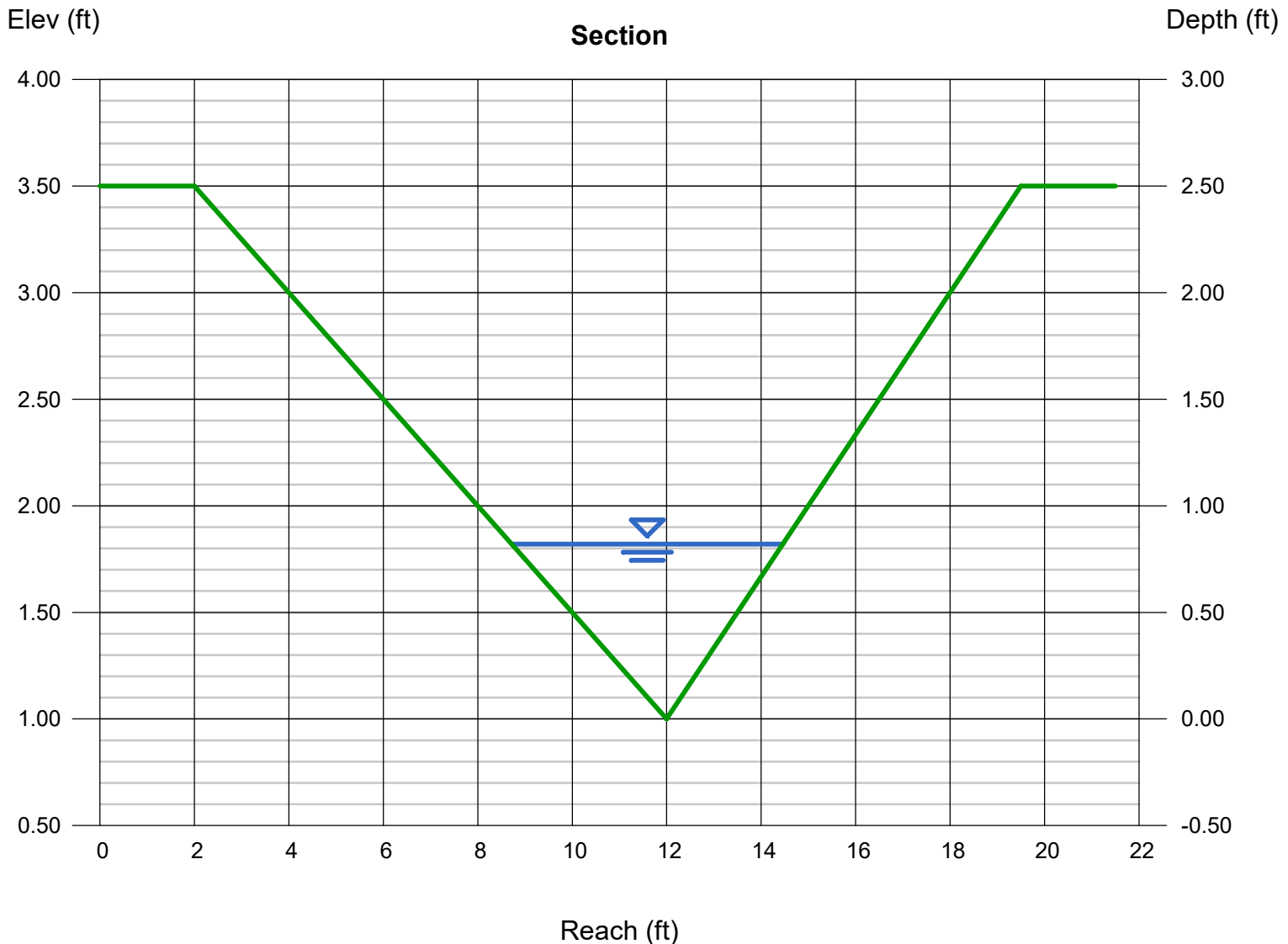

Channel Report

DP1 - Roadside Swale Q100 (8.3 CFS) Capacity

Triangular

Side Slopes (z:1) = 4.00, 3.00
Total Depth (ft) = 2.50

Invert Elev (ft) = 1.00
Slope (%) = 1.00
N-Value = 0.035

Calculations

Compute by: Known Q
Known Q (cfs) = 8.30

Highlighted

Depth (ft) = 0.97
Q (cfs) = 8.300
Area (sqft) = 3.29
Velocity (ft/s) = 2.52
Wetted Perim (ft) = 7.07
Crit Depth, Yc (ft) = 0.82
Top Width (ft) = 6.79
EGL (ft) = 1.07

SEE 1ST PAGE OF APPENDIX C FOR FROUDE # AND ADDITIONAL CALCULATIONS

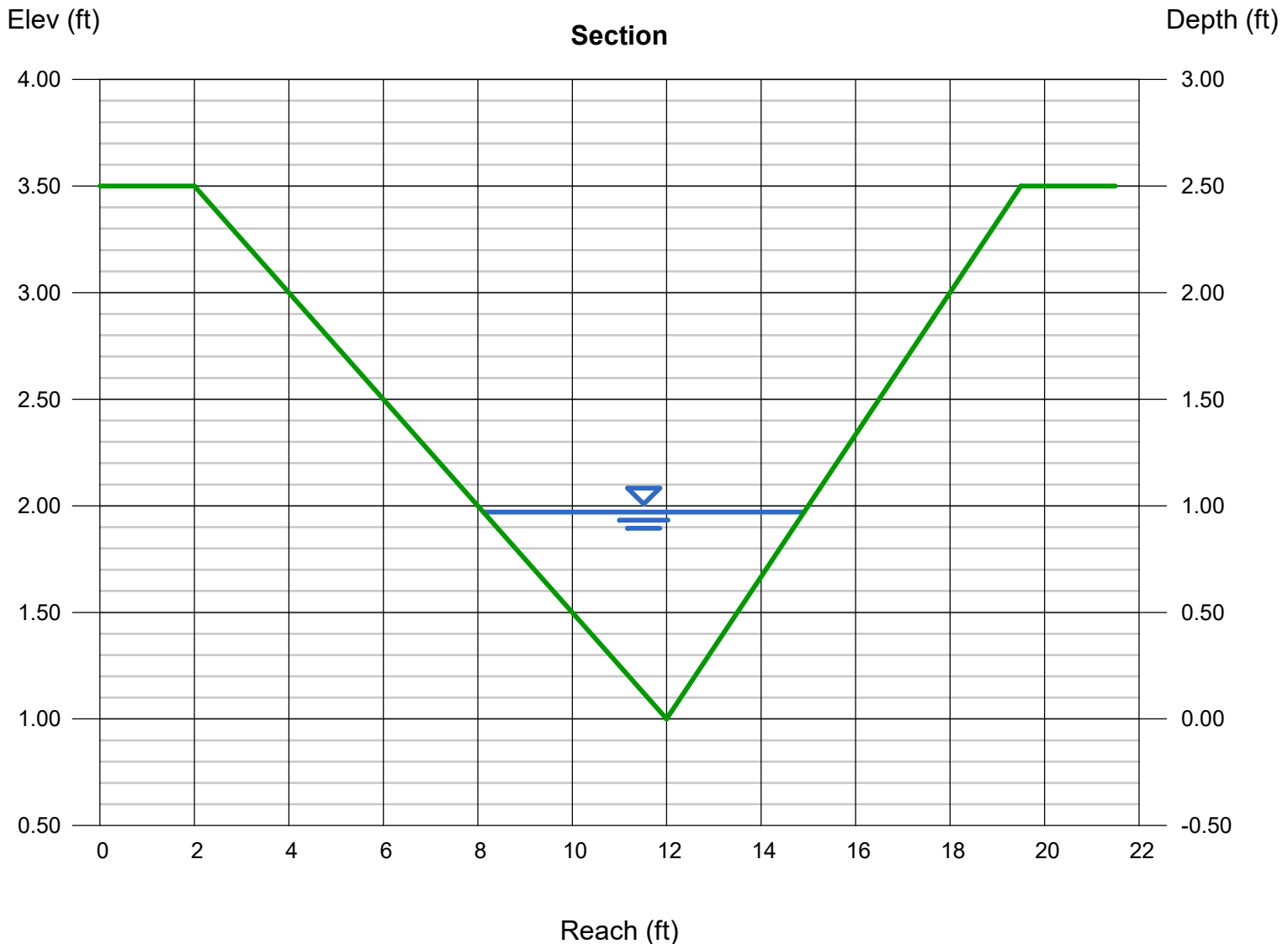

Culvert Report

CULVERT 1 - DP1 (5-YR)

Invert Elev Dn (ft)	= 7267.55
Pipe Length (ft)	= 30.30
Slope (%)	= 2.15
Invert Elev Up (ft)	= 7268.20
Rise (in)	= 18.0
Shape	= Circular
Span (in)	= 18.0
No. Barrels	= 1
n-Value	= 0.013
Culvert Type	= Circular Concrete
Culvert Entrance	= Groove end projecting (C)
Coeff. K,M,c,Y,k	= 0.0045, 2, 0.0317, 0.69, 0.2

Embankment	
Top Elevation (ft)	= 7271.00
Top Width (ft)	= 10.00
Crest Width (ft)	= 5.00

Calculations	
Qmin (cfs)	= 2.10
Qmax (cfs)	= 2.10
Tailwater Elev (ft)	= Critical

Highlighted	
Qtotal (cfs)	= 2.10
Qpipe (cfs)	= 2.10
Qovertop (cfs)	= 0.00
Veloc Dn (ft/s)	= 5.96
Veloc Up (ft/s)	= 3.61
HGL Dn (ft)	= 7267.93
HGL Up (ft)	= 7268.75
Hw Elev (ft)	= 7268.94
Hw/D (ft)	= 0.49
Flow Regime	= Inlet Control

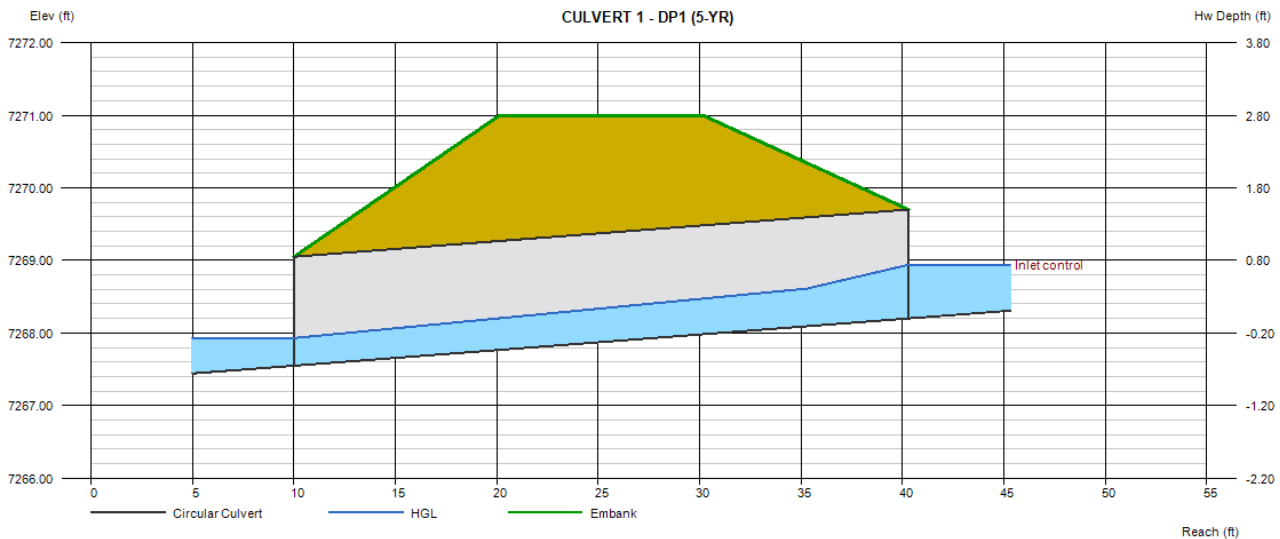

Culvert Report

CULVERT 1 - DP1 (100-YR)

Invert Elev Dn (ft)	= 7267.55
Pipe Length (ft)	= 30.30
Slope (%)	= 2.15
Invert Elev Up (ft)	= 7268.20
Rise (in)	= 18.0
Shape	= Circular
Span (in)	= 18.0
No. Barrels	= 1
n-Value	= 0.013
Culvert Type	= Circular Concrete
Culvert Entrance	= Groove end projecting (C)
Coeff. K,M,c,Y,k	= 0.0045, 2, 0.0317, 0.69, 0.2

Embankment	
Top Elevation (ft)	= 7271.00
Top Width (ft)	= 10.00
Crest Width (ft)	= 5.00

Calculations	
Qmin (cfs)	= 8.30
Qmax (cfs)	= 8.30
Tailwater Elev (ft)	= (dc+D)/2

Highlighted	
Qtotal (cfs)	= 8.30
Qpipe (cfs)	= 8.30
Qovertop (cfs)	= 0.00
Veloc Dn (ft/s)	= 5.08
Veloc Up (ft/s)	= 5.89
HGL Dn (ft)	= 7268.86
HGL Up (ft)	= 7269.32
Hw Elev (ft)	= 7269.94
Hw/D (ft)	= 1.16
Flow Regime	= Inlet Control

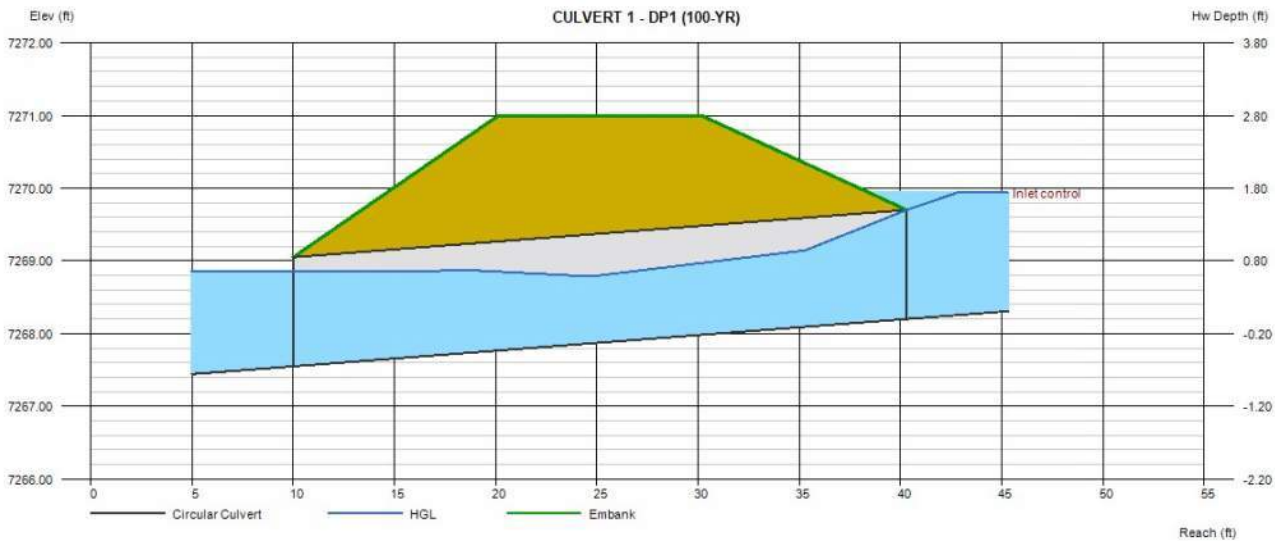

Culvert Report

CULVERT DP6 - CAMELOT Q5

Invert Elev Dn (ft)	= 7284.84
Pipe Length (ft)	= 124.19
Slope (%)	= 2.20
Invert Elev Up (ft)	= 7287.57
Rise (in)	= 30.0
Shape	= Circular
Span (in)	= 30.0
No. Barrels	= 1
n-Value	= 0.013
Culvert Type	= Circular Corrugate Metal Pipe
Culvert Entrance	= Headwall
Coeff. K,M,c,Y,k	= 0.0078, 2, 0.0379, 0.69, 0.5

Embankment	
Top Elevation (ft)	= 7291.25
Top Width (ft)	= 100.00
Crest Width (ft)	= 50.00

Calculations	
Qmin (cfs)	= 11.00
Qmax (cfs)	= 11.00
Tailwater Elev (ft)	= Critical

Highlighted	
Qtotal (cfs)	= 11.00
Qpipe (cfs)	= 11.00
Qovertop (cfs)	= 0.00
Veloc Dn (ft/s)	= 9.26
Veloc Up (ft/s)	= 5.23
HGL Dn (ft)	= 7285.57
HGL Up (ft)	= 7288.68
Hw Elev (ft)	= 7289.12
Hw/D (ft)	= 0.62
Flow Regime	= Inlet Control

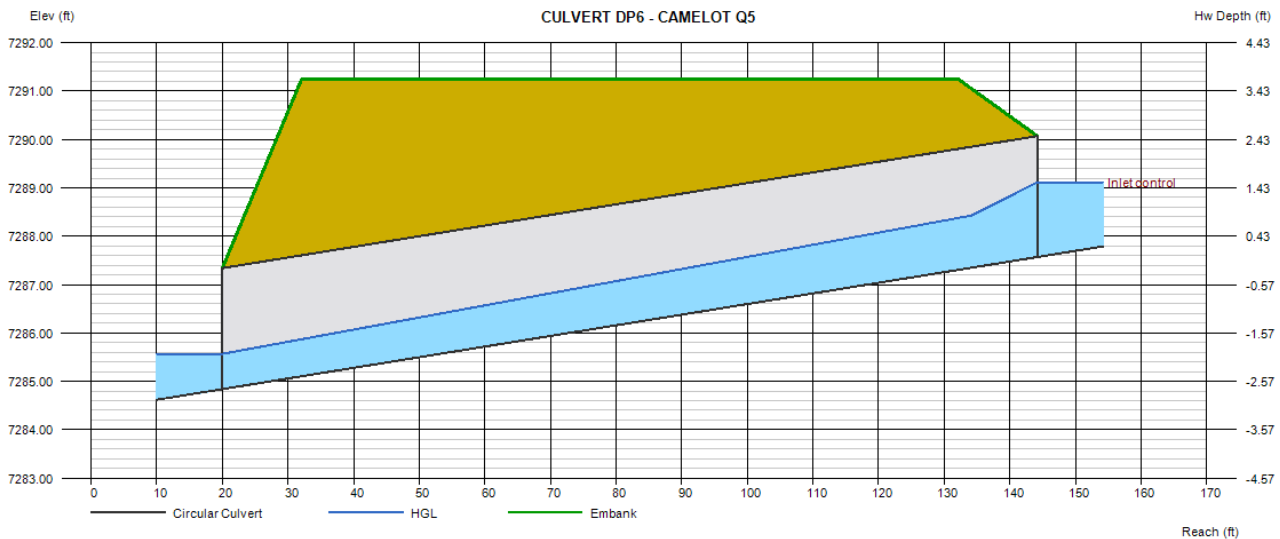

Culvert Report

CULVERT DP6 - CAMELOT Q100

Invert Elev Dn (ft)	= 7284.84
Pipe Length (ft)	= 124.19
Slope (%)	= 2.20
Invert Elev Up (ft)	= 7287.57
Rise (in)	= 30.0
Shape	= Circular
Span (in)	= 30.0
No. Barrels	= 1
n-Value	= 0.013
Culvert Type	= Circular Corrugate Metal Pipe
Culvert Entrance	= Headwall
Coeff. K,M,c,Y,k	= 0.0078, 2, 0.0379, 0.69, 0.5

Embankment	
Top Elevation (ft)	= 7291.25
Top Width (ft)	= 100.00
Crest Width (ft)	= 50.00

Calculations	
Qmin (cfs)	= 22.00
Qmax (cfs)	= 22.00
Tailwater Elev (ft)	= Critical

Highlighted	
Qtotal (cfs)	= 22.00
Qpipe (cfs)	= 22.00
Qovertop (cfs)	= 0.00
Veloc Dn (ft/s)	= 11.07
Veloc Up (ft/s)	= 6.66
HGL Dn (ft)	= 7285.90
HGL Up (ft)	= 7289.16
Hw Elev (ft)	= 7289.98
Hw/D (ft)	= 0.97
Flow Regime	= Inlet Control

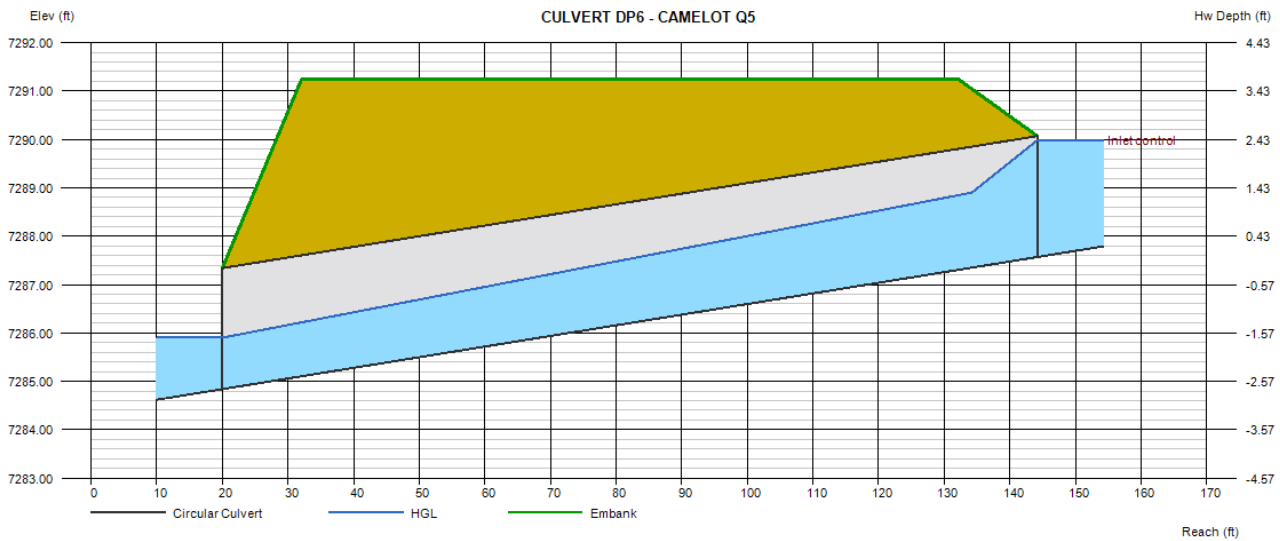

Channel Report

Drainage A Swale - DP6 Camelot (22 CFS)

Triangular

Side Slopes (z:1) = 6.00, 6.00

Total Depth (ft) = 2.33

Invert Elev (ft) = 1.00

Slope (%) = 0.62

N-Value = 0.034

Calculations

Compute by: Known Q

Known Q (cfs) = 22.00

Highlighted

Depth (ft) = 1.23

Q (cfs) = 22.00

Area (sqft) = 9.08

Velocity (ft/s) = 2.42

Wetted Perim (ft) = 14.96

Crit Depth, Yc (ft) = 0.97

Top Width (ft) = 14.76

EGL (ft) = 1.32

SEE 1ST PAGE OF APPENDIX C FOR FROUDE # AND ADDITIONAL CALCULATIONS

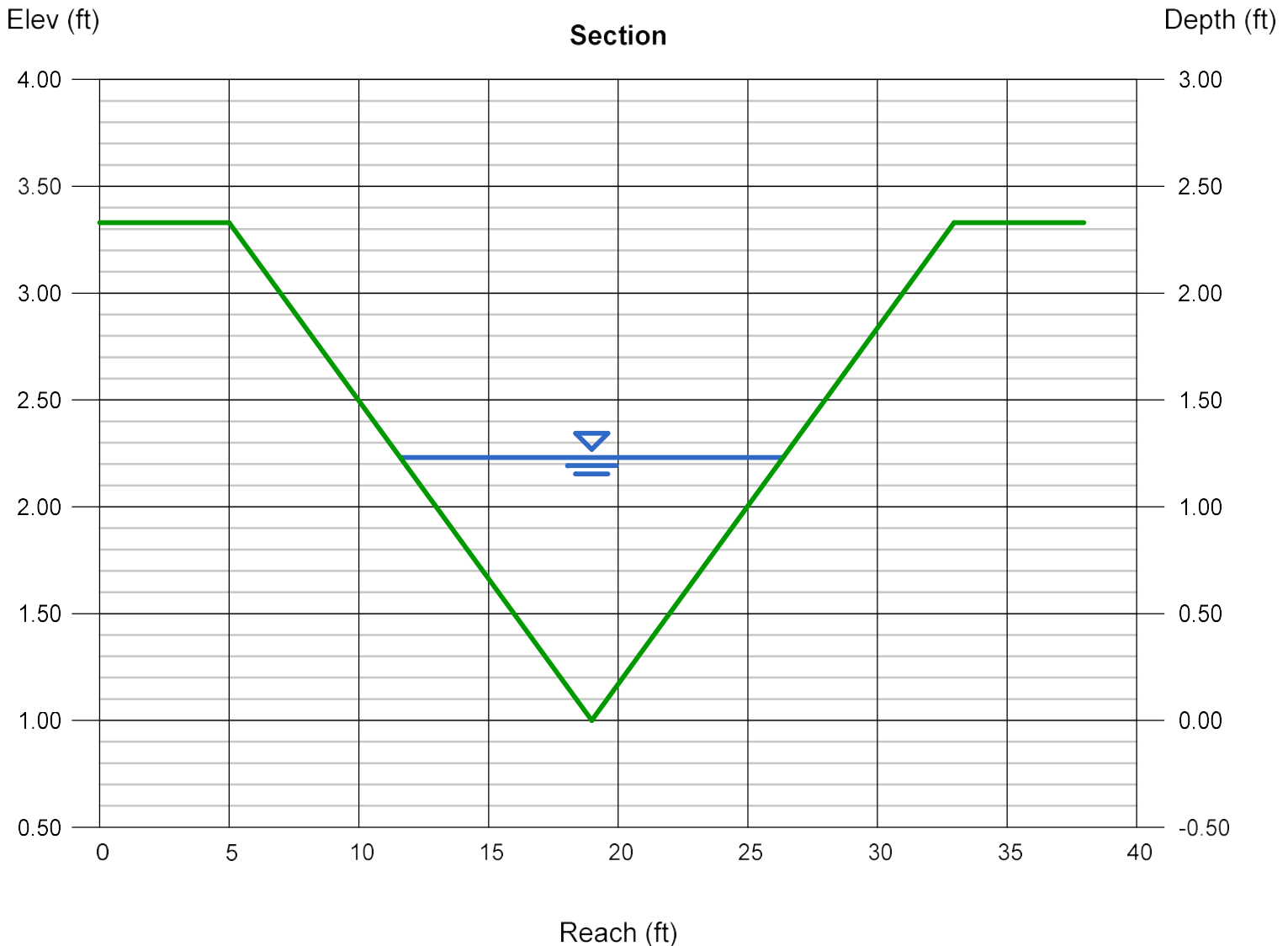

Channel Report

Drainage A Swale - DP 3 Q100 33.9 cfs (MAX SLOPE)

Triangular

Side Slopes (z:1) = 6.00, 6.00

Total Depth (ft) = 2.33

Invert Elev (ft) = 1.00

Slope (%) = 3.00

N-Value = 0.035

Calculations

Compute by: Known Q

Known Q (cfs) = 33.90

Highlighted

Depth (ft) = 1.09

Q (cfs) = 33.90

Area (sqft) = 7.13

Velocity (ft/s) = 4.76

Wetted Perim (ft) = 13.26

Crit Depth, Yc (ft) = 1.15

Top Width (ft) = 13.08

EGL (ft) = 1.44

SEE 1ST PAGE OF APPENDIX C FOR FROUDE # AND ADDITIONAL CALCULATIONS

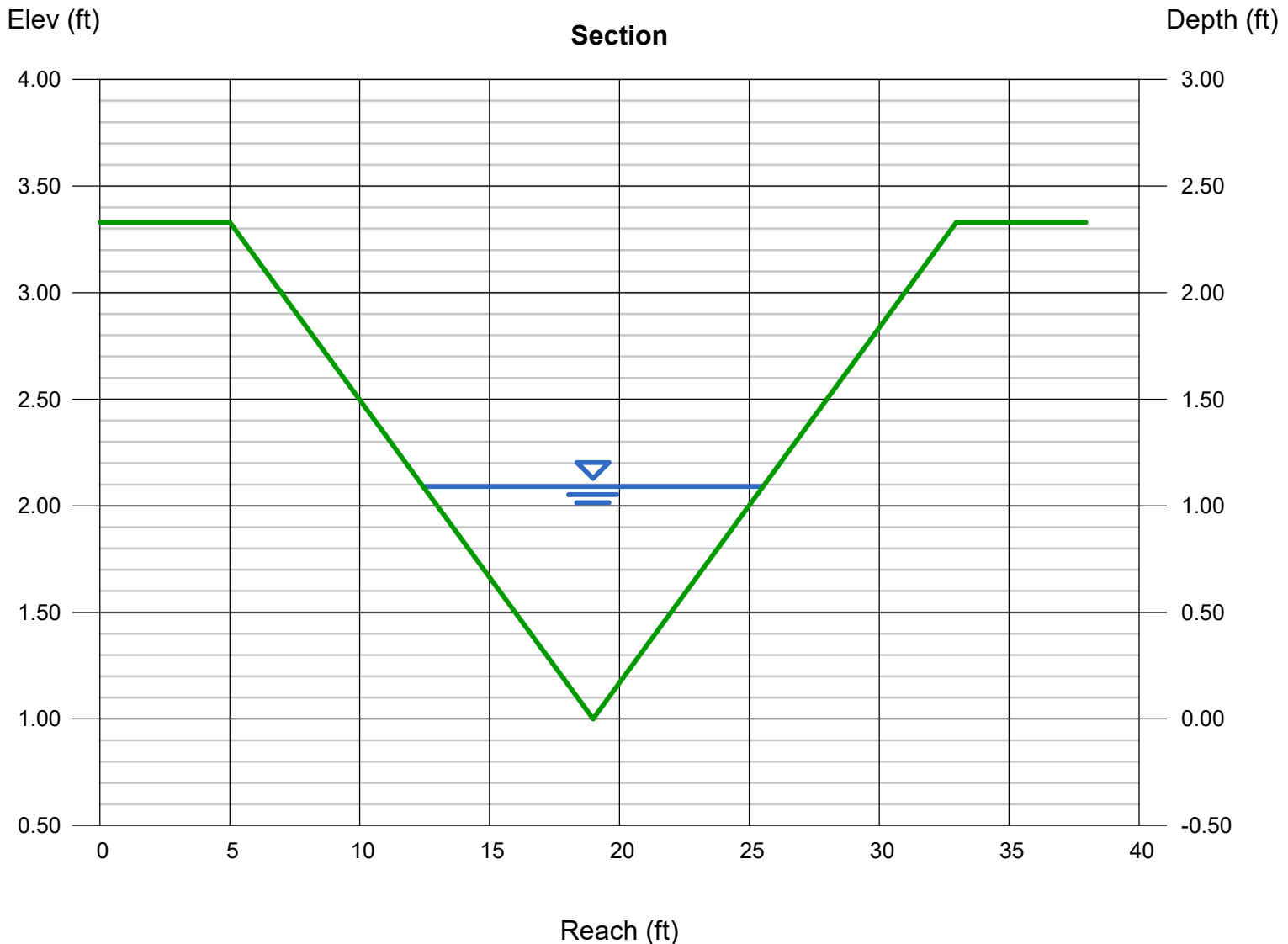

Channel Report

EX SWALE A2-1 - UBS-2 - PROPOSED SWALE A2-1 (Q100 = 69.2)

Trapezoidal

Bottom Width (ft) = 10.00
Side Slopes (z:1) = 4.00, 4.00
Total Depth (ft) = 2.50
Invert Elev (ft) = 1.00
Slope (%) = 1.12
N-Value = 0.040

Highlighted

Depth (ft) = 1.25
Q (cfs) = 69.20
Area (sqft) = 18.75
Velocity (ft/s) = 3.69
Wetted Perim (ft) = 20.31
Crit Depth, Yc (ft) = 1.00
Top Width (ft) = 20.00
EGL (ft) = 1.46

Calculations

Compute by: Known Q
Known Q (cfs) = 69.20

FROUDE # = 0.58

Existing swale

Section

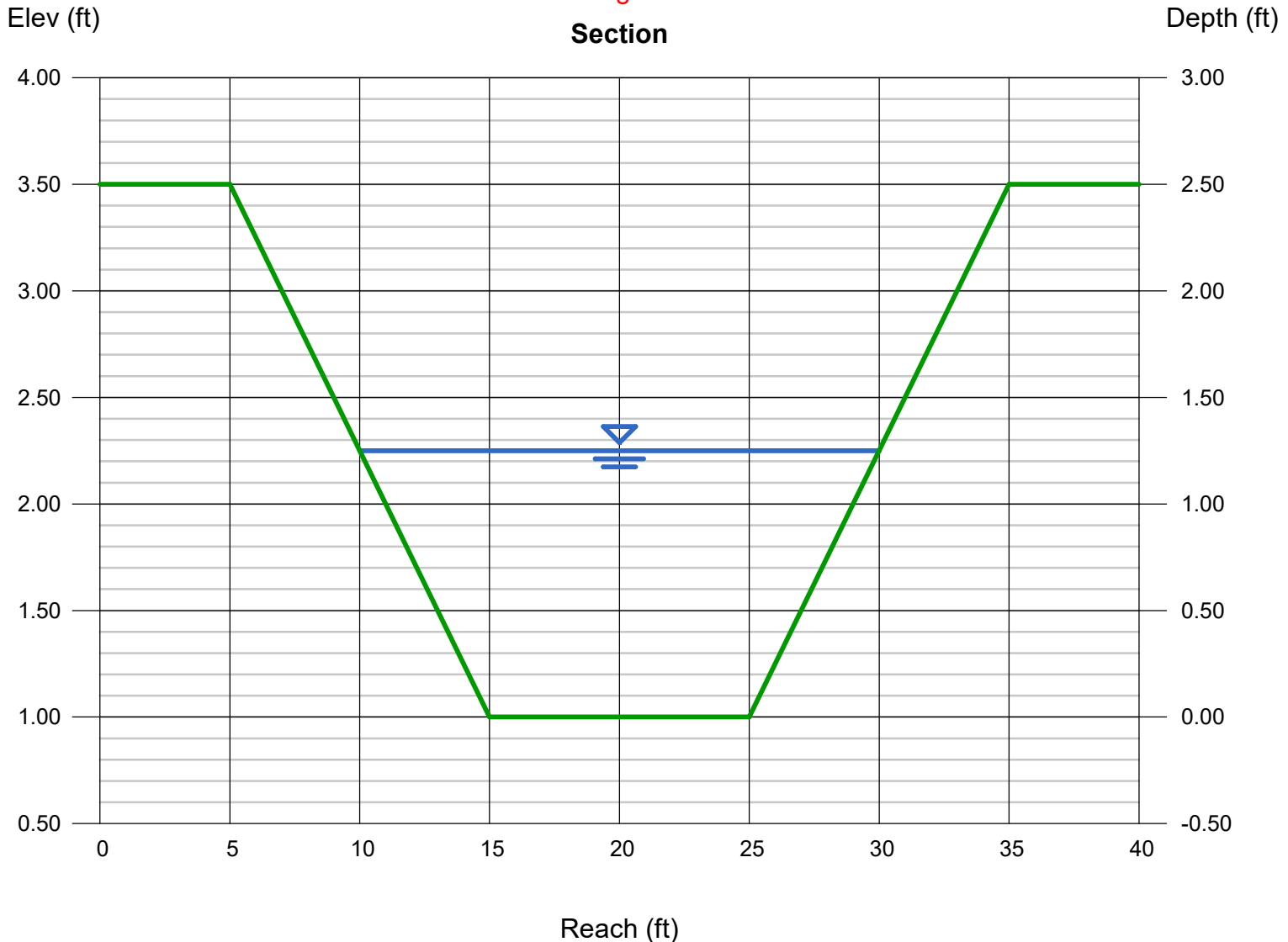

Channel Report

DP5 - Drainage A2 Swale (Q5 = 34.3 cfs)

Trapezoidal

Bottom Width (ft)	= 12.00
Side Slopes (z:1)	= 4.00, 4.00
Total Depth (ft)	= 2.25
Invert Elev (ft)	= 1.00
Slope (%)	= 1.92
N-Value	= 0.040

Highlighted

Depth (ft)	= 0.67
Q (cfs)	= 34.30
Area (sqft)	= 9.84
Velocity (ft/s)	= 3.49
Wetted Perim (ft)	= 17.52
Crit Depth, Yc (ft)	= 0.60
Top Width (ft)	= 17.36
EGL (ft)	= 0.86

Calculations

Compute by:	Known Q
Known Q (cfs)	= 34.30

SEE 1ST PAGE OF APPENDIX C FOR FROUDE # AND ADDITIONAL CALCULATIONS

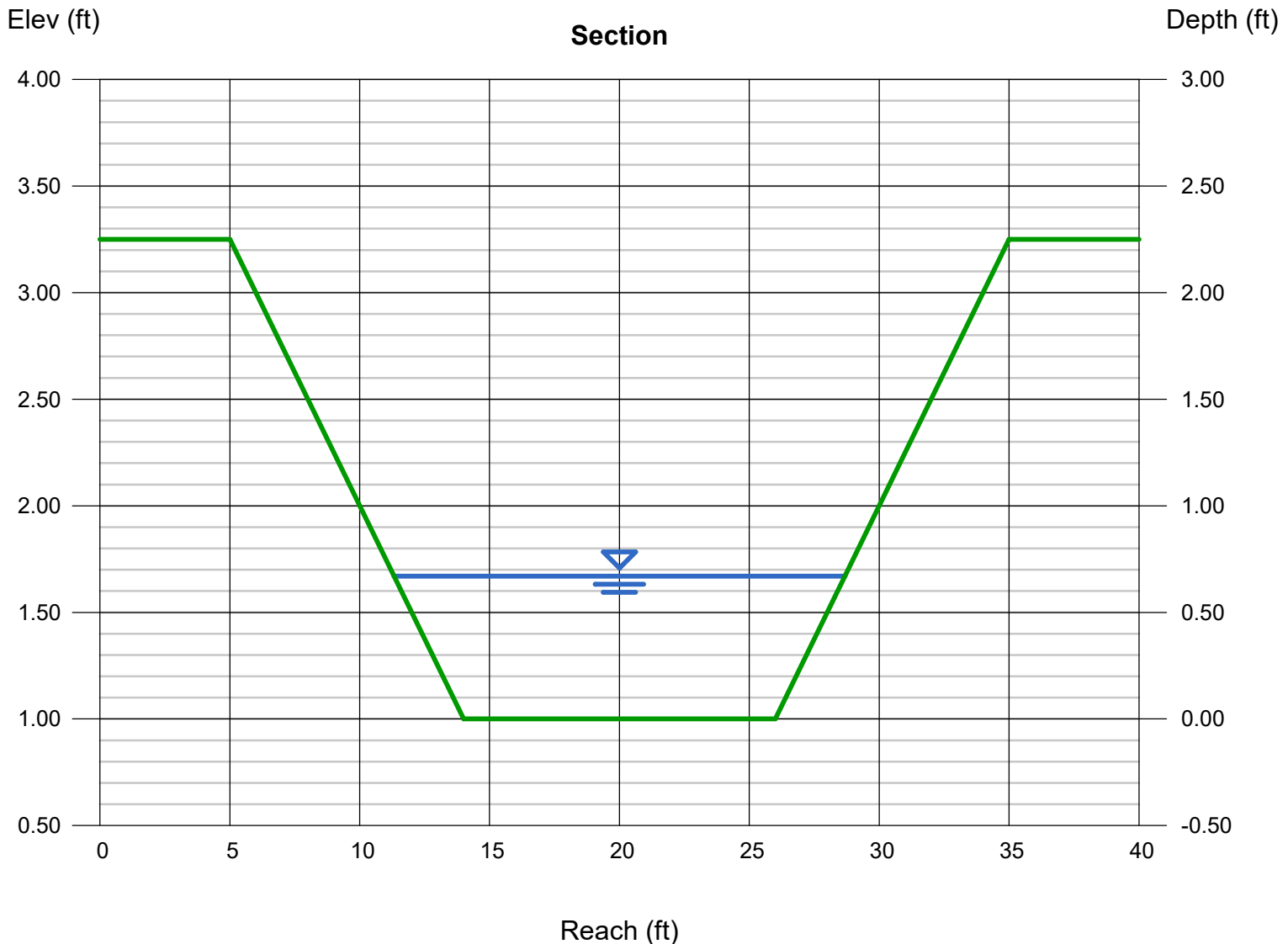

Channel Report

DP5 - Drainage A2 Swale (Q100 = 81 cfs)

Trapezoidal

Bottom Width (ft)	= 12.00
Side Slopes (z:1)	= 4.00, 4.00
Total Depth (ft)	= 2.25
Invert Elev (ft)	= 1.00
Slope (%)	= 1.92
N-Value	= 0.040

Highlighted

Depth (ft)	= 1.09
Q (cfs)	= 81.00
Area (sqft)	= 17.83
Velocity (ft/s)	= 4.54
Wetted Perim (ft)	= 20.99
Crit Depth, Yc (ft)	= 1.00
Top Width (ft)	= 20.72
EGL (ft)	= 1.41

Calculations

Compute by:	Known Q
Known Q (cfs)	= 81.00

SEE 1ST PAGE OF APPENDIX C FOR FROUDE # AND ADDITIONAL CALCULATIONS

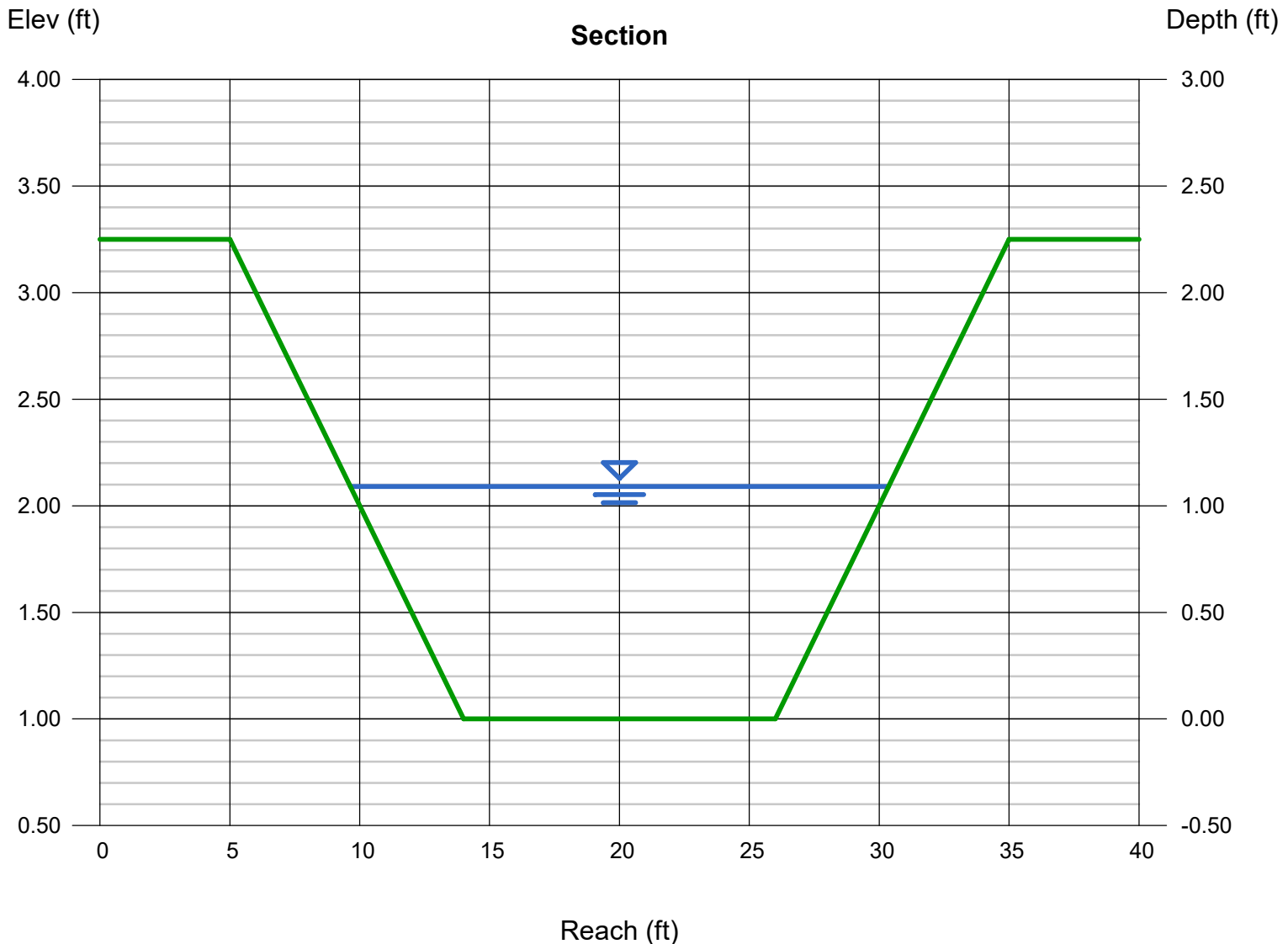

Channel Report

DP 5 - EX NATURAL DRAINAGE (Q5 = 34.3 CFS)

User-defined

Invert Elev (ft) = 7245.46
Slope (%) = 2.57
N-Value = 0.040

Highlighted

Depth (ft) = 0.63
Q (cfs) = 34.30
Area (sqft) = 11.93
Velocity (ft/s) = 2.87
Wetted Perim (ft) = 35.35
Crit Depth, Yc (ft) = 0.60
Top Width (ft) = 35.31
EGL (ft) = 0.76

Calculations

Compute by: Known Q
Known Q (cfs) = 34.30

(Sta, El, n)-(Sta, El, n)...

(10.31, 7249.00)-(43.92, 7245.46, 0.040)-(71.65, 7246.00, 0.040)-(125.04, 7249.00, 0.040)

SEE 1ST PAGE OF APPENDIX C FOR
FROUDE # AND ADDITIONAL
CALCULATIONS

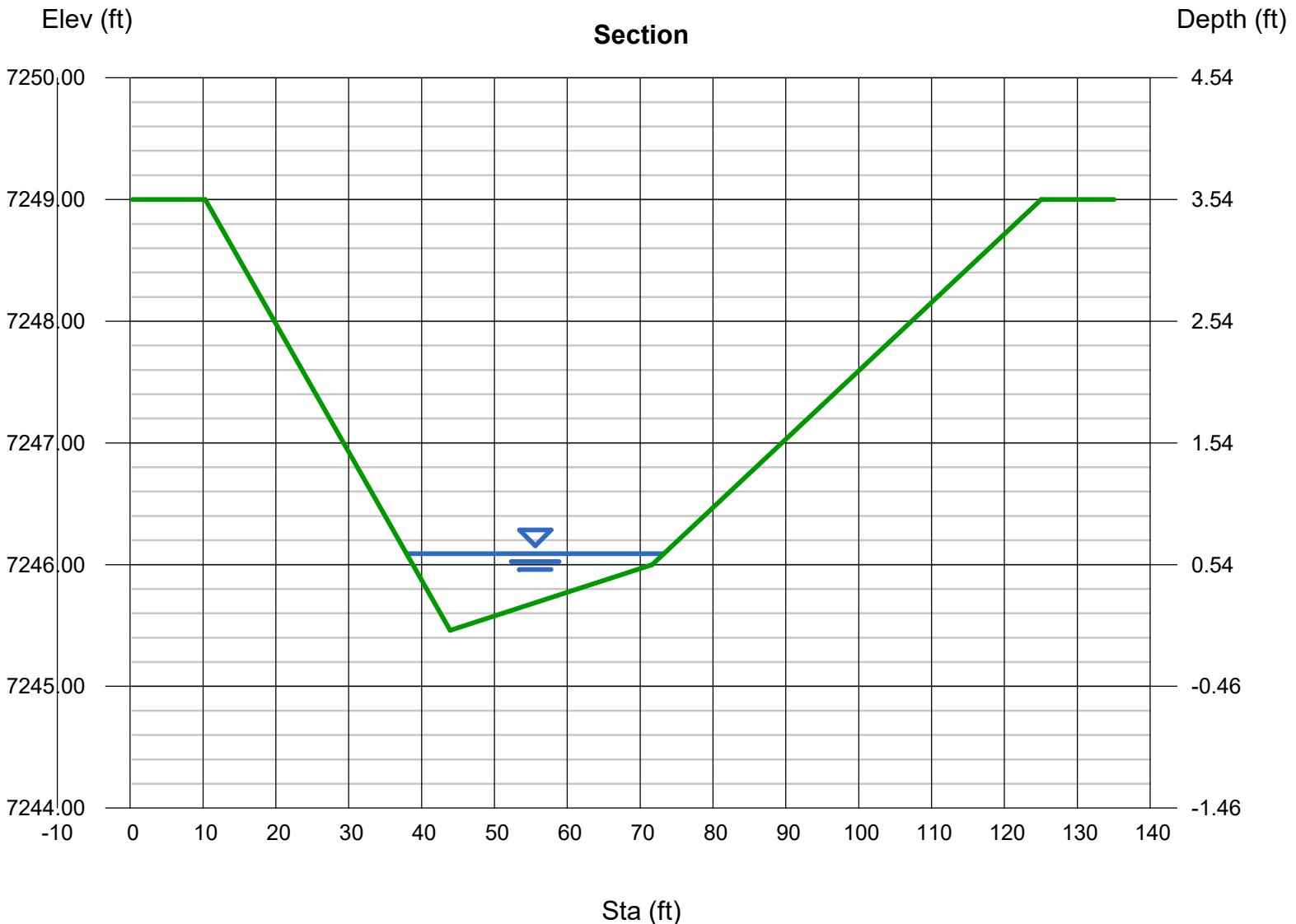

Channel Report

DP 5 - EX NATURAL DRAINAGE (Q100 = 81 CFS)

User-defined

Invert Elev (ft) = 7245.46
Slope (%) = 2.57
N-Value = 0.040

Highlighted

Depth (ft) = 0.88
Q (cfs) = 81.00
Area (sqft) = 21.61
Velocity (ft/s) = 3.75
Wetted Perim (ft) = 42.19
Crit Depth, Yc (ft) = 0.85
Top Width (ft) = 42.13
EGL (ft) = 1.10

Calculations

Compute by: Known Q
Known Q (cfs) = 81.00

(Sta, El, n)-(Sta, El, n)...

(10.31, 7249.00)-(43.92, 7245.46, 0.040)-(71.65, 7246.00, 0.040)-(125.04, 7249.00, 0.040)

SEE 1ST PAGE OF APPENDIX C FOR FROUDE # AND ADDITIONAL CALCULATIONS

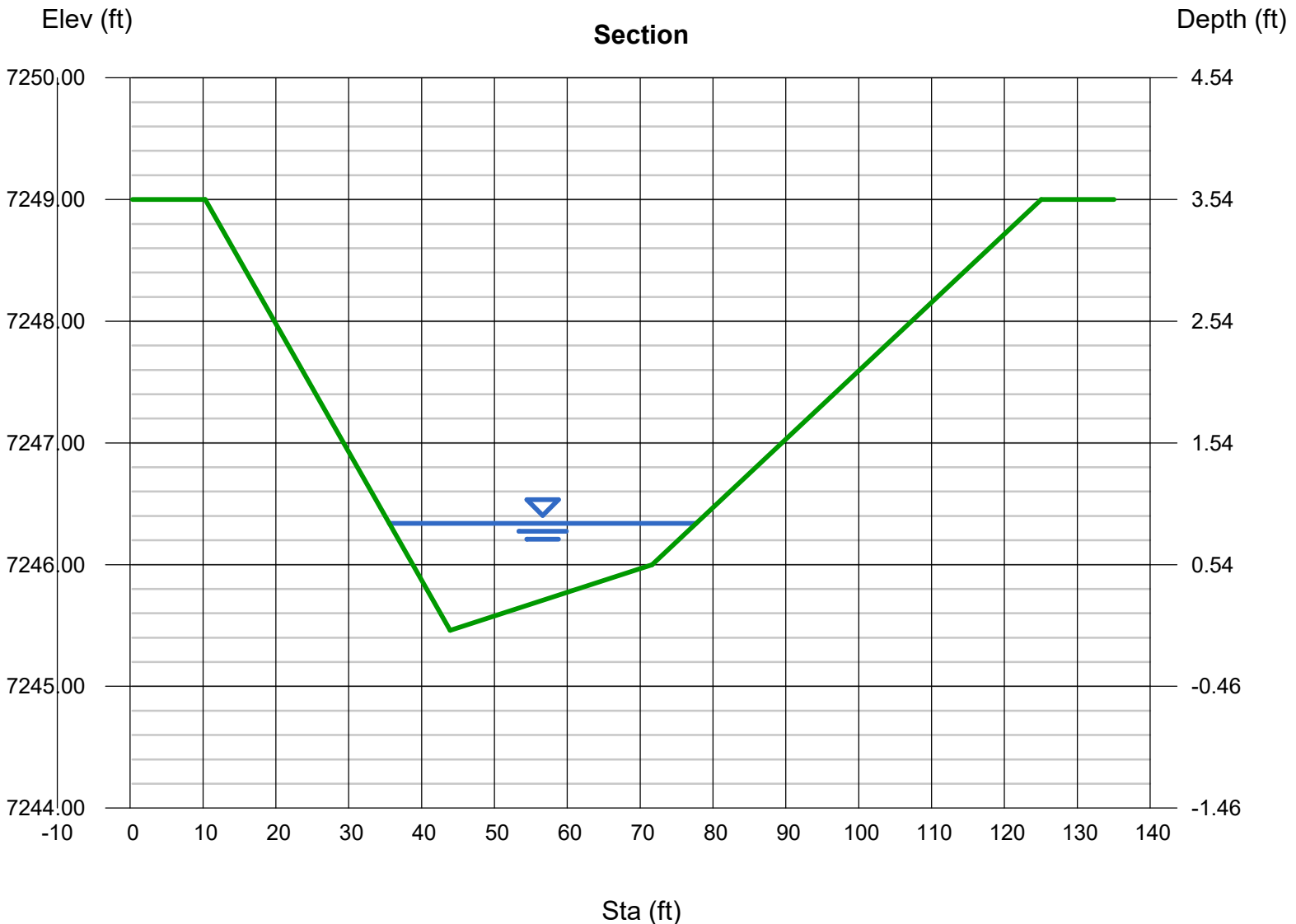

Channel Report

DP2.1 - Pond Outlet Pipe Manning's Calc Q5

Circular

Diameter (ft) = 2.00

Invert Elev (ft) = 1.00

Slope (%) = 1.02

N-Value = 0.013

Calculations

Compute by: Known Q

Known Q (cfs) = 1.50

Highlighted

Depth (ft) = 0.35

Q (cfs) = 1.500

Area (sqft) = 0.37

Velocity (ft/s) = 4.04

Wetted Perim (ft) = 1.73

Crit Depth, Y_c (ft) = 0.43

Top Width (ft) = 1.52

EGL (ft) = 0.60

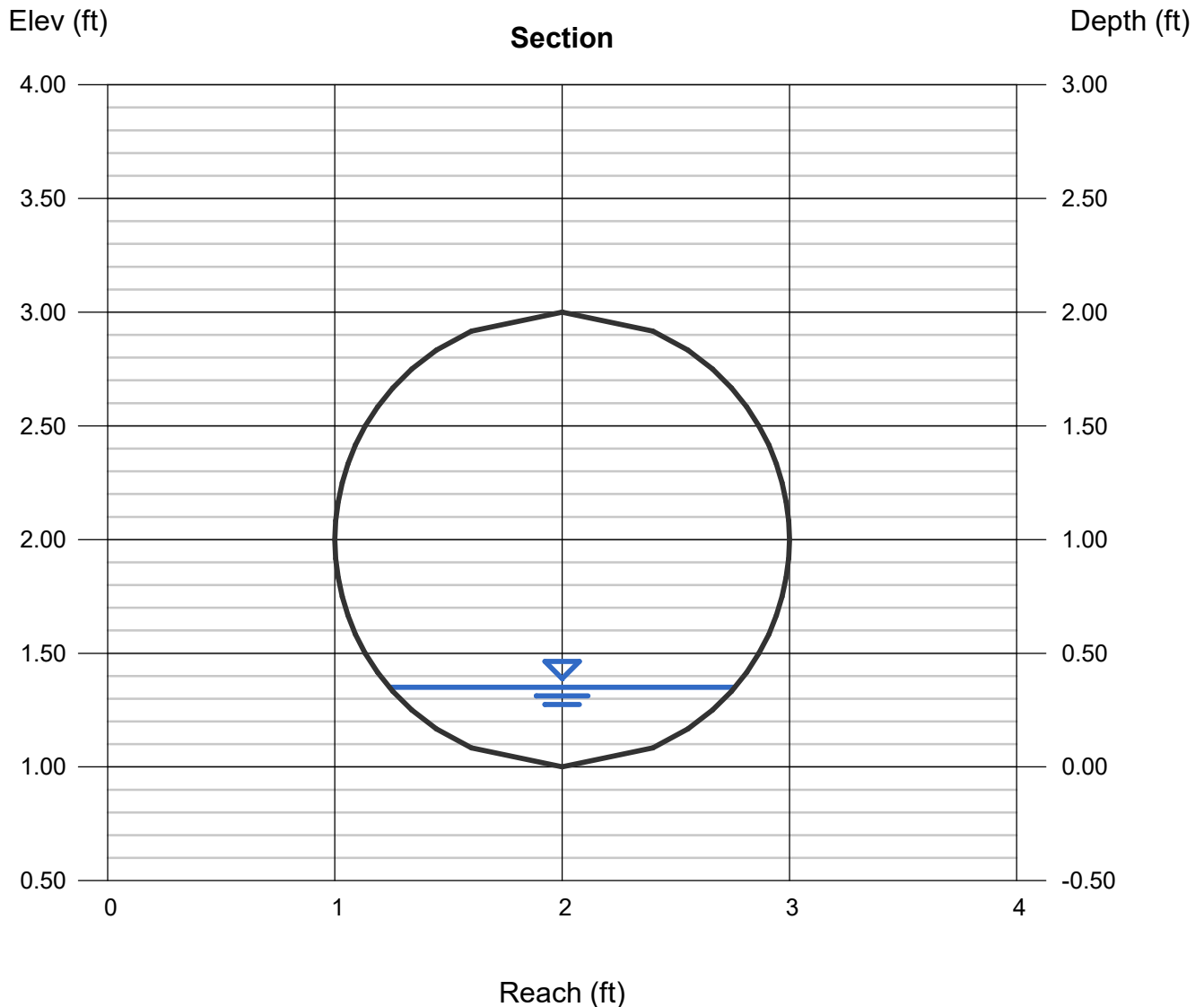

Culvert Report

DP2.1 - 18 Inch RCP (Q5 = 1.5 cfs)

Invert Elev Dn (ft)	= 7261.38
Pipe Length (ft)	= 102.60
Slope (%)	= 1.02
Invert Elev Up (ft)	= 7262.43
Rise (in)	= 18.0
Shape	= Circular
Span (in)	= 18.0
No. Barrels	= 1
n-Value	= 0.013
Culvert Type	= Circular Concrete
Culvert Entrance	= Square edge w/headwall (C)
Coeff. K,M,c,Y,k	= 0.0098, 2, 0.0398, 0.67, 0.5

Embankment	
Top Elevation (ft)	= 7267.50
Top Width (ft)	= 10.00
Crest Width (ft)	= 10.00

Calculations	
Qmin (cfs)	= 1.50
Qmax (cfs)	= 1.50
Tailwater Elev (ft)	= Critical

Highlighted	
Qtotal (cfs)	= 1.50
Qpipe (cfs)	= 1.50
Qovertop (cfs)	= 0.00
Veloc Dn (ft/s)	= 4.26
Veloc Up (ft/s)	= 3.27
HGL Dn (ft)	= 7261.76
HGL Up (ft)	= 7262.89
Hw Elev (ft)	= 7263.06
Hw/D (ft)	= 0.42
Flow Regime	= Inlet Control

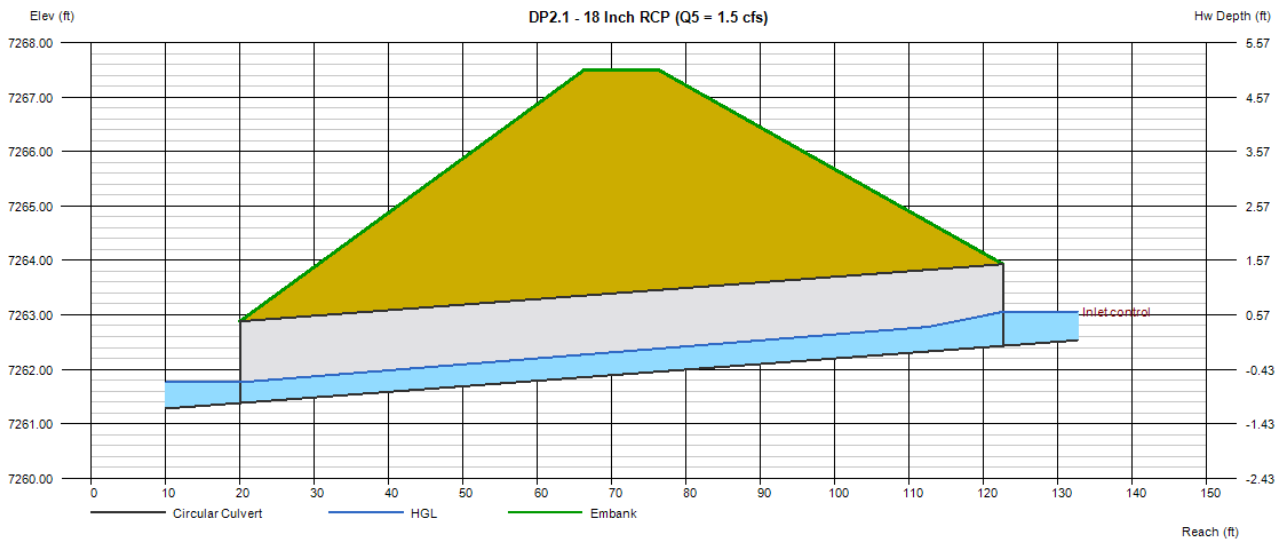

Channel Report

DP2.1 - Pond Outlet Pipe Manning's Calc Q100

Circular

Diameter (ft) = 2.00

Invert Elev (ft) = 1.00

Slope (%) = 1.02

N-Value = 0.013

Calculations

Compute by: Known Q

Known Q (cfs) = 8.70

Highlighted

Depth (ft) = 0.86

Q (cfs) = 8.700

Area (sqft) = 1.30

Velocity (ft/s) = 6.69

Wetted Perim (ft) = 2.87

Crit Depth, Yc (ft) = 1.05

Top Width (ft) = 1.98

EGL (ft) = 1.56

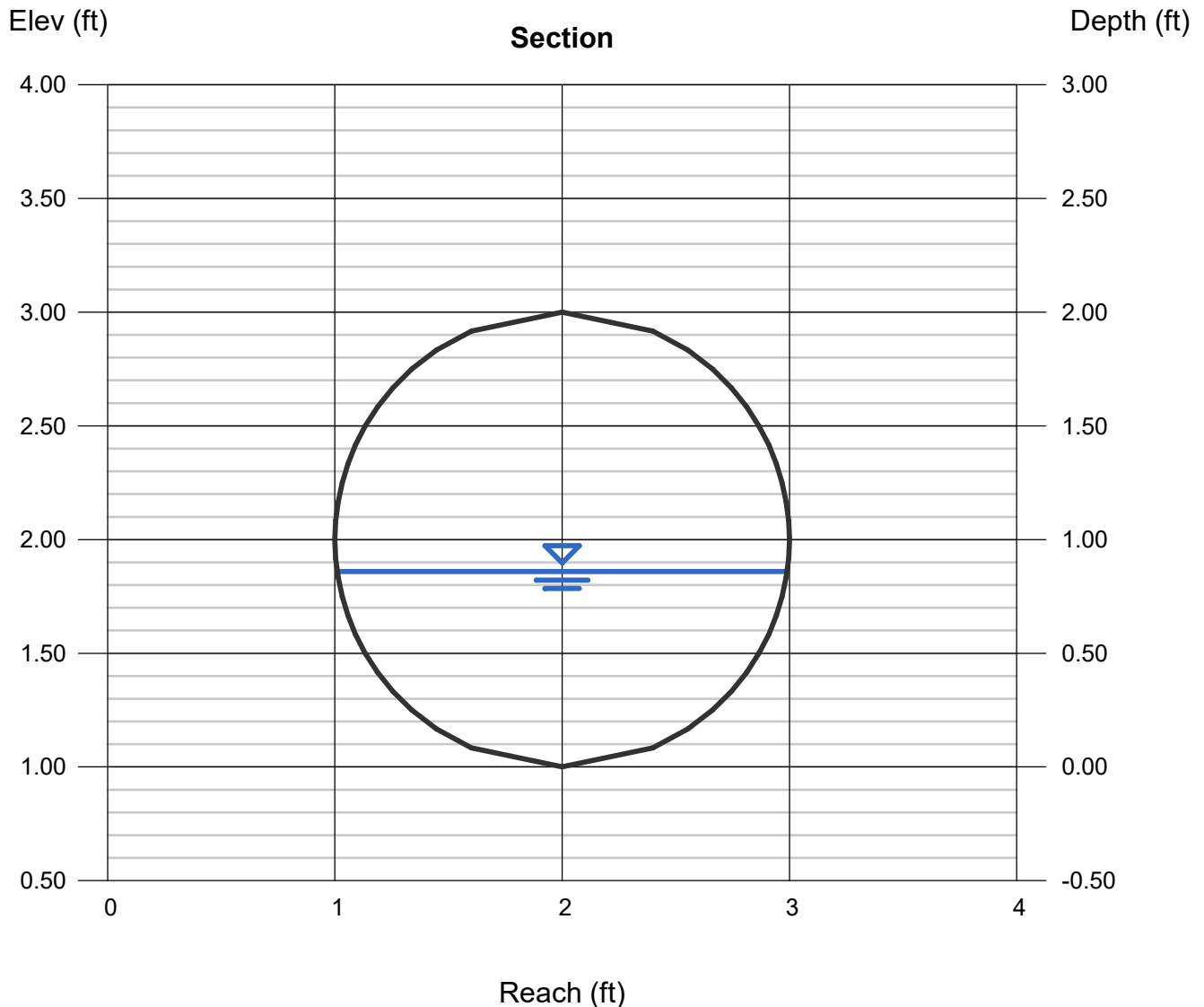

Culvert Report

DP2.1 - 18 Inch RCP (Q100 = 8.7 cfs)

Invert Elev Dn (ft)	=	7261.38
Pipe Length (ft)	=	102.60
Slope (%)	=	1.02
Invert Elev Up (ft)	=	7262.43
Rise (in)	=	18.0
Shape	=	Circular
Span (in)	=	18.0
No. Barrels	=	1
n-Value	=	0.013
Culvert Type	=	Circular Concrete
Culvert Entrance	=	Square edge w/headwall (C)
Coeff. K,M,c,Y,k	=	0.0098, 2, 0.0398, 0.67, 0.5

Embankment	
Top Elevation (ft)	= 7267.50
Top Width (ft)	= 10.00
Crest Width (ft)	= 10.00

Calculations	
Qmin (cfs)	= 8.70
Qmax (cfs)	= 8.70
Tailwater Elev (ft)	= Critical

Highlighted	
Qtotal (cfs)	= 8.70
Qpipe (cfs)	= 8.70
Qovertop (cfs)	= 0.00
Veloc Dn (ft/s)	= 6.69
Veloc Up (ft/s)	= 6.03
HGL Dn (ft)	= 7262.42
HGL Up (ft)	= 7263.57
Hw Elev (ft)	= 7264.39
Hw/D (ft)	= 1.31
Flow Regime	= Inlet Control

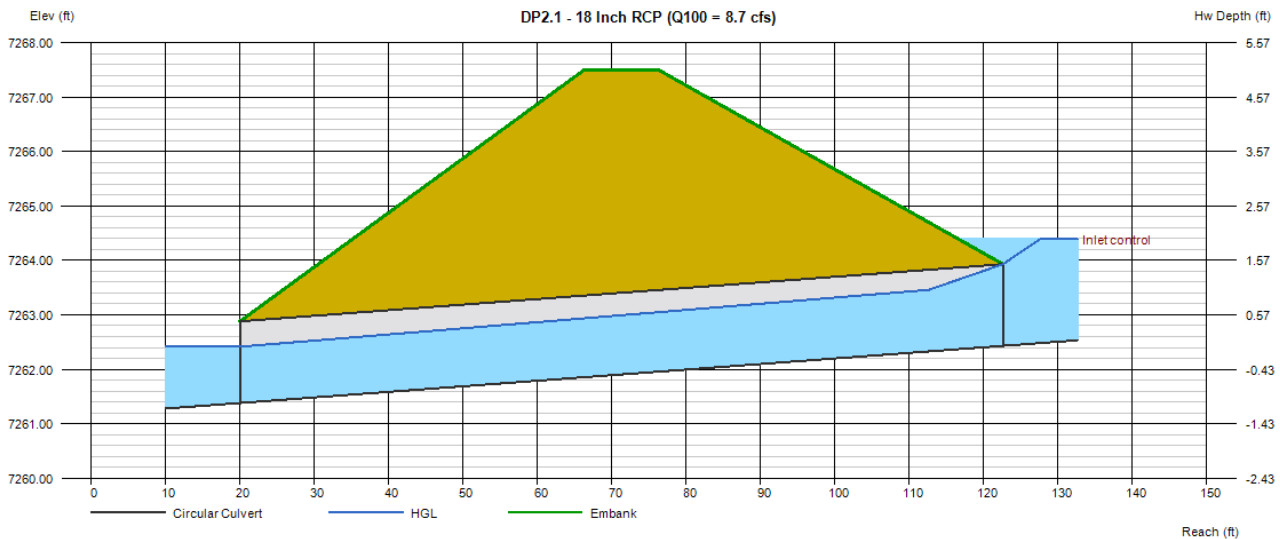

PIPE OUTFALL RIPRAP SIZING CALCULATIONS

Subdivision: Antlers Subdivision Proposed
 Location: El Paso County

Project Name: Antlers Subdivision Proposed
 Project No.: 24031.00
 Calculated By: REB
 Checked By: _____
 Date: 2/22/26

	STORM DRAIN SYSTEM			Notes
	DP6 - CAMELOT	DP2.1	DP1	
Q ₁₀₀ (cfs):	22.0	8.7	8.3	Flows are the greater of proposed vs. future
Conduit	Pipe	Pipe	Pipe	
D _c , Pipe Diameter (in):	30	18	18	
W, Box Width (ft):	N/A	N/A	N/A	
H, Box Height (ft):	N/A	N/A	N/A	
Y _t , Tailwater Depth (ft):	1.00	1.10	0.60	If unknown, use Y _t /D _c (or H)=0.4
Y _t /D _c or Y _t /H	0.40	0.73	0.40	
Q/D ^{2.5} or Q/(WH ^{3/2})	2.23	3.16	3.01	
Supercritical?	No	No	No	
Y _n , Normal Depth (ft) [Supercritical]:				
D _a , H _a (in) [Supercritical]:	N/A	N/A	N/A	D _a =(D _c +Y _n)/2
Riprap d ₅₀ (in) [Supercritical]:	N/A	N/A	N/A	
Riprap d ₅₀ (in) [Subcritical]:	4.61	1.90	3.74	
Required Riprap Size:	L	L	L	Fig. 9-38 or Fig. 9-36
d₅₀ (in):	9	9	9	
Expansion Factor, 1/(2 tan θ):	5.50	6.60	4.30	Read from Fig. 9-35 or 9-36
θ:	0.09	0.08	0.12	
Erosive Soils?	No	No	No	
Area of Flow, A _t (ft ²):	3.14	1.24	1.19	A _t =Q/V
Length of Protection, L _p (ft):	3.5	-2.4	2.0	L=(1/(2 tan θ))(At/Yt - D)
Min Length (ft)	7.5	4.5	4.5	Min L=3D or 3H
Max Length (ft)	25.0	15.0	15.0	Max L=10D or 10H
Min Bottom Width, T (ft):	3.1	1.1	2.0	T=2*(L _p *tanθ)+W
Design Length (ft)	7.5	4.5	4.5	
Design Width (ft)	3.1	1.1	2.0	
Riprap Depth (in)	18	18	18	Depth=2(d ₅₀)
Type II Bedding Depth (in)*	6	6	6	*Not used if Soil Riprap
Cutoff Wall	No	No	No	
Cutoff Wall Depth (ft)				Depth of Riprap and Base
Cutoff Wall Width (ft)				

Note: No Type II Base to be used if Soil Riprap is specified within the plans
 * For use when the flow in the culvert is supercritical (and less than full).

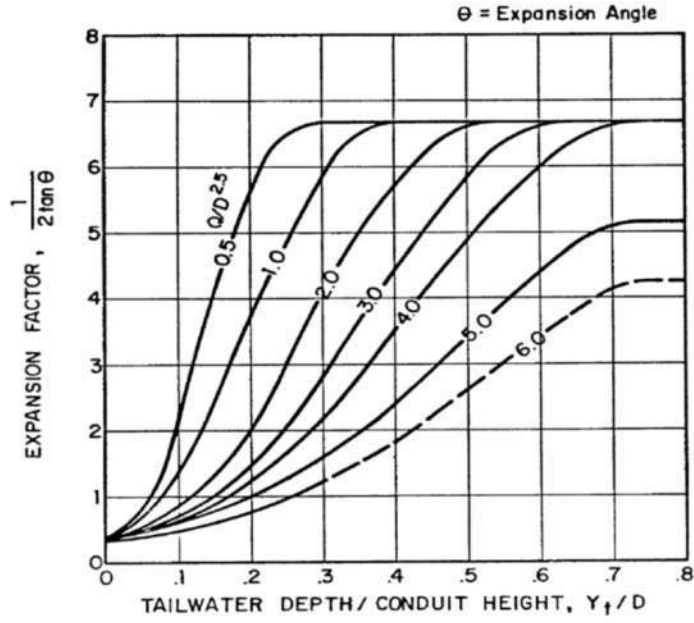

Figure 9-35. Expansion factor for circular conduits

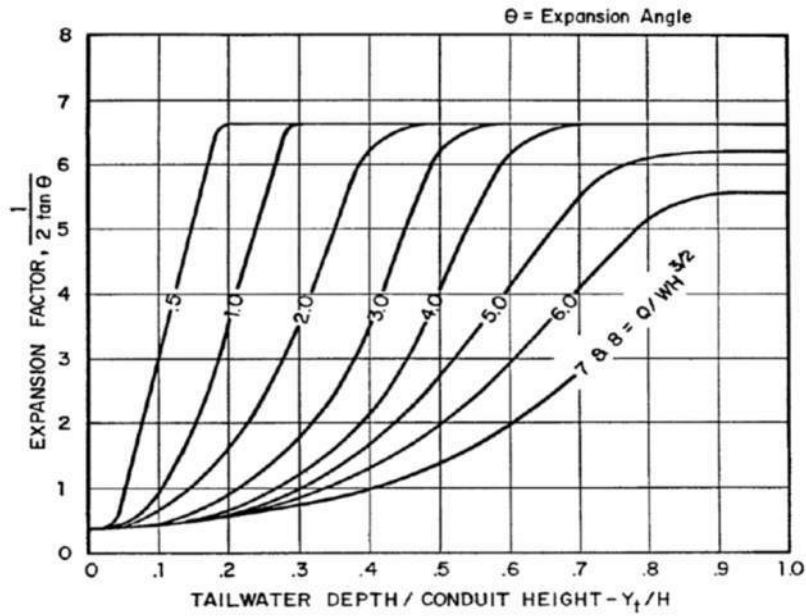

Figure 9-36. Expansion factor for rectangular conduits

MATERIAL PROPERTY DATA SHEET



VMax® SC250™

Permanent • Triple Net • Organic Fiber Matrix • Turf Reinforcement Mat

see drainage map for proposed locations

DESCRIPTION

SC250 Turf Reinforcement Mat (TRM) is composed of 70% straw and 30% coconut fibers mechanically (stitch) bound between a three-dimensional UV stabilized, synthetic net structure. Stitching is secured on two-inch centers using UV stabilized, synthetic thread. SC250 is a permanent, three-dimensional TRM that provides immediate erosion protection and long-term turf reinforcement and is intended for applications requiring erosion protection for greater than thirty-six months.

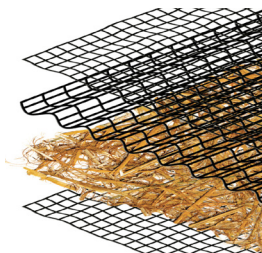

Each roll of SC250 is made in the USA and manufactured under Western Green's Quality Assurance Program to ensure a continuous distribution of fibers and consistent thickness.

Material Content	
Matrix	Straw/Coconut
Netting	Top Net: Mediumweight, UV stable
	Middle Net: Corrugated Ultra-Heavyweight, UV stable
	Bottom Net: Mediumweight, UV stable
Thread	Synthetic, UV Stable

Standard Roll Sizes				
Width	8 ft	(2.4 m)	6.5 ft	(2.0 m)
Length	90 ft	(27.4 m)	55.5 ft	(17.0 m)
Weight ± 10%	70 lb	(32.0 kg)	34 lb	(15.5 kg)
Area	80 sy	(66.9 m ²)	40 sy	(33.4 m ²)

Material available in custom roll sizes

Approvals & Classification	
Classification	FHWA: Type 5.C / ECTC: Type 5.C
TTI Approvals	Class 2 Type H
NTPEP Number	ECP-2019-03-014

Disclaimer: The information contained herein may represent product index data, performance ratings, bench scale testing or other material utility quantifications. Each representation may have unique utility and limitations. Every effort has been made to ensure accuracy, however, no warranty is claimed and no liability shall be assumed by Western Green or its affiliates regarding the completeness, accuracy or fitness of these values for any particular application or interpretation. While testing methods are provided for reference, values shown may be derived from interpolation or adjustment to be representative of intended use. For further information, please feel free to contact Western Green.

©2023, North American Green is a registered trademark from Western Green. Certain products and/or applications described or illustrated herein are protected under one or more U.S. patents. Other U.S. patents are pending, and certain foreign patents and patent applications may also exist. Trademark rights also apply as indicated herein. Final determination of the suitability of any information or material for the use contemplated, and its manner of use, is the sole responsibility of the user. Printed in the

Index Property	Test Method	Typical	
Thickness	ASTM D6525	0.58 in.	(15 mm)
Mass/Unit Area	ASTM D6566	15.0 oz/sy	(500 g/sm)
Tensile Strength – MD	ASTM D6818	700 lbs/ft	(10.2 kN/m)
Tensile Strength – TD	ASTM D6818	675 lbs/ft	(9.9 kN/m)
Elongation - MD	ASTM D6818	30%	
Elongation – TD	ASTM D6818	20%	
UV Stability	ASTM D4355	80% @1000 hr	
Light Penetration	ASTM D6567	5%	
Biomass Improvement	ASTM D7322	400%	
Specific Gravity	ASTM D792	57.4 lb/ft ³	(0.92 g/cm ³)
Porosity	ECTC	N/A	

Design Parameters		
Property	Unvegetated	Vegetated ³
RUSLE C Factor ²	0.05	N/A
Slope Maximum Gradient ¹	0.5H:1V	0.5H:1V
Permissible Shear Stress ²	3.0 psf (145 Pa)	10.0 psf (480 Pa)
Permissible Velocity ²	9.5 fps (2.9 m/s)	15 fps (4.6 m/s)
τ_{veg} / τ_{TRM} (HEC-15)	N/A	0.67

Manning's n Roughness (HEC-15)		
τ_{lower}	τ_{mid}	τ_{upper}
0.038	0.032	0.027

1 Maximum Gradient a recommendation for typical installations.

2 Hydraulic thresholds compliant with ASTM D6459/D6460 but generalized for typical applications.

3 Vegetated values dependent on established stand of vegetation



Rev. 4.2023

Scan for additional and updated product information, or [click here](#).





APPENDIX D – WATER QUALITY & DETENTION

DETENTION BASIN STAGE-STORAGE TABLE BUILDER

MHFD-Detention, Version 4.07 (June 2025)

Project: **Antler Range Filing No. 1**

Basin ID: **Pond A**

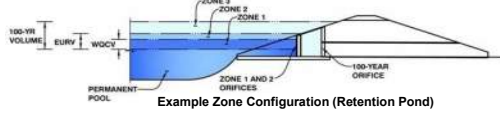

Example Zone Configuration (Retention Pond)

Watershed Information

Selected SCM Type =	EDB
Watershed Area =	5.63 acres
Watershed Length =	811 ft
Watershed Length to Centroid =	220 ft
Watershed Slope =	0.025 ft/ft
Watershed Imperviousness =	18.50% percent
Percentage Hydrologic Soil Group A =	0.0% percent
Percentage Hydrologic Soil Group B =	100.0% percent
Percentage Hydrologic Soil Groups C/D =	0.0% percent
Target WQCV Drain Time =	40.0 hours
Location for 1-hr Rainfall Depths =	User Input

After providing required inputs above including 1-hour rainfall depths, click 'Run CUHP' to generate runoff hydrographs using the embedded Colorado Urban Hydrograph Procedure.

Water Quality Capture Volume (WQCV) =	0.051	acre-feet
Excess Urban Runoff Volume (EURV) =	0.103	acre-feet
2-yr Runoff Volume (P1 = 1.19 in.) =	0.113	acre-feet
5-yr Runoff Volume (P1 = 1.5 in.) =	0.211	acre-feet
10-yr Runoff Volume (P1 = 1.75 in.) =	0.307	acre-feet
25-yr Runoff Volume (P1 = 2 in.) =	0.459	acre-feet
50-yr Runoff Volume (P1 = 2.25 in.) =	0.569	acre-feet
100-yr Runoff Volume (P1 = 2.52 in.) =	0.722	acre-feet
500-yr Runoff Volume (P1 = 3.14 in.) =	1.007	acre-feet
Approximate 2-yr Detention Volume =	0.070	acre-feet
Approximate 5-yr Detention Volume =	0.104	acre-feet
Approximate 10-yr Detention Volume =	0.173	acre-feet
Approximate 25-yr Detention Volume =	0.216	acre-feet
Approximate 50-yr Detention Volume =	0.229	acre-feet
Approximate 100-yr Detention Volume =	0.283	acre-feet

Optional User Overrides

	acre-feet
	acre-feet
1.19	inches
1.50	inches
1.75	inches
2.00	inches
2.25	inches
2.52	inches
	inches

Define Zones and Basin Geometry

Zone 1 Volume (WQCV) =	0.051	acre-feet
Zone 2 Volume (EURV - Zone 1) =	0.052	acre-feet
Zone 3 Volume (100-year - Zones 1 & 2) =	0.180	acre-feet
Total Detention Basin Volume =	0.283	acre-feet
Initial Surcharge Volume (ISV) =	user	ft ³
Initial Surcharge Depth (ISD) =	user	ft
Total Available Detention Depth (H _{total}) =	user	ft
Depth of Trickle Channel (H _{TC}) =	user	ft
Slope of Trickle Channel (S _{TC}) =	user	ft/ft
Slopes of Main Basin Sides (S _{main}) =	user	H:V
Basin Length-to-Width Ratio (R _{LW}) =	user	
Initial Surcharge Area (A _{ISV}) =	user	ft ²
Surcharge Volume Length (L _{ISV}) =	user	ft
Surcharge Volume Width (W _{ISV}) =	user	ft
Depth of Basin Floor (H _{FLOOR}) =	user	ft
Length of Basin Floor (L _{FLOOR}) =	user	ft
Width of Basin Floor (W _{FLOOR}) =	user	ft
Area of Basin Floor (A _{FLOOR}) =	user	ft ²
Volume of Basin Floor (V _{FLOOR}) =	user	ft ³
Depth of Main Basin (H _{MAIN}) =	user	ft
Length of Main Basin (L _{MAIN}) =	user	ft
Width of Main Basin (W _{MAIN}) =	user	ft
Area of Main Basin (A _{MAIN}) =	user	ft ²
Volume of Main Basin (V _{MAIN}) =	user	ft ³
Calculated Total Basin Volume (V _{total}) =	user	acre-feet

Stage - Storage Description	Stage (ft)	Optional Override Stage (ft)	Length (ft)	Width (ft)	Area (ft ²)	Optional Override Area (ft ²)	Area (acre)	Volume (ft ³)	Volume (ac-ft)
7262.9 Top of Micropool	--	0.00	--	--	--	10	0.000	1	0.000
7263	--	0.10	--	--	--	10	0.000	1	0.000
7264	--	1.10	--	--	--	120	0.003	66	0.002
7265	--	2.10	--	--	--	2,903	0.067	1,577	0.036
7266	--	3.10	--	--	--	4,276	0.098	5,167	0.119
7267	--	4.10	--	--	--	5,582	0.128	10,096	0.232
7267.5	--	4.60	--	--	--	6,261	0.144	13,057	0.300
7268	--	5.10	--	--	--	7,047	0.162	16,384	0.376
7269	--	6.10	--	--	--	8,580	0.197	24,197	0.555

DETENTION BASIN STAGE-STORAGE TABLE BUILDER

MHFD-Detention, Version 4.07 (June 2025)

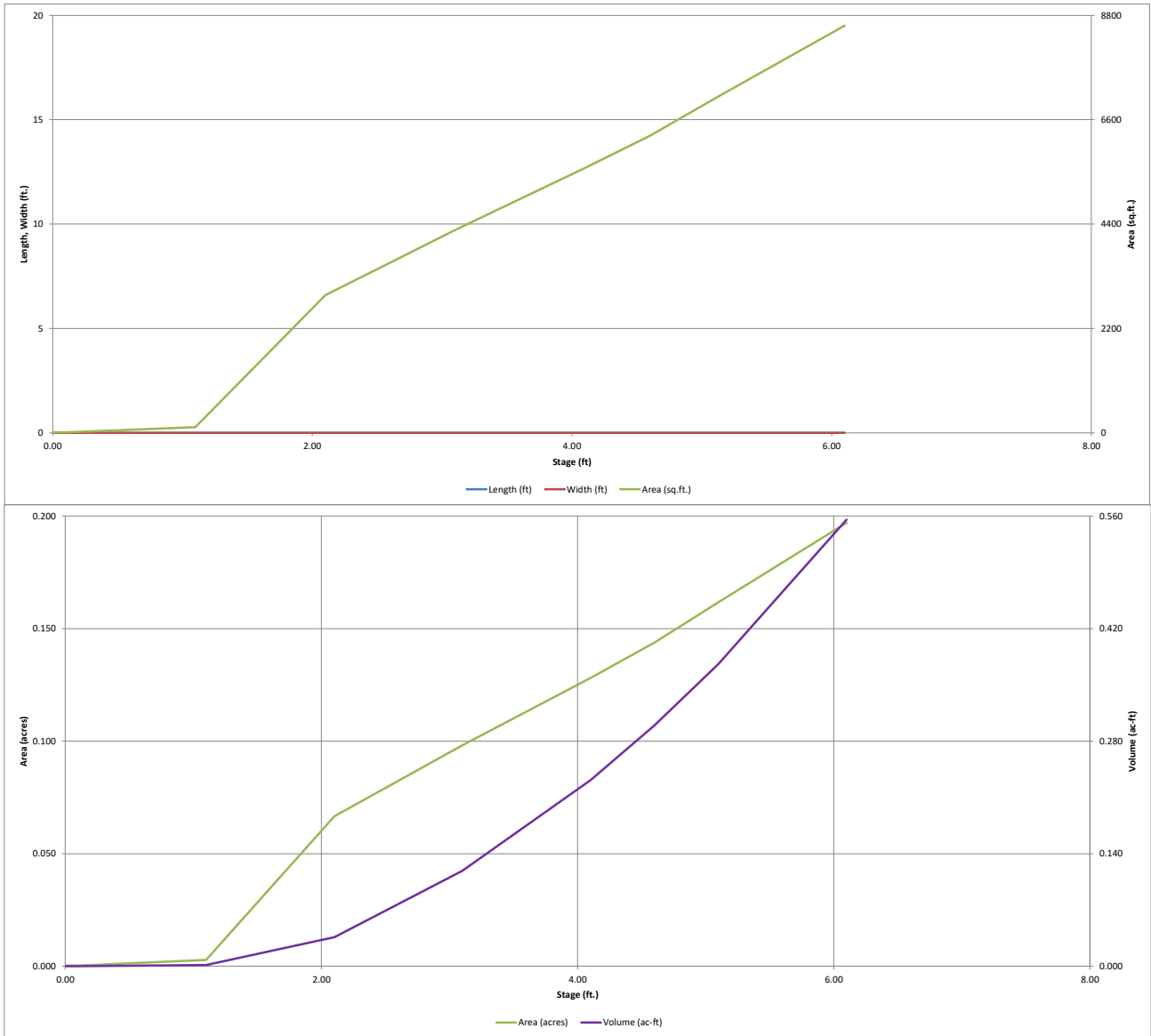

DETENTION BASIN OUTLET STRUCTURE DESIGN

MHFD-Detention, Version 4.07 (June 2025)

Project: Antler Range Filing No. 1
Basin ID: Pond A

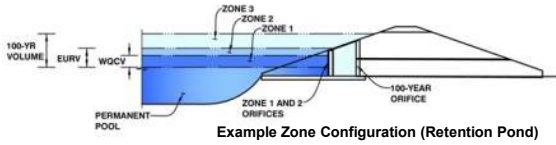

	Estimated Stage (ft)	Estimated Volume (ac-ft)	Outlet Type
Zone 1 (WQCV)	2.32	0.051	Orifice Plate
Zone 2 (EURV)	2.94	0.052	Orifice Plate
Zone 3 (100-year)	4.49	0.180	Weir&Pipe (Restrict)
Total (all zones)		0.283	

User Input: Orifice at Underdrain Outlet (typically used to drain WQCV in a Filtration SCM)

Underdrain Orifice Invert Depth = ft (distance below the filtration media surface)
Underdrain Orifice Diameter = inches

Calculated Parameters for Underdrain
Underdrain Orifice Area = ft²
Underdrain Orifice Centroid = feet

User Input: Orifice Plate with one or more orifices or Elliptical Slot Weir (typically used to drain WQCV and/or EURV in a sedimentation SCM)

Centroid of Lowest Orifice = ft (relative to basin bottom at Stage = 0 ft)
Depth at top of Zone using Orifice Plate = ft (relative to basin bottom at Stage = 0 ft)
Orifice Plate: Orifice Vertical Spacing = inches
Orifice Plate: Orifice Area per Row = sq. inches

Calculated Parameters for Plate
WQ Orifice Area per Row = ft²
Elliptical Half-Width = feet
Elliptical Slot Centroid = feet
Elliptical Slot Area = ft²

User Input: Stage and Total Area of Each Orifice Row (numbered from lowest to highest)

	Row 1 (required)	Row 2 (optional)	Row 3 (optional)	Row 4 (optional)	Row 5 (optional)	Row 6 (optional)	Row 7 (optional)	Row 8 (optional)
Stage of Orifice Centroid (ft)	0.00	0.98	2.10					
Orifice Area (sq. inches)	0.20	0.20	0.20					
	Row 9 (optional)	Row 10 (optional)	Row 11 (optional)	Row 12 (optional)	Row 13 (optional)	Row 14 (optional)	Row 15 (optional)	Row 16 (optional)
Stage of Orifice Centroid (ft)								
Orifice Area (sq. inches)								

User Input: Vertical Orifice (Circular or Rectangular)

Invert of Vertical Orifice = ft (relative to basin bottom at Stage = 0 ft)
Depth at top of Zone using Vertical Orifice = ft (relative to basin bottom at Stage = 0 ft)
Vertical Orifice Diameter = inches

Calculated Parameters for Vertical Orifice
Vertical Orifice Area = ft²
Vertical Orifice Centroid = feet

User Input: Overflow Weir (Dropbox with Flat or Sloped Grate and Outlet Pipe OR Rectangular/Trapezoidal Weir and No Outlet Pipe)

Overflow Weir Front Edge Height, Ho = ft (relative to basin bottom at Stage = 0 ft)
Overflow Weir Front Edge Length = feet
Overflow Weir Grate Slope = H:V
Horiz. Length of Weir Sides = feet
Overflow Grate Type =
Debris Clogging % = %

Calculated Parameters for Overflow Weir
Height of Grate Upper Edge, H_g = feet
Overflow Weir Slope Length = feet
Grate Open Area / 100-yr Orifice Area =
Overflow Grate Open Area w/o Debris = ft²
Overflow Grate Open Area w/ Debris = ft²

User Input: Outlet Pipe w/ Flow Restriction Plate (Circular Orifice, Restrictor Plate, or Rectangular Orifice)

Depth to Invert of Outlet Pipe = ft (distance below basin bottom at Stage = 0 ft)
Outlet Pipe Diameter = inches
Restrictor Plate Height Above Pipe Invert = inches

Calculated Parameters for Outlet Pipe w/ Flow Restriction Plate
Outlet Orifice Area = ft²
Outlet Orifice Centroid = feet
Half-Central Angle of Restrictor Plate on Pipe = radians

User Input: Emergency Spillway (Rectangular or Trapezoidal)

Spillway Invert Stage = ft (relative to basin bottom at Stage = 0 ft)
Spillway Crest Length = feet
Spillway End Slopes = H:V
Freeboard above Max Water Surface = feet

Calculated Parameters for Spillway
Spillway Design Flow Depth = feet
Stage at Top of Freeboard = feet
Basin Area at Top of Freeboard = acres
Basin Volume at Top of Freeboard = acre-ft

Routed Hydrograph Results

The user can override the default CUHP hydrographs and runoff volumes by entering new values in the Inflow Hydrographs table (Columns W through AF).

	WQCV	EURV	2 Year	5 Year	10 Year	25 Year	50 Year	100 Year	500 Year
Design Storm Return Period	N/A	N/A	1.19	1.50	1.75	2.00	2.25	2.52	3.14
One-Hour Rainfall Depth (in)	N/A	N/A	0.113	0.211	0.307	0.459	0.569	0.722	1.007
CUHP Runoff Volume (acre-ft)	0.051	0.103	0.113	0.211	0.307	0.459	0.569	0.722	1.007
Inflow Hydrograph Volume (acre-ft)	N/A	N/A	0.113	0.211	0.307	0.459	0.569	0.722	1.007
CUHP Predevelopment Peak Q (cfs)	N/A	N/A	0.9	2.2	3.3	5.6	7.0	8.7	12.1
OPTIONAL Override Predevelopment Peak Q (cfs)	N/A	N/A							
Predevelopment Unit Peak Flow, q (cfs/acre)	N/A	N/A	0.16	0.40	0.58	1.00	1.25	1.55	2.15
Peak Inflow Q (cfs)	N/A	N/A	1.7	3.1	4.2	6.5	8.0	9.7	13.2
Peak Outflow Q (cfs)	0.0	0.0	0.0	1.5	2.7	5.4	7.0	8.7	9.5
Ratio Peak Outflow to Predevelopment Q	N/A	N/A	N/A	0.7	0.8	1.0	1.0	1.0	0.8
Structure Controlling Flow	Plate	Plate	Plate	Overflow Weir 1	Overflow Weir 1	Overflow Weir 1	Overflow Weir 1	Outlet Plate 1	Outlet Plate 1
Max Velocity through Grate 1 (fps)	N/A	N/A	N/A	0.2	0.4	0.8	1.0	1.2	1.3
Max Velocity through Grate 2 (fps)	N/A	N/A	N/A	N/A	N/A	N/A	N/A	N/A	N/A
Time to Drain 97% of Inflow Volume (hours)	39	64	69	66	64	60	57	53	47
Time to Drain 99% of Inflow Volume (hours)	41	66	72	71	70	68	67	66	63
Maximum Ponding Depth (ft)	2.32	2.94	2.99	3.17	3.26	3.42	3.50	3.60	4.33
Area at Maximum Ponding Depth (acres)	0.07	0.09	0.09	0.10	0.10	0.11	0.11	0.11	0.14
Maximum Volume Stored (acre-ft)	0.052	0.103	0.108	0.126	0.135	0.150	0.159	0.170	0.262

DETENTION BASIN OUTLET STRUCTURE DESIGN

MHFD-Detention, Version 4.07 (June 2025)

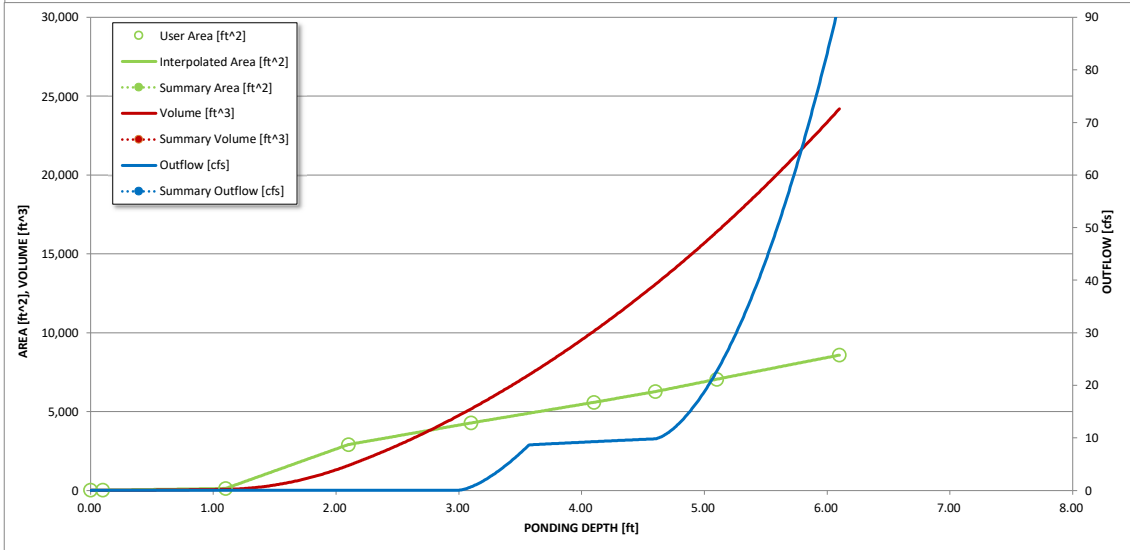
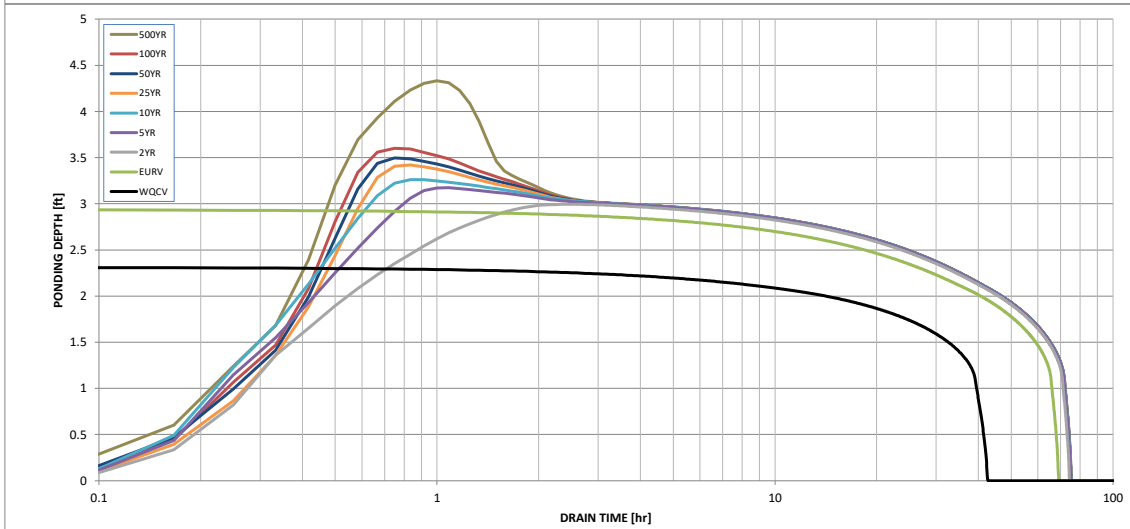
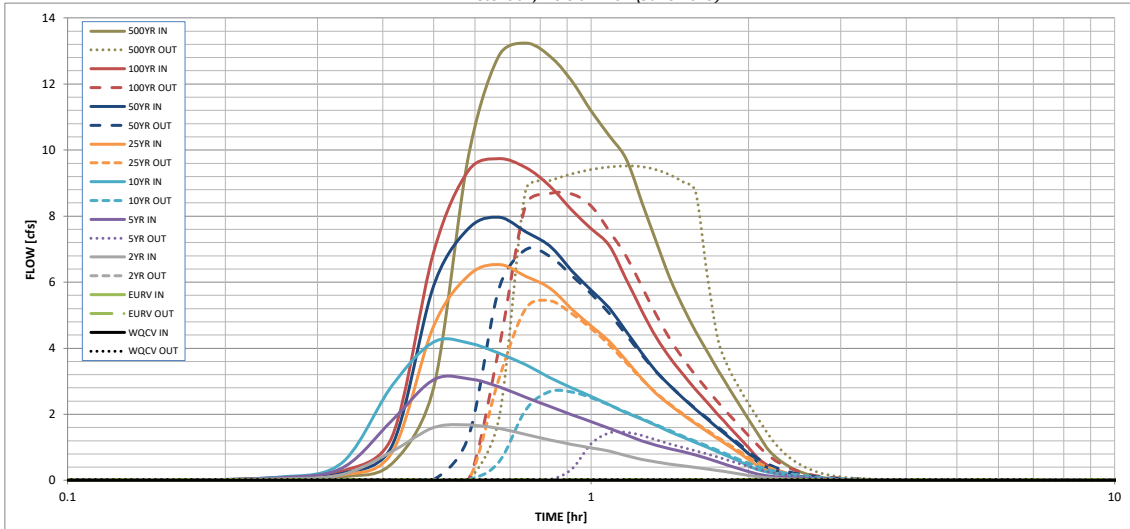

S-A-V-D Chart Axis Override	X-axis	Left Y-Axis	Right Y-Axis
minimum bound			
maximum bound			

DETENTION BASIN OUTLET STRUCTURE DESIGN

Outflow Hydrograph Workbook Filename: _____

Inflow Hydrographs

The user can override the calculated inflow hydrographs from this workbook with inflow hydrographs developed in a separate program.

Time Interval	SOURCE	CUHP	CUHP	CUHP	CUHP	CUHP	CUHP	CUHP	CUHP	CUHP
	TIME	WQCV [cfs]	EURV [cfs]	2 Year [cfs]	5 Year [cfs]	10 Year [cfs]	25 Year [cfs]	50 Year [cfs]	100 Year [cfs]	500 Year [cfs]
5.00 min	0:00:00	0	0.00	0.00	0.00	0.00	0.00	0.00	0.00	0.00
	0:05:00	0	0.00	0.00	0.00	0.00	0.00	0.00	0.00	0.00
	0:10:00	0	0.00	0.00	0.00	0.00	0.00	0.01	0.00	0.02
	0:15:00	0	0.00	0.05	0.07	0.09	0.06	0.08	0.08	0.11
	0:20:00	0	0.00	0.17	0.37	0.52	0.16	0.21	0.28	0.51
	0:25:00	0	0.00	0.87	1.82	2.88	0.85	1.05	1.32	2.81
	0:30:00	0	0.00	1.60	3.05	4.19	4.67	5.89	6.92	9.84
	0:35:00	0	0.00	1.68	3.08	4.16	6.20	7.63	9.38	12.86
	0:40:00	0	0.00	1.57	2.83	3.85	6.54	7.96	9.74	13.24
	0:45:00	0	0.00	1.39	2.51	3.50	6.18	7.52	9.47	12.85
	0:50:00	0	0.00	1.22	2.24	3.11	5.83	7.10	8.92	12.11
	0:55:00	0	0.00	1.09	1.99	2.81	5.20	6.36	8.20	11.18
	1:00:00	0	0.00	0.98	1.78	2.54	4.67	5.75	7.62	10.43
	1:05:00	0	0.00	0.88	1.57	2.29	4.21	5.21	7.11	9.74
	1:10:00	0	0.00	0.75	1.38	2.04	3.63	4.52	6.10	8.43
	1:15:00	0	0.00	0.63	1.20	1.86	3.08	3.86	5.14	7.21
	1:20:00	0	0.00	0.55	1.06	1.66	2.62	3.29	4.32	6.10
	1:25:00	0	0.00	0.49	0.95	1.47	2.28	2.86	3.70	5.23
	1:30:00	0	0.00	0.44	0.86	1.30	1.98	2.48	3.20	4.52
	1:35:00	0	0.00	0.39	0.77	1.14	1.71	2.15	2.76	3.89
	1:40:00	0	0.00	0.34	0.66	1.00	1.48	1.86	2.36	3.33
	1:45:00	0	0.00	0.30	0.56	0.86	1.25	1.58	1.98	2.80
	1:50:00	0	0.00	0.25	0.45	0.72	1.04	1.31	1.63	2.31
	1:55:00	0	0.00	0.20	0.35	0.58	0.83	1.06	1.30	1.85
	2:00:00	0	0.00	0.15	0.26	0.44	0.64	0.81	0.99	1.41
	2:05:00	0	0.00	0.11	0.19	0.33	0.43	0.55	0.67	0.98
	2:10:00	0	0.00	0.08	0.14	0.26	0.30	0.39	0.47	0.71
	2:15:00	0	0.00	0.06	0.11	0.21	0.21	0.28	0.34	0.52
	2:20:00	0	0.00	0.05	0.09	0.17	0.16	0.21	0.24	0.38
	2:25:00	0	0.00	0.04	0.07	0.13	0.11	0.16	0.17	0.27
	2:30:00	0	0.00	0.03	0.06	0.10	0.09	0.12	0.12	0.19
	2:35:00	0	0.00	0.02	0.04	0.08	0.06	0.09	0.08	0.13
	2:40:00	0	0.00	0.02	0.03	0.06	0.05	0.06	0.05	0.09
	2:45:00	0	0.00	0.02	0.03	0.04	0.03	0.05	0.04	0.07
	2:50:00	0	0.00	0.01	0.02	0.03	0.03	0.04	0.03	0.05
	2:55:00	0	0.00	0.01	0.01	0.03	0.02	0.03	0.02	0.04
	3:00:00	0	0.00	0.01	0.01	0.02	0.02	0.02	0.02	0.03
	3:05:00	0	0.00	0.01	0.01	0.01	0.01	0.02	0.01	0.02
	3:10:00	0	0.00	0.00	0.00	0.01	0.01	0.01	0.01	0.02
	3:15:00	0	0.00	0.00	0.00	0.01	0.01	0.01	0.01	0.01
	3:20:00	0	0.00	0.00	0.00	0.00	0.00	0.00	0.00	0.01
	3:25:00	0	0.00	0.00	0.00	0.00	0.00	0.00	0.00	0.00
	3:30:00	0	0.00	0.00	0.00	0.00	0.00	0.00	0.00	0.00
	3:35:00	0	0.00	0.00	0.00	0.00	0.00	0.00	0.00	0.00
	3:40:00	0	0.00	0.00	0.00	0.00	0.00	0.00	0.00	0.00
	3:45:00	0	0.00	0.00	0.00	0.00	0.00	0.00	0.00	0.00
	3:50:00	0	0.00	0.00	0.00	0.00	0.00	0.00	0.00	0.00
	3:55:00	0	0.00	0.00	0.00	0.00	0.00	0.00	0.00	0.00
	4:00:00	0	0.00	0.00	0.00	0.00	0.00	0.00	0.00	0.00
	4:05:00	0	0.00	0.00	0.00	0.00	0.00	0.00	0.00	0.00
	4:10:00	0	0.00	0.00	0.00	0.00	0.00	0.00	0.00	0.00
	4:15:00	0	0.00	0.00	0.00	0.00	0.00	0.00	0.00	0.00
	4:20:00	0	0.00	0.00	0.00	0.00	0.00	0.00	0.00	0.00
	4:25:00	0	0.00	0.00	0.00	0.00	0.00	0.00	0.00	0.00
	4:30:00	0	0.00	0.00	0.00	0.00	0.00	0.00	0.00	0.00
	4:35:00	0	0.00	0.00	0.00	0.00	0.00	0.00	0.00	0.00
	4:40:00	0	0.00	0.00	0.00	0.00	0.00	0.00	0.00	0.00
	4:45:00	0	0.00	0.00	0.00	0.00	0.00	0.00	0.00	0.00
	4:50:00	0	0.00	0.00	0.00	0.00	0.00	0.00	0.00	0.00
	4:55:00	0	0.00	0.00	0.00	0.00	0.00	0.00	0.00	0.00
	5:00:00	0	0.00	0.00	0.00	0.00	0.00	0.00	0.00	0.00
	5:05:00	0	0.00	0.00	0.00	0.00	0.00	0.00	0.00	0.00
	5:10:00	0	0.00	0.00	0.00	0.00	0.00	0.00	0.00	0.00
	5:15:00	0	0.00	0.00	0.00	0.00	0.00	0.00	0.00	0.00
	5:20:00	0	0.00	0.00	0.00	0.00	0.00	0.00	0.00	0.00
	5:25:00	0	0.00	0.00	0.00	0.00	0.00	0.00	0.00	0.00
	5:30:00	0	0.00	0.00	0.00	0.00	0.00	0.00	0.00	0.00
	5:35:00	0	0.00	0.00	0.00	0.00	0.00	0.00	0.00	0.00
	5:40:00	0	0.00	0.00	0.00	0.00	0.00	0.00	0.00	0.00
	5:45:00	0	0.00	0.00	0.00	0.00	0.00	0.00	0.00	0.00
	5:50:00	0	0.00	0.00	0.00	0.00	0.00	0.00	0.00	0.00
	5:55:00	0	0.00	0.00	0.00	0.00	0.00	0.00	0.00	0.00
	6:00:00	0	0.00	0.00	0.00	0.00	0.00	0.00	0.00	0.00

Pond A - Forebay Sizing

$$w = 9.23 (A_{FB} / t) (1 / \sqrt{h_{max}})$$

Equation 4-1

Where:

w = width of the rectangular vertical notch (inches)

A_{FB} = surface area of the forebay (square feet)

t = emptying time of the brim-full forebay (seconds)

h_{max} = maximum depth of the forebay (feet)

TABLE 4-12. FOREBAY SIZING CRITERIA

FOREBAY SIZING CRITERIA	WATERSHED IMPERVIOUS AREA (IA)				
	IA UP TO 2 ACRES	IA 2 UP TO 5 ACRES	IA 5 UP TO 10 ACRES	IA 10 UP TO 20 ACRES	IA GREATER THAN 20 ACRES
Forebay Release Rate and Configuration	Concrete sediment pad with dense grasses surrounding, concrete pad with slotted metal edge, or similar design	Size to drain in 4 to 5 minutes using Equation 4-1			
Minimum Forebay Volume ¹		1% of WQCV			
Forebay Depth ¹		12 to 15 inches	15 to 18 inches	18 to 24 inches	24 to 30 inches

¹ Appropriate volume and depth should consider maintenance and access needs. The values provided are approximate and provide a starting point for design.

IA = 18.5% * 5.63 acres = 1.04 IA's
 Design Depth = 12"

Minimum Volume = 1% of WQCV = 1% *
 0.051 ac-ft * 43,560 = 22.2 CF

Provided Volume ~ 88 CF

$A_{fb} = 102$ sf

$t = 300$ s

$h_{max} = 1$ ft

$w = 9.23 * (102/300) * (1/\sqrt{1}) = 3.14$ "

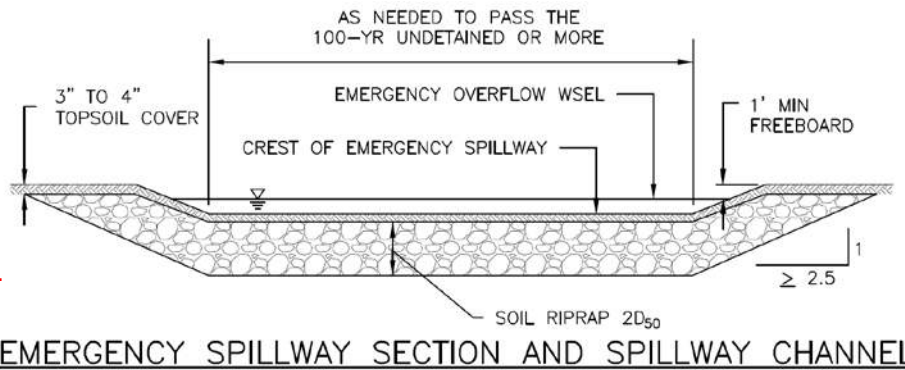
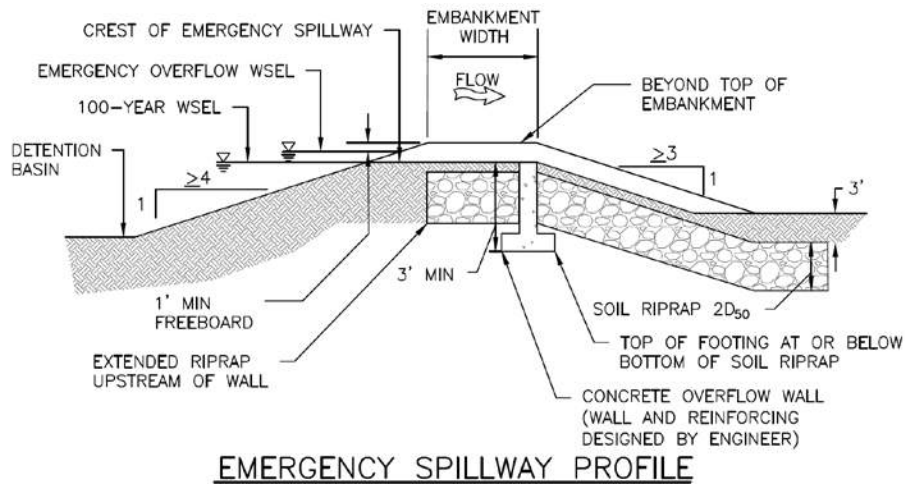

USE TYPE L

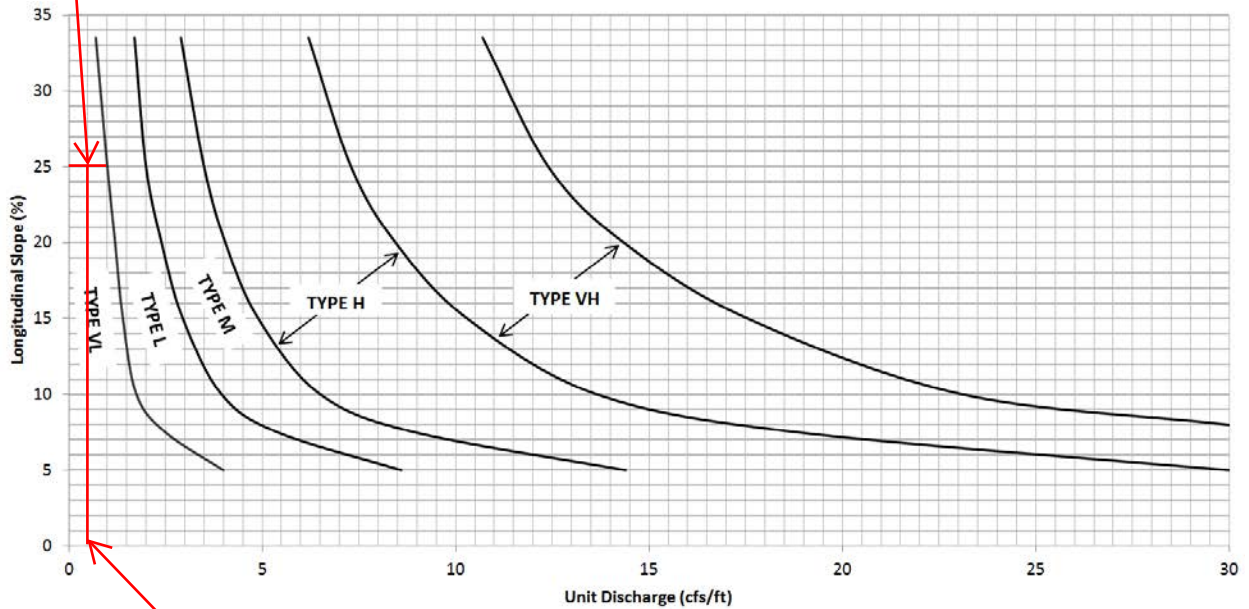

Figure 12-21. Embankment protection details and rock sizing chart (adapted from Arapahoe County)

10 CFS/10' = 1 CFS/FT

Channel Report

POND A SPILLWAY SWALE - 100-YR (EMERGENCY CONDITION)

Triangular

Side Slopes (z:1) = 5.00, 5.00
Total Depth (ft) = 1.00

Invert Elev (ft) = 1.00
Slope (%) = 1.45
N-Value = 0.035

Calculations

Compute by: Known Q
Known Q (cfs) = 9.70

Highlighted

Depth (ft) = 0.84
Q (cfs) = 9.700
Area (sqft) = 3.53
Velocity (ft/s) = 2.75
Wetted Perim (ft) = 8.57
Crit Depth, Yc (ft) = 0.75
Top Width (ft) = 8.40
EGL (ft) = 0.96

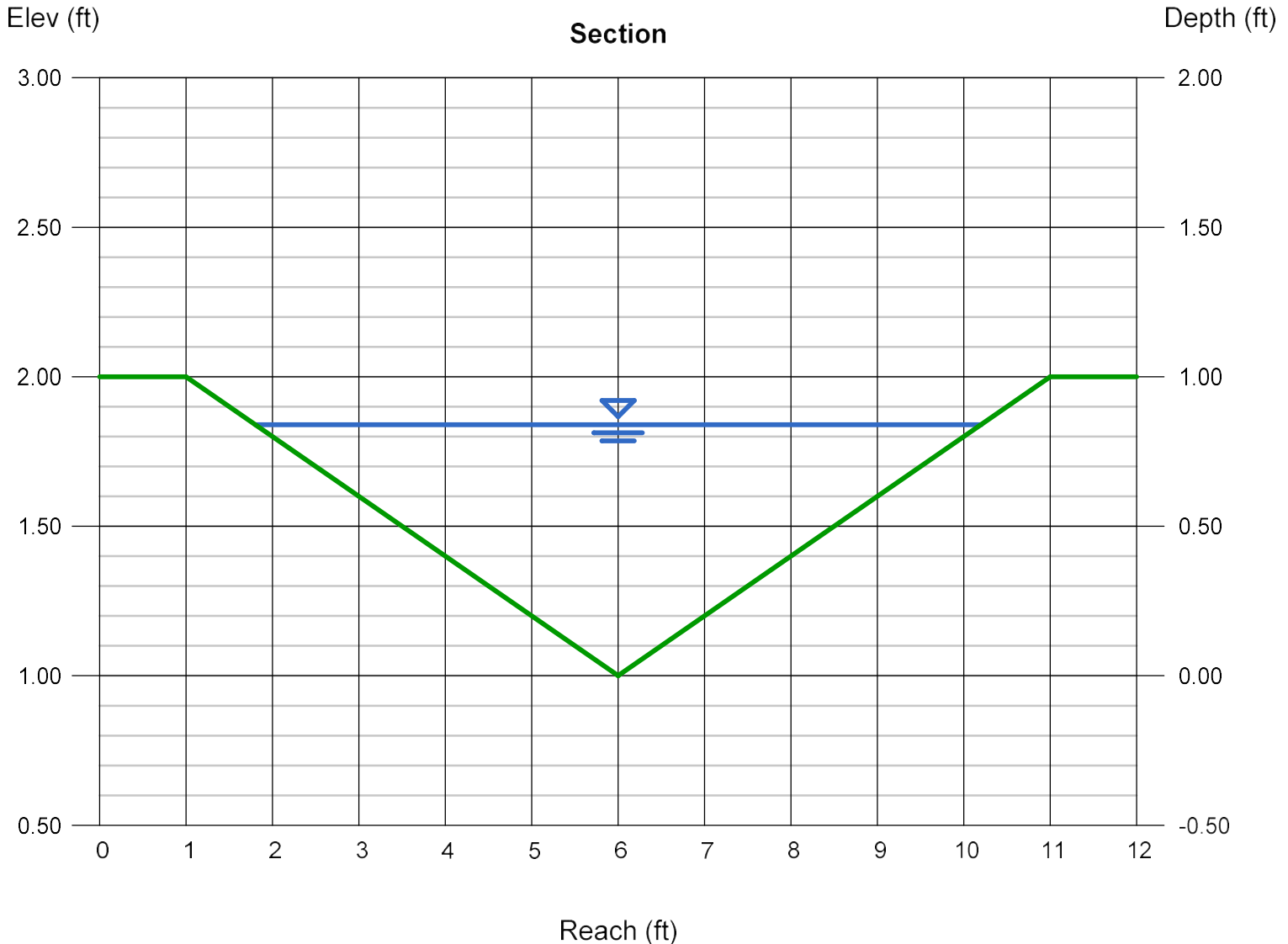



APPENDIX E – REFERENCE MATERIAL

APPROXIMATE SITE

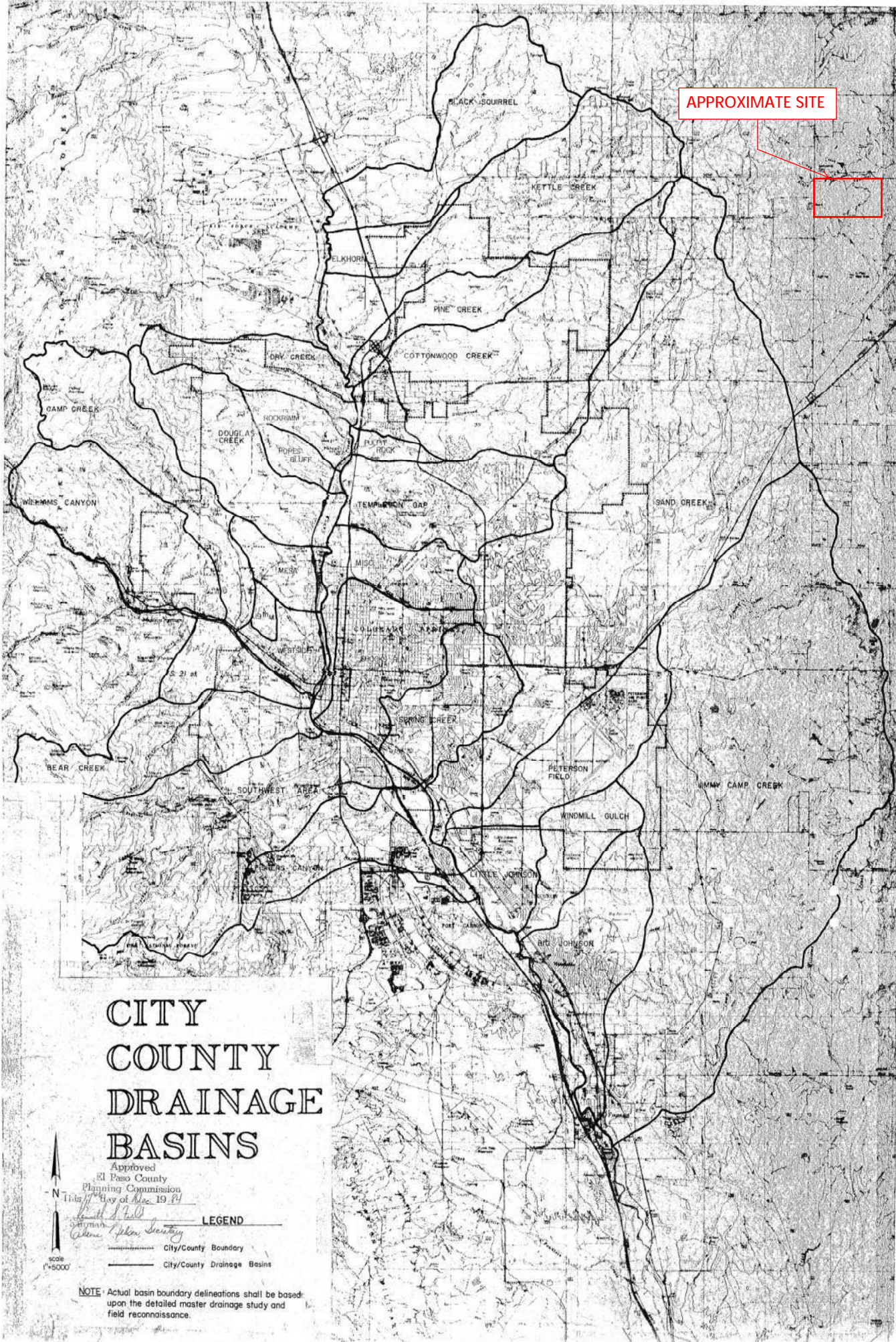

CITY COUNTY DRAINAGE BASINS

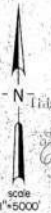

Approved
El Paso County
Planning Commission
This 11th Day of Nov. 19 84

Paul J. Hill
City Engineer

- LEGEND**
- City/County Boundary
 - City/County Drainage Basins

NOTE: Actual basin boundary delineations shall be based upon the detailed master drainage study and field reconnaissance.

APPENDIX E
DETENTION POND CALCULATIONS

ANTLERS RIDGE ESTATES - DEVELOPED CONDITION
 PRELIMINARY/FINAL DRAINAGE REPORT
 (Detention Pond / Sediment Basin Summary)



	Pond:		BR-4	GR-2 N	GR-4 W	GR-4 N
	UBS-2 E	UBS-2 W				
Tributary Area (Ac.)		59.15	25.13	36.72		41.09
Provided Detention Pond Volume (cu. ft.)		69,412	45,297	62,199		87,006
Provided Detention Pond Volume (Ac-ft.)		1.59	1.04	1.43		2.00
Emergency Spillway Elev.		7,264.00	7,235.50	7,216.00		7,209.50
Required Detention Pond Volume (cu. ft.)		58,589	40,727	53,598		80,876
Required Detention Pond Volume (Ac-ft.)		1.34	0.93	1.23		1.86
Calculated 10-yr Water Surface Elev.		7,262.13	7,234.03	7,214.25		7,206.93
Calculated 100-yr Water Surface Elev.		7,263.55	7,235.13	7,215.59		7,209.19
100-yr W.S. Area (sq. ft.)		26,669	17,312	21,240		19,349
Detention Pond W.S. Footprint (Ac-ft.)		0.61	0.40	0.49		0.44
Calculated WQCV (Ac-ft.)		0.43	0.18	0.27		0.30
Calculated Pre-Sedimentation Volume (Ac-ft.)		0.09	0.04	0.05		0.06
Provided Pre-Sedimentation Volume (Ac-ft.)	0.04	0.06	0.10	0.10	0.07	0.02
Provided Pre-Sedimentation Volume (cu-ft.)	1,577	2,613	4,445	4,369	2,954	998
Pre-Sedimentation Depth (ft.)	2.50	2.50	2.00	2.50	1.50	1.50
Berm Length (ft.)	180	100	90	90	50	28
Berm Width (ft.)	0 to 1	0 to 1	4	4	4	4
One-hour Drain Rate (cts)	0.44	0.73	1.23	1.21	0.82	0.28
Outlet Pipe Size (in.)	8	8	8	8	8	8
Outlet Pipe Invert In (Elev.)	7,262.5	7,262.5	7,231.5	7,212.0	7,215.1	7,212.1
Outlet Pipe Invert Out (Elev.)	7,262.0	7,262.0	7,231.0	7,211.8	7,215.0	7,212.0
Outlet Pipe Slope (%)	2.50	2.50	1.25	0.67	0.63	0.83
Outlet Pipe Length (ft.)	20	20	40	30	16	12
Number of Rows in Riser (4" Vert. Spacing)	6	6	5	6	3	3
Number of Holes Per Row	4	4	7	7	5	3
Hole Size (in.)	1	1 1/4	1 1/4	1 1/4	1 3/8	1
Number of Riser Pipes	1	1	1	1	1	1
Riser Pipe Size (in.)	8	8	12	12	8	8

Date: _____
 Checked by: _____

Date: 3/30/2006
 Checked by: _____

UBS-10

CO-EIPaso 10-Year Duration=41 min, Inten=2.25 in/hr

Prepared by {enter your company name here}

Page 2

HydroCAD® 7.00 s/n 002861 © 1986-2003 Applied Microcomputer Systems

3/30/2006

Time span=0.00-3.00 hrs, dt=0.01 hrs, 301 points

Runoff by Rational method, Rise/Fall=1.0/2.0 xTc

Reach routing by Stor-Ind method - Pond routing by Stor-Ind method

Subcatchment 6S: UBS

Runoff Area=59.150 ac Runoff Depth=0.71"

Tc=41.2 min C=0.31 Runoff=41.31 cfs 3.510 af

Pond 5p: UBS-2 Pond

Peak Elev=7,262.13' Storage=23,869 cf Inflow=41.31 cfs 3.510 af

Primary=32.91 cfs 3.510 af Secondary=0.00 cfs 0.000 af Outflow=32.91 cfs 3.510 af

Total Runoff Area = 59.150 ac Runoff Volume = 3.510 af Average Runoff Depth = 0.71"

UBS-10

CO-EIPaso 10-Year Duration=41 min, Inten=2.25 in/hr

Prepared by {enter your company name here}

Page 3

HydroCAD® 7.00 s/n 002861 © 1986-2003 Applied Microcomputer Systems

3/30/2006

Subcatchment 6S: UBS

Runoff = 41.31 cfs @ 0.68 hrs, Volume= 3.510 af, Depth= 0.71"

Runoff by Rational method, Rise/Fall=1.0/2.0 xTc, Time Span= 0.00-3.00 hrs, dt= 0.01 hrs
 CO-EIPaso 10-Year Duration=41 min, Inten=2.25 in/hr

Area (ac)	C	Description
13.070	0.31	PR-1 with C10 value
39.590	0.31	PR-2 with C10 value
1.950	0.30	PR-3 with C10 value
1.390	0.30	PR-5 with C10 value
1.050	0.30	PR-6 with C10 value
2.100	0.30	PR-7 with C10 value
59.150	0.31	Weighted Average

Tc (min)	Length (feet)	Slope (ft/ft)	Velocity (ft/sec)	Capacity (cfs)	Description
41.2					Direct Entry, UBS

Subcatchment 6S: UBS

Hydrograph

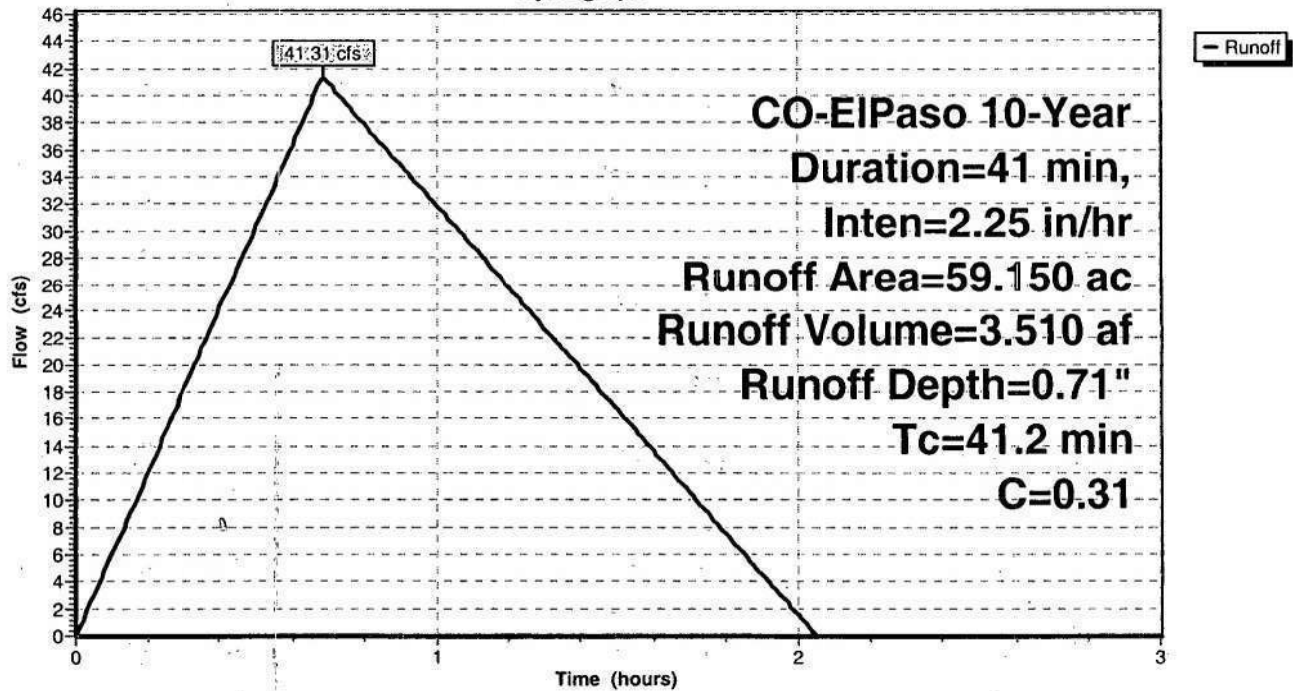

Pond 5p: UBS-2 Pond

Inflow Area = 59.150 ac, Inflow Depth = 0.71" for 10-Year event
 Inflow = 41.31 cfs @ 0.68 hrs, Volume= 3.510 af
Outflow = 32.91 cfs @ 0.96 hrs, Volume= 3.510 af, Atten= 20%, Lag= 16.8 min
 Primary = 32.91 cfs @ 0.96 hrs, Volume= 3.510 af
 Secondary = 0.00 cfs @ 0.00 hrs, Volume= 0.000 af

Routing by Stor-Ind method, Time Span= 0.00-3.00 hrs, dt= 0.01 hrs
 Peak Elev= 7,262.13' @ 0.96 hrs Surf.Area= 20,796 sf Storage= 23,869 cf
 Plug-Flow detention time= 10.1 min calculated for 3.510 af (100% of inflow)
 Center-of-Mass det. time= 10.1 min (64.7 - 54.7)

#	Invert	Avail.Storage	Storage Description
1	7,259.00'	102,261 cf	Custom Stage Data (Prismatic) Listed below

Elevation (feet)	Surf.Area (sq-ft)	Inc.Store (cubic-feet)	Cum.Store (cubic-feet)
7,259.00	40	0	0
7,260.00	3,000	1,520	1,520
7,261.00	7,482	5,241	6,761
7,262.00	20,244	13,863	20,624
7,264.00	28,544	48,788	69,412
7,265.00	37,153	32,849	102,261

#	Routing	Invert	Outlet Devices
1	Primary	7,258.05'	42.0" x 88.0' long Culvert RCP, square edge headwall, Ke= 0.500 Outlet Invert= 7,257.52' S= 0.0060 ' n= 0.013 Cc= 0.900
2	Device 1	7,258.05'	1.00' x 1.00' Vert. Orifice/Grate X 0.27 C= 0.600
3	Device 1	7,259.30'	2.00' x 2.75' Vert. Orifice/Grate C= 0.600
4	Device 1	7,262.30'	5.0' long x 4.5' high Sharp-Crested Rectangular Weir 2 End Contraction(s)
5	Secondary	7,264.00'	200.0' long x 4.0' breadth Broad-Crested Rectangular Weir Head (feet) 0.20 0.40 0.60 0.80 1.00 1.20 1.40 1.60 1.80 2.00 2.50 3.00 3.50 4.00 4.50 5.00 5.50 Coef. (English) 2.38 2.54 2.69 2.68 2.67 2.67 2.65 2.66 2.66 2.68 2.72 2.73 2.76 2.79 2.88 3.07 3.32

Primary OutFlow Max=32.92 cfs @ 0.96 hrs HW=7,262.13' (Free Discharge)

- 1=Culvert (Passes 32.92 cfs of 64.62 cfs potential flow)
- 2=Orifice/Grate (Orifice Controls 2.46 cfs @ 2.5 fps)
- 3=Orifice/Grate (Orifice Controls 30.46 cfs @ 5.5 fps)
- 4=Sharp-Crested Rectangular Weir (Controls 0.00 cfs)

Secondary OutFlow Max=0.00 cfs @ 0.00 hrs HW=7,259.00' (Free Discharge)

- 5=Broad-Crested Rectangular Weir (Controls 0.00 cfs)

UBS-100

CO-EIPaso 100-Year Duration=41 min, Inten=3.43 in/hr

Prepared by {enter your company name here}

Page 3

HydroCAD® 7.00 s/n 002861 © 1986-2003 Applied Microcomputer Systems

3/30/2006

Subcatchment 6S: UBS

Runoff = 85.22 cfs @ 0.68 hrs, Volume= 7.241 af, Depth= 1.47"

Runoff by Rational method, Rise/Fall=1.0/2.0 xTc, Time Span= 0.00-3.00 hrs, dt= 0.01 hrs
 CO-EIPaso 100-Year Duration=41 min, Inten=3.43 in/hr

Area (ac)	C	Description
13.070	0.42	PR-1 with C10 value
39.590	0.42	PR-2 with C10 value
1.950	0.42	PR-3 with C10 value
1.390	0.42	PR-5 with C10 value
1.050	0.42	PR-6 with C10 value
2.100	0.42	PR-7 with C10 value
59.150	0.42	Weighted Average

Tc (min)	Length (feet)	Slope (ft/ft)	Velocity (ft/sec)	Capacity (cfs)	Description
41.2					Direct Entry, UBS

Subcatchment 6S: UBS

Hydrograph

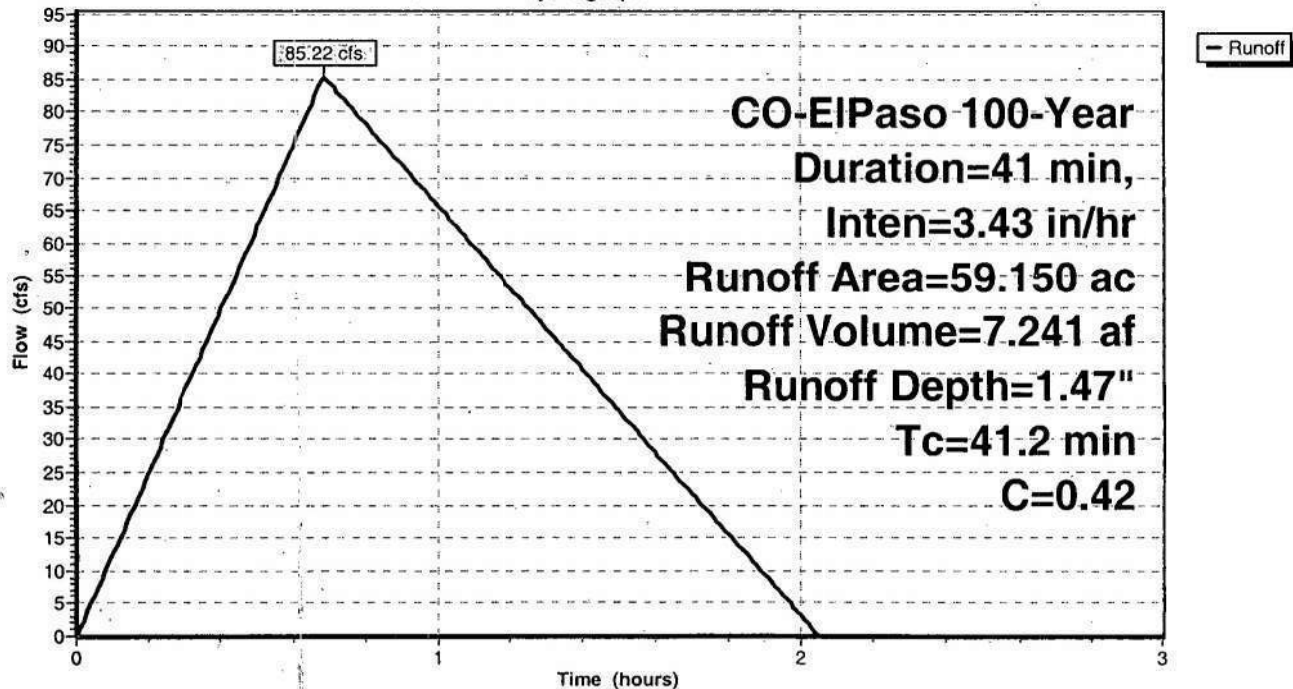

Pond 5p: UBS-2 Pond

Inflow Area = 59.150 ac, Inflow Depth = 1.47" for 100-Year event
 Inflow = 85.22 cfs @ 0.68 hrs, Volume= 7.241 af
Outflow = 69.74 cfs @ 0.93 hrs, Volume= 7.241 af, Atten= 18%, Lag= 15.0 min
 Primary = 69.74 cfs @ 0.93 hrs, Volume= 7.241 af
 Secondary = 0.00 cfs @ 0.00 hrs, Volume= 0.000 af

Routing by Stor-Ind method, Time Span= 0.00-3.00 hrs, dt= 0.01 hrs
 Peak Elev= 7,263.55' @ 0.93 hrs Surf.Area= 26,669 sf Storage= 58,389 cf
 Plug-Flow detention time= 13.3 min calculated for 7.241 af (100% of inflow)
 Center-of-Mass det. time= 13.2 min (67.9 - 54.7)

#	Invert	Avail.Storage	Storage Description
1	7,259.00'	102,261 cf	Custom Stage Data (Prismatic) Listed below

Elevation (feet)	Surf.Area (sq-ft)	Inc.Store (cubic-feet)	Cum.Store (cubic-feet)
7,259.00	40	0	0
7,260.00	3,000	1,520	1,520
7,261.00	7,482	5,241	6,761
7,262.00	20,244	13,863	20,624
7,264.00	28,544	48,788	69,412
7,265.00	37,153	32,849	102,261

#	Routing	Invert	Outlet Devices
1	Primary	7,258.05'	42.0" x 88.0' long Culvert RCP, square edge headwall, Ke= 0.500 Outlet Invert= 7,257.52' S= 0.0060 '/ n= 0.013 Cc= 0.900
2	Device 1	7,258.05'	1.00' x 1.00' Vert. Orifice/Grate X 0.27 C= 0.600
3	Device 1	7,259.30'	2.00' x 2.75' Vert. Orifice/Grate C= 0.600
4	Device 1	7,262.30'	5.0' long x 4.5' high Sharp-Crested Rectangular Weir 2 End Contraction(s)
5	Secondary	7,264.00'	200.0' long x 4.0' breadth Broad-Crested Rectangular Weir Head (feet) 0.20 0.40 0.60 0.80 1.00 1.20 1.40 1.60 1.80 2.00 2.50 3.00 3.50 4.00 4.50 5.00 5.50 Coef. (English) 2.38 2.54 2.69 2.68 2.67 2.67 2.65 2.66 2.66 2.68 2.72 2.73 2.76 2.79 2.88 3.07 3.32

Primary OutFlow Max=69.74 cfs @ 0.93 hrs HW=7,263.55' (Free Discharge)

- 1=Culvert (Passes 69.74 cfs of 86.37 cfs potential flow)
- 2=Orifice/Grate (Orifice Controls 2.91 cfs @ 2.9 fps)
- 3=Orifice/Grate (Orifice Controls 44.44 cfs @ 8.1 fps)
- 4=Sharp-Crested Rectangular Weir (Weir Controls 22.39 cfs @ 3.8 fps)

Secondary OutFlow Max=0.00 cfs @ 0.00 hrs HW=7,259.00' (Free Discharge)

- 5=Broad-Crested Rectangular Weir (Controls 0.00 cfs)

Pond 5p: UBS-2 Pond

Hydrograph

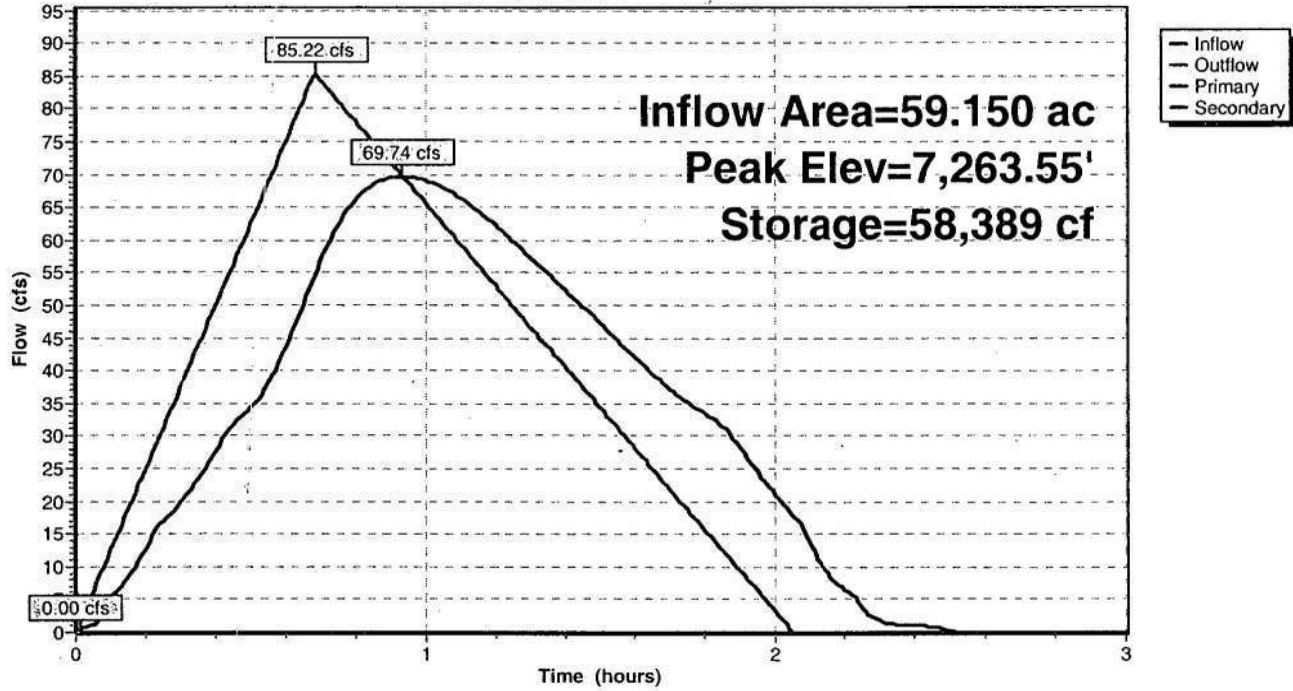

Headwater Depth For Circular Culvert

Project: Antlers Ridge

Pipe ID: UBS-2

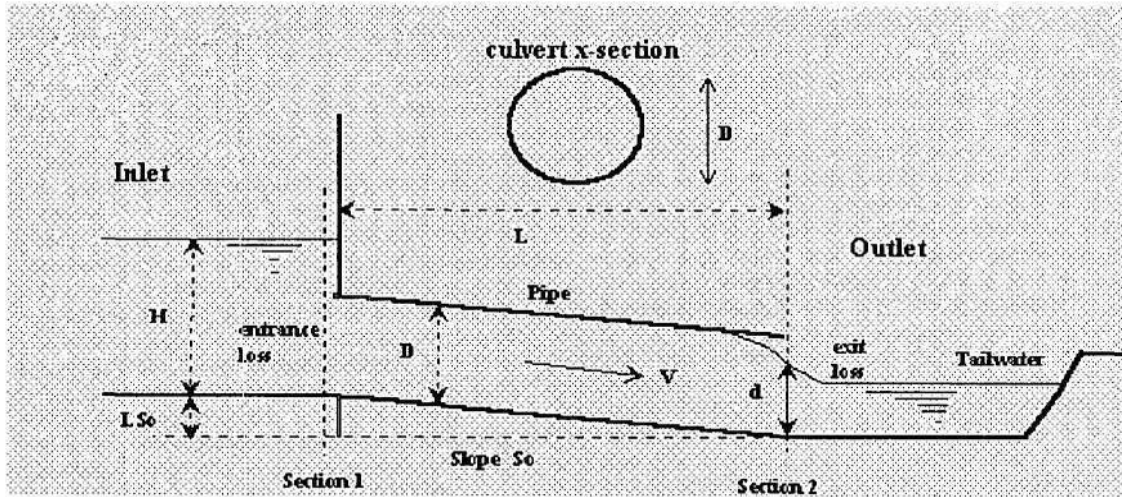

Design Information (input)

Design Discharge	$Q =$	69.2 cfs
Pipe Diameter	$D =$	42.00 inches
Inlet Edge Type (choose from pull-down list)	Inlet Type =	Square End with Headwall
Inlet Invert Elevation	$I_e =$	58.05 ft
Outlet Invert Elevation	$O_e =$	57.52 ft
Pipe Length	$L =$	88.0 ft
Manning's Roughness n-value	$n =$	0.013
Bend Loss Coefficient	$K_b =$	0.00
Exit Loss Coefficient	$K_x =$	0.50
Tailwater Water Surface Elevation	El. $Y_t =$	59.02 ft

Calculations (output)

Pipe Cross Sectional Area	$A_o =$	9.62 sq ft
Culvert Slope	$S_o =$	0.0060 ft/ft
Normal Flow Depth	$Y_n =$	2.56 ft
Critical Flow Depth	$Y_c =$	2.61 ft

Headwater Depth by Inlet Control

Headwater Depth by Inlet Control HW-inlet= 4.40 ft

Headwater Depth by Outlet Control

Tailwater Depth for Design $d =$ 3.05 ft

Friction Loss Coefficient over Culvert Length $K_f =$ 0.52

Sum of All Loss Coefficients $K_s =$ 1.52

Headwater Depth by Outlet Control HW-outlet= 4.54 ft

Design Headwater Depth HW= 4.54 ft

HW/D Ratio = HW/D= 1.30

ANTLERS RIDGE

COUNTY OF EL PASO, STATE OF COLORADO

FINAL DRAINAGE PLAN

DEVELOPED CONDITIONS

MARCH, 2006

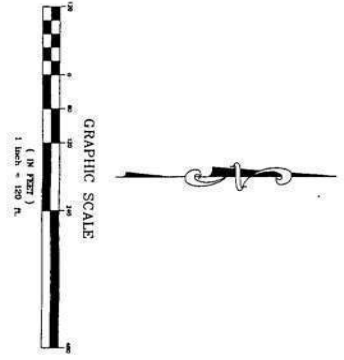
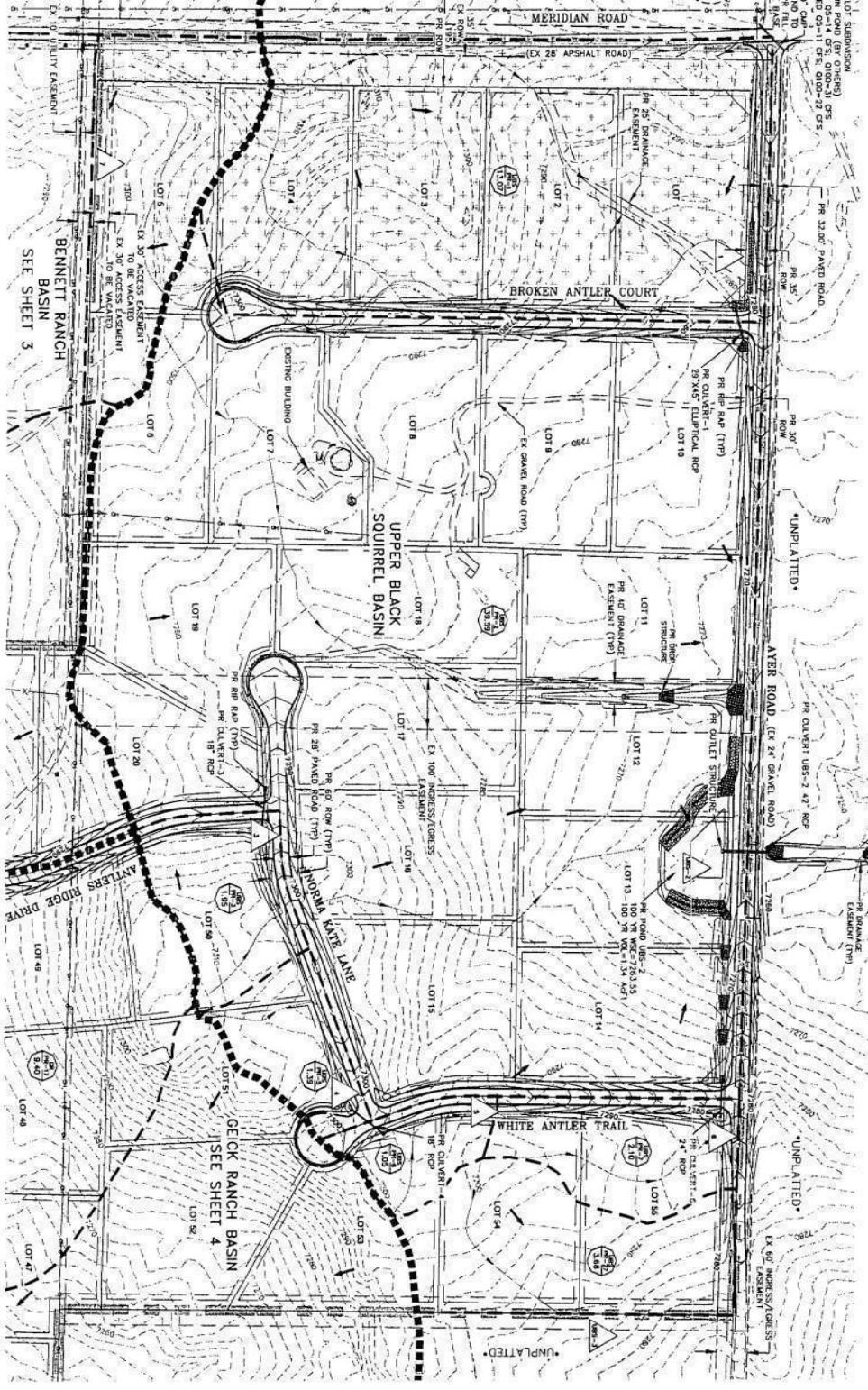

AREA DRAINAGE SUMMARY

AREA	AREA (SQ. FT.)	PERCENT
UPPER BLACK SQUIRREL BASIN	1,507,116	100.0
GECK RANCH BASIN	1,507,116	100.0
TOTAL	3,014,232	200.0

DESIGN POINT 1 SUMMARY

DESIGN AREA	DESIGN POINT 1	DESIGN POINT 2
UPPER BLACK SQUIRREL BASIN	0.0	0.0
GECK RANCH BASIN	0.0	0.0
TOTAL	0.0	0.0

LEGEND

- PROJECT BOUNDARY
- MAJOR BASIN BOUNDARY
- SMALL BASIN BOUNDARY
- DIRECTION OF FLOW
- CONTOUR - MAJOR (20 FT.)
- CONTOUR - MINOR (10 FT.)
- CONTOUR - MINOR (5 FT.)
- SUBDIVISION BOUNDARY
- LOT LINES
- OVERLAND FLOW PATH
- CHANNEL FLOW PATH
- EX OVERHEAD POWER LINE
- EX ELECTRICAL POST
- EX TELEPHONE RISER
- EX FENCE
- EX ELECTRICAL BOX
- EX OUTLINE
- EX DRYPILE
- EX DITCH SILET
- EX BOLLARD
- EX SHADY MANHOLE
- EX WELL
- EX ELECTRIC METER
- EX TRANSFORMER
- EX MAN-FILED DRAINAGE DUMP
- EX EROSION CONTROL TERRACE

NO.	REVISION	DATE	BY	CHKD.

MERRICK
Engineering & Architecture
1310 West 9th Street, Suite 200
Fort Collins, CO 80521
Phone: (970) 226-4444
Fax: (970) 226-4445
www.merrick-engineering.com

DATE	DESCRIPTION
2/11/05	
2/11/05	

ANTLERS RIDGE

CLIENT PROJECT NO. _____

MERRICK PROJECT NO. 18014777

SCALE: 1" = 120'

ANTLERS RIDGE
FINAL DRAINAGE I
DEVELOPED CONDITION
UPPER BLACK SQUIR
47770-DPR01



**FINAL DRAINAGE REPORT
FOR
CAMELOT SUBDIVISION**

OCTOBER 26, 2001

PREPARED FOR:

**TRANSWESTERN DEVELOPMENT COMPANY
3730 SINTON ROAD, #250
COLORADO SPRINGS, CO 80907**

ATTN: MR. JERRY SMITH

PREPARED BY:

**CLASSIC CONSULTING ENGINEERS & SURVEYORS, LLC
6385 CORPORATE DRIVE, SUITE 304
COLORADO SPRINGS, CO 80919
(719) 785-0790**

2037.00



FINAL DRAINAGE REPORT FOR CAMELOT SUBDIVISION

DRAINAGE REPORT STATEMENT

ENGINEER'S STATEMENT:

The attached drainage plan and report were prepared under my direction and supervision and are correct to the best of my knowledge and belief. Said drainage report has been prepared according to the criteria established by the County for drainage reports and said report is in conformity with the master plan of the drainage basin. I accept responsibility for any liability caused by any negligent acts, errors, or omissions on my part in preparing this report.

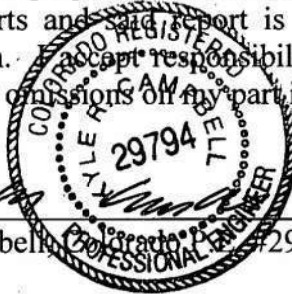

Kyle R. Campbell
Professional Engineer #29794

1-16-02
Date

DEVELOPER'S STATEMENT:

I, the developer, have read and will comply with all of the requirements specified in this drainage report and plan.

Business Name: Transwestern Development Corp.
By: [Signature]
Title: President
Address: P.O. Box 63419
Colo. Spgs CO 80962

EL PASO COUNTY:

Filed in accordance with Section 51.1 of the El Paso Land Development Code, as amended.

[Signature]
El Paso County Engineer/Director

3-7-02
Date

Conditions:

CAMELOT SUBDIVISION

COUNTY OF EL PASO, STATE OF COLORADO

FINAL DRAINAGE MAP

OCTOBER 2001

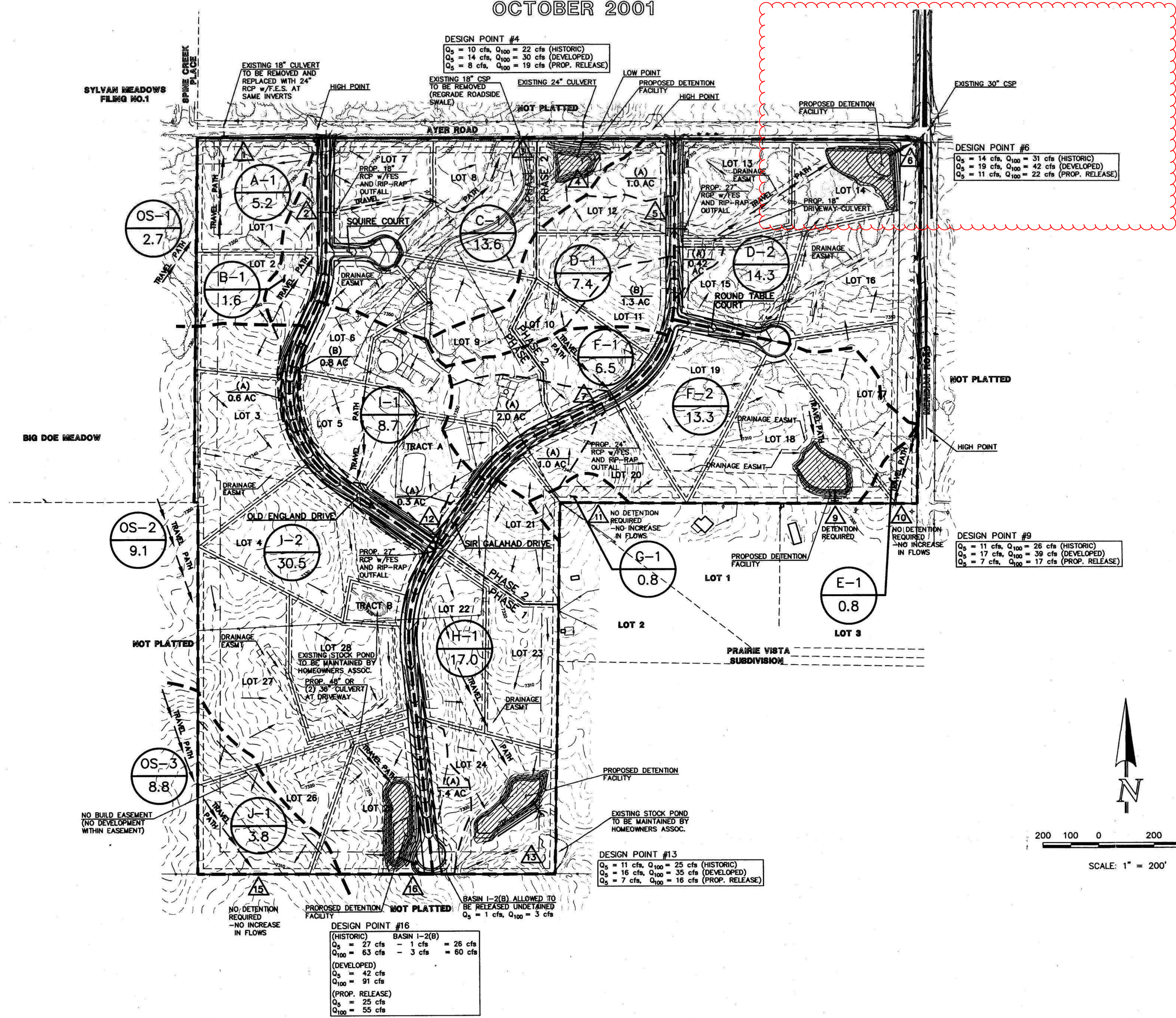

LEGEND	DESCRIPTION	SYMBOL
	EXISTING GROUND CONTOUR	6910
	PROPOSED GROUND CONTOUR	6920
	SUBDIVISION BOUNDARY	---
	BASIN BOUNDARY	---
	BASIN IDENTIFIER	C4
	AREA IN ACRES	22

CAMELOT SUBDIVISION, DESIGN POINT SUMMARY		
DESIGN POINT	PROPOSED	
	Q _s (CFS)	Q ₁₀₀ (CFS)
1	7	16
2	2	3
4	14	30
5	7	16
6	19	42
7	6	14
9	17	39
10	1	2
11	1	2
12	8	18
13	16	35
15	9	21
16	42	91

NOTE:
ALL STORM CROSSINGS TO INCLUDE 5' X 8' RIP-RAP PAD AT OUTFALL AND F.E.S.'S AT EACH END (SEE CONSTRUCTION PLANS).

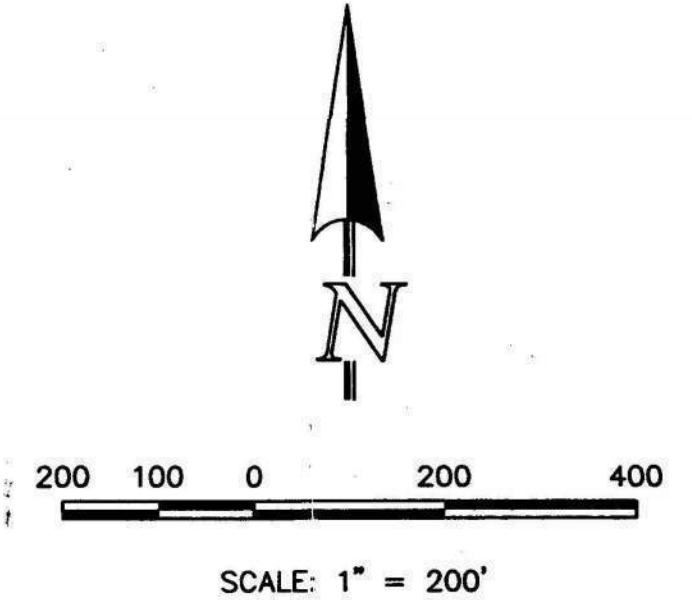

48 HOURS BEFORE YOU DIG, CALL UTILITY LOCATORS
1-800-922-1987
CITY OF COLORADO SPRINGS DEPT. OF UTILITIES
GAS, ELECTRIC, WATER AND WASTEWATER

THE LOCATIONS OF EXISTING UNDERGROUND UTILITIES ARE SHOWN IN AN APPROXIMATE WAY ONLY. THE CONTRACTOR SHALL DETERMINE THE EXACT LOCATION OF ALL EXISTING UTILITIES BEFORE COMMENCING WORK. THE CONTRACTOR SHALL BE FULLY RESPONSIBLE FOR ANY AND ALL DAMAGES WHICH MIGHT BE CAUSED BY HIS FAILURE TO EXACTLY LOCATE AND PRESERVE ANY AND ALL UNDERGROUND UTILITIES.

NO.	REVISION	DATE
1	REVISED PER COUNTY COMMENTS	1/25/02
2	REVISED EXISTING CULVERT SIZE AT DESIGN POINT 4	3/05/02

REVIEW:
PREPARED UNDER MY DIRECT SUPERVISION FOR AND ON BEHALF OF CLASSIC CONSULTING ENGINEERS AND SURVEYORS, LLC

KYLE R. CAMPBELL, COLORADO P.E. #29794 DATE

6385 Corporate Drive, Suite 304
Colorado Springs, Colorado 80919
(719)785-0790
(719)785-0799(Fax)

CAMELOT SUBDIVISION			
FINAL DRAINAGE MAP			
DESIGNED BY	KRC	SCALE	DATE 10/31/01
DRAWN BY	PRA	(H) 1" = 200'	SHEET 1 OF 1
CHECKED BY	(V) 1" = N/A	JOB NO.	2037.00

CLASSIC CONSULTING ENGINEERS & SURVEYORS

X:\203700\DRAWINGS\203700DR.dwg, 03/05/2002 10:36:32 AM, CCEI055C.plt

DETENTION FACILITY SUMMARY

DETENTION FACILITY	HISTORIC	C ₁₀₀	PROPOSED	C ₁₀₀
"A" DP #13	BASIN H		BASIN H-1	
	19.1 AC	C ₁₀₀ = .35	17.0 AC	C ₁₀₀ = .40
	T _C = 33.2		T _C = 19.9	
	Q ₅ = 11		Q ₅ = 16	
	Q ₁₀₀ = 25		Q ₁₀₀ = 35	
"B" DP#4	BASIN B & C		BASIN B-1, C-1	
	15.2 AC	C ₁₀₀ = .35	15.2 AC	C ₁₀₀ = .40
	T _C = 28.7		T _C = 19.9	
	Q ₅ = 10		Q ₅ = 14	
	Q ₁₀₀ = 22		Q ₁₀₀ = 30	
"C" DP#6	BASIN D		BASIN D-1, D-2	
	24.7 AC	C ₁₀₀ = .35	21.7 AC	C ₁₀₀ = .40
	T _C = 36.7		T _C = 21.9	
	Q ₅ = 14		Q ₅ = 19	
	Q ₁₀₀ = 31		Q ₁₀₀ = 42	
"D" DP#16	BASIN I, OS-2		BASIN I-1, I-2, OS-2	
	47.6 AC	C ₁₀₀ = .35	48.3 AC	C ₁₀₀ = .40
	T _C = 33.2		T _C = 21.9	
	Q ₅ = 27		Q ₅ = 42	
	Q ₁₀₀ = 63		Q ₁₀₀ = 91	
"E" DP#9	BASIN F		BASIN F-1, F-2	
	19.8 AC	C ₁₀₀ = .35	19.8 AC	C ₁₀₀ = .40
	T _C = 35.0		T _C = 19.9	
	Q ₅ = 11		Q ₅ = 17	
	Q ₁₀₀ = 26		Q ₁₀₀ = 39	



APPENDIX F – DRAINAGE MAPS

LEGEND

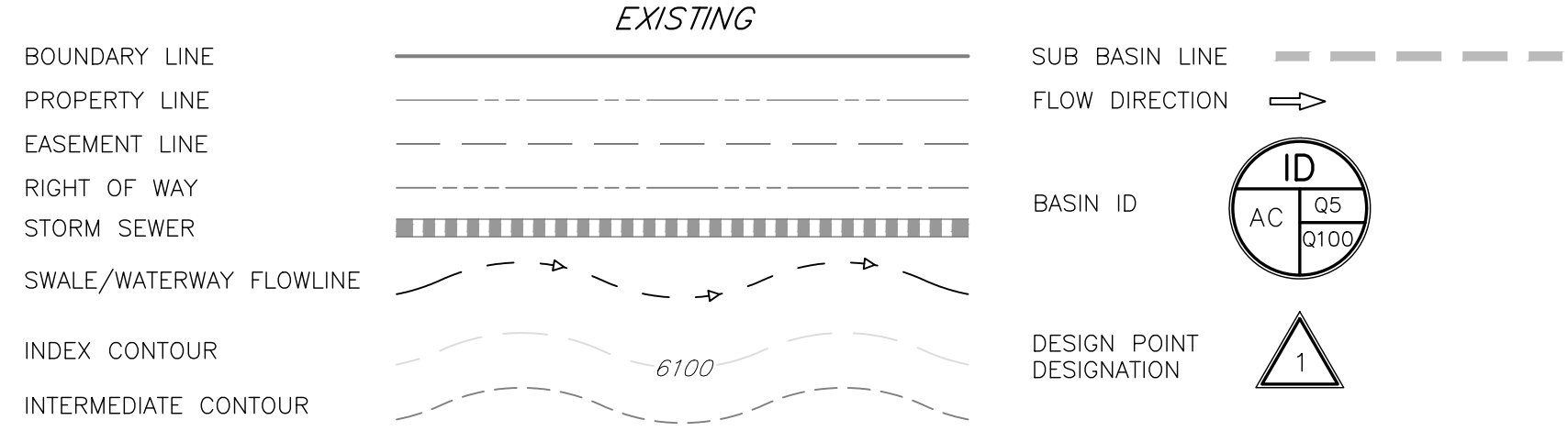

ANTLER RANGE FILING NO. 1

EXISTING DRAINAGE MAP

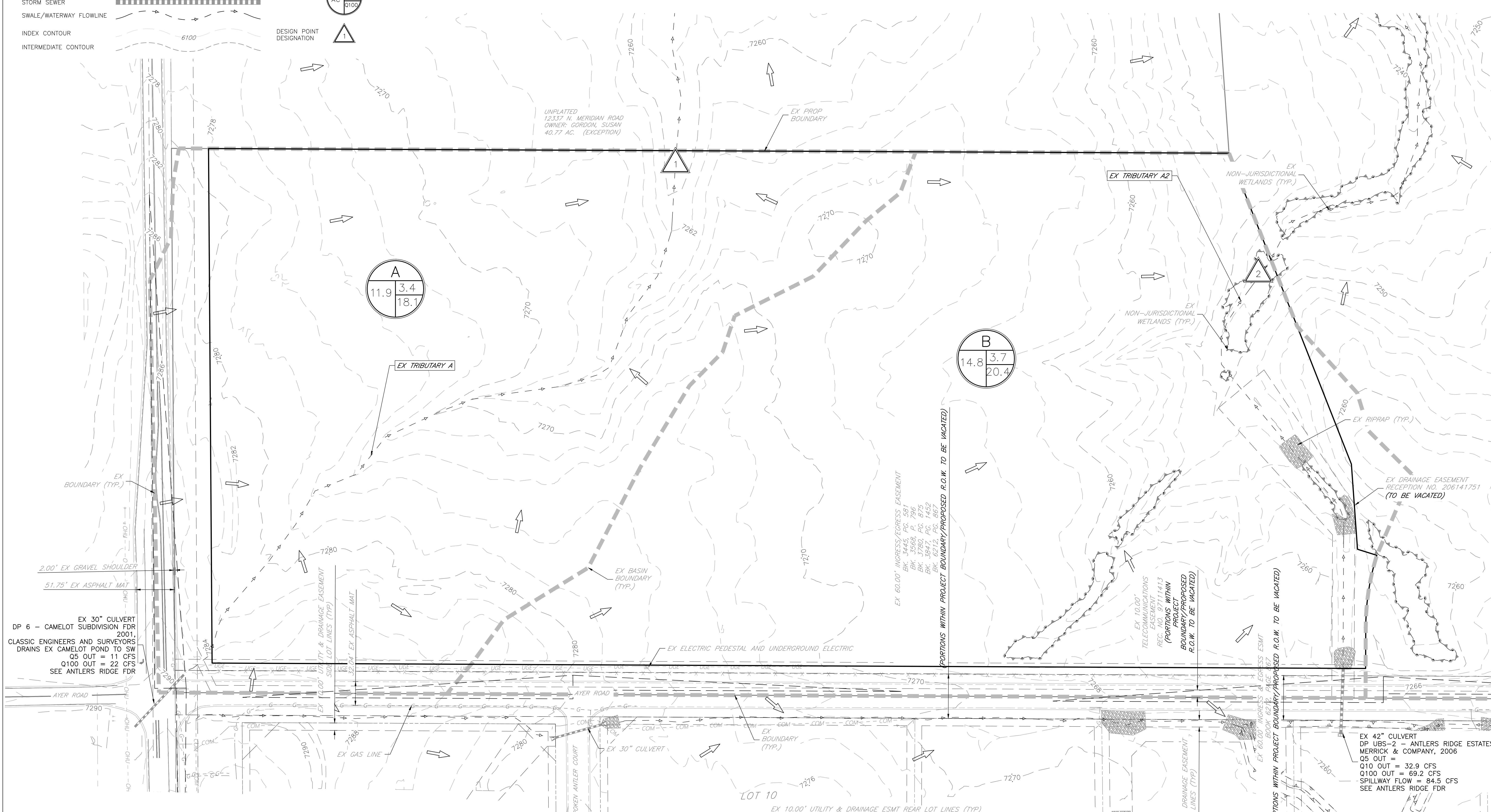

A

11.9	3.4
18.1	

B

14.8	3.7
20.4	

EXISTING CONDITIONS - DESIGN POINT SUMMARY TABLE

DP#	Q ₅ -YR	Q ₁₀₀ -YR
Camelot DP-6*	11.0	22.0
1	12.9	34.3
2	34.3	77.4
Antlers Ridge*	32.9	69.2

EXISTING CONDITIONS - BASIN SUMMARY TABLE

Sub-basin	Area (ac)	Impervious	C _s	C ₁₀₀	t _c (min)	Q ₅ -yr (cfs)	Q ₁₀₀ -yr (cfs)
A	11.86	6%	0.12	0.38	32.2	3.4	18.1
B	14.84	5%	0.12	0.39	38.8	3.7	20.4

EXISTING DRAINAGE MAP

ANTLER RANGE FILING NO. 1	
JOB NO. 24031	SHEET
LOCATION: EPC	1
04/13/2026	



LEGEND

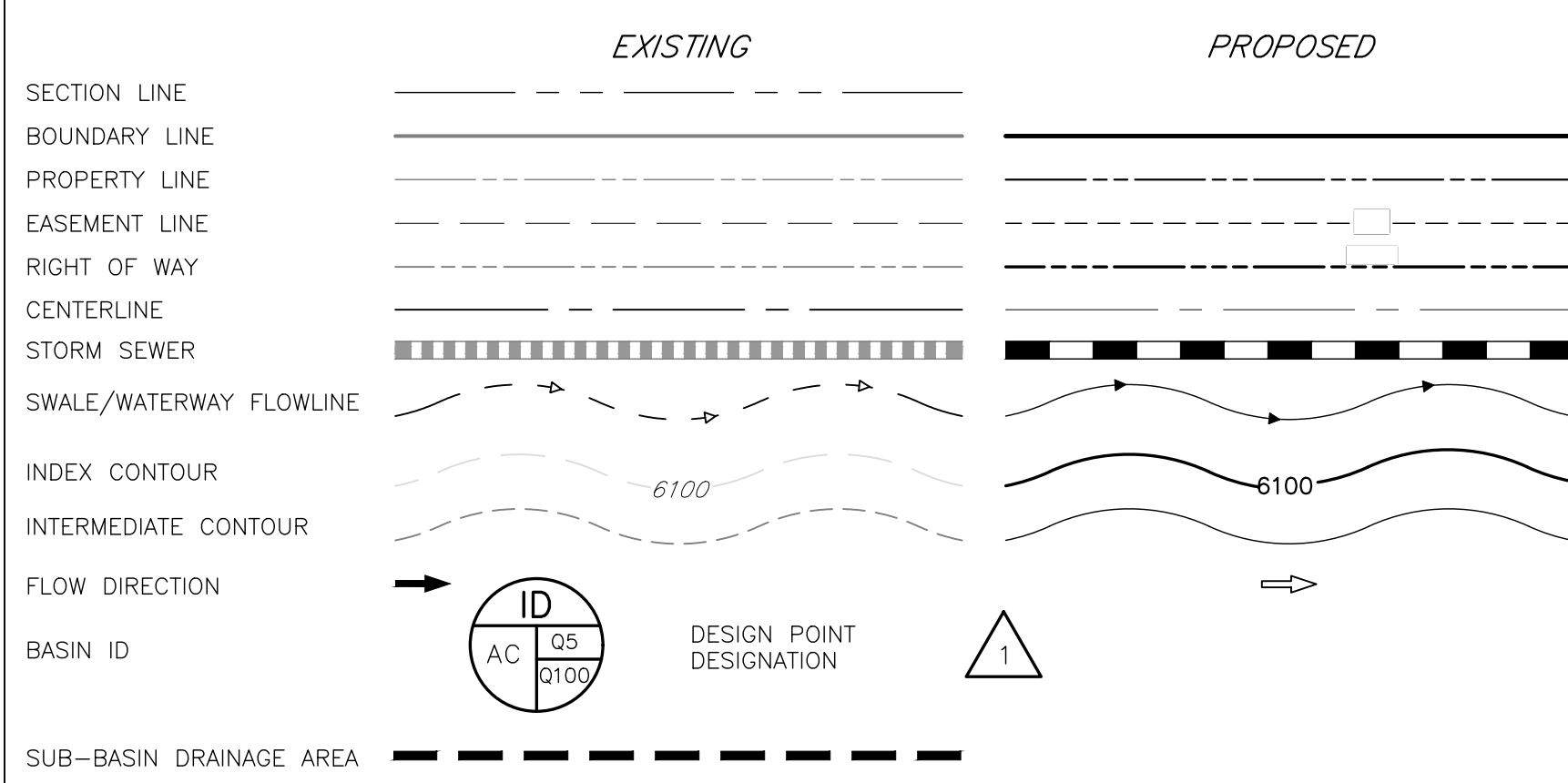

ANTLER RANGE FILING NO. 1

PROPOSED DRAINAGE MAP

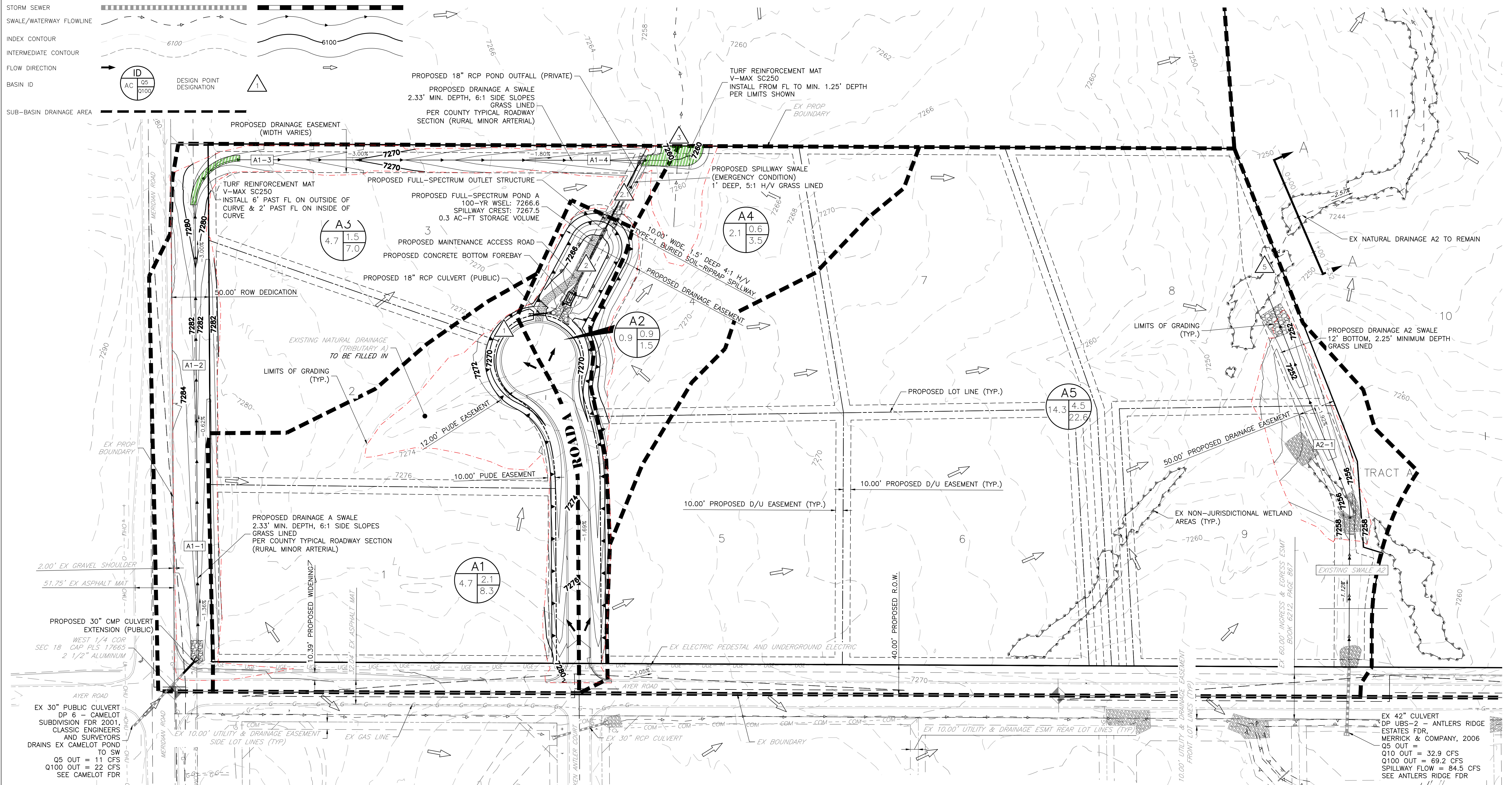

PROPOSED DRAINAGE CALCS - BASIN SUMMARY TABLE

Tributary	Area (acres)	Percent Impervious	C _s	C ₁₀₀	t _c (min)	Q _s (cfs)	Q ₁₀₀ (cfs)
A1	4.71	16%	0.19	0.44	32.39	2.1	8.3
A2	0.91	33%	0.32	0.54	20.68	0.9	1.5
A3	4.70	12%	0.15	0.42	38.81	1.5	7.0
A4	2.08	7%	0.12	0.39	27.90	0.6	3.5
A5	14.28	9%	0.14	0.40	33.09	4.5	22.6

DESIGN POINT SUMMARY TABLE

DP#	Q _s -yr	Q ₁₀₀ -yr
Camelot DP-6	11	22
1	2.1	8.3
2	2.7	10.1
2.1	1.5	8.7
3	11.7	33.9
Antlers Ridge Estates UBS-2	32.9	69.2
5	34.3	81.0

EXISTING V. PROPOSED FLOW (INDIVIDUAL DESIGN POINTS)

DP#	Q _s -yr		Q ₁₀₀ -yr		Δ
	EX	PROP	EX	PROP	
1	3	12.9	11.7	-9%	34.3
2	5	34.3	34.3	0%	77.4
					81.0
					5%

EX NATURAL DRAINAGE DP 5 - SECTION A-A
STA 0+00.00 TO 1+31.95

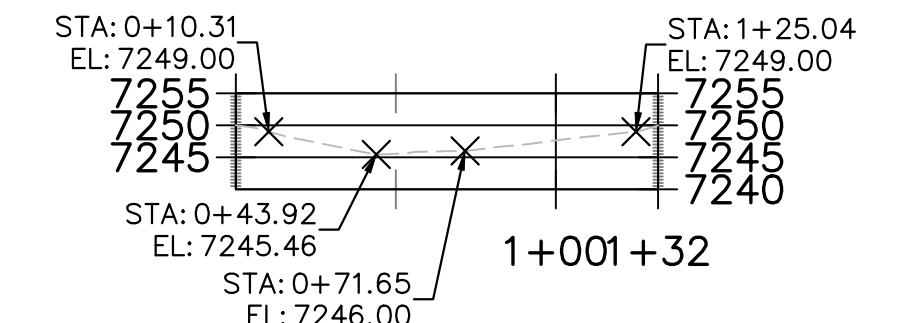

PROPOSED DRAINAGE MAP

ANTLERS RANGE FILING NO. 1

JOB NO. 24031
 LOCATION: EPC
 4/13/2026

SHEET 1

ALL TERRAIN
 ENGINEERING