



LSC TRANSPORTATION CONSULTANTS, INC.
2504 East Pikes Peak Avenue, Suite 304
Colorado Springs, CO 80909
(719) 633-2868
FAX (719) 633-5430
E-mail: lsc@lscctrans.com
Website: <http://www.lscctrans.com>

Grandview Reserve Phase 1
Updated Traffic Impact Analysis
PUDSP-21-010
(LSC #S214240)
May 9, 2022

Traffic Engineer's Statement

This traffic report and supporting information were prepared under my responsible charge and they comport with the standard of care. So far as is consistent with the standard of care, said report was prepared in general conformance with the criteria established by the County for traffic reports.



Developer's Statement

I, the Developer, have read and will comply with all commitments made on my behalf within this report.



PAUL J. HOWARTH AS MANAGER

05/09/2022
Date

Grandview Reserve Phase 1

Updated Traffic Impact Analysis

PUD SP2110

Prepared for:
Mr. Phil Stuepfert
HR Green
5619 DTC Parkway – Suite 1150
Greenwood Village, CO 80111

MAY 9, 2022

LSC Transportation Consultants, Inc.

Prepared by: Jeffrey C. Hodsdon, P.E. and Kirstin D. Ferrin, P.E.

LSC #S214240



CONTENTS

REPORT CONTENTS 1

PREVIOUS TRAFFIC REPORTS..... 2

LAND USE AND ACCESS 2

 Site Plan 2

 Site Access..... 2

 Deviation Request 3

 Pedestrian and Bicycle Accommodations..... 3

 Sight Distance Analysis..... 4

ROADWAY AND TRAFFIC CONDITIONS..... 4

 Area Roadways..... 4

 Existing (2021) Traffic Volumes 5

 Existing Levels of Service 5

 Safety Analysis 6

SHORT-TERM (YEAR 2026) BACKGROUND TRAFFIC 7

2041 BACKGROUND TRAFFIC 8

TRIP GENERATION..... 8

DIRECTIONAL DISTRIBUTION AND ASSIGNMENT 9

TOTAL TRAFFIC..... 10

PROJECTED LEVELS OF SERVICE 10

 Rex/Eastonville..... 10

 Rex Road/Ivybridge Boulevard 11

 Eastonville/Dawlish Drive..... 11

 Eastonville/Brixham Drive 12

 Londonderry/Eastonville 12

 Stapleton/Eastonville 12

 US Hwy 24 Intersection/Stapleton 13

QUEUING ANALYSIS 13

FUNCTIONAL CLASSIFICATIONS AND LANEAGE..... 14

MULTI-MODAL AND PEDESTRIAN/BIKE TRANSPORTATION 15

TRANSPORTATION IMPROVEMENT FEE PROGRAM 16

 Project Fees..... 16

 Potentially Reimbursable Improvements Under the MTCP Fee Program 16

Enclosures: 18

Tables 2-5

Figures 1-13

Appendix Table 1

MTCP Maps

Map 15 Bicycle and Pedestrian Network Improvements

Traffic Count Reports

Crash History Data

Level of Service Reports

Queuing Reports



LSC TRANSPORTATION CONSULTANTS, INC.
2504 East Pikes Peak Avenue, Suite 304
Colorado Springs, CO 80909
(719) 633-2868
FAX (719) 633-5430
E-mail: lsc@lsctrans.com
Website: <http://www.lsctrans.com>

May 9, 2022

Mr. Phil Stuepfert
HR Green
5619 DTC Parkway – Suite 1150
Greenwood Village, CO 80111

RE: Grandview Reserve Phase 1
El Paso County, Colorado
Updated Traffic Impact Analysis
LSC #S214240

Dear Phil:

In response to your request, LSC Transportation Consultants, Inc. has prepared this updated traffic impact analysis for Phase 1 of the Grandview Reserve development in El Paso County, Colorado. As shown in Figure 1, the Phase 1 area is located east of Eastonville Road across from the Falcon Regional Park.

REPORT CONTENTS

This report is being submitted as part of a Preliminary Plan/PUD submittal for Phase 1. It also provides technical information and analysis in support of a deviation request associated with a proposed Phase 1 access to Rex Road, 575 feet east of Eastonville Road.

The report contains the following:

- The traffic count data and street conditions;
- Short-term and 2041 baseline/background traffic-volume estimates;
- The projected average weekday and peak-hour vehicle trips to be generated by the site;
- The assignment of the site's projected traffic volumes to the key area streets and intersections for the short and long term and the resulting total traffic volumes for the short and long term;
- The resulting traffic impacts including level of service analysis at key intersections; and
- Findings and recommendations.

PREVIOUS TRAFFIC REPORTS

LSC completed a Master Traffic Impact Study (TIS) for Grandview Reserve (Sketch Plan) dated December 15, 2020. That report assumed the initial development would occur on the parcels on the east end of the overall development with access to US Highway 24 (US Hwy 24) only. Initial development is now planned to occur on the west side of the site with access only to Eastonville Road and the initial segment of Rex Road east of Eastonville.

A list of other traffic studies in the area of study completed within the past five years (that LSC is aware of) is attached for reference. This study accounts for the land use, trip generation, and the roadway network included in these studies. The older previous area studies generally assumed Rex Road would not extend from Eastonville Road to US Hwy 24 in the 20-year horizon as is now planned. The older previous studies also assumed fewer dwelling units on this site.

A traffic report, entitled Eastonville Road Project Conceptual Design Report was also recently completed for Eastonville Road by Wilson & Company (for El Paso County).

LAND USE AND ACCESS

Site Plan

Figure 2 shows the proposed site plan for Phase 1 of Grandview Reserve. The initial phase is planned include about 189.5 acres and is planned to contain 565 lots for single-family homes, an 11.2-acre church site, and an “amenity center” that is planned to include a 3,000-square-foot community recreation center. Plans for the church site are still preliminary; however, this report assumes the church site will be developed with a 500-seat sanctuary and that the church will offer preschool classes during the week. At this time, there is no plan to phase construction. The Phase 1 plan is consistent with the land uses assumed for this same area in the Master TIS.

Site Access

Two public-street connections, Dawlish Drive and Brixham Drive, are proposed to Eastonville Road and one full-movement access point, Ivybridge Boulevard, is proposed to an extension of Rex Road as part of Phase 1. The intersections with Eastonville and Rex are proposed as full-movement intersections.

Ivybridge Boulevard is proposed as a “T” intersection. The intention is that this intersection would remain a “T” in perpetuity. If future access is needed for the parcels north of Rex Road, it was assumed this access would occur via a second (offset) “T” intersection east of this currently proposed Phase 1 access intersection.

Dawlish Drive could potentially align with a future access point for future park-facilities development within the Falcon Regional Park. However, there are currently no known plans for

an access at this location and, based on existing wetlands areas and the location of planned drainage basins, it is likely that Dawlish Drive/Eastonville Road will remain a “T” intersection in perpetuity.

Brixham Drive could potentially align with a future access point to the Meridian Ranch school site located north of Falcon High School. However, as future plans for the school have not been determined, it was assumed that Brixham Drive will also operate as a “T” intersection. Figure 2 shows the proposed spacing of the access points.

Based on the criteria contained in the El Paso County *Engineering Criteria Manual (ECM)*, the required intersection spacing for Minor Arterial roadways is $\frac{1}{4}$ mile (1,320 feet). Both proposed public street access points to Eastonville Road meet the intersection spacing criteria. However, the access to Rex Road is proposed to be located about 575 feet east of Eastonville Road. This access will require a deviation to the *ECM* criteria.

Two access points are proposed from Ivybridge to the church site. The north access point is proposed as a full-movement access (allowing left and right turns). The south access point is proposed as a right-in/right-out access.

Deviation Request

A deviation request for the proposed full-movement intersection of Rex Road/ Ivybridge Boulevard 575 feet east of Eastonville Road (centerline spacing) is part of this application. The proposed plan for Grandview Reserve Phase 1 is to extend a public street south from Rex Road at this location to serve as one of the access points to this relatively large development. Given this proposed spacing and limited distance for future back-to-back left-turn lanes between this proposed intersection and the Eastonville/Rex intersection, the intent would be that this intersection would be a T intersection with a street on the south side only. Please refer to the associated deviation request form for additional detail.

Pedestrian and Bicycle Accommodations

There are two existing school sites located within two miles of the site, Falcon High School and Meridian Ranch Elementary. A future K-8 school is planned just north of Falcon High School. These schools are located north of Londonderry Drive and west of Eastonville Road. There is also a regional park located just west of the site.

The likely pedestrian path to the school and park sites is Eastonville Road to Londonderry Drive. There are currently sidewalks and school crossings on Londonderry Drive. There are currently no sidewalks on Eastonville Road. However, the *2016 Major Transportation Corridors Plan (MTCP)* shows a proposed primary regional trail along this corridor. The cross section for Eastonville Road north of Stapleton Drive recommended in the *Eastonville Road Conceptual Design Report* dated April 2021 includes an 8-foot detached meandering sidewalk on both sides of the roadway. The

Grandview Reserve site plan includes a trail located outside of the Eastonville right-of-way but within their 30-foot landscape buffer to meet the regional trail requirement. Figure 2 shows the location of the proposed regional trail and other proposed trails within the Grandview Reserve development. All of the internal streets within the Phase 1 area will have sidewalks.

The Rock Island Regional Trail extends southwest to northeast along the US Hwy 24 site frontage (on the north side of the highway).

Sight Distance Analysis

Figure 3a shows a sight-distance analysis at the proposed future intersection with Rex Road just east of Eastonville Road. Figures 3b and 3c show the sight-distance analysis at the future site access points to Eastonville Road. Based on a design speed of 40 miles per hour (mph) and the criteria contained in Table 2-21 of the *ECM*, the required intersection sight distance at these access points is 445 feet. Based on the criteria contained in Table 2-17 of the *ECM*, the required stopping sight distance approaching this intersection is 305 feet. As shown in Figures 3a, 3b, and 3c, the *ECM* criteria can be met at all three of the intersections analyzed.

ROADWAY AND TRAFFIC CONDITIONS

Area Roadways

The major roadways in the site's vicinity are shown in Figure 1 and are described below. Copies of the 2016 *El Paso County Major Transportation Corridors Plan (MTCP) 2040 Roadway Plan*, and 2016 *MTCP 2060 Corridor Preservation Plan (CPP)* with the site location identified on them have been attached to this report.

Eastonville Road extends northeast from Meridian Road to past Hodgen Road. It is shown as a two-lane Minor Arterial on the *El Paso County Major Transportation Corridors Plan* and the *Preserved Corridor Network Plan*. Eastonville Road has a three-lane cross-section (one through lane in each direction plus a center two-way, left-turn lane) from Woodmen Hills Drive to Snaffle Bit Road (approximately midway between Judge Orr Road and Stapleton Road). Eastonville Road is a two-lane roadway north and south of this section. Eastonville Road is currently unpaved north of Londonderry Drive. Pikes Peak Rural Transportation Authority (PPRTA)-funded improvements are anticipated in the future at the intersection of Eastonville Road and Stapleton Drive that would likely add northbound and southbound left-turn lanes. The posted speed limit north of Stapleton Drive is 35 mph.

Rex Road extends east from Goodson Road to Pyramid Peak Drive within the Meridian Ranch development. The posted speed limit on Rex Road is 45 mph between Meridian Road and Mt. Gateway Drive and 35 mph east of Mt. Gateway Drive. The future section of Rex Road between Eastonville Road and US Hwy 24 is shown as a 4-Lane Minor Arterial roadway on the *2016 MTCP 2060 Corridor Preservation Plan (CPP)*. The *CPP* shows Rex Road extending east from Eastonville Road along the north boundary of the site and terminating at Elbert Road just north of US Hwy 24. **However**, as part of the Grandview Reserve Sketch Plan, coordination with El Paso

County, the Colorado Department of Transportation (CDOT), and other local agencies, and associated applications to CDOT, Rex Road is planned to be constructed southeast through Grandview Reserve and will intersect US Hwy 24 (with future phases beyond Phase 1) about 4,255 feet south of Elbert Road and 6,407 feet north of Stapleton Drive. This is shown in Figure 2. The access permit is currently being prepared.

US Highway 24 (US Hwy 24) is generally a two-lane State Highway extending east/west across Colorado connecting the Buena Vista, Colorado Springs, and Limon areas. US Hwy 24 is planned to be widened to four lanes through the Falcon area. The US Hwy 24 PEL identifies this widening as a high priority with a timeline of less than 10 years. US Hwy 24 in the vicinity is classified as an EX – Expressway/Major Bypass by the Colorado Department of Transportation (CDOT). US Hwy 24 is shown as a four-lane Principal Arterial on the *MTCP* and the *Preserved Corridor Network Plan*. The posted speed limit on US Hwy 24 adjacent to the site is 65 miles per hour (mph).

Stapleton Drive is shown as an Urban four-lane Principal Arterial on the El Paso County *Major Transportation Corridors Plan* and El Paso County *Corridor Preservation Plan (CPP)*. Stapleton Drive extends east from Towner Drive to US Hwy 24. Stapleton continues southeast, then south as Curtis Road. It is planned to be ultimately extended west to connect with the Briargate Parkway extension. Stapleton Drive currently is a half-section of a four-lane Principal Arterial street (one through lane in each direction) between Meridian Road and US Hwy 24. The posted speed limit between Eastonville Road and US Hwy 24 is 45 mph.

Existing (2021) Traffic Volumes

Figure 4a shows the existing morning and afternoon peak-hour traffic volumes at the intersections of Stapleton/US 24, Stapleton/Eastonville, and Londonderry/Eastonville. These volumes are based on manual intersection turning-movement counts conducted by LSC in April 2021 (Eastonville/Londonderry) and October 2021 (Stapleton/US Hwy 24 and Stapleton/Eastonville). The morning peak hour at the intersection of Stapleton/US Hwy 24 and Stapleton/Eastonville occurred from 6:45 a.m. to 7:40 a.m. The morning peak hour at the intersection of Eastonville/Londonderry occurred from 7:00 a.m. to 8:00 a.m. The afternoon peak hour at all three intersections occurred from 4:00 p.m. to 5:00 p.m. The northbound left-turn and eastbound right-turn volume at the intersection of Eastonville/Londonderry were adjusted (increased) to account for the minor differences due to seasonal variations and/or the difference in the peak hour. The count-data sheets are attached for reference.

Existing Levels of Service

Level of service (LOS) is a quantitative measure of the level of delay at an intersection. Level of service is indicated on a scale from “A” to “F.” LOS A represents control delay of less than 10 seconds for unsignalized and signalized intersections. LOS F represents control delay of more than 50 seconds for unsignalized intersections and more than 80 seconds for signalized intersections. Table 1 shows the level of service delay ranges.

Table 1: Intersection Levels of Service Delay Ranges

| Level of Service | Signalized Intersections | Unsignalized Intersections |
|------------------|---|--|
| | Average Control Delay (seconds per vehicle) | Average Control Delay (seconds per vehicle) ⁽¹⁾ |
| A | 10 sec or less | 10 sec or less |
| B | 10-20 sec | 10-15 sec |
| C | 20-35 sec | 15-25 sec |
| D | 35-55 sec | 25-35 sec |
| E | 55-80 sec | 35-50 sec |
| F | 80 sec or more | 50 sec or more |

(1) For unsignalized intersections if V/C ratio is greater than 1.0 the level of service is LOS F regardless of the projected average control delay per vehicle.

Figure 4b presents the results of the existing intersection level of service analysis based on the unsignalized method of analysis procedures from the *Highway Capacity Manual, 6th Edition* by the Transportation Research Board. The peak-hour factors used for each approach are based on the traffic volumes for the peak fifteen minutes of the entire intersection. If the peak 15 minutes for an approach occurs during an interval other than the peak 15 minutes of the entire intersection, the suggested peak-hour value based on the total approach volume from Table 9-1 of the Synchro Studio 10 User Guide was used instead. The level of service reports are attached.

The eastbound and westbound left-turn and through lanes at the two-way, stop-sign-controlled intersection of US 24/Stapleton are currently operating at LOS E or LOS F during the peak hours.

The eastbound approach at the two-way, stop-sign-controlled intersection of Stapleton/Eastonville is currently operating at LOS F during the morning peak hour and LOS C during the afternoon peak hour.

The eastbound left-turn movement at the two-way, stop-sign-controlled intersection of Eastonville/Londonderry is currently operating at a LOS D during the morning peak hour and LOS B during the afternoon peak hour.

Safety Analysis

The Colorado State Patrol provided LSC with three years of vehicle-crash data for Eastonville Road between Stapleton Drive and Latigo Boulevard.

There were eight reported crashes at the intersection of Eastonville/Stapleton the past three years, one in 2019, three in 2020 and four between January 29, 2021 and February 3, 2022. The four crashes reported between January 29, 2021 and February 3, 2022 involved motorists on the side street (on one of the stop-sign-controlled approaches) failing to yield right-of-way to the major street traffic. All of these crashes are likely susceptible to correction by a traffic-control

signal and have occurred within approximately a 12-month period. In order to meet a traffic-signal warrant based on crash experience, there needs to be at least five crashes susceptible to correction within a twelve-month period, therefore this intersection does not currently meet this warrant.

There were two crashes reported at the intersection of Londonderry/Eastonville during the past three years. Both crashes involved a single vehicle and would not likely be susceptible to correction by a traffic-control signal.

Two additional crashes were reported along this corridor. The first crashed occurred within the parking lot of Falcon Regional Park and not on Eastonville Road. The location of the second accident is not clear. However, as the road surface code was reported as "dirt" it was assumed to have occurred at a location north of Londonderry Drive. This crash was a single-vehicle crash that lost control while traveling northbound.

It should be noted that the short-term improvements to Eastonville Road, currently in the planning and preliminary design stage, will likely improve the safety of the entire corridor.

SHORT-TERM (YEAR 2026) BACKGROUND TRAFFIC

Background traffic is the traffic estimated to be on the adjacent roadways and at adjacent intersections without the proposed development's trip generation of site-generated traffic volumes. Background traffic includes the through traffic and the traffic generated by nearby developments but assumes zero traffic generated by the site. Figure 5a shows the projected short-term (Year 2026) background traffic volumes.

The addition of new roadways, notably the future completion of Rex Road east to Eastonville Road, will greatly affect the existing traffic patterns. In lieu of a general/"blanket" growth rate, LSC has developed small-area traffic models for Meridian Ranch, Waterbury, and the Latigo Trails as part of previous work completed in the area. The results of these modeling efforts have been combined to estimate the background traffic volumes. These background traffic volumes have been based on the existing traffic volumes (from Figure 4a) plus increases in traffic due to regional growth, including buildout of the following subdivisions in the vicinity of the site:

- The existing and currently proposed subdivisions within Waterbury (located just south of the Grandview Reserve);
- Meridian Ranch Filings 1-3 and Filings 6-8;
- Meridian Ranch Estates Filings 2-3;
- Meridian Ranch Filing 11;
- Stonebridge at Meridian Ranch Filings 1, 2, and 3;
- Meridian Ranch Filing 9;
- The Vistas at Meridian Ranch Filing 1;
- WindingWalk at Meridian Ranch Filing 1;
- The Enclave at Stonebridge at Meridian Ranch;

- The Estates at Rolling Hills Ranch Filing Nos. 1 and 2;
- The Rolling Hills Ranch at Meridian Ranch PUD;
- The areas included in the Meridian Ranch 2021 Sketch Plan Amendment; and
- Latigo Trails Filing Nos. 1 and 2.

The **short-term** background traffic volumes assume Rex Road extended from its existing terminus in Meridian Ranch, across Eastonville to the first Grandview Reserve access east of Eastonville Road but **not** further east. Essentially, there would be no short-term background traffic use of this initial segment east of Eastonville – only site traffic.

Figure 5b shows the lane geometry, traffic control, and level of service at the key area intersections, based on the short-term background volumes.

2041 BACKGROUND TRAFFIC

Figure 6a shows the projected 2041 background-traffic volumes. The small-area model was also used to develop these volumes. In addition to the developments assumed to be developed by 2026, the 2041 background traffic volumes assume buildout of the Meridian Ranch development including buildout of the proposed school site located north of Falcon High School, buildout of Grandview Reserve (except trips to be generated by land uses within the Phase 1 area, as these trips are included in the “site-generated traffic.”), buildout of the Waterbury developments, buildout of Latigo Trails, and buildout of the area generally north of Rex Road between Eastonville Road and US Hwy 24 with 2 ½ acre residential lots. The 2041 background-traffic scenario assumes Stapleton Drive extended west to connect with the Briargate Parkway extension and Rex Road extended east through the future phases of Grandview Reserve to US Hwy 24.

Figure 6b shows the projected 2041-background average weekday-traffic volumes on key internal street segments within Phase 1 due to the development of Phase 1 land uses plus future Grandview Reserve phases.

Figure 6c shows the lane geometry, traffic control, and level of service at the key area intersections, based on the 2041 background volumes.

TRIP GENERATION

The site-generated vehicle trips were estimated using the nationally published trip-generation rates from *Trip Generation, 11th Edition, 2021* by the Institute of Transportation Engineers (ITE). Table 3 shows the trip-generation estimates. The trip-generation estimate is based on 576 single-family homes (ITE Land Use 210 Single Family Detached Housing), a church site with a 500-seat sanctuary (ITE Land Use 560 Church) and a pre-school serving 30 students (ITE Land Use 565 Day Care Center) and the proposed “amenity center” (ITE Lane Use 496 Recreational Community Center).

The total number of vehicle trips generated by the land uses has been reduced to account for the internal vehicle trips made within the site between the single-family homes and the proposed “amenity center” without use of the external streets surrounding the site. As the “amenity center” is intended to primarily serve residents who live within Grandview Reserve, LSC assumed 75% of the trips generated by the center would travel to/from homes within the Phase 1 area. These trips were then balanced with trips to/from the residential areas. The remaining 25% of the trips anticipated to be generated by the “amenity center” were assumed to account for any employees who may live outside the development and visitors hosted by residents. To be conservative, no internal trips were assumed during the weekday for the church parcel.

Following Phase 1, Grandview Reserve is expected to generate about 5,673 new external vehicle trips on the average weekday, with about half entering and half exiting the site during a 24-hour period. During the morning peak hour of the adjacent street traffic, which occurs between 6:45 and 7:45 a.m., about 136 vehicles would enter and 328 vehicles would exit the site. During the afternoon peak hour of the adjacent street traffic, which occurs between 4:00 and 5:00 p.m., about 365 vehicles would enter and 235 vehicles would exit the site.

DIRECTIONAL DISTRIBUTION AND ASSIGNMENT

The directional distribution of the site-generated traffic volumes on the area roadways is an important factor in determining the site’s traffic impacts. Figures 7 and 8 show the short-term and long-term directional-distribution estimates for the site-generated traffic volumes, respectively. The estimates have been based on the following factors: the recent traffic-count data; the Pikes Peak Area Council of Governments’ (PPACG) 2040 traffic projections, the site’s location with respect to the nearby employment, commercial, and activity centers, and the balance of the Falcon and Colorado Springs metropolitan areas; the site’s proposed land use; the site’s proposed access points; and the phasing of the existing and future roadway system serving the site.

The short-term directional-distribution estimate assumes Rex Road has been extended from its existing terminus to the first Grandview Reserve access east of Eastonville Road but not further east. The long-term directional distribution assumes buildout of the area street network including the extension of Rex Road east to US Hwy 24 and Stapleton Drive/Briargate Parkway west to Black Forest Road.

When the distribution percentages (from Figures 7 and 8) were applied to the trip-generation estimates (from Table 3), the short-term site-generated traffic volumes on the area roadways were determined. Figure 9b shows the short-term average weekday site-generated traffic volumes on key internal street segments. Figure 10a shows the long-term site-generated traffic volumes. Figure 10b shows the long-term average weekday site-generated traffic volumes on key internal street segments.

TOTAL TRAFFIC

Figure 11a shows the projected short-term (Year 2026) total-traffic volumes. The short-term total-traffic volumes are the sum of the short-term background-traffic volumes (from Figure 5a) plus the short-term site-generated traffic volumes (from Figure 9a).

Figures 11b and 11c show the lane geometry, traffic control, and level of service at the key area intersections, based on the short-term (Year 2026) total volumes.

Figures 12a and 12b show the projected 2041 total-traffic volumes. The 2041 total-traffic volumes are the sum of the 2041 background-traffic volumes (from Figures 6a and 6b) plus the long-term site-generated traffic volumes (from Figures 10a and 10b).

Figures 12c-12e show the lane geometry, traffic control, and level of service at the key area intersections, based on the 2041 total volumes.

PROJECTED LEVELS OF SERVICE

The key area intersections and site-access points have been analyzed to determine the projected future levels of service based on the unsignalized method of analysis procedures from the *Highway Capacity Manual, 6th Edition* by the Transportation Research Board and Synchro signalized intersection procedures. Based on the criteria contained in the *ECM*, a peak-hour factor of 0.85 was used for the short-term (Year 2026) analysis, except for those intersections whose existing peak-hour factor calculated from traffic counts conducted by LSC was higher than 0.85. In those cases, the existing peak-hour factor was used. A peak-hour factor of 0.95 was used for the long-term (Year 2041). Two percent heavy vehicles were assumed for both the Year 2026 and Year 2041 analysis. The results of the analysis are contained in Figures 5b, 6b, 9b, 9c, and 12c-12e. The 2026 and 2041 level of service results are summarized in Tables 3 and 4, respectively. The level of service reports are attached.

Rex/Eastonville

The short term assumes Rex Road completed between Sunrise Ridge Drive and Eastonville Road, as well as the initial segment of Rex east of Eastonville (with this development) to the first Grandview Reserve access point east of Eastonville Road, Ivybridge Boulevard. The future four-leg intersection of Rex/Eastonville is projected to operate at LOS D or better for all movements during the peak hours as a two-way, stop-sign-controlled (TWSC) intersection, based on the projected short-term total-traffic volumes.

By 2041, it was assumed that Rex Road would be completed through the remainder of Grandview Reserve to US Highway 24.

If the intersection of Eastonville/Rex remains stop-sign controlled, by 2041 the following movements are projected to operate at LOS E or F during the morning peak hour.

- The westbound left-turn movement is projected to operate at LOS F with and without the proposed development
- The eastbound through movement is projected to operate at LOS D without the proposed development and LOS E with the proposed development.

If the intersection of Eastonville/Rex remains stop-sign controlled, by 2041 the following movements are projected to operate at LOS E or F during the afternoon peak hour.

- The westbound left-turn movement is projected to operate at LOS F with and without the proposed development.
- The eastbound left-turn movement is projected to operate at LOS F with and without the proposed development.
- The eastbound through movement is projected to operate at LOS F with and without the proposed development.

If this intersection is constructed as a one-lane modern roundabout or assuming it is eventually traffic-signal controlled, all movements are projected to operate at LOS D or better during the peak hours through 2041. If this intersection is not constructed as a one-lane roundabout, detailed analysis should be conducted at the final plat stage with each Grandview Reserve filing to determine if and when a traffic signal is warranted.

Rex Road/Ivybridge Boulevard

The intersection of Rex Road/Ivybridge Boulevard is projected to operate at LOS A for all movements based on the projected 2026 total traffic volumes and LOS C or better for all movements based on the projected 2041 total traffic volumes as a two-way, stop-sign-controlled "T" intersection. As discussed on page 2, this access to Rex Road is intended to remain a "T" intersection in perpetuity. If future access is needed for the parcels north of Rex Road, it was assumed this access would occur via a second "T" intersection east of the currently-proposed access.

Eastonville/Dawlish Drive

The intersection of Eastonville Road/Dawlish Drive is projected to operate at LOS C or better for all movements during the peak hours as a stop-sign-controlled "T" intersection, based on the short-term (Year 2026) total traffic volumes. By 2041 the westbound left-turn movement is projected to operate at LOS E during the morning peak hour based on the projected total traffic volumes. This movement is projected to operate at a satisfactory level of service based on the projected background volumes (i.e., without the proposed development). This intersection was analyzed as a modern roundabout as required. However, due to wetlands constraints, the preferred option is a conventional intersection. If this intersection were to be converted to traffic-signal control, by 2041 all movements are projected to operate at a satisfactory level of service during the peak hours.

Eastonville/Brixham Drive

The intersection of Eastonville Road/Brixham Drive is projected to operate at LOS C or better for all movements during the peak hours as a stop-sign-controlled “T” intersection, based on the short-term (Year 2026) total traffic volumes. By 2041, the westbound left-turn movement is projected to operate at LOS D during the peak hours.

Londonderry/Eastonville

The eastbound left-turn movement at the stop-sign-controlled intersection of Londonderry/Eastonville is projected to operate at LOS E during the morning peak hour and LOS C during the afternoon peak hour, based on the projected short-term (Year 2026) background traffic volumes. With the addition of the site-generated traffic, the eastbound left-turn movement is projected to operate at LOS F during the morning peak hour and LOS E during the afternoon peak hour and the eastbound right-turn movement is projected to operate at LOS F during the morning peak hour and LOS B during the afternoon peak hour.

By 2041 the eastbound left-turn is projected to operate at LOS F with or without the proposed development if this intersection remains stop-sign controlled. The eastbound right-turn movement is also projected to operate at LOS F during the morning peak hour with or without the proposed development.

The level of service at this intersection could potentially be improved if it were constructed as a channelized “T”. All movements at this intersection are projected to operate at a satisfactory level of service, assuming modern roundabout or traffic-signal control.

If this intersection is not constructed as a channelized “T” or a one-lane roundabout, a signal-warrant analysis will be required as this project builds out (at the final plat stage). Warrant analysis would be used to determine if and when a traffic signal is warranted. This analysis would not be needed if a traffic signal is installed as part of the County Eastonville Road project.

Stapleton/Eastonville

The eastbound approach at the intersection of Stapleton/Eastonville is currently operating at LOS F during the morning peak hour. A PPRTA project is currently planned to improve Eastonville Road in the vicinity of the site. However, the timing of this project is unknown. It is our understanding that in the short-term, Stapleton Drive is planned to be restriped to provide eastbound and westbound left-turn lanes approaching Eastonville Road, short northbound and southbound left-turn lanes are planned to be constructed on Eastonville Road approaching Stapleton Drive, and the intersection is planned to be converted to all-way, stop-sign control. Even with these improvements it will likely be necessary to convert this intersection to traffic-signal control by 2026 to maintain an acceptable level of service.

By 2041, it was assumed that Stapleton Drive would be constructed to its full Principal Arterial cross section and the intersection of Stapleton/Eastonville would be converted to traffic-signal control. Based on the lane geometry shown in Figure 11e, this intersection is projected to operate at LOS D or better for all movements, except for the eastbound left-turn movement which is projected to operate at LOS E during the afternoon peak hour with or without the proposed development. The southbound left-turn movement is projected to operate at LOS C during the afternoon peak hour based on the projected 2041 background traffic volumes and LOS E during the afternoon peak based on the 2041 total traffic volumes. These left-turn movements have projected delays in the LOS E range simply because they arrive at the traffic signal at the beginning of the red phase at an intersection with many phases and a long cycle length. These movements would not be considered “failing” since the volume-to-capacity ratios are less than one. The justification is that to progress through traffic along an arterial corridor, the traffic-signal offsets and left-turn phase times have been adjusted to favor the through band, which can result in higher delay for the left-turn movements even though there is sufficient capacity for them.

US Hwy 24 Intersection/Stapleton

The intersection of US Hwy 24/Stapleton is currently stop-sign controlled. The northbound and southbound left-turn movements and the northbound through movements are currently operating at LOS F during the peak hours. This intersection is planned to be signalized in the (potentially near-term) future. Once signalized, all movements are projected to operate at LOS D or better during the peak hours, based on the projected short-term total traffic volumes.

By 2041, all of the left-turn movements at this intersection are projected to operate at LOS E or F during the morning and afternoon peak hours with or without the proposed development. To maintain an overall LOS D or better as a “conventional” four-leg signalized intersection, it may be necessary to provide three approach through lanes in all directions. Alternate traffic-control options were presented in the US Hwy 24 PEL Study. Alternatives to a “conventional” four-leg signalized intersection may include a jug-handle intersection, a continuous-flow intersection (or partial/half CFI), or a junior interchange. An alternate intersection design may be needed long term to maintain an acceptable level of service.

US Hwy 24/Rex

The intersection of US 24/Rex is not planned to be constructed as part of Phase 1. By 2041, it was assumed that Rex Road would be constructed from Eastonville to US Hwy 24 and that intersection with US Hwy 24 would be constructed as a signal-controlled, channelized “T” intersection. All movements are projected to operate at LOS D, based on the projected 2041 total traffic volumes.

QUEUING ANALYSIS

A queuing analysis was performed using Synchro/SimTraffic for Rex Road between Eastonville and a potential future access point for Four-Way Ranch. The 2041-total morning and afternoon

peak-hour traffic volumes were entered into the Synchro model. Each simulation was run five times and the results were averaged. The SimTraffic queuing reports are attached.

The projected maximum westbound left-turn queue on Rex Road approaching Eastonville Road is 251 feet during the morning peak hour and 159 feet during the afternoon peak hour. As shown in Figure 2, the proposed spacing between Eastonville Road and the first Grandview Reserve access point is 576 feet (centerline to centerline). This access point is intended to remain a "T" intersection in perpetuity. If future access is needed for the parcels north of Rex Road, it was assumed this access would occur via a second "T" intersection east of the currently proposed access.

The projected maximum westbound left-turn queue on Rex Road approaching the first Grandview Reserve access point (Road "V") is about 36 feet during the morning peak hour and about 102 feet during the afternoon peak hour. The projected maximum eastbound left-turn queue on Rex Road approaching the potential future access point for Four Way Ranch is about 12 feet during the afternoon peak hour and about 18 feet during the afternoon peak hour.

FUNCTIONAL CLASSIFICATIONS AND LANEAGE

Figure 13 shows the recommended functional classifications for internal streets within Phase 1 and for the roadways in the vicinity of the site. The functional classifications for the major transportation corridors in the vicinity and number of through lanes are consistent with the current El Paso County *MTCP* and the Grandview Reserve Sketch Plan TIS report.

The projected average daily traffic on Eastonville Road south of Brixham Drive is 7,055 vehicles per day (vpd) based on the projected short-term (Year 2026) total traffic and 14,645 vpd based on the projected 2041 total traffic volumes. The projected daily traffic volumes on this section of Eastonville Road are below the design ADT of 20,000 vpd for an Urban Minor Arterial given in Table 2-6 of the El Paso County Engineering Criteria Manual (*ECM*).

The projected average daily traffic on Rex Road just east of Eastonville Road is 665 vpd based on the projected short-term (Year 2026) total traffic and 11,240 vpd based on the projected 2041 total traffic volumes. The projected daily traffic volumes on this section of Rex Road are below the design ADT of 20,000 vpd for an Urban Minor Arterial given in Table 2-6 of the *ECM*.

The projected average daily traffic volumes on Ivybridge Drive just south of Rex Road is 665 vpd based on the projected short-term (Year 2026) total traffic volumes and 2,650 vpd based on the projected 2041 total traffic volumes. The projected daily traffic volumes on Ivybridge Boulevard are below the design ADT of 10,000 vpd for an Urban Residential Collector given in Table 2-6 of the *ECM*.

The projected average daily traffic volumes on Dawlish Drive between Eastonville Road and Zelda Street is 3,970 vehicles per day (vpd) based on the projected short-term (Year 2026) total traffic volumes and 2,840 vpd based on the projected 2041 total traffic volumes. The projected daily

traffic volumes on this section of Dawlish Drive are below the design ADT of 10,000 vpd for an Urban Residential Collector given in Table 2-6 of the *ECM*.

The projected average daily traffic volumes on Dawlish Drive between Zelda Street and Ivybridge Boulevard is between 315 and 1,965 vpd based on the projected short-term (Year 2026) total traffic and between 1,185 vpd and 1,525 vpd based on the projected 2041 total traffic volumes. The projected daily traffic volumes on this section of Dawlish Drive are below the design ADT of 3,000 vpd for an Urban Local given in Table 2-6 of the *ECM*.

The projected average daily traffic volumes on Brixham Drive just east of Eastonville Road is 1,095 vpd based on the projected short-term (Year 2026) total traffic volumes and 1,370 vpd based on the projected 2041 total traffic volumes. The projected daily traffic volumes on this Brixham Drive are below the design ADT of 3,000 vpd for an Urban Local given in Table 2-6 of the *ECM*.

The projected average daily traffic on Zelda Street just east of Dawlish Drive is 2,010 vpd based on the projected short-term (Year 2026) total traffic and 1,675 vpd based on the projected 2041 total traffic volumes. The projected daily traffic volumes on this Zelda Street are below the design ADT of 3,000 vpd for an Urban Local given in Table 2-6 of the *ECM*.

The three cul-de-sacs (Tintagel Trail, Primley Woods Path and St. Ives Way) on the north end of Dawlish Drive are projected to have average daily traffic volumes below 300 vpd and could be classified as Urban Local (Low-Volume). All of the other internal streets within Grandview Reserve Phase 1 are projected to have average daily traffic volumes below the 3,000 vehicle per day threshold for Urban Local streets.

MULTI-MODAL AND PEDESTRIAN/BIKE TRANSPORTATION

- A park n' ride facility is planned for a site near Meridian Road and US Hwy 24.
- The Rock Island Regional Trail passes adjacent to the site.
- Many of the area County roads have been or will be upgraded to provide paved shoulders for cyclists. Stapleton and Elbert Road are shown as future "bike routes."
- The *MTCP* shows a future primary regional trail along Eastonville Road. Another future primary regional trail is shown extending west from Eastonville Road through Meridian Ranch.
- The US Hwy 24 PEL study also includes multi-modal elements.
- All of the internal streets within Grandview Reserve Phase 1 will have sidewalks that will connect to Rex Road and/or Eastonville Road. The proposed trail system shown in Figure 2 will also connect to the future Waterbury development to the south in addition to connections to Rex Road and Eastonville Road.

TRANSPORTATION IMPROVEMENT FEE PROGRAM

Project Fees

This project will be required to participate in the El Paso County Road Improvement Fee Program. Grandview Reserve will join the ten-mil PID. The ten-mil PID building-permit fee portion associated with this option is \$1,221 per single-family dwelling unit. The total building-permit fee would be \$689,865 for the 565 lots within Phase 1. It is likely that this amount would be paid incrementally with building permits associated with several individual final-plat applications.

Potentially Reimbursable Improvements Under the MTCP Fee Program

Nearby improvement projects potentially reimbursable under the Fee Program are (From MTCP Map No. 13):

- MTCP Project No. U19: Eastonville Road
- MTCP Project No. N4: Rex Road (extended between Eastonville & US Highway 24)
- MTCP Project No C12: Stapleton Road
- Also, potentially intersection improvements and traffic signals/roundabouts at major MTCP roadway intersections per fee program guidelines
- Also, potentially intersection improvements and traffic signals (or CDOT traffic signal escrows)/roundabouts at US 24 intersections with Rex Road and/or Stapleton Road per fee program guidelines

ROADWAY IMPROVEMENTS

The attached Table 5 presents the Phase 1 recommended roadway improvements.

- Based on the 2041 total-traffic volumes shown in Figure 12a and the criteria contained in the El Paso County *Engineering Criteria Manual (ECM)*, a westbound left-turn lane will be required on Rex Road approaching Eastonville Road. This lane should be 350 feet long plus a 100-foot taper. This improvement would not be needed if the intersection is constructed as a modern roundabout.
- Based on the 2041 total-traffic volumes shown in Figure 12a and the criteria contained in the *ECM*, a westbound right-turn deceleration lane will be required on Rex Road approaching Eastonville Road. Based on the *ECM* criteria, this lane should be 155 feet long plus a 160-foot taper. This improvement would not be needed if the intersection is constructed as a modern roundabout.
- Based on the 2041 total-traffic volumes shown in Figure 12a and the criteria contained in the *ECM*, an eastbound right-turn deceleration lane will be required on Rex Road approaching Ivybridge Boulevard. Based on the *ECM* criteria, this lane should be 155 feet long plus a 160-foot taper.
- Based on the 2041 total traffic volumes shown in Figure 12a and the criteria contained in the *ECM*, a southbound left-turn lanes will **not** be required on Eastonville Road

approaching Dawlish. However, LSC recommends a left-turn lane be provided at this intersection. This section of Eastonville Road was included in the *Eastonville Road Project Conceptual Design Report* by Wilson & Company, dated April 2021. The proposed cross section includes a left-turn lane in the center median.

- Based on the 2041 total traffic volumes shown in Figure 12a and the criteria contained in the *ECM*, a southbound left-turn lane will be required on Eastonville Road approaching Brixham. This section of Eastonville Road was included in the *Eastonville Road Project Conceptual Design Report* by Wilson & Company, dated April 2021. The proposed cross section includes a left-turn lane in the center median.
- Based on the short-term (Year 2026) total traffic volumes shown in Figure 11a and the criteria contained in the *ECM*, northbound right-turn deceleration lanes will be required on Eastonville Road approaching Dawlish Drive and Brixham Drive). Based on the *ECM* criteria, these lanes should be 155 feet long plus a 160-foot taper.
- Based on the short-term (Year 2026) total traffic volumes shown in Figure 11a and the criteria contained in the *ECM*, a northbound left-turn lane will be required on Ivybridge Boulevard approaching Rex Road. This lane should be ~~225~~155 feet long plus a ~~75~~90-foot reverse curve taper.
- Based on the 2041 total traffic volumes shown in Figure 12b and the criteria contained in the *ECM*, a northbound left-turn lane will **not** be required on Ivybridge Boulevard approaching the full-movement church access. However, LSC recommends 155 feet long plus a 160-foot taper be constructed at this location.
- Based on the 2041 total traffic volumes shown in Figure 12b and the criteria contained in the *ECM*, a southbound right-turn deceleration lane will be required on Ivybridge Boulevard approaching the full-movement church access. This lane should be 155 feet long plus a 90-foot reverse-curve taper. A southbound right-turn deceleration lane is not projected to be required approaching the right-in/right-out church access.
- Based on the 2041 total traffic volumes shown in Figure 12b and the criteria contained in the *ECM*, a southbound left-turn lane will be required on Ivybridge Boulevard approaching Dawlish Drive. This lane should be 155 feet long plus a 160-foot taper. As this is planned to be a T-intersection, a separate right-turn lane could be provided instead.

* * * * *

Please contact me if you have any questions or need further assistance.

Sincerely,

LSC TRANSPORTATION CONSULTANTS, INC.

By: Jeffrey C. Hodsdon, P.E.
Principal

JCH/KDF:jas

Enclosures: Tables 2-5
Figures 1-13
Appendix Table 1
MTCP Maps
Map 15 Bicycle and Pedestrian Network Improvements
Traffic Count Reports
Crash History Data
Level of Service Reports
Queuing Reports

Tables



Table 2
Trip Generation Estimate
Grandview Reserve Phase 1 Preliminary Plan

| Land Use Code | Land Use Description | Trip Generation Units | Trip Generation Rates ⁽¹⁾ | | | | | Total Trips Generated | | | | | Internal Trips (%) | Internal Trips | | | | | External Trips Generated | | | | |
|---------------|--------------------------------|-----------------------|--------------------------------------|----------------------|-----------------------|------------------------|-------------------------|-------------------------|----------------------|-----------------------|------------------------|-------------------------|--------------------|-------------------------|----------------------|-----------------------|------------------------|-------------------------|--------------------------|----------------------|-----------------------|------------------------|-------------------------|
| | | | Average Weekday Traffic | Morning Peak Hour In | Morning Peak Hour Out | Afternoon Peak Hour In | Afternoon Peak Hour Out | Average Weekday Traffic | Morning Peak Hour In | Morning Peak Hour Out | Afternoon Peak Hour In | Afternoon Peak Hour Out | | Average Weekday Traffic | Morning Peak Hour In | Morning Peak Hour Out | Afternoon Peak Hour In | Afternoon Peak Hour Out | Average Weekday Traffic | Morning Peak Hour In | Morning Peak Hour Out | Afternoon Peak Hour In | Afternoon Peak Hour Out |
| 560 | Church | 500 seats | 0.90 | 0.04 | 0.03 | 0.05 | 0.06 | 450 | 21 | 14 | 23 | 28 | 0% | 0 | 0 | 0 | 0 | 0 | 450 | 21 | 14 | 23 | 28 |
| 565 | Day Care Center | 30 Students | 5.13 | 0.50 | 0.44 | 0.40 | 0.46 | 154 | 15 | 13 | 12 | 14 | 0% | 0 | 0 | 0 | 0 | 0 | 154 | 15 | 13 | 12 | 14 |
| 495 | Recreational Community Center | 3 KSF | 29.91 | 1.26 | 0.65 | 3.44 | 3.88 | 90 | 4 | 2 | 10 | 12 | 75% | 68 | 3 | 2 | 8 | 9 | 22 | 1 | 0 | 2 | 3 |
| 210 | Single-Family Detached Housing | 565 DU ⁽²⁾ | 9.05 | 0.18 | 0.54 | 0.60 | 0.35 | 5,115 | 101 | 304 | 337 | 198 | 1% | 68 | 2 | 3 | 9 | 8 | 5,047 | 99 | 301 | 328 | 190 |
| | | | | | | | | 5,809 | 141 | 333 | 382 | 252 | | 136 | 5 | 5 | 17 | 17 | 5,673 | 136 | 328 | 365 | 235 |

Notes:

(1) Source: "Trip Generation, 11th Edition, 2021" by the Institute of Transportation Engineers (ITE).

The trip generation rates shown were calculated using on the fitted curve equations. The morning and afternoon peak hour rates shown are for the peak hour of adjacent street traffic.

(2) DU = dwelling unit

Source: LSC Transportation Consultants, Inc.

May-22

Table 3
2026 Level of Service Analysis
Grandview Reserve Phase 1

| Intersection | Traffic Control | Movement | Existing Traffic | | 2026 Background Traffic | | 2026 Total Traffic | |
|-----------------------------|---------------------|--------------------------|------------------|-----|-------------------------|-----|--------------------|-----|
| | | | AM | PM | AM | PM | AM | PM |
| #1 Rex/Eastonville | TWSC | Northbound Left | --- | --- | A | A | A | A |
| | | Eastbound Left | --- | --- | B | C | B | C |
| | | Eastbound Through | --- | --- | --- | --- | B | C |
| | | Eastbound Right | --- | --- | B | A | B | A |
| | | Westbound Left | --- | --- | --- | --- | C | D |
| | | Westbound Through/Right | --- | --- | --- | --- | B | C |
| | | Southbound Left | --- | --- | --- | --- | A | A |
| #2 Rex/Ivybridge | TWSC | Northbound Left | --- | --- | --- | --- | A | A |
| #10 Eastonville/Dawlish | TWSC | Westbound Left | --- | --- | --- | --- | C | C |
| | | Westbound Right | --- | --- | --- | --- | A | B |
| | | Southbound Left | --- | --- | --- | --- | A | A |
| #11 Eastonville/Birxham | TWSC | Westbound Left | --- | --- | --- | --- | C | C |
| | | Westbound Right | --- | --- | --- | --- | A | B |
| | | Southbound Left | --- | --- | --- | --- | A | A |
| #12 Eastonville/Londonderry | TWSC | Northbound Approach | A | A | B | A | C | B |
| | | Eastbound Left | D | B | E | C | F | E |
| | | Eastbound Right | B | A | D | B | F | B |
| #13 Eastonville/Stapleton | TWSC | Northbound Approach | A | A | --- | --- | --- | --- |
| | | Eastbound Approach | F | C | --- | --- | --- | --- |
| | | Westbound Left/Through | F | C | --- | --- | --- | --- |
| | | Westbound Right | B | A | --- | --- | --- | --- |
| | | Southbound Approach | A | A | --- | --- | --- | --- |
| | AWSC | Northbound Left | --- | --- | C | B | D | C |
| | | Northbound Right | --- | --- | F | F | F | F |
| | | Eastbound Left | --- | --- | B | B | C | C |
| | | Eastbound Through/Right | --- | --- | E | C | F | E |
| | | Westbound Left | --- | --- | B | B | C | C |
| | | Westbound Through/Right | --- | --- | F | F | F | F |
| | | Southbound Left | --- | --- | F | C | --- | --- |
| | | Southbound Through/Right | --- | --- | F | C | F | F |
| | | Southbound Through | --- | --- | --- | --- | F | E |
| | Southbound Right | --- | --- | --- | --- | C | C | |
| | Signal | Eastbound Left | --- | --- | --- | --- | B | B |
| | | Eastbound Through/Right | --- | --- | --- | --- | C | C |
| | | Westbound Left | --- | --- | --- | --- | B | B |
| | | Westbound Through | --- | --- | --- | --- | C | C |
| | | Westbound Right | --- | --- | --- | --- | A | B |
| | | Northbound Left | --- | --- | --- | --- | B | B |
| | | Northbound Through/Right | --- | --- | --- | --- | D | D |
| | | Southbound Left | --- | --- | --- | --- | D | D |
| | | Southbound Through | --- | --- | --- | --- | C | C |
| | Southbound Right | --- | --- | --- | --- | A | A | |
| | Overall | --- | --- | --- | --- | C | C | |
| | #14 US 24/Stapleton | TWSC | Eastbound Left | A | A | B | B | B |
| Eastbound Through | | | F | F | F | F | F | F |
| Eastbound Right | | | F | F | F | F | F | F |
| Westbound Left | | | B | B | F | C | F | C |
| Westbound Through | | | F | F | F | F | F | F |
| Westbound Right | | | E | E | F | F | F | F |
| Northbound Left | | | A | A | B | B | B | B |
| Southbound Left | | A | A | A | A | A | A | |
| Signal | | Eastbound Left | --- | --- | --- | --- | D | D |
| | | Eastbound Through | --- | --- | --- | --- | D | D |
| | | Eastbound Right | --- | --- | --- | --- | A | A |
| | | Westbound Left | --- | --- | --- | --- | C | C |
| | | Westbound Through | --- | --- | --- | --- | D | D |
| | | Westbound Right | --- | --- | --- | --- | A | A |
| | | Northbound Left | --- | --- | --- | --- | B | D |
| | | Northbound Through | --- | --- | --- | --- | B | B |
| | | Northbound Right | --- | --- | --- | --- | A | A |
| | Southbound Left | --- | --- | --- | --- | A | A | |
| Southbound Through | --- | --- | --- | --- | C | C | | |
| Southbound Right | --- | --- | --- | --- | A | A | | |
| Overall | --- | --- | --- | --- | C | C | | |

Table 4
Page 1 of 2
2041 Level of Service Analysis
Grandview Reserve Phase 1

| Intersection | Traffic Control | Movement | 2041 Background Traffic | | 2041 Total Traffic | | |
|-------------------------|-------------------------|-------------------------------|-------------------------|----------|--------------------|----------|----------|
| | | | AM | PM | AM | PM | |
| #1 Rex/Eastonville | TWSC | Northbound Left | A | A | A | A | |
| | | Eastbound Left | D | F | D | F | |
| | | Eastbound Through | D | F | E | F | |
| | | Eastbound Right | B | A | B | A | |
| | | Westbound Left | F | F | F | F | |
| | | Westbound Through | C | D | C | D | |
| | | Westbound Right | A | A | A | A | |
| | | Southbound Left | A | A | A | A | |
| | Roundabout | Eastbound Left/Through/Right | B | A | C | B | |
| | | Westbound Left/Through/Right | B | B | B | B | |
| | | Northbound Left/Through/Right | A | C | A | C | |
| | | Southbound Left/Through/Right | B | A | B | A | |
| | | Overall | B | C | B | C | |
| | Signal | Eastbound Left | B | B | B | B | |
| | | Eastbound Through | C | C | C | C | |
| | | Eastbound Right | A | A | A | A | |
| | | Westbound Left | C | B | C | B | |
| | | Westbound Through | B | C | B | C | |
| | | Westbound Right | A | A | A | A | |
| | | Northbound Left | B | B | B | B | |
| | | Northbound Through | C | C | C | C | |
| | | Northbound Right | A | A | A | A | |
| | | Southbound Left | B | B | B | B | |
| | | Southbound Through | C | C | C | C | |
| | | Southbound Right | A | A | A | A | |
| | | Overall | B | B | B | B | |
| | #2 Rex/Ivybridge | TWSC | Northbound Left | C | C | C | C |
| | | | Northbound Right | B | B | B | C |
| | | | Westbound Left | A | A | A | B |
| | | Roundabout | Eastbound Through/Right | A | A | A | B |
| | | | Westbound Left/Through | A | A | A | B |
| | | | Northbound Left/Right | A | A | A | C |
| | | | Overall | A | A | A | A |
| #3 Rex/Future Access | TWSC | Eastbound Left | A | A | A | A | |
| | | Southbound Approach | C | C | C | C | |
| #9 Rex/US 24 | Signal | Eastbound Left | D | D | D | D | |
| | | Eastbound Right | A | A | A | A | |
| | | Northbound Left (2) | D | D | D | D | |
| | | Northbound Through (2) | FREE | FREE | FREE | FREE | |
| | | Southbound Through (2) | B | C | B | C | |
| | | Southbound Right | A | A | A | A | |
| Overall | B | C | B | C | | | |
| #10 Eastonville/Dawlish | TWSC | Westbound Left | C | C | E | D | |
| | | Westbound Right | A | A | B | B | |
| | | Southbound Left | A | A | A | B | |
| | Roundabout | Westbound Left/Right | A | A | A | A | |
| | | Northbound Through/Right | A | A | A | B | |
| | | Southbound Left/Through | B | A | B | A | |
| | | Overall | A | A | B | B | |
| | Signal | Westbound Left | --- | --- | D | D | |
| | | Westbound Right | --- | --- | B | B | |
| | | Northbound Through | --- | --- | A | A | |
| | | Northbound Right | --- | --- | A | A | |
| | | Southbound Left | --- | --- | A | A | |
| | | Southbound Through | --- | --- | B | A | |
| | Overall | --- | --- | B | A | | |
| | #11 Eastonville/Birxham | TWSC | Westbound Left | A | A | D | D |
| Westbound Right | | | B | C | B | C | |
| Southbound Left | | | A | B | A | B | |
| Roundabout | | Westbound Left/Right | A | A | A | B | |
| | | Northbound Through/Right | A | B | A | D | |
| | | Southbound Left/Through | B | A | D | A | |
| | | Overall | B | B | C | C | |

**Table 4
Page 2 of 2
2041 Level of Service Analysis
Grandview Reserve**

| Intersection | Traffic Control | Movement | 2041 Background Traffic | | 2041 Total Traffic | | |
|--|---------------------------|--------------------------|-------------------------|----------|--------------------|----------|---|
| | | | AM | PM | AM | PM | |
| #12 Eastonville/Londonderry | TWSC | Northbound Left | C | B | C | B | |
| | | Eastbound Left | F | F | F | F | |
| | | Eastbound Right | F | B | F | C | |
| | Roundabout | Eastbound Left | A | A | A | A | |
| | | Eastbound Right | B | A | C | A | |
| | | Northbound Left | A | A | A | A | |
| | | Northbound Through | A | B | A | C | |
| | | Southbound Through | B | A | B | A | |
| | | Southbound Through/Right | A | A | B | A | |
| | Overall | A | A | B | B | | |
| | Signal | Eastbound Left | D | C | D | D | |
| | | Eastbound Right | B | A | B | A | |
| | | Northbound Left | C | B | D | C | |
| | | Northbound Through (2) | A | A | A | B | |
| | | Southbound Through (2) | C | C | D | C | |
| | | Southbound Right | A | A | A | A | |
| | Overall | B | B | D | B | | |
| | #13 Eastonville/Stapleton | Signal | Eastbound Left | D | E | D | E |
| | | | Eastbound Through (2) | D | C | D | D |
| Eastbound Right | | | A | A | A | A | |
| Westbound Left | | | C | C | D | C | |
| Westbound Through (2) | | | D | D | D | D | |
| Westbound Right | | | A | A | A | B | |
| Northbound Left | | | C | C | C | C | |
| Northbound Through (1) | | | C | D | C | D | |
| Northbound Right | | | A | A | A | A | |
| Southbound Left | | | B | C | B | E | |
| Southbound Through (1) | | | D | C | D | C | |
| Southbound Right | | | A | A | A | A | |
| Overall | | | C | C | C | D | |
| #14 US 24/Stapleton | Signal | Eastbound Left (2) | E | F | E | F | |
| | | Eastbound Through (2) | D | D | D | D | |
| | | Eastbound Right | A | A | A | A | |
| | | Westbound Left (2) | E | E | E | E | |
| | | Westbound Through (2) | E | D | D | D | |
| | | Westbound Right | A | A | A | A | |
| | | Northbound Left (2) | E | E | E | E | |
| | | Northbound Through (2) | C | D | C | D | |
| | | Northbound Right | A | A | A | A | |
| | | Southbound Left (2) | E | E | E | E | |
| | | Southbound Through (2) | C | C | D | D | |
| | | Southbound Right | A | A | A | A | |
| | | Overall | C | D | C | D | |
| Ivybridge/ North Church Access | TWSC | Northbound Left | --- | --- | A | A | |
| | | Eastbound Approach | --- | --- | A | B | |
| Ivybridge/ South Church Access (RIRO) | TWSC | Eastbound Right | --- | --- | A | A | |
| Ivybridge/Dawlish | TWSC | Eastbound Approach | --- | --- | A | A | |
| | | Southbound Left | --- | --- | B | B | |
| | | Southbound Right | --- | --- | A | A | |

| Table 5 Grandview Reserve Phase 1 Roadway Improvements | | | | |
|--|---|--|---|--|
| Item # | Improvement | Trigger | Timing | Responsibility |
| Roadway Segment Improvements | | | | |
| 1 | Eastonville - Stapleton to Londonderry final grading and paving | dependent on PPRTA funding priorities | TBD by EPC; PPRTA "A-List" Project | PPRTA |
| 2 | Eastonville - Londonderry to Rex final grading and paving | With Grandview Reserve development | With Grandview Reserve Phase 1 | Grandview Reserve if development precedes Eastonville Road construction by EPC |
| 3 | Falcon Regional Trail east of Eastonville Road along the site frontage | With Grandview Reserve development | With Grandview Reserve Phase 1 | Grandview Reserve if development precedes Eastonville Road construction by EPC |
| 4 | Eastonville - Rex to Latigo initial grading and paving | average daily traffic > 300 vehicles per day | TBD by EPC; PPRTA "A-List" Project | PPRTA or developers |
| 5 | Eastonville - Rex to Latigo upgrade to Rural Minor Arterial (per MTCP) | dependent on PPRTA funding priorities | TBD by EPC | PPRTA |
| 6 | Eastonville - Stapleton to Grandview Reserve south boundary upgrade to 4-Lane Rural Minor Arterial (per MTCP) | average daily traffic > 20,000 vehicles per day | dependent on PPRTA funding priorities | PPRTA |
| 7 | Construct Rex from Eastonville to first access point east of Eastonville Road | With Grandview Reserve development | With Grandview Reserve Phase 1 | Grandview Reserve |
| 8 | Construct Rex from first access point east of Eastonville Road to US Hwy 24 Adequate right-of-way should be reserved to allow for the construction of left-turn and right-turn deceleration lanes at all potential future access points | With Grandview Reserve development | With future Grandview Reserve filings | Grandview Reserve |
| 9 | Construct Rex from Sunrise Ridge to Eastonville | With adjacent Meridian Ranch development | With future Meridian Ranch filings | Meridian Ranch |
| 10 | Stapleton Drive - US Hwy 24 to Eastonville Road complete southern (eastbound) half | average daily traffic > 18,000 vehicles per day | Shown in 2040 MTCP | El Paso County west of Eastonville Road; Waterbury Metro District east of Eastonville Road. |
| Eastonville/Stapleton | | | | |
| 11 | Construct northbound and southbound left-turn lanes on Eastonville Rd. approaching Stapleton Dr. | --- | Short-Term | PPRTA/El Paso County ⁽¹⁾ |
| 12 | Signalization of the intersection of Stapleton/Eastonville. | Once warrants are met. The decision on timing of traffic signal installation rests with El Paso County Public Works. | anticipated in the short-term | eligible intersection under the fee impact program |
| Eastonville/Rex Intersection | | | | |
| Note regarding a potential roundabout intersection instead of conventional intersection: Planning and preliminary design considerations for Eastonville Road Between Stapleton and Rex are currently in-process. The concept of roundabout traffic control is being considered as an option for some of the intersections in the corridor. | | | | |
| 13 | Construct a northbound right-turn deceleration lane on Eastonville approaching Rex Road (not needed if constructed as a modern roundabout) | northbound right-turn volume > 50 vph | With Grandview Reserve Phase 1 | Grandview Reserve |
| 14 | Construct a southbound left-turn deceleration lane on Eastonville approaching Rex Road (not needed if constructed as a modern roundabout) | southbound left-turn volume > 25 vph | With Grandview Reserve Filing 1 | Potentially included as part of the PPRTA design of Eastonville Road OR Grandview Reserve |
| 15 | Construct a westbound left-turn deceleration lane on Rex Road approaching Eastonville Road (not needed if constructed as a modern roundabout) | westbound left-turn volume > 25 vph | With Grandview Reserve Filing 1 | Grandview Reserve |
| 16 | Construct a westbound right-turn deceleration lane on Rex Road approaching Eastonville Road (not needed if constructed as a modern roundabout) | westbound right-turn volume > 50 vph | With Grandview Reserve Filing 1 | Grandview Reserve |
| 17 | Convert to traffic signal control (not needed if constructed as a modern roundabout) | Once warrants are met. The decision on timing of traffic signal installation rests with El Paso County Public Works. | With Grandview Reserve Filing 1 | likely to be considered an "eligible intersection" under the roadway improvement fee program |
| Rex/Ivybridge | | | | |
| 18 | Construct an eastbound right-turn deceleration lane on Rex Road approaching Ivybridge | eastbound right-turn volume > 50 vph | With the future extension of Rex Road east of this intersection | Grandview Reserve |
| 19 | Construct a westbound left-turn deceleration lane on Rex Road approaching Ivybridge | westbound left-turn volume > 25 vph | With the future extension of Rex Road east of this intersection | Grandview Reserve |
| Eastonville/Dawlish | | | | |
| 20 | Construct a northbound right-turn deceleration lane on Eastonville approaching Dawlish (Not needed if constructed as a modern roundabout. Intersection control is to be determined with the final plat) | northbound right-turn volume > 50 vph | With Grandview Reserve Phase 1 | Grandview Reserve |
| 21 | Construct a southbound left-turn deceleration lane on Eastonville approaching Dawlish (Not needed if constructed as a modern roundabout. Intersection control is to be determined with the final plat) | southbound left-turn volume > 25 vph | With Grandview Reserve Phase 1 | Potentially included as part of the PPRTA design of Eastonville Road OR Grandview Reserve |
| Eastonville/Brixham | | | | |
| 22 | Construct a northbound right-turn deceleration lane on Eastonville approaching Brixham (Not needed if constructed as a modern roundabout. Intersection control is to be determined with the final plat) | northbound right-turn volume > 50 vph | With Grandview Reserve Phase 1 | Grandview Reserve |
| 23 | Construct a southbound left-turn deceleration lane on Eastonville approaching Brixham (Not needed if constructed as a modern roundabout. Intersection control is to be determined with the final plat) | southbound left-turn volume > 25 vph | With Grandview Reserve Phase 1 | Potentially included as part of the PPRTA design of Eastonville Road OR Grandview Reserve |
| Ivybridge/Full-Movement Church Access | | | | |
| 24 | Construct a southbound right-turn deceleration lane on Ivybridge approaching the full-movement church access | southbound right-turn volume > 50 vph | With development of the church parcel | Grandview Reserve |
| 25 | Construct a northbound left-turn deceleration lane on Ivybridge approaching the full-movement church access | northbound left-turn volume > 25 vph | With development of the church parcel | Grandview Reserve |
| Ivybridge/Right-In/Right-Out Church Access | | | | |
| 26 | Southbound right-turn deceleration lane on Ivybridge approaching the right-in/right-out church access | southbound right-turn volume > 50 vph | NOT ANTICIPATED TO BE REQUIRED | |
| Ivybridge/Dawlish | | | | |
| 27 | Southbound right-turn deceleration lane on Ivybridge approaching Dawlish | southbound right-turn volume > 50 vph | With Grandview Reserve Phase 1 | Grandview Reserve |
| Notes: | | | | |
| (1) LSC anticipates that these turn lanes will be included in the project design. The project will be constructed by El Paso County as PPRTA project. | | | | |
| Source: LSC Transportation Consultants, Inc. (May 2022) | | | | |

Figures





Approximate Scale
Scale: 1" = 4,000'

Figure 1
Vicinity
Map

Grandview Reserve Phase 1 (LSC #S214240)

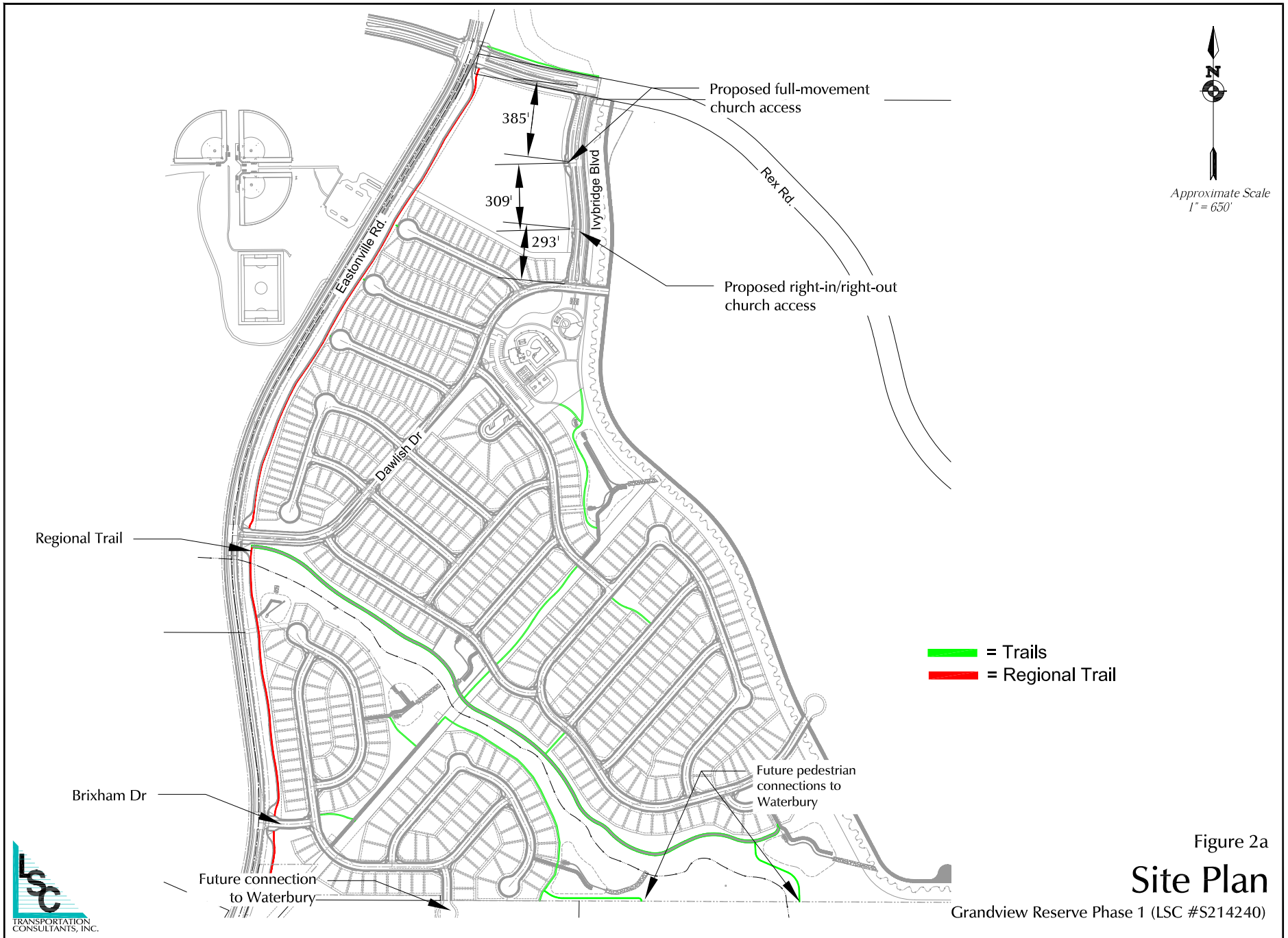

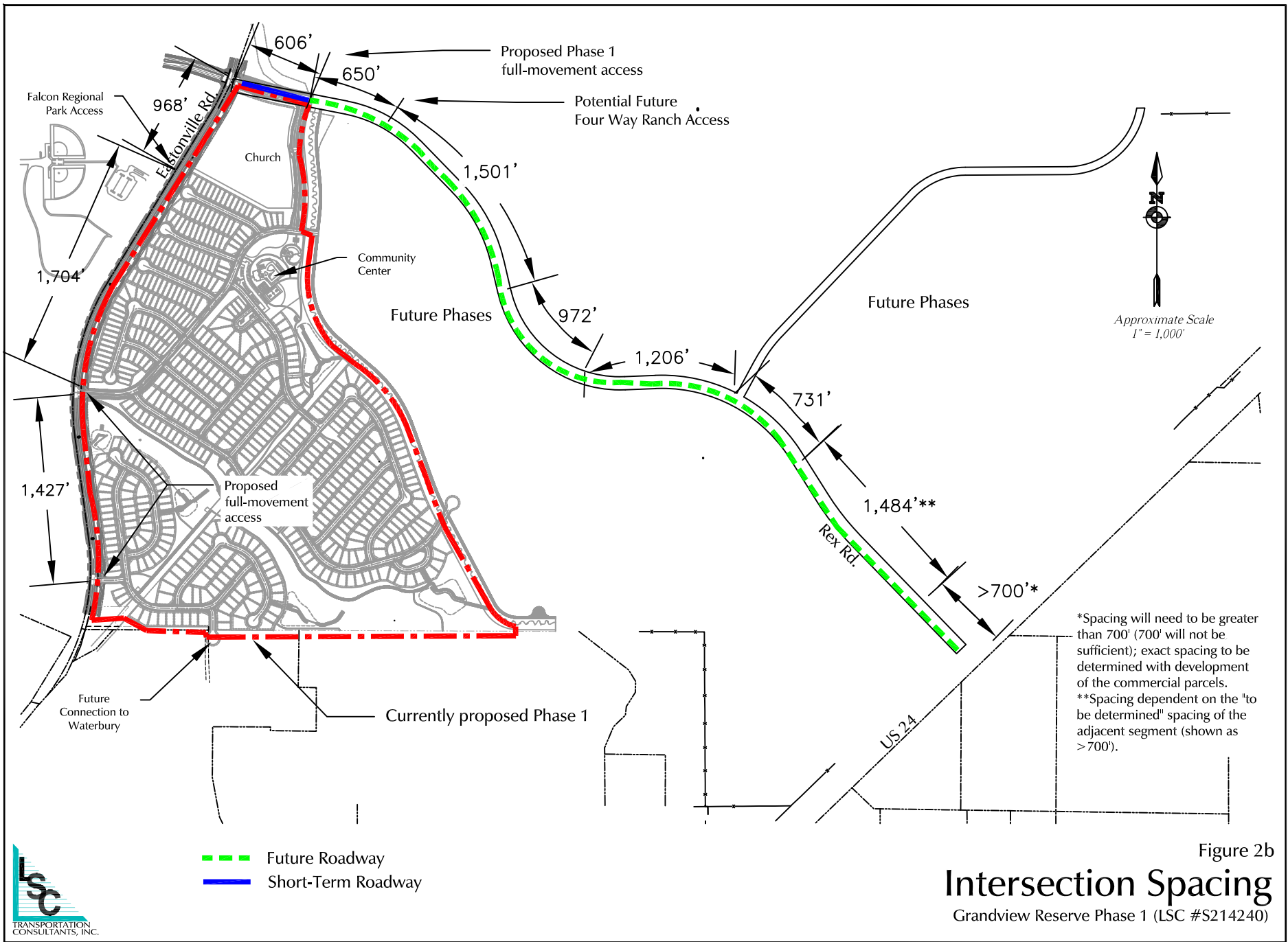

Figure 2b
Intersection Spacing
 Grandview Reserve Phase 1 (LSC #S214240)

- ECM Required Intersection Sight Distance (445' based on a design speed of 40 mph (from table 2-21))
- ECM Required Stopping Sight Distance (305' based on a design speed of 40mph (from table 2-17))



Approximate Scale
NTS

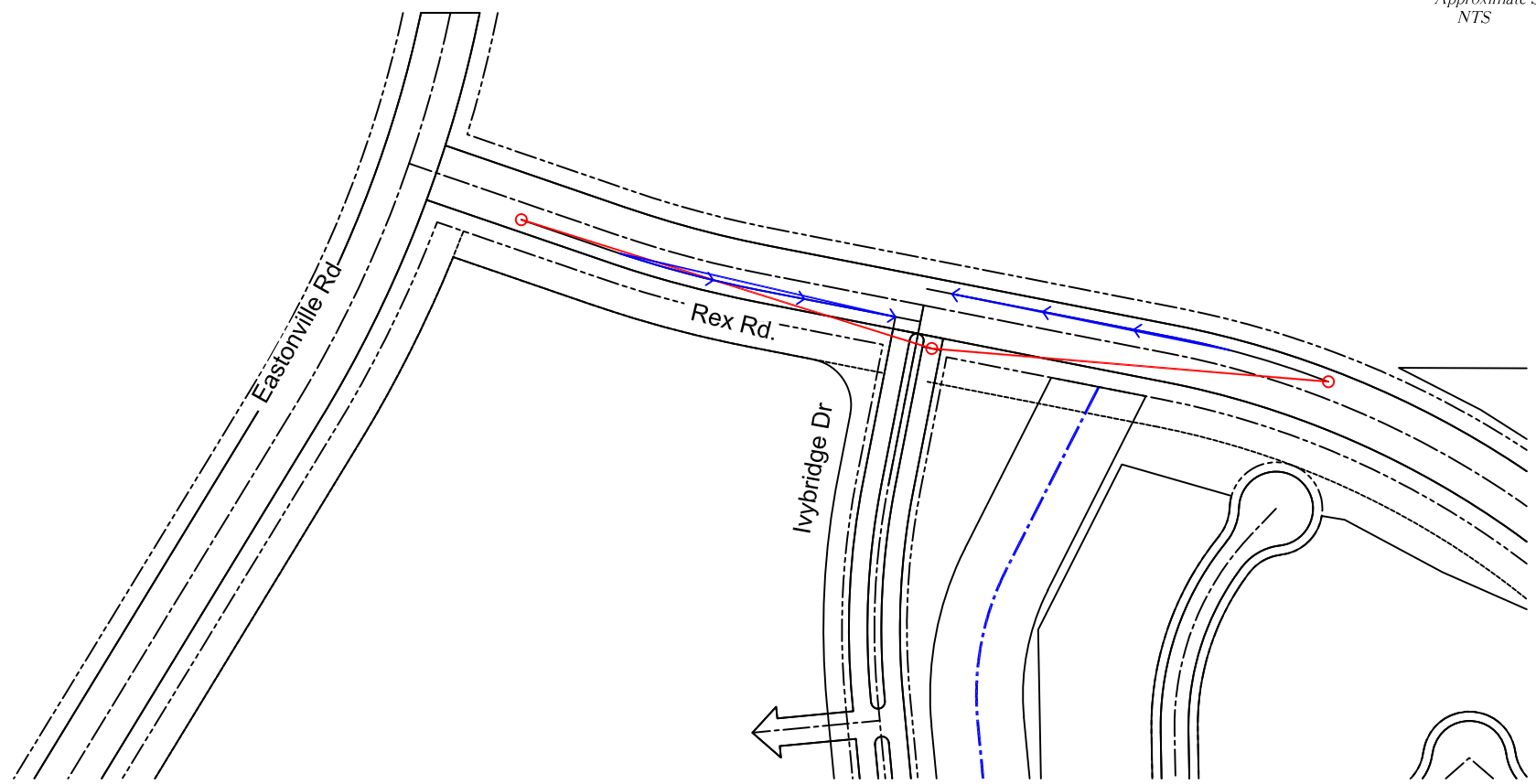
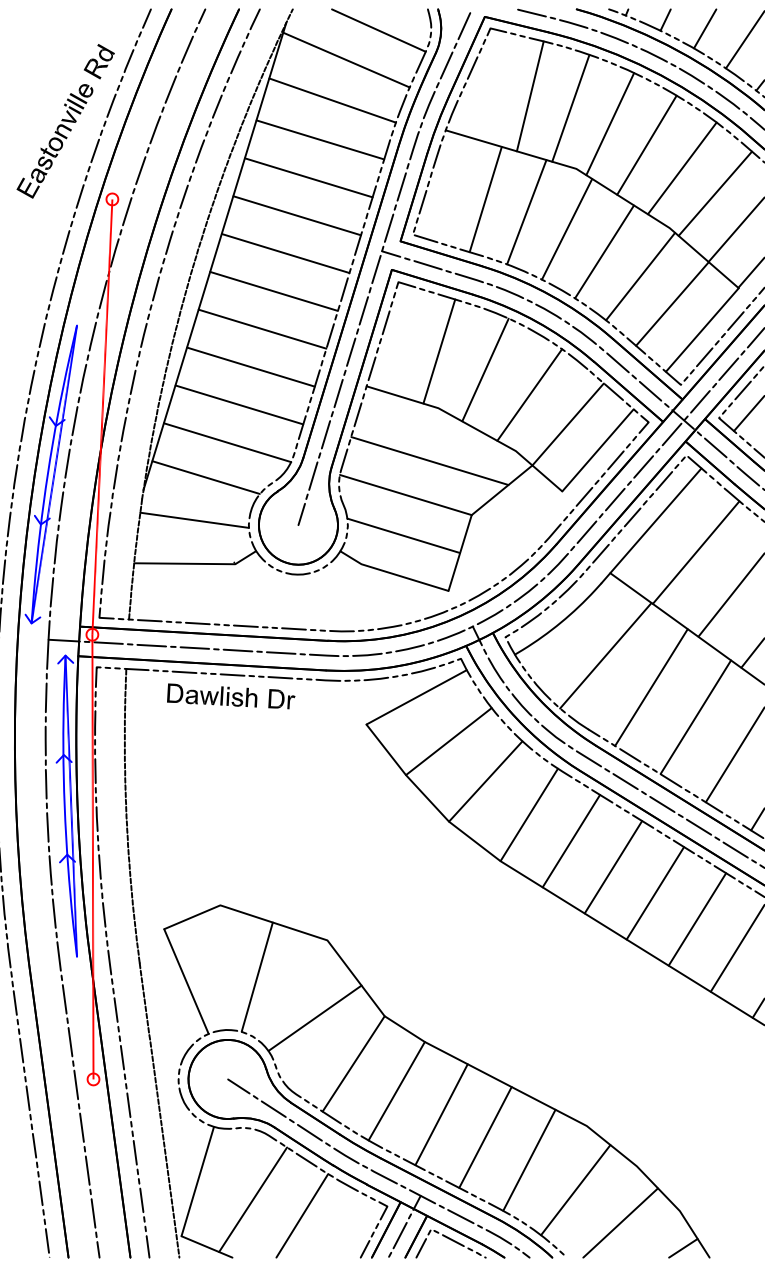

Figure 3a

Sight Distance Analysis Rex Rd/Ivybridge Dr

Grandview Reserve Phase 1 (LSC #S214240)





Approximate Scale
NTS

- ECM Required Intersection Sight Distance
(445' based on a design speed of 40 mph (from table 2-21))
- ECM Required Stopping Sight Distance
(305' based on a design speed of 40mph (from table 2-17))

Figure 3b

Sight Distance Analysis Dawlish Dr/Eastonville Rd

Grandview Reserve Phase 1 (LSC #S214240)



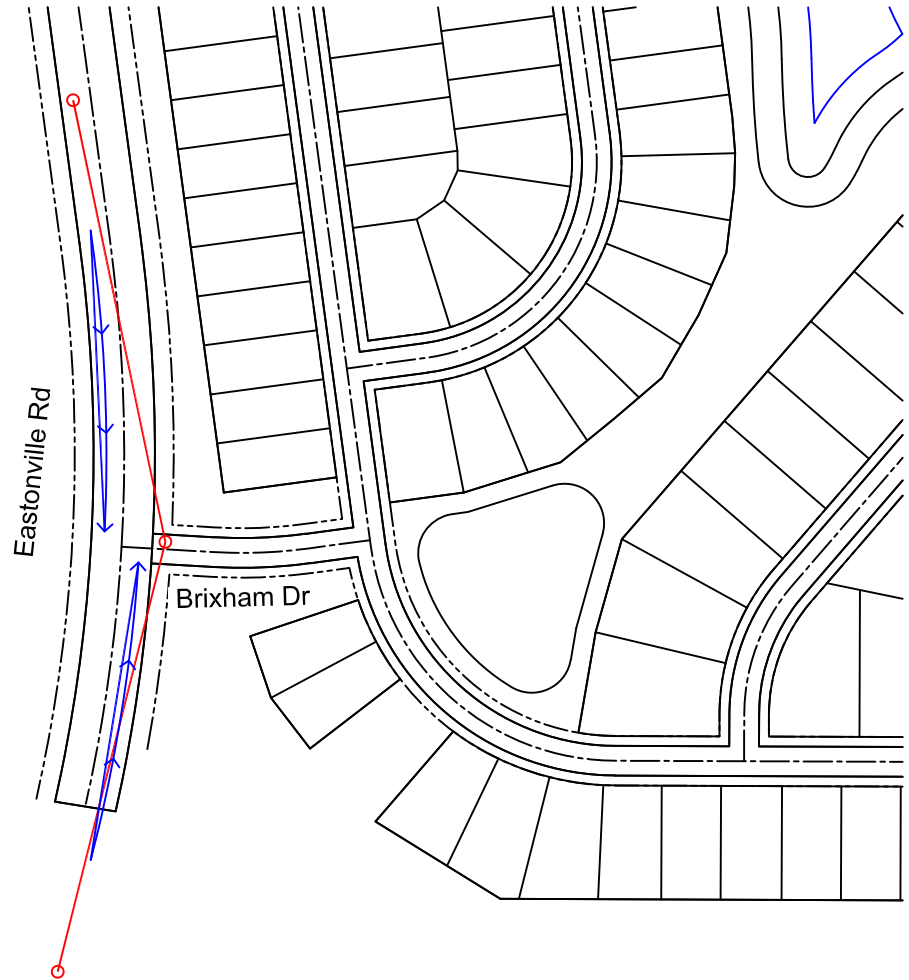

Approximate Scale
NTS

- ECM Required Intersection Sight Distance
(445' based on a design speed of 40 mph (from table 2-21))
- ECM Required Stopping Sight Distance
(305' based on a design speed of 40mph (from table 2-17))

Figure 3c

Sight Distance Analysis Brixham Dr/Eastonville Rd

Grandview Reserve Phase 1 (LSC #S214240)



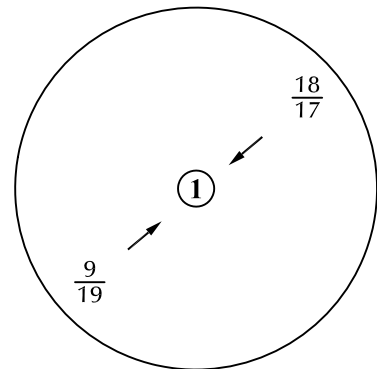

Intentionally
②
Left Blank

Intentionally
③
Left Blank

Intentionally
④
Left Blank

Intentionally
⑤
Left Blank

Intentionally
⑥
Left Blank

Intentionally
⑦
Left Blank

Intentionally
⑧
Left Blank

Intentionally
⑨
Left Blank

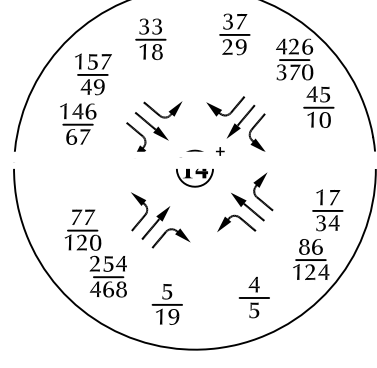
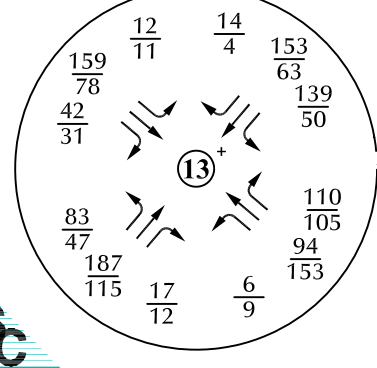
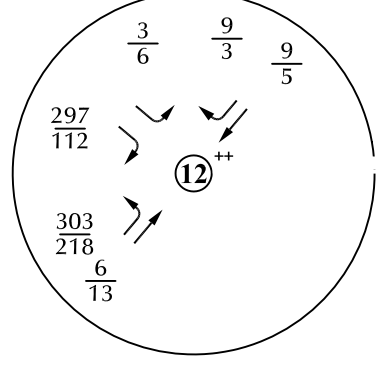
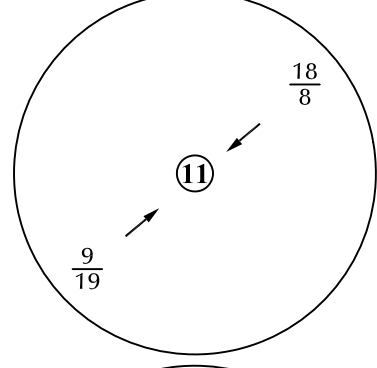
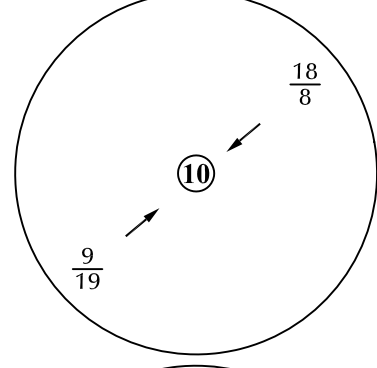

LEGEND:

$\frac{XX}{XX}$ = AM Weekday Peak-Hour Traffic (vehicles per hour)
 $\frac{XX}{XX}$ = PM Weekday Peak-Hour Traffic (vehicles per hour)
 X,XXX = Annual Average Daily Traffic (vehicles per day)

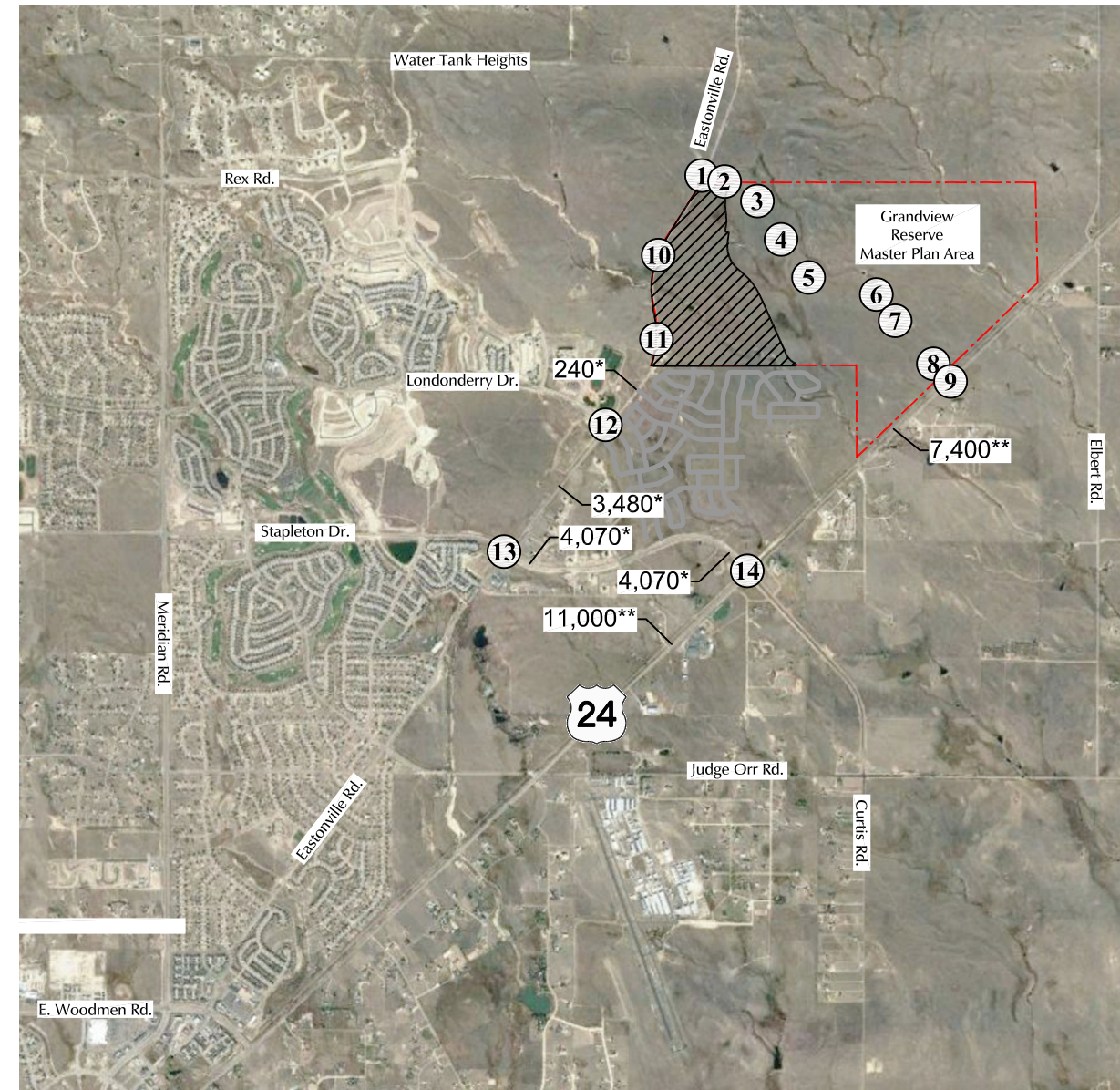
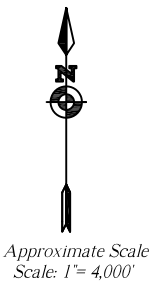

* Estimate by LSC

** CDOT 2020 Average Annual Daily Traffic

+ Based on counts by LSC October 2021

**Based on counts by LSC April 2021. The northbound left-turn and eastbound right-turn volumes have been adjusted based on the more recent counts at Stapleton/Eastonville.

Figure 4a

Existing (2021)⁺ Traffic

Grandview Reserve Phase 1 (LSC #S214240)



Intentionally
①
Left Blank

Intentionally
②
Left Blank

Intentionally
③
Left Blank

Intentionally
④
Left Blank

Intentionally
⑤
Left Blank

Intentionally
⑥
Left Blank

Intentionally
⑦
Left Blank

Intentionally
⑧
Left Blank

Intentionally
⑨
Left Blank

Intentionally
⑩
Left Blank

Intentionally
⑪
Left Blank

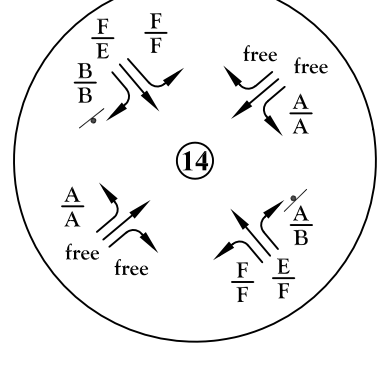
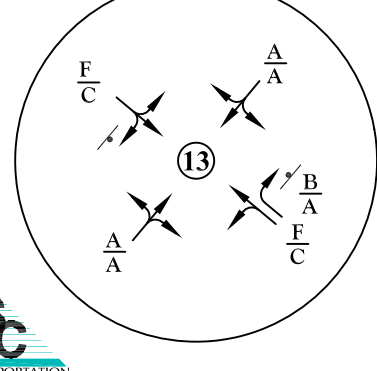
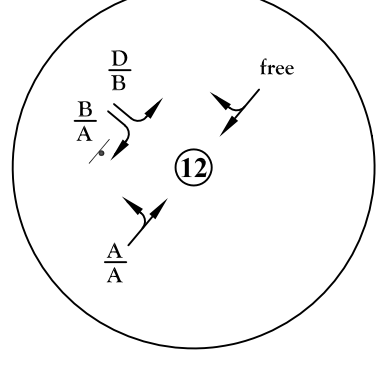

LEGEND:

Traffic Control Used in the Analysis:

↓ = Stop Sign

⊞ = Traffic Signal

LOS Analysis Results:

$\frac{A}{B}$ = AM Individual Movement Peak-Hour Level of Service

$\frac{B}{B}$ = PM Individual Movement Peak-Hour Level of Service

$\frac{C}{C}$ = AM Entire Intersection Peak-Hour Level of Service

$\frac{C}{C}$ = PM Entire Intersection Peak-Hour Level of Service



Approximate Scale
Scale: 1" = 4,000'



Figure 4b

Existing Lane Geometry, Traffic Control and Level of Service

Grandview Reserve Phase 1 (LSC #S214240)

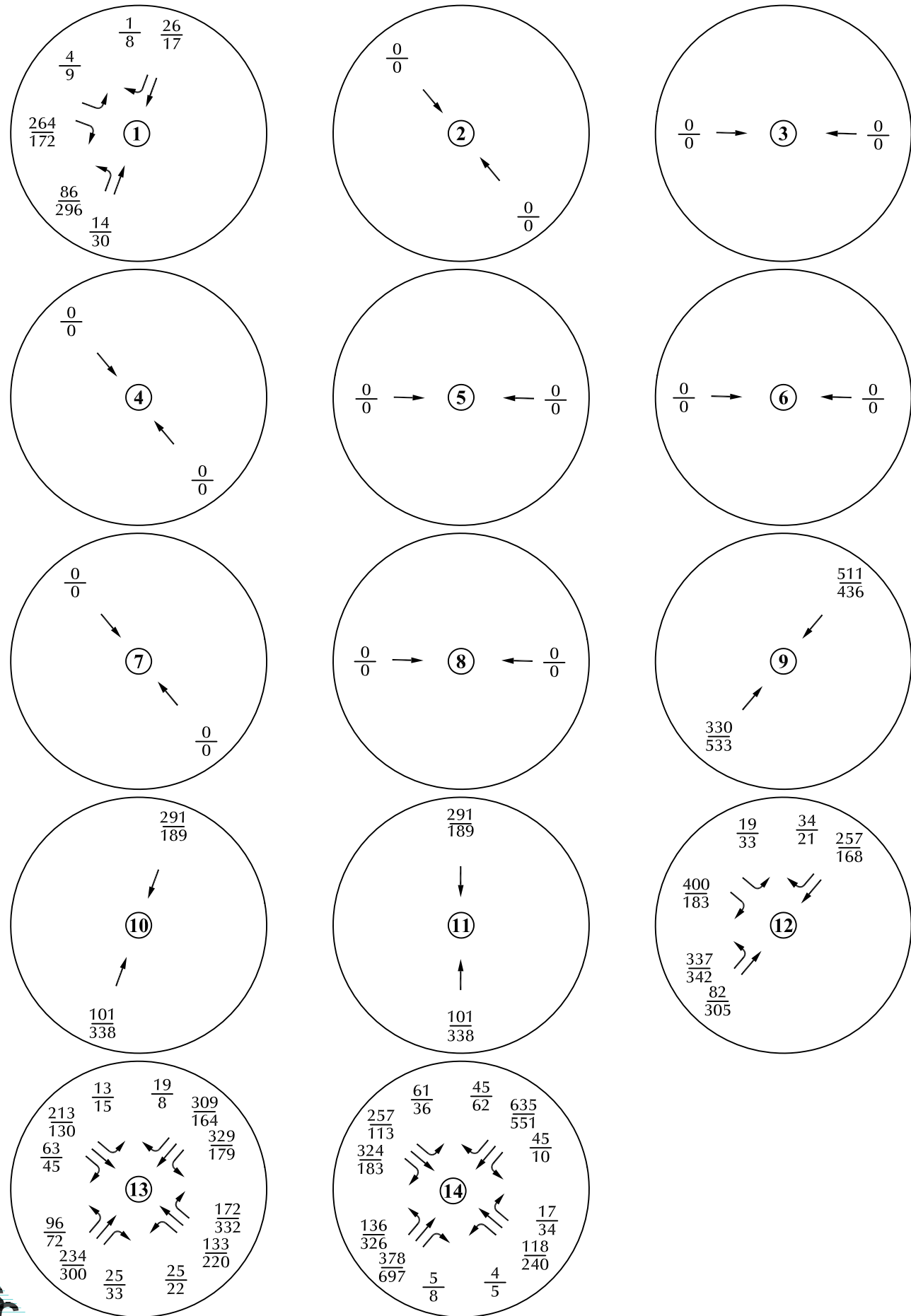

LEGEND:

$\frac{XX}{XX}$ = AM Weekday Peak-Hour Traffic (vehicles per hour)
 PM Weekday Peak-Hour Traffic (vehicles per hour)
 X,XXX = Annual Average Daily Traffic (vehicles per day)

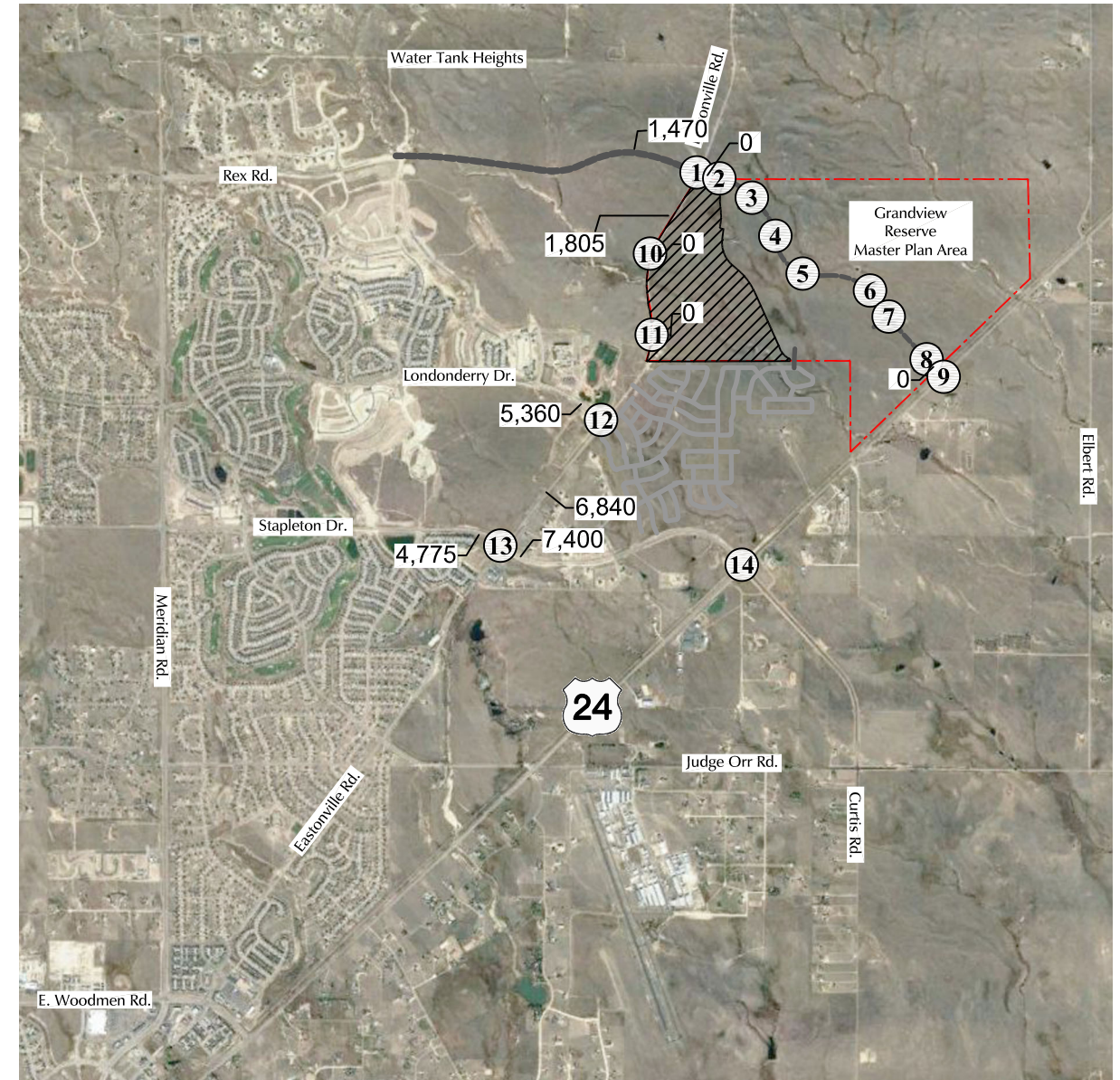
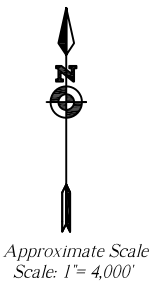
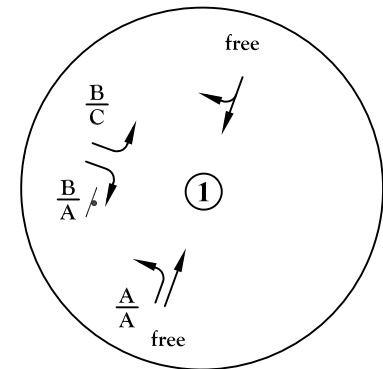

Figure 5a
 Year 2026
 Background Traffic
 Grandview Reserve Phase 1 (LSC #S214240)



Intentionally
② *
Left Blank

Intentionally
③ *
Left Blank

Intentionally
④ *
Left Blank

Intentionally
⑤ *
Left Blank

Intentionally
⑥ *
Left Blank

Intentionally
⑦ *
Left Blank

Intentionally
⑧ *
Left Blank

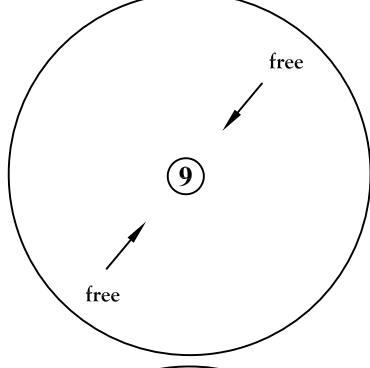

Intentionally
⑩
Left Blank

Intentionally
⑪
Left Blank

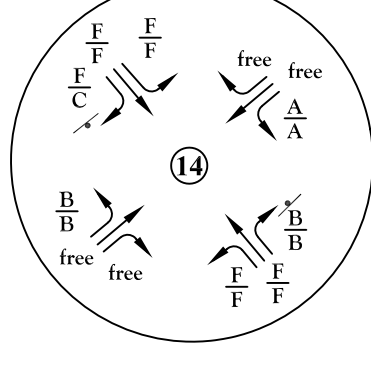
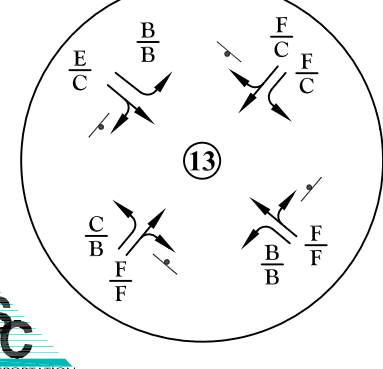
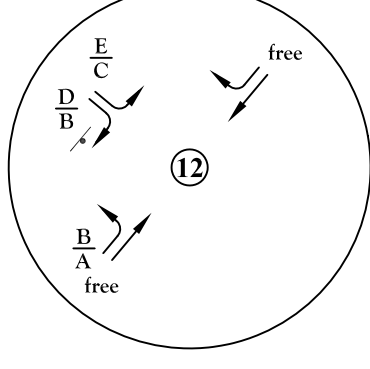

LEGEND:
Traffic Control Used in the Analysis:
⊥ = Stop Sign
⓪ = Traffic Signal
LOS Analysis Results:
A = AM Individual Movement Peak-Hour Level of Service
B = PM Individual Movement Peak-Hour Level of Service
C = AM Entire Intersection Peak-Hour Level of Service
C = PM Entire Intersection Peak-Hour Level of Service

Approximate Scale
Scale: 1" = 4,000'



*This section of Rex Rd. between Ivybridge Blvd and US 24 is not planned to be constructed with Phase 1



Figure 5b
Year 2026 Background Lane Geometry,
Traffic Control and Levels of Service
Grandview Reserve Phase 1 (LSC #S214240)

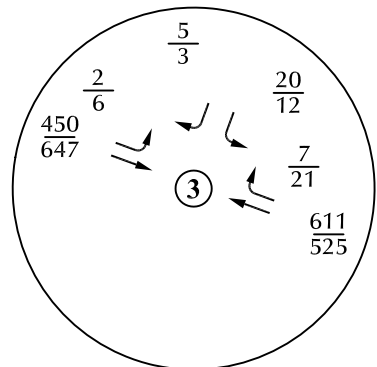
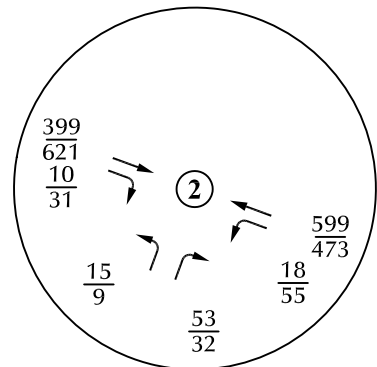
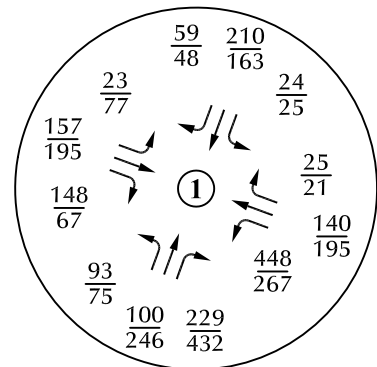

Intentionally
④
Left Blank

Intentionally
⑤
Left Blank

Intentionally
⑥
Left Blank

Intentionally
⑦
Left Blank

Intentionally
⑧
Left Blank

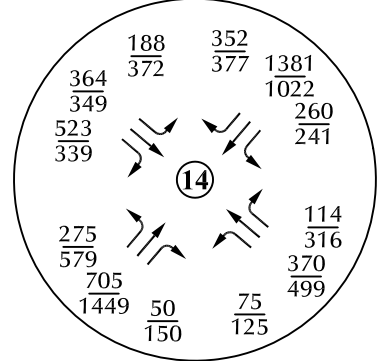
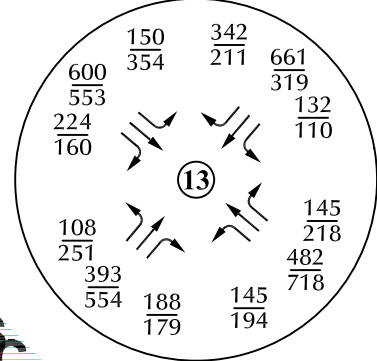
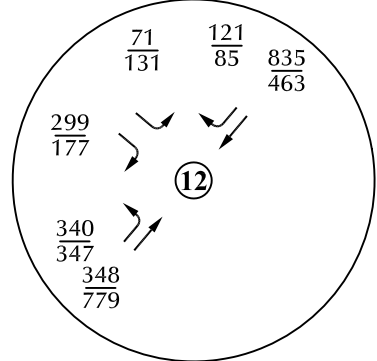
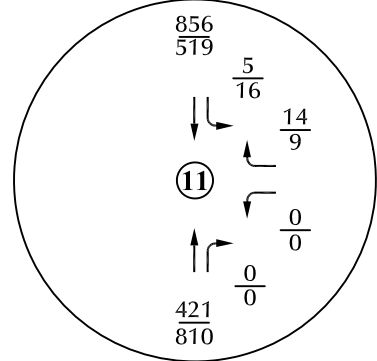
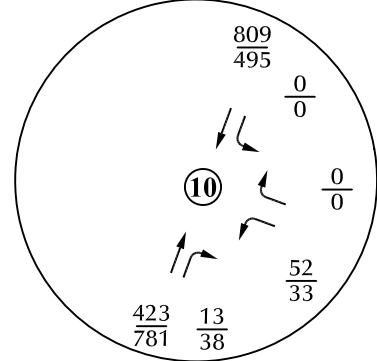
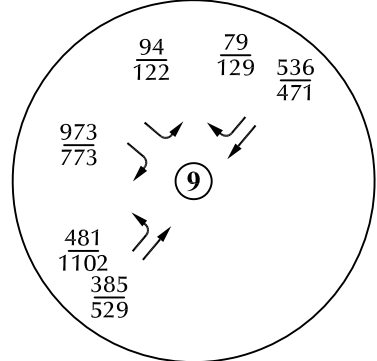

LEGEND:
 $\frac{XX}{XX}$ = AM Weekday Peak-Hour Traffic (vehicles per hour)
 $\frac{XX}{XX}$ = PM Weekday Peak-Hour Traffic (vehicles per hour)
 X,XXX = Annual Average Daily Traffic (vehicles per day)

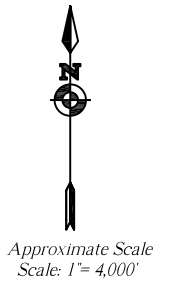

Figure 6a
 Year 2041
 Background Traffic
 Grandview Reserve Phase 1 (LSC #S214240)

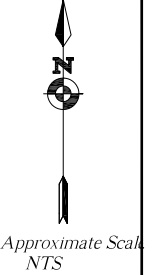
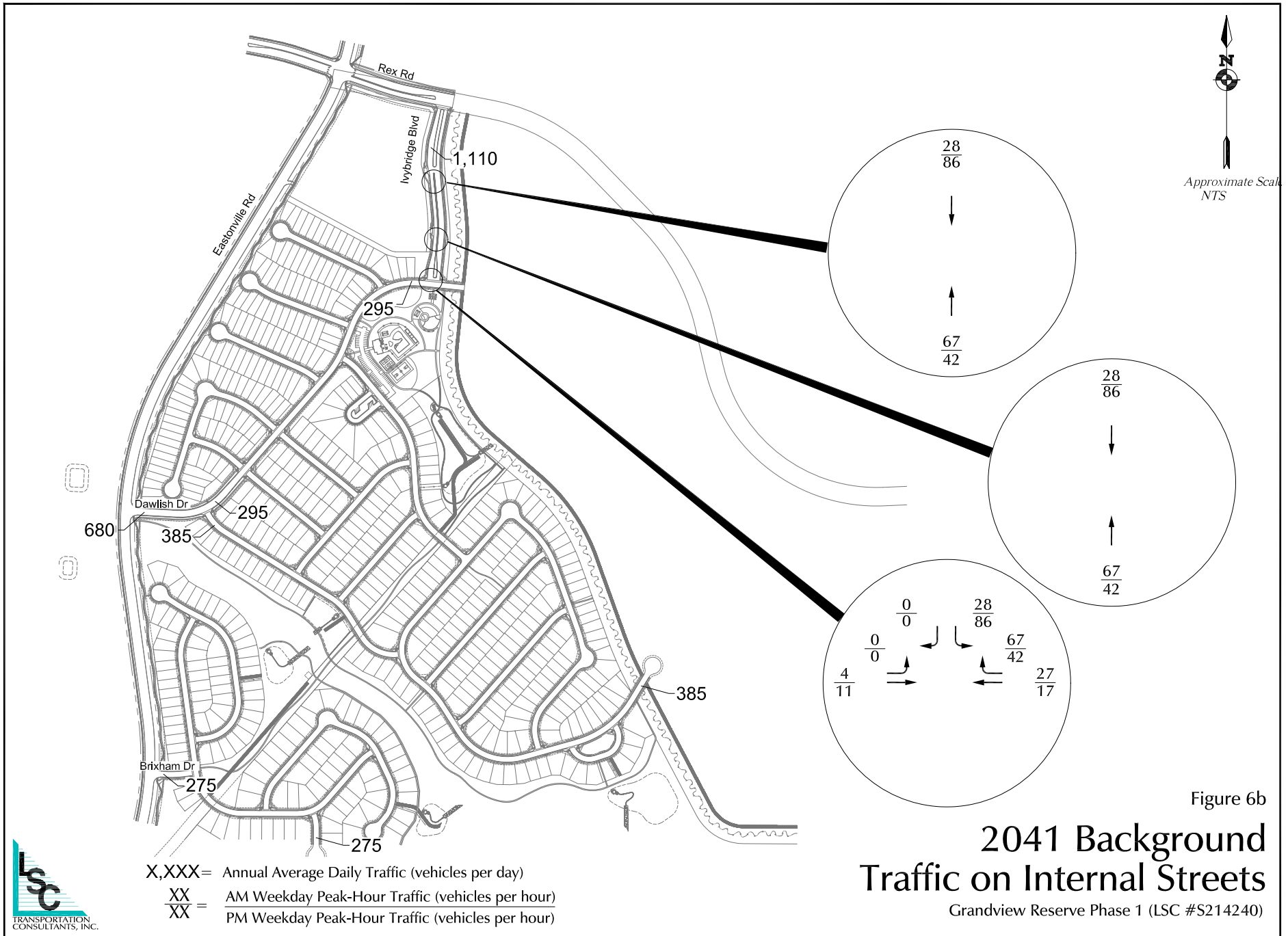
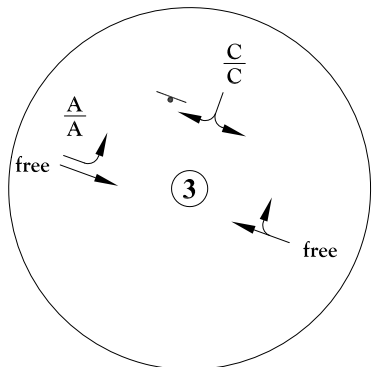
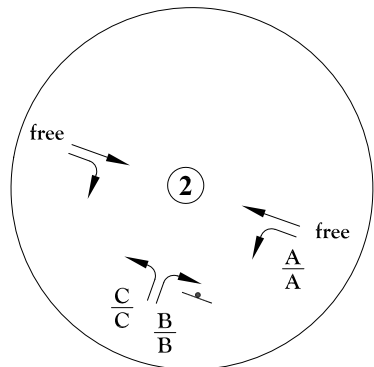
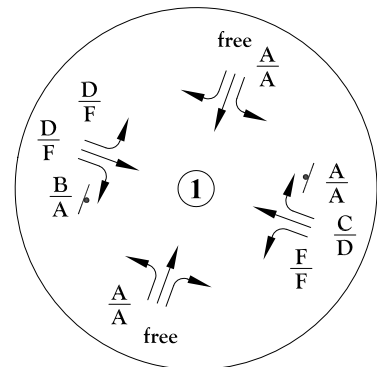

Figure 6b
2041 Background Traffic on Internal Streets
 Grandview Reserve Phase 1 (LSC #S214240)



Intentionally
④
Left Blank

Intentionally
⑤
Left Blank

Intentionally
⑥
Left Blank

Intentionally
⑦
Left Blank

Intentionally
⑧
Left Blank

Intentionally
⑨
Left Blank

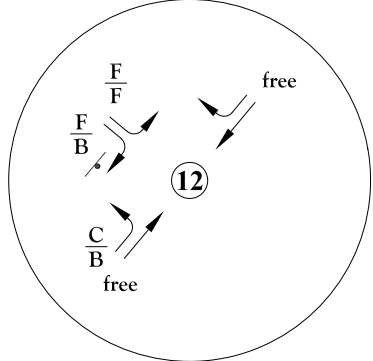
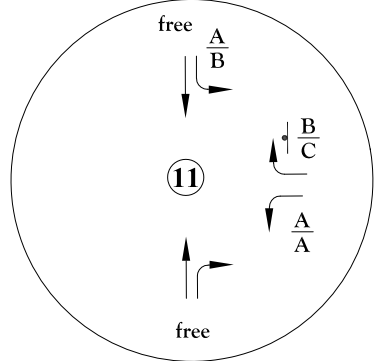
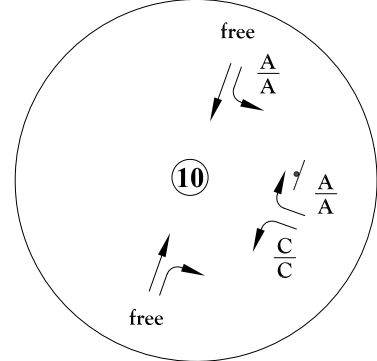

Intentionally
⑬
Left Blank

Intentionally
⑭
Left Blank

LEGEND:

Traffic Control Used in the Analysis:

- = Stop Sign
- = Traffic Signal

LOS Analysis Results:

- $\frac{A}{B}$ = AM Individual Movement Peak-Hour Level of Service
- $\frac{B}{B}$ = PM Individual Movement Peak-Hour Level of Service
- $\frac{C}{C}$ = AM Entire Intersection Peak-Hour Level of Service
- $\frac{C}{C}$ = PM Entire Intersection Peak-Hour Level of Service

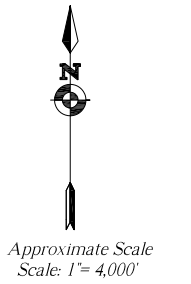
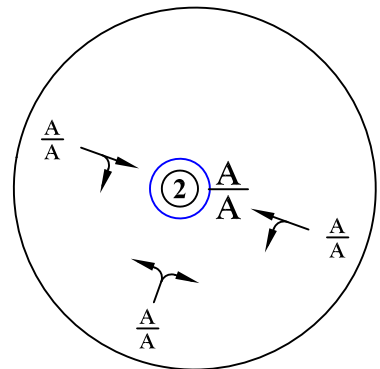
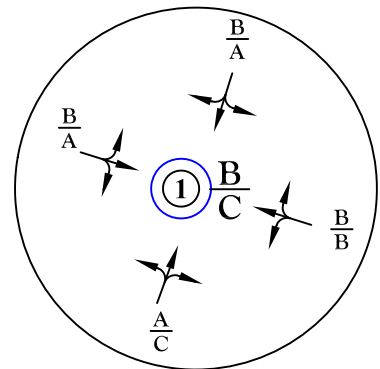

Figure 6c

Year 2041 Background Lane Geometry, Traffic Control and Levels of Service With Two-Way Stop-Sign Control

Grandview Reserve Phase 1 (LSC #S214240)



Intentionally
③
Left Blank

Intentionally
④
Left Blank

Intentionally
⑤
Left Blank

Intentionally
⑥
Left Blank

Intentionally
⑦
Left Blank

Intentionally
⑧
Left Blank

Intentionally
⑨
Left Blank

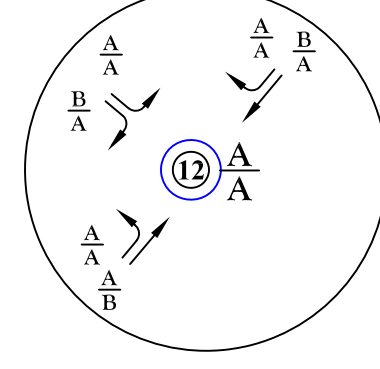
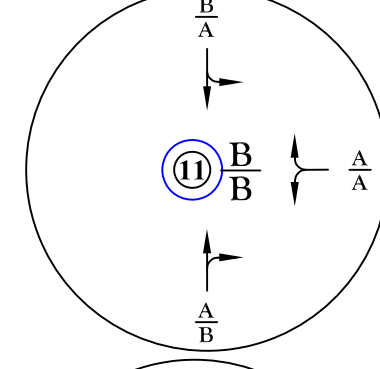
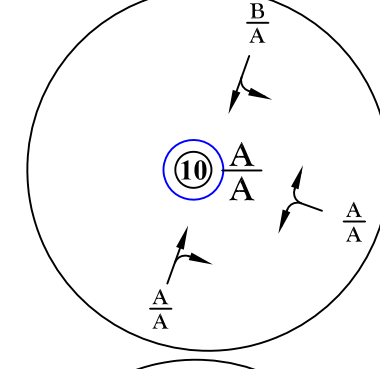

Intentionally
⑬
Left Blank

Intentionally
⑭
Left Blank

LEGEND:

Traffic Control Used in the Analysis:

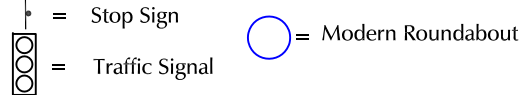

LOS Analysis Results:

- $\frac{A}{B}$ = AM Individual Movement Peak-Hour Level of Service
- $\frac{C}{C}$ = PM Individual Movement Peak-Hour Level of Service
- $\frac{C}{C}$ = AM Entire Intersection Peak-Hour Level of Service
- $\frac{C}{C}$ = PM Entire Intersection Peak-Hour Level of Service

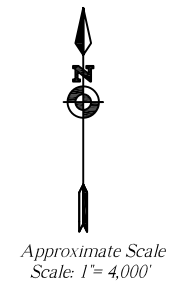
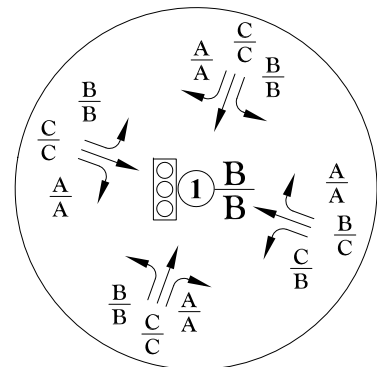

Figure 6d

Year 2041 Background Lane Geometry, Traffic Control and Levels of Service with Modern Roundabouts

Grandview Reserve Phase 1 (LSC #S214240)





Intentionally
②
Left Blank

Intentionally
③
Left Blank

Intentionally
④
Left Blank

Intentionally
⑤
Left Blank

Intentionally
⑥
Left Blank

Intentionally
⑦
Left Blank

Intentionally
⑧
Left Blank

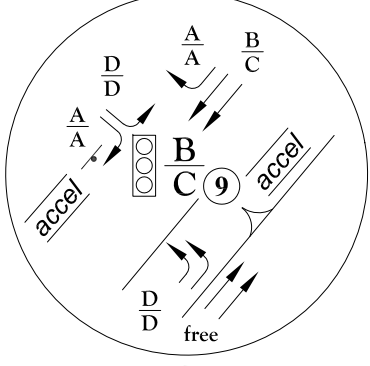

Intentionally
⑩
Left Blank

Intentionally
⑪
Left Blank

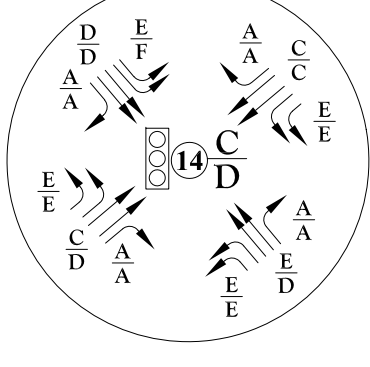
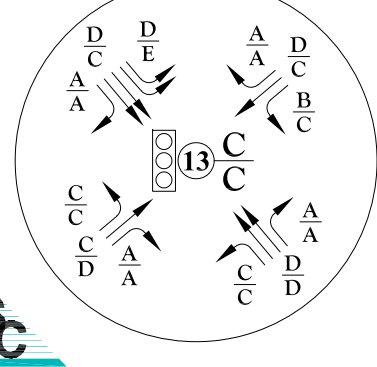
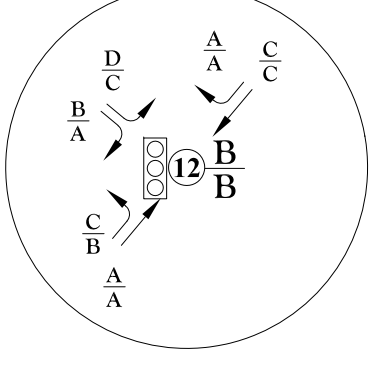

LEGEND:

Traffic Control Used in the Analysis:

- ↓ = Stop Sign
- ⊞ = Traffic Signal

LOS Analysis Results:

- $\frac{A}{B}$ = AM Individual Movement Peak-Hour Level of Service
- $\frac{B}{B}$ = PM Individual Movement Peak-Hour Level of Service
- $\frac{C}{C}$ = AM Entire Intersection Peak-Hour Level of Service
- $\frac{C}{C}$ = PM Entire Intersection Peak-Hour Level of Service

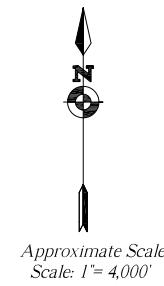

Figure 6e

Year 2041 Background Lane Geometry, Traffic Control and Levels of Service With Signal Control

Grandview Reserve Phase 1 (LSC #S214240)



Approximate Scale
Scale: 1" = 4,000'



Figure 7

Short-Term Directional Distribution of Site-Generated Traffic

LEGEND:

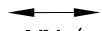

XX% = Percent Directional Distribution



Grandview Reserve Phase 1 (LSC #S214240)



Approximate Scale
Scale: 1" = 4,000'



Figure 8

Long-Term Directional Distribution of Site-Generated Traffic

LEGEND:



XX% = Percent Directional Distribution



Grandview Reserve Phase 1 (LSC #5214240)

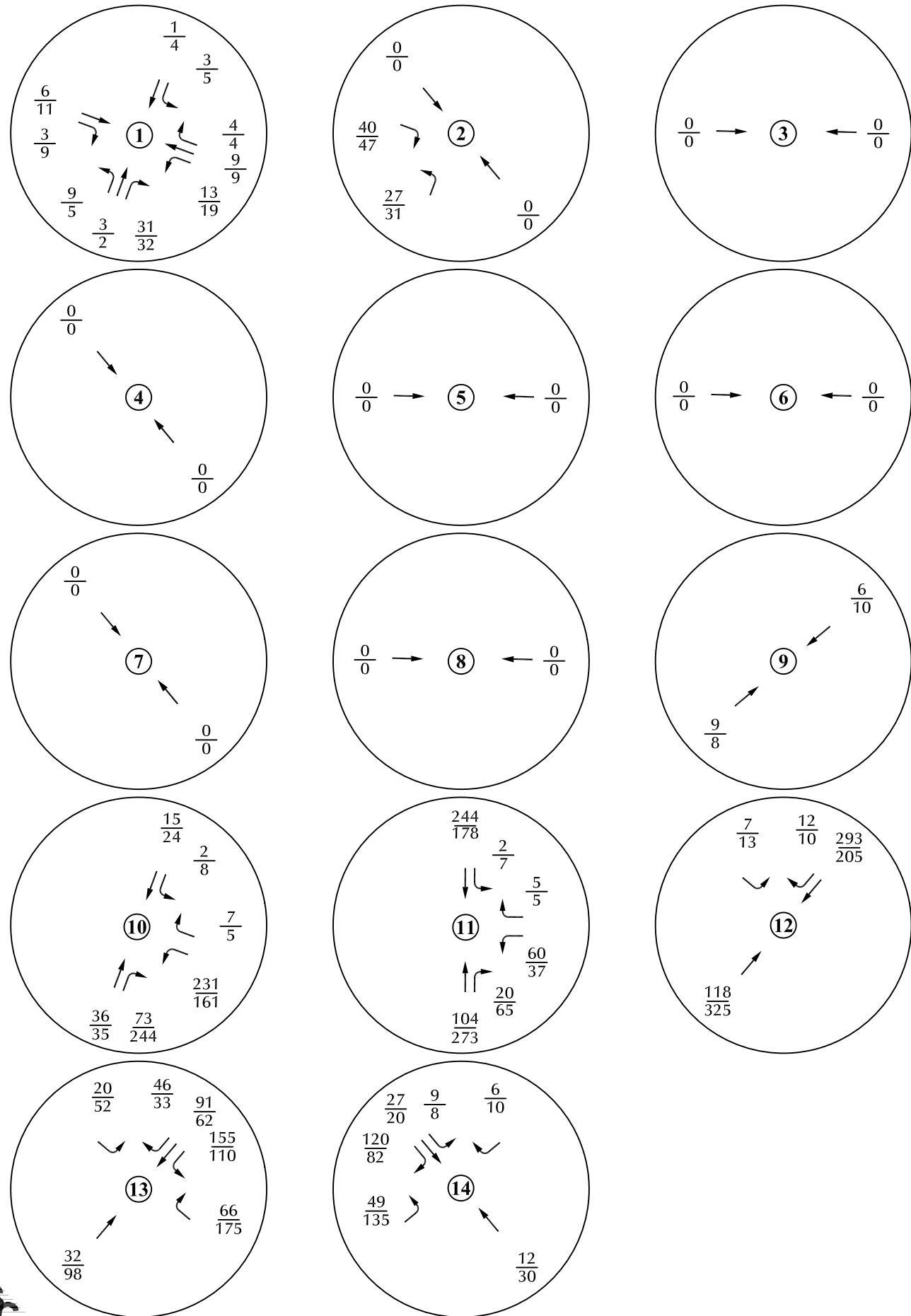

LEGEND:

$\frac{XX}{XX}$ = AM Weekday Peak-Hour Traffic (vehicles per hour)
 $\frac{XX}{XX}$ = PM Weekday Peak-Hour Traffic (vehicles per hour)
 X,XXX = Annual Average Daily Traffic (vehicles per day)

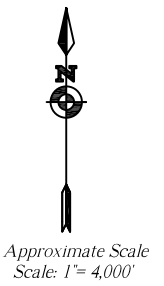

Figure 9a

Assignment of Phase 1 Short-Term Site-Generated Traffic

Grandview Reserve Phase 1 (LSC #S214240)

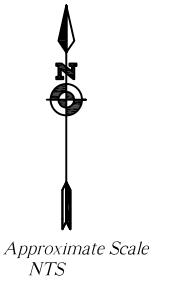
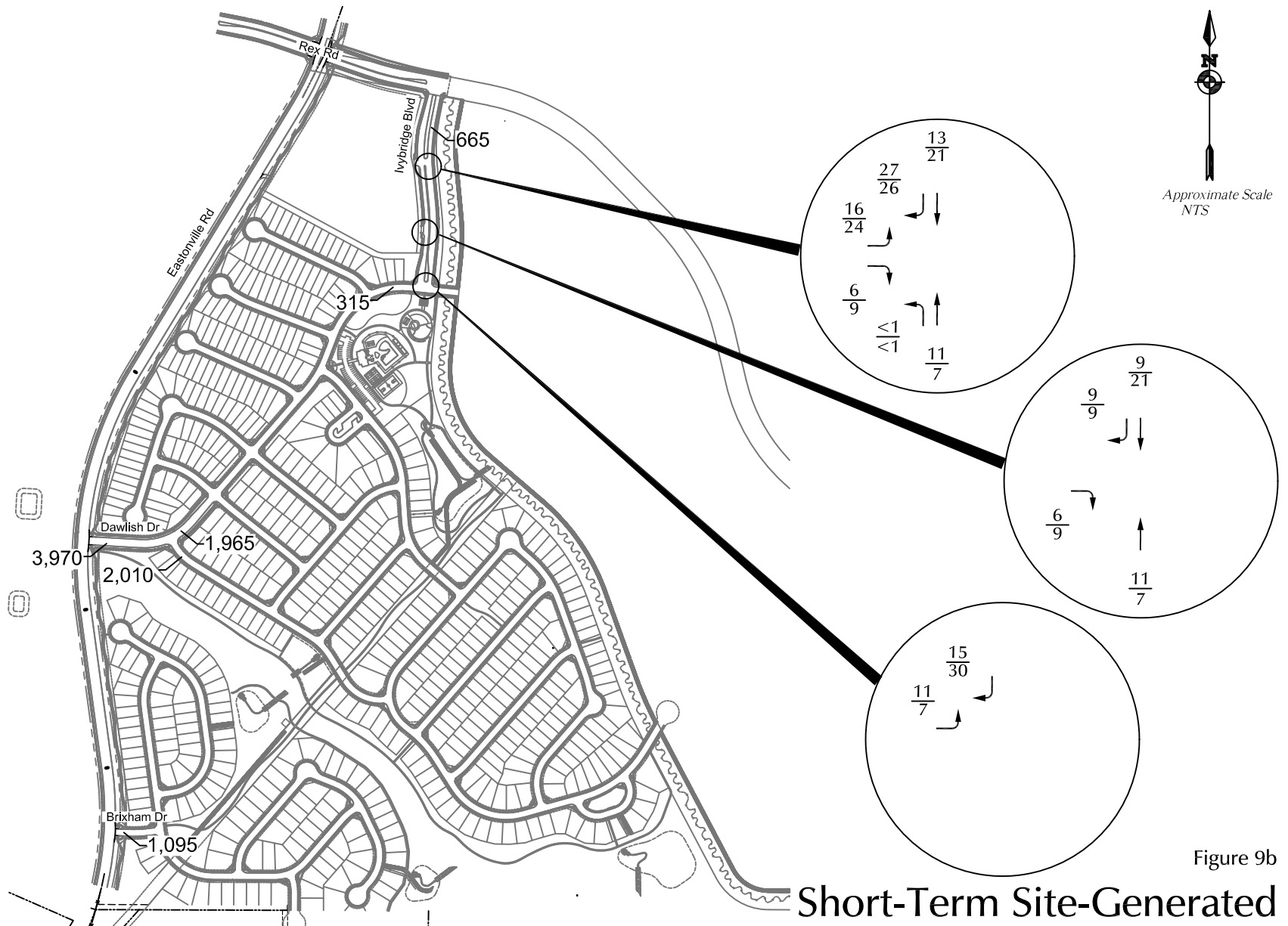

Figure 9b

Short-Term Site-Generated Traffic on Internal Streets

Grandview Reserve Phase 1 (LSC #S214240)



X,XXX = Average Daily Traffic (vehicles per day)
 XX/XX = AM Weekday Peak-Hour Traffic (vehicles per hour)
 XX/XX = PM Weekday Peak-Hour Traffic (vehicles per hour)

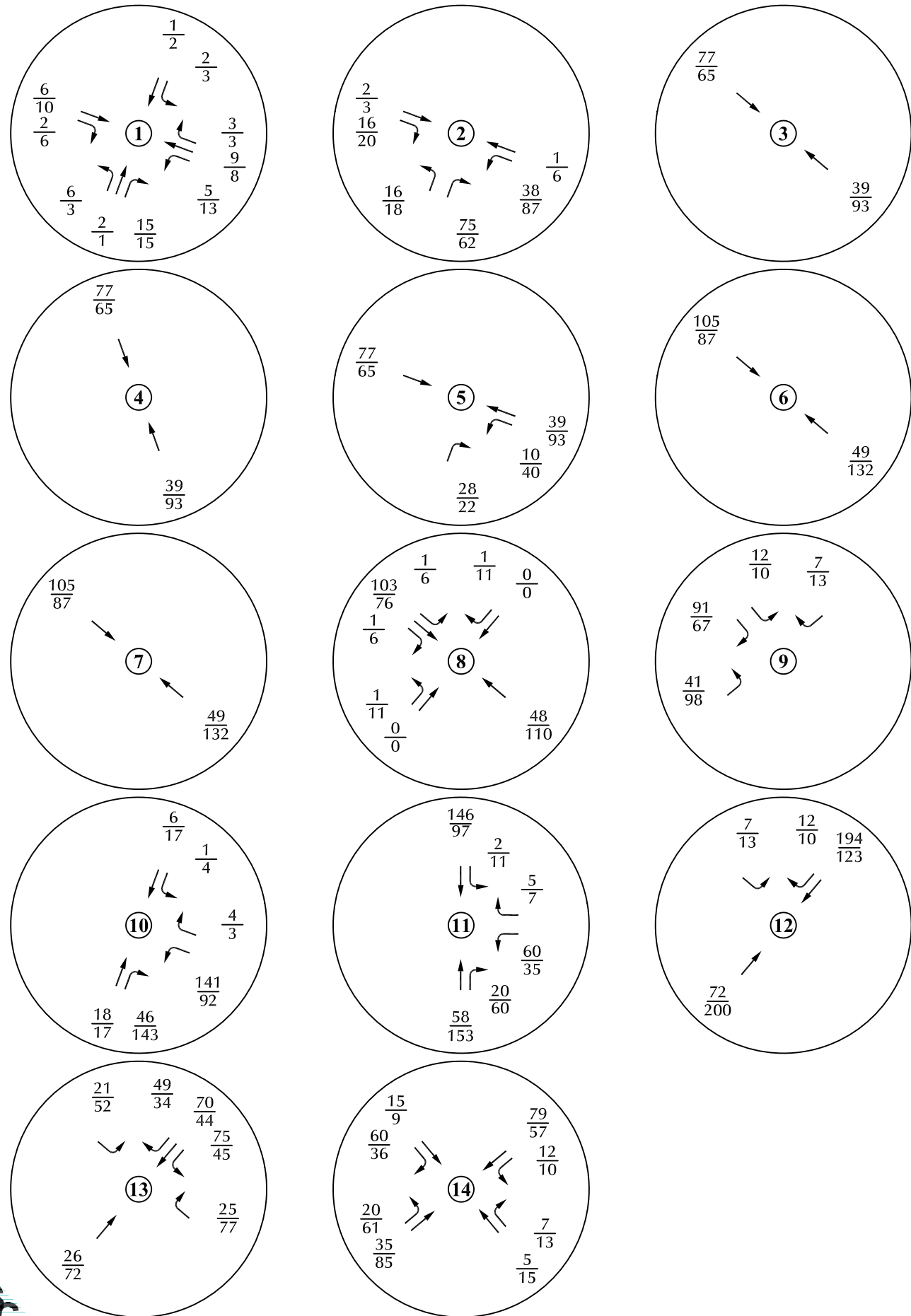

LEGEND:

$\frac{XX}{XX}$ = AM Weekday Peak-Hour Traffic (vehicles per hour)
 $\frac{XX}{XX}$ = PM Weekday Peak-Hour Traffic (vehicles per hour)
 X,XXX = Annual Average Daily Traffic (vehicles per day)

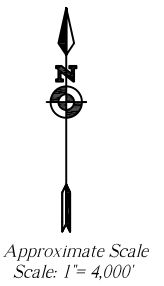
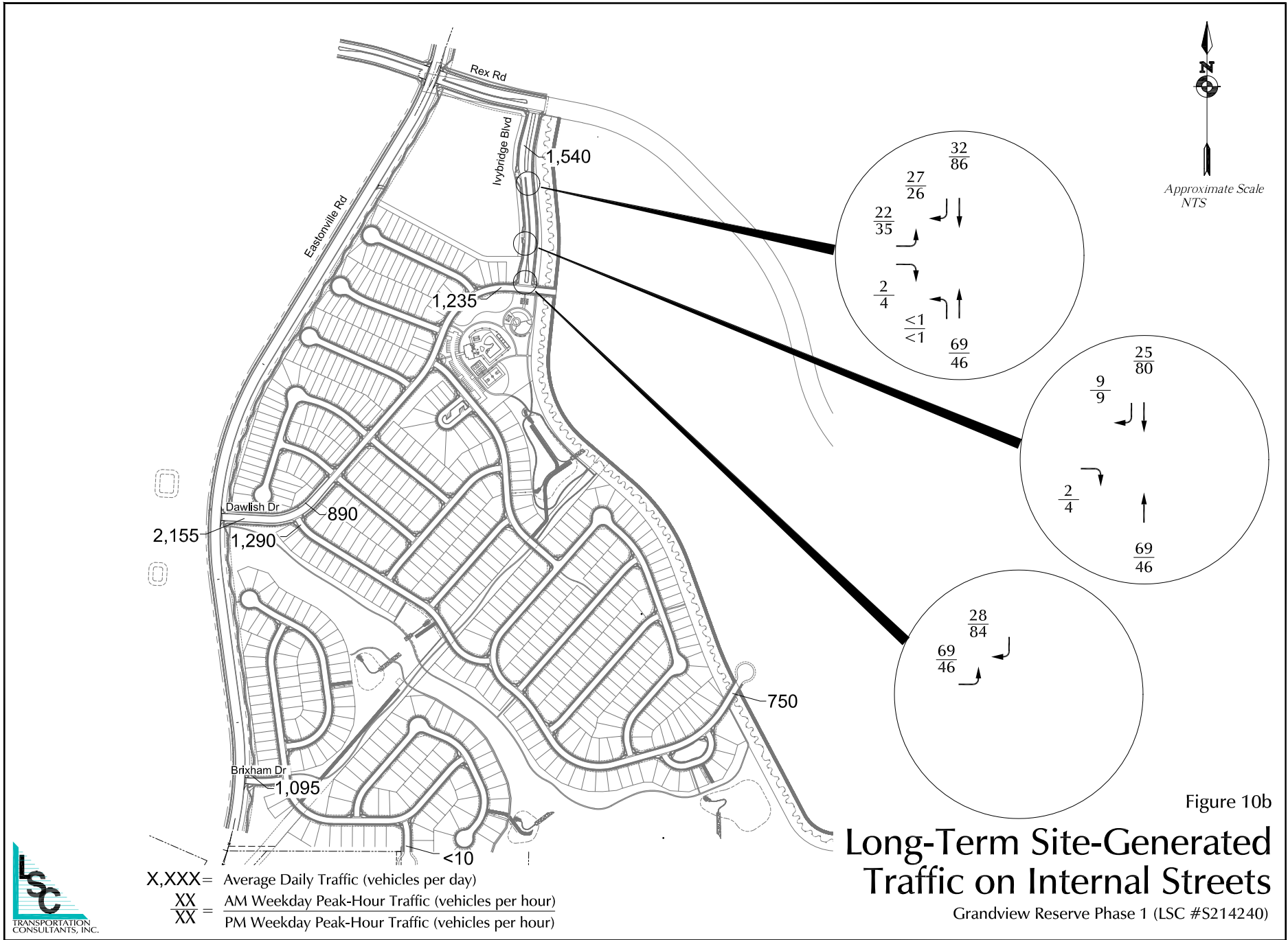
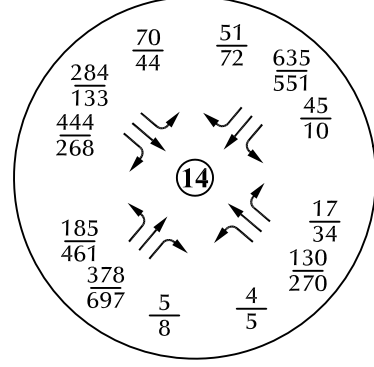
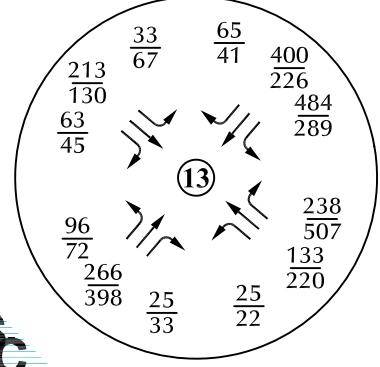
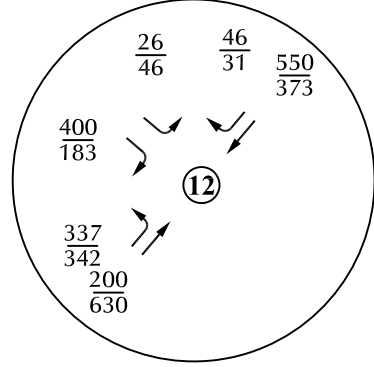
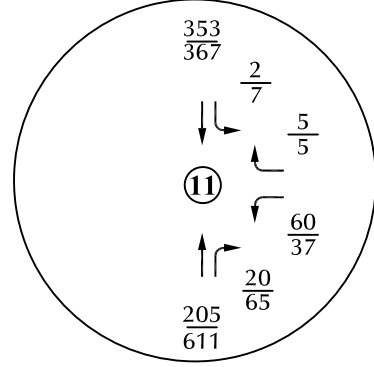
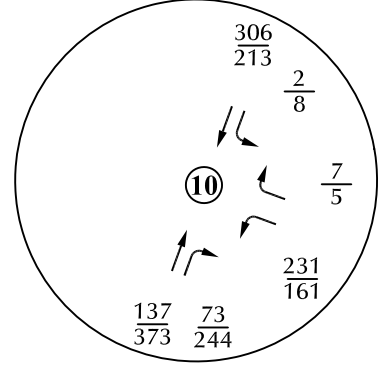
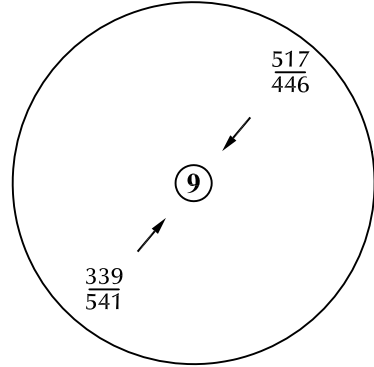
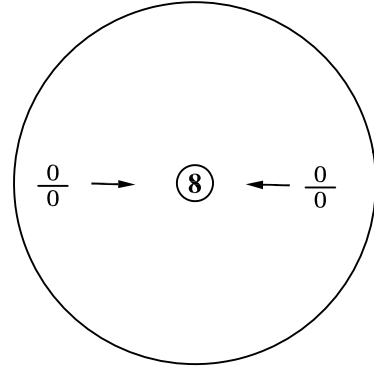
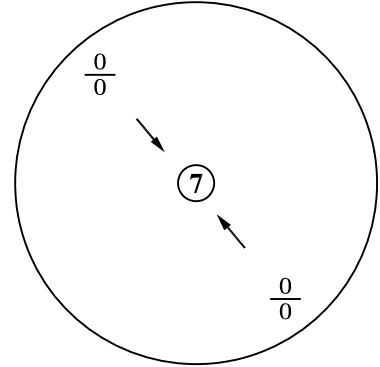
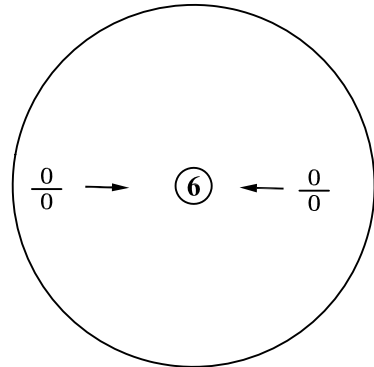
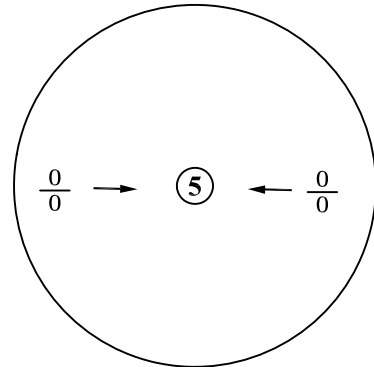
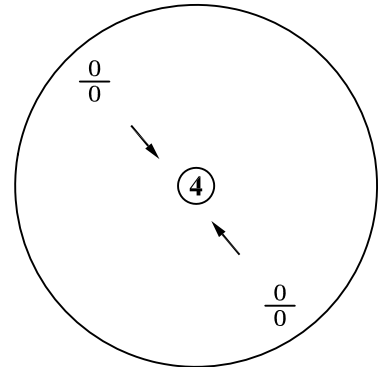
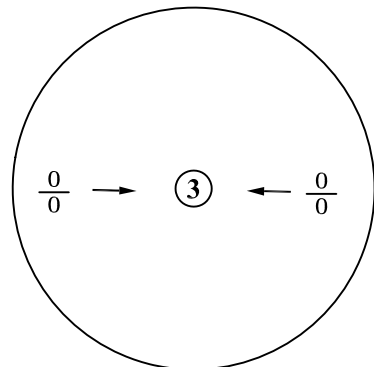
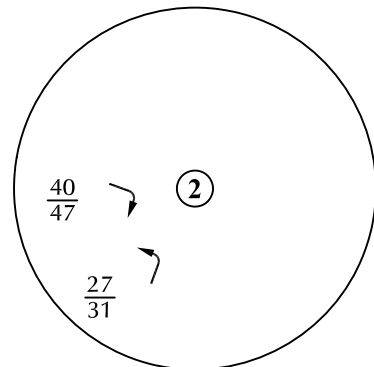
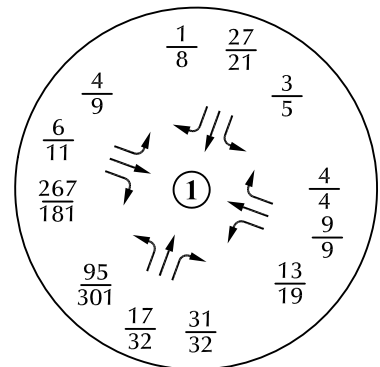

Figure 10a

Assignment of Phase 1 Long-Term Site-Generated Traffic

Grandview Reserve Phase 1 (LSC #S214240)





LEGEND:
 $\frac{XX}{XX}$ = AM Weekday Peak-Hour Traffic (vehicles per hour)
 $\frac{XX}{XX}$ = PM Weekday Peak-Hour Traffic (vehicles per hour)
 X,XXX = Annual Average Daily Traffic (vehicles per day)

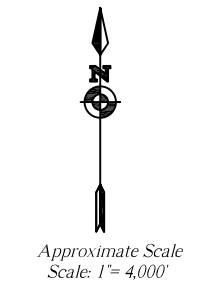
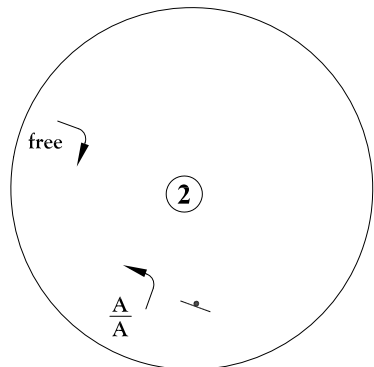
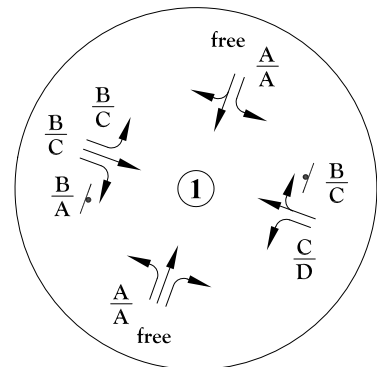

Figure 11a
 Year 2026
 Total Traffic

Grandview Reserve Phase 1 (LSC #S214240)



Intentionally
③ *
Left Blank

Intentionally
④ *
Left Blank

Intentionally
⑤ *
Left Blank

Intentionally
⑥ *
Left Blank

Intentionally
⑦ *
Left Blank

Intentionally
⑧ *
Left Blank

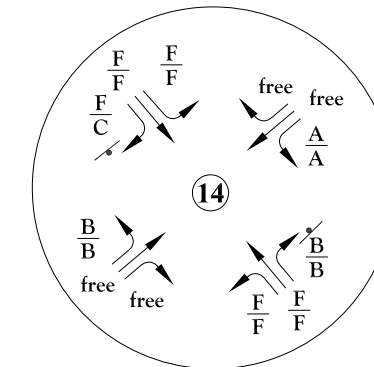
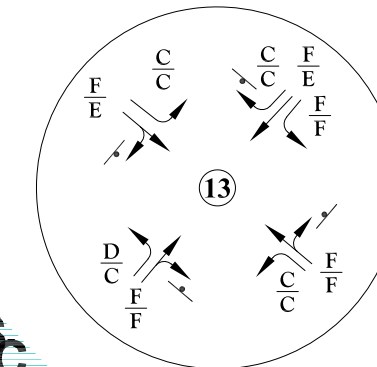
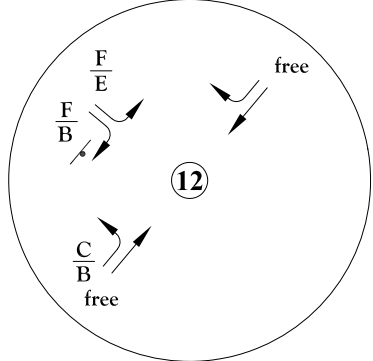
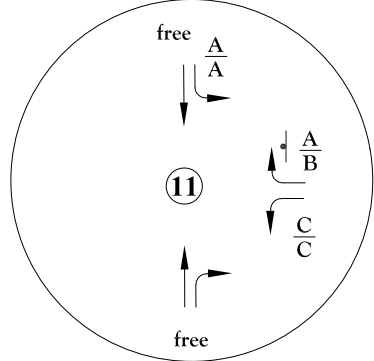
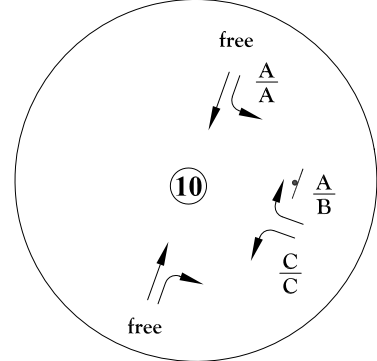
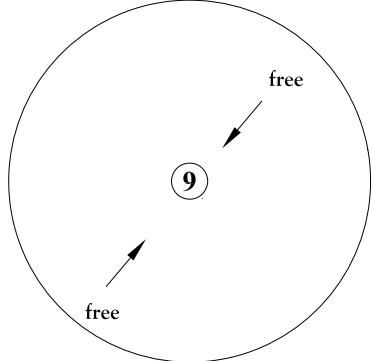

LEGEND:

Traffic Control Used in the Analysis:

⊥ = Stop Sign

⊞ = Traffic Signal

LOS Analysis Results:

A/A = AM Individual Movement Peak-Hour Level of Service

B/B = PM Individual Movement Peak-Hour Level of Service

C/C = AM Entire Intersection Peak-Hour Level of Service

C/C = PM Entire Intersection Peak-Hour Level of Service

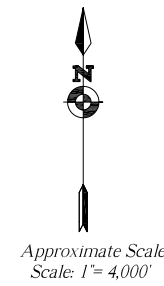

*This section of Rex Rd. between Ivybridge Blvd and US 24 is not planned to be constructed with Phase 1

Figure 11b

Year 2026 Total Lane Geometry, Traffic Control and Levels of Service with Stop-Sign Control

Grandview Reserve Phase 1 (LSC #S214240)

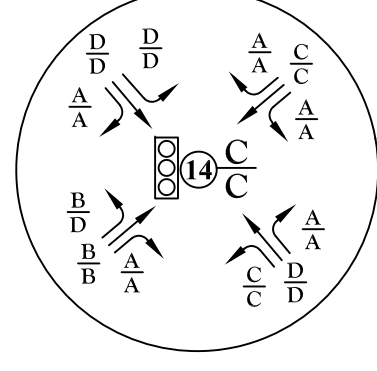
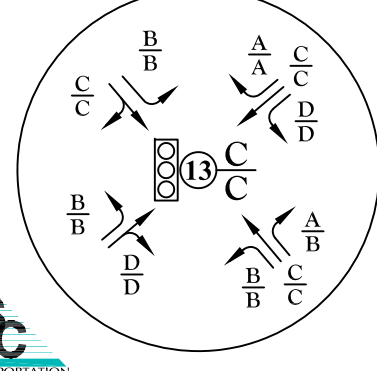
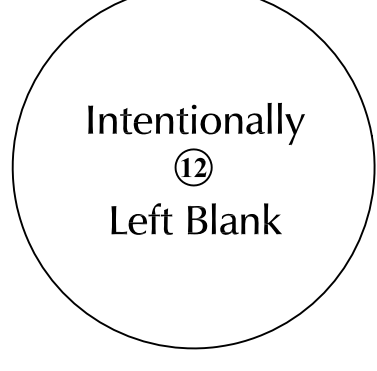
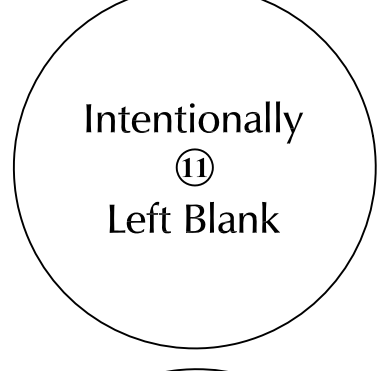
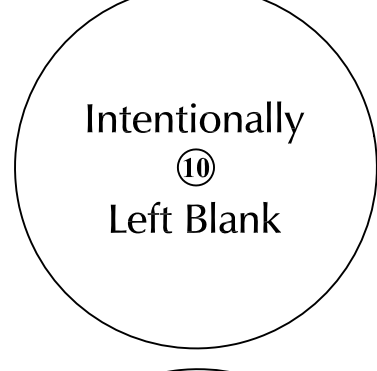
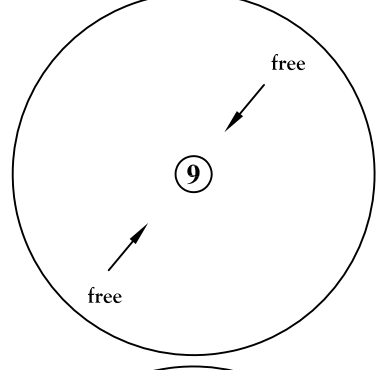
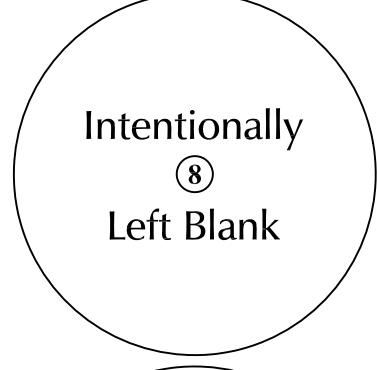
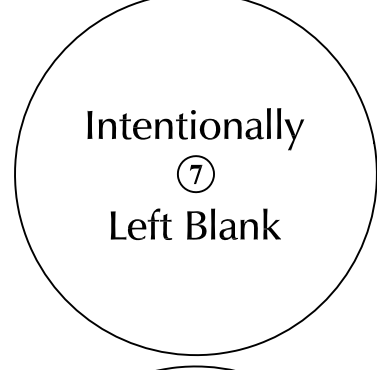
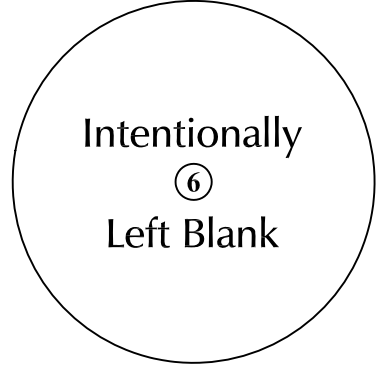
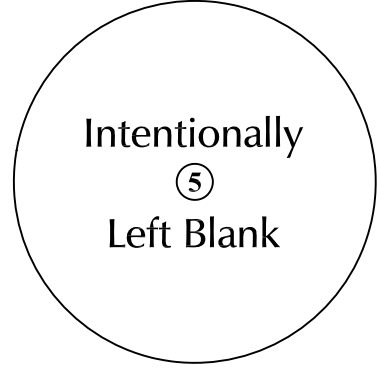
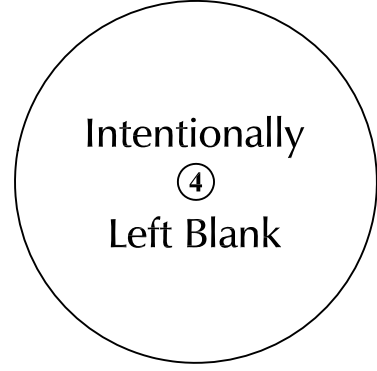
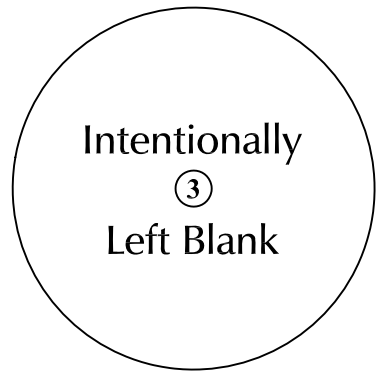
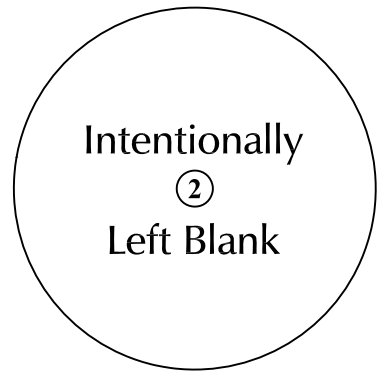
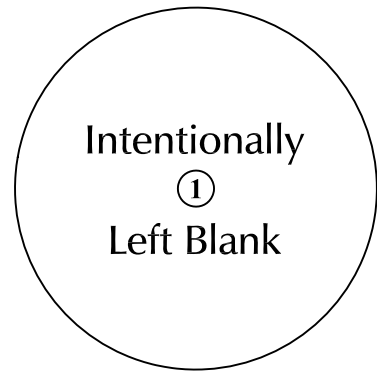

LEGEND:
 Traffic Control Used in the Analysis:
 | = Stop Sign
 [] = Traffic Signal
 LOS Analysis Results:
 A = AM Individual Movement Peak-Hour Level of Service
 B = PM Individual Movement Peak-Hour Level of Service
 C = AM Entire Intersection Peak-Hour Level of Service
 C = PM Entire Intersection Peak-Hour Level of Service

Approximate Scale
 Scale: 1" = 4,000'



Figure 11c

Year 2026 Total Lane Geometry, Traffic Control and Levels of Service with Traffic Signal Control

Grandview Reserve Phase 1 (LSC #S214240)

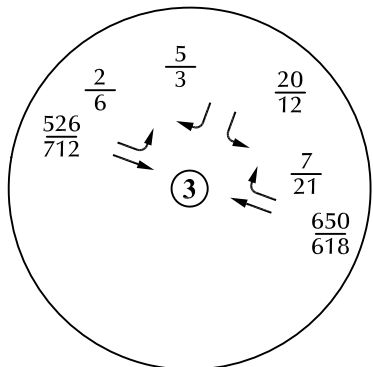
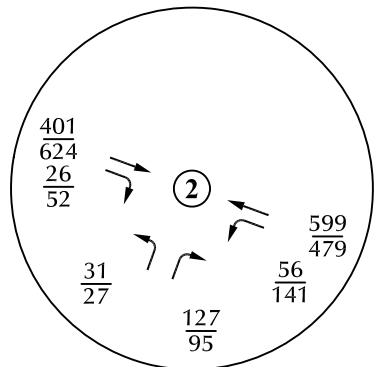
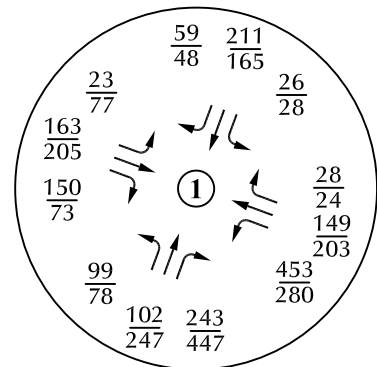

Intentionally
④
Left Blank

Intentionally
⑤
Left Blank

Intentionally
⑥
Left Blank

Intentionally
⑦
Left Blank

Intentionally
⑧
Left Blank

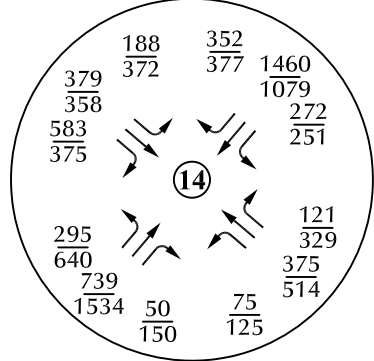
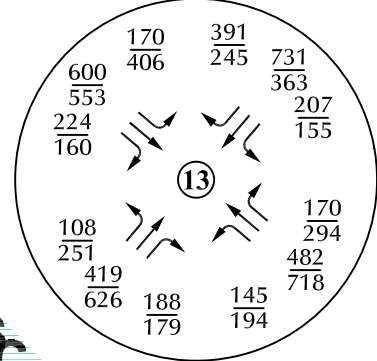
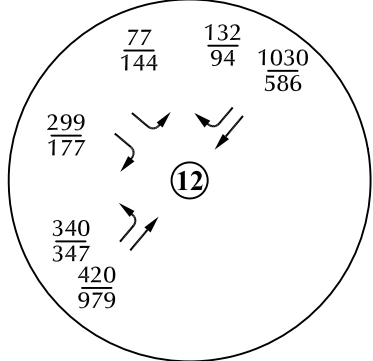
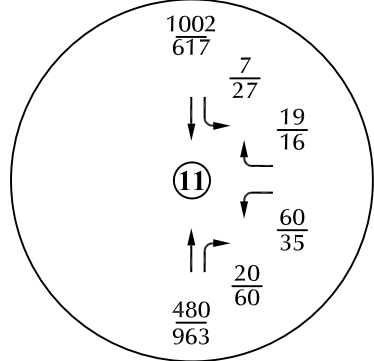
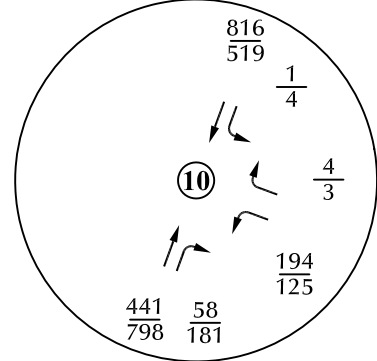
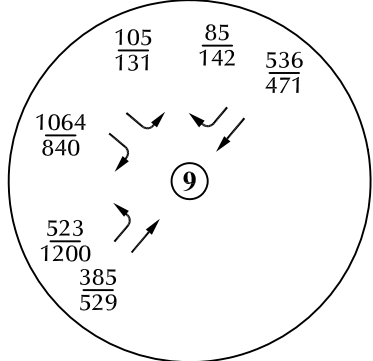

LEGEND:
 $\frac{XX}{XX}$ = AM Weekday Peak-Hour Traffic (vehicles per hour)
 $\frac{XX}{XX}$ = PM Weekday Peak-Hour Traffic (vehicles per hour)
 X,XXX = Annual Average Daily Traffic (vehicles per day)

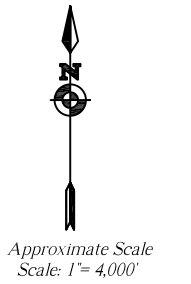
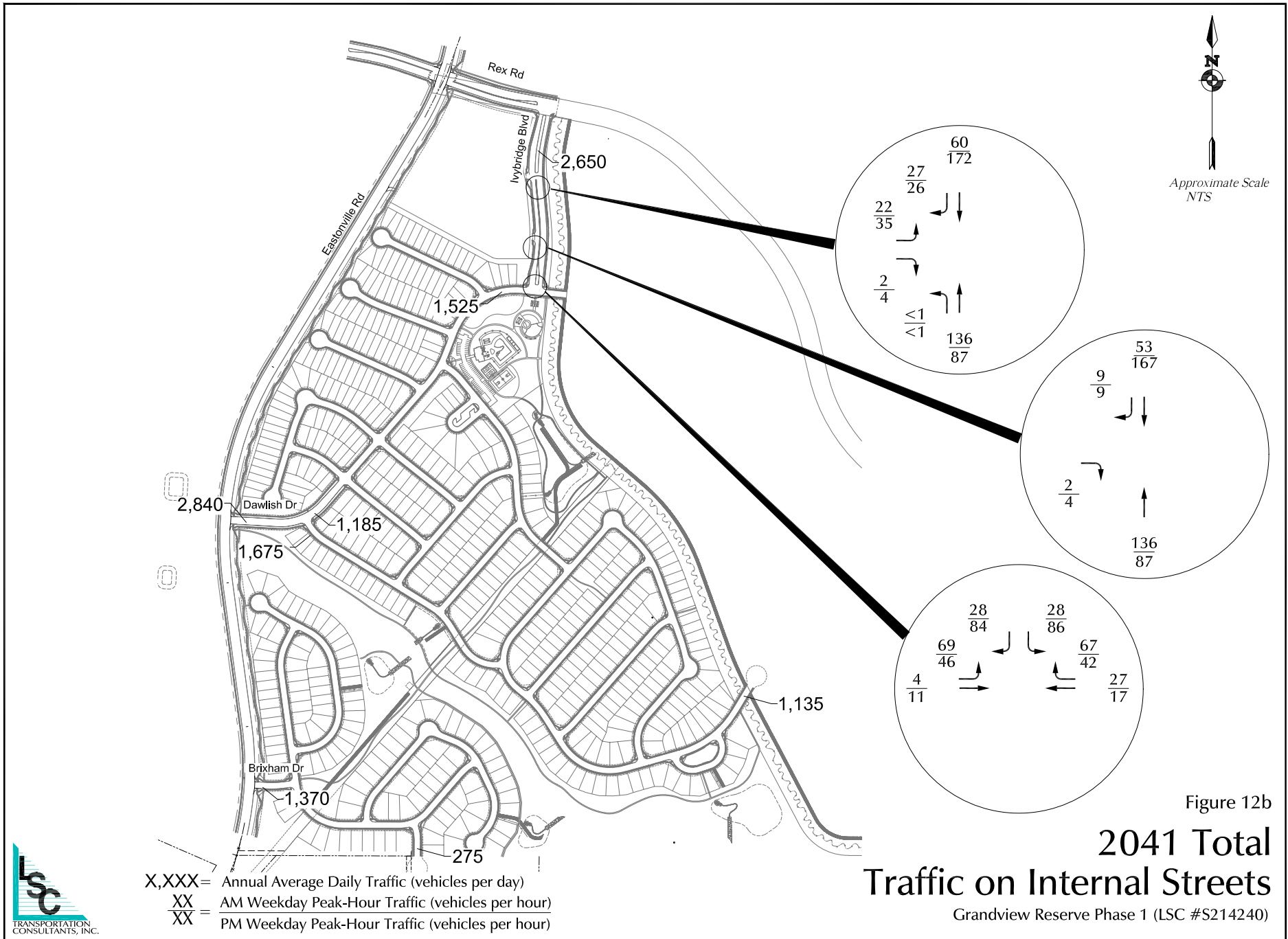
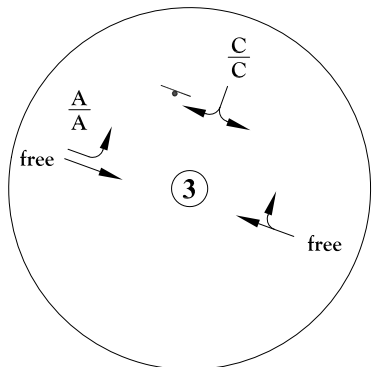
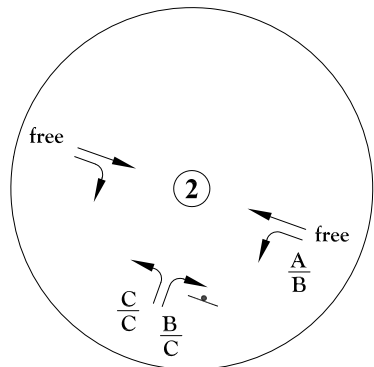
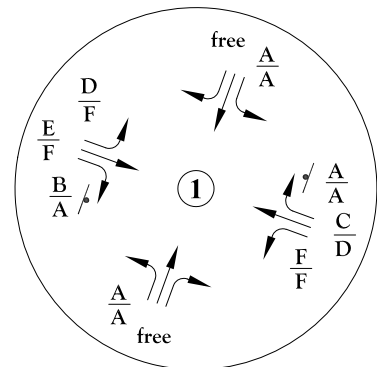

Figure 12a
 Year 2041
 Total Traffic





Intentionally
④
Left Blank

Intentionally
⑤
Left Blank

Intentionally
⑥
Left Blank

Intentionally
⑦
Left Blank

Intentionally
⑧
Left Blank

Intentionally
⑨
Left Blank

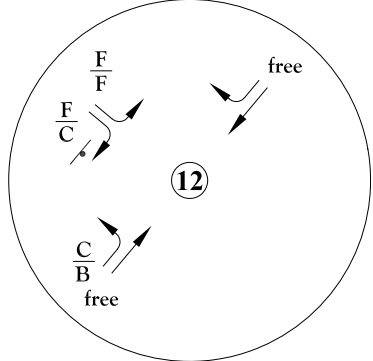
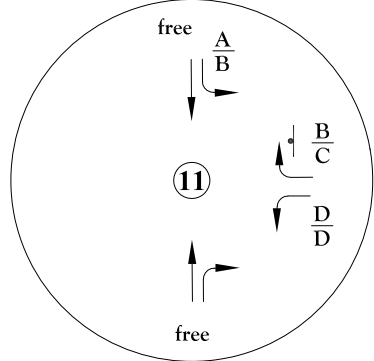
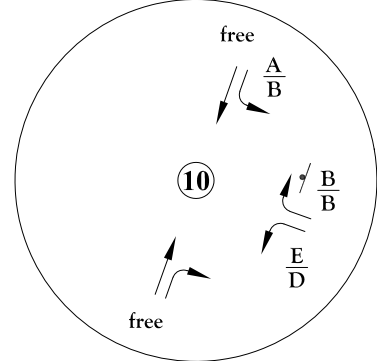

Intentionally
⑬
Left Blank

Intentionally
⑭
Left Blank

LEGEND:
Traffic Control Used in the Analysis:

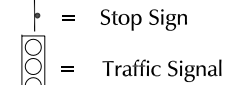

LOS Analysis Results:

$\frac{A}{A}$ = AM Individual Movement Peak-Hour Level of Service
 $\frac{B}{B}$ = PM Individual Movement Peak-Hour Level of Service
 $\frac{C}{C}$ = AM Entire Intersection Peak-Hour Level of Service
 $\frac{C}{C}$ = PM Entire Intersection Peak-Hour Level of Service

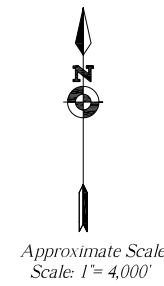
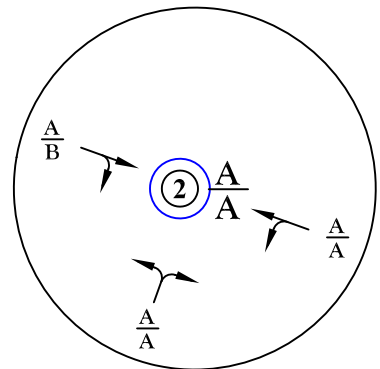
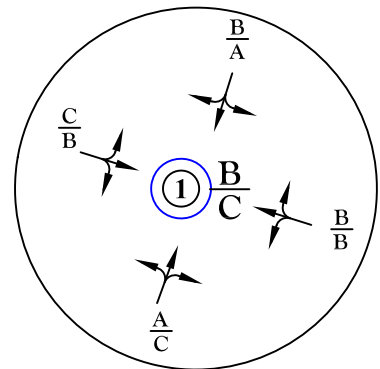

Figure 12c

Year 2040 Total Lane Geometry, Traffic Control and Levels of Service with Two-Way Stop-Sign Control

Grandview Reserve Phase 1 (LSC #S214240)



Intentionally
③
Left Blank

Intentionally
④
Left Blank

Intentionally
⑤
Left Blank

Intentionally
⑥
Left Blank

Intentionally
⑦
Left Blank

Intentionally
⑧
Left Blank

Intentionally
⑨
Left Blank

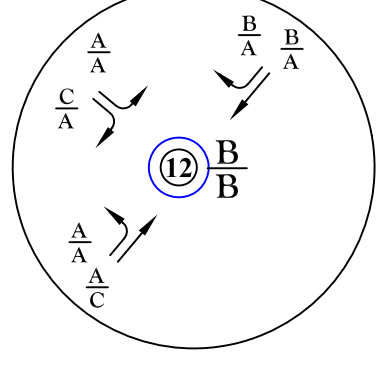
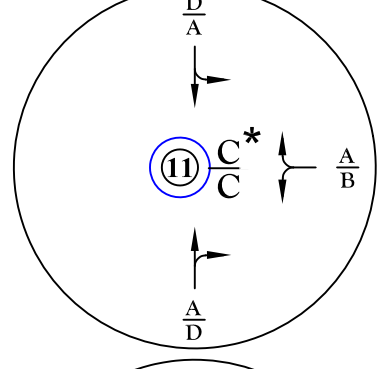
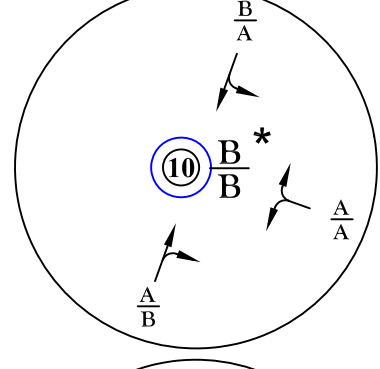

Intentionally
⑬
Left Blank

Intentionally
⑭
Left Blank

LEGEND:

Traffic Control Used in the Analysis:

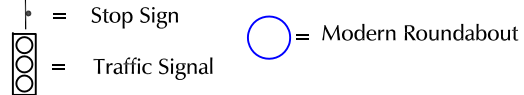

LOS Analysis Results:

- $\frac{A}{B}$ = AM Individual Movement Peak-Hour Level of Service
- $\frac{A}{B}$ = PM Individual Movement Peak-Hour Level of Service
- $\frac{C}{C}$ = AM Entire Intersection Peak-Hour Level of Service
- $\frac{C}{C}$ = PM Entire Intersection Peak-Hour Level of Service

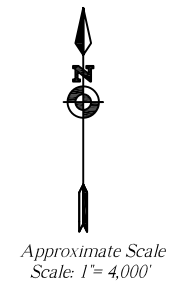

*Note: Roundabout analysis shown, however, due to wetlands constraints, the preferred option is a conventional intersection. The determination will be made at the final plat stage.

Figure 12d

Year 2041 Total Lane Geometry, Traffic Control and Levels of Service with Modern Roundabouts

Grandview Reserve Phase 1 (LSC #S214240)



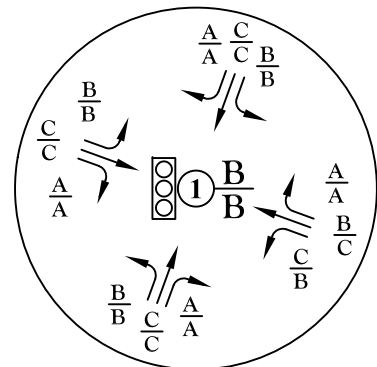

Intentionally
②
Left Blank

Intentionally
③
Left Blank

Intentionally
④
Left Blank

Intentionally
⑤
Left Blank

Intentionally
⑥
Left Blank

Intentionally
⑦
Left Blank

Intentionally
⑧
Left Blank

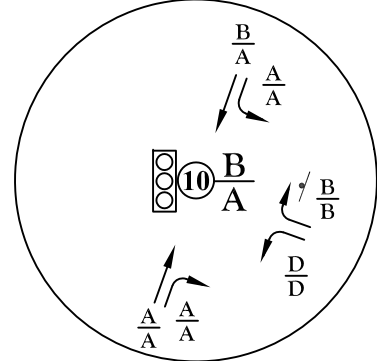
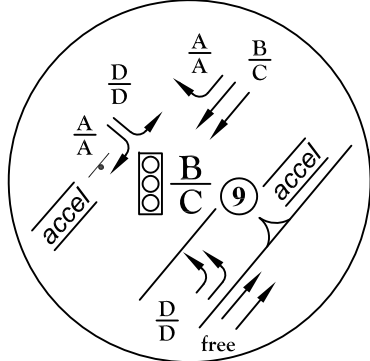

Intentionally
⑪
Left Blank

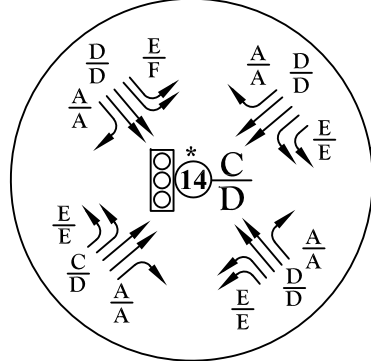
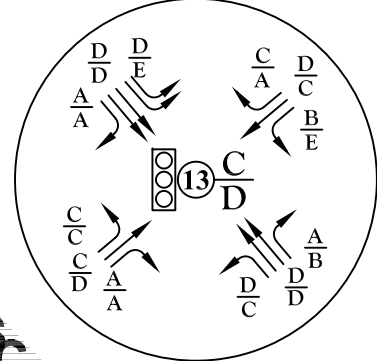
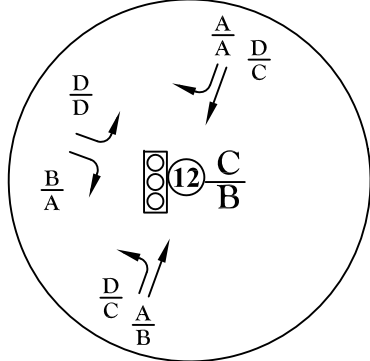

*The US 24 Planning and Environmental Study (October 2017) identifies options for capacity improvements at this intersection, including a jug-handle or jr. interchange.

LEGEND:

Traffic Control Used in the Analysis:

↓ = Stop Sign

⓪ = Traffic Signal

LOS Analysis Results:

$\frac{A}{B}$ = AM Individual Movement Peak-Hour Level of Service

$\frac{B}{B}$ = PM Individual Movement Peak-Hour Level of Service

$\frac{C}{C}$ = AM Entire Intersection Peak-Hour Level of Service

$\frac{C}{C}$ = PM Entire Intersection Peak-Hour Level of Service



Approximate Scale
Scale: 1" = 4,000'



Figure 12e

Year 2041 Total Lane Geometry, Traffic Control and Levels of Service with Traffic Signal Control

Grandview Reserve Phase 1 (LSC #S214240)

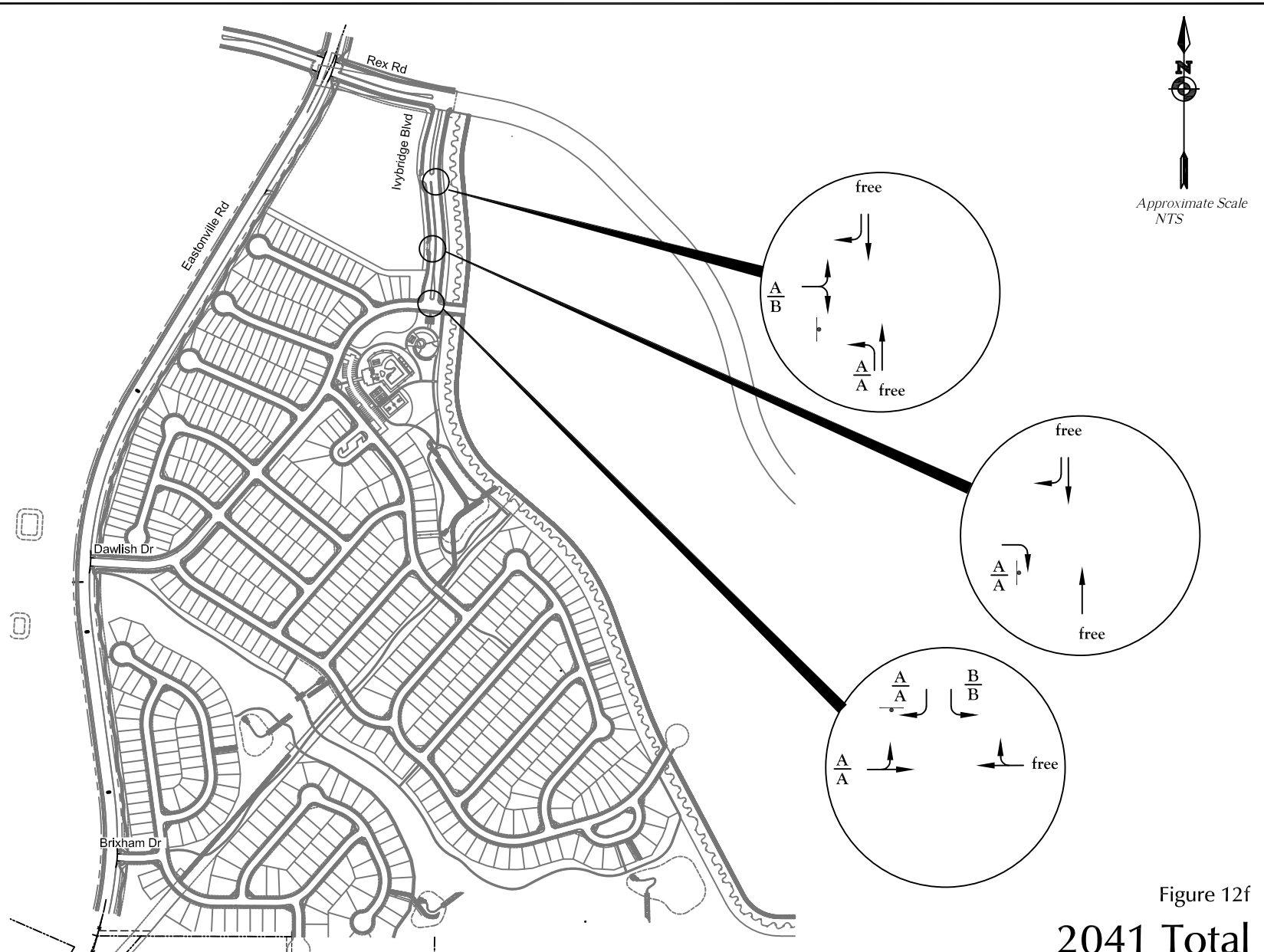

 Approximate Scale
 NTS

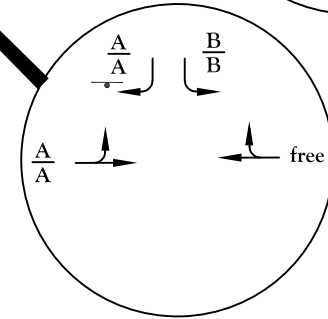
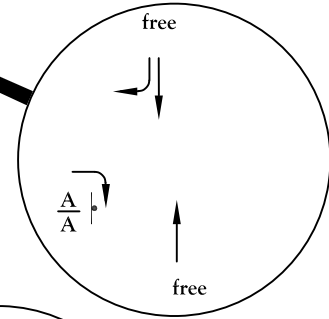
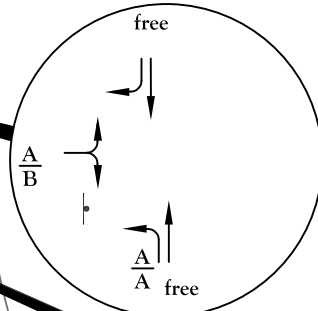

 = Stop Sign
 $\frac{A}{B}$ = AM Individual Movement Peak-Hour Level of Service
 $\frac{B}{B}$ = PM Individual Movement Peak-Hour Level of Service

Figure 12f
2041 Total
Ivybridge Blvd Intersection LOS
 Grandview Reserve Phase 1 (LSC #S214240)





Appendix Tables



**Appendix Table 1
Area Traffic Impact Studies by LSC
Grandview Reserve Phase 1**

| Study | Date |
|--|-------------------|
| Meridian Ranch | |
| Meridian Ranch Sketch Plan TIA | April 11, 2011 |
| Meridian Ranch Filing 11 Updated TIA | November 26, 2013 |
| Stonebridge at Meridian Ranch Filing No. 1 Updated TIA | April 23, 2014 |
| Stonebridge at Meridian Ranch Transportation Memorandum | July 28, 2015 |
| Meridian Ranch Filing 8 Updated TIA | December 23, 2014 |
| Meridian Ranch Filing 9 Updated TIA | May 21, 2015 |
| Meridian Ranch Sketch Plan 2015 Amendment TIA | July 30, 2015 |
| The Vistas at Meridian Ranch TIA | March 24, 2016 |
| Meridian Ranch Estates Filing No. 2 Transportation Memorandum | August 27, 2015 |
| The Vistas at Meridian Ranch Updated Transportation Memorandum | June 20, 2017 |
| Londonderry Drive Pedestrian Operations and Safety Study | February 8, 2017 |
| Stonebridge Filing 3 at Meridian Ranch Updated TIA | March 20, 2017 |
| Meridian Ranch Sketch Plan 2017 Amendment TIA | October 3, 2017 |
| WindingWalk at Meridian Ranch and The Enclave at Stonebridge at Meridian Ranch Updated Traffic Impact Analysis | May 10, 2018 |
| Rolling Hills Ranch at Meridian Ranch PUDSP Traffic Impact Analysis | June 29, 2020 |
| The Estates at Rolling Hills Ranch Filing No. 1 Traffic Impact Analysis | May 13, 2020 |
| Rolling Hills Ranch at Meridian Ranch Filing No. 1 Traffic Impact Analysis | July 14, 2020 |
| The Estates at Rolling Hills Ranch Filing No. 2 Traffic Impact Study | October 8, 2020 |
| Rolling Hills Ranch at Meridian Ranch Filing No. 2 Transportation Memorandum | December 29, 2020 |
| Rolling Hills Ranch at Meridian Ranch Filing No. 3 Transportation Memorandum | June 29, 2021 |
| Meridian Ranch 2021 Sketch Plan Amendment Traffic Impact Study | June 25, 2021 |
| Grandview Reserve | |
| Grandview Reserve Updated Master TIA | December 5, 2020 |
| Waterbury/4-Way Ranch | |
| Waterbury PUD Development Plan Updated TIA | January 10, 2013 |
| Waterbury Filing Nos. 1 and 2 TIA | December 18, 2020 |
| Meadowlake Ranch | |
| Meadowlake Ranch Traffic Impact Analysis | May 29, 2019 |
| Trails | |
| Trails Filing Nos. 9, 10 and 11 | February 12, 2007 |
| <i>Source: LSC Transportation Consultants, Inc. (July 2021)</i> | |

MTCP Maps



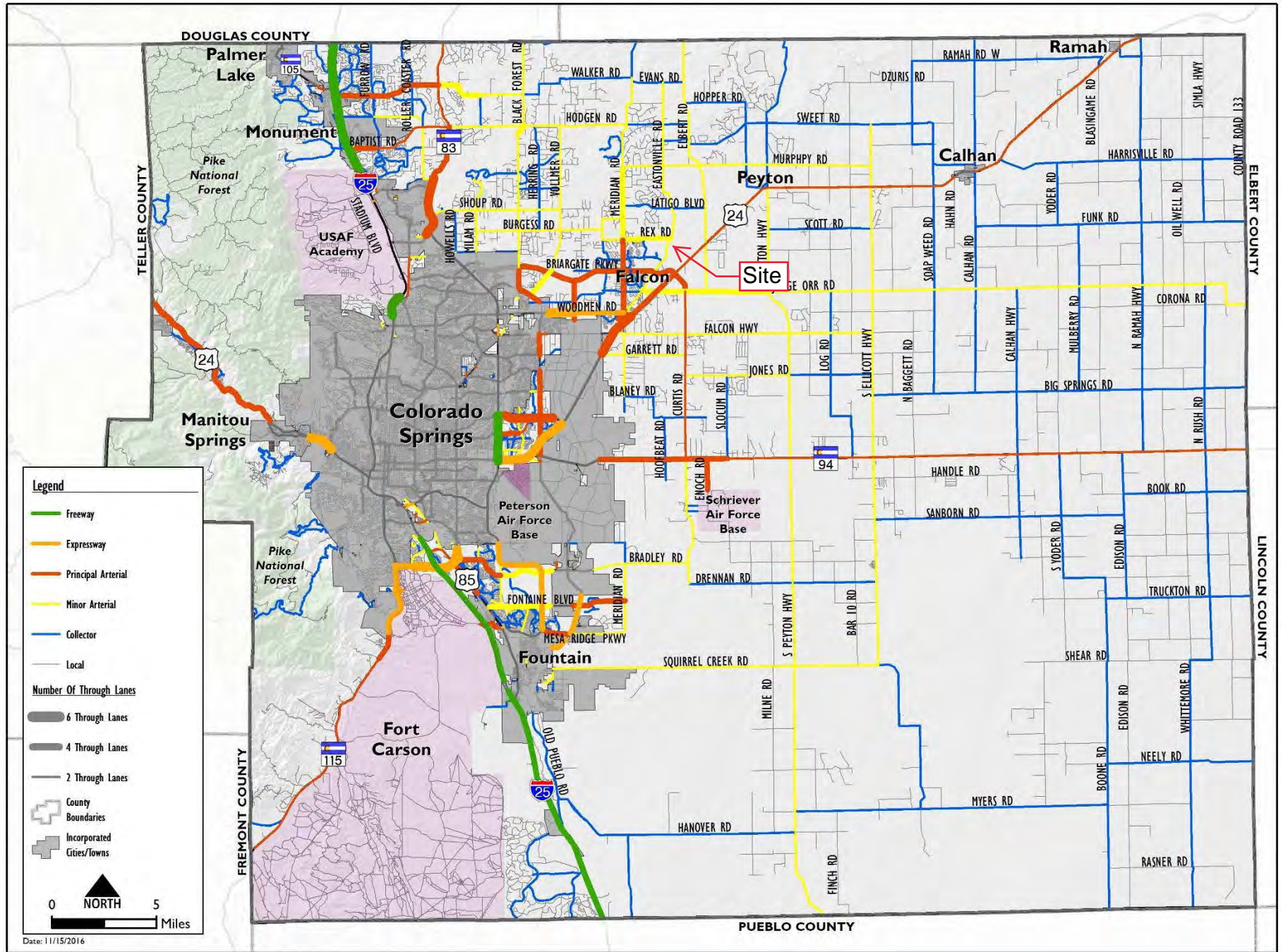

Map 14: 2040 Roadway Plan (Classification and Lanes)

Map 17: 2060 Corridor Preservation

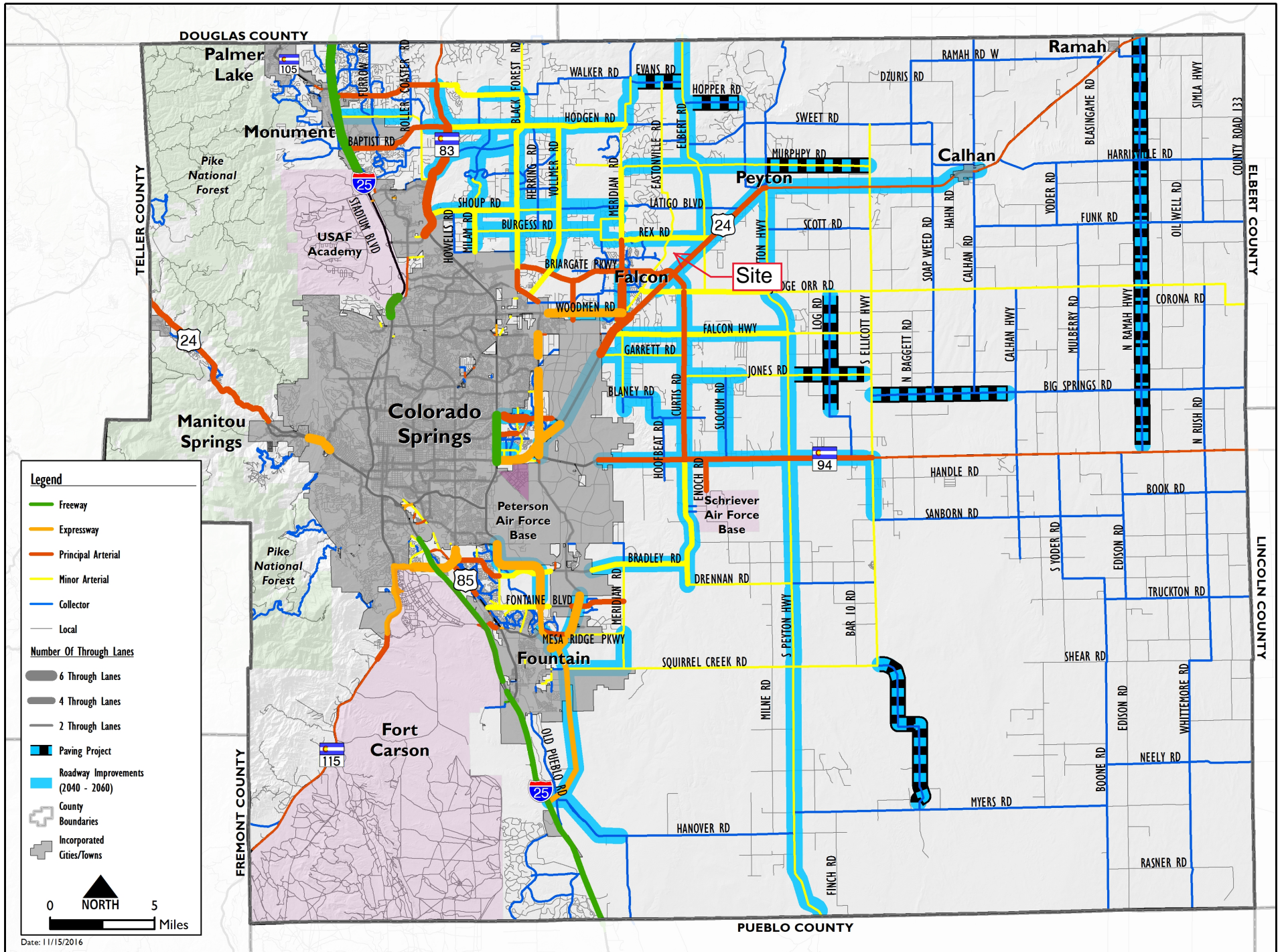

Map 15 Bicycle and Pedestrian Network Improvements



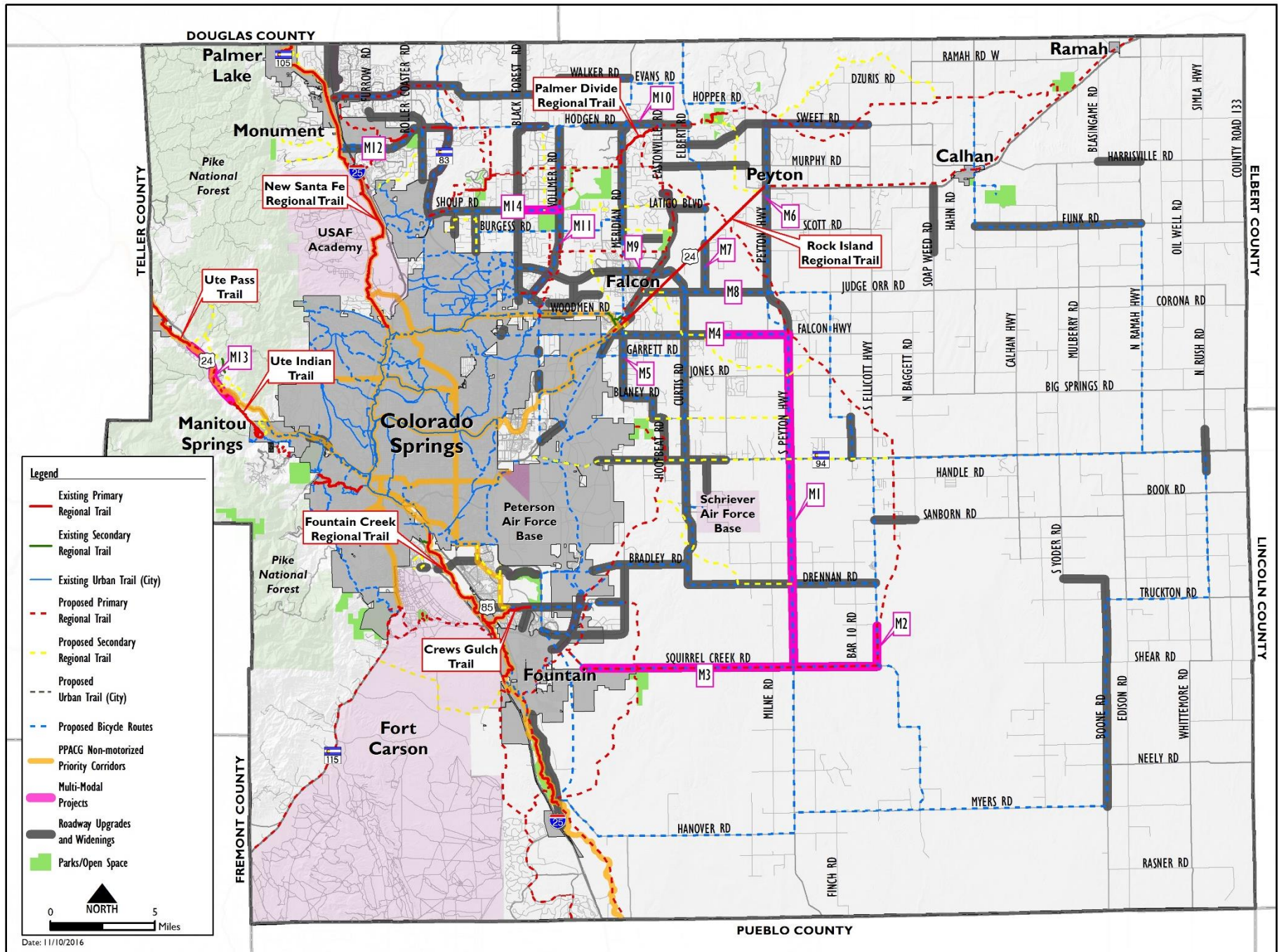

Map 15: Bicycle and Pedestrian Network and Improvements

Traffic Counts



LSC Transportation Consultants, Inc.

545 E Pikes Peak Ave, Suite 210
 Colorado Springs, CO 80905
 719-633-2868

File Name : Eastonville Rd - Stapleton Rd AM
 Site Code : S214870
 Start Date : 10/7/2021
 Page No : 1

Groups Printed- Unshifted

| Start Time | Eastonville Rd Southbound | | | | | Stapleton Rd Westbound | | | | | Eastonville Rd Northbound | | | | | Stapleton Rd Eastbound | | | | | Int. Total |
|-------------|---------------------------|------|-----|-----|------------|------------------------|------|-----|---|------------|---------------------------|------|-----|-----|------------|------------------------|------|------|---|------------|------------|
| | L | T | R | U | App. Total | L | T | R | U | App. Total | L | T | R | U | App. Total | L | T | R | U | App. Total | |
| 06:30 AM | 29 | 8 | 0 | 0 | 37 | 0 | 18 | 8 | 0 | 26 | 2 | 14 | 0 | 0 | 16 | 3 | 32 | 2 | 0 | 37 | 116 |
| 06:45 AM | 36 | 19 | 2 | 0 | 57 | 0 | 11 | 20 | 0 | 31 | 5 | 18 | 1 | 0 | 24 | 5 | 51 | 8 | 0 | 64 | 176 |
| Total | 65 | 27 | 2 | 0 | 94 | 0 | 29 | 28 | 0 | 57 | 7 | 32 | 1 | 0 | 40 | 8 | 83 | 10 | 0 | 101 | 292 |
| 07:00 AM | 31 | 36 | 6 | 0 | 73 | 0 | 16 | 43 | 0 | 59 | 13 | 76 | 2 | 0 | 91 | 2 | 27 | 6 | 0 | 35 | 258 |
| 07:15 AM | 48 | 67 | 4 | 0 | 119 | 3 | 25 | 34 | 0 | 62 | 33 | 69 | 3 | 0 | 105 | 3 | 36 | 13 | 0 | 52 | 338 |
| 07:30 AM | 24 | 31 | 2 | 0 | 57 | 3 | 42 | 13 | 0 | 58 | 32 | 24 | 11 | 0 | 67 | 2 | 45 | 15 | 0 | 62 | 244 |
| 07:45 AM | 15 | 17 | 0 | 0 | 32 | 0 | 20 | 8 | 0 | 28 | 16 | 14 | 1 | 1 | 32 | 0 | 36 | 15 | 0 | 51 | 143 |
| Total | 118 | 151 | 12 | 0 | 281 | 6 | 103 | 98 | 0 | 207 | 94 | 183 | 17 | 1 | 295 | 7 | 144 | 49 | 0 | 200 | 983 |
| 08:00 AM | 11 | 14 | 1 | 1 | 27 | 2 | 20 | 11 | 0 | 33 | 8 | 10 | 1 | 0 | 19 | 1 | 24 | 12 | 0 | 37 | 116 |
| 08:15 AM | 23 | 10 | 0 | 1 | 34 | 1 | 18 | 12 | 0 | 31 | 18 | 9 | 0 | 0 | 27 | 2 | 12 | 11 | 0 | 25 | 117 |
| 08:30 AM | 12 | 8 | 2 | 0 | 22 | 0 | 18 | 6 | 0 | 24 | 4 | 6 | 2 | 0 | 12 | 3 | 21 | 3 | 0 | 27 | 85 |
| Grand Total | 229 | 210 | 17 | 2 | 458 | 9 | 188 | 155 | 0 | 352 | 131 | 240 | 21 | 1 | 393 | 21 | 284 | 85 | 0 | 390 | 1593 |
| Apprch % | 50 | 45.9 | 3.7 | 0.4 | | 2.6 | 53.4 | 44 | 0 | | 33.3 | 61.1 | 5.3 | 0.3 | | 5.4 | 72.8 | 21.8 | 0 | | |
| Total % | 14.4 | 13.2 | 1.1 | 0.1 | 28.8 | 0.6 | 11.8 | 9.7 | 0 | 22.1 | 8.2 | 15.1 | 1.3 | 0.1 | 24.7 | 1.3 | 17.8 | 5.3 | 0 | 24.5 | |

LSC Transportation Consultants, Inc.

545 E Pikes Peak Ave, Suite 210
 Colorado Springs, CO 80905
 719-633-2868

File Name : Eastonville Rd - Stapleton Rd AM
 Site Code : S214870
 Start Date : 10/7/2021
 Page No : 3

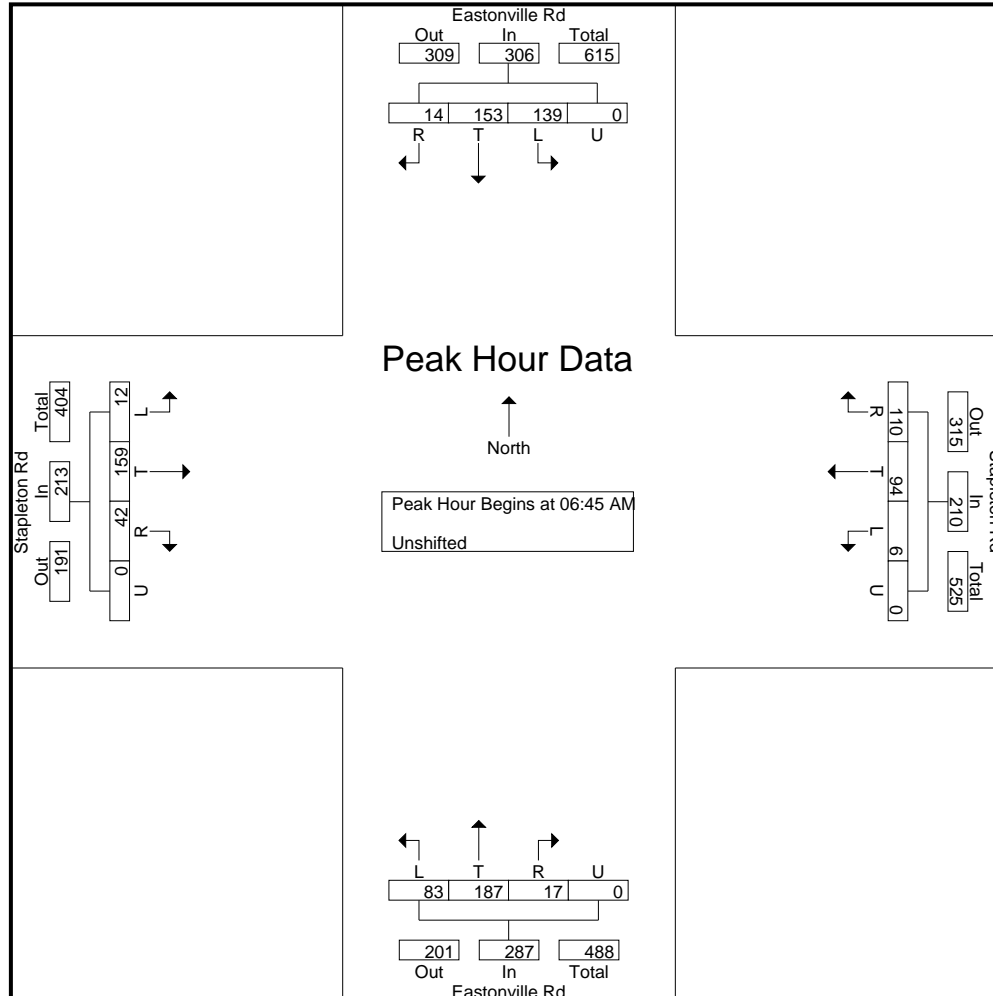

LSC Transportation Consultants, Inc.

545 E Pikes Peak Ave, Suite 210
 Colorado Springs, CO 80905
 719-633-2868

File Name : Eastonville Rd - Stapleton Rd PM
 Site Code : S214870
 Start Date : 10/7/2021
 Page No : 1

Groups Printed- Unshifted

| Start Time | Eastonville Rd Southbound | | | | | Stapleton Rd Westbound | | | | | Eastonville Rd Northbound | | | | | Stapleton Rd Eastbound | | | | | Int. Total |
|-------------|---------------------------|------|-----|-----|------------|------------------------|------|------|---|------------|---------------------------|------|-----|-----|------------|------------------------|------|------|---|------------|------------|
| | L | T | R | U | App. Total | L | T | R | U | App. Total | L | T | R | U | App. Total | L | T | R | U | App. Total | |
| 04:00 PM | 9 | 15 | 2 | 0 | 26 | 1 | 42 | 25 | 0 | 68 | 11 | 23 | 3 | 0 | 37 | 1 | 25 | 8 | 0 | 34 | 165 |
| 04:15 PM | 9 | 20 | 0 | 2 | 31 | 6 | 38 | 27 | 0 | 71 | 6 | 25 | 5 | 0 | 36 | 3 | 23 | 9 | 0 | 35 | 173 |
| 04:30 PM | 11 | 12 | 0 | 0 | 23 | 1 | 39 | 31 | 0 | 71 | 17 | 40 | 2 | 1 | 60 | 2 | 16 | 8 | 0 | 26 | 180 |
| 04:45 PM | 21 | 16 | 2 | 0 | 39 | 1 | 34 | 22 | 0 | 57 | 13 | 27 | 2 | 0 | 42 | 5 | 14 | 6 | 0 | 25 | 163 |
| Total | 50 | 63 | 4 | 2 | 119 | 9 | 153 | 105 | 0 | 267 | 47 | 115 | 12 | 1 | 175 | 11 | 78 | 31 | 0 | 120 | 681 |
| 05:00 PM | 13 | 27 | 2 | 0 | 42 | 3 | 40 | 18 | 0 | 61 | 5 | 24 | 4 | 0 | 33 | 4 | 18 | 3 | 0 | 25 | 161 |
| 05:15 PM | 11 | 27 | 2 | 0 | 40 | 2 | 28 | 29 | 0 | 59 | 11 | 25 | 2 | 0 | 38 | 2 | 21 | 3 | 0 | 26 | 163 |
| 05:30 PM | 14 | 19 | 2 | 0 | 35 | 4 | 30 | 15 | 0 | 49 | 11 | 30 | 2 | 0 | 43 | 0 | 26 | 8 | 0 | 34 | 161 |
| 05:45 PM | 14 | 15 | 1 | 0 | 30 | 3 | 32 | 13 | 0 | 48 | 10 | 32 | 0 | 0 | 42 | 3 | 26 | 5 | 0 | 34 | 154 |
| Total | 52 | 88 | 7 | 0 | 147 | 12 | 130 | 75 | 0 | 217 | 37 | 111 | 8 | 0 | 156 | 9 | 91 | 19 | 0 | 119 | 639 |
| 06:00 PM | 12 | 23 | 5 | 0 | 40 | 2 | 31 | 19 | 0 | 52 | 9 | 22 | 3 | 0 | 34 | 5 | 15 | 1 | 0 | 21 | 147 |
| Grand Total | 114 | 174 | 16 | 2 | 306 | 23 | 314 | 199 | 0 | 536 | 93 | 248 | 23 | 1 | 365 | 25 | 184 | 51 | 0 | 260 | 1467 |
| Apprch % | 37.3 | 56.9 | 5.2 | 0.7 | | 4.3 | 58.6 | 37.1 | 0 | | 25.5 | 67.9 | 6.3 | 0.3 | | 9.6 | 70.8 | 19.6 | 0 | | |
| Total % | 7.8 | 11.9 | 1.1 | 0.1 | 20.9 | 1.6 | 21.4 | 13.6 | 0 | 36.5 | 6.3 | 16.9 | 1.6 | 0.1 | 24.9 | 1.7 | 12.5 | 3.5 | 0 | 17.7 | |

LSC Transportation Consultants, Inc.

545 E Pikes Peak Ave, Suite 210
 Colorado Springs, CO 80905
 719-633-2868

File Name : Eastonville Rd - Stapleton Rd PM
 Site Code : S214870
 Start Date : 10/7/2021
 Page No : 3

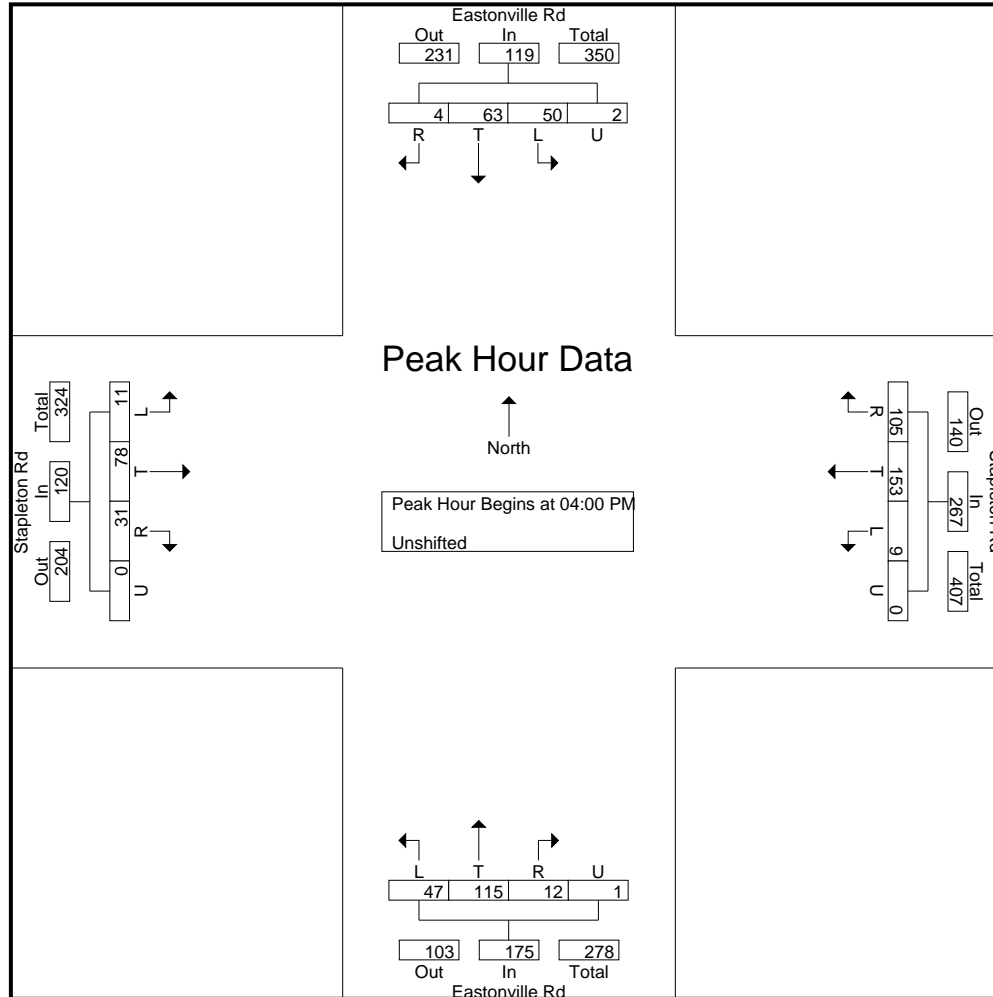

LSC Transportation Consultants, Inc.

545 E Pikes Peak Ave, Suite 210
 Colorado Springs, CO 80905
 719-633-2868

File Name : Hwy 24 - Stapleton Rd AM
 Site Code : S214740
 Start Date : 10/6/2021
 Page No : 1

Groups Printed- Unshifted

| Start Time | Hwy 24 Southbound | | | | | Stapleton Rd Westbound | | | | | Hwy 24 Northbound | | | | | Stapleton Rd Eastbound | | | | | Int. Total |
|-------------|-------------------|------|-----|---|------------|------------------------|------|------|---|------------|-------------------|------|-----|---|------------|------------------------|------|------|-----|------------|------------|
| | L | T | R | U | App. Total | L | T | R | U | App. Total | L | T | R | U | App. Total | L | T | R | U | App. Total | |
| 06:30 AM | 6 | 101 | 2 | 0 | 109 | 0 | 7 | 3 | 0 | 10 | 11 | 79 | 0 | 0 | 90 | 6 | 44 | 20 | 0 | 70 | 279 |
| 06:45 AM | 8 | 112 | 3 | 0 | 123 | 2 | 12 | 2 | 0 | 16 | 24 | 77 | 1 | 0 | 102 | 6 | 32 | 36 | 1 | 75 | 316 |
| Total | 14 | 213 | 5 | 0 | 232 | 2 | 19 | 5 | 0 | 26 | 35 | 156 | 1 | 0 | 192 | 12 | 76 | 56 | 1 | 145 | 595 |
| 07:00 AM | 9 | 98 | 8 | 0 | 115 | 1 | 27 | 4 | 0 | 32 | 17 | 71 | 1 | 0 | 89 | 16 | 41 | 32 | 1 | 90 | 326 |
| 07:15 AM | 16 | 105 | 19 | 0 | 140 | 1 | 29 | 6 | 0 | 36 | 22 | 64 | 3 | 0 | 89 | 7 | 46 | 46 | 0 | 99 | 364 |
| 07:30 AM | 12 | 111 | 7 | 0 | 130 | 0 | 18 | 5 | 0 | 23 | 14 | 42 | 0 | 0 | 56 | 4 | 38 | 32 | 0 | 74 | 283 |
| 07:45 AM | 6 | 71 | 7 | 0 | 84 | 1 | 11 | 3 | 0 | 15 | 12 | 62 | 1 | 0 | 75 | 8 | 23 | 19 | 0 | 50 | 224 |
| Total | 43 | 385 | 41 | 0 | 469 | 3 | 85 | 18 | 0 | 106 | 65 | 239 | 5 | 0 | 309 | 35 | 148 | 129 | 1 | 313 | 1197 |
| 08:00 AM | 4 | 95 | 8 | 0 | 107 | 0 | 9 | 3 | 0 | 12 | 18 | 59 | 3 | 0 | 80 | 1 | 22 | 15 | 0 | 38 | 237 |
| 08:15 AM | 3 | 105 | 4 | 0 | 112 | 0 | 8 | 3 | 0 | 11 | 13 | 48 | 1 | 0 | 62 | 1 | 15 | 20 | 0 | 36 | 221 |
| 08:30 AM | 4 | 44 | 4 | 0 | 52 | 4 | 4 | 2 | 0 | 10 | 4 | 43 | 0 | 0 | 47 | 8 | 9 | 7 | 0 | 24 | 133 |
| Grand Total | 68 | 842 | 62 | 0 | 972 | 9 | 125 | 31 | 0 | 165 | 135 | 545 | 10 | 0 | 690 | 57 | 270 | 227 | 2 | 556 | 2383 |
| Apprch % | 7 | 86.6 | 6.4 | 0 | | 5.5 | 75.8 | 18.8 | 0 | | 19.6 | 79 | 1.4 | 0 | | 10.3 | 48.6 | 40.8 | 0.4 | | |
| Total % | 2.9 | 35.3 | 2.6 | 0 | 40.8 | 0.4 | 5.2 | 1.3 | 0 | 6.9 | 5.7 | 22.9 | 0.4 | 0 | 29 | 2.4 | 11.3 | 9.5 | 0.1 | 23.3 | |

LSC Transportation Consultants, Inc.

545 E Pikes Peak Ave, Suite 210
 Colorado Springs, CO 80905
 719-633-2868

File Name : Hwy 24 - Stapleton Rd AM
 Site Code : S214740
 Start Date : 10/6/2021
 Page No : 3

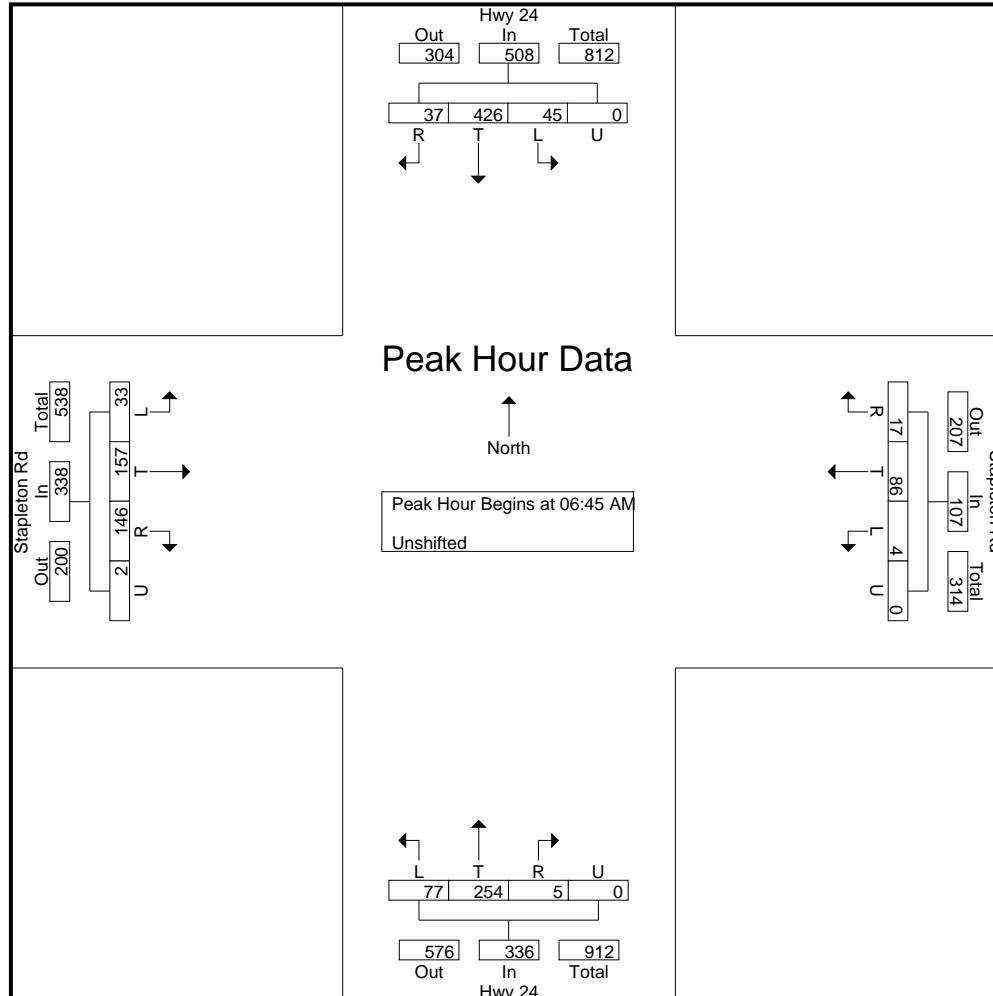

LSC Transportation Consultants, Inc.

545 E Pikes Peak Ave, Suite 210
 Colorado Springs, CO 80905
 719-633-2868

File Name : Hwy 24 - Stapleton Rd PM
 Site Code : S214740
 Start Date : 10/6/2021
 Page No : 1

Groups Printed- Unshifted

| Start Time | Hwy 24 Southbound | | | | | Stapleton Rd Westbound | | | | | Hwy 24 Northbound | | | | | Stapleton Rd Eastbound | | | | | Int. Total |
|--------------------|-------------------|------------|-----------|----------|------------|------------------------|------------|-----------|----------|------------|-------------------|-------------|-----------|----------|-------------|------------------------|------------|------------|----------|------------|-------------|
| | L | T | R | U | App. Total | L | T | R | U | App. Total | L | T | R | U | App. Total | L | T | R | U | App. Total | |
| 04:00 PM | 2 | 100 | 10 | 0 | 112 | 2 | 27 | 6 | 0 | 35 | 32 | 115 | 2 | 0 | 149 | 3 | 11 | 20 | 0 | 34 | 330 |
| 04:15 PM | 4 | 98 | 11 | 0 | 113 | 1 | 35 | 12 | 0 | 48 | 26 | 109 | 4 | 0 | 139 | 3 | 15 | 15 | 0 | 33 | 333 |
| 04:30 PM | 2 | 101 | 3 | 0 | 106 | 2 | 27 | 9 | 0 | 38 | 28 | 124 | 1 | 0 | 153 | 5 | 15 | 16 | 0 | 36 | 333 |
| 04:45 PM | 2 | 71 | 5 | 0 | 78 | 0 | 35 | 7 | 0 | 42 | 34 | 120 | 1 | 0 | 155 | 7 | 8 | 16 | 0 | 31 | 306 |
| Total | 10 | 370 | 29 | 0 | 409 | 5 | 124 | 34 | 0 | 163 | 120 | 468 | 8 | 0 | 596 | 18 | 49 | 67 | 0 | 134 | 1302 |
| 05:00 PM | 0 | 73 | 12 | 0 | 85 | 0 | 25 | 7 | 0 | 32 | 26 | 112 | 10 | 0 | 148 | 5 | 9 | 24 | 0 | 38 | 303 |
| 05:15 PM | 1 | 80 | 9 | 0 | 90 | 2 | 18 | 6 | 0 | 26 | 37 | 122 | 3 | 0 | 162 | 4 | 14 | 20 | 0 | 38 | 316 |
| 05:30 PM | 6 | 82 | 6 | 0 | 94 | 1 | 26 | 6 | 0 | 33 | 29 | 121 | 4 | 0 | 154 | 5 | 9 | 20 | 0 | 34 | 315 |
| 05:45 PM | 1 | 73 | 3 | 1 | 78 | 3 | 22 | 7 | 1 | 33 | 25 | 107 | 3 | 0 | 135 | 10 | 19 | 4 | 1 | 34 | 280 |
| Total | 8 | 308 | 30 | 1 | 347 | 6 | 91 | 26 | 1 | 124 | 117 | 462 | 20 | 0 | 599 | 24 | 51 | 68 | 1 | 144 | 1214 |
| 06:00 PM | 3 | 87 | 2 | 0 | 92 | 2 | 18 | 5 | 0 | 25 | 18 | 108 | 9 | 0 | 135 | 5 | 8 | 24 | 0 | 37 | 289 |
| Grand Total | 21 | 765 | 61 | 1 | 848 | 13 | 233 | 65 | 1 | 312 | 255 | 1038 | 37 | 0 | 1330 | 47 | 108 | 159 | 1 | 315 | 2805 |
| Apprch % | 2.5 | 90.2 | 7.2 | 0.1 | | 4.2 | 74.7 | 20.8 | 0.3 | | 19.2 | 78 | 2.8 | 0 | | 14.9 | 34.3 | 50.5 | 0.3 | | |
| Total % | 0.7 | 27.3 | 2.2 | 0 | 30.2 | 0.5 | 8.3 | 2.3 | 0 | 11.1 | 9.1 | 37 | 1.3 | 0 | 47.4 | 1.7 | 3.9 | 5.7 | 0 | 11.2 | |

LSC Transportation Consultants, Inc.

545 E Pikes Peak Ave, Suite 210
 Colorado Springs, CO 80905
 719-633-2868

File Name : Hwy 24 - Stapleton Rd PM

Site Code : S214740

Start Date : 10/6/2021

Page No : 3

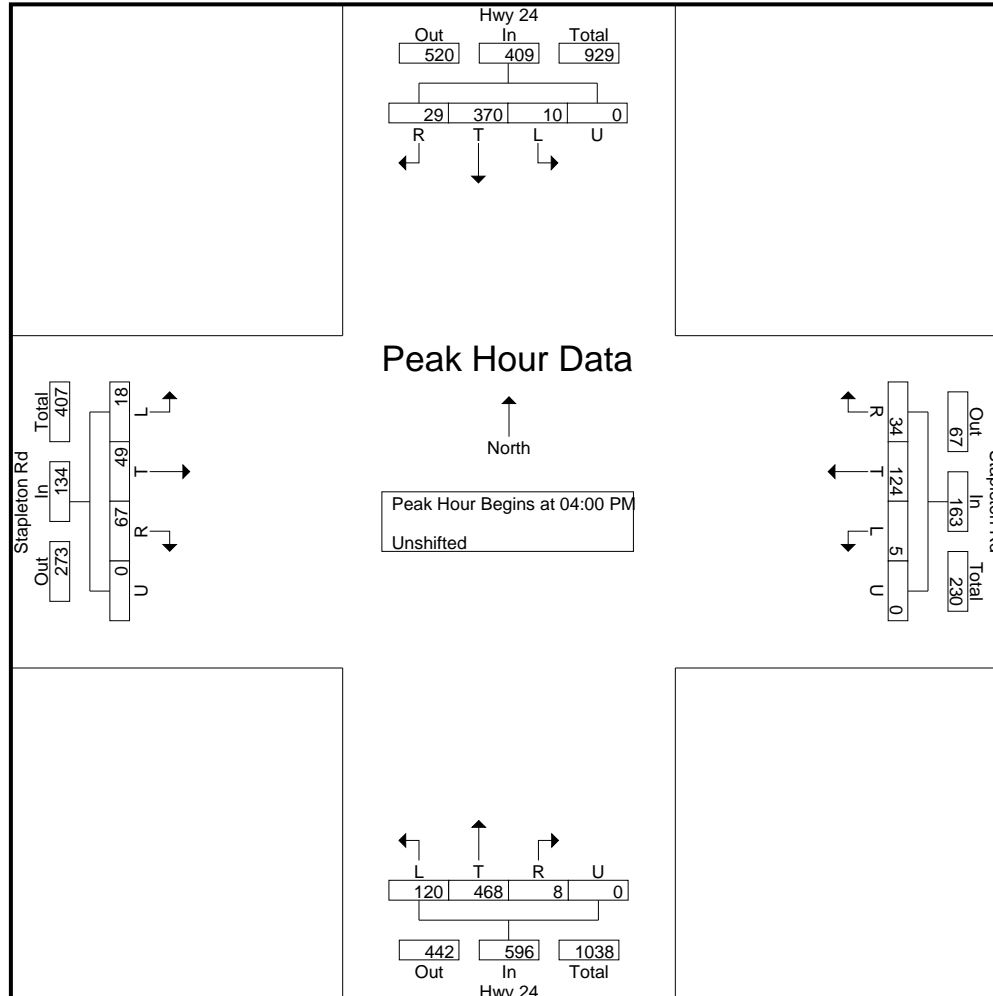

LSC Transportation Consultants, Inc.

545 E Pikes Peak Ave, Suite 210
 Colorado Springs, CO 80905
 719-633-2868

File Name : Eastonville Rd -Londonderry Dr AM
 Site Code : S214250
 Start Date : 4/15/2021
 Page No : 1

Groups Printed- Unshifted

| Start Time | Eastonville Rd Southbound | | | | | Westbound | | | | | Eastonville Rd Northbound | | | | | Londonderry Dr Eastbound | | | | | Int. Total |
|-------------|---------------------------|----|----|---|------------|-----------|---|---|---|------------|---------------------------|-----|---|---|------------|--------------------------|---|------|-----|------------|------------|
| | L | T | R | U | App. Total | L | T | R | U | App. Total | L | T | R | U | App. Total | L | T | R | U | App. Total | |
| 07:00 AM | 0 | 2 | 2 | 0 | 4 | 0 | 0 | 0 | 0 | 0 | 44 | 2 | 0 | 0 | 46 | 0 | 0 | 31 | 0 | 31 | 81 |
| 07:15 AM | 0 | 2 | 3 | 0 | 5 | 0 | 0 | 0 | 0 | 0 | 96 | 1 | 0 | 0 | 97 | 0 | 0 | 74 | 0 | 74 | 176 |
| 07:30 AM | 0 | 2 | 2 | 0 | 4 | 0 | 0 | 0 | 0 | 0 | 22 | 2 | 0 | 0 | 24 | 0 | 0 | 54 | 0 | 54 | 82 |
| 07:45 AM | 0 | 3 | 2 | 0 | 5 | 0 | 0 | 0 | 0 | 0 | 28 | 1 | 0 | 0 | 29 | 3 | 0 | 37 | 1 | 41 | 75 |
| Total | 0 | 9 | 9 | 0 | 18 | 0 | 0 | 0 | 0 | 0 | 190 | 6 | 0 | 0 | 196 | 3 | 0 | 196 | 1 | 200 | 414 |
| 08:00 AM | 0 | 1 | 5 | 0 | 6 | 0 | 0 | 0 | 0 | 0 | 24 | 1 | 0 | 0 | 25 | 0 | 0 | 18 | 0 | 18 | 49 |
| 08:15 AM | 0 | 0 | 2 | 0 | 2 | 0 | 0 | 0 | 0 | 0 | 24 | 2 | 0 | 0 | 26 | 2 | 0 | 37 | 1 | 40 | 68 |
| 08:30 AM | 0 | 1 | 0 | 0 | 1 | 0 | 0 | 0 | 0 | 0 | 13 | 1 | 0 | 0 | 14 | 2 | 0 | 23 | 0 | 25 | 40 |
| 08:45 AM | 0 | 7 | 2 | 0 | 9 | 0 | 0 | 0 | 0 | 0 | 13 | 5 | 0 | 0 | 18 | 0 | 0 | 12 | 0 | 12 | 39 |
| Total | 0 | 9 | 9 | 0 | 18 | 0 | 0 | 0 | 0 | 0 | 74 | 9 | 0 | 0 | 83 | 4 | 0 | 90 | 1 | 95 | 196 |
| Grand Total | 0 | 18 | 18 | 0 | 36 | 0 | 0 | 0 | 0 | 0 | 264 | 15 | 0 | 0 | 279 | 7 | 0 | 286 | 2 | 295 | 610 |
| Apprch % | 0 | 50 | 50 | 0 | | 0 | 0 | 0 | 0 | | 94.6 | 5.4 | 0 | 0 | | 2.4 | 0 | 96.9 | 0.7 | | |
| Total % | 0 | 3 | 3 | 0 | 5.9 | 0 | 0 | 0 | 0 | 0 | 43.3 | 2.5 | 0 | 0 | 45.7 | 1.1 | 0 | 46.9 | 0.3 | 48.4 | |

LSC Transportation Consultants, Inc.

545 E Pikes Peak Ave, Suite 210
 Colorado Springs, CO 80905
 719-633-2868

File Name : Eastonville Rd -Londonderry Dr AM
 Site Code : S214250
 Start Date : 4/15/2021
 Page No : 3

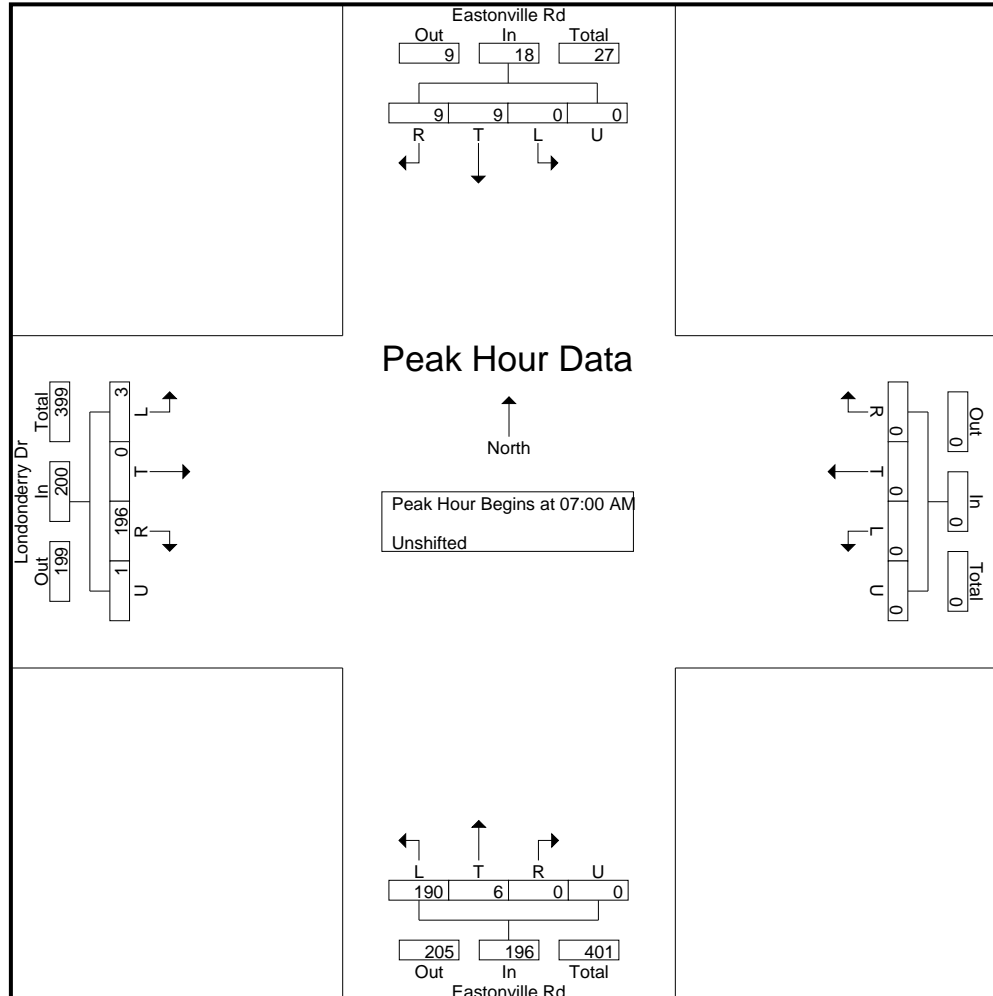

LSC Transportation Consultants, Inc.

545 E Pikes Peak Ave, Suite 210
 Colorado Springs, CO 80905
 719-633-2868

File Name : Eastonville Rd -Londonderry Dr PM
 Site Code : S214250
 Start Date : 4/15/2021
 Page No : 1

Groups Printed- Unshifted

| Start Time | Eastonville Rd Southbound | | | | | Westbound | | | | | Eastonville Rd Northbound | | | | | Londonderry Dr Eastbound | | | | | Int. Total |
|-------------|---------------------------|------|------|---|------------|-----------|---|---|---|------------|---------------------------|-----|---|-----|------------|--------------------------|---|------|---|------------|------------|
| | L | T | R | U | App. Total | L | T | R | U | App. Total | L | T | R | U | App. Total | L | T | R | U | App. Total | |
| 04:00 PM | 0 | 2 | 1 | 0 | 3 | 0 | 0 | 0 | 0 | 0 | 47 | 1 | 0 | 0 | 48 | 2 | 0 | 27 | 0 | 29 | 80 |
| 04:15 PM | 0 | 1 | 0 | 0 | 1 | 0 | 0 | 0 | 0 | 0 | 36 | 3 | 0 | 0 | 39 | 2 | 0 | 19 | 0 | 21 | 61 |
| 04:30 PM | 0 | 1 | 1 | 0 | 2 | 0 | 0 | 0 | 0 | 0 | 40 | 2 | 0 | 0 | 42 | 0 | 0 | 15 | 0 | 15 | 59 |
| 04:45 PM | 0 | 1 | 1 | 0 | 2 | 0 | 0 | 0 | 0 | 0 | 36 | 7 | 0 | 0 | 43 | 2 | 0 | 13 | 0 | 15 | 60 |
| Total | 0 | 5 | 3 | 0 | 8 | 0 | 0 | 0 | 0 | 0 | 159 | 13 | 0 | 0 | 172 | 6 | 0 | 74 | 0 | 80 | 260 |
| 05:00 PM | 0 | 2 | 2 | 0 | 4 | 0 | 0 | 0 | 0 | 0 | 36 | 1 | 0 | 0 | 37 | 0 | 0 | 12 | 0 | 12 | 53 |
| 05:15 PM | 0 | 4 | 0 | 0 | 4 | 0 | 0 | 0 | 0 | 0 | 31 | 1 | 0 | 0 | 32 | 1 | 0 | 8 | 0 | 9 | 45 |
| 05:30 PM | 0 | 1 | 0 | 0 | 1 | 0 | 0 | 0 | 0 | 0 | 35 | 3 | 0 | 1 | 39 | 0 | 0 | 7 | 0 | 7 | 47 |
| 05:45 PM | 0 | 2 | 0 | 0 | 2 | 0 | 0 | 0 | 0 | 0 | 24 | 2 | 0 | 0 | 26 | 0 | 0 | 15 | 0 | 15 | 43 |
| Total | 0 | 9 | 2 | 0 | 11 | 0 | 0 | 0 | 0 | 0 | 126 | 7 | 0 | 1 | 134 | 1 | 0 | 42 | 0 | 43 | 188 |
| Grand Total | 0 | 14 | 5 | 0 | 19 | 0 | 0 | 0 | 0 | 0 | 285 | 20 | 0 | 1 | 306 | 7 | 0 | 116 | 0 | 123 | 448 |
| Apprch % | 0 | 73.7 | 26.3 | 0 | | 0 | 0 | 0 | 0 | | 93.1 | 6.5 | 0 | 0.3 | | 5.7 | 0 | 94.3 | 0 | | |
| Total % | 0 | 3.1 | 1.1 | 0 | 4.2 | 0 | 0 | 0 | 0 | 0 | 63.6 | 4.5 | 0 | 0.2 | 68.3 | 1.6 | 0 | 25.9 | 0 | 27.5 | |

LSC Transportation Consultants, Inc.

545 E Pikes Peak Ave, Suite 210
 Colorado Springs, CO 80905
 719-633-2868

File Name : Eastonville Rd -Londonderry Dr PM
 Site Code : S214250
 Start Date : 4/15/2021
 Page No : 3

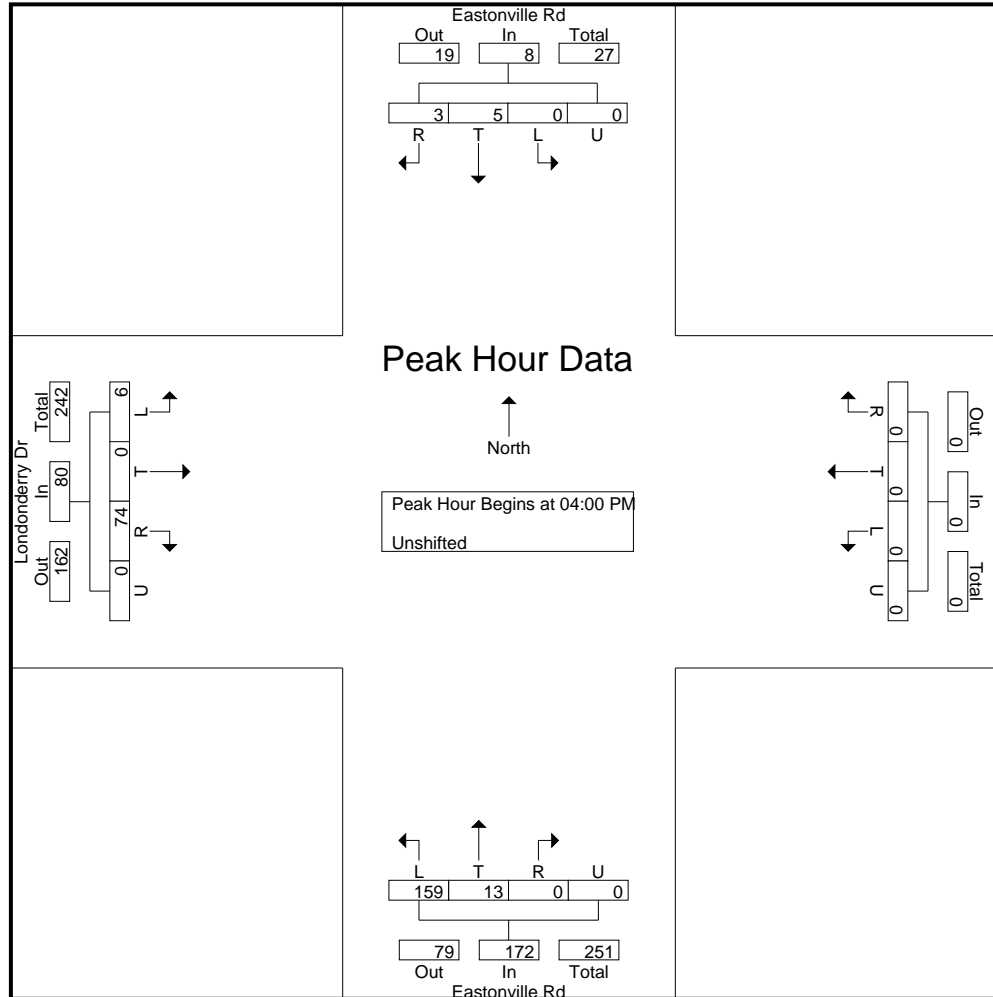

Crash History



| Accident Date | Total Vehicles | Location Road Name | FIP | Reference Point At Name | Road Surface Code | Lighting Condition Code | Adverse Weather Condition Code | Accident Narrative |
|---------------|----------------|--------------------|----------|-------------------------|-------------------|-------------------------|--------------------------------|--|
| 5/8/2019 | 1 | EASTONVILLE | Property | | 05 | 04 | 00 | Vehicle 1 was southbound in a parking lot at 10990 Eastonville Rd [Falcon Regional Park]. Vehicle 1 attempted to turn at a high rate of speed. While turning, vehicle 1 lost traction and began to rotate counter clockwise. Vehicle 1 then collided its front with a concrete base for a utility box. Vehicle 1 came to a rest facing northeast in the parking lot. |
| 11/4/2021 | 1 | EASTONVILLE | Property | | 05 | 04 | | Vehicle #1 was traveling northbound on Eastonville road approaching a left turn. Vehicle #1 lost control on the dirt road and rotated counterclockwise before rolling 3/4 time, then coming to rest on its left side off the left side of the roadway facing south. |
| 2/15/2019 | 1 | EASTONVILLE | Property | LONDONDERRY DR | 05 | 01 | 05 | Vehicle #1 was traveling southbound on Eastonville Road. Vehicle #1 lost control and ran off the right side of the road after rotating 1/4 turn clockwise. Vehicle #1 rolled 1/2 time and came to final rest on its top facing north. |
| 1/20/2022 | 1 | EASTONVILLE | Property | LONDONDERRY DR | 05 | 01 | | Vehicle #1 was traveling northbound on Eastonville Road. Vehicle #1 traveled off the right side of the roadway and collided its front with a fence. After impact, vehicle #1 began to rotate counterclockwise and rolled an undetermined amount of rolls. Vehicle #1 then came to final rest on its left side, facing south. |
| 4/29/2019 | 2 | EASTONVILLE | Property | STAPLETON DR | 02 | 01 | 00 | Vehicle 1 was southbound on Eastonville Road. Vehicle 2 was southbound on Eastonville Road ahead of Vehicle 1. Traffic ahead stopped abruptly. Vehicle 2 slowed. Vehicle 1 slowed and struck Vehicle 2, on its rear, with its front. Both vehicles were moved from the scene prior to officer arrival. |
| 1/14/2020 | 2 | EASTONVILLE | Property | STAPLETON DR | 02 | 04 | 00 | Vehicle #1 was eastbound on Stapleton Dr, stopped at the stop sign at Eastonville Rd. Vehicle #2 was southbound on Eastonville Rd approaching the intersection at Stapleton Dr. Vehicle #1 proceeded into the intersection. Vehicle #2 attempted to brake and steer to the left to avoid the collision. The front of vehicle #2 collided with the left side of vehicle #1 in the intersection. |
| 8/7/2020 | 2 | EASTONVILLE | Property | STAPLETON DR | 02 | 01 | 00 | Vehicle #1 was northbound on Stapleton Road stopped at the intersection for Eastonville Road. Vehicle #2 was westbound on Eastonville Road approaching the intersection with Stapleton Road. Vehicle #1 failed to yield the right of way to through traffic and pulled into the intersection and collided with the side of Vehicle #2. Both vehicles were moved from final rest prior to my investigation. |
| 10/22/2020 | 2 | EASTONVILLE | Property | STAPLETON DR | 02 | 01 | 05 | Vehicle 1 was northbound on Eastonville road in the left turn lane to go westbound on Stapleton drive; Vehicle 2 was southbound on Eastonville in the through lane; Vehicle 3 was stopped at the stop sign facing East on Stapleton drive. Vehicle 1 began to make a left turn to go westbound on Stapleton drive, Vehicle 2 swerved to the right to avoid a collision with Vehicle 1 and collided with its front into the side of Vehicle 3. Vehicles 1 and 2 moved to a dirt lot prior to the investigation, Vehicle 3 came to rest on the roadway facing East on Stapleton drive. |
| 1/29/2021 | 2 | EASTONVILLE | Property | STAPLETON DR | 02 | 04 | 00 | Vehicle 1 was westbound on Stapleton Drive at the stop sign of Eastonville Road. Vehicle 2 was southbound on Eastonville Drive approaching the intersection. The intersection has a stop sign for eastbound and westbound traffic on Stapleton Drive. Vehicle 1 proceeded from the stop sign into the intersection. The front end of Vehicle 2 collided with the right side of Vehicle 1 in the intersection. Both vehicles were moved prior to investigation. |
| 5/7/2021 | 2 | EASTONVILLE | Injury | STAPLETON DR | 02 | 01 | 00 | Vehicle 1 was westbound on Stapleton Dr at Eastonville Rd. Vehicle 2 was southbound on Eastonville Rd at Stapleton Dr. Vehicle 1 failed to yield right of way and proceeded from a stop sign. Vehicle 1 collided its front with the side of vehicle 2. Both vehicles were moved prior to investigation. |
| 12/17/2021 | 2 | EASTONVILLE | Property | STAPLETON DR | 02 | 01 | | Vehicle 1 was westbound on Stapleton Dr at Eastonville Rd. Vehicle 2 was northbound on Eastonville Rd at Stapleton Dr. Vehicle 1 failed to stop at a stop sign and entered the intersection. Vehicle 1 collided its front with the side of vehicle 2. Both vehicles were moved prior to investigation. |
| 2/3/2022 | 2 | EASTONVILLE | Property | STAPLETON DR | 02 | 01 | | Vehicle 1 was westbound on Stapleton Dr at Eastonville Rd. Vehicle 2 was northbound on Eastonville Rd at Stapleton Dr. Vehicle 1 failed to stop at a stop sign and entered the intersection in front of vehicle 2. Vehicle 2 collided its front with the side of vehicle 1. Vehicle 2 began to rotate counter clockwise and collided its side with the side of vehicle 1's trailer. Vehicle 2 came to a rest facing south blocking the eastbound lane of Stapleton Dr. Vehicle 1 left the scene prior to investigation. |

Levels of Service



| Intersection | | | | | | |
|--------------------------|------|------|------|------|------|------|
| Int Delay, s/veh | 9.3 | | | | | |
| Movement | EBL | EBR | NBL | NBT | SBT | SBR |
| Lane Configurations | ↶ | ↷ | | ↶ | ↷ | |
| Traffic Vol, veh/h | 3 | 297 | 303 | 6 | 9 | 9 |
| Future Vol, veh/h | 3 | 297 | 303 | 6 | 9 | 9 |
| Conflicting Peds, #/hr | 0 | 0 | 0 | 0 | 0 | 0 |
| Sign Control | Stop | Stop | Free | Free | Free | Free |
| RT Channelized | - | None | - | None | - | None |
| Storage Length | 0 | 0 | - | - | - | - |
| Veh in Median Storage, # | 0 | - | - | 0 | 0 | - |
| Grade, % | 0 | - | - | 0 | 0 | - |
| Peak Hour Factor | 67 | 67 | 51 | 51 | 90 | 90 |
| Heavy Vehicles, % | 2 | 2 | 2 | 2 | 2 | 2 |
| Mvmt Flow | 4 | 443 | 594 | 12 | 10 | 10 |

| Major/Minor | Minor2 | Major1 | | Major2 | |
|----------------------|--------|--------|-------|--------|---|
| Conflicting Flow All | 1215 | 15 | 20 | 0 | 0 |
| Stage 1 | 15 | - | - | - | - |
| Stage 2 | 1200 | - | - | - | - |
| Critical Hdwy | 6.42 | 6.22 | 4.12 | - | - |
| Critical Hdwy Stg 1 | 5.42 | - | - | - | - |
| Critical Hdwy Stg 2 | 5.42 | - | - | - | - |
| Follow-up Hdwy | 3.518 | 3.318 | 2.218 | - | - |
| Pot Cap-1 Maneuver | 200 | 1065 | 1596 | - | - |
| Stage 1 | 1008 | - | - | - | - |
| Stage 2 | 285 | - | - | - | - |
| Platoon blocked, % | | | | - | - |
| Mov Cap-1 Maneuver | 125 | 1065 | 1596 | - | - |
| Mov Cap-2 Maneuver | 125 | - | - | - | - |
| Stage 1 | 630 | - | - | - | - |
| Stage 2 | 285 | - | - | - | - |

| Approach | EB | NB | SB |
|----------------------|----|-----|----|
| HCM Control Delay, s | 11 | 8.4 | 0 |
| HCM LOS | B | | |

| Minor Lane/Major Mvmt | NBL | NBT | EBLn1 | EBLn2 | SBT | SBR |
|-----------------------|-------|-----|-------|-------|-----|-----|
| Capacity (veh/h) | 1596 | - | 125 | 1065 | - | - |
| HCM Lane V/C Ratio | 0.372 | - | 0.036 | 0.416 | - | - |
| HCM Control Delay (s) | 8.6 | 0 | 34.9 | 10.8 | - | - |
| HCM Lane LOS | A | A | D | B | - | - |
| HCM 95th %tile Q(veh) | 1.8 | - | 0.1 | 2.1 | - | - |

HCM 6th TWSC
13: Eastonville Rd & Stapleton Dr

Existing Traffic
AM Peak Hour

| Intersection | | | | | | | | | | | | |
|--------------------------|-------|------|------|------|------|------|------|------|------|------|------|------|
| Int Delay, s/veh | 108.7 | | | | | | | | | | | |
| Movement | EBL | EBT | EBR | WBL | WBT | WBR | NBL | NBT | NBR | SBL | SBT | SBR |
| Lane Configurations | | ↕ | | | ↕ | ↕ | | ↕ | | | ↕ | |
| Traffic Vol, veh/h | 12 | 159 | 42 | 6 | 94 | 110 | 83 | 187 | 17 | 139 | 153 | 14 |
| Future Vol, veh/h | 12 | 159 | 42 | 6 | 94 | 110 | 83 | 187 | 17 | 139 | 153 | 14 |
| Conflicting Peds, #/hr | 0 | 0 | 0 | 0 | 0 | 0 | 0 | 0 | 0 | 0 | 0 | 0 |
| Sign Control | Stop | Stop | Stop | Stop | Stop | Stop | Free | Free | Free | Free | Free | Free |
| RT Channelized | - | - | None | - | - | None | - | - | None | - | - | None |
| Storage Length | - | - | - | - | - | 250 | - | - | - | - | - | - |
| Veh in Median Storage, # | - | 0 | - | - | 0 | - | - | 0 | - | - | 0 | - |
| Grade, % | - | 0 | - | - | 0 | - | - | 0 | - | - | 0 | - |
| Peak Hour Factor | 87 | 87 | 87 | 85 | 85 | 85 | 68 | 68 | 68 | 64 | 64 | 64 |
| Heavy Vehicles, % | 2 | 2 | 2 | 2 | 2 | 2 | 2 | 2 | 2 | 2 | 2 | 2 |
| Mvmt Flow | 14 | 183 | 48 | 7 | 111 | 129 | 122 | 275 | 25 | 217 | 239 | 22 |

| Major/Minor | Minor2 | | Minor1 | | Major1 | | | Major2 | | | | |
|----------------------|--------|-------|--------|-------|--------|-------|-------|--------|---|-------|---|---|
| Conflicting Flow All | 1336 | 1228 | 250 | 1332 | 1227 | 288 | 261 | 0 | 0 | 300 | 0 | 0 |
| Stage 1 | 684 | 684 | - | 532 | 532 | - | - | - | - | - | - | - |
| Stage 2 | 652 | 544 | - | 800 | 695 | - | - | - | - | - | - | - |
| Critical Hdwy | 7.12 | 6.52 | 6.22 | 7.12 | 6.52 | 6.22 | 4.12 | - | - | 4.12 | - | - |
| Critical Hdwy Stg 1 | 6.12 | 5.52 | - | 6.12 | 5.52 | - | - | - | - | - | - | - |
| Critical Hdwy Stg 2 | 6.12 | 5.52 | - | 6.12 | 5.52 | - | - | - | - | - | - | - |
| Follow-up Hdwy | 3.518 | 4.018 | 3.318 | 3.518 | 4.018 | 3.318 | 2.218 | - | - | 2.218 | - | - |
| Pot Cap-1 Maneuver | 130 | ~ 178 | 789 | 131 | 178 | 751 | 1303 | - | - | 1261 | - | - |
| Stage 1 | 439 | 449 | - | 531 | 526 | - | - | - | - | - | - | - |
| Stage 2 | 457 | 519 | - | 379 | 444 | - | - | - | - | - | - | - |
| Platoon blocked, % | | | | | | | | - | - | - | - | - |
| Mov Cap-1 Maneuver | 22 | ~ 126 | 789 | - | 126 | 751 | 1303 | - | - | 1261 | - | - |
| Mov Cap-2 Maneuver | 22 | ~ 126 | - | - | 126 | - | - | - | - | - | - | - |
| Stage 1 | 389 | 358 | - | 471 | 467 | - | - | - | - | - | - | - |
| Stage 2 | 256 | 460 | - | 139 | 354 | - | - | - | - | - | - | - |

| Approach | EB | | WB | | NB | | SB | |
|----------------------|----------|--|----|--|-----|--|-----|--|
| HCM Control Delay, s | \$ 606.5 | | | | 2.3 | | 3.8 | |
| HCM LOS | F | | | | | | | |

| Minor Lane/Major Mvmt | NBL | NBT | NBR | EBLn1 | WBLn1 | WBLn2 | SBL | SBT | SBR |
|-----------------------|-------|-----|-----|----------|-------|-------|-------|-----|-----|
| Capacity (veh/h) | 1303 | - | - | 114 | - | 751 | 1261 | - | - |
| HCM Lane V/C Ratio | 0.094 | - | - | 2.148 | - | 0.172 | 0.172 | - | - |
| HCM Control Delay (s) | 8 | 0 | | \$ 606.5 | - | 10.8 | 8.4 | 0 | - |
| HCM Lane LOS | A | A | - | F | - | B | A | A | - |
| HCM 95th %tile Q(veh) | 0.3 | - | - | 20.8 | - | 0.6 | 0.6 | - | - |

Notes
 ~: Volume exceeds capacity \$: Delay exceeds 300s +: Computation Not Defined *: All major volume in platoon

| Intersection | | | | | | | | | | | | |
|--------------------------|------|------|------|------|------|------|------|------|------|------|------|------|
| Int Delay, s/veh | 18.2 | | | | | | | | | | | |
| Movement | EBL | EBT | EBR | WBL | WBT | WBR | NBL | NBT | NBR | SBL | SBT | SBR |
| Lane Configurations | ↖ | ↗ | ↖ | ↖ | ↗ | ↖ | ↖ | ↗ | ↖ | ↖ | ↗ | ↖ |
| Traffic Vol, veh/h | 33 | 157 | 146 | 4 | 86 | 17 | 77 | 254 | 5 | 45 | 426 | 37 |
| Future Vol, veh/h | 33 | 157 | 146 | 4 | 86 | 17 | 77 | 254 | 5 | 45 | 426 | 37 |
| Conflicting Peds, #/hr | 0 | 0 | 0 | 0 | 0 | 0 | 0 | 0 | 0 | 0 | 0 | 0 |
| Sign Control | Stop | Stop | Stop | Stop | Stop | Stop | Free | Free | Free | Free | Free | Free |
| RT Channelized | - | - | None | - | - | None | - | - | None | - | - | None |
| Storage Length | 185 | - | 325 | 225 | - | 225 | 1000 | - | 0 | 785 | - | 785 |
| Veh in Median Storage, # | - | 0 | - | - | 0 | - | - | 0 | - | - | 0 | - |
| Grade, % | - | 0 | - | - | 0 | - | - | 0 | - | - | 0 | - |
| Peak Hour Factor | 85 | 85 | 85 | 74 | 74 | 74 | 94 | 94 | 94 | 91 | 91 | 91 |
| Heavy Vehicles, % | 2 | 2 | 2 | 2 | 2 | 2 | 2 | 2 | 2 | 2 | 2 | 2 |
| Mvmt Flow | 39 | 185 | 172 | 5 | 116 | 23 | 82 | 270 | 5 | 49 | 468 | 41 |

| Major/Minor | Minor2 | | Minor1 | | Major1 | | Major2 | | | | | |
|----------------------|--------|-------|--------|-------|--------|-------|--------|---|---|-------|---|---|
| Conflicting Flow All | 1072 | 1005 | 468 | 1199 | 1041 | 270 | 509 | 0 | 0 | 275 | 0 | 0 |
| Stage 1 | 566 | 566 | - | 434 | 434 | - | - | - | - | - | - | - |
| Stage 2 | 506 | 439 | - | 765 | 607 | - | - | - | - | - | - | - |
| Critical Hdwy | 7.12 | 6.52 | 6.22 | 7.12 | 6.52 | 6.22 | 4.12 | - | - | 4.12 | - | - |
| Critical Hdwy Stg 1 | 6.12 | 5.52 | - | 6.12 | 5.52 | - | - | - | - | - | - | - |
| Critical Hdwy Stg 2 | 6.12 | 5.52 | - | 6.12 | 5.52 | - | - | - | - | - | - | - |
| Follow-up Hdwy | 3.518 | 4.018 | 3.318 | 3.518 | 4.018 | 3.318 | 2.218 | - | - | 2.218 | - | - |
| Pot Cap-1 Maneuver | 198 | 241 | 595 | 162 | 230 | 769 | 1056 | - | - | 1288 | - | - |
| Stage 1 | 509 | 507 | - | 600 | 581 | - | - | - | - | - | - | - |
| Stage 2 | 549 | 578 | - | 396 | 486 | - | - | - | - | - | - | - |
| Platoon blocked, % | - | - | - | - | - | - | - | - | - | - | - | - |
| Mov Cap-1 Maneuver | 97 | 214 | 595 | 29 | 204 | 769 | 1056 | - | - | 1288 | - | - |
| Mov Cap-2 Maneuver | 97 | 214 | - | 29 | 204 | - | - | - | - | - | - | - |
| Stage 1 | 469 | 488 | - | 553 | 536 | - | - | - | - | - | - | - |
| Stage 2 | 385 | 533 | - | 168 | 468 | - | - | - | - | - | - | - |

| Approach | EB | | WB | | NB | | SB | |
|----------------------|------|--|------|--|----|--|-----|--|
| HCM Control Delay, s | 48.5 | | 42.5 | | 2 | | 0.7 | |
| HCM LOS | E | | E | | | | | |

| Minor Lane/Major Mvmt | NBL | NBT | NBR | EBLn1 | EBLn2 | EBLn3 | WBLn1 | WBLn2 | WBLn3 | SBL | SBT | SBR |
|-----------------------|-------|-----|-----|-------|-------|-------|-------|-------|-------|-------|-----|-----|
| Capacity (veh/h) | 1056 | - | - | 97 | 214 | 595 | 29 | 204 | 769 | 1288 | - | - |
| HCM Lane V/C Ratio | 0.078 | - | - | 0.4 | 0.863 | 0.289 | 0.186 | 0.57 | 0.03 | 0.038 | - | - |
| HCM Control Delay (s) | 8.7 | - | - | 64.9 | 77.5 | 13.5 | 155.7 | 43.7 | 9.8 | 7.9 | - | - |
| HCM Lane LOS | A | - | - | F | F | B | F | E | A | A | - | - |
| HCM 95th %tile Q(veh) | 0.3 | - | - | 1.6 | 6.7 | 1.2 | 0.6 | 3.1 | 0.1 | 0.1 | - | - |

| Intersection | | | | | | |
|--------------------------|------|------|------|------|------|------|
| Int Delay, s/veh | 7.7 | | | | | |
| Movement | EBL | EBR | NBL | NBT | SBT | SBR |
| Lane Configurations | | | | | | |
| Traffic Vol, veh/h | 6 | 112 | 218 | 13 | 5 | 3 |
| Future Vol, veh/h | 6 | 112 | 218 | 13 | 5 | 3 |
| Conflicting Peds, #/hr | 0 | 0 | 0 | 0 | 0 | 0 |
| Sign Control | Stop | Stop | Free | Free | Free | Free |
| RT Channelized | - | None | - | None | - | None |
| Storage Length | 0 | 0 | - | - | - | - |
| Veh in Median Storage, # | 0 | - | - | 0 | 0 | - |
| Grade, % | 0 | - | - | 0 | 0 | - |
| Peak Hour Factor | 83 | 83 | 79 | 79 | 78 | 78 |
| Heavy Vehicles, % | 2 | 2 | 2 | 2 | 2 | 2 |
| Mvmt Flow | 7 | 135 | 276 | 16 | 6 | 4 |

| Major/Minor | Minor2 | Major1 | | Major2 | |
|----------------------|--------|--------|-------|--------|---|
| Conflicting Flow All | 576 | 8 | 10 | 0 | 0 |
| Stage 1 | 8 | - | - | - | - |
| Stage 2 | 568 | - | - | - | - |
| Critical Hdwy | 6.42 | 6.22 | 4.12 | - | - |
| Critical Hdwy Stg 1 | 5.42 | - | - | - | - |
| Critical Hdwy Stg 2 | 5.42 | - | - | - | - |
| Follow-up Hdwy | 3.518 | 3.318 | 2.218 | - | - |
| Pot Cap-1 Maneuver | 479 | 1074 | 1610 | - | - |
| Stage 1 | 1015 | - | - | - | - |
| Stage 2 | 567 | - | - | - | - |
| Platoon blocked, % | | | | - | - |
| Mov Cap-1 Maneuver | 396 | 1074 | 1610 | - | - |
| Mov Cap-2 Maneuver | 396 | - | - | - | - |
| Stage 1 | 839 | - | - | - | - |
| Stage 2 | 567 | - | - | - | - |

| Approach | EB | NB | SB |
|----------------------|-----|-----|----|
| HCM Control Delay, s | 9.1 | 7.3 | 0 |
| HCM LOS | A | | |

| Minor Lane/Major Mvmt | NBL | NBT | EBLn1 | EBLn2 | SBT | SBR |
|-----------------------|-------|-----|-------|-------|-----|-----|
| Capacity (veh/h) | 1610 | - | 396 | 1074 | - | - |
| HCM Lane V/C Ratio | 0.171 | - | 0.018 | 0.126 | - | - |
| HCM Control Delay (s) | 7.7 | 0 | 14.3 | 8.8 | - | - |
| HCM Lane LOS | A | A | B | A | - | - |
| HCM 95th %tile Q(veh) | 0.6 | - | 0.1 | 0.4 | - | - |

HCM 6th TWSC
13: Eastonville Rd & Stapleton Dr

Existing Traffic
PM Peak Hour

| Intersection | | | | | | | | | | | | |
|--------------------------|------|------|------|------|------|------|------|------|------|------|------|------|
| Int Delay, s/veh | 9.5 | | | | | | | | | | | |
| Movement | EBL | EBT | EBR | WBL | WBT | WBR | NBL | NBT | NBR | SBL | SBT | SBR |
| Lane Configurations | | ↕ | | | ↕ | ↕ | | ↕ | | | ↕ | |
| Traffic Vol, veh/h | 11 | 78 | 31 | 9 | 153 | 105 | 47 | 115 | 12 | 50 | 63 | 4 |
| Future Vol, veh/h | 11 | 78 | 31 | 9 | 153 | 105 | 47 | 115 | 12 | 50 | 63 | 4 |
| Conflicting Peds, #/hr | 0 | 0 | 0 | 0 | 0 | 0 | 0 | 0 | 0 | 0 | 0 | 0 |
| Sign Control | Stop | Stop | Stop | Stop | Stop | Stop | Free | Free | Free | Free | Free | Free |
| RT Channelized | - | - | None | - | - | None | - | - | None | - | - | None |
| Storage Length | - | - | - | - | - | 250 | - | - | - | - | - | - |
| Veh in Median Storage, # | - | 0 | - | - | 0 | - | - | 0 | - | - | 0 | - |
| Grade, % | - | 0 | - | - | 0 | - | - | 0 | - | - | 0 | - |
| Peak Hour Factor | 83 | 83 | 83 | 94 | 94 | 94 | 74 | 74 | 74 | 83 | 83 | 83 |
| Heavy Vehicles, % | 2 | 2 | 2 | 2 | 2 | 2 | 2 | 2 | 2 | 2 | 2 | 2 |
| Mvmt Flow | 13 | 94 | 37 | 10 | 163 | 112 | 64 | 155 | 16 | 60 | 76 | 5 |

| Major/Minor | Minor2 | | Minor1 | | | Major1 | | | Major2 | | | |
|----------------------|--------|-------|--------|-------|-------|--------|-------|---|--------|-------|---|---|
| Conflicting Flow All | 628 | 498 | 79 | 555 | 492 | 163 | 81 | 0 | 0 | 171 | 0 | 0 |
| Stage 1 | 199 | 199 | - | 291 | 291 | - | - | - | - | - | - | - |
| Stage 2 | 429 | 299 | - | 264 | 201 | - | - | - | - | - | - | - |
| Critical Hdwy | 7.12 | 6.52 | 6.22 | 7.12 | 6.52 | 6.22 | 4.12 | - | - | 4.12 | - | - |
| Critical Hdwy Stg 1 | 6.12 | 5.52 | - | 6.12 | 5.52 | - | - | - | - | - | - | - |
| Critical Hdwy Stg 2 | 6.12 | 5.52 | - | 6.12 | 5.52 | - | - | - | - | - | - | - |
| Follow-up Hdwy | 3.518 | 4.018 | 3.318 | 3.518 | 4.018 | 3.318 | 2.218 | - | - | 2.218 | - | - |
| Pot Cap-1 Maneuver | 395 | 474 | 981 | 442 | 478 | 882 | 1517 | - | - | 1406 | - | - |
| Stage 1 | 803 | 736 | - | 717 | 672 | - | - | - | - | - | - | - |
| Stage 2 | 604 | 666 | - | 741 | 735 | - | - | - | - | - | - | - |
| Platoon blocked, % | | | | | | | | - | - | - | - | - |
| Mov Cap-1 Maneuver | 229 | 431 | 981 | 330 | 435 | 882 | 1517 | - | - | 1406 | - | - |
| Mov Cap-2 Maneuver | 229 | 431 | - | 330 | 435 | - | - | - | - | - | - | - |
| Stage 1 | 765 | 703 | - | 683 | 640 | - | - | - | - | - | - | - |
| Stage 2 | 375 | 635 | - | 590 | 702 | - | - | - | - | - | - | - |

| Approach | EB | | WB | | | NB | | | SB | | |
|----------------------|------|--|------|--|--|----|--|--|-----|--|--|
| HCM Control Delay, s | 16.4 | | 15.3 | | | 2 | | | 3.3 | | |
| HCM LOS | C | | C | | | | | | | | |

| Minor Lane/Major Mvmt | NBL | NBT | NBR | EBLn1 | WBLn1 | WBLn2 | SBL | SBT | SBR |
|-----------------------|-------|-----|-----|-------|-------|-------|-------|-----|-----|
| Capacity (veh/h) | 1517 | - | - | 460 | 427 | 882 | 1406 | - | - |
| HCM Lane V/C Ratio | 0.042 | - | - | 0.314 | 0.404 | 0.127 | 0.043 | - | - |
| HCM Control Delay (s) | 7.5 | 0 | - | 16.4 | 19 | 9.7 | 7.7 | 0 | - |
| HCM Lane LOS | A | A | - | C | C | A | A | A | - |
| HCM 95th %tile Q(veh) | 0.1 | - | - | 1.3 | 1.9 | 0.4 | 0.1 | - | - |

| Intersection | | | | | | | | | | | | |
|--------------------------|------|------|------|------|------|------|------|------|------|------|------|------|
| Int Delay, s/veh | 21.2 | | | | | | | | | | | |
| Movement | EBL | EBT | EBR | WBL | WBT | WBR | NBL | NBT | NBR | SBL | SBT | SBR |
| Lane Configurations | ↖ | ↗ | ↖ | ↖ | ↗ | ↖ | ↖ | ↗ | ↖ | ↖ | ↗ | ↖ |
| Traffic Vol, veh/h | 18 | 49 | 67 | 5 | 124 | 34 | 120 | 468 | 8 | 10 | 370 | 29 |
| Future Vol, veh/h | 18 | 49 | 67 | 5 | 124 | 34 | 120 | 468 | 8 | 10 | 370 | 29 |
| Conflicting Peds, #/hr | 0 | 0 | 0 | 0 | 0 | 0 | 0 | 0 | 0 | 0 | 0 | 0 |
| Sign Control | Stop | Stop | Stop | Stop | Stop | Stop | Free | Free | Free | Free | Free | Free |
| RT Channelized | - | - | None | - | - | None | - | - | None | - | - | None |
| Storage Length | 185 | - | 325 | 225 | - | 225 | 1000 | - | 0 | 785 | - | 785 |
| Veh in Median Storage, # | - | 0 | - | - | 0 | - | - | 0 | - | - | 0 | - |
| Grade, % | - | 0 | - | - | 0 | - | - | 0 | - | - | 0 | - |
| Peak Hour Factor | 93 | 93 | 93 | 85 | 85 | 85 | 92 | 92 | 92 | 90 | 90 | 90 |
| Heavy Vehicles, % | 2 | 2 | 2 | 2 | 2 | 2 | 2 | 2 | 2 | 2 | 2 | 2 |
| Mvmt Flow | 19 | 53 | 72 | 6 | 146 | 40 | 130 | 509 | 9 | 11 | 411 | 32 |

| Major/Minor | Minor2 | | Minor1 | | Major1 | | | Major2 | | | | |
|----------------------|--------|-------|--------|-------|--------|-------|-------|--------|---|-------|---|---|
| Conflicting Flow All | 1300 | 1211 | 411 | 1281 | 1234 | 509 | 443 | 0 | 0 | 518 | 0 | 0 |
| Stage 1 | 433 | 433 | - | 769 | 769 | - | - | - | - | - | - | - |
| Stage 2 | 867 | 778 | - | 512 | 465 | - | - | - | - | - | - | - |
| Critical Hdwy | 7.12 | 6.52 | 6.22 | 7.12 | 6.52 | 6.22 | 4.12 | - | - | 4.12 | - | - |
| Critical Hdwy Stg 1 | 6.12 | 5.52 | - | 6.12 | 5.52 | - | - | - | - | - | - | - |
| Critical Hdwy Stg 2 | 6.12 | 5.52 | - | 6.12 | 5.52 | - | - | - | - | - | - | - |
| Follow-up Hdwy | 3.518 | 4.018 | 3.318 | 3.518 | 4.018 | 3.318 | 2.218 | - | - | 2.218 | - | - |
| Pot Cap-1 Maneuver | 138 | 182 | 641 | 142 | 177 | 564 | 1117 | - | - | 1048 | - | - |
| Stage 1 | 601 | 582 | - | 394 | 411 | - | - | - | - | - | - | - |
| Stage 2 | 348 | 407 | - | 545 | 563 | - | - | - | - | - | - | - |
| Platoon blocked, % | - | - | - | - | - | - | - | - | - | - | - | - |
| Mov Cap-1 Maneuver | 20 | 159 | 641 | 85 | 155 | 564 | 1117 | - | - | 1048 | - | - |
| Mov Cap-2 Maneuver | 20 | 159 | - | 85 | 155 | - | - | - | - | - | - | - |
| Stage 1 | 531 | 576 | - | 348 | 363 | - | - | - | - | - | - | - |
| Stage 2 | 171 | 360 | - | 435 | 557 | - | - | - | - | - | - | - |

| Approach | EB | | WB | | NB | | | SB | | |
|----------------------|------|--|------|--|-----|--|--|-----|--|--|
| HCM Control Delay, s | 81.2 | | 91.6 | | 1.7 | | | 0.2 | | |
| HCM LOS | F | | F | | | | | | | |

| Minor Lane/Major Mvmt | NBL | NBT | NBR | EBLn1 | EBLn2 | EBLn3 | WBLn1 | WBLn2 | WBLn3 | SBL | SBT | SBR |
|-----------------------|-------|-----|-----|-------|-------|-------|-------|-------|-------|-------|-----|-----|
| Capacity (veh/h) | 1117 | - | - | 20 | 159 | 641 | 85 | 155 | 564 | 1048 | - | - |
| HCM Lane V/C Ratio | 0.117 | - | - | 0.968 | 0.331 | 0.112 | 0.069 | 0.941 | 0.071 | 0.011 | - | - |
| HCM Control Delay (s) | 8.6 | - | - | 457.8 | 38.5 | 11.3 | 50.5 | 115.1 | 11.9 | 8.5 | - | - |
| HCM Lane LOS | A | - | - | F | E | B | F | F | B | A | - | - |
| HCM 95th %tile Q(veh) | 0.4 | - | - | 2.7 | 1.4 | 0.4 | 0.2 | 6.8 | 0.2 | 0 | - | - |

Intersection

Int Delay, s/veh 8.6

Movement EBL EBR NBL NBT SBT SBR

| | | | | | | |
|--------------------------|------|------|------|------|------|------|
| Lane Configurations | ↙ | ↗ | ↙ | ↑ | ↗ | |
| Traffic Vol, veh/h | 4 | 264 | 86 | 14 | 26 | 1 |
| Future Vol, veh/h | 4 | 264 | 86 | 14 | 26 | 1 |
| Conflicting Peds, #/hr | 0 | 0 | 0 | 0 | 0 | 0 |
| Sign Control | Stop | Stop | Free | Free | Free | Free |
| RT Channelized | - | None | - | None | - | None |
| Storage Length | 300 | - | 250 | - | - | - |
| Veh in Median Storage, # | 0 | - | - | 0 | 0 | - |
| Grade, % | 0 | - | - | 0 | 0 | - |
| Peak Hour Factor | 78 | 78 | 87 | 87 | 94 | 94 |
| Heavy Vehicles, % | 2 | 2 | 2 | 2 | 2 | 2 |
| Mvmt Flow | 5 | 338 | 99 | 16 | 28 | 1 |

Major/Minor Minor2 Major1 Major2

| | | | | | | |
|----------------------|-------|-------|-------|---|---|---|
| Conflicting Flow All | 243 | 29 | 29 | 0 | - | 0 |
| Stage 1 | 29 | - | - | - | - | - |
| Stage 2 | 214 | - | - | - | - | - |
| Critical Hdwy | 6.42 | 6.22 | 4.12 | - | - | - |
| Critical Hdwy Stg 1 | 5.42 | - | - | - | - | - |
| Critical Hdwy Stg 2 | 5.42 | - | - | - | - | - |
| Follow-up Hdwy | 3.518 | 3.318 | 2.218 | - | - | - |
| Pot Cap-1 Maneuver | 745 | 1046 | 1584 | - | - | - |
| Stage 1 | 994 | - | - | - | - | - |
| Stage 2 | 822 | - | - | - | - | - |
| Platoon blocked, % | | | | - | - | - |
| Mov Cap-1 Maneuver | 699 | 1046 | 1584 | - | - | - |
| Mov Cap-2 Maneuver | 699 | - | - | - | - | - |
| Stage 1 | 932 | - | - | - | - | - |
| Stage 2 | 822 | - | - | - | - | - |

Approach EB NB SB

HCM Control Delay, s 10.1 6.4 0
HCM LOS B

Minor Lane/Major Mvmt NBL NBT EBLn1 EBLn2 SBT SBR

| | | | | | | |
|-----------------------|-------|---|-------|-------|---|---|
| Capacity (veh/h) | 1584 | - | 699 | 1046 | - | - |
| HCM Lane V/C Ratio | 0.062 | - | 0.007 | 0.324 | - | - |
| HCM Control Delay (s) | 7.4 | - | 10.2 | 10.1 | - | - |
| HCM Lane LOS | A | - | B | B | - | - |
| HCM 95th %tile Q(veh) | 0.2 | - | 0 | 1.4 | - | - |

| Intersection | | | | | | |
|--------------------------|------|------|------|------|------|------|
| Int Delay, s/veh | 14.4 | | | | | |
| Movement | EBL | EBR | NBL | NBT | SBT | SBR |
| Lane Configurations | ↖ | ↗ | ↖ | ↗ | ↗ | ↖ |
| Traffic Vol, veh/h | 19 | 400 | 337 | 82 | 257 | 34 |
| Future Vol, veh/h | 19 | 400 | 337 | 82 | 257 | 34 |
| Conflicting Peds, #/hr | 0 | 0 | 0 | 0 | 0 | 0 |
| Sign Control | Stop | Stop | Free | Free | Free | Free |
| RT Channelized | - | None | - | None | - | None |
| Storage Length | 0 | 0 | 250 | - | - | 205 |
| Veh in Median Storage, # | 0 | - | - | 0 | 0 | - |
| Grade, % | 0 | - | - | 0 | 0 | - |
| Peak Hour Factor | 67 | 67 | 51 | 85 | 85 | 85 |
| Heavy Vehicles, % | 2 | 2 | 2 | 2 | 2 | 2 |
| Mvmt Flow | 28 | 597 | 661 | 96 | 302 | 40 |

| Major/Minor | Minor2 | Major1 | Major2 | | | |
|----------------------|--------|--------|--------|---|---|---|
| Conflicting Flow All | 1720 | 302 | 342 | 0 | - | 0 |
| Stage 1 | 302 | - | - | - | - | - |
| Stage 2 | 1418 | - | - | - | - | - |
| Critical Hdwy | 6.42 | 6.22 | 4.12 | - | - | - |
| Critical Hdwy Stg 1 | 5.42 | - | - | - | - | - |
| Critical Hdwy Stg 2 | 5.42 | - | - | - | - | - |
| Follow-up Hdwy | 3.518 | 3.318 | 2.218 | - | - | - |
| Pot Cap-1 Maneuver | 98 | 738 | 1217 | - | - | - |
| Stage 1 | 750 | - | - | - | - | - |
| Stage 2 | 224 | - | - | - | - | - |
| Platoon blocked, % | | | | - | - | - |
| Mov Cap-1 Maneuver | 45 | 738 | 1217 | - | - | - |
| Mov Cap-2 Maneuver | 143 | - | - | - | - | - |
| Stage 1 | 343 | - | - | - | - | - |
| Stage 2 | 224 | - | - | - | - | - |

| Approach | EB | NB | SB |
|----------------------|------|----|----|
| HCM Control Delay, s | 27.5 | 10 | 0 |
| HCM LOS | D | | |

| Minor Lane/Major Mvmt | NBL | NBT | EBLn1 | EBLn2 | SBT | SBR |
|-----------------------|-------|-----|-------|-------|-----|-----|
| Capacity (veh/h) | 1217 | - | 143 | 738 | - | - |
| HCM Lane V/C Ratio | 0.543 | - | 0.198 | 0.809 | - | - |
| HCM Control Delay (s) | 11.4 | - | 36.3 | 27.1 | - | - |
| HCM Lane LOS | B | - | E | D | - | - |
| HCM 95th %tile Q(veh) | 3.4 | - | 0.7 | 8.6 | - | - |

| Intersection | |
|---------------------------|-------|
| Intersection Delay, s/veh | 124.2 |
| Intersection LOS | F |

| Movement | EBL | EBT | EBR | WBL | WBT | WBR | NBL | NBT | NBR | SBL | SBT | SBR |
|---------------------|------|------|------|------|------|------|------|------|------|------|------|------|
| Lane Configurations | ↰ | ↱ | | ↰ | ↱ | | ↰ | ↱ | | ↰ | ↱ | |
| Traffic Vol, veh/h | 13 | 213 | 63 | 25 | 133 | 172 | 96 | 234 | 25 | 329 | 309 | 19 |
| Future Vol, veh/h | 13 | 213 | 63 | 25 | 133 | 172 | 96 | 234 | 25 | 329 | 309 | 19 |
| Peak Hour Factor | 0.87 | 0.87 | 0.87 | 0.85 | 0.85 | 0.85 | 0.68 | 0.68 | 0.68 | 0.64 | 0.64 | 0.64 |
| Heavy Vehicles, % | 2 | 2 | 2 | 2 | 2 | 2 | 2 | 2 | 2 | 2 | 2 | 2 |
| Mvmt Flow | 15 | 245 | 72 | 29 | 156 | 202 | 141 | 344 | 37 | 514 | 483 | 30 |
| Number of Lanes | 1 | 1 | 0 | 1 | 1 | 0 | 1 | 1 | 0 | 1 | 1 | 0 |

| Approach | EB | WB | NB | SB |
|----------------------------|------|------|------|-------|
| Opposing Approach | WB | EB | SB | NB |
| Opposing Lanes | 2 | 2 | 2 | 2 |
| Conflicting Approach Left | SB | NB | EB | WB |
| Conflicting Lanes Left | 2 | 2 | 2 | 2 |
| Conflicting Approach Right | NB | SB | WB | EB |
| Conflicting Lanes Right | 2 | 2 | 2 | 2 |
| HCM Control Delay | 45.4 | 54.1 | 56.7 | 210.5 |
| HCM LOS | E | F | F | F |

| Lane | NBLn1 | NBLn2 | EBLn1 | EBLn2 | WBLn1 | WBLn2 | SBLn1 | SBLn2 |
|------------------------|-------|-------|-------|-------|--------|-------|-------|-------|
| Vol Left, % | 100% | 0% | 100% | 0% | 100% | 0% | 100% | 0% |
| Vol Thru, % | 0% | 90% | 0% | 77% | 0% | 44% | 0% | 94% |
| Vol Right, % | 0% | 10% | 0% | 23% | 0% | 56% | 0% | 6% |
| Sign Control | Stop | Stop | Stop | Stop | Stop | Stop | Stop | Stop |
| Traffic Vol by Lane | 96 | 259 | 13 | 276 | 25 | 305 | 329 | 328 |
| LT Vol | 96 | 0 | 13 | 0 | 25 | 0 | 329 | 0 |
| Through Vol | 0 | 234 | 0 | 213 | 0 | 133 | 0 | 309 |
| RT Vol | 0 | 25 | 0 | 63 | 0 | 172 | 0 | 19 |
| Lane Flow Rate | 141 | 381 | 15 | 317 | 29 | 359 | 514 | 512 |
| Geometry Grp | 7 | 7 | 7 | 7 | 7 | 7 | 7 | 7 |
| Degree of Util (X) | 0.384 | 0.976 | 0.042 | 0.84 | 0.082 | 0.913 | 1.415 | 1.33 |
| Departure Headway (Hd) | 9.904 | 9.227 | 10.41 | 9.718 | 10.273 | 9.335 | 9.912 | 9.345 |
| Convergence, Y/N | Yes | Yes | Yes | Yes | Yes | Yes | Yes | Yes |
| Cap | 366 | 392 | 346 | 374 | 351 | 391 | 370 | 390 |
| Service Time | 7.604 | 7.01 | 8.11 | 7.418 | 7.973 | 7.035 | 7.693 | 7.126 |
| HCM Lane V/C Ratio | 0.385 | 0.972 | 0.043 | 0.848 | 0.083 | 0.918 | 1.389 | 1.313 |
| HCM Control Delay | 18.6 | 70.8 | 13.6 | 46.9 | 13.9 | 57.4 | 228.9 | 192 |
| HCM Lane LOS | C | F | B | E | B | F | F | F |
| HCM 95th-tile Q | 1.8 | 11.3 | 0.1 | 7.7 | 0.3 | 9.6 | 26 | 23.8 |

| Intersection | | | | | | | | | | | | |
|--------------------------|------|------|------|------|------|------|------|------|------|------|------|------|
| Int Delay, s/veh | 0.9 | | | | | | | | | | | |
| Movement | EBL | EBT | EBR | WBL | WBT | WBR | NBL | NBT | NBR | SBL | SBT | SBR |
| Lane Configurations | ↖ | ↗ | ↖ | ↖ | ↗ | ↖ | ↖ | ↗ | ↖ | ↖ | ↗ | ↖ |
| Traffic Vol, veh/h | 61 | 257 | 324 | 4 | 118 | 17 | 136 | 378 | 5 | 45 | 635 | 45 |
| Future Vol, veh/h | 61 | 257 | 324 | 4 | 118 | 17 | 136 | 378 | 5 | 45 | 635 | 45 |
| Conflicting Peds, #/hr | 0 | 0 | 0 | 0 | 0 | 0 | 0 | 0 | 0 | 0 | 0 | 0 |
| Sign Control | Stop | Stop | Stop | Stop | Stop | Stop | Free | Free | Free | Free | Free | Free |
| RT Channelized | - | - | None | - | - | None | - | - | None | - | - | None |
| Storage Length | 185 | - | 325 | 225 | - | 225 | 1000 | - | 0 | 785 | - | 785 |
| Veh in Median Storage, # | - | 0 | - | - | 0 | - | - | 0 | - | - | 0 | - |
| Grade, % | - | 0 | - | - | 0 | - | - | 0 | - | - | 0 | - |
| Peak Hour Factor | 85 | 85 | 85 | 85 | 85 | 85 | 85 | 85 | 85 | 85 | 85 | 85 |
| Heavy Vehicles, % | 2 | 2 | 2 | 2 | 2 | 2 | 2 | 2 | 2 | 2 | 2 | 2 |
| Mvmt Flow | 72 | 302 | 381 | 5 | 139 | 20 | 160 | 445 | 6 | 53 | 747 | 53 |

| Major/Minor | Minor2 | | Minor1 | | Major1 | | Major2 | | | | | |
|----------------------|--------|-------|--------|-------|--------|-------|--------|---|---|-------|---|---|
| Conflicting Flow All | 1701 | 1624 | 747 | 1986 | 1671 | 445 | 800 | 0 | 0 | 451 | 0 | 0 |
| Stage 1 | 853 | 853 | - | 765 | 765 | - | - | - | - | - | - | - |
| Stage 2 | 848 | 771 | - | 1221 | 906 | - | - | - | - | - | - | - |
| Critical Hdwy | 7.12 | 6.52 | 6.22 | 7.12 | 6.52 | 6.22 | 4.12 | - | - | 4.12 | - | - |
| Critical Hdwy Stg 1 | 6.12 | 5.52 | - | 6.12 | 5.52 | - | - | - | - | - | - | - |
| Critical Hdwy Stg 2 | 6.12 | 5.52 | - | 6.12 | 5.52 | - | - | - | - | - | - | - |
| Follow-up Hdwy | 3.518 | 4.018 | 3.318 | 3.518 | 4.018 | 3.318 | 2.218 | - | - | 2.218 | - | - |
| Pot Cap-1 Maneuver | 73 | ~ 102 | 413 | 46 | ~ 96 | 613 | 823 | - | - | 1109 | - | - |
| Stage 1 | 354 | 376 | - | 396 | 412 | - | - | - | - | - | - | - |
| Stage 2 | 356 | 410 | - | 220 | 355 | - | - | - | - | - | - | - |
| Platoon blocked, % | - | - | - | - | - | - | - | - | - | - | - | - |
| Mov Cap-1 Maneuver | - | ~ 78 | 413 | - | ~ 74 | 613 | 823 | - | - | 1109 | - | - |
| Mov Cap-2 Maneuver | - | ~ 78 | - | - | ~ 74 | - | - | - | - | - | - | - |
| Stage 1 | 285 | 358 | - | 319 | 332 | - | - | - | - | - | - | - |
| Stage 2 | 161 | 330 | - | ~ 3 | 338 | - | - | - | - | - | - | - |

| Approach | EB | WB | NB | SB |
|----------------------|----|----|-----|-----|
| HCM Control Delay, s | | | 2.7 | 0.5 |
| HCM LOS | - | - | | |

| Minor Lane/Major Mvmt | NBL | NBT | NBR | EBLn1 | EBLn2 | EBLn3 | WBLn1 | WBLn2 | WBLn3 | SBL | SBT | SBR |
|-----------------------|-------|-----|-----|-------|---------|-------|-------|----------|-------|-------|-----|-----|
| Capacity (veh/h) | 823 | - | - | - | 78 | 413 | - | 74 | 613 | 1109 | - | - |
| HCM Lane V/C Ratio | 0.194 | - | - | - | 3.876 | 0.923 | - | 1.876 | 0.033 | 0.048 | - | - |
| HCM Control Delay (s) | 10.4 | - | - | - | \$ 1405 | 59 | - | \$ 533.4 | 11.1 | 8.4 | - | - |
| HCM Lane LOS | B | - | - | - | F | F | - | F | B | A | - | - |
| HCM 95th %tile Q(veh) | 0.7 | - | - | - | 31.6 | 10.1 | - | 12.3 | 0.1 | 0.1 | - | - |

Notes
 ~: Volume exceeds capacity \$: Delay exceeds 300s +: Computation Not Defined *: All major volume in platoon

| Intersection | | | | | | |
|--------------------------|------|------|------|------|------|------|
| Int Delay, s/veh | 7.8 | | | | | |
| Movement | EBL | EBR | NBL | NBT | SBT | SBR |
| Lane Configurations | ↙ | ↗ | ↙ | ↑ | ↗ | |
| Traffic Vol, veh/h | 9 | 172 | 296 | 30 | 17 | 8 |
| Future Vol, veh/h | 9 | 172 | 296 | 30 | 17 | 8 |
| Conflicting Peds, #/hr | 0 | 0 | 0 | 0 | 0 | 0 |
| Sign Control | Stop | Stop | Free | Free | Free | Free |
| RT Channelized | - | None | - | None | - | None |
| Storage Length | 300 | - | 250 | - | - | - |
| Veh in Median Storage, # | 0 | - | - | 0 | 0 | - |
| Grade, % | 0 | - | - | 0 | 0 | - |
| Peak Hour Factor | 78 | 78 | 87 | 87 | 94 | 94 |
| Heavy Vehicles, % | 2 | 2 | 2 | 2 | 2 | 2 |
| Mvmt Flow | 12 | 221 | 340 | 34 | 18 | 9 |

| Major/Minor | Minor2 | Major1 | | Major2 | |
|----------------------|--------|--------|-------|--------|---|
| Conflicting Flow All | 737 | 23 | 27 | 0 | 0 |
| Stage 1 | 23 | - | - | - | - |
| Stage 2 | 714 | - | - | - | - |
| Critical Hdwy | 6.42 | 6.22 | 4.12 | - | - |
| Critical Hdwy Stg 1 | 5.42 | - | - | - | - |
| Critical Hdwy Stg 2 | 5.42 | - | - | - | - |
| Follow-up Hdwy | 3.518 | 3.318 | 2.218 | - | - |
| Pot Cap-1 Maneuver | 386 | 1054 | 1587 | - | - |
| Stage 1 | 1000 | - | - | - | - |
| Stage 2 | 485 | - | - | - | - |
| Platoon blocked, % | | | | - | - |
| Mov Cap-1 Maneuver | 303 | 1054 | 1587 | - | - |
| Mov Cap-2 Maneuver | 303 | - | - | - | - |
| Stage 1 | 786 | - | - | - | - |
| Stage 2 | 485 | - | - | - | - |

| Approach | EB | NB | SB |
|----------------------|-----|-----|----|
| HCM Control Delay, s | 9.7 | 7.2 | 0 |
| HCM LOS | A | | |

| Minor Lane/Major Mvmt | NBL | NBT | EBLn1 | EBLn2 | SBT | SBR |
|-----------------------|-------|-----|-------|-------|-----|-----|
| Capacity (veh/h) | 1587 | - | 303 | 1054 | - | - |
| HCM Lane V/C Ratio | 0.214 | - | 0.038 | 0.209 | - | - |
| HCM Control Delay (s) | 7.9 | - | 17.4 | 9.3 | - | - |
| HCM Lane LOS | A | - | C | A | - | - |
| HCM 95th %tile Q(veh) | 0.8 | - | 0.1 | 0.8 | - | - |

| Intersection | | | | | | |
|--------------------------|------|------|------|------|------|------|
| Int Delay, s/veh | 5.5 | | | | | |
| Movement | EBL | EBR | NBL | NBT | SBT | SBR |
| Lane Configurations | ↖ | ↗ | ↖ | ↗ | ↗ | ↖ |
| Traffic Vol, veh/h | 33 | 183 | 342 | 305 | 168 | 21 |
| Future Vol, veh/h | 33 | 183 | 342 | 305 | 168 | 21 |
| Conflicting Peds, #/hr | 0 | 0 | 0 | 0 | 0 | 0 |
| Sign Control | Stop | Stop | Free | Free | Free | Free |
| RT Channelized | - | None | - | None | - | None |
| Storage Length | 0 | 0 | 250 | - | - | 205 |
| Veh in Median Storage, # | 0 | - | - | 0 | 0 | - |
| Grade, % | 0 | - | - | 0 | 0 | - |
| Peak Hour Factor | 85 | 85 | 85 | 85 | 85 | 85 |
| Heavy Vehicles, % | 2 | 2 | 2 | 2 | 2 | 2 |
| Mvmt Flow | 39 | 215 | 402 | 359 | 198 | 25 |

| Major/Minor | Minor2 | Major1 | Major2 | | | |
|----------------------|--------|--------|--------|---|---|---|
| Conflicting Flow All | 1361 | 198 | 223 | 0 | - | 0 |
| Stage 1 | 198 | - | - | - | - | - |
| Stage 2 | 1163 | - | - | - | - | - |
| Critical Hdwy | 6.42 | 6.22 | 4.12 | - | - | - |
| Critical Hdwy Stg 1 | 5.42 | - | - | - | - | - |
| Critical Hdwy Stg 2 | 5.42 | - | - | - | - | - |
| Follow-up Hdwy | 3.518 | 3.318 | 2.218 | - | - | - |
| Pot Cap-1 Maneuver | 163 | 843 | 1346 | - | - | - |
| Stage 1 | 835 | - | - | - | - | - |
| Stage 2 | 297 | - | - | - | - | - |
| Platoon blocked, % | | | | - | - | - |
| Mov Cap-1 Maneuver | 114 | 843 | 1346 | - | - | - |
| Mov Cap-2 Maneuver | 224 | - | - | - | - | - |
| Stage 1 | 585 | - | - | - | - | - |
| Stage 2 | 297 | - | - | - | - | - |

| Approach | EB | NB | SB |
|----------------------|------|-----|----|
| HCM Control Delay, s | 12.8 | 4.7 | 0 |
| HCM LOS | B | | |

| Minor Lane/Major Mvmt | NBL | NBT | EBLn1 | EBLn2 | SBT | SBR |
|-----------------------|-------|-----|-------|-------|-----|-----|
| Capacity (veh/h) | 1346 | - | 224 | 843 | - | - |
| HCM Lane V/C Ratio | 0.299 | - | 0.173 | 0.255 | - | - |
| HCM Control Delay (s) | 8.8 | - | 24.4 | 10.7 | - | - |
| HCM Lane LOS | A | - | C | B | - | - |
| HCM 95th %tile Q(veh) | 1.3 | - | 0.6 | 1 | - | - |

| Intersection | |
|---------------------------|------|
| Intersection Delay, s/veh | 82.2 |
| Intersection LOS | F |

| Movement | EBL | EBT | EBR | WBL | WBT | WBR | NBL | NBT | NBR | SBL | SBT | SBR |
|---------------------|------|------|------|------|------|------|------|------|------|------|------|------|
| Lane Configurations | ↶ | ↷ | | ↶ | ↷ | | ↶ | ↷ | | ↶ | ↷ | |
| Traffic Vol, veh/h | 15 | 130 | 45 | 22 | 220 | 332 | 72 | 300 | 33 | 179 | 164 | 8 |
| Future Vol, veh/h | 15 | 130 | 45 | 22 | 220 | 332 | 72 | 300 | 33 | 179 | 164 | 8 |
| Peak Hour Factor | 0.83 | 0.83 | 0.83 | 0.94 | 0.94 | 0.94 | 0.85 | 0.85 | 0.85 | 0.83 | 0.83 | 0.83 |
| Heavy Vehicles, % | 2 | 2 | 2 | 2 | 2 | 2 | 2 | 2 | 2 | 2 | 2 | 2 |
| Mvmt Flow | 18 | 157 | 54 | 23 | 234 | 353 | 85 | 353 | 39 | 216 | 198 | 10 |
| Number of Lanes | 1 | 1 | 0 | 1 | 1 | 0 | 1 | 1 | 0 | 1 | 1 | 0 |

| Approach | EB | WB | NB | SB |
|----------------------------|------|-------|----|------|
| Opposing Approach | WB | EB | SB | NB |
| Opposing Lanes | 2 | 2 | 2 | 2 |
| Conflicting Approach Left | SB | NB | EB | WB |
| Conflicting Lanes Left | 2 | 2 | 2 | 2 |
| Conflicting Approach Right | NB | SB | WB | EB |
| Conflicting Lanes Right | 2 | 2 | 2 | 2 |
| HCM Control Delay | 21.8 | 172.7 | 48 | 22.8 |
| HCM LOS | C | F | E | C |

| Lane | NBLn1 | NBLn2 | EBLn1 | EBLn2 | WBLn1 | WBLn2 | SBLn1 | SBLn2 |
|------------------------|-------|-------|--------|-------|-------|-------|--------|-------|
| Vol Left, % | 100% | 0% | 100% | 0% | 100% | 0% | 100% | 0% |
| Vol Thru, % | 0% | 90% | 0% | 74% | 0% | 40% | 0% | 95% |
| Vol Right, % | 0% | 10% | 0% | 26% | 0% | 60% | 0% | 5% |
| Sign Control | Stop | Stop | Stop | Stop | Stop | Stop | Stop | Stop |
| Traffic Vol by Lane | 72 | 333 | 15 | 175 | 22 | 552 | 179 | 172 |
| LT Vol | 72 | 0 | 15 | 0 | 22 | 0 | 179 | 0 |
| Through Vol | 0 | 300 | 0 | 130 | 0 | 220 | 0 | 164 |
| RT Vol | 0 | 33 | 0 | 45 | 0 | 332 | 0 | 8 |
| Lane Flow Rate | 85 | 392 | 18 | 211 | 23 | 587 | 216 | 207 |
| Geometry Grp | 7 | 7 | 7 | 7 | 7 | 7 | 7 | 7 |
| Degree of Util (X) | 0.209 | 0.905 | 0.048 | 0.522 | 0.058 | 1.311 | 0.547 | 0.495 |
| Departure Headway (Hd) | 9.745 | 9.149 | 10.399 | 9.682 | 8.99 | 8.035 | 10.059 | 9.499 |
| Convergence, Y/N | Yes | Yes | Yes | Yes | Yes | Yes | Yes | Yes |
| Cap | 371 | 400 | 346 | 375 | 399 | 452 | 360 | 381 |
| Service Time | 7.445 | 6.849 | 8.099 | 7.382 | 6.737 | 5.781 | 7.759 | 7.199 |
| HCM Lane V/C Ratio | 0.229 | 0.98 | 0.052 | 0.563 | 0.058 | 1.299 | 0.6 | 0.543 |
| HCM Control Delay | 15 | 55.1 | 13.6 | 22.5 | 12.3 | 179.1 | 24.3 | 21.2 |
| HCM Lane LOS | B | F | B | C | B | F | C | C |
| HCM 95th-tile Q | 0.8 | 9.5 | 0.2 | 2.9 | 0.2 | 25.8 | 3.1 | 2.6 |

| Intersection | | | | | | | | | | | | |
|--------------------------|------|------|------|------|------|------|------|------|------|------|------|------|
| Int Delay, s/veh | 1.6 | | | | | | | | | | | |
| Movement | EBL | EBT | EBR | WBL | WBT | WBR | NBL | NBT | NBR | SBL | SBT | SBR |
| Lane Configurations | ↘ | ↗ | ↗ | ↘ | ↗ | ↗ | ↘ | ↗ | ↗ | ↘ | ↗ | ↗ |
| Traffic Vol, veh/h | 36 | 113 | 183 | 5 | 240 | 34 | 326 | 697 | 8 | 10 | 551 | 62 |
| Future Vol, veh/h | 36 | 113 | 183 | 5 | 240 | 34 | 326 | 697 | 8 | 10 | 551 | 62 |
| Conflicting Peds, #/hr | 0 | 0 | 0 | 0 | 0 | 0 | 0 | 0 | 0 | 0 | 0 | 0 |
| Sign Control | Stop | Stop | Stop | Stop | Stop | Stop | Free | Free | Free | Free | Free | Free |
| RT Channelized | - | - | None | - | - | None | - | - | None | - | - | None |
| Storage Length | 185 | - | 325 | 225 | - | 225 | 1000 | - | 0 | 785 | - | 785 |
| Veh in Median Storage, # | - | 0 | - | - | 0 | - | - | 0 | - | - | 0 | - |
| Grade, % | - | 0 | - | - | 0 | - | - | 0 | - | - | 0 | - |
| Peak Hour Factor | 93 | 93 | 93 | 85 | 85 | 85 | 92 | 92 | 92 | 90 | 90 | 90 |
| Heavy Vehicles, % | 2 | 2 | 2 | 2 | 2 | 2 | 2 | 2 | 2 | 2 | 2 | 2 |
| Mvmt Flow | 39 | 122 | 197 | 6 | 282 | 40 | 354 | 758 | 9 | 11 | 612 | 69 |

| Major/Minor | Minor2 | | Minor1 | | Major1 | | Major2 | | | | | |
|----------------------|--------|-------|--------|-------|--------|-------|--------|---|---|-------|---|---|
| Conflicting Flow All | 2266 | 2109 | 612 | 2294 | 2169 | 758 | 681 | 0 | 0 | 767 | 0 | 0 |
| Stage 1 | 634 | 634 | - | 1466 | 1466 | - | - | - | - | - | - | - |
| Stage 2 | 1632 | 1475 | - | 828 | 703 | - | - | - | - | - | - | - |
| Critical Hdwy | 7.12 | 6.52 | 6.22 | 7.12 | 6.52 | 6.22 | 4.12 | - | - | 4.12 | - | - |
| Critical Hdwy Stg 1 | 6.12 | 5.52 | - | 6.12 | 5.52 | - | - | - | - | - | - | - |
| Critical Hdwy Stg 2 | 6.12 | 5.52 | - | 6.12 | 5.52 | - | - | - | - | - | - | - |
| Follow-up Hdwy | 3.518 | 4.018 | 3.318 | 3.518 | 4.018 | 3.318 | 2.218 | - | - | 2.218 | - | - |
| Pot Cap-1 Maneuver | ~ 29 | ~ 51 | 493 | 27 | ~ 47 | 407 | 912 | - | - | 847 | - | - |
| Stage 1 | 467 | 473 | - | 159 | ~ 192 | - | - | - | - | - | - | - |
| Stage 2 | 128 | 190 | - | 365 | 440 | - | - | - | - | - | - | - |
| Platoon blocked, % | - | - | - | - | - | - | - | - | - | - | - | - |
| Mov Cap-1 Maneuver | - | ~ 31 | 493 | - | ~ 28 | 407 | 912 | - | - | 847 | - | - |
| Mov Cap-2 Maneuver | - | ~ 31 | - | - | ~ 28 | - | - | - | - | - | - | - |
| Stage 1 | 286 | 467 | - | 97 | ~ 118 | - | - | - | - | - | - | - |
| Stage 2 | - | ~ 116 | - | 160 | 434 | - | - | - | - | - | - | - |

| Approach | EB | WB | NB | SB |
|----------------------|----|----|-----|-----|
| HCM Control Delay, s | | | 3.6 | 0.1 |
| HCM LOS | - | - | | |

| Minor Lane/Major Mvmt | NBL | NBT | NBR | EBLn1 | EBLn2 | EBLn3 | WBLn1 | WBLn2 | WBLn3 | SBL | SBT | SBR |
|-----------------------|-------|-----|-----|-----------|-------|-----------|---------|-------|-------|-----|-----|-----|
| Capacity (veh/h) | 912 | - | - | - | 31 | 493 | - | 28 | 407 | 847 | - | - |
| HCM Lane V/C Ratio | 0.389 | - | - | - | 3.92 | 0.399 | -10.084 | 0.098 | 0.013 | - | - | - |
| HCM Control Delay (s) | 11.4 | - | - | \$ 1575.7 | 17.1 | \$ 4359.4 | 14.8 | 9.3 | - | - | - | - |
| HCM Lane LOS | B | - | - | - | F | C | - | F | B | A | - | - |
| HCM 95th %tile Q(veh) | 1.9 | - | - | - | 14.5 | 1.9 | - | 34.8 | 0.3 | 0 | - | - |

Notes
 ~: Volume exceeds capacity \$: Delay exceeds 300s +: Computation Not Defined *: All major volume in platoon

| Intersection | | | | | | | | | | | | |
|--------------------------|------|------|------|------|------|------|------|------|------|------|------|------|
| Int Delay, s/veh | 8.3 | | | | | | | | | | | |
| Movement | EBL | EBT | EBR | WBL | WBT | WBR | NBL | NBT | NBR | SBL | SBT | SBR |
| Lane Configurations | ↙ | ↑ | ↗ | ↙ | ↑ | ↗ | ↙ | ↑ | ↗ | ↙ | ↑ | ↗ |
| Traffic Vol, veh/h | 4 | 6 | 267 | 13 | 9 | 4 | 95 | 17 | 31 | 3 | 27 | 1 |
| Future Vol, veh/h | 4 | 6 | 267 | 13 | 9 | 4 | 95 | 17 | 31 | 3 | 27 | 1 |
| Conflicting Peds, #/hr | 0 | 0 | 0 | 0 | 0 | 0 | 0 | 0 | 0 | 0 | 0 | 0 |
| Sign Control | Stop | Stop | Stop | Stop | Stop | Stop | Free | Free | Free | Free | Free | Free |
| RT Channelized | - | - | None | - | - | None | - | - | None | - | - | None |
| Storage Length | 300 | - | 205 | 200 | - | - | 250 | - | 205 | 250 | - | - |
| Veh in Median Storage, # | - | 0 | - | - | 0 | - | - | 0 | - | - | 0 | - |
| Grade, % | - | 0 | - | - | 0 | - | - | 0 | - | - | 0 | - |
| Peak Hour Factor | 78 | 78 | 78 | 86 | 86 | 86 | 87 | 87 | 87 | 94 | 94 | 94 |
| Heavy Vehicles, % | 2 | 2 | 2 | 2 | 2 | 2 | 2 | 2 | 2 | 2 | 2 | 2 |
| Mvmt Flow | 5 | 8 | 342 | 15 | 10 | 5 | 109 | 20 | 36 | 3 | 29 | 1 |

| Major/Minor | Minor2 | | Minor1 | | Major1 | | | Major2 | | | | |
|----------------------|--------|-------|--------|-------|--------|-------|-------|--------|---|-------|---|---|
| Conflicting Flow All | 300 | 310 | 30 | 449 | 274 | 20 | 30 | 0 | 0 | 56 | 0 | 0 |
| Stage 1 | 36 | 36 | - | 238 | 238 | - | - | - | - | - | - | - |
| Stage 2 | 264 | 274 | - | 211 | 36 | - | - | - | - | - | - | - |
| Critical Hdwy | 7.12 | 6.52 | 6.22 | 7.12 | 6.52 | 6.22 | 4.12 | - | - | 4.12 | - | - |
| Critical Hdwy Stg 1 | 6.12 | 5.52 | - | 6.12 | 5.52 | - | - | - | - | - | - | - |
| Critical Hdwy Stg 2 | 6.12 | 5.52 | - | 6.12 | 5.52 | - | - | - | - | - | - | - |
| Follow-up Hdwy | 3.518 | 4.018 | 3.318 | 3.518 | 4.018 | 3.318 | 2.218 | - | - | 2.218 | - | - |
| Pot Cap-1 Maneuver | 652 | 605 | 1044 | 520 | 633 | 1058 | 1583 | - | - | 1549 | - | - |
| Stage 1 | 980 | 865 | - | 765 | 708 | - | - | - | - | - | - | - |
| Stage 2 | 741 | 683 | - | 791 | 865 | - | - | - | - | - | - | - |
| Platoon blocked, % | - | - | - | - | - | - | - | - | - | - | - | - |
| Mov Cap-1 Maneuver | 606 | 562 | 1044 | 327 | 588 | 1058 | 1583 | - | - | 1549 | - | - |
| Mov Cap-2 Maneuver | 606 | 562 | - | 327 | 588 | - | - | - | - | - | - | - |
| Stage 1 | 912 | 863 | - | 712 | 659 | - | - | - | - | - | - | - |
| Stage 2 | 676 | 636 | - | 526 | 863 | - | - | - | - | - | - | - |

| Approach | EB | | WB | | NB | | SB | |
|----------------------|------|--|------|--|-----|--|-----|--|
| HCM Control Delay, s | 10.1 | | 13.5 | | 4.9 | | 0.7 | |
| HCM LOS | B | | B | | | | | |

| Minor Lane/Major Mvmt | NBL | NBT | NBR | EBLn1 | EBLn2 | EBLn3 | WBLn1 | WBLn2 | SBL | SBT | SBR |
|-----------------------|-------|-----|-----|-------|-------|-------|-------|-------|-------|-----|-----|
| Capacity (veh/h) | 1583 | - | - | 606 | 562 | 1044 | 327 | 681 | 1549 | - | - |
| HCM Lane V/C Ratio | 0.069 | - | - | 0.008 | 0.014 | 0.328 | 0.046 | 0.022 | 0.002 | - | - |
| HCM Control Delay (s) | 7.4 | - | - | 11 | 11.5 | 10.1 | 16.5 | 10.4 | 7.3 | - | - |
| HCM Lane LOS | A | - | - | B | B | B | C | B | A | - | - |
| HCM 95th %tile Q(veh) | 0.2 | - | - | 0 | 0 | 1.4 | 0.1 | 0.1 | 0 | - | - |

| Intersection | | | | | | |
|--------------------------|------|------|------|------|------|------|
| Int Delay, s/veh | 3.6 | | | | | |
| Movement | EBT | EBR | WBL | WBT | NBL | NBR |
| Lane Configurations | ↔ | | ↔ | ↑ | ↔ | ↔ |
| Traffic Vol, veh/h | 0 | 40 | 0 | 0 | 27 | 0 |
| Future Vol, veh/h | 0 | 40 | 0 | 0 | 27 | 0 |
| Conflicting Peds, #/hr | 0 | 0 | 0 | 0 | 0 | 0 |
| Sign Control | Free | Free | Free | Free | Stop | Stop |
| RT Channelized | - | None | - | None | - | None |
| Storage Length | - | - | 205 | - | 0 | 0 |
| Veh in Median Storage, # | 0 | - | - | 0 | 0 | - |
| Grade, % | 0 | - | - | 0 | 0 | - |
| Peak Hour Factor | 85 | 85 | 85 | 85 | 85 | 85 |
| Heavy Vehicles, % | 2 | 2 | 2 | 2 | 2 | 2 |
| Mvmt Flow | 0 | 47 | 0 | 0 | 32 | 0 |

| Major/Minor | Major1 | Major2 | Minor1 | | |
|----------------------|--------|--------|--------|---|-------|
| Conflicting Flow All | 0 | 0 | 47 | 0 | 25 |
| Stage 1 | - | - | - | - | 24 |
| Stage 2 | - | - | - | - | 1 |
| Critical Hdwy | - | - | 4.12 | - | 6.42 |
| Critical Hdwy Stg 1 | - | - | - | - | 5.42 |
| Critical Hdwy Stg 2 | - | - | - | - | 5.42 |
| Follow-up Hdwy | - | - | 2.218 | - | 3.518 |
| Pot Cap-1 Maneuver | - | - | 1560 | - | 991 |
| Stage 1 | - | - | - | - | 999 |
| Stage 2 | - | - | - | - | 1022 |
| Platoon blocked, % | - | - | - | - | - |
| Mov Cap-1 Maneuver | - | - | 1560 | - | 991 |
| Mov Cap-2 Maneuver | - | - | - | - | 910 |
| Stage 1 | - | - | - | - | 999 |
| Stage 2 | - | - | - | - | 1022 |

| Approach | EB | WB | NB |
|----------------------|----|----|-----|
| HCM Control Delay, s | 0 | 0 | 9.1 |
| HCM LOS | | | A |

| Minor Lane/Major Mvmt | NBLn1 | NBLn2 | EBT | EBR | WBL | WBT |
|-----------------------|-------|-------|-----|-----|------|-----|
| Capacity (veh/h) | 910 | - | - | - | 1560 | - |
| HCM Lane V/C Ratio | 0.035 | - | - | - | - | - |
| HCM Control Delay (s) | 9.1 | 0 | - | - | 0 | - |
| HCM Lane LOS | A | A | - | - | A | - |
| HCM 95th %tile Q(veh) | 0.1 | - | - | - | 0 | - |

| Intersection | | | | | | |
|--------------------------|------|------|------|------|------|------|
| Int Delay, s/veh | 5.2 | | | | | |
| Movement | WBL | WBR | NBT | NBR | SBL | SBT |
| Lane Configurations | ↘ | ↗ | ↑ | ↗ | ↘ | ↑ |
| Traffic Vol, veh/h | 231 | 7 | 137 | 73 | 2 | 306 |
| Future Vol, veh/h | 231 | 7 | 137 | 73 | 2 | 306 |
| Conflicting Peds, #/hr | 0 | 0 | 0 | 0 | 0 | 0 |
| Sign Control | Stop | Stop | Free | Free | Free | Free |
| RT Channelized | - | None | - | None | - | None |
| Storage Length | 0 | 0 | - | 155 | 205 | - |
| Veh in Median Storage, # | 0 | - | 0 | - | - | 0 |
| Grade, % | 0 | - | 0 | - | - | 0 |
| Peak Hour Factor | 85 | 85 | 85 | 85 | 85 | 85 |
| Heavy Vehicles, % | 2 | 2 | 2 | 2 | 2 | 2 |
| Mvmt Flow | 272 | 8 | 161 | 86 | 2 | 360 |

| Major/Minor | Minor1 | Major1 | Major2 | | |
|----------------------|--------|--------|--------|---|-------|
| Conflicting Flow All | 525 | 161 | 0 | 0 | 247 |
| Stage 1 | 161 | - | - | - | - |
| Stage 2 | 364 | - | - | - | - |
| Critical Hdwy | 6.42 | 6.22 | - | - | 4.12 |
| Critical Hdwy Stg 1 | 5.42 | - | - | - | - |
| Critical Hdwy Stg 2 | 5.42 | - | - | - | - |
| Follow-up Hdwy | 3.518 | 3.318 | - | - | 2.218 |
| Pot Cap-1 Maneuver | 513 | 884 | - | - | 1319 |
| Stage 1 | 868 | - | - | - | - |
| Stage 2 | 703 | - | - | - | - |
| Platoon blocked, % | | | - | - | - |
| Mov Cap-1 Maneuver | 512 | 884 | - | - | 1319 |
| Mov Cap-2 Maneuver | 580 | - | - | - | - |
| Stage 1 | 868 | - | - | - | - |
| Stage 2 | 702 | - | - | - | - |

| Approach | WB | NB | SB |
|----------------------|------|----|-----|
| HCM Control Delay, s | 16.4 | 0 | 0.1 |
| HCM LOS | C | | |

| Minor Lane/Major Mvmt | NBT | NBR | WBLn1 | WBLn2 | SBL | SBT |
|-----------------------|-----|-----|-------|-------|-------|-----|
| Capacity (veh/h) | - | - | 580 | 884 | 1319 | - |
| HCM Lane V/C Ratio | - | - | 0.469 | 0.009 | 0.002 | - |
| HCM Control Delay (s) | - | - | 16.6 | 9.1 | 7.7 | - |
| HCM Lane LOS | - | - | C | A | A | - |
| HCM 95th %tile Q(veh) | - | - | 2.5 | 0 | 0 | - |

| Intersection | | | | | | |
|--------------------------|------|------|------|------|------|------|
| Int Delay, s/veh | 1.2 | | | | | |
| Movement | WBL | WBR | NBT | NBR | SBL | SBT |
| Lane Configurations | ↘ | ↗ | ↑ | ↗ | ↘ | ↑ |
| Traffic Vol, veh/h | 60 | 5 | 205 | 20 | 2 | 535 |
| Future Vol, veh/h | 60 | 5 | 205 | 20 | 2 | 535 |
| Conflicting Peds, #/hr | 0 | 0 | 0 | 0 | 0 | 0 |
| Sign Control | Stop | Stop | Free | Free | Free | Free |
| RT Channelized | - | None | - | None | - | None |
| Storage Length | 0 | 115 | - | 155 | 205 | - |
| Veh in Median Storage, # | 0 | - | 0 | - | - | 0 |
| Grade, % | 0 | - | 0 | - | - | 0 |
| Peak Hour Factor | 85 | 85 | 85 | 85 | 85 | 85 |
| Heavy Vehicles, % | 2 | 2 | 2 | 2 | 2 | 2 |
| Mvmt Flow | 71 | 6 | 241 | 24 | 2 | 629 |

| Major/Minor | Minor1 | Major1 | Major2 | | | |
|----------------------|--------|--------|--------|---|-------|---|
| Conflicting Flow All | 874 | 241 | 0 | 0 | 265 | 0 |
| Stage 1 | 241 | - | - | - | - | - |
| Stage 2 | 633 | - | - | - | - | - |
| Critical Hdwy | 6.42 | 6.22 | - | - | 4.12 | - |
| Critical Hdwy Stg 1 | 5.42 | - | - | - | - | - |
| Critical Hdwy Stg 2 | 5.42 | - | - | - | - | - |
| Follow-up Hdwy | 3.518 | 3.318 | - | - | 2.218 | - |
| Pot Cap-1 Maneuver | 320 | 798 | - | - | 1299 | - |
| Stage 1 | 799 | - | - | - | - | - |
| Stage 2 | 529 | - | - | - | - | - |
| Platoon blocked, % | | | - | - | | - |
| Mov Cap-1 Maneuver | 319 | 798 | - | - | 1299 | - |
| Mov Cap-2 Maneuver | 424 | - | - | - | - | - |
| Stage 1 | 799 | - | - | - | - | - |
| Stage 2 | 528 | - | - | - | - | - |

| Approach | WB | NB | SB |
|----------------------|------|----|----|
| HCM Control Delay, s | 14.8 | 0 | 0 |
| HCM LOS | B | | |

| Minor Lane/Major Mvmt | NBT | NBRWBLn1 | WBLn2 | SBL | SBT |
|-----------------------|-----|----------|-------|-------|-------|
| Capacity (veh/h) | - | - | 424 | 798 | 1299 |
| HCM Lane V/C Ratio | - | - | 0.166 | 0.007 | 0.002 |
| HCM Control Delay (s) | - | - | 15.2 | 9.5 | 7.8 |
| HCM Lane LOS | - | - | C | A | A |
| HCM 95th %tile Q(veh) | - | - | 0.6 | 0 | 0 |

| Intersection | | | | | | |
|--------------------------|------|------|------|------|------|------|
| Int Delay, s/veh | 50.6 | | | | | |
| Movement | EBL | EBR | NBL | NBT | SBT | SBR |
| Lane Configurations | ↘ | ↗ | ↘ | ↗ | ↗ | ↘ |
| Traffic Vol, veh/h | 26 | 400 | 337 | 200 | 550 | 46 |
| Future Vol, veh/h | 26 | 400 | 337 | 200 | 550 | 46 |
| Conflicting Peds, #/hr | 0 | 0 | 0 | 0 | 0 | 0 |
| Sign Control | Stop | Stop | Free | Free | Free | Free |
| RT Channelized | - | None | - | None | - | None |
| Storage Length | 0 | 0 | 250 | - | - | 205 |
| Veh in Median Storage, # | 0 | - | - | 0 | 0 | - |
| Grade, % | 0 | - | - | 0 | 0 | - |
| Peak Hour Factor | 67 | 67 | 51 | 85 | 85 | 85 |
| Heavy Vehicles, % | 2 | 2 | 2 | 2 | 2 | 2 |
| Mvmt Flow | 39 | 597 | 661 | 235 | 647 | 54 |

| Major/Minor | Minor2 | Major1 | Major2 | | | |
|----------------------|--------|--------|--------|---|---|---|
| Conflicting Flow All | 2204 | 647 | 701 | 0 | - | 0 |
| Stage 1 | 647 | - | - | - | - | - |
| Stage 2 | 1557 | - | - | - | - | - |
| Critical Hdwy | 6.42 | 6.22 | 4.12 | - | - | - |
| Critical Hdwy Stg 1 | 5.42 | - | - | - | - | - |
| Critical Hdwy Stg 2 | 5.42 | - | - | - | - | - |
| Follow-up Hdwy | 3.518 | 3.318 | 2.218 | - | - | - |
| Pot Cap-1 Maneuver | 49 | ~ 471 | 896 | - | - | - |
| Stage 1 | 521 | - | - | - | - | - |
| Stage 2 | 191 | - | - | - | - | - |
| Platoon blocked, % | | | | - | - | - |
| Mov Cap-1 Maneuver | ~ 13 | ~ 471 | 896 | - | - | - |
| Mov Cap-2 Maneuver | 79 | - | - | - | - | - |
| Stage 1 | 137 | - | - | - | - | - |
| Stage 2 | 191 | - | - | - | - | - |

| Approach | EB | NB | SB |
|----------------------|-------|------|----|
| HCM Control Delay, s | 157.7 | 14.3 | 0 |
| HCM LOS | F | | |

| Minor Lane/Major Mvmt | NBL | NBT | EBLn1 | EBLn2 | SBT | SBR |
|-----------------------|-------|-----|-------|-------|-----|-----|
| Capacity (veh/h) | 896 | - | 79 | 471 | - | - |
| HCM Lane V/C Ratio | 0.737 | - | 0.491 | 1.268 | - | - |
| HCM Control Delay (s) | 19.4 | - | 88.3 | 162.2 | - | - |
| HCM Lane LOS | C | - | F | F | - | - |
| HCM 95th %tile Q(veh) | 6.8 | - | 2.1 | 24.8 | - | - |

Notes
 ~: Volume exceeds capacity \$: Delay exceeds 300s +: Computation Not Defined *: All major volume in platoon

| Intersection | |
|---------------------------|-------|
| Intersection Delay, s/veh | 339.1 |
| Intersection LOS | F |

| Movement | EBL | EBT | EBR | WBL | WBT | WBR | NBL | NBT | NBR | SBL | SBT | SBR |
|---------------------|------|------|------|------|------|------|------|------|------|------|------|------|
| Lane Configurations | ↶ | ↷ | | ↶ | ↷ | | ↶ | ↷ | | ↶ | ↷ | ↶ |
| Traffic Vol, veh/h | 33 | 213 | 63 | 25 | 133 | 238 | 96 | 266 | 25 | 484 | 400 | 65 |
| Future Vol, veh/h | 33 | 213 | 63 | 25 | 133 | 238 | 96 | 266 | 25 | 484 | 400 | 65 |
| Peak Hour Factor | 0.87 | 0.87 | 0.87 | 0.85 | 0.85 | 0.85 | 0.68 | 0.68 | 0.68 | 0.64 | 0.64 | 0.64 |
| Heavy Vehicles, % | 2 | 2 | 2 | 2 | 2 | 2 | 2 | 2 | 2 | 2 | 2 | 2 |
| Mvmt Flow | 38 | 245 | 72 | 29 | 156 | 280 | 141 | 391 | 37 | 756 | 625 | 102 |
| Number of Lanes | 1 | 1 | 0 | 1 | 1 | 0 | 1 | 1 | 0 | 1 | 1 | 1 |

| Approach | EB | WB | NB | SB |
|----------------------------|------|-------|-------|-------|
| Opposing Approach | WB | EB | SB | NB |
| Opposing Lanes | 2 | 2 | 3 | 2 |
| Conflicting Approach Left | SB | NB | EB | WB |
| Conflicting Lanes Left | 3 | 2 | 2 | 2 |
| Conflicting Approach Right | NB | SB | WB | EB |
| Conflicting Lanes Right | 2 | 3 | 2 | 2 |
| HCM Control Delay | 86.3 | 203.6 | 165.5 | 508.9 |
| HCM LOS | F | F | F | F |

| Lane | NBLn1 | NBLn2 | EBLn1 | EBLn2 | WBLn1 | WBLn2 | SBLn1 | SBLn2 | SBLn3 |
|------------------------|--------|--------|--------|-------|--------|--------|--------|--------|--------|
| Vol Left, % | 100% | 0% | 100% | 0% | 100% | 0% | 100% | 0% | 0% |
| Vol Thru, % | 0% | 91% | 0% | 77% | 0% | 36% | 0% | 100% | 0% |
| Vol Right, % | 0% | 9% | 0% | 23% | 0% | 64% | 0% | 0% | 100% |
| Sign Control | Stop | Stop | Stop | Stop | Stop | Stop | Stop | Stop | Stop |
| Traffic Vol by Lane | 96 | 291 | 33 | 276 | 25 | 371 | 484 | 400 | 65 |
| LT Vol | 96 | 0 | 33 | 0 | 25 | 0 | 484 | 0 | 0 |
| Through Vol | 0 | 266 | 0 | 213 | 0 | 133 | 0 | 400 | 0 |
| RT Vol | 0 | 25 | 0 | 63 | 0 | 238 | 0 | 0 | 65 |
| Lane Flow Rate | 141 | 428 | 38 | 317 | 29 | 436 | 756 | 625 | 102 |
| Geometry Grp | 8 | 8 | 8 | 8 | 8 | 8 | 8 | 8 | 8 |
| Degree of Util (X) | 0.465 | 1.344 | 0.127 | 1.007 | 0.099 | 1.36 | 2.349 | 1.855 | 0.282 |
| Departure Headway (Hd) | 13.639 | 13.054 | 13.787 | 13.1 | 13.666 | 12.685 | 12.865 | 12.331 | 11.584 |
| Convergence, Y/N | Yes | Yes | Yes | Yes | Yes | Yes | Yes | Yes | Yes |
| Cap | 265 | 282 | 262 | 279 | 264 | 292 | 295 | 300 | 312 |
| Service Time | 11.339 | 10.754 | 11.487 | 10.8 | 11.366 | 10.385 | 10.565 | 10.031 | 9.284 |
| HCM Lane V/C Ratio | 0.532 | 1.518 | 0.145 | 1.136 | 0.11 | 1.493 | 2.563 | 2.083 | 0.327 |
| HCM Control Delay | 27.7 | 211 | 18.5 | 94.4 | 17.9 | 216.1 | 644.2 | 424.9 | 18.8 |
| HCM Lane LOS | D | F | C | F | C | F | F | F | C |
| HCM 95th-tile Q | 2.3 | 19.1 | 0.4 | 10.3 | 0.3 | 20 | 51.9 | 36.7 | 1.1 |

| Intersection | | | | | | | | | | | | |
|--------------------------|------|------|------|------|------|------|------|------|------|------|------|------|
| Int Delay, s/veh | 1.1 | | | | | | | | | | | |
| Movement | EBL | EBT | EBR | WBL | WBT | WBR | NBL | NBT | NBR | SBL | SBT | SBR |
| Lane Configurations | ↖ | ↗ | ↖ | ↖ | ↗ | ↖ | ↖ | ↗ | ↖ | ↖ | ↗ | ↖ |
| Traffic Vol, veh/h | 70 | 284 | 444 | 4 | 130 | 17 | 185 | 378 | 5 | 45 | 635 | 51 |
| Future Vol, veh/h | 70 | 284 | 444 | 4 | 130 | 17 | 185 | 378 | 5 | 45 | 635 | 51 |
| Conflicting Peds, #/hr | 0 | 0 | 0 | 0 | 0 | 0 | 0 | 0 | 0 | 0 | 0 | 0 |
| Sign Control | Stop | Stop | Stop | Stop | Stop | Stop | Free | Free | Free | Free | Free | Free |
| RT Channelized | - | - | None | - | - | None | - | - | None | - | - | None |
| Storage Length | 185 | - | 325 | 225 | - | 225 | 1000 | - | 0 | 785 | - | 785 |
| Veh in Median Storage, # | - | 0 | - | - | 0 | - | - | 0 | - | - | 0 | - |
| Grade, % | - | 0 | - | - | 0 | - | - | 0 | - | - | 0 | - |
| Peak Hour Factor | 85 | 85 | 85 | 85 | 85 | 85 | 85 | 85 | 85 | 85 | 85 | 85 |
| Heavy Vehicles, % | 2 | 2 | 2 | 2 | 2 | 2 | 2 | 2 | 2 | 2 | 2 | 2 |
| Mvmt Flow | 82 | 334 | 522 | 5 | 153 | 20 | 218 | 445 | 6 | 53 | 747 | 60 |

| Major/Minor | Minor2 | | Minor1 | | Major1 | | Major2 | | | | | |
|----------------------|--------|-------|--------|-------|--------|-------|--------|---|---|-------|---|---|
| Conflicting Flow All | 1824 | 1740 | 747 | 2192 | 1794 | 445 | 807 | 0 | 0 | 451 | 0 | 0 |
| Stage 1 | 853 | 853 | - | 881 | 881 | - | - | - | - | - | - | - |
| Stage 2 | 971 | 887 | - | 1311 | 913 | - | - | - | - | - | - | - |
| Critical Hdwy | 7.12 | 6.52 | 6.22 | 7.12 | 6.52 | 6.22 | 4.12 | - | - | 4.12 | - | - |
| Critical Hdwy Stg 1 | 6.12 | 5.52 | - | 6.12 | 5.52 | - | - | - | - | - | - | - |
| Critical Hdwy Stg 2 | 6.12 | 5.52 | - | 6.12 | 5.52 | - | - | - | - | - | - | - |
| Follow-up Hdwy | 3.518 | 4.018 | 3.318 | 3.518 | 4.018 | 3.318 | 2.218 | - | - | 2.218 | - | - |
| Pot Cap-1 Maneuver | ~ 59 | ~ 87 | ~ 413 | 33 | ~ 80 | 613 | 818 | - | - | 1109 | - | - |
| Stage 1 | 354 | 376 | - | 341 | 365 | - | - | - | - | - | - | - |
| Stage 2 | 304 | 362 | - | 195 | 352 | - | - | - | - | - | - | - |
| Platoon blocked, % | - | - | - | - | - | - | - | - | - | - | - | - |
| Mov Cap-1 Maneuver | - | ~ 61 | ~ 413 | - | ~ 56 | 613 | 818 | - | - | 1109 | - | - |
| Mov Cap-2 Maneuver | - | ~ 61 | - | - | ~ 56 | - | - | - | - | - | - | - |
| Stage 1 | 259 | 358 | - | 250 | 268 | - | - | - | - | - | - | - |
| Stage 2 | 93 | ~ 265 | - | - | 335 | - | - | - | - | - | - | - |

| Approach | EB | | WB | | NB | | SB | |
|----------------------|----|--|----|--|-----|--|-----|--|
| HCM Control Delay, s | | | | | 3.6 | | 0.5 | |
| HCM LOS | - | | - | | | | | |

| Minor Lane/Major Mvmt | NBL | NBT | NBR | EBLn1 | EBLn2 | EBLn3 | WBLn1 | WBLn2 | WBLn3 | SBL | SBT | SBR |
|-----------------------|-------|-----|-----|-----------|-------|----------|-------|-------|-------|-------|-----|-----|
| Capacity (veh/h) | 818 | - | - | - | 61 | 413 | - | 56 | 613 | 1109 | - | - |
| HCM Lane V/C Ratio | 0.266 | - | - | - | 5.477 | 1.265 | - | 2.731 | 0.033 | 0.048 | - | - |
| HCM Control Delay (s) | 11 | - | - | \$ 2148.6 | 165.5 | \$ 939.1 | - | 11.1 | 8.4 | - | - | - |
| HCM Lane LOS | B | - | - | - | F | F | - | F | B | A | - | - |
| HCM 95th %tile Q(veh) | 1.1 | - | - | - | 37.5 | 22.4 | - | 15.8 | 0.1 | 0.1 | - | - |

Notes
 ~: Volume exceeds capacity \$: Delay exceeds 300s +: Computation Not Defined *: All major volume in platoon

Timings
13: Eastonville Rd & Stapleton Dr

2026 Total Traffic
AM Peak Hour



| Lane Group | EBL | EBT | WBL | WBT | WBR | NBL | NBT | SBL | SBT | SBR |
|----------------------|-------|-------|-------|-------|-------|-------|-------|-------|-------|-------|
| Lane Configurations | | | | | | | | | | |
| Traffic Volume (vph) | 33 | 213 | 25 | 133 | 238 | 96 | 266 | 484 | 400 | 65 |
| Future Volume (vph) | 33 | 213 | 25 | 133 | 238 | 96 | 266 | 484 | 400 | 65 |
| Turn Type | pm+pt | NA | pm+pt | NA | Perm | pm+pt | NA | pm+pt | NA | Perm |
| Protected Phases | 7 | 4 | 3 | 8 | | 5 | 2 | 1 | 6 | |
| Permitted Phases | 4 | | 8 | | 8 | 2 | | 6 | | 6 |
| Detector Phase | 7 | 4 | 3 | 8 | 8 | 5 | 2 | 1 | 6 | 6 |
| Switch Phase | | | | | | | | | | |
| Minimum Initial (s) | 5.0 | 5.0 | 5.0 | 5.0 | 5.0 | 5.0 | 5.0 | 5.0 | 5.0 | 5.0 |
| Minimum Split (s) | 10.0 | 10.0 | 10.0 | 10.0 | 10.0 | 10.0 | 10.0 | 10.0 | 10.0 | 10.0 |
| Total Split (s) | 10.0 | 43.0 | 10.0 | 43.0 | 43.0 | 10.0 | 24.0 | 23.0 | 37.0 | 37.0 |
| Total Split (%) | 10.0% | 43.0% | 10.0% | 43.0% | 43.0% | 10.0% | 24.0% | 23.0% | 37.0% | 37.0% |
| Yellow Time (s) | 3.0 | 3.0 | 3.0 | 3.0 | 3.0 | 3.0 | 3.0 | 3.0 | 3.0 | 3.0 |
| All-Red Time (s) | 2.0 | 2.0 | 2.0 | 2.0 | 2.0 | 2.0 | 2.0 | 2.0 | 2.0 | 2.0 |
| Lost Time Adjust (s) | 0.0 | 0.0 | 0.0 | 0.0 | 0.0 | 0.0 | 0.0 | 0.0 | 0.0 | 0.0 |
| Total Lost Time (s) | 5.0 | 5.0 | 5.0 | 5.0 | 5.0 | 5.0 | 5.0 | 5.0 | 5.0 | 5.0 |
| Lead/Lag | Lead | Lag | Lead | Lag | Lag | Lead | Lag | Lead | Lag | Lag |
| Lead-Lag Optimize? | Yes | Yes | Yes | Yes | Yes | Yes | Yes | Yes | Yes | Yes |
| Recall Mode | None | None | None | None | None | None | None | None | None | None |
| Act Effct Green (s) | 20.5 | 18.8 | 19.5 | 16.8 | 16.8 | 24.1 | 19.0 | 42.4 | 34.7 | 34.7 |
| Actuated g/C Ratio | 0.27 | 0.25 | 0.26 | 0.22 | 0.22 | 0.32 | 0.25 | 0.57 | 0.46 | 0.46 |
| v/c Ratio | 0.11 | 0.70 | 0.12 | 0.37 | 0.49 | 0.32 | 0.73 | 0.97 | 0.55 | 0.09 |
| Control Delay | 17.8 | 33.2 | 18.0 | 27.8 | 6.4 | 16.0 | 38.8 | 50.5 | 21.3 | 1.0 |
| Queue Delay | 0.0 | 0.0 | 0.0 | 0.0 | 0.0 | 0.0 | 0.0 | 0.0 | 0.0 | 0.0 |
| Total Delay | 17.8 | 33.2 | 18.0 | 27.8 | 6.4 | 16.0 | 38.8 | 50.5 | 21.3 | 1.0 |
| LOS | B | C | B | C | A | B | D | D | C | A |
| Approach Delay | | 31.6 | | 14.3 | | | 33.1 | | 34.8 | |
| Approach LOS | | C | | B | | | C | | C | |

Intersection Summary

Cycle Length: 100
 Actuated Cycle Length: 74.9
 Natural Cycle: 90
 Control Type: Actuated-Uncoordinated
 Maximum v/c Ratio: 0.97
 Intersection Signal Delay: 30.0
 Intersection LOS: C
 Intersection Capacity Utilization 78.2%
 ICU Level of Service D
 Analysis Period (min) 15

Splits and Phases: 13: Eastonville Rd & Stapleton Dr

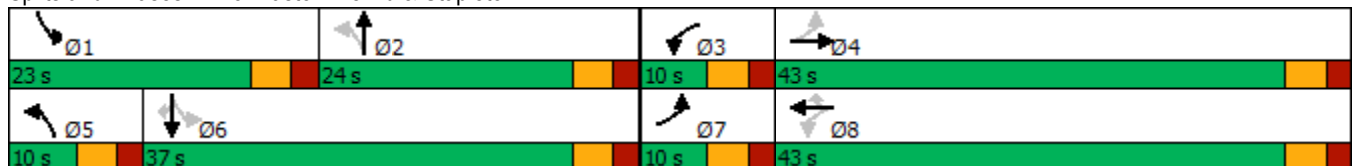

Timings
14: US 24 & Stapleton Dr

2026 Total Traffic
AM Peak Hour

| Lane Group | EBL | EBT | EBR | WBL | WBT | WBR | NBL | NBT | NBR | SBL | SBT | SBR |
|----------------------|-------|-------|-------|-------|-------|-------|-------|-------|-------|-------|-------|-------|
| Lane Configurations | | | | | | | | | | | | |
| Traffic Volume (vph) | 70 | 284 | 444 | 4 | 130 | 17 | 185 | 378 | 5 | 45 | 635 | 51 |
| Future Volume (vph) | 70 | 284 | 444 | 4 | 130 | 17 | 185 | 378 | 5 | 45 | 635 | 51 |
| Turn Type | Perm | NA | Free | Perm | NA | Perm | pm+pt | NA | Perm | pm+pt | NA | Perm |
| Protected Phases | | 4 | | | 8 | | 5 | 2 | | 1 | 6 | |
| Permitted Phases | 4 | | Free | 8 | | 8 | 2 | | 2 | 6 | | 6 |
| Detector Phase | 4 | 4 | | 8 | 8 | 8 | 5 | 2 | 2 | 1 | 6 | 6 |
| Switch Phase | | | | | | | | | | | | |
| Minimum Initial (s) | 1.0 | 1.0 | | 1.0 | 1.0 | 1.0 | 5.0 | 5.0 | 5.0 | 5.0 | 5.0 | 5.0 |
| Minimum Split (s) | 6.0 | 6.0 | | 6.0 | 6.0 | 6.0 | 10.0 | 20.0 | 20.0 | 10.0 | 20.0 | 20.0 |
| Total Split (s) | 40.0 | 40.0 | | 40.0 | 40.0 | 40.0 | 13.0 | 70.0 | 70.0 | 10.0 | 67.0 | 67.0 |
| Total Split (%) | 33.3% | 33.3% | | 33.3% | 33.3% | 33.3% | 10.8% | 58.3% | 58.3% | 8.3% | 55.8% | 55.8% |
| Yellow Time (s) | 3.0 | 3.0 | | 3.0 | 3.0 | 3.0 | 3.0 | 4.0 | 4.0 | 3.0 | 4.0 | 4.0 |
| All-Red Time (s) | 2.0 | 2.0 | | 2.0 | 2.0 | 2.0 | 2.0 | 2.0 | 2.0 | 2.0 | 2.0 | 2.0 |
| Lost Time Adjust (s) | 0.0 | 0.0 | | 0.0 | 0.0 | 0.0 | 0.0 | 0.0 | 0.0 | 0.0 | 0.0 | 0.0 |
| Total Lost Time (s) | 5.0 | 5.0 | | 5.0 | 5.0 | 5.0 | 5.0 | 6.0 | 6.0 | 5.0 | 6.0 | 6.0 |
| Lead/Lag | | | | | | | Lead | Lag | Lag | Lead | Lag | Lag |
| Lead-Lag Optimize? | | | | | | | Yes | Yes | Yes | Yes | Yes | Yes |
| Recall Mode | None | None | | None | None | None | None | Max | Max | None | Max | Max |
| Act Effct Green (s) | 24.8 | 24.8 | 110.1 | 24.8 | 24.8 | 24.8 | 73.7 | 66.4 | 66.4 | 67.2 | 61.2 | 61.2 |
| Actuated g/C Ratio | 0.23 | 0.23 | 1.00 | 0.23 | 0.23 | 0.23 | 0.67 | 0.60 | 0.60 | 0.61 | 0.56 | 0.56 |
| v/c Ratio | 0.34 | 0.80 | 0.33 | 0.05 | 0.37 | 0.05 | 0.63 | 0.40 | 0.01 | 0.09 | 0.72 | 0.07 |
| Control Delay | 39.1 | 54.6 | 0.6 | 33.2 | 37.9 | 0.2 | 17.2 | 14.4 | 0.0 | 7.8 | 24.5 | 3.5 |
| Queue Delay | 0.0 | 0.0 | 0.0 | 0.0 | 0.0 | 0.0 | 0.0 | 0.0 | 0.0 | 0.0 | 0.0 | 0.0 |
| Total Delay | 39.1 | 54.6 | 0.6 | 33.2 | 37.9 | 0.2 | 17.2 | 14.4 | 0.0 | 7.8 | 24.5 | 3.5 |
| LOS | D | D | A | C | D | A | B | B | A | A | C | A |
| Approach Delay | | 23.2 | | | 33.6 | | | 15.2 | | | 22.0 | |
| Approach LOS | | C | | | C | | | B | | | C | |

Intersection Summary

| | |
|---|------------------------|
| Cycle Length: 120 | |
| Actuated Cycle Length: 110.1 | |
| Natural Cycle: 65 | |
| Control Type: Semi Act-Uncoord | |
| Maximum v/c Ratio: 0.80 | |
| Intersection Signal Delay: 21.5 | Intersection LOS: C |
| Intersection Capacity Utilization 79.5% | ICU Level of Service D |
| Analysis Period (min) 15 | |

Splits and Phases: 14: US 24 & Stapleton Dr



| Intersection | | | | | | | | | | | | |
|--------------------------|------|------|------|------|------|------|------|------|------|------|------|------|
| Int Delay, s/veh | 8.5 | | | | | | | | | | | |
| Movement | EBL | EBT | EBR | WBL | WBT | WBR | NBL | NBT | NBR | SBL | SBT | SBR |
| Lane Configurations | ↙ | ↑ | ↗ | ↙ | ↑ | ↗ | ↙ | ↑ | ↗ | ↙ | ↑ | ↗ |
| Traffic Vol, veh/h | 9 | 11 | 181 | 19 | 9 | 4 | 301 | 32 | 32 | 5 | 21 | 8 |
| Future Vol, veh/h | 9 | 11 | 181 | 19 | 9 | 4 | 301 | 32 | 32 | 5 | 21 | 8 |
| Conflicting Peds, #/hr | 0 | 0 | 0 | 0 | 0 | 0 | 0 | 0 | 0 | 0 | 0 | 0 |
| Sign Control | Stop | Stop | Stop | Stop | Stop | Stop | Free | Free | Free | Free | Free | Free |
| RT Channelized | - | - | None | - | - | None | - | - | None | - | - | None |
| Storage Length | 300 | - | 205 | 200 | - | - | 250 | - | 205 | 250 | - | - |
| Veh in Median Storage, # | - | 0 | - | - | 0 | - | - | 0 | - | - | 0 | - |
| Grade, % | - | 0 | - | - | 0 | - | - | 0 | - | - | 0 | - |
| Peak Hour Factor | 78 | 78 | 78 | 86 | 86 | 86 | 87 | 87 | 87 | 94 | 94 | 94 |
| Heavy Vehicles, % | 2 | 2 | 2 | 2 | 2 | 2 | 2 | 2 | 2 | 2 | 2 | 2 |
| Mvmt Flow | 12 | 14 | 232 | 22 | 10 | 5 | 346 | 37 | 37 | 5 | 22 | 9 |

| Major/Minor | Minor2 | | Minor1 | | Major1 | | | Major2 | | | | |
|----------------------|--------|-------|--------|-------|--------|-------|-------|--------|---|-------|---|---|
| Conflicting Flow All | 792 | 803 | 27 | 889 | 770 | 37 | 31 | 0 | 0 | 74 | 0 | 0 |
| Stage 1 | 37 | 37 | - | 729 | 729 | - | - | - | - | - | - | - |
| Stage 2 | 755 | 766 | - | 160 | 41 | - | - | - | - | - | - | - |
| Critical Hdwy | 7.12 | 6.52 | 6.22 | 7.12 | 6.52 | 6.22 | 4.12 | - | - | 4.12 | - | - |
| Critical Hdwy Stg 1 | 6.12 | 5.52 | - | 6.12 | 5.52 | - | - | - | - | - | - | - |
| Critical Hdwy Stg 2 | 6.12 | 5.52 | - | 6.12 | 5.52 | - | - | - | - | - | - | - |
| Follow-up Hdwy | 3.518 | 4.018 | 3.318 | 3.518 | 4.018 | 3.318 | 2.218 | - | - | 2.218 | - | - |
| Pot Cap-1 Maneuver | 307 | 317 | 1048 | 264 | 331 | 1035 | 1582 | - | - | 1526 | - | - |
| Stage 1 | 978 | 864 | - | 414 | 428 | - | - | - | - | - | - | - |
| Stage 2 | 401 | 412 | - | 842 | 861 | - | - | - | - | - | - | - |
| Platoon blocked, % | - | - | - | - | - | - | - | - | - | - | - | - |
| Mov Cap-1 Maneuver | 246 | 247 | 1048 | 163 | 258 | 1035 | 1582 | - | - | 1526 | - | - |
| Mov Cap-2 Maneuver | 246 | 247 | - | 163 | 258 | - | - | - | - | - | - | - |
| Stage 1 | 764 | 861 | - | 323 | 334 | - | - | - | - | - | - | - |
| Stage 2 | 302 | 322 | - | 643 | 858 | - | - | - | - | - | - | - |

| Approach | EB | | WB | | NB | | | SB | | |
|----------------------|------|--|------|--|-----|--|--|-----|--|--|
| HCM Control Delay, s | 10.5 | | 24.7 | | 6.5 | | | 1.1 | | |
| HCM LOS | B | | C | | | | | | | |

| Minor Lane/Major Mvmt | NBL | NBT | NBR | EBLn1 | EBLn2 | EBLn3 | WBLn1 | WBLn2 | SBL | SBT | SBR |
|-----------------------|-------|-----|-----|-------|-------|-------|-------|-------|-------|-----|-----|
| Capacity (veh/h) | 1582 | - | - | 246 | 247 | 1048 | 163 | 335 | 1526 | - | - |
| HCM Lane V/C Ratio | 0.219 | - | - | 0.047 | 0.057 | 0.221 | 0.136 | 0.045 | 0.003 | - | - |
| HCM Control Delay (s) | 7.9 | - | - | 20.4 | 20.5 | 9.4 | 30.5 | 16.3 | 7.4 | - | - |
| HCM Lane LOS | A | - | - | C | C | A | D | C | A | - | - |
| HCM 95th %tile Q(veh) | 0.8 | - | - | 0.1 | 0.2 | 0.8 | 0.5 | 0.1 | 0 | - | - |

| Intersection | | | | | | |
|--------------------------|------|------|------|------|------|------|
| Int Delay, s/veh | 3.6 | | | | | |
| Movement | EBT | EBR | WBL | WBT | NBL | NBR |
| Lane Configurations | ↔ | | ↔ | ↑ | ↔ | ↔ |
| Traffic Vol, veh/h | 0 | 47 | 0 | 0 | 31 | 0 |
| Future Vol, veh/h | 0 | 47 | 0 | 0 | 31 | 0 |
| Conflicting Peds, #/hr | 0 | 0 | 0 | 0 | 0 | 0 |
| Sign Control | Free | Free | Free | Free | Stop | Stop |
| RT Channelized | - | None | - | None | - | None |
| Storage Length | - | - | 205 | - | 0 | 0 |
| Veh in Median Storage, # | 0 | - | - | 0 | 0 | - |
| Grade, % | 0 | - | - | 0 | 0 | - |
| Peak Hour Factor | 85 | 85 | 85 | 85 | 85 | 85 |
| Heavy Vehicles, % | 2 | 2 | 2 | 2 | 2 | 2 |
| Mvmt Flow | 0 | 55 | 0 | 0 | 36 | 0 |

| Major/Minor | Major1 | Major2 | Minor1 | | |
|----------------------|--------|--------|--------|---|-------|
| Conflicting Flow All | 0 | 0 | 55 | 0 | 29 |
| Stage 1 | - | - | - | - | 28 |
| Stage 2 | - | - | - | - | 1 |
| Critical Hdwy | - | - | 4.12 | - | 6.42 |
| Critical Hdwy Stg 1 | - | - | - | - | 5.42 |
| Critical Hdwy Stg 2 | - | - | - | - | 5.42 |
| Follow-up Hdwy | - | - | 2.218 | - | 3.518 |
| Pot Cap-1 Maneuver | - | - | 1550 | - | 986 |
| Stage 1 | - | - | - | - | 995 |
| Stage 2 | - | - | - | - | 1022 |
| Platoon blocked, % | - | - | - | - | - |
| Mov Cap-1 Maneuver | - | - | 1550 | - | 986 |
| Mov Cap-2 Maneuver | - | - | - | - | 907 |
| Stage 1 | - | - | - | - | 995 |
| Stage 2 | - | - | - | - | 1022 |

| Approach | EB | WB | NB |
|----------------------|----|----|-----|
| HCM Control Delay, s | 0 | 0 | 9.1 |
| HCM LOS | | | A |

| Minor Lane/Major Mvmt | NBLn1 | NBLn2 | EBT | EBR | WBL | WBT |
|-----------------------|-------|-------|-----|-----|------|-----|
| Capacity (veh/h) | 907 | - | - | - | 1550 | - |
| HCM Lane V/C Ratio | 0.04 | - | - | - | - | - |
| HCM Control Delay (s) | 9.1 | 0 | - | - | 0 | - |
| HCM Lane LOS | A | A | - | - | A | - |
| HCM 95th %tile Q(veh) | 0.1 | - | - | - | 0 | - |

| Intersection | | | | | | |
|--------------------------|------|------|------|------|------|------|
| Int Delay, s/veh | 2.8 | | | | | |
| Movement | WBL | WBR | NBT | NBR | SBL | SBT |
| Lane Configurations | ↘ | ↗ | ↑ | ↗ | ↘ | ↑ |
| Traffic Vol, veh/h | 161 | 5 | 373 | 244 | 8 | 213 |
| Future Vol, veh/h | 161 | 5 | 373 | 244 | 8 | 213 |
| Conflicting Peds, #/hr | 0 | 0 | 0 | 0 | 0 | 0 |
| Sign Control | Stop | Stop | Free | Free | Free | Free |
| RT Channelized | - | None | - | None | - | None |
| Storage Length | 0 | 0 | - | 155 | 205 | - |
| Veh in Median Storage, # | 0 | - | 0 | - | - | 0 |
| Grade, % | 0 | - | 0 | - | - | 0 |
| Peak Hour Factor | 85 | 85 | 85 | 85 | 85 | 85 |
| Heavy Vehicles, % | 2 | 2 | 2 | 2 | 2 | 2 |
| Mvmt Flow | 189 | 6 | 439 | 287 | 9 | 251 |

| Major/Minor | Minor1 | Major1 | Major2 | | |
|----------------------|--------|--------|--------|---|-------|
| Conflicting Flow All | 708 | 439 | 0 | 0 | 726 |
| Stage 1 | 439 | - | - | - | - |
| Stage 2 | 269 | - | - | - | - |
| Critical Hdwy | 6.42 | 6.22 | - | - | 4.12 |
| Critical Hdwy Stg 1 | 5.42 | - | - | - | - |
| Critical Hdwy Stg 2 | 5.42 | - | - | - | - |
| Follow-up Hdwy | 3.518 | 3.318 | - | - | 2.218 |
| Pot Cap-1 Maneuver | 401 | 618 | - | - | 877 |
| Stage 1 | 650 | - | - | - | - |
| Stage 2 | 776 | - | - | - | - |
| Platoon blocked, % | | | - | - | - |
| Mov Cap-1 Maneuver | 397 | 618 | - | - | 877 |
| Mov Cap-2 Maneuver | 500 | - | - | - | - |
| Stage 1 | 650 | - | - | - | - |
| Stage 2 | 768 | - | - | - | - |

| Approach | WB | NB | SB |
|----------------------|------|----|-----|
| HCM Control Delay, s | 16.3 | 0 | 0.3 |
| HCM LOS | C | | |

| Minor Lane/Major Mvmt | NBT | NBR | WBLn1 | WBLn2 | SBL | SBT |
|-----------------------|-----|-----|-------|-------|-------|-----|
| Capacity (veh/h) | - | - | 500 | 618 | 877 | - |
| HCM Lane V/C Ratio | - | - | 0.379 | 0.01 | 0.011 | - |
| HCM Control Delay (s) | - | - | 16.5 | 10.9 | 9.1 | - |
| HCM Lane LOS | - | - | C | B | A | - |
| HCM 95th %tile Q(veh) | - | - | 1.8 | 0 | 0 | - |

| Intersection | | | | | | |
|--------------------------|------|------|------|------|------|------|
| Int Delay, s/veh | 0.7 | | | | | |
| Movement | WBL | WBR | NBT | NBR | SBL | SBT |
| Lane Configurations | ↘ | ↗ | ↑ | ↗ | ↘ | ↑ |
| Traffic Vol, veh/h | 37 | 5 | 611 | 65 | 7 | 367 |
| Future Vol, veh/h | 37 | 5 | 611 | 65 | 7 | 367 |
| Conflicting Peds, #/hr | 0 | 0 | 0 | 0 | 0 | 0 |
| Sign Control | Stop | Stop | Free | Free | Free | Free |
| RT Channelized | - | None | - | None | - | None |
| Storage Length | 0 | 115 | - | 155 | 205 | - |
| Veh in Median Storage, # | 0 | - | 0 | - | - | 0 |
| Grade, % | 0 | - | 0 | - | - | 0 |
| Peak Hour Factor | 85 | 85 | 85 | 85 | 85 | 85 |
| Heavy Vehicles, % | 2 | 2 | 2 | 2 | 2 | 2 |
| Mvmt Flow | 44 | 6 | 719 | 76 | 8 | 432 |

| Major/Minor | Minor1 | Major1 | Major2 | | |
|----------------------|--------|--------|--------|---|-------|
| Conflicting Flow All | 1167 | 719 | 0 | 0 | 795 |
| Stage 1 | 719 | - | - | - | - |
| Stage 2 | 448 | - | - | - | - |
| Critical Hdwy | 6.42 | 6.22 | - | - | 4.12 |
| Critical Hdwy Stg 1 | 5.42 | - | - | - | - |
| Critical Hdwy Stg 2 | 5.42 | - | - | - | - |
| Follow-up Hdwy | 3.518 | 3.318 | - | - | 2.218 |
| Pot Cap-1 Maneuver | 214 | 428 | - | - | 826 |
| Stage 1 | 483 | - | - | - | - |
| Stage 2 | 644 | - | - | - | - |
| Platoon blocked, % | | | - | - | - |
| Mov Cap-1 Maneuver | 212 | 428 | - | - | 826 |
| Mov Cap-2 Maneuver | 345 | - | - | - | - |
| Stage 1 | 483 | - | - | - | - |
| Stage 2 | 638 | - | - | - | - |

| Approach | WB | NB | SB |
|----------------------|------|----|-----|
| HCM Control Delay, s | 16.5 | 0 | 0.2 |
| HCM LOS | C | | |

| Minor Lane/Major Mvmt | NBT | NBR | WBLn1 | WBLn2 | SBL | SBT |
|-----------------------|-----|-----|-------|-------|------|-----|
| Capacity (veh/h) | - | - | 345 | 428 | 826 | - |
| HCM Lane V/C Ratio | - | - | 0.126 | 0.014 | 0.01 | - |
| HCM Control Delay (s) | - | - | 16.9 | 13.5 | 9.4 | - |
| HCM Lane LOS | - | - | C | B | A | - |
| HCM 95th %tile Q(veh) | - | - | 0.4 | 0 | 0 | - |

| Intersection | | | | | | |
|--------------------------|------|------|------|------|------|------|
| Int Delay, s/veh | 5.1 | | | | | |
| Movement | EBL | EBR | NBL | NBT | SBT | SBR |
| Lane Configurations | ↘ | ↗ | ↘ | ↗ | ↗ | ↘ |
| Traffic Vol, veh/h | 46 | 183 | 342 | 630 | 373 | 31 |
| Future Vol, veh/h | 46 | 183 | 342 | 630 | 373 | 31 |
| Conflicting Peds, #/hr | 0 | 0 | 0 | 0 | 0 | 0 |
| Sign Control | Stop | Stop | Free | Free | Free | Free |
| RT Channelized | - | None | - | None | - | None |
| Storage Length | 0 | 0 | 250 | - | - | 205 |
| Veh in Median Storage, # | 0 | - | - | 0 | 0 | - |
| Grade, % | 0 | - | - | 0 | 0 | - |
| Peak Hour Factor | 85 | 85 | 85 | 85 | 85 | 85 |
| Heavy Vehicles, % | 2 | 2 | 2 | 2 | 2 | 2 |
| Mvmt Flow | 54 | 215 | 402 | 741 | 439 | 36 |

| Major/Minor | Minor2 | Major1 | Major2 | | | |
|----------------------|--------|--------|--------|---|---|---|
| Conflicting Flow All | 1984 | 439 | 475 | 0 | - | 0 |
| Stage 1 | 439 | - | - | - | - | - |
| Stage 2 | 1545 | - | - | - | - | - |
| Critical Hdwy | 6.42 | 6.22 | 4.12 | - | - | - |
| Critical Hdwy Stg 1 | 5.42 | - | - | - | - | - |
| Critical Hdwy Stg 2 | 5.42 | - | - | - | - | - |
| Follow-up Hdwy | 3.518 | 3.318 | 2.218 | - | - | - |
| Pot Cap-1 Maneuver | 67 | 618 | 1087 | - | - | - |
| Stage 1 | 650 | - | - | - | - | - |
| Stage 2 | 194 | - | - | - | - | - |
| Platoon blocked, % | | | | - | - | - |
| Mov Cap-1 Maneuver | ~ 42 | 618 | 1087 | - | - | - |
| Mov Cap-2 Maneuver | 137 | - | - | - | - | - |
| Stage 1 | 410 | - | - | - | - | - |
| Stage 2 | 194 | - | - | - | - | - |

| Approach | EB | NB | SB |
|----------------------|------|-----|----|
| HCM Control Delay, s | 20.6 | 3.6 | 0 |
| HCM LOS | C | | |

| Minor Lane/Major Mvmt | NBL | NBT | EBLn1 | EBLn2 | SBT | SBR |
|-----------------------|------|-----|-------|-------|-----|-----|
| Capacity (veh/h) | 1087 | - | 137 | 618 | - | - |
| HCM Lane V/C Ratio | 0.37 | - | 0.395 | 0.348 | - | - |
| HCM Control Delay (s) | 10.2 | - | 47.5 | 13.9 | - | - |
| HCM Lane LOS | B | - | E | B | - | - |
| HCM 95th %tile Q(veh) | 1.7 | - | 1.7 | 1.6 | - | - |

Notes
 ~: Volume exceeds capacity \$: Delay exceeds 300s +: Computation Not Defined *: All major volume in platoon

| Intersection | |
|---------------------------|-----|
| Intersection Delay, s/veh | 265 |
| Intersection LOS | F |

| Movement | EBL | EBT | EBR | WBL | WBT | WBR | NBL | NBT | NBR | SBL | SBT | SBR |
|---------------------|------|------|------|------|------|------|------|------|------|------|------|------|
| Lane Configurations | ↖ | ↗ | | ↖ | ↗ | | ↖ | ↗ | | ↖ | ↗ | ↖ |
| Traffic Vol, veh/h | 67 | 130 | 45 | 22 | 220 | 507 | 72 | 398 | 33 | 289 | 226 | 41 |
| Future Vol, veh/h | 67 | 130 | 45 | 22 | 220 | 507 | 72 | 398 | 33 | 289 | 226 | 41 |
| Peak Hour Factor | 0.83 | 0.83 | 0.83 | 0.94 | 0.94 | 0.94 | 0.85 | 0.85 | 0.85 | 0.83 | 0.83 | 0.83 |
| Heavy Vehicles, % | 2 | 2 | 2 | 2 | 2 | 2 | 2 | 2 | 2 | 2 | 2 | 2 |
| Mvmt Flow | 81 | 157 | 54 | 23 | 234 | 539 | 85 | 468 | 39 | 348 | 272 | 49 |
| Number of Lanes | 1 | 1 | 0 | 1 | 1 | 0 | 1 | 1 | 0 | 1 | 1 | 1 |

| Approach | EB | WB | NB | SB |
|----------------------------|------|-------|-------|------|
| Opposing Approach | WB | EB | SB | NB |
| Opposing Lanes | 2 | 2 | 3 | 2 |
| Conflicting Approach Left | SB | NB | EB | WB |
| Conflicting Lanes Left | 3 | 2 | 2 | 2 |
| Conflicting Approach Right | NB | SB | WB | EB |
| Conflicting Lanes Right | 2 | 3 | 2 | 2 |
| HCM Control Delay | 35.7 | 541.2 | 223.8 | 72.5 |
| HCM LOS | E | F | F | F |

| Lane | NBLn1 | NBLn2 | EBLn1 | EBLn2 | WBLn1 | WBLn2 | SBLn1 | SBLn2 | SBLn3 |
|------------------------|--------|--------|--------|--------|--------|--------|-------|--------|--------|
| Vol Left, % | 100% | 0% | 100% | 0% | 100% | 0% | 100% | 0% | 0% |
| Vol Thru, % | 0% | 92% | 0% | 74% | 0% | 30% | 0% | 100% | 0% |
| Vol Right, % | 0% | 8% | 0% | 26% | 0% | 70% | 0% | 0% | 100% |
| Sign Control | Stop | Stop | Stop | Stop | Stop | Stop | Stop | Stop | Stop |
| Traffic Vol by Lane | 72 | 431 | 67 | 175 | 22 | 727 | 289 | 226 | 41 |
| LT Vol | 72 | 0 | 67 | 0 | 22 | 0 | 289 | 0 | 0 |
| Through Vol | 0 | 398 | 0 | 130 | 0 | 220 | 0 | 226 | 0 |
| RT Vol | 0 | 33 | 0 | 45 | 0 | 507 | 0 | 0 | 41 |
| Lane Flow Rate | 85 | 507 | 81 | 211 | 23 | 773 | 348 | 272 | 49 |
| Geometry Grp | 8 | 8 | 8 | 8 | 8 | 8 | 8 | 8 | 8 |
| Degree of Util (X) | 0.256 | 1.458 | 0.26 | 0.638 | 0.072 | 2.163 | 1.01 | 0.752 | 0.127 |
| Departure Headway (Hd) | 13.764 | 13.161 | 15.532 | 14.789 | 12.147 | 11.105 | 14.13 | 13.587 | 12.828 |
| Convergence, Y/N | Yes | Yes | Yes | Yes | Yes | Yes | Yes | Yes | Yes |
| Cap | 263 | 279 | 233 | 247 | 297 | 333 | 261 | 270 | 282 |
| Service Time | 11.464 | 10.861 | 13.232 | 12.489 | 9.847 | 8.805 | 11.83 | 11.287 | 10.528 |
| HCM Lane V/C Ratio | 0.323 | 1.817 | 0.348 | 0.854 | 0.077 | 2.321 | 1.333 | 1.007 | 0.174 |
| HCM Control Delay | 21.1 | 257.7 | 23.6 | 40.3 | 15.8 | 557.1 | 99.2 | 48.3 | 17.4 |
| HCM Lane LOS | C | F | C | E | C | F | F | E | C |
| HCM 95th-tile Q | 1 | 22.4 | 1 | 3.9 | 0.2 | 52.2 | 10 | 5.5 | 0.4 |

| Intersection | | | | | | | | | | | | |
|--------------------------|------|------|------|------|------|------|------|------|------|------|------|------|
| Int Delay, s/veh | 2.5 | | | | | | | | | | | |
| Movement | EBL | EBT | EBR | WBL | WBT | WBR | NBL | NBT | NBR | SBL | SBT | SBR |
| Lane Configurations | ↖ | ↗ | ↖ | ↖ | ↗ | ↖ | ↖ | ↗ | ↖ | ↖ | ↗ | ↖ |
| Traffic Vol, veh/h | 44 | 133 | 265 | 5 | 270 | 34 | 461 | 697 | 8 | 10 | 551 | 72 |
| Future Vol, veh/h | 44 | 133 | 265 | 5 | 270 | 34 | 461 | 697 | 8 | 10 | 551 | 72 |
| Conflicting Peds, #/hr | 0 | 0 | 0 | 0 | 0 | 0 | 0 | 0 | 0 | 0 | 0 | 0 |
| Sign Control | Stop | Stop | Stop | Stop | Stop | Stop | Free | Free | Free | Free | Free | Free |
| RT Channelized | - | - | None | - | - | None | - | - | None | - | - | None |
| Storage Length | 185 | - | 325 | 225 | - | 225 | 1000 | - | 0 | 785 | - | 785 |
| Veh in Median Storage, # | - | 0 | - | - | 0 | - | - | 0 | - | - | 0 | - |
| Grade, % | - | 0 | - | - | 0 | - | - | 0 | - | - | 0 | - |
| Peak Hour Factor | 93 | 93 | 93 | 85 | 85 | 85 | 92 | 92 | 92 | 90 | 90 | 90 |
| Heavy Vehicles, % | 2 | 2 | 2 | 2 | 2 | 2 | 2 | 2 | 2 | 2 | 2 | 2 |
| Mvmt Flow | 47 | 143 | 285 | 6 | 318 | 40 | 501 | 758 | 9 | 11 | 612 | 80 |

| Major/Minor | Minor2 | | Minor1 | | Major1 | | Major2 | | | | | |
|----------------------|--------|-------|--------|-------|--------|-------|--------|---|---|-------|---|---|
| Conflicting Flow All | 2578 | 2403 | 612 | 2648 | 2474 | 758 | 692 | 0 | 0 | 767 | 0 | 0 |
| Stage 1 | 634 | 634 | - | 1760 | 1760 | - | - | - | - | - | - | - |
| Stage 2 | 1944 | 1769 | - | 888 | 714 | - | - | - | - | - | - | - |
| Critical Hdwy | 7.12 | 6.52 | 6.22 | 7.12 | 6.52 | 6.22 | 4.12 | - | - | 4.12 | - | - |
| Critical Hdwy Stg 1 | 6.12 | 5.52 | - | 6.12 | 5.52 | - | - | - | - | - | - | - |
| Critical Hdwy Stg 2 | 6.12 | 5.52 | - | 6.12 | 5.52 | - | - | - | - | - | - | - |
| Follow-up Hdwy | 3.518 | 4.018 | 3.318 | 3.518 | 4.018 | 3.318 | 2.218 | - | - | 2.218 | - | - |
| Pot Cap-1 Maneuver | ~ 17 | ~ 33 | 493 | 15 | ~ 30 | 407 | 903 | - | - | 847 | - | - |
| Stage 1 | 467 | 473 | - | 108 | ~ 138 | - | - | - | - | - | - | - |
| Stage 2 | 84 | ~ 136 | - | 338 | 435 | - | - | - | - | - | - | - |
| Platoon blocked, % | - | - | - | - | - | - | - | - | - | - | - | - |
| Mov Cap-1 Maneuver | - | ~ 14 | 493 | - | ~ 13 | 407 | 903 | - | - | 847 | - | - |
| Mov Cap-2 Maneuver | - | ~ 14 | - | - | ~ 13 | - | - | - | - | - | - | - |
| Stage 1 | 208 | 467 | - | 48 | ~ 61 | - | - | - | - | - | - | - |
| Stage 2 | - | ~ 61 | - | 98 | 429 | - | - | - | - | - | - | - |

| Approach | EB | | WB | | NB | | SB | |
|----------------------|----|--|----|--|-----|--|-----|--|
| HCM Control Delay, s | | | | | 5.5 | | 0.1 | |
| HCM LOS | - | | - | | | | | |

| Minor Lane/Major Mvmt | NBL | NBT | NBR | EBLn1 | EBLn2 | EBLn3 | WBLn1 | WBLn2 | WBLn3 | SBL | SBT | SBR |
|-----------------------|-------|-----|-----|-------|--------|-------|-------|---------|-------|-------|-----|-----|
| Capacity (veh/h) | 903 | - | - | - | 14 | 493 | - | 13 | 407 | 847 | - | - |
| HCM Lane V/C Ratio | 0.555 | - | - | - | 10.215 | 0.578 | - | 24.434 | 0.098 | 0.013 | - | - |
| HCM Control Delay (s) | 13.8 | - | - | - | 4676.7 | 21.8 | - | 11108.6 | 14.8 | 9.3 | - | - |
| HCM Lane LOS | B | - | - | - | F | C | - | F | B | A | - | - |
| HCM 95th %tile Q(veh) | 3.5 | - | - | - | 19 | 3.6 | - | 41 | 0.3 | 0 | - | - |

Notes
 ~: Volume exceeds capacity \$: Delay exceeds 300s +: Computation Not Defined *: All major volume in platoon

Timings
13: Eastonville Rd & Stapleton Dr

2026 Total Traffic
PM Peak Hour



| Lane Group | EBL | EBT | WBL | WBT | WBR | NBL | NBT | SBL | SBT | SBR |
|----------------------|-------|-------|-------|-------|-------|-------|-------|-------|-------|-------|
| Lane Configurations | | | | | | | | | | |
| Traffic Volume (vph) | 67 | 130 | 22 | 220 | 507 | 72 | 398 | 289 | 226 | 41 |
| Future Volume (vph) | 67 | 130 | 22 | 220 | 507 | 72 | 398 | 289 | 226 | 41 |
| Turn Type | pm+pt | NA | pm+pt | NA | Perm | pm+pt | NA | pm+pt | NA | Perm |
| Protected Phases | 7 | 4 | 3 | 8 | | 5 | 2 | 1 | 6 | |
| Permitted Phases | 4 | | 8 | | 8 | 2 | | 6 | | 6 |
| Detector Phase | 7 | 4 | 3 | 8 | 8 | 5 | 2 | 1 | 6 | 6 |
| Switch Phase | | | | | | | | | | |
| Minimum Initial (s) | 5.0 | 5.0 | 5.0 | 5.0 | 5.0 | 5.0 | 5.0 | 5.0 | 5.0 | 5.0 |
| Minimum Split (s) | 10.0 | 10.0 | 10.0 | 10.0 | 10.0 | 10.0 | 10.0 | 10.0 | 10.0 | 10.0 |
| Total Split (s) | 10.0 | 43.0 | 10.0 | 43.0 | 43.0 | 10.0 | 29.0 | 18.0 | 37.0 | 37.0 |
| Total Split (%) | 10.0% | 43.0% | 10.0% | 43.0% | 43.0% | 10.0% | 29.0% | 18.0% | 37.0% | 37.0% |
| Yellow Time (s) | 3.0 | 3.0 | 3.0 | 3.0 | 3.0 | 3.0 | 3.0 | 3.0 | 3.0 | 3.0 |
| All-Red Time (s) | 2.0 | 2.0 | 2.0 | 2.0 | 2.0 | 2.0 | 2.0 | 2.0 | 2.0 | 2.0 |
| Lost Time Adjust (s) | 0.0 | 0.0 | 0.0 | 0.0 | 0.0 | 0.0 | 0.0 | 0.0 | 0.0 | 0.0 |
| Total Lost Time (s) | 5.0 | 5.0 | 5.0 | 5.0 | 5.0 | 5.0 | 5.0 | 5.0 | 5.0 | 5.0 |
| Lead/Lag | Lead | Lag | Lead | Lag | Lag | Lead | Lag | Lead | Lag | Lag |
| Lead-Lag Optimize? | Yes | Yes | Yes | Yes | Yes | Yes | Yes | Yes | Yes | Yes |
| Recall Mode | None | None | None | None | None | None | None | None | None | None |
| Act Effct Green (s) | 24.4 | 22.6 | 22.3 | 18.5 | 18.5 | 29.6 | 24.5 | 42.9 | 35.3 | 35.3 |
| Actuated g/C Ratio | 0.31 | 0.28 | 0.28 | 0.23 | 0.23 | 0.37 | 0.31 | 0.54 | 0.45 | 0.45 |
| v/c Ratio | 0.26 | 0.40 | 0.07 | 0.54 | 0.81 | 0.19 | 0.89 | 0.90 | 0.33 | 0.06 |
| Control Delay | 18.8 | 22.9 | 16.2 | 31.0 | 19.0 | 14.7 | 48.8 | 49.6 | 20.2 | 0.1 |
| Queue Delay | 0.0 | 0.0 | 0.0 | 0.0 | 0.0 | 0.0 | 0.0 | 0.0 | 0.0 | 0.0 |
| Total Delay | 18.8 | 22.9 | 16.2 | 31.0 | 19.0 | 14.7 | 48.8 | 49.6 | 20.2 | 0.1 |
| LOS | B | C | B | C | B | B | D | D | C | A |
| Approach Delay | | 21.8 | | 22.5 | | | 43.9 | | 34.0 | |
| Approach LOS | | C | | C | | | D | | C | |

Intersection Summary

Cycle Length: 100
 Actuated Cycle Length: 79.3
 Natural Cycle: 80
 Control Type: Actuated-Uncoordinated
 Maximum v/c Ratio: 0.90
 Intersection Signal Delay: 31.1
 Intersection LOS: C
 Intersection Capacity Utilization 71.4%
 ICU Level of Service C
 Analysis Period (min) 15

Splits and Phases: 13: Eastonville Rd & Stapleton Dr

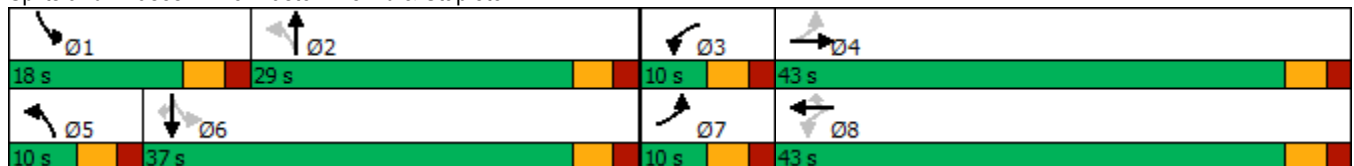

Timings
14: US 24 & Stapleton Dr

2026 Total Traffic
PM Peak Hour

| Lane Group | EBL | EBT | EBR | WBL | WBT | WBR | NBL | NBT | NBR | SBL | SBT | SBR |
|----------------------|-------|-------|-------|-------|-------|-------|-------|-------|-------|-------|-------|-------|
| Lane Configurations | | | | | | | | | | | | |
| Traffic Volume (vph) | 44 | 133 | 265 | 5 | 270 | 34 | 461 | 697 | 8 | 10 | 551 | 72 |
| Future Volume (vph) | 44 | 133 | 265 | 5 | 270 | 34 | 461 | 697 | 8 | 10 | 551 | 72 |
| Turn Type | Perm | NA | Free | Perm | NA | Perm | pm+pt | NA | Perm | pm+pt | NA | Perm |
| Protected Phases | | 4 | | | 8 | | 5 | 2 | | 1 | 6 | |
| Permitted Phases | 4 | | Free | 8 | | 8 | 2 | | 2 | 6 | | 6 |
| Detector Phase | 4 | 4 | | 8 | 8 | 8 | 5 | 2 | 2 | 1 | 6 | 6 |
| Switch Phase | | | | | | | | | | | | |
| Minimum Initial (s) | 1.0 | 1.0 | | 1.0 | 1.0 | 1.0 | 5.0 | 5.0 | 5.0 | 5.0 | 5.0 | 5.0 |
| Minimum Split (s) | 6.0 | 6.0 | | 6.0 | 6.0 | 6.0 | 10.0 | 20.0 | 20.0 | 10.0 | 20.0 | 20.0 |
| Total Split (s) | 45.0 | 45.0 | | 45.0 | 45.0 | 45.0 | 25.0 | 65.0 | 65.0 | 10.0 | 50.0 | 50.0 |
| Total Split (%) | 37.5% | 37.5% | | 37.5% | 37.5% | 37.5% | 20.8% | 54.2% | 54.2% | 8.3% | 41.7% | 41.7% |
| Yellow Time (s) | 3.0 | 3.0 | | 3.0 | 3.0 | 3.0 | 3.0 | 4.0 | 4.0 | 3.0 | 4.0 | 4.0 |
| All-Red Time (s) | 2.0 | 2.0 | | 2.0 | 2.0 | 2.0 | 2.0 | 2.0 | 2.0 | 2.0 | 2.0 | 2.0 |
| Lost Time Adjust (s) | 0.0 | 0.0 | | 0.0 | 0.0 | 0.0 | 0.0 | 0.0 | 0.0 | 0.0 | 0.0 | 0.0 |
| Total Lost Time (s) | 5.0 | 5.0 | | 5.0 | 5.0 | 5.0 | 5.0 | 6.0 | 6.0 | 5.0 | 6.0 | 6.0 |
| Lead/Lag | | | | | | | Lead | Lag | Lag | Lead | Lag | Lag |
| Lead-Lag Optimize? | | | | | | | Yes | Yes | Yes | Yes | Yes | Yes |
| Recall Mode | None | None | | None | None | None | None | Max | Max | None | Max | Max |
| Act Effct Green (s) | 22.7 | 22.7 | 102.9 | 22.7 | 22.7 | 22.7 | 70.2 | 67.4 | 67.4 | 50.1 | 44.1 | 44.1 |
| Actuated g/C Ratio | 0.22 | 0.22 | 1.00 | 0.22 | 0.22 | 0.22 | 0.68 | 0.66 | 0.66 | 0.49 | 0.43 | 0.43 |
| v/c Ratio | 0.48 | 0.35 | 0.18 | 0.02 | 0.78 | 0.09 | 0.96 | 0.62 | 0.01 | 0.03 | 0.77 | 0.11 |
| Control Delay | 51.5 | 35.7 | 0.2 | 30.0 | 50.9 | 0.4 | 50.3 | 15.4 | 0.0 | 9.0 | 34.0 | 2.2 |
| Queue Delay | 0.0 | 0.0 | 0.0 | 0.0 | 0.0 | 0.0 | 0.0 | 0.0 | 0.0 | 0.0 | 0.0 | 0.0 |
| Total Delay | 51.5 | 35.7 | 0.2 | 30.0 | 50.9 | 0.4 | 50.3 | 15.4 | 0.0 | 9.0 | 34.0 | 2.2 |
| LOS | D | D | A | C | D | A | D | B | A | A | C | A |
| Approach Delay | | 16.0 | | | 45.0 | | | 29.1 | | | 30.0 | |
| Approach LOS | | B | | | D | | | C | | | C | |

Intersection Summary

| | |
|---|------------------------|
| Cycle Length: 120 | |
| Actuated Cycle Length: 102.9 | |
| Natural Cycle: 90 | |
| Control Type: Semi Act-Uncoord | |
| Maximum v/c Ratio: 0.96 | |
| Intersection Signal Delay: 29.2 | Intersection LOS: C |
| Intersection Capacity Utilization 89.6% | ICU Level of Service E |
| Analysis Period (min) 15 | |

Splits and Phases: 14: US 24 & Stapleton Dr



| Intersection | | | | | | | | | | | | |
|--------------------------|-------|------|------|------|------|------|------|------|------|------|------|------|
| Int Delay, s/veh | 345.9 | | | | | | | | | | | |
| Movement | EBL | EBT | EBR | WBL | WBT | WBR | NBL | NBT | NBR | SBL | SBT | SBR |
| Lane Configurations | ↖ | ↗ | ↖ | ↖ | ↗ | ↖ | ↖ | ↗ | ↖ | ↖ | ↗ | ↖ |
| Traffic Vol, veh/h | 23 | 157 | 148 | 448 | 140 | 25 | 93 | 100 | 229 | 24 | 210 | 59 |
| Future Vol, veh/h | 23 | 157 | 148 | 448 | 140 | 25 | 93 | 100 | 229 | 24 | 210 | 59 |
| Conflicting Peds, #/hr | 0 | 0 | 0 | 0 | 0 | 0 | 0 | 0 | 0 | 0 | 0 | 0 |
| Sign Control | Stop | Stop | Stop | Stop | Stop | Stop | Free | Free | Free | Free | Free | Free |
| RT Channelized | - | - | None | - | - | None | - | - | None | - | - | None |
| Storage Length | 205 | - | 155 | 350 | - | 155 | 315 | - | 155 | 205 | - | 155 |
| Veh in Median Storage, # | - | 0 | - | - | 0 | - | - | 0 | - | - | 0 | - |
| Grade, % | - | 0 | - | - | 0 | - | - | 0 | - | - | 0 | - |
| Peak Hour Factor | 95 | 95 | 95 | 95 | 95 | 95 | 95 | 95 | 95 | 95 | 95 | 95 |
| Heavy Vehicles, % | 2 | 2 | 2 | 2 | 2 | 2 | 2 | 2 | 2 | 2 | 2 | 2 |
| Mvmt Flow | 24 | 165 | 156 | 472 | 147 | 26 | 98 | 105 | 241 | 25 | 221 | 62 |

| Major/Minor | Minor2 | | Minor1 | | Major1 | | Major2 | | | | | |
|----------------------|--------|-------|--------|-------|--------|-------|--------|---|---|-------|---|---|
| Conflicting Flow All | 779 | 813 | 221 | 764 | 634 | 105 | 283 | 0 | 0 | 346 | 0 | 0 |
| Stage 1 | 271 | 271 | - | 301 | 301 | - | - | - | - | - | - | - |
| Stage 2 | 508 | 542 | - | 463 | 333 | - | - | - | - | - | - | - |
| Critical Hdwy | 7.12 | 6.52 | 6.22 | 7.12 | 6.52 | 6.22 | 4.12 | - | - | 4.12 | - | - |
| Critical Hdwy Stg 1 | 6.12 | 5.52 | - | 6.12 | 5.52 | - | - | - | - | - | - | - |
| Critical Hdwy Stg 2 | 6.12 | 5.52 | - | 6.12 | 5.52 | - | - | - | - | - | - | - |
| Follow-up Hdwy | 3.518 | 4.018 | 3.318 | 3.518 | 4.018 | 3.318 | 2.218 | - | - | 2.218 | - | - |
| Pot Cap-1 Maneuver | 313 | 313 | 819 | ~ 321 | 397 | 949 | 1279 | - | - | 1213 | - | - |
| Stage 1 | 735 | 685 | - | 708 | 665 | - | - | - | - | - | - | - |
| Stage 2 | 547 | 520 | - | 579 | 644 | - | - | - | - | - | - | - |
| Platoon blocked, % | | | | | | | | - | - | - | - | - |
| Mov Cap-1 Maneuver | 193 | 283 | 819 | ~ 130 | 359 | 949 | 1279 | - | - | 1213 | - | - |
| Mov Cap-2 Maneuver | 193 | 283 | - | ~ 130 | 359 | - | - | - | - | - | - | - |
| Stage 1 | 678 | 671 | - | 653 | 614 | - | - | - | - | - | - | - |
| Stage 2 | 373 | 480 | - | ~ 346 | 630 | - | - | - | - | - | - | - |

| Approach | EB | WB | NB | SB |
|----------------------|------|----------|-----|-----|
| HCM Control Delay, s | 22.9 | \$ 920.5 | 1.8 | 0.7 |
| HCM LOS | C | F | | |

| Minor Lane/Major Mvmt | NBL | NBT | NBR | EBLn1 | EBLn2 | EBLn3 | WBLn1 | WBLn2 | WBLn3 | SBL | SBT | SBR |
|-----------------------|-------|-----|-----|-------|-------|-------|--------|-------|-------|-------|-----|-----|
| Capacity (veh/h) | 1279 | - | - | 193 | 283 | 819 | 130 | 359 | 949 | 1213 | - | - |
| HCM Lane V/C Ratio | 0.077 | - | - | 0.125 | 0.584 | 0.19 | 3.628 | 0.41 | 0.028 | 0.021 | - | - |
| HCM Control Delay (s) | 8 | - | - | 26.3 | 34.1 | 10.8 | 1252.2 | 21.8 | 8.9 | 8 | - | - |
| HCM Lane LOS | A | - | - | D | D | B | F | C | A | A | - | - |
| HCM 95th %tile Q(veh) | 0.2 | - | - | 0.4 | 3.4 | 0.7 | 46.5 | 1.9 | 0.1 | 0.1 | - | - |

Notes
 ~: Volume exceeds capacity \$: Delay exceeds 300s +: Computation Not Defined *: All major volume in platoon

| Intersection | | | | | | |
|--------------------------|------|------|------|------|------|------|
| Int Delay, s/veh | 0.9 | | | | | |
| Movement | EBT | EBR | WBL | WBT | NBL | NBR |
| Lane Configurations | ↔ | | ↔ | ↑ | ↔ | ↔ |
| Traffic Vol, veh/h | 399 | 10 | 18 | 599 | 15 | 53 |
| Future Vol, veh/h | 399 | 10 | 18 | 599 | 15 | 53 |
| Conflicting Peds, #/hr | 0 | 0 | 0 | 0 | 0 | 0 |
| Sign Control | Free | Free | Free | Free | Stop | Stop |
| RT Channelized | - | None | - | None | - | None |
| Storage Length | - | - | 155 | - | 205 | 0 |
| Veh in Median Storage, # | 0 | - | - | 0 | 0 | - |
| Grade, % | 0 | - | - | 0 | 0 | - |
| Peak Hour Factor | 92 | 92 | 92 | 92 | 92 | 92 |
| Heavy Vehicles, % | 2 | 2 | 2 | 2 | 2 | 2 |
| Mvmt Flow | 434 | 11 | 20 | 651 | 16 | 58 |

| Major/Minor | Major1 | Major2 | Minor1 | | |
|----------------------|--------|--------|--------|---|-------------|
| Conflicting Flow All | 0 | 0 | 445 | 0 | 1131 440 |
| Stage 1 | - | - | - | - | 440 - |
| Stage 2 | - | - | - | - | 691 - |
| Critical Hdwy | - | - | 4.12 | - | 6.42 6.22 |
| Critical Hdwy Stg 1 | - | - | - | - | 5.42 - |
| Critical Hdwy Stg 2 | - | - | - | - | 5.42 - |
| Follow-up Hdwy | - | - | 2.218 | - | 3.518 3.318 |
| Pot Cap-1 Maneuver | - | - | 1115 | - | 225 617 |
| Stage 1 | - | - | - | - | 649 - |
| Stage 2 | - | - | - | - | 497 - |
| Platoon blocked, % | - | - | - | - | - |
| Mov Cap-1 Maneuver | - | - | 1115 | - | 221 617 |
| Mov Cap-2 Maneuver | - | - | - | - | 352 - |
| Stage 1 | - | - | - | - | 649 - |
| Stage 2 | - | - | - | - | 488 - |

| Approach | EB | WB | NB |
|----------------------|----|-----|------|
| HCM Control Delay, s | 0 | 0.2 | 12.3 |
| HCM LOS | | | B |

| Minor Lane/Major Mvmt | NBLn1 | NBLn2 | EBT | EBR | WBL | WBT |
|-----------------------|-------|-------|-----|-----|-------|-----|
| Capacity (veh/h) | 352 | 617 | - | - | 1115 | - |
| HCM Lane V/C Ratio | 0.046 | 0.093 | - | - | 0.018 | - |
| HCM Control Delay (s) | 15.7 | 11.4 | - | - | 8.3 | - |
| HCM Lane LOS | C | B | - | - | A | - |
| HCM 95th %tile Q(veh) | 0.1 | 0.3 | - | - | 0.1 | - |

| Intersection | | | | | | |
|--------------------------|------|------|------|------|------|------|
| Int Delay, s/veh | 0.4 | | | | | |
| Movement | EBL | EBT | WBT | WBR | SBL | SBR |
| Lane Configurations | | | | | | |
| Traffic Vol, veh/h | 2 | 450 | 611 | 7 | 20 | 5 |
| Future Vol, veh/h | 2 | 450 | 611 | 7 | 20 | 5 |
| Conflicting Peds, #/hr | 0 | 0 | 0 | 0 | 0 | 0 |
| Sign Control | Free | Free | Free | Free | Stop | Stop |
| RT Channelized | - | None | - | None | - | None |
| Storage Length | 155 | - | - | - | 0 | - |
| Veh in Median Storage, # | - | 0 | 0 | - | 0 | - |
| Grade, % | - | 0 | 0 | - | 0 | - |
| Peak Hour Factor | 92 | 92 | 92 | 92 | 92 | 92 |
| Heavy Vehicles, % | 2 | 2 | 2 | 2 | 2 | 2 |
| Mvmt Flow | 2 | 489 | 664 | 8 | 22 | 5 |

| Major/Minor | Major1 | Major2 | Minor2 | | |
|----------------------|--------|--------|--------|---|-------------|
| Conflicting Flow All | 672 | 0 | - | 0 | 1161 668 |
| Stage 1 | - | - | - | - | 668 - |
| Stage 2 | - | - | - | - | 493 - |
| Critical Hdwy | 4.12 | - | - | - | 6.42 6.22 |
| Critical Hdwy Stg 1 | - | - | - | - | 5.42 - |
| Critical Hdwy Stg 2 | - | - | - | - | 5.42 - |
| Follow-up Hdwy | 2.218 | - | - | - | 3.518 3.318 |
| Pot Cap-1 Maneuver | 919 | - | - | - | 216 458 |
| Stage 1 | - | - | - | - | 510 - |
| Stage 2 | - | - | - | - | 614 - |
| Platoon blocked, % | | - | - | - | |
| Mov Cap-1 Maneuver | 919 | - | - | - | 216 458 |
| Mov Cap-2 Maneuver | - | - | - | - | 351 - |
| Stage 1 | - | - | - | - | 509 - |
| Stage 2 | - | - | - | - | 614 - |

| Approach | EB | WB | SB |
|----------------------|----|----|------|
| HCM Control Delay, s | 0 | 0 | 15.6 |
| HCM LOS | | | C |

| Minor Lane/Major Mvmt | EBL | EBT | WBT | WBR | SBLn1 |
|-----------------------|-------|-----|-----|-----|-------|
| Capacity (veh/h) | 919 | - | - | - | 368 |
| HCM Lane V/C Ratio | 0.002 | - | - | - | 0.074 |
| HCM Control Delay (s) | 8.9 | - | - | - | 15.6 |
| HCM Lane LOS | A | - | - | - | C |
| HCM 95th %tile Q(veh) | 0 | - | - | - | 0.2 |

Timings
9: US 24 & Rex Rd

2041 Background Traffic
AM Peak Hour



| Lane Group | EBL | EBR | NBL | NBT | SBT | SBR |
|----------------------|-------|-------|-------|-------|-------|-------|
| Lane Configurations | ↖ | ↗ | ↖↗ | ↕ | ↕ | ↗ |
| Traffic Volume (vph) | 94 | 973 | 481 | 385 | 536 | 79 |
| Future Volume (vph) | 94 | 973 | 481 | 385 | 536 | 79 |
| Turn Type | Prot | Free | Prot | NA | NA | Perm |
| Protected Phases | 6! | | 7 | Free! | 8 | |
| Permitted Phases | | Free | | | | 8 |
| Detector Phase | 6 | | 7 | | 8 | 8 |
| Switch Phase | | | | | | |
| Minimum Initial (s) | 5.0 | | 5.0 | | 5.0 | 5.0 |
| Minimum Split (s) | 20.0 | | 10.0 | | 20.0 | 20.0 |
| Total Split (s) | 24.0 | | 36.0 | | 60.0 | 60.0 |
| Total Split (%) | 20.0% | | 30.0% | | 50.0% | 50.0% |
| Yellow Time (s) | 3.0 | | 3.0 | | 3.0 | 3.0 |
| All-Red Time (s) | 2.0 | | 2.0 | | 2.0 | 2.0 |
| Lost Time Adjust (s) | 0.0 | | 0.0 | | 0.0 | 0.0 |
| Total Lost Time (s) | 5.0 | | 5.0 | | 5.0 | 5.0 |
| Lead/Lag | | | Lead | | Lag | Lag |
| Lead-Lag Optimize? | | | Yes | | Yes | Yes |
| Recall Mode | Max | | None | | C-Max | C-Max |
| Act Effct Green (s) | 19.0 | 120.0 | 22.9 | 120.0 | 63.1 | 63.1 |
| Actuated g/C Ratio | 0.16 | 1.00 | 0.19 | 1.00 | 0.53 | 0.53 |
| v/c Ratio | 0.35 | 0.65 | 0.77 | 0.11 | 0.30 | 0.10 |
| Control Delay | 49.1 | 2.1 | 40.3 | 0.1 | 17.2 | 3.7 |
| Queue Delay | 0.0 | 0.0 | 0.0 | 0.0 | 0.0 | 0.0 |
| Total Delay | 49.1 | 2.1 | 40.3 | 0.1 | 17.2 | 3.7 |
| LOS | D | A | D | A | B | A |
| Approach Delay | 6.2 | | | 22.7 | 15.5 | |
| Approach LOS | A | | | C | B | |

Intersection Summary

Cycle Length: 120
 Actuated Cycle Length: 120
 Offset: 50 (42%), Referenced to phase 8:SBT, Start of Green
 Natural Cycle: 55
 Control Type: Actuated-Coordinated
 Maximum v/c Ratio: 0.77
 Intersection Signal Delay: 14.0
 Intersection LOS: B
 Intersection Capacity Utilization 45.4%
 ICU Level of Service A
 Analysis Period (min) 15
 ! Phase conflict between lane groups.

Splits and Phases: 9: US 24 & Rex Rd

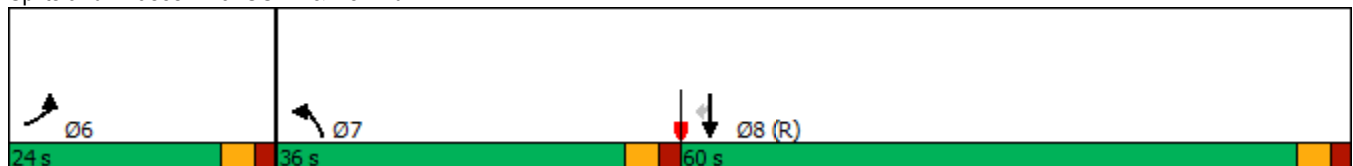

| Intersection | | | | | | |
|--------------------------|------|------|------|------|------|------|
| Int Delay, s/veh | 0.8 | | | | | |
| Movement | WBL | WBR | NBT | NBR | SBL | SBT |
| Lane Configurations | ↘ | ↗ | ↑ | ↗ | ↘ | ↑ |
| Traffic Vol, veh/h | 52 | 0 | 423 | 13 | 0 | 809 |
| Future Vol, veh/h | 52 | 0 | 423 | 13 | 0 | 809 |
| Conflicting Peds, #/hr | 0 | 0 | 0 | 0 | 0 | 0 |
| Sign Control | Stop | Stop | Free | Free | Free | Free |
| RT Channelized | - | None | - | None | - | None |
| Storage Length | 0 | 0 | - | 155 | 205 | - |
| Veh in Median Storage, # | 0 | - | 0 | - | - | 0 |
| Grade, % | 0 | - | 0 | - | - | 0 |
| Peak Hour Factor | 95 | 95 | 95 | 95 | 95 | 95 |
| Heavy Vehicles, % | 2 | 2 | 2 | 2 | 2 | 2 |
| Mvmt Flow | 55 | 0 | 445 | 14 | 0 | 852 |

| Major/Minor | Minor1 | Major1 | Major2 | | |
|----------------------|--------|--------|--------|---|-------|
| Conflicting Flow All | 1297 | 445 | 0 | 0 | 459 |
| Stage 1 | 445 | - | - | - | - |
| Stage 2 | 852 | - | - | - | - |
| Critical Hdwy | 6.42 | 6.22 | - | - | 4.12 |
| Critical Hdwy Stg 1 | 5.42 | - | - | - | - |
| Critical Hdwy Stg 2 | 5.42 | - | - | - | - |
| Follow-up Hdwy | 3.518 | 3.318 | - | - | 2.218 |
| Pot Cap-1 Maneuver | 179 | 613 | - | - | 1102 |
| Stage 1 | 646 | - | - | - | - |
| Stage 2 | 418 | - | - | - | - |
| Platoon blocked, % | | | - | - | - |
| Mov Cap-1 Maneuver | 179 | 613 | - | - | 1102 |
| Mov Cap-2 Maneuver | 308 | - | - | - | - |
| Stage 1 | 646 | - | - | - | - |
| Stage 2 | 418 | - | - | - | - |

| Approach | WB | NB | SB |
|----------------------|------|----|----|
| HCM Control Delay, s | 19.2 | 0 | 0 |
| HCM LOS | C | | |

| Minor Lane/Major Mvmt | NBT | NBRWBLn1WBLn2 | SBL | SBT |
|-----------------------|-----|---------------|--------|-----|
| Capacity (veh/h) | - | - 308 | - 1102 | - |
| HCM Lane V/C Ratio | - | - 0.178 | - | - |
| HCM Control Delay (s) | - | - 19.2 | 0 | 0 |
| HCM Lane LOS | - | - C | A | A |
| HCM 95th %tile Q(veh) | - | - 0.6 | - | 0 |

| Intersection | | | | | | |
|--------------------------|------|------|------|------|------|------|
| Int Delay, s/veh | 0.1 | | | | | |
| Movement | WBL | WBR | NBT | NBR | SBL | SBT |
| Lane Configurations | ↘ | ↗ | ↑ | ↗ | ↘ | ↑ |
| Traffic Vol, veh/h | 0 | 14 | 421 | 0 | 5 | 856 |
| Future Vol, veh/h | 0 | 14 | 421 | 0 | 5 | 856 |
| Conflicting Peds, #/hr | 0 | 0 | 0 | 0 | 0 | 0 |
| Sign Control | Stop | Stop | Free | Free | Free | Free |
| RT Channelized | - | None | - | None | - | None |
| Storage Length | 0 | 115 | - | 155 | 205 | - |
| Veh in Median Storage, # | 0 | - | 0 | - | - | 0 |
| Grade, % | 0 | - | 0 | - | - | 0 |
| Peak Hour Factor | 85 | 85 | 85 | 85 | 85 | 85 |
| Heavy Vehicles, % | 2 | 2 | 2 | 2 | 2 | 2 |
| Mvmt Flow | 0 | 16 | 495 | 0 | 6 | 1007 |

| Major/Minor | Minor1 | Major1 | Major2 | | |
|----------------------|--------|--------|--------|---|-------|
| Conflicting Flow All | 1514 | 495 | 0 | 0 | 495 |
| Stage 1 | 495 | - | - | - | - |
| Stage 2 | 1019 | - | - | - | - |
| Critical Hdwy | 6.42 | 6.22 | - | - | 4.12 |
| Critical Hdwy Stg 1 | 5.42 | - | - | - | - |
| Critical Hdwy Stg 2 | 5.42 | - | - | - | - |
| Follow-up Hdwy | 3.518 | 3.318 | - | - | 2.218 |
| Pot Cap-1 Maneuver | 132 | 575 | - | - | 1069 |
| Stage 1 | 613 | - | - | - | - |
| Stage 2 | 348 | - | - | - | - |
| Platoon blocked, % | | | - | - | - |
| Mov Cap-1 Maneuver | 131 | 575 | - | - | 1069 |
| Mov Cap-2 Maneuver | 255 | - | - | - | - |
| Stage 1 | 613 | - | - | - | - |
| Stage 2 | 346 | - | - | - | - |

| Approach | WB | NB | SB |
|----------------------|------|----|----|
| HCM Control Delay, s | 11.4 | 0 | 0 |
| HCM LOS | B | | |

| Minor Lane/Major Mvmt | NBT | NBRWBLn1 | WBLn2 | SBL | SBT |
|-----------------------|-----|----------|-------|-------|-------|
| Capacity (veh/h) | - | - | - | 575 | 1069 |
| HCM Lane V/C Ratio | - | - | - | 0.029 | 0.006 |
| HCM Control Delay (s) | - | - | 0 | 11.4 | 8.4 |
| HCM Lane LOS | - | - | A | B | A |
| HCM 95th %tile Q(veh) | - | - | - | 0.1 | 0 |

| Intersection | | | | | | |
|--------------------------|------|------|------|------|------|------|
| Int Delay, s/veh | 14.4 | | | | | |
| Movement | EBL | EBR | NBL | NBT | SBT | SBR |
| Lane Configurations | ↔ | ↔ | ↔ | ↑ | ↑ | ↔ |
| Traffic Vol, veh/h | 71 | 299 | 340 | 348 | 835 | 121 |
| Future Vol, veh/h | 71 | 299 | 340 | 348 | 835 | 121 |
| Conflicting Peds, #/hr | 0 | 0 | 0 | 0 | 0 | 0 |
| Sign Control | Stop | Stop | Free | Free | Free | Free |
| RT Channelized | - | None | - | None | - | None |
| Storage Length | 0 | 0 | 0 | - | - | 155 |
| Veh in Median Storage, # | 0 | - | - | 0 | 0 | - |
| Grade, % | 0 | - | - | 0 | 0 | - |
| Peak Hour Factor | 95 | 95 | 95 | 95 | 95 | 95 |
| Heavy Vehicles, % | 2 | 2 | 2 | 2 | 2 | 2 |
| Mvmt Flow | 75 | 315 | 358 | 366 | 879 | 127 |

| Major/Minor | Minor2 | Major1 | Major2 | | | |
|----------------------|--------|--------|--------|---|---|---|
| Conflicting Flow All | 1961 | 879 | 1006 | 0 | - | 0 |
| Stage 1 | 879 | - | - | - | - | - |
| Stage 2 | 1082 | - | - | - | - | - |
| Critical Hdwy | 6.42 | 6.22 | 4.12 | - | - | - |
| Critical Hdwy Stg 1 | 5.42 | - | - | - | - | - |
| Critical Hdwy Stg 2 | 5.42 | - | - | - | - | - |
| Follow-up Hdwy | 3.518 | 3.318 | 2.218 | - | - | - |
| Pot Cap-1 Maneuver | ~ 70 | 347 | 689 | - | - | - |
| Stage 1 | 406 | - | - | - | - | - |
| Stage 2 | 325 | - | - | - | - | - |
| Platoon blocked, % | | | | - | - | - |
| Mov Cap-1 Maneuver | ~ 34 | 347 | 689 | - | - | - |
| Mov Cap-2 Maneuver | 126 | - | - | - | - | - |
| Stage 1 | 195 | - | - | - | - | - |
| Stage 2 | 325 | - | - | - | - | - |

| Approach | EB | NB | SB |
|----------------------|------|-----|----|
| HCM Control Delay, s | 63.9 | 7.8 | 0 |
| HCM LOS | F | | |

| Minor Lane/Major Mvmt | NBL | NBT | EBLn1 | EBLn2 | SBT | SBR |
|-----------------------|-------|-----|-------|-------|-----|-----|
| Capacity (veh/h) | 689 | - | 126 | 347 | - | - |
| HCM Lane V/C Ratio | 0.519 | - | 0.593 | 0.907 | - | - |
| HCM Control Delay (s) | 15.7 | - | 68.5 | 62.8 | - | - |
| HCM Lane LOS | C | - | F | F | - | - |
| HCM 95th %tile Q(veh) | 3 | - | 3 | 9 | - | - |

Notes
 ~: Volume exceeds capacity \$: Delay exceeds 300s +: Computation Not Defined *: All major volume in platoon

Timings
13: Eastonville Rd & Stapleton Dr

2041 Background Traffic
AM Peak Hour

| Lane Group | EBL | EBT | EBR | WBL | WBT | WBR | NBL | NBT | NBR | SBL | SBT | SBR |
|----------------------|-------|-------|-------|-------|-------|-------|-------|-------|-------|-------|-------|-------|
| Lane Configurations | | | | | | | | | | | | |
| Traffic Volume (vph) | 150 | 600 | 224 | 145 | 482 | 145 | 108 | 393 | 188 | 132 | 661 | 342 |
| Future Volume (vph) | 150 | 600 | 224 | 145 | 482 | 145 | 108 | 393 | 188 | 132 | 661 | 342 |
| Turn Type | Prot | NA | Perm | pm+pt | NA | Perm | pm+pt | NA | Perm | pm+pt | NA | Perm |
| Protected Phases | 5 | 2 | | 1 | 6 | | 3 | 8 | | 7 | 4 | |
| Permitted Phases | | | 2 | 6 | | 6 | 8 | | 8 | 4 | | 4 |
| Detector Phase | 5 | 2 | 2 | 1 | 6 | 6 | 3 | 8 | 8 | 7 | 4 | 4 |
| Switch Phase | | | | | | | | | | | | |
| Minimum Initial (s) | 4.0 | 4.0 | 4.0 | 4.0 | 4.0 | 4.0 | 4.0 | 4.0 | 4.0 | 4.0 | 4.0 | 4.0 |
| Minimum Split (s) | 8.0 | 21.0 | 21.0 | 8.0 | 21.0 | 21.0 | 9.0 | 21.0 | 21.0 | 9.0 | 21.0 | 21.0 |
| Total Split (s) | 13.0 | 29.0 | 29.0 | 12.0 | 28.0 | 28.0 | 11.0 | 45.0 | 45.0 | 14.0 | 48.0 | 48.0 |
| Total Split (%) | 13.0% | 29.0% | 29.0% | 12.0% | 28.0% | 28.0% | 11.0% | 45.0% | 45.0% | 14.0% | 48.0% | 48.0% |
| Yellow Time (s) | 3.5 | 3.0 | 3.0 | 3.5 | 3.0 | 3.0 | 3.0 | 3.0 | 3.0 | 3.0 | 3.0 | 3.0 |
| All-Red Time (s) | 0.5 | 2.0 | 2.0 | 0.5 | 2.0 | 2.0 | 2.0 | 2.0 | 2.0 | 2.0 | 2.0 | 2.0 |
| Lost Time Adjust (s) | 0.0 | 0.0 | 0.0 | 0.0 | 0.0 | 0.0 | 0.0 | 0.0 | 0.0 | 0.0 | 0.0 | 0.0 |
| Total Lost Time (s) | 4.0 | 5.0 | 5.0 | 4.0 | 5.0 | 5.0 | 5.0 | 5.0 | 5.0 | 5.0 | 5.0 | 5.0 |
| Lead/Lag | Lead | Lag | Lag | Lead | Lag | Lag | Lead | Lag | Lag | Lead | Lag | Lag |
| Lead-Lag Optimize? | Yes | Yes | Yes | Yes | Yes | Yes | Yes | Yes | Yes | Yes | Yes | Yes |
| Recall Mode | None | None | None | None | None | None | None | None | None | None | None | None |
| Act Effct Green (s) | 8.6 | 21.7 | 21.7 | 30.3 | 21.2 | 21.2 | 40.1 | 33.9 | 33.9 | 45.9 | 39.3 | 39.3 |
| Actuated g/C Ratio | 0.09 | 0.24 | 0.24 | 0.33 | 0.23 | 0.23 | 0.44 | 0.37 | 0.37 | 0.50 | 0.43 | 0.43 |
| v/c Ratio | 0.49 | 0.76 | 0.43 | 0.61 | 0.62 | 0.32 | 0.56 | 0.60 | 0.28 | 0.35 | 0.87 | 0.42 |
| Control Delay | 47.9 | 40.2 | 6.9 | 34.0 | 36.8 | 7.4 | 24.0 | 27.4 | 4.0 | 14.0 | 38.4 | 5.0 |
| Queue Delay | 0.0 | 0.0 | 0.0 | 0.0 | 0.0 | 0.0 | 0.0 | 0.0 | 0.0 | 0.0 | 0.0 | 0.0 |
| Total Delay | 47.9 | 40.2 | 6.9 | 34.0 | 36.8 | 7.4 | 24.0 | 27.4 | 4.0 | 14.0 | 38.4 | 5.0 |
| LOS | D | D | A | C | D | A | C | C | A | B | D | A |
| Approach Delay | | 33.7 | | | 30.7 | | | 20.5 | | | 25.5 | |
| Approach LOS | | C | | | C | | | C | | | C | |

Intersection Summary





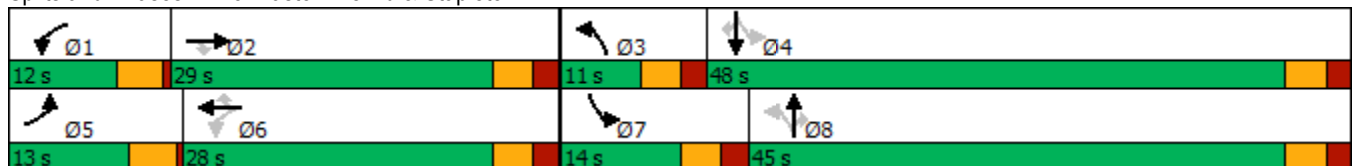



















Cycle Length: 100
 Actuated Cycle Length: 91.7
 Natural Cycle: 70
 Control Type: Actuated-Uncoordinated
 Maximum v/c Ratio: 0.87
 Intersection Signal Delay: 27.9
 Intersection LOS: C
 Intersection Capacity Utilization 81.2%
 ICU Level of Service D
 Analysis Period (min) 15

Splits and Phases: 13: Eastonville Rd & Stapleton Dr



Timings
14: US 24 & Stapleton Dr

2041 Background Traffic
AM Peak Hour

| |  |  |  |  |  |  |  |  |  |  |  |  |
|----------------------|---|---|---|---|---|---|---|---|---|---|---|---|
| Lane Group | EBL | EBT | EBR | WBL | WBT | WBR | NBL | NBT | NBR | SBL | SBT | SBR |
| Lane Configurations |  |  |  |  |  |  |  |  |  |  |  |  |
| Traffic Volume (vph) | 188 | 364 | 523 | 75 | 370 | 114 | 275 | 705 | 50 | 260 | 1381 | 352 |
| Future Volume (vph) | 188 | 364 | 523 | 75 | 370 | 114 | 275 | 705 | 50 | 260 | 1381 | 352 |
| Turn Type | Prot | NA | Free | Prot | NA | Free | Prot | NA | Perm | Prot | NA | Free |
| Protected Phases | 7 | 4 | | 3 | 8 | | 5 | 2 | | 1 | 6 | |
| Permitted Phases | | | Free | | | Free | | | 2 | | | Free |
| Detector Phase | 7 | 4 | | 3 | 8 | | 5 | 2 | 2 | 1 | 6 | |
| Switch Phase | | | | | | | | | | | | |
| Minimum Initial (s) | 5.0 | 5.0 | | 5.0 | 5.0 | | 5.0 | 5.0 | 5.0 | 5.0 | 5.0 | |
| Minimum Split (s) | 10.0 | 10.0 | | 10.0 | 10.0 | | 10.0 | 11.0 | 11.0 | 10.0 | 11.0 | |
| Total Split (s) | 15.0 | 30.0 | | 18.0 | 33.0 | | 12.0 | 60.0 | 60.0 | 12.0 | 60.0 | |
| Total Split (%) | 12.5% | 25.0% | | 15.0% | 27.5% | | 10.0% | 50.0% | 50.0% | 10.0% | 50.0% | |
| Yellow Time (s) | 3.0 | 3.0 | | 3.0 | 3.0 | | 3.0 | 3.0 | 3.0 | 3.0 | 3.0 | |
| All-Red Time (s) | 2.0 | 2.0 | | 2.0 | 2.0 | | 2.0 | 2.0 | 2.0 | 2.0 | 2.0 | |
| Lost Time Adjust (s) | 0.0 | 0.0 | | 0.0 | 0.0 | | 0.0 | 0.0 | 0.0 | 0.0 | 0.0 | |
| Total Lost Time (s) | 5.0 | 5.0 | | 5.0 | 5.0 | | 5.0 | 5.0 | 5.0 | 5.0 | 5.0 | |
| Lead/Lag | Lead | Lag | | Lead | Lag | | Lead | Lag | Lag | Lead | Lag | |
| Lead-Lag Optimize? | Yes | Yes | | Yes | Yes | | Yes | Yes | Yes | Yes | Yes | |
| Recall Mode | None | None | | None | None | | None | C-Max | C-Max | None | C-Max | |
| Act Effct Green (s) | 9.8 | 22.5 | 120.0 | 8.1 | 18.6 | 120.0 | 16.6 | 55.0 | 55.0 | 16.6 | 55.0 | 120.0 |
| Actuated g/C Ratio | 0.08 | 0.19 | 1.00 | 0.07 | 0.16 | 1.00 | 0.14 | 0.46 | 0.46 | 0.14 | 0.46 | 1.00 |
| v/c Ratio | 0.71 | 0.58 | 0.35 | 0.34 | 0.71 | 0.08 | 0.61 | 0.46 | 0.07 | 0.58 | 0.87 | 0.23 |
| Control Delay | 68.1 | 48.7 | 0.6 | 56.9 | 55.2 | 0.1 | 55.8 | 23.4 | 0.2 | 61.8 | 31.5 | 0.3 |
| Queue Delay | 0.0 | 0.0 | 0.0 | 0.0 | 0.0 | 0.0 | 0.0 | 0.0 | 0.0 | 0.0 | 0.0 | 0.0 |
| Total Delay | 68.1 | 48.7 | 0.6 | 56.9 | 55.2 | 0.1 | 55.8 | 23.4 | 0.2 | 61.8 | 31.5 | 0.3 |
| LOS | E | D | A | E | E | A | E | C | A | E | C | A |
| Approach Delay | | 28.7 | | | 44.2 | | | 30.9 | | | 29.9 | |
| Approach LOS | | C | | | D | | | C | | | C | |

Intersection Summary

Cycle Length: 120
 Actuated Cycle Length: 120
 Offset: 0 (0%), Referenced to phase 2:NBT and 6:SBT, Start of Green
 Natural Cycle: 70
 Control Type: Actuated-Coordinated
 Maximum v/c Ratio: 0.87
 Intersection Signal Delay: 31.6
 Intersection LOS: C
 Intersection Capacity Utilization 78.3%
 ICU Level of Service D
 Analysis Period (min) 15

Splits and Phases: 14: US 24 & Stapleton Dr

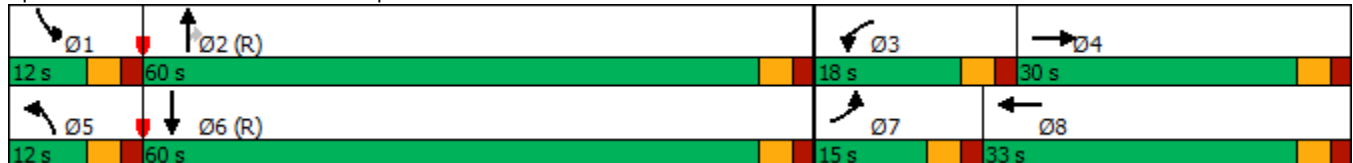

| Intersection | | | | |
|-----------------------------|-------|-------|-------|-------|
| Intersection Delay, s/veh | 11.4 | | | |
| Intersection LOS | B | | | |
| Approach | EB | WB | NB | SB |
| Entry Lanes | 1 | 1 | 1 | 1 |
| Conflicting Circle Lanes | 1 | 1 | 1 | 1 |
| Adj Approach Flow, veh/h | 345 | 645 | 444 | 308 |
| Demand Flow Rate, veh/h | 351 | 658 | 453 | 314 |
| Vehicles Circulating, veh/h | 731 | 231 | 217 | 731 |
| Vehicles Exiting, veh/h | 313 | 439 | 865 | 158 |
| Ped Vol Crossing Leg, #/h | 0 | 0 | 0 | 0 |
| Ped Cap Adj | 1.000 | 1.000 | 1.000 | 1.000 |
| Approach Delay, s/veh | 14.6 | 11.4 | 7.7 | 13.1 |
| Approach LOS | B | B | A | B |
| Lane | Left | Left | Left | Left |
| Designated Moves | LTR | LTR | LTR | LTR |
| Assumed Moves | LTR | LTR | LTR | LTR |
| RT Channelized | | | | |
| Lane Util | 1.000 | 1.000 | 1.000 | 1.000 |
| Follow-Up Headway, s | 2.609 | 2.609 | 2.609 | 2.609 |
| Critical Headway, s | 4.976 | 4.976 | 4.976 | 4.976 |
| Entry Flow, veh/h | 351 | 658 | 453 | 314 |
| Cap Entry Lane, veh/h | 655 | 1090 | 1106 | 655 |
| Entry HV Adj Factor | 0.982 | 0.980 | 0.980 | 0.980 |
| Flow Entry, veh/h | 345 | 645 | 444 | 308 |
| Cap Entry, veh/h | 643 | 1069 | 1084 | 641 |
| V/C Ratio | 0.536 | 0.604 | 0.410 | 0.480 |
| Control Delay, s/veh | 14.6 | 11.4 | 7.7 | 13.1 |
| LOS | B | B | A | B |
| 95th %tile Queue, veh | 3 | 4 | 2 | 3 |

| Intersection | | | |
|-----------------------------|-------|-------|-------|
| Intersection Delay, s/veh | 6.7 | | |
| Intersection LOS | A | | |
| Approach | EB | WB | NB |
| Entry Lanes | 1 | 1 | 1 |
| Conflicting Circle Lanes | 1 | 1 | 1 |
| Adj Approach Flow, veh/h | 431 | 650 | 72 |
| Demand Flow Rate, veh/h | 439 | 663 | 73 |
| Vehicles Circulating, veh/h | 19 | 16 | 428 |
| Vehicles Exiting, veh/h | 660 | 485 | 30 |
| Ped Vol Crossing Leg, #/h | 0 | 0 | 0 |
| Ped Cap Adj | 1.000 | 1.000 | 1.000 |
| Approach Delay, s/veh | 5.6 | 7.7 | 4.9 |
| Approach LOS | A | A | A |
| Lane | Left | Left | Left |
| Designated Moves | TR | LT | LR |
| Assumed Moves | TR | LT | LR |
| RT Channelized | | | |
| Lane Util | 1.000 | 1.000 | 1.000 |
| Follow-Up Headway, s | 2.609 | 2.609 | 2.609 |
| Critical Headway, s | 4.976 | 4.976 | 4.976 |
| Entry Flow, veh/h | 439 | 663 | 73 |
| Cap Entry Lane, veh/h | 1353 | 1358 | 892 |
| Entry HV Adj Factor | 0.981 | 0.981 | 0.986 |
| Flow Entry, veh/h | 431 | 650 | 72 |
| Cap Entry, veh/h | 1327 | 1332 | 880 |
| V/C Ratio | 0.324 | 0.488 | 0.082 |
| Control Delay, s/veh | 5.6 | 7.7 | 4.9 |
| LOS | A | A | A |
| 95th %tile Queue, veh | 1 | 3 | 0 |

| Intersection | | | |
|-----------------------------|-------|-------|-------|
| Intersection Delay, s/veh | 8.7 | | |
| Intersection LOS | A | | |
| Approach | WB | NB | SB |
| Entry Lanes | 1 | 1 | 1 |
| Conflicting Circle Lanes | 2 | 2 | 2 |
| Adj Approach Flow, veh/h | 55 | 459 | 852 |
| Demand Flow Rate, veh/h | 56 | 468 | 869 |
| Vehicles Circulating, veh/h | 454 | 0 | 56 |
| Vehicles Exiting, veh/h | 14 | 925 | 454 |
| Ped Vol Crossing Leg, #/h | 0 | 0 | 0 |
| Ped Cap Adj | 1.000 | 1.000 | 1.000 |
| Approach Delay, s/veh | 4.3 | 5.5 | 10.6 |
| Approach LOS | A | A | B |
| Lane | Left | Left | Left |
| Designated Moves | LR | TR | LT |
| Assumed Moves | LR | TR | LT |
| RT Channelized | | | |
| Lane Util | 1.000 | 1.000 | 1.000 |
| Follow-Up Headway, s | 2.535 | 2.535 | 2.535 |
| Critical Headway, s | 4.328 | 4.328 | 4.328 |
| Entry Flow, veh/h | 56 | 468 | 869 |
| Cap Entry Lane, veh/h | 965 | 1420 | 1354 |
| Entry HV Adj Factor | 0.982 | 0.981 | 0.980 |
| Flow Entry, veh/h | 55 | 459 | 852 |
| Cap Entry, veh/h | 948 | 1393 | 1328 |
| V/C Ratio | 0.058 | 0.330 | 0.642 |
| Control Delay, s/veh | 4.3 | 5.5 | 10.6 |
| LOS | A | A | B |
| 95th %tile Queue, veh | 0 | 1 | 5 |

| Intersection | | | |
|-----------------------------|-------|-------|-------|
| Intersection Delay, s/veh | 11.2 | | |
| Intersection LOS | B | | |
| Approach | WB | NB | SB |
| Entry Lanes | 1 | 1 | 1 |
| Conflicting Circle Lanes | 1 | 1 | 1 |
| Adj Approach Flow, veh/h | 16 | 495 | 1013 |
| Demand Flow Rate, veh/h | 16 | 505 | 1033 |
| Vehicles Circulating, veh/h | 505 | 6 | 0 |
| Vehicles Exiting, veh/h | 6 | 1027 | 521 |
| Ped Vol Crossing Leg, #/h | 0 | 0 | 0 |
| Ped Cap Adj | 1.000 | 1.000 | 1.000 |
| Approach Delay, s/veh | 4.6 | 6.1 | 13.8 |
| Approach LOS | A | A | B |
| Lane | Left | Left | Left |
| Designated Moves | LR | TR | LT |
| Assumed Moves | LR | TR | LT |
| RT Channelized | | | |
| Lane Util | 1.000 | 1.000 | 1.000 |
| Follow-Up Headway, s | 2.609 | 2.609 | 2.609 |
| Critical Headway, s | 4.976 | 4.976 | 4.976 |
| Entry Flow, veh/h | 16 | 505 | 1033 |
| Cap Entry Lane, veh/h | 824 | 1371 | 1380 |
| Entry HV Adj Factor | 1.000 | 0.980 | 0.981 |
| Flow Entry, veh/h | 16 | 495 | 1013 |
| Cap Entry, veh/h | 824 | 1345 | 1353 |
| V/C Ratio | 0.019 | 0.368 | 0.749 |
| Control Delay, s/veh | 4.6 | 6.1 | 13.8 |
| LOS | A | A | B |
| 95th %tile Queue, veh | 0 | 2 | 8 |

| Intersection | | | | | | |
|-----------------------------|-------|-------|-------|-------|-------|-------|
| Intersection Delay, s/veh | 8.8 | | | | | |
| Intersection LOS | A | | | | | |
| Approach | EB | | NB | | SB | |
| Entry Lanes | 2 | | 2 | | 2 | |
| Conflicting Circle Lanes | 2 | | 2 | | 2 | |
| Adj Approach Flow, veh/h | 390 | | 724 | | 1006 | |
| Demand Flow Rate, veh/h | 397 | | 738 | | 1027 | |
| Vehicles Circulating, veh/h | 897 | | 76 | | 365 | |
| Vehicles Exiting, veh/h | 495 | | 1218 | | 449 | |
| Ped Vol Crossing Leg, #/h | 0 | | 0 | | 0 | |
| Ped Cap Adj | 1.000 | | 1.000 | | 1.000 | |
| Approach Delay, s/veh | 12.0 | | 5.4 | | 10.0 | |
| Approach LOS | B | | A | | A | |
| Lane | Left | Right | Left | Right | Left | Right |
| Designated Moves | L | TR | L | TR | LT | TR |
| Assumed Moves | L | TR | L | TR | LT | TR |
| RT Channelized | | | | | | |
| Lane Util | 0.191 | 0.809 | 0.495 | 0.505 | 0.470 | 0.530 |
| Follow-Up Headway, s | 2.667 | 2.535 | 2.667 | 2.535 | 2.667 | 2.535 |
| Critical Headway, s | 4.645 | 4.328 | 4.645 | 4.328 | 4.645 | 4.328 |
| Entry Flow, veh/h | 76 | 321 | 365 | 373 | 483 | 544 |
| Cap Entry Lane, veh/h | 591 | 662 | 1259 | 1331 | 965 | 1041 |
| Entry HV Adj Factor | 0.987 | 0.981 | 0.981 | 0.980 | 0.979 | 0.981 |
| Flow Entry, veh/h | 75 | 315 | 358 | 366 | 473 | 533 |
| Cap Entry, veh/h | 584 | 650 | 1235 | 1305 | 945 | 1021 |
| V/C Ratio | 0.128 | 0.485 | 0.290 | 0.280 | 0.501 | 0.522 |
| Control Delay, s/veh | 7.7 | 13.1 | 5.6 | 5.2 | 10.1 | 9.9 |
| LOS | A | B | A | A | B | A |
| 95th %tile Queue, veh | 0 | 3 | 1 | 1 | 3 | 3 |

Timings
1: Eastonville Rd & Rex Rd

2041 Background Traffic
AM Peak Hour

| Lane Group | EBL | EBT | EBR | WBL | WBT | WBR | NBL | NBT | NBR | SBL | SBT | SBR |
|----------------------|-------|-------|-------|-------|-------|-------|-------|-------|-------|-------|-------|-------|
| Lane Configurations | | | | | | | | | | | | |
| Traffic Volume (vph) | 23 | 157 | 148 | 448 | 140 | 25 | 93 | 100 | 229 | 24 | 210 | 59 |
| Future Volume (vph) | 23 | 157 | 148 | 448 | 140 | 25 | 93 | 100 | 229 | 24 | 210 | 59 |
| Turn Type | pm+pt | NA | Perm | pm+pt | NA | Perm | pm+pt | NA | Perm | pm+pt | NA | Perm |
| Protected Phases | 5 | 2 | | 1 | 6 | | 3 | 8 | | 7 | 4 | |
| Permitted Phases | 2 | | 2 | 6 | | 6 | 8 | | 8 | 4 | | 4 |
| Detector Phase | 5 | 2 | 2 | 1 | 6 | 6 | 3 | 8 | 8 | 7 | 4 | 4 |
| Switch Phase | | | | | | | | | | | | |
| Minimum Initial (s) | 5.0 | 5.0 | 5.0 | 5.0 | 5.0 | 5.0 | 5.0 | 5.0 | 5.0 | 5.0 | 5.0 | 5.0 |
| Minimum Split (s) | 10.0 | 20.0 | 20.0 | 10.0 | 20.0 | 20.0 | 10.0 | 20.0 | 20.0 | 10.0 | 20.0 | 20.0 |
| Total Split (s) | 10.0 | 38.0 | 38.0 | 20.0 | 48.0 | 48.0 | 12.0 | 30.0 | 30.0 | 12.0 | 30.0 | 30.0 |
| Total Split (%) | 10.0% | 38.0% | 38.0% | 20.0% | 48.0% | 48.0% | 12.0% | 30.0% | 30.0% | 12.0% | 30.0% | 30.0% |
| Yellow Time (s) | 3.0 | 3.0 | 3.0 | 3.0 | 3.0 | 3.0 | 3.0 | 3.0 | 3.0 | 3.0 | 3.0 | 3.0 |
| All-Red Time (s) | 2.0 | 2.0 | 2.0 | 2.0 | 2.0 | 2.0 | 2.0 | 2.0 | 2.0 | 2.0 | 2.0 | 2.0 |
| Lost Time Adjust (s) | 0.0 | 0.0 | 0.0 | 0.0 | 0.0 | 0.0 | 0.0 | 0.0 | 0.0 | 0.0 | 0.0 | 0.0 |
| Total Lost Time (s) | 5.0 | 5.0 | 5.0 | 5.0 | 5.0 | 5.0 | 5.0 | 5.0 | 5.0 | 5.0 | 5.0 | 5.0 |
| Lead/Lag | Lead | Lag | Lag | Lead | Lag | Lag | Lead | Lag | Lag | Lead | Lag | Lag |
| Lead-Lag Optimize? | Yes | Yes | Yes | Yes | Yes | Yes | Yes | Yes | Yes | Yes | Yes | Yes |
| Recall Mode | None | Min | Min | None | Min | Min | None | None | None | None | None | None |
| Act Effct Green (s) | 16.9 | 11.6 | 11.6 | 31.0 | 27.6 | 27.6 | 20.4 | 18.0 | 18.0 | 17.8 | 13.2 | 13.2 |
| Actuated g/C Ratio | 0.27 | 0.18 | 0.18 | 0.49 | 0.43 | 0.43 | 0.32 | 0.28 | 0.28 | 0.28 | 0.21 | 0.21 |
| v/c Ratio | 0.06 | 0.49 | 0.36 | 0.75 | 0.18 | 0.03 | 0.27 | 0.20 | 0.39 | 0.06 | 0.57 | 0.13 |
| Control Delay | 12.4 | 31.0 | 5.5 | 22.9 | 15.9 | 0.1 | 16.6 | 21.5 | 5.9 | 14.5 | 31.2 | 0.6 |
| Queue Delay | 0.0 | 0.0 | 0.0 | 0.0 | 0.0 | 0.0 | 0.0 | 0.0 | 0.0 | 0.0 | 0.0 | 0.0 |
| Total Delay | 12.4 | 31.0 | 5.5 | 22.9 | 15.9 | 0.1 | 16.6 | 21.5 | 5.9 | 14.5 | 31.2 | 0.6 |
| LOS | B | C | A | C | B | A | B | C | A | B | C | A |
| Approach Delay | | 18.2 | | | 20.4 | | | 11.9 | | | 23.7 | |
| Approach LOS | | B | | | C | | | B | | | C | |

Intersection Summary

Cycle Length: 100
 Actuated Cycle Length: 63.6
 Natural Cycle: 65
 Control Type: Actuated-Uncoordinated
 Maximum v/c Ratio: 0.75
 Intersection Signal Delay: 18.4
 Intersection LOS: B
 Intersection Capacity Utilization 66.0%
 ICU Level of Service C
 Analysis Period (min) 15

Splits and Phases: 1: Eastonville Rd & Rex Rd

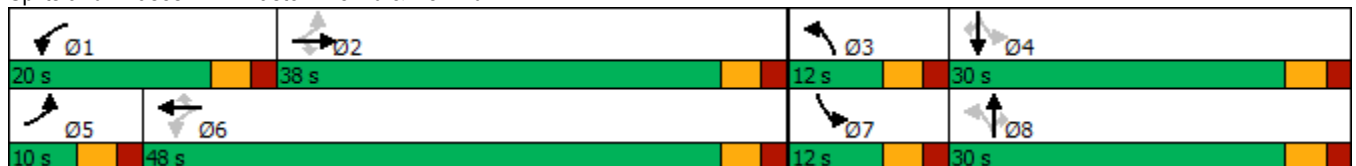

Timings
12: Eastonville Rd & Londonderry Dr

2041 Background Traffic
AM Peak Hour



| Lane Group | EBL | EBR | NBL | NBT | SBT | SBR |
|----------------------|-------|-------|-------|-------|-------|-------|
| Lane Configurations | | | | | | |
| Traffic Volume (vph) | 71 | 299 | 340 | 348 | 835 | 121 |
| Future Volume (vph) | 71 | 299 | 340 | 348 | 835 | 121 |
| Turn Type | Prot | Perm | pm+pt | NA | NA | Perm |
| Protected Phases | 4 | | 5 | 2 | 6 | |
| Permitted Phases | | 4 | 2 | | | 6 |
| Detector Phase | 4 | 4 | 5 | 2 | 6 | 6 |
| Switch Phase | | | | | | |
| Minimum Initial (s) | 4.0 | 4.0 | 4.0 | 4.0 | 4.0 | 4.0 |
| Minimum Split (s) | 21.0 | 21.0 | 9.0 | 21.0 | 21.0 | 21.0 |
| Total Split (s) | 25.0 | 25.0 | 20.0 | 75.0 | 55.0 | 55.0 |
| Total Split (%) | 25.0% | 25.0% | 20.0% | 75.0% | 55.0% | 55.0% |
| Yellow Time (s) | 3.0 | 3.0 | 3.0 | 3.0 | 3.0 | 3.0 |
| All-Red Time (s) | 2.0 | 2.0 | 2.0 | 2.0 | 2.0 | 2.0 |
| Lost Time Adjust (s) | 0.0 | 0.0 | -1.0 | 0.0 | -2.0 | 0.0 |
| Total Lost Time (s) | 5.0 | 5.0 | 4.0 | 5.0 | 3.0 | 5.0 |
| Lead/Lag | | | Lead | | Lag | Lag |
| Lead-Lag Optimize? | | | Yes | | Yes | Yes |
| Recall Mode | None | None | None | Max | Max | Max |
| Act Effct Green (s) | 9.6 | 9.6 | 71.1 | 70.1 | 52.1 | 50.1 |
| Actuated g/C Ratio | 0.11 | 0.11 | 0.79 | 0.78 | 0.58 | 0.56 |
| v/c Ratio | 0.40 | 0.70 | 0.81 | 0.25 | 0.81 | 0.14 |
| Control Delay | 43.3 | 13.5 | 32.7 | 3.5 | 23.5 | 5.3 |
| Queue Delay | 0.0 | 0.0 | 0.0 | 0.0 | 0.0 | 0.0 |
| Total Delay | 43.3 | 13.5 | 32.7 | 3.5 | 23.5 | 5.3 |
| LOS | D | B | C | A | C | A |
| Approach Delay | 19.2 | | | 17.9 | 21.2 | |
| Approach LOS | B | | | B | C | |

Intersection Summary

Cycle Length: 100
 Actuated Cycle Length: 89.7
 Natural Cycle: 90
 Control Type: Semi Act-Uncoord
 Maximum v/c Ratio: 0.81
 Intersection Signal Delay: 19.7
 Intersection Capacity Utilization 77.6%
 Analysis Period (min) 15
 Intersection LOS: B
 ICU Level of Service D

Splits and Phases: 12: Eastonville Rd & Londonderry Dr



| Intersection | | | | | | | | | | | | |
|--------------------------|------|------|------|------|------|------|------|------|------|------|------|------|
| Int Delay, s/veh | 19.2 | | | | | | | | | | | |
| Movement | EBL | EBT | EBR | WBL | WBT | WBR | NBL | NBT | NBR | SBL | SBT | SBR |
| Lane Configurations | ↖ | ↗ | ↖ | ↖ | ↗ | ↖ | ↖ | ↗ | ↖ | ↖ | ↗ | ↖ |
| Traffic Vol, veh/h | 77 | 195 | 67 | 267 | 195 | 21 | 75 | 246 | 432 | 25 | 163 | 48 |
| Future Vol, veh/h | 77 | 195 | 67 | 267 | 195 | 21 | 75 | 246 | 432 | 25 | 163 | 48 |
| Conflicting Peds, #/hr | 0 | 0 | 0 | 0 | 0 | 0 | 0 | 0 | 0 | 0 | 0 | 0 |
| Sign Control | Stop | Stop | Stop | Stop | Stop | Stop | Free | Free | Free | Free | Free | Free |
| RT Channelized | - | - | None | - | - | None | - | - | None | - | - | None |
| Storage Length | 205 | - | 155 | 350 | - | 155 | 315 | - | 155 | 205 | - | 155 |
| Veh in Median Storage, # | - | 0 | - | - | 0 | - | - | 0 | - | - | 0 | - |
| Grade, % | - | 0 | - | - | 0 | - | - | 0 | - | - | 0 | - |
| Peak Hour Factor | 95 | 95 | 95 | 95 | 95 | 95 | 95 | 95 | 95 | 95 | 95 | 95 |
| Heavy Vehicles, % | 2 | 2 | 2 | 2 | 2 | 2 | 2 | 2 | 2 | 2 | 2 | 2 |
| Mvmt Flow | 81 | 205 | 71 | 281 | 205 | 22 | 79 | 259 | 455 | 26 | 172 | 51 |

| Major/Minor | Minor2 | | Minor1 | | Major1 | | Major2 | | | | | |
|----------------------|--------|-------|--------|-------|--------|-------|--------|---|---|-------|---|---|
| Conflicting Flow All | 982 | 1096 | 172 | 805 | 692 | 259 | 223 | 0 | 0 | 714 | 0 | 0 |
| Stage 1 | 224 | 224 | - | 417 | 417 | - | - | - | - | - | - | - |
| Stage 2 | 758 | 872 | - | 388 | 275 | - | - | - | - | - | - | - |
| Critical Hdwy | 7.12 | 6.52 | 6.22 | 7.12 | 6.52 | 6.22 | 4.12 | - | - | 4.12 | - | - |
| Critical Hdwy Stg 1 | 6.12 | 5.52 | - | 6.12 | 5.52 | - | - | - | - | - | - | - |
| Critical Hdwy Stg 2 | 6.12 | 5.52 | - | 6.12 | 5.52 | - | - | - | - | - | - | - |
| Follow-up Hdwy | 3.518 | 4.018 | 3.318 | 3.518 | 4.018 | 3.318 | 2.218 | - | - | 2.218 | - | - |
| Pot Cap-1 Maneuver | 228 | 213 | 872 | 301 | 367 | 780 | 1346 | - | - | 886 | - | - |
| Stage 1 | 779 | 718 | - | 613 | 591 | - | - | - | - | - | - | - |
| Stage 2 | 399 | 368 | - | 636 | 683 | - | - | - | - | - | - | - |
| Platoon blocked, % | | | | | | | | - | - | - | - | - |
| Mov Cap-1 Maneuver | 107 | ~ 195 | 872 | - | 335 | 780 | 1346 | - | - | 886 | - | - |
| Mov Cap-2 Maneuver | 107 | ~ 195 | - | - | 335 | - | - | - | - | - | - | - |
| Stage 1 | 733 | 697 | - | 577 | 556 | - | - | - | - | - | - | - |
| Stage 2 | 230 | 346 | - | 400 | 663 | - | - | - | - | - | - | - |

| Approach | EB | WB | NB | SB |
|----------------------|-------|----|-----|----|
| HCM Control Delay, s | 100.1 | | 0.8 | 1 |
| HCM LOS | F | - | | |

| Minor Lane/Major Mvmt | NBL | NBT | NBR | EBLn1 | EBLn2 | EBLn3 | WBLn1 | WBLn2 | WBLn3 | SBL | SBT | SBR |
|-----------------------|-------|-----|-----|-------|-------|-------|-------|-------|-------|------|-----|-----|
| Capacity (veh/h) | 1346 | - | - | 107 | 195 | 872 | - | 335 | 780 | 886 | - | - |
| HCM Lane V/C Ratio | 0.059 | - | - | 0.758 | 1.053 | 0.081 | - | 0.613 | 0.028 | 0.03 | - | - |
| HCM Control Delay (s) | 7.8 | - | - | 104.3 | 129.6 | 9.5 | - | 31.4 | 9.8 | 9.2 | - | - |
| HCM Lane LOS | A | - | - | F | F | A | - | D | A | A | - | - |
| HCM 95th %tile Q(veh) | 0.2 | - | - | 4.1 | 9.4 | 0.3 | - | 3.8 | 0.1 | 0.1 | - | - |

Notes
 ~: Volume exceeds capacity \$: Delay exceeds 300s +: Computation Not Defined *: All major volume in platoon

| Intersection | | | | | | |
|--------------------------|------|------|------|------|------|------|
| Int Delay, s/veh | 0.9 | | | | | |
| Movement | EBT | EBR | WBL | WBT | NBL | NBR |
| Lane Configurations | ↔ | | ↔ | ↑ | ↔ | ↔ |
| Traffic Vol, veh/h | 621 | 31 | 55 | 473 | 9 | 32 |
| Future Vol, veh/h | 621 | 31 | 55 | 473 | 9 | 32 |
| Conflicting Peds, #/hr | 0 | 0 | 0 | 0 | 0 | 0 |
| Sign Control | Free | Free | Free | Free | Stop | Stop |
| RT Channelized | - | None | - | None | - | None |
| Storage Length | - | - | 155 | - | 205 | 0 |
| Veh in Median Storage, # | 0 | - | - | 0 | 0 | - |
| Grade, % | 0 | - | - | 0 | 0 | - |
| Peak Hour Factor | 92 | 92 | 92 | 92 | 92 | 92 |
| Heavy Vehicles, % | 2 | 2 | 2 | 2 | 2 | 2 |
| Mvmt Flow | 675 | 34 | 60 | 514 | 10 | 35 |

| Major/Minor | Major1 | Major2 | Minor1 | | |
|----------------------|--------|--------|--------|---|-------------|
| Conflicting Flow All | 0 | 0 | 709 | 0 | 1326 692 |
| Stage 1 | - | - | - | - | 692 - |
| Stage 2 | - | - | - | - | 634 - |
| Critical Hdwy | - | - | 4.12 | - | 6.42 6.22 |
| Critical Hdwy Stg 1 | - | - | - | - | 5.42 - |
| Critical Hdwy Stg 2 | - | - | - | - | 5.42 - |
| Follow-up Hdwy | - | - | 2.218 | - | 3.518 3.318 |
| Pot Cap-1 Maneuver | - | - | 890 | - | 172 444 |
| Stage 1 | - | - | - | - | 497 - |
| Stage 2 | - | - | - | - | 529 - |
| Platoon blocked, % | - | - | - | - | - |
| Mov Cap-1 Maneuver | - | - | 890 | - | 160 444 |
| Mov Cap-2 Maneuver | - | - | - | - | 299 - |
| Stage 1 | - | - | - | - | 497 - |
| Stage 2 | - | - | - | - | 494 - |

| Approach | EB | WB | NB |
|----------------------|----|----|------|
| HCM Control Delay, s | 0 | 1 | 14.6 |
| HCM LOS | | | B |

| Minor Lane/Major Mvmt | NBLn1 | NBLn2 | EBT | EBR | WBL | WBT |
|-----------------------|-------|-------|-----|-----|-------|-----|
| Capacity (veh/h) | 299 | 444 | - | - | 890 | - |
| HCM Lane V/C Ratio | 0.033 | 0.078 | - | - | 0.067 | - |
| HCM Control Delay (s) | 17.4 | 13.8 | - | - | 9.3 | - |
| HCM Lane LOS | C | B | - | - | A | - |
| HCM 95th %tile Q(veh) | 0.1 | 0.3 | - | - | 0.2 | - |

| Intersection | | | | | | |
|--------------------------|------|------|------|------|------|------|
| Int Delay, s/veh | 0.3 | | | | | |
| Movement | EBL | EBT | WBT | WBR | SBL | SBR |
| Lane Configurations | | | | | | |
| Traffic Vol, veh/h | 6 | 647 | 525 | 21 | 12 | 3 |
| Future Vol, veh/h | 6 | 647 | 525 | 21 | 12 | 3 |
| Conflicting Peds, #/hr | 0 | 0 | 0 | 0 | 0 | 0 |
| Sign Control | Free | Free | Free | Free | Stop | Stop |
| RT Channelized | - | None | - | None | - | None |
| Storage Length | 155 | - | - | - | 0 | - |
| Veh in Median Storage, # | - | 0 | 0 | - | 0 | - |
| Grade, % | - | 0 | 0 | - | 0 | - |
| Peak Hour Factor | 92 | 92 | 92 | 92 | 92 | 92 |
| Heavy Vehicles, % | 2 | 2 | 2 | 2 | 2 | 2 |
| Mvmt Flow | 7 | 703 | 571 | 23 | 13 | 3 |

| Major/Minor | Major1 | Major2 | Minor2 | | |
|----------------------|--------|--------|--------|---|-------------|
| Conflicting Flow All | 594 | 0 | - | 0 | 1300 583 |
| Stage 1 | - | - | - | - | 583 - |
| Stage 2 | - | - | - | - | 717 - |
| Critical Hdwy | 4.12 | - | - | - | 6.42 6.22 |
| Critical Hdwy Stg 1 | - | - | - | - | 5.42 - |
| Critical Hdwy Stg 2 | - | - | - | - | 5.42 - |
| Follow-up Hdwy | 2.218 | - | - | - | 3.518 3.318 |
| Pot Cap-1 Maneuver | 982 | - | - | - | 178 512 |
| Stage 1 | - | - | - | - | 558 - |
| Stage 2 | - | - | - | - | 484 - |
| Platoon blocked, % | | - | - | - | |
| Mov Cap-1 Maneuver | 982 | - | - | - | 177 512 |
| Mov Cap-2 Maneuver | - | - | - | - | 316 - |
| Stage 1 | - | - | - | - | 554 - |
| Stage 2 | - | - | - | - | 484 - |

| Approach | EB | WB | SB |
|----------------------|-----|----|------|
| HCM Control Delay, s | 0.1 | 0 | 16.1 |
| HCM LOS | | | C |

| Minor Lane/Major Mvmt | EBL | EBT | WBT | WBR | SBLn1 |
|-----------------------|-------|-----|-----|-----|-------|
| Capacity (veh/h) | 982 | - | - | - | 342 |
| HCM Lane V/C Ratio | 0.007 | - | - | - | 0.048 |
| HCM Control Delay (s) | 8.7 | - | - | - | 16.1 |
| HCM Lane LOS | A | - | - | - | C |
| HCM 95th %tile Q(veh) | 0 | - | - | - | 0.1 |

Timings
9: US 24 & Rex Rd

2041 Background Traffic
PM Peak Hour



| Lane Group | EBL | EBR | NBL | NBT | SBT | SBR |
|----------------------|-------|-------|-------|-------|-------|-------|
| Lane Configurations | ↖ | ↗ | ↖↗ | ↕ | ↕ | ↗ |
| Traffic Volume (vph) | 122 | 773 | 1102 | 529 | 471 | 129 |
| Future Volume (vph) | 122 | 773 | 1102 | 529 | 471 | 129 |
| Turn Type | Prot | Free | Prot | NA | NA | Perm |
| Protected Phases | 6! | | 7 | Free! | 8 | |
| Permitted Phases | | Free | | | | 8 |
| Detector Phase | 6 | | 7 | | 8 | 8 |
| Switch Phase | | | | | | |
| Minimum Initial (s) | 5.0 | | 5.0 | | 5.0 | 5.0 |
| Minimum Split (s) | 20.0 | | 10.0 | | 20.0 | 20.0 |
| Total Split (s) | 23.0 | | 49.0 | | 48.0 | 48.0 |
| Total Split (%) | 19.2% | | 40.8% | | 40.0% | 40.0% |
| Yellow Time (s) | 3.0 | | 3.0 | | 3.0 | 3.0 |
| All-Red Time (s) | 2.0 | | 2.0 | | 2.0 | 2.0 |
| Lost Time Adjust (s) | 0.0 | | 0.0 | | 0.0 | 0.0 |
| Total Lost Time (s) | 5.0 | | 5.0 | | 5.0 | 5.0 |
| Lead/Lag | | | Lead | | Lag | Lag |
| Lead-Lag Optimize? | | | Yes | | Yes | Yes |
| Recall Mode | Max | | None | | C-Max | C-Max |
| Act Effct Green (s) | 18.0 | 120.0 | 43.2 | 120.0 | 43.8 | 43.8 |
| Actuated g/C Ratio | 0.15 | 1.00 | 0.36 | 1.00 | 0.36 | 0.36 |
| v/c Ratio | 0.48 | 0.51 | 0.94 | 0.15 | 0.38 | 0.20 |
| Control Delay | 53.6 | 1.2 | 43.0 | 0.0 | 29.4 | 5.1 |
| Queue Delay | 0.0 | 0.0 | 0.0 | 0.0 | 0.0 | 0.0 |
| Total Delay | 53.6 | 1.2 | 43.0 | 0.0 | 29.4 | 5.1 |
| LOS | D | A | D | A | C | A |
| Approach Delay | 8.3 | | | 29.4 | 24.2 | |
| Approach LOS | A | | | C | C | |

Intersection Summary

Cycle Length: 120
 Actuated Cycle Length: 120
 Offset: 50 (42%), Referenced to phase 8:SBT, Start of Green
 Natural Cycle: 70
 Control Type: Actuated-Coordinated
 Maximum v/c Ratio: 0.94
 Intersection Signal Delay: 22.3
 Intersection LOS: C
 Intersection Capacity Utilization 62.9%
 ICU Level of Service B
 Analysis Period (min) 15
 ! Phase conflict between lane groups.

Splits and Phases: 9: US 24 & Rex Rd



| Intersection | | | | | | |
|--------------------------|------|------|------|------|------|------|
| Int Delay, s/veh | 0.5 | | | | | |
| Movement | WBL | WBR | NBT | NBR | SBL | SBT |
| Lane Configurations | ↘ | ↗ | ↑ | ↗ | ↘ | ↑ |
| Traffic Vol, veh/h | 33 | 0 | 781 | 38 | 0 | 503 |
| Future Vol, veh/h | 33 | 0 | 781 | 38 | 0 | 503 |
| Conflicting Peds, #/hr | 0 | 0 | 0 | 0 | 0 | 0 |
| Sign Control | Stop | Stop | Free | Free | Free | Free |
| RT Channelized | - | None | - | None | - | None |
| Storage Length | 0 | 0 | - | 155 | 205 | - |
| Veh in Median Storage, # | 0 | - | 0 | - | - | 0 |
| Grade, % | 0 | - | 0 | - | - | 0 |
| Peak Hour Factor | 95 | 95 | 95 | 95 | 95 | 95 |
| Heavy Vehicles, % | 2 | 2 | 2 | 2 | 2 | 2 |
| Mvmt Flow | 35 | 0 | 822 | 40 | 0 | 529 |

| Major/Minor | Minor1 | Major1 | Major2 | | | |
|----------------------|--------|--------|--------|---|-------|---|
| Conflicting Flow All | 1351 | 822 | 0 | 0 | 862 | 0 |
| Stage 1 | 822 | - | - | - | - | - |
| Stage 2 | 529 | - | - | - | - | - |
| Critical Hdwy | 6.42 | 6.22 | - | - | 4.12 | - |
| Critical Hdwy Stg 1 | 5.42 | - | - | - | - | - |
| Critical Hdwy Stg 2 | 5.42 | - | - | - | - | - |
| Follow-up Hdwy | 3.518 | 3.318 | - | - | 2.218 | - |
| Pot Cap-1 Maneuver | 166 | 374 | - | - | 780 | - |
| Stage 1 | 432 | - | - | - | - | - |
| Stage 2 | 591 | - | - | - | - | - |
| Platoon blocked, % | | | - | - | | |
| Mov Cap-1 Maneuver | 166 | 374 | - | - | 780 | - |
| Mov Cap-2 Maneuver | 301 | - | - | - | - | - |
| Stage 1 | 432 | - | - | - | - | - |
| Stage 2 | 591 | - | - | - | - | - |

| Approach | WB | NB | SB |
|----------------------|------|----|----|
| HCM Control Delay, s | 18.5 | 0 | 0 |
| HCM LOS | C | | |

| Minor Lane/Major Mvmt | NBT | NBRWBLn1 | WBLn2 | SBL | SBT |
|-----------------------|-----|----------|-------|-----|-----|
| Capacity (veh/h) | - | - | 301 | - | 780 |
| HCM Lane V/C Ratio | - | - | 0.115 | - | - |
| HCM Control Delay (s) | - | - | 18.5 | 0 | 0 |
| HCM Lane LOS | - | - | C | A | A |
| HCM 95th %tile Q(veh) | - | - | 0.4 | - | 0 |

| Intersection | | | | | | |
|--------------------------|------|------|------|------|------|------|
| Int Delay, s/veh | 0.2 | | | | | |
| Movement | WBL | WBR | NBT | NBR | SBL | SBT |
| Lane Configurations | ↘ | ↗ | ↑ | ↗ | ↘ | ↑ |
| Traffic Vol, veh/h | 0 | 9 | 810 | 0 | 16 | 519 |
| Future Vol, veh/h | 0 | 9 | 810 | 0 | 16 | 519 |
| Conflicting Peds, #/hr | 0 | 0 | 0 | 0 | 0 | 0 |
| Sign Control | Stop | Stop | Free | Free | Free | Free |
| RT Channelized | - | None | - | None | - | None |
| Storage Length | 0 | 115 | - | 155 | 205 | - |
| Veh in Median Storage, # | 0 | - | 0 | - | - | 0 |
| Grade, % | 0 | - | 0 | - | - | 0 |
| Peak Hour Factor | 85 | 85 | 85 | 85 | 85 | 85 |
| Heavy Vehicles, % | 2 | 2 | 2 | 2 | 2 | 2 |
| Mvmt Flow | 0 | 11 | 953 | 0 | 19 | 611 |

| Major/Minor | Minor1 | Major1 | Major2 | | | |
|----------------------|--------|--------|--------|---|-------|---|
| Conflicting Flow All | 1602 | 953 | 0 | 0 | 953 | 0 |
| Stage 1 | 953 | - | - | - | - | - |
| Stage 2 | 649 | - | - | - | - | - |
| Critical Hdwy | 6.42 | 6.22 | - | - | 4.12 | - |
| Critical Hdwy Stg 1 | 5.42 | - | - | - | - | - |
| Critical Hdwy Stg 2 | 5.42 | - | - | - | - | - |
| Follow-up Hdwy | 3.518 | 3.318 | - | - | 2.218 | - |
| Pot Cap-1 Maneuver | 116 | 314 | - | - | 721 | - |
| Stage 1 | 375 | - | - | - | - | - |
| Stage 2 | 520 | - | - | - | - | - |
| Platoon blocked, % | | | - | - | - | - |
| Mov Cap-1 Maneuver | 113 | 314 | - | - | 721 | - |
| Mov Cap-2 Maneuver | 247 | - | - | - | - | - |
| Stage 1 | 375 | - | - | - | - | - |
| Stage 2 | 506 | - | - | - | - | - |

| Approach | WB | NB | SB |
|----------------------|------|----|-----|
| HCM Control Delay, s | 16.9 | 0 | 0.3 |
| HCM LOS | C | | |

| Minor Lane/Major Mvmt | NBT | NBRWBLn1 | WBLn2 | SBL | SBT |
|-----------------------|-----|----------|-------|-------|-------|
| Capacity (veh/h) | - | - | - | 314 | 721 |
| HCM Lane V/C Ratio | - | - | - | 0.034 | 0.026 |
| HCM Control Delay (s) | - | - | 0 | 16.9 | 10.1 |
| HCM Lane LOS | - | - | A | C | B |
| HCM 95th %tile Q(veh) | - | - | - | 0.1 | 0.1 |

| Intersection | | | | | | |
|--------------------------|------|------|------|------|------|------|
| Int Delay, s/veh | 13.2 | | | | | |
| Movement | EBL | EBR | NBL | NBT | SBT | SBR |
| Lane Configurations | ↘ | ↗ | ↘ | ↗ | ↗ | ↘ |
| Traffic Vol, veh/h | 131 | 177 | 347 | 779 | 463 | 85 |
| Future Vol, veh/h | 131 | 177 | 347 | 779 | 463 | 85 |
| Conflicting Peds, #/hr | 0 | 0 | 0 | 0 | 0 | 0 |
| Sign Control | Stop | Stop | Free | Free | Free | Free |
| RT Channelized | - | None | - | None | - | None |
| Storage Length | 0 | 0 | 0 | - | - | 155 |
| Veh in Median Storage, # | 0 | - | - | 0 | 0 | - |
| Grade, % | 0 | - | - | 0 | 0 | - |
| Peak Hour Factor | 95 | 95 | 95 | 95 | 95 | 95 |
| Heavy Vehicles, % | 2 | 2 | 2 | 2 | 2 | 2 |
| Mvmt Flow | 138 | 186 | 365 | 820 | 487 | 89 |

| Major/Minor | Minor2 | Major1 | Major2 | | | |
|----------------------|--------|--------|--------|---|---|---|
| Conflicting Flow All | 2037 | 487 | 576 | 0 | - | 0 |
| Stage 1 | 487 | - | - | - | - | - |
| Stage 2 | 1550 | - | - | - | - | - |
| Critical Hdwy | 6.42 | 6.22 | 4.12 | - | - | - |
| Critical Hdwy Stg 1 | 5.42 | - | - | - | - | - |
| Critical Hdwy Stg 2 | 5.42 | - | - | - | - | - |
| Follow-up Hdwy | 3.518 | 3.318 | 2.218 | - | - | - |
| Pot Cap-1 Maneuver | ~ 62 | 581 | 997 | - | - | - |
| Stage 1 | 618 | - | - | - | - | - |
| Stage 2 | 193 | - | - | - | - | - |
| Platoon blocked, % | | | | - | - | - |
| Mov Cap-1 Maneuver | ~ 39 | 581 | 997 | - | - | - |
| Mov Cap-2 Maneuver | ~ 133 | - | - | - | - | - |
| Stage 1 | 392 | - | - | - | - | - |
| Stage 2 | 193 | - | - | - | - | - |

| Approach | EB | NB | SB |
|----------------------|------|-----|----|
| HCM Control Delay, s | 73.2 | 3.3 | 0 |
| HCM LOS | F | | |

| Minor Lane/Major Mvmt | NBL | NBT | EBLn1 | EBLn2 | SBT | SBR |
|-----------------------|-------|-----|-------|-------|-----|-----|
| Capacity (veh/h) | 997 | - | 133 | 581 | - | - |
| HCM Lane V/C Ratio | 0.366 | - | 1.037 | 0.321 | - | - |
| HCM Control Delay (s) | 10.7 | - | 153 | 14.1 | - | - |
| HCM Lane LOS | B | - | F | B | - | - |
| HCM 95th %tile Q(veh) | 1.7 | - | 7.5 | 1.4 | - | - |

Notes
 ~: Volume exceeds capacity \$: Delay exceeds 300s +: Computation Not Defined *: All major volume in platoon

Timings
13: Eastonville Rd & Stapleton Dr

2041 Background Traffic
PM Peak Hour

| Lane Group | EBL | EBT | EBR | WBL | WBT | WBR | NBL | NBT | NBR | SBL | SBT | SBR |
|----------------------|-------|-------|-------|-------|-------|-------|-------|-------|-------|-------|-------|-------|
| Lane Configurations | | | | | | | | | | | | |
| Traffic Volume (vph) | 354 | 553 | 160 | 194 | 718 | 218 | 251 | 554 | 179 | 110 | 319 | 211 |
| Future Volume (vph) | 354 | 553 | 160 | 194 | 718 | 218 | 251 | 554 | 179 | 110 | 319 | 211 |
| Turn Type | Prot | NA | Perm | pm+pt | NA | Perm | pm+pt | NA | Perm | pm+pt | NA | Perm |
| Protected Phases | 5 | 2 | | 1 | 6 | | 3 | 8 | | 7 | 4 | |
| Permitted Phases | | | 2 | 6 | | 6 | 8 | | 8 | 4 | | 4 |
| Detector Phase | 5 | 2 | 2 | 1 | 6 | 6 | 3 | 8 | 8 | 7 | 4 | 4 |
| Switch Phase | | | | | | | | | | | | |
| Minimum Initial (s) | 4.0 | 4.0 | 4.0 | 4.0 | 4.0 | 4.0 | 4.0 | 4.0 | 4.0 | 4.0 | 4.0 | 4.0 |
| Minimum Split (s) | 9.0 | 9.0 | 9.0 | 9.0 | 9.0 | 9.0 | 9.0 | 9.0 | 9.0 | 9.0 | 9.0 | 9.0 |
| Total Split (s) | 18.0 | 31.0 | 31.0 | 15.0 | 28.0 | 28.0 | 11.0 | 43.0 | 43.0 | 11.0 | 43.0 | 43.0 |
| Total Split (%) | 18.0% | 31.0% | 31.0% | 15.0% | 28.0% | 28.0% | 11.0% | 43.0% | 43.0% | 11.0% | 43.0% | 43.0% |
| Yellow Time (s) | 3.0 | 3.0 | 3.0 | 3.0 | 3.0 | 3.0 | 3.0 | 3.0 | 3.0 | 3.0 | 3.0 | 3.0 |
| All-Red Time (s) | 2.0 | 2.0 | 2.0 | 2.0 | 2.0 | 2.0 | 2.0 | 2.0 | 2.0 | 2.0 | 2.0 | 2.0 |
| Lost Time Adjust (s) | 0.0 | 0.0 | 0.0 | 0.0 | -2.0 | 0.0 | 0.0 | 0.0 | 0.0 | 0.0 | 0.0 | 0.0 |
| Total Lost Time (s) | 5.0 | 5.0 | 5.0 | 5.0 | 3.0 | 5.0 | 5.0 | 5.0 | 5.0 | 5.0 | 5.0 | 5.0 |
| Lead/Lag | Lead | Lag | Lag | Lead | Lag | Lag | Lead | Lag | Lag | Lead | Lag | Lag |
| Lead-Lag Optimize? | Yes | Yes | Yes | Yes | Yes | Yes | Yes | Yes | Yes | Yes | Yes | Yes |
| Recall Mode | None | None | None | None | None | None | None | None | None | None | None | None |
| Act Effct Green (s) | 12.7 | 25.3 | 25.3 | 31.9 | 24.2 | 22.2 | 40.0 | 34.0 | 34.0 | 40.0 | 34.0 | 34.0 |
| Actuated g/C Ratio | 0.13 | 0.27 | 0.27 | 0.34 | 0.25 | 0.23 | 0.42 | 0.36 | 0.36 | 0.42 | 0.36 | 0.36 |
| v/c Ratio | 0.81 | 0.62 | 0.31 | 0.65 | 0.84 | 0.42 | 0.68 | 0.88 | 0.27 | 0.59 | 0.51 | 0.31 |
| Control Delay | 56.4 | 34.8 | 6.4 | 30.7 | 44.0 | 7.2 | 28.5 | 44.5 | 4.3 | 27.3 | 27.0 | 4.2 |
| Queue Delay | 0.0 | 0.0 | 0.0 | 0.0 | 0.0 | 0.0 | 0.0 | 0.0 | 0.0 | 0.0 | 0.0 | 0.0 |
| Total Delay | 56.4 | 34.8 | 6.4 | 30.7 | 44.0 | 7.2 | 28.5 | 44.5 | 4.3 | 27.3 | 27.0 | 4.2 |
| LOS | E | C | A | C | D | A | C | D | A | C | C | A |
| Approach Delay | | 37.7 | | | 34.6 | | | 33.1 | | | 19.5 | |
| Approach LOS | | D | | | C | | | C | | | B | |

Intersection Summary

Cycle Length: 100
 Actuated Cycle Length: 95.1
 Natural Cycle: 75
 Control Type: Actuated-Uncoordinated
 Maximum v/c Ratio: 0.88
 Intersection Signal Delay: 32.6
 Intersection LOS: C
 Intersection Capacity Utilization 81.0%
 ICU Level of Service D
 Analysis Period (min) 15

Splits and Phases: 13: Eastonville Rd & Stapleton Dr

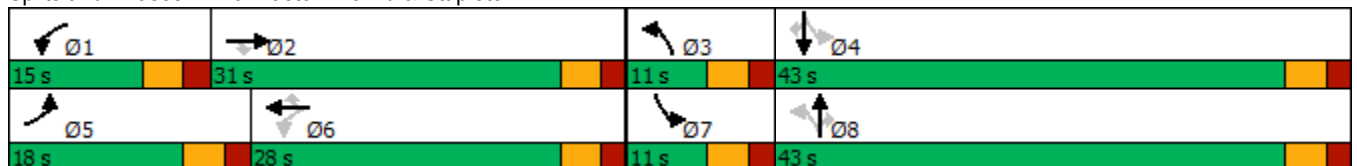

Timings
14: US 24 & Stapleton Dr

2041 Background Traffic
PM Peak Hour

| Lane Group | EBL | EBT | EBR | WBL | WBT | WBR | NBL | NBT | NBR | SBL | SBT | SBR |
|----------------------|-------|-------|-------|-------|-------|-------|-------|-------|-------|-------|-------|-------|
| Lane Configurations | | | | | | | | | | | | |
| Traffic Volume (vph) | 372 | 349 | 339 | 125 | 499 | 316 | 579 | 1449 | 150 | 241 | 1022 | 377 |
| Future Volume (vph) | 372 | 349 | 339 | 125 | 499 | 316 | 579 | 1449 | 150 | 241 | 1022 | 377 |
| Turn Type | Prot | NA | Free | Prot | NA | Free | Prot | NA | Perm | Prot | NA | Free |
| Protected Phases | 7 | 4 | | 3 | 8 | | 5 | 2 | | 1 | 6 | |
| Permitted Phases | | | Free | | | Free | | | 2 | | | Free |
| Detector Phase | 7 | 4 | | 3 | 8 | | 5 | 2 | 2 | 1 | 6 | |
| Switch Phase | | | | | | | | | | | | |
| Minimum Initial (s) | 5.0 | 5.0 | | 5.0 | 5.0 | | 5.0 | 5.0 | 5.0 | 5.0 | 5.0 | |
| Minimum Split (s) | 10.0 | 10.0 | | 10.0 | 10.0 | | 10.0 | 11.0 | 11.0 | 10.0 | 11.0 | |
| Total Split (s) | 15.0 | 30.0 | | 17.0 | 32.0 | | 26.0 | 60.0 | 60.0 | 13.0 | 47.0 | |
| Total Split (%) | 12.5% | 25.0% | | 14.2% | 26.7% | | 21.7% | 50.0% | 50.0% | 10.8% | 39.2% | |
| Yellow Time (s) | 3.0 | 3.0 | | 3.0 | 3.0 | | 3.0 | 3.0 | 3.0 | 3.0 | 3.0 | |
| All-Red Time (s) | 2.0 | 2.0 | | 2.0 | 2.0 | | 2.0 | 2.0 | 2.0 | 2.0 | 2.0 | |
| Lost Time Adjust (s) | 0.0 | 0.0 | | 0.0 | 0.0 | | 0.0 | 0.0 | 0.0 | 0.0 | 0.0 | |
| Total Lost Time (s) | 5.0 | 5.0 | | 5.0 | 5.0 | | 5.0 | 5.0 | 5.0 | 5.0 | 5.0 | |
| Lead/Lag | Lead | Lag | | Lead | Lag | | Lead | Lag | Lag | Lead | Lag | |
| Lead-Lag Optimize? | Yes | Yes | | Yes | Yes | | Yes | Yes | Yes | Yes | Yes | |
| Recall Mode | None | None | | None | None | | None | C-Max | C-Max | None | C-Max | |
| Act Effct Green (s) | 10.0 | 23.2 | 120.0 | 9.8 | 23.0 | 120.0 | 24.4 | 55.0 | 55.0 | 12.0 | 42.6 | 120.0 |
| Actuated g/C Ratio | 0.08 | 0.19 | 1.00 | 0.08 | 0.19 | 1.00 | 0.20 | 0.46 | 0.46 | 0.10 | 0.36 | 1.00 |
| v/c Ratio | 1.37 | 0.54 | 0.23 | 0.47 | 0.77 | 0.21 | 0.87 | 0.94 | 0.20 | 0.74 | 0.83 | 0.25 |
| Control Delay | 228.6 | 46.5 | 0.3 | 57.9 | 54.1 | 0.3 | 61.3 | 43.5 | 6.3 | 70.5 | 34.0 | 0.4 |
| Queue Delay | 0.0 | 0.0 | 0.0 | 0.0 | 0.0 | 0.0 | 0.0 | 0.0 | 0.0 | 0.0 | 0.0 | 0.0 |
| Total Delay | 228.6 | 46.5 | 0.3 | 57.9 | 54.1 | 0.3 | 61.3 | 43.5 | 6.3 | 70.5 | 34.0 | 0.4 |
| LOS | F | D | A | E | D | A | E | D | A | E | C | A |
| Approach Delay | | 95.7 | | | 36.5 | | | 45.6 | | | 31.6 | |
| Approach LOS | | F | | | D | | | D | | | C | |

Intersection Summary

Cycle Length: 120
 Actuated Cycle Length: 120
 Offset: 0 (0%), Referenced to phase 2:NBT and 6:SBT, Start of Green
 Natural Cycle: 90
 Control Type: Actuated-Coordinated
 Maximum v/c Ratio: 1.37
 Intersection Signal Delay: 49.4
 Intersection LOS: D
 Intersection Capacity Utilization 88.0%
 ICU Level of Service E
 Analysis Period (min) 15

Splits and Phases: 14: US 24 & Stapleton Dr



| Intersection | | | | |
|-----------------------------|-------|-------|-------|-------|
| Intersection Delay, s/veh | 15.3 | | | |
| Intersection LOS | C | | | |
| Approach | EB | WB | NB | SB |
| Entry Lanes | 1 | 1 | 1 | 1 |
| Conflicting Circle Lanes | 1 | 1 | 1 | 1 |
| Adj Approach Flow, veh/h | 357 | 508 | 793 | 249 |
| Demand Flow Rate, veh/h | 364 | 518 | 809 | 254 |
| Vehicles Circulating, veh/h | 489 | 428 | 319 | 577 |
| Vehicles Exiting, veh/h | 342 | 700 | 534 | 369 |
| Ped Vol Crossing Leg, #/h | 0 | 0 | 0 | 0 |
| Ped Cap Adj | 1.000 | 1.000 | 1.000 | 1.000 |
| Approach Delay, s/veh | 9.9 | 12.6 | 21.4 | 8.8 |
| Approach LOS | A | B | C | A |
| Lane | Left | Left | Left | Left |
| Designated Moves | LTR | LTR | LTR | LTR |
| Assumed Moves | LTR | LTR | LTR | LTR |
| RT Channelized | | | | |
| Lane Util | 1.000 | 1.000 | 1.000 | 1.000 |
| Follow-Up Headway, s | 2.609 | 2.609 | 2.609 | 2.609 |
| Critical Headway, s | 4.976 | 4.976 | 4.976 | 4.976 |
| Entry Flow, veh/h | 364 | 518 | 809 | 254 |
| Cap Entry Lane, veh/h | 838 | 892 | 997 | 766 |
| Entry HV Adj Factor | 0.980 | 0.981 | 0.980 | 0.979 |
| Flow Entry, veh/h | 357 | 508 | 793 | 249 |
| Cap Entry, veh/h | 822 | 874 | 977 | 750 |
| V/C Ratio | 0.434 | 0.581 | 0.812 | 0.332 |
| Control Delay, s/veh | 9.9 | 12.6 | 21.4 | 8.8 |
| LOS | A | B | C | A |
| 95th %tile Queue, veh | 2 | 4 | 9 | 1 |

| Intersection | | | |
|-----------------------------|-------|-------|-------|
| Intersection Delay, s/veh | 7.8 | | |
| Intersection LOS | A | | |
| Approach | EB | WB | NB |
| Entry Lanes | 1 | 1 | 1 |
| Conflicting Circle Lanes | 1 | 1 | 1 |
| Adj Approach Flow, veh/h | 687 | 556 | 43 |
| Demand Flow Rate, veh/h | 701 | 567 | 44 |
| Vehicles Circulating, veh/h | 59 | 9 | 667 |
| Vehicles Exiting, veh/h | 517 | 702 | 93 |
| Ped Vol Crossing Leg, #/h | 0 | 0 | 0 |
| Ped Cap Adj | 1.000 | 1.000 | 1.000 |
| Approach Delay, s/veh | 8.8 | 6.6 | 5.9 |
| Approach LOS | A | A | A |
| Lane | Left | Left | Left |
| Designated Moves | TR | LT | LR |
| Assumed Moves | TR | LT | LR |
| RT Channelized | | | |
| Lane Util | 1.000 | 1.000 | 1.000 |
| Follow-Up Headway, s | 2.609 | 2.609 | 2.609 |
| Critical Headway, s | 4.976 | 4.976 | 4.976 |
| Entry Flow, veh/h | 701 | 567 | 44 |
| Cap Entry Lane, veh/h | 1299 | 1367 | 699 |
| Entry HV Adj Factor | 0.980 | 0.981 | 0.977 |
| Flow Entry, veh/h | 687 | 556 | 43 |
| Cap Entry, veh/h | 1273 | 1341 | 683 |
| V/C Ratio | 0.540 | 0.415 | 0.063 |
| Control Delay, s/veh | 8.8 | 6.6 | 5.9 |
| LOS | A | A | A |
| 95th %tile Queue, veh | 3 | 2 | 0 |

| Intersection | | | |
|-----------------------------|-------|-------|-------|
| Intersection Delay, s/veh | 8.4 | | |
| Intersection LOS | A | | |
| Approach | WB | NB | SB |
| Entry Lanes | 1 | 1 | 1 |
| Conflicting Circle Lanes | 2 | 2 | 2 |
| Adj Approach Flow, veh/h | 35 | 862 | 529 |
| Demand Flow Rate, veh/h | 36 | 879 | 540 |
| Vehicles Circulating, veh/h | 838 | 0 | 36 |
| Vehicles Exiting, veh/h | 41 | 576 | 838 |
| Ped Vol Crossing Leg, #/h | 0 | 0 | 0 |
| Ped Cap Adj | 1.000 | 1.000 | 1.000 |
| Approach Delay, s/veh | 5.9 | 9.8 | 6.3 |
| Approach LOS | A | A | A |
| Lane | Left | Left | Left |
| Designated Moves | LR | TR | LT |
| Assumed Moves | LR | TR | LT |
| RT Channelized | | | |
| Lane Util | 1.000 | 1.000 | 1.000 |
| Follow-Up Headway, s | 2.535 | 2.535 | 2.535 |
| Critical Headway, s | 4.328 | 4.328 | 4.328 |
| Entry Flow, veh/h | 36 | 879 | 540 |
| Cap Entry Lane, veh/h | 697 | 1420 | 1377 |
| Entry HV Adj Factor | 0.972 | 0.980 | 0.980 |
| Flow Entry, veh/h | 35 | 862 | 529 |
| Cap Entry, veh/h | 677 | 1392 | 1350 |
| V/C Ratio | 0.052 | 0.619 | 0.392 |
| Control Delay, s/veh | 5.9 | 9.8 | 6.3 |
| LOS | A | A | A |
| 95th %tile Queue, veh | 0 | 5 | 2 |

| Intersection | | | |
|-----------------------------|-------|-------|-------|
| Intersection Delay, s/veh | 10.6 | | |
| Intersection LOS | B | | |
| Approach | WB | NB | SB |
| Entry Lanes | 1 | 1 | 1 |
| Conflicting Circle Lanes | 1 | 1 | 1 |
| Adj Approach Flow, veh/h | 11 | 953 | 630 |
| Demand Flow Rate, veh/h | 11 | 972 | 642 |
| Vehicles Circulating, veh/h | 972 | 19 | 0 |
| Vehicles Exiting, veh/h | 19 | 623 | 983 |
| Ped Vol Crossing Leg, #/h | 0 | 0 | 0 |
| Ped Cap Adj | 1.000 | 1.000 | 1.000 |
| Approach Delay, s/veh | 7.3 | 12.9 | 7.3 |
| Approach LOS | A | B | A |
| Lane | Left | Left | Left |
| Designated Moves | LR | TR | LT |
| Assumed Moves | LR | TR | LT |
| RT Channelized | | | |
| Lane Util | 1.000 | 1.000 | 1.000 |
| Follow-Up Headway, s | 2.609 | 2.609 | 2.609 |
| Critical Headway, s | 4.976 | 4.976 | 4.976 |
| Entry Flow, veh/h | 11 | 972 | 642 |
| Cap Entry Lane, veh/h | 512 | 1353 | 1380 |
| Entry HV Adj Factor | 1.000 | 0.980 | 0.981 |
| Flow Entry, veh/h | 11 | 953 | 630 |
| Cap Entry, veh/h | 512 | 1327 | 1354 |
| V/C Ratio | 0.021 | 0.718 | 0.465 |
| Control Delay, s/veh | 7.3 | 12.9 | 7.3 |
| LOS | A | B | A |
| 95th %tile Queue, veh | 0 | 7 | 3 |

| Intersection | | | | | | |
|-----------------------------|-------|-------|-------|-------|-------|-------|
| Intersection Delay, s/veh | 8.5 | | | | | |
| Intersection LOS | A | | | | | |
| Approach | EB | | NB | | SB | |
| Entry Lanes | 2 | | 2 | | 2 | |
| Conflicting Circle Lanes | 2 | | 2 | | 2 | |
| Adj Approach Flow, veh/h | 324 | | 1185 | | 576 | |
| Demand Flow Rate, veh/h | 331 | | 1208 | | 588 | |
| Vehicles Circulating, veh/h | 497 | | 141 | | 372 | |
| Vehicles Exiting, veh/h | 463 | | 687 | | 977 | |
| Ped Vol Crossing Leg, #/h | 0 | | 0 | | 0 | |
| Ped Cap Adj | 1.000 | | 1.000 | | 1.000 | |
| Approach Delay, s/veh | 6.0 | | 10.0 | | 6.7 | |
| Approach LOS | A | | B | | A | |
| Lane | Left | Right | Left | Right | Left | Right |
| Designated Moves | L | TR | L | TR | LT | TR |
| Assumed Moves | L | TR | L | TR | LT | TR |
| RT Channelized | | | | | | |
| Lane Util | 0.426 | 0.574 | 0.308 | 0.692 | 0.469 | 0.531 |
| Follow-Up Headway, s | 2.667 | 2.535 | 2.667 | 2.535 | 2.667 | 2.535 |
| Critical Headway, s | 4.645 | 4.328 | 4.645 | 4.328 | 4.645 | 4.328 |
| Entry Flow, veh/h | 141 | 190 | 372 | 836 | 276 | 312 |
| Cap Entry Lane, veh/h | 855 | 931 | 1186 | 1260 | 959 | 1035 |
| Entry HV Adj Factor | 0.979 | 0.979 | 0.981 | 0.980 | 0.981 | 0.979 |
| Flow Entry, veh/h | 138 | 186 | 365 | 820 | 271 | 305 |
| Cap Entry, veh/h | 836 | 911 | 1163 | 1235 | 941 | 1013 |
| V/C Ratio | 0.165 | 0.204 | 0.314 | 0.664 | 0.288 | 0.301 |
| Control Delay, s/veh | 6.0 | 6.0 | 6.1 | 11.8 | 6.8 | 6.6 |
| LOS | A | A | A | B | A | A |
| 95th %tile Queue, veh | 1 | 1 | 1 | 5 | 1 | 1 |

Timings
1: Eastonville Rd & Rex Rd

2041 Background Traffic
PM Peak Hour

| Lane Group | EBL | EBT | EBR | WBL | WBT | WBR | NBL | NBT | NBR | SBL | SBT | SBR |
|----------------------|-------|-------|-------|-------|-------|-------|-------|-------|-------|-------|-------|-------|
| Lane Configurations | | | | | | | | | | | | |
| Traffic Volume (vph) | 77 | 195 | 67 | 267 | 195 | 21 | 75 | 246 | 432 | 25 | 163 | 48 |
| Future Volume (vph) | 77 | 195 | 67 | 267 | 195 | 21 | 75 | 246 | 432 | 25 | 163 | 48 |
| Turn Type | pm+pt | NA | Perm | pm+pt | NA | Perm | pm+pt | NA | Perm | pm+pt | NA | Perm |
| Protected Phases | 5 | 2 | | 1 | 6 | | 3 | 8 | | 7 | 4 | |
| Permitted Phases | 2 | | 2 | 6 | | 6 | 8 | | 8 | 4 | | 4 |
| Detector Phase | 5 | 2 | 2 | 1 | 6 | 6 | 3 | 8 | 8 | 7 | 4 | 4 |
| Switch Phase | | | | | | | | | | | | |
| Minimum Initial (s) | 5.0 | 5.0 | 5.0 | 5.0 | 5.0 | 5.0 | 5.0 | 5.0 | 5.0 | 5.0 | 5.0 | 5.0 |
| Minimum Split (s) | 10.0 | 20.0 | 20.0 | 10.0 | 20.0 | 20.0 | 10.0 | 20.0 | 20.0 | 10.0 | 20.0 | 20.0 |
| Total Split (s) | 10.0 | 38.0 | 38.0 | 20.0 | 48.0 | 48.0 | 12.0 | 30.0 | 30.0 | 12.0 | 30.0 | 30.0 |
| Total Split (%) | 10.0% | 38.0% | 38.0% | 20.0% | 48.0% | 48.0% | 12.0% | 30.0% | 30.0% | 12.0% | 30.0% | 30.0% |
| Yellow Time (s) | 3.0 | 3.0 | 3.0 | 3.0 | 3.0 | 3.0 | 3.0 | 3.0 | 3.0 | 3.0 | 3.0 | 3.0 |
| All-Red Time (s) | 2.0 | 2.0 | 2.0 | 2.0 | 2.0 | 2.0 | 2.0 | 2.0 | 2.0 | 2.0 | 2.0 | 2.0 |
| Lost Time Adjust (s) | 0.0 | 0.0 | 0.0 | 0.0 | 0.0 | 0.0 | 0.0 | 0.0 | 0.0 | 0.0 | 0.0 | 0.0 |
| Total Lost Time (s) | 5.0 | 5.0 | 5.0 | 5.0 | 5.0 | 5.0 | 5.0 | 5.0 | 5.0 | 5.0 | 5.0 | 5.0 |
| Lead/Lag | Lead | Lag | Lag | Lead | Lag | Lag | Lead | Lag | Lag | Lead | Lag | Lag |
| Lead-Lag Optimize? | Yes | Yes | Yes | Yes | Yes | Yes | Yes | Yes | Yes | Yes | Yes | Yes |
| Recall Mode | None | Min | Min | None | Min | Min | None | None | None | None | None | None |
| Act Effct Green (s) | 18.4 | 13.0 | 13.0 | 30.4 | 23.0 | 23.0 | 21.5 | 19.3 | 19.3 | 18.9 | 14.2 | 14.2 |
| Actuated g/C Ratio | 0.29 | 0.20 | 0.20 | 0.47 | 0.36 | 0.36 | 0.33 | 0.30 | 0.30 | 0.29 | 0.22 | 0.22 |
| v/c Ratio | 0.21 | 0.55 | 0.15 | 0.51 | 0.31 | 0.03 | 0.19 | 0.46 | 0.57 | 0.07 | 0.42 | 0.10 |
| Control Delay | 14.4 | 32.0 | 0.7 | 16.2 | 20.2 | 0.1 | 15.4 | 24.0 | 5.9 | 14.5 | 27.1 | 0.4 |
| Queue Delay | 0.0 | 0.0 | 0.0 | 0.0 | 0.0 | 0.0 | 0.0 | 0.0 | 0.0 | 0.0 | 0.0 | 0.0 |
| Total Delay | 14.4 | 32.0 | 0.7 | 16.2 | 20.2 | 0.1 | 15.4 | 24.0 | 5.9 | 14.5 | 27.1 | 0.4 |
| LOS | B | C | A | B | C | A | B | C | A | B | C | A |
| Approach Delay | | 21.8 | | | 17.1 | | | 12.8 | | | 20.3 | |
| Approach LOS | | C | | | B | | | B | | | C | |

Intersection Summary

Cycle Length: 100
 Actuated Cycle Length: 64.3
 Natural Cycle: 60
 Control Type: Actuated-Uncoordinated
 Maximum v/c Ratio: 0.57
 Intersection Signal Delay: 16.6
 Intersection LOS: B
 Intersection Capacity Utilization 58.8%
 ICU Level of Service B
 Analysis Period (min) 15

Splits and Phases: 1: Eastonville Rd & Rex Rd

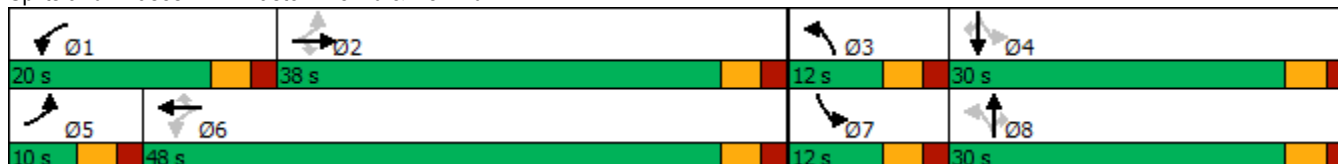

Timings
12: Eastonville Rd & Londonderry Dr

2041 Background Traffic
PM Peak Hour



| Lane Group | EBL | EBR | NBL | NBT | SBT | SBR |
|----------------------|-------|-------|-------|-------|-------|-------|
| Lane Configurations | | | | | | |
| Traffic Volume (vph) | 131 | 177 | 347 | 779 | 463 | 85 |
| Future Volume (vph) | 131 | 177 | 347 | 779 | 463 | 85 |
| Turn Type | Prot | Perm | pm+pt | NA | NA | Perm |
| Protected Phases | 4 | | 5 | 2 | 6 | |
| Permitted Phases | | 4 | 2 | | | 6 |
| Detector Phase | 4 | 4 | 5 | 2 | 6 | 6 |
| Switch Phase | | | | | | |
| Minimum Initial (s) | 4.0 | 4.0 | 4.0 | 4.0 | 4.0 | 4.0 |
| Minimum Split (s) | 21.0 | 21.0 | 9.0 | 21.0 | 21.0 | 21.0 |
| Total Split (s) | 25.0 | 25.0 | 20.0 | 75.0 | 55.0 | 55.0 |
| Total Split (%) | 25.0% | 25.0% | 20.0% | 75.0% | 55.0% | 55.0% |
| Yellow Time (s) | 3.0 | 3.0 | 3.0 | 3.0 | 3.0 | 3.0 |
| All-Red Time (s) | 2.0 | 2.0 | 2.0 | 2.0 | 2.0 | 2.0 |
| Lost Time Adjust (s) | 0.0 | 0.0 | 0.0 | 0.0 | 0.0 | 0.0 |
| Total Lost Time (s) | 5.0 | 5.0 | 5.0 | 5.0 | 5.0 | 5.0 |
| Lead/Lag | | | Lead | | Lag | Lag |
| Lead-Lag Optimize? | | | Yes | | Yes | Yes |
| Recall Mode | None | None | None | None | None | None |
| Act Effct Green (s) | 10.5 | 10.5 | 40.8 | 40.8 | 21.8 | 21.8 |
| Actuated g/C Ratio | 0.17 | 0.17 | 0.66 | 0.66 | 0.35 | 0.35 |
| v/c Ratio | 0.46 | 0.44 | 0.63 | 0.67 | 0.74 | 0.14 |
| Control Delay | 31.1 | 8.5 | 11.9 | 9.7 | 25.1 | 4.2 |
| Queue Delay | 0.0 | 0.0 | 0.0 | 0.0 | 0.0 | 0.0 |
| Total Delay | 31.1 | 8.5 | 11.9 | 9.7 | 25.1 | 4.2 |
| LOS | C | A | B | A | C | A |
| Approach Delay | 18.1 | | | 10.4 | 21.9 | |
| Approach LOS | B | | | B | C | |

Intersection Summary

Cycle Length: 100
 Actuated Cycle Length: 61.7
 Natural Cycle: 60
 Control Type: Actuated-Uncoordinated
 Maximum v/c Ratio: 0.74
 Intersection Signal Delay: 14.8
 Intersection Capacity Utilization 63.4%
 Analysis Period (min) 15
 Intersection LOS: B
 ICU Level of Service B

Splits and Phases: 12: Eastonville Rd & Londonderry Dr



Intersection

Int Delay, s/veh 408.6

| Movement | EBL | EBT | EBR | WBL | WBT | WBR | NBL | NBT | NBR | SBL | SBT | SBR |
|--------------------------|------|------|------|------|------|------|------|------|------|------|------|------|
| Lane Configurations | ↖ | ↗ | ↘ | ↖ | ↗ | ↘ | ↖ | ↗ | ↘ | ↖ | ↗ | ↘ |
| Traffic Vol, veh/h | 23 | 163 | 150 | 453 | 149 | 28 | 99 | 102 | 243 | 26 | 211 | 59 |
| Future Vol, veh/h | 23 | 163 | 150 | 453 | 149 | 28 | 99 | 102 | 243 | 26 | 211 | 59 |
| Conflicting Peds, #/hr | 0 | 0 | 0 | 0 | 0 | 0 | 0 | 0 | 0 | 0 | 0 | 0 |
| Sign Control | Stop | Stop | Stop | Stop | Stop | Stop | Free | Free | Free | Free | Free | Free |
| RT Channelized | - | - | None | - | - | None | - | - | None | - | - | None |
| Storage Length | 205 | - | 155 | 350 | - | 155 | 315 | - | 155 | 205 | - | 155 |
| Veh in Median Storage, # | - | 0 | - | - | 0 | - | - | 0 | - | - | 0 | - |
| Grade, % | - | 0 | - | - | 0 | - | - | 0 | - | - | 0 | - |
| Peak Hour Factor | 95 | 95 | 95 | 95 | 95 | 95 | 95 | 95 | 95 | 95 | 95 | 95 |
| Heavy Vehicles, % | 2 | 2 | 2 | 2 | 2 | 2 | 2 | 2 | 2 | 2 | 2 | 2 |
| Mvmt Flow | 24 | 172 | 158 | 477 | 157 | 29 | 104 | 107 | 256 | 27 | 222 | 62 |

| Major/Minor | Minor2 | | Minor1 | | Major1 | | Major2 | | | | | |
|----------------------|--------|-------|--------|-------|--------|-------|--------|---|---|-------|---|---|
| Conflicting Flow All | 812 | 847 | 222 | 787 | 653 | 107 | 284 | 0 | 0 | 363 | 0 | 0 |
| Stage 1 | 276 | 276 | - | 315 | 315 | - | - | - | - | - | - | - |
| Stage 2 | 536 | 571 | - | 472 | 338 | - | - | - | - | - | - | - |
| Critical Hdwy | 7.12 | 6.52 | 6.22 | 7.12 | 6.52 | 6.22 | 4.12 | - | - | 4.12 | - | - |
| Critical Hdwy Stg 1 | 6.12 | 5.52 | - | 6.12 | 5.52 | - | - | - | - | - | - | - |
| Critical Hdwy Stg 2 | 6.12 | 5.52 | - | 6.12 | 5.52 | - | - | - | - | - | - | - |
| Follow-up Hdwy | 3.518 | 4.018 | 3.318 | 3.518 | 4.018 | 3.318 | 2.218 | - | - | 2.218 | - | - |
| Pot Cap-1 Maneuver | 298 | 299 | 818 | ~ 309 | 387 | 947 | 1278 | - | - | 1196 | - | - |
| Stage 1 | 730 | 682 | - | 696 | 656 | - | - | - | - | - | - | - |
| Stage 2 | 529 | 505 | - | 573 | 641 | - | - | - | - | - | - | - |
| Platoon blocked, % | | | | | | | | - | - | - | - | - |
| Mov Cap-1 Maneuver | 173 | 269 | 818 | ~ 114 | 348 | 947 | 1278 | - | - | 1196 | - | - |
| Mov Cap-2 Maneuver | 173 | 269 | - | ~ 114 | 348 | - | - | - | - | - | - | - |
| Stage 1 | 671 | 666 | - | 640 | 603 | - | - | - | - | - | - | - |
| Stage 2 | 348 | 464 | - | ~ 336 | 626 | - | - | - | - | - | - | - |

| Approach | EB | WB | NB | SB |
|----------------------|------|-----------|-----|-----|
| HCM Control Delay, s | 25.8 | \$ 1091.2 | 1.8 | 0.7 |
| HCM LOS | D | F | | |

| Minor Lane/Major Mvmt | NBL | NBT | NBR | EBLn1 | EBLn2 | EBLn3 | WBLn1 | WBLn2 | WBLn3 | SBL | SBT | SBR |
|-----------------------|-------|-----|-----|-------|-------|-------|--------|-------|-------|-------|-----|-----|
| Capacity (veh/h) | 1278 | - | - | 173 | 269 | 818 | 114 | 348 | 947 | 1196 | - | - |
| HCM Lane V/C Ratio | 0.082 | - | - | 0.14 | 0.638 | 0.193 | 4.183 | 0.451 | 0.031 | 0.023 | - | - |
| HCM Control Delay (s) | 8.1 | - | - | 29.2 | 39.3 | 10.5 | 1509.2 | 23.6 | 8.9 | 8.1 | - | - |
| HCM Lane LOS | A | - | - | D | E | B | F | C | A | A | - | - |
| HCM 95th %tile Q(veh) | 0.3 | - | - | 0.5 | 4 | 0.7 | 49 | 2.2 | 0.1 | 0.1 | - | - |

Notes
 ~: Volume exceeds capacity \$: Delay exceeds 300s +: Computation Not Defined *: All major volume in platoon

| Intersection | | | | | | |
|--------------------------|------|------|------|------|------|------|
| Int Delay, s/veh | 2.1 | | | | | |
| Movement | EBT | EBR | WBL | WBT | NBL | NBR |
| Lane Configurations | ↔ | | ↔ | ↑ | ↔ | ↔ |
| Traffic Vol, veh/h | 401 | 31 | 56 | 599 | 31 | 127 |
| Future Vol, veh/h | 401 | 31 | 56 | 599 | 31 | 127 |
| Conflicting Peds, #/hr | 0 | 0 | 0 | 0 | 0 | 0 |
| Sign Control | Free | Free | Free | Free | Stop | Stop |
| RT Channelized | - | None | - | None | - | None |
| Storage Length | - | - | 155 | - | 205 | 0 |
| Veh in Median Storage, # | 0 | - | - | 0 | 0 | - |
| Grade, % | 0 | - | - | 0 | 0 | - |
| Peak Hour Factor | 92 | 92 | 92 | 92 | 92 | 92 |
| Heavy Vehicles, % | 2 | 2 | 2 | 2 | 2 | 2 |
| Mvmt Flow | 436 | 34 | 61 | 651 | 34 | 138 |

| Major/Minor | Major1 | Major2 | Minor1 | | | |
|----------------------|--------|--------|--------|---|-------|-------|
| Conflicting Flow All | 0 | 0 | 470 | 0 | 1226 | 453 |
| Stage 1 | - | - | - | - | 453 | - |
| Stage 2 | - | - | - | - | 773 | - |
| Critical Hdwy | - | - | 4.12 | - | 6.42 | 6.22 |
| Critical Hdwy Stg 1 | - | - | - | - | 5.42 | - |
| Critical Hdwy Stg 2 | - | - | - | - | 5.42 | - |
| Follow-up Hdwy | - | - | 2.218 | - | 3.518 | 3.318 |
| Pot Cap-1 Maneuver | - | - | 1092 | - | 197 | 607 |
| Stage 1 | - | - | - | - | 640 | - |
| Stage 2 | - | - | - | - | 455 | - |
| Platoon blocked, % | - | - | - | - | - | - |
| Mov Cap-1 Maneuver | - | - | 1092 | - | 186 | 607 |
| Mov Cap-2 Maneuver | - | - | - | - | 315 | - |
| Stage 1 | - | - | - | - | 640 | - |
| Stage 2 | - | - | - | - | 430 | - |

| Approach | EB | WB | NB |
|----------------------|----|-----|------|
| HCM Control Delay, s | 0 | 0.7 | 13.7 |
| HCM LOS | | | B |

| Minor Lane/Major Mvmt | NBLn1 | NBLn2 | EBT | EBR | WBL | WBT |
|-----------------------|-------|-------|-----|-----|-------|-----|
| Capacity (veh/h) | 315 | 607 | - | - | 1092 | - |
| HCM Lane V/C Ratio | 0.107 | 0.227 | - | - | 0.056 | - |
| HCM Control Delay (s) | 17.8 | 12.7 | - | - | 8.5 | - |
| HCM Lane LOS | C | B | - | - | A | - |
| HCM 95th %tile Q(veh) | 0.4 | 0.9 | - | - | 0.2 | - |

Intersection

Int Delay, s/veh 0.3

Movement EBL EBT WBT WBR SBL SBR

| | | | | | | |
|--------------------------|------|------|------|------|------|------|
| Lane Configurations | | | | | | |
| Traffic Vol, veh/h | 2 | 526 | 650 | 7 | 20 | 5 |
| Future Vol, veh/h | 2 | 526 | 650 | 7 | 20 | 5 |
| Conflicting Peds, #/hr | 0 | 0 | 0 | 0 | 0 | 0 |
| Sign Control | Free | Free | Free | Free | Stop | Stop |
| RT Channelized | - | None | - | None | - | None |
| Storage Length | 155 | - | - | - | 0 | - |
| Veh in Median Storage, # | - | 0 | 0 | - | 0 | - |
| Grade, % | - | 0 | 0 | - | 0 | - |
| Peak Hour Factor | 92 | 92 | 92 | 92 | 92 | 92 |
| Heavy Vehicles, % | 2 | 2 | 2 | 2 | 2 | 2 |
| Mvmt Flow | 2 | 572 | 707 | 8 | 22 | 5 |

Major/Minor Major1 Major2 Minor2

| | | | | | | |
|----------------------|-------|---|---|---|-------|-------|
| Conflicting Flow All | 715 | 0 | - | 0 | 1287 | 711 |
| Stage 1 | - | - | - | - | 711 | - |
| Stage 2 | - | - | - | - | 576 | - |
| Critical Hdwy | 4.12 | - | - | - | 6.42 | 6.22 |
| Critical Hdwy Stg 1 | - | - | - | - | 5.42 | - |
| Critical Hdwy Stg 2 | - | - | - | - | 5.42 | - |
| Follow-up Hdwy | 2.218 | - | - | - | 3.518 | 3.318 |
| Pot Cap-1 Maneuver | 885 | - | - | - | 181 | 433 |
| Stage 1 | - | - | - | - | 487 | - |
| Stage 2 | - | - | - | - | 562 | - |
| Platoon blocked, % | | - | - | - | | |
| Mov Cap-1 Maneuver | 885 | - | - | - | 181 | 433 |
| Mov Cap-2 Maneuver | - | - | - | - | 320 | - |
| Stage 1 | - | - | - | - | 486 | - |
| Stage 2 | - | - | - | - | 562 | - |

Approach EB WB SB

| | | | |
|----------------------|---|---|------|
| HCM Control Delay, s | 0 | 0 | 16.6 |
| HCM LOS | | | C |

Minor Lane/Major Mvmt EBL EBT WBT WBR SBLn1

| | | | | | |
|-----------------------|-------|---|---|---|------|
| Capacity (veh/h) | 885 | - | - | - | 338 |
| HCM Lane V/C Ratio | 0.002 | - | - | - | 0.08 |
| HCM Control Delay (s) | 9.1 | - | - | - | 16.6 |
| HCM Lane LOS | A | - | - | - | C |
| HCM 95th %tile Q(veh) | 0 | - | - | - | 0.3 |

| Intersection | | | | | | |
|--------------------------|------|------|------|------|------|------|
| Int Delay, s/veh | 5 | | | | | |
| Movement | WBL | WBR | NBT | NBR | SBL | SBT |
| Lane Configurations | ↘ | ↗ | ↑ | ↗ | ↘ | ↑ |
| Traffic Vol, veh/h | 194 | 4 | 441 | 58 | 1 | 816 |
| Future Vol, veh/h | 194 | 4 | 441 | 58 | 1 | 816 |
| Conflicting Peds, #/hr | 0 | 0 | 0 | 0 | 0 | 0 |
| Sign Control | Stop | Stop | Free | Free | Free | Free |
| RT Channelized | - | None | - | None | - | None |
| Storage Length | 0 | 0 | - | 155 | 205 | - |
| Veh in Median Storage, # | 0 | - | 0 | - | - | 0 |
| Grade, % | 0 | - | 0 | - | - | 0 |
| Peak Hour Factor | 95 | 95 | 95 | 95 | 95 | 95 |
| Heavy Vehicles, % | 2 | 2 | 2 | 2 | 2 | 2 |
| Mvmt Flow | 204 | 4 | 464 | 61 | 1 | 859 |

| Major/Minor | Minor1 | Major1 | Major2 | | |
|----------------------|--------|--------|--------|---|-------|
| Conflicting Flow All | 1325 | 464 | 0 | 0 | 525 |
| Stage 1 | 464 | - | - | - | - |
| Stage 2 | 861 | - | - | - | - |
| Critical Hdwy | 6.42 | 6.22 | - | - | 4.12 |
| Critical Hdwy Stg 1 | 5.42 | - | - | - | - |
| Critical Hdwy Stg 2 | 5.42 | - | - | - | - |
| Follow-up Hdwy | 3.518 | 3.318 | - | - | 2.218 |
| Pot Cap-1 Maneuver | ~ 172 | 598 | - | - | 1042 |
| Stage 1 | 633 | - | - | - | - |
| Stage 2 | 414 | - | - | - | - |
| Platoon blocked, % | | | - | - | - |
| Mov Cap-1 Maneuver | ~ 172 | 598 | - | - | 1042 |
| Mov Cap-2 Maneuver | 302 | - | - | - | - |
| Stage 1 | 633 | - | - | - | - |
| Stage 2 | 414 | - | - | - | - |

| Approach | WB | NB | SB |
|----------------------|----|----|----|
| HCM Control Delay, s | 38 | 0 | 0 |
| HCM LOS | E | | |

| Minor Lane/Major Mvmt | NBT | NBRWBLn1 | WBLn2 | SBL | SBT |
|-----------------------|-----|----------|-------|-------|-------|
| Capacity (veh/h) | - | - | 302 | 598 | 1042 |
| HCM Lane V/C Ratio | - | - | 0.676 | 0.007 | 0.001 |
| HCM Control Delay (s) | - | - | 38.6 | 11.1 | 8.5 |
| HCM Lane LOS | - | - | E | B | A |
| HCM 95th %tile Q(veh) | - | - | 4.6 | 0 | 0 |

Notes
 ~: Volume exceeds capacity \$: Delay exceeds 300s +: Computation Not Defined *: All major volume in platoon

| Intersection | | | | | | |
|--------------------------|------|------|------|------|------|------|
| Int Delay, s/veh | 1.4 | | | | | |
| Movement | WBL | WBR | NBT | NBR | SBL | SBT |
| Lane Configurations | ↘ | ↗ | ↑ | ↗ | ↘ | ↑ |
| Traffic Vol, veh/h | 60 | 19 | 480 | 20 | 7 | 1002 |
| Future Vol, veh/h | 60 | 19 | 480 | 20 | 7 | 1002 |
| Conflicting Peds, #/hr | 0 | 0 | 0 | 0 | 0 | 0 |
| Sign Control | Stop | Stop | Free | Free | Free | Free |
| RT Channelized | - | None | - | None | - | None |
| Storage Length | 0 | 115 | - | 155 | 205 | - |
| Veh in Median Storage, # | 0 | - | 0 | - | - | 0 |
| Grade, % | 0 | - | 0 | - | - | 0 |
| Peak Hour Factor | 85 | 85 | 85 | 85 | 85 | 85 |
| Heavy Vehicles, % | 2 | 2 | 2 | 2 | 2 | 2 |
| Mvmt Flow | 71 | 22 | 565 | 24 | 8 | 1179 |

| Major/Minor | Minor1 | Major1 | Major2 | | |
|----------------------|--------|--------|--------|---|-------|
| Conflicting Flow All | 1760 | 565 | 0 | 0 | 589 |
| Stage 1 | 565 | - | - | - | - |
| Stage 2 | 1195 | - | - | - | - |
| Critical Hdwy | 6.42 | 6.22 | - | - | 4.12 |
| Critical Hdwy Stg 1 | 5.42 | - | - | - | - |
| Critical Hdwy Stg 2 | 5.42 | - | - | - | - |
| Follow-up Hdwy | 3.518 | 3.318 | - | - | 2.218 |
| Pot Cap-1 Maneuver | 93 | 524 | - | - | 986 |
| Stage 1 | 569 | - | - | - | - |
| Stage 2 | 287 | - | - | - | - |
| Platoon blocked, % | | | - | - | - |
| Mov Cap-1 Maneuver | 92 | 524 | - | - | 986 |
| Mov Cap-2 Maneuver | 209 | - | - | - | - |
| Stage 1 | 569 | - | - | - | - |
| Stage 2 | 285 | - | - | - | - |

| Approach | WB | NB | SB |
|----------------------|------|----|-----|
| HCM Control Delay, s | 26.3 | 0 | 0.1 |
| HCM LOS | D | | |

| Minor Lane/Major Mvmt | NBT | NBRWBLn1 | WBLn2 | SBL | SBT |
|-----------------------|-----|----------|-------|-------|-------|
| Capacity (veh/h) | - | - | 209 | 524 | 986 |
| HCM Lane V/C Ratio | - | - | 0.338 | 0.043 | 0.008 |
| HCM Control Delay (s) | - | - | 30.8 | 12.2 | 8.7 |
| HCM Lane LOS | - | - | D | B | A |
| HCM 95th %tile Q(veh) | - | - | 1.4 | 0.1 | 0 |

| Intersection | | | | | | |
|--------------------------|------|------|------|------|------|------|
| Int Delay, s/veh | 29.5 | | | | | |
| Movement | EBL | EBR | NBL | NBT | SBT | SBR |
| Lane Configurations | ↘ | ↗ | ↘ | ↗ | ↗ | ↘ |
| Traffic Vol, veh/h | 77 | 299 | 340 | 420 | 1030 | 132 |
| Future Vol, veh/h | 77 | 299 | 340 | 420 | 1030 | 132 |
| Conflicting Peds, #/hr | 0 | 0 | 0 | 0 | 0 | 0 |
| Sign Control | Stop | Stop | Free | Free | Free | Free |
| RT Channelized | - | None | - | None | - | None |
| Storage Length | 0 | 0 | 0 | - | - | 155 |
| Veh in Median Storage, # | 0 | - | - | 0 | 0 | - |
| Grade, % | 0 | - | - | 0 | 0 | - |
| Peak Hour Factor | 95 | 95 | 95 | 95 | 95 | 95 |
| Heavy Vehicles, % | 2 | 2 | 2 | 2 | 2 | 2 |
| Mvmt Flow | 81 | 315 | 358 | 442 | 1084 | 139 |

| Major/Minor | Minor2 | Major1 | Major2 | | | |
|----------------------|--------|--------|--------|---|---|---|
| Conflicting Flow All | 2242 | 1084 | 1223 | 0 | - | 0 |
| Stage 1 | 1084 | - | - | - | - | - |
| Stage 2 | 1158 | - | - | - | - | - |
| Critical Hdwy | 6.42 | 6.22 | 4.12 | - | - | - |
| Critical Hdwy Stg 1 | 5.42 | - | - | - | - | - |
| Critical Hdwy Stg 2 | 5.42 | - | - | - | - | - |
| Follow-up Hdwy | 3.518 | 3.318 | 2.218 | - | - | - |
| Pot Cap-1 Maneuver | ~ 46 | ~ 264 | 570 | - | - | - |
| Stage 1 | 324 | - | - | - | - | - |
| Stage 2 | 299 | - | - | - | - | - |
| Platoon blocked, % | | | | - | - | - |
| Mov Cap-1 Maneuver | ~ 17 | ~ 264 | 570 | - | - | - |
| Mov Cap-2 Maneuver | 85 | - | - | - | - | - |
| Stage 1 | 121 | - | - | - | - | - |
| Stage 2 | 299 | - | - | - | - | - |

| Approach | EB | NB | SB |
|----------------------|-------|-----|----|
| HCM Control Delay, s | 160.6 | 9.6 | 0 |
| HCM LOS | F | | |

| Minor Lane/Major Mvmt | NBL | NBT | EBLn1 | EBLn2 | SBT | SBR |
|-----------------------|-------|-----|-------|-------|-----|-----|
| Capacity (veh/h) | 570 | - | 85 | 264 | - | - |
| HCM Lane V/C Ratio | 0.628 | - | 0.954 | 1.192 | - | - |
| HCM Control Delay (s) | 21.4 | - | 172.1 | 157.7 | - | - |
| HCM Lane LOS | C | - | F | F | - | - |
| HCM 95th %tile Q(veh) | 4.3 | - | 5.3 | 14.5 | - | - |

Notes
 ~: Volume exceeds capacity \$: Delay exceeds 300s +: Computation Not Defined *: All major volume in platoon

| Intersection | | | | | | |
|--------------------------|------|------|------|------|------|------|
| Int Delay, s/veh | 1 | | | | | |
| Movement | EBL | EBR | NBL | NBT | SBT | SBR |
| Lane Configurations | Y | | Y | ↑ | ↑ | Y |
| Traffic Vol, veh/h | 22 | 2 | 1 | 136 | 60 | 27 |
| Future Vol, veh/h | 22 | 2 | 1 | 136 | 60 | 27 |
| Conflicting Peds, #/hr | 0 | 0 | 0 | 0 | 0 | 0 |
| Sign Control | Stop | Stop | Free | Free | Free | Free |
| RT Channelized | - | None | - | None | - | None |
| Storage Length | 0 | - | 205 | - | - | 205 |
| Veh in Median Storage, # | 0 | - | - | 0 | 0 | - |
| Grade, % | 0 | - | - | 0 | 0 | - |
| Peak Hour Factor | 92 | 92 | 92 | 92 | 92 | 92 |
| Heavy Vehicles, % | 2 | 2 | 2 | 2 | 2 | 2 |
| Mvmt Flow | 24 | 2 | 1 | 148 | 65 | 29 |

| Major/Minor | Minor2 | Major1 | | Major2 | |
|----------------------|--------|--------|-------|--------|---|
| Conflicting Flow All | 215 | 65 | 94 | 0 | 0 |
| Stage 1 | 65 | - | - | - | - |
| Stage 2 | 150 | - | - | - | - |
| Critical Hdwy | 6.42 | 6.22 | 4.12 | - | - |
| Critical Hdwy Stg 1 | 5.42 | - | - | - | - |
| Critical Hdwy Stg 2 | 5.42 | - | - | - | - |
| Follow-up Hdwy | 3.518 | 3.318 | 2.218 | - | - |
| Pot Cap-1 Maneuver | 773 | 999 | 1500 | - | - |
| Stage 1 | 958 | - | - | - | - |
| Stage 2 | 878 | - | - | - | - |
| Platoon blocked, % | | | | - | - |
| Mov Cap-1 Maneuver | 772 | 999 | 1500 | - | - |
| Mov Cap-2 Maneuver | 772 | - | - | - | - |
| Stage 1 | 957 | - | - | - | - |
| Stage 2 | 878 | - | - | - | - |

| Approach | EB | NB | SB |
|----------------------|-----|-----|----|
| HCM Control Delay, s | 9.7 | 0.1 | 0 |
| HCM LOS | A | | |

| Minor Lane/Major Mvmt | NBL | NBT | EBLn1 | SBT | SBR |
|-----------------------|-------|-----|-------|-----|-----|
| Capacity (veh/h) | 1500 | - | 787 | - | - |
| HCM Lane V/C Ratio | 0.001 | - | 0.033 | - | - |
| HCM Control Delay (s) | 7.4 | - | 9.7 | - | - |
| HCM Lane LOS | A | - | A | - | - |
| HCM 95th %tile Q(veh) | 0 | - | 0.1 | - | - |

| Intersection | | | | | | |
|--------------------------|------|------|------|------|------|------|
| Int Delay, s/veh | 0.1 | | | | | |
| Movement | EBL | EBR | NBL | NBT | SBT | SBR |
| Lane Configurations | | ↗ | | ↑ | ↘ | |
| Traffic Vol, veh/h | 0 | 2 | 0 | 136 | 53 | 9 |
| Future Vol, veh/h | 0 | 2 | 0 | 136 | 53 | 9 |
| Conflicting Peds, #/hr | 0 | 0 | 0 | 0 | 0 | 0 |
| Sign Control | Stop | Stop | Free | Free | Free | Free |
| RT Channelized | - | None | - | None | - | None |
| Storage Length | - | 0 | - | - | - | - |
| Veh in Median Storage, # | 0 | - | - | 0 | 0 | - |
| Grade, % | 0 | - | - | 0 | 0 | - |
| Peak Hour Factor | 92 | 92 | 92 | 92 | 92 | 92 |
| Heavy Vehicles, % | 2 | 2 | 2 | 2 | 2 | 2 |
| Mvmt Flow | 0 | 2 | 0 | 148 | 58 | 10 |

| Major/Minor | Minor2 | Major1 | Major2 | | |
|----------------------|--------|--------|--------|---|---|
| Conflicting Flow All | - | 63 | - | 0 | - |
| Stage 1 | - | - | - | - | - |
| Stage 2 | - | - | - | - | - |
| Critical Hdwy | - | 6.22 | - | - | - |
| Critical Hdwy Stg 1 | - | - | - | - | - |
| Critical Hdwy Stg 2 | - | - | - | - | - |
| Follow-up Hdwy | - | 3.318 | - | - | - |
| Pot Cap-1 Maneuver | 0 | 1002 | 0 | - | - |
| Stage 1 | 0 | - | 0 | - | - |
| Stage 2 | 0 | - | 0 | - | - |
| Platoon blocked, % | | | | - | - |
| Mov Cap-1 Maneuver | - | 1002 | - | - | - |
| Mov Cap-2 Maneuver | - | - | - | - | - |
| Stage 1 | - | - | - | - | - |
| Stage 2 | - | - | - | - | - |

| Approach | EB | NB | SB |
|----------------------|-----|----|----|
| HCM Control Delay, s | 8.6 | 0 | 0 |
| HCM LOS | A | | |

| Minor Lane/Major Mvmt | NBT EBLn1 | SBT | SBR |
|-----------------------|-----------|-----|-----|
| Capacity (veh/h) | - 1002 | - | - |
| HCM Lane V/C Ratio | - 0.002 | - | - |
| HCM Control Delay (s) | - 8.6 | - | - |
| HCM Lane LOS | - A | - | - |
| HCM 95th %tile Q(veh) | - 0 | - | - |

| Intersection | | | | | | |
|--------------------------|------|------|------|------|------|------|
| Int Delay, s/veh | 4.7 | | | | | |
| Movement | EBL | EBT | WBT | WBR | SBL | SBR |
| Lane Configurations | | ↖ | ↗ | | ↖ | ↗ |
| Traffic Vol, veh/h | 69 | 4 | 27 | 67 | 28 | 28 |
| Future Vol, veh/h | 69 | 4 | 27 | 67 | 28 | 28 |
| Conflicting Peds, #/hr | 0 | 0 | 0 | 0 | 0 | 0 |
| Sign Control | Free | Free | Free | Free | Stop | Stop |
| RT Channelized | - | None | - | None | - | None |
| Storage Length | - | - | - | - | 0 | 0 |
| Veh in Median Storage, # | - | 0 | 0 | - | 0 | - |
| Grade, % | - | 0 | 0 | - | 0 | - |
| Peak Hour Factor | 92 | 92 | 92 | 92 | 92 | 92 |
| Heavy Vehicles, % | 2 | 2 | 2 | 2 | 2 | 2 |
| Mvmt Flow | 75 | 4 | 29 | 73 | 30 | 30 |

| Major/Minor | Major1 | Major2 | Minor2 | | |
|----------------------|--------|--------|--------|---|-------|
| Conflicting Flow All | 102 | 0 | - | 0 | 220 |
| Stage 1 | - | - | - | - | 66 |
| Stage 2 | - | - | - | - | 154 |
| Critical Hdwy | 4.12 | - | - | - | 6.42 |
| Critical Hdwy Stg 1 | - | - | - | - | 5.42 |
| Critical Hdwy Stg 2 | - | - | - | - | 5.42 |
| Follow-up Hdwy | 2.218 | - | - | - | 3.518 |
| Pot Cap-1 Maneuver | 1490 | - | - | - | 768 |
| Stage 1 | - | - | - | - | 957 |
| Stage 2 | - | - | - | - | 874 |
| Platoon blocked, % | | - | - | - | |
| Mov Cap-1 Maneuver | 1490 | - | - | - | 730 |
| Mov Cap-2 Maneuver | - | - | - | - | 730 |
| Stage 1 | - | - | - | - | 909 |
| Stage 2 | - | - | - | - | 874 |

| Approach | EB | WB | SB |
|----------------------|-----|----|-----|
| HCM Control Delay, s | 7.1 | 0 | 9.4 |
| HCM LOS | | | A |

| Minor Lane/Major Mvmt | EBL | EBT | WBT | WBR | SBLn1 | SBLn2 |
|-----------------------|------|-----|-----|-----|-------|-------|
| Capacity (veh/h) | 1490 | - | - | - | 730 | 998 |
| HCM Lane V/C Ratio | 0.05 | - | - | - | 0.042 | 0.03 |
| HCM Control Delay (s) | 7.5 | 0 | - | - | 10.1 | 8.7 |
| HCM Lane LOS | A | A | - | - | B | A |
| HCM 95th %tile Q(veh) | 0.2 | - | - | - | 0.1 | 0.1 |

Timings
1: Eastonville Rd & Rex Rd

2041 Total Traffic
AM Peak Hour

| Lane Group | EBL | EBT | EBR | WBL | WBT | WBR | NBL | NBT | NBR | SBL | SBT | SBR |
|----------------------|-------|-------|-------|-------|-------|-------|-------|-------|-------|-------|-------|-------|
| Lane Configurations | | | | | | | | | | | | |
| Traffic Volume (vph) | 23 | 163 | 150 | 453 | 149 | 28 | 99 | 102 | 243 | 26 | 211 | 59 |
| Future Volume (vph) | 23 | 163 | 150 | 453 | 149 | 28 | 99 | 102 | 243 | 26 | 211 | 59 |
| Turn Type | pm+pt | NA | Perm | pm+pt | NA | Perm | pm+pt | NA | Perm | pm+pt | NA | Perm |
| Protected Phases | 5 | 2 | | 1 | 6 | | 3 | 8 | | 7 | 4 | |
| Permitted Phases | 2 | | 2 | 6 | | 6 | 8 | | 8 | 4 | | 4 |
| Detector Phase | 5 | 2 | 2 | 1 | 6 | 6 | 3 | 8 | 8 | 7 | 4 | 4 |
| Switch Phase | | | | | | | | | | | | |
| Minimum Initial (s) | 5.0 | 5.0 | 5.0 | 5.0 | 5.0 | 5.0 | 5.0 | 5.0 | 5.0 | 5.0 | 5.0 | 5.0 |
| Minimum Split (s) | 10.0 | 20.0 | 20.0 | 10.0 | 20.0 | 20.0 | 10.0 | 20.0 | 20.0 | 10.0 | 20.0 | 20.0 |
| Total Split (s) | 10.0 | 38.0 | 38.0 | 20.0 | 48.0 | 48.0 | 12.0 | 30.0 | 30.0 | 12.0 | 30.0 | 30.0 |
| Total Split (%) | 10.0% | 38.0% | 38.0% | 20.0% | 48.0% | 48.0% | 12.0% | 30.0% | 30.0% | 12.0% | 30.0% | 30.0% |
| Yellow Time (s) | 3.0 | 3.0 | 3.0 | 3.0 | 3.0 | 3.0 | 3.0 | 3.0 | 3.0 | 3.0 | 3.0 | 3.0 |
| All-Red Time (s) | 2.0 | 2.0 | 2.0 | 2.0 | 2.0 | 2.0 | 2.0 | 2.0 | 2.0 | 2.0 | 2.0 | 2.0 |
| Lost Time Adjust (s) | 0.0 | 0.0 | 0.0 | 0.0 | 0.0 | 0.0 | 0.0 | 0.0 | 0.0 | 0.0 | 0.0 | 0.0 |
| Total Lost Time (s) | 5.0 | 5.0 | 5.0 | 5.0 | 5.0 | 5.0 | 5.0 | 5.0 | 5.0 | 5.0 | 5.0 | 5.0 |
| Lead/Lag | Lead | Lag | Lag | Lead | Lag | Lag | Lead | Lag | Lag | Lead | Lag | Lag |
| Lead-Lag Optimize? | Yes | Yes | Yes | Yes | Yes | Yes | Yes | Yes | Yes | Yes | Yes | Yes |
| Recall Mode | None | Min | Min | None | Min | Min | None | None | None | None | None | None |
| Act Effct Green (s) | 17.1 | 11.9 | 11.9 | 31.3 | 27.9 | 27.9 | 20.4 | 18.0 | 18.0 | 17.9 | 13.2 | 13.2 |
| Actuated g/C Ratio | 0.27 | 0.19 | 0.19 | 0.49 | 0.44 | 0.44 | 0.32 | 0.28 | 0.28 | 0.28 | 0.21 | 0.21 |
| v/c Ratio | 0.06 | 0.50 | 0.36 | 0.76 | 0.19 | 0.04 | 0.29 | 0.20 | 0.41 | 0.07 | 0.58 | 0.13 |
| Control Delay | 12.3 | 31.2 | 5.6 | 23.6 | 15.9 | 0.1 | 17.0 | 21.6 | 5.9 | 14.8 | 31.5 | 0.6 |
| Queue Delay | 0.0 | 0.0 | 0.0 | 0.0 | 0.0 | 0.0 | 0.0 | 0.0 | 0.0 | 0.0 | 0.0 | 0.0 |
| Total Delay | 12.3 | 31.2 | 5.6 | 23.6 | 15.9 | 0.1 | 17.0 | 21.6 | 5.9 | 14.8 | 31.5 | 0.6 |
| LOS | B | C | A | C | B | A | B | C | A | B | C | A |
| Approach Delay | | 18.5 | | | 20.8 | | | 12.0 | | | 23.8 | |
| Approach LOS | | B | | | C | | | B | | | C | |

Intersection Summary

Cycle Length: 100
 Actuated Cycle Length: 64
 Natural Cycle: 65
 Control Type: Actuated-Uncoordinated
 Maximum v/c Ratio: 0.76
 Intersection Signal Delay: 18.6
 Intersection LOS: B
 Intersection Capacity Utilization 66.9%
 ICU Level of Service C
 Analysis Period (min) 15

Splits and Phases: 1: Eastonville Rd & Rex Rd

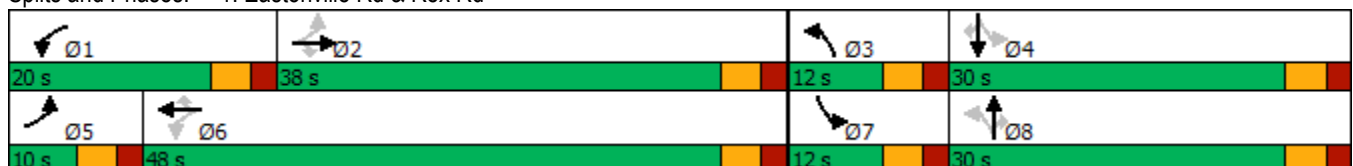

Timings
9: US 24 & Rex Rd

2041 Total Traffic
AM Peak Hour



| Lane Group | EBL | EBR | NBL | NBT | SBT | SBR |
|----------------------|-------|-------|-------|-------|-------|-------|
| Lane Configurations | ↖ | ↗ | ↖↗ | ↕ | ↕ | ↗ |
| Traffic Volume (vph) | 105 | 1064 | 523 | 385 | 536 | 85 |
| Future Volume (vph) | 105 | 1064 | 523 | 385 | 536 | 85 |
| Turn Type | Prot | Free | Prot | NA | NA | Perm |
| Protected Phases | 6! | | 7 | Free! | 8 | |
| Permitted Phases | | Free | | | | 8 |
| Detector Phase | 6 | | 7 | | 8 | 8 |
| Switch Phase | | | | | | |
| Minimum Initial (s) | 5.0 | | 5.0 | | 5.0 | 5.0 |
| Minimum Split (s) | 20.0 | | 10.0 | | 20.0 | 20.0 |
| Total Split (s) | 24.0 | | 36.0 | | 60.0 | 60.0 |
| Total Split (%) | 20.0% | | 30.0% | | 50.0% | 50.0% |
| Yellow Time (s) | 3.0 | | 3.0 | | 3.0 | 3.0 |
| All-Red Time (s) | 2.0 | | 2.0 | | 2.0 | 2.0 |
| Lost Time Adjust (s) | 0.0 | | 0.0 | | 0.0 | 0.0 |
| Total Lost Time (s) | 5.0 | | 5.0 | | 5.0 | 5.0 |
| Lead/Lag | | | Lead | | Lag | Lag |
| Lead-Lag Optimize? | | | Yes | | Yes | Yes |
| Recall Mode | Max | | None | | C-Max | C-Max |
| Act Effct Green (s) | 19.0 | 120.0 | 24.4 | 120.0 | 61.6 | 61.6 |
| Actuated g/C Ratio | 0.16 | 1.00 | 0.20 | 1.00 | 0.51 | 0.51 |
| v/c Ratio | 0.40 | 0.71 | 0.79 | 0.11 | 0.31 | 0.10 |
| Control Delay | 50.2 | 2.7 | 41.1 | 0.1 | 18.1 | 3.8 |
| Queue Delay | 0.0 | 0.0 | 0.0 | 0.0 | 0.0 | 0.0 |
| Total Delay | 50.2 | 2.7 | 41.1 | 0.1 | 18.1 | 3.8 |
| LOS | D | A | D | A | B | A |
| Approach Delay | 7.0 | | | 24.0 | 16.2 | |
| Approach LOS | A | | | C | B | |

Intersection Summary

Cycle Length: 120
 Actuated Cycle Length: 120
 Offset: 50 (42%), Referenced to phase 8:SBT, Start of Green
 Natural Cycle: 55
 Control Type: Actuated-Coordinated
 Maximum v/c Ratio: 0.79
 Intersection Signal Delay: 14.8
 Intersection LOS: B
 Intersection Capacity Utilization 47.2%
 ICU Level of Service A
 Analysis Period (min) 15

! Phase conflict between lane groups.

Splits and Phases: 9: US 24 & Rex Rd

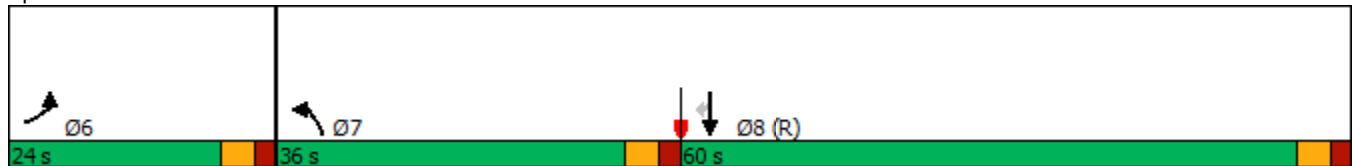

Timings
10: Eastonville Rd & Dawlish Dr

2041 Total Traffic
AM Peak Hour

| Lane Group | WBL | WBR | NBT | NBR | SBL | SBT |
|----------------------|-------|-------|-------|-------|-------|-------|
| Lane Configurations | | | | | | |
| Traffic Volume (vph) | 194 | 4 | 441 | 58 | 1 | 816 |
| Future Volume (vph) | 194 | 4 | 441 | 58 | 1 | 816 |
| Turn Type | Prot | Perm | NA | Perm | Perm | NA |
| Protected Phases | 8 | | 2 | | | 6 |
| Permitted Phases | | 8 | | 2 | 6 | |
| Detector Phase | 8 | 8 | 2 | 2 | 6 | 6 |
| Switch Phase | | | | | | |
| Minimum Initial (s) | 5.0 | 5.0 | 5.0 | 5.0 | 5.0 | 5.0 |
| Minimum Split (s) | 20.0 | 20.0 | 20.0 | 20.0 | 20.0 | 20.0 |
| Total Split (s) | 25.0 | 25.0 | 65.0 | 65.0 | 65.0 | 65.0 |
| Total Split (%) | 27.8% | 27.8% | 72.2% | 72.2% | 72.2% | 72.2% |
| Yellow Time (s) | 3.0 | 3.0 | 3.0 | 3.0 | 3.0 | 3.0 |
| All-Red Time (s) | 2.0 | 2.0 | 2.0 | 2.0 | 2.0 | 2.0 |
| Lost Time Adjust (s) | 0.0 | 0.0 | 0.0 | 0.0 | 0.0 | 0.0 |
| Total Lost Time (s) | 5.0 | 5.0 | 5.0 | 5.0 | 5.0 | 5.0 |
| Lead/Lag | | | | | | |
| Lead-Lag Optimize? | | | | | | |
| Recall Mode | None | None | Max | Max | Max | Max |
| Act Effct Green (s) | 14.7 | 14.7 | 60.1 | 60.1 | 60.1 | 60.1 |
| Actuated g/C Ratio | 0.17 | 0.17 | 0.71 | 0.71 | 0.71 | 0.71 |
| v/c Ratio | 0.67 | 0.01 | 0.35 | 0.05 | 0.00 | 0.65 |
| Control Delay | 43.8 | 18.2 | 6.2 | 1.5 | 5.0 | 10.4 |
| Queue Delay | 0.0 | 0.0 | 0.0 | 0.0 | 0.0 | 0.0 |
| Total Delay | 43.8 | 18.2 | 6.2 | 1.5 | 5.0 | 10.4 |
| LOS | D | B | A | A | A | B |
| Approach Delay | 43.3 | | 5.7 | | | 10.4 |
| Approach LOS | D | | A | | | B |

Intersection Summary

Cycle Length: 90
 Actuated Cycle Length: 84.8
 Natural Cycle: 60
 Control Type: Semi Act-Uncoord
 Maximum v/c Ratio: 0.67
 Intersection Signal Delay: 13.1
 Intersection Capacity Utilization 62.0%
 Analysis Period (min) 15

Intersection LOS: B
 ICU Level of Service B

Splits and Phases: 10: Eastonville Rd & Dawlish Dr



Timings
12: Eastonville Rd & Londonderry Dr

2041 Total Traffic
AM Peak Hour



| Lane Group | EBL | EBR | NBL | NBT | SBT | SBR |
|----------------------|-------|-------|-------|-------|-------|-------|
| Lane Configurations | | | | | | |
| Traffic Volume (vph) | 77 | 299 | 340 | 420 | 1030 | 132 |
| Future Volume (vph) | 77 | 299 | 340 | 420 | 1030 | 132 |
| Turn Type | Prot | Perm | pm+pt | NA | NA | Perm |
| Protected Phases | 4 | | 5 | 2 | 6 | |
| Permitted Phases | | 4 | 2 | | | 6 |
| Detector Phase | 4 | 4 | 5 | 2 | 6 | 6 |
| Switch Phase | | | | | | |
| Minimum Initial (s) | 4.0 | 4.0 | 4.0 | 4.0 | 4.0 | 4.0 |
| Minimum Split (s) | 9.0 | 9.0 | 9.0 | 9.0 | 9.0 | 9.0 |
| Total Split (s) | 20.0 | 20.0 | 22.0 | 80.0 | 58.0 | 58.0 |
| Total Split (%) | 20.0% | 20.0% | 22.0% | 80.0% | 58.0% | 58.0% |
| Yellow Time (s) | 3.0 | 3.0 | 3.0 | 3.0 | 3.0 | 3.0 |
| All-Red Time (s) | 2.0 | 2.0 | 2.0 | 2.0 | 2.0 | 2.0 |
| Lost Time Adjust (s) | 0.0 | 0.0 | 0.0 | 0.0 | -2.0 | 0.0 |
| Total Lost Time (s) | 5.0 | 5.0 | 5.0 | 5.0 | 3.0 | 5.0 |
| Lead/Lag | | | Lead | | Lag | Lag |
| Lead-Lag Optimize? | | | Yes | | Yes | Yes |
| Recall Mode | None | None | None | None | None | None |
| Act Effct Green (s) | 9.9 | 9.9 | 75.1 | 75.1 | 55.1 | 53.1 |
| Actuated g/C Ratio | 0.10 | 0.10 | 0.79 | 0.79 | 0.58 | 0.56 |
| v/c Ratio | 0.44 | 0.70 | 0.91 | 0.30 | 1.00 | 0.15 |
| Control Delay | 47.2 | 14.0 | 54.4 | 3.6 | 50.4 | 6.1 |
| Queue Delay | 0.0 | 0.0 | 0.0 | 0.0 | 0.0 | 0.0 |
| Total Delay | 47.2 | 14.0 | 54.4 | 3.6 | 50.4 | 6.1 |
| LOS | D | B | D | A | D | A |
| Approach Delay | 20.8 | | | 26.4 | 45.4 | |
| Approach LOS | C | | | C | D | |

Intersection Summary

Cycle Length: 100
 Actuated Cycle Length: 95
 Natural Cycle: 90
 Control Type: Actuated-Uncoordinated
 Maximum v/c Ratio: 1.00
 Intersection Signal Delay: 35.1
 Intersection LOS: D
 Intersection Capacity Utilization 89.0%
 ICU Level of Service E
 Analysis Period (min) 15

Splits and Phases: 12: Eastonville Rd & Londonderry Dr



Timings
13: Eastonville Rd & Stapleton Dr

2041 Total Traffic
AM Peak Hour

| Lane Group | EBL | EBT | EBR | WBL | WBT | WBR | NBL | NBT | NBR | SBL | SBT | SBR |
|----------------------|-------|-------|-------|-------|-------|-------|-------|-------|-------|-------|-------|-------|
| Lane Configurations | | | | | | | | | | | | |
| Traffic Volume (vph) | 170 | 600 | 224 | 145 | 482 | 170 | 108 | 419 | 188 | 207 | 731 | 391 |
| Future Volume (vph) | 170 | 600 | 224 | 145 | 482 | 170 | 108 | 419 | 188 | 207 | 731 | 391 |
| Turn Type | Prot | NA | Perm | pm+pt | NA | Perm | pm+pt | NA | Perm | pm+pt | NA | Perm |
| Protected Phases | 5 | 2 | | 1 | 6 | | 3 | 8 | | 7 | 4 | |
| Permitted Phases | | | 2 | 6 | | 6 | 8 | | 8 | 4 | | 4 |
| Detector Phase | 5 | 2 | 2 | 1 | 6 | 6 | 3 | 8 | 8 | 7 | 4 | 4 |
| Switch Phase | | | | | | | | | | | | |
| Minimum Initial (s) | 4.0 | 4.0 | 4.0 | 4.0 | 4.0 | 4.0 | 4.0 | 4.0 | 4.0 | 4.0 | 4.0 | 4.0 |
| Minimum Split (s) | 8.0 | 21.0 | 21.0 | 8.0 | 21.0 | 21.0 | 9.0 | 21.0 | 21.0 | 9.0 | 21.0 | 21.0 |
| Total Split (s) | 13.0 | 29.0 | 29.0 | 12.0 | 28.0 | 28.0 | 11.0 | 45.0 | 45.0 | 14.0 | 48.0 | 48.0 |
| Total Split (%) | 13.0% | 29.0% | 29.0% | 12.0% | 28.0% | 28.0% | 11.0% | 45.0% | 45.0% | 14.0% | 48.0% | 48.0% |
| Yellow Time (s) | 3.5 | 3.0 | 3.0 | 3.5 | 3.0 | 3.0 | 3.0 | 3.0 | 3.0 | 3.0 | 3.0 | 3.0 |
| All-Red Time (s) | 0.5 | 2.0 | 2.0 | 0.5 | 2.0 | 2.0 | 2.0 | 2.0 | 2.0 | 2.0 | 2.0 | 2.0 |
| Lost Time Adjust (s) | 0.0 | 0.0 | 0.0 | 0.0 | 0.0 | 0.0 | 0.0 | 0.0 | 0.0 | 0.0 | 0.0 | 0.0 |
| Total Lost Time (s) | 4.0 | 5.0 | 5.0 | 4.0 | 5.0 | 5.0 | 5.0 | 5.0 | 5.0 | 5.0 | 5.0 | 5.0 |
| Lead/Lag | Lead | Lag | Lag | Lead | Lag | Lag | Lead | Lag | Lag | Lead | Lag | Lag |
| Lead-Lag Optimize? | Yes | Yes | Yes | Yes | Yes | Yes | Yes | Yes | Yes | Yes | Yes | Yes |
| Recall Mode | None | None | None | None | None | None | None | None | None | None | None | None |
| Act Effct Green (s) | 8.7 | 22.0 | 22.0 | 30.2 | 21.3 | 21.3 | 45.4 | 39.4 | 39.4 | 51.0 | 42.2 | 42.2 |
| Actuated g/C Ratio | 0.09 | 0.23 | 0.23 | 0.31 | 0.22 | 0.22 | 0.47 | 0.41 | 0.41 | 0.52 | 0.43 | 0.43 |
| v/c Ratio | 0.58 | 0.79 | 0.44 | 0.67 | 0.66 | 0.37 | 0.61 | 0.58 | 0.26 | 0.53 | 0.95 | 0.48 |
| Control Delay | 51.5 | 43.5 | 7.4 | 38.8 | 39.3 | 7.3 | 29.2 | 26.8 | 3.8 | 17.0 | 50.0 | 7.0 |
| Queue Delay | 0.0 | 0.0 | 0.0 | 0.0 | 0.0 | 0.0 | 0.0 | 0.0 | 0.0 | 0.0 | 0.0 | 0.0 |
| Total Delay | 51.5 | 43.5 | 7.4 | 38.8 | 39.3 | 7.3 | 29.2 | 26.8 | 3.8 | 17.0 | 50.0 | 7.0 |
| LOS | D | D | A | D | D | A | C | C | A | B | D | A |
| Approach Delay | | 36.7 | | | 32.4 | | | 21.1 | | | 32.2 | |
| Approach LOS | | D | | | C | | | C | | | C | |

Intersection Summary

Cycle Length: 100
 Actuated Cycle Length: 97.2
 Natural Cycle: 80
 Control Type: Actuated-Uncoordinated
 Maximum v/c Ratio: 0.95
 Intersection Signal Delay: 31.3
 Intersection LOS: C
 Intersection Capacity Utilization 84.9%
 ICU Level of Service E
 Analysis Period (min) 15

Splits and Phases: 13: Eastonville Rd & Stapleton Dr

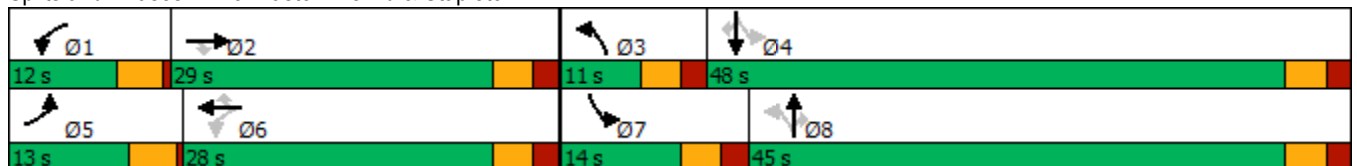

Timings
14: US 24 & Stapleton Dr

2041 Total Traffic
AM Peak Hour

| Lane Group | EBL | EBT | EBR | WBL | WBT | WBR | NBL | NBT | NBR | SBL | SBT | SBR |
|----------------------|-------|-------|-------|-------|-------|-------|-------|-------|-------|-------|-------|-------|
| Lane Configurations | | | | | | | | | | | | |
| Traffic Volume (vph) | 188 | 379 | 583 | 75 | 375 | 121 | 295 | 739 | 50 | 272 | 1460 | 352 |
| Future Volume (vph) | 188 | 379 | 583 | 75 | 375 | 121 | 295 | 739 | 50 | 272 | 1460 | 352 |
| Turn Type | Prot | NA | Free | Prot | NA | Free | Prot | NA | Perm | Prot | NA | Free |
| Protected Phases | 7 | 4 | | 3 | 8 | | 5 | 2 | | 1 | 6 | |
| Permitted Phases | | | Free | | | Free | | | 2 | | | Free |
| Detector Phase | 7 | 4 | | 3 | 8 | | 5 | 2 | 2 | 1 | 6 | |
| Switch Phase | | | | | | | | | | | | |
| Minimum Initial (s) | 5.0 | 5.0 | | 5.0 | 5.0 | | 5.0 | 5.0 | 5.0 | 5.0 | 5.0 | |
| Minimum Split (s) | 10.0 | 10.0 | | 10.0 | 10.0 | | 10.0 | 11.0 | 11.0 | 10.0 | 11.0 | |
| Total Split (s) | 15.0 | 30.0 | | 18.0 | 33.0 | | 12.0 | 60.0 | 60.0 | 12.0 | 60.0 | |
| Total Split (%) | 12.5% | 25.0% | | 15.0% | 27.5% | | 10.0% | 50.0% | 50.0% | 10.0% | 50.0% | |
| Yellow Time (s) | 3.0 | 3.0 | | 3.0 | 3.0 | | 3.0 | 3.0 | 3.0 | 3.0 | 3.0 | |
| All-Red Time (s) | 2.0 | 2.0 | | 2.0 | 2.0 | | 2.0 | 2.0 | 2.0 | 2.0 | 2.0 | |
| Lost Time Adjust (s) | 0.0 | 0.0 | | 0.0 | 0.0 | | 0.0 | 0.0 | 0.0 | 0.0 | 0.0 | |
| Total Lost Time (s) | 5.0 | 5.0 | | 5.0 | 5.0 | | 5.0 | 5.0 | 5.0 | 5.0 | 5.0 | |
| Lead/Lag | Lead | Lag | | Lead | Lag | | Lead | Lag | Lag | Lead | Lag | |
| Lead-Lag Optimize? | Yes | Yes | | Yes | Yes | | Yes | Yes | Yes | Yes | Yes | |
| Recall Mode | None | None | | None | None | | None | C-Max | C-Max | None | C-Max | |
| Act Effct Green (s) | 9.8 | 22.7 | 120.0 | 8.1 | 18.9 | 120.0 | 16.3 | 55.0 | 55.0 | 16.3 | 55.0 | 120.0 |
| Actuated g/C Ratio | 0.08 | 0.19 | 1.00 | 0.07 | 0.16 | 1.00 | 0.14 | 0.46 | 0.46 | 0.14 | 0.46 | 1.00 |
| v/c Ratio | 0.71 | 0.60 | 0.39 | 0.34 | 0.71 | 0.08 | 0.67 | 0.48 | 0.07 | 0.61 | 0.92 | 0.23 |
| Control Delay | 68.1 | 48.9 | 0.7 | 56.9 | 54.9 | 0.1 | 57.9 | 23.8 | 0.2 | 62.3 | 35.6 | 0.3 |
| Queue Delay | 0.0 | 0.0 | 0.0 | 0.0 | 0.0 | 0.0 | 0.0 | 0.0 | 0.0 | 0.0 | 0.0 | 0.0 |
| Total Delay | 68.1 | 48.9 | 0.7 | 56.9 | 54.9 | 0.1 | 57.9 | 23.8 | 0.2 | 62.3 | 35.6 | 0.3 |
| LOS | E | D | A | E | D | A | E | C | A | E | D | A |
| Approach Delay | | 27.6 | | | 43.6 | | | 32.0 | | | 33.0 | |
| Approach LOS | | C | | | D | | | C | | | C | |

Intersection Summary

Cycle Length: 120
 Actuated Cycle Length: 120
 Offset: 0 (0%), Referenced to phase 2:NBT and 6:SBT, Start of Green
 Natural Cycle: 80
 Control Type: Actuated-Coordinated
 Maximum v/c Ratio: 0.92
 Intersection Signal Delay: 32.8
 Intersection LOS: C
 Intersection Capacity Utilization 81.2%
 ICU Level of Service D
 Analysis Period (min) 15

Splits and Phases: 14: US 24 & Stapleton Dr

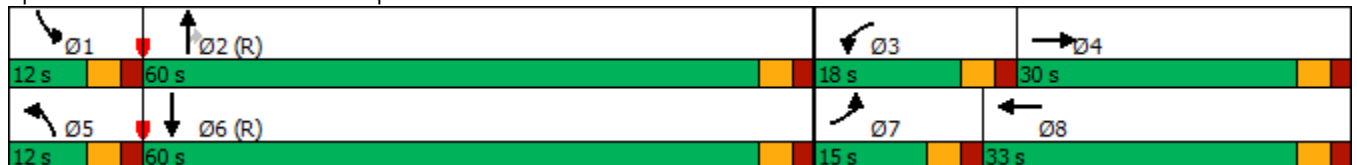

| Intersection | | | | |
|-----------------------------|-------|-------|-------|-------|
| Intersection Delay, s/veh | 11.9 | | | |
| Intersection LOS | B | | | |
| Approach | EB | WB | NB | SB |
| Entry Lanes | 1 | 1 | 1 | 1 |
| Conflicting Circle Lanes | 1 | 1 | 1 | 1 |
| Adj Approach Flow, veh/h | 354 | 663 | 467 | 311 |
| Demand Flow Rate, veh/h | 360 | 677 | 476 | 317 |
| Vehicles Circulating, veh/h | 741 | 239 | 227 | 753 |
| Vehicles Exiting, veh/h | 329 | 464 | 874 | 163 |
| Ped Vol Crossing Leg, #/h | 0 | 0 | 0 | 0 |
| Ped Cap Adj | 1.000 | 1.000 | 1.000 | 1.000 |
| Approach Delay, s/veh | 15.3 | 12.0 | 8.1 | 13.7 |
| Approach LOS | C | B | A | B |
| Lane | Left | Left | Left | Left |
| Designated Moves | LTR | LTR | LTR | LTR |
| Assumed Moves | LTR | LTR | LTR | LTR |
| RT Channelized | | | | |
| Lane Util | 1.000 | 1.000 | 1.000 | 1.000 |
| Follow-Up Headway, s | 2.609 | 2.609 | 2.609 | 2.609 |
| Critical Headway, s | 4.976 | 4.976 | 4.976 | 4.976 |
| Entry Flow, veh/h | 360 | 677 | 476 | 317 |
| Cap Entry Lane, veh/h | 648 | 1081 | 1095 | 640 |
| Entry HV Adj Factor | 0.982 | 0.979 | 0.981 | 0.980 |
| Flow Entry, veh/h | 354 | 663 | 467 | 311 |
| Cap Entry, veh/h | 636 | 1059 | 1074 | 627 |
| V/C Ratio | 0.555 | 0.626 | 0.435 | 0.495 |
| Control Delay, s/veh | 15.3 | 12.0 | 8.1 | 13.7 |
| LOS | C | B | A | B |
| 95th %tile Queue, veh | 3 | 5 | 2 | 3 |

| Intersection | | | |
|-----------------------------|-------|-------|-------|
| Intersection Delay, s/veh | 7.4 | | |
| Intersection LOS | A | | |
| Approach | EB | WB | NB |
| Entry Lanes | 1 | 1 | 1 |
| Conflicting Circle Lanes | 1 | 1 | 1 |
| Adj Approach Flow, veh/h | 455 | 690 | 167 |
| Demand Flow Rate, veh/h | 464 | 704 | 171 |
| Vehicles Circulating, veh/h | 60 | 34 | 430 |
| Vehicles Exiting, veh/h | 678 | 567 | 94 |
| Ped Vol Crossing Leg, #/h | 0 | 0 | 0 |
| Ped Cap Adj | 1.000 | 1.000 | 1.000 |
| Approach Delay, s/veh | 6.2 | 8.4 | 6.1 |
| Approach LOS | A | A | A |
| Lane | Left | Left | Left |
| Designated Moves | TR | LT | LR |
| Assumed Moves | TR | LT | LR |
| RT Channelized | | | |
| Lane Util | 1.000 | 1.000 | 1.000 |
| Follow-Up Headway, s | 2.609 | 2.609 | 2.609 |
| Critical Headway, s | 4.976 | 4.976 | 4.976 |
| Entry Flow, veh/h | 464 | 704 | 171 |
| Cap Entry Lane, veh/h | 1298 | 1333 | 890 |
| Entry HV Adj Factor | 0.980 | 0.981 | 0.977 |
| Flow Entry, veh/h | 455 | 690 | 167 |
| Cap Entry, veh/h | 1272 | 1307 | 869 |
| V/C Ratio | 0.357 | 0.528 | 0.192 |
| Control Delay, s/veh | 6.2 | 8.4 | 6.1 |
| LOS | A | A | A |
| 95th %tile Queue, veh | 2 | 3 | 1 |

| Intersection | | | |
|-----------------------------|-------|-------|-------|
| Intersection Delay, s/veh | 10.8 | | |
| Intersection LOS | B | | |
| Approach | WB | NB | SB |
| Entry Lanes | 1 | 1 | 1 |
| Conflicting Circle Lanes | 2 | 2 | 2 |
| Adj Approach Flow, veh/h | 208 | 525 | 860 |
| Demand Flow Rate, veh/h | 212 | 535 | 877 |
| Vehicles Circulating, veh/h | 473 | 1 | 208 |
| Vehicles Exiting, veh/h | 63 | 1084 | 477 |
| Ped Vol Crossing Leg, #/h | 0 | 0 | 0 |
| Ped Cap Adj | 1.000 | 1.000 | 1.000 |
| Approach Delay, s/veh | 6.1 | 6.0 | 14.9 |
| Approach LOS | A | A | B |
| Lane | Left | Left | Left |
| Designated Moves | LR | TR | LT |
| Assumed Moves | LR | TR | LT |
| RT Channelized | | | |
| Lane Util | 1.000 | 1.000 | 1.000 |
| Follow-Up Headway, s | 2.535 | 2.535 | 2.535 |
| Critical Headway, s | 4.328 | 4.328 | 4.328 |
| Entry Flow, veh/h | 212 | 535 | 877 |
| Cap Entry Lane, veh/h | 950 | 1419 | 1190 |
| Entry HV Adj Factor | 0.981 | 0.981 | 0.980 |
| Flow Entry, veh/h | 208 | 525 | 860 |
| Cap Entry, veh/h | 932 | 1392 | 1167 |
| V/C Ratio | 0.223 | 0.377 | 0.737 |
| Control Delay, s/veh | 6.1 | 6.0 | 14.9 |
| LOS | A | A | B |
| 95th %tile Queue, veh | 1 | 2 | 7 |

| Intersection | | | |
|-----------------------------|-------|-------|-------|
| Intersection Delay, s/veh | 22.9 | | |
| Intersection LOS | C | | |
| Approach | WB | NB | SB |
| Entry Lanes | 1 | 1 | 1 |
| Conflicting Circle Lanes | 1 | 1 | 1 |
| Adj Approach Flow, veh/h | 93 | 589 | 1187 |
| Demand Flow Rate, veh/h | 94 | 600 | 1211 |
| Vehicles Circulating, veh/h | 576 | 8 | 72 |
| Vehicles Exiting, veh/h | 32 | 1275 | 598 |
| Ped Vol Crossing Leg, #/h | 0 | 0 | 0 |
| Ped Cap Adj | 1.000 | 1.000 | 1.000 |
| Approach Delay, s/veh | 6.0 | 6.9 | 32.2 |
| Approach LOS | A | A | D |
| Lane | Left | Left | Left |
| Designated Moves | LR | TR | LT |
| Assumed Moves | LR | TR | LT |
| RT Channelized | | | |
| Lane Util | 1.000 | 1.000 | 1.000 |
| Follow-Up Headway, s | 2.609 | 2.609 | 2.609 |
| Critical Headway, s | 4.976 | 4.976 | 4.976 |
| Entry Flow, veh/h | 94 | 600 | 1211 |
| Cap Entry Lane, veh/h | 767 | 1369 | 1282 |
| Entry HV Adj Factor | 0.989 | 0.981 | 0.981 |
| Flow Entry, veh/h | 93 | 589 | 1187 |
| Cap Entry, veh/h | 759 | 1343 | 1257 |
| V/C Ratio | 0.123 | 0.438 | 0.945 |
| Control Delay, s/veh | 6.0 | 6.9 | 32.2 |
| LOS | A | A | D |
| 95th %tile Queue, veh | 0 | 2 | 17 |

| Intersection | | | | | | |
|-----------------------------|-------|-------|-------|-------|-------|-------|
| Intersection Delay, s/veh | 11.0 | | | | | |
| Intersection LOS | B | | | | | |
| Approach | EB | | NB | | SB | |
| Entry Lanes | 2 | | 2 | | 2 | |
| Conflicting Circle Lanes | 2 | | 2 | | 2 | |
| Adj Approach Flow, veh/h | 396 | | 800 | | 1223 | |
| Demand Flow Rate, veh/h | 404 | | 816 | | 1248 | |
| Vehicles Circulating, veh/h | 1106 | | 83 | | 365 | |
| Vehicles Exiting, veh/h | 507 | | 1427 | | 534 | |
| Ped Vol Crossing Leg, #/h | 0 | | 0 | | 0 | |
| Ped Cap Adj | 1.000 | | 1.000 | | 1.000 | |
| Approach Delay, s/veh | 16.5 | | 5.8 | | 12.6 | |
| Approach LOS | C | | A | | B | |
| Lane | Left | Right | Left | Right | Left | Right |
| Designated Moves | L | TR | L | TR | LT | TR |
| Assumed Moves | L | TR | L | TR | LT | TR |
| RT Channelized | | | | | | |
| Lane Util | 0.205 | 0.795 | 0.447 | 0.553 | 0.470 | 0.530 |
| Follow-Up Headway, s | 2.667 | 2.535 | 2.667 | 2.535 | 2.667 | 2.535 |
| Critical Headway, s | 4.645 | 4.328 | 4.645 | 4.328 | 4.645 | 4.328 |
| Entry Flow, veh/h | 83 | 321 | 365 | 451 | 587 | 661 |
| Cap Entry Lane, veh/h | 488 | 555 | 1251 | 1323 | 965 | 1041 |
| Entry HV Adj Factor | 0.976 | 0.981 | 0.981 | 0.980 | 0.979 | 0.981 |
| Flow Entry, veh/h | 81 | 315 | 358 | 442 | 575 | 648 |
| Cap Entry, veh/h | 476 | 544 | 1227 | 1297 | 945 | 1021 |
| V/C Ratio | 0.170 | 0.579 | 0.292 | 0.341 | 0.608 | 0.635 |
| Control Delay, s/veh | 10.0 | 18.2 | 5.6 | 5.9 | 12.6 | 12.6 |
| LOS | A | C | A | A | B | B |
| 95th %tile Queue, veh | 1 | 4 | 1 | 2 | 4 | 5 |

| Intersection | | | | | | | | | | | | |
|--------------------------|------|------|------|------|------|------|------|------|------|------|------|------|
| Int Delay, s/veh | 24.8 | | | | | | | | | | | |
| Movement | EBL | EBT | EBR | WBL | WBT | WBR | NBL | NBT | NBR | SBL | SBT | SBR |
| Lane Configurations | ↖ | ↗ | ↖ | ↖ | ↗ | ↖ | ↖ | ↗ | ↖ | ↖ | ↗ | ↖ |
| Traffic Vol, veh/h | 77 | 205 | 73 | 280 | 203 | 24 | 78 | 247 | 447 | 28 | 165 | 48 |
| Future Vol, veh/h | 77 | 205 | 73 | 280 | 203 | 24 | 78 | 247 | 447 | 28 | 165 | 48 |
| Conflicting Peds, #/hr | 0 | 0 | 0 | 0 | 0 | 0 | 0 | 0 | 0 | 0 | 0 | 0 |
| Sign Control | Stop | Stop | Stop | Stop | Stop | Stop | Free | Free | Free | Free | Free | Free |
| RT Channelized | - | - | None | - | - | None | - | - | None | - | - | None |
| Storage Length | 205 | - | 155 | 350 | - | 155 | 315 | - | 155 | 205 | - | 155 |
| Veh in Median Storage, # | - | 0 | - | - | 0 | - | - | 0 | - | - | 0 | - |
| Grade, % | - | 0 | - | - | 0 | - | - | 0 | - | - | 0 | - |
| Peak Hour Factor | 95 | 95 | 95 | 95 | 95 | 95 | 95 | 95 | 95 | 95 | 95 | 95 |
| Heavy Vehicles, % | 2 | 2 | 2 | 2 | 2 | 2 | 2 | 2 | 2 | 2 | 2 | 2 |
| Mvmt Flow | 81 | 216 | 77 | 295 | 214 | 25 | 82 | 260 | 471 | 29 | 174 | 51 |

| Major/Minor | Minor2 | | Minor1 | | Major1 | | Major2 | | | | | |
|----------------------|--------|-------|--------|-------|--------|-------|--------|---|---|-------|---|---|
| Conflicting Flow All | 1011 | 1127 | 174 | 828 | 707 | 260 | 225 | 0 | 0 | 731 | 0 | 0 |
| Stage 1 | 232 | 232 | - | 424 | 424 | - | - | - | - | - | - | - |
| Stage 2 | 779 | 895 | - | 404 | 283 | - | - | - | - | - | - | - |
| Critical Hdwy | 7.12 | 6.52 | 6.22 | 7.12 | 6.52 | 6.22 | 4.12 | - | - | 4.12 | - | - |
| Critical Hdwy Stg 1 | 6.12 | 5.52 | - | 6.12 | 5.52 | - | - | - | - | - | - | - |
| Critical Hdwy Stg 2 | 6.12 | 5.52 | - | 6.12 | 5.52 | - | - | - | - | - | - | - |
| Follow-up Hdwy | 3.518 | 4.018 | 3.318 | 3.518 | 4.018 | 3.318 | 2.218 | - | - | 2.218 | - | - |
| Pot Cap-1 Maneuver | 218 | ~ 205 | 869 | ~ 290 | 360 | 779 | 1344 | - | - | 873 | - | - |
| Stage 1 | 771 | 713 | - | 608 | 587 | - | - | - | - | - | - | - |
| Stage 2 | 389 | 359 | - | 623 | 677 | - | - | - | - | - | - | - |
| Platoon blocked, % | | | | | | | | - | - | - | - | - |
| Mov Cap-1 Maneuver | 94 | ~ 186 | 869 | - | 327 | 779 | 1344 | - | - | 873 | - | - |
| Mov Cap-2 Maneuver | 94 | ~ 186 | - | - | 327 | - | - | - | - | - | - | - |
| Stage 1 | 724 | 689 | - | 571 | 551 | - | - | - | - | - | - | - |
| Stage 2 | 216 | 337 | - | 377 | 655 | - | - | - | - | - | - | - |

| Approach | EB | WB | NB | SB |
|----------------------|-------|----|-----|-----|
| HCM Control Delay, s | 128.5 | | 0.8 | 1.1 |
| HCM LOS | F | - | | |

| Minor Lane/Major Mvmt | NBL | NBT | NBR | EBLn1 | EBLn2 | EBLn3 | WBLn1 | WBLn2 | WBLn3 | SBL | SBT | SBR |
|-----------------------|-------|-----|-----|-------|-------|-------|-------|-------|-------|-------|-----|-----|
| Capacity (veh/h) | 1344 | - | - | 94 | 186 | 869 | - | 327 | 779 | 873 | - | - |
| HCM Lane V/C Ratio | 0.061 | - | - | 0.862 | 1.16 | 0.088 | - | 0.653 | 0.032 | 0.034 | - | - |
| HCM Control Delay (s) | 7.9 | - | - | 138.1 | 167.2 | 9.5 | - | 34.6 | 9.8 | 9.3 | - | - |
| HCM Lane LOS | A | - | - | F | F | A | - | D | A | A | - | - |
| HCM 95th %tile Q(veh) | 0.2 | - | - | 4.8 | 11 | 0.3 | - | 4.3 | 0.1 | 0.1 | - | - |

Notes
 ~: Volume exceeds capacity \$: Delay exceeds 300s +: Computation Not Defined *: All major volume in platoon

| Intersection | | | | | | |
|--------------------------|------|------|------|------|------|------|
| Int Delay, s/veh | 2.5 | | | | | |
| Movement | EBT | EBR | WBL | WBT | NBL | NBR |
| Lane Configurations | ↔ | | ↔ | ↑ | ↔ | ↔ |
| Traffic Vol, veh/h | 624 | 57 | 141 | 479 | 27 | 95 |
| Future Vol, veh/h | 624 | 57 | 141 | 479 | 27 | 95 |
| Conflicting Peds, #/hr | 0 | 0 | 0 | 0 | 0 | 0 |
| Sign Control | Free | Free | Free | Free | Stop | Stop |
| RT Channelized | - | None | - | None | - | None |
| Storage Length | - | - | 155 | - | 205 | 0 |
| Veh in Median Storage, # | 0 | - | - | 0 | 0 | - |
| Grade, % | 0 | - | - | 0 | 0 | - |
| Peak Hour Factor | 92 | 92 | 92 | 92 | 92 | 92 |
| Heavy Vehicles, % | 2 | 2 | 2 | 2 | 2 | 2 |
| Mvmt Flow | 678 | 62 | 153 | 521 | 29 | 103 |

| Major/Minor | Major1 | Major2 | Minor1 | | | |
|----------------------|--------|--------|--------|---|-------|-------|
| Conflicting Flow All | 0 | 0 | 740 | 0 | 1536 | 709 |
| Stage 1 | - | - | - | - | 709 | - |
| Stage 2 | - | - | - | - | 827 | - |
| Critical Hdwy | - | - | 4.12 | - | 6.42 | 6.22 |
| Critical Hdwy Stg 1 | - | - | - | - | 5.42 | - |
| Critical Hdwy Stg 2 | - | - | - | - | 5.42 | - |
| Follow-up Hdwy | - | - | 2.218 | - | 3.518 | 3.318 |
| Pot Cap-1 Maneuver | - | - | 867 | - | 128 | 434 |
| Stage 1 | - | - | - | - | 488 | - |
| Stage 2 | - | - | - | - | 430 | - |
| Platoon blocked, % | - | - | - | - | - | - |
| Mov Cap-1 Maneuver | - | - | 867 | - | 105 | 434 |
| Mov Cap-2 Maneuver | - | - | - | - | 234 | - |
| Stage 1 | - | - | - | - | 488 | - |
| Stage 2 | - | - | - | - | 354 | - |

| Approach | EB | WB | NB |
|----------------------|----|-----|------|
| HCM Control Delay, s | 0 | 2.3 | 17.4 |
| HCM LOS | | | C |

| Minor Lane/Major Mvmt | NBLn1 | NBLn2 | EBT | EBR | WBL | WBT |
|-----------------------|-------|-------|-----|-----|-------|-----|
| Capacity (veh/h) | 234 | 434 | - | - | 867 | - |
| HCM Lane V/C Ratio | 0.125 | 0.238 | - | - | 0.177 | - |
| HCM Control Delay (s) | 22.6 | 15.9 | - | - | 10 | - |
| HCM Lane LOS | C | C | - | - | B | - |
| HCM 95th %tile Q(veh) | 0.4 | 0.9 | - | - | 0.6 | - |

| Intersection | | | | | | |
|--------------------------|------|------|------|------|------|------|
| Int Delay, s/veh | 0.2 | | | | | |
| Movement | EBL | EBT | WBT | WBR | SBL | SBR |
| Lane Configurations | | | | | | |
| Traffic Vol, veh/h | 6 | 712 | 618 | 21 | 12 | 3 |
| Future Vol, veh/h | 6 | 712 | 618 | 21 | 12 | 3 |
| Conflicting Peds, #/hr | 0 | 0 | 0 | 0 | 0 | 0 |
| Sign Control | Free | Free | Free | Free | Stop | Stop |
| RT Channelized | - | None | - | None | - | None |
| Storage Length | 155 | - | - | - | 0 | - |
| Veh in Median Storage, # | - | 0 | 0 | - | 0 | - |
| Grade, % | - | 0 | 0 | - | 0 | - |
| Peak Hour Factor | 92 | 92 | 92 | 92 | 92 | 92 |
| Heavy Vehicles, % | 2 | 2 | 2 | 2 | 2 | 2 |
| Mvmt Flow | 7 | 774 | 672 | 23 | 13 | 3 |

| Major/Minor | Major1 | Major2 | Minor2 | | |
|----------------------|--------|--------|--------|---|-------------|
| Conflicting Flow All | 695 | 0 | - | 0 | 1472 684 |
| Stage 1 | - | - | - | - | 684 - |
| Stage 2 | - | - | - | - | 788 - |
| Critical Hdwy | 4.12 | - | - | - | 6.42 6.22 |
| Critical Hdwy Stg 1 | - | - | - | - | 5.42 - |
| Critical Hdwy Stg 2 | - | - | - | - | 5.42 - |
| Follow-up Hdwy | 2.218 | - | - | - | 3.518 3.318 |
| Pot Cap-1 Maneuver | 901 | - | - | - | 140 449 |
| Stage 1 | - | - | - | - | 501 - |
| Stage 2 | - | - | - | - | 448 - |
| Platoon blocked, % | | - | - | - | |
| Mov Cap-1 Maneuver | 901 | - | - | - | 139 449 |
| Mov Cap-2 Maneuver | - | - | - | - | 278 - |
| Stage 1 | - | - | - | - | 497 - |
| Stage 2 | - | - | - | - | 448 - |

| Approach | EB | WB | SB |
|----------------------|-----|----|------|
| HCM Control Delay, s | 0.1 | 0 | 17.6 |
| HCM LOS | | | C |

| Minor Lane/Major Mvmt | EBL | EBT | WBT | WBR | SBLn1 |
|-----------------------|-------|-----|-----|-----|-------|
| Capacity (veh/h) | 901 | - | - | - | 301 |
| HCM Lane V/C Ratio | 0.007 | - | - | - | 0.054 |
| HCM Control Delay (s) | 9 | - | - | - | 17.6 |
| HCM Lane LOS | A | - | - | - | C |
| HCM 95th %tile Q(veh) | 0 | - | - | - | 0.2 |

| Intersection | | | | | | |
|--------------------------|------|------|------|------|------|------|
| Int Delay, s/veh | 2.1 | | | | | |
| Movement | WBL | WBR | NBT | NBR | SBL | SBT |
| Lane Configurations | ↘ | ↗ | ↑ | ↗ | ↘ | ↑ |
| Traffic Vol, veh/h | 125 | 3 | 798 | 181 | 4 | 519 |
| Future Vol, veh/h | 125 | 3 | 798 | 181 | 4 | 519 |
| Conflicting Peds, #/hr | 0 | 0 | 0 | 0 | 0 | 0 |
| Sign Control | Stop | Stop | Free | Free | Free | Free |
| RT Channelized | - | None | - | None | - | None |
| Storage Length | 0 | 0 | - | 155 | 205 | - |
| Veh in Median Storage, # | 0 | - | 0 | - | - | 0 |
| Grade, % | 0 | - | 0 | - | - | 0 |
| Peak Hour Factor | 95 | 95 | 95 | 95 | 95 | 95 |
| Heavy Vehicles, % | 2 | 2 | 2 | 2 | 2 | 2 |
| Mvmt Flow | 132 | 3 | 840 | 191 | 4 | 546 |

| Major/Minor | Minor1 | Major1 | Major2 | | |
|----------------------|--------|--------|--------|---|-------|
| Conflicting Flow All | 1394 | 840 | 0 | 0 | 1031 |
| Stage 1 | 840 | - | - | - | - |
| Stage 2 | 554 | - | - | - | - |
| Critical Hdwy | 6.42 | 6.22 | - | - | 4.12 |
| Critical Hdwy Stg 1 | 5.42 | - | - | - | - |
| Critical Hdwy Stg 2 | 5.42 | - | - | - | - |
| Follow-up Hdwy | 3.518 | 3.318 | - | - | 2.218 |
| Pot Cap-1 Maneuver | 156 | 365 | - | - | 674 |
| Stage 1 | 424 | - | - | - | - |
| Stage 2 | 575 | - | - | - | - |
| Platoon blocked, % | | | - | - | - |
| Mov Cap-1 Maneuver | 155 | 365 | - | - | 674 |
| Mov Cap-2 Maneuver | 291 | - | - | - | - |
| Stage 1 | 424 | - | - | - | - |
| Stage 2 | 572 | - | - | - | - |

| Approach | WB | NB | SB |
|----------------------|------|----|-----|
| HCM Control Delay, s | 26.9 | 0 | 0.1 |
| HCM LOS | D | | |

| Minor Lane/Major Mvmt | NBT | NBR | WBLn1 | WBLn2 | SBL | SBT |
|-----------------------|-----|-----|-------|-------|-------|-----|
| Capacity (veh/h) | - | - | 291 | 365 | 674 | - |
| HCM Lane V/C Ratio | - | - | 0.452 | 0.009 | 0.006 | - |
| HCM Control Delay (s) | - | - | 27.2 | 14.9 | 10.4 | - |
| HCM Lane LOS | - | - | D | B | B | - |
| HCM 95th %tile Q(veh) | - | - | 2.2 | 0 | 0 | - |

| Intersection | | | | | | |
|--------------------------|------|------|------|------|------|------|
| Int Delay, s/veh | 1 | | | | | |
| Movement | WBL | WBR | NBT | NBR | SBL | SBT |
| Lane Configurations | ↘ | ↗ | ↑ | ↗ | ↘ | ↑ |
| Traffic Vol, veh/h | 35 | 16 | 963 | 60 | 27 | 617 |
| Future Vol, veh/h | 35 | 16 | 963 | 60 | 27 | 617 |
| Conflicting Peds, #/hr | 0 | 0 | 0 | 0 | 0 | 0 |
| Sign Control | Stop | Stop | Free | Free | Free | Free |
| RT Channelized | - | None | - | None | - | None |
| Storage Length | 0 | 115 | - | 155 | 205 | - |
| Veh in Median Storage, # | 0 | - | 0 | - | - | 0 |
| Grade, % | 0 | - | 0 | - | - | 0 |
| Peak Hour Factor | 85 | 85 | 85 | 85 | 85 | 85 |
| Heavy Vehicles, % | 2 | 2 | 2 | 2 | 2 | 2 |
| Mvmt Flow | 41 | 19 | 1133 | 71 | 32 | 726 |

| Major/Minor | Minor1 | Major1 | Major2 | | |
|----------------------|--------|--------|--------|---|-------|
| Conflicting Flow All | 1923 | 1133 | 0 | 0 | 1204 |
| Stage 1 | 1133 | - | - | - | - |
| Stage 2 | 790 | - | - | - | - |
| Critical Hdwy | 6.42 | 6.22 | - | - | 4.12 |
| Critical Hdwy Stg 1 | 5.42 | - | - | - | - |
| Critical Hdwy Stg 2 | 5.42 | - | - | - | - |
| Follow-up Hdwy | 3.518 | 3.318 | - | - | 2.218 |
| Pot Cap-1 Maneuver | 74 | 247 | - | - | 580 |
| Stage 1 | 307 | - | - | - | - |
| Stage 2 | 447 | - | - | - | - |
| Platoon blocked, % | | | - | - | - |
| Mov Cap-1 Maneuver | 70 | 247 | - | - | 580 |
| Mov Cap-2 Maneuver | 193 | - | - | - | - |
| Stage 1 | 307 | - | - | - | - |
| Stage 2 | 422 | - | - | - | - |

| Approach | WB | NB | SB |
|----------------------|------|----|-----|
| HCM Control Delay, s | 26.2 | 0 | 0.5 |
| HCM LOS | D | | |

| Minor Lane/Major Mvmt | NBT | NBR | WBLn1 | WBLn2 | SBL | SBT |
|-----------------------|-----|-----|-------|-------|-------|-----|
| Capacity (veh/h) | - | - | 193 | 247 | 580 | - |
| HCM Lane V/C Ratio | - | - | 0.213 | 0.076 | 0.055 | - |
| HCM Control Delay (s) | - | - | 28.6 | 20.8 | 11.6 | - |
| HCM Lane LOS | - | - | D | C | B | - |
| HCM 95th %tile Q(veh) | - | - | 0.8 | 0.2 | 0.2 | - |

| Intersection | | | | | | |
|--------------------------|------|------|------|------|------|------|
| Int Delay, s/veh | 24 | | | | | |
| Movement | EBL | EBR | NBL | NBT | SBT | SBR |
| Lane Configurations | ↙ | ↗ | ↙ | ↗ | ↗ | ↙ |
| Traffic Vol, veh/h | 144 | 177 | 347 | 979 | 586 | 94 |
| Future Vol, veh/h | 144 | 177 | 347 | 979 | 586 | 94 |
| Conflicting Peds, #/hr | 0 | 0 | 0 | 0 | 0 | 0 |
| Sign Control | Stop | Stop | Free | Free | Free | Free |
| RT Channelized | - | None | - | None | - | None |
| Storage Length | 0 | 0 | 0 | - | - | 155 |
| Veh in Median Storage, # | 0 | - | - | 0 | 0 | - |
| Grade, % | 0 | - | - | 0 | 0 | - |
| Peak Hour Factor | 95 | 95 | 95 | 95 | 95 | 95 |
| Heavy Vehicles, % | 2 | 2 | 2 | 2 | 2 | 2 |
| Mvmt Flow | 152 | 186 | 365 | 1031 | 617 | 99 |

| Major/Minor | Minor2 | Major1 | Major2 | | | |
|----------------------|--------|--------|--------|---|---|---|
| Conflicting Flow All | 2378 | 617 | 716 | 0 | - | 0 |
| Stage 1 | 617 | - | - | - | - | - |
| Stage 2 | 1761 | - | - | - | - | - |
| Critical Hdwy | 6.42 | 6.22 | 4.12 | - | - | - |
| Critical Hdwy Stg 1 | 5.42 | - | - | - | - | - |
| Critical Hdwy Stg 2 | 5.42 | - | - | - | - | - |
| Follow-up Hdwy | 3.518 | 3.318 | 2.218 | - | - | - |
| Pot Cap-1 Maneuver | ~ 38 | 490 | 885 | - | - | - |
| Stage 1 | 538 | - | - | - | - | - |
| Stage 2 | ~ 151 | - | - | - | - | - |
| Platoon blocked, % | | | | - | - | - |
| Mov Cap-1 Maneuver | ~ 22 | 490 | 885 | - | - | - |
| Mov Cap-2 Maneuver | ~ 102 | - | - | - | - | - |
| Stage 1 | 316 | - | - | - | - | - |
| Stage 2 | ~ 151 | - | - | - | - | - |

| Approach | EB | NB | SB |
|----------------------|-----|-----|----|
| HCM Control Delay, s | 161 | 3.1 | 0 |
| HCM LOS | F | | |

| Minor Lane/Major Mvmt | NBL | NBT | EBLn1 | EBLn2 | SBT | SBR |
|-----------------------|-------|-----|----------|-------|-----|-----|
| Capacity (veh/h) | 885 | - | 102 | 490 | - | - |
| HCM Lane V/C Ratio | 0.413 | - | 1.486 | 0.38 | - | - |
| HCM Control Delay (s) | 11.9 | - | \$ 338.2 | 16.8 | - | - |
| HCM Lane LOS | B | - | F | C | - | - |
| HCM 95th %tile Q(veh) | 2 | - | 11.2 | 1.8 | - | - |

Notes
 ~: Volume exceeds capacity \$: Delay exceeds 300s +: Computation Not Defined *: All major volume in platoon

| Intersection | | | | | | |
|--------------------------|------|------|------|------|------|------|
| Int Delay, s/veh | 1.3 | | | | | |
| Movement | EBL | EBR | NBL | NBT | SBT | SBR |
| Lane Configurations | Y | | Y | ↑ | ↑ | Y |
| Traffic Vol, veh/h | 35 | 4 | 1 | 87 | 172 | 26 |
| Future Vol, veh/h | 35 | 4 | 1 | 87 | 172 | 26 |
| Conflicting Peds, #/hr | 0 | 0 | 0 | 0 | 0 | 0 |
| Sign Control | Stop | Stop | Free | Free | Free | Free |
| RT Channelized | - | None | - | None | - | None |
| Storage Length | 0 | - | 205 | - | - | 205 |
| Veh in Median Storage, # | 0 | - | - | 0 | 0 | - |
| Grade, % | 0 | - | - | 0 | 0 | - |
| Peak Hour Factor | 92 | 92 | 92 | 92 | 92 | 92 |
| Heavy Vehicles, % | 2 | 2 | 2 | 2 | 2 | 2 |
| Mvmt Flow | 38 | 4 | 1 | 95 | 187 | 28 |

| Major/Minor | Minor2 | Major1 | Major2 | | | |
|----------------------|--------|--------|--------|---|---|---|
| Conflicting Flow All | 284 | 187 | 215 | 0 | - | 0 |
| Stage 1 | 187 | - | - | - | - | - |
| Stage 2 | 97 | - | - | - | - | - |
| Critical Hdwy | 6.42 | 6.22 | 4.12 | - | - | - |
| Critical Hdwy Stg 1 | 5.42 | - | - | - | - | - |
| Critical Hdwy Stg 2 | 5.42 | - | - | - | - | - |
| Follow-up Hdwy | 3.518 | 3.318 | 2.218 | - | - | - |
| Pot Cap-1 Maneuver | 706 | 855 | 1355 | - | - | - |
| Stage 1 | 845 | - | - | - | - | - |
| Stage 2 | 927 | - | - | - | - | - |
| Platoon blocked, % | | | | - | - | - |
| Mov Cap-1 Maneuver | 705 | 855 | 1355 | - | - | - |
| Mov Cap-2 Maneuver | 705 | - | - | - | - | - |
| Stage 1 | 844 | - | - | - | - | - |
| Stage 2 | 927 | - | - | - | - | - |

| Approach | EB | NB | SB |
|----------------------|------|-----|----|
| HCM Control Delay, s | 10.3 | 0.1 | 0 |
| HCM LOS | B | | |

| Minor Lane/Major Mvmt | NBL | NBT | EBLn1 | SBT | SBR |
|-----------------------|-------|-----|-------|-----|-----|
| Capacity (veh/h) | 1355 | - | 718 | - | - |
| HCM Lane V/C Ratio | 0.001 | - | 0.059 | - | - |
| HCM Control Delay (s) | 7.7 | - | 10.3 | - | - |
| HCM Lane LOS | A | - | B | - | - |
| HCM 95th %tile Q(veh) | 0 | - | 0.2 | - | - |

Intersection

Int Delay, s/veh 0.1

Movement EBL EBR NBL NBT SBT SBR

| | | | | | | |
|--------------------------|------|------|------|------|------|------|
| Lane Configurations | | ↗ | | ↑ | ↘ | |
| Traffic Vol, veh/h | 0 | 4 | 0 | 87 | 167 | 9 |
| Future Vol, veh/h | 0 | 4 | 0 | 87 | 167 | 9 |
| Conflicting Peds, #/hr | 0 | 0 | 0 | 0 | 0 | 0 |
| Sign Control | Stop | Stop | Free | Free | Free | Free |
| RT Channelized | - | None | - | None | - | None |
| Storage Length | - | 0 | - | - | - | - |
| Veh in Median Storage, # | 0 | - | - | 0 | 0 | - |
| Grade, % | 0 | - | - | 0 | 0 | - |
| Peak Hour Factor | 92 | 92 | 92 | 92 | 92 | 92 |
| Heavy Vehicles, % | 2 | 2 | 2 | 2 | 2 | 2 |
| Mvmt Flow | 0 | 4 | 0 | 95 | 182 | 10 |

Major/Minor Minor2 Major1 Major2

| | | | | | | |
|----------------------|---|-------|---|---|---|---|
| Conflicting Flow All | - | 187 | - | 0 | - | 0 |
| Stage 1 | - | - | - | - | - | - |
| Stage 2 | - | - | - | - | - | - |
| Critical Hdwy | - | 6.22 | - | - | - | - |
| Critical Hdwy Stg 1 | - | - | - | - | - | - |
| Critical Hdwy Stg 2 | - | - | - | - | - | - |
| Follow-up Hdwy | - | 3.318 | - | - | - | - |
| Pot Cap-1 Maneuver | 0 | 855 | 0 | - | - | - |
| Stage 1 | 0 | - | 0 | - | - | - |
| Stage 2 | 0 | - | 0 | - | - | - |
| Platoon blocked, % | | | | - | - | - |
| Mov Cap-1 Maneuver | - | 855 | - | - | - | - |
| Mov Cap-2 Maneuver | - | - | - | - | - | - |
| Stage 1 | - | - | - | - | - | - |
| Stage 2 | - | - | - | - | - | - |

Approach EB NB SB

| | | | |
|----------------------|-----|---|---|
| HCM Control Delay, s | 9.2 | 0 | 0 |
| HCM LOS | A | | |

Minor Lane/Major Mvmt NBT EBLn1 SBT SBR

| | | | | |
|-----------------------|---|-------|---|---|
| Capacity (veh/h) | - | 855 | - | - |
| HCM Lane V/C Ratio | - | 0.005 | - | - |
| HCM Control Delay (s) | - | 9.2 | - | - |
| HCM Lane LOS | - | A | - | - |
| HCM 95th %tile Q(veh) | - | 0 | - | - |

| Intersection | | | | | | |
|--------------------------|------|------|------|------|------|------|
| Int Delay, s/veh | 6.8 | | | | | |
| Movement | EBL | EBT | WBT | WBR | SBL | SBR |
| Lane Configurations | | ↔ | ↔ | | ↔ | ↔ |
| Traffic Vol, veh/h | 46 | 11 | 17 | 42 | 86 | 84 |
| Future Vol, veh/h | 46 | 11 | 17 | 42 | 86 | 84 |
| Conflicting Peds, #/hr | 0 | 0 | 0 | 0 | 0 | 0 |
| Sign Control | Free | Free | Free | Free | Stop | Stop |
| RT Channelized | - | None | - | None | - | None |
| Storage Length | - | - | - | - | 0 | 0 |
| Veh in Median Storage, # | - | 0 | 0 | - | 0 | - |
| Grade, % | - | 0 | 0 | - | 0 | - |
| Peak Hour Factor | 92 | 92 | 92 | 92 | 92 | 92 |
| Heavy Vehicles, % | 2 | 2 | 2 | 2 | 2 | 2 |
| Mvmt Flow | 50 | 12 | 18 | 46 | 93 | 91 |

| Major/Minor | Major1 | Major2 | Minor2 | | |
|----------------------|--------|--------|--------|---|-------|
| Conflicting Flow All | 64 | 0 | - | 0 | 153 |
| Stage 1 | - | - | - | - | 41 |
| Stage 2 | - | - | - | - | 112 |
| Critical Hdwy | 4.12 | - | - | - | 6.42 |
| Critical Hdwy Stg 1 | - | - | - | - | 5.42 |
| Critical Hdwy Stg 2 | - | - | - | - | 5.42 |
| Follow-up Hdwy | 2.218 | - | - | - | 3.518 |
| Pot Cap-1 Maneuver | 1538 | - | - | - | 839 |
| Stage 1 | - | - | - | - | 981 |
| Stage 2 | - | - | - | - | 913 |
| Platoon blocked, % | | - | - | - | |
| Mov Cap-1 Maneuver | 1538 | - | - | - | 811 |
| Mov Cap-2 Maneuver | - | - | - | - | 811 |
| Stage 1 | - | - | - | - | 949 |
| Stage 2 | - | - | - | - | 913 |

| Approach | EB | WB | SB |
|----------------------|----|----|-----|
| HCM Control Delay, s | 6 | 0 | 9.4 |
| HCM LOS | | | A |

| Minor Lane/Major Mvmt | EBL | EBT | WBT | WBR | SBLn1 | SBLn2 |
|-----------------------|-------|-----|-----|-----|-------|-------|
| Capacity (veh/h) | 1538 | - | - | - | 811 | 1030 |
| HCM Lane V/C Ratio | 0.033 | - | - | - | 0.115 | 0.089 |
| HCM Control Delay (s) | 7.4 | 0 | - | - | 10 | 8.8 |
| HCM Lane LOS | A | A | - | - | B | A |
| HCM 95th %tile Q(veh) | 0.1 | - | - | - | 0.4 | 0.3 |

Timings
1: Eastonville Rd & Rex Rd

2041 Total Traffic
PM Peak Hour

| Lane Group | EBL | EBT | EBR | WBL | WBT | WBR | NBL | NBT | NBR | SBL | SBT | SBR |
|----------------------|-------|-------|-------|-------|-------|-------|-------|-------|-------|-------|-------|-------|
| Lane Configurations | | | | | | | | | | | | |
| Traffic Volume (vph) | 77 | 205 | 73 | 280 | 203 | 24 | 78 | 247 | 447 | 28 | 165 | 48 |
| Future Volume (vph) | 77 | 205 | 73 | 280 | 203 | 24 | 78 | 247 | 447 | 28 | 165 | 48 |
| Turn Type | pm+pt | NA | Perm | pm+pt | NA | Perm | pm+pt | NA | Perm | pm+pt | NA | Perm |
| Protected Phases | 5 | 2 | | 1 | 6 | | 3 | 8 | | 7 | 4 | |
| Permitted Phases | 2 | | 2 | 6 | | 6 | 8 | | 8 | 4 | | 4 |
| Detector Phase | 5 | 2 | 2 | 1 | 6 | 6 | 3 | 8 | 8 | 7 | 4 | 4 |
| Switch Phase | | | | | | | | | | | | |
| Minimum Initial (s) | 5.0 | 5.0 | 5.0 | 5.0 | 5.0 | 5.0 | 5.0 | 5.0 | 5.0 | 5.0 | 5.0 | 5.0 |
| Minimum Split (s) | 10.0 | 20.0 | 20.0 | 10.0 | 20.0 | 20.0 | 10.0 | 20.0 | 20.0 | 10.0 | 20.0 | 20.0 |
| Total Split (s) | 10.0 | 38.0 | 38.0 | 20.0 | 48.0 | 48.0 | 12.0 | 30.0 | 30.0 | 12.0 | 30.0 | 30.0 |
| Total Split (%) | 10.0% | 38.0% | 38.0% | 20.0% | 48.0% | 48.0% | 12.0% | 30.0% | 30.0% | 12.0% | 30.0% | 30.0% |
| Yellow Time (s) | 3.0 | 3.0 | 3.0 | 3.0 | 3.0 | 3.0 | 3.0 | 3.0 | 3.0 | 3.0 | 3.0 | 3.0 |
| All-Red Time (s) | 2.0 | 2.0 | 2.0 | 2.0 | 2.0 | 2.0 | 2.0 | 2.0 | 2.0 | 2.0 | 2.0 | 2.0 |
| Lost Time Adjust (s) | 0.0 | 0.0 | 0.0 | 0.0 | 0.0 | 0.0 | 0.0 | 0.0 | 0.0 | 0.0 | 0.0 | 0.0 |
| Total Lost Time (s) | 5.0 | 5.0 | 5.0 | 5.0 | 5.0 | 5.0 | 5.0 | 5.0 | 5.0 | 5.0 | 5.0 | 5.0 |
| Lead/Lag | Lead | Lag | Lag | Lead | Lag | Lag | Lead | Lag | Lag | Lead | Lag | Lag |
| Lead-Lag Optimize? | Yes | Yes | Yes | Yes | Yes | Yes | Yes | Yes | Yes | Yes | Yes | Yes |
| Recall Mode | None | Min | Min | None | Min | Min | None | None | None | None | None | None |
| Act Effct Green (s) | 19.0 | 13.6 | 13.6 | 31.6 | 24.1 | 24.1 | 21.6 | 19.4 | 19.4 | 19.1 | 14.4 | 14.4 |
| Actuated g/C Ratio | 0.29 | 0.21 | 0.21 | 0.48 | 0.37 | 0.37 | 0.33 | 0.30 | 0.30 | 0.29 | 0.22 | 0.22 |
| v/c Ratio | 0.21 | 0.56 | 0.16 | 0.53 | 0.31 | 0.04 | 0.20 | 0.47 | 0.59 | 0.08 | 0.43 | 0.10 |
| Control Delay | 14.4 | 32.3 | 0.7 | 16.4 | 20.1 | 0.1 | 16.0 | 24.7 | 6.1 | 15.0 | 27.8 | 0.4 |
| Queue Delay | 0.0 | 0.0 | 0.0 | 0.0 | 0.0 | 0.0 | 0.0 | 0.0 | 0.0 | 0.0 | 0.0 | 0.0 |
| Total Delay | 14.4 | 32.3 | 0.7 | 16.4 | 20.1 | 0.1 | 16.0 | 24.7 | 6.1 | 15.0 | 27.8 | 0.4 |
| LOS | B | C | A | B | C | A | B | C | A | B | C | A |
| Approach Delay | | 21.9 | | | 17.1 | | | 13.0 | | | 20.9 | |
| Approach LOS | | C | | | B | | | B | | | C | |

Intersection Summary

Cycle Length: 100
 Actuated Cycle Length: 65.6
 Natural Cycle: 60
 Control Type: Actuated-Uncoordinated
 Maximum v/c Ratio: 0.59
 Intersection Signal Delay: 16.8
 Intersection LOS: B
 Intersection Capacity Utilization 60.1%
 ICU Level of Service B
 Analysis Period (min) 15

Splits and Phases: 1: Eastonville Rd & Rex Rd

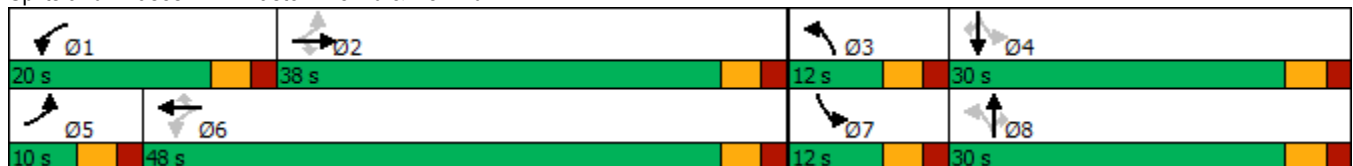

Timings
9: US 24 & Rex Rd

2041 Total Traffic
PM Peak Hour



| Lane Group | EBL | EBR | NBL | NBT | SBT | SBR |
|----------------------|-------|-------|-------|-------|-------|-------|
| Lane Configurations | ↖ | ↗ | ↖↗ | ↕ | ↕ | ↗ |
| Traffic Volume (vph) | 131 | 840 | 1200 | 529 | 471 | 142 |
| Future Volume (vph) | 131 | 840 | 1200 | 529 | 471 | 142 |
| Turn Type | Prot | Free | Prot | NA | NA | Perm |
| Protected Phases | 6! | | 7 | Free! | 8 | |
| Permitted Phases | | Free | | | | 8 |
| Detector Phase | 6 | | 7 | | 8 | 8 |
| Switch Phase | | | | | | |
| Minimum Initial (s) | 5.0 | | 5.0 | | 5.0 | 5.0 |
| Minimum Split (s) | 20.0 | | 10.0 | | 20.0 | 20.0 |
| Total Split (s) | 23.0 | | 49.0 | | 48.0 | 48.0 |
| Total Split (%) | 19.2% | | 40.8% | | 40.0% | 40.0% |
| Yellow Time (s) | 3.0 | | 3.0 | | 3.0 | 3.0 |
| All-Red Time (s) | 2.0 | | 2.0 | | 2.0 | 2.0 |
| Lost Time Adjust (s) | 0.0 | | 0.0 | | 0.0 | 0.0 |
| Total Lost Time (s) | 5.0 | | 5.0 | | 5.0 | 5.0 |
| Lead/Lag | | | Lead | | Lag | Lag |
| Lead-Lag Optimize? | | | Yes | | Yes | Yes |
| Recall Mode | Max | | None | | C-Max | C-Max |
| Act Effct Green (s) | 18.0 | 120.0 | 44.0 | 120.0 | 43.0 | 43.0 |
| Actuated g/C Ratio | 0.15 | 1.00 | 0.37 | 1.00 | 0.36 | 0.36 |
| v/c Ratio | 0.52 | 0.56 | 1.00 | 0.15 | 0.39 | 0.23 |
| Control Delay | 54.8 | 1.4 | 52.7 | 0.0 | 29.9 | 5.0 |
| Queue Delay | 0.0 | 0.0 | 0.0 | 0.0 | 0.0 | 0.0 |
| Total Delay | 54.8 | 1.4 | 52.7 | 0.0 | 29.9 | 5.0 |
| LOS | D | A | D | A | C | A |
| Approach Delay | 8.6 | | | 37.0 | 24.1 | |
| Approach LOS | A | | | D | C | |

Intersection Summary

Cycle Length: 120
 Actuated Cycle Length: 120
 Offset: 50 (42%), Referenced to phase 8:SBT, Start of Green
 Natural Cycle: 70
 Control Type: Actuated-Coordinated
 Maximum v/c Ratio: 1.00
 Intersection Signal Delay: 26.2
 Intersection LOS: C
 Intersection Capacity Utilization 66.2%
 ICU Level of Service C
 Analysis Period (min) 15
 ! Phase conflict between lane groups.

Splits and Phases: 9: US 24 & Rex Rd

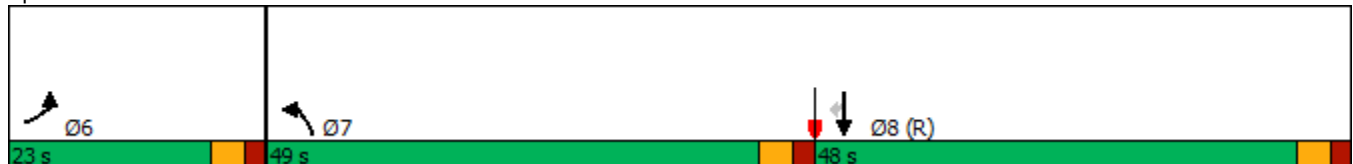

Timings
10: Eastonville Rd & Dawlish Dr

2041 Total Traffic
PM Peak Hour

| Lane Group | WBL | WBR | NBT | NBR | SBL | SBT |
|----------------------|-------|-------|-------|-------|-------|-------|
| Lane Configurations | | | | | | |
| Traffic Volume (vph) | 125 | 3 | 798 | 181 | 4 | 519 |
| Future Volume (vph) | 125 | 3 | 798 | 181 | 4 | 519 |
| Turn Type | Prot | Perm | NA | Perm | Perm | NA |
| Protected Phases | 8 | | 2 | | | 6 |
| Permitted Phases | | 8 | | 2 | 6 | |
| Detector Phase | 8 | 8 | 2 | 2 | 6 | 6 |
| Switch Phase | | | | | | |
| Minimum Initial (s) | 5.0 | 5.0 | 5.0 | 5.0 | 5.0 | 5.0 |
| Minimum Split (s) | 20.0 | 20.0 | 20.0 | 20.0 | 20.0 | 20.0 |
| Total Split (s) | 25.0 | 25.0 | 65.0 | 65.0 | 65.0 | 65.0 |
| Total Split (%) | 27.8% | 27.8% | 72.2% | 72.2% | 72.2% | 72.2% |
| Yellow Time (s) | 3.0 | 3.0 | 3.0 | 3.0 | 3.0 | 3.0 |
| All-Red Time (s) | 2.0 | 2.0 | 2.0 | 2.0 | 2.0 | 2.0 |
| Lost Time Adjust (s) | 0.0 | 0.0 | 0.0 | 0.0 | 0.0 | 0.0 |
| Total Lost Time (s) | 5.0 | 5.0 | 5.0 | 5.0 | 5.0 | 5.0 |
| Lead/Lag | | | | | | |
| Lead-Lag Optimize? | | | | | | |
| Recall Mode | None | None | Max | Max | Max | Max |
| Act Effct Green (s) | 11.3 | 11.3 | 60.1 | 60.1 | 60.1 | 60.1 |
| Actuated g/C Ratio | 0.14 | 0.14 | 0.74 | 0.74 | 0.74 | 0.74 |
| v/c Ratio | 0.54 | 0.01 | 0.61 | 0.16 | 0.01 | 0.40 |
| Control Delay | 40.8 | 20.0 | 8.0 | 1.0 | 3.8 | 5.4 |
| Queue Delay | 0.0 | 0.0 | 0.0 | 0.0 | 0.0 | 0.0 |
| Total Delay | 40.8 | 20.0 | 8.0 | 1.0 | 3.8 | 5.4 |
| LOS | D | B | A | A | A | A |
| Approach Delay | 40.3 | | 6.7 | | | 5.4 |
| Approach LOS | D | | A | | | A |

Intersection Summary

| | |
|---|------------------------|
| Cycle Length: 90 | |
| Actuated Cycle Length: 81.4 | |
| Natural Cycle: 60 | |
| Control Type: Semi Act-Uncoord | |
| Maximum v/c Ratio: 0.61 | |
| Intersection Signal Delay: 8.9 | Intersection LOS: A |
| Intersection Capacity Utilization 57.3% | ICU Level of Service B |
| Analysis Period (min) 15 | |

Splits and Phases: 10: Eastonville Rd & Dawlish Dr

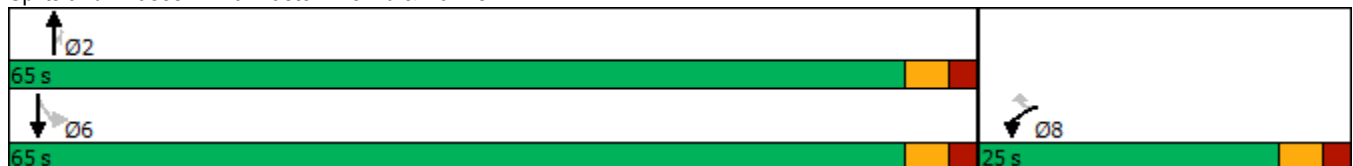

Timings
12: Eastonville Rd & Londonderry Dr

2041 Total Traffic
PM Peak Hour



| Lane Group | EBL | EBR | NBL | NBT | SBT | SBR |
|----------------------|-------|-------|-------|-------|-------|-------|
| Lane Configurations | ↖ | ↗ | ↖ | ↑ | ↑ | ↗ |
| Traffic Volume (vph) | 144 | 177 | 347 | 979 | 586 | 94 |
| Future Volume (vph) | 144 | 177 | 347 | 979 | 586 | 94 |
| Turn Type | Prot | Perm | pm+pt | NA | NA | Perm |
| Protected Phases | 4 | | 5 | 2 | 6 | |
| Permitted Phases | | 4 | 2 | | | 6 |
| Detector Phase | 4 | 4 | 5 | 2 | 6 | 6 |
| Switch Phase | | | | | | |
| Minimum Initial (s) | 4.0 | 4.0 | 4.0 | 4.0 | 4.0 | 4.0 |
| Minimum Split (s) | 21.0 | 21.0 | 9.0 | 21.0 | 21.0 | 21.0 |
| Total Split (s) | 25.0 | 25.0 | 20.0 | 75.0 | 55.0 | 55.0 |
| Total Split (%) | 25.0% | 25.0% | 20.0% | 75.0% | 55.0% | 55.0% |
| Yellow Time (s) | 3.0 | 3.0 | 3.0 | 3.0 | 3.0 | 3.0 |
| All-Red Time (s) | 2.0 | 2.0 | 2.0 | 2.0 | 2.0 | 2.0 |
| Lost Time Adjust (s) | 0.0 | 0.0 | 0.0 | 0.0 | 0.0 | 0.0 |
| Total Lost Time (s) | 5.0 | 5.0 | 5.0 | 5.0 | 5.0 | 5.0 |
| Lead/Lag | | | Lead | | Lag | Lag |
| Lead-Lag Optimize? | | | Yes | | Yes | Yes |
| Recall Mode | None | None | None | None | None | None |
| Act Effct Green (s) | 12.0 | 12.0 | 51.2 | 51.2 | 30.4 | 30.4 |
| Actuated g/C Ratio | 0.16 | 0.16 | 0.70 | 0.70 | 0.41 | 0.41 |
| v/c Ratio | 0.53 | 0.45 | 0.70 | 0.80 | 0.80 | 0.14 |
| Control Delay | 37.9 | 9.2 | 20.3 | 13.8 | 27.5 | 4.8 |
| Queue Delay | 0.0 | 0.0 | 0.0 | 0.0 | 0.0 | 0.0 |
| Total Delay | 37.9 | 9.2 | 20.3 | 13.8 | 27.5 | 4.8 |
| LOS | D | A | C | B | C | A |
| Approach Delay | 22.1 | | | 15.5 | 24.3 | |
| Approach LOS | C | | | B | C | |

Intersection Summary

Cycle Length: 100
 Actuated Cycle Length: 73.6
 Natural Cycle: 70
 Control Type: Actuated-Uncoordinated
 Maximum v/c Ratio: 0.80
 Intersection Signal Delay: 19.0
 Intersection Capacity Utilization 70.5%
 Analysis Period (min) 15
 Intersection LOS: B
 ICU Level of Service C

Splits and Phases: 12: Eastonville Rd & Londonderry Dr

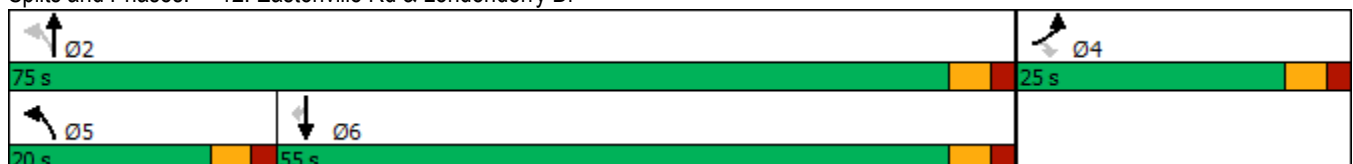

Timings
13: Eastonville Rd & Stapleton Dr

2041 Total Traffic
PM Peak Hour

| Lane Group | EBL | EBT | EBR | WBL | WBT | WBR | NBL | NBT | NBR | SBL | SBT | SBR |
|----------------------|-------|-------|-------|-------|-------|-------|-------|-------|-------|-------|-------|-------|
| Lane Configurations | | | | | | | | | | | | |
| Traffic Volume (vph) | 406 | 553 | 160 | 194 | 718 | 294 | 251 | 626 | 179 | 155 | 363 | 245 |
| Future Volume (vph) | 406 | 553 | 160 | 194 | 718 | 294 | 251 | 626 | 179 | 155 | 363 | 245 |
| Turn Type | Prot | NA | Perm | pm+pt | NA | Perm | pm+pt | NA | Perm | pm+pt | NA | Perm |
| Protected Phases | 5 | 2 | | 1 | 6 | | 3 | 8 | | 7 | 4 | |
| Permitted Phases | | | 2 | 6 | | 6 | 8 | | 8 | 4 | | 4 |
| Detector Phase | 5 | 2 | 2 | 1 | 6 | 6 | 3 | 8 | 8 | 7 | 4 | 4 |
| Switch Phase | | | | | | | | | | | | |
| Minimum Initial (s) | 4.0 | 4.0 | 4.0 | 4.0 | 4.0 | 4.0 | 4.0 | 4.0 | 4.0 | 4.0 | 4.0 | 4.0 |
| Minimum Split (s) | 9.0 | 9.0 | 9.0 | 9.0 | 9.0 | 9.0 | 9.0 | 9.0 | 9.0 | 9.0 | 9.0 | 9.0 |
| Total Split (s) | 18.0 | 31.0 | 31.0 | 15.0 | 28.0 | 28.0 | 11.0 | 43.0 | 43.0 | 11.0 | 43.0 | 43.0 |
| Total Split (%) | 18.0% | 31.0% | 31.0% | 15.0% | 28.0% | 28.0% | 11.0% | 43.0% | 43.0% | 11.0% | 43.0% | 43.0% |
| Yellow Time (s) | 3.0 | 3.0 | 3.0 | 3.0 | 3.0 | 3.0 | 3.0 | 3.0 | 3.0 | 3.0 | 3.0 | 3.0 |
| All-Red Time (s) | 2.0 | 2.0 | 2.0 | 2.0 | 2.0 | 2.0 | 2.0 | 2.0 | 2.0 | 2.0 | 2.0 | 2.0 |
| Lost Time Adjust (s) | 0.0 | 0.0 | 0.0 | 0.0 | -2.0 | 0.0 | 0.0 | 0.0 | 0.0 | 0.0 | 0.0 | 0.0 |
| Total Lost Time (s) | 5.0 | 5.0 | 5.0 | 5.0 | 3.0 | 5.0 | 5.0 | 5.0 | 5.0 | 5.0 | 5.0 | 5.0 |
| Lead/Lag | Lead | Lag | Lag | Lead | Lag | Lag | Lead | Lag | Lag | Lead | Lag | Lag |
| Lead-Lag Optimize? | Yes | Yes | Yes | Yes | Yes | Yes | Yes | Yes | Yes | Yes | Yes | Yes |
| Recall Mode | None | None | None | None | None | None | None | None | None | None | None | None |
| Act Effct Green (s) | 13.0 | 25.8 | 25.8 | 32.2 | 24.5 | 22.5 | 42.8 | 36.8 | 36.8 | 42.8 | 36.8 | 36.8 |
| Actuated g/C Ratio | 0.13 | 0.26 | 0.26 | 0.33 | 0.25 | 0.23 | 0.44 | 0.37 | 0.37 | 0.44 | 0.37 | 0.37 |
| v/c Ratio | 0.94 | 0.63 | 0.31 | 0.67 | 0.86 | 0.60 | 0.73 | 0.95 | 0.27 | 0.89 | 0.55 | 0.34 |
| Control Delay | 73.4 | 35.8 | 6.4 | 32.5 | 46.6 | 17.7 | 31.7 | 54.5 | 5.7 | 63.0 | 27.8 | 4.1 |
| Queue Delay | 0.0 | 0.0 | 0.0 | 0.0 | 0.0 | 0.0 | 0.0 | 0.0 | 0.0 | 0.0 | 0.0 | 0.0 |
| Total Delay | 73.4 | 35.8 | 6.4 | 32.5 | 46.6 | 17.7 | 31.7 | 54.5 | 5.7 | 63.0 | 27.8 | 4.1 |
| LOS | E | D | A | C | D | B | C | D | A | E | C | A |
| Approach Delay | | 45.3 | | | 37.3 | | | 40.8 | | | 27.3 | |
| Approach LOS | | D | | | D | | | D | | | C | |

Intersection Summary

Cycle Length: 100
 Actuated Cycle Length: 98.3
 Natural Cycle: 90
 Control Type: Actuated-Uncoordinated
 Maximum v/c Ratio: 0.95
 Intersection Signal Delay: 38.5
 Intersection LOS: D
 Intersection Capacity Utilization 88.8%
 ICU Level of Service E
 Analysis Period (min) 15

Splits and Phases: 13: Eastonville Rd & Stapleton Dr

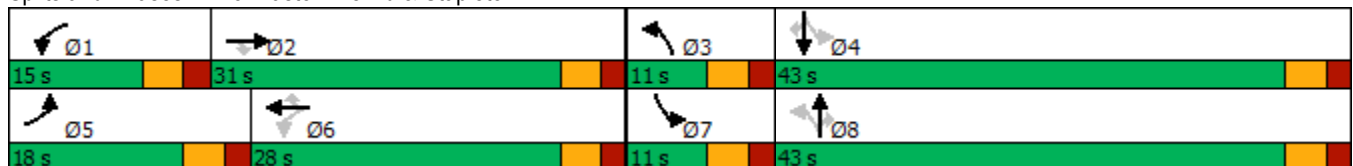

Timings
14: US 24 & Stapleton Dr

2041 Total Traffic
PM Peak Hour

| Lane Group | EBL | EBT | EBR | WBL | WBT | WBR | NBL | NBT | NBR | SBL | SBT | SBR |
|----------------------|-------|-------|-------|-------|-------|-------|-------|-------|-------|-------|-------|-------|
| Lane Configurations | | | | | | | | | | | | |
| Traffic Volume (vph) | 372 | 358 | 375 | 125 | 514 | 329 | 640 | 1534 | 150 | 251 | 1079 | 377 |
| Future Volume (vph) | 372 | 358 | 375 | 125 | 514 | 329 | 640 | 1534 | 150 | 251 | 1079 | 377 |
| Turn Type | Prot | NA | Free | Prot | NA | Free | Prot | NA | Perm | Prot | NA | Free |
| Protected Phases | 7 | 4 | | 3 | 8 | | 5 | 2 | | 1 | 6 | |
| Permitted Phases | | | Free | | | Free | | | 2 | | | Free |
| Detector Phase | 7 | 4 | | 3 | 8 | | 5 | 2 | 2 | 1 | 6 | |
| Switch Phase | | | | | | | | | | | | |
| Minimum Initial (s) | 5.0 | 5.0 | | 5.0 | 5.0 | | 5.0 | 5.0 | 5.0 | 5.0 | 5.0 | |
| Minimum Split (s) | 10.0 | 10.0 | | 10.0 | 10.0 | | 10.0 | 11.0 | 11.0 | 10.0 | 11.0 | |
| Total Split (s) | 15.0 | 30.0 | | 17.0 | 32.0 | | 26.0 | 60.0 | 60.0 | 13.0 | 47.0 | |
| Total Split (%) | 12.5% | 25.0% | | 14.2% | 26.7% | | 21.7% | 50.0% | 50.0% | 10.8% | 39.2% | |
| Yellow Time (s) | 3.0 | 3.0 | | 3.0 | 3.0 | | 3.0 | 3.0 | 3.0 | 3.0 | 3.0 | |
| All-Red Time (s) | 2.0 | 2.0 | | 2.0 | 2.0 | | 2.0 | 2.0 | 2.0 | 2.0 | 2.0 | |
| Lost Time Adjust (s) | 0.0 | 0.0 | | 0.0 | 0.0 | | 0.0 | 0.0 | 0.0 | 0.0 | 0.0 | |
| Total Lost Time (s) | 5.0 | 5.0 | | 5.0 | 5.0 | | 5.0 | 5.0 | 5.0 | 5.0 | 5.0 | |
| Lead/Lag | Lead | Lag | | Lead | Lag | | Lead | Lag | Lag | Lead | Lag | |
| Lead-Lag Optimize? | Yes | Yes | | Yes | Yes | | Yes | Yes | Yes | Yes | Yes | |
| Recall Mode | None | None | | None | None | | None | C-Max | C-Max | None | C-Max | |
| Act Effct Green (s) | 10.0 | 23.6 | 120.0 | 9.8 | 23.4 | 120.0 | 24.6 | 55.0 | 55.0 | 11.6 | 42.0 | 120.0 |
| Actuated g/C Ratio | 0.08 | 0.20 | 1.00 | 0.08 | 0.20 | 1.00 | 0.20 | 0.46 | 0.46 | 0.10 | 0.35 | 1.00 |
| v/c Ratio | 1.37 | 0.54 | 0.25 | 0.47 | 0.78 | 0.22 | 0.96 | 1.00 | 0.20 | 0.80 | 0.89 | 0.25 |
| Control Delay | 228.6 | 46.3 | 0.4 | 57.9 | 54.3 | 0.3 | 73.2 | 54.0 | 7.0 | 74.6 | 38.5 | 0.4 |
| Queue Delay | 0.0 | 0.0 | 0.0 | 0.0 | 0.0 | 0.0 | 0.0 | 0.0 | 0.0 | 0.0 | 0.0 | 0.0 |
| Total Delay | 228.6 | 46.3 | 0.4 | 57.9 | 54.3 | 0.3 | 73.2 | 54.0 | 7.0 | 74.6 | 38.5 | 0.4 |
| LOS | F | D | A | E | D | A | E | D | A | E | D | A |
| Approach Delay | | 92.1 | | | 36.4 | | | 56.3 | | | 35.3 | |
| Approach LOS | | F | | | D | | | E | | | D | |

Intersection Summary

Cycle Length: 120
 Actuated Cycle Length: 120
 Offset: 0 (0%), Referenced to phase 2:NBT and 6:SBT, Start of Green
 Natural Cycle: 90
 Control Type: Actuated-Coordinated
 Maximum v/c Ratio: 1.37
 Intersection Signal Delay: 53.9
 Intersection LOS: D
 Intersection Capacity Utilization 91.1%
 ICU Level of Service F
 Analysis Period (min) 15

Splits and Phases: 14: US 24 & Stapleton Dr



| Intersection | | | | |
|-----------------------------|-------|-------|-------|-------|
| Intersection Delay, s/veh | 16.9 | | | |
| Intersection LOS | C | | | |
| Approach | EB | WB | NB | SB |
| Entry Lanes | 1 | 1 | 1 | 1 |
| Conflicting Circle Lanes | 1 | 1 | 1 | 1 |
| Adj Approach Flow, veh/h | 374 | 534 | 813 | 254 |
| Demand Flow Rate, veh/h | 382 | 545 | 829 | 259 |
| Vehicles Circulating, veh/h | 508 | 432 | 333 | 603 |
| Vehicles Exiting, veh/h | 354 | 730 | 557 | 373 |
| Ped Vol Crossing Leg, #/h | 0 | 0 | 0 | 0 |
| Ped Cap Adj | 1.000 | 1.000 | 1.000 | 1.000 |
| Approach Delay, s/veh | 10.6 | 13.5 | 24.3 | 9.3 |
| Approach LOS | B | B | C | A |
| Lane | Left | Left | Left | Left |
| Designated Moves | LTR | LTR | LTR | LTR |
| Assumed Moves | LTR | LTR | LTR | LTR |
| RT Channelized | | | | |
| Lane Util | 1.000 | 1.000 | 1.000 | 1.000 |
| Follow-Up Headway, s | 2.609 | 2.609 | 2.609 | 2.609 |
| Critical Headway, s | 4.976 | 4.976 | 4.976 | 4.976 |
| Entry Flow, veh/h | 382 | 545 | 829 | 259 |
| Cap Entry Lane, veh/h | 822 | 888 | 983 | 746 |
| Entry HV Adj Factor | 0.978 | 0.979 | 0.980 | 0.979 |
| Flow Entry, veh/h | 374 | 534 | 813 | 254 |
| Cap Entry, veh/h | 804 | 870 | 963 | 730 |
| V/C Ratio | 0.465 | 0.614 | 0.844 | 0.347 |
| Control Delay, s/veh | 10.6 | 13.5 | 24.3 | 9.3 |
| LOS | B | B | C | A |
| 95th %tile Queue, veh | 2 | 4 | 10 | 2 |

HCM 6th Roundabout
2: Ivybridge Blvd & Rex Rd

2041 Total Traffic
PM Peak Hour

| Intersection | | | |
|-----------------------------|-------|-------|-------|
| Intersection Delay, s/veh | 9.4 | | |
| Intersection LOS | A | | |
| Approach | EB | WB | NB |
| Entry Lanes | 1 | 1 | 1 |
| Conflicting Circle Lanes | 1 | 1 | 1 |
| Adj Approach Flow, veh/h | 717 | 652 | 128 |
| Demand Flow Rate, veh/h | 731 | 665 | 131 |
| Vehicles Circulating, veh/h | 151 | 29 | 670 |
| Vehicles Exiting, veh/h | 543 | 772 | 212 |
| Ped Vol Crossing Leg, #/h | 0 | 0 | 0 |
| Ped Cap Adj | 1.000 | 1.000 | 1.000 |
| Approach Delay, s/veh | 11.1 | 7.9 | 7.4 |
| Approach LOS | B | A | A |
| Lane | Left | Left | Left |
| Designated Moves | TR | LT | LR |
| Assumed Moves | TR | LT | LR |
| RT Channelized | | | |
| Lane Util | 1.000 | 1.000 | 1.000 |
| Follow-Up Headway, s | 2.609 | 2.609 | 2.609 |
| Critical Headway, s | 4.976 | 4.976 | 4.976 |
| Entry Flow, veh/h | 731 | 665 | 131 |
| Cap Entry Lane, veh/h | 1183 | 1340 | 697 |
| Entry HV Adj Factor | 0.981 | 0.980 | 0.977 |
| Flow Entry, veh/h | 717 | 652 | 128 |
| Cap Entry, veh/h | 1160 | 1313 | 681 |
| V/C Ratio | 0.618 | 0.496 | 0.188 |
| Control Delay, s/veh | 11.1 | 7.9 | 7.4 |
| LOS | B | A | A |
| 95th %tile Queue, veh | 4 | 3 | 1 |

| Intersection | | | |
|-----------------------------|-------|-------|-------|
| Intersection Delay, s/veh | 11.0 | | |
| Intersection LOS | B | | |
| Approach | WB | NB | SB |
| Entry Lanes | 1 | 1 | 1 |
| Conflicting Circle Lanes | 2 | 2 | 2 |
| Adj Approach Flow, veh/h | 135 | 1031 | 550 |
| Demand Flow Rate, veh/h | 138 | 1052 | 561 |
| Vehicles Circulating, veh/h | 857 | 4 | 135 |
| Vehicles Exiting, veh/h | 199 | 692 | 860 |
| Ped Vol Crossing Leg, #/h | 0 | 0 | 0 |
| Ped Cap Adj | 1.000 | 1.000 | 1.000 |
| Approach Delay, s/veh | 7.7 | 13.4 | 7.4 |
| Approach LOS | A | B | A |
| Lane | Left | Left | Left |
| Designated Moves | LR | TR | LT |
| Assumed Moves | LR | TR | LT |
| RT Channelized | | | |
| Lane Util | 1.000 | 1.000 | 1.000 |
| Follow-Up Headway, s | 2.535 | 2.535 | 2.535 |
| Critical Headway, s | 4.328 | 4.328 | 4.328 |
| Entry Flow, veh/h | 138 | 1052 | 561 |
| Cap Entry Lane, veh/h | 685 | 1415 | 1266 |
| Entry HV Adj Factor | 0.978 | 0.980 | 0.981 |
| Flow Entry, veh/h | 135 | 1031 | 550 |
| Cap Entry, veh/h | 670 | 1387 | 1241 |
| V/C Ratio | 0.201 | 0.743 | 0.443 |
| Control Delay, s/veh | 7.7 | 13.4 | 7.4 |
| LOS | A | B | A |
| 95th %tile Queue, veh | 1 | 7 | 2 |

| Intersection | | | |
|-----------------------------|-------|-------|-------|
| Intersection Delay, s/veh | 20.4 | | |
| Intersection LOS | C | | |
| Approach | WB | NB | SB |
| Entry Lanes | 1 | 1 | 1 |
| Conflicting Circle Lanes | 1 | 1 | 1 |
| Adj Approach Flow, veh/h | 60 | 1204 | 758 |
| Demand Flow Rate, veh/h | 61 | 1228 | 774 |
| Vehicles Circulating, veh/h | 1156 | 33 | 42 |
| Vehicles Exiting, veh/h | 105 | 783 | 1175 |
| Ped Vol Crossing Leg, #/h | 0 | 0 | 0 |
| Ped Cap Adj | 1.000 | 1.000 | 1.000 |
| Approach Delay, s/veh | 10.8 | 27.7 | 9.6 |
| Approach LOS | B | D | A |
| Lane | Left | Left | Left |
| Designated Moves | LR | TR | LT |
| Assumed Moves | LR | TR | LT |
| RT Channelized | | | |
| Lane Util | 1.000 | 1.000 | 1.000 |
| Follow-Up Headway, s | 2.609 | 2.609 | 2.609 |
| Critical Headway, s | 4.976 | 4.976 | 4.976 |
| Entry Flow, veh/h | 61 | 1228 | 774 |
| Cap Entry Lane, veh/h | 424 | 1334 | 1322 |
| Entry HV Adj Factor | 0.984 | 0.981 | 0.980 |
| Flow Entry, veh/h | 60 | 1204 | 758 |
| Cap Entry, veh/h | 417 | 1308 | 1295 |
| V/C Ratio | 0.144 | 0.920 | 0.585 |
| Control Delay, s/veh | 10.8 | 27.7 | 9.6 |
| LOS | B | D | A |
| 95th %tile Queue, veh | 0 | 16 | 4 |

| Intersection | | | | | | | |
|-----------------------------|-------|-------|-------|-------|-------|-------|--|
| Intersection Delay, s/veh | 12.8 | | | | | | |
| Intersection LOS | B | | | | | | |
| Approach | EB | | NB | | SB | | |
| Entry Lanes | 2 | | 2 | | 2 | | |
| Conflicting Circle Lanes | 2 | | 2 | | 2 | | |
| Adj Approach Flow, veh/h | 338 | | 1396 | | 716 | | |
| Demand Flow Rate, veh/h | 345 | | 1424 | | 730 | | |
| Vehicles Circulating, veh/h | 629 | | 155 | | 372 | | |
| Vehicles Exiting, veh/h | 473 | | 819 | | 1207 | | |
| Ped Vol Crossing Leg, #/h | 0 | | 0 | | 0 | | |
| Ped Cap Adj | 1.000 | | 1.000 | | 1.000 | | |
| Approach Delay, s/veh | 7.0 | | 16.9 | | 7.6 | | |
| Approach LOS | A | | C | | A | | |
| Lane | Left | Right | Left | Right | Left | Right | |
| Designated Moves | L | TR | L | TR | LT | TR | |
| Assumed Moves | L | TR | L | TR | LT | TR | |
| RT Channelized | | | | | | | |
| Lane Util | 0.449 | 0.551 | 0.261 | 0.739 | 0.470 | 0.530 | |
| Follow-Up Headway, s | 2.667 | 2.535 | 2.667 | 2.535 | 2.667 | 2.535 | |
| Critical Headway, s | 4.645 | 4.328 | 4.645 | 4.328 | 4.645 | 4.328 | |
| Entry Flow, veh/h | 155 | 190 | 372 | 1052 | 343 | 387 | |
| Cap Entry Lane, veh/h | 757 | 832 | 1170 | 1245 | 959 | 1035 | |
| Entry HV Adj Factor | 0.981 | 0.979 | 0.981 | 0.980 | 0.981 | 0.980 | |
| Flow Entry, veh/h | 152 | 186 | 365 | 1031 | 336 | 379 | |
| Cap Entry, veh/h | 742 | 814 | 1148 | 1220 | 940 | 1015 | |
| V/C Ratio | 0.205 | 0.228 | 0.318 | 0.845 | 0.358 | 0.374 | |
| Control Delay, s/veh | 7.1 | 6.9 | 6.2 | 20.7 | 7.7 | 7.5 | |
| LOS | A | A | A | C | A | A | |
| 95th %tile Queue, veh | 1 | 1 | 1 | 11 | 2 | 2 | |

Queuing Reports



Queuing and Blocking Report

Intersection: 1: Eastonville Rd & Rex Rd

| Movement | EB | EB | EB | WB | WB | WB | NB | NB | NB | SB | SB | SB |
|-----------------------|-----|-----|-----|-----|-----|-----|-----|-----|-----|-----|------|-----|
| Directions Served | L | T | R | L | T | R | L | T | R | L | T | R |
| Maximum Queue (ft) | 56 | 138 | 97 | 252 | 97 | 34 | 98 | 101 | 105 | 55 | 170 | 43 |
| Average Queue (ft) | 13 | 65 | 41 | 121 | 34 | 6 | 40 | 37 | 45 | 17 | 78 | 18 |
| 95th Queue (ft) | 40 | 116 | 78 | 206 | 76 | 23 | 77 | 76 | 86 | 47 | 137 | 36 |
| Link Distance (ft) | | 719 | | | 500 | | | 879 | | | 1170 | |
| Upstream Blk Time (%) | | | | | | | | | | | | |
| Queuing Penalty (veh) | | | | | | | | | | | | |
| Storage Bay Dist (ft) | 205 | | 155 | 350 | | 155 | 315 | | 155 | 205 | | 155 |
| Storage Blk Time (%) | | 0 | | 0 | | | | | | | 0 | |
| Queuing Penalty (veh) | | 0 | | 0 | | | | | | | 0 | |

Intersection: 2: Ivybridge Blvd & Rex Rd

| Movement | EB | WB | NB | NB |
|-----------------------|-----|-----|-----|-----|
| Directions Served | TR | L | L | R |
| Maximum Queue (ft) | 4 | 48 | 53 | 80 |
| Average Queue (ft) | 0 | 14 | 19 | 40 |
| 95th Queue (ft) | 3 | 40 | 46 | 66 |
| Link Distance (ft) | 500 | | | 316 |
| Upstream Blk Time (%) | | | | |
| Queuing Penalty (veh) | | | | |
| Storage Bay Dist (ft) | | 155 | 205 | |
| Storage Blk Time (%) | | | | |
| Queuing Penalty (veh) | | | | |

Intersection: 3: Rex Rd & Future Access

| Movement | EB | SB |
|-----------------------|-----|-----|
| Directions Served | L | LR |
| Maximum Queue (ft) | 12 | 54 |
| Average Queue (ft) | 0 | 17 |
| 95th Queue (ft) | 6 | 44 |
| Link Distance (ft) | | 330 |
| Upstream Blk Time (%) | | |
| Queuing Penalty (veh) | | |
| Storage Bay Dist (ft) | 155 | |
| Storage Blk Time (%) | | |
| Queuing Penalty (veh) | | |

Queuing and Blocking Report

Intersection: 133: Ivybridge Blvd & North Church Access

| Movement | EB |
|-----------------------|-----|
| Directions Served | LR |
| Maximum Queue (ft) | 26 |
| Average Queue (ft) | 12 |
| 95th Queue (ft) | 33 |
| Link Distance (ft) | 262 |
| Upstream Blk Time (%) | |
| Queuing Penalty (veh) | |
| Storage Bay Dist (ft) | |
| Storage Blk Time (%) | |
| Queuing Penalty (veh) | |

Intersection: 134: Ivybridge Blvd & South Church Access

| Movement | EB |
|-----------------------|-----|
| Directions Served | R |
| Maximum Queue (ft) | 16 |
| Average Queue (ft) | 1 |
| 95th Queue (ft) | 8 |
| Link Distance (ft) | 245 |
| Upstream Blk Time (%) | |
| Queuing Penalty (veh) | |
| Storage Bay Dist (ft) | |
| Storage Blk Time (%) | |
| Queuing Penalty (veh) | |

Intersection: 305: Dawlish Dr & Ivybridge Blvd

| Movement | EB | WB | SB | SB |
|-----------------------|-----|-----|-----|-----|
| Directions Served | LT | TR | L | R |
| Maximum Queue (ft) | 49 | 4 | 43 | 56 |
| Average Queue (ft) | 9 | 0 | 14 | 18 |
| 95th Queue (ft) | 35 | 3 | 40 | 46 |
| Link Distance (ft) | 225 | 208 | 239 | 239 |
| Upstream Blk Time (%) | | | | |
| Queuing Penalty (veh) | | | | |
| Storage Bay Dist (ft) | | | | |
| Storage Blk Time (%) | | | | |
| Queuing Penalty (veh) | | | | |

Zone Summary

| |
|------------------------------|
| Zone wide Queuing Penalty: 1 |
|------------------------------|