

Item Numbers refer to SWMP Checklist

**STORM WATER MANAGEMENT PLAN  
FOR  
A-1 CHIPSEAL  
7245 COLE VIEW, COLORADO SPRINGS**

**MAY 2022**

Prepared For:

**A-1 CHIPSEAL**  
2505 E 74<sup>TH</sup> Avenue  
Denver, CO 80229  
(720) 540-8264  
c/o Stephanie Wallis

Prepared By:

**TERRA NOVA ENGINEERING, INC.**  
721 S. 23<sup>rd</sup> ST.  
Colorado Springs, CO 80904  
(719) 635-6422

Job No. 2173.00

County Job No. #####

PCD File No. COM-22-014

## CONTACT INFORMATION

### SWMP APPLICANT:

TBD

520 West 21<sup>st</sup> Street, G-2 #710  
Norfolk, VA 23517  
(757) 333-3144

### CONTRACTOR:

TBD

520 West 21<sup>st</sup> Street, G-2 #710  
Norfolk, VA 23517  
(757) 333-3144

### ENGINEER:

Terra Nova Engineering, Inc.  
Dane Frank, P.E.  
721 S. 23<sup>rd</sup> St.  
Colorado Springs, CO 80904  
719-635-6422 Office  
[dane@tnesinc.com](mailto:dane@tnesinc.com)

### QUALIFIED STORMWATER MANAGER / GEC ADMINISTRATOR:

TBD

520 West 21<sup>st</sup> Street, G-2 #710  
Norfolk, VA 23517  
(757) 333-3144

Item 1. Add Qualified Stormwater Manager and Contractor Information to cover/title sheet. If unknown, add a placeholder to be updated prior to the pre-construction meeting:

#### QUALIFIED STORMWATER MANAGER

Name: \_\_\_\_\_

Company: \_\_\_\_\_

Address: \_\_\_\_\_

#### CONTRACTOR

Name: \_\_\_\_\_

Company: \_\_\_\_\_

Address: \_\_\_\_\_

**SWMP is to be maintained on site in the construction trailer whenever work is occurring. If construction trailer is not available, another alternative must be provided.**

## **COLORADO DISCHARGE PERMIT SYSTEM (CDPS)**

TO: Site Inspector Responsible For All CDPS Requirements

The following storm water pollution management plan (SWMP) is a detailed account of the requirements for the CDPS permit. The main objective of this plan is to prevent any contamination of the storm water while construction activity is taking place.

This document must be kept at the construction site at all times and be made available to the public and any representative of the Colorado Department of Health – Water Quality Control Division, if requested.

Enclosed are temporary erosion control details for the construction site and storm sewer outfall points (Detail A). The operation and maintenance inspection record should be used as a guideline for the inspection of permanent and temporary control devices. Items to be inspected are not limited to those listed. The inspections should be made at regular intervals and before and after storm events. The inspection records must be signed and kept in this binder for no less than three (3) years.

**STORM WATER MANAGEMENT PLAN FOR  
A-1 Chipseal – 7245 Cole View**

**TABLE OF CONTENTS**

Site Description and Existing Conditions	Page 5
Construction Activities	Page 6
Construction Schedule and Sequence	Page 6
Potential Sources of Pollution	Page 7
Implementation of Control Measures	Page 8
Materials Handling	Page 8
Waste Management and Disposal	Page 8
Spill Prevention and Control Plan	Page 8
Maintenance, Inspection, and Repair	Page 12
Final Stabilization and Long Term Stormwater Management	Page 13
State Requirements That Are Not Applicable	Page 13

**APPENDIX**

GENERAL LOCATION MAP  
EROSION CONTROL PLAN & DETAILS  
SELECT UDFCD BMP DESCRIPTION SHEETS  
GENERAL PERMIT APPLICATION  
OPERATION AND MAINTENANCE INSPECTION FORM  
OPERATION AND MAINTENANCE INSPECTION RECORD

# **STORM WATER MANAGEMENT PLAN FOR A-1 Chipseal – 7245 Cole View**

## **SITE DESCRIPTION & EXISTING CONDITIONS**

This site is approximately 1.36 acres of developed land located at 7245 Cole View. This site is currently in use as a paving business. The site is in the northeast quarter of Section 8, Township 14 South, Range 65 West of the 6<sup>th</sup> Principal Meridian within El Paso County. The parcels are bounded to the north and west by Sand Creek, to the southwest by LOT 35 CLAREMONT BUSINESS PARK FIL NO 2, to the southeast by LOTS 13 AND 14 CLAREMONT BUSINESS PARK FIL NO 2, and to the north by LOT 39 CLAREMONT BUSINESS PARK FIL NO 2. (see vicinity map).

The site lies within the Sand Creek Basin, with storm runoff surface draining west across the site, then into a gutter that flows off the site to the south, eventually entering a storm inlet, which drains into the adjacent East Fork Sand Creek. There are also storm inlets in Marksheffel Road that flow into a storm sewer that flows south along Markcheffel to an unknown outfall, which presumably also drains into Sand Creek.

Soils for this project are delineated by the map in the appendix as Ellicott loamy coarse sand, 0 to 5 percent slopes (28). Soils in the study area are shown as mapped by NRCS in the “Soils Survey of El Paso County Area” and contains soils of Hydrologic Group D.

The site is developed with mostly pavement and roof surfaces, and a small amount of landscaping. The site drains to the west, with an average slope of 3.7%. Existing vegetative ground cover is approximately 1% based on aerial photos (site is 95% building and pavement).

No known toxic materials have been treated, stored, disposed, spilled or leaked onto the site.

No stream crossings are located on the site.

No dewatering is anticipated.

This project does not rely on control measures owned or operated by another entity.

### **CONSTRUCTION ACTIVITY AND STORAGE**

The proposed development is a sand filter in an existing paved area. Proposed construction activities include digging a hole for the sand filter and building the sand filter. Potential pollutants at the site include suspended solids, fuels, and lubricants.

Practices to minimize contact of construction materials, equipment and vehicles with the storm water include sub-contractor cleaning and hauling of excess debris and material upon completion of work. Construction material loading and unloading, and access to such areas occur from paved staging areas shown on the map. The concrete washout area will be removed and disposed of as required by this permit as well as the SWMP permit. Potential pollutants such as paints, adhesives, porta potty runoff, and oil spills will also be dealt with as required. All paints, adhesives, et. will be properly stored or disposed of as applicable. There will always be a spill kit onsite to deal with spill incidents and prevent damage to surrounding environment. The porta potty will be placed at least 10 feet from any vehicle right-of-way, storm drain inlet, or waterway, and a minimum of 50 feet from state waters. The porta potty will be staked to the ground or fastened in a way that will prevent a spill from tipping. The porta potty will be cleaned on a weekly basis and inspected daily for spills. Soils are not to be tracked offsite, and any soils tracked offsite should be swept up.

There will be no on-site mobile fueling. Contractor shall have the Hazardous Material emergency response number posted on the site. No concrete or asphalt batch plants are planned for the construction site. The site will be considered stabilized when site vegetation is 70% of pre-disturbed levels and grading and building construction has been completed (note: the entire construction area is currently paved). There will be zero acres of disturbed soil area. The estimate for cut on this site is 152 cy and for fill it is 0 cy for a net cut of 154 cy. Extra earthen material will be transported offsite.

0.03 acres

No non-stormwater discharges are anticipated at the site.

### **CONSTRUCTION SCHEDULE AND SEQUENCE**

Erosion control measures shall be implemented in a manner that will protect properties and public facilities from the adverse effects of erosion and sedimentation as a result of construction and earthwork activities.

Grading will begin in Summer 2022 and the site will be considered stabilized in the Summer 2022.

Grading will begin in Summer 2022 with completion of construction activities anticipated to be in the Summer of 2022. The construction sequence will be: saw cut pavement, excavate sand filter volume, install sand filter, and cleanup.

Before clearing and grubbing may begin the first level of BMP'S are to be installed. These measures include a concrete washout area (CWA). The Staging Area (SSA) also is setup with appropriate measures to protect downstream.

The second level of BMP's shall be installed once the previous BMP's and construction are completed. These measures include mulching (MU) and permanent seeding (PS). All temporary soil erosion control measures and BMP's shall be maintained until permanent soil erosion control measures are implemented (seeding and mulching) and vegetation has been established to 70% of pre-disturbed levels on areas not to be covered with pavement or other finished products. Note: The entire construction area is currently paved, so revegetation is unlikely to be necessary.

Erosion control measures shall be implemented in a manner that will protect properties and public facilities from the adverse effects of erosion and sedimentation as a result of construction and earthwork activities.

## **POTENTIAL SOURCES OF POLLUTION**

The potential sources of pollution associated with this development are:

- Disturbed and stored soils
- Vehicle tracking of sediments
- Management of contaminated soils (if exist)
- Loading and unloading operations
- Outdoor storage activities (erodible building materials, fertilizers, chemicals, etc.)
- Vehicle and equipment maintenance and fueling
- Significant dust or particulate generating processes
- Routine maintenance activities involving fertilizers, pesticides, herbicides, fuels, solvents, etc.)
- Onsite waste management practices (waste piles, liquid wastes, dumpsters)

- Concrete truck / equipment washing
- Non-industrial waste sources such as worker trash and portable toilets

## **IMPLEMENTATION OF CONTROL MEASURES**

BMP design specifications and implementation information can be found in the UDFCD BMP Description Sheets included in the Appendix. This project does not rely on control measures owned or operated by another entity.

list all proposed structural and non structural BMPs to be utilized at the Site

## **MATERIALS HANDLING**

All construction materials shall be handled in a manner to minimize the chance of stormwater contamination. Stockpile and material staging areas are shown on the Erosion Control Plan. Additional materials handling info is included in the Spill Prevention and Control Plan section.

## **WASTE MANAGEMENT AND DISPOSAL**

All waste and debris created by construction activities at the site shall be disposed of in compliance with all laws, regulations, and ordinances of the federal, state and local agencies. Waste bins will be checked for leaks and remaining capacity each time they are used. Waste bins will be emptied when they are full (at a minimum).

## **SPILL PREVENTION AND CONTROL PLAN**

The Site Superintendent will act as the point of contact for any spill that occurs at this jobsite. The Construction Manager will be responsible for implementation of prevention practices, spill containment / cleanup, worker training, reporting and complete documentation in the event of a spill. The Site Superintendent shall immediately notify the Owner, /Construction Manager, State and the Local Fire Department in addition to the legally required Federal, State, and Local reporting channels (including the National Response Center, 800.424.8802) if a reportable quantity is released to the environment.



## SPILL PREVENTION BEST MANAGEMENT PRACTICES

This section describes spill prevention methods Best Management Practices (BMP) that will be practiced to eliminate spills before they happen.

### Equipment Staging and Maintenance

- Store and maintain equipment in a designated area.
- Reduce the amount of hazardous materials and waste by substituting non-hazardous or less hazardous materials.
- Use secondary containment (drain pan) to catch spills when removing or changing fluids.
- Use proper equipment (pumps, funnels) to transfer fluids.
- Keep spill kits readily accessible.
- Check incoming vehicles for leaking oil and fluids.
- Transfer used fluids and oil filters to waste or recycling drums immediately following generation.
- Inspect equipment routinely for leaks and spills.
- Repair equipment immediately, if necessary implement a preventative maintenance schedule for equipment and vehicles.

### Fueling Area

- Perform fueling in designated fueling area minimum 50' away from federal waters.
- Use secondary containment (drain pan) to catch spills.
- Use proper equipment (pumps, funnels) to transfer fluids.
- Keep spill kits readily accessible.
- Inspect fueling areas routinely for leaks and spills.
- Hazardous Material Storage Areas: Reduce the amount of hazardous materials by substituting non-hazardous or less hazardous materials.

### Hazardous Material Storage Areas

- Minimize the quantity of hazardous materials brought onsite.
- Store hazardous materials in a designated area away from drainage points.

### Unexpected Contaminated Soil and Water

- Investigate historical site use.
- Perform all excavation activities carefully and only after the Owner/Construction.
- Manager directs any activities.

### SPILL CONTAINMENT METHODS

The following discussion identifies the types of secondary containment that will be used in the event of a spill. Table 1 summarizes the containment methods for each potential source.

- **Equipment Staging and Maintenance Area:** An equipment leak from a fuel tank, equipment seal, or hydraulic line will be contained within a spill containment cell placed beneath all stationary potential leak sources. An undetected leak from parked equipment will be cleaned up using hand shovels and containerized in a 55-gallon steel drum for offsite disposal.
- **Fueling Area:** A small spill during fueling operations will be contained using fuel absorbent pads at the nozzle. The transfer of fuel into portable equipment will be performed using a funnel and/or hand pump and a spill pad used to absorb any incidental spills/drips. Any leaking tanks or drums will have fluids removed and transferred to another tank, drum, or container for the fluids. A spill response kit will be located near the fueling area or on the fuel truck for easy access. The spill response kit will include plastic sheeting, tarps, over pack drums, absorbent litter, and shovels.
- **Hazardous Material Storage Area:** A spill from containers or cans in a hazardous material storage area will be contained within the storage cabinet these materials are kept in.
- **Unexpected Contaminated Soil:** If contaminated soil is encountered during the project, the Owner/Construction Manager will be notified immediately. Small quantities of suspected contaminated soil will be placed on a 6-mil plastic liner and covered with 6-mil plastic. A soil berm

or silt fence will be used to contain the stockpile and prevent migration of contaminated liquids in the soil.

**Table 1: Spill Prevention and Containment Methods**

Potential Spill Source	Containment Method(s)
Equipment staging and maintenance area	Spill containment pad, spill kit, pumps, funnels
Fueling area (site equipment only)	Spill containment pad, spill kit, pumps, funnels
Hazardous material staging area	Spill containment pad, spill kit, pumps, funnels
Unexpected contaminated soil	Plastic liner, plastic cover, soil berm, hay bales, lined super sacks

SPILL COUNTERMEASURES

Every preventative measure shall be taken to keep contaminated or hazardous materials contained. If a release occurs, the following actions shall be taken:

1. **Stop the Spill:** The severity of a spill at the site is anticipated to be minimal as large containers/quantities of Hazardous Materials are not anticipated. The type of spill would occur while dispensing material at the hazardous materials storage facility and would likely be contained in secondary containment. Thus, the use spill kits or other available absorbent materials should stop the spill.

2. **Warn Others:** Notify co-workers and supervisory personnel of the release. Notify emergency responders if appropriate. For site personnel, an alarm system will consist of three one second blasts on an air horn sounded by the person discovering a spill or fire. In the event of any spill, the Superintendent and Project Manager shall be notified if the spill is 5 gallons or more the STATE will be contacted along with the Fire Department.

3. **Isolate the Area:** Prevent public access to the area and continue to minimize the spread of the material.

Minimize personal exposure throughout emergency response actions.

4. **Containment:** A spill shall only be contained by trained personnel and if it is safe to do so. DO NOT PLACE YOURSELF IN DANGER. Attempt to extinguish a fire only if it is in the incipient stage; trash can size or smaller. For larger spills, wait for the arrival of emergency response personnel and provide directions to the location of the emergency.

5. **Complete a Spill and Incident Report:** For each spill of a Hazardous Material a spill and incident report shall be completed and submitted to the Owner/Construction Manager and if applicable to the Engineer and the State of Colorado Department of Public Health and Environment.

#### **MAINTENANCE, INSPECTION, AND REPAIR**

The owner or his representative shall inspect and monitor all drainage facilities using the enclosed Inspection Forms in the appendix. In order to ensure that all graded surfaces, structures, vegetation, erosion and sediment control measures and other protective devices identified in the erosion control plan are maintained in good and effective condition, an Operation and Maintenance Inspection Monitoring Program will be implemented by the permit holder during the construction phase. A systematic inspection of all the above mentioned protective devices will be performed by trained personnel using the operation and maintenance inspection record form in the appendix at least once every 14 days. Also, post-storm event inspections must be conducted within 24 hours after the end of any precipitation or snowmelt event that causes surface erosion. Provided the timing is appropriate, the post-storm inspections may be used to fulfill the 14-day routine inspection requirement. A more frequent inspection schedule than the minimum inspections described may be necessary to ensure that BMPs continue to operate as needed to comply with the plan. All monitoring records are to include the signature of the inspector and are to be kept with the SWMP for a period of no less than three (3) years. All maintenance of temporary and permanent erosion and sediment control facilities shall be per the details included in this report.

This lot will be considered stabilized when all construction activities have been completed and vegetation has been re-established. Erosion control measures, including silt fence, must be removed after final stabilization.

Any major revisions or modification to this Storm Water Management Plan will require a report addendum and erosion control map revision. Minor revisions may be made by the Stormwater Manager by redlining the Storm Water Management Plan or inserting additional pages. The SWMP should be viewed as a “living document” that is continuously being reviewed and modified as a part of the overall process of evaluating and managing stormwater quality issues at the site. The Qualified Stormwater Manager shall amend the SWMP when there is a change in design, construction, operation or maintenance of the site which would require the implementation of new or revised BMPs or if the SWMP proves to be ineffective in achieving the general objectives of controlling pollutants in stormwater discharges associated with construction activity or when BMPs are no longer necessary and are removed.

The onsite SWMP will be located at:

### **FINAL STABILIZATION AND LONG TERM STORMWATER MANAGEMENT**

Permanent stabilization measures include landscaping per the approved landscaping plan, seeding, and mulching. These temporary BMPS’s are to be removed once the 70% of pre-disturbed levels vegetation or permanent landscaping has been established. At this point in the construction process, all landscaping should be in place and maintained for a period of time that allows for its establishment on the site.

Long term stormwater management is provided by the onsite detention basin on the southeast corner of the site.

### **STATE REQUIREMENTS THAT ARE NOT APPLICABLE**

The requirement for a phasing plan is not applicable as only one construction phase is proposed.

The requirement for spill prevention and pollution controls for dedicated batch plants is not applicable as no batch plants are proposed.

The requirement to show the location of any dedicated asphalt / concrete batch plants is no applicable as no batch plants are proposed.

**PREPARED BY:**

**Terra Nova Engineering, Inc.**  
Dane Frank, P.E.  
Project Engineer

Jobs/217300/Word/217300 SWMP.doc

## **GENERAL LOCATION MAP**



# A-1 Chipseal - Location Map

Image Dated May 2020

EAST  
FORK  
SAND  
CREEK

SITE

Cole View

Google Earth



100 ft





**EROSION CONTROL PLAN & DETAILS**  
**(see back pocket)**

# A-1 CHIPSEAL

## GRADING AND EROSION CONTROL PLAN

### EROSION CONTROL PLAN

MAY 2022

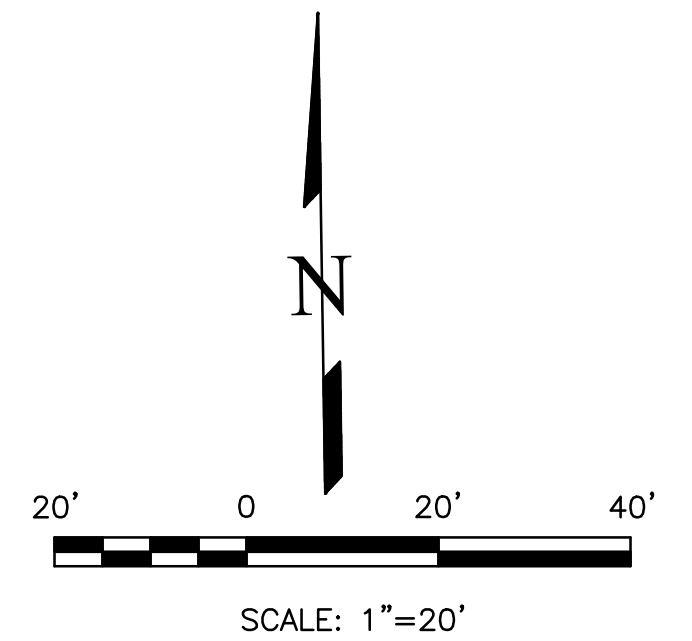

#### LEGEND

EXISTING CONTOURS - MINOR	---	61.32	---
EXISTING CONTOURS - MAJOR	---	61.30	---
GRADE & DIRECTION	2.2%		
PROPOSED CONTOUR	62		
PROPOSED	PR		
EXISTING	EX		
WATER LINE	---	W	---
SEWER LINE	---	SS	---
STORM LINE	---	ST	---
OVERHEAD ELECTRICAL LINE	---	OE	---
CHAIN LINK FENCE	[Symbol]		
FIRE HYDRANT	[Symbol]		
CONCRETE EDGE	CE		
FINISHED GROUND	FG		
FINISHED SURFACE	FS		
FLOWLINE	FL		
SPOT ELEVATION	SE		
ASPHALT EDGE	AE		
LOW POINT	LP		
HIGH POINT	HP		
EXISTING ELEVATION	12.00*		
EXISTING SPOT GRADE	X 7314.00		
PROPOSED SPOT GRADE	X 7314.00		
CONSTRUCTION SITE BOUNDARY & AREA OF SOIL DISTURBANCE	[Symbol]		
CUT FILL AREA BOUNDARY	[Symbol]		

#### EROSION CONTROL LEGEND

KEY	TITLE	SYMBOL	IMPLEMENTATION PHASE
(SF)	SILT FENCE	[Symbol]	INITIAL
(SSA)	STABILIZED STAGING AREA	[Symbol]	INITIAL
(VTC)	VEHICLE TRACKING CONTROL	[Symbol]	INITIAL
(SP)	STOCKPILE MANAGEMENT WITH PROTECTION	[Symbol]	INITIAL
(CWA)	CONCRETE WASHOUT AREA	[Symbol]	INITIAL
(IP)	INLET PROTECTION	[Symbol]	INITIAL
(MU)	MULCHING - CRIMP FLAT AREAS, HYDROSEED ON SLOPES	[Symbol]	FINAL
(PS)	PERMANENT SEEDING - DRILL SEED FLAT AREAS, BROADCAST SEED OR HYDROSEED ON SLOPES, SEED MIX PER DRAINAGE CRITERIA MANUAL (MAY 2014) VOL 1, TABLE 14-12	[Symbol]	FINAL
(SB)	SEDIMENT BASIN	[Symbol]	INITIAL

#### NOTES

1. SEDIMENT CONTROL LOGS MAY BE SUBSTITUTED FOR SILT FENCE AND VICE VERSA.
2. SEED AND MULCH DISTURBED AREAS ONLY.
3. EXISTING SITE VEGETATION IS LANDSCAPING (PER AERIAL PHOTOS).
4. LOCATIONS OF WASTE CONTAINER, PORTABLE TOILETS, AND SWMP STORAGE ARE TBD.
5. THE ONLY PROPOSED DEVELOPMENT IS THE SAND FILTER. THE AREA AROUND THE SAND FILTER IS CURRENTLY PAVED OUT TO THE STREET.
6. AS THE ENTIRE WORK AREA IS ALREADY PAVED, NO VEHICLE TRACKING CONTROL IS PROPOSED. SOIL TRACKING SHALL BE CONTROLLED WITH SWEEPING.
7. NO SOIL STOCKPILE AREA IS PROPOSED AS THE PROPOSED WORK IS DIGGING A HOLE IN A PAVED AREA TO INSTALL A SAND FILTER. NO SOIL IS TO BE STOCKPILED ONSITE.

#### EROSION CONTROL COST OPINION:

1. 1 EA-CONCRETE WASHOUT @ \$932/EA	\$ 932
2. 40% MAINTENANCE AND REPLACEMENT	\$ 373
<b>TOTAL</b>	<b>\$ 1,305</b>

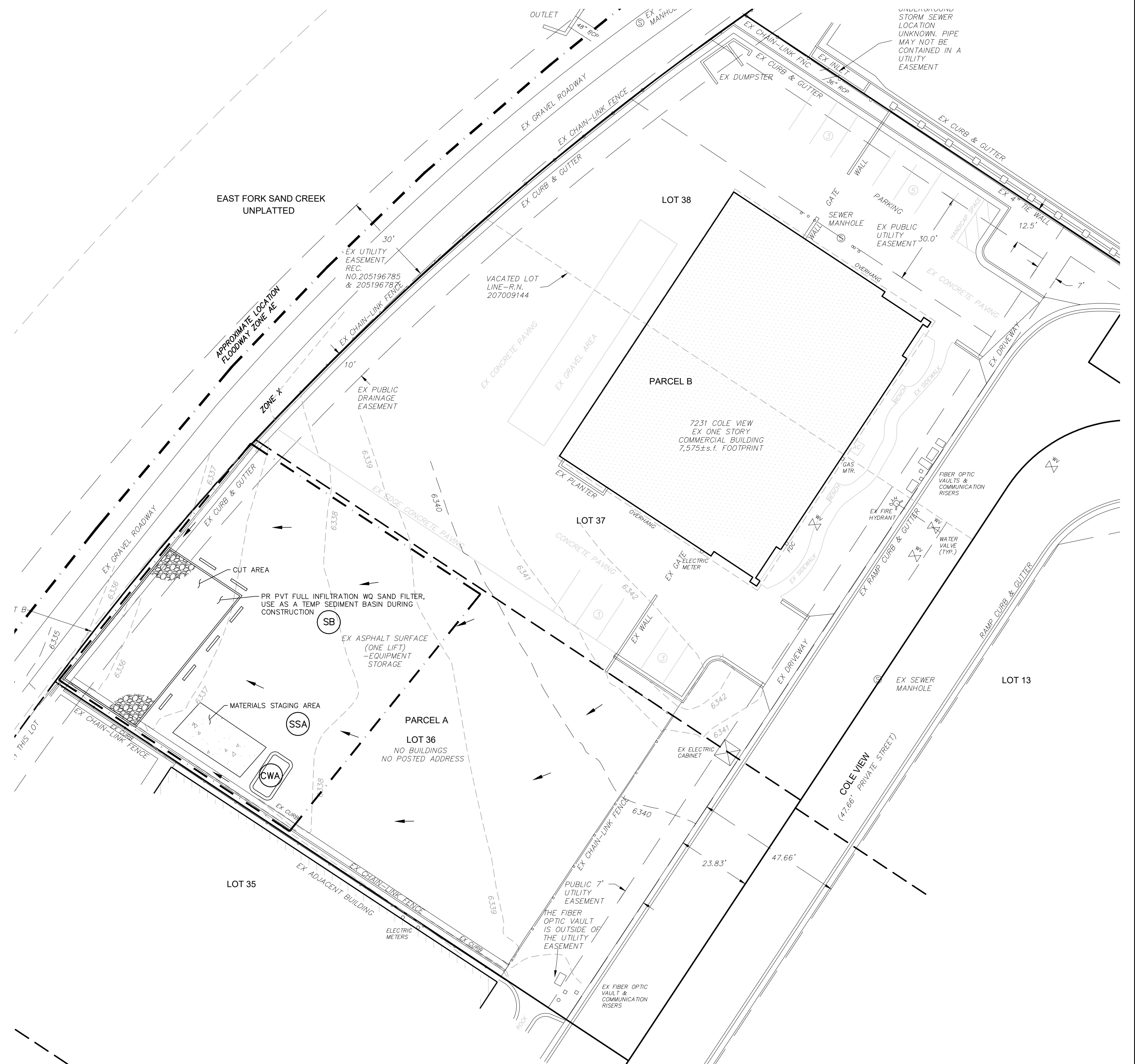

THIS DESIGN WAS PREPARED UNDER MY DIRECT SUPERVISION FOR AND ON BEHALF OF TERRA NOVA ENGINEERING, INC.

DANE FRANK  
COLORADO P.E. # 50207

REVISIONS NO.	DESCRIPTION	DATE

UNTIL SUCH TIME AS THESE DRAWINGS ARE APPROVED BY THE BOARD OF ENGINEERS, THE TERRA NOVA ENGINEERING, INC. APPROVES THEIR USE ONLY FOR THE PROJECT AND FOR THE MOST PART BY WRITTEN AUTHORIZATION.

PREPARED FOR:  
**A-1 CHIPSEAL**  
ATTN: STEPHANIE WALLIS  
2505 E 74TH AVE  
DENVER, CO 80229  
720.540.8264

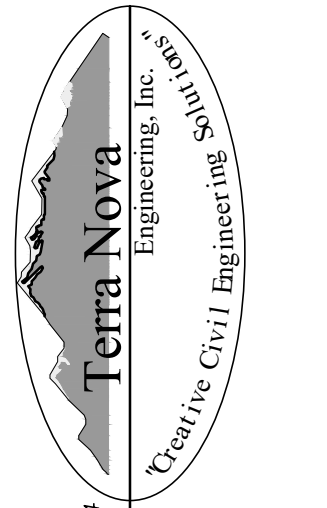

721 S. 23RD STREET  
COLORADO SPRINGS, CO 80904  
OFFICE: 719-635-6422  
FAX: 719-635-6426  
www.tnenginc.com

**A-1 CHIPSEAL**  
GRADING AND EROSION CONTROL PLAN  
EROSION CONTROL PLAN

DESIGNED BY DLF
DRAWN BY DLF
CHECKED BY LD
H-SCALE AS SHOWN
V-SCALE N/A
JOB NO. 2173.00
DATE ISSUED 05/02/22
SHEET NO. 4 OF 5



**Concrete Washout Area (CWA) MM-1**

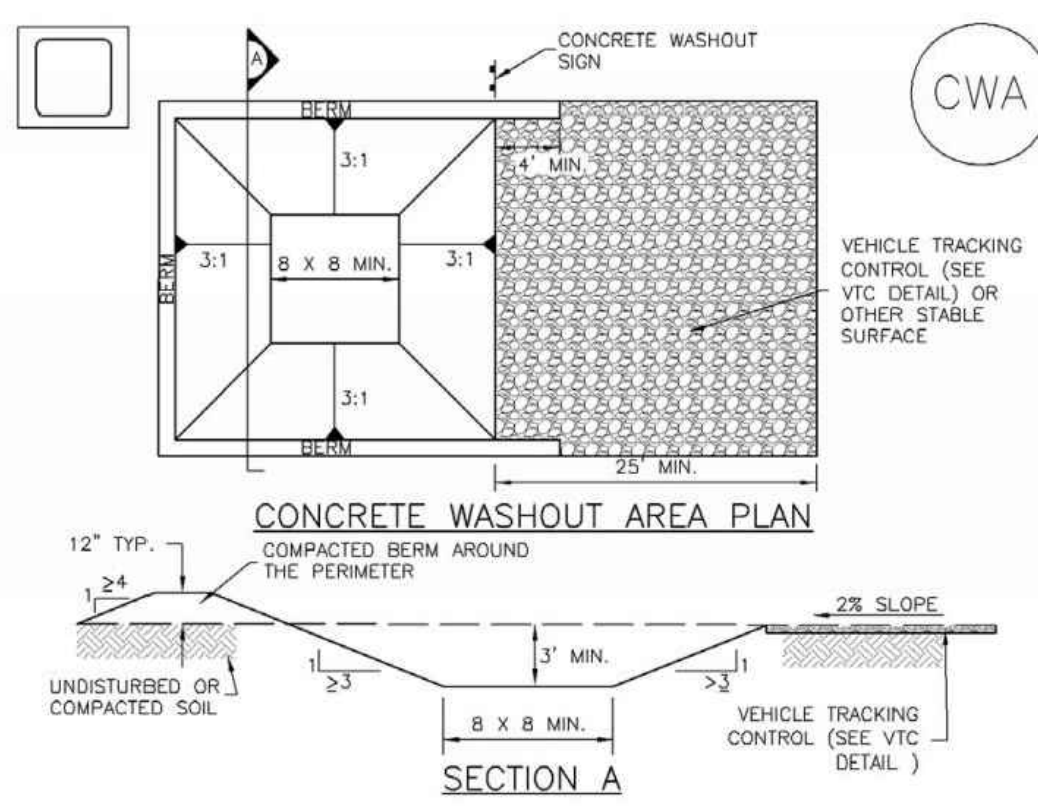

- CWA-1. CONCRETE WASHOUT AREA**
- CWA INSTALLATION NOTES**
- SEE PLAN VIEW FOR:
    - CWA INSTALLATION LOCATION.
  - DO NOT LOCATE AN UNLINED CWA WITHIN 400' OF ANY NATURAL DRAINAGE PATHWAY OR WATERBODY. DO NOT LOCATE WITHIN 1,000' OF ANY WELLS OR DRINKING WATER SOURCES. IF SITE CONSTRAINTS MAKE THIS INFEASIBLE, OR IF HIGHLY PERMEABLE SOILS EXIST ON SITE, THE CWA MUST BE INSTALLED WITH AN IMPERMEABLE LINER (16 MIL MIN. THICKNESS) OR SURFACE STORAGE ALTERNATIVES USING PREFABRICATED CONCRETE WASHOUT DEVICES OR A LINED ABOVE GROUND STORAGE ARE SHOULD BE USED.
  - THE CWA SHALL BE INSTALLED PRIOR TO CONCRETE PLACEMENT ON SITE.
  - CWA SHALL INCLUDE A FLAT SUBSURFACE PIT THAT IS AT LEAST 8' BY 8' SLOPES LEADING OUT OF THE SUBSURFACE PIT SHALL BE 3:1 OR FLATTER. THE PIT SHALL BE AT LEAST 3' DEEP.
  - BERM SURROUNDING SIDES AND BACK OF THE CWA SHALL HAVE MINIMUM HEIGHT OF 1'.
  - VEHICLE TRACKING PAD SHALL BE SLOPED 2% TOWARDS THE CWA.
  - SIGNS SHALL BE PLACED AT THE CONSTRUCTION ENTRANCE, AT THE CWA, AND ELSEWHERE AS NECESSARY TO CLEARLY INDICATE THE LOCATION OF THE CWA TO OPERATORS OF CONCRETE TRUCKS AND PUMP TRIGS.
  - USE EXCAVATED MATERIAL FOR PERIMETER BERM CONSTRUCTION.

**MM-1 Concrete Washout Area (CWA)**

- CWA MAINTENANCE NOTES**
- INSPECT BMPs EACH WORKDAY, AND MAINTAIN THEM IN EFFECTIVE OPERATING CONDITION. MAINTENANCE OF BMPs SHOULD BE PROACTIVE, NOT REACTIVE. INSPECT BMPs AS SOON AS POSSIBLE (AND ALWAYS WITHIN 24 HOURS) FOLLOWING A STORM THAT CAUSES SURFACE EROSION, AND PERFORM NECESSARY MAINTENANCE.
  - FREQUENT OBSERVATIONS AND MAINTENANCE ARE NECESSARY TO MAINTAIN BMPs IN EFFECTIVE OPERATING CONDITION. INSPECTIONS AND CORRECTIVE MEASURES SHOULD BE DOCUMENTED THOROUGHLY.
  - WHERE BMPs HAVE FAILED, REPAIR OR REPLACEMENT SHOULD BE INITIATED UPON DISCOVERY OF THE FAILURE.
  - THE CWA SHALL BE REPAIRED, CLEANED, OR ENLARGED AS NECESSARY TO MAINTAIN CAPACITY FOR CONCRETE WASTE. CONCRETE MATERIALS ACCUMULATED IN PIT, SHALL BE REMOVED ONCE THE MATERIALS HAVE REACHED A DEPTH OF 2'.
  - CONCRETE WASHOUT WATER, WASTED PIECES OF CONCRETE AND ALL OTHER DEBRIS IN THE SUBSURFACE PIT SHALL BE TRANSPORTED FROM THE JOB SITE IN A WATER-TIGHT CONTAINER AND DISPOSED OF PROPERLY.
  - THE CWA SHALL REMAIN IN PLACE UNTIL ALL CONCRETE FOR THE PROJECT IS PLACED.
  - WHEN THE CWA IS REMOVED, COVER THE DISTURBED AREA WITH TOP SOIL, SEED AND MULCH OR OTHERWISE STABILIZED IN A MANNER APPROVED BY THE LOCAL JURISDICTION.
- (DETAILS ADAPTED FROM DOUGLAS COUNTY, COLORADO AND THE CITY OF PAPER, COLORADO, NOT AVAILABLE IN AUTOCAD)
- NOTE:** MANY JURISDICTIONS HAVE BMP DETAILS THAT VARY FROM UDFCD STANDARD DETAILS. CONSULT WITH LOCAL JURISDICTIONS AS TO WHICH DETAIL SHOULD BE USED WHEN DIFFERENCES ARE NOTED.

**Stabilized Staging Area (SSA) SM-6**

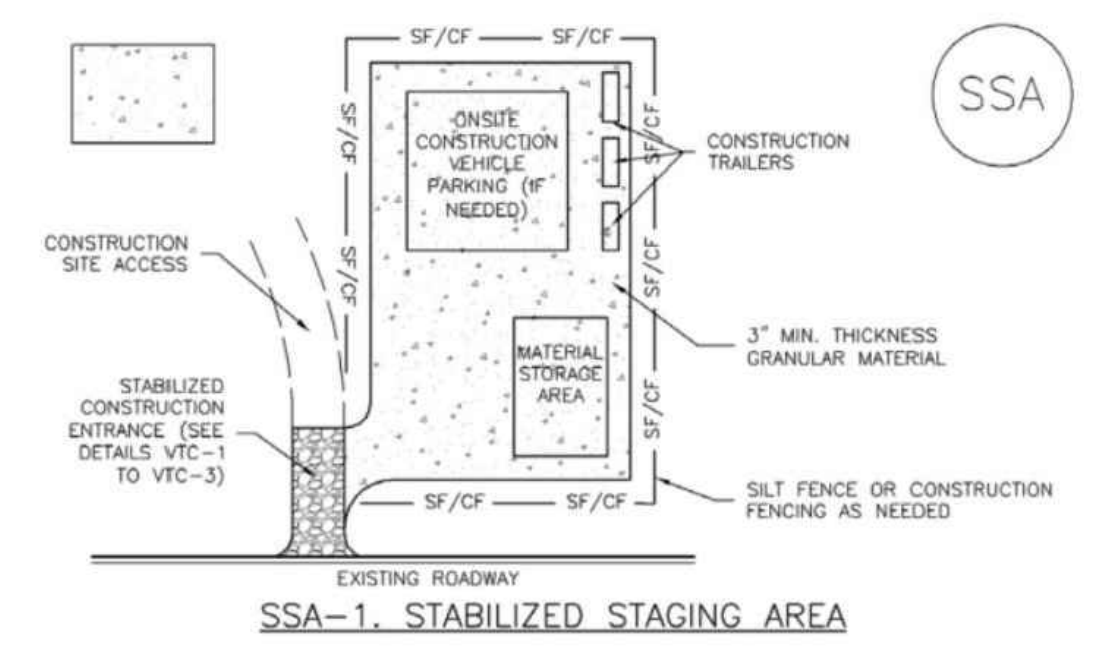

- SSA-1. STABILIZED STAGING AREA**
- STABILIZED STAGING AREA INSTALLATION NOTES**
- SEE PLAN VIEW FOR:
    - LOCATION OF STAGING AREA(S).
    - CONTRACTOR MAY ADJUST LOCATION AND SIZE OF STAGING AREA WITH APPROVAL FROM THE LOCAL JURISDICTION.
  - STABILIZED STAGING AREA SHOULD BE APPROPRIATE FOR THE NEEDS OF THE SITE. OVERSIZING RESULTS IN A LARGER AREA TO STABILIZE FOLLOWING CONSTRUCTION.
  - STAGING AREA SHALL BE STABILIZED PRIOR TO OTHER OPERATIONS ON THE SITE.
  - THE STABILIZED STAGING AREA SHALL CONSIST OF A MINIMUM 3" THICK GRANULAR MATERIAL.
  - UNLESS OTHERWISE SPECIFIED BY LOCAL JURISDICTION, ROCK SHALL CONSIST OF DOT SECT. #703, MSHTO #3 COARSE AGGREGATE OR 8" (MINUS) ROCK.
  - ADDITIONAL PERIMETER BMPs MAY BE REQUIRED INCLUDING BUT NOT LIMITED TO SILT FENCE AND CONSTRUCTION FENCING.
- STABILIZED STAGING AREA MAINTENANCE NOTES**
- INSPECT BMPs EACH WORKDAY, AND MAINTAIN THEM IN EFFECTIVE OPERATING CONDITION. MAINTENANCE OF BMPs SHOULD BE PROACTIVE, NOT REACTIVE. INSPECT BMPs AS SOON AS POSSIBLE (AND ALWAYS WITHIN 24 HOURS) FOLLOWING A STORM THAT CAUSES SURFACE EROSION, AND PERFORM NECESSARY MAINTENANCE.
  - FREQUENT OBSERVATIONS AND MAINTENANCE ARE NECESSARY TO MAINTAIN BMPs IN EFFECTIVE OPERATING CONDITION. INSPECTIONS AND CORRECTIVE MEASURES SHOULD BE DOCUMENTED THOROUGHLY.
  - WHERE BMPs HAVE FAILED, REPAIR OR REPLACEMENT SHOULD BE INITIATED UPON DISCOVERY OF THE FAILURE.
  - ROCK SHALL BE REAPPLIED OR REGRADED AS NECESSARY IF RUTTING OCCURS OR UNDERLYING SUBGRADE BECOMES EXPOSED.

**SM-6 Stabilized Staging Area (SSA)**

- STABILIZED STAGING AREA MAINTENANCE NOTES**
- STABILIZED STAGING AREA SHALL BE ENLARGED IF NECESSARY TO CONTAIN PARKING, STORAGE, AND UNLOADING/LOADING OPERATIONS.
  - THE STABILIZED STAGING AREA SHALL BE REMOVED AT THE END OF CONSTRUCTION. THE GRANULAR MATERIAL SHALL BE REMOVED OR, IF APPROVED BY THE LOCAL JURISDICTION, USED ON SITE, AND THE AREA COVERED WITH TOPSOIL, SEED, AND MULCH OR OTHERWISE STABILIZED IN A MANNER APPROVED BY LOCAL JURISDICTION.
- NOTE:** MANY MUNICIPALITIES PROHIBIT THE USE OF RECYCLED CONCRETE AS GRANULAR MATERIAL FOR STABILIZED STAGING AREAS DUE TO DIFFICULTIES WITH RE-ESTABLISHMENT OF VEGETATION IN AREAS WHERE RECYCLED CONCRETE WAS PLACED.
- NOTE:** MANY JURISDICTIONS HAVE BMP DETAILS THAT VARY FROM UDFCD STANDARD DETAILS. CONSULT WITH LOCAL JURISDICTIONS AS TO WHICH DETAIL SHOULD BE USED WHEN DIFFERENCES ARE NOTED.
- (DETAILS ADAPTED FROM DOUGLAS COUNTY, COLORADO, NOT AVAILABLE IN AUTOCAD)

**Sediment Basin (SB) SC-7**

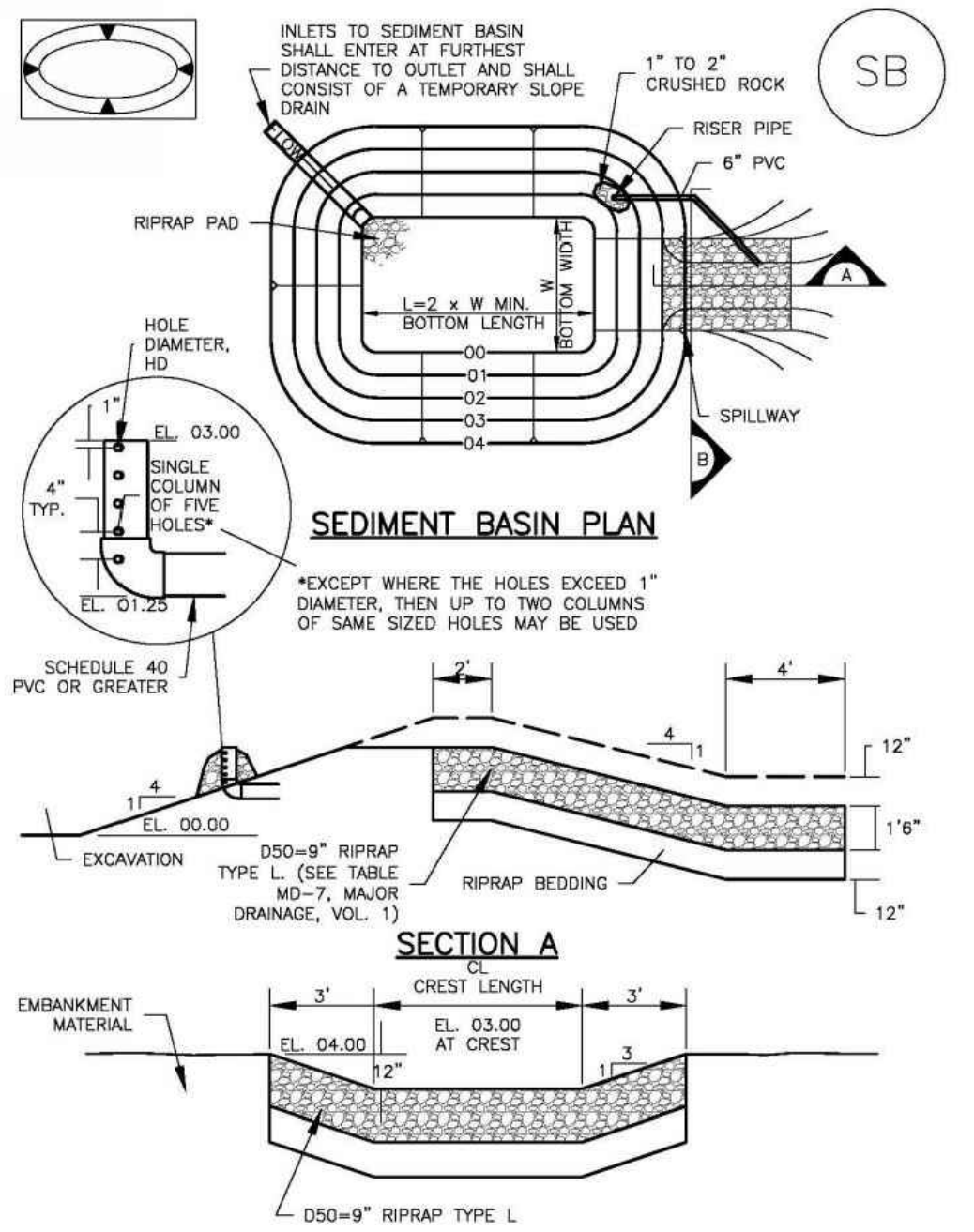

- SEDIMENT BASIN PLAN**
- SECTION A**

**SC-7 Sediment Basin (SB)**

**TABLE SB-1. SIZING INFORMATION FOR STANDARD SEDIMENT BASIN**

Upstream Drainage Area (rounded to nearest acre), (ac)	Basin Bottom Width (W), (ft)	Spillway Crest Length (CL), (ft)	Hole Diameter (HD), (in)
1	12 1/2	2	8 1/2
2	21	3	10 1/4
3	28	4	11 1/2
4	33 1/2	5	12 1/2
5	38 1/2	6	13 1/2
6	43	7	14 1/2
7	47 1/2	8	15 1/2
8	51	9	16 1/2
9	55	10	17 1/2
10	58 1/2	11	18 1/2
11	61	12	19 1/2
12	64	13	20 1/2
13	67 1/2	14	21 1/2
14	70 1/2	15	22 1/2
15	73 1/2	16	23 1/2

- SEDIMENT BASIN INSTALLATION NOTES**
- SEE PLAN VIEW FOR:
    - LOCATION OF SEDIMENT BASIN.
    - TYPE OF BASIN (STANDARD BASIN OR NONSTANDARD BASIN).
    - FOR STANDARD BASIN, BOTTOM WIDTH W, CREST LENGTH CL, AND HOLE DIAMETER, HD.
    - FOR NONSTANDARD BASIN, SEE CONSTRUCTION DRAWINGS FOR DESIGN OF BASIN INCLUDING RISER HEIGHT H, NUMBER OF COLUMNS N, HOLE DIAMETER HD AND PIPE DIAMETER D.
  - FOR STANDARD BASIN, BOTTOM DIMENSION MAY BE MODIFIED AS LONG AS BOTTOM AREA IS NOT REDUCED.
  - SEDIMENT BASINS SHALL BE INSTALLED PRIOR TO ANY OTHER LAND-DISTURBING ACTIVITY THAT RELIES ON ON BASINS AS A STORMWATER CONTROL.
  - EMBANKMENT MATERIAL SHALL CONSIST OF SOIL FREE OF DEBRIS, ORGANIC MATERIAL, AND ROCKS OR CONCRETE GREATER THAN 3 INCHES AND SHALL HAVE A MINIMUM OF 15 PERCENT BY WEIGHT PASSING THE NO. 200 SIEVE.
  - EMBANKMENT MATERIAL SHALL BE COMPACTED TO AT LEAST 95 PERCENT OF MAXIMUM DENSITY IN ACCORDANCE WITH ASTM D698.
  - PIPE SCH 40 OR GREATER SHALL BE USED.
  - THE DETAILS SHOWN ON THESE SHEETS PERTAIN TO STANDARD SEDIMENT BASIN(S) FOR DRAINAGE AREAS LESS THAN 15 ACRES. SEE CONSTRUCTION DRAWINGS FOR EMBANKMENT, STORAGE VOLUME, SPILLWAY, OUTLET, AND OUTLET PROTECTION DETAILS FOR ANY SEDIMENT BASIN(S) THAT HAVE BEEN INDIVIDUALLY DESIGNED FOR DRAINAGE AREAS LARGER THAN 15 ACRES.

**Sediment Basin (SB) SC-7**

- SEDIMENT BASIN MAINTENANCE NOTES**
- INSPECT BMPs EACH WORKDAY, AND MAINTAIN THEM IN EFFECTIVE OPERATING CONDITION. MAINTENANCE OF BMPs SHOULD BE PROACTIVE, NOT REACTIVE. INSPECT BMPs AS SOON AS POSSIBLE (AND ALWAYS WITHIN 24 HOURS) FOLLOWING A STORM THAT CAUSES SURFACE EROSION, AND PERFORM NECESSARY MAINTENANCE.
  - FREQUENT OBSERVATIONS AND MAINTENANCE ARE NECESSARY TO MAINTAIN BMPs IN EFFECTIVE OPERATING CONDITION. INSPECTIONS AND CORRECTIVE MEASURES SHOULD BE DOCUMENTED THOROUGHLY.
  - WHERE BMPs HAVE FAILED, REPAIR OR REPLACEMENT SHOULD BE INITIATED UPON DISCOVERY OF THE FAILURE.
  - SEDIMENT ACCUMULATED IN BASIN SHALL BE REMOVED AS NEEDED TO MAINTAIN BMP EFFECTIVENESS, TYPICALLY WHEN SEDIMENT DEPTH REACHES ONE FOOT (I.E., TWO FEET BELOW THE SPILLWAY CREST).
  - SEDIMENT BASINS ARE TO REMAIN IN PLACE UNTIL THE UPSTREAM DISTURBED AREA IS STABILIZED AND GRASS COVER IS ACCEPTED BY THE LOCAL JURISDICTION.
  - WHEN SEDIMENT BASINS ARE REMOVED, ALL DISTURBED AREAS SHALL BE COVERED WITH TOPSOIL, SEED, AND MULCH OR OTHERWISE STABILIZED AS APPROVED BY LOCAL JURISDICTION.
- (DETAILS ADAPTED FROM DOUGLAS COUNTY, COLORADO)
- NOTE:** MANY JURISDICTIONS HAVE BMP DETAILS THAT VARY FROM UDFCD STANDARD DETAILS. CONSULT WITH LOCAL JURISDICTIONS AS TO WHICH DETAIL SHOULD BE USED WHEN DIFFERENCES ARE NOTED.

**REVISIONS**

NO.	DESCRIPTION	DATE

**UNTIL SUCH TIME AS THESE DRAWINGS ARE APPROVED BY THE RELEVANT AGENCIES, THE TERRA NOVA ENGINEERING, INC. APPROVES THEIR USE ONLY FOR THE PROJECT AND FOR THE MOST RECENT WRITTEN AUTHORIZATION.**

PREPARED FOR:  
**A-1 CHIPSEAL**  
 ATTN: STEPHANIE WALLIS  
 2505 E 74TH AVE  
 DENVER, CO 80229  
 720.540.8264

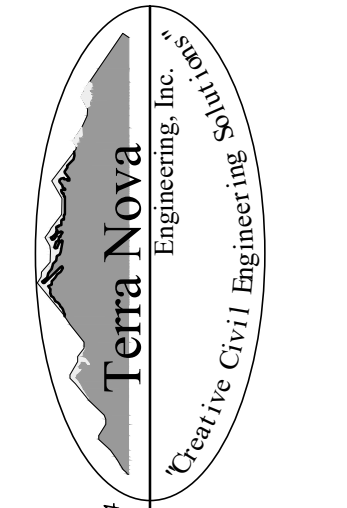

721 S. ZABO STREET  
 COLORADO SPRINGS, CO 80904  
 OFFICE: 719-635-6422  
 FAX: 719-635-6426  
 www.tnenginc.com

**A-1 CHIPSEAL**









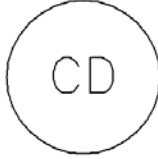
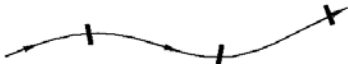
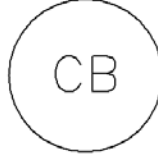
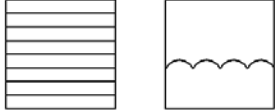
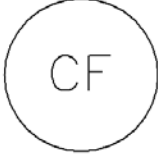

GRADING AND EROSION CONTROL PLAN  
 EROSION CONTROL DETAILS

DESIGNED BY DLF  
 DRAWN BY DLF  
 CHECKED BY LD  
 H-SCALE AS SHOWN  
 V-SCALE N/A  
 JOB NO. 2173.00  
 DATE ISSUED 05/02/22  
 SHEET NO. 5 OF 5

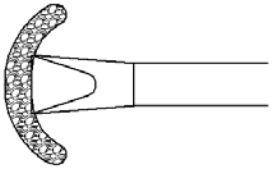

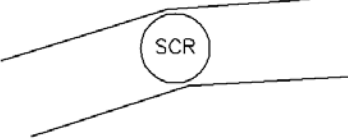

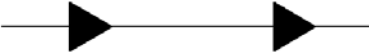

N:\jobs\2173.00\Drawings\217300 GEC.dwg, 5/2/2022 11:54:29 AM

**SELECT UDFCD BMP DESCRIPTION SHEETS**

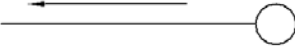

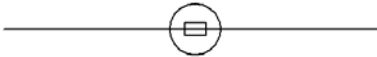

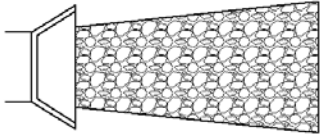
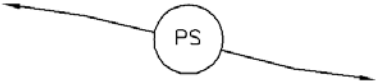







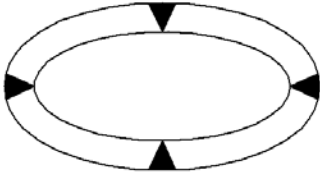

# Construction BMP Plan Symbols

<u>TITLE</u>	<u>KEY</u>	<u>SYMBOL</u>
BRUSH BARRIER		
CHECK DAM		
COMPOST BLANKET AND BERMS		
CONSTRUCTION FENCE		
CULVERT INLET PROTECTION		
STABILIZED CONSTRUCTION ROADWAY		
CONCRETE WASHOUT AREA		
DIVERSION DITCHES/CHANNELS		

# Construction BMP Plan Symbols

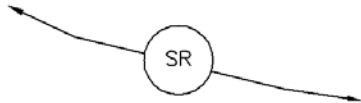

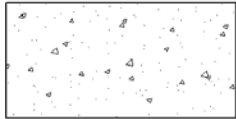

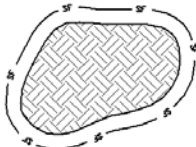





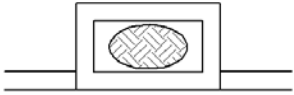

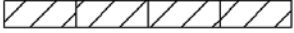

<u>TITLE</u>	<u>KEY</u>	<u>SYMBOL</u>
DEWATERING OPERATIONS	DW	
EARTH DIKES AND DRAINAGE SWALES	ED/ DS	
EROSION CONTROL BLANKET	ECB TRM	
INLET PROTECTION	IP	
MULCHING	MU	
OUTLET PROTECTION	OP	
PERMANENT SEEDING	PS	
REINFORCED CHECK DAM	RCD	

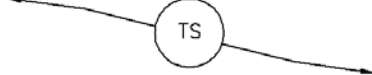
# Construction BMP Plan Symbols

TITLE	KEY	SYMBOL
ROCK SOCKS		
ROUGH CUT STREET CONTROL		
SEDIMENT BASIN		
SEDIMENT CONTROL LOG		
SILT FENCE		
SURFACE ROUGHENING		
STABILIZED STAGING AREA		
STOCKPILE MANAGEMENT W/ PROTECTION		

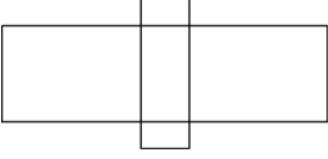

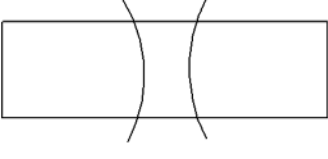

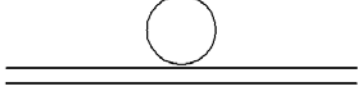

# Construction BMP Plan Symbols

---

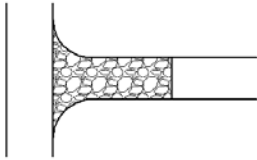
<u>TITLE</u>	<u>KEY</u>	<u>SYMBOL</u>
STOCKPILE MANAGEMENT W/ PROTECTION IN ROADWAY	 SPR	
STRAW BALE BARRIER	 SBB	
SEDIMENT TRAP	 ST	
TEMPORARY SEEDING	 TS	
TERRACING	 TER	
TEMPORARY STREAM CROSSING W/CULVERT	 TSCC	
TEMPORARY STREAM CROSSING W/FORD	 TSCF	
TEMPORARY SLOPE DRAIN	 TSD	

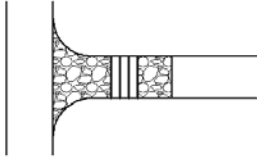

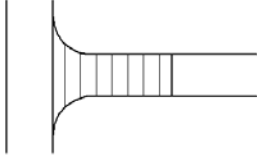
# Construction BMP Plan Symbols

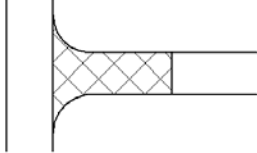
TITLE	KEY	SYMBOL
VEHICLE TRACKING CONTROL		
VEHICLE TRACKING CONTROL W/ WHEEL WASH		
VEHICLE TRACKING CONTROL W/ CONSTRUCTION MAT		
VEHICLE TRACKING CONTROL W/ TRM		

include details for silt fence, erosion control logs, seeding, inlet protection

## Description

Concrete waste management involves designating and properly managing a specific area of the construction site as a concrete washout area. A concrete washout area can be created using one of several approaches designed to receive wash water from washing of tools and concrete mixer chutes, liquid concrete waste from dump trucks, mobile batch mixers, or pump trucks. Three basic approaches are available: excavation of a pit in the ground, use of an above ground storage area, or use of prefabricated haul-away concrete washout containers. Surface discharges of concrete washout water from construction sites are prohibited.



**Photograph CWA-1.** Example of concrete washout area. Note gravel tracking pad for access and sign.

## Appropriate Uses

Concrete washout areas must be designated on all sites that will generate concrete wash water or liquid concrete waste from onsite concrete mixing or concrete delivery.

Because pH is a pollutant of concern for washout activities, when unlined pits are used for concrete washout, the soil must have adequate buffering capacity to result in protection of state groundwater standards; otherwise, a liner/containment must be used. The following management practices are recommended to prevent an impact from unlined pits to groundwater:

- The use of the washout site should be temporary (less than 1 year), and
- The washout site should be not be located in an area where shallow groundwater may be present, such as near natural drainages, springs, or wetlands.

## Design and Installation

Concrete washout activities must be conducted in a manner that does not contribute pollutants to surface waters or stormwater runoff. Concrete washout areas may be lined or unlined excavated pits in the ground, commercially manufactured prefabricated washout containers, or aboveground holding areas constructed of berms, sandbags or straw bales with a plastic liner.

Although unlined washout areas may be used, lined pits may be required to protect groundwater under certain conditions.

**Do not locate an unlined washout area within 400 feet of any natural drainage pathway or waterbody or within 1,000 feet of any wells or drinking water sources.** Even for lined concrete washouts, it is advisable to locate the facility away from waterbodies and drainage paths. If site constraints make these

Concrete Washout Area	
<b>Functions</b>	
Erosion Control	No
Sediment Control	No
Site/Material Management	Yes

setbacks infeasible or if highly permeable soils exist in the area, then the pit must be installed with an impermeable liner (16 mil minimum thickness) or surface storage alternatives using prefabricated concrete washout devices or a lined aboveground storage area should be used.

Design details with notes are provided in Detail CWA-1 for pits and CWA-2 for aboveground storage areas. Pre-fabricated concrete washout container information can be obtained from vendors.

## Maintenance and Removal

A key consideration for concrete washout areas is to ensure that adequate signage is in place identifying the location of the washout area. Part of inspecting and maintaining washout areas is ensuring that adequate signage is provided and in good repair and that the washout area is being used, as opposed to washout in non-designated areas of the site.

Remove concrete waste in the washout area, as needed to maintain BMP function (typically when filled to about two-thirds of its capacity). Collect concrete waste and deliver offsite to a designated disposal location.

Upon termination of use of the washout site, accumulated solid waste, including concrete waste and any contaminated soils, must be removed from the site to prevent on-site disposal of solid waste. If the wash water is allowed to evaporate and the concrete hardens, it may be recycled.



**Photograph CWA-2.** Prefabricated concrete washout. Photo courtesy of CDOT.



**Photograph CWA-3.** Earthen concrete washout. Photo courtesy of CDOT.

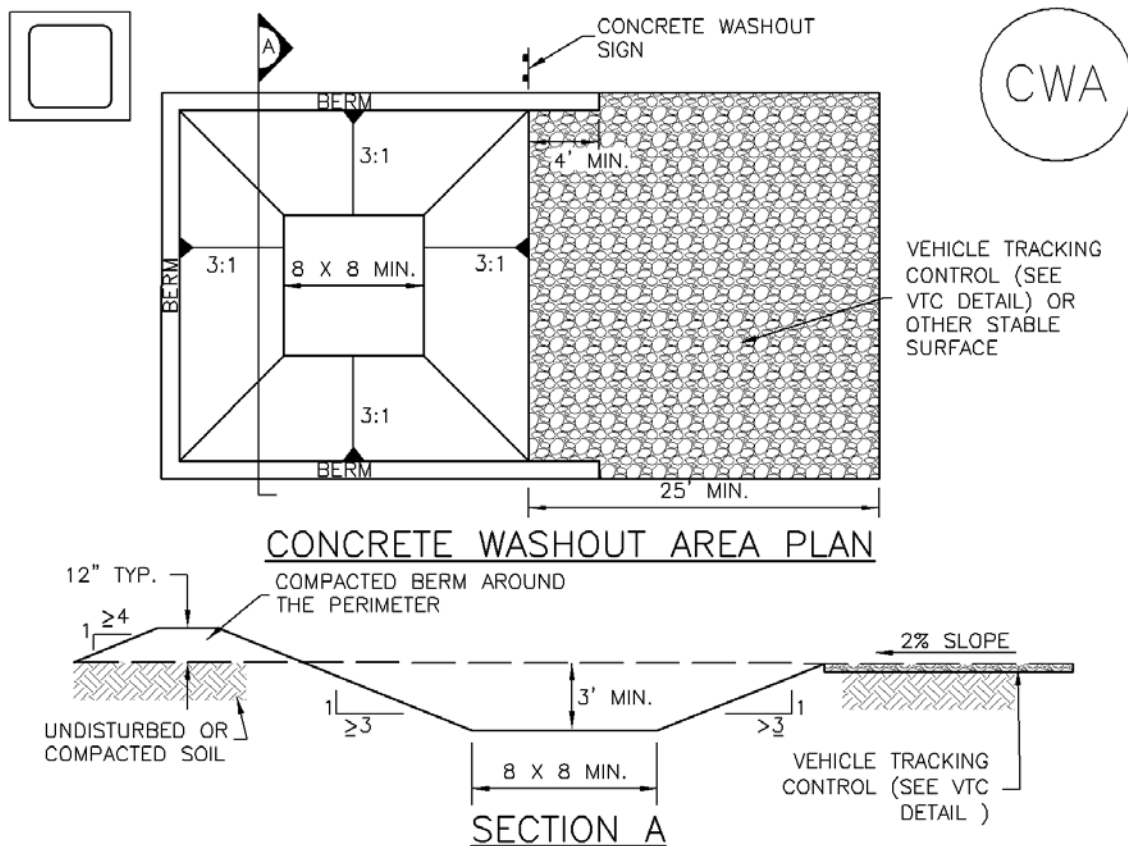

## CWA-1. CONCRETE WASHOUT AREA

### CWA INSTALLATION NOTES

1. SEE PLAN VIEW FOR:  
-CWA INSTALLATION LOCATION.
2. DO NOT LOCATE AN UNLINED CWA WITHIN 400' OF ANY NATURAL DRAINAGE PATHWAY OR WATERBODY. DO NOT LOCATE WITHIN 1,000' OF ANY WELLS OR DRINKING WATER SOURCES. IF SITE CONSTRAINTS MAKE THIS INFEASIBLE, OR IF HIGHLY PERMEABLE SOILS EXIST ON SITE, THE CWA MUST BE INSTALLED WITH AN IMPERMEABLE LINER (16 MIL MIN. THICKNESS) OR SURFACE STORAGE ALTERNATIVES USING PREFABRICATED CONCRETE WASHOUT DEVICES OR A LINED ABOVE GROUND STORAGE ARE SHOULD BE USED.
3. THE CWA SHALL BE INSTALLED PRIOR TO CONCRETE PLACEMENT ON SITE.
4. CWA SHALL INCLUDE A FLAT SUBSURFACE PIT THAT IS AT LEAST 8' BY 8' SLOPES LEADING OUT OF THE SUBSURFACE PIT SHALL BE 3:1 OR FLATTER. THE PIT SHALL BE AT LEAST 3' DEEP.
5. BERM SURROUNDING SIDES AND BACK OF THE CWA SHALL HAVE MINIMUM HEIGHT OF 1'.
6. VEHICLE TRACKING PAD SHALL BE SLOPED 2% TOWARDS THE CWA.
7. SIGNS SHALL BE PLACED AT THE CONSTRUCTION ENTRANCE, AT THE CWA, AND ELSEWHERE AS NECESSARY TO CLEARLY INDICATE THE LOCATION OF THE CWA TO OPERATORS OF CONCRETE TRUCKS AND PUMP RIGS.
8. USE EXCAVATED MATERIAL FOR PERIMETER BERM CONSTRUCTION.

CWA MAINTENANCE NOTES

1. INSPECT BMPs EACH WORKDAY, AND MAINTAIN THEM IN EFFECTIVE OPERATING CONDITION. MAINTENANCE OF BMPs SHOULD BE PROACTIVE, NOT REACTIVE. INSPECT BMPs AS SOON AS POSSIBLE (AND ALWAYS WITHIN 24 HOURS) FOLLOWING A STORM THAT CAUSES SURFACE EROSION, AND PERFORM NECESSARY MAINTENANCE.

2. FREQUENT OBSERVATIONS AND MAINTENANCE ARE NECESSARY TO MAINTAIN BMPs IN EFFECTIVE OPERATING CONDITION. INSPECTIONS AND CORRECTIVE MEASURES SHOULD BE DOCUMENTED THOROUGHLY.

3. WHERE BMPs HAVE FAILED, REPAIR OR REPLACEMENT SHOULD BE INITIATED UPON DISCOVERY OF THE FAILURE.

4. THE CWA SHALL BE REPAIRED, CLEANED, OR ENLARGED AS NECESSARY TO MAINTAIN CAPACITY FOR CONCRETE WASTE. CONCRETE MATERIALS, ACCUMULATED IN PIT, SHALL BE REMOVED ONCE THE MATERIALS HAVE REACHED A DEPTH OF 2'.

5. CONCRETE WASHOUT WATER, WASTED PIECES OF CONCRETE AND ALL OTHER DEBRIS IN THE SUBSURFACE PIT SHALL BE TRANSPORTED FROM THE JOB SITE IN A WATER-TIGHT CONTAINER AND DISPOSED OF PROPERLY.

6. THE CWA SHALL REMAIN IN PLACE UNTIL ALL CONCRETE FOR THE PROJECT IS PLACED.

7. WHEN THE CWA IS REMOVED, COVER THE DISTURBED AREA WITH TOP SOIL, SEED AND MULCH OR OTHERWISE STABILIZED IN A MANNER APPROVED BY THE LOCAL JURISDICTION.

(DETAIL ADAPTED FROM DOUGLAS COUNTY, COLORADO AND THE CITY OF PARKER, COLORADO, NOT AVAILABLE IN AUTOCAD).

NOTE: MANY JURISDICTIONS HAVE BMP DETAILS THAT VARY FROM UDFCD STANDARD DETAILS. CONSULT WITH LOCAL JURISDICTIONS AS TO WHICH DETAIL SHOULD BE USED WHEN DIFFERENCES ARE NOTED.

## Description

Implement construction site good housekeeping practices to prevent pollution associated with solid, liquid and hazardous construction-related materials and wastes. Stormwater Management Plans (SWMPs) should clearly specify BMPs including these good housekeeping practices:

- Provide for waste management.
- Establish proper building material staging areas.
- Designate paint and concrete washout areas.
- Establish proper equipment/vehicle fueling and maintenance practices.
- Control equipment/vehicle washing and allowable non-stormwater discharges.
- Develop a spill prevention and response plan.

**Acknowledgement:** This Fact Sheet is based directly on EPA guidance provided in *Developing Your Stormwater Pollution Prevent Plan (EPA 2007)*.



Photographs GH-1 and GH-2. Proper materials storage and secondary containment for fuel tanks are important good housekeeping practices. Photos courtesy of CDOT and City of Aurora.

## Appropriate Uses

Good housekeeping practices are necessary at all construction sites.

## Design and Installation

The following principles and actions should be addressed in SWMPs:

- **Provide for Waste Management.** Implement management procedures and practices to prevent or reduce the exposure and transport of pollutants in stormwater from solid, liquid and sanitary wastes that will be generated at the site. Practices such as trash disposal, recycling, proper material handling, and cleanup measures can reduce the potential for stormwater runoff to pick up construction site wastes and discharge them to surface waters. Implement a comprehensive set of waste-management practices for hazardous or toxic materials, such as paints, solvents, petroleum products, pesticides, wood preservatives, acids, roofing tar, and other materials. Practices should include storage, handling, inventory, and cleanup procedures, in case of spills. Specific practices that should be considered include:

### Solid or Construction Waste

- Designate trash and bulk waste-collection areas on-site.

Good Housekeeping	
Functions	
Erosion Control	No
Sediment Control	No
Site/Material Management	Yes



- Recycle materials whenever possible (e.g., paper, wood, concrete, oil).
- Segregate and provide proper disposal options for hazardous material wastes.
- Clean up litter and debris from the construction site daily.
- Locate waste-collection areas away from streets, gutters, watercourses, and storm drains. Waste-collection areas (dumpsters, and such) are often best located near construction site entrances to minimize traffic on disturbed soils. Consider secondary containment around waste collection areas to minimize the likelihood of contaminated discharges.
- Empty waste containers before they are full and overflowing.

**Sanitary and Septic Waste**

- Provide convenient, well-maintained, and properly located toilet facilities on-site.
- Locate toilet facilities away from storm drain inlets and waterways to prevent accidental spills and contamination of stormwater.
- Maintain clean restroom facilities and empty portable toilets regularly.
- Where possible, provide secondary containment pans under portable toilets.
- Provide tie-downs or stake-downs for portable toilets.
- Educate employees, subcontractors, and suppliers on locations of facilities.
- Treat or dispose of sanitary and septic waste in accordance with state or local regulations. Do not discharge or bury wastewater at the construction site.
- Inspect facilities for leaks. If found, repair or replace immediately.
- Special care is necessary during maintenance (pump out) to ensure that waste and/or biocide are not spilled on the ground.

**Hazardous Materials and Wastes**

- Develop and implement employee and subcontractor education, as needed, on hazardous and toxic waste handling, storage, disposal, and cleanup.
- Designate hazardous waste-collection areas on-site.
- Place all hazardous and toxic material wastes in secondary containment.



**Photograph GH-3.** Locate portable toilet facilities on level surfaces away from waterways and storm drains. Photo courtesy of WWE.

- Hazardous waste containers should be inspected to ensure that all containers are labeled properly and that no leaks are present.
- **Establish Proper Building Material Handling and Staging Areas.** The SWMP should include comprehensive handling and management procedures for building materials, especially those that are hazardous or toxic. Paints, solvents, pesticides, fuels and oils, other hazardous materials or building materials that have the potential to contaminate stormwater should be stored indoors or under cover whenever possible or in areas with secondary containment. Secondary containment measures prevent a spill from spreading across the site and may include dikes, berms, curbing, or other containment methods. Secondary containment techniques should also ensure the protection of groundwater. Designate staging areas for activities such as fueling vehicles, mixing paints, plaster, mortar, and other potential pollutants. Designated staging areas enable easier monitoring of the use of materials and clean up of spills. Training employees and subcontractors is essential to the success of this pollution prevention principle. Consider the following specific materials handling and staging practices:
  - Train employees and subcontractors in proper handling and storage practices.
  - Clearly designate site areas for staging and storage with signs and on construction drawings. Staging areas should be located in areas central to the construction site. Segment the staging area into sub-areas designated for vehicles, equipment, or stockpiles. Construction entrances and exits should be clearly marked so that delivery vehicles enter/exit through stabilized areas with vehicle tracking controls (See Vehicle Tracking Control Fact Sheet).
  - Provide storage in accordance with Spill Protection, Control and Countermeasures (SPCC) requirements and plans and provide cover and impermeable perimeter control, as necessary, for hazardous materials and contaminated soils that must be stored on site.
  - Ensure that storage containers are regularly inspected for leaks, corrosion, support or foundation failure, or other signs of deterioration and tested for soundness.
  - Reuse and recycle construction materials when possible.
- **Designate Concrete Washout Areas.** Concrete contractors should be encouraged to use the washout facilities at their own plants or dispatch facilities when feasible; however, concrete washout commonly occurs on construction sites. If it is necessary to provide for concrete washout areas on-site, designate specific washout areas and design facilities to handle anticipated washout water. Washout areas should also be provided for paint and stucco operations. Because washout areas can be a source of pollutants from leaks or spills, care must be taken with regard to their placement and proper use. See the Concrete Washout Area Fact Sheet for detailed guidance.

Both self-constructed and prefabricated washout containers can fill up quickly when concrete, paint, and stucco work are occurring on large portions of the site. Be sure to check for evidence that contractors are using the washout areas and not dumping materials onto the ground or into drainage facilities. If the washout areas are not being used regularly, consider posting additional signage, relocating the facilities to more convenient locations, or providing training to workers and contractors.

When concrete, paint, or stucco is part of the construction process, consider these practices which will help prevent contamination of stormwater. Include the locations of these areas and the maintenance and inspection procedures in the SWMP.



- Do not washout concrete trucks or equipment into storm drains, streets, gutters, uncontained areas, or streams. Only use designated washout areas.
- Establish washout areas and advertise their locations with signs. Ensure that signage remains in good repair.
- Provide adequate containment for the amount of wash water that will be used.
- Inspect washout structures daily to detect leaks or tears and to identify when materials need to be removed.
- Dispose of materials properly. The preferred method is to allow the water to evaporate and to recycle the hardened concrete. Full service companies may provide dewatering services and should dispose of wastewater properly. Concrete wash water can be highly polluted. It should not be discharged to any surface water, storm sewer system, or allowed to infiltrate into the ground in the vicinity of waterbodies. Washwater should not be discharged to a sanitary sewer system without first receiving written permission from the system operator.
- **Establish Proper Equipment/Vehicle Fueling and Maintenance Practices.** Create a clearly designated on-site fueling and maintenance area that is clean and dry. The on-site fueling area should have a spill kit, and staff should know how to use it. If possible, conduct vehicle fueling and maintenance activities in a covered area. Consider the following practices to help prevent the discharge of pollutants to stormwater from equipment/vehicle fueling and maintenance. Include the locations of designated fueling and maintenance areas and inspection and maintenance procedures in the SWMP.
  - Train employees and subcontractors in proper fueling procedures (stay with vehicles during fueling, proper use of pumps, emergency shutoff valves, etc.).
  - Inspect on-site vehicles and equipment regularly for leaks, equipment damage, and other service problems.
  - Clearly designate vehicle/equipment service areas away from drainage facilities and watercourses to prevent stormwater run-on and runoff.
  - Use drip pans, drip cloths, or absorbent pads when replacing spent fluids.
  - Collect all spent fluids, store in appropriate labeled containers in the proper storage areas, and recycle fluids whenever possible.
- **Control Equipment/Vehicle Washing and Allowable Non-Stormwater Discharges.** Implement practices to prevent contamination of surface and groundwater from equipment and vehicle wash water. Representative practices include:
  - Educate employees and subcontractors on proper washing procedures.
  - Use off-site washing facilities, when available.
  - Clearly mark the washing areas and inform workers that all washing must occur in this area.
  - Contain wash water and treat it using BMPs. Infiltrate washwater when possible, but maintain separation from drainage paths and waterbodies.

- Use high-pressure water spray at vehicle washing facilities without detergents. Water alone can remove most dirt adequately.
- Do not conduct other activities, such as vehicle repairs, in the wash area.
- Include the location of the washing facilities and the inspection and maintenance procedures in the SWMP.
- **Develop a Spill Prevention and Response Plan.** Spill prevention and response procedures must be identified in the SWMP. Representative procedures include identifying ways to reduce the chance of spills, stop the source of spills, contain and clean up spills, dispose of materials contaminated by spills, and train personnel responsible for spill prevention and response. The plan should also specify material handling procedures and storage requirements and ensure that clear and concise spill cleanup procedures are provided and posted for areas in which spills may potentially occur. When developing a spill prevention plan, include the following:
  - Note the locations of chemical storage areas, storm drains, tributary drainage areas, surface waterbodies on or near the site, and measures to stop spills from leaving the site.
  - Provide proper handling and safety procedures for each type of waste. Keep Material Safety Data Sheets (MSDSs) for chemical used on site with the SWMP.
  - Establish an education program for employees and subcontractors on the potential hazards to humans and the environment from spills and leaks.
  - Specify how to notify appropriate authorities, such as police and fire departments, hospitals, or municipal sewage treatment facilities to request assistance. Emergency procedures and contact numbers should be provided in the SWMP and posted at storage locations.
  - Describe the procedures, equipment and materials for immediate cleanup of spills and proper disposal.
  - Identify personnel responsible for implementing the plan in the event of a spill. Update the spill prevention plan and clean up materials as changes occur to the types of chemicals stored and used at the facility.

**Spill Prevention, Control, and Countermeasure (SPCC) Plan**

Construction sites may be subject to 40 CFR Part 112 regulations that require the preparation and implementation of a SPCC Plan to prevent oil spills from aboveground and underground storage tanks. The facility is subject to this rule if it is a non-transportation-related facility that:

- Has a total storage capacity greater than 1,320 gallons or a completely buried storage capacity greater than 42,000 gallons.
- Could reasonably be expected to discharge oil in quantities that may be harmful to navigable waters of the United States and adjoining shorelines.

Furthermore, if the facility is subject to 40 CFR Part 112, the SWMP should reference the SPCC Plan. To find out more about SPCC Plans, see EPA's website on SPPC at [www.epa.gov/oilspill/spcc.htm](http://www.epa.gov/oilspill/spcc.htm).

**Reporting Oil Spills**

In the event of an oil spill, contact the National Response Center toll free at 1-800-424- 8802 for assistance, or for more details, visit their website: [www.nrc.uscg.mil](http://www.nrc.uscg.mil).

**Maintenance and Removal**

Effective implementation of good housekeeping practices is dependent on clear designation of personnel responsible for supervising and implementing good housekeeping programs, such as site cleanup and disposal of trash and debris, hazardous material management and disposal, vehicle and equipment maintenance, and other practices. Emergency response "drills" may aid in emergency preparedness.

Checklists may be helpful in good housekeeping efforts.

Staging and storage areas require permanent stabilization when the areas are no longer being used for construction-related activities.

Construction-related materials, debris and waste must be removed from the construction site once construction is complete.

**Design Details**

See the following Fact Sheets for related Design Details:

MM-1 Concrete Washout Area

MM-2 Stockpile Management

SM-4 Vehicle Tracking Control

Design details are not necessary for other good housekeeping practices; however, be sure to designate where specific practices will occur on the appropriate construction drawings.

## Description

A sediment basin is a temporary pond built on a construction site to capture eroded or disturbed soil transported in storm runoff prior to discharge from the site. Sediment basins are designed to capture site runoff and slowly release it to allow time for settling of sediment prior to discharge. Sediment basins are often constructed in locations that will later be modified to serve as post-construction stormwater basins.



**Photograph SB-1.** Sediment basin at the toe of a slope. Photo courtesy of WWE.

## Appropriate Uses

Most large construction sites (typically greater than 2 acres) will require one or more sediment basins for effective management of construction site runoff. On linear construction projects, sediment basins may be impractical; instead, sediment traps or other combinations of BMPs may be more appropriate.

Sediment basins should not be used as stand-alone sediment controls. Erosion and other sediment controls should also be implemented upstream.

When feasible, the sediment basin should be installed in the same location where a permanent post-construction detention pond will be located.

## Design and Installation

The design procedure for a sediment basin includes these steps:

- **Basin Storage Volume:** Provide a storage volume of at least 3,600 cubic feet per acre of drainage area. To the extent practical, undisturbed and/or off-site areas should be diverted around sediment basins to prevent “clean” runoff from mixing with runoff from disturbed areas. For undisturbed areas (both on-site and off-site) that cannot be diverted around the sediment basin, provide a minimum of 500 ft<sup>3</sup>/acre of storage for undeveloped (but stable) off-site areas in addition to the 3,600 ft<sup>3</sup>/acre for disturbed areas. For stable, developed areas that cannot be diverted around the sediment basin, storage volume requirements are summarized in Table SB-1.
- **Basin Geometry:** Design basin with a minimum length-to-width ratio of 2:1 (L:W). If this cannot be achieved because of site space constraints, baffling may be required to extend the effective distance between the inflow point(s) and the outlet to minimize short-circuiting.
- **Dam Embankment:** It is recommended that embankment slopes be 4:1 (H:V) or flatter and no steeper than 3:1 (H:V) in any location.

Sediment Basins	
Functions	
Erosion Control	No
Sediment Control	Yes
Site/Material Management	No

- **Inflow Structure:** For concentrated flow entering the basin, provide energy dissipation at the point of inflow.

**Table SB-1. Additional Volume Requirements for Undisturbed and Developed Tributary Areas Draining through Sediment Basins**

Imperviousness (%)	Additional Storage Volume (ft <sup>3</sup> ) Per Acre of Tributary Area
Undeveloped	500
10	800
20	1230
30	1600
40	2030
50	2470
60	2980
70	3560
80	4360
90	5300
100	6460

- **Outlet Works:** The outlet pipe shall extend through the embankment at a minimum slope of 0.5 percent. Outlet works can be designed using one of the following approaches:
  - **Riser Pipe (Simplified Detail):** Detail SB-1 provides a simplified design for basins treating no more than 15 acres.
  - **Orifice Plate or Riser Pipe:** Follow the design criteria for Full Spectrum Detention outlets in the EDB Fact Sheet provided in Chapter 4 of this manual for sizing of outlet perforations with an emptying time of approximately 72 hours. In lieu of the trash rack, pack uniformly sized 1½ - to 2-inch gravel in front of the plate or surrounding the riser pipe. This gravel will need to be cleaned out frequently during the construction period as sediment accumulates within it. The gravel pack will need to be removed and disposed of following construction to reclaim the basin for use as a permanent detention facility. If the basin will be used as a permanent extended detention basin for the site, a trash rack will need to be installed once contributing drainage areas have been stabilized and the gravel pack and accumulated sediment have been removed.
  - **Floating Skimmer:** If a floating skimmer is used, install it using manufacturer’s recommendations. Illustration SB-1 provides an illustration of a Faircloth Skimmer Floating Outlet™, one of the more commonly used floating skimmer outlets. A skimmer should be designed to release the design volume in no less than 48 hours. The use of a floating skimmer outlet can increase the sediment capture efficiency of a basin significantly. A floating outlet continually decants cleanest water off the surface of the pond and releases cleaner water than would discharge from a perforated riser pipe or plate.

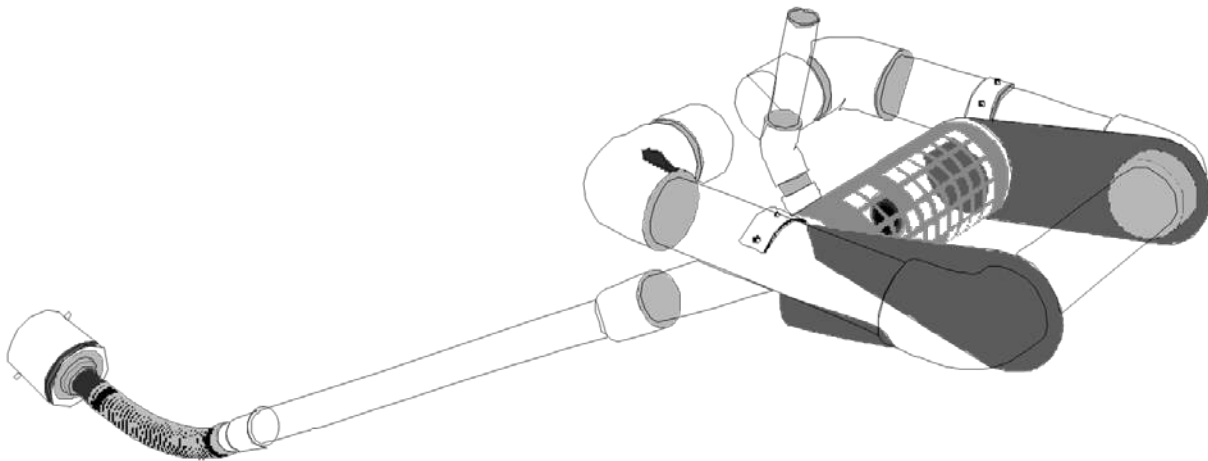

**Illustration SB-1.** Outlet structure for a temporary sediment basin - Faircloth Skimmer Floating Outlet. Illustration courtesy of J. W. Faircloth & Sons, Inc., FairclothSkimmer.com.

- **Outlet Protection and Spillway:** Consider all flow paths for runoff leaving the basin, including protection at the typical point of discharge as well as overtopping.
  - **Outlet Protection:** Outlet protection should be provided where the velocity of flow will exceed the maximum permissible velocity of the material of the waterway into which discharge occurs. This may require the use of a riprap apron at the outlet location and/or other measures to keep the waterway from eroding.
  - **Emergency Spillway:** Provide a stabilized emergency overflow spillway for rainstorms that exceed the capacity of the sediment basin volume and its outlet. Protect basin embankments from erosion and overtopping. If the sediment basin will be converted to a permanent detention basin, design and construct the emergency spillway(s) as required for the permanent facility. If the sediment basin will not become a permanent detention basin, it may be possible to substitute a heavy polyvinyl membrane or properly bedded rock cover to line the spillway and downstream embankment, depending on the height, slope, and width of the embankments.

## Maintenance and Removal

Maintenance activities include the following:

- Dredge sediment from the basin, as needed to maintain BMP effectiveness, typically when the design storage volume is no more than one-third filled with sediment.
- Inspect the sediment basin embankments for stability and seepage.
- Inspect the inlet and outlet of the basin, repair damage, and remove debris. Remove, clean and replace the gravel around the outlet on a regular basis to remove the accumulated sediment within it and keep the outlet functioning.
- Be aware that removal of a sediment basin may require dewatering and associated permit requirements.
- Do not remove a sediment basin until the upstream area has been stabilized with vegetation.

Final disposition of the sediment basin depends on whether the basin will be converted to a permanent post-construction stormwater basin or whether the basin area will be returned to grade. For basins being converted to permanent detention basins, remove accumulated sediment and reconfigure the basin and outlet to meet the requirements of the final design for the detention facility. If the sediment basin is not to be used as a permanent detention facility, fill the excavated area with soil and stabilize with vegetation.

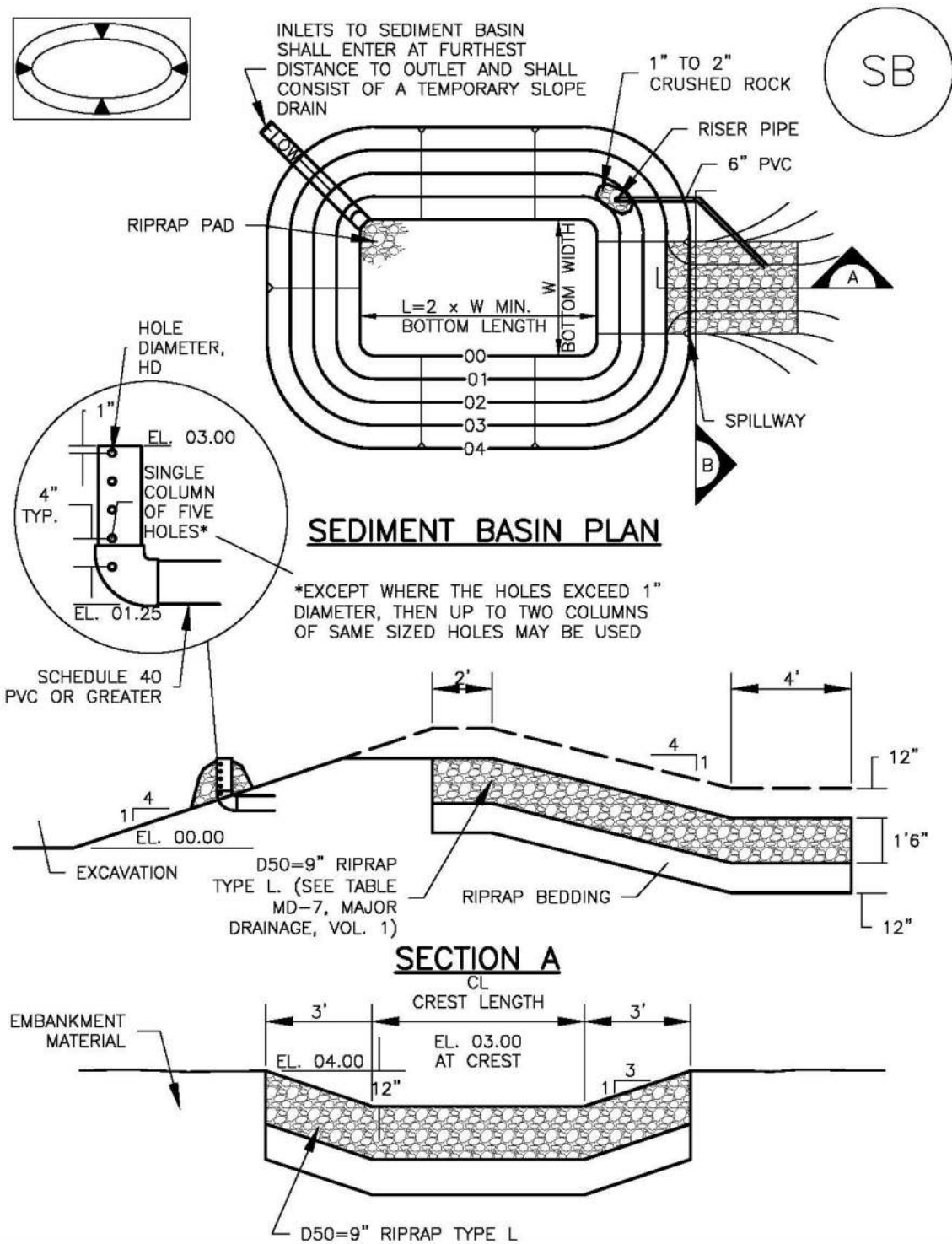



TABLE SB-1. SIZING INFORMATION FOR STANDARD SEDIMENT BASIN			
Upstream Drainage Area (rounded to nearest acre), (ac)	Basin Bottom Width (W), (ft)	Spillway Crest Length (CL), (ft)	Hole Diameter (HD), (in)
1	12 1/2	2	9/32
2	21	3	13/16
3	28	5	1/2
4	33 1/2	6	9/16
5	38 1/2	8	2 1/32
6	43	9	2 1/32
7	47 1/4	11	2 5/32
8	51	12	2 7/32
9	55	13	7/8
10	58 1/4	15	1 5/16
11	61	16	3 1/32
12	64	18	1
13	67 1/2	19	1 1/16
14	70 1/2	21	1 1/8
15	73 1/4	22	1 3/16

SEDIMENT BASIN INSTALLATION NOTES

1. SEE PLAN VIEW FOR:
  - LOCATION OF SEDIMENT BASIN.
  - TYPE OF BASIN (STANDARD BASIN OR NONSTANDARD BASIN).
  - FOR STANDARD BASIN, BOTTOM WIDTH W, CREST LENGTH CL, AND HOLE DIAMETER, HD.
  - FOR NONSTANDARD BASIN, SEE CONSTRUCTION DRAWINGS FOR DESIGN OF BASIN INCLUDING RISER HEIGHT H, NUMBER OF COLUMNS N, HOLE DIAMETER HD AND PIPE DIAMETER D.
2. FOR STANDARD BASIN, BOTTOM DIMENSION MAY BE MODIFIED AS LONG AS BOTTOM AREA IS NOT REDUCED.
3. SEDIMENT BASINS SHALL BE INSTALLED PRIOR TO ANY OTHER LAND-DISTURBING ACTIVITY THAT RELIES ON ON BASINS AS AS A STORMWATER CONTROL.
4. EMBANKMENT MATERIAL SHALL CONSIST OF SOIL FREE OF DEBRIS, ORGANIC MATERIAL, AND ROCKS OR CONCRETE GREATER THAN 3 INCHES AND SHALL HAVE A MINIMUM OF 15 PERCENT BY WEIGHT PASSING THE NO. 200 SIEVE.
5. EMBANKMENT MATERIAL SHALL BE COMPACTED TO AT LEAST 95 PERCENT OF MAXIMUM DENSITY IN ACCORDANCE WITH ASTM D698.
6. PIPE SCH 40 OR GREATER SHALL BE USED.
7. THE DETAILS SHOWN ON THESE SHEETS PERTAIN TO STANDARD SEDIMENT BASIN(S) FOR DRAINAGE AREAS LESS THAN 15 ACRES. SEE CONSTRUCTION DRAWINGS FOR EMBANKMENT, STORAGE VOLUME, SPILLWAY, OUTLET, AND OUTLET PROTECTION DETAILS FOR ANY SEDIMENT BASIN(S) THAT HAVE BEEN INDIVIDUALLY DESIGNED FOR DRAINAGE AREAS LARGER THAN 15 ACRES.

## SEDIMENT BASIN MAINTENANCE NOTES

1. INSPECT BMPs EACH WORKDAY, AND MAINTAIN THEM IN EFFECTIVE OPERATING CONDITION. MAINTENANCE OF BMPs SHOULD BE PROACTIVE, NOT REACTIVE. INSPECT BMPs AS SOON AS POSSIBLE (AND ALWAYS WITHIN 24 HOURS) FOLLOWING A STORM THAT CAUSES SURFACE EROSION, AND PERFORM NECESSARY MAINTENANCE.
2. FREQUENT OBSERVATIONS AND MAINTENANCE ARE NECESSARY TO MAINTAIN BMPs IN EFFECTIVE OPERATING CONDITION. INSPECTIONS AND CORRECTIVE MEASURES SHOULD BE DOCUMENTED THOROUGHLY.
3. WHERE BMPs HAVE FAILED, REPAIR OR REPLACEMENT SHOULD BE INITIATED UPON DISCOVERY OF THE FAILURE.
4. SEDIMENT ACCUMULATED IN BASIN SHALL BE REMOVED AS NEEDED TO MAINTAIN BMP EFFECTIVENESS, TYPICALLY WHEN SEDIMENT DEPTH REACHES ONE FOOT (I.E., TWO FEET BELOW THE SPILLWAY CREST).
5. SEDIMENT BASINS ARE TO REMAIN IN PLACE UNTIL THE UPSTREAM DISTURBED AREA IS STABILIZED AND GRASS COVER IS ACCEPTED BY THE LOCAL JURISDICTION.
6. WHEN SEDIMENT BASINS ARE REMOVED, ALL DISTURBED AREAS SHALL BE COVERED WITH TOPSOIL, SEEDED AND MULCHED OR OTHERWISE STABILIZED AS APPROVED BY LOCAL JURISDICTION.

(DETAILS ADAPTED FROM DOUGLAS COUNTY, COLORADO)

NOTE: MANY JURISDICTIONS HAVE BMP DETAILS THAT VARY FROM UDFCD STANDARD DETAILS. CONSULT WITH LOCAL JURISDICTIONS AS TO WHICH DETAIL SHOULD BE USED WHEN DIFFERENCES ARE NOTED.

## Description

A construction fence restricts site access to designated entrances and exits, delineates construction site boundaries, and keeps construction out of sensitive areas such as natural areas to be preserved as open space, wetlands and riparian areas.



**Photograph CF-1.** A construction fence helps delineate areas where existing vegetation is being protected. Photo courtesy of Douglas County.

## Appropriate Uses

A construction fence can be used to delineate the site perimeter and locations within the site where access is restricted to protect natural resources such as wetlands, waterbodies, trees, and other natural areas of the site that should not be disturbed.

If natural resource protection is an objective, then the construction fencing should be used in combination with other perimeter control BMPs such as silt fence, sediment control logs or similar measures.

## Design and Installation

Construction fencing may be chain link or plastic mesh and should be installed following manufacturer’s recommendations. See Detail CF-1 for typical installations.

Do not place construction fencing in areas within work limits of machinery.

## Maintenance and Removal

- Inspect fences for damage; repair or replace as necessary.
- Fencing should be tight and any areas with slumping or fallen posts should be reinstalled.
- Fencing should be removed once construction is complete.

<b>Construction Fence</b>	
<b>Functions</b>	
Erosion Control	No
Sediment Control	No
Site/Material Management	Yes

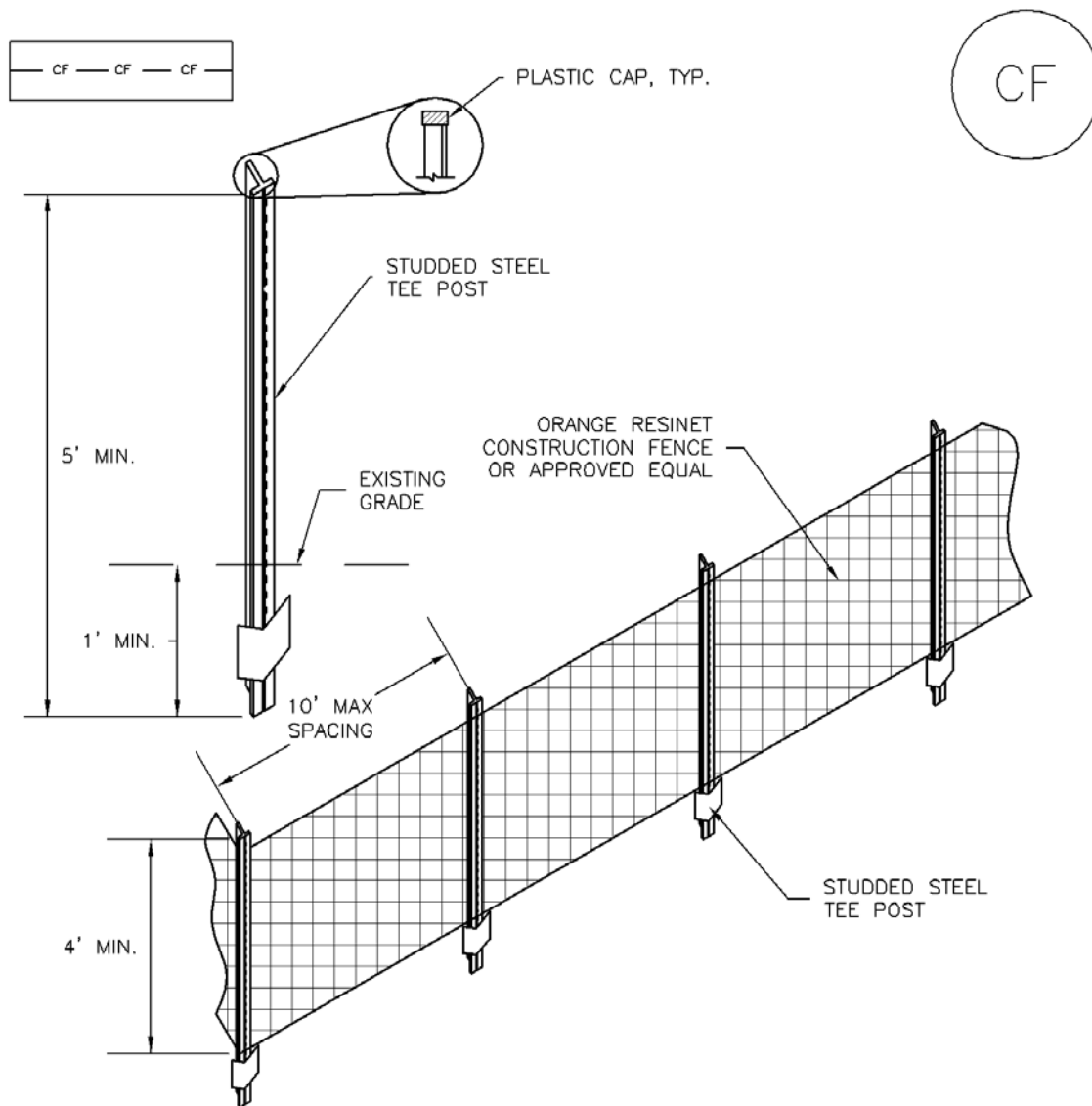

CF-1. PLASTIC MESH CONSTRUCTION FENCE

CONSTRUCTION FENCE INSTALLATION NOTES

1. SEE PLAN VIEW FOR:  
-LOCATION OF CONSTRUCTION FENCE.
2. CONSTRUCTION FENCE SHOWN SHALL BE INSTALLED PRIOR TO ANY LAND DISTURBING ACTIVITIES.
3. CONSTRUCTION FENCE SHALL BE COMPOSED OF ORANGE, CONTRACTOR-GRADE MATERIAL THAT IS AT LEAST 4' HIGH. METAL POSTS SHOULD HAVE A PLASTIC CAP FOR SAFETY.
4. STUDED STEEL TEE POSTS SHALL BE UTILIZED TO SUPPORT THE CONSTRUCTION FENCE. MAXIMUM SPACING FOR STEEL TEE POSTS SHALL BE 10'.
5. CONSTRUCTION FENCE SHALL BE SECURELY FASTENED TO THE TOP, MIDDLE, AND BOTTOM OF EACH POST.

## CONSTRUCTION FENCE MAINTENANCE NOTES

1. INSPECT BMPs EACH WORKDAY, AND MAINTAIN THEM IN EFFECTIVE OPERATING CONDITION. MAINTENANCE OF BMPs SHOULD BE PROACTIVE, NOT REACTIVE. INSPECT BMPs AS SOON AS POSSIBLE (AND ALWAYS WITHIN 24 HOURS) FOLLOWING A STORM THAT CAUSES SURFACE EROSION, AND PERFORM NECESSARY MAINTENANCE.
2. FREQUENT OBSERVATIONS AND MAINTENANCE ARE NECESSARY TO MAINTAIN BMPs IN EFFECTIVE OPERATING CONDITION. INSPECTIONS AND CORRECTIVE MEASURES SHOULD BE DOCUMENTED THOROUGHLY.
3. WHERE BMPs HAVE FAILED, REPAIR OR REPLACEMENT SHOULD BE INITIATED UPON DISCOVERY OF THE FAILURE.
4. CONSTRUCTION FENCE SHALL BE REPAIRED OR REPLACED WHEN THERE ARE SIGNS OF DAMAGE SUCH AS RIPS OR SAGS. CONSTRUCTION FENCE IS TO REMAIN IN PLACE UNTIL THE UPSTREAM DISTURBED AREA IS STABILIZED AND APPROVED BY THE LOCAL JURISDICTION.
5. WHEN CONSTRUCTION FENCES ARE REMOVED, ALL DISTURBED AREAS ASSOCIATED WITH THE INSTALLATION, MAINTENANCE, AND/OR REMOVAL OF THE FENCE SHALL BE COVERED WITH TOPSOIL, SEEDED AND MULCHED, OR OTHERWISE STABILIZED AS APPROVED BY LOCAL JURISDICTION.

NOTE: MANY JURISDICTIONS HAVE BMP DETAILS THAT VARY FROM UDFCD STANDARD DETAILS. CONSULT WITH LOCAL JURISDICTIONS AS TO WHICH DETAIL SHOULD BE USED WHEN DIFFERENCES ARE NOTED.

(DETAIL ADAPTED FROM TOWN OF PARKER, COLORADO, NOT AVAILABLE IN AUTOCAD)

## Description

A stabilized staging area is a clearly designated area where construction equipment and vehicles, stockpiles, waste bins, and other construction-related materials are stored. The contractor office trailer may also be located in this area. Depending on the size of the construction site, more than one staging area may be necessary.



**Photograph SSA-1.** Example of a staging area with a gravel surface to prevent mud tracking and reduce runoff. Photo courtesy of Douglas County.

## Appropriate Uses

Most construction sites will require a staging area, which should be clearly designated in SWMP drawings. The layout of the staging area may vary depending on the type of construction activity. Staging areas located in roadways due to space constraints require special measures to avoid materials being washed into storm inlets.

## Design and Installation

Stabilized staging areas should be completed prior to other construction activities beginning on the site. Major components of a stabilized staging area include:

- Appropriate space to contain storage and provide for loading/unloading operations, as well as parking if necessary.
- A stabilized surface, either paved or covered, with 3-inch diameter aggregate or larger.
- Perimeter controls such as silt fence, sediment control logs, or other measures.
- Construction fencing to prevent unauthorized access to construction materials.
- Provisions for Good Housekeeping practices related to materials storage and disposal, as described in the Good Housekeeping BMP Fact Sheet.
- A stabilized construction entrance/exit, as described in the Vehicle Tracking Control BMP Fact Sheet, to accommodate traffic associated with material delivery and waste disposal vehicles.

Over-sizing the stabilized staging area may result in disturbance of existing vegetation in excess of that required for the project. This increases costs, as well as requirements for long-term stabilization following the construction period. When designing the stabilized staging area, minimize the area of disturbance to the extent practical.

<b>Stabilized Staging Area</b>	
<b>Functions</b>	
Erosion Control	Yes
Sediment Control	Moderate
Site/Material	Yes

**Minimizing Long-Term Stabilization Requirements**

- Utilize off-site parking and restrict vehicle access to the site.
- Use construction mats in lieu of rock when staging is provided in an area that will not be disturbed otherwise.
- Consider use of a bermed contained area for materials and equipment that do not require a stabilized surface.
- Consider phasing of staging areas to avoid disturbance in an area that will not be otherwise disturbed.

See Detail SSA-1 for a typical stabilized staging area and SSA-2 for a stabilized staging area when materials staging in roadways is required.

**Maintenance and Removal**

Maintenance of stabilized staging areas includes maintaining a stable surface cover of gravel, repairing perimeter controls, and following good housekeeping practices.

When construction is complete, debris, unused stockpiles and materials should be recycled or properly disposed. In some cases, this will require disposal of contaminated soil from equipment leaks in an appropriate landfill. Staging areas should then be permanently stabilized with vegetation or other surface cover planned for the development.

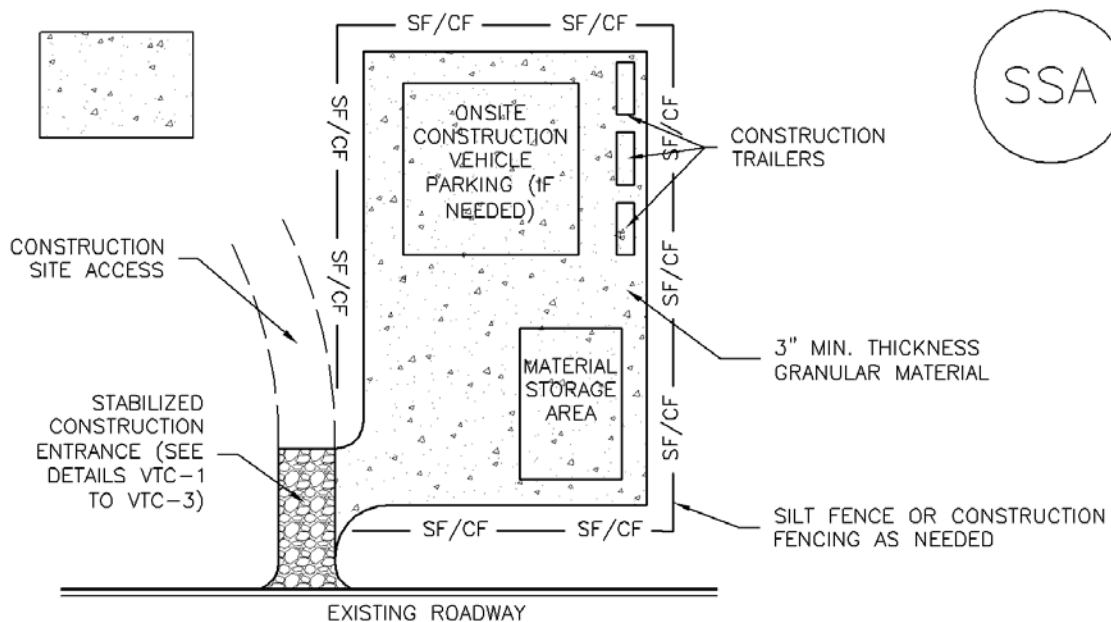

## SSA-1. STABILIZED STAGING AREA

### STABILIZED STAGING AREA INSTALLATION NOTES

1. SEE PLAN VIEW FOR
  - LOCATION OF STAGING AREA(S).
  - CONTRACTOR MAY ADJUST LOCATION AND SIZE OF STAGING AREA WITH APPROVAL FROM THE LOCAL JURISDICTION.
2. STABILIZED STAGING AREA SHOULD BE APPROPRIATE FOR THE NEEDS OF THE SITE. OVERSIZING RESULTS IN A LARGER AREA TO STABILIZE FOLLOWING CONSTRUCTION.
3. STAGING AREA SHALL BE STABILIZED PRIOR TO OTHER OPERATIONS ON THE SITE.
4. THE STABILIZED STAGING AREA SHALL CONSIST OF A MINIMUM 3" THICK GRANULAR MATERIAL.
5. UNLESS OTHERWISE SPECIFIED BY LOCAL JURISDICTION, ROCK SHALL CONSIST OF DOT SECT. #703, AASHTO #3 COARSE AGGREGATE OR 6" (MINUS) ROCK.
6. ADDITIONAL PERIMETER BMPs MAY BE REQUIRED INCLUDING BUT NOT LIMITED TO SILT FENCE AND CONSTRUCTION FENCING.

### STABILIZED STAGING AREA MAINTENANCE NOTES

1. INSPECT BMPs EACH WORKDAY, AND MAINTAIN THEM IN EFFECTIVE OPERATING CONDITION. MAINTENANCE OF BMPs SHOULD BE PROACTIVE, NOT REACTIVE. INSPECT BMPs AS SOON AS POSSIBLE (AND ALWAYS WITHIN 24 HOURS) FOLLOWING A STORM THAT CAUSES SURFACE EROSION, AND PERFORM NECESSARY MAINTENANCE.
2. FREQUENT OBSERVATIONS AND MAINTENANCE ARE NECESSARY TO MAINTAIN BMPs IN EFFECTIVE OPERATING CONDITION. INSPECTIONS AND CORRECTIVE MEASURES SHOULD BE DOCUMENTED THOROUGHLY.
3. WHERE BMPs HAVE FAILED, REPAIR OR REPLACEMENT SHOULD BE INITIATED UPON DISCOVERY OF THE FAILURE.
4. ROCK SHALL BE REAPPLIED OR REGRADED AS NECESSARY IF RUTTING OCCURS OR UNDERLYING SUBGRADE BECOMES EXPOSED.



STABILIZED STAGING AREA MAINTENANCE NOTES

5. STABILIZED STAGING AREA SHALL BE ENLARGED IF NECESSARY TO CONTAIN PARKING, STORAGE, AND UNLOADING/LOADING OPERATIONS.

6. THE STABILIZED STAGING AREA SHALL BE REMOVED AT THE END OF CONSTRUCTION. THE GRANULAR MATERIAL SHALL BE REMOVED OR, IF APPROVED BY THE LOCAL JURISDICTION, USED ON SITE, AND THE AREA COVERED WITH TOPSOIL, SEEDED AND MULCHED OR OTHERWISE STABILIZED IN A MANNER APPROVED BY LOCAL JURISDICTION.

NOTE: MANY MUNICIPALITIES PROHIBIT THE USE OF RECYCLED CONCRETE AS GRANULAR MATERIAL FOR STABILIZED STAGING AREAS DUE TO DIFFICULTIES WITH RE-ESTABLISHMENT OF VEGETATION IN AREAS WHERE RECYCLED CONCRETE WAS PLACED.

NOTE: MANY JURISDICTIONS HAVE BMP DETAILS THAT VARY FROM UDFCD STANDARD DETAILS. CONSULT WITH LOCAL JURISDICTIONS AS TO WHICH DETAIL SHOULD BE USED WHEN DIFFERENCES ARE NOTED.

(DETAILS ADAPTED FROM DOUGLAS COUNTY, COLORADO, NOT AVAILABLE IN AUTOCAD)

## Description

Street sweeping and vacuuming remove sediment that has been tracked onto roadways to reduce sediment transport into storm drain systems or a surface waterway.

## Appropriate Uses

Use this practice at construction sites where vehicles may track sediment offsite onto paved roadways.

## Design and Installation

Street sweeping or vacuuming should be conducted when there is noticeable sediment accumulation on roadways adjacent to the construction site. Typically, this will be concentrated at the entrance/exit to the construction site. Well-maintained stabilized construction entrances, vehicle tracking controls and tire wash facilities can help reduce the necessary frequency of street sweeping and vacuuming.

On smaller construction sites, street sweeping can be conducted manually using a shovel and broom. Never wash accumulated sediment on roadways into storm drains.

## Maintenance and Removal

- Inspect paved roads around the perimeter of the construction site on a daily basis and more frequently, as needed. Remove accumulated sediment, as needed.
- Following street sweeping, check inlet protection that may have been displaced during street sweeping.
- Inspect area to be swept for materials that may be hazardous prior to beginning sweeping operations.



**Photograph SS-1.** A street sweeper removes sediment and potential pollutants along the curb line at a construction site. Photo courtesy of Tom Gore.

<b>Street Sweeping/ Vacuuming</b>	
<b>Functions</b>	
Erosion Control	No
Sediment Control	Yes
Site/Material Management	Yes

## Description

Manage runoff from paving and grinding operations to reduce pollutants entering storm drainage systems and natural drainageways.

## Appropriate Uses

Use runoff management practices during all paving and grinding operations such as surfacing, resurfacing, and saw cutting.



**Photograph PGO-1.** Paving operations on a Colorado highway. Photo courtesy of CDOT.

## Design and Installation

There are a variety of management strategies that can be used to manage runoff from paving and grinding operations:

- Establish inlet protection for all inlets that could potentially receive runoff.
- Schedule paving operations when dry weather is forecasted.
- Keep spill kits onsite for equipment spills and keep drip pans onsite for stored equipment.
- Install perimeter controls when asphalt material is used on embankments or shoulders near waterways, drainages, or inlets.
- Do not wash any paved surface into receiving storm drain inlets or natural drainageways. Instead, loose material should be swept or vacuumed following paving and grinding operations.
- Store materials away from drainages or waterways.
- Recycle asphalt and pavement material when feasible. Material that cannot be recycled must be disposed of in accordance with applicable regulations.

See BMP Fact Sheets for Inlet Protection, Silt Fence and other perimeter controls selected for use during paving and grinding operations.

## Maintenance and Removal

Perform maintenance and removal of inlet protection and perimeter controls in accordance with their respective fact sheets.

Promptly respond to spills in accordance with the spill prevention and control plan.

<b>Paving and Grinding Operations</b>	
<b>Functions</b>	
Erosion Control	No
Sediment Control	No
Site/Material Management	Yes

**GENERAL PERMIT APPLICATION**

## **OPERATION AND MAINTENANCE INSPECTION RECORD**

**The following inspection records are to be used at each bi-monthly stormwater management system inspection and after any precipitation or snowmelt event that causes surface runoff. As a result of these inspections, the SWMP may need to be revised. The inspection records and revised SWMP shall be made available to the division upon request. If the construction activity lasts more than 12 months, a copy of the inspection records and revised SWMP shall be sent to the division by May 1 of each year covering April 1 to March 31.**

# CONSTRUCTION STORMWATER SITE INSPECTION REPORT

Facility Name		Permittee					
Date of Inspection		Weather Conditions					
Permit Certification #		Disturbed Acreage					
Phase of Construction		Inspector Title					
Inspector Name							
Is the above inspector a qualified stormwater manager? (permittee is responsible for ensuring that the inspector is a qualified stormwater manager)			<table border="1" style="width: 100%; border-collapse: collapse;"> <tr> <td style="width: 50%; text-align: center;">YES</td> <td style="width: 50%; text-align: center;">NO</td> </tr> <tr> <td style="text-align: center;"><input type="checkbox"/></td> <td style="text-align: center;"><input type="checkbox"/></td> </tr> </table>	YES	NO	<input type="checkbox"/>	<input type="checkbox"/>
YES	NO						
<input type="checkbox"/>	<input type="checkbox"/>						

INSPECTION FREQUENCY					
Check the box that describes the minimum inspection frequency utilized when conducting each inspection					
At least one inspection every 7 calendar days	<input type="checkbox"/>				
At least one inspection every 14 calendar days, with post-storm event inspections conducted within 24 hours after the end of any precipitation or snowmelt event that causes surface erosions	<input type="checkbox"/>				
<ul style="list-style-type: none"> <li>• This is this a post-storm event inspection. Event Date: _____</li> </ul>	<input type="checkbox"/>				
Reduced inspection frequency - Include site conditions that warrant reduced inspection frequency	<input type="checkbox"/>				
<ul style="list-style-type: none"> <li>• Post-storm inspections at temporarily idle sites</li> </ul>	<input type="checkbox"/>				
<ul style="list-style-type: none"> <li>• Inspections at completed sites/area</li> </ul>	<input type="checkbox"/>				
<ul style="list-style-type: none"> <li>• Winter conditions exclusion</li> </ul>	<input type="checkbox"/>				
Have there been any deviations from the minimum inspection schedule? If yes, describe below.	<table border="1" style="width: 100%; border-collapse: collapse;"> <tr> <td style="width: 50%; text-align: center;">YES</td> <td style="width: 50%; text-align: center;">NO</td> </tr> <tr> <td style="text-align: center;"><input type="checkbox"/></td> <td style="text-align: center;"><input type="checkbox"/></td> </tr> </table>	YES	NO	<input type="checkbox"/>	<input type="checkbox"/>
YES	NO				
<input type="checkbox"/>	<input type="checkbox"/>				

INSPECTION REQUIREMENTS*
i. Visually verify all implemented control measures are in effective operational condition and are working as designed in the specifications
ii. Determine if there are new potential sources of pollutants
iii. Assess the adequacy of control measures at the site to identify areas requiring new or modified control measures to minimize pollutant discharges
iv. Identify all areas of non-compliance with the permit requirements, and if necessary, implement corrective action
*Use the attached <b>Control Measures Requiring Routine Maintenance</b> and <b>Inadequate Control Measures Requiring Corrective Action</b> forms to document results of this assessment that trigger either maintenance or corrective actions

AREAS TO BE INSPECTED			
Is there evidence of, or the potential for, pollutants leaving the construction site boundaries, entering the stormwater drainage system or discharging to state waters at the following locations?			
	NO	YES	If "YES" describe discharge or potential for discharge below. Document related maintenance, inadequate control measures and corrective actions <b>Inadequate Control Measures Requiring Corrective Action</b> form
Construction site perimeter	<input type="checkbox"/>	<input type="checkbox"/>	
All disturbed areas	<input type="checkbox"/>	<input type="checkbox"/>	
Designated haul routes	<input type="checkbox"/>	<input type="checkbox"/>	
Material and waste storage areas exposed to precipitation	<input type="checkbox"/>	<input type="checkbox"/>	
Locations where stormwater has the potential to discharge offsite	<input type="checkbox"/>	<input type="checkbox"/>	
Locations where vehicles exit the site	<input type="checkbox"/>	<input type="checkbox"/>	
Other: _____	<input type="checkbox"/>	<input type="checkbox"/>	







## REPORTING REQUIREMENTS

The permittee shall report the following circumstances orally within twenty-four (24) hours from the time the permittee becomes aware of the circumstances, and shall mail to the division a written report containing the information requested within five (5) working days after becoming aware of the following circumstances. The division may waive the written report required if the oral report has been received within 24 hours.

<b>All Noncompliance Requiring 24-Hour Notification per Part II.L.6 of the Permit</b>		
<b>a. Endangerment to Health or the Environment</b> Circumstances leading to any noncompliance which may endanger health or the environment regardless of the cause of the incident (See Part II.L.6.a of the Permit) <i>This category would primarily result from the discharge of pollutants in violation of the permit</i>		
<b>b. Numeric Effluent Limit Violations</b> <ul style="list-style-type: none"> <li>o Circumstances leading to any unanticipated bypass which exceeds any effluent limitations (See Part II.L.6.b of the Permit)</li> <li>o Circumstances leading to any upset which causes an exceedance of any effluent limitation (See Part II.L.6.c of the Permit)</li> <li>o Daily maximum violations (See Part II.L.6.d of the Permit)</li> </ul> <i>Numeric effluent limits are very uncommon in certifications under the COR400000 general permit. This category of noncompliance only applies if numeric effluent limits are included in a permit certification.</i>		

Has there been an incident of noncompliance requiring 24-hour notification?	NO	YES	
	<input type="checkbox"/>	<input type="checkbox"/>	If "YES" document below

Date and Time of Incident	Location	Description of Noncompliance	Description of Corrective Action	Date and Time of 24 Hour Oral Notification	Date of 5 Day Written Notification *

\*Attach copy of 5 day written notification to report. Indicate if written notification was waived, including the name of the division personnel who granted waiver.

After adequate corrective action(s) and maintenance have been taken, or where a report does not identify any incidents requiring corrective action or maintenance, the individual(s) designated as the Qualified Stormwater Manager, shall sign and certify the below statement:

“I verify that, to the best of my knowledge and belief, all corrective action and maintenance items identified during the inspection are complete, and the site is currently in compliance with the permit.”

\_\_\_\_\_  
Name of Qualified Stormwater Manager

\_\_\_\_\_  
Title of Qualified Stormwater Manager

\_\_\_\_\_  
Signature of Qualified Stormwater Manager

\_\_\_\_\_  
Date

Notes/Comments

**OPERATION AND MAINTENANCE INSPECTION RECORD**