

FINAL DRAINAGE REPORT
for
SILVERADO RANCH FILING NO. 2

Prepared for:

Silverado Ranch, Inc.
18911 Cherry Springs Ranch Dr.
Monument, CO 80132

January 31, 2024
Revised June 7, 2024

Prepared by:

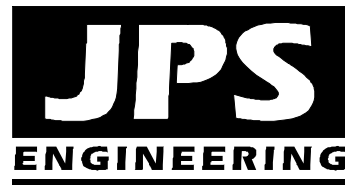

19 E. Willamette Avenue
Colorado Springs, CO 80903
(719)-477-9429
(719)-471-0766 fax
www.jpsengr.com

JPS Project No. 080603
PCD Project No. SF246

SILVERADO RANCH FILING NO. 2 – FINAL DRAINAGE REPORT
TABLE OF CONTENTS

	<u>PAGE</u>
DRAINAGE STATEMENT	i
I. GENERAL LOCATION AND DESCRIPTION.....	1
II. DRAINAGE BASINS AND SUB-BASINS.....	3
III. DRAINAGE DESIGN CRITERIA	4
IV. DRAINAGE PLANNING FOUR-STEP PROCESS	5
V. GENERAL DRAINAGE RECOMMENDATIONS	6
VI. DRAINAGE FACILITY DESIGN	6
VII. EROSION / SEDIMENT CONTROL	12
VIII. COST ESTIMATE AND DRAINAGE FEES.....	13
IX. SUMMARY	13

APPENDICES

APPENDIX A	Excerpts from Previous Subdivision Drainage Report
APPENDIX B	SCS Soils Information
APPENDIX C1	Hydrologic Calculations (SCS Method)
APPENDIX C2	Hydrologic Calculations (Rational Method)
APPENDIX D	Hydraulic Calculations
APPENDIX E	Stormwater Quality / PLD Calculations
APPENDIX F	Drainage Cost Estimate
APPENDIX G	Figures
	Vicinity Map
	Floodplain Exhibit
Figure EX1:	Major Basin / Historic Drainage Plan
Figure EX2:	Historic Drainage Plan
Figure D1:	Master Development Drainage Plan
Figure D1.2:	Filing No. 2 Developed Drainage Plan

DRAINAGE STATEMENT

Engineer's Statement:

The attached drainage plan and report were prepared under my direction and supervision and are correct to the best of my knowledge and belief. Said drainage report has been prepared according to the criteria established by the County for drainage reports and said report is in conformity with the master plan of the drainage basin. I accept responsibility for liability caused by negligent acts, errors or omissions on my part in preparing this report.

John P. Schwab, P.E. #29891

Developer's Statement:

I, the developer, have read and will comply with all of the requirements specified in this drainage report and plan.

By:

Printed Name: Stan Searle, President Date
Silverado Ranch, Inc., 18911 Cherry Springs Ranch Drive, Monument, CO 80132

El Paso County's Statement

Filed in accordance with the requirements of the El Paso County Land Development Code, Drainage Criteria Manual, Volumes 1 and 2, and Engineering Criteria Manual as amended.

Joshua Palmer, P.E. Date
County Engineer / ECM Administrator

Conditions:

I. GENERAL LOCATION AND DESCRIPTION

A. Background

Silverado Ranch is a rural residential subdivision located in the Ellicott Valley area of eastern El Paso County, Colorado. The development is located at the southeast corner of Drennan Road and Peyton Highway. The Silverado Ranch project will ultimately consist of 64 rural residential lots (2.5-acre minimum) on the 320-acre property. The gross density of the project is 5 acres per residential lot. The El Paso County Board of County Commissioners approved the PUD and Preliminary Plan for Silverado Ranch on August 28, 2008.

The developer, Silverado Ranch, Inc., completed recording of the initial phase of development (Filing No. 1) in 2018. The existing Silverado Ranch Filing No. 1 consists of 10 lots on 106.4 acres in the northwest area of the property.

Silverado Ranch Filing No. 1A was approved by the County in October, 2023 as an Amendment to the Filing No. 1 plat, allowing for the subdivision streets to be constructed as private roads.

The current proposal for Silverado Ranch Filing No. 2 is the second phase of this subdivision development, and this filing consists of 15 lots on 48.9 acres in the northeast part of the property.

B. Scope

This report is intended to fulfill the El Paso County requirements for a Final Drainage Report (FDR) in support of the final plat submittal for Filing No. 2. The report will provide a summary of site drainage issues impacting the proposed development, including analysis of impacts from upstream drainage areas, site-specific developed drainage patterns, and impacts on downstream facilities. This report was prepared based on the guidelines and criteria presented in the El Paso County Engineering Criteria Manual (ECM) and Drainage Criteria Manual (DCM).

C. Site Location and Description

The Silverado Ranch property is described as the north half of Section 16, Township 15 South, Range 63 West of the 6th Principal Meridian. The Silverado Ranch Filing No. 2 site is a part of the unplatted balance of the Silverado Ranch property (El Paso County Assessor's Parcel Number 35000-00-082). The undeveloped balance of the Silverado Ranch property is currently vacant ranch land. Peyton Highway borders the subdivision property to the west, and Drennan Road borders the property to the north. Unplatted properties zoned RR3 (rural residential – 5-acre lots) border this parcel on all sides.

Ground elevations within the property range from a high point of approximately 5,880 feet above mean sea level at the west boundary of the site, to a low point of 5,780 at the southeast corner of the property.

In accordance with the approved PUD, the overall Silverado Ranch development will ultimately include 64 rural residential lots, maintaining a gross density of 5 units per acre. Subdivision infrastructure improvements will include gravel paving and utility installation along the roads within the site. Subdivision streets will be classified as private rural residential roads.

Filing No. 1 included construction of Drover Canyon View, providing subdivision access to Drennan Road along the north boundary of the subdivision. Filing No. 1 also included construction of the initial segment of Silverado Hill View, which will ultimately serve as a loop road within the subdivision.

Filing No. 2 will include construction of Silverado Hill View extending easterly as a private road from the existing street termination at the east end of Filing No. 1. Silverado Hill View will provide direct access to the 15 residential lots within Filing No. 2.

A future phase of subdivision development will include construction of Mill Iron View at the western site boundary, providing a subdivision access connection to Peyton Highway.

The natural drainage channels throughout this area flow to tributaries of Upper Dry Squirrel Creek, which outfalls into Black Squirrel Creek southeast of this site. The site is located entirely within the Drennan Drainage Basin (CHDS0400).

The terrain is generally flat with gentle northwest to southeast slopes ranging from one to three percent. Historic drainage flows from the site are conveyed overland towards the southerly boundary of the site. Existing vegetation within the site consists of native prairie grasses.

D. General Soil Conditions

According to the Soil Survey of El Paso County prepared by the Soil Conservation Service, on-site soils are comprised of the following soil types (see Appendix B):

- Type 5 - "Bijou loamy sand": rapid permeability, slow surface runoff, severe erosion hazard, Hydrologic Group B (approximately 65% of site, encompassing central and eastern areas of parcel)
- Type 6 - "Bijou sandy loam": rapid permeability, slow surface runoff, moderate erosion hazard, Hydrologic Group B (small area near easterly site boundary)
- Type 106 - "Wigton loamy sand": rapid permeability, slow surface runoff, moderate to high erosion hazard, Hydrologic Group A (approximately 35% of site, encompassing western area of parcel)

The soils within this parcel are classified as hydrologic soils group A/B.

E. References

City of Colorado Springs “Drainage Criteria Manual, Volumes 1 and 2,” revised October 31, 2018.

El Paso County “Engineering Criteria Manual,” revised October 14, 2020.

FEMA, Flood Insurance Rate Map (FIRM) Number 08041C1025G, December 7, 2018.

JPS Engineering, Inc., “Final Drainage Report for Silverado Ranch Filing No. 1,” June 18, 2018 (approved by El Paso County 8/8/18; EDARP Project No. SF-18-011).

JPS Engineering, Inc., “Master Development Drainage Plan and Preliminary Drainage Report for Silverado Ranch,” June 24, 2008 (approved by El Paso County 8/18/08).

USDA/NRCS, “Soil Survey of El Paso County Area, Colorado,” August 13, 2009.

II. DRAINAGE BASINS AND SUB-BASINS

A. Major Basin Description

The major drainage basins lying in and around the proposed development are depicted in Figure EX1. The proposed development lies completely within the Drennan Drainage Basin (CHDS0400) as classified by El Paso County. The Drennan Basin comprises a total drainage area in excess of 16 square miles. As such, the 320-acre Silverado Ranch development represents less than three percent of the total basin area, which is primarily agricultural land.

No drainage planning study has been completed for this drainage basin or any adjacent drainage basins. The Silverado Ranch parcel is impacted by several large off-site basins to the northwest of the site, which combine with on-site basins flowing southeasterly towards Dry Squirrel Creek.

B. Floodplain Impacts

This site is not impacted by any delineated 100-year floodplains, as studied by the Federal Emergency Management Agency (FEMA). The 100-year floodplain limits in the vicinity of the site are shown in Flood Insurance Rate Map (FIRM) Numbers 08041C0815G and 08041C1025G, dated December 7, 2018, and depicted in the Firmette Exhibit in Appendix G.

C. Sub-Basin Description

The developed drainage basins lying within the proposed development are depicted in Figures D1 and D1.2 (Appendix G). The interior site layout has been divided into several sub-basins (A1-A6, B1-B7, C, D) based on the proposed road layout and grading concept within the site. The natural drainage patterns will be impacted through development by site grading and concentration of runoff in subdivision roadside ditches and channels. The majority of sub-basins drain to the southeast,

collecting in the interior roads and drainage channels. On-site flows will be diverted to natural swales draining towards the southerly site boundary, following historic drainage paths.

As shown in Figures D1 and D1.2, Filing No. 2 lies within parts of Drainage Basins B4, B6, B7, and D. There will be no developed drainage impact to Basins A and C with development of Filing No. 2.

III. DRAINAGE DESIGN CRITERIA

A. Development Criteria Reference

The Drennan Drainage Basin has not had a Drainage Basin Planning Study performed for the basin. The majority of areas within the basin are comprised of agricultural lands and rural residential uses.

B. Hydrologic Criteria

SCS procedures were utilized for analysis of major basin flows impacting the site. In accordance with El Paso County drainage criteria, SCS hydrologic calculations were based on the following assumptions:

- Design storm (minor) 5-year
- Design storm (major) 100-year
- 100-year, 24-hour rainfall 4.4 inches per hour (NOAA isopluvial map)
- 5-year, 24-hour rainfall 2.6 inches per hour (NOAA isopluvial map)
- Hydrologic soil type B
- SCS curve number - undeveloped conditions 61 (pasture / range)
- SCS curve number - undeveloped conditions 50 (pasture / range with upstream retention)
- SCS curve number - developed 5-acre lots 63.59

In accordance with the previously approved subdivision drainage reports, historic flows have been calculated using an SCS Curve Number of 50 for the off-site basins recognizing the existence of upstream (off-site) retention pond areas.

Rational method procedures were utilized for calculation of peak flows within the on-site drainage basins. Rational method hydrologic calculations were based on the following assumptions:

- Design storm (minor) 5-year
 - Design storm (major) 100-year
 - Rainfall Intensities El Paso County I-D-F Curve
 - Hydrologic soil type B
- | | | |
|--|-----------|-------------|
| | <u>C5</u> | <u>C100</u> |
| • Runoff Coefficients - undeveloped: | | |
| Existing pasture/range areas | 0.08 | 0.35 |
| • Runoff Coefficients - developed: | | |
| Proposed lot areas (5-acre average lots) | 0.137 | 0.393 |

Composite runoff coefficients (C-values) have been calculated based on the proposed rural residential lot sizes. Hydrologic calculations are enclosed in Appendix C, and peak design flows are identified on the drainage basin drawings.

IV. DRAINAGE PLANNING FOUR STEP PROCESS

El Paso County Drainage Criteria require drainage planning to include a Four Step Process for receiving water protection that focuses on reducing runoff volumes, treating the water quality capture volume (WQCV), stabilizing drainageways, and implementing long-term source controls. As stated in DCM Volume 2, the Four Step Process is applicable to all new and re-development projects with construction activities that disturb 1 acre or greater or that disturb less than 1 acre but are part of a larger common plan of development. The Four Step Process has been implemented as follows in the planning of this project:

Step 1: Employ Runoff Reduction Practices

- **Minimize Impacts:** The proposed rural residential subdivision is an inherently low impact development. The proposed gross density of 5-acres per lot will significantly minimize drainage impacts in comparison to higher density development alternatives.

Step 2: Stabilize Drainageways

- There are no major drainageways within the site. Vegetated buffer strips will be maintained between developed areas of the site and downstream drainage channels.

Step 3: Provide Water Quality Capture Volume (WQCV)

- Water quality detention is not required for the residential lots based on the rural residential development proposed (5-acre minimum lot sizes). According to ECM Appendix I Section I.7.1.B.5, single-family residential lots greater than or equal to 2.5 acres in size per dwelling and having a lot impervious area of less than 10 percent are excluded from permanent WQ control measures. As detailed in Appendix B, the assumed impervious area for the new lots is 7 percent, which meets the criteria for exclusion from water quality requirements.
- Water quality mitigation for the subdivision roadway improvements will be provided by the existing full-infiltration Porous Landscape Detention (PLD) facility at the southeast corner of Filing No. 2.

Step 4: Consider Need for Industrial and Commercial BMPs

- No industrial or commercial land uses are proposed as part of this development.

V. GENERAL DRAINAGE RECOMMENDATIONS

The developed drainage plan for the site is to provide and maintain positive drainage away from structures and conform to the established drainage patterns for the overall subdivision. JPS Engineering recommends that positive drainage be established and maintained away from all structures within the site in conformance with applicable building codes and geotechnical engineering recommendations.

Individual lot grading and drainage is the sole responsibility of the individual builders and property owners. Final grading of each home site should establish proper protective slopes and positive drainage in accordance with HUD guidelines and building codes. In general, main floor elevations for each home should be established a minimum of 2 feet above the top of curb (or pavement) of the adjoining street.

We recommend a minimum of 6 inches clearance from the top of concrete foundation walls to adjacent finished site grades. Positive drainage slopes should be maintained away from all structures, with a minimum recommended slope of 5 percent for the first 10 feet away from buildings in landscaped areas, a minimum recommended slope of 2 percent for the first 10 feet away from buildings in paved areas, and a minimum slope of 1 percent for paved areas beyond buildings.

VI. DRAINAGE FACILITY DESIGN

A. General Concept

Development of Silverado Ranch Filing No. 2 will include site grading and roadway construction, resulting in additional impervious areas across the site. The general drainage pattern will consist of grading away from home sites to swales and roadside ditches along the internal roads within the subdivision, conveying runoff flows through the site. Runoff from the site will flow by roadside ditches to cross culverts at low points in the road profiles, and grass-lined channels connecting to existing natural swales at the site boundaries.

The stormwater management concept for Silverado Ranch Filing No. 2 will be to provide roadside ditches and natural swales as required to convey developed drainage through the site to existing natural drainage channel outfalls. Individual lot grading will provide positive drainage away from building sites, and direct developed flows into the system of roadside ditches and drainage swales running through the subdivision.

Two existing Porous Landscape Detention (PLD) areas within the overall Silverado Ranch site will be maintained to mitigate the impact of developed flows. One PLD ("PLD-A") is located at the northwest corner of the property (west of Filing No. 1), and overflows from PLD-A would drain southeasterly to the larger PLD ("PLD-B") located on the southeast side of Filing No. 2.

B. Specific Details

1. Existing Drainage Conditions

Drainage planning for the Silverado Ranch Subdivision has been studied in several previously approved drainage reports. The most recent report on file is the “Final Drainage Report for Silverado Ranch Filing No. 1” by JPS Engineering, Inc. dated June 18, 2018 (approved by El Paso County 8/8/18; EDARP Project No. SF-18-011).

Historic drainage conditions are depicted in Figures EX1 and EX2. There are no existing drainage facilities within the Filing No. 2 area, with the exception of an existing culvert crossing Drennan Road at the north boundary of the property, and the existing PLD areas. The “Major Basin / Historic Drainage Plan” (Sh. EX1, Appendix G) has been updated in this report utilizing El Paso County GIS mapping to more accurately model the upstream drainage basin areas (in comparison to the USGS mapping used in the previous drainage reports for this subdivision).

The overall Silverado Ranch property is characterized by two large PLD areas as depicted on Sheet EX2. Based on the substantial upstream drainage areas, major storm flows would be expected to overtop the existing PLD areas within the site and overflow towards the southern boundary of the site. Historic overflows from this site would drain to existing grass-lined drainage swales downstream.

Off-site flows from Basin OA1 drain across Drennan Road into the existing depression within Basin A1 at the northwest corner of the parcel. Off-site Basin OA1 discharges historic peak flows of $Q_5 = 22.9$ cfs and $Q_{100} = 165.3$ cfs (SCS Method). An existing 18-inch CMP culvert conveys flows from Basin OA1 across the low point in Drennan Road. This undersized culvert would be expected to overtop during major storm events.

Off-site Basin OA2 consists of a tributary area at the southwest corner of Drennan Road and Peyton Highway, which discharges historic peak flows of $Q_5 = 0.9$ cfs and $Q_{100} = 6.1$ cfs (SCS Method), entering the northwest corner of the Silverado Ranch property. There is currently no culvert crossing the south side of Drennan Road at Peyton Highway. Historic flows from Basin OA2 would be expected to overtop Peyton Highway at this location.

The existing northwest PLD (PLD-A) has a storage volume of approximately 36.5 acre-feet between the 5845 and 5857 contours. Overflows from PLD-A would drain southeasterly through Basin A1 and continue flowing southeasterly along Channel A1 towards PLD-B in the southeastern part of the property. Off-site flows from Basins OA1 and OA2 combine with on-site flows from Basin A, with calculated historic peak flows (SCS Method) of $Q_5 = 24.9$ cfs and $Q_{100} = 172.2$ cfs at Design Point #A1. Channel A1 is a broad, grass-lined stable channel.

Off-site drainage from the large northwesterly Basin OB1 crosses Drennan Road at an existing 18-inch CMP culvert crossing, which would be expected to overtop during large storm events. Off-site Basin OB1 discharges historic peak flows of $Q_5 = 15.9$ cfs and $Q_{100} = 113.7$ cfs (SCS Method), flowing southeasterly into Basin B. Channel B is a broad, grass-lined stable channel which conveys the flow from Basin OB1 southeasterly to PLD-B.

There is currently no culvert crossing where drainage from off-site Basin OB2 crosses an existing low point in Drennan Road at the north boundary of the site. Based on the topography, overflows from Basin OB2 would overtop Drennan Road and flow south into Basin B. Off-site Basin OB2 contributes historic peak flows of $Q_5 = 2.5$ cfs and $Q_{100} = 16.6$ cfs (SCS Method), entering the north boundary of the Silverado Ranch property. Channel OB21 is a broad, grass-lined stable channel which conveys the flow from Basin OB2 to PLD-B.

The easterly PLD (PLD-B) within the Silverado Ranch site has a storage volume of approximately 74.3 acre-feet between the 5790 and 5796 contours. In the event the existing PLD was completely full, overflows from this PLD would drain towards the southeast corner of the site. Flows from Basins OA1, OA2, A1, OB1, OB2, and B combine at Design Point #2, with calculated historic peak flows (SCS Method) of $Q_5 = 55.7$ cfs and $Q_{100} = 313.6$ cfs.

Basin A2 (not a part of Filing No. 2) comprises the drainage area in the southwest corner of the property, which flows towards Design Point #1 at the southern boundary of the site, with calculated historic peak flows (Rational Method) of $Q_5 = 8.3$ cfs and $Q_{100} = 61.0$ cfs.

Basin C comprises the area in the southeasterly part of the overall Silverado site (not a part of Filing No. 2), which flows towards Design Point #3 at the southeast corner of the site, with calculated historic peak flows (Rational Method) of $Q_5 = 2.3$ cfs and $Q_{100} = 16.8$ cfs.

Basin D comprises the area in the northeast corner of the overall Silverado site, which flows towards Design Point #4 near the northeast corner of the site, with calculated historic peak flows (Rational Method) of $Q_5 = 2.6$ cfs and $Q_{100} = 19.1$ cfs.

2. Developed Drainage Conditions

The developed drainage basins and projected flows are shown in the Developed Drainage Plan (Figure D1, Appendix G). Off-site flows from Basins OA1 and OA2 will continue to flow into the existing PLD-A within Basin A1 at the northwest corner of the subdivision.

Developed peak flows at Design Point #A1 are calculated as $Q_5 = 25.1$ cfs and $Q_{100} = 171.2$ cfs (SCS Method). Overflows from PLD-A will flow southeasterly across the subdivision to PLD-B.

The proposed Filing No. 2 development impacts parts of Basins B1.1, B4, B6, B7, and D.

Basin B1.1 comprises the proposed drainage channel area extending southeast from the existing Culvert OB1 which crosses Drennan Road northwest of the Filing No. 2 area. Off-site flows from Basin OB1 combine with Basin B1.1 at Design Point #B1.1, with developed peak flows calculated as $Q_5 = 14.3$ cfs and $Q_{100} = 102.9$ cfs (SCS Method). These flows will be conveyed across the Silverado Hill View roadway through Culvert B1.1 (42" RCP), and Channel B1.1 will extend south and then easterly along the south side of the Filing No. 2 area, flowing into PLD-B. A series of sediment control logs (SCL) will be provided for erosion control during construction of Channel B1.1, and grass-lining will provide long-term channel stability. A temporary sediment trap (ST) and permanent rock check dam (RCD) will be installed where the channel discharges into the existing PLD-B.

The majority of proposed Filing No. 2 lots on the north side of Silverado Hill View lie within Basin B4, which flows to a proposed culvert crossing at a low point in Silverado Hill View between Lots 4 and 12. Off-site flows from Basin OB2 combine with Basin B4 at Design Point #B4.1, with developed peak flows calculated as $Q_5 = 5.8$ cfs and $Q_{100} = 38.6$ cfs (SCS Method). These flows will be conveyed across the roadway through Culvert B4.1 (24" RCP), and Channel B4.1 will extend southeasterly across Lot 12 into PLD-B. A series of sediment control logs (SCL) will be provided for erosion control during construction of Channel B4.1, and grass-lining will provide long-term channel stability. A temporary sediment trap (ST) and permanent rock check dam (RCD) will be installed where the channel discharges into the existing PLD-B.

The proposed Filing No. 2 lots on the south side of Silverado Hill View lie within Basin B6, which sheet flows southeasterly into PLD-B. Developed peak flows for Basin B6 are calculated as $Q_5 = 21.5$ cfs and $Q_{100} = 103.6$ cfs (Rational Method). Drainage easements have been provided on the subdivision plat restricting building areas to elevations above the adjoining PLD overflow elevation.

This phase of development has a minor impact in Basin B7, consisting only of the proposed Lot 8 at the east edge of Filing No. 2. Basin B7 flows southeasterly towards the south boundary of the subdivision, with ultimate developed peak flows calculated as $Q_5 = 8.6$ cfs and $Q_{100} = 41.4$ cfs (Rational Method). Filing No. 2 impacts from the single lot within Basin B7 will be negligible. As detailed in Appendix C1, the "Filing No. 2 only" developed peak flows for Basin B7 are calculated as $Q_5 = 5.5$ cfs and $Q_{100} = 37.0$ cfs (Rational Method), and the "Filing No. 2 only" runoff coefficients for Basin B7 are essentially equal to historic conditions (Developed $C_5 = .088$ and $Q_{100} = 0.356$ vs. Historic $C_5 = .08$ and $Q_{100} = 0.35$).

This phase of development also has a minor impact within Basin D, consisting only of the proposed Lot 9 at the northeast corner of Filing No. 2. Basin D flows southeasterly towards the east boundary of the subdivision, with ultimate developed peak flows at Design Point #4 calculated as $Q_5 = 4.6$ cfs and $Q_{100} = 22.0$ cfs (Rational Method). Filing No. 2 impacts from the single lot within Basin D will be negligible (100-year developed flow increase of 2.9 cfs).

Channel A is a broad, grass-lined stable channel which will continue to convey the upstream

flows from Basins OA1, OA2, A1, A5, A6 southeasterly to PLD-B.

Flows from Basins OA1-OA2, A1, A5, A6, OB1-OB2, and B1-B6 will continue to flow into PLD-B at Design Point #B6.1, with developed peak flows of $Q_5 = 67.2$ cfs and $Q_{100} = 305.2$ cfs (SCS Method). In the event of an overflow of PLD-B, overflows would drain southeasterly across the existing broad, grass-lined overflow swale (designated as “Overflow Channel B6” on Sh. D1 and D1.2), flowing southeasterly across Basin B7 to Design Point #2.

Flows from Basins OA1-OA2, A1, A5, A6, OB1, and OB2 will continue to combine with on-site flows from Basins B1-B7 at Design Point #2, with developed peak flows of $Q_5 = 71.2$ cfs and $Q_{100} = 309.5$ cfs (SCS Method). The developed flow impact at Design Point #2 is negligible (no 100-year developed flow increase calculated based on the large size of the off-site basins impacting this site in comparison to the relatively small rural subdivision area).

Silverado Ranch Filing No. 2 will not have any developed drainage impact within Basins A or C.

C. Stormwater Detention / Water Quality / Porous Landscape Detention (PLD) Areas

Developed runoff impacts from the project will be mitigated by preservation of the two existing PLD areas within the site. While previous drainage reports for this subdivision identified the existing PLD's as “Retention Ponds,” these PLD areas are now being discussed and modeled as “Porous Landscape Detention” Areas. The existing PLD areas are natural, historic topographic depressions, and the PLD areas do not have embankments or outlet structures. Given that there are no existing embankments, our understanding is that there are no water rights issues associated with preservation of these natural depression areas, which are common in eastern El Paso County.

Stormwater retention storage capacity was evaluated in detail in the previously approved 2018 “Final Drainage Report for Silverado Ranch Filing No. 1” (see excerpts in Appendix A). As discussed in the previous report, the existing PLD areas will be protected and preserved to the greatest extent possible, matching historic drainage conditions. As previously noted, the existing northwest PLD (PLD-A) has a storage volume of approximately 36.5 acre-feet between the 5845 and 5857 contours. The easterly PLD (PLD-B) has a storage volume of approximately 74.3 acre-feet between the 5790 and 5796 contours. The previous FDR included infiltration calculations projecting a drain time of 23.9 hours for PLD-A and a drain time of 14 hours for PLD-B.

As discussed above, there will be a negligible increase in developed flows due to the rural residential nature of the development and the large upstream drainage basin areas in comparison to the subdivision area. As such, there is no need for stormwater detention for this subdivision. While the previous subdivision drainage report included recommendations for improvements to the existing “retention” areas during future phases of the project, no improvements to the existing PLD's are recommended based on the analysis in this report.

The existing PLD areas will continue to function as full-infiltration landscape detention facilities, and the PLD's have ample capacity to meet current County Water Quality requirements for the Silverado Ranch Subdivision. As detailed in Appendix E, design calculations for the PLD areas have been performed using the "UD-BMP_v3.07" software, and design parameters for the PLD's are summarized as follows:

PLD	Design Point	Tributary Area (ac)	Impervious Percentage	Min. WQCV (af)	Existing WQCV Volume (af)
A	A1	1357	2.1	1.4	7.7
B	2	2481	2.5	3.1	19.3

In Appendix E, the Filing No. 2 roadway area draining into the north side of the existing PLD-B has been modeled as "PLD-B4.2." The existing PLD area at the southeast corner of Filing No. 2 provides ample WQCV volume to meet the water quality requirements for "PLD-B4.2."

In the unlikely event of an overflow, the existing PLD areas have existing broad, grass-lined overflow channels to safely convey overflows downstream. Developed flows will enter the PLD areas through extended grass-lined drainage channels, minimizing potential concerns with sediment entering the PLD's. Sediment traps and rock check dams will be installed at points where developed flows enter the existing PLD areas (forebays are typically not required for PLD facilities).

The PLD's will continue to be privately maintained by the subdivision homeowners association, and a detention maintenance agreement was filed with El Paso County during the platting of Filing No. 1. Provisions for maintenance of the PLD facilities are included in the Operation and Maintenance (O&M) manual on file with the subdivision documents.

D. On-Site Drainage Facility Design

Developed sub-basins and proposed drainage improvements are depicted in the enclosed Drainage Plans (Sheet D1 and D1.2).

On-site drainage facilities will consist of roadside ditches, grass-lined channels, and culverts. Hydraulic calculations for sizing of on-site drainage facilities are enclosed in Appendix D, and design criteria are summarized as follows:

1. Culverts

The internal road system will be graded to drain roadside ditches to low points along the road profile, where cross-culverts will convey developed flows into grass-lined channels following historic drainage paths. Culvert pipes have been specified as reinforced concrete pipe (RCP) with a minimum diameter of 18-inches. Culvert sizes have been identified based on a maximum headwater-to-depth ratio (HW/D) of 1.0 for the minor (5-year) design storm. Final culvert design has been performed utilizing the FHWA HY-8 software package to perform a

detailed analysis of inlet and outlet control conditions, meeting El Paso County criteria for allowable overtopping. Riprap outlet protection will be provided at all culverts. Culvert sizes are detailed in the “Culvert Sizing Table” in Appendix D.

2. Open Channels

Proposed drainage channels will generally be grass-lined channels designed to convey 100-year flows, with a trapezoidal cross-section, 4:1 maximum side slopes, 1-foot freeboard, and a minimum slope of 0.4 percent. The proposed drainage channels have been sized utilizing Manning’s equation for open channel flow, assuming a friction factor (“n”) of 0.030 for dry-land grass channels. Maximum allowable velocities have been evaluated based on El Paso County drainage criteria, typically allowing for a maximum 100-year velocity of 5 feet per second. Erosion control blanket (turf-reinforcement mat) channel lining will be provided where required based on erosive velocities.

Channel hydraulic calculations are enclosed in Appendix D, including tables summarizing design parameters for channels and roadside ditches. The proposed channels will be seeded with native grasses for erosion control. Primary drainage swales crossing proposed lots have been placed in drainage easements, with variable widths based on the required channel sections.

E. Analysis of Existing and Proposed Downstream Facilities

The proposed drainage concept is to preserve the existing on-site PLD areas to ensure that flows leaving the developed site remain consistent with historic levels. Based on the maintenance of existing on-site PLD’s, no downstream or off-site drainage improvements are proposed.

F. Anticipated Drainage Problems and Solutions

The primary drainage problems anticipated within this rural residential subdivision development will consist of maintenance of the proposed drainage channels, culverts, and PLD areas. Care will need to be taken to implement proper erosion control measures in the proposed roadside ditches and swales. Ditches have been designed to meet allowable velocity criteria. Erosion control blankets will be installed where necessary to minimize erosion concerns in ditches and channels. Maintenance of the existing retention ponds will minimize downstream drainage impacts.

VII. EROSION / SEDIMENT CONTROL

Appropriate control measures (CM’s) will be implemented for erosion and sediment control during construction. Sediment control measures will include installation of silt fence at the toe of disturbed slopes and straw bales protecting drainage ditches. Cut slopes will be stabilized during excavation as necessary and vegetation will be established for stabilization of disturbed areas as soon as possible.

All ditches have been designed to meet El Paso County criteria for slope and velocity. Vehicle tracking control pads will be installed at construction access points.

VIII. COST ESTIMATE AND DRAINAGE FEES

A cost estimate for proposed drainage improvements is enclosed in Appendix F, with a total estimated cost of approximately \$48,689 for Filing No. 2 drainage improvements. The developer will finance all costs for proposed roadway and drainage improvements.

Private subdivision infrastructure improvements, including private roads and drainage facilities within private rights-of-way and drainage tracts, will be owned and maintained by the subdivision homeowners association (HOA). Shared private drainage facilities, including the existing PLD's, will be owned and maintained by the subdivision HOA. Drainage swales crossing individual lots will be owned and maintained by the individual property owners.

This parcel is located entirely within the Drennan Drainage Basin (CHDS0400), which does not have a drainage or bridge fee requirement. No drainage and bridge fees will be due at time of recordation of the final plat as the subject site is not located in a fee basin.

IX. SUMMARY

Silverado Ranch is a rural residential subdivision located southeast of Drennan Road and Peyton Highway. The Silverado Ranch project will ultimately consist of 64 rural residential units on a 320-acre parcel (2.5-acre minimum lot size; 5-acre gross density). Filing No. 2 consists of 15 lots on 48.9 acres in the northeast part of the property.

Development of the Silverado Ranch Subdivision will generate a marginal increase in developed runoff from the site, which will be mitigated through preservation and maintenance of the two existing on-site Porous Landscape Detention (PLD) areas. Based on the large size of the off-site basins impacting this site in comparison to the rural nature of the proposed development, developed flow impacts from the project will be minimal.

The proposed drainage patterns will remain consistent with historic conditions, and new drainage facilities constructed to El Paso County standards will safely convey runoff to the existing PLD's. Preservation of the existing PLD's and construction of the proposed on-site drainage and erosion control facilities will ensure that this subdivision has no significant adverse drainage impact on downstream or surrounding areas.

APPENDIX A

EXCERPTS FROM PREVIOUS SUBDIVISION DRAINAGE REPORT

FINAL DRAINAGE REPORT
for
SILVERADO RANCH FILING NO. 1

Prepared for:

Silverado Ranch, Inc.
18911 Cherry Springs Ranch Dr.
Monument, CO 80132

June 18, 2018

Prepared by:

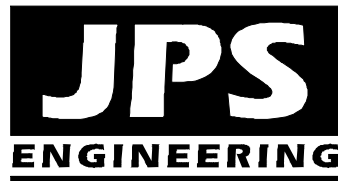

19 E. Willamette Avenue
Colorado Springs, CO 80903
(719)-477-9429
(719)-471-0766 fax
www.jpsegr.com

JPS Project No. 080603
SF-18-011

IV. DRAINAGE FACILITY DESIGN

A. General Concept

Development of Silverado Ranch Filing No. 1 will require site grading and roadway construction, resulting in additional impervious areas across the site. The general drainage pattern will consist of grading away from home sites to swales and roadside ditches along the internal roads within the subdivision, conveying runoff flows through the site. Runoff from the site will flow by roadside ditches to cross culverts at low points in the road profiles, and grass-lined channels connecting to existing natural swales at the site boundaries.

The stormwater management concept for Silverado Ranch Filing No. 1 will be to provide roadside ditches and natural swales as required to convey developed drainage through the site to existing natural drainage channel outfalls. Individual lot grading will provide positive drainage away from building sites, and direct developed flows into the system of roadside ditches and drainage swales running through the subdivision.

Two existing retention ponds within the overall Silverado Ranch site will be maintained and upgraded to mitigate the impact of developed flows and ensure that historic flows are maintained downstream of the proposed subdivision. One pond is located at the northwest corner of the property (west of Filing No. 1), and overflows from this pond drain southeasterly to a larger pond located in the future subdivision filing area in the southeast part of the Silverado Ranch property.

The following development practices are generally recommended as good practice for future development within this drainage basin:

- Preserve natural drainageways and floodplains.
- Locate roadways on ridges to minimize crossings and impacts to natural drainage areas.
- Maximize use of grass-lined swales for stormwater quality management.
- Regionalize detention pond facilities where possible to minimize maintenance requirements.

B. Specific Details

1. Existing Drainage Conditions

Historic drainage conditions are depicted in Figures EX1 and EX2. There are no existing drainage facilities within or adjacent to the site, with the exception of an existing culvert crossing Drennan Road at the north boundary of the property, and the existing stock pond areas within the site. The overall Silverado Ranch property is characterized by two large drainage retention areas, as depicted on Sheet EX2. Based on the substantial upstream drainage area, major storm flows (5-year and 100-year) would be expected to overtop the existing retention ponds within the site and overflow towards the southern boundary of the site. Historic overflows from this site would drain to existing grass-lined drainage swales downstream.

Off-site flows from Basin OA1 drain across Drennan Road into the existing depression within Basin A1 at the northwest corner of the parcel. Off-site Basin OA1 discharges historic peak flows of $Q_5 = 34.6$ cfs and $Q_{100} = 261.3$ cfs (SCS Method). An existing 18-inch CMP culvert conveys flows from Basin OA1 across the low point in Drennan Road. This undersized culvert would be expected to overtop during major storm events.

Off-site Basin OA2 consists of a tributary area at the southwest corner of Drennan Road and Peyton Highway, which discharges historic peak flows of $Q_5 = 19.6$ cfs and $Q_{100} = 48.4$ cfs (Rational Method), entering the northwest corner of the Silverado Ranch property. There is currently no culvert crossing the south side of Drennan Road at Peyton Highway. Historic flows from Basin OA2 would be expected to overtop Peyton Highway at this location.

The existing retention area (Retention Pond A) has a storage volume of approximately 36.5 acre-feet between the 5845 and 5857 contours. Based on topographic survey data, overflows from Retention Pond A would drain southeasterly through Basin A1 towards Pond B in the southeastern part of the property. Off-site flows from Basins OA1 and OA2 combine with on-site flows from Basin A, and the combined flows are routed through Pond A to Design Point #A1, with calculated historic peak flows (SCS Method) of $Q_5 = 4.1$ cfs and $Q_{100} = 216.6$ cfs.

These historic flows have been calculated using an SCS Curve Number of 50 for the major off-site basins (OA1 and OB1) recognizing the existence of several upstream (off-site) retention pond areas.

Off-site drainage from the large northwesterly Basin OB1 crosses Drennan Road at an existing 18-inch CMP culvert crossing, which would be expected to overtop during large storm events. Off-site Basin OB1 discharges historic peak flows of $Q_5 = 38.7$ cfs and $Q_{100} = 289.4$ cfs (SCS Method), flowing southeasterly into Basin B.

There is currently no culvert crossing where drainage from off-site Basin OB2 crosses an existing low point in Drennan Road at the north boundary of the site. Based on the topography, overflows from Basin OB2 would overtop Drennan Road and flow south into Basin B. Off-site Basin OB2 contributes historic peak flows of $Q_5 = 22.3$ cfs and $Q_{100} = 54.6$ cfs (Rational Method), entering the north boundary of the Silverado Ranch property.

Calculations for potential widths of roadway overtopping at the existing off-site drainage basin crossings of Drennan Road along the north boundary of the subdivision (Design Points OA1, OB1 and OB2) are enclosed in Appendix C. As calculated in the appendix, the 100-year depths at these drainage crossings are anticipated to remain less than 12 inches, which is within allowable standards for roadway crossings. Based on field observations at the site, the theoretical 100-year flows calculated in this report would appear to be extremely conservative (high) as indicated by the lack of any significant defined drainage channels approaching these crossings and the existence of only 18-inch diameter culverts with no apparent signs of historic overtopping.

The easterly retention area (Retention Pond B) within the Silverado Ranch site has a storage volume of approximately 74.3 acre-feet between the 5790 and 5796 contours. In the event the existing retention pond was completely full, overflows from this retention area would drain towards the southeast corner of the site. Flows from Basins OA1, OA2, A1, OB1, OB2, and B combine at Design Point #2, with calculated historic peak flows (SCS Method) of $Q_5 = 0.0$ cfs (completely retained during the 5-year event) and $Q_{100} = 355.6$ cfs.

Basin A2 comprises the drainage area in the southwest corner of the property, which flows towards Design Point #1 at the southern boundary of the site, with calculated historic peak flows (Rational Method) of $Q_5 = 23.9$ cfs and $Q_{100} = 60.1$ cfs.

Basin C comprises the area in the southeasterly part of the overall Silverado site (not part of Filing No. 1), which flows towards Design Point #3 at the southeast corner of the site, with calculated historic peak flows (Rational Method) of $Q_5 = 6.8$ cfs and $Q_{100} = 17.1$ cfs.

Basin D comprises the area in the northeast corner of the overall Silverado site (not part of Filing No. 1), which flows towards Design Point #4 near the northeast corner of the site, with calculated historic peak flows (Rational Method) of $Q_5 = 8.5$ cfs and $Q_{100} = 20.2$ cfs.

2. Developed Drainage Conditions

The developed drainage basins and projected flows are shown in the Developed Drainage Plan (Figure D1, Appendix F). In the developed condition, Basin A has been divided into sub-basins A1-A5 by the proposed public road layout within the site. Off-site flows from Basins OA1 and OA2 will continue to flow into the existing Retention Pond A within Basin A1 at the northwest corner of the site.

As detailed in Appendix D, in order to meet retention pond design criteria, the calculated 100-year, 24-hour retention storage volume required for Pond A would be 162.3 acre-feet. The available retention storage volume up to the 5857 contour level within Basin A is approximately 36.5 acre-feet (without freeboard), so major storm events would be expected to overtop Pond A and overflow southeasterly following the existing improved drainage channels and existing drainage swales downstream.

Off-site flows from Basins OA1 and OA2 will combine with flows from Basin A1 at Design Point #A1, with developed peak flows of $Q_5 = 7.2$ cfs and $Q_{100} = 222.0$ cfs (SCS Method).

Silverado Ranch Filing No. 1 will include construction of Culverts A6 and B1 to convey site drainage across the new public roads (see hydraulic calculations in Appendix C). Culvert A6 is an 18" RCP culvert crossing Drover Canyon Lane on the north side of the intersection with Silverado Hill Loop. Culvert B1 is a 24" RCP culvert crossing Silverado Hill Loop on the south side of Lot 5.

Overflows from the existing Retention Pond A will ultimately cross Silverado Hill Loop west of Filing No. 1, and these flows will continue southeasterly through Basin A5, ultimately flowing to Pond B. Recognizing that some rough grading of Silverado Hill Loop was previously performed at this site, an interim graded spillway will be provided at Design Point A1 to allow for potential overflows from Pond A to overtop the rough-graded roadway and flow southeasterly through Channel A1 towards Pond B. Calculations for the interim spillway are enclosed in Appendix C. Future final design of the roadway and culvert crossing at Design Point A1 will include adequate provisions to safely convey overflows to the downstream drainage channel flowing to Pond B.

Off-site flows from Basin OB1 will overtop Drennan Road and flow easterly through Basin B1 to the existing natural drainage swale flowing south into Retention Pond B (within Basin B6). Filing No. 1 will include construction of Channel OB1 to divert the off-site drainage from Basin OB1 easterly along the south side of Drennan Road beyond the limits of Filing No. 1, allowing the off-site drainage to follow the general historic drainage pattern within the property, flowing southeasterly to Retention Pond B.

During future phases of the subdivision, culverts will be installed at Design Point B6 where flows from this major basin cross the new public roadway. Off-site flows from Basin OB2 will also overtop Drennan Road and flow southeasterly to Retention Pond B.

Flows from Basins OA1-OA2, A1, A5, A6, OB1, and OB2 will continue to combine with on-site flows from Basins B1-B7 at Design Point #2, with developed peak flows of $Q_5 = 12.1$ cfs and $Q_{100} = 342.2$ cfs (SCS Method). Based on the significant existing retention storage volume within Pond B, the developed flow impact at Design Point #2 is negligible.

Retention Pond B has a calculated storage volume of 77.1 acre-feet (without freeboard) between the existing bottom elevation of 5790.0 and the overflow elevation of 5796.0 (matching existing). With ultimate development of the subdivision, a limited amount of pond grading will be performed to ensure adequate buildable areas within Lots 30-32 while maintaining the historic storage volume in Pond B. As detailed in Appendix E, in order to meet retention pond design criteria, the calculated 100-year, 24-hour retention volume required at Design Point #2 would be 352.5 acre-feet, which is much greater than the available pond volume. Based on the limited storage volume in comparison to the large off-site drainage basin sizes, major storm events would be expected to overtop Pond B and overflow southeasterly following the existing drainage swales downstream.

Developed Basins A2-A4 will continue to follow historic drainage patterns in the southwesterly part of the site, flowing towards Design Point #1 at the southern site boundary, with calculated developed peak flows (Rational Method) of $Q_5 = 27.4$ cfs and $Q_{100} = 64.1$ cfs.

Silverado Ranch Filing No. 1 will not have any developed drainage impact within Basins C or D.

C. Comparison of Developed to Historic Discharges

Based on the hydrologic calculations in Appendix B, the proposed development will result in calculated developed flows marginally exceeding historic flows from the parcel, although the increases are relatively insignificant considering the large size of the off-site tributary drainage areas relative to the on-site development area. The comparison of developed to historic discharges at key design points is summarized as follows:

Design Point	Historic Flow			Developed Flow			Comparison of Developed to Historic Flow (Q ₁₀₀)
	Area (ac)	Q ₅ (cfs)	Q ₁₀₀ (cfs)	Area (ac)	Q ₅ (cfs)	Q ₁₀₀ (cfs)	
1	56.3	23.9	60.1	47.4	27.4	64.1	107% (increase + 4.0 cfs)
2	5755	0	355.6	5754	12.1	342.2	96% (decrease – 13.4 cfs)

Based on the large size of the off-site basins impacting this site in comparison to the rural nature of the proposed development, developed flow impacts from the project will be minimal. The developed drainage impacts will be attenuated through preservation of the existing on-site stormwater retention ponds.

D. Retention Ponds

Developed runoff impacts from the project will be mitigated by preservation of two existing stormwater retention ponds within the site. The existing retention ponds provide sufficient volume to meet stormwater detention requirements, mitigating developed drainage impacts from the subdivision.

Stormwater retention storage capacity has been evaluated at each of the existing retention ponds based on Denver Urban Drainage and Flood Control District (UDFCD) design criteria. The UDFCD criteria require stormwater retention ponds to have a storage volume of 1.5 times the 24-hour, 100-year volume. Detention volume sizing parameters are summarized as follows (see details in Appendix D):

Pond	Required 100-Year Retention Volume (ac-ft)	Existing Storage Volume w/ 1' freeboard (ac-ft)
A (DP-A1)	162.3	28.9
B (DP2)	352.5	57.8

As indicated in the table above, based on the large off-site drainage areas flowing into the site, Ponds A and B do not have sufficient capacity to meet the recommended stormwater retention volume, and as such both ponds would be anticipated to overtop during major storm events. Based

on the relatively small impact of developed flows from this site in comparison to the large off-site drainage areas flowing through the site, together with the routing of flows through the existing retention ponds, the impact of developed flows from the Silverado Ranch Subdivision is negligible. As indicated in the HEC-HMS modeling in Appendix C1, The SCS flow calculations indicate no increase in developed flows at Design Point #2 based on maintaining the existing retention storage volume.

Retention pond drain times have been evaluated based on percolation testing performed by Front Range Geotechnical, Inc. As detailed in Appendix D, Pond A is projected to have a drain time of 23.9 hours and Pond B is projected to have a drain time of 14 hours.

Overflow swales will be provided downstream of each pond to convey major storm discharges or back-to-back storm events following historic drainage patterns. 15-foot wide gravel maintenance access roads will be provided for all stormwater retention facilities. The proposed retention ponds will be privately maintained by the subdivision homeowners' association, and a detention pond maintenance agreement will be filed with El Paso County during the final platting stage of the project. Provisions for maintenance of the retention ponds are included in the BMP operation and maintenance (O&M) manual provided in Appendix D.

E. On-Site Drainage Facility Design

Developed sub-basins and proposed drainage improvements are depicted in the enclosed Drainage Plan (Sheet D1). In accordance with El Paso County standards, the interior roads on this relatively flat parcel will be graded with a minimum longitudinal slope of 1.0 percent.

On-site drainage facilities will consist of roadside ditches, grass-lined channels, and culverts. Hydraulic calculations for preliminary sizing of major on-site drainage facilities are enclosed in Appendix D, and design criteria are summarized as follows:

1. Culverts

The internal road system will be graded to drain roadside ditches to low points along the road profile, where cross-culverts will convey developed flows into grass-lined channels following historic drainage paths. Culvert pipes have been specified as reinforced concrete pipe (RCP) with a minimum diameter of 18-inches. Culvert sizes have been identified based on a maximum headwater-to-depth ratio (HW/D) of 1.0 for the minor (5-year) design storm. Final culvert design has been performed utilizing the FHWA HY-8 software package to perform a detailed analysis of inlet and outlet control conditions, meeting El Paso County criteria for allowable overtopping. Riprap outlet protection will be provided at all culverts. Culvert sizes are detailed in the "Culvert Sizing Table" in Appendix C.

APPENDIX D

RETENTION POND CALCULATIONS AND

OPERATION & MAINTENANCE MANUAL

consequences of a facility failure. Generally, embankments should be fortified against and/or have spillways that, at a minimum, are capable of conveying the total not-routed peak 100-year storm discharge from a fully developed total tributary catchment, including all off-site areas, if any. Detailed analysis, however, of downstream hazards should be performed and may indicate that the embankment protection and/or spillway design needs to be for events much larger than the 100-year design storm.

3.3.4 Retention Facilities

A retention facility (a basin with a zero release rate or a very slow release rate) is used when there is no available formal downstream drainageway, or one that is grossly inadequate. When designing a retention facility, the hydrologic basis of design is difficult to describe because of the stochastic nature of rainfall events. Thus, sizing for a given set of assumptions does not ensure that another scenario produced by nature (e.g., a series of small storms that add up to large volumes over a week or two) will not overwhelm the intended design. For this reason, retention basins are not recommended as a permanent solution for drainage problems. They have been used in some instances as temporary measures until a formal system is developed downstream. When used, they can become a major nuisance to the community due to problems that may include mosquito breeding, safety concerns, odors, etc.

When a retention basin is proposed as a temporary solution, the District recommends that it be sized to capture, as a minimum, the runoff equal to 1.5 times the 24-hour, 100-year storm plus 1-foot of freeboard. The facility also has to be situated and designed so that when it overtops, no human-occupied or critical structures (e.g., electrical vaults, homes, etc.) will be flooded, and no catastrophic failure at the facility (e.g., loss of dam embankment) will occur. It is also recommended that retention facilities be as shallow as possible to encourage infiltration and other losses of the captured urban runoff. When a trickle outflow can be accepted downstream or a small conduit can be built, provided and sized it in accordance with the locally approved release rates, preferably capable of emptying the full volume in 14 days or less.

3.4 Reservoir Routing of Storm Hydrographs for Sizing of Storage Volumes

The reservoir routing procedure for the sizing of detention storage volumes is more complex and time consuming than the use of empirical equations, FAA procedure or the simplified *Full Spectrum Detention* protocol. Its use requires the designer to develop an inflow hydrograph for the facility. This is generally accomplished using CUHP and UDSWM computer models as described in the RUNOFF chapter of this *Manual*. The hydrograph routing sizing method is an iterative procedure that follows the steps detailed below (Guo 1999b).

1. **Select Location**: The detention facility's location should be based upon criteria developed for the specific project. Regional storage facilities are normally placed where they provide the greatest overall benefit. Multi-use objectives such as the use of the detention facility as a park or for open space, preserving or providing wetlands and/or wildlife habitat, or others uses and community

SILVERADO RANCH - EXISTING CONDITIONS
POND A STAGE-STORAGE-DISCHARGE TABLE

POND DEPTH (FT)	SURFACE AREA (SF)	SURFACE AREA (AC)	INCREMENTAL VOLUME (CF)	TOTAL VOLUME (CF)	TOTAL VOLUME (AF)	SPILLWAY WEIR L (FT)	SPILLWAY WEIR H (FT)	DISCHARGE (CFS)
5845	5,629	0.13	0	0	0			0
5846	27,321	0.63	16475	16475	0.38			0.00
5848	53,233	1.22	80554	97029	2.23			0.00
5850	88,319	2.03	141552	238581	5.48			0.00
5852	130,854	3.00	219173	457754	10.51			0.00
5853	160,460	3.68	145657	603411	13.85			0.00
5854	190,065	4.36	175262.5	778673.5	17.88			0.00
5855	239,746	5.50	214905.5	993579	22.81			0.00
5856	289,427	6.64	264586.5	1258166	28.88			0.00
5857	377,975	8.68	333701	1591867	36.54			0.00
5858	477,083	10.95	427529	2019396	46.36	500.00	0.90	1280.72
5860	601,129	13.80	1078212	3097608	71.11	750.00	2.90	11111.67

STORAGE VOLUME (1' FREEBOARD)
EXISTING OVERFLOW

SILVERADO RANCH - PROPOSED / DEVELOPED CONDITIONS
POND A STAGE-STORAGE-DISCHARGE TABLE

POND DEPTH (FT)	SURFACE AREA (SF)	SURFACE AREA (AC)	INCREMENTAL VOLUME (CF)	TOTAL VOLUME (CF)	TOTAL VOLUME (AF)	SPILLWAY WEIR L (FT)	SPILLWAY WEIR H (FT)	DISCHARGE (CFS)
5845	5,629	0.13	0	0	0			0
5846	27,321	0.63	16475	16475	0.38			0.00
5848	53,233	1.22	80554	97029	2.23			0.00
5850	88,319	2.03	141552	238581	5.48			0.00
5852	130,854	3.00	219173	457754	10.51			0.00
5853	160,460	3.68	145657	603411	13.85			0.00
5854	190,065	4.36	175262.5	778673.5	17.88			0.00
5855	239,746	5.50	214905.5	993579	22.81	45.00	1.00	135.00
5856	289,427	6.64	264586.5	1258166	28.88	53.00	2.00	449.72
5857	377,975	8.68	333701	1591867	36.54	61.00	3.00	950.90
5858	477,083	10.95	427529	2019396	46.36	500.00	4.00	12000.00
5860	601,129	13.80	1078212	3097608	71.11	750.00	5.00	25155.76

PROPOSED OVERFLOW
STORAGE VOLUME (1' FREEBOARD)
EXISTING OVERFLOW

DISCHARGE CALCULATION:
WEIR FLOW: $Q = 3.0 * L * H^{1.5}$ (BROAD-CRESTED WEIR)

RETENTION POND - BASIN A

REQUIRED 100-YEAR POND VOLUME, V:

$$V = Q * A * 1.5 \quad (\text{RETENTION POND VOLUME, ACRE-FEET})$$
$$= (100\text{-YEAR; 24-HOUR RUNOFF}) * (\text{BASIN AREA}) / (12 \text{ IN/FT}) * 1.5$$

(UDFCD RETENTION STORAGE CRITERIA)

ASSUMPTIONS:

A =	2722.5 AC	(DRAINAGE BASIN AREA, AC)
CN =	50.287	(WEIGHTED CURVE NUMBER FROM CN-SPREADSHEET)
P =	4.4 IN	(100-YEAR; 24-HOUR STORM RAINFALL PER EL PASO COUNTY)
S =	9.89	$S = (1000/CN)^{-10}$
Q =	0.48 IN	$Q = (P - 0.2S)^2 / (P + 0.8S)$ (100-YEAR; 24-HOUR STORM RUNOFF PER SCS TR-55)

REQUIRED 100-YEAR RETENTION VOLUME, V:

V = 162.30 AC-FT

AVAILABLE RETENTION POND VOLUME:

V = 36.50 AC-FT (TOTAL)
V = 28.90 AC-FT (W/ 1' FREEBOARD)

RETENTION POND DRAIN TIME:

DEPTH = 9 FEET
PERC RATE = 13.3 MIN/IN (TEST HOLE P-1)
DRAIN TIME = 23.9 HOURS

SILVERADO RANCH - EXISTING CONDITIONS
POND B STAGE-STORAGE-DISCHARGE TABLE

POND DEPTH (FT)	SURFACE AREA (SF)	SURFACE AREA (AC)	INCREM. VOLUME (CF)	TOTAL VOLUME (CF)	TOTAL VOLUME (AF)	SPILLWAY WEIR L (FT)	SPILLWAY WEIR H (FT)	DISCHARGE (CFS)	
5790	83,163	1.91	0	0	0			0.00	
5792	441,955	10.15	525118	525118	12.06			0.00	
5794	657,591	15.10	1099546	1624664	37.30			0.00	
5795	805484	18.49	731537.5	2356202	54.09			0.00	STORAGE VOLUME (1' FREEBOARD)
5796	953,377	21.89	879430.5	3235632	74.28			0.00	EXISTING OVERFLOW
5798	1,278,276	29.35	2231653	5467285	125.51	400.00	1.70	2659.83	

SILVERADO RANCH - PROPOSED CONDITIONS
POND B STAGE-STORAGE-DISCHARGE TABLE

POND DEPTH (FT)	SURFACE AREA (SF)	SURFACE AREA (AC)	INCREM. VOLUME (CF)	TOTAL VOLUME (CF)	TOTAL VOLUME (AF)	SPILLWAY WEIR L (FT)	SPILLWAY WEIR H (FT)	DISCHARGE (CFS)	
5790	83,163	1.91	0	0	0			0.00	
5792	441,955	10.15	525118	525118	12.06			0.00	
5794	762,220	17.50	1204175	1729293	39.70			0.00	
5795	814,212	18.69	788216	2517509	57.79			0.00	STORAGE VOLUME (1' FREEBOARD)
5796	871,277	20.00	842744.5	3360254	77.14			0.00	OVERFLOW
5798	1,278,276	29.35	2149553	5509807	126.49	400.00	1.70	2659.83	

DISCHARGE CALCULATION:

WEIR FLOW: $Q = 3.0 * L * H^{1.5}$

(BROAD-CRESTED WEIR)

RETENTION POND - BASIN B

REQUIRED 100-YEAR POND VOLUME, V:

$$V = Q * A * 1.5 \quad (\text{RETENTION POND VOLUME, ACRE-FEET})$$
$$= (100\text{-YEAR; 24-HOUR RUNOFF}) * (\text{BASIN AREA}) / (12 \text{ IN/FT}) * 1.5$$

(UDFCD RETENTION STORAGE CRITERIA)

ASSUMPTIONS:

A =	5729.2 AC	(DRAINAGE BASIN AREA, AC)
CN =	50.636	(WEIGHTED CURVE NUMBER FROM CN-SPREADSHEET)
P =	4.4 IN	(100-YEAR; 24-HOUR STORM RAINFALL PER EL PASO COUNTY)
S =	9.75	$S = (1000/CN)-10$
Q =	0.49 IN	$Q = (P - 0.2S)^2 / (P + 0.8S)$ (100-YEAR; 24-HOUR STORM RUNOFF PER SCS TR-55)

CALCULATED 100-YEAR POND VOLUME, V:

V = 352.45 AC-FT

AVAILABLE RETENTION POND VOLUME:

V = 77.10 AC-FT (TOTAL)
V = 57.80 AC-FT (W/ 1' FREEBOARD)

RETENTION POND DRAIN TIME:

DEPTH = 4 FEET
PERC RATE = 17.6 MIN/IN (AVG. OF P-5, P-6, P-12, P-13, P-14)
DRAIN TIME = 14 HOURS

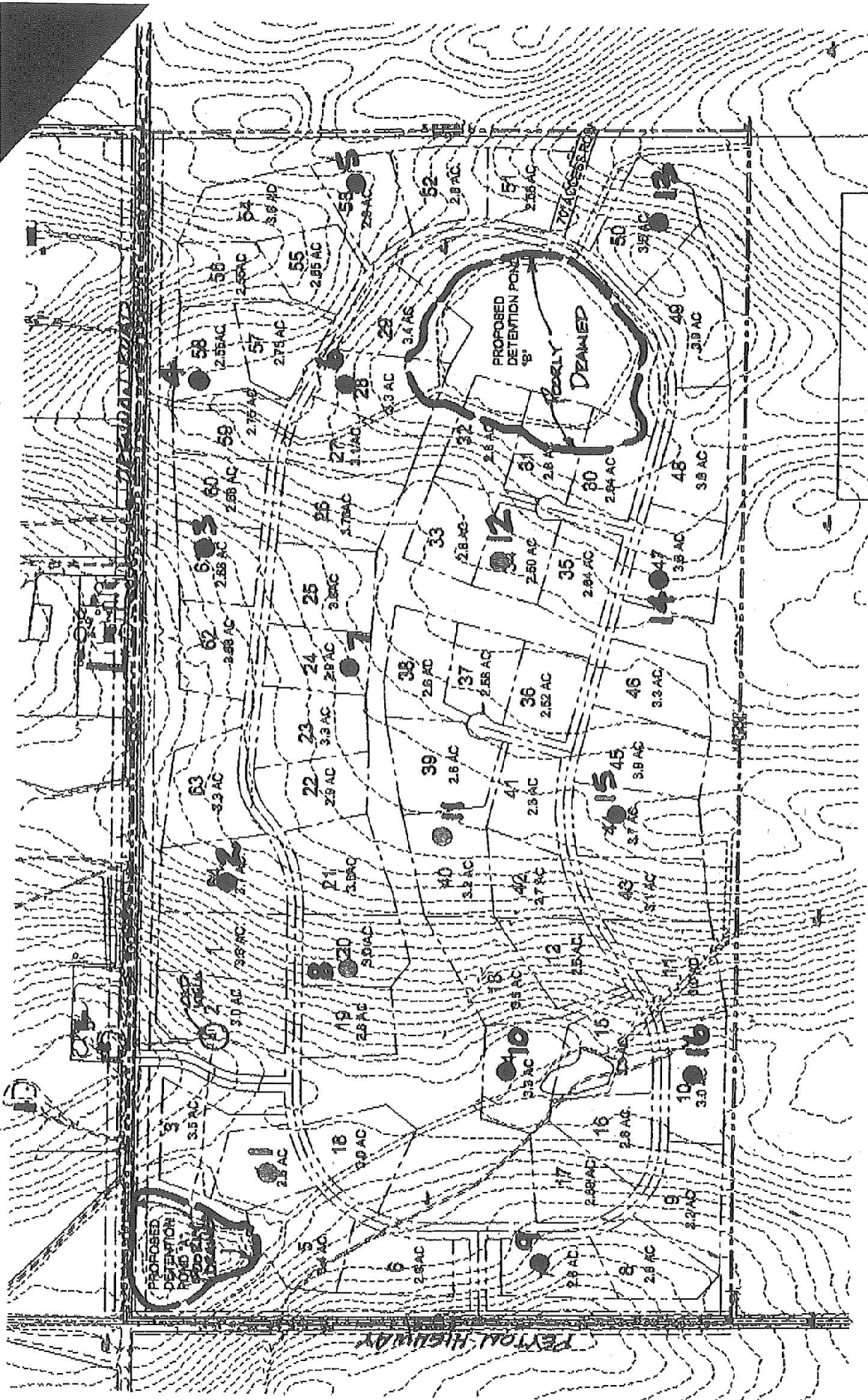

NOTE: ENTIRE SITE UNDERLAIN BY EOLIAN SAND

● - APPROX. LOCATION OF PERCOLATION TEST

PRELIMINARY GEOLOGIC MAP

FIGURE 2



**FRONT RANGE
GEOTECHNICAL
INC.**

DRILL LOGS

JOB#: 15365	DEPTH (in ft.)	SYMBOL	SAMPLES	BLOW COUNT	WATER %	SOIL TYPE
TEST BORING NO.: P-1						
DATE: 08-24-06						
0"-4" <u>SANDY LOAM</u>	0					
4"-10' <u>SAND</u>	4					
fine-medium grained						
low density						
low moisture content						
low clay content						
non-plastic						
buff color						
	2					
	4					
	6					
	8					
	10					
	12					
	14					
	16					
	18					
	20					
[Perc rate: 1" in 13.3 minutes]						

JOB#: 15365	DEPTH (in ft.)	SYMBOL	SAMPLES	BLOW COUNT	WATER %	SOIL TYPE
TEST BORING NO.: P-2						
DATE: 08-24-06						
0"-6" <u>SANDY LOAM</u>	0					
6"-10' <u>SAND</u>	6					
fine grained						
low density						
low-mod moisture content						
low clay content						
low plasticity						
<u>slight inc. w/depth</u>						
<u>light-brown color becomes buff @ 7'</u>						
	2					
	4					
	6					
	8					
	10					
	12					
	14					
	16					
	18					
	20					
[Perc rate: 1" in 12.3 minutes]						



**FRONT RANGE
GEOTECHNICAL
INC.**

DRILL LOGS

JOB#:	DEPTH (in ft.)	SYMBOL	SAMPLES	BLOW COUNT	WATER %	SOIL TYPE
15365						
TEST BORING NO.: P-5						
DATE: 08-24-06						
0"-4" <u>SANDY LOAM</u>	0					
4"-6" <u>SAND</u>	2					
fine grained						
low density						
low-mod moisture content	4					
low clay content						
low plasticity	6					
light-brown color	8					
6'-12' <u>SAND</u>	10					
fine-medium grained						
low-mod density	12					
low-mod moisture content						
low clay content	14					
low plasticity	16					
buff color	18					
	20					
[Perc rate: 1" in 13.3 minutes]						

JOB#:	DEPTH (in ft.)	SYMBOL	SAMPLES	BLOW COUNT	WATER %	SOIL TYPE
15365						
TEST BORING NO.: P-6						
DATE: 08-24-06						
0"-3" <u>SANDY LOAM</u>	0					
3"-3.5" <u>SAND</u>	2					
fine grained						
low density	4					
low moisture content						
low clay content	6					
low plasticity	8					
brown color	10					
3.5'-10' <u>SAND</u>	12					
fine-medium grained						
low-mod density	14					
low-mod moisture content	16					
moderate clay content	18					
moderate plasticity	20					
buff color						
[Perc rate: 1" in 22.9 minutes]						



**FRONT RANGE
GEOTECHNICAL
INC.**

DRILL LOGS

JOB#: 15365	DEPTH (in ft.)	SYMBOL	SAMPLES	BLOW COUNT	WATER %	SOIL TYPE
TEST BORING NO.: P-11						
DATE: 08-24-06						
0"-6" <u>SANDY LOAM</u>	0					
6"-8' <u>SAND</u>	2					
fine-medium grained						
low density						
low moisture content						
low clay content						
low plasticity						
brown color						
8'-12' <u>SAND</u>	8					
fine grained	10					
low density						
low moisture content						
low clay content						
low plasticity						
buff color						
[Perc rate: 1" in 20 minutes]	20					

JOB#: 15365	DEPTH (in ft.)	SYMBOL	SAMPLES	BLOW COUNT	WATER %	SOIL TYPE
TEST BORING NO.: P-12						
DATE: 08-24-06						
0"-5" <u>SANDY LOAM</u>	0					
6"-11' <u>SAND</u>	2					
fine grained						
low density						
low-mod moisture content						
<u>increases w/depth</u>						
low clay content						
low plasticity						
brown color						
<u>becomes buff @ 6'</u>						
<u>becomes brown @ 8'</u>						
<u>weakly oxidized @ 8'</u>						
[Perc rate: 1" in 16 minutes]	20					



**FRONT RANGE
GEOTECHNICAL
INC.**

DRILL LOGS

JOB#: 15365	DEPTH (in ft.)	SYMBOL	SAMPLES	BLOW COUNT	WATER %	SOIL TYPE
TEST BORING NO.: P-13						
DATE: 08-24-06						
0"-4" SANDY LOAM	0					
4"-12' SAND	4					
fine grained	2					
low-moderate density	4			12	4.0	SM
low-mod moisture content	6					
low clay content	8					
non-plastic	10					
tan color	12					
	14					
	16					
	18					
	20					
[Perc rate: 1" in 26.7 minutes]						

JOB#: 15365	DEPTH (in ft.)	SYMBOL	SAMPLES	BLOW COUNT	WATER %	SOIL TYPE
TEST BORING NO.: P-14						
DATE: 08-24-06						
0"-4" SANDY LOAM	0					
4"-11' SAND	4					
fine grained	2					
low density	4					
low-mod moisture content	6					
low clay content	8					
low plasticity	10					
tan color	12					
oxidized @ 3'	14					
	16					
	18					
	20					
[Perc rate: 1" in 8.9 minutes]						

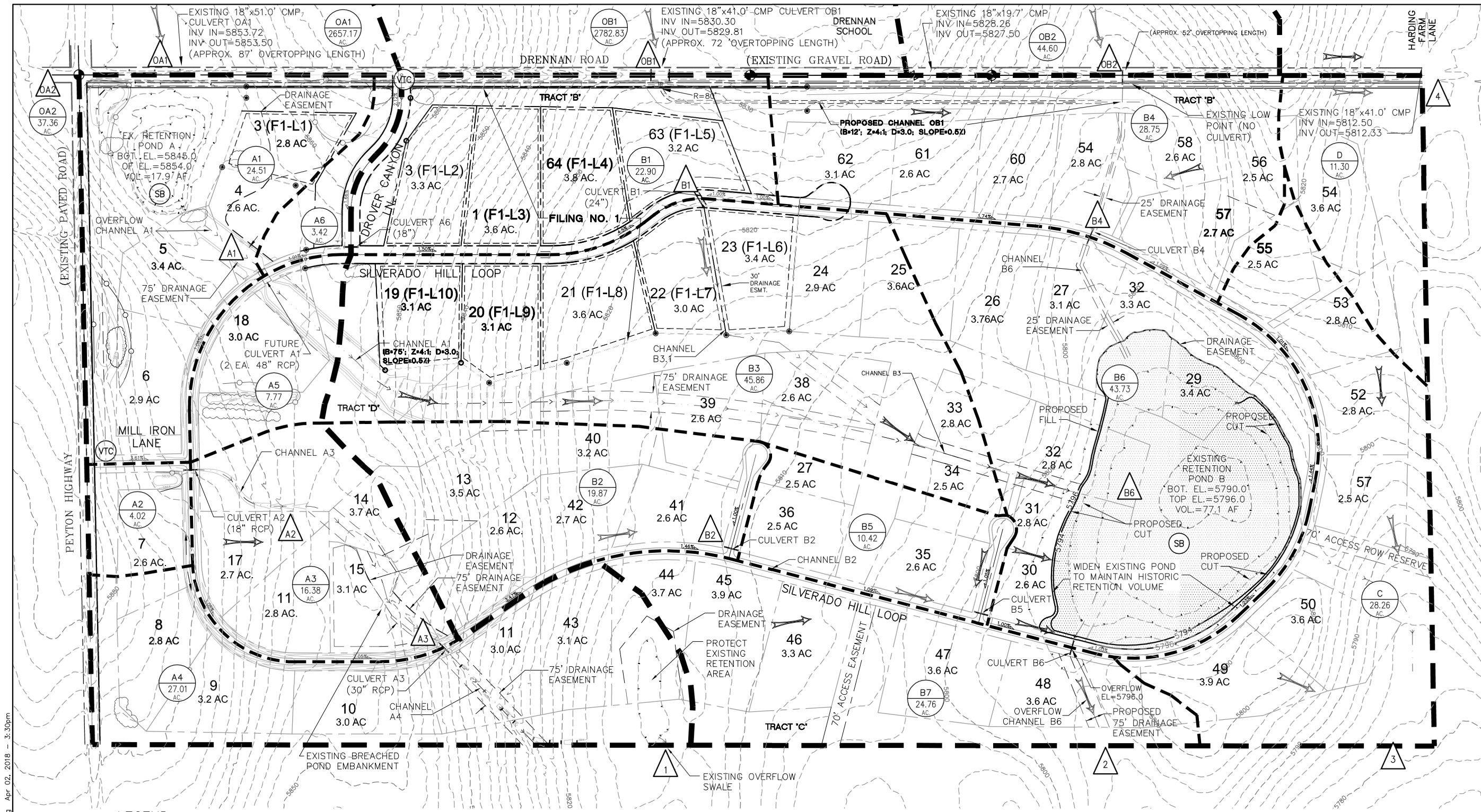

C:\Civil3D\2018\projects\080603\silverado-mp\dwg\Drainage\1.dwg Apr. 02, 2018 - 3:30pm

LEGEND

- FILING LIMITS
- MAJOR DRAINAGE BASIN BOUNDARY
- MINOR DRAINAGE BASIN BOUNDARY
- 6520 EXISTING CONTOUR
- FLOW DIRECTION ARROW
- FLOWLINE
- DESIGN POINT
- DEVELOPED BASIN DESIGNATION
- BASIN AREA (ACRES)

EROSION CONTROL LEGEND:

- SILT FENCE
- VEHICLE TRACKING CONTROL PAD
- TEMPORARY SEED AND MULCH ON DISTURBED AREAS
- INLET PROTECTION
- SEDIMENT BASIN
- EROSION CONTROL BLANKETS

SUMMARY HYDROLOGY TABLE

DESIGN POINT	Q ₅ (CFS)	Q ₁₀₀ (CFS)
A2	3.5	8.0
A3	13.6	31.5
1	27.4	64.1
OA1	34.9	263.1
OA2	4.2	28.6
A1	7.2	222.0
OB1	39.0	291.5
OB2	22.3	54.6
B1	19.2	45.1
B2	12.4	29.2
B4	41.9	299.2
B5	15.5	36.8
B6	18.7	77.9
2	12.1	342.2
3	12.3	28.9
4	9.8	22.7

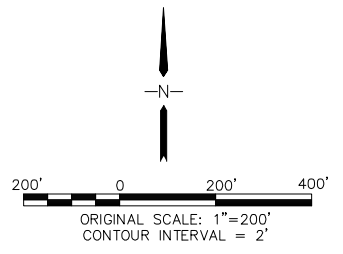

SILVERADO RANCH

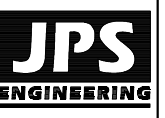

19 E. Willamette Ave.
Colorado Springs, CO 80903
PH: 719-477-9429
FAX: 719-471-0766
www.jpseng.com



CALL UTILITY NOTIFICATION CENTER OF COLORADO
1-800-922-1987
CALL 2-BUSINESS DAYS IN ADVANCE BEFORE YOU DIG, GRADE, OR EXCAVATE FOR THE MARKING OF UNDERGROUND MEMBER UTILITIES.

NO.	REVISION	DATE
1	COUNTY SUBMITTAL	3/30/18

DEVELOPED DRAINAGE PLAN

HORZ. SCALE:	1"=200'	DRAWN:	RMD
VERT. SCALE:	N/A	DESIGNED:	JPS
SURVEYED:	LWA	CHECKED:	JPS
CREATED:	8/28/06	LAST MODIFIED:	4/2/18
PROJECT NO:	080603	MODIFIED BY:	MSP
SHEET:			D1

APPENDIX B

SCS SOILS INFORMATION

J:\psprojects\080603.silverado\dwg\Civil\B-F1.dwg Aug 13, 2009 - 11:01am

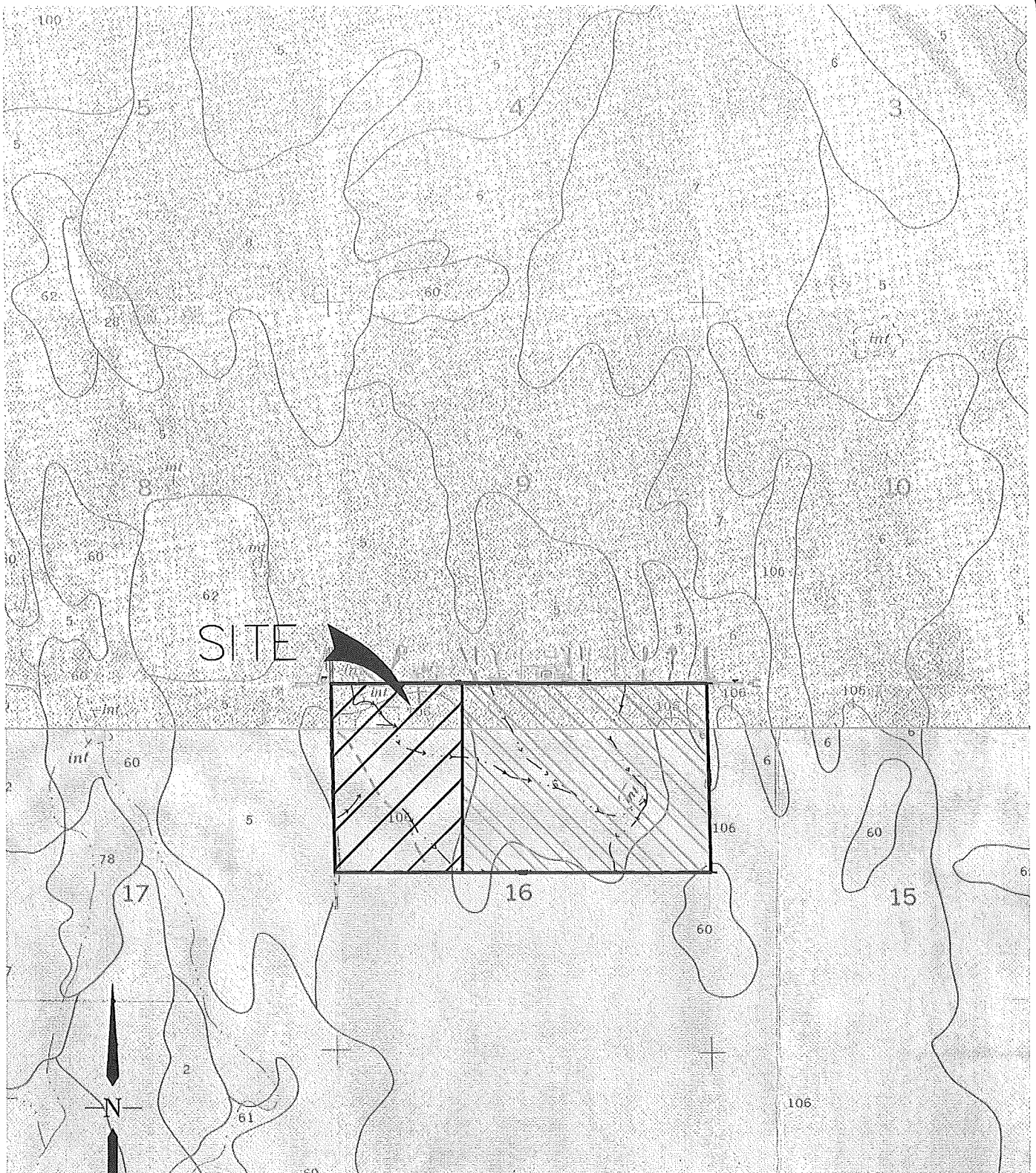

SCALE: 1"=2000'

(EL PASO COUNTY SCS SHEETS NO. 19 & 26)

SCS SOILS MAP

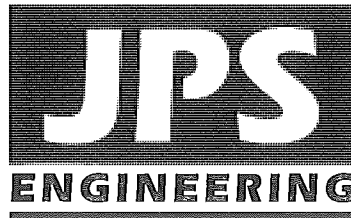

SILVERADO RANCH
SUBDIVISION - FIL. #1

FIGURE B

JPS PROJ NO. 080603

of Calhan; the Corral Bluffs, east of Colorado Springs; the southwestern part of the survey area on Fort Carson; and the old Golden Cycle gold ore processing mill in the western part of Colorado Springs.

Runoff is very rapid, and the hazard of erosion is high. The reaction of the tailings material is slightly acid to extremely acid. Little or no soil development has taken place. Gullying is severe in most areas of Badland.

Vegetation grows only in small patches of soil material in drainageways and in some of the less eroded areas. The sloping part of Badland is extremely gullied and lacks vegetation.

Most areas of Badland are used for wildlife habitat. In the mill tailings area in the western part of Colorado Springs, some urban development has taken place in level areas that have had a layer of topsoil applied to the surface. Capability subclass VIIIa.

5—Bijou loamy sand, 1 to 8 percent slopes. This deep, somewhat excessively drained soil is on flood plains, terraces, and uplands. It formed in sandy alluvium and eolian material derived from arkose deposits. Elevation ranges from 5,400 to 6,200 feet. The average annual precipitation is about 13 inches, the average annual air temperature is about 49 degrees F, and the average frost-free period is about 145 days.

Typically, the surface layer is brown loamy sand 8 inches thick. The subsoil is grayish brown sandy loam about 20 inches thick. The substratum is pale brown loamy coarse sand.

Included with this soil in mapping are small areas of Olney sandy loam, 3 to 5 percent slopes; Valent sand, 1 to 9 percent slopes; Vona sandy loam, 3 to 9 percent slopes, and Wigton loamy sand, 1 to 8 percent slopes.

Permeability of this Bijou soil is rapid. Effective rooting depth is 60 inches or more. Available water capacity is moderate. Organic matter content of the surface layer is low. Surface runoff is slow, and the hazards of erosion and soil blowing are severe.

Most areas of this soil are used for range. A small acreage is used for crops grown under sprinkler irrigation.

This soil is not suited to dryfarming, because of the soil blowing hazard. Corn, pasture, and alfalfa are the principal crops grown under irrigation. Corn and pasture require moderate to heavy applications of nitrogen. Alfalfa generally responds to phosphate fertilizer. Some zinc deficiency has been noted on corn. Crop residue management must be used at all times to control soil blowing. Crops that produce little or no residue are not suited to this soil.

Native vegetation is mainly sandreed, sand bluestem, blue grama, and needleandthread. Sand sagebrush makes up only a small part of the total ground cover.

In overgrazed areas mechanical and chemical sagebrush control may be needed. This soil is highly susceptible to soil blowing, and water erosion occurs when the plant cover is inadequate. Interseeding should be used in overgrazed areas. Proper location of livestock watering facilities helps to control grazing.

Windbreaks and environmental plantings are fairly well suited to this soil. Blowing sand and low available water capacity are the principal limitations to the establishment of trees and shrubs. The soil is so loose that trees need to be planted in shallow furrows and plant cover needs to be maintained between the rows. Supplemental irrigation may be needed to insure survival. Trees that are best suited and have good survival are Rocky Mountain juniper, eastern redcedar, ponderosa pine, and Siberian elm. Shrubs that are best suited are skunkbush sumac, lilac, and Siberian peashrub.

This soil is suited to wildlife habitat. It is best suited to habitat for openland and rangeland wildlife. Rangeland wildlife, such as pronghorn antelope, can be encouraged by developing livestock watering facilities, properly managing livestock grazing, and reseeding range where needed.

This soil has good potential for homesites. Shallow excavation is severely limited because cut banks cave in. This soil requires special management practices to reduce water erosion and soil blowing because it is sandy. Capability subclasses VIe, nonirrigated, and IVe, irrigated.

6—Bijou sandy loam, 1 to 3 percent slopes. This deep, well drained soil is on flood plains, terraces, and uplands. It formed in sandy alluvium and in eolian material derived from arkose deposits. Elevation ranges from 5,400 to 6,200 feet. The average annual precipitation is about 13 inches, the average annual air temperature is about 49 degrees F, and the average frost-free period is about 145 days.

Typically, the surface layer is brown sandy loam about 4 inches thick. The subsoil is brown or grayish brown sandy loam about 24 inches thick. The substratum is pale brown loamy coarse sand.

Included with this soil in mapping are small areas of Olney sandy loam, 0 to 3 percent slopes; Vona sandy loam, 1 to 3 percent slopes; and Wigton loamy sand, 1 to 8 percent slopes.

Permeability of this Bijou soil is rapid. Effective rooting depth is 60 inches or more. Available water capacity is moderate. Organic matter content of the surface layer is low. Surface runoff is slow, and the hazards of erosion and soil blowing are moderate.

Most areas of this soil are used for range, but some areas are used for dryland or irrigated farming.

Corn, sorghum, and wheat are the principal nonirrigated crops. Corn, alfalfa, and pasture are the main crops grown under irrigation. Irrigated crops respond to phosphate and nitrogen fertilizer. Dryfarmed corn and sorghum generally respond to nitrogen fertilizer. Management of crop residue is necessary to control soil blowing. Stripcropping helps to control soil blowing. Sprinkler irrigation is the most suitable and widely practiced method of applying water.

Native vegetation is dominantly blue grama, sand dropseed, needleandthread, side-oats grama, and buckwheat.

Seeding is advisable if the range has deteriorated. Seeding the native grasses is a good practice. If the range

managing livestock grazing, and reseeding range where needed.

This soil has good potential for use as homesites. The main limitations of this soil for roads and streets are limited ability to support a load and frost action potential. Roads must be designed to overcome these limitations. This soil should be stabilized after site preparation, and as much of the existing vegetation as possible should be left on the soil. During site preparation, only small areas of this soil should be disturbed at a time. Capability subclass VIe.

106—Wigton loamy sand, 1 to 8 percent slopes. This deep, excessively drained soil formed in noncalcareous, sandy eolian material on dunelike uplands. Elevation ranges from 5,300 to 6,000 feet. The average annual precipitation is about 13 inches, the average annual air temperature is about 49 degrees F, and the average frost-free period is about 145 days.

Typically, the surface layer is brown loamy sand about 8 inches thick. The next layer is brown loamy sand about 11 inches thick. The underlying material is very pale brown sand to a depth of 60 inches or more.

Included with this soil in mapping are small areas of Bijou loamy sand, 1 to 8 percent slopes; Bijou sandy loam, 1 to 3 percent slopes; Bijou sandy loam, 3 to 8 percent slopes; and Valent sand, 1 to 9 percent slopes.

Permeability of this Wigton soil is rapid. Effective rooting depth is 60 inches or more. Available water capacity is low to moderate. Surface runoff is low, the hazard of erosion is moderate to high, and the hazard of soil blowing is high.

This soil is used mostly as rangeland.

If sprinkler irrigation is used, this soil is suited to limited use as cropland and pasture if crop residue is maintained on the surface. Only a very small acreage of this soil is cultivated, and it is used for alfalfa and grasses that are harvested for hay or are grazed by livestock. Nitrogen and phosphorus fertilizer is required for satisfactory yields. The soil is unsuited to nonirrigated crops.

Rangeland vegetation on this soil is mainly sand reedgrass, and bluestem, and needleandthread. Sand sagebrush is present in the stand, but it makes up only a small part of the total ground cover.

Mechanical and chemical methods of sagebrush control may be needed in overgrazed areas. This soil is highly susceptible to soil blowing, and it is subject to water erosion when the plant cover is inadequate. Interseeding is needed in overgrazed areas. Properly locating livestock watering facilities helps to control grazing.

Windbreaks and environmental plantings are fairly well suited to this soil. Blowing sand and low available water capacity are the main limitations for the establishment of trees and shrubs. The soil is so loose that trees need to be planted in shallow furrows and plant cover needs to be maintained between the rows. Supplemental irrigation may be needed to insure survival. Trees that are best suited and have good survival are Rocky Mountain ju-

niper, eastern redcedar, ponderosa pine, and Siberian elm. Shrubs that are best suited are skunkbush sumac, lilac, and Siberian peashrub.

This soil is suited to wildlife habitat. It is best suited to habitat for openland and rangeland wildlife. Rangeland wildlife, such as pronghorn antelope, can be encouraged by developing livestock watering facilities, properly managing livestock grazing, and reseeding range where needed.

The main limitations of this soil for homesites are unstable cut banks during excavation and the hazard of soil blowing. Trenches for pipelines and shallow excavations must be made in such a way that cut banks remain stable, thus providing proper protection for workmen. Special practices must be used to control soil blowing. Only small areas of this soil should be disturbed at a time during construction in order to leave as much vegetation on the surface as possible. Capability subclasses VIe, nonirrigated, and IVe, irrigated.

107—Wiley silt loam, 1 to 3 percent slopes. This deep, well drained soil formed in calcareous, silty eolian material. Elevation ranges from 5,200 to 6,200 feet. The average annual precipitation is about 13 inches, the average annual air temperature is about 49 degrees F, and the average frost-free period is about 145 days.

Typically, the surface layer is pale brown silt loam about 5 inches thick. The subsoil is very pale brown heavy silt loam about 18 inches thick. The substratum is very pale brown silt loam to a depth of 60 inches or more. Visible soft masses of lime are in the lower part of the subsoil and in the substratum.

Included with this soil in mapping are small areas of Fort Collins loam, 0 to 3 percent slopes; Keith silt loam, 0 to 3 percent slopes; and Satanta loam, 0 to 3 percent slopes.

Permeability of this Wiley soil is moderate. Effective rooting depth is 60 inches or more. Available water capacity is high. Surface runoff is slow, the hazard of erosion is slight to moderate, and the hazard of soil blowing is high.

Most areas of this soil are used as rangeland, but a few small areas are dryfarmed.

This soil is well suited to the production of native vegetation suitable for grazing. The native vegetation is mainly blue grama western wheatgrass, sand dropseed, and galleta.

Fencing and properly locating livestock watering facilities help to control grazing. Deferment of grazing may be necessary to maintain a needed balance between livestock use and forage production. In areas where the plant cover has been depleted, pitting can be used to help the native vegetation recover. Chemical control practices may be needed in disturbed areas where dense stands of pricklypear occur. Ample amounts of litter and forage should be left on the soil because of the high hazard of soil blowing.

Windbreaks and environmental plantings generally are well suited to this soil. Summer fallow a year prior to

TABLE 16.--SOIL AND WATER FEATURES

[Absence of an entry indicates the feature is not a concern. See "flooding" in Glossary for definition of terms as "rare," "brief," and "very brief." The symbol > means greater than]

Soil name and map symbol	Hydro-logic group	Flooding			Bedrock		Potential frost action
		Frequency	Duration	Months	Depth	Hardness	
Alamosa: 1-----	C	Frequent-----	Brief-----	May-Jun	In >60	---	High.
Ascalon: 2, 3-----	B	None-----	---	---	>60	---	Moderate.
Badland: 4-----	D	---	---	---	---	---	---
Bijou: 5, 6, 7-----	B	None-----	---	---	>60	---	Low.
Blakeland: 8-----	A	None-----	---	---	>60	---	Low.
19: Blakeland part-	A	None-----	---	---	>60	---	Low.
Fluvaquentic Haplaquolls part-----	D	Common-----	Very brief----	Mar-Aug	>60	---	High.
Blendon: 10-----	B	None-----	---	---	>60	---	Moderate.
Bresser: 11, 12, 13-----	B	None-----	---	---	>60	---	Low.
Brussett: 14, 15-----	B	None-----	---	---	>60	---	Moderate.
Chaseville: 16, 17-----	A	None-----	---	---	>60	---	Low.
118: Chaseville part	A	None-----	---	---	>60	---	Low.
Midway part----	D	None-----	---	---	10-20	Rippable	Moderate.
Columbine: 19-----	A	None to rare	---	---	>60	---	Low.
Connerton: 120: Connerton part-	B	None-----	---	---	>60	---	High.
Rock outcrop part-----	D	---	---	---	---	---	---
Cruckton: 21-----	B	None-----	---	---	>60	---	Moderate.
Cushman: 22, 23-----	C	None-----	---	---	20-40	Rippable	Moderate.
124: Cushman part---	C	None-----	---	---	20-40	Rippable	Moderate.
Kutch part----	C	None-----	---	---	20-40	Rippable	Moderate.
Elbeth: 25, 26-----	B	None-----	---	---	>60	---	Moderate.
127: Elbeth part----	B	None-----	---	---	>60	---	Moderate.

See footnote at end of table.

TABLE 16.--SOIL AND WATER FEATURES--Continued

Soil name and map symbol	Hydro-logic group	Flooding			Bedrock		Potential frost action
		Frequency	Duration	Months	Depth	Hardness	
Tomah: 192, 193:					In		
Tomah part-----	B	None-----	---	---	>60	---	Moderate.
Crowfoot part--	B	None-----	---	---	>60	---	Moderate.
Travessilla: 194:							
Travessilla part-----	D	None-----	---	---	6-20	Hard	Low.
Rock outcrop part-----	D	---	---	---	---	---	---
Truckton: 95, 96, 97-----	B	None-----	---	---	>60	---	Moderate.
198:							
Truckton part--	B	None-----	---	---	>60	---	Moderate.
Blakeland part-	A	None-----	---	---	>60	---	Low.
199, 1100:							
Truckton part--	B	None-----	---	---	>60	---	Moderate.
Bresser part---	B	None-----	---	---	>60	---	Low.
Ustic Torrifluvents: 101-----	B	Occasional----	Very brief----	Mar-Aug	>60	---	Moderate.
Valent: 102, 103-----	A	None-----	---	---	>60	---	Low.
Vona: 104, 105-----	B	None-----	---	---	>60	---	Moderate.
Wigton: 106-----	A	None-----	---	---	>60	---	Low.
Wiley: 107, 108-----	B	None-----	---	---	>60	---	Low.
Yoder: 109, 110-----	B	None-----	---	---	>60	---	Low.

¹This map unit is made up of two or more dominant kinds of soil. See map unit description for the composition and behavior characteristics of the map unit.

APPENDIX C1

HYDROLOGIC CALCULATIONS (SCS METHOD)

TABLE 5-4
 RUNOFF CURVE NUMBERS FOR HYDROLOGIC SOIL
 COVER COMPLEXES - RURAL CONDITIONS
 (Antecedent Moisture Condition II, and Ia = 0.2 S)
 (From: U.S. Dept. of Agriculture,
 Soil Conservation Service, 1977)

Land Use	Cover Treatment or Practice	Hydrologic Condition	Runoff Curve Number by Hydrologic Soil Group			
			A	B	C	D
Fallow	Straight Row	----	77	86	91	94
Row Crops	Straight Row	Poor	72	81	88	91
	Straight Row	Good	67	78	85	89
	Contoured	Poor	70	79	84	88
	Contoured	Good	65	75	82	86
	Cont. & Terraced	Poor	66	74	80	82
	Cont. & Terraced	Good	62	71	78	81
Small Grain	Straight Row	Poor	65	76	84	88
	Straight Row	Good	63	75	83	87
	Contoured	Poor	63	74	82	85
	Contoured	Good	61	73	81	84
	Cont. & Terraced	Poor	61	72	79	82
	Cont. & Terraced	Good	59	70	78	81
Close-seeded legumes 1/ or rotation meadow	straight Row	Poor	66	77	85	89
	straight Row	Good	58	72	81	85
	Contoured	Poor	64	75	83	85
	Contoured	Good	55	69	78	83
	Cont. & Terraced	Poor	63	73	80	83
	Cont. & Terraced	Good	51	67	76	80
Pasture or range		Poor	68	79	86	89
		Fair	49	69	79	84
		Good	39	61	74	80
	Contoured	Poor	47	67	81	88
	Contoured	Fair	25	59	75	83
	Contoured	Good	6	35	70	79
Meadow		Good	30	58	71	78
Woods		Poor	45	66	77	83
		Fair	36	60	73	79
		Good	25	55	70	77
Farmsteads		----	59	74	82	86
Roads (dirt) 2/ (hard surface) 2/		----	72	82	87	89
		----	74	84	90	92

1/ Close-drilled or broadcast
 2/ Including right-of-way

TABLE 5-5
**RUNOFF CURVE NUMBERS FOR HYDROLOGIC SOIL
 COVER COMPLEXES - URBAN AND SUBURBAN CONDITIONS 1/
 (Antecedent Moisture Condition II)
 (From: U.S. Dept. of Agriculture,
 Soil Conservation Service, 1977)**

<u>Land Use</u>	<u>Hydrologic Soil Group</u>			
	<u>A</u>	<u>B</u>	<u>C</u>	<u>D</u>
Open spaces, lawns, parks, golf courses, cemeteries, etc.				
Good condition: grass cover on 75% or more of the area	39*	61	74	80
Fair condition: grass cover on 50% to 75% of the area	49*	69	79	84
Commercial and Business areas (85% Impervious)	89*	92	94	95
Industrial Districts 72% Impervious)	81*	88	91	93
Residential: 2/ <u>Acres per Dwelling Unit</u>				
		<u>Average % Impervious 3/</u>		
1/8 acre or less	65	77*	85	90
1/4 acre	38	61*	75	83
1/3 acre	30	57*	72	81
1/2 acre	25	54*	70	80
1 acre	20	51*	68	79
Paved parking lots, roofs, driveways, etc.	98	98	98	98
Streets and Roads:				
paved with curbs and storm sewers	98	98	98	98
gravel	76*	85	89	91
dirt	72*	82	87	89

1/ For a more detailed description of agricultural land use curve numbers, refer to the National Engineering Handbook (U.S. Dept. of Agriculture, Soil Conservation Service, 1972).

2/ Curve numbers are computed assuming the runoff from the house and driveway is directed towards the street with a minimum of roof water directed to lawns where additional infiltration could occur.

3/ The remaining pervious areas (lawn) are considered to be in good pasture condition for these curve numbers.

* Not to be used wherever overlot grading or filling is to occur.

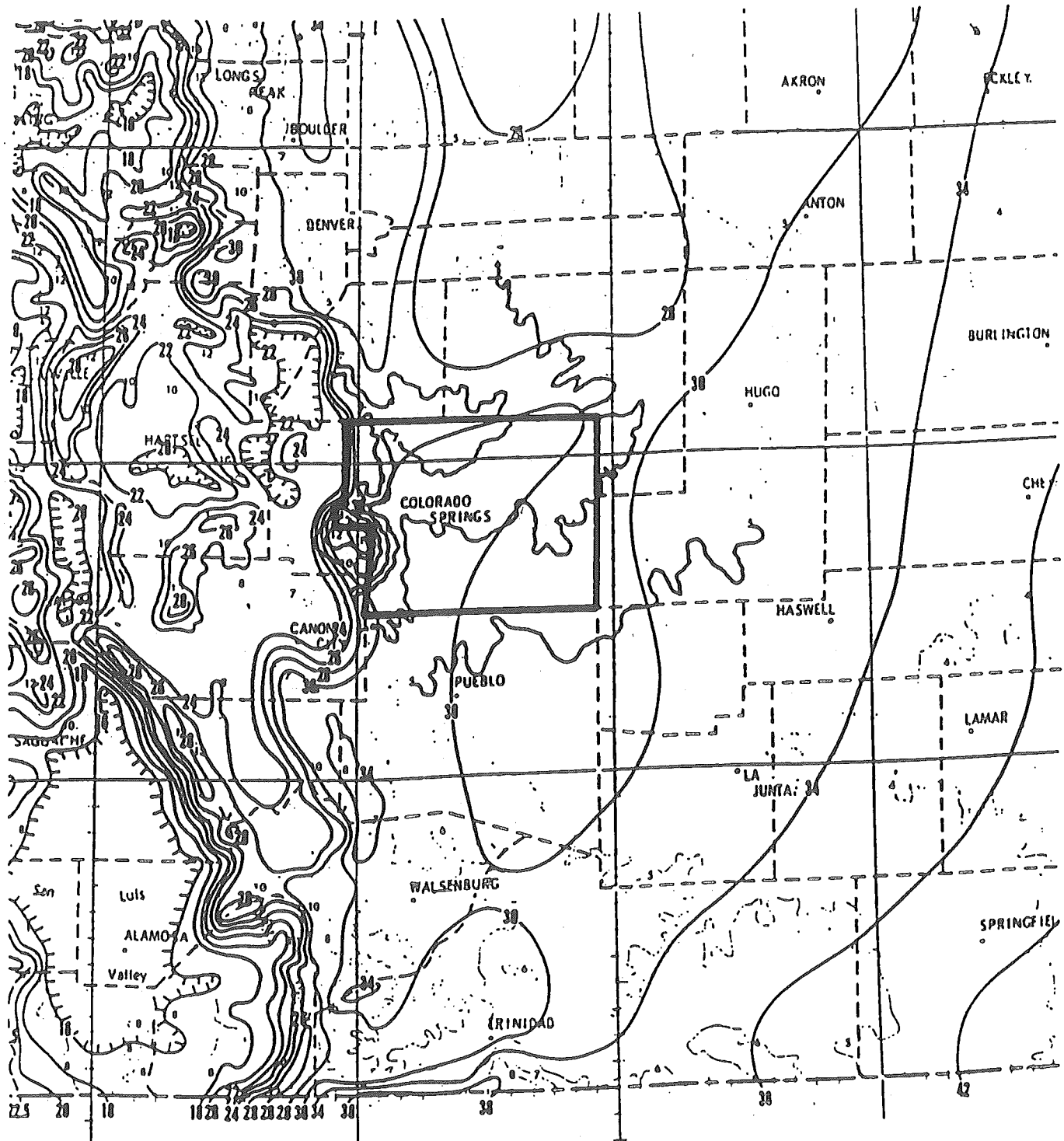

NOAA ATLAS 2, Volume III

Prepared by U.S. Department of Commerce
National Oceanic and Atmospheric Administration
National Weather Service, Office of Hydrology

Prepared for U.S. Department of Agriculture,
Soil Conservation Service, Engineering Division

**ISOPLUVIALS OF 10-YR 24-HR PRECIPITATION
IN TENTHS OF AN INCH**



HDR Infrastructure, Inc.
A Centerra Company

The City of Colorado Springs / El Paso County
Drainage Criteria Manual

Date
OCT. 1987

Figure
A4

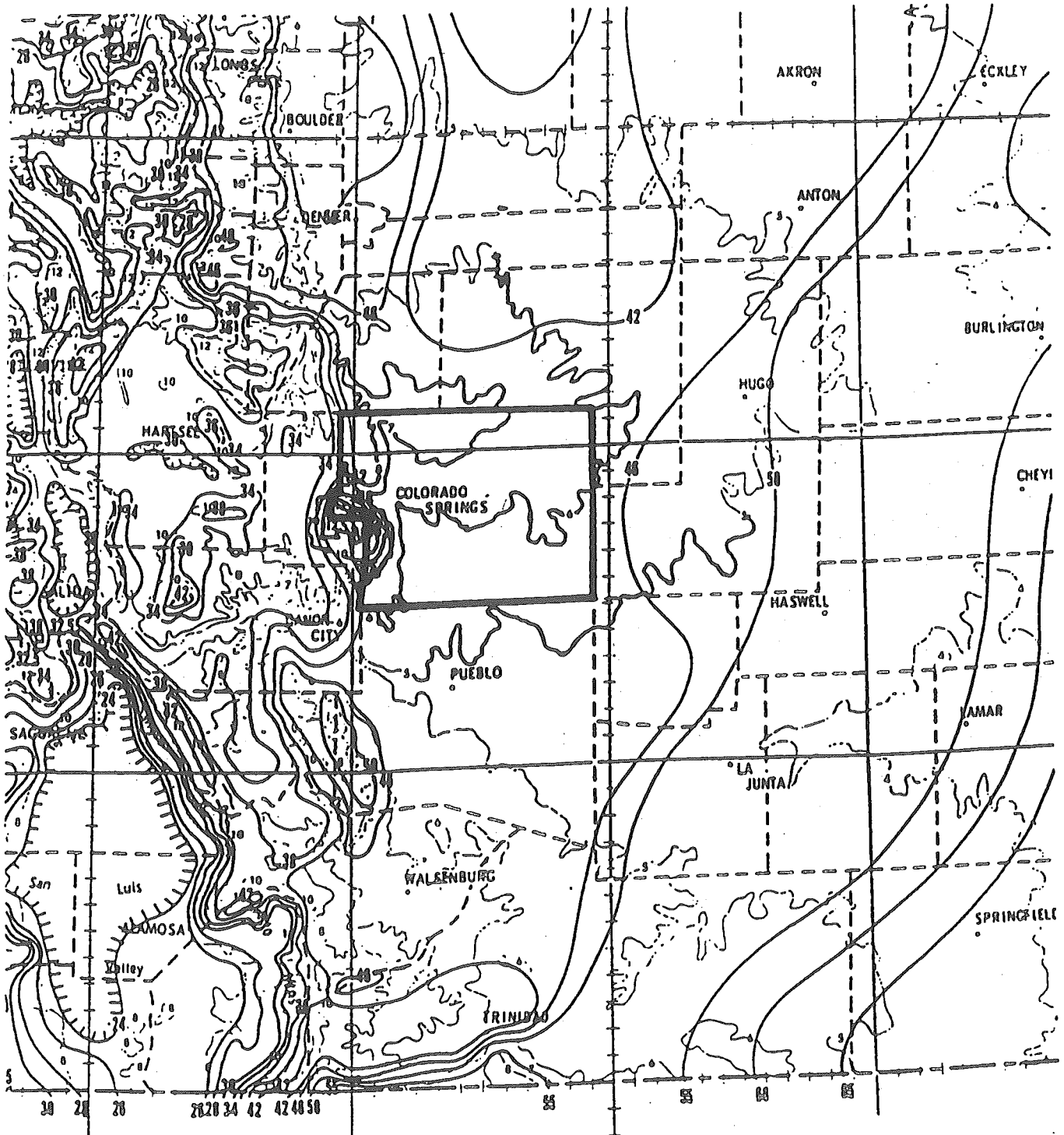

NOAA ATLAS 2, Volume III

Prepared by U.S. Department of Commerce
 National Oceanic and Atmospheric Administration
 National Weather Service, Office of Hydrology

Prepared for U.S. Department of Agriculture,
 Soil Conservation Service, Engineering Division

ISOPLUVIALS OF 100-YR 24-HR PRECIPITATION
 IN TENTHS OF AN INCH



HDR Infrastructure, Inc.
 A Centerra Company

The City of Colorado Springs / El Paso County
 Drainage Criteria Manual

Date

OCT. 1987

Figure

A5

SILVERADO RANCH
COMPOSITE RUNOFF COEFFICIENTS

HISTORIC CONDITIONS												
SCS CN VALUES												
BASIN	TOTAL AREA (AC)	SOIL TYPE	(AC)	SUB-AREA 1 DEVELOPMENT/COVER	CN	AREA (AC)	SUB-AREA 2 DEVELOPMENT/COVER	CN	(AC)	SUB-AREA 3 DEVELOPMENT/COVER	CN	WEIGHTED CN VALUE
OA1	1314.6	B	1314.6	MEADOW	50							50.00
OA2	18	B	18	MEADOW	50							50.00
A1	34.6	B	34.6	MEADOW	61							61.00
OA1,OA2,A1	1367.2	B										50.28
OB1	841.5	B	841.5	MEADOW	50							50.00
OB2	61.9	B	61.9	MEADOW	50							50.00
B	202.5	B	202.5	MEADOW	61							61.00
OA1-OB2,A1,B	2473.1	B										51.05

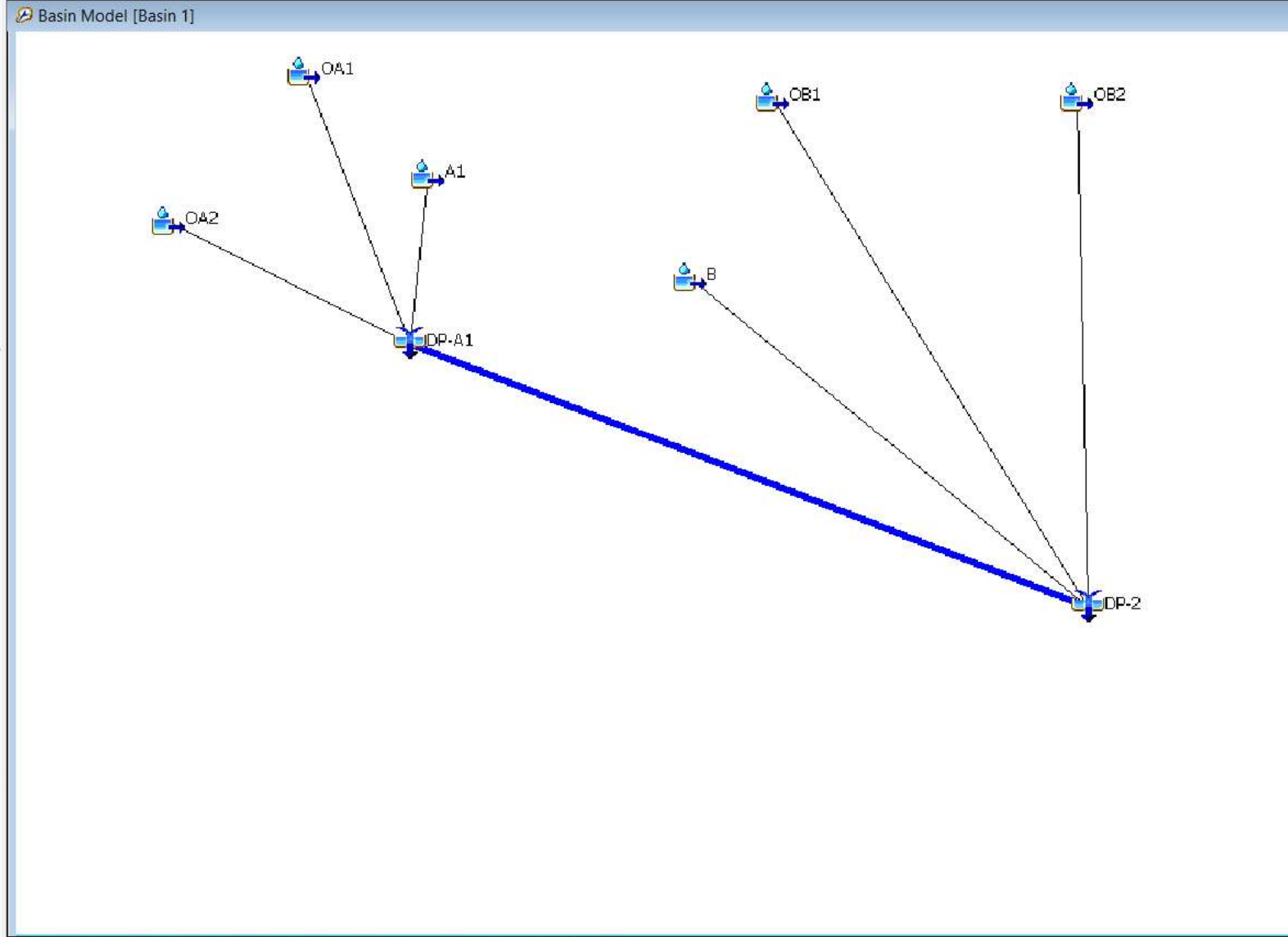
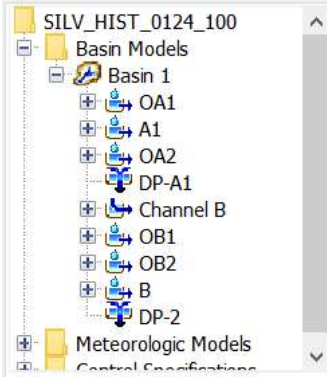

Components Compute Results

Transform	Options
Subbasin	Loss

Basin Name: Basin 1
Element Name: OA1

Description:

Downstream: DP-A1

*Area (MI2) 2.05

Latitude Degrees:

Longitude Degrees:

Discretization Method: --None--

Canopy Method: --None--

Snow Method: --None--

Surface Method: --None--

Loss Method: SCS Curve N

Transform Method: SCS Unit Hy

Baseflow Method: --None--

TWOFILE 10101: Opened control specifications: Control 1 at time 20Jan2024, 23:22:40.

Project: Silv Hist 0124 5

Simulation Run: Run 1

Simulation Start: 1 January 3000, 01:00

Simulation End: 2 January 3000, 01:30

HMS Version: 4.11

Executed: 20 May 2024, 02:03

Global Parameter Summary - Subbasin

Area (MI²)

Element Name	Area (MI ²)
Oa1	2.05
A1	0.05
Oa2	0.03
Ob1	1.31
B	0.32
Ob2	0.1

Downstream

Element Name	Downstream
Oa1	DP - A1
A1	DP - A1
Oa2	DP - A1
Ob1	DP - 2
B	DP - 2
Ob2	DP - 2

Loss Rate: Scs

Element Name	Percent Impervious Area	Curve Number	Initial Abstraction
Oa1	2	50	2
A1	2	61	1.28
Oa2	2	50	2
Ob1	2	50	2
B	2	61	1.28
Ob2	2	50	2

Transform: Scs

Element Name	Lag	Unitgraph Type
Oa1	63.44	Standard
A1	21.17	Standard
Oa2	13.3	Standard
Ob1	56.54	Standard
B	6.38	Standard
Ob2	19.01	Standard

Global Parameter Summary - Reach**Downstream**

Element Name	Downstream
Channel B	DP - 2

Route: Lag

Element Name	Method	Initial Variable	Lag
Channel B	Lag	Combined Inflow	16.16

Global Results Summary

Hydrologic Element	Drainage Area (MI ²)	Peak Discharge (CFS)	Time of Peak	Volume (IN)
Oa1	2.05	22.89	01Jan3000, 13:55	0.08
A1	0.05	3.81	01Jan3000, 13:19	0.27
Oa2	0.03	0.86	01Jan3000, 13:06	0.09
DP - A1	2.14	24.86	01Jan3000, 13:52	0.09
Channel B	2.14	24.86	01Jan3000, 14:08	0.09
Ob1	1.31	15.94	01Jan3000, 13:48	0.08
B	0.32	43.94	01Jan3000, 13:03	0.27
Ob2	0.1	2.46	01Jan3000, 13:11	0.09
DP - 2	3.86	55.66	01Jan3000, 13:04	0.1

Project: Silv Hist 0124 100

Simulation Run: Run 1

Simulation Start: 1 January 3000, 01:00

Simulation End: 2 January 3000, 01:30

HMS Version: 4.11

Executed: 20 May 2024, 01:55

Global Parameter Summary - Subbasin

Area (MI²)

Element Name	Area (MI ²)
Oa1	2.05
A1	0.05
Oa2	0.03
Ob1	1.31
B	0.32
Ob2	0.1

Downstream

Element Name	Downstream
Oa1	DP - A1
A1	DP - A1
Oa2	DP - A1
Ob1	DP - 2
B	DP - 2
Ob2	DP - 2

Loss Rate: Scs

Element Name	Percent Impervious Area	Curve Number	Initial Abstraction
Oa1	2	50	2
A1	2	61	1.28
Oa2	2	50	2
Ob1	2	50	2
B	2	61	1.28
Ob2	2	50	2

Transform: Scs

Element Name	Lag	Unitgraph Type
Oa1	63.44	Standard
A1	21.17	Standard
Oa2	13.3	Standard
Ob1	56.54	Standard
B	6.38	Standard
Ob2	19.01	Standard

Global Parameter Summary - Reach**Downstream**

Element Name	Downstream
Channel B	DP - 2

Route: Lag

Element Name	Method	Initial Variable	Lag
Channel B	Lag	Combined Inflow	16.16

Global Results Summary

Hydrologic Element	Drainage Area (MI ²)	Peak Discharge (CFS)	Time of Peak	Volume (IN)
Oa1	2.05	165.26	01Jan3000, 14:12	0.53
A1	0.05	26.09	01Jan3000, 13:16	1.09
Oa2	0.03	6.06	01Jan3000, 13:10	0.54
DP - A1	2.14	172.16	01Jan3000, 14:10	0.54
Channel B	2.14	172.16	01Jan3000, 14:26	0.54
Ob1	1.31	113.72	01Jan3000, 14:03	0.53
B	0.32	290.77	01Jan3000, 13:01	1.09
Ob2	0.1	16.6	01Jan3000, 13:16	0.54
DP - 2	3.86	313.61	01Jan3000, 13:01	0.58

SILVERADO RANCH
HISTORIC FLOWS - SCS METHOD HYDROLOGY

BASIN	DESIGN POINT	AREA (AC)	AREA (SM)	RUNOFF COEFFICIENT (C5)	CURVE No. (CN)	S	la	PERCENT IMPERVIOUS (%)	Overland Flow			Channel flow						Time of Concentration Tc ⁽²⁾ (MIN)	Total Lag Time Tl ⁽²⁾ (HR)	Total Lag Time Tl ⁽²⁾ (MIN)	Peak Flow SCS		
									LENGTH (FT)	SLOPE (FT/FT)	Tco ⁽¹⁾ (MIN)	HIGH ELEV. (FT)	LOW ELEV. (FT)	H (FT)	CHANNEL LENGTH (FT)	CHANNEL LENGTH (MI)	SLOPE (%)				Tt ⁽¹⁾ (MIN)	Q5 ⁽³⁾ (CFS)	Q100 ⁽³⁾ (CFS)
OA1	OA1	1314.6	2.054	0.08	50	10.00	2.00	2	300	0.032	22.0	6208	5860	348	21720	4.11	1.6%	83.78	105.74	1.06	63.44	22.9	165.3
OA2	OA2	18.0	0.028	0.08	50	10.00	2.00	2	300	0.053	18.6	5870	5858	12	465	0.09	2.6%	3.61	22.17	0.22	13.30	0.9	6.1
A1		34.6	0.054	0.137	61	6.39	1.28	2	300	0.030	21.2	5879	5857	22	1850	0.35	1.2%	14.10	35.28	0.35	21.17		
OA1_OA2_A1	A1	1367.2	2.136	0.08	50.25	9.90	1.98	2											141.02	1.41	84.61	24.9	172.2
OB1	OB1	841.5	1.315	0.08	50	10.00	2.00	2	300	0.016	27.7	6051	5830	221	15300	2.90	1.4%	66.58	94.23	0.94	56.54	15.9	113.7
OB2	OB2	61.9	0.097	0.08	50	10.00	2.00	2	300	0.034	21.5	5844	5810	34	1610	0.30	2.1%	10.16	31.68	0.32	19.01	2.5	16.6
B		202.5	0.316	0.137	61	6.39	1.28	2			0.0	5808	5802	6	940	0.18	0.6%	10.64	10.64	0.11	6.38		
CHANNEL B												5855	5795	60	4525	0.86	1.3%	26.93	26.93	0.27	16.16		
OA1-OA2_OB1-OB2_A,B	2	2473.1	3.864																167.95	1.68	100.77	55.7	313.6

NOTE: REFER TO RATIONAL METHOD CALCULATIONS FOR BASINS A2,C, & D AND DESIGN POINTS 1,3, &4

- 1) OVERLAND FLOW Tco = (0.395*(1.1-RUNOFF COEFFICIENT))*(OVERLAND FLOW LENGTH^(0.5))/(SLOPE^(0.333)).....DCM1 CH. 6 EQN 6-8
- 2) TRAVEL TIME, Tt = ((11.9*L^3)/H)^(0.385)
- 3) Tc = Tco + Tt
- 4) SCS LAG TIME, Tl = 0.6 * Tt
- 5) PEAK FLOWS CALCULATED BY HEC-HMS 4.11
- 6) 5-YR, 24-HR RAINFALL = 2.6 IN; 100-YR, 24-HR RAINFALL = 4.4 IN

SILVERADO RANCH
COMPOSITE RUNOFF COEFFICIENTS

DEVELOPED CONDITIONS												
SCS CN VALUES												
BASIN	TOTAL AREA (AC)	SOIL TYPE	(AC)	SUB-AREA 1 DEVELOPMENT/ COVER	CN	AREA (AC)	SUB-AREA 2 DEVELOPMENT/ COVER	CN	(AC)	SUB-AREA 3 DEVELOPMENT/ COVER	CN	WEIGHTED CN VALUE
OA1	1314.6	B	1314.6	MEADOW	50							50.00
OA2	18	B	18	MEADOW	50							50.00
A1	24.5	B	24.5	5 AC LOTS	63.59							63.59
OA1,OA2,A1	1357.1	B										50.25
OB1	841.5	B	841.5	MEADOW	50							50.00
B1.1	2.98	B	2.98	5 AC LOTS	63.59							63.59
OB1,B1.1	844.48	B										50.05
OB2	61.9	B	61.9	MEADOW	50							50.00
B4	28.4	B	28.4	5 AC LOTS	63.59							63.59
OB2,B4	90.3	B										54.27
B (A5-A6,B1-3,B5-B6)	155.1	B	155.1	5 AC LOTS	63.59							63.59
OA1-OB2,A1,B	2446.98	B										51.17
B7	34.0	B	34	5 AC LOTS	63.59							63.59
OA1-OB2,A1,B	2481.0	B										51.34

Run: Run 1

Max Min

- Channel B
 - OB1-B1.1
 - B (A5-A6,B1-3,B5-B6)
 - OB2-B4
 - DP-B6
- Reach-B7
 - B7
 - DP2
- Meteorologic Models
 - Met 1
 - Hypothetical Storm
 - A1
 - B (A5-A6,B1-3,B5-B6)

Components Compute Results

Hypothetical Storm

Met Name: Met 1
Method: SCS Type 2
*Point Depth (IN): 4.4
Area Reduction: --None--
Spatial Distribution: Uniform For All Subbas

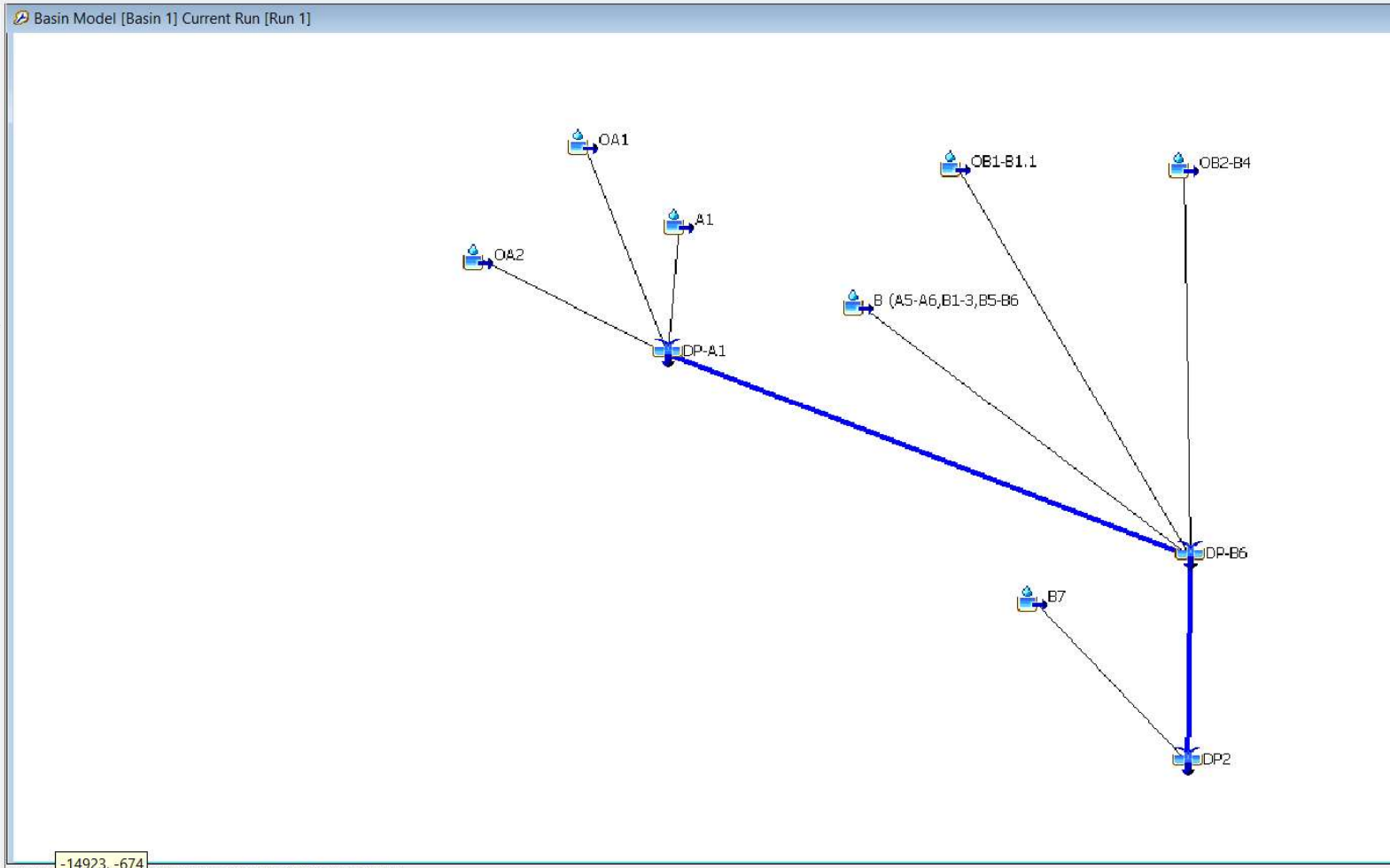

Project: SILV_DEV_OI24b_5

Simulation Run: Run 1

Simulation Start: 1 January 3000, 01:00

Simulation End: 2 January 3000, 01:30

HMS Version: 4.11

Executed: 20 May 2024, 02:20

Global Parameter Summary - Subbasin

Area (MI²)

Element Name	Area (MI ²)
Oa1	2.05
A1	0.04
Oa2	0.03
OB1 - B1.1	1.32
B (A5 - A6,B1 - 3,B5 - B6	0.24
OB2 - B4	0.14
B7	0.05

Downstream

Element Name	Downstream
Oa1	DP - A1
A1	DP - A1
Oa2	DP - A1
OB1 - B1.1	DP - B6
B (A5 - A6,B1 - 3,B5 - B6	DP - B6
OB2 - B4	DP - B6
B7	Dp2

Loss Rate: Scs

Element Name	Percent Impervious Area	Curve Number	Initial Abstraction
Oa1	2	50	2
A1	7	63.59	1.15
Oa2	2	50	2
OB1 - B1.1	2.02	50.05	2
B (A5 - A6,B1 - 3,B5 - B6	7	63.59	1.15
OB2 - B4	3.57	54.27	1.69
B7	7	63.59	1.15

Transform: Scs

Element Name	Lag	Unitgraph Type
Oa1	63.44	Standard
A1	21.17	Standard
Oa2	13.3	Standard
OB1 - B1.1	67.05	Standard
B (A5 - A6,B1 - 3,B5 - B6	13.69	Standard
OB2 - B4	23.2	Standard
B7	4.7	Standard

Global Parameter Summary - Reach**Downstream**

Element Name	Downstream
Channel B	DP - B6
Reach - B7	Dp2

Route: Lag

Element Name	Method	Initial Variable	Lag
Channel B	Lag	Combined Inflow	13.7
Reach - B7	Lag	Combined Inflow	4.7

Global Results Summary

Hydrologic Element	Drainage Area (MI ²)	Peak Discharge (CFS)	Time of Peak	Volume (IN)
Oa1	2.05	22.89	01Jan3000, 13:55	0.08
A1	0.04	5.91	01Jan3000, 13:16	0.45
Oa2	0.03	0.86	01Jan3000, 13:06	0.09
DP - A1	2.12	25.12	01Jan3000, 13:51	0.09
Channel B	2.12	25.12	01Jan3000, 14:04	0.09
OB1 - B1.1	1.32	14.27	01Jan3000, 13:59	0.08

B (A5 - A6,B1 - 3,B5 - B6	0.24	49.32	01Jan3000, 13:09	0.45
OB2 - B4	0.14	5.76	01Jan3000, 13:15	0.18
DP - B6	3.82	67.21	01Jan3000, 13:10	0.11
Reach - B7	3.82	67.21	01Jan3000, 13:14	0.11
B7	0.05	16.74	01Jan3000, 13:00	0.45
Dp2	3.88	71.19	01Jan3000, 13:14	0.12

Project: SILV_DEV_OI24a_100

Simulation Run: Run 1

Simulation Start: 1 January 3000, 01:00

Simulation End: 2 January 3000, 01:30

HMS Version: 4.11

Executed: 20 May 2024, 02:13

Global Parameter Summary - Subbasin

Area (MI²)

Element Name	Area (MI ²)
Oa1	2.05
A1	0.04
Oa2	0.03
OB1 - B1.1	1.32
B (A5 - A6,B1 - 3,B5 - B6	0.24
OB2 - B4	0.14
B7	0.05

Downstream

Element Name	Downstream
Oa1	DP - A1
A1	DP - A1
Oa2	DP - A1
OB1 - B1.1	DP - B6
B (A5 - A6,B1 - 3,B5 - B6	DP - B6
OB2 - B4	DP - B6
B7	Dp2

Loss Rate: Scs

Element Name	Percent Impervious Area	Curve Number	Initial Abstraction
Oa1	2	50	2
A1	7	63.59	1.15
Oa2	2	50	2
OB1 - B1.1	2.02	50.05	2
B (A5 - A6,B1 - 3,B5 - B6	7	63.59	1.15
OB2 - B4	3.57	54.27	1.69
B7	7	63.59	1.15

Transform: Scs

Element Name	Lag	Unitgraph Type
Oa1	63.44	Standard
A1	21.17	Standard
Oa2	13.3	Standard
OB1 - B1.1	67.05	Standard
B (A5 - A6,B1 - 3,B5 - B6	13.69	Standard
OB2 - B4	23.2	Standard
B7	4.7	Standard

Global Parameter Summary - Reach**Downstream**

Element Name	Downstream
Channel B	DP - B6
Reach - B7	Dp2

Route: Lag

Element Name	Method	Initial Variable	Lag
Channel B	Lag	Combined Inflow	13.7
Reach - B7	Lag	Combined Inflow	4.7

Global Results Summary

Hydrologic Element	Drainage Area (MI ²)	Peak Discharge (CFS)	Time of Peak	Volume (IN)
Oa1	2.05	165.26	01Jan3000, 14:12	0.53
A1	0.04	24.63	01Jan3000, 13:15	1.4
Oa2	0.03	6.06	01Jan3000, 13:10	0.54
DP - A1	2.12	171.23	01Jan3000, 14:11	0.54
Channel B	2.12	171.23	01Jan3000, 14:24	0.54
OB1 - B1.1	1.32	102.93	01Jan3000, 14:17	0.53

B (A5 - A6,B1 - 3,B5 - B6	0.24	207.05	01Jan3000, 13:08	1.4
OB2 - B4	0.14	38.57	01Jan3000, 13:19	0.79
DP - B6	3.82	305.22	01Jan3000, 14:19	0.6
Reach - B7	3.82	305.22	01Jan3000, 14:23	0.6
B7	0.05	68.14	01Jan3000, 12:59	1.4
Dp2	3.88	309.49	01Jan3000, 14:23	0.61

SILVERADO RANCH
DEVELOPED FLOWS - SCS METHOD HYDROLOGY

BASIN	DESIGN POINT	AREA (AC)	AREA (SM)	RUNOFF COEFFICIENT (C5)	CURVE No. (CN)	S	Ia	PERCENT IMPERVIOUS (%)	Overland Flow			Channel flow						Time of Concentration Tc ⁽²⁾ (MIN)	Total Lag Time Tl ⁽²⁾ (HR)	Total Lag Time Tl ⁽²⁾ (MIN)	Peak Flow SCS		
									LENGTH (FT)	SLOPE (FT/FT)	Tco ⁽¹⁾ (MIN)	HIGH ELEV. (FT)	LOW ELEV. (FT)	H (FT)	CHANNEL LENGTH (FT)	CHANNEL LENGTH (MI)	SLOPE (%)				Tt ⁽¹⁾ (MIN)	Q5 ⁽³⁾ (CFS)	Q100 ⁽³⁾ (CFS)
OA1	OA1	1314.6	2.054	0.08	50	10.00	2.00	2	300	0.032	22.0	6208	5860	348	21720	4.11	1.6%	83.78	105.74	1.06	63.44	22.9	165.3
OA2	OA2	18.0	0.028	0.08	50	10.00	2.00	2	300	0.053	18.6	5870	5858	12	465	0.09	2.6%	3.61	22.17	0.22	13.30		
A1		24.5	0.038	0.137	63.59	5.73	1.15	7	300	0.030	21.2	5879	5857	22	1850	0.35	1.2%	14.10	35.28	0.35	21.17		
OA1_OA2,A1	A1	1357.1	2.120	0.08	50.25	9.90	1.98	2											141.02	1.41	84.61	25.1	171.2
OB1	OB1	841.5	1.315	0.08	50	10.00	2.00	2	300	0.016	27.7	6051	5830	221	15300	2.90	1.4%	66.58	94.23	0.94	56.54		
CHANNEL B1.1												5828	5802	26	2360	0.45	1.1%	17.52	17.52	0.18	10.51		
B1.1		2.98	0.005	0.137	63.59	5.73	1.15	7	70	0.020	11.7			9.9	900	0.17	1.1%	8.34	20.05	0.20	12.03		
OB1_B1.1	B1.1	844.5	1.320	0.08	50.05	9.98	2.00	2.02											111.75	1.12	67.05	14.3	102.9
OB2	OB2	61.9	0.097	0.08	50	10.00	2.00	2	300	0.034	21.5	5844	5810	34	1610	0.30	2.1%	10.16	31.68	0.32	19.01		
B4		28.4	0.044	0.137	63.59	5.73	1.15	7			0.0			5.9	650	0.12	0.9%	6.99	6.99	0.07	4.20		
OB2_B4	B4.1	90.3	0.141	0.10	54.18	8.46	1.69	3.57											38.67	0.39	23.20	5.8	38.6
B (A5-A6,B1-B3,B5-B6)		155.1	0.242	0.137	63.59	5.73	1.15	7			0.0	5855	5790	65	4025	0.76	1.6%	22.81	22.81	0.23	13.69		
CHANNEL B												5855	5790	65	4025	0.76	1.6%	22.81	22.81	0.23	13.69		
OA1-OA2,A1,OB1-OB2,A,B	B6.1	2447.0	3.823																163.83	1.64	98.30	67.2	305.2
B7		34.0	0.053	0.137	63.59	5.73	1.15	7			0.0	5796	5794	2	500	0.09	0.4%	7.83	7.83	0.08	4.70		
CHANNEL B7											0.0	5796	5794	2	500	0.09	0.4%	7.83	7.83	0.08	4.70		
OA1-OA2,OB1-OB2,A,B	2	2481.0	3.877																171.67	1.72	103.00	71.2	309.5

1) OVERLAND FLOW Tco = (0.395*(1.1-RUNOFF COEFFICIENT)*(OVERLAND FLOW LENGTH^(0.5)/(SLOPE^(0.333)).....DCM1 CH. 6 EQN 6-8

2) TRAVEL TIME, Tt = ((11.9*L^3)/H)^(0.385)

3) Tc = Tco + Tt

4) SCS LAG TIME, Tl = 0.6 * Tt

5) PEAK FLOWS CALCULATED BY HEC-HMS 4.11 (FILE: "SILV_DEV_0124a_100.hms")

6) 5-YR, 24-HR RAINFALL = 2.6 IN; 100-YR, 24-HR RAINFALL = 4.4 IN

APPENDIX C2

HYDROLOGIC CALCULATIONS (RATIONAL METHOD)

Table 6-6. Runoff Coefficients for Rational Method

(Source: UDFCD 2001)

Land Use or Surface Characteristics	Percent Impervious	Runoff Coefficients											
		2-year		5-year		10-year		25-year		50-year		100-year	
		HSG A&B	HSG C&D	HSG A&B	HSG C&D	HSG A&B	HSG C&D	HSG A&B	HSG C&D	HSG A&B	HSG C&D	HSG A&B	HSG C&D
Business													
Commercial Areas	95	0.79	0.80	0.81	0.82	0.83	0.84	0.85	0.87	0.87	0.88	0.88	0.89
Neighborhood Areas	70	0.45	0.49	0.49	0.53	0.53	0.57	0.58	0.62	0.60	0.65	0.62	0.68
Residential													
1/8 Acre or less	65	0.41	0.45	0.45	0.49	0.49	0.54	0.54	0.59	0.57	0.62	0.59	0.65
1/4 Acre	40	0.23	0.28	0.30	0.35	0.36	0.42	0.42	0.50	0.46	0.54	0.50	0.58
1/3 Acre	30	0.18	0.22	0.25	0.30	0.32	0.38	0.39	0.47	0.43	0.52	0.47	0.57
1/2 Acre	25	0.15	0.20	0.22	0.28	0.30	0.36	0.37	0.46	0.41	0.51	0.46	0.56
1 Acre	20	0.12	0.17	0.20	0.26	0.27	0.34	0.35	0.44	0.40	0.50	0.44	0.55
Industrial													
Light Areas	80	0.57	0.60	0.59	0.63	0.63	0.66	0.66	0.70	0.68	0.72	0.70	0.74
Heavy Areas	90	0.71	0.73	0.73	0.75	0.75	0.77	0.78	0.80	0.80	0.82	0.81	0.83
Parks and Cemeteries	7	0.05	0.09	0.12	0.19	0.20	0.29	0.30	0.40	0.34	0.46	0.39	0.52
Playgrounds	13	0.07	0.13	0.16	0.23	0.24	0.31	0.32	0.42	0.37	0.48	0.41	0.54
Railroad Yard Areas	40	0.23	0.28	0.30	0.35	0.36	0.42	0.42	0.50	0.46	0.54	0.50	0.58
Undeveloped Areas													
Historic Flow Analysis-- Greenbelts, Agriculture	2	0.03	0.05	0.09	0.16	0.17	0.26	0.26	0.38	0.31	0.45	0.36	0.51
Pasture/Meadow	0	0.02	0.04	0.08	0.15	0.15	0.25	0.25	0.37	0.30	0.44	0.35	0.50
Forest	0	0.02	0.04	0.08	0.15	0.15	0.25	0.25	0.37	0.30	0.44	0.35	0.50
Exposed Rock	100	0.89	0.89	0.90	0.90	0.92	0.92	0.94	0.94	0.95	0.95	0.96	0.96
Offsite Flow Analysis (when landuse is undefined)	45	0.26	0.31	0.32	0.37	0.38	0.44	0.44	0.51	0.48	0.55	0.51	0.59
Streets													
Paved	100	0.89	0.89	0.90	0.90	0.92	0.92	0.94	0.94	0.95	0.95	0.96	0.96
Gravel	80	0.57	0.60	0.59	0.63	0.63	0.66	0.66	0.70	0.68	0.72	0.70	0.74
Drive and Walks	100	0.89	0.89	0.90	0.90	0.92	0.92	0.94	0.94	0.95	0.95	0.96	0.96
Roofs	90	0.71	0.73	0.73	0.75	0.75	0.77	0.78	0.80	0.80	0.82	0.81	0.83
Lawns	0	0.02	0.04	0.08	0.15	0.15	0.25	0.25	0.37	0.30	0.44	0.35	0.50

3.2 Time of Concentration

One of the basic assumptions underlying the Rational Method is that runoff is a function of the average rainfall rate during the time required for water to flow from the hydraulically most remote part of the drainage area under consideration to the design point. However, in practice, the time of concentration can be an empirical value that results in reasonable and acceptable peak flow calculations.

For urban areas, the time of concentration (t_c) consists of an initial time or overland flow time (t_i) plus the travel time (t_r) in the storm sewer, paved gutter, roadside drainage ditch, or drainage channel. For non-urban areas, the time of concentration consists of an overland flow time (t_i) plus the time of travel in a concentrated form, such as a swale or drainageway. The travel portion (t_r) of the time of concentration can be estimated from the hydraulic properties of the storm sewer, gutter, swale, ditch, or drainageway. Initial time, on the other hand, will vary with surface slope, depression storage, surface cover, antecedent rainfall, and infiltration capacity of the soil, as well as distance of surface flow. The time of concentration is represented by Equation 6-7 for both urban and non-urban areas.

$$t_c = t_i + t_t \quad (\text{Eq. 6-7})$$

Where:

t_c = time of concentration (min)

t_i = overland (initial) flow time (min)

t_t = travel time in the ditch, channel, gutter, storm sewer, etc. (min)

3.2.1 Overland (Initial) Flow Time

The overland flow time, t_i , may be calculated using Equation 6-8.

$$t_i = \frac{0.395(1.1 - C_5)\sqrt{L}}{S^{0.33}} \quad (\text{Eq. 6-8})$$

Where:

t_i = overland (initial) flow time (min)

C_5 = runoff coefficient for 5-year frequency (see Table 6-6)

L = length of overland flow (300 ft maximum for non-urban land uses, 100 ft maximum for urban land uses)

S = average basin slope (ft/ft)

Note that in some urban watersheds, the overland flow time may be very small because flows quickly concentrate and channelize.

3.2.2 Travel Time

For catchments with overland and channelized flow, the time of concentration needs to be considered in combination with the travel time, t_t , which is calculated using the hydraulic properties of the swale, ditch, or channel. For preliminary work, the overland travel time, t_t , can be estimated with the help of Figure 6-25 or Equation 6-9 (Guo 1999).

$$V = C_v S_w^{0.5} \quad (\text{Eq. 6-9})$$

Where:

V = velocity (ft/s)

C_v = conveyance coefficient (from Table 6-7)

S_w = watercourse slope (ft/ft)

Table 6-7. Conveyance Coefficient, C_v

Type of Land Surface	C_v
Heavy meadow	2.5
Tillage/field	5
Riprap (not buried)*	6.5
Short pasture and lawns	7
Nearly bare ground	10
Grassed waterway	15
Paved areas and shallow paved swales	20

* For buried riprap, select C_v value based on type of vegetative cover.

The travel time is calculated by dividing the flow distance (in feet) by the velocity calculated using Equation 6-9 and converting units to minutes.

The time of concentration (t_c) is then the sum of the overland flow time (t_i) and the travel time (t_t) per Equation 6-7.

3.2.3 First Design Point Time of Concentration in Urban Catchments

Using this procedure, the time of concentration at the first design point (typically the first inlet in the system) in an urbanized catchment should not exceed the time of concentration calculated using Equation 6-10. The first design point is defined as the point where runoff first enters the storm sewer system.

$$t_c = \frac{L}{180} + 10 \quad (\text{Eq. 6-10})$$

Where:

t_c = maximum time of concentration at the first design point in an urban watershed (min)

L = waterway length (ft)

Equation 6-10 was developed using the rainfall-runoff data collected in the Denver region and, in essence, represents regional “calibration” of the Rational Method. Normally, Equation 6-10 will result in a lesser time of concentration at the first design point and will govern in an urbanized watershed. For subsequent design points, the time of concentration is calculated by accumulating the travel times in downstream drainageway reaches.

3.2.4 Minimum Time of Concentration

If the calculations result in a t_c of less than 10 minutes for undeveloped conditions, it is recommended that a minimum value of 10 minutes be used. The minimum t_c for urbanized areas is 5 minutes.

3.2.5 Post-Development Time of Concentration

As Equation 6-8 indicates, the time of concentration is a function of the 5-year runoff coefficient for a drainage basin. Typically, higher levels of imperviousness (higher 5-year runoff coefficients) correspond to shorter times of concentration, and lower levels of imperviousness correspond to longer times of

Figure 6-5. Colorado Springs Rainfall Intensity Duration Frequency

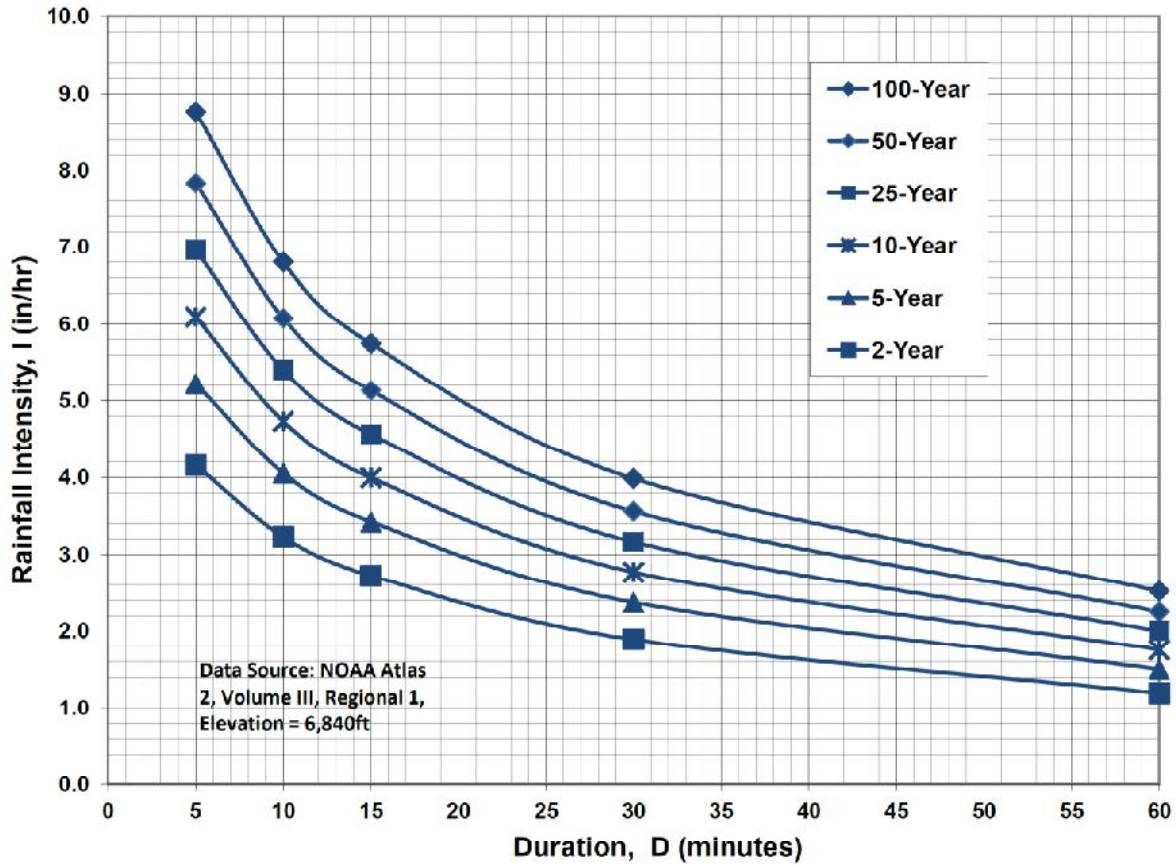

IDF Equations

$$I_{100} = -2.52 \ln(D) + 12.735$$

$$I_{50} = -2.25 \ln(D) + 11.375$$

$$I_{25} = -2.00 \ln(D) + 10.111$$

$$I_{10} = -1.75 \ln(D) + 8.847$$

$$I_5 = -1.50 \ln(D) + 7.583$$

$$I_2 = -1.19 \ln(D) + 6.035$$

Note: Values calculated by equations may not precisely duplicate values read from figure.

SILVERADO RANCH FILING NO. 2
RATIONAL METHOD

HISTORIC FLOWS

BASIN	DESIGN POINT	AREA (AC)	C		Overland Flow			Channel flow					TOTAL Tc ⁽⁴⁾ (MIN)	TOTAL Tc ⁽⁴⁾ (MIN)	INTENSITY ⁽⁵⁾		PEAK FLOW	
			5-YEAR ⁽⁷⁾	100-YEAR ⁽⁷⁾	LENGTH (FT)	SLOPE (FT/FT)	Tco ⁽¹⁾ (MIN)	CHANNEL LENGTH (FT)	CONVEYANCE COEFFICIENT C	SLOPE (FT/FT)	SCS ⁽²⁾ VELOCITY (FT/S)	Tt ⁽³⁾ (MIN)			5-YR (IN/HR)	100-YR (IN/HR)	Q5 ⁽⁶⁾ (CFS)	Q100 ⁽⁶⁾ (CFS)
A2	1	52.17	0.080	0.350	300	0.028	23.0	2600	15	0.024	2.32	18.6	41.6	41.6	1.99	3.34	8.31	60.99
C	3	18.12	0.080	0.350	300	0.032	22.0	2650	15	0.008	1.34	32.9	54.9	54.9	1.58	2.64	2.28	16.76
D	4	11.30	0.080	0.350	300	0.042	20.1	300	15	0.013	1.71	2.9	23.0	23.0	2.88	4.84	2.60	19.13

1) OVERLAND FLOW $T_{co} = (0.395 * (1.1 - \text{RUNOFF COEFFICIENT}) * (\text{OVERLAND FLOW LENGTH}^{0.5}) / (\text{SLOPE}^{0.333}))$

2) SCS VELOCITY = $C * ((\text{SLOPE}(\text{FT}/\text{FT})^{0.5})$

C = 2.5 FOR HEAVY MEADOW

C = 5 FOR TILLAGE/FIELD

C = 7 FOR SHORT PASTURE AND LAWNS

C = 10 FOR NEARLY BARE GROUND

C = 15 FOR GRASSED WATERWAY

C = 20 FOR PAVED AREAS AND SHALLOW PAVED SWALES

3) MANNING'S CHANNEL TRAVEL TIME = L/V (WHEN CHANNEL VELOCITY IS KNOWN)

4) $T_c = T_{co} + T_t$

*** IF TOTAL TIME OF CONCENTRATION IS LESS THAN 5 MINUTES, THEN 5 MINUTES IS USED

5) INTENSITY BASED ON I-D-F EQUATIONS IN CITY OF COLORADO SPRINGS DRAINAGE CRITERIA MANUAL

$$I_5 = -1.5 * \ln(T_c) + 7.583$$

$$I_{100} = -2.52 * \ln(T_c) + 12.735$$

6) $Q = C_i A$

7) WEIGHTED AVERAGE C VALUES FOR COMBINED BASINS

SILVERADO RANCH SUBDIVISION
 COMPOSITE RUNOFF COEFFICIENTS - TYPICAL RURAL RESIDENTIAL LOTS

DEVELOPED CONDITIONS											
5-YEAR C VALUES											
BASIN	TOTAL AREA (AC)	AREA (%)	SUB-AREA 1 DEVELOPMENT/ COVER	C	AREA (%)	SUB-AREA 2 DEVELOPMENT/ COVER	C	AREA (%)	SUB-AREA 3 DEVELOPMENT/ COVER	C	WEIGHTED C VALUE
5-ACRE LOTS	5.0	7.00	BUILDING / PAVEMENT	0.90	93.00	MEADOW / LS	0.08				0.137
100-YEAR C VALUES											
BASIN	TOTAL AREA (AC)	AREA (%)	SUB-AREA 1 DEVELOPMENT/ COVER	C	AREA (AC)	SUB-AREA 2 DEVELOPMENT/ COVER	C	AREA (%)	SUB-AREA 3 DEVELOPMENT/ COVER	C	WEIGHTED C VALUE
5-ACRE LOTS	5.0	7.00	BUILDING / PAVEMENT	0.96	93.00	MEADOW / LS	0.35				0.393
SCS RUNOFF CURVE NUMBERS - CN-VALUES											
BASIN	TOTAL AREA (AC)	AREA (%)	SUB-AREA 1 DEVELOPMENT/ COVER	CN	AREA (AC)	SUB-AREA 2 DEVELOPMENT/ COVER	CN	AREA (%)	SUB-AREA 3 DEVELOPMENT/ COVER	CN	WEIGHTED CN- VALUE
5-ACRE LOTS	5.0	7.00	BUILDING / PAVEMENT	98	93.00	MEADOW / LS	61				63.590
IMPERVIOUS AREAS											
BASIN	TOTAL AREA (AC)	AREA (%)	SUB-AREA 1 DEVELOPMENT/ COVER	PERCENT IMPERVIOUS	AREA (%)	SUB-AREA 2 DEVELOPMENT/ COVER	PERCENT IMPERVIOUS	AREA (%)	SUB-AREA 3 DEVELOPMENT/ COVER	PERCENT IMPERVIOUS	WEIGHTED % IMP
5-ACRE LOTS	5.0	7.00	BUILDING / PAVEMENT	100	93.00	MEADOW / LS	0				7.000

SILVERADO RANCH FILING NO. 2
COMPOSITE RUNOFF COEFFICIENTS

DEVELOPED CONDITIONS											
5-YEAR C VALUES											
BASIN	TOTAL AREA (AC)	(AC)	SUB-AREA 1 DEVELOPMENT/ COVER	C	AREA (AC)	SUB-AREA 2 DEVELOPMENT/ COVER	C	(AC)	SUB-AREA 3 DEVELOPMENT/ COVER	C	WEIGHTED C VALUE
B1.1	2.98	2.98	5-AC LOTS	0.137							0.137
B3	45.86	45.86	5-AC LOTS	0.137							0.137
OB2	61.93	61.93	MEADOW	0.080							0.080
B4	28.4	28.4	5-AC LOTS	0.137							0.137
OB2,B4	90.33										0.098
B6	43.73	43.73	5-AC LOTS	0.137							0.137
B7 (ULTIMATE)	34.00	34.00	5-AC LOTS	0.137							0.137
B7 (FLG. 2 ONLY)	34.00	5.000	5-AC LOTS	0.137	29.000	MEADOW	0.08				0.088
C	18.12	18.12	5-AC LOTS	0.137							0.137
D	11.30	11.30	5-AC LOTS	0.137							0.137
100-YEAR C VALUES											
BASIN	TOTAL AREA (AC)	(AC)	SUB-AREA 1 DEVELOPMENT/ COVER	C	AREA (AC)	SUB-AREA 2 DEVELOPMENT/ COVER	C	(AC)	SUB-AREA 3 DEVELOPMENT/ COVER	C	WEIGHTED C VALUE
B1.1	2.98	2.98	5-AC LOTS	0.393							0.393
B3	45.86	45.86	5-AC LOTS	0.393							0.393
OB2	61.93	61.93	MEADOW	0.350							0.350
B4	28.4	28.4	5-AC LOTS	0.393							0.393
OB2,B4	90.33										0.364
B6	43.73	43.73	5-AC LOTS	0.393							0.393
B7 (ULTIMATE)	34.00	34.00	5-AC LOTS	0.393							0.393
B7 (FLG. 2 ONLY)	34.00	5.000	5-AC LOTS	0.393	29.000	MEADOW	0.35				0.356
C	18.12	18.12	5-AC LOTS	0.393							0.393
D	11.30	11.30	5-AC LOTS	0.393							0.393

SILVERADO RANCH FILING NO. 2
RATIONAL METHOD

DEVELOPED FLOWS

BASIN	DESIGN POINT	AREA (AC)	C		Overland Flow			Channel flow					TOTAL Tc ⁽⁴⁾ (MIN)	TOTAL Tc ⁽⁴⁾ (MIN)	INTENSITY ⁽⁵⁾		PEAK FLOW		
			5-YEAR ⁽⁷⁾	100-YEAR ⁽⁷⁾	LENGTH (FT)	SLOPE (FT/FT)	Tco ⁽¹⁾ (MIN)	CHANNEL LENGTH (FT)	CONVEYANCE COEFFICIENT C	SLOPE (FT/FT)	SCS ⁽²⁾ VELOCITY (FT/S)	Tt ⁽³⁾ (MIN)			5-YR (IN/HR)	100-YR (IN/HR)	Q5 ⁽⁶⁾ (CFS)	Q100 ⁽⁶⁾ (CFS)	
			A2-A4	1	47.43	0.137	0.393	100	0.060	9.7	2600	15			0.023	2.27	19.0	28.8	28.8
B1.1		2.98	0.137	0.393	70	0.020	11.7	900	15	0.011	1.57	9.5	21.2	21.2	3.00	5.03	1.22	5.90	
B3	B3	39.38	0.137	0.393			0.0	1800	15	0.012	1.66	18.1	18.1	18.1	3.24	5.44	17.47	84.13	
FILING NO. 2 BASINS:																			
B4		28.4	0.137	0.393			0.0	650	15	0.009	1.42	7.6	7.6	7.6	4.54	7.62	17.66	85.05	
B6		50.20	0.137	0.393	100	0.020	14.0	900	15	0.033	2.72	5.5	19.5	19.5	3.13	5.25	21.51	103.57	
B7 (ULTIMATE)	B7	34.0	0.137	0.393	100	0.020	14.0	2720	15	0.009	1.42	31.9	45.9	45.9	1.84	3.09	8.59	41.35	
B7 (FLG. 2 ONLY)	B7	34.0	0.088	0.356	100	0.020	14.7	2720	15	0.009	1.42	31.9	46.6	46.6	1.82	3.06	5.45	36.99	
C	3	18.12	0.137	0.393	300	0.032	20.7	2650	15	0.008	1.34	32.9	53.6	53.6	1.61	2.70	4.00	19.22	
D	4	11.30	0.137	0.393	300	0.042	18.9	300	15	0.013	1.71	2.9	21.9	21.9	2.96	4.96	4.58	22.04	

* NOTE: DESIGN POINTS ON THIS TABLE PROVIDE THE APPLICABLE CALCULATIONS FOR ON-SITE DRAINAGE BASINS UNDER 100-ACRES

1) OVERLAND FLOW Tco = (0.395*(1.1-RUNOFF COEFFICIENT)*(OVERLAND FLOW LENGTH^(0.5))/(SLOPE^(0.333))

2) SCS VELOCITY = C * ((SLOPE(FT/FT)^0.5)

C = 2.5 FOR HEAVY MEADOW

C = 5 FOR TILLAGE/FIELD

C = 7 FOR SHORT PASTURE AND LAWNS

C = 10 FOR NEARLY BARE GROUND

C = 15 FOR GRASSED WATERWAY

C = 20 FOR PAVED AREAS AND SHALLOW PAVED SWALES

3) MANNING'S CHANNEL TRAVEL TIME = L/V (WHEN CHANNEL VELOCITY IS KNOWN)

4) Tc = Tco + Tt

*** IF TOTAL TIME OF CONCENTRATION IS LESS THAN 5 MINUTES, THEN 5 MINUTES IS USED

5) INTENSITY BASED ON I-D-F EQUATIONS IN CITY OF COLORADO SPRINGS DRAINAGE CRITERIA MANUAL

I₅ = -1.5 * ln(Tc) + 7.583

I₁₀₀ = -2.52 * ln(Tc) + 12.735

6) Q = CiA

7) WEIGHTED AVERAGE C VALUES FOR COMBINED BASINS

APPENDIX D
HYDRAULIC CALCULATIONS

TABLE 10-2 (Continued)

TYPICAL ROUGHNESS COEFFICIENTS FOR OPEN CHANNELS

<u>Type of Channel and Description</u>	<u>Minimum</u>	<u>Normal</u>	<u>Maximum</u>
c. Concrete bottom float finished with sides of			
1. Dressed stone in mortar	0.015	0.017	0.020
2. Random stone in mortar	0.017	0.020	0.024
3. Cement rubble masonry, plastered	0.016	0.020	0.024
4. Cement rubble masonry	0.020	0.025	0.030
5. Dry rubble or riprap	0.020	0.030	0.035
d. Gravel bottom with sides of			
1. Formed concrete	0.017	0.020	0.025
2. Random stone in mortar	0.020	0.023	0.026
3. Dry rubble or riprap	0.023	0.033	0.036
e. Asphalt			
1. Smooth		0.013	
2. Rough		0.016	
f. Grassed	0.030	0.040	0.050

TABLE 10-3

MAXIMUM PERMISSIBLE DESIGN
OPEN CHANNEL FLOW VELOCITIES IN EARTH*

<u>Soil Types</u>	<u>Permissible Mean Channel Velocity</u> (ft/sec)
Fine Sand (noncolloidal)	2.0
Coarse Sand (noncolloidal)	4.0
Sandy Loam (noncolloidal)	2.5
Silt Loam (noncolloidal)	3.0
Ordinary Firm Loam	3.5
Silty Clay	3.5
Fine Gravel	5.0
Stiff Clay (very colloidal)	5.0
Graded, Loam to Cobbles (noncolloidal)	5.0
Graded, Silt to Cobbles (colloidal)	5.5
Alluvial Silts (noncolloidal)	3.5
Alluvial Silts (colloidal)	5.0
Coarse Gravel (noncolloidal)	6.0
Cobbles and Shingles	5.5
Hard Shales and Hard Pans	6.0
Soft Shales	3.5
Soft Sandstone	8.0
Sound rock (usu. igneous or hard metamorphic)	20.0

* These velocities shall be used in conjunction with scour calculations and as approved by City/County.

TABLE 10-2

TYPICAL ROUGHNESS COEFFICIENTS FOR OPEN CHANNELS
 (Reference: Chow, Ven Te, 1959; Open-Channel Hydraulics)

<u>Type of Channel and Description</u>	<u>Minimum</u>	<u>Normal</u>	<u>Maximum</u>
EXCAVATED OR DREDGED			
a. Earth, straight and uniform			
1. Clean, recently completed	0.016	0.018	0.020
2. Clean, after weathering	0.018	0.022	0.025
3. Gravel, uniform section, clean	0.022	0.025	0.030
4. With short grass, few weeds	0.022	0.027	0.033
b. Earth, winding and sluggish			
1. No vegetation	0.023	0.025	0.030
2. Grass, some weeds	0.025	0.030	0.033
3. Dense weeds or aquatic plants in deep channels	0.030	0.035	0.040
4. Earth bottom and rubble sides	0.028	0.030	0.035
5. Stony bottom and weedy banks	0.025	0.035	0.040
6. Cobble bottom and clean sides	0.030	0.040	0.050
c. Dragline-excavated or dredged			
1. No vegetation	0.025	0.028	0.033
2. Light brush on banks	0.035	0.050	0.060
d. Rock cuts			
1. Smooth and uniform	0.025	0.035	0.040
2. Jagged and irregular	0.035	0.040	0.050
e. Channels not maintained, weeds and brush uncut			
1. Dense weeds, high as flow depth	0.050	0.080	0.120
2. Clean bottom, brush on sides	0.040	0.050	0.080
3. Same, highest stage of flow	0.045	0.070	0.110
4. Dense brush, high stage	0.080	0.100	0.140

TABLE 10-4

MAXIMUM PERMISSIBLE VELOCITIES FOR EARTH CHANNELS WITH
VARIED GRASS LININGS AND SLOPES

<u>Channel Slope</u>	<u>Lining</u>	<u>Permissible Mean Channel Velocity *</u> (ft/sec)	
0 - 5%	Sodded grass	7	
	Bermudagrass	6	
	Reed canarygrass	5	
	Tall fescue	5	
	Kentucky bluegrass	5	
	Grass-legume mixture	4	
	Red fescue	2.5	
	Redtop	2.5	
	Sericea lespedeza	2.5	
	Annual lespedeza	2.5	
	Small grains (temporary)	2.5	
	5 - 10%	Sodded grass	6
		Bermudagrass	5
Reed canarygrass		4	
Tall fescue		4	
Kentucky bluegrass		4	
Grass-legume mixture		3	
Greater than 10%	Sodded grass	5	
	Bermudagrass	4	
	Reed canarygrass	3	
	Tall fescue	3	
	Kentucky bluegrass	3	

* For highly erodible soils, decrease permissible velocities by 25%.

* Grass lined channels are dependent upon assurances of continuous growth and maintenance of grass.

The complete line of RollMax™ products offers a variety of options for both short-term and permanent erosion control needs. Reference the RollMax Products Chart below to find the right solution for your next project.



RollMax Product Selection Chart

		TEMPORARY						
		ERONET						BIONET
								
		DS75	DS150	S75	S150	SC150	C125	S75BN
Longevity		45 days	60 days	12 mo.	12 mo.	24 mo.	36 mo.	12 mo.
Applications		Low Flow Channels 4:1-3:1 Slopes	Moderate Flow Channels 3:1-2:1 Slopes	Low Flow Channels 4:1-3:1 Slopes	Moderate Flow Channels 3:1-2:1 Slopes	Medium Flow Channels 2:1-1:1 Slopes	High-Flow Channels 1:1 and Greater Slopes	Low Flow Channels 4:1-3:1 Slopes
Design Permissible Shear Stress	lbs/ft ² (Pa)	Unvegetated 1.55 (74)	Unvegetated 1.75 (84)	Unvegetated 1.55 (74)	Unvegetated 1.75 (84)	Unvegetated 2.00 (96)	Unvegetated 2.25 (108)	Unvegetated 1.60 (76)
Design Permissible Velocity	ft/s (m/s)	Unvegetated 5.00 (1.52)	Unvegetated 6.00 (1.52)	Unvegetated 5.00 (1.2)	Unvegetated 6.00 (1.83)	Unvegetated 8.00 (2.44)	Unvegetated 10.00 (3.05)	Unvegetated 5.00 (1.52)
Top Net		Lightweight accelerated photodegradable polypropylene 1.50 lbs/1000 ft ² (0.73 kg/100 m ²) approx wt	Lightweight accelerated photodegradable polypropylene 1.50 lbs/1000 ft ² (0.73 kg/100 m ²) approx wt	Lightweight photodegradable polypropylene 1.50 lbs/1000 ft ² (0.73 kg/100 m ²) approx wt	Lightweight photodegradable polypropylene 1.50 lbs/1000 ft ² (0.73 kg/100 m ²) approx wt	Heavyweight UV-stabilized polypropylene 2.9 lbs/1000 ft ² (1.47 kg/100 m ²) approx wt	Heavyweight UV-stabilized polypropylene 2.9 lbs/1000 ft ² (1.47 kg/100 m ²) approx wt	Leno woven, 100% biodegradable jute fiber 9.30 lbs/1000 ft ² (4.53 kg/100 m ²) approx wt
Center Net		N/A	N/A	N/A	N/A	N/A	N/A	N/A
Fiber Matrix		Straw fiber 0.50 lbs/yd ² (0.27 kg/m ²)	Straw fiber 0.50 lbs/yd ² (0.27 kg/m ²)	Straw fiber 0.50 lbs/yd ² (0.27 kg/m ²)	Straw fiber 0.50 lbs/yd ² (0.27 kg/m ²)	Straw/coconut matrix 70% Straw 0.35 lbs/yd ² (0.19 kg/m ²) 30% Coconut 0.15 lbs/yd ² (0.08 kg/m ²)	Coconut fiber 0.50 lbs/yd ² (0.27 kg/m ²)	Straw fiber 0.50 lbs/yd ² (0.27 kg/m ²)
Bottom Net		N/A	Lightweight accelerated photodegradable polypropylene 1.50 lbs/1000 ft ² (0.73 kg/100 m ²) approx wt	N/A	Lightweight photodegradable polypropylene 1.50 lbs/1000 ft ² (0.73 kg/100 m ²) approx wt	Lightweight photodegradable polypropylene 1.50 lbs/1000 ft ² (0.73 kg/100 m ²) approx wt	Heavyweight UV-stabilized polypropylene 2.9 lbs/1000 ft ² (1.47 kg/100 m ²) approx wt	N/A
Thread		Accelerated degradable	Accelerated degradable	Degradable	Degradable	Degradable	UV-stabilized polypropylene	Biodegradable

**SILVERADO RANCH FILING NO. 2
DITCH CALCULATION SUMMARY**

PROPOSED ROADSIDE DITCHES

ROADWAY	SHEET	FROM STA	TO STA	SIDE	PROPOSED SLOPE (%)	SIDE SLOPE (Z)	CHANNEL DEPTH (FT)	FRICTION FACTOR (n)	ROW WIDTH (ft)	BASIN	Q100 FLOW (CFS)	DITCH FLOW % OF BASIN	DITCH FLOW (CFS)	Q100 DEPTH (FT)	Q100 FREEBOARD (FT)	Q100 VELOCITY (FT/S)	DITCH LINING
SILVERADO HILL VIEW - N	PP4	40+00	46+00	N	1.00	4:1/3:1	2.5	0.030	60	B4	82.3	20	16.5	1.2	1.3	3.4	GRASS
SILVERADO HILL VIEW - N	PP4	40+00	46+00	S	1.00	4:1/3:1	2.5	0.030	60	B6	103.6	5	5.2	0.8	1.7	2.5	GRASS
SILVERADO HILL VIEW - N	PP4	46+00	52+25	N	3.00	4:1/3:1	2.5	0.030	60	B4	82.3	40	32.9	1.2	1.3	6.1	GRASS / TRM
SILVERADO HILL VIEW - N	PP4	46+00	52+25	S	3.00	4:1/3:1	2.5	0.030	60	B6	103.6	10	10.4	0.8	1.7	4.6	GRASS
SILVERADO HILL VIEW - N	PP5	52+25	58+25	N	1.00	4:1/3:1	2.5	0.030	60	B4	82.3	20	16.5	1.2	1.3	3.4	GRASS
SILVERADO HILL VIEW - N	PP5	52+25	58+25	S	1.00	4:1/3:1	2.5	0.030	60	B6	103.6	5	5.2	0.8	1.7	2.5	GRASS
SILVERADO HILL VIEW - N	PP5	58+25	61+25	N	1.00	4:1/3:1	2.5	0.030	60	B7	42.5	10	4.3	0.7	1.8	2.4	GRASS
SILVERADO HILL VIEW - N	PP5	58+25	61+25	S	1.00	4:1/3:1	2.5	0.030	60	B6	103.6	5	5.2	0.8	1.7	2.5	GRASS

- 1) Channel flow calculations based on Manning's Equation
- 2) n = 0.03 for grass-lined non-irrigated channels (minimum)
- 3) n = 0.035 for riprap-lined channels
- 4) Vmax = 5.0 fps for 100-year flows w/ grass-lined channels
- 5) Vmax = 8.0 fps for 100-year flows w/ Turf Reinforcement Mat Lining (NAG C350 or equal)

Hydraulic Analysis Report

Project Data

Project Title: Project - Silverado Ranch Flg. 2 - Roadside Ditches
Designer: JPS
Project Date: Tuesday, January 30, 2024
Project Units: U.S. Customary Units
Notes:

Channel Analysis: Channel Analysis-Ditch-4000-4600-N

Notes:

Input Parameters

Channel Type: Triangular
Side Slope 1 (Z1): 4.0000 ft/ft
Side Slope 2 (Z2): 3.0000 ft/ft
Longitudinal Slope: 0.0100 ft/ft
Manning's n: 0.0300
Flow: 16.5000 cfs

Result Parameters

Depth: 1.1791 ft
Area of Flow: 4.8657 ft²
Wetted Perimeter: 8.5900 ft
Hydraulic Radius: 0.5664 ft
Average Velocity: 3.3911 ft/s
Top Width: 8.2535 ft
Froude Number: 0.7783
Critical Depth: 1.0710 ft
Critical Velocity: 4.1099 ft/s
Critical Slope: 0.0167 ft/ft
Critical Top Width: 7.65 ft
Calculated Max Shear Stress: 0.7357 lb/ft²
Calculated Avg Shear Stress: 0.3535 lb/ft²

SEE "DITCH CALCULATION
SUMMARY" TABLE FOR
FREEBOARD CALCULATIONS
DEMONSTRATING 1' MIN.
FREEBOARD

Channel Analysis: Channel Analysis-Ditch-4000-4600-S

Notes:

Input Parameters

Channel Type: Triangular
Side Slope 1 (Z1): 4.0000 ft/ft
Side Slope 2 (Z2): 3.0000 ft/ft
Longitudinal Slope: 0.0100 ft/ft
Manning's n: 0.0300
Flow: 5.2000 cfs

Result Parameters

Depth: 0.7647 ft
Area of Flow: 2.0466 ft²
Wetted Perimeter: 5.5711 ft
Hydraulic Radius: 0.3674 ft
Average Velocity: 2.5408 ft/s
Top Width: 5.3528 ft
Froude Number: 0.7241
Critical Depth: 0.6748 ft
Critical Velocity: 3.2624 ft/s
Critical Slope: 0.0195 ft/ft
Critical Top Width: 4.82 ft
Calculated Max Shear Stress: 0.4772 lb/ft²
Calculated Avg Shear Stress: 0.2292 lb/ft²

Channel Analysis: Channel Analysis-Ditch-4600-5225-N

Notes:

Input Parameters

Channel Type: Triangular
Side Slope 1 (Z1): 4.0000 ft/ft
Side Slope 2 (Z2): 3.0000 ft/ft
Longitudinal Slope: 0.0300 ft/ft
Manning's n: 0.0300
Flow: 32.9000 cfs

Result Parameters

Depth: 1.2430 ft
Area of Flow: 5.4077 ft²
Wetted Perimeter: 9.0558 ft
Hydraulic Radius: 0.5972 ft
Average Velocity: 6.0839 ft/s USE TRM DITCH LINING
Top Width: 8.7010 ft
Froude Number: 1.3600
Critical Depth: 1.4115 ft
Critical Velocity: 4.7182 ft/s
Critical Slope: 0.0152 ft/ft
Critical Top Width: 10.09 ft
Calculated Max Shear Stress: 2.3269 lb/ft²
Calculated Avg Shear Stress: 1.1179 lb/ft²

Channel Analysis: Channel Analysis-Ditch-4600-5225-S

Notes:

Input Parameters

Channel Type: Triangular
Side Slope 1 (Z1): 4.0000 ft/ft
Side Slope 2 (Z2): 3.0000 ft/ft
Longitudinal Slope: 0.0300 ft/ft
Manning's n: 0.0300
Flow: 10.4000 cfs

Result Parameters

Depth: 0.8071 ft
Area of Flow: 2.2798 ft²
Wetted Perimeter: 5.8798 ft
Hydraulic Radius: 0.3877 ft
Average Velocity: 4.5619 ft/s
Top Width: 5.6495 ft
Froude Number: 1.2655
Critical Depth: 0.8905 ft
Critical Velocity: 3.7475 ft/s
Critical Slope: 0.0178 ft/ft
Critical Top Width: 6.36 ft
Calculated Max Shear Stress: 1.5108 lb/ft²
Calculated Avg Shear Stress: 0.7258 lb/ft²

Channel Analysis: Channel Analysis-Ditch-5225-5825-N

Notes:

Input Parameters

Channel Type: Triangular
Side Slope 1 (Z1): 4.0000 ft/ft
Side Slope 2 (Z2): 3.0000 ft/ft
Longitudinal Slope: 0.0100 ft/ft
Manning's n: 0.0300
Flow: 16.5000 cfs

Result Parameters

Depth: 1.1791 ft
Area of Flow: 4.8657 ft²
Wetted Perimeter: 8.5900 ft
Hydraulic Radius: 0.5664 ft
Average Velocity: 3.3911 ft/s
Top Width: 8.2535 ft
Froude Number: 0.7783
Critical Depth: 1.0710 ft
Critical Velocity: 4.1099 ft/s
Critical Slope: 0.0167 ft/ft
Critical Top Width: 7.65 ft
Calculated Max Shear Stress: 0.7357 lb/ft²
Calculated Avg Shear Stress: 0.3535 lb/ft²

Channel Analysis: Channel Analysis-Ditch-5225-2825-S

Notes:

Input Parameters

Channel Type: Triangular
Side Slope 1 (Z1): 4.0000 ft/ft
Side Slope 2 (Z2): 3.0000 ft/ft
Longitudinal Slope: 0.0100 ft/ft
Manning's n: 0.0300
Flow: 5.2000 cfs

Result Parameters

Depth: 0.7647 ft
Area of Flow: 2.0466 ft²
Wetted Perimeter: 5.5711 ft
Hydraulic Radius: 0.3674 ft
Average Velocity: 2.5408 ft/s
Top Width: 5.3528 ft
Froude Number: 0.7241
Critical Depth: 0.6748 ft
Critical Velocity: 3.2624 ft/s
Critical Slope: 0.0195 ft/ft
Critical Top Width: 4.82 ft
Calculated Max Shear Stress: 0.4772 lb/ft²
Calculated Avg Shear Stress: 0.2292 lb/ft²

Channel Analysis: Channel Analysis-Ditch-5825-6125-N

Notes:

Input Parameters

Channel Type: Triangular
Side Slope 1 (Z1): 4.0000 ft/ft
Side Slope 2 (Z2): 3.0000 ft/ft
Longitudinal Slope: 0.0100 ft/ft
Manning's n: 0.0300
Flow: 4.3000 cfs

Result Parameters

Depth: 0.7121 ft
Area of Flow: 1.7748 ft²
Wetted Perimeter: 5.1878 ft
Hydraulic Radius: 0.3421 ft
Average Velocity: 2.4229 ft/s
Top Width: 4.9846 ft
Froude Number: 0.7156
Critical Depth: 0.6254 ft
Critical Velocity: 3.1407 ft/s
Critical Slope: 0.0200 ft/ft
Critical Top Width: 4.47 ft
Calculated Max Shear Stress: 0.4443 lb/ft²
Calculated Avg Shear Stress: 0.2135 lb/ft²

Channel Analysis: Channel Analysis-Ditch-5825-6125-S

Notes:

Input Parameters

Channel Type: Triangular
Side Slope 1 (Z1): 4.0000 ft/ft
Side Slope 2 (Z2): 3.0000 ft/ft
Longitudinal Slope: 0.0100 ft/ft
Manning's n: 0.0300
Flow: 5.2000 cfs

Result Parameters

Depth: 0.7647 ft
Area of Flow: 2.0466 ft²
Wetted Perimeter: 5.5711 ft
Hydraulic Radius: 0.3674 ft
Average Velocity: 2.5408 ft/s
Top Width: 5.3528 ft
Froude Number: 0.7241
Critical Depth: 0.6748 ft
Critical Velocity: 3.2624 ft/s
Critical Slope: 0.0195 ft/ft
Critical Top Width: 4.82 ft
Calculated Max Shear Stress: 0.4772 lb/ft²
Calculated Avg Shear Stress: 0.2292 lb/ft²

SEE "DITCH CALCULATION
SUMMARY" TABLE FOR
FREEBOARD CALCULATIONS
DEMONSTRATING 1' MIN.
FREEBOARD

**SILVERADO RANCH - FILING NO. 2
CHANNEL CALCULATIONS
DEVELOPED FLOWS**

PROPOSED CHANNELS

CHANNEL	DESIGN POINT	PROPOSED SLOPE (%)	BOTTOM WIDTH (B, FT)	SIDE SLOPE (Z)	CHANNEL DEPTH (FT)	FRICTION FACTOR (n)	Q100 FLOW (CFS)	Q100 DEPTH (FT)	Q100 FREEBOARD (FT)	Q100 VELOCITY (FT/S)	CHANNEL LINING
B1.1	B1.1	0.40	12	4:1	3.0	0.030	102.9	1.6	1.4	3.5	GRASS
B4.1	B4.1	0.45	10	4:1	2.0	0.030	38.6	1.0	1.0	2.8	GRASS

- 1) Channel flow calculations based on Manning's Equation
- 2) Channel depth includes 1' minimum freeboard
- 3) n = 0.03 for grass-lined non-irrigated channels (minimum)
- 4) n = 0.035 for riprap-lined channels
- 5) Vmax = 5.0 fps per El Paso County criteria (p. 10-13) for fescue (dry land grass) for 100-year flows
- 6) Vmax = 8.0 fps with Erosion Control Blankets (NAG C350 or equal)

Hydraulic Analysis Report

Project Data

Project Title: Project - Silverado Ranch Fig. 2 - Channels
Designer: JPS
Project Date: Tuesday, January 30, 2024
Project Units: U.S. Customary Units
Notes:

Channel Analysis: Channel Analysis-B1.1

Notes:

Input Parameters

Channel Type: Trapezoidal
Side Slope 1 (Z1): 4.0000 ft/ft
Side Slope 2 (Z2): 4.0000 ft/ft
Channel Width: 12.0000 ft
Longitudinal Slope: 0.0040 ft/ft
Manning's n: 0.0300
Flow: 93.0000 cfs

Result Parameters

Depth: 1.5212 ft
Area of Flow: 27.5109 ft²
Wetted Perimeter: 24.5442 ft
Hydraulic Radius: 1.1209 ft
Average Velocity: 3.3805 ft/s
Top Width: 24.1697 ft
Froude Number: 0.5584
Critical Depth: 1.0840 ft
Critical Velocity: 5.2519 ft/s
Critical Slope: 0.0141 ft/ft
Critical Top Width: 20.67 ft
Calculated Max Shear Stress: 0.3797 lb/ft²
Calculated Avg Shear Stress: 0.2798 lb/ft²

Channel Analysis: Channel Analysis-B4.1

Notes:

Input Parameters

Channel Type: Triangular
Side Slope 1 (Z1): 4.0000 ft/ft
Side Slope 2 (Z2): 4.0000 ft/ft
Longitudinal Slope: 0.0045 ft/ft
Manning's n: 0.0300
Flow: 30.4000 cfs

Result Parameters

Depth: 1.6341 ft
Area of Flow: 10.6817 ft²
Wetted Perimeter: 13.4755 ft
Hydraulic Radius: 0.7927 ft
Average Velocity: 2.8460 ft/s
Top Width: 13.0731 ft
Froude Number: 0.5549
Critical Depth: 1.2911 ft
Critical Velocity: 4.5592 ft/s
Critical Slope: 0.0158 ft/ft
Critical Top Width: 10.33 ft
Calculated Max Shear Stress: 0.4589 lb/ft²
Calculated Avg Shear Stress: 0.2226 lb/ft²

**SILVERADO RANCH FILING NO. 2
CULVERT DESIGN SUMMARY**

BASIN	DESIGN POINT	RD CL ELEV	INV IN ELEV	INV OUT ELEV	PIPE LENGTH (FT)	N0. OF PIPES	PIPE DIA (FT)	TOTAL Q ₅ (CFS)	PER PIPE Q ₅ (CFS)	Q ₅ MAX ALLOWABLE HEADWATER ¹	CALC Q ₅ HW ELEV	TOTAL Q ₁₀₀ (CFS)	PER PIPE Q ₁₀₀ (CFS)	Q ₁₀₀ MAX ALLOWABLE HEADWATER ²	CALC Q ₁₀₀ HW ELEV
SILVERADO HILL VIEW:															
B1.1	B1.1	5822.16	5816.35	5816.00	70.0	1	3.5	14.3	14.3	5819.9	5817.9	102.9	102.9	5822.34	5822.2
B4.1	B4.1	5801.03	5797.53	5797.13	70.0	1	2.0	5.8	5.8	5799.5	5798.7	38.6	38.6	5801.21	5801.17

¹ Q₅ MAX. ALLOWABLE HEADWATER, HW/D = 1.0

² Q₁₀₀ MAX. ALLOWABLE HEADWATER = 6" DEPTH AT SHOULDER (PER DCM TABLE 6-1)

HY-8 Culvert Analysis Report

Crossing Discharge Data – Culvert B1.1

Discharge Selection Method: Specify Minimum, Design, and Maximum Flow

Minimum Flow: 5.00 cfs

Design Flow: 14.30 cfs

Maximum Flow: 102.90 cfs

Table 1 - Summary of Culvert Flows at Crossing: Crossing B1.1

Headwater Elevation (ft)	Total Discharge (cfs)	Culvert B1.1 Discharge (cfs)	Roadway Discharge (cfs)	Iterations
5817.25	5.00	5.00	0.00	1
5817.92	14.30	14.30	0.00	1
5818.49	24.58	24.58	0.00	1
5818.95	34.37	34.37	0.00	1
5819.35	44.16	44.16	0.00	1
5819.74	53.95	53.95	0.00	1
5820.24	63.74	63.74	0.00	1
5820.64	73.53	73.53	0.00	1
5821.13	83.32	83.32	0.00	1
5821.71	93.11	93.11	0.00	1
5822.20	102.90	100.50	2.18	19
5822.16	99.89	99.89	0.00	Overtopping

Rating Curve Plot for Crossing: Crossing B1.1

Total Rating Curve
Crossing: Crossing B1.1

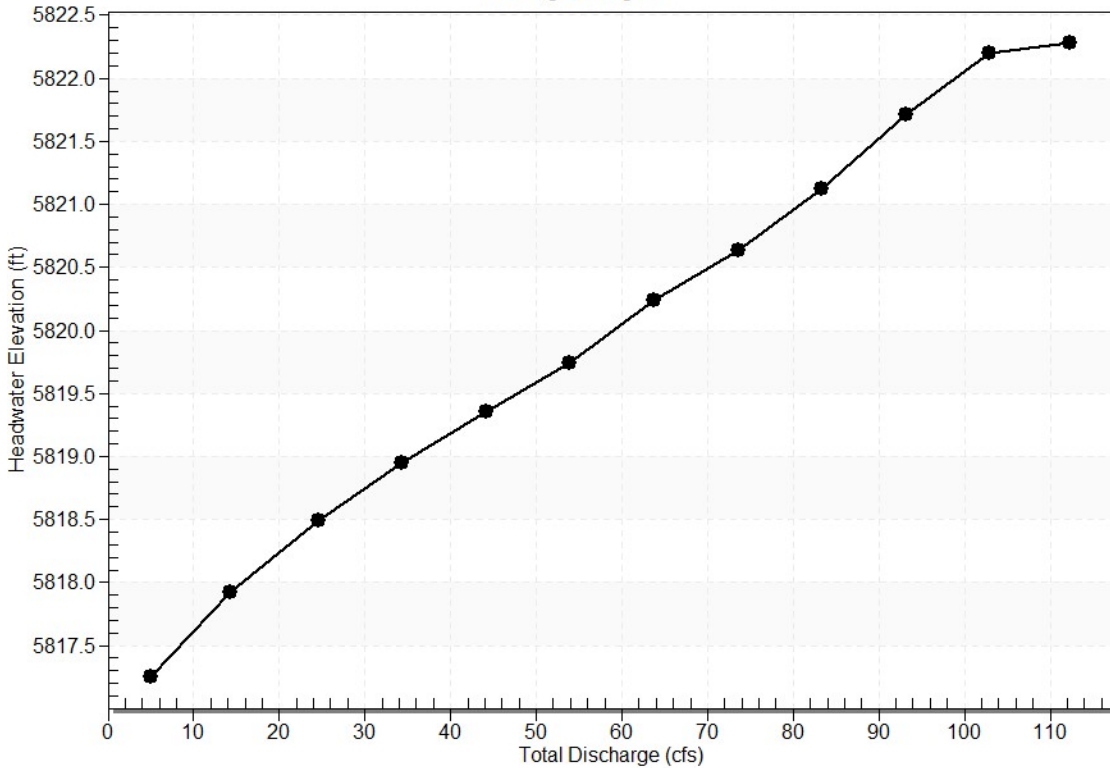

Culvert Data: Culvert B1.1

Table 1 - Culvert Summary Table: Culvert B1.1

Total Discharge (cfs)	Culvert Discharge (cfs)	Headwater Elevation (ft)	Inlet Control Depth (ft)	Outlet Control Depth (ft)	Flow Type	Normal Depth (ft)	Critical Depth (ft)	Outlet Depth (ft)	Tailwater Depth (ft)	Outlet Velocity (ft/s)	Tailwater Velocity (ft/s)
5.00 cfs	5.00 cfs	5817.25	0.90	0.327	1-S2n	0.63	0.67	0.63	0.51	4.27	1.63
14.30 cfs	14.30 cfs	5817.92	1.57	0.856	1-S2n	1.06	1.15	1.06	0.87	5.79	2.19
24.58 cfs	24.58 cfs	5818.49	2.14	1.338	1-S2n	1.42	1.52	1.42	1.14	6.70	2.53
34.37 cfs	34.37 cfs	5818.95	2.60	1.786	1-S2n	1.71	1.82	1.71	1.33	7.32	2.77

44.16 cfs	44.16 cfs	5819.3 5	3.00	2.24 8	1- S2 n	1.99	2.07	2.0 0	1.50	7.78	2.95
53.95 cfs	53.95 cfs	5819.7 4	3.39	2.73 4	1- S2 n	2.28	2.30	2.2 8	1.64	8.15	3.11
63.74 cfs	63.74 cfs	5820.2 4	3.81	3.89 1	7- M2 c	2.58	2.50	2.5 0	1.77	8.66	3.25
73.53 cfs	73.53 cfs	5820.6 4	4.26	4.28 7	7- M2 c	2.98	2.68	2.6 8	1.89	9.28	3.37
83.32 cfs	83.32 cfs	5821.1 3	4.78	4.72 0	7- M2 c	3.50	2.85	2.8 5	2.00	9.94	3.48
93.11 cfs	93.11 cfs	5821.7 1	5.36	5.21 8	7- M2 c	3.50	2.98	2.9 8	2.10	10.6 5	3.58
102.9 0 cfs	100.5 0 cfs	5822.2 0	5.85	5.67 1	7- M2 c	3.50	3.07	3.0 7	2.19	11.2 2	3.67

Culvert Barrel Data

Culvert Barrel Type Straight Culvert

Inlet Elevation (invert): 5816.35 ft,

Outlet Elevation (invert): 5816.00 ft

Culvert Length: 70.00 ft,

Culvert Slope: 0.0050

Culvert Performance Curve Plot: Culvert B1.1

Performance Curve
Culvert: Culvert B1.1

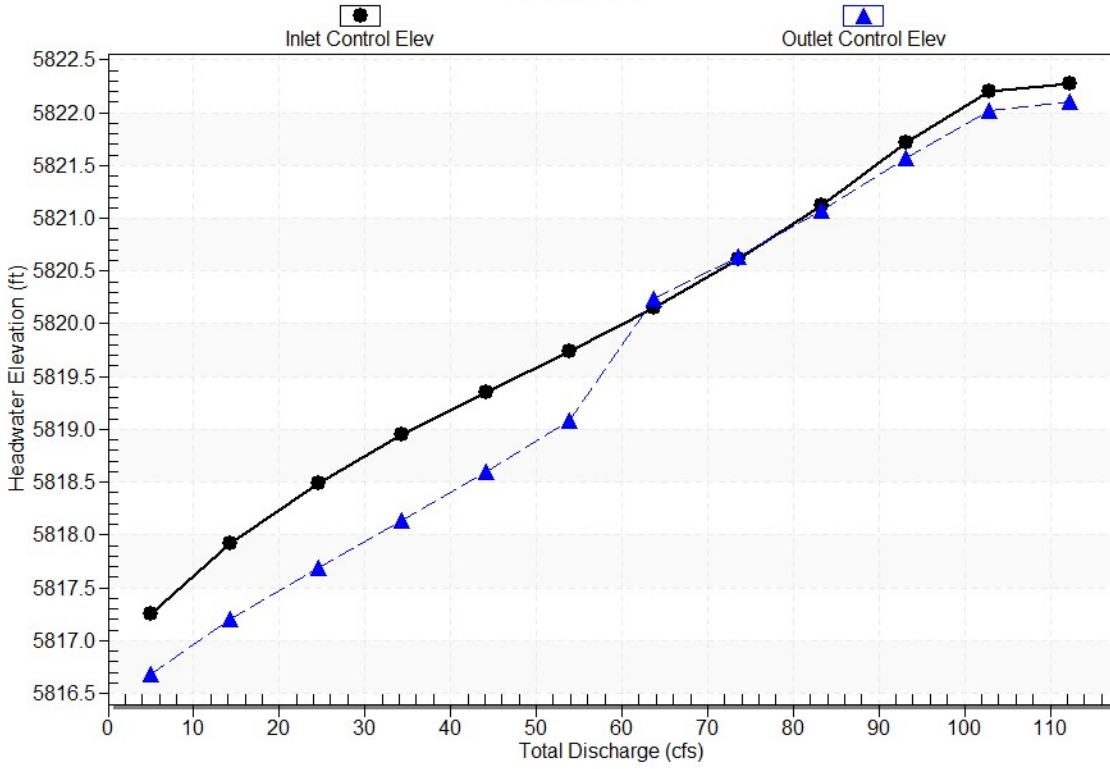

Water Surface Profile Plot for Culvert: Culvert B1.1

Crossing - Crossing B1.1, Design Discharge - 14.3 cfs
Culvert - Culvert B1.1, Culvert Discharge - 14.3 cfs

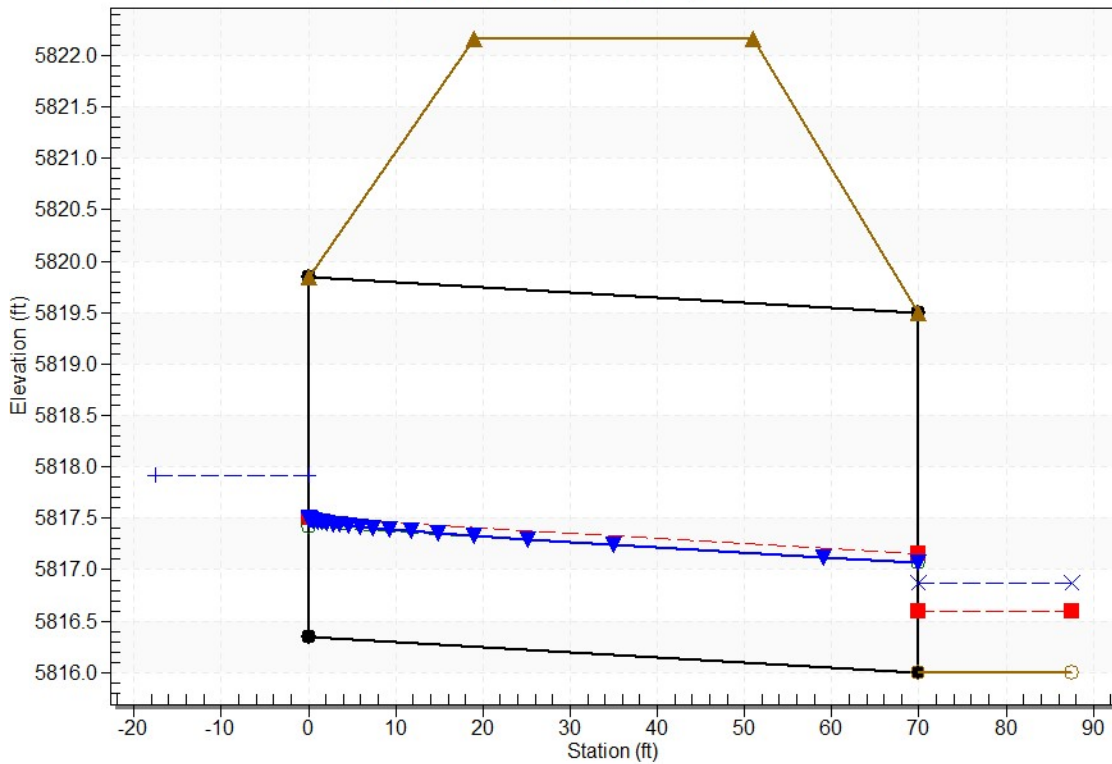

Site Data - Culvert B1.1

Site Data Option: Culvert Invert Data

Inlet Station: 0.00 ft

Inlet Elevation: 5816.35 ft

Outlet Station: 70.00 ft

Outlet Elevation: 5816.00 ft

Number of Barrels: 1

Culvert Data Summary - Culvert B1.1

Barrel Shape: Circular

Barrel Diameter: 3.50 ft

Barrel Material: Concrete

Embedment: 0.00 in

Barrel Manning's n: 0.0130

Culvert Type: Straight

Inlet Configuration: Grooved End Projecting (Ke=0.2)

Inlet Depression: None

Tailwater Data for Crossing: Crossing B1.1

Table 2 - Downstream Channel Rating Curve (Crossing: Crossing B1.1)

Flow (cfs)	Water Surface Elev (ft)	Velocity (ft/s)	Depth (ft)	Shear (psf)	Froude Number
5.00	5816.51	0.51	1.63	0.13	0.47
14.30	5816.87	0.87	2.19	0.22	0.50
24.58	5817.14	1.14	2.53	0.28	0.52
34.37	5817.33	1.33	2.77	0.33	0.53
44.16	5817.50	1.50	2.95	0.37	0.54
53.95	5817.64	1.64	3.11	0.41	0.54
63.74	5817.77	1.77	3.25	0.44	0.55
73.53	5817.89	1.89	3.37	0.47	0.56
83.32	5818.00	2.00	3.48	0.50	0.56
93.11	5818.10	2.10	3.58	0.52	0.56
102.90	5818.19	2.19	3.67	0.55	0.57

Tailwater Channel Data - Crossing B1.1

Tailwater Channel Option: Trapezoidal Channel

Bottom Width: 4.00 ft

Side Slope (H:V): 4.00 (:1)

Channel Slope: 0.0040

Channel Manning's n: 0.0300

Channel Invert Elevation: 5816.00 ft

Roadway Data for Crossing: Crossing B1.1

Roadway Profile Shape: Constant Roadway Elevation

Crest Length: 100.00 ft

Crest Elevation: 5822.16 ft

Roadway Surface: Gravel

Roadway Top Width: 32.00 ft

Crossing Discharge Data – Culvert B4.1

Discharge Selection Method: Specify Minimum, Design, and Maximum Flow

Minimum Flow: 3.00 cfs

Design Flow: 5.80 cfs

Maximum Flow: 38.60 cfs

Table 3 - Summary of Culvert Flows at Crossing: Crossing B4.1

Headwater Elevation (ft)	Total Discharge (cfs)	Culvert B4.1 Discharge (cfs)	Roadway Discharge (cfs)	Iterations
5798.35	3.00	3.00	0.00	1
5798.72	5.80	5.80	0.00	1
5799.17	10.12	10.12	0.00	1
5799.57	13.68	13.68	0.00	1
5799.90	17.24	17.24	0.00	1
5800.31	20.80	20.80	0.00	1
5800.94	24.36	24.36	0.00	1
5801.08	27.92	25.17	2.61	9
5801.11	31.48	25.36	5.97	4
5801.14	35.04	25.50	9.47	4
5801.17	38.60	25.63	12.81	3
5801.03	24.88	24.88	0.00	Overtopping

Rating Curve Plot for Crossing: Crossing B4.1

Total Rating Curve
Crossing: Crossing B4.1

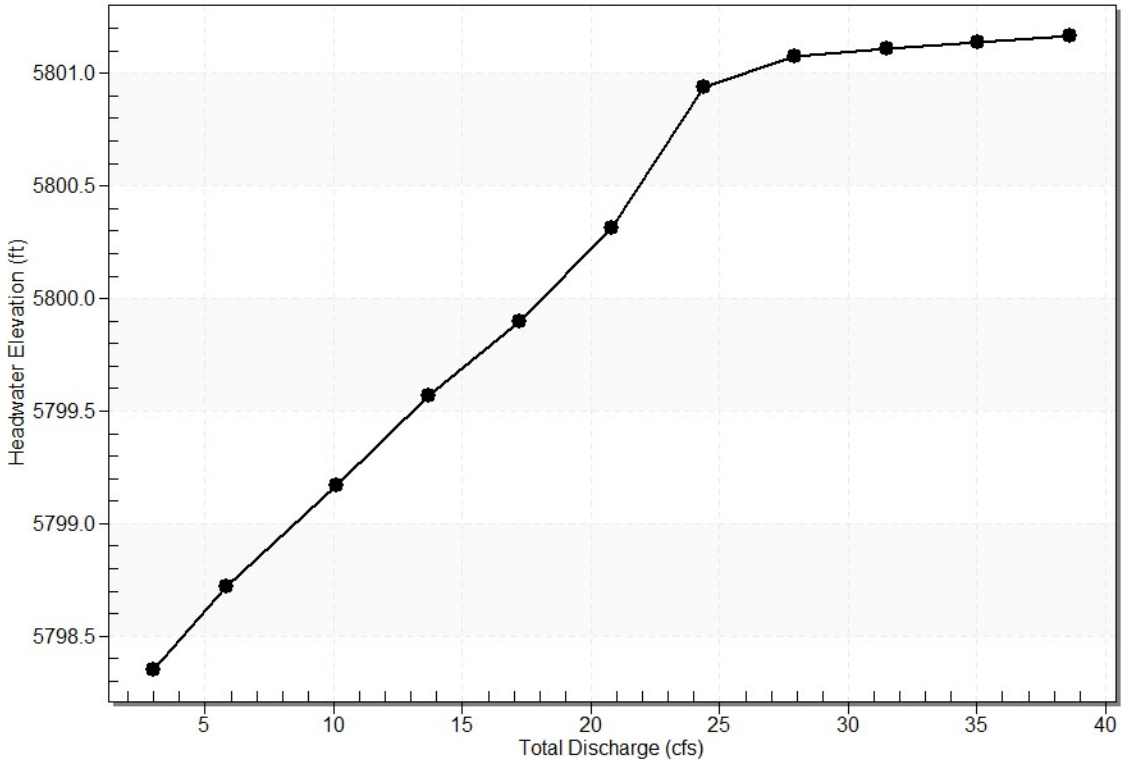

Culvert Data: Culvert B4.1

Table 2 - Culvert Summary Table: Culvert B4.1

Total Discharge (cfs)	Culvert Discharge (cfs)	Headwater Elevation (ft)	Inlet Control Depth (ft)	Outlet Control Depth (ft)	Flow Type	Normal Depth (ft)	Critical Depth (ft)	Outlet Depth (ft)	Tailwater Depth (ft)	Outlet Velocity (ft/s)	Tailwater Velocity (ft/s)
3.00 cfs	3.00 cfs	5798.35	0.82	0.315	1- JS1 t	0.57	0.60	0.69	0.69	3.15	1.60
5.80 cfs	5.80 cfs	5798.72	1.19	0.587	1- S2 n	0.80	0.85	0.80	0.88	4.93	1.88
10.12 cfs	10.12 cfs	5799.17	1.64	1.071	1- S2 n	1.11	1.14	1.11	1.08	5.68	2.16
13.68 cfs	13.68 cfs	5799.57	1.97	2.035	7- M2 c	1.35	1.33	1.33	1.21	6.16	2.33

17.24 cfs	17.24 cfs	5799.9 0	2.33	2.36 8	7- M2 c	1.65	1.50	1.5 0	1.32	6.84	2.47
20.80 cfs	20.80 cfs	5800.3 1	2.76	2.78 4	7- M2 c	2.00	1.63	1.6 3	1.42	7.57	2.59
24.36 cfs	24.36 cfs	5800.9 4	3.27	3.40 8	7- M2 c	2.00	1.74	1.7 4	1.50	8.38	2.69
27.92 cfs	25.17 cfs	5801.0 8	3.40	3.54 7	7- M2 c	2.00	1.77	1.7 7	1.58	8.57	2.79
31.48 cfs	25.36 cfs	5801.1 1	3.43	3.58 2	7- M2 c	2.00	1.77	1.7 7	1.66	8.62	2.87
35.04 cfs	25.50 cfs	5801.1 4	3.46	3.60 7	7- M2 c	2.00	1.77	1.7 7	1.72	8.66	2.95
38.60 cfs	25.63 cfs	5801.1 7	3.48	3.63 5	7- M2 t	2.00	1.78	1.7 9	1.79	8.65	3.02

Culvert Barrel Data

Culvert Barrel Type Straight Culvert

Inlet Elevation (invert): 5797.53 ft,

Outlet Elevation (invert): 5797.13 ft

Culvert Length: 70.00 ft,

Culvert Slope: 0.0057

Culvert Performance Curve Plot: Culvert B4.1

Performance Curve

Culvert: Culvert B4.1

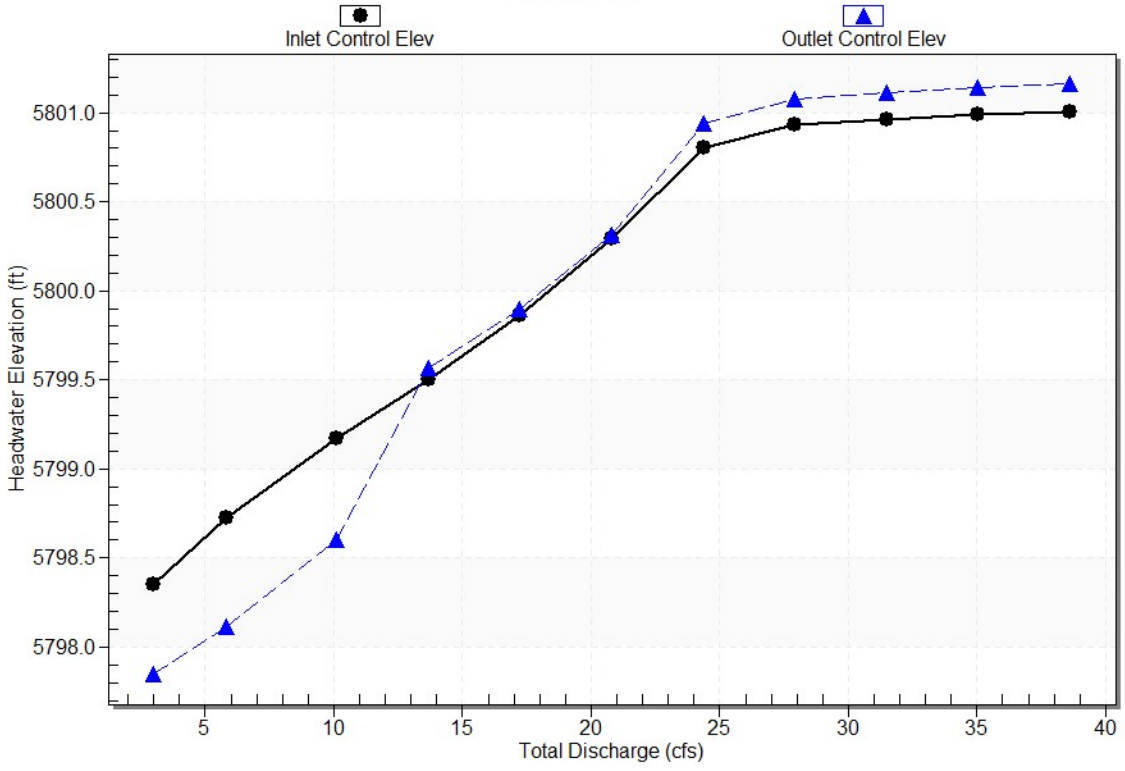

Water Surface Profile Plot for Culvert: Culvert B4.1

Crossing - Crossing B4.1, Design Discharge - 5.8 cfs
Culvert - Culvert B4.1, Culvert Discharge - 5.8 cfs

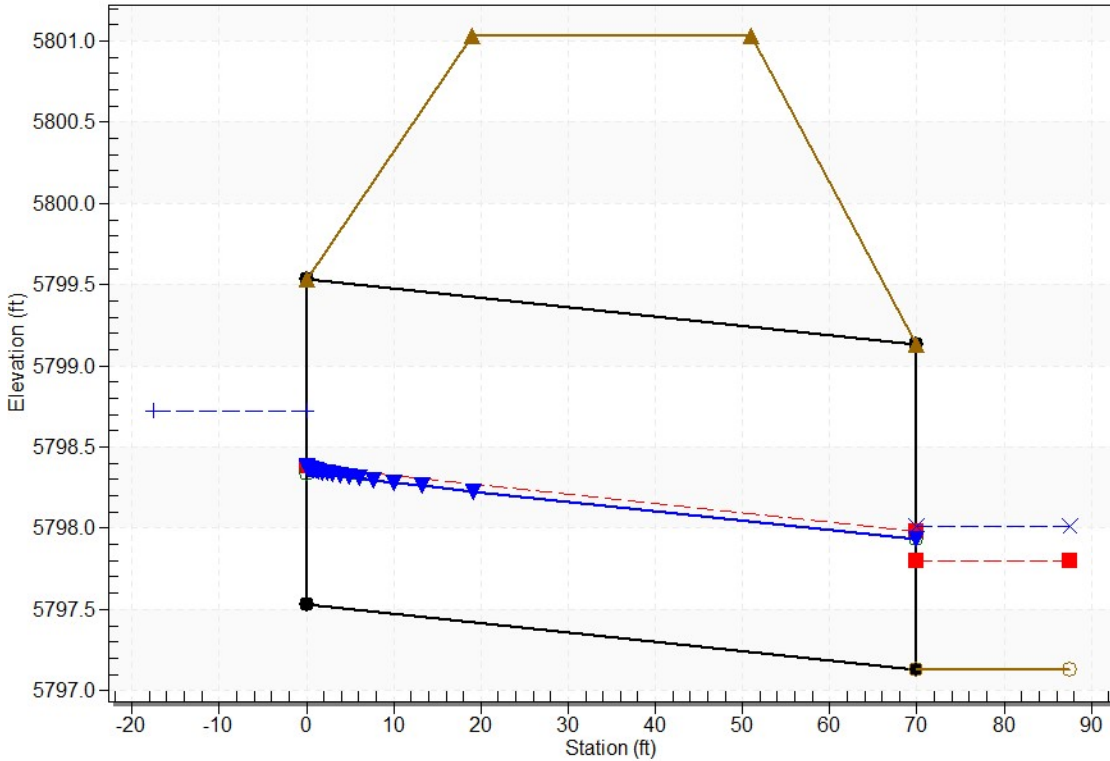

Site Data - Culvert B4.1

Site Data Option: Culvert Invert Data

Inlet Station: 0.00 ft

Inlet Elevation: 5797.53 ft

Outlet Station: 70.00 ft

Outlet Elevation: 5797.13 ft

Number of Barrels: 1

Culvert Data Summary - Culvert B4.1

Barrel Shape: Circular

Barrel Diameter: 2.00 ft

Barrel Material: Concrete

Embedment: 0.00 in

Barrel Manning's n: 0.0130

Culvert Type: Straight

Inlet Configuration: Grooved End Projecting (Ke=0.2)

Inlet Depression: None

Tailwater Data for Crossing: Crossing B4.1

Table 4 - Downstream Channel Rating Curve (Crossing: Crossing B4.1)

Flow (cfs)	Water Surface Elev (ft)	Velocity (ft/s)	Depth (ft)	Shear (psf)	Froude Number
3.00	5797.82	0.69	1.60	0.19	0.48
5.80	5798.01	0.88	1.88	0.25	0.50
10.12	5798.21	1.08	2.16	0.30	0.52
13.68	5798.34	1.21	2.33	0.34	0.53
17.24	5798.45	1.32	2.47	0.37	0.54
20.80	5798.55	1.42	2.59	0.40	0.54
24.36	5798.63	1.50	2.69	0.42	0.55
27.92	5798.71	1.58	2.79	0.44	0.55
31.48	5798.79	1.66	2.87	0.46	0.56
35.04	5798.85	1.72	2.95	0.48	0.56
38.60	5798.92	1.79	3.02	0.50	0.56

Tailwater Channel Data - Crossing B4.1

Tailwater Channel Option: Triangular Channel

Side Slope (H:V): 4.00 (:1)

Channel Slope: 0.0045

Channel Manning's n: 0.0300

Channel Invert Elevation: 5797.13 ft

Roadway Data for Crossing: Crossing B4.1

Roadway Profile Shape: Constant Roadway Elevation

Crest Length: 100.00 ft

Crest Elevation: 5801.03 ft

Roadway Surface: Gravel

Roadway Top Width: 32.00 ft

SILVERAD RANCH FILING NO. 1 - SPILLWAY MODELING (OVERTOPPING OF ROADWAYS)

DESIGN POINT	DESIGN FEATURE	Q100 FLOW (CFS)	Q100 DEPTH (FT)	Q100 LENGTH (FT)
OA1	OVERTOPPING DRENNAN ROAD	165.3	1.0	55.1
OB1	OVERTOPPING DRENNAN ROAD	113.7	0.7	64.7
OB2	OVERTOPPING DRENNAN ROAD	16.6	0.5	15.7

- 1) Overtopping calculations based on Broad-Crested Weir Flow
- 2) $Q = (3.0 * L * H^{1.5})$
- 3) $L = Q / (3 * H^{1.5})$

APPENDIX E

STORMWATER QUALITY / PLD CALCULATIONS

SILVERADO RANCH
COMPOSITE IMPERVIOUS AREAS

DEVELOPED CONDITIONS												
IMPERVIOUS AREAS												
BASIN	TOTAL AREA (AC)	SOIL TYPE	(AC)	SUB-AREA 1 DEVELOPMENT/COVER	% IMP	AREA (AC)	SUB-AREA 2 DEVELOPMENT/COVER	% IMP	(AC)	SUB-AREA 3 DEVELOPMENT/COVER	% IMP	WEIGHTED % IMP
OA1	1314.6	B	1314.6	MEADOW	2							2.00
OA2	18	B	18	MEADOW	2							2.00
A1	24.5	B	24.5	5 AC LOTS	7							7.00
OA1,OA2,A1	1357.1	B										2.09
OB1	841.5	B	841.5	MEADOW	2							2.00
B1.1	2.98	B	2.98	5 AC LOTS	7							7.00
OB1,B1.1	844.48	B										2.02
OB2	61.9	B	61.9	MEADOW	2							2.00
B4	28.4	B	28.4	5 AC LOTS	7							7.00
OB2,B4	90.3	B										3.57
B (A5-A6,B1-3,B5-B6)	155.1	B	155.1	5 AC LOTS	7							7.00
OA1-OB2,A1,B	2446.98	B										2.43
B7	34.0	B	34	5 AC LOTS	7							7.00
OA1-OB2,A1,B	2481.0	B										2.49

Design Procedure Form: Rain Garden (RG)

UD-BMP (Version 3.07, March 2018)

Sheet 1 of 2

Designer: JPS
Company: JPS
Date: June 7, 2024
Project: SILVERADO RANCH FILING NO. 2
Location: PLD-A

<p>1. Basin Storage Volume</p> <p>A) Effective Imperviousness of Tributary Area, I_a (100% if all paved and roofed areas upstream of rain garden)</p> <p>B) Tributary Area's Imperviousness Ratio ($i = I_a/100$)</p> <p>C) Water Quality Capture Volume (WQCV) for a 12-hour Drain Time ($WQCV = 0.8 * (0.91 * i^3 - 1.19 * i^2 + 0.78 * i)$)</p> <p>D) Contributing Watershed Area (including rain garden area)</p> <p>E) Water Quality Capture Volume (WQCV) Design Volume $Vol = (WQCV / 12) * Area$</p> <p>F) For Watersheds Outside of the Denver Region, Depth of Average Runoff Producing Storm</p> <p>G) For Watersheds Outside of the Denver Region, Water Quality Capture Volume (WQCV) Design Volume</p> <p>H) User Input of Water Quality Capture Volume (WQCV) Design Volume (Only if a different WQCV Design Volume is desired)</p>	<p>$I_a =$ <input type="text" value="2.1"/> %</p> <p>$i =$ <input type="text" value="0.021"/></p> <p>WQCV = <input type="text" value="0.01"/> watershed inches</p> <p>Area = <input type="text" value="59,115,276"/> sq ft</p> <p>$V_{WQCV} =$ <input type="text" value="62,231"/> cu ft</p> <p>$d_g =$ <input type="text" value=""/> in</p> <p>$V_{WQCV\ OTHER} =$ <input type="text" value=""/> cu ft</p> <p>$V_{WQCV\ USER} =$ <input type="text" value=""/> cu ft</p>
<p>2. Basin Geometry</p> <p>A) WQCV Depth (12-inch maximum)</p> <p>B) Rain Garden Side Slopes ($Z = 4$ min., horiz. dist per unit vertical) (Use "0" if rain garden has vertical walls)</p> <p>C) Minimum Flat Surface Area</p> <p>D) Actual Flat Surface Area</p> <p>E) Area at Design Depth (Top Surface Area)</p> <p>F) Rain Garden Total Volume ($V_T = ((A_{Top} + A_{Actual}) / 2) * Depth$)</p>	<p>$D_{WQCV} =$ <input type="text" value="12"/> in</p> <p>$Z =$ <input type="text" value="4.00"/> ft / ft</p> <p>$A_{Min} =$ <input type="text" value="24710"/> sq ft</p> <p>$A_{Actual} =$ <input type="text" value="289427"/> sq ft</p> <p>$A_{Top} =$ <input type="text" value="377975"/> sq ft</p> <p>$V_T =$ <input type="text" value="333,701"/> cu ft</p>
<p>3. Growing Media</p>	<div style="border: 1px solid black; padding: 5px;"> <p>Choose One</p> <p><input type="radio"/> 18" Rain Garden Growing Media</p> <p><input checked="" type="radio"/> Other (Explain):</p> <p style="margin-left: 20px;">Existing Grass-lined Meadow</p> </div>
<p>4. Underdrain System</p> <p>A) Are underdrains provided?</p> <p>B) Underdrain system orifice diameter for 12 hour drain time</p> <p style="margin-left: 20px;">i) Distance From Lowest Elevation of the Storage Volume to the Center of the Orifice</p> <p style="margin-left: 20px;">ii) Volume to Drain in 12 Hours</p> <p style="margin-left: 20px;">iii) Orifice Diameter, 3/8" Minimum</p>	<div style="border: 1px solid black; padding: 5px;"> <p>Choose One</p> <p><input type="radio"/> YES</p> <p><input checked="" type="radio"/> NO</p> </div> <p>$y =$ <input type="text" value="N/A"/> ft</p> <p>$Vol_{12} =$ <input type="text" value="N/A"/> cu ft</p> <p>$D_o =$ <input type="text" value="N/A"/> in</p>

Design Procedure Form: Rain Garden (RG)

Sheet 2 of 2

Designer: JPS
Company: JPS
Date: June 7, 2024
Project: SILVERADO RANCH FILING NO. 2
Location: PLD-A

<p>5. Impermeable Geomembrane Liner and Geotextile Separator Fabric</p> <p>A) Is an impermeable liner provided due to proximity of structures or groundwater contamination?</p>	<p>Choose One</p> <p><input type="radio"/> YES</p> <p><input type="radio"/> NO</p>
<p>6. Inlet / Outlet Control</p> <p>A) Inlet Control</p>	<p>Choose One</p> <p><input type="radio"/> Sheet Flow- No Energy Dissipation Required</p> <p><input checked="" type="radio"/> Concentrated Flow- Energy Dissipation Provided</p>
<p>7. Vegetation</p>	<p>Choose One</p> <p><input checked="" type="radio"/> Seed (Plan for frequent weed control)</p> <p><input type="radio"/> Plantings</p> <p><input type="radio"/> Sand Grown or Other High Infiltration Sod</p>
<p>8. Irrigation</p> <p>A) Will the rain garden be irrigated?</p>	<p>Choose One</p> <p><input type="radio"/> YES</p> <p><input checked="" type="radio"/> NO</p>
<p>Notes: _____</p> <p>_____</p> <p>_____</p>	

Design Procedure Form: Rain Garden (RG)

UD-BMP (Version 3.07, March 2018)

Sheet 1 of 2

Designer: JPS
Company: JPS
Date: June 7, 2024
Project: SILVERADO RANCH FILING NO. 2
Location: PLD-B

<p>1. Basin Storage Volume</p> <p>A) Effective Imperviousness of Tributary Area, I_a (100% if all paved and roofed areas upstream of rain garden)</p> <p>B) Tributary Area's Imperviousness Ratio ($i = I_a/100$)</p> <p>C) Water Quality Capture Volume (WQCV) for a 12-hour Drain Time ($WQCV = 0.8 * (0.91 * i^3 - 1.19 * i^2 + 0.78 * i)$)</p> <p>D) Contributing Watershed Area (including rain garden area)</p> <p>E) Water Quality Capture Volume (WQCV) Design Volume $Vol = (WQCV / 12) * Area$</p> <p>F) For Watersheds Outside of the Denver Region, Depth of Average Runoff Producing Storm</p> <p>G) For Watersheds Outside of the Denver Region, Water Quality Capture Volume (WQCV) Design Volume</p> <p>H) User Input of Water Quality Capture Volume (WQCV) Design Volume (Only if a different WQCV Design Volume is desired)</p>	<p>$I_a =$ <input type="text" value="2.5"/> %</p> <p>$i =$ <input type="text" value="0.025"/></p> <p>WQCV = <input type="text" value="0.01"/> watershed inches</p> <p>Area = <input type="text" value="108,072,360"/> sq ft</p> <p>$V_{WQCV} =$ <input type="text" value="134,718"/> cu ft</p> <p>$d_g =$ <input type="text" value=""/> in</p> <p>$V_{WQCV\ OTHER} =$ <input type="text" value=""/> cu ft</p> <p>$V_{WQCV\ USER} =$ <input type="text" value=""/> cu ft</p>
<p>2. Basin Geometry</p> <p>A) WQCV Depth (12-inch maximum)</p> <p>B) Rain Garden Side Slopes ($Z = 4$ min., horiz. dist per unit vertical) (Use "0" if rain garden has vertical walls)</p> <p>C) Minimum Flat Surface Area</p> <p>D) Actual Flat Surface Area</p> <p>E) Area at Design Depth (Top Surface Area)</p> <p>F) Rain Garden Total Volume ($V_T = ((A_{Top} + A_{Actual}) / 2) * Depth$)</p>	<p>$D_{WQCV} =$ <input type="text" value="12"/> in</p> <p>$Z =$ <input type="text" value="4.00"/> ft / ft</p> <p>$A_{Min} =$ <input type="text" value="53820"/> sq ft</p> <p>$A_{Actual} =$ <input type="text" value="814212"/> sq ft</p> <p>$A_{Top} =$ <input type="text" value="871277"/> sq ft</p> <p>$V_T =$ <input type="text" value="842,745"/> cu ft</p>
<p>3. Growing Media</p>	<p>Choose One</p> <p><input type="radio"/> 18" Rain Garden Growing Media</p> <p><input checked="" type="radio"/> Other (Explain):</p> <p><u>Existing Grass-lined Meadow</u></p>
<p>4. Underdrain System</p> <p>A) Are underdrains provided?</p> <p>B) Underdrain system orifice diameter for 12 hour drain time</p> <p style="margin-left: 20px;">i) Distance From Lowest Elevation of the Storage Volume to the Center of the Orifice</p> <p style="margin-left: 20px;">ii) Volume to Drain in 12 Hours</p> <p style="margin-left: 20px;">iii) Orifice Diameter, 3/8" Minimum</p>	<p>Choose One</p> <p><input type="radio"/> YES</p> <p><input checked="" type="radio"/> NO</p> <p>$y =$ <input type="text" value="N/A"/> ft</p> <p>$Vol_{12} =$ <input type="text" value="N/A"/> cu ft</p> <p>$D_o =$ <input type="text" value="N/A"/> in</p>

Design Procedure Form: Rain Garden (RG)

Sheet 2 of 2

Designer: JPS
Company: JPS
Date: June 7, 2024
Project: SILVERADO RANCH FILING NO. 2
Location: PLD-B

<p>5. Impermeable Geomembrane Liner and Geotextile Separator Fabric</p> <p>A) Is an impermeable liner provided due to proximity of structures or groundwater contamination?</p>	<p>Choose One</p> <p><input type="radio"/> YES</p> <p><input type="radio"/> NO</p>
<p>6. Inlet / Outlet Control</p> <p>A) Inlet Control</p>	<p>Choose One</p> <p><input type="radio"/> Sheet Flow- No Energy Dissipation Required</p> <p><input checked="" type="radio"/> Concentrated Flow- Energy Dissipation Provided</p>
<p>7. Vegetation</p>	<p>Choose One</p> <p><input checked="" type="radio"/> Seed (Plan for frequent weed control)</p> <p><input type="radio"/> Plantings</p> <p><input type="radio"/> Sand Grown or Other High Infiltration Sod</p>
<p>8. Irrigation</p> <p>A) Will the rain garden be irrigated?</p>	<p>Choose One</p> <p><input type="radio"/> YES</p> <p><input checked="" type="radio"/> NO</p>
<p>Notes: _____</p> <p>_____</p> <p>_____</p>	

SILVERADO RANCH FILING NO. 2
 COMPOSITE IMPERVIOUS AREA CALCULATIONS

DEVELOPED CONDITIONS											
IMPERVIOUS AREAS											
BASIN	TOTAL AREA (AC)	(AC)	SUB-AREA 1 DEVELOPMENT/ COVER	% IMP	AREA (AC)	SUB-AREA 2 DEVELOPMENT/ COVER	% IMP	(AC)	SUB-AREA 3 DEVELOPMENT/ COVER	% IMP	WEIGHTED % IMP
PLD-B4.2:											
OB2	61.93	61.93	MEADOW	0							0.000
B4	28.4	28.40	5-AC LOTS	7							7.000
OB2,B4	90.33										2.201
B4.2	1.45	0.661	GRAVEL ROAD	80	0.789	LANDSCAPED	0				36.469
OB2,B4,B6.1	91.78										2.742

NOTE: BASIN B4.2 IS THE SUB-AREA (WITHIN BASIN B6) COMPRISING THE SOUTH SIDE OF THE SILVERADO HILL VIEW ROADWAY

Design Procedure Form: Rain Garden (RG)

UD-BMP (Version 3.07, March 2018)

Sheet 1 of 2

Designer: JPS
Company: JPS
Date: June 7, 2024
Project: SILVERADO RANCH FILING NO. 2
Location: PLD-B4.2

<p>1. Basin Storage Volume</p> <p>A) Effective Imperviousness of Tributary Area, I_a (100% if all paved and roofed areas upstream of rain garden)</p> <p>B) Tributary Area's Imperviousness Ratio ($i = I_a/100$)</p> <p>C) Water Quality Capture Volume (WQCV) for a 12-hour Drain Time ($WQCV = 0.8 * (0.91 * i^3 - 1.19 * i^2 + 0.78 * i)$)</p> <p>D) Contributing Watershed Area (including rain garden area)</p> <p>E) Water Quality Capture Volume (WQCV) Design Volume $Vol = (WQCV / 12) * Area$</p> <p>F) For Watersheds Outside of the Denver Region, Depth of Average Runoff Producing Storm</p> <p>G) For Watersheds Outside of the Denver Region, Water Quality Capture Volume (WQCV) Design Volume</p> <p>H) User Input of Water Quality Capture Volume (WQCV) Design Volume (Only if a different WQCV Design Volume is desired)</p>	<p>$I_a =$ <input style="width: 50px;" type="text" value="2.7"/> %</p> <p>$i =$ <input style="width: 50px;" type="text" value="0.027"/></p> <p>WQCV = <input style="width: 50px;" type="text" value="0.02"/> watershed inches</p> <p>Area = <input style="width: 50px;" type="text" value="3,997,937"/> sq ft</p> <p>$V_{WQCV} =$ <input style="width: 50px;" type="text" value="5,463"/> cu ft</p> <p>$d_g =$ <input style="width: 50px;" type="text" value=""/> in</p> <p>$V_{WQCV\ OTHER} =$ <input style="width: 50px;" type="text" value=""/> cu ft</p> <p>$V_{WQCV\ USER} =$ <input style="width: 50px;" type="text" value=""/> cu ft</p>
<p>2. Basin Geometry</p> <p>A) WQCV Depth (12-inch maximum)</p> <p>B) Rain Garden Side Slopes ($Z = 4$ min., horiz. dist per unit vertical) (Use "0" if rain garden has vertical walls)</p> <p>C) Minimum Flat Surface Area</p> <p>D) Actual Flat Surface Area</p> <p>E) Area at Design Depth (Top Surface Area)</p> <p>F) Rain Garden Total Volume ($V_T = ((A_{Top} + A_{Actual}) / 2) * Depth$)</p>	<p>$D_{WQCV} =$ <input style="width: 50px;" type="text" value="12"/> in</p> <p>$Z =$ <input style="width: 50px;" type="text" value="4.00"/> ft / ft</p> <p>$A_{Min} =$ <input style="width: 50px;" type="text" value="2191"/> sq ft</p> <p>$A_{Actual} =$ <input style="width: 50px;" type="text" value="12000"/> sq ft</p> <p>$A_{Top} =$ <input style="width: 50px;" type="text" value="12680"/> sq ft</p> <p>$V_T =$ <input style="width: 50px;" type="text" value="12,340"/> cu ft</p>
<p>3. Growing Media</p>	<p>Choose One</p> <p><input type="radio"/> 18" Rain Garden Growing Media</p> <p><input checked="" type="radio"/> Other (Explain):</p> <p style="border: 1px solid black; padding: 2px;">Existing Grass-lined Meadow</p> <hr/>
<p>4. Underdrain System</p> <p>A) Are underdrains provided?</p> <p>B) Underdrain system orifice diameter for 12 hour drain time</p> <p style="margin-left: 20px;">i) Distance From Lowest Elevation of the Storage Volume to the Center of the Orifice</p> <p style="margin-left: 20px;">ii) Volume to Drain in 12 Hours</p> <p style="margin-left: 20px;">iii) Orifice Diameter, 3/8" Minimum</p>	<p>Choose One</p> <p><input type="radio"/> YES</p> <p><input checked="" type="radio"/> NO</p> <p>$y =$ <input style="width: 50px;" type="text" value="N/A"/> ft</p> <p>$Vol_{12} =$ <input style="width: 50px;" type="text" value="N/A"/> cu ft</p> <p>$D_o =$ <input style="width: 50px;" type="text" value="N/A"/> in</p>

Design Procedure Form: Rain Garden (RG)

Sheet 2 of 2

Designer: JPS
Company: JPS
Date: June 7, 2024
Project: SILVERADO RANCH FILING NO. 2
Location: PLD-B4.2

<p>5. Impermeable Geomembrane Liner and Geotextile Separator Fabric</p> <p>A) Is an impermeable liner provided due to proximity of structures or groundwater contamination?</p>	<p>Choose One</p> <p><input type="radio"/> YES</p> <p><input type="radio"/> NO</p>
<p>6. Inlet / Outlet Control</p> <p>A) Inlet Control</p>	<p>Choose One</p> <p><input type="radio"/> Sheet Flow- No Energy Dissipation Required</p> <p><input checked="" type="radio"/> Concentrated Flow- Energy Dissipation Provided</p>
<p>7. Vegetation</p>	<p>Choose One</p> <p><input checked="" type="radio"/> Seed (Plan for frequent weed control)</p> <p><input type="radio"/> Plantings</p> <p><input type="radio"/> Sand Grown or Other High Infiltration Sod</p>
<p>8. Irrigation</p> <p>A) Will the rain garden be irrigated?</p>	<p>Choose One</p> <p><input type="radio"/> YES</p> <p><input checked="" type="radio"/> NO</p>
<p>Notes: _____</p> <p>_____</p> <p>_____</p>	

APPENDIX F

DRAINAGE COST ESTIMATE

**SILVERADO RANCH - FILING NO. 2
DRAINAGE IMPROVEMENTS COST ESTIMATE**

Item No.	Description	Quantity	Unit	Unit Cost (\$\$)	Total Cost (\$\$)
DRAINAGE IMPROVEMENTS					
203	Grass-Lined Drainage Channels	2940	LF	\$5	\$14,700
506	Riprap Culvert Aprons ($d_{50} = 12"$)	30	TN	\$104	\$3,120
603	24" RCP Culvert w/ FES	82	LF	\$98	\$8,036
603	42" RCP Culvert w/ FES	82	LF	\$201	\$16,482
SUBTOTAL					\$42,338
Contingency @ 15%					\$6,351
TOTAL					\$48,689

APPENDIX G

FIGURES

National Flood Hazard Layer FIRMette



104°27'5"W 38°45'13"N

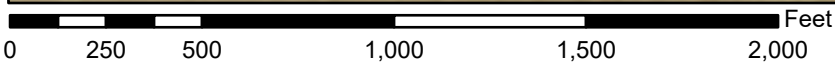
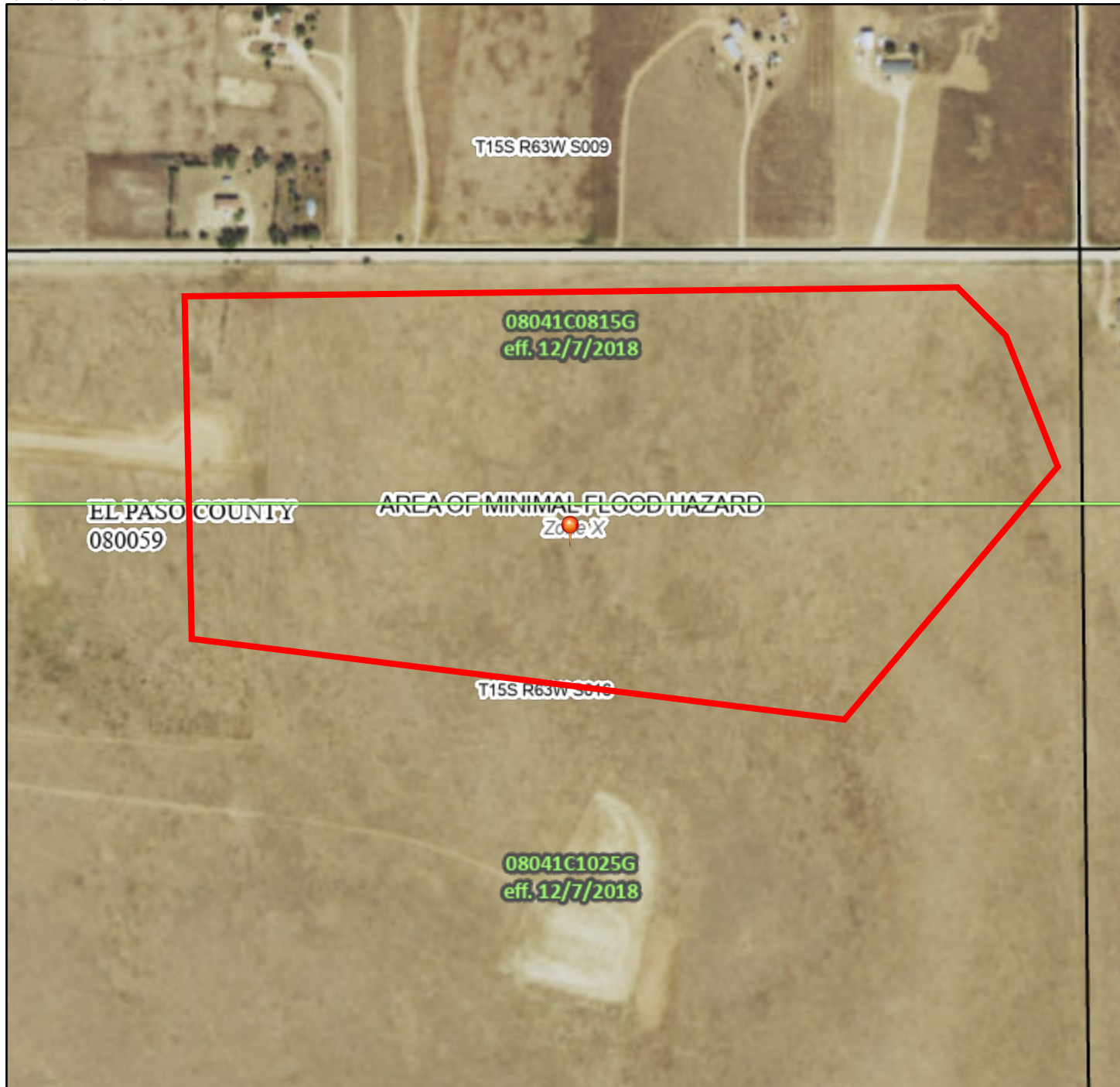

1:6,000

104°26'28"W 38°44'45"N

Basemap Imagery Source: USGS National Map 2023

Legend

SEE FIS REPORT FOR DETAILED LEGEND AND INDEX MAP FOR FIRM PANEL LAYOUT

SPECIAL FLOOD HAZARD AREAS		Without Base Flood Elevation (BFE) <i>Zone A, V, A99</i>
		With BFE or Depth <i>Zone AE, AO, AH, VE, AR</i>
		Regulatory Floodway
OTHER AREAS OF FLOOD HAZARD		0.2% Annual Chance Flood Hazard, Areas of 1% annual chance flood with average depth less than one foot or with drainage areas of less than one square mile <i>Zone X</i>
		Future Conditions 1% Annual Chance Flood Hazard <i>Zone X</i>
		Area with Reduced Flood Risk due to Levee. See Notes. <i>Zone X</i>
		Area with Flood Risk due to Levee <i>Zone D</i>
OTHER AREAS		NO SCREEN Area of Minimal Flood Hazard <i>Zone X</i>
		Effective LOMRs
GENERAL STRUCTURES		Area of Undetermined Flood Hazard <i>Zone D</i>
		Channel, Culvert, or Storm Sewer
		Levee, Dike, or Floodwall
OTHER FEATURES		20.2 Cross Sections with 1% Annual Chance Water Surface Elevation
		17.5 Cross Sections with 1% Annual Chance Water Surface Elevation
		Coastal Transect
		Base Flood Elevation Line (BFE)
		Limit of Study
MAP PANELS		Digital Data Available
		No Digital Data Available
		Unmapped
		The pin displayed on the map is an approximate point selected by the user and does not represent an authoritative property location.



This map complies with FEMA's standards for the use of digital flood maps if it is not void as described below. The basemap shown complies with FEMA's basemap accuracy standards

The flood hazard information is derived directly from the authoritative NFHL web services provided by FEMA. This map was exported on **6/6/2024 at 5:58 PM** and does not reflect changes or amendments subsequent to this date and time. The NFHL and effective information may change or become superseded by new data over time.

This map image is void if the one or more of the following map elements do not appear: basemap imagery, flood zone labels, legend, scale bar, map creation date, community identifiers, FIRM panel number, and FIRM effective date. Map images for unmapped and unmodernized areas cannot be used for regulatory purposes.

BASIN SUMMARY TABLE		
BASIN	Q ₅ (CFS)	Q ₁₀₀ (CFS)
OA1	22.9	165.3
OA2	0.9	6.1
OB1	15.9	113.7
OB2	2.5	16.6

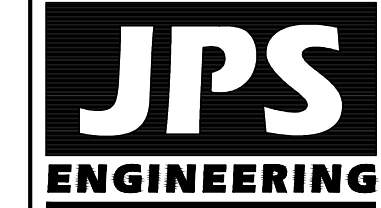

19 E. Willamette Ave.
Colorado Springs, CO
80903
PH: 719-477-9429
FAX: 719-471-0766

SILVERADO RANCH FILING NO. 2

MAJOR BASIN/ HISTORIC DRAINAGE PLAN

HORIZ. SCALE: 1"=1000'	DRAWN: RMD
VERT. SCALE: N/A	DESIGNED: JPS
SURVEYED: LWA/GIS	CHECKED: JPS
CREATED: 8/28/06	LAST MODIFIED: 02/01/24
PROJECT NO: 080603	MODIFIED BY: PV

SHEET: **EX1**

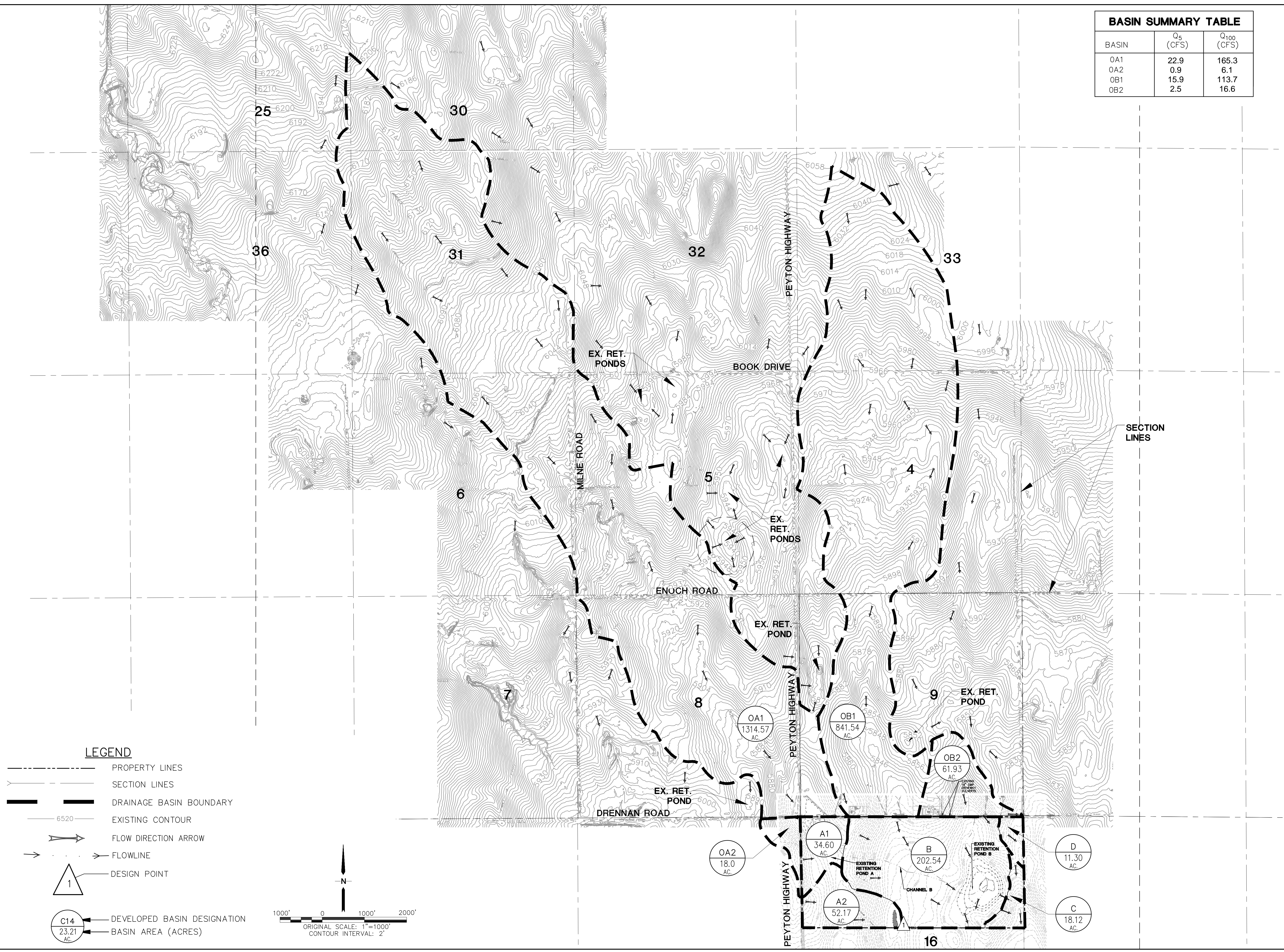

LEGEND

- PROPERTY LINES
- - - SECTION LINES
- DRAINAGE BASIN BOUNDARY
- 6520 EXISTING CONTOUR
- FLOW DIRECTION ARROW
- FLOWLINE
- △ DESIGN POINT
- C14 23.21 AC DEVELOPED BASIN DESIGNATION
- BASIN AREA (ACRES)

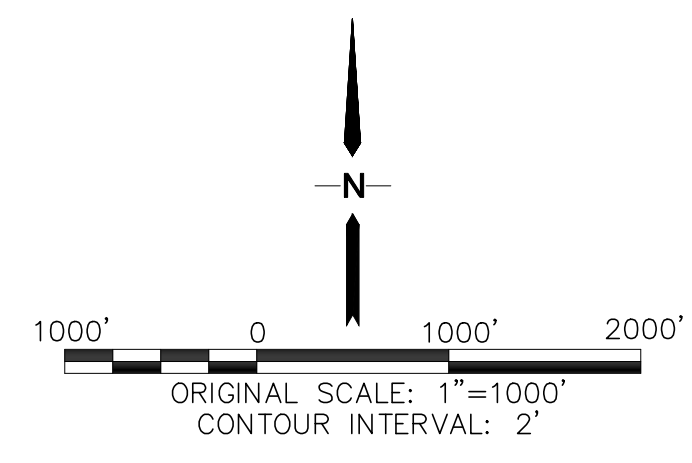

SILVERADO RANCH FILING NO. 2

HISTORIC DRAINAGE PLAN

NO.	REVISION	BY	DATE

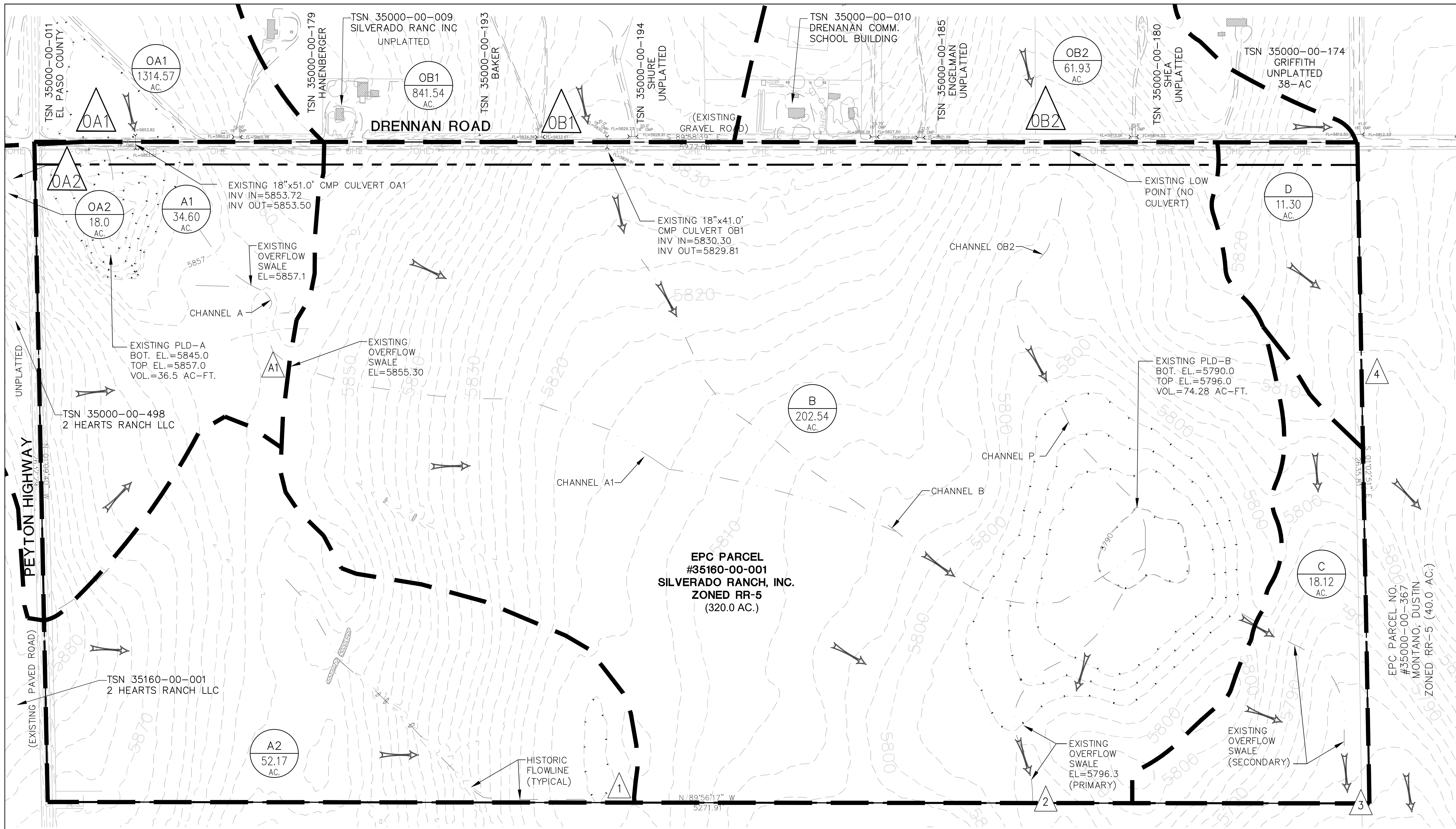

LEGEND

- PROPERTY LINES
- DRAINAGE BASIN BOUNDARY
- 6520 --- EXISTING CONTOUR
- FLOW DIRECTION ARROW
- FLOWLINE
- △ DESIGN POINT
- XX DEVELOPED BASIN DESIGNATION
- XXXX AC BASIN AREA (ACRES)

SUMMARY HYDROLOGY TABLE

DESIGN POINT	Q ₅ (CFS)	Q ₁₀₀ (CFS)
OA1	22.9	165.3
OA2	0.9	6.1
OB1	15.9	113.7
OB2	2.5	16.6
A1	24.9	172.2
1	8.3	61.0
2	55.7	313.6
3	2.3	16.8
4	2.6	19.1

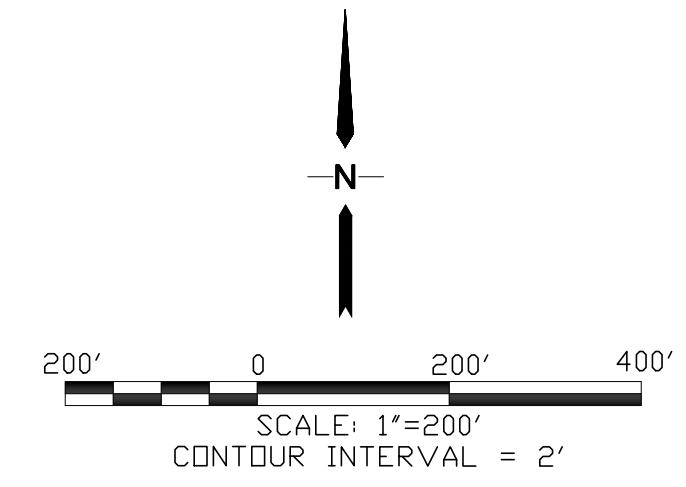

HORIZ. SCALE: 1"=200'	DRAWN: RMD
VERT. SCALE: N/A	DESIGNED: JPS
SURVEYED: LWA	CHECKED: JPS
CREATED: 8/28/06	LAST MODIFIED: 06/07/24
PROJECT NO: 080603	MODIFIED BY: PV

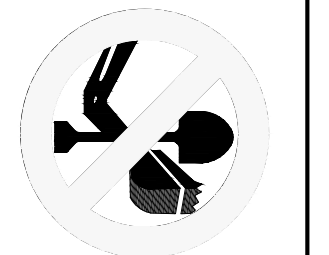

No.	REVISION	BY	DATE

**MASTER DEVELOPMENT
DRAINAGE PLAN**

HORZ. SCALE: 1"=200'	DRAWN: PV
VERT. SCALE: N/A	DESIGNED: JPS
SURVEYED: LWA	CHECKED: JPS
CREATED: 8/28/06	LAST MODIFIED: 06/07/24
PROJECT NO: 080603	MODIFIED BY: PV

SILVERADO RANCH

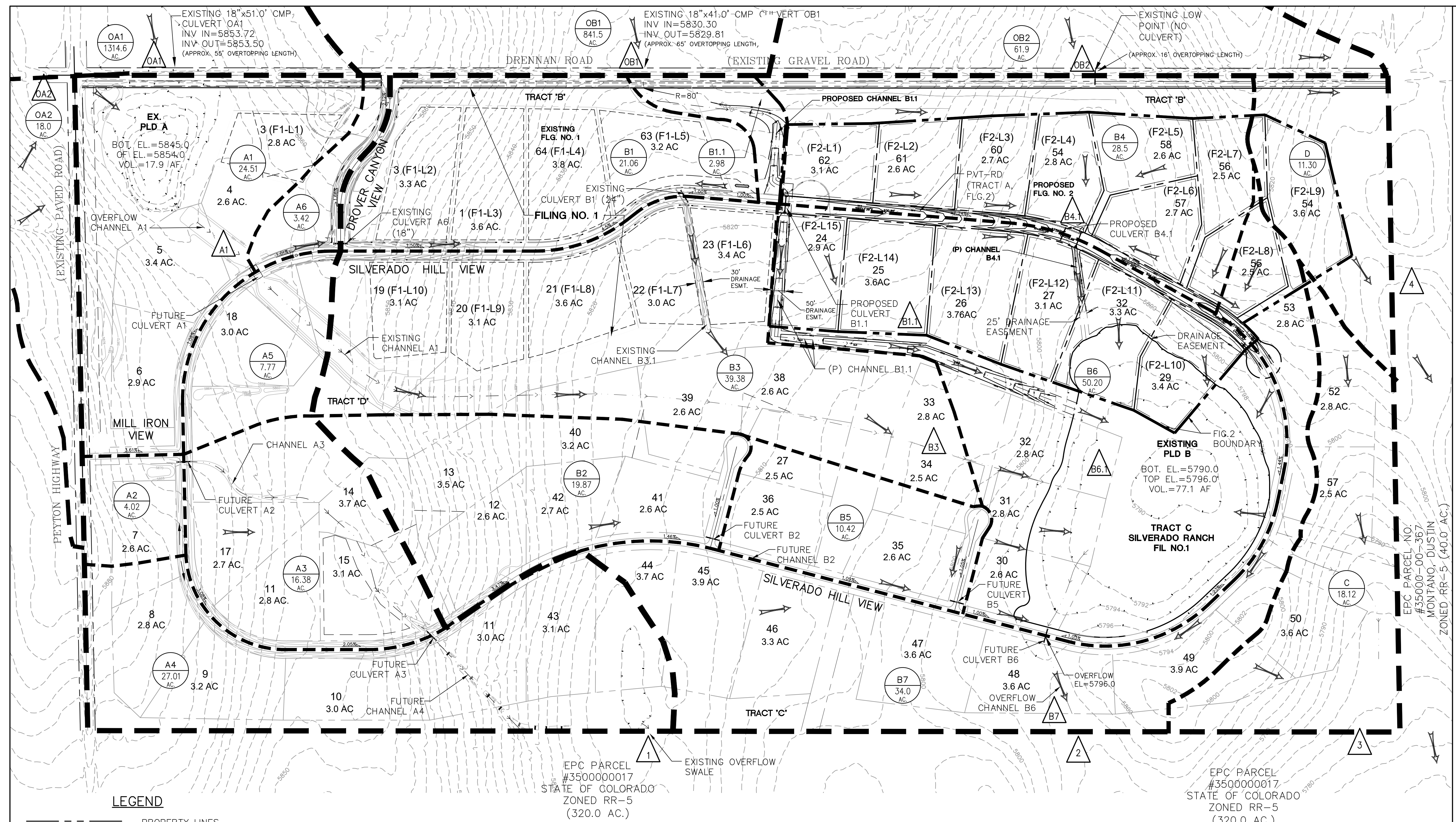

LEGEND

- PROPERTY LINES
- MAJOR DRAINAGE BASIN BOUNDARY
- MINOR DRAINAGE BASIN BOUNDARY
- 6520 --- EXISTING CONTOUR
- FLOW DIRECTION ARROW
- FLOWLINE
- △ DESIGN POINT
- DEVELOPED BASIN DESIGNATION
- BASIN AREA (ACRES)

SUMMARY HYDROLOGY TABLE

DESIGN POINT	Q ₅ (CFS)	Q ₁₀₀ (CFS)
1	16.5	79.6
OA1	22.9	165.3
OA2	0.9	6.1
A1	25.1	171.2
OB1	15.9	113.7
OB2	2.5	16.6
B1.1	14.3	102.9
B3	17.5	84.1
B4.1	5.8	38.6
B6.1	67.2	305.2
B7	8.6	41.4
2	71.2	309.5
3	4.0	19.2
4	4.6	22.0

BASIN SUMMARY TABLE

BASIN	Q ₅ (CFS)	Q ₁₀₀ (CFS)
B3	17.5	84.1
B4	17.7	85.1
B6	21.5	103.6
B7	8.6	41.4
C	4.0	19.2
D	4.6	22.0

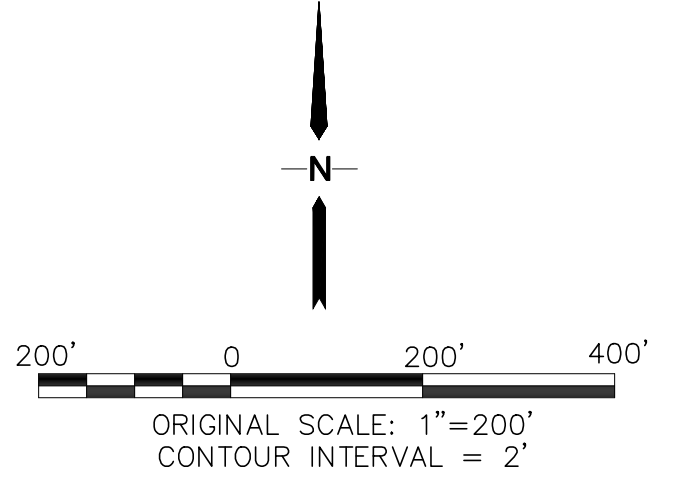

NOTE: SEE ADJOINING PARCEL OWNER INFO ON SH. EX2

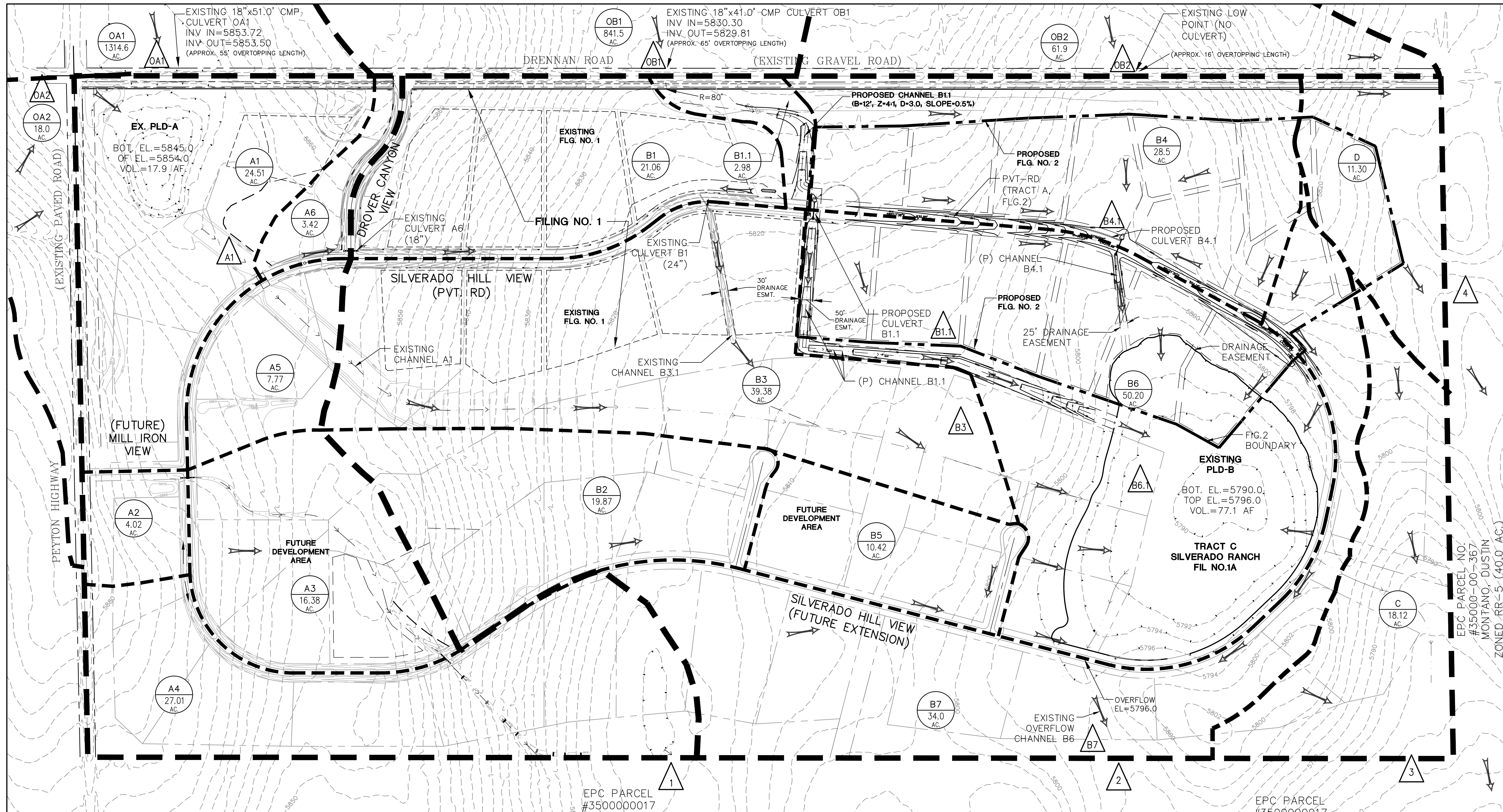

LEGEND

- PROPERTY LINES
- MAJOR DRAINAGE BASIN BOUNDARY
- MINOR DRAINAGE BASIN BOUNDARY
- 6520 --- EXISTING CONTOUR
- FLOW DIRECTION ARROW
- FLOWLINE
- △ DESIGN POINT
- C14 23.21 AC DEVELOPED BASIN DESIGNATION
- BASIN AREA (ACRES)

SUMMARY HYDROLOGY TABLE

DESIGN POINT	Q5 (CFS)	Q100 (CFS)
1	16.5	79.6
OA1	22.9	165.3
OA2	0.9	6.1
A1	25.1	171.2
OB1	15.9	113.7
OB2	2.5	16.6
B1.1	14.3	102.9
B3	17.5	84.1
B4.1	5.8	38.6
B6.1	67.2	305.2
B7	8.6	41.4
2	71.2	309.5
3	4.0	19.2
4	4.6	22.0

BASIN SUMMARY TABLE

BASIN	Q5 (CFS)	Q100 (CFS)
B3	17.5	84.1
B4	17.7	85.1
B6	21.5	103.6
B7	8.6	41.4
C	4.0	19.2
D	4.6	22.0

NOTE: ALL PROPOSED STORM FACILITIES ARE PRIVATE (HOA-MAINTAINED)

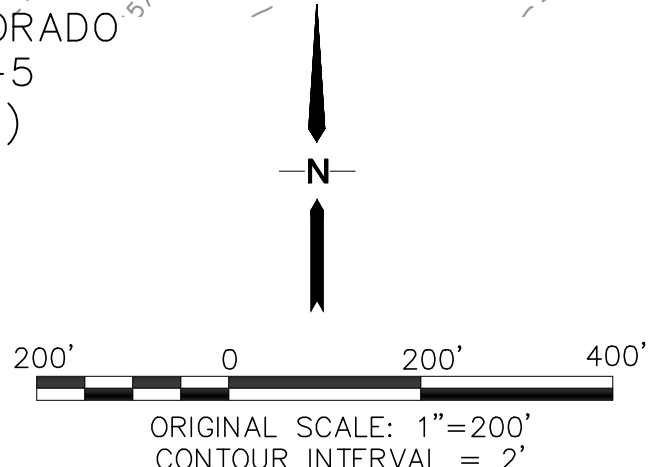
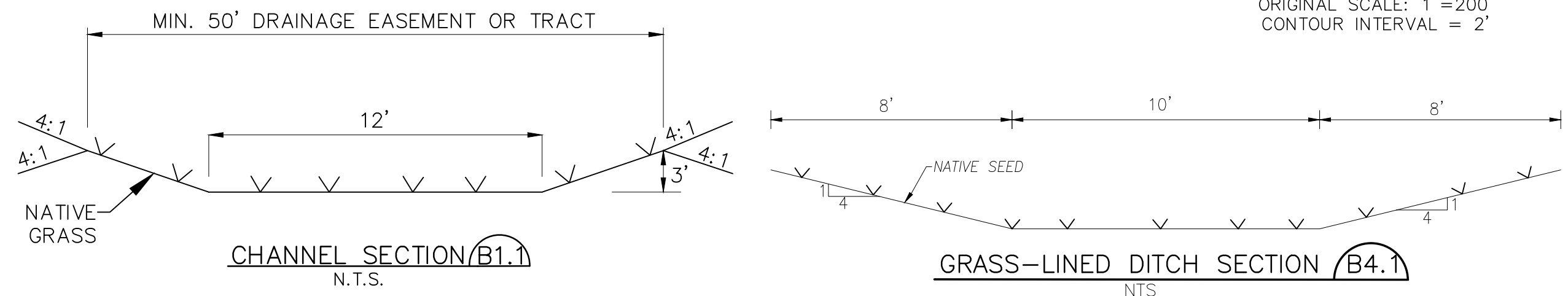

SILVERADO RANCH

JPS ENGINEERING
 19 E. Willamette Ave.
 Colorado Springs, CO 80903
 PH: 719-477-9429
 FAX: 719-471-0766
 www.jpsegr.com

CALL UTILITY NOTIFICATION CENTER OF COLORADO
1-800-922-1987
 CALL 2-BUSINESS DAYS IN ADVANCE BEFORE YOU DIG, GRAD, OR EXCAVATE FOR THE MEMBER UTILITIES.

NO.	REVISION	BY	DATE

FILING NO. 2 DEVELOPED DRAINAGE PLAN

HORIZ. SCALE: 1"=200'	DRAWN: PV
VERT. SCALE: N/A	DESIGNED: JPS
SURVEYED: LWA	CHECKED: JPS
CREATED: 8/28/06	LAST MODIFIED: 06/07/24
PROJECT NO: 080603	MODIFIED BY: PV

D1.2