



EPC STORMWATER REVIEW COMMENTS ARE  
SHOWN IN ORANGE BOXES WITH BLACK TEXT

▶ [HRGREEN.COM](http://HRGREEN.COM)

## The Cottages at Mesa Ridge Preliminary Drainage Report

August 2021

HR Green Project No: 200541

Add PCD File No. PUDSP2111

**Prepared For:**

Goodwin Knight

Contact: Bryan D. Kniep

8605 Explorer Drive, Suite 250

Colorado Springs, CO 80920

**Prepared By:**

HR Green Development, LLC

Contact: Ken Huhn, PE

[khuhn@hrgreen.com](mailto:khuhn@hrgreen.com)

(720) 602-4965



**ENGINEER'S STATEMENT**

The attached drainage plan and report were prepared under my direction and supervision and are correct to the best of my knowledge and belief. Said drainage report has been prepared according to the criteria established by El Paso County for drainage reports and said report is in conformity with the master plan of the drainage basin. I accept responsibility for any liability caused by negligent acts, errors, or omission on my part in preparing this report.

---

Ken Huhn, PE                      Date

Registered Professional Engineer State of Colorado No. \_\_\_\_\_

For and on behalf of HR Green Development, LLC

**DEVELOPER'S STATEMENT**

I, the developer, have read and will comply with all of the requirements specified in this drainage report and plan.

---

Name of Developer	Authorized Signature	Date
-------------------	----------------------	------

---

Printed Name	Title	Address
--------------	-------	---------

**EL PASO COUNTY**

Filed in accordance with the requirements of the El Paso County Land Development Code, Drainage Criteria Manual, Volumes 1 and 2 and Engineering Criteria Manual, as amended.

---

Jennifer Irvine, P.E.  
County Engineer/ECM Administrator



## Table of Contents

- Table of Contents .....2
- I. General Purpose, Location and Description.....3
  - a. Purpose .....3
  - b. Location .....3
  - c. Description of Property .....3
  - d. Floodplain Statement.....3
- II. Drainage Basins and Subbasins .....3
  - a. Major Basin Description.....3
  - b. Existing Subbasin Description .....4
  - c. Proposed Subbasin Description .....4
- III. Drainage Design Criteria .....5
  - a. Development Criteria Reference .....5
  - b. Hydrologic Criteria .....5
- IV. Drainage Facility Design.....5
  - a. General Concept .....5
  - b. Water Quality & Detention .....5
  - c. Inspection and Maintenance.....8
  - d. Four Step Method to Minimize Adverse Impacts of Urbanization .....8
  - e. Drainage and Bridge Fees.....9
- V. Summary .....9
- VI. Drawings .....9
- VII. References .....9

## Appendices

- A. Vicinity Map, FEMA Map, NRCS Soil Survey
- B. Hydrologic Analysis
- C. Hydraulic Analysis
- D. Water Quality and Detention Calculations
- E. Reference Material
- F. Drainage Maps

## I. General Purpose, Location and Description

### a. Purpose

The purpose of this Preliminary Drainage Report (PDR) is to describe the onsite and offsite drainage patterns, existing and proposed storm infrastructure, and the planned stormwater management for The Cottages at Mesa Ridge. This report will support the development plan that is currently in review with El Paso County.

### b. Location

The Cottages at Mesa Ridge, referred to as ‘the site’ herein, is in a portion of the northeast quarter of section 29, the southeast quarter of section 20, the southwest quarter of section 21, and the northwest quarter of section 28, township 15 south, range 65 west of the 6<sup>th</sup> P.M., County of El Paso, Colorado. The site is bound by S. Powers Boulevard to the east, multi-family residential development to the south, single-family residential development to the west and undeveloped land to the north. Surrounding platted developments include Mesa Ridge Filing 8 and 9 to the south, Sunrise Ridge to the west and the Glen at Widefield to the east. A vicinity map is presented in Appendix A.

### c. Description of Property

The site is approximately 10.22 acres of undeveloped land with existing vegetation consisting of native grasses. Once developed, the site will include 122 dwelling units, a club house and open space tracts. The site will be platted as a single lot. In general, the site slopes south towards the Fountain Mutual Irrigation Co canal. Onsite elevations range from 5750’ - 5795’ with slopes ranging 1 – 33%. Per a NRCS soil survey, the site is made up of Type B Stoneham sandy loam and Type B Nelson-Tassel fine sand loams. The NRCS soil survey is presented in Appendix A.

There are no major drainageways or irrigation facilities that traverse the site nor does the site fall within the Streamside Overlay Zone. Onsite, existing utilities include water, sewer, fiberoptic, underground gas and underground electric/telecommunication. An existing drainage map is presented in Appendix F.

### d. Floodplain Statement

Based on FEMA Firm map 08041C0956G dated December 8, 2018, the site is Zone X, which are areas determined to be outside the 0.2% annual chance flood.

The site is within the West Fork Jimmy Camp Creek Drainage Basin. The DBPS was prepared by Kiowa Engineering. Please revise the text accordingly

## II. Drainage Basins and Subbasins

### a. Major Basin Description

The site is not located within one of the major drainage basins from the City of Colorado Springs Drainage Basin Planning Study Inventory prepared by Kiowa Engineering Corporation, 2017. The site’s drainage characteristics were previously studied in the following reports:

1. “Master Development Drainage Plan Mesa Ridge Development” prepared by Kiowa Engineering Corporation, December 17, 2006. (2006 MDDP)
2. “Mesa Ridge Development Master Development Drainage Plan Update” prepared by Kiowa Engineering Corporation, January 15, 2013. (2013 MDDP)

In the 2006 MDDP, the site was identified as Basin 1040 and Basin 1030. Basin 1040 was planned to be routed to Detention Basin D (located within Mesa Ridge Subdivision Filing 8) while Basin 1030 was routed to

Per previous approved grading plans for the site at the NE corner of Powers/Mesa Ridge, the pond referenced is a temporary sediment basin. Also it appears that DP2 is being conveyed by the 24" RCP to the outfall of the temporary sediment basin. Please revise accordingly. I have attached a link to the previously approved grading plans for the site in question.

HRGreen

<https://epcdevplanreview.com/Public/ProjectDetails/103180>

Detention Basin 1031 (located on the east side of S. Powers Boulevard adjacent to the site). The 2013 MDDP did not alter the planned detention scenario for the site.

### b. Existing Subbasin Description

The site's existing drainage is split into five basins. An existing drainage map is presented in Appendix B. See below for existing basin descriptions:

Basin EX1 is 5.69 acres of undeveloped area and existing single family residential lots. Existing stormwater from this basin ( $Q_5 = 2.5$  cfs  $Q_{100} = 13.7$  cfs) is conveyed onsite to DP1.

Basin EX2 is 3.12 acres of undeveloped area and a portion of S. Powers Boulevard. Existing stormwater from this basin ( $Q_5 = 4.2$  cfs  $Q_{100} = 12.4$  cfs) is conveyed in an existing roadside swale to DP2. An existing area inlet at DP2 conveys the stormwater underneath S. Powers Boulevard to an existing detention pond.

Basin EX3 is 1.46 acres of undeveloped area. Existing stormwater from this basin ( $Q_5 = 1.6$  cfs  $Q_{100} = 5.1$  cfs) is conveyed to the existing irrigation canal to DP3.

Basin EX4 is 0.28 acres of undeveloped area. Existing stormwater from this basin ( $Q_5 = 0.1$  cfs  $Q_{100} = 0.8$  cfs) is conveyed in an existing roadside swale to DP4.

Basin EX5 is 3.38 acres of undeveloped area and existing single family residential lots. Existing stormwater from this basin ( $Q_5 = 2.8$  cfs  $Q_{100} = 11.9$  cfs) flows offsite along the site's southern boundary at DP5.

### c. Proposed Subbasin Description

The proposed site has been divided into 9 subbasins for analysis. All storm sewer and appurtenances are private. A drainage map has been presented in Appendix F. See below for basin descriptions:

Basin 1 is 3.56 acres of single-family residential lots, duplex homes, roadway and landscaping. Stormwater from this basin ( $Q_5 = 7.6$  cfs  $Q_{100} = 16.1$  cfs) is conveyed in curb and gutter to a 15' Type R on-grade inlet at DP1. Basin 1 stormwater is piped to the full spectrum detention pond for water quality and detention.

Basin 2 is 4.93 acres of single-family residential lots, duplex homes, roadway and landscaping. Stormwater from this basin ( $Q_5 = 9.5$  cfs  $Q_{100} = 20.3$  cfs) is conveyed in curb and gutter to a 15' Type R on-grade inlet at DP2. Basin 2 stormwater is piped to the full spectrum detention pond for water quality and detention.

Basin 3 is 3.03 acres of existing roadway (S. Powers Boulevard) and undeveloped area. Stormwater from this basin ( $Q_5 = 3.4$  cfs  $Q_{100} = 9.7$  cfs) follows historic drainage patterns in an existing roadside swale to an existing Type C inlet at DP3.

Basin 4 is 0.52 acres of landscaping and undeveloped area. Stormwater from this basin ( $Q_5 = 0.4$  cfs  $Q_{100} = 1.8$  cfs) follows historic drainage patterns towards S. Powers Boulevard at DP4.

Basin 5 is 1.50 acres of landscaping and a fire access road. Stormwater from this basin ( $Q_5 = 2.1$  cfs  $Q_{100} = 5.7$  cfs) is captured in a grass-lined swale and captured in a Type C inlet. Basin 5 stormwater is piped to the full spectrum detention pond for water quality and detention.

Basin 6 is 0.63 acres of undeveloped area. Stormwater from this basin ( $Q_5 = 0.2$  cfs  $Q_{100} = 1.2$  cfs) follows historic drainage patterns in an existing roadside swale along S. Powers Boulevard at DP5.

Basin 7 is 0.56 acres of landscaping and existing single family residential. Stormwater from this basin ( $Q_5 = 0.4$  cfs  $Q_{100} = 1.8$  cfs) follows historic drainage patterns towards DP7.

Please identify that this is an existing FSD pond

DP6 per the drainage plan. Revise.

Clarify where the stormwater is conveyed to (and how) after these design points.

Please provide additional information regarding the conveyance to the existing detention pond. Per the plans the storm system is out-falling north of Landover Ln where then it piped via an existing storm sewer to the pond. This information should be provided. At Final drainage report analysis of this conveyance to the pond shall be provided to ensure that the existing facilities are adequate.



Basin 8 is 0.24 acres of roadway. Stormwater from this basin ( $Q_5 = 1.1$  cfs  $Q_{100} = 2.0$  cfs) is conveyed in curb and gutter down Landover Lane to a 10' Type R inlet at DP8. Basin 8 stormwater is piped to the full spectrum detention pond for water quality and detention.

Basin 9 is 0.14 acres of roadway. Stormwater from this basin ( $Q_5 = 0.7$  cfs  $Q_{100} = 1.2$  cfs) is conveyed in curb and gutter down Landover Lane to a 10' Type R inlet at DP9. Basin 9 stormwater is piped to the full spectrum detention pond for water quality and detention.

### III. Drainage Design Criteria

#### a. Development Criteria Reference

The drainage analysis, proposed storm sewer system, and proposed full spectrum water quality and detention pond follow the criteria from the "City of Colorado Springs Drainage Criteria Manual" Volumes 1 and 2" (CCSDCM, latest revision).

#### b. Hydrologic Criteria

Hydrologic data was obtained from the "City of Colorado Springs Drainage Criteria Manual – Chapter 6 Hydrology". Onsite drainage improvements are designed for the 5-year storm (minor event) and 100-year storm (major event) using rainfall values from CCSDCM Table 6-2 below. Runoff was calculated per CCSDCM Section 6.3.0 - Rational Method. Full spectrum pond design was completed using the latest version of Mile High Flood District's (MHFD) UD-Detention per CCSDCM Section 13.3.2.1 – Full Spectrum Detention in addition to CUHP v.2.0.1 and EPA-SWMM v.5.1. Detention pond allowable release rate will be limited to less than or equal to those noted in the 2013 Mesa Ridge MD

Return Period (yr)
1-hr Rainfall Depth (in)

Please be sure that you also list the El Paso County Drainage Criteria Manual as one of the criteria that was followed in your design.

FYI: the county adopted (in 2015) Ch6 and Ch13 section 3.2.1 of the cities May 2014 Drainage Criteria manual

### IV. Drainage Facility Design

#### a. General Concept

Onsite stormwater will be conveyed via Type 5 curb and gutter to Type R inlets. Captured stormwater will be piped to and detained in an existing, full spectrum detention pond located in Mesa Ridge Filing 9 south of the site. The full spectrum detention pond will outfall at less than historic values to the east side of S. Powers Boulevard and to the site's historic outfall. See below section regarding the existing detention basin analysis and retrofit. The ultimate outfall for the site is Jimmy Camp Creek, south of Hale Reservoir.

#### b. Water Quality & Detention

The Cottages at Mesa Ridge will utilize the existing regional Full Spectrum Detention Basin D for water quality and detention. This pond was included originally as flood control in the 2006 MDDP and was updated to provide Full Spectrum detention with the 2013 MDDP. In addition, the record drawings for the retrofit of the pond confirmed the use of an orifice plate to control the full spectrum volume. Record documents are titled: Mesa Ridge Filings 8 & 9, Detention Basin 'D', Full Spectrum Detention Modifications, Final Design Drawings, by Kiowa Engineering Corporation, dated October 2011. Both MDDPs show Basin 1040 routed to Full

Engineer must confirm in the Drainage Report that the existing pond is functioning as intended.

Spectrum Detention Basin D. However, the basin characteristics provided with the most recent MDDP included The Cottages at Mesa Ridge site as historic.

In order to confirm that the existing Full Spectrum Detention Basin D has capacity for development of The Cottages at Mesa Ridge, updated modeling with proposed basin 1040 characteristics is necessary.

Hydrology and hydraulics included with the previous MDDPs utilized HEC-1 software to determine peak runoff quantities at specific design points and routing elements. These HEC-1 models were not available for use, so an effort was made to update them to the more current HEC-HMS program. However, there were too many unknown variables with the program to get it to provide reliable results.

Current CCSDCM V.1 CH.6 1.4 Selecting Methods for Estimating Design Flows notes in part that:

- For more complex drainage basins and routing requirements, the HEC-HMS model or the EPA SWMM method is better suited but requires more experience and expertise to properly apply. The EPA SWMM method also provides hydrographs, reservoir routing, and the ability to evaluate runoff reduction practices in detail.
- If detention facilities are to be sized based on hydrograph routing, or if hydrograph information is desired for any other reason, the EPA SWMM or the NRCS method must be used.

Therefore, CUHP and EPA SWMM methodology were selected as appropriate modeling programs to confirm volumes and release rates for Full Spectrum Detention Basin D are in line with the intent of the previous MDDPs and current CCSDCM criteria.

### **CUHP**

A new CUHP model was prepared streamlined with only the MDDP basins being updated at this time and major basins tributary to Full Spectrum Detention Basin D. This includes Basin 1040, 6001, 6005, 6010, 6011 and 6020. Basin parameters included in the CUHP as follows:

- Basin parameters for Basin 1040 were updated based on the most current design information available and correspond to the Rational Method calculations noted elsewhere in this report. The area to Basin 1040 increased from what was accounted for in the previous MDDPs.
- Basins 6001, 6005, 6010, 6011 and 6020 used area and length parameters taken directly from the HEC-1 noted above.
- Basins 6001, 6005, 6010, 6011 and 6020 utilized percent impervious estimated from existing as-constructed land uses.
- All basins used the standard depression storage and infiltration parameters for Hydrologic Soil Type B.

Rainfall data was taken from NOAA Atlas 14 Point Precipitation for a 60-minute (1-hour) recurrence interval depth, 100=2.74 in. The 1-hour point precipitation was chosen in part because the MHFD-Detention worksheet uses the 1-hour depth as an input parameter to run the CUHP program in the background. This allows a more accurate review of the existing pond by using consistent storms across both the CUHP and MHFD-Detention software.

Input parameters and results for the 100-year event are included with Appendix D.

### **EPA SWMM**

Similar to the CUHP modeling, a simplified hydraulic routing model was prepared. In this case, the U.S. Environmental Protection Agency Stormwater Management Model (EPA SWMM) software was used for the proposed conditions with the development of The Cottages at Mesa Ridge.

The model includes a stage-storage curve for Pond D extracted directly from the pond grading shown on the 2011 Full Spectrum Detention Modifications Plan noted above. The proposed Pond D stage-release curve was developed through an iterative process, described more in depth below.

The other separate existing pond (Detention Basin 6002) which is tributary to Pond D provides storage for Basin 6001. Parameters for modeling Detention Basin 6002 were taken directly from the 2013 MDDP HEC-1. Additionally, EPA SWMM element routing parameters such as channel length and size were taken directly from the previous HEC-1 model with the exception of elevations (not used in HEC-1). For this a reasonable starting (downstream) elevation was used from the Pond D plans, and slope/length parameters from HEC-1 used to set all other upstream elevations. A back-check was completed to ensure resultant upstream elevations seem reasonable given rough elevations on 2013 MDDP Exhibit.

Input parameters and results for the 100-year event are included with Appendix D.

### **Full Spectrum Detention Basin D**

MHFD-Detention worksheets were set up using updated total watershed area and percent imperviousness for several reasons, they include:

- To confirm the updated full spectrum volume required within Pond D. Note, because an inflow hydrograph will be used for the 100-year event only the resultant full spectrum volumes are relevant from this data.
- To review how the existing pond is functioning under the proposed condition by incorporating the as-built stage-storage and stage-release data into the workbook. Note, the release structure was surveyed to provide accurate structure parameters.
- To route the 100-year hydrograph developed in the CUHP and EPA SWMM through the provided pond volume and as-built release structure.

MHFD-Detention (as-built) results from routing the proposed 100-year hydrograph through the as-built pond volume and release structure indicate that there is adequate 100-year volume in the existing pond for development of The Cottages at Mesa Ridge site. However, results also indicate that the existing pond is exceeding drain time limitations noted in current MHFD criteria and Colorado Revised Statute 37-92-602(8).

To rectify the drain times discrepancy a separate MHFD-Detention (proposed) worksheet was set up matching the previously noted stage-storage curve and input hydrograph but altering the release structure (and corresponding stage-release curve). The drain times were revised by enlarging the orifice areas and updating the detention stages to correlate with the new Full Spectrum volume. Once the 100-year peak release rate was confirmed to be at or below the threshold established with the 2013 MDDP (223 cfs) the resultant stage-release curve was transferred back to the prepared SWMM and re-run to confirm the same results as found with the MHFD-Detention (proposed) analysis.



Key pond parameters from the 2011 Full Spectrum Detention Modifications Plan along with the values determined with this Preliminary Drainage Report are summarized below.

<b>Full Spectrum Detention Basin D Summary</b>			
	<b>2011 Full Spectrum Modifications</b>	<b>As-Built Pond D without Modifications</b>	<b>As-Built Pond D with Proposed Modifications</b>
Tributary Area (acres)	not provided	98.8	98.8
% Impervious (%)	not provided	48.8	48.8
Full Spectrum Volume (acre-ft)	4.2	5.1	5.1
Full Spectrum WSEL (ft)	5686.8	5687.2	5687.2
Full Spectrum Drain Time (hrs)	not provided	> 120	73
100-yr volume (acre-ft)	8.3	11.6	12.5
Release Rate (cfs)	219	252	232
100-yr WSEL (ft)	5690.2	5691.2	5691.7
100-yr Drain Time (hrs)	not provided	> 120	70

Conclusions from the analysis presented with this Report are that Full Spectrum Detention Basin D will function as intended in the proposed conditions taking into consideration the Basin 1040 changes (including increase in basin area) that will occur with development of The Cottages at Mesa Ridge. No modifications to the as-built volume are anticipated at this time. Minor modifications are expected to the release structure to bring the existing pond in conformance with current drain time and stage-storage requirements. The detailed extent of modifications to the existing structure will be provided with the Final Drainage Report as the project design progresses.

**c. Inspection and Maintenance**

An Inspection and maintenance manual will be provided with the Final Drainage Report. The manual will specify maintenance intervals and required actions to maintain the function of the extended detention basin and appurtenances.

**d. Grading and Erosion Control Plan**

Due to the project disturbance area, a separate Grading and Erosion Control plan will be required. The Grading and Erosion Control Plan will be submitted in conjunction with the Final Drainage Report and Construction Drawings.

**e. Four Step Method to Minimize Adverse Impacts of Urbanization**

Step 1 – Reducing Runoff Volumes: Roof drains will route across landscape areas and grass lined swales are used for stormwater conveyance, whenever possible to promote infiltration.

Step 2 – Treat and slowly release the WQCV: An onsite full spectrum detention pond provides water quality treatment for the site. The WQCV is released over a period of 44 hours.

Per the text above the pond that is providing water quality/detention is offsite. Revise accordingly.

The site is within the west fork Jimmy Camp Creek drainage basin which is a fee basin. Fees will be due at time of platting. I have provided a link to the el paso county drainage fees website for use when calculating the fees with the future final drainage report. Please be aware that the fees are typically updated at the beginning of each year.



HRG

The Cottages at Mesa Ridge  
Preliminary Drainage Report  
Project No.: 200541

<https://planningdevelopment.elpasoco.com/#1515613078895-69552b09-44a4>

Step 3 – Stabilize stream channels: Drainage swales will be lined with non-erosive soils and permanently seeded to provide stabilization. If required due to erosive velocities, additional protection will be provided in the form of riprap lining and drop structures to reduce stormwater velocities and provide stabilization.

Step 4 – Consider the need for source controls: No industrial or commercial uses are proposed within this development and therefore no source controls are proposed.

#### **f. Drainage and Bridge Fees**

Cottages at Mesa Ridge are not within a defined major drainage basin per Colorado Springs and therefore no drainage fees are due at time of platting.

#### **g. Opinion of Probable Cost**

We respectfully request that the engineer's opinion of probable cost be postponed until the Final Drainage Report.

## **V. Summary**

The Cottages at Mesa Ridge development remains consistent with pre-development drainage conditions with the construction of the recommended drainage improvements. The proposed development will not adversely affect downstream stormwater infrastructure or surrounding developments. This report meets the latest El Paso County Drainage criteria and is in accordance with the Mesa Ridge MDDP.

## **VI. Drawings**

Please refer to the appendices for vicinity and drainage basin maps.

## **VII. References**

1. City of Colorado Springs – Drainage Criteria Manual, May 2014, Revised January 2021.
2. Urban Storm Drainage Criteria Manual, Mile High Flood District, January 2018.
3. *Master Development Drainage Plan Mesa Ridge Development*, Kiowa Engineering Corporation, December 17, 2006.
4. *Mesa Ridge Development Master Development Drainage Plan Update*, Kiowa Engineering Corporation, January 15, 2013.
5. *Mesa Ridge Filings 8 & 9, Detention Basin 'D', Full Spectrum Detention Modifications, Final Design Drawings*, by Kiowa Engineering Corporation, October 2011.
6. Colorado Unit Hydrograph Procedure (CUHP), Version 2.0.1, October 2019.
7. Environmental Protection Agency Stormwater Management Model (EPA SWMM), Version 5.1, 2020.
8. Mile High Flood District Detention Basin Design Workbook (MHFD-Detention), Version 4.04, February 2021.

Please provide discussion regarding the design points that are not being routed to the existing pond (DP 3,4, 6, and 7). State whether these flows meet historic/existing values, are less than, or have increased. If there is an increase, is the downstream capable/adequate to receive the increase in flows? etc.

Please feel free to give me a call/email to discuss any comments (blue) provided on this report.

Daniel Torres, 719 520-6305, [danieltorres@elpasoco.com](mailto:danieltorres@elpasoco.com)



## **APPENDIX A – VICINITY MAP, SOIL MAP, FEMA MAP**

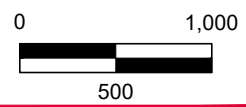
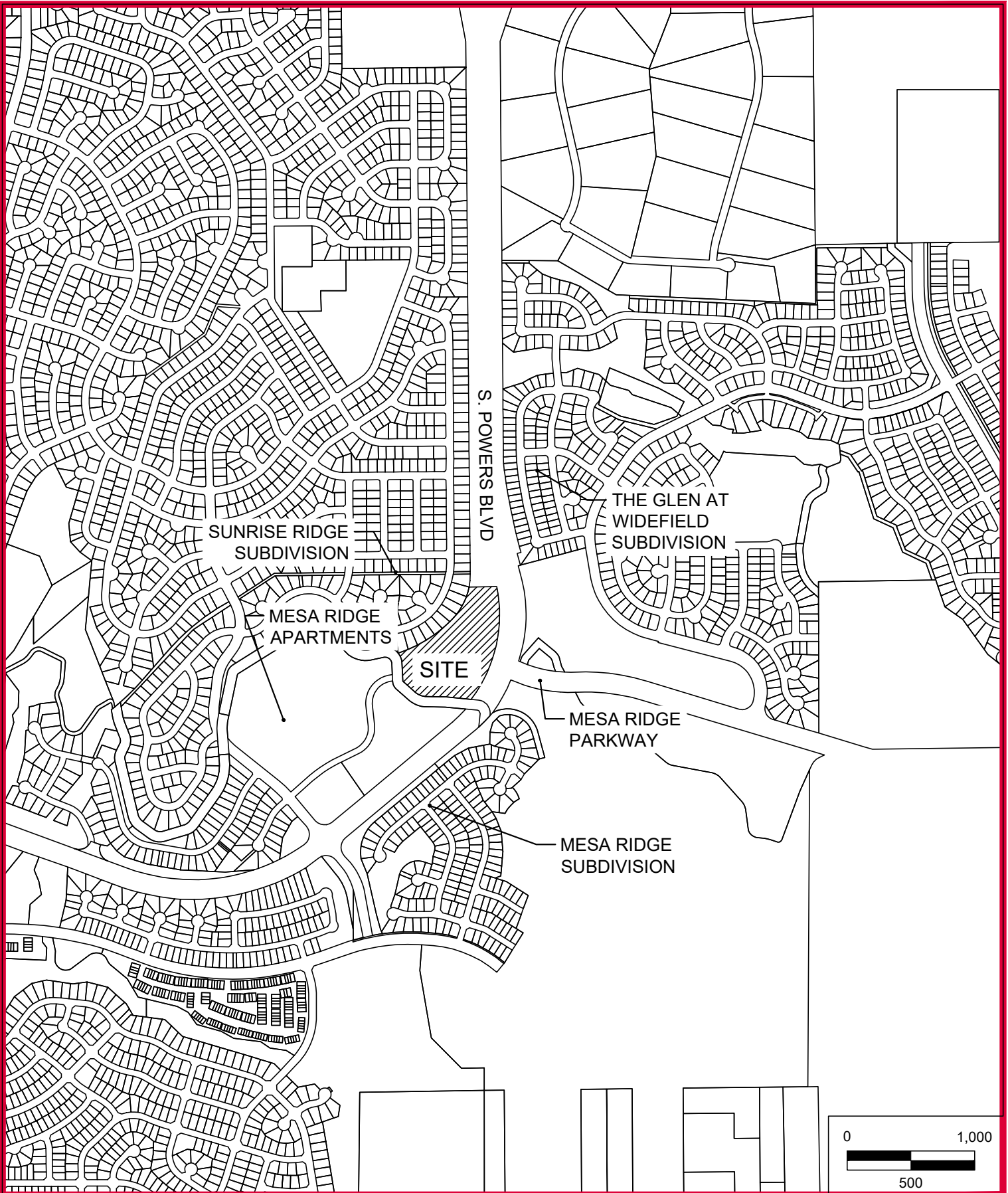

Xrefs: 8.5x11\_Titleblock



HRGreen.com



SHEET  
VICINITY MAP

SCALE: 1"=1,000'  
DATE: 03/29/2021



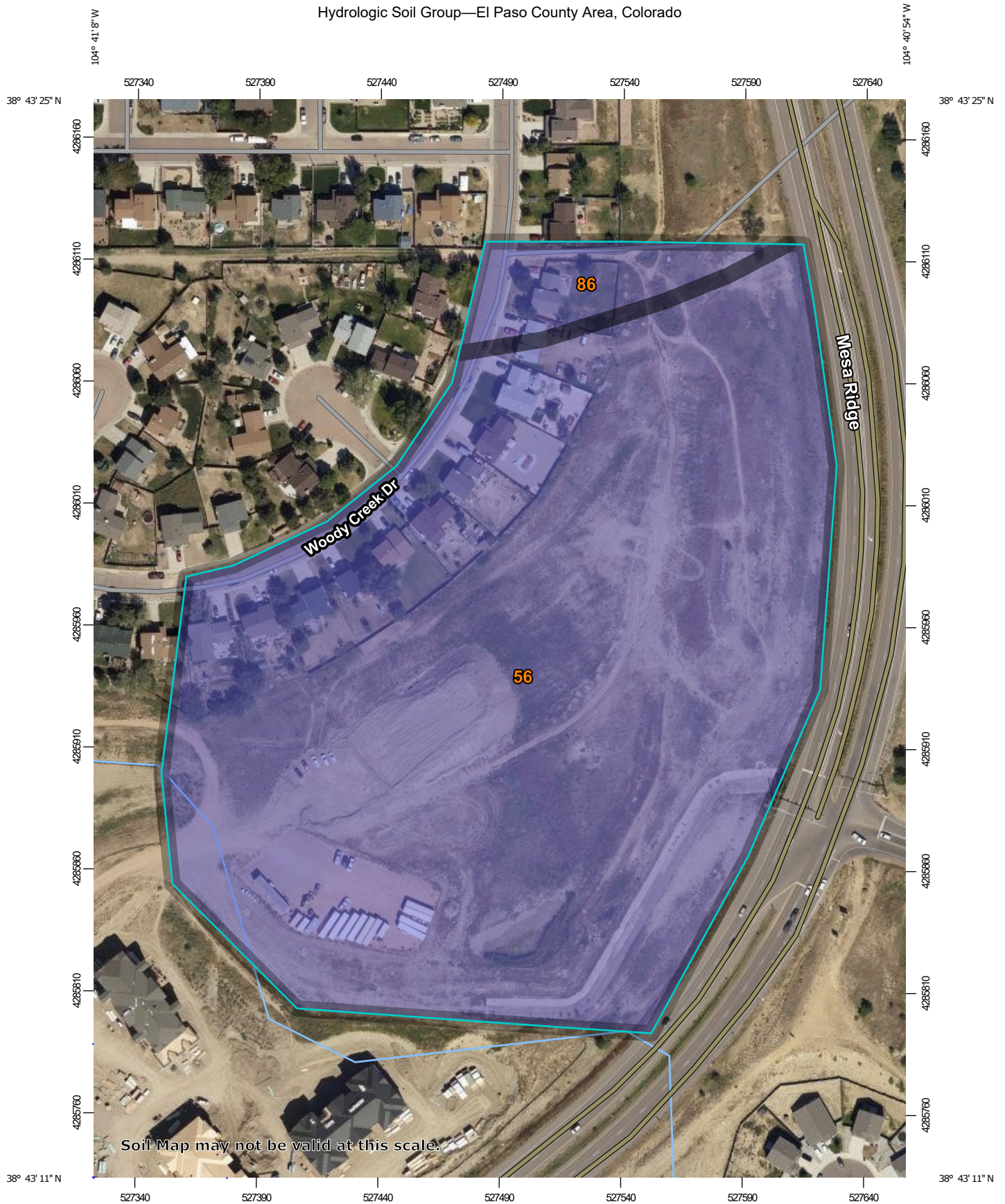



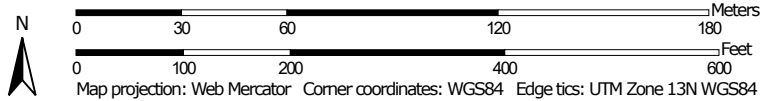

























Hydrologic Soil Group—El Paso County Area, Colorado



Map Scale: 1:2,150 if printed on A portrait (8.5" x 11") sheet.



### MAP LEGEND

- Area of Interest (AOI)**
  -  Area of Interest (AOI)
- Soils**
  - Soil Rating Polygons**
    -  A
    -  A/D
    -  B
    -  B/D
    -  C
    -  C/D
    -  D
    -  Not rated or not available
  - Soil Rating Lines**
    -  A
    -  A/D
    -  B
    -  B/D
    -  C
    -  C/D
    -  D
    -  Not rated or not available
  - Soil Rating Points**
    -  A
    -  A/D
    -  B
    -  B/D
-  C
-  C/D
-  D
-  Not rated or not available
- Water Features**
  -  Streams and Canals
- Transportation**
  -  Rails
  -  Interstate Highways
  -  US Routes
  -  Major Roads
  -  Local Roads
- Background**
  -  Aerial Photography

### MAP INFORMATION

The soil surveys that comprise your AOI were mapped at 1:24,000.

**Warning:** Soil Map may not be valid at this scale.  
 Enlargement of maps beyond the scale of mapping can cause misunderstanding of the detail of mapping and accuracy of soil line placement. The maps do not show the small areas of contrasting soils that could have been shown at a more detailed scale.

Please rely on the bar scale on each map sheet for map measurements.

Source of Map: Natural Resources Conservation Service  
 Web Soil Survey URL:  
 Coordinate System: Web Mercator (EPSG:3857)

Maps from the Web Soil Survey are based on the Web Mercator projection, which preserves direction and shape but distorts distance and area. A projection that preserves area, such as the Albers equal-area conic projection, should be used if more accurate calculations of distance or area are required.

This product is generated from the USDA-NRCS certified data as of the version date(s) listed below.

Soil Survey Area: El Paso County Area, Colorado  
 Survey Area Data: Version 17, Sep 13, 2019

Soil map units are labeled (as space allows) for map scales 1:50,000 or larger.

Date(s) aerial images were photographed: Aug 14, 2018—Sep 23, 2018

The orthophoto or other base map on which the soil lines were compiled and digitized probably differs from the background imagery displayed on these maps. As a result, some minor shifting of map unit boundaries may be evident.

## Hydrologic Soil Group

Map unit symbol	Map unit name	Rating	Acres in AOI	Percent of AOI
56	Nelson-Tassel fine sandy loams, 3 to 18 percent slopes	B	15.6	94.7%
86	Stoneham sandy loam, 3 to 8 percent slopes	B	0.9	5.3%
<b>Totals for Area of Interest</b>			<b>16.5</b>	<b>100.0%</b>

### Description

Hydrologic soil groups are based on estimates of runoff potential. Soils are assigned to one of four groups according to the rate of water infiltration when the soils are not protected by vegetation, are thoroughly wet, and receive precipitation from long-duration storms.

The soils in the United States are assigned to four groups (A, B, C, and D) and three dual classes (A/D, B/D, and C/D). The groups are defined as follows:

Group A. Soils having a high infiltration rate (low runoff potential) when thoroughly wet. These consist mainly of deep, well drained to excessively drained sands or gravelly sands. These soils have a high rate of water transmission.

Group B. Soils having a moderate infiltration rate when thoroughly wet. These consist chiefly of moderately deep or deep, moderately well drained or well drained soils that have moderately fine texture to moderately coarse texture. These soils have a moderate rate of water transmission.

Group C. Soils having a slow infiltration rate when thoroughly wet. These consist chiefly of soils having a layer that impedes the downward movement of water or soils of moderately fine texture or fine texture. These soils have a slow rate of water transmission.

Group D. Soils having a very slow infiltration rate (high runoff potential) when thoroughly wet. These consist chiefly of clays that have a high shrink-swell potential, soils that have a high water table, soils that have a claypan or clay layer at or near the surface, and soils that are shallow over nearly impervious material. These soils have a very slow rate of water transmission.

If a soil is assigned to a dual hydrologic group (A/D, B/D, or C/D), the first letter is for drained areas and the second is for undrained areas. Only the soils that in their natural condition are in group D are assigned to dual classes.





## **APPENDIX B – HYDROLOGIC CALCULATIONS**

**COTTAGES AT MESA RIDGE****Calc'd by:****NQJ****EXISTING CONDITIONS****Checked by:****LOCATION: COLORADO SPRINGS, COLORADO****Date:****8/10/2021****SUMMARY RUNOFF TABLE**

BASIN	AREA (ac)	% IMPERVIOUS	Q <sub>5</sub> (cfs)	Q <sub>100</sub> (cfs)
EX1	5.69	7	2.5	13.7
EX2	3.12	28	4.2	12.4
EX3	1.46	24	1.6	5.1
EX4	0.28	2	0.1	0.8
EX5	3.38	15	2.8	11.9

**DESIGN POINT SUMMARY TABLE**

DESIGN POINT	UPSTREAM BASIN	ΣQ <sub>5</sub> (cfs)	ΣQ <sub>100</sub> (cfs)
1	EX1	2.5	13.7
2	EX2	4.2	12.4
3	EX3	1.6	5.1
4	EX4	0.1	0.8
5	EX5	2.8	11.9



**COTTAGES AT MESA RIDGE**

**EXISTING CONDITIONS**

**LOCATION: COLORADO SPRINGS, COLORADO**

**NQJ**

**Calc'd by:**

**Checked by:**

**8/10/2021**

**Date:**

**COMPOSITE 'C' FACTORS**

BASIN	UNDEVELOPED	PAVED	SINGLE FAMILY LOT	TOTAL	SOIL TYPE	UNDEVELOPED			PAVED			SINGLE FAMILY LOT			COMPOSITE IMPERVIOUSNESS & C		
	ACRES					%I	C <sub>5</sub>	C <sub>100</sub>	%I	C <sub>5</sub>	C <sub>100</sub>	%I	C <sub>5</sub>	C <sub>100</sub>	%I	C <sub>5</sub>	C <sub>100</sub>
	EX1	5.25	0.00	0.44		5.69	B	2	0.09	0.36	100	0.90	0.96	65	0.45	0.69	7
EX2	2.28	0.84	0.00	3.12	B	2	0.16	0.51	100	0.90	0.96	65	0.45	0.69	28	0.36	0.63
EX3	1.13	0.33	0.00	1.46	B	2	0.16	0.51	100	0.90	0.96	65	0.45	0.69	24	0.33	0.61
EX4	0.28	0.00	0.00	0.28	B	2	0.16	0.51	100	0.90	0.96	65	0.45	0.69	2	0.16	0.51
EX5	2.70	0.00	0.68	3.38	B	2	0.16	0.51	100	0.90	0.96	65	0.45	0.69	15	0.22	0.55
Total				13.93													15.30

runoff coefficients for 2% impervious in table 6-6 is 0.09 & 0.36 for 5yr & 100yr as provided in basin EX1. revise accordingly.

runoff coefficients for 65% impervious in table 6-6 is 0.59 for 100yr. revise accordingly.

	<b>COTTAGES AT MESA RIDGE</b>					<b>Calc'd by:</b>		<b>NQJ</b>			
	<b>EXISTING CONDITIONS</b>					<b>Checked by:</b>					
	<b>LOCATION: COLORADO SPRINGS, COLORADO</b>					<b>Date:</b>		<b>8/10/2021</b>			
<b>TIME OF CONCENTRATION</b>											
<b>BASIN DATA</b>			<b>OVERLAND TIME (T<sub>o</sub>)</b>			<b>TRAVEL TIME (T<sub>t</sub>)</b>					<b>TOTAL</b>
DESIGNATION	C <sub>s</sub>	AREA (ac)	LENGTH (ft)	SLOPE %	t <sub>o</sub> (min)	C <sub>v</sub>	LENGTH (ft)	SLOPE %	V (ft/s)	t <sub>t</sub> (min)	t <sub>c</sub> (min)
EX1	0.12	5.69	100	25.0	6.2	10	750	3.2	1.8	7.0	13.1
EX2	0.36	3.12	158	7.1	8.9	10	620	6.5	2.5	4.1	12.9
EX3	0.33	1.46	25	25.0	2.4	20	520	0.1	0.6	13.7	16.1
EX4	0.16	0.28	75	1.0	14.9	10	305	5.4	2.3	2.2	17.1
EX5	0.22	3.38	42	1.8	8.6	10	440	4.2	2.0	3.6	12.2



**COTTAGES AT MESA RIDGE**

**EXISTING CONDITIONS**

**DESIGN STORM: 5-YEAR**

Calc'd by:

NQJ

Checked by:

Date:

8/10/2021

			DIRECT RUNOFF						TOTAL RUNOFF				STREET			PIPE				TRAVEL TIME			REMARKS
STREET	DESIGN POINT	BASIN ID	AREA (ac)	C <sub>5</sub>	t <sub>c</sub> (min)	C <sub>5</sub> *A (ac)	I (in./hr.)	Q (cfs)	t <sub>c</sub> (min)	C <sub>5</sub> *A (ac)	I (in./hr.)	Q (cfs)	Q <sub>street</sub> (cfs)	C <sub>5</sub> *A (ac)	SLOPE %	Q <sub>PIPE</sub> (cfs)	C <sub>5</sub> *A (ac)	SLOPE %	PIPE SIZE (in)	LENGTH (FT)	VEL. (FPS)	TRAVEL TIME (min)	
	1	EX1	5.69	0.12	13.1	0.67	3.72	2.5															
	2	EX2	3.12	0.36	12.9	1.12	3.74	4.2															
	3	EX3	1.46	0.33	16.1	0.48	3.41	1.6															
	4	EX4	0.28	0.16	17.1	0.04	3.32	0.1															
	5	EX5	3.38	0.22	12.2	0.74	3.83	2.8															



**COTTAGES AT MESA RIDGE**

Calc'd by:

NQJ

EXISTING CONDITIONS

Checked by:

DESIGN STORM: 100-YEAR

Date:

8/10/2021

STREET	DESIGN POINT	BASIN ID	DIRECT RUNOFF						TOTAL RUNOFF				STREET			PIPE			TRAVEL TIME			REMARKS
			AREA (ac)	C <sub>100</sub>	t <sub>c</sub> (min)	C <sub>100</sub> *A (ac)	I (in./hr.)	Q (cfs)	t <sub>c</sub> (min)	C <sub>100</sub> *A (ac)	I (in./hr.)	Q (cfs)	Q <sub>street</sub> (cfs)	C <sub>100</sub> *A (ac)	SLOPE %	Q <sub>PIPE</sub> (cfs)	C <sub>100</sub> *A (ac)	SLOPE %	PIPE SIZE (ft)	LENGTH (ft)	VEL. (ft/s)	
	1	EX1	5.69	0.39	13.1	2.19	6.24	13.7														
	2	EX2	3.12	0.63	12.9	1.97	6.28	12.4														
	3	EX3	1.46	0.61	16.1	0.89	5.73	5.1														
	4	EX4	0.28	0.51	17.1	0.14	5.58	0.8														
	5	EX5	3.38	0.55	12.2	1.85	6.43	11.9														



<b>COTTAGES AT MESA RIDGE</b>	<b>Calc'd by:</b>	<b>NQJ</b>
<b>PROPOSED CONDITIONS</b>	<b>Checked by:</b>	
<b>LOCATION: COLORADO SPRINGS, COLORADO</b>	<b>Date:</b>	<b>8/11/2021</b>

BASIN	AREA (ac)	% IMPERVIOUS	Q <sub>5</sub> (cfs)	Q <sub>100</sub> (cfs)
1	3.56	63	7.6	16.1
2	4.93	59	9.5	20.3
3	3.03	29	3.4	9.7
4	0.52	8	0.4	1.8
5	1.50	32	2.1	5.7
6	0.63	2	0.2	1.2
7	0.56	26	0.5	1.6
8	0.24	100	1.1	2.0
9	0.14	100	0.7	1.2

DESIGN POINT	UPSTREAM BASIN	ΣQ <sub>5</sub> (cfs)	ΣQ <sub>100</sub> (cfs)
1	1	7.6	16.1
2	2	9.5	20.3
2.1	3	15.6	29.9
3	4	3.4	9.7
4	5	0.4	1.8
5	5	2.1	5.7
6	6	0.2	1.2
7	7	0.5	1.6
8	8	1.1	2.0
9	9	1.1	1.2
9.1	8&9	17.1	39.6

identify this design point on the drainage plan



**COTTAGES AT MESA RIDGE**

**PROPOSED CONDITIONS**

**LOCATION: COLORADO SPRINGS, COLORADO**

Calc'd by:

Checked by:

Date:

**COMPOSITE 'C' FACTORS**

BASIN	LANDSCAPING	PAVED	ROOFS	SINGLE FAMILY	TOTAL	SOIL TYPE	LANDSCAPING			PAVED			ROOFS			SINGLE FAMILY			COMPOSITE IMPERVIOUSNESS & C					
							ACRES			%I	C <sub>5</sub>	C <sub>100</sub>	%I	C <sub>5</sub>	C <sub>100</sub>	%I	C <sub>5</sub>	C <sub>100</sub>	%I	C <sub>5</sub>	C <sub>100</sub>	%I	C <sub>5</sub>	C <sub>100</sub>
1	0.86	1.38	0.66	0.66	3.56	B	2	0.09	0.36	100	0.90	0.96	90	0.73	0.81	40	0.30	0.50	63	0.56	0.70			
2	1.76	1.69	1.21	0.27	4.93	B	2	0.09	0.36	100	0.90	0.96	90	0.73	0.81	40	0.30	0.50	59	0.54	0.68			
3	2.19	0.84	0.00	0.00	3.03	B	2	0.09	0.36	100	0.90	0.96	90	0.73	0.81	40	0.30	0.50	29	0.31	0.53			
4	0.49	0.03	0.00	0.00	0.52	B	2	0.09	0.36	100	0.90	0.96	90	0.73	0.81	40	0.30	0.50	8	0.14	0.39			
5	1.04	0.46	0.00	0.00	1.50	B	2	0.09	0.36	100	0.90	0.96	90	0.73	0.81	40	0.30	0.50	32	0.34	0.54			
6	0.63	0.00	0.00	0.00	0.63	B	2	0.09	0.36	100	0.90	0.96	90	0.73	0.81	40	0.30	0.50	2	0.09	0.36			
7	0.21	0.00	0.00	0.35	0.56	B	2	0.09	0.36	100	0.90	0.96	90	0.73	0.81	40	0.30	0.50	26	0.22	0.45			
8	0.00	0.24	0.00	0.00	0.24	B	2	0.09	0.36	100	0.90	0.96	90	0.73	0.81	40	0.30	0.50	100	0.90	0.96			
9	0.00	0.14	0.00	0.00	0.14	B	2	0.09	0.36	100	0.90	0.96	90	0.73	0.81	40	0.30	0.50	100	0.90	0.96			
Pond					11.56														54					
Total					15.11																			



	<b>COTTAGES AT MESA RIDGE</b>					Calc'd by:	<b>NQJ</b>				
	<b>PROPOSED CONDITIONS</b>					Checked by:					
	<b>LOCATION: COLORADO SPRINGS, COLORADO</b>					Date:	<b>8/10/2021</b>				
<b>TIME OF CONCENTRATION</b>											
<b>BASIN DATA</b>			<b>OVERLAND TIME (<math>T_i</math>)</b>			<b>TRAVEL TIME (<math>T_t</math>)</b>					<b>TOTAL</b>
DESIGNATION	$C_s$	AREA (ac)	LENGTH (ft)	SLOPE %	$t_i$ (min)	$C_v$	LENGTH (ft)	SLOPE %	V (ft/s)	$t_t$ (min)	$t_c$ (min)
1	0.56	3.56	100	2.0	7.8	20	900	2.9	3.4	4.4	12.2
2	0.54	4.93	100	2.0	8.2	20	1160	2.5	3.2	6.1	14.3
3	0.31	3.03	65	2.0	9.2	10	715	6.0	2.4	4.9	14.1
4	0.14	0.52	22	25.0	2.8	20	92	9.0	6.0	0.3	5.0
5	0.34	1.50	54	25.0	3.5	10	260	0.5	0.7	6.1	9.6
6	0.09	0.63	70	1.0	15.5	10	380	5.5	2.3	2.7	18.2
7	0.22	0.56	58	2.0	9.7	10	260	3.0	1.7	2.5	12.2
8	0.90	0.24	16	2.0	1.2	20	270	9.0	6.0	0.8	5.0
9	0.90	0.14	16	2.0	1.2	20	270	9.0	6.0	0.8	5.0



**COTTAGES AT MESA RIDGE**  
**PROPOSED CONDITIONS**  
**DESIGN STORM: 5-YEAR**

Calc'd by: **NQJ**  
 Checked by:  
 Date: **8/10/2021**

STREET	DESIGN POINT	BASIN ID	DIRECT RUNOFF						TOTAL RUNOFF				STREET			PIPE				TRAVEL TIME			REMARKS			
			AREA (ac)	C <sub>s</sub>	t <sub>c</sub> (min)	C <sub>s</sub> *A (ac)	I (in./hr.)	Q (cfs)	t <sub>c</sub> (min)	C <sub>s</sub> *A (ac)	I (in./hr.)	Q (cfs)	Q <sub>street</sub> (cfs)	C <sub>s</sub> *A (ac)	SLOPE %	Q <sub>PIPE</sub> (cfs)	C <sub>s</sub> *A (ac)	SLOPE %	PIPE SIZE (in)	LENGTH (FT)	VEL. (FPS)	TRAVEL TIME (min)				
	1	1	3.56	0.56	12.2	2.00	3.83	7.6						0.2	0.07	2.0		7.4	1.93	9.0	18.0	16	21.6	0.01	BASIN 1 FLOW CAPTURED IN 15' TYPE R INLET (ON GRADE) DP1 FLOW BY, C&G FLOW TO DP8	
	2	2	4.93	0.54	14.3	2.64	3.59	9.5						0.8	0.22	2.0		8.7	2.42	9.0	18.0	16	21.6	0.01	BASIN 2 FLOW CAPTURED IN 15' TYPE R INLET (ON GRADE) DP2 FLOW BY, C&G FLOW TO DP9	
	3	3	3.03	0.31	14.1	0.95	3.62	3.4																	BASIN 3 FLOW, SWALE FLOW TO EX TYPE C INLET @ DP3	
	4	4	0.52	0.14	5.0	0.07	5.17	0.4																	BASIN 4 FLOW, FOLLOW HISTORIC DRAINAGE PATTERNS TO DP4 BASIN 5 FLOW @ DP5, CAPTURED IN TYPE C INLET, PIPE TO DP2.1	
	5	5	1.5	0.34	9.6	0.51	4.18	2.1										2.1	0.51	0.5	18.0	536	5.1	1.75		
	2.1								14.3	4.36	3.59	15.6						15.6	4.36	9.0	18.0	280	21.6	0.22	COMBINED DP1 & DP2 FLOW, PIPE TO DP9.1	
	6	6	0.63	0.09	18.2	0.06	3.23	0.2																	BASIN 6 FLOW @ DP6, FOLLOWS HISTORIC DRAINAGE PATTERNS	
	7	7	0.56	0.22	12.2	0.12	3.83	0.5																	BASIN 7 FLOW @ DP7, FOLLOWS HISTORIC DRAINAGE PATTERNS BASIN 8 AND DP1 FLOW BY, CAPTURED IN 10' TYPE R INLET (ON GRADE) DP8 FLOW BY, C&G FLOW TO LANDOVER LANE	
	8	8	0.24	0.90	5.0	0.22	5.17	1.1	13.9	0.28	3.64	1.0						1.0	0.28	2.0	18.0	16	10.2	0.03	BASIN 9 AND DP2 FLOW BY, CAPTURED IN 10' TYPE R INLET (ON GRADE) DP9 FLOW BY, C&G FLOW TO LANDOVER LANE	
	9	9	0.14	0.90	5.0	0.13	5.17	0.7	16.0	0.35	3.43	1.2						1.2	0.35	2.0	18.0	16	10.2	0.03		
	9.1								16.0	4.98	3.42	17.1														COMBINED DP2.1, DP8 DP9 FLOW, PIPE TO EX DETENTION POND D



**COTTAGES AT MESA RIDGE**

**PROPOSED CONDITIONS**

**DESIGN STORM: 100-YEAR**

Calc'd by:

NQJ

Checked by:

Date:

8/10/2021

			DIRECT RUNOFF						TOTAL RUNOFF				STREET			PIPE			TRAVEL TIME			REMARKS		
STREET	DESIGN POINT	BASIN ID	AREA (ac)	C <sub>100</sub>	t <sub>c</sub> (min)	C <sub>100</sub> *A (ac)	I (in./hr.)	Q (cfs)	t <sub>c</sub> (min)	C <sub>100</sub> *A (ac)	I (in./hr.)	Q (cfs)	Q <sub>street</sub> (cfs)	C <sub>100</sub> *A (ac)	SLOPE %	Q <sub>PIPE</sub> (cfs)	C <sub>100</sub> *A (ac)	SLOPE %	PIPE SIZE (ft)	LENGTH (ft)	VEL. (ft/s)	TRAVEL TIME (min)		
	1	1	3.56	0.70	12.2	2.50	6.42	16.1					4.0	0.62	9.0	12.1	1.88	2.0	18.0	16	10.2	0.03	BASIN 1 FLOW CAPTURED IN 15' TYPE R INLET (ON GRADE)	
																				280	6.0	0.78	DP1 FLOW BY, C&G FLOW TO DP8	
	2	2	4.93	0.68	14.3	3.37	6.03	20.3					6.7	1.11	9.0	13.6	2.26	2.0	18.0	16	10.2	0.03	BASIN 2 FLOW CAPTURED IN 15' TYPE R INLET (ON GRADE)	
																				280	6.0	0.78	DP2 FLOW BY, C&G FLOW TO DP9	
	3	3	3.03	0.53	14.1	1.59	6.07	9.7															BASIN 3 FLOW, SWALE FLOW TO EX TYPE C INLET @ DP3	
	4	4	0.52	0.39	5.0	0.21	8.68	1.8															BASIN 4 FLOW, FOLLOW HISTORIC DRAINAGE PATTERNS TO DP4	
	5	5	1.5	0.54	9.6	0.82	7.03	5.7								5.7	0.82	0.5	18.0	536	5.1	1.75	BASIN 5 FLOW @ DP5, CAPTURED IN TYPE C INLET, PIPE TO DP2.1	
	2.1								14.3	4.96	6.02	29.9				29.9	4.96	9.0	18.0	280	21.6	0.22	COMBINED DP1 & DP2 FLOW, PIPE TO DP9.1	
	6	6	0.63	0.36	18.2	0.23	5.42	1.2															BASIN 6 FLOW @ DP6, FOLLOWS HISTORIC DRAINAGE PATTERNS	
	7	7	0.56	0.45	12.2	0.25	6.42	1.6															BASIN 7 FLOW @ DP7, FOLLOWS HISTORIC DRAINAGE PATTERNS	
	8	8	0.24	0.96	5.0	0.23	8.68	2.0	13.0	0.85	6.27	5.3	0.5	0.08	9.0	4.8	0.77	9.0	18.0	16	21.6	0.01	BASIN 8 AND DP1 FLOW BY, CAPTURED IN 10' TYPE R INLET (ON GRADE)	
																								DP8 FLOW BY, C&G FLOW TO LANDOVER LANE
	9	9	0.14	0.96	5.0	0.13	8.68	1.2	15.1	1.25	5.89	7.4	1.5	0.25	9.0	5.9	1.00	9.0	18.0	16	21.6	0.01	BASIN 9 AND DP3 FLOW BY, CAPTURED IN 10' TYPE R INLET (ON GRADE)	
																								DP9 FLOW BY, C&G FLOW TO LANDOVER LANE
	9.1								15.1	6.72	5.89	39.6												COMBINED DP2.1, DP8 DP9 FLOW, PIPE TO EX DETENTION POND D

FYI: at final drainage report, analysis that Landover Ln has the capacity to accept the flow by of these inlets shall be provided.

## **APPENDIX C – HYDRAULIC CALCULATIONS\***

**\* HYDRAULIC CALCULATIONS INCLUDING INLET, STREET CAPACITY AND HYDRAULIC MODELING WILL BE INCLUDED WITH THE FINAL DRAINAGE REPORT.**



## **APPENDIX D – WATER QUALITY & DETENTION**

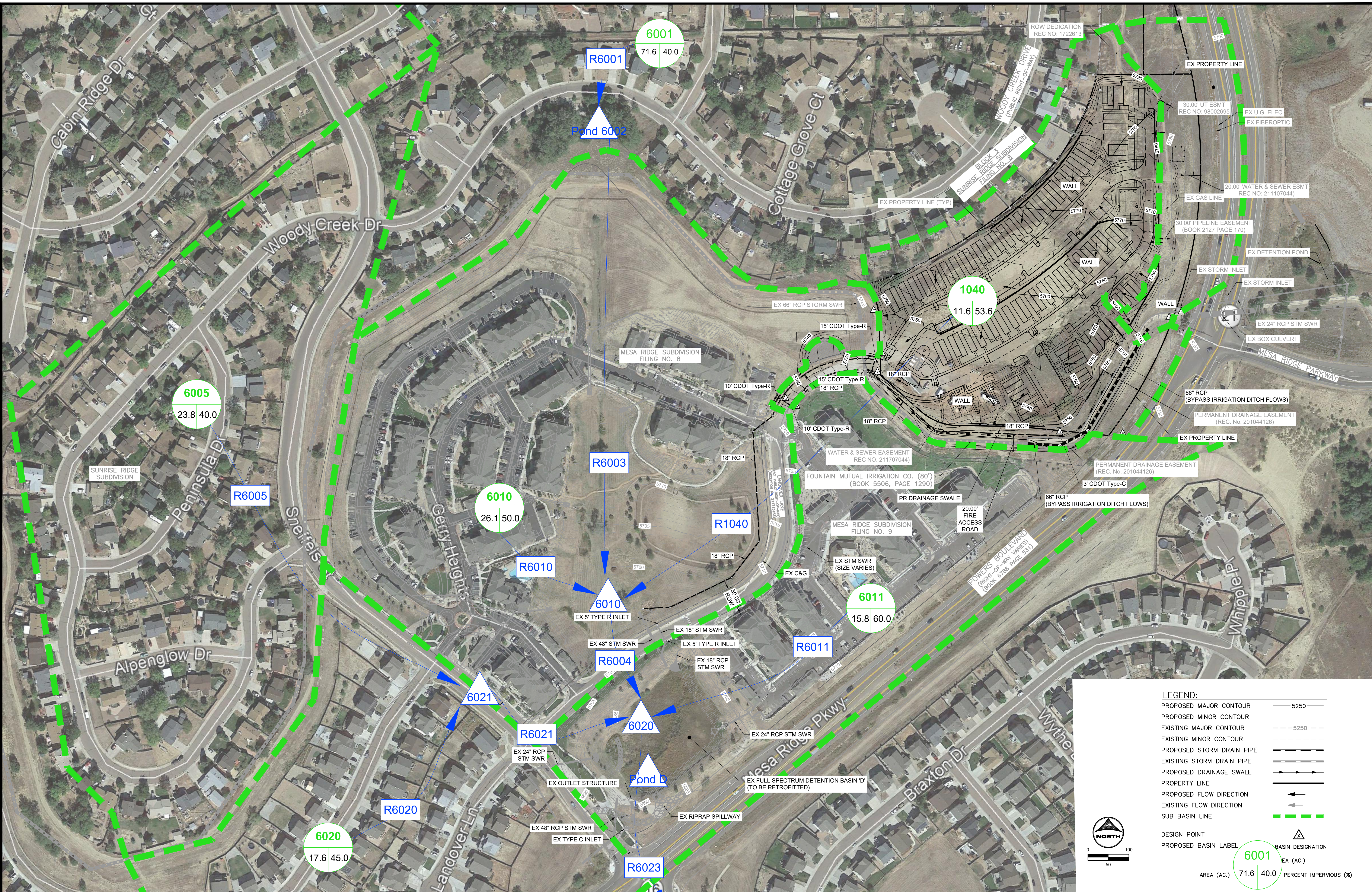

**LEGEND:**

- PROPOSED MAJOR CONTOUR ——— 5250 ———
- PROPOSED MINOR CONTOUR ——— 5250 ———
- EXISTING MAJOR CONTOUR ——— 5250 ———
- EXISTING MINOR CONTOUR ——— 5250 ———
- PROPOSED STORM DRAIN PIPE ———
- EXISTING STORM DRAIN PIPE ———
- PROPOSED DRAINAGE SWALE ———
- PROPERTY LINE ———
- PROPOSED FLOW DIRECTION ———
- EXISTING FLOW DIRECTION ———
- SUB BASIN LINE ———

DESIGN POINT (triangle symbol)

PROPOSED BASIN LABEL (circle symbol)

BASIN DESIGNATION (triangle symbol)

EA (AC.) (circle symbol)

AREA (AC.) 71.6 40.0 PERCENT IMPERVIOUS (%)

**Scale:** 0 50 100

**North Arrow:** NORTH

DRAWN BY: NQJ JOB DATE: 8/18/2021  
 APPROVED: KMH JOB NUMBER: 200541  
 CAD DATE: 8/18/2021  
 CAD FILE: J:\2020\200541\CAD\Drawings\C\Drainage\Pr\_Drn\_Map\_PondD

BAR IS ONE INCH ON OFFICIAL DRAWINGS.  
 0" = 1"  
 IF NOT ONE INCH, ADJUST SCALE ACCORDINGLY.

NO.	DATE	BY	REVISION DESCRIPTION

**HRGreen**  
 HR GREEN - COLORADO SPRINGS  
 7222 COMMERCE CENTER DR SUITE 220  
 COLORADO SPRINGS CO 80919  
 PHONE: 719.300.4140 TOLL FREE: 800.728.7805  
 FAX: 844.273.1057 | HRGreen.com

**THE COTTAGES AT MESA RIDGE**  
 GOODWIN KNIGHT  
 EL PASO COUNTY, COLORADO

PRELIMINARY DRAINAGE REPORT  
 REGIONAL POND D MAP

SHEET DRN 2

# CUHP SUBCATCHMENTS - PROPOSED CONDITION

## CUHP SUBCATCHMENTS

Columns with this color heading are for required user-input  
 Columns with this color heading are for optional override values  
 Columns with this color heading are for program-calculated values

Subcatchment Name	EPA SWMM Target Node	Raingage	Area (mi <sup>2</sup> )	Length to Centroid (mi)	Length (mi)	Slope (ft/ft)	Percent Imperviousness	Maximum Depression Storage (Watershed inches)		Horton's Infiltration Parameters			DCIA	Comment
								Pervious	Impervious	Initial Rate (in/hr)	Decay Coefficient (1/seconds)	Final Rate (in/hr)	Level 0, 1, or 2	
6001	E6001	100-YR	0.1120	0.2178	0.4356	0.0120	40.0	0.35	0.1	4.5	0.0018	0.6	0	
6005	E6005	100-YR	0.0362	0.0786	0.2235	0.0300	40.0	0.35	0.1	4.5	0.0018	0.6	0	
6010	E6010	100-YR	0.0433	0.1009	0.2216	0.0490	50.0	0.35	0.1	4.5	0.0018	0.6	0	Updated imperviousness to include open space
6011	E6011	100-YR	0.0267	0.1621	0.3136	0.0362	60.0	0.35	0.1	4.5	0.0018	0.6	0	
6020	E6020	100-YR	0.0300	0.1345	0.2083	0.0504	45.0	0.35	0.1	4.5	0.0018	0.6	0	Updated to single-family imperviousness
1040	E1040	100-YR	0.0181	0.0758	0.1894	0.0220	53.6	0.35	0.1	4.5	0.0018	0.6	0	Updated for new size and imperviousness

**Summary of Unit Hydrograph Parameters Used By Program and Calculated Results (Version 2.0.1)**

Catchment Name/ID	User Comment for Catchment	Unit Hydrograph Parameters and Results									Excess Precip.		Storm Hydrograph			
		CT	Cp	W50 (min.)	W50 Before Peak	W75 (min.)	W75 Before Peak	Time to Peak (min.)	Peak (cfs)	Volume (c.f)	Excess (inches)	Excess (c.f.)	Time to Peak (min.)	Peak Flow (cfs)	Total Volume (c.f.)	Runoff per Unit Area (cfs/acre)
6,001		0.094	0.178	23.1	3.45	12.0	2.44	5.7	146	260,198	2.09	542,819	40.0	173	542,806	2.41
6,005		0.094	0.107	13.7	1.42	7.1	1.01	2.4	79	84,100	2.09	175,447	36.0	77	175,455	3.32
6,010	Updated imperviousness to include open space	0.089	0.131	10.5	1.36	5.5	0.96	2.3	123	100,595	2.22	223,481	35.0	110	223,473	3.96
6,011		0.084	0.115	18.3	1.91	9.5	1.35	3.2	44	62,029	2.36	146,231	37.0	51	146,214	2.99
6,020	Updated to single-family imperviousness	0.091	0.105	15.0	1.51	7.8	1.07	2.5	60	69,696	2.15	150,108	36.0	62	150,075	3.21
1,040	Updated for new size and imperviousness	0.087	0.092	14.5	1.32	7.5	0.93	2.2	37	42,050	2.27	95,468	36.0	39	95,489	3.36



# The Cottages at Mesa Ridge

01/01/2005 00:05:00

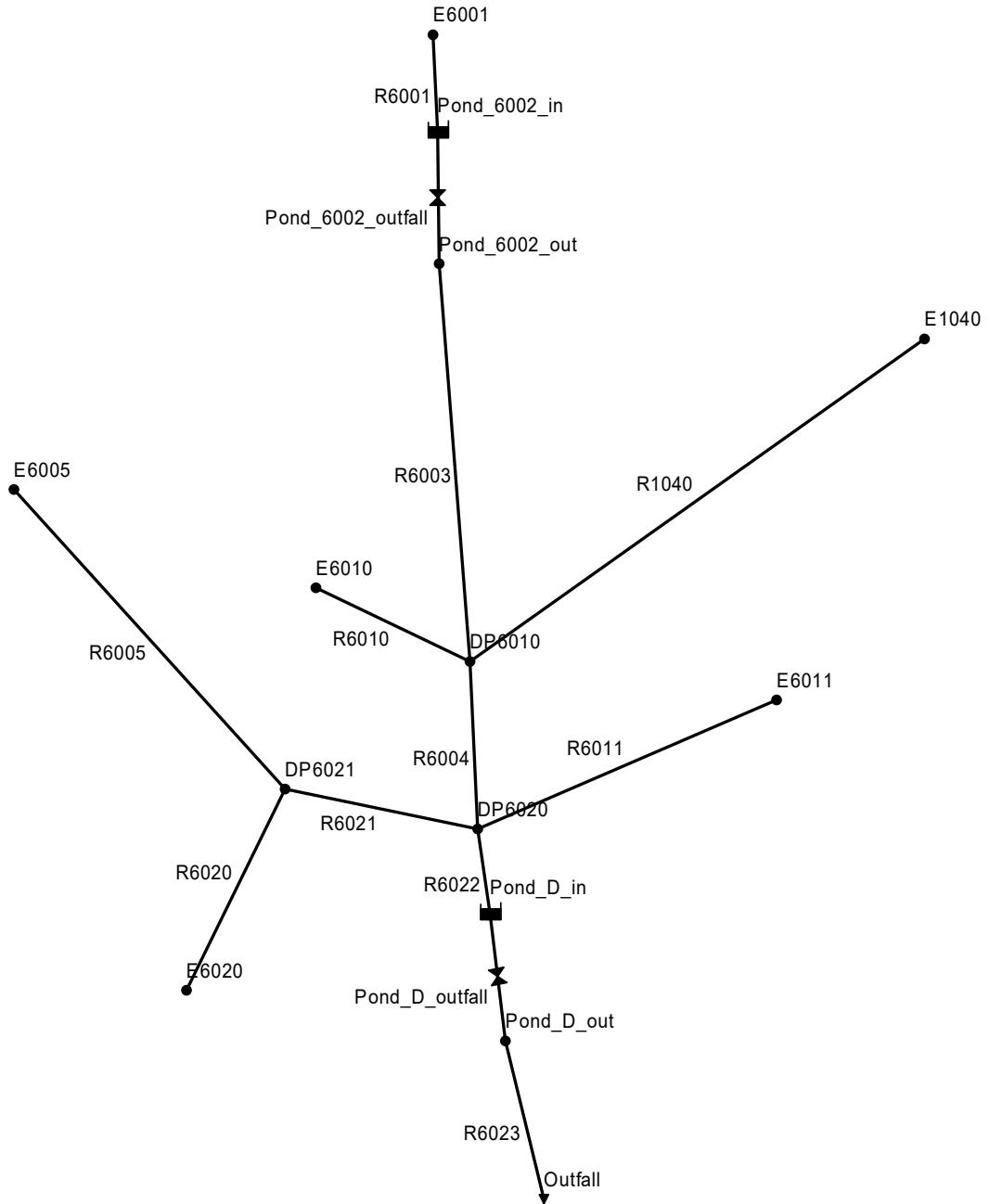

EPA STORM WATER MANAGEMENT MODEL - VERSION 5.1 (Build 5.1.012)

WARNING 04: minimum elevation drop used for Conduit R6022

\*\*\*\*\*  
NOTE: The summary statistics displayed in this report are based on results found at every computational time step, not just on results from each reporting time step.  
\*\*\*\*\*

\*\*\*\*\*  
Analysis Options  
\*\*\*\*\*  
Flow Units ..... CFS  
Process Models:  
  Rainfall/Runoff ..... NO  
  RDII ..... NO  
  Snowmelt ..... NO  
  Groundwater ..... NO  
  Flow Routing ..... YES  
  Ponding Allowed ..... NO  
  Water Quality ..... NO  
Flow Routing Method ..... KINWAVE  
Starting Date ..... 01/01/2005 00:00:00  
Ending Date ..... 01/01/2005 12:00:00  
Antecedent Dry Days ..... 0.0  
Report Time Step ..... 00:05:00  
Routing Time Step ..... 60.00 sec

	Volume acre-feet	Volume 10 <sup>6</sup> gal
Flow Routing Continuity	-----	-----
Dry Weather Inflow .....	0.000	0.000
Wet Weather Inflow .....	0.000	0.000
Groundwater Inflow .....	0.000	0.000
RDII Inflow .....	0.000	0.000
External Inflow .....	30.612	9.975
External Outflow .....	25.293	8.242
Flooding Loss .....	0.000	0.000
Evaporation Loss .....	0.000	0.000
Exfiltration Loss .....	0.000	0.000
Initial Stored Volume ....	0.000	0.000
Final Stored Volume .....	5.306	1.729
Continuity Error (%) .....	0.042	

\*\*\*\*\*  
Highest Flow Instability Indexes  
\*\*\*\*\*  
All links are stable.

\*\*\*\*\*  
Routing Time Step Summary  
\*\*\*\*\*  
Minimum Time Step : 60.00 sec  
Average Time Step : 60.00 sec  
Maximum Time Step : 60.00 sec  
Percent in Steady State : 0.00  
Average Iterations per Step : 1.13  
Percent Not Converging : 0.00

\*\*\*\*\*  
Node Depth Summary  
\*\*\*\*\*

Node	Type	Average Depth Feet	Maximum Depth Feet	Maximum HGL Feet	Time of Max Occurrence days hr:min	Reported Max Depth Feet
E6005	JUNCTION	0.14	1.79	5715.48	0 00:37	1.76
E6010	JUNCTION	0.00	0.00	5693.19	0 00:00	0.00
E6001	JUNCTION	0.00	0.00	5750.46	0 00:00	0.00
E1040	JUNCTION	0.04	0.53	5732.80	0 00:37	0.53
E6011	JUNCTION	0.00	0.00	5688.69	0 00:00	0.00
E6020	JUNCTION	0.00	0.00	5691.39	0 00:00	0.00

The Cottages at Mesa Ridge  
Preliminary Drainage Report  
EPA SWMM Results – 100-year with pond modifications

DP6010	JUNCTION	0.48	3.14	5691.33	0	00:42	3.08
DP6021	JUNCTION	0.18	2.13	5693.32	0	00:37	2.09
DP6020	JUNCTION	0.48	3.14	5686.83	0	00:42	3.06
Pond_D_out	JUNCTION	0.18	1.06	5683.65	0	01:13	1.06
Pond_6002_out	JUNCTION	0.18	1.25	5749.71	0	00:59	1.24
Outfall1	OUTFALL	0.18	1.06	5673.90	0	01:13	1.06
Pond_6002_in	STORAGE	4.90	9.61	5759.07	0	00:59	9.61
Pond_D_in	STORAGE	5.06	9.34	5693.03	0	01:13	9.32

\*\*\*\*\*  
Node Inflow Summary  
\*\*\*\*\*

Node	Type	Maximum Lateral Inflow CFS	Maximum Total Inflow CFS	Time of Max Occurrence days hr:min	Lateral Inflow Volume 10^6 gal	Total Inflow Volume 10^6 gal	Flow Balance Error Percent
E6005	JUNCTION	76.91	76.91	0 00:37	1.31	1.31	0.000
E6010	JUNCTION	109.76	109.76	0 00:36	1.67	1.67	0.000
E6001	JUNCTION	172.95	172.95	0 00:41	4.06	4.06	0.000
E1040	JUNCTION	38.88	38.88	0 00:37	0.714	0.714	-0.000
E6011	JUNCTION	51.06	51.06	0 00:38	1.09	1.09	0.000
E6020	JUNCTION	61.62	61.62	0 00:37	1.12	1.12	0.000
DP6010	JUNCTION	0.00	231.62	0 00:42	0	6.26	0.000
DP6021	JUNCTION	0.00	138.54	0 00:37	0	2.43	0.000
DP6020	JUNCTION	0.00	412.18	0 00:41	0	9.79	0.000
Pond_D_out	JUNCTION	0.00	233.78	0 01:13	0	8.24	0.000
Pond_6002_out	JUNCTION	0.00	136.68	0 00:59	0	3.87	0.000
Outfall1	OUTFALL	0.00	233.77	0 01:13	0	8.24	0.000
Pond_6002_in	STORAGE	0.00	172.95	0 00:41	0	4.06	0.152
Pond_D_in	STORAGE	0.00	412.18	0 00:41	0	9.79	0.048

\*\*\*\*\*  
Node Flooding Summary  
\*\*\*\*\*

No nodes were flooded.

\*\*\*\*\*  
Storage Volume Summary  
\*\*\*\*\*

Storage Unit	Average Volume 1000 ft3	Avg Pcnt Full	Evap Pcnt Loss	Exfil Pcnt Loss	Maximum Volume 1000 ft3	Max Pcnt Full	Time of Max Occurrence days hr:min	Maximum Outflow CFS
Pond_6002_in	45.849	16	0	0	126.976	45	0 00:59	136.68
Pond_D_in	246.767	32	0	0	548.176	70	0 01:13	233.78

\*\*\*\*\*  
Outfall Loading Summary  
\*\*\*\*\*

Outfall Node	Flow Freq Pcnt	Avg Flow CFS	Max Flow CFS	Total Volume 10^6 gal
Outfall1	97.92	26.05	233.77	8.242
System	97.92	26.05	233.77	8.242

The Cottages at Mesa Ridge  
Preliminary Drainage Report  
EPA SWMM Results – 100-year with pond modifications

\*\*\*\*\*  
Link Flow Summary  
\*\*\*\*\*

Link	Type	Maximum  Flow  CFS	Time of Max Occurrence days hr:min	Maximum  Veloc  ft/sec	Max/ Full Flow	Max/ Full Depth
R1040	CONDUIT	38.58	0 00:38	6.04	0.01	0.11
R6003	CONDUIT	136.55	0 01:01	8.00	0.06	0.25
R6004	CONDUIT	231.40	0 00:42	19.56	0.83	0.70
R6005	CONDUIT	76.92	0 00:37	17.52	0.67	0.60
R6011	DUMMY	51.06	0 00:38			
R6010	DUMMY	109.76	0 00:36			
R6021	CONDUIT	138.54	0 00:37	20.33	0.56	0.53
R6020	DUMMY	61.62	0 00:37			
R6001	DUMMY	172.95	0 00:41			
R6022	DUMMY	412.18	0 00:41			
R6023	CONDUIT	233.77	0 01:13	18.44	0.10	0.18
Pond_6002_outfall	DUMMY	136.68	0 00:59			
Pond_D_outfall	DUMMY	233.78	0 01:13			

\*\*\*\*\*  
Conduit Surcharge Summary  
\*\*\*\*\*

No conduits were surcharged.

Analysis begun on: Tue Aug 17 14:10:59 2021  
Analysis ended on: Tue Aug 17 14:10:59 2021  
Total elapsed time: < 1 sec



# DETENTION BASIN OUTLET STRUCTURE DESIGN

MHFD-Detention, Version 4.04 (February 2021)

**Project:** Mesa Ridge Cottages  
**Basin ID:** Existing Pond D Sizing Confirmation

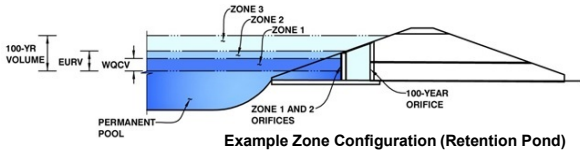

	Estimated Stage (ft)	Estimated Volume (ac-ft)	Outlet Type
Zone 1 (User)	4.79	5.144	Orifice Plate
Zone 2 (User)	5.01	0.318	Orifice Plate
Zone 3 (User)	8.76	6.104	Weir&Pipe (Rect.)
Total (all zones)		11.566	

**User Input: Orifice at Underdrain Outlet (typically used to drain WQCV in a Filtration BMP)**

Underdrain Orifice Invert Depth =  ft (distance below the filtration media surface)  
 Underdrain Orifice Diameter =  inches

**Calculated Parameters for Underdrain**

Underdrain Orifice Area =  ft<sup>2</sup>  
 Underdrain Orifice Centroid =  feet

**User Input: Orifice Plate with one or more orifices or Elliptical Slot Weir (typically used to drain WQCV and/or EURV in a sedimentation BMP)**

**Calculated Parameters for Plate**

Invert of Lowest Orifice =  0.00 ft (relative to basin bottom at Stage = 0 ft)  
 Depth at top of Zone using Orifice Plate =  4.46 ft (relative to basin bottom at Stage = 0 ft)  
 Orifice Plate: Orifice Vertical Spacing =  N/A inches  
 Orifice Plate: Orifice Area per Row =  N/A inches

WQ Orifice Area per Row =  N/A ft<sup>2</sup>  
 Elliptical Half-Width =  N/A feet  
 Elliptical Slot Centroid =  N/A feet  
 Elliptical Slot Area =  N/A ft<sup>2</sup>

**User Input: Stage and Total Area of Each Orifice Row (numbered from lowest to highest)**

	Row 1 (required)	Row 2 (optional)	Row 3 (optional)	Row 4 (optional)	Row 5 (optional)	Row 6 (optional)	Row 7 (optional)	Row 8 (optional)
Stage of Orifice Centroid (ft)	0.85	1.19	1.52	1.85	2.19	2.52	2.85	3.19
Orifice Area (sq. inches)	3.93	3.93	3.93	3.93	3.93	3.93	3.93	3.93

	Row 9 (optional)	Row 10 (optional)	Row 11 (optional)	Row 12 (optional)	Row 13 (optional)	Row 14 (optional)	Row 15 (optional)	Row 16 (optional)
Stage of Orifice Centroid (ft)		0.00	0.00	0.00	0.00	0.00	0.00	0.00
Orifice Area (sq. inches)								

**User Input: Vertical Orifice (Circular or Rectangular)**

**Calculated Parameters for Vertical Orifice**

	Not Selected	Not Selected	
Invert of Vertical Orifice =	N/A	N/A	ft (relative to basin bottom at Stage = 0 ft)
Depth at top of Zone using Vertical Orifice =	N/A	N/A	ft (relative to basin bottom at Stage = 0 ft)
Vertical Orifice Diameter =	N/A	N/A	inches

	Not Selected	Not Selected	
Vertical Orifice Area =	N/A	N/A	ft <sup>2</sup>
Vertical Orifice Centroid =	N/A	N/A	feet

**User Input: Overflow Weir (Dropbox with Flat or Sloped Gate and Outlet Pipe OR Rectangular/Trapezoidal Weir (and No Outlet Pipe))**

**Calculated Parameters for Overflow Weir**

	Zone 3 Weir	Not Selected	
Overflow Weir Front Edge Height, Ho =	4.46	N/A	ft (relative to basin bottom at Stage = 0 ft)
Overflow Weir Front Edge Length =	12.00	N/A	feet
Overflow Weir Gate Slope =	3.00	N/A	H:V
Horiz. Length of Weir Sides =	6.00	N/A	feet
Overflow Gate Type =	Close Mesh Gate	N/A	
Debris Clogging % =	0%	N/A	%

	Zone 3 Weir	Not Selected	
Height of Gate Upper Edge, H <sub>1</sub> =	6.46	N/A	feet
Overflow Weir Slope Length =	6.32	N/A	feet
Gate Open Area / 100-yr Orifice Area =	3.34	N/A	
Overflow Gate Open Area w/o Debris =	60.03	N/A	ft <sup>2</sup>
Overflow Gate Open Area w/ Debris =	60.03	N/A	ft <sup>2</sup>

**User Input: Outlet Pipe w/ Flow Restriction Plate (Circular Orifice, Restrictor Plate, or Rectangular Orifice)**

**Calculated Parameters for Outlet Pipe w/ Flow Restriction Plate**

	Zone 3 Rectangular	Not Selected	
Depth to Invert of Outlet Pipe =	1.21	N/A	ft (distance below basin bottom at Stage = 0 ft)
Rectangular Orifice Width =	72.00	N/A	inches
Rectangular Orifice Height =	36.00	N/A	inches

	Zone 3 Rectangular	Not Selected	
Outlet Orifice Area =	18.00	N/A	ft <sup>2</sup>
Outlet Orifice Centroid =	1.50	N/A	feet
Half-Central Angle of Restrictor Plate on Pipe =	N/A	N/A	radians

**User Input: Emergency Spillway (Rectangular or Trapezoidal)**

**Calculated Parameters for Spillway**

Spillway Invert Stage =	11.00	ft (relative to basin bottom at Stage = 0 ft)
Spillway Crest Length =	185.00	feet
Spillway End Slopes =	4.00	H:V
Freeboard above Max Water Surface =	0.40	feet

Spillway Design Flow Depth =	0.59	feet
Stage at Top of Freeboard =	11.99	feet
Basin Area at Top of Freeboard =	2.00	acres
Basin Volume at Top of Freeboard =	16.89	acre-ft

## Routed Hydrograph Results

The user can override the default CUHP hydrographs and runoff volumes by entering new values in the Inflow Hydrographs table (Columns W through AF).

	WQCV	EURV	2 Year	5 Year	10 Year	25 Year	50 Year	100 Year	500 Year
Design Storm Return Period			1.00	1.28	1.55	1.97	2.34	2.74	3.84
One-Hour Rainfall Depth (in)	N/A	N/A	1.00	1.28	1.55	1.97	2.34	2.74	3.84
CUHP Runoff Volume (acre-ft)	1.671	5.144	3.741	5.462	7.357	11.295	14.367	18.116	27.672
User Override Inflow Hydrograph Volume (acre-ft)	N/A	N/A	3.741	7.663	7.357	11.295	14.367	29.508	27.672
CUHP Predevelopment Peak Q (cfs)	N/A	N/A	1.1	11.3	25.6	67.8	94.1	127.9	209.2
OPTIONAL Override Predevelopment Peak Q (cfs)	N/A	N/A							
Predevelopment Unit Peak Flow, q (cfs/acre)	N/A	N/A	0.01	0.11	0.26	0.69	0.95	1.29	2.12
Peak Inflow Q (cfs)	N/A	N/A	48.9	94.1	98.7	161.4	204.6	407.9	385.0
Peak Outflow Q (cfs)	0.5	6.0	1.3	21.3	20.1	64.1	99.5	252.3	246.5
Ratio Peak Outflow to Predevelopment Q	N/A	N/A	N/A	1.9	0.8	0.9	1.1	2.0	1.2
Structure Controlling Flow	Plate	Overflow Weir 1	Plate	Overflow Weir 1	Overflow Weir 1	Overflow Weir 1	Overflow Weir 1	Outlet Plate 1	Outlet Plate 1
Max Velocity through Gate 1 (fps)	N/A	0.08	N/A	0.3	0.3	1.0	1.6	4.2	4.1
Max Velocity through Gate 2 (fps)	N/A	N/A	N/A	N/A	N/A	N/A	N/A	N/A	N/A
Time to Drain 97% of Inflow Volume (hours)	>120	>120	>120	>120	>120	>120	116	71	74
Time to Drain 99% of Inflow Volume (hours)	>120	>120	>120	>120	>120	>120	>120	>120	>120
Maximum Ponding Depth (ft)	2.22	4.79	3.66	5.27	5.24	6.08	6.57	8.76	8.38
Area at Maximum Ponding Depth (acres)	1.23	1.49	1.35	1.52	1.52	1.58	1.61	1.72	1.69
Maximum Volume Stored (acre-ft)	1.674	5.147	3.537	5.869	5.823	7.107	7.888	11.566	10.904
Equivalent Elevation (ft)		5687.19	5686.06	5687.67	5687.64	5688.48	5688.97	5691.16	
Pond Bottom (ft)									5682.400

# DETENTION BASIN OUTLET STRUCTURE DESIGN

*MHFD-Detention, Version 4.04 (February 2021)*

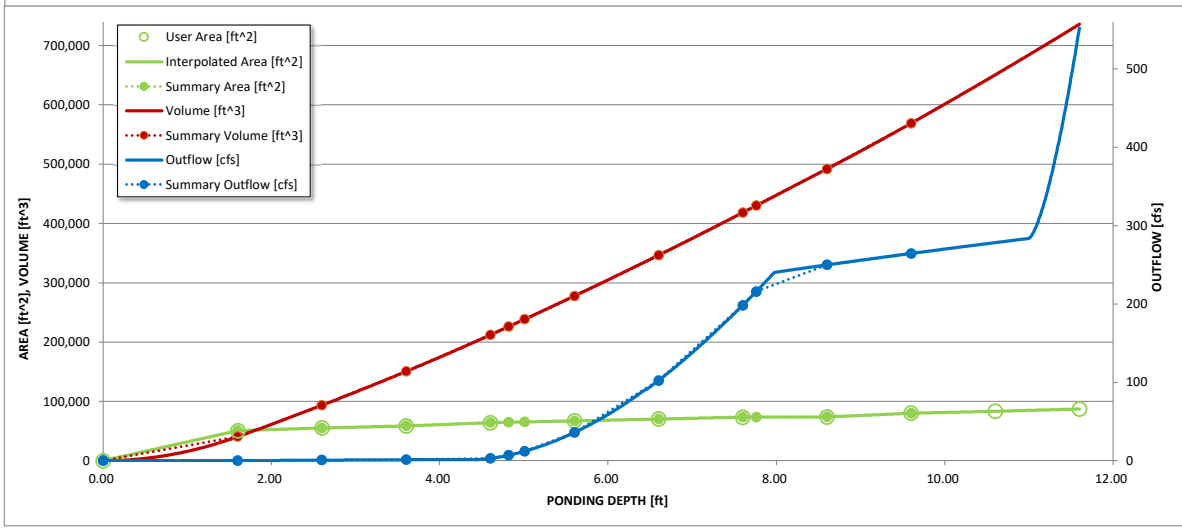
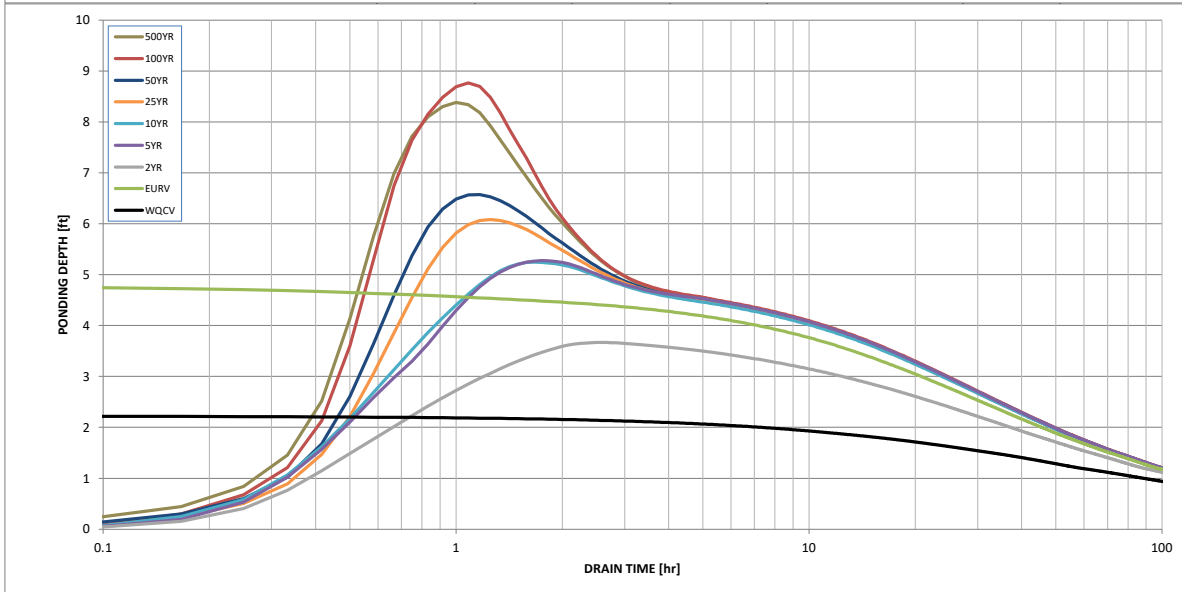
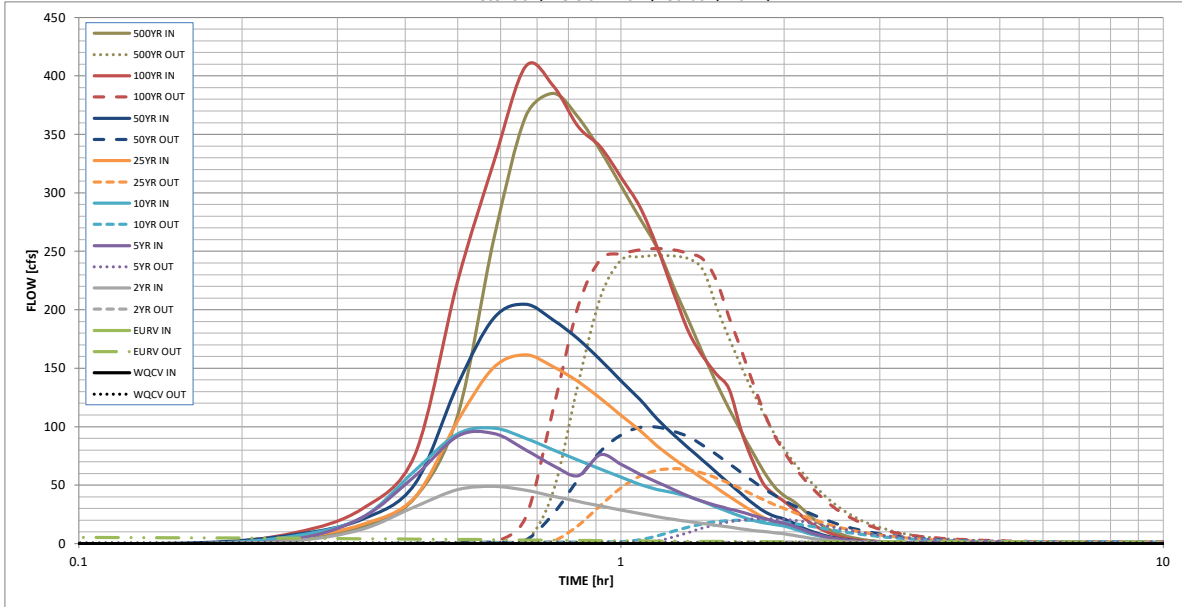

S-A-V-D Chart Axis Override	X-axis	Left Y-Axis	Right Y-Axis
minimum bound			
maximum bound			

# DETENTION BASIN OUTLET STRUCTURE DESIGN

Outflow Hydrograph Workbook Filename: \_\_\_\_\_

**Inflow Hydrographs**

The user can override the calculated inflow hydrographs from this workbook with inflow hydrographs developed in a separate program.

Time Interval	SOURCE	CUHP	CUHP	CUHP	USER	CUHP	CUHP	CUHP	USER	CUHP	
	TIME	WQCV [cfs]	EURV [cfs]	2 Year [cfs]	5 Year [cfs]	10 Year [cfs]	25 Year [cfs]	50 Year [cfs]	100 Year [cfs]	500 Year [cfs]	
5.00 min	0:00:00	0.00	0.00	0.00	0.00	0.00	0.00	0.00	0.00	0.00	
	0:05:00	0.00	0.00	0.00	0.00	0.00	0.00	0.00	0.00	0.00	
	0:10:00	0.00	0.00	0.00	0.00	0.00	0.00	0.00	0.70	0.00	3.09
	0:15:00	0.00	0.00	2.43	3.68	6.53	5.30	7.67	9.15	14.49	14.49
	0:20:00	0.00	0.00	12.29	22.29	22.28	16.37	20.88	29.83	38.98	38.98
	0:25:00	0.00	0.00	31.51	57.69	62.37	39.54	50.87	75.72	109.68	109.68
	0:30:00	0.00	0.00	46.16	91.81	93.76	105.05	136.02	224.60	260.83	260.83
	0:35:00	0.00	0.00	48.87	94.12	98.66	150.75	193.05	326.49	365.14	365.14
	0:40:00	0.00	0.00	45.61	80.25	90.11	161.36	204.64	407.93	385.04	385.04
	0:45:00	0.00	0.00	40.59	66.76	80.26	151.30	191.18	391.67	364.86	364.86
	0:50:00	0.00	0.00	35.99	58.09	71.47	138.64	175.05	356.83	336.13	336.13
	0:55:00	0.00	0.00	32.15	76.08	63.78	124.09	157.03	339.23	306.19	306.19
	1:00:00	0.00	0.00	28.77	67.82	56.86	109.79	139.37	313.47	278.30	278.30
	1:05:00	0.00	0.00	25.79	59.43	50.69	96.85	123.27	288.08	252.85	252.85
	1:10:00	0.00	0.00	23.01	52.50	46.30	83.54	106.61	253.54	220.13	220.13
	1:15:00	0.00	0.00	20.74	46.35	43.41	72.79	93.34	214.87	190.34	190.34
	1:20:00	0.00	0.00	18.86	40.52	40.10	63.61	81.64	180.99	162.52	162.52
	1:25:00	0.00	0.00	17.22	36.01	35.76	55.52	71.12	160.14	137.32	137.32
	1:30:00	0.00	0.00	15.66	32.65	31.27	47.74	60.92	145.01	115.32	115.32
	1:35:00	0.00	0.00	14.12	29.66	27.06	40.42	51.35	132.08	95.75	95.75
	1:40:00	0.00	0.00	12.62	27.15	23.26	33.66	42.55	96.68	77.90	77.90
	1:45:00	0.00	0.00	11.30	24.16	19.99	27.50	34.55	70.46	61.83	61.83
	1:50:00	0.00	0.00	10.40	21.51	17.80	22.22	27.75	50.89	48.98	48.98
	1:55:00	0.00	0.00	9.39	19.21	16.39	18.85	23.57	42.17	41.05	41.05
	2:00:00	0.00	0.00	8.38	17.41	15.05	16.81	20.99	36.08	35.98	35.98
	2:05:00	0.00	0.00	7.01	14.97	12.69	13.93	17.36	29.63	29.23	29.23
	2:10:00	0.00	0.00	5.61	11.89	10.11	10.84	13.48	22.74	22.26	22.26
	2:15:00	0.00	0.00	4.44	9.04	7.93	8.34	10.34	16.89	16.62	16.62
	2:20:00	0.00	0.00	3.50	7.02	6.20	6.43	7.94	12.61	12.36	12.36
	2:25:00	0.00	0.00	2.75	5.27	4.81	4.94	6.07	9.30	9.21	9.21
	2:30:00	0.00	0.00	2.14	4.09	3.67	3.78	4.62	6.83	6.99	6.99
	2:35:00	0.00	0.00	1.67	3.12	2.78	2.86	3.48	4.99	5.26	5.26
	2:40:00	0.00	0.00	1.28	2.39	2.10	2.16	2.62	3.71	4.01	4.01
	2:45:00	0.00	0.00	0.98	1.78	1.61	1.65	2.00	2.77	3.10	3.10
	2:50:00	0.00	0.00	0.72	1.41	1.20	1.25	1.51	2.08	2.33	2.33
	2:55:00	0.00	0.00	0.51	1.22	0.86	0.90	1.09	1.53	1.67	1.67
	3:00:00	0.00	0.00	0.34	1.11	0.58	0.61	0.74	1.24	1.12	1.12
	3:05:00	0.00	0.00	0.20	1.06	0.35	0.38	0.45	1.11	0.67	0.67
	3:10:00	0.00	0.00	0.10	1.03	0.18	0.20	0.24	1.05	0.34	0.34
	3:15:00	0.00	0.00	0.04	1.02	0.07	0.08	0.09	1.03	0.12	0.12
	3:20:00	0.00	0.00	0.01	1.02	0.01	0.01	0.01	1.02	0.00	0.00
	3:25:00	0.00	0.00	0.00	1.01	0.00	0.00	0.00	1.02	0.00	0.00
	3:30:00	0.00	0.00	0.00	1.01	0.00	0.00	0.00	1.01	0.00	0.00
	3:35:00	0.00	0.00	0.00	1.01	0.00	0.00	0.00	1.01	0.00	0.00
	3:40:00	0.00	0.00	0.00	1.01	0.00	0.00	0.00	1.01	0.00	0.00
	3:45:00	0.00	0.00	0.00	1.01	0.00	0.00	0.00	1.01	0.00	0.00
	3:50:00	0.00	0.00	0.00	1.01	0.00	0.00	0.00	1.01	0.00	0.00
	3:55:00	0.00	0.00	0.00	1.00	0.00	0.00	0.00	1.00	0.00	0.00
	4:00:00	0.00	0.00	0.00	1.00	0.00	0.00	0.00	1.00	0.00	0.00
	4:05:00	0.00	0.00	0.00	1.00	0.00	0.00	0.00	1.00	0.00	0.00
	4:10:00	0.00	0.00	0.00	1.00	0.00	0.00	0.00	1.00	0.00	0.00
	4:15:00	0.00	0.00	0.00	1.00	0.00	0.00	0.00	1.00	0.00	0.00
	4:20:00	0.00	0.00	0.00	1.00	0.00	0.00	0.00	1.00	0.00	0.00
	4:25:00	0.00	0.00	0.00	1.00	0.00	0.00	0.00	1.00	0.00	0.00
	4:30:00	0.00	0.00	0.00	1.00	0.00	0.00	0.00	1.00	0.00	0.00
	4:35:00	0.00	0.00	0.00	1.00	0.00	0.00	0.00	1.00	0.00	0.00
	4:40:00	0.00	0.00	0.00	1.00	0.00	0.00	0.00	1.00	0.00	0.00
	4:45:00	0.00	0.00	0.00	1.00	0.00	0.00	0.00	1.00	0.00	0.00
	4:50:00	0.00	0.00	0.00	1.00	0.00	0.00	0.00	1.00	0.00	0.00
	4:55:00	0.00	0.00	0.00	1.00	0.00	0.00	0.00	1.00	0.00	0.00
	5:00:00	0.00	0.00	0.00	1.00	0.00	0.00	0.00	1.00	0.00	0.00
	5:05:00	0.00	0.00	0.00	0.00	0.00	0.00	0.00	0.00	0.00	0.00
	5:10:00	0.00	0.00	0.00	0.00	0.00	0.00	0.00	0.00	0.00	0.00
	5:15:00	0.00	0.00	0.00	0.00	0.00	0.00	0.00	0.00	0.00	0.00
	5:20:00	0.00	0.00	0.00	0.00	0.00	0.00	0.00	0.00	0.00	0.00
	5:25:00	0.00	0.00	0.00	0.00	0.00	0.00	0.00	0.00	0.00	0.00
	5:30:00	0.00	0.00	0.00	0.00	0.00	0.00	0.00	0.00	0.00	0.00
	5:35:00	0.00	0.00	0.00	0.00	0.00	0.00	0.00	0.00	0.00	0.00
	5:40:00	0.00	0.00	0.00	0.00	0.00	0.00	0.00	0.00	0.00	0.00
	5:45:00	0.00	0.00	0.00	0.00	0.00	0.00	0.00	0.00	0.00	0.00
	5:50:00	0.00	0.00	0.00	0.00	0.00	0.00	0.00	0.00	0.00	0.00
	5:55:00	0.00	0.00	0.00	0.00	0.00	0.00	0.00	0.00	0.00	0.00
6:00:00	0.00	0.00	0.00	0.00	0.00	0.00	0.00	0.00	0.00	0.00	







# DETENTION BASIN OUTLET STRUCTURE DESIGN

*MHFD-Detention, Version 4.04 (February 2021)*

**Project:** Mesa Ridge Cottages

**Basin ID:** Existing Pond D Sizing Confirmation - with Structure Modifications

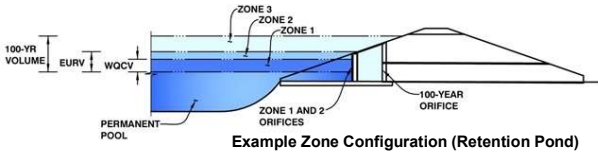

	Estimated Stage (ft)	Estimated Volume (ac-ft)	Outlet Type
Zone 1 (User)	4.79	5.144	Orifice Plate
Zone 2 (User)	5.01	0.318	Rectangular Orifice
Zone 3 (User)	9.30	7.035	Weir&Pipe (Rect.)
<b>Total (all zones)</b>		<b>12.497</b>	

**User Input:** Orifice at Underdrain Outlet (typically used to drain WQCV in a Filtration BMP)

Underdrain Orifice Invert Depth =  ft (distance below the filtration media surface)  
 Underdrain Orifice Diameter =  inches

**Calculated Parameters for Underdrain**  
 Underdrain Orifice Area =  ft<sup>2</sup>  
 Underdrain Orifice Centroid =  feet

**User Input:** Orifice Plate with one or more orifices or Elliptical Slot Weir (typically used to drain WQCV and/or EURV in a sedimentation BMP)

Invert of Lowest Orifice =  ft (relative to basin bottom at Stage = 0 ft)  
 Depth at top of Zone using Orifice Plate =  ft (relative to basin bottom at Stage = 0 ft)  
 Orifice Plate: Orifice Vertical Spacing =  inches  
 Orifice Plate: Orifice Area per Row =  sq. inches (use rectangular openings)

**Calculated Parameters for Plate**  
 WQ Orifice Area per Row =  ft<sup>2</sup>  
 Elliptical Half-Width =  feet  
 Elliptical Slot Centroid =  feet  
 Elliptical Slot Area =  ft<sup>2</sup>

**User Input:** Stage and Total Area of Each Orifice Row (numbered from lowest to highest)

	Row 1 (required)	Row 2 (optional)	Row 3 (optional)	Row 4 (optional)	Row 5 (optional)	Row 6 (optional)	Row 7 (optional)	Row 8 (optional)
Stage of Orifice Centroid (ft)	0.00	1.60	3.19					
Orifice Area (sq. inches)	11.10	11.10	11.10					

	Row 9 (optional)	Row 10 (optional)	Row 11 (optional)	Row 12 (optional)	Row 13 (optional)	Row 14 (optional)	Row 15 (optional)	Row 16 (optional)
Stage of Orifice Centroid (ft)								
Orifice Area (sq. inches)								

**User Input:** Vertical Orifice (Circular or Rectangular)

	Zone 2 Rectangular	Not Selected	
Invert of Vertical Orifice =	<input type="text" value="4.79"/>	<input type="text" value="N/A"/>	ft (relative to basin bottom at Stage = 0 ft)
Depth at top of Zone using Vertical Orifice =	<input type="text" value="5.01"/>	<input type="text" value="N/A"/>	ft (relative to basin bottom at Stage = 0 ft)
Vertical Orifice Height =	<input type="text" value="2.00"/>	<input type="text" value="N/A"/>	inches
Vertical Orifice Width =	<input type="text" value="72.00"/>	<input type="text" value="N/A"/>	inches

**Calculated Parameters for Vertical Orifice**  

	Zone 2 Rectangular	Not Selected	
Vertical Orifice Area =	<input type="text" value="1.00"/>	<input type="text" value="N/A"/>	ft <sup>2</sup>
Vertical Orifice Centroid =	<input type="text" value="0.08"/>	<input type="text" value="N/A"/>	feet

**User Input:** Overflow Weir (Dropbox with Flat or Sloped Grate and Outlet Pipe OR Rectangular/Trapezoidal Weir (and No Outlet Pipe).

	Zone 3 Weir	Not Selected	
Overflow Weir Front Edge Height, Ho =	<input type="text" value="5.01"/>	<input type="text" value="N/A"/>	ft (relative to basin bottom at Stage = 0 ft)
Overflow Weir Front Edge Length =	<input type="text" value="12.00"/>	<input type="text" value="N/A"/>	feet
Overflow Weir Grate Slope =	<input type="text" value="3.00"/>	<input type="text" value="N/A"/>	H:V
Horiz. Length of Weir Sides =	<input type="text" value="6.00"/>	<input type="text" value="N/A"/>	feet
Overflow Grate Type =	<input type="text" value="Close Mesh Grate"/>	<input type="text" value="N/A"/>	
Debris Clogging % =	<input type="text" value="0%"/>	<input type="text" value="N/A"/>	%

**Calculated Parameters for Overflow Weir**  

	Zone 3 Weir	Not Selected	
Height of Grate Upper Edge, H <sub>g</sub> =	<input type="text" value="7.01"/>	<input type="text" value="N/A"/>	feet
Overflow Weir Slope Length =	<input type="text" value="6.32"/>	<input type="text" value="N/A"/>	feet
Grate Open Area / 100-yr Orifice Area =	<input type="text" value="3.75"/>	<input type="text" value="N/A"/>	
Overflow Grate Open Area w/o Debris =	<input type="text" value="60.03"/>	<input type="text" value="N/A"/>	ft <sup>2</sup>
Overflow Grate Open Area w/ Debris =	<input type="text" value="60.03"/>	<input type="text" value="N/A"/>	ft <sup>2</sup>

**User Input:** Outlet Pipe w/ Flow Restriction Plate (Circular Orifice, Restrictor Plate, or Rectangular Orifice)

	Zone 3 Rectangular	Not Selected	
Depth to Invert of Outlet Pipe =	<input type="text" value="1.21"/>	<input type="text" value="N/A"/>	ft (distance below basin bottom at Stage = 0 ft)
Rectangular Orifice Width =	<input type="text" value="72.00"/>	<input type="text" value="N/A"/>	inches
Rectangular Orifice Height =	<input type="text" value="32.00"/>	<input type="text" value="N/A"/>	inches

**Calculated Parameters for Outlet Pipe w/ Flow Restriction Plate**  

	Zone 3 Rectangular	Not Selected	
Outlet Orifice Area =	<input type="text" value="16.00"/>	<input type="text" value="N/A"/>	ft <sup>2</sup>
Outlet Orifice Centroid =	<input type="text" value="1.33"/>	<input type="text" value="N/A"/>	feet
Half-Central Angle of Restrictor Plate on Pipe =	<input type="text" value="N/A"/>	<input type="text" value="N/A"/>	radians

**User Input:** Emergency Spillway (Rectangular or Trapezoidal)

Spillway Invert Stage =	<input type="text" value="11.00"/>	ft (relative to basin bottom at Stage = 0 ft)
Spillway Crest Length =	<input type="text" value="185.00"/>	feet
Spillway End Slopes =	<input type="text" value="4.00"/>	H:V
Freeboard above Max Water Surface =	<input type="text" value="0.40"/>	feet

**Calculated Parameters for Spillway**  

Spillway Design Flow Depth =	<input type="text" value="0.59"/>	feet
Stage at Top of Freeboard =	<input type="text" value="11.99"/>	feet
Basin Area at Top of Freeboard =	<input type="text" value="2.00"/>	acres
Basin Volume at Top of Freeboard =	<input type="text" value="16.89"/>	acre-ft

**Routed Hydrograph Results**

*The user can override the default CUHP hydrographs and runoff volumes by entering new values in the Inflow Hydrographs table (Columns W through AF).*

	WQCV	EURV	2 Year	5 Year	10 Year	25 Year	50 Year	100 Year	500 Year
Design Storm Return Period	N/A	N/A	1.00	1.28	1.55	1.97	2.34	2.74	3.84
One-Hour Rainfall Depth (in)	1.671	5.144	3.741	5.462	7.357	11.295	14.367	18.116	27.672
CUHP Runoff Volume (acre-ft)	N/A	N/A	3.741	7.663	7.357	11.295	14.367	29.508	27.672
User Override Inflow Hydrograph Volume (acre-ft)	N/A	N/A	1.1	11.3	25.6	67.8	94.1	127.9	209.2
OPTIONAL Predevelopment Peak Q (cfs)	N/A	N/A							
Predevelopment Unit Peak Flow, q (cfs/acre)	N/A	N/A	0.01	0.11	0.26	0.69	0.95	1.29	2.12
Peak Inflow Q (cfs)	N/A	N/A	48.9	94.1	98.7	161.4	204.6	407.9	385.0
Peak Outflow Q (cfs)	0.8	1.9	1.5	16.0	14.5	55.9	91.5	233.4	228.2
Ratio Peak Outflow to Predevelopment Q	N/A	N/A	N/A	1.4	0.6	0.8	1.0	1.8	1.1
Structure Controlling Flow	Plate	Vertical Orifice 1	Plate	Overflow Weir 1	Overflow Weir 1	Overflow Weir 1	Overflow Weir 1	Outlet Plate 1	Outlet Plate 1
Max Velocity through Grate 1 (fps)	N/A	N/A	N/A	0.2	0.1	0.8	1.4	3.7	3.6
Max Velocity through Grate 2 (fps)	N/A	N/A	N/A	N/A	N/A	N/A	N/A	N/A	N/A
Time to Drain 97% of Inflow Volume (hours)	41	69	62	72	71	67	64	52	53
Time to Drain 99% of Inflow Volume (hours)	43	73	65	78	77	76	75	70	70
Maximum Ponding Depth (ft)	2.22	4.79	3.63	5.54	5.50	6.40	6.91	9.30	8.90
Area at Maximum Ponding Depth (acres)	1.23	1.49	1.35	1.54	1.54	1.60	1.64	1.79	1.74
Maximum Volume Stored (acre-ft)	1.674	5.147	3.496	6.282	6.205	7.615	8.440	12.497	11.791
Equivalent Elevation (ft)		5687.19	5686.03	5687.94	5687.90	5688.80	5689.31	5691.70	
Pond Bottom (ft)	5682.400								

spillway?

# DETENTION BASIN OUTLET STRUCTURE DESIGN

*MHFD-Detention, Version 4.04 (February 2021)*

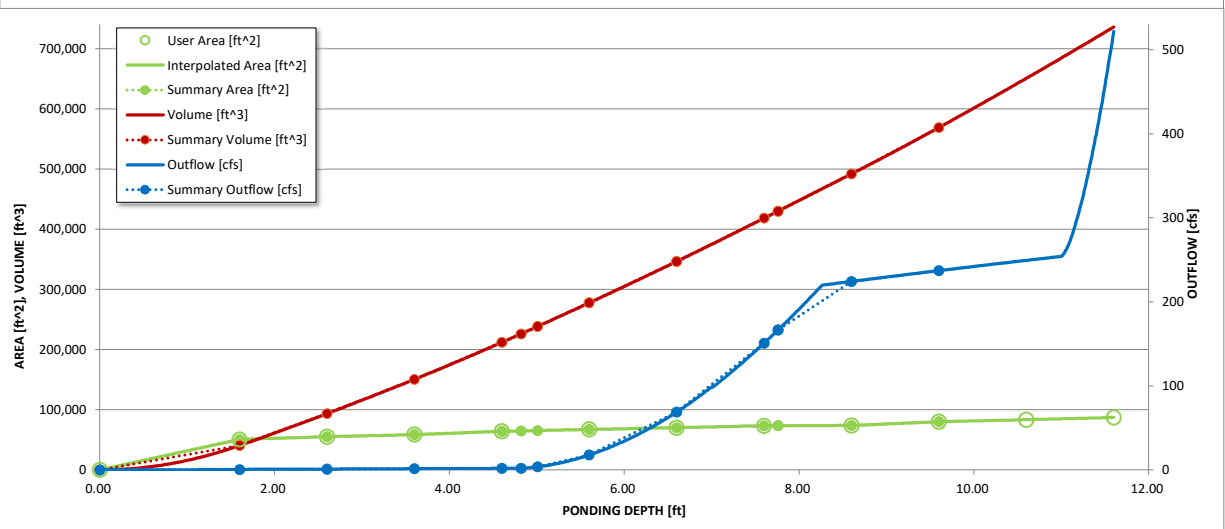
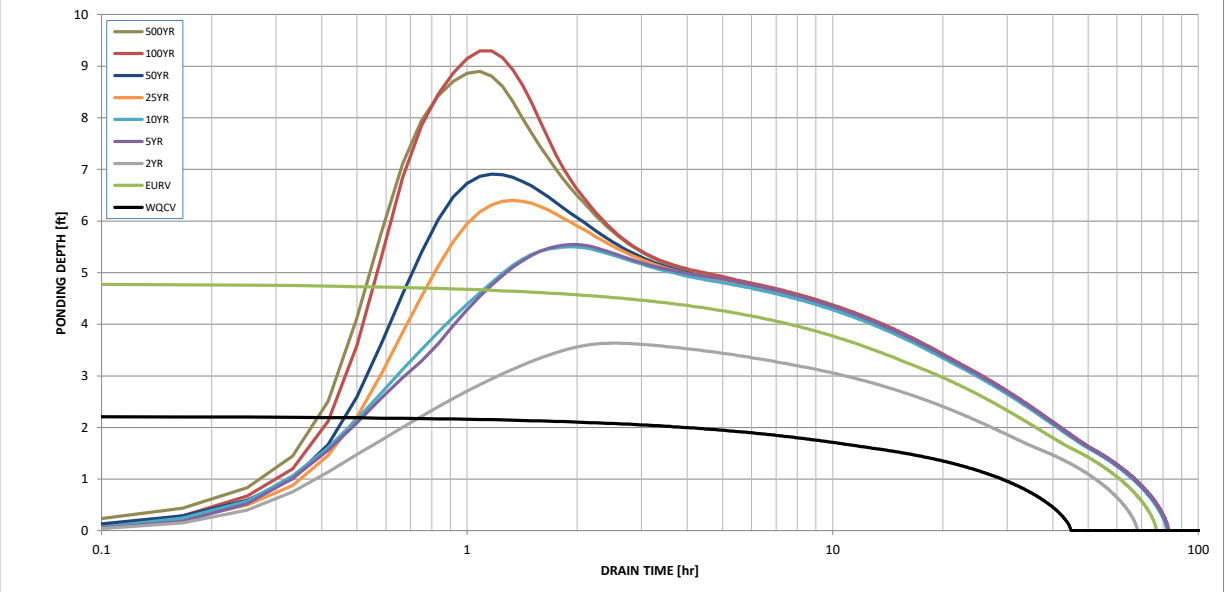
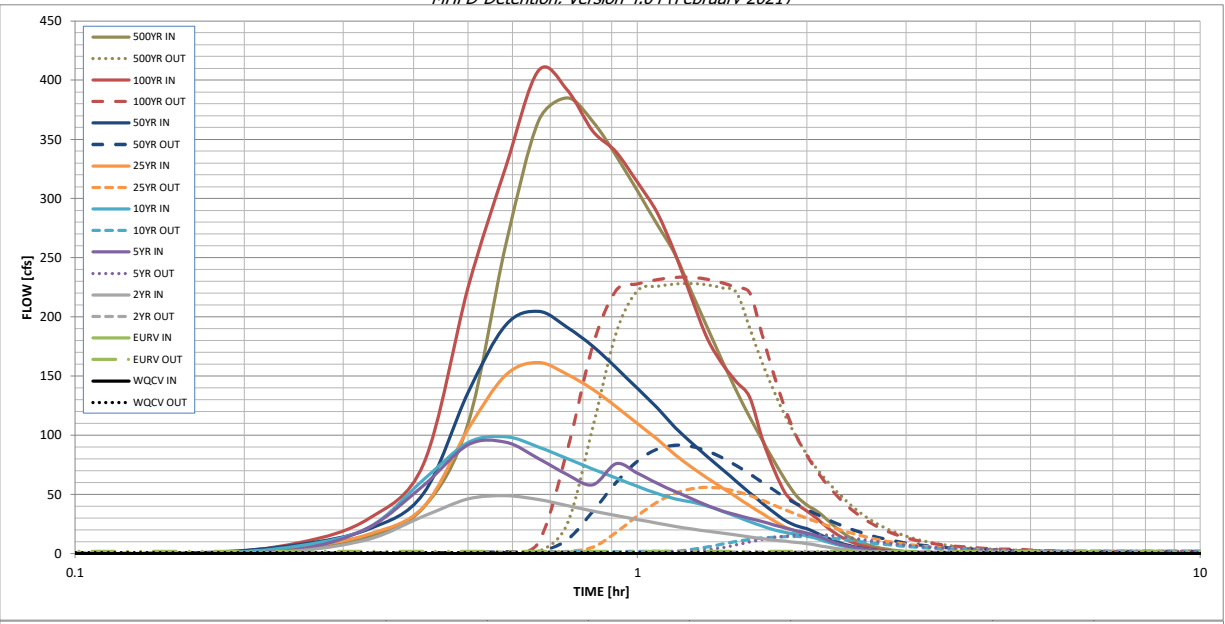

S-A-V-D Chart Axis Override	X-axis	Left Y-Axis	Right Y-Axis
minimum bound			
maximum bound			

# DETENTION BASIN OUTLET STRUCTURE DESIGN

Outflow Hydrograph Workbook Filename: \_\_\_\_\_

## Inflow Hydrographs

The user can override the calculated inflow hydrographs from this workbook with inflow hydrographs developed in a separate program.

Time Interval	SOURCE	CUHP	CUHP	CUHP	USER	CUHP	CUHP	CUHP	USER	CUHP
	TIME	WQCV [cfs]	EURV [cfs]	2 Year [cfs]	5 Year [cfs]	10 Year [cfs]	25 Year [cfs]	50 Year [cfs]	100 Year [cfs]	500 Year [cfs]
5.00 min	0:00:00	0.00	0.00	0.00	0.00	0.00	0.00	0.00	0.00	0.00
	0:05:00	0.00	0.00	0.00	0.00	0.00	0.00	0.00	0.00	0.00
	0:10:00	0.00	0.00	0.00	0.00	0.00	0.00	0.70	0.00	3.09
	0:15:00	0.00	0.00	2.43	3.68	6.53	5.30	7.67	9.15	14.49
	0:20:00	0.00	0.00	12.29	22.29	22.28	16.37	20.88	29.83	38.98
	0:25:00	0.00	0.00	31.51	57.69	62.37	39.54	50.87	75.72	109.68
	0:30:00	0.00	0.00	46.16	91.81	93.76	105.05	136.02	224.60	260.83
	0:35:00	0.00	0.00	48.87	94.12	98.66	150.75	193.05	326.49	365.14
	0:40:00	0.00	0.00	45.61	80.25	90.11	161.36	204.64	407.93	385.04
	0:45:00	0.00	0.00	40.59	66.76	80.26	151.30	191.18	391.67	364.86
	0:50:00	0.00	0.00	35.99	58.09	71.47	138.64	175.05	356.83	336.13
	0:55:00	0.00	0.00	32.15	76.08	63.78	124.09	157.03	339.23	306.19
	1:00:00	0.00	0.00	28.77	67.82	56.86	109.79	139.37	313.47	278.30
	1:05:00	0.00	0.00	25.79	59.43	50.69	96.85	123.27	288.08	252.85
	1:10:00	0.00	0.00	23.01	52.50	46.30	83.54	106.61	253.54	220.13
	1:15:00	0.00	0.00	20.74	46.35	43.41	72.79	93.34	214.87	190.34
	1:20:00	0.00	0.00	18.86	40.52	40.10	63.61	81.64	180.99	162.52
	1:25:00	0.00	0.00	17.22	36.01	35.76	55.52	71.12	160.14	137.32
	1:30:00	0.00	0.00	15.66	32.65	31.27	47.74	60.92	145.01	115.32
	1:35:00	0.00	0.00	14.12	29.66	27.06	40.42	51.35	132.08	95.75
	1:40:00	0.00	0.00	12.62	27.15	23.26	33.66	42.55	96.68	77.90
	1:45:00	0.00	0.00	11.30	24.16	19.99	27.50	34.55	70.46	61.83
	1:50:00	0.00	0.00	10.40	21.51	17.80	22.22	27.75	50.89	48.98
	1:55:00	0.00	0.00	9.39	19.21	16.39	18.85	23.57	42.17	41.05
	2:00:00	0.00	0.00	8.38	17.41	15.05	16.81	20.99	36.08	35.98
	2:05:00	0.00	0.00	7.01	14.97	12.69	13.93	17.36	29.63	29.23
	2:10:00	0.00	0.00	5.61	11.89	10.11	10.84	13.48	22.74	22.26
	2:15:00	0.00	0.00	4.44	9.04	7.93	8.34	10.34	16.89	16.62
	2:20:00	0.00	0.00	3.50	7.02	6.20	6.43	7.94	12.61	12.36
	2:25:00	0.00	0.00	2.75	5.27	4.81	4.94	6.07	9.30	9.21
	2:30:00	0.00	0.00	2.14	4.09	3.67	3.78	4.62	6.83	6.99
	2:35:00	0.00	0.00	1.67	3.12	2.78	2.86	3.48	4.99	5.26
	2:40:00	0.00	0.00	1.28	2.39	2.10	2.16	2.62	3.71	4.01
	2:45:00	0.00	0.00	0.98	1.78	1.61	1.65	2.00	2.77	3.10
	2:50:00	0.00	0.00	0.72	1.41	1.20	1.25	1.51	2.08	2.33
	2:55:00	0.00	0.00	0.51	1.22	0.86	0.90	1.09	1.53	1.67
	3:00:00	0.00	0.00	0.34	1.11	0.58	0.61	0.74	1.24	1.12
	3:05:00	0.00	0.00	0.20	1.06	0.35	0.38	0.45	1.11	0.67
	3:10:00	0.00	0.00	0.10	1.03	0.18	0.20	0.24	1.05	0.34
	3:15:00	0.00	0.00	0.04	1.02	0.07	0.08	0.09	1.03	0.12
	3:20:00	0.00	0.00	0.01	1.02	0.01	0.01	0.01	1.02	0.00
	3:25:00	0.00	0.00	0.00	1.01	0.00	0.00	0.00	1.02	0.00
	3:30:00	0.00	0.00	0.00	1.01	0.00	0.00	0.00	1.01	0.00
	3:35:00	0.00	0.00	0.00	1.01	0.00	0.00	0.00	1.01	0.00
	3:40:00	0.00	0.00	0.00	1.01	0.00	0.00	0.00	1.01	0.00
	3:45:00	0.00	0.00	0.00	1.01	0.00	0.00	0.00	1.01	0.00
	3:50:00	0.00	0.00	0.00	1.01	0.00	0.00	0.00	1.01	0.00
	3:55:00	0.00	0.00	0.00	1.00	0.00	0.00	0.00	1.00	0.00
	4:00:00	0.00	0.00	0.00	1.00	0.00	0.00	0.00	1.00	0.00
	4:05:00	0.00	0.00	0.00	1.00	0.00	0.00	0.00	1.00	0.00
	4:10:00	0.00	0.00	0.00	1.00	0.00	0.00	0.00	1.00	0.00
	4:15:00	0.00	0.00	0.00	1.00	0.00	0.00	0.00	1.00	0.00
	4:20:00	0.00	0.00	0.00	1.00	0.00	0.00	0.00	1.00	0.00
	4:25:00	0.00	0.00	0.00	1.00	0.00	0.00	0.00	1.00	0.00
	4:30:00	0.00	0.00	0.00	1.00	0.00	0.00	0.00	1.00	0.00
	4:35:00	0.00	0.00	0.00	1.00	0.00	0.00	0.00	1.00	0.00
	4:40:00	0.00	0.00	0.00	1.00	0.00	0.00	0.00	1.00	0.00
	4:45:00	0.00	0.00	0.00	1.00	0.00	0.00	0.00	1.00	0.00
	4:50:00	0.00	0.00	0.00	1.00	0.00	0.00	0.00	1.00	0.00
	4:55:00	0.00	0.00	0.00	1.00	0.00	0.00	0.00	1.00	0.00
5:00:00	0.00	0.00	0.00	1.00	0.00	0.00	0.00	1.00	0.00	
5:05:00	0.00	0.00	0.00	0.00	0.00	0.00	0.00	0.00	0.00	
5:10:00	0.00	0.00	0.00	0.00	0.00	0.00	0.00	0.00	0.00	
5:15:00	0.00	0.00	0.00	0.00	0.00	0.00	0.00	0.00	0.00	
5:20:00	0.00	0.00	0.00	0.00	0.00	0.00	0.00	0.00	0.00	
5:25:00	0.00	0.00	0.00	0.00	0.00	0.00	0.00	0.00	0.00	
5:30:00	0.00	0.00	0.00	0.00	0.00	0.00	0.00	0.00	0.00	
5:35:00	0.00	0.00	0.00	0.00	0.00	0.00	0.00	0.00	0.00	
5:40:00	0.00	0.00	0.00	0.00	0.00	0.00	0.00	0.00	0.00	
5:45:00	0.00	0.00	0.00	0.00	0.00	0.00	0.00	0.00	0.00	
5:50:00	0.00	0.00	0.00	0.00	0.00	0.00	0.00	0.00	0.00	
5:55:00	0.00	0.00	0.00	0.00	0.00	0.00	0.00	0.00	0.00	
6:00:00	0.00	0.00	0.00	0.00	0.00	0.00	0.00	0.00	0.00	





## **APPENDIX E – REFERENCE MATERIAL**

**Mesa Ridge Development  
Master Development Drainage Plan Update**

**Fountain, Colorado**

Prepared for:  
Nor'wood Development  
111 South Tejon Suite 222  
Colorado Springs, Colorado 80903

Prepared by:

**Kiowa**  
Engineering Corporation

1604 South 21st Street  
Colorado Springs, Colorado 80904  
(719) 630-7342

Kiowa Project No. 11045

January 15, 2013



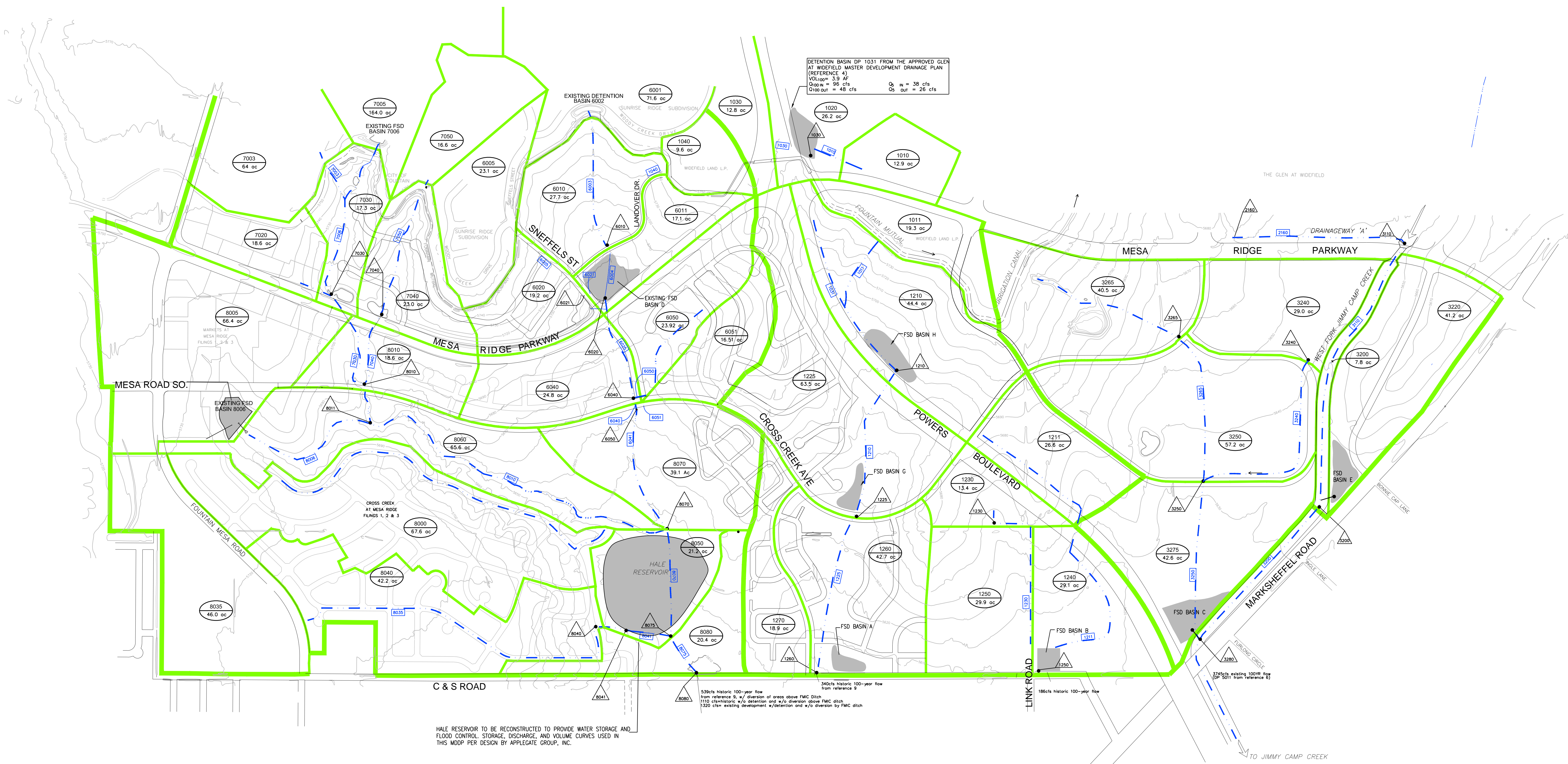

DETENTION BASIN DP 1031 FROM THE APPROVED GLEN AT WIDEFIELD MASTER DEVELOPMENT DRAINAGE PLAN (REFERENCE A)  
 VOLUME = 3.9 ac-ft  
 Q<sub>100</sub> = 96 cfs  
 Q<sub>5</sub> = 38 cfs  
 Q<sub>100</sub> = 48 cfs

HALE RESERVOIR TO BE RECONSTRUCTED TO PROVIDE WATER STORAGE AND FLOOD CONTROL, STORAGE, DISCHARGE, AND VOLUME CURVES USED IN THIS MDDP PER DESIGN BY APPLICABLE GROUP, INC.

53% historic 100-year flow from reference #, w/ diversion of cross above FMC ditch  
 110% historic w/o diversion and w/o diversion above FMC ditch  
 130% cfs = existing development w/ detention and w/o diversion by FMC ditch

18% historic 100-year flow from reference #  
 24% historic 100-year flow (DP 3201 from reference #)

SUMMARY OF PROPOSED FSD BASIN DATA (24-HOUR STORM)			
PROPOSED FS DETENTION BASIN A		PROPOSED FS DETENTION BASIN B	
Q <sub>5</sub>	Q <sub>100</sub>	Q <sub>5</sub>	Q <sub>100</sub>
IN 69 cfs	187 cfs	IN 102 cfs	297 cfs
OUT 9 cfs	52 cfs	OUT 13 cfs	91 cfs
100 yr VOLUME = 6.8 ac-ft		100 yr VOLUME = 8.4 ac-ft	
EURV VOLUME = 3.1 ac-ft		EURV VOLUME = 3.1 ac-ft	
PROPOSED FS DETENTION BASIN C		AS-BUILT FS DETENTION BASIN D	
Q <sub>5</sub>	Q <sub>100</sub>	Q <sub>5</sub>	Q <sub>100</sub>
IN 158 cfs	490 cfs	IN 109 cfs	375 cfs
OUT 9 cfs	145 cfs	OUT 24 cfs	233 cfs
100 yr VOLUME = 14.8 ac-ft		100 yr VOLUME = 8.0 ac-ft	
EURV VOLUME = 8.3 ac-ft		5 yr VOLUME = 4.1 ac-ft	
PROPOSED FS DETENTION BASIN E		RECONSTRUCTED DAM & RESERVOIR BASIN F	
Q <sub>5</sub>	Q <sub>100</sub>	Q <sub>5</sub>	Q <sub>100</sub>
IN 41 cfs	120 cfs	IN 540 cfs	1540 cfs
OUT 5 cfs	24 cfs	OUT 7 cfs	255 cfs
100 yr VOLUME = 3.9 ac-ft		100 yr VOLUME = 95.9 ac-ft	
EURV VOLUME = 1.3 ac-ft		5 yr VOLUME = 50.0 ac-ft	
PROPOSED FS DETENTION BASIN G		PROPOSED FS DETENTION BASIN H	
Q <sub>5</sub>	Q <sub>100</sub>	Q <sub>5</sub>	Q <sub>100</sub>
IN 74 cfs	216 cfs	IN 161 cfs	323 cfs
OUT 10 cfs	51 cfs	OUT 23 cfs	56 cfs
100 yr VOLUME = 6.6 ac-ft		100 yr VOLUME = 13.2 ac-ft	
EURV VOLUME = 2.2 ac-ft		EURV VOLUME = 2.5 ac-ft	

SUMMARY OF DESIGN POINT DISCHARGES (24-HOUR STORM WITH FSD)					
DESIGN POINT	LOCATION	DRAINAGE AREA	5 Year	100 Year	
DP 6010	AT LANDOVER	108.9 ac	0.18 sm	43 cfs	196 cfs
DP 6020	INFLOW TO DETENTION BASIN D	168.3 ac	0.27 sm	109 cfs	375 cfs
DB 6030	OUTFLOW FROM DETENTION BASIN D	168.3 ac	0.27 sm	24 cfs	233 cfs
DP 6040	U/S CROSS CREEK	217.0 ac	0.35 sm	74 cfs	334 cfs
DP 6050	DS CROSS CREEK AVE	233.5 ac	0.37 sm	92 cfs	358 cfs
DP 7030	AT OUTLET OF BASIN 7030	283.9 ac	0.41 sm	183 cfs	420 cfs
DP 7040	AT OUTLET OF BASIN 7040	39.6 ac	0.06 sm	30 cfs	110 cfs
DP 8010	AT OUTLET OF BASIN 8010	322.1 ac	0.50 sm	241 cfs	603 cfs
DP 8070	U/S OF HALE RESERVOIR	726.7 ac	1.15 sm	446 cfs	1259 cfs
DP 8075	INFLOW TO HALE RESERVOIR	908.9 ac	1.42 sm	540 cfs	1540 cfs
DB 8075	OUTFLOW FROM HALE RESERVOIR	908.8 ac	1.42 sm	7 cfs	255 cfs
DP 8080	C&S ROAD	928 ac	1.45 sm	13 cfs	257 cfs
DP 1031	D/S POWERS BOULEVARD	51.0 ac	0.08 sm	28 cfs	55 cfs
DP 1211	INFLOW TO DET. BASIN H	108.8 ac	0.17 sm	161 cfs	323 cfs
DB 1210	OUTFLOW FROM DET. BASIN H	108.8 ac	0.17 sm	23 cfs	36 cfs
SB 1225	INFLOW TO DETENTION BASIN G	70.4 ac	0.11 sm	74 cfs	216 cfs
DP 1225	AT CROSS CREEK AVENUE	185.6 ac	0.29 sm	33 cfs	104 cfs
DP 1250	INFLOW TO DETENTION BASIN B	96.0 ac	0.15 sm	102 cfs	297 cfs
DB 1250	OUTFLOW FROM DETENTION BASIN B	96.0 ac	0.15 sm	13 cfs	91 cfs
DP 1265	INFLOW TO DETENTION BASIN A	64 ac	0.10 sm	69 cfs	187 cfs
DP 1260	AT C & S ROAD	243 ac	0.38 sm	41 cfs	156 cfs
DP 2160	DESIGN POINT 2160	448 ac	0.70 sm	188 cfs	640 cfs
DP 3110	AT MESA RIDGE PARKWAY	2163.2 ac	3.38 sm	766 cfs	3095 cfs
DP 3200	DESIGN POINT 3200	2208 ac	3.44 sm	764 cfs	3089 cfs
DP 3250	AT COLLECTOR ROAD	126.7 ac	0.20 sm	130 cfs	380 cfs
DP 3265	AT OUTLET OF BASIN 3265	40.5 ac	0.06 sm	52 cfs	135 cfs
DP 3275	INFLOW TO DET. BASIN C	172.8 ac	0.27 sm	158 cfs	490 cfs
DB 3280	OUTFLOW FROM DETENTION BASIN C	172.8 ac	0.27 sm	9 cfs	145 cfs
DP 3280	AT MARKSHEFFEL ROAD	2381.0 ac	3.72 sm	772 cfs	3215 cfs

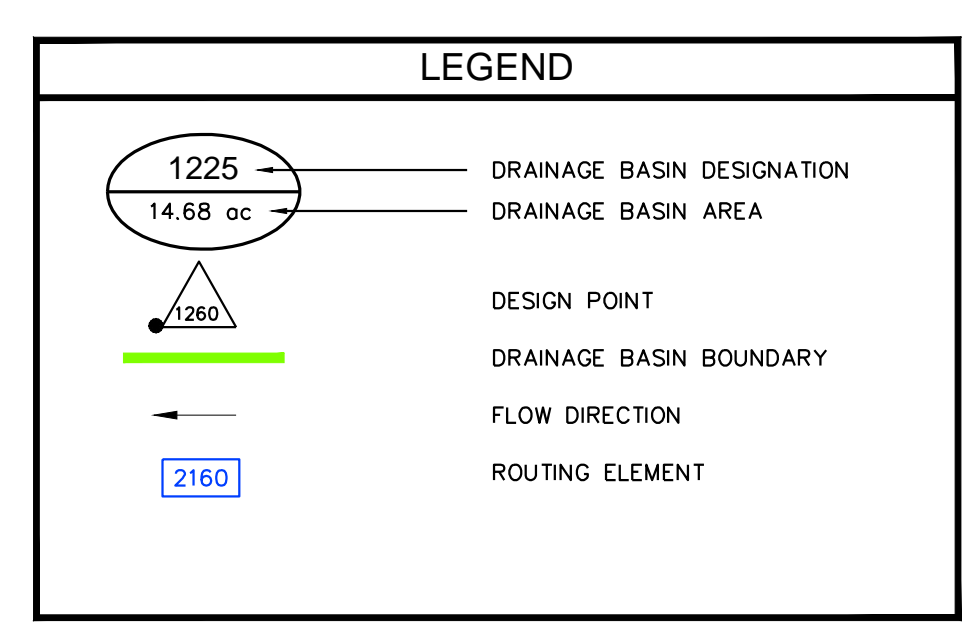

SUMMARY OF HISTORIC DISCHARGES			
DESIGN POINT	LOCATION	5 Year	100 Year
3280	HF JIMMY CAMP CREEK @ MARKSHEFFEL ROAD	992 cfs	3745 cfs
1250	@ C & S ROAD	35 cfs	186 cfs
1260	@ C & S ROAD	48 cfs	340 cfs
8080 (1)	@ C & S ROAD	152 cfs	1110 cfs

(1) AREA ABOVE FOUNTAIN MUTUAL IRRIGATION CANAL ASSUMED TRIBUTARY TO THIS DESIGN POINT. FMC CANAL ASSUMED TO CONVEY IRRIGATION FLOW ONLY.

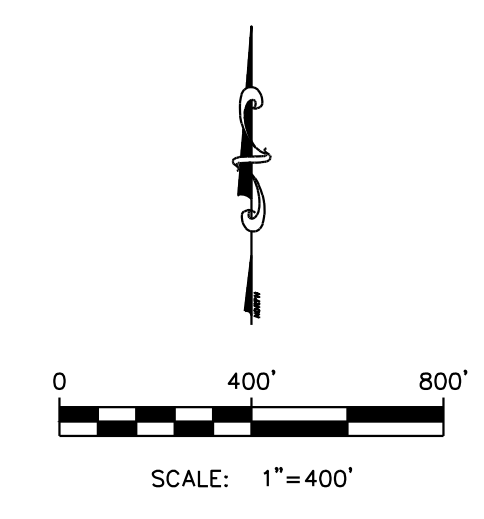

NOTE: TOPOGRAPHY USED IN THIS MDDP MAY NOT REFLECT THE EXISTING CONDITIONS FOR ALL AREAS OF THE DRAINAGE BASINS.

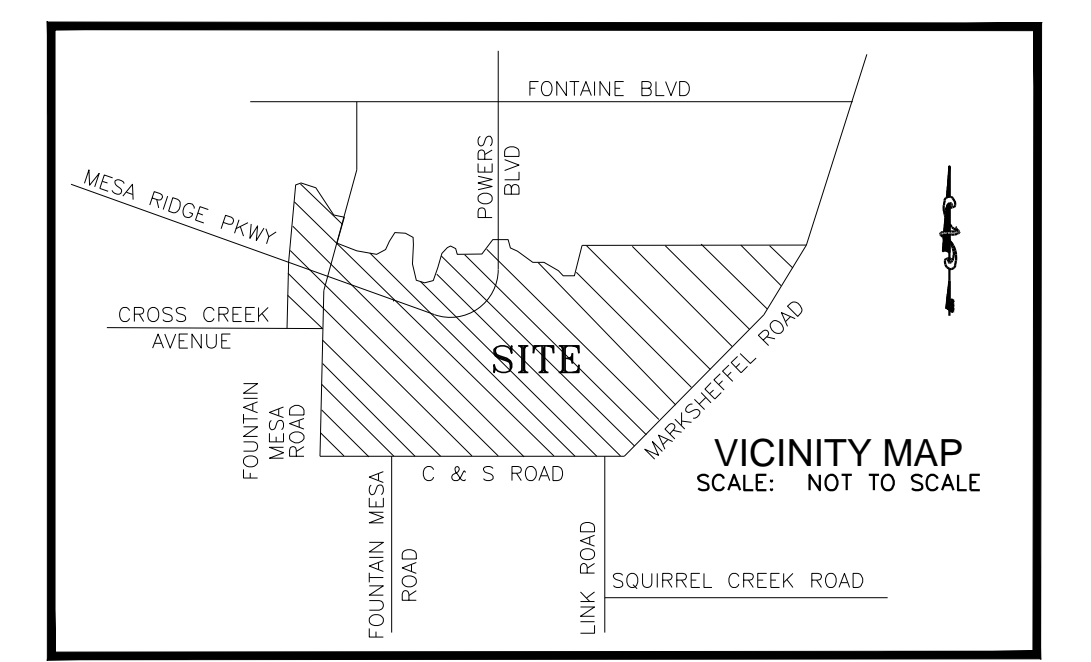

**EXHIBIT 1**  
**MESA RIDGE DEVELOPMENT**  
**MASTER DEVELOPMENT DRAINAGE PLAN UPDATE**  
**HYDROLOGIC SUB-BASIN MAP**  
 DEVELOPED WITH EXISTING & PROPOSED DETENTION  
 FOUNTAIN, COLORADO

**Kiowa Engineering Corporation**  
 1604 South 21st Street  
 Colorado Springs, Colorado  
 80904 - 4208  
 (719) 630-7342

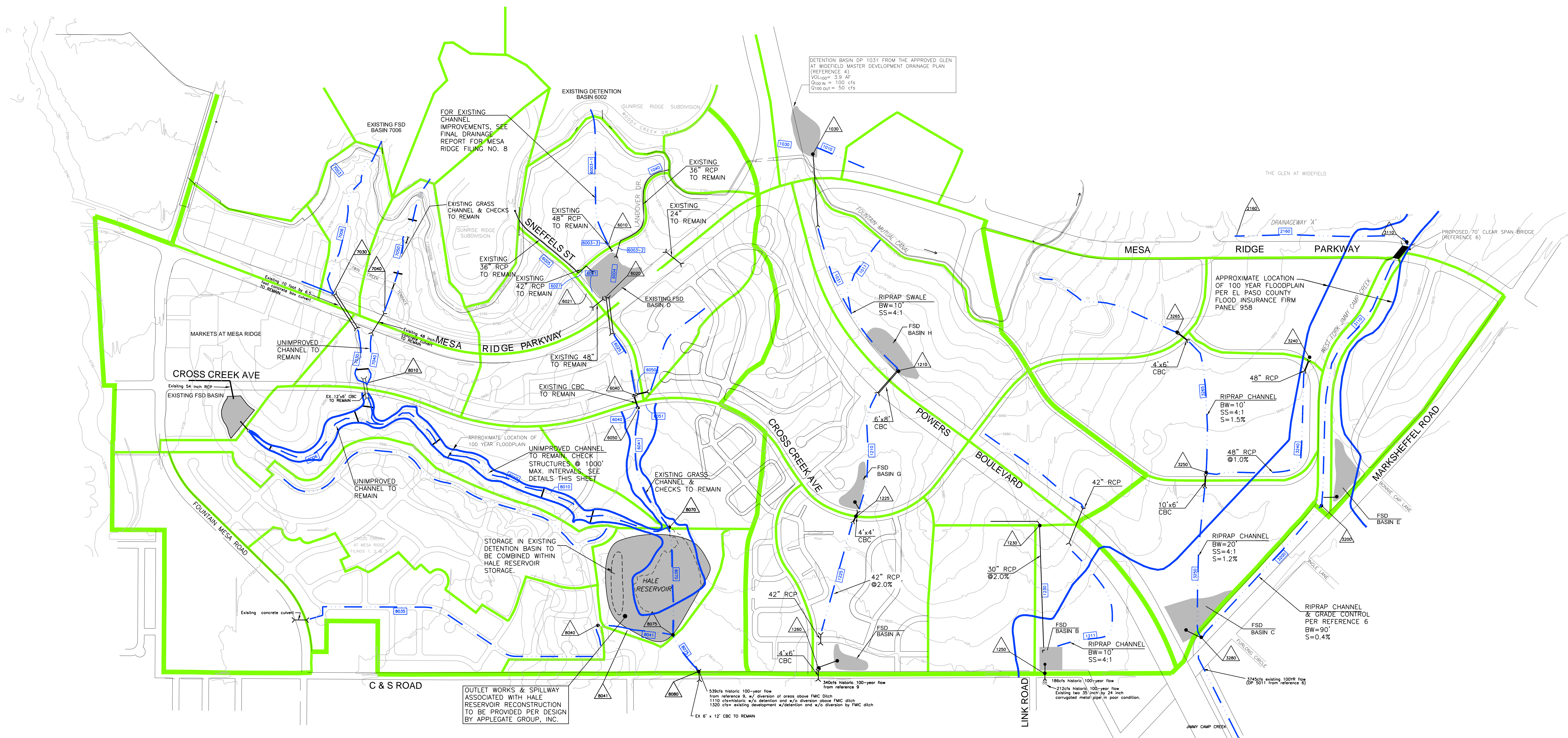

**SUMMARY OF PROPOSED FSD BASIN DATA (24-HOUR STORM)**

PROPOSED FS DETENTION BASIN A	PROPOSED FS DETENTION BASIN B
$Q_5$ IN 69 cfs $Q_{100}$ OUT 187 cfs 100 yr VOLUME= 6.8 ac-ft EURV VOLUME= 3.1 ac-ft	$Q_5$ IN 102 cfs $Q_{100}$ OUT 297 cfs 100 yr VOLUME= 8.4 ac-ft EURV VOLUME= 3.1 ac-ft
PROPOSED FS DETENTION BASIN C	AS-BUILT FS DETENTION BASIN D
$Q_5$ IN 158 cfs $Q_{100}$ OUT 490 cfs 100 yr VOLUME= 14.8 ac-ft EURV VOLUME= 8.3 ac-ft	$Q_5$ IN 109 cfs $Q_{100}$ OUT 375 cfs 100 yr VOLUME= 8.0 ac-ft 5 yr VOLUME= 4.1 ac-ft
PROPOSED FS DETENTION BASIN E	RECONSTRUCTED DAM & RESERVOIR BASIN F
$Q_5$ IN 41 cfs $Q_{100}$ OUT 120 cfs 100 yr VOLUME= 3.9 ac-ft EURV VOLUME= 1.3 ac-ft	$Q_5$ IN 540 cfs $Q_{100}$ OUT 1540 cfs 100 yr VOLUME= 95.9 ac-ft 5 yr VOLUME= 50.0 ac-ft
PROPOSED FS DETENTION BASIN G	PROPOSED FS DETENTION BASIN H
$Q_5$ IN 74 cfs $Q_{100}$ OUT 216 cfs 100 yr VOLUME= 6.6 ac-ft EURV VOLUME= 2.2 ac-ft	$Q_5$ IN 161 cfs $Q_{100}$ OUT 323 cfs 100 yr VOLUME= 13.2 ac-ft EURV VOLUME= 2.5 ac-ft

**SUMMARY OF DESIGN POINT DISCHARGES (24-HOUR STORM WITH FSD)**

DESIGN POINT	LOCATION	DRAINAGE AREA	5 Year	100 Year
DP 6010	AT LANDOVER	108.9 ac	0.18 sm	4.3 cfs
DP 6020	INFLOW TO DETENTION BASIN D	168.3 ac	0.27 sm	10.9 cfs
DB 6020	OUTFLOW FROM DETENTION BASIN D	168.3 ac	0.27 sm	24 cfs
DP 6040	U/S CROSS CREEK	217.0 ac	0.35 sm	74 cfs
DP 6050	D/S CROSS CREEK AVE	233.5 ac	0.37 sm	92 cfs
DP 7030	AT OUTLET OF BASIN 7030	263.9 ac	0.41 sm	183 cfs
DP 7040	AT OUTLET OF BASIN 7040	39.6 ac	0.06 sm	30 cfs
DP 8010	AT OUTLET OF BASIN 8010	322.1 ac	0.50 sm	241 cfs
DP 8070	U/S OF HAILE RESERVOIR	726.7 ac	1.15 sm	446 cfs
DP 8075	INFLOW TO HAILE RESERVOIR	908.8 ac	1.42 sm	540 cfs
DB 8075	OUTFLOW FROM HAILE RESERVOIR	908.8 ac	1.42 sm	7 cfs
DP 8080	C&S ROAD	928 ac	1.45 sm	13 cfs
DP 1031	D/S POWERS BOULEVARD	51.0 ac	0.08 sm	28 cfs
DP 1211	INFLOW TO DET. BASIN H 1210, POWERS BLVD	108.8 ac	0.17 sm	161 cfs
DP 1210	OUTFLOW FROM DET. BASIN H	108.8 ac	0.17 sm	23 cfs
SB 1225	INFLOW TO DETENTION BASIN G	70.4 ac	0.11 sm	74 cfs
DP 1225	AT CROSS CREEK AVENUE	185.6 ac	0.29 sm	33 cfs
DP 1250	INFLOW TO DETENTION BASIN B	96.0 ac	0.15 sm	102 cfs
DB 1250	OUTFLOW FROM DETENTION BASIN B	96.0 ac	0.15 sm	13 cfs
DP 1265	INFLOW TO DETENTION BASIN A	64 ac	0.10 sm	69 cfs
DP 1260	AT C & S ROAD	243 ac	0.38 sm	41 cfs
DP 2160	DESIGN POINT 2160	448 ac	0.70 sm	188 cfs
DP 3110	AT MESA RIDGE PARKWAY	2163.2 ac	3.38 sm	766 cfs
DP 3200	DESIGN POINT 3200	2208 ac	3.44 sm	764 cfs
DP 3250	AT COLLECTOR ROAD	126.7 ac	0.20 sm	130 cfs
DP 3265	AT OUTLET OF BASIN 3265	40.5 ac	0.06 sm	52 cfs
DP 3281	INFLOW TO DET. BASIN C	172.8 ac	0.27 sm	158 cfs
DB 3281	OUTFLOW FROM DETENTION BASIN C	172.8 ac	0.27 sm	9 cfs
DP 3280	AT MARKSHEFFEL ROAD	2381.0 ac	3.72 sm	772 cfs

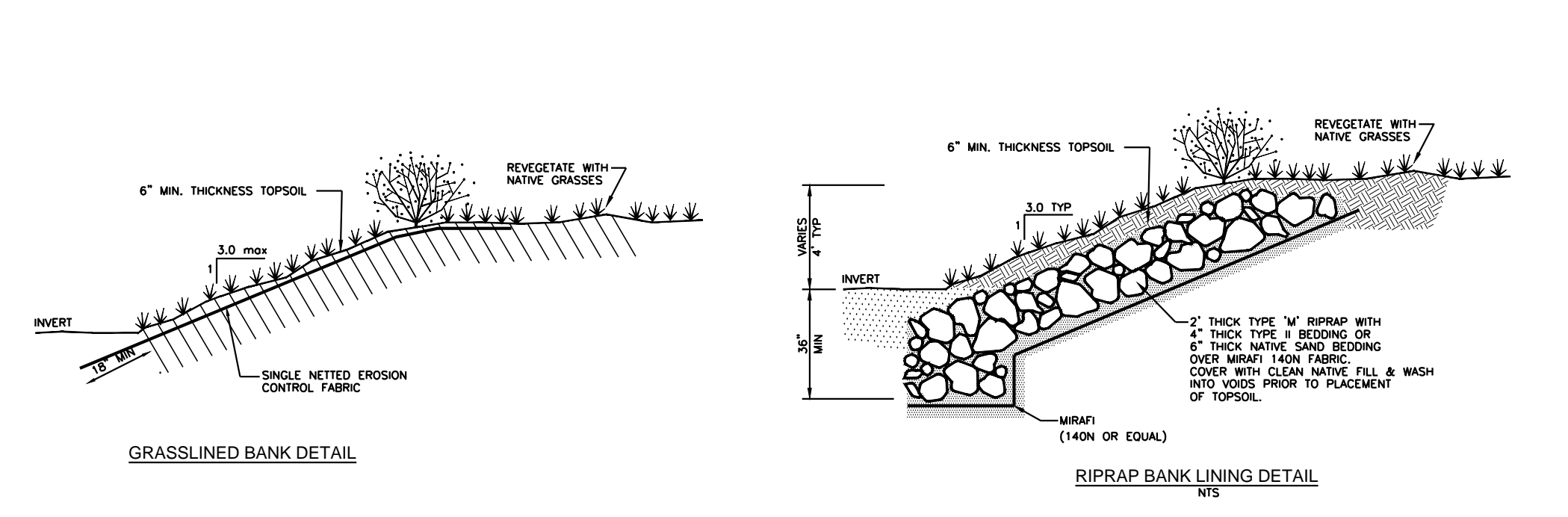

**RIPRAP GRADATIONS**

TYPE	INTERMEDIATE ROCK DIMENSION IN INCHES	% SMALLER THAN GIVEN SIZE BY WEIGHT	D <sub>50</sub> INCHES
TYPE M RIPRAP	30	100	18
	24	50-70	13
	18	35-50	9
TYPE M RIPRAP	21	100	12
	18	50-70	9
	12	35-50	6

**SEED MIX**

AREAS DISTURBED BY THE EARTHWORK SHALL BE PERMANENTLY REVEGETATED WITH NATIVE GRASSES. NATIVE SEED MIX FOR THIS PROJECT SHALL BE AS FOLLOWS:

NATIVE SEED MIX	pl/acre
BLUE GRAMA	2.0
SIDONIA'S GRAMA	3.0
SLENDER WHEATGRASS	2.0
WESTERN WHEATGRASS	4.0
<i>Chenopodium heterotus</i>	2.0
<i>Bouteloua curtipendula</i>	3.0
<i>Agropyron trachycalium trachycalium</i>	2.0
<i>Agropyron smithii</i>	4.0
<b>TOTAL</b>	<b>11.0 lbs</b>

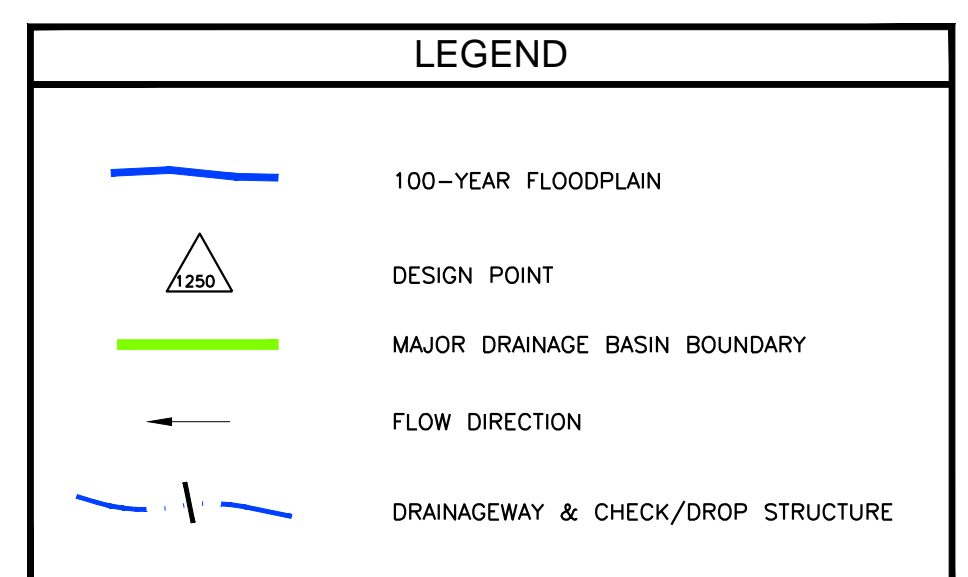
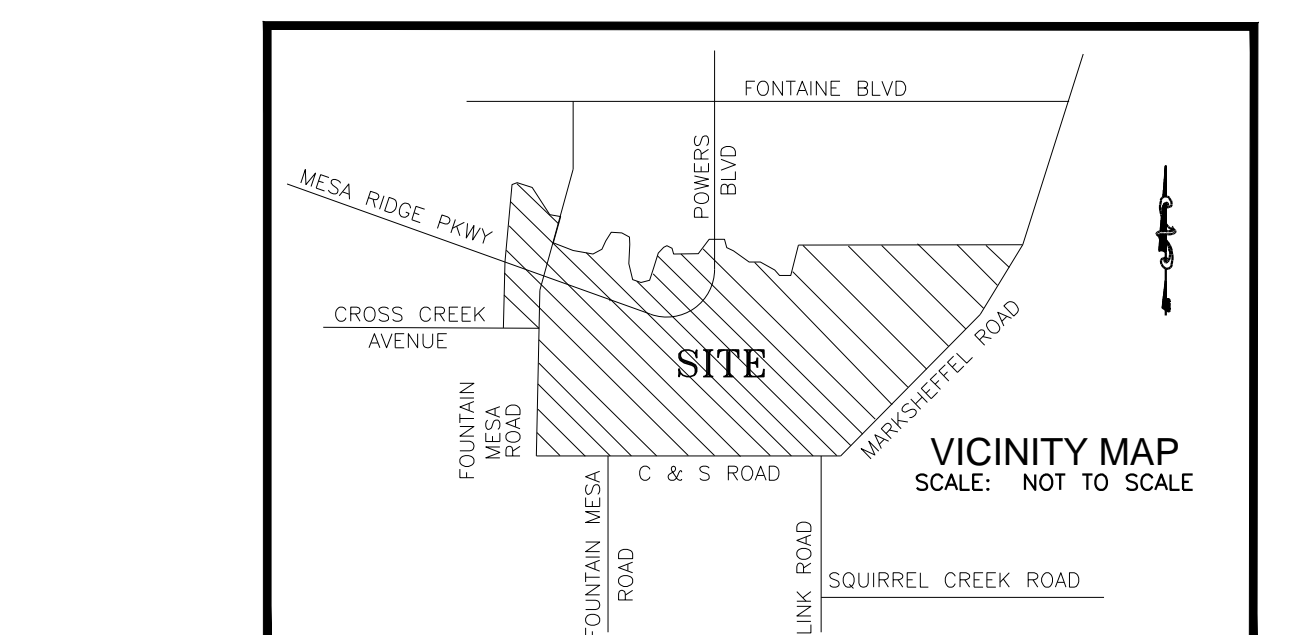
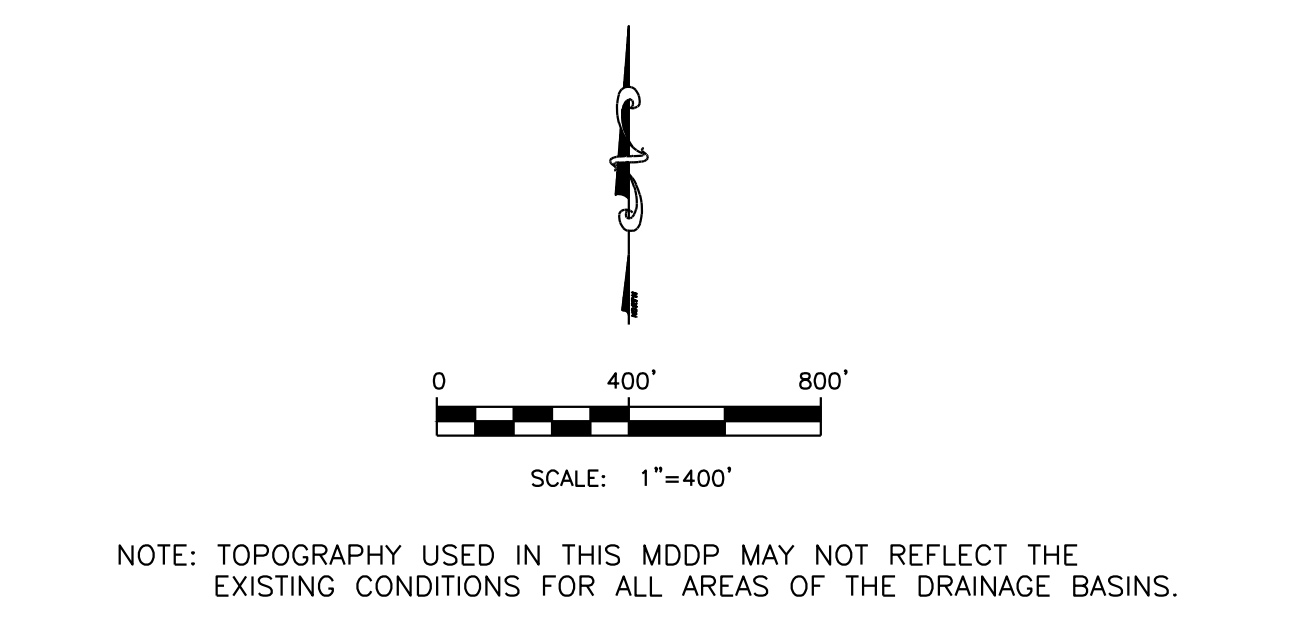
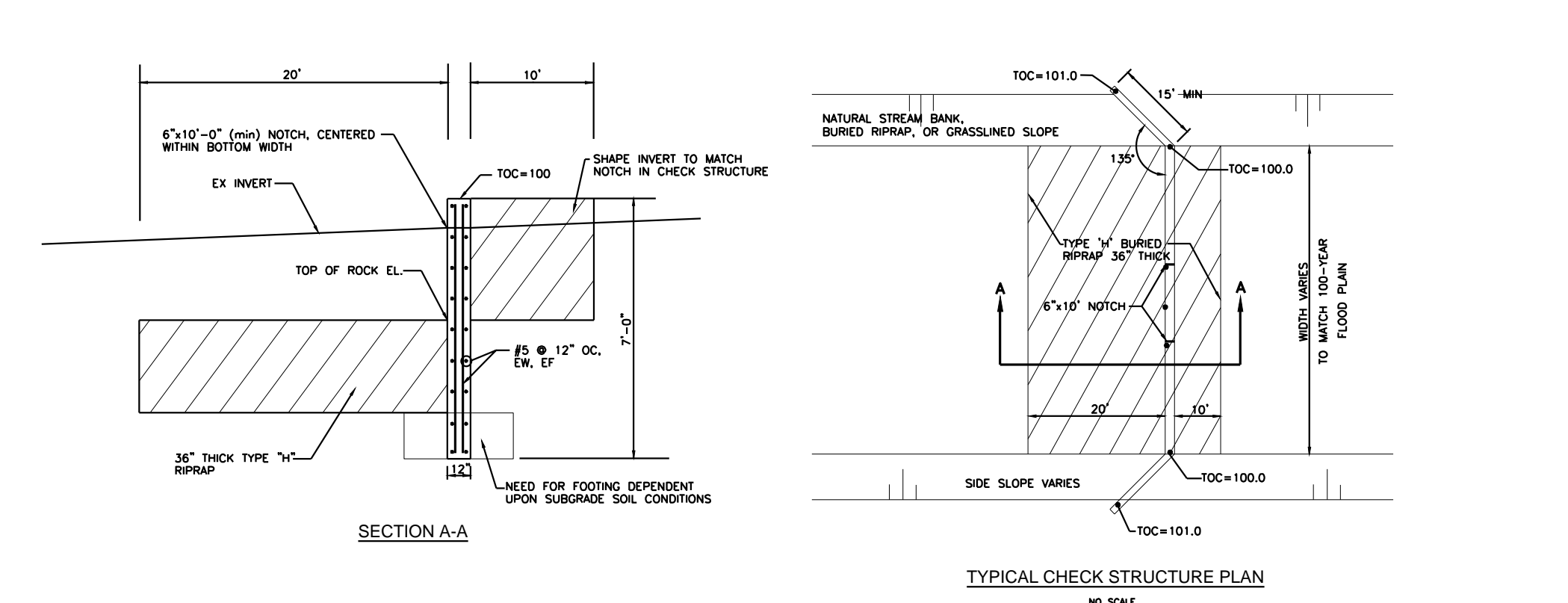

**EXHIBIT 2**  
**MESA RIDGE DEVELOPMENT**  
**MASTER DEVELOPMENT DRAINAGE PLAN UPDATE**  
**PROPOSED FACILITIES PLAN**  
**DEVELOPED WITH REGIONAL DETENTION**  
**FOUNTAIN, COLORADO**

**Kiowa Engineering Corporation**  
 1604 South 21st Street  
 Colorado Springs, Colorado  
 80904 - 4208  
 (719) 630-7342

Master Development Drainage Plan  
Mesa Ridge Development

City of Fountain, Colorado

Prepared For:

Norwood Development  
111 South Tejon #222  
Colorado Springs, CO 80903

Prepared By:

Kiowa Engineering Corporation  
1604 South 21<sup>st</sup> Street  
Colorado Springs, Colorado 80904

Project Number 05011  
December 17, 2006



NEW DOC







Kiowa Records 10/25/11

PROJECT SPECIFIC GRADING AND EROSION CONTROL NOTES

- All earthwork required of this construction shall be completed in accordance with all applicable sections of the Project Specifications and Soil Investigation Report (Geotechnical Report).
- Rubbish including timber, concrete rubble, trees, brush, and asphalt shall not be backfilled adjacent to any of the structures or be in the placement of any unclassified fill. The Contractor shall be responsible for the removal and hauling of such materials to a suitable spoil area. Costs associated with the removal of such materials shall be paid for as documented in the Project Specifications.
- Excess excavation shall become the property of the Contractor and shall be disposed of at the Contractor's expense. The cost of haulage and spilling of excess excavated materials shall be paid for as documented in the Project Specifications.
- Water shall be used as a dust palliative as required and shall be included in the cost for earthwork item(s). No separate payment will be made for dust control associated with the site construction.
- The road grades shall be cleared of vegetation and the topsoil stockpiled for later use.
- All grading shall be in conformance with the Geotechnical Report for the area.
- Placement of fill for roadway embankments shall be completed in conformance with the Geotechnical Report.
- Grading contours shown on this plan are to final grade.
- Compaction under filled areas, including roadway and detention basin embankments, shall be 95 percent of the maximum Standard Proctor Density (ASTM D698) at two (2) percent of optimum moisture content.
- No rubble or debris shall be placed in the backfill under any of the proposed buildings, streets, curb & gutter, sidewalk and drainage structures or within five (5) feet of a building footprint. Properly graded rubble may be used in some locations as specified and verified by the Geotechnical Engineer.
- Contractor is responsible for reviewing the site prior to bidding to verify site conditions.
- Contractor is responsible for providing erosion control measures as approved by the City of Fountain Dept. of Public Works Division and as may be required by the El Paso County Inspector.
- All slopes equal to or greater than 3:1 shall require erosion control blanket, single netted fabric, American Excelsior or equal.
- The Developer is responsible for maintaining erosion control measures until a mature stage of vegetation is established.
- All soils used for fill must be approved by a representative of the Geotechnical Engineer.
- All natural ground to receive fill must be properly scarified, watered and compacted prior to placing fill.
- The Contractor is solely responsible for the design, maintenance and operation of any required dewatering system. The Contractor shall perform such independent investigation as he deems necessary to satisfy himself as to the subsurface groundwater conditions and unstable soil conditions to be encountered throughout the construction.
- No fill shall be placed, spread or rolled while it is frozen, thawing or during unfavorable weather conditions. When the work is interrupted by heavy rain, fill operations shall not be resumed until a representative of the Geotechnical Engineer indicates that the moisture content and density of the previously placed fill are as specified. Fill surfaces may be scarified and recompact after rainfall if necessary, to obtain proper moisture density relation.
- Additional erosion control structures and/or grading may be required at the time of construction.
- Sediment removal for erosion control facilities shall be performed continuously for proper function.
- Base mapping was provided by Rockwell Consulting. The date of the survey was January 2008.
- Proposed Construction Schedule:  
Begin Construction: FEBRUARY 25, 2011  
End Construction: FEBRUARY 28, 2012  
Total Site Area = 3.8 Acres
- Area to be disturbed = 3.8 Acres (est.)  
Existing 100-year runoff coefficient = 0.40  
Proposed 100-year runoff coefficient = 0.40  
Existing Hydrological Soil Groups: B & C
- Site is currently undeveloped and covered with native grasses on mild slopes (2%-7%).
- Site is located in the Jimmy Camp Creek Drainage Basin.
- All grading and erosion control shall be completed in accordance with the City of Fountain Municipal Code Sections 12.04.160 and 12.10.

# MESA RIDGE FILINGS 8 & 9

## DETENTION BASIN 'D'

### FULL SPECTRUM DETENTION MODIFICATIONS

### FINAL DESIGN DRAWINGS

### FOUNTAIN, COLORADO

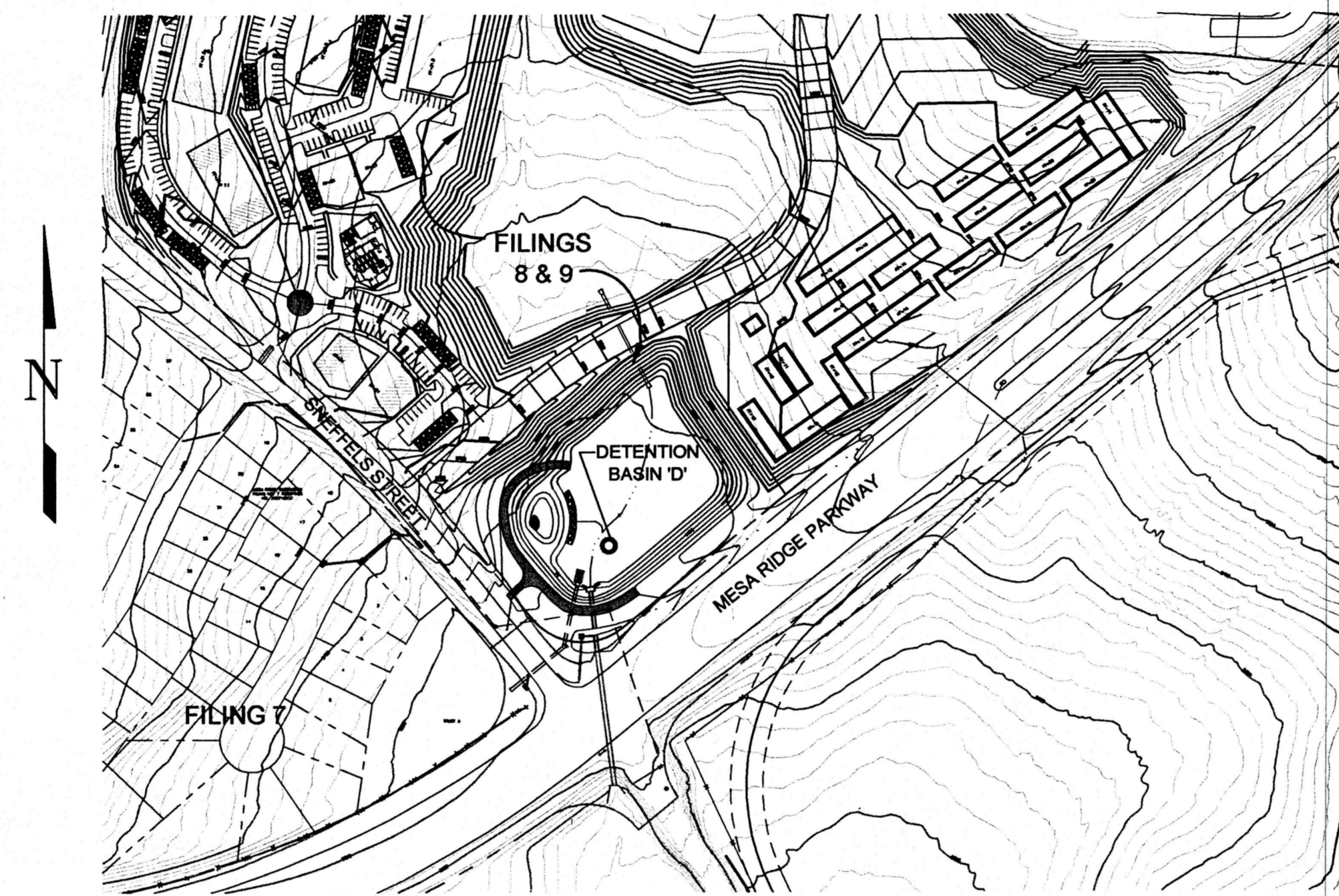

SITE MAP  
SCALE: 1"=200'

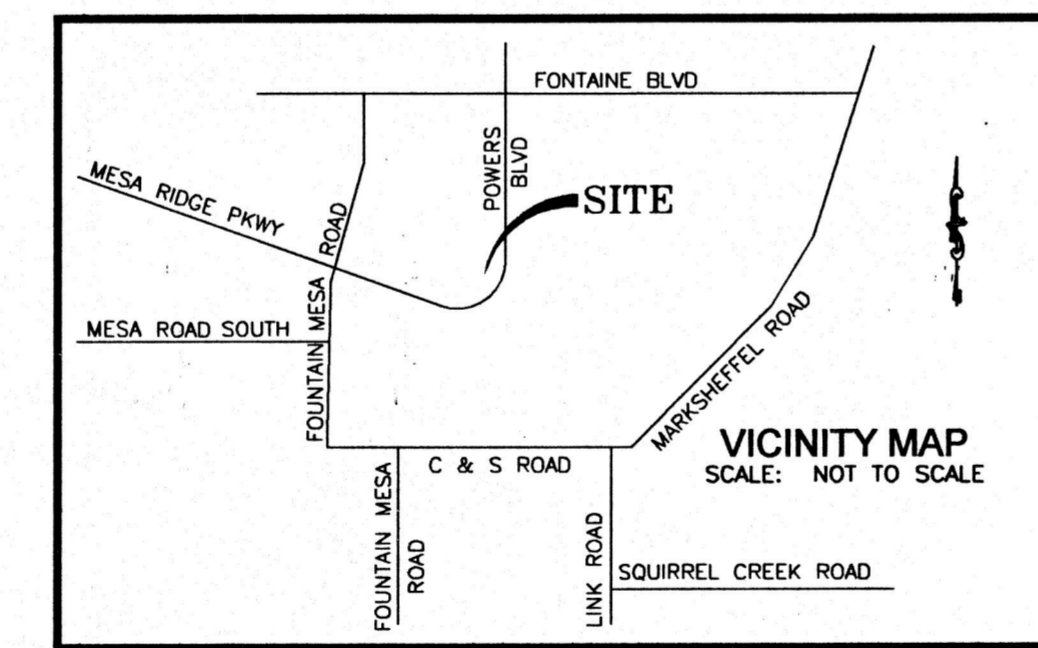

GENERAL NOTES

- ALL WORK REQUIRED OF THESE PLANS SHALL BE COMPLETED IN ACCORDANCE WITH CITY OF COLORADO SPRINGS, ENGINEERING DIVISION, STANDARD SPECIFICATIONS, AND WITH THE APPLICABLE SECTIONS OF THE COLORADO DEPARTMENT OF TRANSPORTATION, STANDARD SPECIFICATIONS FOR ROAD AND BRIDGE CONSTRUCTION.
- THE CONTRACTOR IS RESPONSIBLE FOR THE FIELD VERIFICATION OF ALL PUBLIC AND PRIVATE UTILITIES PRIOR TO THE COMMENCEMENT OF WORK. THE UTILITIES SHOWN ON THESE PLANS HAVE BEEN LOCATED USING THE BEST AVAILABLE INFORMATION. SHOULD A UTILITY BE DAMAGED AS A RESULT OF THIS CONSTRUCTION, IT SHALL BE REPAIRED IMMEDIATELY BY EITHER THE CONTRACTOR OR THE AFFECTED UTILITY OWNER. THE FULL COST OF SUCH A REPAIR SHALL BE THE RESPONSIBILITY OF THE CONTRACTOR.
- SURFACE AND GROUNDWATER AT THE SITE MAY CREATE A NEED FOR DEWATERING DURING THE CONSTRUCTION OF THE DRAINAGEWAY FACILITIES. CONTRACTOR SHALL BE RESPONSIBLE FOR THE MAINTENANCE OF TEMPORARY DEWATERING STRUCTURES, AND PROVIDE FOR THE SAFE AND STABLE DISCHARGE OF WATER FROM THE CONSTRUCTION SITE. THE COST OF DEWATERING IS CONSIDERED INCIDENTAL TO THE CONSTRUCTION AND WILL NOT BE PAID FOR UNDER A SPECIFIC ITEM IN THE BID DOCUMENTS.
- CLASS III RCP SHALL BE USED FOR ALL STORM SEWERS UNLESS OTHERWISE SPECIFIED.
- THE CONTRACTOR SHALL NOTIFY THE CITY OF FOUNTAIN DEPARTMENT OF PUBLIC WORKS 48 HOURS PRIOR TO THE START OF CONSTRUCTION TO OUTLINE METHODS OF CONSTRUCTION, SCHEDULING, AND ISSUING OF INSPECTION PERMITS.

STRUCTURAL CONCRETE NOTES

- ALL CONSTRUCTION INVOLVING THE PLACEMENT OF STRUCTURAL CONCRETE SHALL BE COMPLETED IN ACCORDANCE WITH SECTION 600 OF THE CITY OF COLORADO SPRINGS ENGINEERING DIVISION STANDARD SPECIFICATIONS.
- STEEL REINFORCING SHALL BE GRADE 60 FOR ALL REINFORCING STEEL GREATER THAN #4. A TABLE SPECIFYING MINIMUM SPLICE LENGTHS HAS BEEN PROVIDED ON THE STRUCTURAL DETAIL SHEETS. ALL REINFORCING SHALL HAVE A 2-INCH MINIMUM COVER UNLESS OTHERWISE SPECIFIED. REBAR SHOP DRAWINGS SHALL BE SUBMITTED TO THE ENGINEER FOR REVIEW PRIOR TO FABRICATION.
- CAST-IN-PLACE CONCRETE SHALL HAVE A MINIMUM COMPRESSIVE STRENGTH (F'C) OF 4,000 PSI AT 28 DAYS. ALL CONCRETE PLACED AGAINST SOIL SHALL BE TYPE II/V PORTLAND CEMENT. ALL EXPOSED CORNERS SHALL BE FORMED WITH A 3/4" CHAMFER UNLESS OTHERWISE SPECIFIED.
- EXPANSION JOINT MATERIAL SHALL MEET AASHTO SPECIFICATION M-213.
- BACKFILL AGAINST STRUCTURES SHALL NOT COMMENCE UNTIL ALL SUPPORTING DIAPHRAGMS ARE IN PLACE AND CONCRETE HAS OBTAINED ITS FULL SEVEN DAY STRENGTH. BACKFILL SHALL BE PLACED EQUALLY ON EACH SIDE OF CHECK STRUCTURES AND CUTOFF WALLS UNTIL THE FINAL GRADE IS REACHED.
- FOOTING EXCAVATIONS SHALL BE EXAMINED BY THE GEOTECHNICAL ENGINEER PRIOR TO THE FORMING AND PLACING OF CONCRETE.
- CONTRACTOR IS RESPONSIBLE FOR PROVIDING THE ENGINEER AND GEOTECHNICAL ENGINEER WITH A 24-HOUR MINIMUM NOTIFICATION FOR REBAR OBSERVATION, SOIL AND/OR CONCRETE TESTING. PLACEMENT OF CONCRETE IN THE ABSENCE OF TESTING SHALL BE COMPLETED AT THE SOLE RISK OF THE CONTRACTOR.
- CONCRETE:
  - NO ADMIXTURES PERMITTED WITHOUT THE REVIEW OF ENGINEER. SUBMIT DESIGN MIX FOR ENGINEER APPROVAL.
  - CONTRACTOR IS RESPONSIBLE FOR THE ADEQUACY OF FORMS AND SHORING AND FOR SAFE PRACTICE IN THEIR USE AND REMOVAL.
  - COMPRESSIVE STRENGTH SHALL BE 4,000 psi, MIN.
- REINFORCING STEEL:
  - TO BE BILLET STEEL CONFORMING TO THE LATEST A.S.T.M./ A615 GRADE 60 SPECIFICATION, FABRICATED IN ACCORDANCE WITH MANUAL OF STANDARD PRACTICE OF THE C.R.S.I. AND PLACED IN ACCORDANCE WITH A.C.I. 315 AND A.C.I. MANUAL OF PRACTICE.
  - MINIMUM OF CONCRETE COVER UNLESS OTHERWISE DETAILED ON DRAWINGS: FOOTINGS 3 INCHES, WALLS 3 INCHES, SLABS EXPOSED TO WEATHER 1-1/2 INCHES, SLABS ON GRADE 1-1/2 INCHES MEASURED FROM TOP OF SLAB.
  - SLAB REINFORCEMENT: LAPPED 36 BAR DIAMETER OR MINIMUM 18 INCHES. BOTTOM BARS SPLICED ONLY AT SUPPORTS, TOP BARS SPLICED ONLY AT MID-SPAN. ALL TOP BARS HOOKED AT NON-CONTINUOUS EDGES (U.O.N.) ALL HOOKS TO BE STANDARD 90 DEGREE OR 180 DEGREE HOOKS AS REQUIRED (U.O.N.), DOWELS IN FOUNDATION TO MATCH REINFORCING ABOVE.
  - SUBMIT SHOP DRAWINGS FOR REINFORCING PRIOR TO FABRICATION.

- FOUNDATIONS:
  - STRUCTURES SHALL BEAR ON SOIL HAVING A MINIMUM BEARING CAPACITY OF 2,000 P.S.F. COMPACTION FOR SUBGRADE PREPARATION SHALL BE IN ACCORDANCE WITH REQUIREMENTS OF THE SOILS REPORT. SUBGRADE PREPARATION SHALL BE MONITORED BY THE SOILS ENGINEER.
- BACKFILL AND STABILIZATION MATERIAL:
  - BACKFILL MATERIAL CONSISTING OF SELECT, GRANULAR, NON-SWELLING MATERIAL TO BE PLACED ALONG THE SIDES OF THE VAULTS EXTENDING 3 FEET OUTSIDE THE VAULT WALLS.
  - 3/4-INCH ROCK, 12-INCHES DEEP, TO BE PLACED UNDER ALL VAULTS.
  - 2-INCH TO 4-INCH STABILIZATION MATERIAL SHALL BE PLACED UNDER THE 3/4" ROCK IF SUBGRADE STABILIZATION IS REQUIRED.
- ABBREVIATIONS
 

E.C. -- EPOXY COATED	O.F. -- OUTSIDE FACE	E.F. -- EACH FACE
E.W. -- EACH WAY	I.F. -- INSIDE FACE	N.F. -- NEAR FACE
T.O.C. -- TOP OF CONCRETE	B.O.C. -- BOTTOM OF CONCRETE	
CONT. -- CONTINUOUS		

INDEX OF SHEETS

- COVER SHEET
- GRADING AND EROSION CONTROL PLAN & STORM PROFILE
- OUTLET STRUCTURE DETAILS

ABBREVIATIONS

ASSY = ASSEMBLY	HORIZ = HORIZONTAL	PVC = POINT OF VERTICAL CURVATURE
BNDY = BOUNDARY	HYD = HYDRANT	PMI = POINT OF VERTICAL INTERSECTION
B.O.P. = BOTTOM OF PIPE	I.D. = INSIDE DIAMETER	PVT = POINT OF VERTICAL TANGENCY
CL = CENTERLINE	LT = LEFT	RCB = REINFORCED CONCRETE BOX
CRA = CONCRETE REVERSE ANCHOR	LF = LINEAR FEET	RCP = REINFORCED CONCRETE PIPE
CTR = CONCRETE THRUST BLOCK	LP = LOW POINT	RT = RIGHT OF WAY
CR = POINT OF CURB RETURN	MAX. = MAXIMUM	RT = RIGHT
DIP = DUCTILE IRON PIPE	M.H. = MANHOLE	SHT = SHEET
EL = ELEVATION	MIN. = MINIMUM	SS = SANITARY SEWER
ESMT = EASEMENT	NTS = NOT TO SCALE	STA. = STATION
EX. = EXISTING	O.D. = OUTSIDE DIAMETER	STD. = STANDARD
FG = FACE OF CURB	P.C. = POINT OF CURVATURE	T.O.P. = TOP OF PIPE
FES = FLARED END SECTION	PCHC = POINT OF CURVATURE ON HORIZ. CURVE	TYP. = TYPICAL
FG = FLANGE	PP = PROPOSED	VC = VERTICAL CURVE
FL = FLOWLINE	PT = POINT OF HORIZONTAL TANGENCY	VERT. = VERTICAL
FB = GRADE BREAK	PTHC = POINT OF TANGENCY ON HORIZ. CURVE	
HP = HIGH POINT	PVC = POLY VINYL CHLORIDE PIPE	

\*A.G.A./A.P.W.A. STANDARD UTILITY MARKING COLOR CODE

NATURAL GAS	YELLOW
ELECTRIC	RED
WATER	BLUE
WASTEWATER	GREEN

CALL BEFORE YOU DIG... 1-800-922-1987

48 HOURS BEFORE YOU DIG, CALL UTILITY LOCATIONS FOR LOCATING AND MARKING GAS, ELECTRIC, WATER AND WASTEWATER

STATEMENTS

**CITY OF FOUNTAIN ACCEPTANCE:**  
THE PLANS OR REPORT SUBMITTED APPEAR TO BE IN CONFORMANCE WITH THE CITY OF FOUNTAIN SUBMITTAL REQUIREMENTS AND STANDARD ENGINEERING PRINCIPALS AND PRACTICES APPEAR TO HAVE BEEN FOLLOWED. THE PROFESSIONAL ENGINEER SUBMITTING AND SEALING THE PLANS OR REPORT IS SOLELY RESPONSIBLE FOR THEIR ACCURACY AND VALIDITY. THIS REVIEW IS ONLY VALID FOR ONE (1) YEAR FROM THE DATE BELOW.

*Duane Greenwood*  
DUANE GREENWOOD, PUBLIC WORKS DIR./CITY ENGINEER  
DATE: 10/25/2011

**DETAILED DRAINAGE CONSTRUCTION PLANS & SPECIFICATIONS**  
**ENGINEER'S STATEMENT:**  
THESE DETAILED PLANS AND SPECIFICATIONS WERE PREPARED UNDER MY DIRECTION AND SUPERVISION. SAID DETAILED PLANS AND SPECIFICATIONS HAVE BEEN PREPARED ACCORDING TO THE CRITERIA ESTABLISHED BY THE CITY FOR DETAILED DRAINAGE PLANS AND SPECIFICATIONS. SAID DETAILED DRAINAGE PLANS AND SPECIFICATIONS MEET THE PURPOSES FOR WHICH THE PARTICULAR DRAINAGE FACILITY(S) IS DESIGNED. I ACCEPT RESPONSIBILITY FOR LIABILITY CAUSED BY NEGLIGENT ACTS, ERRORS OR OMISSIONS, ON MY PART IN PREPARATION OF THE DETAILED DRAINAGE PLANS AND SPECIFICATIONS.

*Richard N. Wray*  
RICHARD N. WRAY, P.E. #19310  
DATE: 10/25/11

*Richard N. Wray*  
DEVELOPER  
DATE: 10/24/11

COMPANY: NORWOOD DEVELOPMENT  
ADDRESS: PLAZA OF THE ROCKIES  
11 S. TEJON STREET, SUITE 222  
COLORADO SPRINGS, COLORADO 80903

GRADING AND EROSION CONTROL NOTES

- ALL GRADING AND EROSION CONTROL SHALL BE COMPLETED IN ACCORDANCE WITH THE CITY OF FOUNTAIN MUNICIPAL CODE SECTIONS 12.04.160 AND 12.10.
- ALL FILL AREAS SHALL BE COMPACTED IN ACCORDANCE WITH THE GEOTECHNICAL ENGINEER'S RECOMMENDATIONS.
- SOIL EROSION CONTROL MEASURES FOR ALL SLOPES, CHANNELS, DITCHES, OR ANY DISTURBED LAND AREA SHALL BE COMPLETED WITHIN TWENTY ONE (21) CALENDAR DAYS AFTER FINAL GRADING, OR FINAL EARTH DISTURBANCE HAS BEEN COMPLETED. AN AREA THAT IS GOING TO REMAIN IN AN OPEN STATE FOR MORE THAN 60 DAYS SHALL ALSO BE SEEDED. ALL TEMPORARY SOIL EROSION CONTROL MEASURES AND BMPs SHALL BE MAINTAINED UNTIL PERMANENT SOIL EROSION CONTROL MEASURES ARE IMPLEMENTED.
- EROSION CONTROL SHALL CONSIST OF SILT FENCES AND HAY BALES AS SHOWN ON THE DRAWING, AND TOPSOIL WITH GRASS SEED WHICH WILL BE WATERED UNTIL VEGETATION HAS BEEN REESTABLISHED.
- EROSION CONTROL BALES OR SILT FENCE SHALL BE PLACED AT THE TOE AND DRAINAGE OUTFALL POINTS OF ALL SLOPES 4:1 OR STEEPER TO PREVENT SILTATION ON STREETS. REFER TO STORM WATER MANAGEMENT PLAN FOR DETAIL AND LOCATION OF EROSION CONTROL MEASURES.
- CONTRACTOR SHALL COMPLY WITH ALL LOCAL, COUNTY AND STATE REGULATIONS PERTAINING TO GRADING, DUST AND EROSION.
- NATURAL VEGETATION SHALL BE RETAINED AND PROTECTED WHEREVER POSSIBLE. EXPOSURE OF SOIL TO EROSION BY REMOVAL OR DISTURBANCE OF VEGETATION SHALL BE LIMITED TO THE AREA REQUIRED FOR IMMEDIATE CONSTRUCTION OPERATIONS AND FOR THE SHORTEST PRACTICAL PERIOD OF TIME.
- TOPSOIL SHALL BE STOCKPILED TO THE EXTENT PRACTICABLE ON THE SITE FOR USE ON AREAS TO BE REVEGETATED. ANY AND ALL STOCKPILES SHALL BE LOCATED AND PROTECTED FROM EROSION ELEMENTS.
- AT ALL TIMES, THE PROPERTY SHALL BE MAINTAINED AND/OR WATERED TO PREVENT WIND-CAUSED EROSION. EARTHWORK OPERATIONS SHALL BE DISCONTINUED WHEN FUGITIVE DUST SIGNIFICANTLY IMPACTS ADJACENT PROPERTY. IF EARTHWORK IS COMPLETE OR DISCONTINUED AND DUST FROM THE SITE CONTINUES TO CREATE PROBLEMS, THE OWNER/DEVELOPER SHALL IMMEDIATELY INSTITUTE MITIGATIVE MEASURES AND SHALL CORRECT DAMAGE TO ADJACENT PROPERTY.
- ALL PERSONS ENGAGED IN EARTH DISTURBANCE SHALL IMPLEMENT AND MAINTAIN ACCEPTABLE SOIL EROSION AND SEDIMENT CONTROL MEASURES INCLUDING BMPs IN CONFORMANCE WITH THE EROSION CONTROL TECHNICAL STANDARDS OF THE MANUAL AND IN ACCORDANCE WITH THE EROSION AND STORMWATER QUALITY CONTROL PLAN APPROVED BY THE CITY OF FOUNTAIN, IF REQUIRED.
- ALL EARTH DISTURBANCE SHALL BE CONDUCTED IN SUCH A MANNER SO AS TO EFFECTIVELY REDUCE ACCELERATED SOIL EROSION.
- ALL EARTH DISTURBANCE SHALL BE DESIGNED, CONSTRUCTED, AND COMPLETED IN SUCH A MANNER SO THAT THE EXPOSED AREA OF ANY DISTURBED LAND SHALL BE LIMITED TO THE SHORTEST PRACTICAL PERIOD OF TIME.
- ALL EARTH DISTURBANCE SHALL BE DONE IN A MANNER THAT MINIMIZES POLLUTION OF ANY ON-SITE OR OFF-SITE WATERS.
- SUSPENDED SEDIMENT CAUSED BY ACCELERATED SOIL EROSION SHALL BE MINIMIZED IN RUNOFF WATER BEFORE IT LEAVES THE SITE.
- TEMPORARY SOIL EROSION CONTROL FACILITIES SHALL BE REMOVED AND EARTH DISTURBANCE AREAS GRADED AND STABILIZED WITH PERMANENT SOIL EROSION CONTROL MEASURES PURSUANT TO THE STANDARDS AND SPECIFICATIONS PRESCRIBED IN THE MANUAL, AND IN ACCORDANCE WITH THE PERMANENT EROSION CONTROL FEATURES SHOWN ON THE EROSION AND STORMWATER CONTROL PLANS APPROVED BY THE CITY OF FOUNTAIN, IF REQUIRED.
- ANY STREET OR DRAINAGE FACILITY WHICH HAS HAD EROSION SEDIMENT DEPOSITED IN IT DUE TO CONSTRUCTION, GRADING, OR OTHER DEVELOPMENT ACTIVITY, MUST BE CLEANED IMMEDIATELY AT THE EXPENSE OF THE CONTRACTOR, DEVELOPER, HOMEOWNER, OR WHOEVER IS RESPONSIBLE FOR THE CONSTRUCTION, GRADING, OR LAND DEVELOPMENT ACTIVITY. IF THE FACILITY IS NOT CLEANED IMMEDIATELY OR WITHIN A RESPONSIBLE PERIOD OF TIME AFTER NOTIFICATION BY THE CITY, THE CITY MAY PERFORM THE WORK OR HAVE THE WORK DONE AND BILL THE RESPONSIBLE PARTY.
- IT IS THE RESPONSIBILITY OF THE OWNER TO ENSURE THAT VEHICLE TRACKING CONTROL IS IN PLACE, FUNCTIONAL, AND MAINTAINED THROUGHOUT THE CONSTRUCTION PHASE OF THIS PROJECT.
- INDIVIDUALS SHALL COMPLY WITH THE "COLORADO WATER QUALITY CONTROL ACT" (TITLE 25, ARTICLE 8, CRS), AND THE "CLEAN WATER ACT" (33USC 1344), REGULATIONS PROMULGATED, CERTIFICATIONS OR PERMITS ISSUED, IN ADDITION TO CITY OF FOUNTAIN REQUIREMENTS. IN THE EVENT OF CONFLICTS BETWEEN THESE REQUIREMENTS, THE MORE RESTRICTIVE LAWS, RULES, OR REGULATIONS SHALL APPLY.

DEVELOPER:  
NORWOOD DEVELOPMENT  
PLAZA OF THE ROCKIES  
11 S. TEJON STREET, SUITE 222  
COLORADO SPRINGS, COLORADO 80903

PREPARED BY:  
**Kiowa Engineering Corporation**  
1604 South 21st Street  
Colorado Springs, Colorado  
80904-4208  
(719) 630-7342

Kiowa Project No. 09061  
October 25, 2011





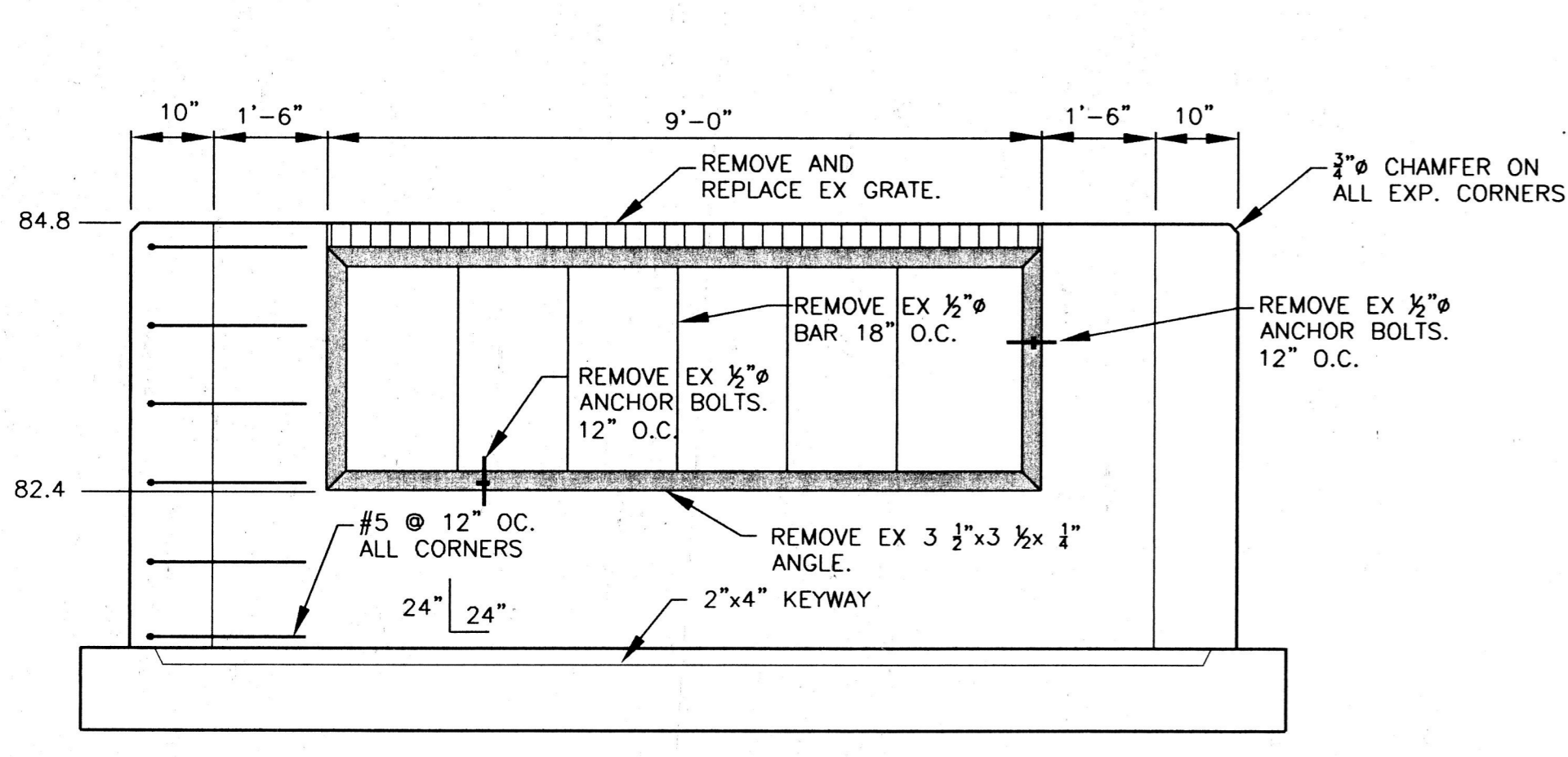

**SECTION C-C**  
SCALE: 1"=2"

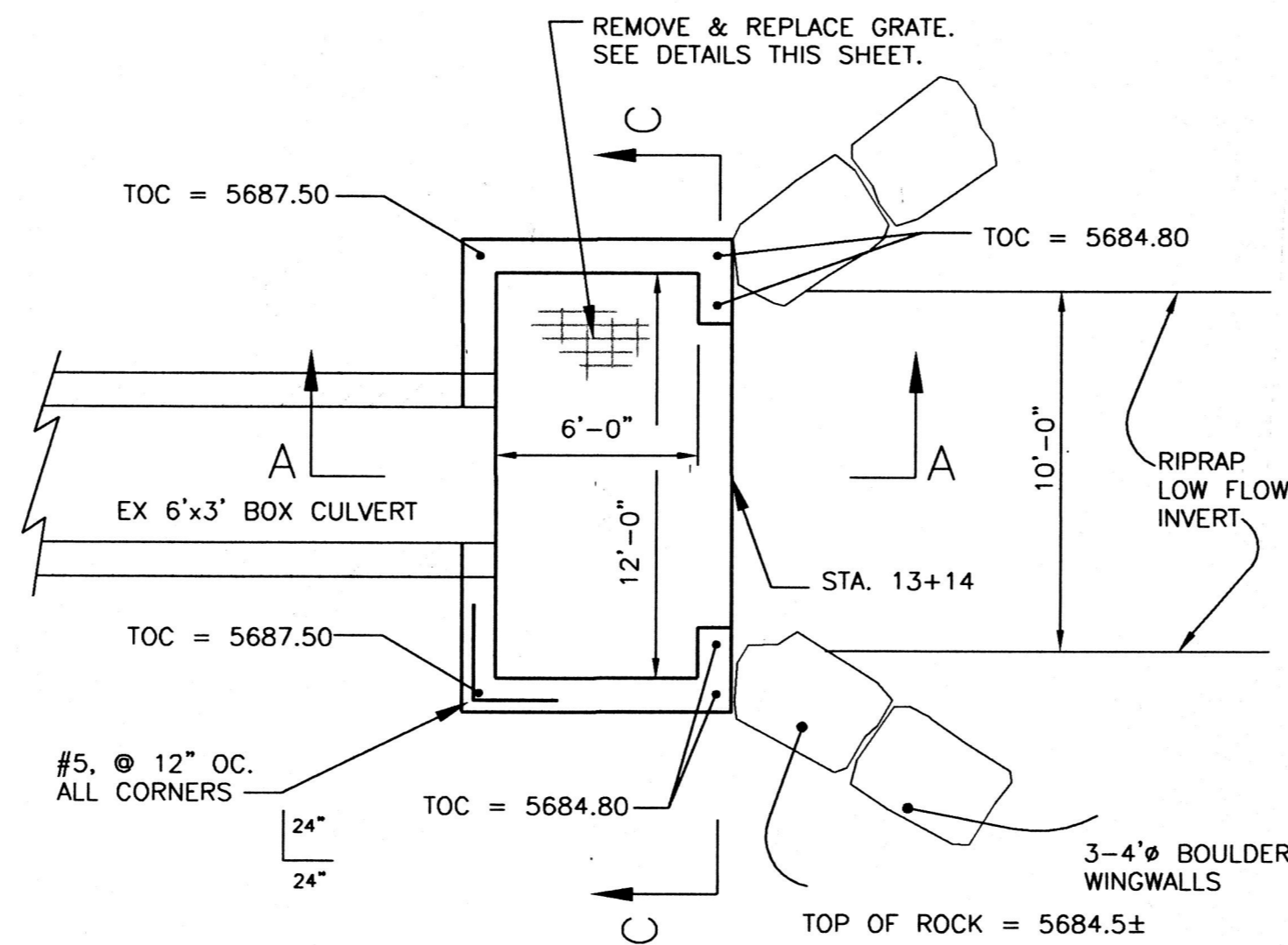

**EX. OUTLET STRUCTURE PLAN**  
SCALE: N.T.S.

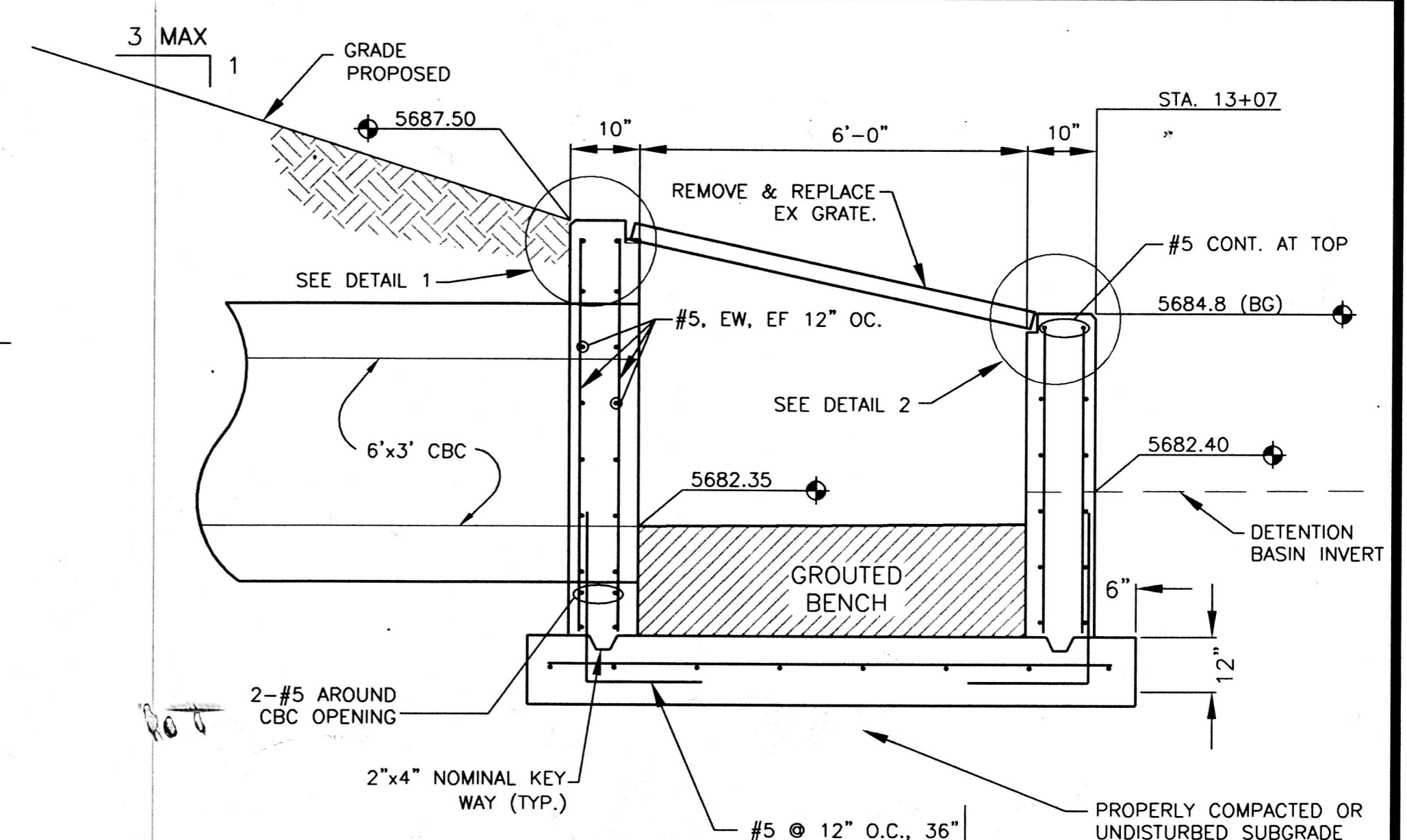

**SECTION A-A**  
SCALE: 1"=2"

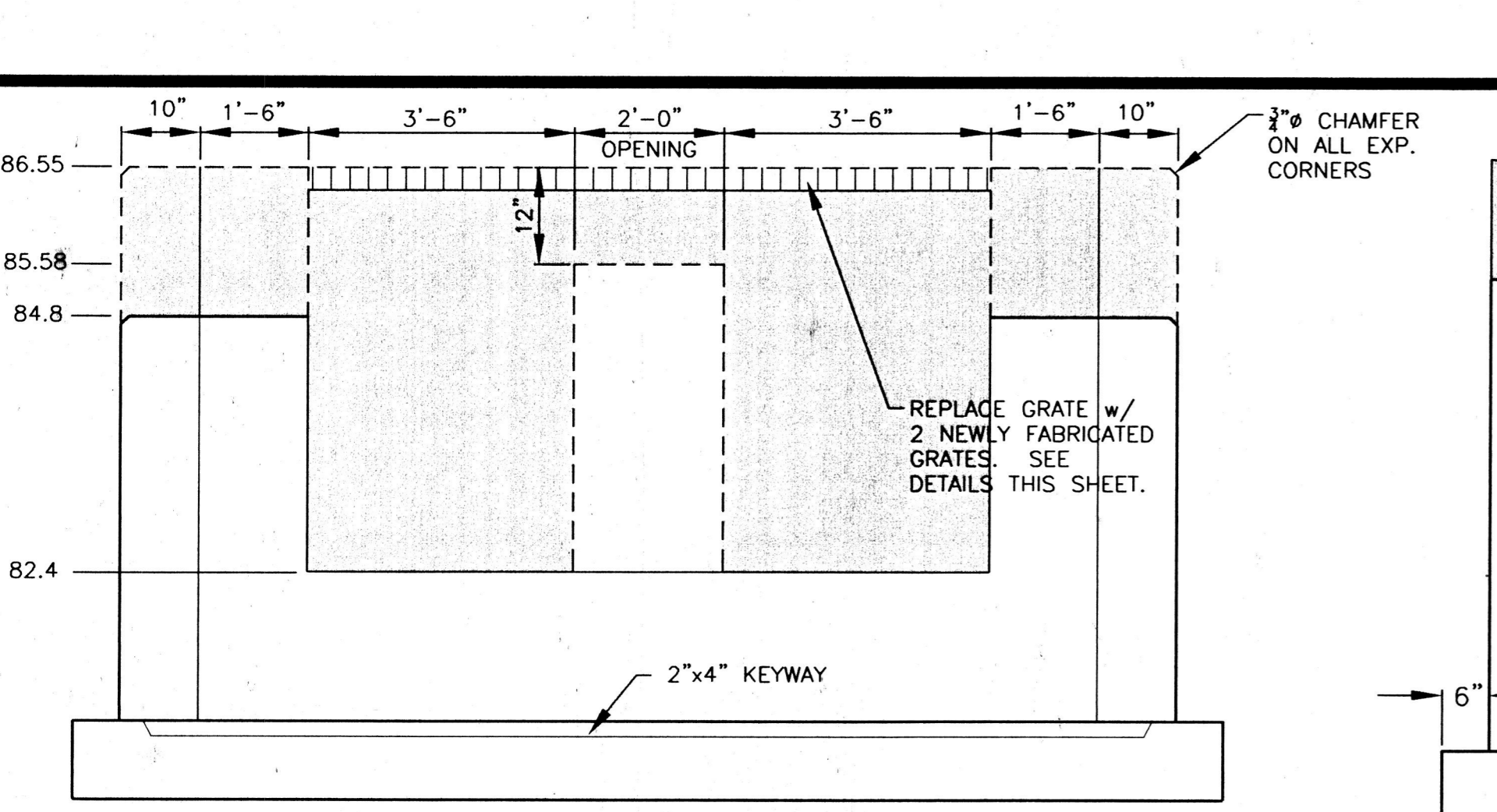

**SECTION C-C**  
SCALE: 1"=2"

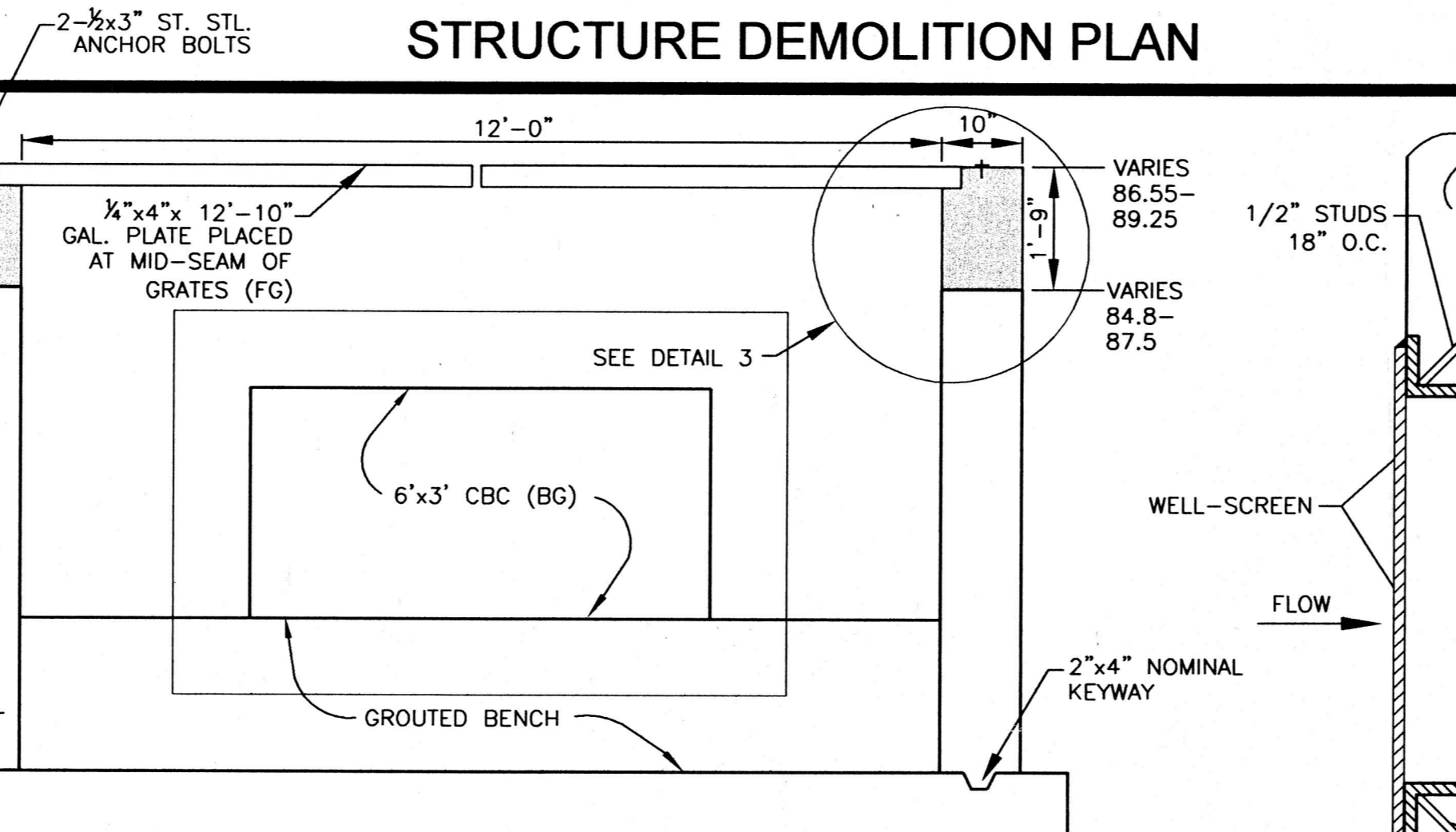

**STRUCTURE DEMOLITION PLAN**

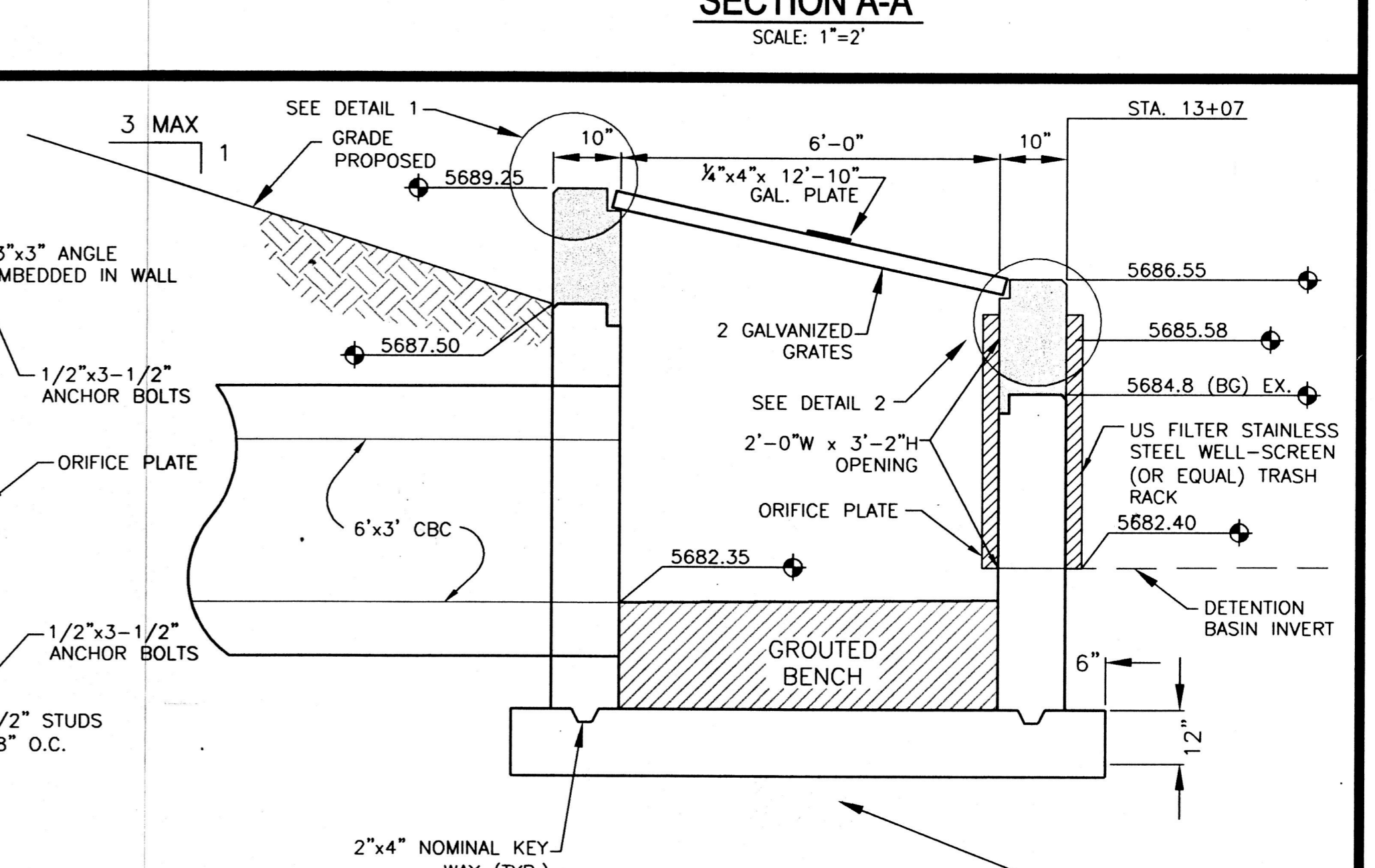

**SECTION A-A**  
SCALE: 1"=2"

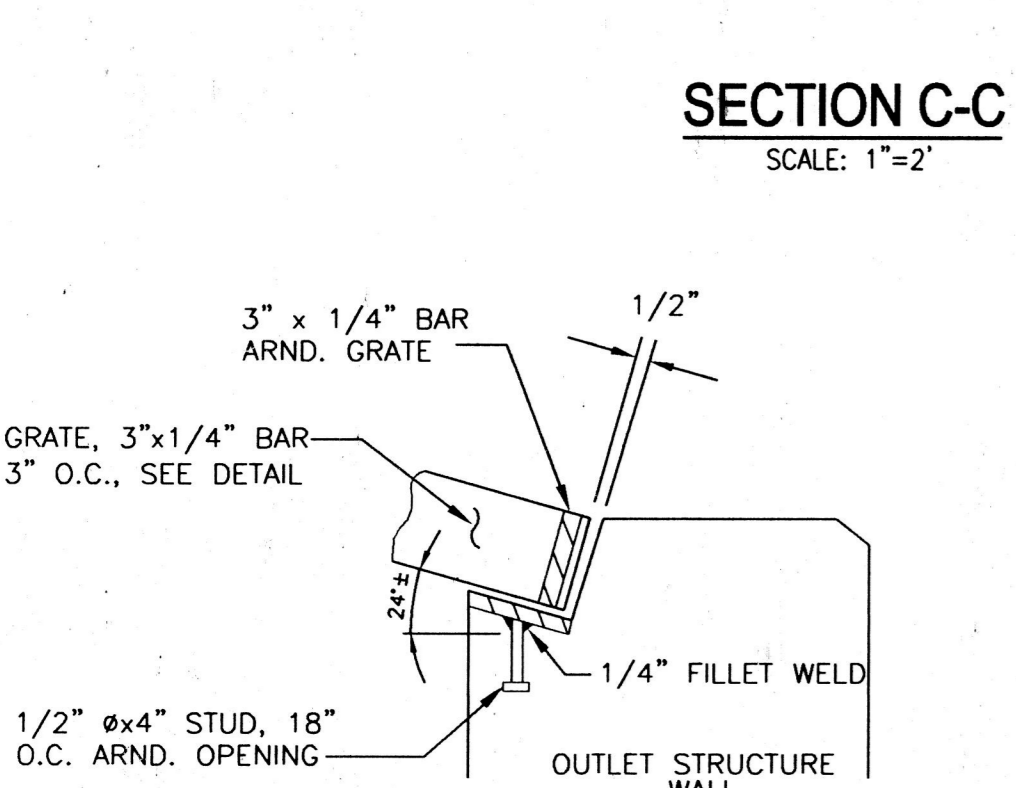

**DETAIL 2**  
SCALE: N.T.S.

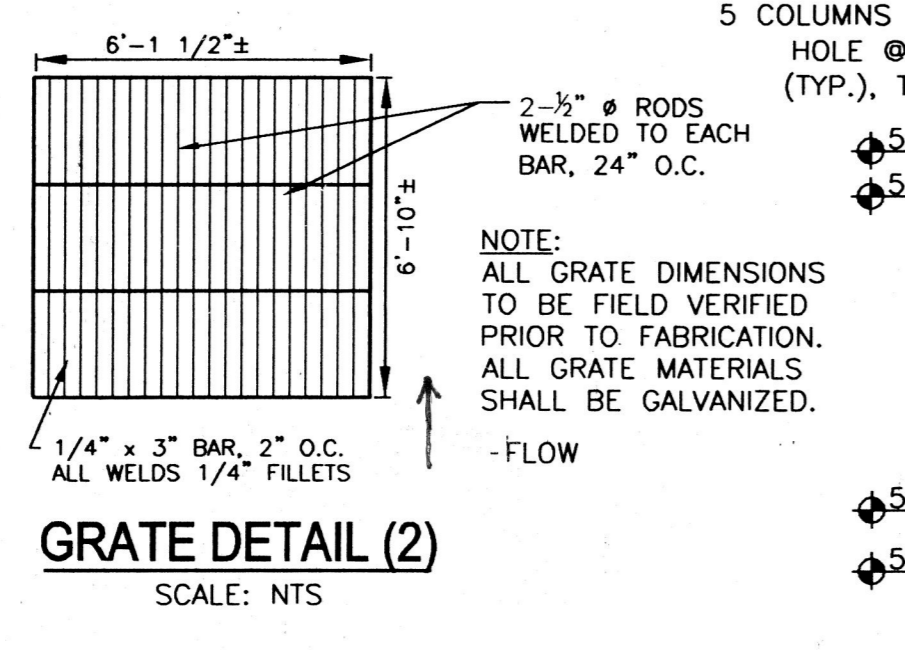

**GRATE DETAIL (2)**  
SCALE: N.T.S.

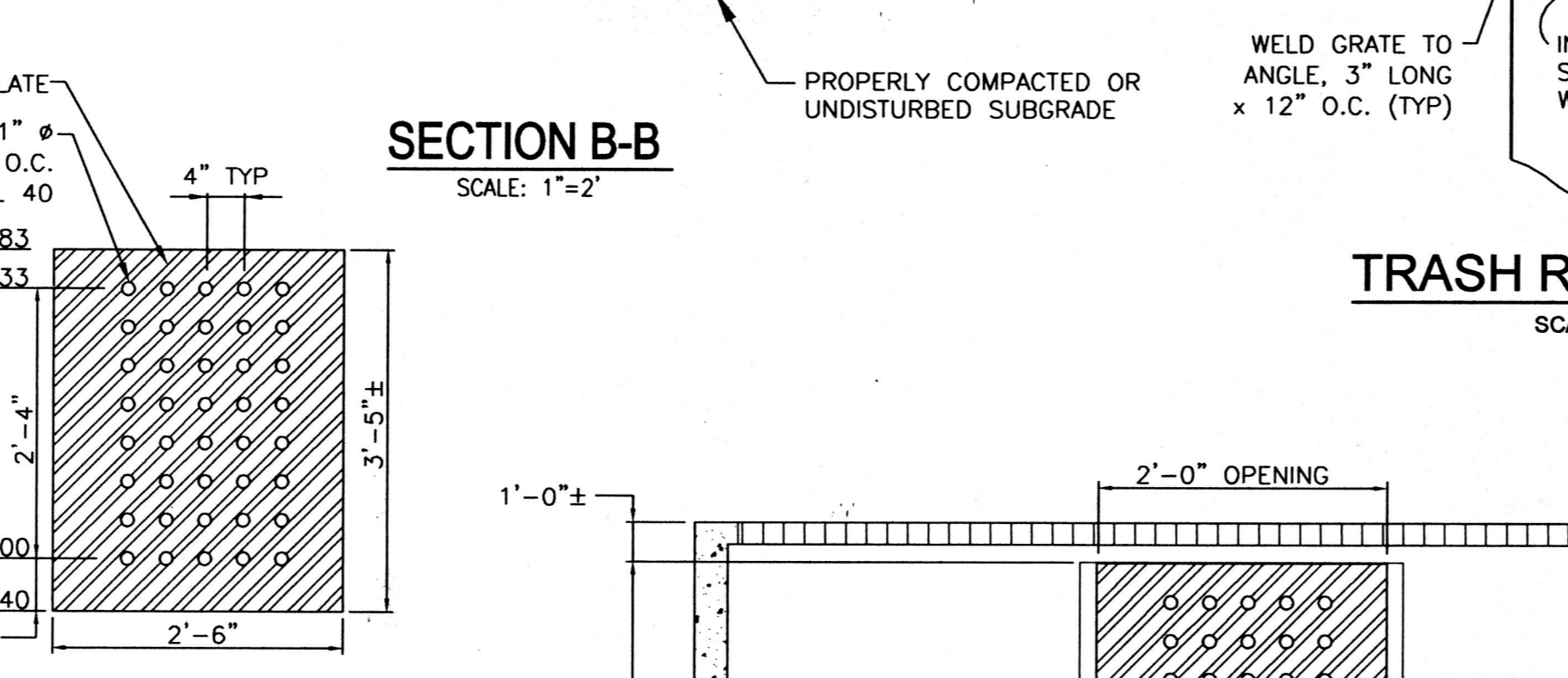

**TRASH RACK DETAIL**  
SCALE: N.T.S.

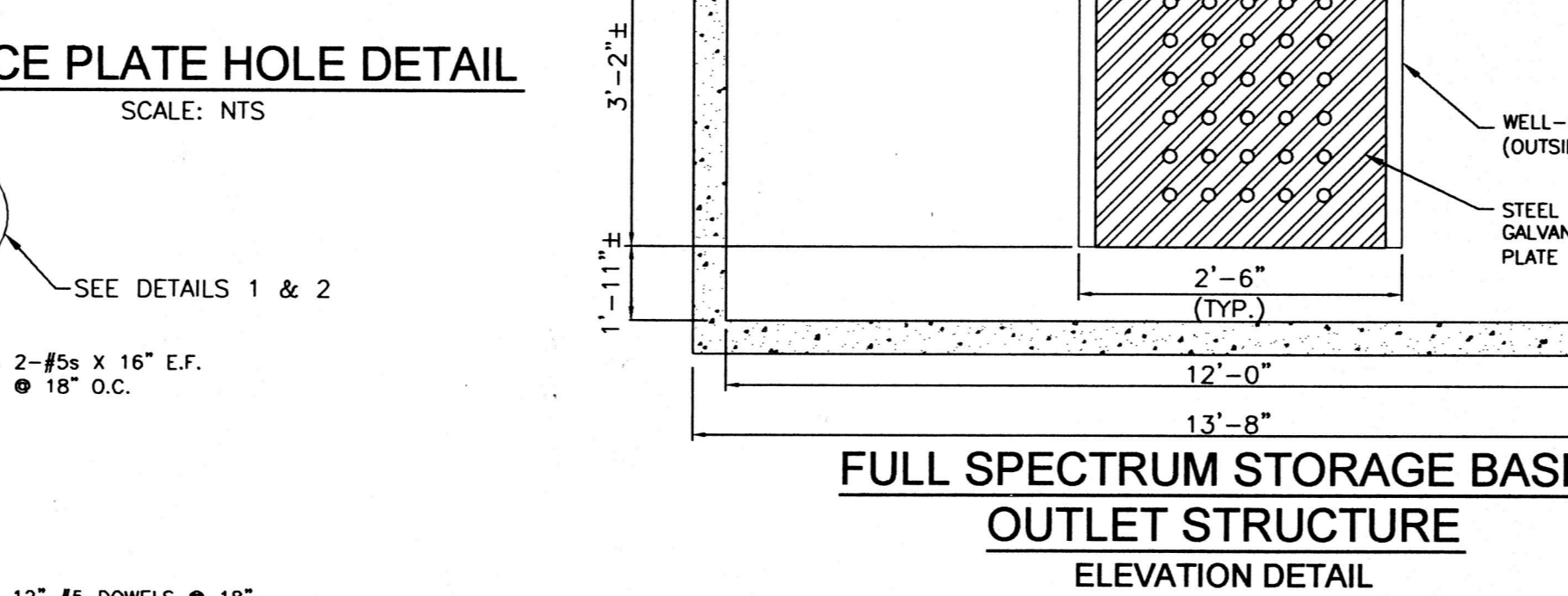

**ORIFICE PLATE HOLE DETAIL**  
SCALE: N.T.S.

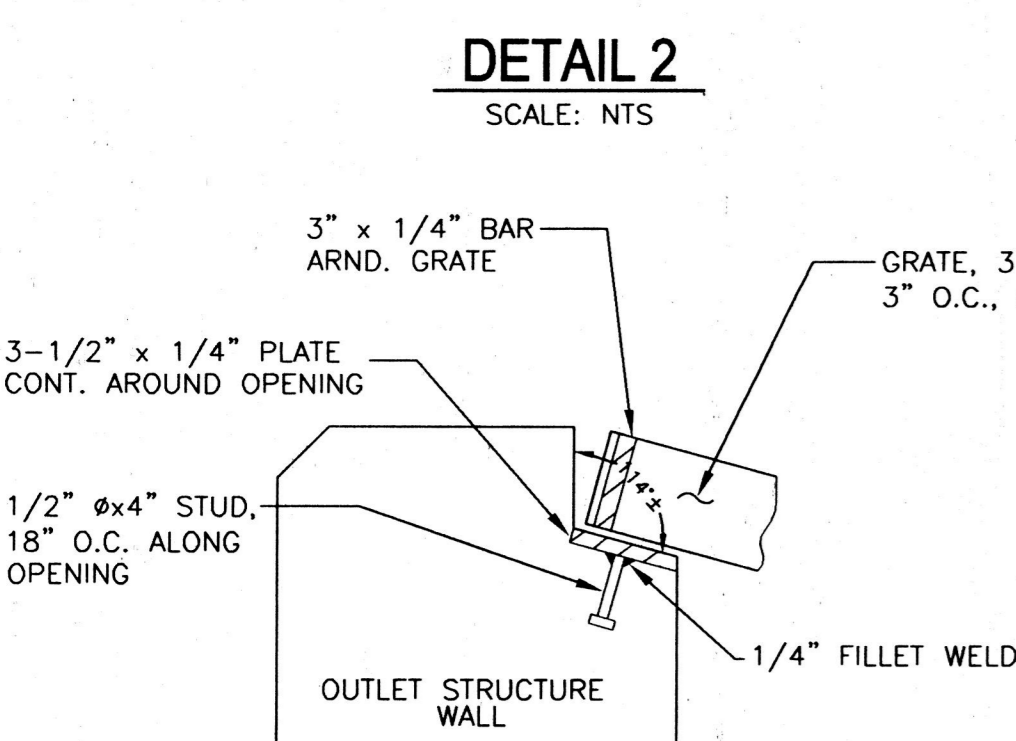

**DETAIL 1**  
SCALE: N.T.S.

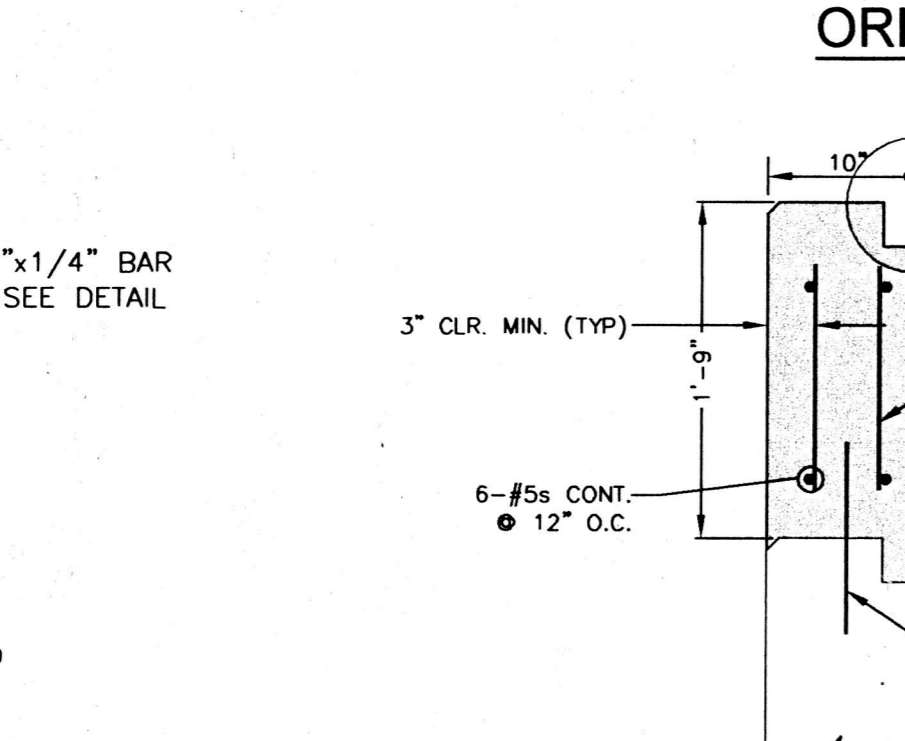

**DETAIL 3**  
SCALE: 1/2"=1'-0"

**STRUCTURE MODIFICATION PLAN**

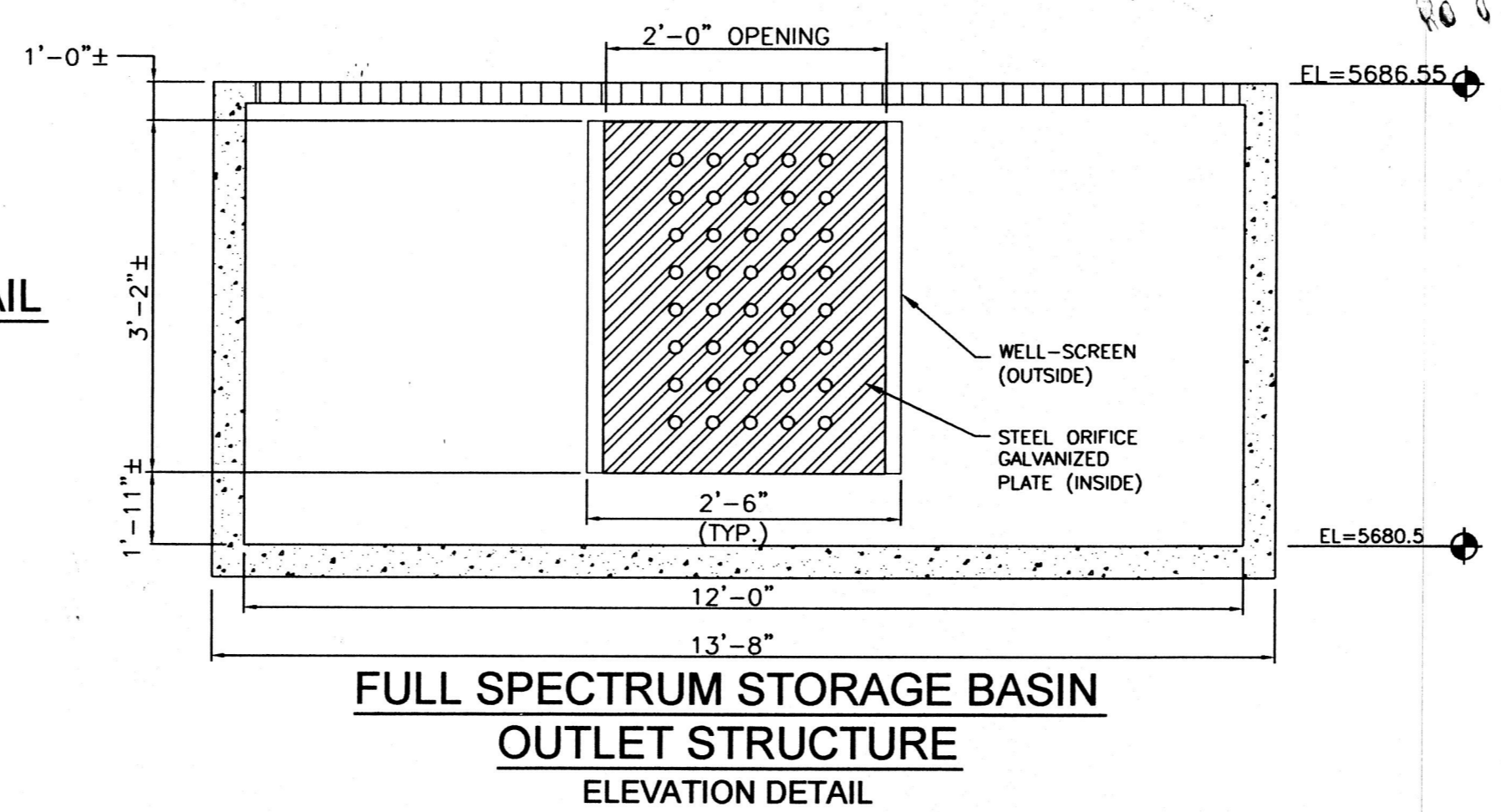

**FULL SPECTRUM STORAGE BASIN OUTLET STRUCTURE ELEVATION DETAIL**  
SCALE: N.T.S.

NOTE:  
ALL METAL PLATE &  
EMBEDMENTS SHALL BE  
GALVANIZED STEEL.  
ALL BOLTS & NUTS SHALL  
BE STAINLESS STEEL.

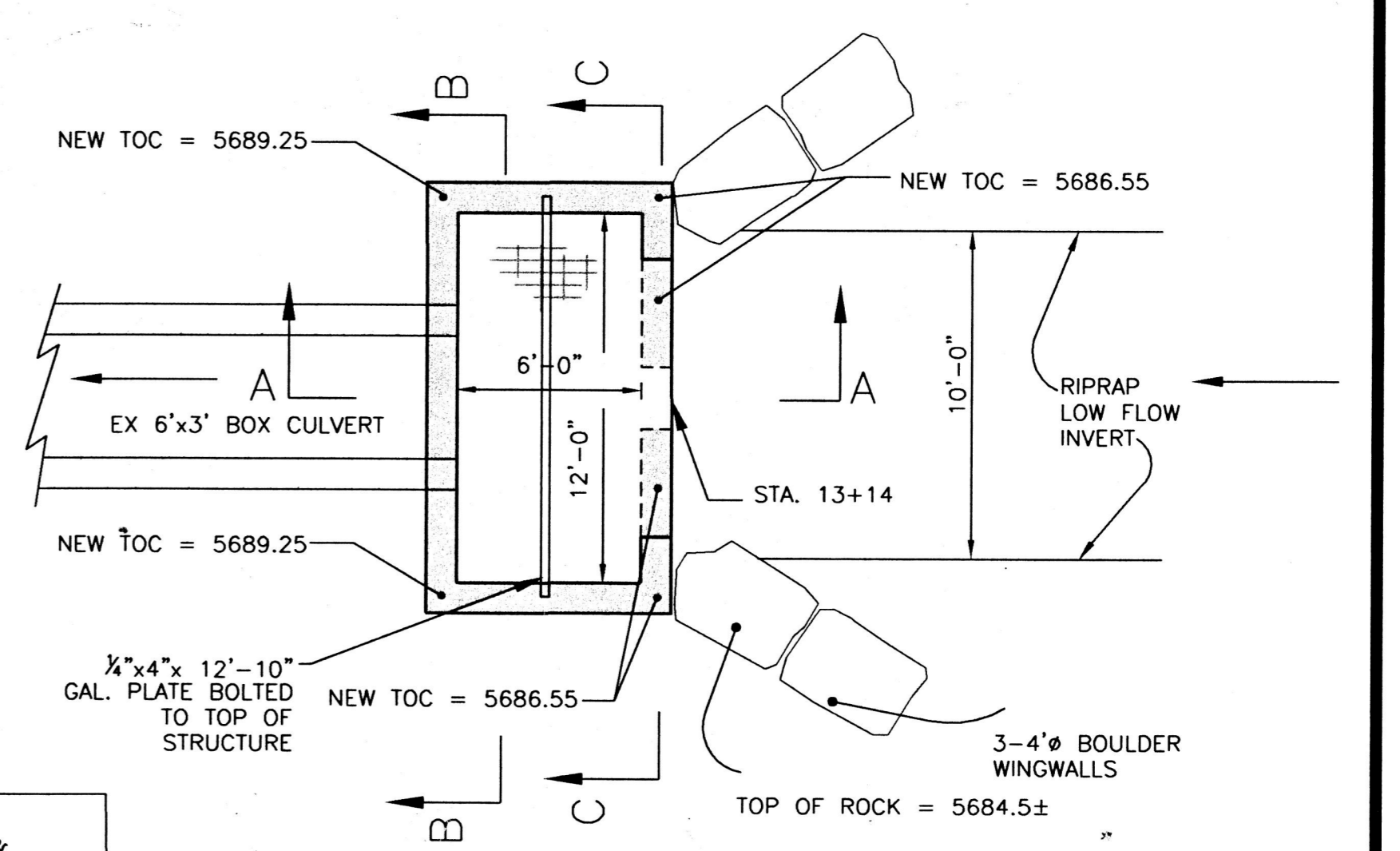

**OUTLET STRUCTURE PLAN**  
SCALE: N.T.S.

**Kiowa Engineering Corporation**  
1604 South 21st Street  
Colorado Springs, Colorado  
80904-4208  
(719) 630-7342

**MESA RIDGE FILINGS 8 & 9 - DETENTION BASIN 'D'**  
**FULL SPECTRUM DETENTION MODIFICATIONS**  
**OUTLET STRUCTURE DETAILS**  
FOUNTAIN, COLORADO

Project No.:	09061
Date:	October 24, 2011
Design:	RNW
Drawn:	JGD
Check:	RNW
Revisions:	



## **APPENDIX F – DRAINAGE MAPS**

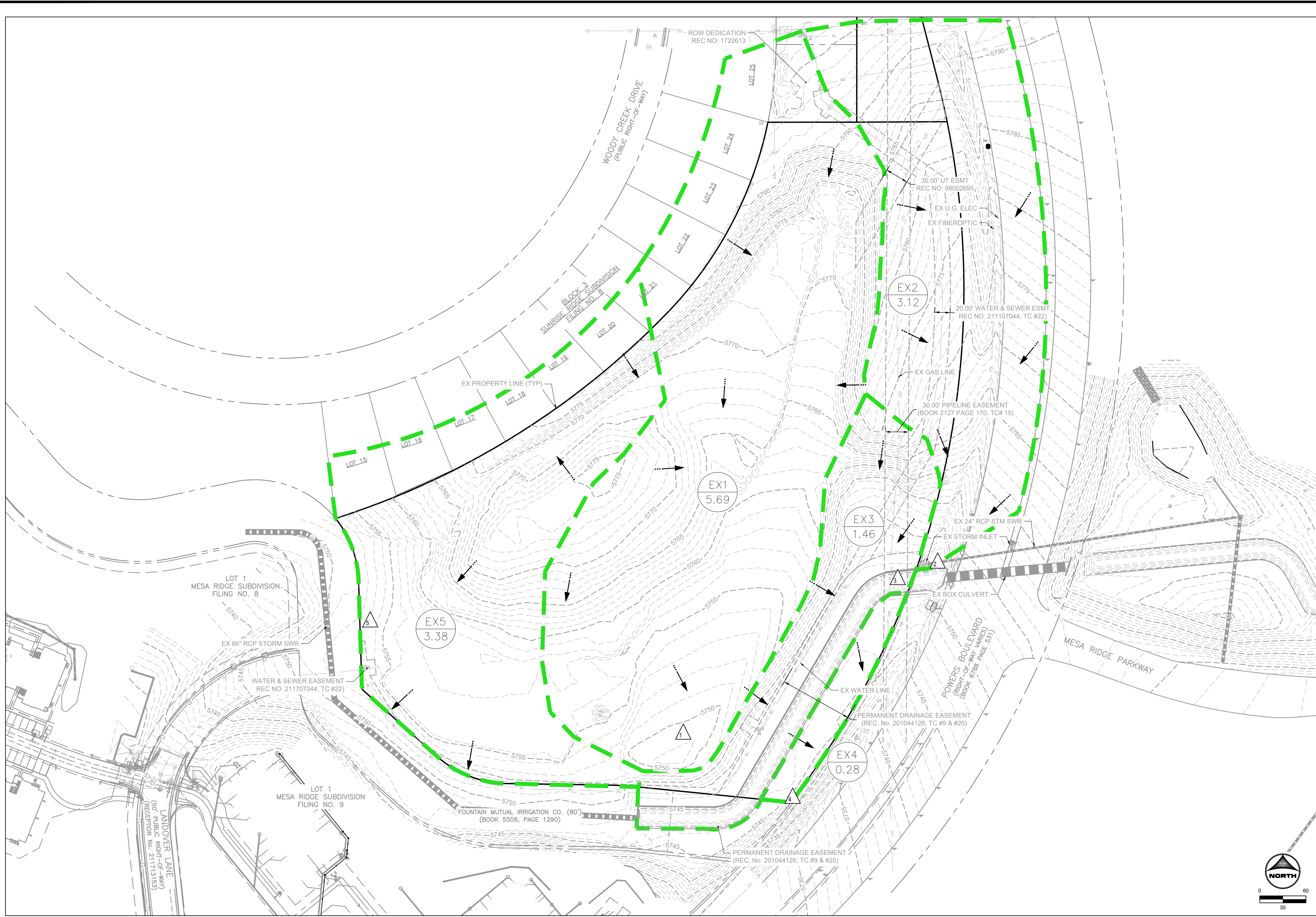

**LEGEND:**

PROPOSED MAJOR CONTOUR	— 5250 —
PROPOSED MINOR CONTOUR	— 5250 —
EXISTING MAJOR CONTOUR	--- 5250 ---
EXISTING MINOR CONTOUR	--- 5250 ---
PROPOSED STORM DRAIN PIPE	— — — — —
EXISTING STORM DRAIN PIPE	— — — — —
PROPOSED DRAINAGE SWALE	— — — — —
PROPERTY LINE	— — — — —
EXISTING FLOW DIRECTION	←
SUB BASIN LINE	— — — — —
DESIGN POINT	△
PROPOSED BASIN LABEL	11 1.25 BASIN DESIGNATION AREA (AC.)

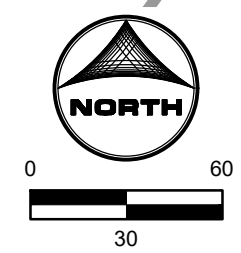

**SUMMARY RUNOFF TABLE**

BASIN	AREA (ac)	% IMPERVIOUS	Q <sub>5</sub> (cfs)	Q <sub>100</sub> (cfs)
EX1	5.69	7	2.5	13.7
EX2	3.12	28	4.2	12.4
EX3	1.46	24	1.6	5.1
EX4	0.28	2	0.1	0.8
EX5	3.38	15	2.8	11.9

**DESIGN POINT SUMMARY TABLE**

DESIGN POINT	UPSTREAM BASIN	ΣQ <sub>5</sub> (cfs)	ΣQ <sub>100</sub> (cfs)
1	EX1	2.5	13.7
2	EX2	4.2	12.4
3	EX3	1.6	5.1
4	EX4	0.1	0.8
5	EX5	2.8	11.9

DRAWN BY: YOU JOB DATE: 8/9/2021  
 APPROVED: KEN JOB NUMBER: 200541  
 CAD DATE: 8/10/2021  
 CAD FILE: J:\2020\200541\CAD\Drawings\C\Drainage\Ex\_Drn\_Map

BAR IS ONE INCH ON OFFICIAL DRAWINGS.  
 IF NOT ONE INCH, ADJUST SCALE ACCORDINGLY.

NO.	DATE	BY	REVISION DESCRIPTION

**HRGreen**  
 HR GREEN - COLORADO SPRINGS  
 7222 COMMERCE CENTER DR SUITE 220  
 COLORADO SPRINGS CO 80919  
 PHONE: 719.300.4140 TOLL FREE: 800.728.7805  
 FAX: 844.273.1057 | HRGreen.com

**THE COTTAGES AT MESA RIDGE**  
 GOODWIN KNIGHT  
 EL PASO COUNTY, COLORADO

PRELIMINARY DRAINAGE REPORT  
 EXISTING DRAINAGE MAP

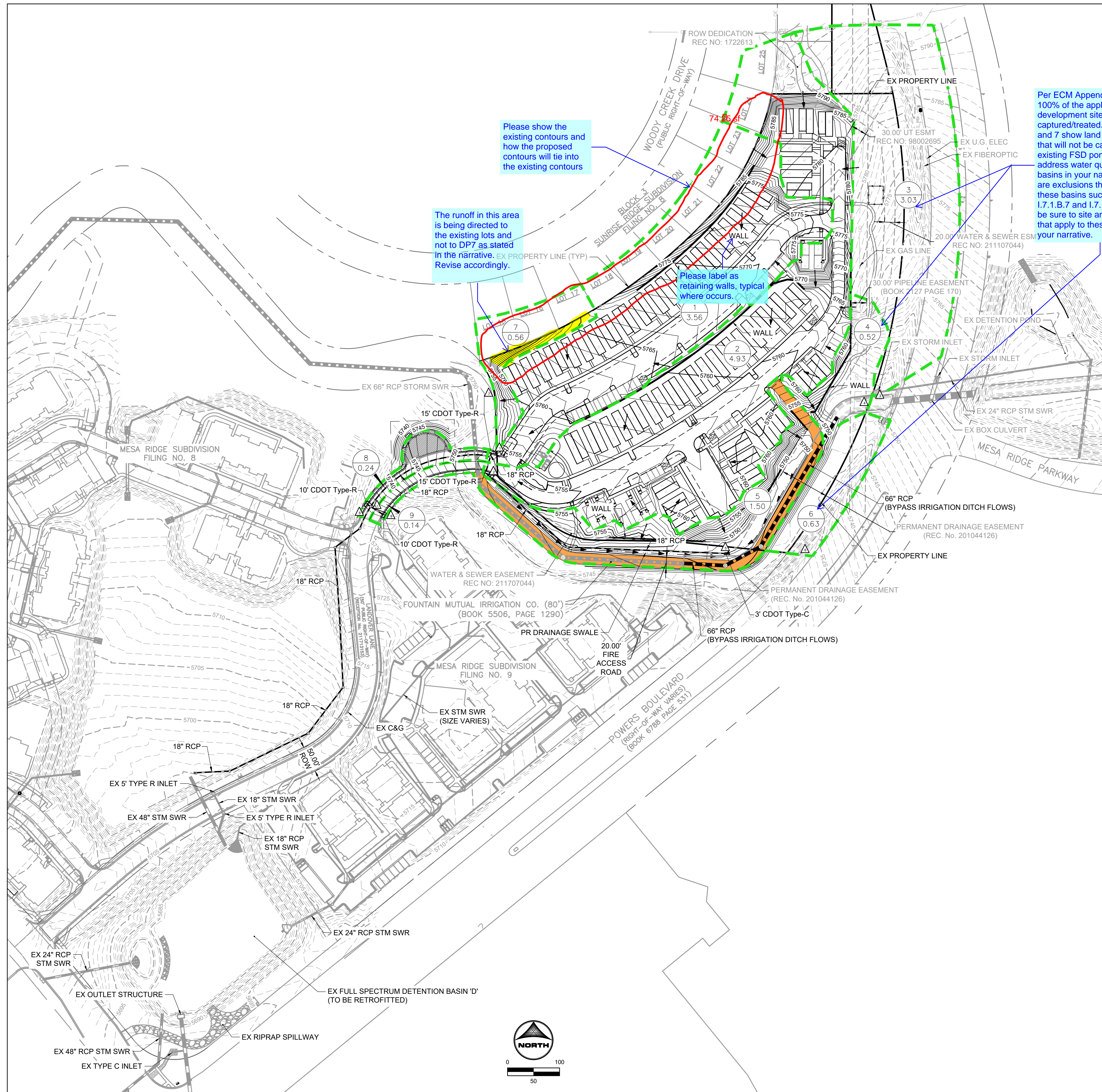

**LEGEND:**

- PROPOSED MAJOR CONTOUR ——— 5250 ———
- PROPOSED MINOR CONTOUR - - - - - 5250 - - - - -
- EXISTING MAJOR CONTOUR - - - - - 5250 - - - - -
- EXISTING MINOR CONTOUR - - - - - 5250 - - - - -
- PROPOSED STORM DRAIN PIPE ———
- EXISTING STORM DRAIN PIPE - - - - -
- PROPOSED DRAINAGE SWALE ———
- PROPERTY LINE ———
- PROPOSED FLOW DIRECTION ———
- EXISTING FLOW DIRECTION - - - - -
- SUB BASIN LINE - - - - -
- DESIGN POINT ———
- PROPOSED BASIN LABEL (11) ———
- BASIN DESIGNATION (1.25) ———
- AREA (AC.) ———

Per ECM Appendix I.7.1.C.1., 100% of the applicable development site shall be captured/treated. Basins 3, 4, 6, and 7 show land disturbance that will not be captured by the existing FSD pond. Please address water quality for these basins in your narrative. There are exclusions that may apply to these basins such as ECM I.7.1.B.7 and I.7.1.B.9. Please be sure to site any exclusions that apply to these basins in your narrative.

Please show the existing contours and how the proposed contours will tie into the existing contours

The runoff in this area is being directed to the existing lots and not to DP7 as stated in the narrative. Revise accordingly.

Please label as retaining walls, typical where occurs.

**SUMMARY RUNOFF TABLE**

BASIN	AREA (ac)	% IMPERVIOUS	Q <sub>5</sub> (cfs)	Q <sub>100</sub> (cfs)
1	3.56	63	7.6	16.1
2	4.93	59	9.5	20.3
3	3.03	29	3.4	9.7
4	0.52	8	0.4	1.8
5	1.50	32	2.1	5.7
6	0.63	2	0.2	1.2
7	0.56	26	0.5	1.6
8	0.24	100	1.1	2.0
9	0.14	100	0.7	1.2

**DESIGN POINT SUMMARY TABLE**

DESIGN POINT	UPSTREAM BASIN	ΣQ <sub>5</sub> (cfs)	ΣQ <sub>100</sub> (cfs)
1	1	7.6	16.1
2	2	9.5	20.3
2.1	3	15.6	29.9
3	4	3.4	9.7
4	5	0.4	1.8
5	5	2.1	5.7
6	6	0.2	1.2
7	7	0.5	1.6
8	8	1.1	2.0
9	9	1.1	1.2
9.1	8&9	17.1	39.6

Please locate the design point on the plan.

NO.	DATE	BY	REVISION DESCRIPTION