

SP06 PROFILE
STA 1+00.00 TO 7+77.62

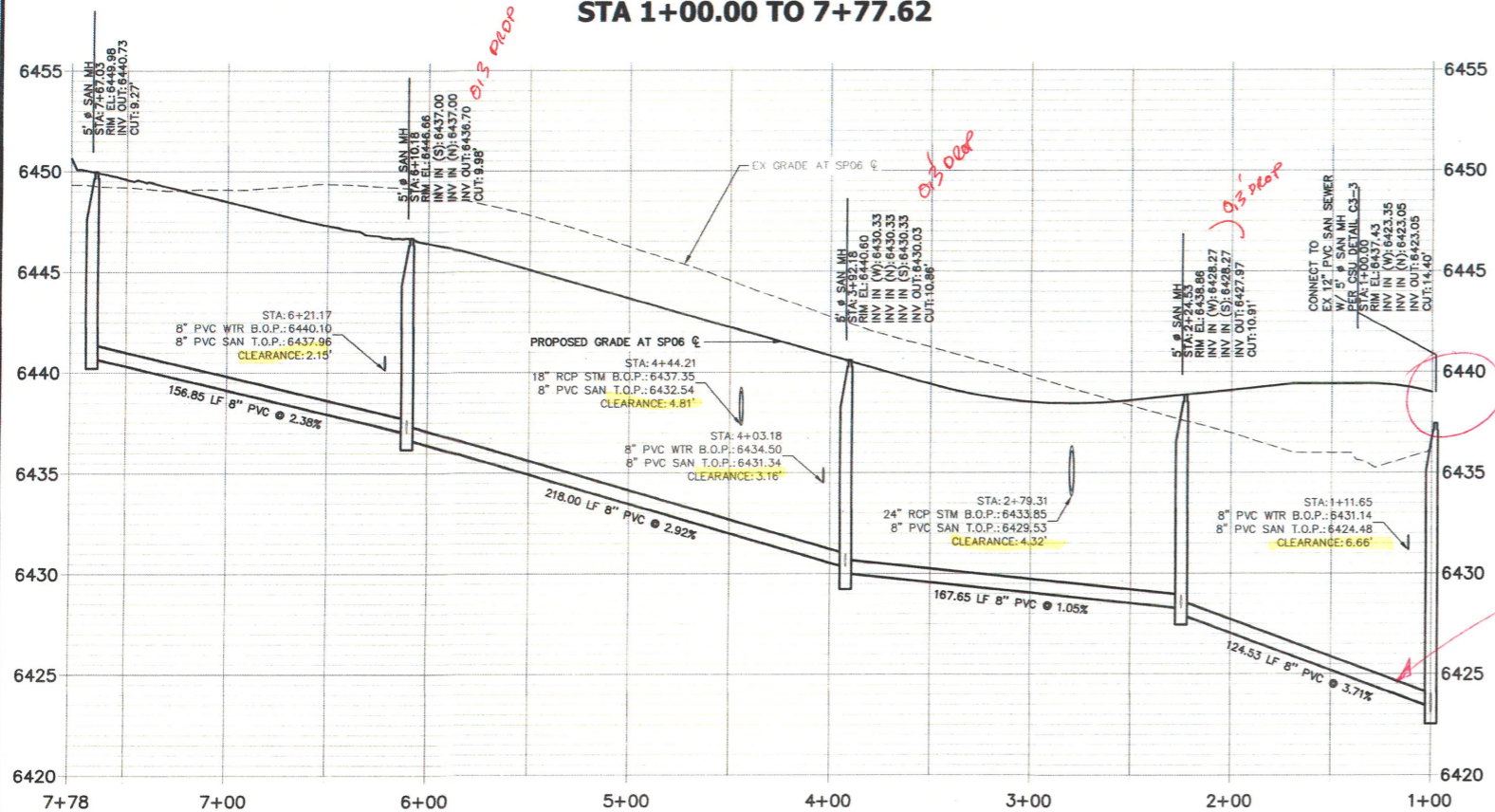

SP07 PROFILE
STA 1+00.00 TO 2+81.50

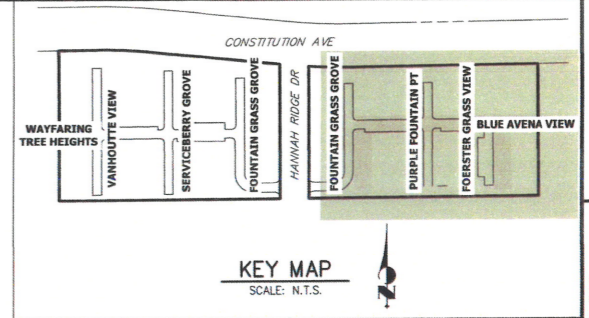
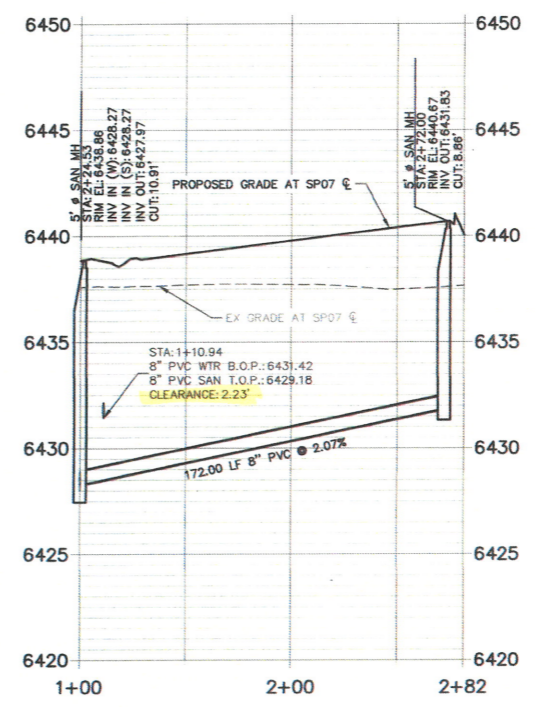

NOTES:

1. ALL PROPOSED SANITARY SEWER ON THESE PLANS IS PUBLIC, UNLESS OTHERWISE NOTED.
2. SEE PROFILE VIEW FOR PIPE SLOPES AND GRADE.
3. SEE PROFILE VIEW FOR MANHOLE RIM ELEVATIONS AND INVERT ELEVATIONS.
4. SEE JR POTABLE WATER PLANS FOR WATER DESIGN AND DETAILS.
5. SEE JR UTILITY SERVICE PLANS FOR WATER AND SANITARY SEWER SERVICE CONNECTIONS.
6. SEE JR STREET, STORM, AND GESC PLANS FOR SURFACE IMPROVEMENTS, GRADING, AND STORM WATER SYSTEM DESIGNS.
7. ALL PIPES SHALL BE SDR-35, EXCEPT AS NOTED.
8. CONTRACTOR TO REMOVE THE EXISTING SECTION OF 8" SANITARY SEWER THAT IS STUBBED ONTO THE SITE (WEST SIDE).

ENGINEER'S STATEMENT

PREPARED UNDER MY DIRECT SUPERVISION AND ON BEHALF OF JR ENGINEERING
 GLENN D. ELLIS, P.E.
 COLORADO P.E. 38861
 FOR AND ON BEHALF OF JR ENGINEERING, LLC



UNTIL SUCH TIME AS THESE DRAWINGS ARE APPROVED BY THE AGENCIES: JR ENGINEERING ONLY FOR THE PURPOSES DESIGNATED BY WRITTEN AUTHORIZATION. PREPARED FOR MDC HOLDINGS RICHMOND AMERICAN HOMES 4350 S. MONACO STREET DENVER, CO 80237 ATTN: JASON POCK 720-977-3827	
J.R. ENGINEERING A Western Company Centennial 303-740-9888 • Colorado Springs 719-592-2588 Fort Collins 970-491-9888 • www.jrengineering.com	
BY	DATE
No.	REVISION
H-SCALE	1"=40'
V-SCALE	1"=4'
DATE	10-30-20
DESIGNED BY	APL
DRAWN BY	APL
CHECKED BY	
URBAN COLLECTION AT PALMER VILLAGE SANITARY SEWER PLAN & PROFILE WASTEWATER CONSTRUCTION PLAN	
SHEET	5 OF 8
JOB NO.	25149.01

THE LOCATIONS OF EXISTING ABOVE GROUND AND UNDERGROUND UTILITIES ARE SHOWN IN AN APPROXIMATE WAY ONLY. THE CONTRACTOR SHALL DETERMINE THE EXACT LOCATION OF ALL EXISTING UTILITIES BEFORE COMMENCING WORK. THE CONTRACTOR SHALL BE FULLY RESPONSIBLE FOR ANY AND ALL DAMAGES WHICH MIGHT BE CAUSED BY HIS FAILURE TO EXACTLY LOCATE AND PRESERVE ANY AND ALL ABOVE GROUND AND UNDERGROUND UTILITIES.

EXTENT MH TO 1 TO GRADE
 PIPE COVER EXCEEDS 14' - USE SDR-26 PIPE FOR 125' LENGTH JLM/CMD

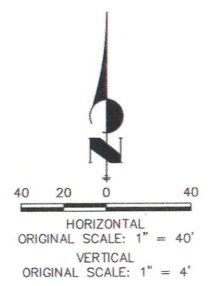

UNTIL SUCH TIME AS THESE DRAWINGS ARE APPROVED BY THE APPROPRIATE REVIEWING AGENCIES, JR ENGINEERING APPROVES THEIR USES DESIGNATED BY WRITTEN AUTHORIZATION.

PREPARED FOR
MDC HOLDINGS
 RICHMOND AMERICAN HOMES
 4350 S. MONACO STREET
 DENVER, CO 80237
 ATTN: JASON POCK
 720-977-3827

J.R. ENGINEERING
 A Wastwin Company
 Centennial 303-740-9888 • Colorado Springs 719-566-2688
 Fort Collins 970-491-9888 • www.jrengineering.com

DATE		BY		NO.	REVISION	H-SCALE	N/A	V-SCALE	N/A	DATE	DESIGNED BY	DRAWN BY	CHECKED BY
										10-30-20	APL	APL	

URBAN COLLECTION AT PALMER VILLAGE
 DETAILS
 WASTEWATER CONSTRUCTION PLAN

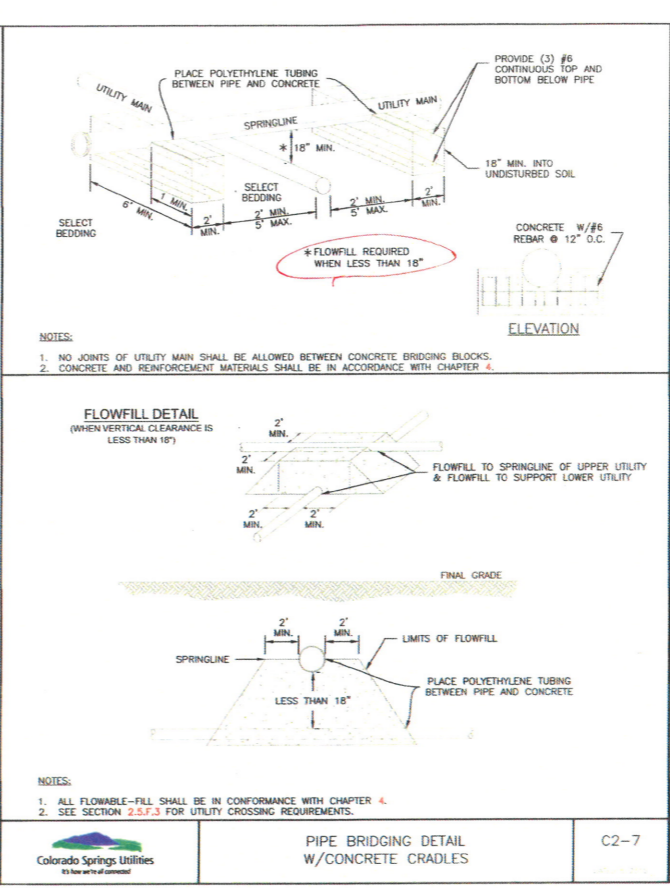
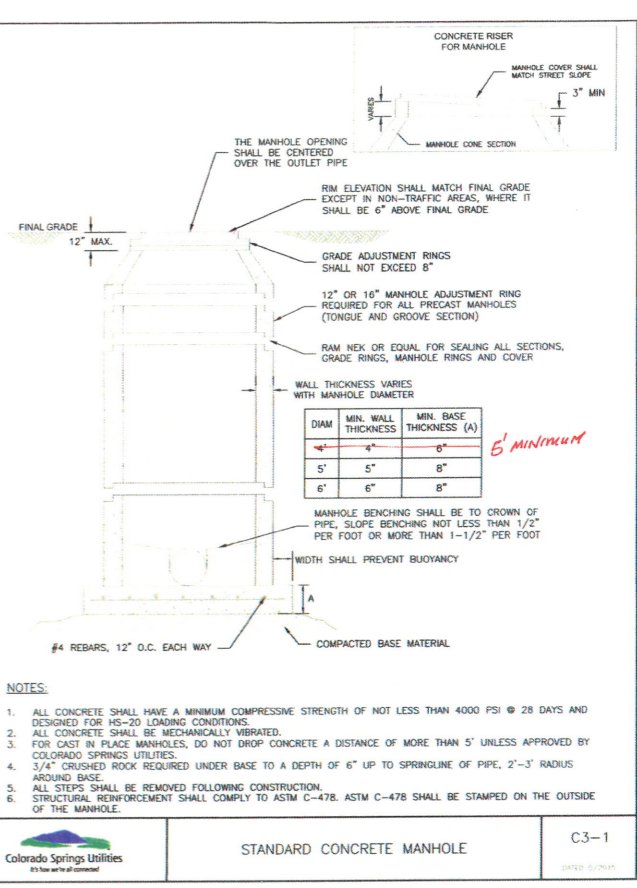

MINIMUM RADIUS FOR DIP AND PVC PIPE

PIPE SIZE AND MATERIAL	ALLOWABLE DEFLECTION	20'	18'	16'	14'	12'	10'	8'	6'	4'
4" - 12" DIP	4'00"	286'	258'	229'	200'	172'	143'	115'	100'	100'
14" - 16" DIP	3'12"	358'	322'	287'	251'	215'	179'	143'	107'	100'
18" - 36" DIP	2'24"	477'	430'	382'	334'	286'	238'	191'	143'	100'
4" - 36" SDR 35 PVC	3'00"	382'	344'	306'	267'	230'	191'	153'	115'	100'

NOTES:

- COLORADO SPRINGS UTILITIES USES A 1.25 SAFETY FACTOR FOR DIP SLIP JOINT DEFLECTION FROM THE MANUFACTURER'S ALLOWABLE DEFLECTION.
- SDR 35 PVC SHALL NOT BE DEFLECTED WITHOUT THE USE OF FABRICATED 3" BENDS.
- MINIMUM RADIUS FOR DIP AND SDR 35 PVC SHALL BE 100'.

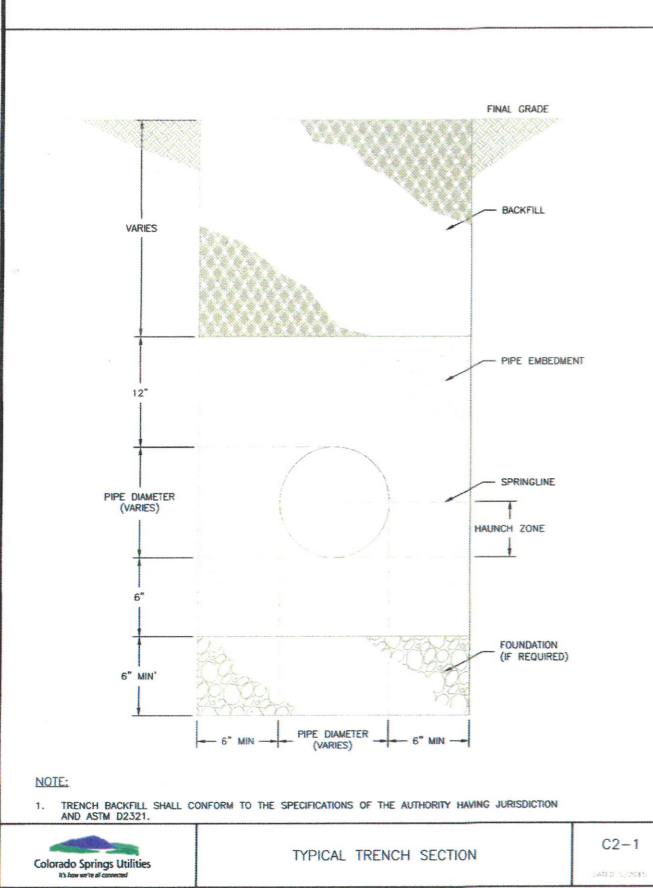

TYPICAL TRENCH SECTION C2-1

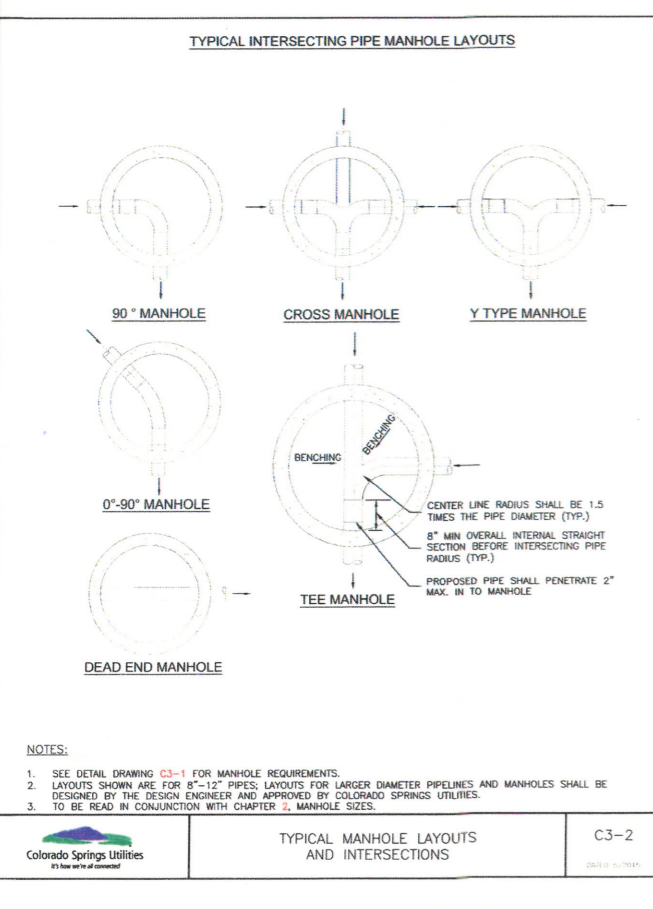
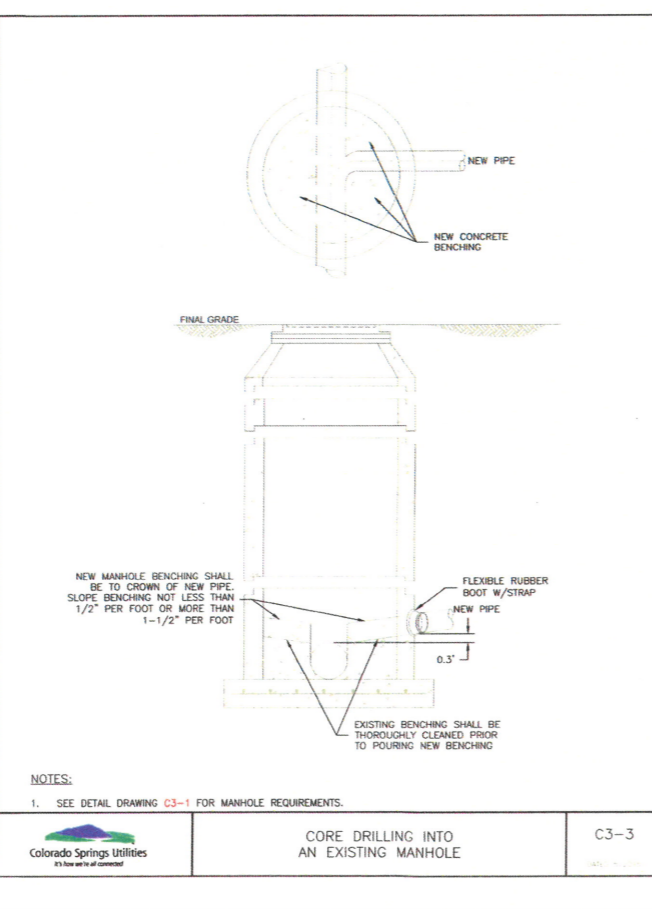
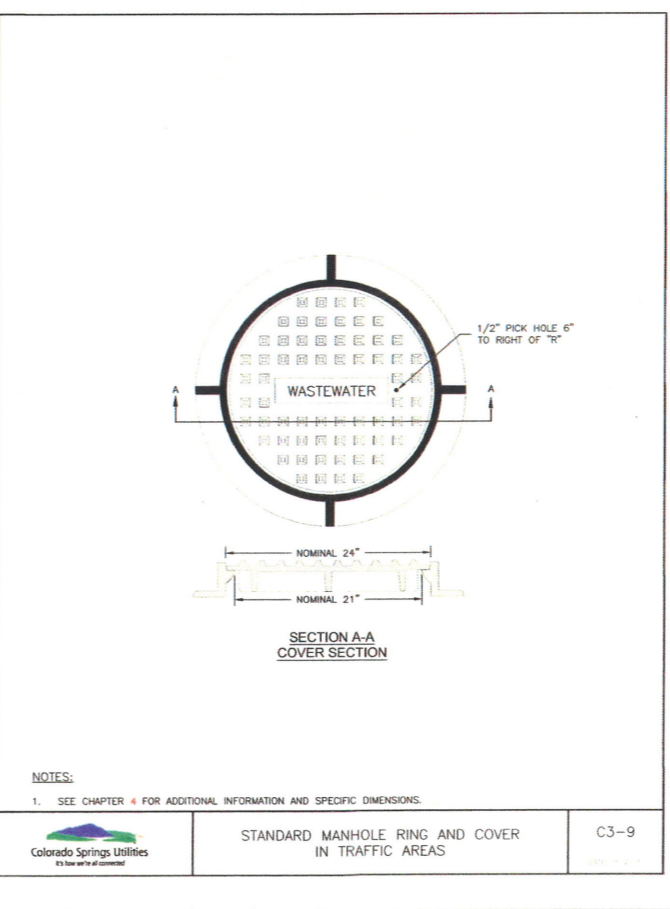
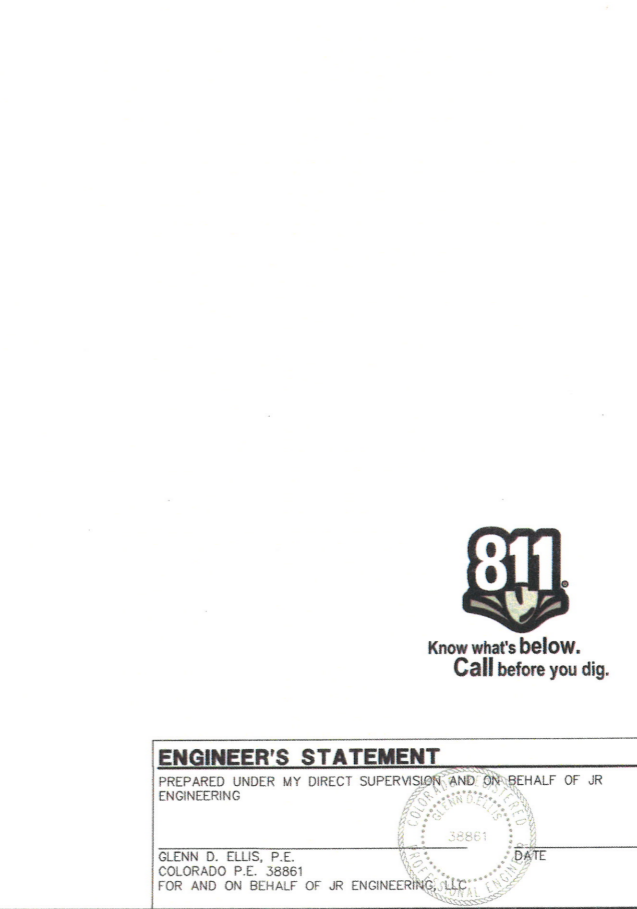

TYPICAL MANHOLE LAYOUTS AND INTERSECTIONS C3-2

ENGINEER'S STATEMENT

PREPARED UNDER MY DIRECT SUPERVISION AND ON BEHALF OF JR ENGINEERING

GLENN D. ELLIS, P.E.
 COLORADO P.E. 38861
 FOR AND ON BEHALF OF JR ENGINEERING, LLC

DATE



TYPICAL INTERSECTING PIPE MANHOLE LAYOUTS C3-2

CORE DRILLING INTO AN EXISTING MANHOLE C3-3

STANDARD MANHOLE RING AND COVER IN TRAFFIC AREAS C3-9

TYPICAL MANHOLE LAYOUTS AND INTERSECTIONS C3-2

CORE DRILLING INTO AN EXISTING MANHOLE C3-3

STANDARD MANHOLE RING AND COVER IN TRAFFIC AREAS C3-9

TYPICAL TRENCH SECTION C2-1

MINIMUM RADIUS FOR DIP AND PVC PIPE C2-2

PIPE BRIDGING DETAIL W/CONCRETE CRADLES C2-7

STANDARD CONCRETE MANHOLE C3-1

TYPICAL MANHOLE LAYOUTS AND INTERSECTIONS C3-2

CORE DRILLING INTO AN EXISTING MANHOLE C3-3

STANDARD MANHOLE RING AND COVER IN TRAFFIC AREAS C3-9

STANDARD CONCRETE MANHOLE C3-1

TYPICAL TRENCH SECTION C2-1

MINIMUM RADIUS FOR DIP AND PVC PIPE C2-2

PIPE BRIDGING DETAIL W/CONCRETE CRADLES C2-7

STANDARD CONCRETE MANHOLE C3-1

TYPICAL MANHOLE LAYOUTS AND INTERSECTIONS C3-2

CORE DRILLING INTO AN EXISTING MANHOLE C3-3

STANDARD MANHOLE RING AND COVER IN TRAFFIC AREAS C3-9

STANDARD CONCRETE MANHOLE C3-1

TYPICAL TRENCH SECTION C2-1

MINIMUM RADIUS FOR DIP AND PVC PIPE C2-2

PIPE BRIDGING DETAIL W/CONCRETE CRADLES C2-7

STANDARD CONCRETE MANHOLE C3-1

TYPICAL MANHOLE LAYOUTS AND INTERSECTIONS C3-2

CORE DRILLING INTO AN EXISTING MANHOLE C3-3

STANDARD MANHOLE RING AND COVER IN TRAFFIC AREAS C3-9

STANDARD CONCRETE MANHOLE C3-1

TYPICAL TRENCH SECTION C2-1

MINIMUM RADIUS FOR DIP AND PVC PIPE C2-2

PIPE BRIDGING DETAIL W/CONCRETE CRADLES C2-7

STANDARD CONCRETE MANHOLE C3-1

TYPICAL MANHOLE LAYOUTS AND INTERSECTIONS C3-2

CORE DRILLING INTO AN EXISTING MANHOLE C3-3

STANDARD MANHOLE RING AND COVER IN TRAFFIC AREAS C3-9

STANDARD CONCRETE MANHOLE C3-1

TYPICAL TRENCH SECTION C2-1

MINIMUM RADIUS FOR DIP AND PVC PIPE C2-2

PIPE BRIDGING DETAIL W/CONCRETE CRADLES C2-7

STANDARD CONCRETE MANHOLE C3-1

TYPICAL MANHOLE LAYOUTS AND INTERSECTIONS C3-2

CORE DRILLING INTO AN EXISTING MANHOLE C3-3

STANDARD MANHOLE RING AND COVER IN TRAFFIC AREAS C3-9

STANDARD CONCRETE MANHOLE C3-1

TYPICAL TRENCH SECTION C2-1

MINIMUM RADIUS FOR DIP AND PVC PIPE C2-2

PIPE BRIDGING DETAIL W/CONCRETE CRADLES C2-7

STANDARD CONCRETE MANHOLE C3-1

TYPICAL MANHOLE LAYOUTS AND INTERSECTIONS C3-2

CORE DRILLING INTO AN EXISTING MANHOLE C3-3

STANDARD MANHOLE RING AND COVER IN TRAFFIC AREAS C3-9

STANDARD CONCRETE MANHOLE C3-1

TYPICAL TRENCH SECTION C2-1

MINIMUM RADIUS FOR DIP AND PVC PIPE C2-2

PIPE BRIDGING DETAIL W/CONCRETE CRADLES C2-7

STANDARD CONCRETE MANHOLE C3-1

TYPICAL MANHOLE LAYOUTS AND INTERSECTIONS C3-2

CORE DRILLING INTO AN EXISTING MANHOLE C3-3

STANDARD MANHOLE RING AND COVER IN TRAFFIC AREAS C3-9

STANDARD CONCRETE MANHOLE C3-1

TYPICAL TRENCH SECTION C2-1

MINIMUM RADIUS FOR DIP AND PVC PIPE C2-2

PIPE BRIDGING DETAIL W/CONCRETE CRADLES C2-7

STANDARD CONCRETE MANHOLE C3-1

TYPICAL MANHOLE LAYOUTS AND INTERSECTIONS C3-2

CORE DRILLING INTO AN EXISTING MANHOLE C3-3

STANDARD MANHOLE RING AND COVER IN TRAFFIC AREAS C3-9

STANDARD CONCRETE MANHOLE C3-1

TYPICAL TRENCH SECTION C2-1

MINIMUM RADIUS FOR DIP AND PVC PIPE C2-2

PIPE BRIDGING DETAIL W/CONCRETE CRADLES C2-7

STANDARD CONCRETE MANHOLE C3-1

TYPICAL MANHOLE LAYOUTS AND INTERSECTIONS C3-2

CORE DRILLING INTO AN EXISTING MANHOLE C3-3

STANDARD MANHOLE RING AND COVER IN TRAFFIC AREAS C3-9

STANDARD CONCRETE MANHOLE C3-1

TYPICAL TRENCH SECTION C2-1

MINIMUM RADIUS FOR DIP AND PVC PIPE C2-2

PIPE BRIDGING DETAIL W/CONCRETE CRADLES C2-7

STANDARD CONCRETE MANHOLE C3-1

TYPICAL MANHOLE LAYOUTS AND INTERSECTIONS C3-2

CORE DRILLING INTO AN EXISTING MANHOLE C3-3

STANDARD MANHOLE RING AND COVER IN TRAFFIC AREAS C3-9

STANDARD CONCRETE MANHOLE C3-1

TYPICAL TRENCH SECTION C2-1

MINIMUM RADIUS FOR DIP AND PVC PIPE C2-2

PIPE BRIDGING DETAIL W/CONCRETE CRADLES C2-7

STANDARD CONCRETE MANHOLE C3-1

TYPICAL MANHOLE LAYOUTS AND INTERSECTIONS C3-2

CORE DRILLING INTO AN EXISTING MANHOLE C3-3

STANDARD MANHOLE RING AND COVER IN TRAFFIC AREAS C3-9

STANDARD CONCRETE MANHOLE C3-1

TYPICAL TRENCH SECTION C2-1

MINIMUM RADIUS FOR DIP AND PVC PIPE C2-2

PIPE BRIDGING DETAIL W/CONCRETE CRADLES C2-7

STANDARD CONCRETE MANHOLE C3-1

TYPICAL MANHOLE LAYOUTS AND INTERSECTIONS C3-2

CORE DRILLING INTO AN EXISTING MANHOLE C3-3

STANDARD MANHOLE RING AND COVER IN TRAFFIC AREAS C3-9

STANDARD CONCRETE MANHOLE C3-1

TYPICAL TRENCH SECTION C2-1

MINIMUM RADIUS FOR DIP AND PVC PIPE C2-2

PIPE BRIDGING DETAIL W/CONCRETE CRADLES C2-7

STANDARD CONCRETE MANHOLE C3-1

TYPICAL MANHOLE LAYOUTS AND INTERSECTIONS C3-2

CORE DRILLING INTO AN EXISTING MANHOLE C3-3

STANDARD MANHOLE RING AND COVER IN TRAFFIC AREAS C3-9

STANDARD CONCRETE MANHOLE C3-1

TYPICAL TRENCH SECTION C2-1

MINIMUM RADIUS FOR DIP AND PVC PIPE C2-2

PIPE BRIDGING DETAIL W/CONCRETE CRADLES C2-7

STANDARD CONCRETE MANHOLE C3-1

TYPICAL MANHOLE LAYOUTS AND INTERSECTIONS C3-2

CORE DRILLING INTO AN EXISTING MANHOLE C3-3

STANDARD MANHOLE RING AND COVER IN TRAFFIC AREAS C3-9

STANDARD CONCRETE MANHOLE C3-1

TYPICAL TRENCH SECTION C2-1

MINIMUM RADIUS FOR DIP AND PVC PIPE C2-2

PIPE BRIDGING DETAIL W/CONCRETE CRADLES C2-7

STANDARD CONCRETE MANHOLE C3-1

TYPICAL MANHOLE LAYOUTS AND INTERSECTIONS C3-2

CORE DRILLING INTO AN EXISTING MANHOLE C3-3

STANDARD MANHOLE RING AND COVER IN TRAFFIC AREAS C3-9

STANDARD CONCRETE MANHOLE C3-1

TYPICAL TRENCH SECTION C2-1

MINIMUM RADIUS FOR DIP AND PVC PIPE C2-2

PIPE BRIDGING DETAIL W/CONCRETE CRADLES C2-7

STANDARD CONCRETE MANHOLE C3-1

TYPICAL MANHOLE LAYOUTS AND INTERSECTIONS C3-2

CORE DRILLING INTO AN EXISTING MANHOLE C3-3

STANDARD MANHOLE RING AND COVER IN TRAFFIC AREAS C3-9

STANDARD CONCRETE MANHOLE C3-1

TYPICAL TRENCH SECTION C2-1

MINIMUM RADIUS FOR DIP AND PVC PIPE C2-2

PIPE BRIDGING DETAIL W/CONCRETE CRADLES C2-7

STANDARD CONCRETE MANHOLE C3-1

TYPICAL MANHOLE LAYOUTS AND INTERSECTIONS C3-2

CORE DRILLING INTO AN EXISTING MANHOLE C3-3

STANDARD MANHOLE RING AND COVER IN TRAFFIC AREAS C3-9

STANDARD CONCRETE MANHOLE C3-1

TYPICAL TRENCH SECTION C2-1

MINIMUM RADIUS FOR DIP AND PVC PIPE C2-2

PIPE BRIDGING DETAIL W/CONCRETE CRADLES C2-7

STANDARD CONCRETE MANHOLE C3-1

TYPICAL MANHOLE LAYOUTS AND INTERSECTIONS C3-2

CORE DRILLING INTO AN EXISTING MANHOLE C3-3

STANDARD MANHOLE RING AND COVER IN TRAFFIC AREAS C3-9

STANDARD CONCRETE MANHOLE C3-1

TYPICAL TRENCH SECTION C2-1

MINIMUM RADIUS FOR DIP AND PVC PIPE C2-2

PIPE BRIDGING DETAIL W/CONCRETE CRADLES C2-7

STANDARD CONCRETE MANHOLE C3-1

TYPICAL MANHOLE LAYOUTS AND INTERSECTIONS C3-2

CORE DRILLING INTO AN EXISTING MANHOLE C3-3

STANDARD MANHOLE RING AND COVER IN TRAFFIC AREAS C3-9

STANDARD CONCRETE MANHOLE C3-1

TYPICAL TRENCH SECTION C2-1

MINIMUM RADIUS FOR DIP AND PVC PIPE C2-2

PIPE BRIDGING DETAIL W/CONCRETE CRADLES C2-7

STANDARD CONCRETE MANHOLE C3-1

TYPICAL MANHOLE LAYOUTS AND INTERSECTIONS C3-2

CORE DRILLING INTO AN EXISTING MANHOLE C3-3

STANDARD MANHOLE RING AND COVER IN TRAFFIC AREAS C3-9

STANDARD CONCRETE MANHOLE C3-1

TYPICAL TRENCH SECTION C2-1

MINIMUM RADIUS FOR DIP AND PVC PIPE C2-2

PIPE BRIDGING DETAIL W/CONCRETE CRADLES C2-7