

# URBAN COLLECTION AT PALMER VILLAGE

SITUATED IN THE NORTHEAST QUARTER OF SECTION 5,  
TOWNSHIP 14 SOUTH, RANGE 65 WEST OF THE SIXTH PRINCIPAL MERIDIAN,  
COUNTY OF EL PASO, STATE OF COLORADO.

## KNOWN ALL MEN BY THESE PRESENTS:

FEATHERGRASS INVESTMENTS LLC, A COLORADO LIMITED LIABILITY COMPANY, BEING THE OWNER OF THE FOLLOWING DESCRIBED TRACT OF LAND, TO WIT:

## LEGAL DESCRIPTION

TWO (2) PARCELS OF LAND SITUATED IN THE NORTHEAST QUARTER OF SECTION 5, TOWNSHIP 14 SOUTH, RANGE 65 WEST OF THE 6TH PRINCIPAL MERIDIAN, COUNTY OF EL PASO, STATE OF COLORADO, MORE PARTICULARLY DESCRIBED AS FOLLOWS:

### PARCEL I:

**BEGINNING** AT THE NORTH QUARTER CORNER OF SAID SECTION 5, SAID CORNER BEING ON THE SOUTHERLY RIGHT-OF-WAY OF CONSTITUTION AVENUE AS DESCRIBED IN "CONSTITUTION AVENUE / PETERSON ROAD RIGHT-OF-WAY", RECORDED IN PLAT BOOK V-3 AT PAGE 169 OF THE RECORDS OF SAID COUNTY, WHENCE THE NORTH LINE OF THE NORTHWEST QUARTER OF THE NORTHEAST QUARTER OF SAID SECTION 5 BEARS NORTH 89°09'25" EAST, A DISTANCE OF 1,321.85 FEET, ALL BEARINGS HEREON ARE REFERENCED THERETO;

THENCE ALONG SAID SOUTHERLY RIGHT-OF-WAY THE FOLLOWING THREE (3) COURSES:

- NORTH 89°10'23" EAST, A DISTANCE OF 107.89 FEET TO THE BEGINNING OF A TANGENT CURVE CONCAVE SOUTHERLY HAVING A RADIUS OF 1,310.93 FEET;
- EASTERLY ALONG SAID CURVE THROUGH A CENTRAL ANGLE OF 06°04'26", AN ARC LENGTH OF 138.97 FEET;
- SOUTH 84°34'51" EAST, A DISTANCE OF 364.70 FEET TO THE WESTERLY RIGHT OF WAY OF HANNAH RIDGE DRIVE, AN 80 FOOT RIGHT OF WAY AS SHOWN ON JESSICA HEIGHTS FILING NO .1 AS RECORDED UNDER RECEPTION NO. 206712249 OF THE RECORDS OF SAID COUNTY;

THENCE ALONG SAID WESTERLY RIGHT-OF-WAY, SOUTH 00°24'28" EAST, A DISTANCE OF 371.32 FEET TO THE NORTHEAST CORNER OF LOT 26 OF SAID JESSICA HEIGHTS FILING NO. 1;

THENCE ALONG THE NORTHERLY LINES OF LOTS 26, 25, 24, 15, 14, AND 13 OF SAID JESSICA HEIGHTS FILING NO. 1, SOUTH 89°35'45" WEST, A DISTANCE OF 609.46 FEET TO THE NORTHWEST CORNER OF SAID LOT 13, SAID CORNER ALSO BEING ON THE WEST LINE OF SAID NORTHEAST QUARTER OF SECTION 5;

THENCE ALONG SAID WEST LINE, NORTH 00°24'28" WEST, A DISTANCE OF 413.87 FEET TO THE **POINT OF BEGINNING**.

CONTAINING AN AREA OF 5.588 ACRES, (243,396 SQUARE FEET), MORE OR LESS.

### PARCEL II:

**COMMENCING** AT THE NORTH QUARTER CORNER OF SAID SECTION 5, SAID CORNER BEING ON THE SOUTHERLY RIGHT-OF-WAY OF CONSTITUTION AVENUE AS DESCRIBED IN "CONSTITUTION AVENUE / PETERSON ROAD RIGHT-OF-WAY", RECORDED IN PLAT BOOK V-3 AT PAGE 169 OF THE RECORDS OF SAID COUNTY, WHENCE THE NORTH LINE OF THE NORTHWEST QUARTER OF THE NORTHEAST QUARTER OF SAID SECTION 5 BEARS NORTH 89°09'25" EAST, A DISTANCE OF 1,321.85 FEET, ALL BEARINGS HEREON ARE REFERENCED THERETO;

THENCE ALONG SAID NORTH LINE NORTH 89°09'25" EAST, A DISTANCE OF 1,321.85 FEET;

THENCE SOUTH 00°27'24" EAST, A DISTANCE OF 60.00 FEET TO THE SOUTHERLY RIGHT-OF-WAY OF SAID CONSTITUTION AVENUE, AND **THE POINT OF BEGINNING**;

THENCE ALONG SAID SOUTHERLY RIGHT-OF-WAY, NORTH 89°09'18" EAST, A DISTANCE OF 1,165.85 FEET;

THENCE DEPARTING SAID SOUTHERLY RIGHT-OF-WAY, SOUTH 51°33'54" EAST, A DISTANCE OF 46.42 FEET;

THENCE SOUTH 29°19'15" EAST, A DISTANCE OF 62.27 FEET;

THENCE SOUTH 00°40'54" EAST, A DISTANCE OF 350.88 FEET;

THENCE SOUTH 89°09'18" WEST, A DISTANCE OF 1,233.42 FEET;

THENCE NORTH 00°27'24" WEST, A DISTANCE OF 71.02 FEET TO THE NORTHEAST CORNER OF LOT 85, JESSICA HEIGHTS FILING NO. 1, RECORDED AT RECEPTION NO. 206712249 IN SAID RECORDS;

THENCE ALONG THE NORTHERLY LINE OF LOTS 85, 86, 87, 96, 97, 98 OF SAID JESSICA HEIGHTS, SOUTH 89°35'45" WEST, A DISTANCE OF 632.71 FEET TO THE EASTERLY RIGHT-OF-WAY OF HANNAH RIDGE DRIVE, AS SHOWN ON JESSICA HEIGHTS FILING NO. 1;

THENCE ALONG SAID EASTERLY RIGHT-OF-WAY, NORTH 00°24'28" WEST, A DISTANCE OF 363.75 FEET TO SAID SOUTHERLY RIGHT-OF-WAY OF CONSTITUTION AVENUE AND THE BEGINNING OF A NON-TANGENT CURVE CONCAVE NORTHERLY HAVING A RADIUS OF 1,430.93 FEET, THE RADIUS POINT OF SAID CURVE BEARS NORTH 03°45'42" EAST;

THENCE ALONG SAID SOUTHERLY RIGHT-OF-WAY THE FOLLOWING TWO (2) COURSES:

- EASTERLY ALONG SAID CURVE THROUGH A CENTRAL ANGLE OF 04°20'25", AN ARC LENGTH OF 108.40 FEET;
- NORTH 89°09'25" EAST, A DISTANCE OF 524.11 FEET TO **THE POINT OF BEGINNING**.

CONTAINING AN AREA OF 17.512 ACRES, (762,829 SQUARE FEET), MORE OR LESS.

## DEDICATION:

THE ABOVE OWNER HAS CAUSED SAID LAND TO BE SURVEYED AND PLATTED INTO LOTS, EASEMENTS, AND STREETS AS SHOWN ON THE ACCOMPANYING PLAT, WHICH PLAT IS DRAWN TO A FIXED SCALE AS INDICATED AND ACCURATELY SETS FORTH THE BOUNDARIES AND DIMENSIONS OF SAID PLAT AND THE LOCATION OF SAID EASEMENTS AS PLATTED ARE HEREBY DEDICATED TO PUBLIC USE AND SAID OWNER DOES HEREBY COVENANT AND AGREE THAT ALL PLATTED STREETS WILL BE CONSTRUCTED AND THAT PROPER DRAINAGE FOR THE SAME WILL BE PROVIDED AT THE OWNER(S) EXPENSE, ALL TO THE SATISFACTION OF THE BOARD OF COUNTY COMMISSIONERS OF EL PASO COUNTY, COLORADO. THIS TRACT SO PLATTED SHALL BE KNOWN AS "URBAN COLLECTION AT PALMER VILLAGE", EL PASO COUNTY, COLORADO.

## EASEMENTS:

1. UNLESS OTHERWISE INDICATED, ALL SIDE, FRONT, AND REAR LOT LINES ARE HEREBY PLATTED ON EITHER SIDE WITH A 5 FOOT PUBLIC UTILITY AND DRAINAGE EASEMENT, EXCEPT FOR THE SHARED COMMON LOT LINE BETWEEN RESIDENTIAL LOTS. ALL EXTERIOR SUBDIVISION BOUNDARIES ARE HEREBY PLATTED WITH A 7 FOOT PUBLIC UTILITY AND DRAINAGE EASEMENT. THE SOLE RESPONSIBILITY FOR MAINTENANCE OF THESE EASEMENTS IS HEREBY VESTED WITH THE INDIVIDUAL PROPERTY OWNERS.

2. ACCESS AND UTILITY EASEMENTS AS DEPICTED HEREIN ARE FOR PUBLIC ACCESS OVER THE PRIVATE STREETS TO THE LOTS AS PLATTED HEREIN.

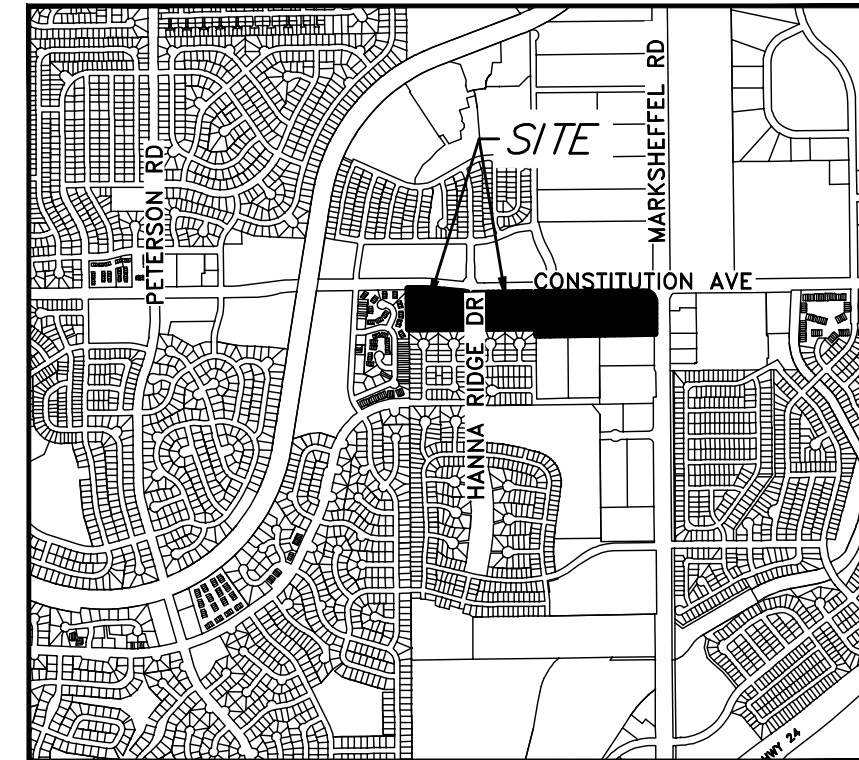

VICINITY MAP  
SCALE: 1"=2000'

## OWNERS CERTIFICATE:

THE UNDERSIGNED, BEING ALL THE OWNERS, MORTGAGEES, BENEFICIARIES OF DEEDS OF TRUST AND HOLDERS OF OTHER INTERESTS IN THE LAND DESCRIBED HEREIN, HAVE LAID OUT, SUBDIVIDED, AND PLATTED SAID LANDS INTO LOTS, TRACTS, STREETS, AND EASEMENTS AS SHOWN HEREON UNDER THE NAME AND SUBDIVISION OF URBAN COLLECTION AT PALMER VILLAGE. THE UTILITY EASEMENTS SHOWN HEREON ARE HEREBY DEDICATED FOR PUBLIC UTILITIES AND COMMUNICATION SYSTEMS AND OTHER PURPOSES AS SHOWN HEREON. THE ENTITIES RESPONSIBLE FOR PROVIDING THE SERVICES FOR WHICH THE EASEMENTS ARE ESTABLISHED ARE HEREBY GRANTED THE PERPETUAL RIGHT OF INGRESS AND EGRESS FROM AND TO ADJACENT PROPERTIES FOR INSTALLATION, MAINTENANCE, AND REPLACEMENT OF UTILITY LINES AND RELATED FACILITIES.

### OWNER:

FEATHERGRASS INVESTMENTS LLC, A COLORADO LIMITED-LIABILITY COMPANY

BY: \_\_\_\_\_

TITLE: \_\_\_\_\_

MY COMMISSION EXPIRES \_\_\_\_\_

WITNESS MY HAND AND OFFICIAL SEAL \_\_\_\_\_  
NOTARY PUBLIC

### APPLICANT:

MDC HOLDING, INC. - RICHMOND AMERICAN HOMES OF COLORADO, INC. A DELAWARE CORPORATION

BY: \_\_\_\_\_

TITLE: \_\_\_\_\_

MY COMMISSION EXPIRES \_\_\_\_\_

WITNESS MY HAND AND OFFICIAL SEAL \_\_\_\_\_  
NOTARY PUBLIC

## ACCEPTANCE CERTIFICATE FOR TRACTS:

THE DEDICATION OF TRACTS B, C, D, E, F, G, H, I, J, K, M, & N, WITH USES STATED IN THE TRACT TABLE, ARE HEREBY ACCEPTED FOR OWNERSHIP AND MAINTENANCE BY THE PALMER VILLAGE DUPLEX OWNERS ASSOCIATION, INC.

BY: \_\_\_\_\_

TITLE: \_\_\_\_\_

OF THE PALMER VILLAGE DUPLEX OWNERS ASSOCIATION, INC..

STATE OF COLORADO )  
 ) SS.  
COUNTY OF EL PASO )

ACKNOWLEDGED BEFORE ME THIS \_\_\_\_\_ DAY OF \_\_\_\_\_, 20\_\_\_\_ BY

\_\_\_\_\_ AS \_\_\_\_\_ OF THE PALMER VILLAGE DUPLEX OWNERS ASSOCIATION, INC.

MY COMMISSION EXPIRES \_\_\_\_\_

WITNESS MY HAND AND OFFICIAL SEAL \_\_\_\_\_  
NOTARY PUBLIC

## NOTE:

THIS PLAT HAS BEEN REVIEWED AND APPROVED BY ENUMERATIONS AS RECORDED AT RECEPTION NUMBER \_\_\_\_\_ IN THE RECORDS OF THE EL PASO COUNTY CLERK AND RECORDER'S OFFICE.

## SHEET INDEX

SHEET 1 - COVER, LEGAL DESCRIPTION, VICINITY MAP  
SHEET 2 - GENERAL NOTES  
SHEET 3 - OVERALL BOUNDARY, TRACT TABLE  
SHEETS 4-7 - DETAIL SHEETS

## SURVEYOR'S CERTIFICATION:

I MICHAEL J. NOFFSINGER, A DULY REGISTERED PROFESSIONAL LAND SURVEYOR IN THE STATE OF COLORADO, DO HEREBY CERTIFY THAT THIS PLAT TRULY AND CORRECTLY REPRESENTS THE RESULTS OF A SURVEY MADE ON DATE OF SURVEY, BY ME OR UNDER MY DIRECT SUPERVISION AND THAT ALL MONUMENTS EXIST AS SHOWN HEREON; THAT MATHEMATICAL CLOSURE ERRORS ARE LESS THAN 1:10,000 ; AND THAT SAID PLAT HAS BEEN PREPARED IN FULL COMPLIANCE WITH ALL APPLICABLE LAWS OF THE STATE OF COLORADO DEALING WITH MONUMENTS, SUBDIVISION, OR SURVEYING OF LAND AND ALL APPLICABLE PROVISIONS OF THE EL PASO COUNTY LAND DEVELOPMENT CODE.

I ATTEST THE ABOVE ON THIS \_\_\_\_\_ DAY OF \_\_\_\_\_, 20\_\_\_\_.

MICHAEL J. NOFFSINGER DATE  
COLORADO REGISTERED PLS #38367

MICHAEL J. NOFFSINGER, COLORADO LICENSED PROFESSIONAL LAND SURVEYOR, P.L.S. 38367  
FOR AND ON BEHALF OF AZTEC CONSULTANTS, INC.  
300 E. MINERAL AVENUE, SUITE 1  
LITTLETON, CO. 80122  
(303) 713-1898

NOTICE: ACCORDING TO COLORADO LAW YOU MUST COMMENCE ANY LEGAL ACTION BASED UPON ANY DEFECT IN THIS SURVEY WITHIN THREE YEARS AFTER YOU FIRST DISCOVER SUCH DEFECT. IN NO EVENT MAY ANY ACTION BASED UPON ANY DEFECT IN THIS SURVEY BE COMMENCED MORE THAN TEN YEARS FROM THE DATE OF THE CERTIFICATION SHOWN HEREON.

NOTICE: PER THE STATE OF COLORADO BOARD OF LICENSURE FOR ARCHITECTS, PROFESSIONAL ENGINEERS, AND PROFESSIONAL LAND SURVEYORS RULE 1.6.B.2 THE WORD "CERTIFY" AS USED HEREON MEANS AN EXPRESSION OF PROFESSIONAL OPINION AND DOES NOT CONSTITUTE A WARRANTY OR GUARANTEE, EXPRESSED OR IMPLIED. THE SURVEY REPRESENTED HEREON HAS BEEN PERFORMED BY ME OR UNDER MY DIRECT SUPERVISION IN ACCORDANCE WITH APPLICABLE STANDARDS OF PRACTICE AND IS BASED UPON MY KNOWLEDGE, INFORMATION AND BELIEF.

## COUNTY APPROVALS:

THIS PLAT FOR URBAN COLLECTION AT PALMER VILLAGE WAS APPROVED FOR FILING BY THE EL PASO COUNTY, COLORADO PLANNING AND COMMUNITY DEVELOPMENT DEPARTMENT DIRECTOR ON THE \_\_\_\_\_ DAY OF \_\_\_\_\_, 20\_\_\_\_. SUBJECT TO ANY NOTES OR CONDITIONS SPECIFIED HEREON.

PLANNING AND COMMUNITY DEVELOPMENT DIRECTOR

## RECORDING:

STATE OF COLORADO )  
 ) SS.  
COUNTY OF EL PASO )

I HEREBY CERTIFY THAT THIS INSTRUMENT WAS FILED FOR RECORD IN MY OFFICE AT

\_\_\_\_\_ O'CLOCK \_\_M., THIS \_\_\_\_\_ DAY OF \_\_\_\_\_, 2021 A.D.,

AND IS DULY RECORDED AT RECEPTION NO. \_\_\_\_\_ OF THE RECORDS OF

EL PASO COUNTY, COLORADO.

CHUCK BROERMAN, RECORDER

SURCHARGE: \_\_\_\_\_

BY: \_\_\_\_\_ DEPUTY

FEE: \_\_\_\_\_

## FEES:

DRAINAGE FEE: \$111,688

BRIDGE FEE: \$45,683

URBAN PARK FEE: \_\_\_\_\_

REGIONAL PARK FEE: \_\_\_\_\_

SCHOOL FEE: \_\_\_\_\_

	300 East Mineral Ave., Suite 1 Littleton, Colorado 80122 Phone: (303) 713-1898 Fax: (303) 713-1897 www.aztecconsultants.com	DEVELOPER RICHMOND AMERICAN HOMES OF COLORADO, INC., A DELAWARE CORP. 4350 S. MONACO ST. DENVER, CO 80237	DATE OF PREPARATION: 03-19-2020
	SCALE:	N/A	SHEET 1 OF 8

LAST REVISED: 07/15/2021

AzTec Proj. No.: 21419-48

Drawn By: CWB

# URBAN COLLECTION AT PALMER VILLAGE

SITUATED IN THE NORTHEAST QUARTER OF SECTION 5,  
TOWNSHIP 14 SOUTH, RANGE 65 WEST OF THE SIXTH PRINCIPAL MERIDIAN,  
COUNTY OF EL PASO, STATE OF COLORADO.

## GENERAL NOTES:

- THE FIELD WORK FOR THIS SURVEY WAS PERFORMED BY AN AZTEC CONSULTANTS, INC. SURVEY CREW ON OCTOBER 02, 2019.
- PER C.R.S. 38-51-106, "ALL LINEAL UNITS DEPICTED ON THIS LAND SURVEY PLAT ARE U.S. SURVEY FEET. ONE METER EQUALS 39.37/12 U.S. SURVEY FEET, EXACTLY ACCORDING TO THE NATIONAL INSTITUTE OF STANDARDS AND TECHNOLOGY."
- BASIS OF BEARINGS:** BEARINGS SHOWN HEREON ARE GRID BEARINGS DERIVED FROM GPS OBSERVATIONS BASED UPON THE COLORADO COORDINATE SYSTEM OF 1983 SOUTH ZONE (NAD 83, 2011), REFERENCED TO THE NORTH LINE OF THE NORTHWEST QUARTER OF THE NORTHEAST QUARTER OF SECTION 5, TOWNSHIP 14 SOUTH, RANGE 65 WEST OF THE 6TH PRINCIPAL MERIDIAN, BEING MONUMENTED AT THE NORTH QUARTER CORNER BY A NO. 6 REBAR WITH 3-1/4" ALUMINUM CAP STAMPED "PLS 30829 SURVCON INC 2003" AND AT THE EAST 1/16TH CORNER BY A 60-FOOT WITNESS CORNER MONUMENTED BY A NO. 6 REBAR WITH NO CAP, TAKEN TO BEAR NORTH 89°09'25" EAST.
- THE SUBJECT PROPERTY SHOWN HEREIN LIES WITHIN ZONE X, AREAS DETERMINED TO BE OUTSIDE THE 500-YEAR FLOODPLAIN, AS SHOWN ON FEDERAL EMERGENCY MANAGEMENT AGENCY FLOOD INSURANCE RATE MAP INDEX NO. 08041C0752F, MAP REVISED MARCH 17, 1997, AND PANEL NUMBER 08041C0752G, EFFECTIVE DECEMBER 7, 2018.
- STEWART TITLE GUARANTY COMPANY, ORDER NO. 18000311012A, WITH AN EFFECTIVE DATE OF JULY 24, 2021 AT 5:30 P.M. WAS RELIED UPON FOR RECORD INFORMATION REGARDING RIGHTS-OF-WAY, EASEMENT(S) AND ENCUMBRANCE(S). THIS SURVEY DOES NOT REPRESENT A TITLE SEARCH BY AZTEC CONSULTANTS, INC. TO DETERMINE OWNERSHIP, RIGHT(S)-OF-WAY, EASEMENT(S), OR OTHER MATTERS OF PUBLIC RECORD.
- TRACTS F AND G ARE FOR PRIVATE ACCESS, PUBLIC UTILITIES AND PARKING. ALL PRIVATE STREETS ARE TO BE PRIVATELY OWNED AND MAINTAINED BY THE PALMER VILLAGE DUPLEX OWNERS ASSOCIATION, INC..
- TRACTS E AND J ARE SUBJECT TO A PRIVATE DETENTION BASIN/STORMWATER QUALITY BMP MAINTENANCE AGREEMENT AND EASEMENT AS RECORDED AT RECEPTION NO. \_\_\_\_\_ OF THE RECORDS OF EL PASO COUNTY. THE PALMER VILLAGE DUPLEX OWNERS ASSOCIATION IS RESPONSIBLE FOR MAINTENANCE OF THE SUBJECT DRAINAGE FACILITIES AND THE WHOLE PRIVATE STORM DRAIN SYSTEM SERVING THIS SUBDIVISION.
- TRACTS A & L WILL BE DEDICATED AS RIGHT-OF-WAY TO BE OWNED AND MAINTAINED BY THE COUNTY OF EL PASO. OWNERSHIP OF TRACTS IS TO BE CONVEYED BY SEPARATE DOCUMENT.
- TRACTS B, C, D, E, F, G, H, I, J, & K WILL BE OWNED AND MAINTAINED BY THE PALMER VILLAGE DUPLEX OWNERS ASSOCIATION, INC.. OWNERSHIP OF TRACTS IS TO BE CONVEYED BY SEPARATE DOCUMENT. THE PALMER VILLAGE DUPLEX OWNERS ASSOCIATION WILL BE RESPONSIBLE FOR INSTALLING AND MAINTAINING THE EMERGENCY ACCESS GATES IN TRACT F AND G.
- FACILITIES AND COMMON AREA LANDSCAPE WILL BE MAINTAINED BY THE PALMER VILLAGE DUPLEX OWNERS ASSOCIATION, INC..
- LANDSCAPE WALKS WITHIN PRIVATE RESIDENTIAL LOTS WILL BE MAINTAINED BY THE PALMER VILLAGE DUPLEX OWNERS ASSOCIATION, INC.. CROSS ACCESS WILL BE PERMITTED IN COMMON WALKWAYS AND OPEN SPACE FOR ALL RESIDENTS OF URBAN COLLECTION AT PALMER VILLAGE AND THEIR GUEST.
- THIS SITE IS NOT WITHIN A DESIGNATED F.E.M.A FLOODPLAIN AS DETERMINED BY THE FLOOD INSURANCE RATE MAP, COMMUNITY PANEL NUMBER 08041C0752G, EFFECTIVE DECEMBER 7, 2018.
- THERE SHALL BE NO DIRECT LOT ACCESS TO CONSTITUTION AVENUE, MARKSHEFFEL ROAD, OR HANNAH RIDGE DRIVE.
- GEOLOGIC HAZARD NOTE:**  
THE FOLLOWING LOTS HAVE BEEN FOUND TO BE IMPACTED BY GEOLOGIC HAZARDS. MITIGATION MEASURES AND A MAP OF THE HAZARD AREA CAN BE FOUND IN THE GEOTECHNICAL INVESTIGATION AND GEOLOGIC HAZARD EVALUATION PREPARED BY CTL THOMPSON INC., DATED APRIL 24, 2020 AND IS HELD IN THE URBAN COLLECTION A PALMER VILLAGE PUD PRELIMINARY PLAN FILE (PUDSP-19-011) AT THE EL PASO COUNTY PLANNING AND COMMUNITY DEVELOPMENT DEPARTMENTS.  
ARTIFICIAL/UNDOCUMENTED FILL (THE MAJORITY OF LOTS)  
EXPANSIVE SOILS AND BEDROCK (LOTS 85-100)  
POTENTIAL SHALLOW GROUNDWATER (LOTS 85-100)  
THESE CONDITIONS CAN BE MITIGATED BY REGARDING, PROPERLY ENGINEERED FOUNDATIONS, AND RECOGNIZED CONSTRUCTION TECHNIQUES. THE PROPOSED UNITS WITHIN THIS SUBDIVISION WILL NOT INCLUDE BASEMENTS, WHICH WILL MITIGATE THE POTENTIAL SHALLOW GROUNDWATER CONSTRAINT.
- THE PARTIES RESPONSIBLE FOR THIS PLAN HAVE FAMILIARIZED THEMSELVES WITH ALL CURRENT ACCESSIBILITY CRITERIA AND SPECIFICATIONS AND THE PROPOSED PLAN REFLECTS ALL SITE ELEMENTS REQUIRED BY THE APPLICABLE ADA DESIGN STANDARDS AND GUIDELINES AS PUBLISHED BY THE UNITED STATES DEPARTMENT OF JUSTICE. APPROVAL OF THIS PLAN BY EL PASO COUNTY DOES NOT ASSURE COMPLIANCE WITH THE ADA OR ANY REGULATIONS OR GUIDELINE ENACTED OR PROMULGATED UNDER OR WITH RESPECT TO SUCH LAWS.
- NO PARKING WILL BE ALLOWED IN FRONT OF GARAGES, EXCEPT FOR LOTS 69-73 WHERE DRIVEWAYS ARE A MINIMUM OF 20' IN LENGTH FROM GARAGE FACE TO EDGE OF ACCESS ROAD.
- SNOW STORAGE SHALL BE ACCOMMODATED ONSITE IN AVAILABLE TRACTS AND AT ENDS OF THE PRIVATE DRIVE AISLES, NOT IN THE PUBLIC RIGHT-OF-WAY.
- EMERGENCY ACCESS GATES ARE TO BE DESIGNED BY THE DEVELOPER AND MUST INCLUDE THE DIABLO CONTROL PROXIMITY AUTO OPENING SYSTEM (WWW.DIABLOCONTROLS.COM) AND OVERRIDE TO PROVIDE EMERGENCY AND FIRE DEPARTMENT INGRESS AND EGRESS.
- ANY PERSON WHO KNOWINGLY REMOVES OR KNOWINGLY CAUSES TO BE REMOVED ANY PUBLIC LAND SURVEY MONUMENT, AS DEFINED BY SECTION 38-53-103 (18), C.R.S., OR CONTROL CORNER, AS DEFINED IN SECTION 38-53-103 (6), C.R.S., OR A RESTORATION OF ANY SUCH MONUMENT OR WHO KNOWINGLY REMOVES OR KNOWINGLY CAUSES TO BE REMOVED ANY BEARING TREE KNOWING SUCH IS A BEARING TREE OR OTHER ACCESSORY, AS DEFINED BY SECTION 38-53-103 (1), C.R.S., EVEN IF SAID PERSON HAS TITLE TO THE LAND ON WHICH SAID MONUMENT OR ACCESSORY IS LOCATED, COMMITS A CLASS 2 MISDEMEANOR UNLESS, PRIOR TO SUCH REMOVAL, SAID PERSON HAS CAUSED A COLORADO PROFESSIONAL LAND SURVEYOR TO ESTABLISH AT LEAST TWO WITNESS CORNERS OR REFERENCE MARKS FOR EACH SUCH MONUMENT OR ACCESSORY REMOVED AND HAS FILED OR CAUSED TO BE FILED A MONUMENT RECORD PURSUANT TO ARTICLE 53 OF TITLE 38, C.R.S.
- A STANDARD AVIGATION EASEMENT CONVEYED TO THE CITY OF COLORADO SPRINGS, APPURTENANT TO THE COLORADO SPRINGS AIRPORT RECORDED MARCH 14, 1989 IN BOOK 5612 AT PAGE 726 COVERS THE SUBJECT PROPERTY BUT IS NOT SHOWN HEREIN.
- A STANDARD AVIGATION EASEMENT RECORDED MARCH 20, 2014 AT RECEPTION NO. 214022685 COVERS THE SUBJECT PROPERTY BUT IS NOT SHOWN HEREIN.

delete the number  
- this is part of  
note #22

- NO LOTS SHALL BE SOLD, CONVEYED, OR TRANSFERRED TO A PARTY OTHER THAN ONE THAT PURCHASES THE ENTIRE SUBDIVISION, WHETHER BY DEED OR BY CONTRACT, UNLESS AND UNTIL THE REQUIRED PUBLIC AND COMMON DEVELOPMENT IMPROVEMENTS FOR THE SUBDIVISION HAVE BEEN CONSTRUCTED AND COMPLETED IN ACCORDANCE WITH THE SUBDIVISION IMPROVEMENTS AGREEMENT RECORDED AT RECEPTION NO. \_\_\_\_\_ AND THE APPROVED CONSTRUCTION PLANS AND PRELIMINARY ACCEPTANCE OF SAID IMPROVEMENTS HAS BEEN RECEIVED FROM EL PASO COUNTY. SHOULD A PARTY PURCHASE THE ENTIRE SUBDIVISION, LOTS WITHIN THE SUBDIVISION MAY BE SOLD, CONVEYED, OR TRANSFERRED AND HAVE BUILDING PERMITS ISSUED UPON RECEIPT OF COLLATERAL ACCEPTABLE TO THE COUNTY WHICH IS SUFFICIENT TO GUARANTEE CONSTRUCTION OF THE IMPROVEMENTS IN THE APPROVED FINANCIAL ASSURANCE ESTIMATE. IF SUBDIVIDER OR A PURCHASER POSTS COLLATERAL MORE THAN NINETY (90) DAYS FOLLOWING PLAT RECORDING, AN UPDATED FINANCIAL ASSURANCE ESTIMATE MAY BE REQUIRED.
- THIS PLAT RESTRICTION MAY BE REMOVED OR RESCINDED BY THE BOARD OF COUNTY COMMISSIONERS OR, IF PERMITTED BY THE SUBDIVISION IMPROVEMENTS AGREEMENT, BY THE PLANNING AND COMMUNITY DEVELOPMENT DEPARTMENT DIRECTOR UPON EITHER APPROVAL OF AN ALTERNATIVE FORM OF COLLATERAL OR COMPLETION AND PRELIMINARY ACCEPTANCE BY THE EL PASO BOARD OF COUNTY COMMISSIONERS OF ALL IMPROVEMENTS REQUIRED TO BE CONSTRUCTED AND COMPLETED IN ACCORDANCE WITH SAID SUBDIVISION IMPROVEMENTS AGREEMENT. THE PARTIAL RELEASE OF LOTS FOR SALE, CONVEYANCE OR TRANSFER MAY ONLY BE GRANTED IN ACCORDANCE WITH ANY PLANNED PARTIAL RELEASE OF LOTS AUTHORIZED BY THE SUBDIVISION IMPROVEMENTS AGREEMENT.
- ACCESS: BOTH PORTIONS OF THE SITE HAVE 24-HOUR LEGAL ACCESS VIA HANNAH RIDGE DRIVE AND PRIVATE ROADS WITHIN THE DEVELOPMENT. A GATED EMERGENCY SECOND POINT OF ACCESS IS PROVIDED ON THE EAST AND WEST PORTION OF THE SITE FOR EMERGENCY INGRESS AND EGRESS ONLY TO CONSTITUTION AVENUE. THE EAST EMERGENCY ACCESS IS PROVIDED THROUGH THE ADJACENT PROPERTY (TRACT M). GATES TO BE PROVIDED BY DEVELOPER.
- NOISE MITIGATION NOTE: LOTS 9 TO 16, 33 TO 40, 41 TO 49, 60 TO 68, AND 81 TO 88 ARE WITHIN THE DNL 65 NOISE CONTOUR AND WILL REQUIRE NOISE MITIGATION FOR COMPLIANCE WITH HUD INTERIOR 45 DNL NOISE REQUIREMENTS. THIS WILL BE ACCOMPLISHED BY ADHERENCE TO THE INTERIOR NOISE REDUCTION CONSTRUCTION METHODS RELATED TO EXTERIOR WALLS, ATTIC SPACE INSULATION, EXTERIOR GLAZING AND ROOFING MATERIALS, AS RECOMMENDED IN THE TRAFFIC AND AIRCRAFT NOISE ASSESSMENT PREPARED BY ENGINEERING DYNAMICS INCORPORATED, DATED 13 MAY, 2020.
- THE SUBDIVIDER(S) AGREES ON BEHALF OF HIM/HERSELF AND ANY DEVELOPER OR BUILDER SUCCESSORS AND ASSIGNEES THAT SUBDIVIDER AND/OR SAID SUCCESSORS AND ASSIGNS SHALL BE REQUIRED TO PAY TRAFFIC IMPACT FEES IN ACCORDANCE WITH THE EL PASO COUNTY ROAD IMPACT FEE PROGRAM RESOLUTION (RESOLUTION NO. 19-471), OR ANY AMENDMENTS THERETO, AT OR PRIOR TO THE TIME OF BUILDING PERMIT SUBMITTALS. THE FEE OBLIGATION, IF NOT PAID AT FINAL PLAT RECORDING, SHALL BE DOCUMENTED ON ALL SALES DOCUMENTS AND ON PLAT NOTES TO ENSURE THAT A TITLE SEARCH WOULD FIND THE FEE OBLIGATION BEFORE SALE OF THE PROPERTY.
- ALL PROPERTY WITHIN THIS SUBDIVISION EXCEPT TRACTS M & N (FUTURE DEVELOPMENT) IS SUBJECT TO A DECLARATION OF COVENANTS AS RECORDED AT RECEPTION NO. \_\_\_\_\_ OF THE RECORDS OF THE EL PASO COUNTY CLERK AND RECORDER.
- NOTICE OF POTENTIAL AIRCRAFT OVERFLIGHT AND NOISE IMPACT ASSOCIATED WITH AIRPORT: THIS SERVES AS NOTICE OF POTENTIAL AIRCRAFT OVERFLIGHT AND NOISE IMPACTS ON THIS PROPERTY DUE TO ITS CLOSE PROXIMITY TO AN AIRPORT, WHICH IS BEING DISCLOSED TO ALL PROSPECTIVE PURCHASERS CONSIDERING THE USE OF THIS PROPERTY FOR RESIDENTIAL AND OTHER PURPOSES. THIS PROPERTY IS SUBJECT TO THE OVERFLIGHT AND ASSOCIATED NOISE OF ARRIVING AND DEPARTING AIRCRAFT DURING THE COURSE OF NORMAL AIRPORT OPERATIONS.
- ALL PROPERTY OWNERS ARE RESPONSIBLE FOR MAINTAINING PROPER STORM WATER DRAINAGE IN AND THROUGH THEIR PROPERTY. PUBLIC DRAINAGE EASEMENTS AS SPECIFICALLY NOTED ON THE PLAT SHALL BE MAINTAINED BY THE INDIVIDUAL LOT OWNERS UNLESS OTHERWISE INDICATED. STRUCTURES, FENCES, MATERIALS OR LANDSCAPING THAT COULD IMPEDE THE FLOW OF RUNOFF SHALL NOT BE PLACED IN DRAINAGE EASEMENTS.
- NO DRIVEWAY SHALL BE ESTABLISHED UNLESS AN ACCESS PERMIT HAS BEEN GRANTED BY EL PASO COUNTY.
- MAILBOXES SHALL BE INSTALLED IN ACCORDANCE WITH ALL EL PASO COUNTY AND UNITED STATES POSTAL SERVICE REGULATIONS.
- THE FOLLOWING REPORTS HAVE BEEN SUBMITTED IN ASSOCIATION WITH THE PRELIMINARY PLAN OR FINAL PLAT FOR THIS SUBDIVISION AND ARE ON FILE AT THE COUNTY PLANNING AND COMMUNITY DEVELOPMENT DEPARTMENT: TRANSPORTATION IMPACT STUDY; DRAINAGE REPORT; WATER RESOURCES REPORT; WASTEWATER DISPOSAL REPORT; GEOLOGY AND SOILS REPORT; FIRE PROTECTION REPORT; NOISE REPORT.
- THE PRIVATE ROADS AS SHOWN ON THIS PLAT WILL NOT BE MAINTAINED BY EL PASO COUNTY UNTIL AND UNLESS THE STREETS ARE CONSTRUCTED IN CONFORMANCE WITH EL PASO COUNTY STANDARDS IN EFFECT AT THE DATE OF THE REQUEST FOR DEDICATION AND MAINTENANCE.
- DEVELOPER SHALL COMPLY WITH FEDERAL AND STATE LAWS, REGULATIONS, ORDINANCES, REVIEW AND PERMIT REQUIREMENTS, AND OTHER AGENCY REQUIREMENTS, IF ANY, OF APPLICABLE AGENCIES INCLUDING, BUT NOT LIMITED TO, THE COLORADO DIVISION OF WILDLIFE, COLORADO DEPARTMENT OF TRANSPORTATION, U.S. ARMY CORPS OF ENGINEERS AND THE U.S. FISH AND WILDLIFE SERVICE REGARDING THE ENDANGERED SPECIES ACT, PARTICULARLY AS IT RELATES TO THE LISTED SPECIES (E.G., PREBLE'S MEADOW JUMPING MOUSE).
- THE ADDRESSES EXHIBITED ON THIS PLAT ARE FOR INFORMATIONAL PURPOSES ONLY. THEY ARE NOT THE LEGAL DESCRIPTION AND ARE SUBJECT TO CHANGE.
- THE LAND WITHIN THE PLAT IS ZONED PUD AS IDENTIFIED WITHIN PCD FILE NUMBER PUDSP-19-11. THE PUD DEVELOPMENT PLAN, GUIDELINES AND LANDSCAPE PLAN ARE RECORDED AT RECEPTION NO. \_\_\_\_\_
- UTILITY PROVIDERS:  
SANITARY SEWER: CHEROKEE METROPOLITAN DISTRICT  
WATER: CHEROKEE METROPOLITAN DISTRICT  
ELECTRIC: COLORADO SPRINGS UTILITIES  
GAS: COLORADO SPRINGS UTILITIES

delete highlighted portion and replace with a sentence stating the HOA is the maintenance entity.

replace with "Parks and"



300 East Mineral Ave., Suite 1  
Littleton, Colorado 80122  
Phone: (303) 713-1898  
Fax: (303) 713-1897  
www.aztecconsultants.com

DEVELOPER  
RICHMOND AMERICAN HOMES  
OF COLORADO, INC., A DELAWARE CORP.  
4350 S. MONACO ST.  
DENVER, CO 80237

DATE OF PREPARATION:	03-19-2020
SCALE:	N/A
SHEET 2 OF 8	

LAST REVISED: 07/28/2021

AzTec Proj No.: 21419-48

Drawn By: CWB

# URBAN COLLECTION AT PALMER VILLAGE

SITUATED IN THE NORTHEAST QUARTER OF SECTION 5,  
TOWNSHIP 14 SOUTH, RANGE 65 WEST OF THE SIXTH PRINCIPAL MERIDIAN,  
COUNTY OF EL PASO, STATE OF COLORADO.

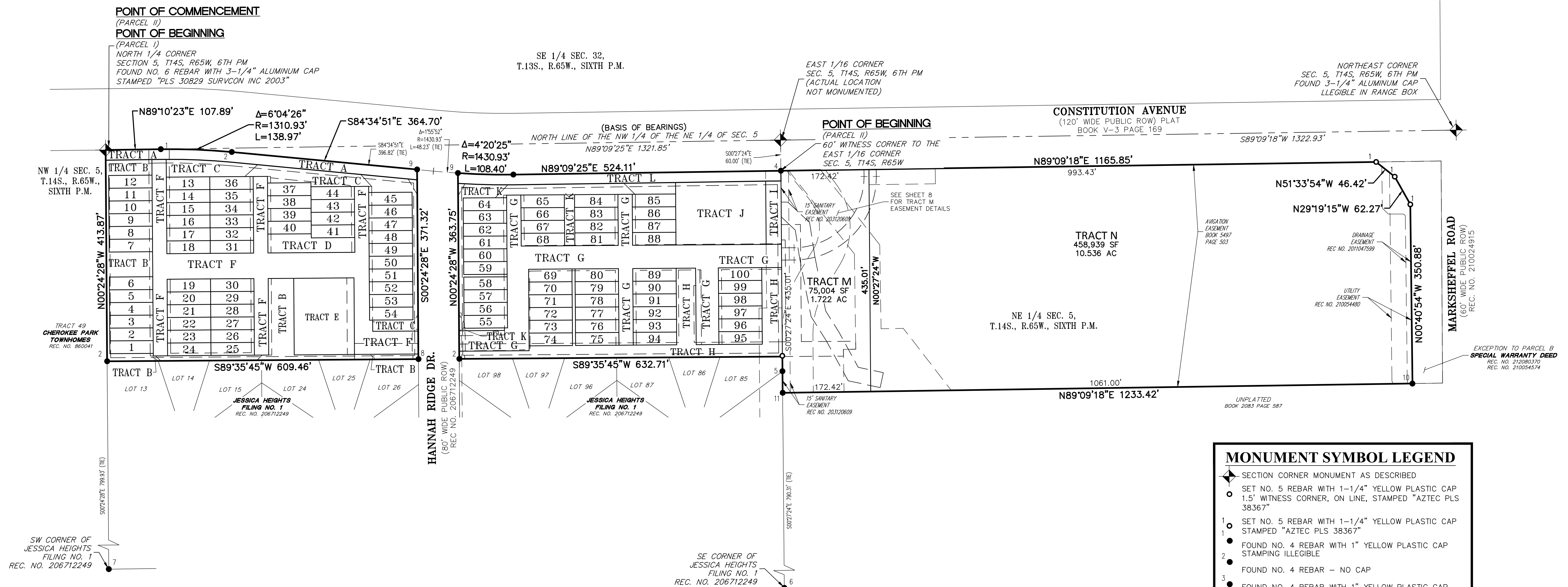

### MONUMENT SYMBOL LEGEND

- ◆ SECTION CORNER MONUMENT AS DESCRIBED
- SET NO. 5 REBAR WITH 1-1/4" YELLOW PLASTIC CAP 1.5" WITNESS CORNER, ON LINE, STAMPED "AZTEC PLS 38367"
- ① SET NO. 5 REBAR WITH 1-1/4" YELLOW PLASTIC CAP STAMPED "AZTEC PLS 38367"
- ② FOUND NO. 4 REBAR WITH 1" YELLOW PLASTIC CAP STAMPING ILLEGIBLE
- ③ FOUND NO. 4 REBAR - NO CAP
- ④ FOUND NO. 4 REBAR WITH 1" YELLOW PLASTIC CAP STAMPED "PLS 4842 WK CLARK"
- ⑤ FOUND NO. 6 REBAR - NO CAP
- ⑥ FOUND 1-1/2" WASHER STAMPED "RLS 25968 ON TOP OF WALL"
- ⑦ FOUND NO. 4 REBAR WITH 1" YELLOW PLASTIC CAP STAMPED "RLS 17665 MVE"
- ⑧ FOUND NO. 5 REBAR - NO CAP
- ⑨ FOUND NO. 5 REBAR WITH 1-1/4" YELLOW PLASTIC CAP STAMPED "AZTEC PLS 38367"
- ⑩ FOUND 1" BRASS DISK STAMPED "AZTEC LS 38367"
- ⑪ FOUND NO. 5 REBAR WITH 1-1/4" YELLOW PLASTIC CAP STAMPED "AZTEC PLS 36567"
- ⑫ FOUND 1" WITNESS CORNER WITH 1-1/4" ORANGE PLASTIC CAP STAMPED "PLS 38069"
- (ROW) RIGHT-OF-WAY
- (M) MEASURED DISTANCE
- (R) RECORD DISTANCE PER SPECIAL WARRANTY DEED RECORDED AT RECEPTION NO. 212080370

TRACT	AREA (SQ.FT)	AREA (AC ±)	USE	OWNED BY / MAINTAINED BY
TRACT A	12,231	0.281	RIGHT OF WAY DEDICATION	EL PASO COUNTY *
TRACT B	22,693	0.521	OPEN SPACE, LANDSCAPE BUFFER, PEDESTRIAN CIRCULATION, DETENTION MAINTENANCE ACCESS, PUBLIC AND PRIVATE UTILITIES	PALMER VILLAGE DUPLEX OWNERS ASSOCIATION, INC.
TRACT C	18,782	0.431	OPEN SPACE, LANDSCAPE SETBACK, PEDESTRIAN CIRCULATION, SIGNAGE, PUBLIC AND PRIVATE UTILITIES	PALMER VILLAGE DUPLEX OWNERS ASSOCIATION, INC.
TRACT D	5,606	0.129	OPEN SPACE, PEDESTRIAN CIRCULATION, PUBLIC AND PRIVATE UTILITIES	PALMER VILLAGE DUPLEX OWNERS ASSOCIATION, INC.
TRACT E	17,701	0.406	FULL SPECTRUM DETENTION, PUBLIC AND PRIVATE UTILITIES	PALMER VILLAGE DUPLEX OWNERS ASSOCIATION, INC.
TRACT F	51,632	1.185	PRIVATE ROAD ACCESS, PARKING, PEDESTRIAN CIRCULATION, PUBLIC AND PRIVATE UTILITIES, & EMERGENCY ACCESS GATE	PALMER VILLAGE DUPLEX OWNERS ASSOCIATION, INC.
TRACT G	51,480	1.182	PRIVATE ROAD ACCESS, PARKING, PEDESTRIAN CIRCULATION, PUBLIC AND PRIVATE UTILITIES, & EMERGENCY ACCESS GATE	PALMER VILLAGE DUPLEX OWNERS ASSOCIATION, INC.
TRACT H	26,653	0.612	OPEN SPACE, LANDSCAPE SETBACK, LANDSCAPE BUFFER, PEDESTRIAN CIRCULATION, SIGNAGE, PUBLIC AND PRIVATE UTILITIES	PALMER VILLAGE DUPLEX OWNERS ASSOCIATION, INC.
TRACT I	3,715	0.085	PUBLIC AND PRIVATE UTILITIES	PALMER VILLAGE DUPLEX OWNERS ASSOCIATION, INC.
TRACT J	21,717	0.499	FULL SPECTRUM DETENTION, PUBLIC AND PRIVATE UTILITIES	PALMER VILLAGE DUPLEX OWNERS ASSOCIATION, INC.
TRACT K	14,920	0.343	OPEN SPACE, LANDSCAPE SETBACK, PEDESTRIAN CIRCULATION, SIGNAGE, PUBLIC AND PRIVATE UTILITIES	PALMER VILLAGE DUPLEX OWNERS ASSOCIATION, INC.
TRACT L	12,650	0.290	RIGHT OF WAY DEDICATION	EL PASO COUNTY *
TRACT M	75,004	1.722	FULL SPECTRUM DETENTION, DRAINAGE, EMERGENCY ACCESS, FUTURE DEVELOPMENT	FEATHERGRASS INVESTMENTS LLC
TRACT N	458,939	10.536	FULL SPECTRUM DETENTION, DRAINAGE, EMERGENCY ACCESS, FUTURE DEVELOPMENT	FEATHERGRASS INVESTMENTS LLC
LOTS	212,486	4.878		
TOTAL	1,006,209	23.100		

\* LANDSCAPE ADJACENT TO SUBJECT PROPERTY UP TO THE BACK OF CURB OF THE PUBLIC ROAD WILL BE MAINTAINED BY THE HOMEOWNERS ASSOCIATION.

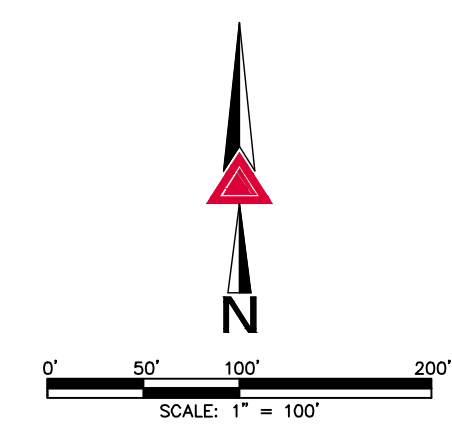

**AZTEC**  
CONSULTANTS, INC.

300 East Mineral Ave., Suite 1  
Littleton, Colorado 80122  
Phone: (303) 713-1898  
Fax: (303) 713-1897  
www.aztecconsultants.com

AzTec Proj. No.: 21419-48 Drawn By: CWB

**DEVELOPER**  
RICHMOND AMERICAN HOMES  
OF COLORADO, INC., A DELAWARE CORP.

4350 S. MONACO ST.  
DENVER, CO 80237

DATE OF PREPARATION:	03-19-2020
SCALE:	1" = 50'
SHEET 3 OF 8	

FOR AND ON BEHALF OF  
AZTEC CONSULTANTS, INC.

# URBAN COLLECTION AT PALMER VILLAGE

SITUATED IN THE NORTHEAST QUARTER OF SECTION 5,  
TOWNSHIP 14 SOUTH, RANGE 65 WEST OF THE SIXTH PRINCIPAL MERIDIAN,  
COUNTY OF EL PASO, STATE OF COLORADO.

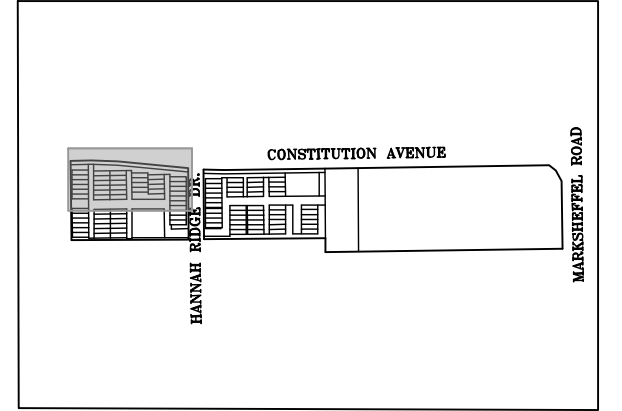

VICINITY MAP  
SCALE: 1"=1000'

SE 1/4 SEC. 32,  
T.13S., R.65W., SIXTH P.M.

NW 1/4, NE 1/4 SEC. 5,  
T.14S., R.65W., SIXTH P.M.

POINT OF COMMENCEMENT  
(PARCEL II)  
POINT OF BEGINNING  
(PARCEL I)

NORTH 1/4 CORNER  
SECTION 5, T14S., R65W., 6TH PM  
FOUND NO. 6 REBAR WITH 3-1/4" ALUMINUM CAP STAMPED "PLS 30829 SURVCON INC 2003"

CONSTITUTION AVENUE  
(120' WIDE PUBLIC ROW) PLAT  
BOOK V-3 PAGE 169

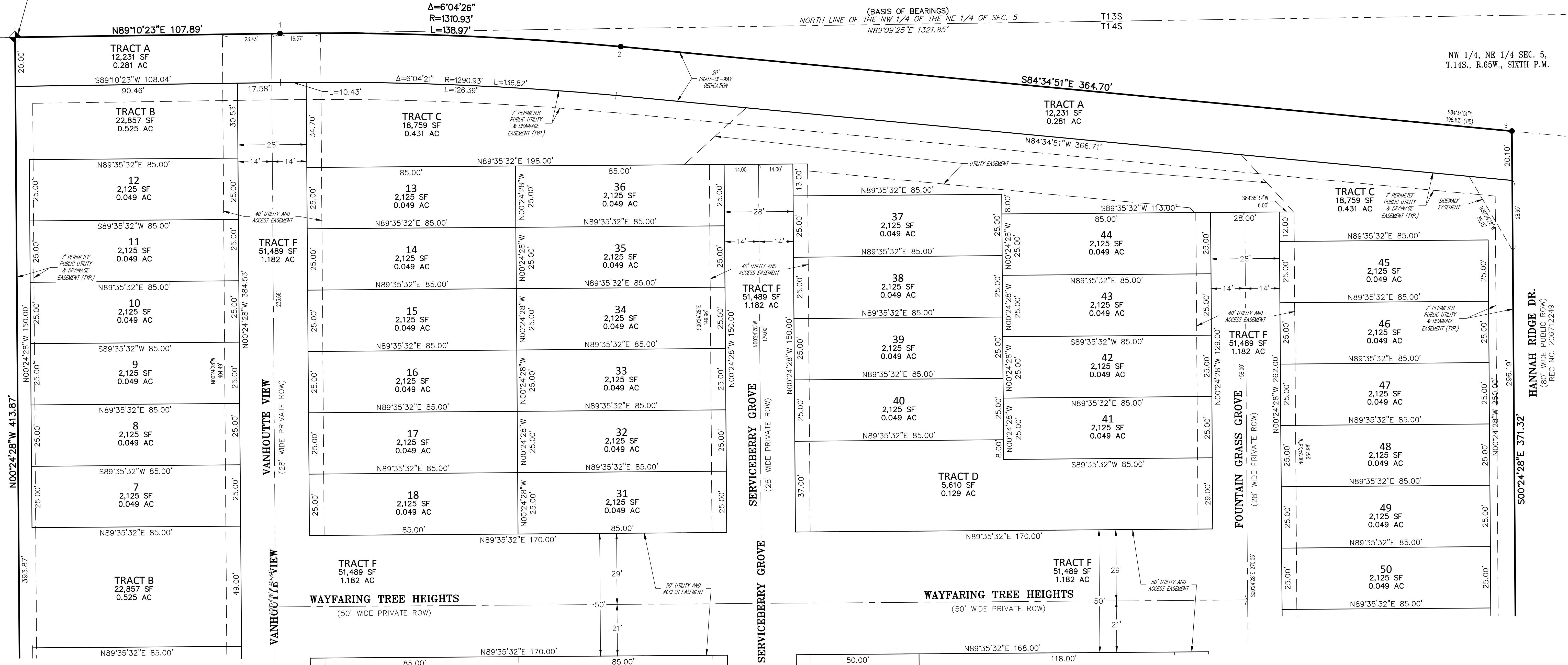

SEE SHEET 6

SEE SHEET 5

HANNAH RIDGE DR.  
(80' WIDE PUBLIC ROW)  
REC. NO. 206712249

S00°24'28"E 371.32'

FOR AND ON BEHALF OF  
AZTEC CONSULTANTS, INC.

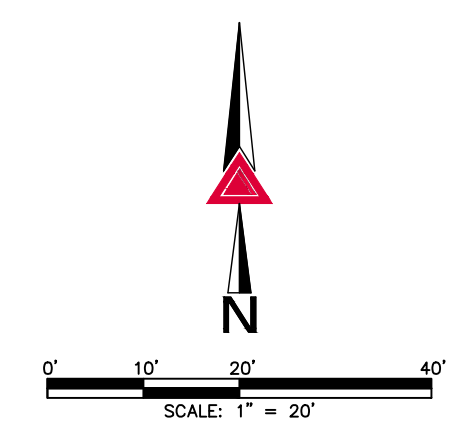

**AZTEC**  
CONSULTANTS, INC.  
300 East Mineral Ave., Suite 1  
Littleton, Colorado 80122  
Phone: (303) 713-1898  
Fax: (303) 713-1897  
www.aztecconsultants.com

**DEVELOPER**  
RICHMOND AMERICAN HOMES  
OF COLORADO, INC., A DELAWARE CORP.  
4350 S. MONACO ST.  
DENVER, CO 80237

DATE OF PREPARATION:	03-19-2020
SCALE:	1" = 20'
SHEET 4 OF 8	

AzTec Proj. No.: 21419-48 Drawn By: CWB

# URBAN COLLECTION AT PALMER VILLAGE

SITUATED IN THE NORTHEAST QUARTER OF SECTION 5,  
TOWNSHIP 14 SOUTH, RANGE 65 WEST OF THE SIXTH PRINCIPAL MERIDIAN,  
COUNTY OF EL PASO, STATE OF COLORADO.

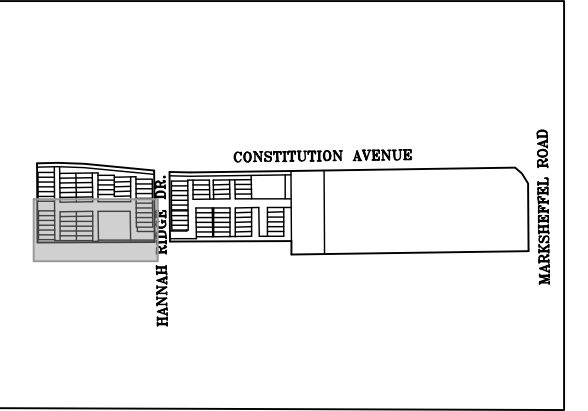

VICINITY MAP  
SCALE: 1"=1000'

SEE SHEET 4

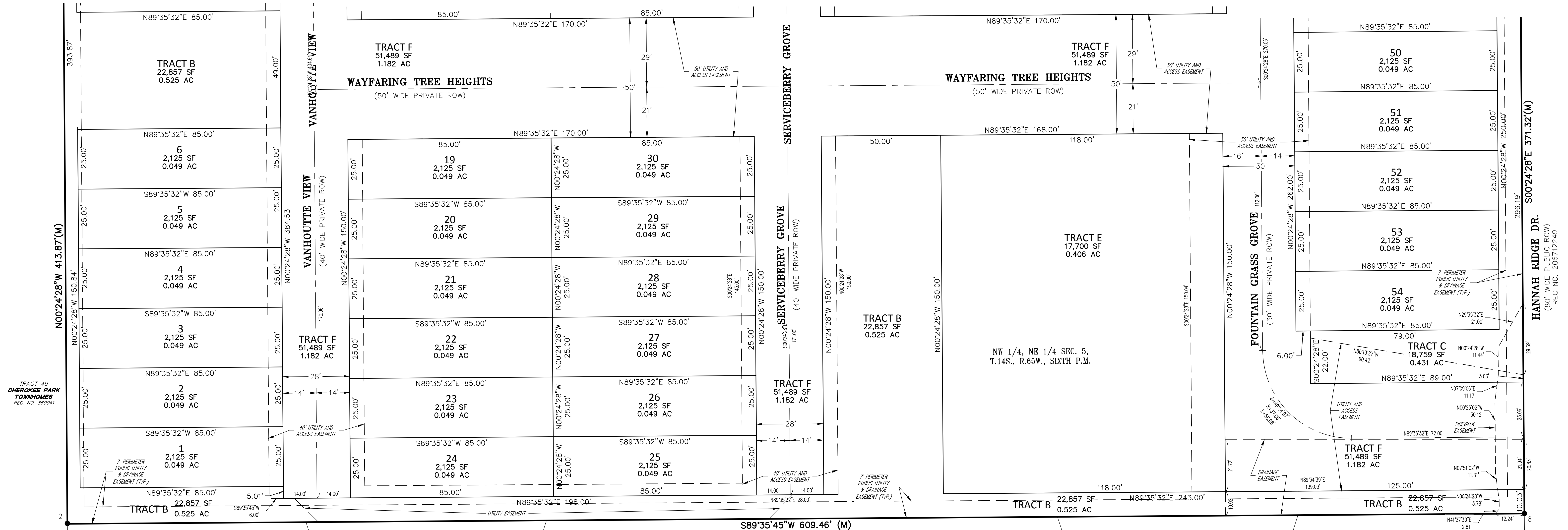

HANNAH RIDGE DR.  
(80' WIDE PUBLIC ROW)  
REC. NO. 206712249

SEE SHEET 6

TRACT 49  
CHEROKEE PARK  
TOWNHOMES  
REC. NO. 860041

LOT 13  
JESSICA HEIGHTS  
FLING NO. 1  
REC. NO. 206712249

LOT 14  
JESSICA HEIGHTS  
FLING NO. 1  
REC. NO. 206712249

LOT 15  
JESSICA HEIGHTS  
FLING NO. 1  
REC. NO. 206712249

LOT 24  
JESSICA HEIGHTS  
FLING NO. 1  
REC. NO. 206712249

LOT 25  
JESSICA HEIGHTS  
FLING NO. 1  
REC. NO. 206712249

LOT 26  
JESSICA HEIGHTS  
FLING NO. 1  
REC. NO. 206712249

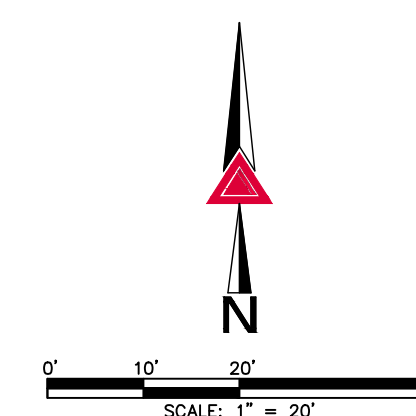

**AZTEC**  
CONSULTANTS, INC.  
300 East Mineral Ave., Suite 1  
Littleton, Colorado 80122  
Phone: (303) 713-1898  
Fax: (303) 713-1897  
www.aztecconsultants.com

**DEVELOPER**  
RICHMOND AMERICAN HOMES  
OF COLORADO, INC., A DELAWARE CORP.  
4350 S. MONACO ST.  
DENVER, CO 80237

DATE OF PREPARATION:	03-19-2020
SCALE:	1" = 20'
SHEET 5 OF 8	

FOR AND ON BEHALF OF  
AZTEC CONSULTANTS, INC.

AzTec Proj. No.: 21419-48 Drawn By: CWB

# URBAN COLLECTION AT PALMER VILLAGE

SITUATED IN THE NORTHEAST QUARTER OF SECTION 5,  
TOWNSHIP 14 SOUTH, RANGE 65 WEST OF THE SIXTH PRINCIPAL MERIDIAN,  
COUNTY OF EL PASO, STATE OF COLORADO.

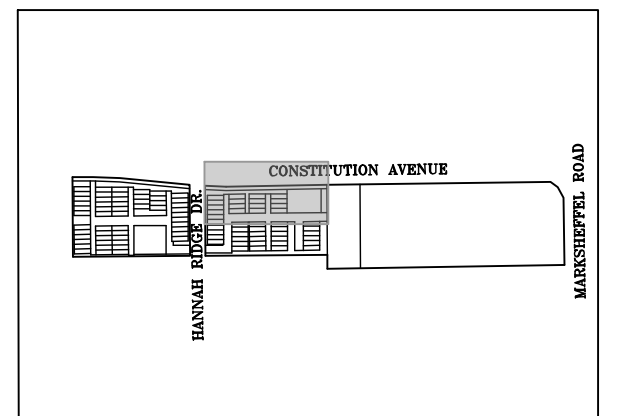

VICINITY MAP  
SCALE: 1"=1000'

CONSTITUTION AVENUE

SE 1/4 SEC. 32, (120' WIDE PUBLIC ROW) PLAT  
T.13S., R.65W., SIXTH P.M. BOOK V-3 PAGE 169

(BASIS OF BEARINGS)  
NORTH LINE OF THE NW 1/4 OF THE NE 1/4 OF SEC. 5  
N89°09'25"E 1321.85'

T13S

T.14S., R.65W., SIXTH P.M.

CONSTITUTION AVENUE  
(120' WIDE PUBLIC ROW) PLAT  
BOOK V-3 PAGE 169

POINT OF BEGINNING  
(PARCEL II)  
60' WITNESS CORNER TO THE  
EAST 1/16 CORNER  
SEC. 5, T14S, R65W, 6TH PM  
(ACTUAL LOCATION  
NOT MONUMENTED)

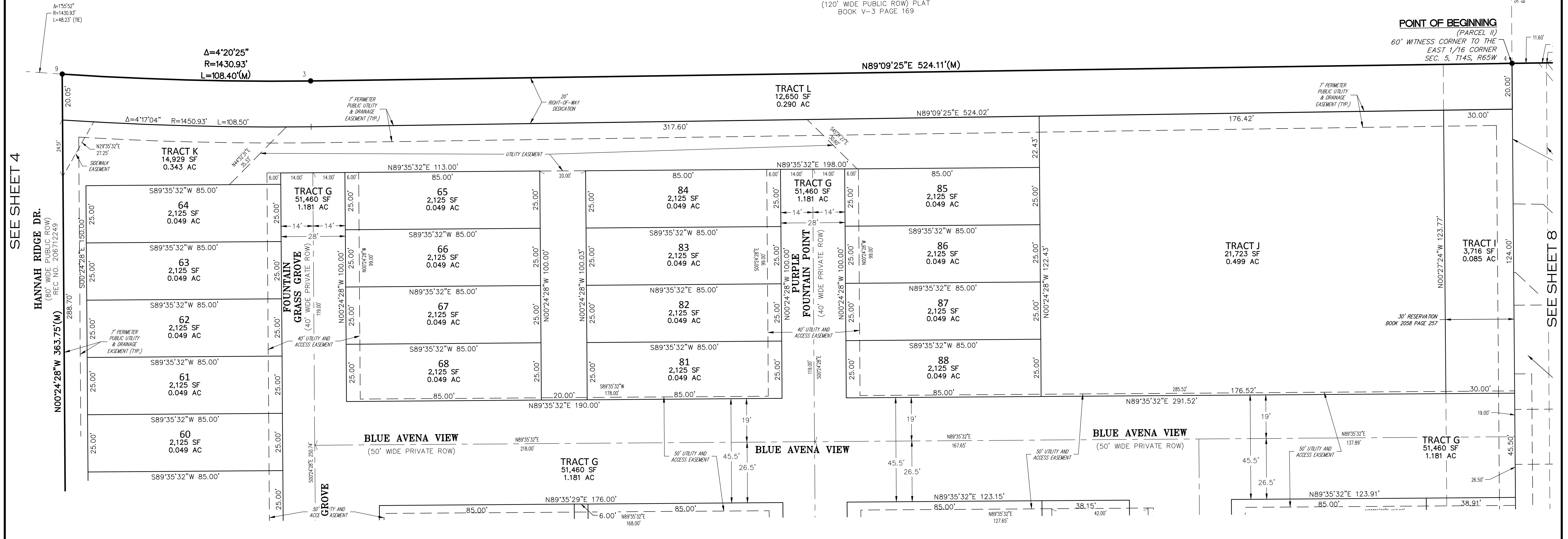

SEE SHEET 4

SEE SHEET 8

SEE SHEET 7

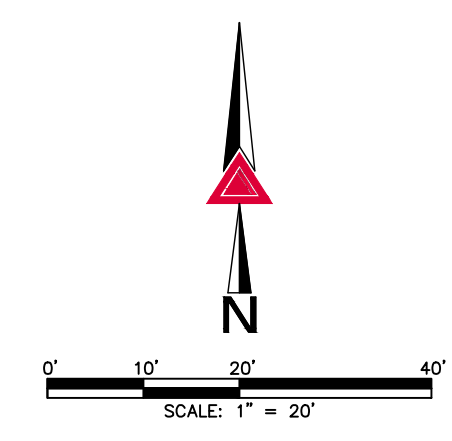

**AZTEC**  
CONSULTANTS, INC.  
300 East Mineral Ave., Suite 1  
Littleton, Colorado 80122  
Phone: (303) 713-1898  
Fax: (303) 713-1897  
www.aztecconsultants.com

DEVELOPER  
**RICHMOND AMERICAN HOMES  
OF COLORADO, INC., A DELAWARE CORP.**  
4350 S. MONACO ST.  
DENVER, CO 80237

DATE OF PREPARATION:	03-19-2020
SCALE:	1" = 20'
SHEET 6 OF 8	

FOR AND ON BEHALF OF  
AZTEC CONSULTANTS, INC

AzTec Proj. No.: 21419-48 Drawn By: CWB

# URBAN COLLECTION AT PALMER VILLAGE

SITUATED IN THE NORTHEAST QUARTER OF SECTION 5,  
TOWNSHIP 14 SOUTH, RANGE 65 WEST OF THE SIXTH PRINCIPAL MERIDIAN,  
COUNTY OF EL PASO, STATE OF COLORADO.

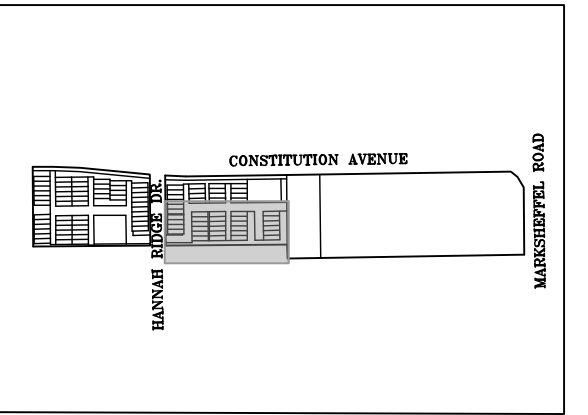

VICINITY MAP  
SCALE: 1"=1000'

SEE SHEET 6



SEE SHEET 5

SEE SHEET 8

HANNAH RIDGE DR.  
(60' WIDE PUBLIC ROW)  
REC. NO. 206712249

N00°24'28"W 363.75'(M)

S89°35'45"W 632.71'(M)

NW 1/4, NE 1/4 SEC. 5,  
T.14S., R.65W., SIXTH P.M.

LOT 98  
JESSICA HEIGHTS  
FILING NO. 1  
REC. NO. 206712249

LOT 97  
JESSICA HEIGHTS  
FILING NO. 1  
REC. NO. 206712249

LOT 96  
JESSICA HEIGHTS  
FILING NO. 1  
REC. NO. 206712249

LOT 87  
JESSICA HEIGHTS  
FILING NO. 1  
REC. NO. 206712249

LOT 86  
JESSICA HEIGHTS  
FILING NO. 1  
REC. NO. 206712249

LOT 85  
JESSICA HEIGHTS  
FILING NO. 1  
REC. NO. 206712249

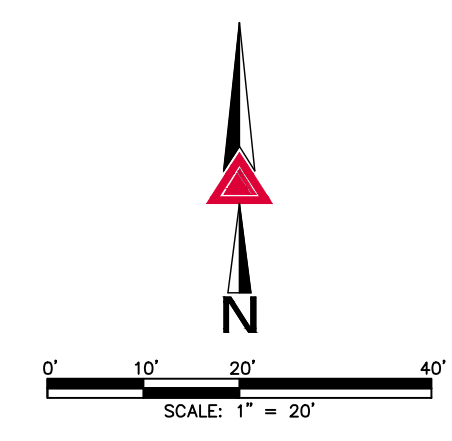

**AZTEC**  
CONSULTANTS, INC.  
300 East Mineral Ave., Suite 1  
Littleton, Colorado 80122  
Phone: (303) 713-1898  
Fax: (303) 713-1897  
www.aztecconsultants.com

DEVELOPER  
**RICHMOND AMERICAN HOMES  
OF COLORADO, INC., A DELAWARE CORP.**  
4350 S. MONACO ST.  
DENVER, CO 80237

DATE OF PREPARATION:	03-19-2020
SCALE:	1" = 20'
SHEET 7 OF 8	

FOR AND ON BEHALF OF  
AZTEC CONSULTANTS, INC.

# URBAN COLLECTION AT PALMER VILLAGE

SITUATED IN THE NORTHEAST QUARTER OF SECTION 5,  
TOWNSHIP 14 SOUTH, RANGE 65 WEST OF THE SIXTH PRINCIPAL MERIDIAN,  
COUNTY OF EL PASO, STATE OF COLORADO.

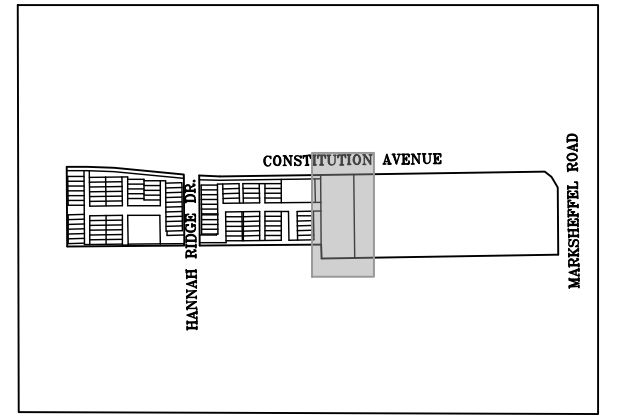

VICINITY MAP  
SCALE: 1"=1000'

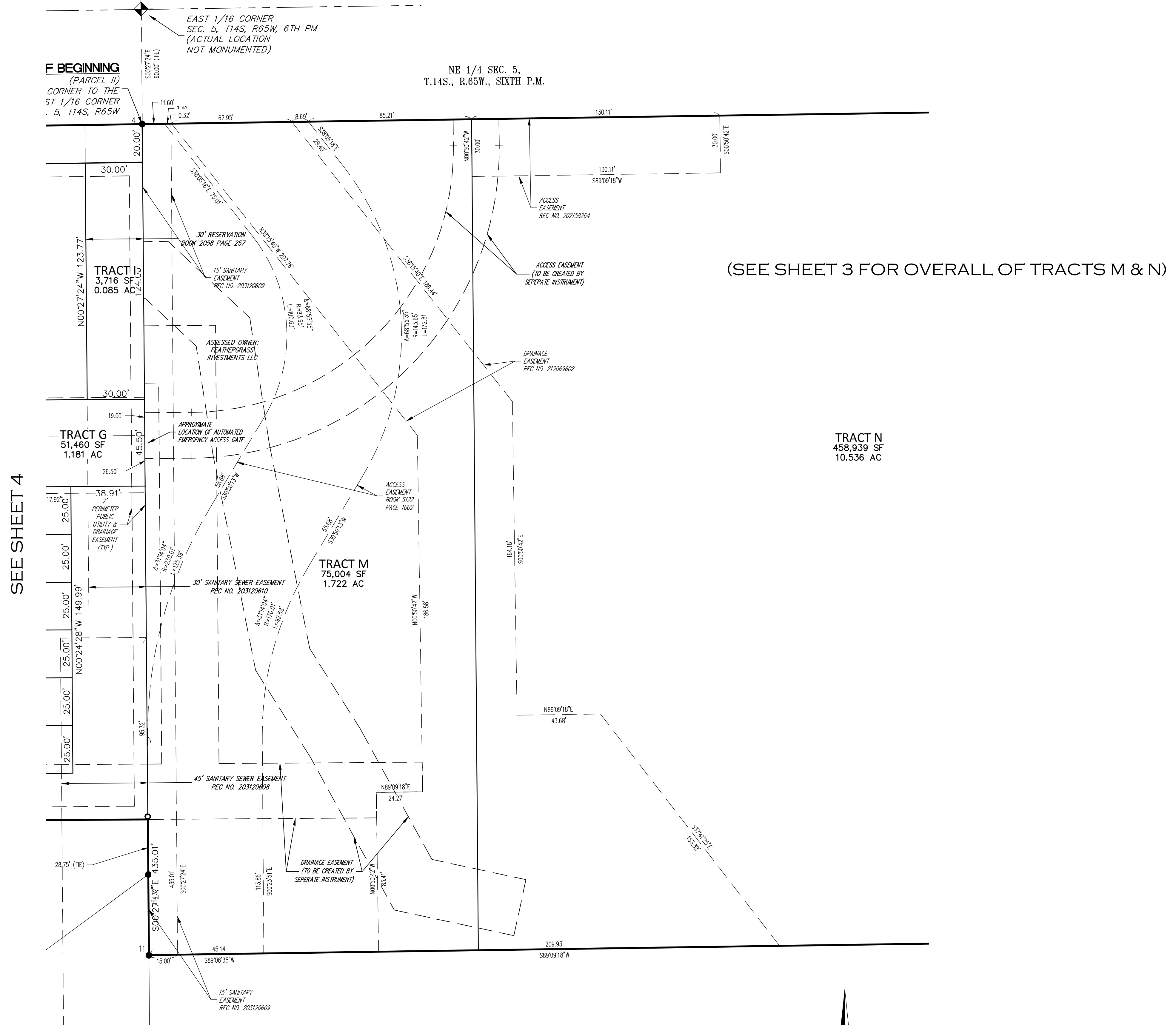

SEE SHEET 4

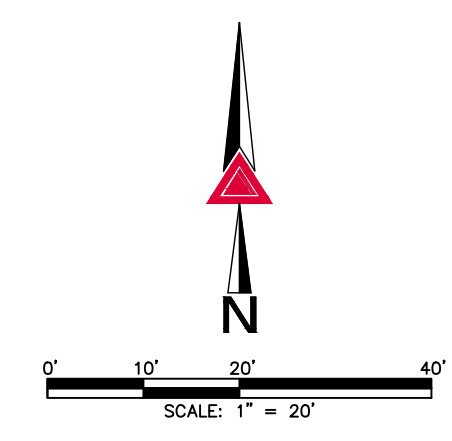

FOR AND ON BEHALF OF  
AZTEC CONSULTANTS, INC.

<p>300 East Mineral Ave., Suite 1 Littleton, Colorado 80122 Phone: (303) 713-1898 Fax: (303) 713-1897 www.aztecconsultants.com</p>	<p>DEVELOPER <b>RICHMOND AMERICAN HOMES OF COLORADO, INC., A DELAWARE CORP.</b> 4350 S. MONACO ST. DENVER, CO 80237</p>		<p>DATE OF PREPARATION: 03-19-2020</p>
	<p>AzTec Proj. No.: 21419-48      Drawn By: CWB</p>		<p>SCALE: 1" = 20'</p>
			<p>SHEET 8 OF 8</p>