

**FINAL DRAINAGE REPORT  
FOR  
MC CLINTOCK STATION LOT A  
(VOLLMER ROAD RV STORAGE)**

**Prepared For:  
Belknap Ventures LLC  
3603 First Light Drive  
Castle Rock, CO 80109**

**November 2023  
Project No. 25251.00**



**Prepared By:  
JR Engineering, LLC  
5475 Tech Center Drive  
Colorado Springs, CO 80919  
719-593-2593**

**PCD File No. PPR-2245**

**Final Drainage Report  
Mc Clintock Station Lot A (Vollmer Road RV Storage)**

**ENGINEER'S STATEMENT:**

The attached drainage plan and report were prepared under my direction and supervision and are correct to the best of my knowledge and belief. Said drainage report has been prepared according to the criteria established by El Paso County for drainage reports and said report is in conformity with the master plan of the drainage basin. I accept responsibility for any liability caused by any negligent acts, errors, or omissions on my part in preparing this report.

  
Ryan Burns, Colorado P.E. #0054412412  
For and On Behalf of JR Engineering, LLC  

11/20/2023  
Date

**DEVELOPER'S STATEMENT:**

I, the developer, have read and will comply with all of the requirements specified in this drainage report and plan.

Business Name: Scott Belknap

By: \_\_\_\_\_

Title: \_\_\_\_\_

Address: 3603 First Light Drive  
Castle Rock, CO 80109

**El Paso County:**

Filed in accordance with the requirements of the El Paso County Land Development Code, Drainage Criteria Manual, Volumes 1 and 2 and Engineering Criteria Manual, as amended.

\_\_\_\_\_  
Joshua Palmer, P.E.  
County Engineer/ ECM Administrator

\_\_\_\_\_  
Date

Conditions:



# CONTENTS

---

<b>PURPOSE.....</b>	<b>2</b>
<b>GENERAL LOCATION AND DESCRIPTION.....</b>	<b>2</b>
LOCATION.....	2
DESCRIPTION OF PROPERTY.....	2
FLOODPLAIN STATEMENT.....	3
<b>DRAINAGE BASINS AND SUB-BASINS.....</b>	<b>3</b>
EXISTING MAJOR BASIN DESCRIPTIONS.....	3
EXISTING SUB-BASIN DRAINAGE.....	3
PROPOSED SUB-BASIN DRAINAGE.....	4
<b>DRAINAGE DESIGN CRITERIA.....</b>	<b>6</b>
DEVELOPMENT CRITERIA REFERENCE.....	6
HYDROLOGIC CRITERIA.....	6
HYDRAULIC CRITERIA.....	6
<b>DRAINAGE FACILITY DESIGN.....</b>	<b>7</b>
SPECIFIC DETAILS.....	7
<i>Four Step Process to Minimize Adverse Impacts of Urbanization</i> .....	7
<i>Water Quality</i> .....	8
<i>Erosion Control Plan</i> .....	8
<i>Operation &amp; Maintenance</i> .....	8
<i>Drainage &amp; Bridge Fees</i> .....	9
<i>Construction Cost Opinion</i> .....	9
<b>SUMMARY.....</b>	<b>9</b>
 <b>APPENDICES</b>	
A. Vicinity Map, Soils, FEMA	
B. Hydrologic Calculations	
C. Hydraulic Calculations	
D. Reference Materials	
E. Drainage Maps	



## PURPOSE

---

This document is the Final Drainage Report for Mc Clintock Station Lot A herein known as “Vollmer Road RV Storage”. The purpose of this document is to identify and analyze the on and offsite drainage patterns and to ensure that post development runoff is routed through the site safely and in a manner that satisfies the requirements set forth by the El Paso County Drainage Criteria Manual. The following report is an analysis of the drainage for the site and surrounding areas.

## GENERAL LOCATION AND DESCRIPTION

---

### Location

Vollmer Road RV Storage herein known as “the site” is located in Section 34, Township 12 South, and Range 65 West of the 6<sup>th</sup> Principal Meridian. The site is bound on the northwest by existing Vollmer Road. Vollmer Road borders Wildridge Subdivision II Lot 1, Blocks 1 and 2 to the northwest of Vollmer Road. The property is bound to the east by the Sterling Ranch Filing 1 and by Lots B and C of the Mc Clintock Station Subdivision, as well as Vollmer Place to the south. Vollmer Road RV Storage lies within the Sand Creek Drainage Basin. Flows from this site are tributary to Sand Creek. A vicinity map is presented in Appendix A.

### Description of Property

Vollmer Road RV Storage consists of 6.4 acres and is presently has an existing shed as well as a greenhouse and a concrete pathway, with a majority of the property being undeveloped. Vegetation is sparse, consisting of native grasses. Existing site terrain generally slopes from north to south at grade rates that vary between 2% and 8%.

Vollmer Road RV Storage is currently zoned "I-2" for light industrial and manufacturing development. Improvements proposed for the site includes recycled asphalt drives and parking, fencing, storm drainage improvements, drainage swales, and a detention pond. A full spectrum detention pond is proposed to be constructed to provide water quality treatment and detain storm water for the development.

Soils for this project are classified as Pring Coarse Sandy Loam (71), which is characterized as Hydrologic Soil Types "B". Group B soils exhibit moderate infiltration rate when thoroughly wet, and consist primarily of deep, moderately well drained or well drained soils that have moderately fine texture to moderately coarse texture. A soil map of the site can be found in Appendix A.

There are no major drainage ways or known irrigation facilities located on the project site. There are no known existing onsite utilities.

Final Drainage Report  
Mc Clintock Station Lot A (Vollmer Road RV Storage)  
Floodplain Statement

Based on the FEMA FIRM Maps number 08041C0533G, dated December 7, 2018, all of the proposed development lies within Zone X. Zone X is defined as area outside the Special Flood Hazard Area (SFHA) and higher than the elevation of the 0.2-percent-annual-chance (or 500-year) flood. A FIRM Map is presented in Appendix A.

## DRAINAGE BASINS AND SUB-BASINS

---

### Existing Major Basin Descriptions

The Vollmer Road RV Storage site consists of 6.4 acres and is located in the Sand Creek Drainage Basin. The site area was previously studied in the "Sand Creek Drainage Basin Planning Study" (DBPS) prepared by Stantec, January 2021.

The Sand Creek DBPS assumed the Vollmer Road RV Storage property to have an undeveloped use for the site. However, the site is zoned I-2 for light industrial and manufacturing development. The site generally drains from northwest to southeast. Currently, the site is undeveloped. Sand Creek is located east of the site running north to south.

Downstream flow patterns have been studied in "Final Drainage Report for Barbarick Subdivision, Portions of Lots 1, 2 and Lots 3 & 4," by Matrix Design Group, June 2016, and "Woodmen Storage Final Drainage Report", by Calibre Engineering Inc, Revised February 2010. Applicable excerpts from these reports can be found in Appendix D.

A summary of peak runoff for the basins and designated design points are depicted on the Existing Conditions Drainage Map in the appendix.

### Existing Sub-basin Drainage

Basin EX-1 ( $Q_5=0.2$  cfs,  $Q_{100}=1.0$  cfs) is 0.48 acres of open space. Runoff from this basin drains overland flows to the south east to DP 1. Flows from Basins EX-1 and OS-6 combine at DP1.1 ( $Q_5=0.3$  cfs,  $Q_{100}=1.5$  cfs) where flow continues onto Lot B of the McClintock Station Subdivision.

Basin EX-2 ( $Q_5=0.9$  cfs,  $Q_{100}=5.9$  cfs) is 3.41 acres of open space. Runoff from this basin overland flows southeast to DP 2. Flows from Basins OS-7, OS-8 and EX-2 combine at DP2.1 ( $Q_5=1.5$  cfs,  $Q_{100}=7.6$  cfs) and continues onto Lot C of the McClintock Station Subdivision.

Basin EX-3 ( $Q_5=0.2$  cfs,  $Q_{100}=1.3$  cfs) is 0.56 acres of open space. Runoff from this basin overland flows east across the property line to DP3 and onto Homestead at Sterling Ranch Filing No. 1. Runoff is then captured by an existing swale. Flows from the site were not accounted for by the Homestead at Sterling Ranch Final Drainage report, however this basin flows historic drainage patterns.

Basin EX-4 ( $Q_5=0.4$  cfs,  $Q_{100}=1.6$  cfs) is 0.73 and consists of an existing shed and concrete sidewalk and native vegetation. Runoff from this basin overland flows south across the property line to DP4



## Final Drainage Report

Mc Clintock Station Lot A (Vollmer Road RV Storage)

and onto Lot C of the McClintock Station Subdivision. Flows from DP4 are routed through basin OS-9 and EX-5 to DP 5.1 ( $Q_5=1.3$  cfs,  $Q_{100}=5.4$  cfs).

Basin EX-5 ( $Q_5=0.5$  cfs,  $Q_{100}=2.8$  cfs) is 1.66 acres and is comprised of a shed, portions of existing Vollmer Place, road side swale and existing native vegetation. Runoff from this basin overland flows onto the site at DP5 where flow enters the roadside swale and combines with flows from DP9.1 ( $Q_5=1.0$  cfs,  $Q_{100}=3.1$  cfs) at DP5.1 ( $Q_5=1.3$  cfs,  $Q_{100}=5.4$  cfs). Flow in the roadside swale flows south and follows historic drainage patterns towards sand creek.

Basin OS-6 ( $Q_5=0.3$  cfs,  $Q_{100}=0.7$  cfs) is 0.14 acres and is comprised of the existing Vollmer Road and road side swale. Runoff from this offsite basin overland flows onto the site at DP6 where flow enters Basin EX-1.

Basin OS-7 ( $Q_5=0.4$  cfs,  $Q_{100}=1.2$  cfs) is 0.27 acres and is comprised of the existing Vollmer Road and native vegetation. Runoff from this offsite basin overland flows to the property line and enter the site at DP7 where flow enters Basin EX-2.

Basin OS-8 ( $Q_5=0.6$  cfs,  $Q_{100}=1.5$  cfs) is 0.41 acres and is comprised of the existing Vollmer Road and road side swale. Runoff from this offsite basin overland flows to the roadside ditch and then enter the site at DP8 where flow enters Basin EX-2.

Basin OS-9 ( $Q_5=0.7$  cfs,  $Q_{100}=1.7$  cfs) is 0.46 acres and is comprised of the existing building, concrete sidewalk, and asphalt parking. Runoff from this offsite basin overland flows southeast to the roadside ditch along Vollmer Place at DP9. Flows for DP4 ( $Q_5=0.4$  cfs,  $Q_{100}=1.6$  cfs) and DP9 ( $Q_5=0.7$  cfs,  $Q_{100}=1.7$  cfs) are routed together at DP9.1 ( $Q_5=1.0$  cfs,  $Q_{100}=3.1$  cfs) and then enter the site into Basin EX-5.

## Proposed Sub-basin Drainage

The following is a description of the offsite and onsite basins for the developed condition. Calculations have been provided to show the proposed storm infrastructure will adequately convey flows. The following basins parameters and developed runoff were determined using the Rational Method. Calculation can be found in Appendix C.

Basin A ( $Q_5=4.2$  cfs,  $Q_{100}=8.4$  cfs) consists of approximately 1.43 acres and consists of recycled asphalt parking and drives, and landscaping. Runoff from this basin is conveyed via sheet flow across the proposed asphalt mat to DP1, where flow enters a Type C Inlet in sump. The emergency over flow path for the inlet is to the south to Inlet B, a Type C inlet in sump. Flow is routed through the proposed storm sewer system to DP3.1 ( $Q_5=15.7$  cfs,  $Q_{100}=30.7$  cfs) where flow will be captured and treated in the full spectrum detention pond.

Basin B ( $Q_5=7.0$  cfs,  $Q_{100}=13.5$  cfs) consists of approximately 2.20 acres and consists of recycled asphalt parking and drives, and landscaping. Runoff from this basin is conveyed via sheet flow across the proposed asphalt mat to DP2, where flow enters a Type C Inlet in sump. The emergency overflow path for this inlet is the proposed full spectrum detention pond to the south. Flow is routed through



## Final Drainage Report

Mc Clintock Station Lot A (Vollmer Road RV Storage)

the proposed storm sewer system to DP3.1 ( $Q_5=15.7$  cfs,  $Q_{100}=30.7$  cfs) where flow will be captured and treated in the full spectrum detention pond.

Basin C ( $Q_5=4.8$  cfs,  $Q_{100}=9.5$  cfs) consists of approximately 1.57 acres and consists of recycled asphalt parking and drives, and landscaping. Runoff from this basin is conveyed via sheet flow across the proposed asphalt mat to DP3, where flow enters a Type C Inlet in sump. The emergency overflow path for this inlet is the proposed full spectrum detention pond to the southeast. Flow is routed through the proposed storm sewer system to DP3.1 ( $Q_5=15.7$  cfs,  $Q_{100}=30.7$  cfs) where flow will be captured and treated in the full spectrum detention pond.

Basin D ( $Q_5=1.6$  cfs,  $Q_{100}=3.7$  cfs) is 0.82 acres and consists of recycled asphalt drives and parking, landscaping, and the proposed full spectrum detention pond. Runoff for this basin is collected in the bottom of the pond at DP4 where it is treated.

Basin E ( $Q_5=0.1$  cfs,  $Q_{100}=0.5$  cfs) is 0.17 acres of landscaping and a small portion of the recycled asphalt drive. Runoff from this basin drains via overland flow to the south east across the site boundary and onto Homestead at Sterling Ranch Filing No. 1 at DP 5. In the existing condition the site sends more water to Homestead at Sterling Ranch Filing No. 1, existing DP3 ( $Q_5=0.2$  cfs,  $Q_{100}=3.7$  cfs).

Basin F ( $Q_5=0.0$  cfs,  $Q_{100}=0.2$  cfs) is 0.07 acres of landscaping. Runoff from this basin drains via overland flow to the south across the site boundary and onto Homestead at Sterling Ranch Filing No. 1 at DP6. There is no increase in flow in the 5 year condition, all flow will infiltrate into the ground. In the 100 year condition there is a small increase inflow across the boundary. It is the opinion of the engineer that the increase in flows is indicated below. Swale with the increased flow to show it still functions properly and meets design criteria.

Basin G ( $Q_5=0.1$  cfs,  $Q_{100}=0.8$  cfs) is 0.23 acres and is comprised of landscaping and swale section B-B. Runoff from this basin overland flows to roadside swale B-B and then enters the proposed culvert under the access at DP7, flow continues to DP7.1 ( $Q_5=0.8$  cfs,  $Q_{100}=2.3$  cfs) where flows from Basins G and OS-9 combine, and continues to flow through the proposed culvert to swale C-C located in Basin I.

Basin H ( $Q_5=0.1$  cfs,  $Q_{100}=0.3$  cfs) is 0.12 acres and is comprised of landscaping. Runoff from this basin overland flows to onto Lot B of the McClintock Station Subdivision at DP8. Flow follows existing drainage patterns to the southwest and are lower than in the existing condition, existing DP1.1 ( $Q_5=0.3$  cfs,  $Q_{100}=1.5$  cfs).

Basin I ( $Q_5=0.5$  cfs,  $Q_{100}=1.2$  cfs) is 0.24 acres. Flow follows existing drainage patterns to roadside ditch DP9, flow continues to DP9.1 (DP9 combine. Flow follows existing drainage Plan presented in Appendix D. Flows released existing DP5 ( $Q_5=0.5$  cfs,  $Q_{100}=2.8$  cfs). Flows at DP 9.1 should compare to existing DP5, as this the total flow leaving project site at this location for existing and proposed conditions. It appears proposed flows exiting site are more than existing flows. Released flows exiting site need to be less than existing. Per ECM Section 3.2.4, a suitable outfall needs to be provided. Is existing ditch capable of conveying flows, meet flow, depth, velocity, etc criteria per ECM/DCM?

DPP1 ( $Q_5=0.8$  cfs,  $Q_{100}=5.7$  cfs) is the outfall point for the proposed full spectrum water quality and detention pond. Flow will be routed from the pond via a proposed 18" RCP storm pipe and enter the



Final Drainage Report  
Mc Clintock Station Lot A (Vollmer Road RV Storage)

proposed swale C-C. The outlet structure for the pond shall reduce the release rates for all storm events to less than historic rates to minimize adverse impacts to downstream stormwater facilities. Proposed swale C-C will convey concentrated flows from the pond to the end of the cul-de-sac on Vollmer Place. Flow will then follow historic drainage patterns per Woodmen View Storage Plot Plan presented in Appendix D.

Basin OS-9 ( $Q_5=0.7$  cfs,  $Q_{100}=1.7$  cfs) is 0.46 acres and is comprised of the existing building, concrete sidewalk, and asphalt parking. Runoff from this offsite basin overland flows southeast to the roadside ditch along Vollmer Place at DPO9. Flows for DP7 ( $Q_5=0.1$  cfs,  $Q_{100}=0.8$  cfs) and DPO9 ( $Q_5=0.7$  cfs,  $Q_{100}=1.7$  cfs) are routed together at DP7.1 ( $Q_5=0.8$  cfs,  $Q_{100}=2.3$  cfs) and then enter the access culvert and into swale C-C located in Basin I.

Basin OS-10 ( $Q_5=0.9$  cfs,  $Q_{100}=2.4$  cfs) is 0.81 acres and is comprised existing Vollmer Road, proposed road side swale A-A. Runoff from this basin overland flows to proposed swale A-A and flows south west in the swale along Vollmer Road to DPO10 where flow enters a proposed 18" access culvert for the neighboring property to south and then continues to flow in the roadside ditch.

## DRAINAGE DESIGN CRITERIA

---

### Development Criteria Reference

Storm drainage analysis and design criteria for the project were taken from the “*City of Colorado Spring/El Paso County Drainage Criteria Manual*” Volumes 1 and 2 (EPCDCM), dated October 12, 1994, the “*Urban Storm Drainage Criteria Manual*” Volumes 1 - 3 (USDCM) and Chapter 6 and Section 3.2.1 of Chapter 13 of the “*Colorado Springs Drainage Criteria Manual (CCSDCM)*”, dated May 2014, as adopted by El Paso County.

### Hydrologic Criteria

All hydrologic data was obtained from the “*El Paso Drainage Criteria Manual*” Volumes 1 and 2, and the “*Urban Drainage and Flood Control District Urban Storm Drainage Criteria Manual*” Volumes 1, 2, and 3. Onsite drainage improvements were designed based on the 5 year (minor) storm event and the 100-year (major) storm event. One hour point rainfall data for the storm events is identified in the table below. Rational Method calculations were prepared, in accordance with Section 3.0 of the EPCDCM. Rational method calculations are presented in Appendix B.

**Table 1: 1-hr Point Rainfall Data**

<b>Storm</b>	<b>Rainfall (in.)</b>
5-year	1.50
100-year	2.52

### Hydraulic Criteria

Mile High Flood District’s MHFD-Detention, Version 4.05 workbook was used for pond sizing. Required detention volumes and allowable release rates were designed per USDCM and





Final Drainage Report  
Mc Clintock Station Lot A (Vollmer Road RV Storage)  
CCS/EPCDCM. Pond sizing spreadsheets are presented in Appendix C. Inlets were sized using UDFCD UD-Inlet v4.05. StormCAD was used to model the proposed storm sewer system and to analyze the proposed HGL calculations for the Construction Drawings. The Manning's equation has been utilized to size the proposed drive access culvert. Autodesk Hydraflow express was used to size the swales. Refer to Appendix C for pipe and swale capacity calculations.

## DRAINAGE FACILITY DESIGN

---

### Specific Details

#### ***Four Step Process to Minimize Adverse Impacts of Urbanization***

In accordance with the El Paso County Drainage Criteria Manual Volume 2, this site has implemented the four step process to minimize adverse impacts of urbanization. The four step process includes reducing runoff volumes, stabilizing drainageways, treating the water quality capture volume (WQCV), and consider the need for Industrial Commercial BMP's.

**Step 1, Reducing Runoff Volumes:** The development of the project site consist of recycled asphalt parking and drives and landscaped areas. Proposed landscaped areas help disconnect impervious areas.

**Step 2, Stabilize Drainageways:** Drainage fees were paid at the time of platting for McClintock Station Subdivision. Drainage fees go towards channel stabilization projects throughout the drainage basin. The proposed outfall for the site (DP5.1) is swale C-C. Proposed swale C-C is stable and sufficient. Velocity in the propose swale is less than 5ft/s, therefore the proposed grass lined swale is stable, see Appendix C for supporting calculations.

**Step 3, Treat the WQCV:** Water Quality treatment for the site is provided in a proposed full spectrum water quality detention ponds located in the south west corner of the site. In general, the runoff from this site will be routed via overland flow to the proposed. A forebay is provided and sized to hold a minimum of 2% of the WQCV. A trickle channel is also incorporated into the ponds to minimize the amount of standing water. The outlet structure has been designed to detain the water quality capture volume (WQCV) for 40 hours, and the extended urban runoff volume (EURV) for 72 hours. Flows released from the pond will be reduced to less than historic rates. The pond will facilitate pollutant removal for the site, while also reducing peak stormwater rates down stream. Per ECM 1.7.C.a up to 20% not to exceed 1 acre of the applicable development site may be excluded where it is not practical to capture runoff. Approximately 13% or 0.87 acres of the site is unable to be captured due to existing grades and vertical constraints. See Appendix I for supporting Water Quality Map.

**Step 4, Consider the need for Industrial and Commercial BMP's:** Temporary BMPs will be utilized during construction to minimize off-site contaminates and to protect the downstream receiving waters, Site specific temporary source control BMPs that will be implement include, but are not limited to, silt fencing, construction vehicle tracking pads, designated fueling areas, covered storage areas, spill containment and control, etc. The permanent erosion control BMPs include recycled asphalt parking and drives, permanent vegetation, a storm culvert under the access, and a full spectrum water quality and detention pond.



**Water Quality**

Water quality for the site is provided by a private full-spectrum detention and water quality pond (Pond V1) in the southeast corner of the site. Table 2 below shows the basin parameters. The proposed pond is sized so that the WQCV for the pond shall be released within 40 hours and the EURV shall be released within 72 hours. Table 3 below gives the design storm results. The proposed pond will utilize a forebay, trickle channel, and outlet structure to dissipate energy and treat flows. The outlet structure for the pond shall reduce the release rates for all storm events to less than historic rates to minimize adverse impacts to downstream stormwater facilities. A broad crested weir will be provided as an emergency spillway and will convey emergency flows to proposed swale B-B. Per ECM 1.7.C.a up to 20% not to exceed 1 acre of the applicable development site may be excluded where it is not practical to capture runoff. Basins H, G, F, and I are not feasible to route to propose Pond V1. These basins boarder adjacent properties and the existing grades at the property line make it so it is not feasible to capture and treat runoff from these basins. Runoff from these basins are all less in the proposed condition than in the existing condition so there are no negative downstream impacts anticipated with the development of this site. Approximately 13% or 0.87 acres of the site is unable to be captured due to existing grades and vertical constraints, which meets ECM 1.7.C.a. See Appendix E for supporting Water Quality Map.

In the hydrology write up, basin F has an increased flow. Please revise statement and address accordingly.

**Table 2 - Watershed Design Parameter**

Watershed Area	6.02 AC
Percent Impervious	71.0%
Watershed Slope	0.021 ft/ft

**Table 3 - Design Storm Results**

Design Storm Period	Estimated Volume (AC-FT)	Design Volume (AC-FT)	Depth (FT)	Q <sub>out 100</sub> (CFS)
WQCV	0.14	0.14	2.61	0.1
EURV	0.33	0.36	4.42	0.2
100-YR	0.74	0.74	5.4	5.7

**Erosion Control Plan**

The El Paso County Drainage Criteria Manual specifies an Erosion Control Plan and associated cost estimate must be submitted with each Final Drainage Report. The Erosion Control Plan for Vollmer RV Storage has been submitted with this report.

**Operation & Maintenance**

In order to ensure the function and effectiveness of the stormwater infrastructure, maintenance activities such as inspection, routine maintenance, restorative maintenance, rehabilitation and repair, are required. All proposed drainage structures within any platted County ROW will be owned and maintained by El Paso County. All proposed drainage structures within the property will be owned and maintained by Scott Belknap. Access to the pond bottom, forebay, and outlet structure have been provided by a 15' gravel maintenance access road. These access points have been confirmed by the



Final Drainage Report  
 Mc Clintock Station Lot A (Vollmer Road RV Storage)  
 property owner, Scott Belknap, to be sufficient for the expected maintenance equipment to be used. An Inspection & Maintenance Plan has been submitted concurrently with this final drainage report that details the required maintenance activities and intervals to ensure proper function of all stormwater infrastructures in the future. The full spectrum detention pond, Pond V1, and onsite storm sewer system will be owned & maintained by the property owner, Scott Belknap.

***Drainage & Bridge Fees***

The site lies within the Sand Creek Drainage Basin. It is assumed that all fees were paid at the time of platting for Mc Clintock Station Lot A.

***Construction Cost Opinion***

Private Storm Facilities- (For Information Only):

<b>Item</b>	<b>Description</b>	<b>Quantity</b>	<b>Unit</b>	<b>Unit Cost</b>	<b>Cost</b>
1	Concrete Pavement 6" Trickle Channel	100	LF	\$ 40.00	\$ 4,000.00
2	Forebay	1	EA	\$12,000.00	\$ 12,000.00
3	Outlet Structure	1	EA	\$10,000.00	\$ 10,000.00
4	Emergency Spillway-Type VL Riprap	50	CY	\$ 60.00	\$ 3,000.00
5	18" RCP	95	LF	\$ 67.00	\$ 6,365.00
6	24" RCP	186	LF	\$ 91.00	\$ 16,926.00
7	30" RCP	112	LF	\$ 114.00	\$ 12,768.00
8	36" RCP	41	LF	\$ 128.00	\$ 5,248.00
9	18" FES	1	EA	\$ 402.00	\$ 402.00
Subtotal					\$ 70,709.00
25% Engineering & Contingencies					\$ 17,677.25
<b>TOTAL</b>					<b>\$ 88,386.25</b>

See FAE for proposed public improvements. JR Engineering cannot and does not guarantee that the construction cost will not vary from these opinions of probable construction costs.

**SUMMARY**

The Mc Clintock Station Lot A known as the Vollmer RV Storage site consists of recycled asphalt parking and drive aisles, a proposed fill spectrum water quality and detention pond, and landscaped areas. The proposed development will not adversely affect downstream drainage infrastructure as the site will provide water quality and detention for the developed flows to release below historic rates. Establishment of maintenance procedures and the implementation of temporary and permanent BMP's will insure the site has no adverse drainage impacts on adjacent properties, surrounding developments, or downstream infrastructure. This report is in conformance with the latest El Paso County Stormwater Drainage Criteria requirements for this site.



## REFERENCES:

---

1. City of Colorado Springs Drainage Criteria Manual, Volume 1 & 2, Colorado Springs, CO, 2014.
2. El Paso County Drainage Criteria Manual Volume 1, El Paso County, CO, 1990.
3. El Paso County Drainage Criteria Manual Update (City Chapter 6), El Paso County, CO, 2015.
4. El Paso County Engineering Criteria Manual Revision 6, El Paso County, CO, 2016.
5. Final Drainage Report for Barbarick Subdivision, Portions of Lots 1, 2 and Lots 3 & 4, by Matrix Design Group, dated June 2016.
6. Drainage Report for McClintock Station, by Alden Surveying Co., dated March 1978.
7. Sand Creek Drainage Basin Planning Study, by Stantec, dated January 2021.
8. Urban Storm Drainage Criteria Manual, Urban Drainage and Flood Control District, Latest Revision.

Final Drainage Report  
Mc Clintock Station Lot A (Vollmer Road RV Storage)

## **APPENDIX A**

### **Vicinity Map, Soils, FEMA**

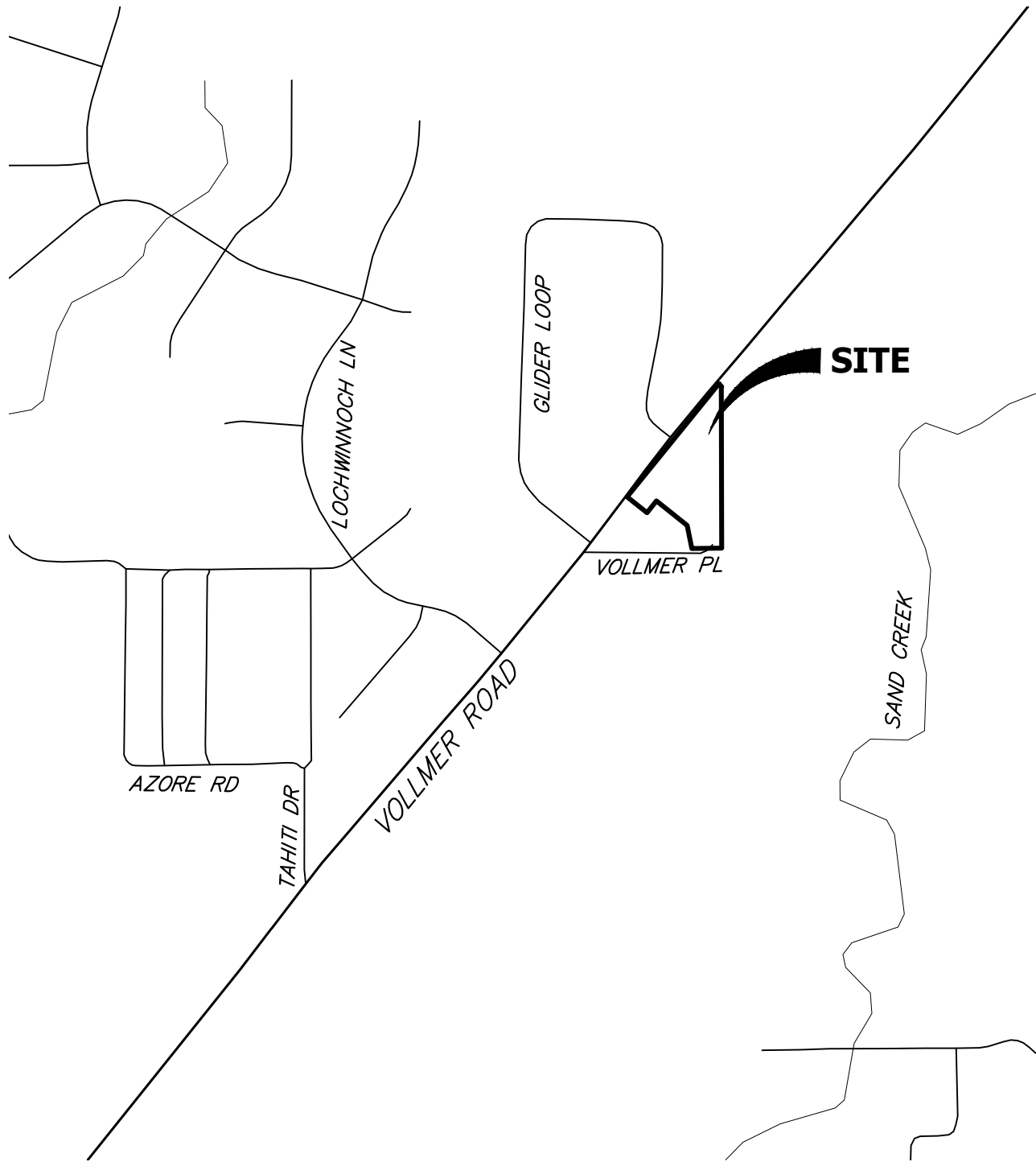

1000 500 0 1000

ORIGINAL SCALE: 1" = 1000'

VICINITY MAP  
 VOLLMER RV STORAGE  
 JOB NO. 25251.00  
 03/21/2023  
 SHEET 1 OF 1



**J-R ENGINEERING**

A Westrian Company

Centennial 303-740-9393 • Colorado Springs 719-593-2593  
 Fort Collins 970-491-9888 • [www.jrengineering.com](http://www.jrengineering.com)

Hydrologic Soil Group—El Paso County Area, Colorado

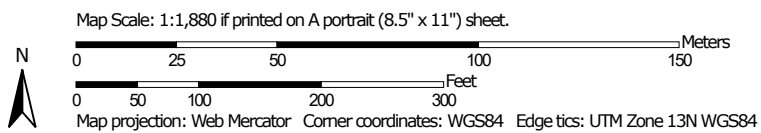

## MAP LEGEND

### Area of Interest (AOI)









 Area of Interest (AOI)

### Soils

#### Soil Rating Polygons





 A  
 A/D  
 B  
 B/D  
 C  
 C/D  
 D  
 Not rated or not available

#### Soil Rating Lines

 A  
 A/D  
 B  
 B/D  
 C  
 C/D  
 D  
 Not rated or not available

#### Soil Rating Points

 A  
 A/D  
 B  
 B/D

 C  
 C/D  
 D  
 Not rated or not available

### Water Features

 Streams and Canals

### Transportation

 Rails  
 Interstate Highways  
 US Routes  
 Major Roads  
 Local Roads

### Background

 Aerial Photography

## MAP INFORMATION

The soil surveys that comprise your AOI were mapped at 1:24,000.

Warning: Soil Map may not be valid at this scale.

Enlargement of maps beyond the scale of mapping can cause misunderstanding of the detail of mapping and accuracy of soil line placement. The maps do not show the small areas of contrasting soils that could have been shown at a more detailed scale.

Please rely on the bar scale on each map sheet for map measurements.

Source of Map: Natural Resources Conservation Service  
 Web Soil Survey URL:  
 Coordinate System: Web Mercator (EPSG:3857)

Maps from the Web Soil Survey are based on the Web Mercator projection, which preserves direction and shape but distorts distance and area. A projection that preserves area, such as the Albers equal-area conic projection, should be used if more accurate calculations of distance or area are required.

This product is generated from the USDA-NRCS certified data as of the version date(s) listed below.

Soil Survey Area: El Paso County Area, Colorado  
 Survey Area Data: Version 20, Sep 2, 2022

Soil map units are labeled (as space allows) for map scales 1:50,000 or larger.

Date(s) aerial images were photographed: Sep 11, 2018—Oct 20, 2018

The orthophoto or other base map on which the soil lines were compiled and digitized probably differs from the background imagery displayed on these maps. As a result, some minor shifting of map unit boundaries may be evident.



## Hydrologic Soil Group

Map unit symbol	Map unit name	Rating	Acres in AOI	Percent of AOI
71	Pring coarse sandy loam, 3 to 8 percent slopes	B	6.8	100.0%
<b>Totals for Area of Interest</b>			<b>6.8</b>	<b>100.0%</b>

### Description

Hydrologic soil groups are based on estimates of runoff potential. Soils are assigned to one of four groups according to the rate of water infiltration when the soils are not protected by vegetation, are thoroughly wet, and receive precipitation from long-duration storms.

The soils in the United States are assigned to four groups (A, B, C, and D) and three dual classes (A/D, B/D, and C/D). The groups are defined as follows:

Group A. Soils having a high infiltration rate (low runoff potential) when thoroughly wet. These consist mainly of deep, well drained to excessively drained sands or gravelly sands. These soils have a high rate of water transmission.

Group B. Soils having a moderate infiltration rate when thoroughly wet. These consist chiefly of moderately deep or deep, moderately well drained or well drained soils that have moderately fine texture to moderately coarse texture. These soils have a moderate rate of water transmission.

Group C. Soils having a slow infiltration rate when thoroughly wet. These consist chiefly of soils having a layer that impedes the downward movement of water or soils of moderately fine texture or fine texture. These soils have a slow rate of water transmission.

Group D. Soils having a very slow infiltration rate (high runoff potential) when thoroughly wet. These consist chiefly of clays that have a high shrink-swell potential, soils that have a high water table, soils that have a claypan or clay layer at or near the surface, and soils that are shallow over nearly impervious material. These soils have a very slow rate of water transmission.

If a soil is assigned to a dual hydrologic group (A/D, B/D, or C/D), the first letter is for drained areas and the second is for undrained areas. Only the soils that in their natural condition are in group D are assigned to dual classes.

### Rating Options

*Aggregation Method:* Dominant Condition

*Component Percent Cutoff: None Specified*

*Tie-break Rule: Higher*

**NOTES TO USERS**

This map is for use in administering the National Flood Insurance Program. It does not necessarily identify all areas subject to flooding, particularly from local drainage sources of small size. The community map repository should be consulted for possible updated or additional flood hazard information.

To obtain more detailed information in areas where **Base Flood Elevations (BFEs)** and/or **floodways** have been determined, users are encouraged to consult the Flood Profiles and Floodway Data and/or Summary of Stillwater Elevations tables contained within the Flood Insurance Study (FIS) report that accompanies this FIRM. Users should be aware that BFEs shown on the FIRM represent rounded whole-foot elevations. These BFEs are intended for flood insurance rating purposes only and should not be used as the sole source of flood elevation information. Accordingly, flood elevation data presented in the FIS report should be utilized in conjunction with the FIRM for purposes of construction and/or floodplain management.

**Coastal Base Flood Elevations** shown on this map apply only landward of 0.0' North American Vertical Datum of 1988 (NAVD88). Users of this FIRM should be aware that coastal flood elevations are also provided in the Summary of Stillwater Elevations table in the Flood Insurance Study report for this jurisdiction. Elevations shown in the Summary of Stillwater Elevations table should be used for construction and/or floodplain management purposes when they are higher than the elevations shown on this FIRM.

Boundaries of the **floodways** were computed at cross sections and interpolated between cross sections. The floodways were based on hydraulic considerations with regard to requirements of the National Flood Insurance Program. Floodway widths and other pertinent floodway data are provided in the Flood Insurance Study report for this jurisdiction.

Certain areas not in Special Flood Hazard Areas may be protected by **flood control structures**. Refer to section 2.4 "Flood Protection Measures" of the Flood Insurance Study report for information on flood control structures for this jurisdiction.

The **projection** used in the preparation of this map was Universal Transverse Mercator (UTM) zone 13. The **horizontal datum** was NAD83, GRS80 spheroid. Differences in datum, spheroid, projection or UTM zones zones used in the production of FIRMs for adjacent jurisdictions may result in slight positional differences in map features across jurisdiction boundaries. These differences do not affect the accuracy of this FIRM.

Flood elevations on this map are referenced to the **North American Vertical Datum of 1988 (NAVD88)**. These flood elevations must be compared to structure and ground elevations referenced to the same **vertical datum**. For information regarding conversion between the National Geodetic Vertical Datum of 1929 and the North American Vertical Datum of 1988, visit the National Geodetic Survey website at <http://www.ngs.noaa.gov/> or contact the National Geodetic Survey at the following address:

NGS Information Services  
NOAA, NIMS12  
National Geodetic Survey  
SSMC-3, #9202  
1315 East-West Highway  
Silver Spring, MD 20910-3282

To obtain current elevation, description, and/or location information for **bench marks** shown on this map, please contact the Information Services Branch of the National Geodetic Survey at (301) 713-3242 or visit its website at <http://www.ngs.noaa.gov/>.

**Base Map** information shown on this FIRM was provided in digital format by El Paso County, Colorado Springs Utilities, and Anderson Consulting Engineers, Inc. These data are current as of 2008.

This map reflects more detailed and up-to-date **stream channel configurations and floodplain delineations** than those shown on the previous FIRM for this jurisdiction. The floodplains and floodways that were transferred from the previous FIRM may have been adjusted to conform to these new stream channel configurations. As a result, the Flood Profiles and Floodway Data tables in the Flood Insurance Study Report (which contains authoritative hydraulic data) may reflect stream channel distances that differ from what is shown on this map. The profile baselines depicted on this map represent the hydraulic modeling baselines that match the flood profiles and Floodway Data Tables if applicable, in the FIS report. As a result, the profile baselines may deviate significantly from the new base map channel representation and may appear outside of the floodplain.

**Corporate limits** shown on this map are based on the best data available at the time of publication. Because changes due to annexations or de-annexations may have occurred after this map was published, map users should contact appropriate community officials to verify current corporate limit locations.

Please refer to the separately printed **Map Index** for an overview map of the county showing the layout of map panels; community map repository addresses; and a Listing of Communities table containing National Flood Insurance Program dates for each community as well as a listing of the panels on which each community is located.

Contact **FEMA Map Service Center (MSC)** via the FEMA Map Information eXchange (FIRM) 1-877-336-2627 for information on available products associated with this FIRM. Available products may include previously issued Letters of Map Change, a Flood Insurance Study Report, and/or digital versions of this map. The MSC may also be reached by Fax at 1-800-358-9620 and its website at <http://www.msc.fema.gov/>.

If you have **questions about this map** or questions concerning the National Flood Insurance Program in general, please call **1-877-FEMA MAP (1-877-336-2627)** or visit the FEMA website at <http://www.fema.gov/business/nfp>.

**El Paso County Vertical Datum Offset Table**

Flooding Source	Vertical Datum Offset (ft)

REFER TO SECTION 3.3 OF THE EL PASO COUNTY FLOOD INSURANCE STUDY FOR STREAM BY STREAM VERTICAL DATUM CONVERSION INFORMATION

**Panel Location Map**

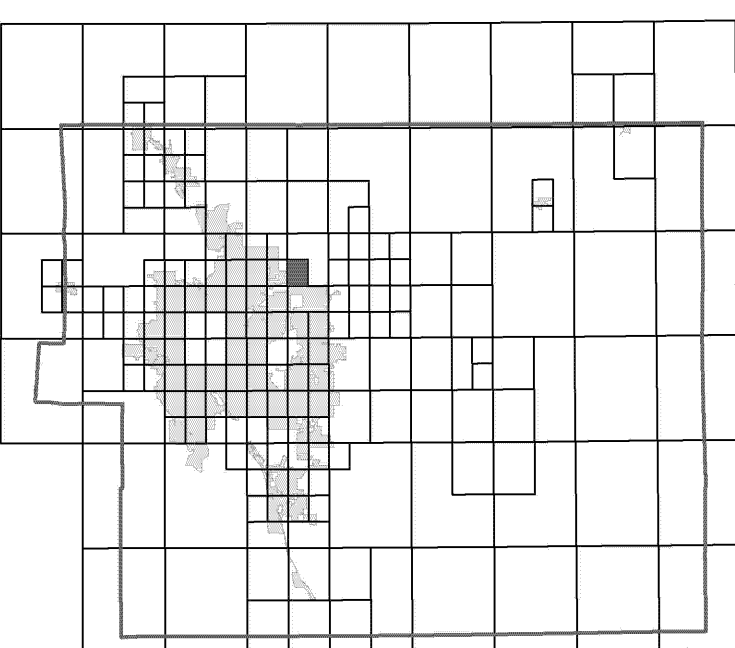

This Digital Flood Insurance Rate Map (DFIRM) was produced through a Cooperating Technical Partner (CTP) agreement between the State of Colorado Water Conservation Board (CWCB) and the Federal Emergency Management Agency (FEMA).



Additional Flood Hazard information and resources are available from local communities and the Colorado Water Conservation Board.

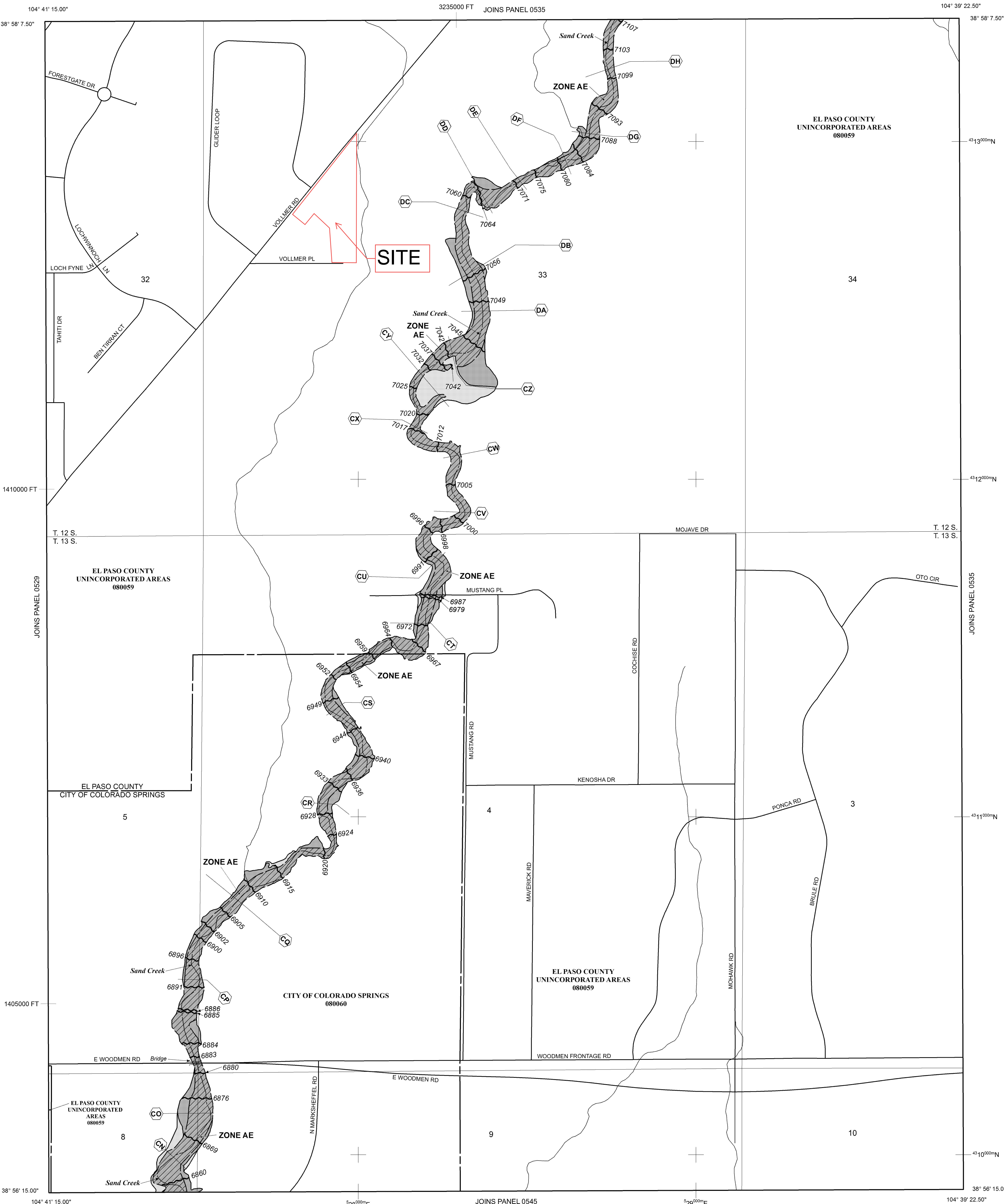

NOTE: MAP AREA SHOWN ON THIS PANEL IS LOCATED WITHIN TOWNSHIP 12 SOUTH, RANGE 65 WEST, AND TOWNSHIP 13 SOUTH, RANGE 65 WEST.

**LEGEND**

**SPECIAL FLOOD HAZARD AREAS (SFHAS) SUBJECT TO INUNDATION BY THE 1% ANNUAL CHANCE FLOOD**

The 1% annual chance flood (100-year flood), also known as the base flood, is the flood that has a 1% chance of being equalled or exceeded in any given year. The Special Flood Hazard Area is the area subject, to flooding by the 1% annual chance flood. Areas of Special Flood Hazard include Zones A, AE, AH, AO, AR, A99, V, and VE. The Base Flood Elevation is the water-surface elevation of the 1% annual chance flood.

- ZONE A** No Base Flood Elevations determined.
- ZONE AE** Base Flood Elevations determined.
- ZONE AH** Flood depths of 1 to 3 feet (usually areas of ponding); Base Flood Elevations determined.
- ZONE AO** Flood depths of 1 to 3 feet (usually sheet flow on sloping terrain); average depths determined. For areas of alluvial fan flooding, velocities also determined.
- ZONE AR** Special Flood Hazard Area Formerly protected from the 1% annual chance flood by a flood control system that was subsequently decertified. Zone AR indicates that the former flood control system is being restored to provide protection from the 1% annual chance or greater flood.
- ZONE A99** Area to be protected from 1% annual chance flood by a Federal flood protection system under construction; no Base Flood Elevations determined.
- ZONE V** Coastal flood zone with velocity hazard (wave action); no Base Flood Elevations determined.
- ZONE VE** Coastal flood zone with velocity hazard (wave action); Base Flood Elevations determined.

**FLOODWAY AREAS IN ZONE AE**  
The floodway is the channel of a stream plus any adjacent floodplain areas that must be kept free of encroachment so that the 1% annual chance flood can be carried without substantial increases in flood heights.

**OTHER FLOOD AREAS**  
**ZONE X** Areas of 0.2% annual chance flood; areas of 1% annual chance flood with average depths of less than 1 foot or with drainage areas less than 1 square mile; and areas protected by levees from 1% annual chance flood.

**OTHER AREAS**  
**ZONE X** Areas determined to be outside the 0.2% annual chance floodplain.

**ZONE D** Areas in which flood hazards are undetermined, but possible.

**COASTAL BARRIER RESOURCES SYSTEM (CBRS) AREAS**

**OTHERWISE PROTECTED AREAS (OPAs)**

CBRS areas and OPAs are normally located within or adjacent to Special Flood Hazard Areas.

- Floodplain boundary
- Floodway boundary
- Zone D Boundary
- CBRS and OPA boundary

Boundary dividing Special Flood Hazard Areas of different Base Flood Elevations, flood depths or flood velocities.

Base Flood Elevation value and value; elevation in feet\* (EL 987)

Base Flood Elevation value where uniform within zone; elevation in feet\*

\* Referenced to the North American Vertical Datum of 1988 (NAVD 88)

Cross section line

Transsect line

Geographic coordinates referenced to the North American Datum of 1983 (NAD 83)

1000-meter Universal Transverse Mercator grid ticks, zone 13

5000-foot grid ticks: Colorado State Plane coordinate system, central zone (EPSZONE 0502), Lambert Conformal Conic Projection

Bench mark (see explanation in Notes to Users section of this FIRM panel)

River Mile

MAP REPOSITORIES  
Refer to Map Repositories list on Map Index

EFFECTIVE DATE OF COUNTYWIDE FLOOD INSURANCE RATE MAP

MARCH 17, 1997

EFFECTIVE DATE(S) OF REVISION(S) TO THIS PANEL

DECEMBER 7, 2018 - to update corporate limits, to change Base Flood Elevations and Special Flood Hazard Areas, to update map format, to add roads and road names, and to incorporate previously issued Letters of Map Revision.

For community map revision history prior to countywide mapping, refer to the Community Map History Table located in the Flood Insurance Study report for this jurisdiction.

To determine if flood insurance is available in this community, contact your insurance agent or call the National Flood Insurance Program at 1-800-638-6620.

MAP SCALE 1" = 500'

250 0 500 1000 FEET

150 0 150 300 METERS

**NFIP**

**PANEL 0533G**

---

**FIRM**  
**FLOOD INSURANCE RATE MAP**  
**EL PASO COUNTY,**  
**COLORADO**  
**AND INCORPORATED AREAS**

**PANEL 533 OF 1300**  
(SEE MAP INDEX FOR FIRM PANEL LAYOUT)

CONTAINS:

COMMUNITY	NUMBER	PANEL	SUFFIX
COLORADO SPRINGS, CITY OF	08060	0533	G
EL PASO COUNTY	08059	0533	G

Notice to User: The Map Number shown below should be used when placing map orders. The Community Number shown above should be used on insurance applications for the subject community.

**MAP NUMBER**  
**08041C0533G**

**MAP REVISED**  
**DECEMBER 7, 2018**  
Federal Emergency Management Agency

**APPENDIX B**

**HYDROLOGIC CALCULATIONS**

## COMPOSITE % IMPERVIOUS CALCULATIONS - EXISTING CONDITIONS

**Subdivision:** MC CLINTOCK STATION  
**Location:** Colorado Springs

**Project Name:** Vollmer Road RV Storage  
**Project No.:** 25251.00  
**Calculated By:** APL  
**Checked By:** REB  
**Date:** 5/10/23

Basin ID	Total Area (ac)	Drives/Walks (100% Imp.)				Roofs (90%)				Pasture/Meadow (2% Imp.)				Basins Total Weighted C		Basins Total Weighted
		C <sub>5</sub>	C <sub>100</sub>	Area (ac)	Weighted % Imp.	C <sub>5</sub>	C <sub>100</sub>	Area (ac)	Weighted % Imp.	C <sub>5</sub>	C <sub>100</sub>	Area (ac)	Weighted % Imp.	C <sub>5</sub>	C <sub>100</sub>	
EX-1	0.48	0.90	0.96	0.00	0.0%	0.73	0.81	0.00	0.0%	0.09	0.36	0.48	2.0%	0.09	0.36	2.0%
EX-2	3.41	0.90	0.96	0.00	0.0%	0.73	0.81	0.00	0.0%	0.09	0.36	3.41	2.0%	0.09	0.36	2.0%
EX-3	0.56	0.90	0.96	0.00	0.0%	0.73	0.81	0.00	0.0%	0.09	0.36	0.56	2.0%	0.09	0.36	2.0%
EX-4	0.73	0.90	0.96	0.03	3.5%	0.73	0.81	0.05	6.0%	0.09	0.36	0.66	1.8%	0.16	0.41	11.3%
EX-5	1.66	0.90	0.96	0.02	1.0%	0.73	0.81	0.02	1.1%	0.09	0.36	1.62	2.0%	0.11	0.37	4.0%
OS-6	0.14	0.90	0.96	0.05	34.3%	0.73	0.81	0.00	0.0%	0.09	0.36	0.09	1.3%	0.37	0.57	35.6%
OS-7	0.27	0.90	0.96	0.08	28.1%	0.73	0.81	0.00	0.0%	0.09	0.36	0.19	1.4%	0.32	0.53	29.5%
OS-8	0.41	0.90	0.96	0.12	30.4%	0.73	0.81	0.00	0.0%	0.09	0.36	0.29	1.4%	0.34	0.54	31.8%
OS-9	0.46	0.90	0.96	0.10	22.0%	0.73	0.81	0.12	23.5%	0.09	0.36	0.24	1.0%	0.43	0.61	46.5%
Total (EX1-5)	<b>6.84</b>															<b>3.5%</b>
<b>TOTAL</b>	<b>8.12</b>															<b>8.8%</b>

## STANDARD FORM SF-2 - EXISTING CONDITIONS TIME OF CONCENTRATION

Subdivision: MC CLINTOCK STATION  
Location: El Paso County

Project Name: Vollmer Road RV Storage  
Project No.: 25251.00  
Calculated By: APL  
Checked By: REB  
Date: 5/10/23

SUB-BASIN						INITIAL/OVERLAND			TRAVEL TIME					tc CHECK			FINAL
DATA						(Ti)			(Ti)					(URBANIZED BASINS)			
BASIN ID	D.A. (ac)	Hydrologic Soils Group	Impervious (%)	C <sub>5</sub>	C <sub>100</sub>	L (ft)	S <sub>o</sub> (%)	t <sub>i</sub> (min)	L <sub>t</sub> (ft)	S <sub>t</sub> (%)	K	VEL. (ft/s)	t <sub>t</sub> (min)	COMP. t <sub>c</sub> (min)	TOTAL LENGTH (ft)	Urbanized t <sub>c</sub> (min)	
EX-1	0.48	B	2%	0.09	0.36	136	2.8%	15.2	0	0.0%	7.0	0.0	0.0	15.2	136.0	25.7	15.2
EX-2	3.41	B	2%	0.09	0.36	226	4.2%	17.0	423	2.5%	7.0	1.1	6.4	23.4	649.0	30.5	23.4
EX-3	0.56	B	2%	0.09	0.36	122	5.6%	11.4	0	0.0%	7.0	0.0	0.0	11.4	121.7	25.7	11.4
EX-4	0.73	B	11%	0.16	0.41	116	1.8%	15.0	219	2.8%	7.0	1.2	3.1	18.2	335.0	26.1	18.2
EX-5	1.66	B	4%	0.11	0.37	300	2.5%	23.0	260	3.2%	7.0	1.2	3.5	26.5	560.0	27.9	26.5
OS-6	0.14	B	36%	0.37	0.57	40	5.7%	4.7	0	0.0%	7.0	0.0	0.0	4.7	39.5	19.9	5.0
OS-7	0.27	B	30%	0.32	0.53	40	5.7%	5.0	0	0.0%	7.0	0.0	0.0	5.0	39.5	21.0	5.0
OS-8	0.41	B	32%	0.34	0.54	22	9.0%	3.1	455	2.5%	7.0	1.1	6.9	10.0	476.9	24.2	10.0
OS-9	0.46	B	46%	0.43	0.61	92	1.8%	9.5	241	2.0%	7.0	1.0	4.1	13.6	333.0	19.9	13.6

**NOTES:**

$$t_c = t_i + t_t$$

Where:

t<sub>c</sub> = computed time of concentration (minutes)

t<sub>i</sub> = overland (initial) flow time (minutes)

t<sub>t</sub> = channelized flow time (minutes).

$$t_t = \frac{L_t}{60K\sqrt{S_o}} = \frac{L_t}{60V_t}$$

Where:

t<sub>t</sub> = channelized flow time (travel time, min)

L<sub>t</sub> = waterway length (ft)

S<sub>o</sub> = waterway slope (ft/ft)

V<sub>t</sub> = travel time velocity (ft/sec) = K√S<sub>o</sub>

K = NRCS conveyance factor (see Table 6-2).

Equation 6-2 
$$t_i = \frac{0.395(1.1 - C_5)\sqrt{L_i}}{S_o^{0.33}}$$

Where:

t<sub>i</sub> = overland (initial) flow time (minutes)

C<sub>5</sub> = runoff coefficient for 5-year frequency (from Table 6-4)

L<sub>i</sub> = length of overland flow (ft)

S<sub>o</sub> = average slope along the overland flow path (ft/ft).

Equation 6-4 
$$t_t = (26 - 17i) + \frac{L_t}{60(14i + 9)\sqrt{S_o}}$$

Where:

t<sub>t</sub> = minimum time of concentration for first design point when less than t<sub>c</sub> from Equation 6-1.

L<sub>t</sub> = length of channelized flow path (ft)

i = imperviousness (expressed as a decimal)

S<sub>o</sub> = slope of the channelized flow path (ft/ft).

Equation 6-3

Table 6-2. NRCS Conveyance factors, K

Type of Land Surface	Conveyance Factor, K
Heavy meadow	2.5
Tillage/field	5
Short pasture and lawns	7
Nearly bare ground	10
Grassed waterway	15
Paved areas and shallow paved swales	20

**STANDARD FORM SF-3 - EXISTING CONDITIONS**  
**STORM DRAINAGE SYSTEM DESIGN**  
(RATIONAL METHOD PROCEDURE)

Subdivision: MC CLINTOCK STATION  
Location: El Paso County  
Design Storm: 5-Year

Project Name: Vollmer Road RV Storage  
Project No.: 25251.00  
Calculated By: APL  
Checked By: REB  
Date: 5/10/23

STREET	Design Point	DIRECT RUNOFF							TOTAL RUNOFF				STREET			PIPE				TRAVEL TIME			REMARKS
		Basin ID	Area (Ac)	Runoff Coeff.	$t_c$ (min)	C*A (Ac)	I (in/hr)	Q (cfs)	$t_c$ (min)	C*A (ac)	I (in/hr)	Q (cfs)	$Q_{street}$ (cfs)	C*A (ac)	Slope (%)	$Q_{pipe}$ (cfs)	C*A (ac)	Slope (%)	Pipe Size (inches)	Length (ft)	Velocity (fps)	$t_c$ (min)	
	6	OS-6	0.14	0.37	5.0	0.05	5.17	0.3															Runoff from Basin OS-6, overland flows southeast, across Vollmer Road and into the Site at DP6.
	1	EX-1	0.48	0.09	15.2	0.04	3.50	0.2															Runoff from Basin EX-1, overland flows southeast, across the property line to Lot B at DP1.
	1.1								15.2	0.09	3.50	0.3											Runoff from Basins EX-1 and OS-1 combine at DP1.1 and continue onto Lot B
	7	OS-7	0.27	0.32	5.0	0.09	5.17	0.4															Runoff from Basin OS-7, overland flows southeast, across Vollmer Road and into the Site at DP7.
	8	OS-8	0.41	0.34	10.0	0.14	4.13	0.6															Runoff from Basin OS-8, overland flows southeast, across Vollmer Road and into a road side swale, flow from the swale enters the Site at DP8.
	2	EX-2	3.41	0.09	23.4	0.31	2.85	0.9															Runoff from Basin EX-2, overland flows southeast, across the property line to Lot C at DP2.
	2.1								23.4	0.53	2.85	1.5											Runoff from Basins EX-2, OS-7, and OS-8 combine at DP2.1 and continue onto Lot C
	3	EX-3	0.56	0.09	11.4	0.05	3.93	0.2															Runoff from Basin EX-3, overland flows east, across the property line to an existing swale in the Homestead at Stearling Ranch Development
	4	EX-4	0.73	0.16	18.2	0.12	3.23	0.4															Runoff from Basin EX-4, overland flows south, across the property line to Lot C at DP4. Flow continues to DP9.1
	9	OS-9	0.46	0.43	13.6	0.20	3.66	0.7															Runoff from Basin OS-9, overland flows southeast, to a roadsideswale and into the Site at DP9.
	9.1								18.2	0.32	3.23	1.0											Runoff from Basins EX-4, and OS-9 combine at DP9.1 and continue onto the site
	5	EX-5	1.66	0.11	26.5	0.18	2.67	0.5															Runoff from Basin EX-5, overland flows south to a roadside ditch along Vollmer PI and leaves the site at DP5
	5.1								26.5	0.49	2.67	1.3											Runoff from Basins EX-5, and DP9.1 combine at DP5.1 and continue to flow in the roadside swale to the south

Notes:  
Street and Pipe C\*A values are determined by Q/i using the catchment's intensity value.

**STANDARD FORM SF-3 - EXISTING CONDITIONS**  
**STORM DRAINAGE SYSTEM DESIGN**  
(RATIONAL METHOD PROCEDURE)

Subdivision: MC CLINTOCK STATION  
Location: El Paso County  
Design Storm: 100-Year

Project Name: Vollmer Road RV Storage  
Project No.: 25251.00  
Calculated By: APL  
Checked By: REB  
Date: 5/10/23

STREET	Design Point	DIRECT RUNOFF						TOTAL RUNOFF			STREET			PIPE			TRAVEL TIME			REMARKS		
		Basin ID	Area (ac)	Runoff Coeff.	t <sub>c</sub> (min)	C*A (ac)	I (in/hr)	Q (cfs)	t <sub>c</sub> (min)	C*A (ac)	I (in/hr)	Q (cfs)	Q <sub>street</sub> (cfs)	C*A (ac)	Slope (%)	Q <sub>pipe</sub> (cfs)	C*A (ac)	Slope (%)	Pipe Size (inches)		Length (ft)	Velocity (fps)
	6	OS-6	0.14	0.57	5.0	0.08	8.68	0.7														Runoff from Basin OS-6, overland flows southeast, across Vollmer Road and into the Site at DP6.
	1	EX-1	0.48	0.36	15.2	0.17	5.87	1.0														Runoff from Basin EX-1, overland flows southeast, across the property line to Lot B at DP1.
	1.1								15.2	0.25	5.87	1.5										Runoff from Basins EX-1 and OS-1 combine at DP1.1 and continue onto Lot B
	7	OS-7	0.27	0.53	5.0	0.14	8.68	1.2														Runoff from Basin OS-7, overland flows southeast, across Vollmer Road and into the Site at DP7.
	8	OS-8	0.41	0.54	10.0	0.22	6.93	1.5														Runoff from Basin OS-8, overland flows southeast, across Vollmer Road and into a road side swale, flow from the swale enters the Site at DP8.
	2	EX-2	3.41	0.36	23.4	1.23	4.79	5.9														Runoff from Basin EX-2, overland flows southeast, across the property line to Lot C at DP2.
	2.1								23.4	1.59	4.79	7.6										Runoff from Basins EX-2, OS-7, and OS-8 combine at DP2.1 and continue onto Lot C
	3	EX-3	0.56	0.36	11.4	0.20	6.61	1.3														Runoff from Basin EX-3, overland flows east, across the property line to an existing swale in the Homestead at Stearling Ranch Development
	4	EX-4	0.73	0.41	18.2	0.30	5.43	1.6														Runoff from Basin EX-4, overland flows south, across the property line to Lot C at DP4. Flow continues to DP9.1
	9	OS-9	0.46	0.61	13.6	0.28	6.15	1.7														Runoff from Basin OS-9, overland flows southeast, to a roadsideswale and into the Site at DP9.
	9.1								18.2	0.58	5.43	3.1										Runoff from Basins EX-4, and OS-9 combine at DP9.1 and continue onto the site
	5	EX-5	1.66	0.37	26.5	0.62	4.48	2.8														Runoff from Basin EX-5, overland flows south to a roadside ditch along Vollmer Pl and leaves the site at DP5
	5.1								26.5	1.20	4.48	5.4										Runoff from Basins EX-5, and DP9.1 combine at DP5.1 and continue to flow in the roadside swale to the south

Notes:  
Street and Pipe C\*A values are determined by Q/I using the catchment's intensity value.



## COMPOSITE % IMPERVIOUS CALCULATIONS - PROPOSED CONDITIONS

Subdivision: MC CLINTOCK STATION  
 Location: El Paso County

Project Name: Vollmer Road RV Storage  
 Project No.: 25251.00  
 Calculated By: APL  
 Checked By: REB  
 Date: 11/16/23

Basin ID	Total Area (ac)	Drives/Walks (100% Imp.)				Roofs (90%)				Pasture/Meadow (2% Imp.)				Basins Total Weighted C		Basins Total Weighted % Imp.
		C <sub>5</sub>	C <sub>100</sub>	Area (ac)	Weighted % Imp.	C <sub>5</sub>	C <sub>100</sub>	Area (ac)	Weighted % Imp.	C <sub>5</sub>	C <sub>100</sub>	Area (ac)	Weighted % Imp.	C <sub>5</sub>	C <sub>100</sub>	
A	1.43	0.90	0.96	0.98	68.5%	0.73	0.81	0.00	0.0%	0.09	0.36	0.45	0.6%	0.65	0.77	69.2%
B	2.20	0.90	0.96	1.72	78.2%	0.73	0.81	0.00	0.0%	0.09	0.36	0.48	0.4%	0.72	0.83	78.6%
C	1.57	0.90	0.96	1.17	74.5%	0.73	0.81	0.00	0.0%	0.09	0.36	0.40	0.5%	0.69	0.81	75.0%
D	0.82	0.90	0.96	0.38	46.3%	0.73	0.81	0.00	0.0%	0.09	0.36	0.44	1.1%	0.47	0.64	47.4%
E	0.17	0.90	0.96	0.01	5.9%	0.73	0.81	0.00	0.0%	0.09	0.36	0.16	1.9%	0.14	0.40	7.8%
F	0.07	0.90	0.96	0.00	0.0%	0.73	0.81	0.00	0.0%	0.09	0.36	0.07	2.0%	0.09	0.36	2.0%
G	0.24	0.90	0.96	0.00	0.0%	0.73	0.81	0.00	0.0%	0.09	0.36	0.24	2.0%	0.09	0.36	2.0%
H	0.12	0.90	0.96	0.00	0.0%	0.73	0.81	0.00	0.0%	0.09	0.36	0.12	2.0%	0.09	0.36	2.0%
I	0.24	0.90	0.96	0.11	45.5%	0.73	0.81	0.00	0.0%	0.09	0.36	0.13	1.1%	0.46	0.63	46.5%
OS-9	0.46	0.90	0.96	0.10	21.7%	0.73	0.81	0.12	23.5%	0.09	0.36	0.24	1.0%	0.43	0.61	46.3%
OS-10	0.81	0.90	0.96	0.24	29.6%	0.73	0.81	0.00	0.0%	0.09	0.36	0.57	1.4%	0.33	0.54	31.0%
<b>TOTAL</b>	<b>8.13</b>															<b>57.0%</b>

Pond Total (A-D) 6.02

71%

## STANDARD FORM SF-2 - PROPOSED CONDITIONS TIME OF CONCENTRATION

Subdivision: MC CLINTOCK STATION  
Location: El Paso County

Project Name: Vollmer Road RV Storage  
Project No.: 25251.00  
Calculated By: APL  
Checked By: REB  
Date: 11/16/23

SUB-BASIN						INITIAL/OVERLAND			TRAVEL TIME					tc CHECK			FINAL
DATA						(Ti)			(Ti)					(URBANIZED BASINS)			
BASIN ID	D.A. (ac)	Hydrologic Soils Group	Impervious (%)	C <sub>s</sub>	C <sub>100</sub>	L (ft)	S <sub>o</sub> (%)	t <sub>i</sub> (min)	L <sub>t</sub> (ft)	S <sub>t</sub> (%)	K	VEL. (ft/s)	t <sub>c</sub> (min)	COMP. t <sub>c</sub> (min)	TOTAL LENGTH (ft)	Urbanized t <sub>c</sub> (min)	
A	1.43	B	69%	0.65	0.77	100.0	3.8%	5.3	441.0	2.4%	20.0	3.1	2.4	7.7	541.0	16.8	7.7
B	2.20	B	79%	0.72	0.83	100.0	3.0%	4.7	515.0	1.5%	20.0	2.4	3.6	8.3	615.0	16.2	8.3
C	1.57	B	75%	0.69	0.81	100.0	1.8%	6.0	302.4	1.6%	20.0	2.5	2.0	8.1	402.4	15.3	8.1
D	0.82	B	47%	0.47	0.64	100.0	3.2%	7.8	129.0	4.7%	7.0	1.5	1.4	9.2	229.0	18.6	9.2
E	0.17	B	8%	0.14	0.40	50.6	5.5%	7.1	0.0	0.0%	7.0	0.0	0.0	7.1	50.6	24.7	7.1
F	0.07	B	2%	0.09	0.36	26.6	1.7%	7.9	0.0	0.0%	7.0	0.0	0.0	7.9	26.6	25.7	7.9
G	0.24	B	2%	0.09	0.36	19.5	29.0%	2.7	0.0	0.0%	7.0	0.0	0.0	2.7	19.5	25.7	5.0
H	0.12	B	2%	0.09	0.36	17.3	30.0%	2.5	0.0	0.0%	7.0	0.0	0.0	2.5	17.3	25.7	5.0
I	0.24	B	47%	0.46	0.63	57.7	3.1%	6.1	89.1	5.0%	20.0	4.5	0.3	6.4	146.8	18.5	6.4
OS-9	0.46	B	46%	0.43	0.61	92.0	1.8%	9.5	241.0	2.0%	7.0	1.0	4.1	13.6	333.0	20.0	13.6
OS-10	0.81	B	31%	0.33	0.54	22.0	10.0%	3.0	932.5	2.1%	7.0	1.0	15.2	18.3	954.5	28.7	18.3

**NOTES:**

$$t_c = t_i + t_t$$

Where:

t<sub>c</sub> = computed time of concentration (minutes)

t<sub>i</sub> = overland (initial) flow time (minutes)

t<sub>t</sub> = channelized flow time (minutes).

$$t_t = \frac{L_t}{60K\sqrt{S_o}} = \frac{L_t}{60V_t}$$

Where:

t<sub>t</sub> = channelized flow time (travel time, min)

L<sub>t</sub> = waterway length (ft)

S<sub>o</sub> = waterway slope (ft/ft)

V<sub>t</sub> = travel time velocity (ft/sec) = K√S<sub>o</sub>

K = NRCS conveyance factor (see Table 6-2).

Equation 6-2

$$t_i = \frac{0.395(1.1 - C_s)\sqrt{L}}{S_o^{0.33}}$$

Where:

t<sub>i</sub> = overland (initial) flow time (minutes)

C<sub>s</sub> = runoff coefficient for 5-year frequency (from Table 6-4)

L = length of overland flow (ft)

S<sub>o</sub> = average slope along the overland flow path (ft/ft).

Equation 6-4

$$t_c = (26 - 17i) + \frac{L_t}{60(14i + 9)\sqrt{S_o}}$$

Where:

t<sub>c</sub> = minimum time of concentration for first design point when less than t<sub>c</sub> from Equation 6-1.

L<sub>t</sub> = length of channelized flow path (ft)

i = imperviousness (expressed as a decimal)

S<sub>o</sub> = slope of the channelized flow path (ft/ft).

Equation 6-3

Table 6-2. NRCS Conveyance factors, K

Type of Land Surface	Conveyance Factor, K
Heavy meadow	2.5
Tillage/field	5
Short pasture and lawns	7
Nearly bare ground	10
Grassed waterway	15
Paved areas and shallow paved swales	20

Use a minimum t<sub>c</sub> value of 5 minutes for urbanized areas and a minimum t<sub>c</sub> value of 10 minutes for areas that are not considered urban. Use minimum values even when calculations result in a lesser time of concentration.

**STANDARD FORM SF-3 - PROPOSED CONDITIONS**  
**STORM DRAINAGE SYSTEM DESIGN**  
(RATIONAL METHOD PROCEDURE)

Subdivision: MC CLINTOCK STATION  
Location: El Paso County  
Design Storm: 5-Year

Project Name: Vollmer Road RV Storage  
Project No.: 25251.00  
Calculated By: APL  
Checked By: REB  
Date: 11/16/23

STREET	Design Point	DIRECT RUNOFF							TOTAL RUNOFF				STREET			PIPE				TRAVEL TIME			REMARKS
		Basin ID	Area (Ac)	Runoff Coeff.	t <sub>c</sub> (min)	C*A (Ac)	I (in/hr)	Q (cfs)	t <sub>c</sub> (min)	C*A (ac)	I (in/hr)	Q (cfs)	Q <sub>street</sub> (cfs)	C*A (ac)	Slope (%)	Q <sub>pipe</sub> (cfs)	C*A (ac)	Slope (%)	Pipe Size (inches)	Length (ft)	Velocity (fps)	t <sub>t</sub> (min)	
	1	A	1.43	0.65	7.7	0.92	4.52	4.2							4.2	0.92	1.6	18	139	6.6	0.4	Runoff from Basin A, overland flows south to DP1 , flow enters Inlet A a Type C inlet in sump. Flow passes through the proposed sewer to DP 2.1	
	2	B	2.20	0.72	8.3	1.59	4.41	7.0														Runoff from Basin B, overland flows south to DP2, flow enters Inlet B a Type C inlet in sump. Flow passes through the proposed sewer to DP 2.1	
	2.1								8.3	2.51	4.41	11.1			11.1	2.51	0.5	24	114	5.5	0.3	Flows for DP1 and DP2 combine in proposed storm sewer system.	
	3	C	1.57	0.69	8.1	1.09	4.45	4.8							4.8	1.09	0.5	18	47	4.4	0.2	Runoff from Basin B, overland flows to DP3 , flow enters Inlet C a Type C inlet in sump. Flow passes through the proposed sewer to DP 3.1	
	3.1								8.6	3.60	4.35	15.7										Flows for DP2.1 and DP3 combine in proposed storm sewer system.	
	4	D	0.82	0.47	9.2	0.38	4.25	1.6														Runoff from Basin D, overland flows to the trickle channel at the bottom of the pond	
	5	E	0.17	0.14	7.1	0.02	4.65	0.1														Runoff from Basin E, overland flows east, across the property line to an existng swale in the Homestead at Stearling Ranch Development at DP5	
	6	F	0.07	0.09	7.9	0.01	4.48	0.0														Runoff from Basin F, overland flows east, across the property line to the Homestead at Stearling Ranch Development at DP 6	
	09	OS-9	0.46	0.43	13.6	0.20	3.67	0.7														Runoff from Basin OS-9, overland flows southeast to the roadside swale along Vollmer Place at DPO9	
	7	G	0.24	0.09	5.0	0.02	5.17	0.1														Runoff from Basin G, overland flows south to the roadside swale along Vollmer Place at DP7.	
	7.1								13.6	0.22	3.67	0.8										Basins G and OS-9 combin in roadside swale before entering culvert at site access	
	9	I	0.24	0.46	6.4	0.11	4.80	0.5														Runoff from Basin I overland slows southeast to the roadside swale along Vollmer Place to DP9	
	P1							0.8														5 year reale from the pond	
	9.1								13.6	0.33	3.67	2.0										Flows from DP9 and DP7.1 combine in the roadside swale before existing the site at DP9.1 and flowing existng drainage patterns	
	8	H	0.12	0.09	5.0	0.01	5.17	0.1														Runoff from Basin H, overland flows south, across the property line to Mc Clintock Stations B and C .	
	010	OS-10	0.81	0.33	18.3	0.27	3.22	0.9														Offsite basin runoff is collected in the roadside swale along Vollmer Road to DPO10 where flow enters a proposed 18" driveway culvert	

Notes:  
Street and Pipe C\*A values are determined by Q/i using the catchment's intensity value.

**STANDARD FORM SF-3 - PROPOSED CONDITIONS**  
**STORM DRAINAGE SYSTEM DESIGN**  
(RATIONAL METHOD PROCEDURE)

Subdivision: MC CLINTOCK STATION  
Location: El Paso County  
Design Storm: 100-Year

Project Name: Vollmer Road RV Storage  
Project No.: 25251.00  
Calculated By: APL  
Checked By: REB  
Date: 11/16/23

STREET	Design Point	DIRECT RUNOFF							TOTAL RUNOFF				STREET			PIPE				TRAVEL TIME			REMARKS
		Basin ID	Area (ac)	Runoff Coeff.	t <sub>c</sub> (min)	C*A (ac)	I (in/hr)	Q (cfs)	t <sub>c</sub> (min)	C*A (ac)	I (in/hr)	Q (cfs)	Q <sub>street</sub> (cfs)	C*A (ac)	Slope (%)	Q <sub>pipe</sub> (cfs)	C*A (ac)	Slope (%)	Pipe Size (inches)	Length (ft)	Velocity (fps)	t <sub>r</sub> (min)	
	1	A	1.43	0.77	7.7	1.10	7.59	8.4							8.4	1.10	1.6	18	139	7.9	0.3	Runoff from Basin A, overland flows south to DP1 , flow enters Inlet A a Type C inlet in sump. Flow passes through the proposed sewer to DP 2.1	
	2	B	2.20	0.83	8.3	1.82	7.41	13.5														Runoff from Basin B, overland flows south to DP2, flow enters Inlet B a Type C inlet in sump. Flow passes through the proposed sewer to DP 2.1	
	2.1								8.3	2.92	7.41	21.6			21.6	2.92	0.5	24	114	6.9	0.3	Flows for DP1 and DP2 combine in proposed storm sewer system.	
	3	C	1.57	0.81	8.1	1.27	7.48	9.5							9.5	1.27	0.5	18	47	5.4	0.1	Runoff from Basin B, overland flows to DP3 , flow enters Inlet C a Type C inlet in sump. Flow passes through the proposed sewer to DP 3.1	
	3.1								8.5	4.19	7.33	30.7										Flows for DP2.1 and DP3 combine in proposed storm sewer system.	
	4	D	0.82	0.64	9.2	0.52	7.14	3.7														Runoff from Basin D, overland flows to the trickle channel at the bottom of the pond	
	5	E	0.17	0.40	7.1	0.07	7.81	0.5														Runoff from Basin E, overland flows east, across the property line to an existng swale in the Homestead at Stearling Ranch Development at DP5	
	6	F	0.07	0.36	7.9	0.03	7.52	0.2														Runoff from Basin F, overland flows east, across the property line to the Homestead at Stearling Ranch Development at DP 6	
	09	OS-9	0.46	0.61	13.6	0.28	6.16	1.7														Runoff from Basin OS-9, overland flows southeast to the roadside swale along Vollmer Place at DPO9	
	7	G	0.24	0.36	5.0	0.09	8.68	0.8														Runoff from Basin G, overland flows south to the roadside swale along Vollmer Place at DP7.	
	7.1								13.6	0.37	6.16	2.3										Basins G and OS-9 combin in roadside swale before entering culvert at site access	
	9	I	0.24	0.63	6.4	0.15	8.06	1.2														Runoff from Basin I overland slows southeast to the roadside swale along Vollmer Place to DP9	
	P1							5.7														100 year realse from the pond	
	9.1								13.6	0.52	6.16	8.9										Flows from DP9 and DP7.1 combine in the roadside swale before existing the site at DP9.1 and flowing existng drainage patterns	
	8	H	0.12	0.36	5.0	0.04	8.68	0.3														Runoff from Basin H, overland flows south, across the property line to Mc Clintock Stations B and C .	
	O10	OS-10	0.81	0.54	18.3	0.44	5.41	2.4														Offsite basin runoff is collected in the roadside swale along Vollmer Road to DPO10 where flow enters a proposed 18" driveway culvert	

Notes:  
Street and Pipe C\*A values are determined by Q/i using the catchment's intensity value.

**APPENDIX C**

**HYDRAULIC CALCULATIONS**

# Scenario: 5 YEAR

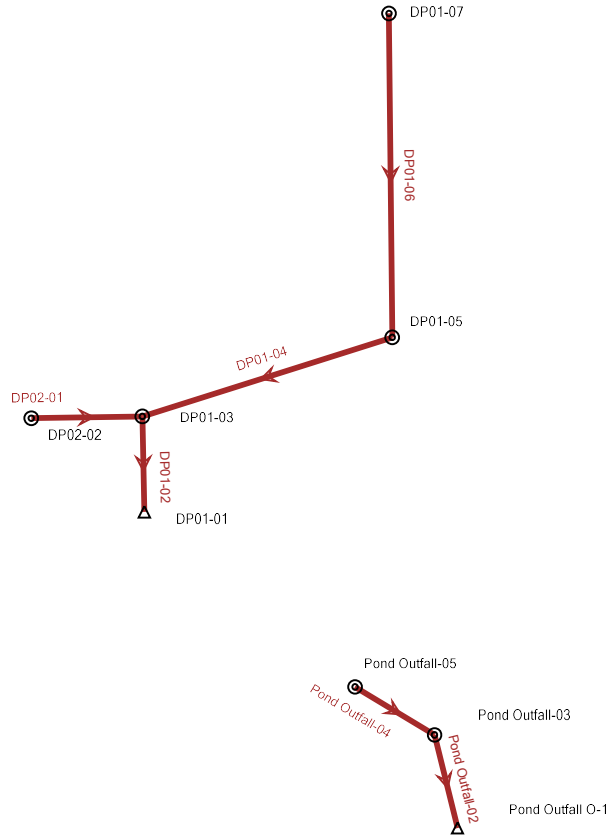

**Scenario: 5 YEAR**  
**Current Time Step: 0.000 h**  
**Conduit FlexTable: Combined Pipe/Node Report**

Upstream Structure	Label	Flow (cfs)	Capacity (Full Flow) (cfs)	Diameter (in)	Length (User Defined) (ft)	Slope (Calculated) (ft/ft)	Invert (Start) (ft)	Invert (Stop) (ft)	Elevation Ground (Start) (ft)	Elevation Ground (Stop) (ft)	HGL (In) (ft)	HGL (Out) (ft)	Energy Grade Line (In) (ft)	Energy Grade Line (Out) (ft)	Velocity (ft/s)	Upstream Structure Headloss Coefficient	Manning's n
DP01-03	DP01-02	15.70	47.73	36.0	41.0	0.005	7,057.97	7,057.76	7,063.85	7,062.12	7,060.78	7,060.76	7,060.86	7,060.84	6.05	1.000	0.013
DP01-05	DP01-04	11.10	36.60	30.0	111.7	0.008	7,059.36	7,058.47	7,064.00	7,063.85	7,060.83	7,060.86	7,061.04	7,060.94	6.54	0.630	0.013
DP01-07	DP01-06	4.20	30.57	24.0	140.1	0.018	7,062.42	7,059.86	7,067.15	7,064.00	7,063.14	7,060.97	7,063.40	7,061.05	6.82	0.100	0.013
DP02-02	DP02-01	4.80	16.08	24.0	45.5	0.005	7,059.20	7,058.97	7,062.75	7,063.85	7,060.87	7,060.86	7,060.91	7,060.90	4.47	0.100	0.013
Pond Outfall-03	Pond Outfall-02	0.80	12.36	18.0	42.0	0.014	7,055.15	7,054.57	7,059.23	7,056.28	7,055.48	7,054.83	7,055.60	7,055.07	3.94	0.300	0.013
Pond Outfall-05	Pond Outfall-04	0.80	12.52	18.0	52.8	0.014	7,055.90	7,055.15	7,062.13	7,059.23	7,056.23	7,055.52	7,056.35	7,055.61	3.97	0.100	0.013

X:\2520000.all\2525100\StormCAD\2023-04-24\_STORM CAD.stsw

DP01 - 5 YEAR

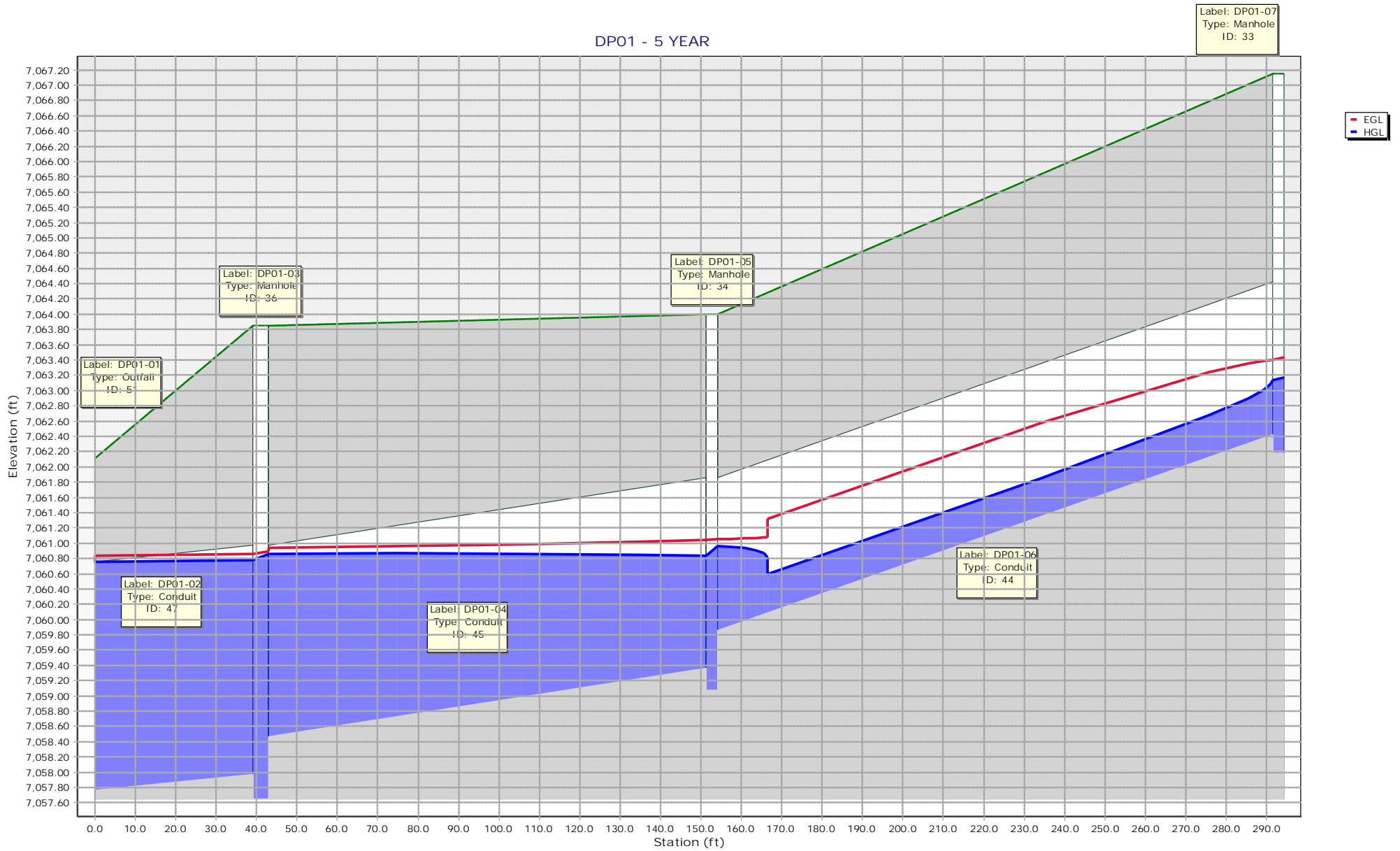



DP02 - 5 YEAR

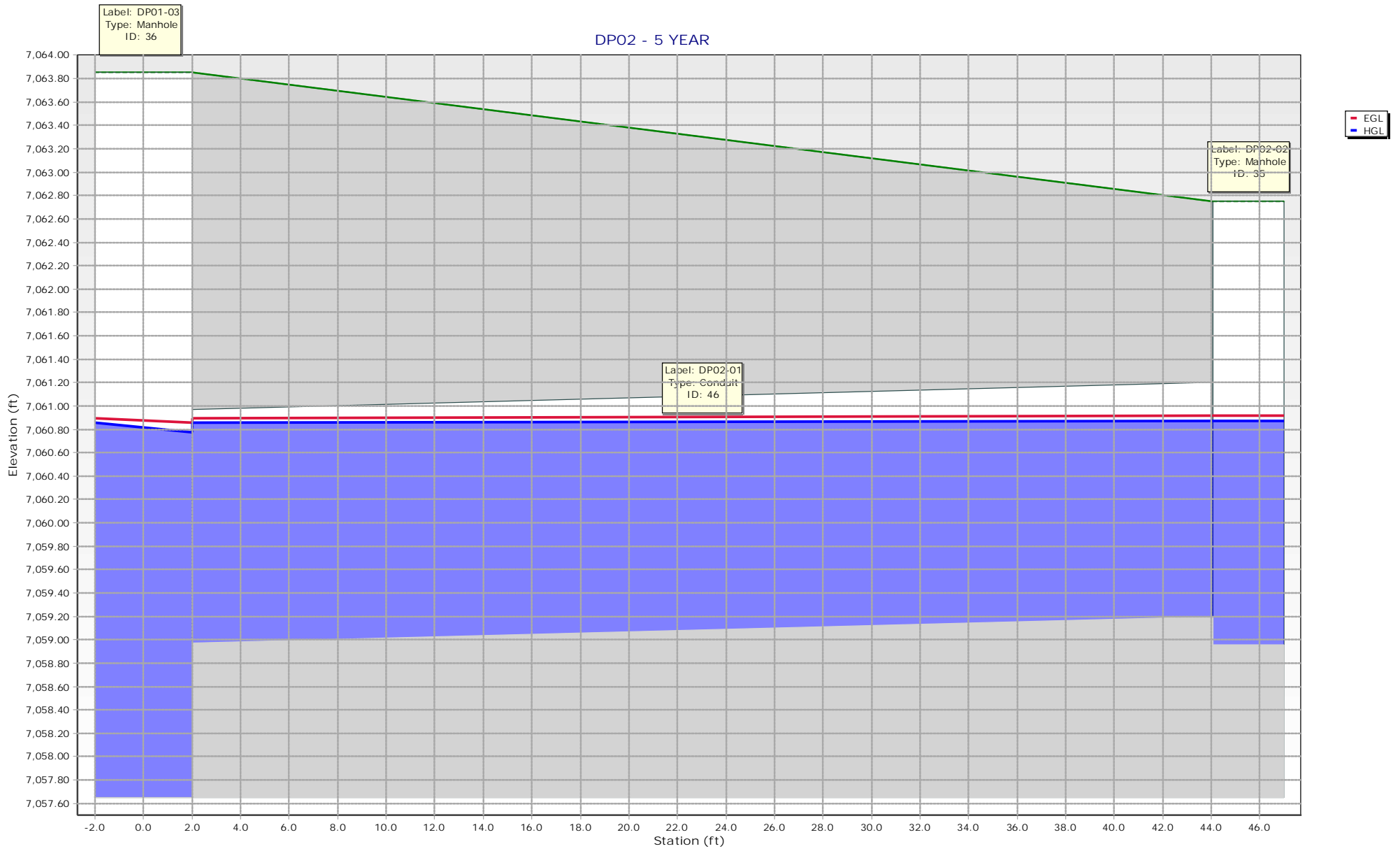

# Pond Outfall - 5 YEAR

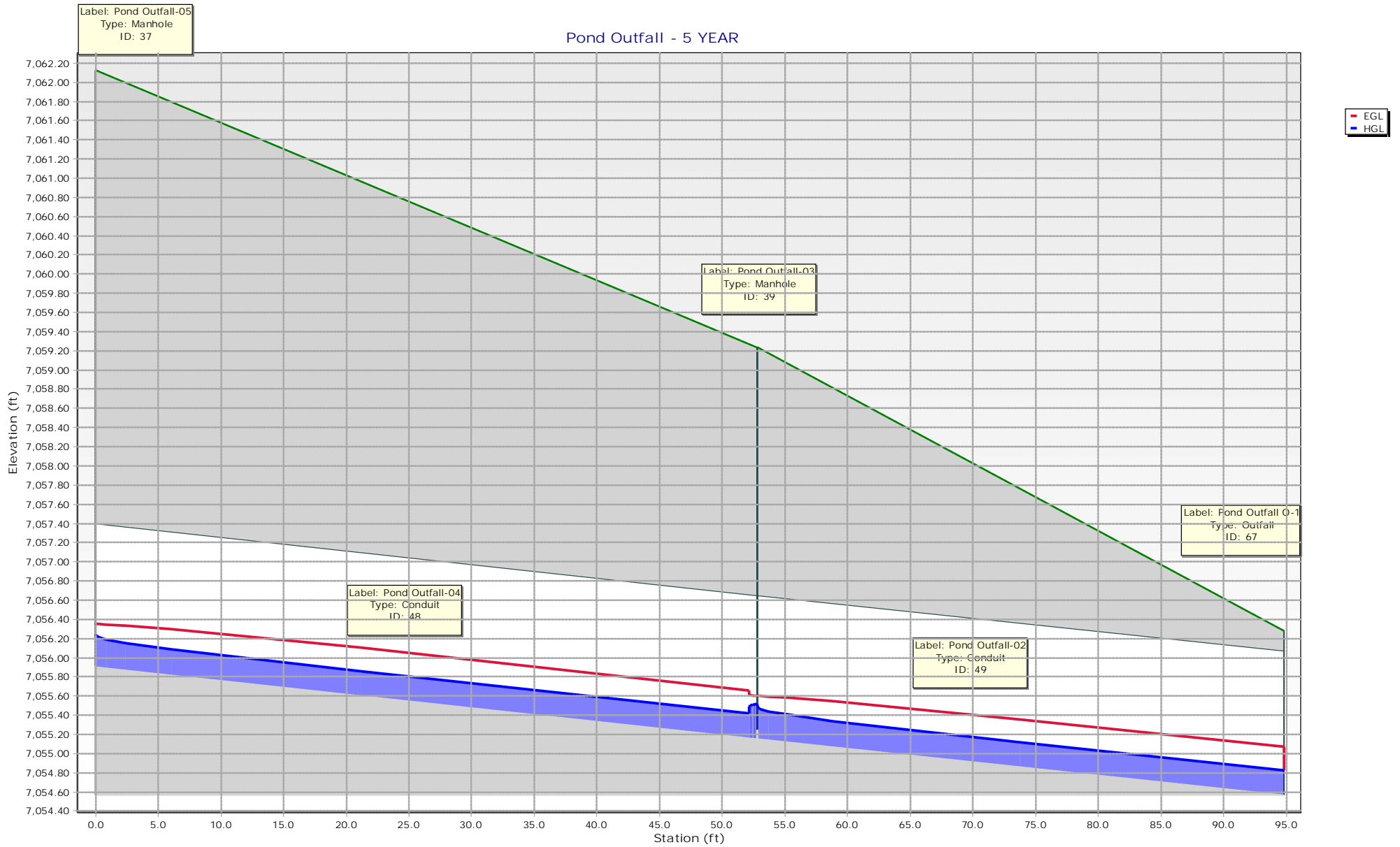

**Scenario: 100 YEAR**  
**Current Time Step: 0.000 h**  
**Conduit FlexTable: Combined Pipe/Node Report**

Upstream Structure	Label	Flow (cfs)	Capacity (Full Flow) (cfs)	Diameter (in)	Length (User Defined) (ft)	Slope (Calculated) (ft/ft)	Invert (Start) (ft)	Invert (Stop) (ft)	Elevation Ground (Start) (ft)	Elevation Ground (Stop) (ft)	HGL (In) (ft)	HGL (Out) (ft)	Energy Grade Line (In) (ft)	Energy Grade Line (Out) (ft)	Velocity (ft/s)	Upstream Structure Headloss Coefficient	Manning's n
DP01-03	DP01-02	30.70	47.73	36.0	41.0	0.005	7,057.97	7,057.76	7,063.85	7,062.12	7,061.64	7,061.55	7,061.93	7,061.84	4.34	1.000	0.013
DP01-05	DP01-04	21.60	36.60	30.0	111.7	0.008	7,059.36	7,058.47	7,064.00	7,063.85	7,062.24	7,061.93	7,062.54	7,062.23	4.40	0.630	0.013
DP01-07	DP01-06	8.40	30.57	24.0	140.1	0.018	7,062.42	7,059.86	7,067.15	7,064.00	7,063.45	7,062.43	7,063.86	7,062.54	8.30	0.100	0.013
DP02-02	DP02-01	9.50	16.08	24.0	45.5	0.005	7,059.20	7,058.97	7,062.75	7,063.85	7,062.01	7,061.93	7,062.15	7,062.07	3.02	0.100	0.013
Pond Outfall-03	Pond Outfall-02	5.70	12.36	18.0	42.0	0.014	7,055.15	7,054.57	7,059.23	7,056.28	7,056.07	7,055.30	7,056.46	7,056.00	6.85	0.300	0.013
Pond Outfall-05	Pond Outfall-04	5.70	12.52	18.0	52.8	0.014	7,055.90	7,055.15	7,062.13	7,059.23	7,056.82	7,056.19	7,057.21	7,056.48	6.92	0.100	0.013

X:\2520000.all\2525100\StormCAD\2023-04-24\_STORM CAD.stsw

DP01 - 100 YEAR

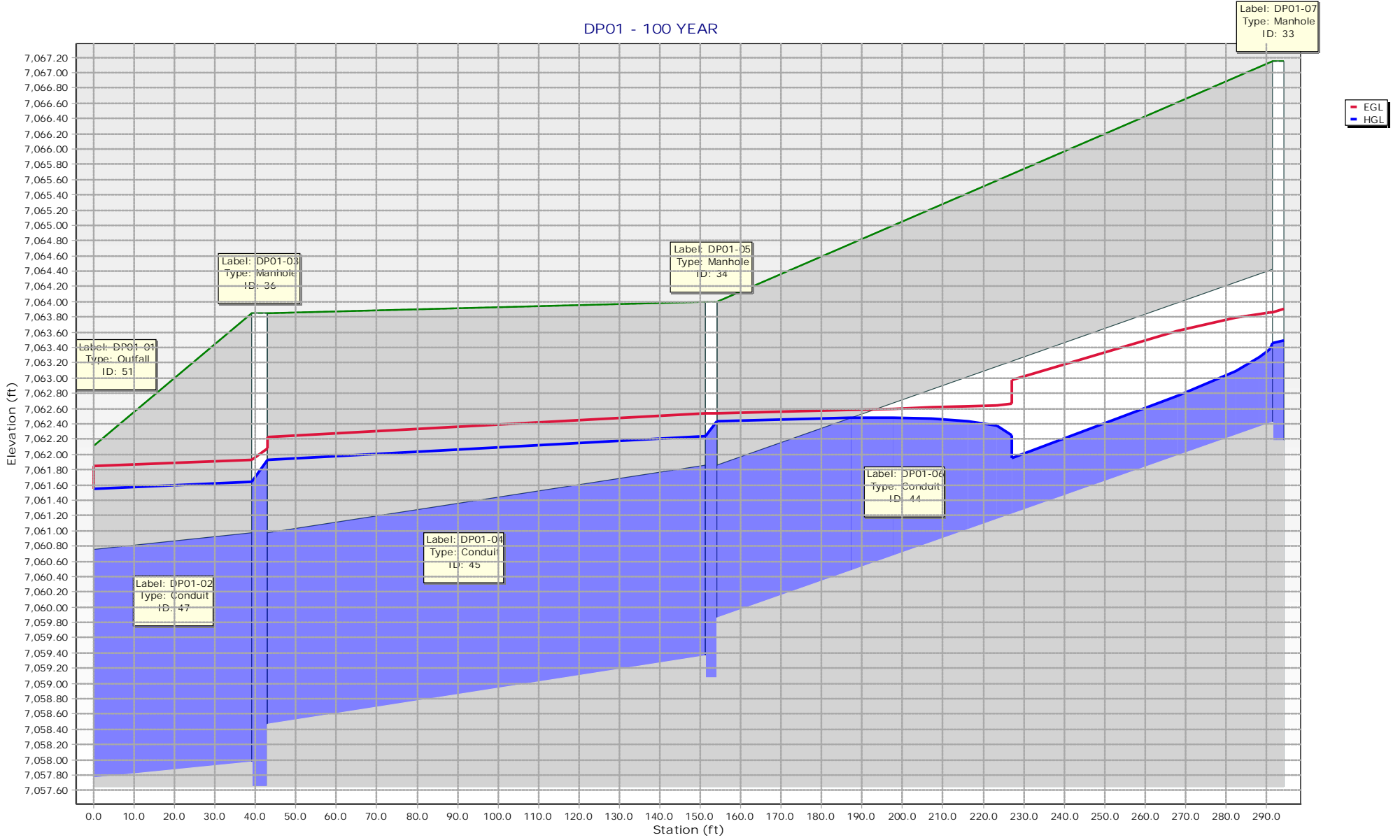

DP02 - 100 YEAR

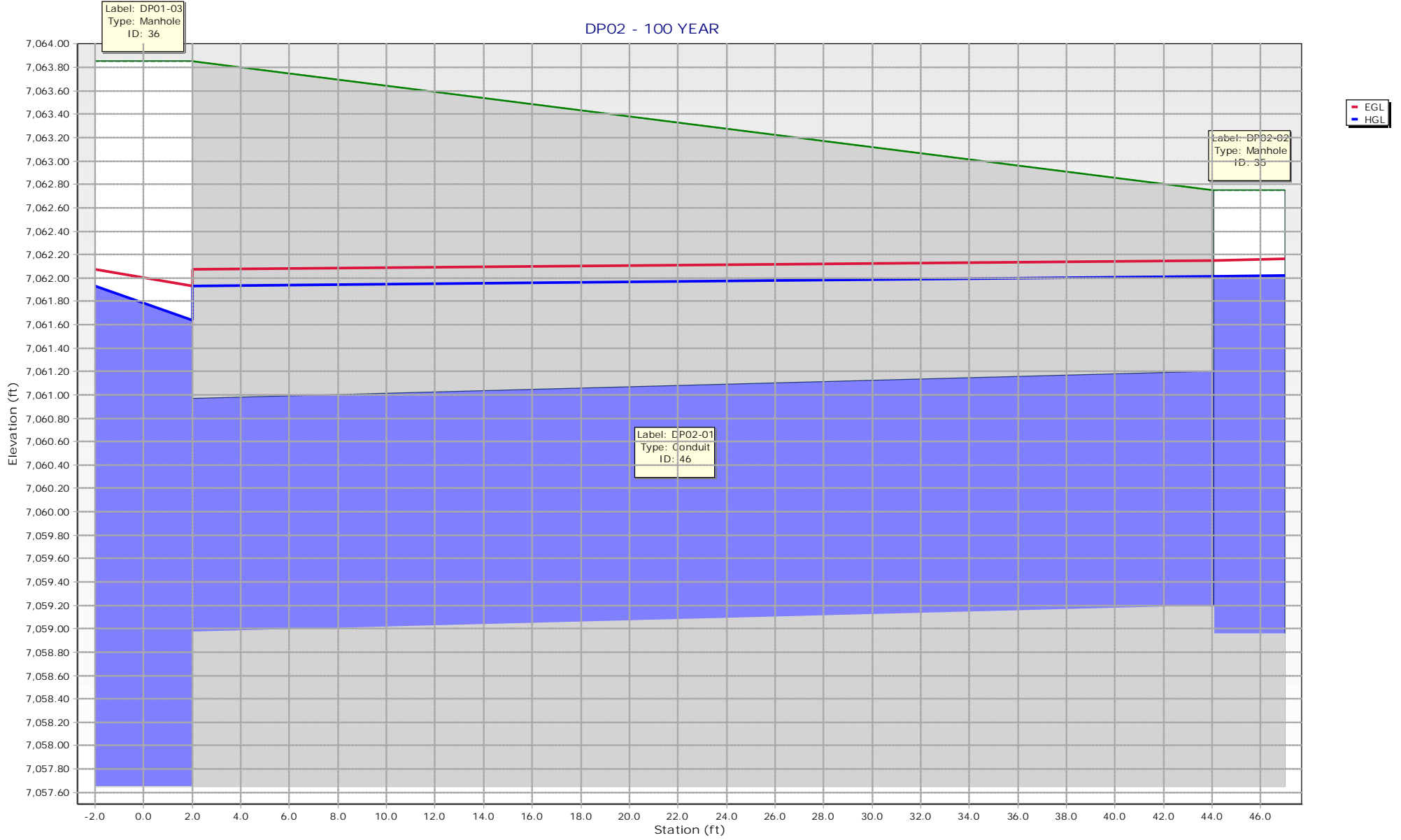

Pond Outfall - 100 YEAR

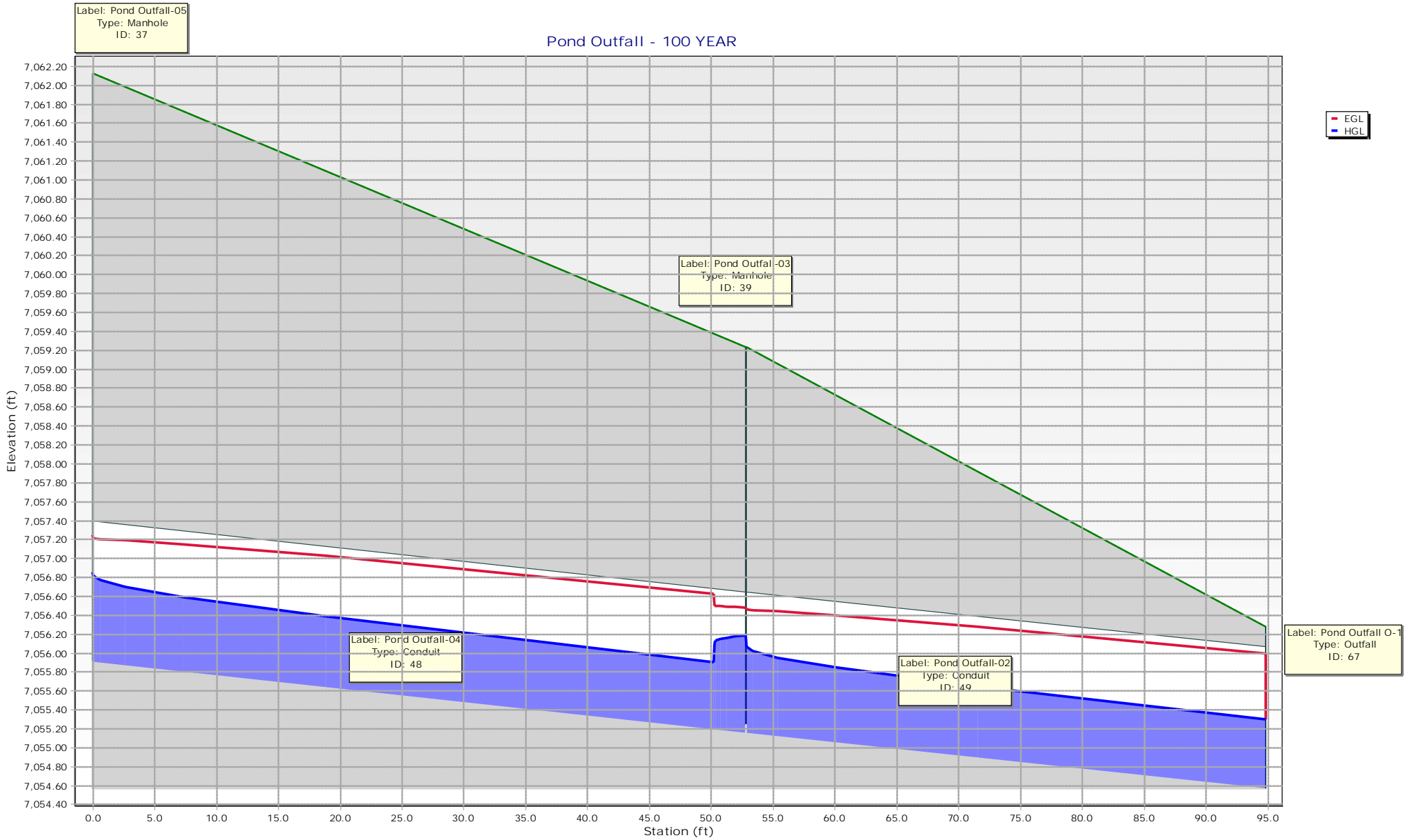

# INLET MANAGEMENT

Worksheet Protected

INLET NAME	Inlet C	Inlet B	Inlet A
Site Type (Urban or Rural)	URBAN	URBAN	URBAN
Inlet Application (Street or Area)	AREA	AREA	AREA
Hydraulic Condition	Swale	Swale	Swale
Inlet Type	CDOT Type C (Depressed)	CDOT Type C (Depressed)	CDOT Type C (Depressed)

## USER-DEFINED INPUT

User-Defined Design Flows			
Minor $Q_{Known}$ (cfs)	4.8	7.0	4.2
Major $Q_{Known}$ (cfs)	9.5	13.5	8.4
Bypass (Carry-Over) Flow from Upstream			
Receive Bypass Flow from:	No Bypass Flow Received	No Bypass Flow Received	No Bypass Flow Received
Minor Bypass Flow Received, $Q_b$ (cfs)	0.0	0.0	0.0
Major Bypass Flow Received, $Q_b$ (cfs)	0.0	0.0	0.0
Watershed Characteristics			
Subcatchment Area (acres)			
Percent Impervious			
NRCS Soil Type			
Watershed Profile			
Overland Slope (ft/ft)			
Overland Length (ft)			
Channel Slope (ft/ft)			
Channel Length (ft)			
Minor Storm Rainfall Input			
Design Storm Return Period, $T_r$ (years)			
One-Hour Precipitation, $P_1$ (inches)			
Major Storm Rainfall Input			
Design Storm Return Period, $T_r$ (years)			
One-Hour Precipitation, $P_1$ (inches)			

## CALCULATED OUTPUT

<b>Minor Total Design Peak Flow, <math>Q</math> (cfs)</b>	<b>4.8</b>	<b>7.0</b>	<b>4.2</b>
<b>Major Total Design Peak Flow, <math>Q</math> (cfs)</b>	<b>9.5</b>	<b>13.5</b>	<b>8.4</b>
Minor Flow Bypassed Downstream, $Q_b$ (cfs)	0.0	0.0	0.0
Major Flow Bypassed Downstream, $Q_b$ (cfs)	0.0	0.0	0.0

## AREA INLET IN A SWALE

**Inlet C**

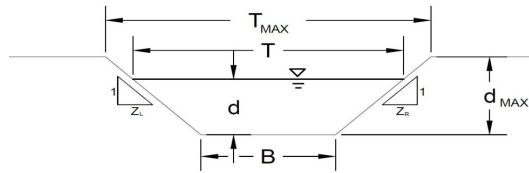

This worksheet uses the NRCS vegetative retardance method to determine Manning's n.  
For more information see Section 7.2.3 of the USDCM.

**Analysis of Trapezoidal Grass-Lined Channel Using SCS Method**

NRCS Vegetal Retardance (A, B, C, D, or E) A, B, C, D, or E =

Manning's n (Leave cell D16 blank to manually enter an n value) n = 0.013

Channel Invert Slope S<sub>0</sub> = 0.0176 ft/ft

Bottom Width B = 4.00 ft

Left Side Slope Z<sub>1</sub> = 25.00 ft/ft

Right Side Slope Z<sub>2</sub> = 100.00 ft/ft

Check one of the following soil types:

Soil Type:	Max. Velocity (V <sub>MAX</sub> )	Max Froude No. (F <sub>MAX</sub> )
Non-Cohesive	5.0 fps	0.60
Cohesive	7.0 fps	0.80
Paved	N/A	N/A

Choose One:

Non-Cohesive

Cohesive

Paved

	Minor Storm	Major Storm	
Maximum Allowable Top Width of Channel for Minor & Major Storm	<b>T<sub>MAX</sub> = 25.00</b>	<b>50.00</b>	ft
Maximum Allowable Water Depth in Channel for Minor & Major Storm	<b>d<sub>MAX</sub> = 0.25</b>	<b>0.50</b>	ft

---

**Allowable Channel Capacity Based On Channel Geometry**

MINOR STORM Allowable Capacity is based on Top Width Criterion Minor Storm

MAJOR STORM Allowable Capacity is based on Top Width Criterion Major Storm

	Minor Storm	Major Storm	
Q <sub>allow</sub> =	<b>7.8</b>	<b>51.4</b>	cfs
d <sub>allow</sub> =	<b>0.17</b>	<b>0.37</b>	ft

---

**Water Depth in Channel Based On Design Peak Flow**

Design Peak Flow Q<sub>o</sub> =

Water Depth d =

	Minor Storm	Major Storm	
Q <sub>o</sub> =	<b>4.8</b>	<b>9.5</b>	cfs
d =	<b>0.14</b>	<b>0.18</b>	ft

Minor storm max. allowable capacity GOOD - greater than the design flow given on sheet 'Inlet Management'  
 Major storm max. allowable capacity GOOD - greater than the design flow given on sheet 'Inlet Management'



MHFD-Inlet, Version 5.01 (April 2021)  
**AREA INLET IN A SWALE**

**Inlet C**

**Inlet Design Information (Input)**

Type of Inlet:  Inlet Type =

Angle of Inclined Grate (must be  $\leq 30$  degrees)  $\theta = 0.00$  degrees

Width of Grate  $W = 3.00$  ft

Length of Grate  $L = 3.00$  ft

Open Area Ratio  $A_{RATIO} = 0.70$

Height of Inclined Grate  $H_B = 0.00$  ft

Clogging Factor  $C_f = 0.50$

Grate Discharge Coefficient  $C_d = 0.84$

Orifice Coefficient  $C_o = 0.56$

Weir Coefficient  $C_w = 1.81$

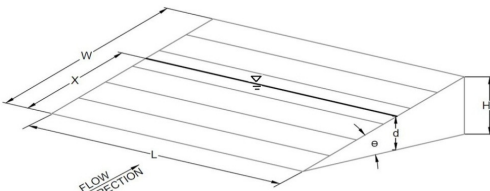

Water Depth at Inlet (for depressed inlets, 1 foot is added for depression)

	MINOR	MAJOR	
$d =$	1.14	1.18	
$Q_a =$	15.2	15.5	cfs
$Q_b =$	0.0	0.0	cfs
$C\% =$	100	100	%

Total Inlet Interception Capacity (assumes clogged condition)

Bypassed Flow

Capture Percentage =  $Q_a/Q_o$

## AREA INLET IN A SWALE

**Inlet B**

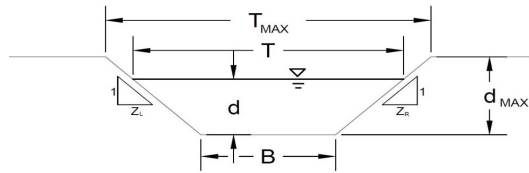

This worksheet uses the NRCS vegetative retardance method to determine Manning's n.  
For more information see Section 7.2.3 of the USDCM.

<b>Analysis of Trapezoidal Grass-Lined Channel Using SCS Method</b>			A, B, C, D, or E =	
NRCS Vegetal Retardance (A, B, C, D, or E)			n = 0.013	
Manning's n (Leave cell D16 blank to manually enter an n value)			S <sub>0</sub> = 0.0132 ft/ft	
Channel Invert Slope			B = 4.00 ft	
Bottom Width			Z1 = 40.00 ft/ft	
Left Side Slope			Z2 = 100.00 ft/ft	
Right Side Slope			Choose One: <input checked="" type="checkbox"/> Non-Cohesive <input type="checkbox"/> Cohesive <input type="checkbox"/> Paved	
Check one of the following soil types:			Minor Storm      Major Storm T <sub>MAX</sub> = 30.00      50.00 ft d <sub>MAX</sub> = 0.25      0.50 ft	
<b>Soil Type:</b>	<b>Max. Velocity (V<sub>MAX</sub>)</b>	<b>Max Froude No. (F<sub>MAX</sub>)</b>		
Non-Cohesive	5.0 fps	0.60		
Cohesive	7.0 fps	0.80		
Paved	N/A	N/A		
Maximum Allowable Top Width of Channel for Minor & Major Storm				
Maximum Allowable Water Depth in Channel for Minor & Major Storm				
<b>Allowable Channel Capacity Based On Channel Geometry</b>			Minor Storm      Major Storm Q <sub>allow</sub> = 9.3      36.9 cfs d <sub>allow</sub> = 0.19      0.33 ft	
MINOR STORM Allowable Capacity is based on Top Width Criterion				
MAJOR STORM Allowable Capacity is based on Top Width Criterion				
<b>Water Depth in Channel Based On Design Peak Flow</b>			Q <sub>o</sub> = 7.0      13.5 cfs d = 0.16      0.22 ft	
Design Peak Flow				
Water Depth				
<p style="color: red; margin: 0;"><b>Minor storm max. allowable capacity GOOD - greater than the design flow given on sheet 'Inlet Management'</b></p> <p style="color: red; margin: 0;"><b>Major storm max. allowable capacity GOOD - greater than the design flow given on sheet 'Inlet Management'</b></p>				

MHFD-Inlet, Version 5.01 (April 2021)  
**AREA INLET IN A SWALE**

**Inlet B**

**Inlet Design Information (Input)**

Type of Inlet:  Inlet Type =

Angle of Inclined Gate (must be  $\leq 30$  degrees)  $\theta = 0.00$  degrees

Width of Gate  $W = 3.00$  ft

Length of Gate  $L = 3.00$  ft

Open Area Ratio  $A_{RATIO} = 0.70$

Height of Inclined Gate  $H_B = 0.00$  ft

Clogging Factor  $C_f = 0.50$

Grate Discharge Coefficient  $C_d = 0.84$

Orifice Coefficient  $C_o = 0.56$

Weir Coefficient  $C_w = 1.81$

Water Depth at Inlet (for depressed inlets, 1 foot is added for depression)

	MINOR	MAJOR	
$d =$	1.16	1.22	
$Q_a =$	15.4	15.7	cfs
$Q_b =$	0.0	0.0	cfs
$C\% =$	100	100	%

Total Inlet Interception Capacity (assumes clogged condition)

Bypassed Flow

Capture Percentage =  $Q_a/Q_o$

## AREA INLET IN A SWALE

**Inlet A**

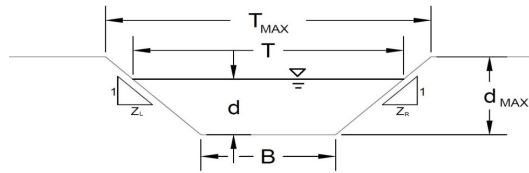

This worksheet uses the NRCS vegetative retardance method to determine Manning's n.  
For more information see Section 7.2.3 of the USDCM.

**Analysis of Trapezoidal Grass-Lined Channel Using SCS Method**

NRCS Vegetal Retardance (A, B, C, D, or E) A, B, C, D, or E =

Manning's n (Leave cell D16 blank to manually enter an n value) n = 0.013

Channel Invert Slope S<sub>0</sub> = 0.0217 ft/ft

Bottom Width B = 4.00 ft

Left Side Slope Z<sub>1</sub> = 50.00 ft/ft

Right Side Slope Z<sub>2</sub> = 50.00 ft/ft

Check one of the following soil types:

Soil Type:	Max. Velocity (V <sub>MAX</sub> )	Max Froude No. (F <sub>MAX</sub> )
Non-Cohesive	5.0 fps	0.60
Cohesive	7.0 fps	0.80
Paved	N/A	N/A

Choose One:

Non-Cohesive

Cohesive

Paved

	Minor Storm	Major Storm	
Maximum Allowable Top Width of Channel for Minor & Major Storm	<b>T<sub>MAX</sub> = 20.00</b>	<b>30.00</b>	ft
Maximum Allowable Water Depth in Channel for Minor & Major Storm	<b>d<sub>MAX</sub> = 0.25</b>	<b>0.50</b>	ft

---

**Allowable Channel Capacity Based On Channel Geometry**

MINOR STORM Allowable Capacity is based on Top Width Criterion Minor Storm

MAJOR STORM Allowable Capacity is based on Top Width Criterion Major Storm

	Minor Storm	Major Storm	
Q <sub>allow</sub> =	<b>6.8</b>	<b>20.8</b>	cfs
d <sub>allow</sub> =	<b>0.16</b>	<b>0.26</b>	ft

---

**Water Depth in Channel Based On Design Peak Flow**

Design Peak Flow Q<sub>o</sub> =

Water Depth d =

	Minor Storm	Major Storm	
Q <sub>o</sub> =	<b>4.2</b>	<b>8.4</b>	cfs
d =	<b>0.13</b>	<b>0.18</b>	ft

Minor storm max. allowable capacity GOOD - greater than the design flow given on sheet 'Inlet Management'  
 Major storm max. allowable capacity GOOD - greater than the design flow given on sheet 'Inlet Management'

MHFD-Inlet, Version 5.01 (April 2021)  
**AREA INLET IN A SWALE**

**Inlet A**

**Inlet Design Information (Input)**

Type of Inlet:  Inlet Type =

Angle of Inclined Grate (must be <= 30 degrees)  $\theta = 0.00$  degrees

Width of Grate  $W = 3.00$  ft

Length of Grate  $L = 3.00$  ft

Open Area Ratio  $A_{RATIO} = 0.70$

Height of Inclined Grate  $H_B = 0.00$  ft

Clogging Factor  $C_f = 0.50$

Grate Discharge Coefficient  $C_d = 0.84$

Orifice Coefficient  $C_o = 0.56$

Weir Coefficient  $C_w = 1.81$

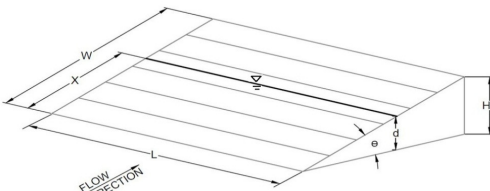

Water Depth at Inlet (for depressed inlets, 1 foot is added for depression)

Total Inlet Interception Capacity (assumes clogged condition)

Bypassed Flow

Capture Percentage =  $Q_a/Q_o$

	MINOR	MAJOR	
$d =$	1.13	1.18	
$Q_a =$	15.1	15.4	cfs
$Q_b =$	0.0	0.0	cfs
$C\% =$	100	100	%

# Channel Report

## Swale A\_A

### Triangular

Side Slopes (z:1) = 8.00, 10.00  
Total Depth (ft) = 1.30

Invert Elev (ft) = 1.00  
Slope (%) = 2.00  
N-Value = 0.035

### Calculations

Compute by: Known Q  
Known Q (cfs) = 2.40

### Highlighted

Depth (ft) = 0.38  
Q (cfs) = 2.400  
Area (sqft) = 1.30  
Velocity (ft/s) = 1.85  
Wetted Perim (ft) = 6.88  
Crit Depth, Yc (ft) = 0.34  
Top Width (ft) = 6.84  
EGL (ft) = 0.43

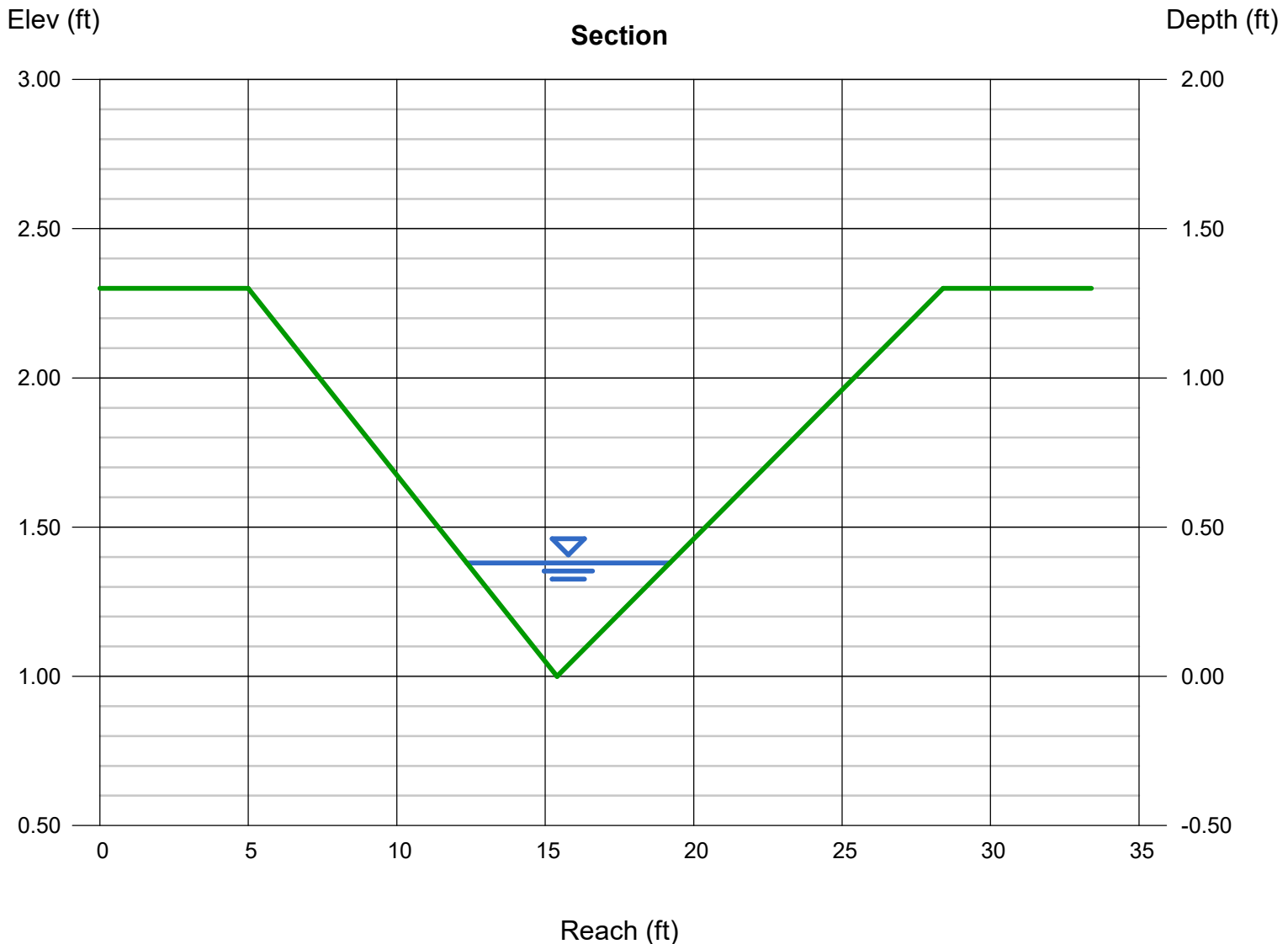

# Channel Report

## SWALE B-B

### Triangular

Side Slopes (z:1) = 20.00, 4.00

Total Depth (ft) = 1.00

Invert Elev (ft) = 1.00

Slope (%) = 0.56

N-Value = 0.035

### Calculations

Compute by: Known Q

Known Q (cfs) = 2.30

### Highlighted

Depth (ft) = 0.42

Q (cfs) = 2.300

Area (sqft) = 2.12

Velocity (ft/s) = 1.09

Wetted Perim (ft) = 10.14

Crit Depth, Yc (ft) = 0.30

Top Width (ft) = 10.08

EGL (ft) = 0.44

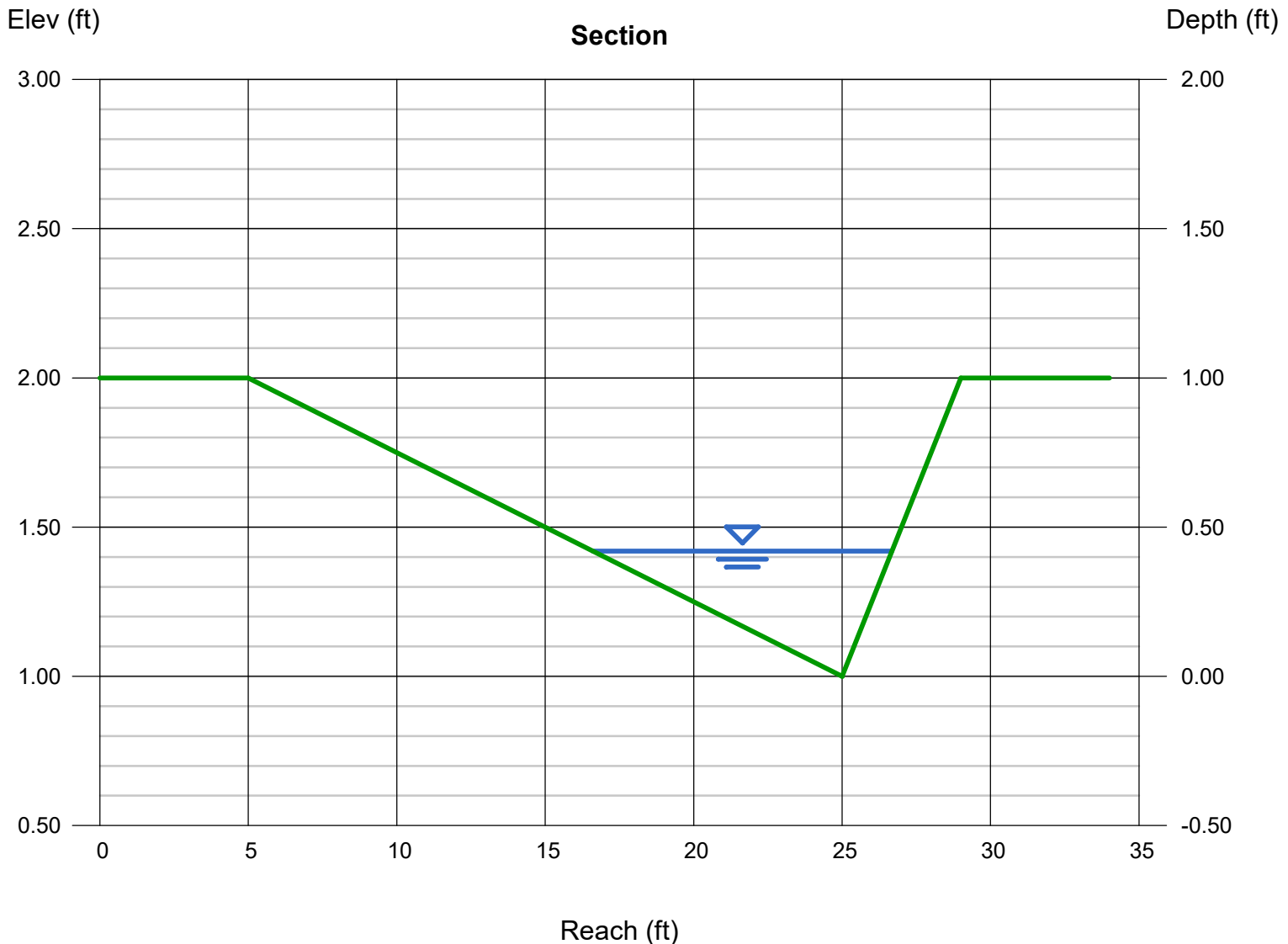

# Channel Report

## SWALE B-B EMERGENCY CONDITION

### Triangular

Side Slopes (z:1) = 20.00, 4.00

Total Depth (ft) = 1.00

Invert Elev (ft) = 1.00

Slope (%) = 0.56

N-Value = 0.035

### Calculations

Compute by: Known Q

Known Q (cfs) = 17.10

### Highlighted

Depth (ft) = 0.89

Q (cfs) = 17.10

Area (sqft) = 9.51

Velocity (ft/s) = 1.80

Wetted Perim (ft) = 21.49

Crit Depth, Yc (ft) = 0.67

Top Width (ft) = 21.36

EGL (ft) = 0.94

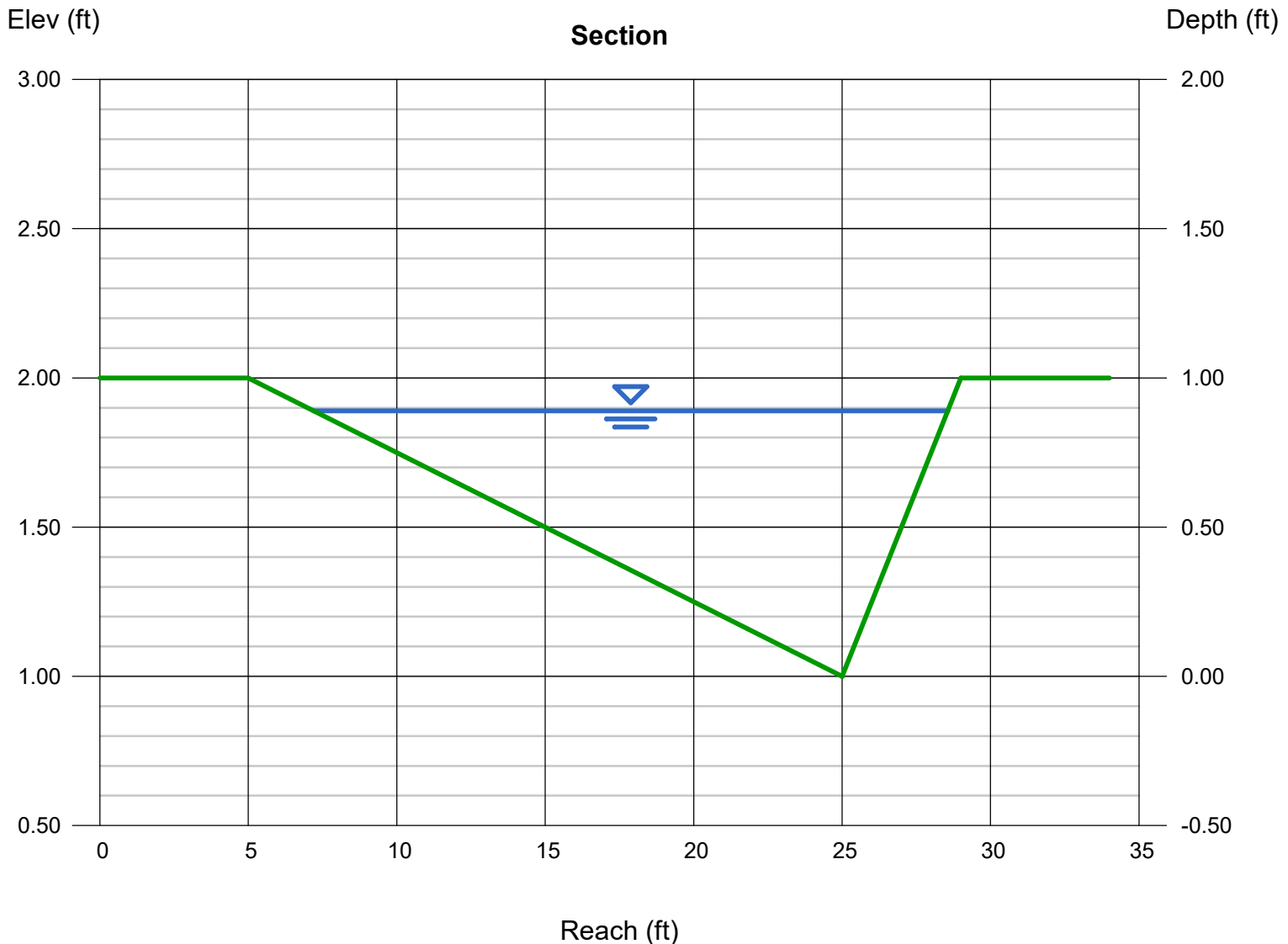



# Channel Report

## SWALE C-C

### Triangular

Side Slopes (z:1) = 3.00, 3.00

Total Depth (ft) = 1.50

Invert Elev (ft) = 1.00

Slope (%) = 0.56

N-Value = 0.035

### Calculations

Compute by: Known Q

Known Q (cfs) = 8.90

### Highlighted

Depth (ft) = 1.18

Q (cfs) = 8.900

Area (sqft) = 4.18

Velocity (ft/s) = 2.13

Wetted Perim (ft) = 7.46

Crit Depth, Yc (ft) = 0.89

Top Width (ft) = 7.08

EGL (ft) = 1.25

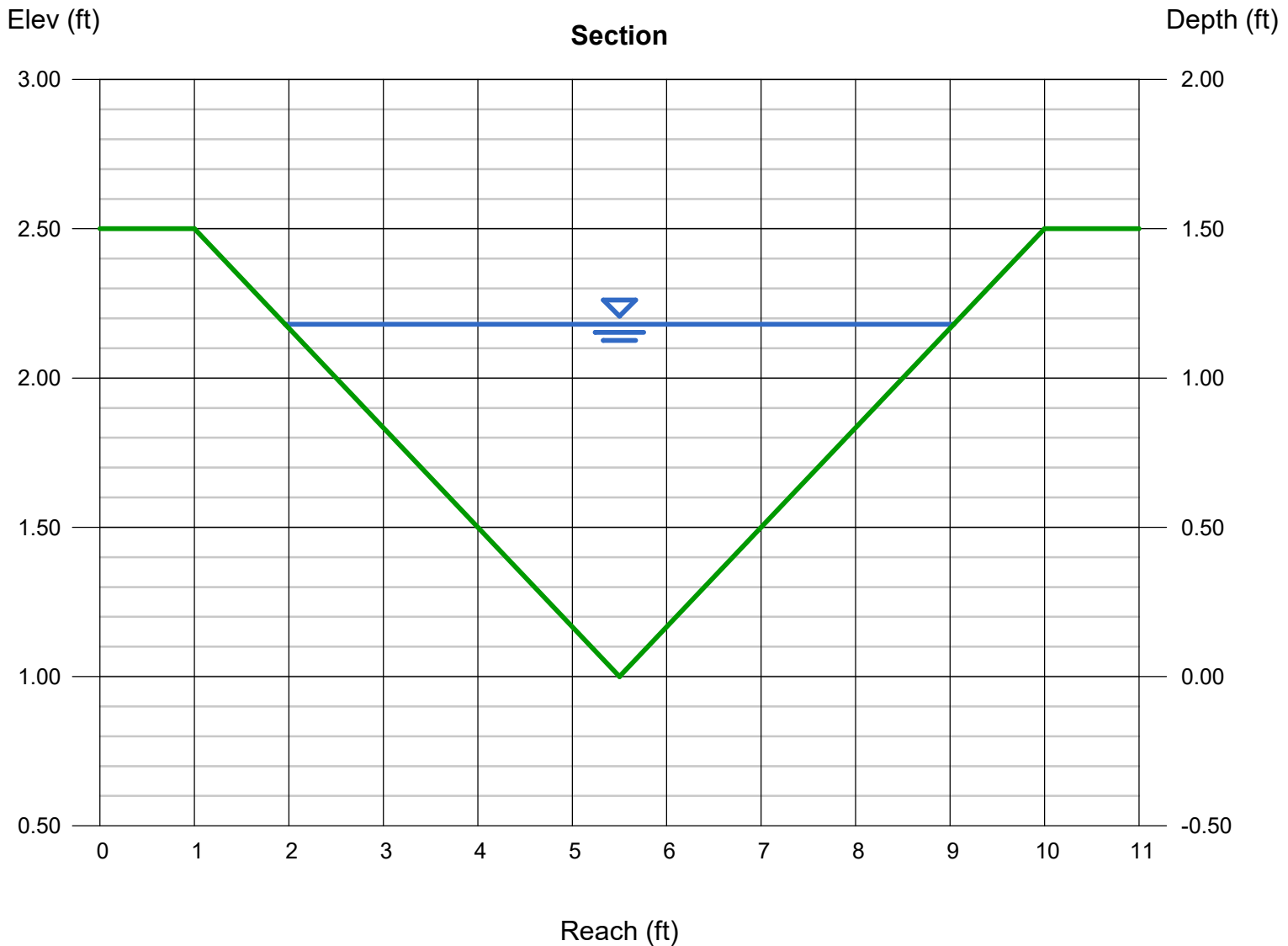

# DETENTION BASIN STAGE-STORAGE TABLE BUILDER

MHFD-Detention, Version 4.06 (July 2022)

Project: **Vollmer RV Storage**

Basin ID: **Pond V1**

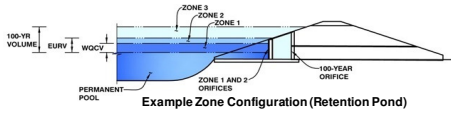

**Example Zone Configuration (Retention Pond)**

**Watershed Information**

Selected BMP Type =	<b>EDB</b>
Watershed Area =	6.02 acres
Watershed Length =	1,200 ft
Watershed Length to Centroid =	400 ft
Watershed Slope =	0.021 ft/ft
Watershed Imperviousness =	71.00% percent
Percentage Hydrologic Soil Group A =	0.0% percent
Percentage Hydrologic Soil Group B =	100.0% percent
Percentage Hydrologic Soil Groups C/D =	0.0% percent
Target WQC Drain Time =	40.0 hours
Location for 1-hr Rainfall Depths =	User Input

After providing required inputs above including 1-hour rainfall depths, click "Run CUHP" to generate runoff hydrographs using the embedded Colorado Urban Hydrograph Procedure.

Water Quality Capture Volume (WQCV) =	0.140 acre-feet
Excess Urban Runoff Volume (EURV) =	0.470 acre-feet
2-yr Runoff Volume (P1 = 1.19 in.) =	0.419 acre-feet
5-yr Runoff Volume (P1 = 1.5 in.) =	0.563 acre-feet
10-yr Runoff Volume (P1 = 1.75 in.) =	0.685 acre-feet
25-yr Runoff Volume (P1 = 2 in.) =	0.828 acre-feet
50-yr Runoff Volume (P1 = 2.25 in.) =	0.955 acre-feet
100-yr Runoff Volume (P1 = 2.52 in.) =	1.106 acre-feet
500-yr Runoff Volume (P1 = 4 in.) =	1.879 acre-feet
Approximate 2-yr Detention Volume =	0.368 acre-feet
Approximate 5-yr Detention Volume =	0.489 acre-feet
Approximate 10-yr Detention Volume =	0.617 acre-feet
Approximate 25-yr Detention Volume =	0.662 acre-feet
Approximate 50-yr Detention Volume =	0.689 acre-feet
Approximate 100-yr Detention Volume =	0.737 acre-feet

**Optional User Overrides**

	acre-feet
	acre-feet
1.19	inches
1.50	inches
1.75	inches
2.00	inches
2.25	inches
2.52	inches
4.00	inches

**Define Zones and Basin Geometry**

Zone 1 Volume (WQCV) =	0.140 acre-feet
Zone 2 Volume (EURV - Zone 1) =	0.330 acre-feet
Zone 3 Volume (100-year - Zones 1 & 2) =	0.267 acre-feet
Total Detention Basin Volume =	0.737 acre-feet
Initial Surcharge Volume (ISV) =	user ft <sup>3</sup>
Initial Surcharge Depth (ISD) =	user ft
Total Available Detention Depth (H <sub>total</sub> ) =	user ft
Depth of Trickle Channel (H <sub>TC</sub> ) =	user ft
Slope of Trickle Channel (S <sub>TC</sub> ) =	user ft/ft
Slopes of Main Basin Sides (S <sub>main</sub> ) =	user H:V
Basin Length-to-Width Ratio (R <sub>L/W</sub> ) =	user
Initial Surcharge Area (A <sub>ISV</sub> ) =	user ft <sup>2</sup>
Surcharge Volume Length (L <sub>LSV</sub> ) =	user ft
Surcharge Volume Width (W <sub>LSV</sub> ) =	user ft
Depth of Basin Floor (H <sub>FLOOR</sub> ) =	user ft
Length of Basin Floor (L <sub>FLOOR</sub> ) =	user ft
Width of Basin Floor (W <sub>FLOOR</sub> ) =	user ft
Area of Basin Floor (A <sub>FLOOR</sub> ) =	user ft <sup>2</sup>
Volume of Basin Floor (V <sub>FLOOR</sub> ) =	user ft <sup>3</sup>
Depth of Main Basin (H <sub>MAIN</sub> ) =	user ft
Length of Main Basin (L <sub>MAIN</sub> ) =	user ft
Width of Main Basin (W <sub>MAIN</sub> ) =	user ft
Area of Main Basin (A <sub>MAIN</sub> ) =	user ft <sup>2</sup>
Volume of Main Basin (V <sub>MAIN</sub> ) =	user ft <sup>3</sup>
Calculated Total Basin Volume (V <sub>total</sub> ) =	user acre-feet

Stage - Storage Description	Stage (ft)	Optional Override Stage (ft)	Length (ft)	Width (ft)	Area (ft <sup>2</sup> )	Optional Override Area (ft <sup>2</sup> )	Area (acre)	Volume (ft <sup>3</sup> )	Volume (ac-ft)
56.15 Top of Micropool	--	0.00	--	--	--	10	0.000		
56.48	--	0.33	--	--	--	49	0.001	10	0.000
57	--	0.85	--	--	--	259	0.006	90	0.002
58	--	1.85	--	--	--	4,052	0.093	2,245	0.052
59	--	2.85	--	--	--	6,898	0.158	7,720	0.177
60	--	3.85	--	--	--	8,477	0.195	15,407	0.354
61	--	4.85	--	--	--	10,043	0.231	24,667	0.566
62	--	5.85	--	--	--	11,736	0.269	35,557	0.816
63	--	6.85	--	--	--	13,446	0.309	48,148	1.105

# DETENTION BASIN STAGE-STORAGE TABLE BUILDER

*MHFD-Detention, Version 4.06 (July 2022)*

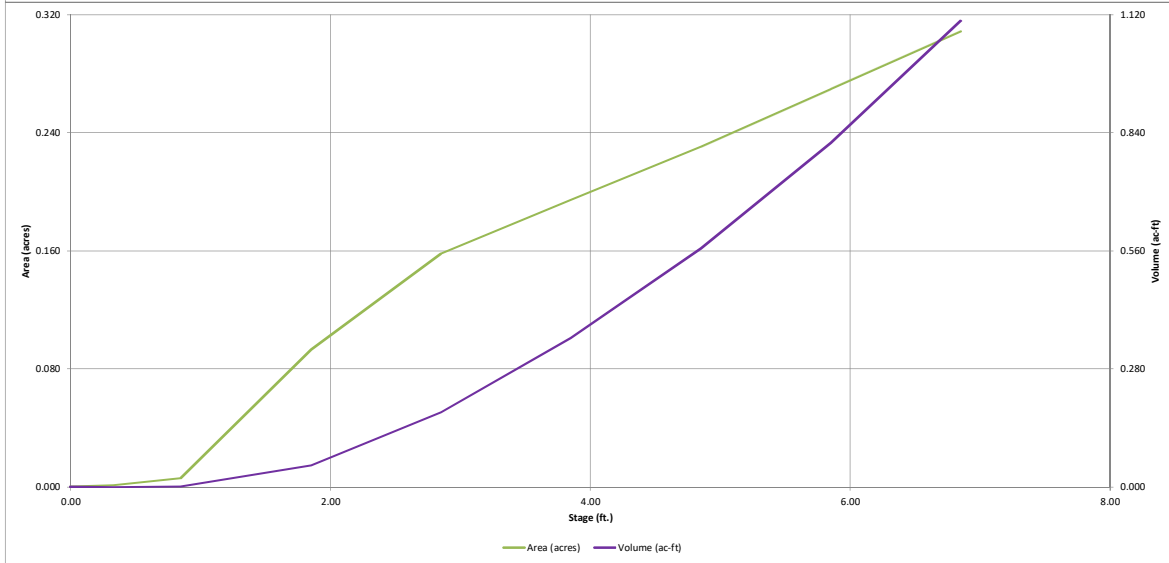
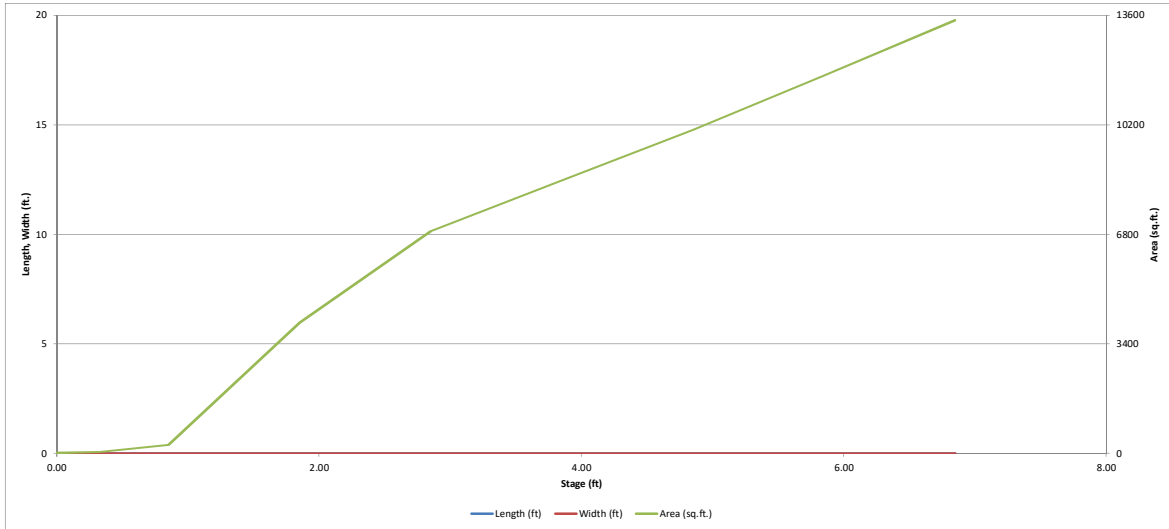

# DETENTION BASIN OUTLET STRUCTURE DESIGN

MHFD-*Detention*, Version 4.06 (July 2022)

**Project: Vollmer RV Storage**  
**Basin ID: Pond V1**

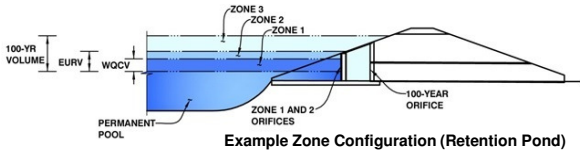

	Estimated Stage (ft)	Estimated Volume (ac-ft)	Outlet Type
Zone 1 (WQCV)	2.61	0.140	Orifice Plate
Zone 2 (EURV)	4.42	0.330	Circular Orifice
Zone 3 (100-year)	5.55	0.267	Weir&Pipe (Restrict)
<b>Total (all zones)</b>		<b>0.737</b>	

**Example Zone Configuration (Retention Pond)**

User Input: Orifice at Underdrain Outlet (typically used to drain WQCV in a Filtration BMP)

Underdrain Orifice Invert Depth =	N/A	ft (distance below the filtration media surface)
Underdrain Orifice Diameter =	N/A	inches

Calculated Parameters for Underdrain

Underdrain Orifice Area =	N/A	ft <sup>2</sup>
Underdrain Orifice Centroid =	N/A	feet

User Input: Orifice Plate with one or more orifices or Elliptical Slot Weir (typically used to drain WQCV and/or EURV in a sedimentation BMP)

Centroid of Lowest Orifice =	0.00	ft (relative to basin bottom at Stage = 0 ft)
Depth at top of Zone using Orifice Plate =	2.67	ft (relative to basin bottom at Stage = 0 ft)
Orifice Plate: Orifice Vertical Spacing =	N/A	inches
Orifice Plate: Orifice Area per Row =	N/A	sq. inches

Calculated Parameters for Plate

WQ Orifice Area per Row =	N/A	ft <sup>2</sup>
Elliptical Half-Width =	N/A	feet
Elliptical Slot Centroid =	N/A	feet
Elliptical Slot Area =	N/A	ft <sup>2</sup>

User Input: Stage and Total Area of Each Orifice Row (numbered from lowest to highest)

	Row 1 (required)	Row 2 (optional)	Row 3 (optional)	Row 4 (optional)	Row 5 (optional)	Row 6 (optional)	Row 7 (optional)	Row 8 (optional)
Stage of Orifice Centroid (ft)	0.00	0.75	1.67					
Orifice Area (sq. inches)	0.44	0.44	0.44					

	Row 9 (optional)	Row 10 (optional)	Row 11 (optional)	Row 12 (optional)	Row 13 (optional)	Row 14 (optional)	Row 15 (optional)	Row 16 (optional)
Stage of Orifice Centroid (ft)								
Orifice Area (sq. inches)								

User Input: Vertical Orifice (Circular or Rectangular)

	Zone 2 Circular	Not Selected	
Invert of Vertical Orifice =	2.67	N/A	ft (relative to basin bottom at Stage = 0 ft)
Depth at top of Zone using Vertical Orifice =	5.00	N/A	ft (relative to basin bottom at Stage = 0 ft)
Vertical Orifice Diameter =	1.75	N/A	inches

Calculated Parameters for Vertical Orifice

	Zone 2 Circular	Not Selected	
Vertical Orifice Area =	0.02	N/A	ft <sup>2</sup>
Vertical Orifice Centroid =	0.07	N/A	feet

User Input: Overflow Weir (Dropbox with Flat or Sloped Gate and Outlet Pipe OR Rectangular/Trapezoidal Weir and No Outlet Pipe)

	Zone 3 Weir	Not Selected	
Overflow Weir Front Edge Height, Ho =	4.50	N/A	ft (relative to basin bottom at Stage = 0 ft)
Overflow Weir Front Edge Length =	2.50	N/A	feet
Overflow Weir Gate Slope =	0.00	N/A	H:V
Horiz. Length of Weir Sides =	2.50	N/A	feet
Overflow Gate Type =	Type C Gate	N/A	
Debris Clogging % =	50%	N/A	%

Calculated Parameters for Overflow Weir

	Zone 3 Weir	Not Selected	
Height of Gate Upper Edge, H <sub>g</sub> =	4.50	N/A	feet
Overflow Weir Slope Length =	2.50	N/A	feet
Grate Open Area / 100-yr Orifice Area =	8.44	N/A	
Overflow Gate Open Area w/o Debris =	4.35	N/A	ft <sup>2</sup>
Overflow Gate Open Area w/ Debris =	2.18	N/A	ft <sup>2</sup>

User Input: Outlet Pipe w/ Flow Restriction Plate (Circular Orifice, Restrictor Plate, or Rectangular Orifice)

	Zone 3 Restrictor	Not Selected	
Depth to Invert of Outlet Pipe =	0.25	N/A	ft (distance below basin bottom at Stage = 0 ft)
Outlet Pipe Diameter =	18.00	N/A	inches
Restrictor Plate Height Above Pipe Invert =	6.00	N/A	inches

Calculated Parameters for Outlet Pipe w/ Flow Restriction Plate

	Zone 3 Restrictor	Not Selected	
Outlet Orifice Area =	0.52	N/A	ft <sup>2</sup>
Outlet Orifice Centroid =	0.29	N/A	feet
Half-Central Angle of Restrictor Plate on Pipe =	1.23	N/A	radians

User Input: Emergency Spillway (Rectangular or Trapezoidal)

Spillway Invert Stage =	5.58	ft (relative to basin bottom at Stage = 0 ft)
Spillway Crest Length =	40.00	feet
Spillway End Slopes =	4.00	H:V
Freeboard above Max Water Surface =	1.00	feet

Calculated Parameters for Spillway

Spillway Design Flow Depth =	0.26	feet
Stage at Top of Freeboard =	6.84	feet
Basin Area at Top of Freeboard =	0.31	acres
Basin Volume at Top of Freeboard =	1.10	acre-ft

## Routed Hydrograph Results

*The user can override the default CUHP hydrographs and runoff volumes by entering new values in the Inflow Hydrographs table (Columns W through AF).*

	WQCV	EURV	2 Year	5 Year	10 Year	25 Year	50 Year	100 Year	500 Year
Design Storm Return Period =	N/A	N/A	1.19	1.50	1.75	2.00	2.25	2.52	4.00
One-Hour Rainfall Depth (in) =	N/A	N/A	0.419	0.563	0.685	0.828	0.955	1.106	1.879
CUHP Runoff Volume (acre-ft) =	N/A	N/A	0.419	0.563	0.685	0.828	0.955	1.106	1.879
Inflow Hydrograph Volume (acre-ft) =	N/A	N/A	0.5	1.5	2.2	4.0	5.1	6.5	12.8
CUHP Predevelopment Peak Q (cfs) =	N/A	N/A							
OPTIONAL Override Predevelopment Peak Q (cfs) =	N/A	N/A							
Predevelopment Unit Peak Flow, q (cfs/acre) =	N/A	N/A	0.09	0.24	0.37	0.67	0.84	1.08	2.13
Peak Inflow Q (cfs) =	N/A	N/A	6.4	8.6	10.2	12.7	14.6	17.1	28.8
Peak Outflow Q (cfs) =	0.1	0.2	0.2	0.8	2.0	4.3	5.5	5.7	21.1
Ratio Peak Outflow to Predevelopment Q =	N/A	N/A	N/A	0.5	0.9	1.1	1.1	0.9	1.6
Structure Controlling Flow =	Plate	Vertical Orifice 1	Vertical Orifice 1	Overflow Weir 1	Overflow Weir 1	Overflow Weir 1	Outlet Plate 1	Outlet Plate 1	Spillway
Max Velocity through Gate 1 (fps) =	N/A	N/A	N/A	0.1	0.4	0.9	1.2	1.3	1.3
Max Velocity through Gate 2 (fps) =	N/A	N/A	N/A	N/A	N/A	N/A	N/A	N/A	N/A
Time to Drain 97% of Inflow Volume (hours) =	39	66	64	69	68	66	65	63	56
Time to Drain 99% of Inflow Volume (hours) =	41	71	68	74	74	73	73	72	69
Maximum Ponding Depth (ft) =	2.61	4.42	4.04	4.61	4.73	4.90	5.04	5.40	5.83
Area at Maximum Ponding Depth (acres) =	0.14	0.22	0.20	0.22	0.23	0.23	0.24	0.25	0.27
Maximum Volume Stored (acre-ft) =	0.141	0.470	0.391	0.510	0.539	0.578	0.608	0.699	0.808

# DETENTION BASIN OUTLET STRUCTURE DESIGN

*MHFD-Detention, Version 4.06 (July 2022)*

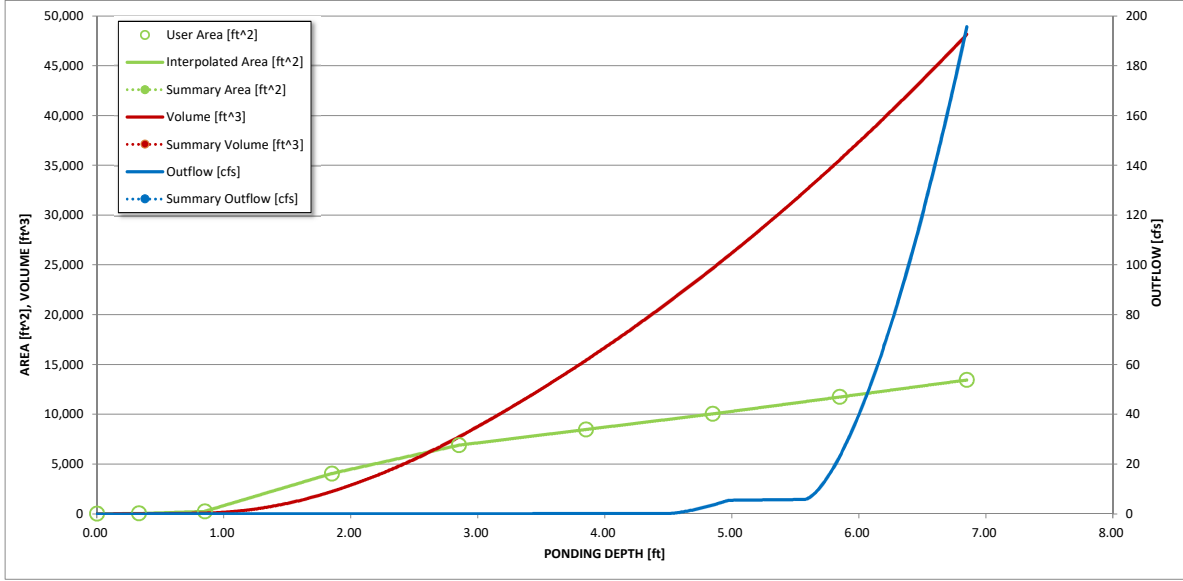
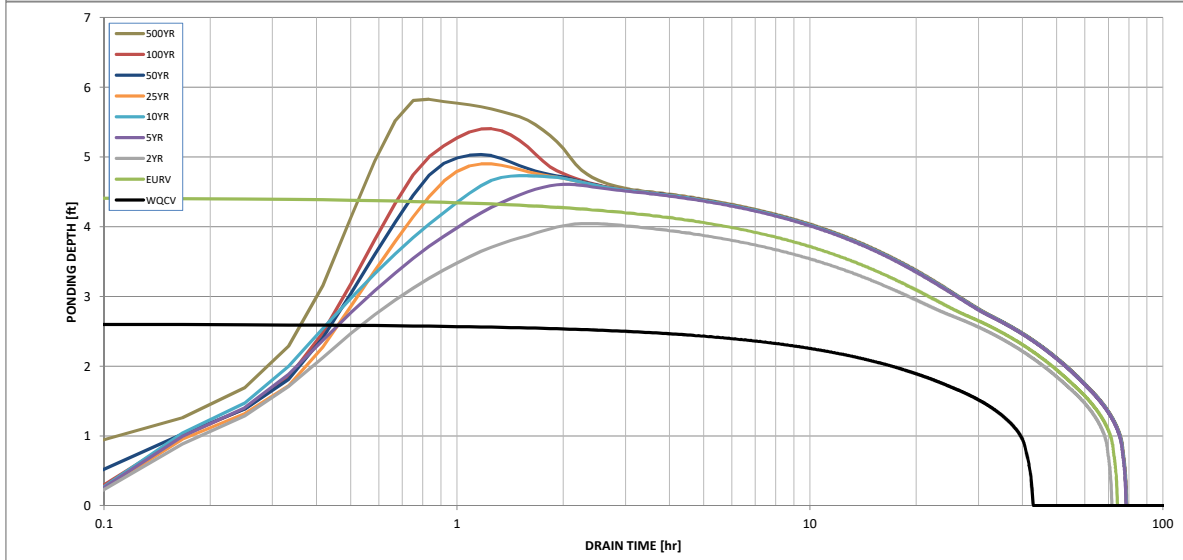
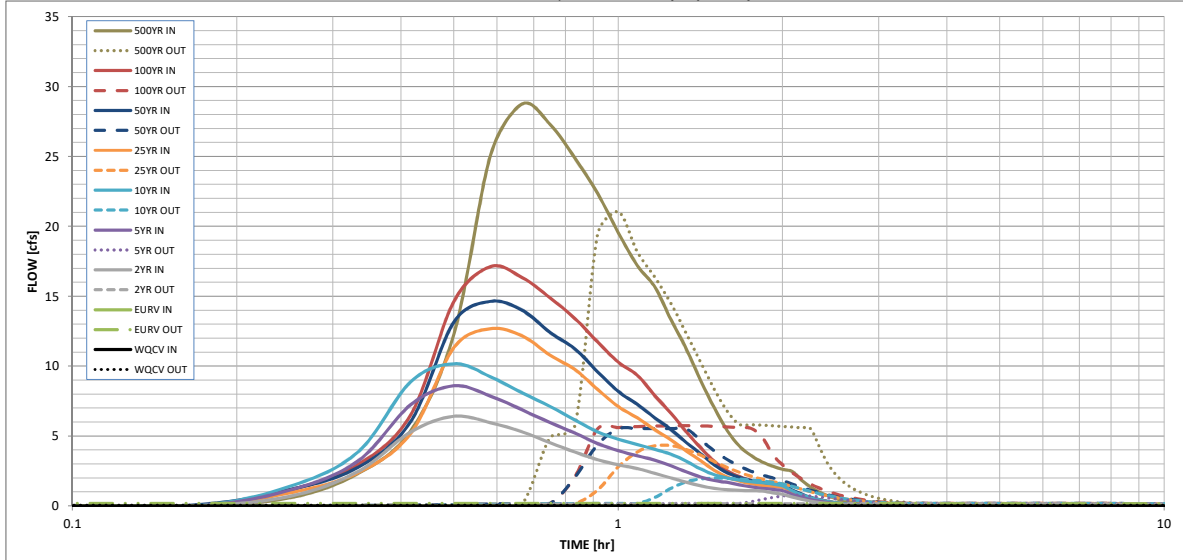

S-A-V-D Chart Axis Override	X-axis	Left Y-Axis	Right Y-Axis
minimum bound			
maximum bound			

# DETENTION BASIN OUTLET STRUCTURE DESIGN

Outflow Hydrograph Workbook Filename: \_\_\_\_\_

## Inflow Hydrographs

The user can override the calculated inflow hydrographs from this workbook with inflow hydrographs developed in a separate program.

Time Interval	SOURCE	CUHP	CUHP	CUHP	CUHP	CUHP	CUHP	CUHP	CUHP	CUHP
	TIME	WQCV [cfs]	EURV [cfs]	2 Year [cfs]	5 Year [cfs]	10 Year [cfs]	25 Year [cfs]	50 Year [cfs]	100 Year [cfs]	500 Year [cfs]
5.00 min	0:00:00	0.00	0.00	0.00	0.00	0.00	0.00	0.00	0.00	0.00
	0:05:00	0.00	0.00	0.00	0.00	0.00	0.00	0.00	0.00	0.00
	0:10:00	0.00	0.00	0.00	0.00	0.00	0.00	0.08	0.01	0.59
	0:15:00	0.00	0.00	0.70	1.14	1.41	0.94	1.17	1.15	2.32
	0:20:00	0.00	0.00	2.46	3.22	3.86	2.38	2.76	2.96	5.39
	0:25:00	0.00	0.00	5.30	7.26	8.89	5.21	6.05	6.54	12.34
	0:30:00	0.00	0.00	6.42	8.60	10.18	11.35	13.18	14.66	25.10
	0:35:00	0.00	0.00	5.96	7.86	9.25	12.68	14.64	17.13	28.77
	0:40:00	0.00	0.00	5.31	6.88	8.10	12.16	14.00	16.34	27.29
	0:45:00	0.00	0.00	4.52	5.97	7.12	10.79	12.41	14.89	24.87
	0:50:00	0.00	0.00	3.86	5.22	6.14	9.76	11.23	13.40	22.35
	0:55:00	0.00	0.00	3.32	4.47	5.31	8.33	9.59	11.72	19.55
	1:00:00	0.00	0.00	2.95	3.96	4.78	7.11	8.19	10.29	17.20
	1:05:00	0.00	0.00	2.69	3.60	4.40	6.30	7.27	9.35	15.67
	1:10:00	0.00	0.00	2.33	3.28	4.05	5.46	6.30	7.89	13.29
	1:15:00	0.00	0.00	2.00	2.87	3.70	4.72	5.46	6.62	11.20
	1:20:00	0.00	0.00	1.70	2.44	3.20	3.92	4.53	5.29	8.95
	1:25:00	0.00	0.00	1.44	2.07	2.64	3.23	3.72	4.15	7.01
	1:30:00	0.00	0.00	1.26	1.82	2.24	2.55	2.93	3.19	5.40
	1:35:00	0.00	0.00	1.17	1.69	2.01	2.07	2.38	2.51	4.28
	1:40:00	0.00	0.00	1.12	1.51	1.86	1.79	2.04	2.11	3.61
	1:45:00	0.00	0.00	1.10	1.37	1.75	1.60	1.83	1.84	3.16
	1:50:00	0.00	0.00	1.08	1.27	1.67	1.48	1.68	1.66	2.85
	1:55:00	0.00	0.00	0.95	1.19	1.58	1.39	1.58	1.53	2.63
	2:00:00	0.00	0.00	0.84	1.10	1.43	1.33	1.51	1.44	2.47
	2:05:00	0.00	0.00	0.64	0.84	1.09	1.01	1.15	1.08	1.85
	2:10:00	0.00	0.00	0.48	0.63	0.81	0.75	0.85	0.79	1.36
	2:15:00	0.00	0.00	0.36	0.47	0.60	0.56	0.63	0.59	1.01
	2:20:00	0.00	0.00	0.27	0.34	0.44	0.41	0.46	0.44	0.75
	2:25:00	0.00	0.00	0.19	0.25	0.32	0.30	0.34	0.32	0.55
	2:30:00	0.00	0.00	0.14	0.17	0.23	0.21	0.24	0.23	0.39
	2:35:00	0.00	0.00	0.10	0.12	0.16	0.16	0.18	0.17	0.28
	2:40:00	0.00	0.00	0.06	0.08	0.11	0.11	0.12	0.12	0.20
	2:45:00	0.00	0.00	0.04	0.05	0.07	0.07	0.08	0.07	0.13
	2:50:00	0.00	0.00	0.02	0.03	0.04	0.04	0.04	0.04	0.07
	2:55:00	0.00	0.00	0.01	0.01	0.02	0.02	0.02	0.02	0.03
	3:00:00	0.00	0.00	0.00	0.00	0.00	0.00	0.00	0.00	0.01
	3:05:00	0.00	0.00	0.00	0.00	0.00	0.00	0.00	0.00	0.00
	3:10:00	0.00	0.00	0.00	0.00	0.00	0.00	0.00	0.00	0.00
	3:15:00	0.00	0.00	0.00	0.00	0.00	0.00	0.00	0.00	0.00
	3:20:00	0.00	0.00	0.00	0.00	0.00	0.00	0.00	0.00	0.00
	3:25:00	0.00	0.00	0.00	0.00	0.00	0.00	0.00	0.00	0.00
	3:30:00	0.00	0.00	0.00	0.00	0.00	0.00	0.00	0.00	0.00
	3:35:00	0.00	0.00	0.00	0.00	0.00	0.00	0.00	0.00	0.00
	3:40:00	0.00	0.00	0.00	0.00	0.00	0.00	0.00	0.00	0.00
	3:45:00	0.00	0.00	0.00	0.00	0.00	0.00	0.00	0.00	0.00
	3:50:00	0.00	0.00	0.00	0.00	0.00	0.00	0.00	0.00	0.00
	3:55:00	0.00	0.00	0.00	0.00	0.00	0.00	0.00	0.00	0.00
	4:00:00	0.00	0.00	0.00	0.00	0.00	0.00	0.00	0.00	0.00
	4:05:00	0.00	0.00	0.00	0.00	0.00	0.00	0.00	0.00	0.00
	4:10:00	0.00	0.00	0.00	0.00	0.00	0.00	0.00	0.00	0.00
	4:15:00	0.00	0.00	0.00	0.00	0.00	0.00	0.00	0.00	0.00
	4:20:00	0.00	0.00	0.00	0.00	0.00	0.00	0.00	0.00	0.00
	4:25:00	0.00	0.00	0.00	0.00	0.00	0.00	0.00	0.00	0.00
	4:30:00	0.00	0.00	0.00	0.00	0.00	0.00	0.00	0.00	0.00
	4:35:00	0.00	0.00	0.00	0.00	0.00	0.00	0.00	0.00	0.00
	4:40:00	0.00	0.00	0.00	0.00	0.00	0.00	0.00	0.00	0.00
	4:45:00	0.00	0.00	0.00	0.00	0.00	0.00	0.00	0.00	0.00
	4:50:00	0.00	0.00	0.00	0.00	0.00	0.00	0.00	0.00	0.00
	4:55:00	0.00	0.00	0.00	0.00	0.00	0.00	0.00	0.00	0.00
	5:00:00	0.00	0.00	0.00	0.00	0.00	0.00	0.00	0.00	0.00
	5:05:00	0.00	0.00	0.00	0.00	0.00	0.00	0.00	0.00	0.00
	5:10:00	0.00	0.00	0.00	0.00	0.00	0.00	0.00	0.00	0.00
	5:15:00	0.00	0.00	0.00	0.00	0.00	0.00	0.00	0.00	0.00
	5:20:00	0.00	0.00	0.00	0.00	0.00	0.00	0.00	0.00	0.00
	5:25:00	0.00	0.00	0.00	0.00	0.00	0.00	0.00	0.00	0.00
	5:30:00	0.00	0.00	0.00	0.00	0.00	0.00	0.00	0.00	0.00
	5:35:00	0.00	0.00	0.00	0.00	0.00	0.00	0.00	0.00	0.00
	5:40:00	0.00	0.00	0.00	0.00	0.00	0.00	0.00	0.00	0.00
	5:45:00	0.00	0.00	0.00	0.00	0.00	0.00	0.00	0.00	0.00
	5:50:00	0.00	0.00	0.00	0.00	0.00	0.00	0.00	0.00	0.00
	5:55:00	0.00	0.00	0.00	0.00	0.00	0.00	0.00	0.00	0.00
	6:00:00	0.00	0.00	0.00	0.00	0.00	0.00	0.00	0.00	0.00



**Design Procedure Form: Extended Detention Basin (EDB)**

UD-BMP (Version 3.07, March 2018)

Sheet 1 of 3

**Designer:** APL  
**Company:** JR Engineering  
**Date:** November 17, 2023  
**Project:** Vollmer RV Storage  
**Location:** El Paso County

**1. Basin Storage Volume**

- A) Effective Imperviousness of Tributary Area,  $I_a$
- B) Tributary Area's Imperviousness Ratio ( $i = I_a / 100$ )
- C) Contributing Watershed Area
- D) For Watersheds Outside of the Denver Region, Depth of Average Runoff Producing Storm
- E) Design Concept  
(Select EURV when also designing for flood control)
- F) Design Volume (WQCV) Based on 40-hour Drain Time  
( $V_{DESIGN} = (1.0 * (0.91 * i^2 - 1.19 * i^2 + 0.78 * i) / 12 * Area)$ )
- G) For Watersheds Outside of the Denver Region, Water Quality Capture Volume (WQCV) Design Volume  
( $V_{WQCV\ OTHER} = (d_6 * (V_{DESIGN} / 0.43))$ )
- H) User Input of Water Quality Capture Volume (WQCV) Design Volume  
(Only if a different WQCV Design Volume is desired)
- I) NRCS Hydrologic Soil Groups of Tributary Watershed
  - i) Percentage of Watershed consisting of Type A Soils
  - ii) Percentage of Watershed consisting of Type B Soils
  - iii) Percentage of Watershed consisting of Type C/D Soils
- J) Excess Urban Runoff Volume (EURV) Design Volume  
 For HSG A:  $EURV_A = 1.68 * i^{1.28}$   
 For HSG B:  $EURV_B = 1.36 * i^{1.08}$   
 For HSG C/D:  $EURV_{C/D} = 1.20 * i^{1.08}$
- K) User Input of Excess Urban Runoff Volume (EURV) Design Volume  
(Only if a different EURV Design Volume is desired)

$I_a =$   %  
 $i =$    
 Area =  ac  
 $d_6 =$   in  
 Choose One  
 Water Quality Capture Volume (WQCV)  
 Excess Urban Runoff Volume (EURV)  
 $V_{DESIGN} =$   ac-ft  
 $V_{DESIGN\ OTHER} =$   ac-ft  
 $V_{DESIGN\ USER} =$   ac-ft  
 $HSG_A =$   %  
 $HSG_B =$   %  
 $HSG_{C/D} =$   %  
 $EURV_{DESIGN} =$   ac-ft  
 $EURV_{DESIGN\ USER} =$   ac-ft

**2. Basin Shape: Length to Width Ratio**  
(A basin length to width ratio of at least 2:1 will improve TSS reduction.)

$L : W =$   : 1

**3. Basin Side Slopes**

- A) Basin Maximum Side Slopes  
(Horizontal distance per unit vertical, 4:1 or flatter preferred)

$Z =$   ft / ft  
DIFFICULT TO MAINTAIN, INCREASE WHERE POSSIBLE

**4. Inlet**

- A) Describe means of providing energy dissipation at concentrated inflow locations:

\_\_\_\_\_

\_\_\_\_\_

\_\_\_\_\_

**5. Forebay**

- A) Minimum Forebay Volume  
( $V_{FMIN} =$   % of the WQCV)
- B) Actual Forebay Volume
- C) Forebay Depth  
( $D_F =$   inch maximum)
- D) Forebay Discharge
  - i) Undetained 100-year Peak Discharge
  - ii) Forebay Discharge Design Flow  
( $Q_F = 0.02 * Q_{100}$ )
- E) Forebay Discharge Design
- F) Discharge Pipe Size (minimum 8-inches)
- G) Rectangular Notch Width

$V_{FMIN} =$   ac-ft  
 $V_F =$   ac-ft  
 $D_F =$   in  
 $Q_{100} =$   cfs  
 $Q_F =$   cfs  
 Choose One  
 Berm With Pipe  
 Wall with Rect. Notch  
 Wall with V-Notch Weir  
 Calculated  $D_p =$   in  
 Calculated  $W_N =$   in

Flow too small for berm w/ pipe



**Design Procedure Form: Extended Detention Basin (EDB)**

**Designer:** APL  
**Company:** JR Engineering  
**Date:** November 17, 2023  
**Project:** Vollmer RV Storage  
**Location:** El Paso County

<p>6. Trickle Channel</p> <p>A) Type of Trickle Channel</p>  <p>F) Slope of Trickle Channel</p>	<div style="border: 1px solid black; padding: 2px; margin-bottom: 5px;">             Choose One  <input checked="" type="radio"/> Concrete  <input type="radio"/> Soft Bottom         </div> <p>S = <input style="width: 50px;" type="text" value="0.0050"/> ft / ft</p>
<p>7. Micropool and Outlet Structure</p> <p>A) Depth of Micropool (2.5-foot minimum)</p> <p>B) Surface Area of Micropool (10 ft<sup>2</sup> minimum)</p> <p>C) Outlet Type</p>   <p>D) Smallest Dimension of Orifice Opening Based on Hydrograph Routing (Use UD-Detention)</p> <p>E) Total Outlet Area</p>	<p>D<sub>M</sub> = <input style="width: 50px;" type="text" value="2.5"/> ft</p> <p>A<sub>M</sub> = <input style="width: 50px;" type="text" value="10"/> sq ft</p> <div style="border: 1px solid black; padding: 2px; margin-bottom: 5px;">             Choose One  <input checked="" type="radio"/> Orifice Plate  <input type="radio"/> Other (Describe):         </div> <hr/> <hr/> <hr/> <p>D<sub>orifice</sub> = <input style="width: 50px;" type="text" value="0.74"/> inches</p> <p>A<sub>ot</sub> = <input style="width: 50px;" type="text" value="3.73"/> square inches</p>
<p>8. Initial Surcharge Volume</p> <p>A) Depth of Initial Surcharge Volume (Minimum recommended depth is 4 inches)</p> <p>B) Minimum Initial Surcharge Volume (Minimum volume of 0.3% of the WQCV)</p> <p>C) Initial Surcharge Provided Above Micropool</p>	<p>D<sub>IS</sub> = <input style="width: 50px;" type="text" value="4"/> in</p> <p>V<sub>IS</sub> = <input style="width: 50px;" type="text" value=""/> cu ft</p> <p>V<sub>s</sub> = <input style="width: 50px;" type="text" value="3.3"/> cu ft</p>
<p>9. Trash Rack</p> <p>A) Water Quality Screen Open Area: <math>A_t = A_{ot} * 38.5 * (e^{-0.095D})</math></p> <p>B) Type of Screen (If specifying an alternative to the materials recommended in the USDCM, indicate "other" and enter the ratio of the total open are to the total screen are for the material specified.)</p> <p style="margin-left: 40px;">Other (Y/N): <input style="width: 50px;" type="text" value="N"/></p> <p>C) Ratio of Total Open Area to Total Area (only for type 'Other')</p> <p>D) Total Water Quality Screen Area (based on screen type)</p> <p>E) Depth of Design Volume (EURV or WQCV) (Based on design concept chosen under 1E)</p> <p>F) Height of Water Quality Screen (H<sub>TR</sub>)</p> <p>G) Width of Water Quality Screen Opening (W<sub>opening</sub>) (Minimum of 12 inches is recommended)</p>	<p>A<sub>t</sub> = <input style="width: 50px;" type="text" value="134"/> square inches</p> <div style="border: 1px solid black; padding: 2px; margin-bottom: 5px; width: fit-content;">             S.S. Well Screen with 60% Open Area         </div> <hr/> <hr/> <hr/> <p>User Ratio = <input style="width: 50px;" type="text" value=""/></p> <p>A<sub>total</sub> = <input style="width: 50px;" type="text" value="223"/> sq. in.</p> <p>H = <input style="width: 50px;" type="text" value="4.56"/> feet</p> <p>H<sub>TR</sub> = <input style="width: 50px;" type="text" value="82.72"/> inches</p> <p>W<sub>opening</sub> = <input style="width: 50px;" type="text" value="12.0"/> inches <span style="color: red; font-size: small;">VALUE LESS THAN RECOMMENDED MIN. WIDTH. WIDTH HAS BEEN SET TO 12 INCHES.</span></p>

Design Procedure Form: Extended Detention Basin (EDB)

Designer: APL  
Company: JR Engineering  
Date: November 17, 2023  
Project: Vollmer RV Storage  
Location: El Paso County

10. Overflow Embankment

A) Describe embankment protection for 100-year and greater overtopping:

\_\_\_\_\_  
\_\_\_\_\_

B) Slope of Overflow Embankment  
(Horizontal distance per unit vertical, 4:1 or flatter preferred)

Ze =  ft / ft

11. Vegetation

Choose One  
 Irrigated  
 Not Irrigated

12. Access

A) Describe Sediment Removal Procedures

\_\_\_\_\_  
\_\_\_\_\_  
\_\_\_\_\_  
\_\_\_\_\_

Notes:

\_\_\_\_\_  
\_\_\_\_\_  
\_\_\_\_\_

# Channel Report

## Trickle Channel

### Rectangular

Bottom Width (ft) = 2.00

Total Depth (ft) = 0.50

Invert Elev (ft) = 1.00

Slope (%) = 0.50

N-Value = 0.012

### Calculations

Compute by: Known Q

Known Q (cfs) = 0.68

### Highlighted

Depth (ft) = 0.16

Q (cfs) = 0.680

Area (sqft) = 0.32

Velocity (ft/s) = 2.13

Wetted Perim (ft) = 2.32

Crit Depth,  $Y_c$  (ft) = 0.16

Top Width (ft) = 2.00

EGL (ft) = 0.23

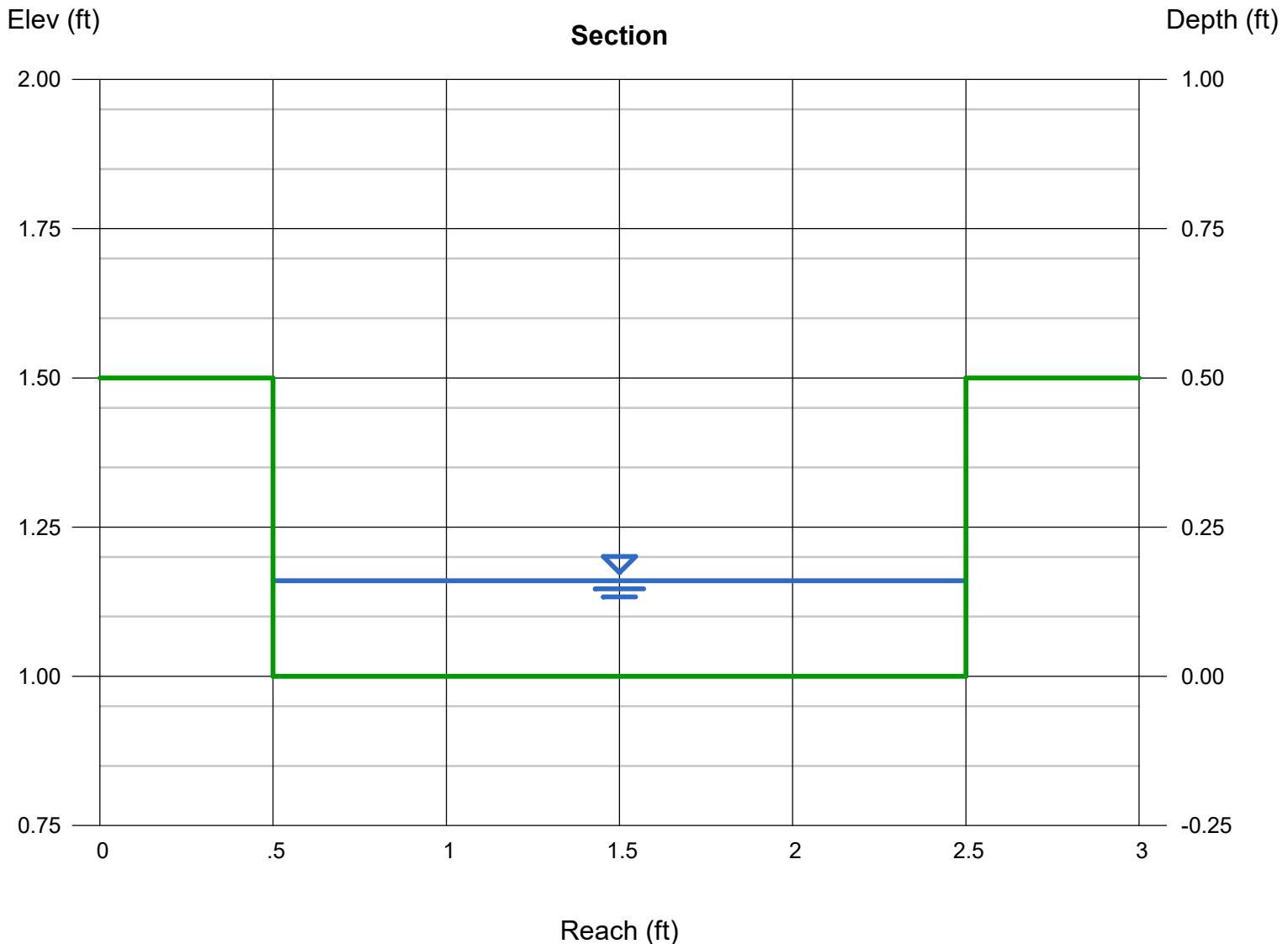

# Weir Report

## Forebay Weir Notch Pond V1

### Rectangular Weir

Crest = Sharp  
Bottom Length (ft) = 0.31  
Total Depth (ft) = 1.00

### Highlighted

Depth (ft) = 0.48  
Q (cfs) = 0.340  
Area (sqft) = 0.15  
Velocity (ft/s) = 2.30  
Top Width (ft) = 0.31

### Calculations

Weir Coeff. Cw = 3.33  
Compute by: Known Q  
Known Q (cfs) = 0.34

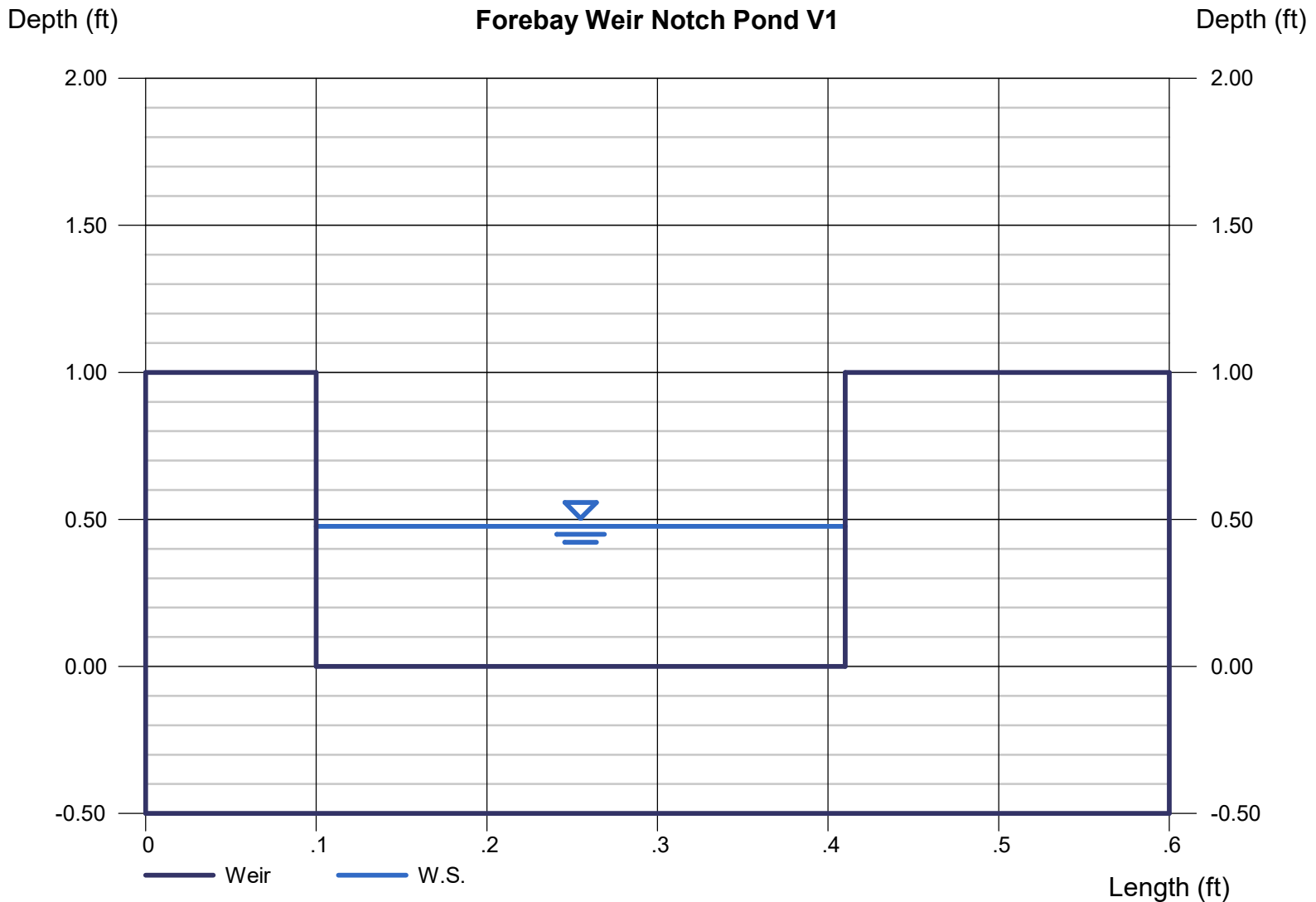

**Figure 13-12c. Emergency Spillway Protection**

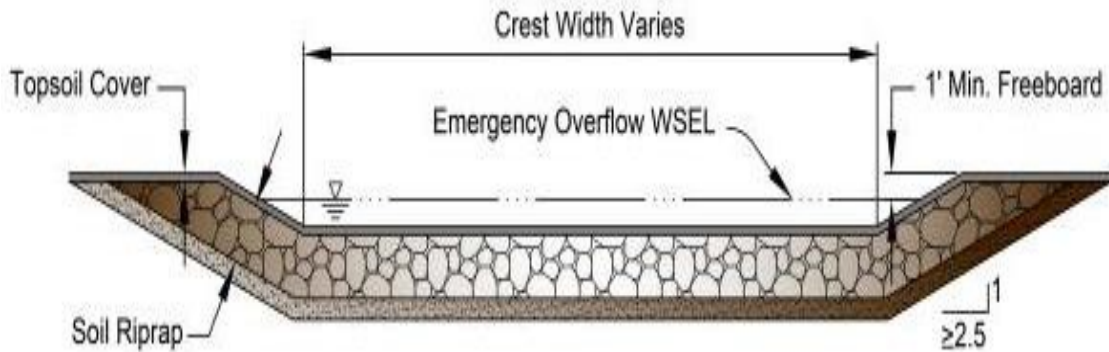

**Figure 13-12d. Riprap Types for Emergency Spillway Protection**

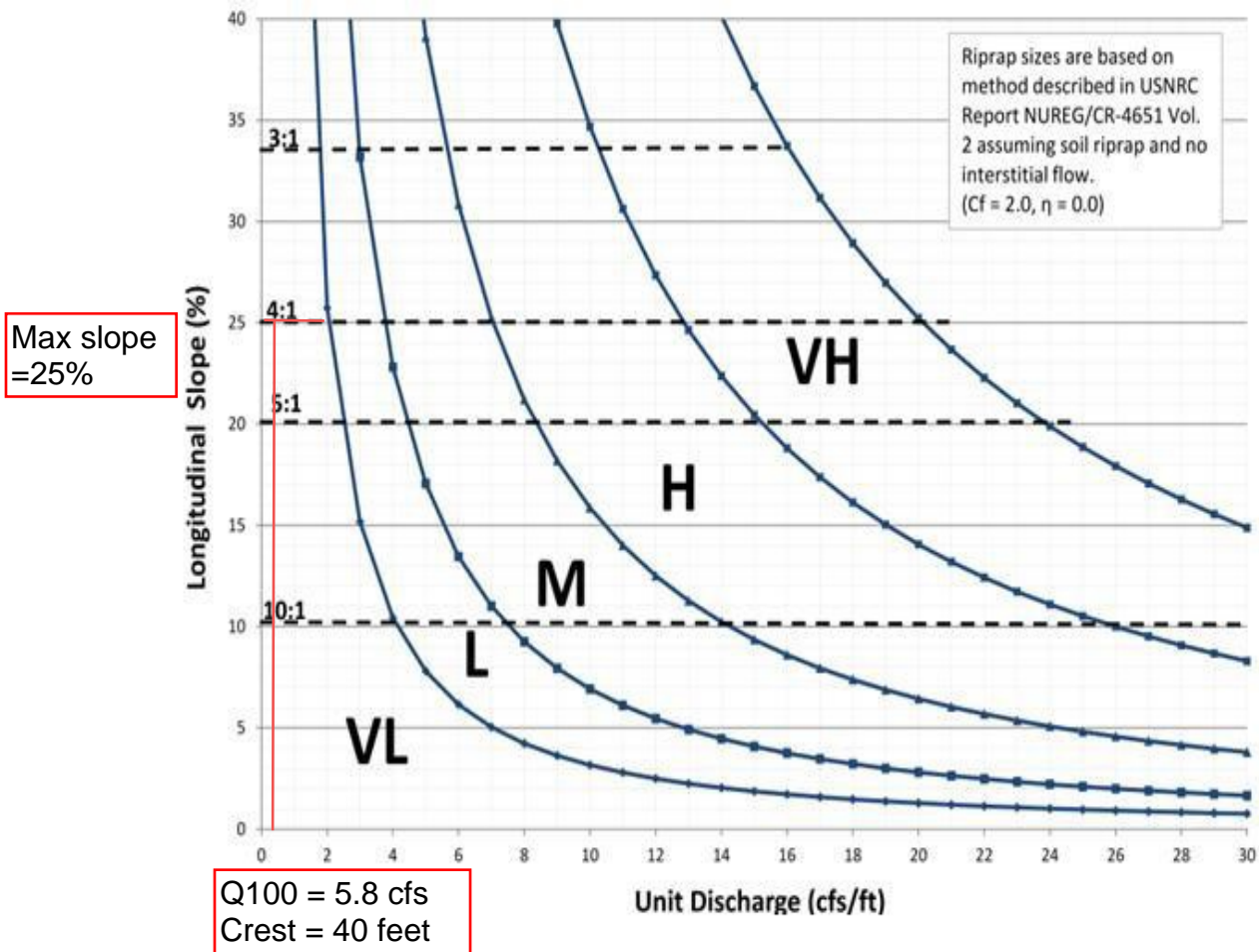

# Culvert Report

## Site Access Culvert DP7.1

Invert Elev Dn (ft)	=	7054.54
Pipe Length (ft)	=	44.67
Slope (%)	=	0.60
Invert Elev Up (ft)	=	7054.81
Rise (in)	=	18.0
Shape	=	Circular
Span (in)	=	18.0
No. Barrels	=	1
n-Value	=	0.012
Culvert Type	=	Circular Concrete
Culvert Entrance	=	Groove end projecting (C)
Coeff. K,M,c,Y,k	=	0.0045, 2, 0.0317, 0.69, 0.2

<b>Embankment</b>	
Top Elevation (ft)	= 7057.42
Top Width (ft)	= 26.00
Crest Width (ft)	= 15.00

<b>Calculations</b>	
Qmin (cfs)	= 2.30
Qmax (cfs)	= 2.30
Tailwater Elev (ft)	= (dc+D)/2

<b>Highlighted</b>	
Qtotal (cfs)	= 2.30
Qpipe (cfs)	= 2.30
Qovertop (cfs)	= 0.00
Veloc Dn (ft/s)	= 1.77
Veloc Up (ft/s)	= 3.71
HGL Dn (ft)	= 7055.58
HGL Up (ft)	= 7055.38
Hw Elev (ft)	= 7055.60
Hw/D (ft)	= 0.53
Flow Regime	= Inlet Control

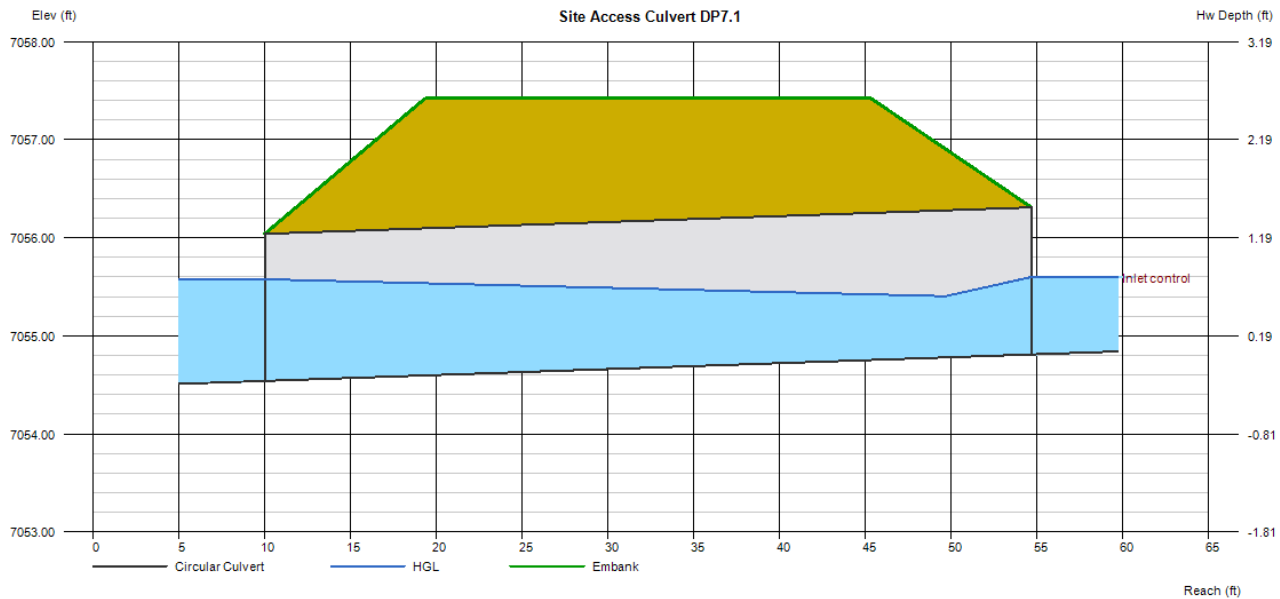

# Culvert Report

## Neighbor Driveway Access Culvert DPO10

Invert Elev Dn (ft)	= 7065.89
Pipe Length (ft)	= 45.58
Slope (%)	= 0.79
Invert Elev Up (ft)	= 7066.25
Rise (in)	= 18.0
Shape	= Circular
Span (in)	= 18.0
No. Barrels	= 1
n-Value	= 0.012
Culvert Type	= Circular Concrete
Culvert Entrance	= Groove end projecting (C)
Coeff. K,M,c,Y,k	= 0.0045, 2, 0.0317, 0.69, 0.2

<b>Embankment</b>	
Top Elevation (ft)	= 7068.83
Top Width (ft)	= 24.00
Crest Width (ft)	= 15.00

<b>Calculations</b>	
Qmin (cfs)	= 2.40
Qmax (cfs)	= 2.40
Tailwater Elev (ft)	= (dc+D)/2

<b>Highlighted</b>	
Qtotal (cfs)	= 2.40
Qpipe (cfs)	= 2.40
Qovertop (cfs)	= 0.00
Veloc Dn (ft/s)	= 1.83
Veloc Up (ft/s)	= 3.72
HGL Dn (ft)	= 7066.93
HGL Up (ft)	= 7066.84
Hw Elev (ft)	= 7067.06
Hw/D (ft)	= 0.54
Flow Regime	= Inlet Control

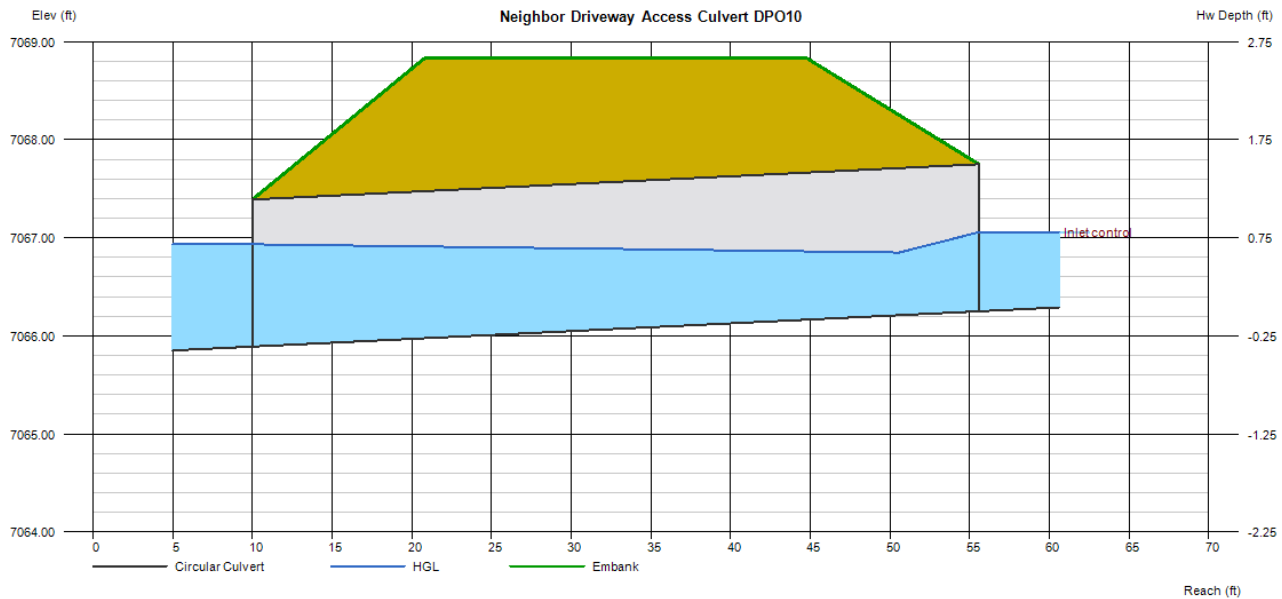

## PIPE OUTFALL RIPRAP SIZING CALCULATIONS

Subdivision: MC CLINTOCK STATION  
 Location: El Paso County

Project Name: Vollmer Road RV Storage  
 Project No.: 25251.00  
 Calculated By: APL  
 Checked By: GAG  
 Date: 11/16/23

	STORM DRAIN SYSTEM			Notes
	DP 010	DP 9.1	DP 3.1	
Q <sub>100</sub> (cfs):	2.4	8.9	30.7	Flows are the greater of proposed vs. future
Conduit	Pipe	Pipe	Pipe	
D <sub>c</sub> , Pipe Diameter (in):	18	18	36	
W, Box Width (ft):	N/A	N/A	N/A	
H, Box Height (ft):	N/A	N/A	N/A	
Y <sub>t</sub> , Tailwater Depth (ft):	0.60	0.60	1.20	If unknown, use Y <sub>t</sub> /D <sub>c</sub> (or H)=0.4
Y <sub>t</sub> /D <sub>c</sub> or Y <sub>t</sub> /H	0.40	0.40	0.40	
Q/D <sup>2.5</sup> or Q/(WH <sup>3/2</sup> )	0.87	3.23	1.97	
Supercritical?	No	No	No	
Y <sub>n</sub> , Normal Depth (ft) [Supercritical]:				
D <sub>a</sub> , H <sub>a</sub> (in) [Supercritical]:	N/A	N/A	N/A	D <sub>a</sub> =(D <sub>c</sub> +Y <sub>n</sub> )/2
Riprap d <sub>50</sub> (in) [Supercritical]:	N/A	N/A	N/A	
Riprap d <sub>50</sub> (in) [Subcritical]:	1.08	4.02	4.90	
<b>Required Riprap Size:</b>	<b>L</b>	<b>L</b>	<b>L</b>	<b>Fig. 9-38 or Fig. 9-36</b>
<b>d<sub>50</sub> (in):</b>	<b>9</b>	<b>9</b>	<b>9</b>	
Expansion Factor, 1/(2 tan θ):	6.60	4.20	5.80	Read from Fig. 9-35 or 9-36
θ:	0.08	0.12	0.09	
Erosive Soils?	No	No	No	
Area of Flow, A <sub>t</sub> (ft <sup>2</sup> ):	0.34	1.27	4.39	A <sub>t</sub> =Q/V
Length of Protection, L <sub>p</sub> (ft):	-6.1	2.6	3.8	L=(1/(2 tan θ))(A <sub>t</sub> /Y <sub>t</sub> - D)
Min Length (ft)	4.5	4.5	9.0	Min L=3D or 3H
Max Length (ft)	15.0	15.0	30.0	Max L=10D or 10H
Min Bottom Width, T (ft):	0.6	2.1	3.7	T=2*(L <sub>p</sub> *tanθ)+W
<b>Design Length (ft)</b>	<b>4.5</b>	<b>4.5</b>	<b>9.0</b>	
<b>Design Width (ft)</b>	<b>0.6</b>	<b>2.1</b>	<b>3.7</b>	
<b>Riprap Depth (in)</b>	<b>18</b>	<b>18</b>	<b>18</b>	Depth=2(d <sub>50</sub> )
Type II Bedding Depth (in)*	6	6	6	*Not used if Soil Riprap
Cutoff Wall	No	No	No	
Cutoff Wall Depth (ft)				Depth of Riprap and Base
Cutoff Wall Width (ft)				

Note: No Type II Base to be used if Soil Riprap is specified within the plans  
 \* For use when the flow in the culvert is supercritical (and less than full).



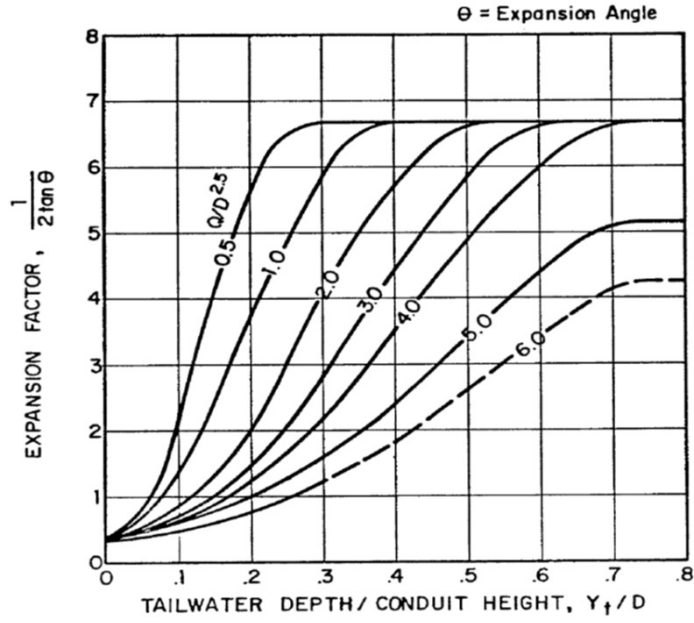

Figure 9-35. Expansion factor for circular conduits

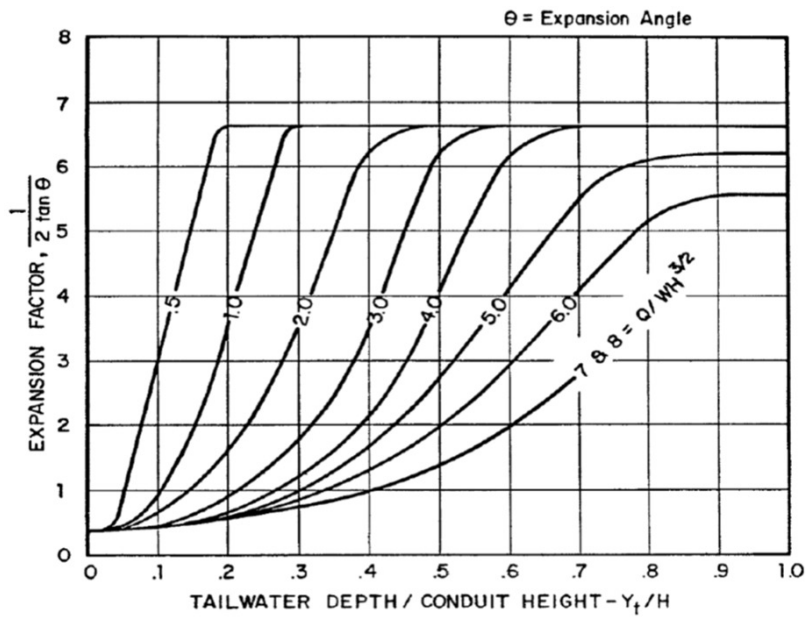

Figure 9-36. Expansion factor for rectangular conduits

**APPENDIX D**

**REFERENCE MATERIALS**



# SAND CREEK DRAINAGE BASIN PLANNING STUDY FINAL REPORT JANUARY 2021

Prepared for:



Prepared by:



SAND CREEK – SAND CREEK DRAINAGE BASIN PLANNING STUDY

Basin Characteristics and Environmental Resources

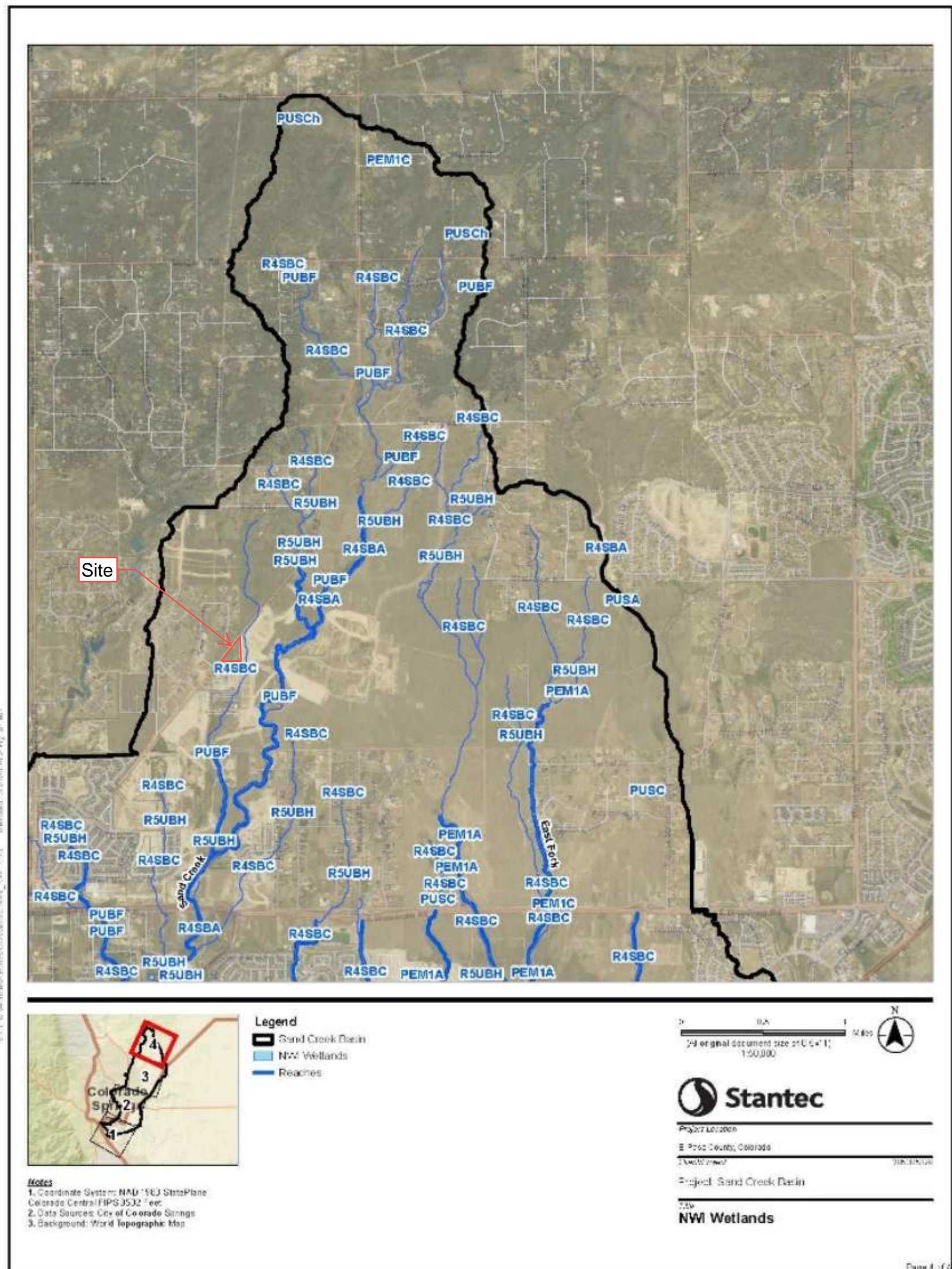

Disclaimer: This document has been prepared based on information provided by others as cited in the Notes section. Stantec has not verified the accuracy and/or completeness of this information and shall not be responsible for any errors or omissions which may be incorporated herein as a result. Stantec assumes no responsibility for data supplied in electronic format, and the recipient accepts full responsibility for verifying the accuracy and completeness of the data.

Figure 2-7: NWI Wetlands Located in Sand Creek Drainage Basin (Page 4)

SAND CREEK – SAND CREEK DRAINAGE BASIN PLANNING STUDY

Hydrology

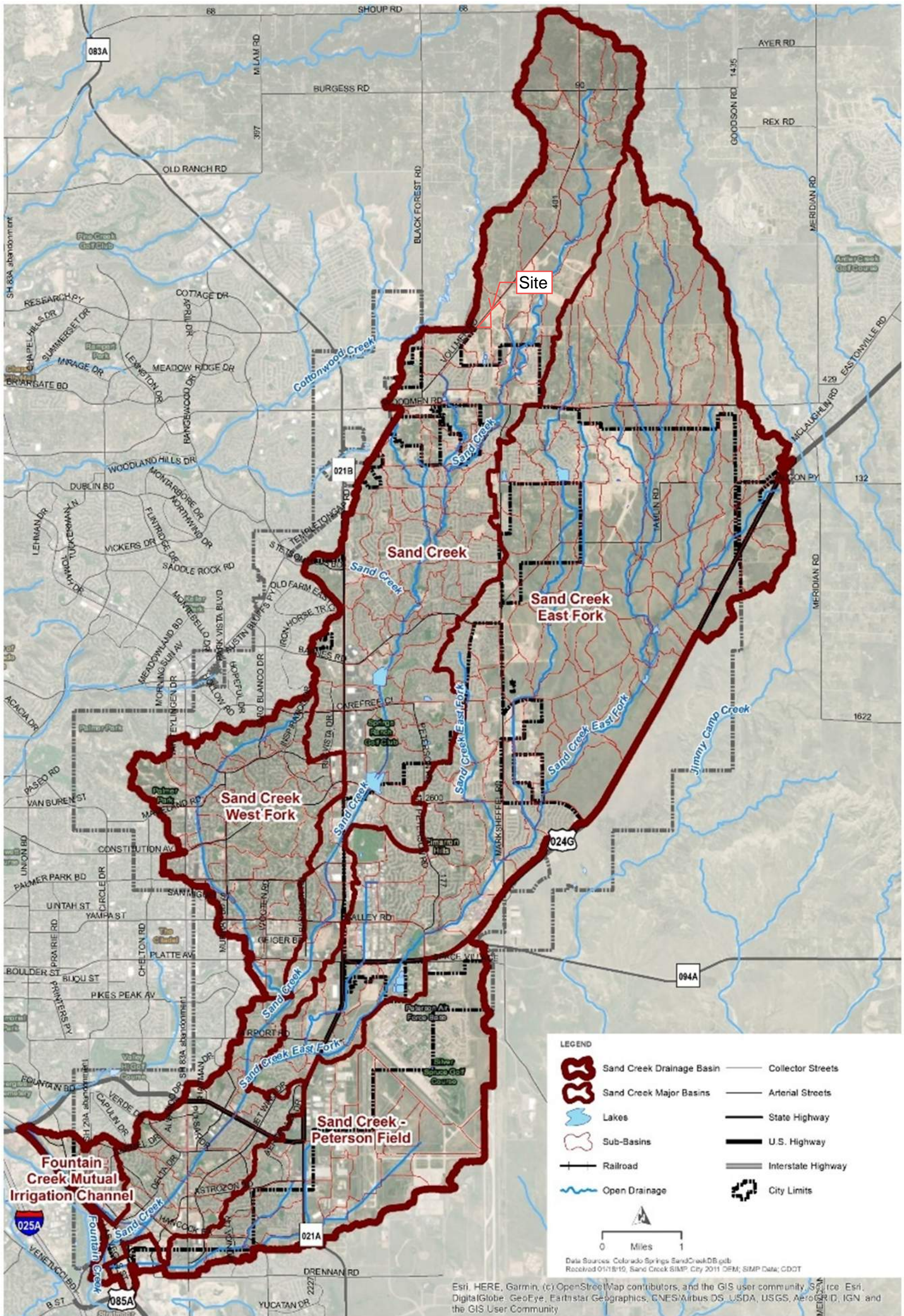

Figure 3-1. Major Sub-basin Map

SAND CREEK – SAND CREEK DRAINAGE BASIN PLANNING STUDY

Hydrology

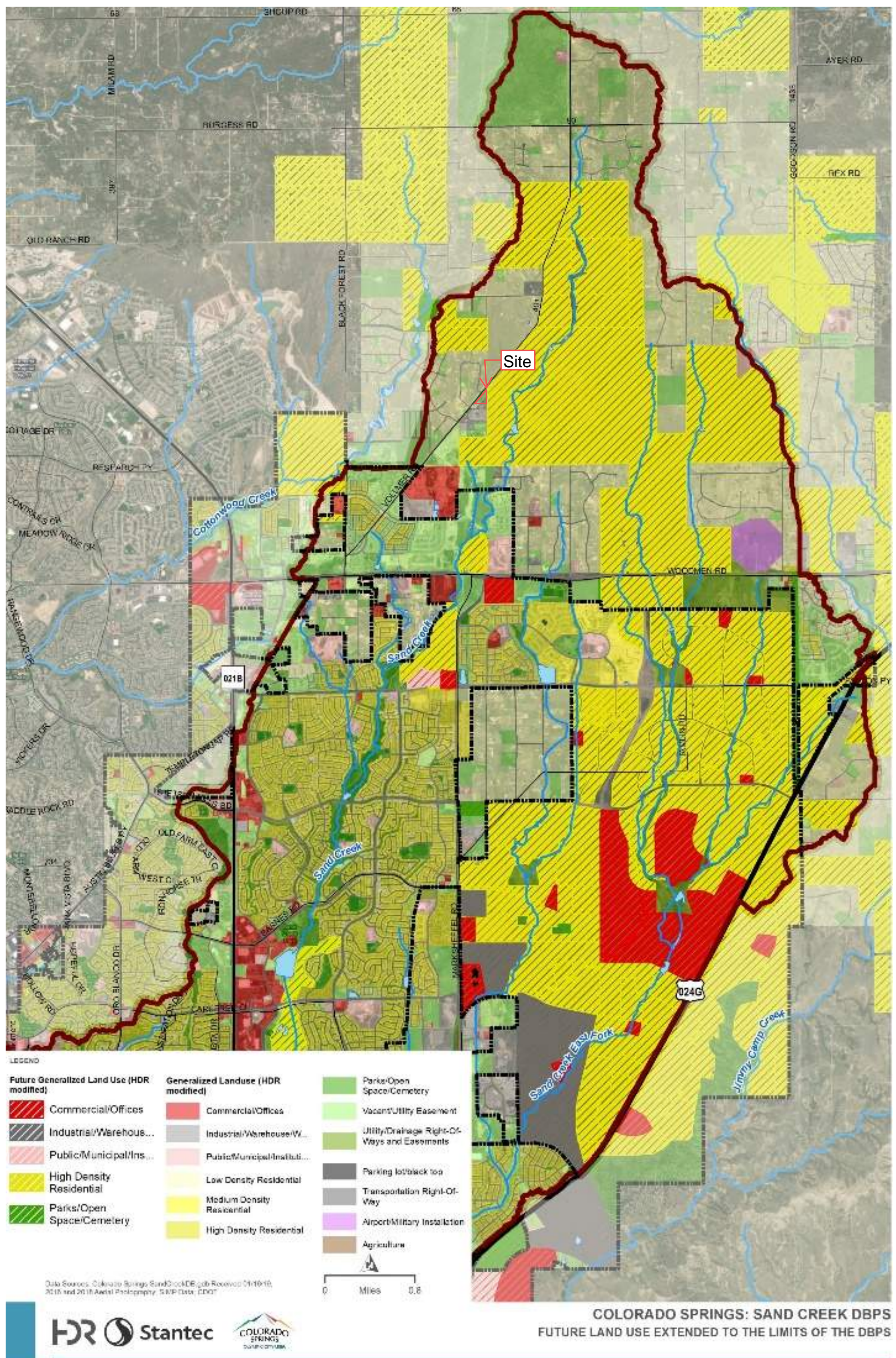
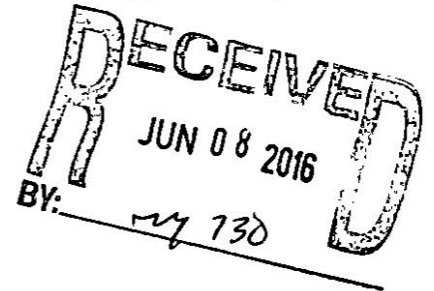

Figure 3-15. Future Land Use MapFuture Condition Model Results



**FINAL DRAINAGE REPORT**  
For  
**BARBARICK SUBDIVISION,**  
**PORTIONS OF LOTS 1, 2 and LOTS 3 & 4**  
El Paso County, Colorado  
**Sand Creek Drainage Basin**

Prepared for:  
**El Paso County Development Services**  
**Engineering Division**



On Behalf of:  
**Wykota Construction**  
430 Beacon Light Road, Suite 130  
Monument, CO 80132

Prepared by:



2435 Research Parkway, Suite 300  
Colorado Springs, CO 80920  
(719) 575-0100  
Fax (719) 572-0208

June 6, 2016

15.789.001

plus the time of travel ( $t_t$ ) in concentrated form, such as a swale or drainageway. A minimum  $T_c$  of 5 minutes and 10 minutes were used for the final calculations in developed and undeveloped conditions, respectively.

### **Storm Drain Systems**

All proposed storm drain infrastructure will be located within private property and will be owned and maintained by the property owner.

The storm drain hydraulics is analyzed using *Bentley's FlowMaster*, *CulvertMaster* & *StormCAD* design software. Colorado Department of Transportation (CDOT) type inlets will be used where necessary.

The designated outfall locations for the proposed on-site storm drains are the natural drainage ways at the south end of the property. The proposed storm drain infrastructure will be discussed in more detail below.

## **EXISTING DRAINAGE REPORT DISCUSSION**

The approved Barbarick Subdivision Final Drainage Report (BS-FDR) and the approved Woodmen Storage Final Drainage Report (WS-FDR) both apply to the existing general drainage conditions for this site. The off-site basins and general flow patterns in the BS-FDR and WS-FDR still apply. Excerpts from these reports are provided below for reference.

### ***On-site and Off-Site Basin Descriptions from the BS-FDR and WS-FDR:***

The following summary is taken from the Barbarick Subdivision Final Drainage Report (BS-FDR):

#### **Off-site:**

**Off-site Basin O3** This basin encompasses approximately 7.03 acres and represents the area north and northwest of Lot 1. This basin drains into Lot 1 through a series of (2) 24" CMP pipes which control the flow of 14/36 cfs in the 5/100 year storm events.

**Lots 1 & 2** – these lots are considered fully developed lots and drain north to south collecting at the existing concrete settling pond on Lot 2. This developed flow (20.8 cfs /57.2 cfs) combines with Off-site Basin O3 to total 30.5 cfs / 80.8 cfs in the greenbelt offsite south of Lot 2. At the time of development permit for these developed lots, a detention pond for water quality will be required, probably in the area of the existing concrete settling pond, that will accommodate Lots 1 and 2 west of the gas easement and flood plain area.



**On-site:****On-site Basins A1 and B1 (for portions of Lots 1 and 2, and Lots 3 & 4)**

These basins encompass approximately 5.3 & 3.8 acres and represent the buildable portions of the property as described in the BS-FDR (see Basin Map from BS-FDR below). These basins were slated (in the BS-FDR) to drain into small detention ponds that would release to historic rates. These discharge rates were calculated to be 2.9/7.3 and 2.2/5.4 cfs (5/100 year). The BS-FDR does not include the drainage ways in any hydrology calculations due to the fact that this no-build drainage area was not planned on being developed. This drainage way allowed off-site flows from O1+O2 to pass-through Lots 3 & 4. The drainage way to the west of A1 passes through flows from offsite O3. Since the approval of this report, offsite tributary basins O1+O2 have been changed, and the development of the property encompasses the whole property, including the previously determined no-build area.

The following summary is taken from the Woodmen Storage Final Drainage Report (WS-FDR):

**Off-site:**

**Design Point 5** - This design point encompasses approximately 19.69 acres and represents the tributary area north of the project site. This basin drains into a proposed detention pond near the northeast corner of the property and generates 57.4/92.7 cfs in the 10/100 year storm events, historic flows are 16.7/30.3 cfs. The releases rates from this pond are lower than historic 16.1 cfs/29.4 cfs in the 10/100-year storm events. These flows are conveyed along the east property line of the site and into the eastern natural drainage way that leaves the property to the south.

**Review of the Sterling Ranch Preliminary Drainage Report (SR-PDR):**

The Barbarick Subdivision is surrounded on three sides by the planned Sterling Ranch Development. The approved Sterling Ranch PDR was prepared by M&S Civil Consultants in May of 2015. This Sterling Ranch PDR re-analyzes runoff from Barbarick Subdivision and plans for storm drain improvements to convey this runoff to a full spectrum detention and water quality pond to be located down stream of Barbarick Subdivision as part of Sterling Ranch Phase One.

In summary; the Sterling Ranch PDR is planning on receiving 73.3/139.2 cfs (5/100 year) from Basin OS3. A 54" RCP is planned to convey this flow through Sterling Ranch. The Sterling Ranch PDR is planning on receiving 45/86 cfs (5/100 year) from OS2, encompasses Lots 1 & 2 and OS3 encompasses Lots 3 & 4 and the Basin north of Lot 3. A 48" RCP is planned to convey this flow through Sterling Ranch. The cumulative runoff from the northerly property and Lots 1 through 4 does not exceed the anticipated rates in the SR-PDR.

condition rangeland and generates 0.3/2.7 cfs in the 5/100 year storm events. This basin sheet flows offsite where it is captured in a small swale between the site and existing roadway and conveyed westerly to the low point south of the outfall of Basin H1.

These existing basins encompass the previously unmodelled drainage area from the BS-FDR. The total historic flow from the site is 3.8/34.6 cfs in the 5/100 year storm events. The following design point table is for combined allowable discharge rates from the property at respective locations including historic flows from the tributary upstream basins:

<u>Design Point</u>	<u>5/100 Release</u>	<u>Comments</u>
DP H1	16.7*/30.3 cfs	DP H5 WS-FDR - * is 10year
DP H2	13.7/35.5 cfs	O3 BS-FDR
DP H3	56.7 cfs	DPH1+H1+H3 (100-year)
DP H4	14.6/43.7 cfs	DPH2 + H2

Design Point H3 will release a flow lower than previously anticipated within the BS-FDR (52.9/170 cfs). It is the introduction of development within the Sterling Ranch site that has eliminated offsite flows from BS-FDR Basin O1 that significantly changed the drainage pattern. The historic release is now contained solely to the historic flows from WS-FDR design point H5 and the proposed onsite historic flows.

Design Point H4 will combine with the western half of Lots 1&2. Per the BS-FDR the combined portions of Lots 1&2 and O3 to release a combined flow of 30.5/80.8 cfs downstream. The flow anticipated in the BS-FDR appears consistent with the smaller basin analysis of this report and should be used for downstream analysis.

## **PROPOSED DRAINAGE DISCUSSION**

### ***Introduction***

The proposed site will be developed differently than anticipated in the previous BS-FDR. The previous plan for this site maintained the existing native drainage way down the middle of Lots 1 & 2 and 3 & 4, thereby splitting the buildable area into the outer thirds of these lots. The native drainage way and "Drainage Boundary – No Build Area" (as shown on the Plat & FDR) will be eliminated with the proposed development. The proposed site and proposed drainage improvements will allow this native drainage way to be eliminated while maintaining the pass through of major flows. These modifications to the site and to the drainage patterns will allow a larger buildable area.

The existing retention pond, located just north of Lot 3, will be modified by others to become a water quality/detention pond pursuant to the WS-FDR. A new outlet works and a storm drain pipe will convey runoff from this detention pond (16.1/29.4 cfs in the 10/100 year storm events) discharging at the property line. This development is proposing a CDOT Type D inlet to capture the discharged flow and pipe it downstream along the east side of Lots 3 & 4 to discharge into the proposed Full Spectrum Extended

Detention Basin (EDB) in Lot 4. The EDB is designed to pass through, and not treat or detain, these offsite flows.

A new EDB will be provided in Lot 4. This detention basin will provide water quality treatment for portions of Lots 1 & 2, and Lots 3 & 4. In the approved Barbarick FDR there were to be two separate ponds. The new site development has been planned for a single pond to treat the developed flows. Tributary water sheet flow across the site to shallow swales that will direct runoff to the proposed EDB. The EDB will have a forebay at the confluence of the two pipe outfalls, a concrete trickle channel that terminates at a micropool structure, and is designed to treat the WQCV, EURV and 100-year detention.

A second SFB water quality with detention catchment basin will be provided at the south east/downstream end of Lot 2. This SFB will not have an outlet structure to release flows due to requirements from the gas main utility ownership of no structure to be built within the existing easements. There will be a small spillway to allow the release of large storm events. Runoff will be directed to the proposed SFB where possible.

Flow from the area north of Lot 1 (Basin O3) will pass through the site via two 24" culverts and will be discharged at the southern boundary of Lot 2, as historically done. An earthen channel will run north-south along the east side of the existing Lot 1 and Lot 2 developments. The channel is approximately 1-ft deep with 4:1 side slopes and will capture and convey any westerly flowing nuisance runoff from the proposed improvements to the sand filter detention pond as discussed in the original Barbarick Subdivision FDR, instead of the existing Lot 1 and 2 improved areas.

Runoff from the property is at historic flows and will not exceed the anticipated runoff as determined in the Sterling Ranch PDR. This is described in more detail below. The Sterling Ranch PDR includes an analysis of future drainage conditions and includes recommended infrastructure to convey this runoff. Since the Sterling Ranch surrounds the Barbarick Subdivision, it is appropriate to include the recommendations from the SR-PDR in this Proposed Drainage Discussion.

***Proposed On-Site Basin Descriptions: (See Basin Map in the pocket)***

**On-site Basin D1** (D for Developed condition) - This developed basin encompasses approximately 11.4 acres - the majority of Lots 3 & 4 and small portions of Lots 1 & 2. This basin generates 19.7/56.0 cfs in the 5/100 year storm events and sheet flows into shallow swales that direct the runoff into the proposed EDB to be located in Lot 4. Lot 3 is based on Owner provided information for a gravel parking/vehicle storage area, and Lot 4 has been based on proposed building site improvements as identified in the rezoning application. Any changes to the land use will require an update to the Final Drainage Report; much like the original Barbarick Subdivision Final Drainage Report is being updated with the grading and Lot 4 development application.

**On-site Basin D2** This undeveloped basin encompasses 1.2 acres and represents the south portion of Lot 4, below and south of the two detention ponds. This basin is historic in nature and generates 0.8/3.0 cfs and drains directly into a road side ditch within the Sterling Ranch development.

**On-site Basin D3** This developed basin encompasses approximately 3.13 acres - the remaining proposed infill portions of Lots 1 and 2 (east of the currently built out Lots 1&2). As discussed in the original Barbarick Subdivision FDR, development of these areas will require a detention water quality pond. This basin generates 4.1/11.6 cfs in the 5/100 year storm events and sheet flows southerly to the proposed SFB located at the southern-most portion of Lot 2.

The following design point table is for combined allowable discharge rates from the property at respective locations including historic flows from the tributary upstream basins:

<u>Design Point</u>	<u>5/100 Year</u>	<u>Comments</u>
DP D1	85.4 cfs (100)	D1+O2 Pass Through
DP D2	48.9 cfs (100)	Pond Release+D2
DP D3	4.1/11.6 cfs	D3
DP D4	13.8/39.1 cfs	Pond Release +O3 Pass Through

All release flows downstream are at or below historic levels.

**RECOMMENDED DESIGN**

***Off-site Detention Facility:***

This shallow pond will be modified for the proposed development to the north as part of the WS-FDR. This will eliminate the retention properties in this pond, will provide detention for off-site flows, will provide a suitable outlet structure, and will remove accumulated sediment. The modified pond will store up to 1.52 acft (66,211 cuft) to the principal spillway (elevation = 7048.05). A summary of flows into and out of this pond:

<u>Off-site Pond Flow Summary (cfs)</u>	<u>5 year</u>	<u>100 year</u>
<b>Proposed Flow into offsite pond (Basin G/DP 5)</b>	<b><u>57.4</u></b>	<b><u>92.7</u></b>
Increase in peak flow due to development	46.2	51.3
<b>Proposed flow out of modified pond</b>	<b><u>16.1</u></b>	<b><u>29.4</u></b>
Reduction in peak flow	41.3	63.3

For complete pond design, refer to the WS-FDR.

**Proposed 30” HDPE Storm Drain from Modified Off-site Detention Pond:**

This storm drain will capture flows from the discharged offsite pond and route them along the perimeter of the property daylighting into the EDB in Lot 4. 4’ precast concrete manholes will be used for maintenance access at all bends and grade breaks. A grouted riprap forebay will help dissipate energy at the outlet of the pipe, and allow for settling prior to entering the pond. See the Appendix for the hydraulic analysis of this storm drain (StormCAD).

In the event of an emergency and the offsite pond fails, developed flow (Q100=93.0 cfs) will overtop the pond and be collected between the proposed roadway and pond berm.. Flow not captured by the proposed inlet will bypass easterly to the proposed offsite swale between this property and the Sterling Ranch property and conveyed southerly.

**Proposed 18” HDPE Storm Drain Culvert:**

A 18” HDPE culvert will convey collected runoff from Lot 3 (Developed Q100 = 15.90cfs) through Lot 4 to the FSD Pond and join sheet flow from Lot 4 and the 30” piped bypass flow from basin O2. This culvert will be privately owned and maintained by the property owners. See the Appendix for open channel calculations.

**On-site FSD - EDB Pond in Lot 4 (Basin D1):**

This On-site Full Spectrum Extended Detention Basin Pond provides water quality, EURV and 100-year detention. Onsite flows will combine with the 30-inch bypass flows from the north and pass through the EDB. The pond has been sized for the release of historic flows from Basin D1, as well as provides capacity for pass through conveyance of historic flows from the north.

The following table outlines the onsite existing and developed flow, required detention, and modifications to required detention utilizing the upstream over detention.

<u>On-site Basin Flow Summary (cfs)</u>	<u>5 year</u>	<u>100 year</u>
Existing On-site Flow at Pond	2.2	16.5
Developed On-site Flow (Basin D1)	<u>19.7</u>	<u>56.0</u>
Increase in peak flow due to development	17.5	39.5
Proposed Pass Through Flow from Off-Site Pond	<u>16.1*</u>	<u>29.4</u>
Proposed total flow out of EDB pond	<u>0.3</u>	<u>45.9**</u>

\*Includes 10 year from WS-FDR

\*\*Includes Pass Through flow of 29.4 cfs



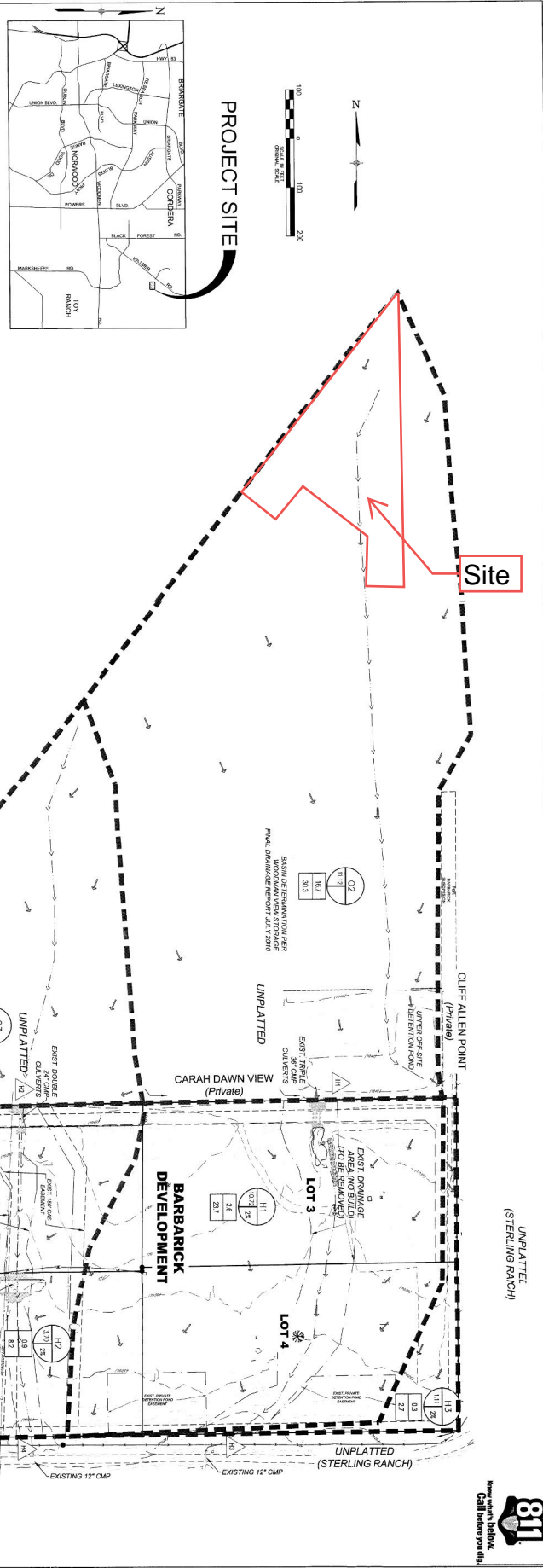

**VICINITY MAP**  
N.T.S.

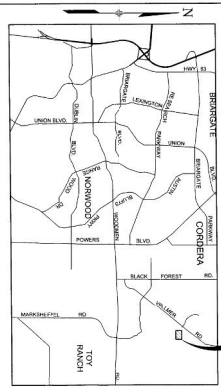

**PROJECT SITE**

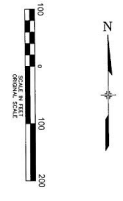

**LEGEND**

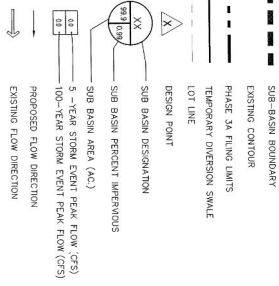

**BARBARICK DRAINAGE SUMMARY TABLE**

BASIN	AREA (AC)	Q(5)	Q(100)	COMMENT
H1	10.72	4.3	18.5	REF: WOODMEN STORAGE PDR
H2	3.70	0.9	8.2	REF: BARBARICK PDR 2005
H3	1.11	0.3	2.7	REF: BARBARICK PDR 2005
H4	10.73	4.37	18.5	REF: WOODMAN STORAGE PDR 2010

**REFERENCE DRAWINGS**

NO.	DATE	DESCRIPTION	BY

**REVISIONS**

NO.	DATE	DESCRIPTION	BY

**VERTICAL BENCHMARK**

THE VERTICAL BENCHMARK FOR THIS PROJECT IS THE NATIONAL GEODETIC CONTROL POINT OF 1424.86. THE 2005 NATIONAL ADJUSTMENT FROM AROUND 1.27' ABOVE THE BENCHMARK TO THE SUBDIVISION BOUNDARY IS 1.27' ABOVE THE BENCHMARK. THE 2005 NATIONAL ADJUSTMENT FROM AROUND 1.27' ABOVE THE BENCHMARK TO THE SUBDIVISION BOUNDARY IS 1.27' ABOVE THE BENCHMARK. THE 2005 NATIONAL ADJUSTMENT FROM AROUND 1.27' ABOVE THE BENCHMARK TO THE SUBDIVISION BOUNDARY IS 1.27' ABOVE THE BENCHMARK.

**PREPARED UNDERWAY FOR DIRECT SUPERVISION FOR DESIGN GROUP, INC.**

**Matrix DESIGN GROUP**  
2424 Fremont Parkway, Suite 300  
Farmingdale, NY 11735  
Phone: 718.278.0100  
Fax: 718.278.0200

**BARBARICK SUBDIVISION LOTS 1-4**

**EXISTING CONDITIONS DRAINAGE PLAN**

DESIGNED BY: H1 SCALE: 1"=40'

DATE SHOWN: 11/20/14

NO. SHEETS: 1 OF 2 SHEETS

DP01

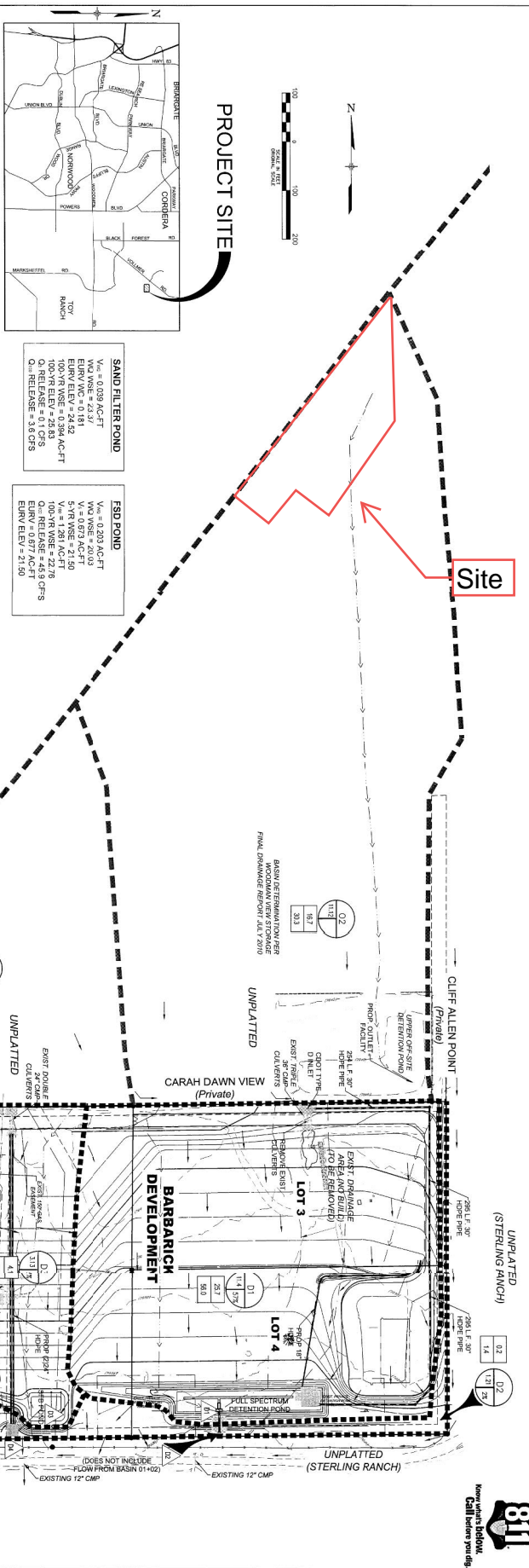

**VICINITY MAP**  
N.T.S.

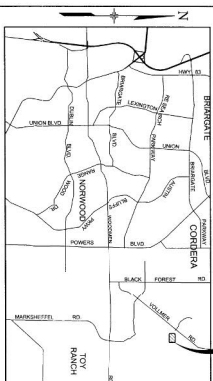

**BARBARICK DRAINAGE SUMMARY TABLE**

BASIN	AREA (AC)	Q16 (CFS)	Q100 (CFS)	% IMP	COMMENT
D1	11.40	25.7	56.0	57%	D1 BASIN TO FSD +022 PASS THROUGH
D2	1.21	0.8	3.0	2%	POUND RELEASE + D2
D3	3.13	4.1	11.6	57%	D3 BASIN TO SFB
D4	11.12	16.7	30.3		POUND RELEASE + 03 PIPE PASS THROUGH
	7.03	13.7	35.5		REF: BARBARICK FDR 2005

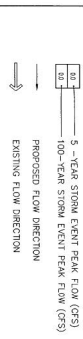

**REFERENCE DRAWINGS**

NO.	DATE	DESCRIPTION	BY
		REVISIONS	
		BENCHMARK DATA (E.V.)	
		(DATA)	
		(DESCRIPTION/LOCATION)	

**VERTICAL BENCHMARK**

DATE: 10/20/2010 11:46:23 AM  
PROJECT: 10/20/2010 11:46:23 AM  
PROJECT: 10/20/2010 11:46:23 AM

**Matrix DESIGN GROUP**

3265 Research Parkway, Suite 200  
Cincinnati, OH 45244  
Phone: 718-275-0000  
Fax: 718-275-0208

**BARBARICK SUBDIVISION LOTS 1-4**

**PROPOSED DRAINAGE PLAN**

RESIGNED BY: [Signature]  
SCALE: [Scale]  
DATE ISSUED: [Date]  
SHEET NO. 1 OF 2 SHEETS  
APPENDIX: [Appendix]  
PROJECT: DP02







# **WOODMAN VIEW STORAGE FINAL DRAINAGE REPORT**

**JULY 2004  
REVISED FEBRUARY 2010  
REVISED MAY 2010  
REVISED JULY 2010**

**For:**

**Woodmen View Storage  
2720 Meridian Road  
Peyton, CO 80831**



**WOODMAN VIEW STORAGE**  
**FINAL DRAINAGE REPORT**  
**PAGE 2 of 5**

**2.2 Sub-Basin Description**

- Historically, the runoff sheet-flows across the site to the south where it enters one of two draws to Sand Creek.
- A large upstream basin sheet-flows across the site.
- The offsite basin will continue to sheet-flow through the site in the developed conditions and is routed through the onsite detention pond.
- A swale is provided along the west property line to convey the discharge from the existing culvert under Vollmer Place.

**3.0 DRAINAGE DESIGN CRITERIA**

**3.1 Development Criteria Reference and Constraints**

- Previous studies for the proposed site or the surrounding areas are not available.
- The *Sand Creek Drainage Basin Planning Study* does not affect the proposed site.
- This study is in compliance with the following Standards except where stated herein:
  - *City of Colorado Springs and El Paso County Drainage Criteria Manual Volume 1 & 2*
- The simplicity and proposed use of the site do not create any drainage constraints.
- The proposed detention pond and outlet works must be constructed within the proposed site.

**3.2 Hydrological Criteria**

- Design rainfall is from the City/County's Criteria.
- The rational method was used to calculate peak runoff rates for the development.
- The 10-year storm was used as the minor event.
- The 100-year storm was used as the major event.
- Detention storage requirements were calculated using the Rational Stored Rate Method.

**WOODMAN VIEW STORAGE**  
**FINAL DRAINAGE REPORT**  
**PAGE 3 of 5**

- The Water Quality Capture Volume was calculated using the City/County's criteria.
- The combined runoff from the detention pond and developed undetained basins will be less than or equal to the total historic runoff rate from the site.

## **4.0 DRAINAGE FACILITY DESIGN**

### **4.1 General Concepts**

The following are concepts and typical drainage patterns of the proposed drainage system:

- Runoff generated in both the minor and major storm events will sheet-flow overland to the onsite detention pond.
  - A swale is graded along the west property line to convey runoff from the north side of Vollmer Place and to keep onsite runoff from leaving the site.
  - The proposed development is divided into seven basins (A, B, C, D, E, F, and G).
  - Basins A-D are offsite basins. The offsite basins will continue to flow through the site and will be routed through the onsite detention pond.
  - Basins E-G are made up entirely of the proposed development.
  - Basin E will sheet-flow to the onsite detention pond.
  - Basins F and G will be released from the site undetained.
- Offsite runoff will be handled in the following ways:
- Offsite flows entering the site are conveyed through the site and proposed detention pond.

The following tables, charts, and figures are presented in the appendix of this report:

- Vicinity Map and Soils Map
- <sup>1</sup>FIRM Map
- Runoff computation sheets
- Detention Pond calculations
- Water Quality Capture Volume calculations
- <sup>1</sup>Pond Outfall Sizing spreadsheet
- <sup>1</sup>Restrictor Plate Sizing
- <sup>1</sup>Weir Design Spreadsheet
- <sup>2</sup>Culvert Calculations

**WOODMAN VIEW STORAGE**  
**FINAL DRAINAGE REPORT**  
**PAGE 4 of 5**

- <sup>2</sup>Riprap Sizing Calculations
- Tables and charts from *City of Colorado Springs and El Paso County Drainage Criteria Manual*

**4.2 Specific Details**

- It is anticipated the site will be developed in two phases.
- The detention facility must be constructed with the first phase.
- <sup>2</sup>The flows released from the detention pond (16.1 cfs and 29.4 cfs) during the 10-year and 100-year events respectively, are equal to the historic flow rates at Design Point H5 (16.7 cfs and 30.3 cfs) less the developed flows released from the site undetained at Design Point 7 (0.6 cfs and 0.9 cfs).
- The detention volume was calculated using the City/County's Criteria.
- The WQCV was calculated using the City/County's Criteria.
- <sup>1</sup> The outlet structure for the detention pond consists of a Modified Type D inlet. The rim of the inlet is set at the water quality water surface elevation and will collect the 10-year flow.
- <sup>1</sup> The 100-year flow will outfall over a weir directly to one of the draws that drain to Sand Creek.
- An 18" HDPE culvert is provided at DP3 to convey the 100-year flow, 12.5cfs, from the onsite swale along the west property line to the onsite detention pond.
- Maintenance access to the detention pond will be provided via proposed drive aisles within the development and a gentle slope to the bottom of the pond per the City/Counties criteria.
- It is the responsibility of the property owner to maintain all drainage facilities.
- There are no immediate adverse impacts on downstream properties. The flows released from the site are equal to the historic flow rates through the site.



### DETENTION POND CALCULATIONS

Woodman View Storage  
El Paso County, CO

### DETENTION POND CRITERIA

Peak release rate for the developed 10-yr and 100-yr events shall not exceed the historic rate for the drainage area

**Criteria References:**

El Paso County/City of Colorado Springs Drainage Criteria Manual  
Urban Drainage and Flood Control District Criteria Manual

### DETENTION POND RELEASE RATE CALCULATION

10-yr Historic Runoff (cfs) Design Point H5 = 16.7 Design Point H7 = 15.3	10-yr Developed Runoff (cfs) Design Point 5 = 57.4 Design Point 6 = 2.3 Design Point 7 = 0.6
---	---

100-yr Historic Runoff (cfs) Design Point H5 = 30.3 Design Point H7 = 30.0	100-yr Developed Runoff (cfs) Design Point 5 = 92.7 Design Point 6 = 3.7 Design Point 7 = 0.9
--	--

Allowable Release Rate at DP 5 (cfs) 10-yr = 16.1 (DP H5 - DP 7) 100-yr = 29.4 (DP H5 - DP 7)
---

Allowable Release Rate at DP 6 (cfs) 10-yr = 15.3 (Developed < Historic therefore no detention 100-yr = 30.0 at this location)
--

### DETENTION POND VOLUME CALCULATION

Water Quality Capture Volume (WQCV) = 0.30	AC-FT	UDFCD WQCV Calculation	7045.74
10-yr Volume = 0.85	AC-FT	Rational Storage Rate Method	
10-yr Volume + WQCV = 1.15	AC-FT		7047.47
100-yr Volume = 1.37	AC-FT	Rational Storage Rate Method	
100-yr Volume + WQCV/2 = 1.52	AC-FT		7048.05

## STAGE-STORAGE SIZING FOR POLYGONAL, ELLIPTICAL, OR IRREGULAR PONDS

**Project:** Woodman View Storage Final Drainage

**Basin ID:** \_\_\_\_\_

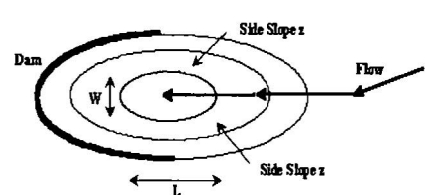
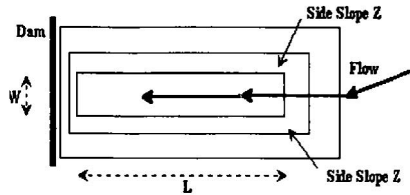
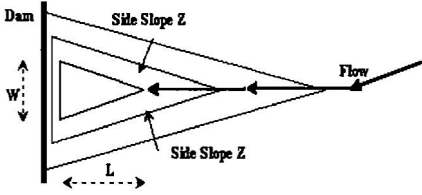

**Design Information (Input):**

Width of Pond Bottom, W =  ft  
 Length of Pond Bottom, L =  ft  
 Dam Side-slope (H:V), Z<sub>d</sub> =  ft/ft

**Check Pond Shape**

Right Triangle  OR...  
 Isosceles Triangle  OR...  
 Rectangle  OR...  
 Circle / Ellipse  OR...  
 Irregular  (Use Override values in cells G32:G52)

**Stage-Storage Relationship:**

	MINOR	MAJOR	
Storage Requirement from Sheet 'Modified FAA':			acre-ft.
Storage Requirement from Sheet 'Hydrograph':			acre-ft.
Storage Requirement from Sheet 'Full-Spectrum':			acre-ft.

Labels for WQCV, Minor, & Major Storage Stages (input)	Stage (input) ft	Side Slope (H:V) ft/ft Below El. (input)	Pond Width at Stage (output) ft	Pond Length at Stage (output) ft	Surface Area at Stage (output) ft <sup>2</sup>	Surface Area at Stage (output) ft <sup>2</sup> User Override	Volume Below Stage (output) ft <sup>3</sup>	Surface Area at Stage (output) acres	Volume Below Stage (output) acre-ft	Target Volumes for WQCV, Minor, & Major Storage Volumes (for goal seek)
	7043.00					0		0.000	0.000	
	7043.20		0.00	0.00		85	8	0.002	0.000	
	7043.40		0.00	0.00		541	71	0.012	0.002	
	7043.60		0.00	0.00		1,206	246	0.028	0.006	
	7043.80		0.00	0.00		1,802	547	0.041	0.013	
	7044.00		0.00	0.00		2,468	974	0.057	0.022	
	7044.20		0.00	0.00		3,221	1,542	0.074	0.035	
	7044.40		0.00	0.00		4,074	2,272	0.094	0.052	
	7044.60		0.00	0.00		5,029	3,182	0.115	0.073	
	7044.80		0.00	0.00		6,067	4,292	0.139	0.099	
	7045.00		0.00	0.00		7,256	5,624	0.167	0.129	
	7045.20		0.00	0.00		8,604	7,210	0.198	0.166	
	7045.40		0.00	0.00		10,126	9,083	0.232	0.209	
	7045.60		0.00	0.00		11,774	11,273	0.270	0.259	
WQCV	7045.80		0.00	0.00		13,756	13,826	0.316	0.317	0.30 REQUIRED
	7046.00		0.00	0.00		16,086	16,810	0.369	0.386	
	7046.20		0.00	0.00		18,669	20,286	0.429	0.466	
	7046.40		0.00	0.00		21,153	24,268	0.486	0.557	
	7046.60		0.00	0.00		22,506	28,634	0.517	0.657	
	7046.80		0.00	0.00		23,692	33,254	0.544	0.763	
	7047.00		0.00	0.00		24,730	38,096	0.568	0.875	
	7047.20		0.00	0.00		25,577	43,127	0.587	0.990	
	7047.40		0.00	0.00		26,259	48,310	0.603	1.109	
10-YR WSEL	7047.60		0.00	0.00		26,971	53,633	0.619	1.231	1.15 REQUIRED
	7047.80		0.00	0.00		27,873	59,118	0.640	1.357	
	7048.00		0.00	0.00		28,982	64,803	0.665	1.488	
100-YR WSEL	7048.20		0.00	0.00		30,276	70,729	0.695	1.624	1.52 REQUIRED
	7048.40		0.00	0.00		31,774	76,934	0.729	1.766	

# RESTRICTOR PLATE SIZING FOR CIRCULAR VERTICAL ORIFICES

**Project:** Woodman View Storage Final Drainage

**Basin ID:** \_\_\_\_\_

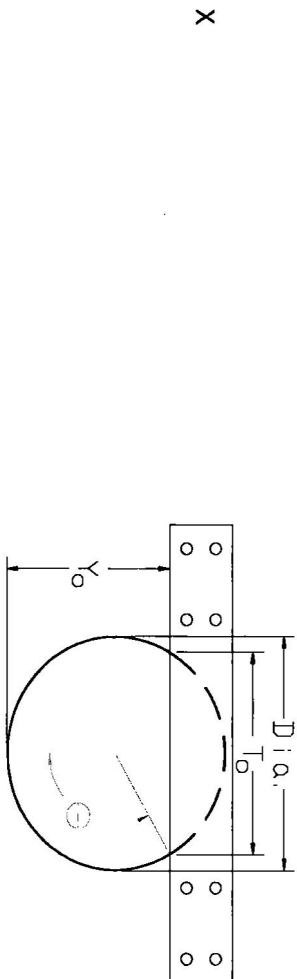

**Sizing the Restrictor Plate for Circular Vertical Orifices or Pipes (Input)**

Water Surface Elevation at Design Depth  
 Pipe/Vertical Orifice Entrance Invert Elevation  
 Required Peak Flow through Orifice at Design Depth  
 Pipe/Vertical Orifice Diameter (Inches)  
 Orifice Coefficient

	#1 Vertical Orifice	#2 Vertical Orifice
Elev: WS =	7.047.74	
Elev: Invert =	7.042.67	
Q =	8.05	
Dia =	18.0	
C <sub>o</sub> =	0.65	

**Full-flow Capacity (Calculated)**

Full-flow area  
 Half Central Angle in Radians  
 Full-flow capacity

Af =	1.77		sq ft
Theta =	3.14		rad
Qf =	19.2		cfs
Percent of Design Flow =	238%		

**Calculation of Orifice Flow Condition**

Half Central Angle ( $0 < \text{Theta} < 3.1416$ )  
 Flow area  
 Top width of Orifice (Inches)  
 Height from Invert of Orifice to Bottom of Plate (feet)  
 Elevation of Bottom of Plate  
 Resultant Peak Flow Through Orifice at Design Depth

Theta =	1.42		rad
A <sub>o</sub> =	0.71		sq ft
T <sub>o</sub> =	17.78		Inches
Y <sub>o</sub> =	0.63		feet
Elev Plate Bottom Edge =	7.043.30		feet
Q <sub>o</sub> =	8.1		cfs

Width of Equivalent Rectangular Vertical Orifice  
 Centroid Elevation of Equivalent Rectangular Vertical Orifice

Equivalent Width =	1.13		feet
Equiv. Centroid El. =	7.042.99		feet

## STAGE-DISCHARGE SIZING OF THE WEIRS AND ORIFICES (INLET CONTROL)

**Project:** Woodman View Storage Final Drainage  
**Basin ID:** \_\_\_\_\_

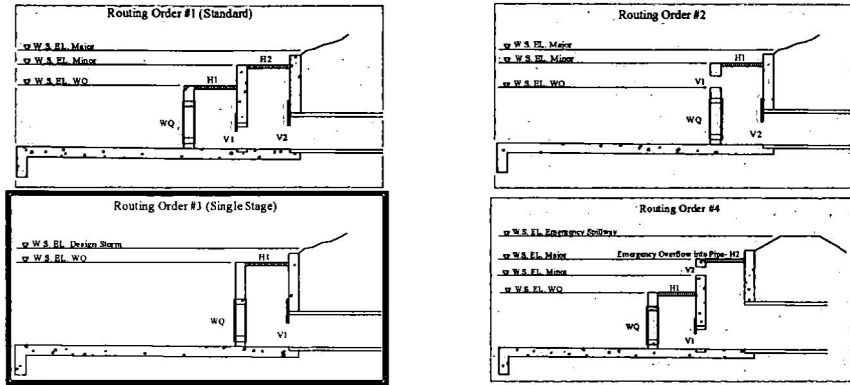

**Current Routing Order is #3**

**Design Information (Input):**

Circular Opening: Diameter in Inches  
**OR**  
 Rectangular Opening: Width in Feet  
 Length (Height for Vertical)  
 Percentage of Open Area After Trash Rack Reduction  
 Orifice Coefficient  
 Weir Coefficient  
 Orifice Elevation (Bottom for Vertical)

	#1 Horiz.	#2 Horiz.	#1 Vert.	#2 Vert.	
Dia. =					inches
W =	2.92		1.55		ft.
L or H =	5.67		0.93		ft.
% open =	38		100		%
C <sub>o</sub> =	0.65		0.65		
C <sub>w</sub> =	2.55				
E <sub>o</sub> =	7045.74		7,042.67		ft.

**Calculation of Collection Capacity:**

Net Opening Area (after Trash Rack Reduction)  
 OPTIONAL: User-Override Net Opening Area  
 Perimeter as Weir Length  
 OPTIONAL: User-Override Weir Length

A <sub>o</sub> =	6.21	1.44	sq. ft.
A <sub>w</sub> =			sq. ft.
L <sub>w</sub> =	13.53		ft.
L <sub>w</sub> =			ft.
Top Elevation of Vertical Orifice Opening, Top =	7043.60		ft.
Center Elevation of Vertical Orifice Opening, Cen =	7043.14		ft.

**Routing 3: Single Stage - Water flows through WQCV plate and #1 horizontal opening into #1 vertical opening. This flow will be applied to culvert sheet (#2 vertical & horizontal openings is not used).**

Labels for WQCV, Minor, & Major Storage W.S. Elevations (input)	Water Surface Elevation ft (linked)	WQCV Plate/Riser Flow cfs (User-linked)	Horizontal Orifices				Vertical Orifices		Total Collection Capacity cfs (output)	Target Volumes for WQCV, Minor, & Major Storage Volumes (link for goal seek)
			#1 Horiz. Weir Flow cfs (output)	#1 Horiz. Orifice Flow cfs (output)	#2 Horiz. Weir Flow cfs (output)	#2 Horiz. Orifice Flow cfs (output)	#1 Vert. Collection Capacity cfs (output)	#2 Vert. Collection Capacity cfs (output)		
	7043.00	0.00	0.00	0.00	0.00	0.00	1.08	0.00	0.00	
	7043.20	0.01	0.00	0.00	0.00	0.00	2.20	0.00	0.01	
	7043.40	0.02	0.00	0.00	0.00	0.00	3.56	0.00	0.02	
	7043.60	0.03	0.00	0.00	0.00	0.00	5.12	0.00	0.03	
	7043.80	0.04	0.00	0.00	0.00	0.00	6.13	0.00	0.04	
	7044.00	0.05	0.00	0.00	0.00	0.00	6.99	0.00	0.05	
	7044.20	0.07	0.00	0.00	0.00	0.00	7.75	0.00	0.07	
	7044.40	0.09	0.00	0.00	0.00	0.00	8.45	0.00	0.09	
	7044.60	0.11	0.00	0.00	0.00	0.00	9.09	0.00	0.11	
	7044.80	0.13	0.00	0.00	0.00	0.00	9.69	0.00	0.13	
	7045.00	0.14	0.00	0.00	0.00	0.00	10.26	0.00	0.14	
	7045.20	0.17	0.00	0.00	0.00	0.00	10.79	0.00	0.17	
	7045.40	0.19	0.00	0.00	0.00	0.00	11.30	0.00	0.19	
	7045.60	0.21	0.00	0.00	0.00	0.00	11.79	0.00	0.21	
<b>WQCV</b>	7045.80	0.23	0.51	7.93	0.00	0.00	12.26	0.00	0.74	.30 REQUIRED
	7046.00	0.24	4.57	16.51	0.00	0.00	12.71	0.00	4.81	
	7046.20	0.25	10.76	21.97	0.00	0.00	13.15	0.00	11.01	
	7046.40	0.27	18.50	26.31	0.00	0.00	13.57	0.00	13.57	
	7046.60	0.28	27.52	30.03	0.00	0.00	13.98	0.00	13.98	
	7046.80	0.29	37.65	33.34	0.00	0.00	14.38	0.00	14.38	
	7047.00	0.30	48.80	36.35	0.00	0.00	14.77	0.00	14.77	
	7047.20	0.31	60.86	39.13	0.00	0.00	15.14	0.00	15.14	
	7047.40	0.33	73.79	41.73	0.00	0.00	15.51	0.00	15.51	
	7047.60	0.34	87.52	44.17	0.00	0.00	15.87	0.00	15.87	
<b>10-YR WSEL</b>	7047.80	0.35	102.01	46.48	0.00	0.00	16.22	0.00	16.22	1.15 REQUIRED
	7048.00	0.35	117.22	48.69	0.00	0.00	16.57	0.00	16.57	
<b>100-YR</b>	7048.20	0.36	133.12	50.80	0.00	0.00	16.90	0.00	16.90	1.52 REQUIRED
	7048.40	0.37	149.68	52.82	0.00	0.00	17.24	0.00	17.24	



**STORM DRAINAGE SYSTEM DESIGN**

**WEIR DESIGN SPREADSHEET**

PROJECT: Woodman View Storage  
 CITY/COUNTY: Colorado Springs/El Paso

DATE: 7-May-10  
 DESIGNER: JLT  
 REVIEWER: TAJ

100 Year Weir must pass: 12.5 cfs      Q = 100 year flow (29.4) - 100 year inlet capacity (16.9\*)  
 Emergency Weir must pass: 93.0 cfs      Q = 100 year flow

Bottom of weir elevation = 7047.74      100-yr Available head = 0.31 feet  
 100 Year water elev. = 7048.05      Emergency Overflow Available head= 1.26 feet  
 Top of pond = 7049.00      Weir Coefficient = 3.1

Length of Rectangular Weir      22.8 FEET  
 Side Slope 1      25% Angle 1      75.96 DEGREES  
 Side Slope 2      25% Angle 2      75.96 DEGREES  
 Total Angle For V-notch Weir      151.93

WSE	head (ft.)	Freeboard (ft.)	Rect weir (cfs)	v-notch (cfs)	total Q (cfs)	
7048.05	0.3	0.9	12.2	0.3	12.5	<----Q(100) Flow
7049.00	1.3	0.0	100.0	9.8	109.8	<----Q(Emergency) Flow

\*Total Collection Capacity at 100-yr WSEL (see inlet control spreadsheet)

SUMMARY RUNOFF TABLE						
DESIGN POINT	BASIN	TOTAL AREA (ACRES)	Q10 (CFS)	TOTAL Q10 (CFS)	Q100 (CFS)	TOTAL Q100 (CFS)
HISTORIC						
H1	H-1	1.80	4.5	4.5	8.0	8.0
H2	H-2	0.45	2.2	2.2	3.4	3.4
H3	H-3	0.61	2.0	2.0	3.4	3.4
H4	H-4	1.80	6.0	6.0	10.4	10.4
H5	H-5	11.12	4.3	16.7	8.6	30.3
H6	H-6	5.63	13.2	13.2	25.7	25.7
H7	H-7	9.17	2.3	15.3	4.6	30.0
DEVELOPED						
1.00	A	1.80	4.5	4.5	8.0	8.0
2.00	B	0.85	2.2	2.2	3.4	3.4
3.00	C	2.64	2.9	7.2	4.9	12.5
4.00	D	7.43	22.8	22.8	43.0	43.0
5.00	E	19.69	32.5	57.4	52.1	92.7
6.00	F	0.48	2.3	2.3	3.7	3.7
7.00	G	0.12	0.6	2.9	0.9	4.6

# WOODMEN VIEW S' ORAGE PLOT PLAN

## LEGEND

DEVELOPED BASIN DESIGNATION  
 AREA (AC) 2.00 0.02 10-YR RUNOFF COEFFICIENT 0.97 100-YR RUNOFF COEFFICIENT

HISTORIC BASIN DESIGNATION  
 AREA (AC) 2.25 0.02 10-YR RUNOFF COEFFICIENT 0.90 100-YR RUNOFF COEFFICIENT

HISTORIC BASIN BOUNDARY

DEVELOPED BASIN BOUNDARY

DRAINAGE ARROW

DESIGN POINT

EXISTING MAJOR CONTOUR (5')

EXISTING MINOR CONTOUR (1')

PROPOSED MAJOR CONTOUR (5')

PROPOSED MINOR CONTOUR (1')

SITE

outfall point

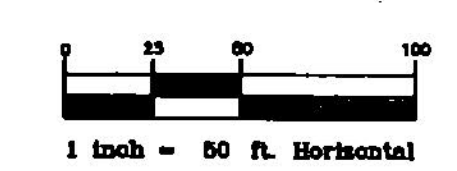

**DETENTION POND**

$V_{w0} = 0.30$  AC-FT  
 $WQ$  WSE=7045.74  
 $V_{10} = 1.15$  AC-FT  
 10 YR WSE=7047.47  
 $V_{100} = 1.52$  AC-FT  
 100 YR WSE=7048.05  
 $Q_{10}$  RELEASE=16.1 cfs  
 $Q_{100}$  RELEASE=29.4 cfs

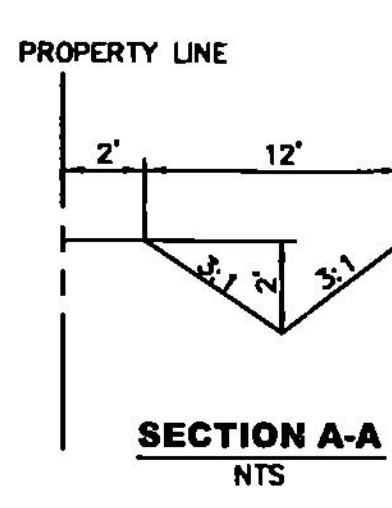
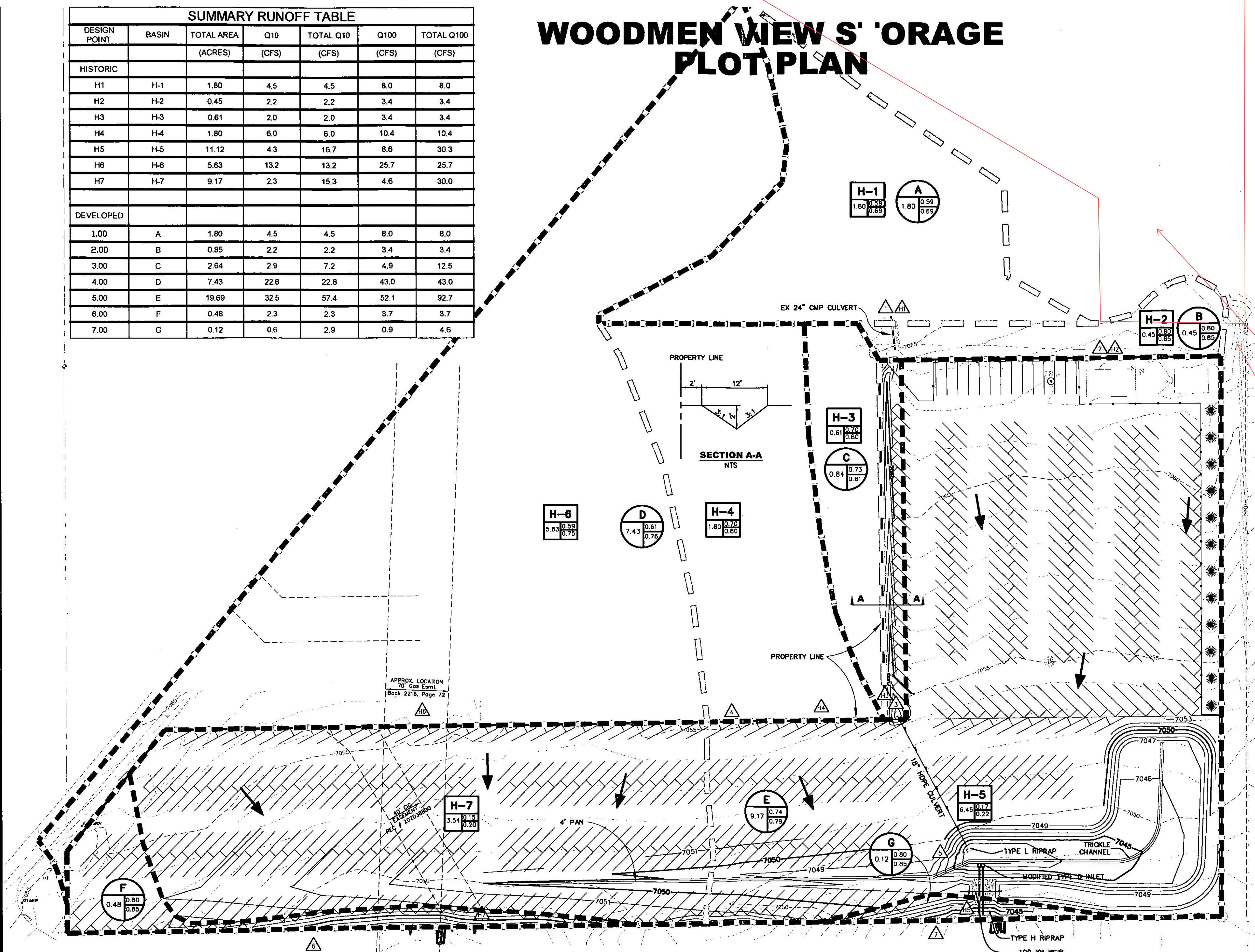

DATE	REVISION DESCRIPTION

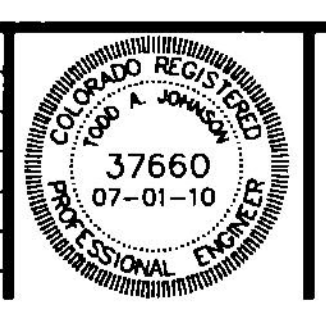

**Calibre** ENGINEERING, INC.  
 37660  
 07-01-10  
 PROFESSIONAL ENGINEER

**WOODMEN VIEW STORAGE PLOT PLAN FINAL DRAINAGE REPORT**

Prepared by: WOODMEN VIEW STORAGE

JULY 1, 2010

DR1  
 of 1 sheets  
 EMB  
 P.W. RYAN/CALIBRE

2010 CALIBRE ENGINEERING, INC. ALL RIGHTS RESERVED. 11

PRELIMINARY PLAT

MC CLINTOCK STATION A SUBDIVISION

IN EL PASO COUNTY, COLORADO

DRAINAGE PLAN

LEGAL DESCRIPTION

A TRACT OF LAND BEING A PORTION OF THE WEST ONE-HALF OF THE WEST ONE-HALF OF SECTION 33 AND A PORTION OF THE NORTHEAST ONE-QUARTER OF THE SOUTHEAST ONE-QUARTER OF SECTION 32 ALL IN TOWNSHIP 12 SOUTH, RANGE 65 WEST OF THE 6TH PRINCIPAL MERIDIAN, SITUATE IN EL PASO COUNTY, COLORADO AND MORE PARTICULARLY DESCRIBED AS FOLLOWS:  
 BEGINNING AT A POINT ON THE WEST LINE OF SAID SECTION 33, FROM WHICH THE WEST ONE-QUARTER OF SAID SECTION 33 REARS N 0° 22' 30" E, 54'.89 FEET, THENCE (1) S 0° 22' 30" W ON THE SAID WEST LINE OF SECTION 33, 91.87 FEET; (2) N 89° 42' 17" E, 1287.51 FEET; (3) N 0° 22' 33" E, 627.94 FEET; (4) S 89° 42' 17" W, 854.01 FEET; (5) N 39° 04' 18" E ON THE SOUTHEASTERLY RIGHT OF WAY LINE OF A COUNTY ROAD (VOLLMER ROAD), 77.61 FEET; (6) N 89° 42' 17" E, 296.35 FEET; (7) N 39° 04' 18" E, 80.00 FEET; (8) N 50° 45' 42" W, 229.11 FEET; (9) N 39° 04' 18" E ON THE SAID SOUTHEASTERLY RIGHT OF WAY LINE OF A COUNTY ROAD (VOLLMER ROAD), 1067.67 FEET; (10) S 0° 22' 33" W ON THE EAST LINE OF SAID WEST ONE-HALF OF SECTION 33, 2414.21 FEET; (11) S 89° 42' 17" W, 1317.49 FEET; (12) N 0° 22' 30" E ON THE WEST LINE OF SAID SECTION 33, 63'.27 FEET; (13) ANGLE LEFT 90° 00' 00" TO THE TANGENT OF A CURVE TO THE RIGHT, SAID CURVE HAVING A RADIUS OF 130.00 FEET, A CENTRAL ANGLE OF 38° 04' 18" FOR AN ARC LENGTH OF 87.80 FEET; (14) N 50° 55' 42" W, 13.67 FEET; (15) N 39° 04' 18" E ON THE AFORESAID SOUTHEASTERLY RIGHT OF WAY LINE OF A COUNTY ROAD (VOLLMER ROAD), 147.07 FEET TO THE POINT OF BEGINNING,  
 CONTAINING 31.71 ACRES OF LAND, MORE OR LESS.

SUBDIVIDER:

J. MARCUS BROWN  
 1120 NORTH CIRCLE DR. SUITE C  
 COLO. SPRS, COLORADO 80909

1. SANITARY SEWER AND WATER RESPONSIBILITY OF INDIVIDUAL OWNER.
2. EASEMENTS: 10' EACH SIDE OF LOT LINE, 20' ADJACENT TO BOUNDARY LINE
3. CONTOUR INTERVAL (-5') FIVE FEET.



SCALE 1" = 100'

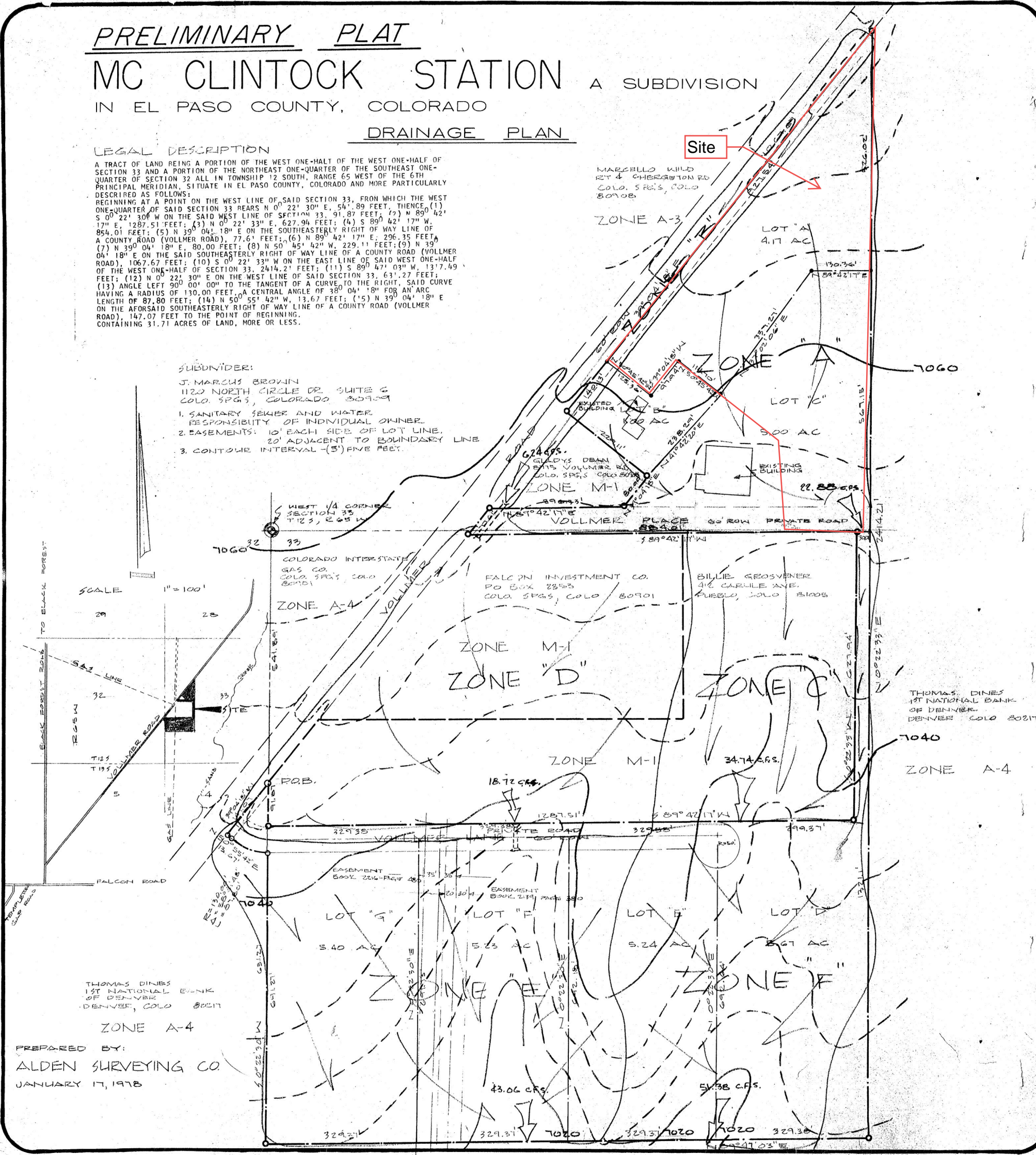

THOMAS DINES  
 1ST NATIONAL BANK  
 DENVER, COLO 80217

ZONE A-4  
 PREPARED BY:  
 ALDEN SURVEYING CO.  
 JANUARY 17, 1978

Final Drainage Report  
Mc Clintock Station Lot A (Vollmer Road RV Storage)

## **APPENDIX E**

### **DRAINAGE MAPS & PLANS**

# VOLLMER RV STORAGE

## EXISTING DRAINAGE MAP

BASIN SUMMARY TABLE							
Tributary Sub-basin	Area (acres)	Percent Impervious	C <sub>s</sub>	C <sub>100</sub>	t <sub>c</sub> (min)	Q <sub>s</sub> (cfs)	Q <sub>100</sub> (cfs)
EX-1	0.48	2%	0.09	0.36	15.2	0.2	1.0
EX-2	3.41	2%	0.09	0.36	23.4	0.9	5.9
EX-3	0.56	2%	0.09	0.36	11.4	0.2	1.3
EX-4	0.73	11%	0.16	0.41	18.2	0.4	1.6
EX-5	1.66	4%	0.11	0.37	26.5	0.5	2.8
OS-6	0.14	36%	0.37	0.57	5.0	0.3	0.7
OS-7	0.27	30%	0.32	0.53	5.0	0.4	1.2
OS-8	0.41	32%	0.34	0.54	10.0	0.6	1.5
OS-9	0.46	46%	0.43	0.61	13.6	0.7	1.7

DESIGN POINT SUMMARY TABLE		
DP#	Q <sub>s</sub> -YR	Q <sub>100</sub> -YR
1	0.2	1.0
1.1	0.3	1.5
2	0.9	5.9
2.1	1.5	7.6
3	0.2	1.3
4	0.4	1.6
5	0.5	2.8
5.1	1.3	5.4
6	0.3	0.7
7	0.4	1.2
8	0.6	1.5
9	0.7	1.7
9.1	1.0	3.1

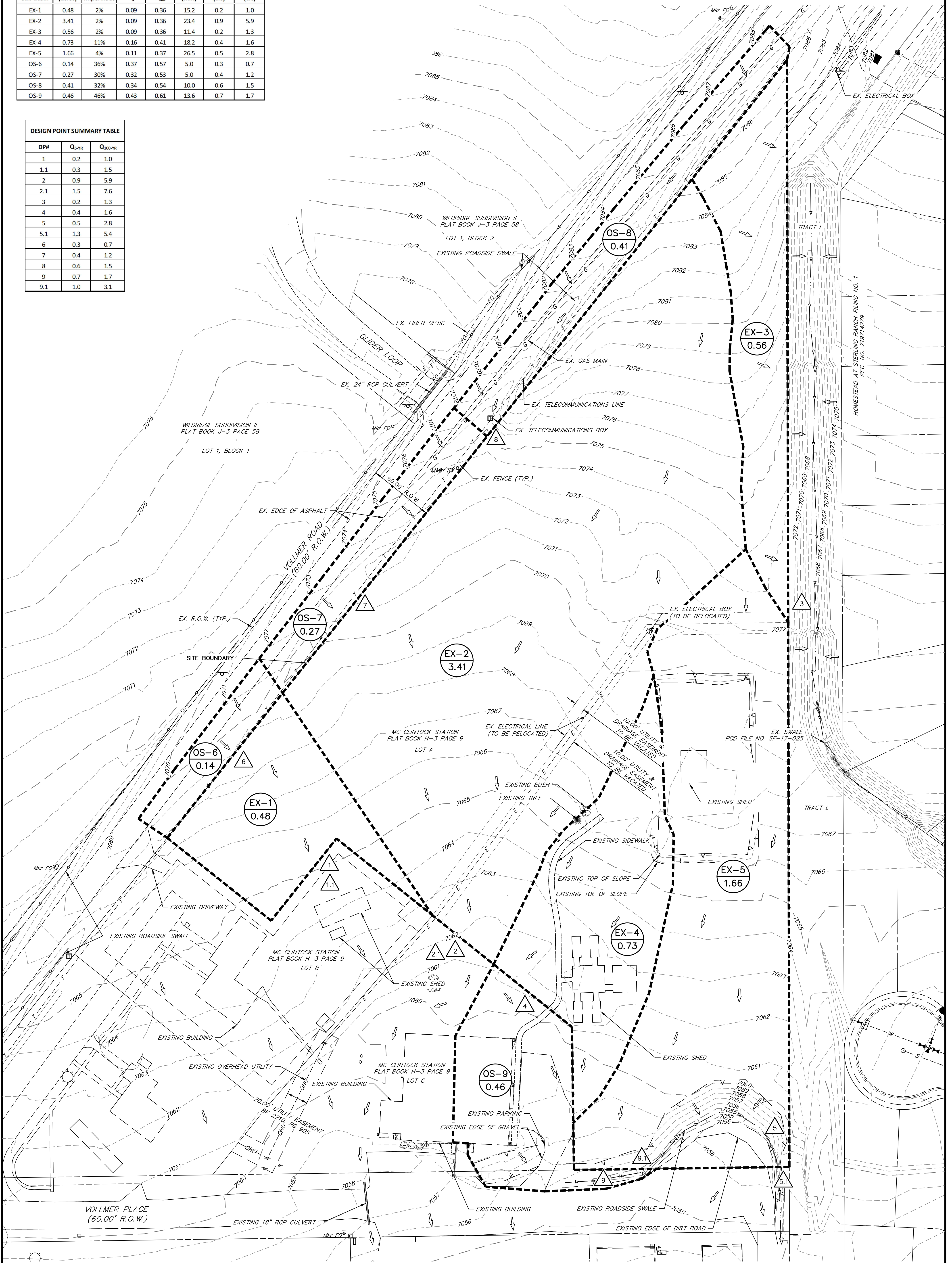

THE LOCATIONS OF EXISTING ABOVE GROUND AND UNDERGROUND UTILITIES ARE SHOWN IN AN APPROXIMATE WAY ONLY. THE CONTRACTOR SHALL DETERMINE THE EXACT LOCATION OF ALL EXISTING UTILITIES BEFORE COMMENCING WORK. THE CONTRACTOR SHALL BE FULLY RESPONSIBLE FOR ANY AND ALL DAMAGES WHICH MIGHT BE CAUSED BY HIS FAILURE TO EXACTLY LOCATE AND PRESERVE ANY AND ALL ABOVE GROUND AND UNDERGROUND UTILITIES.



- LEGEND:**
- 6000 — EXISTING MAJOR CONTOUR
  - - - - - EXISTING MINOR CONTOUR
  - - - - - DRAINAGE BASIN
  - A B A = BASIN DESIGNATION B = AREA IN ACRES
  - 1 DESIGN POINT
  - ← EXISTING DRAINAGE ARROW

EXISTING DRAINAGE MAP  
VOLLMER RV STORAGE  
JOB NO. 25251.00  
11/16/2023  
SHEET 1 OF 1



Centennial 303-740-9393 • Colorado Springs 719-593-2593  
Fort Collins 970-491-9888 • www.jrengineering.com

**LEGEND.**

- 6000— PROPOSED MAJOR CONTOUR
  - PROPOSED MINOR CONTOUR
  - 6000— EXISTING MAJOR CONTOUR
  - EXISTING MINOR CONTOUR
  - DRAINAGE BASIN
- 
- |   |                               |
|---|-------------------------------|
| A | A = BASIN DESIGNATION         |
| B | B = AREA IN ACRES             |
| C | C = 5-YR RUNOFF COEFFICIENT   |
| D | D = 100-YR RUNOFF COEFFICIENT |
- 
- △ DESIGN POINT
  - DRAINAGE ARROW
  - ← EXISTING DRAINAGE ARROW

**DESIGN POINT SUMMARY TABLE**

DP#	Q <sub>5-YR</sub>	Q <sub>100-YR</sub>
1	4.2	8.4
2	7.0	13.5
2.1	11.1	21.6
3	4.8	9.5
3.1	15.7	30.7
4	1.6	3.7
5	0.1	0.5
6	0.0	0.2
7	0.1	0.8
7.1	0.8	2.3
8	0.1	0.3
9	0.5	1.2
9.1	2.0	8.9
O9	0.7	1.7
O10	0.9	2.4
P1	0.8	5.7

**BASIN SUMMARY TABLE**

Tributary Sub-basin	Area (acres)	Percent Impervious	C <sub>s</sub>	C <sub>100</sub>	t <sub>c</sub> (min)	Q <sub>s</sub> (cfs)	Q <sub>100</sub> (cfs)
A	1.43	69%	0.65	0.77	7.7	4.2	8.4
B	2.20	79%	0.72	0.83	8.3	7.0	13.5
C	1.57	75%	0.69	0.81	8.1	4.8	9.5
D	0.82	47%	0.47	0.64	9.2	1.6	3.7
E	0.17	8%	0.14	0.40	7.1	0.1	0.5
F	0.07	2%	0.09	0.36	7.9	0.0	0.2
G	0.24	2%	0.09	0.36	5.0	0.1	0.8
H	0.12	2%	0.09	0.36	5.0	0.1	0.3
I	0.24	47%	0.46	0.63	6.4	0.5	1.2
OS-9	0.46	46%	0.43	0.61	13.6	0.7	1.7
OS-10	0.81	31%	0.33	0.54	18.3	0.9	2.4

THE LOCATIONS OF EXISTING ABOVE GROUND AND UNDERGROUND UTILITIES ARE SHOWN IN AN APPROXIMATE WAY ONLY. THE CONTRACTOR SHALL DETERMINE THE EXACT LOCATION OF ALL EXISTING UTILITIES BEFORE COMMENCING WORK. THE CONTRACTOR SHALL BE FULLY RESPONSIBLE FOR ANY AND ALL DAMAGES WHICH MIGHT BE CAUSED BY HIS FAILURE TO EXACTLY LOCATE AND PRESERVE ANY AND ALL ABOVE GROUND AND UNDERGROUND UTILITIES.

# VOLLMER RV STORAGE PROPOSED DRAINAGE MAP

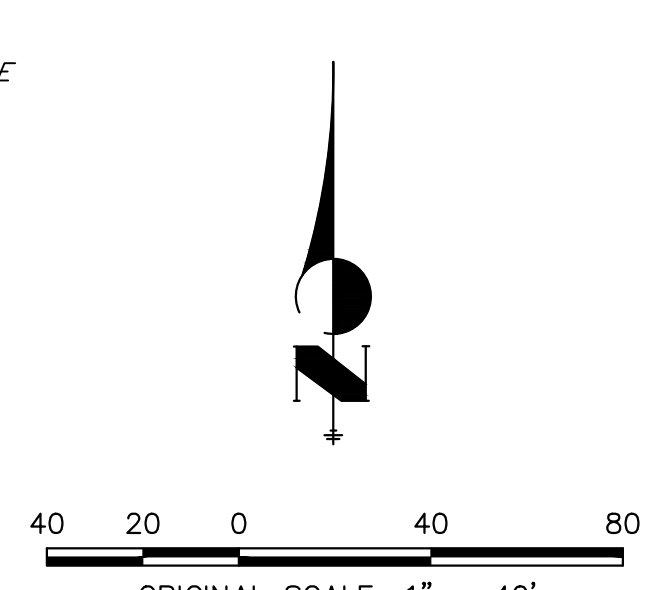
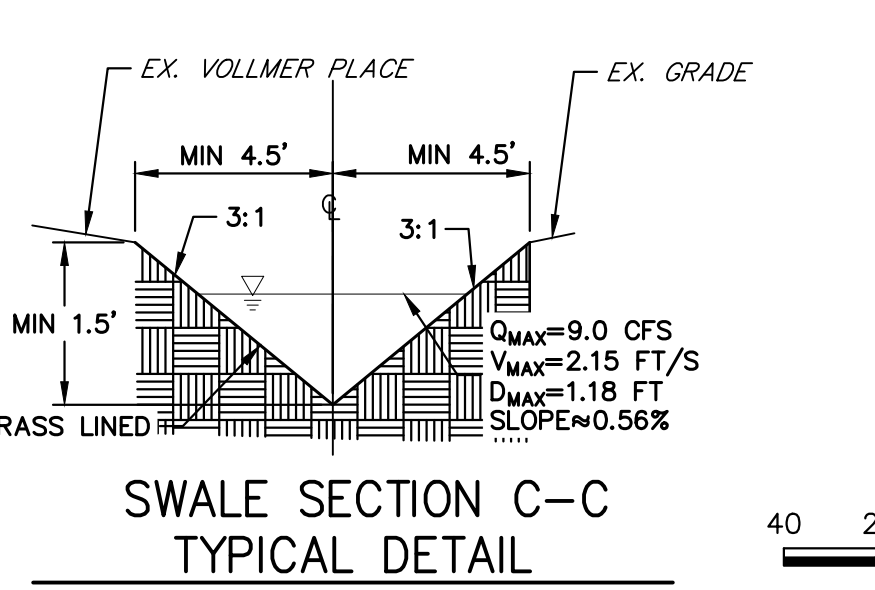
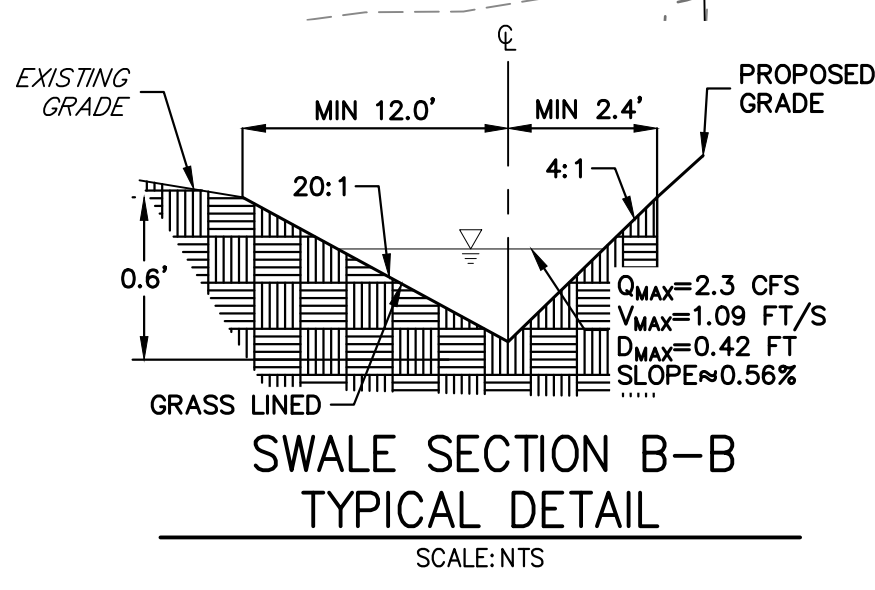
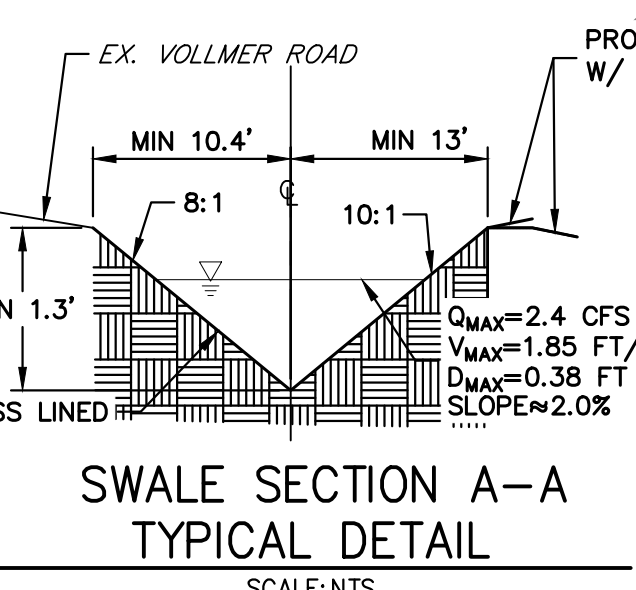
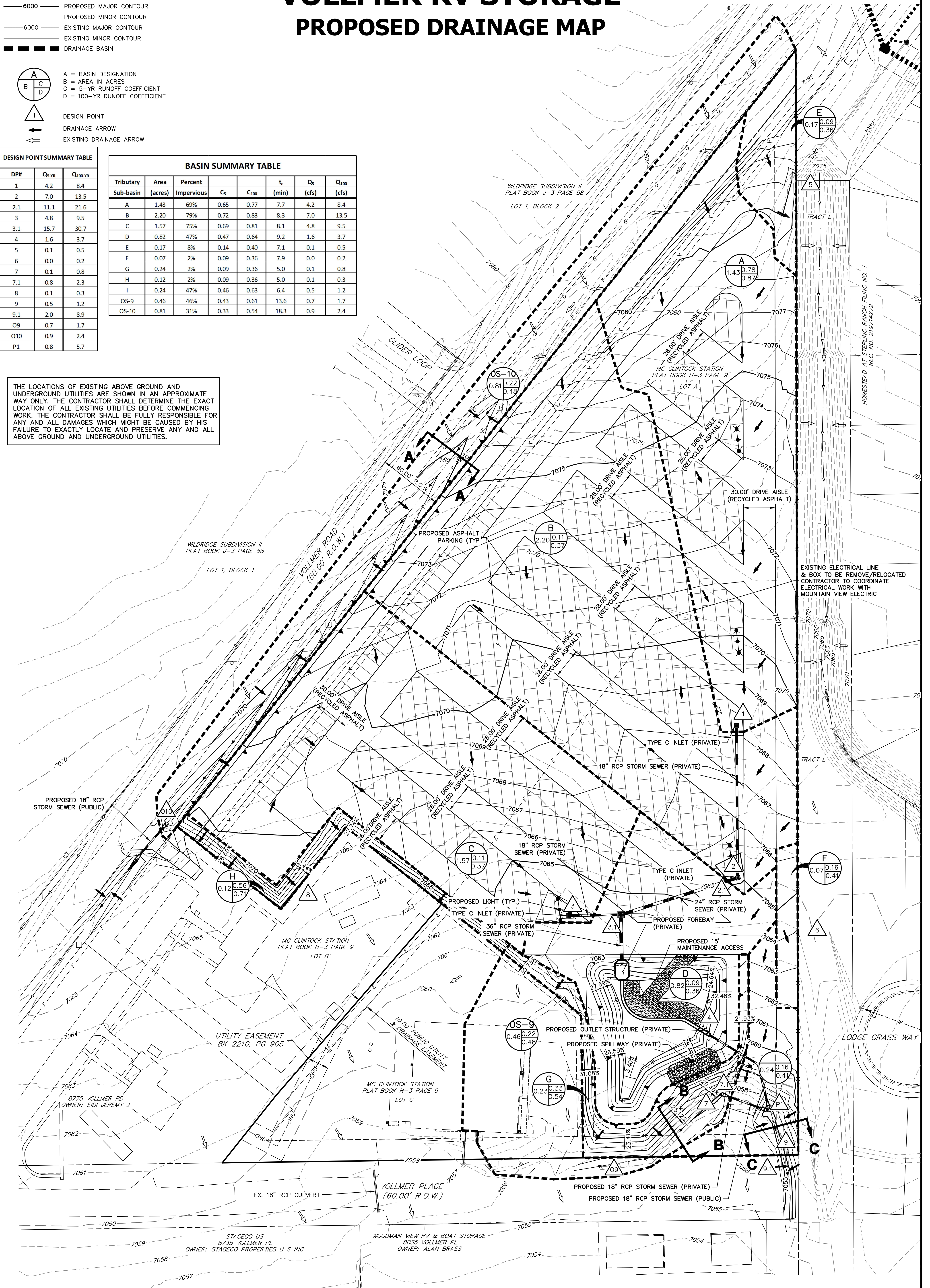

PROPOSED DRAINAGE MAP  
VOLLMER RV STORAGE  
JOB NO. 25251.00  
11/16/2023  
SHEET 1 OF 1

**J-R ENGINEERING**  
A Westrian Company

Centennial 303-740-9393 • Colorado Springs 719-593-2593  
Fort Collins 970-491-9888 • www.jrengineering.com

# VOLLMER RV STORAGE

## PROPOSED CONDITION WATER QUALITY MAP

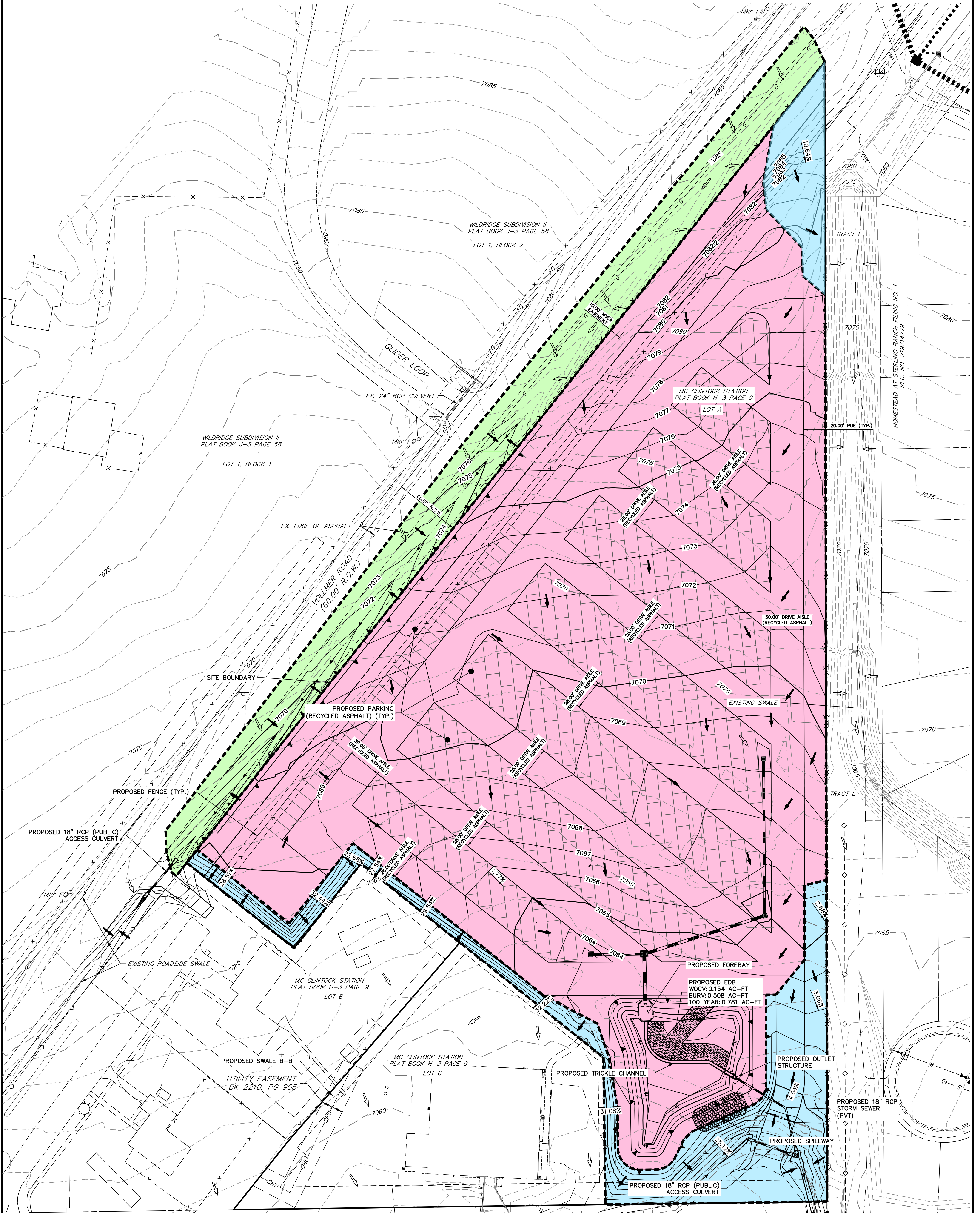

### LEGEND

	AREA DRAINS TO PROPOSED EDB: 6.02 (87% OF TOTAL SITE)
	EXCLUDED APPLICABLE DEVELOPMENT AREA TO DRAIN OFFSITE: 0.83 AC (13% OF TOTAL SITE) (SEE NOTE)
	OFFSITE DRAINAGE TO REMAIN OFFSITE: 0.81

TOTAL SITE AREA 4.1 ACRES

NOTE: PER ECM 1.7.C.d UP TO 20% NOT TO EXCEED 1 ACRE OF THE APPLICABLE DEVELOPMENT SITE MAY BE EXCLUDED WHERE IT IS NOT PRACTICAL TO CAPTURE RUNOFF. THIS CRITERIA HAS BEEN MET AS SHOWN IN THE DESIGN ABOVE.

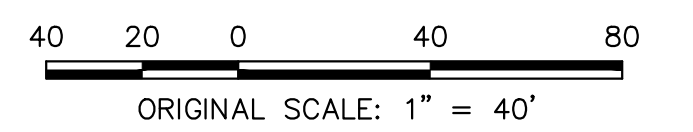

VOLLMER RV STORAGE  
WQ MAP  
JOB NO. 2525100  
11/17/2023  
SHEET 1 OF 1



Centennial 303-740-9393 • Colorado Springs 719-593-2593  
Fort Collins 970-491-9888 • www.jrengineering.com

