

Post Construction Stormwater Management Applicability Evaluation Form

This form is to be used by the Engineer of Record to evaluate applicable construction activities to determine if the activities are eligible for an exclusion to permanent stormwater quality management requirements. Additionally Part III of the form is used to identify and document which allowable control measure design standard is used for the structure.

Part I. Project Information	
1. Project Name: Vollmer RV Storage	
2. El Paso County Project #: PPR-22-045	3. ESQCP #:
4. Project Location: South of the intersection of Vollmer Road and Northern entrance to Glider Loop.	Project Location in MS4 Permit Area (Y or N): N
5. Project Description: RV Storage	
If project is located within the El Paso County MS4 Permit Area, please provide copy of this completed form to the Stormwater Quality Coordinator for reporting purposes; and save completed form with project file.	

Part II. Exclusion Evaluation: Determine if Post-Construction Stormwater Management exclusion criteria are met. Note: Questions A thru K directly correlate to the MS4 permit Part I.E.4.a.i (A) thru (K). If Yes, to any of the following questions, then mark Not Applicable in Part III, Question 2.				
Questions	Yes	No	Not Applicable	Notes:
A. Is this project a "Pavement Management Site" as defined in Permit Part I E.4.a.i.(A)?		X		This exclusion applies to "roadways" only. Areas used primarily for parking or access to parking are not included.
B. Is the project "Excluded Roadway Development"?				
• Does the site add less than 1 acre of paved area per mile?		X		
• Does the site add 8.25 feet or less of paved width at any location to the existing roadway?		X		
C. Does the project increase the width of the existing roadway by less than 2 times the existing width?		X		For redevelopment of existing roadways, only the area of the existing roadway is excluded from post-construction requirements when the site does not increase the width by two times or more. <i>This exclusion only excludes the original roadway area it does NOT apply to entire project.</i>
D. Is the project considered an aboveground and Underground Utilities activity?		X		Activity can NOT permanently alter the terrain, ground cover or drainage patterns from those present prior to the activity
E. Is the project considered a "Large Lot Single-Family Site"?		X		Must be a single-residential lot or agricultural zoned land, ≥ 2.5 acres per dwelling and total lot impervious area < 10 percent.

Questions (cont'd)	Yes	No	Not Applicable	Notes
F. Do Non-Residential or Non-Commercial Infiltration Conditions exist? Post-development surface conditions do not result in concentrated stormwater flow or surface water discharge during an 80 th percentile stormwater runoff event.		x		Exclusion does not apply to residential or commercial sites for buildings. A site specific study is required and must show: rainfall and soil conditions; allowable slopes; surface conditions; and ratios of imperviousness area to pervious area.
G. Is the project land disturbance to Undeveloped Land where undeveloped land remains undeveloped following the activity?		x		Project must be on land with no human made structures such as buildings or pavement.
H. Is the project a Stream Stabilization Site?		x		Standalone stream stabilization projects are excluded.
I. Is the project a bike or pedestrian trail?		x		Bike lanes for roadways are not included in this exclusion, but may qualify if part of larger roadway activity is excluded in A, B or C above.
J. Is the project Oil and Gas Exploration?		x		Activities and facilities associated with oil and gas exploration are excluded.
K. Is the project in a County Growth Area?				Note, El Paso County does not apply this exclusion. All Applicable Construction Activity in El Paso County must comply the Post-Construction Stormwater Management criteria.

Part III. Post Construction (Permanent) Stormwater Control Determination		
Questions	Yes	No
1. Is project an Applicable Construction Activity?	x	
2. Do any of the Exclusions (A-K in Part II) apply?		x
<p>If the project is an Applicable Construction Activity and no Exclusions apply then Post-Construction (Permanent) Stormwater Management is required. Complete the applicable sections of Part IV below and then coordinate signatures for form and place in project file.</p> <p>If the project is not an Applicable Construction Activity, or Exclusion(s) apply then Post-Construction (Permanent) Stormwater Management is NOT required. Coordinate signatures for form and place in project file.</p>		

Part IV: Onsite PWQ Requirements, Documentation and Considerations	Yes	No
1. Check which Design Standard(s) the project will utilize. Standards align with Control Measure Requirements identified in permit Part I.E.4.a.iv.		
A. Water Quality Capture Volume (WQCV) Standard	X	
B. Pollutant Removal/80% Total Suspended Solids Removal (TSS)		X
C. Runoff Reduction Standard		X
D. Applicable Development Site Draining to a Regional WQCV Control Measure		X
E. Applicable Development Site Draining to a Regional WQCV Facility		X
F. Constrained Redevelopment Sites Standard		X
G. Previous Permit Term Standard		X
2. Will any of the project permanent stormwater control measure(s) be maintained by another MS4? If Yes, you must obtain a structure specific maintenance agreement with the other MS4 prior to advertisement.		X
3. Will any of the project permanent stormwater control measures be maintained by a private entity or quasi-governmental agency (e.g. HOA or Special District, respectively)? If Yes, a Private Detention Basin/Stormwater Quality Best Management Practice Maintenance Agreement and Easement must be recorded with the El Paso County Clerk and Recorder.	X	

Part V Notes (attach an additional sheet if you need more space)

Project design is complete to include the project design, construction plans, drainage report, specifications, and maintenance and access agreements as required. The engineering, drainage considerations and information used to complete these documents is complete, true, and accurate to the best of my belief and knowledge.

 Signature and Stamp of Engineer of Record



11/24/23
 Date

Post-Construction Stormwater Management Applicability Form has been reviewed and the project design, construction plans, drainage report, specifications, and maintenance and access agreements as required, have been reviewed for compliance with the Post Construction Stormwater Management process and MS4 Permit requirements. **Engineering Review**

Signature of El Paso County Project Engineer

02/01/2024 3:36:49 PM

dohartford

Date

EPC Department of Public Works

LEGEND.

- 6000— PROPOSED MAJOR CONTOUR
 - PROPOSED MINOR CONTOUR
 - 6000— EXISTING MAJOR CONTOUR
 - EXISTING MINOR CONTOUR
 - DRAINAGE BASIN
-
- | | |
|---|-------------------------------|
| A | A = BASIN DESIGNATION |
| B | B = AREA IN ACRES |
| C | C = 5-YR RUNOFF COEFFICIENT |
| D | D = 100-YR RUNOFF COEFFICIENT |
-
- △ DESIGN POINT
 - DRAINAGE ARROW
 - ← EXISTING DRAINAGE ARROW

DESIGN POINT SUMMARY TABLE

DP#	Q _{5-YR}	Q _{100-YR}
1	4.2	8.4
2	7.0	13.5
2.1	11.1	21.6
3	4.8	9.5
3.1	15.7	30.7
4	1.6	3.7
5	0.1	0.5
6	0.0	0.2
7	0.1	0.8
7.1	0.8	2.3
8	0.1	0.3
9	0.5	1.2
9.1	2.0	8.9
O9	0.7	1.7
O10	0.9	2.4
P1	0.8	5.7

BASIN SUMMARY TABLE

Tributary Sub-basin	Area (acres)	Percent Impervious	C _s	C ₁₀₀	t _c (min)	Q _s (cfs)	Q ₁₀₀ (cfs)
A	1.43	69%	0.65	0.77	7.7	4.2	8.4
B	2.20	79%	0.72	0.83	8.3	7.0	13.5
C	1.57	75%	0.69	0.81	8.1	4.8	9.5
D	0.82	47%	0.47	0.64	9.2	1.6	3.7
E	0.17	8%	0.14	0.40	7.1	0.1	0.5
F	0.07	2%	0.09	0.36	7.9	0.0	0.2
G	0.24	2%	0.09	0.36	5.0	0.1	0.8
H	0.12	2%	0.09	0.36	5.0	0.1	0.3
I	0.24	47%	0.46	0.63	6.4	0.5	1.2
OS-9	0.46	46%	0.43	0.61	13.6	0.7	1.7
OS-10	0.81	31%	0.33	0.54	18.3	0.9	2.4

THE LOCATIONS OF EXISTING ABOVE GROUND AND UNDERGROUND UTILITIES ARE SHOWN IN AN APPROXIMATE WAY ONLY. THE CONTRACTOR SHALL DETERMINE THE EXACT LOCATION OF ALL EXISTING UTILITIES BEFORE COMMENCING WORK. THE CONTRACTOR SHALL BE FULLY RESPONSIBLE FOR ANY AND ALL DAMAGES WHICH MIGHT BE CAUSED BY HIS FAILURE TO EXACTLY LOCATE AND PRESERVE ANY AND ALL ABOVE GROUND AND UNDERGROUND UTILITIES.

VOLLMER RV STORAGE

PROPOSED DRAINAGE MAP

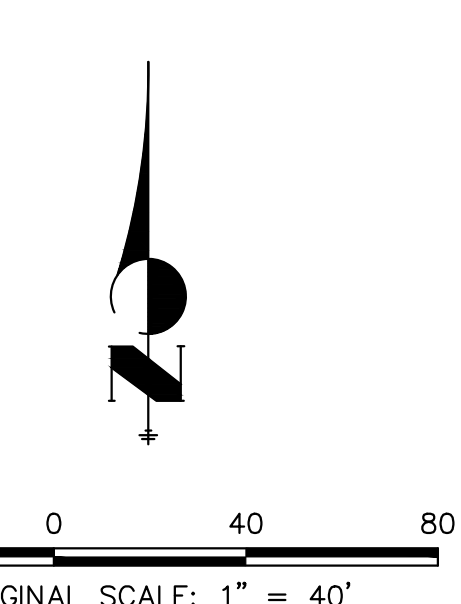
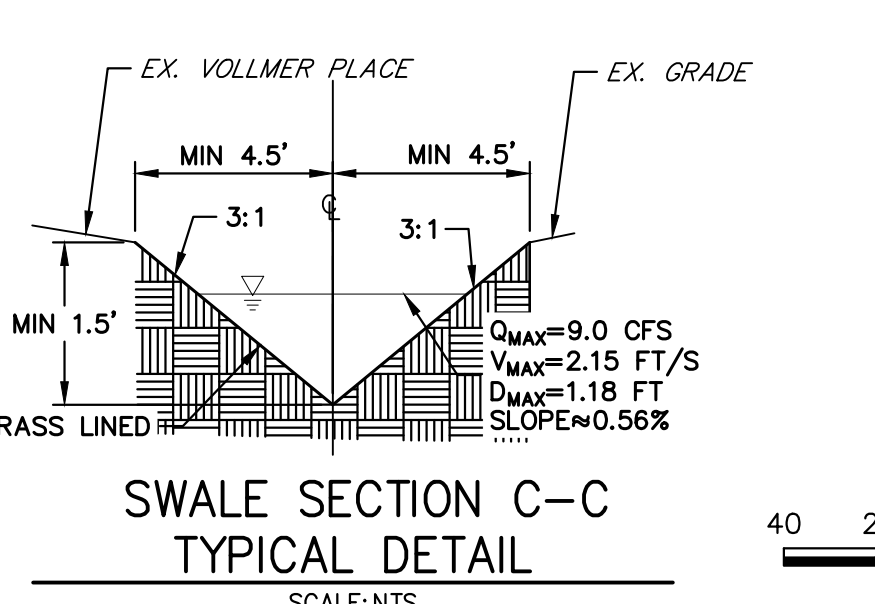
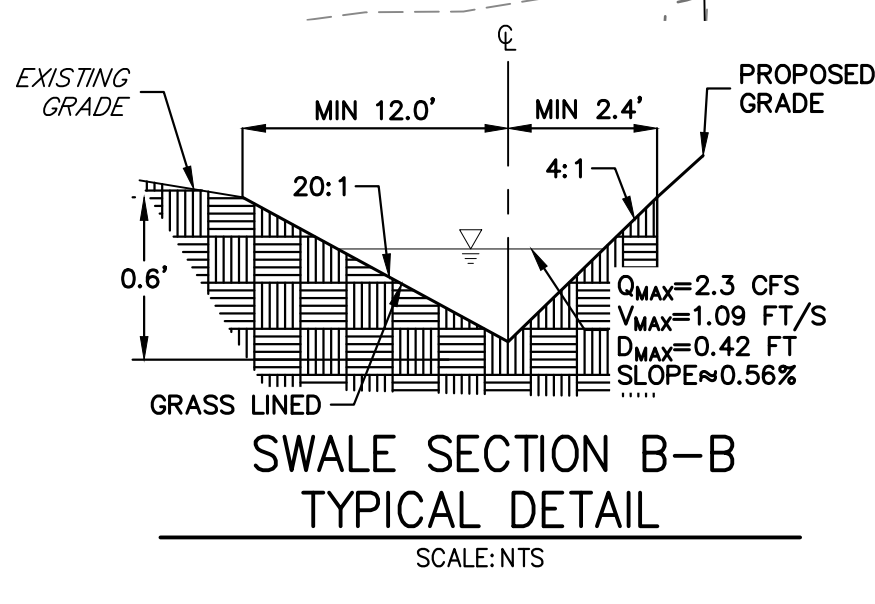
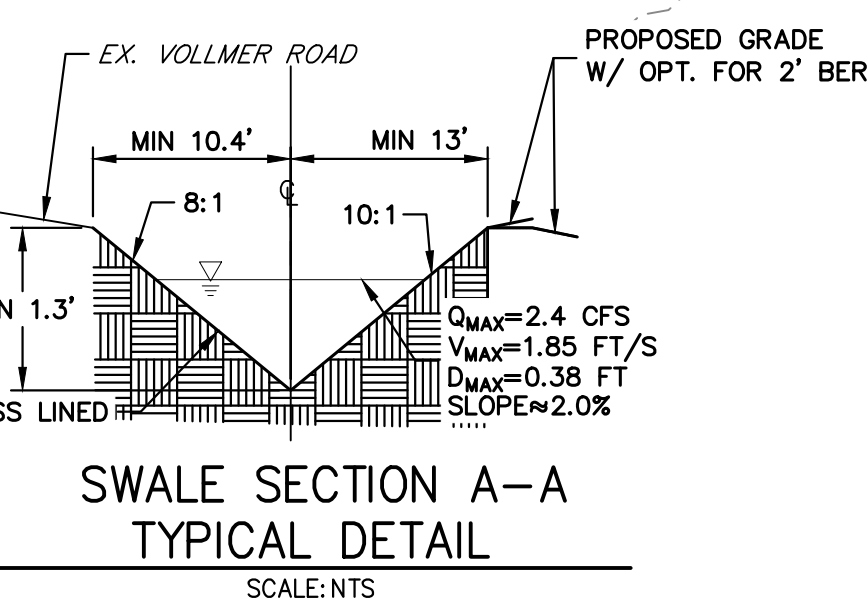
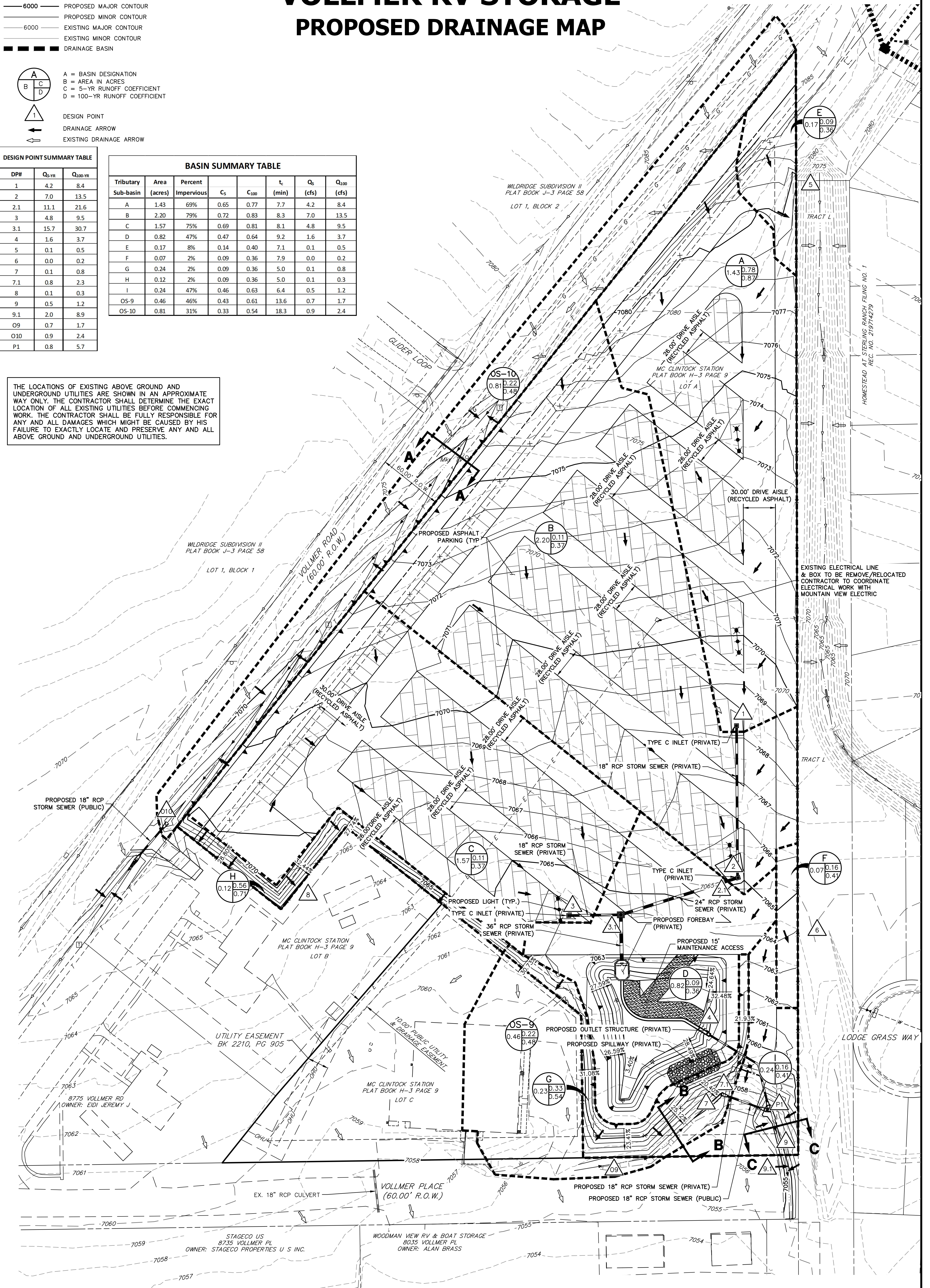

PROPOSED DRAINAGE MAP
VOLLMER RV STORAGE
JOB NO. 25251.00
11/16/2023
SHEET 1 OF 1

J-R ENGINEERING
A Westrian Company

Centennial 303-740-9393 • Colorado Springs 719-593-2593
Fort Collins 970-491-9888 • www.jrengineering.com