

**FINAL DRAINAGE REPORT
FOR
McCLINTOCK STATION FILING NO. 1A
(VOLLMER ROAD RV STORAGE)**

**Prepared For:
Belknap Ventures LLC
3603 First Light Drive
Castle Rock, CO 80109**

**January 2024
Project No. 25251.00**

**Prepared By:
JR Engineering, LLC
5475 Tech Center Drive
Colorado Springs, CO 80919
719-593-2593**

PCD File No. PPR-2245

**Final Drainage Report
McClintock Station Filing No. 1A (Vollmer Road RV Storage)**

ENGINEER'S STATEMENT:

The attached drainage plan and report were prepared under my direction and supervision and are correct to the best of my knowledge and belief. Said drainage report has been prepared according to the criteria established by El Paso County for drainage reports and said report is in conformity with the master plan of the drainage basin. I accept responsibility for any liability caused by any negligent acts, errors, or omissions on my part in preparing this report.



Ryan Burns, Colorado P.E. # 0054412
For and On Behalf of JR Engineering, LLC



3/26/24

Date

DEVELOPER'S STATEMENT:

I, the developer, have read and will comply with all of the requirements specified in this drainage report and plan.

Business Name: Scott Belknap

By: 

Title: Developer, Belknap Ventures LLC.
Address: 3603 First Light Drive
Castle Rock, CO 80109

El Paso County:

Filed in accordance with the requirements of the El Paso County Land Development Code, Drainage Criteria Manual, Volumes 1 and 2 and Engineering Criteria Manual, as amended.

Joshua Palmer, P.E.
County Engineer/ ECM Administrator

Date

Conditions:



CONTENTS

PURPOSE.....	2
GENERAL LOCATION AND DESCRIPTION.....	2
LOCATION.....	2
DESCRIPTION OF PROPERTY.....	2
FLOODPLAIN STATEMENT.....	3
DRAINAGE BASINS AND SUB-BASINS.....	3
EXISTING MAJOR BASIN DESCRIPTIONS.....	3
EXISTING SUB-BASIN DRAINAGE.....	3
PROPOSED SUB-BASIN DRAINAGE.....	4
DRAINAGE DESIGN CRITERIA.....	6
DEVELOPMENT CRITERIA REFERENCE.....	6
HYDROLOGIC CRITERIA.....	6
HYDRAULIC CRITERIA.....	7
DRAINAGE FACILITY DESIGN.....	7
SPECIFIC DETAILS.....	7
<i>Four Step Process to Minimize Adverse Impacts of Urbanization</i>	7
<i>Water Quality</i>	8
<i>Erosion Control Plan</i>	9
<i>Operation & Maintenance</i>	9
<i>Drainage & Bridge Fees</i>	9
<i>Construction Cost Opinion</i>	9
SUMMARY.....	10

APPENDICES

- A. Vicinity Map, Soils, FEMA
- B. Hydrologic Calculations
- C. Hydraulic Calculations
- D. Reference Materials
- E. Drainage Maps



PURPOSE

This document is the Final Drainage Report for McClintock Station Filing No. 1A herein known as “Vollmer Road RV Storage”. The purpose of this document is to identify and analyze the on and offsite drainage patterns and to ensure that post development runoff is routed through the site safely and in a manner that satisfies the requirements set forth by the El Paso County Drainage Criteria Manual. The following report is an analysis of the drainage for the site and surrounding areas.

GENERAL LOCATION AND DESCRIPTION

Location

Vollmer Road RV Storage herein known as “the site” is located in Section 34, Township 12 South, and Range 65 West of the 6th Principal Meridian. The site is bound on the northwest by existing Vollmer Road. Vollmer Road borders Wildridge Subdivision II Lot 1, Blocks 1 and 2 to the northwest of Vollmer Road. The property is bound to the east by the Sterling Ranch Filing 1 and by Lots B of the McClintock Station Subdivision, as well as Vollmer Place to the south. Vollmer Road RV Storage lies within the Sand Creek Drainage Basin. Flows from this site are tributary to Sand Creek. A vicinity map is presented in Appendix A.

Description of Property

Vollmer Road RV Storage consists of 6.4 acres and is presently has an existing shed as well as a greenhouse and a concrete pathway, with a majority of the property being undeveloped. Vegetation is sparse, consisting of native grasses. Existing site terrain generally slopes from north to south at grade rates that vary between 2% and 8%.

Vollmer Road RV Storage is currently zoned "I-2" for light industrial and manufacturing development. Improvements proposed for the site includes recycled asphalt drives and parking, fencing, storm drainage improvements, drainage swales, and a detention pond. A full spectrum detention pond is proposed to be constructed to provide water quality treatment and detain storm water for the development.

Soils for this project are classified as Pring Coarse Sandy Loam (71), which is characterized as Hydrologic Soil Types "B". Group B soils exhibit moderate infiltration rate when thoroughly wet, and consist primarily of deep, moderately well drained or well drained soils that have moderately fine texture to moderately coarse texture. A soil map of the site can be found in Appendix A.

There are no major drainage ways or known irrigation facilities located on the project site. There are no known existing onsite utilities.



Final Drainage Report
McClintock Station Filing No. 1A (Vollmer Road RV Storage)
Floodplain Statement

Based on the FEMA FIRM Maps number 08041C0533G, dated December 7, 2018, all of the proposed development lies within Zone X. Zone X is defined as area outside the Special Flood Hazard Area (SFHA) and higher than the elevation of the 0.2-percent-annual-chance (or 500-year) flood. A FIRM Map is presented in Appendix A.

DRAINAGE BASINS AND SUB-BASINS

Existing Major Basin Descriptions

The Vollmer Road RV Storage site consists of 6.4 acres and is located in the Sand Creek Drainage Basin. The site area was previously studied in the "Sand Creek Drainage Basin Planning Study" (DBPS) prepared by Stantec, January 2021.

The Sand Creek DBPS assumed the Vollmer Road RV Storage property to have an undeveloped use for the site. However, the site is zoned I-2 for light industrial and manufacturing development. The site generally drains from northwest to southeast. Currently, the site is undeveloped. Sand Creek is located east of the site running north to south.

Downstream flow patterns have been studied in "Final Drainage Report for Barbarick Subdivision, Portions of Lots 1, 2 and Lots 3 & 4," by Matrix Design Group, June 2016, and "Woodmen Storage Final Drainage Report", by Calibre Engineering Inc, Revised February 2010. Applicable excerpts from these reports can be found in Appendix D.

A summary of peak runoff for the basins and designated design points are depicted on the Existing Conditions Drainage Map in the appendix.

Existing Sub-basin Drainage

Basin EX-1 ($Q_5=0.2$ cfs, $Q_{100}=1.0$ cfs) is approximately 0.48 acres of open space. Runoff from this basin drains overland flows to the south east to DP1. Flows from Basins EX-1 and OS-6 combine at DP1.1 ($Q_5=0.3$ cfs, $Q_{100}=1.5$ cfs) where flow continues onto Lot B of the McClintock Station Subdivision.

Basin EX-2 ($Q_5=0.9$ cfs, $Q_{100}=5.9$ cfs) is approximately 3.41 acres of open space. Runoff from this basin overland flows southeast to DP 2. Flows from Basins OS-7, OS-8 and EX-2 combine at DP2.1 ($Q_5=1.5$ cfs, $Q_{100}=7.6$ cfs) and continues onto Lot C of the McClintock Station Subdivision. Flows from DP2.1 are routed through basin OS-9 and EX-5 to DP5.1 1 ($Q_5=2.8$ cfs, $Q_{100}=12.8$ cfs).

Basin EX-3 ($Q_5=0.2$ cfs, $Q_{100}=1.3$ cfs) is approximately 0.56 acres of open space. Runoff from this basin overland flows east across the property line to DP3 and onto Homestead at Sterling Ranch Filing No. 1. Runoff is then captured by an existing swale. Flows from the site were not accounted for by the Homestead at Sterling Ranch Final Drainage report, however this basin flows historic drainage patterns.



Final Drainage Report

McClintock Station Filing No. 1A (Vollmer Road RV Storage)

Basin EX-4 ($Q_5=0.4$ cfs, $Q_{100}=1.6$ cfs) is approximately 0.73 and consists of an existing shed and concrete sidewalk and native vegetation. Runoff from this basin overland flows south across the property line to DP4 and onto Lot C of the McClintock Station Subdivision. Flows from DP4 are routed through basin OS-9 and EX-5 to DP5.1 ($Q_5=2.8$ cfs, $Q_{100}=12.8$ cfs).

Basin EX-5 ($Q_5=0.5$ cfs, $Q_{100}=2.8$ cfs) is approximately 1.66 acres and is comprised of a shed, portions of existing Vollmer Place, road side swale and existing native vegetation. Runoff from this basin overland flows onto the site at DP5 where flow enters the roadside swale and combines with flows from DP9.1 ($Q_5=2.4$ cfs, $Q_{100}=10.5$ cfs) at DP5.1 ($Q_5=2.8$ cfs, $Q_{100}=12.8$ cfs). Flow in the roadside swale flows south and follows historic drainage patterns towards sand creek.

Basin OS-6 ($Q_5=0.3$ cfs, $Q_{100}=0.7$ cfs) is approximately 0.14 acres and is comprised of the existing Vollmer Road and road side swale. Runoff from this offsite basin overland flows onto the site at DP6 where flow enters Basin EX-1.

Basin OS-7 ($Q_5=0.4$ cfs, $Q_{100}=1.2$ cfs) is approximately 0.27 acres and is comprised of the existing Vollmer Road and native vegetation. Runoff from this offsite basin overland flows to the property line and enter the site at DP7 where flow enters Basin EX-2.

Basin OS-8 ($Q_5=0.6$ cfs, $Q_{100}=1.5$ cfs) is approximately 0.41 acres and is comprised of the existing Vollmer Road and road side swale. Runoff from this offsite basin overland flows to the roadside ditch and then enter the site at DP8 where flow enters Basin EX-2.

Basin OS-9 ($Q_5=0.7$ cfs, $Q_{100}=1.7$ cfs) is approximately 0.52 acres and is comprised of the existing building, concrete sidewalk, and asphalt parking. Runoff from this offsite basin overland flows southeast to the roadside ditch along Vollmer Place at DP9. Flows for DP4 ($Q_5=0.4$ cfs, $Q_{100}=1.6$ cfs) and DP9 ($Q_5=0.7$ cfs, $Q_{100}=1.7$ cfs) are routed together at DP9.1 ($Q_5=2.4$ cfs, $Q_{100}=10.5$ cfs) and then enter the site into Basin EX-5.

Basin OS-11 ($Q_5=0.0$ cfs, $Q_{100}=0.3$ cfs) is approximately 0.12 acres and is comprised of undeveloped land to the east of the site. Runoff from this offsite basin overland flows west and onto the site into Basin EX-5 at DPO11.

Proposed Sub-basin Drainage

The following is a description of the offsite and onsite basins for the developed condition. Calculations have been provided to show the proposed storm infrastructure will adequately convey flows. The following basins parameters and developed runoff were determined using the Rational Method. Calculation can be found in Appendix C.

Basin A ($Q_5=4.2$ cfs, $Q_{100}=8.4$ cfs) is approximately 1.43 acres and consists of recycled asphalt parking and drives, and landscaping. Runoff from this basin is conveyed via sheet flow across the proposed asphalt mat to DP1, where flow enters a Type C Inlet in sump. The emergency over flow path for the inlet is to the south to Inlet B, a Type C inlet in sump. Flow is routed through the proposed storm sewer system to DP3.1 ($Q_5=15.7$ cfs, $Q_{100}=30.7$ cfs) where flow will be captured and treated in the full spectrum detention pond.



Final Drainage Report

McClintock Station Filing No. 1A (Vollmer Road RV Storage)

Basin B ($Q_5=7.0$ cfs, $Q_{100}=13.5$ cfs) is approximately 2.20 acres and consists of recycled asphalt parking and drives, and landscaping. Runoff from this basin is conveyed via sheet flow across the proposed asphalt mat to DP2, where flow enters a Type C Inlet in sump. The emergency overflow path for this inlet is the proposed full spectrum detention pond to the south. Flow is routed through the proposed storm sewer system to DP3.1 ($Q_5=15.7$ cfs, $Q_{100}=30.7$ cfs) where flow will be captured and treated in the full spectrum detention pond.

Basin C ($Q_5=4.8$ cfs, $Q_{100}=9.5$ cfs) is approximately 1.57 acres and consists of recycled asphalt parking and drives, and landscaping. Runoff from this basin is conveyed via sheet flow across the proposed asphalt mat to DP3, where flow enters a Type C Inlet in sump. The emergency overflow path for this inlet is the proposed full spectrum detention pond to the southeast. Flow is routed through the proposed storm sewer system to DP3.1 ($Q_5=15.7$ cfs, $Q_{100}=30.7$ cfs) where flow will be captured and treated in the full spectrum detention pond.

Basin D ($Q_5=1.6$ cfs, $Q_{100}=3.7$ cfs) is approximately 0.82 acres and consists of recycled asphalt drives and parking, landscaping, and the proposed full spectrum detention pond. Runoff for this basin is collected in the bottom of the pond at DP4 where it is treated.

Basin E ($Q_5=0.1$ cfs, $Q_{100}=0.5$ cfs) is approximately 0.17 acres of landscaping and a small portion of the recycled asphalt drive. Runoff from this basin drains via overland flow to the south east across the site boundary and onto Homestead at Sterling Ranch Filing No. 1 at DP5. In the existing condition the site sends more water to Homestead at Sterling Ranch Filing No. 1 at existing DP3 ($Q_5=0.2$ cfs, $Q_{100}=1.3$ cfs).

Basin F ($Q_5=0.0$ cfs, $Q_{100}=0.2$ cfs) is approximately 0.07 acres of landscaping. Runoff from this basin drains via overland flow to the south across the site boundary and onto Homestead at Sterling Ranch Filing No. 1 offsite basin OS-11 at DP6. Flows combine at DPO11.1.

Basin G ($Q_5=0.1$ cfs, $Q_{100}=0.8$ cfs) is approximately 0.24 acres and is comprised of landscaping and swale section B-B. Runoff from this basin overland flows to roadside swale B-B and then enters the proposed culvert under the access at DP7, flow continues to DP7.1 ($Q_5=0.8$ cfs, $Q_{100}=2.2$ cfs) where flows from Basins G and OS-9 combine, and continues to flow through the proposed culvert to swale C-C located in Basin I.

Basin H ($Q_5=0.1$ cfs, $Q_{100}=0.3$ cfs) is approximately 0.11 acres and is comprised of landscaping. Runoff from this basin overland flows to onto Lot B of the McClintock Station Subdivision at DP8. Flow follows existing drainage patterns to the southwest and are lower than in the existing condition at existing DP1.1 ($Q_5=0.3$ cfs, $Q_{100}=1.5$ cfs).

Basin I ($Q_5=0.5$ cfs, $Q_{100}=1.2$ cfs) is approximately 0.24 acres and is comprised of the existing Vollmer Place, proposed roadside swale C-C, and the drive access. Runoff from this basin overland flows to the roadside ditch DP9, flow continues to DP9.1 ($Q_5=2.0$ cfs, $Q_{100}=9.1$ cfs) where flows from DP7.1, DPO11.1, DPP1 and DP9 combine. Flow follows existing drainage patterns to the south per Woodmen View Storage Plot Plan presented in Appendix D. Flows released from this basin are less than in the existing condition, existing DP5.1 ($Q_5=2.8$ cfs, $Q_{100}=12.8$ cfs).



Final Drainage Report

McClintock Station Filing No. 1A (Vollmer Road RV Storage)

DPP1 ($Q_5=0.8$ cfs, $Q_{100}=5.7$ cfs) is the outfall point for the proposed full spectrum water quality and detention pond. Flow will be routed from the pond via a proposed 18" RCP storm pipe and enter the proposed swale C-C. The outlet structure for the pond shall reduce the release rates for all storm events to less than historic rates to minimize adverse impacts to downstream stormwater facilities. Proposed swale C-C will convey concentrated flows from the pond to the end of the cul-de-sac on Vollmer Place. Flow will then follow historic drainage patterns per Woodmen View Storage Plot Plan presented in Appendix D.

Basin OS-9 ($Q_5=0.7$ cfs, $Q_{100}=1.7$ cfs) is approximately 0.52 acres and is comprised of the existing building, concrete sidewalk, and asphalt parking. Runoff from this offsite basin overland flows southeast to the roadside ditch along Vollmer Place at DPO9. Flows for DP7 ($Q_5=0.1$ cfs, $Q_{100}=0.8$ cfs) and DPO9 ($Q_5=0.7$ cfs, $Q_{100}=1.7$ cfs) are routed together at DP7.1 ($Q_5=0.8$ cfs, $Q_{100}=2.2$ cfs) and then enter the access culvert and into swale C-C located in Basin I.

Basin OS-10 ($Q_5=0.9$ cfs, $Q_{100}=2.4$ cfs) is approximately 0.81 acres and is comprised existing Vollmer Road, proposed roadside swale A-A. Runoff from this basin overland flows to proposed swale A-A and flows south west in the swale along Vollmer Road to DPO10 where flow enters a proposed 18" access culvert for the neighboring property to south and then continues to flow in the roadside ditch.

Basin OS-11 ($Q_5=0.0$ cfs, $Q_{100}=0.3$ cfs) is approximately 0.12 acres and is comprised of undeveloped land to the east of the site. Runoff from this offsite basin overland flows west and combines flow with DP6 at DPO11.1 ($Q_5=0.1$ cfs, $Q_{100}=0.5$ cfs). DPO11.1 flows then enter the site and combine at DP9.1 within Basin I.

DRAINAGE DESIGN CRITERIA

Development Criteria Reference

Storm drainage analysis and design criteria for the project were taken from the "*City of Colorado Spring/El Paso County Drainage Criteria Manual*" Volumes 1 and 2 (EPCDCM), dated October 12, 1994, the "*Urban Storm Drainage Criteria Manual*" Volumes 1 - 3 (USDCM) and Chapter 6 and Section 3.2.1 of Chapter 13 of the "*Colorado Springs Drainage Criteria Manual (CCSDCM)*", dated May 2014, as adopted by El Paso County.

Hydrologic Criteria

All hydrologic data was obtained from the "El Paso Drainage Criteria Manual" Volumes 1 and 2, and the "Urban Drainage and Flood Control District Urban Storm Drainage Criteria Manual" Volumes 1, 2, and 3. Onsite drainage improvements were designed based on the 5 year (minor) storm event and the 100-year (major) storm event. One hour point rainfall data for the storm events is identified in the table below. Rational Method calculations were prepared, in accordance with Section 3.0 of the EPCDCM. Rational method calculations are presented in Appendix B.



Table 1: 1-hr Point Rainfall Data

Storm	Rainfall (in.)
5-year	1.50
100-year	2.52

Hydraulic Criteria

Mile High Flood District's MHFD-Detention, Version 4.05 workbook was used for pond sizing. Required detention volumes and allowable release rates were designed per USDCM and CCS/EPCDCM. Pond sizing spreadsheets are presented in Appendix C. Inlets were sized using UDFCD UD-Inlet v4.05. StormCAD was used to model the proposed storm sewer system and to analyze the proposed HGL calculations for the Construction Drawings. The Manning's equation has been utilized to size the proposed drive access culvert. Autodesk Hydraflow express was used to size the swales. Refer to Appendix C for pipe and swale capacity calculations.

DRAINAGE FACILITY DESIGN

Specific Details

Four Step Process to Minimize Adverse Impacts of Urbanization

In accordance with the El Paso County Drainage Criteria Manual Volume 2, this site has implemented the four step process to minimize adverse impacts of urbanization. The four step process includes reducing runoff volumes, stabilizing drainageways, treating the water quality capture volume (WQCV), and consider the need for Industrial Commercial BMP's.

Step 1, Reducing Runoff Volumes: The development of the project site consist of recycled asphalt parking and drives and landscaped areas. Proposed landscaped areas help disconnect impervious areas.

Step 2, Stabilize Drainageways: Drainage fees were paid at the time of platting for McClintock Station Subdivision. Drainage fees go towards channel stabilization projects throughout the drainage basin. The proposed outfall for the site (DP5.1) is swale C-C. Proposed swale C-C is stable and sufficient. Velocity in the propose swale is less than 5ft/s, therefore the proposed grass lined swale is stable, see Appendix C for supporting calculations.

Step 3, Treat the WQCV: Water Quality treatment for the site is provided in a proposed full spectrum water quality detention ponds located in the south west corner of the site. In general, the runoff from this site will be routed via overland flow to the proposed. A forebay is provided and sized to hold a minimum of 2% of the WQCV. A trickle channel is also incorporated into the ponds to minimize the amount of standing water. The outlet structure has been designed to detain the water quality capture volume (WQCV) for 40 hours, and the extended urban runoff volume (EURV) for 72 hours. Flows released from the pond will be reduced to less than historic rates. The pond will facilitate pollutant removal for the site, while also reducing peak stormwater rates down stream. Per ECM 1.7.C.a up to 20% not to exceed 1 acre of the applicable development site may be excluded where it is not practical to capture runoff. Approximately 13% or 0.83 acres of the site is unable to



be captured due to existing grades and vertical constraints. See Appendix I for supporting Water Quality Map.

Step 4, Consider the need for Industrial and Commercial BMP's: Temporary BMPs will be utilized during construction to minimize off-site contaminants and to protect the downstream receiving waters, Site specific temporary source control BMPs that will be implement include, but are not limited to, silt fencing, construction vehicle tracking pads, designated fueling areas, covered storage areas, spill containment and control, etc. The permanent erosion control BMPs include recycled asphalt parking and drives, permanent vegetation, a storm culvert under the access, and a full spectrum water quality and detention pond.

Water Quality

Water quality for the site is provided by a private full-spectrum detention and water quality pond (Pond V1) in the southeast corner of the site. Table 2 below shows the basin parameters. The proposed pond is sized so that the WQCV for the pond shall be released within 40 hours and the EURV shall be released within 72 hours. Table 3 below gives the design storm results. The proposed pond will utilize a forebay, trickle channel, and outlet structure to dissipate energy and treat flows. The outlet structure for the pond shall reduce the release rates for all storm events to less than historic rates to minimize adverse impacts to downstream stormwater facilities. A broad crested weir will be provided as an emergency spillway and will convey emergency flows to proposed swale B-B. Per ECM 1.7.C.a up to 20% not to exceed 1 acre of the applicable development site may be excluded where it is not practical to capture runoff. Basins E, H, G, F, and I are not feasible to route to propose Pond V1. These basins boarder adjacent properties and the existing grades at the property line make it so it is not feasible to capture and treat runoff from these basins. Runoff from these basins are all less in the proposed condition than in the existing condition so there are no negative downstream impacts anticipated with the development of this site. Approximately 13% or 0.83 acres of the site is unable to be captured due to existing grades and vertical constraints, which meets ECM 1.7.C.a. See Appendix E for supporting Water Quality Map.

Table 2 - Watershed Design Parameters

Watershed Area	6.02 AC
Percent Impervious	71.0%
Watershed Slope	0.021 ft/ft

Table 3 - Design Storm Results

Design Storm Period	Estimated Volume (AC-FT)	Design Volume (AC-FT)	Depth (FT)	Q _{out 100} (CFS)
WQCV	0.14	0.14	2.61	0.1
EURV	0.33	0.36	4.42	0.2
100-YR	0.74	0.74	5.4	5.7



Erosion Control Plan

The El Paso County Drainage Criteria Manual specifies an Erosion Control Plan and associated cost estimate must be submitted with each Final Drainage Report. The Erosion Control Plan for Vollmer RV Storage has been submitted with this report.

Operation & Maintenance

In order to ensure the function and effectiveness of the stormwater infrastructure, maintenance activities such as inspection, routine maintenance, restorative maintenance, rehabilitation and repair, are required. All proposed drainage structures within any platted County ROW will be owned and maintained by El Paso County. All proposed drainage structures within the property will be owned and maintained by Scott Belknap. Access to the pond bottom, forebay, and outlet structure have been provided by a 15' gravel maintenance access road. These access points have been confirmed by the property owner, Scott Belknap, to be sufficient for the expected maintenance equipment to be used. An Inspection & Maintenance Plan has been submitted concurrently with this final drainage report that details the required maintenance activities and intervals to ensure proper function of all stormwater infrastructures in the future. The full spectrum detention pond, Pond V1, and onsite storm sewer system will be owned & maintained by the property owner, Scott Belknap.

Drainage & Bridge Fees

The site lies within the Sand Creek Drainage Basin. It is assumed that all fees were paid at the time of platting for McClintock Station Filing No. 1A.

Construction Cost Opinion

Private Storm Facilities- (For Information Only):

Item	Description	Quantity	Unit	Unit Cost	Cost
1	Concrete Pavement 6" Trickle Channel	100	LF	\$ 40.00	\$ 4,000.00
2	Forebay	1	EA	\$12,000.00	\$ 12,000.00
3	Outlet Structure	1	EA	\$10,000.00	\$ 10,000.00
4	Emergency Spillway- Type VL Riprap	50	CY	\$ 60.00	\$ 3,000.00
5	18" RCP	95	LF	\$ 67.00	\$ 6,365.00
6	24" RCP	186	LF	\$ 91.00	\$ 16,926.00
7	30" RCP	112	LF	\$ 114.00	\$ 12,768.00
8	36" RCP	41	LF	\$ 128.00	\$ 5,248.00
9	18" FES	1	EA	\$ 402.00	\$ 402.00
Subtotal					\$ 70,709.00
25% Engineering & Contingencies					\$ 17,677.25
TOTAL					\$ 88,386.25

See FAE for proposed public improvements. JR Engineering cannot and does not guarantee that the construction cost will not vary from these opinions of probable construction costs.



SUMMARY

The McClintock Station Filing No. 1A known as the Vollmer RV Storage site consists of recycled asphalt parking and drive aisles, a proposed fill spectrum water quality and detention pond, and landscaped areas. The proposed development will not adversely affect downstream drainage infrastructure as the site will provide water quality and detention for the developed flows to release below historic rates. Establishment of maintenance procedures and the implementation of temporary and permanent BMP's will insure the site has no adverse drainage impacts on adjacent properties, surrounding developments, or downstream infrastructure. This report is in conformance with the latest El Paso County Stormwater Drainage Criteria requirements for this site.

REFERENCES

1. City of Colorado Springs Drainage Criteria Manual, Volume 1 & 2, Colorado Springs, CO, 2014.
2. El Paso County Drainage Criteria Manual Volume 1, El Paso County, CO, 1990.
3. El Paso County Drainage Criteria Manual Update (City Chapter 6), El Paso County, CO, 2015.
4. El Paso County Engineering Criteria Manual Revision 6, El Paso County, CO, 2016.
5. Final Drainage Report for Barbarick Subdivision, Portions of Lots 1, 2 and Lots 3 & 4, by Matrix Design Group, dated June 2016.
6. Drainage Report for McClintock Station, by Alden Surveying Co., dated March 1978.
7. Sand Creek Drainage Basin Planning Study, by Stantec, dated January 2021.
8. Urban Storm Drainage Criteria Manual, Urban Drainage and Flood Control District, Latest Revision.

Final Drainage Report
Mc Clintock Station Lot A (Vollmer Road RV Storage)

APPENDIX A

Vicinity Map, Soils, FEMA

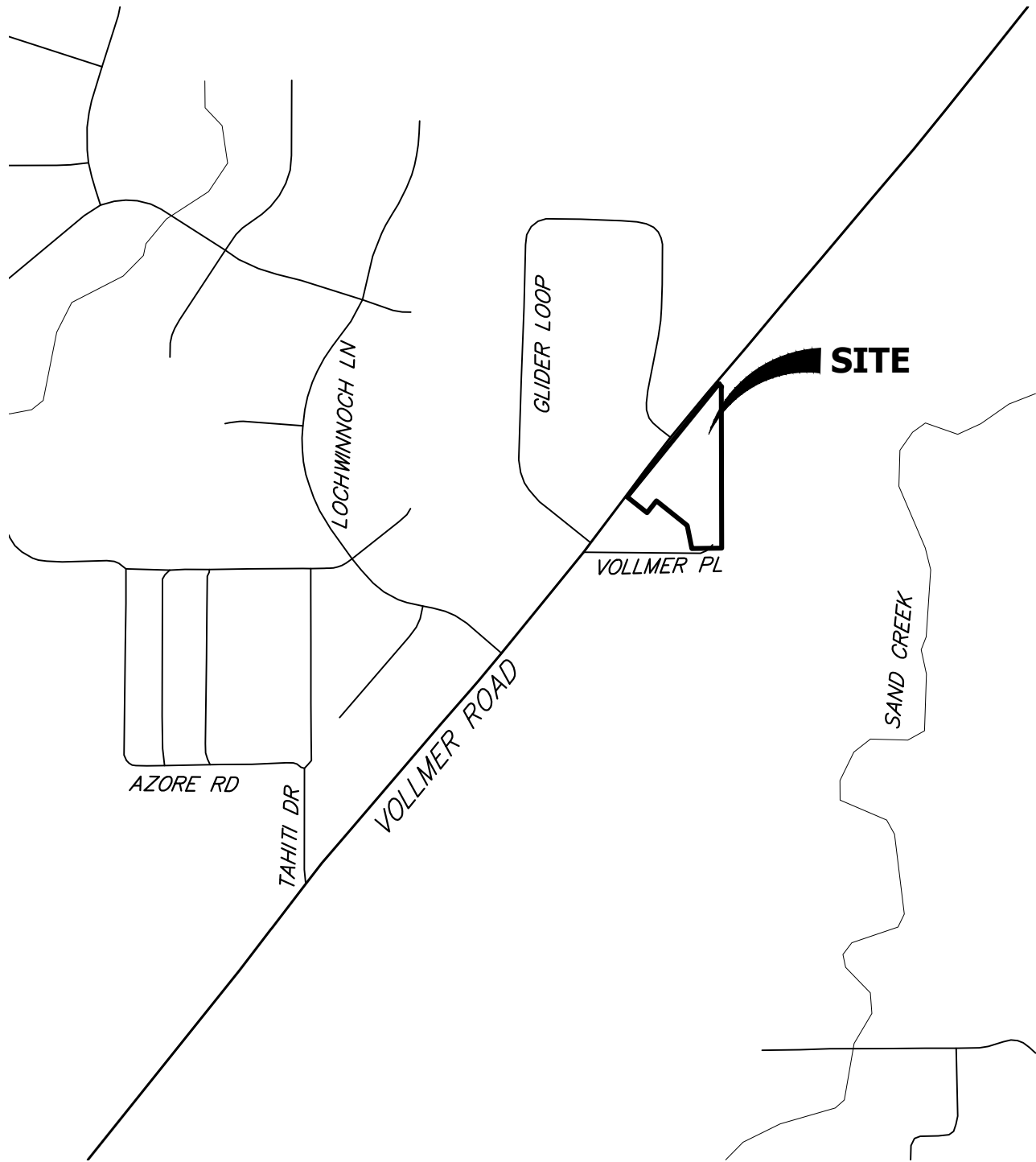

1000 500 0 1000

ORIGINAL SCALE: 1" = 1000'

VICINITY MAP
 VOLLMER RV STORAGE
 JOB NO. 25251.00
 03/21/2023
 SHEET 1 OF 1



J-R ENGINEERING

A Westrian Company

Centennial 303-740-9393 • Colorado Springs 719-593-2593
 Fort Collins 970-491-9888 • www.jrengineering.com

Hydrologic Soil Group—El Paso County Area, Colorado

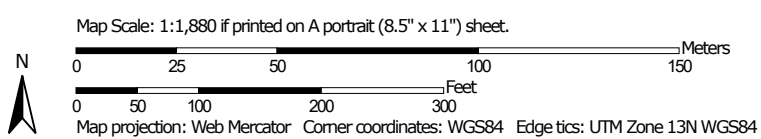

MAP LEGEND

Area of Interest (AOI)









 Area of Interest (AOI)

Soils

Soil Rating Polygons





-  A
-  A/D
-  B
-  B/D
-  C
-  C/D
-  D
-  Not rated or not available

Soil Rating Lines

-  A
-  A/D
-  B
-  B/D
-  C
-  C/D
-  D
-  Not rated or not available

Soil Rating Points





-  A
-  A/D
-  B
-  B/D

-  C
-  C/D
-  D
-  Not rated or not available

Water Features

 Streams and Canals

Transportation

-  Rails
-  Interstate Highways
-  US Routes
-  Major Roads
-  Local Roads

Background

 Aerial Photography

MAP INFORMATION

The soil surveys that comprise your AOI were mapped at 1:24,000.

Warning: Soil Map may not be valid at this scale.

Enlargement of maps beyond the scale of mapping can cause misunderstanding of the detail of mapping and accuracy of soil line placement. The maps do not show the small areas of contrasting soils that could have been shown at a more detailed scale.

Please rely on the bar scale on each map sheet for map measurements.

Source of Map: Natural Resources Conservation Service
 Web Soil Survey URL:
 Coordinate System: Web Mercator (EPSG:3857)

Maps from the Web Soil Survey are based on the Web Mercator projection, which preserves direction and shape but distorts distance and area. A projection that preserves area, such as the Albers equal-area conic projection, should be used if more accurate calculations of distance or area are required.

This product is generated from the USDA-NRCS certified data as of the version date(s) listed below.

Soil Survey Area: El Paso County Area, Colorado
 Survey Area Data: Version 20, Sep 2, 2022

Soil map units are labeled (as space allows) for map scales 1:50,000 or larger.

Date(s) aerial images were photographed: Sep 11, 2018—Oct 20, 2018

The orthophoto or other base map on which the soil lines were compiled and digitized probably differs from the background imagery displayed on these maps. As a result, some minor shifting of map unit boundaries may be evident.

Hydrologic Soil Group

Map unit symbol	Map unit name	Rating	Acres in AOI	Percent of AOI
71	Pring coarse sandy loam, 3 to 8 percent slopes	B	6.8	100.0%
Totals for Area of Interest			6.8	100.0%

Description

Hydrologic soil groups are based on estimates of runoff potential. Soils are assigned to one of four groups according to the rate of water infiltration when the soils are not protected by vegetation, are thoroughly wet, and receive precipitation from long-duration storms.

The soils in the United States are assigned to four groups (A, B, C, and D) and three dual classes (A/D, B/D, and C/D). The groups are defined as follows:

Group A. Soils having a high infiltration rate (low runoff potential) when thoroughly wet. These consist mainly of deep, well drained to excessively drained sands or gravelly sands. These soils have a high rate of water transmission.

Group B. Soils having a moderate infiltration rate when thoroughly wet. These consist chiefly of moderately deep or deep, moderately well drained or well drained soils that have moderately fine texture to moderately coarse texture. These soils have a moderate rate of water transmission.

Group C. Soils having a slow infiltration rate when thoroughly wet. These consist chiefly of soils having a layer that impedes the downward movement of water or soils of moderately fine texture or fine texture. These soils have a slow rate of water transmission.

Group D. Soils having a very slow infiltration rate (high runoff potential) when thoroughly wet. These consist chiefly of clays that have a high shrink-swell potential, soils that have a high water table, soils that have a claypan or clay layer at or near the surface, and soils that are shallow over nearly impervious material. These soils have a very slow rate of water transmission.

If a soil is assigned to a dual hydrologic group (A/D, B/D, or C/D), the first letter is for drained areas and the second is for undrained areas. Only the soils that in their natural condition are in group D are assigned to dual classes.

Rating Options

Aggregation Method: Dominant Condition

Component Percent Cutoff: None Specified

Tie-break Rule: Higher

NOTES TO USERS

This map is for use in administering the National Flood Insurance Program. It does not necessarily identify all areas subject to flooding, particularly from local drainage sources of small size. The community map repository should be consulted for possible updated or additional flood hazard information.

To obtain more detailed information in areas where **Base Flood Elevations (BFEs)** and/or **floodways** have been determined, users are encouraged to consult the Flood Profiles and Floodway Data and/or Summary of Stillwater Elevations tables contained within the Flood Insurance Study (FIS) report that accompanies this FIRM. Users should be aware that BFEs shown on the FIRM represent rounded whole-foot elevations. These BFEs are intended for flood insurance rating purposes only and should not be used as the sole source of flood elevation information. Accordingly, flood elevation data presented in the FIS report should be utilized in conjunction with the FIRM for purposes of construction and/or floodplain management.

Coastal Base Flood Elevations shown on this map apply only landward of 0.0' North American Vertical Datum of 1988 (NAVD88). Users of this FIRM should be aware that coastal flood elevations are also provided in the Summary of Stillwater Elevations table in the Flood Insurance Study report for this jurisdiction. Elevations shown in the Summary of Stillwater Elevations table should be used for construction and/or floodplain management purposes when they are higher than the elevations shown on this FIRM.

Boundaries of the **floodways** were computed at cross sections and interpolated between cross sections. The floodways were based on hydraulic considerations with regard to requirements of the National Flood Insurance Program. Floodway widths and other pertinent floodway data are provided in the Flood Insurance Study report for this jurisdiction.

Certain areas not in Special Flood Hazard Areas may be protected by **flood control structures**. Refer to section 2.4 "Flood Protection Measures" of the Flood Insurance Study report for information on flood control structures for this jurisdiction.

The **projection** used in the preparation of this map was Universal Transverse Mercator (UTM) zone 13. The **horizontal datum** was NAD83, GRS80 spheroid. Differences in datum, spheroid, projection or UTM zones zones used in the production of FIRMs for adjacent jurisdictions may result in slight positional differences in map features across jurisdiction boundaries. These differences do not affect the accuracy of this FIRM.

Flood elevations on this map are referenced to the **North American Vertical Datum of 1988 (NAVD88)**. These flood elevations must be compared to structure and ground elevations referenced to the same **vertical datum**. For information regarding conversion between the National Geodetic Vertical Datum of 1929 and the North American Vertical Datum of 1988, visit the National Geodetic Survey website at <http://www.ngs.noaa.gov/> or contact the National Geodetic Survey at the following address:

NGS Information Services
NOAA, NIMS12
National Geodetic Survey
SSMC-3, #9202
1315 East-West Highway
Silver Spring, MD 20910-3282

To obtain current elevation, description, and/or location information for **bench marks** shown on this map, please contact the Information Services Branch of the National Geodetic Survey at (301) 713-3242 or visit its website at <http://www.ngs.noaa.gov/>.

Base Map information shown on this FIRM was provided in digital format by El Paso County, Colorado Springs Utilities, and Anderson Consulting Engineers, Inc. These data are current as of 2008.

This map reflects more detailed and up-to-date **stream channel configurations and floodplain delineations** than those shown on the previous FIRM for this jurisdiction. The floodplains and floodways that were transferred from the previous FIRM may have been adjusted to conform to these new stream channel configurations. As a result, the Flood Profiles and Floodway Data tables in the Flood Insurance Study Report (which contains authoritative hydraulic data) may reflect stream channel distances that differ from what is shown on this map. The profile baselines depicted on this map represent the hydraulic modeling baselines that match the flood profiles and Floodway Data Tables if applicable, in the FIS report. As a result, the profile baselines may deviate significantly from the new base map channel representation and may appear outside of the floodplain.

Corporate limits shown on this map are based on the best data available at the time of publication. Because changes due to annexations or de-annexations may have occurred after this map was published, map users should contact appropriate community officials to verify current corporate limit locations.

Please refer to the separately printed **Map Index** for an overview map of the county showing the layout of map panels; community map repository addresses; and a Listing of Communities table containing National Flood Insurance Program dates for each community as well as a listing of the panels on which each community is located.

Contact **FEMA Map Service Center (MSC)** via the FEMA Map Information eXchange (FIRM) 1-877-336-2627 for information on available products associated with this FIRM. Available products may include previously issued Letters of Map Change, a Flood Insurance Study Report, and/or digital versions of this map. The MSC may also be reached by Fax at 1-800-358-9620 and its website at <http://www.msc.fema.gov/>.

If you have **questions about this map** or questions concerning the National Flood Insurance Program in general, please call **1-877-FEMA MAP (1-877-336-2627)** or visit the FEMA website at <http://www.fema.gov/business/nfp>.

El Paso County Vertical Datum Offset Table

Flooding Source	Vertical Datum Offset (ft)

REFER TO SECTION 3.3 OF THE EL PASO COUNTY FLOOD INSURANCE STUDY FOR STREAM BY STREAM VERTICAL DATUM CONVERSION INFORMATION

Panel Location Map

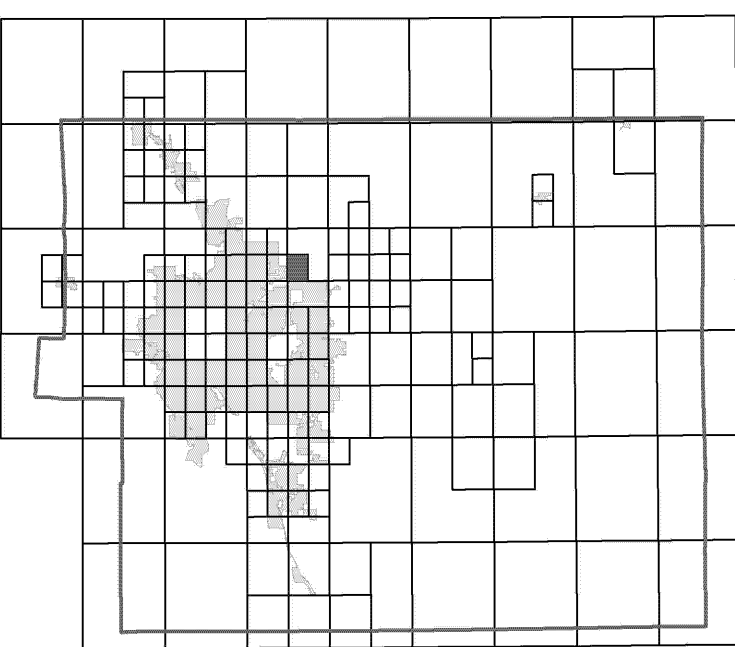

This Digital Flood Insurance Rate Map (DFIRM) was produced through a Cooperating Technical Partner (CTP) agreement between the State of Colorado Water Conservation Board (CWCB) and the Federal Emergency Management Agency (FEMA).



Additional Flood Hazard information and resources are available from local communities and the Colorado Water Conservation Board.

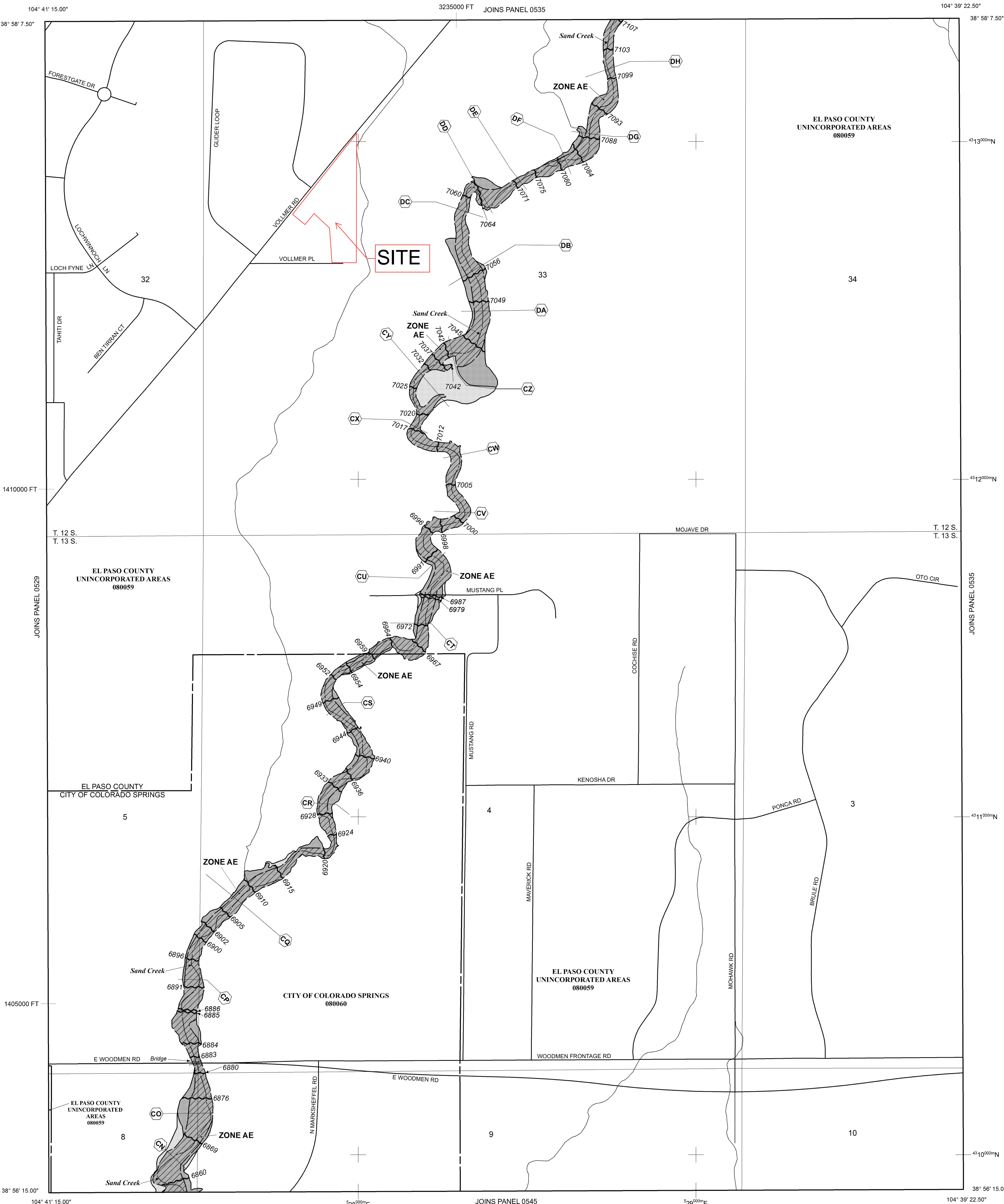

NOTE: MAP AREA SHOWN ON THIS PANEL IS LOCATED WITHIN TOWNSHIP 12 SOUTH, RANGE 65 WEST, AND TOWNSHIP 13 SOUTH, RANGE 65 WEST.

LEGEND

SPECIAL FLOOD HAZARD AREAS (SFHAS) SUBJECT TO INUNDATION BY THE 1% ANNUAL CHANCE FLOOD

The 1% annual chance flood (100-year flood), also known as the base flood, is the flood that has a 1% chance of being equalled or exceeded in any given year. The Special Flood Hazard Area is the area subject to flooding by the 1% annual chance flood. Areas of Special Flood Hazard include Zones A, AE, AH, AO, AR, A99, V, and VE. The Base Flood Elevation is the water-surface elevation of the 1% annual chance flood.

- ZONE A** No Base Flood Elevations determined.
- ZONE AE** Base Flood Elevations determined.
- ZONE AH** Flood depths of 1 to 3 feet (usually areas of ponding); Base Flood Elevations determined.
- ZONE AO** Flood depths of 1 to 3 feet (usually sheet flow on sloping terrain); average depths determined. For areas of alluvial fan flooding, velocities also determined.
- ZONE AR** Special Flood Hazard Area Formerly protected from the 1% annual chance flood by a flood control system that was subsequently decertified. Zone AR indicates that the former flood control system is being restored to provide protection from the 1% annual chance or greater flood.
- ZONE A99** Area to be protected from 1% annual chance flood by a Federal flood protection system under construction; no Base Flood Elevations determined.
- ZONE V** Coastal flood zone with velocity hazard (wave action); no Base Flood Elevations determined.
- ZONE VE** Coastal flood zone with velocity hazard (wave action); Base Flood Elevations determined.

FLOODWAY AREAS IN ZONE AE
The floodway is the channel of a stream plus any adjacent floodplain areas that must be kept free of encroachment so that the 1% annual chance flood can be carried without substantial increases in flood heights.

OTHER FLOOD AREAS
ZONE X Areas of 0.2% annual chance flood; areas of 1% annual chance flood with average depths of less than 1 foot or with drainage areas less than 1 square mile; and areas protected by levees from 1% annual chance flood.

OTHER AREAS
ZONE X Areas determined to be outside the 0.2% annual chance floodplain.
ZONE D Areas in which flood hazards are undetermined, but possible.

COASTAL BARRIER RESOURCES SYSTEM (CBRS) AREAS
OTHERWISE PROTECTED AREAS (OPAs)

CBRS areas and OPAs are normally located within or adjacent to Special Flood Hazard Areas.

- Floodplain boundary
- Floodway boundary
- Zone D Boundary
- CBRS and OPA boundary
- Boundary dividing Special Flood Hazard Areas of different Base Flood Elevations, flood depths or flood velocities.
- (EL 987) Base Flood Elevation value and value; elevation in feet*
- Base Flood Elevation value where uniform within zone; elevation in feet*

* Referenced to the North American Vertical Datum of 1988 (NAVD 88)

- Cross section line
- Transsect line
- Geographic coordinates referenced to the North American Datum of 1983 (NAD 83)
- 1000-meter Universal Transverse Mercator grid ticks, zone 13
- 5000-foot grid ticks: Colorado State Plane coordinate system, central zone (EPSZONE 0502), Lambert Conformal Conic Projection
- Bench mark (see explanation in Notes to Users section of this FIRM panel)
- River Mile

MAP REPOSITORIES
Refer to Map Repositories list on Map Index

EFFECTIVE DATE OF COUNTYWIDE FLOOD INSURANCE RATE MAP
MARCH 17, 1997

EFFECTIVE DATE(S) OF REVISION(S) TO THIS PANEL
DECEMBER 7, 2018 - to update corporate limits, to change Base Flood Elevations and Special Flood Hazard Areas, to update map format, to add roads and road names, and to incorporate previously issued Letters of Map Revision.

For community map revision history prior to countywide mapping, refer to the Community Map History Table located in the Flood Insurance Study report for this jurisdiction.

To determine if flood insurance is available in this community, contact your insurance agent or call the National Flood Insurance Program at 1-800-638-6620.

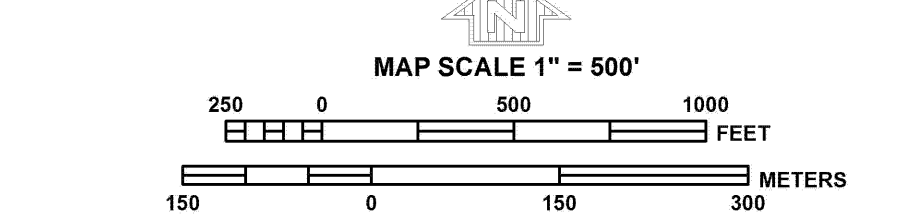

NFIP **PANEL 0533G**

FIRM
FLOOD INSURANCE RATE MAP
EL PASO COUNTY,
COLORADO
AND INCORPORATED AREAS

PANEL 533 OF 1300
(SEE MAP INDEX FOR FIRM PANEL LAYOUT)

CONTAINS:

COMMUNITY	NUMBER	PANEL	SUFFIX
COLORADO SPRINGS, CITY OF	08060	0533	G
EL PASO COUNTY	08059	0533	G

Notice to User: The Map Number shown below should be used when placing map orders. The Community Number shown above should be used on insurance applications for the subject community.

MAP NUMBER
08041C0533G

MAP REVISED
DECEMBER 7, 2018
Federal Emergency Management Agency

APPENDIX B

HYDROLOGIC CALCULATIONS

COMPOSITE % IMPERVIOUS CALCULATIONS - EXISTING CONDITIONS

Subdivision: McClintock Station Filing No. 1A
 Location: Colorado Springs

Project Name: Vollmer Road RV Storage
 Project No.: 25251.00
 Calculated By: APL
 Checked By: REB
 Date: 1/12/24

Basin ID	Total Area (ac)	Drives/Walks (100% Imp.)				Roofs (90%)				Pasture/Meadow (2% Imp.)				Basins Total Weighted C		Basins Total Weighted % Imp.
		C ₅	C ₁₀₀	Area (ac)	Weighted % Imp.	C ₅	C ₁₀₀	Area (ac)	Weighted % Imp.	C ₅	C ₁₀₀	Area (ac)	Weighted % Imp.	C ₅	C ₁₀₀	
EX-1	0.48	0.90	0.96	0.00	0.0%	0.73	0.81	0.00	0.0%	0.09	0.36	0.48	2.0%	0.09	0.36	2.0%
EX-2	3.41	0.90	0.96	0.00	0.0%	0.73	0.81	0.00	0.0%	0.09	0.36	3.41	2.0%	0.09	0.36	2.0%
EX-3	0.56	0.90	0.96	0.00	0.0%	0.73	0.81	0.00	0.0%	0.09	0.36	0.56	2.0%	0.09	0.36	2.0%
EX-4	0.73	0.90	0.96	0.03	3.5%	0.73	0.81	0.05	6.0%	0.09	0.36	0.66	1.8%	0.16	0.41	11.3%
EX-5	1.66	0.90	0.96	0.02	1.0%	0.73	0.81	0.02	1.1%	0.09	0.36	1.62	2.0%	0.11	0.37	4.0%
OS-6	0.14	0.90	0.96	0.05	34.3%	0.73	0.81	0.00	0.0%	0.09	0.36	0.09	1.3%	0.37	0.57	35.6%
OS-7	0.27	0.90	0.96	0.08	28.1%	0.73	0.81	0.00	0.0%	0.09	0.36	0.19	1.4%	0.32	0.53	29.5%
OS-8	0.41	0.90	0.96	0.12	30.4%	0.73	0.81	0.00	0.0%	0.09	0.36	0.29	1.4%	0.34	0.54	31.8%
OS-9	0.52	0.90	0.96	0.10	19.4%	0.73	0.81	0.12	20.8%	0.09	0.36	0.30	1.2%	0.40	0.58	41.3%
OS-11	0.12	0.90	0.96	0.00	0.0%	0.73	0.81	0.00	0.0%	0.09	0.36	0.12	2.0%	0.09	0.36	2.0%
Total (EX 1-5)	6.84															3.5%
Total	8.30															8.6%

STANDARD FORM SF-2 - EXISTING CONDITIONS TIME OF CONCENTRATION

Subdivision: McClintock Station Filing No. 1A
 Location: El Paso County

Project Name: Vollmer Road RV Storage
 Project No.: 25251.00
 Calculated By: APL
 Checked By: REB
 Date: 1/12/24

SUB-BASIN						INITIAL/OVERLAND			TRAVEL TIME					tc CHECK			FINAL
DATA						(T _i)			(T _t)					(URBANIZED BASINS)			
BASIN ID	D.A. (ac)	Hydrologic Soils Group	Impervious (%)	C ₅	C ₁₀₀	L (ft)	S _o (%)	t _i (min)	L _t (ft)	S _t (%)	K	VEL. (ft/s)	t _t (min)	COMP. t _c (min)	TOTAL LENGTH (ft)	Urbanized t _c (min)	t _c (min)
EX-1	0.48	B	2%	0.09	0.36	136	2.8%	15.2	0	0.0%	7.0	0.0	0.0	15.2	136.0	25.7	15.2
EX-2	3.41	B	2%	0.09	0.36	226	4.2%	17.0	423	2.5%	7.0	1.1	6.4	23.4	649.0	30.5	23.4
EX-3	0.56	B	2%	0.09	0.36	122	5.6%	11.4	0	0.0%	7.0	0.0	0.0	11.4	121.7	25.7	11.4
EX-4	0.73	B	11%	0.16	0.41	116	1.8%	15.0	219	2.8%	7.0	1.2	3.1	18.2	335.0	26.1	18.2
EX-5	1.66	B	4%	0.11	0.37	300	2.5%	23.0	260	3.2%	7.0	1.2	3.5	26.5	560.0	27.9	26.5
OS-6	0.14	B	36%	0.37	0.57	40	5.7%	4.7	0	0.0%	7.0	0.0	0.0	4.7	39.5	19.9	5.0
OS-7	0.27	B	30%	0.32	0.53	40	5.7%	5.0	0	0.0%	7.0	0.0	0.0	5.0	39.5	21.0	5.0
OS-8	0.41	B	32%	0.34	0.54	22	9.0%	3.1	455	2.5%	7.0	1.1	6.9	10.0	476.9	24.2	10.0
OS-9	0.52	B	41%	0.40	0.58	150	1.8%	12.9	260	2.0%	7.0	1.0	4.4	17.3	410.0	21.1	17.3
OS-11	0.12	B	2%	0.09	0.36	25	10.0%	4.3	0	0.0%	7.0	0.0	0.0	4.3	25.0	25.7	10.0

NOTES:

$$t_c = t_i + t_t$$

Where:

t_c = computed time of concentration (minutes)

t_i = overland (initial) flow time (minutes)

t_t = channelized flow time (minutes).

$$t_t = \frac{L_t}{60K\sqrt{S_o}} = \frac{L_t}{60V_t}$$

Where:

t_t = channelized flow time (travel time, min)

L_t = waterway length (ft)

S_o = waterway slope (ft/ft)

V_t = travel time velocity (ft/sec) = K√S_o

K = NRCS conveyance factor (see Table 6-2).

Use a minimum t_c value of 5 minutes for urbanized areas and a minimum t_c value of 10 minutes for areas that are not considered urban. Use minimum values even when calculations result in a lesser time of concentration.

$$t_i = \frac{0.395(1.1 - C_s)\sqrt{L_i}}{S_o^{0.33}}$$

Where:

t_i = overland (initial) flow time (minutes)

C_s = runoff coefficient for 5-year frequency (from Table 6-4)

L_i = length of overland flow (ft)

S_o = average slope along the overland flow path (ft/ft).

Equation 6-4

Equation 6-3

Table 6-2. NRCS Conveyance factors, K

Type of Land Surface	Conveyance Factor, K
Heavy meadow	2.5
Tillage/field	5
Short pasture and lawns	7
Nearly bare ground	10
Grassed waterway	15
Paved areas and shallow paved swales	20

$$t_t = (26 - 17i) + \frac{L_t}{60(14i + 9)\sqrt{S_t}}$$

Equation 6-5

Where:

t_c = minimum time of concentration for first design point when less than t_c from Equation 6-1.

L_t = length of channelized flow path (ft)

i = imperviousness (expressed as a decimal)

S_t = slope of the channelized flow path (ft/ft).

STANDARD FORM SF-3 - EXISTING CONDITIONS
STORM DRAINAGE SYSTEM DESIGN
(RATIONAL METHOD PROCEDURE)

Subdivision: McClintock Station Filing No. 1A
 Location: El Paso County
 Design Storm: 5-Year

Project Name: Vollmer Road RV Storage
 Project No.: 25251.00
 Calculated By: APL
 Checked By: REB
 Date: 1/12/24

STREET	Design Point	DIRECT RUNOFF							TOTAL RUNOFF				STREET			PIPE				TRAVEL TIME			REMARKS
		Basin ID	Area (Ac)	Runoff Coeff.	t _c (min)	C*A (Ac)	I (in/hr)	Q (cfs)	t _c (min)	C*A (ac)	I (in/hr)	Q (cfs)	Q _{street} (cfs)	C*A (ac)	Slope (%)	Q _{pipe} (cfs)	C*A (ac)	Slope (%)	Pipe Size (inches)	Length (ft)	Velocity (fps)	t _t (min)	
	6	OS-6	0.14	0.37	5.0	0.05	5.17	0.3															Runoff from Basin OS-6, overland flows southeast, across Vollmer Road and into the Site at DP6.
	1	EX-1	0.48	0.09	15.2	0.04	3.50	0.2															Runoff from Basin EX-1, overland flows southeast, across the property line to Lot B at DP1.
	1.1								15.2	0.09	3.50	0.3											Runoff from DP6 and DP1 combine at DP1.1 and continue onto Lot B
	7	OS-7	0.27	0.32	5.0	0.09	5.17	0.4															Runoff from Basin OS-7, overland flows southeast, across Vollmer Road and into the Site at DP7.
	8	OS-8	0.41	0.34	10.0	0.14	4.13	0.6															Runoff from Basin OS-8, overland flows southeast, across Vollmer Road and into a road side swale, flow from the swale enters the Site at DP8.
	2	EX-2	3.41	0.09	23.4	0.31	2.85	0.9															Runoff from Basin EX-2, overland flows southeast, across the property line to Lot C at DP2.
	2.1								23.4	0.53	2.85	1.5											Runoff from DP7, DP8, and DP2 combine at DP2.1 and continue onto Lot C
	3	EX-3	0.56	0.09	11.4	0.05	3.93	0.2															Runoff from Basin EX-3, overland flows east, across the property line to an existing swale in the Homestead at Stearling Ranch Development
	4	EX-4	0.73	0.16	18.2	0.12	3.23	0.4															Runoff from Basin EX-4, overland flows south, across the property line to Lot C at DP4. Flow continues to DP9.1
	9	OS-9	0.52	0.40	17.3	0.21	3.31	0.7															Runoff from Basin OS-9, overland flows southeast, to a roadsideswale and into the Site at DP9.
	9.1								23.4	0.85	2.85	2.4											Runoff from DP2.1, DP4, and DP9 combine at DP9.1 and continue onto the site
	O11	OS-11	0.12	0.09	10.0	0.01	4.13	0.0															Runoff from Basin OS-11, overland flows west into the Site at DP10.
	5	EX-5	1.66	0.11	26.5	0.18	2.67	0.5															Runoff from Basin EX-5, overland flows south to a roadside ditch along Vollmer Pl and leaves the site at DP5
	5.1								26.5	1.04	2.67	2.8											Runoff from DP5, DP9.1, and DPO11 combine at DP5.1 and continue to flow in the roadside swale to the south

Notes:
 Street and Pipe C*A values are determined by Q/I using the catchment's intensity value.

STANDARD FORM SF-3 - EXISTING CONDITIONS
STORM DRAINAGE SYSTEM DESIGN
(RATIONAL METHOD PROCEDURE)

Subdivision: McClintock Station Filing No. 1A
Location: El Paso County
Design Storm: 100-Year

Project Name: Vollmer Road RV Storage
Project No.: 25251.00
Calculated By: APL
Checked By: REB
Date: 1/12/24

STREET	Design Point	DIRECT RUNOFF							TOTAL RUNOFF				STREET			PIPE				TRAVEL TIME			REMARKS
		Basin ID	Area (ac)	Runoff Coeff.	t _c (min)	C*A (ac)	I (in/hr)	Q (cfs)	t _c (min)	C*A (ac)	I (in/hr)	Q (cfs)	Q _{street} (cfs)	C*A (ac)	Slope (%)	C _{pipe} (cfs)	C*A (ac)	Slope (%)	Pipe Size (inches)	Length (ft)	Velocity (fps)	t _t (min)	
	6	OS-6	0.14	0.57	5.0	0.08	8.68	0.7															Runoff from Basin OS-6, overland flows southeast, across Vollmer Road and into the Site at DP6.
	1	EX-1	0.48	0.36	15.2	0.17	5.87	1.0															Runoff from Basin EX-1, overland flows southeast, across the property line to Lot B at DP1.
	1.1								15.2	0.25	5.87	1.5											Runoff from DP6 and DP1 combine at DP1.1 and continue onto Lot B
	7	OS-7	0.27	0.53	5.0	0.14	8.68	1.2															Runoff from Basin OS-7, overland flows southeast, across Vollmer Road and into the Site at DP7.
	8	OS-8	0.41	0.54	10.0	0.22	6.93	1.5															Runoff from Basin OS-8, overland flows southeast, across Vollmer Road and into a road side swale, flow from the swale enters the Site at DP8.
	2	EX-2	3.41	0.36	23.4	1.23	4.79	5.9															Runoff from Basin EX-2, overland flows southeast, across the property line to Lot C at DP2.
	2.1								23.4	1.59	4.79	7.6											Runoff from DP7, DP8, and DP2 combine at DP2.1 and continue onto Lot C
	3	EX-3	0.56	0.36	11.4	0.20	6.61	1.3															Runoff from Basin EX-3, overland flows east, across the property line to an existng swale in the Homestead at Stearling Ranch Development
	4	EX-4	0.73	0.41	18.2	0.30	5.43	1.6															Runoff from Basin EX-4, overland flows south, across the property line to Lot C at DP4. Flow continues to DP9.1
	9	OS-9	0.52	0.58	17.3	0.30	5.55	1.7															Runoff from Basin OS-9, overland flows southeast, to a roadsideswale and into the Site at DP9.
	9.1								23.4	2.19	4.79	10.5											Runoff from DP2.1, DP4, and DP9 combine at DP9.1 and continue onto the site
	O11	OS-11	0.12	0.36	10.0	0.04	6.93	0.3															Runoff from Basin OS-11, overland flows west into the Site at DPO11.
	5	EX-5	1.66	0.37	26.5	0.62	4.48	2.8															Runoff from Basin EX-5, overland flows south to a roadside ditch along Vollmer Pl and leaves the site at DP5
	5.1								26.5	2.85	4.48	12.8											Runoff from DP5, DP9.1, and DPO11 combine at DP5.1 and continue to flow in the roadside swale to the south

Notes:
Street and Pipe C*A values are determined by Q/i using the catchment's intensity value.

COMPOSITE % IMPERVIOUS CALCULATIONS - PROPOSED CONDITIONS

Subdivision: McClintock Station Filing No. 1A
 Location: El Paso County

Project Name: Vollmer Road RV Storage
 Project No.: 25251.00
 Calculated By: APL
 Checked By: REB
 Date: 2/8/24

Basin ID	Total Area (ac)	Drives/Walks (100% Imp.)				Roofs (90%)				Pasture/Meadow (2% Imp.)				Basins Total Weighted C		Basins Total Weighted % Imp.
		C ₅	C ₁₀₀	Area (ac)	Weighted % Imp.	C ₅	C ₁₀₀	Area (ac)	Weighted % Imp.	C ₅	C ₁₀₀	Area (ac)	Weighted % Imp.	C ₅	C ₁₀₀	
A	1.43	0.90	0.96	0.98	68.5%	0.73	0.81	0.00	0.0%	0.09	0.36	0.45	0.6%	0.65	0.77	69.2%
B	2.20	0.90	0.96	1.72	78.2%	0.73	0.81	0.00	0.0%	0.09	0.36	0.48	0.4%	0.72	0.83	78.6%
C	1.57	0.90	0.96	1.17	74.5%	0.73	0.81	0.00	0.0%	0.09	0.36	0.40	0.5%	0.69	0.81	75.0%
D	0.82	0.90	0.96	0.38	46.3%	0.73	0.81	0.00	0.0%	0.09	0.36	0.44	1.1%	0.47	0.64	47.4%
E	0.17	0.90	0.96	0.01	5.9%	0.73	0.81	0.00	0.0%	0.09	0.36	0.16	1.9%	0.14	0.40	7.8%
F	0.07	0.90	0.96	0.00	0.0%	0.73	0.81	0.00	0.0%	0.09	0.36	0.07	2.0%	0.09	0.36	2.0%
G	0.24	0.90	0.96	0.00	0.0%	0.73	0.81	0.00	0.0%	0.09	0.36	0.24	2.0%	0.09	0.36	2.0%
H	0.11	0.90	0.96	0.00	0.0%	0.73	0.81	0.00	0.0%	0.09	0.36	0.11	2.0%	0.09	0.36	2.0%
I	0.24	0.90	0.96	0.11	45.5%	0.73	0.81	0.00	0.0%	0.09	0.36	0.13	1.1%	0.46	0.63	46.5%
OS-9	0.52	0.90	0.96	0.10	19.4%	0.73	0.81	0.12	20.8%	0.09	0.36	0.30	1.2%	0.40	0.58	41.3%
OS-10	0.81	0.90	0.96	0.24	29.6%	0.73	0.81	0.00	0.0%	0.09	0.36	0.57	1.4%	0.33	0.54	31.0%
OS-11	0.12	0.90	0.96	0.00	0.0%	0.73	0.81	0.00	0.0%	0.09	0.36	0.12	2.0%	0.09	0.36	2.0%
Total	8.30															58.9%
Pond Total (A-D)	6.02															71%

STANDARD FORM SF-2 - PROPOSED CONDITIONS TIME OF CONCENTRATION

Subdivision: McClintock Station Filing No. 1A
Location: El Paso County

Project Name: Vollmer Road RV Storage
Project No.: 25251.00
Calculated By: APL
Checked By: REB
Date: 2/8/24

SUB-BASIN						INITIAL/OVERLAND			TRAVEL TIME					tc CHECK			FINAL
DATA						(T _i)			(T _t)					(URBANIZED BASINS)			
BASIN ID	D.A. (ac)	Hydrologic Soils Group	Impervious (%)	C ₅	C ₁₀₀	L (ft)	S _o (%)	t _i (min)	L _t (ft)	S _t (%)	K	VEL. (ft/s)	t _t (min)	COMP. t _c (min)	TOTAL LENGTH (ft)	Urbanized t _c (min)	
A	1.43	B	69%	0.65	0.77	100	3.8%	5.3	441	2.4%	20.0	3.1	2.4	7.7	541.0	16.8	7.7
B	2.20	B	79%	0.72	0.83	100	3.0%	4.7	515	1.5%	20.0	2.4	3.6	8.3	615.0	16.2	8.3
C	1.57	B	75%	0.69	0.81	100	1.8%	6.0	302	1.6%	20.0	2.5	2.0	8.1	402.4	15.3	8.1
D	0.82	B	47%	0.47	0.64	100	3.2%	7.8	129	4.7%	7.0	1.5	1.4	9.2	229.0	18.6	9.2
E	0.17	B	8%	0.14	0.40	51	5.5%	7.1	0	0.0%	7.0	0.0	0.0	7.1	50.6	24.7	7.1
F	0.07	B	2%	0.09	0.36	27	1.7%	7.9	0	0.0%	7.0	0.0	0.0	7.9	26.6	25.7	7.9
G	0.24	B	2%	0.09	0.36	20	29.0%	2.7	0	0.0%	7.0	0.0	0.0	2.7	19.5	25.7	5.0
H	0.11	B	2%	0.09	0.36	17	30.0%	2.5	0	0.0%	7.0	0.0	0.0	2.5	17.3	25.7	5.0
I	0.24	B	47%	0.46	0.63	58	3.1%	6.1	89	5.0%	20.0	4.5	0.3	6.4	146.8	18.5	6.4
OS-9	0.52	B	41%	0.40	0.58	150	1.8%	12.9	260	2.0%	7.0	1.0	4.4	17.3	410.0	21.1	17.3
OS-10	0.81	B	31%	0.33	0.54	22	10.0%	3.0	933	2.1%	7.0	1.0	15.2	18.3	954.5	28.7	18.3
OS-11	0.12	B	2%	0.09	0.36	25	10.0%	4.3	0	0.0%	7.0	0.0	0.0	4.3	25.0	25.7	10.0

NOTES:

$$t_c = t_i + t_t$$

Where:

t_c = computed time of concentration (minutes)

t_i = overland (initial) flow time (minutes)

t_t = channelized flow time (minutes).

$$t_t = \frac{L_t}{60K\sqrt{S_o}} = \frac{L_t}{60V_t}$$

Where:

t_t = channelized flow time (travel time, min)

L_t = waterway length (ft)

S_o = waterway slope (ft/ft)

V_t = travel time velocity (ft/sec) = K√S_o

K = NRCS conveyance factor (see Table 6-2).

Equation 6-2

$$t_i = \frac{0.395(1.1 - C_5)\sqrt{L_i}}{S_o^{0.33}}$$

Where:

t_i = overland (initial) flow time (minutes)

C₅ = runoff coefficient for 5-year frequency (from Table 6-4)

L_i = length of overland flow (ft)

S_o = average slope along the overland flow path (ft/ft).

Equation 6-4

$$t_i = (26 - 17i) + \frac{L_i}{60(14i + 9)\sqrt{S_i}}$$

Where:

t_i = minimum time of concentration for first design point when less than t_c from Equation 6-1.

L_i = length of channelized flow path (ft)

i = imperviousness (expressed as a decimal)

S_i = slope of the channelized flow path (ft/ft).

Equation 6-3

Table 6-2. NRCS Conveyance factors, K

Type of Land Surface	Conveyance Factor, K
Heavy meadow	2.5
Tillage/field	5
Short pasture and lawns	7
Nearly bare ground	10
Grassed waterway	15
Paved areas and shallow paved swales	20

Equation 6-5

Use a minimum t_c value of 5 minutes for urbanized areas and a minimum t_c value of 10 minutes for areas that are not considered urban. Use minimum values even when calculations result in a lesser time of concentration.

STANDARD FORM SF-3 - PROPOSED CONDITIONS
STORM DRAINAGE SYSTEM DESIGN
(RATIONAL METHOD PROCEDURE)

Subdivision: McClintock Station Filing No. 1A
Location: El Paso County
Design Storm: 5-Year

Project Name: Vollmer Road RV Storage
Project No.: 25251.00
Calculated By: APL
Checked By: REB
Date: 2/8/24

STREET	Design Point	DIRECT RUNOFF							TOTAL RUNOFF				STREET			PIPE				TRAVEL TIME			REMARKS
		Basin ID	Area (Ac)	Runoff Coeff.	t _c (min)	C*A (Ac)	I (in/hr)	Q (cfs)	t _c (min)	C*A (ac)	I (in/hr)	Q (cfs)	Q _{street} (cfs)	C*A (ac)	Slope (%)	Q _{pipe} (cfs)	C*A (ac)	Slope (%)	Pipe Size (inches)	Length (ft)	Velocity (fps)	t _c (min)	
	1	A	1.43	0.65	7.7	0.92	4.52	4.2							4.2	0.92	1.6	18	139	6.6	0.4	Runoff from Basin A, overland flows south to DP1, flow enters Inlet A, a Type C inlet in sump. Flow is piped via proposed storm sewer to DP2.1.	
	2	B	2.20	0.72	8.3	1.59	4.41	7.0														Runoff from Basin B, overland flows south to DP2, flow enters Inlet B a Type C inlet in sump. Flow is piped via proposed storm sewer to DP2.1.	
	2.1								8.3	2.51	4.41	11.1			11.1	2.51	0.5	24	114	5.5	0.3	Flows for DP1 and DP2 combine in proposed storm sewer system. Flow is piped via proposed storm sewer to DP3.1	
	3	C	1.57	0.69	8.1	1.09	4.45	4.8							4.8	1.09	0.5	18	47	4.4	0.2	Runoff from Basin B, overland flows to DP3, flow enters Inlet C, a Type C inlet in sump. Flow is piped via proposed sewer to DP3.1.	
	3.1								8.6	3.60	4.35	15.7										Flows for DP2.1 and DP3 combine in proposed storm sewer system. Flow is piped via proposed storm sewer to pond.	
	4	D	0.82	0.47	9.2	0.38	4.25	1.6														Runoff from Basin D, overland flows to the trickle channel at the bottom of the pond.	
	5	E	0.17	0.14	7.1	0.02	4.65	0.1														Runoff from Basin E, overland flows east, across the property line to an existing swale in the Homestead at Sterling Ranch Development at DP5.	
	6	F	0.07	0.09	7.9	0.01	4.48	0.0														Runoff from Basin F, overland flows east across the property line to the Homestead at Sterling Ranch Development at DP6. Combines flow at DPO11.1.	
	09	OS-9	0.52	0.40	17.3	0.21	3.31	0.7														Runoff from Basin OS-9, overland flows southeast to the roadside swale along Vollmer Place at DPO9.	
	7	G	0.24	0.09	5.0	0.02	5.17	0.1														Runoff from Basin G, overland flows south to the roadside swale along Vollmer Place at DP7. Combines flow in proposed FES at DP7.1	
	7.1								17.3	0.23	3.31	0.8										DPO9 and DP7 combine in roadside swale before entering culvert at site access. Flow continues to DP9.1.	
	O11	OS-11	0.12	0.09	10.0	0.01	4.13	0.0														Runoff from Basin OS-11, overland flows west into the Site at DPO11. Combines flow at DPO11.1	
	O11.1								10.0	0.02	4.13	0.1										DP6 and DPO11 combine sheet flowing back on-site. Flow continues to DP9.1.	
	9	I	0.24	0.46	6.4	0.11	4.80	0.5														Runoff from Basin I overland flows southeast to the roadside swale along Vollmer Place to DP9.	
	P1							0.8														5 year release from the pond.	
	9.1								17.3	0.35	3.31	2.0										Flows from DP7.1, DPO11.1, and DP9 combine in the roadside swale before exiting the site at DP9.1 and following existing drainage patterns.	
	8	H	0.11	0.09	5.0	0.01	5.17	0.1														Runoff from Basin H, overland flows south, across the property line to Mc Clintock Stations B and C.	
	O10	OS-10	0.81	0.33	18.3	0.27	3.22	0.9														Off-site basin runoff is collected in the roadside swale along Vollmer Road to DPO10 where flow enters a proposed 18" driveway culvert.	

Notes:
Street and Pipe C*A values are determined by Q/i using the catchment's intensity value.

STANDARD FORM SF-3 - PROPOSED CONDITIONS
STORM DRAINAGE SYSTEM DESIGN
(RATIONAL METHOD PROCEDURE)

Subdivision: McClintock Station Filing No. 1A
Location: El Paso County
Design Storm: 100-Year

Project Name: Vollmer Road RV Storage
Project No.: 25251.00
Calculated By: APL
Checked By: REB
Date: 2/8/24

STREET	Design Point	DIRECT RUNOFF							TOTAL RUNOFF				STREET			PIPE			TRAVEL TIME			REMARKS
		Basin ID	Area (ac)	Runoff Coeff.	t _c (min)	C*A (ac)	I (in/hr)	Q (cfs)	t _c (min)	C*A (ac)	I (in/hr)	Q (cfs)	Q _{street} (cfs)	C*A (ac)	Slope (%)	Q _{pipe} (cfs)	C*A (ac)	Slope (%)	Pipe Size (inches)	Length (ft)	Velocity (fps)	
	1	A	1.43	0.77	7.7	1.10	7.59	8.4							8.4	1.10	1.6	18	139	7.9	0.3	Runoff from Basin A, overland flows south to DP1, flow enters Inlet A, a Type C inlet in sump. Flow is piped via proposed storm sewer to DP2.1.
	2	B	2.20	0.83	8.3	1.82	7.41	13.5														Runoff from Basin B, overland flows south to DP2, flow enters Inlet B a Type C inlet in sump. Flow is piped via proposed storm sewer to DP2.1.
	2.1								8.3	2.92	7.41	21.6			21.6	2.92	0.5	24	114	6.9	0.3	Flows for DP1 and DP2 combine in proposed storm sewer system. Flow is piped via proposed storm sewer to DP3.1
	3	C	1.57	0.81	8.1	1.27	7.48	9.5							9.5	1.27	0.5	18	47	5.4	0.1	Runoff from Basin B, overland flows to DP3, flow enters Inlet C, a Type C inlet in sump. Flow is piped via proposed sewer to DP3.1.
	3.1								8.5	4.19	7.33	30.7										Flows for DP2.1 and DP3 combine in proposed storm sewer system. Flow is piped via proposed storm sewer to pond.
	4	D	0.82	0.64	9.2	0.52	7.14	3.7														Runoff from Basin D, overland flows to the trickle channel at the bottom of the pond.
	5	E	0.17	0.40	7.1	0.07	7.81	0.5														Runoff from Basin E, overland flows east, across the property line to an existing swale in the Homestead at Sterling Ranch Development at DP5.
	6	F	0.07	0.36	7.9	0.03	7.52	0.2														Runoff from Basin F, overland flows east across the property line to the Homestead at Sterling Ranch Development at DP6. Combines flow at DPO11.1.
	O9	OS-9	0.52	0.58	17.3	0.30	5.55	1.7														Runoff from Basin OS-9, overland flows southeast to the roadside swale along Vollmer Place at DPO9.
	7	G	0.24	0.36	5.0	0.09	8.68	0.8														Runoff from Basin G, overland flows south to the roadside swale along Vollmer Place at DP7. Combines flow in proposed FES at DP7.1
	7.1								17.3	0.39	5.55	2.2										DPO9 and DP7 combine in roadside swale before entering culvert at site access. Flow continues to DP9.1.
	O11	OS-11	0.12	0.36	10.0	0.04	6.93	0.3														Runoff from Basin OS-11, overland flows west into the Site at DPO11. Combines flow at DPO11.1
	O11.1								10.0	0.07	6.93	0.5										DP6 and DPO11 combine sheet flowing back on-site. Flow continues to DP9.1.
	9	I	0.24	0.63	6.4	0.15	8.06	1.2														Runoff from Basin I overland flows southeast to the roadside swale along Vollmer Place to DP9.
	P1							5.7														100 year release from the pond.
	9.1								17.3	0.61	5.55	9.1										Flows from DP7.1, DPO11.1, and DP9 combine in the roadside swale before exiting the site at DP9.1 and following existing drainage patterns.
	8	H	0.11	0.36	5.0	0.04	8.68	0.3														Runoff from Basin H, overland flows south, across the property line to Mc Clintock Stations B and C.
	O10	OS-10	0.81	0.54	18.3	0.44	5.41	2.4														Off-site basin runoff is collected in the roadside swale along Vollmer Road to DPO10 where flow enters a proposed 18" driveway culvert.

Notes:
Street and Pipe C*A values are determined by Q/i using the catchment's intensity value.

APPENDIX C

HYDRAULIC CALCULATIONS

Scenario: 5 YEAR

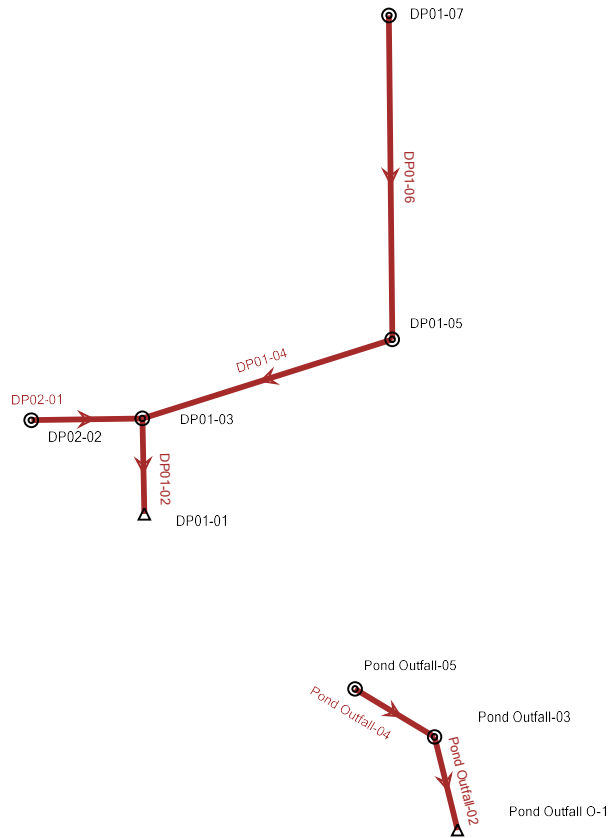

Scenario: 5 YEAR
Current Time Step: 0.000 h
Conduit FlexTable: Combined Pipe/Node Report

Upstream Structure	Label	Flow (cfs)	Capacity (Full Flow) (cfs)	Diameter (in)	Length (User Defined) (ft)	Slope (Calculated) (ft/ft)	Invert (Start) (ft)	Invert (Stop) (ft)	Elevation Ground (Start) (ft)	Elevation Ground (Stop) (ft)	HGL (In) (ft)	HGL (Out) (ft)	Energy Grade Line (In) (ft)	Energy Grade Line (Out) (ft)	Velocity (ft/s)	Upstream Structure Headloss Coefficient	Manning's n
DP01-03	DP01-02	15.70	47.73	36.0	41.0	0.005	7,057.97	7,057.76	7,063.85	7,062.12	7,060.78	7,060.76	7,060.86	7,060.84	6.05	1.000	0.013
DP01-05	DP01-04	11.10	36.60	30.0	111.7	0.008	7,059.36	7,058.47	7,064.00	7,063.85	7,060.83	7,060.86	7,061.04	7,060.94	6.54	0.630	0.013
DP01-07	DP01-06	4.20	30.57	24.0	140.1	0.018	7,062.42	7,059.86	7,067.15	7,064.00	7,063.14	7,060.97	7,063.40	7,061.05	6.82	0.100	0.013
DP02-02	DP02-01	4.80	16.08	24.0	45.5	0.005	7,059.20	7,058.97	7,062.75	7,063.85	7,060.87	7,060.86	7,060.91	7,060.90	4.47	0.100	0.013
Pond Outfall-03	Pond Outfall-02	0.80	12.36	18.0	42.0	0.014	7,055.15	7,054.57	7,059.23	7,056.28	7,055.48	7,054.83	7,055.60	7,055.07	3.94	0.300	0.013
Pond Outfall-05	Pond Outfall-04	0.80	12.52	18.0	52.8	0.014	7,055.90	7,055.15	7,062.13	7,059.23	7,056.23	7,055.52	7,056.35	7,055.61	3.97	0.100	0.013

X:\2520000.all\2525100\StormCAD\2023-04-24_STORM CAD.stsw

DP01 - 5 YEAR

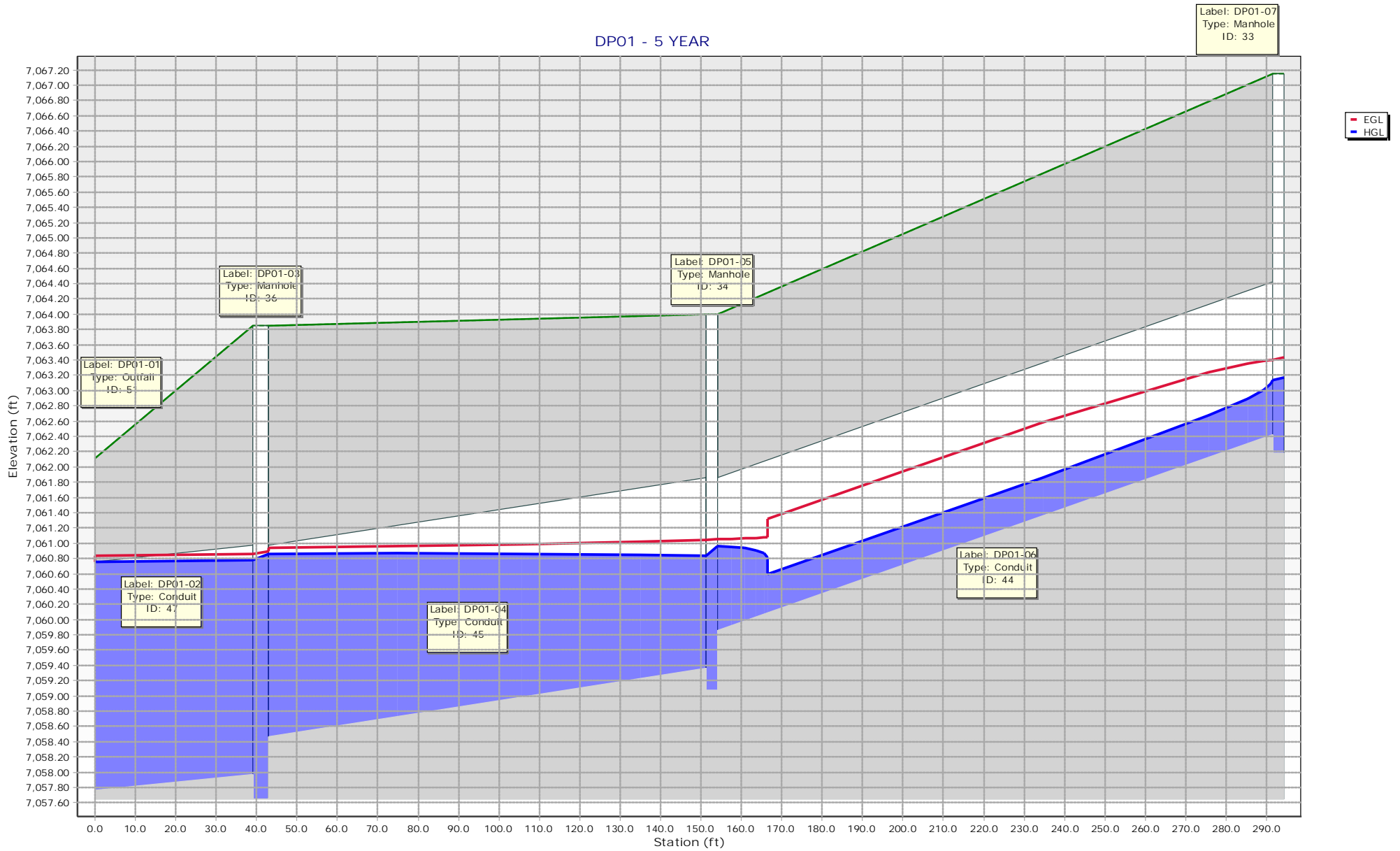

DP02 - 5 YEAR

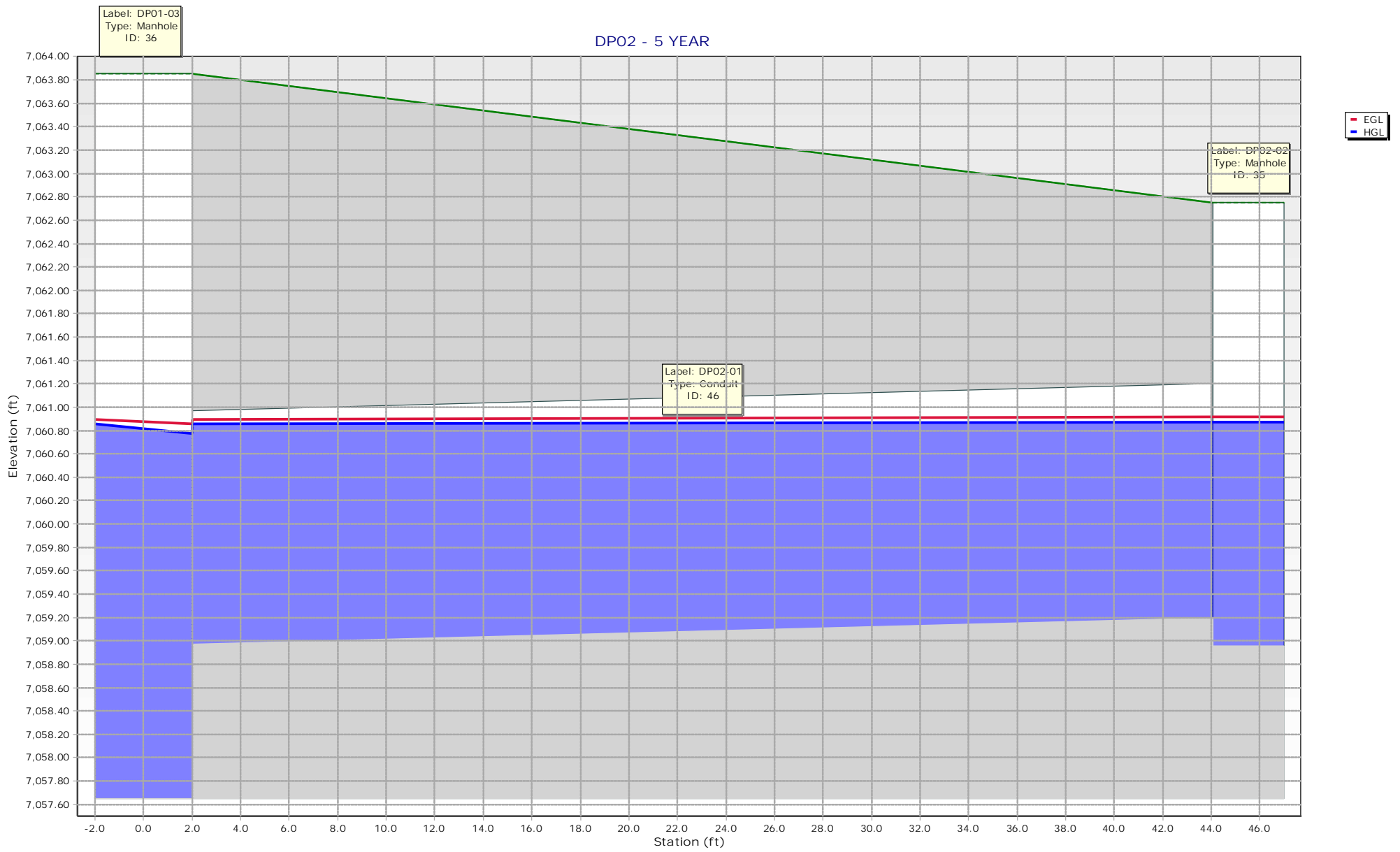

Pond Outfall - 5 YEAR

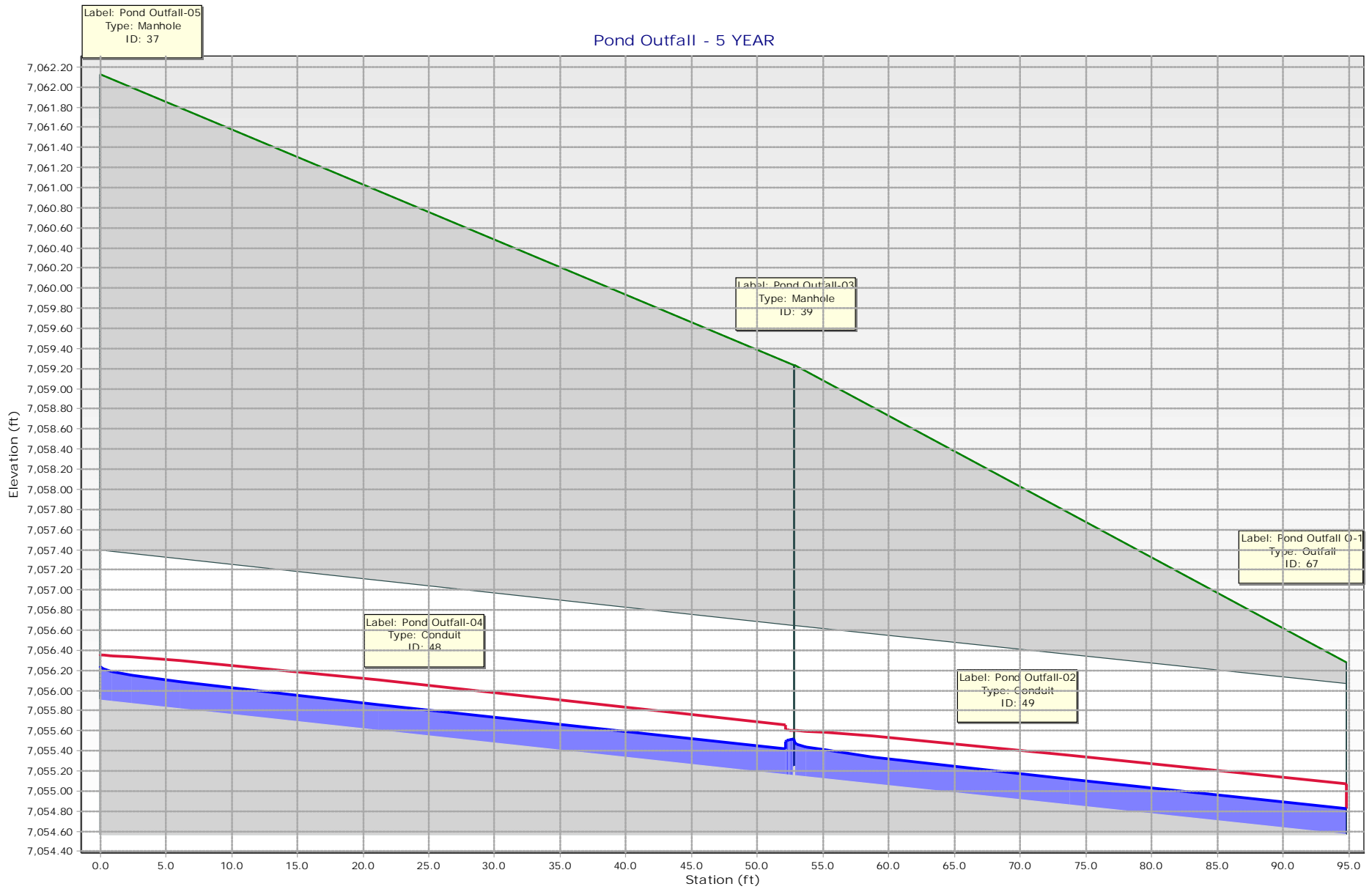

Scenario: 100 YEAR
Current Time Step: 0.000 h
Conduit FlexTable: Combined Pipe/Node Report

Upstream Structure	Label	Flow (cfs)	Capacity (Full Flow) (cfs)	Diameter (in)	Length (User Defined) (ft)	Slope (Calculated) (ft/ft)	Invert (Start) (ft)	Invert (Stop) (ft)	Elevation Ground (Start) (ft)	Elevation Ground (Stop) (ft)	HGL (In) (ft)	HGL (Out) (ft)	Energy Grade Line (In) (ft)	Energy Grade Line (Out) (ft)	Velocity (ft/s)	Upstream Structure Headloss Coefficient	Manning's n
DP01-03	DP01-02	30.70	47.73	36.0	41.0	0.005	7,057.97	7,057.76	7,063.85	7,062.12	7,061.64	7,061.55	7,061.93	7,061.84	4.34	1.000	0.013
DP01-05	DP01-04	21.60	36.60	30.0	111.7	0.008	7,059.36	7,058.47	7,064.00	7,063.85	7,062.24	7,061.93	7,062.54	7,062.23	4.40	0.630	0.013
DP01-07	DP01-06	8.40	30.57	24.0	140.1	0.018	7,062.42	7,059.86	7,067.15	7,064.00	7,063.45	7,062.43	7,063.86	7,062.54	8.30	0.100	0.013
DP02-02	DP02-01	9.50	16.08	24.0	45.5	0.005	7,059.20	7,058.97	7,062.75	7,063.85	7,062.01	7,061.93	7,062.15	7,062.07	3.02	0.100	0.013
Pond Outfall-03	Pond Outfall-02	5.70	12.36	18.0	42.0	0.014	7,055.15	7,054.57	7,059.23	7,056.28	7,056.07	7,055.30	7,056.46	7,056.00	6.85	0.300	0.013
Pond Outfall-05	Pond Outfall-04	5.70	12.52	18.0	52.8	0.014	7,055.90	7,055.15	7,062.13	7,059.23	7,056.82	7,056.19	7,057.21	7,056.48	6.92	0.100	0.013

X:\2520000.all\2525100\StormCAD\2023-04-24_STORM CAD.stsw

DP01 - 100 YEAR

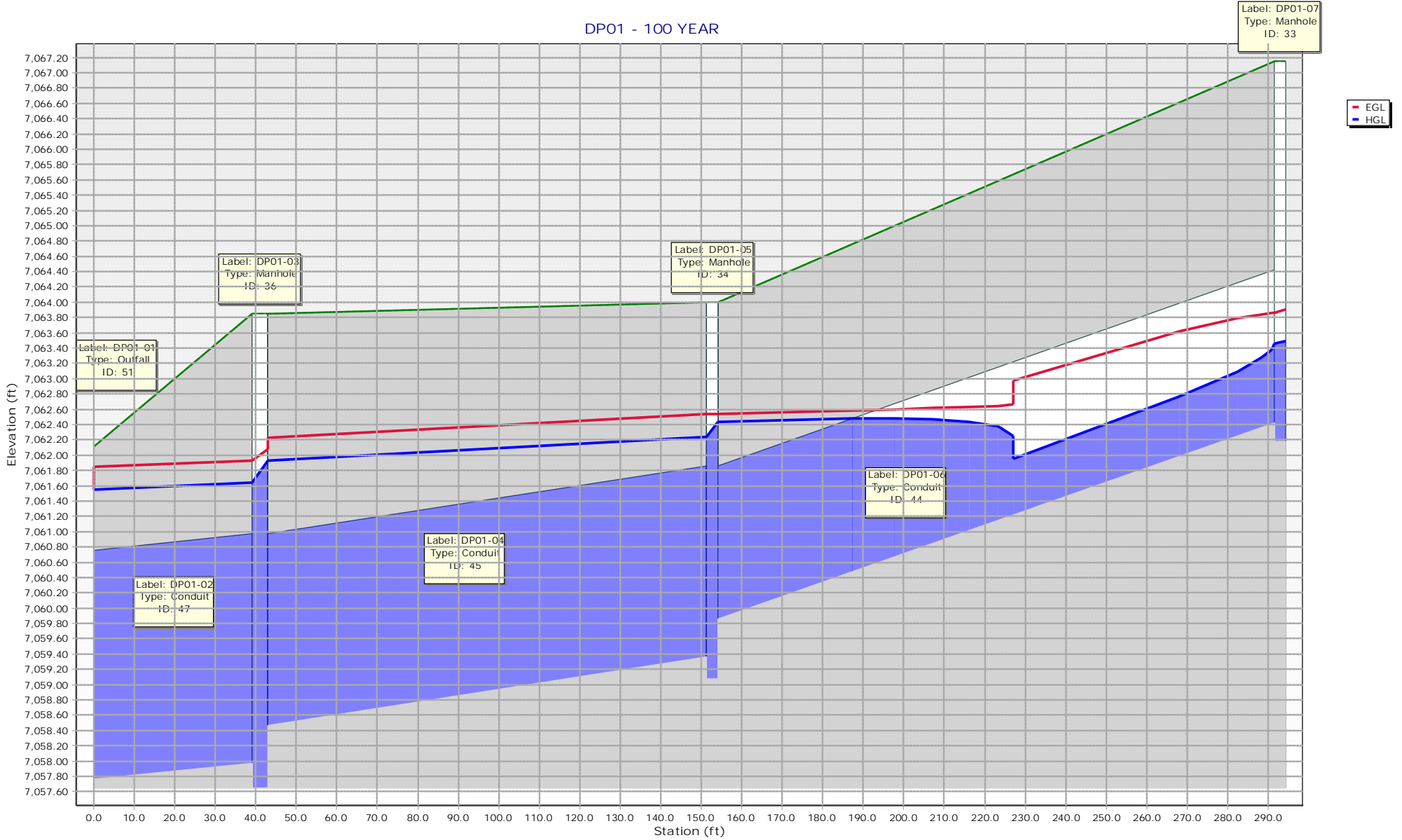

DP02 - 100 YEAR

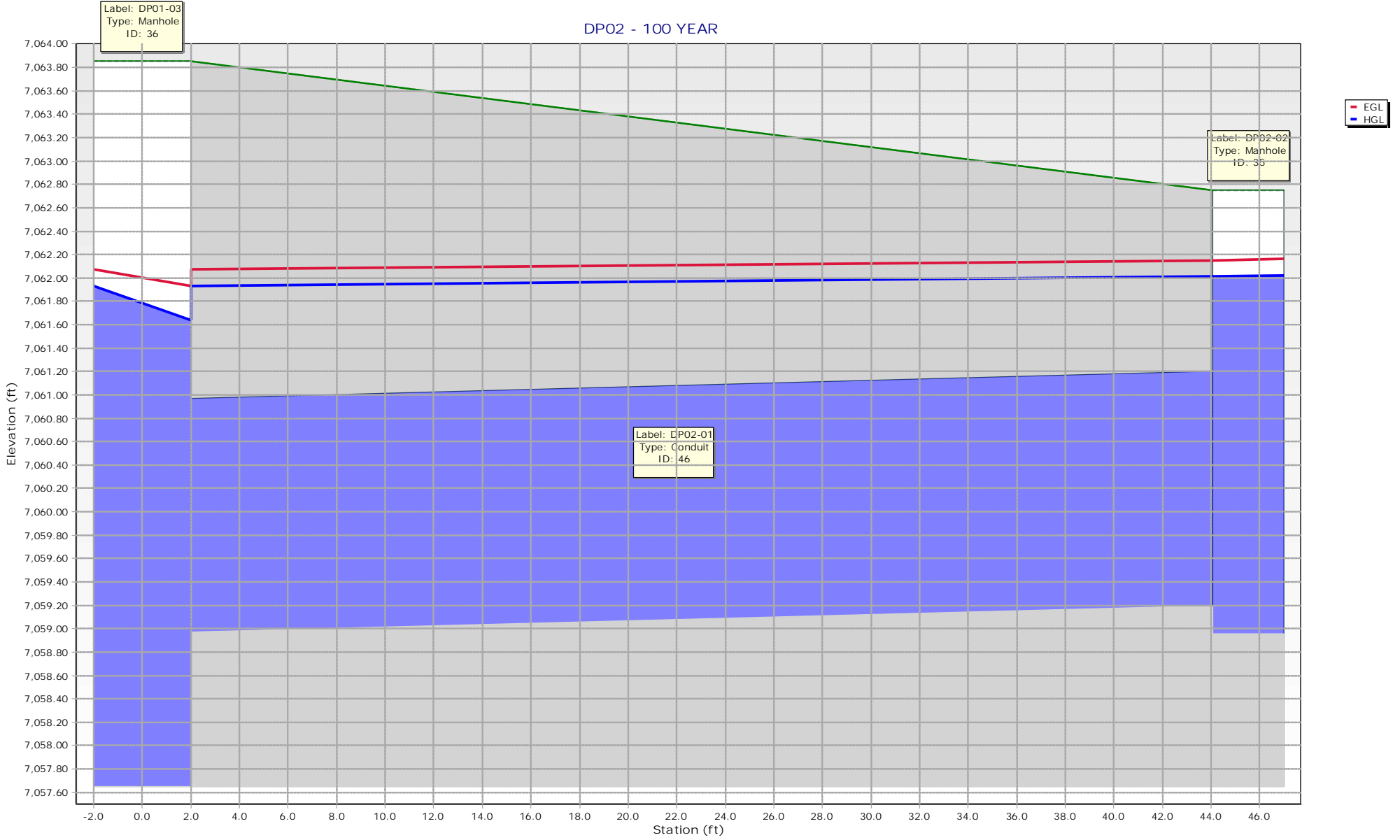

Pond Outfall - 100 YEAR

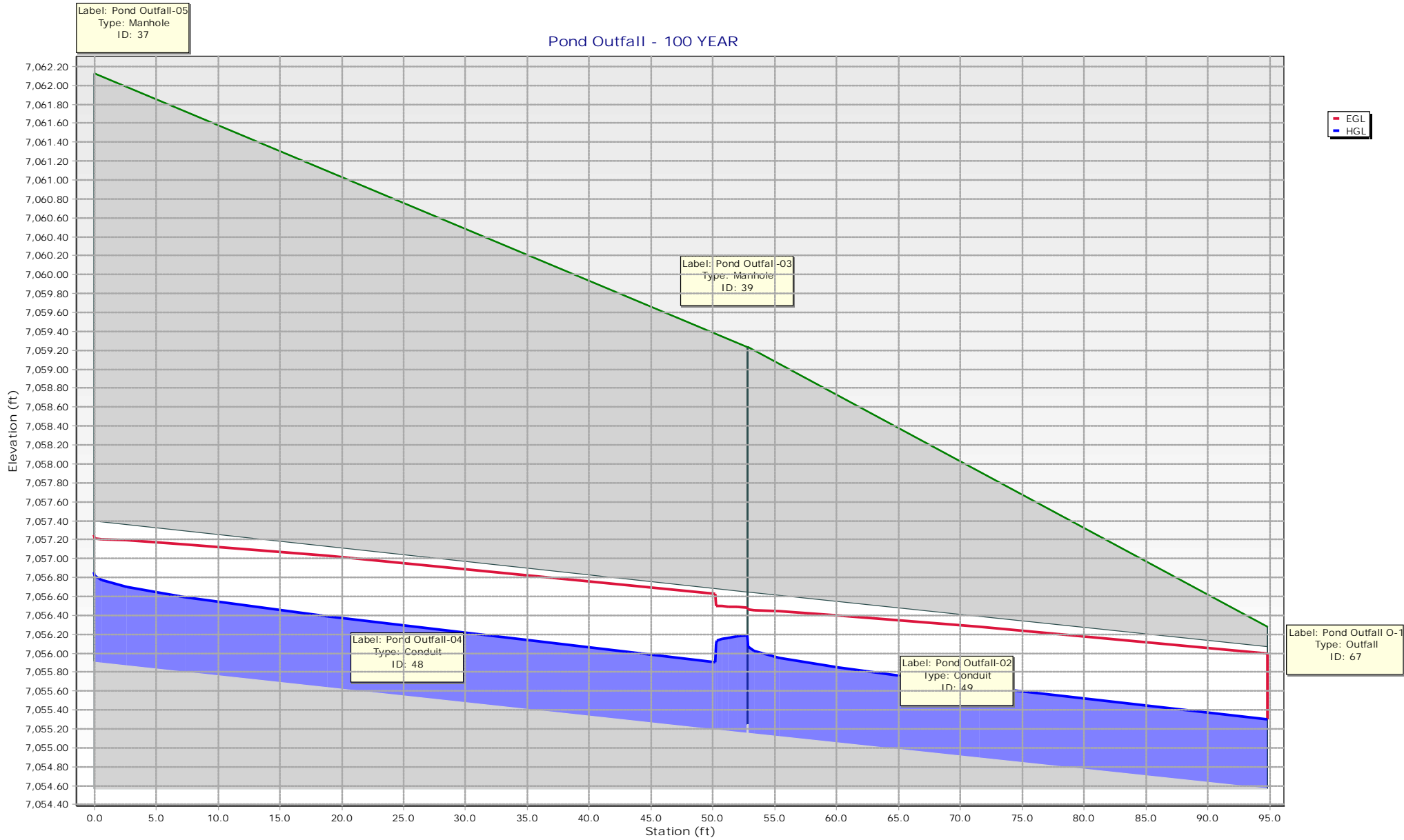

INLET MANAGEMENT

Worksheet Protected

INLET NAME	Inlet C	Inlet B	Inlet A
Site Type (Urban or Rural)	URBAN	URBAN	URBAN
Inlet Application (Street or Area)	AREA	AREA	AREA
Hydraulic Condition	Swale	Swale	Swale
Inlet Type	CDOT Type C (Depressed)	CDOT Type C (Depressed)	CDOT Type C (Depressed)

USER-DEFINED INPUT

User-Defined Design Flows			
Minor Q_{Known} (cfs)	4.8	7.0	4.2
Major Q_{Known} (cfs)	9.5	13.5	8.4
Bypass (Carry-Over) Flow from Upstream			
Receive Bypass Flow from:	No Bypass Flow Received	No Bypass Flow Received	No Bypass Flow Received
Minor Bypass Flow Received, Q_b (cfs)	0.0	0.0	0.0
Major Bypass Flow Received, Q_b (cfs)	0.0	0.0	0.0
Watershed Characteristics			
Subcatchment Area (acres)			
Percent Impervious			
NRCS Soil Type			
Watershed Profile			
Overland Slope (ft/ft)			
Overland Length (ft)			
Channel Slope (ft/ft)			
Channel Length (ft)			
Minor Storm Rainfall Input			
Design Storm Return Period, T_r (years)			
One-Hour Precipitation, P_1 (inches)			
Major Storm Rainfall Input			
Design Storm Return Period, T_r (years)			
One-Hour Precipitation, P_1 (inches)			

CALCULATED OUTPUT

Minor Total Design Peak Flow, Q (cfs)	4.8	7.0	4.2
Major Total Design Peak Flow, Q (cfs)	9.5	13.5	8.4
Minor Flow Bypassed Downstream, Q_b (cfs)	0.0	0.0	0.0
Major Flow Bypassed Downstream, Q_b (cfs)	0.0	0.0	0.0

AREA INLET IN A SWALE

Inlet C

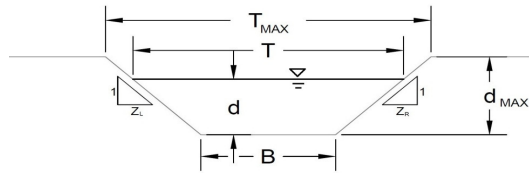

This worksheet uses the NRCS vegetative retardance method to determine Manning's n.
For more information see Section 7.2.3 of the USDCM.

Analysis of Trapezoidal Grass-Lined Channel Using SCS Method

NRCS Vegetal Retardance (A, B, C, D, or E) A, B, C, D, or E =

Manning's n (Leave cell D16 blank to manually enter an n value) n = 0.013

Channel Invert Slope S₀ = 0.0176 ft/ft

Bottom Width B = 4.00 ft

Left Side Slope Z₁ = 25.00 ft/ft

Right Side Slope Z₂ = 100.00 ft/ft

Check one of the following soil types:

Soil Type:	Max. Velocity (V _{MAX})	Max Froude No. (F _{MAX})
Non-Cohesive	5.0 fps	0.60
Cohesive	7.0 fps	0.80
Paved	N/A	N/A

Choose One:

Non-Cohesive

Cohesive

Paved

	Minor Storm	Major Storm	
Maximum Allowable Top Width of Channel for Minor & Major Storm	T_{MAX} = 25.00	50.00	ft
Maximum Allowable Water Depth in Channel for Minor & Major Storm	d_{MAX} = 0.25	0.50	ft

Allowable Channel Capacity Based On Channel Geometry

MINOR STORM Allowable Capacity is based on Top Width Criterion Minor Storm

MAJOR STORM Allowable Capacity is based on Top Width Criterion Major Storm

	Minor Storm	Major Storm	
Q _{allow} =	7.8	51.4	cfs
d _{allow} =	0.17	0.37	ft

Water Depth in Channel Based On Design Peak Flow

Design Peak Flow Q_o =

Water Depth d =

	Minor Storm	Major Storm	
Q _o =	4.8	9.5	cfs
d =	0.14	0.18	ft

Minor storm max. allowable capacity GOOD - greater than the design flow given on sheet 'Inlet Management'

Major storm max. allowable capacity GOOD - greater than the design flow given on sheet 'Inlet Management'

MHFD-Inlet, Version 5.01 (April 2021)
AREA INLET IN A SWALE

Inlet C

Inlet Design Information (Input)

Type of Inlet: Inlet Type =

Angle of Inclined Gate (must be <= 30 degrees) $\theta = 0.00$ degrees

Width of Gate $W = 3.00$ ft

Length of Gate $L = 3.00$ ft

Open Area Ratio $A_{RATIO} = 0.70$

Height of Inclined Gate $H_B = 0.00$ ft

Clogging Factor $C_f = 0.50$

Grate Discharge Coefficient $C_d = 0.84$

Orifice Coefficient $C_o = 0.56$

Weir Coefficient $C_w = 1.81$

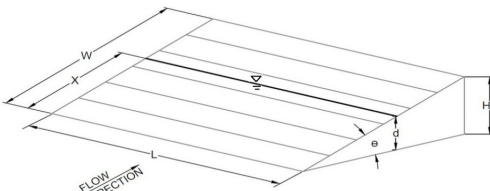

Water Depth at Inlet (for depressed inlets, 1 foot is added for depression)

Total Inlet Interception Capacity (assumes clogged condition)

Bypassed Flow

Capture Percentage = Q_a/Q_o

	MINOR	MAJOR	
d =	1.14	1.18	
Q_a =	15.2	15.5	cfs
Q_b =	0.0	0.0	cfs
C% =	100	100	%

MHFD-Inlet, Version 5.01 (April 2021)
AREA INLET IN A SWALE

Inlet B

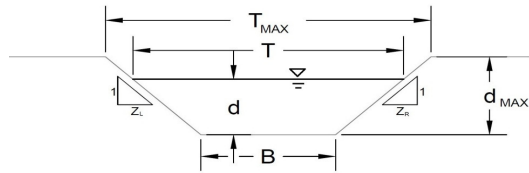

This worksheet uses the NRCS vegetative retardance method to determine Manning's n.
 For more information see Section 7.2.3 of the USDCM.

Analysis of Trapezoidal Grass-Lined Channel Using SCS Method			A, B, C, D, or E =					
NRCS Vegetal Retardance (A, B, C, D, or E)			n =	0.013				
Manning's n (Leave cell D16 blank to manually enter an n value)			S ₀ =	0.0132 ft/ft				
Channel Invert Slope			B =	4.00 ft				
Bottom Width			Z1 =	40.00 ft/ft				
Left Side Slope			Z2 =	100.00 ft/ft				
Right Side Slope			Choose One:					
Check one of the following soil types:			<input type="checkbox"/> Non-Cohesive <input type="checkbox"/> Cohesive <input checked="" type="checkbox"/> Paved					
Soil Type:	Max. Velocity (V _{MAX})	Max Froude No. (F _{MAX})						
Non-Cohesive	5.0 fps	0.60						
Cohesive	7.0 fps	0.80						
Paved	N/A	N/A						
Maximum Allowable Top Width of Channel for Minor & Major Storm			T _{MAX} =	<table border="1"> <tr> <th>Minor Storm</th> <th>Major Storm</th> </tr> <tr> <td>30.00</td> <td>50.00</td> </tr> </table> ft	Minor Storm	Major Storm	30.00	50.00
Minor Storm	Major Storm							
30.00	50.00							
Maximum Allowable Water Depth in Channel for Minor & Major Storm			d _{MAX} =	<table border="1"> <tr> <th>Minor Storm</th> <th>Major Storm</th> </tr> <tr> <td>0.25</td> <td>0.50</td> </tr> </table> ft	Minor Storm	Major Storm	0.25	0.50
Minor Storm	Major Storm							
0.25	0.50							
Allowable Channel Capacity Based On Channel Geometry								
MINOR STORM Allowable Capacity is based on Top Width Criterion			Q _{allow} =	<table border="1"> <tr> <th>Minor Storm</th> <th>Major Storm</th> </tr> <tr> <td>9.3</td> <td>36.9</td> </tr> </table> cfs	Minor Storm	Major Storm	9.3	36.9
Minor Storm	Major Storm							
9.3	36.9							
MAJOR STORM Allowable Capacity is based on Top Width Criterion			d _{allow} =	<table border="1"> <tr> <th>Minor Storm</th> <th>Major Storm</th> </tr> <tr> <td>0.19</td> <td>0.33</td> </tr> </table> ft	Minor Storm	Major Storm	0.19	0.33
Minor Storm	Major Storm							
0.19	0.33							
Water Depth in Channel Based On Design Peak Flow								
Design Peak Flow			Q _o =	<table border="1"> <tr> <th>Minor Storm</th> <th>Major Storm</th> </tr> <tr> <td>7.0</td> <td>13.5</td> </tr> </table> cfs	Minor Storm	Major Storm	7.0	13.5
Minor Storm	Major Storm							
7.0	13.5							
Water Depth			d =	<table border="1"> <tr> <th>Minor Storm</th> <th>Major Storm</th> </tr> <tr> <td>0.16</td> <td>0.22</td> </tr> </table> ft	Minor Storm	Major Storm	0.16	0.22
Minor Storm	Major Storm							
0.16	0.22							
<p>Minor storm max. allowable capacity GOOD - greater than the design flow given on sheet 'Inlet Management' Major storm max. allowable capacity GOOD - greater than the design flow given on sheet 'Inlet Management'</p>								

MHFD-Inlet, Version 5.01 (April 2021)
AREA INLET IN A SWALE

Inlet B

Inlet Design Information (Input)

Type of Inlet: Inlet Type =

Angle of Inclined Gate (must be <= 30 degrees) $\theta = 0.00$ degrees

Width of Gate $W = 3.00$ ft

Length of Gate $L = 3.00$ ft

Open Area Ratio $A_{RATIO} = 0.70$

Height of Inclined Gate $H_B = 0.00$ ft

Clogging Factor $C_f = 0.50$

Grate Discharge Coefficient $C_d = 0.84$

Orifice Coefficient $C_o = 0.56$

Weir Coefficient $C_w = 1.81$

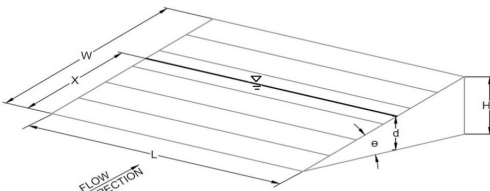

Water Depth at Inlet (for depressed inlets, 1 foot is added for depression)

Total Inlet Interception Capacity (assumes clogged condition)

Bypassed Flow

Capture Percentage = Q_a/Q_o

	MINOR	MAJOR	
$d =$	1.16	1.22	
$Q_a =$	15.4	15.7	cfs
$Q_b =$	0.0	0.0	cfs
$C\% =$	100	100	%

AREA INLET IN A SWALE

Inlet A

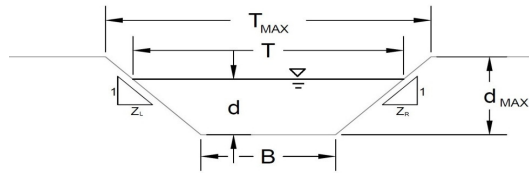

This worksheet uses the NRCS vegetative retardance method to determine Manning's n.
For more information see Section 7.2.3 of the USDCM.

Analysis of Trapezoidal Grass-Lined Channel Using SCS Method			A, B, C, D, or E =	
NRCS Vegetal Retardance (A, B, C, D, or E)			n =	0.013
Manning's n (Leave cell D16 blank to manually enter an n value)			S ₀ =	0.0217 ft/ft
Channel Invert Slope			B =	4.00 ft
Bottom Width			Z1 =	50.00 ft/ft
Left Side Slope			Z2 =	50.00 ft/ft
Right Side Slope			Choose One:	
Check one of the following soil types:			<input type="checkbox"/> Non-Cohesive <input type="checkbox"/> Cohesive <input checked="" type="checkbox"/> Paved	
Soil Type:	Max. Velocity (V _{MAX})	Max Froude No. (F _{MAX})		
Non-Cohesive	5.0 fps	0.60		
Cohesive	7.0 fps	0.80		
Paved	N/A	N/A		
Maximum Allowable Top Width of Channel for Minor & Major Storm			Minor Storm	Major Storm
Maximum Allowable Water Depth in Channel for Minor & Major Storm			T _{MAX} =	20.00 ft
			d _{MAX} =	0.25 ft
Allowable Channel Capacity Based On Channel Geometry			Minor Storm	Major Storm
MINOR STORM Allowable Capacity is based on Top Width Criterion			Q _{allow} =	6.8 cfs
MAJOR STORM Allowable Capacity is based on Top Width Criterion			d _{allow} =	0.16 ft
Water Depth in Channel Based On Design Peak Flow				
Design Peak Flow			Q _o =	4.2 cfs
Water Depth			d =	0.13 ft
Minor storm max. allowable capacity GOOD - greater than the design flow given on sheet 'Inlet Management' Major storm max. allowable capacity GOOD - greater than the design flow given on sheet 'Inlet Management'				

MHFD-Inlet, Version 5.01 (April 2021)
AREA INLET IN A SWALE

Inlet A

Inlet Design Information (Input)

Type of Inlet: Inlet Type =

Angle of Inclined Gate (must be <= 30 degrees) $\theta = 0.00$ degrees

Width of Gate $W = 3.00$ ft

Length of Gate $L = 3.00$ ft

Open Area Ratio $A_{RATIO} = 0.70$

Height of Inclined Gate $H_B = 0.00$ ft

Clogging Factor $C_f = 0.50$

Grate Discharge Coefficient $C_d = 0.84$

Orifice Coefficient $C_o = 0.56$

Weir Coefficient $C_w = 1.81$

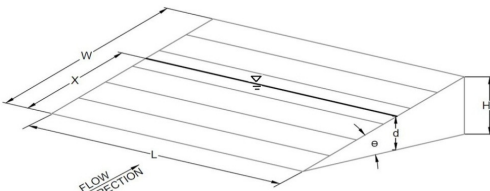

Water Depth at Inlet (for depressed inlets, 1 foot is added for depression)

	MINOR	MAJOR	
$d =$	1.13	1.18	
$Q_a =$	15.1	15.4	cfs
$Q_b =$	0.0	0.0	cfs
$C\% =$	100	100	%

Total Inlet Interception Capacity (assumes clogged condition)

Bypassed Flow

Capture Percentage = Q_a/Q_o

Channel Report

Swale A_A

Triangular

Side Slopes (z:1) = 8.00, 10.00
Total Depth (ft) = 1.30

Invert Elev (ft) = 1.00
Slope (%) = 2.00
N-Value = 0.035

Calculations

Compute by: Known Q
Known Q (cfs) = 2.40

Highlighted

Depth (ft) = 0.38
Q (cfs) = 2.400
Area (sqft) = 1.30
Velocity (ft/s) = 1.85
Wetted Perim (ft) = 6.88
Crit Depth, Yc (ft) = 0.34
Top Width (ft) = 6.84
EGL (ft) = 0.43

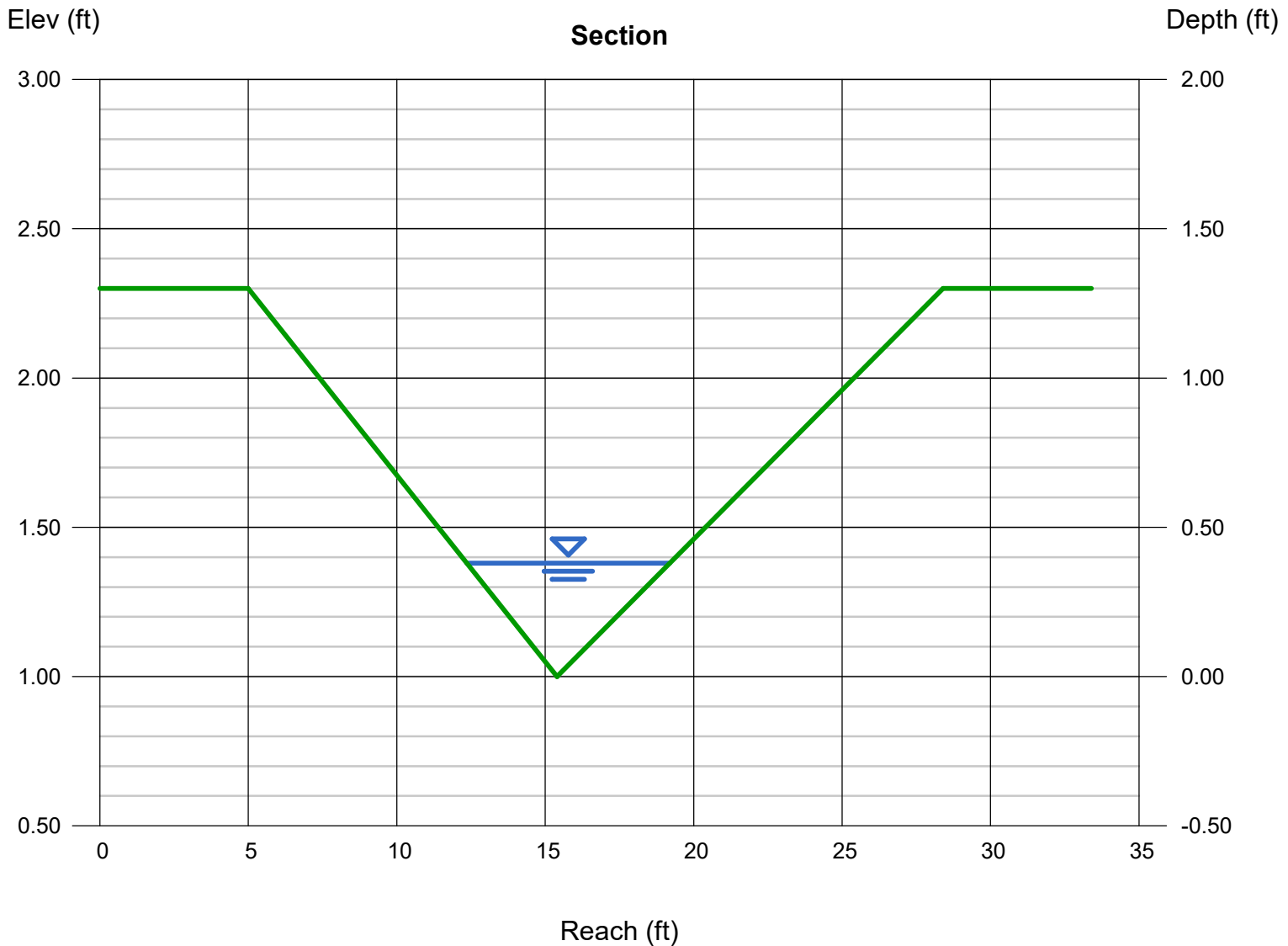

Channel Report

SWALE B-B

Triangular

Side Slopes (z:1) = 20.00, 4.00
Total Depth (ft) = 1.00

Invert Elev (ft) = 1.00
Slope (%) = 0.56
N-Value = 0.035

Calculations

Compute by: Known Q
Known Q (cfs) = 2.20

Highlighted

Depth (ft) = 0.41
Q (cfs) = 2.200
Area (sqft) = 2.02
Velocity (ft/s) = 1.09
Wetted Perim (ft) = 9.90
Crit Depth, Yc (ft) = 0.30
Top Width (ft) = 9.84
EGL (ft) = 0.43

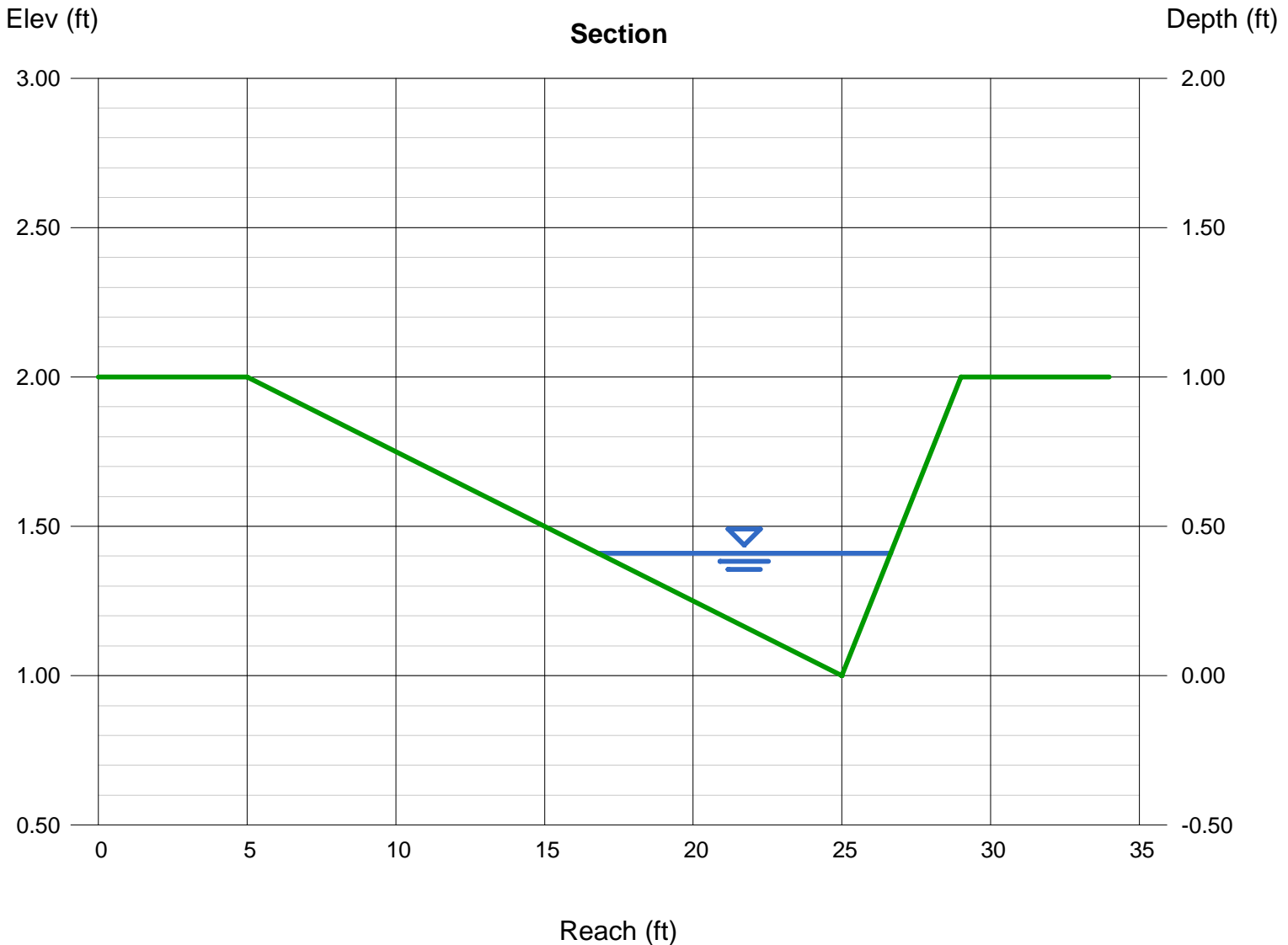

Channel Report

SWALE B-B EMERGENCY CONDITION

Triangular

Side Slopes (z:1) = 20.00, 4.00

Total Depth (ft) = 1.00

Invert Elev (ft) = 1.00

Slope (%) = 0.56

N-Value = 0.035

Calculations

Compute by: Known Q

Known Q (cfs) = 17.10

Highlighted

Depth (ft) = 0.89

Q (cfs) = 17.10

Area (sqft) = 9.51

Velocity (ft/s) = 1.80

Wetted Perim (ft) = 21.49

Crit Depth, Yc (ft) = 0.67

Top Width (ft) = 21.36

EGL (ft) = 0.94

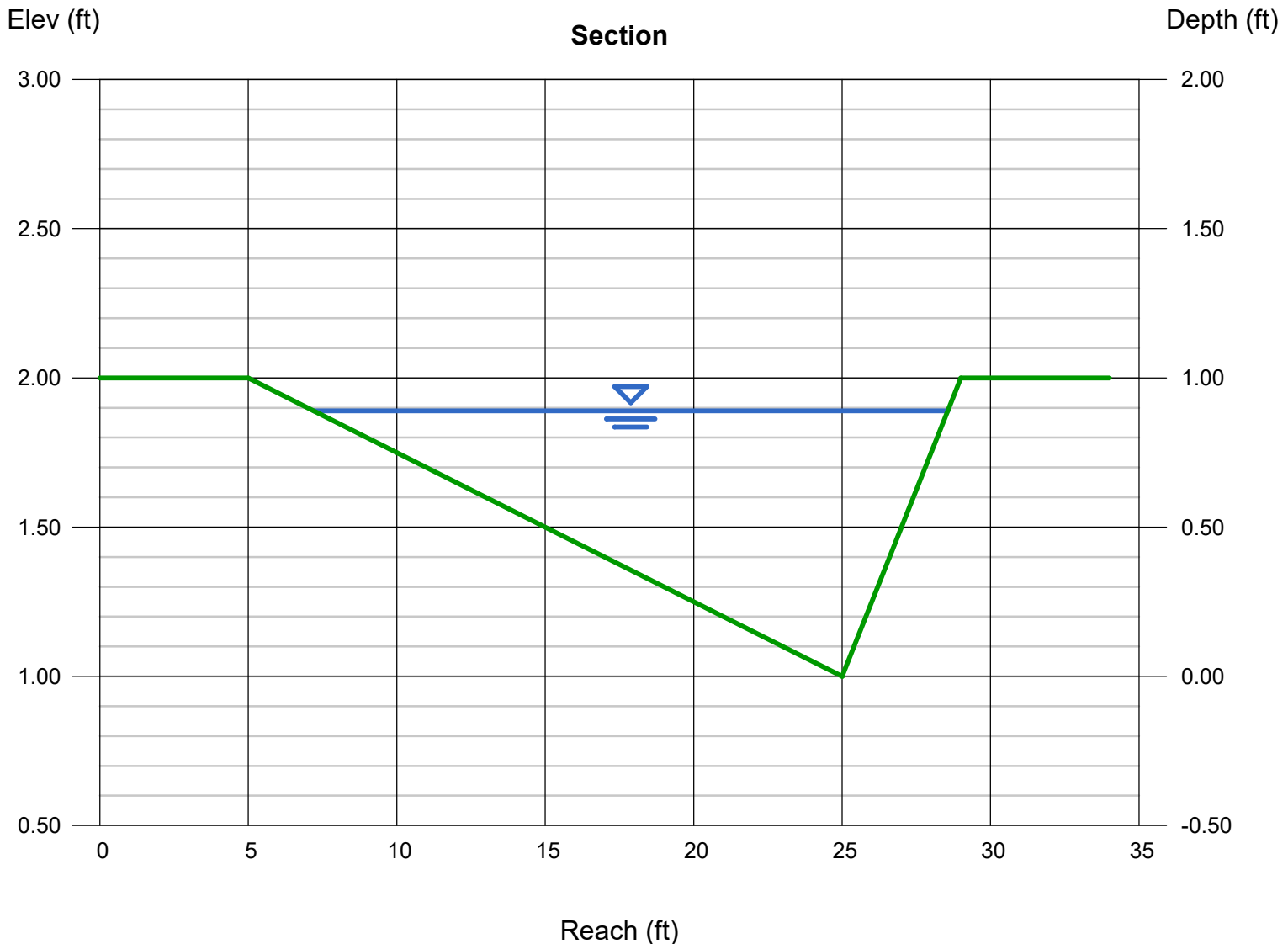

Channel Report

SWALE C-C

Triangular

Side Slopes (z:1) = 3.00, 3.00
Total Depth (ft) = 1.50

Invert Elev (ft) = 1.00
Slope (%) = 0.56
N-Value = 0.035

Calculations

Compute by: Known Q
Known Q (cfs) = 9.10

Highlighted

Depth (ft) = 1.19
Q (cfs) = 9.100
Area (sqft) = 4.25
Velocity (ft/s) = 2.14
Wetted Perim (ft) = 7.53
Crit Depth, Yc (ft) = 0.90
Top Width (ft) = 7.14
EGL (ft) = 1.26

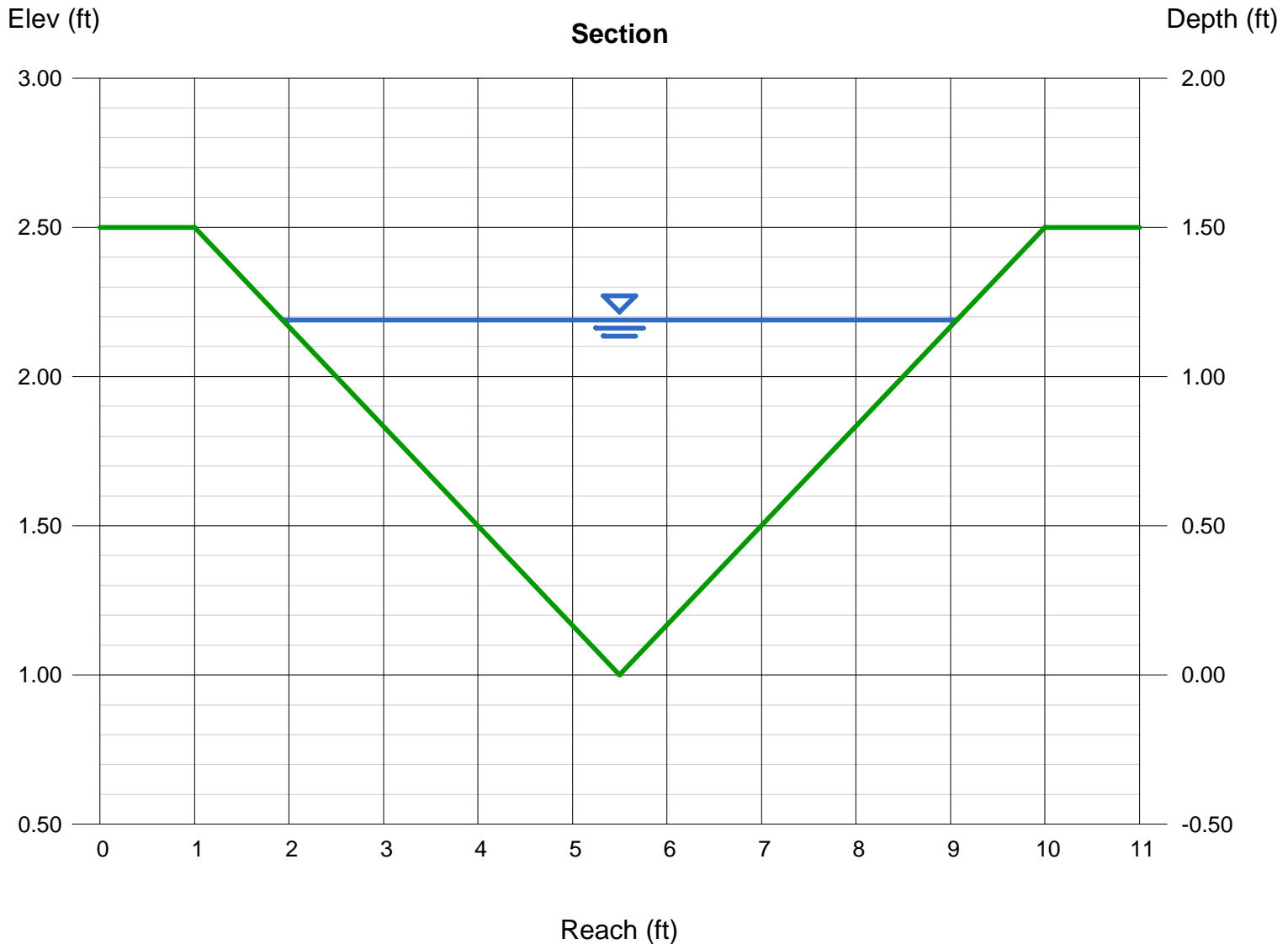

DETENTION BASIN STAGE-STORAGE TABLE BUILDER

MHFD-Detention, Version 4.06 (July 2022)

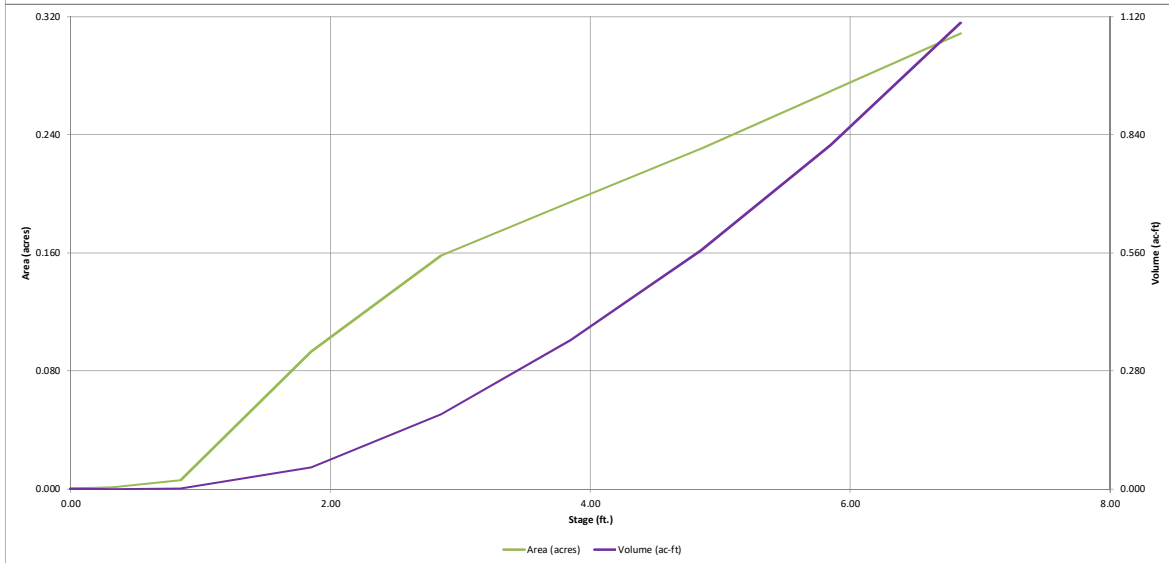
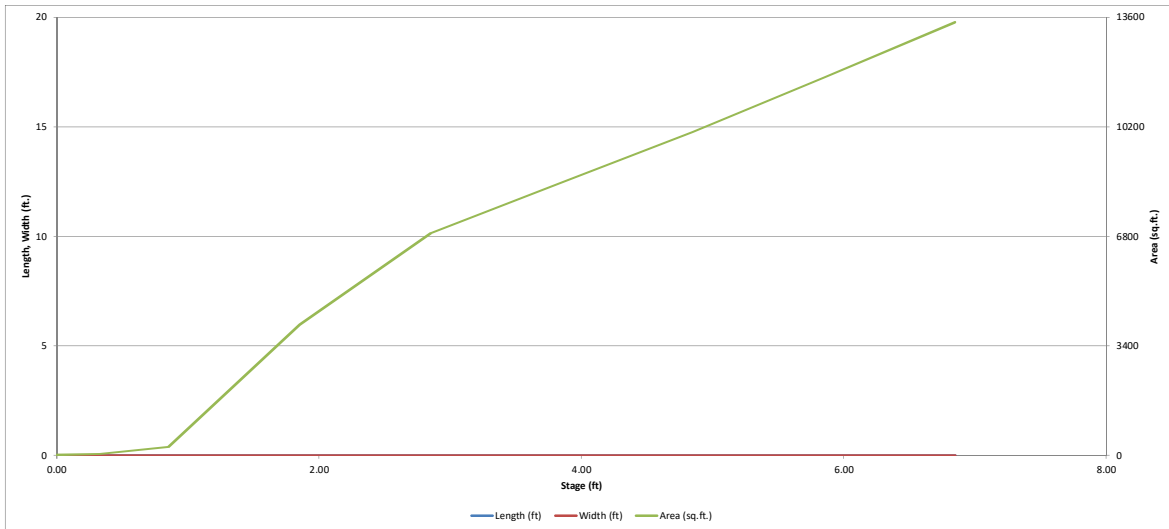

DETENTION BASIN OUTLET STRUCTURE DESIGN

MHFD-*Detention*, Version 4.06 (July 2022)

Project: Vollmer RV Storage
Basin ID: Pond V1

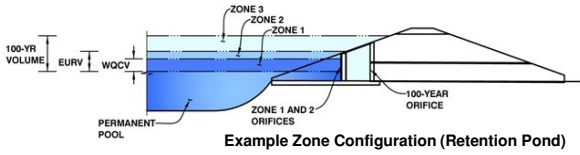

Example Zone Configuration (Retention Pond)

	Estimated Stage (ft)	Estimated Volume (ac-ft)	Outlet Type
Zone 1 (WQCV)	2.61	0.140	Orifice Plate
Zone 2 (EURV)	4.42	0.330	Circular Orifice
Zone 3 (100-year)	5.55	0.267	Weir&Pipe (Restrict)
Total (all zones)		0.737	

User Input: Orifice at Underdrain Outlet (typically used to drain WQCV in a Filtration BMP)

Underdrain Orifice Invert Depth = ft (distance below the filtration media surface)
 Underdrain Orifice Diameter = inches

Calculated Parameters for Underdrain
 Underdrain Orifice Area = ft²
 Underdrain Orifice Centroid = feet

User Input: Orifice Plate with one or more orifices or Elliptical Slot Weir (typically used to drain WQCV and/or EURV in a sedimentation BMP)

Centroid of Lowest Orifice = ft (relative to basin bottom at Stage = 0 ft)
 Depth at top of Zone using Orifice Plate = ft (relative to basin bottom at Stage = 0 ft)
 Orifice Plate: Orifice Vertical Spacing = inches
 Orifice Plate: Orifice Area per Row = sq. inches

Calculated Parameters for Plate
 WQ Orifice Area per Row = ft²
 Elliptical Half-Width = feet
 Elliptical Slot Centroid = feet
 Elliptical Slot Area = ft²

User Input: Stage and Total Area of Each Orifice Row (numbered from lowest to highest)

	Row 1 (required)	Row 2 (optional)	Row 3 (optional)	Row 4 (optional)	Row 5 (optional)	Row 6 (optional)	Row 7 (optional)	Row 8 (optional)
Stage of Orifice Centroid (ft)	0.00	0.75	1.67					
Orifice Area (sq. inches)	0.44	0.44	0.44					

	Row 9 (optional)	Row 10 (optional)	Row 11 (optional)	Row 12 (optional)	Row 13 (optional)	Row 14 (optional)	Row 15 (optional)	Row 16 (optional)
Stage of Orifice Centroid (ft)								
Orifice Area (sq. inches)								

User Input: Vertical Orifice (Circular or Rectangular)

	Zone 2 Circular	Not Selected	
Invert of Vertical Orifice =	2.67	N/A	ft (relative to basin bottom at Stage = 0 ft)
Depth at top of Zone using Vertical Orifice =	5.00	N/A	ft (relative to basin bottom at Stage = 0 ft)
Vertical Orifice Diameter =	1.75	N/A	inches

Calculated Parameters for Vertical Orifice

	Zone 2 Circular	Not Selected	
Vertical Orifice Area =	0.02	N/A	ft ²
Vertical Orifice Centroid =	0.07	N/A	feet

User Input: Overflow Weir (Dropbox with Flat or Sloped Gate and Outlet Pipe OR Rectangular/Trapezoidal Weir and No Outlet Pipe)

	Zone 3 Weir	Not Selected	
Overflow Weir Front Edge Height, Ho =	4.50	N/A	ft (relative to basin bottom at Stage = 0 ft)
Overflow Weir Front Edge Length =	2.50	N/A	feet
Overflow Weir Gate Slope =	0.00	N/A	H:V
Horiz. Length of Weir Sides =	2.50	N/A	feet
Overflow Gate Type =	Type C Gate	N/A	
Debris Clogging % =	50%	N/A	%

Calculated Parameters for Overflow Weir

	Zone 3 Weir	Not Selected	
Height of Gate Upper Edge, H _g =	4.50	N/A	feet
Overflow Weir Slope Length =	2.50	N/A	feet
Gate Open Area / 100-yr Orifice Area =	8.44	N/A	
Overflow Gate Open Area w/o Debris =	4.35	N/A	ft ²
Overflow Gate Open Area w/ Debris =	2.18	N/A	ft ²

User Input: Outlet Pipe w/ Flow Restriction Plate (Circular Orifice, Restrictor Plate, or Rectangular Orifice)

	Zone 3 Restrictor	Not Selected	
Depth to Invert of Outlet Pipe =	0.25	N/A	ft (distance below basin bottom at Stage = 0 ft)
Outlet Pipe Diameter =	18.00	N/A	inches
Restrictor Plate Height Above Pipe Invert =	6.00	N/A	inches

Calculated Parameters for Outlet Pipe w/ Flow Restriction Plate

	Zone 3 Restrictor	Not Selected	
Outlet Orifice Area =	0.52	N/A	ft ²
Outlet Orifice Centroid =	0.29	N/A	feet
Half-Central Angle of Restrictor Plate on Pipe =	1.23	N/A	radians

User Input: Emergency Spillway (Rectangular or Trapezoidal)

Spillway Invert Stage =	5.58	ft (relative to basin bottom at Stage = 0 ft)
Spillway Crest Length =	40.00	feet
Spillway End Slopes =	4.00	H:V
Freeboard above Max Water Surface =	1.00	feet

Calculated Parameters for Spillway

Spillway Design Flow Depth =	0.26	feet
Stage at Top of Freeboard =	6.84	feet
Basin Area at Top of Freeboard =	0.31	acres
Basin Volume at Top of Freeboard =	1.10	acre-ft

Routed Hydrograph Results

The user can override the default CUHP hydrographs and runoff volumes by entering new values in the Inflow Hydrographs table (Columns W through AF).

	WQCV	EURV	2 Year	5 Year	10 Year	25 Year	50 Year	100 Year	500 Year
Design Storm Return Period =	N/A	N/A	1.19	1.50	1.75	2.00	2.25	2.52	4.00
One-Hour Rainfall Depth (in) =	0.140	0.470	0.419	0.563	0.685	0.828	0.955	1.106	1.879
CUHP Runoff Volume (acre-ft) =	N/A	N/A	0.419	0.563	0.685	0.828	0.955	1.106	1.879
Inflow Hydrograph Volume (acre-ft) =	N/A	N/A	0.5	1.5	2.2	4.0	5.1	6.5	12.8
CUHP Predevelopment Peak Q (cfs) =	N/A	N/A	N/A	N/A	N/A	N/A	N/A	N/A	N/A
OPTIONAL Override Predevelopment Peak Q (cfs) =	N/A	N/A	N/A	N/A	N/A	N/A	N/A	N/A	N/A
Predevelopment Unit Peak Flow, q (cfs/acre) =	N/A	N/A	0.09	0.24	0.37	0.67	0.84	1.08	2.13
Peak Inflow Q (cfs) =	N/A	N/A	6.4	8.6	10.2	12.7	14.6	17.1	28.8
Peak Outflow Q (cfs) =	0.1	0.2	0.2	0.8	2.0	4.3	5.5	5.7	21.1
Ratio Peak Outflow to Predevelopment Q =	N/A	N/A	N/A	0.5	0.9	1.1	1.1	0.9	1.6
Structure Controlling Flow =	Plate	Vertical Orifice 1	Vertical Orifice 1	Overflow Weir 1	Overflow Weir 1	Overflow Weir 1	Outlet Plate 1	Outlet Plate 1	Spillway
Max Velocity through Gate 1 (fps) =	N/A	N/A	N/A	0.1	0.4	0.9	1.2	1.3	1.3
Max Velocity through Gate 2 (fps) =	N/A	N/A	N/A	N/A	N/A	N/A	N/A	N/A	N/A
Time to Drain 97% of Inflow Volume (hours) =	39	66	64	69	68	66	65	63	56
Time to Drain 99% of Inflow Volume (hours) =	41	71	68	74	74	73	73	72	69
Maximum Ponding Depth (ft) =	2.61	4.42	4.04	4.61	4.73	4.90	5.04	5.40	5.83
Area at Maximum Ponding Depth (acres) =	0.14	0.22	0.20	0.22	0.23	0.23	0.24	0.25	0.27
Maximum Volume Stored (acre-ft) =	0.141	0.470	0.391	0.510	0.539	0.578	0.608	0.699	0.808

DETENTION BASIN OUTLET STRUCTURE DESIGN

MHFD-Detention, Version 4.06 (July 2022)

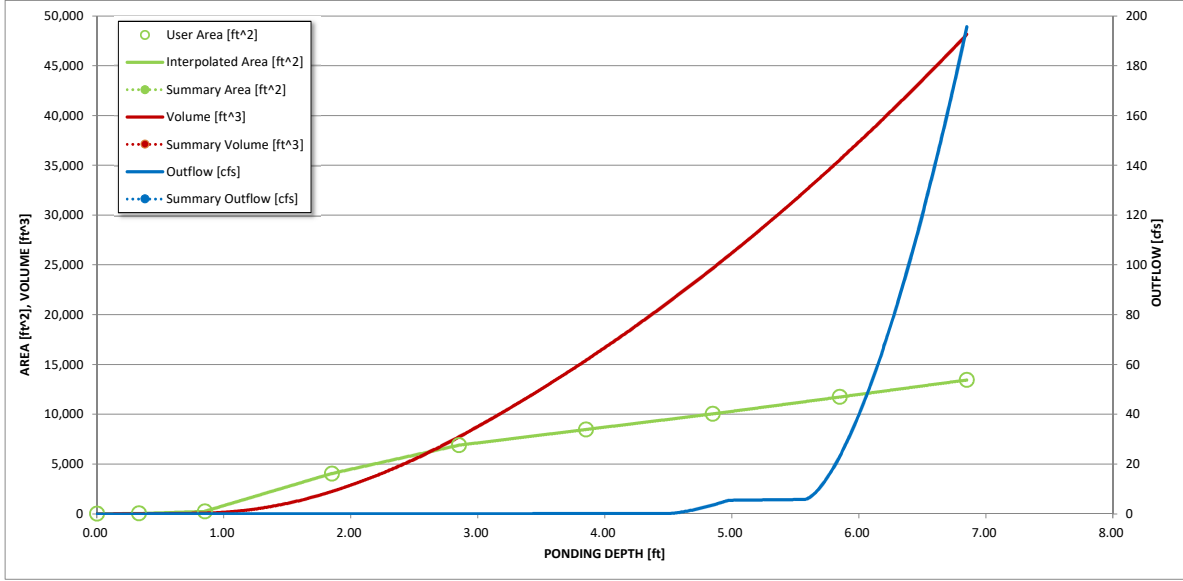
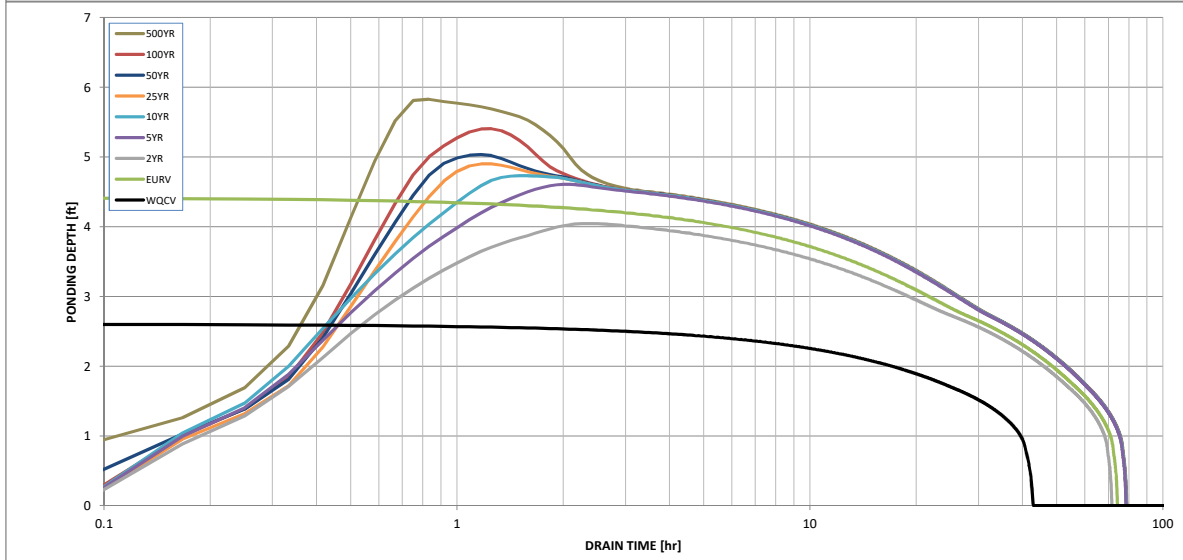
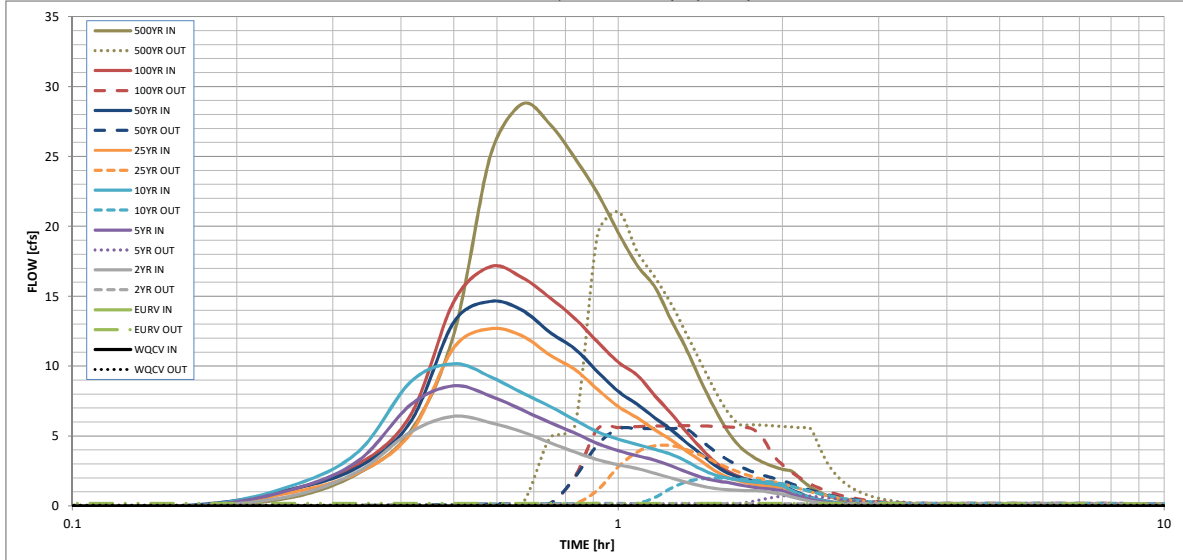

S-A-V-D Chart Axis Override	X-axis	Left Y-Axis	Right Y-Axis
minimum bound			
maximum bound			

DETENTION BASIN OUTLET STRUCTURE DESIGN

Outflow Hydrograph Workbook Filename: _____

Inflow Hydrographs

The user can override the calculated inflow hydrographs from this workbook with inflow hydrographs developed in a separate program.

Time Interval	SOURCE	CUHP	CUHP	CUHP	CUHP	CUHP	CUHP	CUHP	CUHP	CUHP
	TIME	WQCV [cfs]	EURV [cfs]	2 Year [cfs]	5 Year [cfs]	10 Year [cfs]	25 Year [cfs]	50 Year [cfs]	100 Year [cfs]	500 Year [cfs]
5.00 min	0:00:00	0.00	0.00	0.00	0.00	0.00	0.00	0.00	0.00	0.00
	0:05:00	0.00	0.00	0.00	0.00	0.00	0.00	0.00	0.00	0.00
	0:10:00	0.00	0.00	0.00	0.00	0.00	0.00	0.08	0.01	0.59
	0:15:00	0.00	0.00	0.70	1.14	1.41	0.94	1.17	1.15	2.32
	0:20:00	0.00	0.00	2.46	3.22	3.86	2.38	2.76	2.96	5.39
	0:25:00	0.00	0.00	5.30	7.26	8.89	5.21	6.05	6.54	12.34
	0:30:00	0.00	0.00	6.42	8.60	10.18	11.35	13.18	14.66	25.10
	0:35:00	0.00	0.00	5.96	7.86	9.25	12.68	14.64	17.13	28.77
	0:40:00	0.00	0.00	5.31	6.88	8.10	12.16	14.00	16.34	27.29
	0:45:00	0.00	0.00	4.52	5.97	7.12	10.79	12.41	14.89	24.87
	0:50:00	0.00	0.00	3.86	5.22	6.14	9.76	11.23	13.40	22.35
	0:55:00	0.00	0.00	3.32	4.47	5.31	8.33	9.59	11.72	19.55
	1:00:00	0.00	0.00	2.95	3.96	4.78	7.11	8.19	10.29	17.20
	1:05:00	0.00	0.00	2.69	3.60	4.40	6.30	7.27	9.35	15.67
	1:10:00	0.00	0.00	2.33	3.28	4.05	5.46	6.30	7.89	13.29
	1:15:00	0.00	0.00	2.00	2.87	3.70	4.72	5.46	6.62	11.20
	1:20:00	0.00	0.00	1.70	2.44	3.20	3.92	4.53	5.29	8.95
	1:25:00	0.00	0.00	1.44	2.07	2.64	3.23	3.72	4.15	7.01
	1:30:00	0.00	0.00	1.26	1.82	2.24	2.55	2.93	3.19	5.40
	1:35:00	0.00	0.00	1.17	1.69	2.01	2.07	2.38	2.51	4.28
	1:40:00	0.00	0.00	1.12	1.51	1.86	1.79	2.04	2.11	3.61
	1:45:00	0.00	0.00	1.10	1.37	1.75	1.60	1.83	1.84	3.16
	1:50:00	0.00	0.00	1.08	1.27	1.67	1.48	1.68	1.66	2.85
	1:55:00	0.00	0.00	0.95	1.19	1.58	1.39	1.58	1.53	2.63
	2:00:00	0.00	0.00	0.84	1.10	1.43	1.33	1.51	1.44	2.47
	2:05:00	0.00	0.00	0.64	0.84	1.09	1.01	1.15	1.08	1.85
	2:10:00	0.00	0.00	0.48	0.63	0.81	0.75	0.85	0.79	1.36
	2:15:00	0.00	0.00	0.36	0.47	0.60	0.56	0.63	0.59	1.01
	2:20:00	0.00	0.00	0.27	0.34	0.44	0.41	0.46	0.44	0.75
	2:25:00	0.00	0.00	0.19	0.25	0.32	0.30	0.34	0.32	0.55
	2:30:00	0.00	0.00	0.14	0.17	0.23	0.21	0.24	0.23	0.39
	2:35:00	0.00	0.00	0.10	0.12	0.16	0.16	0.18	0.17	0.28
	2:40:00	0.00	0.00	0.06	0.08	0.11	0.11	0.12	0.12	0.20
	2:45:00	0.00	0.00	0.04	0.05	0.07	0.07	0.08	0.07	0.13
	2:50:00	0.00	0.00	0.02	0.03	0.04	0.04	0.04	0.04	0.07
	2:55:00	0.00	0.00	0.01	0.01	0.02	0.02	0.02	0.02	0.03
	3:00:00	0.00	0.00	0.00	0.00	0.00	0.00	0.00	0.00	0.01
	3:05:00	0.00	0.00	0.00	0.00	0.00	0.00	0.00	0.00	0.00
	3:10:00	0.00	0.00	0.00	0.00	0.00	0.00	0.00	0.00	0.00
	3:15:00	0.00	0.00	0.00	0.00	0.00	0.00	0.00	0.00	0.00
	3:20:00	0.00	0.00	0.00	0.00	0.00	0.00	0.00	0.00	0.00
	3:25:00	0.00	0.00	0.00	0.00	0.00	0.00	0.00	0.00	0.00
	3:30:00	0.00	0.00	0.00	0.00	0.00	0.00	0.00	0.00	0.00
	3:35:00	0.00	0.00	0.00	0.00	0.00	0.00	0.00	0.00	0.00
	3:40:00	0.00	0.00	0.00	0.00	0.00	0.00	0.00	0.00	0.00
	3:45:00	0.00	0.00	0.00	0.00	0.00	0.00	0.00	0.00	0.00
	3:50:00	0.00	0.00	0.00	0.00	0.00	0.00	0.00	0.00	0.00
	3:55:00	0.00	0.00	0.00	0.00	0.00	0.00	0.00	0.00	0.00
	4:00:00	0.00	0.00	0.00	0.00	0.00	0.00	0.00	0.00	0.00
	4:05:00	0.00	0.00	0.00	0.00	0.00	0.00	0.00	0.00	0.00
	4:10:00	0.00	0.00	0.00	0.00	0.00	0.00	0.00	0.00	0.00
	4:15:00	0.00	0.00	0.00	0.00	0.00	0.00	0.00	0.00	0.00
	4:20:00	0.00	0.00	0.00	0.00	0.00	0.00	0.00	0.00	0.00
	4:25:00	0.00	0.00	0.00	0.00	0.00	0.00	0.00	0.00	0.00
	4:30:00	0.00	0.00	0.00	0.00	0.00	0.00	0.00	0.00	0.00
	4:35:00	0.00	0.00	0.00	0.00	0.00	0.00	0.00	0.00	0.00
	4:40:00	0.00	0.00	0.00	0.00	0.00	0.00	0.00	0.00	0.00
	4:45:00	0.00	0.00	0.00	0.00	0.00	0.00	0.00	0.00	0.00
	4:50:00	0.00	0.00	0.00	0.00	0.00	0.00	0.00	0.00	0.00
	4:55:00	0.00	0.00	0.00	0.00	0.00	0.00	0.00	0.00	0.00
	5:00:00	0.00	0.00	0.00	0.00	0.00	0.00	0.00	0.00	0.00
	5:05:00	0.00	0.00	0.00	0.00	0.00	0.00	0.00	0.00	0.00
	5:10:00	0.00	0.00	0.00	0.00	0.00	0.00	0.00	0.00	0.00
	5:15:00	0.00	0.00	0.00	0.00	0.00	0.00	0.00	0.00	0.00
	5:20:00	0.00	0.00	0.00	0.00	0.00	0.00	0.00	0.00	0.00
	5:25:00	0.00	0.00	0.00	0.00	0.00	0.00	0.00	0.00	0.00
	5:30:00	0.00	0.00	0.00	0.00	0.00	0.00	0.00	0.00	0.00
	5:35:00	0.00	0.00	0.00	0.00	0.00	0.00	0.00	0.00	0.00
	5:40:00	0.00	0.00	0.00	0.00	0.00	0.00	0.00	0.00	0.00
	5:45:00	0.00	0.00	0.00	0.00	0.00	0.00	0.00	0.00	0.00
	5:50:00	0.00	0.00	0.00	0.00	0.00	0.00	0.00	0.00	0.00
	5:55:00	0.00	0.00	0.00	0.00	0.00	0.00	0.00	0.00	0.00
	6:00:00	0.00	0.00	0.00	0.00	0.00	0.00	0.00	0.00	0.00

Design Procedure Form: Extended Detention Basin (EDB)

UD-BMP (Version 3.07, March 2018)

Sheet 1 of 3

Designer: APL
Company: JR Engineering
Date: November 17, 2023
Project: Vollmer RV Storage
Location: El Paso County

1. Basin Storage Volume

- A) Effective Imperviousness of Tributary Area, I_a
- B) Tributary Area's Imperviousness Ratio ($i = I_a / 100$)
- C) Contributing Watershed Area
- D) For Watersheds Outside of the Denver Region, Depth of Average Runoff Producing Storm
- E) Design Concept
(Select EURV when also designing for flood control)
- F) Design Volume (WQCV) Based on 40-hour Drain Time
($V_{DESIGN} = (1.0 * (0.91 * i^2 - 1.19 * i^2 + 0.78 * i) / 12 * Area)$)
- G) For Watersheds Outside of the Denver Region, Water Quality Capture Volume (WQCV) Design Volume
($V_{WQCV\ OTHER} = (d_6 * (V_{DESIGN} / 0.43))$)
- H) User Input of Water Quality Capture Volume (WQCV) Design Volume
(Only if a different WQCV Design Volume is desired)
- I) NRCS Hydrologic Soil Groups of Tributary Watershed
 - i) Percentage of Watershed consisting of Type A Soils
 - ii) Percentage of Watershed consisting of Type B Soils
 - iii) Percentage of Watershed consisting of Type C/D Soils
- J) Excess Urban Runoff Volume (EURV) Design Volume
 For HSG A: $EURV_A = 1.68 * i^{1.28}$
 For HSG B: $EURV_B = 1.36 * i^{1.08}$
 For HSG C/D: $EURV_{C/D} = 1.20 * i^{1.08}$
- K) User Input of Excess Urban Runoff Volume (EURV) Design Volume
(Only if a different EURV Design Volume is desired)

$I_a =$ %
 $i =$
 Area = ac
 $d_6 =$ in
 Choose One
 Water Quality Capture Volume (WQCV)
 Excess Urban Runoff Volume (EURV)
 $V_{DESIGN} =$ ac-ft
 $V_{DESIGN\ OTHER} =$ ac-ft
 $V_{DESIGN\ USER} =$ ac-ft
 $HSG_A =$ %
 $HSG_B =$ %
 $HSG_{C/D} =$ %
 $EURV_{DESIGN} =$ ac-ft
 $EURV_{DESIGN\ USER} =$ ac-ft

- 2. Basin Shape: Length to Width Ratio
(A basin length to width ratio of at least 2:1 will improve TSS reduction.)

$L : W =$: 1

3. Basin Side Slopes

- A) Basin Maximum Side Slopes
(Horizontal distance per unit vertical, 4:1 or flatter preferred)

$Z =$ ft / ft
DIFFICULT TO MAINTAIN, INCREASE WHERE POSSIBLE

4. Inlet

- A) Describe means of providing energy dissipation at concentrated inflow locations:

5. Forebay

- A) Minimum Forebay Volume
($V_{FMIN} =$ of the WQCV)
- B) Actual Forebay Volume
- C) Forebay Depth
($D_F =$ inch maximum)
- D) Forebay Discharge
 - i) Undetained 100-year Peak Discharge
 - ii) Forebay Discharge Design Flow
($Q_F = 0.02 * Q_{100}$)
- E) Forebay Discharge Design
- F) Discharge Pipe Size (minimum 8-inches)
- G) Rectangular Notch Width

$V_{FMIN} =$ ac-ft
 $V_F =$ ac-ft
 $D_F =$ in
 $Q_{100} =$ cfs
 $Q_F =$ cfs
 Choose One
 Berm With Pipe
 Wall with Rect. Notch
 Wall with V-Notch Weir
 Calculated $D_p =$ in
 Calculated $W_N =$ in

Flow too small for berm w/ pipe

Design Procedure Form: Extended Detention Basin (EDB)

Designer: APL
Company: JR Engineering
Date: November 17, 2023
Project: Vollmer RV Storage
Location: El Paso County

<p>6. Trickle Channel</p> <p>A) Type of Trickle Channel</p> <p>F) Slope of Trickle Channel</p>	<p>Choose One</p> <p><input checked="" type="radio"/> Concrete</p> <p><input type="radio"/> Soft Bottom</p> <p>S = <input type="text" value="0.0050"/> ft / ft</p>
<p>7. Micropool and Outlet Structure</p> <p>A) Depth of Micropool (2.5-foot minimum)</p> <p>B) Surface Area of Micropool (10 ft² minimum)</p> <p>C) Outlet Type</p> <p>D) Smallest Dimension of Orifice Opening Based on Hydrograph Routing (Use UD-Detention)</p> <p>E) Total Outlet Area</p>	<p>D_M = <input type="text" value="2.5"/> ft</p> <p>A_M = <input type="text" value="10"/> sq ft</p> <p>Choose One</p> <p><input checked="" type="radio"/> Orifice Plate</p> <p><input type="radio"/> Other (Describe):</p> <hr/> <hr/> <p>D_{orifice} = <input type="text" value="0.74"/> inches</p> <p>A_{ot} = <input type="text" value="3.73"/> square inches</p>
<p>8. Initial Surcharge Volume</p> <p>A) Depth of Initial Surcharge Volume (Minimum recommended depth is 4 inches)</p> <p>B) Minimum Initial Surcharge Volume (Minimum volume of 0.3% of the WQCV)</p> <p>C) Initial Surcharge Provided Above Micropool</p>	<p>D_{IS} = <input type="text" value="4"/> in</p> <p>V_{IS} = <input type="text"/> cu ft</p> <p>V_s = <input type="text" value="3.3"/> cu ft</p>
<p>9. Trash Rack</p> <p>A) Water Quality Screen Open Area: $A_t = A_{ot} * 38.5 * (e^{-0.095D})$</p> <p>B) Type of Screen (If specifying an alternative to the materials recommended in the USDCM, indicate "other" and enter the ratio of the total open are to the total screen are for the material specified.)</p> <p style="margin-left: 40px;">Other (Y/N): <input type="text" value="N"/></p> <p>C) Ratio of Total Open Area to Total Area (only for type 'Other')</p> <p>D) Total Water Quality Screen Area (based on screen type)</p> <p>E) Depth of Design Volume (EURV or WQCV) (Based on design concept chosen under 1E)</p> <p>F) Height of Water Quality Screen (H_{TR})</p> <p>G) Width of Water Quality Screen Opening (W_{opening}) (Minimum of 12 inches is recommended)</p>	<p>A_t = <input type="text" value="134"/> square inches</p> <p><input type="text" value="S.S. Well Screen with 60% Open Area"/></p> <hr/> <hr/> <p>User Ratio = <input type="text"/></p> <p>A_{total} = <input type="text" value="223"/> sq. in.</p> <p>H = <input type="text" value="4.56"/> feet</p> <p>H_{TR} = <input type="text" value="82.72"/> inches</p> <p>W_{opening} = <input type="text" value="12.0"/> inches VALUE LESS THAN RECOMMENDED MIN. WIDTH. WIDTH HAS BEEN SET TO 12 INCHES.</p>

Design Procedure Form: Extended Detention Basin (EDB)

Designer: APL
Company: JR Engineering
Date: November 17, 2023
Project: Vollmer RV Storage
Location: El Paso County

10. Overflow Embankment

A) Describe embankment protection for 100-year and greater overtopping:

B) Slope of Overflow Embankment
(Horizontal distance per unit vertical, 4:1 or flatter preferred)

Ze = ft / ft

11. Vegetation

Choose One
 Irrigated
 Not Irrigated

12. Access

A) Describe Sediment Removal Procedures

Notes:

Channel Report

Trickle Channel

Rectangular

Bottom Width (ft) = 2.00

Total Depth (ft) = 0.50

Invert Elev (ft) = 1.00

Slope (%) = 0.50

N-Value = 0.012

Calculations

Compute by: Known Q

Known Q (cfs) = 0.68

Highlighted

Depth (ft) = 0.16

Q (cfs) = 0.680

Area (sqft) = 0.32

Velocity (ft/s) = 2.13

Wetted Perim (ft) = 2.32

Crit Depth, Y_c (ft) = 0.16

Top Width (ft) = 2.00

EGL (ft) = 0.23

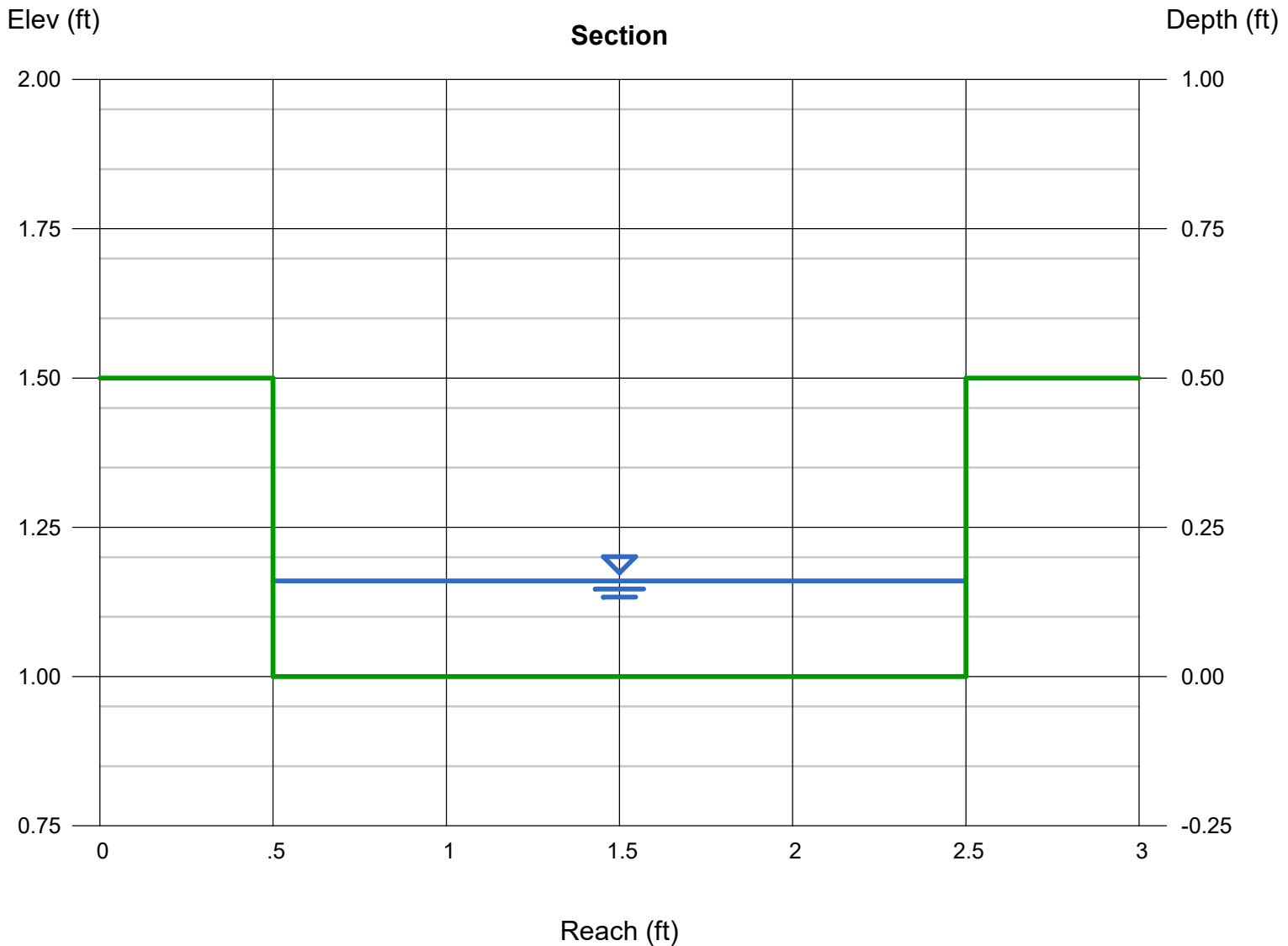

Weir Report

Forebay Weir Notch Pond V1

Rectangular Weir

Crest = Sharp
Bottom Length (ft) = 0.31
Total Depth (ft) = 1.00

Highlighted

Depth (ft) = 0.48
Q (cfs) = 0.340
Area (sqft) = 0.15
Velocity (ft/s) = 2.30
Top Width (ft) = 0.31

Calculations

Weir Coeff. Cw = 3.33
Compute by: Known Q
Known Q (cfs) = 0.34

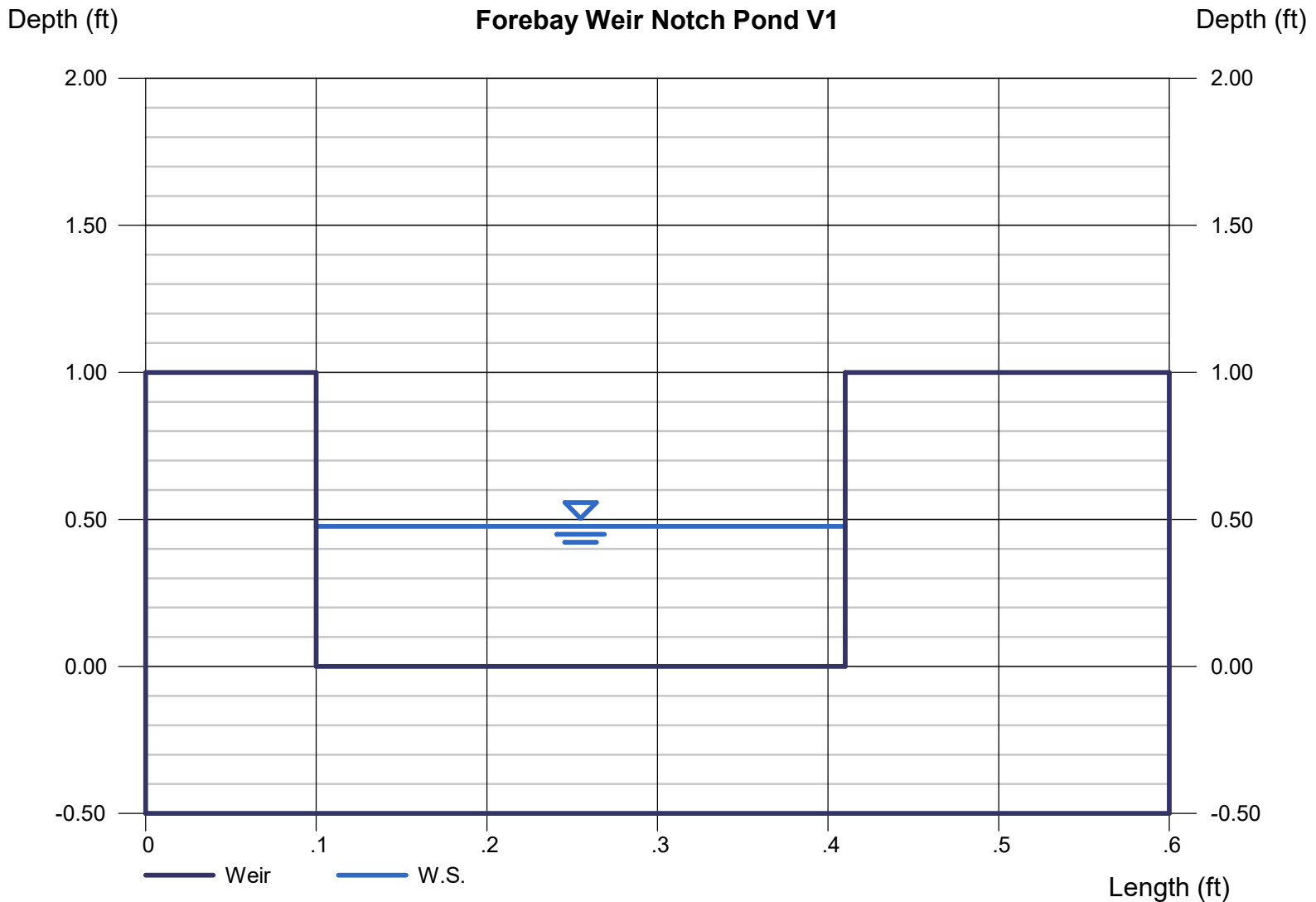

Figure 13-12c. Emergency Spillway Protection

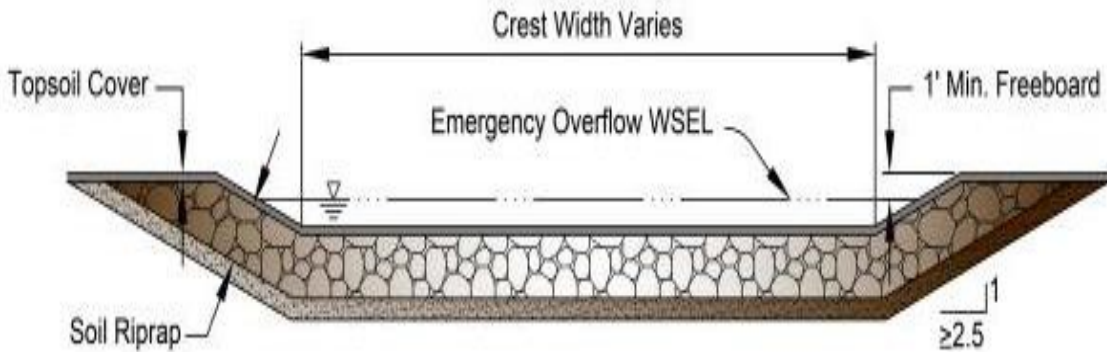
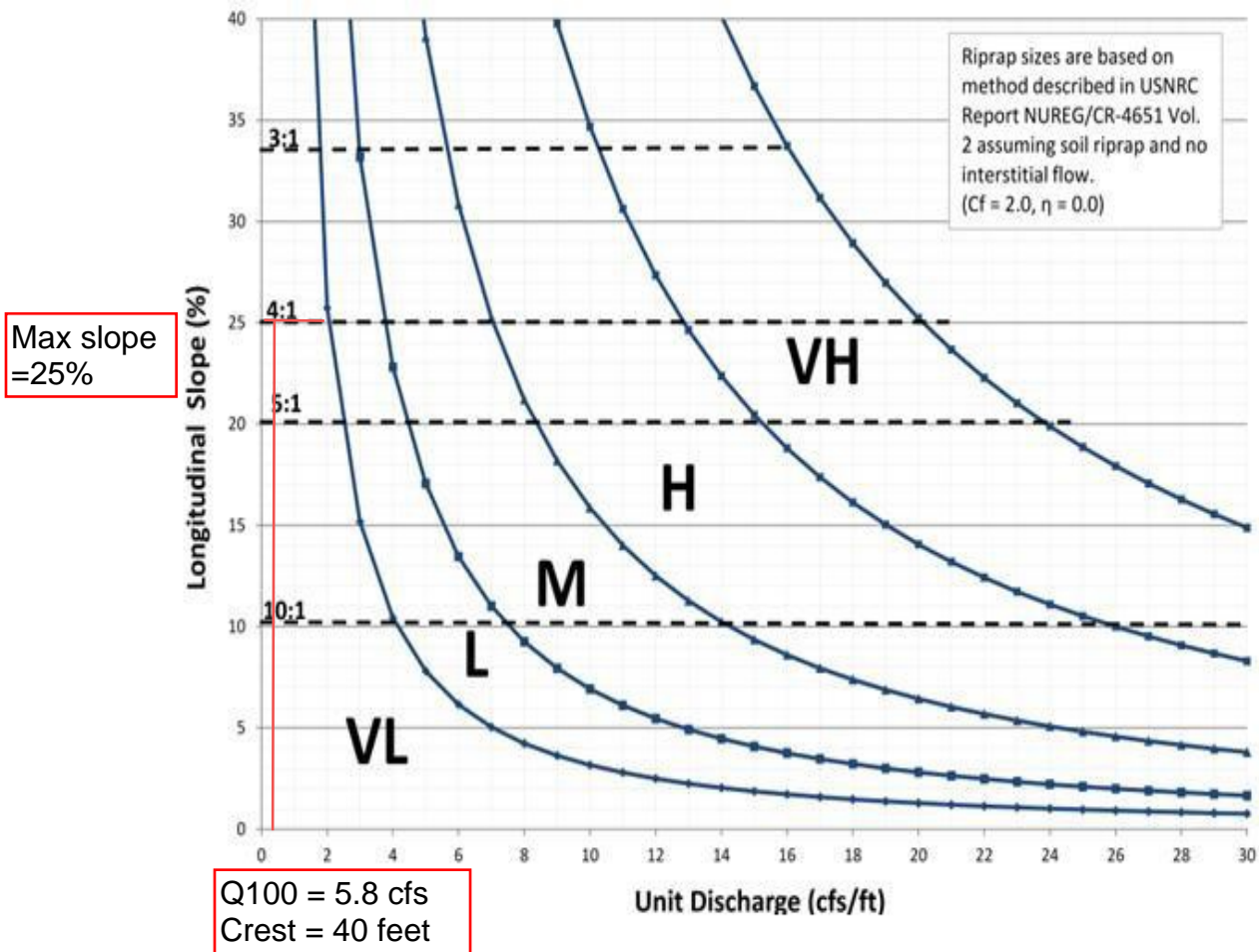

Figure 13-12d. Riprap Types for Emergency Spillway Protection



Culvert Report

Site Access Culvert DP7.1

Invert Elev Dn (ft)	= 7054.54
Pipe Length (ft)	= 44.67
Slope (%)	= 0.60
Invert Elev Up (ft)	= 7054.81
Rise (in)	= 18.0
Shape	= Circular
Span (in)	= 18.0
No. Barrels	= 1
n-Value	= 0.012
Culvert Type	= Circular Concrete
Culvert Entrance	= Groove end projecting (C)
Coeff. K,M,c,Y,k	= 0.0045, 2, 0.0317, 0.69, 0.2

Embankment	
Top Elevation (ft)	= 7057.42
Top Width (ft)	= 26.00
Crest Width (ft)	= 15.00

Calculations	
Qmin (cfs)	= 2.20
Qmax (cfs)	= 2.20
Tailwater Elev (ft)	= (dc+D)/2

Highlighted	
Qtotal (cfs)	= 2.20
Qpipe (cfs)	= 2.20
Qovertop (cfs)	= 0.00
Veloc Dn (ft/s)	= 1.70
Veloc Up (ft/s)	= 3.66
HGL Dn (ft)	= 7055.57
HGL Up (ft)	= 7055.37
Hw Elev (ft)	= 7055.58
Hw/D (ft)	= 0.51
Flow Regime	= Inlet Control

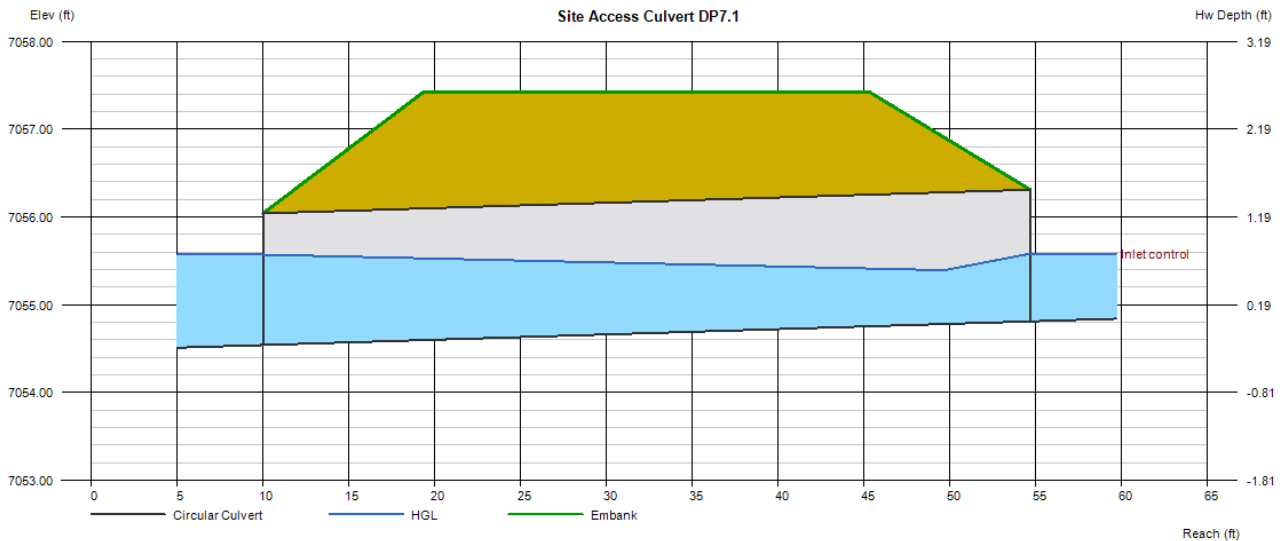

Culvert Report

Neighbor Driveway Access Culvert DPO10

Invert Elev Dn (ft)	= 7065.89
Pipe Length (ft)	= 45.58
Slope (%)	= 0.79
Invert Elev Up (ft)	= 7066.25
Rise (in)	= 18.0
Shape	= Circular
Span (in)	= 18.0
No. Barrels	= 1
n-Value	= 0.012
Culvert Type	= Circular Concrete
Culvert Entrance	= Groove end projecting (C)
Coeff. K,M,c,Y,k	= 0.0045, 2, 0.0317, 0.69, 0.2

Embankment	
Top Elevation (ft)	= 7068.83
Top Width (ft)	= 24.00
Crest Width (ft)	= 15.00

Calculations	
Qmin (cfs)	= 2.40
Qmax (cfs)	= 2.40
Tailwater Elev (ft)	= (dc+D)/2

Highlighted	
Qtotal (cfs)	= 2.40
Qpipe (cfs)	= 2.40
Qovertop (cfs)	= 0.00
Veloc Dn (ft/s)	= 1.83
Veloc Up (ft/s)	= 3.72
HGL Dn (ft)	= 7066.93
HGL Up (ft)	= 7066.84
Hw Elev (ft)	= 7067.06
Hw/D (ft)	= 0.54
Flow Regime	= Inlet Control

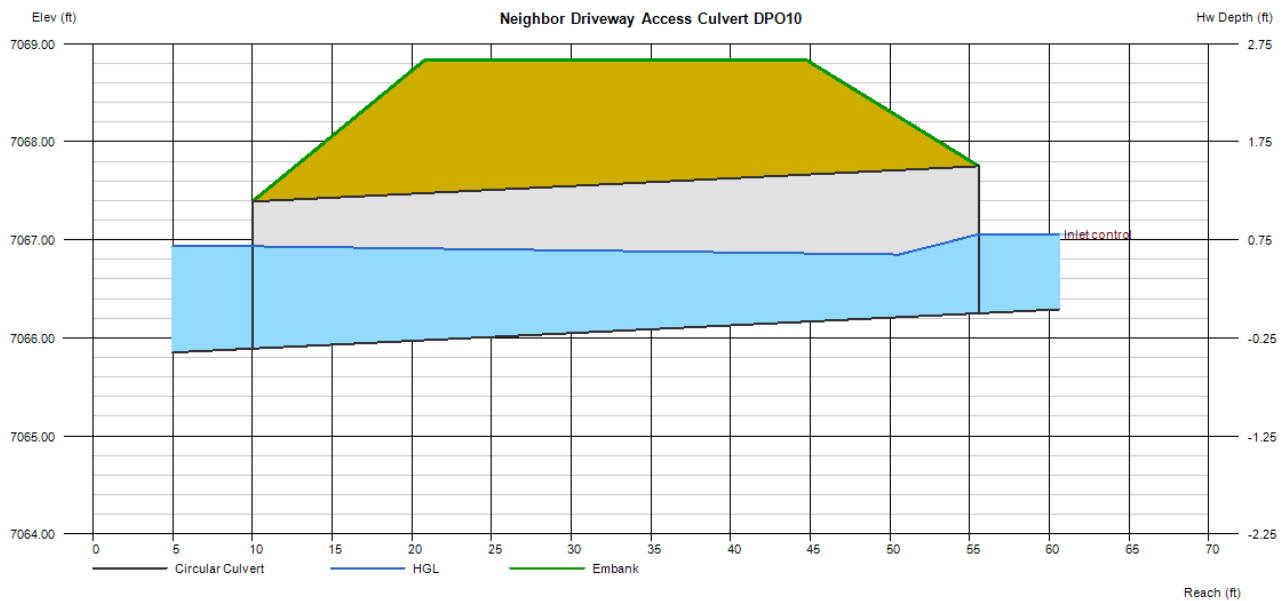

PIPE OUTFALL RIPRAP SIZING CALCULATIONS

Subdivision: McClintock Station Filing No. 1A
 Location: El Paso County

Project Name: Vollmer Road RV Storage
 Project No.: 25251.00
 Calculated By: APL
 Checked By: GAG
 Date: 1/12/24

	STORM DRAIN SYSTEM			Notes
	DPO10	DP9.1	DP3.1	
Q_{100} (cfs):	2.4	9.1	30.7	Flows are the greater of proposed vs. future
Conduit	Pipe	Pipe	Pipe	
D_c , Pipe Diameter (in):	18	18	36	
W , Box Width (ft):	N/A	N/A	N/A	
H , Box Height (ft):	N/A	N/A	N/A	
Y_t , Tailwater Depth (ft):	0.60	0.60	1.20	If unknown, use Y_t/D_c (or H)=0.4
Y_t/D_c or Y_t/H	0.40	0.40	0.40	
$Q/D^{2.5}$ or $Q/(WH^{3/2})$	0.87	3.30	1.97	
Supercritical?	No	No	No	
Y_n , Normal Depth (ft) [Supercritical]:				
D_a , H_a (in) [Supercritical]:	N/A	N/A	N/A	$D_a=(D_c+Y_n)/2$
Riprap d_{50} (in) [Supercritical]:	N/A	N/A	N/A	
Riprap d_{50} (in) [Subcritical]:	1.08	4.11	4.90	
Required Riprap Size:	L	L	L	Fig. 9-38 or Fig. 9-36
d_{50} (in):	9	9	9	
Expansion Factor, $1/(2 \tan \theta)$:	6.60	4.20	5.80	Read from Fig. 9-35 or 9-36
θ :	0.08	0.12	0.09	
Erosive Soils?	No	No	No	
Area of Flow, A_t (ft ²):	0.34	1.30	4.39	$A_t=Q/V$
Length of Protection, L_p (ft):	-6.1	2.8	3.8	$L=(1/(2 \tan \theta))(A_t/Y_t - D)$
Min Length (ft)	4.5	4.5	9.0	Min $L=3D$ or $3H$
Max Length (ft)	15.0	15.0	30.0	Max $L=10D$ or $10H$
Min Bottom Width, T (ft):	0.6	2.2	3.7	$T=2*(L_p*\tan \theta)+W$
Design Length (ft)	4.5	4.5	9.0	
Design Width (ft)	0.6	2.2	3.7	
Riprap Depth (in)	18	18	18	Depth=2(d_{50})
Type II Bedding Depth (in)*	6	6	6	*Not used if Soil Riprap
Cutoff Wall	No	No	No	
Cutoff Wall Depth (ft)				Depth of Riprap and Base
Cutoff Wall Width (ft)				

Note: No Type II Base to be used if Soil Riprap is specified within the plans
 * For use when the flow in the culvert is supercritical (and less than full).

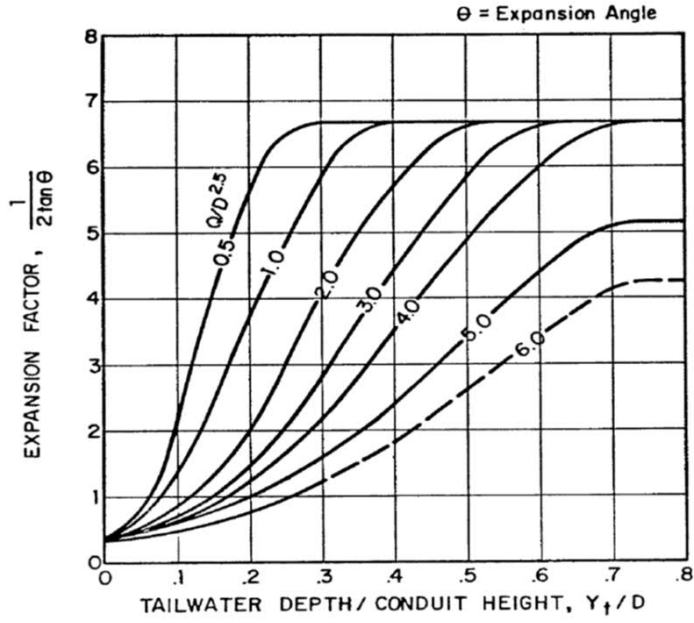

Figure 9-35. Expansion factor for circular conduits

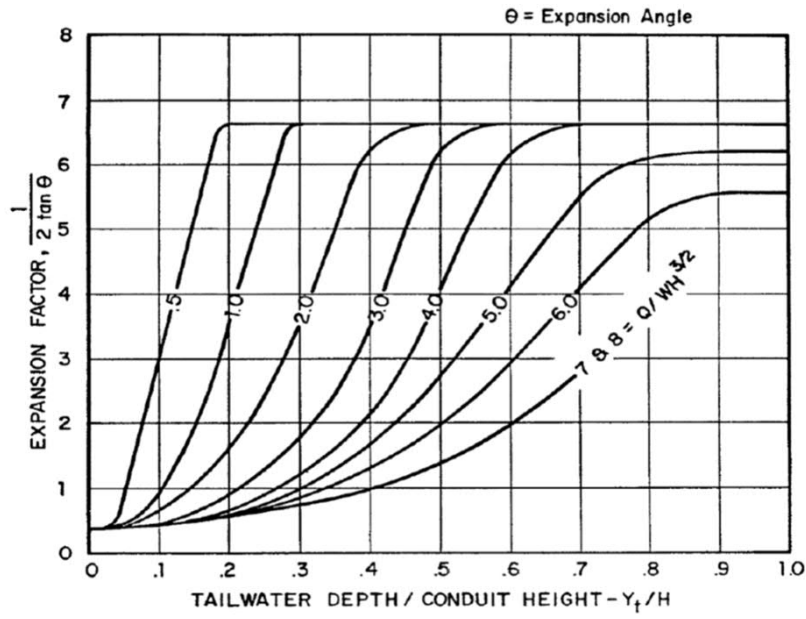

Figure 9-36. Expansion factor for rectangular conduits

Final Drainage Report
McClintock Station Filing No. 1A (Vollmer Road RV Storage)

APPENDIX D

REFERENCE MATERIALS



SAND CREEK DRAINAGE BASIN PLANNING STUDY FINAL REPORT JANUARY 2021

Prepared for:



Prepared by:



SAND CREEK – SAND CREEK DRAINAGE BASIN PLANNING STUDY

Basin Characteristics and Environmental Resources

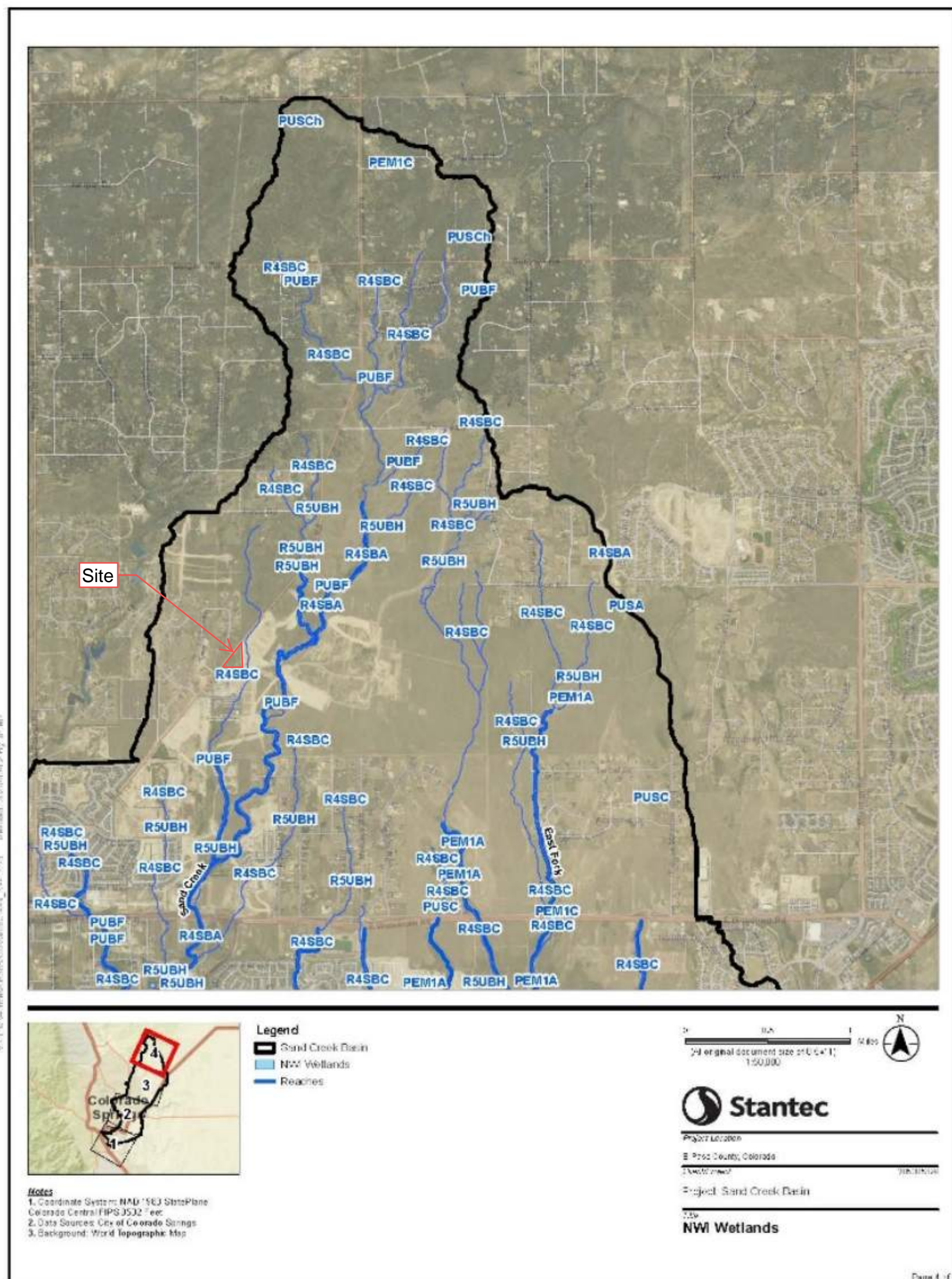

Disclaimer: This document has been prepared based on information provided by others as cited in the Notes section. Stantec has not verified the accuracy and/or completeness of this information and shall not be responsible for any errors or omissions which may be incorporated herein as a result. Stantec assumes no responsibility for data supplied in electronic format, and the recipient accepts full responsibility for verifying the accuracy and completeness of the data.

Figure 2-7: NWI Wetlands Located in Sand Creek Drainage Basin (Page 4)

SAND CREEK – SAND CREEK DRAINAGE BASIN PLANNING STUDY

Hydrology

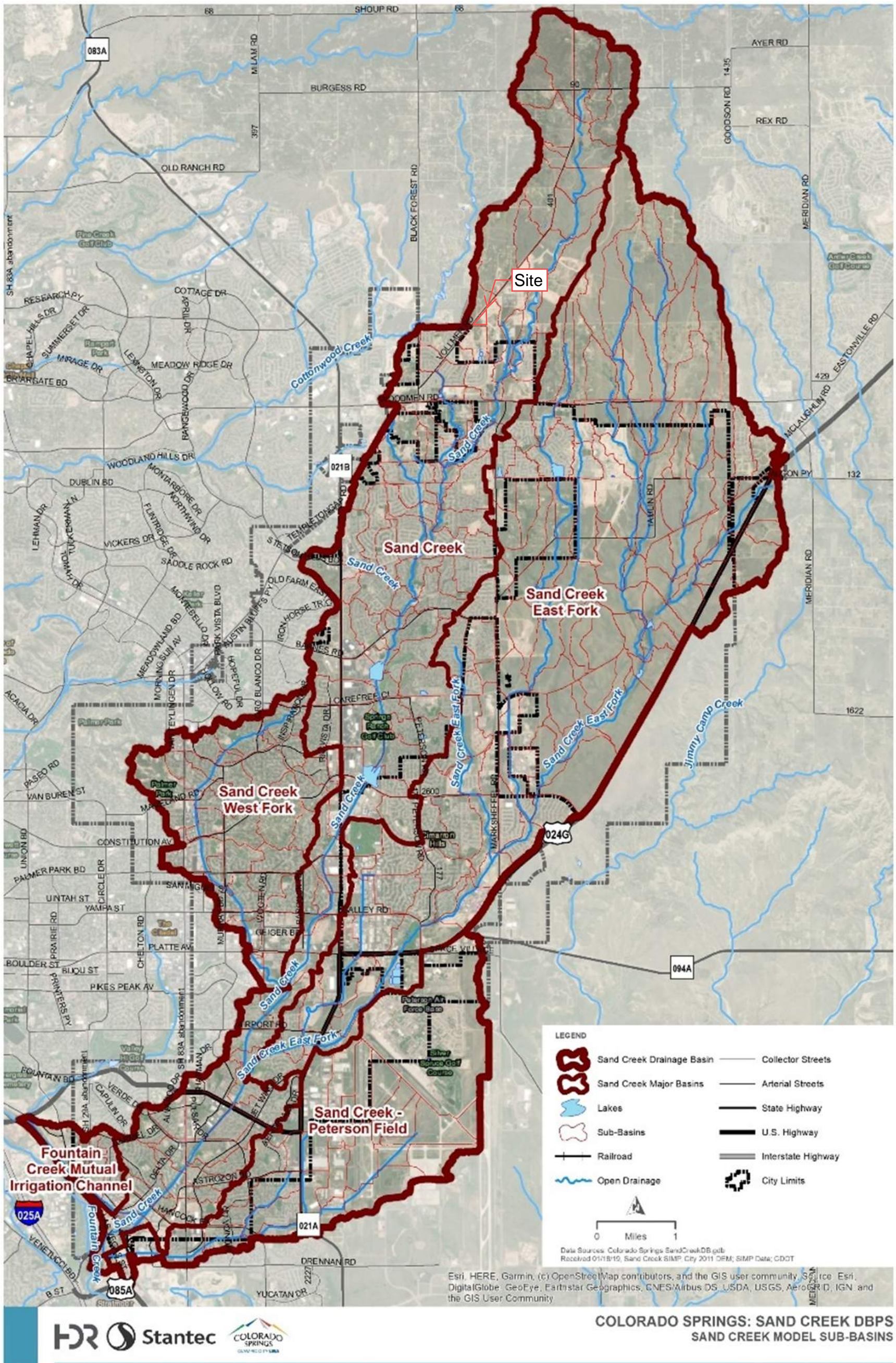

Figure 3-1. Major Sub-basin Map

Hydrology

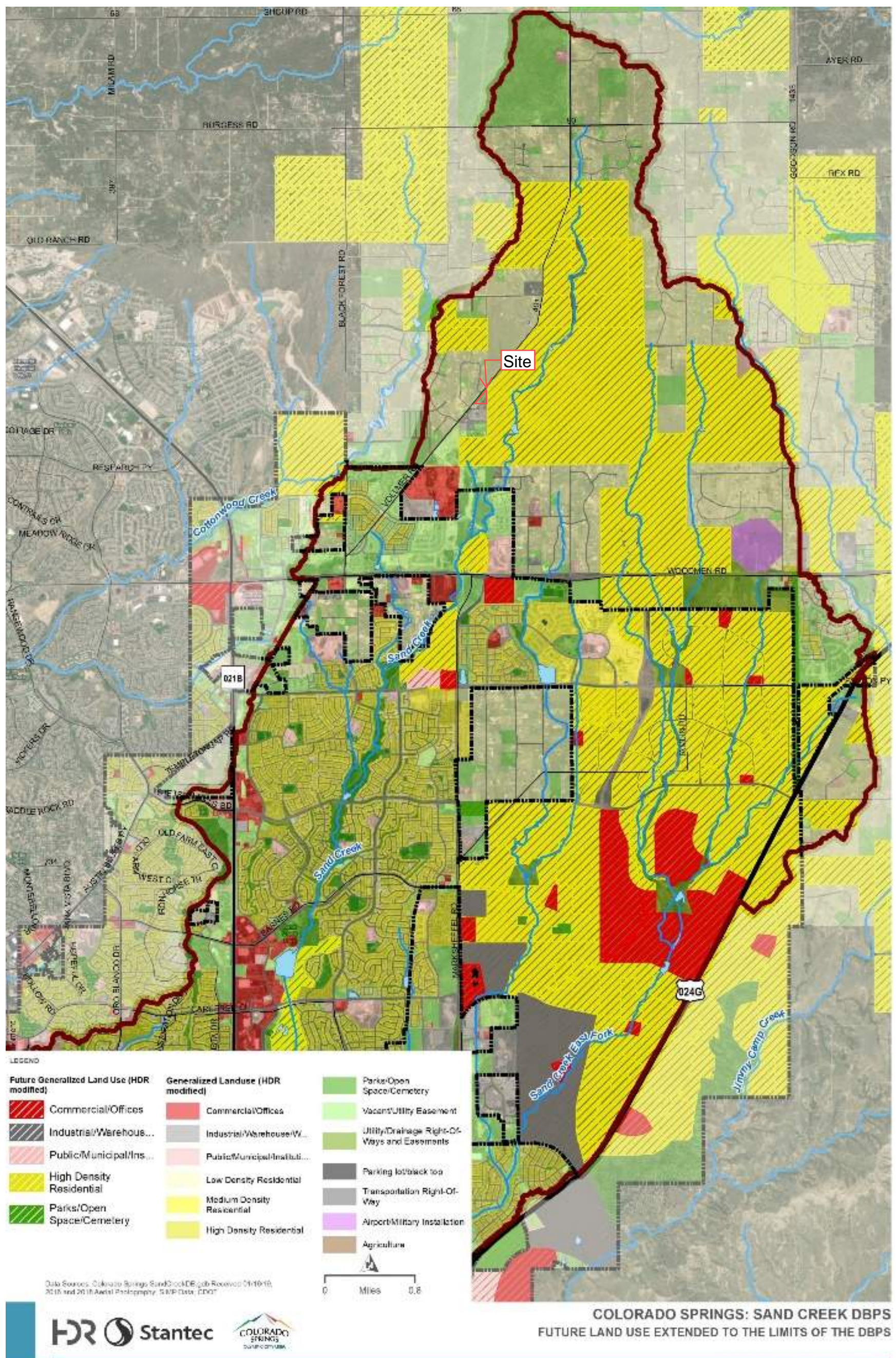
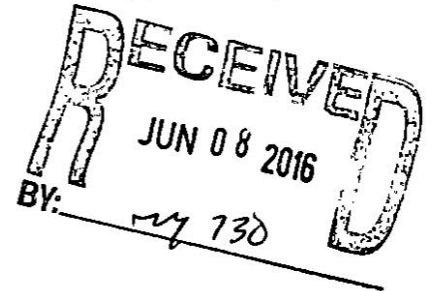

Figure 3-15. Future Land Use MapFuture Condition Model Results



FINAL DRAINAGE REPORT
For
BARBARICK SUBDIVISION,
PORTIONS OF LOTS 1, 2 and LOTS 3 & 4
El Paso County, Colorado
Sand Creek Drainage Basin

Prepared for:
El Paso County Development Services
Engineering Division



On Behalf of:
Wykota Construction
430 Beacon Light Road, Suite 130
Monument, CO 80132

Prepared by:



2435 Research Parkway, Suite 300
Colorado Springs, CO 80920
(719) 575-0100
Fax (719) 572-0208

June 6, 2016

15.789.001

plus the time of travel (t_t) in concentrated form, such as a swale or drainageway. A minimum T_c of 5 minutes and 10 minutes were used for the final calculations in developed and undeveloped conditions, respectively.

Storm Drain Systems

All proposed storm drain infrastructure will be located within private property and will be owned and maintained by the property owner.

The storm drain hydraulics is analyzed using *Bentley's FlowMaster*, *CulvertMaster* & *StormCAD* design software. Colorado Department of Transportation (CDOT) type inlets will be used where necessary.

The designated outfall locations for the proposed on-site storm drains are the natural drainage ways at the south end of the property. The proposed storm drain infrastructure will be discussed in more detail below.

EXISTING DRAINAGE REPORT DISCUSSION

The approved Barbarick Subdivision Final Drainage Report (BS-FDR) and the approved Woodmen Storage Final Drainage Report (WS-FDR) both apply to the existing general drainage conditions for this site. The off-site basins and general flow patterns in the BS-FDR and WS-FDR still apply. Excerpts from these reports are provided below for reference.

On-site and Off-Site Basin Descriptions from the BS-FDR and WS-FDR:

The following summary is taken from the Barbarick Subdivision Final Drainage Report (BS-FDR):

Off-site:

Off-site Basin O3 This basin encompasses approximately 7.03 acres and represents the area north and northwest of Lot 1. This basin drains into Lot 1 through a series of (2) 24" CMP pipes which control the flow of 14/36 cfs in the 5/100 year storm events.

Lots 1 & 2 – these lots are considered fully developed lots and drain north to south collecting at the existing concrete settling pond on Lot 2. This developed flow (20.8 cfs /57.2 cfs) combines with Off-site Basin O3 to total 30.5 cfs / 80.8 cfs in the greenbelt offsite south of Lot 2. At the time of development permit for these developed lots, a detention pond for water quality will be required, probably in the area of the existing concrete settling pond, that will accommodate Lots 1 and 2 west of the gas easement and flood plain area.

On-site:**On-site Basins A1 and B1 (for portions of Lots 1 and 2, and Lots 3 & 4)**

These basins encompass approximately 5.3 & 3.8 acres and represent the buildable portions of the property as described in the BS-FDR (see Basin Map from BS-FDR below). These basins were slated (in the BS-FDR) to drain into small detention ponds that would release to historic rates. These discharge rates were calculated to be 2.9/7.3 and 2.2/5.4 cfs (5/100 year). The BS-FDR does not include the drainage ways in any hydrology calculations due to the fact that this no-build drainage area was not planned on being developed. This drainage way allowed off-site flows from O1+O2 to pass-through Lots 3 & 4. The drainage way to the west of A1 passes through flows from offsite O3. Since the approval of this report, offsite tributary basins O1+O2 have been changed, and the development of the property encompasses the whole property, including the previously determined no-build area.

The following summary is taken from the Woodmen Storage Final Drainage Report (WS-FDR):

Off-site:

Design Point 5 - This design point encompasses approximately 19.69 acres and represents the tributary area north of the project site. This basin drains into a proposed detention pond near the northeast corner of the property and generates 57.4/92.7 cfs in the 10/100 year storm events, historic flows are 16.7/30.3 cfs. The releases rates from this pond are lower than historic 16.1 cfs/29.4 cfs in the 10/100-year storm events. These flows are conveyed along the east property line of the site and into the eastern natural drainage way that leaves the property to the south.

Review of the Sterling Ranch Preliminary Drainage Report (SR-PDR):

The Barbarick Subdivision is surrounded on three sides by the planned Sterling Ranch Development. The approved Sterling Ranch PDR was prepared by M&S Civil Consultants in May of 2015. This Sterling Ranch PDR re-analyzes runoff from Barbarick Subdivision and plans for storm drain improvements to convey this runoff to a full spectrum detention and water quality pond to be located down stream of Barbarick Subdivision as part of Sterling Ranch Phase One.

In summary; the Sterling Ranch PDR is planning on receiving 73.3/139.2 cfs (5/100 year) from Basin OS3. A 54" RCP is planned to convey this flow through Sterling Ranch. The Sterling Ranch PDR is planning on receiving 45/86 cfs (5/100 year) from OS2, encompasses Lots 1 & 2 and OS3 encompasses Lots 3 & 4 and the Basin north of Lot 3. A 48" RCP is planned to convey this flow through Sterling Ranch. The cumulative runoff from the northerly property and Lots 1 through 4 does not exceed the anticipated rates in the SR-PDR.

condition rangeland and generates 0.3/2.7 cfs in the 5/100 year storm events. This basin sheet flows offsite where it is captured in a small swale between the site and existing roadway and conveyed westerly to the low point south of the outfall of Basin H1.

These existing basins encompass the previously unmodelled drainage area from the BS-FDR. The total historic flow from the site is 3.8/34.6 cfs in the 5/100 year storm events. The following design point table is for combined allowable discharge rates from the property at respective locations including historic flows from the tributary upstream basins:

<u>Design Point</u>	<u>5/100 Release</u>	<u>Comments</u>
DP H1	16.7*/30.3 cfs	DP H5 WS-FDR - * is 10year
DP H2	13.7/35.5 cfs	O3 BS-FDR
DP H3	56.7 cfs	DPH1+H1+H3 (100-year)
DP H4	14.6/43.7 cfs	DPH2 + H2

Design Point H3 will release a flow lower than previously anticipated within the BS-FDR (52.9/170 cfs). It is the introduction of development within the Sterling Ranch site that has eliminated offsite flows from BS-FDR Basin O1 that significantly changed the drainage pattern. The historic release is now contained solely to the historic flows from WS-FDR design point H5 and the proposed onsite historic flows.

Design Point H4 will combine with the western half of Lots 1&2. Per the BS-FDR the combined portions of Lots 1&2 and O3 to release a combined flow of 30.5/80.8 cfs downstream. The flow anticipated in the BS-FDR appears consistent with the smaller basin analysis of this report and should be used for downstream analysis.

PROPOSED DRAINAGE DISCUSSION

Introduction

The proposed site will be developed differently than anticipated in the previous BS-FDR. The previous plan for this site maintained the existing native drainage way down the middle of Lots 1 & 2 and 3 & 4, thereby splitting the buildable area into the outer thirds of these lots. The native drainage way and "Drainage Boundary – No Build Area" (as shown on the Plat & FDR) will be eliminated with the proposed development. The proposed site and proposed drainage improvements will allow this native drainage way to be eliminated while maintaining the pass through of major flows. These modifications to the site and to the drainage patterns will allow a larger buildable area.

The existing retention pond, located just north of Lot 3, will be modified by others to become a water quality/detention pond pursuant to the WS-FDR. A new outlet works and a storm drain pipe will convey runoff from this detention pond (16.1/29.4 cfs in the 10/100 year storm events) discharging at the property line. This development is proposing a CDOT Type D inlet to capture the discharged flow and pipe it downstream along the east side of Lots 3 & 4 to discharge into the proposed Full Spectrum Extended

Detention Basin (EDB) in Lot 4. The EDB is designed to pass through, and not treat or detain, these offsite flows.

A new EDB will be provided in Lot 4. This detention basin will provide water quality treatment for portions of Lots 1 & 2, and Lots 3 & 4. In the approved Barbarick FDR there were to be two separate ponds. The new site development has been planned for a single pond to treat the developed flows. Tributary water sheet flow across the site to shallow swales that will direct runoff to the proposed EDB. The EDB will have a forebay at the confluence of the two pipe outfalls, a concrete trickle channel that terminates at a micropool structure, and is designed to treat the WQCV, EURV and 100-year detention.

A second SFB water quality with detention catchment basin will be provided at the south east/downstream end of Lot 2. This SFB will not have an outlet structure to release flows due to requirements from the gas main utility ownership of no structure to be built within the existing easements. There will be a small spillway to allow the release of large storm events. Runoff will be directed to the proposed SFB where possible.

Flow from the area north of Lot 1 (Basin O3) will pass through the site via two 24" culverts and will be discharged at the southern boundary of Lot 2, as historically done. An earthen channel will run north-south along the east side of the existing Lot 1 and Lot 2 developments. The channel is approximately 1-ft deep with 4:1 side slopes and will capture and convey any westerly flowing nuisance runoff from the proposed improvements to the sand filter detention pond as discussed in the original Barbarick Subdivision FDR, instead of the existing Lot 1 and 2 improved areas.

Runoff from the property is at historic flows and will not exceed the anticipated runoff as determined in the Sterling Ranch PDR. This is described in more detail below. The Sterling Ranch PDR includes an analysis of future drainage conditions and includes recommended infrastructure to convey this runoff. Since the Sterling Ranch surrounds the Barbarick Subdivision, it is appropriate to include the recommendations from the SR-PDR in this Proposed Drainage Discussion.

Proposed On-Site Basin Descriptions: (See Basin Map in the pocket)

On-site Basin D1 (D for Developed condition) - This developed basin encompasses approximately 11.4 acres - the majority of Lots 3 & 4 and small portions of Lots 1 & 2. This basin generates 19.7/56.0 cfs in the 5/100 year storm events and sheet flows into shallow swales that direct the runoff into the proposed EDB to be located in Lot 4. Lot 3 is based on Owner provided information for a gravel parking/vehicle storage area, and Lot 4 has been based on proposed building site improvements as identified in the rezoning application. Any changes to the land use will require an update to the Final Drainage Report; much like the original Barbarick Subdivision Final Drainage Report is being updated with the grading and Lot 4 development application.

On-site Basin D2 This undeveloped basin encompasses 1.2 acres and represents the south portion of Lot 4, below and south of the two detention ponds. This basin is historic in nature and generates 0.8/3.0 cfs and drains directly into a road side ditch within the Sterling Ranch development.

On-site Basin D3 This developed basin encompasses approximately 3.13 acres - the remaining proposed infill portions of Lots 1 and 2 (east of the currently built out Lots 1&2). As discussed in the original Barbarick Subdivision FDR, development of these areas will require a detention water quality pond. This basin generates 4.1/11.6 cfs in the 5/100 year storm events and sheet flows southerly to the proposed SFB located at the southern-most portion of Lot 2.

The following design point table is for combined allowable discharge rates from the property at respective locations including historic flows from the tributary upstream basins:

<u>Design Point</u>	<u>5/100 Year</u>	<u>Comments</u>
DP D1	85.4 cfs (100)	D1+O2 Pass Through
DP D2	48.9 cfs (100)	Pond Release+D2
DP D3	4.1/11.6 cfs	D3
DP D4	13.8/39.1 cfs	Pond Release +O3 Pass Through

All release flows downstream are at or below historic levels.

RECOMMENDED DESIGN

Off-site Detention Facility:

This shallow pond will be modified for the proposed development to the north as part of the WS-FDR. This will eliminate the retention properties in this pond, will provide detention for off-site flows, will provide a suitable outlet structure, and will remove accumulated sediment. The modified pond will store up to 1.52 acft (66,211 cuft) to the principal spillway (elevation = 7048.05). A summary of flows into and out of this pond:

<u>Off-site Pond Flow Summary (cfs)</u>	<u>5 year</u>	<u>100 year</u>
Proposed Flow into offsite pond (Basin G/DP 5)	<u>57.4</u>	<u>92.7</u>
Increase in peak flow due to development	46.2	51.3
Proposed flow out of modified pond	<u>16.1</u>	<u>29.4</u>
Reduction in peak flow	41.3	63.3

For complete pond design, refer to the WS-FDR.

Proposed 30" HDPE Storm Drain from Modified Off-site Detention Pond:

This storm drain will capture flows from the discharged offsite pond and route them along the perimeter of the property daylighting into the EDB in Lot 4. 4' precast concrete manholes will be used for maintenance access at all bends and grade breaks. A grouted riprap forebay will help dissipate energy at the outlet of the pipe, and allow for settling prior to entering the pond. See the Appendix for the hydraulic analysis of this storm drain (StormCAD).

In the event of an emergency and the offsite pond fails, developed flow (Q100=93.0 cfs) will overtop the pond and be collected between the proposed roadway and pond berm.. Flow not captured by the proposed inlet will bypass easterly to the proposed offsite swale between this property and the Sterling Ranch property and conveyed southerly.

Proposed 18" HDPE Storm Drain Culvert:

A 18" HDPE culvert will convey collected runoff from Lot 3 (Developed Q100 = 15.90cfs) through Lot 4 to the FSD Pond and join sheet flow from Lot 4 and the 30" piped bypass flow from basin O2. This culvert will be privately owned and maintained by the property owners. See the Appendix for open channel calculations.

On-site FSD - EDB Pond in Lot 4 (Basin D1):

This On-site Full Spectrum Extended Detention Basin Pond provides water quality, EURV and 100-year detention. Onsite flows will combine with the 30-inch bypass flows from the north and pass through the EDB. The pond has been sized for the release of historic flows from Basin D1, as well as provides capacity for pass through conveyance of historic flows from the north.

The following table outlines the onsite existing and developed flow, required detention, and modifications to required detention utilizing the upstream over detention.

<u>On-site Basin Flow Summary (cfs)</u>	<u>5 year</u>	<u>100 year</u>
Existing On-site Flow at Pond	2.2	16.5
Developed On-site Flow (Basin D1)	<u>19.7</u>	<u>56.0</u>
Increase in peak flow due to development	17.5	39.5
Proposed Pass Through Flow from Off-Site Pond	<u>16.1*</u>	<u>29.4</u>
Proposed total flow out of EDB pond	<u>0.3</u>	<u>45.9**</u>

*Includes 10 year from WS-FDR

**Includes Pass Through flow of 29.4 cfs

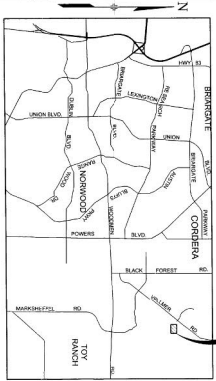

PROJECT SITE

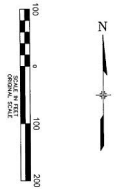

LEGEND

- SUB-BASIN BOUNDARY
- EXISTING CONDUIT
- PHASE 3A FILING LIMITS
- TEMPORARY DIVERSION SWALE
- LOT LINE
- DESIGN POINT
- SUB BASIN DESIGNATION
- SUB BASIN PERCENT INFERRIOUS
- SUB BASIN AREA (A.C.)
- 5 - 1/2" DIA. STORM SIGHT PEAK FLOW (FS)
- 100 - 1/2" DIA. STORM SIGHT PEAK FLOW (FS)
- PREFERRED FLOW DIRECTION
- EXISTING FLOW DIRECTION

BARBARICK DRAINAGE SUMMARY TABLE

BASIN	AREA (A.C.)	Q(5) (CFS)	Q(100) (CFS)	COMMENT
H1	10.72	4.3	18.5	REF: WOODMEN STORAGE FDR
H2	3.70	0.9	8.2	REF: BARBARICK FDR 2005
H3	1.11	0.3	2.7	REF: BARBARICK FDR 2005
H4	10.73	4.37	18.5	REF: WOODMAN STORAGE FDR 2010

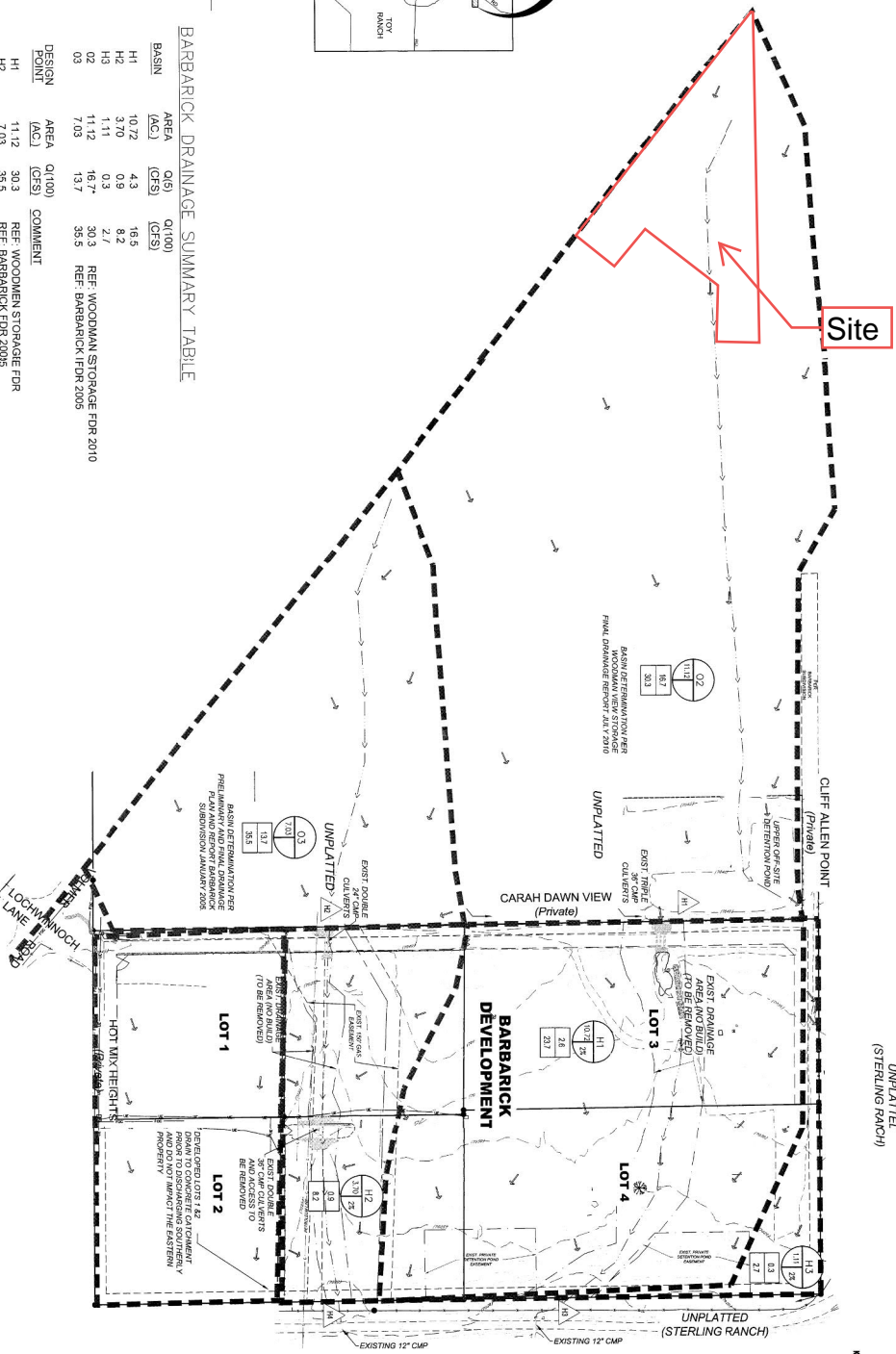

REFERENCE DRAWINGS

REVISIONS

NO.	DATE	DESCRIPTION	BY

BENCHMARK DATA (E.V.)

VERTICAL BENCHMARK

PREPARED UNDER A PROFESSIONAL ENGINEERING CONTRACT FOR THE BARBARICK DEVELOPMENT

Matrix DESIGN GROUP

BARBARICK SUBDIVISION LOTS 1-4 EXISTING CONDITIONS DRAINAGE PLAN

DP01

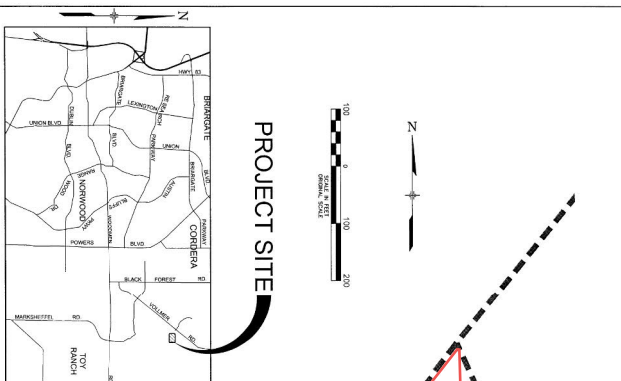

VICINITY MAP
N.T.S.

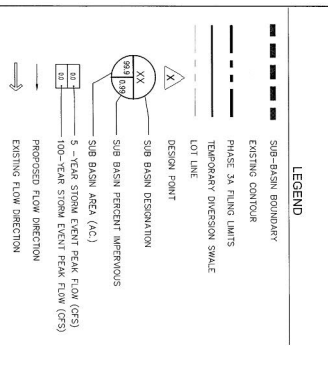

BARBARICK DRAINAGE SUMMARY TABLE

BASIN	AREA (A.C.)	Q16 (CFS)	Q100 (CFS)	% IMP.	COMMENT
D1	11.40	25.7	56.0	57%	D1 BASIN TO FSD +022 PASS THROUGH
D2	1.21	0.8	3.0	2%	POND RELEASE + D2
D3	3.13	4.1	11.6	57%	D3 BASIN TO SFB
D4	11.12	16.7	30.3		POND RELEASE + 03 PIPE PASS THROUGH
	7.03	13.7	35.5		REF: BARBARICK FDR 2005
	10.16	38.1			

SAND FILTER POND
 V₁₀₀ = 0.039 AC-FT
 W₁₀₀ WSE = 23.37
 UPRV W/C = 0.181
 EIRV W/C = 0.232
 100-YR WSE = 0.394 AC-FT
 100-YR ELEV = 23.83
 O₁ RELEASE = 1.35 CFS

FSD POND
 V₁₀₀ = 0.203 AC-FT
 W₁₀₀ WSE = 20.03
 UPRV W/C = 0.181
 EIRV W/C = 0.232
 100-YR WSE = 1.281 AC-FT
 100-YR ELEV = 22.78
 EIRV = 0.97 CFS
 O₁ RELEASE = 21.50
 EIRV ELEV = 21.50

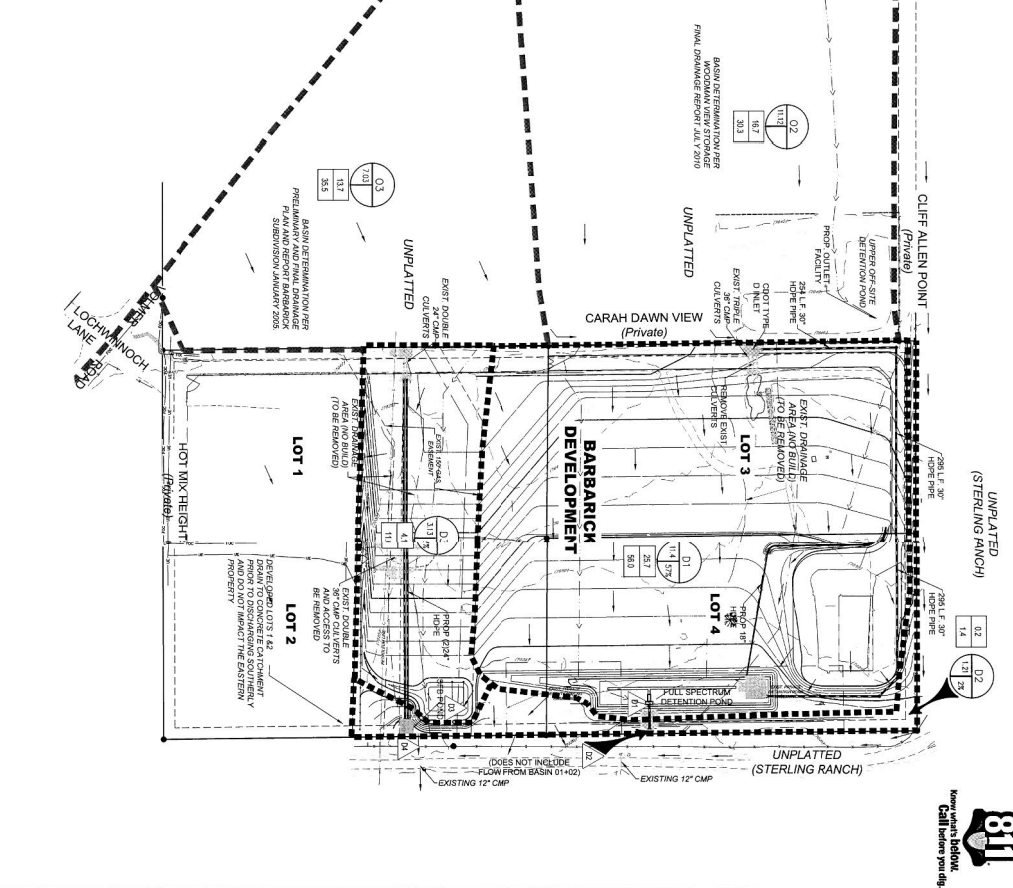

VERTICAL BENCHMARK

DATE OF SURVEY: 08/11/2009
 SURVEYOR: JAMES W. HARRIS, P.E.
 PROJECT: BARBARICK DEVELOPMENT
 BENCHMARK: 100-TEAR STORM EVENT PEAK FLOW (CF5)
 POINT ELEV: 76.41
 DATE: 08/11/2009

PREPARED UNDER A PROFESSIONAL ENGINEERING CONTRACT WITH THE STATE OF TEXAS. THE ENGINEER'S RESPONSIBILITY IS LIMITED TO THE DESIGN AND CONSTRUCTION OF THE DRAINAGE SYSTEM SHOWN ON THIS PLAN. THE ENGINEER DOES NOT WARRANT THE ACCURACY OF THE DATA PROVIDED BY THE CLIENT OR THE SUITABILITY OF THE DESIGN FOR ANY OTHER PURPOSES. THE CLIENT SHALL BE RESPONSIBLE FOR OBTAINING ALL NECESSARY PERMITS AND APPROVALS FROM THE APPROPRIATE AGENCIES.

REFERENCE DRAWINGS

NO.	DATE	DESCRIPTION	BY
1	08/11/2009	BARBARICK DEVELOPMENT (DATA)	JWH
2	08/11/2009	BARBARICK DEVELOPMENT (DESIGN)	JWH

REVISIONS

NO.	DATE	DESCRIPTION	BY
1	08/11/2009	BARBARICK DEVELOPMENT (DATA)	JWH
2	08/11/2009	BARBARICK DEVELOPMENT (DESIGN)	JWH

Matrix DESIGN GROUP

3268 Research Parkway, Suite 200
 Houston, Texas 77057
 Phone: 713-275-7000
 Fax: 713-275-0208

BARBARICK SUBDIVISION LOTS 1-4

PROPOSED DRAINAGE PLAN

DP02

811
 Community Help
 Call before you dig



WOODMAN VIEW STORAGE FINAL DRAINAGE REPORT

**JULY 2004
REVISED FEBRUARY 2010
REVISED MAY 2010
REVISED JULY 2010**

For:

**Woodmen View Storage
2720 Meridian Road
Peyton, CO 80831**



WOODMAN VIEW STORAGE
FINAL DRAINAGE REPORT
PAGE 2 of 5

2.2 Sub-Basin Description

- Historically, the runoff sheet-flows across the site to the south where it enters one of two draws to Sand Creek.
- A large upstream basin sheet-flows across the site.
- The offsite basin will continue to sheet-flow through the site in the developed conditions and is routed through the onsite detention pond.
- A swale is provided along the west property line to convey the discharge from the existing culvert under Vollmer Place.

3.0 DRAINAGE DESIGN CRITERIA

3.1 Development Criteria Reference and Constraints

- Previous studies for the proposed site or the surrounding areas are not available.
- The *Sand Creek Drainage Basin Planning Study* does not affect the proposed site.
- This study is in compliance with the following Standards except where stated herein:
 - *City of Colorado Springs and El Paso County Drainage Criteria Manual Volume 1 & 2*
- The simplicity and proposed use of the site do not create any drainage constraints.
- The proposed detention pond and outlet works must be constructed within the proposed site.

3.2 Hydrological Criteria

- Design rainfall is from the City/County's Criteria.
- The rational method was used to calculate peak runoff rates for the development.
- The 10-year storm was used as the minor event.
- The 100-year storm was used as the major event.
- Detention storage requirements were calculated using the Rational Stored Rate Method.

WOODMAN VIEW STORAGE
FINAL DRAINAGE REPORT
PAGE 3 of 5

- The Water Quality Capture Volume was calculated using the City/County's criteria.
- The combined runoff from the detention pond and developed undetained basins will be less than or equal to the total historic runoff rate from the site.

4.0 DRAINAGE FACILITY DESIGN

4.1 General Concepts

The following are concepts and typical drainage patterns of the proposed drainage system:

- Runoff generated in both the minor and major storm events will sheet-flow overland to the onsite detention pond.
 - A swale is graded along the west property line to convey runoff from the north side of Vollmer Place and to keep onsite runoff from leaving the site.
 - The proposed development is divided into seven basins (A, B, C, D, E, F, and G).
 - Basins A-D are offsite basins. The offsite basins will continue to flow through the site and will be routed through the onsite detention pond.
 - Basins E-G are made up entirely of the proposed development.
 - Basin E will sheet-flow to the onsite detention pond.
 - Basins F and G will be released from the site undetained.
- Offsite runoff will be handled in the following ways:
- Offsite flows entering the site are conveyed through the site and proposed detention pond.

The following tables, charts, and figures are presented in the appendix of this report:

- Vicinity Map and Soils Map
- ¹FIRM Map
- Runoff computation sheets
- Detention Pond calculations
- Water Quality Capture Volume calculations
- ¹Pond Outfall Sizing spreadsheet
- ¹Restrictor Plate Sizing
- ¹Weir Design Spreadsheet
- ²Culvert Calculations

WOODMAN VIEW STORAGE
FINAL DRAINAGE REPORT
PAGE 4 of 5

- ²Riprap Sizing Calculations
- Tables and charts from *City of Colorado Springs and El Paso County Drainage Criteria Manual*

4.2 Specific Details

- It is anticipated the site will be developed in two phases.
- The detention facility must be constructed with the first phase.
- ²The flows released from the detention pond (16.1 cfs and 29.4 cfs) during the 10-year and 100-year events respectively, are equal to the historic flow rates at Design Point H5 (16.7 cfs and 30.3 cfs) less the developed flows released from the site undetained at Design Point 7 (0.6 cfs and 0.9 cfs).
- The detention volume was calculated using the City/County's Criteria.
- The WQCV was calculated using the City/County's Criteria.
- ¹ The outlet structure for the detention pond consists of a Modified Type D inlet. The rim of the inlet is set at the water quality water surface elevation and will collect the 10-year flow.
- ¹ The 100-year flow will outfall over a weir directly to one of the draws that drain to Sand Creek.
- An 18" HDPE culvert is provided at DP3 to convey the 100-year flow, 12.5cfs, from the onsite swale along the west property line to the onsite detention pond.
- Maintenance access to the detention pond will be provided via proposed drive aisles within the development and a gentle slope to the bottom of the pond per the City/Counties criteria.
- It is the responsibility of the property owner to maintain all drainage facilities.
- There are no immediate adverse impacts on downstream properties. The flows released from the site are equal to the historic flow rates through the site.



DETENTION POND CALCULATIONS

Woodman View Storage
El Paso County, CO

DETENTION POND CRITERIA

Peak release rate for the developed 10-yr and 100-yr events shall not exceed the historic rate for the drainage area

Criteria References:

El Paso County/City of Colorado Springs Drainage Criteria Manual
Urban Drainage and Flood Control District Criteria Manual

DETENTION POND RELEASE RATE CALCULATION

10-yr Historic Runoff (cfs) Design Point H5 = 16.7 Design Point H7 = 15.3	10-yr Developed Runoff (cfs) Design Point 5 = 57.4 Design Point 6 = 2.3 Design Point 7 = 0.6
---	---

100-yr Historic Runoff (cfs) Design Point H5 = 30.3 Design Point H7 = 30.0	100-yr Developed Runoff (cfs) Design Point 5 = 92.7 Design Point 6 = 3.7 Design Point 7 = 0.9
--	--

Allowable Release Rate at DP 5 (cfs) 10-yr = 16.1 (DP H5 - DP 7) 100-yr = 29.4 (DP H5 - DP 7)

Allowable Release Rate at DP 6 (cfs) 10-yr = 15.3 (Developed < Historic therefore no detention 100-yr = 30.0 at this location)
--

DETENTION POND VOLUME CALCULATION

Water Quality Capture Volume (WQCV) = 0.30	AC-FT	UDFCD WQCV Calculation	7045.74
10-yr Volume = 0.85	AC-FT	Rational Storage Rate Method	
10-yr Volume + WQCV = 1.15	AC-FT		7047.47
100-yr Volume = 1.37	AC-FT	Rational Storage Rate Method	
100-yr Volume + WQCV/2 = 1.52	AC-FT		7048.05

STAGE-STORAGE SIZING FOR POLYGONAL, ELLIPTICAL, OR IRREGULAR PONDS

Project: Woodman View Storage Final Drainage

Basin ID: _____

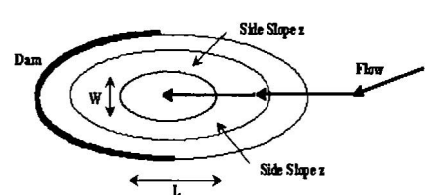
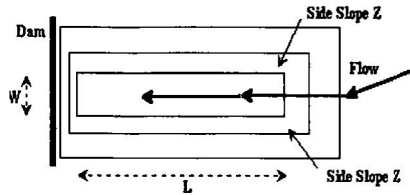
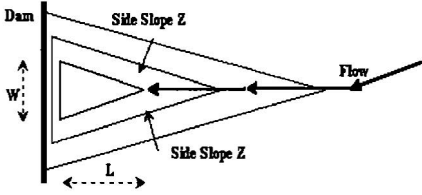

Design Information (Input):

Width of Pond Bottom, W = ft
 Length of Pond Bottom, L = ft
 Dam Side-slope (H:V), Z_d = ft/ft

Check Pond Shape

Right Triangle OR...
 Isosceles Triangle OR...
 Rectangle OR...
 Circle / Ellipse OR...
 Irregular (Use Override values in cells G32:G52)

Stage-Storage Relationship:

	MINOR	MAJOR	
Storage Requirement from Sheet 'Modified FAA':			acre-ft.
Storage Requirement from Sheet 'Hydrograph':			acre-ft.
Storage Requirement from Sheet 'Full-Spectrum':			acre-ft.

Labels for WQCV, Minor, & Major Storage Stages (input)	Stage ft (input)	Side Slope (H:V) ft/ft Below El. (input)	Pond Width at Stage ft (output)	Pond Length at Stage ft (output)	Surface Area at Stage ft ² (output)	Surface Area at Stage ft ² User Override	Volume Below Stage ft ³ (output)	Surface Area at Stage acres (output)	Volume Below Stage acre-ft (output)	Target Volumes for WQCV, Minor, & Major Storage Volumes (for goal seek)
	7043.00					0		0.000	0.000	
	7043.20		0.00	0.00		85	8	0.002	0.000	
	7043.40		0.00	0.00		541	71	0.012	0.002	
	7043.60		0.00	0.00		1,206	246	0.028	0.006	
	7043.80		0.00	0.00		1,802	547	0.041	0.013	
	7044.00		0.00	0.00		2,468	974	0.057	0.022	
	7044.20		0.00	0.00		3,221	1,542	0.074	0.035	
	7044.40		0.00	0.00		4,074	2,272	0.094	0.052	
	7044.60		0.00	0.00		5,029	3,182	0.115	0.073	
	7044.80		0.00	0.00		6,067	4,292	0.139	0.099	
	7045.00		0.00	0.00		7,256	5,624	0.167	0.129	
	7045.20		0.00	0.00		8,604	7,210	0.198	0.166	
	7045.40		0.00	0.00		10,126	9,083	0.232	0.209	
	7045.60		0.00	0.00		11,774	11,273	0.270	0.259	
WQCV	7045.80		0.00	0.00		13,756	13,826	0.316	0.317	0.30 REQUIRED
	7046.00		0.00	0.00		16,086	16,810	0.369	0.386	
	7046.20		0.00	0.00		18,669	20,286	0.429	0.466	
	7046.40		0.00	0.00		21,153	24,268	0.486	0.557	
	7046.60		0.00	0.00		22,506	28,634	0.517	0.657	
	7046.80		0.00	0.00		23,692	33,254	0.544	0.763	
	7047.00		0.00	0.00		24,730	38,096	0.568	0.875	
	7047.20		0.00	0.00		25,577	43,127	0.587	0.990	
	7047.40		0.00	0.00		26,259	48,310	0.603	1.109	
10-YR WSEL	7047.60		0.00	0.00		26,971	53,633	0.619	1.231	1.15 REQUIRED
	7047.80		0.00	0.00		27,873	59,118	0.640	1.357	
	7048.00		0.00	0.00		28,982	64,803	0.665	1.488	
100-YR WSEL	7048.20		0.00	0.00		30,276	70,729	0.695	1.624	1.52 REQUIRED
	7048.40		0.00	0.00		31,774	76,934	0.729	1.766	

RESTRICTOR PLATE SIZING FOR CIRCULAR VERTICAL ORIFICES

Project: Woodman View Storage Final Drainage

Basin ID: _____

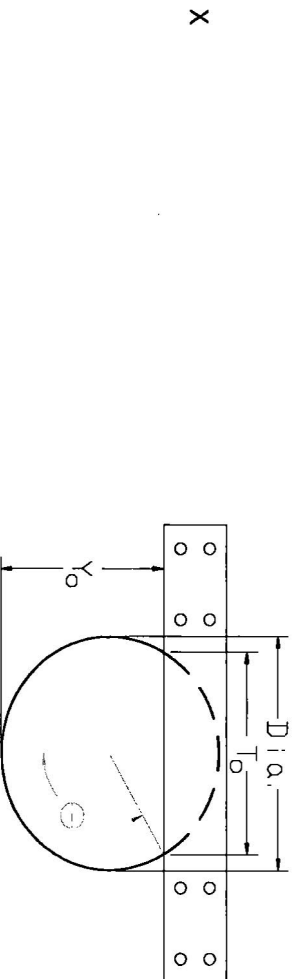

Sizing the Restrictor Plate for Circular Vertical Orifices or Pipes (Input)

Water Surface Elevation at Design Depth
 Pipe/Vertical Orifice Entrance Invert Elevation
 Required Peak Flow through Orifice at Design Depth
 Pipe/Vertical Orifice Diameter (Inches)
 Orifice Coefficient

	#1 Vertical Orifice	#2 Vertical Orifice
Elev: WS =	7.047.74	
Elev: Invert =	7.042.67	
Q =	8.05	
Dia =	18.0	
C _o =	0.65	

Full-flow Capacity (Calculated)

Full-flow area
 Half Central Angle in Radians
 Full-flow capacity

Af =	1.77		sq ft
Theta =	3.14		rad
Qf =	19.2		cfs
Percent of Design Flow =	238%		

Calculation of Orifice Flow Condition

Half Central Angle ($0 < \theta < 3.1416$)
 Flow area
 Top width of Orifice (Inches)
 Height from Invert of Orifice to Bottom of Plate (feet)
 Elevation of Bottom of Plate
 Resultant Peak Flow Through Orifice at Design Depth

Theta =	1.42		rad
A _o =	0.71		sq ft
T _o =	17.78		Inches
Y _o =	0.63		feet
Elev Plate Bottom Edge =	7.043.30		feet
Q _o =	8.1		cfs

Width of Equivalent Rectangular Vertical Orifice
 Centroid Elevation of Equivalent Rectangular Vertical Orifice

Equivalent Width =	1.13		feet
Equiv. Centroid El. =	7.042.99		feet

STAGE-DISCHARGE SIZING OF THE WEIRS AND ORIFICES (INLET CONTROL)

Project: Woodman View Storage Final Drainage
Basin ID: _____

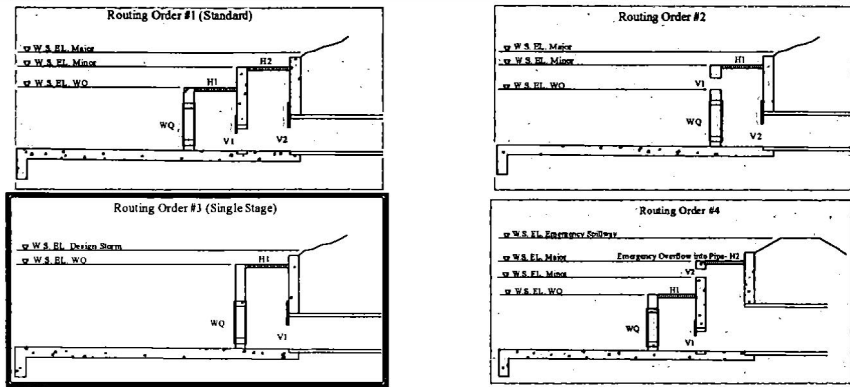

Current Routing Order is #3

Design Information (Input):

Circular Opening: Diameter in Inches
OR
 Rectangular Opening: Width in Feet
 Length (Height for Vertical)
 Percentage of Open Area After Trash Rack Reduction
 Orifice Coefficient
 Weir Coefficient
 Orifice Elevation (Bottom for Vertical)

	#1 Horiz.	#2 Horiz.	#1 Vert.	#2 Vert.	
Dia. =					inches
W =	2.92		1.55		ft.
L or H =	5.67		0.93		ft.
% open =	38		100		%
C _o =	0.65		0.65		
C _w =	2.55				
E _o =	7045.74		7,042.67		ft.

Calculation of Collection Capacity:

Net Opening Area (after Trash Rack Reduction)
 OPTIONAL: User-Override Net Opening Area
 Perimeter as Weir Length
 OPTIONAL: User-Override Weir Length

A _o =	6.21	1.44	sq. ft.
A _w =			sq. ft.
L _w =	13.53		ft.
L _w =			ft.
Top Elevation of Vertical Orifice Opening, Top =	7043.60		ft.
Center Elevation of Vertical Orifice Opening, Cen =	7043.14		ft.

Routing 3: Single Stage - Water flows through WQCV plate and #1 horizontal opening into #1 vertical opening. This flow will be applied to culvert sheet (#2 vertical & horizontal openings is not used).

Labels for WQCV, Minor, & Major Storage W.S. Elevations (input)	Water Surface Elevation ft (linked)	WQCV Plate/Riser Flow cfs (User-linked)	Horizontal Orifices				Vertical Orifices		Total Collection Capacity cfs (output)	Target Volumes for WQCV, Minor, & Major Storage Volumes (link for goal seek)
			#1 Horiz. Weir Flow cfs (output)	#1 Horiz. Orifice Flow cfs (output)	#2 Horiz. Weir Flow cfs (output)	#2 Horiz. Orifice Flow cfs (output)	#1 Vert. Collection Capacity cfs (output)	#2 Vert. Collection Capacity cfs (output)		
	7043.00	0.00	0.00	0.00	0.00	0.00	1.08	0.00	0.00	
	7043.20	0.01	0.00	0.00	0.00	0.00	2.20	0.00	0.01	
	7043.40	0.02	0.00	0.00	0.00	0.00	3.56	0.00	0.02	
	7043.60	0.03	0.00	0.00	0.00	0.00	5.12	0.00	0.03	
	7043.80	0.04	0.00	0.00	0.00	0.00	6.13	0.00	0.04	
	7044.00	0.05	0.00	0.00	0.00	0.00	6.99	0.00	0.05	
	7044.20	0.07	0.00	0.00	0.00	0.00	7.75	0.00	0.07	
	7044.40	0.09	0.00	0.00	0.00	0.00	8.45	0.00	0.09	
	7044.60	0.11	0.00	0.00	0.00	0.00	9.09	0.00	0.11	
	7044.80	0.13	0.00	0.00	0.00	0.00	9.69	0.00	0.13	
	7045.00	0.14	0.00	0.00	0.00	0.00	10.26	0.00	0.14	
	7045.20	0.17	0.00	0.00	0.00	0.00	10.79	0.00	0.17	
	7045.40	0.19	0.00	0.00	0.00	0.00	11.30	0.00	0.19	
	7045.60	0.21	0.00	0.00	0.00	0.00	11.79	0.00	0.21	
WQCV	7045.80	0.23	0.51	7.93	0.00	0.00	12.26	0.00	0.74	.30 REQUIRED
	7046.00	0.24	4.57	16.51	0.00	0.00	12.71	0.00	4.81	
	7046.20	0.25	10.76	21.97	0.00	0.00	13.15	0.00	11.01	
	7046.40	0.27	18.50	26.31	0.00	0.00	13.57	0.00	13.57	
	7046.60	0.28	27.52	30.03	0.00	0.00	13.98	0.00	13.98	
	7046.80	0.29	37.65	33.34	0.00	0.00	14.38	0.00	14.38	
	7047.00	0.30	48.80	36.35	0.00	0.00	14.77	0.00	14.77	
	7047.20	0.31	60.86	39.13	0.00	0.00	15.14	0.00	15.14	
	7047.40	0.33	73.79	41.73	0.00	0.00	15.51	0.00	15.51	
	7047.60	0.34	87.52	44.17	0.00	0.00	15.87	0.00	15.87	
10-YR WSEL	7047.80	0.35	102.01	46.48	0.00	0.00	16.22	0.00	16.22	1.15 REQUIRED
	7048.00	0.35	117.22	48.69	0.00	0.00	16.57	0.00	16.57	
100-YR	7048.20	0.36	133.12	50.80	0.00	0.00	16.90	0.00	16.90	1.52 REQUIRED
	7048.40	0.37	149.68	52.82	0.00	0.00	17.24	0.00	17.24	

STORM DRAINAGE SYSTEM DESIGN

WEIR DESIGN SPREADSHEET

PROJECT: Woodman View Storage
 CITY/COUNTY: Colorado Springs/El Paso

DATE: 7-May-10
 DESIGNER: JLT
 REVIEWER: TAJ

100 Year Weir must pass: 12.5 cfs Q = 100 year flow (29.4) - 100 year inlet capacity (16.9*)
 Emergency Weir must pass: 93.0 cfs Q = 100 year flow

Bottom of weir elevation = 7047.74 100-yr Available head = 0.31 feet
 100 Year water elev. = 7048.05 Emergency Overflow Available head= 1.26 feet
 Top of pond = 7049.00 Weir Coefficient = 3.1

Length of Rectangular Weir 22.8 FEET
 Side Slope 1 25% Angle 1 75.96 DEGREES
 Side Slope 2 25% Angle 2 75.96 DEGREES
 Total Angle For V-notch Weir 151.93

WSE	head (ft.)	Freeboard (ft.)	Rect weir (cfs)	v-notch (cfs)	total Q (cfs)	
7048.05	0.3	0.9	12.2	0.3	12.5	<----Q(100) Flow
7049.00	1.3	0.0	100.0	9.8	109.8	<----Q(Emergency) Flow

*Total Collection Capacity at 100-yr WSEL (see inlet control spreadsheet)

SUMMARY RUNOFF TABLE						
DESIGN POINT	BASIN	TOTAL AREA (ACRES)	Q10 (CFS)	TOTAL Q10 (CFS)	Q100 (CFS)	TOTAL Q100 (CFS)
HISTORIC						
H1	H-1	1.80	4.5	4.5	8.0	8.0
H2	H-2	0.45	2.2	2.2	3.4	3.4
H3	H-3	0.61	2.0	2.0	3.4	3.4
H4	H-4	1.80	6.0	6.0	10.4	10.4
H5	H-5	11.12	4.3	16.7	8.6	30.3
H6	H-6	5.63	13.2	13.2	25.7	25.7
H7	H-7	9.17	2.3	15.3	4.6	30.0
DEVELOPED						
1.00	A	1.80	4.5	4.5	8.0	8.0
2.00	B	0.85	2.2	2.2	3.4	3.4
3.00	C	2.64	2.9	7.2	4.9	12.5
4.00	D	7.43	22.8	22.8	43.0	43.0
5.00	E	19.69	32.5	57.4	52.1	92.7
6.00	F	0.48	2.3	2.3	3.7	3.7
7.00	G	0.12	0.6	2.9	0.9	4.6

WOODMEN VIEW S' ORAGE PLOT PLAN

LEGEND

- DEVELOPED BASIN DESIGNATION
 AREA (AC) 2.00 0.02 10-YR RUNOFF COEFFICIENT 0.91 100-YR RUNOFF COEFFICIENT
- HISTORIC BASIN DESIGNATION
 AREA (AC) 2.25 0.02 10-YR RUNOFF COEFFICIENT 0.90 100-YR RUNOFF COEFFICIENT
- HISTORIC BASIN BOUNDARY
- DEVELOPED BASIN BOUNDARY
- DRAINAGE ARROW
- DESIGN POINT
- EXISTING MAJOR CONTOUR (5') -5525
- EXISTING MINOR CONTOUR (1')
- PROPOSED MAJOR CONTOUR (5')
- PROPOSED MINOR CONTOUR (1')

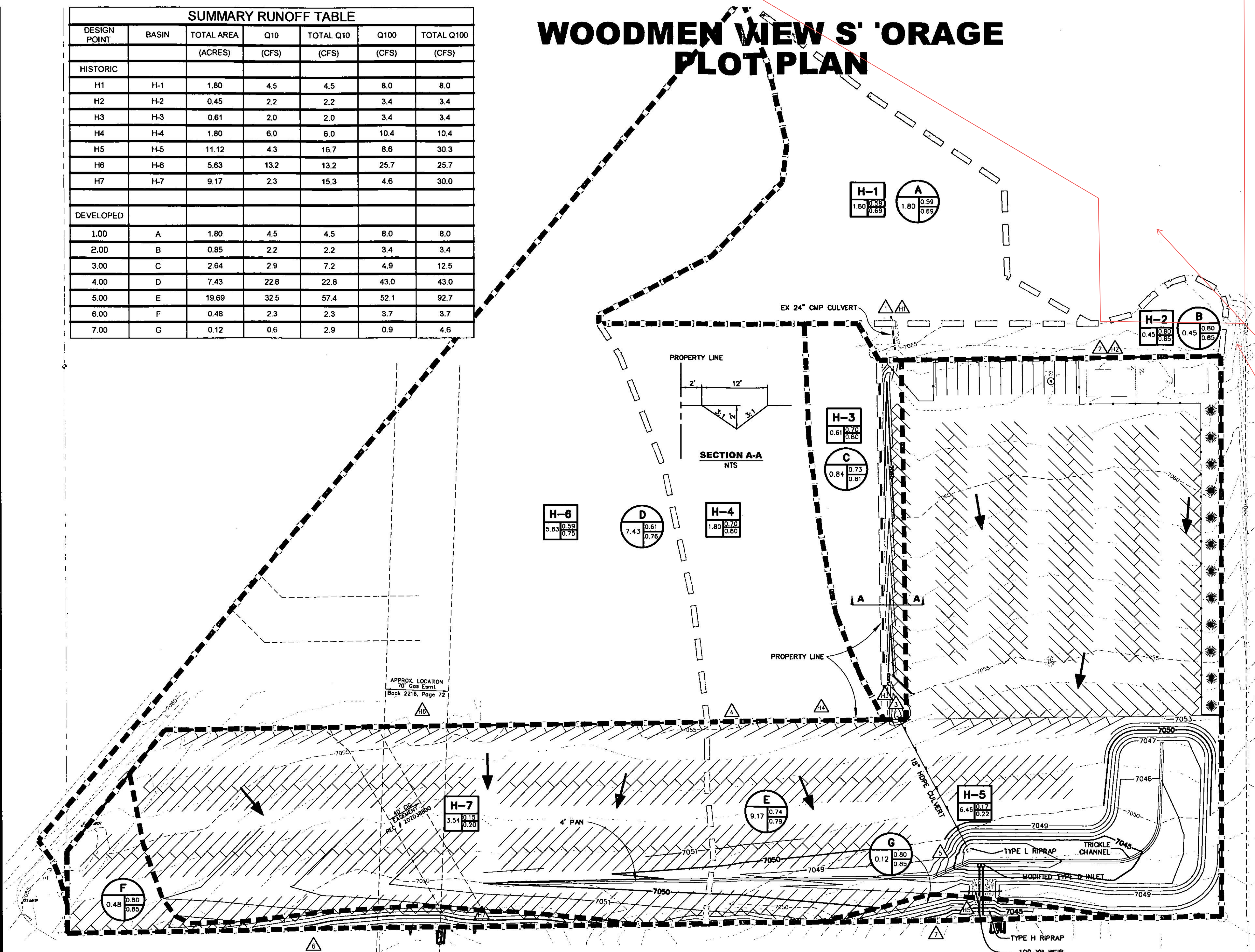

SITE
outfall point

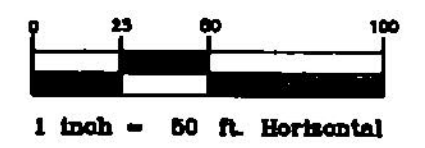

DETENTION POND	
V _{wo}	=0.30 AC-FT
WQ WSE	=7045.74
V ₁₀	=1.15 AC-FT
10 YR WSE	=7047.47
V ₁₀₀	=1.52 AC-FT
100 YR WSE	=7048.05
Q ₁₀ RELEASE	=16.1 cfs
Q ₁₀₀ RELEASE	=29.4 cfs

DATE	REVISION DESCRIPTION



Calibre
 ENGINEERING, INC.
 37660
 07-01-10
 PROFESSIONAL ENGINEER

WOODMEN VIEW STORAGE PLOT PLAN FINAL DRAINAGE REPORT
 JULY 1, 2010

DR1
 of 1 sheets
 Prepared by: P.W. RYAN/CALIBRE

2010 CALIBRE ENGINEERING, INC. ALL RIGHTS RESERVED. 11

PRELIMINARY PLAT

MC CLINTOCK STATION A SUBDIVISION

IN EL PASO COUNTY, COLORADO

DRAINAGE PLAN

LEGAL DESCRIPTION

A TRACT OF LAND BEING A PORTION OF THE WEST ONE-HALF OF THE WEST ONE-HALF OF SECTION 33 AND A PORTION OF THE NORTHEAST ONE-QUARTER OF THE SOUTHEAST ONE-QUARTER OF SECTION 32 ALL IN TOWNSHIP 12 SOUTH, RANGE 65 WEST OF THE 6TH PRINCIPAL MERIDIAN, SITUATE IN EL PASO COUNTY, COLORADO AND MORE PARTICULARLY DESCRIBED AS FOLLOWS:
 BEGINNING AT A POINT ON THE WEST LINE OF SAID SECTION 33, FROM WHICH THE WEST ONE-QUARTER OF SAID SECTION 33 REARS N 0° 22' 30" E, 54'.89 FEET, THENCE (1) S 0° 22' 30" W ON THE SAID WEST LINE OF SECTION 33, 91.87 FEET; (2) N 89° 42' 17" E, 1287.51 FEET; (3) N 0° 22' 33" E, 627.94 FEET; (4) S 89° 42' 17" W, 854.01 FEET; (5) N 39° 04' 18" E ON THE SOUTHEASTERLY RIGHT OF WAY LINE OF A COUNTY ROAD (VOLLMER ROAD), 77.61 FEET; (6) N 89° 42' 17" E, 296.35 FEET; (7) N 39° 04' 18" E, 80.00 FEET; (8) N 50° 45' 42" W, 229.11 FEET; (9) N 39° 04' 18" E ON THE SAID SOUTHEASTERLY RIGHT OF WAY LINE OF A COUNTY ROAD (VOLLMER ROAD), 1067.67 FEET; (10) S 0° 22' 33" W ON THE EAST LINE OF SAID WEST ONE-HALF OF SECTION 33, 2414.21 FEET; (11) S 89° 47' 03" W, 1317.49 FEET; (12) N 0° 22' 30" E ON THE WEST LINE OF SAID SECTION 33, 63'.27 FEET; (13) ANGLE LEFT 90° 00' 00" TO THE TANGENT OF A CURVE TO THE RIGHT, SAID CURVE HAVING A RADIUS OF 130.00 FEET, A CENTRAL ANGLE OF 38° 04' 18" FOR AN ARC LENGTH OF 87.80 FEET; (14) N 50° 55' 42" W, 13.67 FEET; (15) N 39° 04' 18" E ON THE AFORESAID SOUTHEASTERLY RIGHT OF WAY LINE OF A COUNTY ROAD (VOLLMER ROAD), 147.07 FEET TO THE POINT OF BEGINNING,
 CONTAINING 31.71 ACRES OF LAND, MORE OR LESS.

SUBDIVIDER:

J. MARCUS BROWN
 1120 NORTH CIRCLE DR. SUITE C
 COLO. SPRS, COLORADO 80909

1. SANITARY SEWER AND WATER RESPONSIBILITY OF INDIVIDUAL OWNER.
2. EASEMENTS: 10' EACH SIDE OF LOT LINE, 20' ADJACENT TO BOUNDARY LINE
3. CONTOUR INTERVAL (-5') FIVE FEET.

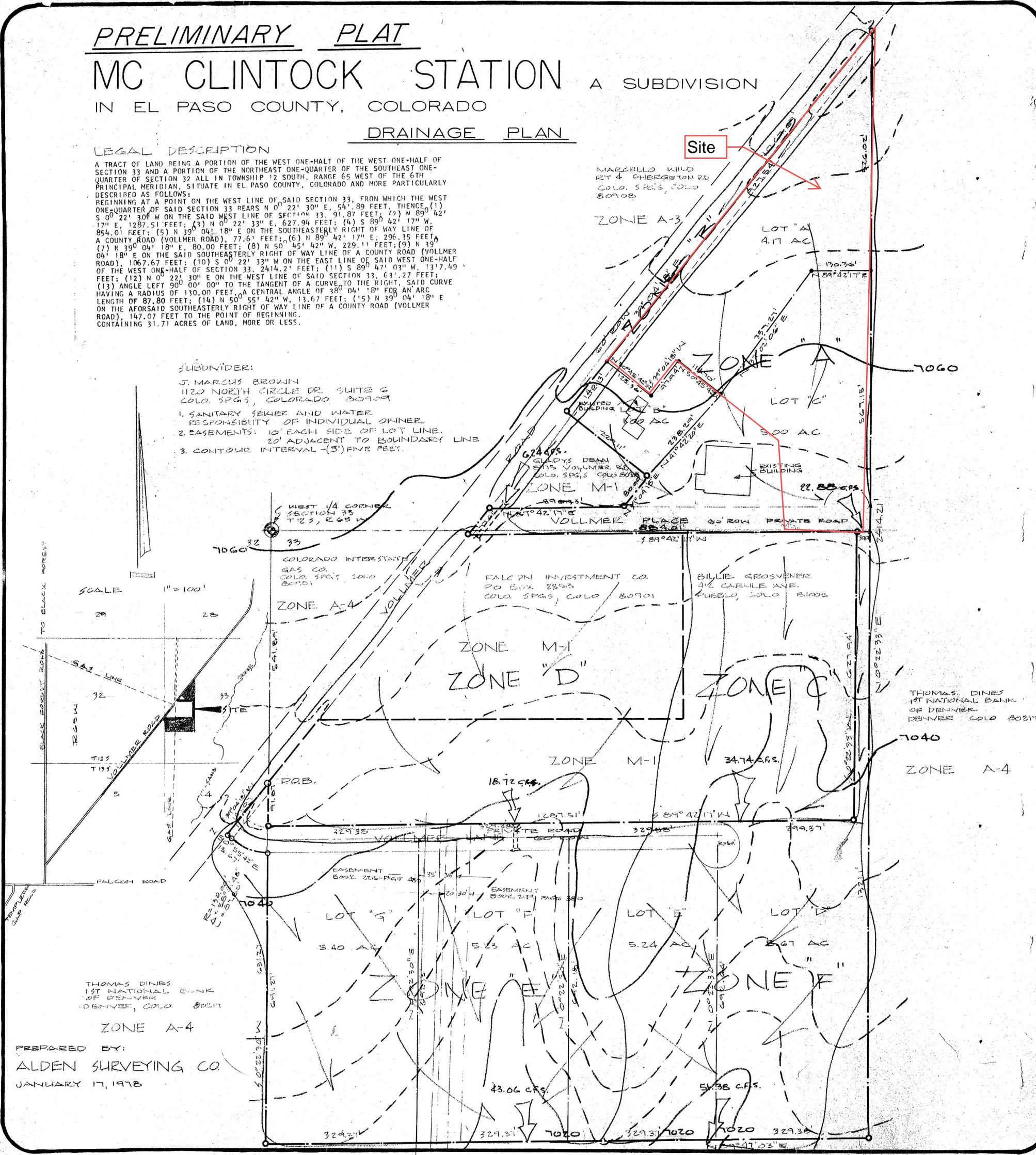

SCALE 1" = 100'

THOMAS DINES
 1ST NATIONAL BANK
 OF DENVER
 DENVER, COLO 80217

ZONE A-4
 PREPARED BY:
 ALDEN SURVEYING CO.
 JANUARY 17, 1978

Final Drainage Report
McClintock Station Filing No. 1A (Vollmer Road RV Storage)

APPENDIX E

DRAINAGE MAPS & PLANS

VOLLMER RV STORAGE

EXISTING DRAINAGE MAP

BASIN SUMMARY TABLE

Tributary Sub-basin	Area (acres)	Percent Impervious	C _s	C ₁₀₀	t _c (min)	Q _s (cfs)	Q ₁₀₀ (cfs)
EX-1	0.48	2%	0.09	0.36	15.2	0.2	1.0
EX-2	3.41	2%	0.09	0.36	23.4	0.9	5.9
EX-3	0.56	2%	0.09	0.36	11.4	0.2	1.3
EX-4	0.73	11%	0.16	0.41	18.2	0.4	1.6
EX-5	1.66	4%	0.11	0.37	26.5	0.5	2.8
OS-6	0.14	36%	0.37	0.57	5.0	0.3	0.7
OS-7	0.27	30%	0.32	0.53	5.0	0.4	1.2
OS-8	0.41	32%	0.34	0.54	10.0	0.6	1.5
OS-9	0.52	41%	0.40	0.58	17.3	0.7	1.7
OS-11	0.12	2%	0.09	0.36	10.0	0.0	0.3

DESIGN POINT SUMMARY TABLE

DP#	Q _s -YR	Q ₁₀₀ -YR
1	0.2	1.0
1.1	0.3	1.5
2	0.9	5.9
2.1	1.5	7.6
3	0.2	1.3
4	0.4	1.6
5	0.5	2.8
5.1	2.8	12.8
6	0.3	0.7
7	0.4	1.2
8	0.6	1.5
9	0.7	1.7
9.1	2.4	10.5
O11	0.0	0.3

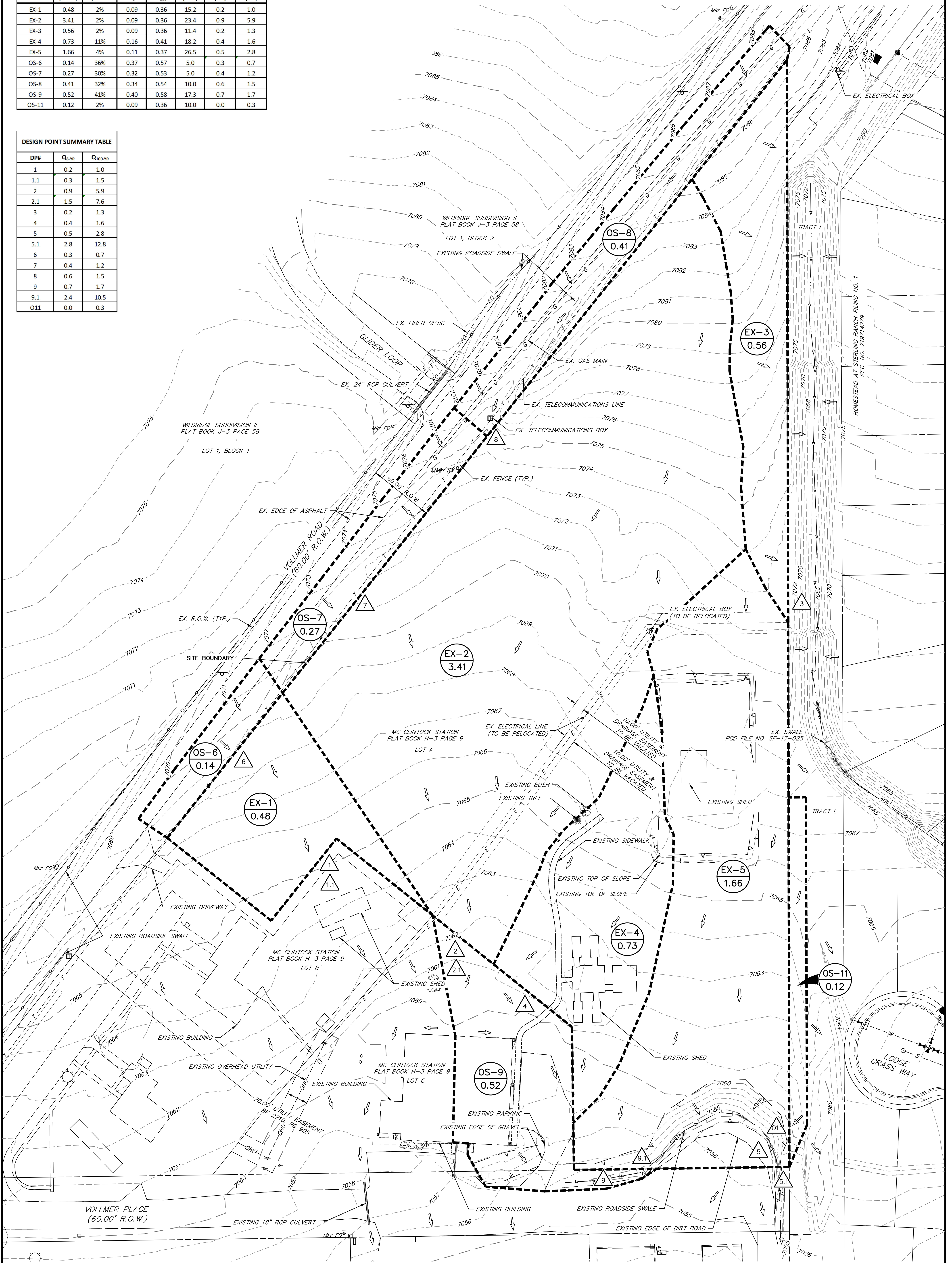

THE LOCATIONS OF EXISTING ABOVE GROUND AND UNDERGROUND UTILITIES ARE SHOWN IN AN APPROXIMATE WAY ONLY. THE CONTRACTOR SHALL DETERMINE THE EXACT LOCATION OF ALL EXISTING UTILITIES BEFORE COMMENCING WORK. THE CONTRACTOR SHALL BE FULLY RESPONSIBLE FOR ANY AND ALL DAMAGES WHICH MIGHT BE CAUSED BY HIS FAILURE TO EXACTLY LOCATE AND PRESERVE ANY AND ALL ABOVE GROUND AND UNDERGROUND UTILITIES.



LEGEND:

- 6000 — EXISTING MAJOR CONTOUR
- - - - - EXISTING MINOR CONTOUR
- DRAINAGE BASIN
- (A) A = BASIN DESIGNATION
- (B) B = AREA IN ACRES
- △ DESIGN POINT
- EXISTING DRAINAGE ARROW

EXISTING DRAINAGE MAP
 VOLLMER RV STORAGE
 JOB NO. 25251.00
 01/15/2024
 SHEET 1 OF 1

J-R ENGINEERING
 A Westrian Company
 Centennial 303-740-9393 • Colorado Springs 719-593-2593
 Fort Collins 970-491-9888 • www.jrengineering.com

LEGEND.

- 6000— PROPOSED MAJOR CONTOUR
 - PROPOSED MINOR CONTOUR
 - 6000— EXISTING MAJOR CONTOUR
 - EXISTING MINOR CONTOUR
 - DRAINAGE BASIN
-
- | | |
|---|-------------------------------|
| A | A = BASIN DESIGNATION |
| B | B = AREA IN ACRES |
| C | C = 5-YR RUNOFF COEFFICIENT |
| D | D = 100-YR RUNOFF COEFFICIENT |
-
- △ DESIGN POINT
 - DRAINAGE ARROW
 - ← EXISTING DRAINAGE ARROW

VOLLMER RV STORAGE PROPOSED DRAINAGE MAP

DESIGN POINT SUMMARY TABLE

DP#	Q _{5-YR}	Q _{100-YR}
1	4.2	8.4
2	7.0	13.5
2.1	11.1	21.6
3	4.8	9.5
3.1	15.7	30.7
4	1.6	3.7
5	0.1	0.5
6	0.0	0.2
7	0.1	0.8
7.1	0.8	2.2
8	0.1	0.3
9	0.5	1.2
9.1	2.0	9.1
O9	0.7	1.7
O10	0.9	2.4
O11	0.0	0.3
O11.1	0.1	0.5
P1	0.8	5.7

BASIN SUMMARY TABLE

Tributary Sub-basin	Area (acres)	Percent Impervious	C _s	C ₁₀₀	t _t (min)	Q _s (cfs)	Q ₁₀₀ (cfs)
A	1.43	69%	0.65	0.77	7.7	4.2	8.4
B	2.20	79%	0.72	0.83	8.3	7.0	13.5
C	1.57	75%	0.69	0.81	8.1	4.8	9.5
D	0.82	47%	0.47	0.64	9.2	1.6	3.7
E	0.17	8%	0.14	0.40	7.1	0.1	0.5
F	0.07	2%	0.09	0.36	7.9	0.0	0.2
G	0.24	2%	0.09	0.36	5.0	0.1	0.8
H	0.11	2%	0.09	0.36	5.0	0.1	0.3
I	0.24	47%	0.46	0.63	6.4	0.5	1.2
OS-9	0.52	41%	0.40	0.58	17.3	0.7	1.7
OS-10	0.81	31%	0.33	0.54	18.3	0.9	2.4
OS-11	0.12	2%	0.09	0.36	10.0	0.0	0.3

THE LOCATIONS OF EXISTING ABOVE GROUND AND UNDERGROUND UTILITIES ARE SHOWN IN AN APPROXIMATE WAY ONLY. THE CONTRACTOR SHALL DETERMINE THE EXACT LOCATION OF ALL EXISTING UTILITIES BEFORE COMMENCING WORK. THE CONTRACTOR SHALL BE FULLY RESPONSIBLE FOR ANY AND ALL DAMAGES WHICH MIGHT BE CAUSED BY HIS FAILURE TO EXACTLY LOCATE AND PRESERVE ANY AND ALL ABOVE GROUND AND UNDERGROUND UTILITIES.

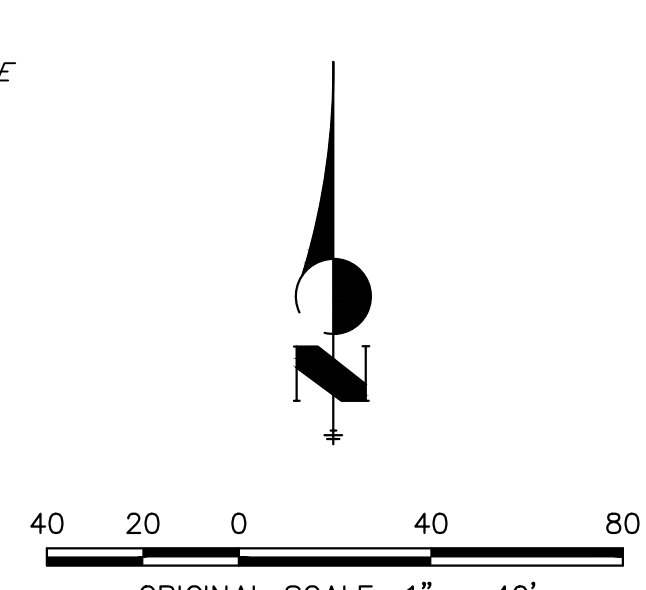
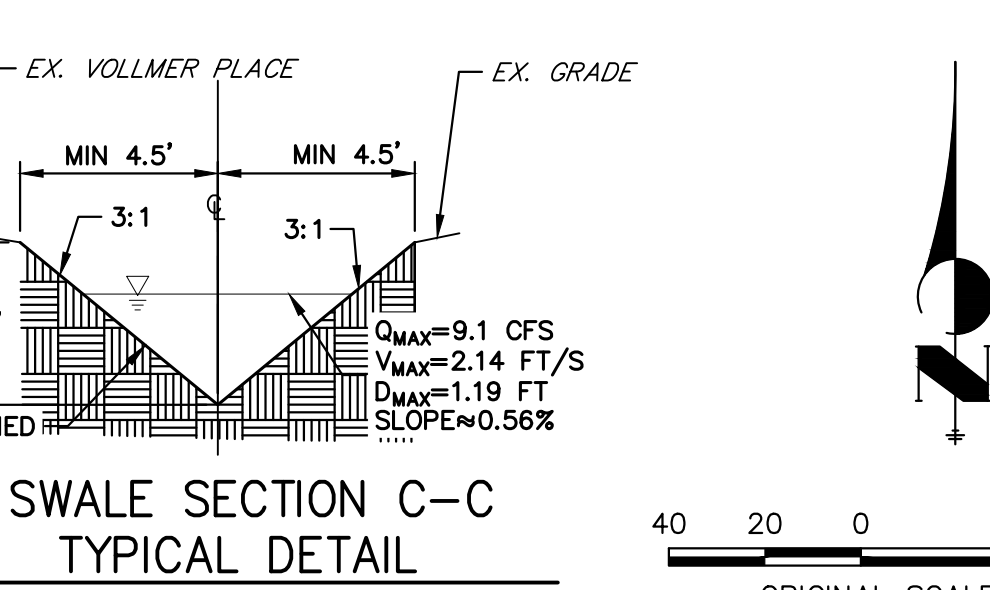
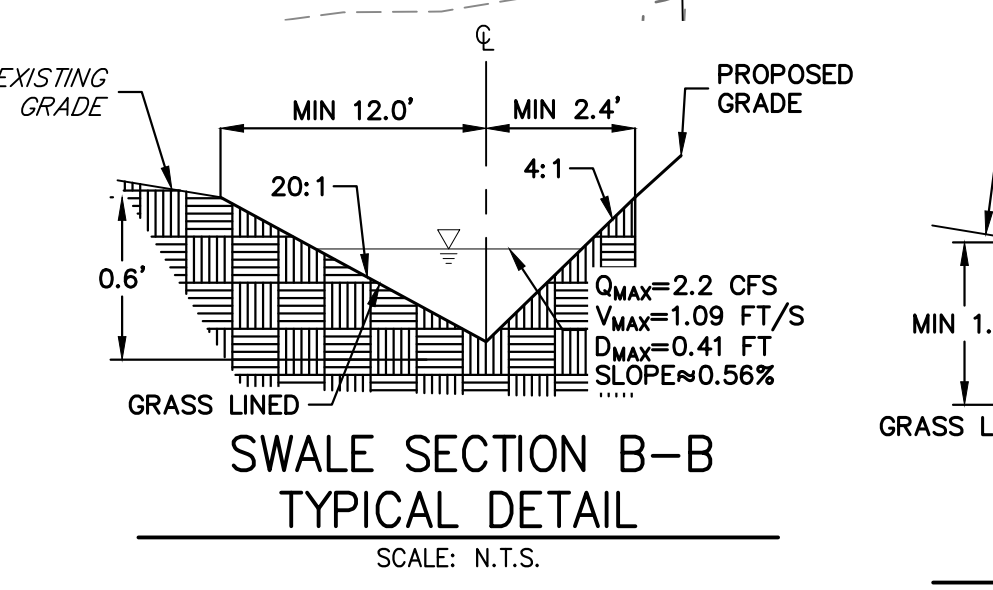
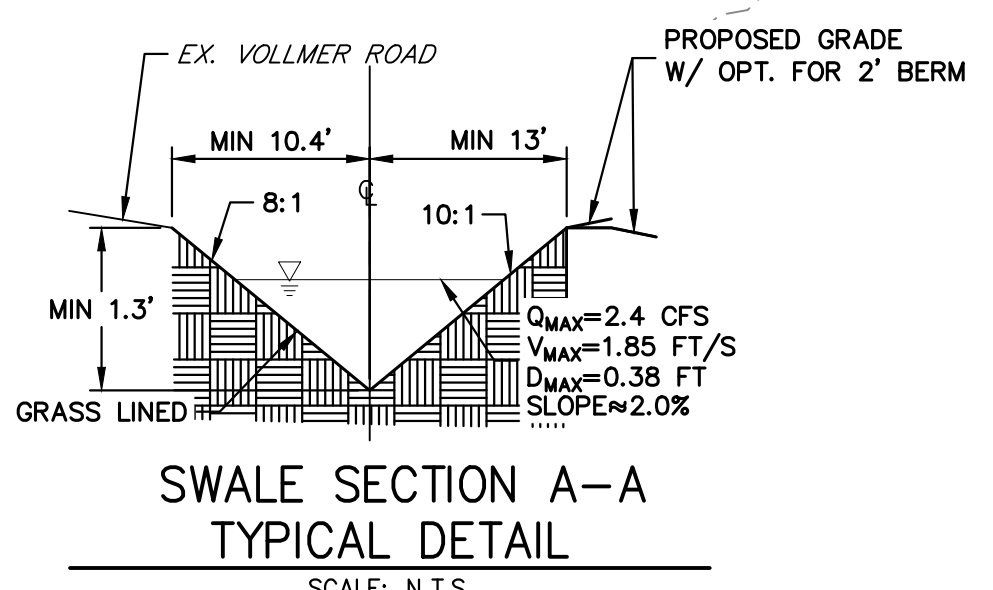
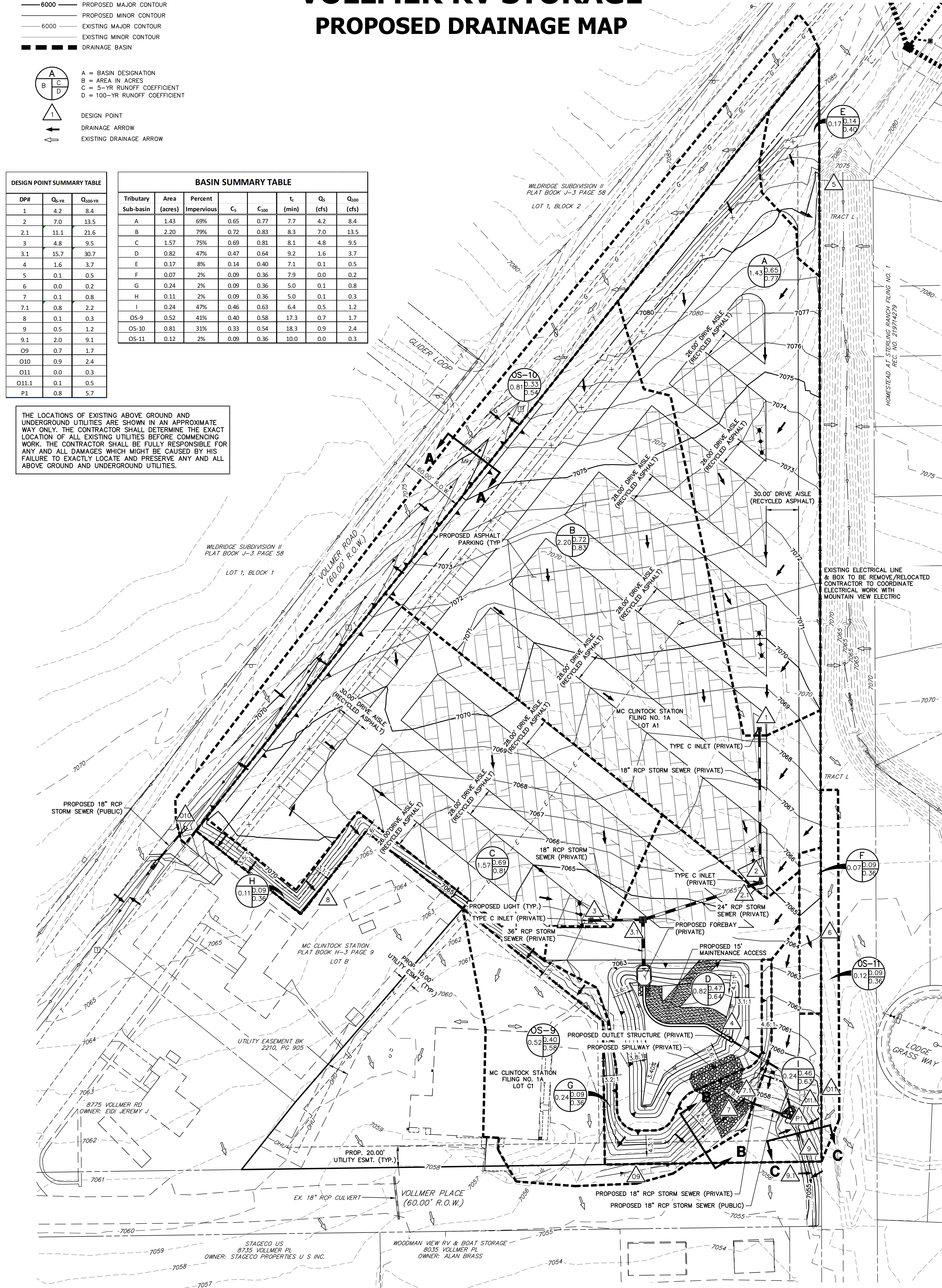

PROPOSED DRAINAGE MAP
VOLLMER RV STORAGE
JOB NO. 25251.00
02/08/2024
SHEET 1 OF 1

J-R ENGINEERING
A Westrian Company

Centennial 303-740-9393 • Colorado Springs 719-593-2593
Fort Collins 970-491-9888 • www.jrengineering.com

VOLLMER RV STORAGE

PROPOSED CONDITION WATER QUALITY MAP

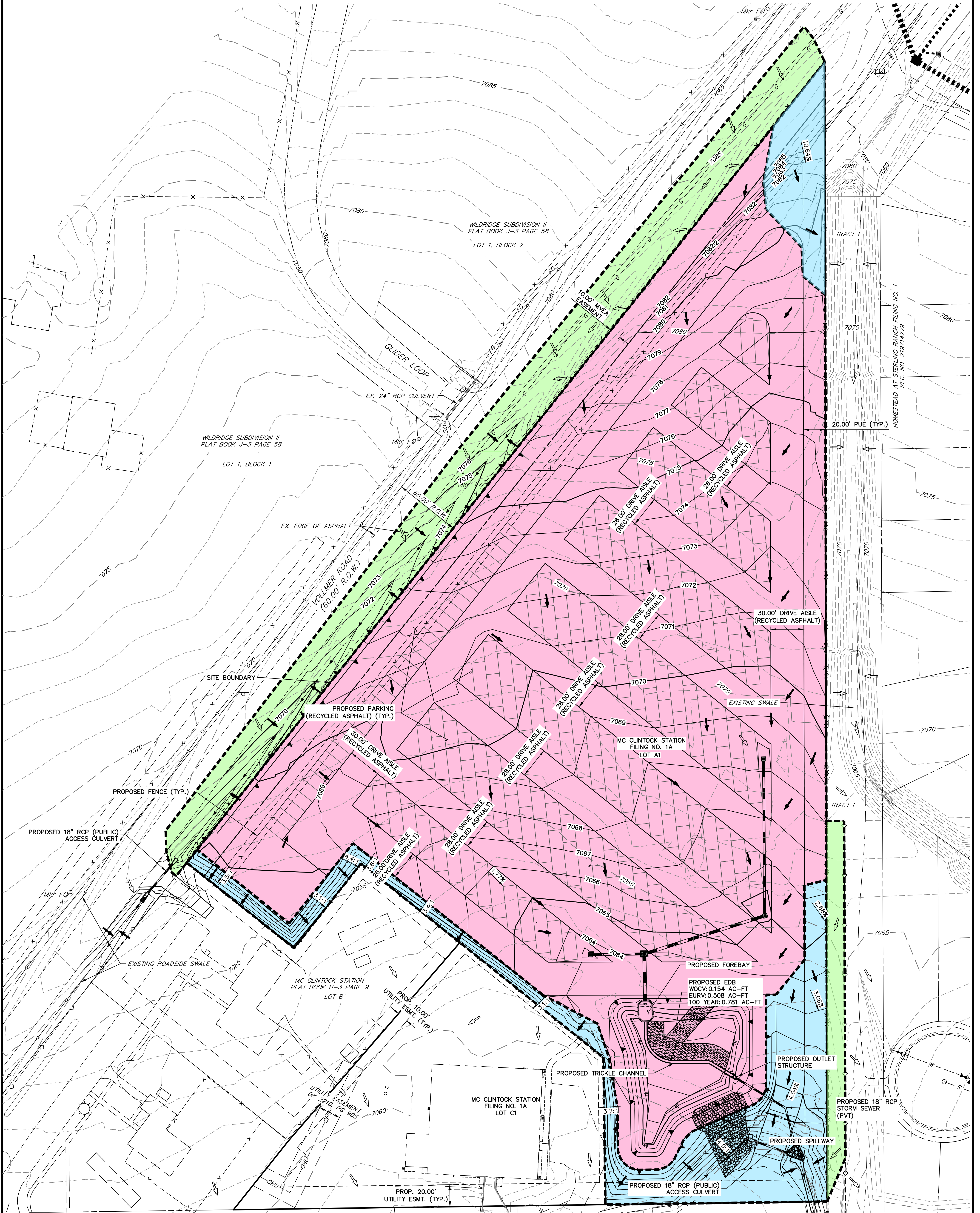

LEGEND

	AREA DRAINS TO PROPOSED EDB: 6.02 AC (87% OF TOTAL SITE)
	EXCLUDED APPLICABLE DEVELOPMENT AREA TO DRAIN OFFSITE: 0.83 AC (12% OF TOTAL SITE) (SEE NOTE)
	OFFSITE DRAINAGE TO DRAIN OFFSITE: 0.93 AC
<hr/>	
TOTAL SITE AREA	6.4 ACRES

NOTE: PER ECM 1.7.C.d UP TO 20% NOT TO EXCEED 1 ACRE OF THE APPLICABLE DEVELOPMENT SITE MAY BE EXCLUDED WHERE IT IS NOT PRACTICAL TO CAPTURE RUNOFF. THIS CRITERIA HAS BEEN MET AS SHOWN IN THE DESIGN ABOVE.

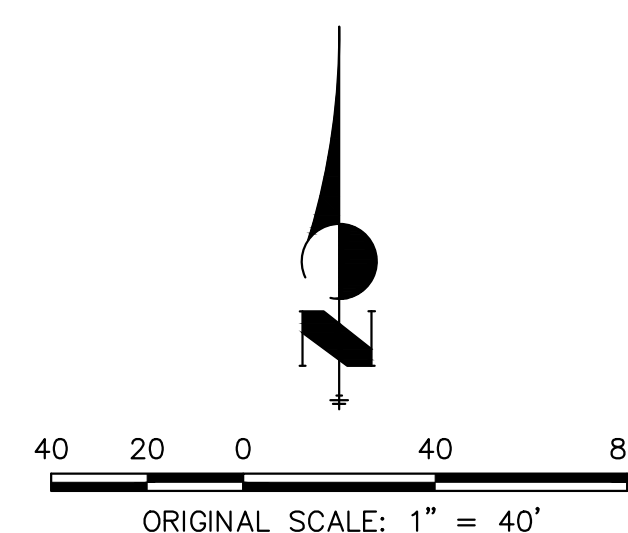

VOLLMER RV STORAGE
 WATER QUALITY MAP
 JOB NO. 2525100
 01/15/2024
 SHEET 1 OF 1

J-R ENGINEERING
 A Westrian Company

Centennial 303-740-9393 • Colorado Springs 719-593-2593
 Fort Collins 970-491-9888 • www.jrengineering.com