

**FINAL DRAINAGE REPORT
FOR
LATIGO TRAILS FILING NO. 9
AND
ADDENDUM TO MASTER DEVELOPMENT/
PRELIMINARY DRAINAGE PLAN
FOR LATIGO TRAILS,
EL PASO COUNTY, COLORADO**

September 2021

Prepared For:

BRJM, LLC
101 N. Cascade, Suite 200
Colorado Springs CO 80903
(719) 475-7474

Prepared By:

JR ENGINEERING
5475 Tech Center Drive
Colorado Springs, CO 80919
(719) 593-2593

Job No. 25175.01

Add "PCD File No. SF-21-037"

**Final Drainage Report Latigo Trails Filing 9
& Addendum to MDDP/Preliminary Plan Latigo Trails**

ENGINEER'S STATEMENT:

The attached drainage plan and report were prepared under my direction and supervision and are correct to the best of my knowledge and belief. Said drainage report has been prepared according to the criteria established by El Paso County for drainage reports and said report is in conformity with the master plan of the drainage basin. I accept responsibility for any liability caused by any negligent acts, errors, or omissions on my part in preparing this report.

Mike Bramlett, Colorado P.E. # 32314
For and On Behalf of JR Engineering, LLC

Date

DEVELOPER'S STATEMENT:

I, the developer, have read and will comply with all of the requirements specified in this drainage report and plan.

Business Name: BRJM, LLC

By: _____
Bob Irwin

Title: _____
Address: 101 N. Cascade, Suite 200
Colorado Springs CO 80903

El Paso County:

Filed in accordance with the requirements of the El Paso County Land Development Code, Drainage Criteria Manual, Volumes 1 and 2 and Engineering Criteria Manual, as amended.

Jennifer Irvine, P.E.
County Engineer/ ECM Administrator

Date

Conditions:



CONTENTS

PURPOSE	1
GENERAL LOCATION AND DESCRIPTION	1
LOCATION	1
DESCRIPTION OF PROPERTY	1
FLOODPLAIN STATEMENT	1
MAJOR DRAINAGE BASINS AND SUBBASINS	2
ADDENDUM TO MASTER DEVELOPMENT/ PRELIMINARY DRAINAGE PLAN	2
MAJOR BASIN DESCRIPTIONS	2
PROPOSED SUB-BASIN DRAINAGE.....	7
DRAINAGE DESIGN CRITERIA	11
DEVELOPMENT CRITERIA REFERENCE	11
HYDROLOGIC CRITERIA	11
HYDRAULIC CRITERIA	11
DRAINAGE FACILITY DESIGN	12
GENERAL CONCEPT	12
SPECIFIC DETAILS	12
<i>Four Step Process to Minimize Adverse Impacts of Urbanization</i>	<i>12</i>
EROSION CONTROL PLAN:	13
OPERATION AND MAINTENANCE:	13
DRAINAGE AND BRIDGE FEES:	13
SUMMARY:	14
REFERENCES:	14

APPENDICES

- A. Figures and Exhibits
- B. Hydrologic Calculations
- C. Hydraulic Calculations
- D. Detention and Water Quality Calculations
- E. Reference Materials
- F. Drainage Maps

LIST OF TABLES:

- 1. Historical Flow Comparison UBS
- 2. Drainage & Bridge Fees



PURPOSE

The purpose of this report is to serve as the Final Drainage Report for Latigo Trails Filing 9 known as the “site” from herein, and to amend the “Master Development/Preliminary Drainage Plan for Latigo Trails” (MDDP) by URS, dated October 2001. The proposed Latigo Trails Development that this report covers, known herein as the “proposed development” consists of five filings (9-13). Filing 9 will be discussed further in this report.

This drainage study identifies and analyzes the proposed drainage patterns, determines proposed runoff quantities, sizes drainage facilities, presents solutions to on and off-site drainage impacts resulting from this development, and safely routes developed storm water runoff to the appropriate outfall facilities as delineated in previous reports.

GENERAL LOCATION AND DESCRIPTION

Location

The proposed site is located within portions of Sections 8, 9, 16, & 17, Township 12 South, Range 64 West of the 6th Principal Meridian, El Paso County, Colorado. The site is bound by Latigo Boulevard to the North, The Trails Filling No. 8 to the West, and by future Latigo Trails Filings No. 11 and 12 to the South and East. A vicinity map is presented in Appendix A.

Description of Property

The proposed Latigo Trails Development contains approximately 497 acres and will be comprised of 179, 2.5 acre lots or larger. Filing 9 consists of 37 of the lots and is 101.6 acres. The site is currently unoccupied and undeveloped. The existing ground cover is sparse vegetation and open space, typical of a Colorado rolling range land condition. It should be noted that Filings 2, 7, and 8 are currently developed, and therefore, this report covers the undeveloped portions, including Filings 9 – 13. Previously developed areas part of the 2001 MDDP for Latigo Trails by URS, will remain unchanged and as is.

The site is split by a major basin boundary. Approximately 27.7 acres will drain to the Gieck Ranch basin, while the remaining 73.9 acres is tributary to the Upper Black Squirrel basin. In general the Upper Black Squirrel basin drains from southwest to northeast across the site, while the Gieck Ranch basin flows from northwest to southeast.

Per a NRCS web soil survey of the area, the site is made up of B soils. Type B soils have a moderate infiltration when thoroughly wet. A NRCS soil survey map has been presented in Appendix A.

Floodplain Statement

Based on the FEMA FIRM Map number 08041C0339G, dated December 7, 2018, the site lies within Zone A, Zone AE, and Zone X. Zone A is defined as areas subject to inundation by the 1-percent-

**Final Drainage Report Latigo Trails Filing 9
& Addendum to MDDP/Preliminary Plan Latigo Trails**

annual-chance flood determined using approximate methodologies because BFEs have not been established. Zone AE is defined as area subject to inundation by the 1-percent-annual-chance flood event. Zone X is defined as area outside the Special Flood Hazard Area (SFHA) and higher than the elevation of the 0.2-percent-annual-chance (or 500-year) flood. All proposed development within the site will occur in Zone X.

MAJOR DRAINAGE BASINS AND SUBBASINS

Addendum to Master Development/ Preliminary Drainage Plan

For Latigo Trails Filing 9, The Master Development/Preliminary Drainage Plan for Latigo Trails, by URS, will be amended as follows:

- a. The hydrology below existing Pond S12 has been modified per this study and current land plan. All hydrology has been updated per current El Paso County criteria.
- b. The storm water runoff within the UBS Creek Major Drainage Basin from Trails Filings 2, 7, 8, 9, 11, 12, & 13, will be conveyed north by a system of swales, and culverts to the proposed Black Squirrel Pond, a full spectrum EDB. This will replace the existing temporary retention/WQ pond (WQCVP) located southwest of the intersection of Latigo Blvd & Eastonville Road.
- c. The existing WQCVP southwest of the Latigo Blvd and Eastonville Road intersection will be modified to accept and provide WQCV for the proposed Filing 9 site part of the Upper Black Squirrel Basin.
- d. Proposed Pond G18 has been sized and designed to meet 2021 El Paso County Drainage Criteria. Ponds G1, G19, and G11 (“South Pond”) will be evaluated with the development of future filings (10-13) and the MDDP shall be amended as needed.

Major Basin Descriptions

The site lies within two major drainage basins: the Gieck Ranch Drainage Basin and the Upper Black Squirrel Drainage basins. A Master Development Drainage Plan (MDDP) has been approved for Latigo Trails and is titled “Master Development/Preliminary Drainage Plan for Latigo Trails,” by URS, dated October 2001; it is referenced and used as a Master Plan for the project. The “Final Drainage Report for The Trails Filing No. 8 and Addendum to Master Development/Preliminary Drainage Plan,” by JR Engineering, dated January 3, 2007, is also referenced for this report as is the “Final Drainage Report for The Trails Filing No. 7 Subdivision,” by URS, dated March 07, 2005. Referenced reports can be found in Appendix D.

The proposed development is split by a major basin boundary. Approximately 263 acres will drain to the Gieck Ranch basin, while the remaining 234 acres is tributary to the Upper Black Squirrel basin. In general the Upper Black Squirrel basin drains from southwest to northeast across the proposed development, while the Gieck Ranch basin flows from northwest to southeast.

Hydrology

**Final Drainage Report Latigo Trails Filing 9
& Addendum to MDDP/Preliminary Plan Latigo Trails**

With the development of the Trails Filing 8, Pond S12 was made a permanent full spectrum Extended Detention Basin (EBD). It provides water quality and detention for developed portions of Filing 2, 7 and 8 and releases flows into the Upper Black Squirrel portion of the development, part of Filing No. 9 (the Site). This flow will be combined with developed flows from Filings 9, 11, 12, & 13 upon full-build out/ultimate condition and routed to the proposed Full Spectrum Black Squirrel Pond. The existing WQCVP discussed in the Filing No. 8 FDR/MDDP will be removed upon construction of the Black Squirrel Pond, to be built with future Filings (11/12/13).

Due to changes in criteria, design storms, rainfall depths, and modified land plans, detention and water quality sizing methodologies, and a pond in series condition, JR Engineering has provided updated hydrology and routing utilizing CUHP/SWMM for developed portions of the Development (Filings 9, 11, 12, & 13) within the Upper Black Squirrel drainage basin. See Appendix B for applicable Hydrologic Calculations and the Black Squirrel Pond design.

Revise rainfall depths per the current criteria. See City DCM Chapter 6 Table 6-2 (Also noted in pg 11 of this FDR) 2.7" and 4.6"

The CUHP/SWMM models run utilized the following

- Design Storms: 5-year & 100-year 24-hour storm, type II Design Storm Distribution, <10 mi², Table 6-4 (DCM)
- Rainfall Depths: ~~2.4" and 4.4"~~ respectively (matches URS MDDP)
- Historic Analysis basin parameters:
 - 2% imperviousness
 - 0.6' nervous depression storage
 - 0.1'
 - DC
- Proposed A
 - Cor
 - 0.3'
 - 0.0:
 - DC

CUHP BASIN RUNOFF SUMMARY TABLE- HISTORICAL CONDITIONS							
		INTERIM			ULTIMATE		
Basin	% IMP	Area(AC)	Q5(CFS)	Q100(CFS)	Area (AC)	Q5(CFS)	Q100(CFS)
H-1	2%	191.5	159	284	284.2	260	459
H-2	2%	455.4	328	589	455.4	328	589

Historic Condition Analysis
Ultimate Condition/Full-Build Out

Update.

This report has re-studied the portions of the Latigo Trails Development that are tributary to the Black Squirrel Creek and not detained in the existing Pond S12 for the purposes of determining the allowable release rate to the Upper Black Squirrel Creek. This area was found to be approximately 284 acres and delineated as Basin H-1. Because HEC-1 is no longer available on current operating systems, the analysis in this report was completed with CUHP/SWMM for the 5 and 100 year, 24-hour design storms for the historical/undeveloped conditions. Runoff from this basin was found to be Q5 = 274 cfs and Q100 = 482 cfs. See Appendix B for applicable calculations and printouts and Appendix F for the Historical Drainage Map.

Interim Condition/F9 Only

**Final Drainage Report Latigo Trails Filing 9
& Addendum to MDDP/Preliminary Plan Latigo Trails**

For the purposes of sizing the proposed, Interim (F9 developed) condition Black Squirrel Pond, an interim, historical conditions model was created to determine the historical/pre-development runoff from the area contiguous with the interim Pond, is proposed to be located where the FDR/MDDP by JR Engineering) and the pond southwest of the Latigo Blvd. and Eastonville Road. The pond has a tributary basin of approximate $Q_5 = 159$ cfs, and $Q_{100} = 284$ cfs.

Proposed Conditions Analysis:

Ultimate Condition/Full-Build Out

The proposed, ultimate condition was analyzed for areas Tributary to the Upper Black Squirrel Creek utilizing a CUHP/SWMM model for the 5 and 100 year, 24-hour storm events, as the total area of this basin is well over the limitations of the rational method, and existing Pond S12's controlled release is routed through the proposed development. The proposed ultimate condition basins include 2.5 acre lots w/ an assumed 10,000 S.F roof area, and roadways. Basins BS-1, BS-2, and BS-3 are consistent in location and area with the Historic Condition Basin H-1. Runoff from proposed Basins BS-1, BS-2, and BS-3 will all be captured in the proposed Black Squirrel Pond, a Full Spectrum EDB. The Routed flow for the ultimate proposed condition at the proposed Black Squirrel Pond is $Q_5 = 292$ cfs and $Q_{100} = 501$ cfs.

Interim Condition/F9 Only

In the interim condition, only existing developed areas and the proposed Filing 9 development area that area part of the Black Squirrel Creek major drainage basin, will be captured in the proposed interim condition Black Squirrel Pond. This pond will also be in series with the existing Pond S-12. Because of this, a CUHP/SWMM model was also used to size the interim condition pond. The interim condition pond is located southwest of the intersection of Latigo Blvd, and Eastonville Road, and therefore, is upstream of the proposed CUHP/SWMM basins/nodes BS-3 and BS-4. Proposed CUHP/SWMM basins BS-1 and BS-2 were modified to only include the F9 developed areas, and existing developed areas part of previous filings. It was found that the total routed flow tributary to the interim pond was found to be $Q_5 = 194$ cfs, and $Q_{100} = 324$ cfs

Basin BS-4 will continue to follow existing drainage patterns and will discharge directly into Black Squirrel Creek, $Q_5 = 20$ cfs, $Q_{100} = 35$ cfs.

Black Squirrel Pond (Ultimate)

The Black Squirrel Pond is proposed to provide Water Quality and Detention, per Full-Spectrum Design methodology for all areas tributary to the Upper Black Squirrel Creek and part of the Latigo Trails Development per the ultimate conditions/full-build out. It will limit release rates to the Black Squirrel Creek to below historic levels. Because it will be in series with existing Pond S12, the

Explain why the existing WQCVP is being retrofitted to an EDP in the interim versus constructing the ultimate pond. It seems to be a significant cost to build a full EDB in the interim and then removing/replacing with the final pond just downstream.

Why not construct the ultimate pond and designing the orifice plate for the interim conditions. Subsequent filings would only have to modify the orifice plate.

**Final Drainage Report Latigo Trails Filing 9
& Addendum to MDDP/Preliminary Plan Latigo Trails**

proposed Black Squirrel Pond was sized utilizing a CUHP/SWMM model based on the following methodology:

- Provide Detention for ultimate condition of all areas tributary to the Upper Black Squirrel Creek that were not previously detained in the Existing S12 pond
- Provide WQ that was previously provided in Pond S12 (1.09 ac-ft per F8 MDDP/FDR) + WQ & EURV for all other developed areas tributary to the Upper Black Squirrel Creek (2.939 ac-ft total WQCV + .315 ac-ft EURV)
- 40 hour WQCV release time
- <=72 hour EURV release time
- Total release <= to historic rates

Add <= 120 hours 100yr drain time.

In order to size the proposed Upper Black Squirrel Pond, a new historical analysis of the areas downstream of existing Pond S12 was run utilizing CUHP/SWMM to determine the allowable release for the 5 and 100 year storms. A proposed, ultimate condition CUHP/SWMM model was then created for the tributary areas to the Proposed Upper Black Squirrel Pond which included the outflow hydrograph per the Latigo Trails Filing No. 8 FDR routed through the SWMM model to the proposed Upper Black Squirrel Pond. The inflow Hydrograph from the SWMM model for the proposed Black Squirrel Pond was then input into UD-Detention to design the outlet structure. The stage release curve was then input back into the SWMM model along the proposed stage-storage curve for the Upper Black Squirrel Pond to confirm sizing. The total required pond size below the spillway for WQCV, EURV, and detention was found to be approximately 6.1 ac-ft. See Appendices B and C for applicable calculations and supporting design information.

This pond is proposed to span nearly the entire length between the proposed twin (2) 3' x 10' box culverts underneath Latigo Blvd and the Black Squirrel Creek. Due to site topography, there is approximately only 0.1% of fall between the outlet end of the proposed box culverts and the Zone AE 100-yr water surface elevation in the Creek. Therefore, the maximum slope in this pond will be around 0.1% for its entire length.

Black Squirrel Pond (F9), modified WQCV from Filing No. 8 FDR

This report proposes to modify the existing retention and water quality pond located southwest of the intersection of the Latigo Blvd and Eastonville Road. The pond was sized with the same methodology, and modeling methods described for the “ultimate Black Squirrel Pond” above, however, all development outside of F9 was removed from the model/basin parameters. This model resulted in slightly higher than historic flows for both the 5 year and 100 year models, and therefore, the proposed pond was sized as a temporary, full-spectrum extended detention basin utilizing a CUHP/SWMM model in conjunction with UD-detention, as described above. See below for a summary of the pond design parameters:

- Provide Detention for F9 only interim condition of all areas tributary to the Upper Black Squirrel Creek that were not previously detained in the Existing S12 pond

**Final Drainage Report Latigo Trails Filing 9
& Addendum to MDDP/Preliminary Plan Latigo Trails**

- Provide WQ that was previously provided in Pond S12 (1.09 ac-ft per F8 MDDP/FDR) + WQ & EURV for all other developed areas tributary to the Upper Black Squirrel Creek (2.051 ac-ft total WQCV + 0.049 ac-ft EURV)
- Total Volume 8.0 ac-ft
- 40 hour WQCV release time
- ≤ 72 hour EURV release time
- Total release \leq to historic rates
 - Qin 5-yr = 183 cfs
 - Qout 5-yr = 162 cfs
 - Qin 100-yr = 318 cfs
 - Qout 100-yr = 284 cfs
- Access from on-site areas through easements, provide a stabilized access to pond bottom and outlet
- Emergency overflow will be directed to the proposed Latigo Box culverts

This pond will utilize an outlet design with a water quality plate/orifices to control the WQ and EURV release rates, and will utilize a concrete weir to control the release of larger storms. This weir will outfall to a graded channel that will direct water to the proposed twin (2) 3 foot x 10 foot box culverts underneath Latigo Boulevard to the north. Flows will then continue north in a graded channel sized for the 100 year peak flow, approximately 2000 feet to the Black Squirrel Creek. This swale will be graded at approximately 0.1% of slope for its entire length, which is all the difference in elevation between the proposed outlet end of the 3' x 10' Latigo Box culverts and the existing FEMA, 100-yr Zone AE flood plain allow.

Pond G18 Ultimate

Pond G18 has remained consistent in location and concept with the approved MDDP. However, it will be sized and designed per current criteria & full-spectrum design methodology, upon the development of future Latigo Trails Filing No. 11 and 12.

- WQCV = 0.020 ac-ft (per UD-BMP IRF spreadsheet)
- EURV = 0.064 ac-ft
- Total Volume = 0.218 ac-ft
- 40 hour WQCV release time
- ≤ 72 hour EURV release time
- Total release \leq to historic rates
 - Qin 5-yr = 183 cfs
 - Qout 5-yr = 162 cfs
 - Qin 100-yr = 318 cfs
 - Qout 100-yr = 284 cfs
- Access from on-site areas through easements, provide a stabilized access to pond bottom and outlet

**Final Drainage Report Latigo Trails Filing 9
& Addendum to MDDP/Preliminary Plan Latigo Trails**

- Emergency overflow will be directed to the proposed Latigo Box culverts

Pond G18 Interim/F9 Only

For the interim condition, Pond G18 was sized utilizing MHFD UD-Detention Versions 4.04. CUHP/SWMM was not needed for this pond, as it is not in series. For the interim pond sizing, the pond tributary basin included existing developed areas, undeveloped areas, and the proposed F9 developed areas in the composite percent imperviousness calculations. No other future development was considered. The pond was sized and designed to be a full-spectrum extended detention basin.

Proposed Sub-basin Drainage

The proposed basin delineation for Latigo Trails Filing 9 is as follows;

Basin A is approximately 11.48 acres and in its existing condition runoff generally flows northeast to the exiting swale along Latigo Boulevard. In the proposed condition, Basin A will be rural 2.5 acre lots and roadway. Runoff from this basin will be collected in road side swales and conveyed east to DP2 before reaching DP14.1 that outfall to the Black Squirrel Pond. The peak flow rate for Basin A in the 5 and 100-year storm are 5.1 cfs and 22.7 cfs, respectively.

Basin B is approximately 5.30 acres and in its existing condition runoff generally flows northeast across the site and into the exiting water quality retention pond at the southwest corner of the intersection of Latigo Boulevard and Eastonville Road. In the proposed condition, Basin B will be rural 2.5 acre lots and paved roadway. Runoff from this basin will be collected in road side swales and conveyed to DP4 where flow will be piped under Oregon Wagon Trail and continue in the proposed drainage system to DP14.1 where flow will enter the interim Black Squirrel Pond. The peak flow rate for Basin B in the 5 and 100-year storm are 2.4 cfs and 10.0 cfs, respectively.

Basin C is approximately 8.44 acres and in its existing condition runoff generally flows northeast across the site and into the exiting water quality retention pond at the southwest corner of the intersection of Latigo Boulevard and Eastonville Road. In the proposed condition, Basin C will be rural 2.5 acre lots and paved roadway. Runoff from this basin will be collected in road side swales and conveyed to DP5. Flow will continue through the proposed drainage system to the Black Squirrel Pond. The peak flow rate for Basin C in the 5 and 100-year storm are 5.3 cfs and 20.2 cfs, respectively.

Basin D is approximately 25.55 acres and in its existing condition runoff generally flows northeast across the site and into the exiting water quality retention pond at the southwest corner of the intersection of Latigo Boulevard and Eastonville Road. In the proposed condition, Basin D will be rural 2.5 acre lots and paved roadway. Runoff from this basin will be collected in road side swales and conveyed to DP8 where flow will be piped under Oregon Wagon Trail. Flow will continue

**Final Drainage Report Latigo Trails Filing 9
& Addendum to MDDP/Preliminary Plan Latigo Trails**

through the proposed drainage system and enter the Black Squirrel Pond. The peak flow rate for Basin D in the 5 and 100-year storm are 11.4 cfs and 46.7 cfs, respectively.

Basin E is approximately 2.54 acres and in its existing condition runoff flows northeast across the basin and into existing pond S12. In the proposed condition, Basin E will be rural 2.5 acre lots. No grading is proposed in this basin; therefor runoff from this basin will be conveyed to existing pond S12. The peak flow rate for Basin E in the 5 and 100-year storm are 1.1 cfs and 5.3 cfs, respectively.

Basin F is approximately 9.21 acres and in its existing condition runoff generally overland flows northeast across the site and into the exiting water quality retention pond at the southwest corner of the intersection of Latigo Boulevard and Eastonville Road. In the proposed condition, Basin F will be rural 2.5 acre lots and paved roadway. Runoff from this basin will be collected in road side swales and conveyed to DP10 where flow will be piped under Frenchman Trail and continue along the proposed drainage system before entering the Black Squirrel Pond. The peak flow rate for Basin F in the 5 and 100-year storm are 5.2 cfs and 21.0 cfs, respectively.

Basin G is approximately 13.73 acres and in its existing runoff generally overland flows northeast across the site and into the exiting water quality retention pond at the southwest corner of the intersection of Latigo Boulevard and Eastonville Road. In the proposed condition, Basin G will be rural 2.5 acre lots and paved roadway. Runoff from this basin will be collected in a proposed swale and conveyed to DP9 where flow will continue along the proposed drainage system and enter the Black Squirrel Pond at DP14.1. The peak flow rate for Basin G in the 5 and 100-year storm are 7.5 cfs and 30.7, respectively.

Basin H is approximately 9.93 acres and in its existing condition runoff flows northeast across the basin towards the existing roadside swale along Eastonville Road. In the proposed condition, Basin H will be rural 2.5 acre lots and paved roadway. Flows from this basin will be collected in a proposed ditch along Oregon Wagon Trail and Fontenelle Trail, which will be conveyed to the proposed drainage system to the Black Squirrel Pond. In the final condition, when Filings 11 and 12 are constructed, flows from the lots in this basin will be conveyed via swales and culverts to proposed Pond G19. In the interim condition developed, a maximum of 10% impervious and therefore, this basin can be excluded from permanent stormwater detention per Section I.7.B.5 of the ECM Stormwater Quality Policy and Procedures (2.5+ acre lots with imperviousness less than 10% can be excluded from permanent stormwater management practices). The peak flow rate for Basin H in the 5 and 100-year storm are 5.8 cfs and 24.0 cfs, respectively.

This exclusion is for the large lots only. WQ for the roadway still needs to be addressed. Staff recommends conducting a runoff reduction calculation to see if in the interim 100% WQCV reduction can be met. Recommend including the open area west of filing 9 for the RPA in the interim condition.

Basin I is approximately 7.44 acres and in its existing condition runoff generally flows east across the basin towards the existing roadside swale along Eastonville Road. In the proposed condition, Basin I will be rural 2.5 acre lots and paved roadway. In the final condition, when future Latigo Trails Filings 11 and 12 are constructed, flows will be conveyed via swales and culverts to proposed Pond G18. In the interim condition flows will travel through the proposed road side swale and be released

**Final Drainage Report Latigo Trails Filing 9
& Addendum to MDDP/Preliminary Plan Latigo Trails**

at the site boundary where flow will follow existing drainage patterns. A runoff reduction analysis for this basin was performed using Storm Water Best Management Practice Design Workbook V3.06 by Urban Drainage and Flood Control District. A 64.6% reduction in water quality control and a 55.8% reduction in detention for the 100 year event were awarded. Runoff from this basin will enter the proposed swale that outfall into proposed Pond G18. The peak flow rate for Basin I in the 5 and 100-year storm are 4.5 cfs and 18.2 cfs, respectively.

Basin J is approximately 5.62 acres and in its existing condition runoff generally flows southeast across the basin towards the existing roadside swale along Eastonville Road. In the proposed condition, Basin J will be rural 2.5 acre lots. In the final condition, when future Latigo Trails Filings 11 and 12 are constructed, flows from the lots in this basin will be conveyed via swales and culverts to proposed Pond G18. In the interim condition development will be limited to a maximum of 10% impervious and therefore, this basin can be excluded from permanent stormwater detention per Section I.7.1.B.5 of the ECM Stormwater Quality Policy and Procedures (2.5+ acre lots with imperviousness less than 10% can be excluded from permanent stormwater management practices). The peak flow rate for Basin J in the 5 and 100-year storm are 2.9 cfs and 13.6 cfs, respectively.

Basin K is approximately 0.68 acres and in its existing condition runoff generally flows south across the basin towards the southern boundary of Latigo Trails proposed development. In the proposed condition, Basin K will contain a portion of rural 2.5 acre lots. In the final condition, when future Latigo Trails Filings 11 and 12 are constructed, flows from the lots in this basin will be conveyed via swales and culverts to proposed Pond G18. In the interim condition development will be limited to a maximum of 10% impervious and therefore, this basin can be excluded from permanent stormwater detention per Section I.7.1.B.5 of the ECM Stormwater Quality Policy and Procedures (2.5+ acre lots with imperviousness less than 10% can be excluded from permanent stormwater management practices). The peak flow rate for Basin K in the 5 and 100-year storm are 0.35 cfs and 1.7 cfs, respectively.

Basin L is approximately 3.87 acres and in its existing condition runoff generally flows south across the basin and into the existing South Pond. In the proposed condition, Basin L will contain rural 2.5 acre lots. In the final condition, when future Latigo Trails Filings 11 and 12 are constructed, flows from the lots in this basin will be conveyed via swales and culverts to a modified South Pond. In the interim condition development will be limited to a maximum of 10% impervious and therefore, this basin can be excluded from permanent stormwater detention per Section I.7.1.B.5 of the ECM Stormwater Quality Policy and Procedures (2.5+ acre lots with imperviousness less than 10% can be excluded from permanent stormwater management practices). The peak flow rate for Basin L in the 5 and 100-year storm are 2.1 cfs and 9.4 cfs, respectively.

Basin O1 is approximately 32.63 acres and is comprised of existing rural 2.5+ acre residential lots and roadways. This basin will follow existing drainage patterns in the proposed condition. Runoff from Basin O1 will enter the site at DP1 before continuing in the roadside swale along Latigo

**Final Drainage Report Latigo Trails Filing 9
& Addendum to MDDP/Preliminary Plan Latigo Trails**

Boulevard that will outfall into the Black Squirrel Pond. The peak flow rates for Basin O1 in the 5 and 100-year storm are 16.1 cfs and 62.7 cfs, respectively.

Basin O2 is approximately 9.50 acres and is comprised of existing rural 2.5+ acre residential lots and roadways. This basin will follow existing drainage patterns in the proposed condition. Runoff from Basin O2 will enter the site at DP3 before continuing in the roadside swale along Irish Hunter Trail. Flow from this basin will outfall into the Black Squirrel Pond. The peak flow rates for Basin O2 in the 5 and 100-year storm are 5.6 cfs and 20.7 cfs, respectively.

Basin O3 is approximately 13.28 acres and is comprised of existing rural 2.5+ acre residential lots and roadways. This basin will follow existing drainage patterns in the proposed condition. Runoff from Basin O3 will overland flow and enter the site at DP7. Runoff from Basins D and O3 combine at DP8.1 where flow will be conveyed in the proposed drainage system that will outfall into the Black Squirrel Pond. The peak flow rates for Basin O3 in the 5 and 100-year storm are 6.2 cfs and 29.3 cfs, respectively.

Basin O4 is approximately 6.82 acres and is covered by sparse native vegetation and will follow existing drainage patterns in the proposed condition. Runoff from Basin O4 will enter the proposed drainage system at DP6. Flow from this basin will outfall into the Black Squirrel Pond. The peak flow rates for Basin O4 in the 5 and 100-year storm are 3.4 cfs and 14.9 cfs, respectively.

Basin O5 is approximately 16.07 acres and is covered by sparse native vegetation and will follow existing drainage patterns in the proposed condition. Runoff from Basin O5 will enter the proposed drainage system at DP14. Flow from this basin will outfall into the Black Squirrel Pond. The peak flow rates for Basin O5 in the 5 and 100-year storm are 7.0 cfs and 30.6 cfs, respectively.

Basin O6 is approximately 14.17 acres and is covered by sparse native vegetation and will follow existing drainage patterns in the proposed condition. Runoff from Basin O6 will enter the proposed drainage system at DP11. Flow from this basin will outfall into the Black Squirrel Pond. The peak flow rates for Basin O6 in the 5 and 100-year storm are 6.6 cfs and 29.0 cfs, respectively.

Basin O7 is approximately 10.18 acres and is covered by sparse native vegetation and will follow existing drainage patterns in the proposed condition. Runoff from Basin O7 will enter the proposed drainage system at DP13 before continuing in the road side swale along Eastonville Road. Flow from this basin will outfall into the Black Squirrel Pond. The peak flow rates for Basin O7 in the 5 and 100-year storm are 4.8 cfs and 21.2 cfs, respectively.

Basin O8 is approximately 15.60 acres and is covered by sparse native vegetation and will follow existing drainage patterns in the proposed condition. Runoff from Basin O8 will enter the proposed drainage system at DP12 before continuing in the road side swale along Eastonville Road. Flow from this basin will outfall into the Black Squirrel Pond. The peak flow rates for Basin O8 in the 5 and 100-year storm are 8.1 cfs and 35.4 cfs, respectively.

A summary of all basin parameters has been presented in Appendix B.

DRAINAGE DESIGN CRITERIA

Development Criteria Reference

Storm drainage analysis and design criteria for the project were taken from the “*City of Colorado Spring/El Paso County Drainage Criteria Manual*” Volumes 1 and 2 (EPCDCM), dated October 12, 1994, the “*Urban Storm Drainage Criteria Manual*” Volumes 1 - 3 (USDCM) and Chapter 6 and Section 3.2.1 of Chapter 13 of the “*Colorado Springs Drainage Criteria Manual (CCSDCM)*”, dated May 2014, as adopted by El Paso County, as well as the July 2019 El Paso County Engineering Criteria Manual update.

Hydrologic Criteria

All hydrologic data was obtained from the “El Paso Drainage Criteria Manual” Volumes 1 and 2, and the “Urban Drainage and Flood Control District Urban Storm Drainage Criteria Manual” Volumes 1, 2, and 3. Onsite drainage improvements were designed based on the 5 year (minor) storm event and the 100-year (major) storm event. Runoff was calculated using CUHP Version 2.0.1, developed by Urban Drainage and Flood Control District. The model utilizes the rain gage classified as “user defined hyetograph”. Table 6-4 in Chapter 6 of the CCSDCM was utilized for the distribution. The following Colorado Springs rainfall depths were utilized in the model: 2.7 inches for 24-hour 5-year depth and 4.6 inches for 24-hour 100-year depth. EPA SWMM 5.1 was utilized to route runoff flow rates for the sizing of stormwater storage facilities. The CUHP calculations and SWMM model are presented in Appendix B.

Urban Drainage and Flood Control District’s UD-Detention, Version 4.04 workbook was used for pond sizing. Required detention volumes and allowable release rates were designed per USDCM and CCS/EPCDCM. Pond sizing spreadsheets are presented in Appendix D.

Hydraulic Criteria

The Federal Highway Administration’s HY-8 program (Volume 7.50) was used to analyze the proposed culverts within the Latigo Trails development. Per Section 6.4.1 of the EPCDCM, culverts were sized as to not overtop the road in the 100 year storm. The emergency spillway flows from the exiting S12 pond were accounted when sizing culverts downstream of the spill, and overtopping of the road was limited to 6” in this event. Culvert design sheets are presented in Appendix C.

Autodesk Inc.’s Hydraflow Express Extension (Volume 10.5) was used for roadside ditch design. For the purposes of this FDR/MDDP, the maximum roadside ditch size was determined based on peak 100-year flows and maximum roadway slopes within each basin. Swales were checked for velocity

per the EPC DCM Chapter 10, Table 10-4. Swale cross sections with a 100-year velocity greater than 5 ft/ will be lined with turf reinforcing mat and native grasses, or another approved method of stabilization, to limit erosive potential. Swale design sheets are presented in Appendix C.

Add the specific product you are looking to use. Add the specs sheet in the appendix.

STORMWATER TREATMENT FACILITY DESIGN

label on drainage maps (pages 254 and 255)

Concept

The proposed stormwater conveyance system was designed to convey the Upper Black Squirrel developed flow from Filing 9 to a modified water quality only pond via roadside ditches and local street culverts. Flow from the Gieck Ranch basin will be conveyed via a system of swales to proposed Pond G18. Detention ponds will be designed to release at less than historic rates to minimize adverse impacts downstream. Undeveloped basins are allowed to follow existing drainage patterns.

Discuss "Proposed Interim Black Squirrel Pond"

Drainage swales have been designed and sized for the 100 year storm. Velocities in grass lined swales will be limited to 5 feet per second. Swales with greater than 5 feet per second velocities will be lined with turf-reinforcing-mat to stabilize them.

Future driveway-way culverts have been sized in this report. See appendix C.

Proposed roadway culverts have been sized utilizing HY-8 for the 100-yr storms to County criteria. See appendix C for applicable calculations.

Development will be limited to 10% for areas that do not have a water quality feature down stream in order to satisfy Section I.7.1.B.5 of the ECM Stormwater Quality Policy and Procedure.

typo

Specific Details

Four Step Process to Minimize Adverse Impacts of Urbanization

In accordance with the El Paso County Drainage Criteria Manual, Volume 2 this site has implemented the four step process to minimize adverse impacts of urbanization. The four step process includes reducing runoff volumes; stabilizing drainageways, treating the water quality capture volume (WQCV), and consider the need for Industrial Commercial BMP's.

Step 1, Reducing Runoff Volumes: The development of the project site is proposed as single family residential (2.5 ac. min.) with lawn areas interspersed within the development which helps disconnect impervious areas and reduce runoff volumes. Roadways will utilize roadside ditches to further disconnecting impervious areas. These practices will also allow for increased infiltration and reduce runoff volume.

**Final Drainage Report Latigo Trails Filing 9
& Addendum to MDDP/Preliminary Plan Latigo Trails**

Step 2, Stabilize Drainageways: This site will utilize roadside ditches with culvert crossings throughout the site. These roadside ditches will then direct the on-site development flows to the multiple detention ponds within the project that will be designed to release at or below historic rates. The roadside ditches will be stabilized in reaches with high velocity (>5 fps) by the use of turf reinforcement mats. Based upon the proposed reduction in released flows compared to the pre-developed flows, no impact to downstream drainageways is anticipated.

Step 3, Provide WQCV: Runoff from this development will be treated through capture and slow release of the WQCV in multiple detention basins that will be designed per current El Paso County drainage criteria. Low impact development techniques are utilized through grass buffers and grass lined swales throughout the development. An UD-BMP, IRF spreadsheet was included for the Pond G-18 design.

and Interim Black Squirrel Pond?

Step 4, Consider the need for Industrial and Commercial BMP's: No industrial or commercial uses are proposed within this development. However, a site specific storm water quality and erosion control plan and narrative will be prepared for each future Filing. Site specific temporary source control BMPs as well as permanent BMP's will be detailed in this plan and narrative to protect receiving waters.

EROSION CONTROL PLAN:

A grading and erosion control plan & stormwater management report has been submitted with this FDR to support the proposed Filing No. 9 development.

OPERATION AND MAINTENANCE:

and detention

In order to ensure the function and effectiveness of the stormwater infrastructure, maintenance activities such as inspection, routine maintenance, restorative maintenance, rehabilitation and repair, are required. All proposed drainage structures within the any platted County ROW (roadside ditches and local road culverts) will be owned and maintained by El Paso County. All proposed drainage structures within easements or tracts (full spectrum water quality ponds, drainageway culverts and drainageway improvements) will be owned and maintained by the Latigo Creek Metropolitan District. Inspection access for El Paso County will be provided through a maintenance easement.

DRIANAGE AND BRIDGE FEES:

An estimate of total basin fees for the proposed development within Upper Black Squirrel Drainage Basin is provided in Table 2. A portion of Latigo Trails Filing 9 (Basins H, I, J) is not within an approved drainage basin in this area. Drainage basins are required for rural lots or permanent easements.

Revise the paragraph under the drainage and bridge fees.

Both Upper Black Squirrel Creek (CHBS2000) and Geick Ranch (CHMS0400) drainage basins are not in the El Paso County Drainage Basin Fee program. Therefore no drainage or bridge fees are due at the time of plat recordation.

Final Drainage Report Latigo Trails Filing 9 & Addendum to MDDP/Preliminary Plan/Latigo Trails

Table 2: Drainage Basin Fees

El Paso County – Black Squirrel Creek Drainage Basin Fees						
Area (acre)	Composite % Impervious	Total Impervious Acreage	2021 Drainage Fee (per Impervious Acre)	2021 Bridge Fee (per Impervious Acre)	Latigo Trails F9 Drainage Fee	Latigo Trails F9 Bridge Fee
73.94	12%	8.87	\$8,968	\$565	\$79,547	\$5,012

SUMMARY:

The proposed Latigo Trails Filing No. 9 development drainage improvements, including storm sewer and two full spectrum water quality and detention ponds were designed to meet or exceed the El Paso County Drainage Criteria. The proposed development will not adversely affect the offsite drainageways or surrounding development. This report is in conformance and meets the latest El Paso County Storm Drainage Criteria requirements for this site.

REFERENCES:

1. City of Colorado Springs Drainage Criteria Manual Volume 1, City of Colorado Springs, CO, May 2014.
2. Urban Storm Drainage Criteria Manual, Urban Drainage and Flood Control District, Latest Revision.
3. “Master Development/Preliminary Drainage Plan for Latigo Trails,” URS, October 2001.
4. “Final Drainage Report for The Trails Filing No. 7 Subdivision,” URS, March 07, 2005.
5. “Final Drainage Report for The Trails Filing No. 8 Subdivision,” JR Engineering, January 03, 2007.

APPENDIX A

FIGURES AND EXHIBITS

X:\2510000_all\2517501\Drawings\Blocks\Vicinity Map (All Filings)\2021-08-23_Vicinity Map_Latigo Trails.dwg, 8.5x11 Portrait, 8/23/2021 3:28:54 PM, CS

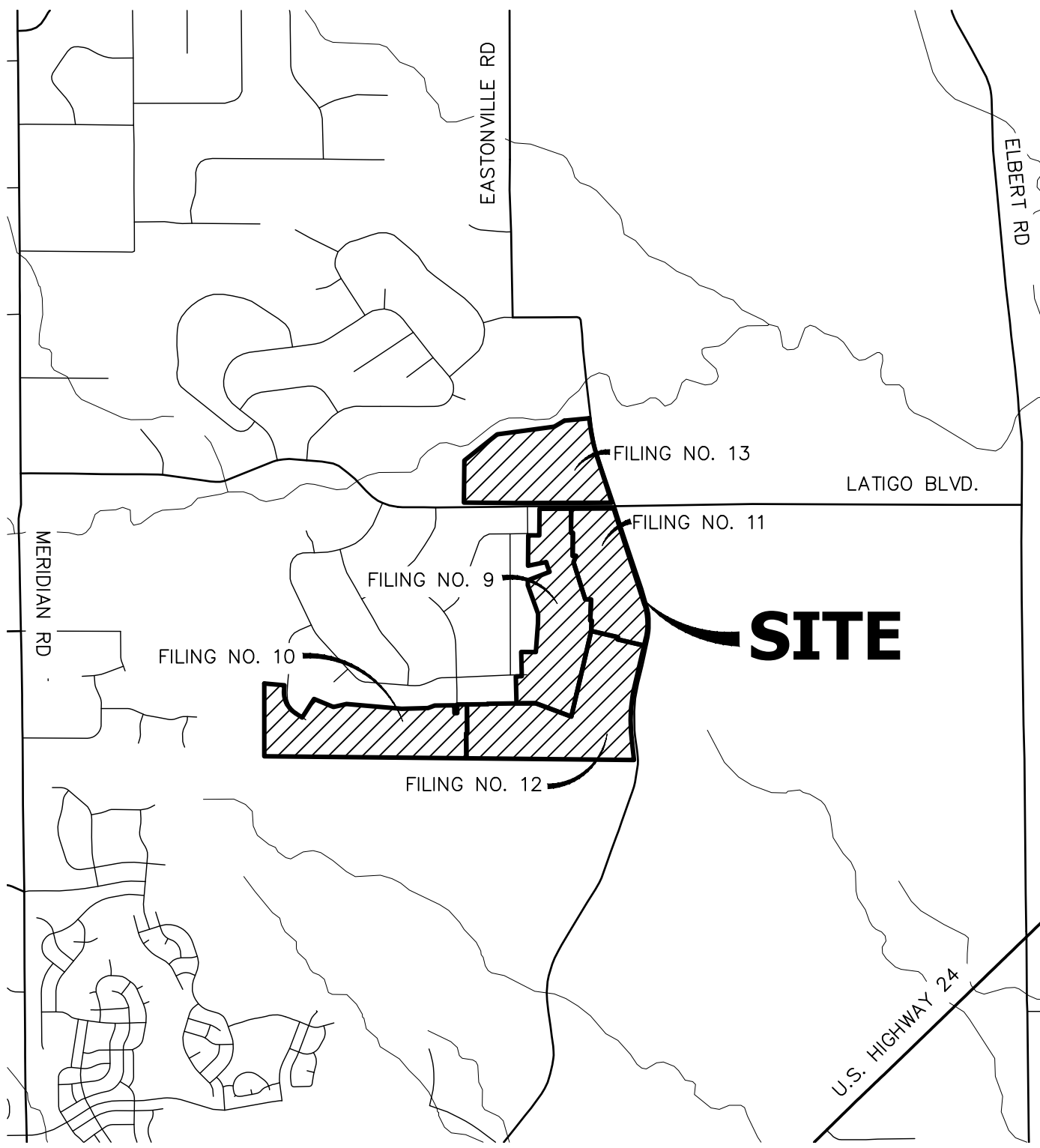

ORIGINAL SCALE: 1" = 3000'



VICINITY MAP
 LATIGO TRAILS
 JOB NO. 25175.01
 08/23/21
 SHEET 1 OF 1



Centennial 303-740-9393 • Colorado Springs 719-593-2593
 Fort Collins 970-491-9888 • www.jrengineering.com

Hydrologic Soil Group—El Paso County Area, Colorado

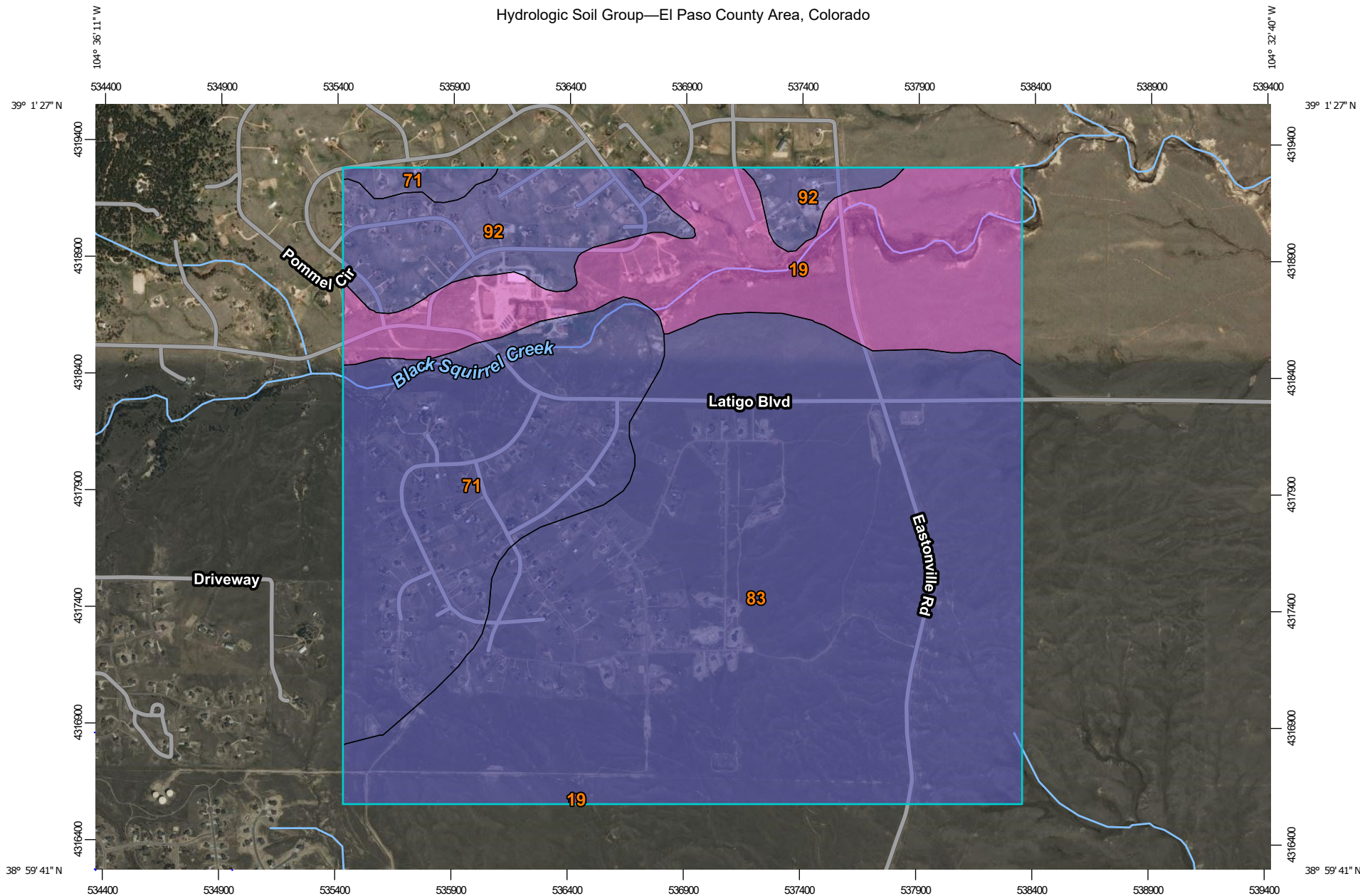

Map Scale: 1:23,100 if printed on A landscape (11" x 8.5") sheet.

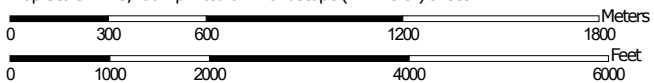

Map projection: Web Mercator Corner coordinates: WGS84 Edge tics: UTM Zone 13N WGS84



MAP LEGEND

Area of Interest (AOI)









 Area of Interest (AOI)

Soils

Soil Rating Polygons





-  A
-  A/D
-  B
-  B/D
-  C
-  C/D
-  D
-  Not rated or not available

Soil Rating Lines

-  A
-  A/D
-  B
-  B/D
-  C
-  C/D
-  D
-  Not rated or not available

Soil Rating Points





-  A
-  A/D
-  B
-  B/D

-  C
-  C/D
-  D
-  Not rated or not available

Water Features

 Streams and Canals

Transportation

-  Rails
-  Interstate Highways
-  US Routes
-  Major Roads
-  Local Roads

Background

 Aerial Photography

MAP INFORMATION

The soil surveys that comprise your AOI were mapped at 1:24,000.

Please rely on the bar scale on each map sheet for map measurements.

Source of Map: Natural Resources Conservation Service
 Web Soil Survey URL:
 Coordinate System: Web Mercator (EPSG:3857)

Maps from the Web Soil Survey are based on the Web Mercator projection, which preserves direction and shape but distorts distance and area. A projection that preserves area, such as the Albers equal-area conic projection, should be used if more accurate calculations of distance or area are required.

This product is generated from the USDA-NRCS certified data as of the version date(s) listed below.

Soil Survey Area: El Paso County Area, Colorado
 Survey Area Data: Version 18, Jun 5, 2020

Soil map units are labeled (as space allows) for map scales 1:50,000 or larger.

Date(s) aerial images were photographed: Sep 8, 2018—May 26, 2019

The orthophoto or other base map on which the soil lines were compiled and digitized probably differs from the background imagery displayed on these maps. As a result, some minor shifting of map unit boundaries may be evident.

Hydrologic Soil Group

Map unit symbol	Map unit name	Rating	Acres in AOI	Percent of AOI
19	Columbine gravelly sandy loam, 0 to 3 percent slopes	A	330.2	16.7%
71	Pring coarse sandy loam, 3 to 8 percent slopes	B	393.4	19.9%
83	Stapleton sandy loam, 3 to 8 percent slopes	B	1,081.8	54.7%
92	Tomah-Crowfoot loamy sands, 3 to 8 percent slopes	B	172.5	8.7%
Totals for Area of Interest			1,977.9	100.0%

Description

Hydrologic soil groups are based on estimates of runoff potential. Soils are assigned to one of four groups according to the rate of water infiltration when the soils are not protected by vegetation, are thoroughly wet, and receive precipitation from long-duration storms.

The soils in the United States are assigned to four groups (A, B, C, and D) and three dual classes (A/D, B/D, and C/D). The groups are defined as follows:

Group A. Soils having a high infiltration rate (low runoff potential) when thoroughly wet. These consist mainly of deep, well drained to excessively drained sands or gravelly sands. These soils have a high rate of water transmission.

Group B. Soils having a moderate infiltration rate when thoroughly wet. These consist chiefly of moderately deep or deep, moderately well drained or well drained soils that have moderately fine texture to moderately coarse texture. These soils have a moderate rate of water transmission.

Group C. Soils having a slow infiltration rate when thoroughly wet. These consist chiefly of soils having a layer that impedes the downward movement of water or soils of moderately fine texture or fine texture. These soils have a slow rate of water transmission.

Group D. Soils having a very slow infiltration rate (high runoff potential) when thoroughly wet. These consist chiefly of clays that have a high shrink-swell potential, soils that have a high water table, soils that have a claypan or clay layer at or near the surface, and soils that are shallow over nearly impervious material. These soils have a very slow rate of water transmission.

If a soil is assigned to a dual hydrologic group (A/D, B/D, or C/D), the first letter is for drained areas and the second is for undrained areas. Only the soils that in their natural condition are in group D are assigned to dual classes.

Rating Options

Aggregation Method: Dominant Condition

Component Percent Cutoff: None Specified

Tie-break Rule: Higher

NOTES TO USERS

This map is for use in administering the National Flood Insurance Program. It does not necessarily identify all areas subject to flooding, particularly from local drainage sources of small size. The community map repository should be consulted for possible updated or additional flood hazard information.

To obtain more detailed information in areas where **Base Flood Elevations (BFEs)** and/or **floodways** have been determined, users are encouraged to consult the Flood Profiles and Floodway Data and/or Summary of Stillwater Elevations tables contained within the Flood Insurance Study (FIS) report that accompanies this FIRM. Users should be aware that BFEs shown on the FIRM represent rounded whole-foot elevations. These BFEs are intended for flood insurance rating purposes only and should not be used as the sole source of flood elevation information. Accordingly, flood elevation data presented in the FIS report should be utilized in conjunction with the FIRM for purposes of construction and/or floodplain management.

Coastal Base Flood Elevations shown on this map apply only landward of 0.0' North American Vertical Datum of 1988 (NAVD88). Users of this FIRM should be aware that coastal flood elevations are also provided in the Summary of Stillwater Elevations table in the Flood Insurance Study report for this jurisdiction. Elevations shown in the Summary of Stillwater Elevations table should be used for construction and/or floodplain management purposes when they are higher than the elevations shown on this FIRM.

Boundaries of the **floodways** were computed at cross sections and interpolated between cross sections. The floodways were based on hydraulic considerations with regard to requirements of the National Flood Insurance Program. Floodway widths and other pertinent floodway data are provided in the Flood Insurance Study report for this jurisdiction.

Certain areas not in Special Flood Hazard Areas may be protected by **flood control structures**. Refer to section 2.4 "Flood Protection Measures" of the Flood Insurance Study report for information on flood control structures for this jurisdiction.

The **projection** used in the preparation of this map was Universal Transverse Mercator (UTM) zone 13. The **horizontal datum** was NAD83, GRS80 spheroid. Differences in datum, spheroid, projection or UTM zones zones used in the production of FIRMs for adjacent jurisdictions may result in slight positional differences in map features across jurisdiction boundaries. These differences do not affect the accuracy of this FIRM.

Flood elevations on this map are referenced to the **North American Vertical Datum of 1988 (NAVD88)**. These flood elevations must be compared to structure and ground elevations referenced to the same **vertical datum**. For information regarding conversion between the National Geodetic Vertical Datum of 1929 and the North American Vertical Datum of 1988, visit the National Geodetic Survey website at <http://www.ngs.noaa.gov/> or contact the National Geodetic Survey at the following address:

NGS Information Services
NOAA, NIMS12
National Geodetic Survey
SSMC-3, #9202
1315 East-West Highway
Silver Spring, MD 20910-3282

To obtain current elevation, description, and/or location information for **bench marks** shown on this map, please contact the Information Services Branch of the National Geodetic Survey at (301) 713-3242 or visit its website at <http://www.ngs.noaa.gov/>.

Base Map information shown on this FIRM was provided in digital format by El Paso County, Colorado Springs Utilities, City of Fountain, Bureau of Land Management, National Oceanic and Atmospheric Administration, United States Geological Survey, and Anderson Consulting Engineers, Inc. These data are current as of 2006.

This map reflects more detailed and up-to-date **stream channel configurations and floodplain delineations** than those shown on the previous FIRM for this jurisdiction. The floodplains and floodways that were transferred from the previous FIRM may have been adjusted to conform to these new stream channel configurations. As a result, the Flood Profiles and Floodway Data tables in the Flood Insurance Study Report (which contains authoritative hydraulic data) may reflect stream channel distances that differ from what is shown on this map. The profile baselines depicted on this map represent the hydraulic modeling baselines that match the flood profiles and Floodway Data Tables if applicable, in the FIS report. As a result, the profile baselines may deviate significantly from the new base map channel representation and may appear outside of the floodplain.

Corporate limits shown on this map are based on the best data available at the time of publication. Because changes due to annexations or de-annexations may have occurred after this map was published, map users should contact appropriate community officials to verify current corporate limit locations.

Please refer to the separately printed **Map Index** for an overview map of the county showing the layout of map panels; community map repository addresses; and a Listing of Communities table containing National Flood Insurance Program dates for each community as well as a listing of the panels on which each community is located.

Contact **FEMA Map Service Center (MSC)** via the FEMA Map Information eXchange (FMIX) 1-877-336-2627 for information on available products associated with this FIRM. Available products may include previously issued Letters of Map Change, a Flood Insurance Study Report, and/or digital versions of this map. The MSC may also be reached by Fax at 1-800-358-9620 and its website at <http://www.msc.fema.gov/>.

If you have **questions about this map** or questions concerning the National Flood Insurance Program in general, please call 1-877-FEMA MAP (1-877-336-2627) or visit the FEMA website at <http://www.fema.gov/business/nfp>.

El Paso County Vertical Datum Offset Table

Flooding Source	Vertical Datum Offset (ft)
REFER TO SECTION 3.3 OF THE EL PASO COUNTY FLOOD INSURANCE STUDY FOR STREAM BY STREAM VERTICAL DATUM CONVERSION INFORMATION	

Panel Location Map

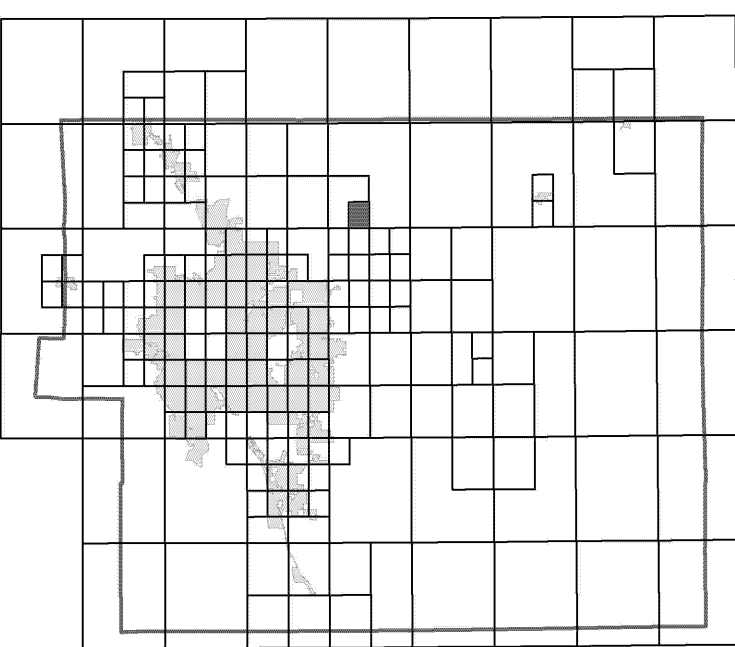

This Digital Flood Insurance Rate Map (DFIRM) was produced through a Cooperating Technical Partner (CTP) agreement between the State of Colorado Water Conservation Board (CWCB) and the Federal Emergency Management Agency (FEMA).



Additional Flood Hazard information and resources are available from local communities and the Colorado Water Conservation Board.

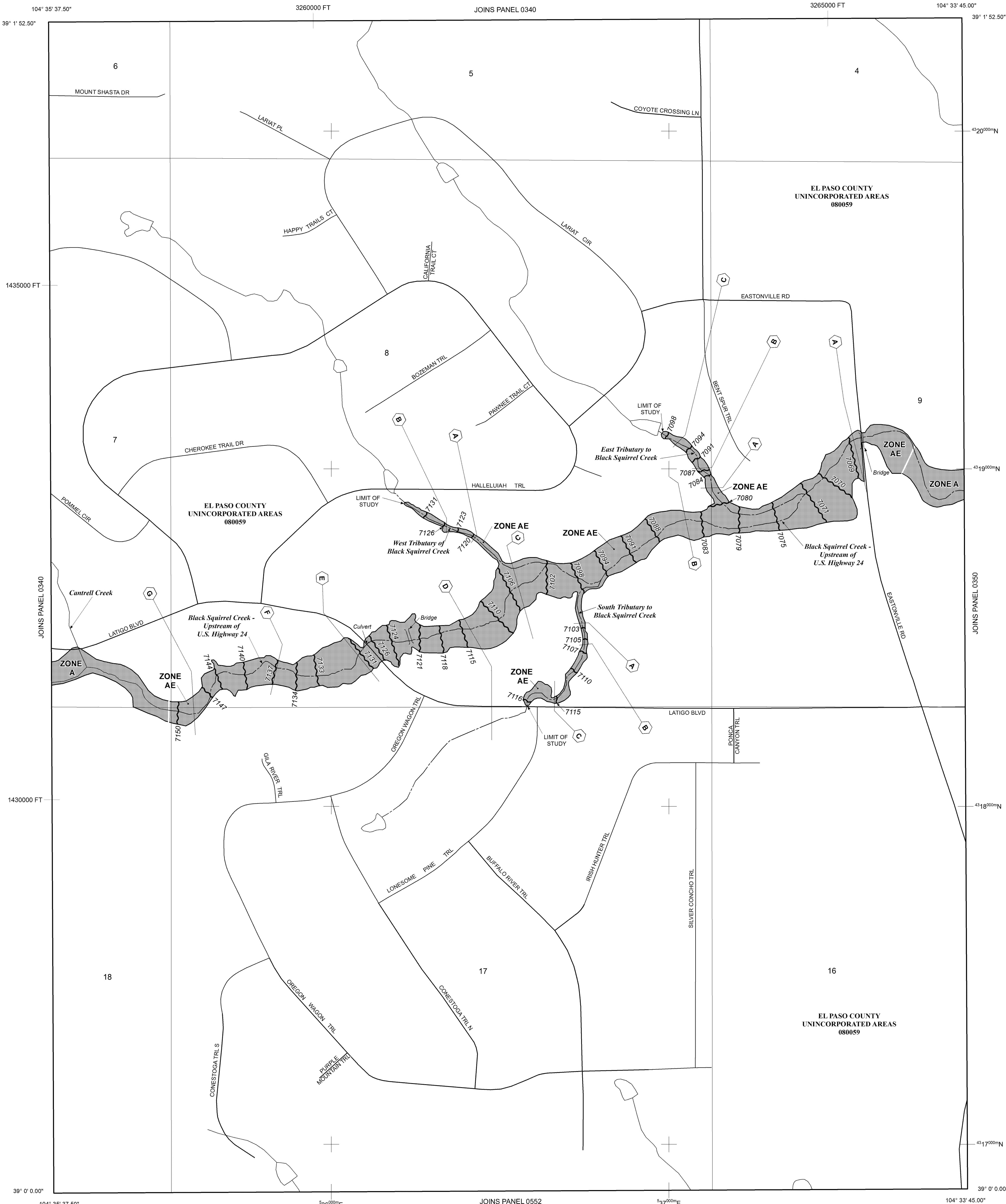

NOTE: MAP AREA SHOWN ON THIS PANEL IS LOCATED WITHIN TOWNSHIP 12 SOUTH, RANGE 64 WEST.

LEGEND

- SPECIAL FLOOD HAZARD AREAS (SFHAS) SUBJECT TO INUNDATION BY THE 1% ANNUAL CHANCE FLOOD
- The 1% annual chance flood (100-year flood), also known as the base flood, is the flood that has a 1% chance of being equalled or exceeded in any given year. The Special Flood Hazard Area is the area subject, to flooding by the 1% annual chance flood. Areas of Special Flood Hazard include Zones A, AE, AH, AO, AR, A99, V, and VE. The Base Flood Elevation is the water-surface elevation of the 1% annual chance flood.
- ZONE A** No Base Flood Elevations determined.
- ZONE AE** Base Flood Elevations determined.
- ZONE AH** Flood depths of 1 to 3 feet (usually areas of ponding); Base Flood Elevations determined.
- ZONE AO** Flood depths of 1 to 3 feet (usually sheet flow on sloping terrain); average depths determined. For areas of alluvial fan flooding, velocities also determined.
- ZONE AR** Special Flood Hazard Area Formerly protected from the 1% annual chance flood by a flood control system that was subsequently decertified. Zone AR indicates that the former flood control system is being restored to provide protection from the 1% annual chance or greater flood.
- ZONE A99** Area to be protected from 1% annual chance flood by a Federal flood protection system under construction; no Base Flood Elevations determined.
- ZONE V** Coastal flood zone with velocity hazard (wave action); no Base Flood Elevations determined.
- ZONE VE** Coastal flood zone with velocity hazard (wave action); Base Flood Elevations determined.
- FLOODWAY AREAS IN ZONE AE
- The floodway is the channel of a stream plus any adjacent floodplain areas that must be kept free of encroachment so that the 1% annual chance flood can be carried without substantial increases in flood heights.
- OTHER FLOOD AREAS
- ZONE X** Areas of 0.2% annual chance flood; areas of 1% annual chance flood with average depths of less than 1 foot or with drainage areas less than 1 square mile; and areas protected by levees from 1% annual chance flood.
- OTHER AREAS
- ZONE X** Areas determined to be outside the 0.2% annual chance floodplain.
- ZONE D** Areas in which flood hazards are undetermined, but possible.
- COASTAL BARRIER RESOURCES SYSTEM (CBRS) AREAS
- OTHERWISE PROTECTED AREAS (OPAs)

- CBRS areas and OPAs are normally located within or adjacent to Special Flood Hazard Areas.
- Floodplain boundary
- Floodway boundary
- Zone D boundary
- CBRS and OPA boundary
- Boundary dividing Special Flood Hazard Areas of different Base Flood Elevations, flood depths or flood velocities
- Base Flood Elevation line and value; elevation in feet* (EL 987)
- Base Flood Elevation value where uniform within zone; elevation in feet*

- * Referenced to the North American Vertical Datum of 1988 (NAVD 88)
- Cross section line
- Transsect line

- 57° 07' 30.00" 32° 22' 30.00" Geographic coordinates referenced to the North American Datum of 1983 (NAD 83)
- 4275000mN 1000-meter Universal Transverse Mercator grid ticks, zone 13
- 6000000 FT 5000-foot grid ticks; Colorado State Plane coordinate system, central zone (FIPSZONE 0502), Lambert Conformal Conic Projection
- DX5510 Bench mark (see explanation in Notes to Users section of this FIRM panel)
- M1.5 River Mile

- MAP REPOSITORIES Refer to Map Repositories list on Map Index
- EFFECTIVE DATE OF COUNTYWIDE FLOOD INSURANCE RATE MAP MARCH 17, 1997
- EFFECTIVE DATE(S) OF REVISION(S) TO THIS PANEL DECEMBER 7, 2018 - to update corporate limits, to change Base Flood Elevations and Special Flood Hazard Areas, to update map format, to add roads and road names, and to incorporate previously issued Letters of Map Revision.

For community map revision history prior to countywide mapping, refer to the Community Map History Table located in the Flood Insurance Study report for this jurisdiction. To determine if flood insurance is available in this community, contact your insurance agent or call the National Flood Insurance Program at 1-800-638-6620.

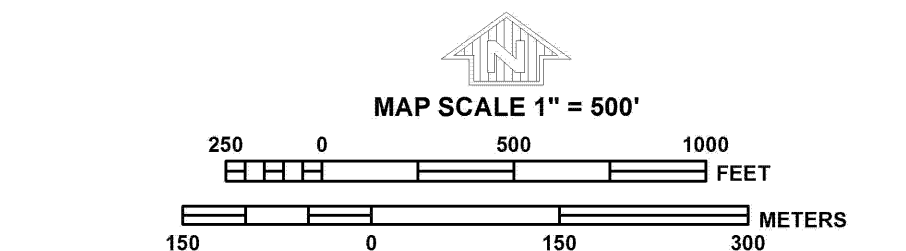

NFIP PANEL 0339G

FIRM
FLOOD INSURANCE RATE MAP
EL PASO COUNTY,
COLORADO
AND INCORPORATED AREAS

PANEL 339 OF 1300
(SEE MAP INDEX FOR FIRM PANEL LAYOUT)

CONTAINS:	COMMUNITY	NUMBER	PANEL	SUFFIX
EL PASO COUNTY	080059	0339	G	

Notice to User: The Map Number shown below should be used when placing map orders. The Community Number shown above should be used on insurance applications for the subject community.

MAP NUMBER
08041C0339G

MAP REVISED
DECEMBER 7, 2018
Federal Emergency Management Agency

APPENDIX B
HYDROLOGIC CALCULATIONS

PROPOSED COMPOSITE % IMPERVIOUS/C VALUE CALCULATIONS

Subdivision: Latigo Trails
 Location: El Paso County

Filing 9
 25175.01
 APL
 7/28/21

Basin ID	Total Area (ac)	Hardscape (100% Impervious)				ROOFS (90% Impervious)(10K sf per 2.5 ac lot)				Lawns (0% Impervious)				Basin Total Weighted C		Basins Total Weighted % Imp.
		C ₅	C ₁₀₀	Area (ac)	Weighted % Imp.	C5	C100	Area (ac)	Weighted % Imp.	C ₅	C ₁₀₀	Area (ac)	Weighted % Imp.	C		
														C ₅	C ₁₀₀	
A	11.48	0.90	0.96	0.18	1.6%	0.73	0.82	1.04	8.1%	0.08	0.35	10.26	0.0%	0.15	0.40	9.7%
B	5.30	0.90	0.96	0.17	3.2%	0.73	0.82	0.47	8.0%	0.08	0.35	4.66	0.0%	0.16	0.41	11.2%
C	8.44	0.90	0.96	0.54	6.4%	0.73	0.82	0.73	7.7%	0.08	0.35	7.17	0.0%	0.19	0.43	14.1%
D	25.55	0.90	0.96	1.01	4.0%	0.73	0.82	2.25	7.9%	0.08	0.35	22.29	0.0%	0.17	0.42	11.9%
E	2.54	0.90	0.96	0.00	0.0%	0.73	0.82	0.23	8.3%	0.08	0.35	2.31	0.0%	0.14	0.39	8.3%
F	9.21	0.90	0.96	0.41	4.5%	0.73	0.82	0.81	7.9%	0.08	0.35	7.99	0.0%	0.17	0.42	12.3%
G	13.73	0.90	0.96	0.57	4.2%	0.73	0.82	1.21	7.9%	0.08	0.35	11.95	0.0%	0.17	0.42	12.1%
H	9.93	0.90	0.96	0.38	3.8%	0.73	0.82	0.88	7.9%	0.08	0.35	8.67	0.0%	0.17	0.41	11.8%
I	7.44	0.90	0.96	0.31	4.2%	0.73	0.82	0.65	7.9%	0.08	0.35	6.48	0.0%	0.17	0.42	12.1%
J	5.62	0.90	0.96	0.01	0.2%	0.73	0.82	0.51	8.2%	0.08	0.35	5.10	0.0%	0.14	0.39	8.4%
K	0.68	0.90	0.96	0.00	0.0%	0.73	0.82	0.06	8.3%	0.08	0.35	0.62	0.0%	0.14	0.39	8.3%
L	3.87	0.90	0.96	0.05	1.3%	0.73	0.82	0.35	8.2%	0.08	0.35	3.47	0.0%	0.15	0.40	9.4%
O1	32.63	0.90	0.96	1.87	5.7%	0.73	0.82	2.82	7.8%	0.08	0.35	27.94	0.0%	0.18	0.43	13.5%
O2	9.50	0.90	0.96	0.75	7.9%	0.73	0.82	0.80	7.6%	0.08	0.35	7.95	0.0%	0.20	0.44	15.5%
O3	13.28	0.90	0.96	0.00	0.0%	0.73	0.82	1.22	8.3%	0.08	0.35	12.06	0.0%	0.14	0.39	8.3%
O4	6.82	0.90	0.96	0.14	2.0%	0.73	0.82	0.68	9.0%	0.08	0.35	6.68	0.0%	0.17	0.44	11.0%
O5	16.07	0.90	0.96	0.32	2.0%	0.73	0.82	1.61	9.0%	0.08	0.35	15.75	0.0%	0.17	0.44	11.0%
O6	14.17	0.90	0.96	0.28	2.0%	0.73	0.82	1.42	9.0%	0.08	0.35	13.89	0.0%	0.17	0.44	11.0%
O7	10.18	0.90	0.96	0.20	2.0%	0.73	0.82	1.02	9.0%	0.08	0.35	9.98	0.0%	0.17	0.44	11.0%
O8	15.60	0.90	0.96	0.31	2.0%	0.73	0.82	1.56	9.0%	0.08	0.35	15.29	0.0%	0.17	0.44	11.0%
TOTAL	222.04															11.6%

**PROPOSED STANDARD FORM SF-2
TIME OF CONCENTRATION**

Subdivision: Latigo Trails
Location: El Paso County

Project Name: Filing 9
Project No.: 25175.01
Calculated By: APL
Checked By: _____
Date: 7/28/21

SUB-BASIN						INITIAL/OVERLAND			TRAVEL TIME					tc CHECK			FINAL
DATA						(Ti)			(Ti)					(URBANIZED BASINS)			
BASIN ID	D.A. (ac)	Hydrologic Soils Group	Impervious (%)	C _s	C ₁₀₀	L (ft)	S _o (%)	t _i (min)	L _t (ft)	S _t (%)	K	VEL. (ft/s)	t _t (min)	COMP. t _c (min)	TOTAL LENGTH (ft)	Urbanized t _c (min)	
A	11.48	B	10%	0.15	0.40	200	1.7%	20.2	271	2.2%	15.0	2.2	2.0	22.2	471.0	27.3	22.2
B	5.30	B	11%	0.16	0.41	200	1.0%	23.9	150	1.5%	15.0	1.8	1.4	25.3	350.0	26.1	25.3
C	8.44	B	14%	0.19	0.43	200	2.5%	17.2	0	0.0%	15.0	0.0	0.0	17.2	200.0	23.6	17.2
D	25.55	B	12%	0.17	0.42	200	2.7%	17.2	2220	5.9%	15.0	3.7	10.1	27.3	2420.0	38.2	27.3
E	2.54	B	8%	0.14	0.39	200	2.2%	19.0	0	0.0%	15.0	0.0	0.0	19.0	200.0	24.6	19.0
F	9.21	B	12%	0.17	0.42	200	3.7%	15.4	305	1.6%	15.0	1.9	2.7	18.0	505.0	27.6	18.0
G	13.73	B	12%	0.17	0.42	200	2.1%	18.6	0	0.0%	15.0	0.0	0.0	18.6	200.0	23.9	18.6
H	9.93	B	12%	0.17	0.41	200	3.7%	15.5	0	0.0%	15.0	0.0	0.0	15.5	200.0	24.0	15.5
I	7.44	B	12%	0.17	0.42	200	7.4%	12.2	516	3.7%	15.0	2.9	3.0	15.2	716.0	28.1	15.2
J	5.62	B	8%	0.14	0.39	200	5.8%	13.7	0	0.0%	15.0	0.0	0.0	13.7	200.0	24.6	13.7
K	0.68	B	8%	0.14	0.39	200	6.3%	13.4	0	0.0%	15.0	0.0	0.0	13.4	200.0	24.6	13.4
L	3.87	B	9%	0.15	0.40	200	5.2%	14.1	0	0.0%	15.0	0.0	0.0	14.1	200.0	24.4	14.1
O1	32.63	B	14%	0.18	0.43	200	3.4%	15.6	1384	2.2%	15.0	2.2	10.5	26.1	1584.0	38.1	26.1
O2	9.50	B	16%	0.20	0.44	200	3.0%	16.1	673	1.8%	15.0	2.0	5.6	21.7	873.0	30.9	21.7
O3	13.28	B	8%	0.14	0.39	200	3.1%	16.9	0	0.0%	15.0	0.0	0.0	16.9	200.0	24.6	16.9
O4	6.82	B	11%	0.17	0.44	200	2.6%	17.3	338	0.6%	15.0	1.2	4.8	22.2	538.0	31.0	22.2
O5	16.07	B	11%	0.17	0.44	200	2.4%	17.8	719	0.6%	15.0	1.1	10.8	28.6	919.0	39.5	28.6
O6	14.17	B	11%	0.17	0.44	200	2.5%	17.6	478	0.5%	15.0	1.1	7.5	25.1	678.0	34.8	25.1
O7	10.18	B	11%	0.17	0.44	200	2.5%	17.5	532	0.8%	15.0	1.3	6.8	24.3	732.0	33.8	24.3
O8	15.60	B	11%	0.17	0.44	200	6.3%	12.9	897	1.7%	15.0	2.0	7.6	20.6	1097.0	35.0	20.6

NOTES:

$$t_c = t_i + t_t$$

Where:

t_c = computed time of concentration (minutes)

t_i = overland (initial) flow time (minutes)

t_t = channelized flow time (minutes).

$$t_t = \frac{L_t}{60K\sqrt{S_o}} = \frac{L_t}{60V_t}$$

Where:

Equation 6-2

$$t_i = \frac{0.395(1.1 - C_s)\sqrt{L}}{S_o^{0.33}}$$

Where:

t_i = overland (initial) flow time (minutes)

C_s = runoff coefficient for 5-year frequency (from Table 6-4)

L_t = length of overland flow (ft)

S_o = average slope along the overland flow path (ft/ft).

Equation 6-4

$$t_t = (26 - 17t_i) + \frac{L_t}{60(14i + 9)\sqrt{S_o}}$$

Equation 6-3

Table 6-2. NRCS Conveyance factors, K

Type of Land Surface	Conveyance Factor, K
Heavy meadow	2.5
Tillage/field	5
Short pasture and lawns	7
Nearly bare ground	10
Grassed waterway	15
Paved areas and shallow paved swales	20

Equation 6-5

**PROPOSED STANDARD FORM SF-2
TIME OF CONCENTRATION**

Subdivision: Latigo Trails
Location: El Paso County

Project Name: Filing 9
Project No.: 25175.01
Calculated By: APL
Checked By: _____
Date: 7/28/21

SUB-BASIN						INITIAL/OVERLAND			TRAVEL TIME					t _c CHECK			FINAL
DATA						(T _i)			(T _i)					(URBANIZED BASINS)			
BASIN ID	D.A. (ac)	Hydrologic Soils Group	Impervious (%)	C ₅	C ₁₀₀	L (ft)	S _o (%)	t _i (min)	L _t (ft)	S _t (%)	K	VEL. (ft/s)	t _t (min)	COMP. t _c (min)	TOTAL LENGTH (ft)	Urbanized t _c (min)	

t_i = channelized flow time (travel time, min)
L_t = waterway length (ft)
S_o = waterway slope (ft/ft)
V_t = travel time velocity (ft/sec) = K√S_o
K = NRCS conveyance factor (see Table 6-2).

Where:

t_c = minimum time of concentration for first design point when less than t_c from Equation 6-1.
L_t = length of channelized flow path (ft)
i = imperviousness (expressed as a decimal)
S_t = slope of the channelized flow path (ft/ft).

Use a minimum t_c value of 5 minutes for urbanized areas and a minimum t_c value of 10 minutes for areas that are not considered urban. Use minimum values even when calculations result in a lesser time of concentration.

PROPOSED STANDARD FORM SF-3
STORM DRAINAGE SYSTEM DESIGN
(RATIONAL METHOD PROCEDURE)

Subdivision: Latigo Trails
Location: El Paso County
Design Storm: 5-Year

Project Name: Filing 9
Project No.: 25175.01
Calculated By: APL
Checked By: _____
Date: 7/28/21

STREET	Design Point	DIRECT RUNOFF							TOTAL RUNOFF				STREET			PIPE			TRAVEL TIME			REMARKS	
		Basin ID	Area (Ac)	Runoff Coeff.	t_c (min)	C*A (Ac)	I (in/hr)	Q (cfs)	t_c (min)	C*A (ac)	I (in/hr)	Q (cfs)	Q_{street} (cfs)	C*A (ac)	Slope (%)	Q_{pipe} (cfs)	C*A (ac)	Slope (%)	Pipe Size (inches)	Length (ft)	Velocity (fps)		t_r (min)
	2	A	11.48	0.15	22.2	1.74	2.93	5.1															Overland flows to existing swale at DP2
	2.1								34.8	7.72	2.26	17.4								582	2.4	4.1	Flows from DP2 and DP1 combine at DP2.1 in existing swale continues to DP14.1
	4	B	5.30	0.16	25.3	0.87	2.74	2.4															Overland flows to DP4 in proposed swale
	4.1								25.3	2.77	2.74	7.6								498	2.1	3.9	Flows from DP4 and DP3 combine at DP4.1 and continues to DP5.1
	5	C	8.44	0.19	17.2	1.59	3.32	5.3															Overland flows to proposed swale at DP5
	5.1								29.2	4.36	2.52	11.0								366	2.1	2.9	Flows from DP5 and DP4.1 combine in swale at DP5.1 and continues to DP6.1
	8	D	25.55	0.17	27.3	4.34	2.62	11.4															Overland flows to proposed swale along Oregon Wagon Trail at DP8
	8.1								27.3	6.19	2.62	16.2								485	2.1	3.8	Flows from DP7 and DP8 combine at DP8.1 and continues to DP9.1
		E	2.54	0.14	19.0	0.35	3.17	1.1															Flows from basin E overland flow to existing Pond S12
	10	F	9.21	0.17	18.0	1.60	3.24	5.2												1218	2.1	9.7	Basin F flows to a proposed culvert under Frenchmans Tr. at DP10 & continues to DP11.1
	S12		147.0		30.0			17.0															Existing pond S12 discharges flows to the proposed swale system at DPS12
	9	G	13.73	0.17	18.6	2.35	3.20	7.5															Overland flows to Proposed swale at DP9
	9.1								31.1	8.54	2.43	37.7								503	2.2	3.8	Flows for DP9 and DP8.1 Combine at DP9.1 and continues to DP11.1
		H	9.93	0.17	15.5	1.68	3.47	5.8															Overland flows to proposed pond G19
	15	I	7.44	0.17	15.2	1.27	3.50	4.4	15.2	1.27	3.50	4.4								1518	2.8	9.1	Overland flows to proposed swale and continues to proposed pond G18
		J	5.62	0.14	13.7	0.79	3.65	2.9															Overland flows to proposed swale and continues to proposed pond G18
		K	0.68	0.14	13.4	0.09	3.69	0.3															Overland flows to proposed swale and continues to proposed pond G18
		L	3.87	0.15	14.1	0.58	3.62	2.1															Overland flows to existing South pond
	1	O1	32.63	0.18	26.1	5.98	2.69	16.1												918	1.8	8.7	Offsite flow enters site in existing swale at DP1 along southern side of Latigo Blvd
	3	O2	9.50	0.20	21.7	1.90	2.97	5.6												128	3.8	0.6	Offsite flow enters site in existing swale at DP3 and continues to DP4.1
	7	O3	13.28	0.14	16.9	1.85	3.34	6.2															Offsite basin overland flows into Basin D at DP7
	6	O4	6.82	0.17	22.2	1.16	2.93	3.4															Overland flows to proposed swale along Irish Hunter Trail at DP6
	6.1								32.1	5.52	2.38	13.1								358	1.6	7.7	Flows from DP6 and DP5.1 combine at DP6.1 and continues to DP14.1
	14	O5	16.07	0.17	28.6	2.72	2.55	6.9															Overland flows to proposed swale system that converges at DP14
	14.1								50.2	32.86	1.71	73.1											Flows from DP14, DP2.1, DP6.1, and DP13.1 combine at DP14.1
	11	O6	14.17	0.17	25.1	2.40	2.75	6.6															Overland flows to proposed swale system at DP11
	11.1								34.9	12.54	2.25	45.3								440	1.6	2.8	Flows from DP9.1, DP10, and DP11 combine at DP11.1 and continues to DP13.1
	13	O7	10.18	0.17	24.3	1.72	2.80	4.8															Overland flows to existing swale along Eastonville Road at DP13
	13.1								37.7	16.90	2.14	53.1								212	0.9	12.5	DP13 and DP12 flows combine at DP13.1 and continues to DP14.1
	12	O8	15.60	0.17	20.6	2.64	3.05	8.0												693	1.4	8.3	Basin O8 overland flows to existing swale at DP12 and continues to DP13.1

Notes:
Street and Pipe C*A values are determined by Q/I using the catchment's intensity value.

PROPOSED STANDARD FORM SF-3
STORM DRAINAGE SYSTEM DESIGN
(RATIONAL METHOD PROCEDURE)

Subdivision: Latigo Trails
Location: El Paso County
Design Storm: 100-Year

Project Name: Filling 9
Project No.: 25175.01
Calculated By: APL
Checked By: _____
Date: 7/28/21

STREET	Design Point	DIRECT RUNOFF							TOTAL RUNOFF				STREET			PIPE			TRAVEL TIME			REMARKS	
		Basin ID	Area (ac)	Runoff Coeff.	t_c (min)	C*A (ac)	I (in/hr)	Q _i (cfs)	t_{tc} (min)	C*A (ac)	I (in/hr)	Q _t (cfs)	Q _{street} (cfs)	C*A (ac)	Slope (%)	Q _{pipe} (cfs)	C*A (ac)	Slope (%)	Pipe Size (inches)	Length (ft)	Velocity (fps)		t_t (min)
	2	A	11.48	0.40	22.2	4.62	4.92	22.7															Overland flows to existing swale at DP2
	2.1								34.8	18.51	3.79	70.2								582	2.4	4.1	Flows from DP2 and DP1 combine at DP2.1 in existing swale continues to DP14.1
	4	B	5.30	0.41	25.3	2.18	4.60	10.0															Overland flows to DP4 in proposed swale
	4.1								25.3	6.34	4.60	29.1								498	2.1	3.9	Flows from DP4 and DP3 combine at DP4.1 and continues to DP5.1
	5	C	8.44	0.43	17.2	3.62	5.57	20.1															Overland flows to proposed swale at DP5
	5.1								29.2	9.96	4.23	42.2								366	2.1	2.9	Flows from DP5 and DP4.1 combine in swale at DP5.1 and continues to DP6.1
	8	D	25.55	0.42	27.3	10.62	4.40	46.7															Overland flows to proposed swale along Oregon Wagon Trail at DP8
	8.1								27.3	15.84	4.40	69.7								485	2.1	3.8	Flows from DP7 and DP8 combine at DP8.1 and continues to DP9.1
		E	2.54	0.39	19.0	1.00	5.32	5.3															Flows from basin E overland flow to existing Pond S12
	10	F	9.21	0.42	18.0	3.85	5.45	21.0												1218	2.1	9.7	Basin F flows to a proposed culvert under Frenchmans Tr. at DP10 & continues to DP11.1
	S12		147.0		30.0			58.0															Existing pond S12 discharges flows to the proposed swale system at DP512
	9	G	13.73	0.42	18.6	5.72	5.37	30.7															Overland flows to Proposed swale at DP9
	9.1								31.1	21.56	4.07	118.5								503	2.2	3.8	Flows for DP9 and DP8.1 Combine at DP9.1 and continues to DP11.1
		H	9.93	0.41	15.5	4.12	5.83	24.0															Overland flows to proposed pond G19
	15	I	7.44	0.42	15.2	3.10	5.87	18.2	9.1	3.10	7.16	22.2								1518	2.8	9.1	Overland flows to proposed swale and continues to proposed pond G18
		J	5.62	0.39	13.7	2.22	6.13	13.6															Overland flows to proposed swale and continues to proposed pond G18
		K	0.68	0.39	13.4	0.27	6.20	1.7															Overland flows to proposed swale and continues to proposed pond G18
		L	3.87	0.40	14.1	1.55	6.07	9.4															Overland flows to existing South pond
	1	O1	32.63	0.43	26.1	13.89	4.52	62.7												918	1.8	8.7	Offsite flow enters site in existing swale at DP1 along southern side of Latigo Blvd
	3	O2	9.50	0.44	21.7	4.16	4.98	20.7												128	3.8	0.6	Offsite flow enters site in existing swale at DP3 and continues to DP4.1
	7	O3	13.28	0.39	16.9	5.22	5.61	29.3															Offsite basin overland flows into Basin D at DP7
	6	O4	6.82	0.44	22.2	3.03	4.92	14.9															Overland flows to proposed swale along Irish Hunter Trail at DP6
	6.1								32.1	12.99	4.00	51.9								358	1.6	3.8	Flows from DP6 and DP5.1 combine at DP6.1 and continues to DP14.1
	14	O5	16.07	0.44	28.6	7.14	4.29	30.6															Overland flows to proposed swale system that converges at DP14
	14.1								41.4	81.79	3.35	332.0											Flows from DP14, DP2.1, DP6.1, and DP13.1 combine at DP14.1
	11	O6	14.17	0.44	25.1	6.29	4.61	29.0															Overland flows to proposed swale system at DP11
	11.1								34.9	31.70	3.78	177.9								440	1.6	2.8	Flows from DP9.1, DP10, and DP11 combine at DP11.1 and continues to DP13.1
	13	O7	10.18	0.44	24.3	4.52	4.69	21.2															Overland flows to existing swale along Eastonville Road at DP13
	13.1								37.7	43.15	3.59	212.8								212	0.9	3.7	DP13 and DP12 flows combine at DP13.1 and continues to DP14.1
	12	O8	15.60	0.44	20.6	6.93	5.11	35.4												693	1.4	8.3	Basin O8 overland flows to existing swale at DP12 and continues to DP13.1

Notes:
Street and Pipe C*A values are determined by Q/i using the catchment's intensity value.

APPENDIX B

HYDROLOGIC CALCULATIONS
(CUHP/SWMM)

CUHP SUBCATCHMENTS

Latigo_Historic 5-YR_Ultimate Pond Sizing

Columns with this color heading are for required user-input
Columns with this color heading are for optional override values
Columns with this color heading are for program-calculated values

								Maximum Depression Storage (Watershed inches)		Horton's Infiltration Parameters			DCIA
Subcatchment Name	EPA SWMM Target Node	Raingage	Area (mi ²)	Length to Centroid (mi)	Length (mi)	Slope (ft/ft)	Percent Imperviousness	Pervious	Impervious	Initial Rate (in/hr)	Decay Coefficient (1/seconds)	Final Rate (in/hr)	Level 0, 1, or 2
H-1	H1	EPC 24 Hour	0.4442188	0.452719508	1.1013951	0.01	2	0.6	0.1	4.5	0.6	0.0018	2
H-2	H2	EPC 24 Hour	0.7115625	0.819478977	1.568183	0.01	2	0.6	0.1	4.5	0.6	0.0018	2

Summary of Unit Hydrograph Parameters Used By Program and Calculated Results (Version 2.0.1)

Ultimate_Historical_5 Year

Catchment Name/ID	User Comment for Catchment	Unit Hydrograph Parameters and Results									Excess Precip.		Storm Hydrograph			
		CT	Cp	W50 (min.)	W50 Before Peak	W75 (min.)	W75 Before Peak	Time to Peak (min.)	Peak (cfs)	Volume (c.f)	Excess (inches)	Excess (c.f.)	Time to Peak (min.)	Peak Flow (cfs)	Total Volume (c.f.)	Runoff per Unit Area (cfs/acre)
H-1		0.156	0.282	56.2	12.45	29.2	8.79	20.7	237	1,032,009	2.05	2,118,157	752.0	260	2,118,120	0.91
H-2		0.156	0.324	76.8	19.43	39.9	13.73	32.4	278	1,653,102	2.05	3,392,925	763.0	328	3,392,929	0.72

Summary of CUHP Input Parameters (Version 2.0.1)

Ultimate_Historical_5 Year

Catchment Name/ID	SWMM Node/ID	Raingage Name/ID	Area (sq.mi.)	Dist. to Centroid (miles)	Length (miles)	Slope (ft./ft.)	Percent Imperv.	Depression Storage		Horton's Infiltration Parameters			DCIA Level and Fractions			Percent Eff. Imperv.
								Pervious (inches)	Imperv. (inches)	Initial Rate (in./hr.)	Final Rate (in.hr.)	Decay Coeff. (1/sec.)	DCIA Level	Dir. Con'ct Imperv. Fraction	Receiv. Perv. Fraction	
H-1	H1	EPC 24 HOUR	0.444	0.453	1.101	0.010	2.0	0.60	0.10	4.50	0.00	0.6000	2.00	0.01	0.06	1.88
H-2	H2	EPC 24 HOUR	0.712	0.819	1.568	0.010	2.0	0.60	0.10	4.50	0.00	0.6000	2.00	0.01	0.06	1.88

Latigo Historical Condition (5yr/100yr)

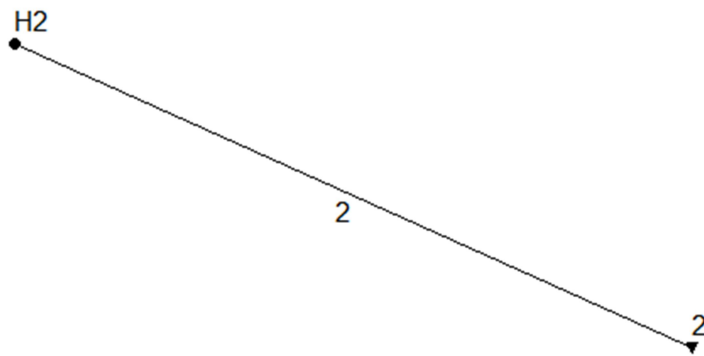
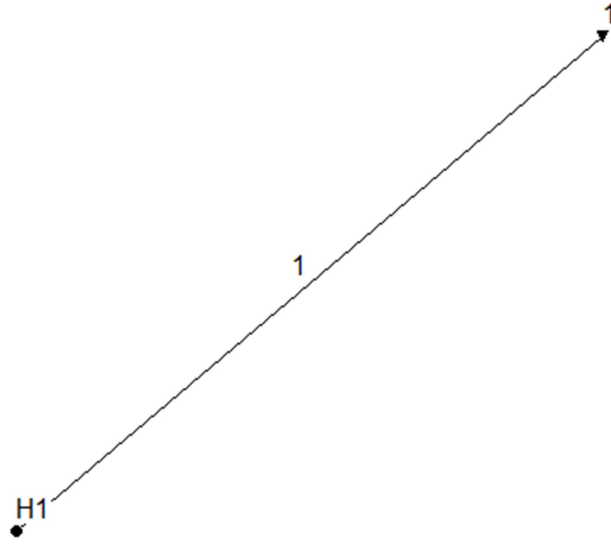

Historic Ultimate Condition 5-yr

EPA STORM WATER MANAGEMENT MODEL - VERSION 5.1 (Build 5.1.015)

NOTE: The summary statistics displayed in this report are based on results found at every computational time step, not just on results from each reporting time step.

Analysis Options

Flow Units CFS
Process Models:
Rainfall/Runoff NO
RDII NO
Snowmelt NO
Groundwater NO
Flow Routing YES
Ponding Allowed NO
Water Quality NO
Flow Routing Method KINWAVE
Starting Date 01/01/2005 00:00:00
Ending Date 01/04/2005 06:00:00
Antecedent Dry Days 0.0
Report Time Step 00:15:00
Routing Time Step 30.00 sec

Table with 3 columns: Category, Volume acre-feet, Volume 10^6 gal. Rows include Flow Routing Continuity, Dry Weather Inflow, Wet Weather Inflow, Groundwater Inflow, RDII Inflow, External Inflow, External Outflow, Flooding Loss, Evaporation Loss, Exfiltration Loss, Initial Stored Volume, Final Stored Volume, and Continuity Error (%).

Highest Flow Instability Indexes

All links are stable.

Routing Time Step Summary

Minimum Time Step : 30.00 sec
 Average Time Step : 30.00 sec
 Maximum Time Step : 30.00 sec
 Percent in Steady State : 0.00
 Average Iterations per Step : 1.00
 Percent Not Converging : 0.00

Node Depth Summary

Node	Type	Average Depth Feet	Maximum Depth Feet	Maximum HGL Feet	Time of Max Occurrence days hr:min	Reported Max Depth Feet
H1	JUNCTION	0.00	0.00	7213.00	0 00:00	0.00
H2	JUNCTION	0.00	0.00	7263.00	0 00:00	0.00
1	OUTFALL	0.00	0.00	7063.00	0 00:00	0.00
2	OUTFALL	0.00	0.00	7051.00	0 00:00	0.00

Node Inflow Summary

Total Inflow Volume gal	Flow Balance Error Percent	Type	Maximum Lateral Inflow CFS	Maximum Total Inflow CFS	Time of Max Occurrence days hr:min	Lateral Inflow Volume 10^6 gal
H1	15.8	JUNCTION	259.59	259.59	0 12:32	15.8
	0.000					

H2		JUNCTION	327.75	327.75	0	12:43	25.4
25.4	0.000						
1		OUTFALL	0.00	259.59	0	12:32	0
15.8	0.000						
2		OUTFALL	0.00	327.75	0	12:43	0
25.4	0.000						

Node Flooding Summary

No nodes were flooded.

Outfall Loading Summary

Outfall Node	Flow Freq Pcmt	Avg Flow CFS	Max Flow CFS	Total Volume 10^6 gal
1	29.43	25.63	259.59	15.844
2	31.19	38.75	327.75	25.379
System	30.31	64.37	576.55	41.223

Link Flow Summary

Link	Type	Maximum Flow CFS	Time of Max Occurrence days hr:min	Maximum Veloc ft/sec	Max/ Full Flow	Max/ Full Depth
1	DUMMY	259.59	0 12:32			
2	DUMMY	327.75	0 12:43			

Conduit Surcharge Summary

No conduits were surcharged.

Analysis begun on: Mon Sep 13 12:48:30 2021
Analysis ended on: Mon Sep 13 12:48:31 2021
Total elapsed time: 00:00:01

CUHP SUBCATCHMENTS

Latigo_Histroic_100-YR_Ultimate Pond Sizing

Columns with this color heading are for required user-input
Columns with this color heading are for optional override values
Columns with this color heading are for program-calculated values

								Maximum Depression Storage (Watershed inches)		Horton's Infiltration Parameters			DCIA
Subcatchment Name	EPA SWMM Target Node	Raingage	Area (mi ²)	Length to Centroid (mi)	Length (mi)	Slope (ft/ft)	Percent Imperviousness	Pervious	Impervious	Initial Rate (in/hr)	Decay Coefficient (1/seconds)	Final Rate (in/hr)	Level 0, 1, or 2
H-1	H1	24 Hour EPC	0.4442188	0.452719508	1.1013951	0.01	2	0.6	0.1	4.5	0.6	0.0018	2
H-2	H2	24 Hour EPC	0.7115625	0.819478977	1.568183	0.01	2	0.6	0.1	4.5	0.6	0.0018	2

Summary of Unit Hydrograph Parameters Used By Program and Calculated Results (Version 2.0.1)

Ultimate_Historical_100 Year

Catchment Name/ID	User Comment for Catchment	Unit Hydrograph Parameters and Results									Excess Precip.		Storm Hydrograph			
		CT	Cp	W50 (min.)	W50 Before Peak	W75 (min.)	W75 Before Peak	Time to Peak (min.)	Peak (cfs)	Volume (c.f)	Excess (inches)	Excess (c.f.)	Time to Peak (min.)	Peak Flow (cfs)	Total Volume (c.f.)	Runoff per Unit Area (cfs/acre)
H-1		0.156	0.281	56.2	12.43	29.2	8.79	20.7	237	1,032,009	3.95	4,080,992	751.0	459	4,080,920	1.61
H-2		0.156	0.324	76.8	19.41	39.9	13.72	32.4	278	1,653,102	3.95	6,537,050	762.0	589	6,537,062	1.29

Summary of CUHP Input Parameters (Version 2.0.1)

Ultimate_Historical_100 Year

Catchment Name/ID	SWMM Node/ID	Raingage Name/ID	Area (sq.mi.)	Dist. to Centroid (miles)	Length (miles)	Slope (ft./ft.)	Percent Imperv.	Depression Storage		Horton's Infiltration Parameters			DCIA Level and Fractions			Percent Eff. Imperv.
								Pervious (inches)	Imperv. (inches)	Initial Rate (in./hr.)	Final Rate (in.hr.)	Decay Coeff. (1/sec.)	DCIA Level	Dir. Con'ct Imperv. Fraction	Receiv. Perv. Fraction	
H-1	H1	24 HOUR EPC	0.444	0.453	1.101	0.010	2.0	0.60	0.10	4.50	0.00	0.6000	2.00	0.01	0.06	1.92
H-2	H2	24 HOUR EPC	0.712	0.819	1.568	0.010	2.0	0.60	0.10	4.50	0.00	0.6000	2.00	0.01	0.06	1.92

Latigo Historical Condition (5yr/100yr)

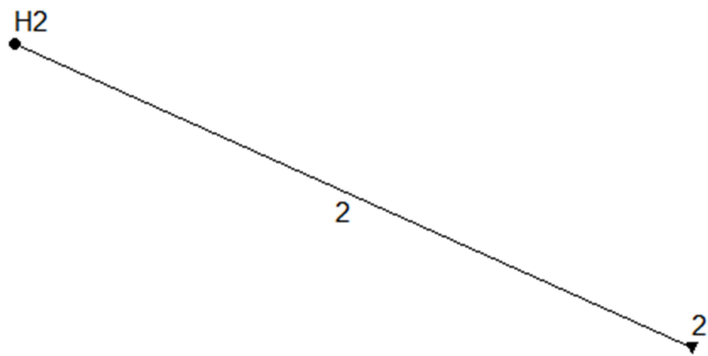
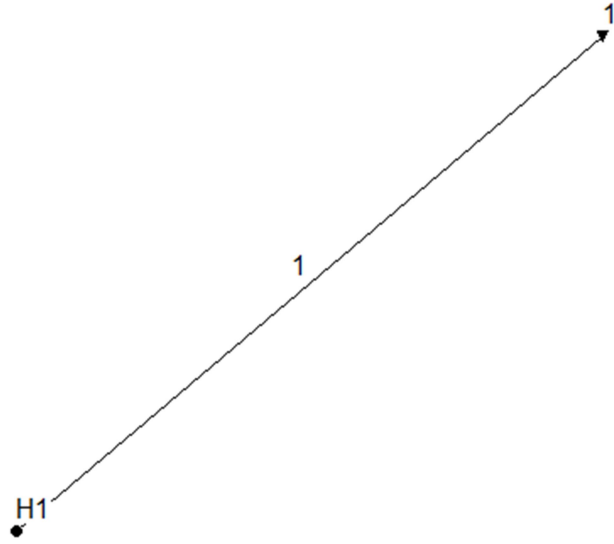

Historic Ultimate Condition 100-yr

EPA STORM WATER MANAGEMENT MODEL - VERSION 5.1 (Build 5.1.015)

NOTE: The summary statistics displayed in this report are based on results found at every computational time step, not just on results from each reporting time step.

Analysis Options

Flow Units CFS
Process Models:
Rainfall/Runoff NO
RDII NO
Snowmelt NO
Groundwater NO
Flow Routing YES
Ponding Allowed NO
Water Quality NO
Flow Routing Method KINWAVE
Starting Date 01/01/2005 00:00:00
Ending Date 01/04/2005 06:00:00
Antecedent Dry Days 0.0
Report Time Step 00:15:00
Routing Time Step 30.00 sec

Table with 3 columns: Category, Volume acre-feet, Volume 10^6 gal. Rows include Flow Routing Continuity, Dry Weather Inflow, Wet Weather Inflow, Groundwater Inflow, RDII Inflow, External Inflow, External Outflow, Flooding Loss, Evaporation Loss, Exfiltration Loss, Initial Stored Volume, Final Stored Volume, and Continuity Error (%).

Highest Flow Instability Indexes

All links are stable.

Routing Time Step Summary

Minimum Time Step : 30.00 sec
 Average Time Step : 30.00 sec
 Maximum Time Step : 30.00 sec
 Percent in Steady State : 0.00
 Average Iterations per Step : 1.00
 Percent Not Converging : 0.00

Node Depth Summary

Node	Type	Average Depth Feet	Maximum Depth Feet	Maximum HGL Feet	Time of Max Occurrence days hr:min	Reported Max Depth Feet
H1	JUNCTION	0.00	0.00	7213.00	0 00:00	0.00
H2	JUNCTION	0.00	0.00	7263.00	0 00:00	0.00
1	OUTFALL	0.00	0.00	7063.00	0 00:00	0.00
2	OUTFALL	0.00	0.00	7051.00	0 00:00	0.00

Node Inflow Summary

Total Inflow Volume gal	Flow Balance Error Percent	Type	Maximum Lateral Inflow CFS	Maximum Total Inflow CFS	Time of Max Occurrence days hr:min	Lateral Inflow Volume 10^6 gal
H1 30.5	0.000	JUNCTION	458.82	458.82	0 12:31	30.5

H2		JUNCTION	589.18	589.18	0	12:42	48.9
48.9	0.000						
1		OUTFALL	0.00	458.82	0	12:31	0
30.5	0.000						
2		OUTFALL	0.00	589.18	0	12:42	0
48.9	0.000						

Node Flooding Summary

No nodes were flooded.

Outfall Loading Summary

Outfall Node	Flow Freq Pcnt	Avg Flow CFS	Max Flow CFS	Total Volume 10^6 gal
1	31.81	45.69	458.82	30.525
2	33.45	69.60	589.18	48.897
System	32.63	115.29	1029.40	79.423

Link Flow Summary

Link	Type	Maximum Flow CFS	Time of Max Occurrence days hr:min	Maximum Veloc ft/sec	Max/ Full Flow	Max/ Full Depth
1	DUMMY	458.82	0 12:31			
2	DUMMY	589.18	0 12:42			

Conduit Surcharge Summary

No conduits were surcharged.

Analysis begun on: Mon Sep 13 13:13:43 2021
Analysis ended on: Mon Sep 13 13:13:44 2021
Total elapsed time: 00:00:01

CUHP SUBCATCHMENTS

Latigo_Proposed_5-yr_ultimate

Columns with this color heading are for required user-input
Columns with this color heading are for optional override values
Columns with this color heading are for program-calculated values

								Maximum Depression Storage (Watershed inches)		Horton's Infiltration Parameters			DCIA
Subcatchment Name	EPA SWMM Target Node	Raingage	Area (mi ²)	Length to Centroid (mi)	Length (mi)	Slope (ft/ft)	Percent Imperviousness	Pervious	Impervious	Initial Rate (in/hr)	Decay Coefficient (1/seconds)	Final Rate (in/hr)	Level 0, 1, or 2
BS-1	BS1	EPC 24 Hour	0.0967188	0.442486553	0.8477538	0.022	12	0.35	0.05	4.5	0.6	0.0018	1
BS-2	BS2	EPC 24 Hour	0.2026563	0.384944318	0.8470165	0.019	12	0.35	0.05	4.5	0.6	0.0018	1
BS-3	BS3	EPC 24 Hour	0.1448438	0.265492424	0.7254102	0.017	12	0.35	0.05	4.5	0.6	0.0018	1
BS-4	BS4	EPC 24 Hour	0.0184375	0.057916667	0.1307157	0.02	12	0.35	0.05	4.5	0.6	0.0018	1

Summary of Unit Hydrograph Parameters Used By Program and Calculated Results (Version 2.0.1)

Ultimate_Proposed_5-year

Catchment Name/ID	User Comment for Catchment	Unit Hydrograph Parameters and Results									Excess Precip.		Storm Hydrograph			
		CT	Cp	W50 (min.)	W50 Before Peak	W75 (min.)	W75 Before Peak	Time to Peak (min.)	Peak (cfs)	Volume (c.f)	Excess (inches)	Excess (c.f.)	Time to Peak (min.)	Peak Flow (cfs)	Total Volume (c.f.)	Runoff per Unit Area (cfs/acre)
BS-1		0.123	0.133	67.7	8.43	35.2	5.96	14.0	43	224,697	2.32	521,175	745.0	50	520,952	0.81
BS-2		0.123	0.182	48.1	8.21	25.0	5.80	13.7	126	470,811	2.32	1,092,026	745.0	135	1,091,551	1.04
BS-3		0.123	0.160	43.6	6.85	22.7	4.84	11.4	100	336,501	2.32	780,500	740.0	104	780,462	1.12
BS-4		0.123	0.063	22.4	2.59	11.7	1.83	4.3	25	42,834	2.32	99,352	735.0	20	96,898	1.72

Summary of CUHP Input Parameters (Version 2.0.1)

Ultimate_Proposed_5-year

Catchment Name/ID	SWMM Node/ID	Raingage Name/ID	Area (sq.mi.)	Dist. to Centroid (miles)	Length (miles)	Slope (ft./ft.)	Percent Imperv.	Depression Storage		Horton's Infiltration Parameters			DCIA Level and Fractions			Percent Eff. Imperv.
								Pervious (inches)	Imperv. (inches)	Initial Rate (in./hr.)	Final Rate (in.hr.)	Decay Coeff. (1/sec.)	DCIA Level	Dir. Con'ct Imperv. Fraction	Receiv. Perv. Fraction	
BS-1	BS1	EPC 24 HOUR	0.097	0.442	0.848	0.022	12.0	0.35	0.05	4.50	0.00	0.6000	1.00	0.13	0.21	11.51
BS-2	BS2	EPC 24 HOUR	0.203	0.385	0.847	0.019	12.0	0.35	0.05	4.50	0.00	0.6000	1.00	0.13	0.21	11.51
BS-3	BS3	EPC 24 HOUR	0.145	0.265	0.725	0.017	12.0	0.35	0.05	4.50	0.00	0.6000	1.00	0.13	0.21	11.51
BS-4	BS4	EPC 24 HOUR	0.018	0.058	0.131	0.020	12.0	0.35	0.05	4.50	0.00	0.6000	1.00	0.13	0.21	11.51

Latigo Ultimate Proposed Condition (5yr/100yr)

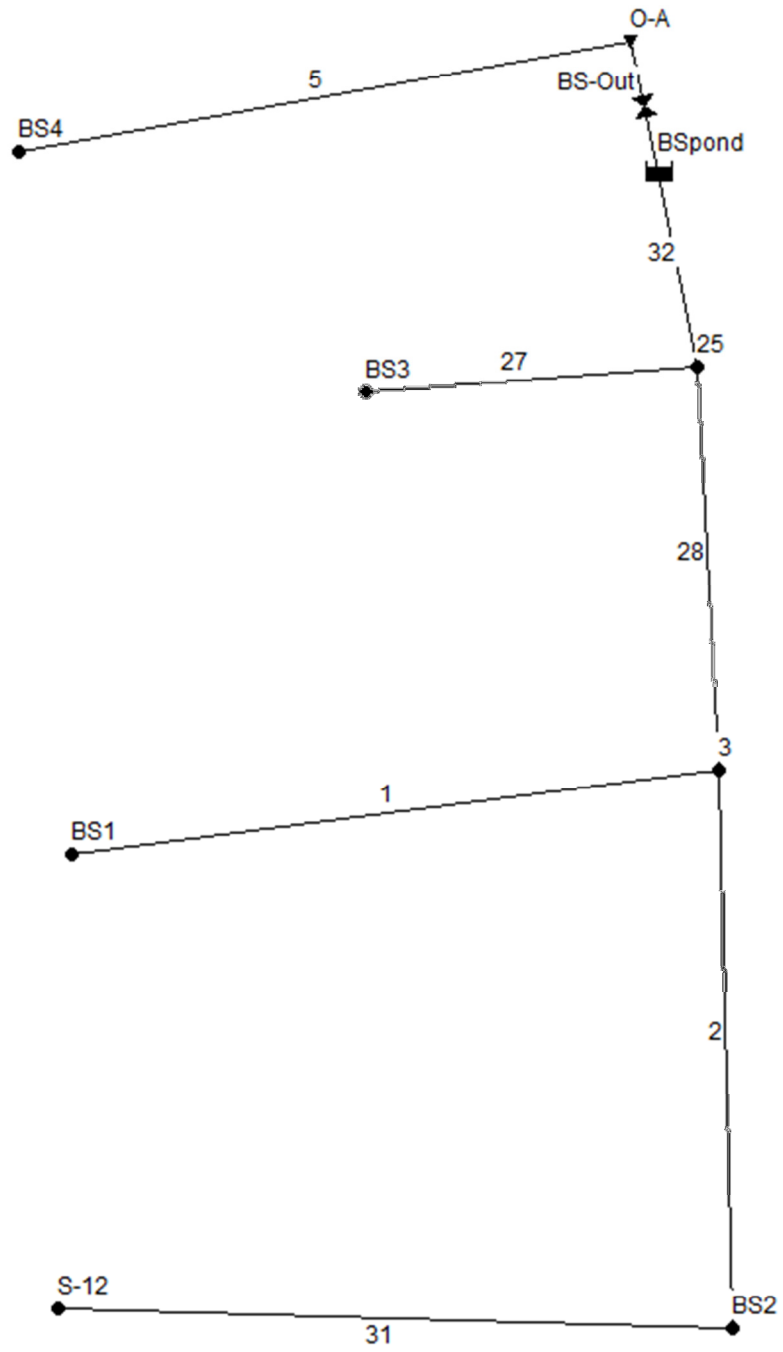

Proposed Ultimate Condition 5-yr

EPA STORM WATER MANAGEMENT MODEL - VERSION 5.1 (Build 5.1.015)

WARNING 04: minimum elevation drop used for Conduit 31

Element Count

Number of rain gages 0
Number of subcatchments ... 0
Number of nodes 9
Number of links 8
Number of pollutants 0
Number of land uses 0

Node Summary

Name	Type	Invert Elev.	Max. Depth	Ponded Area	External Inflow
BS1	JUNCTION	7165.00	0.00	0.0	
BS2	JUNCTION	7100.00	0.00	0.0	
3	JUNCTION	7070.00	0.00	0.0	
BS3	JUNCTION	7130.00	0.00	0.0	
BS4	JUNCTION	7120.00	0.00	0.0	
25	JUNCTION	7067.00	0.00	0.0	
S-12	JUNCTION	7100.00	0.00	0.0	Yes
O-A	OUTFALL	7065.00	0.00	0.0	
BSpond	STORAGE	7066.00	9.00	0.0	

Link Summary

Name	From Node	To Node	Type	Length
1	BS1	3	CONDUIT	400.0
24.4496 2	0.0100 BS2	3	CONDUIT	400.0
7.5212 5	0.0100 BS4	O-A	CONDUIT	400.0
13.8819 27	0.0100 BS3	25	CONDUIT	400.0
15.9491	0.0100			

28		3	25	CONDUIT	400.0
0.7500	0.0100				
31		S-12	BS2	CONDUIT	400.0
0.0003	0.0100				
32		25	BSpond	CONDUIT	400.0
0.2500	0.0100				
BS-Out		BSpond	O-A	OUTLET	

Cross Section Summary

Full Conduit Flow	Shape	Full Depth	Full Area	Hyd. Rad.	Max. Width	No. of Barrels

1	DUMMY	0.00	0.00	0.00	0.00	1
0.00						
2	DUMMY	0.00	0.00	0.00	0.00	1
0.00						
5	DUMMY	0.00	0.00	0.00	0.00	1
0.00						
27	DUMMY	0.00	0.00	0.00	0.00	1
0.00						
28	DUMMY	0.00	0.00	0.00	0.00	1
0.00						
31	DUMMY	0.00	0.00	0.00	0.00	1
0.00						
32	DUMMY	0.00	0.00	0.00	0.00	1
0.00						

NOTE: The summary statistics displayed in this report are based on results found at every computational time step, not just on results from each reporting time step.

Analysis Options

Flow Units CFS
Process Models:
 Rainfall/Runoff NO
 RDII NO
 Snowmelt NO

Groundwater NO
 Flow Routing YES
 Ponding Allowed NO
 Water Quality NO
 Flow Routing Method KINWAVE
 Starting Date 01/01/2005 00:00:00
 Ending Date 01/04/2005 06:00:00
 Antecedent Dry Days 0.0
 Report Time Step 00:30:00
 Routing Time Step 30.00 sec

 Control Actions Taken

	Volume acre-feet	Volume 10 ⁶ gal
	-----	-----
Flow Routing Continuity		
Dry Weather Inflow	0.000	0.000
Wet Weather Inflow	0.000	0.000
Groundwater Inflow	0.000	0.000
RDII Inflow	0.000	0.000
External Inflow	63.472	20.683
External Outflow	63.532	20.703
Flooding Loss	0.000	0.000
Evaporation Loss	0.000	0.000
Exfiltration Loss	0.000	0.000
Initial Stored Volume	0.000	0.000
Final Stored Volume	0.000	0.000
Continuity Error (%)	-0.094	

 Highest Flow Instability Indexes

 All links are stable.

 Routing Time Step Summary

Minimum Time Step	:	30.00 sec
Average Time Step	:	30.00 sec
Maximum Time Step	:	30.00 sec
Percent in Steady State	:	0.00
Average Iterations per Step	:	1.00
Percent Not Converging	:	0.00

Node Depth Summary

Node	Type	Average Depth Feet	Maximum Depth Feet	Maximum HGL Feet	Time of Max Occurrence days hr:min	Reported Max Depth Feet
BS1	JUNCTION	0.00	0.00	7165.00	0 00:00	0.00
BS2	JUNCTION	0.00	0.00	7100.00	0 00:00	0.00
3	JUNCTION	0.00	0.00	7070.00	0 00:00	0.00
BS3	JUNCTION	0.00	0.00	7130.00	0 00:00	0.00
BS4	JUNCTION	0.00	0.00	7120.00	0 00:00	0.00
25	JUNCTION	0.00	0.00	7067.00	0 00:00	0.00
S-12	JUNCTION	0.00	0.00	7100.00	0 00:00	0.00
O-A	OUTFALL	0.00	0.00	7065.00	0 00:00	0.00
BSpond	STORAGE	2.51	4.81	7070.81	0 12:16	4.80

Node Inflow Summary

Total Inflow Volume gal	Flow Balance Error Percent	Type	Maximum Lateral Inflow CFS	Maximum Total Inflow CFS	Time of Max Occurrence days hr:min	Lateral Inflow Volume 10^6 gal
BS1 3.9	0.000	JUNCTION	50.32	50.32	0 12:25	3.9
BS2 10.2	0.000	JUNCTION	135.07	139.07	0 12:25	8.16
3 14.1	0.000	JUNCTION	0.00	189.39	0 12:25	0
BS3 5.84	0.000	JUNCTION	104.12	104.12	0 12:20	5.84
BS4 0.725	0.000	JUNCTION	20.30	20.30	0 12:15	0.725
25		JUNCTION	0.00	291.63	0 12:20	0

20	0.000							
S-12		JUNCTION	14.00	14.00	0	06:55	2.06	
2.06	0.000							
O-A		OUTFALL	0.00	378.93	0	12:16	0	
20.7	0.000							
BSpnd		STORAGE	0.00	291.63	0	12:20	0	
20	-0.097							

Node Flooding Summary

No nodes were flooded.

Storage Volume Summary

of Max Occurrence	Maximum Outflow Storage Unit	Average Volume	Avg Pcnt Full	Evap Pcnt Loss	Exfil Pcnt Loss	Maximum Volume	Max Pcnt Full	Time days
hr:min	CFS	1000 ft3				1000 ft3		
BSpnd 12:16	359.07	79.145	12	0	0	215.523	32	0

Outfall Loading Summary

Outfall Node	Flow Freq Pcnt	Avg Flow CFS	Max Flow CFS	Total Volume 10^6 gal
O-A	95.22	10.35	378.93	20.701
System	95.22	10.35	378.93	20.701

 Link Flow Summary

Link	Type	Maximum Flow CFS	Time of Max Occurrence days hr:min	Maximum Veloc ft/sec	Max/ Full Flow	Max/ Full Depth
1	DUMMY	50.32	0 12:25			
2	DUMMY	139.07	0 12:25			
5	DUMMY	20.30	0 12:15			
27	DUMMY	104.12	0 12:20			
28	DUMMY	189.39	0 12:25			
31	DUMMY	14.00	0 06:55			
32	DUMMY	291.63	0 12:20			
BS-Out	DUMMY	359.07	0 12:16			

 Conduit Surcharge Summary

No conduits were surcharged.

Analysis begun on: Fri Sep 10 12:18:10 2021
 Analysis ended on: Fri Sep 10 12:18:10 2021
 Total elapsed time: < 1 sec

Pond S12 - 5 yr outflow hydrograph

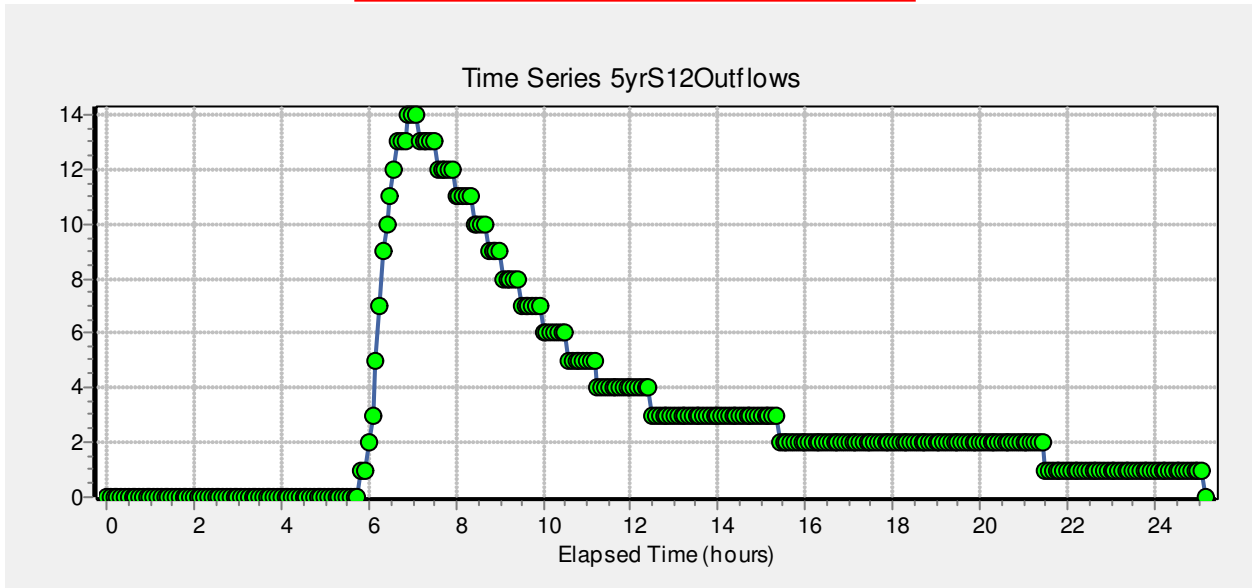

From "Final Drainage Report for The Trails Filing No. 8 and Addendum to Master Development Preliminary Drainage Plans for Latigo Trails" by JR Engineering, dated January 2007
Used as "inflows" to node S12 in all 5-yr proposed condition models

Storage Curve Editor

Curve Name:

Description:

	Depth (ft)	Area (ft2)
1	0.00	0
2	1.00	14953
3	2.00	44800
4	3.00	57801
5	4.00	71058
6	5.00	84571
7	6.00	98340
8	7.00	112364
9	8.00	126605
10	8.33	131780
11		

View... Load... Save... OK Cancel Help

Rating Curve Editor

Curve Name:

Description:

	Head (ft)	Outflow (CFS)
1	0	0
2	0.5	0.32
3	1	0.53
4	1.5	0.69
5	2	0.82
6	2.5	0.93
7	3	1.03
8	3.5	1.11
9	4	1.20
10	4.2	30.04
11	4.4	82.76

View... Load... Save... OK Cancel Help

12	4.6	151.02
13	4.8	231.85
14	5.0	323.53
15	5.1	373.06
16	5.2	424.89
17	5.3	443.40
18	5.4	447.56
19	5.5	451.68
20	5.6	455.77
21	5.7	459.82

22	5.8	463.84
23	5.9	467.82
24	6.0	471.77
25		
26		

Stage storage and stage/head release curves were taken from the MHFD UD-Detention V4.04 design workbook.

CUHP SUBCATCHMENTS

Latigo_Proposed_100yr_Ultimate

Columns with this color heading are for required user-input
Columns with this color heading are for optional override values
Columns with this color heading are for program-calculated values

								Maximum Depression Storage (Watershed inches)		Horton's Infiltration Parameters			DCIA
Subcatchment Name	EPA SWMM Target Node	Raingage	Area (mi ²)	Length to Centroid (mi)	Length (mi)	Slope (ft/ft)	Percent Imperviousness	Pervious	Impervious	Initial Rate (in/hr)	Decay Coefficient (1/seconds)	Final Rate (in/hr)	Level 0, 1, or 2
BS-1	BS1	EPC 24 Hour	0.0967188	0.442486553	0.8477538	0.022	12	0.35	0.05	4.5	0.6	0.0018	1
BS-2	BS2	EPC 24 Hour	0.2026563	0.384944318	0.8470165	0.019	12	0.35	0.05	4.5	0.6	0.0018	1
BS-3	BS3	EPC 24 Hour	0.1448438	0.265492424	0.7254102	0.017	12	0.35	0.05	4.5	0.6	0.0018	1
BS-4	BS4	EPC 24 Hour	0.0184375	0.057916667	0.1307157	0.02	12	0.35	0.05	4.5	0.6	0.0018	1

Summary of Unit Hydrograph Parameters Used By Program and Calculated Results (Version 2.0.1)

Ultimate_Proposed_100-year

Catchment Name/ID	User Comment for Catchment	Unit Hydrograph Parameters and Results									Excess Precip.		Storm Hydrograph			
		CT	Cp	W50 (min.)	W50 Before Peak	W75 (min.)	W75 Before Peak	Time to Peak (min.)	Peak (cfs)	Volume (c.f)	Excess (inches)	Excess (c.f.)	Time to Peak (min.)	Peak Flow (cfs)	Total Volume (c.f.)	Runoff per Unit Area (cfs/acre)
BS-1		0.123	0.133	67.6	8.41	35.1	5.94	14.0	43	224,697	4.20	943,416	745.0	86	943,027	1.39
BS-2		0.123	0.181	48.0	8.19	25.0	5.79	13.6	127	470,811	4.20	1,976,754	745.0	230	1,975,896	1.78
BS-3		0.123	0.160	43.5	6.84	22.6	4.83	11.4	100	336,501	4.20	1,412,838	740.0	178	1,412,780	1.92
BS-4		0.123	0.063	22.4	2.59	11.6	1.83	4.3	25	42,834	4.20	179,843	735.0	35	175,389	2.93

Summary of CUHP Input Parameters (Version 2.0.1)

Ultimate_Proposed_100-year

Catchment Name/ID	SWMM Node/ID	Raingage Name/ID	Area (sq.mi.)	Dist. to Centroid (miles)	Length (miles)	Slope (ft./ft.)	Percent Imperv.	Depression Storage		Horton's Infiltration Parameters			DCIA Level and Fractions			Percent Eff. Imperv.
								Pervious (inches)	Imperv. (inches)	Initial Rate (in./hr.)	Final Rate (in.hr.)	Decay Coeff. (1/sec.)	DCIA Level	Dir. Con'ct Imperv. Fraction	Receiv. Perv. Fraction	
BS-1	BS1	EPC 24 HOUR	0.097	0.442	0.848	0.022	12.0	0.35	0.05	4.50	0.00	0.6000	1.00	0.13	0.21	11.72
BS-2	BS2	EPC 24 HOUR	0.203	0.385	0.847	0.019	12.0	0.35	0.05	4.50	0.00	0.6000	1.00	0.13	0.21	11.72
BS-3	BS3	EPC 24 HOUR	0.145	0.265	0.725	0.017	12.0	0.35	0.05	4.50	0.00	0.6000	1.00	0.13	0.21	11.72
BS-4	BS4	EPC 24 HOUR	0.018	0.058	0.131	0.020	12.0	0.35	0.05	4.50	0.00	0.6000	1.00	0.13	0.21	11.72

Latigo Ultimate Proposed Condition (5yr/100yr)

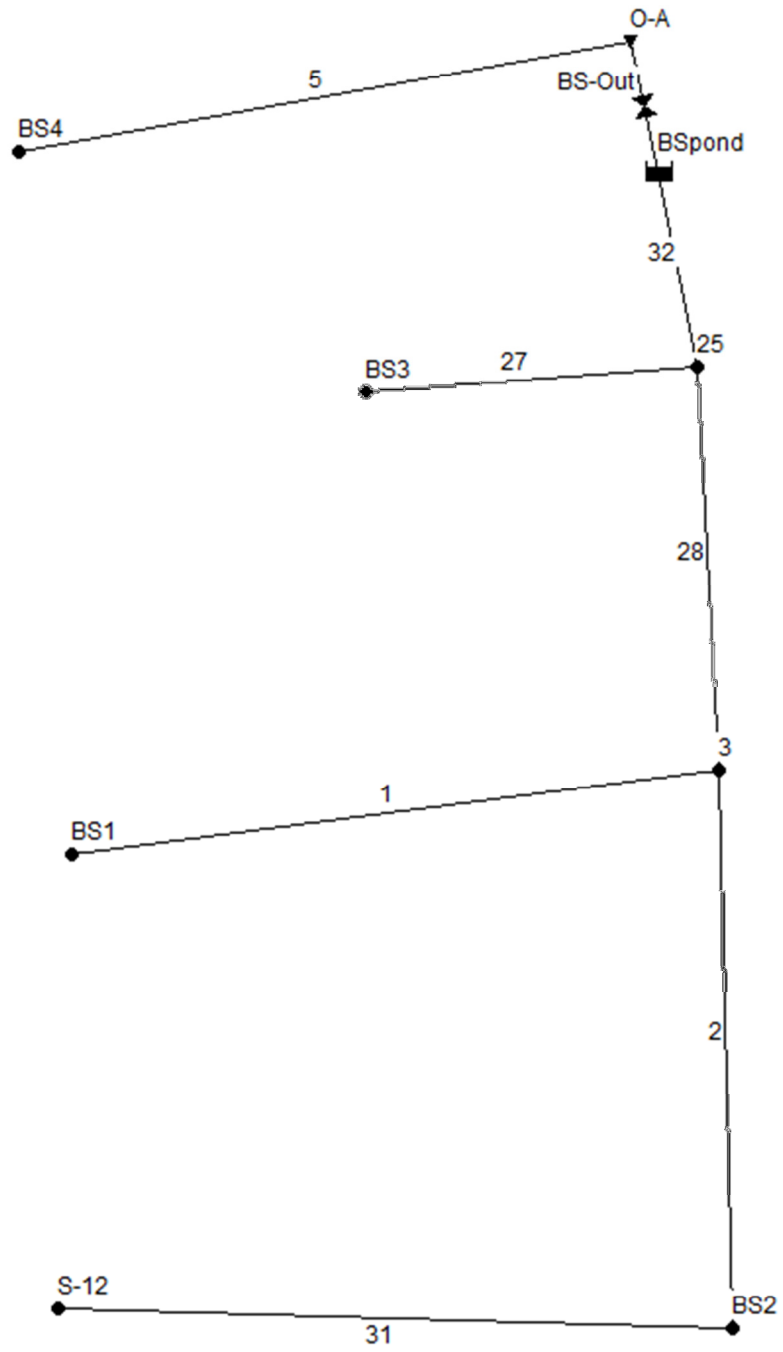

Proposed Ultimate Condition 100-yr

EPA STORM WATER MANAGEMENT MODEL - VERSION 5.1 (Build 5.1.015)

WARNING 04: minimum elevation drop used for Conduit 31

Element Count

Number of rain gages 0
 Number of subcatchments ... 0
 Number of nodes 9
 Number of links 8
 Number of pollutants 0
 Number of land uses 0

Node Summary

Name	Type	Invert Elev.	Max. Depth	Ponded Area	External Inflow
BS1	JUNCTION	7165.00	0.00	0.0	
BS2	JUNCTION	7100.00	0.00	0.0	
3	JUNCTION	7070.00	0.00	0.0	
BS3	JUNCTION	7130.00	0.00	0.0	
BS4	JUNCTION	7120.00	0.00	0.0	
25	JUNCTION	7067.00	0.00	0.0	
S-12	JUNCTION	7100.00	0.00	0.0	Yes
O-A	OUTFALL	7065.00	0.00	0.0	
BSpond	STORAGE	7066.00	8.00	0.0	

Link Summary

Name	From Node	To Node	Type	Length
1	BS1	3	CONDUIT	400.0
24.4496	0.0100			
2	BS2	3	CONDUIT	400.0
7.5212	0.0100			
5	BS4	O-A	CONDUIT	400.0
13.8819	0.0100			
27	BS3	25	CONDUIT	400.0
15.9491	0.0100			

28		3	25	CONDUIT	400.0
0.7500	0.0100				
31		S-12	BS2	CONDUIT	400.0
0.0003	0.0100				
32		25	BSpond	CONDUIT	400.0
0.2500	0.0100				
BS-Out		BSpond	O-A	OUTLET	

Cross Section Summary

Full Conduit Flow	Shape	Full Depth	Full Area	Hyd. Rad.	Max. Width	No. of Barrels

1	DUMMY	0.00	0.00	0.00	0.00	1
0.00						
2	DUMMY	0.00	0.00	0.00	0.00	1
0.00						
5	DUMMY	0.00	0.00	0.00	0.00	1
0.00						
27	DUMMY	0.00	0.00	0.00	0.00	1
0.00						
28	DUMMY	0.00	0.00	0.00	0.00	1
0.00						
31	DUMMY	0.00	0.00	0.00	0.00	1
0.00						
32	DUMMY	0.00	0.00	0.00	0.00	1
0.00						

NOTE: The summary statistics displayed in this report are based on results found at every computational time step, not just on results from each reporting time step.

Analysis Options

Flow Units CFS
Process Models:
 Rainfall/Runoff NO
 RDII NO
 Snowmelt NO

Groundwater NO
 Flow Routing YES
 Ponding Allowed NO
 Water Quality NO
 Flow Routing Method KINWAVE
 Starting Date 01/01/2005 00:00:00
 Ending Date 01/04/2005 06:00:00
 Antecedent Dry Days 0.0
 Report Time Step 00:30:00
 Routing Time Step 30.00 sec

 Control Actions Taken

	Volume acre-feet	Volume 10 ⁶ gal
	-----	-----
Flow Routing Continuity		
Dry Weather Inflow	0.000	0.000
Wet Weather Inflow	0.000	0.000
Groundwater Inflow	0.000	0.000
RDII Inflow	0.000	0.000
External Inflow	122.913	40.053
External Outflow	122.693	39.981
Flooding Loss	0.000	0.000
Evaporation Loss	0.000	0.000
Exfiltration Loss	0.000	0.000
Initial Stored Volume	0.000	0.000
Final Stored Volume	0.137	0.045
Continuity Error (%)	0.068	

 Highest Flow Instability Indexes

 All links are stable.

 Routing Time Step Summary

Minimum Time Step	:	30.00 sec
Average Time Step	:	30.00 sec
Maximum Time Step	:	30.00 sec
Percent in Steady State	:	0.00
Average Iterations per Step	:	1.00
Percent Not Converging	:	0.00

Node Depth Summary

Node	Type	Average Depth Feet	Maximum Depth Feet	Maximum HGL Feet	Time of Max Occurrence days hr:min	Reported Max Depth Feet
BS1	JUNCTION	0.00	0.00	7165.00	0 00:00	0.00
BS2	JUNCTION	0.00	0.00	7100.00	0 00:00	0.00
3	JUNCTION	0.00	0.00	7070.00	0 00:00	0.00
BS3	JUNCTION	0.00	0.00	7130.00	0 00:00	0.00
BS4	JUNCTION	0.00	0.00	7120.00	0 00:00	0.00
25	JUNCTION	0.00	0.00	7067.00	0 00:00	0.00
S-12	JUNCTION	0.00	0.00	7100.00	0 00:00	0.00
O-A	OUTFALL	0.00	0.00	7065.00	0 00:00	0.00
BSpond	STORAGE	2.97	5.66	7071.66	0 12:36	5.61

Node Inflow Summary

Total Inflow Volume gal	Flow Balance Error Percent	Type	Maximum Lateral Inflow CFS	Maximum Total Inflow CFS	Time of Max Occurrence days hr:min	Lateral Inflow Volume 10^6 gal
BS1 7.05	0.000	JUNCTION	85.96	85.96	0 12:25	7.05
BS2 21.1	0.000	JUNCTION	230.42	240.42	0 12:25	14.8
3 28.2	0.000	JUNCTION	0.00	326.38	0 12:25	0
BS3 10.6	0.000	JUNCTION	177.66	177.66	0 12:20	10.6
BS4 1.31	0.000	JUNCTION	34.63	34.63	0 12:15	1.31
25		JUNCTION	0.00	500.99	0 12:20	0

38.7	0.000							
S-12		JUNCTION	55.00	55.00	0	06:40	6.34	
6.34	0.000							
O-A		OUTFALL	0.00	480.13	0	12:31	0	
40	0.000							
BSpond		STORAGE	0.00	500.99	0	12:20	0	
38.7	0.071							

Node Flooding Summary

No nodes were flooded.

Storage Volume Summary

of Max Occurrence		Maximum Outflow	Average Volume	Avg Pcnt Full	Evap Pcnt Loss	Exfil Pcnt Loss	Maximum Volume	Max Pcnt Full	Time days
hr:min	Storage Unit	CFS	1000 ft3	Full	Loss	Loss	1000 ft3	Full	
12:35	BSpond	458.22	99.589	18	0	0	289.806	53	0

Outfall Loading Summary

Outfall Node	Flow Freq Pcnt	Avg Flow CFS	Max Flow CFS	Total Volume 10^6 gal
O-A	98.42	19.34	480.13	39.978
System	98.42	19.34	480.13	39.978

 Link Flow Summary

Link	Type	Maximum Flow CFS	Time of Max Occurrence days hr:min	Maximum Veloc ft/sec	Max/ Full Flow	Max/ Full Depth
1	DUMMY	85.96	0 12:25			
2	DUMMY	240.42	0 12:25			
5	DUMMY	34.63	0 12:15			
27	DUMMY	177.66	0 12:20			
28	DUMMY	326.38	0 12:25			
31	DUMMY	55.00	0 06:40			
32	DUMMY	500.99	0 12:20			
BS-Out	DUMMY	458.22	0 12:36			

 Conduit Surcharge Summary

No conduits were surcharged.

Analysis begun on: Fri Sep 10 12:23:54 2021
 Analysis ended on: Fri Sep 10 12:23:54 2021
 Total elapsed time: < 1 sec

Pond S12 - 100 yr outflow hydrograph

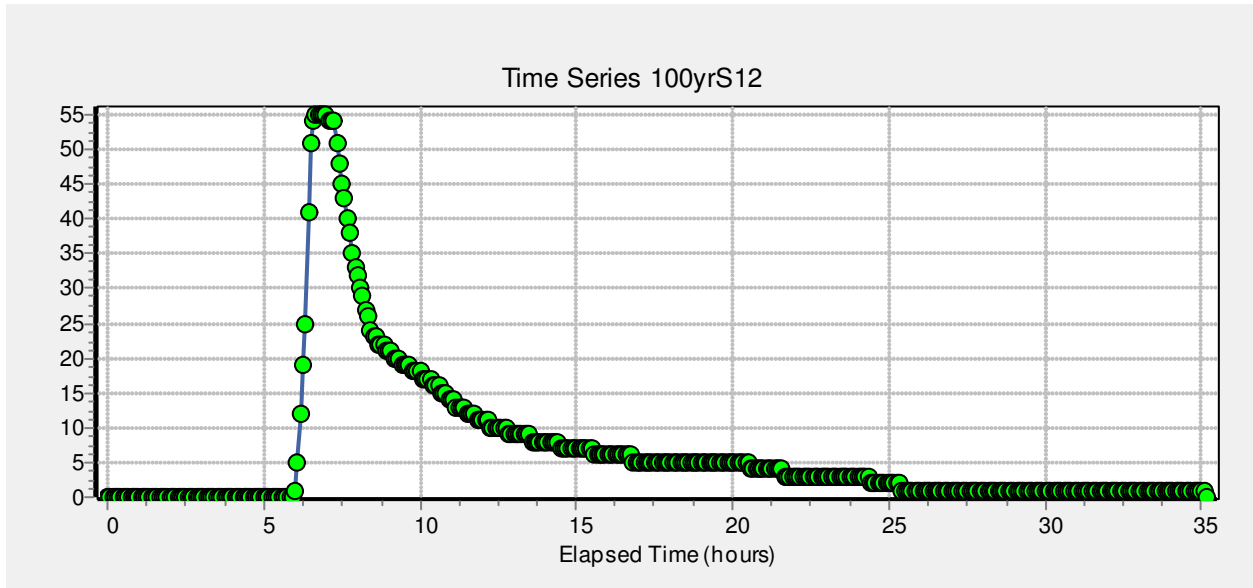

From "Final Drainage Report for The Trails Filing No. 8 and Addendum to Master Development Preliminary Drainage Plans for Latigo Trails" by JR Engineering, dated January 2007
Used as "inflows" to node S12 in all 100-yr proposed condition models

Storage Curve Editor

Curve Name:

Description:

	Depth (ft)	Area (ft2)
1	0.00	0
2	1.00	14953
3	2.00	44800
4	3.00	57801
5	4.00	71058
6	5.00	84571
7	6.00	98340
8	7.00	112364
9	8.00	126605
10	8.33	131780
11		

View... Load... Save... OK Cancel Help

Rating Curve Editor

Curve Name:

Description:

	Head (ft)	Outflow (CFS)
1	0	0
2	0.5	0.32
3	1	0.53
4	1.5	0.69
5	2	0.82
6	2.5	0.93
7	3	1.03
8	3.5	1.11
9	4	1.20
10	4.2	30.04
11	4.4	82.76

View... Load... Save... OK Cancel Help

12	4.6	151.02
13	4.8	231.85
14	5.0	323.53
15	5.1	373.06
16	5.2	424.89
17	5.3	443.40
18	5.4	447.56
19	5.5	451.68
20	5.6	455.77
21	5.7	459.82

22	5.8	463.84
23	5.9	467.82
24	6.0	471.77
25		
26		

Stage storage and stage/head release curves were taken from the MHFD UD-Detention V4.04 design workbook.

CUHP SUBCATCHMENTS

Latigo Histroical 5-yr F9 Interim Pond Sizing

Columns with this color heading are for required user-input
Columns with this color heading are for optional override values
Columns with this color heading are for program-calculated values

								Maximum Depression Storage (Watershed inches)		Horton's Infiltration Parameters			DCIA
Subcatchment Name	EPA SWMM Target Node	Raingage	Area (mi ²)	Length to Centroid (mi)	Length (mi)	Slope (ft/ft)	Percent Imperviousness	Pervious	Impervious	Initial Rate (in/hr)	Decay Coefficient (1/seconds)	Final Rate (in/hr)	Level 0, 1, or 2
H-1	H1	EPC 24 Hour	0.299375	0.452719508	1.1013951	0.01	2	0.6	0.1	4.5	0.6	0.0018	2
H-2	H2	EPC 24 Hour	0.7115625	0.819478977	1.568183	0.01	2	0.6	0.1	4.5	0.6	0.0018	2

Summary of Unit Hydrograph Parameters Used By Program and Calculated Results (Version 2.0.1)

Latigo 5-yr Historical_F9 Interim

Catchment Name/ID	User Comment for Catchment	Unit Hydrograph Parameters and Results									Excess Precip.		Storm Hydrograph			
		CT	Cp	W50 (min.)	W50 Before Peak	W75 (min.)	W75 Before Peak	Time to Peak (min.)	Peak (cfs)	Volume (c.f)	Excess (inches)	Excess (c.f.)	Time to Peak (min.)	Peak Flow (cfs)	Total Volume (c.f.)	Runoff per Unit Area (cfs/acre)
H-1		0.156	0.250	63.2	12.45	32.9	8.79	20.7	142	695,508	2.05	1,427,502	753.0	159	1,427,487	0.83
H-2		0.156	0.324	76.8	19.43	39.9	13.73	32.4	278	1,653,102	2.05	3,392,925	763.0	328	3,392,929	0.72

Summary of CUHP Input Parameters (Version 2.0.1)

Latigo 5-yr Historical_F9 Interim

Catchment Name/ID	SWMM Node/ID	Raingage Name/ID	Area (sq.mi.)	Dist. to Centroid (miles)	Length (miles)	Slope (ft./ft.)	Percent Imperv.	Depression Storage		Horton's Infiltration Parameters			DCIA Level and Fractions			Percent Eff. Imperv.
								Pervious (inches)	Imperv. (inches)	Initial Rate (in./hr.)	Final Rate (in.hr.)	Decay Coeff. (1/sec.)	DCIA Level	Dir. Con'ct Imperv. Fraction	Receiv. Perv. Fraction	
H-1	H1	EPC 24 HOUR	0.299	0.453	1.101	0.010	2.0	0.60	0.10	4.50	0.00	0.6000	2.00	0.01	0.06	1.88
H-2	H2	EPC 24 HOUR	0.712	0.819	1.568	0.010	2.0	0.60	0.10	4.50	0.00	0.6000	2.00	0.01	0.06	1.88

Interim Latigo Historical Condition (5yr/100yr)

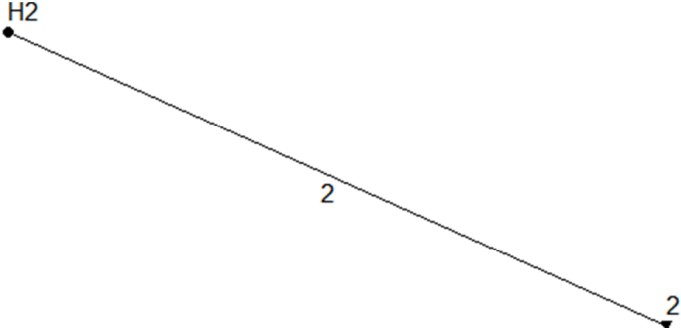
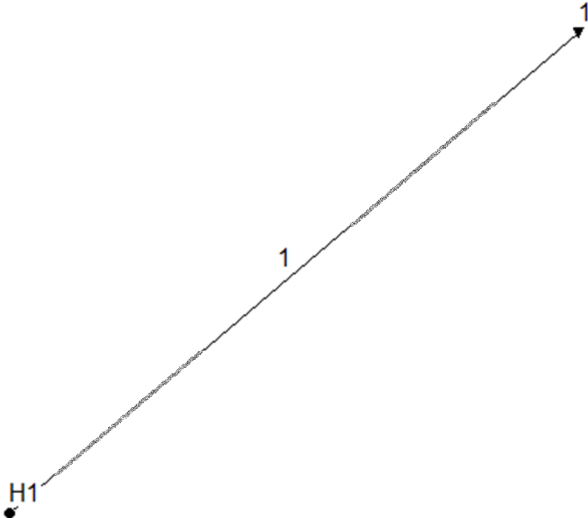

Historical Interim Condition 5-yr (F9-only)

EPA STORM WATER MANAGEMENT MODEL - VERSION 5.1 (Build 5.1.015)

NOTE: The summary statistics displayed in this report are based on results found at every computational time step, not just on results from each reporting time step.

Analysis Options

Flow Units CFS
Process Models:
Rainfall/Runoff NO
RDII NO
Snowmelt NO
Groundwater NO
Flow Routing YES
Ponding Allowed NO
Water Quality NO
Flow Routing Method KINWAVE
Starting Date 01/01/2005 00:00:00
Ending Date 01/04/2005 06:00:00
Antecedent Dry Days 0.0
Report Time Step 00:15:00
Routing Time Step 30.00 sec

Table with 3 columns: Category, Volume acre-feet, Volume 10^6 gal. Rows include Flow Routing Continuity, Dry Weather Inflow, Wet Weather Inflow, Groundwater Inflow, RDII Inflow, External Inflow, External Outflow, Flooding Loss, Evaporation Loss, Exfiltration Loss, Initial Stored Volume, Final Stored Volume, and Continuity Error (%).

Highest Flow Instability Indexes

All links are stable.

Routing Time Step Summary

Minimum Time Step : 30.00 sec
 Average Time Step : 30.00 sec
 Maximum Time Step : 30.00 sec
 Percent in Steady State : 0.00
 Average Iterations per Step : 1.00
 Percent Not Converging : 0.00

Node Depth Summary

Node	Type	Average Depth Feet	Maximum Depth Feet	Maximum HGL Feet	Time of Max Occurrence days hr:min	Reported Max Depth Feet
H1	JUNCTION	0.00	0.00	7213.00	0 00:00	0.00
H2	JUNCTION	0.00	0.00	7263.00	0 00:00	0.00
1	OUTFALL	0.00	0.00	7063.00	0 00:00	0.00
2	OUTFALL	0.00	0.00	7051.00	0 00:00	0.00

Node Inflow Summary

Total Inflow Volume gal	Flow Balance Error Percent	Type	Maximum Lateral Inflow CFS	Maximum Total Inflow CFS	Time of Max Occurrence days hr:min	Lateral Inflow Volume 10^6 gal
H1	10.7	JUNCTION	159.08	159.08	0 12:33	10.7
	0.000					

H2		JUNCTION	327.75	327.75	0	12:43	25.4
25.4	0.000						
1		OUTFALL	0.00	159.08	0	12:33	0
10.7	0.000						
2		OUTFALL	0.00	327.75	0	12:43	0
25.4	0.000						

Node Flooding Summary

No nodes were flooded.

Outfall Loading Summary

Outfall Node	Flow Freq Pcmt	Avg Flow CFS	Max Flow CFS	Total Volume 10^6 gal
1	29.32	17.34	159.08	10.678
2	31.19	38.75	327.75	25.379
System	30.25	56.09	481.58	36.057

Link Flow Summary

Link	Type	Maximum Flow CFS	Time of Max Occurrence days hr:min	Maximum Veloc ft/sec	Max/ Full Flow	Max/ Full Depth
1	DUMMY	159.08	0 12:33			
2	DUMMY	327.75	0 12:43			

Conduit Surcharge Summary

No conduits were surcharged.

Analysis begun on: Fri Sep 10 14:55:05 2021
Analysis ended on: Fri Sep 10 14:55:05 2021
Total elapsed time: < 1 sec

CUHP SUBCATCHMENTS

Latigo 100-yr Historical_F9 Interim

Columns with this color heading are for required user-input
Columns with this color heading are for optional override values
Columns with this color heading are for program-calculated values

									Maximum Depression Storage (Watershed inches)		Horton's Infiltration Parameters			DCIA
Subcatchment Name	EPA SWMM Target Node	Raingage	Area (mi ²)	Length to Centroid (mi)	Length (mi)	Slope (ft/ft)	Percent Imperviousness	Pervious	Impervious	Initial Rate (in/hr)	Decay Coefficient (1/seconds)	Final Rate (in/hr)	Level 0, 1, or 2	
H-1	H1	24 Hour EPC	0.299375	0.452719508	1.1013951	0.01	2	0.6	0.1	4.5	0.6	0.0018	2	
H-2	H2	24 Hour EPC	0.7115625	0.819478977	1.568183	0.01	2	0.6	0.1	4.5	0.6	0.0018	2	

Summary of Unit Hydrograph Parameters Used By Program and Calculated Results (Version 2.0.1)

Latigo 100-yr Historical_F9 Interim

Catchment Name/ID	User Comment for Catchment	Unit Hydrograph Parameters and Results									Excess Precip.		Storm Hydrograph			
		CT	Cp	W50 (min.)	W50 Before Peak	W75 (min.)	W75 Before Peak	Time to Peak (min.)	Peak (cfs)	Volume (c.f)	Excess (inches)	Excess (c.f.)	Time to Peak (min.)	Peak Flow (cfs)	Total Volume (c.f.)	Runoff per Unit Area (cfs/acre)
H-1		0.156	0.250	63.2	12.43	32.9	8.79	20.7	142	695,508	3.95	2,750,327	752.0	284	2,750,301	1.48
H-2		0.156	0.324	76.8	19.41	39.9	13.72	32.4	278	1,653,102	3.95	6,537,050	762.0	589	6,537,062	1.29

Summary of Unit Hydrograph Parameters Used By Program and Calculated Results (Version 2.0.1)

Latigo 100-yr Historical_F9 Interim

Catchment Name/ID	User Comment for Catchment	Unit Hydrograph Parameters and Results									Excess Precip.		Storm Hydrograph			
		CT	Cp	W50 (min.)	W50 Before Peak	W75 (min.)	W75 Before Peak	Time to Peak (min.)	Peak (cfs)	Volume (c.f)	Excess (inches)	Excess (c.f.)	Time to Peak (min.)	Peak Flow (cfs)	Total Volume (c.f.)	Runoff per Unit Area (cfs/acre)
H-1		0.156	0.250	63.2	12.43	32.9	8.79	20.7	142	695,508	3.95	2,750,327	752.0	284	2,750,301	1.48
H-2		0.156	0.324	76.8	19.41	39.9	13.72	32.4	278	1,653,102	3.95	6,537,050	762.0	589	6,537,062	1.29

Interim Latigo Historical Condition (5yr/100yr)

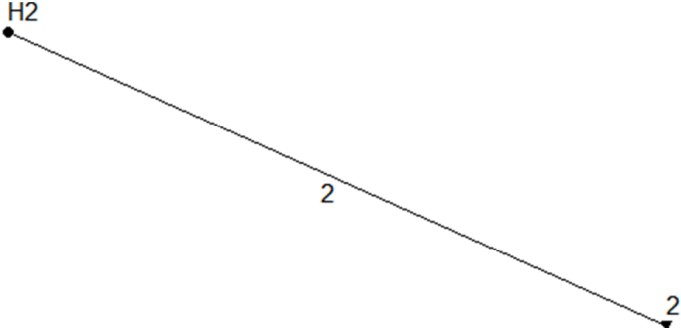
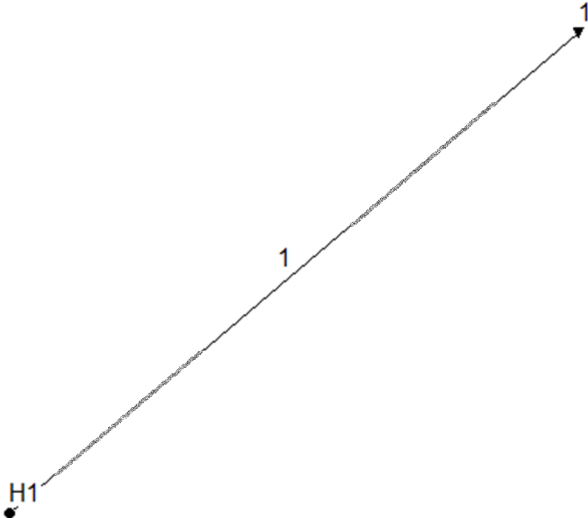

Historical Interim Condition 100-yr (F9-only)

EPA STORM WATER MANAGEMENT MODEL - VERSION 5.1 (Build 5.1.015)

NOTE: The summary statistics displayed in this report are based on results found at every computational time step, not just on results from each reporting time step.

Analysis Options

Flow Units CFS
Process Models:
Rainfall/Runoff NO
RDII NO
Snowmelt NO
Groundwater NO
Flow Routing YES
Ponding Allowed NO
Water Quality NO
Flow Routing Method KINWAVE
Starting Date 01/01/2005 00:00:00
Ending Date 01/04/2005 06:00:00
Antecedent Dry Days 0.0
Report Time Step 00:15:00
Routing Time Step 30.00 sec

Table with 3 columns: Flow Routing Continuity, Volume acre-feet, Volume 10^6 gal. Rows include Dry Weather Inflow, Wet Weather Inflow, Groundwater Inflow, RDII Inflow, External Inflow, External Outflow, Flooding Loss, Evaporation Loss, Exfiltration Loss, Initial Stored Volume, Final Stored Volume, and Continuity Error (%).

Highest Flow Instability Indexes

All links are stable.

Routing Time Step Summary

Minimum Time Step : 30.00 sec
 Average Time Step : 30.00 sec
 Maximum Time Step : 30.00 sec
 Percent in Steady State : 0.00
 Average Iterations per Step : 1.00
 Percent Not Converging : 0.00

Node Depth Summary

Node	Type	Average Depth Feet	Maximum Depth Feet	Maximum HGL Feet	Time of Max Occurrence days hr:min	Reported Max Depth Feet
H1	JUNCTION	0.00	0.00	7213.00	0 00:00	0.00
H2	JUNCTION	0.00	0.00	7263.00	0 00:00	0.00
1	OUTFALL	0.00	0.00	7063.00	0 00:00	0.00
2	OUTFALL	0.00	0.00	7051.00	0 00:00	0.00

Node Inflow Summary

Total Inflow Volume gal	Flow Balance Error Percent	Type	Maximum Lateral Inflow CFS	Maximum Total Inflow CFS	Time of Max Occurrence days hr:min	Lateral Inflow Volume 10^6 gal
H1	20.6	JUNCTION	283.51	283.51	0 12:32	20.6
	0.000					

H2		JUNCTION	589.18	589.18	0	12:42	48.9
48.9	0.000						
1		OUTFALL	0.00	283.51	0	12:32	0
20.6	0.000						
2		OUTFALL	0.00	589.18	0	12:42	0
48.9	0.000						

Node Flooding Summary

No nodes were flooded.

Outfall Loading Summary

Outfall Node	Flow Freq Pcnt	Avg Flow CFS	Max Flow CFS	Total Volume 10^6 gal
1	31.93	30.67	283.51	20.572
2	33.45	69.60	589.18	48.897
System	32.69	100.27	863.29	69.469

Link Flow Summary

Link	Type	Maximum Flow CFS	Time of Max Occurrence days hr:min	Maximum Veloc ft/sec	Max/ Full Flow	Max/ Full Depth
1	DUMMY	283.51	0 12:32			
2	DUMMY	589.18	0 12:42			

Conduit Surcharge Summary

No conduits were surcharged.

Analysis begun on: Fri Sep 10 13:55:59 2021
Analysis ended on: Fri Sep 10 13:55:59 2021
Total elapsed time: < 1 sec

CUHP SUBCATCHMENTS

F9_Proposed_5_YR (Interim)

Columns with this color heading are for required user-input
Columns with this color heading are for optional override values
Columns with this color heading are for program-calculated values

								Maximum Depression Storage (Watershed inches)		Horton's Infiltration Parameters			DCIA
Subcatchment Name	EPA SWMM Target Node	Raingage	Area (mi ²)	Length to Centroid (mi)	Length (mi)	Slope (ft/ft)	Percent Imperviousness	Pervious	Impervious	Initial Rate (in/hr)	Decay Coefficient (1/seconds)	Final Rate (in/hr)	Level 0, 1, or 2
BS-1	BS1	EPC 24 Hour	0.0967188	0.442486553	0.8477538	0.022	7.18	0.35	0.05	4.5	0.6	0.0018	1
BS-2	BS2	EPC 24 Hour	0.2026563	0.384944318	0.8470165	0.019	10.89	0.35	0.05	4.5	0.6	0.0018	1
BS-3	BS3	EPC 24 Hour	0.1448438	0.265492424	0.7254102	0.017	2	0.35	0.05	4.5	0.6	0.0018	1
BS-4	BS4	EPC 24 Hour	0.0184375	0.057916667	0.1307157	0.02	2	0.35	0.05	4.5	0.6	0.0018	1

Summary of Unit Hydrograph Parameters Used By Program and Calculated Results (Version 2.0.1)

F9_Proposed_5 Year

Catchment Name/ID	User Comment for Catchment	Unit Hydrograph Parameters and Results									Excess Precip.		Storm Hydrograph			
		CT	Cp	W50 (min.)	W50 Before Peak	W75 (min.)	W75 Before Peak	Time to Peak (min.)	Peak (cfs)	Volume (c.f)	Excess (inches)	Excess (c.f.)	Time to Peak (min.)	Peak Flow (cfs)	Total Volume (c.f.)	Runoff per Unit Area (cfs/acre)
BS-1		0.138	0.146	69.2	9.23	36.0	6.52	15.4	42	224,697	2.31	518,896	745.0	50	518,652	0.80
BS-2		0.125	0.183	48.4	8.31	25.2	5.87	13.9	126	470,811	2.32	1,090,926	745.0	135	1,090,384	1.04
BS-3		0.156	0.196	45.1	8.27	23.4	5.84	13.8	96	336,501	2.30	773,417	745.0	101	772,750	1.09
BS-4		0.156	0.077	23.2	2.88	12.1	2.03	4.8	24	42,834	2.30	98,450	735.0	20	96,675	1.71

Summary of CUHP Input Parameters (Version 2.0.1)

F9_Proposed_5 Year

Catchment Name/ID	SWMM Node/ID	Raingage Name/ID	Area (sq.mi.)	Dist. to Centroid (miles)	Length (miles)	Slope (ft./ft.)	Percent Imperv.	Depression Storage		Horton's Infiltration Pa	
								Pervious (inches)	Imperv. (inches)	Initial Rate (in./hr.)	Final Rate (in.hr.)
BS-1	BS1	EPC 24 HOUR	0.097	0.442	0.848	0.022	7.2	0.35	0.05	4.50	0.00
BS-2	BS2	EPC 24 HOUR	0.203	0.385	0.847	0.019	10.9	0.35	0.05	4.50	0.00
BS-3	BS3	EPC 24 HOUR	0.145	0.265	0.725	0.017	2.0	0.35	0.05	4.50	0.00
BS-4	BS4	EPC 24 HOUR	0.018	0.058	0.131	0.020	2.0	0.35	0.05	4.50	0.00

Parameters	DCIA Level and Fractions			
Decay Coeff. (1/sec.)	DCIA Level	Dir. Con'ct Imperv. Fraction	Receiv. Perv. Fraction	Percent Eff. Imperv.
0.6000	1.00	0.08	0.14	6.84
0.6000	1.00	0.12	0.20	10.42
0.6000	1.00	0.02	0.04	1.90
0.6000	1.00	0.00	0.04	1.90

Interim Latigo Proposed Condition (5yr/100yr)

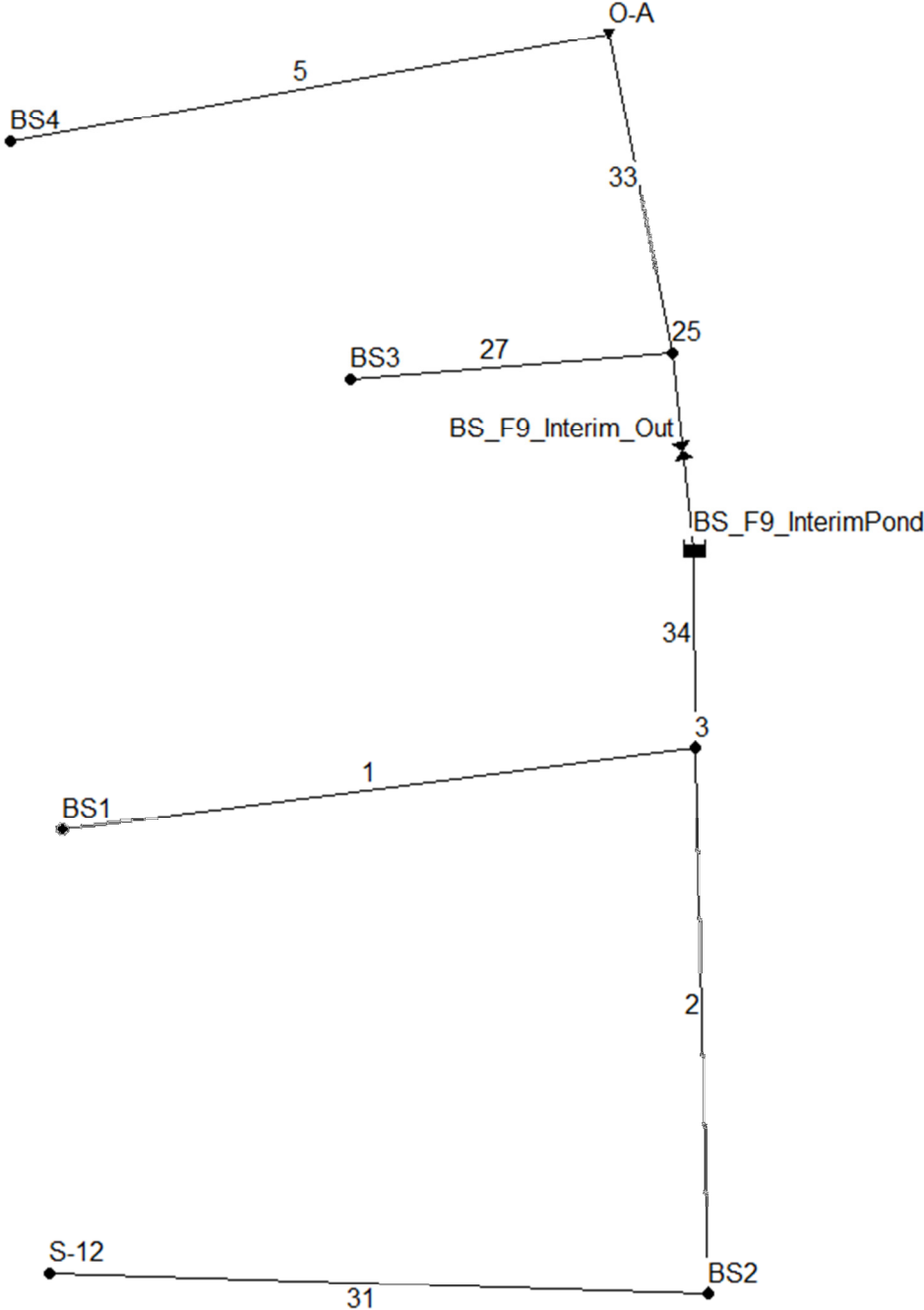

Proposed Interim Condition 5-yr (F9-only)

EPA STORM WATER MANAGEMENT MODEL - VERSION 5.1 (Build 5.1.015)

WARNING 04: minimum elevation drop used for Conduit 31
 WARNING 08: elevation drop exceeds length for Conduit 34
 WARNING 10: crest elevation is below downstream invert for regulator Link

BS_F9_Interim_Out

 Element Count

Number of rain gages 0
 Number of subcatchments ... 0
 Number of nodes 9
 Number of links 8
 Number of pollutants 0
 Number of land uses 0

 Node Summary

Name	Type	Invert Elev.	Max. Depth	Ponded Area	External Inflow
BS1	JUNCTION	7165.00	0.00	0.0	
BS2	JUNCTION	7100.00	0.00	0.0	
3	JUNCTION	7070.00	0.00	0.0	
BS3	JUNCTION	7130.00	0.00	0.0	
BS4	JUNCTION	7120.00	0.00	0.0	
25	JUNCTION	7067.00	0.00	0.0	
S-12	JUNCTION	7100.00	0.00	0.0	Yes
O-A	OUTFALL	7065.00	0.00	0.0	
BS_F9_InterimPond	STORAGE	6069.00	3.35	0.0	

 Link Summary

Name	From Node	To Node	Type	Length
1	BS1	3	CONDUIT	400.0
2	BS2	3	CONDUIT	400.0
5	BS4	O-A	CONDUIT	400.0

%Slope Roughness

 24.4496 0.0100

7.5212 0.0100

```

13.8819    0.0100
 27        BS3          25          CONDUIT          400.0
15.9491    0.0100
 31        S-12        BS2          CONDUIT          400.0
0.0003     0.0100
 33        25          O-A          CONDUIT          400.0
0.5000     0.0100
 34        3           BS_F9_InterimPond CONDUIT          400.0
250.2500   0.0100
  BS_F9_Interim_Out BS_F9_InterimPond 25          OUTLET

```

Cross Section Summary

Full Conduit Flow	Shape	Full Depth	Full Area	Hyd. Rad.	Max. Width	No. of Barrels

1 0.00	DUMMY	0.00	0.00	0.00	0.00	1
2 0.00	DUMMY	0.00	0.00	0.00	0.00	1
5 0.00	DUMMY	0.00	0.00	0.00	0.00	1
27 0.00	DUMMY	0.00	0.00	0.00	0.00	1
31 0.00	DUMMY	0.00	0.00	0.00	0.00	1
33 0.00	DUMMY	0.00	0.00	0.00	0.00	1
34 0.00	DUMMY	0.00	0.00	0.00	0.00	1

NOTE: The summary statistics displayed in this report are based on results found at every computational time step, not just on results from each reporting time step.

Analysis Options

Flow Units CFS
Process Models:

```

Rainfall/Runoff ..... NO
RDII ..... NO
Snowmelt ..... NO
Groundwater ..... NO
Flow Routing ..... YES
Ponding Allowed ..... NO
Water Quality ..... NO
Flow Routing Method ..... KINWAVE
Starting Date ..... 01/01/2005 00:00:00
Ending Date ..... 01/04/2005 06:00:00
Antecedent Dry Days ..... 0.0
Report Time Step ..... 00:30:00
Routing Time Step ..... 30.00 sec

```

```

*****
Control Actions Taken
*****

```

```

*****
Flow Routing Continuity
*****

```

	Volume acre-feet	Volume 10 ⁶ gal
	-----	-----
Dry Weather Inflow	0.000	0.000
Wet Weather Inflow	0.000	0.000
Groundwater Inflow	0.000	0.000
RDII Inflow	0.000	0.000
External Inflow	76.344	24.878
External Outflow	76.213	24.835
Flooding Loss	0.000	0.000
Evaporation Loss	0.000	0.000
Exfiltration Loss	0.000	0.000
Initial Stored Volume	0.000	0.000
Final Stored Volume	0.098	0.032
Continuity Error (%)	0.044	

```

*****
Highest Flow Instability Indexes
*****
All links are stable.

```

```

*****
Routing Time Step Summary
*****
Minimum Time Step      : 30.00 sec
Average Time Step      : 30.00 sec
Maximum Time Step      : 30.00 sec
Percent in Steady State : 0.00

```

Average Iterations per Step : 1.00
 Percent Not Converging : 0.00

 Node Depth Summary

Node	Type	Average Depth Feet	Maximum Depth Feet	Maximum HGL Feet	Time of Max Occurrence days hr:min	Reported Max Depth Feet
BS1	JUNCTION	0.00	0.00	7165.00	0 00:00	0.00
BS2	JUNCTION	0.00	0.00	7100.00	0 00:00	0.00
3	JUNCTION	0.00	0.00	7070.00	0 00:00	0.00
BS3	JUNCTION	0.00	0.00	7130.00	0 00:00	0.00
BS4	JUNCTION	0.00	0.00	7120.00	0 00:00	0.00
25	JUNCTION	0.00	0.00	7067.00	0 00:00	0.00
S-12	JUNCTION	0.00	0.00	7100.00	0 00:00	0.00
O-A	OUTFALL	0.00	0.00	7065.00	0 00:00	0.00
BS_F9_InterimPond	STORAGE	0.47	2.13	6071.13	0 12:41	2.06

 Node Inflow Summary

Total Inflow Volume gal	Flow Balance Error Percent	Type	Maximum Lateral Inflow CFS	Maximum Total Inflow CFS	Time of Max Occurrence days hr:min	Lateral Inflow Volume 10^6 gal
BS1 3.88	0.000	JUNCTION	49.69	49.69	0 12:25	3.88
BS2 14.5	0.000	JUNCTION	134.68	144.68	0 12:25	8.16
3 18.4	0.000	JUNCTION	0.00	194.36	0 12:25	0
BS3 5.78	0.000	JUNCTION	101.42	101.42	0 12:25	5.78

BS4		JUNCTION	20.12	20.12	0	12:15	0.723
0.723	0.000						
25		JUNCTION	0.00	261.96	0	12:35	0
24.1	0.000						
S-12		JUNCTION	55.00	55.00	0	06:40	6.34
6.34	0.000						
O-A		OUTFALL	0.00	274.36	0	12:34	0
24.8	0.000						
BS_F9_InterimPond		STORAGE	0.00	194.36	0	12:25	0
18.4	0.060						

Node Flooding Summary

No nodes were flooded.

Storage Volume Summary

of Max Occurrence	Maximum Outflow Storage Unit	Average Volume	Avg Pcnt Full	Evap Pcnt Loss	Exfil Pcnt Loss	Maximum Volume	Max Pcnt Full	Time days
hr:min	CFS	1000 ft3				1000 ft3		
12:40	173.45	57.244	13	0	0	274.589	61	0

Outfall Loading Summary

Outfall Node	Flow Freq Pcnt	Avg Flow CFS	Max Flow CFS	Total Volume 10^6 gal
O-A	96.89	12.20	274.36	24.833

System 96.89 12.20 274.36 24.833

Link Flow Summary

Link	Type	Maximum Flow CFS	Time of Max Occurrence days hr:min	Maximum Veloc ft/sec	Max/ Full Flow	Max/ Full Depth
1	DUMMY	49.69	0 12:25			
2	DUMMY	144.68	0 12:25			
5	DUMMY	20.12	0 12:15			
27	DUMMY	101.42	0 12:25			
31	DUMMY	55.00	0 06:40			
33	DUMMY	261.96	0 12:35			
34	DUMMY	194.36	0 12:25			
BS_F9_Interim_Out	DUMMY	173.45	0 12:41			

Conduit Surcharge Summary

No conduits were surcharged.

Analysis begun on: Mon Sep 13 10:32:19 2021

Analysis ended on: Mon Sep 13 10:32:20 2021

Total elapsed time: 00:00:01

Pond S12 - 5 yr outflow hydrograph

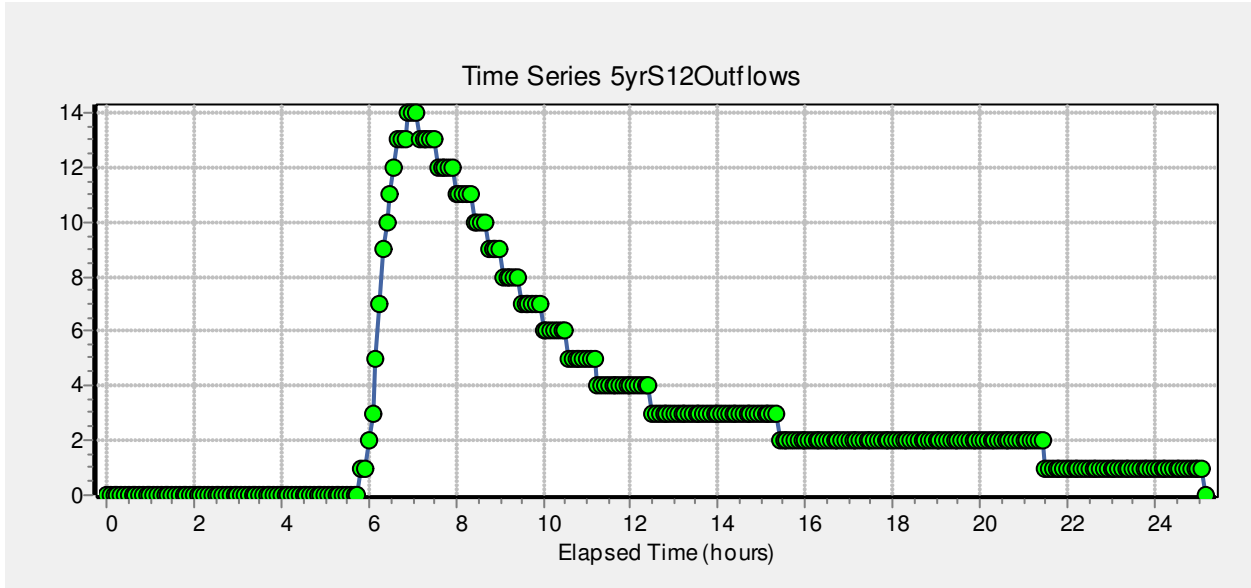

From "Final Drainage Report for The Trails Filing No. 8 and Addendum to Master Development Preliminary Drainage Plans for Latigo Trails" by JR Engineering, dated January 2007
Used as "inflows" to node S12 in all 5-yr proposed condition models

Storage Curve Editor

Curve Name: BS_F9_Interim

Description: Temp Pond South of Latigo for F9 Building Out

	Depth (ft)	Area (ft2)
1	0	114669
2	.35	123430
3	1.35	131935
4	2.35	140528
5	3.35	149213
6		
7		
8		
9		
10		
11		

Buttons: View..., Load..., Save..., OK, Cancel, Help

Stage storage curve and stage/head release curve taken from MHFD UD Detention Design workbook.

Rating Curve Editor

Curve Name: BS_F9_Interim_Out

Description: From UD-Detention BSP_interim

	Head (ft)	Outflow (CFS)
1	0	0
2	.25	.51
3	.5	1.22
4	.75	2.09
5	1	14.15
6	1.5	66.51
7	2	146.56
8	2.5	251.79
9	3	381.68
10	3.35	487.3
11		

Buttons: View..., Load..., Save..., OK, Cancel, Help

CUHP SUBCATCHMENTS

F9_Proposed_100-YR (Interim)

Columns with this color heading are for required user-input
Columns with this color heading are for optional override values
Columns with this color heading are for program-calculated values

								Maximum Depression Storage (Watershed inches)		Horton's Infiltration Parameters			DCIA
Subcatchment Name	EPA SWMM Target Node	Raingage	Area (mi ²)	Length to Centroid (mi)	Length (mi)	Slope (ft/ft)	Percent Imperviousness	Pervious	Impervious	Initial Rate (in/hr)	Decay Coefficient (1/seconds)	Final Rate (in/hr)	Level 0, 1, or 2
BS-1	BS1	EPC 24 Hour	0.0967188	0.442486553	0.8477538	0.022	7.18	0.35	0.05	4.5	0.6	0.0018	1
BS-2	BS2	EPC 24 Hour	0.2026563	0.384944318	0.8470165	0.019	10.89	0.35	0.05	4.5	0.6	0.0018	1
BS-3	BS3	EPC 24 Hour	0.1448438	0.265492424	0.7254102	0.017	2	0.35	0.05	4.5	0.6	0.0018	1
BS-4	BS4	EPC 24 Hour	0.0184375	0.057916667	0.1307157	0.02	2	0.35	0.05	4.5	0.6	0.0018	1

Summary of CUHP Input Parameters (Version 2.0.1)

F9_Proposed_100 Year

Catchment Name/ID	SWMM Node/ID	Raingage Name/ID	Area (sq.mi.)	Dist. to Centroid (miles)	Length (miles)	Slope (ft./ft.)	Percent Imperv.	Depression Storage		Horton's Infiltration Parameters			DCIA Level and Fractions			Percent Eff. Imperv.
								Pervious (inches)	Imperv. (inches)	Initial Rate (in./hr.)	Final Rate (in.hr.)	Decay Coeff. (1/sec.)	DCIA Level	Dir. Con'ct Imperv. Fraction	Receiv. Perv. Fraction	
BS-1	BS1	EPC 24 HOUR	0.097	0.442	0.848	0.022	7.2	0.35	0.05	4.50	0.00	0.6000	1.00	0.08	0.14	6.98
BS-2	BS2	EPC 24 HOUR	0.203	0.385	0.847	0.019	10.9	0.35	0.05	4.50	0.00	0.6000	1.00	0.12	0.20	10.62
BS-3	BS3	EPC 24 HOUR	0.145	0.265	0.725	0.017	2.0	0.35	0.05	4.50	0.00	0.6000	1.00	0.02	0.04	1.94
BS-4	BS4	EPC 24 HOUR	0.018	0.058	0.131	0.020	2.0	0.35	0.05	4.50	0.00	0.6000	1.00	0.00	0.04	1.94

Summary of Unit Hydrograph Parameters Used By Program and Calculated Results (Version 2.0.1)

F9_Proposed_100 Year

Catchment Name/ID	User Comment for Catchment	Unit Hydrograph Parameters and Results									Excess Precip.		Storm Hydrograph			
		CT	Cp	W50 (min.)	W50 Before Peak	W75 (min.)	W75 Before Peak	Time to Peak (min.)	Peak (cfs)	Volume (c.f)	Excess (inches)	Excess (c.f.)	Time to Peak (min.)	Peak Flow (cfs)	Total Volume (c.f.)	Runoff per Unit Area (cfs/acre)
BS-1		0.137	0.145	69.1	9.20	36.0	6.50	15.3	42	224,697	4.19	942,160	745.0	85	941,716	1.37
BS-2		0.125	0.183	48.3	8.29	25.1	5.86	13.8	126	470,811	4.20	1,976,148	745.0	230	1,975,200	1.77
BS-3		0.156	0.195	45.1	8.26	23.4	5.84	13.8	96	336,501	4.19	1,408,936	745.0	173	1,407,716	1.87
BS-4		0.156	0.077	23.2	2.88	12.1	2.03	4.8	24	42,834	4.19	179,347	735.0	34	176,108	2.91

Interim Latigo Proposed Condition (5yr/100yr)

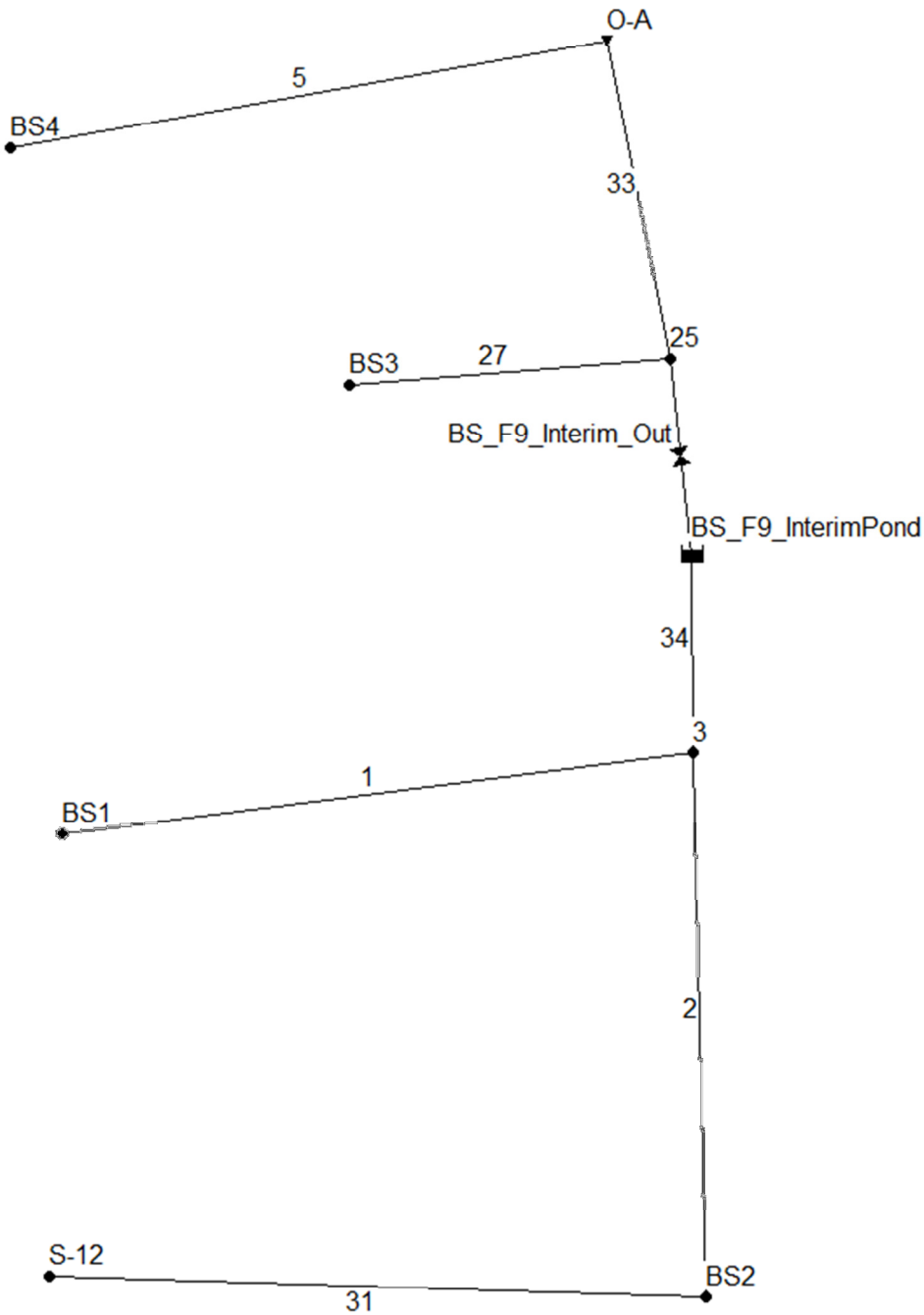

Proposed Interim Condition 100-yr (F9-only)

EPA STORM WATER MANAGEMENT MODEL - VERSION 5.1 (Build 5.1.015)

WARNING 04: minimum elevation drop used for Conduit 31
 WARNING 08: elevation drop exceeds length for Conduit 34
 WARNING 10: crest elevation is below downstream invert for regulator Link

BS_F9_Interim_Out

 Element Count

Number of rain gages 0
 Number of subcatchments ... 0
 Number of nodes 9
 Number of links 8
 Number of pollutants 0
 Number of land uses 0

 Node Summary

Name	Type	Invert Elev.	Max. Depth	Ponded Area	External Inflow
BS1	JUNCTION	7165.00	0.00	0.0	
BS2	JUNCTION	7100.00	0.00	0.0	
3	JUNCTION	7070.00	0.00	0.0	
BS3	JUNCTION	7130.00	0.00	0.0	
BS4	JUNCTION	7120.00	0.00	0.0	
25	JUNCTION	7067.00	0.00	0.0	
S-12	JUNCTION	7100.00	0.00	0.0	Yes
O-A	OUTFALL	7065.00	0.00	0.0	
BS_F9_InterimPond	STORAGE	6069.00	3.35	0.0	

 Link Summary

Name	From Node	To Node	Type	Length
1	BS1	3	CONDUIT	400.0
2	BS2	3	CONDUIT	400.0
5	BS4	O-A	CONDUIT	400.0

%Slope Roughness

24.4496	0.0100			
7.5212	0.0100			

```

13.8819    0.0100
  27      BS3      25      CONDUIT      400.0
15.9491    0.0100
  31      S-12     BS2      CONDUIT      400.0
0.0003    0.0100
  33      25      O-A      CONDUIT      400.0
0.5000    0.0100
  34      3      BS_F9_InterimPond CONDUIT      400.0
250.2500  0.0100
  BS_F9_Interim_Out BS_F9_InterimPond 25      OUTLET

```

Cross Section Summary

Full Conduit Flow	Shape	Full Depth	Full Area	Hyd. Rad.	Max. Width	No. of Barrels

1 0.00	DUMMY	0.00	0.00	0.00	0.00	1
2 0.00	DUMMY	0.00	0.00	0.00	0.00	1
5 0.00	DUMMY	0.00	0.00	0.00	0.00	1
27 0.00	DUMMY	0.00	0.00	0.00	0.00	1
31 0.00	DUMMY	0.00	0.00	0.00	0.00	1
33 0.00	DUMMY	0.00	0.00	0.00	0.00	1
34 0.00	DUMMY	0.00	0.00	0.00	0.00	1

NOTE: The summary statistics displayed in this report are based on results found at every computational time step, not just on results from each reporting time step.

Analysis Options

Flow Units CFS
Process Models:

Rainfall/Runoff NO
 RDII NO
 Snowmelt NO
 Groundwater NO
 Flow Routing YES
 Ponding Allowed NO
 Water Quality NO
 Flow Routing Method KINWAVE
 Starting Date 01/01/2005 00:00:00
 Ending Date 01/04/2005 06:00:00
 Antecedent Dry Days 0.0
 Report Time Step 00:30:00
 Routing Time Step 30.00 sec

 Control Actions Taken

*****	Volume	Volume
Flow Routing Continuity	acre-feet	10 ⁶ gal
*****	-----	-----
Dry Weather Inflow	0.000	0.000
Wet Weather Inflow	0.000	0.000
Groundwater Inflow	0.000	0.000
RDII Inflow	0.000	0.000
External Inflow	122.767	40.006
External Outflow	122.604	39.952
Flooding Loss	0.000	0.000
Evaporation Loss	0.000	0.000
Exfiltration Loss	0.000	0.000
Initial Stored Volume	0.000	0.000
Final Stored Volume	0.098	0.032
Continuity Error (%)	0.053	

 Highest Flow Instability Indexes

 All links are stable.

 Routing Time Step Summary

 Minimum Time Step : 30.00 sec
 Average Time Step : 30.00 sec
 Maximum Time Step : 30.00 sec
 Percent in Steady State : 0.00

Average Iterations per Step : 1.00
 Percent Not Converging : 0.00

 Node Depth Summary

Node	Type	Average Depth Feet	Maximum Depth Feet	Maximum HGL Feet	Time of Max Occurrence days hr:min	Reported Max Depth Feet
BS1	JUNCTION	0.00	0.00	7165.00	0 00:00	0.00
BS2	JUNCTION	0.00	0.00	7100.00	0 00:00	0.00
3	JUNCTION	0.00	0.00	7070.00	0 00:00	0.00
BS3	JUNCTION	0.00	0.00	7130.00	0 00:00	0.00
BS4	JUNCTION	0.00	0.00	7120.00	0 00:00	0.00
25	JUNCTION	0.00	0.00	7067.00	0 00:00	0.00
S-12	JUNCTION	0.00	0.00	7100.00	0 00:00	0.00
O-A	OUTFALL	0.00	0.00	7065.00	0 00:00	0.00
BS_F9_InterimPond	STORAGE	0.51	2.67	6071.67	0 12:38	2.62

 Node Inflow Summary

Total Inflow Volume gal	Flow Balance Error Percent	Type	Maximum Lateral Inflow CFS	Maximum Total Inflow CFS	Time of Max Occurrence days hr:min	Lateral Inflow Volume 10^6 gal
BS1 7.04	0.000	JUNCTION	84.86	84.86	0 12:25	7.04
BS2 21.1	0.000	JUNCTION	229.73	239.73	0 12:25	14.8
3 28.2	0.000	JUNCTION	0.00	324.60	0 12:25	0
BS3 10.5	0.000	JUNCTION	172.91	172.91	0 12:25	10.5

BS4		JUNCTION	34.29	34.29	0	12:15	1.32
1.32	0.000						
25		JUNCTION	0.00	452.63	0	12:33	0
38.6	0.000						
S-12		JUNCTION	55.00	55.00	0	06:40	6.34
6.34	0.000						
O-A		OUTFALL	0.00	475.49	0	12:31	0
39.9	0.000						
BS_F9_InterimPond		STORAGE	0.00	324.60	0	12:25	0
28.2	0.075						

Node Flooding Summary

No nodes were flooded.

Storage Volume Summary

of Max Occurrence	Maximum Outflow Storage Unit	Average Volume 1000 ft3	Avg Pcnt Full	Evap Pcnt Loss	Exfil Pcnt Loss	Maximum Volume 1000 ft3	Max Pcnt Full	Time days
12:37	297.20	62.397	14	0	0	351.719	78	0

Outfall Loading Summary

Outfall Node	Flow Freq Pcnt	Avg Flow CFS	Max Flow CFS	Total Volume 10^6 gal
O-A	97.93	19.42	475.49	39.949

System 97.93 19.42 475.49 39.949

Link Flow Summary

Link	Type	Maximum Flow CFS	Time of Max Occurrence days hr:min	Maximum Veloc ft/sec	Max/ Full Flow	Max/ Full Depth
1	DUMMY	84.86	0 12:25			
2	DUMMY	239.73	0 12:25			
5	DUMMY	34.29	0 12:15			
27	DUMMY	172.91	0 12:25			
31	DUMMY	55.00	0 06:40			
33	DUMMY	452.63	0 12:33			
34	DUMMY	324.60	0 12:25			
BS_F9_Interim_Out	DUMMY	297.20	0 12:38			

Conduit Surcharge Summary

No conduits were surcharged.

Analysis begun on: Mon Sep 13 09:53:33 2021

Analysis ended on: Mon Sep 13 09:53:33 2021

Total elapsed time: < 1 sec

Pond S12 - 100 yr outflow hydrograph

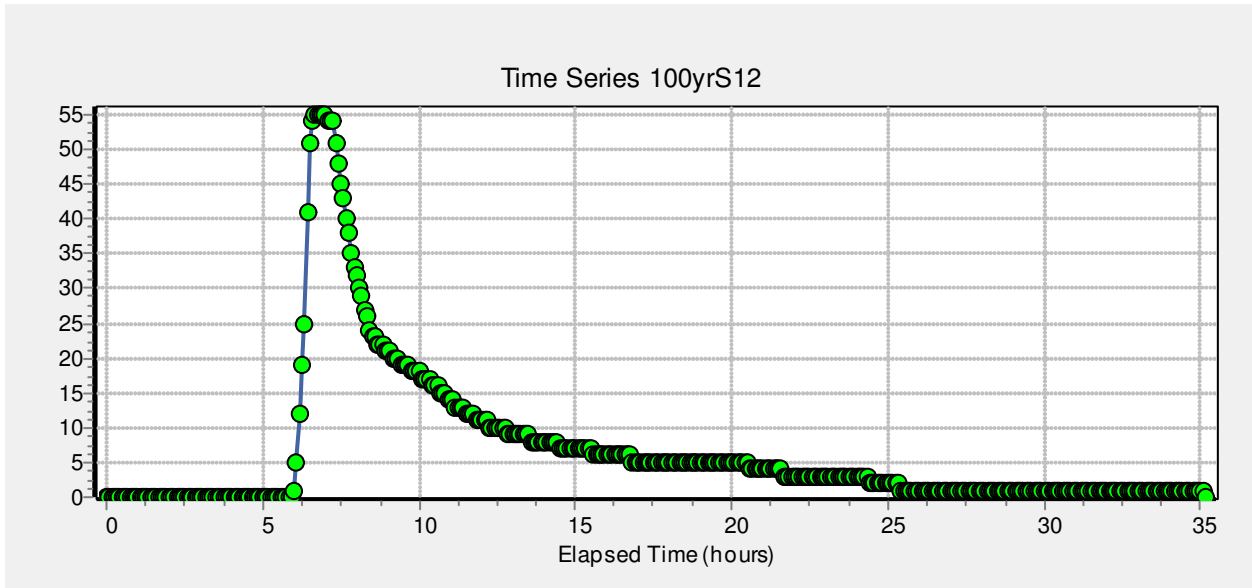

From "Final Drainage Report for The Trails Filing No. 8 and Addendum to Master Development Preliminary Drainage Plans for Latigo Trails" by JR Engineering. dated January 2007

Storage Curve Editor

Curve Name: BS_F9_Interim

Description: Temp Pond South of Latigo for F9 Building Out

	Depth (ft)	Area (ft2)
1	0	114669
2	.35	123430
3	1.35	131935
4	2.35	140528
5	3.35	149213
6		
7		
8		
9		
10		
11		

Buttons: View..., Load..., Save..., OK, Cancel, Help

Stage storage curve and stage/head release curve taken from MHFD UD Detention Design workbook.

Rating Curve Editor

Curve Name: BS_F9_Interim_Out

Description: From UD-Detention BSP_interim

	Head (ft)	Outflow (CFS)
1	0	0
2	.25	.51
3	.5	1.22
4	.75	2.09
5	1	14.15
6	1.5	66.51
7	2	146.56
8	2.5	251.79
9	3	381.68
10	3.35	487.3
11		

Buttons: View..., Load..., Save..., OK, Cancel, Help

APPENDIX C

HYDRAULIC CALCULATIONS

Provide the supporting riprap sizing calculation for the proposed riprap at the culvert inlet/outlet.

HY-8 Culvert Analysis Report

Culvert Crossing Fontenelle Trail

Crossing Discharge Data

Discharge Selection Method: Specify Minimum, Design, and Maximum Flow

Minimum Flow: 0 cfs

Design Flow: 2.9 cfs

Maximum Flow: 2.9 cfs

Table 1 - Summary of Culvert Flows at Crossing: Fontenelle Crossing

Headwater Elevation (ft)	Total Discharge (cfs)	Culvert 1 Discharge (cfs)	Roadway Discharge (cfs)	Iterations
7128.58	0.00	0.00	0.00	1
7128.86	0.29	0.29	0.00	1
7128.98	0.58	0.58	0.00	1
7129.08	0.87	0.87	0.00	1
7129.16	1.16	1.16	0.00	1
7129.23	1.45	1.45	0.00	1
7129.30	1.74	1.74	0.00	1
7129.36	2.03	2.03	0.00	1
7129.42	2.32	2.32	0.00	1
7129.48	2.61	2.61	0.00	1
7129.54	2.90	2.90	0.00	1
7131.61	11.38	11.38	0.00	Overtopping

Rating Curve Plot for Crossing: Fontenelle Crossing

Total Rating Curve
Crossing: Fontenelle Crossing

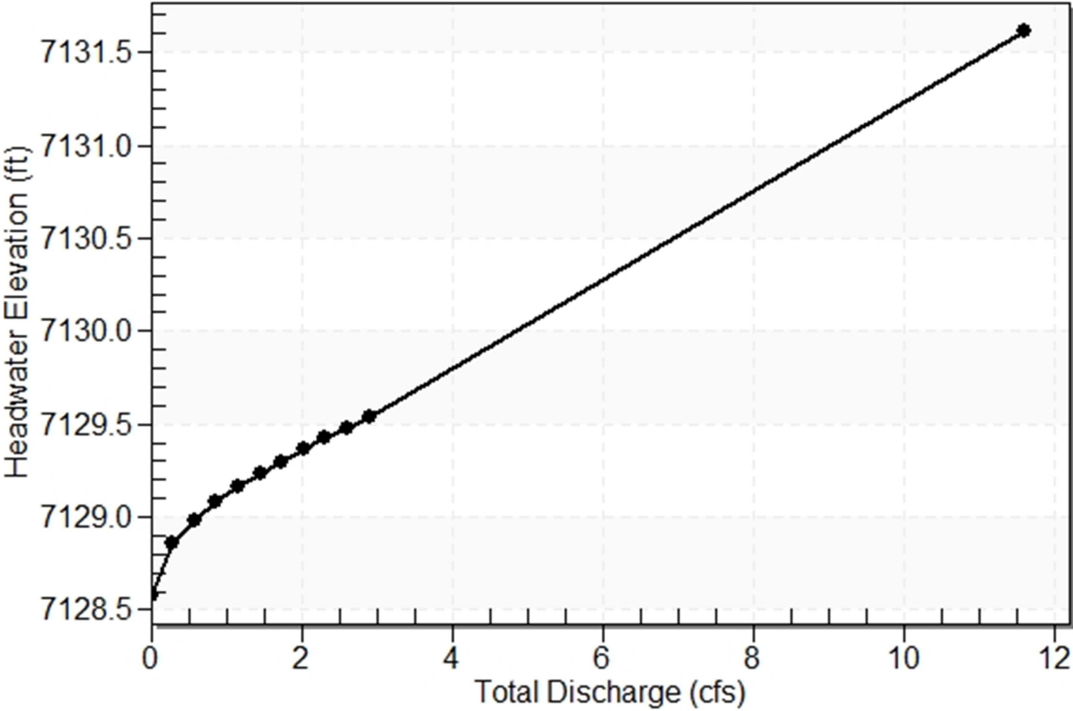

Table 2 - Culvert Summary Table: Culvert 1

Total Discharge (cfs)	Culvert Discharge (cfs)	Headwater Elevation (ft)	Inlet Control Depth (ft)	Outlet Control Depth (ft)	Flow Type	Normal Depth (ft)	Critical Depth (ft)	Outlet Depth (ft)	Tailwater Depth (ft)	Outlet Velocity (ft/s)	Tailwater Velocity (ft/s)
0.00	0.00	7128.58	0.000	0.000	0-NF	0.000	0.000	0.000	0.000	0.000	0.000
0.29	0.29	7128.86	0.282	0.0*	1-JS1t	0.161	0.198	0.263	0.263	1.393	1.050
0.58	0.58	7128.98	0.403	0.0*	1-S2n	0.226	0.282	0.226	0.341	3.466	1.248
0.87	0.87	7129.08	0.498	0.0*	1-S2n	0.275	0.347	0.275	0.397	3.907	1.382
1.16	1.16	7129.16	0.579	0.0*	1-S2n	0.317	0.402	0.317	0.442	4.252	1.485
1.45	1.45	7129.23	0.652	0.0*	1-S2n	0.355	0.451	0.355	0.481	4.536	1.570
1.74	1.74	7129.30	0.718	0.0*	1-S2n	0.389	0.496	0.389	0.515	4.780	1.643
2.03	2.03	7129.36	0.782	0.0*	1-S2n	0.421	0.537	0.421	0.545	4.994	1.707
2.32	2.32	7129.42	0.843	0.0*	1-S2n	0.451	0.576	0.451	0.573	5.190	1.765
2.61	2.61	7129.48	0.901	0.0*	1-S2n	0.479	0.612	0.483	0.599	5.313	1.818
2.90	2.90	7129.54	0.955	0.0*	1-S2n	0.507	0.647	0.508	0.623	5.508	1.867

* Full Flow Headwater elevation is below inlet invert.

Straight Culvert

Inlet Elevation (invert): 7128.58 ft, Outlet Elevation (invert): 7127.80 ft

Culvert Length: 72.89 ft, Culvert Slope: 0.0107

Culvert Performance Curve Plot: Culvert 1

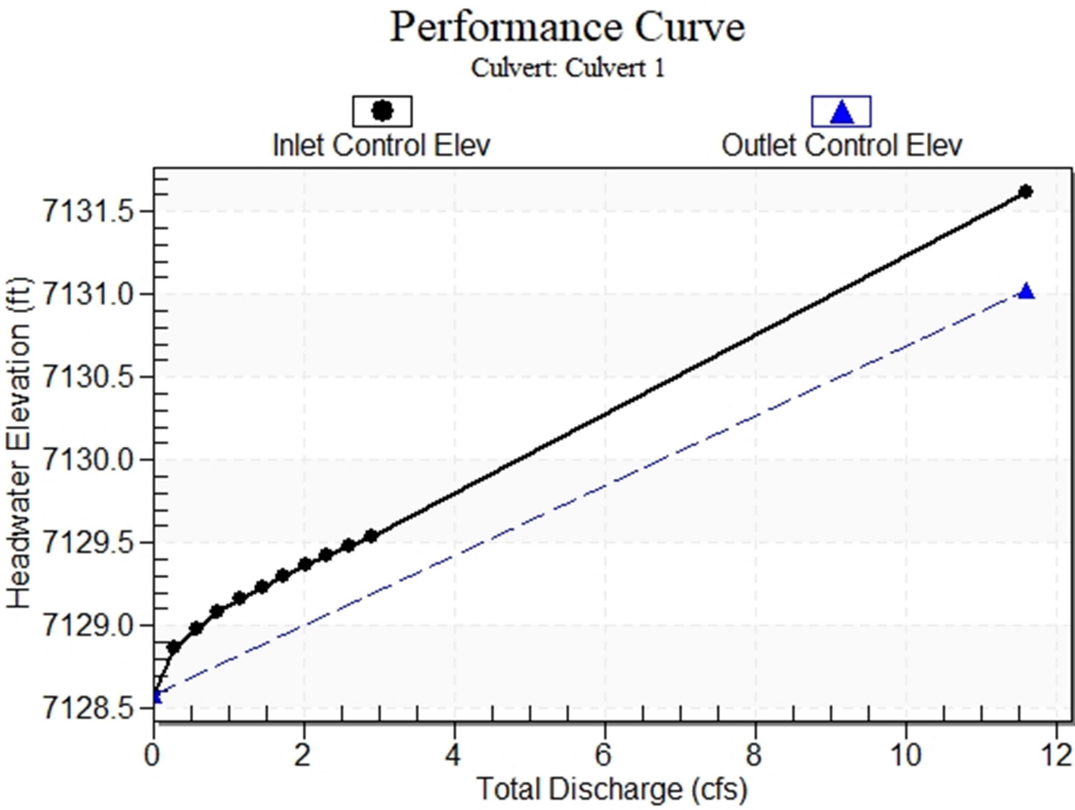

Water Surface Profile Plot for Culvert: Culvert 1

Crossing - Fontenelle Crossing, Design Discharge - 2.9 cfs

Culvert - Culvert 1, Culvert Discharge - 2.9 cfs

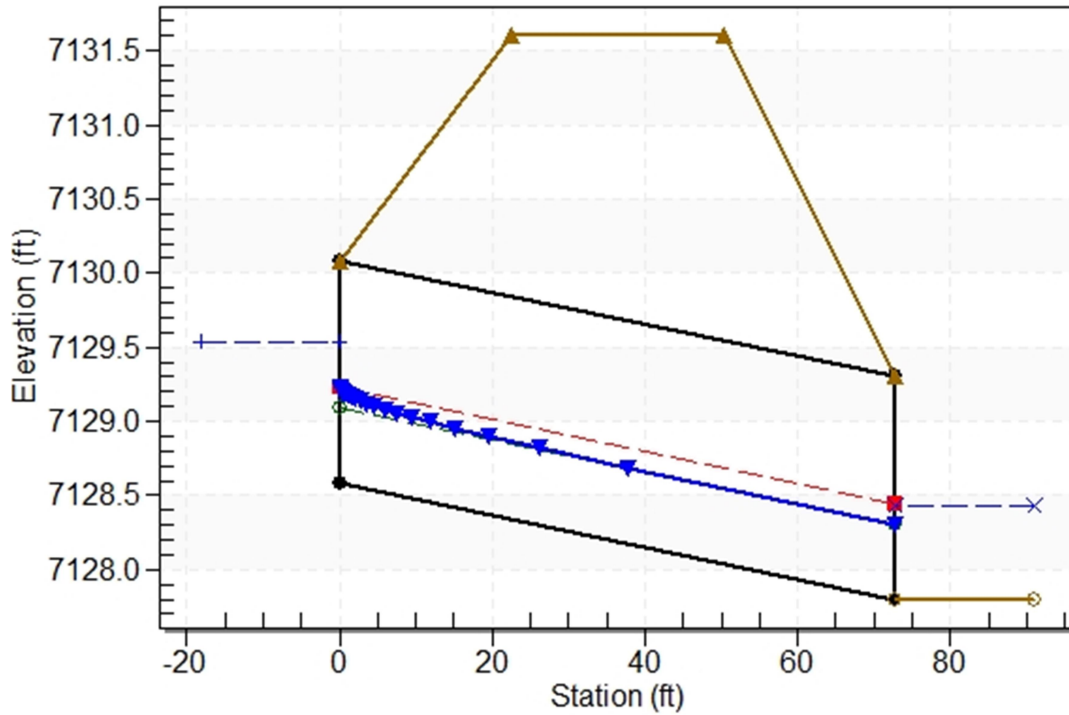

Site Data - Culvert 1

Site Data Option: Culvert Invert Data

Inlet Station: 0.00 ft

Inlet Elevation: 7128.58 ft

Outlet Station: 72.89 ft

Outlet Elevation: 7127.80 ft

Number of Barrels: 1

Culvert Data Summary - Culvert 1

Barrel Shape: Circular

Barrel Diameter: 1.50 ft

Barrel Material: Concrete

Embedment: 0.00 in

Barrel Manning's n: 0.0120

Culvert Type: Straight

Inlet Configuration: Mitered to Conform to Slope

Inlet Depression: None

Table 3 - Downstream Channel Rating Curve (Crossing: Fontenelle Crossing)

Flow (cfs)	Water Surface Elev (ft)	Depth (ft)	Velocity (ft/s)	Shear (psf)	Froude Number
0.00	7127.80	0.00	0.00	0.00	0.00
0.29	7128.06	0.26	1.05	0.11	0.51
0.58	7128.14	0.34	1.25	0.15	0.53
0.87	7128.20	0.40	1.38	0.17	0.55
1.16	7128.24	0.44	1.48	0.19	0.56
1.45	7128.28	0.48	1.57	0.21	0.56
1.74	7128.31	0.51	1.64	0.22	0.57
2.03	7128.35	0.55	1.71	0.24	0.58
2.32	7128.37	0.57	1.77	0.25	0.58
2.61	7128.40	0.60	1.82	0.26	0.59
2.90	7128.42	0.62	1.87	0.27	0.59

Tailwater Channel Data - Fontenelle Crossing

Tailwater Channel Option: Triangular Channel

Side Slope (H:V): 4.00 (_:1)

Channel Slope: 0.0070

Channel Manning's n: 0.0300

Channel Invert Elevation: 7127.80 ft

Roadway Data for Crossing: Fontenelle Crossing

Roadway Profile Shape: Constant Roadway Elevation

Crest Length: 70.00 ft

Crest Elevation: 7131.61 ft

Roadway Surface: Paved

Roadway Top Width: 28.00 ft

HY-8 Culvert Analysis Report

Culvert Crossing Frenchman's Trail

Crossing Discharge Data

Discharge Selection Method: Specify Minimum, Design, and Maximum Flow

Minimum Flow: 0 cfs

Design Flow: 20.97 cfs

Maximum Flow: 20.97 cfs

Table 1 - Summary of Culvert Flows at Crossing: Frenchmans Crossing

Headwater Elevation (ft)	Total Discharge (cfs)	Culvert 1 Discharge (cfs)	Roadway Discharge (cfs)	Iterations
7096.58	0.00	0.00	0.00	1
7097.25	2.10	2.10	0.00	1
7097.55	4.19	4.19	0.00	1
7097.78	6.29	6.29	0.00	1
7097.99	8.39	8.39	0.00	1
7098.18	10.48	10.48	0.00	1
7098.35	12.58	12.58	0.00	1
7098.52	14.68	14.68	0.00	1
7098.68	16.78	16.78	0.00	1
7098.85	18.87	18.87	0.00	1
7099.03	20.97	20.97	0.00	1
7101.55	40.36	40.36	0.00	Overtopping

Rating Curve Plot for Crossing: Frenchmans Crossing

Total Rating Curve

Crossing: Frenchmans Crossing

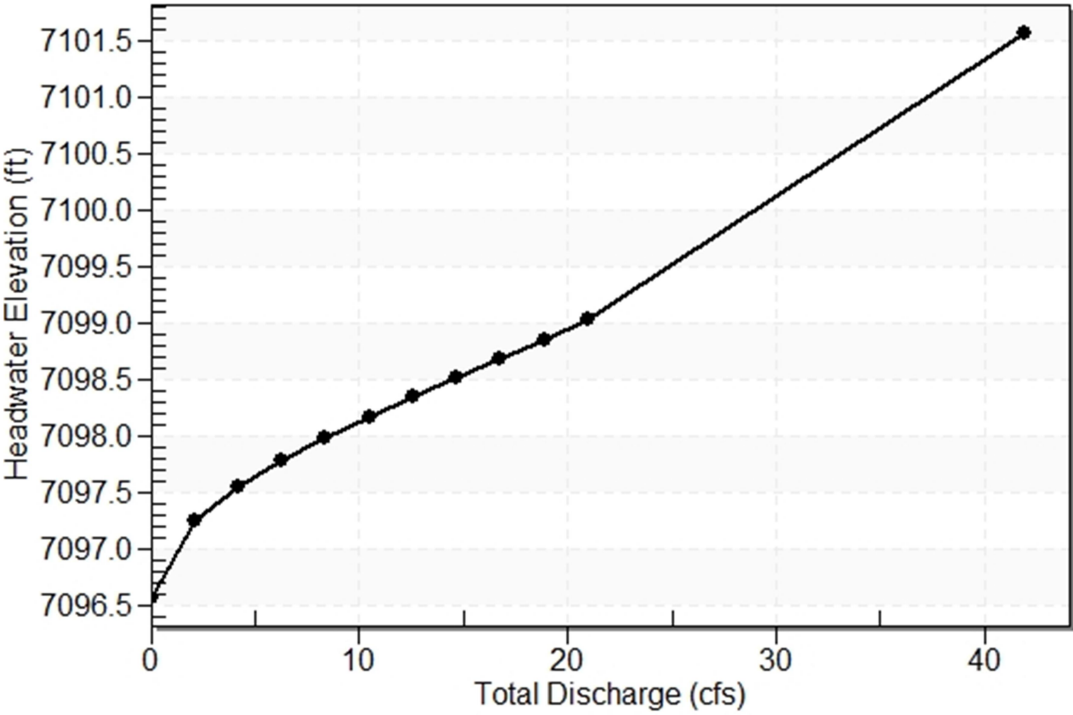

Table 2 - Culvert Summary Table: Culvert 1

Total Discharge (cfs)	Culvert Discharge (cfs)	Headwater Elevation (ft)	Inlet Control Depth (ft)	Outlet Control Depth (ft)	Flow Type	Normal Depth (ft)	Critical Depth (ft)	Outlet Depth (ft)	Tailwater Depth (ft)	Outlet Velocity (ft/s)	Tailwater Velocity (ft/s)
0.00	0.00	7096.58	0.000	0.000	0-NF	0.000	0.000	0.000	0.000	0.000	0.000
2.10	2.10	7097.25	0.674	0.0*	1-S2n	0.367	0.472	0.367	0.460	4.680	2.473
4.19	4.19	7097.55	0.968	0.0*	1-S2n	0.516	0.674	0.516	0.597	5.731	2.941
6.29	6.29	7097.78	1.202	0.089	1-S2n	0.632	0.830	0.639	0.695	6.357	3.255
8.39	8.39	7097.99	1.411	0.269	1-S2n	0.732	0.964	0.743	0.774	6.861	3.498
10.48	10.48	7098.18	1.599	0.447	1-S2n	0.822	1.083	0.838	0.842	7.268	3.698
12.58	12.58	7098.35	1.770	0.627	1-S2n	0.905	1.191	0.925	0.901	7.614	3.871
14.68	14.68	7098.52	1.935	0.813	1-S2n	0.984	1.291	1.008	0.955	7.923	4.023
16.78	16.78	7098.68	2.100	1.005	1-S2n	1.059	1.385	1.088	1.004	8.179	4.159
18.87	18.87	7098.85	2.271	1.204	1-S2n	1.131	1.473	1.164	1.049	8.423	4.284
20.97	20.97	7099.03	2.452	1.412	1-S2n	1.202	1.556	1.239	1.092	8.645	4.398

* Full Flow Headwater elevation is below inlet invert.

Straight Culvert

Inlet Elevation (invert): 7096.58 ft, Outlet Elevation (invert): 7095.78 ft

Culvert Length: 78.82 ft, Culvert Slope: 0.0101

Culvert Performance Curve Plot: Culvert 1

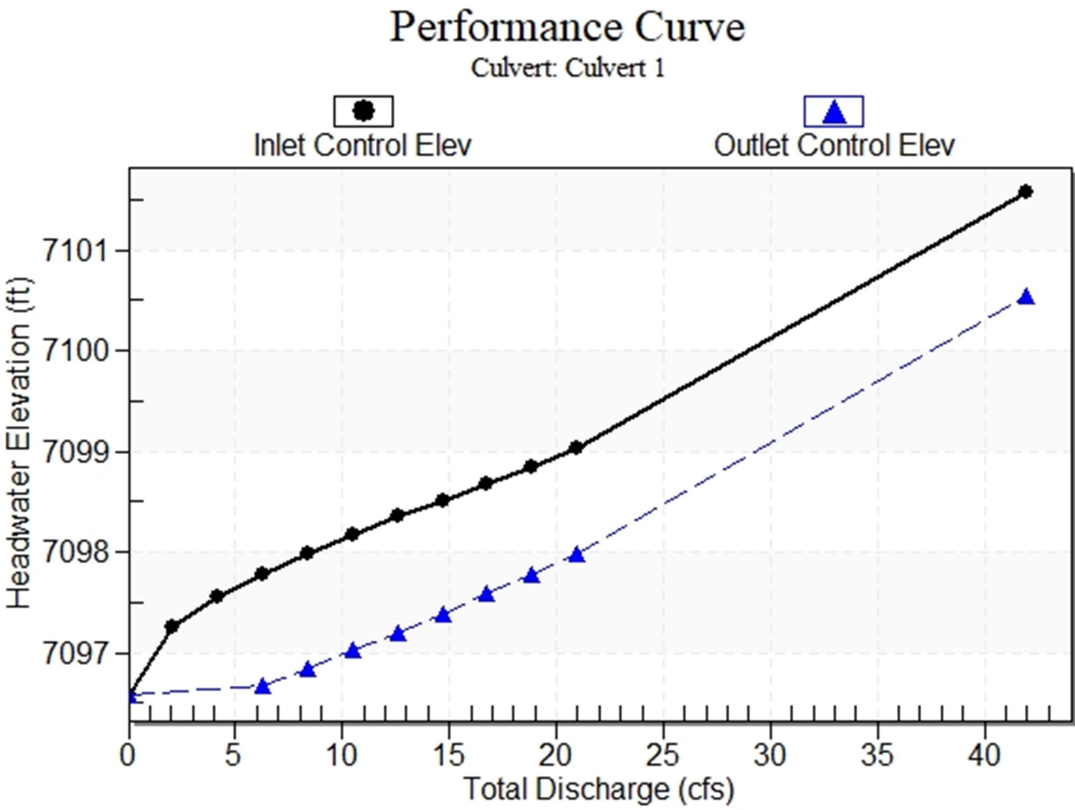

Water Surface Profile Plot for Culvert: Culvert 1

Crossing - Frenchmans Crossing, Design Discharge - 21.0 cfs

Culvert - Culvert 1, Culvert Discharge - 21.0 cfs

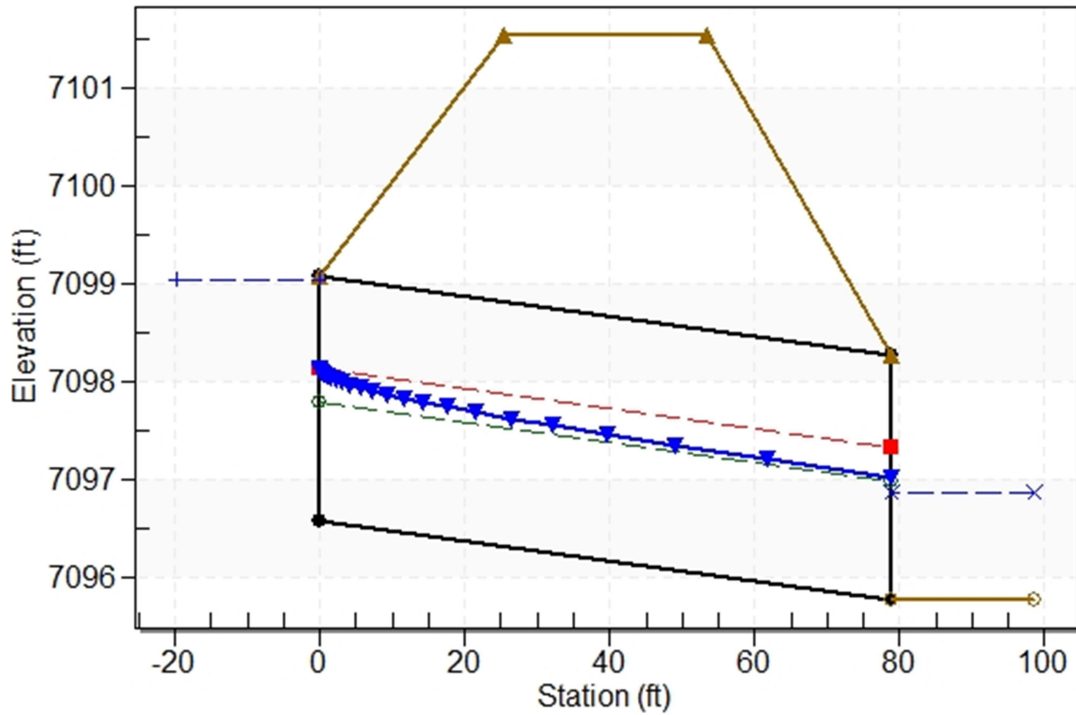

Site Data - Culvert 1

Site Data Option: Culvert Invert Data

Inlet Station: 0.00 ft

Inlet Elevation: 7096.58 ft

Outlet Station: 78.82 ft

Outlet Elevation: 7095.78 ft

Number of Barrels: 1

Culvert Data Summary - Culvert 1

Barrel Shape: Circular

Barrel Diameter: 2.50 ft

Barrel Material: Concrete

Embedment: 0.00 in

Barrel Manning's n: 0.0120

Culvert Type: Straight

Inlet Configuration: Mitered to Conform to Slope

Inlet Depression: None

Table 3 - Downstream Channel Rating Curve (Crossing: Frenchmans Crossing)

Flow (cfs)	Water Surface Elev (ft)	Depth (ft)	Velocity (ft/s)	Shear (psf)	Froude Number
0.00	7095.78	0.00	0.00	0.00	0.00
2.10	7096.24	0.46	2.47	0.53	0.91
4.19	7096.38	0.60	2.94	0.69	0.95
6.29	7096.48	0.70	3.25	0.80	0.97
8.39	7096.55	0.77	3.50	0.89	0.99
10.48	7096.62	0.84	3.70	0.97	1.00
12.58	7096.68	0.90	3.87	1.04	1.02
14.68	7096.74	0.96	4.02	1.10	1.03
16.78	7096.78	1.00	4.16	1.15	1.03
18.87	7096.83	1.05	4.28	1.20	1.04
20.97	7096.87	1.09	4.40	1.25	1.05

Tailwater Channel Data - Frenchmans Crossing

Tailwater Channel Option: Triangular Channel

Side Slope (H:V): 4.00 (_:1)

Channel Slope: 0.0184

Channel Manning's n: 0.0300

Channel Invert Elevation: 7095.78 ft

Roadway Data for Crossing: Frenchmans Crossing

Roadway Profile Shape: Constant Roadway Elevation

Crest Length: 100.00 ft

Crest Elevation: 7101.55 ft

Roadway Surface: Paved

Roadway Top Width: 28.00 ft

HY-8 Culvert Analysis Report

Culvert Crossing South of Pond S-12 Outlet

Crossing Discharge Data

Discharge Selection Method: Specify Minimum, Design, and Maximum Flow

Minimum Flow: 0 cfs

Design Flow: 69.72 cfs

Maximum Flow: 69.72 cfs

Table 1 - Summary of Culvert Flows at Crossing: Crossing S of S-12

Headwater Elevation (ft)	Total Discharge (cfs)	Culvert 1 Discharge (cfs)	Roadway Discharge (cfs)	Iterations
7097.55	0.00	0.00	0.00	1
7098.69	6.97	6.97	0.00	1
7099.19	13.94	13.94	0.00	1
7099.61	20.92	20.92	0.00	1
7099.97	27.89	27.89	0.00	1
7100.30	34.86	34.86	0.00	1
7100.63	41.83	41.83	0.00	1
7100.99	48.80	48.80	0.00	1
7101.39	55.78	55.78	0.00	1
7101.85	62.75	62.75	0.00	1
7102.35	69.72	69.72	0.00	1
7103.04	78.10	78.10	0.00	Overtopping

Rating Curve Plot for Crossing: Crossing S of S-12

Total Rating Curve

Crossing: Crossing S of S-12

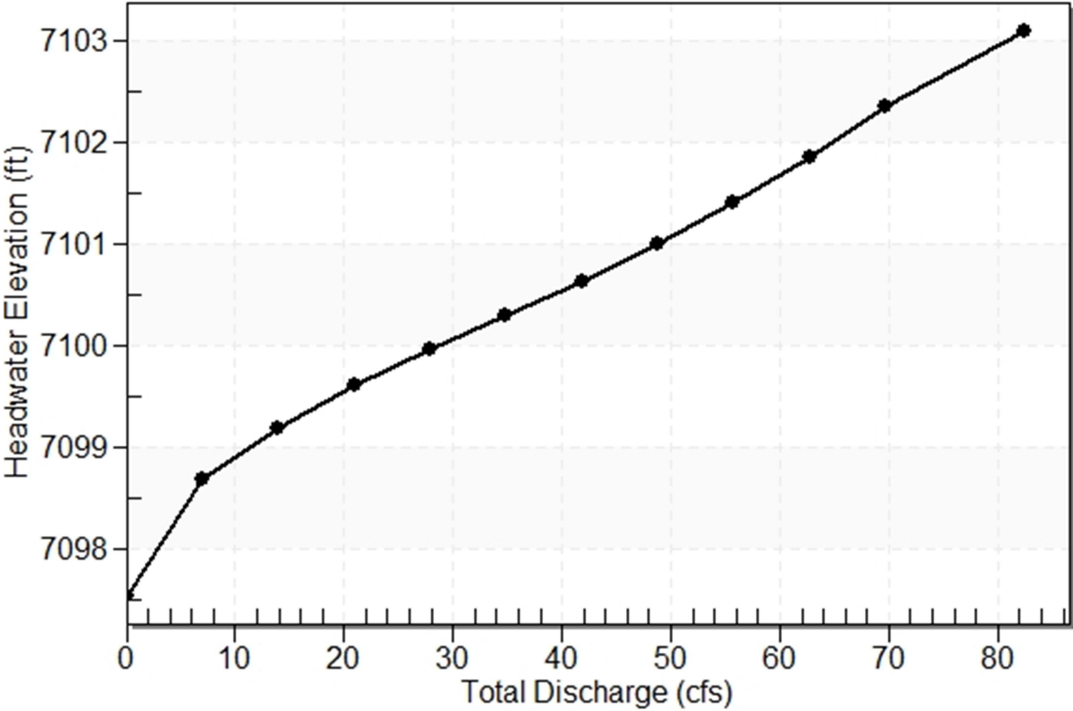

Table 2 - Culvert Summary Table: Culvert 1

Total Discharge (cfs)	Culvert Discharge (cfs)	Headwater Elevation (ft)	Inlet Control Depth (ft)	Outlet Control Depth (ft)	Flow Type	Normal Depth (ft)	Critical Depth (ft)	Outlet Depth (ft)	Tailwater Depth (ft)	Outlet Velocity (ft/s)	Tailwater Velocity (ft/s)
0.00	0.00	7097.55	0.000	0.000	0-NF	0.000	0.000	0.000	0.000	0.000	0.000
6.97	6.97	7098.69	1.138	0.0*	1-S2n	0.598	0.795	0.598	0.687	6.369	3.690
13.94	13.94	7099.19	1.641	0.296	1-S2n	0.844	1.135	0.862	0.891	7.573	4.388
20.92	20.92	7099.61	2.057	0.650	1-S2n	1.038	1.401	1.069	1.038	8.406	4.856
27.89	27.89	7099.97	2.416	1.000	1-S2n	1.206	1.628	1.252	1.156	9.017	5.218
34.86	34.86	7100.30	2.747	1.359	1-S2n	1.360	1.830	1.423	1.257	9.490	5.517
41.83	41.83	7100.63	3.082	1.736	1-S2n	1.503	2.013	1.580	1.346	9.921	5.775
48.80	48.80	7100.99	3.442	2.133	1-S2n	1.640	2.182	1.728	1.426	10.312	6.001
55.78	55.78	7101.39	3.843	2.553	5-S2n	1.773	2.338	1.873	1.499	10.642	6.205
62.75	62.75	7101.85	4.295	2.996	5-S2n	1.904	2.483	2.012	1.567	10.961	6.391
69.72	69.72	7102.35	4.803	3.464	5-S2n	2.033	2.616	2.148	1.630	11.260	6.561

* Full Flow Headwater elevation is below inlet invert.

Straight Culvert

Inlet Elevation (invert): 7097.55 ft, Outlet Elevation (invert): 7096.64 ft

Culvert Length: 91.20 ft, Culvert Slope: 0.0100

Culvert Performance Curve Plot: Culvert 1

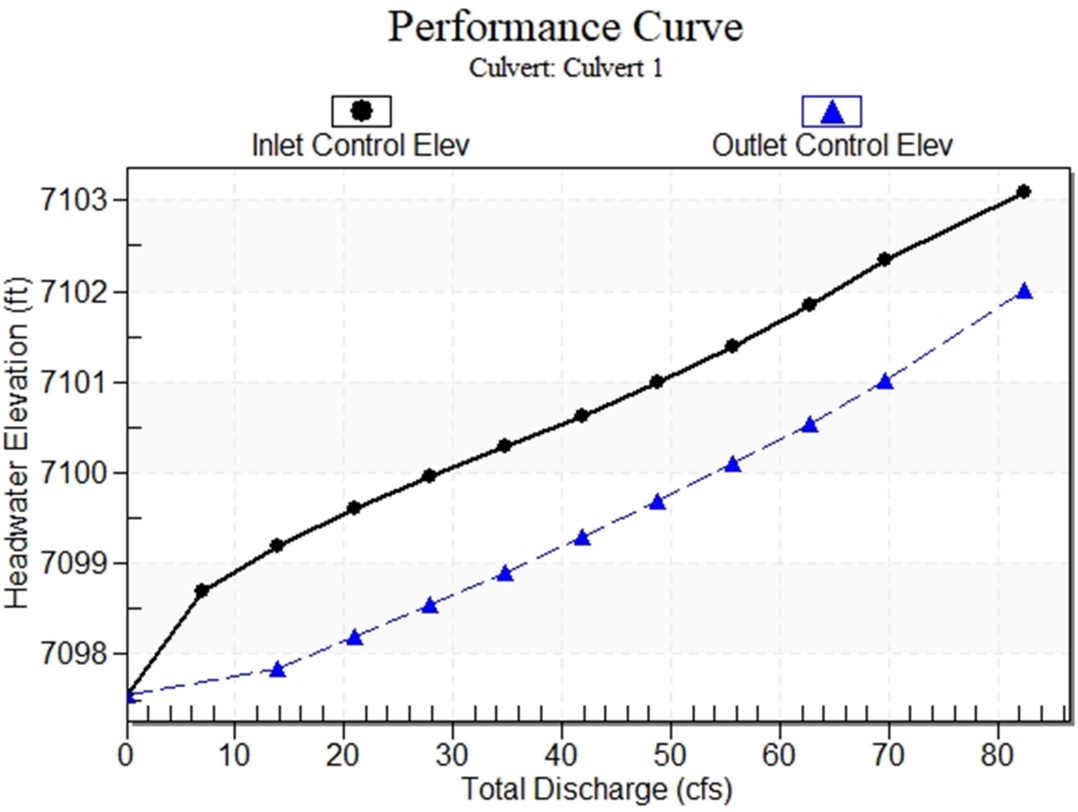

Water Surface Profile Plot for Culvert: Culvert 1

Crossing - Crossing S of S-12, Design Discharge - 69.7 cfs

Culvert - Culvert 1, Culvert Discharge - 69.7 cfs

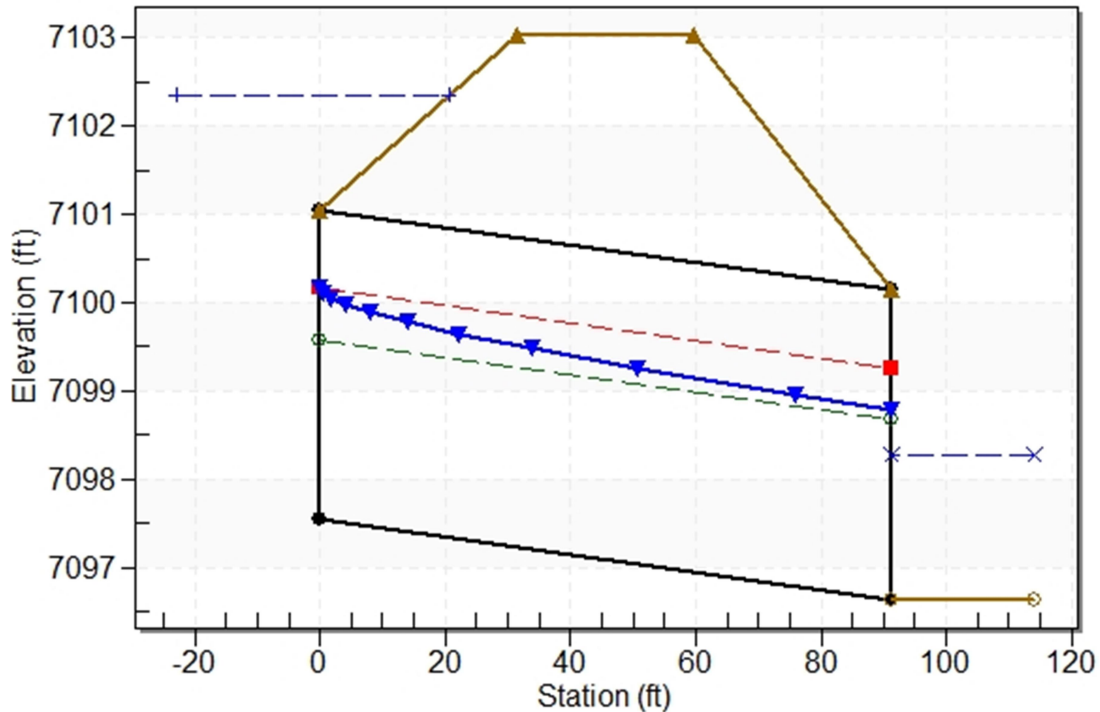

Site Data - Culvert 1

Site Data Option: Culvert Invert Data

Inlet Station: 0.00 ft

Inlet Elevation: 7097.55 ft

Outlet Station: 91.20 ft

Outlet Elevation: 7096.64 ft

Number of Barrels: 1

Culvert Data Summary - Culvert 1

Barrel Shape: Circular

Barrel Diameter: 3.50 ft

Barrel Material: Concrete

Embedment: 0.00 in

Barrel Manning's n: 0.0120

Culvert Type: Straight

Inlet Configuration: Mitered to Conform to Slope

Inlet Depression: None

Table 3 - Downstream Channel Rating Curve (Crossing: Crossing S of S-12)

Flow (cfs)	Water Surface Elev (ft)	Depth (ft)	Velocity (ft/s)	Shear (psf)	Froude Number
0.00	7096.64	0.00	0.00	0.00	0.00
6.97	7097.33	0.69	3.69	1.03	1.11
13.94	7097.53	0.89	4.39	1.33	1.16
20.92	7097.68	1.04	4.86	1.55	1.19
27.89	7097.80	1.16	5.22	1.73	1.21
34.86	7097.90	1.26	5.52	1.88	1.23
41.83	7097.99	1.35	5.77	2.02	1.24
48.80	7098.07	1.43	6.00	2.14	1.25
55.78	7098.14	1.50	6.21	2.24	1.26
62.75	7098.21	1.57	6.39	2.35	1.27
69.72	7098.27	1.63	6.56	2.44	1.28

Tailwater Channel Data - Crossing S of S-12

Tailwater Channel Option: Triangular Channel

Side Slope (H:V): 4.00 (_:1)

Channel Slope: 0.0240

Channel Manning's n: 0.0300

Channel Invert Elevation: 7096.64 ft

Roadway Data for Crossing: Crossing S of S-12

Roadway Profile Shape: Constant Roadway Elevation

Crest Length: 100.00 ft

Crest Elevation: 7103.04 ft

Roadway Surface: Paved

Roadway Top Width: 28.00 ft

HY-8 Culvert Analysis Report

Culvert Outfall of Pond S-12

Crossing Discharge Data

Discharge Selection Method: Specify Minimum, Design, and Maximum Flow

Minimum Flow: 0 cfs

Design Flow: 59 cfs

Maximum Flow: 59 cfs

Table 1 - Summary of Culvert Flows at Crossing: S-12 OUTLET

Headwater Elevation (ft)	Total Discharge (cfs)	Culvert 1 Discharge (cfs)	Roadway Discharge (cfs)	Iterations
7099.12	0.00	0.00	0.00	1
7099.88	5.90	5.90	0.00	1
7100.21	11.80	11.80	0.00	1
7100.50	17.70	17.70	0.00	1
7100.78	23.60	23.60	0.00	1
7101.02	29.50	29.50	0.00	1
7101.25	35.40	35.40	0.00	1
7101.48	41.30	41.30	0.00	1
7101.71	47.20	47.20	0.00	1
7101.95	53.10	53.10	0.00	1
7102.22	59.00	59.00	0.00	1
7107.19	124.40	124.40	0.00	Overtopping

Rating Curve Plot for Crossing: S-12 OUTLET

Total Rating Curve
Crossing: S-12 OUTLET

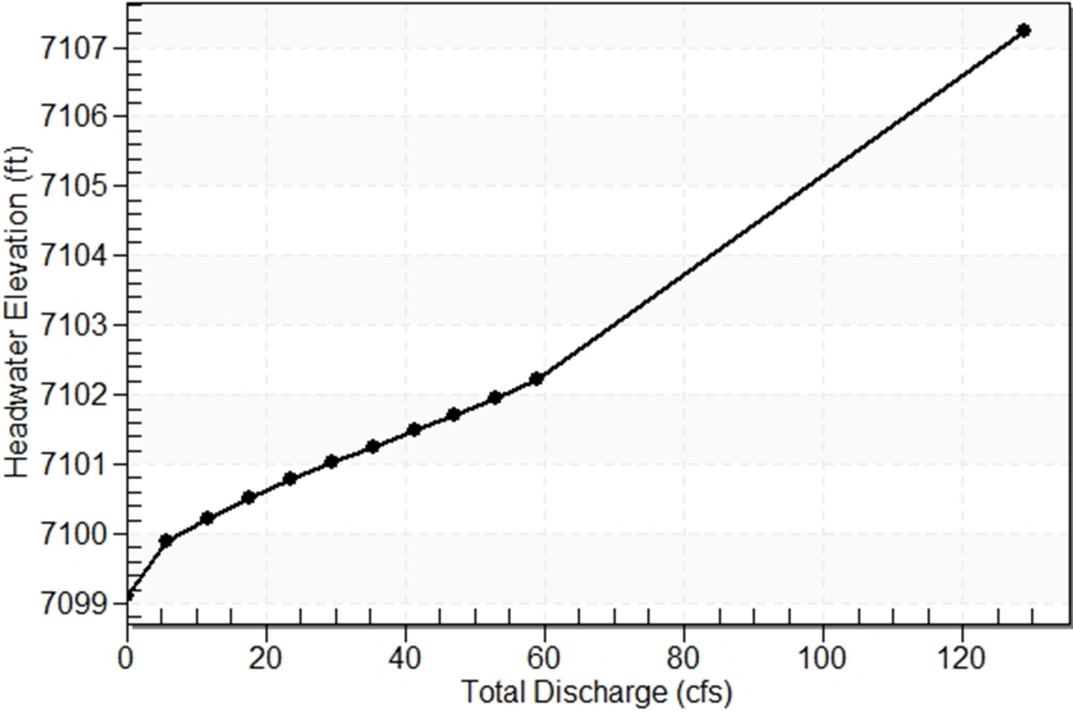

Table 2 - Culvert Summary Table: Culvert 1

Total Discharge (cfs)	Culvert Discharge (cfs)	Headwater Elevation (ft)	Inlet Control Depth (ft)	Outlet Control Depth (ft)	Flow Type	Normal Depth (ft)	Critical Depth (ft)	Outlet Depth (ft)	Tailwater Depth (ft)	Outlet Velocity (ft/s)	Tailwater Velocity (ft/s)
0.00	0.00	7099.12	0.000	0.000	0-NF	0.000	0.000	0.000	0.000	0.000	0.000
5.90	5.90	7099.88	0.760	0.0*	1-S2n	0.393	0.562	0.393	0.696	5.962	3.047
11.80	11.80	7100.21	1.094	0.0*	1-S2n	0.553	0.803	0.553	0.902	7.312	3.623
17.70	17.70	7100.50	1.383	0.0*	1-S2n	0.678	0.991	0.689	1.051	8.032	4.010
23.60	23.60	7100.78	1.658	0.0*	1-S2n	0.787	1.152	0.806	1.170	8.622	4.309
29.50	29.50	7101.02	1.903	0.196	1-S2n	0.885	1.294	0.910	1.272	9.127	4.556
35.40	35.40	7101.25	2.132	0.463	1-S2n	0.976	1.424	1.016	1.362	9.450	4.768
41.30	41.30	7101.48	2.357	0.745	1-S2n	1.062	1.543	1.106	1.443	9.856	4.956
47.20	47.20	7101.71	2.589	1.042	5-S2n	1.145	1.654	1.198	1.518	10.157	5.124
53.10	53.10	7101.95	2.834	1.357	5-S2n	1.226	1.756	1.287	1.586	10.429	5.277
59.00	59.00	7102.22	3.101	1.689	5-S2n	1.305	1.852	1.371	1.650	10.705	5.418

* Full Flow Headwater elevation is below inlet invert.

Straight Culvert

Inlet Elevation (invert): 7099.12 ft, Outlet Elevation (invert): 7097.71 ft

Culvert Length: 92.78 ft, Culvert Slope: 0.0152

Culvert Performance Curve Plot: Culvert 1

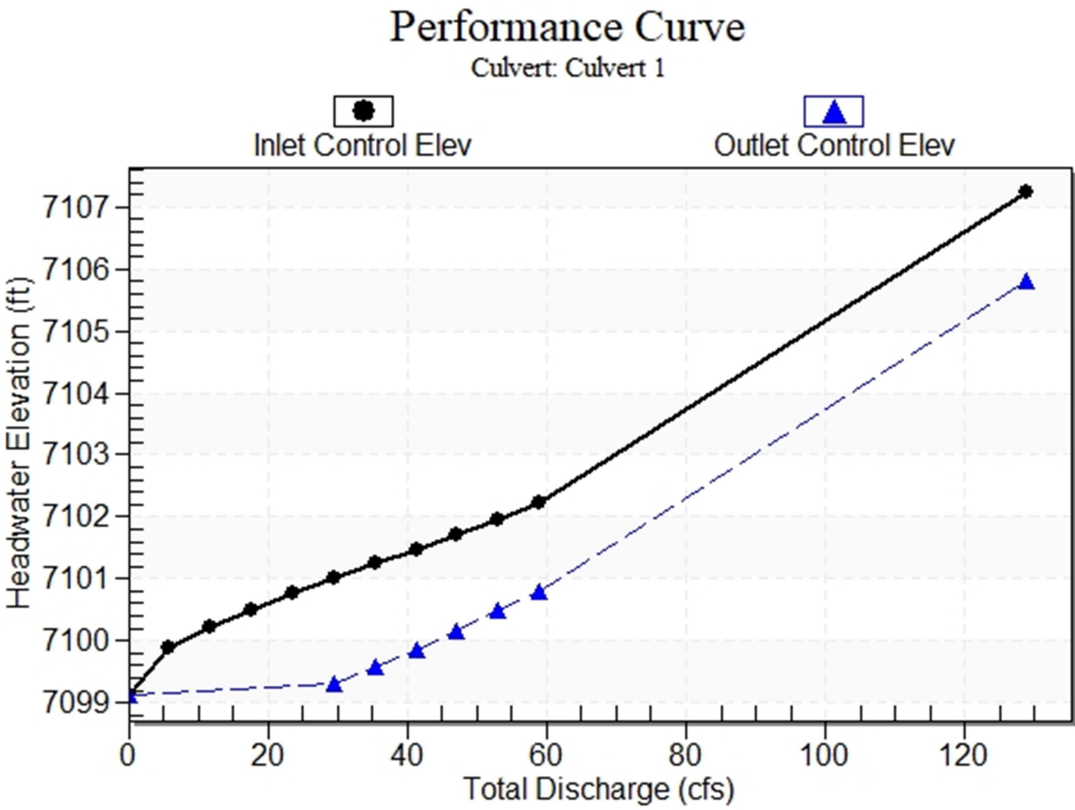

Water Surface Profile Plot for Culvert: Culvert 1

Crossing - S-12 OUTLET, Design Discharge - 59.0 cfs

Culvert - Culvert 1, Culvert Discharge - 59.0 cfs

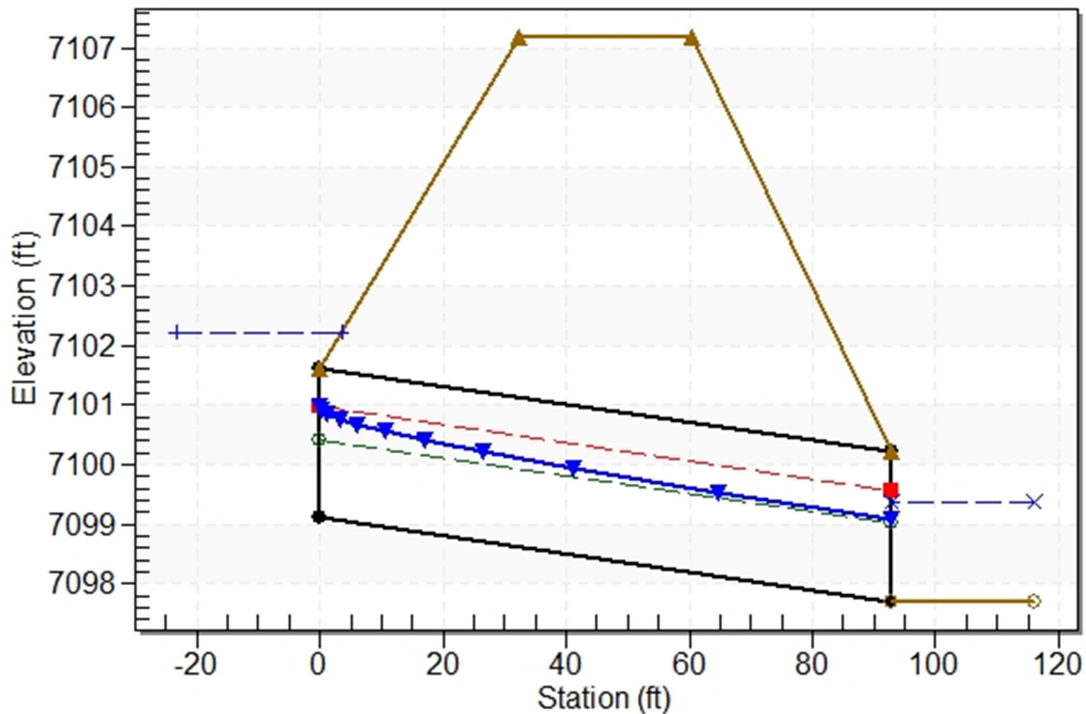

Site Data - Culvert 1

Site Data Option: Culvert Invert Data

Inlet Station: 0.00 ft

Inlet Elevation: 7099.12 ft

Outlet Station: 92.77 ft

Outlet Elevation: 7097.71 ft

Number of Barrels: 2

Culvert Data Summary - Culvert 1

Barrel Shape: Circular

Barrel Diameter: 2.50 ft

Barrel Material: Smooth HDPE

Embedment: 0.00 in

Barrel Manning's n: 0.0120

Culvert Type: Straight

Inlet Configuration: Square Edge with Headwall

Inlet Depression: None

Table 3 - Downstream Channel Rating Curve (Crossing: S-12 OUTLET)

Flow (cfs)	Water Surface Elev (ft)	Depth (ft)	Velocity (ft/s)	Shear (psf)	Froude Number
0.00	7097.71	0.00	0.00	0.00	0.00
5.90	7098.41	0.70	3.05	0.70	0.91
11.80	7098.61	0.90	3.62	0.91	0.95
17.70	7098.76	1.05	4.01	1.06	0.97
23.60	7098.88	1.17	4.31	1.18	0.99
29.50	7098.98	1.27	4.56	1.28	1.01
35.40	7099.07	1.36	4.77	1.37	1.02
41.30	7099.15	1.44	4.96	1.45	1.03
47.20	7099.23	1.52	5.12	1.52	1.04
53.10	7099.30	1.59	5.28	1.59	1.04
59.00	7099.36	1.65	5.42	1.66	1.05

Tailwater Channel Data - S-12 OUTLET

Tailwater Channel Option: Triangular Channel

Side Slope (H:V): 4.00 (_:1)

Channel Slope: 0.0161

Channel Manning's n: 0.0300

Channel Invert Elevation: 7097.71 ft

Roadway Data for Crossing: S-12 OUTLET

Roadway Profile Shape: Constant Roadway Elevation

Crest Length: 100.00 ft

Crest Elevation: 7107.19 ft

Roadway Surface: Paved

Roadway Top Width: 28.00 ft

HY-8 Culvert Analysis Report

Culvert Crossing North End of Oregon Wagon Trail

Crossing Discharge Data

Discharge Selection Method: Specify Minimum, Design, and Maximum Flow

Minimum Flow: 0 cfs

Design Flow: 29.13 cfs

Maximum Flow: 29.13 cfs

Table 1 - Summary of Culvert Flows at Crossing: N Oregon Crossing

Headwater Elevation (ft)	Total Discharge (cfs)	Culvert 1 Discharge (cfs)	Roadway Discharge (cfs)	Iterations
7088.80	0.00	0.00	0.00	1
7089.21	2.91	2.91	0.00	1
7089.35	5.83	5.83	0.00	1
7089.48	8.74	8.74	0.00	1
7089.59	11.65	11.65	0.00	1
7089.69	14.57	14.57	0.00	1
7089.78	17.48	17.48	0.00	1
7089.87	20.39	20.39	0.00	1
7089.95	23.30	23.30	0.00	1
7090.03	26.22	26.22	0.00	1
7090.10	29.13	29.13	0.00	1
7094.06	187.94	187.94	0.00	Overtopping

Rating Curve Plot for Crossing: N Oregon Crossing

Total Rating Curve
Crossing: N Oregon Crossing

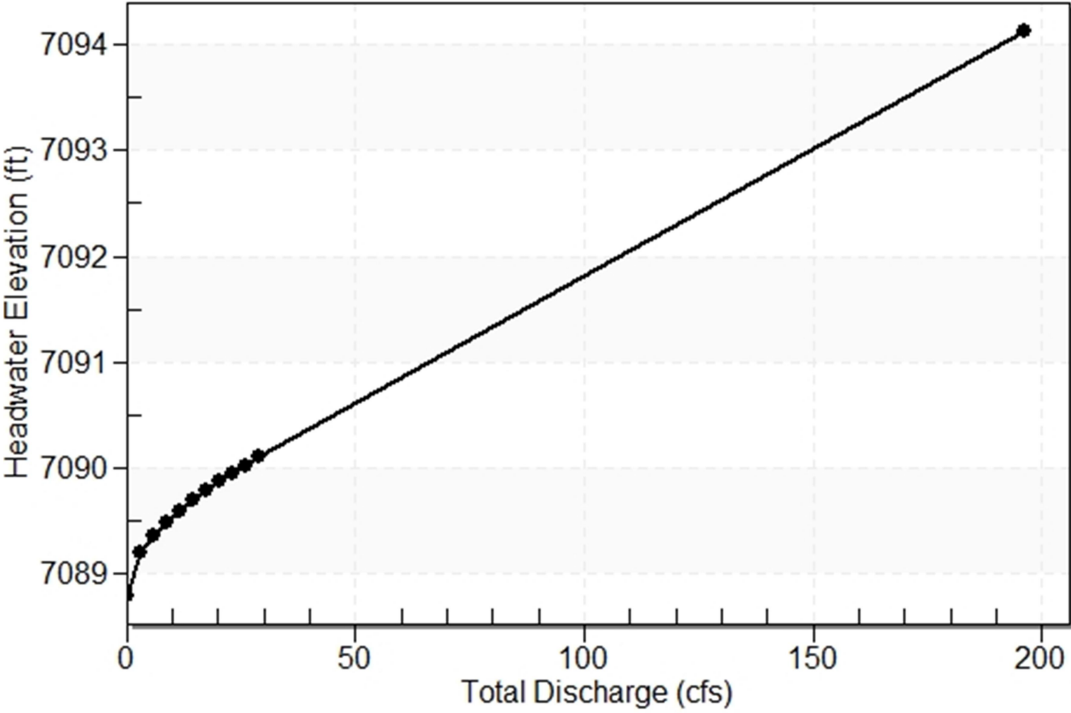

Table 2 - Culvert Summary Table: Culvert 1

Total Discharge (cfs)	Culvert Discharge (cfs)	Headwater Elevation (ft)	Inlet Control Depth (ft)	Outlet Control Depth (ft)	Flow Type	Normal Depth (ft)	Critical Depth (ft)	Outlet Depth (ft)	Tailwater Depth (ft)	Outlet Velocity (ft/s)	Tailwater Velocity (ft/s)
0.00	0.00	7088.80	0.000	0.000	0-NF	0.000	0.000	0.000	0.000	0.000	0.000
2.91	2.91	7089.21	0.408	0.038	1-JS1t	0.254	0.293	0.528	0.528	1.072	1.805
5.83	5.83	7089.35	0.553	0.197	1-JS1t	0.354	0.414	0.684	0.684	1.492	2.146
8.74	8.74	7089.48	0.683	0.312	1-JS1t	0.428	0.508	0.797	0.797	1.820	2.375
11.65	11.65	7089.59	0.794	0.407	1-JS1t	0.490	0.588	0.887	0.887	2.099	2.552
14.57	14.57	7089.69	0.893	0.490	1-JS1t	0.545	0.660	0.965	0.965	2.348	2.698
17.48	17.48	7089.78	0.985	0.565	1-JS1t	0.596	0.725	1.033	1.033	2.576	2.824
20.39	20.39	7089.87	1.070	0.634	1-JS1t	0.643	0.786	1.094	1.094	2.788	2.935
23.30	23.30	7089.95	1.150	0.699	1-JS1t	0.686	0.843	1.151	1.151	2.987	3.035
26.22	26.22	7090.03	1.226	0.761	1-JS1t	0.728	0.897	1.203	1.203	3.176	3.126
29.13	29.13	7090.10	1.299	0.821	1-JS1t	0.767	0.948	1.251	1.251	3.356	3.209

Straight Culvert

Inlet Elevation (invert): 7088.80 ft, Outlet Elevation (invert): 7088.31 ft

Culvert Length: 75.39 ft, Culvert Slope: 0.0065

Culvert Performance Curve Plot: Culvert 1

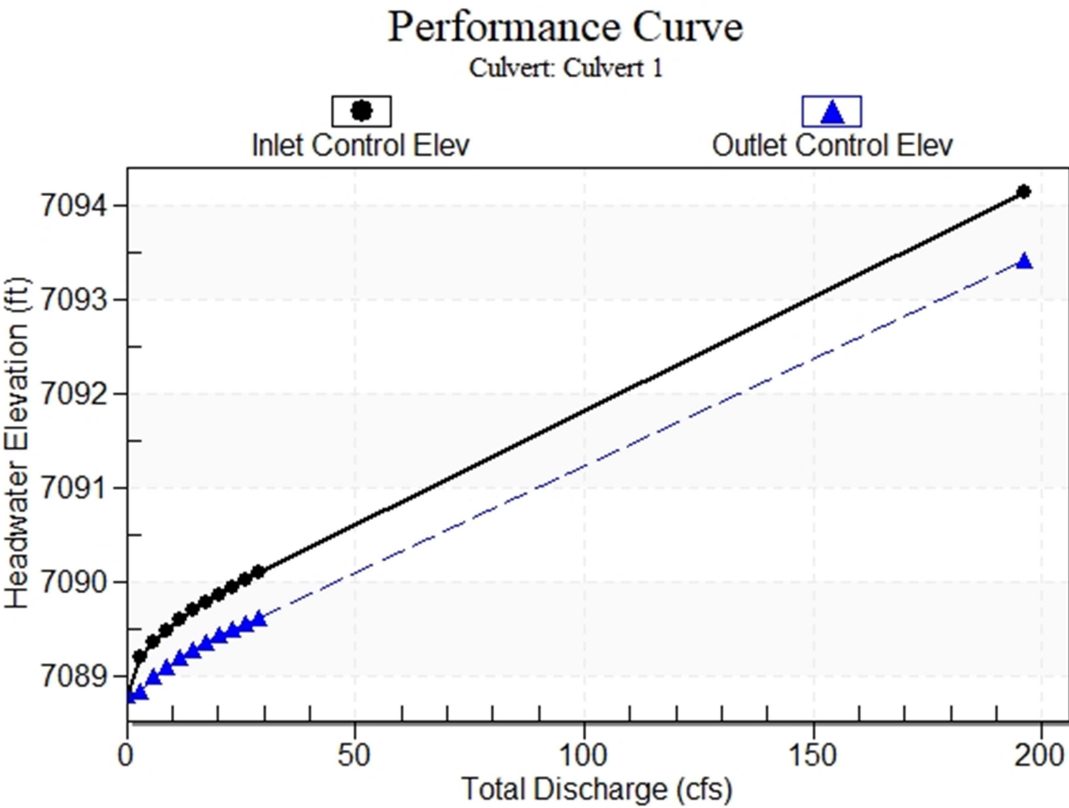

Water Surface Profile Plot for Culvert: Culvert 1

Crossing - N Oregon Crossing, Design Discharge - 29.1 cfs

Culvert - Culvert 1, Culvert Discharge - 29.1 cfs

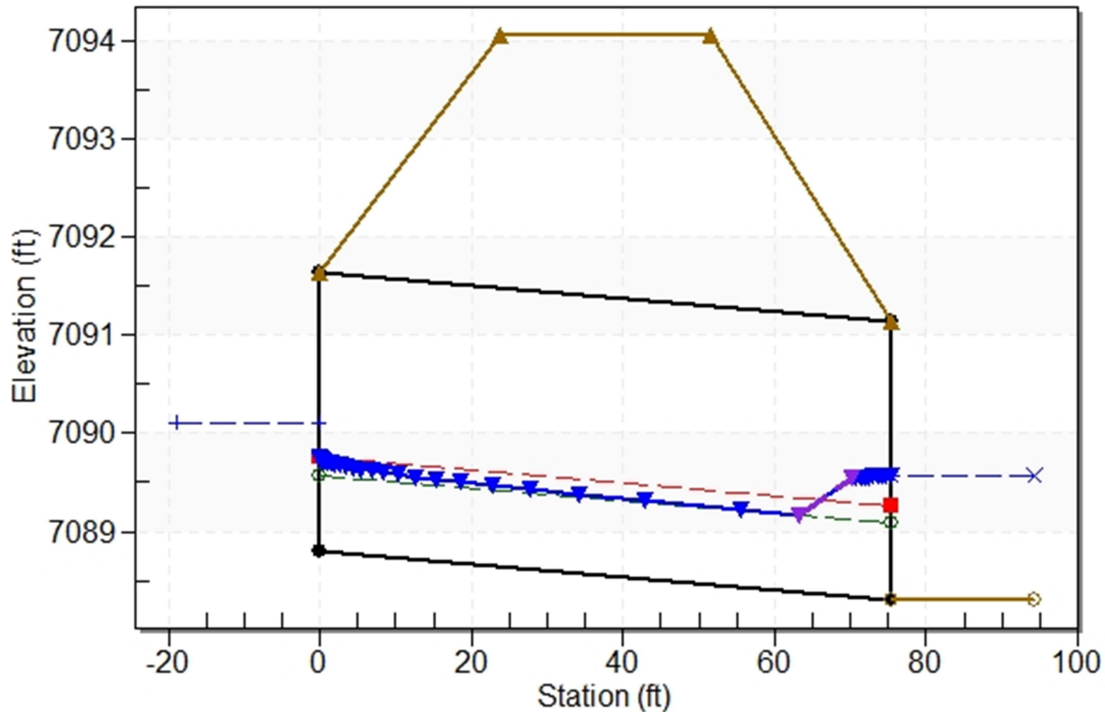

Site Data - Culvert 1

Site Data Option: Culvert Invert Data

Inlet Station: 0.00 ft

Inlet Elevation: 7088.80 ft

Outlet Station: 75.39 ft

Outlet Elevation: 7088.31 ft

Number of Barrels: 2

Culvert Data Summary - Culvert 1

Barrel Shape: Elliptical

Barrel Span: 53.00 in

Barrel Rise: 34.00 in

Barrel Material: Concrete

Embedment: 0.00 in

Barrel Manning's n: 0.0120

Culvert Type: Straight

Inlet Configuration: Square Edge with Headwall

Inlet Depression: None

Table 3 - Downstream Channel Rating Curve (Crossing: N Oregon Crossing)

Flow (cfs)	Water Surface Elev (ft)	Depth (ft)	Velocity (ft/s)	Shear (psf)	Froude Number
0.00	7088.31	0.00	0.00	0.00	0.00
2.91	7088.84	0.53	1.80	0.26	0.62
5.83	7088.99	0.68	2.15	0.34	0.65
8.74	7089.11	0.80	2.37	0.40	0.66
11.65	7089.20	0.89	2.55	0.44	0.68
14.57	7089.27	0.96	2.70	0.48	0.68
17.48	7089.34	1.03	2.82	0.52	0.69
20.39	7089.40	1.09	2.94	0.55	0.70
23.30	7089.46	1.15	3.03	0.57	0.71
26.22	7089.51	1.20	3.13	0.60	0.71
29.13	7089.56	1.25	3.21	0.62	0.72

Tailwater Channel Data - N Oregon Crossing

Tailwater Channel Option: Triangular Channel

Side Slope (H:V): 5.80 (_:1)

Channel Slope: 0.0080

Channel Manning's n: 0.0300

Channel Invert Elevation: 7088.31 ft

Roadway Data for Crossing: N Oregon Crossing

Roadway Profile Shape: Constant Roadway Elevation

Crest Length: 100.00 ft

Crest Elevation: 7094.06 ft

Roadway Surface: Paved

Roadway Top Width: 28.00 ft

HY-8 Culvert Analysis Report
Emergency Spillway Overflow from S-12 Pond
Culvert Crossing North End of Oregon Wagon Trail

Crossing Discharge Data

Discharge Selection Method: Specify Minimum, Design, and Maximum Flow

Minimum Flow: 0 cfs

Design Flow: 289 cfs

Maximum Flow: 289 cfs

Table 1 - Summary of Culvert Flows at Crossing: N Oregon Crossing

Headwater Elevation (ft)	Total Discharge (cfs)	Culvert 1 Discharge (cfs)	Roadway Discharge (cfs)	Iterations
7088.80	0.00	0.00	0.00	1
7090.09	28.90	28.90	0.00	1
7090.76	57.80	57.80	0.00	1
7091.36	86.70	86.70	0.00	1
7091.98	115.60	115.60	0.00	1
7092.70	144.50	144.50	0.00	1
7093.56	173.40	173.40	0.00	1
7094.17	202.30	191.06	11.11	10
7094.31	231.20	194.70	36.33	6
7094.41	260.10	197.52	62.46	5
7094.50	289.00	199.93	88.87	4
7094.06	187.94	187.94	0.00	Overtopping

Rating Curve Plot for Crossing: N Oregon Crossing

Total Rating Curve

Crossing: N Oregon Crossing

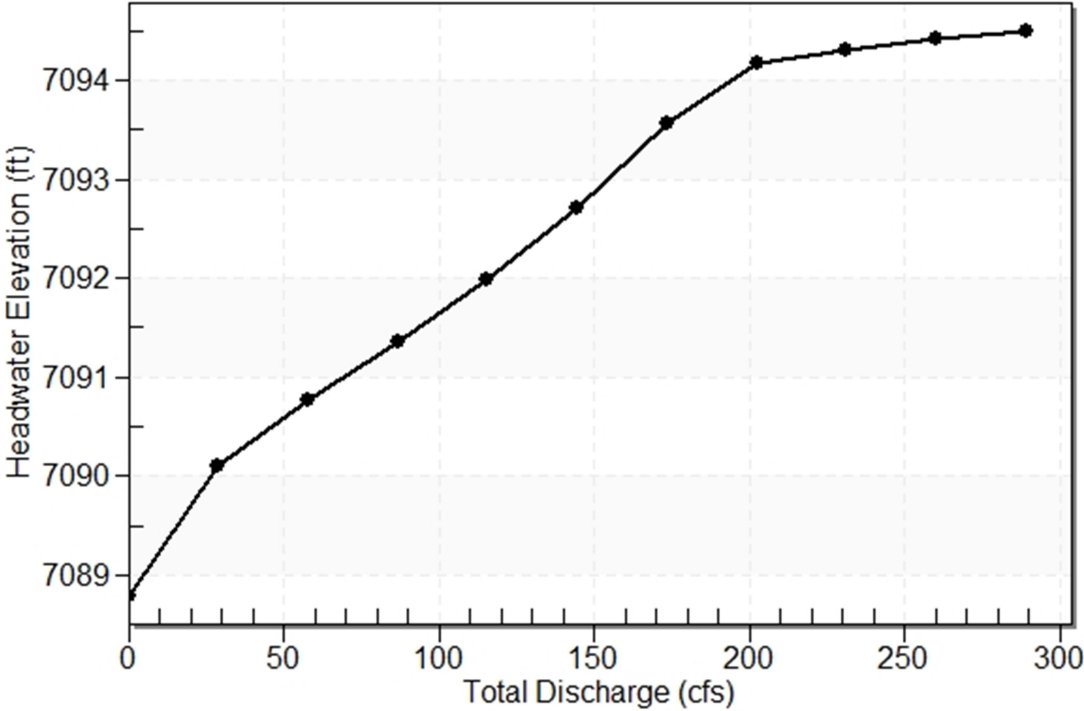

Table 2 - Culvert Summary Table: Culvert 1

Total Discharge (cfs)	Culvert Discharge (cfs)	Headwater Elevation (ft)	Inlet Control Depth (ft)	Outlet Control Depth (ft)	Flow Type	Normal Depth (ft)	Critical Depth (ft)	Outlet Depth (ft)	Tailwater Depth (ft)	Outlet Velocity (ft/s)	Tailwater Velocity (ft/s)
0.00	0.00	7088.80	0.000	0.000	0-NF	0.000	0.000	0.000	0.000	0.000	0.000
28.90	28.90	7090.09	1.293	0.816	1-JS1t	0.764	0.944	1.247	1.247	3.342	3.203
57.80	57.80	7090.76	1.962	1.363	1-S2n	1.094	1.368	1.126	1.618	7.617	3.809
86.70	86.70	7091.36	2.559	1.924	1-S2n	1.368	1.702	1.419	1.883	8.521	4.215
115.60	115.60	7091.98	3.180	2.551	5-S2n	1.617	1.985	1.687	2.098	9.215	4.529
144.50	144.50	7092.70	3.899	3.264	5-S2n	1.864	2.228	1.940	2.281	9.816	4.789
173.40	173.40	7093.56	4.763	4.073	5-S2n	2.127	2.424	2.192	2.442	10.345	5.012
202.30	191.06	7094.17	5.372	4.673	5-S2n	2.315	2.515	2.359	2.588	10.615	5.209
231.20	194.70	7094.31	5.506	4.905	5-JS1t	2.362	2.531	2.720	2.720	9.709	5.386
260.10	197.52	7094.41	5.611	5.106	4-FFf	2.400	2.543	2.833	2.843	9.710	5.547
289.00	199.93	7094.50	5.703	5.288	4-FFf	2.439	2.553	2.833	2.958	9.828	5.695

Straight Culvert

Inlet Elevation (invert): 7088.80 ft, Outlet Elevation (invert): 7088.31 ft

Culvert Length: 75.39 ft, Culvert Slope: 0.0065

Culvert Performance Curve Plot: Culvert 1

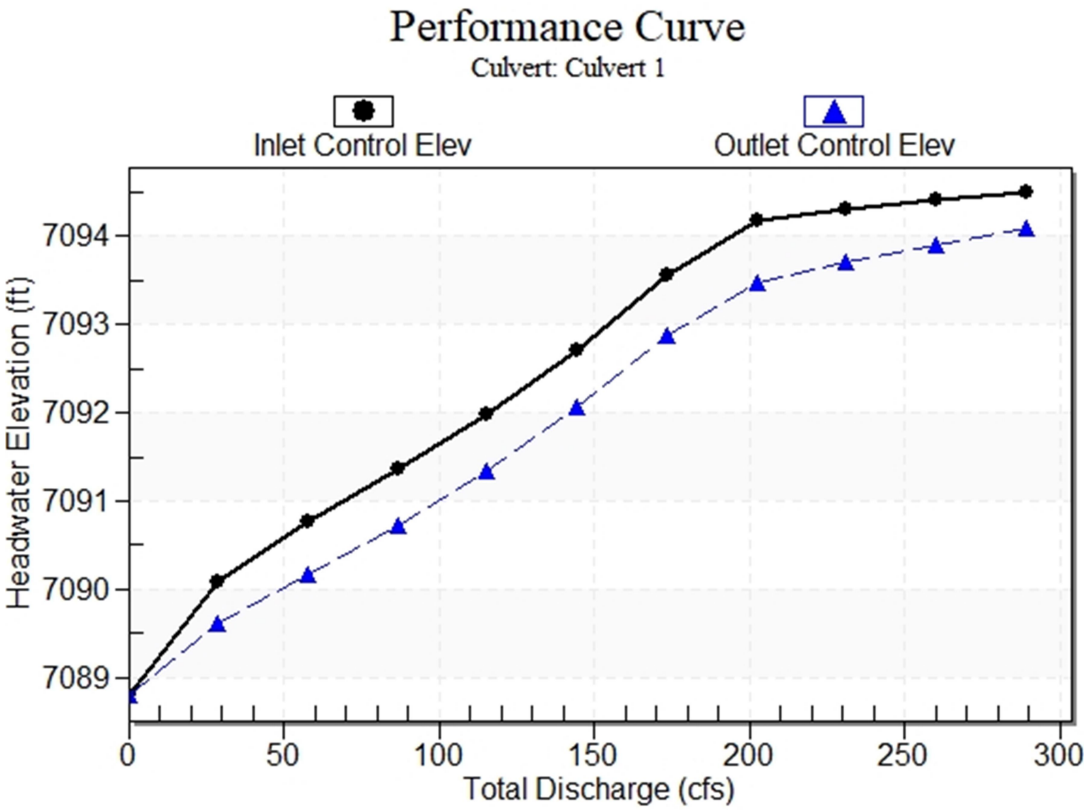

Water Surface Profile Plot for Culvert: Culvert 1

Crossing - N Oregon Crossing, Design Discharge - 289.0 cfs

Culvert - Culvert 1, Culvert Discharge - 199.9 cfs

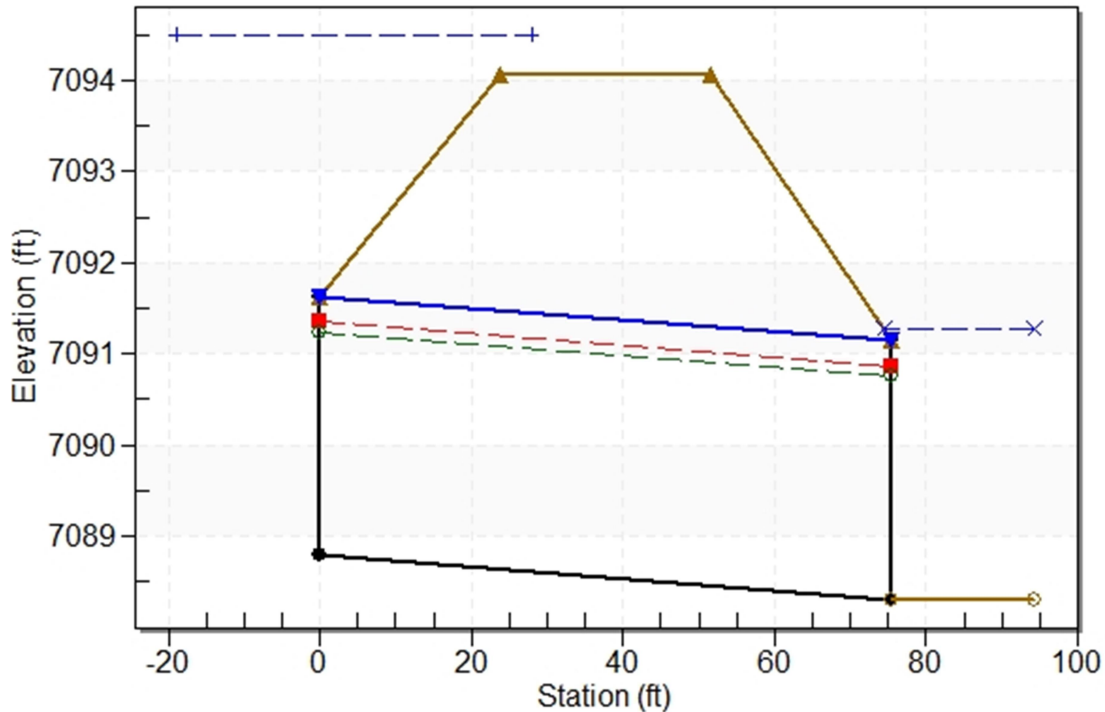

Site Data - Culvert 1

Site Data Option: Culvert Invert Data

Inlet Station: 0.00 ft

Inlet Elevation: 7088.80 ft

Outlet Station: 75.39 ft

Outlet Elevation: 7088.31 ft

Number of Barrels: 2

Culvert Data Summary - Culvert 1

Barrel Shape: Elliptical

Barrel Span: 53.00 in

Barrel Rise: 34.00 in

Barrel Material: Concrete

Embedment: 0.00 in

Barrel Manning's n: 0.0120

Culvert Type: Straight

Inlet Configuration: Square Edge with Headwall

Inlet Depression: None

Table 3 - Downstream Channel Rating Curve (Crossing: N Oregon Crossing)

Flow (cfs)	Water Surface Elev (ft)	Depth (ft)	Velocity (ft/s)	Shear (psf)	Froude Number
0.00	7088.31	0.00	0.00	0.00	0.00
28.90	7089.56	1.25	3.20	0.62	0.71
57.80	7089.93	1.62	3.81	0.81	0.75
86.70	7090.19	1.88	4.21	0.94	0.77
115.60	7090.41	2.10	4.53	1.05	0.78
144.50	7090.59	2.28	4.79	1.14	0.79
173.40	7090.75	2.44	5.01	1.22	0.80
202.30	7090.90	2.59	5.21	1.29	0.81
231.20	7091.03	2.72	5.39	1.36	0.81
260.10	7091.15	2.84	5.55	1.42	0.82
289.00	7091.27	2.96	5.70	1.48	0.83

Tailwater Channel Data - N Oregon Crossing

Tailwater Channel Option: Triangular Channel

Side Slope (H:V): 5.80 (_:1)

Channel Slope: 0.0080

Channel Manning's n: 0.0300

Channel Invert Elevation: 7088.31 ft

Roadway Data for Crossing: N Oregon Crossing

Roadway Profile Shape: Constant Roadway Elevation

Crest Length: 100.00 ft

Crest Elevation: 7094.06 ft

Roadway Surface: Paved

Roadway Top Width: 28.00 ft

HY-8 Culvert Analysis Report

Culvert Crossing Latigo Blvd

Crossing Discharge Data

Discharge Selection Method: Specify Minimum, Design, and Maximum Flow

Minimum Flow: 0 cfs

Design Flow: 319.17 cfs

Maximum Flow: 319.17 cfs

Table 1 - Summary of Culvert Flows at Crossing: Latigo Crossing Culvert

Headwater Elevation (ft)	Total Discharge (cfs)	Culvert 1 Discharge (cfs)	Roadway Discharge (cfs)	Iterations
7064.51	0.00	0.00	0.00	1
7065.24	31.92	31.92	0.00	1
7065.68	63.83	63.83	0.00	1
7066.04	95.75	95.75	0.00	1
7066.37	127.67	127.67	0.00	1
7066.67	159.59	159.59	0.00	1
7066.94	191.50	191.50	0.00	1
7067.21	223.42	223.42	0.00	1
7067.47	255.34	255.34	0.00	1
7067.72	287.25	287.25	0.00	1
7067.97	319.17	319.17	0.00	1
7069.56	493.13	493.13	0.00	Overtopping

Rating Curve Plot for Crossing: Latigo Crossing Culvert

Total Rating Curve
Crossing: Latigo Crossing Culvert

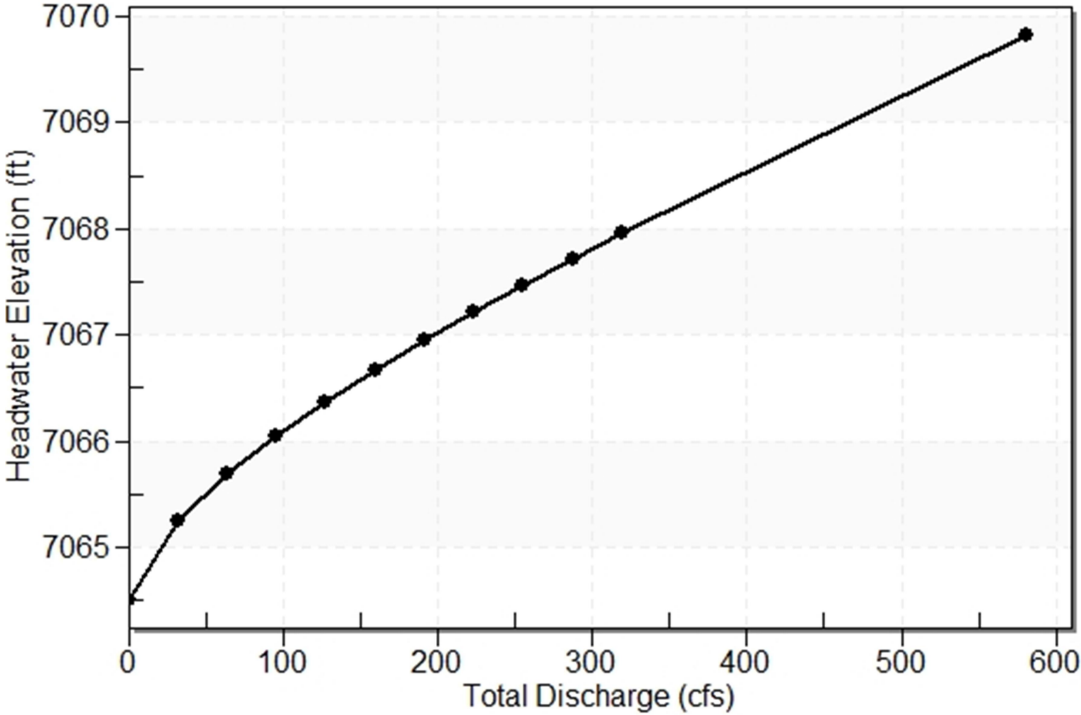

Table 2 - Culvert Summary Table: Culvert 1

Total Discharge (cfs)	Culvert Discharge (cfs)	Headwater Elevation (ft)	Inlet Control Depth (ft)	Outlet Control Depth (ft)	Flow Type	Normal Depth (ft)	Critical Depth (ft)	Outlet Depth (ft)	Tailwater Depth (ft)	Outlet Velocity (ft/s)	Tailwater Velocity (ft/s)
0.00	0.00	7064.51	0.000	0.000	0-NF	0.000	0.000	0.000	0.000	0.000	0.000
31.92	31.92	7065.24	0.733	0.491	1-JS1t	0.366	0.429	0.803	0.803	1.986	3.006
63.83	63.83	7065.68	1.164	1.174	1-S1t	0.563	0.681	1.172	1.172	2.724	3.710
95.75	95.75	7066.04	1.525	1.534	1-S1t	0.727	0.893	1.451	1.451	3.298	4.174
127.67	127.67	7066.37	1.836	1.858	1-S1t	0.873	1.082	1.685	1.685	3.789	4.528
159.59	159.59	7066.67	2.123	2.156	1-S1t	1.007	1.255	1.887	1.887	4.228	4.819
191.50	191.50	7066.94	2.392	2.435	1-S1t	1.133	1.417	2.068	2.068	4.629	5.066
223.42	223.42	7067.21	2.650	2.700	1-S1t	1.252	1.571	2.233	2.233	5.002	5.284
255.34	255.34	7067.47	2.903	2.956	1-S1t	1.367	1.717	2.385	2.385	5.353	5.479
287.25	287.25	7067.72	3.155	3.206	1-S1t	1.477	1.857	2.526	2.526	5.685	5.655
319.17	319.17	7067.97	3.413	3.455	1-S1t	1.584	1.992	2.659	2.659	6.002	5.817

Straight Culvert

Inlet Elevation (invert): 7064.51 ft, Outlet Elevation (invert): 7064.19 ft

Culvert Length: 62.08 ft, Culvert Slope: 0.0052

Culvert Performance Curve Plot: Culvert 1

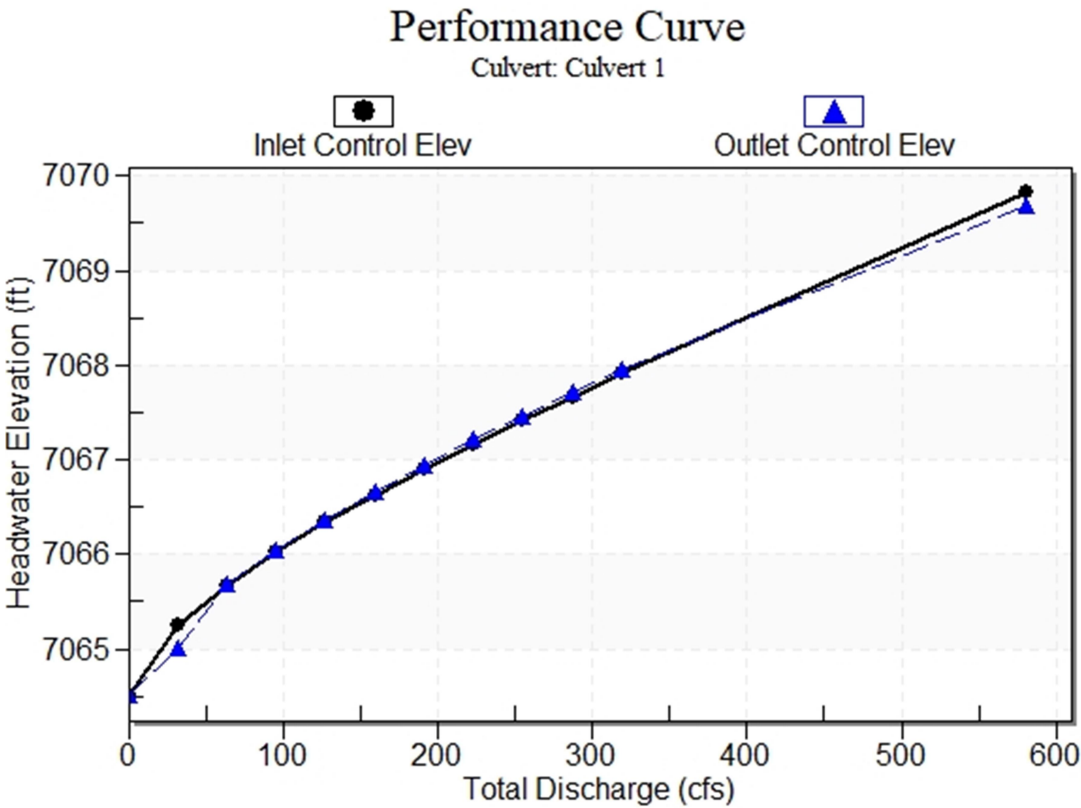

Water Surface Profile Plot for Culvert: Culvert 1

Crossing - Latigo Crossing Culvert, Design Discharge - 319.2 cfs

Culvert - Culvert 1, Culvert Discharge - 319.2 cfs

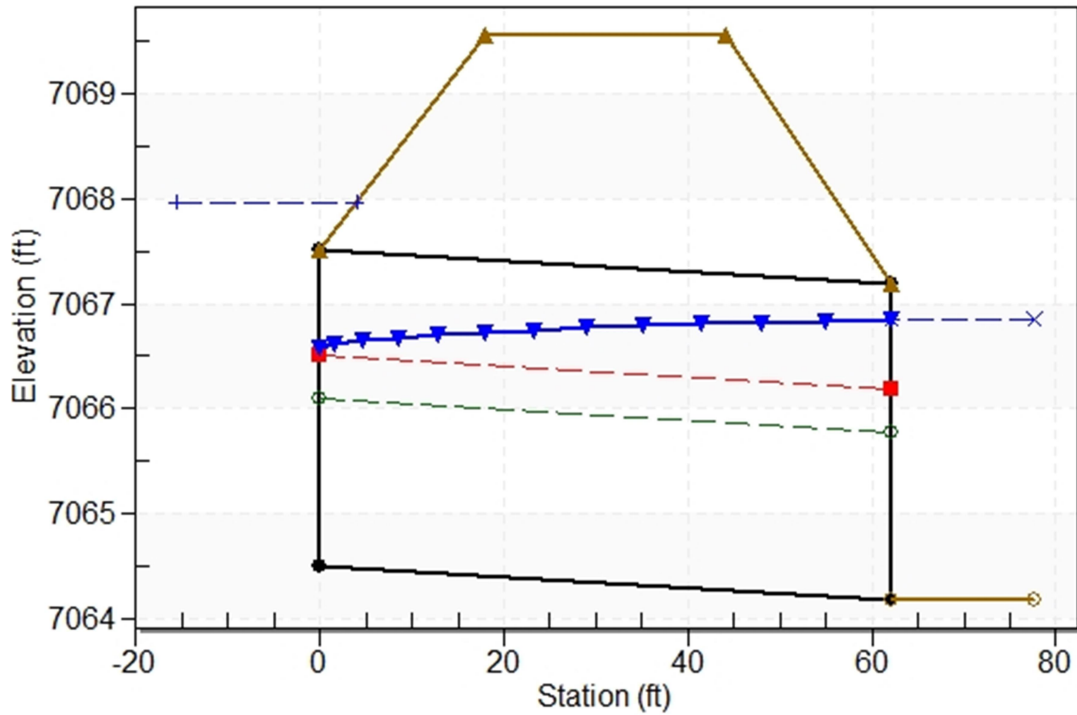

Site Data - Culvert 1

Site Data Option: Culvert Invert Data

Inlet Station: 0.00 ft

Inlet Elevation: 7064.51 ft

Outlet Station: 62.08 ft

Outlet Elevation: 7064.19 ft

Number of Barrels: 2

Culvert Data Summary - Culvert 1

Barrel Shape: Concrete Box

Barrel Span: 10.00 ft

Barrel Rise: 3.00 ft

Barrel Material: Concrete

Embedment: 0.00 in

Barrel Manning's n: 0.0120

Culvert Type: Straight

Inlet Configuration: Square Edge (90°) Headwall

Inlet Depression: None

Table 3 - Downstream Channel Rating Curve (Crossing: Latigo Crossing Culvert)

Flow (cfs)	Water Surface Elev (ft)	Depth (ft)	Velocity (ft/s)	Shear (psf)	Froude Number
0.00	7064.19	0.00	0.00	0.00	0.00
31.92	7064.99	0.80	3.01	0.34	0.66
63.83	7065.36	1.17	3.71	0.49	0.69
95.75	7065.64	1.45	4.17	0.61	0.71
127.67	7065.87	1.68	4.53	0.70	0.73
159.59	7066.08	1.89	4.82	0.79	0.74
191.50	7066.26	2.07	5.07	0.86	0.75
223.42	7066.42	2.23	5.28	0.93	0.76
255.34	7066.58	2.39	5.48	1.00	0.76
287.25	7066.72	2.53	5.66	1.06	0.77
319.17	7066.85	2.66	5.82	1.11	0.77

Tailwater Channel Data - Latigo Crossing Culvert

Tailwater Channel Option: Trapezoidal Channel

Bottom Width: 10.00 ft

Side Slope (H:V): 4.00 (_:1)

Channel Slope: 0.0067

Channel Manning's n: 0.0300

Channel Invert Elevation: 7064.19 ft

Roadway Data for Crossing: Latigo Crossing Culvert

Roadway Profile Shape: Constant Roadway Elevation

Crest Length: 150.00 ft

Crest Elevation: 7069.56 ft

Roadway Surface: Paved

Roadway Top Width: 26.00 ft

Filing 9 Proposed Driveway Culverts	
Lot #	Culvert Type
1 to 4	18" RCP
5	2, 24" RCP
6	None
7	30" RCP
8 to 15	18" RCP
16	None
17 to 22	18" RCP
23	None
24	18" RCP
25	None
26 to 28	18" RCP
29 to 32	19"x30" HERCP
33 - 34	18" RCP
35 -37	18" RCP

Channel Report

Swale Section A-A Capacity Check

Triangular

Side Slopes (z:1) = 3.10, 4.30
Total Depth (ft) = 3.00

Invert Elev (ft) = 1.00
Slope (%) = 1.00
N-Value = 0.040

Calculations

Compute by: Known Q
Known Q (cfs) = 46.75

Highlighted

Depth (ft) = 1.90
Q (cfs) = 46.75
Area (sqft) = 13.36
Velocity (ft/s) = 3.50
Wetted Perim (ft) = 14.58
Crit Depth, Yc (ft) = 1.59
Top Width (ft) = 14.06
EGL (ft) = 2.09

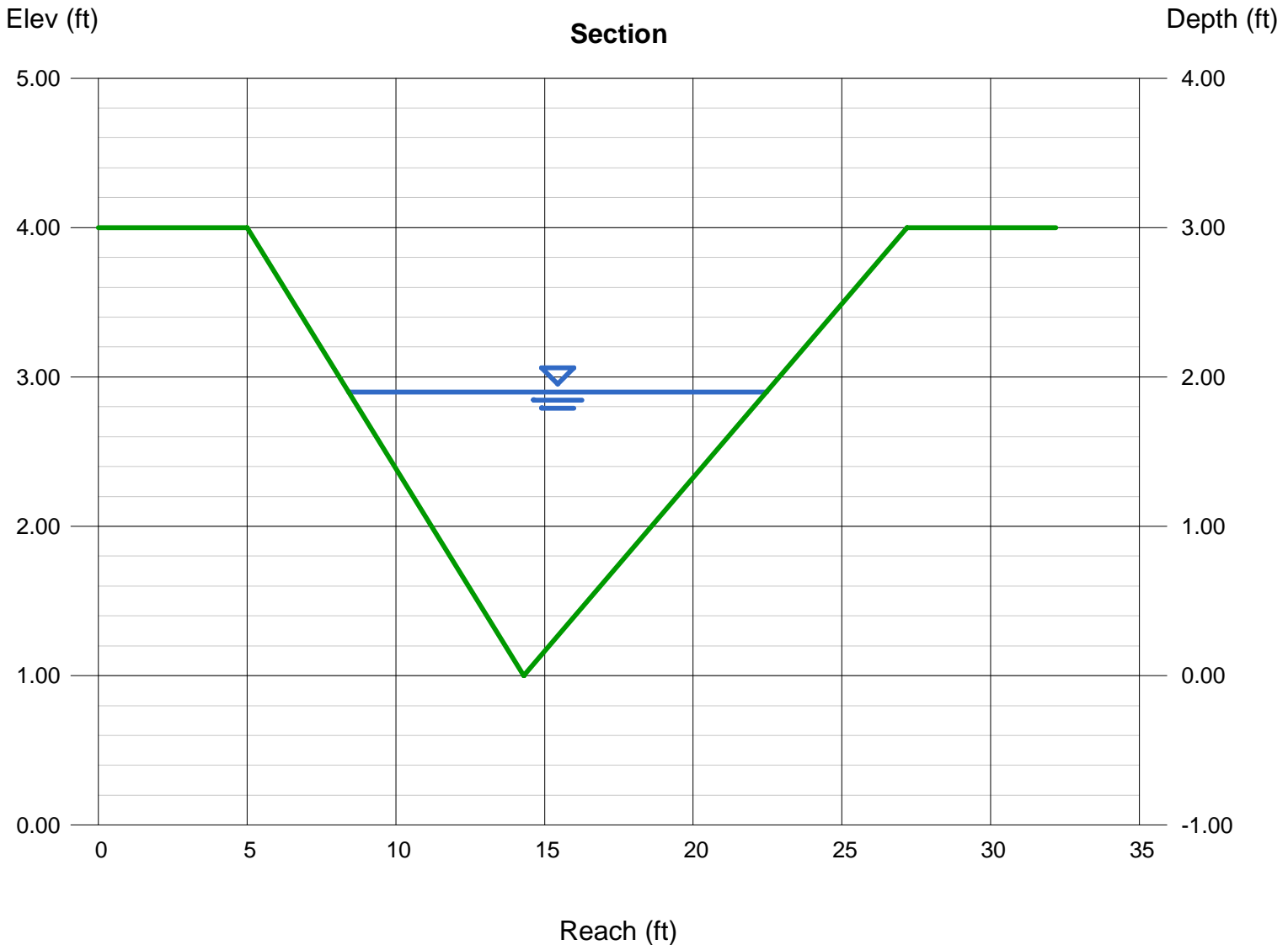

Channel Report

Swale Section A-A Velocity Check

Triangular

Side Slopes (z:1) = 3.10, 4.30

Total Depth (ft) = 3.00

Invert Elev (ft) = 1.00

Slope (%) = 4.00

N-Value = 0.030

Calculations

Compute by: Known Q

Known Q (cfs) = 46.75

Highlighted

Depth (ft) = 1.32

Q (cfs) = 46.75

Area (sqft) = 6.45

Velocity (ft/s) = 7.25

Wetted Perim (ft) = 10.13

Crit Depth, Yc (ft) = 1.59

Top Width (ft) = 9.77

EGL (ft) = 2.14

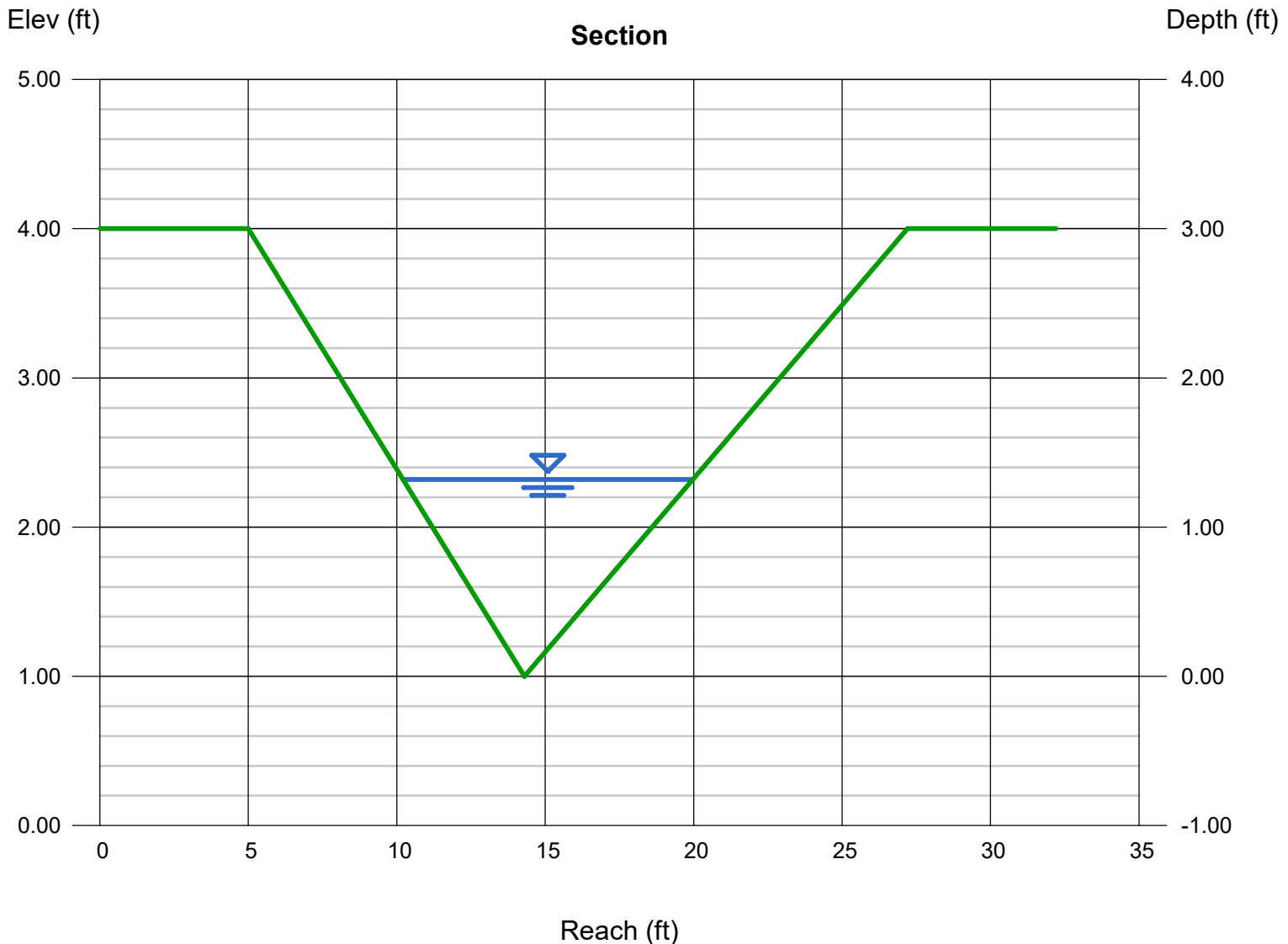

Channel Report

Swale Section B-B Capacity Check

Triangular

Side Slopes (z:1) = 3.10, 4.60
Total Depth (ft) = 3.00

Invert Elev (ft) = 1.00
Slope (%) = 0.98
N-Value = 0.040

Calculations

Compute by: Known Q
Known Q (cfs) = 46.75

Highlighted

Depth (ft) = 1.88
Q (cfs) = 46.75
Area (sqft) = 13.61
Velocity (ft/s) = 3.44
Wetted Perim (ft) = 14.97
Crit Depth, Yc (ft) = 1.56
Top Width (ft) = 14.48
EGL (ft) = 2.06

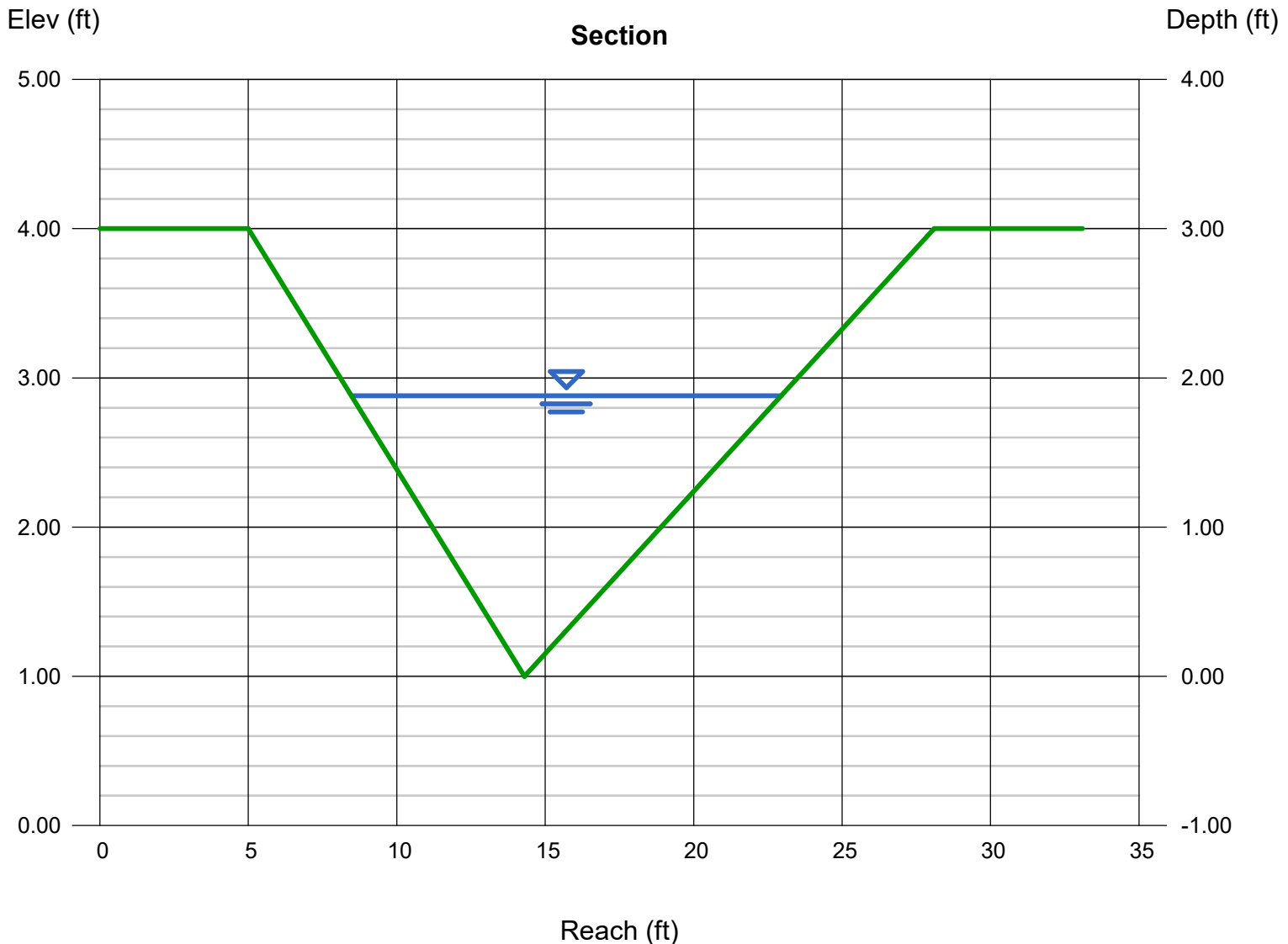

Channel Report

Swale Section B-B Velocity Check

Triangular

Side Slopes (z:1) = 3.10, 4.60

Total Depth (ft) = 3.00

Invert Elev (ft) = 1.00

Slope (%) = 4.86

N-Value = 0.030

Calculations

Compute by: Known Q

Known Q (cfs) = 46.75

Highlighted

Depth (ft) = 1.25

Q (cfs) = 46.75

Area (sqft) = 6.02

Velocity (ft/s) = 7.77

Wetted Perim (ft) = 9.96

Crit Depth, Yc (ft) = 1.56

Top Width (ft) = 9.62

EGL (ft) = 2.19

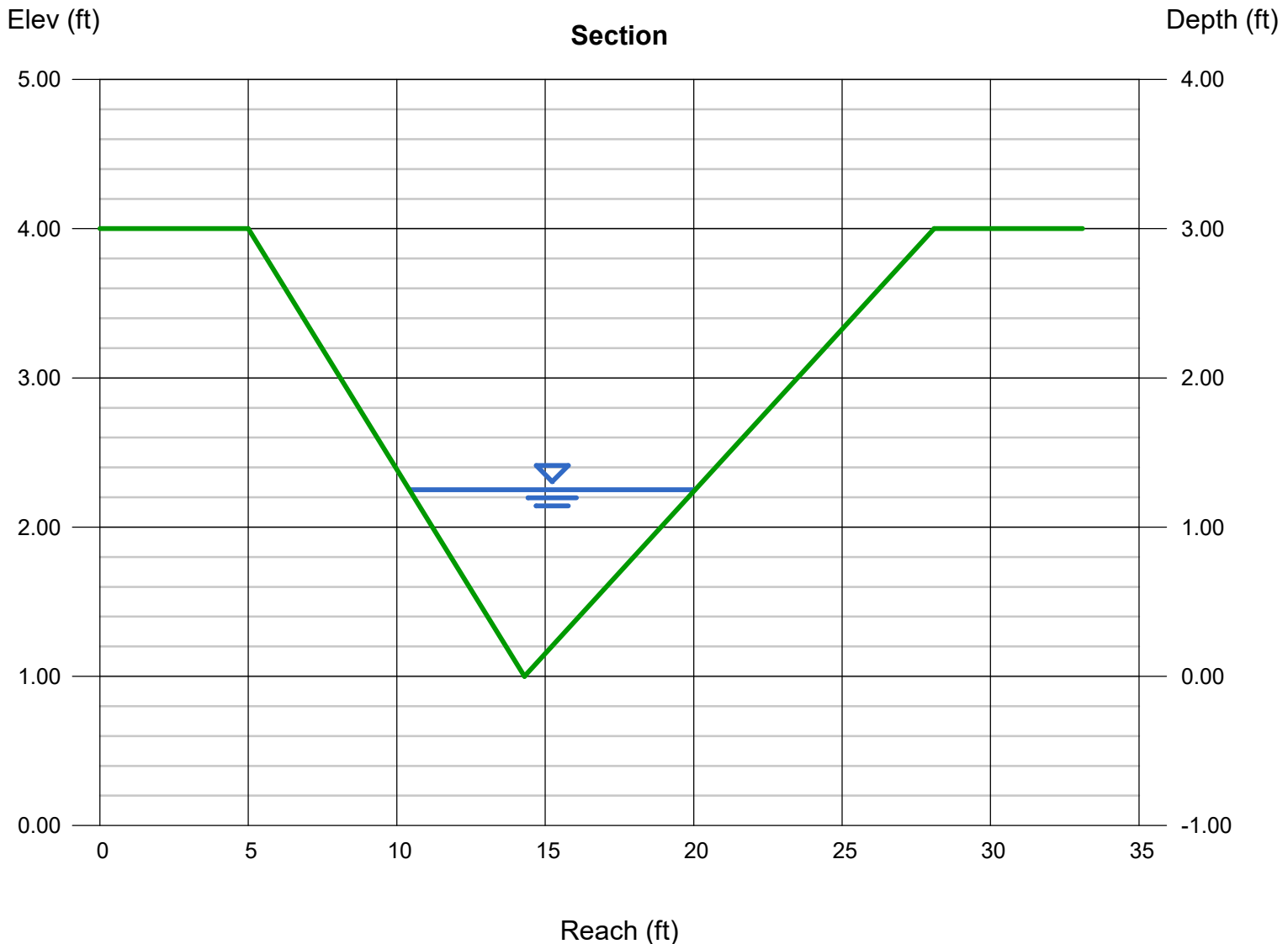

Channel Report

Swale Section C-C Capacity Check

Triangular

Side Slopes (z:1) = 3.10, 5.60
Total Depth (ft) = 3.00

Invert Elev (ft) = 1.00
Slope (%) = 1.15
N-Value = 0.040

Calculations

Compute by: Known Q
Known Q (cfs) = 10.02

Highlighted

Depth (ft) = 0.98
Q (cfs) = 10.02
Area (sqft) = 4.18
Velocity (ft/s) = 2.40
Wetted Perim (ft) = 8.77
Crit Depth, Yc (ft) = 0.81
Top Width (ft) = 8.53
EGL (ft) = 1.07

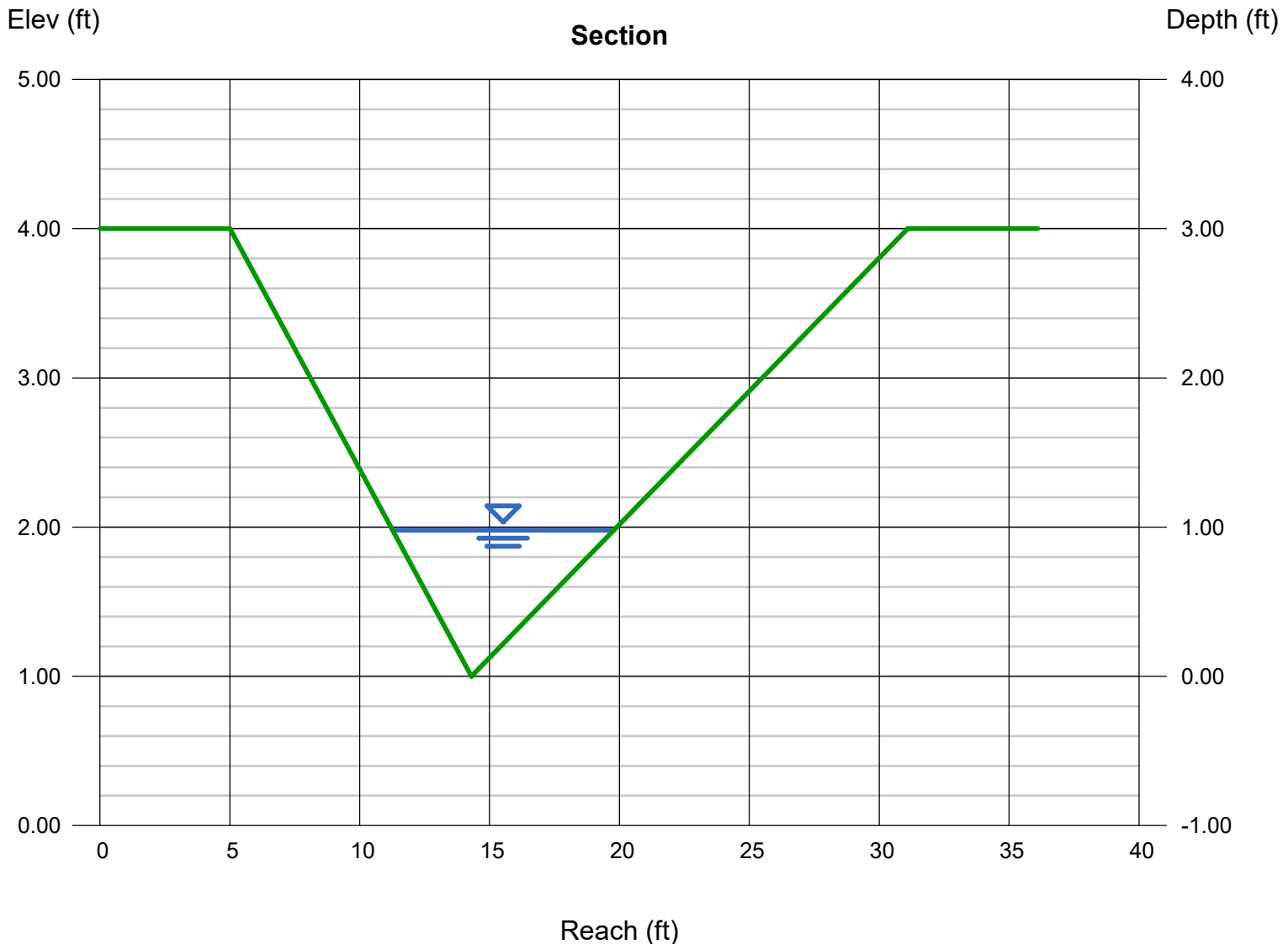

Channel Report

Swale Section C-C S12 Spillway Capacity Check

Triangular

Side Slopes (z:1) = 3.10, 5.60
Total Depth (ft) = 3.00

Invert Elev (ft) = 1.00
Slope (%) = 2.34
N-Value = 0.040

Calculations

Compute by: Known Q
Known Q (cfs) = 268.00

Highlighted

Depth (ft) = 2.93
Q (cfs) = 268.00
Area (sqft) = 37.34
Velocity (ft/s) = 7.18
Wetted Perim (ft) = 26.21
Crit Depth, Yc (ft) = 2.99
Top Width (ft) = 25.49
EGL (ft) = 3.73

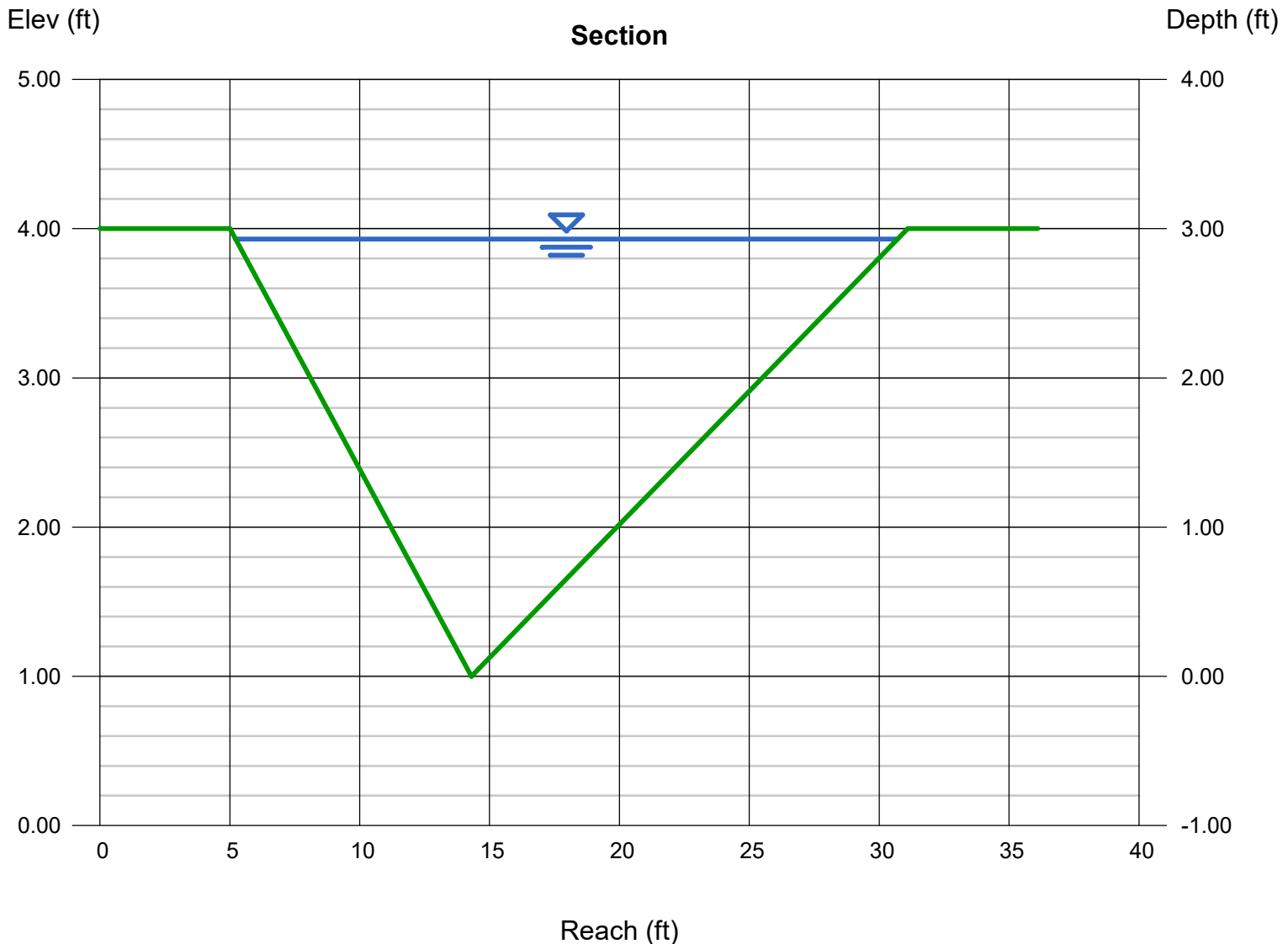

Channel Report

Swale Section C-C Velocity Check

Triangular

Side Slopes (z:1) = 3.10, 5.60
Total Depth (ft) = 3.00

Invert Elev (ft) = 1.00
Slope (%) = 2.34
N-Value = 0.030

Calculations

Compute by: Known Q
Known Q (cfs) = 10.02

Highlighted

Depth (ft) = 0.77
Q (cfs) = 10.02
Area (sqft) = 2.58
Velocity (ft/s) = 3.89
Wetted Perim (ft) = 6.89
Crit Depth, Yc (ft) = 0.81
Top Width (ft) = 6.70
EGL (ft) = 1.00

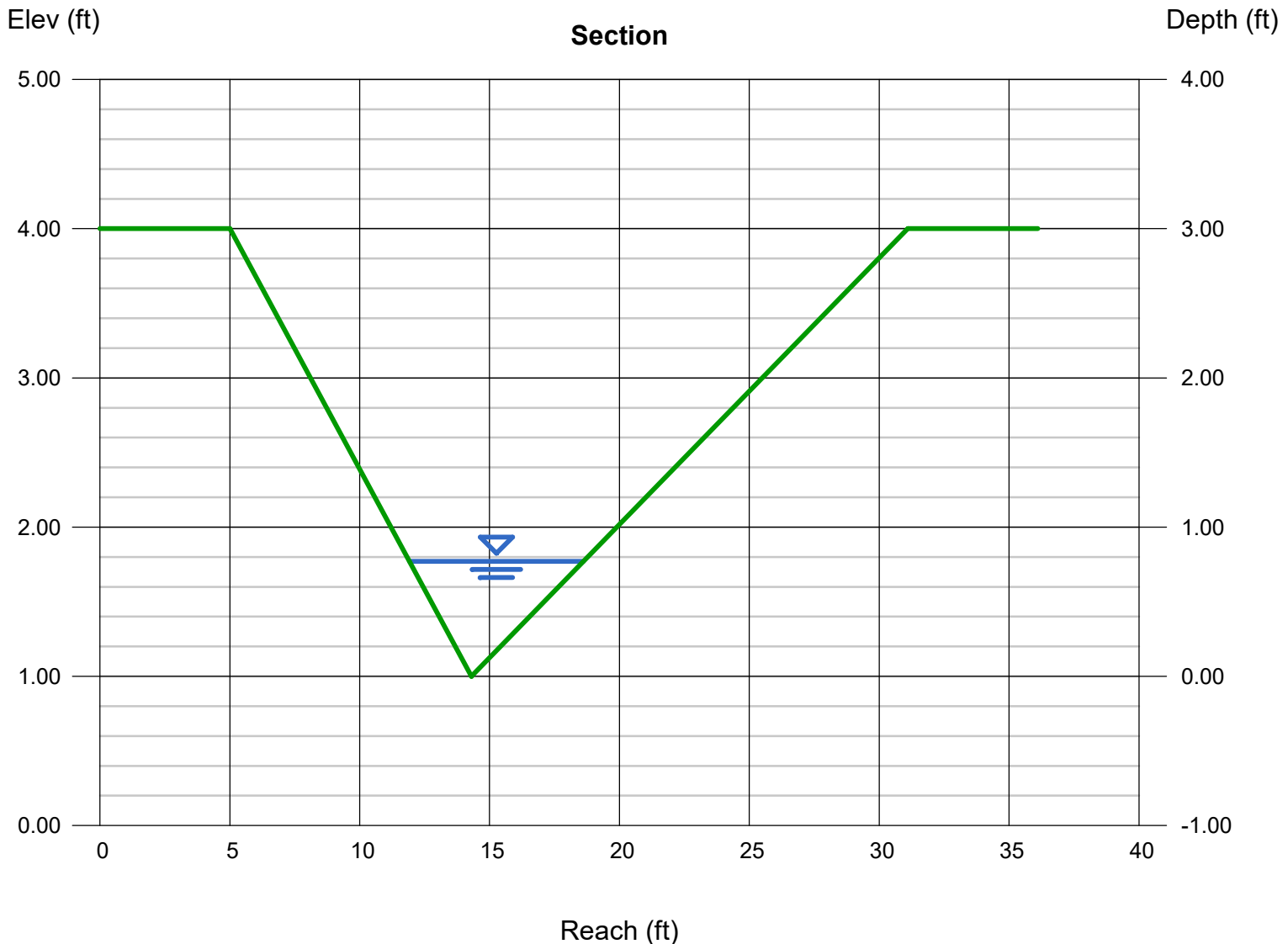

Channel Report

Swale Section D-D Capacity Check

Trapezoidal

Bottom Width (ft) = 6.00
Side Slopes (z:1) = 6.00, 6.00
Total Depth (ft) = 4.00
Invert Elev (ft) = 1.00
Slope (%) = 1.00
N-Value = 0.040

Highlighted

Depth (ft) = 1.23
Q (cfs) = 51.91
Area (sqft) = 16.46
Velocity (ft/s) = 3.15
Wetted Perim (ft) = 20.96
Crit Depth, Yc (ft) = 0.97
Top Width (ft) = 20.76
EGL (ft) = 1.38

Calculations

Compute by: Known Q
Known Q (cfs) = 51.91

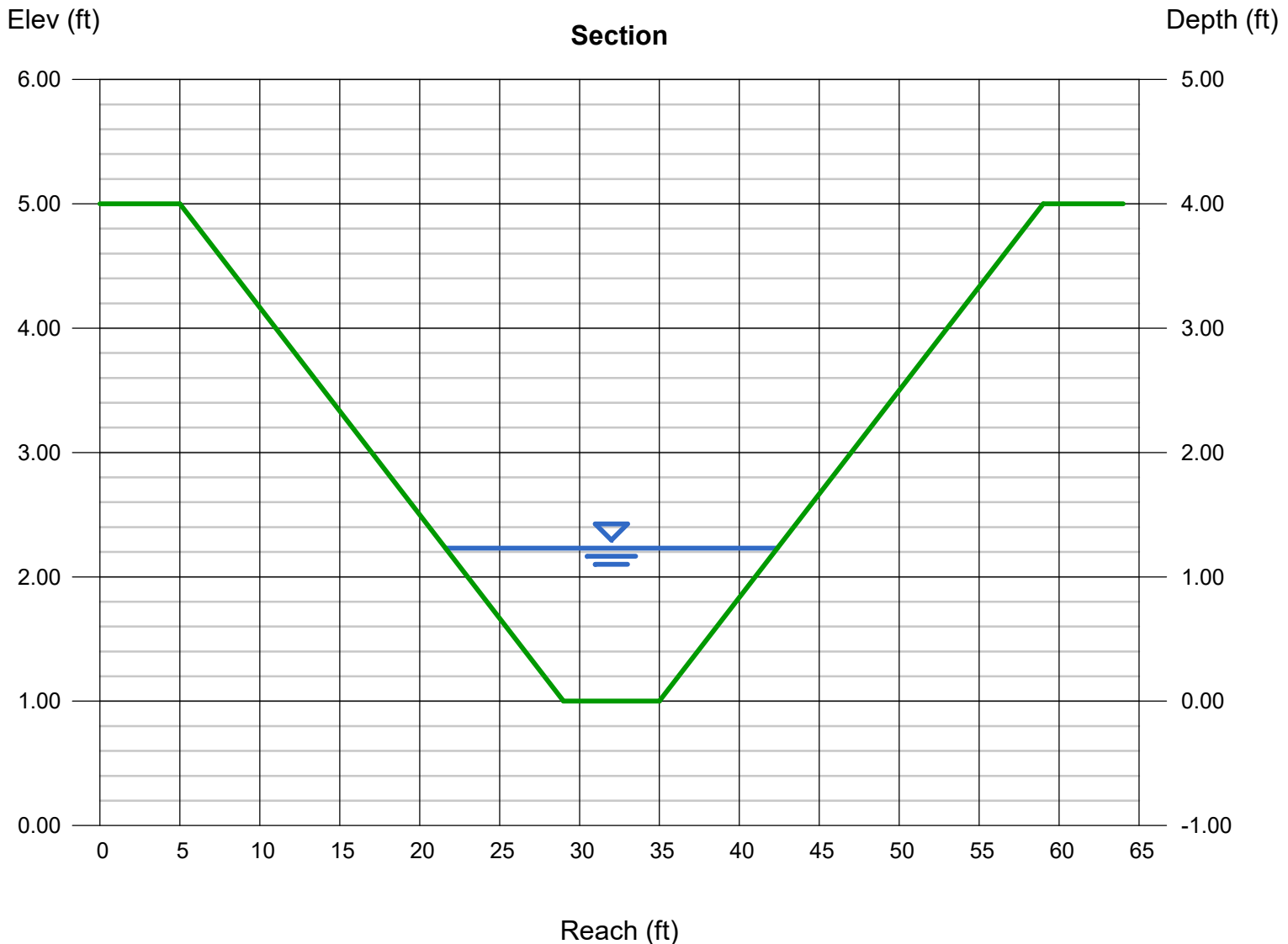

Channel Report

Swale Section D-D S12 Spillway Capacity Check

Trapezoidal

Bottom Width (ft) = 6.00
Side Slopes (z:1) = 6.00, 6.00
Total Depth (ft) = 4.00
Invert Elev (ft) = 1.00
Slope (%) = 1.00
N-Value = 0.040

Highlighted

Depth (ft) = 2.59
Q (cfs) = 268.00
Area (sqft) = 55.79
Velocity (ft/s) = 4.80
Wetted Perim (ft) = 37.51
Crit Depth, Yc (ft) = 2.18
Top Width (ft) = 37.08
EGL (ft) = 2.95

Calculations

Compute by: Known Q
Known Q (cfs) = 268.00

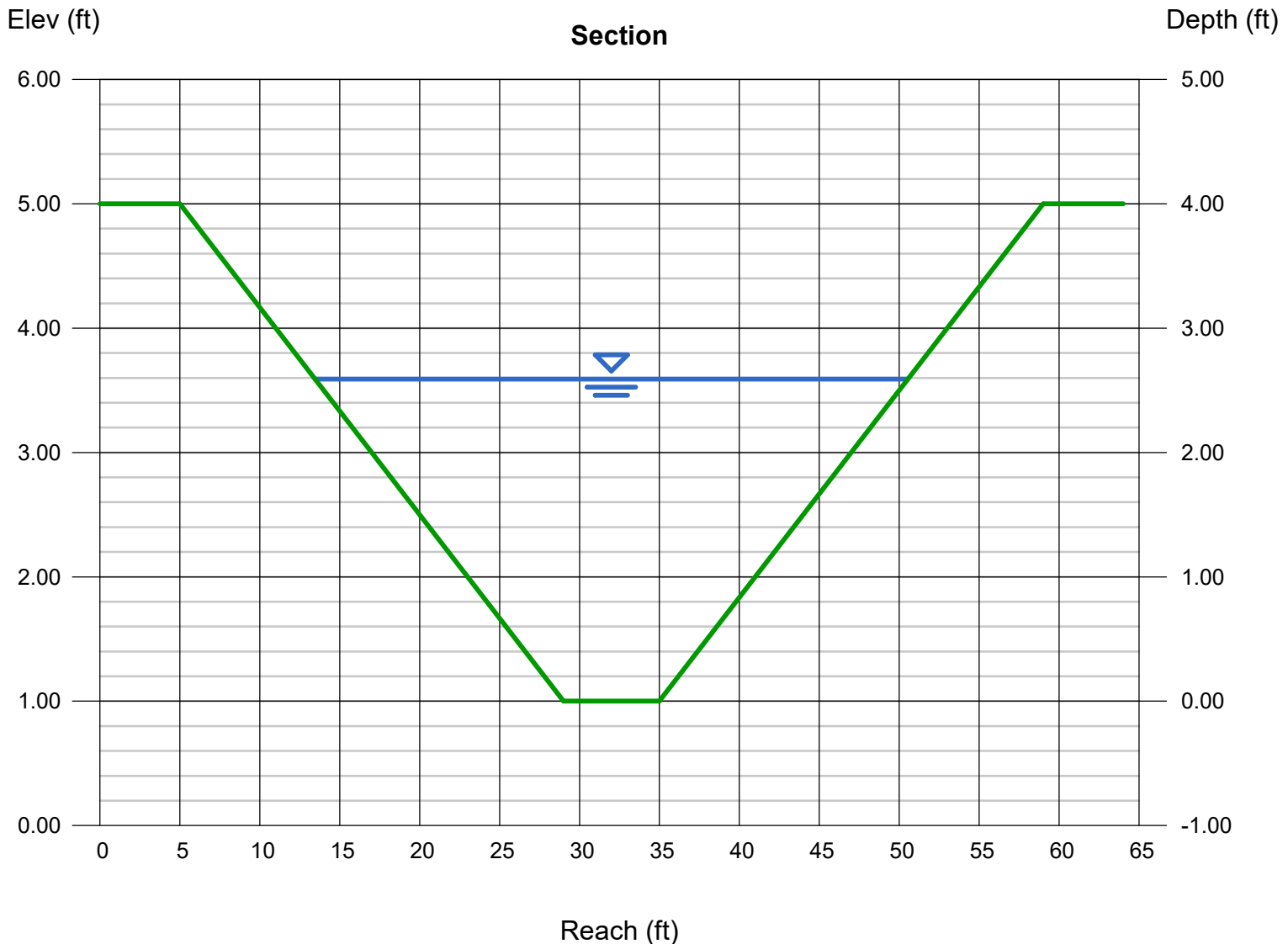

Channel Report

Swale Section D-D Velocity Check

Trapezoidal

Bottom Width (ft) = 6.00
Side Slopes (z:1) = 6.00, 6.00
Total Depth (ft) = 4.00
Invert Elev (ft) = 1.00
Slope (%) = 2.00
N-Value = 0.030

Highlighted

Depth (ft) = 0.91
Q (cfs) = 51.91
Area (sqft) = 10.43
Velocity (ft/s) = 4.98
Wetted Perim (ft) = 17.07
Crit Depth, Yc (ft) = 0.97
Top Width (ft) = 16.92
EGL (ft) = 1.30

Calculations

Compute by: Known Q
Known Q (cfs) = 51.91

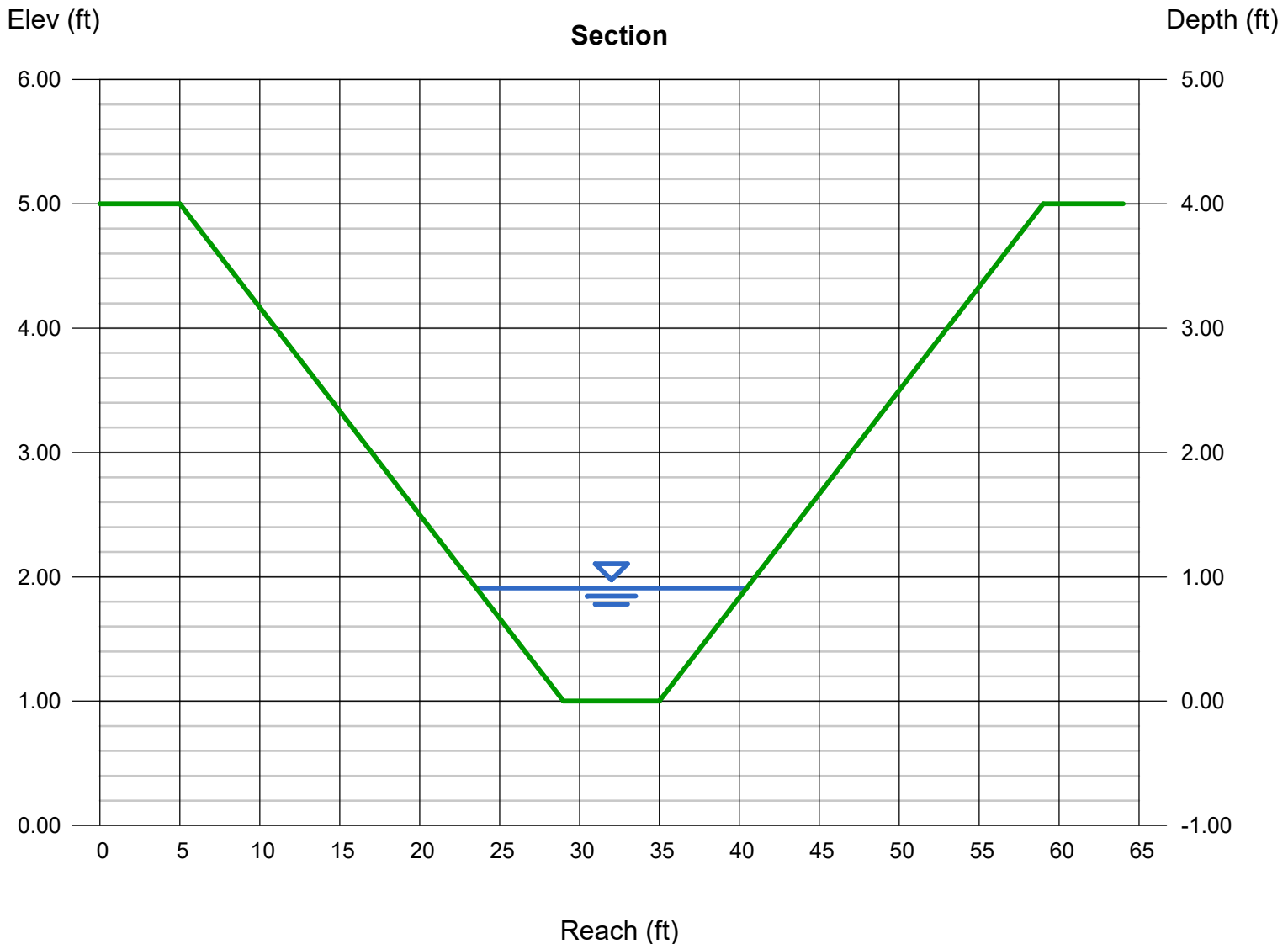

Channel Report

Swale Section E-E Capacity Check

Triangular

Side Slopes (z:1) = 4.30, 4.00
Total Depth (ft) = 3.00

Invert Elev (ft) = 1.00
Slope (%) = 1.22
N-Value = 0.040

Calculations

Compute by: Known Q
Known Q (cfs) = 30.61

Highlighted

Depth (ft) = 1.50
Q (cfs) = 30.61
Area (sqft) = 9.34
Velocity (ft/s) = 3.28
Wetted Perim (ft) = 12.81
Crit Depth, Yc (ft) = 1.28
Top Width (ft) = 12.45
EGL (ft) = 1.67

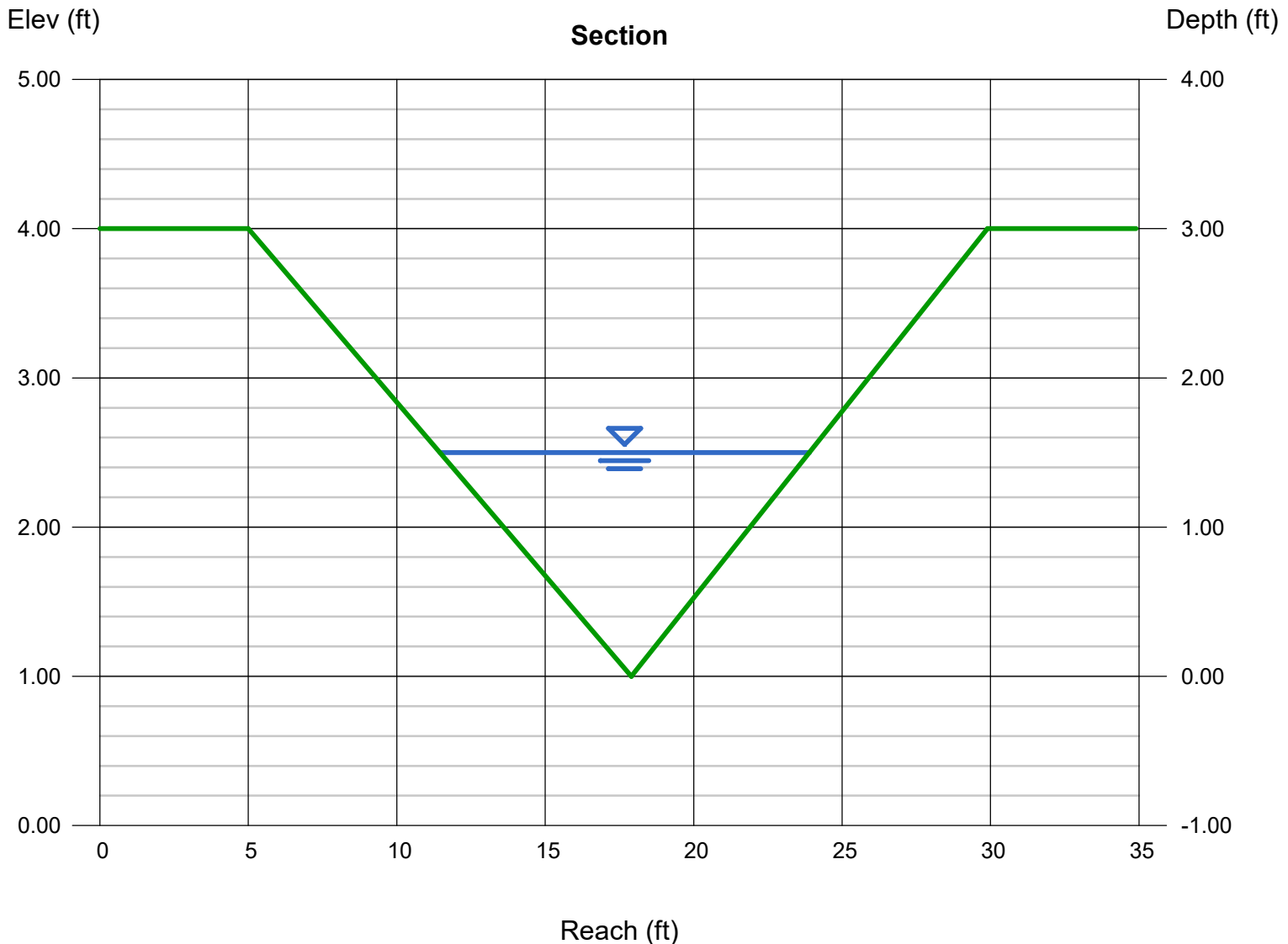

Channel Report

Swale Section E-E Velocity Check

Triangular

Side Slopes (z:1) = 4.30, 4.00

Total Depth (ft) = 3.00

Invert Elev (ft) = 1.00

Slope (%) = 2.00

N-Value = 0.030

Calculations

Compute by: Known Q

Known Q (cfs) = 30.61

Highlighted

Depth (ft) = 1.23

Q (cfs) = 30.61

Area (sqft) = 6.28

Velocity (ft/s) = 4.88

Wetted Perim (ft) = 10.50

Crit Depth, Yc (ft) = 1.28

Top Width (ft) = 10.21

EGL (ft) = 1.60

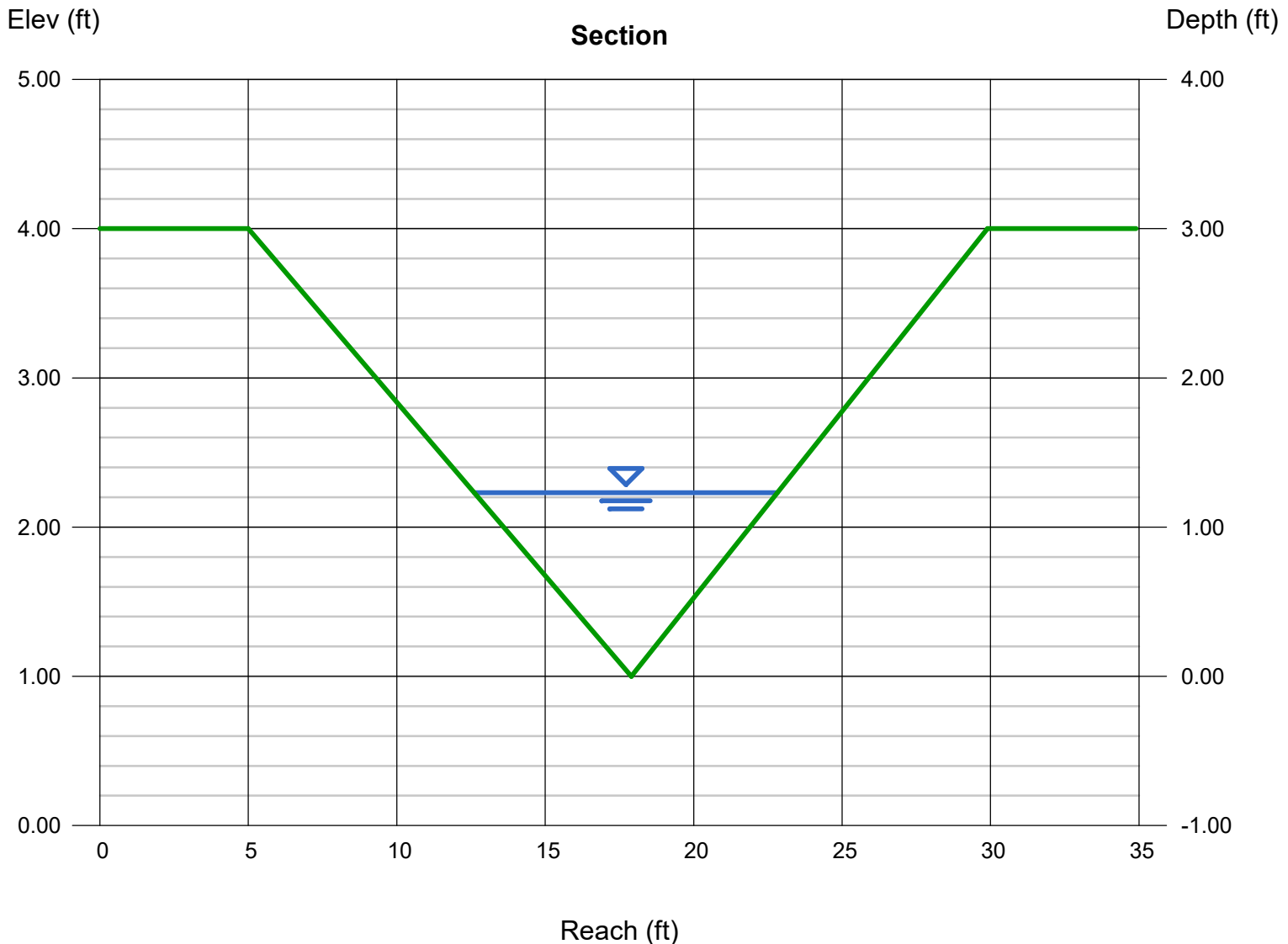

Channel Report

Swale Section E1-E1 Capacity Check

Triangular

Side Slopes (z:1) = 4.30, 4.00

Total Depth (ft) = 3.00

Invert Elev (ft) = 1.00

Slope (%) = 1.10

N-Value = 0.040

Calculations

Compute by: Known Q

Known Q (cfs) = 20.15

Highlighted

Depth (ft) = 1.31

Q (cfs) = 20.15

Area (sqft) = 7.12

Velocity (ft/s) = 2.83

Wetted Perim (ft) = 11.18

Crit Depth, Y_c (ft) = 1.08

Top Width (ft) = 10.87

EGL (ft) = 1.43

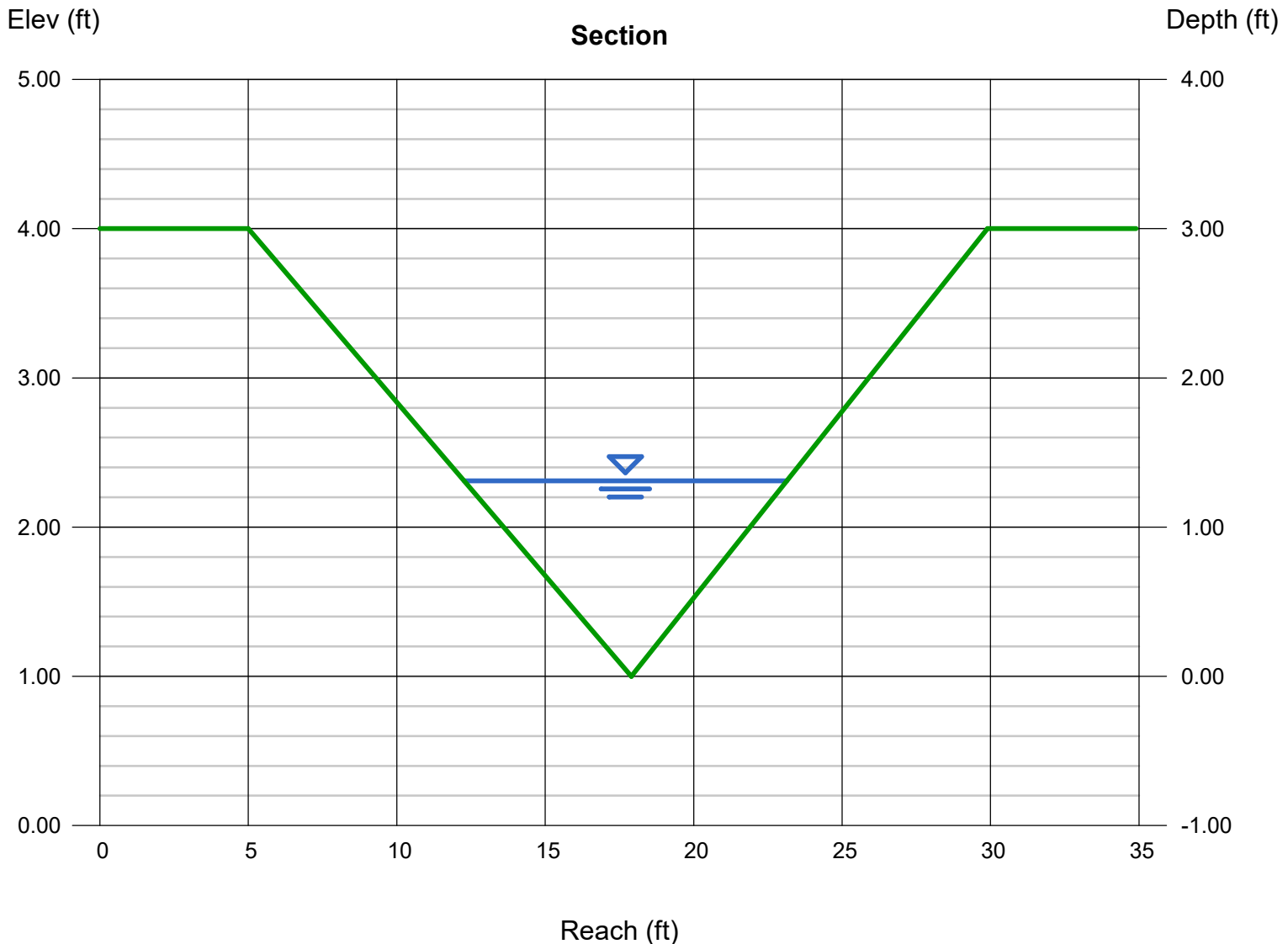

Channel Report

Swale Section E1-E1 Velocity Check

Triangular

Side Slopes (z:1) = 4.30, 4.00

Total Depth (ft) = 3.00

Invert Elev (ft) = 1.00

Slope (%) = 2.47

N-Value = 0.030

Calculations

Compute by: Known Q

Known Q (cfs) = 20.15

Highlighted

Depth (ft) = 1.01

Q (cfs) = 20.15

Area (sqft) = 4.23

Velocity (ft/s) = 4.76

Wetted Perim (ft) = 8.62

Crit Depth, Yc (ft) = 1.08

Top Width (ft) = 8.38

EGL (ft) = 1.36

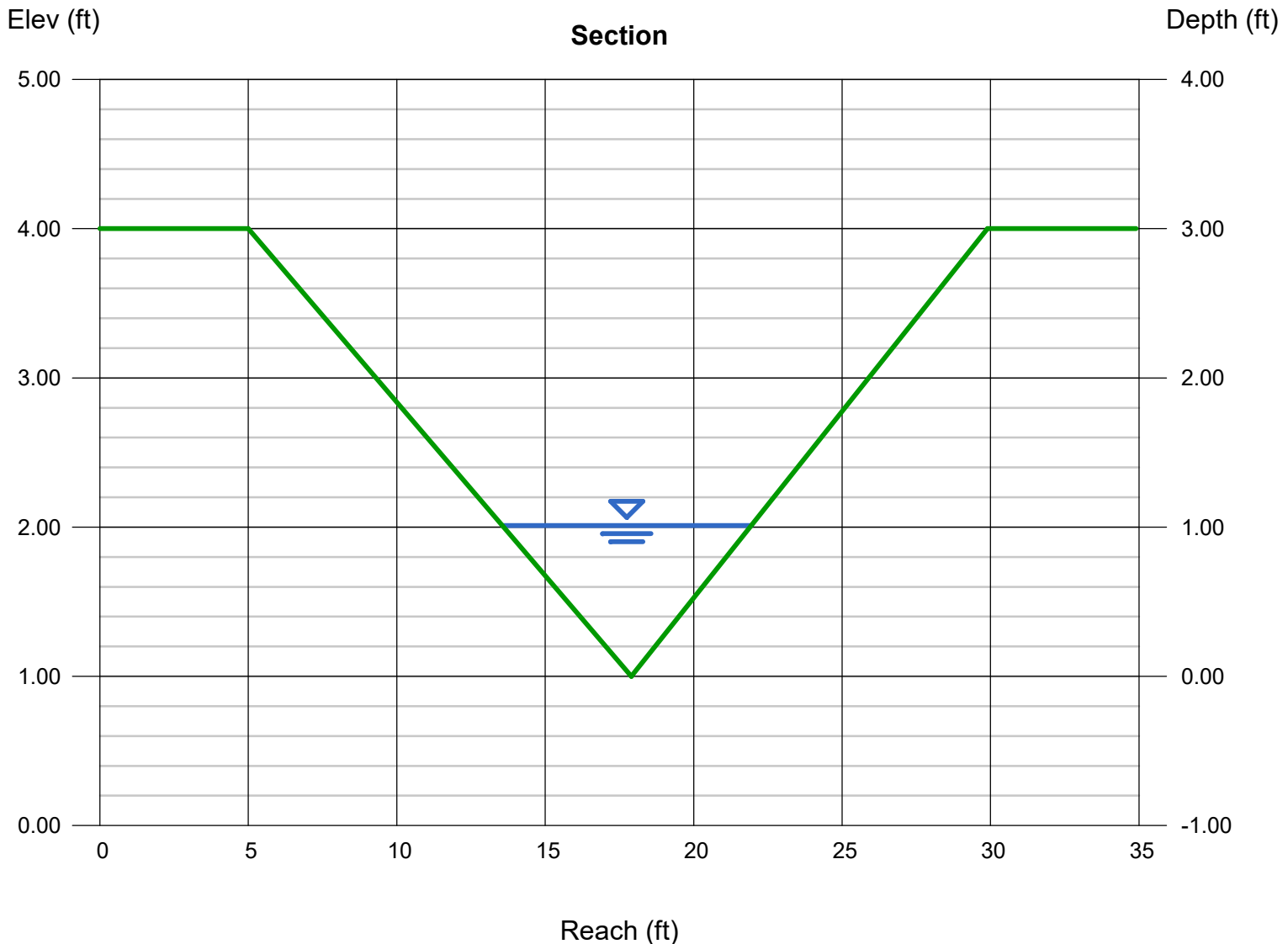

Channel Report

Swale Section G-G Capacity Check

Triangular

Side Slopes (z:1) = 4.30, 4.30
Total Depth (ft) = 3.00

Invert Elev (ft) = 1.00
Slope (%) = 1.00
N-Value = 0.040

Calculations

Compute by: Known Q
Known Q (cfs) = 18.20

Highlighted

Depth (ft) = 1.26
Q (cfs) = 18.20
Area (sqft) = 6.83
Velocity (ft/s) = 2.67
Wetted Perim (ft) = 11.13
Crit Depth, Yc (ft) = 1.03
Top Width (ft) = 10.84
EGL (ft) = 1.37

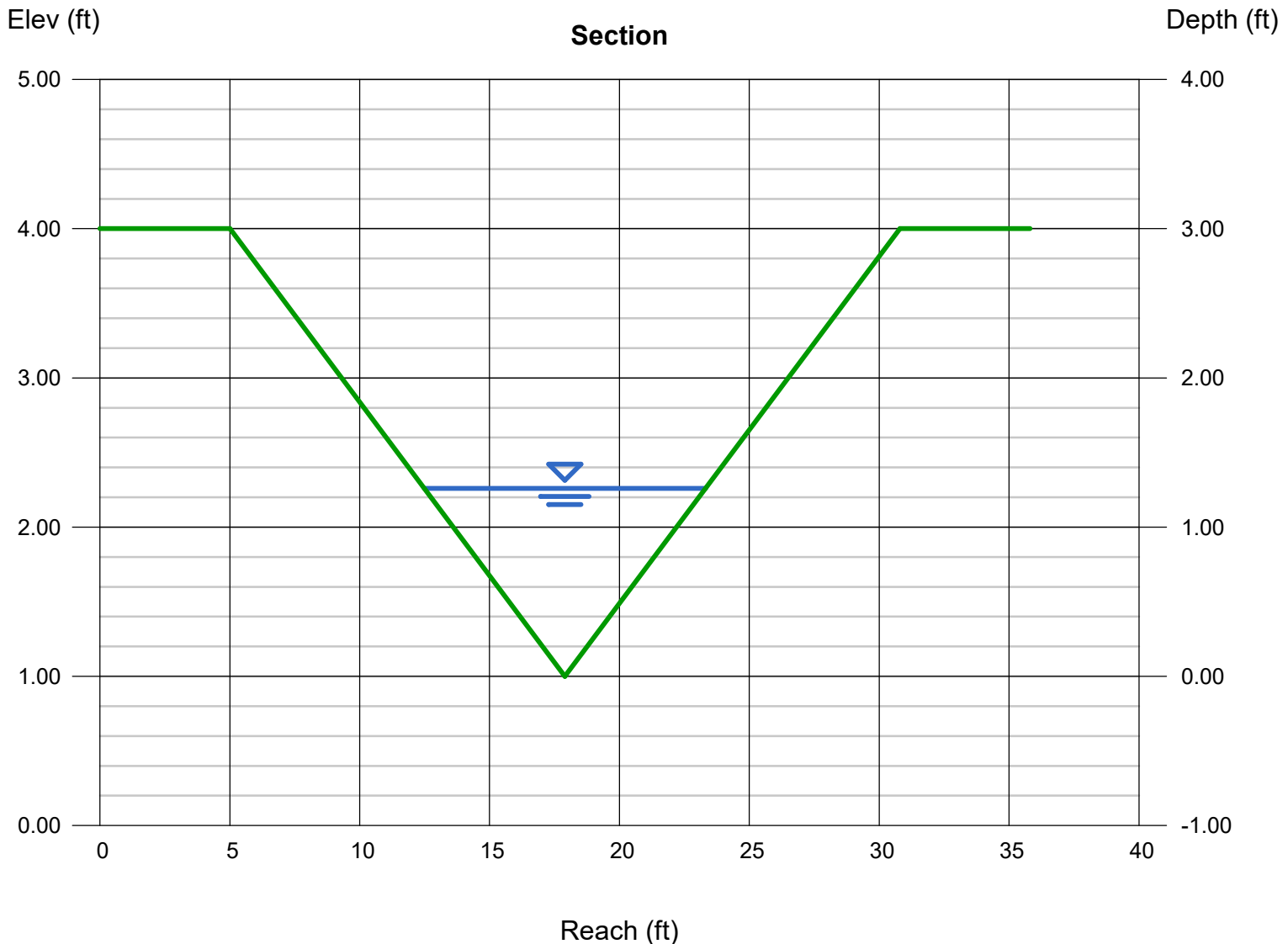

Channel Report

Swale Section G-G Velocity Check

Triangular

Side Slopes (z:1) = 4.30, 4.30

Total Depth (ft) = 3.00

Invert Elev (ft) = 1.00

Slope (%) = 7.00

N-Value = 0.040

Calculations

Compute by: Known Q

Known Q (cfs) = 18.20

Highlighted

Depth (ft) = 0.88

Q (cfs) = 18.20

Area (sqft) = 3.33

Velocity (ft/s) = 5.47

Wetted Perim (ft) = 7.77

Crit Depth, Yc (ft) = 1.03

Top Width (ft) = 7.57

EGL (ft) = 1.34

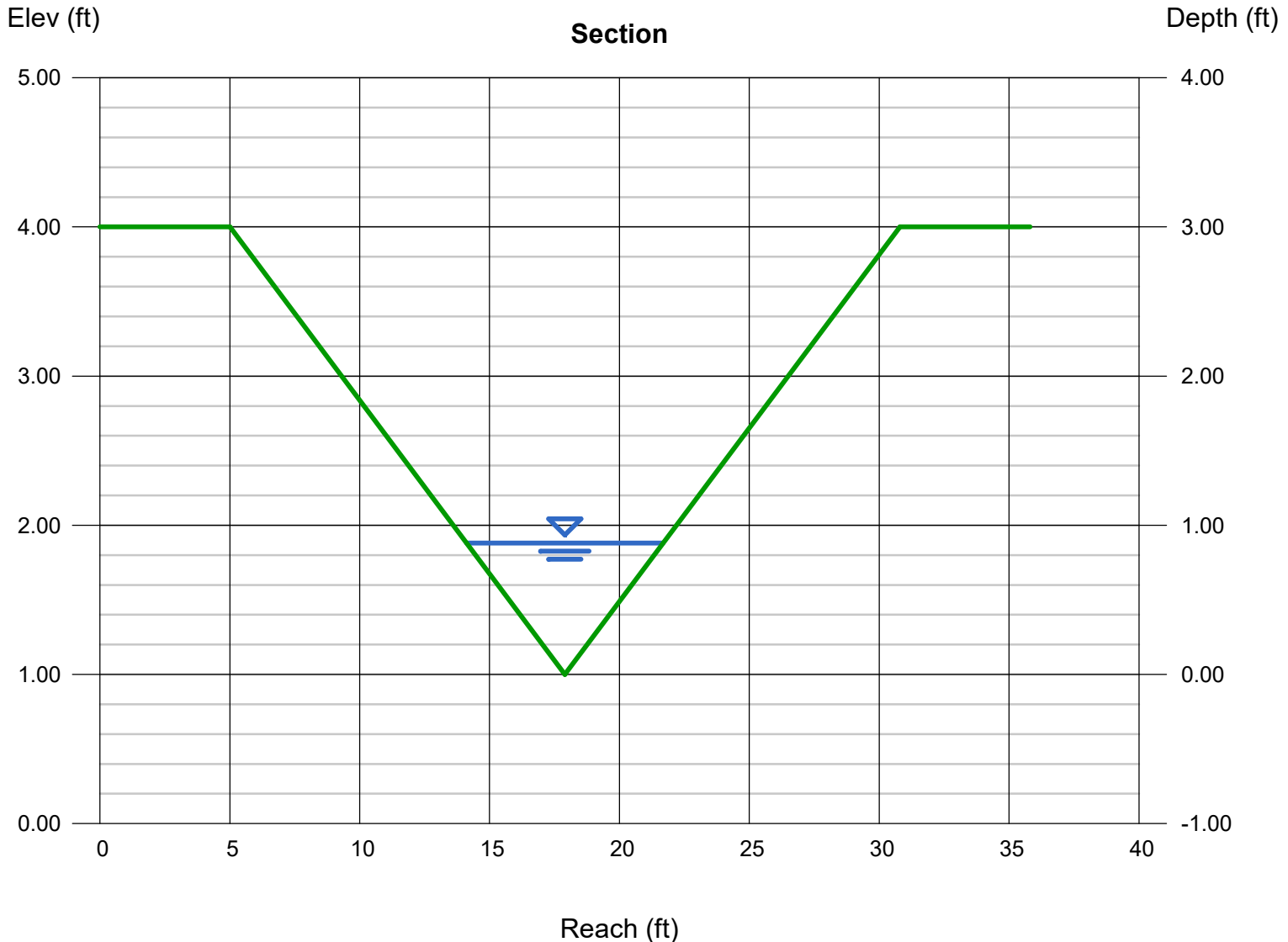

Channel Report

Swale Section H-H Capacity Check

Trapezoidal

Bottom Width (ft) = 8.00
Side Slopes (z:1) = 4.30, 4.30
Total Depth (ft) = 3.00
Invert Elev (ft) = 1.00
Slope (%) = 1.00
N-Value = 0.040

Highlighted

Depth (ft) = 0.74
Q (cfs) = 20.97
Area (sqft) = 8.27
Velocity (ft/s) = 2.53
Wetted Perim (ft) = 14.53
Crit Depth, Yc (ft) = 0.54
Top Width (ft) = 14.36
EGL (ft) = 0.84

Calculations

Compute by: Known Q
Known Q (cfs) = 20.97

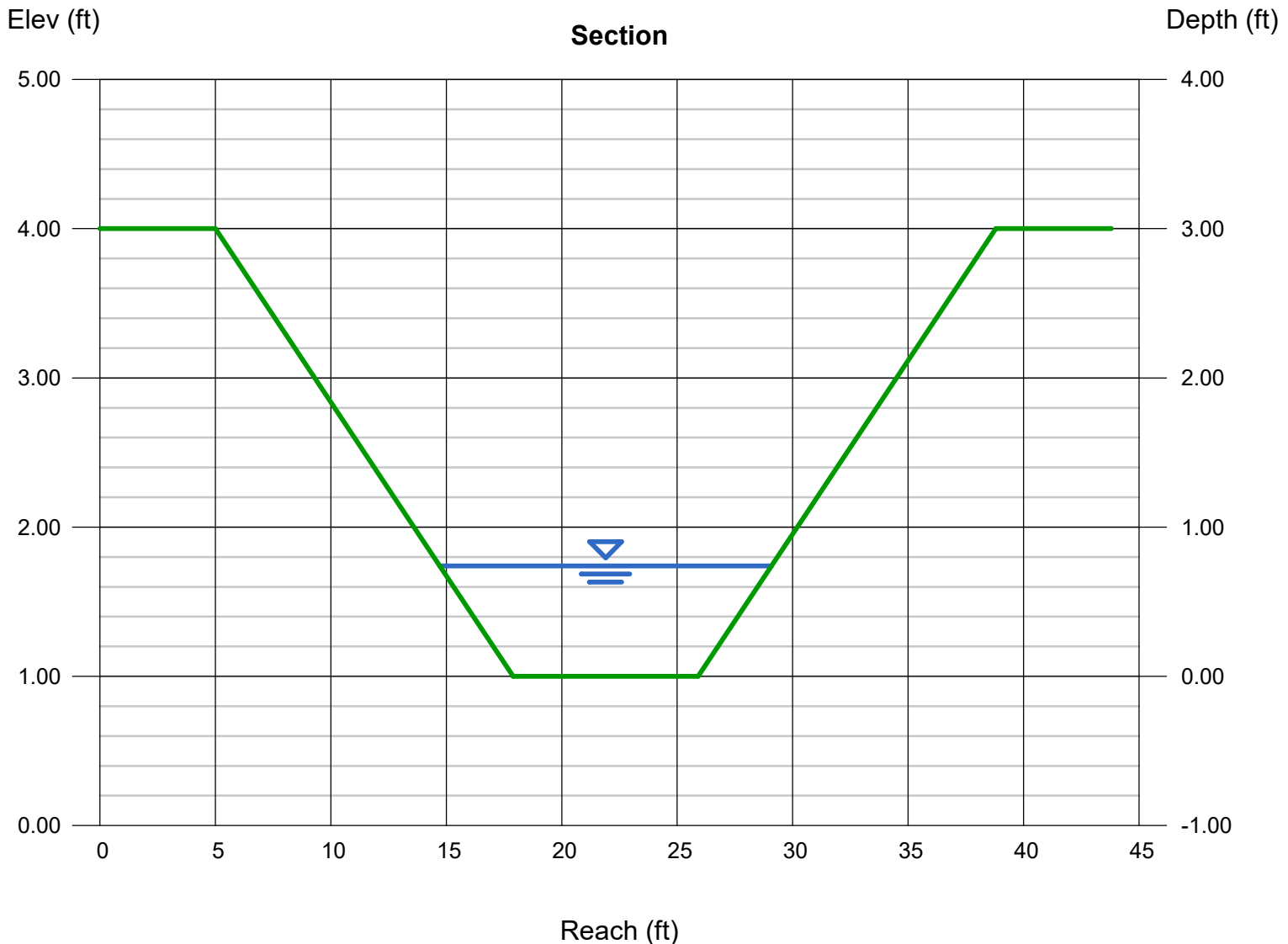

Channel Report

Swale Section H-H Velocity Check

Trapezoidal

Bottom Width (ft) = 8.00
Side Slopes (z:1) = 4.30, 4.30
Total Depth (ft) = 3.00
Invert Elev (ft) = 1.00
Slope (%) = 4.00
N-Value = 0.030

Highlighted

Depth (ft) = 0.43
Q (cfs) = 20.97
Area (sqft) = 4.24
Velocity (ft/s) = 4.95
Wetted Perim (ft) = 11.80
Crit Depth, Yc (ft) = 0.54
Top Width (ft) = 11.70
EGL (ft) = 0.81

Calculations

Compute by: Known Q
Known Q (cfs) = 20.97

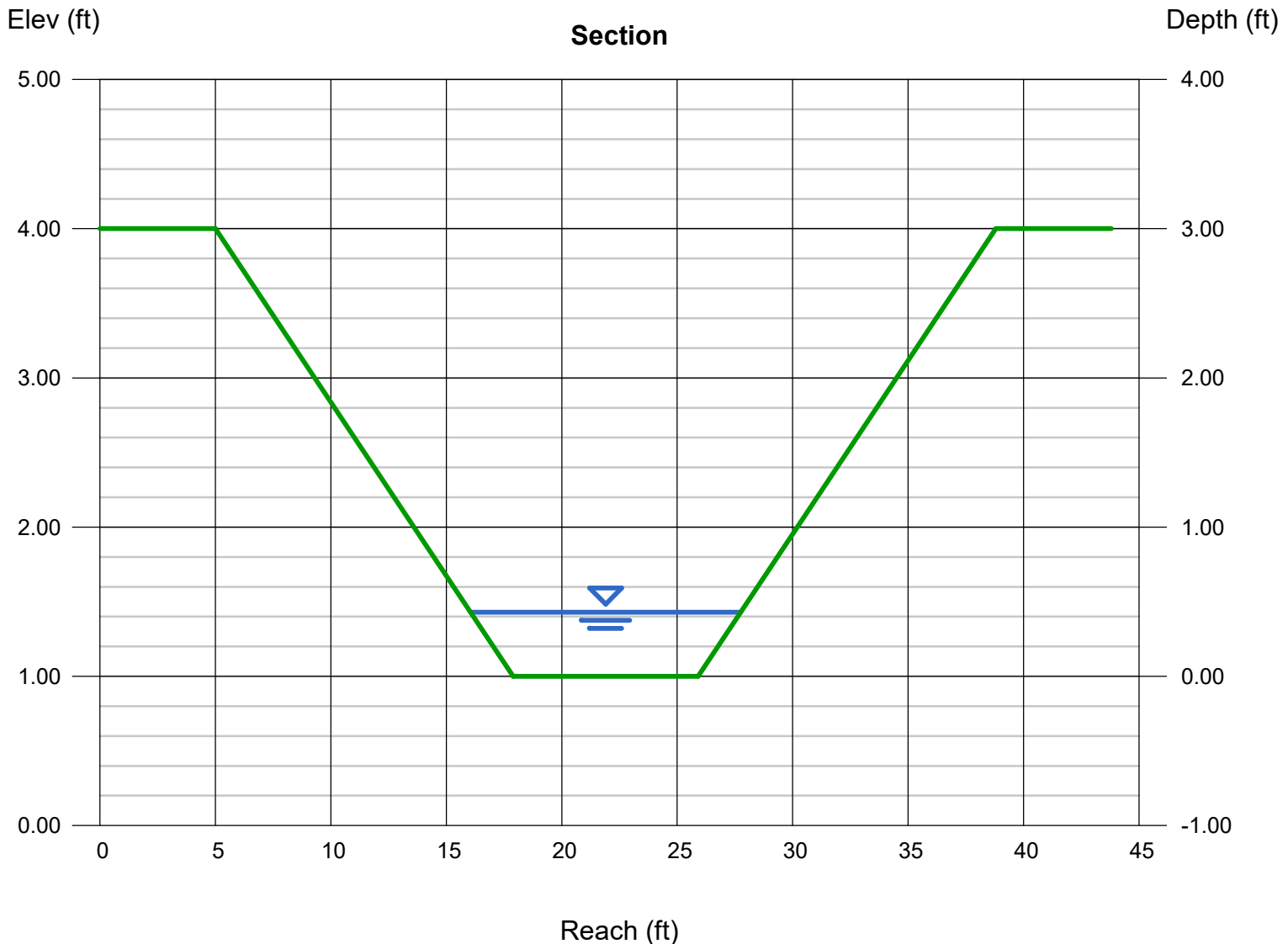

Channel Report

Swale Section H1-H1 Velocity Check

Trapezoidal

Bottom Width (ft) = 8.00
Side Slopes (z:1) = 4.30, 4.30
Total Depth (ft) = 2.00
Invert Elev (ft) = 1.00
Slope (%) = 2.82
N-Value = 0.030

Highlighted

Depth (ft) = 0.59
Q (cfs) = 30.74
Area (sqft) = 6.22
Velocity (ft/s) = 4.94
Wetted Perim (ft) = 13.21
Crit Depth, Y_c (ft) = 0.68
Top Width (ft) = 13.07
EGL (ft) = 0.97

Calculations

Compute by: Known Q
Known Q (cfs) = 30.74

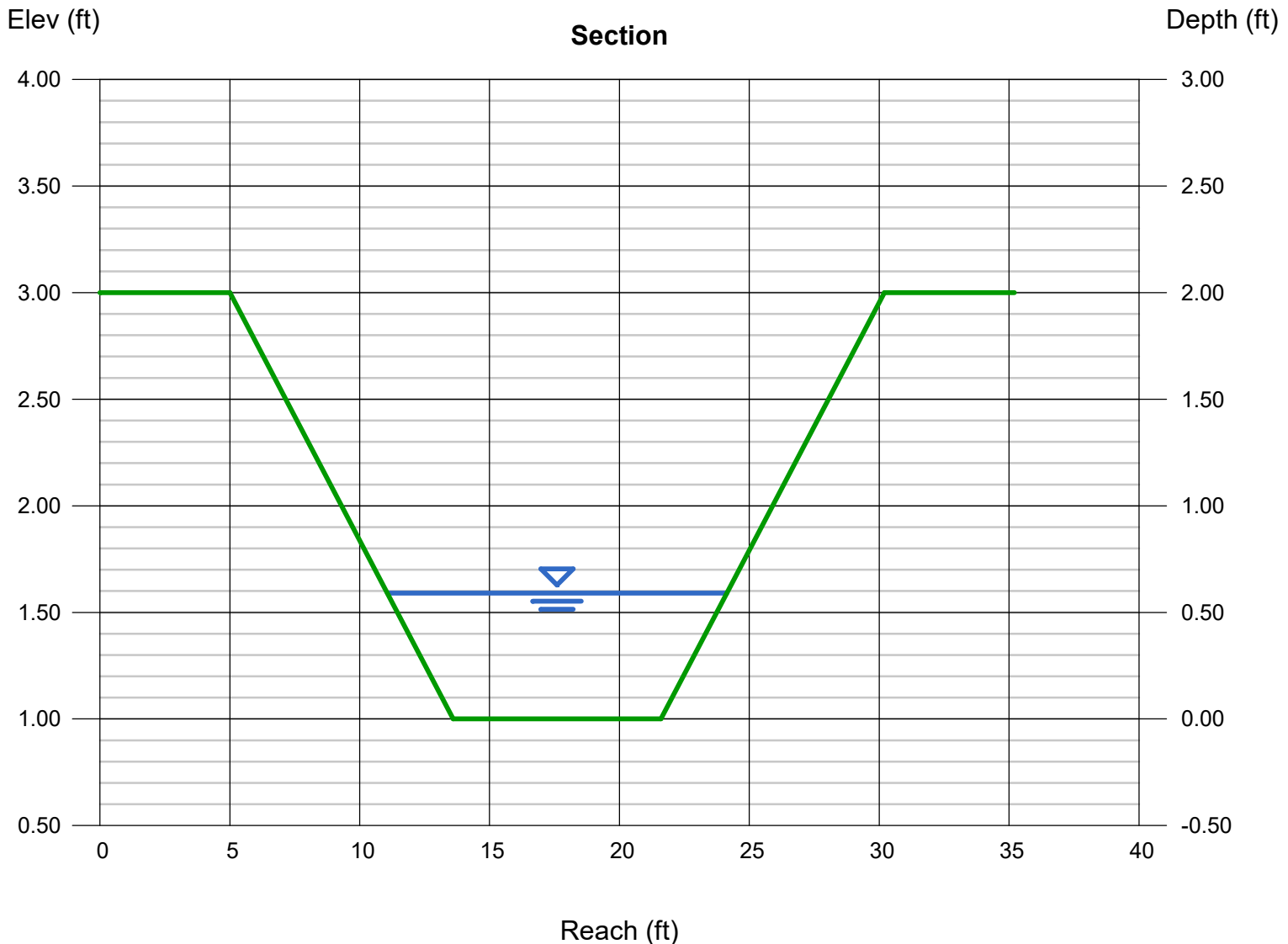

Channel Report

Swale Section H2-H2 Capacity Check

Trapezoidal

Bottom Width (ft) = 8.00
Side Slopes (z:1) = 4.30, 4.30
Total Depth (ft) = 3.00
Invert Elev (ft) = 1.00
Slope (%) = 1.61
N-Value = 0.040

Highlighted

Depth (ft) = 1.13
Q (cfs) = 59.00
Area (sqft) = 14.53
Velocity (ft/s) = 4.06
Wetted Perim (ft) = 17.98
Crit Depth, Y_c (ft) = 1.00
Top Width (ft) = 17.72
EGL (ft) = 1.39

Calculations

Compute by: Known Q
Known Q (cfs) = 59.00

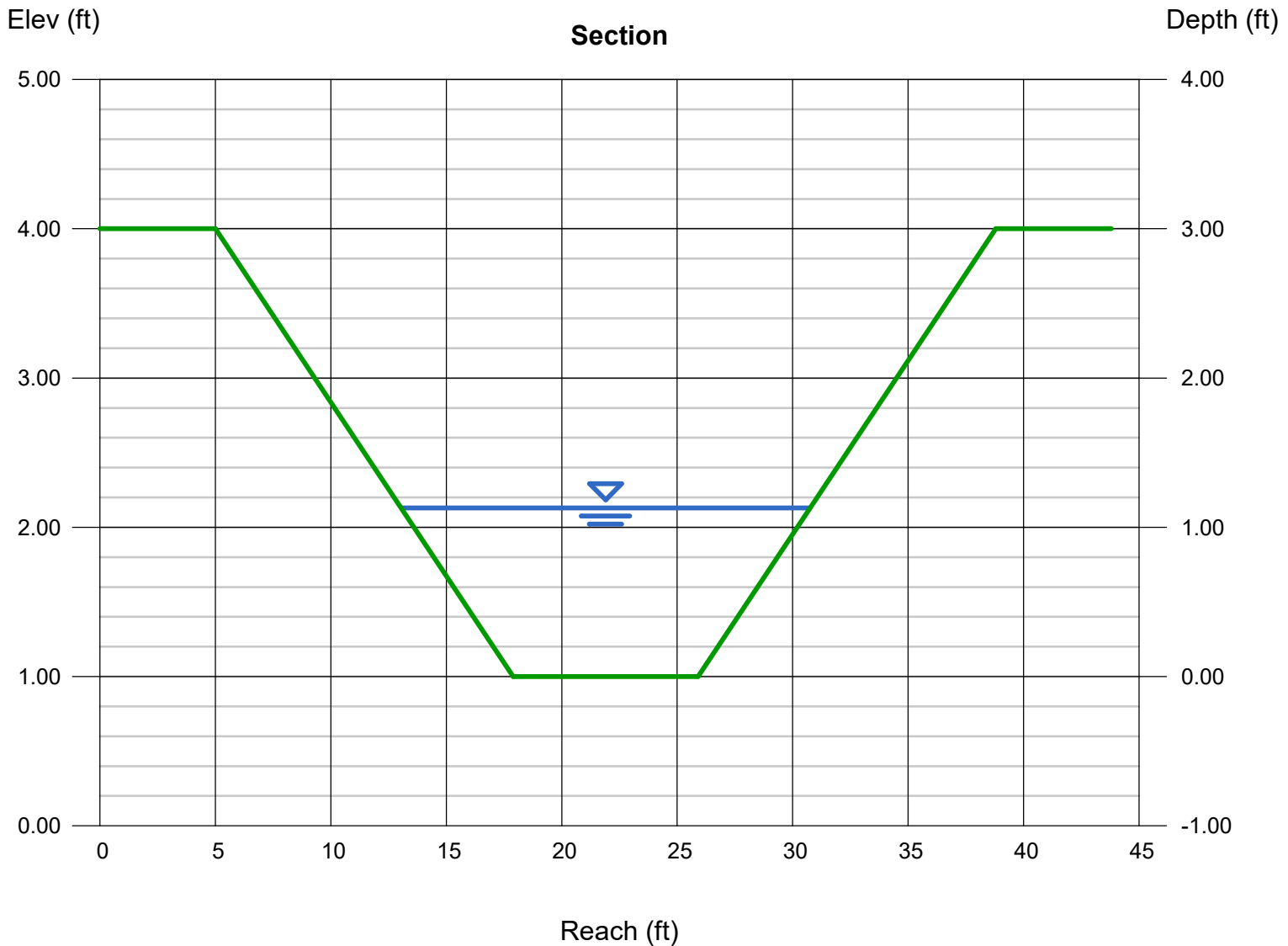

Channel Report

Swale Section H2-H2 Velocity Check

Trapezoidal

Bottom Width (ft) = 8.00
Side Slopes (z:1) = 4.30, 4.30
Total Depth (ft) = 3.00
Invert Elev (ft) = 1.00
Slope (%) = 1.61
N-Value = 0.030

Highlighted

Depth (ft) = 0.97
Q (cfs) = 59.00
Area (sqft) = 11.81
Velocity (ft/s) = 5.00
Wetted Perim (ft) = 16.56
Crit Depth, Yc (ft) = 1.00
Top Width (ft) = 16.34
EGL (ft) = 1.36

Calculations

Compute by: Known Q
Known Q (cfs) = 59.00

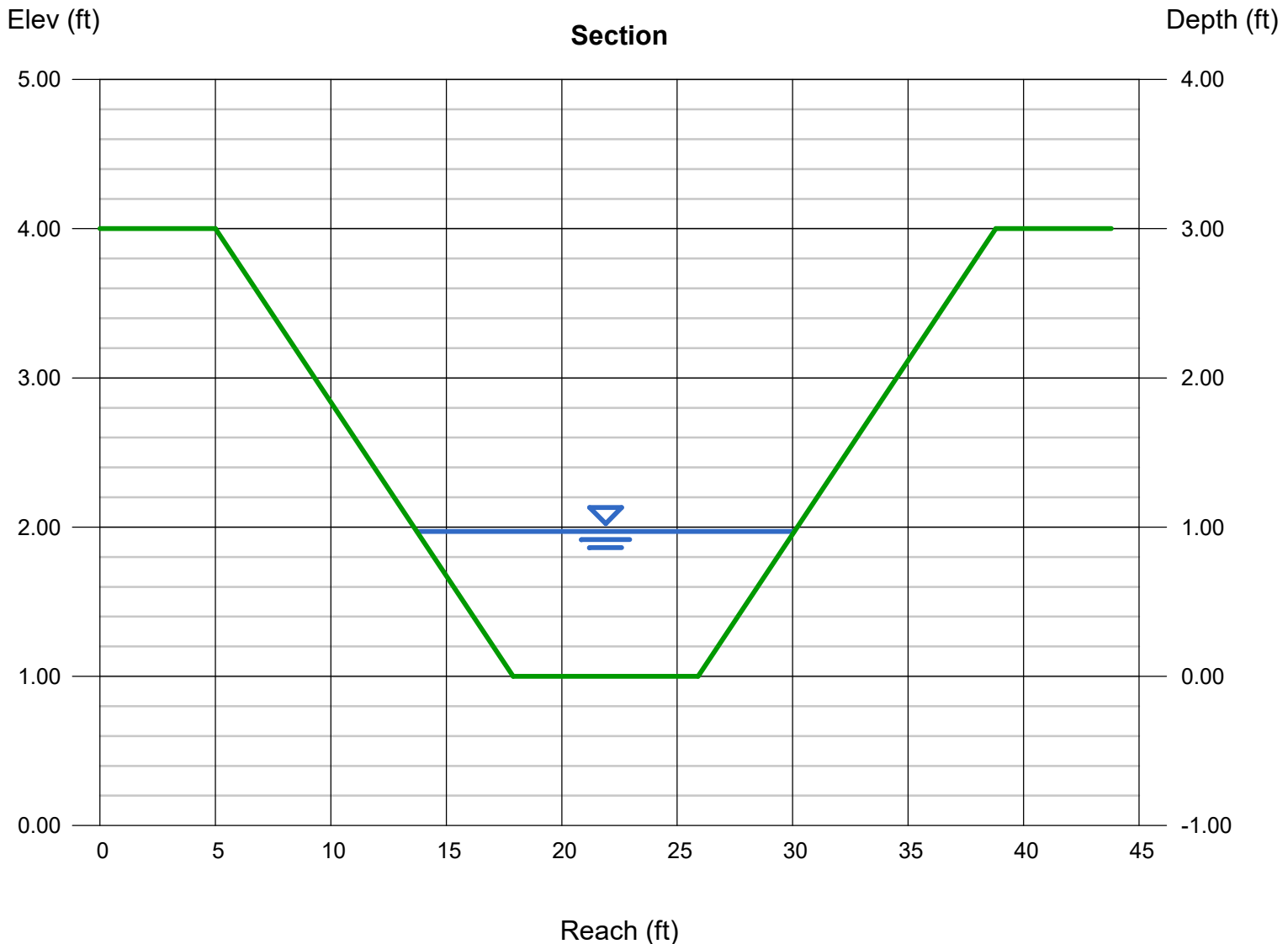

Channel Report

Swale Section H3-H3 Capacity Check

Trapezoidal

Bottom Width (ft) = 8.00
Side Slopes (z:1) = 4.30, 4.30
Total Depth (ft) = 2.00
Invert Elev (ft) = 1.00
Slope (%) = 1.50
N-Value = 0.040

Highlighted

Depth (ft) = 1.06
Q (cfs) = 49.98
Area (sqft) = 13.31
Velocity (ft/s) = 3.75
Wetted Perim (ft) = 17.36
Crit Depth, Yc (ft) = 0.91
Top Width (ft) = 17.12
EGL (ft) = 1.28

Calculations

Compute by: Known Q
Known Q (cfs) = 49.98 Flows from DP10 and DP11 combined

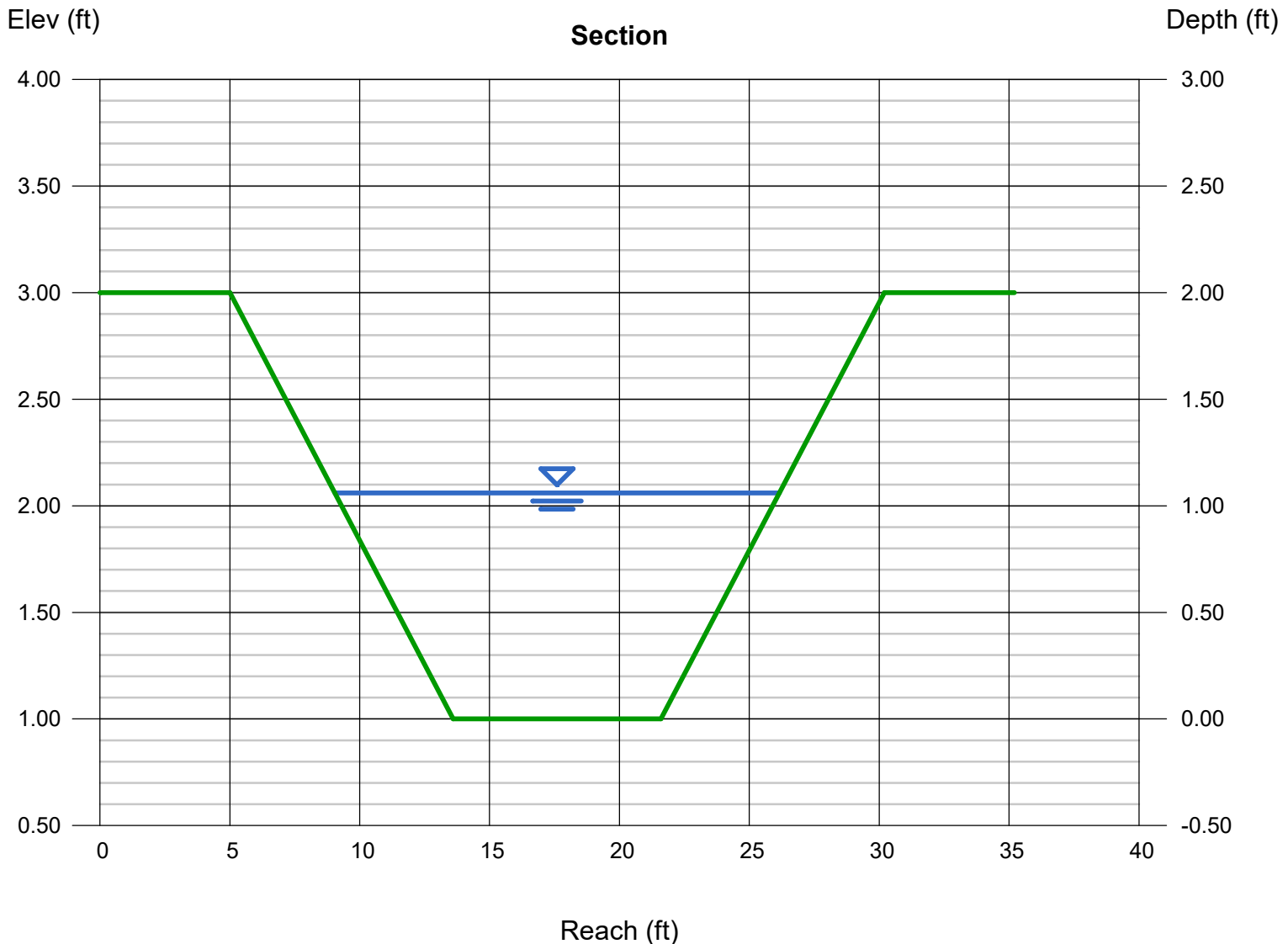

Channel Report

Swale Section H3-H3 Velocity Check

Trapezoidal

Bottom Width (ft) = 8.00
Side Slopes (z:1) = 4.30, 4.30
Total Depth (ft) = 3.00
Invert Elev (ft) = 1.00
Slope (%) = 1.80
N-Value = 0.030

Highlighted

Depth (ft) = 0.87
Q (cfs) = 49.98
Area (sqft) = 10.21
Velocity (ft/s) = 4.89
Wetted Perim (ft) = 15.68
Crit Depth, Yc (ft) = 0.91
Top Width (ft) = 15.48
EGL (ft) = 1.24

Calculations

Compute by: Known Q
Known Q (cfs) = 49.98 Flows from DP10 and DP11 combined

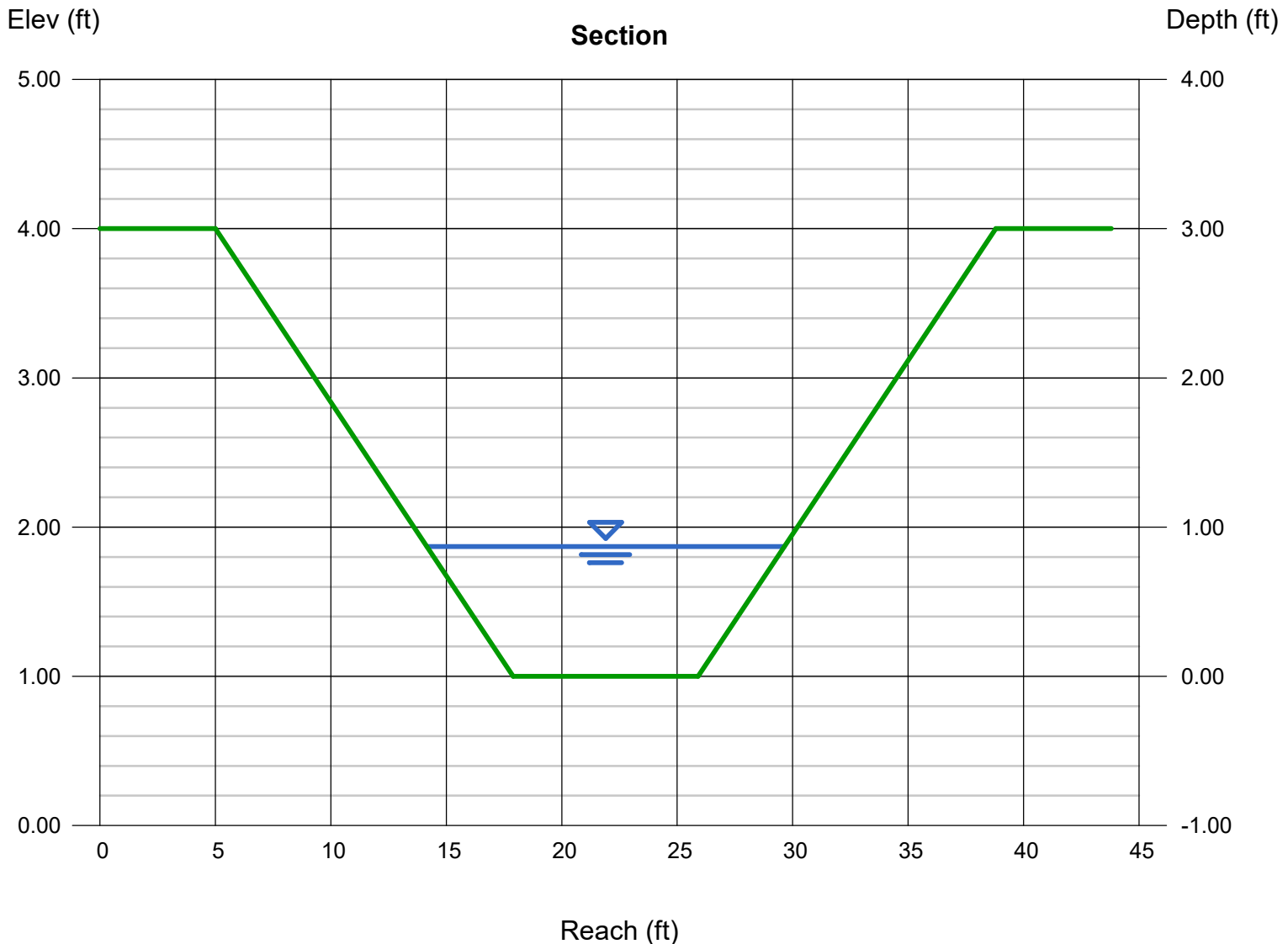

Channel Report

Swale Section H1-H1 Capacity Check

Trapezoidal

Bottom Width (ft) = 8.00
Side Slopes (z:1) = 4.30, 4.30
Total Depth (ft) = 2.00
Invert Elev (ft) = 1.00
Slope (%) = 0.78
N-Value = 0.040

Highlighted

Depth (ft) = 0.97
Q (cfs) = 30.74
Area (sqft) = 11.81
Velocity (ft/s) = 2.60
Wetted Perim (ft) = 16.56
Crit Depth, Y_c (ft) = 0.68
Top Width (ft) = 16.34
EGL (ft) = 1.08

Calculations

Compute by: Known Q
Known Q (cfs) = 30.74

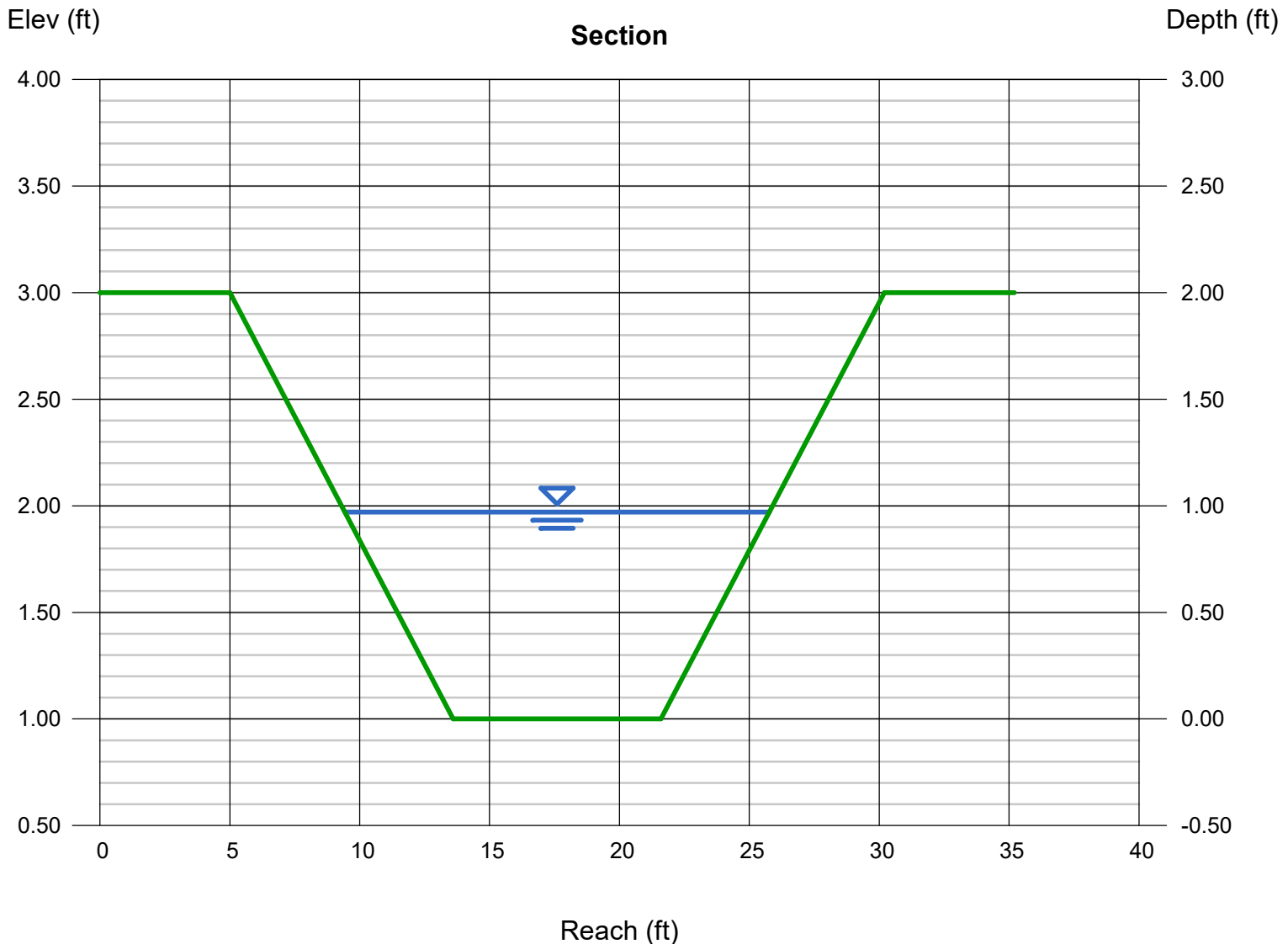

Channel Report

Swale Section J-J Velocity Check

Triangular

Side Slopes (z:1) = 4.50, 5.20

Total Depth (ft) = 4.00

Invert Elev (ft) = 1.00

Slope (%) = 1.18

N-Value = 0.030

Calculations

Compute by: Known Q

Known Q (cfs) = 82.52

Highlighted

Depth (ft) = 1.85

Q (cfs) = 82.52

Area (sqft) = 16.60

Velocity (ft/s) = 4.97

Wetted Perim (ft) = 18.32

Crit Depth, Yc (ft) = 1.79

Top Width (ft) = 17.94

EGL (ft) = 2.23

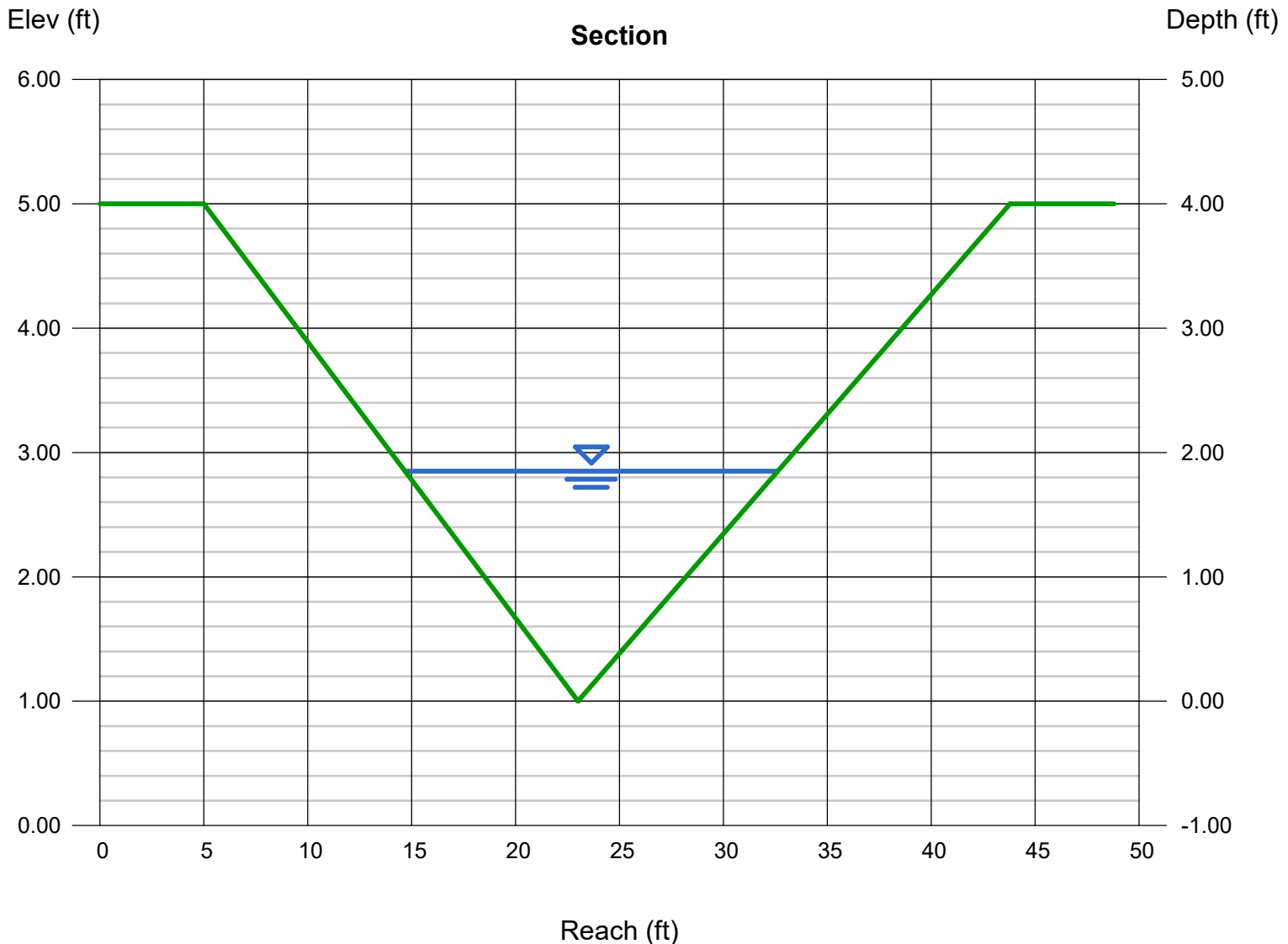

Channel Report

Swale Section K1-K1 Capacity Check

Triangular

Side Slopes (z:1) = 6.00, 6.00
Total Depth (ft) = 3.00

Invert Elev (ft) = 1.00
Slope (%) = 1.53
N-Value = 0.040

Calculations

Compute by: Known Q
Known Q (cfs) = 100.79

Highlighted

Depth (ft) = 1.95
Q (cfs) = 100.79
Area (sqft) = 22.81
Velocity (ft/s) = 4.42
Wetted Perim (ft) = 23.72
Crit Depth, Yc (ft) = 1.78
Top Width (ft) = 23.40
EGL (ft) = 2.25

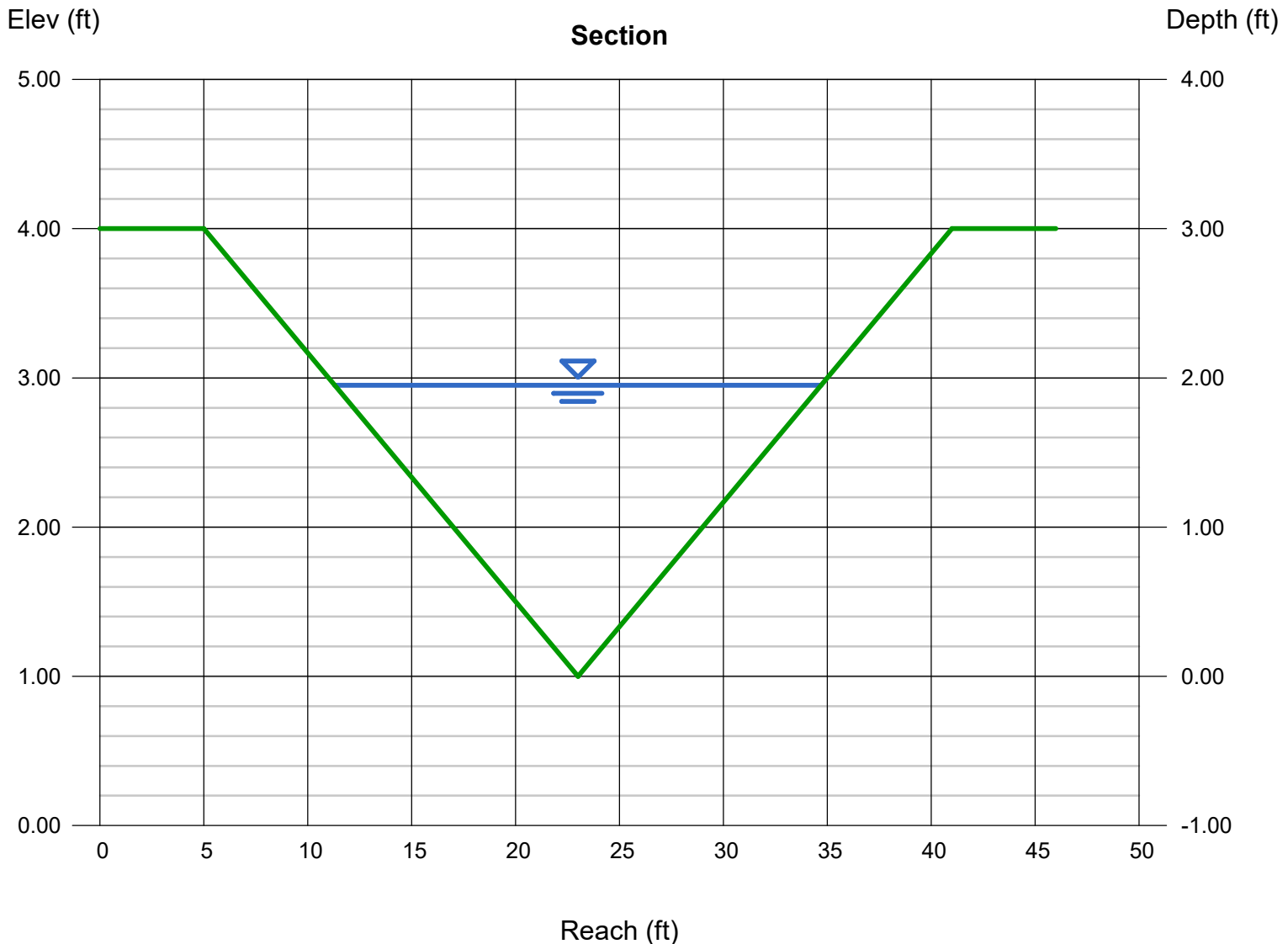

Channel Report

Swale Section K1-K1 Velocity Check

Triangular

Side Slopes (z:1) = 6.00, 6.00

Total Depth (ft) = 3.00

Invert Elev (ft) = 1.00

Slope (%) = 1.53

N-Value = 0.030

Calculations

Compute by: Known Q

Known Q (cfs) = 100.79

Highlighted

Depth (ft) = 1.75

Q (cfs) = 100.79

Area (sqft) = 18.37

Velocity (ft/s) = 5.49

Wetted Perim (ft) = 21.29

Crit Depth, Yc (ft) = 1.78

Top Width (ft) = 21.00

EGL (ft) = 2.22

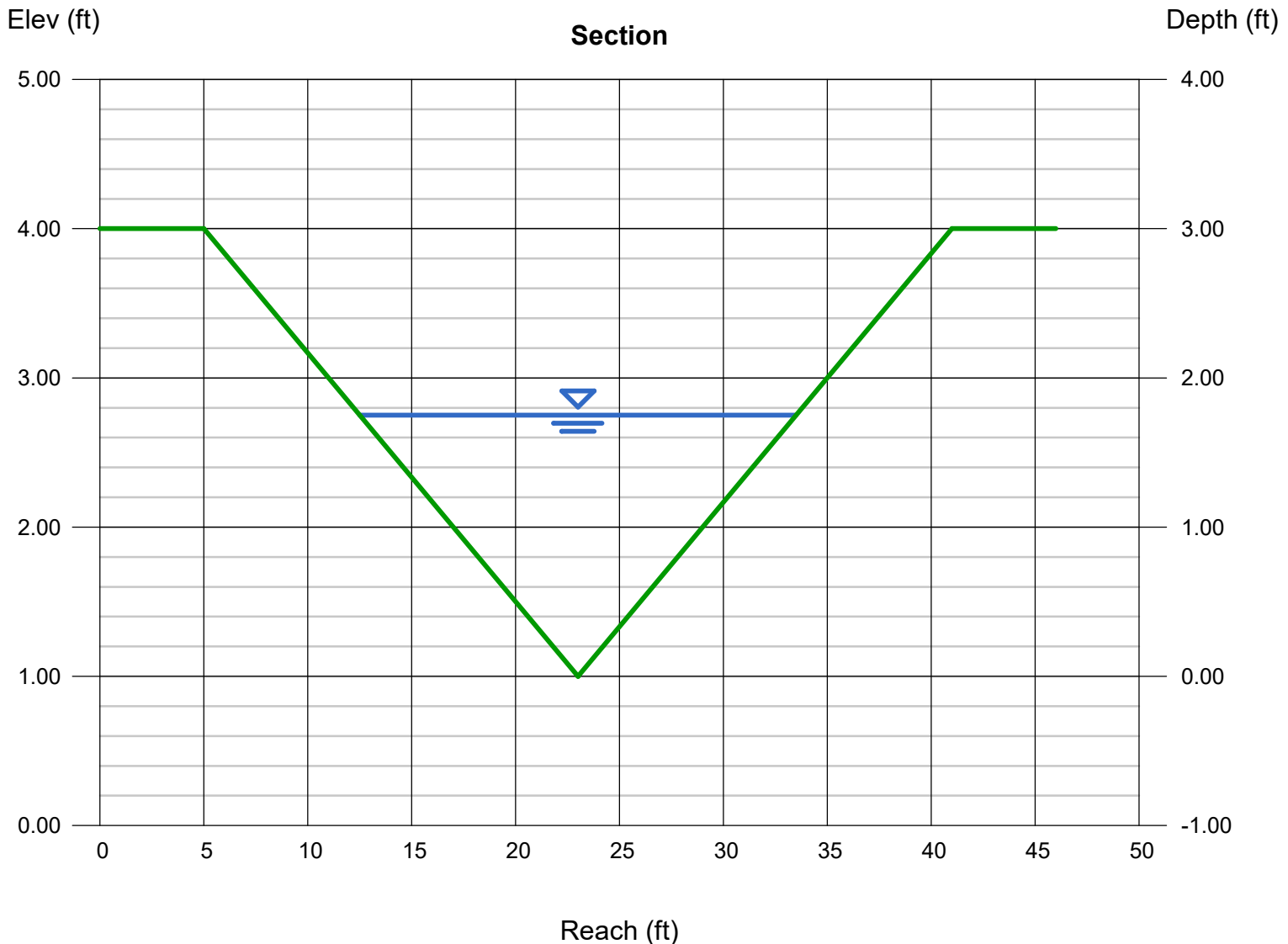

Channel Report

Swale Section L-L Capacity Check

Trapezoidal

Bottom Width (ft) = 15.00
Side Slopes (z:1) = 4.50, 4.50
Total Depth (ft) = 5.00
Invert Elev (ft) = 1.00
Slope (%) = 0.10
N-Value = 0.040

Highlighted

Depth (ft) = 3.97
Q (cfs) = 284.00
Area (sqft) = 130.47
Velocity (ft/s) = 2.18
Wetted Perim (ft) = 51.60
Crit Depth, Yc (ft) = 1.85
Top Width (ft) = 50.73
EGL (ft) = 4.04

Calculations

Compute by: Known Q
Known Q (cfs) = 284.00

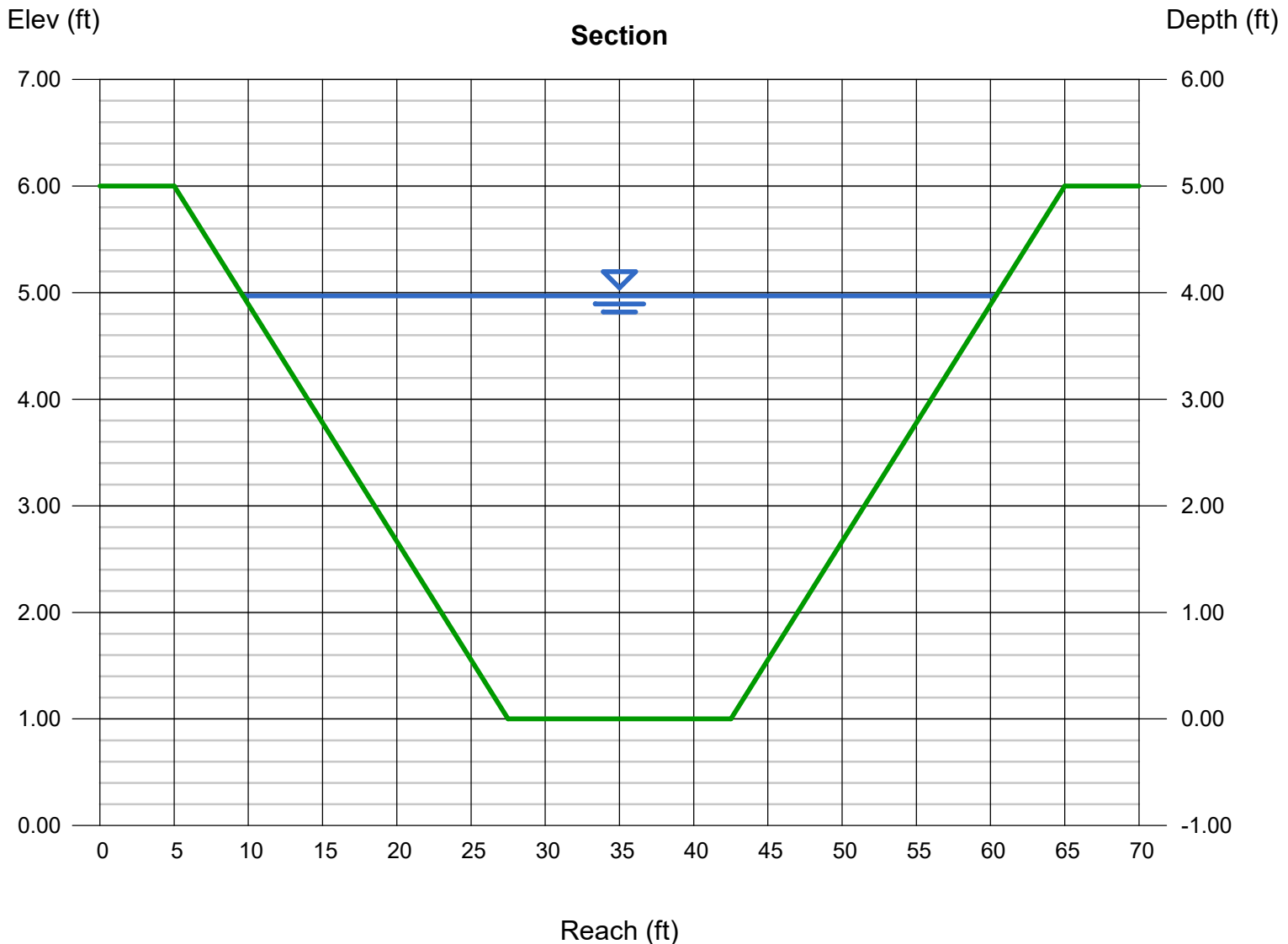

Channel Report

Swale Section L-L Velocity Check

Trapezoidal

Bottom Width (ft) = 15.00
Side Slopes (z:1) = 4.50, 4.50
Total Depth (ft) = 5.00
Invert Elev (ft) = 1.00
Slope (%) = 0.10
N-Value = 0.030

Highlighted

Depth (ft) = 3.46
Q (cfs) = 284.00
Area (sqft) = 105.77
Velocity (ft/s) = 2.69
Wetted Perim (ft) = 46.90
Crit Depth, Y_c (ft) = 1.85
Top Width (ft) = 46.14
EGL (ft) = 3.57

Calculations

Compute by: Known Q
Known Q (cfs) = 284.00

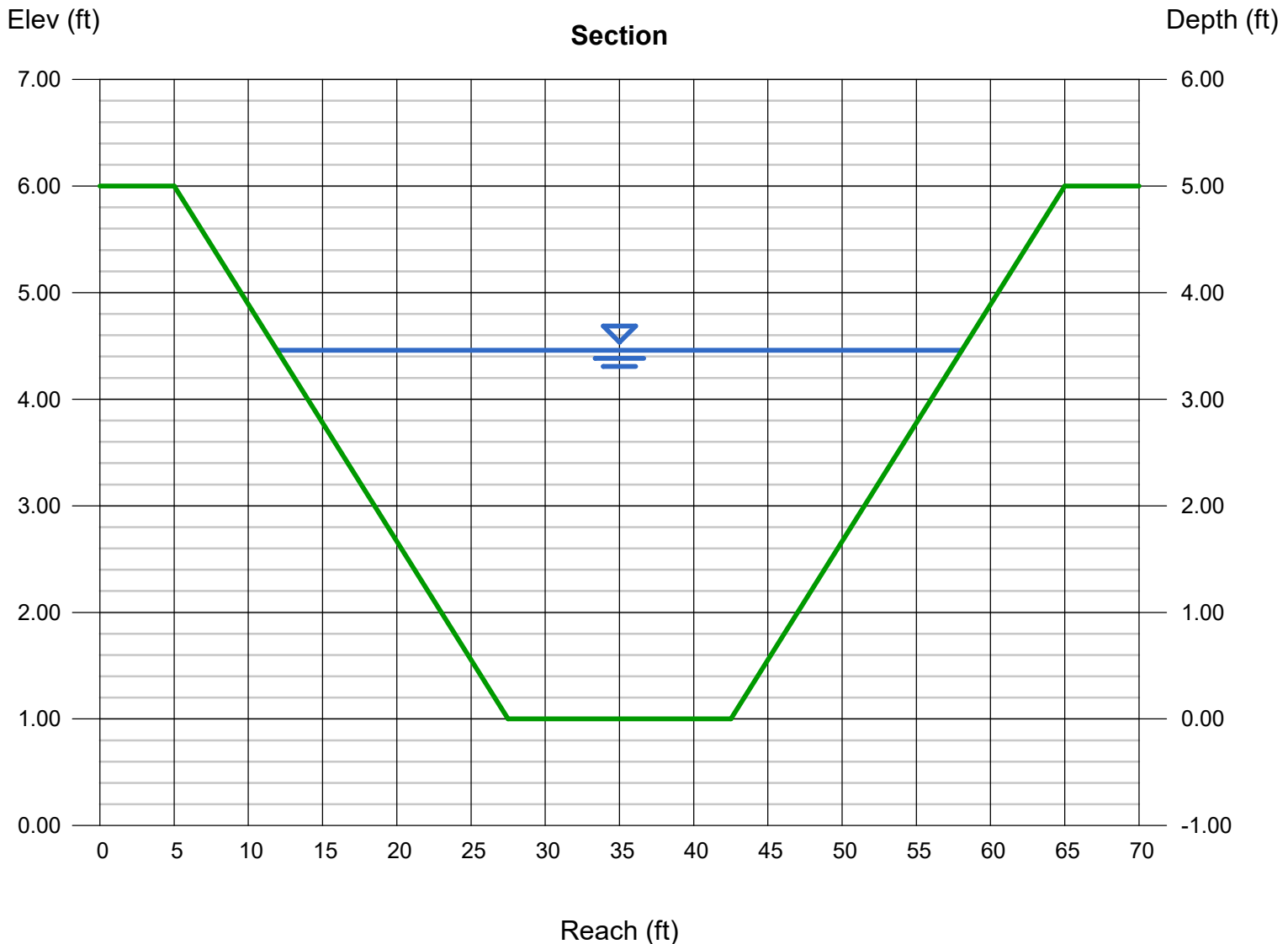

Channel Report

Swale Section I-I Capacity Check

Trapezoidal

Bottom Width (ft) = 10.00
Side Slopes (z:1) = 3.30, 3.30
Total Depth (ft) = 4.50
Invert Elev (ft) = 1.00
Slope (%) = 0.93
N-Value = 0.040

Highlighted

Depth (ft) = 2.82
Q (cfs) = 292.39
Area (sqft) = 54.44
Velocity (ft/s) = 5.37
Wetted Perim (ft) = 29.45
Crit Depth, Yc (ft) = 2.31
Top Width (ft) = 28.61
EGL (ft) = 3.27

Calculations

Compute by: Known Q
Known Q (cfs) = 292.39

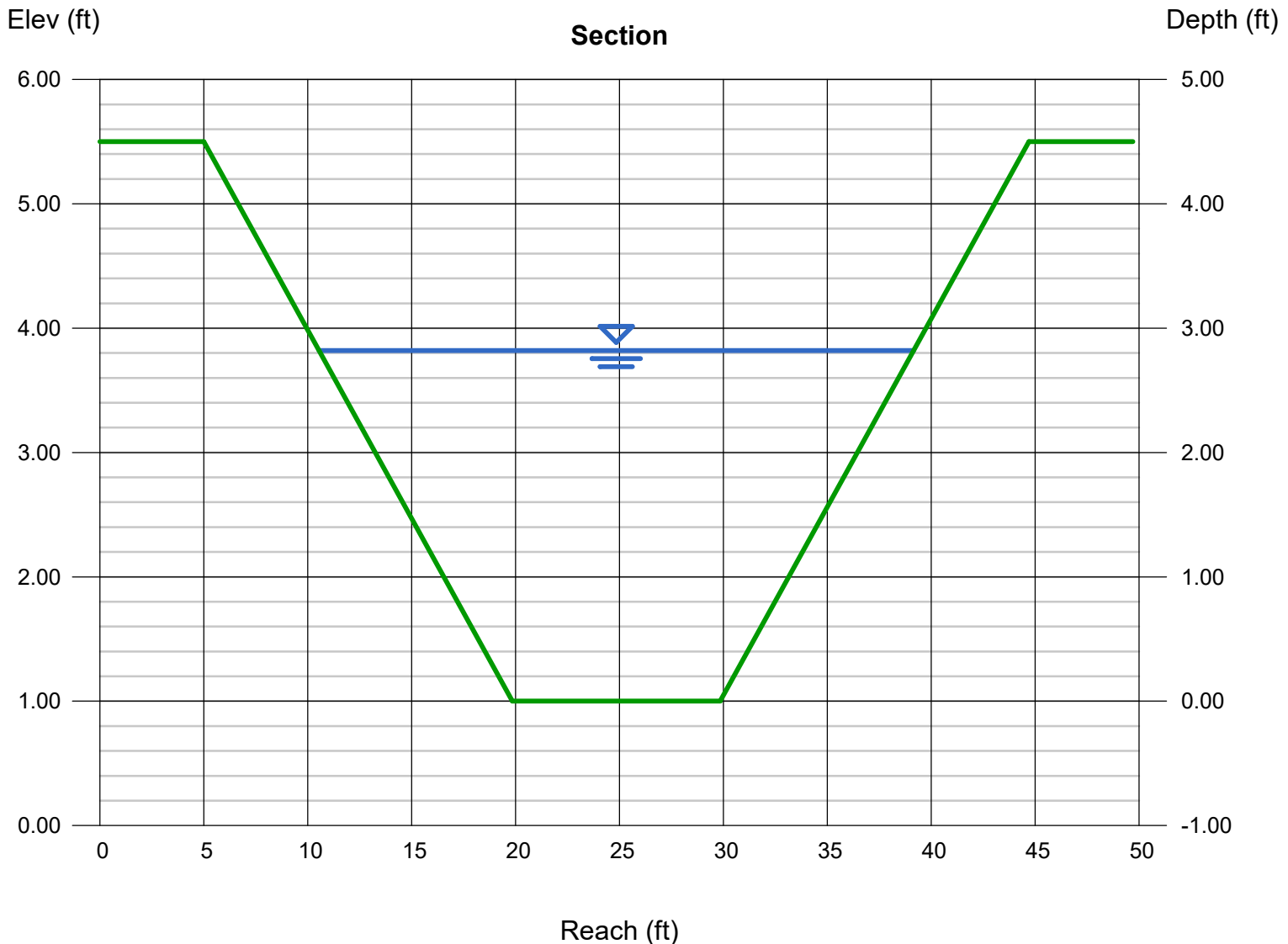

Channel Report

Swale Section I-I Velocity Check

Trapezoidal

Bottom Width (ft) = 10.00
Side Slopes (z:1) = 3.30, 3.30
Total Depth (ft) = 4.50
Invert Elev (ft) = 1.00
Slope (%) = 0.93
N-Value = 0.030

Highlighted

Depth (ft) = 2.44
Q (cfs) = 292.39
Area (sqft) = 44.05
Velocity (ft/s) = 6.64
Wetted Perim (ft) = 26.83
Crit Depth, Yc (ft) = 2.31
Top Width (ft) = 26.10
EGL (ft) = 3.13

Calculations

Compute by: Known Q
Known Q (cfs) = 292.39

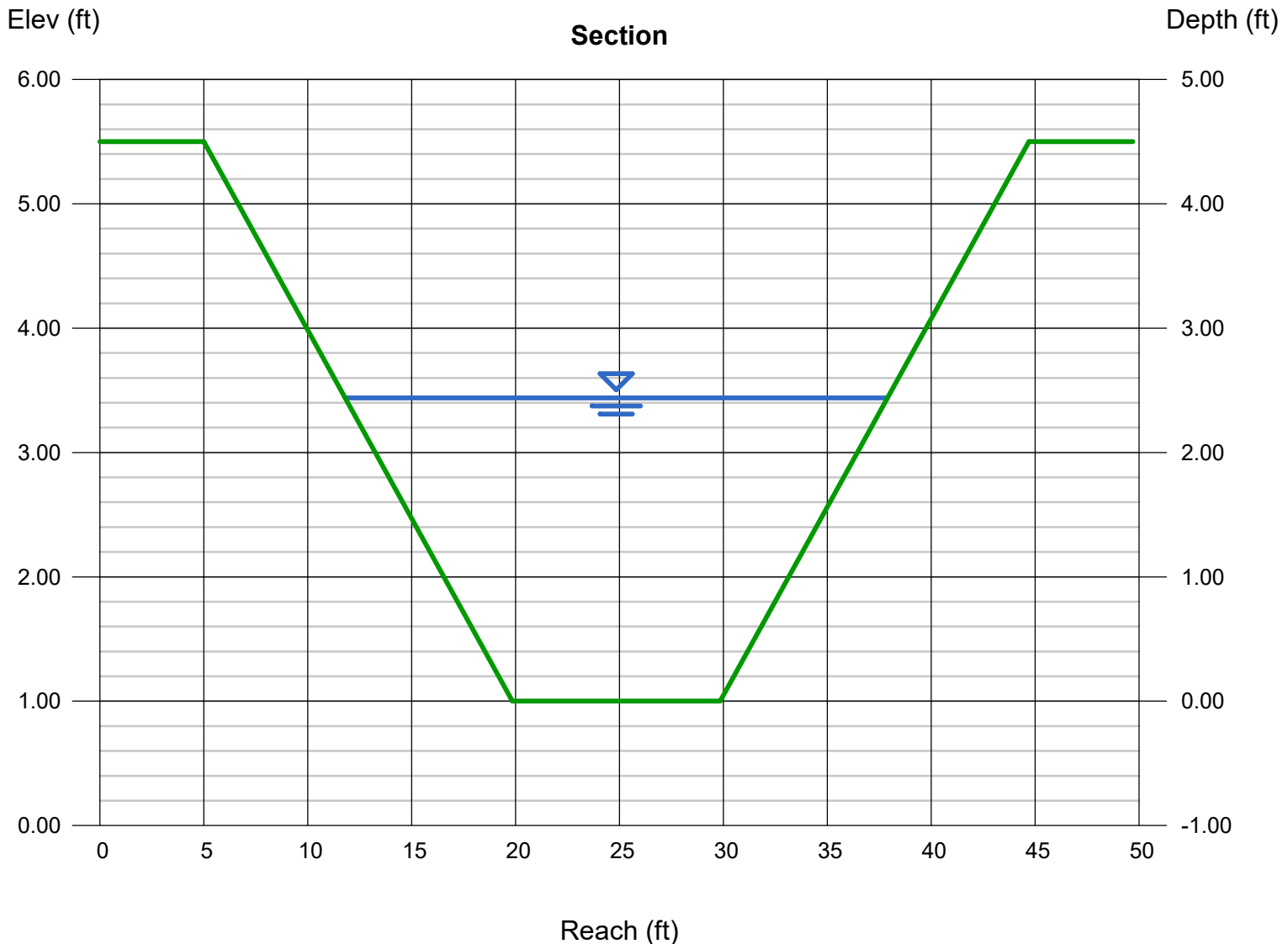

Channel Report

Swale Section J-J Capacity Check

Triangular

Side Slopes (z:1) = 4.50, 5.20
Total Depth (ft) = 4.00

Invert Elev (ft) = 1.00
Slope (%) = 1.18
N-Value = 0.040

Calculations

Compute by: Known Q
Known Q (cfs) = 82.52

Highlighted

Depth (ft) = 2.06
Q (cfs) = 82.52
Area (sqft) = 20.58
Velocity (ft/s) = 4.01
Wetted Perim (ft) = 20.40
Crit Depth, Yc (ft) = 1.79
Top Width (ft) = 19.98
EGL (ft) = 2.31

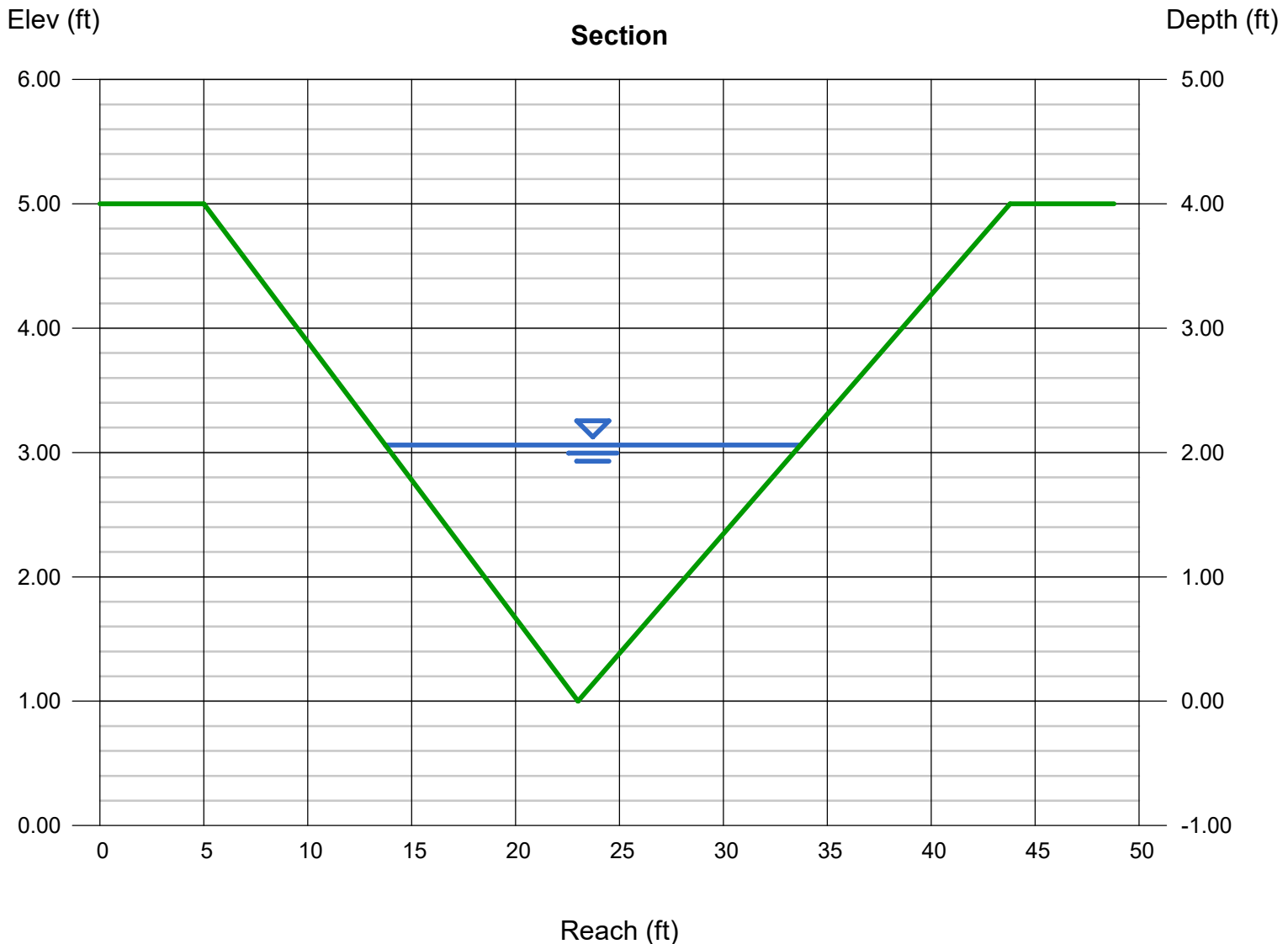

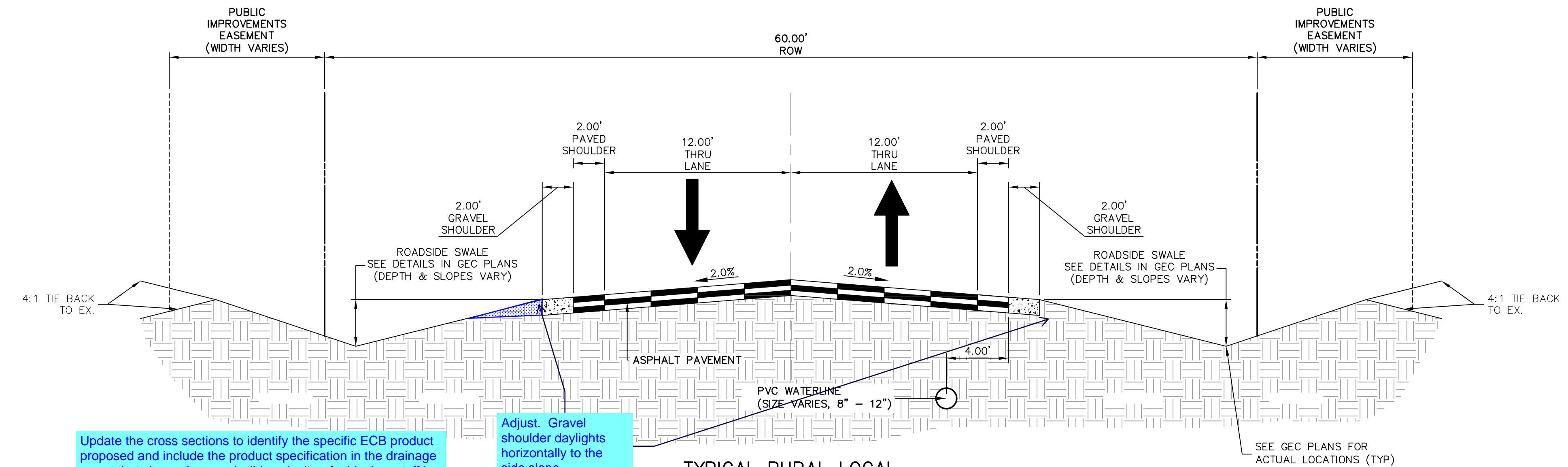

TYPICAL RURAL LOCAL
 POSTED SPEED LIMIT = 30 MPH, DESIGN SPEED LIMIT = 30 MPH
 FONTENELLE TRAIL, FRENCHMANS TRAIL, IRISH HUNTER TRAIL,
 OREGON WAGON TRAIL,
 SCALE: 1" = 5'

Update the cross sections to identify the specific ECB product proposed and include the product specification in the drainage report that shows the permissible velocity. At this time staff is unable to confirm if the swale velocity is less than or greater than the permissible velocity of the ECB. Review the swale velocity check relative to the ECB product will be conducted on the resubmittal.

Typical for all swale sections.

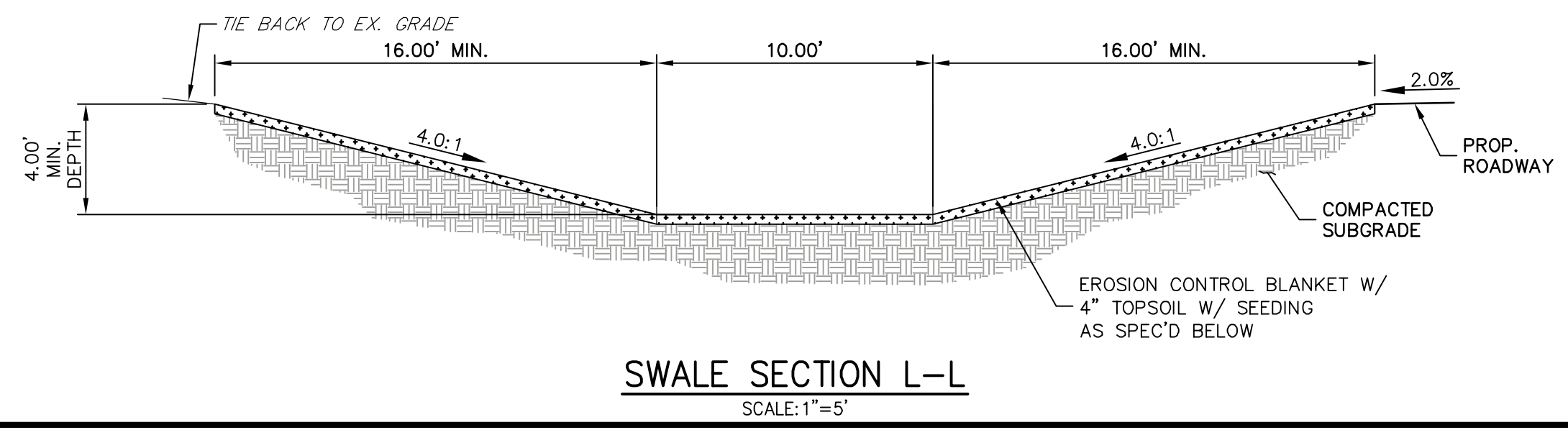
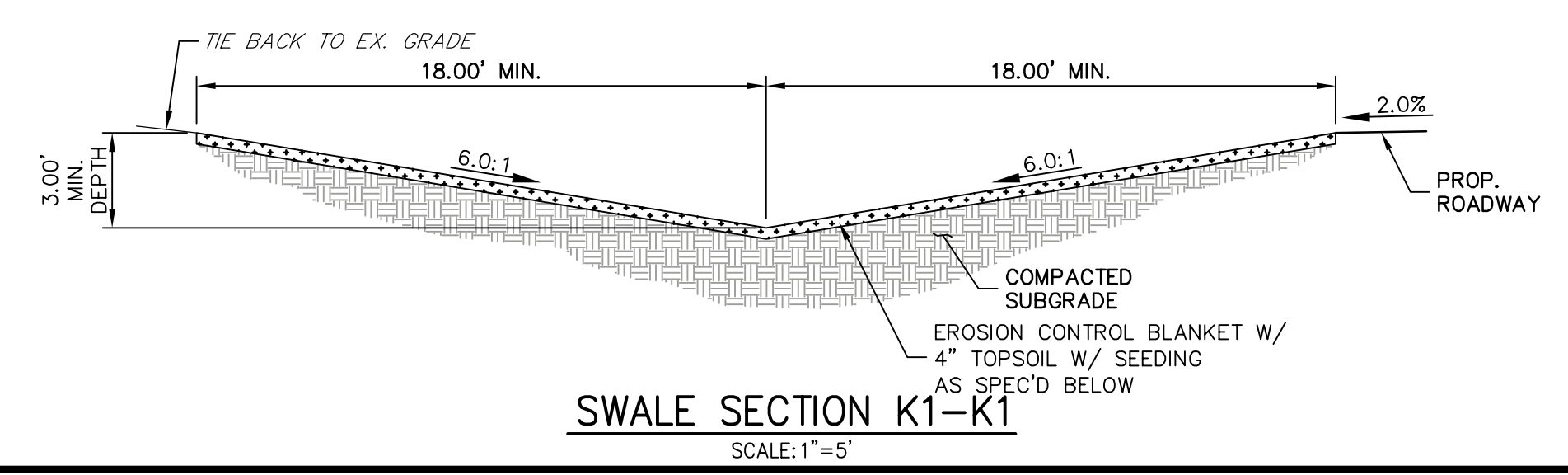
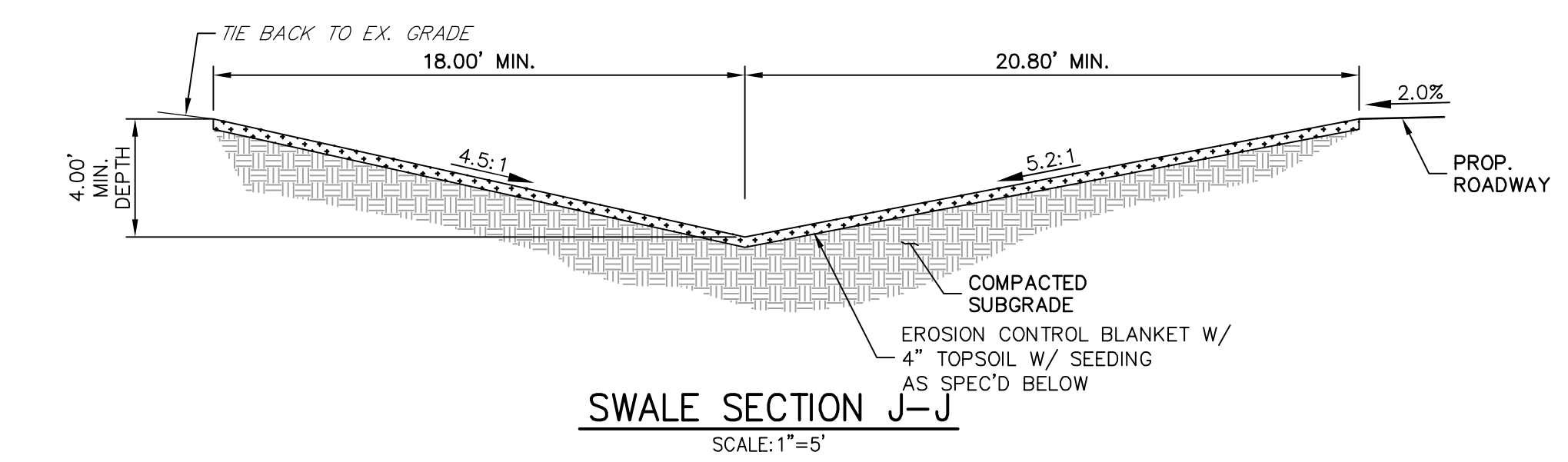
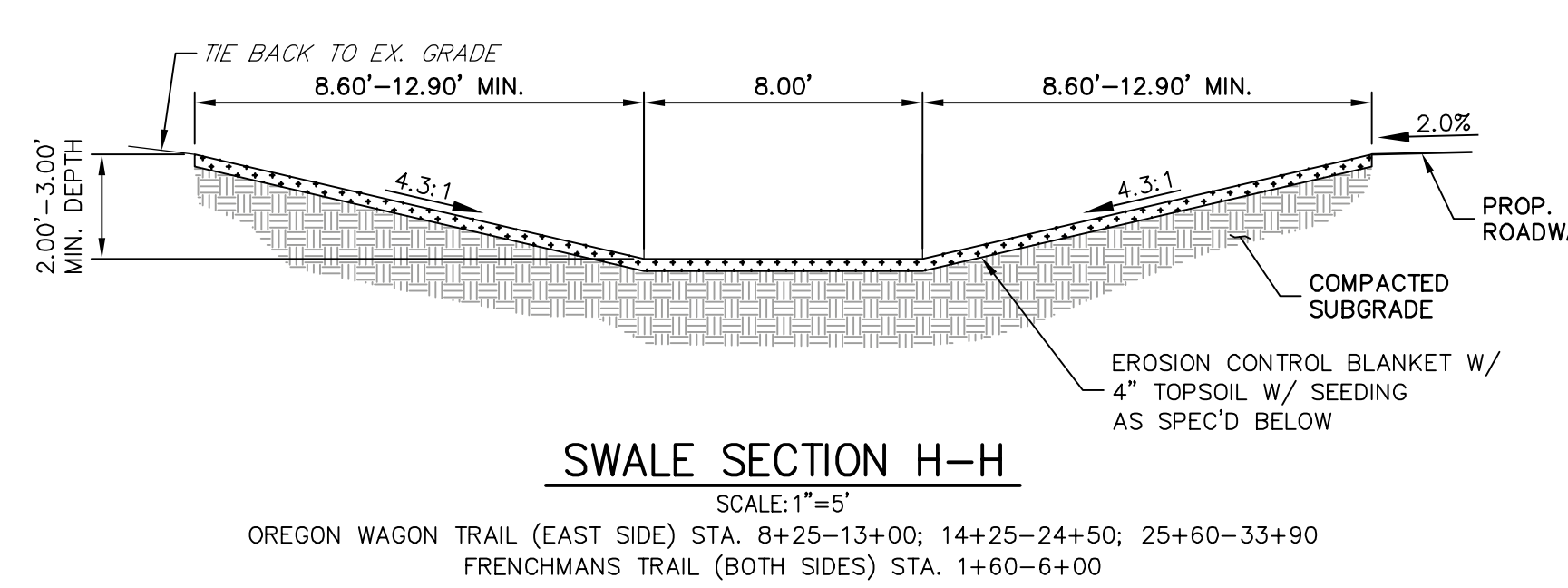
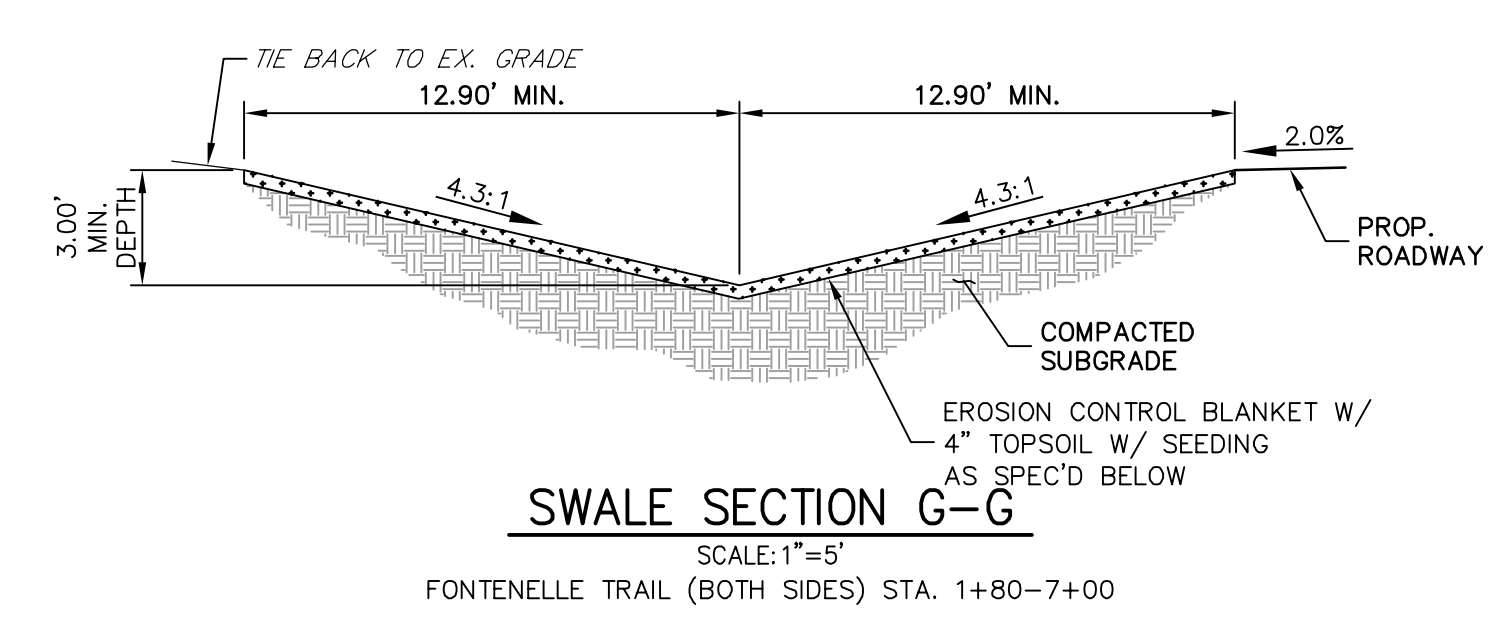
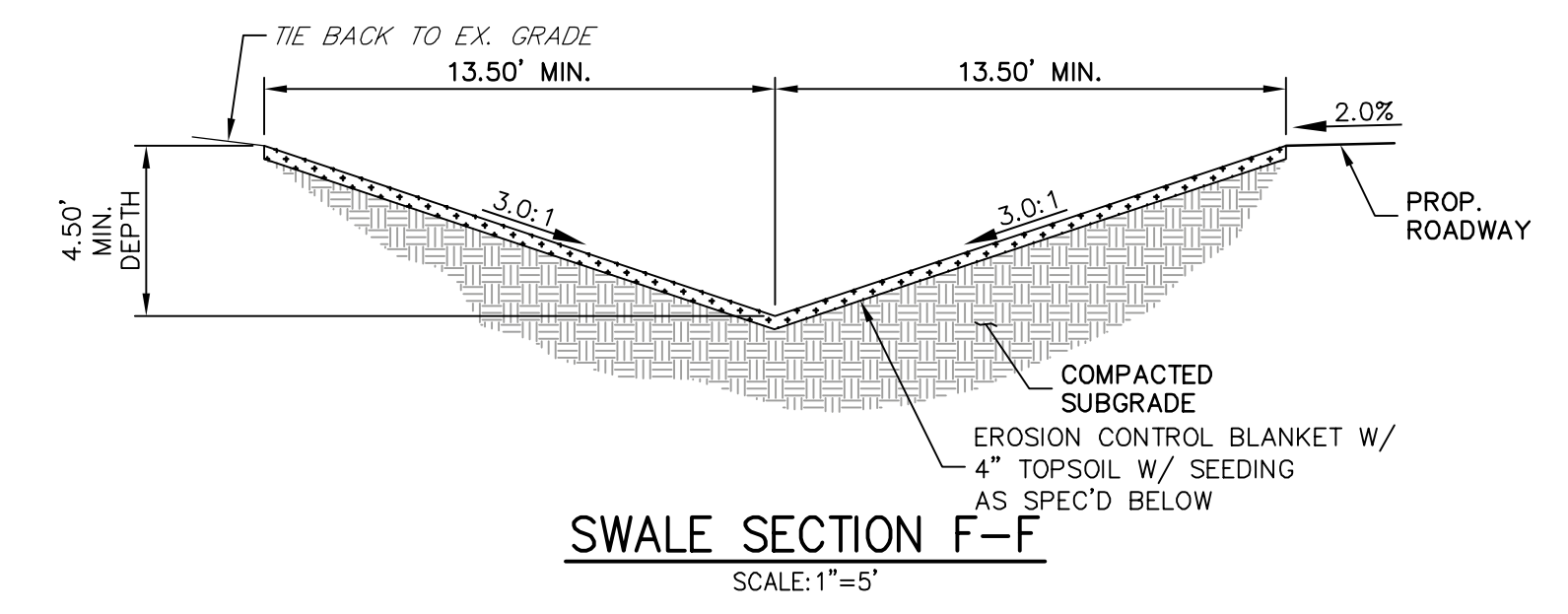
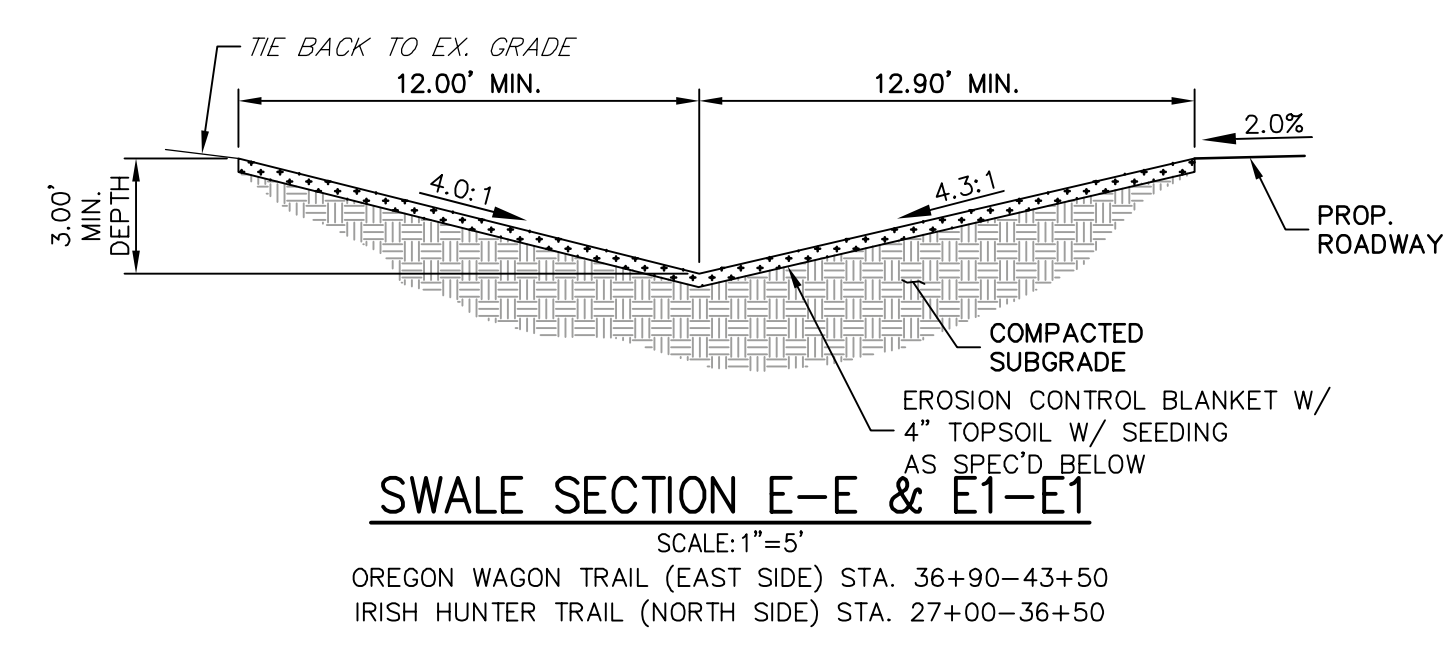
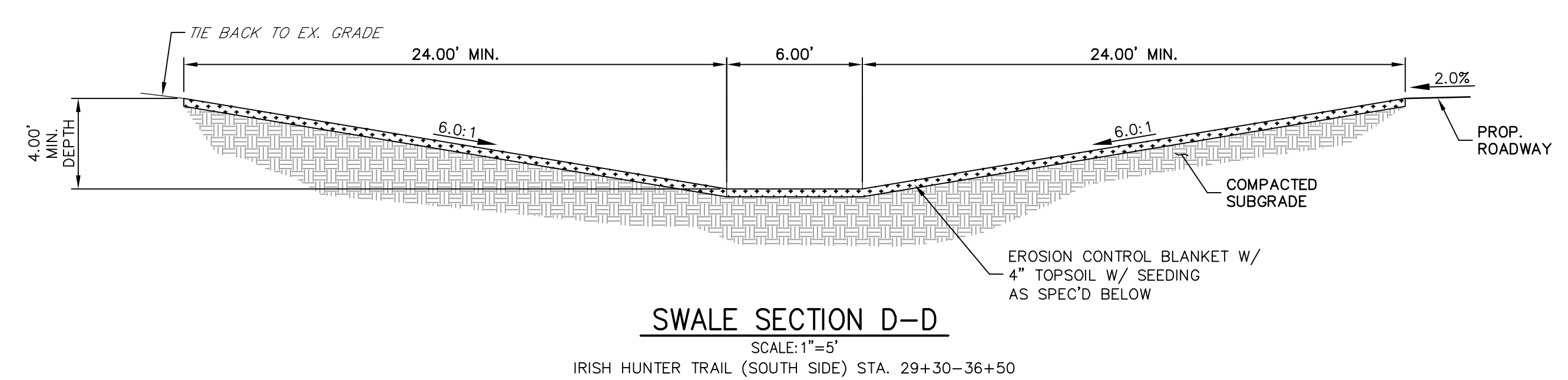
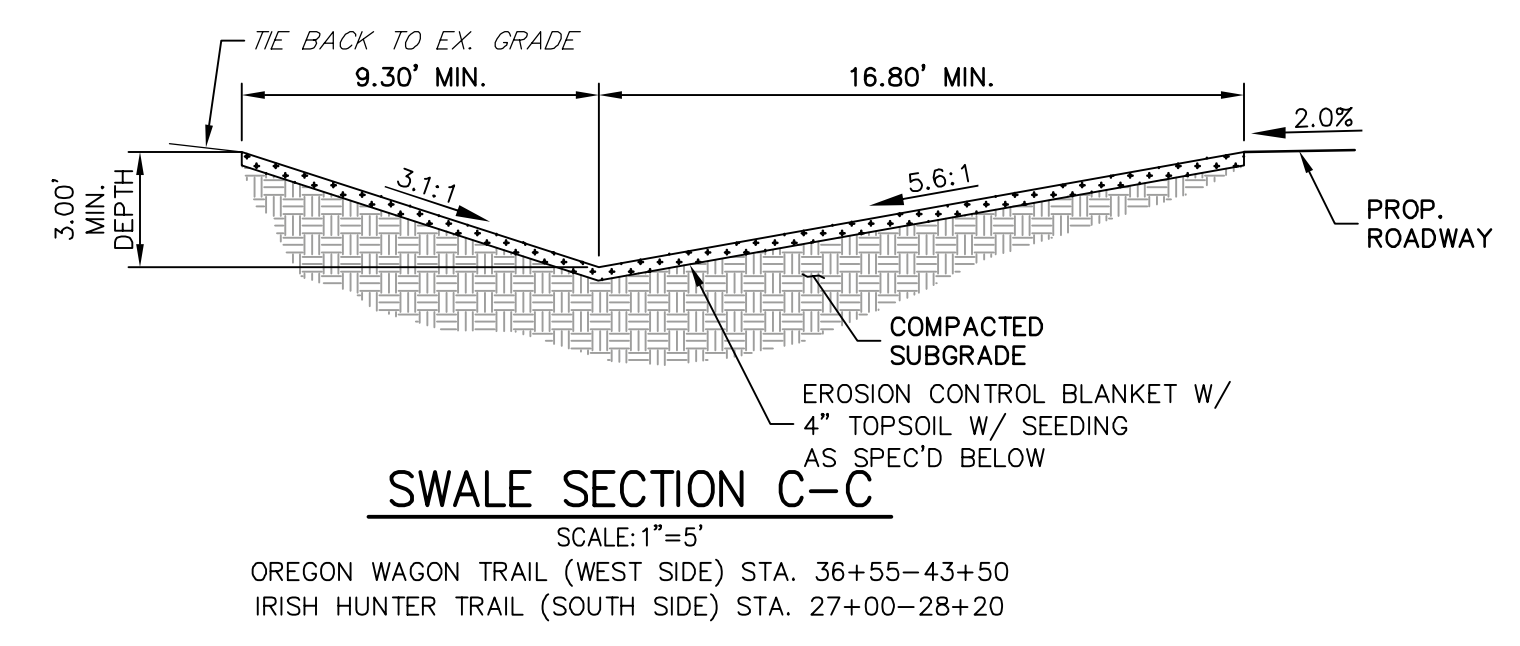
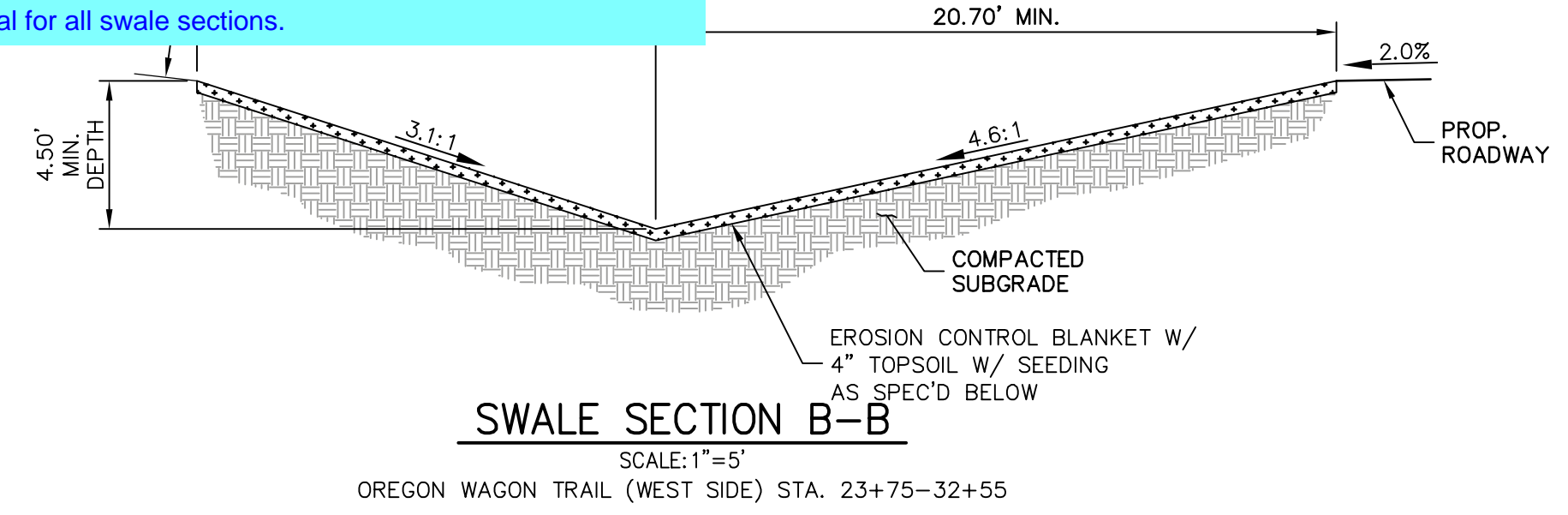
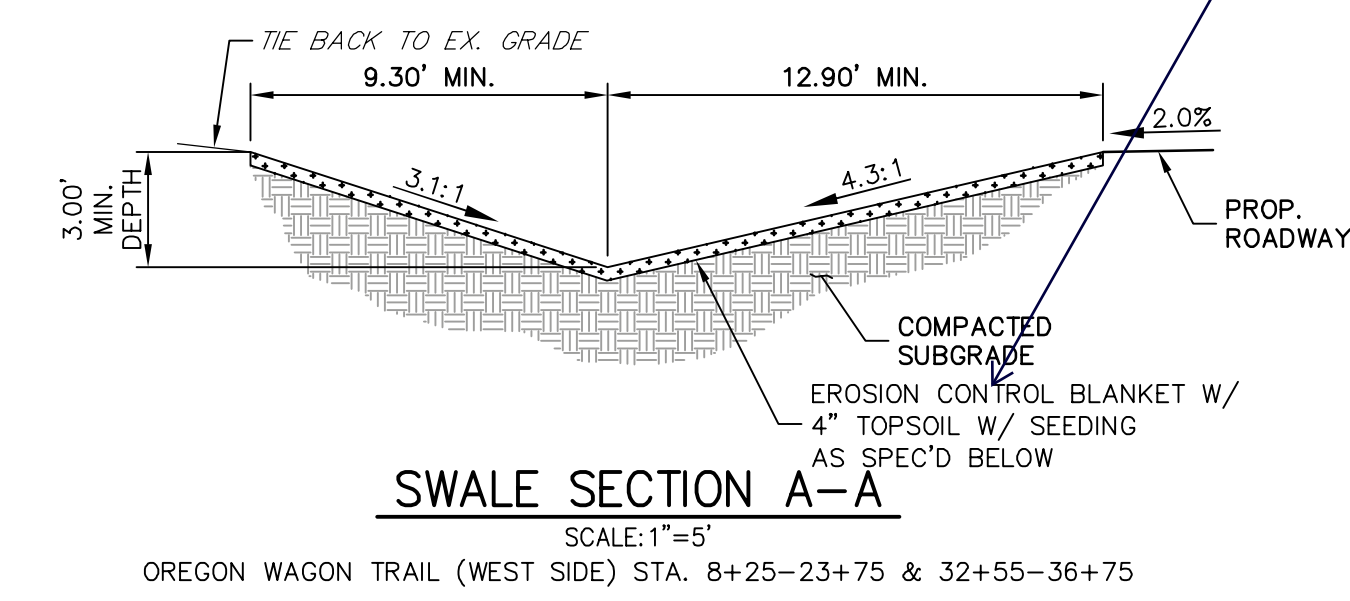

ENGINEER'S STATEMENT
 PREPARED UNDER MY DIRECT SUPERVISION AND ON BEHALF OF JR ENGINEERING
 MIKE A. BRAMLETT, P.E.
 COLORADO P.E. 32314
 FOR AND ON BEHALF OF JR ENGINEERING, LLC LOCAL ENGINEER
 DATE

UNTIL SUCH TIME AS THESE DRAWINGS ARE APPROVED BY THE AGENCIES, OR ENGINEERING APPROVES THEIR USES DESIGNATED BY WRITTEN AUTHORIZATION.	
PREPARED FOR	BRUM, LLC 101 N. CASCADE, SUITE 200 COLORADO SPRINGS, CO 80903 ATTN: BOB IRWIN P-(719)-475-7474
J.R. ENGINEERING A Westman Company Central 303-740-9883 • Colorado Springs 719-593-2583 Fort Collins 970-491-9888 • www.jrengineering.com	
BY	DATE
No.	REVISION
H-SCALE 1" = 5'	DESIGNED BY APL
V-SCALE 1" = 5'	DRAWN BY RWK
DATE 09/10/21	CHECKED BY
LATIGO TRAILS - FILING NO. 9	
TYPICAL SECTIONS	
SHEET 3 OF 12	JOB NO. 25175.01

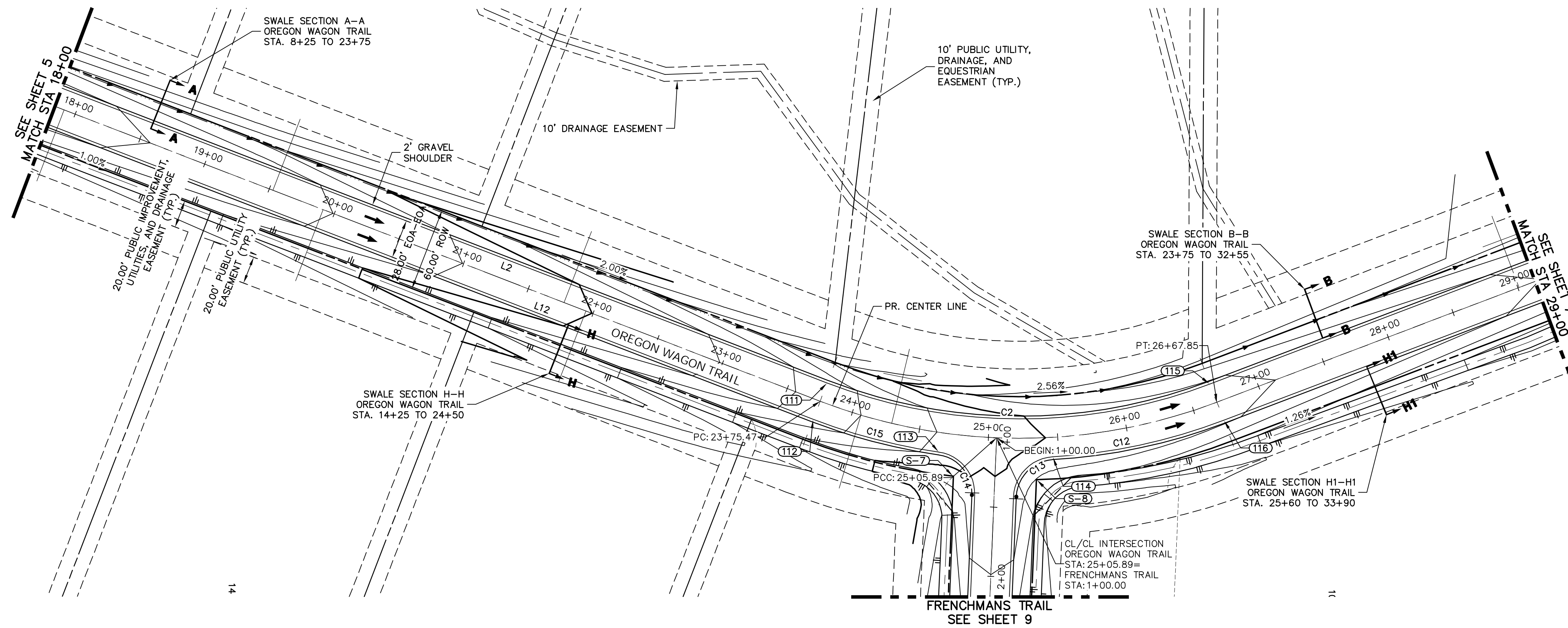

OREGON WAGON TRAIL PROFILE (2)
STA 18+00.00 TO 29+00.00

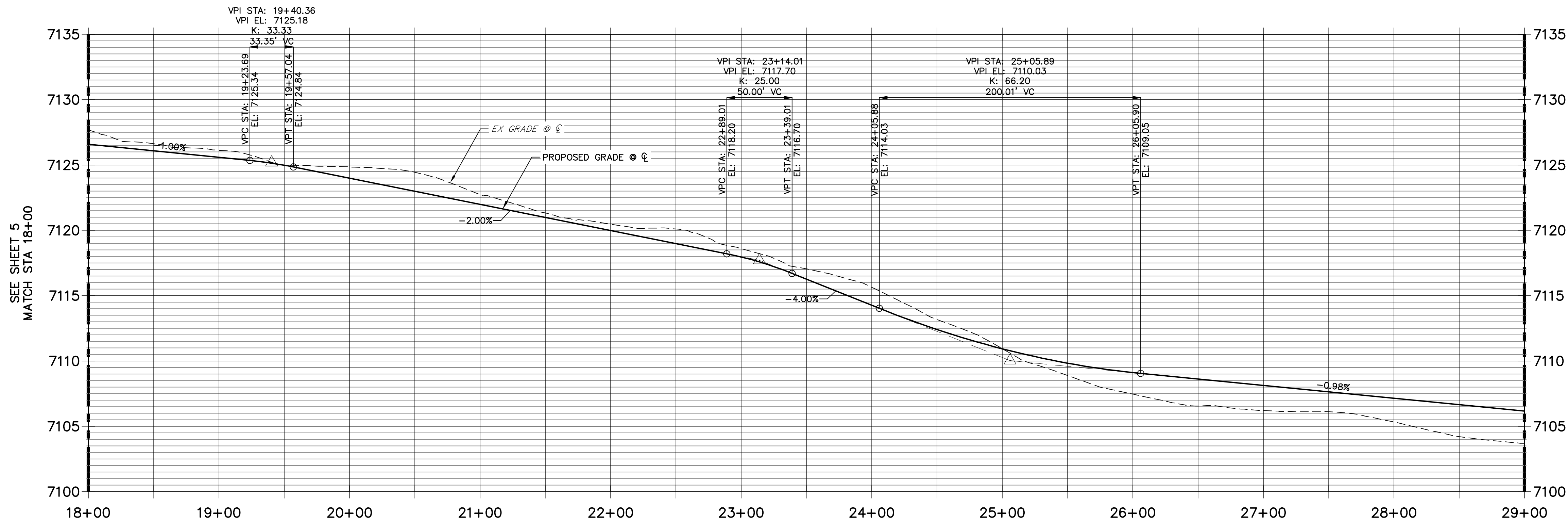

LINE AND CURVE TABLE

LINE/CURVE	BEARING/Delta	LENGTH	RADIUS
C2	231°1'57"	156.29'	386.00'
C14	84°18'46"	44.15'	30.00'
C12	17°30'43"	126.54'	414.00'
C13	84°18'46"	44.15'	30.00'
L2	S21°04'50"W	782.42'	
L12	N21°04'50"E	782.42'	
C15	12°59'35"	93.88'	414.00'

POINT TABULATION

POINT NUMBER	STATION	OFFSET	ALIGNMENT	ELEVATION	NOTES	DESCRIPTION
111	23+75.47	14.00' (LT)	OREGON WAGON TRAIL	7114.96		PC
112	23+75.47	14.00' (RT)	OREGON WAGON TRAIL	7114.96		PC
113	24+66.18	14.00' (RT)	OREGON WAGON TRAIL	7111.61		PCR
114	25+45.59	14.00' (RT)	OREGON WAGON TRAIL	7109.64		PCR
115	26+67.85	14.00' (LT)	OREGON WAGON TRAIL	7108.16		PT
116	26+67.85	14.00' (RT)	OREGON WAGON TRAIL	7108.16		PT

POINT TABULATION

POINT NUMBER	STATION	OFFSET	ALIGNMENT	ELEVATION	NOTES	DESCRIPTION
S-7	24+77.96	30.00' (RT)	OREGON WAGON TRAIL	7109.10		SWALE PI
S-8	25+33.82	30.00' (RT)	OREGON WAGON TRAIL	7107.91		SWALE PI

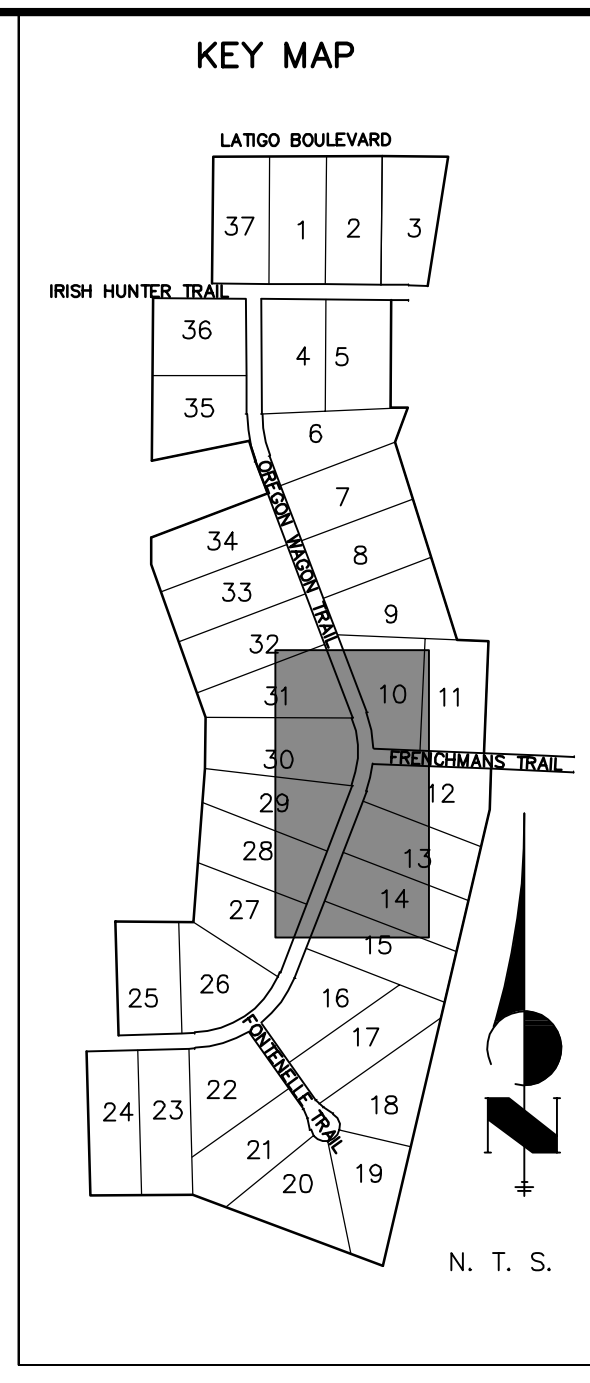

UNTIL SUCH TIME AS THESE DRAWINGS ARE APPROVED BY THE AGENCIES, OR ENGINEERING APPROVES THEIR USES DESIGNATED BY WRITTEN AUTHORIZATION.

PREPARED FOR
BRUM, LLC
101 N. CASCADE, SUITE 200
COLORADO SPRINGS, CO 80903
ATTN: BOB IRWIN
P-(719)-475-7474

J.R. ENGINEERING
A Westman Company
Central 303-740-9883 • Colorado Springs 719-583-2593
Fort Collins 970-491-9888 • www.jrengineering.com

STREET IMPROVEMENT NOTES

1. ALL STATIONING IS \odot , UNLESS OTHERWISE NOTED.
2. ALL PROFILE ELEVATIONS ARE \odot , UNLESS OTHERWISE NOTED.
3. ALL POINT TABULATIONS ARE EDGE OF ASPHALT, UNLESS OTHERWISE NOTED.
4. ALL CURB RETURN RADII ARE 20', UNLESS OTHERWISE NOTED.
5. ALL SLOPE LABELS ARE SWALE CENTERLINE, UNLESS OTHERWISE NOTED.
6. SEE SHEET 3 FOR TYPICAL STREET SECTIONS, SWALE SECTION A-A AND SECTION B-B DIMENSIONS AND DETAILS.
7. ALL PROPOSED ROW WIDTHS ARE 60', UNLESS OTHERWISE NOTED.
8. ABBREVIATIONS: EOA = EDGE OF ASPHALT, P.I.E. = PUBLIC IMPROVEMENTS EASEMENT.

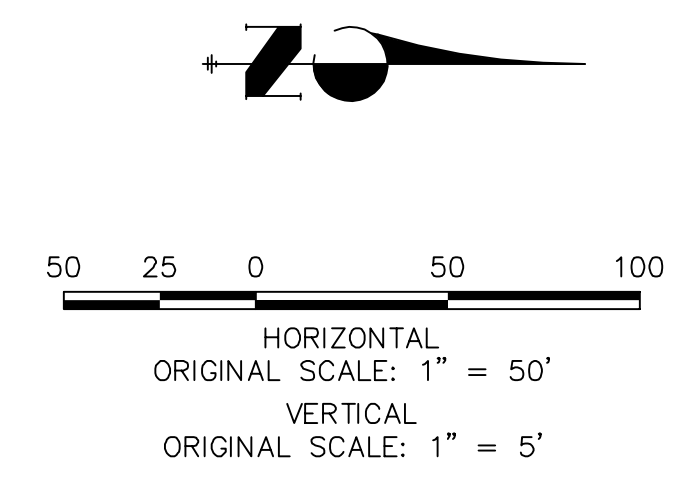

ENGINEER'S STATEMENT
PREPARED UNDER MY DIRECT SUPERVISION AND ON BEHALF OF JR ENGINEERING

MIKE A. BRAMLETT, P.E.
COLORADO P.E. 32314
FOR AND ON BEHALF OF JR ENGINEERING, LLC

No.	REVISION	BY	DATE	H-SCALE		V-SCALE		DATE	DESIGNED BY	DRAWN BY	CHECKED BY
				1"=50'	1"=5'	1"=50'	1"=5'				
								09/10/21	XXX	CRB	

LATIGO TRAILS - FILING NO. 9
STREET IMPROVEMENT PLAN AND PROFILE
SHEET 6 OF 12
JOB NO. 25175.01

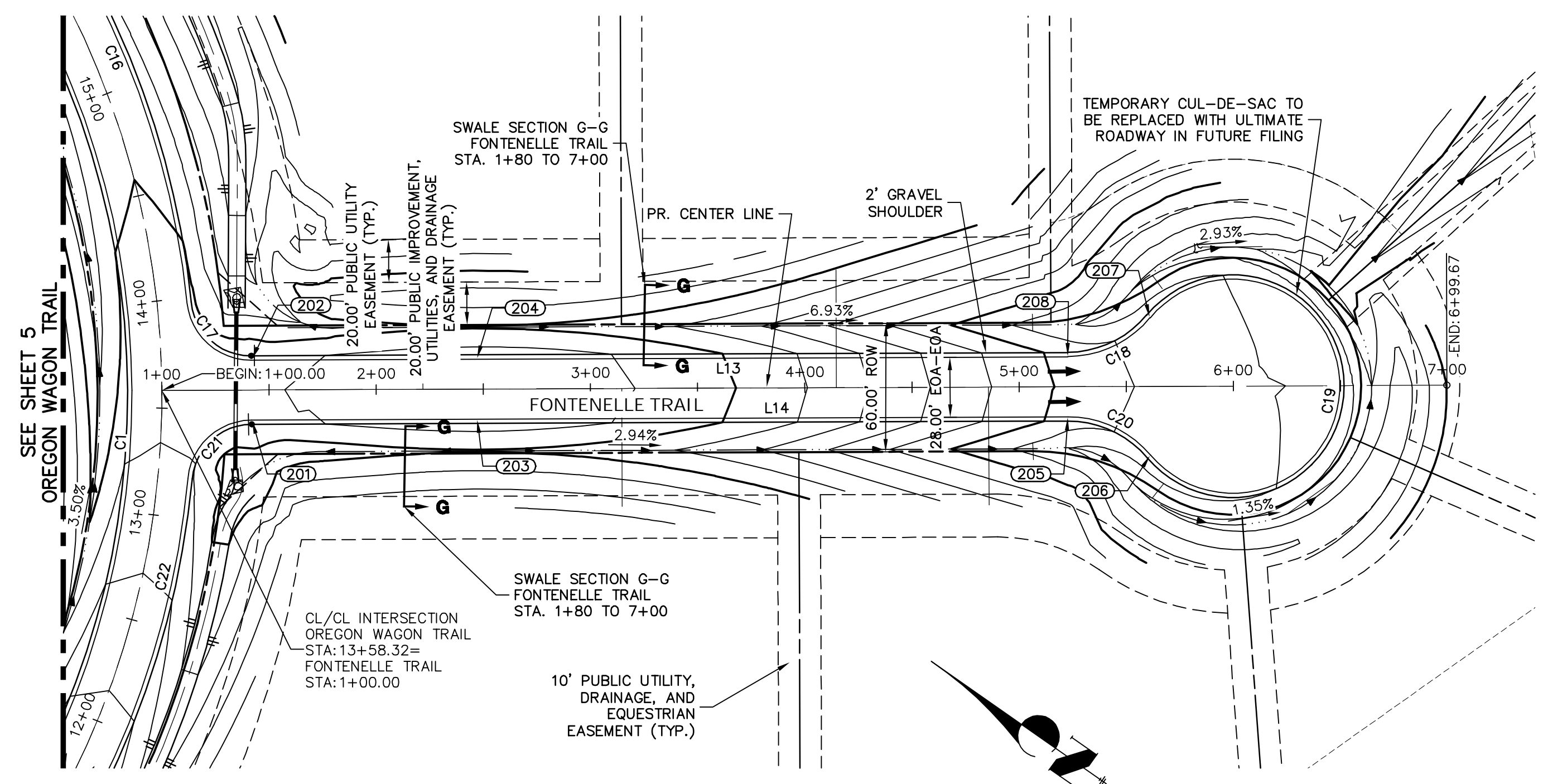

FONTENELLE TRAIL PROFILE
STA 1+00.00 TO 6+99.67

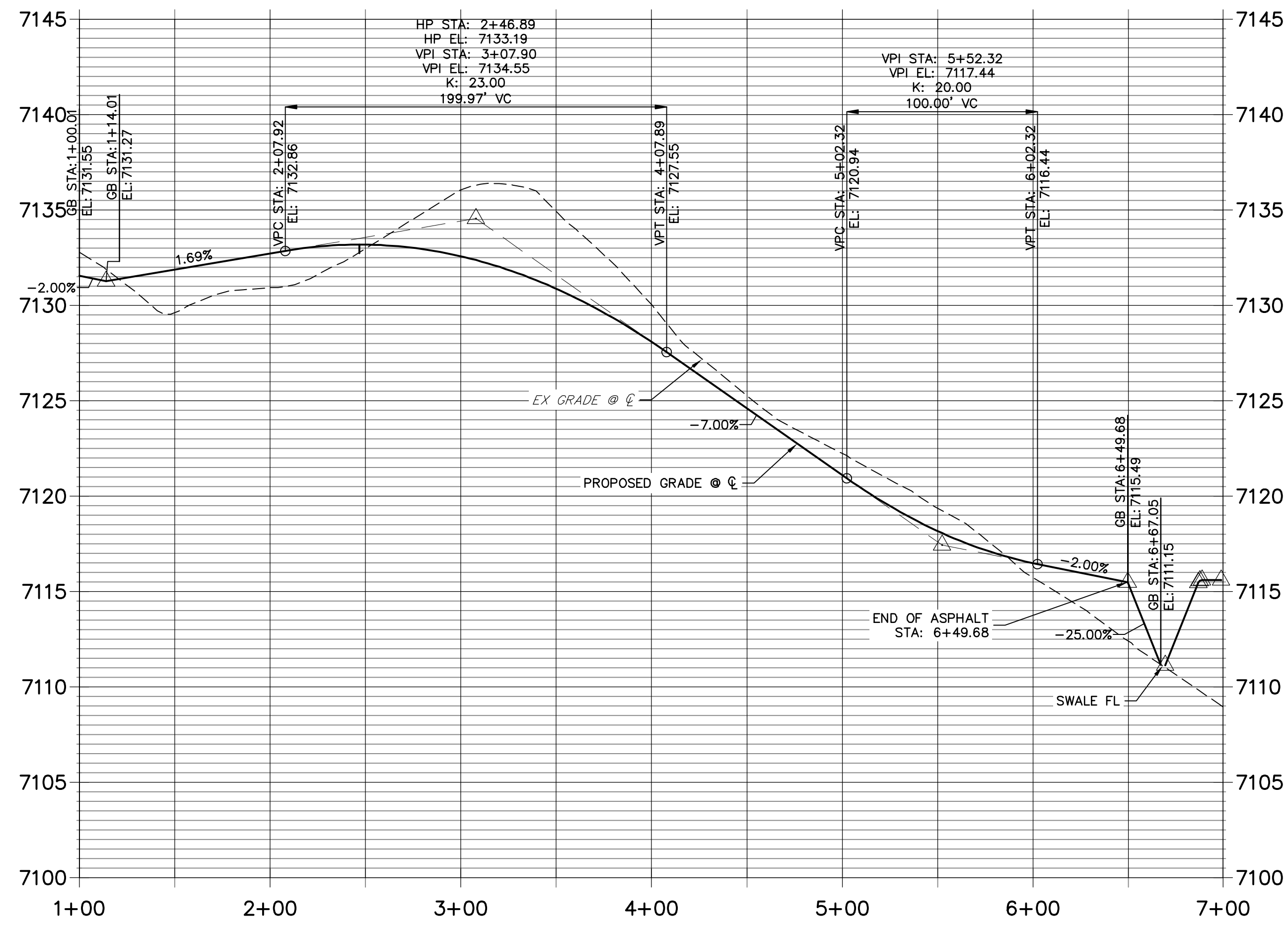

STREET IMPROVEMENT NOTES

1. ALL STATIONING IS @, UNLESS OTHERWISE NOTED.
2. ALL PROFILE ELEVATIONS ARE @, UNLESS OTHERWISE NOTED.
3. ALL POINT TABULATIONS ARE EDGE OF ASPHALT, UNLESS OTHERWISE NOTED.
4. ALL CURB RETURN RADII ARE 20', UNLESS OTHERWISE NOTED.
5. ALL SLOPE LABELS ARE SWALE CENTERLINE, UNLESS OTHERWISE NOTED.
6. SEE SHEET 3 FOR TYPICAL STREET SECTIONS, SWALE SECTION A-A AND SECTION B-B DIMENSIONS AND DETAILS.
7. ALL PROPOSED ROW WIDTHS ARE 60', UNLESS OTHERWISE NOTED.
8. ABBREVIATIONS: EOA = EDGE OF ASPHALT, P.I.E. = PUBLIC IMPROVEMENTS EASEMENT.

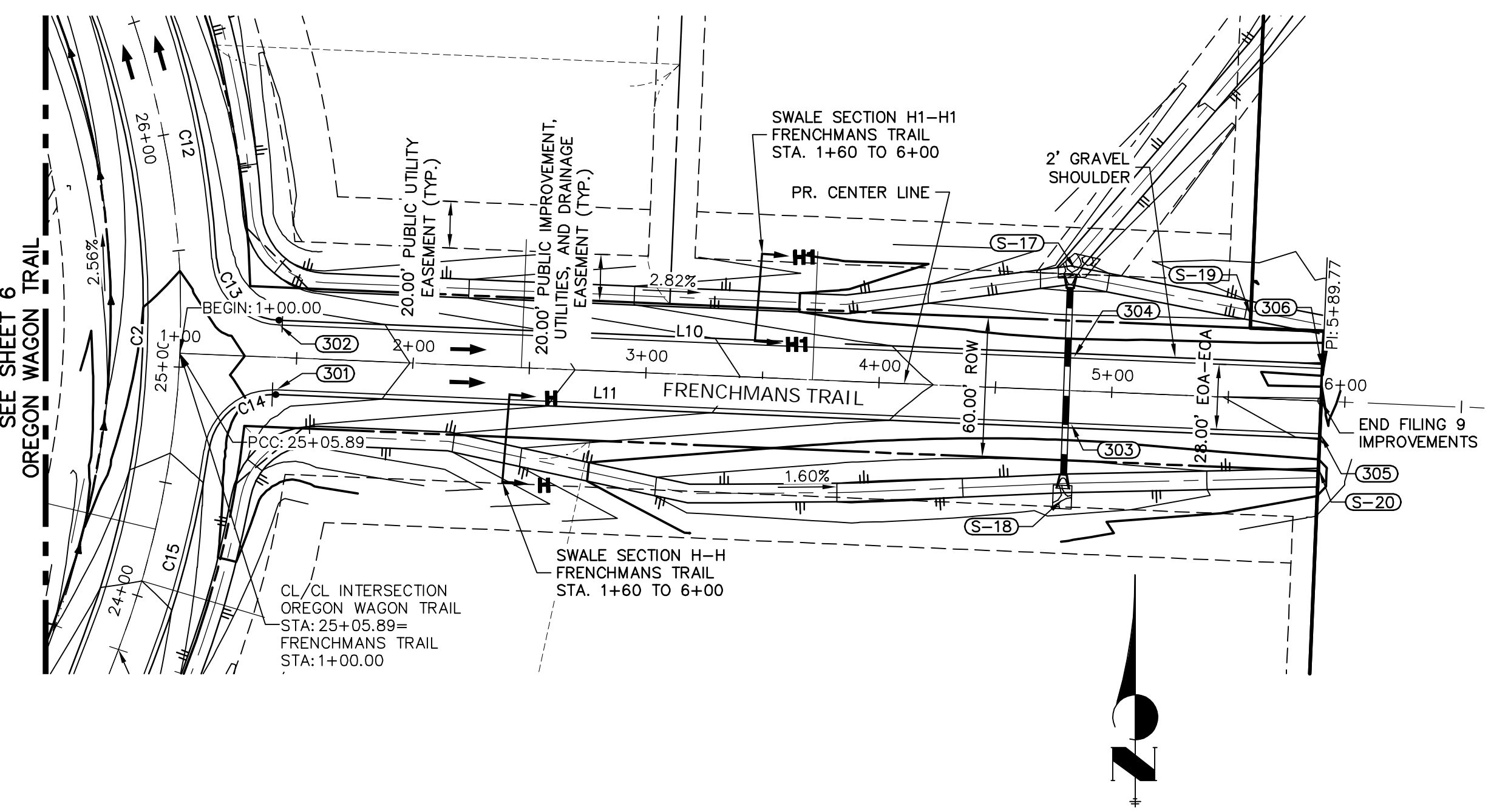

FRENCHMANS TRAIL PROFILE
STA 1+00.00 TO 5+90.00

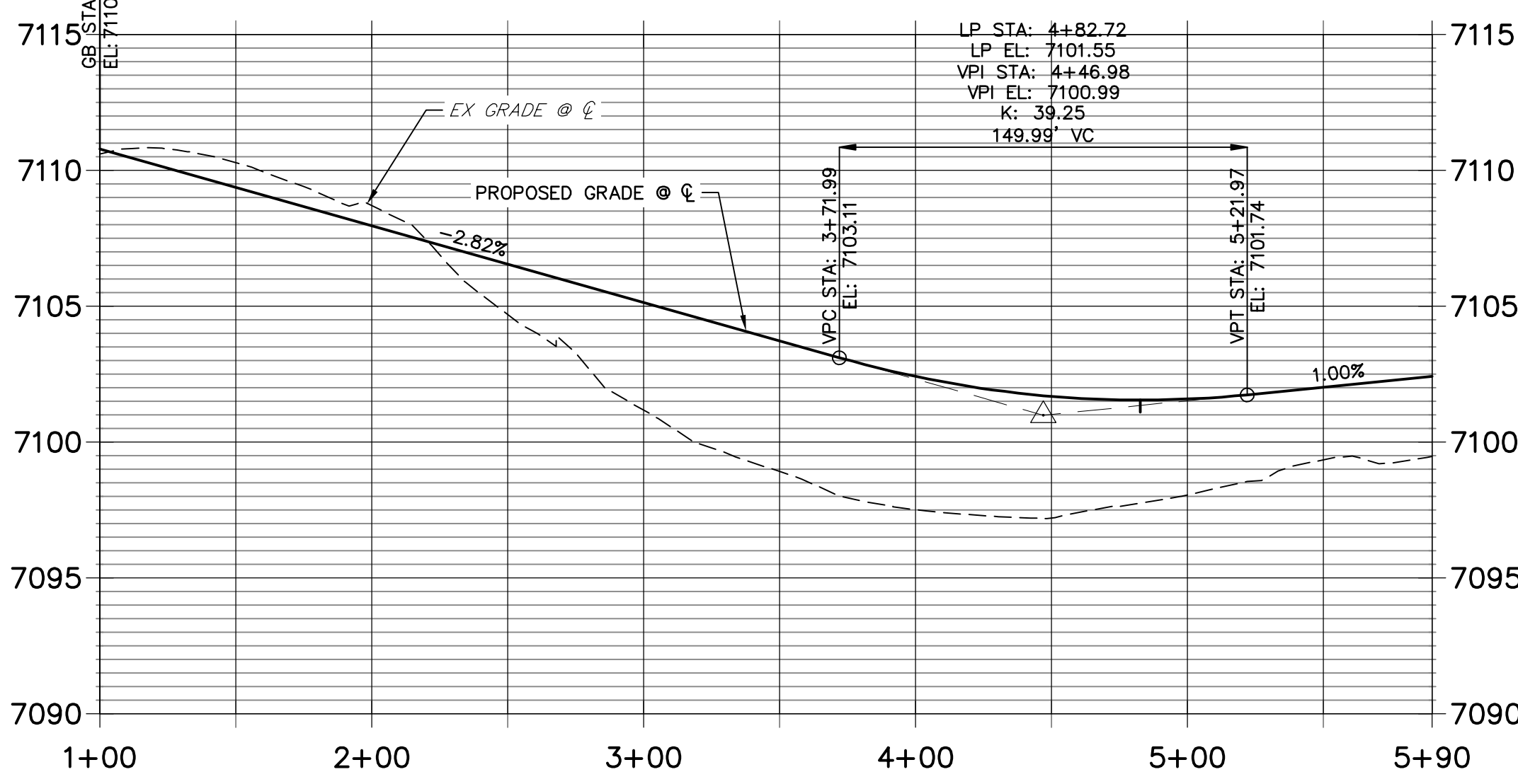

LINE/CURVE	BEARING/Delta	LENGTH	RADIUS
L13	N35°13'35"W	381.07'	
L14	S35°13'35"E	380.97'	
C20	50°12'29"	43.81'	50.00'
C18	50°12'29"	43.81'	50.00'
C19	280°24'59"	244.71'	50.00'
L11	S87°35'59"E	447.96'	
L10	S87°35'59"E	447.96'	
C2	23°11'57"	156.29'	386.00'
C22	28°04'29"	202.86'	414.00'
C21	84°22'34"	44.18'	30.00'
C16	27°56'32"	201.90'	414.00'
C17	84°14'57"	44.11'	30.00'
C14	84°18'46"	44.15'	30.00'
C12	17°30'43"	126.54'	414.00'
C13	84°18'46"	44.15'	30.00'
C1	33°46'07"	227.50'	386.00'
C15	12°59'35"	93.88'	414.00'

POINT NUMBER	STATION	OFFSET	ALIGNMENT	ELEVATION	NOTES	DESCRIPTION
201	1+41.86	14.00' (RT)	FONTENELLE TRAIL	7131.59		PCR
202	1+41.77	14.00' (LT)	FONTENELLE TRAIL	7131.46		PCR
203	2+46.89	14.00' (RT)	FONTENELLE TRAIL	7132.90		HP
204	2+46.89	14.00' (LT)	FONTENELLE TRAIL	7132.90		HP
205	5+22.84	14.00' (RT)	FONTENELLE TRAIL	7119.10		PCR
206	5+61.26	32.00' (RT)	FONTENELLE TRAIL	7117.08		PCR
207	5+61.26	32.00' (LT)	FONTENELLE TRAIL	7117.07		PCR
208	5+22.84	14.00' (LT)	FONTENELLE TRAIL	7119.34		PCR
301	1+41.81	14.00' (RT)	FRENCHMANS TRAIL	7109.32		PCR

POINT NUMBER	STATION	OFFSET	ALIGNMENT	ELEVATION	NOTES	DESCRIPTION
302	1+41.81	14.00' (LT)	FRENCHMANS TRAIL	7109.32		PCR
303	4+82.72	14.00' (RT)	FRENCHMANS TRAIL	7101.27		LP
304	4+82.72	14.00' (LT)	FRENCHMANS TRAIL	7101.27		LP
305	5+89.77	14.00' (RT)	FRENCHMANS TRAIL	7102.14		END OF IMPROVEMENTS
306	5+89.77	14.00' (LT)	FRENCHMANS TRAIL	7102.14		END OF IMPROVEMENTS

POINT NUMBER	STATION	OFFSET	ALIGNMENT	ELEVATION	NOTES	DESCRIPTION
S-17	4+82.52	51.67' (LT)	FRENCHMANS TRAIL	7095.52		SWALE GB
S-18	4+81.05	46.65' (RT)	FRENCHMANS TRAIL	7096.54		SWALE GB
S-19	5+58.17	35.29' (LT)	FRENCHMANS TRAIL	7098.08		BEGIN SWALE
S-20	5+89.77	29.00' (RT)	FRENCHMANS TRAIL	7099.10		BEGIN SWALE



Know what's below.
Call before you dig.



HORIZONTAL ORIGINAL SCALE: 1" = 50'
VERTICAL ORIGINAL SCALE: 1" = 5'

ENGINEER'S STATEMENT

PREPARED UNDER MY DIRECT SUPERVISION AND ON BEHALF OF JR ENGINEERING

MIKE A. BRAMLETT, P.E.
COLORADO P.E. 32314

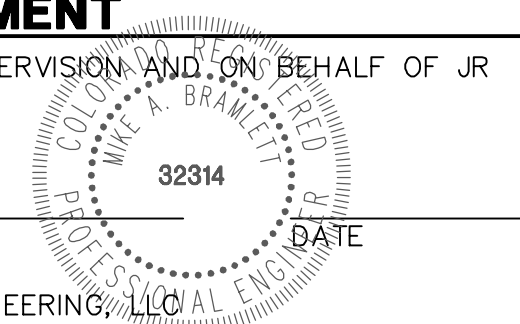

DATE

FOR AND ON BEHALF OF JR ENGINEERING, LLC

LOCAL ENGINEER

DATE

DATE

DATE

DATE

DATE

DATE

DATE

DATE

DATE

DATE

DATE

DATE

DATE

DATE

DATE

DATE

DATE

DATE

DATE

DATE

DATE

DATE

DATE

DATE

DATE

DATE

DATE

DATE

DATE

DATE

DATE

DATE

DATE

DATE

DATE

DATE

DATE

DATE

DATE

DATE

DATE

DATE

DATE

DATE

DATE

DATE

DATE

DATE

DATE

DATE

DATE

DATE

DATE

DATE

DATE

DATE

DATE

DATE

DATE

DATE

DATE

DATE

DATE

DATE

DATE

DATE

DATE

DATE

DATE

DATE

DATE

DATE

DATE

DATE

DATE

DATE

DATE

DATE

DATE

DATE

DATE

DATE

DATE

DATE

DATE

DATE

DATE

DATE

DATE

DATE

DATE

DATE

DATE

DATE

DATE

DATE

DATE

DATE

DATE

DATE

DATE

DATE

DATE

DATE

DATE

DATE

DATE

DATE

DATE

DATE

DATE

DATE

DATE

DATE

DATE

DATE

DATE

DATE

DATE

DATE

DATE

DATE

DATE

DATE

DATE

DATE

DATE

DATE

DATE

DATE

DATE

DATE

DATE

DATE

DATE

DATE

DATE

DATE

DATE

DATE

DATE

DATE

DATE

DATE

DATE

DATE

DATE

DATE

DATE

DATE

DATE

DATE

DATE

DATE

DATE

DATE

DATE

DATE

DATE

DATE

DATE

DATE

DATE

DATE

DATE

DATE

DATE

DATE

DATE

DATE

DATE

DATE

DATE

DATE

DATE

DATE

DATE

DATE

DATE

DATE

DATE

DATE

DATE

DATE

DATE

DATE

DATE

DATE

DATE

DATE

DATE

APPENDIX D

WATER QUALITY AND DETENTION CALCULATIONS

DETENTION BASIN STAGE-STORAGE TABLE BUILDER

MHFD-Detention, Version 4.04 (February 2021)

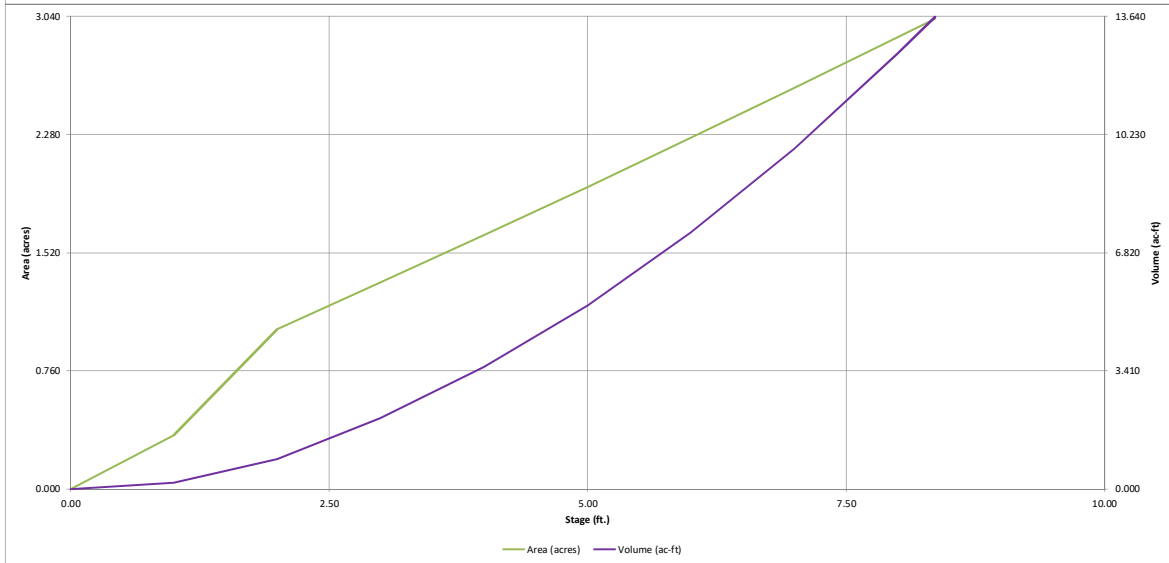
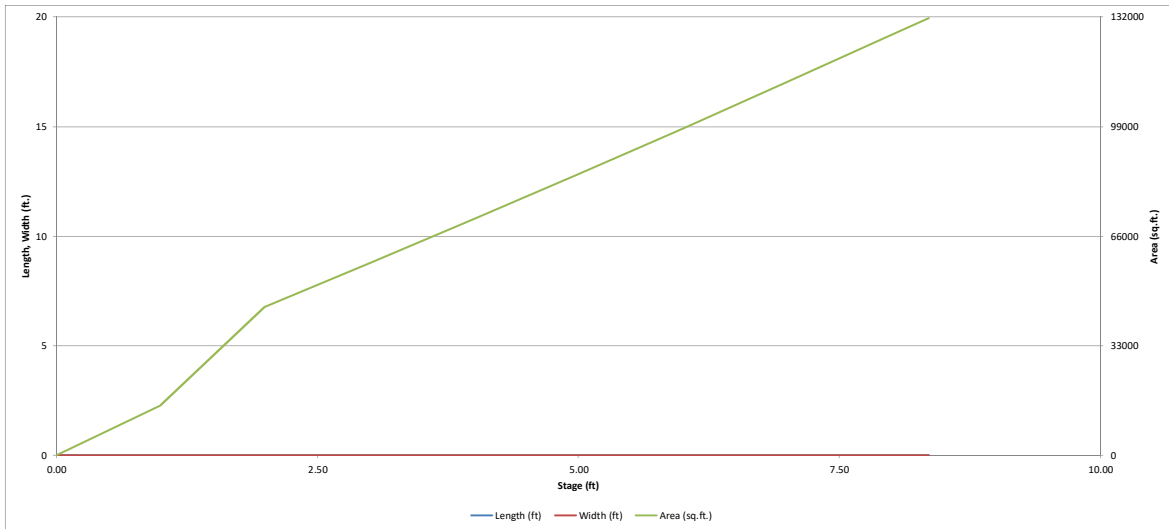

DETENTION BASIN OUTLET STRUCTURE DESIGN

MHFD-Detention, Version 4.04 (February 2021)

Project: Latigo Trails

Basin ID: Black Squirrel Pond-Ultimate

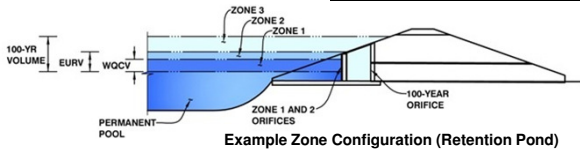

Example Zone Configuration (Retention Pond)

	Estimated Stage (ft)	Estimated Volume (ac-ft)	Outlet Type
Zone 1 (WQCV)	3.64	2.939	Orifice Plate
Zone 2 (EURV)	3.84	0.315	Orifice Plate
Zone 3 (100-year)	7.61	8.191	Weir&Pipe (Rect.)
Total (all zones)		11.445	

User Input: Orifice at Underdrain Outlet (typically used to drain WQCV in a Filtration BMP)

Underdrain Orifice Invert Depth =	N/A	ft (distance below the filtration media surface)
Underdrain Orifice Diameter =	N/A	inches

Calculated Parameters for Underdrain		
Underdrain Orifice Area =	N/A	ft ²
Underdrain Orifice Centroid =	N/A	feet

User Input: Orifice Plate with one or more orifices or Elliptical Slot Weir (typically used to drain WQCV and/or EURV in a sedimentation BMP)

Invert of Lowest Orifice =	0.00	ft (relative to basin bottom at Stage = 0 ft)
Depth at top of Zone using Orifice Plate =	3.84	ft (relative to basin bottom at Stage = 0 ft)
Orifice Plate: Orifice Vertical Spacing =	N/A	inches
Orifice Plate: Orifice Area per Row =	N/A	inches

Calculated Parameters for Plate		
WQ Orifice Area per Row =	N/A	ft ²
Elliptical Half-Width =	N/A	feet
Elliptical Slot Centroid =	N/A	feet
Elliptical Slot Area =	N/A	ft ²

User Input: Stage and Total Area of Each Orifice Row (numbered from lowest to highest)

	Row 1 (required)	Row 2 (optional)	Row 3 (optional)	Row 4 (optional)	Row 5 (optional)	Row 6 (optional)	Row 7 (optional)	Row 8 (optional)
Stage of Orifice Centroid (ft)	0.00	0.25	0.50	0.75	1.00			
Orifice Area (sq. inches)	8.00	8.00	0.79	0.79	0.79			

	Row 9 (optional)	Row 10 (optional)	Row 11 (optional)	Row 12 (optional)	Row 13 (optional)	Row 14 (optional)	Row 15 (optional)	Row 16 (optional)
Stage of Orifice Centroid (ft)								
Orifice Area (sq. inches)								

User Input: Vertical Orifice (Circular or Rectangular)

	Not Selected	Not Selected	
Invert of Vertical Orifice =	N/A	N/A	ft (relative to basin bottom at Stage = 0 ft)
Depth at top of Zone using Vertical Orifice =	N/A	N/A	ft (relative to basin bottom at Stage = 0 ft)
Vertical Orifice Diameter =	N/A	N/A	inches

Calculated Parameters for Vertical Orifice		
Vertical Orifice Area =	N/A	ft ²
Vertical Orifice Centroid =	N/A	feet

User Input: Overflow Weir (Dropbox with Flat or Sloped Gate and Outlet Pipe OR Rectangular/Trapezoidal Weir (and No Outlet Pipe))

	Zone 3 Weir	Not Selected	
Overflow Weir Front Edge Height, Ho =	4.00	N/A	ft (relative to basin bottom at Stage = 0 ft)
Overflow Weir Front Edge Length =	25.00	N/A	feet
Overflow Weir Gate Slope =	0.00	N/A	H:V
Horiz. Length of Weir Sides =	25.00	N/A	feet
Overflow Gate Type =	Type C Gate	N/A	
Debris Clogging % =	0%	N/A	%

Calculated Parameters for Overflow Weir		
Height of Gate Upper Edge, H ₁ =	4.00	feet
Overflow Weir Slope Length =	25.00	feet
Gate Open Area / 100-yr Orifice Area =	10.88	
Overflow Gate Open Area w/o Debris =	435.00	ft ²
Overflow Gate Open Area w/ Debris =	435.00	ft ²

User Input: Outlet Pipe w/ Flow Restriction Plate (Circular Orifice, Restrictor Plate, or Rectangular Orifice)

	Zone 3 Rectangular	Not Selected	
Depth to Invert of Outlet Pipe =	2.50	N/A	ft (distance below basin bottom at Stage = 0 ft)
Rectangular Orifice Width =	96.00	N/A	inches
Rectangular Orifice Height =	60.00	N/A	inches

Calculated Parameters for Outlet Pipe w/ Flow Restriction Plate		
Outlet Orifice Area =	40.00	ft ²
Outlet Orifice Centroid =	2.50	feet
Half-Central Angle of Restrictor Plate on Pipe =	N/A	radians

User Input: Emergency Spillway (Rectangular or Trapezoidal)

Spillway Invert Stage =	6.00	ft (relative to basin bottom at Stage = 0 ft)
Spillway Crest Length =	100.00	feet
Spillway End Slopes =	4.00	H:V
Freeboard above Max Water Surface =	1.00	feet

Calculated Parameters for Spillway		
Spillway Design Flow Depth =	1.36	feet
Stage at Top of Freeboard =	8.36	feet
Basin Area at Top of Freeboard =	3.03	acres
Basin Volume at Top of Freeboard =	13.63	acre-ft

Routed Hydrograph Results

The user can override the default CUHP hydrographs and runoff volumes by entering new values in the Inflow Hydrographs table (Columns W through AF).

	WQCV	EURV	2 Year	5 Year	10 Year	25 Year	50 Year	100 Year	500 Year
Design Storm Return Period	N/A	N/A	1.19	1.50	1.75	2.00	2.25	2.52	3.00
One-Hour Rainfall Depth (in)	N/A	N/A	4.269	8.978	13.627	21.749	27.349	35.345	46.604
CUHP Runoff Volume (acre-ft)	2.939	3.254	4.269	8.978	13.627	21.749	27.349	35.345	46.604
User Override Inflow Hydrograph Volume (acre-ft)	N/A	N/A	25.615	61.039	81.760	130.495	164.089	187.152	279.621
CUHP Predevelopment Peak Q (cfs)	N/A	N/A	15.9	45.3	71.6	133.9	169.3	223.0	293.4
OPTIONAL Override Predevelopment Peak Q (cfs)	N/A	N/A	274.2	274.2	274.2	274.2	274.2	482.0	482.0
Predevelopment Unit Peak Flow, q (cfs/acre)	N/A	N/A	0.06	0.96	0.25	0.47	0.60	1.70	1.03
Peak Inflow Q (cfs)	N/A	N/A	29.5	291.6	89.2	150.1	186.8	501.0	311.6
Peak Outflow Q (cfs)	1.1	1.2	38.8	264.8	89.2	154.0	187.8	447.7	313.8
Ratio Peak Outflow to Predevelopment Q	N/A	N/A	N/A	1.0	1.2	1.2	1.1	0.9	1.1
Structure Controlling Flow	Plate	Plate	Overflow Weir 1	Overflow Weir 1	Overflow Weir 1	Overflow Weir 1	Overflow Weir 1	Outlet Plate 1	Overflow Weir 1
Max Velocity through Gate 1 (fps)	N/A	N/A	0.09	0.6	0.6	0.6	0.6	1.0	0.7
Max Velocity through Gate 2 (fps)	N/A	N/A	N/A	N/A	N/A	N/A	N/A	N/A	N/A
Time to Drain 97% of Inflow Volume (hours)	40	43	62	45	43	17	7	29	6
Time to Drain 99% of Inflow Volume (hours)	42	45	71	61	44	57	53	61	41
Maximum Ponding Depth (ft)	3.64	3.84	4.24	4.87	4.42	4.61	4.69	5.40	4.98
Area at Maximum Ponding Depth (acres)	1.52	1.58	1.70	1.90	1.76	1.82	1.85	2.07	1.93
Maximum Volume Stored (acre-ft)	2.947	3.257	3.898	5.051	4.227	4.549	4.714	6.103	5.243

these needs to be less than or equal to 1.0

DETENTION BASIN OUTLET STRUCTURE DESIGN

MHFD-Detention, Version 4.04 (February 2021)

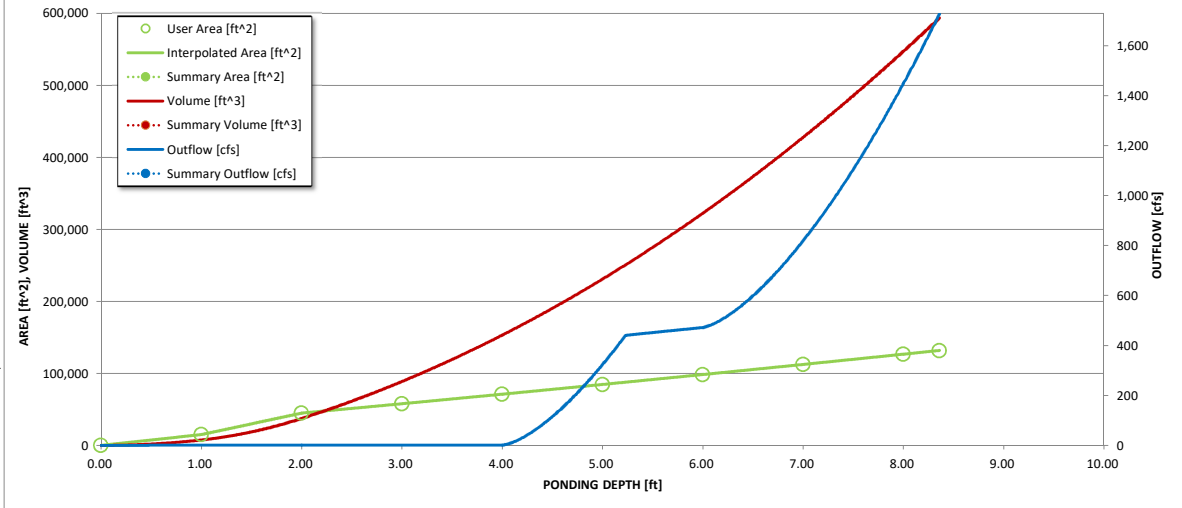
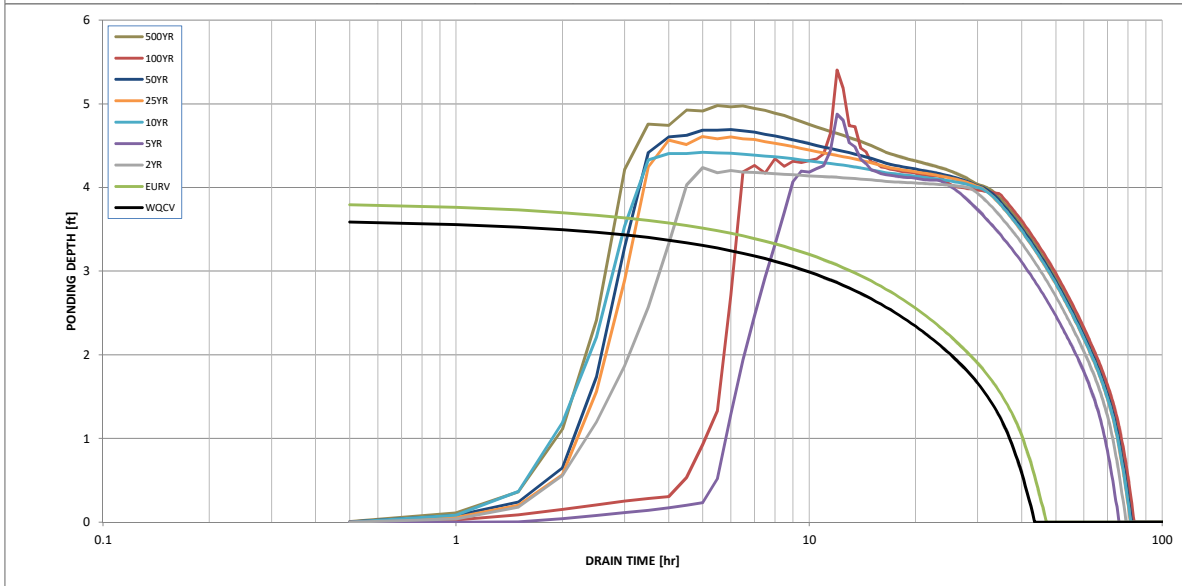
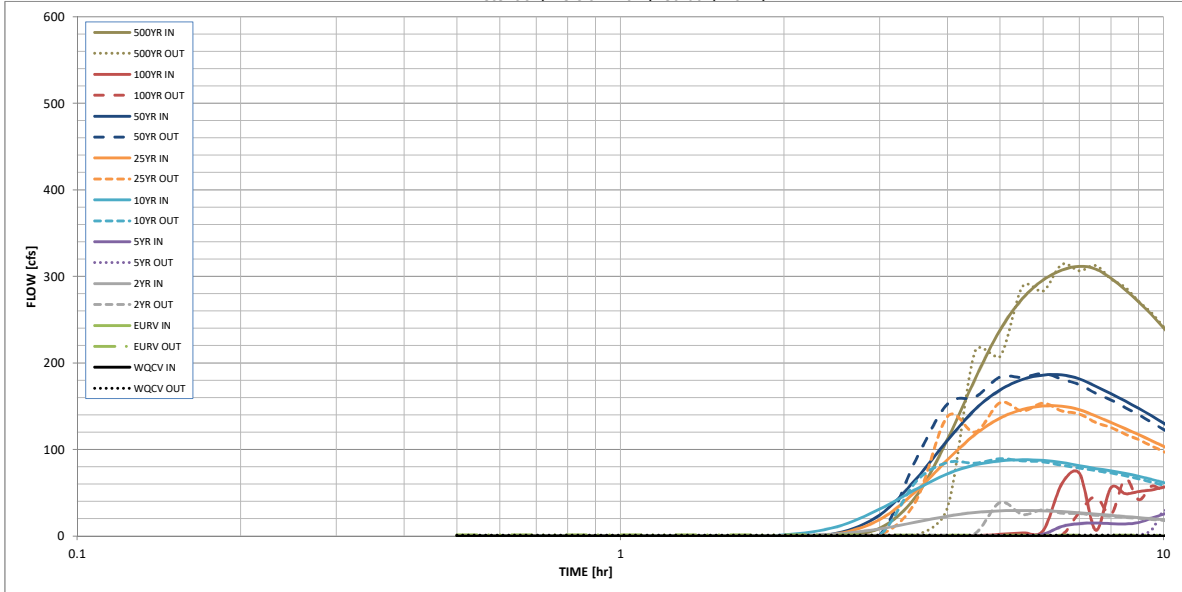

S-A-V-D Chart Axis Override	X-axis	Left Y-Axis	Right Y-Axis
minimum bound			
maximum bound			

DETENTION BASIN OUTLET STRUCTURE DESIGN

Outflow Hydrograph Workbook Filename: _____

Inflow Hydrographs

The user can override the calculated inflow hydrographs from this workbook with inflow hydrographs developed in a separate program.

User-Defined	SOURCE	CUHP	CUHP	CUHP	USER	CUHP	CUHP	CUHP	USER	CUHP
Time Interval	TIME	WQCV [cfs]	EURV [cfs]	2 Year [cfs]	5 Year [cfs]	10 Year [cfs]	25 Year [cfs]	50 Year [cfs]	100 Year [cfs]	500 Year [cfs]
30.00 min	0:00:00	0.00	0.00	0.00	0.00	0.00	0.00	0.00	0.00	0.00
	0:30:00	0.00	0.00	0.00	0.00	0.00	0.00	0.00	0.00	0.00
	1:00:00	0.00	0.00	0.00	0.00	0.00	0.00	0.01	0.00	0.02
	1:30:00	0.00	0.00	0.07	0.00	0.13	0.09	0.13	0.05	0.19
	2:00:00	0.00	0.00	0.36	0.01	1.25	0.41	0.50	0.13	1.14
	2:30:00	0.00	0.00	2.42	0.07	10.62	2.41	3.06	0.18	8.94
	3:00:00	0.00	0.00	8.18	0.10	30.99	18.79	24.13	0.21	45.53
	3:30:00	0.00	0.00	16.03	0.12	53.90	51.67	65.63	0.23	111.58
	4:00:00	0.00	0.00	22.88	0.13	71.77	87.95	110.42	0.24	181.67
	4:30:00	0.00	0.00	27.21	0.16	82.15	117.46	146.31	0.27	237.90
	5:00:00	0.00	0.00	29.06	0.17	86.73	136.11	168.70	1.89	274.33
	5:30:00	0.00	0.00	29.46	0.18	88.04	146.14	180.84	3.66	295.62
	6:00:00	0.00	0.00	29.12	2.09	87.31	150.13	185.95	6.06	307.14
	6:30:00	0.00	0.00	28.27	11.10	84.96	149.89	186.03	60.53	311.62
	7:00:00	0.00	0.00	26.90	14.34	81.34	145.90	181.57	72.46	308.44
	7:30:00	0.00	0.00	25.26	15.10	77.98	138.68	173.12	6.74	297.75
	8:00:00	0.00	0.00	23.81	14.30	75.27	131.14	164.37	55.71	284.62
	8:30:00	0.00	0.00	22.54	13.99	72.42	124.06	155.96	48.91	270.52
	9:00:00	0.00	0.00	21.32	15.56	69.12	117.16	147.54	51.38	255.73
	9:30:00	0.00	0.00	20.12	20.73	65.49	110.25	138.98	53.07	240.61
	10:00:00	0.00	0.00	18.91	25.15	61.74	103.40	130.45	56.49	225.49
	10:30:00	0.00	0.00	17.79	29.48	58.35	96.67	122.04	59.34	210.79
	11:00:00	0.00	0.00	16.86	35.92	55.48	90.75	114.70	68.39	197.93
	11:30:00	0.00	0.00	16.08	47.13	52.86	85.76	108.50	86.43	187.02
	12:00:00	0.00	0.00	15.34	106.21	50.28	81.26	102.86	185.87	177.08
	12:30:00	0.00	0.00	14.58	291.63	47.69	76.97	97.48	500.99	167.62
	13:00:00	0.00	0.00	13.80	199.27	45.06	72.79	92.20	343.72	158.35
	13:30:00	0.00	0.00	13.00	137.27	42.40	68.65	86.96	237.94	149.20
	14:00:00	0.00	0.00	12.19	96.88	39.72	64.54	81.74	168.13	140.19
	14:30:00	0.00	0.00	11.39	66.53	37.07	60.47	76.58	115.47	131.38
	15:00:00	0.00	0.00	10.59	43.50	34.45	56.43	71.47	76.18	122.68
	15:30:00	0.00	0.00	9.80	32.45	31.87	52.41	66.38	59.14	114.02
	16:00:00	0.00	0.00	9.01	26.02	29.33	48.40	61.32	47.19	105.39
	16:30:00	0.00	0.00	8.24	22.29	26.87	44.42	56.29	40.86	96.84
	17:00:00	0.00	0.00	7.57	20.43	24.92	40.56	51.43	36.70	88.78
	17:30:00	0.00	0.00	7.08	18.71	23.45	37.61	47.76	33.79	82.53
	18:00:00	0.00	0.00	6.71	17.81	22.20	35.31	44.86	32.25	77.46
	18:30:00	0.00	0.00	6.38	16.15	21.04	33.37	42.39	29.41	73.01
	19:00:00	0.00	0.00	6.07	15.05	19.95	31.62	40.14	27.55	68.99
	19:30:00	0.00	0.00	5.77	14.44	18.89	30.03	38.09	26.51	65.29
	20:00:00	0.00	0.00	5.48	14.13	17.87	28.52	36.14	25.98	61.82
	20:30:00	0.00	0.00	5.19	12.75	16.88	27.07	34.28	23.63	58.57
	21:00:00	0.00	0.00	4.91	11.83	15.93	25.67	32.49	21.07	55.54
	21:30:00	0.00	0.00	4.64	10.42	15.00	24.29	30.73	20.20	52.58
	22:00:00	0.00	0.00	4.36	10.03	14.11	22.93	29.01	18.70	49.66
	22:30:00	0.00	0.00	4.09	9.87	13.24	21.58	27.30	18.43	46.75
	23:00:00	0.00	0.00	3.83	9.81	12.38	20.23	25.59	18.33	43.85
	23:30:00	0.00	0.00	3.56	9.79	11.52	18.89	23.90	18.29	40.96
	0:00:00	0.00	0.00	3.29	8.19	10.67	17.56	22.21	15.51	38.08
	0:30:00	0.00	0.00	3.03	4.96	9.82	16.23	20.53	8.89	35.20
	1:00:00	0.00	0.00	2.77	3.11	8.98	14.90	18.85	5.66	32.34
	1:30:00	0.00	0.00	2.51	1.08	8.15	13.57	17.17	2.87	29.48
	2:00:00	0.00	0.00	2.25	0.46	7.32	12.25	15.51	1.80	26.63
	2:30:00	0.00	0.00	1.99	0.16	6.50	10.93	13.84	1.28	23.78
	3:00:00	0.00	0.00	1.74	0.06	5.67	9.61	12.18	1.11	20.94
	3:30:00	0.00	0.00	1.48	0.02	4.85	8.29	10.52	1.03	18.10
	4:00:00	0.00	0.00	1.22	0.00	4.02	6.97	8.86	1.00	15.26
	4:30:00	0.00	0.00	0.97	0.00	3.20	5.65	7.20	1.00	12.42
	5:00:00	0.00	0.00	0.71	0.00	2.38	4.33	5.54	1.00	9.59
	5:30:00	0.00	0.00	0.47	0.00	1.63	3.04	3.91	1.00	6.87
	6:00:00	0.00	0.00	0.28	0.00	1.19	1.88	2.49	1.00	4.63
	6:30:00	0.00	0.00	0.20	0.00	0.95	1.23	1.70	1.00	3.23
	7:00:00	0.00	0.00	0.16	0.00	0.76	0.83	1.19	1.00	2.29
	7:30:00	0.00	0.00	0.13	0.00	0.61	0.57	0.85	1.00	1.60
	8:00:00	0.00	0.00	0.10	0.00	0.49	0.39	0.60	1.00	1.09
	8:30:00	0.00	0.00	0.08	0.00	0.39	0.28	0.43	1.00	0.72
	9:00:00	0.00	0.00	0.07	0.00	0.29	0.19	0.31	1.00	0.45
	9:30:00	0.00	0.00	0.05	0.00	0.22	0.14	0.22	1.00	0.30
	10:00:00	0.00	0.00	0.04	0.00	0.16	0.10	0.16	1.00	0.22
	10:30:00	0.00	0.00	0.03	0.00	0.11	0.08	0.12	1.00	0.17
	11:00:00	0.00	0.00	0.03	0.00	0.09	0.06	0.09	1.00	0.14
	11:30:00	0.00	0.00	0.02	0.00	0.07	0.04	0.07	0.00	0.10
	12:00:00	0.00	0.00	0.01	0.00	0.05	0.03	0.05	0.00	0.08

DETENTION BASIN STAGE-STORAGE TABLE BUILDER

MHFD-Detention, Version 4.04 (February 2021)

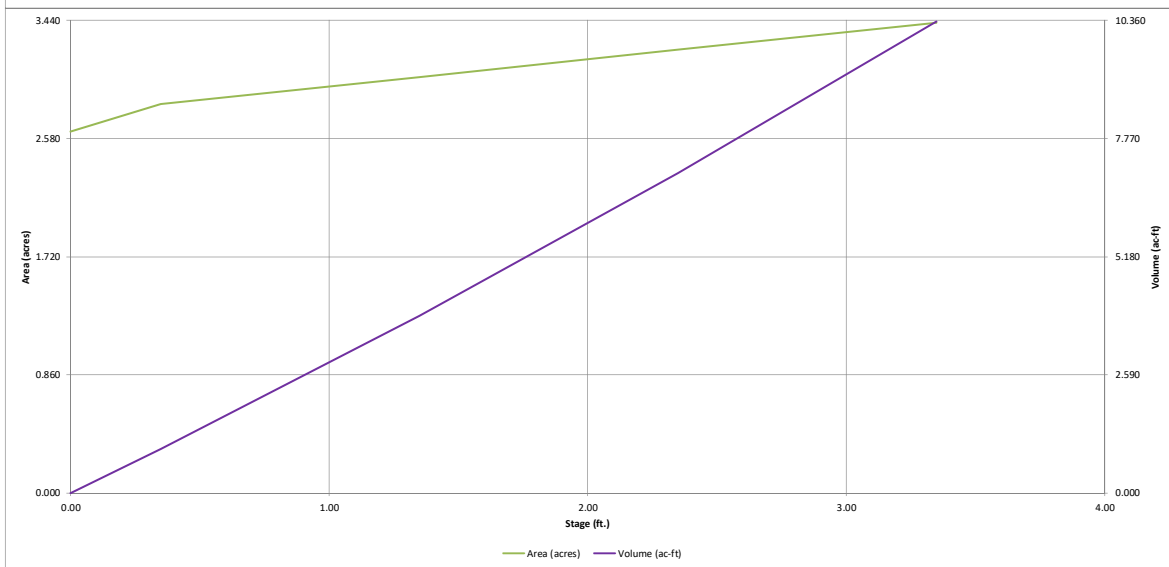
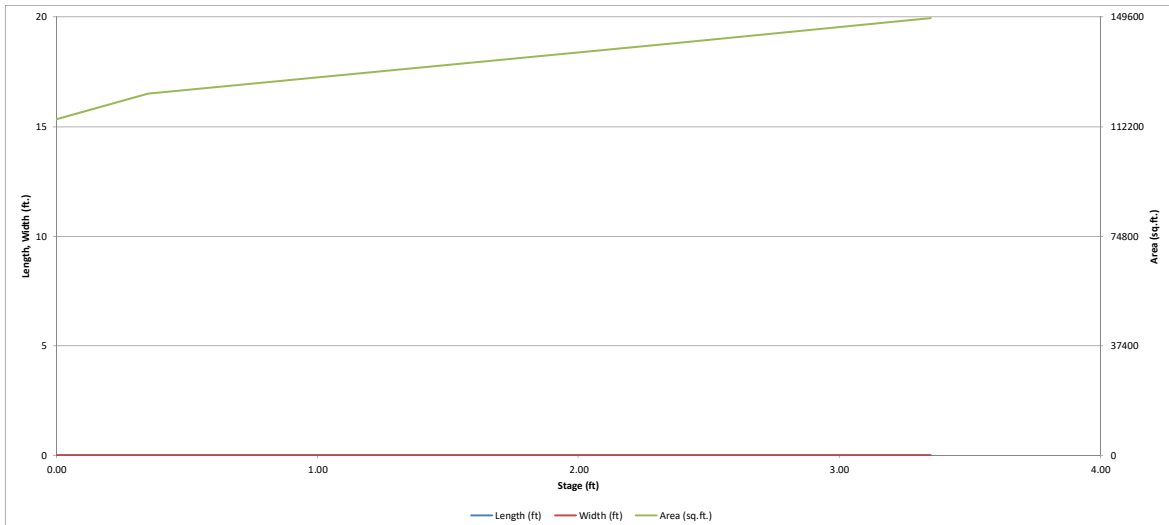

The orifice area per row seems large. Double check.

Likely typo. Do you mean it to be 30in or maybe 3ft?

DETENTION BASIN OUTLET STRUCTURE DESIGN

MHFD-Detention, Version 4.04 (February 2021)

Project: Latigo Trails-Filing No. 9
Basin ID: Black Squirrel Pond - Interim

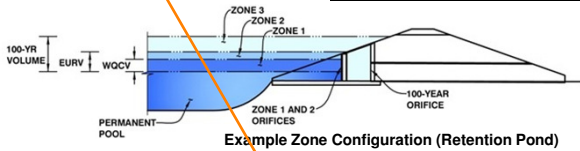

Example Zone Configuration (Retention Pond)

	Estimated Stage (ft)	Estimated Volume (ac-ft)	Outlet Type
Zone 1 (WQCV)	0.74	2.051	Orifice Plate
Zone 2 (EURV)	0.75	0.049	Not Utilized
Zone 3 (100-year)	2.25	4.574	Weir (No Pipe)
Total (all zones)		6.674	

User Input: Orifice at Underdrain Outlet (typically used to drain WQCV in a Filtration BMP)

Underdrain Orifice Invert Depth =	N/A	ft (distance below the filtration media surface)
Underdrain Orifice Diameter =	N/A	inches

Calculated Parameters for Underdrain		
Underdrain Orifice Area =	N/A	ft ²
Underdrain Orifice Centroid =	N/A	feet

User Input: Orifice Plate with one or more orifices or Elliptical Slot Weir (typically used to drain WQCV and/or EURV in a sedimentation BMP)

Invert of Lowest Orifice =	0.00	ft (relative to basin bottom at Stage = 0 ft)
Depth at top of Zone using Orifice Plate =	0.76	ft (relative to basin bottom at Stage = 0 ft)
Orifice Plate: Orifice Vertical Spacing =	3.00	inches
Orifice Plate: Orifice Area per Row =	30.28	sq. inches (use rectangular openings)

Calculated Parameters for Plate		
WQ Orifice Area per Row =	2.103E-01	ft ²
Elliptical Half-Width =	N/A	feet
Elliptical Slot Centroid =	N/A	feet
Elliptical Slot Area =	N/A	ft ²

User Input: Stage and Total Area of Each Orifice Row (numbered from lowest to highest)

	Row 1 (required)	Row 2 (optional)	Row 3 (optional)	Row 4 (optional)	Row 5 (optional)	Row 6 (optional)	Row 7 (optional)	Row 8 (optional)
Stage of Orifice Centroid (ft)	0.00	0.25	0.51					
Orifice Area (sq. inches)	30.28	30.28	30.28					

	Row 9 (optional)	Row 10 (optional)	Row 11 (optional)	Row 12 (optional)	Row 13 (optional)	Row 14 (optional)	Row 15 (optional)	Row 16 (optional)
Stage of Orifice Centroid (ft)								
Orifice Area (sq. inches)								

User Input: Vertical Orifice (Circular or Rectangular)

	Not Selected	Not Selected	
Invert of Vertical Orifice =	N/A	N/A	ft (relative to basin bottom at Stage = 0 ft)
Depth at top of Zone using Vertical Orifice =	N/A	N/A	ft (relative to basin bottom at Stage = 0 ft)
Vertical Orifice Diameter =	N/A	N/A	inches

Calculated Parameters for Vertical Orifice	Not Selected	Not Selected	
Vertical Orifice Area =	N/A	N/A	ft ²
Vertical Orifice Centroid =	N/A	N/A	feet

User Input: Overflow Weir (Dropbox with Flat or Sloped Gate and Outlet Pipe OR Rectangular/Trapezoidal Weir (and No Outlet Pipe))

	Zone 3 Weir	Not Selected	
Overflow Weir Front Edge Height, Ho =	0.75	N/A	ft (relative to basin bottom at Stage = 0 ft)
Overflow Weir Bottom Length =	30.00	N/A	feet
Overflow Weir Side Slopes =	4.00	N/A	H:V
Horiz. Length of Weir Sides =	N/A	N/A	feet
Overflow Gate Type =	N/A	N/A	
Debris Clogging % =	N/A	N/A	%

Calculated Parameters for Overflow Weir	Zone 3 Weir	Not Selected	
Height of Gate Upper Edge, H _g =	N/A	N/A	feet
Overflow Weir Slope Length =	N/A	N/A	feet
Grate Open Area / 100-yr Orifice Area =	N/A	N/A	
Overflow Grate Open Area w/o Debris =	N/A	N/A	ft ²
Overflow Grate Open Area w/ Debris =	N/A	N/A	ft ²

User Input: Outlet Pipe w/ Flow Restriction Plate (Circular Orifice, Restrictor Plate, or Rectangular Orifice)

	Not Selected	Not Selected	
Depth to Invert of Outlet Pipe =	N/A	N/A	ft (distance below basin bottom at Stage = 0 ft)
Circular Orifice Diameter =	N/A	N/A	inches

Calculated Parameters for Outlet Pipe w/ Flow Restriction Plate	Not Selected	Not Selected	
Outlet Orifice Area =	N/A	N/A	ft ²
Outlet Orifice Centroid =	N/A	N/A	feet
Half-Central Angle of Restrictor Plate on Pipe =	N/A	N/A	radians

User Input: Emergency Spillway (Rectangular or Trapezoidal)

Spillway Invert Stage =	3.00	ft (relative to basin bottom at Stage = 0 ft)
Spillway Crest Length =	99.00	feet
Spillway End Slopes =	4.00	H:V
Freeboard above Max Water Surface =	1.00	feet
Spillway position relative to Overflow Weir =		

Calculated Parameters for Spillway		
Spillway Design Flow Depth =	1.34	feet
Stage at Top of Freeboard =	5.34	feet
Basin Area at Top of Freeboard =	3.43	acres
Basin Volume at Top of Freeboard =	10.34	acre-ft

Routed Hydrograph Results

The user can override the default CUHP hydrographs and runoff volumes by entering new values in the Inflow Hydrographs table (Columns W through AF).

	WQCV	EURV	2 Year	5 Year	10 Year	25 Year	50 Year	100 Year	500 Year
Design Storm Return Period	N/A	N/A	1.19	1.50	1.75	2.00	2.25	2.52	3.00
One-Hour Rainfall Depth (in)	N/A	N/A	2.392	5.443	8.512	14.053	17.801	23.227	30.786
CUHP Runoff Volume (acre-ft)	2.051	2.100	2.392	5.443	8.512	14.053	17.801	23.227	30.786
User Override Inflow Hydrograph Volume (acre-ft)	N/A	N/A	14.350	42.926	51.069	84.320	106.804	184.714	184.714
CUHP Predevelopment Peak Q (cfs)	N/A	N/A	14.8	41.9	65.2	120.4	151.4	194.6	254.6
OPTIONAL Override Predevelopment Peak Q (cfs)	N/A	N/A	159.0	159.0	159.0	159.0	159.0	284.0	284.0
Predevelopment Unit Peak Flow, q (cfs/acre)	N/A	N/A	0.08	0.83	0.34	0.63	0.79	1.48	1.33
Peak Inflow Q (cfs)	N/A	N/A	22.9	183.5	74.5	128.8	160.0	317.9	263.9
Peak Outflow Q (cfs)	2.0	2.0	20.5	162.1	74.1	128.5	159.7	284.0	263.2
Ratio Peak Outflow to Predevelopment Q	N/A	N/A	N/A	1.0	1.1	1.1	1.1	1.0	1.0
Structure Controlling Flow	Plate	Overflow Weir 1	Overflow Weir 1	Overflow Weir 1	Overflow Weir 1	Overflow Weir 1	Overflow Weir 1	Overflow Weir 1	Overflow Weir 1
Max Velocity through Gate 1 (fps)	N/A	N/A	N/A	N/A	N/A	N/A	N/A	N/A	N/A
Max Velocity through Gate 2 (fps)	N/A	N/A	N/A	N/A	N/A	N/A	N/A	N/A	N/A
Time to Drain 97% of Inflow Volume (hours)	37	37	42	33	28	21	18	24	11
Time to Drain 99% of Inflow Volume (hours)	41	41	53	47	43	36	33	41	27
Maximum Ponding Depth (ft)	0.74	0.75	1.08	2.08	1.56	1.90	2.07	2.63	2.55
Area at Maximum Ponding Depth (acres)	2.91	2.91	2.98	3.17	3.07	3.14	3.17	3.28	3.26
Maximum Volume Stored (acre-ft)	2.076	2.106	3.077	6.151	4.497	5.552	6.088	7.926	7.632

these flowrates should not be less than the previous storm's. Revise.

DETENTION BASIN OUTLET STRUCTURE DESIGN

MHFD-Detention, Version 4.04 (February 2021)

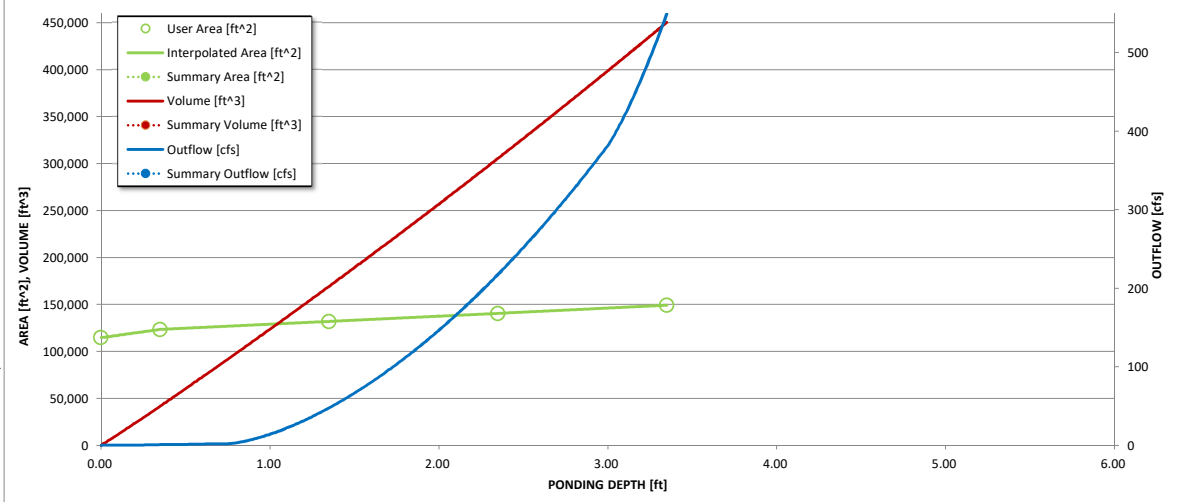
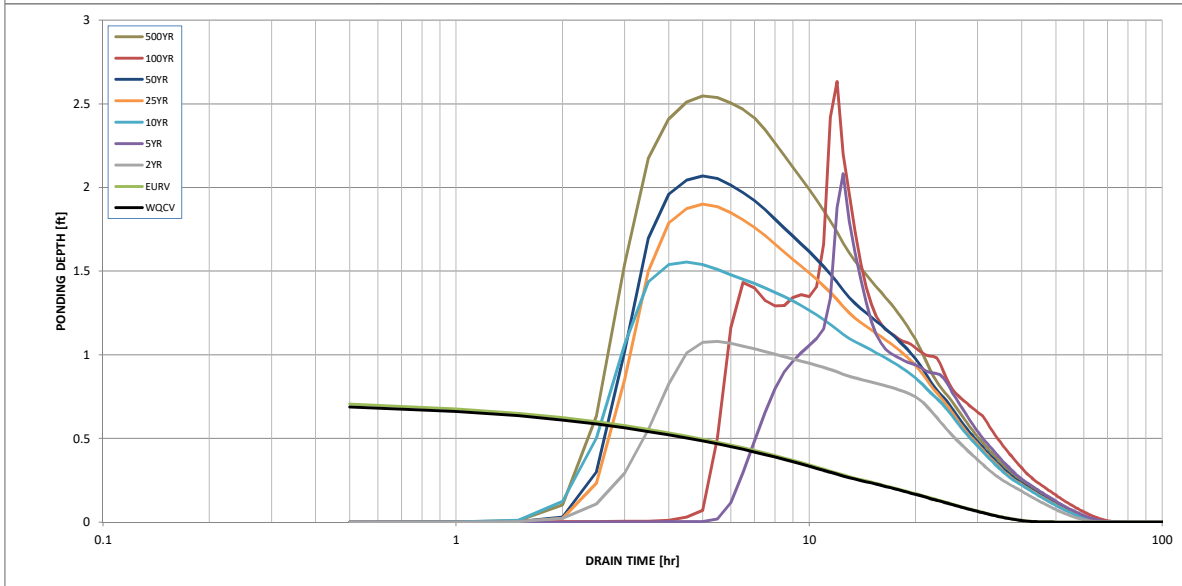
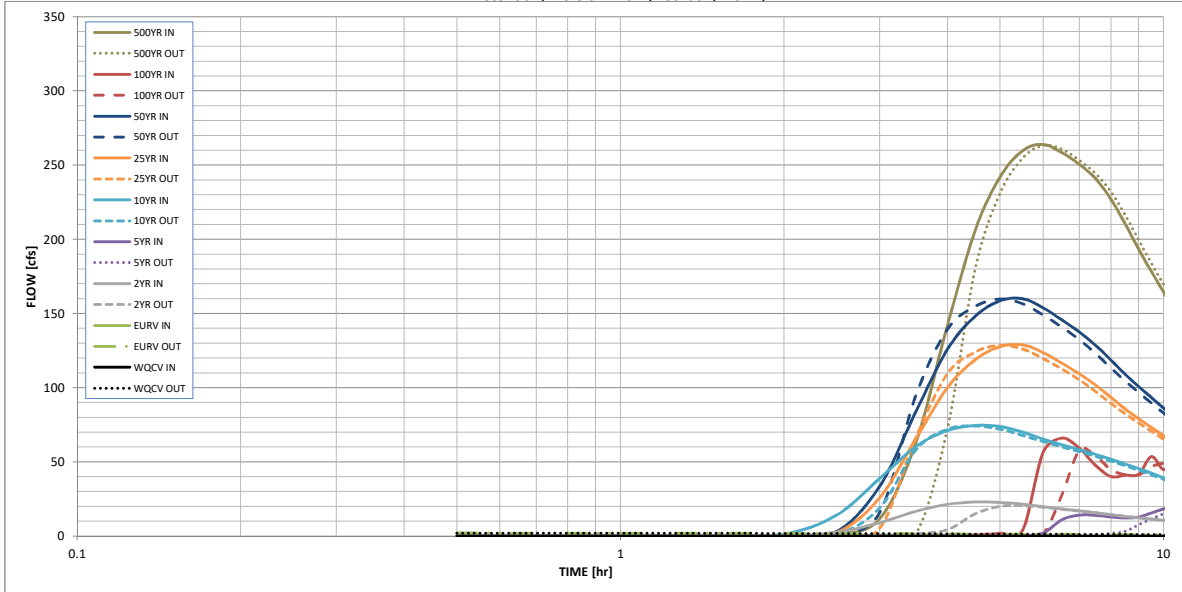

S-A-V-D Chart Axis Override	X-axis	Left Y-Axis	Right Y-Axis
minimum bound			
maximum bound			

DETENTION BASIN OUTLET STRUCTURE DESIGN

Outflow Hydrograph Workbook Filename: _____

Inflow Hydrographs

The user can override the calculated inflow hydrographs from this workbook with inflow hydrographs developed in a separate program.

User-Defined	SOURCE	CUHP	CUHP	CUHP	USER	CUHP	CUHP	CUHP	USER	CUHP
Time Interval	TIME	WQCV [cfs]	EURV [cfs]	2 Year [cfs]	5 Year [cfs]	10 Year [cfs]	25 Year [cfs]	50 Year [cfs]	100 Year [cfs]	500 Year [cfs]
30.00 min	0:00:00	0.00	0.00	0.00	0.00	0.00	0.00	0.00	0.00	0.00
	0:30:00	0.00	0.00	0.00	0.00	0.00	0.00	0.00	0.00	0.00
	1:00:00	0.00	0.00	0.00	0.00	0.00	0.00	0.01	0.02	0.02
	1:30:00	0.00	0.00	0.06	0.00	0.11	0.08	0.11	0.06	0.15
	2:00:00	0.00	0.00	0.28	0.00	1.20	0.31	0.38	0.08	1.02
	2:30:00	0.00	0.00	2.47	0.03	14.03	2.40	3.13	0.09	11.51
	3:00:00	0.00	0.00	8.98	0.04	38.69	25.66	33.38	0.10	62.93
	3:30:00	0.00	0.00	16.64	0.05	60.31	65.65	83.90	0.11	141.74
	4:00:00	0.00	0.00	21.38	0.06	71.06	99.96	125.74	0.12	205.87
	4:30:00	0.00	0.00	22.89	0.07	74.50	118.84	148.11	0.76	241.86
	5:00:00	0.00	0.00	22.66	0.08	73.81	127.58	158.49	1.85	259.57
	5:30:00	0.00	0.00	21.46	0.08	70.00	128.80	159.95	3.74	263.89
	6:00:00	0.00	0.00	19.79	1.99	65.30	123.66	153.86	56.24	258.32
	6:30:00	0.00	0.00	18.26	10.99	61.48	116.44	145.55	65.98	250.48
	7:00:00	0.00	0.00	16.98	14.10	58.21	109.35	137.46	59.13	240.86
	7:30:00	0.00	0.00	15.67	13.95	55.04	101.66	128.46	47.56	227.05
	8:00:00	0.00	0.00	14.36	12.78	51.72	93.49	118.64	40.11	210.33
	8:30:00	0.00	0.00	13.18	12.20	48.57	85.60	108.91	41.09	193.33
	9:00:00	0.00	0.00	12.26	12.75	45.47	79.05	100.75	41.58	178.22
	9:30:00	0.00	0.00	11.42	15.56	42.35	73.10	93.23	53.54	164.40
	10:00:00	0.00	0.00	10.61	18.27	39.26	67.57	86.22	44.76	151.69
	10:30:00	0.00	0.00	9.82	21.24	36.22	62.30	79.53	49.80	139.76
	11:00:00	0.00	0.00	9.02	25.10	33.25	57.22	73.10	60.73	128.30
	11:30:00	0.00	0.00	8.22	32.07	30.31	52.22	66.78	120.90	117.18
	12:00:00	0.00	0.00	7.42	68.16	27.35	47.30	60.58	317.85	106.36
	12:30:00	0.00	0.00	6.61	183.54	24.39	42.42	54.42	233.13	95.71
	13:00:00	0.00	0.00	5.90	134.42	22.13	37.63	48.35	168.08	85.58
	13:30:00	0.00	0.00	5.43	96.27	20.46	34.13	43.96	120.99	77.90
	14:00:00	0.00	0.00	5.05	69.22	18.98	31.38	40.44	86.70	71.59
	14:30:00	0.00	0.00	4.71	49.64	17.61	29.05	37.42	59.83	66.02
	15:00:00	0.00	0.00	4.39	33.93	16.33	26.94	34.65	45.81	60.97
	15:30:00	0.00	0.00	4.07	24.67	15.08	25.02	32.14	36.10	56.33
	16:00:00	0.00	0.00	3.76	19.55	13.88	23.18	29.75	30.34	51.98
	16:30:00	0.00	0.00	3.46	16.16	12.72	21.41	27.45	26.85	47.92
	17:00:00	0.00	0.00	3.17	14.70	11.60	19.71	25.25	24.73	44.13
	17:30:00	0.00	0.00	2.88	13.45	10.52	18.02	23.09	23.59	40.41
	18:00:00	0.00	0.00	2.59	12.78	9.47	16.36	20.97	21.70	36.76
	18:30:00	0.00	0.00	2.30	11.68	8.45	14.70	18.85	20.41	33.11
	19:00:00	0.00	0.00	2.02	10.92	7.43	13.05	16.75	19.65	29.46
	19:30:00	0.00	0.00	1.74	10.47	6.41	11.40	14.65	19.25	25.83
	20:00:00	0.00	0.00	1.45	10.23	5.40	9.75	12.55	17.74	22.20
	20:30:00	0.00	0.00	1.17	9.35	4.39	8.11	10.46	15.66	18.58
	21:00:00	0.00	0.00	0.89	8.71	3.40	6.47	8.37	15.03	14.96
	21:30:00	0.00	0.00	0.62	7.45	2.42	4.83	6.30	13.67	11.37
	22:00:00	0.00	0.00	0.37	7.14	1.62	3.23	4.26	13.46	7.95
	22:30:00	0.00	0.00	0.21	7.01	1.16	1.95	2.68	13.36	5.31
	23:00:00	0.00	0.00	0.14	6.95	0.91	1.23	1.78	13.32	3.67
	23:30:00	0.00	0.00	0.11	6.93	0.72	0.80	1.21	11.66	2.55
	0:00:00	0.00	0.00	0.09	5.98	0.57	0.52	0.83	6.99	1.73
	0:30:00	0.00	0.00	0.07	3.87	0.45	0.34	0.56	4.81	1.14
	1:00:00	0.00	0.00	0.05	2.62	0.34	0.22	0.39	2.53	0.71
	1:30:00	0.00	0.00	0.04	0.88	0.25	0.14	0.26	1.75	0.42
	2:00:00	0.00	0.00	0.03	0.43	0.18	0.09	0.17	1.31	0.26
	2:30:00	0.00	0.00	0.03	0.18	0.12	0.07	0.13	1.13	0.19
	3:00:00	0.00	0.00	0.02	0.07	0.09	0.05	0.09	1.04	0.14
	3:30:00	0.00	0.00	0.02	0.02	0.07	0.04	0.07	1.00	0.11
	4:00:00	0.00	0.00	0.01	0.00	0.05	0.03	0.05	1.00	0.09
	4:30:00	0.00	0.00	0.01	0.00	0.03	0.02	0.04	1.00	0.06
	5:00:00	0.00	0.00	0.01	0.00	0.02	0.01	0.03	1.00	0.04
	5:30:00	0.00	0.00	0.00	0.00	0.01	0.01	0.02	1.00	0.03
	6:00:00	0.00	0.00	0.00	0.00	0.01	0.01	0.01	1.00	0.02
	6:30:00	0.00	0.00	0.00	0.00	0.00	0.00	0.00	1.00	0.01
	7:00:00	0.00	0.00	0.00	0.00	0.00	0.00	0.00	1.00	0.00
	7:30:00	0.00	0.00	0.00	0.00	0.00	0.00	0.00	1.00	0.00
	8:00:00	0.00	0.00	0.00	0.00	0.00	0.00	0.00	0.00	0.00
	8:30:00	0.00	0.00	0.00	0.00	0.00	0.00	0.00	0.00	0.00
	9:00:00	0.00	0.00	0.00	0.00	0.00	0.00	0.00	0.00	0.00
	9:30:00	0.00	0.00	0.00	0.00	0.00	0.00	0.00	0.00	0.00
	10:00:00	0.00	0.00	0.00	0.00	0.00	0.00	0.00	0.00	0.00
	10:30:00	0.00	0.00	0.00	0.00	0.00	0.00	0.00	0.00	0.00
	11:00:00	0.00	0.00	0.00	0.00	0.00	0.00	0.00	0.00	0.00
	11:30:00	0.00	0.00	0.00	0.00	0.00	0.00	0.00	0.00	0.00
	12:00:00	0.00	0.00	0.00	0.00	0.00	0.00	0.00	0.00	0.00

DETENTION BASIN STAGE-STORAGE TABLE BUILDER

MHFD-Detention, Version 4.04 (February 2021)

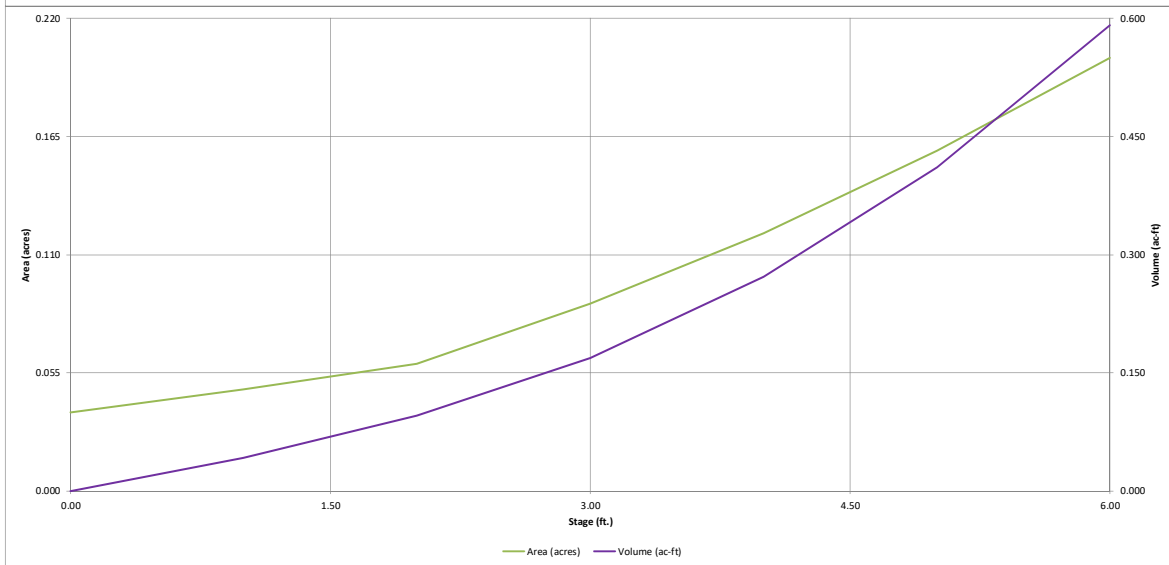
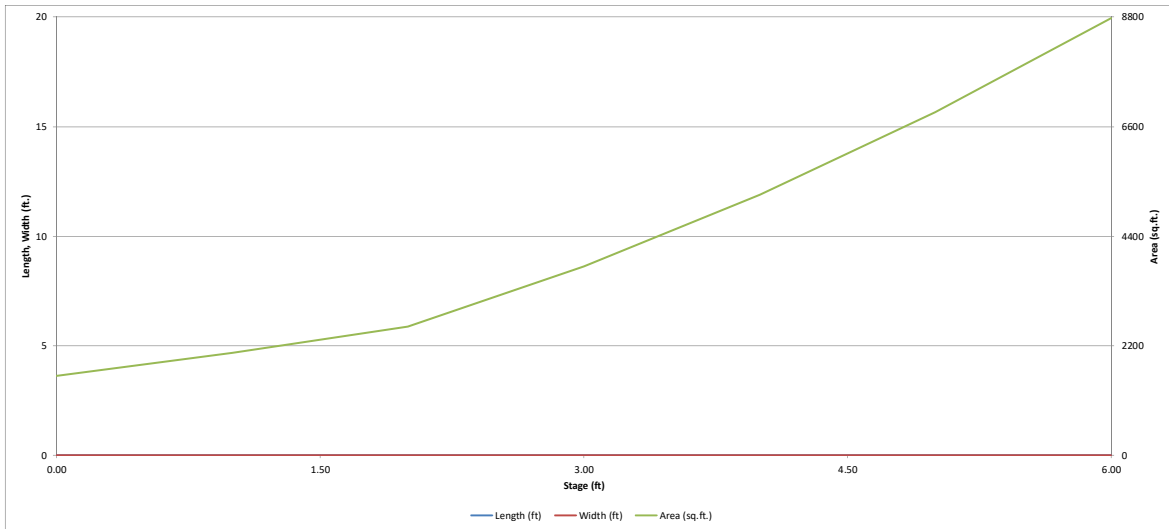

This and other pond calcs will be reviewed in more details once pond outlet details/sections are provided in CD's.

DETENTION BASIN OUTLET STRUCTURE DESIGN

MHFD-Detention, Version 4.04 (February 2021)

Project: Latigo Trails Filing 9
Basin ID: G18 - Interim

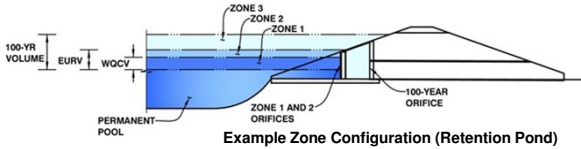

Example Zone Configuration (Retention Pond)

	Estimated Stage (ft)	Estimated Volume (ac-ft)	Outlet Type
Zone 1 (WQCV)	0.51	0.020	Orifice Plate
Zone 2 (EURV)	1.82	0.064	Orifice Plate
Zone 3 (User)	3.53	0.134	Weir&Pipe (Rect.)
Total (all zones)		0.218	

User Input: Orifice at Underdrain Outlet (typically used to drain WQCV in a Filtration BMP)

Underdrain Orifice Invert Depth =	<input type="text"/>	ft (distance below the filtration media surface)
Underdrain Orifice Diameter =	<input type="text"/>	inches

Calculated Parameters for Underdrain		
Underdrain Orifice Area =	<input type="text"/>	ft ²
Underdrain Orifice Centroid =	<input type="text"/>	feet

User Input: Orifice Plate with one or more orifices or Elliptical Slot Weir (typically used to drain WQCV and/or EURV in a sedimentation BMP)

Invert of Lowest Orifice =	<input type="text"/>	0.00	ft (relative to basin bottom at Stage = 0 ft)
Depth at top of Zone using Orifice Plate =	<input type="text"/>	3.00	ft (relative to basin bottom at Stage = 0 ft)
Orifice Plate: Orifice Vertical Spacing =	<input type="text"/>	N/A	inches
Orifice Plate: Orifice Area per Row =	<input type="text"/>	N/A	inches

Calculated Parameters for Plate		
WQ Orifice Area per Row =	<input type="text"/>	N/A
Elliptical Half-Width =	<input type="text"/>	N/A
Elliptical Slot Centroid =	<input type="text"/>	N/A
Elliptical Slot Area =	<input type="text"/>	N/A

User Input: Stage and Total Area of Each Orifice Row (numbered from lowest to highest)

	Row 1 (required)	Row 2 (optional)	Row 3 (optional)	Row 4 (optional)	Row 5 (optional)	Row 6 (optional)	Row 7 (optional)	Row 8 (optional)
Stage of Orifice Centroid (ft)	<input type="text"/>	<input type="text"/>	<input type="text"/>	<input type="text"/>	<input type="text"/>	<input type="text"/>	<input type="text"/>	<input type="text"/>
Orifice Area (sq. inches)	<input type="text"/>	<input type="text"/>	<input type="text"/>	<input type="text"/>	<input type="text"/>	<input type="text"/>	<input type="text"/>	<input type="text"/>

	Row 9 (optional)	Row 10 (optional)	Row 11 (optional)	Row 12 (optional)	Row 13 (optional)	Row 14 (optional)	Row 15 (optional)	Row 16 (optional)
Stage of Orifice Centroid (ft)	<input type="text"/>	<input type="text"/>	<input type="text"/>	<input type="text"/>	<input type="text"/>	<input type="text"/>	<input type="text"/>	<input type="text"/>
Orifice Area (sq. inches)	<input type="text"/>	<input type="text"/>	<input type="text"/>	<input type="text"/>	<input type="text"/>	<input type="text"/>	<input type="text"/>	<input type="text"/>

User Input: Vertical Orifice (Circular or Rectangular)

	<input type="checkbox"/> Not Selected	<input type="checkbox"/> Not Selected	
Invert of Vertical Orifice =	<input type="text"/>	N/A	ft (relative to basin bottom at Stage = 0 ft)
Depth at top of Zone using Vertical Orifice =	<input type="text"/>	N/A	ft (relative to basin bottom at Stage = 0 ft)
Vertical Orifice Diameter =	<input type="text"/>	N/A	inches

Calculated Parameters for Vertical Orifice		
Vertical Orifice Area =	<input type="text"/>	N/A
Vertical Orifice Centroid =	<input type="text"/>	N/A

User Input: Overflow Weir (Dropbox with Flat or Sloped Gate and Outlet Pipe OR Rectangular/Trapezoidal Weir (and No Outlet Pipe))

	Zone 3 Weir	Not Selected	
Overflow Weir Front Edge Height, Ho =	<input type="text"/>	N/A	ft (relative to basin bottom at Stage = 0 ft)
Overflow Weir Front Edge Length =	<input type="text"/>	N/A	feet
Overflow Weir Gate Slope =	<input type="text"/>	N/A	H:V
Horiz. Length of Weir Sides =	<input type="text"/>	N/A	feet
Overflow Gate Type =	<input type="text"/>	N/A	
Debris Clogging % =	<input type="text"/>	N/A	%

Calculated Parameters for Overflow Weir		
Height of Gate Upper Edge, H ₁ =	<input type="text"/>	N/A
Overflow Weir Slope Length =	<input type="text"/>	N/A
Grate Open Area / 100-yr Orifice Area =	<input type="text"/>	N/A
Overflow Gate Open Area w/o Debris =	<input type="text"/>	N/A
Overflow Gate Open Area w/ Debris =	<input type="text"/>	N/A

User Input: Outlet Pipe w/ Flow Restriction Plate (Circular Orifice, Restrictor Plate, or Rectangular Orifice)

	<input type="checkbox"/> Zone 3 Rectangular	<input type="checkbox"/> Not Selected	
Depth to Invert of Outlet Pipe =	<input type="text"/>	N/A	ft (distance below basin bottom at Stage = 0 ft)
Rectangular Orifice Width =	<input type="text"/>	N/A	inches
Rectangular Orifice Height =	<input type="text"/>	N/A	inches

Calculated Parameters for Outlet Pipe w/ Flow Restriction Plate		
Outlet Orifice Area =	<input type="text"/>	N/A
Outlet Orifice Centroid =	<input type="text"/>	N/A
Half-Central Angle of Restrictor Plate on Pipe =	<input type="text"/>	N/A

User Input: Emergency Spillway (Rectangular or Trapezoidal)

Spillway Invert Stage =	<input type="text"/>	4.50	ft (relative to basin bottom at Stage = 0 ft)
Spillway Crest Length =	<input type="text"/>	20.00	feet
Spillway End Slopes =	<input type="text"/>	4.00	H:V
Freeboard above Max Water Surface =	<input type="text"/>	1.00	feet

Calculated Parameters for Spillway		
Spillway Design Flow Depth =	<input type="text"/>	0.44
Stage at Top of Freeboard =	<input type="text"/>	5.94
Basin Area at Top of Freeboard =	<input type="text"/>	0.20
Basin Volume at Top of Freeboard =	<input type="text"/>	0.58

Routed Hydrograph Results

The user can override the default CUHP hydrographs and runoff volumes by entering new values in the Inflow Hydrographs table (Columns W through AF).

	WQCV	EURV	2 Year	5 Year	10 Year	25 Year	50 Year	100 Year	500 Year
Design Storm Return Period	N/A	N/A	1.19	1.50	1.75	2.00	2.25	2.52	3.00
One-Hour Rainfall Depth (in)	N/A	N/A	1.19	1.50	1.75	2.00	2.25	2.52	3.00
CUHP Runoff Volume (acre-ft)	0.020	0.084	0.176	0.443	0.718	1.237	1.578	2.081	2.771
Inflow Hydrograph Volume (acre-ft)	N/A	N/A	0.176	0.443	0.718	1.237	1.578	2.081	2.771
CUHP Predevelopment Peak Q (cfs)	N/A	N/A	1.5	4.2	6.4	11.6	14.6	18.7	24.4
OPTIONAL Override Predevelopment Peak Q (cfs)	N/A	N/A							
Predevelopment Unit Peak Flow, q (cfs/acre)	N/A	N/A	0.08	0.24	0.36	0.66	0.82	1.05	1.38
Peak Inflow Q (cfs)	N/A	N/A	1.9	4.6	6.8	12.0	15.0	19.1	24.8
Peak Outflow Q (cfs)	0.0	0.0	0.9	4.3	6.9	12.1	14.9	17.0	23.0
Ratio Peak Outflow to Predevelopment Q	N/A	N/A	N/A	1.0	1.1	1.0	1.0	0.9	0.9
Structure Controlling Flow	Plate	Plate	Overflow Weir 1	Overflow Weir 1	Overflow Weir 1	Overflow Weir 1	Overflow Weir 1	Outlet Plate 1	Spillway
Max Velocity through Gate 1 (fps)	N/A	N/A	0.10	0.4	0.7	1.2	1.5	1.7	1.8
Max Velocity through Gate 2 (fps)	N/A	N/A	N/A	N/A	N/A	N/A	N/A	N/A	N/A
Time to Drain 97% of Inflow Volume (hours)	37	64	64	51	41	28	22	16	8
Time to Drain 99% of Inflow Volume (hours)	40	71	74	66	61	53	48	42	35
Maximum Ponding Depth (ft)	0.51	1.81	2.12	2.31	2.42	2.62	2.72	3.53	4.67
Area at Maximum Ponding Depth (acres)	0.04	0.06	0.06	0.07	0.07	0.08	0.08	0.10	0.15
Maximum Volume Stored (acre-ft)	0.020	0.084	0.102	0.114	0.123	0.137	0.144	0.218	0.361

DETENTION BASIN OUTLET STRUCTURE DESIGN

MHFD-Detention, Version 4.04 (February 2021)

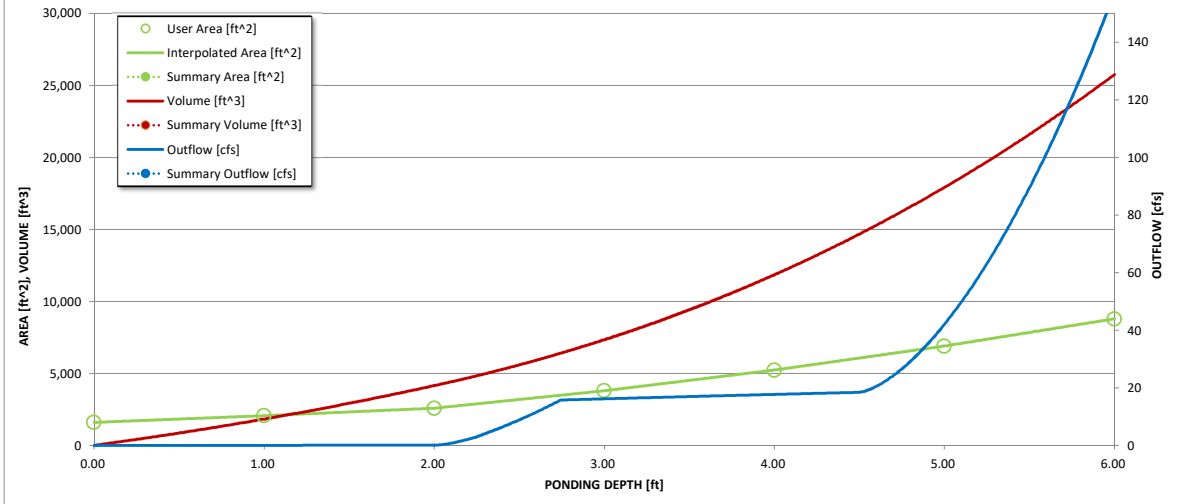
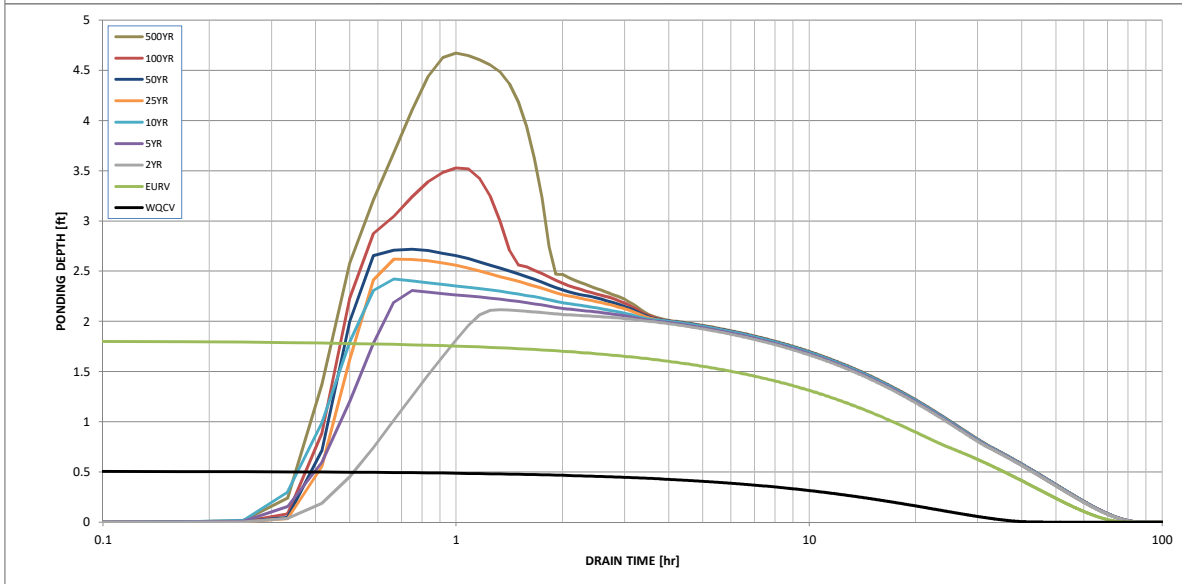
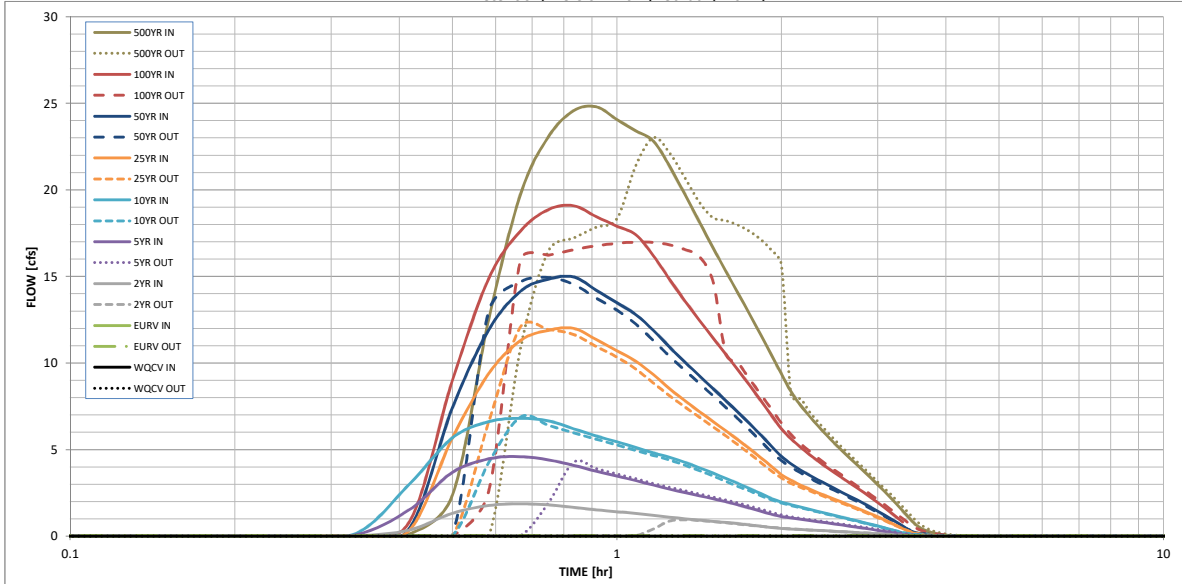

S-A-V-D Chart Axis Override	X-axis	Left Y-Axis	Right Y-Axis
minimum bound			
maximum bound			

DETENTION BASIN OUTLET STRUCTURE DESIGN

Outflow Hydrograph Workbook Filename: _____

Inflow Hydrographs

The user can override the calculated inflow hydrographs from this workbook with inflow hydrographs developed in a separate program.

Time Interval	SOURCE	CUHP	CUHP	CUHP	CUHP	CUHP	CUHP	CUHP	CUHP	CUHP
	TIME	WQCV [cfs]	EURV [cfs]	2 Year [cfs]	5 Year [cfs]	10 Year [cfs]	25 Year [cfs]	50 Year [cfs]	100 Year [cfs]	500 Year [cfs]
5.00 min	0:00:00	0.00	0.00	0.00	0.00	0.00	0.00	0.00	0.00	0.00
	0:05:00	0.00	0.00	0.00	0.00	0.00	0.00	0.00	0.00	0.00
	0:10:00	0.00	0.00	0.00	0.00	0.00	0.00	0.00	0.00	0.00
	0:15:00	0.00	0.00	0.01	0.01	0.01	0.01	0.01	0.01	0.01
	0:20:00	0.00	0.00	0.02	0.09	0.16	0.02	0.03	0.04	0.13
	0:25:00	0.00	0.00	0.35	1.52	2.99	0.33	0.43	0.79	2.35
	0:30:00	0.00	0.00	1.32	3.68	5.67	5.66	7.40	8.97	12.56
	0:35:00	0.00	0.00	1.77	4.47	6.61	9.40	11.92	14.90	19.75
	0:40:00	0.00	0.00	1.87	4.59	6.80	11.30	14.15	17.62	23.08
	0:45:00	0.00	0.00	1.80	4.40	6.66	11.89	14.84	18.87	24.57
	0:50:00	0.00	0.00	1.67	4.09	6.20	12.00	14.97	19.08	24.79
	0:55:00	0.00	0.00	1.53	3.75	5.79	11.35	14.21	18.45	24.06
	1:00:00	0.00	0.00	1.42	3.47	5.45	10.71	13.48	17.90	23.41
	1:05:00	0.00	0.00	1.31	3.21	5.12	10.10	12.79	17.41	22.81
	1:10:00	0.00	0.00	1.20	2.95	4.80	9.33	11.88	16.19	21.34
	1:15:00	0.00	0.00	1.09	2.71	4.55	8.51	10.91	14.81	19.70
	1:20:00	0.00	0.00	1.01	2.51	4.26	7.81	10.04	13.57	18.12
	1:25:00	0.00	0.00	0.93	2.33	3.95	7.20	9.25	12.46	16.65
	1:30:00	0.00	0.00	0.86	2.16	3.64	6.62	8.52	11.44	15.29
	1:35:00	0.00	0.00	0.79	1.99	3.34	6.08	7.82	10.49	14.02
	1:40:00	0.00	0.00	0.72	1.81	3.04	5.55	7.15	9.58	12.81
	1:45:00	0.00	0.00	0.65	1.63	2.75	5.04	6.49	8.70	11.63
	1:50:00	0.00	0.00	0.58	1.44	2.46	4.53	5.85	7.84	10.48
	1:55:00	0.00	0.00	0.51	1.27	2.18	4.03	5.21	7.00	9.36
	2:00:00	0.00	0.00	0.45	1.14	1.97	3.56	4.61	6.20	8.34
	2:05:00	0.00	0.00	0.42	1.05	1.82	3.22	4.18	5.62	7.57
	2:10:00	0.00	0.00	0.39	0.98	1.68	2.95	3.83	5.14	6.93
	2:15:00	0.00	0.00	0.36	0.91	1.56	2.72	3.53	4.72	6.36
	2:20:00	0.00	0.00	0.33	0.84	1.44	2.51	3.25	4.34	5.85
	2:25:00	0.00	0.00	0.31	0.77	1.32	2.32	3.00	4.00	5.37
	2:30:00	0.00	0.00	0.28	0.71	1.21	2.14	2.76	3.67	4.93
	2:35:00	0.00	0.00	0.26	0.65	1.10	1.96	2.53	3.36	4.51
	2:40:00	0.00	0.00	0.23	0.58	0.99	1.79	2.31	3.08	4.12
	2:45:00	0.00	0.00	0.21	0.52	0.89	1.62	2.09	2.79	3.74
	2:50:00	0.00	0.00	0.19	0.46	0.79	1.45	1.87	2.51	3.36
	2:55:00	0.00	0.00	0.16	0.40	0.69	1.28	1.66	2.23	2.98
	3:00:00	0.00	0.00	0.14	0.34	0.59	1.11	1.44	1.94	2.60
	3:05:00	0.00	0.00	0.11	0.28	0.49	0.95	1.23	1.66	2.22
	3:10:00	0.00	0.00	0.09	0.22	0.39	0.78	1.01	1.38	1.85
	3:15:00	0.00	0.00	0.07	0.16	0.29	0.61	0.80	1.10	1.47
	3:20:00	0.00	0.00	0.04	0.10	0.20	0.44	0.59	0.81	1.10
	3:25:00	0.00	0.00	0.02	0.05	0.13	0.28	0.38	0.54	0.74
	3:30:00	0.00	0.00	0.01	0.03	0.09	0.17	0.23	0.35	0.49
	3:35:00	0.00	0.00	0.01	0.02	0.07	0.10	0.15	0.23	0.34
	3:40:00	0.00	0.00	0.00	0.02	0.05	0.06	0.10	0.15	0.23
	3:45:00	0.00	0.00	0.00	0.01	0.04	0.04	0.06	0.09	0.15
	3:50:00	0.00	0.00	0.00	0.01	0.03	0.02	0.04	0.05	0.09
	3:55:00	0.00	0.00	0.00	0.01	0.02	0.01	0.03	0.03	0.05
	4:00:00	0.00	0.00	0.00	0.01	0.02	0.01	0.02	0.01	0.03
	4:05:00	0.00	0.00	0.00	0.00	0.01	0.01	0.01	0.01	0.02
	4:10:00	0.00	0.00	0.00	0.00	0.01	0.00	0.01	0.01	0.01
	4:15:00	0.00	0.00	0.00	0.00	0.00	0.00	0.01	0.00	0.01
	4:20:00	0.00	0.00	0.00	0.00	0.00	0.00	0.00	0.00	0.01
	4:25:00	0.00	0.00	0.00	0.00	0.00	0.00	0.00	0.00	0.01
	4:30:00	0.00	0.00	0.00	0.00	0.00	0.00	0.00	0.00	0.00
	4:35:00	0.00	0.00	0.00	0.00	0.00	0.00	0.00	0.00	0.00
	4:40:00	0.00	0.00	0.00	0.00	0.00	0.00	0.00	0.00	0.00
	4:45:00	0.00	0.00	0.00	0.00	0.00	0.00	0.00	0.00	0.00
	4:50:00	0.00	0.00	0.00	0.00	0.00	0.00	0.00	0.00	0.00
	4:55:00	0.00	0.00	0.00	0.00	0.00	0.00	0.00	0.00	0.00
	5:00:00	0.00	0.00	0.00	0.00	0.00	0.00	0.00	0.00	0.00
	5:05:00	0.00	0.00	0.00	0.00	0.00	0.00	0.00	0.00	0.00
	5:10:00	0.00	0.00	0.00	0.00	0.00	0.00	0.00	0.00	0.00
	5:15:00	0.00	0.00	0.00	0.00	0.00	0.00	0.00	0.00	0.00
	5:20:00	0.00	0.00	0.00	0.00	0.00	0.00	0.00	0.00	0.00
	5:25:00	0.00	0.00	0.00	0.00	0.00	0.00	0.00	0.00	0.00
	5:30:00	0.00	0.00	0.00	0.00	0.00	0.00	0.00	0.00	0.00
	5:35:00	0.00	0.00	0.00	0.00	0.00	0.00	0.00	0.00	0.00
	5:40:00	0.00	0.00	0.00	0.00	0.00	0.00	0.00	0.00	0.00
	5:45:00	0.00	0.00	0.00	0.00	0.00	0.00	0.00	0.00	0.00
	5:50:00	0.00	0.00	0.00	0.00	0.00	0.00	0.00	0.00	0.00
	5:55:00	0.00	0.00	0.00	0.00	0.00	0.00	0.00	0.00	0.00
	6:00:00	0.00	0.00	0.00	0.00	0.00	0.00	0.00	0.00	0.00

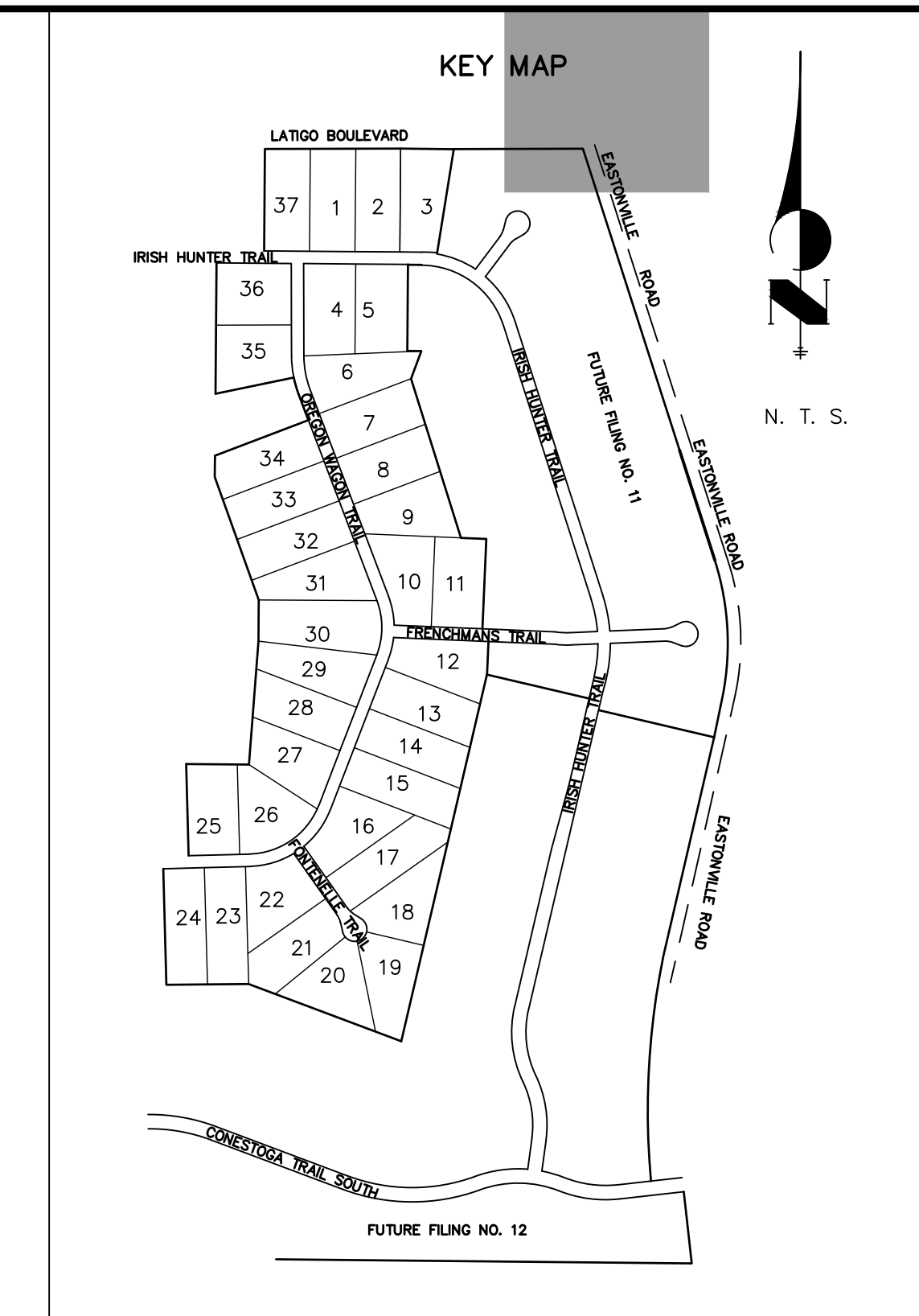
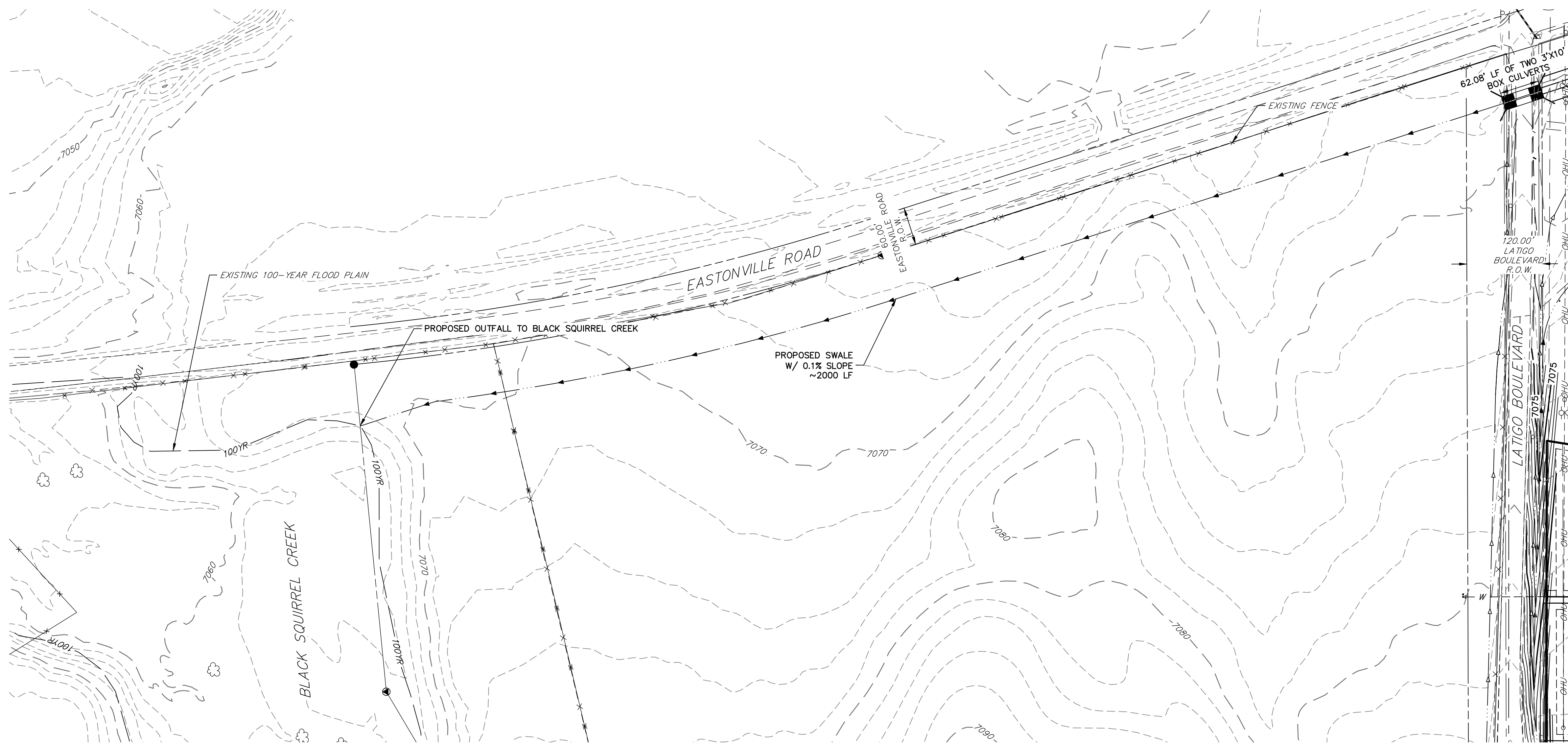

811
Know what's below.
Call before you dig.

100 50 0 100 200
ORIGINAL SCALE: 1" = 100'

ENGINEER'S STATEMENT
PREPARED UNDER MY DIRECT SUPERVISION AND ON BEHALF OF JR ENGINEERING

MIKE A. BRAMLETT, P.E.
COLORADO P.E. 32314
FOR AND ON BEHALF OF JR ENGINEERING, LLC

DATE

<p>UNTIL SUCH TIME AS THESE DRAWINGS ARE APPROVED BY THE AGENCIES, JR ENGINEERING APPROVES THEIR USE. DESIGNATED BY WRITTEN AUTHORIZATION.</p>	
<p>PREPARED FOR BRJM, LLC 101 N. CASCADE, SUITE 200 COLORADO SPRINGS, CO 80903 ATTN: BOB IRWIN P~(719)-475-7474</p>	<p>J.R. ENGINEERING A Westman Company Central 303-740-9888 • Colorado Springs 719-588-2583 Fort Collins 970-491-9888 • www.jrengineering.com</p>
<p>BY</p>	<p>DATE</p>
<p>No.</p>	<p>REVISION</p>
<p>H-SCALE 1"=100'</p>	<p>V-SCALE N/A</p>
<p>DATE 09/10/21</p>	<p>DESIGNED BY APL</p>
<p>DRAWN BY APL</p>	<p>CHECKED BY</p>
<p>LATIGO TRAILS - FILING NO. 9</p>	<p>BLACK SQUIRREL POND OUTFALL</p>
<p>SHEET 1 OF 1</p>	<p>JOB NO. 25175.01</p>

X:\2517501\Drawings\Sheet\Drawings\2517501_BS-OUTFALL.dwg, BS, 9/14/2021 1:46:24 PM, CS

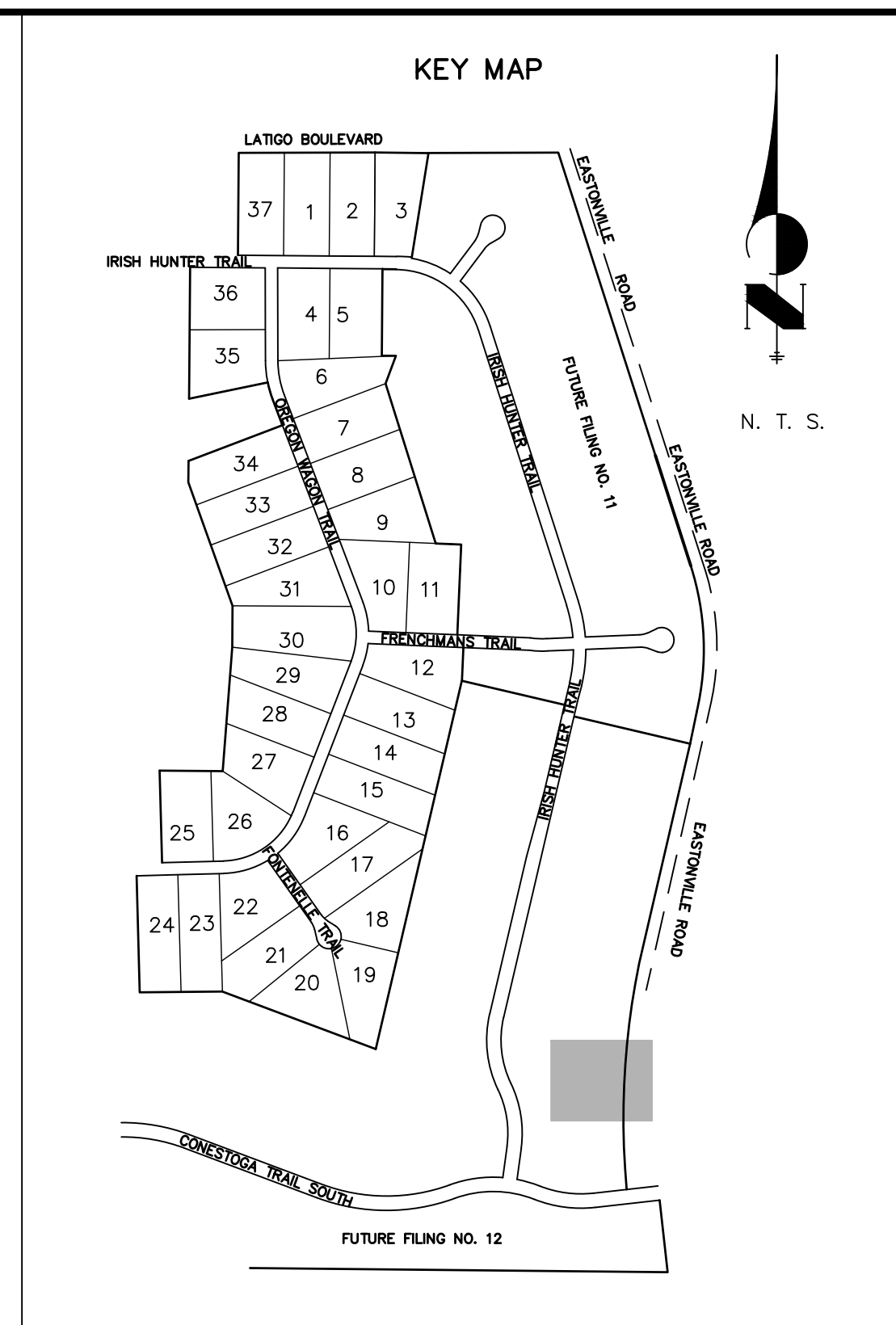
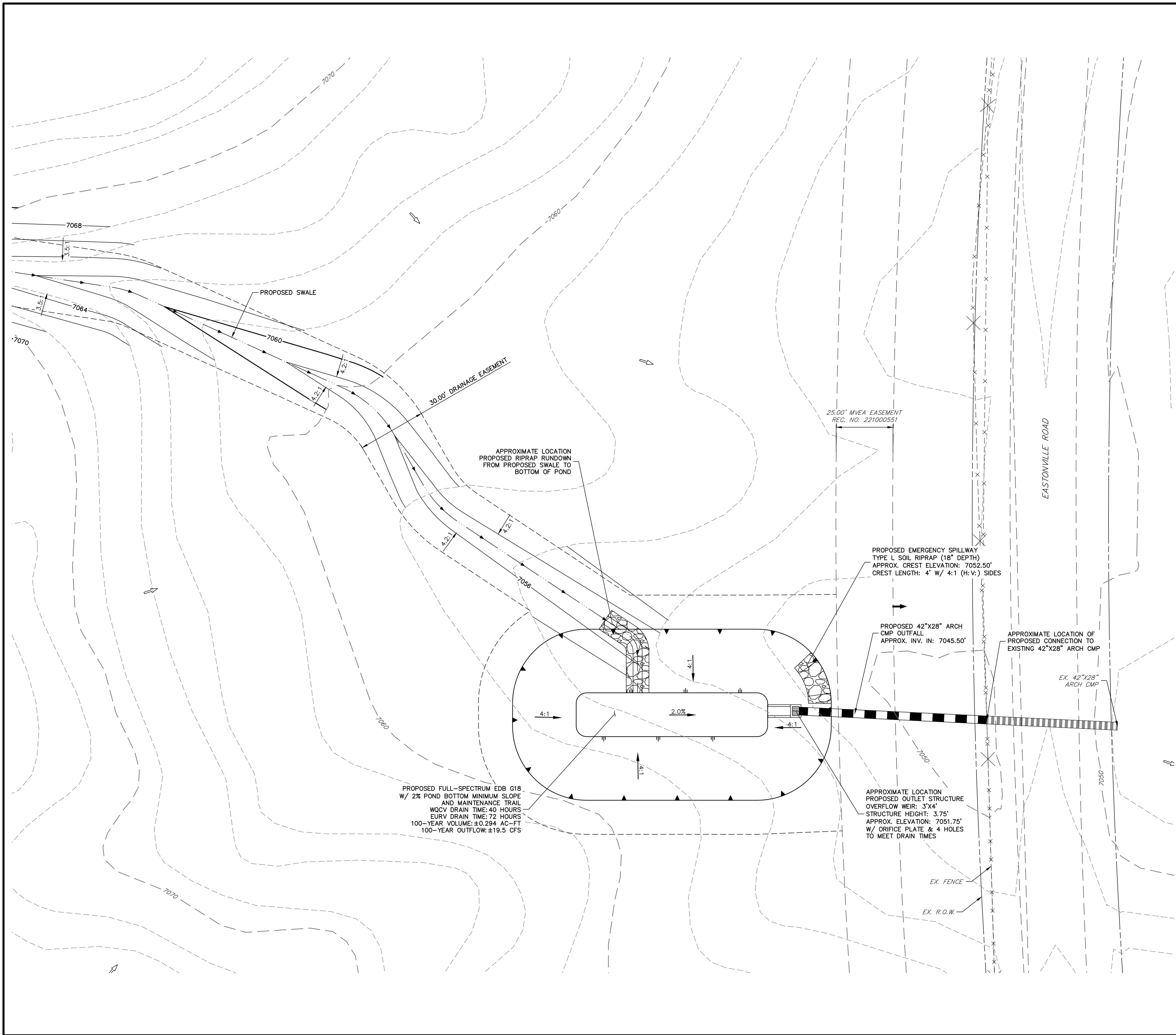

UNTIL SUCH TIME AS THESE DRAWINGS ARE APPROVED BY THE APPROPRIATE REVIEWING AGENCIES, JR ENGINEERING APPROVES THEIR USE AS DESIGNATED BY WRITTEN AUTHORIZATION.

PREPARED FOR
BRJM, LLC
101 N. CASCADE, SUITE 200
COLORADO SPRINGS, CO 80903
ATTN: BOB IRWIN
P~(719)-475-7474

J.R. ENGINEERING
A Westman Company
Central 303-740-9888 • Colorado Springs 719-588-2583
Fort Collins 970-491-9888 • www.jrengineering.com

BY	DATE	No.	REVISION

H-SCALE	1"=20'
V-SCALE	N/A
DATE	09/10/21
DESIGNED BY	GAG
DRAWN BY	GAG
CHECKED BY	

Know what's below.
Call before you dig.

ORIGINAL SCALE: 1" = 20'

ENGINEER'S STATEMENT
PREPARED UNDER MY DIRECT SUPERVISION AND ON BEHALF OF JR ENGINEERING

MIKE A. BRAMLETT, P.E.
COLORADO P.E. 32314
FOR AND ON BEHALF OF JR ENGINEERING, LLC

32314

DATE

LATIGO TRAILS - FILING NO. 9
POND PLANS

SHEET 6 OF 7
JOB NO. 25175.01

X:\25175.01\Drawings\Sheet\Drawings\25175.01_G18-P001.dwg, G18, 9/13/2021, 3:57:06 PM, CS

APPENDIX E
REFERENCE MATERIALS



**MASTER DEVELOPMENT /
PRELIMINARY DRAINAGE PLAN
LATIGO TRAILS
EL PASO COUNTY, COLORADO**

October 4, 2001

Prepared for:

**RMBG, LLC #2
5170 Mark Dabling Blvd.
COLORADO SPRINGS, CO 80918**

PREPARED BY:

URS

9960 Federal Drive, Suite 300
Colorado Springs, CO 80921

URS PROJECT NO. 67-00042443

Drainage Design Criteria

SCS Hydrograph Procedure

The Soil Conservation Service (SCS) Hydrograph procedure was used to determine runoff for some of the above-named basins and their sub-basins (basins of approximately 100-acres or more). Basin and sub-basin areas were calculated using AutoCAD and aerial topography of the site. There are no entire offsite basins contributing runoff to the subject area, but small areas on the western edge of the site have been included in their respective on-site basins for simplicity. Times of concentration were estimated using the procedures described in the DCM. Based upon the hydrologic soil type, the natural conditions found in the basins and the runoff curve numbers (CN) chart from Table 5-4 of the DCM, the following CN values were used for the given conditions:

Table 2a: SCS Runoff Curve Numbers

Condition	CN	Assumptions
Best	65	Best pasture / undisturbed
Undeveloped	66	Fair pasture
Residential Lots (2.5 acre)	70-71	
Disturbed / Seeded Ground	69	0.6 acres per lot
Dirt Road / Drive	85	10'x150' per lot and gravel roads
Roof / Pavement / Asphalt	98	5000 s.f. per lot and asphalt roads

The 100-year, 24 hour storm precipitation selected from the NOAA isopluvial map in DCM Figure 5-4e is 4.4 inches. The 5-year, 24 hour storm precipitation selected from the rainfall depth-duration relationship chart in DCM Figure 5-6 is 2.6 inches. These numbers along with SCS information were used as input to the HEC-1 computer model to determine design runoffs.

HEC-1 results are shown in Appendix A : Existing Condition HEC-1 Computer Results, Appendix B : Developed Condition HEC-1 Computer Results (without Detention), and Appendix C : Developed Condition HEC-1 Computer Results (with Detention). A tabular summary of all HEC-1 and rational method information is shown in Appendix E : Summary Information.

DRAINAGE FACILITY DESIGN

General Concept

Latigo Trails is divided into two basins, as described above in the Drainage Basin section. The basin boundaries will have very minor modifications, only along the roads in the central portion of the development, depending on final road profiles. Figure 4: Existing Condition Major Drainage Basins Map and Figure 5: Developed Condition Major Drainage Basins Map outline the major basin boundaries for existing and proposed conditions.

The Upper Black Squirrel Creek and Gieck Ranch Basins do not currently have DBPS. The existing natural drainageways will be left in their existing condition where practical. In cooperation with Meridian Ranch to the south, the basins will utilize detention facilities that release at historic levels or less across Eastonville Road.

Existing Drainage Characteristics

Figure 6, at the end of this section, illustrates the sub-basin boundaries used for the hydrologic analysis for each of the major basins. Table 3 summarizes existing condition peak flows for the sub-basins shown on Figure 6. Existing and developed peak flows at key design points are listed in Table 4, also at the end of this section.

Upper Black Squirrel Creek Basin

The Upper Black Squirrel Creek Basin covers the northern half of the subject area, draining mainly to the east. Many of the existing drainageways are not clearly defined. Three culverts cross Eastonville Road south of Latigo Blvd.: a 21" RCP at Latigo Blvd., a 12" RCP about 800' south of that, and a 36" CMP about 1200' south of that. North of Latigo Blvd., there are two low points at Eastonville Road that appear to pond up to the point that excess runoff would overtop Eastonville Road and flow to the east. A small portion of the basin drains directly to Upper Black Squirrel Creek.

Seven sub-basins, varying from 20 to 99 acres, lie south of Latigo Boulevard, draining to the 21" RCP at the intersection of Latigo Blvd. and Eastonville Road and the 12" RCP 800' south of that. It appears that the intersection would be overtopped in the event of a 100-year storm, based on the capacity of the 21" RCP (18 cfs). Eastonville Road at the 12" RCP would also be overtopped during a storm of any duration, based on the capacity of that pipe (5 cfs).

One sub-basin (7.01) drains to the 36" CMP crossing Eastonville Road approximately 2000' south of the intersection of Latigo and Eastonville. The existing pipe is adequate for existing and developed flows, with capacity for 47 cfs.

Four sub-basins, varying from 3 to 53 acres, lie north of Latigo Blvd, draining mainly to the east, with excess runoff ponding at Eastonville Road and eventually overtopping it. One of these basins (9.71) drains directly to Upper Black Squirrel Creek. There is a Zone-A, unstudied FEMA floodplain to the north of the proposed development, in the open space / Upper Black Squirrel Creek area.

Gieck Ranch Basin

The Gieck Ranch Basin covers the southern half of the subject area. Runoff is generally southeasterly, draining to Meridian Ranch to the south, and crossing Eastonville Road at three points to the east. As with the Upper Black Squirrel Creek Basin, many of the existing drainageways (mainly to the south) are not clearly defined.

The major drainage course begins at the west-central portion of the site, traversing the Gieck Ranch Basin to design point G11 to the southeast. Six sub-basins, varying from 19 to 39 acres, contribute to this drainage course, which collects approximately 65% of the runoff generated within the Gieck Basin in Latigo Trails. To the west of this, eight sub-basins drain to five design points along the Meridian Ranch boundary, two of which (G5 and G6) combine shortly after entering Meridian Ranch, at G6b.

There are eight small sub-basins east of the major drainage course, varying from 2 to 41 acres. All but one drain at their own design point, either crossing Eastonville Road or onto Meridian Ranch. The three culverts crossing Eastonville Road include an 18" CMP, a 30" CMP, and a 42"x28" Arch CMP. The 30" CMP has the capacity for 31 cfs, which is inadequate for existing flows. The other two pipes are adequate for existing and developed flows. The drainageways entering Meridian Ranch are not very well defined.

Four stock ponds exist on the site, but are assumed to be full at the beginning of a storm as part of this analysis. If the ponds were empty, flows at G2 may be reduced by about 30 cfs, flows at G10 and G11 may be reduced by about 34 cfs, flows at G13 may be reduced by about 23 cfs, and flows at B1, B2 and B3 may be reduced by about 45 cfs (for flows up to 100-year storm estimates).

See Tables 3 and 4 for flow calculations at specific design points and further comments.

Table 3 - Existing Condition Peak Flows

The Trails MDDP

EXISTING CONDITIONS HYDROLOGY BASE DATA: BASIN DATA

URS Job Nos. 6742443

original 3/8/2001

updated 7/20/2001

SUB-BASIN	TOTAL AREA		CN/C	Tc (hr)	UD (hr)	DESIGN FLOWS (cfs) CN = 66		COMMENTS	Rational DESIGN FLOWS (cfs) C = 24, 34	
	(Ac)	(sq.mi.)				5-YR	100-YR		5-YR	100-YR
GIECK RANCH										
2.11	26.86	0.042	66	0.323	0.194	8	40	scs	19	47
6.41	38.89	0.061	66	0.164	0.098	16	74	scs	38	94
2.21	25.26	0.039	66	0.336	0.201	7	36	scs	18	44
2.31	26.98	0.042	66	0.288	0.173	9	42	scs	20	50
6.31	18.75	0.029	66	0.474	0.285	4	22	scs	11	27
6.61	19.56	0.031	66	0.319	0.192	6	30	scs	14	35
2.61	16.52	0.026	66	0.233	0.140	6	28	scs	14	34
2.71	15.92	0.025	66	0.299	0.179	5	25	scs	12	29
2.41	24.52	0.038	66	0.322	0.193	7	36	scs	17	43
5.11	19.42	0.030	66	0.505	0.303	4	22	scs	11	27
5.21	18.16	0.028	66	0.518	0.311	4	20	scs	10	24
3.11 *	19.06	0.030	0.24	0.297	0.178			rat	14	35
3.21 *	32.44	0.051	0.24	0.301	0.181			rat	24	59
6.21 *	33.94	0.053	0.24	0.387	0.232			rat	22	54
4.21 *	4.13	0.006	0.24	0.252	0.151			rat	3	8
4.31 *	16.15	0.025	0.24	0.457	0.274			rat	9	23
4.41 *	7.48	0.012	0.24	0.268	0.161			rat	6	14
4.51 *	20.13	0.031	0.24	0.427	0.256			rat	12	30
4.61 *	24.56	0.038	0.25	0.371	0.223			rat	17	41
4.91 *	2.30	0.004	0.28	0.193	0.116			rat	2	6
4.71 *	40.95	0.064	0.25	0.378	0.227			rat	27	67
4.81 *	2.37	0.004	0.24	0.198	0.119			rat	2	5
UPPER BLACK SQUIRREL CREEK										
7.11	99.19	0.155	66	0.669	0.402	19	94	scs	46	114
7.21	49.10	0.077	66	0.499	0.299	12	57	scs	27	68
7.31	36.03	0.056	66	0.528	0.317	8	40	scs	20	48
7.71	20.06	0.031	66	0.686	0.412	4	19	scs	9	23
8.61	24.99	0.039	67	0.308	0.185	9	41	scs	19	47
8.21	46.19	0.072	66	0.438	0.263	12	58	scs	28	69
8.11	45.13	0.071	66	0.782	0.469	8	39	scs	19	48
7.01 *	16.44	0.026	0.26	0.328	0.197	15	25	rat	13	31
9.11 *	39.62	0.062	0.26	0.322	0.193	14	63	rat	31	74
9.31 *	52.64	0.082	0.24	0.813	0.488	19	44	rat	22	54
9.71 *	10.20	0.016	0.24	0.497	0.298	12	12	rat	6	14
9.91 *	2.72	0.004	0.26	0.473	0.284	11	14	rat	2	4

* NOTE: Basins are too small for a HEC1 analysis to be accurate; use a Rational analysis instead

Table 4 - Design Points

THE TRAILS MDDP
 HYDROLOGY OUTPUT: DESIGN POINTS
 URS Job No. 6742443

DESIGN FLOWS (cfs)											
DESIGN POINT				EXISTING		DEVELOPED-BASE			DEVELOPED-DETN		
DP		Basin		5-YR	100-YR	Method	5-YR**	100-YR	Area*	5-YR	100-YR
UBSC: BASIN				TRMEBxxx:OUT				TRMDBxxx:OUT			
S2	D	7.12				scs	14	30	16.4		
S3	D	+					27	63	34.4		
B11	E	7.11		46	94						
S5	D	+					52	118	66.7		
S6	D	7.17				scs	8	19	10.2		
S10	D	7.24				scs	28	58	32.4		
S11	D	+				scs	33	69	38.3		
S12	D	+					63	151	88.4	63	140
S14	D	7.32				scs	9	19	9.5		
B2	B	+		28	145		118	287	170.3	118	274
S17	D	7.72				scs	8	17	9.7		
B3	B	+		39	199		142	343	202.1	142	332
S15	D	7.02				rat	1	3	1.3		
S16	D	+				rat	4	10	4.2		
B4	B	+		13	31		14	32	15.1	13	30
B5	B	+		26	123		223	542	324.9	222	531
B6	B	8.62/2		19	41		13	30	14.0		
S1	D	8.12				scs	8	18	9.2		
S4	D	+					15	34	16.8		
S8S	D	8.24					10	23	12.1		
S8W	D	+					22	48	55.4		
S8E	D	+					47	102	67.4		
S7	D	8.16				scs	6	12	6.5		
S9	D	+					60	131	67.4		
S13S	D	+					17	40	21.4		
S13	D	+					77	171	88.8		
B7	B	+		25	109		97	220	161.6		
N10	D	9.12	x 0.7				7	16	5.9		
N11	D	9.12	x 0.4			rat	4	9	3.2		
N12	D	+					15	36	23.7		
B8	B	+					238	572	364.7	142	562
N14	D	9.34				rat	13	30	16.5		
B9	B	+					232	557	364.7		
B11	B	+					243	599	390.4		
BSC	B	+		132	464		253	635	430.1	130	462



J·R ENGINEERING
A Westrian Company

**FINAL DRAINAGE REPORT FOR
THE TRAILS FILING NO. 8
AND
ADDENDUM TO MASTER DEVELOPMENT/
PRELIMINARY DRAINAGE PLAN
FOR LATIGO TRAILS,
EL PASO COUNTY, COLORADO**

*VA-06-002
SF-06-016*

January 3, 2007

Prepared For:

FALCON TRAILS, LLC
PO Box 63479
Colorado Springs CO 80962
(719) 314-2500

Prepared By:

JR ENGINEERING
4310 ArrowsWest Drive
Colorado Springs, CO 80907
(719) 593-2593

Job No. 29278.01

RECEIVED

JAN 11 2007

EPC DEVELOPMENT SERVICES

Detention Pond S12

The S12 detention pond was designed in the “Final Drainage Report The Trails Filing No. 7 Subdivision,” by URS, dated March 2005, as a temporary facility that may become permanent in the future. Flow rates from Design Point 3 are conveyed to the pond through a 4’ deep trapezoidal channel with a 12’ bottom and 4:1 side slopes. (See Appendix for channel calculations.)

Due to the size and nature of the existing temporary detention pond S12, it was determined that rerouting flows from portions of The Trails Filing No. 8 to the pond would be the best way to make use of the ponds storage capacity. With the subject development, Detention Pond S12 will become a permanent facility to be owned and maintained by the development’s HOA.

The existing detention pond and release structure was designed to receive flows of $Q_5=68$ cfs and $Q_{100}=246$ cfs and release $Q_5=14$ cfs and $Q_{100}=73$ cfs, with a maximum storage volume of 7.7 Ac-ft at elevation 7104.3 and capacity for 13.2 Ac-ft at elevation 7107.0.

The designed release rates from the reconfigured detention pond are $Q_5=17$ cfs and $Q_{100}=58$ cfs, which are less than the historic $Q_5=46$ cfs and $Q_{100}=94$ cfs (per the “Final Drainage Report for Filing No.7”). The existing retention volume in Pond S12 is eliminated with this development, which provides less storage volume, 12.0 ac-ft. (See Appendix for HEC-1 analysis). Improvements to Detention Pond S12 are discussed in the Detention Pond Modifications section of this report.

Gieck Ranch Drainage Basin

Design Point 4 is located at the northeast corner of the Silver Concho Trail and Oregon Wagon Trail. An 18” RCP accepts storm water runoff from Basin P ($A = 1.95$ acre, $Q_5 = 2.4$ cfs, $Q_{100} = 5.1$ cfs) and conveys the storm water to the west side of Silver Concho Trail. Storm water from Basin O ($A = 3.75$ acre, $Q_5 = 4.1$ cfs, $Q_{100} = 9.0$ cfs) is combined with the flow from Basin P ($A = 1.95$ acre, $Q_5 = 2.4$ cfs, $Q_{100} = 5.1$ cfs) at Design Point 5 (routed flow rates of $Q_5 = 6.5$ cfs, $Q_{100} = 14.1$ cfs). A 24” RCP conveys storm water runoff from Design Point 5 to the south side of Oregon Wagon Trail. The storm water runoff is spread through energy dissipating rip rap at the outlet of the pipe, to a natural existing swale.

Design Point 6 is located at the southern boundary of the development, which conveys storm water runoff from upstream Design Points 4, 5 and approximately 58% of Basin Q ($A = 4.76$ acre, $Q_5 = 4.06$ cfs, $Q_{100} = 9.0$ cfs), where the remaining 42% of Basin Q is not channelized and will continue to overland sheet flow off the property. The storm water runoff quantities at Design Point 6 are $Q_5 = 9.5$ cfs, $Q_{100} = 13.1$ cfs.

As future Trails development occurs to the south, appropriate downstream drainage facilities will be designed to continue the conveyance of storm water flows from this point. The storm water runoff from this area is part of the original storm water drainage sub-basins in the MDDP. Since these developed flow rates are small compared to the larger sub-basin flow rates, the developed storm water runoff rates from sub-Basins O, P and Q will not have any adverse impacts to downstream infrastructure or properties. Existing swales will continue to convey the storm water runoff to the existing G11 detention pond, as designed and constructed for Filing No. 7 improvements.

ADDENDUM TO MASTER DEVELOPMENT/PRELIMINARY DRAINAGE PLAN

This discussion and presentation of development options and recommendations for two major revisions to the MDDP are as follows:

Permanent Detention Pond S12

The Temporary Detention Pond S12, as identified in the MDDP and designed and built with the Filing No. 7 development, would better serve the Latigo Trails development and downstream improvements and properties as a Permanent Detention Pond. With this study, it is shown that with minor modifications to the existing outlet structure and slight grading revisions to the proposed drainage swale to the pond, the excess capacity can be utilized to provide less than historic flow rates and less impact to downstream properties. The drainage basins affected by the proposed storm water flow path redirection are Basins 8.12, 8.14 and 8.22. The MDDP had planned this runoff to be free-released to Design Point B5 (the southwest corner of the Latigo Boulevard and Eastonville Road intersection).

The 150.7-acre Basin BS2, identified and described in the MDDP within the Upper Black Squirrel Creek Basin, is the largest basin of the Latigo Trails Development. The Trails Filing No. 8 is the last portion of Basin BS2 to be developed and will complement the existing improvements from Filings No. 2 and No. 7. Also, when modeling the property downstream of Filing No. 8 (Trails Filing No. 9) as undeveloped, the modifications to the existing outlet of Permanent Pond S12 will lower the historic 5-year flow rates from 39 to 38 cfs and historic 100-year flow rates from 199 to 157 cfs at Analysis Point B3 (south of Latigo/Eastonville Road intersection at the existing 12" RCP).

Detention Pond S12 Modifications

The existing Detention Pond S12 will be reconfigured to be a permanent facility. The existing vegetation in the bottom of the pond shall be removed and clean fill brought in to raise the bottom of the pond to elevation 7099.20 (the existing bottom of pond is at elevation 7097.69). A 4' concrete pan shall be installed on a grade of 0.5% to the drainage swale Section D-D at the southwest corner of the pond, which directs storm water from Silver Concho Trail (DP3) to the detention pond. Raising the bottom of the pond eliminates the permanent pool and provides a positive draining detention basin. The existing Water Quality orifice plate for the Extended Detention Basin (EDB) will be replaced to allow for a 40-hour release time. The WQCV for the reconfigured pond is 1.46 ac-ft. and is provided at elevation 7101.42, which is more than the required 1.09 ac-ft. Calculations for the EDB as well as Pond S12 volumes and rating tables are included in the Appendix.

The existing 5-year rectangular orifice release control (3' wide by 1.5' high) is located at elevation 7100.89 in the existing structure. A 4' x 1' steel plate will be installed to cover a portion of the existing 3' x 1.5' orifice to meet the water quality control volume elevation. The orifice plate for the water quality extended detention basin shall be replaced with a plate with two columns of four rows of 1-1/2" diameter holes. This orifice plate will provide the required 40-hour drain time with the existing release structure. Photos of the existing structure and proposed improvements are included in the Appendix.

The 2 ac-ft 5-year storage volume is provided in the reconfigured pond at elevation 7103.03, which is less than the top of outlet structure elevation at 7104.00. The existing, slightly

modified, 5-year release control orifice with the proposed 4' x 1' steel plate limits the 5-yr release rate to 17 cfs, which is less than the historic 46 cfs. The existing 100-year release control, at elevation 7104.00, still flows sufficient water to be restricted by the two 30" HDPE pipes from the release structure. The 9 ac-ft storage volume for the 100-year event is provided at elevation 7106.05. Since the detention pond has excess storage volume, the excess volume has been utilized by installing a 3.5' x 1.75' steel plate over the top half of each 30" HDPE orifice in the existing outlet structure. The 100-year release rate from the detention pond will be restricted to 58 cfs, which is less than the historic 94 cfs.

An emergency overflow is provided for Pond S12, located at the northeast corner of the pond. A 114' long sill wall shall be installed for the emergency overflow, where the 100' long weir crest at elevation 7107.25, will pass 268 cfs. This meets the storm water inflow quantity to the pond. A foot of freeboard is provided above the 100-year water surface elevation. The minimum top of pond elevation of 7108.7 provides an additional foot of freeboard, for the emergency overflow.

The outfall swale from the existing release structure was designed for the Filing No. 7 subdivision and will be maintained for the subject Filing No. 8 subdivision. As stated in the "Final Drainage Report for Filing No.7," the outfall swale was designed to convey 73 cfs from Detention Pond S12, and with the reduced release rates from the reconfigured permanent detention pond, the swale has sufficient capacity to convey the storm water to the temporary WQVCP. With release rates being below historical levels, the proposed Filing No. 8 improvements will not have adverse effects upon existing infrastructure or properties as historically experienced.

A Geotechnical investigation of the embankment for the Permanent Detention Pond S12 will be required to ensure that the addition of storage volume depths in the pond, and the addition of 1' of fill be added to the northern and southern "Top of Pond," will have no effect to the existing embankment.

Water Quality Volume Control Pond (WQVCP)

Even though the 5 and 100-year flow rates have been reduced from historic rates with the Pond S12 modifications and drainage basin storm water flow path redirection, the storm water volume

arriving at each B3 and B5 has increased from historic conditions. Historically, storm water runoff collects on the west side of Eastonville Road, outlets first through both the 12" pipe (B3), and the 18" pipe (B5), continues to pond up and eventually overtops the road. With the proposed WQVCP, approximately 3 ac-ft of storm water runoff will be collected and retained within the WQVCP below the 12" culvert invert elevation. As the runoff ponds up above the 12" culvert, the WQVCP will act as a detention pond and runoff will be released in the 12" culvert, then the 18" culvert, and over the road. The amount of overtopping the road is approximated in the weir calculation contained in the Appendix. During a 100-year storm Eastonville Road will be overtopped 0.25 feet, which is less than under existing conditions (0.43 feet).

The increase/decrease in storm water volume arriving at historical drainage outfall points was not considered in the MDDP or the previous FDR's for Trails Developments No. 2 or 7. However, El Paso County is requiring The Trails Filing No. 8 to install a temporary WQVCP to address the increase in storm water volumes and maintain historic volume received by downstream properties. The WQVCP will provide an immediate, yet temporary solution.

The WQVCP has been designed using the following El Paso County approved methodology, as discussed at the September 29, 2006 meeting with Staff. The difference in storm water volume produced under developed conditions vs. historic conditions at DP3 and DP5 is calculated and combined. Storm water volume was combined due to the physical proximity of existing culverts. The developed condition quantity is assuming Latigo filings 2, 7, and 8 are developed.

Table 1
Stormwater Volume Comparison for a 24 Hour, 100-yr Event
Located at Eastonville Road at Design Points B3 and B5

Developed Stormwater Volume:	B3	32.73 ac-ft	
Data from: Revised HEC-1 Output	B5	7.65 ac-ft	40.38 Total
Historic Stormwater Volume:	B3	22.70 ac-ft	
Data from: MDDP HEC-1 Output	B5	13.05 ac-ft	35.75 Total
Increased Volume due			
To Development (or runoff redirection):	B3	10.03 ac-ft	
Developed-historic	B5	-5.40 ac-ft	4.63 Total
Upstream WQCV at Pond S12:	Pond S12	1.09 ac-ft	1.09 Total

Using the different Filings of Latigo Trails within the Upper Black Squirrel Basin, south of Latigo Blvd., the following table defines the Proportionate Share of the Developed Volume per acre. The area of the Upper Black Squirrel Basin directing storm water runoff to Analysis Points B3 and B5 is **320.63** ac.

Table 2
Proportionate Share of the Developed Volume
Latigo Trails Filings 2, 7, 8 & 9

Filing	Area (ac)	% Share of Developed Volume	Pond Size (ac-ft)	Note
2	47.94	14.95	0.53	Historic "Pass Through"
7	41.36	12.90	0.46	
8	109.90	34.28	1.21	
9	<u>121.43</u>	<u>37.87</u>	<u>1.34</u>	
SUM: 320.63		100.00	3.54	

Therefore, the Volume Control Quantity needed at Eastonville Road is 3.01 ac-ft [40.38 (developed volume) – 35.75 (existing volume) - 1.09 (WQ @ S12) – 0.53 (Pass Through Historic Volume)].

The volume control retention factor for the WQVC Pond will be a maximum 1.5' depth. The WQVC Pond is located in future Filing 9 adjacent to Eastonville Road and is approximately 1000' long by 110' feet in width. The 3.07 ac-ft retention pond will serve as a secondary water quality pond, which compliments the water quality provided in Pond S12. Sediment is allowed to settle out of storm water runoff within the retention pond, before releasing in the existing 12" and 18" culverts below Eastonville Road. The WQVC Pond will also function as a detention pond, which utilizes the existing culverts as release structures. The WQVC Pond is 10.7 ac-ft prior to storm water overtopping the existing Eastonville Road centerline. The existing culverts will control the 5-year release rate from total historic values of 65 to 8 cfs at B3 and B5. The

100-year release rates from total historic values of 322 to 137 cfs at B3 and B5. The depths overtopping Eastonville Road in existing and proposed conditions were discussed earlier. Additional detention could be attained during the improvements to Eastonville Road. The addition of the WQVC Pond significantly reduces the overall impact to downstream properties from the Latigo Trails Development.

Summary of MDDP Amendment

Therefore, the following amendments to the Master Development/Preliminary Drainage Plan are:

- a. Change of status from Temporary to Permanent, for the existing Detention Pond S12;
- b. A Water Quality Volume Control Pond is proposed as a temporary solution for the increased volume of runoff at Eastonville Road due to development of The Trails Filing Nos. 2, 7 and 8.

EROSION CONTROL PLAN

The City of Colorado Springs and El Paso County Drainage Criteria Manual specifies that an Erosion Control Plan and associated cost estimate be submitted in conjunction with the Final Drainage Report. We have included preliminary erosion control cost estimates in the construction cost opinion listed below and have the Grading and Erosion Control Plan is part of the construction drawings for The Trails Filing No. 8.

Energy dissipaters such as rip rap pads and plunge pools are an integral part of the Grading and Erosion Control Plan. Almost every culvert, public and private, has a riprap pad at both upstream and downstream ends. All of the culverts that convey large quantities of off-site storm water are designed with plunge pools as described in the DCM so that exiting velocities are lowered substantially. See the Appendix for riprap and plunge pool sizing calculations.

Erosion control matting is called out in those channels and roadside ditches where velocities are greater than 3 fps. Haestad's Flowmaster was used to estimate velocity in several typical roadside ditches and the high flow channels are modeled specifically. See the Appendix for velocity calculations.

APPENDIX F
DRAINAGE MAPS

LATIGO TRAILS HISTORICAL MDDP CUHP SWWM HISTORICAL CONDITIONS

show a few more drainage flow arrows

show Filing 9 boundary

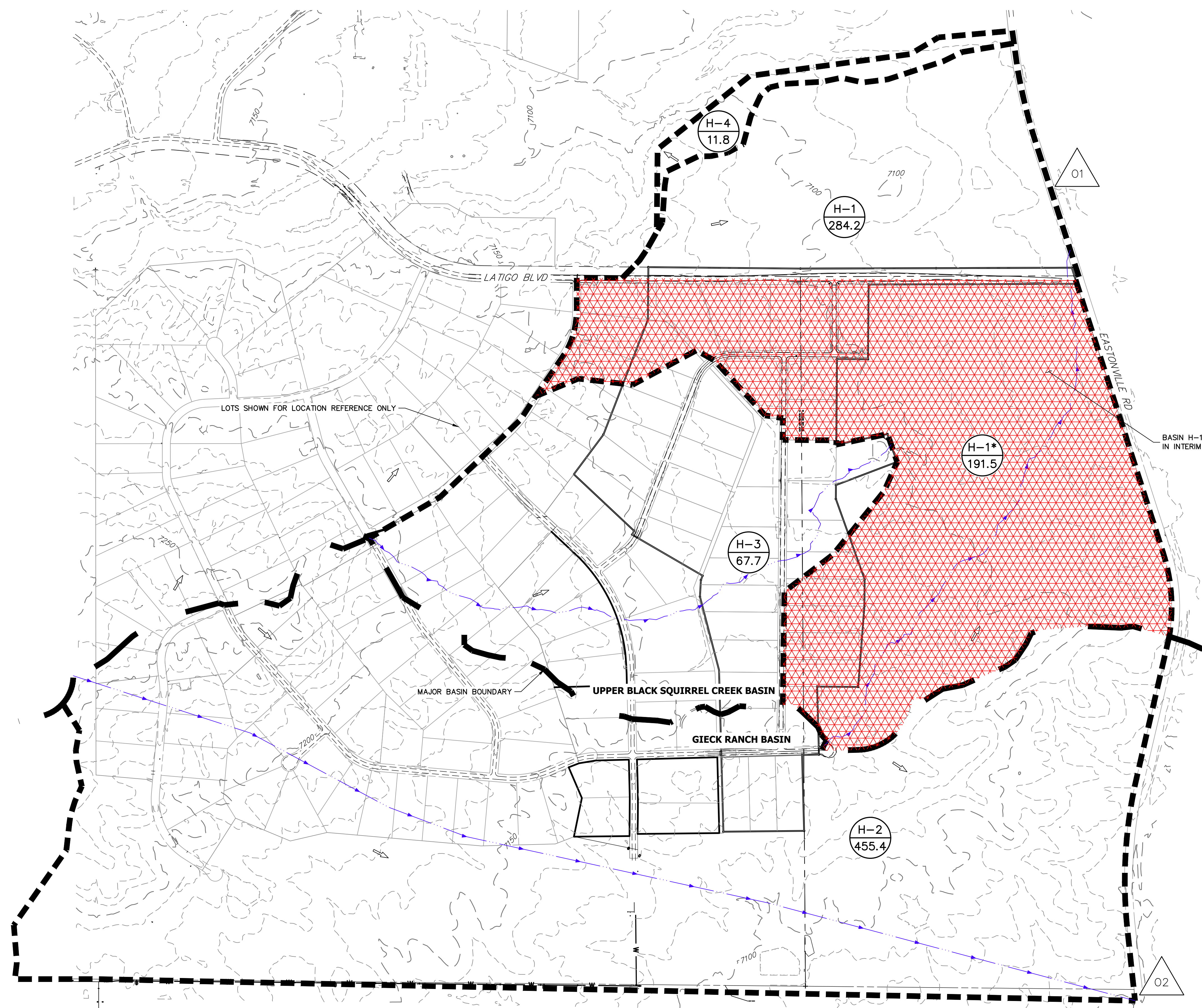

CUHP BASIN RUNOFF SUMMARY TABLE- HISTORICAL CONDITIONS							
Basin	% IMP	INTERIM			ULTIMATE		
		Area(AC)	Q5(CFS)	Q100(CFS)	Area (AC)	Q5(CFS)	Q100(CFS)
H-1	2%	191.5	159	284	284.2	260	459
H-2	2%	455.4	328	589	455.4	328	589

BASIN H-1 MODELED AS H-1* (RED)
IN INTERIM CONDITION (FILING 9 BUILD OUT ONLY)

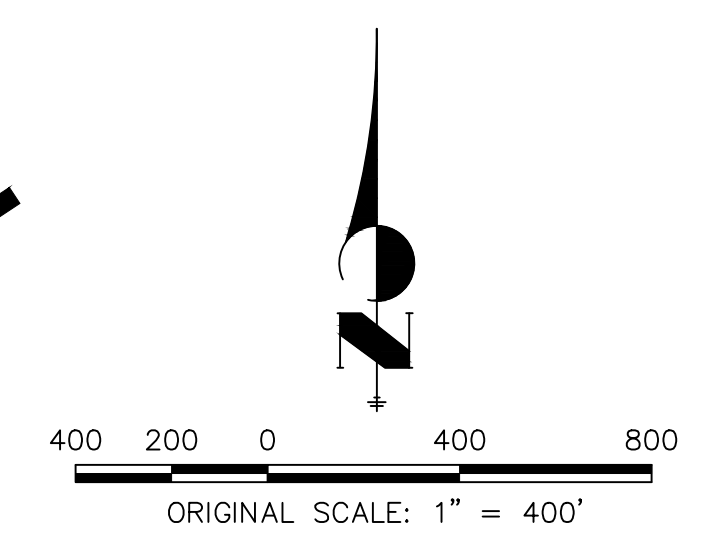

HISTORICAL CONDITIONS
LATIGO TRAILS
JOB NO. 25175.01
9/14/2021
SHEET 1 OF 1



Centennial 303-740-9393 • Colorado Springs 719-593-2593
Fort Collins 970-491-9888 • www.jrengineering.com

X:\2517501\Drawings\Sheet\Drawings\Hst_CUHP_SWMM.dwg - Historical Conditions, 9/14/2021 12:41:44 PM, CS

LATIGO TRAILS ULTIMATE CONDITIONS MDDP

CUHP SWMM ULTIMATE/INTERIM CONDITIONS

label limits of FEMA 100-yr floodplain
(typical all drainage maps)

LEGEND

- POND
- POND
- MAJOR BASIN BOUNDARY
- SUB-BASIN BOUNDARY

Add design points O-A. Report needs to show that during both interim and ultimate conditions the development is maintaining a peak release rate equal to or less than historic (DP-O1) at the ultimate outfall.

CUHP BASIN RUNOFF SUMMARY TABLE- PROPOSED CONDITIONS							
Basin	Area (AC)	% Imp	INTERIM		ULTIMATE		
			Q5(CFS)	Q100(CFS)	Q5(CFS)	Q100(CFS)	
BS-1	61.9	7.2%	50	85	12.0%	50	86
BS-2	129.7	10.9%	135	230	12.0%	135	230
BS-3	92.7	2.0%	101	173	12.0%	104	178
BS-4	11.8	2.0%	20	34	12.0%	20	35

Add a pond summary table:
 - Storage (ac-ft)
 - Qin
 - Qout
 - release time.
 Report needs to show time to drain is in conformance with SB 15-212

show Filing 9 boundary

PROPOSED INTERIM BLACK SQUIRREL POND

63.9 ACRES MODELED AS UNDEVELOPED IN INTERIM CONDITION (FILING 9 BUILD OUT ONLY)

MAJOR BASIN BOUNDARY

FUTURE ULTIMATE POND G19

PROPOSED INTERIM/ULTIMATE POND G18

FUTURE ULTIMATE POND G1

EXISTING SOUTH POND

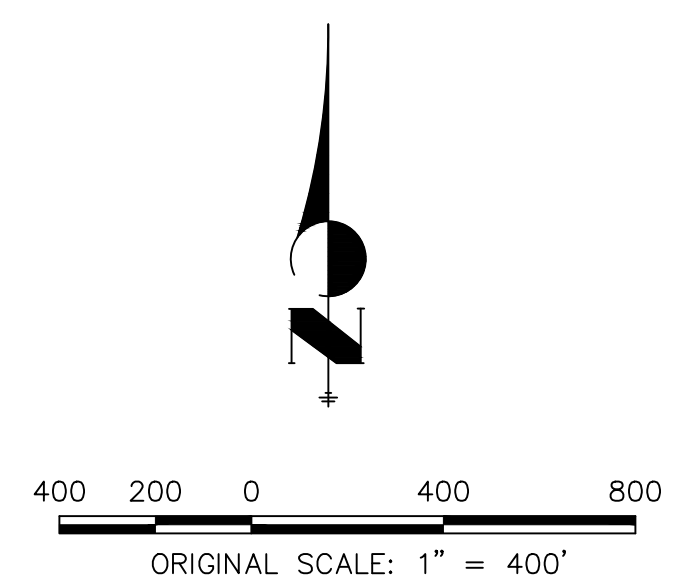
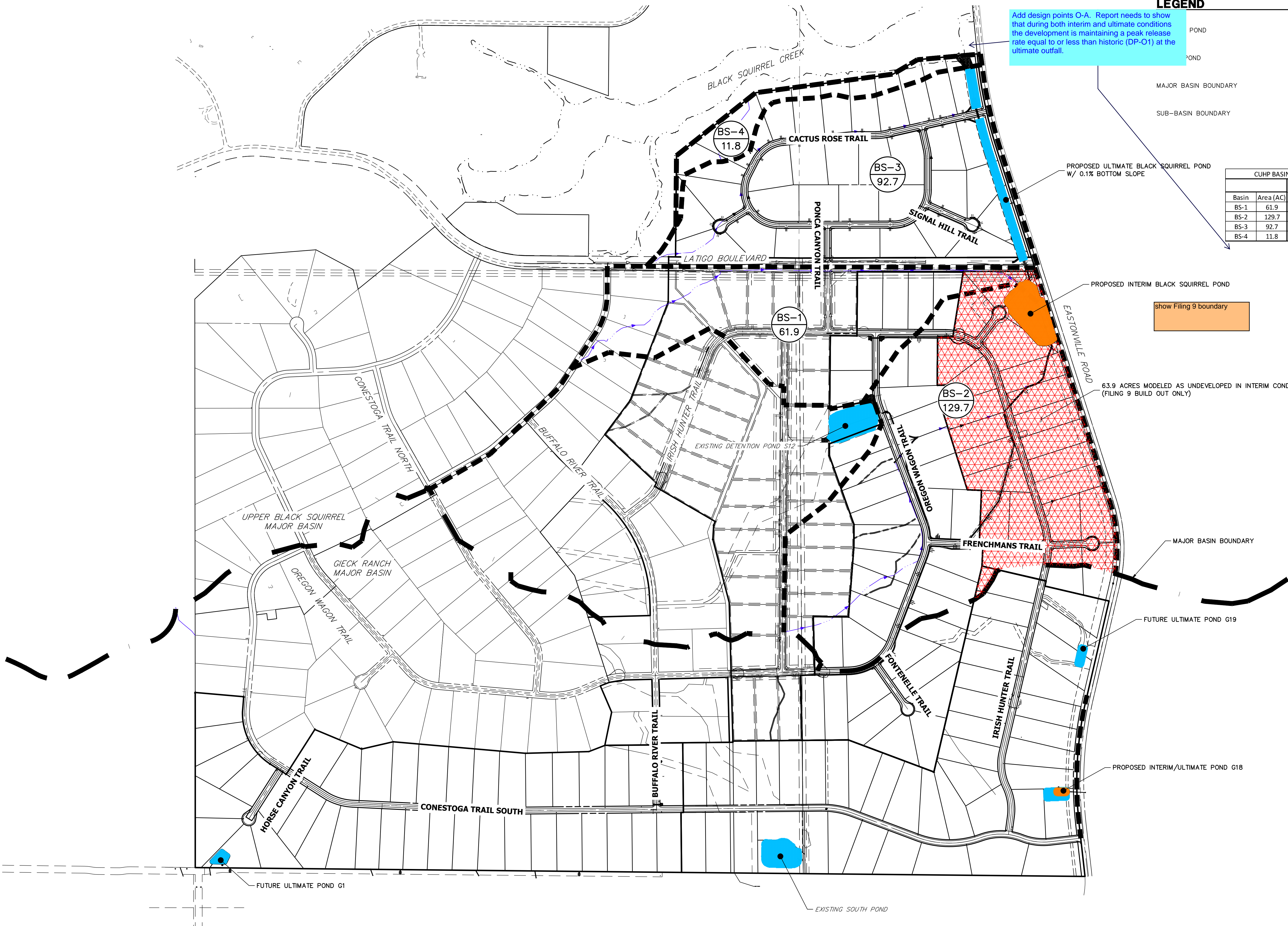

PROPOSED CUHP/SWMM MAP
 LATIGO TRAILS ULTIMATE CONDITION
 JOB NO. 25175.01
 9/14/2021
 SHEET 1 OF 1



Centennial 303-740-9393 • Colorado Springs 719-593-2593
 Fort Collins 970-491-9888 • www.jrengineering.com

X:\25175\000\all\25175\01\Drawings\Sheet\Drawings\Proposed_CUHP_SWMM.dwg, Proposed Conditions, 9/14/2021, 12:28:48 PM, CS

LATIGO TRAILS - FILING 9 PROPOSED DRAINAGE MAP

- show a few more drainage flow arrows
- on this map or a new one, include color shading that shows areas tributary to each type of PBMP (each pond, runoff reduction, etc.) and those areas that are not captured by a PBMP, with the applicable exclusion(s) labeled --- for this filing.

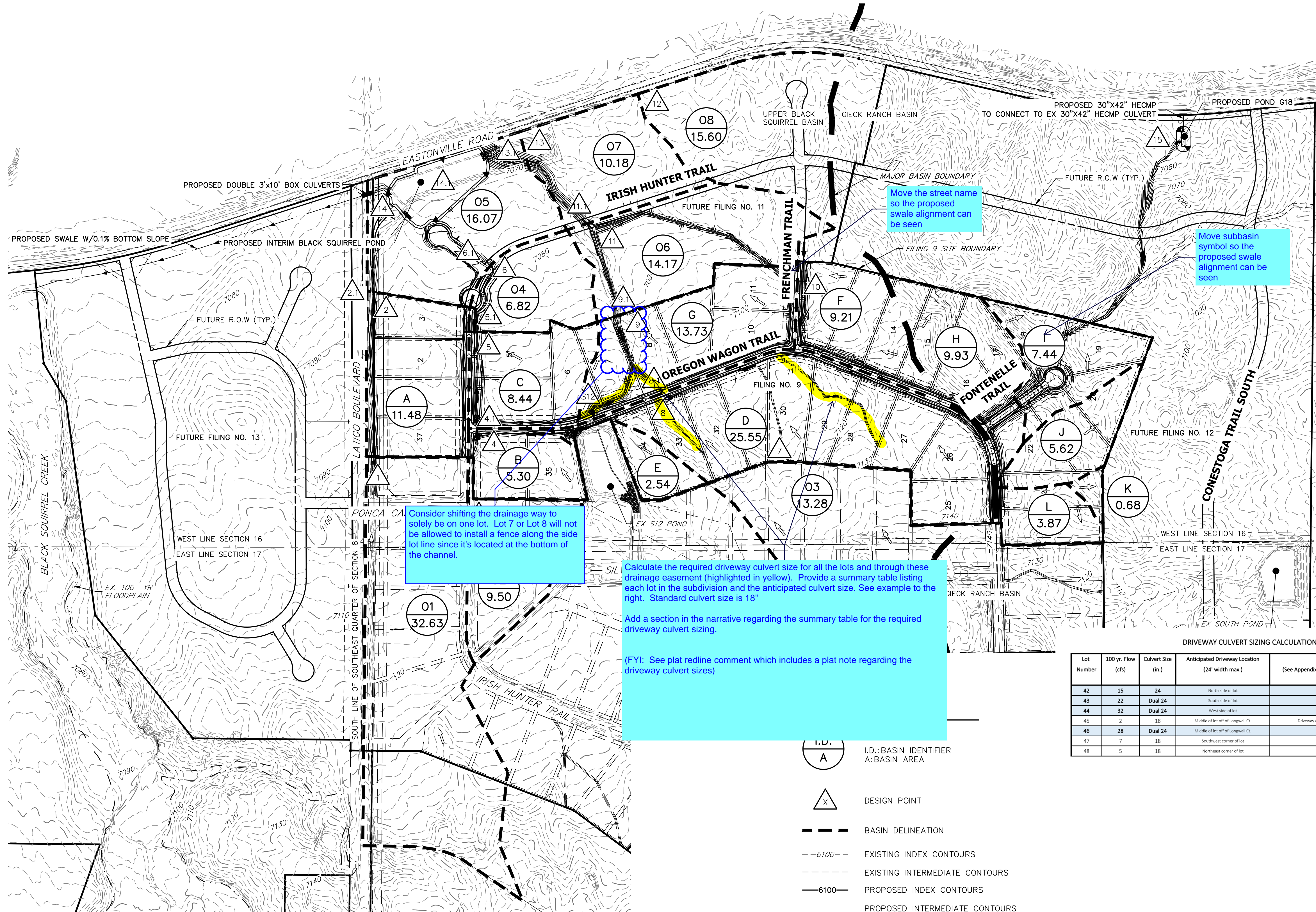

Tributary Sub-basin	Area (acres)	Percent Impervious	C _s	C ₁₀₀	t _c (min)	Q _s (cfs)	Q ₁₀₀ (cfs)
A	11.48	10%	0.15	0.40	22.2	5.10	22.72
B	5.30	11%	0.16	0.41	25.3	2.38	10.02
C	8.44	14%	0.19	0.43	17.2	5.27	20.17
D	25.55	12%	0.17	0.42	27.3	11.37	46.74
E	2.54	8%	0.14	0.39	19.0	1.12	5.31
F	9.21	12%	0.17	0.42	18.0	5.18	20.98
G	13.73	12%	0.17	0.42	18.6	7.53	30.74
H	9.93	12%	0.17	0.41	15.5	5.82	24.00
I	7.44	12%	0.17	0.42	15.2	4.46	18.20
J	5.62	8%	0.14	0.39	13.7	2.90	13.59
K	0.68	8%	0.14	0.39	13.4	0.35	1.66
L	3.87	9%	0.15	0.40	14.1	2.09	9.41
O1	32.63	14%	0.18	0.43	26.1	16.09	62.71
O2	9.50	16%	0.20	0.44	21.7	5.63	20.72
O3	13.28	8%	0.14	0.39	16.9	6.20	29.31
O4	6.82	11%	0.17	0.44	22.2	3.39	14.92
O5	16.07	11%	0.17	0.44	28.6	6.95	30.60
O6	14.17	11%	0.17	0.44	25.1	6.60	29.03
O7	10.18	11%	0.17	0.44	24.3	4.82	21.22
O8	15.60	11%	0.17	0.44	20.6	8.05	35.43

DP#	Q _s	Q ₁₀₀
1	16.09	62.72
2	5.10	22.75
2.1	17.44	70.18
3	5.64	20.72
4	2.38	10.02
4.1	7.58	29.13
5	5.27	20.15
5.1	11.00	42.16
6	3.40	14.92
6.1	13.14	51.91
7	6.19	29.30
8	11.38	46.75
8.1	16.23	69.72
9	7.52	30.74
9.1	37.72	118.54
10	5.19	20.97
11	6.59	29.01
11.1	45.28	177.94
12	8.04	35.43
13	4.81	21.21
13.1	53.13	212.81
14	6.95	30.61
14.1	73.14	332.02
15	4.44	22.19

DRIVEWAY CULVERT SIZING CALCULATIONS

Lot Number	100 yr. Flow (cfs)	Culvert Size (in.)	Anticipated Driveway Location (24' width max.)	Notes (See Appendix for non-std. driveway culvert calculations)
42	15	24	North side of lot	
43	22	Dual 24	South side of lot	
44	32	Dual 24	West side of lot	
45	2	18	Middle of lot off of Longleaf Ct.	Driveway access required to be at Highpoint of Longleaf Ct.
46	28	Dual 24	Middle of lot off of Longleaf Ct.	
47	7	18	Southwest corner of lot	
48	5	18	Northeast corner of lot	

- I.D.: BASIN IDENTIFIER
- A: BASIN AREA
- DESIGN POINT
- BASIN DELINEATION
- EXISTING INDEX CONTOURS
- EXISTING INTERMEDIATE CONTOURS
- PROPOSED INDEX CONTOURS
- PROPOSED INTERMEDIATE CONTOURS
- EXISTING FLOW DIRECTION
- PROPOSED FLOW DIRECTION

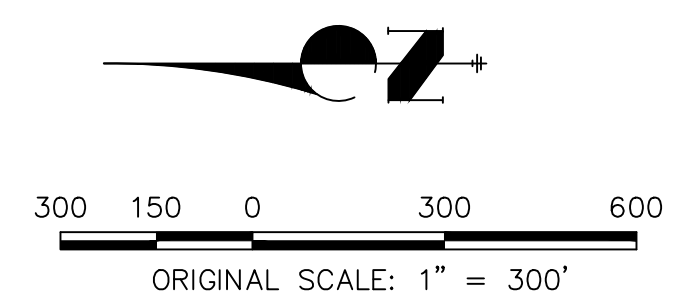

LATIGO TRAILS FILING 9
PROPOSED DRAINAGE MAP
JOB NO. 25175.01
09/13/21
SHEET 1 OF 1



Centennial 303-740-9393 • Colorado Springs 719-593-2593
Fort Collins 970-491-9888 • www.jrengineering.com