



REPORTING REQUIREMENTS

ANTICIPATED STARTING AND COMPLETION TIME PERIOD OF SITE GRADING: October 1, 2022
 EXPECTED DATE ON WHICH THE FINAL STABILIZATION WILL BE COMPLETED: June 30, 2023
 TOTAL AREA OF THE SITE TO BE CLEARED, EXCAVATED OR GRADED: 3.4 acres
 NAME OF RECEIVING WATERS: East Fork of Sand Creek, discharging to Sand Creek which discharges to Fountain Creek
 SOILS INFORMATION: Blendon Sandy Loam (0-3% slopes), Blakeland Loamy Sand (1-9% slopes) [NRCS Soil Survey]

GENERAL NOTES

1. Stormwater discharges from construction sites shall not cause or threaten to cause pollution, contamination, or degradation of State Waters. All work and earth disturbance shall be done in a manner that minimizes pollution of any on-site or offsite waters, including wetlands.
2. Notwithstanding anything depicted in these plans in words or graphic representation, all design and construction related to roads, storm drainage and erosion control shall conform to the standards and requirements of the most recent version of the relevant adopted El Paso County standards, including the Land Development Code, the Engineering Criteria Manual, the Drainage Criteria Manual, and the Drainage Criteria Manual Volume 2. Any deviations to regulations and standards must be requested, and approved, in writing.
3. A separate Stormwater Management Plan (SMWP) for this project shall be completed and an Erosion and Stormwater Quality Control Permit (ESQCP) issued prior to commencing construction. During construction the SWMP is the responsibility of the designated Qualified Stormwater Manager or Certified Erosion Control Inspector and shall be located on site at all times during construction and shall be kept up to date with work progress and changes in the field.
4. Once the ESQCP is approved and a "Notice to Proceed" has been issued, the contractor may install the initial stage erosion and sediment control measures as indicated on the approved GEC. A Preconstruction Meeting between the contractor, engineer, and El Paso County will be held prior to any construction. It is the responsibility of the applicant to coordinate the meeting time and place with County staff.
5. Control measures must be installed prior to commencement of activities that may contribute pollutants to stormwater. Temporary sediment and erosion control measures for all slopes, channels, ditches, or any disturbed land area shall be completed immediately upon completion of the disturbance.
6. All temporary sediment and erosion control measures shall be maintained and remain in effective operating condition until permanent soil erosion control measures are implemented and final stabilization is established. All persons engaged in land disturbance activities shall assess the adequacy of control measures at the site and identify if changes to those control measures is needed to ensure the continued effective performance of the control measures. All changes to temporary sediment and erosion control measures must be incorporated into the Stormwater Management Plan prior to implementation.
7. Temporary stabilization shall be implemented on disturbed areas and stockpiles where ground disturbing construction activity has permanently ceased or temporarily ceased for longer than 14 days. An area that is going to remain in an interim state for more than 60 days shall also be stabilized.
8. Final stabilization must be implemented at all applicable construction sites. Final stabilization is achieved when all ground disturbing activities are complete and all disturbed areas either have a uniform vegetative cover with individual plan density of 70 percent of pre-disturbance levels established or equivalent permanent alternative stabilization method is implemented. All temporary sediment and erosion control measures shall be removed upon final stabilization and before permit closure.
9. All permanent stormwater management facilities shall be installed as designed in the approved plans. Any proposed changes that effect the design or function of permanent stormwater management structures must be approved by the ECM Administrator prior to implementation.
10. Earth disturbances shall be conducted in such a manner so as to effectively minimize accelerated soil erosion and resulting sedimentation. All disturbances shall be designed, constructed, and completed so that the exposed area of any disturbed land shall be limited to the shortest practical period of time. Pre-existing vegetation shall be protected and maintained within 50 horizontal feet of a waters of the state unless shown to be infeasible and specifically requested and approved.
11. Compaction of soil must be prevented in areas designated for infiltration control measures or where final stabilization will be achieved by vegetative cover. Areas designated for infiltration control shall also be protected from sedimentation during construction until final stabilization is achieved.
12. Any temporary or permanent facility designed and constructed for the conveyance of stormwater around, through, or from the earth disturbance area shall be a stabilized conveyance designed to minimize erosion and the discharge of sediment off site.
13. Concrete wash water shall be contained and disposed of in accordance with the SWMP. No wash water shall be discharged to or allowed to enter State Waters, including any surface or subsurface storm drainage system or facilities. Concrete washouts shall not be located in an area where shallow groundwater may be present, or within 50 feet of a surface water body, creek or stream.
14. During dewatering operations, uncontaminated groundwater may be discharged on-site, but shall not leave the site in the form of surface runoff unless an approved State dewatering permit is in place.
15. Erosion control blanketing is to be used on slopes steeper than 3:1.
16. Building, construction, excavation, or other waste materials shall not be temporarily placed or stored in the street, alley, or other public way, unless in accordance with an approved Traffic Control Plan. BMP's may be required by El Paso County Engineering if deemed necessary, based on specific conditions and circumstances.
17. Vehicle tracking of soils and construction debris off-site shall be minimized. Materials tracked offsite shall be cleaned up and properly disposed of immediately.
18. Contractor shall be responsible for the removal of all wastes from the construction site for disposal in accordance with local and State regulatory requirements. No construction debris, tree slash, building material wastes or unused building materials shall be buried, dumped, or discharged at the site.
19. The owner, site developer, contractor, and/or their authorized agents shall be responsible for the removal of all construction debris, dirt, trash, rock, sediment, and sand that may accumulate in the storm sewer or other drainage conveyance system and stormwater appurtenances as a result of site development.
20. The quantity of materials stored on the project site shall be limited, as much as practical, to that quantity required to perform the work in an orderly sequence. All materials stored on-site shall be stored in a neat, orderly manner, in their original containers, with original manufacturer's labels.
21. No chemicals are to be used by the contractor, which have the potential to be released in stormwater unless permission for the use of a specific chemical is granted in writing by the ECM Administrator. In granting the use of such chemicals, special conditions and monitoring may be required.
22. Bulk storage of petroleum products or other liquid chemicals in excess of 55 gallons shall have adequate secondary containment protection to contain all spills and prevent any spilled material from entering State Waters, including any surface or subsurface storm drainage system or facilities.
23. No person shall cause the impediment of stormwater flow in the flow line of the curb and gutter or in the ditch flow line.
24. Owner/developer and their agents shall comply with the "Colorado Water Quality Control Act" (Title 25, Article 8, CRS), and the "Clean Water Act" (33 USC 1344), in addition to the requirements of the Land Development Code, DCM Volume II and the ECM Appendix I. All appropriate permits must be obtained by the contractor prior to construction (1041, NPDES, Floodplain, 404, fugitive dust, etc.). In the event of conflicts between these requirements and other laws, rules, or regulations of other Federal, State, local, or County agencies, the most restrictive laws, rules, or regulations shall apply.
25. All construction traffic must enter/exit the site at approved construction access points.
26. Prior to actual construction the permittee shall verify the location of existing utilities.
27. A water source shall be available on site during earthwork operations and utilized as required to minimize dust from earthwork equipment and wind.
28. The soils report for this site has been prepared by National Resources Conservation Service, dated May 27, 2022, and shall be considered a part of these plans.
29. At least ten (10) days prior to the anticipated start of construction, for projects that will disturb 1 acre or more, the owner or operator of construction activity shall submit a permit application for stormwater discharge to the Colorado Department of Public Health and Environment, Water Quality Division. The application contains certification of completion of a stormwater management plan (SWMP), of which this grading and erosion control plan may be a part. For information or application materials contact:
 Colorado Department of Public Health and Environment
 Water Quality Control Division
 WQCD - Permits
 4300 Cherry Creek Drive South
 Denver, CO 80246-1530
 Attn: Permits Unit

SUBDIVISION NAME: N/A.

CONTROL MEASURE COST ESTIMATE: (not inclusive of pavement or curb & gutter repair)

Rock Socks max 30 bags x \$3/unit = \$90
 Sediment Control Log 1,500 ft x \$3/LF = \$4,500
 Street Sweeping 15 days * \$220/day = \$3,300 (Assume three times a week during construction)
 Vehicle Tracking 1 Tracking Pad * \$1,800/pad = \$1,800 for VTC
 Restoration max 1 acre * \$2,900/acre = \$2,900 for Hydrseeding/mulching/tackifier
 Subtotal = \$12,590
 Subtotal x 40% Maintenance of CONTROL MEASURES = \$5,036
 Total = \$17,626

PROPOSED TOPOGRAPHY: The site will be returned as closely as possible to its pre-construction grade

LOCATION OF ANY OTHER PROPOSED FEATURES AND STRUCTURES ON THIS SITE: N/A

LOCATION AND PLANS FOR ALL DRAINAGE FEATURES: Figures 2-4

LOCATION OF PERMANENT SOIL EROSION AND SEDIMENT CONTROL MEASURES: Figures 2-4

LOCATION OF ANY DEDICATED ASPHALT OR CONCRETE BATCH PLANTS: N/A

EMERGENCY OVERFLOW SWALES: N/A

FLOW ROUTE - FLOW THROUGH AND OVERFLOW OF PERMANENT CONTROL MEASURES AND TEMPORARY SEDIMENT

BASINS: Figure 4

DETAIL DRAWINGS OF PERMANENT CONTROL MEASURES: Appendix 3 to the SWMP

NOTES:

Fueling of equipment may occur along the project route; fueling guidelines are included in the SWMP. Approximately 13% of the disturbance area is within the designated 100-year floodplain.

ENGINEER'S STATEMENT

This Grading and Erosion Control Plan was prepared under my direction and supervision and is correct to the best of my knowledge and belief. Said plan has been prepared according to the criteria established by the County for Grading and Erosion Control Plans. I accept responsibility for errors or omissions on my part in preparing this Plan.

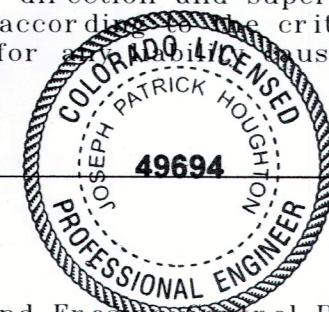

Joseph Houghton, PE# 49694

9/23/22 Date

OWNER'S STATEMENT

The Owner will comply with the requirements of the Grading and Erosion Control Plan.

Tim Benedict, Field Engineering Supervisor

Colorado Springs Utilities
 7710 Durant Drive
 Colorado Springs CO 80920

9/26/22 Date

EL PASO COUNTY

County plan review is provided only for general conformance with County Design Criteria. The County is not responsible for the accuracy and adequacy of the design, dimensions, and/or elevations which shall be confirmed at the job site. The County through the approval of this document assumes no responsibility for completeness and/or accuracy of this document.

Filed in accordance with the requirements of the El Paso County Land Development Code, Drainage Criteria Manual, Volumes 1 and 2, and Engineering Criteria Manual as amended.

In accordance with ECM Section 1.12, these construction documents will be valid for construction for a period of 2 years from the date signed by the El Paso County Engineer. If construction has not started within those 2 years, the plans will need to be resubmitted for approval, including payment of review fees at the Planning and Community Development Directors discretion.

APPROVED
Engineering Department

Joshua Palmer, P.E.
 County Engineer / ECM Administrator

10/12/2022 11:07:33 AM
 dsdnijkamp
 EPC Planning & Community
 Development Department

Date



ENVIRONMENTAL SERVICES
DEPARTMENT
TECHNICAL SERVICES SECTION

P.O. Box 1103, Mail Code 940
 COLORADO SPRINGS, CO 80947
 (719) 668-8426

TITLE PAGE
EROSION AND STORMWATER
QUALITY CONTROL PLAN

Aura at Crossroads
Electric and Gas Main Installation

PCD Filing No: CDR-22-013

Prepared By: JPH

Date: September 2022

Figure
 1

Sediment Control Log (SCL) SC-2

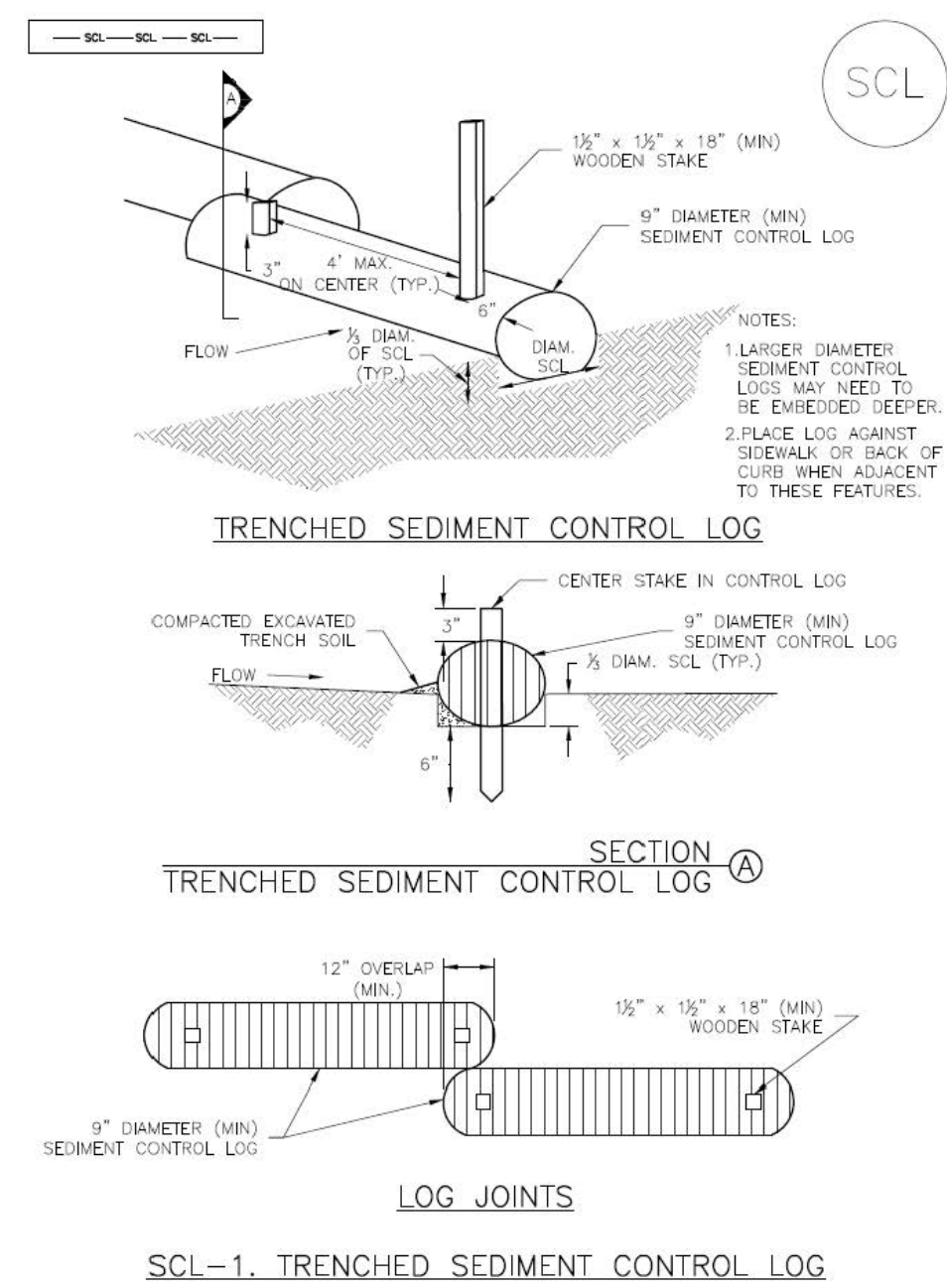

November 2015 Urban Drainage and Flood Control District SC-3
Urban Storm Drainage Criteria Manual Volume 3

SC-2 Sediment Control Log (SCL)

SEDIMENT CONTROL LOG INSTALLATION NOTES

- SEE PLAN VIEW FOR LOCATION AND LENGTH OF SEDIMENT CONTROL LOGS.
- SEDIMENT CONTROL LOGS THAT ACT AS A PERIMETER CONTROL SHALL BE INSTALLED PRIOR TO ANY UPGRADIENT LAND-DISTURBING ACTIVITIES.
- SEDIMENT CONTROL LOGS SHALL CONSIST OF STRAW, COMPOST, EXCELSIOR OR COCONUT FIBER, AND SHALL BE FREE OF ANY NOXIOUS WEED SEEDS OR DEFECTS INCLUDING RIPS, HOLES AND OBVIOUS WEAR.
- SEDIMENT CONTROL LOGS MAY BE USED AS SMALL CHECK DAMS IN DITCHES AND SWALES. HOWEVER, THEY SHOULD NOT BE USED IN PERENNIAL STREAMS.
- IT IS RECOMMENDED THAT SEDIMENT CONTROL LOGS BE TRENCHED INTO THE GROUND TO A DEPTH OF APPROXIMATELY 1/2 OF THE DIAMETER OF THE LOG. IF TRENCHING TO THIS DEPTH IS NOT FEASIBLE AND/OR DESIRABLE (SHORT TERM INSTALLATION WITH DESIRE NOT TO DAMAGE LANDSCAPE) A LESSER TRENCHING DEPTH MAY BE ACCEPTABLE WITH MORE ROBUST STAKING. COMPOST LOGS THAT ARE 8 LB/FT DO NOT NEED TO BE TRENCHED.
- THE UPHILL SIDE OF THE SEDIMENT CONTROL LOG SHALL BE BACKFILLED WITH SOIL OR FILTER MATERIAL THAT IS FREE OF ROCKS AND DEBRIS. THE SOIL SHALL BE TIGHTLY COMPACTED INTO THE SHAPE OF A RIGHT TRIANGLE USING A SHOVEL OR WEIGHTED LAWN ROLLER OR BLOWN IN PLACE.
- FOLLOW MANUFACTURERS' GUIDANCE FOR STAKING. IF MANUFACTURERS' INSTRUCTIONS DO NOT SPECIFY SPACING, STAKES SHALL BE PLACED ON 4' CENTERS AND EMBEDDED A MINIMUM OF 6" INTO THE GROUND. 3" OF THE STAKE SHALL PROTRUDE FROM THE TOP OF THE LOG. STAKES THAT ARE BROKEN PRIOR TO INSTALLATION SHALL BE REPLACED. COMPOST LOGS SHOULD BE STAKED 10' ON CENTER.

SEDIMENT CONTROL LOG MAINTENANCE NOTES

- INSPECT BMPs EACH WORKDAY, AND MAINTAIN THEM IN EFFECTIVE OPERATING CONDITION. MAINTENANCE OF BMPs SHOULD BE PROACTIVE, NOT REACTIVE. INSPECT BMPs AS SOON AS POSSIBLE (AND ALWAYS WITHIN 24 HOURS) FOLLOWING A STORM THAT CAUSES SURFACE EROSION, AND PERFORM NECESSARY MAINTENANCE.
- FREQUENT OBSERVATIONS AND MAINTENANCE ARE NECESSARY TO MAINTAIN BMPs IN EFFECTIVE OPERATING CONDITION. INSPECTIONS AND CORRECTIVE MEASURES SHOULD BE DOCUMENTED THOROUGHLY.
- WHERE BMPs HAVE FAILED, REPAIR OR REPLACEMENT SHOULD BE INITIATED UPON DISCOVERY OF THE FAILURE.
- SEDIMENT ACCUMULATED UPSTREAM OF SEDIMENT CONTROL LOG SHALL BE REMOVED AS NEEDED TO MAINTAIN FUNCTIONALITY OF THE BMP. TYPICALLY WHEN DEPTH OF ACCUMULATED SEDIMENTS IS APPROXIMATELY 1/2 OF THE HEIGHT OF THE SEDIMENT CONTROL LOG.
- SEDIMENT CONTROL LOG SHALL BE REMOVED AT THE END OF CONSTRUCTION. COMPOST FROM COMPOST LOGS MAY BE LEFT IN PLACE AS LONG AS BAGS ARE REMOVED AND THE AREA SEEDS IF DISTURBED AREAS EXIST AFTER REMOVAL. THEY SHALL BE COVERED WITH TOP SOIL, SEEDED AND MULCHED OR OTHERWISE STABILIZED IN A MANNER APPROVED BY THE LOCAL JURISDICTION.

(DETAILS ADAPTED FROM TOWN OF PARKER, COLORADO, JEFFERSON COUNTY, COLORADO, DOUGLAS COUNTY, COLORADO, AND CITY OF AURORA, COLORADO, NOT AVAILABLE IN AUTOCAD)
NOTE: MANY JURISDICTIONS HAVE BMP DETAILS THAT VARY FROM UDFCD STANDARD DETAILS. CONSULT WITH LOCAL JURISDICTIONS AS TO WHICH DETAIL SHOULD BE USED WHEN DIFFERENCES ARE NOTED.

SC-6 Urban Drainage and Flood Control District November 2015
Urban Storm Drainage Criteria Manual Volume 3

SC-5 Rock Sock (RS)

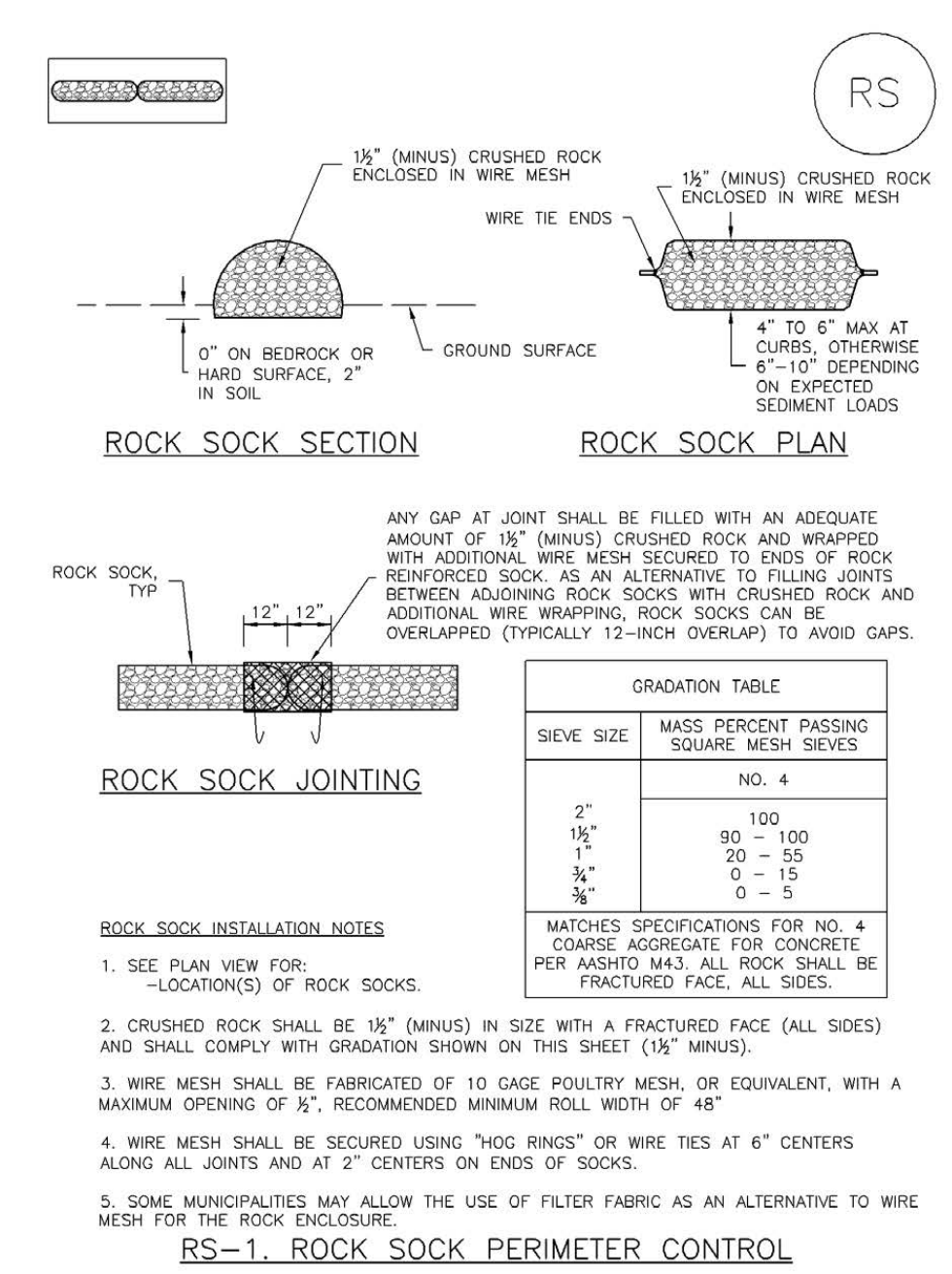

RS-2 Urban Drainage and Flood Control District November 2010
Urban Storm Drainage Criteria Manual Volume 3

Rock Sock (RS) SC-5

ROCK SOCK MAINTENANCE NOTES

- INSPECT BMPs EACH WORKDAY, AND MAINTAIN THEM IN EFFECTIVE OPERATING CONDITION. MAINTENANCE OF BMPs SHOULD BE PROACTIVE, NOT REACTIVE. INSPECT BMPs AS SOON AS POSSIBLE (AND ALWAYS WITHIN 24 HOURS) FOLLOWING A STORM THAT CAUSES SURFACE EROSION, AND PERFORM NECESSARY MAINTENANCE.
- FREQUENT OBSERVATIONS AND MAINTENANCE ARE NECESSARY TO MAINTAIN BMPs IN EFFECTIVE OPERATING CONDITION. INSPECTIONS AND CORRECTIVE MEASURES SHOULD BE DOCUMENTED THOROUGHLY.
- WHERE BMPs HAVE FAILED, REPAIR OR REPLACEMENT SHOULD BE INITIATED UPON DISCOVERY OF THE FAILURE.
- ROCK SOCKS SHALL BE REPLACED IF THEY BECOME HEAVILY SOILED, OR DAMAGED BEYOND REPAIR.
- SEDIMENT ACCUMULATED UPSTREAM OF ROCK SOCKS SHALL BE REMOVED AS NEEDED TO MAINTAIN FUNCTIONALITY OF THE BMP. TYPICALLY WHEN DEPTH OF ACCUMULATED SEDIMENTS IS APPROXIMATELY 1/2 OF THE HEIGHT OF THE ROCK SOCK.
- ROCK SOCKS ARE TO REMAIN IN PLACE UNTIL THE UPSTREAM DISTURBED AREA IS STABILIZED AND APPROVED BY THE LOCAL JURISDICTION.
- WHEN ROCK SOCKS ARE REMOVED, ALL DISTURBED AREAS SHALL BE COVERED WITH TOPSOIL, SEEDED AND MULCHED OR OTHERWISE STABILIZED AS APPROVED BY LOCAL JURISDICTION.

(DETAIL ADAPTED FROM TOWN OF PARKER, COLORADO AND CITY OF AURORA, COLORADO, NOT AVAILABLE IN AUTOCAD)
NOTE: MANY JURISDICTIONS HAVE BMP DETAILS THAT VARY FROM UDFCD STANDARD DETAILS. CONSULT WITH LOCAL JURISDICTIONS AS TO WHICH DETAIL SHOULD BE USED WHEN DIFFERENCES ARE NOTED.

November 2010 Urban Drainage and Flood Control District RS-3
Urban Storm Drainage Criteria Manual Volume 3

Stockpile Management (SP) MM-2

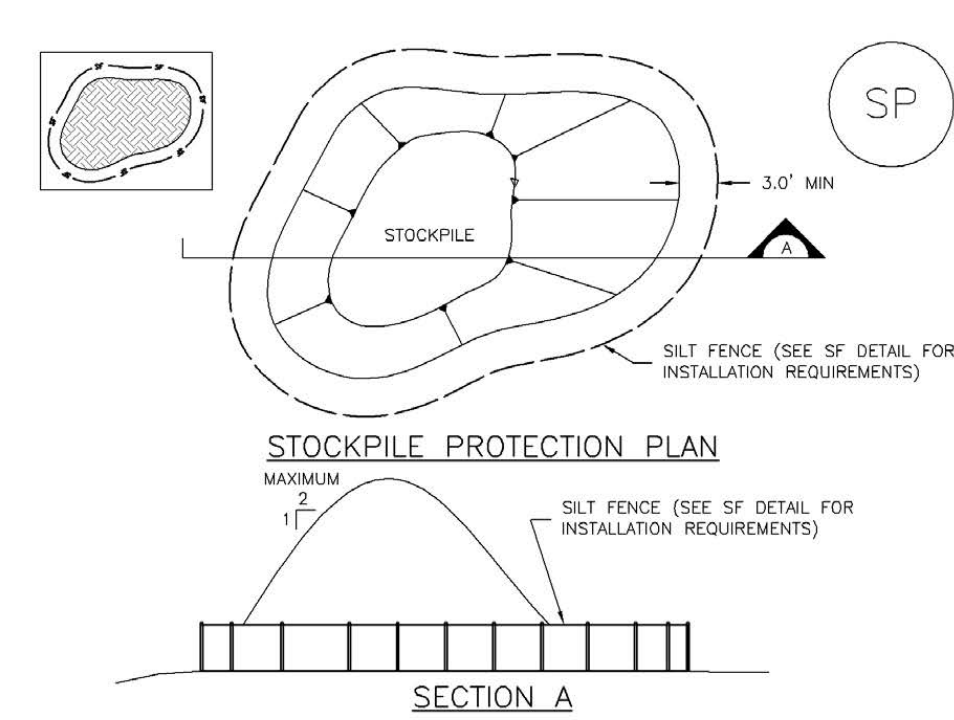

SP-1. STOCKPILE PROTECTION

STOCKPILE PROTECTION INSTALLATION NOTES

- SEE PLAN VIEW FOR: LOCATION OF STOCKPILES. TYPE OF STOCKPILE PROTECTION.
- INSTALL PERIMETER CONTROLS IN ACCORDANCE WITH THEIR RESPECTIVE DESIGN DETAILS. SILT FENCE IS SHOWN IN THE STOCKPILE PROTECTION DETAILS. HOWEVER, OTHER TYPES OF PERIMETER CONTROLS INCLUDING SEDIMENT CONTROL LOGS OR ROCK SOCKS MAY BE SUITABLE IN SOME CIRCUMSTANCES. CONSIDERATIONS FOR DETERMINING THE APPROPRIATE TYPE OF PERIMETER CONTROL FOR A STOCKPILE INCLUDE WHETHER THE STOCKPILE IS LOCATED ON A PERVIOUS OR IMPERVIOUS SURFACE, THE RELATIVE HEIGHTS OF THE PERIMETER CONTROL AND STOCKPILE, THE ABILITY OF THE PERIMETER CONTROL TO CONTAIN THE STOCKPILE WITHOUT FAILING IN THE EVENT THAT MATERIAL FROM THE STOCKPILE SHIFTS OR SLUMPS AGAINST THE PERIMETER, AND OTHER FACTORS.
- STABILIZE THE STOCKPILE SURFACE WITH SURFACE ROUGHENING, TEMPORARY SEEDING AND MULCHING, EROSION CONTROL BLANKETS, OR SOIL BINDERS. SOILS STOCKPILED FOR AN EXTENDED PERIOD (TYPICALLY FOR MORE THAN 60 DAYS) SHOULD BE SEEDED AND MULCHED WITH A TEMPORARY GRASS COVER ONCE THE STOCKPILE IS PLACED (TYPICALLY WITHIN 14 DAYS). USE OF MULCH ONLY OR A SOIL BINDER IS ACCEPTABLE IF THE STOCKPILE WILL BE IN PLACE FOR A MORE LIMITED TIME PERIOD (TYPICALLY 30-60 DAYS).
- FOR TEMPORARY STOCKPILES ON THE INTERIOR PORTION OF A CONSTRUCTION SITE, WHERE OTHER DOWNGRADIENT CONTROLS, INCLUDING PERIMETER CONTROL, ARE IN PLACE, STOCKPILE PERIMETER CONTROLS MAY NOT BE REQUIRED.

November 2010 Urban Drainage and Flood Control District SP-3
Urban Storm Drainage Criteria Manual Volume 3

MM-2 Stockpile Management (SM)

STOCKPILE PROTECTION MAINTENANCE NOTES

- INSPECT BMPs EACH WORKDAY, AND MAINTAIN THEM IN EFFECTIVE OPERATING CONDITION. MAINTENANCE OF BMPs SHOULD BE PROACTIVE, NOT REACTIVE. INSPECT BMPs AS SOON AS POSSIBLE (AND ALWAYS WITHIN 24 HOURS) FOLLOWING A STORM THAT CAUSES SURFACE EROSION, AND PERFORM NECESSARY MAINTENANCE.
- FREQUENT OBSERVATIONS AND MAINTENANCE ARE NECESSARY TO MAINTAIN BMPs IN EFFECTIVE OPERATING CONDITION. INSPECTIONS AND CORRECTIVE MEASURES SHOULD BE DOCUMENTED THOROUGHLY.
- WHERE BMPs HAVE FAILED, REPAIR OR REPLACEMENT SHOULD BE INITIATED UPON DISCOVERY OF THE FAILURE.
- IF PERIMETER PROTECTION MUST BE MOVED TO ACCESS SOIL STOCKPILE, REPLACE PERIMETER CONTROLS BY THE END OF THE WORKDAY.
- STOCKPILE PERIMETER CONTROLS CAN BE REMOVED ONCE ALL THE MATERIAL FROM THE STOCKPILE HAS BEEN USED.

(DETAILS ADAPTED FROM PARKER, COLORADO, NOT AVAILABLE IN AUTOCAD)
NOTE: MANY JURISDICTIONS HAVE BMP DETAILS THAT VARY FROM UDFCD STANDARD DETAILS. CONSULT WITH LOCAL JURISDICTIONS AS TO WHICH DETAIL SHOULD BE USED WHEN DIFFERENCES ARE NOTED.

SP-4 Urban Drainage and Flood Control District November 2010
Urban Storm Drainage Criteria Manual Volume 3

EPC 10/12/2022

Additional erosion control details on maintenance and installation are located in Attachment 4 to the SWMP/GESQCP Narrative

Temporary and Permanent Seeding (TS/PS) EC-2

Description

Temporary seeding can be used to stabilize disturbed areas that will be inactive for an extended period. Permanent seeding should be used to stabilize areas at final grade that will not be otherwise stabilized. Effective seeding includes preparation of a seedbed, selection of an appropriate seed mixture, proper planting techniques, and protection of the seeded area with mulch, geotextiles, or other appropriate measures.



Photograph TS/PS-1. Equipment used to drill seed. Photo courtesy of Douglas County.

Appropriate Uses

When the soil surface is disturbed and will remain inactive for an extended period (typically, 30 days or longer), proactive stabilization measures should be implemented. If the inactive period is short-lived (on the order of two weeks), techniques such as surface roughening may be appropriate. For longer periods of inactivity, temporary seeding and mulching can provide effective erosion control. Permanent seeding should be used on finished areas that have not been otherwise stabilized.

Typically, local governments have their own seed mixes and timelines for seeding. Check jurisdictional requirements for seeding and temporary stabilization.

Design and Installation

Effective seeding requires proper seedbed preparation, selection of an appropriate seed mixture, use of appropriate seeding equipment to ensure proper coverage and density, and protection with mulch or fabric until plants are established.

The USDCM Volume 2 *Revegetation* Chapter contains detailed seed mix, soil preparations, and seeding and mulching recommendations that may be referenced to supplement this Fact Sheet.

Drill seeding is the preferred seeding method. Hydroseding is not recommended except in areas where steep slopes prevent use of drill seeding equipment, and even in these instances it is preferable to hand seed and mulch. Some jurisdictions do not allow hydroseding or hydromulching.

Seedbed Preparation

Prior to seeding, ensure that areas to be revegetated have soil conditions capable of supporting vegetation. Overlot grading can result in loss of topsoil, resulting in poor quality subsoils at the ground surface that have low nutrient values, little organic matter content, few soil microorganisms, rooting restrictions, and conditions less conducive to infiltration of precipitation. As a result, it is typically necessary to provide stockpiled topsoil, compost, or other

Temporary and Permanent Seeding	
Functions	
Erosion Control	Yes
Sediment Control	No
Site/Material Management	No

June 2012 Urban Drainage and Flood Control District Urban Storm Drainage Criteria Manual Volume 3 TS/PS-1

EC-2 Temporary and Permanent Seeding (TS/PS)

soil amendments and rototill them into the soil to a depth of 6 inches or more.

Topsoil should be salvaged during grading operations for use and spread on areas to be revegetated later. Topsoil should be viewed as an important resource to be utilized for vegetation establishment, due to its water-holding capacity, structure, texture, organic matter content, biological activity, and nutrient content. The rooting depth of most native grasses in the semi-arid Denver metropolitan area is 6 to 18 inches. At a minimum, the upper 6 inches of topsoil should be stripped, stockpiled, and ultimately respread across areas that will be revegetated.

Where topsoil is not available, subsoils should be amended to provide an appropriate plant-growth medium. Organic matter, such as well digested compost, can be added to improve soil characteristics conducive to plant growth. Other treatments can be used to adjust soil pH conditions when needed. Soil testing, which is typically inexpensive, should be completed to determine and optimize the types and amounts of amendments that are required.

If the disturbed ground surface is compacted, rip or rototill the surface prior to placing topsoil. If adding compost to the existing soil surface, rototilling is necessary. Surface roughening will assist in placement of a stable topsoil layer on steeper slopes, and allow infiltration and root penetration to greater depth.

Prior to seeding, the soil surface should be rough and the seedbed should be firm, but neither too loose nor compacted. The upper layer of soil should be in a condition suitable for seeding at the proper depth and conducive to plant growth. Seed-to-soil contact is the key to good germination.

Seed Mix for Temporary Vegetation

To provide temporary vegetative cover on disturbed areas which will not be paved, built upon, or fully landscaped or worked for an extended period (typically 30 days or more), plant an annual grass appropriate for the time of planting and mulch the planted areas. Annual grasses suitable for the Denver metropolitan area are listed in Table TS/PS-1. These are to be considered only as general recommendations when specific design guidance for a particular site is not available. Local governments typically specify seed mixes appropriate for their jurisdiction.

Seed Mix for Permanent Revegetation

To provide vegetative cover on disturbed areas that have reached final grade, a perennial grass mix should be established. Permanent seeding should be performed promptly (typically within 14 days) after reaching final grade. Each site will have different characteristics and a landscape professional or the local jurisdiction should be contacted to determine the most suitable seed mix for a specific site. In lieu of a specific recommendation, one of the perennial grass mixes appropriate for site conditions and growth season listed in Table TS/PS-2 can be used. The pure live seed (PLS) rates of application recommended in these tables are considered to be absolute minimum rates for seed applied using proper drill-seeding equipment.

If desired for wildlife habitat or landscape diversity, shrubs such as rubber rabbitbrush (*Chrysothamnus nauseosus*), fourwing saltbush (*Atriplex canescens*) and skunkbrush sumac (*Rhus trilobata*) could be added to the upland seedmixes at 0.25, 0.5 and 1 pound PLS/acre, respectively. In riparian zones, planting root stock of such species as American plum (*Prunus americana*), woods rose (*Rosa woodsii*), plains cottonwood (*Populus sargentii*), and willow (*Populus spp.*) may be considered. On non-topsoiled upland sites, a legume such as Ladak alfalfa at 1 pound PLS/acre can be included as a source of nitrogen for perennial grasses.

TS/PS-2 Urban Drainage and Flood Control District Urban Storm Drainage Criteria Manual Volume 3 June 2012

Temporary and Permanent Seeding (TS/PS) EC-2

Seeding dates for the highest success probability of perennial species along the Front Range are generally in the spring from April through early May and in the fall after the first of September until the ground freezes. If the area is irrigated, seeding may occur in summer months, as well. See Table TS/PS-3 for appropriate seeding dates.

Table TS/PS-1. Minimum Drill Seeding Rates for Various Temporary Annual Grasses

Species* (Common name)	Growth Season	Pounds of Pure Live Seed (PLS)/acre ²	Planting Depth (inches)
1. Oats	Cool	35 - 50	1 - 2
2. Spring wheat	Cool	25 - 35	1 - 2
3. Spring barley	Cool	25 - 35	1 - 2
4. Annual ryegrass	Cool	10 - 15	½
5. Millet	Warm	3 - 15	½ - ¾
6. Sudangrass	Warm	5 - 10	½ - ¾
7. Sorghum	Warm	5 - 10	½ - ¾
8. Winter wheat	Cool	20 - 35	1 - 2
9. Winter barley	Cool	20 - 35	1 - 2
10. Winter rye	Cool	20 - 35	1 - 2
11. Triticale	Cool	25 - 40	1 - 2

¹ Successful seeding of annual grass resulting in adequate plant growth will usually produce enough dead-plant residue to provide protection from wind and water erosion for an additional year. This assumes that the cover is not disturbed or mowed closer than 8 inches.

Hydraulic seeding may be substituted for drilling only where slopes are steeper than 3:1 or where access limitations exist. When hydraulic seeding is used, hydraulic mulching should be applied as a separate operation, when practical, to prevent the seeds from being encapsulated in the mulch.

² See Table TS/PS-3 for seeding dates. Irrigation, if consistently applied, may extend the use of cool season species during the summer months.

³ Seeding rates should be doubled if seed is broadcast, or increased by 50 percent if done using a Brillion Drill or by hydraulic seeding.

June 2012 Urban Drainage and Flood Control District Urban Storm Drainage Criteria Manual Volume 3 TS/PS-3

EC-2 Temporary and Permanent Seeding (TS/PS)

Table TS/PS-2. Minimum Drill Seeding Rates for Perennial Grasses

Common Name	Botanical Name	Growth Season ¹	Growth Form	Seeds/ Pound	Pounds of PLS/acre
Alkali Soil Seed Mix					
Alkali sycation	<i>Sporobolus airoides</i>	Cool	Bunch	1,750,000	0.25
Basin wildrye	<i>Elymus cinereus</i>	Cool	Bunch	165,000	2.5
Sodar streambank wheatgrass	<i>Agropyron riparium 'Soda'</i>	Cool	Sod	170,000	2.5
Jose tall wheatgrass	<i>Agropyron elongatum 'Jose'</i>	Cool	Bunch	79,000	7.0
Arriba western wheatgrass	<i>Agropyron smithii 'Arriba'</i>	Cool	Sod	110,000	5.5
Total					17.75
Fertile Loamy Soil Seed Mix					
Ephraim crested wheatgrass	<i>Agropyron cristatum 'Ephraim'</i>	Cool	Sod	175,000	2.0
Dural hard fescue	<i>Festuca ovina 'duralcula'</i>	Cool	Bunch	565,000	1.0
Lincoln smooth brome	<i>Bromus inermis leysii 'Lincoln'</i>	Cool	Sod	130,000	3.0
Sodar streambank wheatgrass	<i>Agropyron riparium 'Soda'</i>	Cool	Sod	170,000	2.5
Arriba western wheatgrass	<i>Agropyron smithii 'Arriba'</i>	Cool	Sod	110,000	7.0
Total					15.5
High Water Table Soil Seed Mix					
Meadow foxtail	<i>Alopecurus pratensis</i>	Cool	Sod	900,000	0.5
Redtop	<i>Agrostis alba</i>	Warm	Open sod	5,000,000	0.25
Reed canarygrass	<i>Phalaris arundinacea</i>	Cool	Sod	68,000	0.5
Lincoln smooth brome	<i>Bromus inermis leysii 'Lincoln'</i>	Cool	Sod	130,000	3.0
Pathfinder switchgrass	<i>Panicum virgatum 'Pathfinder'</i>	Warm	Sod	389,000	1.0
Albar tall wheatgrass	<i>Agropyron elongatum 'Albar'</i>	Cool	Bunch	79,000	5.5
Total					10.75
Transition Turf Seed Mix²					
Ruebens Canadian bluegrass	<i>Poa compressa 'Ruebens'</i>	Cool	Sod	2,500,000	0.5
Dural hard fescue	<i>Festuca ovina 'duralcula'</i>	Cool	Bunch	565,000	1.0
Citation perennial ryegrass	<i>Lolium perenne 'Citation'</i>	Cool	Sod	247,000	3.0
Lincoln smooth brome	<i>Bromus inermis leysii 'Lincoln'</i>	Cool	Sod	130,000	3.0
Total					7.5

TS/PS-4 Urban Drainage and Flood Control District Urban Storm Drainage Criteria Manual Volume 3 June 2012

Temporary and Permanent Seeding (TS/PS) EC-2

Table TS/PS-2. Minimum Drill Seeding Rates for Perennial Grasses (cont.)

Common Name	Botanical Name	Growth Season ¹	Growth Form	Seeds/ Pound	Pounds of PLS/acre
Sandy Soil Seed Mix					
Blue grama	<i>Bouteloua gracilis</i>	Warm	Sod-forming bunchgrass	825,000	0.5
Camper little bluestem	<i>Schizachyrium scoparium 'Camper'</i>	Warm	Bunch	240,000	1.0
Prairie sandreed	<i>Calamovilfa longifolia</i>	Warm	Open sod	274,000	1.0
Sand dropseed	<i>Sporobolus cristatus</i>	Cool	Bunch	5,298,000	0.25
Vaughn sideoats grama	<i>Bouteloua curtipendula 'Vaughn'</i>	Warm	Sod	191,000	2.0
Arriba western wheatgrass	<i>Agropyron smithii 'Arriba'</i>	Cool	Sod	110,000	5.5
Total					10.25
Heavy Clay, Rocky Foothill Seed Mix					
Ephraim crested wheatgrass ⁴	<i>Agropyron cristatum 'Ephraim'</i>	Cool	Sod	175,000	1.5
Oahe intermediate wheatgrass	<i>Agropyron intermedium 'Oahe'</i>	Cool	Sod	115,000	5.5
Vaughn sideoats grama ⁴	<i>Bouteloua curtipendula 'Vaughn'</i>	Warm	Sod	191,000	2.0
Lincoln smooth brome	<i>Bromus inermis leysii 'Lincoln'</i>	Cool	Sod	130,000	3.0
Arriba western wheatgrass	<i>Agropyron smithii 'Arriba'</i>	Cool	Sod	110,000	5.5
Total					17.5

¹ All of the above seeding mixes and rates are based on drill seeding followed by crimped straw mulch. These rates should be doubled if seed is broadcast and should be increased by 50 percent if the seeding is done using a Brillion Drill or is applied through hydraulic seeding. Hydraulic seeding may be substituted for drilling only where slopes are steeper than 3:1. If hydraulic seeding is used, hydraulic mulching should be done as a separate operation.

² See Table TS/PS-3 for seeding dates.

³ If site is to be irrigated, the transition turf seed rates should be doubled.

⁴ Crested wheatgrass should not be used on slopes steeper than 6:1 to 1:1.

⁵ Can substitute 0.5 lbs PLS of blue grama for the 2.0 lbs PLS of Vaughn sideoats grama.

June 2012 Urban Drainage and Flood Control District Urban Storm Drainage Criteria Manual Volume 3 TS/PS-5

EC-2 Temporary and Permanent Seeding (TS/PS)

Table TS/PS-3. Seeding Dates for Annual and Perennial Grasses

Seeding Dates	Annual Grasses (Numbers in table reference species in Table TS/PS-1)		Perennial Grasses	
	Warm	Cool	Warm	Cool
January 1 - March 15			✓	✓
March 16 - April 30	4	1,2,3	✓	✓
May 1 - May 15	4		✓	
May 16 - June 30	4,5,6,7			
July 1 - July 15	5,6,7			
July 16 - August 31				
September 1 - September 30		8,9,10,11		
October 1 - December 31			✓	✓

Mulch

Cover seeded areas with mulch or an appropriate rolled erosion control product to promote establishment of vegetation. Anchor mulch by crimping, netting or use of a non-toxic tackifier. See the Mulching BMP Fact Sheet for additional guidance.

Maintenance and Removal

Monitor and observe seeded areas to identify areas of poor growth or areas that fail to germinate. Reseed and mulch these areas, as needed.

An area that has been permanently seeded should have a good stand of vegetation within one growing season if irrigated and within three growing seasons without irrigation in Colorado. Reseed portions of the site that fail to germinate or remain bare after the first growing season.

Seeded areas may require irrigation, particularly during extended dry periods. Targeted weed control may also be necessary.

Protect seeded areas from construction equipment and vehicle access.

TS/PS-6 Urban Drainage and Flood Control District Urban Storm Drainage Criteria Manual Volume 3 June 2012

Additional erosion control details on maintenance and installation are located in Attachment 4 to the SWMP/GESQCP Narrative

EPC 10/12/2022



ENVIRONMENTAL SERVICES DEPARTMENT
TECHNICAL SERVICES SECTION

P.O. Box 1103, Mail Code 940
COLORADO SPRINGS, CO 80947
(719) 668-8426

**CONTROL MEASURE DETAILS
EROSION AND STORMWATER
QUALITY CONTROL PLAN**

**Aura at Crossroads
Electric and Gas Main Installation**

PCD Filing No: CDR-22-013

Prepared By: JPH

Date: September 2022



Colorado Springs Utilities

It's how we're all connected

Environmental Services Department
 121 South Tejon Street, Fourth Floor
 Colorado Springs, Colorado 80903

- Legend:**
- Streets
 - Stormwater Inlets
 - Construction Project Location
 - Boundary of Planned Construction Disturbance
 - Tree Removal
 - Crossroads GEC Plan Area

- Notes:**
1. The Eastern half of the project area has been recently graded and had no vegetation. It is shown as developer graded area.
 2. Vegetation in the disturbance area consists of mostly grasses and weeds.
 3. A stand of trees exists within the disturbance area. Most will be left alone. Approximately 4 trees will be removed from the alignment. The property owner supports the removal of these trees. Location of trees shown on the Figure.
 4. Following construction, the dirt trails will be returned to pre-construction grade and remain dirt trails. Impacted vegetation will be re-established.

SWMP/ESQCP EXISTING SITE CONDITIONS

Aura at Crossroads G&E
 EPC 10/12/2022

Project No: PCD File No.: CDR-22-013

Prepared By: J HOUGHTON

Date: SEPTEMBER 2022

**Figure
 Number
 2 WEST**

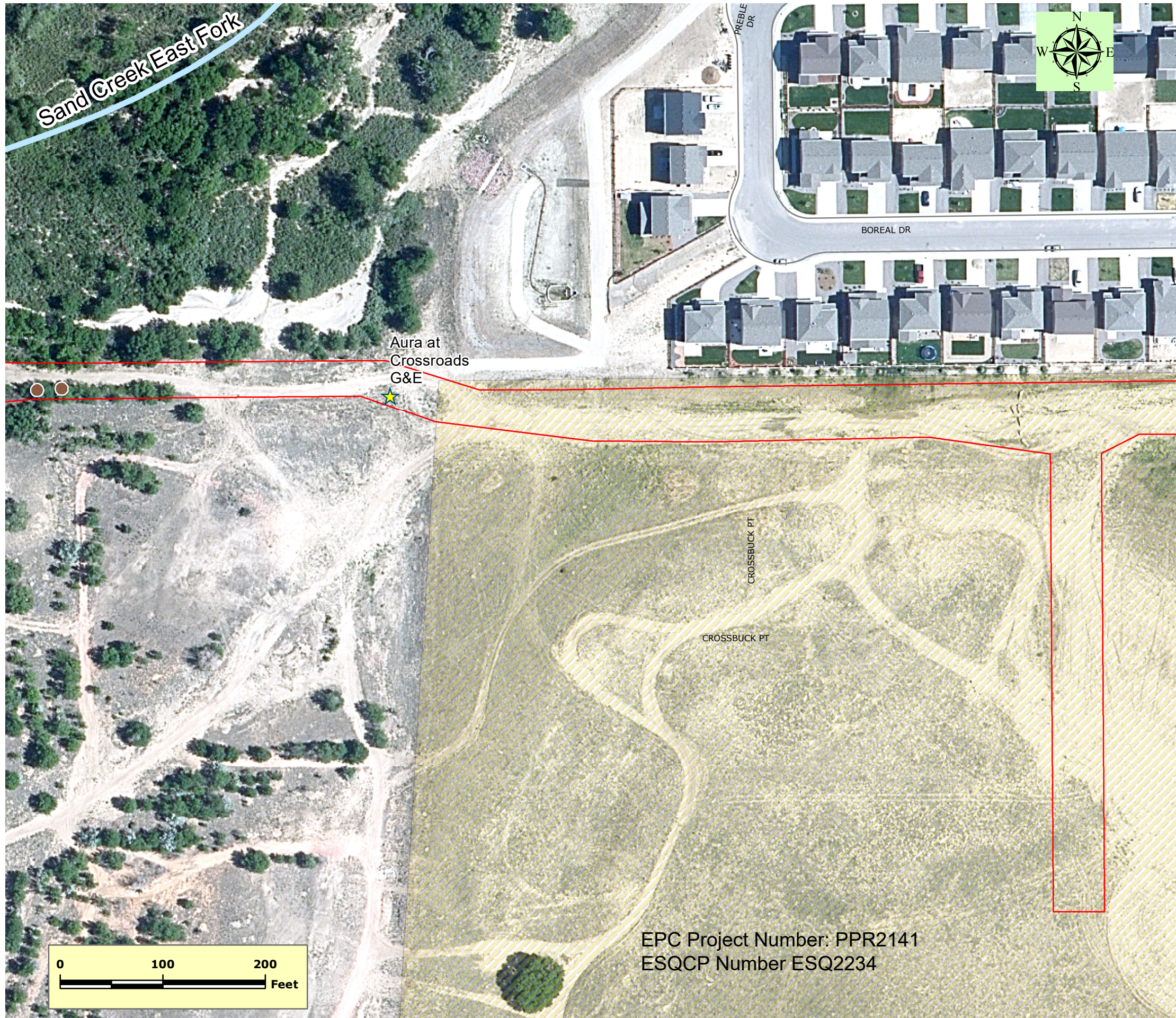

Colorado Springs Utilities

It's how we're all connected

Environmental Services Department
 121 South Tejon Street, Fourth Floor
 Colorado Springs, Colorado 80903

- Legend:**
- Streets
 - Stormwater Inlets
 - Construction Project Location
 - Boundary of Planned Construction Disturbance
 - Tree Removal
 - Crossroads GEC Plan Area

- Notes:**
1. The Eastern half of the project area has been recently graded and had no vegetation. It is shown as developer graded area.
 2. Vegetation in the disturbance area consists of mostly grasses and weeds.
 3. A stand of trees exists within the disturbance area. Most will be left alone. Approximately 4 trees will be removed from the alignment. The property owner supports the removal of these trees. Location of trees shown on the Figure.
 4. Following construction, the dirt trails will be returned to pre-construction grade and remain dirt trails. Impacted vegetation will be re-established.

SWMP/ESQCP EXISTING SITE CONDITIONS

Aura at Crossroads G&E
 EPC 10/12/2022

Project No: PCD File No.: CDR-22-013

Prepared By: J HOUGHTON

Date: SEPTEMBER 2022

**Figure
 Number**

2 CENTRAL

EPC Project Number: PPR2141
 ESQCP Number ESQ2234

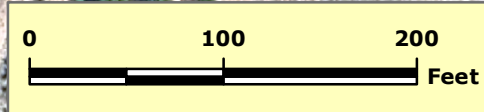

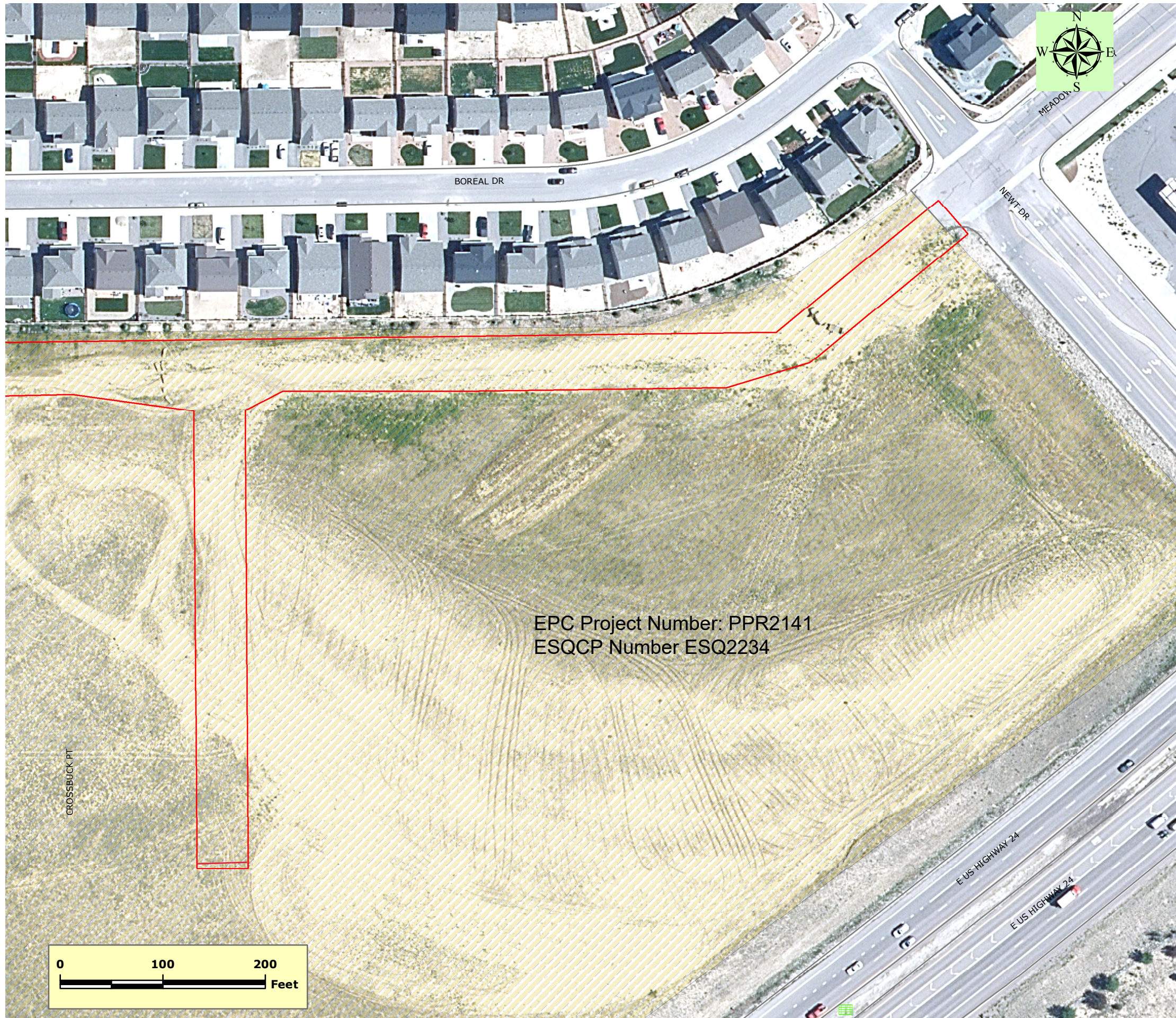

Colorado Springs Utilities

It's how we're all connected

Environmental Services Department
 121 South Tejon Street, Fourth Floor
 Colorado Springs, Colorado 80903

- Legend:**
- Streets
 - Stormwater Inlets
 - Construction Project Location
 - Boundary of Planned Construction Disturbance
 - Tree Removal
 - Crossroads GEC Plan Area

- Notes:**
1. The Eastern half of the project area has been recently graded and had no vegetation. It is shown as developer graded area.
 2. Vegetation in the disturbance area consists of mostly grasses and weeds.
 3. A stand of trees exists within the disturbance area. Most will be left alone. Approximately 4 trees will be removed from the alignment. The property owner supports the removal of these trees. Location of trees shown on the Figure.
 4. Following construction, the dirt trails will be returned to pre-construction grade and remain dirt trails. Impacted vegetation will be re-established.

SWMP/ESQCP EXISTING SITE CONDITIONS

Aura at Crossroads G&E
 EPC 10/12/2022

Project No: PCD File No.: CDR-22-013

Prepared By: J HOUGHTON

Date: SEPTEMBER 2022



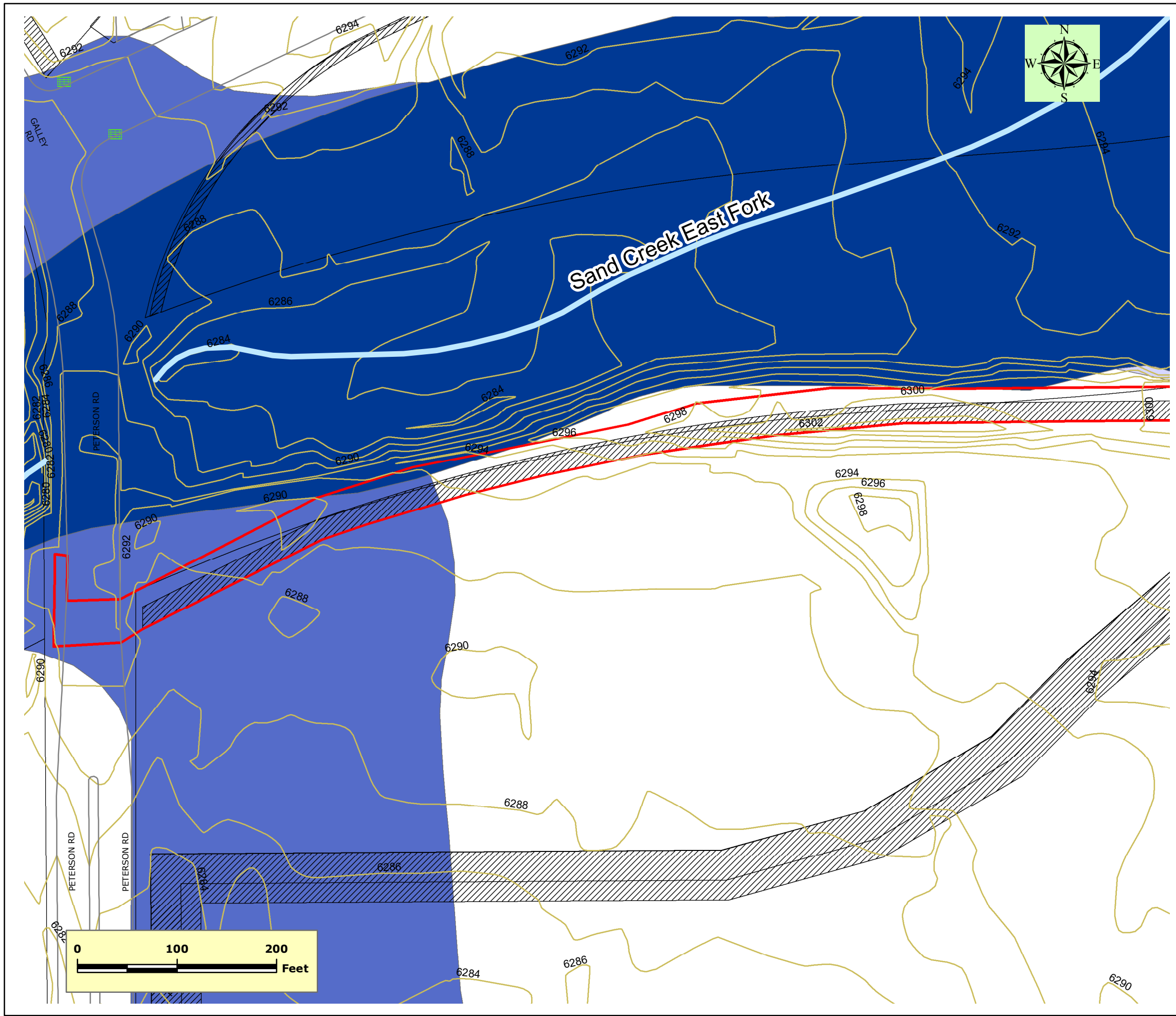







**Figure
Number
2 EAST**



Colorado Springs Utilities

It's how we're all connected

Environmental Services Department
 121 South Tejon Street, Fourth Floor
 Colorado Springs, Colorado 80903

- Legend:**
-  Streets
 -  Stormwater Inlets
 -  Construction Project Location
 -  Existing and Proposed Contours (2ft Intervals)
 -  Boundary of Construction Project
 -  Crossroads GEC Plan Area (ESQCP Number ESQ2234)
 -  Property Boundaries
 -  Utility Easements
 -  10 Year FEMA Flood Zone
 -  100 Year FEMA Flood Zone
 -  500 Year FEMA Flood Zone

**SWMP/ESQCP
 SITE TOPOGRAPHY/EASEMENTS/FLOODPLAIN**





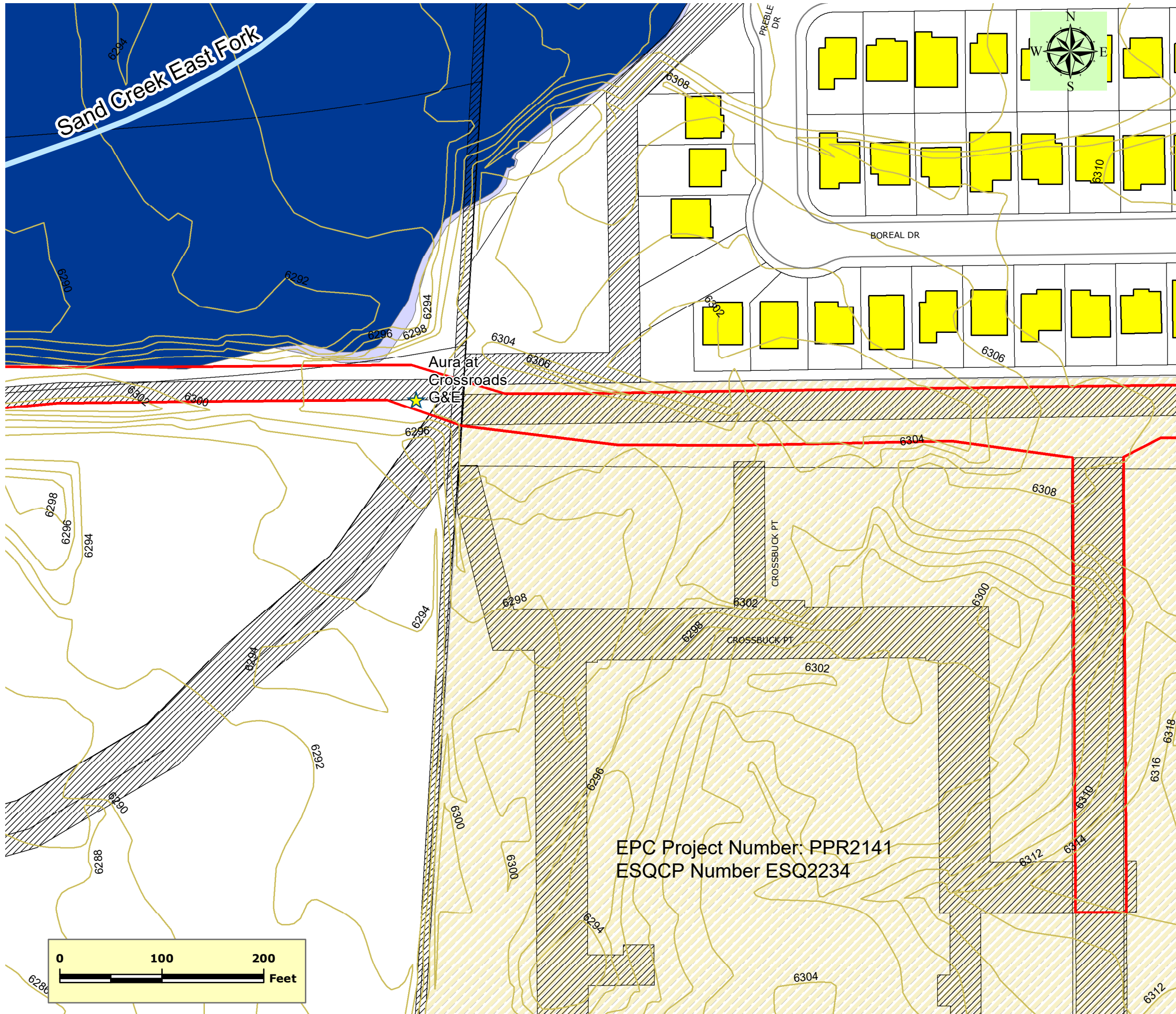

EPC 10/12/2022

Aura at Crossroads G&E

Project No: PCD File No.: CDR-22-013
Prepared By: J HOUGHTON
Date: SEPTEMBER 2022

**Figure
 Number
 3 WEST**



- Legend:**
-  Streets
 -  Stormwater Inlets
 -  Construction Project Location
 -  Existing and Proposed Contours (2ft Intervals)
 -  Boundary of Construction Project
 -  Crossroads GEC Plan Area (ESQCP Number ESQ2234)
 -  Property Boundaries
 -  Utility Easements
 -  10 Year FEMA Flood Zone
 -  100 Year FEMA Flood Zone
 -  500 Year FEMA Flood Zone

EPC Project Number: PPR2141
 ESQCP Number ESQ2234

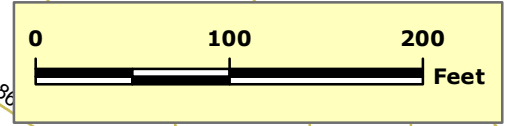

**SWMP/ESQCP
 SITE TOPOGRAPHY/EASEMENTS/FLOODPLAIN**
 EPC 10/12/2022

Aura at Crossroads G&E		Figure Number 3 CENTRAL
Project No:	PCD File No.: CDR-22-013	
Prepared By:	J HOUGHTON	
Date:	SEPTEMBER 2022	



Colorado Springs Utilities

It's how we're all connected

Environmental Services Department
121 South Tejon Street, Fourth Floor
Colorado Springs, Colorado 80903

Legend:

- Streets
- Stormwater Inlets
- Construction Project Location
- Existing and Proposed Contours (2ft Intervals)
- Boundary of Construction Project
- Crossroads GEC Plan Area (ESQCP Number ESQ2234)
- Property Boundaries
- Utility Easements
- 10 Year FEMA Flood Zone
- 100 Year FEMA Flood Zone
- 500 Year FEMA Flood Zone

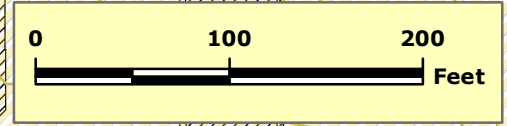
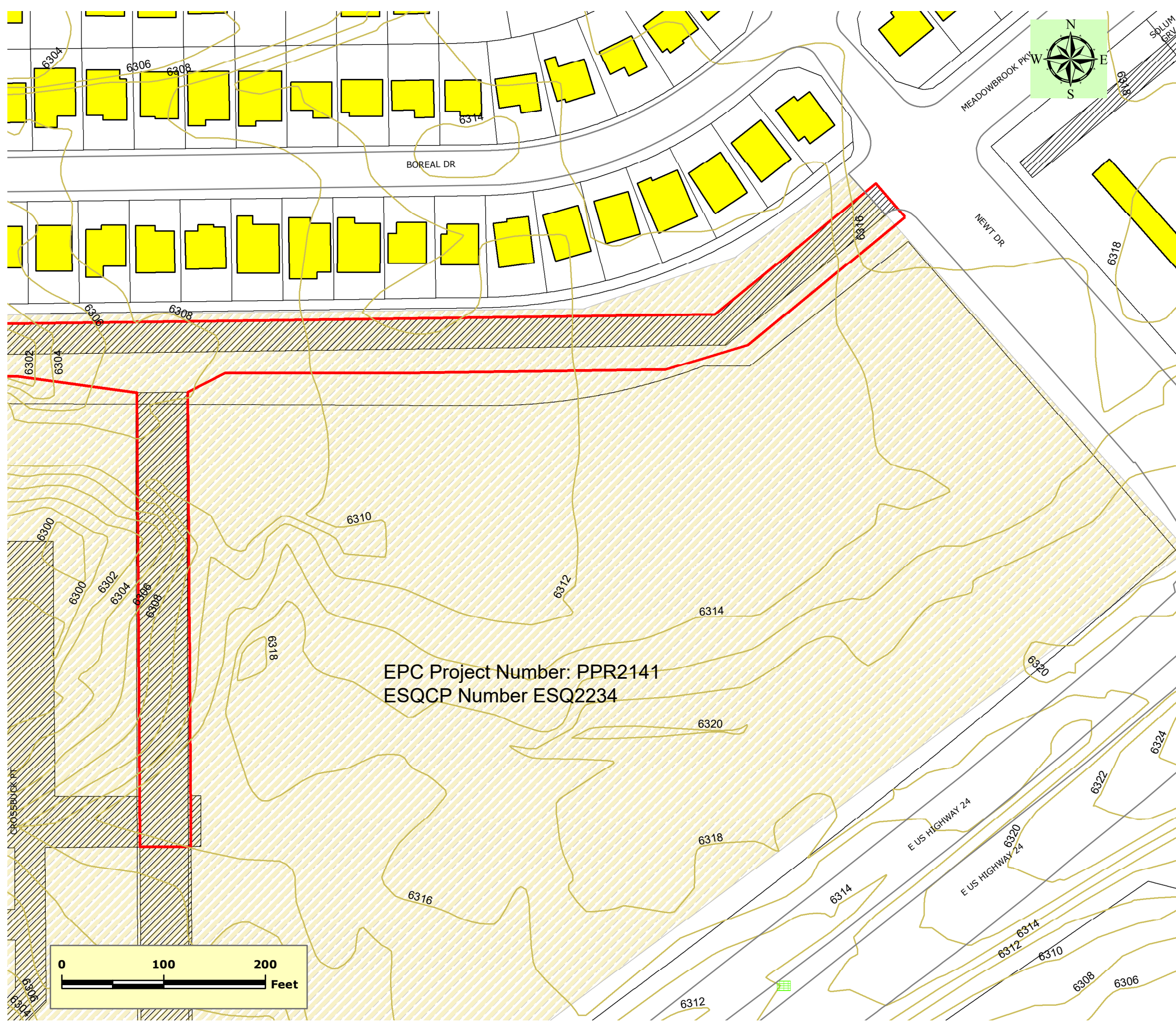

SWMP/ESQCP SITE TOPOGRAPHY/EASEMENTS/FLOODPLAIN

EPC 10/12/2022

Aura at Crossroads G&E

Project No: PCD File No.: CDR-22-013

Prepared By: J HOUGHTON

Date: SEPTEMBER 2022

**Figure
Number
3 EAST**



Colorado Springs Utilities

It's how we're all connected

Environmental Services Department
121 South Tejon Street, Fourth Floor
Colorado Springs, Colorado 80903

Legend:

- Streets
- ☐ Stormwater Inlets
- Control Measures - Is Action Needed?
- Install Before Disturbance Begins
- N/A - Owned and Maintained by Others - Active
- No
- Yes
- Silt Fence
- SCL
- Const Fencing
- Existing Contours (2ft Intervals) and Proposed Contours
- ➔ Approximate Surface Flow Direction
- Pollutant Source - Present?
- No
- Yes
- Disturbance Area - Current Status
- Construction
- Finally Stabilized
- Not Started
- Other
- Restoration / Stabilization
- ▨ Crossroads GEC Plan Area
- ▨ Waterway_Buffer50ft

Notes:

1. Specific locations of staging areas, stockpiles, and any other material storage will be determined by site crew. These locations, and location of accompanying stockpile protection control measures (rock socks or sediment control logs) will be marked and updated on this plan throughout construction. Due to the nature of the project, it is expected that some or all of these items may be located in several areas and may be moved daily.
2. Once construction begins, if additional Control Measures are needed, locations will be identified on the inspection report map updates.
3. Street sweeping will be performed as needed. Areas in need will be marked on this map.
4. There will be no concrete or asphalt batch plants on site.
5. All construction vehicles limited to identified disturbance area to protect adjacent areas.
6. Following construction, the dirt trails will be returned to pre-construction grade and remain dirt trails. Impacted vegetation will be re-established.

Abbreviations for Initial and Forseeable Control Measures

- VTC - Vehicle Tracking Control
- SCL - Sediment Control Log
- IP-1 - On Grade Inlet Protection
- CD - Check Dam
- SP - Stockpile Protection
- RS - Rock Sock

GEC PLAN PLANNED CONTROL MEASURES EPC 10/12/2022

Aura at Crossroads G&E

Project No: PCD File No.: CDR-22-013

Prepared By: J HOUGHTON

Date: SEPTEMBER 2022

**Figure
Number
4 WEST**

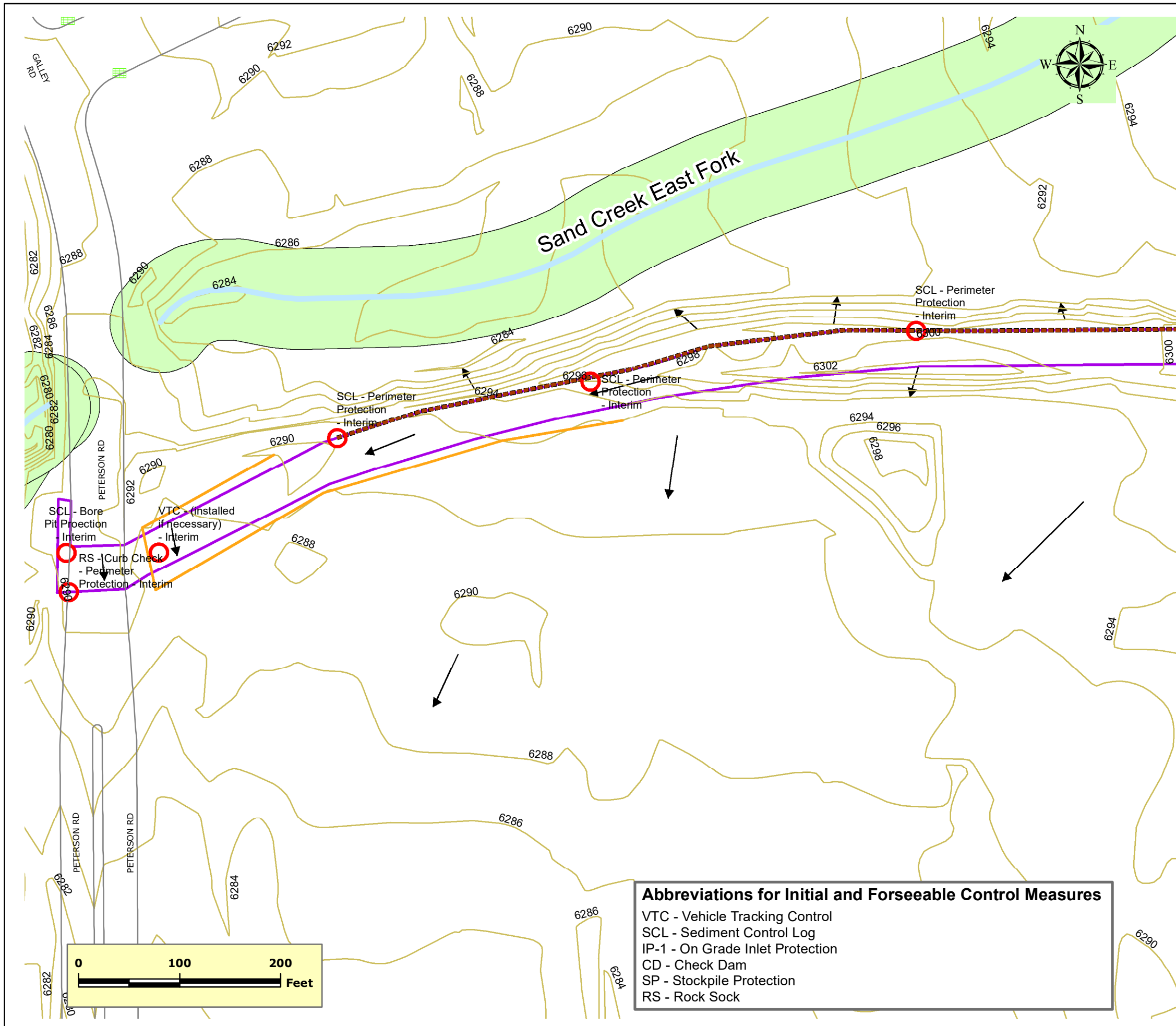



Colorado Springs Utilities

It's how we're all connected

Environmental Services Department
121 South Tejon Street, Fourth Floor
Colorado Springs, Colorado 80903

Legend:

- Streets
- ☐ Stormwater Inlets
- Control Measures - Is Action Needed?
- Install Before Disturbance Begins
- N/A - Owned and Maintained by Others - Active
- No
- Yes
- ▬ Silt_Fence
- ▬ SCL
- ▬ Const Fencing
- ▬ Existing Contours (2ft Intervals) and Proposed Contours
- ➔ Approximate Surface Flow Direction
- Pollutant Source - Present?
- No
- Yes
- Disturbance Area - Current Status
- ▬ Construction
- ▬ Finally Stabilized
- ▬ Not Started
- ▬ Other
- ▬ Restoration / Stabilization
- ▨ Crossroads GEC Plan Area (ESQCP Number ESQ2234)
- ▨ Waterway_Buffer50ft

Notes:

1. Specific locations of staging areas, stockpiles, and any other material storage will be determined by site crew. These locations, and location of accompanying stockpile protection control measures (rock socks or sediment control logs) will be marked and updated on this plan throughout construction. Due to the nature of the project, it is expected that some or all of these items may be located in several areas and may be moved daily.
2. Once construction begins, if additional Control Measures are needed, locations will be identified on the inspection report map updates.
3. Street sweeping will be performed as needed. Areas in need will be marked on this map.
4. There will be no concrete or asphalt batch plants on site.
5. All construction vehicles limited to identified disturbance area to protect adjacent areas.
6. Following construction, the dirt trails will be returned to pre-construction grade and remain dirt trails. Impacted vegetation will be re-established.

EPC Project Number: PPR2141
ESQCP Number ESQ2234

Abbreviations for Initial and Forseeable Control Measures

- VTC - Vehicle Tracking Control
- SCL - Sediment Control Log
- IP-1 - On Grade Inlet Protection
- CD - Check Dam
- SP - Stockpile Protection
- RS - Rock Sock

GEC PLAN PLANNED CONTROL MEASURES

EPC 10/12/2022
Aura at Crossroads G&E

Project No: PCD File No.: CDR-22-013

Prepared By: J HOUGHTON

Date: SEPTEMBER 2022

Figure
Number

4 CENTRAL

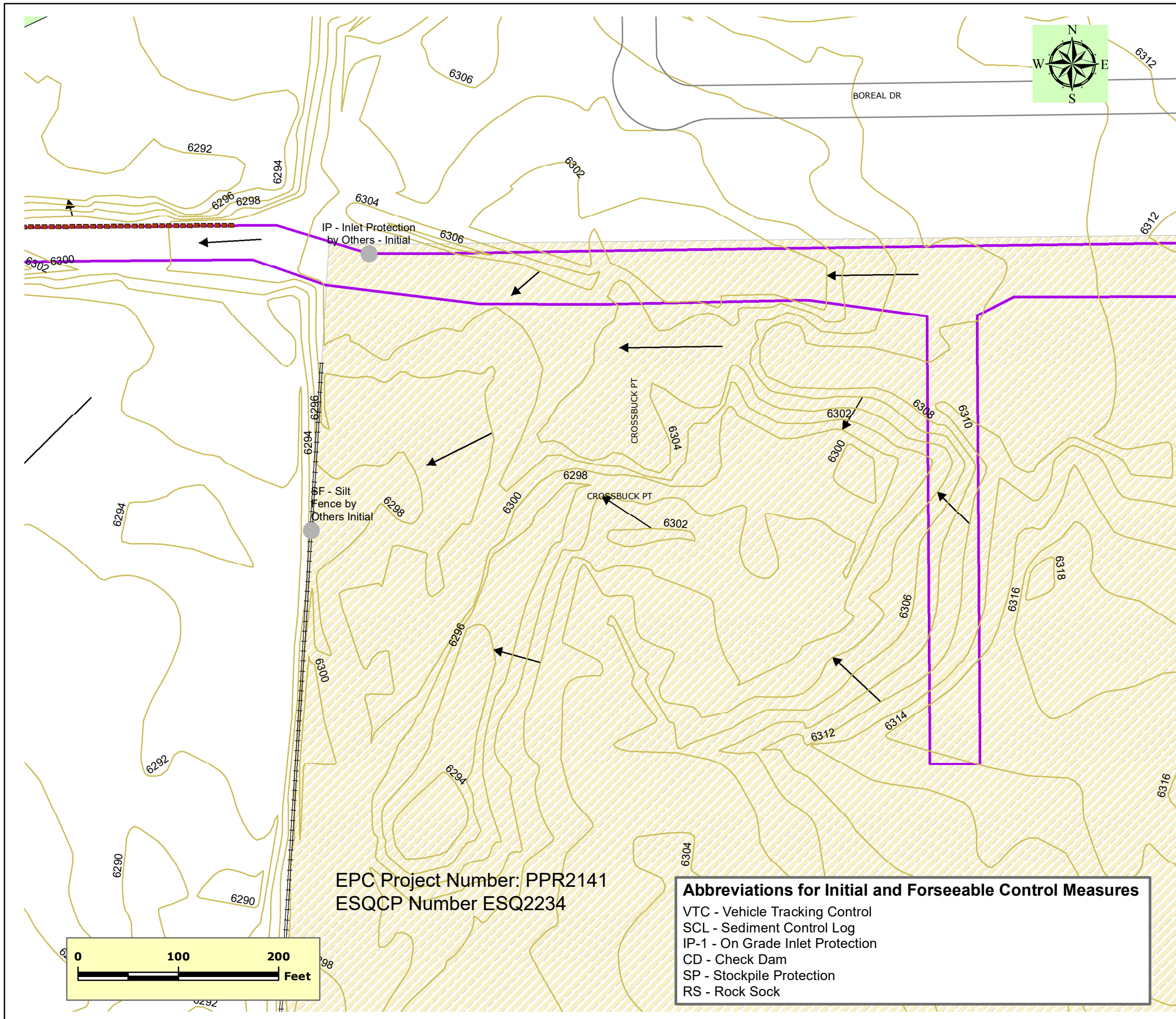
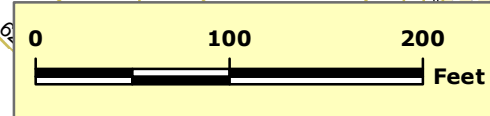



Colorado Springs Utilities

It's how we're all connected

Environmental Services Department
121 South Tejon Street, Fourth Floor
Colorado Springs, Colorado 80903

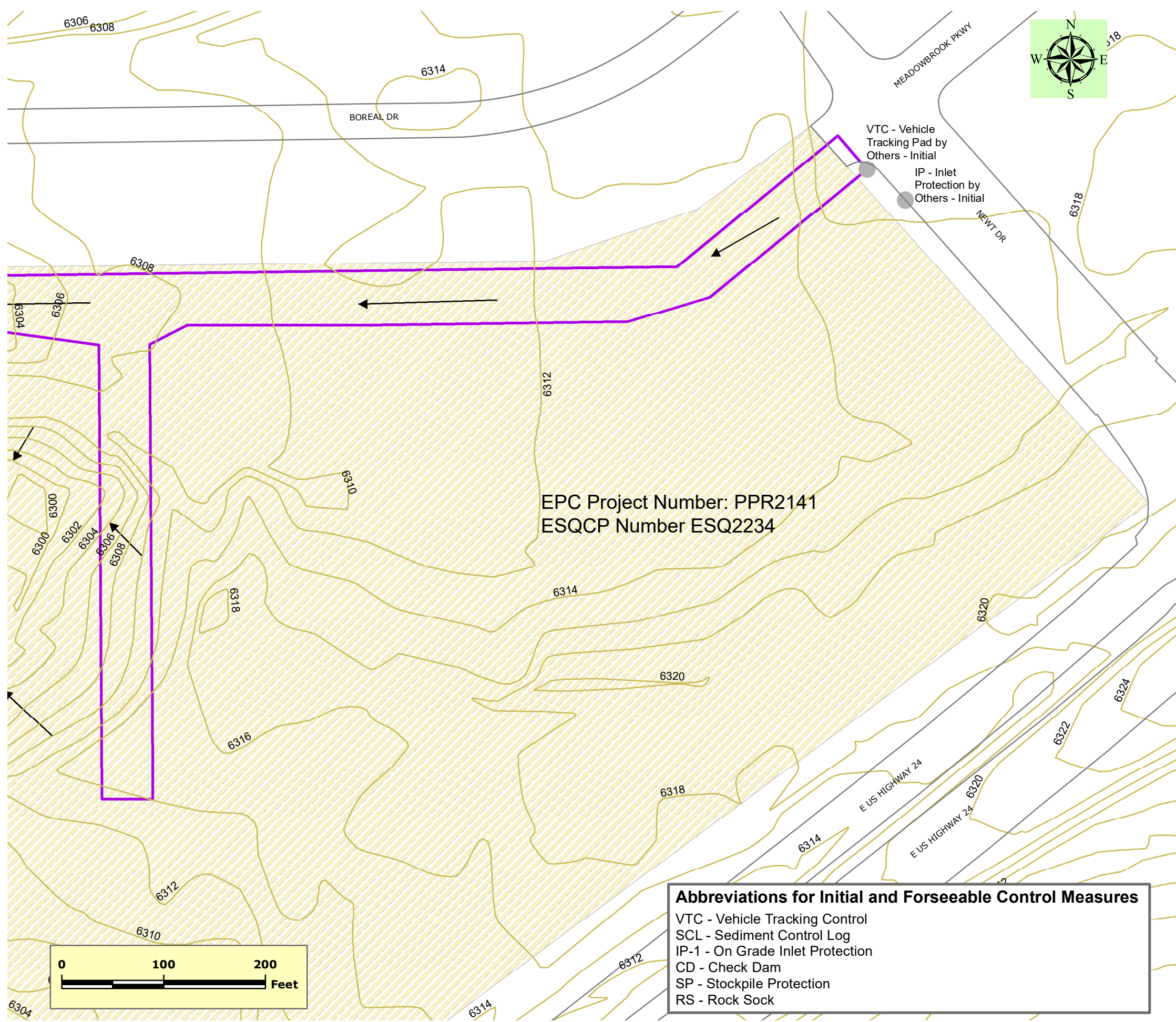

EPC Project Number: PPR2141
ESQCP Number ESQ2234

Abbreviations for Initial and Forseeable Control Measures
 VTC - Vehicle Tracking Control
 SCL - Sediment Control Log
 IP-1 - On Grade Inlet Protection
 CD - Check Dam
 SP - Stockpile Protection
 RS - Rock Sock

Legend:

- Streets
- ☐ Stormwater Inlets
- Control Measures - Is Action Needed?
- Install Before Disturbance Begins
- N/A - Owned and Maintained by Others - Active
- No
- Yes
- ▬ Silt Fence
- ▬ SCL
- ▬ Const Fencing
- ▬ Existing Contours (2ft Intervals) and Proposed Contours
- ➔ Approximate Surface Flow Direction
- Pollutant Source - Present?
- No
- Yes
- Disturbance Area - Current Status
- ▬ Construction
- ▬ Finally Stabilized
- ▬ Not Started
- ▬ Other
- ▬ Restoration / Stabilization
- ▬ Crossroads GEC Plan Area (ESQCP Number ESQ2234)
- ▬ Waterway_Buffer50ft

Notes:

1. Specific locations of staging areas, stockpiles, and any other material storage will be determined by site crew. These locations, and location of accompanying stockpile protection control measures (rock socks or sediment control logs) will be marked and updated on this plan throughout construction. Due to the nature of the project, it is expected that some or all of these items may be located in several areas and may be moved daily.
2. Once construction begins, if additional Control Measures are needed, locations will be identified on the inspection report map updates.
3. Street sweeping will be performed as needed. Areas in need will be marked on this map.
4. There will be no concrete or asphalt batch plants on site.
5. All construction vehicles limited to identified disturbance area to protect adjacent areas.
6. Following construction, the dirt trails will be returned to pre-construction grade and remain dirt trails. Impacted vegetation will be re-established.

**GEC PLAN
PLANNED CONTROL MEASURES
EPC 10/12/2022**

Aura at Crossroads G&E

Project No: PCD File No.: CDR-22-013	Figure Number 4 EAST
Prepared By: J HOUGHTON	
Date: SEPTEMBER 2022	

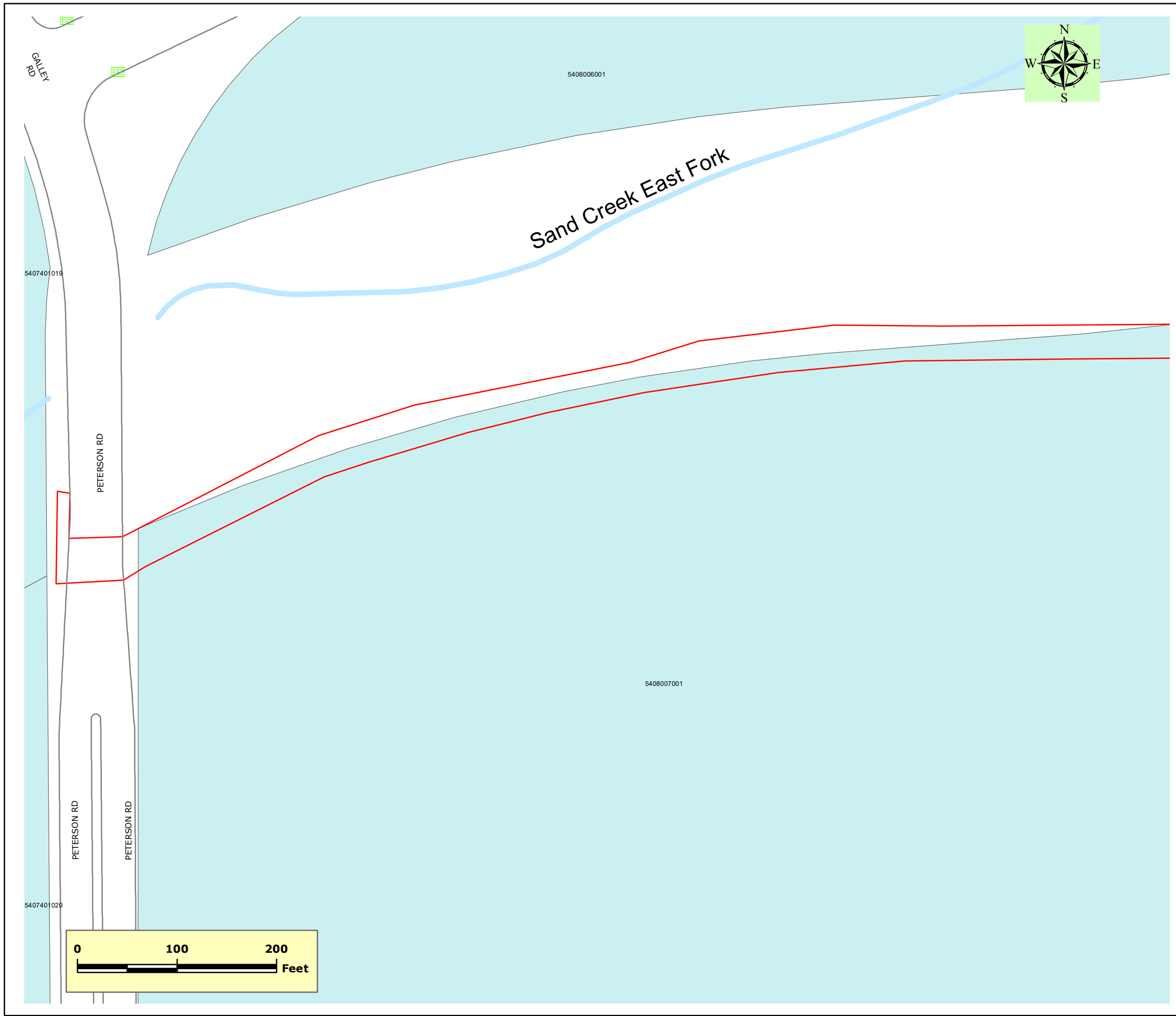

Colorado Springs Utilities

It's how we're all connected

Environmental Services Department
 121 South Tejon Street, Fourth Floor
 Colorado Springs, Colorado 80903

- Legend:**
- Streets
 - Stormwater Inlets
 - Construction Project Location
 - Boundary of Planned Construction Disturbance
 - Parcels and Tax Schedule Numbers

EPC 10/12/2022

**GRADING AND EROSION CONTROL PLAN
 TAX SCHEDULE NUMBER
 OF ADJACENT PARCELS
 Aura at Crossroads G&E**

Project No: PCD File No.: CDR-22-013

Prepared By: J HOUGHTON

Date: SEPTEMBER 2022

**Figure
 Number
 5 WEST**

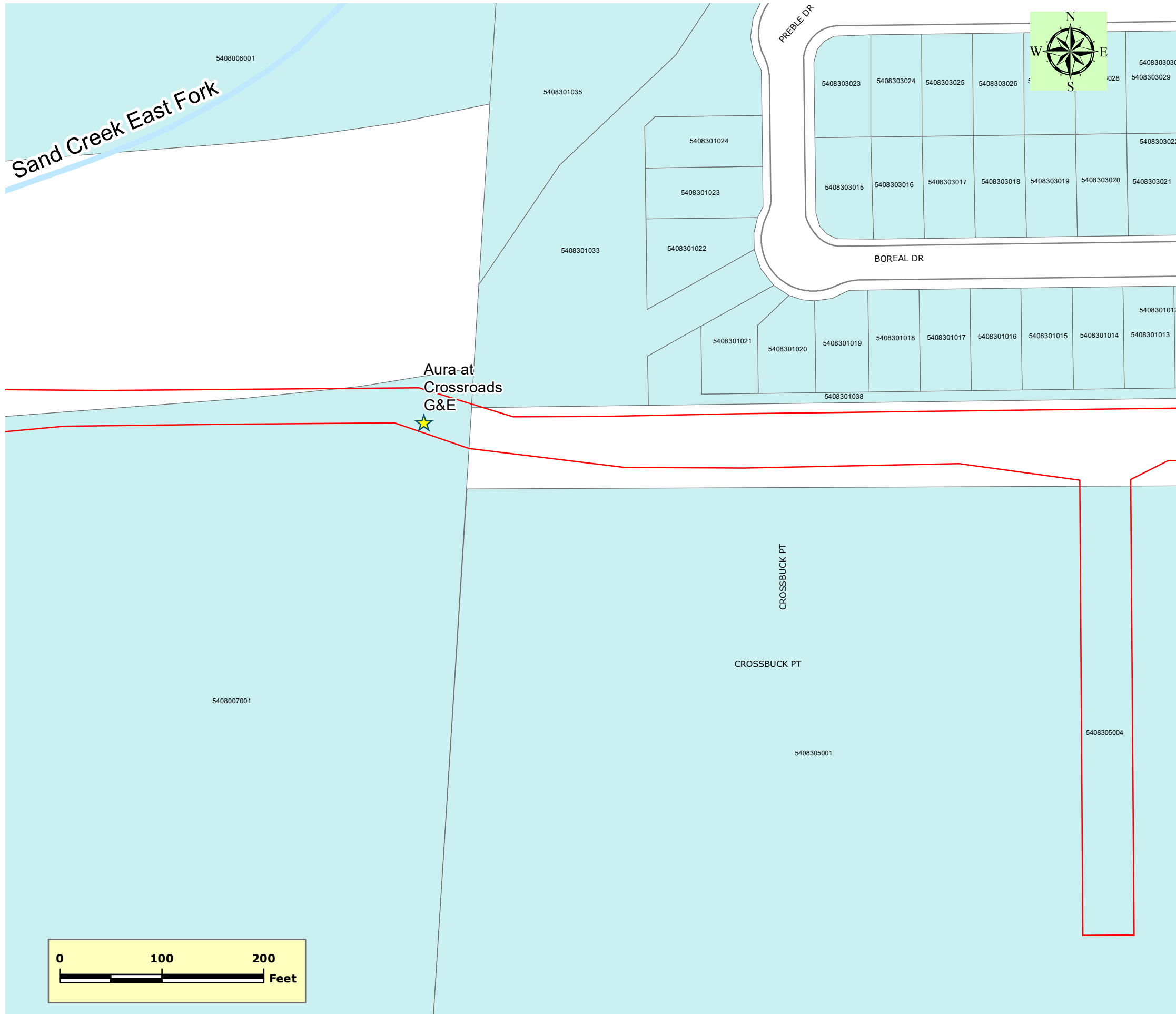

Colorado Springs Utilities

It's how we're all connected

Environmental Services Department
 121 South Tejon Street, Fourth Floor
 Colorado Springs, Colorado 80903

- Legend:**
- Streets
 - Stormwater Inlets
 - Construction Project Location
 - Boundary of Planned Construction Disturbance
 - Parcels and Tax Schedule Numbers

EPC 10/12/2022

**GRADING AND EROSION CONTROL PLAN
 TAX SCHEDULE NUMBER
 OF ADJACENT PARCELS
 Aura at Crossroads G&E**

Project No: PCD File No.: CDR-22-013

Prepared By: J HOUGHTON

Date: SEPTEMBER 2022

**Figure
 Number
 5 CENTRAL**

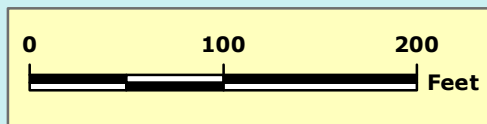







Colorado Springs Utilities

It's how we're all connected

Environmental Services Department
121 South Tejon Street, Fourth Floor
Colorado Springs, Colorado 80903

Legend:

-  Streets
-  Stormwater Inlets
-  Construction Project Location
-  Boundary of Planned Construction Disturbance
-  Parcels and Tax Schedule Numbers

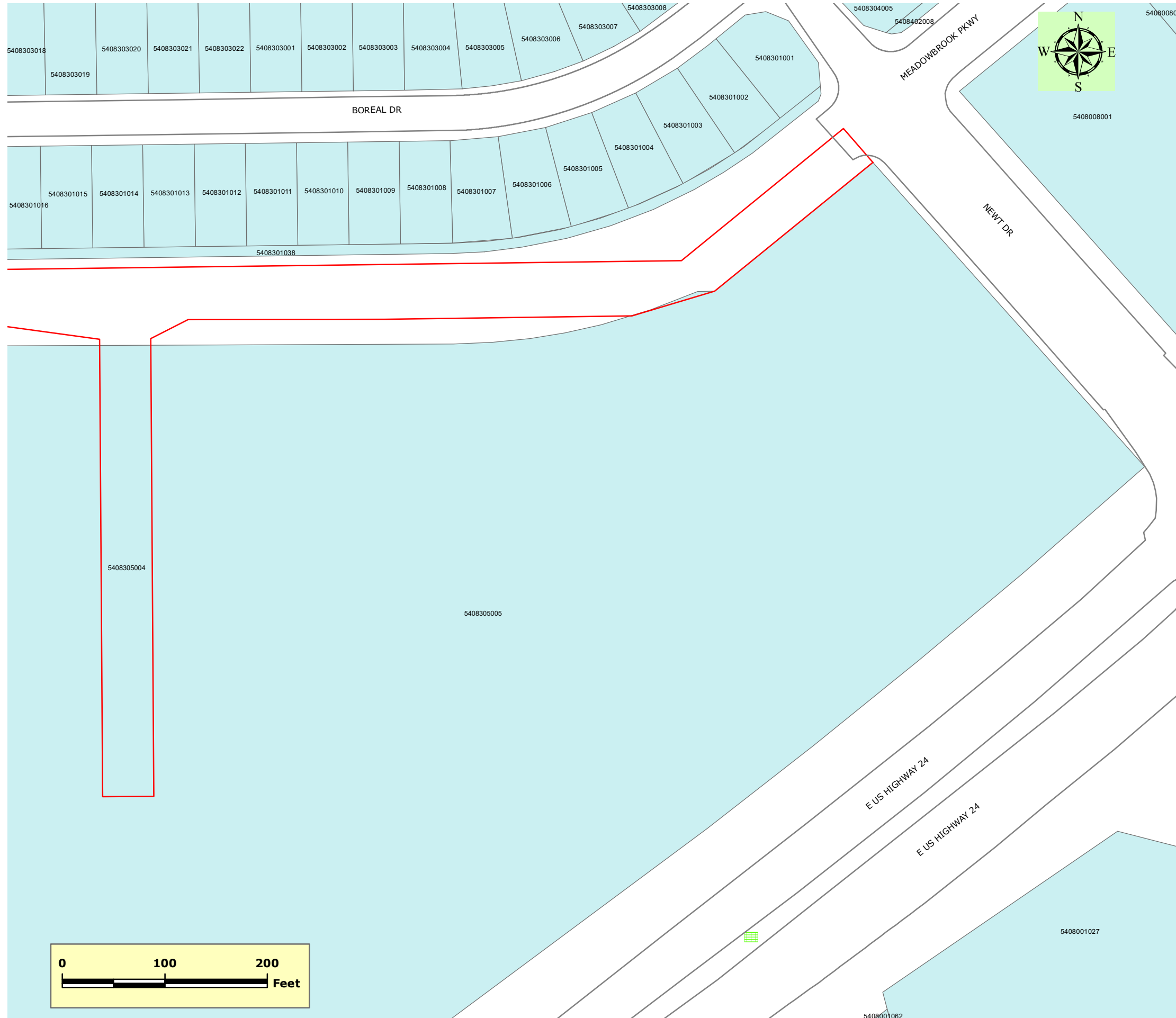

EPC 10/12/2022

**GRADING AND EROSION CONTROL PLAN
TAX SCHEDULE NUMBER
OF ADJACENT PARCELS
Aura at Crossroads G&E**

Project No: PCD File No.: CDR-22-013

Prepared By: J HOUGHTON

Date: SEPTEMBER 2022

**Figure
Number
5 EAST**