



STORMWATER MANAGEMENT PLAN FOR LOT 168, TOP O THE MOOR II

February 2022

Prepared for:

COLORADO DEPARTMENT PUBLIC HEALTH AND ENVIRONMENT
WATER QUALITY CONTROL DIVISION-STORMWATER PROGRAM
WQCD-Permits-B2
4300 Cherry Creek Drive South
Denver, CO 80246-1530

Applicant/Owner: The Maynard Company
1364 Old Cedar Grove
Monument, CO 80132
307-730-3474

SWMP Preparer: Catamount Engineering
321 W. Henrietta Ave., Suite A
Woodland Park, CO
David Mijares, PE
(719) 426-2124

Stormwater Manager: xxx
Xxx
Xxx
Xxx

Contractor Information: xxx
Xxx
Xxx
Xxx

PCD Filing No.: CDR225

Catamount Engineering Job 21-337

STORMWATER MANAGEMENT PLAN
Lot 168, TOP O THE MOOR II

TABLE OF CONTENTS

Purpose	Page 2
Site Description	Page 2
Floodplain Statement	Page 3
Basic Grading, Erosion, and Storm water Requirements	Page 3
Construction Activities	Page 5
BMP Erosion Control Measures	Page 7
<i>Structural Practices</i>	Page 7
<i>Recommended Seed Mix</i>	Page 8
<i>Nonstructural Practices</i>	Page 8
<i>Other Controls</i>	Page 8
<i>Final Stabilization and Long-Term Storm water Quality</i>	Page 9
<i>Inspection and Maintenance</i>	Page 9

APPENDIX

-Vicinity Map	
-General Permit Application	
-Recommended BMP Maintenance Inspection Checklist	
-Sample Spill Response Plan & Spill Report Form	
-Federal, State, or Local Storm water or other Environmental Inspector Site Visit Log	
-Details & Drawings	
<i>Silt Fence</i>	
<i>Concrete Wash-out Detail</i>	
<i>Stabilized Staging Area</i>	
<i>Stockpile Management</i>	
<i>Straw Bale Barrier</i>	
<i>Port-o-Let Detail</i>	
<i>Vehicle Tracking Control Pad</i>	

STORMWATER MANAGEMENT PLAN LOT 168, TOP O THE MOOR II

PURPOSE

The following storm water management plan (SWMP) is a detailed account of the requirements for the CDPS permit. The primary objective of this plan is to prevent storm water contamination during construction activity.

It is estimated that clearing, grading, roadway construction will impact 0.46 acres of the 0.71 acre site. Grading operations required approximately 700 CY of import material that has been placed on the site. Grading operations began in Fall 2021 with final site stabilization proposed in Summer 2022.

This document must be kept at the construction site at all times; and be made available to the public and any representative of the Colorado Department of Health - Water Quality Control Division or El Paso County Representative, if requested.

The Grading & Erosion Control Plans are considered part of this SWMP and are included in the appendix. These plans shall be kept at the site at all times. Modifications to the erosion control plan may be necessary occasionally based on site inspections. Any additions or deletions of erosion control measures should be documented on the site copy of the Grading & Erosion Control Plans.

Construction of a Single Family lot on existing lot with limited footprint will change rational method C₅ values from 0.09 (agricultural) to 0.90 (weighted average) and C₁₀₀ values from 0.36 (agricultural) to 0.96 (weighted average) for minor portions of the overall lot.

No on-site batch plant is proposed with the development. There is no dewatering operation anticipated to take place within the construction site area of the gravel road.

SITE DESCRIPTION

The subject 0.71 acres consists of an existing lot within a developed subdivision to be developed into a single residence and driveway. The parcel is located on a portion of Section 1, Township 11 South, Range 67 West of the 6th principal meridian in unincorporated El Paso County.

The parcel is bounded to the north and west platted residential lots within the Top O the Moor II subdivision.

Using Google aerial photos and drive-by images, it is estimated that the site is vegetated with native grasses and occasional trees with an area of coverage rate of approximately 80%. Existing soils on the site consist of Kettle gravelly loam, hydrologic soil group A as determined by the Natural Resources Conservation Service Web Soil Survey. The parcel is poorly vegetated and exhibits moderate slopes and low erosion potential. No ongoing erosion was evident on the undeveloped parcel. The site is located within the Dirty Woman Creek drainage. The parcel

sheet flows south onto adjacent residential lots at slopes between 7% and 33%. There is no stream crossing within the project area.

FLOODPLAIN STATEMENT

No portion of the site lies within an F.E.M.A. designated floodplain per FIRM 08041C0277 G, effective December 07, 2018.

BASIC GRADING, EROSION AND STORMWATER QUALITY REQUIREMENTS AND GENERAL PROHIBITIONS

*Information taken from the City of Colorado Springs/ El Paso County Drainage Criteria Manual Volume 2, herein referred to as the “Manual.”

1. Storm water discharges from construction sites shall not cause or threaten to cause pollution, contamination, or degradation of State Waters.
2. Concrete wash water shall not be discharged to or allowed to runoff to the Municipal Separate Sewer System (MS4).
3. Building, construction, excavation, or other waste materials shall not be temporarily placed or stored in the street, alley, or other public way, unless in accordance with an approved Traffic Control Plan. BMPs may be required by the MS4 Permittee if deemed necessary, based on specific conditions and circumstances (e.g., estimated time of exposure, season of the year, etc.).
4. Vehicle tracking of soils off-site shall be minimized.
5. All wastes composed of building materials must be removed from the construction site for disposal in accordance with local and state regulatory requirements. No building material wastes or unused building materials shall be buried, dumped, or discharged at the site.
6. No chemicals are to be added to the discharge unless permission for the use of a specific chemical is granted by the state. In granting the use of such chemicals, special conditions and monitoring may be required.
7. Bulk storage structures for petroleum products and other chemicals shall have secondary containment or equivalent adequate protection so as to contain all spills and prevent any spilled material from entering the MS4, including any surface or subsurface storm drainage system or facilities.
8. All persons engaged in earth disturbance shall implement and maintain acceptable soil erosion and sediment control measures including BMPs in conformance with the erosion control technical standards of the Drainage Criteria Manual, Volume 2 and in accordance with the approved Erosion and Stormwater Quality Control Plan approved by the MS4 permittee, if required.
9. All temporary erosion control facilities including BMPs and all permanent facilities intended to control erosion of any earth disturbance operations shall be installed as defined in the approved Erosion and Stormwater Quality Control Plan and the Drainage Criteria Manual, Volume 2 and maintained throughout the duration of the earth disturbance operation. The installation of the first level of temporary erosion control

facilities and BMPs shall be installed and inspected prior to any earth disturbance operations taking place.

10. Any earth disturbance shall be conducted in such a manner so as to effectively reduce accelerated soil erosion and resulting sedimentation.
11. All earth disturbances shall be designed, constructed, and completed in such a manner so that the exposed area of any disturbed land shall be limited to the shortest practical period of time.
12. All work and earth disturbance shall be done in a manner that minimizes pollution of any on-site or off-site waters, including wetlands.
13. Suspended sediment caused by accelerated soil erosion shall be minimized in runoff water before it leaves the site of the earth disturbance.
14. Any temporary or permanent facility designed and constructed for the conveyance of stormwater around, through, or from the earth disturbance area shall be designed to limit the discharge to a non-erosive velocity.
15. Temporary soil erosion control facilities shall be removed and earth disturbance areas graded and stabilized with permanent soil erosion control measures pursuant to the standards and specifications prescribed in the Drainage Criteria Manual, Volume 2, and in accordance with the permanent erosion control features shown on the approved Erosion and Stormwater Quality Control Plans approved by the City of Colorado Springs/El Paso County, if required.
16. Soil erosion control measures for all slopes, channels, ditches, or any disturbed land area shall be completed within twenty-one (21) calendar days after final grading, or final earth disturbance, has been completed. Disturbed areas and stockpiles which are not at final grade but will remain dormant for longer than 30 days shall also be mulched within 21 days after interim grading. An area that is going to remain in an interim state for more than 60 days shall also be seeded. On a case-by-case basis, the MS4 permittee may allow appropriate BMP to be in place that prevents sediment from leaving the site. All temporary soil erosion control measures and BMPs shall be maintained until permanent soil erosion control measures are implemented.
17. No person shall cause, permit, or contribute to the discharge into the municipal separate storm sewer pollutants that could cause the MS4 permittee to be in violation of its Colorado Discharge Permit System MS4 Permit.
18. The owner, site developer, contractor, and/or their authorized agents shall be responsible for the removal of all construction debris, dirt, trash, rock, sediment, and sand that may accumulate in the storm sewer or other drainage conveyance system and stormwater appurtenances as a result of site development.
19. No person shall cause the impediment of stormwater flow in the flow line of the curb and gutter, including the temporary or permanent ramping with materials for vehicle access.
20. Individuals shall comply with the "Colorado Water Quality Control Act" (Title 25, Article 8, CRS), and the "Clean Water Act" (33 USC 1344), regulations promulgated, certifications or permits issued, in addition to the requirements included in the Drainage Criteria Manual, Volume 2. In the event of conflicts between these requirements and water quality control laws, rules, or regulations of other Federal or State agencies, the more restrictive laws, rules, or regulations shall apply.
21. The quantity of materials stored on the project site shall be limited, as much as practical, to that quantity required to perform the work in an orderly sequence. All materials stored on-site shall be stored in a neat, orderly manner, in their original containers, with original

manufacturer's labels. Materials shall not be stored in a location where they may be carried by stormwater runoff into the MS4 at any time.

22. Spill prevention and containment measures shall be used at storage, and equipment fueling and servicing areas to prevent pollution from discharging to the MS4. All spills shall be cleaned up immediately after discovery, or contained until appropriate cleanup methods can be employed. Manufacturer's recommended methods for spill cleanup shall be followed, along with proper disposal methods.

BMP PHASING PLAN

Phase 1: Earthmoving activities began in Fall 2021 and were halted due to grading plan requirement. Home construction will begin immediately after plan approvals have been obtained. Initial erosion control measures such as roadside drainage swales, silt fence, stabilized staging and stockpile areas, straw bale barriers, portable toilet, concrete washout and vehicle tracking control are a part of the Initial phase of construction activity.

Phase 2: The Interim phase of construction is anticipated to begin in the Spring of 2022. Many initial erosion control measures such as roadside drainage swales, silt fence, stabilized staging and stockpile areas, straw bale barriers, portable toilet, concrete washout and vehicle tracking control are to remain in place. This phase is anticipated to be completed by the end of Spring 2022.

Phase 3: The Final phase of construction is anticipated to begin in the Summer of 2022. Removal of the initial and interim erosion control measures such as driveway drainage swales, silt fence, stabilized staging and stockpile areas, portable toilet, concrete washout and vehicle tracking control are to be removed. Seeding and mulching of the disturbed areas will occur during this phase. Straw bale barriers will remain in place until vegetative cover of 70% has been reached. This phase is anticipated to be completed by the end of Fall 2022.

CONSTRUCTION ACTIVITIES

The following is a list of major construction activities and the anticipated order of construction.

- 1. Import grading of driveway and homesite.**
 - a. Install initial erosion control measures.
 - i. Develop Stabilized Staging Area*
 - ii. Vehicle tracking control.*
 - iii. Perimeter silt fence.*
 - iv. Install external erosion control measures.*
 1. Straw Bale Barriers.
 - b. Grade portions of the site.
 - i. Strip and stockpile topsoil.*
 1. Install silt fence around topsoil stockpile.
 - ii. Overlot grade site.*
 - c. Install remaining site erosion control measures.

- i. *Additional silt fence.*
- ii. *Straw Bale Barriers.*
- iii. *Crimp & mulch.*
- iv. *Seed exposed areas not intended for further development*

2. Site construction

- a. Dry utility installation (trench & backfill)

It is ultimately the property owner’s responsibility to ensure that the work at the site is in compliance with this SWMP, the Grading and Erosion Control Plan, and all applicable statutes and ordinances. For this project the overall property owner is responsible for installing, inspecting, and maintaining all erosion control measures and BMP’s during the overlot grading process. Catamount Engineering recommends that the responsibility for compliance be transferred with property ownership to the buyer of any individual lot or other portion of this site. For example, if a retail developer purchases a lot, then that developer should become responsible for compliance with this SWMP and all applicable statutes and ordinances on that lot. Catamount Engineering recommends that the current overall property owner establish an agreement with potential buyers to knowingly transfer this responsibility with property ownership.

The main potential pollutant to Stormwater on this site is sediment from the soil stockpile, grading and vehicle tracking.

Other known potential sources of pollution:

	<u>Notes</u>
▪ Vehicle fueling.....Yes	See Below
▪ Vehicle washing.....No	
▪ Vehicle maintenance.....Yes	See Below
▪ Site Ingress/Egress/Vehicle tracking Yes	See Below
▪ Waste incineration, treatment, storage, or disposal.....No	
▪ Storage of chemical/fertilizers.....No	
▪ Concrete washoutYes	See Below
▪ Other (specify) – Portable Toilets.....Yes	See Below

Non-stormwater components of discharge:

	<u>Notes</u>
▪ Landscape irrigation return flow.....No	
▪ Springs.....No	
▪ Other (specify).....No	

Notes:

- Vehicle Fueling – there is no known vehicle fueling station to be installed or used on this site. However, it is anticipated that construction equipment may be refueled during construction. Spill prevention and containment measures shall be used at equipment fueling and servicing areas to prevent the pollution of any state waters, including wetlands. A sample spill report form is included in the Appendix of this report. All spills shall be cleaned up immediately after discovery, or contained until appropriate cleanup methods can be employed. Manufacturer’s recommended methods for spill cleanup shall be followed, along with proper disposal methods. The contractor shall follow the recommendations of the appropriate Hazard Communication Plan of the site construction manager, general contractor, or site superintendent. Vehicle refueling should be done in an area surrounded by an earthen berm to contain any fuel spills. Containment berming should be of sufficient size to safely contain a spill from the largest tank truck or other containment device located inside the possible spill area. In the event of a spill, a method of removal must be provided, such as application of absorbent materials and the use of a pump or vacuum truck. Any material removed from the spill site must be disposed of according to local, state, and federal standards. Stormwater and snowmelt runoff shall be diverted away from the containment berming area. Water that collects within the berming due to rainfall or snowmelt must be treated to meet standards before release from the spill area.
- Vehicle Maintenance – from time to time it may be necessary for the contractor to perform maintenance on the construction equipment being used on the site. If possible, major repairs to construction equipment shall be done off-site. Basic vehicle maintenance shall be performed in the vehicle fueling area and all recommendations listed above shall be followed.
- Site construction access will be limited to single connection point at the end of existing Red Barn Road. Access will be controlled with vehicle tracking pad conforming to El Paso County standards. The conformation tracking pad will be installed prior to on-site construction activities and will remain in place until final roadway surfacing. Existing Red Barn Road connection will be monitored for tracking of on-site soils. If vehicle conveyance of soils off-site is evident the tracking pad length will be increased beyond El Paso County standards and excess soils will be removed.
- Concrete wash water shall not be discharged to or allowed to runoff to State Waters, including any surface or subsurface storm drainage system or facilities. Any concrete wash water shall be done in a temporary pit on site. The area around this pit shall be protected per the detail provided and concrete inside the pit shall be removed when done.
- Portable toilets located on the site shall be staked in place using t-posts to prevent them from tipping over during high winds. Portable toilets will be located a minimum of 10 feet from stormwater inlets and 50 feet from state waters. They shall be adequately staked and cleaned on a weekly basis. They will be inspected daily for spills.

SITE MAP

See attached plans.

BMP EROSION CONTROL MEASURES

Steps to prevent sediment from entering the Stormwater discharge system are listed below. This project does not rely on control measures owned or operated by another entity.

Structural Practices:

Structural sediment control measures include the following:

1. Use of filter fabric silt fencing at site perimeter locations and throughout the site (*before commencement of construction activities*). Silt fence shall also be located around homesites and dirt stockpiles during home building operations. Erosion control measures on individual home sites are the responsibility of the homebuilder. This responsibility should be transferred to the homebuilder with the purchase of any lot. The transfer of erosion control responsibility should be clearly stated in the purchase contract for any lot(s).
2. Straw bale barriers to protect ditches and swales (*immediately after construction of each item*).
3. Vehicle tracking control devices at construction traffic ingress/egress points to prevent sediment tracking onto surrounding streets (*before commencement of construction activities*).
4. All disturbed areas shall have crimped straw installed and shall be reseeded. A recommended seed mix and application rate is included below.
5. All slopes not covered with slope protection erosion control blankets shall be roughed. Roughening shall be performed to follow the contour of the slope, that is, the roughening shall be perpendicular to surface runoff flow direction.
6. Runoff during construction operations will be directed to the temporary sedimentation basin located at the low point of the roadway extension within the parcel. The contractor should be aware that the sedimentation basin is considered a last line of defense and that the majority of sediment should be contained on the site near the source of the erosion using the other structural sediment control measures described in this report. Accumulated sedimentation shall be removed periodically to ensure proper functioning of the facility to capture sediment. The contractor shall remove any accumulated sediment prior to landscaping or seeding.
7. It is recommended that construction haul roads, if used on this site, have small stormwater diversions installed at intermittent locations and low points to prevent rutting and erosion on the roads.

See attached Grading and Erosion Control, and Detail sheets in the Appendix for locations and technical drawings for structural BMP's.

Recommended Seed Mix:

Sandy Soils

30 lbs/ acre

25% Sideoats Gramma

25% Little Bluestem
15% Blue Gramma
15% Prairie Sandreed
20% Switch Grass

Nonstructural Practices:

Temporary or permanent seeding will be employed in all areas disturbed by construction activities. Should excessive blowing of sediment become apparent, then the contractor shall water the site for dust control.

Other Controls:

Contractors shall take steps to keep the site reasonably free from large amounts of construction debris during construction. All waste materials generated by construction activities shall be removed from the site. All wastes composed of building materials must be removed from the construction site for disposal in accordance with local and state regulatory requirements. No building material wastes or unused building materials shall be buried, dumped, or discharged at the site.

Spill prevention and containment measures shall be used at storage, and equipment fueling and servicing areas to prevent the pollution of any state waters, including wetlands. While only a suggestion, a tarp staked down and used to line a depression in the ground could be utilized as a containment option. The contractor is responsible for installing and maintaining an area (whether using a tarp or a kiddie pool or some other method of containment) established for spill prevention and containment.

A sample of the spill report form is included in the Appendix of this report. All spills shall be cleaned up immediately after discovery, or contained until appropriate cleanup methods can be employed. Manufacturer's recommended methods for spill cleanup shall be followed, along with proper disposal methods. The contractor shall follow the recommendations of the appropriate Hazard Communication Plan of the site construction manager, general contractor, or site superintendent.

Final Stabilization and Long-Term Stormwater Quality:

Permanent sediment control measures include the installation of landscaping and reseeding with a native grass seed mix. The contractor shall consult the approved Landscape Plan for the proper location, species, and installation methods for landscaping on the site. If the owner reasonably maintains the landscaping and reseeding, then it will provide good soil stability and sediment control. After these permanent measures are installed and final stabilization is achieved, then temporary measures can be removed. Final stabilization is considered achieved when all earth disturbing activities at the site have been completed and uniform vegetative cover has been established with a density of at least 70% of pre-disturbance levels and such cover is capable of adequately controlling soil erosion. Runoff reduction of impervious areas is developed through use of LID techniques. Impervious area of driveway and home will be conveyed through pervious grassed areas prior to release off-site providing reduction in required WQCV.

Receiving Waters:

The parcel is ultimately tributary to the Dirty Woman Creek Drainage. The Dirty Woman Creek Drainage is an unstudied natural drainage characterized by vegetated grass swales within the upper reaches and sandy low flow channels farther downstream.

Inspection and Maintenance:

The site construction manager or site inspector responsible for these measures shall inspect them every 14 days and after every storm or snowmelt event that causes surface erosion. Self-Monitoring Inspections and reports thereof shall be completed by a Qualified Stormwater Manager (QSM) sufficiently qualified for the required duties per the ECM Appendix 1.5. This report recommends that all erosion control measures on the site are inspected a minimum of once every 7 days, except during winter snow pack conditions where no melting is occurring or when all construction activities are completed. Repairs shall be made within 24 to 48 hours after deficiencies are discovered. A record of all inspections made shall be kept with the SWMP Report for a minimum of 3 years. Inspection logs must be signed. A sample BMP Checklist is included in the Appendix of this report. See attached Detail sheet for specific maintenance requirements for individual BMP's.

SWMP Revision procedures:

The site construction manager or site inspector is responsible for updating the on-site SWMP report to reflect field conditions and project phasing. Upon determination that addition, modification, or deletion of proposed erosion control measures, the site construction manager will notify the El Paso County Inspector and the project engineer of proposed modifications. Any field modifications shall be reflected within the on-site copy upon completion of modifications.

The SWMP is considered a 'living document' that is continuously being reviewed and modified as a part of the overall process of evaluating and managing stormwater quality issues at the site. The Qualified Stormwater manager shall amend the SWMP when there is a change in design, construction, operation or maintenance of the site which would require the implementation of new or revised BMPs or if the SWMP proves to be ineffective in achieving the general objectives of the controlling pollutants in stormwater discharges associated with construction activity or when BMPs are no longer necessary and are removed.

Prepared by:



David L. Mijares, Colorado PE #40510
For and on behalf of Catamount Engineering

6.15.22

Date

APPENDIX

VICINITY MAP

GENERAL PERMIT APPLICATION

**RECOMMENDED BMP MAINTENANCE INSPECTION
CHECKLIST**

**SAMPLE SPILL RESPONSE PLAN
AND SPILL REPORT FORM**

**FEDERAL, STATE, OR LOCAL STORM
WATER OR OTHER ENVIRONMENTAL
INSPECTOR SITE VISIT LOG**

DETAILS & DRAWINGS

APPENDIX

VICINITY MAP

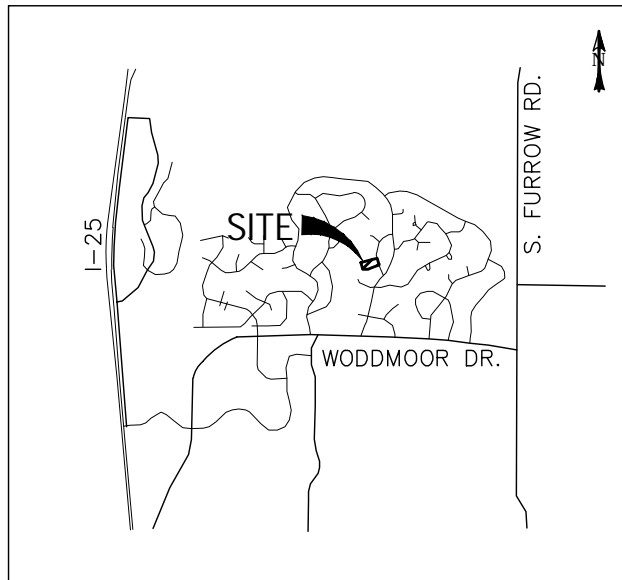

VICINITY MAP
SCALE: N.T.S.



PO BOX 692 DIVIDE, CO 80814 (719) 426-2124

19580 FOUR WINDS WAY

VICINITY MAP

SCALE: N/A

JOB NO.: **21-337**

DATE: 11/03/20

SHEET: 1 OF 1

GENERAL PERMIT APPLICATION



COLORADO

Department of Public Health & Environment

Dedicated to protecting and improving the health and environment of the people of Colorado

ASSIGNED PERMIT NUMBER

Date Received ____/____/____
MM DD YYYY
Revised: 3-2016

STORMWATER DISCHARGE ASSOCIATED WITH CONSTRUCTION ACTIVITIES APPLICATION COLORADO DISCHARGE PERMIT SYSTEM (CDPS)

PHOTO COPIES, FAXED COPIES, PDF COPIES OR EMAILS WILL NOT BE ACCEPTED.

For Applications submitted on paper - Please print or type. Original signatures are required.

All items must be completed accurately and in their entirety for the application to be deemed complete. Incomplete applications will not be processed until all information is received which will ultimately delay the issuance of a permit. If more space is required to answer any question, please attach additional sheets to the application form. Applications or signature pages for the application may be submitted by mail or hand delivered to:

Colorado Department of Public Health and Environment, 4300 Cherry Creek Drive South, WQCD-P-B2, Denver, CO 80246-1530

For Applications submitted electronically

Please note that you can ONLY complete the feedback form by downloading it to a PC or Mac/Apple computer and opening the Application with Adobe Reader or a similar PDF reader. The form will NOT work with web browsers, Google preview, Mac preview software or on mobile devices using iOS or Android operating systems.

If application is submitted electronically, processing of the application will begin at that time and not be delayed for receipt of the signed document.

Any additional information that you would like the Division to consider in developing the permit should be provided with the application. Examples include effluent data and/or modeling and planned pollutant removal strategies.

Beginning July 1, 2016, invoices will be based on acres disturbed.

DO NOT PAY THE FEES NOW - Invoices will be sent after the receipt of the application.

Disturbed Acreage for this application (see page 4)

- Less than 1 acre (\$83 initial fee, \$165 annual fee)
- 1-30 acres (\$175 initial fee, \$350 annual fee)
- Greater than 30 acres (\$270 initial fee, \$540 annual fee)

PERMIT INFORMATION

Reason for Application: NEW CERT RENEW CERT EXISTING CERT# _____

Applicant is: Property Owner Contractor/Operator

A. CONTACT INFORMATION - *indicates required

* PERMITTED ORGANIZATION FORMAL NAME: _____

1) * PERMIT OPERATOR - the party that has operational control over day to day activities - may be the same as owner.

Responsible Person (Title): _____

Currently Held By (Person): FirstName: _____ LastName: _____

Telephone: _____ Email Address: _____

Organization: _____

Mailing Address: _____

City: _____ State: _____ Zip Code: _____

Per Regulation 61 : All reports required by permits, and other information requested by the Division shall be signed by the permittee or by a duly authorized representative of that person. A person is a duly authorized representative only if:

- (i) The authorization is made in writing by the permittee
- (ii) The authorization specifies either an individual or a position having responsibility for the overall operation of the regulated facility or activity such as the position of plant manager, operator of a well or a well field, superintendent, position of equivalent responsibility, or an individual or position having overall responsibility for environmental matters for the company. (A duly authorized representative may thus be either a named individual or any individual occupying a named position); and
- (iii) The written authorization is submitted to the Division

2) **OWNER - party has ownership or long term lease of property - may be the same as the operator.**

Same as 1) Permit Operator

Responsible Person (Title): _____

Currently Held By (Person): FirstName: _____ LastName: _____

Telephone: _____ Email Address: _____

Organization: _____

Mailing Address: _____

City: _____ State: _____ Zip Code: _____

Per Regulation 61 : All reports required by permits, and other information requested by the Division shall be signed by the permittee or by a duly authorized representative of that person. A person is a duly authorized representative only if:

- i. The authorization is made in writing by the permittee.
- ii. The authorization specifies either an individual or a position having responsibility for the overall operation of the regulated facility or activity such as the position of plant manager, operator of a well or a well field, superintendent, position of equivalent responsibility, or an individual or position having overall responsibility for environmental matters for the company. (A duly authorized representative may thus be either a **named individual** or any individual occupying a **named position**); and
- iii. The written authorization is submitted to the Division.

3) ***SITE CONTACT** local contact for questions relating to the facility & discharge authorized by this permit for the facility

Same as 1) Permit Operator

Responsible Person (Title): _____

Currently Held By (Person): FirstName: _____ LastName: _____

Telephone: _____ Email Address: _____

Organization: _____

Mailing Address: _____

City: _____ State: _____ Zip Code: _____

4) ***BILLING CONTACT** if different than the permittee.

Same as 1) Permit Operator

Responsible Person (Title): _____

Currently Held By (Person): FirstName: _____ LastName: _____

Telephone: _____ Email Address: _____

Organization: _____

Mailing Address: _____

City: _____ State: _____ Zip Code: _____

5) **OTHER CONTACT TYPES (check below) Add pages if necessary:**

Responsible Person (Title): _____

Currently Held By (Person): FirstName: _____ LastName: _____

Telephone: _____ Email Address: _____

Organization: _____

Mailing Address: _____

City: _____ State: _____ Zip Code: _____

Environmental Contact

Consultant

Stormwater MS4 Responsible Person

Inspection Facility Contact

Compliance Contact

Stormwater Authorized Representative

B) PERMITTED PROJECT/FACILITY INFORMATION

Project/Facility Name _____

Street Address or Cross Streets _____

(e.g., Park St and 5 Ave; CR 21 and Hwy 10; 44 Ave and Clear Creek) ; A street name without an address, intersection, mile marker, or other identifying information describing the location of the project is not adequate. For **linear projects**, the route of the project should be described as best as possible using the starting point for the address and latitude and longitude - more clearly defined in the required map)

City: _____ County: _____ Zip Code: _____

Facility Latitude/Longitude - List the latitude and longitude of the excavation(s) resulting in the discharge(s). If the exact soil disturbing location(s) are not known, list the latitude and longitude of the center point of the construction project. If using the center point, be sure to specify that it is the center point of construction activity. The preferred method is GPS and Decimal Degrees.

Latitude _____ . _____ Longitude _____ . _____ (e.g., 39.70312°, 104.93348°)
Decimal Degrees (to 5 decimal places) Decimal Degrees (to 5 decimal places)

This information may be obtained from a variety of sources, including:

- **Surveyors or engineers** for the project should have, or be able to calculate, this information.
- **U.S. Geological Survey topographical map(s)**, available at area map stores.
- Using a **Global Positioning System (GPS) unit** to obtain a direct reading.
- **Google** - enter address in search engine, select the map, right click on location, and select "what's here".

Note: the latitude/longitude required above is not the directional degrees, minutes, and seconds provided on a site legal description to define property boundaries.

C) MAP (Attachment) If no map is submitted, the application cannot be submitted.

Map: Attach a map that indicates the site location and that CLEARLY shows the boundaries of the area that will be disturbed. A vicinity map is not adequate for this purpose.

D) LEGAL DESCRIPTION - only for Subdivisions

Legal description: If subdivided, provide the legal description below, or indicate that it is not applicable (**do not** supply Township/Range/Section or metes and bounds description of site)

Subdivision(s): _____ Lot(s): _____ Block(s) _____

OR Not applicable (site has not been subdivided)

E) AREA OF CONSTRUCTION SITE - SEE PAGE 1 - WILL DETERMINE FEE

Provide both the total area of the construction site, and the area that will undergo disturbance, in acres.

Total area of project disturbance site (acres): _____

Note: aside from clearing, grading and excavation activities, disturbed areas also include areas receiving overburden (e.g., stockpiles), demolition areas, and areas with heavy equipment/vehicle traffic and storage that disturb existing vegetative cover.

Part of Larger Common Plan of Development or Sale, (i.e., total, including all phases, filings, lots, and infrastructure not covered by this application)

F) NATURE OF CONSTRUCTION ACTIVITY

Check the appropriate box(es) or provide a brief description that indicates the general nature of the construction activities. (The full description of activities must be included in the Stormwater Management Plan.)

Commercial Development

Residential Development

Highway and Transportation Development

Pipeline and Utilities (including natural gas, electricity, water, and communications)

Oil and Gas Exploration and Well Pad Development

Non-structural and other development (i.e. parks, trails, stream realignment, bank stabilization, demolition, etc.)

G) ANTICIPATED CONSTRUCTION SCHEDULE

Construction Start Date: _____ Final Stabilization Date: _____

- *Construction Start Date* - This is the day you expect to begin ground disturbing activities, including grubbing, stockpiling, excavating, demolition, and grading activities.
- *Final Stabilization Date* - in terms of permit coverage, this is when the site is finally stabilized. This means that all ground surface disturbing activities at the site have been completed, and all disturbed areas have been either built on, paved, or a uniform vegetative cover has been established with an individual plant density of at least 70 percent of pre-disturbance levels. **Permit coverage must be maintained until the site is finally stabilized. Even if you are only doing one part of the project, the estimated final stabilization date must be for the overall project.** If permit coverage is still required once your part is completed, the permit certification may be transferred or reassigned to a new responsible entity(s).

H) RECEIVING WATERS (If discharge is to a ditch or storm sewer, include the name of the ultimate receiving waters)

Immediate Receiving Water(s): _____

Ultimate Receiving Water(s): _____

Identify the receiving water of the stormwater from your site. Receiving waters are any waters of the State of Colorado. This includes all water courses, even if they are usually dry. If stormwater from the construction site enters a ditch or storm sewer system, identify that system and indicate the ultimate receiving water for the ditch or storm sewer. **Note:** a stormwater discharge permit does not allow a discharge into a ditch or storm sewer system without the approval of the owner/operator of that system.

I) SIGNATURE PAGE

1. You may print and sign this document and mail the hard copy to the State along with required documents (address on page one).

2. Electronic Submission Signature

You may choose to submit your application electronically, along with required attachments. To do so, click the SUBMIT button below which will direct you, via e-mail, to sign the document electronically using the DocuSign Electronic Signature process. Once complete, you will receive via e-mail, an electronically stamped Adobe pdf of this application. Print the signature page from the electronically stamped pdf, sign it and mail it to the WQCD Permits Section to complete the application process (address is on page one of the application).

- The Division encourages use of the electronic submission of the application and electronic signature. This method meets signature requirements as required by the State of Colorado.
- The ink signed copy of the electronically stamped pdf signature page is also required to meet Federal EPA Requirements.
- Processing of the application will begin with the receipt of the valid electronic signature.

STORMWATER MANAGEMENT PLAN CERTIFICATION

By checking this box "I certify under penalty of law that a complete Stormwater Management Plan, as described in Appendix B of this application, has been prepared for my activity. Based on my inquiry of the person or persons who manage the system, or those persons directly responsible for gathering the information, the Stormwater Management Plan is, to the best of my knowledge and belief, true, accurate, and complete. I am aware that there are significant penalties for falsely certifying the completion of said SWMP, including the possibility of fine and imprisonment for knowing violations."

"I certify under penalty of law that this document and all attachments were prepared under my direction or supervision in accordance with a system designed to assure that qualified personnel properly gather and evaluate the information submitted. Based on my inquiry of the person or persons who manage the system, or those persons directly responsible for gathering the information, the information submitted is to the best of my knowledge and belief, true, accurate and complete. I am aware that there are significant penalties for submitting false information, including the possibility of fine and imprisonment for knowing violations."

"I understand that submittal of this application is for coverage under the State of Colorado General Permit for Stormwater Discharges Associated with Construction Activity for the entirety of the construction site/project described and applied for, until such time as the application is amended or the certification is transferred, inactivated, or expired." [Reg 61.4(1)(h)]

For DocuSign

Electronic Signature _____ Ink Signature _____ Date: _____

Signature of Legally Responsible Person or Authorized Agent (submission must include original signature)

Name (printed)

Title

Signature: The applicant must be either the owner and operator of the construction site. Refer to Part B of the instructions for additional information.

The application must be signed by the applicant to be considered complete. In all cases, it shall be signed as follows:

(Regulation 61.4 (1e))

- In the case of corporations, by the responsible corporate officer is responsible for the overall operation of the facility from which the discharge described in the form originates
- In the case of a partnership, by a general partner.
- In the case of a sole proprietorship, by the proprietor.
- In the case of a municipal, state, or other public facility, by either a principal executive officer, ranking elected official, (a principal executive officer has responsibility for the overall operation of the facility from which the discharge originates).

3rd Party Preparer: If this form was prepared by an authorized agent on behalf of the Permittee, please complete the field below.

Preparer Name (printed)

Email Address

**DO NOT INCLUDE A COPY OF THE STORMWATER MANAGEMENT PLAN
DO NOT INCLUDE PAYMENT—AN INVOICE WILL BE SENT AFTER THE CERTIFICATION IS ISSUED.**

<input type="text"/>	Attach Map
<input type="text"/>	Attach File
<input type="text"/>	Attach File
<input type="text"/>	Attach File
<input type="text"/>	Attach File

**RECOMMENDED BMP MAINTENANCE INSPECTION
CHECKLIST**

Appendix C Inspection Checklist – Grading Erosion, and Stormwater Quality Controls

CITY OF COLORADO SPRINGS

DATE/TIME:
INSPECTOR:
TYPE OF INSPECTION: Self-Monitoring _____ Initial _____ Compliance _____ Follow-Up _____ Reconnaissance _____ Complaint _____ Final _____

SITE:	DATE OF PERMIT:
ADDRESS:	
CONTRACTOR: CONTACT: PHONE:	OWNER/OWNER'S REPRESENTATIVE: CONTACT: PHONE:
STAGE OF CONSTRUCTION: Initial BMP Installation/Prior to Construction _____ Clearing & Grubbing _____ Rough Grading _____ Finish Grading _____ Utility Construction _____ Building Construction _____ Final Stabilization _____	

OVERALL SITE INSPECTION	YES/NO/N.A.	REMARKS/ACTIONS
Is there any evidence of sediment leaving the construction site? If so, note areas.		
Have any adverse impacts such as flooding, structural damage, erosion, spillage, or accumulation of sediment, debris or litter occurred on or within public or private property, wetlands or surface waters -to include intermittent drainageways and the City's stormwater system (storm sewers, gutters, ditches, etc.)?		
Are the BMPs properly installed and maintained?		
Have the BMPs been placed as shown on approved plans?		
Are the BMPs functioning as intended?		
Is work being done according to approved plans and any phased construction schedule?		
Is the construction schedule on track?		
Are drainage channels and outlets adequately stabilized?		
Is there any evidence of discharges or spills of fuels, lubricants, chemicals, etc.?		

BMP MAINTENANCE CHECKLIST	YES/NO/N.A.	REMARKS/ACTIONS NECESSARY
<p>CHECK DAM</p> <p>Has accumulated sediment and debris been removed per maintenance requirements?</p>		
<p>EROSION CONTROL BLANKET</p> <p>Is fabric damaged, loose or in need of repairs?</p>		
<p>INLET PROTECTION</p> <p>Is the inlet protection damaged, ineffective or in need of repairs?</p> <p>Has sediment been removed per maintenance requirements?</p>		
<p>MULCHING</p> <p>Distributed uniformly on all disturbed areas?</p> <p>Is the application rate adequate?</p> <p>Any evidence of mulch being blown or washed away?</p> <p>Has the mulched area been seeded, if necessary?</p>		
<p>SEDIMENT BASIN</p> <p>Is the sediment basin properly constructed and operational?</p> <p>Has sediment and debris been cleaned out of the basin?</p>		
<p>SILT FENCE</p> <p>Is the fence damaged, collapsed, unentrenched or ineffective?</p> <p>Has sediment been removed per maintenance requirements?</p> <p>Is the silt fence properly located?</p>		
<p>SLOPE DRAIN</p> <p>Is water bypassing or undercutting the inlet or pipe?</p> <p>Is erosion occurring at the outlet of the pipe?</p>		
<p>STRAW BALE BARRIER</p> <p>Are the straw bales damaged, ineffective or unentrenched?</p> <p>Has sediment been removed per maintenance requirements?</p> <p>Are the bales installed and positioned correctly?</p>		

BMP MAINTENANCE CHECKLIST	YES/NO/N.A.	REMARKS/ACTIONS NECESSARY
SURFACE ROUGHENING Is the roughening consistent/ uniform on slopes?? Any evidence of erosion?		
TEMPORARY SEEDING Are the seedbeds protected by mulch? Has any erosion occurred in the seeded area? Any evidence of vehicle tracking on seeded areas?		
TEMPORARY SWALES Has any sediment or debris been deposited within the swales? Have the slopes of the swale eroded or has damage occurred to the lining? Are the swales properly located?		
VEHICLE TRACKING Is gravel surface clogged with mud or sediment? Is the gravel surface sinking into the ground? Has sediment been tracked onto any roads and has it been cleaned up? Is inlet protection placed around curb inlets near construction entrance?		
OTHER		

FINAL INSPECTION CHECKLIST	YES/NO/N.A.	REMARKS/ACTIONS NECESSARY
Has all grading been completed in compliance with the approved Plan, and all stabilization completed, including vegetation, retaining walls or other approved measures?		
Has final stabilization been achieved - uniform vegetative cover with a density of at least 70 percent of pre-disturbance levels, and cover capable of adequately controlling soil erosion; or permanent, physical erosion methods?		
Have all temporary measures been removed?		
Have all stockpiles, construction materials and construction equipment been removed?		
Are all paved surfaces clean (on-site and off-site)?		
Has sediment and debris been removed from drainage facilities (on-site and off-site) and other off-site property, including proper restoration of any damaged property?		
Have all permanent stormwater quality BMPs been installed and completed?		

ADDITIONAL COMMENTS:

The items noted as needing action must be remedied no later than _____.
The contractor shall notify the inspector when all the items noted above have been addressed.

By signing this inspection form, the owner/owner's representative and the contractor acknowledge that they have received a copy of the inspection report and are aware it is their responsibility to take corrective actions by the date noted above. Failure to sign does not relieve the contractor and owner/owner's representative of their responsibility to take the necessary corrective action and of their liability for any damages that have occurred or may occur.

INSPECTOR'S SIGNATURE:	DATE:
OWNER/OWNER'S REPRESENTATIVE SIGNATURE:	DATE:
CONTRACTOR'S SIGNATURE:	DATE:

**SAMPLE SPILL RESPONSE PLAN
AND SPILL REPORT FORM**

SPILL RESPONSE PLAN

Points of Contact in case of a reportable quantity release:

EPA National Response Center (800) 424-8802

Colorado Department of Public Health and Environment (877) 518-5608

Leak or Spill

- Report spills immediately to owner
- Employees will not be punished for reporting spills
- Contain spill, start cleanup, report if over reportable quantity

REPORTABLE QUANTITIES		
Material	Media Released To	Reportable Quantity
Engine oil, fuel, hydraulic & brake fluid	Land	25 gallons
Engine oil, fuel, hydraulic & brake fluid	Water	Visible Sheen
Antifreeze	Land	100 lbs. (13 gal.)
Battery Acid	Land, Water	100 lbs.
Refrigerant	Air	1 lb.
Gasoline	Air, Land, Water	100 lbs.
Engine Degreasers	Air, Land, Water	100 lbs.

Spill Report Form

Project Type and Location: _____ Store Number: _____

Spill Reported by: _____

Date/Time Spill: _____

Describe spill location and events leading to spill: _____

Material spilled: _____

Source of spill: _____

Amount spilled: _____ Amount spilled to waterway: _____

Containment or clean up action: _____

Approximate depth of soil excavation: _____

List Injuries or Personal Contamination: _____

Action to be taken to prevent future spills: _____

Modifications to the SWPPP necessary due to this spill: _____

Agencies notified of the spill: _____

I certify under penalty of law that this document and all attachments were prepared under my direction or supervision in accordance with a system designed to assure that qualified personnel properly gather and evaluate the information submitted. Based on my inquiry of the person or persons who manage the system, or those persons directly responsible for gathering the information, the information submitted is, to the best of my knowledge and belief, true, accurate, and complete. I am aware that there are significant penalties for submitting false information, including the possibility of fine and imprisonment for knowing violations.

Contractor Superintendent

Date

**FEDERAL, STATE, OR LOCAL STORM
WATER OR OTHER ENVIRONMENTAL
INSPECTOR SITE VISIT LOG**

DETAILS & DRAWINGS

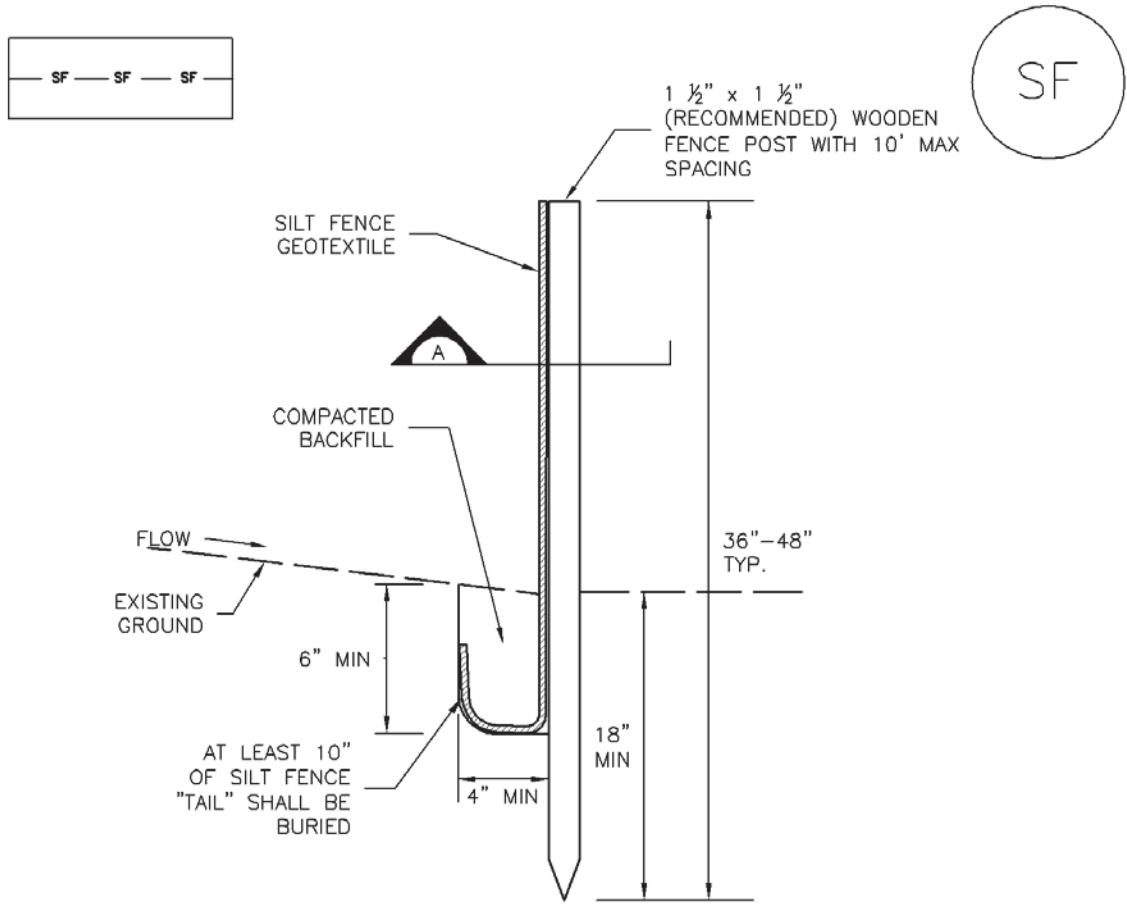

SILT FENCE

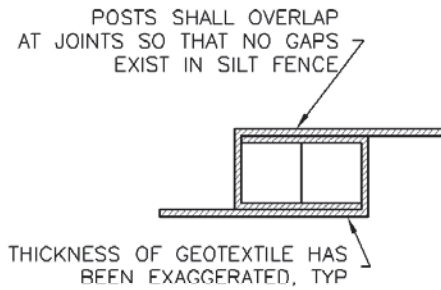
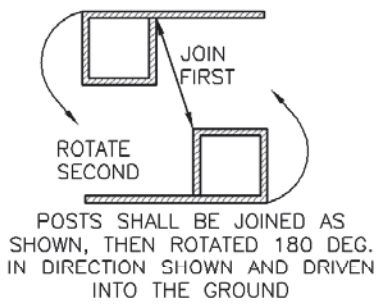

SECTION A

SF-1. SILT FENCE

SILT FENCE INSTALLATION NOTES

1. SILT FENCE MUST BE PLACED AWAY FROM THE TOE OF THE SLOPE TO ALLOW FOR WATER PONDING. SILT FENCE AT THE TOE OF A SLOPE SHOULD BE INSTALLED IN A FLAT LOCATION AT LEAST SEVERAL FEET (2-5 FT) FROM THE TOE OF THE SLOPE TO ALLOW ROOM FOR PONDING AND DEPOSITION.
2. A UNIFORM 6" X 4" ANCHOR TRENCH SHALL BE EXCAVATED USING TRENCHER OR SILT FENCE INSTALLATION DEVICE. NO ROAD GRADERS, BACKHOES, OR SIMILAR EQUIPMENT SHALL BE USED.
3. COMPACT ANCHOR TRENCH BY HAND WITH A "JUMPING JACK" OR BY WHEEL ROLLING. COMPACTION SHALL BE SUCH THAT SILT FENCE RESISTS BEING PULLED OUT OF ANCHOR TRENCH BY HAND.
4. SILT FENCE SHALL BE PULLED TIGHT AS IT IS ANCHORED TO THE STAKES. THERE SHOULD BE NO NOTICEABLE SAG BETWEEN STAKES AFTER IT HAS BEEN ANCHORED TO THE STAKES.
5. SILT FENCE FABRIC SHALL BE ANCHORED TO THE STAKES USING 1" HEAVY DUTY STAPLES OR NAILS WITH 1" HEADS. STAPLES AND NAILS SHOULD BE PLACED 3" ALONG THE FABRIC DOWN THE STAKE.
6. AT THE END OF A RUN OF SILT FENCE ALONG A CONTOUR, THE SILT FENCE SHOULD BE TURNED PERPENDICULAR TO THE CONTOUR TO CREATE A "J-HOOK." THE "J-HOOK" EXTENDING PERPENDICULAR TO THE CONTOUR SHOULD BE OF SUFFICIENT LENGTH TO KEEP RUNOFF FROM FLOWING AROUND THE END OF THE SILT FENCE (TYPICALLY 10' - 20').
7. SILT FENCE SHALL BE INSTALLED PRIOR TO ANY LAND DISTURBING ACTIVITIES.

SILT FENCE MAINTENANCE NOTES

1. INSPECT BMPs EACH WORKDAY, AND MAINTAIN THEM IN EFFECTIVE OPERATING CONDITION. MAINTENANCE OF BMPs SHOULD BE PROACTIVE, NOT REACTIVE. INSPECT BMPs AS SOON AS POSSIBLE (AND ALWAYS WITHIN 24 HOURS) FOLLOWING A STORM THAT CAUSES SURFACE EROSION, AND PERFORM NECESSARY MAINTENANCE.
2. FREQUENT OBSERVATIONS AND MAINTENANCE ARE NECESSARY TO MAINTAIN BMPs IN EFFECTIVE OPERATING CONDITION. INSPECTIONS AND CORRECTIVE MEASURES SHOULD BE DOCUMENTED THOROUGHLY.
3. WHERE BMPs HAVE FAILED, REPAIR OR REPLACEMENT SHOULD BE INITIATED UPON DISCOVERY OF THE FAILURE.
4. SEDIMENT ACCUMULATED UPSTREAM OF THE SILT FENCE SHALL BE REMOVED AS NEEDED TO MAINTAIN THE FUNCTIONALITY OF THE BMP, TYPICALLY WHEN DEPTH OF ACCUMULATED SEDIMENTS IS APPROXIMATELY 6".
5. REPAIR OR REPLACE SILT FENCE WHEN THERE ARE SIGNS OF WEAR, SUCH AS SAGGING, TEARING, OR COLLAPSE.
6. SILT FENCE IS TO REMAIN IN PLACE UNTIL THE UPSTREAM DISTURBED AREA IS STABILIZED AND APPROVED BY THE LOCAL JURISDICTION, OR IS REPLACED BY AN EQUIVALENT PERIMETER SEDIMENT CONTROL BMP.
7. WHEN SILT FENCE IS REMOVED, ALL DISTURBED AREAS SHALL BE COVERED WITH TOPSOIL, SEEDED AND MULCHED OR OTHERWISE STABILIZED AS APPROVED BY LOCAL JURISDICTION.

(DETAIL ADAPTED FROM TOWN OF PARKER, COLORADO AND CITY OF AURORA, NOT AVAILABLE IN AUTOCAD)

NOTE: MANY JURISDICTIONS HAVE BMP DETAILS THAT VARY FROM UDFCD STANDARD DETAILS. CONSULT WITH LOCAL JURISDICTIONS AS TO WHICH DETAIL SHOULD BE USED WHEN DIFFERENCES ARE NOTED.

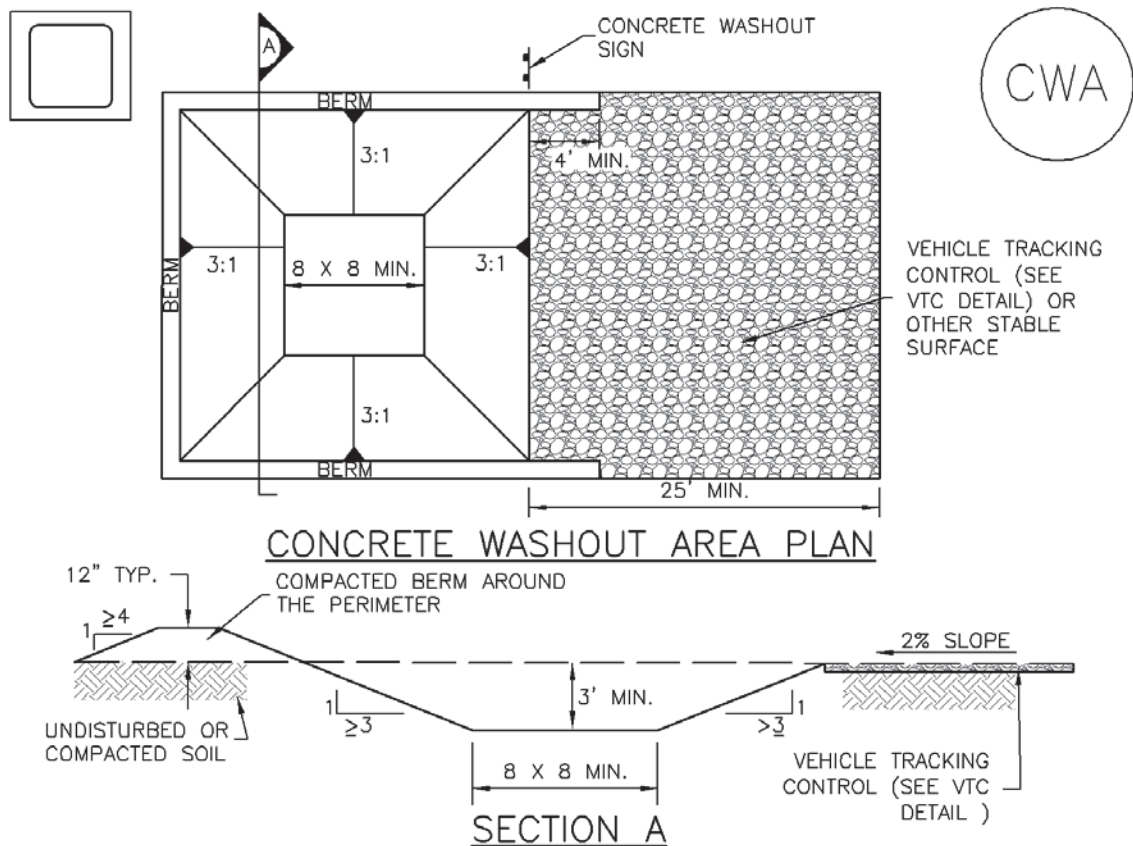

CWA-1. CONCRETE WASHOUT AREA

CWA INSTALLATION NOTES

1. SEE PLAN VIEW FOR:
-CWA INSTALLATION LOCATION.
2. DO NOT LOCATE AN UNLINED CWA WITHIN 400' OF ANY NATURAL DRAINAGE PATHWAY OR WATERBODY. DO NOT LOCATE WITHIN 1,000' OF ANY WELLS OR DRINKING WATER SOURCES. IF SITE CONSTRAINTS MAKE THIS INFEASIBLE, OR IF HIGHLY PERMEABLE SOILS EXIST ON SITE, THE CWA MUST BE INSTALLED WITH AN IMPERMEABLE LINER (16 MIL MIN. THICKNESS) OR SURFACE STORAGE ALTERNATIVES USING PREFABRICATED CONCRETE WASHOUT DEVICES OR A LINED ABOVE GROUND STORAGE ARE SHOULD BE USED.
3. THE CWA SHALL BE INSTALLED PRIOR TO CONCRETE PLACEMENT ON SITE.
4. CWA SHALL INCLUDE A FLAT SUBSURFACE PIT THAT IS AT LEAST 8' BY 8' SLOPES LEADING OUT OF THE SUBSURFACE PIT SHALL BE 3:1 OR FLATTER. THE PIT SHALL BE AT LEAST 3' DEEP.
5. BERM SURROUNDING SIDES AND BACK OF THE CWA SHALL HAVE MINIMUM HEIGHT OF 1'.
6. VEHICLE TRACKING PAD SHALL BE SLOPED 2% TOWARDS THE CWA.
7. SIGNS SHALL BE PLACED AT THE CONSTRUCTION ENTRANCE, AT THE CWA, AND ELSEWHERE AS NECESSARY TO CLEARLY INDICATE THE LOCATION OF THE CWA TO OPERATORS OF CONCRETE TRUCKS AND PUMP RIGS.
8. USE EXCAVATED MATERIAL FOR PERIMETER BERM CONSTRUCTION.

CWA MAINTENANCE NOTES

1. INSPECT BMPs EACH WORKDAY, AND MAINTAIN THEM IN EFFECTIVE OPERATING CONDITION. MAINTENANCE OF BMPs SHOULD BE PROACTIVE, NOT REACTIVE. INSPECT BMPs AS SOON AS POSSIBLE (AND ALWAYS WITHIN 24 HOURS) FOLLOWING A STORM THAT CAUSES SURFACE EROSION, AND PERFORM NECESSARY MAINTENANCE.
2. FREQUENT OBSERVATIONS AND MAINTENANCE ARE NECESSARY TO MAINTAIN BMPs IN EFFECTIVE OPERATING CONDITION. INSPECTIONS AND CORRECTIVE MEASURES SHOULD BE DOCUMENTED THOROUGHLY.
3. WHERE BMPs HAVE FAILED, REPAIR OR REPLACEMENT SHOULD BE INITIATED UPON DISCOVERY OF THE FAILURE.
4. THE CWA SHALL BE REPAIRED, CLEANED, OR ENLARGED AS NECESSARY TO MAINTAIN CAPACITY FOR CONCRETE WASTE. CONCRETE MATERIALS, ACCUMULATED IN PIT, SHALL BE REMOVED ONCE THE MATERIALS HAVE REACHED A DEPTH OF 2'.
5. CONCRETE WASHOUT WATER, WASTED PIECES OF CONCRETE AND ALL OTHER DEBRIS IN THE SUBSURFACE PIT SHALL BE TRANSPORTED FROM THE JOB SITE IN A WATER-TIGHT CONTAINER AND DISPOSED OF PROPERLY.
6. THE CWA SHALL REMAIN IN PLACE UNTIL ALL CONCRETE FOR THE PROJECT IS PLACED.
7. WHEN THE CWA IS REMOVED, COVER THE DISTURBED AREA WITH TOP SOIL, SEED AND MULCH OR OTHERWISE STABILIZED IN A MANNER APPROVED BY THE LOCAL JURISDICTION.

(DETAIL ADAPTED FROM DOUGLAS COUNTY, COLORADO AND THE CITY OF PARKER, COLORADO, NOT AVAILABLE IN AUTOCAD).

NOTE: MANY JURISDICTIONS HAVE BMP DETAILS THAT VARY FROM UDFCD STANDARD DETAILS. CONSULT WITH LOCAL JURISDICTIONS AS TO WHICH DETAIL SHOULD BE USED WHEN DIFFERENCES ARE NOTED.

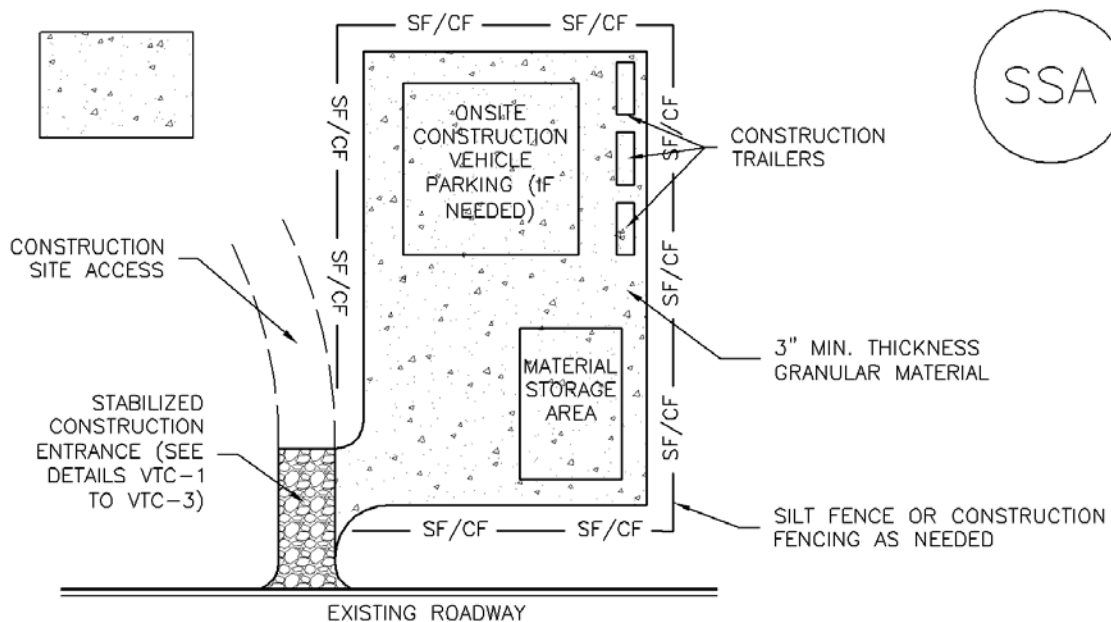

SSA-1. STABILIZED STAGING AREA

STABILIZED STAGING AREA INSTALLATION NOTES

1. SEE PLAN VIEW FOR
 - LOCATION OF STAGING AREA(S).
 - CONTRACTOR MAY ADJUST LOCATION AND SIZE OF STAGING AREA WITH APPROVAL FROM THE LOCAL JURISDICTION.
2. STABILIZED STAGING AREA SHOULD BE APPROPRIATE FOR THE NEEDS OF THE SITE. OVERSIZING RESULTS IN A LARGER AREA TO STABILIZE FOLLOWING CONSTRUCTION.
3. STAGING AREA SHALL BE STABILIZED PRIOR TO OTHER OPERATIONS ON THE SITE.
4. THE STABILIZED STAGING AREA SHALL CONSIST OF A MINIMUM 3" THICK GRANULAR MATERIAL.
5. UNLESS OTHERWISE SPECIFIED BY LOCAL JURISDICTION, ROCK SHALL CONSIST OF DOT SECT. #703, AASHTO #3 COARSE AGGREGATE OR 6" (MINUS) ROCK.
6. ADDITIONAL PERIMETER BMPs MAY BE REQUIRED INCLUDING BUT NOT LIMITED TO SILT FENCE AND CONSTRUCTION FENCING.

STABILIZED STAGING AREA MAINTENANCE NOTES

1. INSPECT BMPs EACH WORKDAY, AND MAINTAIN THEM IN EFFECTIVE OPERATING CONDITION. MAINTENANCE OF BMPs SHOULD BE PROACTIVE, NOT REACTIVE. INSPECT BMPs AS SOON AS POSSIBLE (AND ALWAYS WITHIN 24 HOURS) FOLLOWING A STORM THAT CAUSES SURFACE EROSION, AND PERFORM NECESSARY MAINTENANCE.
2. FREQUENT OBSERVATIONS AND MAINTENANCE ARE NECESSARY TO MAINTAIN BMPs IN EFFECTIVE OPERATING CONDITION. INSPECTIONS AND CORRECTIVE MEASURES SHOULD BE DOCUMENTED THOROUGHLY.
3. WHERE BMPs HAVE FAILED, REPAIR OR REPLACEMENT SHOULD BE INITIATED UPON DISCOVERY OF THE FAILURE.
4. ROCK SHALL BE REAPPLIED OR REGRADED AS NECESSARY IF RUTTING OCCURS OR UNDERLYING SUBGRADE BECOMES EXPOSED.

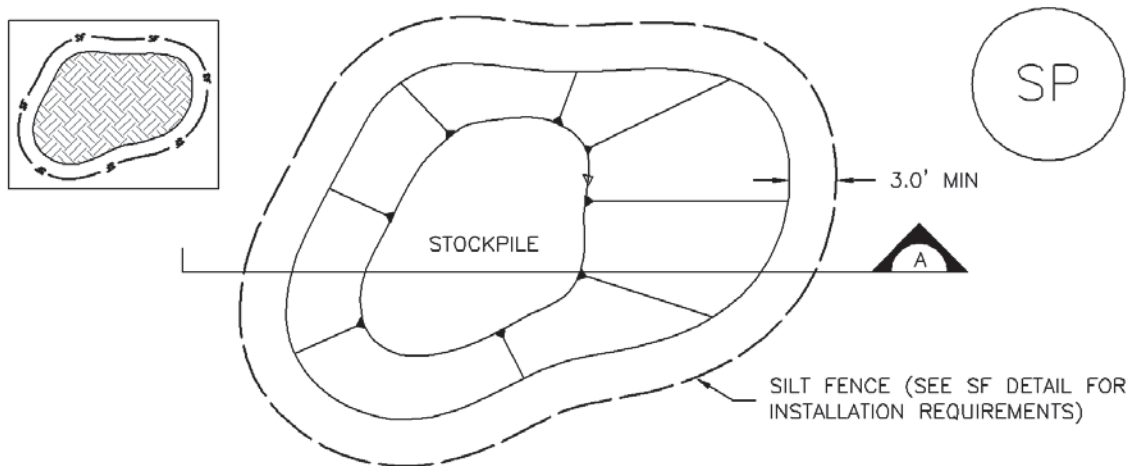

STOCKPILE PROTECTION PLAN

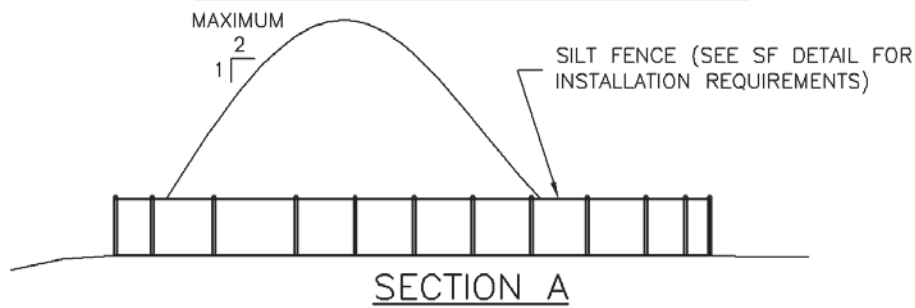

SP-1. STOCKPILE PROTECTION

STOCKPILE PROTECTION INSTALLATION NOTES

1. SEE PLAN VIEW FOR:
 - LOCATION OF STOCKPILES.
 - TYPE OF STOCKPILE PROTECTION.
2. INSTALL PERIMETER CONTROLS IN ACCORDANCE WITH THEIR RESPECTIVE DESIGN DETAILS. SILT FENCE IS SHOWN IN THE STOCKPILE PROTECTION DETAILS; HOWEVER, OTHER TYPES OF PERIMETER CONTROLS INCLUDING SEDIMENT CONTROL LOGS OR ROCK SOCKS MAY BE SUITABLE IN SOME CIRCUMSTANCES. CONSIDERATIONS FOR DETERMINING THE APPROPRIATE TYPE OF PERIMETER CONTROL FOR A STOCKPILE INCLUDE WHETHER THE STOCKPILE IS LOCATED ON A PERVIOUS OR IMPERVIOUS SURFACE, THE RELATIVE HEIGHTS OF THE PERIMETER CONTROL AND STOCKPILE, THE ABILITY OF THE PERIMETER CONTROL TO CONTAIN THE STOCKPILE WITHOUT FAILING IN THE EVENT THAT MATERIAL FROM THE STOCKPILE SHIFTS OR SLUMPS AGAINST THE PERIMETER, AND OTHER FACTORS.
3. STABILIZE THE STOCKPILE SURFACE WITH SURFACE ROUGHENING, TEMPORARY SEEDING AND MULCHING, EROSION CONTROL BLANKETS, OR SOIL BINDERS. SOILS STOCKPILED FOR AN EXTENDED PERIOD (TYPICALLY FOR MORE THAN 60 DAYS) SHOULD BE SEEDED AND MULCHED WITH A TEMPORARY GRASS COVER ONCE THE STOCKPILE IS PLACED (TYPICALLY WITHIN 14 DAYS). USE OF MULCH ONLY OR A SOIL BINDER IS ACCEPTABLE IF THE STOCKPILE WILL BE IN PLACE FOR A MORE LIMITED TIME PERIOD (TYPICALLY 30-60 DAYS).
4. FOR TEMPORARY STOCKPILES ON THE INTERIOR PORTION OF A CONSTRUCTION SITE, WHERE OTHER DOWNGRADIENT CONTROLS, INCLUDING PERIMETER CONTROL, ARE IN PLACE, STOCKPILE PERIMETER CONTROLS MAY NOT BE REQUIRED.

STOCKPILE PROTECTION MAINTENANCE NOTES

1. INSPECT BMPs EACH WORKDAY, AND MAINTAIN THEM IN EFFECTIVE OPERATING CONDITION. MAINTENANCE OF BMPs SHOULD BE PROACTIVE, NOT REACTIVE. INSPECT BMPs AS SOON AS POSSIBLE (AND ALWAYS WITHIN 24 HOURS) FOLLOWING A STORM THAT CAUSES SURFACE EROSION, AND PERFORM NECESSARY MAINTENANCE.

2. FREQUENT OBSERVATIONS AND MAINTENANCE ARE NECESSARY TO MAINTAIN BMPs IN EFFECTIVE OPERATING CONDITION. INSPECTIONS AND CORRECTIVE MEASURES SHOULD BE DOCUMENTED THOROUGHLY.

3. WHERE BMPs HAVE FAILED, REPAIR OR REPLACEMENT SHOULD BE INITIATED UPON DISCOVERY OF THE FAILURE.

STOCKPILE PROTECTION MAINTENANCE NOTES

4. IF PERIMETER PROTECTION MUST BE MOVED TO ACCESS SOIL STOCKPILE, REPLACE PERIMETER CONTROLS BY THE END OF THE WORKDAY.

5. STOCKPILE PERIMETER CONTROLS CAN BE REMOVED ONCE ALL THE MATERIAL FROM THE STOCKPILE HAS BEEN USED.

(DETAILS ADAPTED FROM PARKER, COLORADO, NOT AVAILABLE IN AUTOCAD)

NOTE: MANY JURISDICTIONS HAVE BMP DETAILS THAT VARY FROM UDFCD STANDARD DETAILS. CONSULT WITH LOCAL JURISDICTIONS AS TO WHICH DETAIL SHOULD BE USED WHEN DIFFERENCES ARE NOTED.

Description

A stabilized staging area is a clearly designated area where construction equipment and vehicles, stockpiles, waste bins, and other construction-related materials are stored. The contractor office trailer may also be located in this area. Depending on the size of the construction site, more than one staging area may be necessary.



Photograph SSA-1. Example of a staging area with a gravel surface to prevent mud tracking and reduce runoff. Photo courtesy of Douglas County.

Appropriate Uses

Most construction sites will require a staging area, which should be clearly designated in SWMP drawings. The layout of the staging area may vary depending on the type of construction activity. Staging areas located in roadways due to space constraints require special measures to avoid materials being washed into storm inlets.

Design and Installation

Stabilized staging areas should be completed prior to other construction activities beginning on the site. Major components of a stabilized staging area include:

- Appropriate space to contain storage and provide for loading/unloading operations, as well as parking if necessary.
- A stabilized surface, either paved or covered, with 3-inch diameter aggregate or larger.
- Perimeter controls such as silt fence, sediment control logs, or other measures.
- Construction fencing to prevent unauthorized access to construction materials.
- Provisions for Good Housekeeping practices related to materials storage and disposal, as described in the Good Housekeeping BMP Fact Sheet.
- A stabilized construction entrance/exit, as described in the Vehicle Tracking Control BMP Fact Sheet, to accommodate traffic associated with material delivery and waste disposal vehicles.

Over-sizing the stabilized staging area may result in disturbance of existing vegetation in excess of that required for the project. This increases costs, as well as requirements for long-term stabilization following the construction period. When designing the stabilized staging area, minimize the area of disturbance to the extent practical.

Stabilized Staging Area	
Functions	
Erosion Control	Yes
Sediment Control	Moderate
Site/Material	Yes

Minimizing Long-Term Stabilization Requirements

- Utilize off-site parking and restrict vehicle access to the site.
- Use construction mats in lieu of rock when staging is provided in an area that will not be disturbed otherwise.
- Consider use of a bermed contained area for materials and equipment that do not require a stabilized surface.
- Consider phasing of staging areas to avoid disturbance in an area that will not be otherwise disturbed.

See Detail SSA-1 for a typical stabilized staging area and SSA-2 for a stabilized staging area when materials staging in roadways is required.

Maintenance and Removal

Maintenance of stabilized staging areas includes maintaining a stable surface cover of gravel, repairing perimeter controls, and following good housekeeping practices.

When construction is complete, debris, unused stockpiles and materials should be recycled or properly disposed. In some cases, this will require disposal of contaminated soil from equipment leaks in an appropriate landfill. Staging areas should then be permanently stabilized with vegetation or other surface cover planned for the development.

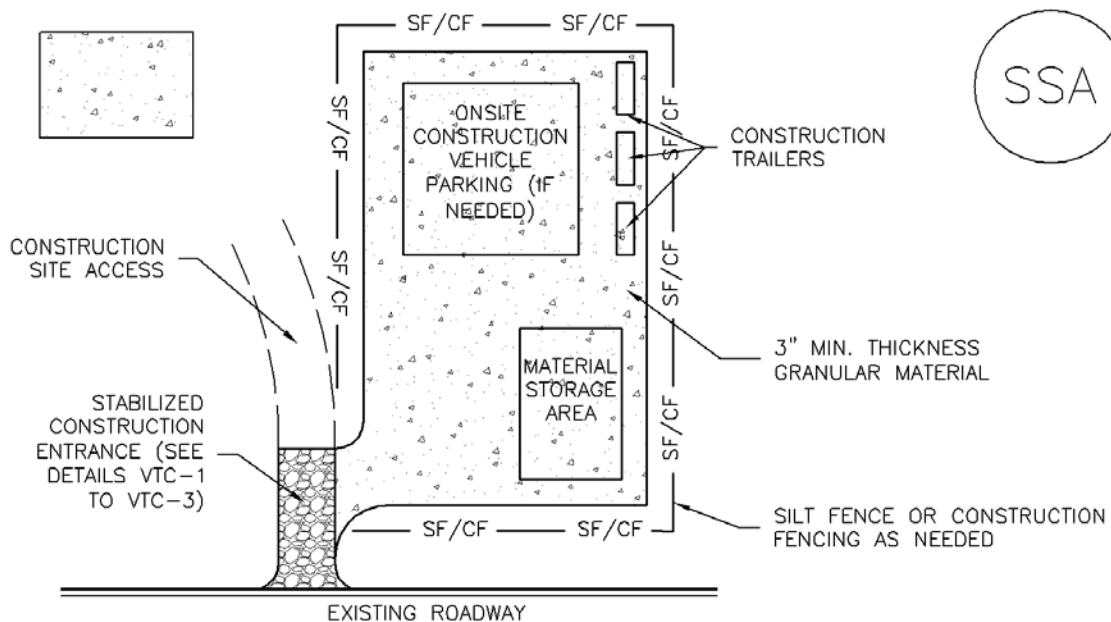

SSA-1. STABILIZED STAGING AREA

STABILIZED STAGING AREA INSTALLATION NOTES

1. SEE PLAN VIEW FOR
 - LOCATION OF STAGING AREA(S).
 - CONTRACTOR MAY ADJUST LOCATION AND SIZE OF STAGING AREA WITH APPROVAL FROM THE LOCAL JURISDICTION.
2. STABILIZED STAGING AREA SHOULD BE APPROPRIATE FOR THE NEEDS OF THE SITE. OVERSIZING RESULTS IN A LARGER AREA TO STABILIZE FOLLOWING CONSTRUCTION.
3. STAGING AREA SHALL BE STABILIZED PRIOR TO OTHER OPERATIONS ON THE SITE.
4. THE STABILIZED STAGING AREA SHALL CONSIST OF A MINIMUM 3" THICK GRANULAR MATERIAL.
5. UNLESS OTHERWISE SPECIFIED BY LOCAL JURISDICTION, ROCK SHALL CONSIST OF DOT SECT. #703, AASHTO #3 COARSE AGGREGATE OR 6" (MINUS) ROCK.
6. ADDITIONAL PERIMETER BMPs MAY BE REQUIRED INCLUDING BUT NOT LIMITED TO SILT FENCE AND CONSTRUCTION FENCING.

STABILIZED STAGING AREA MAINTENANCE NOTES

1. INSPECT BMPs EACH WORKDAY, AND MAINTAIN THEM IN EFFECTIVE OPERATING CONDITION. MAINTENANCE OF BMPs SHOULD BE PROACTIVE, NOT REACTIVE. INSPECT BMPs AS SOON AS POSSIBLE (AND ALWAYS WITHIN 24 HOURS) FOLLOWING A STORM THAT CAUSES SURFACE EROSION, AND PERFORM NECESSARY MAINTENANCE.
2. FREQUENT OBSERVATIONS AND MAINTENANCE ARE NECESSARY TO MAINTAIN BMPs IN EFFECTIVE OPERATING CONDITION. INSPECTIONS AND CORRECTIVE MEASURES SHOULD BE DOCUMENTED THOROUGHLY.
3. WHERE BMPs HAVE FAILED, REPAIR OR REPLACEMENT SHOULD BE INITIATED UPON DISCOVERY OF THE FAILURE.
4. ROCK SHALL BE REAPPLIED OR REGRADED AS NECESSARY IF RUTTING OCCURS OR UNDERLYING SUBGRADE BECOMES EXPOSED.

STABILIZED STAGING AREA MAINTENANCE NOTES

5. STABILIZED STAGING AREA SHALL BE ENLARGED IF NECESSARY TO CONTAIN PARKING, STORAGE, AND UNLOADING/LOADING OPERATIONS.

6. THE STABILIZED STAGING AREA SHALL BE REMOVED AT THE END OF CONSTRUCTION. THE GRANULAR MATERIAL SHALL BE REMOVED OR, IF APPROVED BY THE LOCAL JURISDICTION, USED ON SITE, AND THE AREA COVERED WITH TOPSOIL, SEEDED AND MULCHED OR OTHERWISE STABILIZED IN A MANNER APPROVED BY LOCAL JURISDICTION.

NOTE: MANY MUNICIPALITIES PROHIBIT THE USE OF RECYCLED CONCRETE AS GRANULAR MATERIAL FOR STABILIZED STAGING AREAS DUE TO DIFFICULTIES WITH RE-ESTABLISHMENT OF VEGETATION IN AREAS WHERE RECYCLED CONCRETE WAS PLACED.

NOTE: MANY JURISDICTIONS HAVE BMP DETAILS THAT VARY FROM UDFCD STANDARD DETAILS. CONSULT WITH LOCAL JURISDICTIONS AS TO WHICH DETAIL SHOULD BE USED WHEN DIFFERENCES ARE NOTED.

(DETAILS ADAPTED FROM DOUGLAS COUNTY, COLORADO, NOT AVAILABLE IN AUTOCAD)

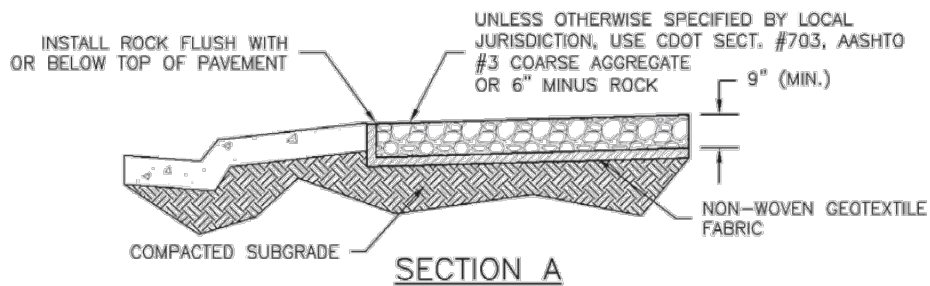
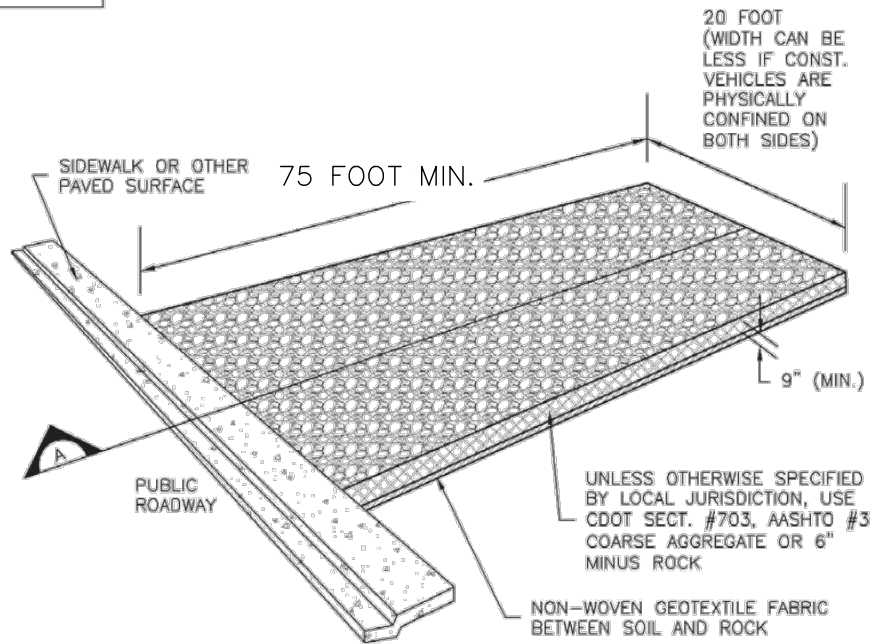
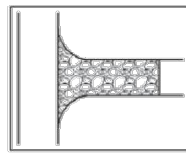

VTC-1. AGGREGATE VEHICLE TRACKING CONTROL

STABILIZED CONSTRUCTION ENTRANCE/EXIT INSTALLATION NOTES

1. SEE PLAN VIEW FOR
 - LOCATION OF CONSTRUCTION ENTRANCE(S)/EXIT(S);
 - TYPE OF CONSTRUCTION ENTRANCE(S)/EXITS(S) (WITH/WITHOUT WHEEL WASH; CONSTRUCTION MAT OR TRM).
2. CONSTRUCTION MAT OR TRM STABILIZED CONSTRUCTION ENTRANCES ARE ONLY TO BE USED ON SHORT-DURATION PROJECTS (TYPICALLY RANGING FROM A WEEK TO A MONTH) WHERE THERE WILL BE LIMITED VEHICULAR ACCESS.
3. A STABILIZED CONSTRUCTION ENTRANCE/EXIT SHALL BE LOCATED AT ALL ACCESS POINTS WHERE VEHICLES ACCESS THE CONSTRUCTION SITE FROM PAVED RIGHT-OF-WAYS.
4. STABILIZED CONSTRUCTION ENTRANCE/EXIT SHALL BE INSTALLED PRIOR TO ANY LAND-DISTURBING ACTIVITIES.
5. A NON-WOVEN GEOTEXTILE FABRIC SHALL BE PLACED UNDER THE STABILIZED CONSTRUCTION ENTRANCE/EXIT PRIOR TO THE PLACEMENT OF ROCK.
6. UNLESS OTHERWISE SPECIFIED BY LOCAL JURISDICTION, ROCK SHALL CONSIST OF DOT SECT. #703, AASHTO #3 COARSE AGGREGATE OR 6" (MINUS) ROCK.

STABILIZED CONSTRUCTION ENTRANCE/EXIT MAINTENANCE NOTES

1. INSPECT BMPs EACH WORKDAY AND MAINTAIN THEM IN EFFECTIVE OPERATING CONDITION. MAINTENANCE OF BMPs SHOULD BE PROACTIVE, NOT REACTIVE. INSPECT BMPs AS SOON AS POSSIBLE (AND ALWAYS WITHIN 24 HOURS) FOLLOWING A STORM THAT CAUSES SURFACE EROSION, AND PERFORM NECESSARY MAINTENANCE.
2. FREQUENT OBSERVATIONS AND MAINTENANCE ARE NECESSARY TO MAINTAIN BMPs IN EFFECTIVE OPERATING CONDITION. INSPECTIONS AND CORRECTIVE MEASURES SHOULD BE DOCUMENTED THOROUGHLY.
3. WHERE BMPs HAVE FAILED, REPAIR OR REPLACEMENT SHOULD BE INITIATED UPON DISCOVERY OF THE FAILURE.
4. ROCK SHALL BE REAPPLIED OR REGRADED AS NECESSARY TO THE STABILIZED ENTRANCE/EXIT TO MAINTAIN A CONSISTENT DEPTH.
5. SEDIMENT TRACKED ONTO PAVED ROADS IS TO BE REMOVED THROUGHOUT THE DAY AND AT THE END OF THE DAY BY SHOVELING OR SWEEPING. SEDIMENT MAY NOT BE WASHED DOWN STORM SEWER DRAINS.

NOTE: MANY JURISDICTIONS HAVE BMP DETAILS THAT VARY FROM UDFCD STANDARD DETAILS. CONSULT WITH LOCAL JURISDICTIONS AS TO WHICH DETAIL SHOULD BE USED WHEN DIFFERENCES ARE NOTED.

(DETAILS ADAPTED FROM CITY OF BROOMFIELD, COLORADO. NOT AVAILABLE IN AUTOCAD)

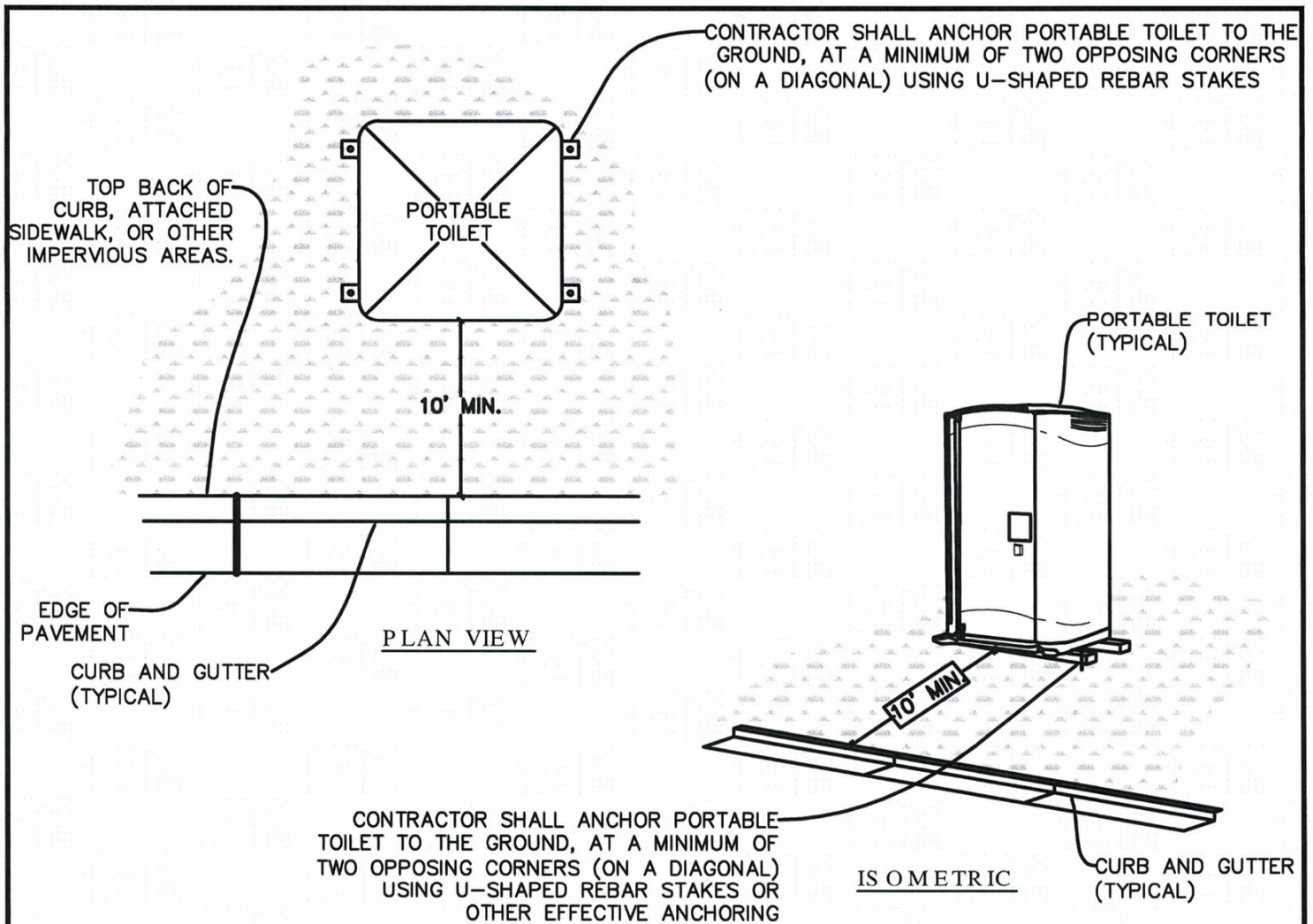

PORTABLE TOILET PROTECTION INSTALLATION NOTES

1. PORTABLE TOILETS SHALL BE PLACED A MINIMUM OF 10.0' BEHIND ALL CURBS, SIDEWALKS, AND OTHER IMPERVIOUS AREAS, 50' FROM STORM INLET, AND 100' FROM WATERWAYS.
2. ALL PORTABLE TOILETS MUST BE GROUPED TOGETHER.
3. PORTABLE TOILETS SHALL BE SECURELY ANCHORED TO THE GROUND USING U-SHAPED REBAR STAKES.
4. U-SHAPED REBAR STAKES, OR OTHER EFFECTIVE ANCHORING, SHALL BE POSITIONED ON AT LEAST 2 OPPOSING (DIGITAL) CORNERS.

PORTABLE TOILET PROTECTION INSPECTION AND MAINTENANCE NOTES

1. THE SWMP ADMINISTRATOR SHALL REGULARLY INSPECT THE PORTABLE TOILET PROTECTION.
2. PORTABLE TOILETS SHALL BE SERVICED AT THE NECESSARY INTERVALS TO ELIMINATE THE POSSIBILITY OF OVERFLOW.
3. WHEN THE PORTABLE TOILETS ARE REMOVED, ANY DISTURBED AREAS ASSOCIATED WITH THE INSTALLATION, MAINTENANCE, AND/OR REMOVAL OF THE TOILETS MAY NEED TO BE LANDSCAPED OR STABILIZED PER THE DCM REQUIREMENTS.
4. PORTABLE TOILETS THAT ARE NOT CONSISTENTLY MAINTAINED IN ACCORDANCE WITH THESE REQUIREMENTS MAY NEED TO BE CLUSTERED TOGETHER IN ONE CENTRALIZED LOCATION IN ORDER TO INCREASE COMPLIANCE AND REDUCE THE CHANCE OF A SPILL.



PORTABLE TOILET MANAGEMENT

DATE: 2/23/2017

STD. DRAWING NO. D-PTM

PORTABLE TOILET DETAILS FOR CONSTRUCTION SITES

Revised: August 23, 2017

OVERVIEW:

The release of pollutants, sewage, and/or contaminated wash waters associated with the transport, cleaning, washing or flushing of portable toilets directly or indirectly to the storm drain system, storm water conveyances or waterways is a violation of federal, state and local laws, regulations and ordinances. The wastes and associated wash water from cleaning of portable toilets, their reservoirs or tank compartments, hoses, vacuum and pumping equipment, transfer tanks and transport tank trucks must be contained and discharged to a sanitary sewer or other appropriate sanitary wastewater treatment facility.

The discharge of waste, wastewater or contaminated wash water from any such portable toilet transporting, cleaning or maintenance operations to the City of Colorado Springs' Municipal Separate Storm Sewer System (MS4) is prohibited. The City of Colorado Springs does not currently have a policy for placement of portable toilets on construction sites. The purpose of this document is to define the placement policy requirements.

Portable Toilet Protection Installation for Construction Sites

- Portable toilets shall be placed a minimum of 10 feet behind all curbs and/or sidewalks.
- Portable toilets shall be a minimum of 50 feet from stormwater inlet structures.
- Portable toilets shall be placed at least 100 feet from waterways.
- Portable toilets shall be placed on a flat surface.
- Portable toilets shall be grouped together whenever practicable.
- Portable toilets shall be securely anchored to the ground using u-shaped rebar stakes.
- U-shaped stakes shall be positioned on at least two diagonal corners of the structure.
- Portable toilets that have tipped over shall be placed upright immediately upon discovery. Any spilled waste shall be cleared up immediately and disposed of properly. Portable toilets shall be properly re-staked.

Portable Toilet Protection Installation for Roadway Construction

- When possible, portable toilets shall be placed out of the right-of-way at a minimum of 10 feet behind all curbs and/or sidewalks.
- If portable toilets must be in the right-of-way, it is best to place them on mobile trailers and must be anchored or weighted down.
- If portable toilets must be directly in the right-of-way, on pavement, they must be anchored or weighted down with BMPs completely around the base of the unit.
- Portable toilets shall ALWAYS be a minimum of 50 feet from protected stormwater inlet structures and the downstream inlet must have inlet protection in accordance with DCM standards and specifications.
- Portable toilets shall be placed at least 100 feet from waterways.

Portable Toilet Protection Inspection and Maintenance Notes

- The erosion control inspector shall inspect that the portable facility is staked down and the appropriate distance from the curb line each time they are in the area.
- Portable toilet protection shall be repaired immediately when any stakes are loose, damaged, or removed.
- Portable toilets shall be serviced at the necessary intervals to eliminate the possibility of overflow.
- When the portable toilets are removed, and disturbed areas associated with the installation, maintenance, and/or removal of the toilets shall be landscaped or roughened, seeded, mulched, and crimped per the specifications.

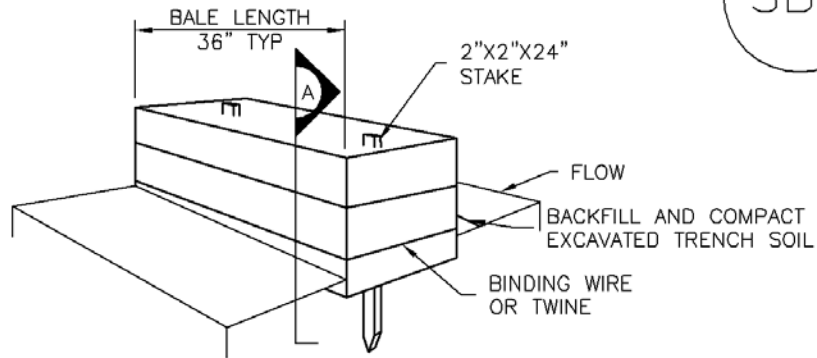

STRAW BALE

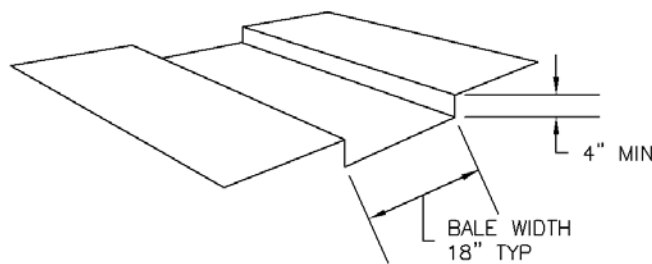

TRENCH FOR STRAW BALE

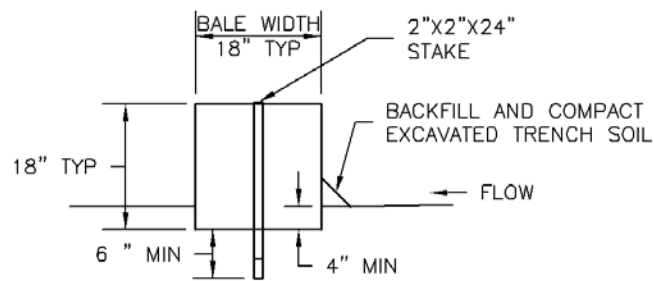

SECTION A

SBB-1. STRAW BALE

STRAW BALE INSTALLATION NOTES

1. SEE PLAN VIEW FOR:
-LOCATION(S) OF STRAW BALES.
2. STRAW BALES SHALL CONSIST OF CERTIFIED WEED FREE STRAW OR HAY. LOCAL JURISDICTIONS MAY REQUIRE PROOF THAT BALES ARE WEED FREE.
3. STRAW BALES SHALL CONSIST OF APPROXIMATELY 5 CUBIC FEET OF STRAW OR HAY AND WEIGH NOT LESS THAN 35 POUNDS.
4. WHEN STRAW BALES ARE USED IN SERIES AS A BARRIER, THE END OF EACH BALE SHALL BE TIGHTLY ABUTTING ONE ANOTHER.
5. STRAW BALE DIMENSIONS SHALL BE APPROXIMATELY 36"X18"X18".
6. A UNIFORM ANCHOR TRENCH SHALL BE EXCAVATED TO A DEPTH OF 4". STRAW BALES SHALL BE PLACED SO THAT BINDING TWINE IS ENCOMPASSING THE VERTICAL SIDES OF THE BALE(S). ALL EXCAVATED SOIL SHALL BE PLACED ON THE UPHILL SIDE OF THE STRAW BALE(S) AND COMPACTED.
7. TWO (2) WOODEN STAKES SHALL BE USED TO HOLD EACH BALE IN PLACE. WOODEN STAKES SHALL BE 2"X2"X24". WOODEN STAKES SHALL BE DRIVEN 6" INTO THE GROUND.

STRAW BALE MAINTENANCE NOTES

1. INSPECT BMPs EACH WORKDAY, AND MAINTAIN THEM IN EFFECTIVE OPERATING CONDITION. MAINTENANCE OF BMPs SHOULD BE PROACTIVE, NOT REACTIVE. INSPECT BMPs AS SOON AS POSSIBLE (AND ALWAYS WITHIN 24 HOURS) FOLLOWING A STORM THAT CAUSES SURFACE EROSION, AND PERFORM NECESSARY MAINTENANCE.
2. FREQUENT OBSERVATIONS AND MAINTENANCE ARE NECESSARY TO MAINTAIN BMPs IN EFFECTIVE OPERATING CONDITION. INSPECTIONS AND CORRECTIVE MEASURES SHOULD BE DOCUMENTED THOROUGHLY.
3. WHERE BMPs HAVE FAILED, REPAIR OR REPLACEMENT SHOULD BE INITIATED UPON DISCOVERY OF THE FAILURE.
4. STRAW BALES SHALL BE REPLACED IF THEY BECOME HEAVILY SOILED, ROTTEN, OR DAMAGED BEYOND REPAIR.
5. SEDIMENT ACCUMULATED UPSTREAM OF STRAW BALE BARRIER SHALL BE REMOVED AS NEEDED TO MAINTAIN FUNCTIONALITY OF THE BMP, TYPICALLY WHEN DEPTH OF ACCUMULATED SEDIMENTS IS APPROXIMATELY $\frac{1}{4}$ OF THE HEIGHT OF THE STRAW BALE BARRIER.
6. STRAW BALES ARE TO REMAIN IN PLACE UNTIL THE UPSTREAM DISTURBED AREA IS STABILIZED AND APPROVED BY THE LOCAL JURISDICTION.
7. WHEN STRAW BALES ARE REMOVED, ALL DISTURBED AREAS SHALL BE COVERED WITH TOPSOIL, SEEDED AND MULCHED OR OTHERWISE STABILIZED AS APPROVED BY LOCAL JURISDICTION.

(DETAILS ADAPTED FROM TOWN OF PARKER, COLORADO, NOT AVAILABLE IN AUTOCAD)

NOTE: MANY JURISDICTIONS HAVE BMP DETAILS THAT VARY FROM UDFCD STANDARD DETAILS. CONSULT WITH LOCAL JURISDICTIONS AS TO WHICH DETAIL SHOULD BE USED WHEN DIFFERENCES ARE NOTED.