

No change from latest  
PUD/PP submittal



LSC TRANSPORTATION CONSULTANTS, INC.  
2504 East Pikes Peak Avenue, Suite 304  
Colorado Springs, CO 80909  
(719) 633-2868  
FAX (719) 633-5430  
E-mail: [lsc@lsctrans.com](mailto:lsc@lsctrans.com)  
Website: <http://www.lsctrans.com>

Cottages at Mesa Ridge  
Traffic Impact Analysis  
(LSC #S214580)  
January 17, 2022  
(w/Minor Rev. 2/18/2022)

**Traffic Engineer's Statement**

This traffic report and supporting information were prepared under my responsible charge and they comport with the standard of care. So far as is consistent with the standard of care, said report was prepared in general conformance with the criteria established by the County for traffic reports.

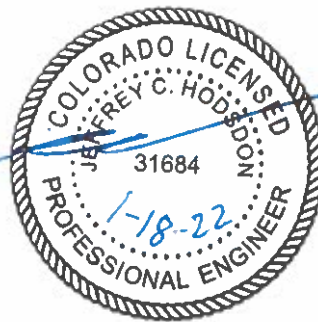

**Developer's Statement**

I, the Developer, have read and will comply with all commitments made on my behalf within this report.

A handwritten signature in blue ink, written over a horizontal line. The signature is stylized and appears to be 'B. H. O.'.

1-18-22  
Date

# Cottages at Mesa Ridge

## Traffic Impact Analysis Report

### PCD File No. PUDSP2111

Prepared for:  
Dave Morrison  
Goodwin Knight  
8605 Explorer Drive, #250  
Colorado Springs, CO 80920

JANUARY 17, 2022 (w/Minor Rev. 2/18/2022)

---

LSC Transportation Consultants  
Prepared by: Jeffrey C. Hodsdon, P.E.

LSC #S214580



CONTENTS

REPORT CONTENTS ..... 1

RECENT AREA TRAFFIC REPORTS..... 1

SITE DEVELOPMENT AND LAND USE ..... 2

STUDY AREA ..... 2

ROADWAY AND TRAFFIC CONDITIONS..... 2

    Area Roadways..... 2

    Study Area Intersections ..... 3

        Intersection Traffic Control and Lane Geometry ..... 3

        Intersection Sight Distance..... 3

    Existing Traffic Volumes ..... 3

    Short-Term Baseline Traffic Volumes ..... 4

TRIP GENERATION ..... 4

TRIP DISTRIBUTION AND ASSIGNMENT..... 5

    Trip Directional Distribution..... 5

    Site-Generated Traffic..... 5

SHORT-TERM TOTAL TRAFFIC ..... 5

2041 BACKGROUND TRAFFIC ..... 5

2041 TOTAL TRAFFIC..... 6

LEVEL OF SERVICE ANALYSIS ..... 6

    Mesa Ridge Parkway/Sneffels Street ..... 7

        Short Term ..... 7

        Long Term ..... 7

    Sneffels Street/Landover Lane ..... 7

    Sneffels Street/Pinfeather Drive ..... 8

VEHICLE QUEUEING ANALYSIS ..... 8

    Queuing Analysis Terminology ..... 8

    Analysis Assumptions..... 8

    Analysis Results..... 9

        Short-Term Total ..... 9

        2041 Total ..... 9

AUXILIARY TURN-LANE ANALYSIS..... 10

Mesa Ridge Parkway .....	10
Eastbound Left-Turn Deceleration Lane .....	10
Southbound-to-Westbound Right-Turn Acceleration Lane .....	10
Westbound Right-Turn Deceleration Lane .....	11
Sneffels Street .....	11
Landover Lane and landover lane Extension .....	12
CDOT ACCESS PERMITTING .....	12
MTCP CONFORMANCE .....	13
Roadway Classifications .....	13
Multi-Modal Transportation and TDM Opportunities .....	13
DEVIATION REQUESTS.....	13
EL PASO COUNTY ROAD IMPROVEMENT FEE PROGRAM .....	13
CONCLUSIONS AND RECOMMENDATIONS .....	13
Trip Generation .....	13
Projected Levels of Service.....	14
Queuing Analysis.....	14
Auxiliary Turn Lanes & Other Roadway Improvements.....	14
Enclosures: .....	15
Tables 3 and 4	
Figure 1 - Figure 9	
MTCP Maps 13, 14, and 15	
Traffic Count Reports	
SimTraffic Queue Reports	
Synchro Level of Service Reports	



LSC TRANSPORTATION CONSULTANTS, INC.  
2504 East Pikes Peak Avenue, Suite 304  
Colorado Springs, CO 80909  
(719) 633-2868  
FAX (719) 633-5430  
E-mail: [lsc@lsctrans.com](mailto:lsc@lsctrans.com)  
Website: <http://www.lsctrans.com>

January 17, 2022  
(w/Minor Rev. 2/18/2022)

Mr. Dave Morrison  
Goodwin Knight  
8605 Explorer Drive, #250  
Colorado Springs, CO 80920

RE: Cottages at Mesa Ridge  
Traffic Impact Analysis Report  
El Paso County, Colorado  
LSC #S214580

Dear Mr. Morrison:

LSC Transportation Consultants, Inc. has prepared this traffic impact analysis report for the proposed Cottages at Mesa Ridge development. As shown on Figure 1, the site is located north of Mesa Ridge Parkway and east of Sneffels Street in unincorporated El Paso County, Colorado. Site access would be to Landover Lane, which connects to Sneffels Street just north of Mesa Ridge Parkway.

## REPORT CONTENTS

This report identifies: the proposed land use, the site access points, the projected trip generation, site-generated traffic volumes, short- and long-term background traffic volumes, the projected future total traffic volumes, an assessment of the site's traffic impacts.

The report includes analysis of the current and projected traffic operations at the intersections of Mesa Ridge Parkway/Sneffels Street and Sneffels Street/Landover Lane. The report includes findings and recommendations.

## RECENT AREA TRAFFIC REPORTS

LSC is aware of the following TIS reports in the area in the past five years. previous traffic reports to assist in the production of this report:

- The Glen at Widefield East (near Marksheffel/Mesa Ridge)
- Carson Liquors – in the Markets at Mesa Ridge

## **SITE DEVELOPMENT AND LAND USE**

Figure 2 shows the site plan. The site is located within unincorporated El Paso County. However, the adjacent development to the west and Landover Lane are located within the City of Fountain. The site is planned to be developed for 122 cottage-style residential dwelling units. Access to the site is proposed via be to Landover Lane, which intersects Sneffels Street about 388 feet north of Mesa Ridge Parkway. No direct access to Mesa Ridge Parkway (State Highway 16) is proposed.

## **STUDY AREA**

The TIS study area does **not** include offsite intersections such as Fountain Mesa Road/Mesa Ridge Parkway and Mesa Ridge Parkway/Powers Boulevard because the projected site traffic would not increase existing traffic on these intersection approaches by five percent or more (criteria in *ECM* Appendix B).

## **ROADWAY AND TRAFFIC CONDITIONS**

### **Area Roadways**

Figure 1 shows the roadways in the vicinity of the site. The major roadways are identified below, followed by a brief description.

**Mesa Ridge Parkway** (State Highway 16) is a four-lane, median-divided Arterial adjacent to the site (CDOT Classification NR-A). Mesa Ridge Parkway extends east from Interstate-25 to Powers Boulevard. East of Quebec Street, Mesa Ridge is classified as EX- Expressway/Major bypass. The east end of Mesa Ridge Parkway and the south end of Powers Boulevard connect to form the interim south connection of Powers Boulevard to Interstate 25. The El Paso County portion of Mesa Ridge Parkway extends east from Powers Boulevard to Marksheffel Road. The County portion of Mesa Ridge Parkway extends east from Powers beginning at its intersection with Powers located about 1,955 feet northeast of the Mesa Ridge Parkway/Sneffels intersection. Adjacent to the site, the posted speed limit on Mesa Ridge Parkway is 55 miles per hour (mph). Auxiliary left- and right-turn deceleration lanes exist on both the eastbound and westbound approaches at Sneffels Street. A southbound-to-westbound right-turn acceleration lane also exists at the intersection of Mesa Ridge Parkway/Sneffels Street.

**Sneffels Street** is a two-lane Minor Collector that extends north and south from Mesa Ridge Parkway. Sneffels north of Mesa Ridge terminates within the Sunrise Ridge neighborhood at Red Cloud Street. Sneffels Street extends south of Mesa Ridge Parkway to its terminus at a T-intersection with Cross Creek Avenue. The posted speed limit in the vicinity of the site is 25 mph. Auxiliary left- and right-turn deceleration lanes exist on both the southbound and northbound approaches at Mesa Ridge Parkway.

**Landover Lane** is classified by the City of Fountain as a two-lane, Local Street extending southwest and northeast from Sneffels Street. The intersection of Sneffels/Landover is about 450 feet northwest of the Mesa Ridge/Sneffels intersection. Landover Lane northeast of Sneffels currently provides access to the Mesa Ridge Apartments. The street is 36 feet wide (flowline to flowline) with curb, gutter, and storm sewer system for conveying stormwater. There is an attached sidewalk along the north side of the street. Landover lane is proposed to be extended east into the proposed development as a private street.

## **Study Area Intersections**

### Intersection Traffic Control and Lane Geometry

Intersection traffic control and lane geometry at the following study-area intersections are shown in Figure 3.

- Mesa Ridge Parkway/Sneffels Street
- Sneffels Street/Landover Lane
- Sneffels Street/Pinfeather Drive/Pitcher Point

### Intersection Sight Distance

The existing intersection of Landover/Sneffels would provide access to the site (via Landover Lane) and would remain a stop-sign-controlled, full-movement intersection. This is an existing intersection. However, public-roadway intersections must meet *City of Fountain* and potentially *County Engineering Criteria Manual (ECM)* standards for sight distance (as this project is in the County).

LSC recorded sight-distance field measurements utilizing a driver's eye height of 3.5 feet and a height of 3.5 feet for a southbound vehicle approaching from the north. The minimum intersection sight distance for passenger vehicles (per *ECM* Table 2-21) is 335 feet. Per the *ECM*, Field-measured sight distances for passenger vehicles at the intersection of Landover/Sneffels are as follows:

- To the north: 745 feet
- To the south: 392 feet (unobstructed to Mesa Ridge Parkway)

Therefore, entering sight distance along Sneffels Street at Landover Lane is acceptable.

## **Existing Traffic Volumes**

Existing traffic volumes at the following intersections are shown in Figure 3. The traffic volumes are from traffic counts conducted by LSC in July 2021. Traffic count reports are attached.

- Mesa Ridge Parkway/Sneffels Street
- Sneffels Street/Landover Lane
- Sneffels Street/Pinfeather Drive/Pitcher Point

### Short-Term Baseline Traffic Volumes

Figure 4 shows estimated “short-term baseline” traffic volumes on the study-area streets and at the study-area intersections (short-term peak-hour turning-movement volumes). These estimates do not include the completion of several planned future Mesa Ridge development filings southeast of the intersection of Mesa Ridge Parkway/Sneffels Street, as those were assumed to have been completed during the long term. Previous LSC traffic counts in the study area were also referenced to establish short-term baseline traffic volumes, as those counts were not affected by changes in travel patterns due to the COVID-19 pandemic.

Additionally, a “COVID-19 adjustment factor” of approximately 2 percent per year has been applied to the July 2021 counts in order to account for growth in the study area that may be affected by remaining effects of the COVID-19 pandemic.

### TRIP GENERATION

Estimates of the existing and projected vehicle trips to be generated by the site have been made using the following nationally-published average trip-generation rates land use code “220 – Multi-Family (Low-Rise) Housing” in *Trip Generation, 10<sup>th</sup> Edition, 2017* by the Institute of Transportation Engineers (ITE).

Table 1 below presents a summary of the estimated site trip generation. A detailed trip-generation estimate for the development, including ITE rates for the proposed land uses, is presented in Table 3 (attached).

**Table 1: Estimated External Site Vehicle-Trip Generation**

Analysis Period	Weekday		
	In	Out	Total
Morning Peak Hour	23	68	91
Evening Peak Hour	76	45	121
Daily/24-hour	576	576	1,152

Based on the ITE estimate for the proposed Cottages at Mesa Ridge residential development, the site would generate about 1,152 external vehicle trips on the average weekday. During the weekday morning peak hour, approximately 23 vehicles would enter, and 68 vehicles would exit the site. Approximately 76 entering vehicles and 45 exiting vehicles are projected for the weekday evening peak hour.



## **TRIP DISTRIBUTION AND ASSIGNMENT**

### **Trip Directional Distribution**

Estimating the directional distribution of site-generated vehicle trips to the study-area roads and intersections is a necessary component in determining the site's traffic impacts. Figure 5 shows the percentages of the site-generated vehicle trips projected to be oriented to and from the site's major approaches. Estimates have been based on the following factors: the proposed land use, the area street and road system serving the site, the site's geographic location relative to the Pikes Peak region, current traffic-count data, and previously-conducted traffic studies in the vicinity of the site.

The distribution estimate first considered the north/south distribution of trips to/from the existing apartment development based on the existing traffic counts. The peak-hour turning movements at Sneffels/Mesa Ridge were reviewed, with a focus on the morning exiting peak-hour turning movements and the afternoon peak-hour turning movements by intersection approach. The estimate considers that the existing intersection turning movements to/from the north on Sneffels are a combination of trips from the apartments and the single-family developments to the west and north. The distribution takes into account that existing distribution of trips to/from the west on Mesa Ridge is higher than for this particular site because the trip route to/from areas to the north/northeast via Powers Boulevard for many residents in Sunrise Ridge does not pass through the Sneffels/Mesa Ridge intersection. The prior distribution estimate for the apartment development was also considered in the estimate.

### **Site-Generated Traffic**

Figure 6 shows the projected site-generated traffic volumes for the weekday morning and evening peak hours. Site-generated traffic volumes at the following intersections have been calculated by applying the directional-distribution percentages estimated by LSC (from Figure 5) to the trip-generation estimates (from Table 3):

- Mesa Ridge Parkway/Sneffels Street
- Sneffels Street/Landover Lane
- Sneffels Street/Pinfeather Drive/Pitcher Point

### **SHORT-TERM TOTAL TRAFFIC**

Figure 7 shows the projected short-term total traffic volumes, which are the sum of short-term baseline traffic volumes (from Figure 4) plus the estimated Cottages at Mesa Ridge development site-generated traffic (from Figure 6).

### **2041 BACKGROUND TRAFFIC**

Figure 8 shows the background traffic volumes for the year 2041. Background traffic is the traffic estimated to be on the adjacent roadway system without consideration of the proposed

development. Background traffic includes the through traffic and the traffic generated by adjacent developments (existing and anticipated future) but assumes zero traffic generated by the site. The background traffic volume estimates are based on existing and previous traffic-count data, 2045 forecasts contained in the City of Fountain 2021 Transportation Master Plan, and previous work completed in the area by LSC. The background-traffic volumes for 2041 assume Mesa Ridge (SH 16) as the continued interim south connection of Powers Boulevard to Interstate 25 – i.e., the anticipated Powers Boulevard extension south not yet complete.

**2041 TOTAL TRAFFIC**

Figure 8 shows the total traffic volumes for the year 2041 at the study-area intersections, which are the sum of the 2041 background traffic volumes (from Figure 8) plus the site-generated traffic volumes (from Figure 6).

**LEVEL OF SERVICE ANALYSIS**

The following intersections have been analyzed to determine the projected intersection levels of service for short- and long-term traffic scenarios for the morning and evening peak-hour time periods:

- Mesa Ridge Parkway/Sneffels Street
- Sneffels Street/Landover Lane
- Sneffels Street/Pinfeather Drive/Pitcher Point

Level of service (LOS) is a quantitative measure of the level of congestion or delay at an intersection and is indicated on a scale from “A” to “F.” LOS A is indicative of little congestion or delay. LOS F indicates a high level of congestion or delay. Table 2 shows the level of service delay ranges for signalized and unsignalized intersections.

**Table 2: Intersection Levels of Service Delay Ranges**

Level of Service	Signalized Intersections	Unsignalized Intersections
	Average Control Delay (Seconds Per Vehicle)	Average Control Delay (Seconds Per Vehicle) <sup>1</sup>
A	10.0 sec or less	10.0 sec or less
B	10.1-20.0 sec	10.1-15.0 sec
C	20.1-35.0 sec	15.1-25.0 sec
D	35.1-55.0 sec	25.1-35.0 sec
E	55.1-80.0 sec	35.1-50.0 sec
F	80.1 sec or more	50.1 sec or more

<sup>1</sup> For unsignalized intersections, if V/C ratio is greater than 1.0 the level of service is LOS F, regardless of the projected average control delay per vehicle.

Detailed Synchro reports are attached. A summary of LOS during the weekday morning and evening peak hours for the following unsignalized intersections is shown in the following figures:

- Figure 3: Existing Traffic, Lane Geometry, Traffic Control, and LOS
- Figure 4: Short-Term Baseline Traffic, Lane Geometry, Traffic Control, and LOS
- Figure 7: Short-Term Total Traffic, Lane Geometry, Traffic Control, and LOS
- Figure 8: 2041 Background Traffic, Lane Geometry, Traffic Control, and LOS
- Figure 9: 2041 Background + Site Traffic, Lane Geometry, Traffic Control, and LOS

### **Mesa Ridge Parkway/Sneffels Street**

#### Short Term

All individual turning movements at the Mesa Ridge Parkway/Sneffels Street intersection currently operate at and are projected to remain at LOS C or better during both short-term peak hours, with or without the addition of site-generated traffic. No modifications have been assumed to the existing lane geometry or traffic control at this intersection.

#### Long Term

LSC has assumed that the intersection of Mesa Ridge Parkway/Sneffels Street may need dual westbound left-turn lanes by 2041 to accommodate projected future development south of the signalized intersection (to be consistent with past reports).

Analysis results, based on LSC projections in this report, show a volume-to-capacity (v/c) ratio of over 1.00 for the eastbound-through movement during background and total long-term afternoon traffic scenarios if Mesa Ridge Parkway were to remain a four-lane Expressway (two through lanes per direction).

Overall, the signalized intersection of Mesa Ridge Parkway/Sneffels Street is projected to operate at LOS D or better through 2041, with or without the addition of site-generated traffic. The following individual turning movements are projected to operate at LOS E during at least one long-term peak hour, **with or without the addition of site-generated traffic**: southbound-through, westbound-left, westbound-through, northbound-left, and northbound-through.

### **Sneffels Street/Landover Lane**

All approaches and individual turning movements at the Sneffels Street/Landover Lane intersection currently operate at and are projected to remain at LOS C or better through 2041 during both peak hours, with or without the addition of site-generated traffic.

### **Sneffels Street/Pinfeather Drive**

All approaches and individual turning movements at the Sneffels Street/Pinfeather Drive intersection currently operate at and are projected to remain at LOS C or better through 2041 during both peak hours, with or without the addition of site-generated traffic. No modifications have been assumed to the existing lane geometry or traffic control at this intersection.

### **VEHICLE QUEUEING ANALYSIS**

A SimTraffic queueing analysis was performed to estimate the maximum and average queues at the intersection of Mesa Ridge Parkway/Sneffels Street during the morning and afternoon peaks.

#### **Queueing Analysis Terminology**

“Upstream block time” represents the percent of time during the peak hour in which the entry point for a turn lane upstream of the subject intersection is blocked by a queue in the adjacent through lane. “Storage block time” is the proportion of time in which the turn lane’s queue exceeds the available storage length and left-turning vehicles overspill the turn lane in the model and into the adjacent through lane.

“Maximum queue” represents the maximum queue length observed for each individual lane during the 15-minute analysis period. SimTraffic records the maximum back of queue observed for every two-minute period. In SimTraffic, a vehicle is considered queued whenever it is behind another vehicle traveling at less than 10 feet/second (approximately 7 mph) or at a stop bar. The maximum observed queue might not occur during the same interval in which the highest upstream block time (percent) or storage block time (percent) occurs. SimTraffic reports have reported the highest value for each metric for each turn lane/approach, regardless of whether or not they occur in the same 15-minute interval.

Reported queue length for auxiliary turn lanes in SimTraffic is generally limited by the turn-lane length. SimTraffic simply reports the maximum observed queue length during simulations. The reported 95th-percentile queue is also part of the results.

#### **Analysis Assumptions**

Analysis has been run to estimate the queue length that the southbound approach at Mesa Ridge Parkway/Sneffels Street will extend back to the intersection of Sneffels Street/Landover Lane. There are about 375 feet between the stop line on the southbound approach on Sneffels Street and the Sneffels Street/Landover Lane intersection.

However, the presence of back-to-back left-turn lanes between these intersections limits the available stacking distance on each approach. The southbound left-turn lane currently consists

of 185 feet of full-width lane plus a shared 90-foot taper. The northbound left-turn lane at Landover Lane currently consists of 100 feet of full-width lane plus the shared 90-foot taper.

## **Analysis Results**

### Short-Term Total

SimTraffic-reported maximum queue lengths for the Short-Term Total scenario are as follows:

- AM peak hour – 0 percent upstream or storage block time for all approaches
- Southbound-left – 81 feet
- Southbound-through – 41 feet
- Southbound-right – 66 feet
- Eastbound-left – 125 feet
- Northbound-left (at Landover Lane) – 15 feet
- PM peak hour – 0 percent upstream or storage block time for all approaches
- Southbound-left – 88 feet
- Southbound-through – 58 feet
- Southbound-right – 34 feet
- Eastbound-left – 201 feet
- Northbound-left (at Landover Lane) – ≤1 vehicle

Results from the SimTraffic queuing reports indicate that queues extending back from the southbound approach at Mesa Ridge Parkway/Sneffels Street would be accommodated by the existing southbound stacking distance during both short-term peak hours.

### 2041 Total

SimTraffic-reported maximum queue lengths for the 2041 Total scenario are as follows:

- AM peak hour – 0 percent upstream or storage block time for all approaches
- Southbound-left – 113 feet
- Southbound-through – 58 feet
- Southbound-right – 50 feet
- Eastbound-left – 355 feet
- Northbound-left (at Landover Lane) – 22 feet
- PM peak hour – 0 percent upstream or storage block time
- Southbound-left – 122 feet
- Southbound-through – 86 feet
- Southbound-right – 44 feet
- Eastbound-left – 217 feet
- Northbound-left at Landover Lane (back-to-back left) – ≤1 vehicle

Results from the SimTraffic queuing reports indicate that queues extending back from the **southbound** approach at Mesa Ridge Parkway/Sneffels Street would **not** extend past the proposed turn-bay stacking distances on Sneffels Street during either long-term peak hour.

Please refer to the “Auxiliary Turn Lane Analysis” section for more detail regarding modifications to existing striping on Sneffels Street between Landover Lane and Mesa Ridge Parkway.

Long-term analysis assumes that the intersection of Mesa Ridge Parkway/Sneffels Street would include dual westbound left-turn lanes, which are reflected in the long-term Synchro and SimTraffic models. SimTraffic queuing reports indicate that queues extending to the east from the westbound left-turn lane at Mesa Ridge Parkway/Sneffels Street would **not** exceed the available stacking distance during either long-term peak hour.

## **AUXILIARY TURN-LANE ANALYSIS**

### **Mesa Ridge Parkway**

#### Eastbound Left-Turn Deceleration Lane

Mesa Ridge Parkway is classified as “NR-A Non-Rural Arterial” east and west of Sneffels Street with a posted speed limit of 55 mph in the vicinity of the site. Currently, the eastbound left-turn lane on Mesa Ridge Parkway approaching Sneffels Road is 695 feet long, consisting of 485 feet of full-width lane and a 210-foot transition taper.

Per criteria in CDOT’s *State Highway Access Code*, left-turn deceleration lanes should consist of the following design:

- 800-foot total lane length
- 378 feet of full-width lane
- 222-foot transition taper (18.5:1 ratio)
- 274 feet of storage length (Access Code Table 4-8) or SimTraffic results - 217’ of storage

Based on the traffic projections herein, the lane would need to be 125 feet longer to meet SHAC criteria based on SimTraffic projected queuing and about 180’ longer based on Access Code Table 4-8. Details regarding this auxiliary lane and CDOT requirements (terms and conditions) to be determined through the access permit process. To meet the required 800-foot minimum. Alternatively, the taper could potentially be modified (abbreviated) to provide a longer lane-storage length.

#### Southbound-to-Westbound Right-Turn Acceleration Lane

Currently, the southbound-to-westbound right-turn acceleration lane on Mesa Ridge Parkway from Sneffels Road is 820 feet long, consisting of 670 feet of full-width lane and a 130-foot transition taper.

Per criteria in CDOT's *State Highway Access Code*, right-turn acceleration lanes should consist of the following design:

- 960-foot total lane length
- 738 feet of full-width lane
- 222-foot transition taper (18.5:1 ratio)

As such, the existing eastbound right-turn acceleration lane would need to be lengthened by about 140 feet to meet the required 960-foot minimum. As the full-width portion of the lane is close to 738-feet and there is a paved shoulder downstream which could be restriped for a longer taper, potentially no new construction would be needed. Potentially, CDOT may want to maintain the existing separation between the end of the acceleration lane and the beginning of the deceleration lane for the next intersection to the west.

#### Westbound Right-Turn Deceleration Lane

Currently, the westbound-right-turn deceleration lane on Mesa Ridge Parkway approaching Sneffels Road is 525 feet long, consisting of 365 feet of full-width lane and a 160-foot transition taper.

Per criteria in CDOT's *State Highway Access Code*, left-turn deceleration lanes should consist of the following design:

- 600-foot total lane length
- 378 feet of full-width lane
- 222-foot transition taper (18.5:1 ratio)

As such, the existing eastbound right-turn lane would need to be lengthened by about 85 feet to meet the required 600-foot minimum. As the full-width portion of the lane is close to 378 feet and there is a paved shoulder upstream which could be restriped for a longer taper, potentially no new construction would be needed.

#### **Sneffels Street**

The existing back-to-back left-turn lanes on Sneffels Street between Mesa Ridge Parkway and Landover Lane consist of the following dimensions:

- Southbound left-turn lane at Mesa Ridge Parkway – 275 feet total, consisting of 185 feet of full-width lane plus an 90-foot taper.
- Northbound left-turn lane at Landover Lane – 190 feet total, consisting of 100 feet of full-width lane plus the 90-foot shared taper.
- The westbound approach at the Sneffels/Landover Lane intersection is a single-lane approach (no exclusive turn lanes).
- The westbound approach at the Sneffels/Landover Lane intersection is a single-lane approach (no exclusive turn lanes). The projected long-term level of service for this approach is LOS C or better, and the 95<sup>th</sup> percentile queue is not projected to exceed

74 feet. The existing single-lane approach will be sufficient to accommodate the projected traffic from this development. No additional auxiliary turn lanes are recommended.

Table 4 presents the recommended roadway improvements, including these modifications to auxiliary turn lanes.

### **LANDOVER LANE AND LANDOVER LANE EXTENSION**

A five-foot wide sidewalk currently exists on the north side of Landover Lane approaching the proposed site access. The applicant would be required to extend this sidewalk from its current terminus to the site. No additional width or striping improvements on Landover Lane would be required.

Landover Lane would remain a two-lane, Local street following site buildout. The applicant intends for the extension of Landover Lane to be a public roadway owned and maintained by the City of Fountain until the roadway reaches the site's property line. On-site, the roadway is intended to be private.

Private driveways/drive aisles within the development site/property will be constructed as shown on the Preliminary Plan.

Existing Landover Lane will be able to accommodate the additional trips to be added by this project.

The Landover Lane extension is included in the improvements table (Table 4).

### **CDOT ACCESS PERMITTING**

CDOT has indicated the following in a recent review letter:

- "Section 2.6 Change in land use and Access use to SH 21 and Sneffels Street of the State Highway Access Code, states that an updated access permit will be required to record the development and the intersection roadway improvements."
- "State Highway roadway Improvements are required due to increase in traffic operations and will be detailed [in] the future updated access permit with CDOT. El Paso County will decide on the direction of application for Permittee and Applicant." (LSC Note: The applicant, LSC and CDOT are in the process of discussing this comment. To reflect this, Table 4 indicates "details regarding this auxiliary lane and CDOT requirements (terms and conditions) to be determined through the access permit process.)



## **MTCP CONFORMANCE**

### **Roadway Classifications**

No study-area roadway improvements are shown on Map 13 of El Paso County's 2016 *MTCP*. However, Map 16 of the 2016 *MTCP* shows corridor preservation for a planned extension of Powers Boulevard south of the site.

See the attached *MTCP* maps for reference.

### **Multi-Modal Transportation and TDM Opportunities**

No multi-modal improvement projects have been identified as being needed by the year 2040 per Map 15 and Table 5 of El Paso County's 2016 *MTCP*.

## **DEVIATION REQUESTS**

No deviation requests have been submitted in association with this proposed development.

## **EL PASO COUNTY ROAD IMPROVEMENT FEE PROGRAM**

This project will be required to participate in the El Paso County Road Improvement Fee Program.

The applicant will be able to join one of the two special districts or opt out of the district options. The applicant will select an option, but hypothetically, the opt-out option building permit fee for multi-family residential would be \$2,407 per dwelling unit. The project with 122 dwelling units would translate to a building permit fee of \$293,654.

Note: This is based on the current rate, which is subject to change. El Paso County updates this rate periodically.

## **CONCLUSIONS AND RECOMMENDATIONS**

Based on the preceding analysis, the following summarizes the report findings regarding the traffic impacts of the proposed Cottages at Mesa Ridge Development and recommendations.

### **Trip Generation**

- The site is projected to generate about 1,152 vehicle-trips on the average weekday, with about 576 vehicles entering and 576 vehicles exiting the site in a 24-hour period.
- During the morning peak hour, about 23 vehicles would enter and 68 vehicles would exit the site.

- Approximately 76 vehicles would enter and 45 vehicles would exit the site during the afternoon peak hour.

### **Projected Levels of Service**

- During the short term, all study-area intersections are projected to remain at LOS C or better during both peak hours, with or without the addition of site-generated traffic.
- During the long term, overall, the signalized intersection of Mesa Ridge Parkway/Sneffels Street is projected to operate at LOS D or better through 2041, with or without the addition of site-generated traffic. The following individual turning movements are projected to operate to operate at LOS E during at least one long-term peak hour, with or without the addition of site-generated traffic: southbound-through, northbound-left, northbound-through, westbound-through, and westbound-left. Lower levels of service are predominantly due to high projected through (background) traffic volumes eastbound and westbound on Mesa Ridge Parkway.

### **Queuing Analysis**

- The back-to-back left-turn lanes on Sneffels Street between Mesa Ridge Parkway and Landover Lane will provide sufficient space for the projected 95th-percentile vehicle queues during both short-term and long-term peak hours.
- Please refer to the “Queuing Analysis” section for additional detail regarding queues, including for the eastbound left turn at Mesa Ridge Parkway/Sneffels Street.

### **Auxiliary Turn Lanes & Other Roadway Improvements**

- Some minimal modifications may be needed to the existing acceleration/deceleration lanes. Please refer to the “Auxiliary Turn Lane Analysis” section for more detail, and please refer to the attached Table 4 – Roadway Improvements Table.

\* \* \* \* \*

Please contact me if you have any questions regarding this report.

Respectfully Submitted,

LSC TRANSPORTATION CONSULTANTS, INC.

By: Jeffrey C. Hodsdon, P.E.  
Principal

JCH/JAB:jas

Enclosures:    Tables 3 and 4  
                    Figure 1 - Figure 9  
                    MTCP Maps 13, 14, and 15  
                    Traffic Count Reports  
                    SimTraffic Queue Reports  
                    Synchro Level of Service Reports

# Tables

---



**Table 3: Detailed Trip Generation Estimate**

ITE		Value	Units <sup>1</sup>	Trip Generation Rates <sup>2</sup>				Total Trips Generated					
Code	Description			Average	A.M.		P.M.		Average	A.M.		P.M.	
				Weekday	In	Out	In	Out	Weekday	In	Out	In	Out
210	Multi-Family Housing (Low-Rise)	122	DU	9.44	0.19	0.56	0.62	0.37	1152	23	68	76	45

<sup>1</sup> DU = dwelling units

<sup>2</sup> Source: Trip Generation, 10th Edition, 2017, by the Institute of Transportation Engineers (ITE)

**Table 4: Roadway Improvements**

**Existing County Roadway Segment Improvements**

Item #	Improvement	Timing	Responsibility
1.1	N/A (no "Roadway Improvement Projects" adjacent to the site are shown on the 2040 MTCP)	N/A	N/A

**Existing City of Fountain Streets**

Item #	Improvement	Timing	Responsibility
2.1	Extend Landover Lane to the site boundary and construct the public street terminus shown on the site plan. (Note: the street will continue into the site as a private street)	With site development	Applicant

**Off-Site, CDOT Intersection**

**State Highway 16/Sneffels Road Intersection**

Item #	Improvement	Timing	Responsibility
3.1	<u>Eastbound-Left Turn Deceleration Lane</u> Based on the traffic projections herein, the lane would need to be 125' (or 180' longer -see report narrative) to meet SHAC criteria. Details regarding this auxiliary lane and CDOT requirements (terms and conditions) to be determined through the access permit process.	With site development	Applicant
3.2	<u>Westbound Right Turn Acceleration Lane</u> Lengthen existing acceleration lane to meet criteria in CDOT's <i>State Highway Access Code</i> . This could potentially be accomplished through restriping. Details to be determined through the access permit process.	With site development	Applicant.
3.3	<u>Westbound-Right Turn Deceleration Lane</u> Lengthen existing turn lane by 120 feet to meet criteria in CDOT's <i>State Highway Access Code</i> . This could potentially be accomplished through restriping. Details to be determined through the access permit process.	With site development	Applicant

Source: LSC Transportation Consultants, Inc. (Revised 1/17/2022)

# Figures

---



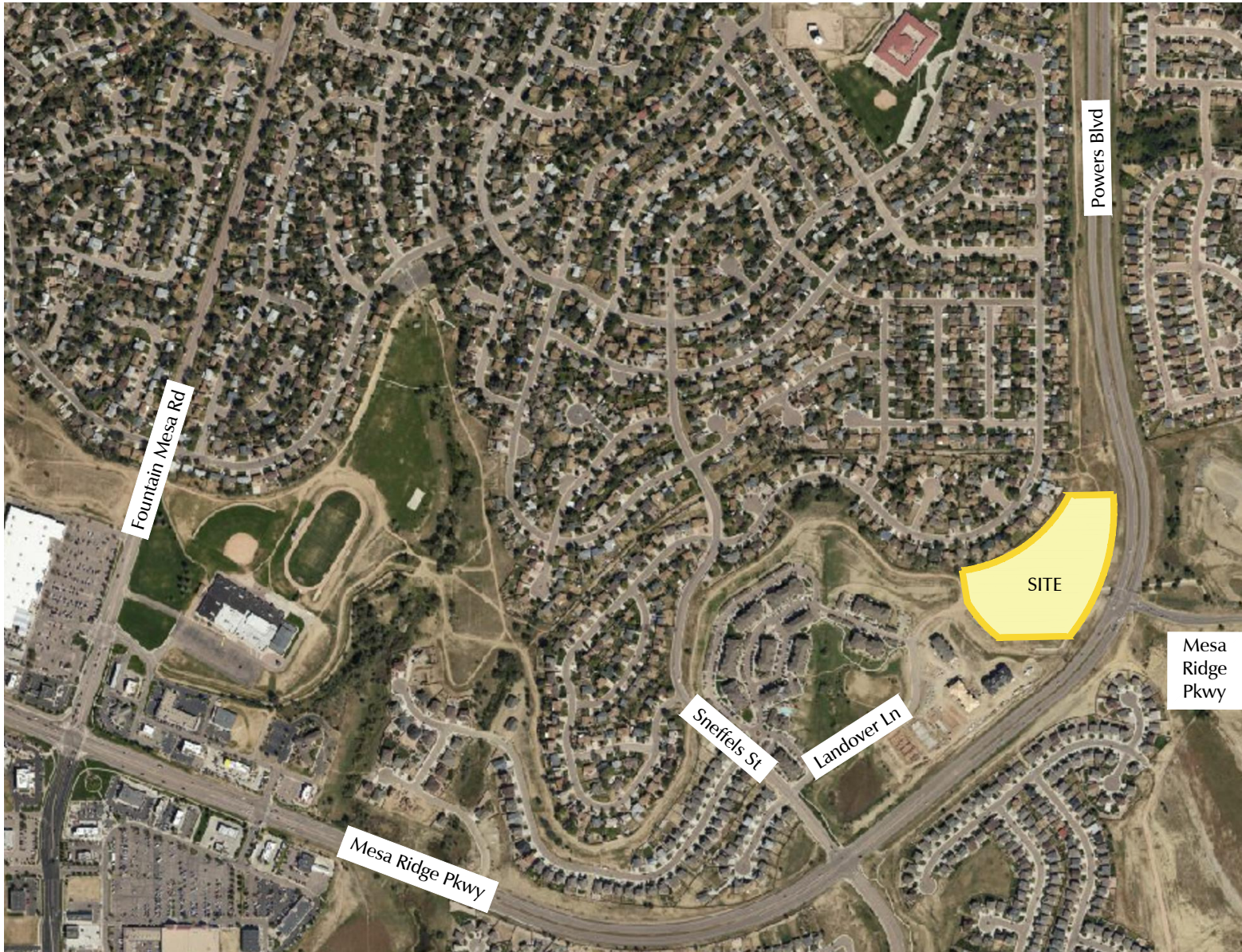

Not to scale

Figure 1  
Vicinity  
Map





Not to scale



Figure 2

# Site Plan

Cottages at Mesa Ridge (LSC #S214580)

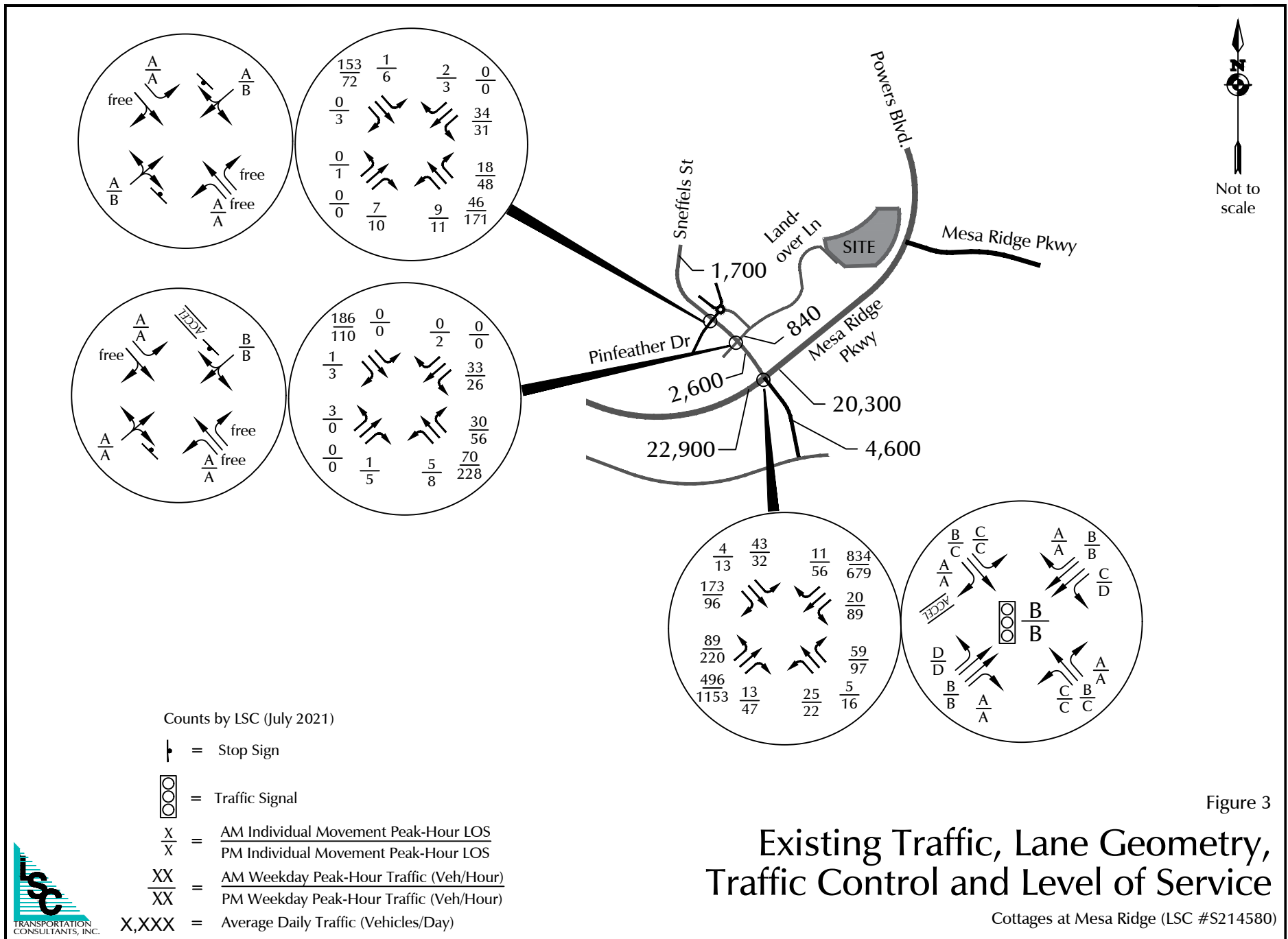

Figure 3

# Existing Traffic, Lane Geometry, Traffic Control and Level of Service

Cottages at Mesa Ridge (LSC #S214580)



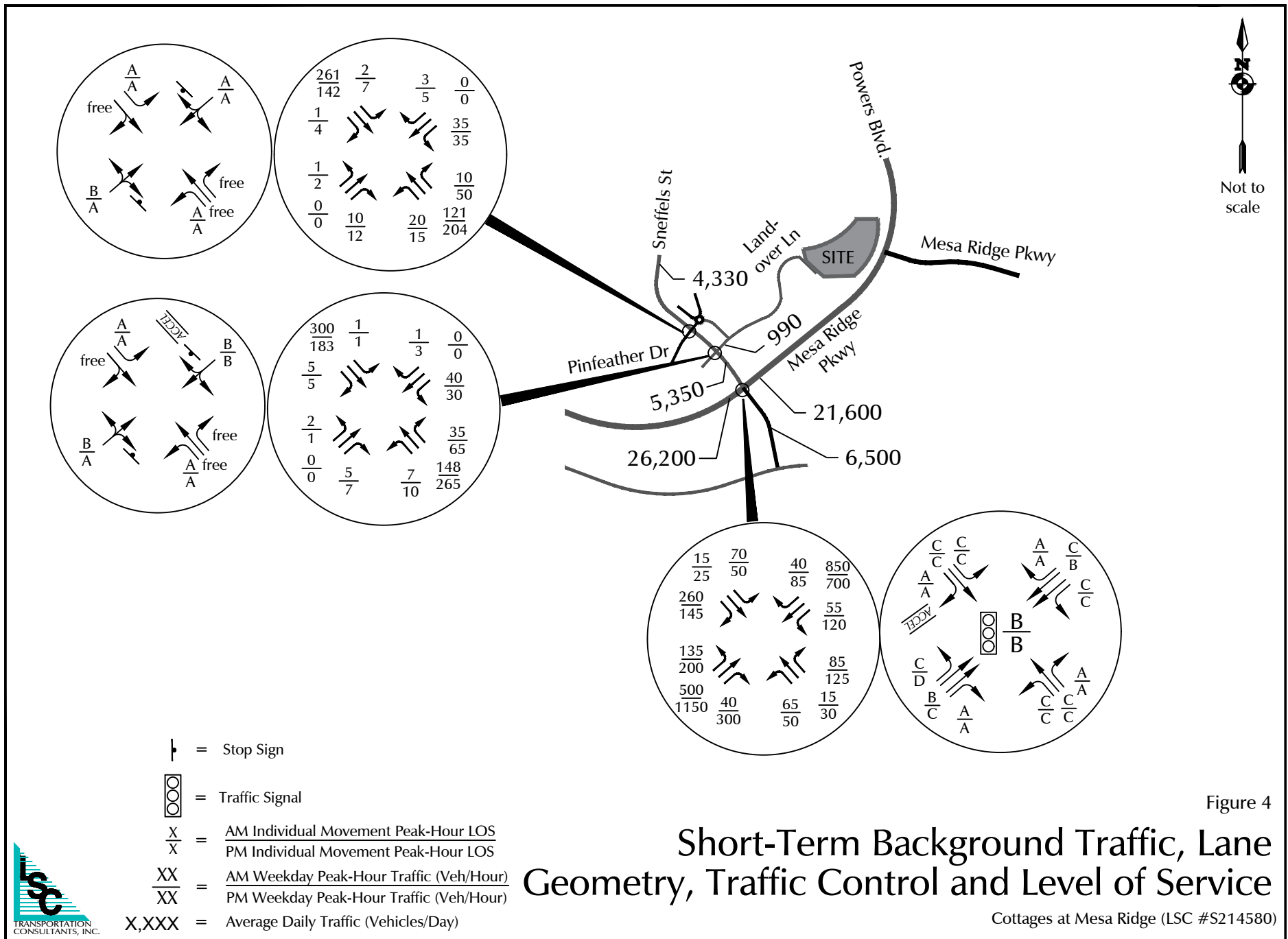
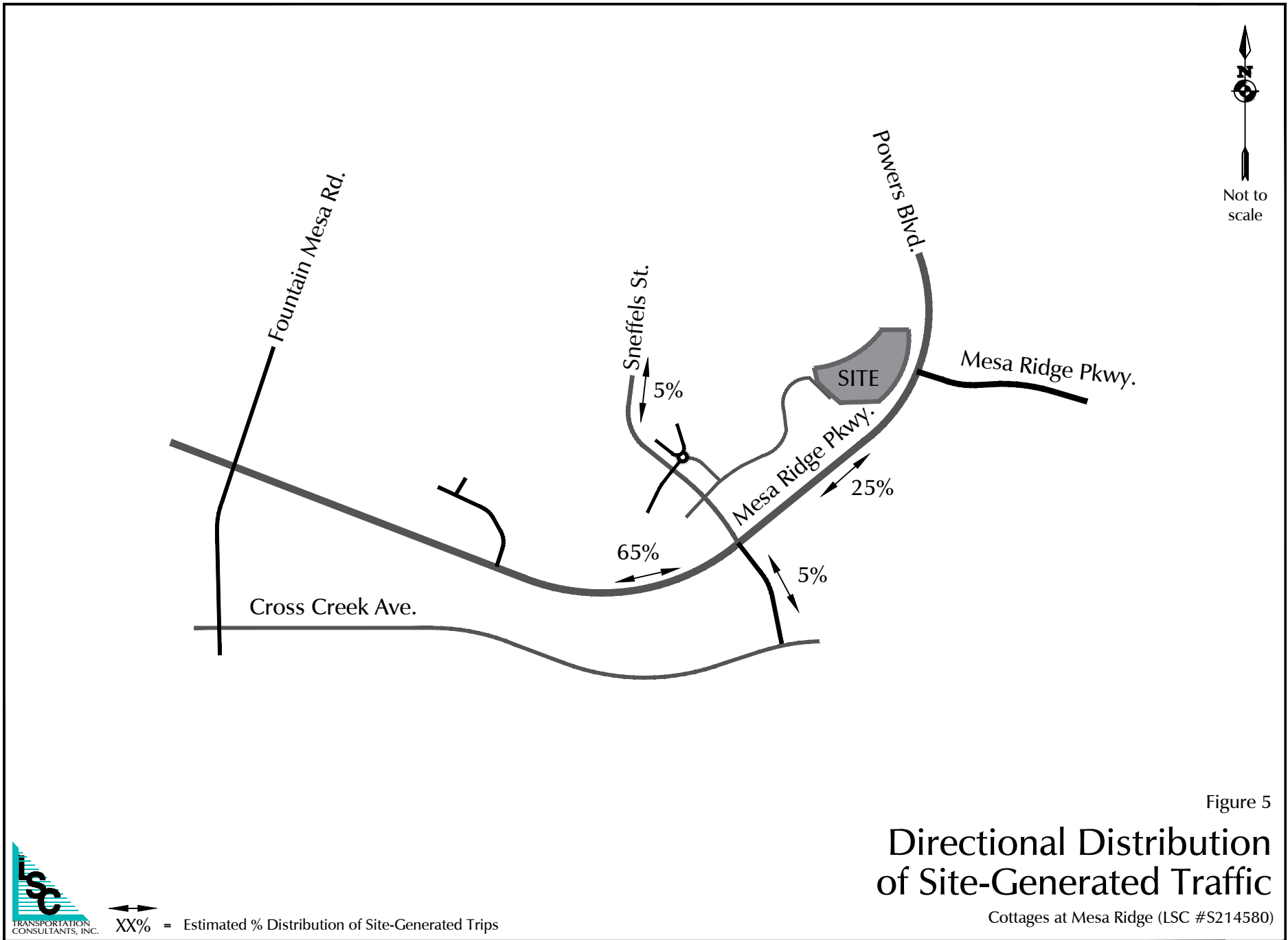
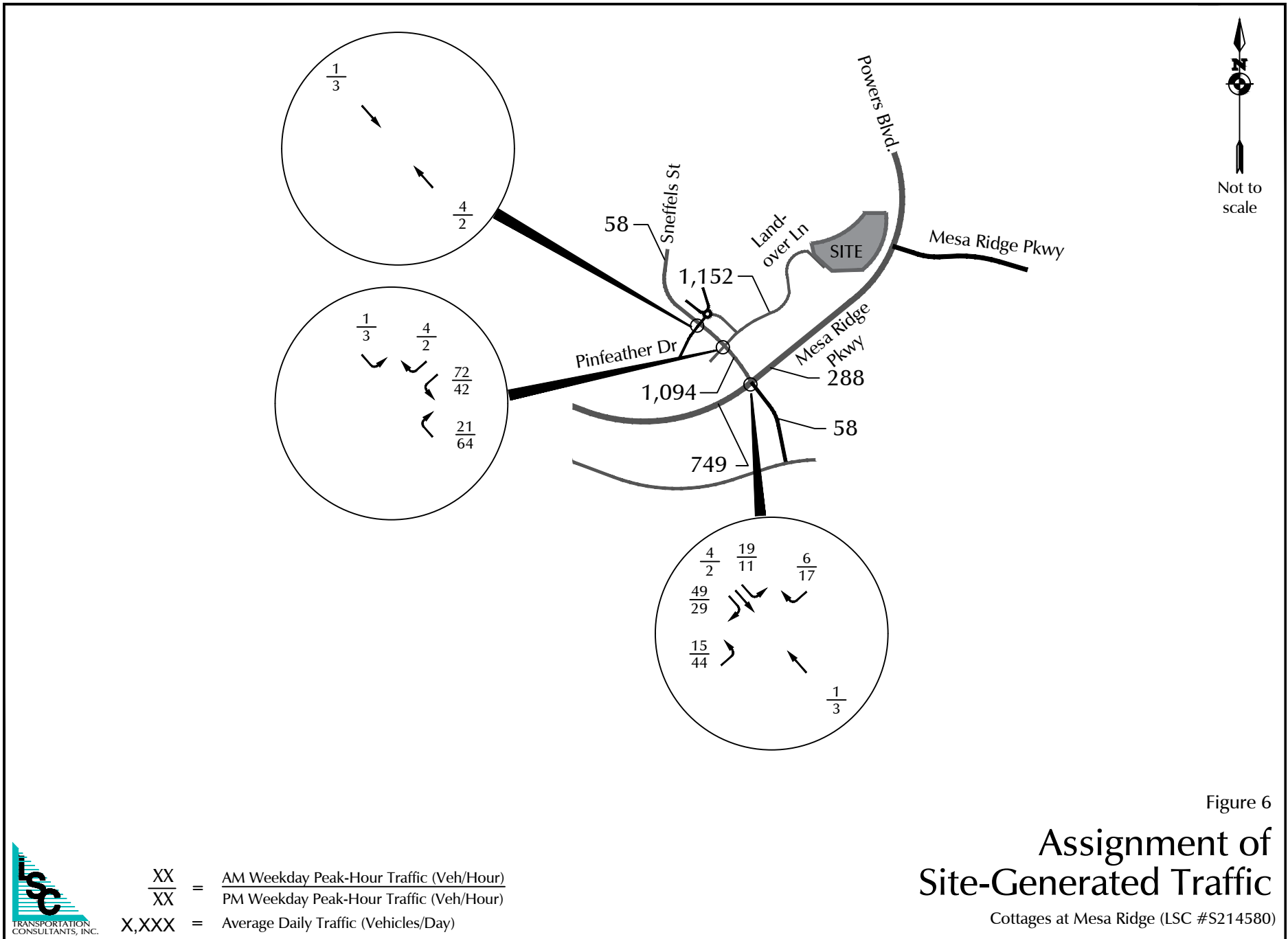

Figure 4

# Short-Term Background Traffic, Lane Geometry, Traffic Control and Level of Service

Cottages at Mesa Ridge (LSC #S214580)





  
 Not to scale

Figure 6  
**Assignment of  
 Site-Generated Traffic**  
 Cottages at Mesa Ridge (LSC #S214580)



$\frac{XX}{XX}$  = AM Weekday Peak-Hour Traffic (Veh/Hour)  
 $\frac{XX}{XX}$  = PM Weekday Peak-Hour Traffic (Veh/Hour)  
 X,XXX = Average Daily Traffic (Vehicles/Day)

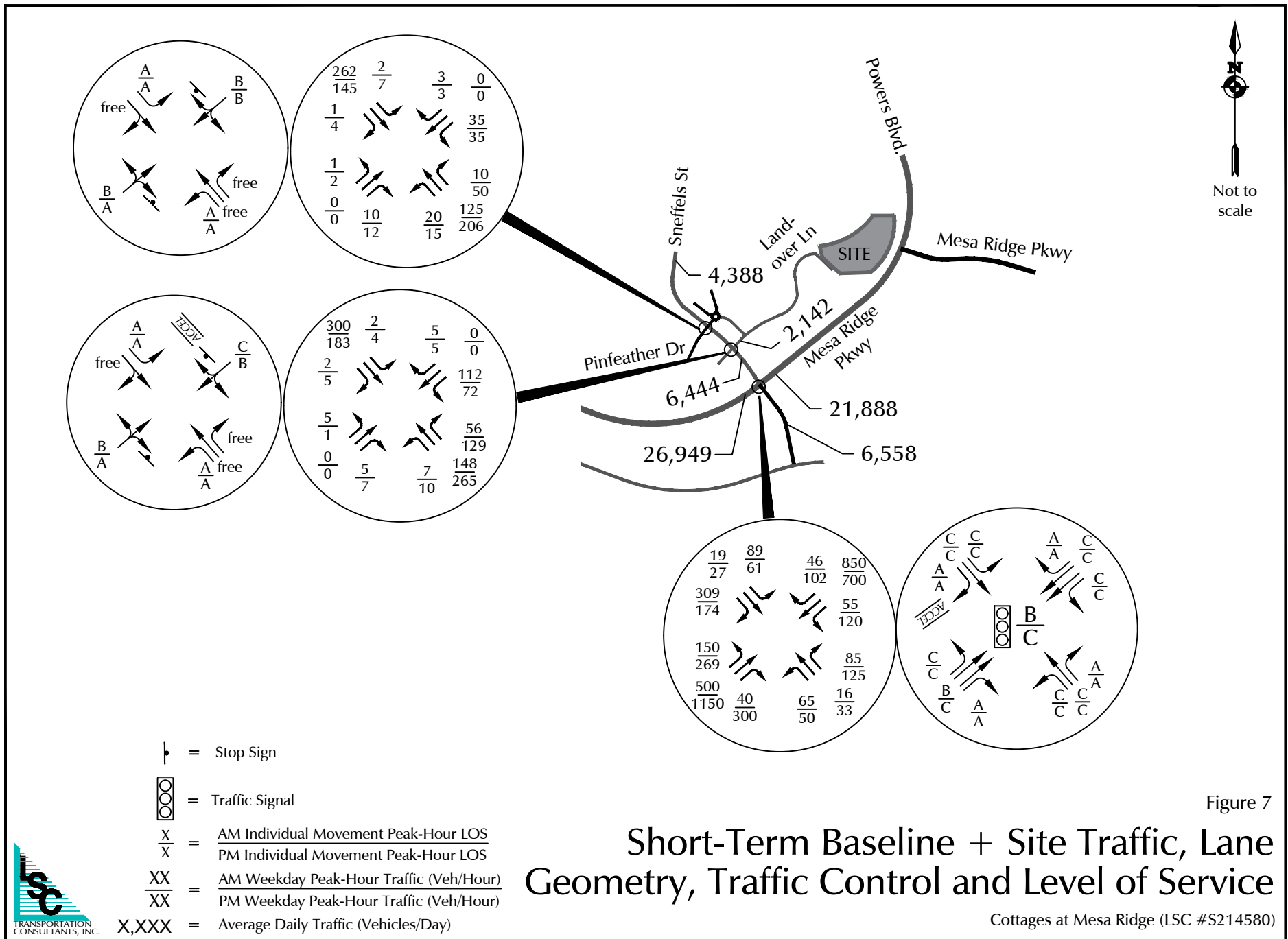

Figure 7

## Short-Term Baseline + Site Traffic, Lane Geometry, Traffic Control and Level of Service

Cottages at Mesa Ridge (LSC #S214580)



- = Stop Sign
- = Traffic Signal
- $\frac{X}{X}$  =  $\frac{\text{AM Individual Movement Peak-Hour LOS}}{\text{PM Individual Movement Peak-Hour LOS}}$
- $\frac{XX}{XX}$  =  $\frac{\text{AM Weekday Peak-Hour Traffic (Veh/Hour)}}{\text{PM Weekday Peak-Hour Traffic (Veh/Hour)}}$
- X,XXX = Average Daily Traffic (Vehicles/Day)

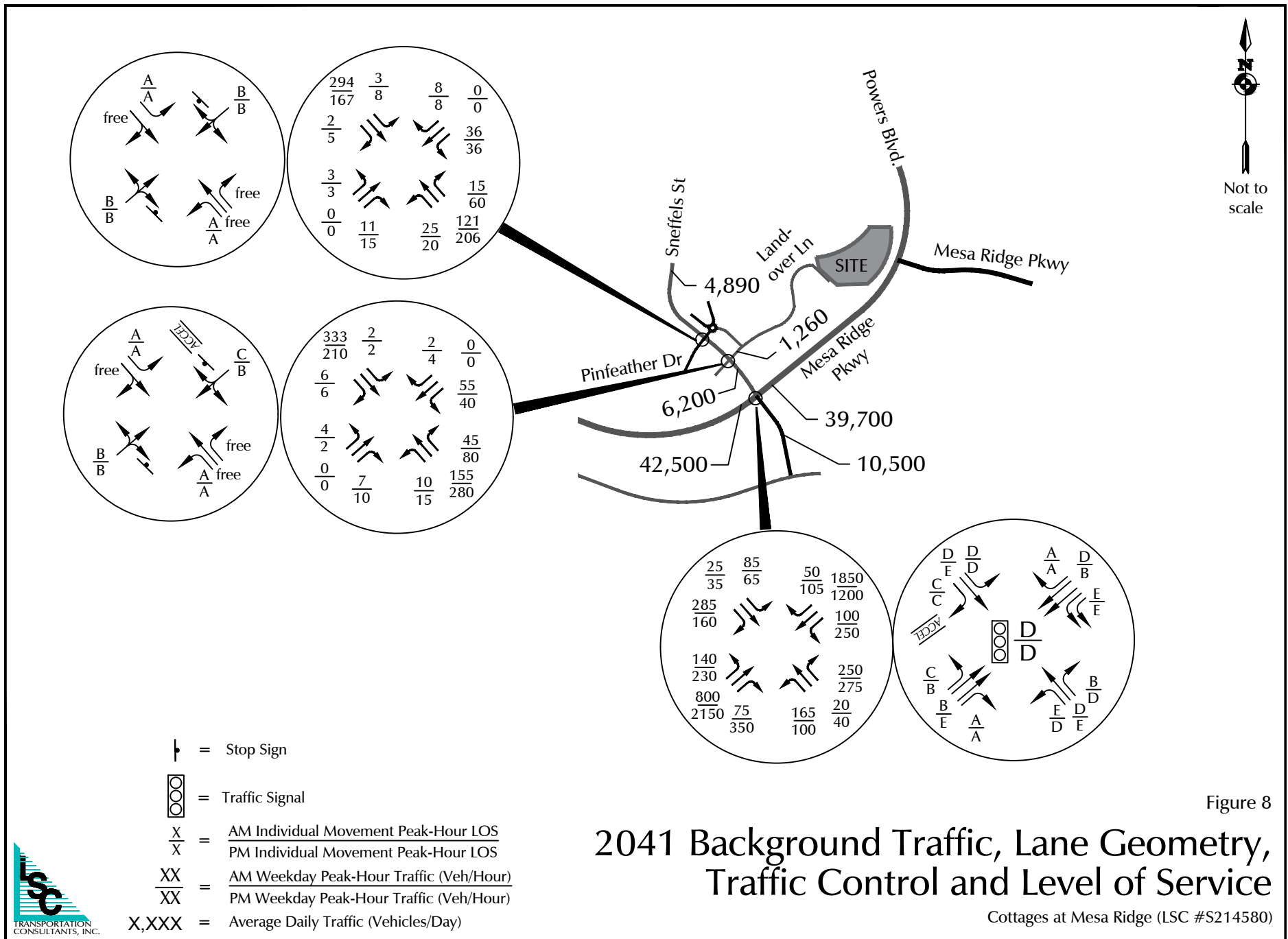

Figure 8

# 2041 Background Traffic, Lane Geometry, Traffic Control and Level of Service

Cottages at Mesa Ridge (LSC #S214580)





Not to scale

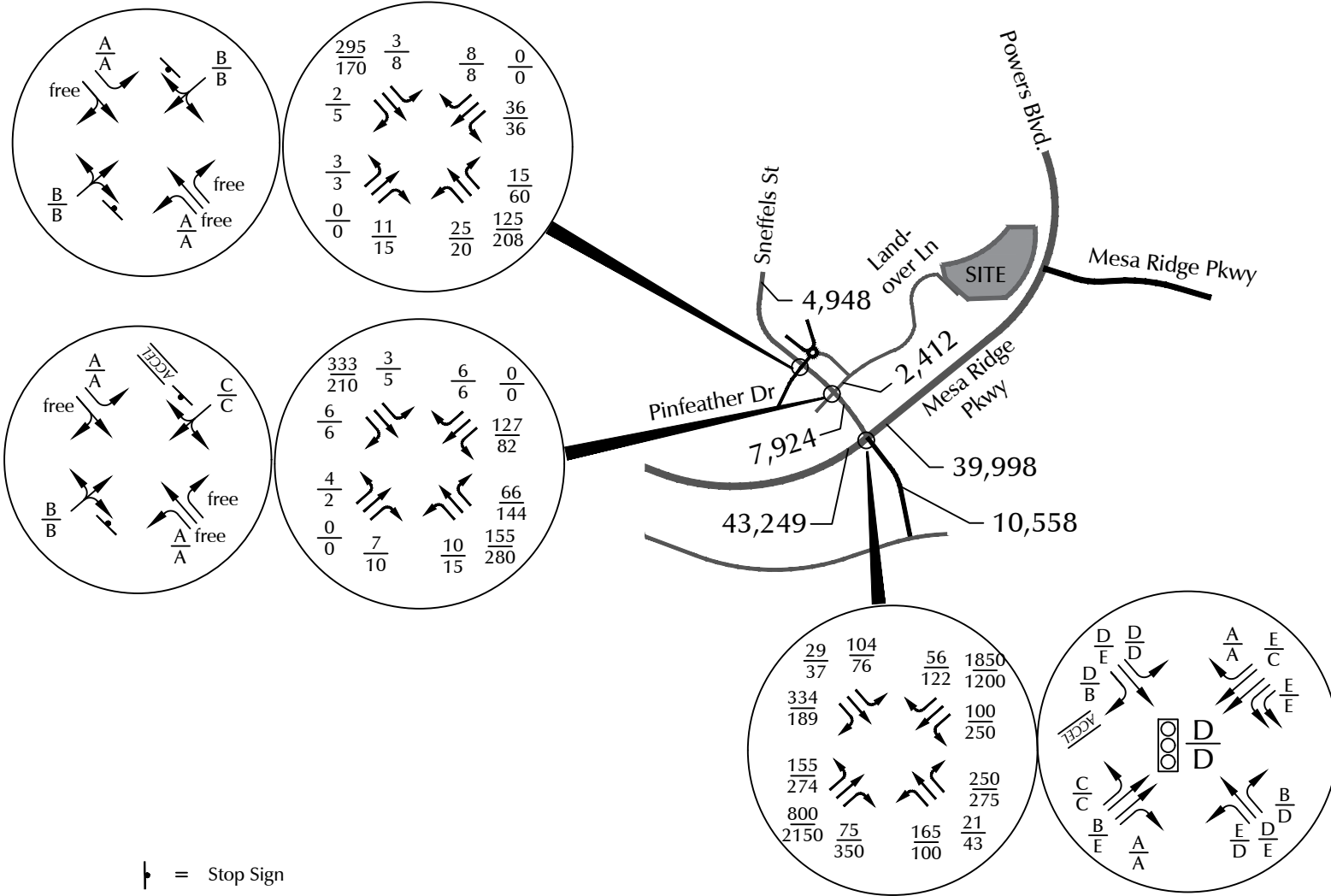

┆ = Stop Sign

⊞ = Traffic Signal

$\frac{X}{X}$  = AM Individual Movement Peak-Hour LOS  
 PM Individual Movement Peak-Hour LOS

XX = AM Weekday Peak-Hour Traffic (Veh/Hour)  
 XX = PM Weekday Peak-Hour Traffic (Veh/Hour)

X,XXX = Average Daily Traffic (Vehicles/Day)



# 2041 Total Traffic, Lane Geometry, Traffic Control and Level of Service

Cottages at Mesa Ridge (LSC #S214580)

Figure 9



# MTCP Maps

---





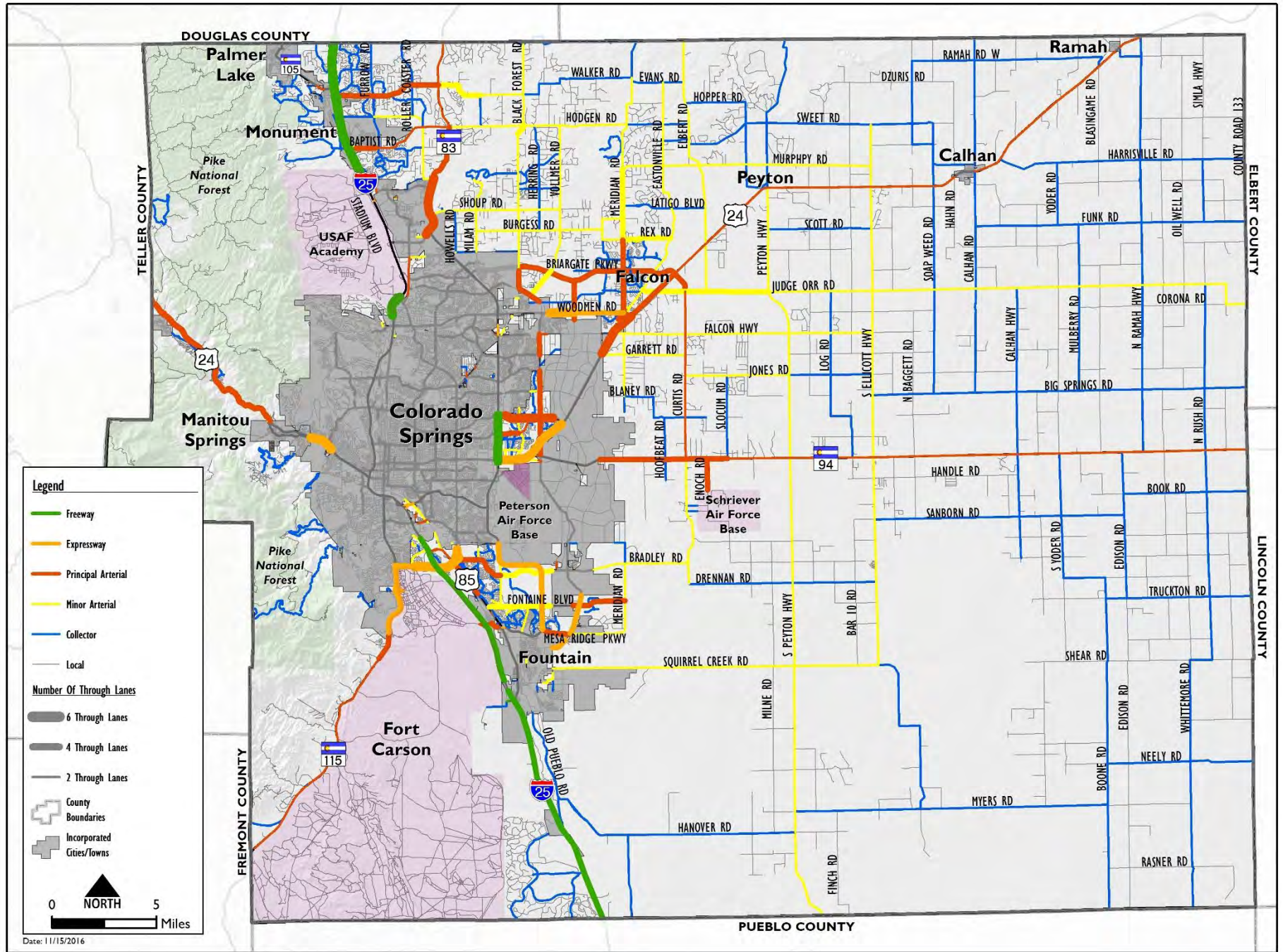

Map 14: 2040 Roadway Plan (Classification and Lanes)

# Map 15: Multimodal Improvements

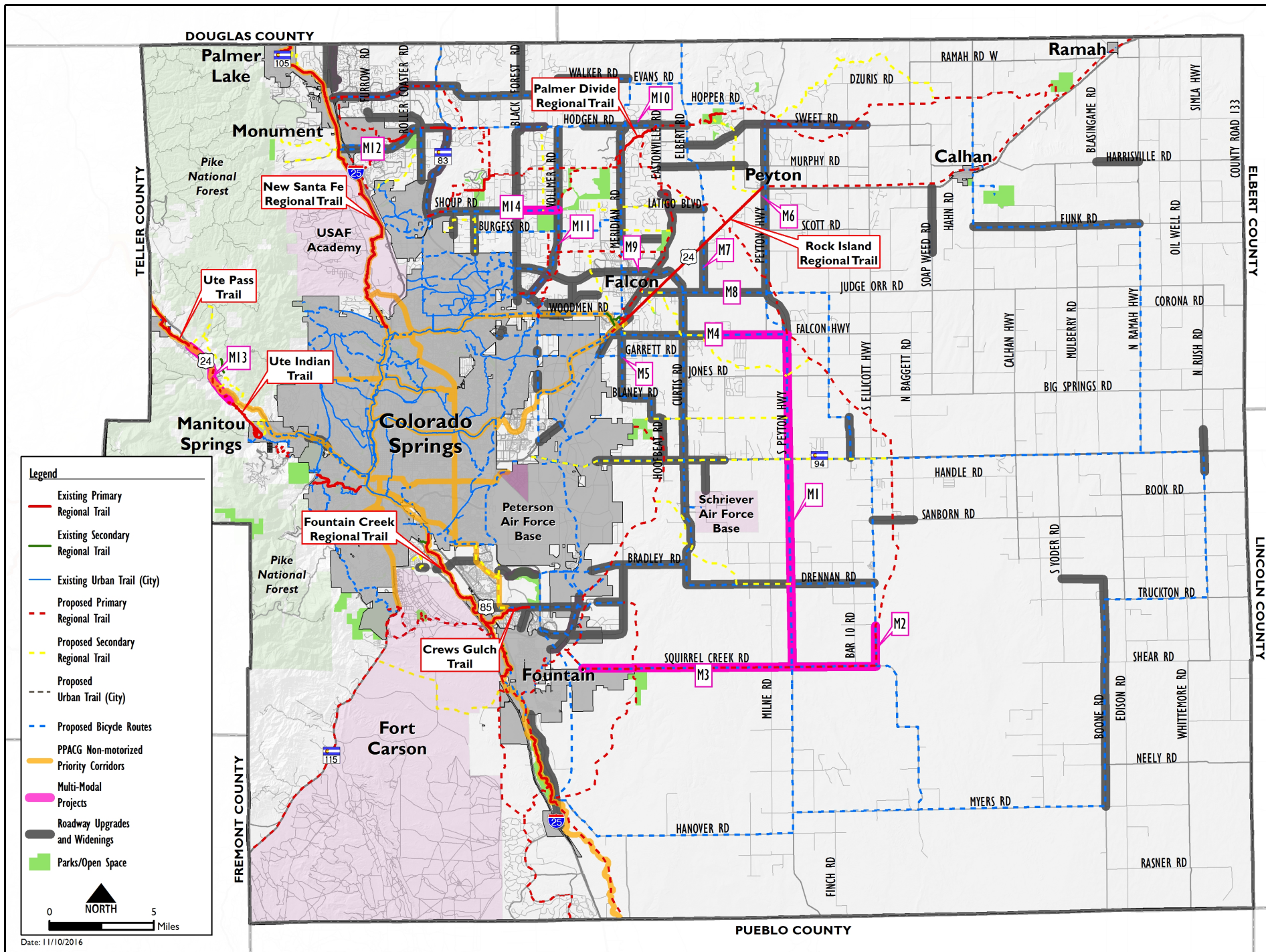

# Traffic Counts

---



# LSC Transportation Consultants, Inc.

2504 E Pikes Peak Ave, Suite 304  
 Colorado Springs, CO 80909  
 719-633-2868

File Name : Mesa Ridge Pkwy - Sneffels St AM  
 Site Code : S214580  
 Start Date : 7/7/2021  
 Page No : 1

## Groups Printed- Unshifted

Start Time	Mesa Ridge Pkwy Southbound					Sneffels St Westbound					Mesa Ridge Pkwy Northbound					Sneffels St Eastbound					Int. Total
	L	T	R	U	App. Total	L	T	R	U	App. Total	L	T	R	U	App. Total	L	T	R	U	App. Total	
06:30 AM	8	213	5	0	226	1	1	11	0	13	16	111	2	0	129	8	1	32	0	41	409
06:45 AM	11	175	2	0	188	3	3	10	0	16	17	125	1	0	143	10	2	40	0	52	399
Total	19	388	7	0	414	4	4	21	0	29	33	236	3	0	272	18	3	72	0	93	808
07:00 AM	4	197	1	0	202	9	1	14	0	24	16	121	0	0	137	12	1	46	0	59	422
07:15 AM	7	228	3	0	238	5	1	14	0	20	19	127	6	0	152	9	2	51	0	62	472
07:30 AM	4	203	3	0	210	9	2	17	0	28	28	123	2	0	153	14	1	42	0	57	448
07:45 AM	5	206	4	0	215	2	1	14	0	17	26	127	5	0	158	8	0	34	0	42	432
Total	20	834	11	0	865	25	5	59	0	89	89	498	13	0	600	43	4	173	0	220	1774
08:00 AM	2	218	1	0	221	5	0	15	0	20	22	99	5	0	126	7	0	39	0	46	413
08:15 AM	11	252	10	0	273	6	0	14	0	20	7	100	2	0	109	8	0	52	0	60	462
Grand Total	52	1692	29	0	1773	40	9	109	0	158	151	933	23	0	1107	76	7	336	0	419	3457
Apprch %	2.9	95.4	1.6	0		25.3	5.7	69	0		13.6	84.3	2.1	0		18.1	1.7	80.2	0		
Total %	1.5	48.9	0.8	0	51.3	1.2	0.3	3.2	0	4.6	4.4	27	0.7	0	32	2.2	0.2	9.7	0	12.1	

# LSC Transportation Consultants, Inc.

2504 E Pikes Peak Ave, Suite 304  
 Colorado Springs, CO 80909  
 719-633-2868

File Name : Mesa Ridge Pkwy - Sneffels St AM  
 Site Code : S214580  
 Start Date : 7/7/2021  
 Page No : 2

Start Time	Mesa Ridge Pkwy Southbound					Sneffels St Westbound					Mesa Ridge Pkwy Northbound					Sneffels St Eastbound					Int. Total
	L	T	R	U	App. Total	L	T	R	U	App. Total	L	T	R	U	App. Total	L	T	R	U	App. Total	
<b>Peak Hour Analysis From 6:30:00 AM to 8:15:00 AM - Peak 1 of 1</b>																					
Peak Hour for Entire Intersection Begins at 7:00:00 AM																					
7:00:00 AM	4	197	1	0	202	<b>9</b>	1	14	0	24	16	121	0	0	137	12	1	46	0	59	422
7:15:00 AM	<b>7</b>	<b>228</b>	3	0	<b>238</b>	5	1	14	0	20	19	<b>127</b>	<b>6</b>	0	152	9	<b>2</b>	<b>51</b>	0	<b>62</b>	<b>472</b>
7:30:00 AM	4	203	3	0	210	9	<b>2</b>	<b>17</b>	0	<b>28</b>	<b>28</b>	123	2	0	153	<b>14</b>	1	42	0	57	448
7:45:00 AM	5	206	<b>4</b>	0	215	2	1	14	0	17	26	127	5	0	<b>158</b>	8	0	34	0	42	432
Total Volume	20	834	11	0	865	25	5	59	0	89	89	498	13	0	600	43	4	173	0	220	1774
% App. Total	2.3	96.4	1.3	0		28.1	5.6	66.3	0		14.8	83	2.2	0		19.5	1.8	78.6	0		
PHF	.714	.914	.688	.000	.909	.694	.625	.868	.000	.795	.795	.980	.542	.000	.949	.768	.500	.848	.000	.887	.940

# LSC Transportation Consultants, Inc.

2504 E Pikes Peak Ave, Suite 304  
 Colorado Springs, CO 80909  
 719-633-2868

File Name : Mesa Ridge Pkwy - Sneffels St AM  
 Site Code : S214580  
 Start Date : 7/7/2021  
 Page No : 3

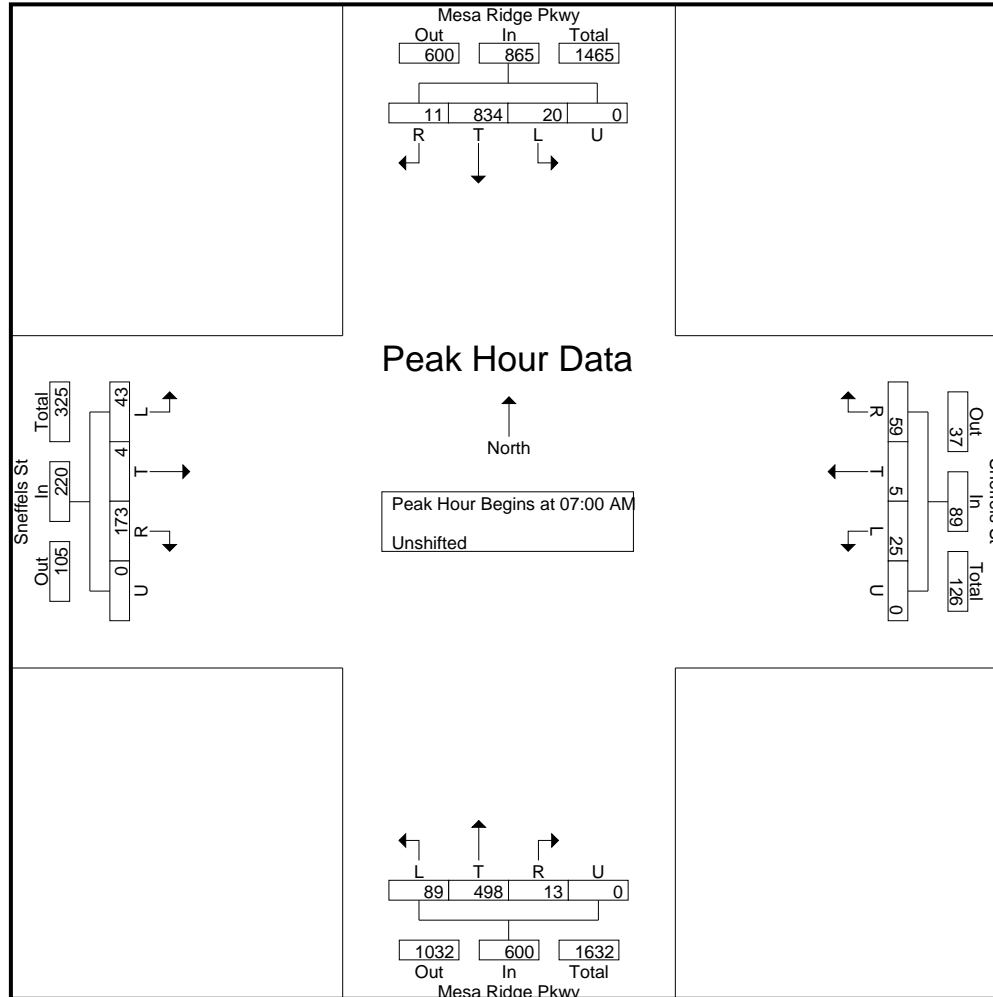



# LSC Transportation Consultants, Inc.

2504 E Pikes Peak Ave, Suite 304  
 Colorado Springs, CO 80909  
 719-633-2868

File Name : Mesa Ridge Pkwy - Sneffels St AM  
 Site Code : S214580  
 Start Date : 7/7/2021  
 Page No : 4

Start Time	Mesa Ridge Pkwy Southbound					Sneffels St Westbound					Mesa Ridge Pkwy Northbound					Sneffels St Eastbound					Int. Total
	L	T	R	U	App. Total	L	T	R	U	App. Total	L	T	R	U	App. Total	L	T	R	U	App. Total	
<b>Peak Hour Analysis From 6:30:00 AM to 8:15:00 AM - Peak 1 of 1</b>																					
Peak Hour for Each Approach Begins at:																					
	7:30:00 AM					7:00:00 AM					7:00:00 AM					6:45:00 AM					
+0 mins.	4	203	3	0	210	<b>9</b>	1	14	0	24	16	121	0	0	137	10	<b>2</b>	40	0	52	
+5 mins.	5	206	4	0	215	5	1	14	0	20	19	<b>127</b>	<b>6</b>	0	152	12	1	46	0	59	
+10 mins.	2	218	1	0	221	9	<b>2</b>	<b>17</b>	0	<b>28</b>	<b>28</b>	123	2	0	153	9	2	<b>51</b>	0	<b>62</b>	
+15 mins.	<b>11</b>	<b>252</b>	<b>10</b>	0	<b>273</b>	2	1	14	0	17	26	127	5	0	<b>158</b>	<b>14</b>	1	42	0	57	
Total Volume	22	879	18	0	919	25	5	59	0	89	89	498	13	0	600	45	6	179	0	230	
% App. Total	2.4	95.6	2	0		28.1	5.6	66.3	0		14.8	83	2.2	0		19.6	2.6	77.8	0		
PHF	.500	.872	.450	.000	.842	.694	.625	.868	.000	.795	.795	.980	.542	.000	.949	.804	.750	.877	.000	.927	

# LSC Transportation Consultants, Inc.

2504 E Pikes Peak Ave, Suite 304  
 Colorado Springs, CO 80909  
 719-633-2868

File Name : Mesa Ridge Pkwy - Sneffels St AM  
 Site Code : S214580  
 Start Date : 7/7/2021  
 Page No : 5

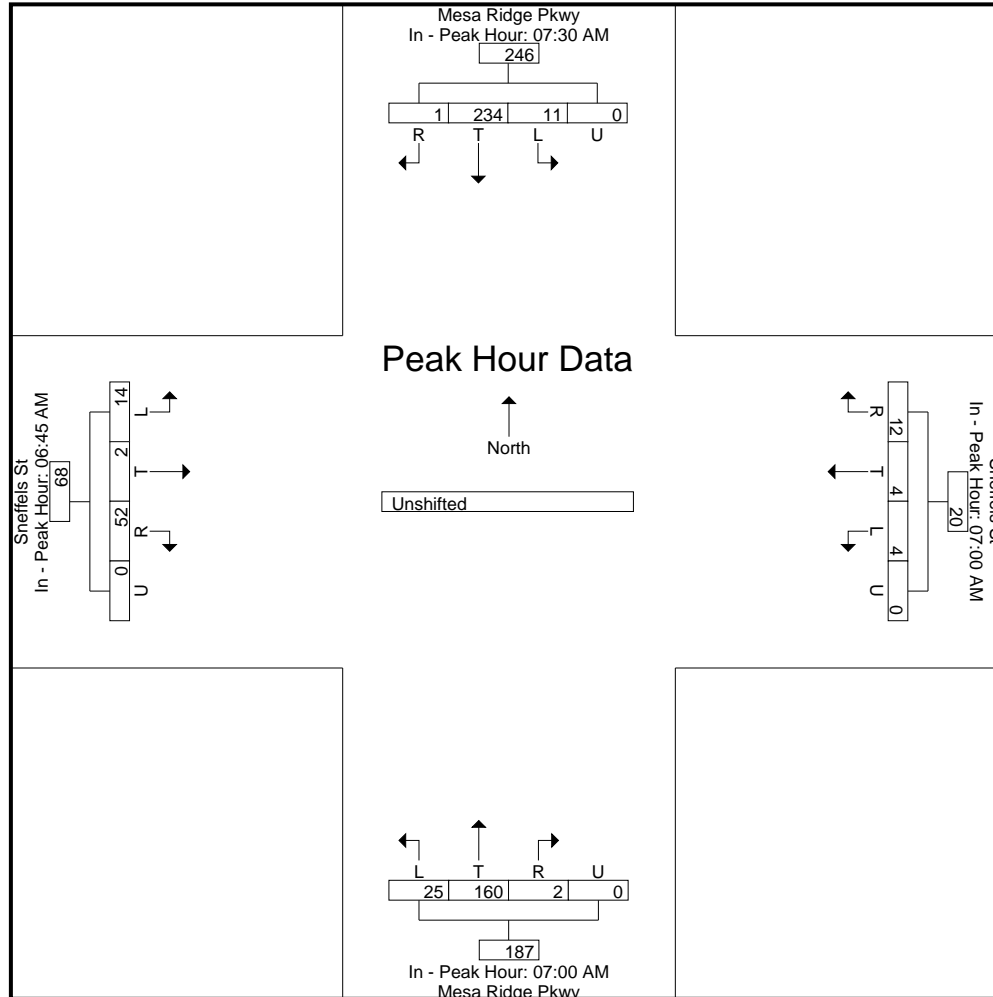

# LSC Transportation Consultants, Inc.

2504 E Pikes Peak Ave, Suite 304  
 Colorado Springs, CO 80909  
 719-633-2868

File Name : Mesa Ridge Pkwy - Sneffels St PM  
 Site Code : S214580  
 Start Date : 7/7/2021  
 Page No : 1

### Groups Printed- Unshifted

Start Time	Mesa Ridge Pkwy Southbound					Sneffels St Westbound					Mesa Ridge Pkwy Northbound					Sneffels St Eastbound					Int. Total
	L	T	R	U	App. Total	L	T	R	U	App. Total	L	T	R	U	App. Total	L	T	R	U	App. Total	
04:00 PM	15	159	9	0	183	2	4	22	0	28	51	261	8	0	320	7	3	30	0	40	571
04:15 PM	31	171	12	1	215	2	3	15	0	20	45	283	8	0	336	6	5	24	0	35	606
04:30 PM	19	178	10	0	207	7	3	29	0	39	57	312	13	0	382	10	3	27	0	40	668
04:45 PM	21	168	18	0	207	4	5	26	0	35	53	260	12	0	325	12	3	21	0	36	603
Total	86	676	49	1	812	15	15	92	0	122	206	1116	41	0	1363	35	14	102	0	151	2448
05:00 PM	22	152	12	0	186	8	2	20	0	30	70	256	11	0	337	3	6	22	0	31	584
05:15 PM	27	181	16	0	224	3	6	22	0	31	40	325	11	0	376	7	1	26	0	34	665
05:30 PM	18	168	16	0	202	2	9	13	0	24	47	248	10	0	305	7	0	20	0	27	558
05:45 PM	39	189	13	0	241	1	6	24	0	31	50	221	18	0	289	7	4	29	1	41	602
Total	106	690	57	0	853	14	23	79	0	116	207	1050	50	0	1307	24	11	97	1	133	2409
Grand Total	192	1366	106	1	1665	29	38	171	0	238	413	2166	91	0	2670	59	25	199	1	284	4857
Apprch %	11.5	82	6.4	0.1		12.2	16	71.8	0		15.5	81.1	3.4	0		20.8	8.8	70.1	0.4		
Total %	4	28.1	2.2	0	34.3	0.6	0.8	3.5	0	4.9	8.5	44.6	1.9	0	55	1.2	0.5	4.1	0	5.8	

# LSC Transportation Consultants, Inc.

2504 E Pikes Peak Ave, Suite 304  
 Colorado Springs, CO 80909  
 719-633-2868

File Name : Mesa Ridge Pkwy - Sneffels St PM  
 Site Code : S214580  
 Start Date : 7/7/2021  
 Page No : 2

Start Time	Mesa Ridge Pkwy Southbound					Sneffels St Westbound					Mesa Ridge Pkwy Northbound					Sneffels St Eastbound					Int. Total
	L	T	R	U	App. Total	L	T	R	U	App. Total	L	T	R	U	App. Total	L	T	R	U	App. Total	
<b>Peak Hour Analysis From 4:00:00 PM to 5:45:00 PM - Peak 1 of 1</b>																					
Peak Hour for Entire Intersection Begins at 4:30:00 PM																					
4:30:00 PM	19	178	10	0	207	7	3	<b>29</b>	0	<b>39</b>	57	312	<b>13</b>	0	<b>382</b>	10	3	<b>27</b>	0	<b>40</b>	<b>668</b>
4:45:00 PM	21	168	<b>18</b>	0	207	4	5	26	0	35	53	260	12	0	325	<b>12</b>	3	21	0	36	603
5:00:00 PM	22	152	12	0	186	<b>8</b>	2	20	0	30	<b>70</b>	256	11	0	337	3	<b>6</b>	22	0	31	584
5:15:00 PM	<b>27</b>	<b>181</b>	16	0	<b>224</b>	3	<b>6</b>	22	0	31	40	<b>325</b>	11	0	376	7	1	26	0	34	665
Total Volume	89	679	56	0	824	22	16	97	0	135	220	1153	47	0	1420	32	13	96	0	141	2520
% App. Total	10.8	82.4	6.8	0		16.3	11.9	71.9	0		15.5	81.2	3.3	0		22.7	9.2	68.1	0		
PHF	.824	.938	.778	.000	.920	.688	.667	.836	.000	.865	.786	.887	.904	.000	.929	.667	.542	.889	.000	.881	.943

# LSC Transportation Consultants, Inc.

2504 E Pikes Peak Ave, Suite 304  
 Colorado Springs, CO 80909  
 719-633-2868

File Name : Mesa Ridge Pkwy - Sneffels St PM  
 Site Code : S214580  
 Start Date : 7/7/2021  
 Page No : 3

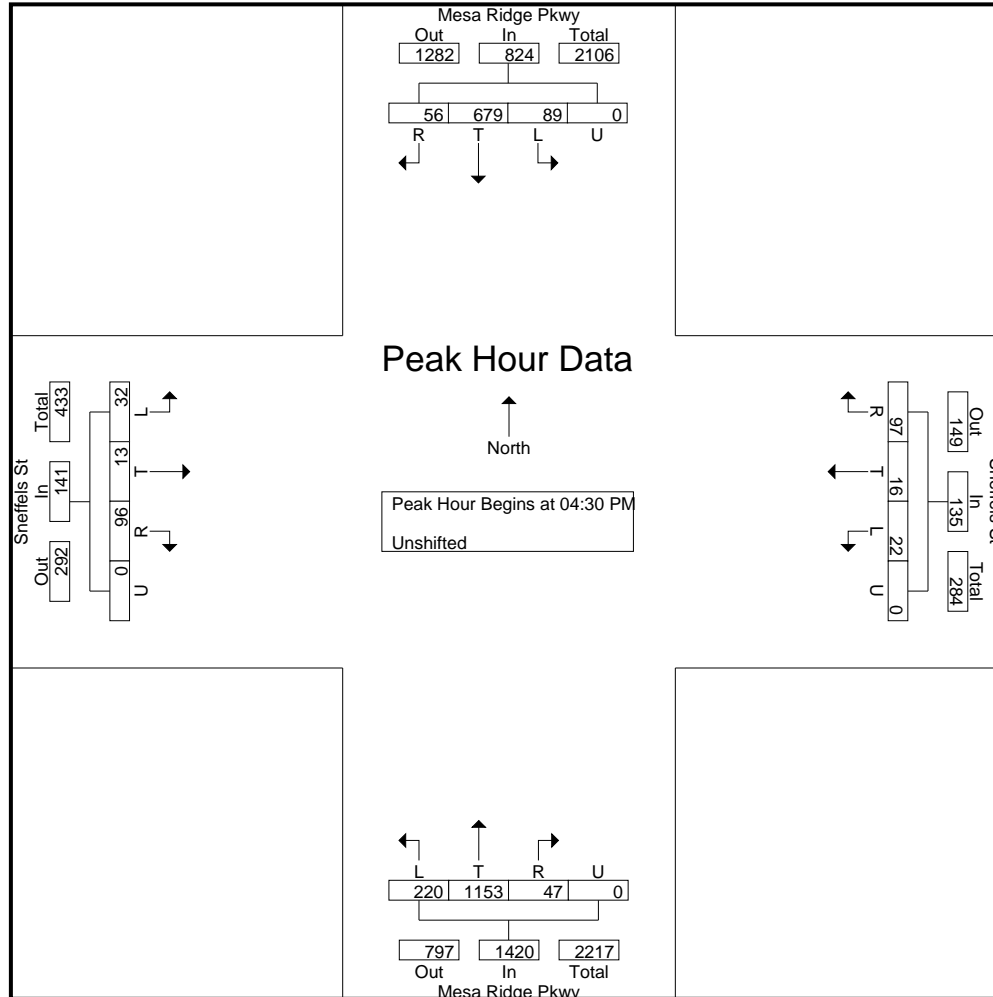

# LSC Transportation Consultants, Inc.

2504 E Pikes Peak Ave, Suite 304  
 Colorado Springs, CO 80909  
 719-633-2868

File Name : Mesa Ridge Pkwy - Sneffels St PM  
 Site Code : S214580  
 Start Date : 7/7/2021  
 Page No : 4

Start Time	Mesa Ridge Pkwy Southbound					Sneffels St Westbound					Mesa Ridge Pkwy Northbound					Sneffels St Eastbound					Int. Total
	L	T	R	U	App. Total	L	T	R	U	App. Total	L	T	R	U	App. Total	L	T	R	U	App. Total	
<b>Peak Hour Analysis From 4:00:00 PM to 5:45:00 PM - Peak 1 of 1</b>																					
Peak Hour for Each Approach Begins at:																					
	5:00:00 PM					4:30:00 PM					4:30:00 PM					4:00:00 PM					
+0 mins.	22	152	12	0	186	7	3	<b>29</b>	0	<b>39</b>	57	312	<b>13</b>	0	<b>382</b>	7	3	<b>30</b>	0	<b>40</b>	
+5 mins.	27	181	<b>16</b>	0	224	4	5	26	0	35	53	260	12	0	325	6	<b>5</b>	24	0	35	
+10 mins.	18	168	16	0	202	<b>8</b>	2	20	0	30	<b>70</b>	256	11	0	337	10	3	27	0	40	
+15 mins.	<b>39</b>	<b>189</b>	13	0	<b>241</b>	3	<b>6</b>	22	0	31	40	<b>325</b>	11	0	376	<b>12</b>	3	21	0	36	
Total Volume	106	690	57	0	853	22	16	97	0	135	220	1153	47	0	1420	35	14	102	0	151	
% App. Total	12.4	80.9	6.7	0		16.3	11.9	71.9	0		15.5	81.2	3.3	0		23.2	9.3	67.5	0		
PHF	.679	.913	.891	.000	.885	.688	.667	.836	.000	.865	.786	.887	.904	.000	.929	.729	.700	.850	.000	.944	

# LSC Transportation Consultants, Inc.

2504 E Pikes Peak Ave, Suite 304  
 Colorado Springs, CO 80909  
 719-633-2868

File Name : Mesa Ridge Pkwy - Sneffels St PM  
 Site Code : S214580  
 Start Date : 7/7/2021  
 Page No : 5

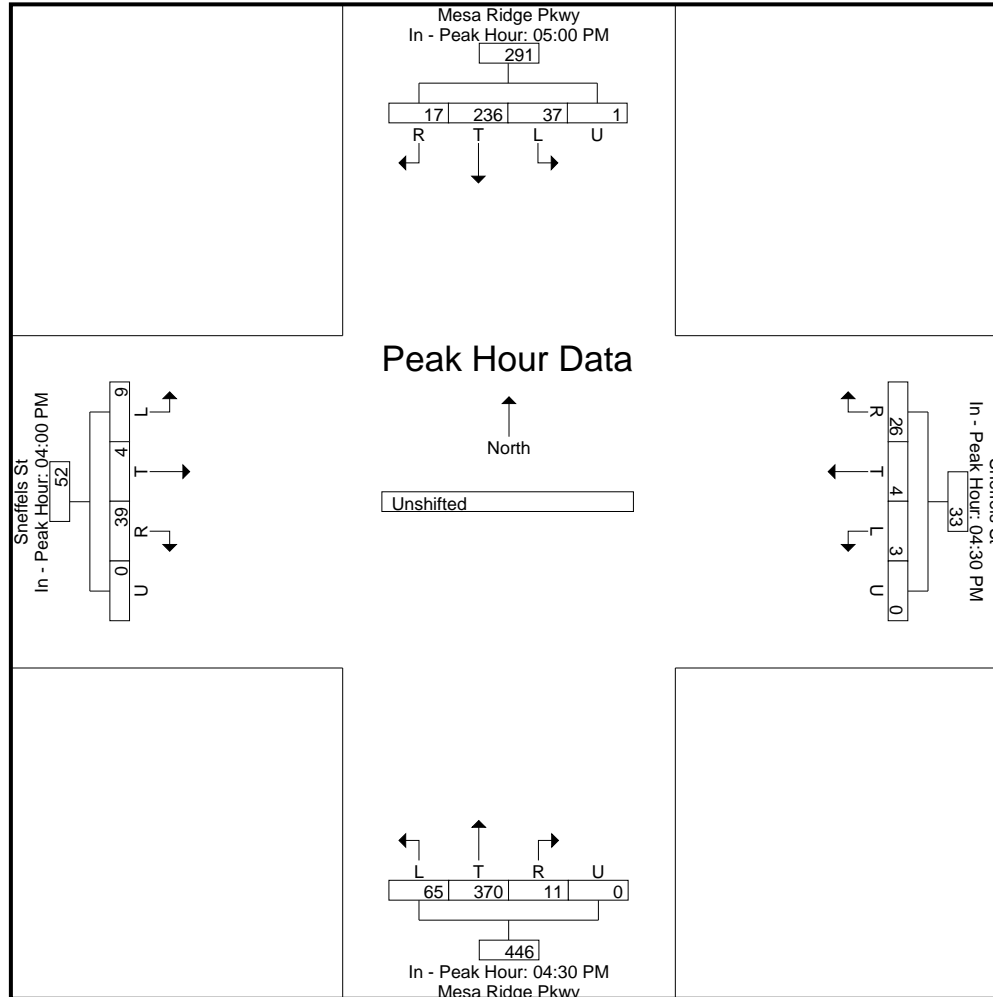

# LSC Transportation Consultants, Inc.

2504 E Pikes Peak Ave, Suite 304  
 Colorado Springs, CO 80909  
 719-633-2868

File Name : Landover Ln - Sneffels St AM  
 Site Code : S214580  
 Start Date : 7/8/2021  
 Page No : 1

### Groups Printed- Bank 1

Start Time	Landover Ln Southbound					Sneffels St Westbound					Landover Ln Northbound					Sneffels St Eastbound					Int. Total	
	L	T	R	U	App. Total	L	T	R	U	App. Total	L	T	R	U	App. Total	L	T	R	U	App. Total		
06:30 AM	3	0	0	0	3	0	0	1	0	1	0	0	1	0	1	0	0	0	0	0	0	5
06:45 AM	8	0	0	0	8	0	0	5	0	5	0	0	2	0	2	0	0	0	0	0	0	15
Total	11	0	0	0	11	0	0	6	0	6	0	0	3	0	3	0	0	0	0	0	0	20
07:00 AM	6	0	0	0	6	0	0	3	0	3	0	0	0	0	0	0	0	0	0	0	0	9
07:15 AM	7	0	0	0	7	3	0	6	0	9	1	0	1	0	2	0	0	0	0	0	0	18
07:30 AM	7	0	0	0	7	1	0	14	0	15	1	0	0	0	1	0	0	0	0	0	0	23
07:45 AM	13	0	0	0	13	1	0	7	0	8	1	0	0	0	1	0	0	1	0	1	1	23
Total	33	0	0	0	33	5	0	30	0	35	3	0	1	0	4	0	0	1	0	1	1	73
08:00 AM	17	0	0	0	17	0	0	6	0	6	0	0	1	0	1	0	0	0	0	0	0	24
08:15 AM	16	0	0	0	16	2	0	7	0	9	1	0	3	0	4	0	0	0	0	0	0	29
Grand Total	77	0	0	0	77	7	0	49	0	56	4	0	8	0	12	0	0	1	0	1	1	146
Apprch %	100	0	0	0		12.5	0	87.5	0		33.3	0	66.7	0		0	0	100	0			
Total %	52.7	0	0	0	52.7	4.8	0	33.6	0	38.4	2.7	0	5.5	0	8.2	0	0	0.7	0	0.7		



# LSC Transportation Consultants, Inc.

2504 E Pikes Peak Ave, Suite 304  
 Colorado Springs, CO 80909  
 719-633-2868

File Name : Landover Ln - Sneffels St AM  
 Site Code : S214580  
 Start Date : 7/8/2021  
 Page No : 2

Start Time	Landover Ln Southbound					Sneffels St Westbound					Landover Ln Northbound					Sneffels St Eastbound					Int. Total
	L	T	R	U	App. Total	L	T	R	U	App. Total	L	T	R	U	App. Total	L	T	R	U	App. Total	
<b>Peak Hour Analysis From 6:30:00 AM to 8:15:00 AM - Peak 1 of 1</b>																					
Peak Hour for Entire Intersection Begins at 7:30:00 AM																					
7:30:00 AM	7	0	0	0	7	1	0	14	0	15	1	0	0	0	1	0	0	0	0	0	23
7:45:00 AM	13	0	0	0	13	1	0	7	0	8	1	0	0	0	1	0	0	1	0	1	23
8:00:00 AM	17	0	0	0	17	0	0	6	0	6	0	0	1	0	1	0	0	0	0	0	24
8:15:00 AM	16	0	0	0	16	2	0	7	0	9	1	0	3	0	4	0	0	0	0	0	29
Total Volume	53	0	0	0	53	4	0	34	0	38	3	0	4	0	7	0	0	1	0	1	99
% App. Total	100	0	0	0		10.5	0	89.5	0		42.9	0	57.1	0		0	0	100	0		
PHF	.779	.000	.000	.000	.779	.500	.000	.607	.000	.633	.750	.000	.333	.000	.438	.000	.000	.250	.000	.250	.853

# LSC Transportation Consultants, Inc.

2504 E Pikes Peak Ave, Suite 304  
 Colorado Springs, CO 80909  
 719-633-2868

File Name : Landover Ln - Sneffels St AM  
 Site Code : S214580  
 Start Date : 7/8/2021  
 Page No : 3

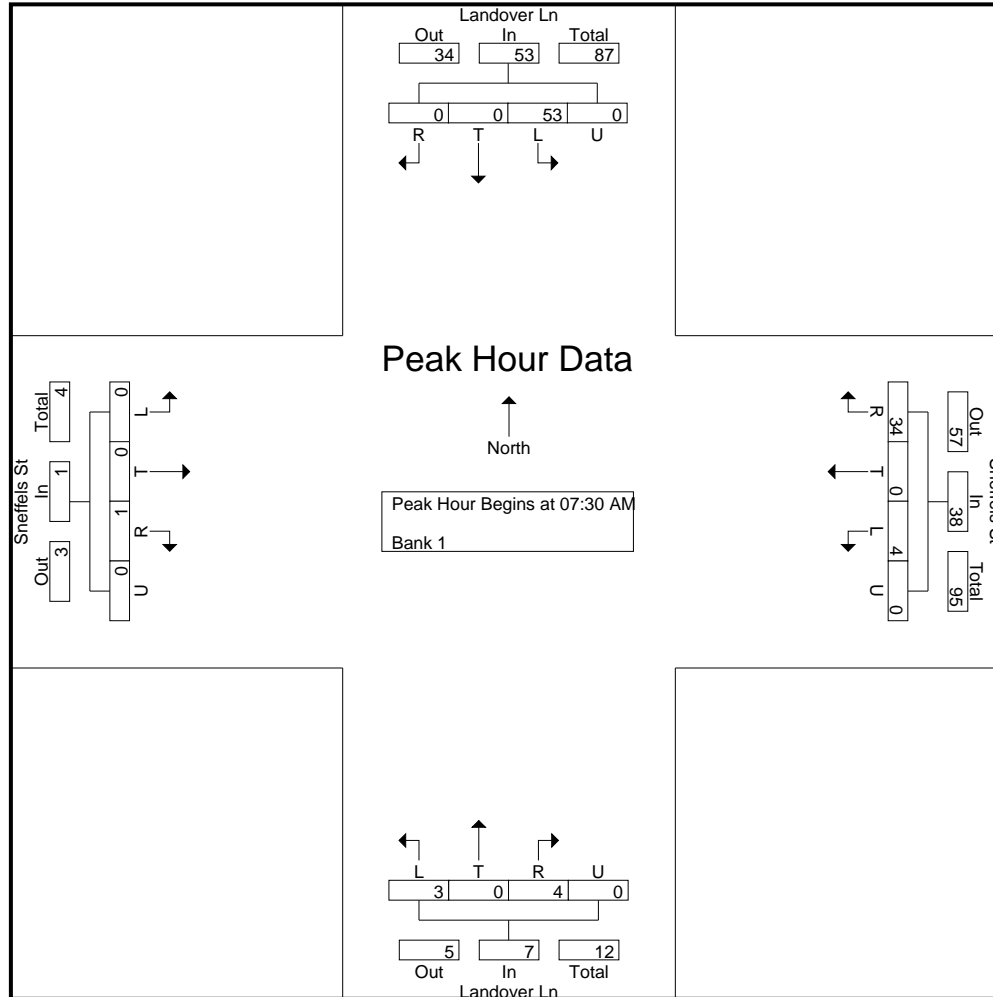

# LSC Transportation Consultants, Inc.

2504 E Pikes Peak Ave, Suite 304  
 Colorado Springs, CO 80909  
 719-633-2868

File Name : Landover Ln - Sneffels St AM  
 Site Code : S214580  
 Start Date : 7/8/2021  
 Page No : 4

Start Time	Landover Ln Southbound					Sneffels St Westbound					Landover Ln Northbound					Sneffels St Eastbound					Int. Total
	L	T	R	U	App. Total	L	T	R	U	App. Total	L	T	R	U	App. Total	L	T	R	U	App. Total	
<b>Peak Hour Analysis From 6:30:00 AM to 8:15:00 AM - Peak 1 of 1</b>																					
Peak Hour for Each Approach Begins at:																					
	7:30:00 AM					7:15:00 AM					7:30:00 AM					7:00:00 AM					
+0 mins.	7	0	0	0	7	3	0	6	0	9	1	0	0	0	1	0	0	0	0	0	
+5 mins.	13	0	0	0	13	1	0	14	0	15	1	0	0	0	1	0	0	0	0	0	
+10 mins.	17	0	0	0	17	1	0	7	0	8	0	0	1	0	1	0	0	0	0	0	
+15 mins.	16	0	0	0	16	0	0	6	0	6	1	0	3	0	4	0	0	1	0	1	
Total Volume	53	0	0	0	53	5	0	33	0	38	3	0	4	0	7	0	0	1	0	1	
% App. Total	100	0	0	0		13.2	0	86.8	0		42.9	0	57.1	0		0	0	100	0		
PHF	.779	.000	.000	.000	.779	.417	.000	.589	.000	.633	.750	.000	.333	.000	.438	.000	.000	.250	.000	.250	

# LSC Transportation Consultants, Inc.

2504 E Pikes Peak Ave, Suite 304  
Colorado Springs, CO 80909  
719-633-2868

File Name : Landover Ln - Sneffels St AM  
Site Code : S214580  
Start Date : 7/8/2021  
Page No : 5

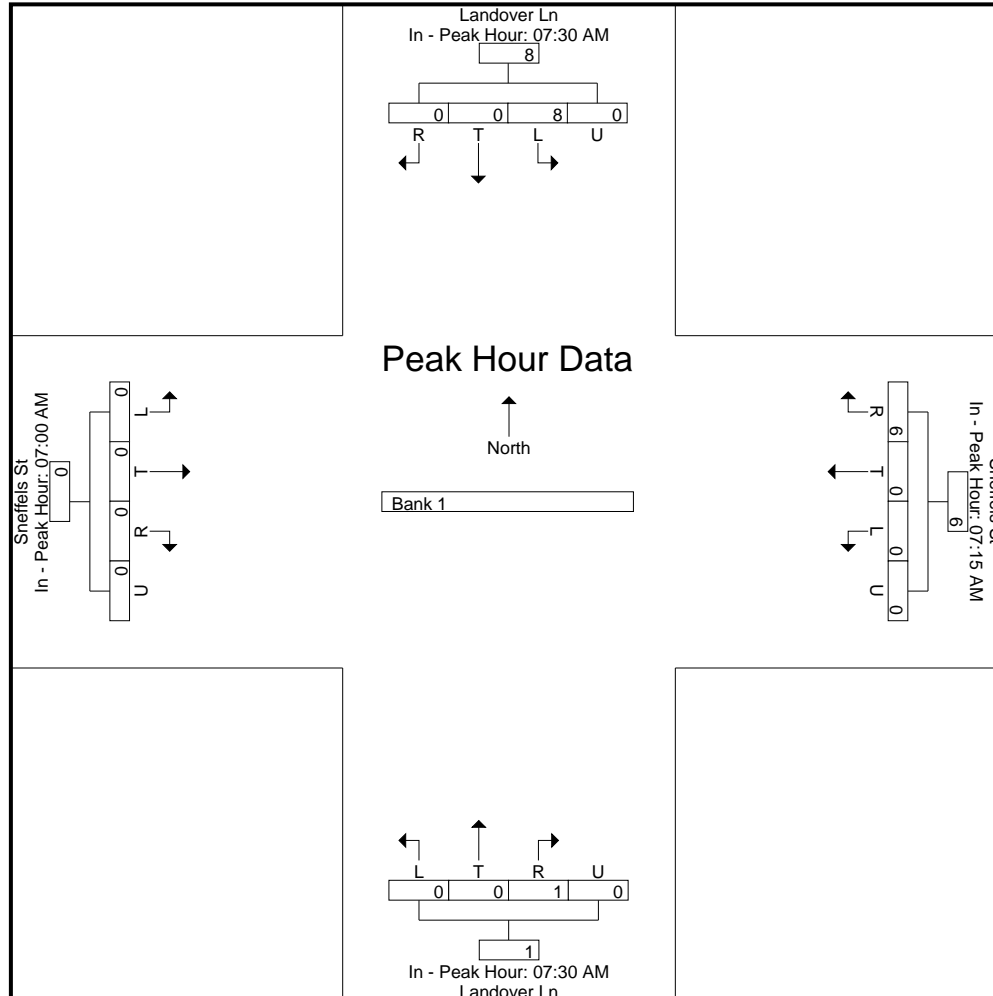

# LSC Transportation Consultants, Inc.

2504 E Pikes Peak Ave, Suite 304  
 Colorado Springs, CO 80909  
 719-633-2868

File Name : Landover Ln - Sneffels St PM  
 Site Code : S214580  
 Start Date : 7/15/2021  
 Page No : 1

## Groups Printed- Bank 1

Start Time	Landover Ln Southbound					Sneffels St Westbound					Landover Ln Northbound					Sneffels St Eastbound					Int. Total
	L	T	R	U	App. Total	L	T	R	U	App. Total	L	T	R	U	App. Total	L	T	R	U	App. Total	
04:00 PM	9	0	0	0	9	3	0	10	0	13	0	0	2	0	2	0	0	0	0	0	24
04:15 PM	6	0	0	0	6	0	0	14	0	14	1	0	0	0	1	0	0	0	0	0	21
04:30 PM	6	0	1	0	7	3	0	10	0	13	0	0	1	0	1	0	0	1	0	1	22
04:45 PM	9	0	1	0	10	2	0	16	0	18	0	0	2	0	2	0	0	0	0	0	30
Total	30	0	2	0	32	8	0	50	0	58	1	0	5	0	6	0	0	1	0	1	97
05:00 PM	5	0	0	0	5	2	0	14	0	16	0	0	0	0	0	0	0	1	0	1	22
05:15 PM	6	0	0	0	6	1	0	16	0	17	0	0	2	0	2	0	0	1	0	1	26
05:30 PM	7	0	0	0	7	1	0	17	0	18	0	0	0	0	0	0	0	0	0	0	25
05:45 PM	5	0	0	0	5	1	0	8	0	9	1	0	0	0	1	1	0	0	0	1	16
Total	23	0	0	0	23	5	0	55	0	60	1	0	2	0	3	1	0	2	0	3	89
Grand Total	53	0	2	0	55	13	0	105	0	118	2	0	7	0	9	1	0	3	0	4	186
Apprch %	96.4	0	3.6	0		11	0	89	0		22.2	0	77.8	0		25	0	75	0		
Total %	28.5	0	1.1	0	29.6	7	0	56.5	0	63.4	1.1	0	3.8	0	4.8	0.5	0	1.6	0	2.2	

# LSC Transportation Consultants, Inc.

2504 E Pikes Peak Ave, Suite 304  
 Colorado Springs, CO 80909  
 719-633-2868

File Name : Landover Ln - Sneffels St PM  
 Site Code : S214580  
 Start Date : 7/15/2021  
 Page No : 2

Start Time	Landover Ln Southbound					Sneffels St Westbound					Landover Ln Northbound					Sneffels St Eastbound					Int. Total
	L	T	R	U	App. Total	L	T	R	U	App. Total	L	T	R	U	App. Total	L	T	R	U	App. Total	
<b>Peak Hour Analysis From 4:00:00 PM to 5:45:00 PM - Peak 1 of 1</b>																					
Peak Hour for Entire Intersection Begins at 4:45:00 PM																					
4:45:00 PM	9	0	1	0	10	2	0	16	0	18	0	0	2	0	2	0	0	0	0	0	30
5:00:00 PM	5	0	0	0	5	2	0	14	0	16	0	0	0	0	0	0	0	1	0	1	22
5:15:00 PM	6	0	0	0	6	1	0	16	0	17	0	0	2	0	2	0	0	1	0	1	26
5:30:00 PM	7	0	0	0	7	1	0	17	0	18	0	0	0	0	0	0	0	0	0	0	25
Total Volume	27	0	1	0	28	6	0	63	0	69	0	0	4	0	4	0	0	2	0	2	103
% App. Total	96.4	0	3.6	0		8.7	0	91.3	0		0	0	100	0		0	0	100	0		
PHF	.750	.000	.250	.000	.700	.750	.000	.926	.000	.958	.000	.000	.500	.000	.500	.000	.000	.500	.000	.500	.858

# LSC Transportation Consultants, Inc.

2504 E Pikes Peak Ave, Suite 304  
 Colorado Springs, CO 80909  
 719-633-2868

File Name : Landover Ln - Sneffels St PM  
 Site Code : S214580  
 Start Date : 7/15/2021  
 Page No : 3

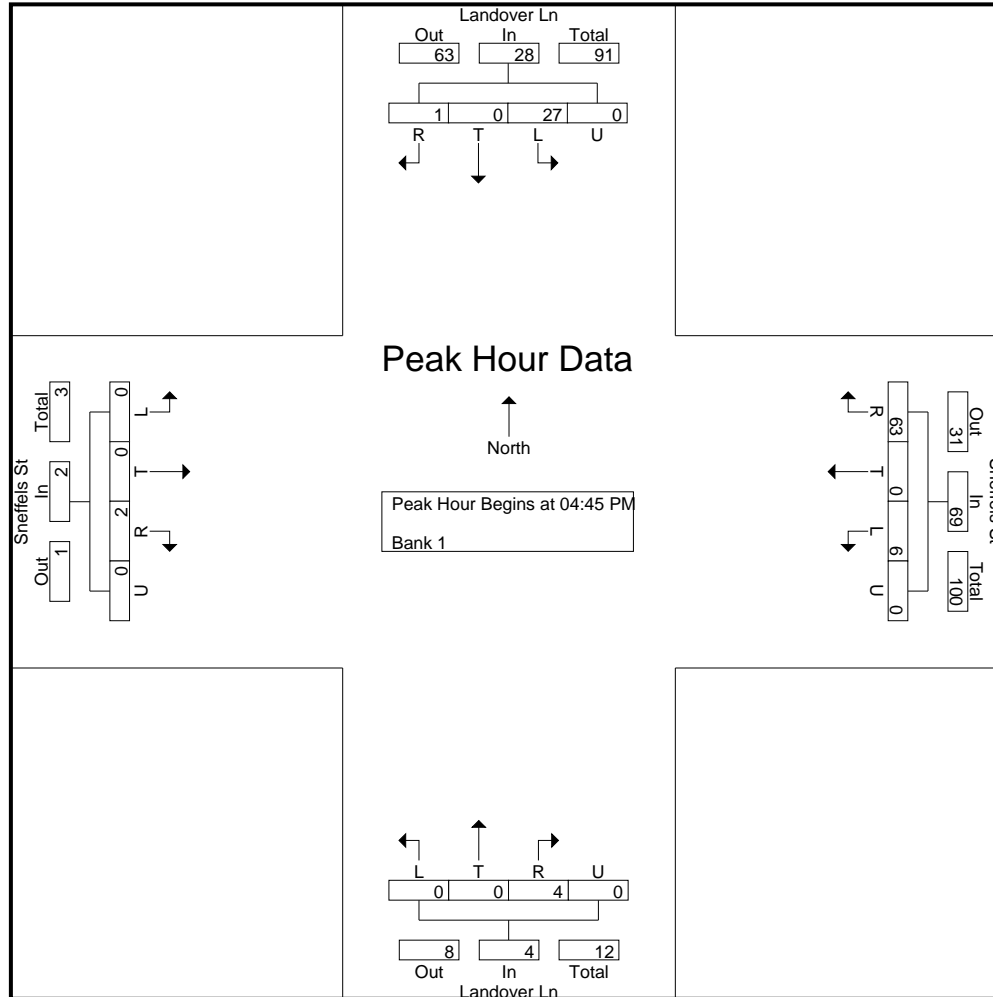

# LSC Transportation Consultants, Inc.

2504 E Pikes Peak Ave, Suite 304  
 Colorado Springs, CO 80909  
 719-633-2868

File Name : Landover Ln - Sneffels St PM  
 Site Code : S214580  
 Start Date : 7/15/2021  
 Page No : 4

Start Time	Landover Ln Southbound					Sneffels St Westbound					Landover Ln Northbound					Sneffels St Eastbound					Int. Total
	L	T	R	U	App. Total	L	T	R	U	App. Total	L	T	R	U	App. Total	L	T	R	U	App. Total	

**Peak Hour Analysis From 4:00:00 PM to 5:45:00 PM - Peak 1 of 1**

Peak Hour for Each Approach Begins at:

	4:00:00 PM					4:45:00 PM					4:00:00 PM					4:30:00 PM				
+0 mins.	9	0	0	0	9	2	0	16	0	18	0	0	2	0	2	0	0	1	0	1
+5 mins.	6	0	0	0	6	2	0	14	0	16	1	0	0	0	1	0	0	0	0	0
+10 mins.	6	0	1	0	7	1	0	16	0	17	0	0	1	0	1	0	0	1	0	1
+15 mins.	9	0	1	0	10	1	0	17	0	18	0	0	2	0	2	0	0	1	0	1
Total Volume	30	0	2	0	32	6	0	63	0	69	1	0	5	0	6	0	0	3	0	3
% App. Total	93.8	0	6.2	0		8.7	0	91.3	0		16.7	0	83.3	0		0	0	100	0	
PHF	.833	.000	.500	.000	.800	.750	.000	.926	.000	.958	.250	.000	.625	.000	.750	.000	.000	.750	.000	.750



# LSC Transportation Consultants, Inc.

2504 E Pikes Peak Ave, Suite 304  
 Colorado Springs, CO 80909  
 719-633-2868

File Name : Landover Ln - Sneffels St PM  
 Site Code : S214580  
 Start Date : 7/15/2021  
 Page No : 5

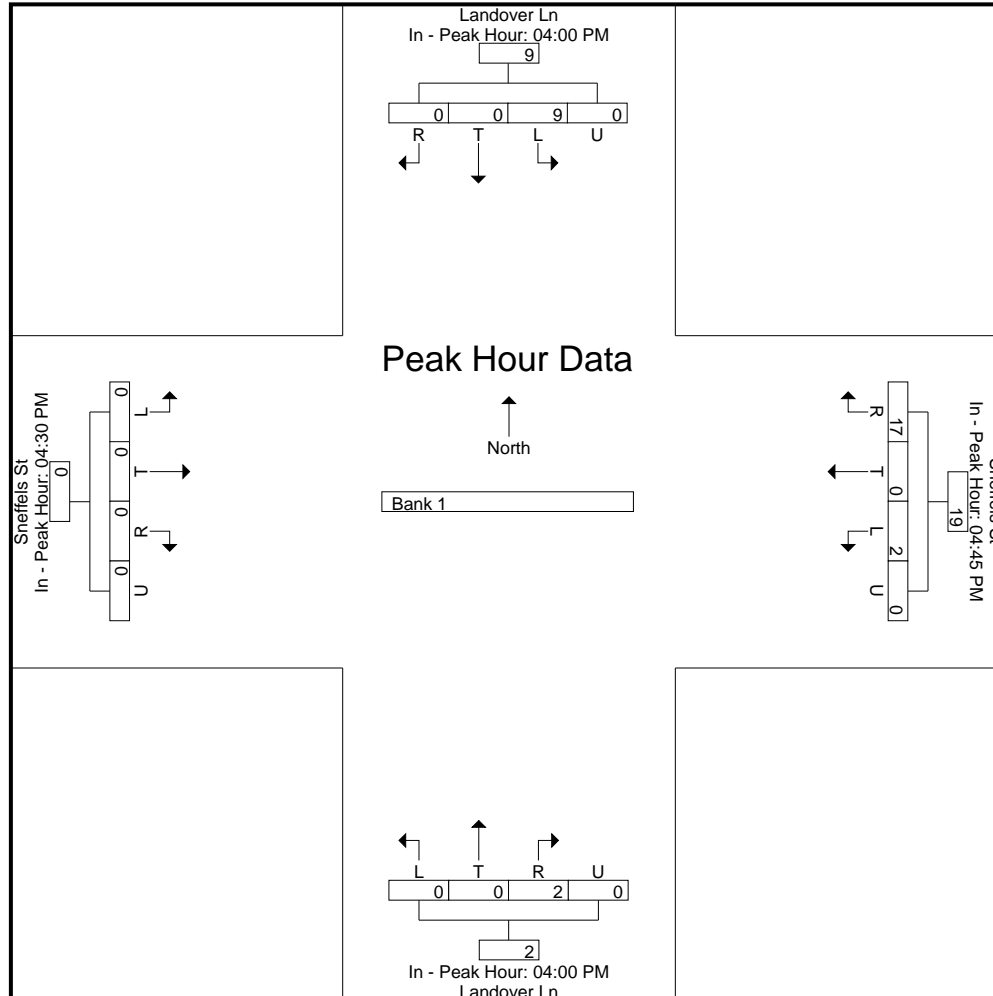

# LSC Transportation Consultants, Inc.

2504 E Pikes Peak Ave, Suite 304  
 Colorado Springs, CO 80909  
 719-633-2868

File Name : Pinefeather Dr - Sneffels St AM  
 Site Code : S214580  
 Start Date : 7/8/2021  
 Page No : 1

### Groups Printed- Unshifted

Start Time	Pinefeather Dr Southbound					Sneffels St Westbound					Pinefeather Dr Northbound					Sneffels St Eastbound					Int. Total
	L	T	R	U	App. Total	L	T	R	U	App. Total	L	T	R	U	App. Total	L	T	R	U	App. Total	
06:30 AM	6	0	0	0	6	0	3	4	0	7	0	0	5	0	5	0	34	1	0	35	53
06:45 AM	9	0	0	0	9	0	6	5	0	11	0	0	5	0	5	0	25	0	0	25	50
Total	15	0	0	0	15	0	9	9	0	18	0	0	10	0	10	0	59	1	0	60	103
07:00 AM	10	0	1	0	11	2	7	5	0	14	0	0	1	0	1	0	32	0	0	32	58
07:15 AM	8	0	0	0	8	1	11	3	0	15	0	0	1	0	1	0	34	0	0	34	58
07:30 AM	8	0	0	0	8	2	6	6	0	14	0	0	3	0	3	1	37	0	0	38	63
07:45 AM	8	0	1	0	9	4	10	4	0	18	0	0	2	0	2	0	26	0	0	26	55
Total	34	0	2	0	36	9	34	18	0	61	0	0	7	0	7	1	129	0	0	130	234
08:00 AM	7	0	0	0	7	1	10	8	0	19	0	0	4	0	4	0	22	0	0	22	52
08:15 AM	10	0	1	0	11	1	13	1	0	15	0	0	3	0	3	1	38	0	0	39	68
Grand Total	66	0	3	0	69	11	66	36	0	113	0	0	24	0	24	2	248	1	0	251	457
Apprch %	95.7	0	4.3	0		9.7	58.4	31.9	0		0	0	100	0		0.8	98.8	0.4	0		
Total %	14.4	0	0.7	0	15.1	2.4	14.4	7.9	0	24.7	0	0	5.3	0	5.3	0.4	54.3	0.2	0	54.9	

# LSC Transportation Consultants, Inc.

2504 E Pikes Peak Ave, Suite 304  
 Colorado Springs, CO 80909  
 719-633-2868

File Name : Pinefeather Dr - Sneffels St AM  
 Site Code : S214580  
 Start Date : 7/8/2021  
 Page No : 2

Start Time	Pinefeather Dr Southbound					Sneffels St Westbound					Pinefeather Dr Northbound					Sneffels St Eastbound					Int. Total
	L	T	R	U	App. Total	L	T	R	U	App. Total	L	T	R	U	App. Total	L	T	R	U	App. Total	
<b>Peak Hour Analysis From 6:30:00 AM to 8:15:00 AM - Peak 1 of 1</b>																					
Peak Hour for Entire Intersection Begins at 7:30:00 AM																					
7:30:00 AM	8	0	0	0	8	2	6	6	0	14	0	0	3	0	3	1	37	0	0	38	63
7:45:00 AM	8	0	1	0	9	4	10	4	0	18	0	0	2	0	2	0	26	0	0	26	55
8:00:00 AM	7	0	0	0	7	1	10	8	0	19	0	0	4	0	4	0	22	0	0	22	52
8:15:00 AM	10	0	1	0	11	1	13	1	0	15	0	0	3	0	3	1	38	0	0	39	68
Total Volume	33	0	2	0	35	8	39	19	0	66	0	0	12	0	12	2	123	0	0	125	238
% App. Total	94.3	0	5.7	0		12.1	59.1	28.8	0		0	0	100	0		1.6	98.4	0	0		
PHF	.825	.000	.500	.000	.795	.500	.750	.594	.000	.868	.000	.000	.750	.000	.750	.500	.809	.000	.000	.801	.875

# LSC Transportation Consultants, Inc.

2504 E Pikes Peak Ave, Suite 304  
 Colorado Springs, CO 80909  
 719-633-2868

File Name : Pinefeather Dr - Sneffels St AM  
 Site Code : S214580  
 Start Date : 7/8/2021  
 Page No : 3

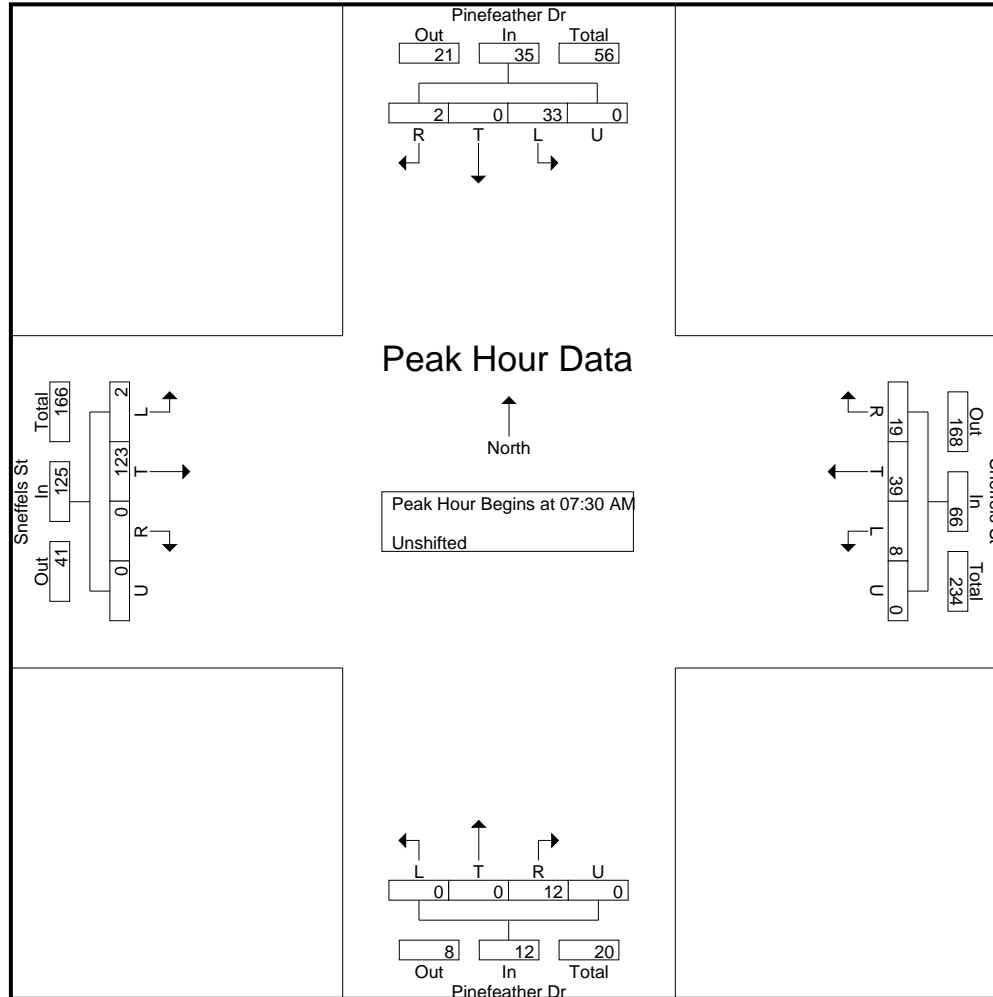

# LSC Transportation Consultants, Inc.

2504 E Pikes Peak Ave, Suite 304  
 Colorado Springs, CO 80909  
 719-633-2868

File Name : Pinefeather Dr - Sneffels St AM  
 Site Code : S214580  
 Start Date : 7/8/2021  
 Page No : 4

Start Time	Pinefeather Dr Southbound					Sneffels St Westbound					Pinefeather Dr Northbound					Sneffels St Eastbound					Int. Total
	L	T	R	U	App. Total	L	T	R	U	App. Total	L	T	R	U	App. Total	L	T	R	U	App. Total	

**Peak Hour Analysis From 6:30:00 AM to 8:15:00 AM - Peak 1 of 1**

Peak Hour for Each Approach Begins at:

	6:45:00 AM					7:15:00 AM					6:30:00 AM					7:00:00 AM				
+0 mins.	9	0	0	0	9	1	<b>11</b>	3	0	15	0	0	<b>5</b>	0	<b>5</b>	0	32	0	0	32
+5 mins.	<b>10</b>	0	<b>1</b>	0	<b>11</b>	2	6	6	0	14	0	0	5	0	5	0	34	0	0	34
+10 mins.	8	0	0	0	8	<b>4</b>	10	4	0	18	0	0	1	0	1	<b>1</b>	<b>37</b>	0	0	<b>38</b>
+15 mins.	8	0	0	0	8	1	10	<b>8</b>	0	<b>19</b>	0	0	1	0	1	0	26	0	0	26
Total Volume	35	0	1	0	36	8	37	21	0	66	0	0	12	0	12	1	129	0	0	130
% App. Total	97.2	0	2.8	0		12.1	56.1	31.8	0		0	0	100	0		0.8	99.2	0	0	
PHF	.875	.000	.250	.000	.818	.500	.841	.656	.000	.868	.000	.000	.600	.000	.600	.250	.872	.000	.000	.855

# LSC Transportation Consultants, Inc.

2504 E Pikes Peak Ave, Suite 304  
 Colorado Springs, CO 80909  
 719-633-2868

File Name : Pinefeather Dr - Sneffels St AM  
 Site Code : S214580  
 Start Date : 7/8/2021  
 Page No : 5

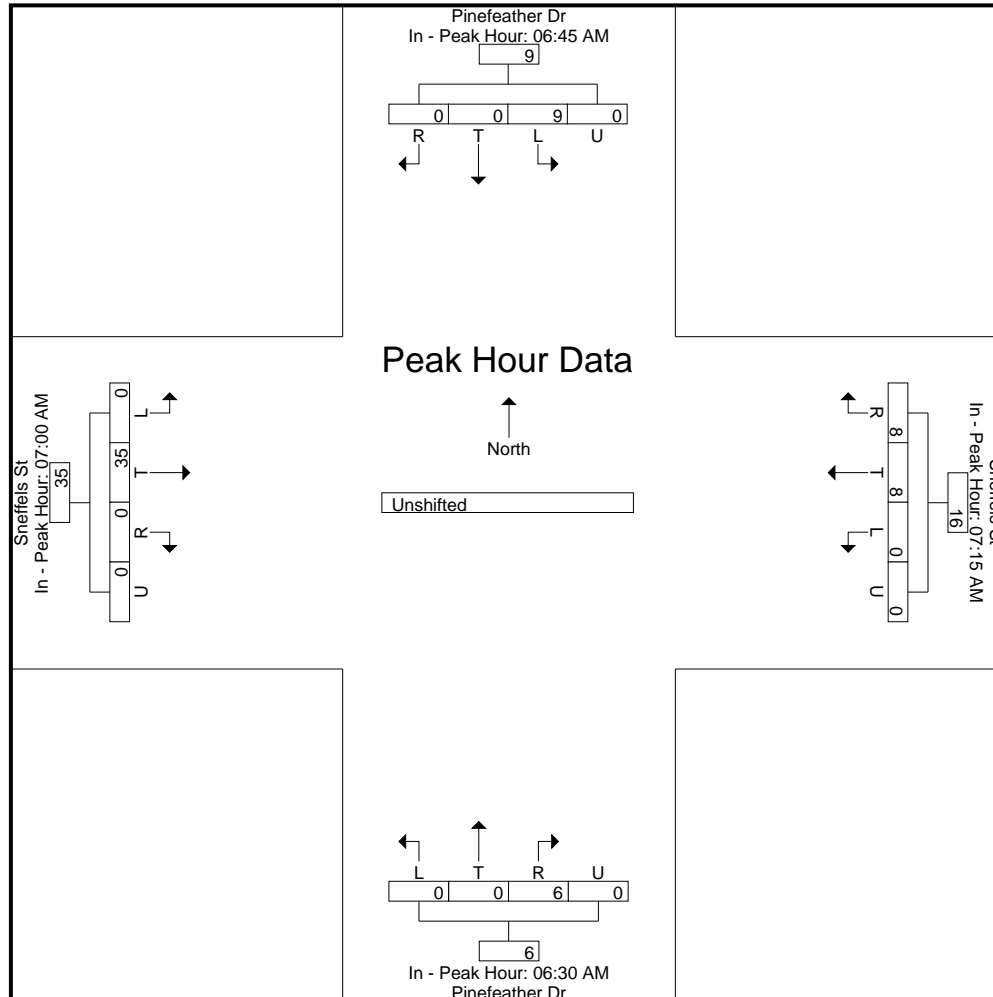

# LSC Transportation Consultants, Inc.

2504 E Pikes Peak Ave, Suite 304  
 Colorado Springs, CO 80909  
 719-633-2868

File Name : Pinefeather Dr - Sneffels St PM  
 Site Code : S214580  
 Start Date : 7/15/2021  
 Page No : 1

## Groups Printed- Unshifted

Start Time	Pinefeather Dr Southbound					Pinefeather Dr Westbound					Landover Ln Northbound					Pinefeather Dr Eastbound					Int. Total
	L	T	R	U	App. Total	L	T	R	U	App. Total	L	T	R	U	App. Total	L	T	R	U	App. Total	
04:00 PM	7	0	0	0	7	2	31	9	0	42	1	0	2	0	3	0	18	0	0	18	70
04:15 PM	12	0	0	0	12	1	38	13	0	52	1	0	3	0	4	3	19	0	0	22	90
04:30 PM	8	0	2	0	10	2	43	11	0	56	0	0	2	0	2	2	24	1	0	27	95
04:45 PM	9	0	1	0	10	6	39	13	0	58	0	0	2	0	2	1	32	0	0	33	103
Total	36	0	3	0	39	11	151	46	0	208	2	0	9	0	11	6	93	1	0	100	358
05:00 PM	5	0	0	0	5	0	44	13	0	57	0	0	5	0	5	2	30	1	0	33	100
05:15 PM	9	0	0	0	9	3	49	11	0	63	1	0	1	0	2	1	22	1	0	24	98
05:30 PM	12	0	0	0	12	6	52	10	0	68	0	0	3	0	3	1	41	0	0	42	125
05:45 PM	11	0	1	0	12	4	41	10	0	55	0	0	2	0	2	1	23	0	0	24	93
Total	37	0	1	0	38	13	186	44	0	243	1	0	11	0	12	5	116	2	0	123	416
Grand Total	73	0	4	0	77	24	337	90	0	451	3	0	20	0	23	11	209	3	0	223	774
Apprch %	94.8	0	5.2	0		5.3	74.7	20	0		13	0	87	0		4.9	93.7	1.3	0		
Total %	9.4	0	0.5	0	9.9	3.1	43.5	11.6	0	58.3	0.4	0	2.6	0	3	1.4	27	0.4	0	28.8	

# LSC Transportation Consultants, Inc.

2504 E Pikes Peak Ave, Suite 304  
 Colorado Springs, CO 80909  
 719-633-2868

File Name : Pinefeather Dr - Sneffels St PM  
 Site Code : S214580  
 Start Date : 7/15/2021  
 Page No : 2

Start Time	Pinefeather Dr Southbound					Pinefeather Dr Westbound					Landover Ln Northbound					Pinefeather Dr Eastbound					Int. Total
	L	T	R	U	App. Total	L	T	R	U	App. Total	L	T	R	U	App. Total	L	T	R	U	App. Total	
<b>Peak Hour Analysis From 4:00:00 PM to 5:45:00 PM - Peak 1 of 1</b>																					
Peak Hour for Entire Intersection Begins at 4:45:00 PM																					
4:45:00 PM	9	0	1	0	10	6	39	13	0	58	0	0	2	0	2	1	32	0	0	33	103
5:00:00 PM	5	0	0	0	5	0	44	13	0	57	0	0	5	0	5	2	30	1	0	33	100
5:15:00 PM	9	0	0	0	9	3	49	11	0	63	1	0	1	0	2	1	22	1	0	24	98
5:30:00 PM	12	0	0	0	12	6	52	10	0	68	0	0	3	0	3	1	41	0	0	42	125
Total Volume	35	0	1	0	36	15	184	47	0	246	1	0	11	0	12	5	125	2	0	132	426
% App. Total	97.2	0	2.8	0		6.1	74.8	19.1	0		8.3	0	91.7	0		3.8	94.7	1.5	0		
PHF	.729	.000	.250	.000	.750	.625	.885	.904	.000	.904	.250	.000	.550	.000	.600	.625	.762	.500	.000	.786	.852



# LSC Transportation Consultants, Inc.

2504 E Pikes Peak Ave, Suite 304  
 Colorado Springs, CO 80909  
 719-633-2868

File Name : Pinefeather Dr - Sneffels St PM  
 Site Code : S214580  
 Start Date : 7/15/2021  
 Page No : 3

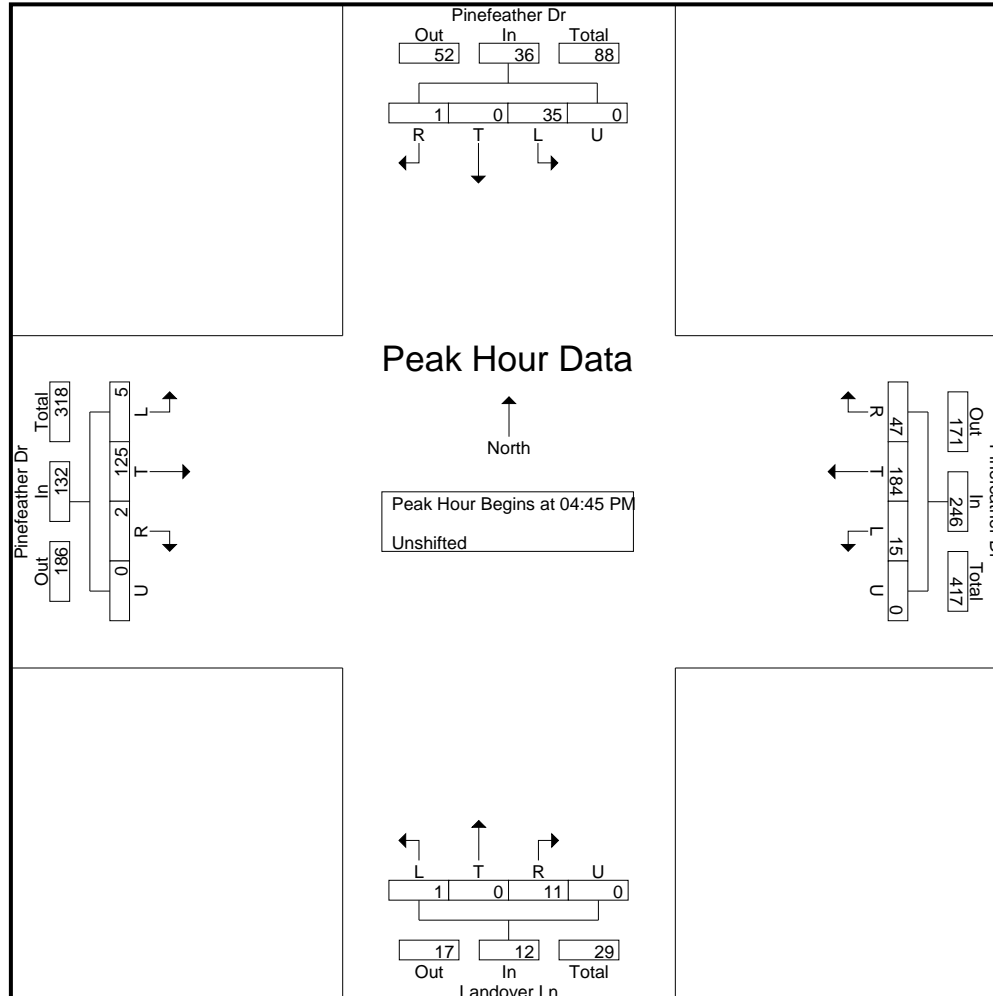

# LSC Transportation Consultants, Inc.

2504 E Pikes Peak Ave, Suite 304  
 Colorado Springs, CO 80909  
 719-633-2868

File Name : Pinefeather Dr - Sneffels St PM  
 Site Code : S214580  
 Start Date : 7/15/2021  
 Page No : 4

Start Time	Pinefeather Dr Southbound					Pinefeather Dr Westbound					Landover Ln Northbound					Pinefeather Dr Eastbound					Int. Total
	L	T	R	U	App. Total	L	T	R	U	App. Total	L	T	R	U	App. Total	L	T	R	U	App. Total	
<b>Peak Hour Analysis From 4:00:00 PM to 5:45:00 PM - Peak 1 of 1</b>																					
Peak Hour for Each Approach Begins at:																					
	4:00:00 PM					4:45:00 PM					4:15:00 PM					4:45:00 PM					
+0 mins.	7	0	0	0	7	6	39	13	0	58	1	0	3	0	4	1	32	0	0	33	
+5 mins.	12	0	0	0	12	0	44	13	0	57	0	0	2	0	2	2	30	1	0	33	
+10 mins.	8	0	2	0	10	3	49	11	0	63	0	0	2	0	2	1	22	1	0	24	
+15 mins.	9	0	1	0	10	6	52	10	0	68	0	0	5	0	5	1	41	0	0	42	
Total Volume	36	0	3	0	39	15	184	47	0	246	1	0	12	0	13	5	125	2	0	132	
% App. Total	92.3	0	7.7	0		6.1	74.8	19.1	0		7.7	0	92.3	0		3.8	94.7	1.5	0		
PHF	.750	.000	.375	.000	.813	.625	.885	.904	.000	.904	.250	.000	.600	.000	.650	.625	.762	.500	.000	.786	

# LSC Transportation Consultants, Inc.

2504 E Pikes Peak Ave, Suite 304  
 Colorado Springs, CO 80909  
 719-633-2868

File Name : Pinefeather Dr - Sneffels St PM  
 Site Code : S214580  
 Start Date : 7/15/2021  
 Page No : 5

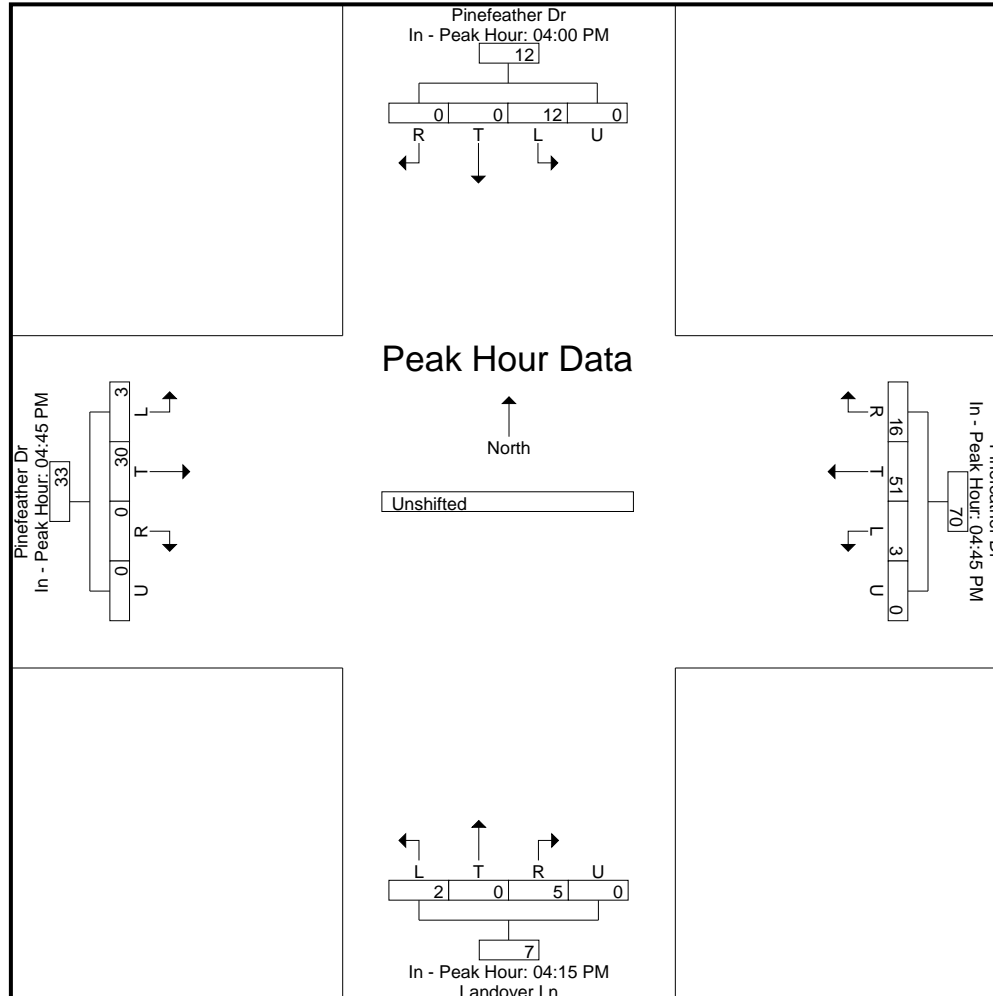

# Queuing Reports

---



Intersection: 1: Sneffels St & Mesa Ridge Pkwy, Interval #1

Movement	EB	EB	EB	EB	WB	WB	WB	WB	SE	SE	SE	NW		
Directions Served	L	T	T	R	L	T	T	R	L	T	R	L		
Maximum Queue (ft)	111	121	88	17	55	183	145	3	63	38	63	66		
Average Queue (ft)	68	59	39	6	20	114	80	0	43	13	34	40		
95th Queue (ft)	121	120	88	18	55	194	156	4	74	41	66	74		
Link Distance (ft)											363			
Upstream Blk Time (%)														
Queuing Penalty (veh)														
Storage Bay Dist (ft)	325				315	510			225	160			160	315
Storage Blk Time (%)														
Queuing Penalty (veh)														

Intersection: 1: Sneffels St & Mesa Ridge Pkwy, Interval #1

Movement	NW	NW
Directions Served	T	R
Maximum Queue (ft)	25	105
Average Queue (ft)	10	70
95th Queue (ft)	29	113
Link Distance (ft)		
Upstream Blk Time (%)		
Queuing Penalty (veh)		
Storage Bay Dist (ft)		
Storage Blk Time (%)		
Queuing Penalty (veh)		

Intersection: 1: Sneffels St & Mesa Ridge Pkwy, Interval #2

Movement	EB	EB	EB	EB	WB	WB	WB	WB	SE	SE	SE	NW		
Directions Served	L	T	T	R	L	T	T	R	L	T	R	L		
Maximum Queue (ft)	124	130	94	11	41	201	179	12	81	41	59	81		
Average Queue (ft)	72	72	45	4	17	127	87	2	41	12	39	49		
95th Queue (ft)	124	144	100	13	47	212	179	16	79	40	62	87		
Link Distance (ft)											363			
Upstream Blk Time (%)														
Queuing Penalty (veh)														
Storage Bay Dist (ft)	325				315	510			225	160			160	315
Storage Blk Time (%)														
Queuing Penalty (veh)														

Intersection: 1: Sneffels St & Mesa Ridge Pkwy, Interval #2

Movement	NW	NW
Directions Served	T	R
Maximum Queue (ft)	32	113
Average Queue (ft)	16	73
95th Queue (ft)	38	122
Link Distance (ft)		
Upstream Blk Time (%)		
Queuing Penalty (veh)		
Storage Bay Dist (ft)		
Storage Blk Time (%)		
Queuing Penalty (veh)		

Intersection: 1: Sneffels St & Mesa Ridge Pkwy, Interval #3

Movement	EB	EB	EB	EB	WB	WB	WB	WB	SE	SE	SE	NW	
Directions Served	L	T	T	R	L	T	T	R	L	T	R	L	
Maximum Queue (ft)	122	128	86	15	35	172	134	11	67	32	60	74	
Average Queue (ft)	78	60	33	4	13	115	75	2	36	12	31	38	
95th Queue (ft)	125	126	73	14	32	184	141	15	81	36	56	73	
Link Distance (ft)											363		
Upstream Blk Time (%)													
Queuing Penalty (veh)													
Storage Bay Dist (ft)	325			315		510		225		160		160	315
Storage Blk Time (%)											0		
Queuing Penalty (veh)											0		

Intersection: 1: Sneffels St & Mesa Ridge Pkwy, Interval #3

Movement	NW	NW
Directions Served	T	R
Maximum Queue (ft)	36	112
Average Queue (ft)	13	66
95th Queue (ft)	39	117
Link Distance (ft)		
Upstream Blk Time (%)		
Queuing Penalty (veh)		
Storage Bay Dist (ft)		
Storage Blk Time (%)		
Queuing Penalty (veh)		

Intersection: 1: Sneffels St & Mesa Ridge Pkwy, Interval #4

Movement	EB	EB	EB	EB	WB	WB	WB	WB	SE	SE	SE	NW	
Directions Served	L	T	T	R	L	T	T	R	L	T	R	L	
Maximum Queue (ft)	110	102	70	11	52	194	158	4	72	31	54	86	
Average Queue (ft)	69	63	37	5	19	110	70	1	35	11	36	43	
95th Queue (ft)	116	109	76	12	50	199	151	5	77	34	62	82	
Link Distance (ft)											363		
Upstream Blk Time (%)													
Queuing Penalty (veh)													
Storage Bay Dist (ft)	325			315		510		225		160		160	315
Storage Blk Time (%)	0												
Queuing Penalty (veh)	0												

Intersection: 1: Sneffels St & Mesa Ridge Pkwy, Interval #4

Movement	NW	NW
Directions Served	T	R
Maximum Queue (ft)	32	106
Average Queue (ft)	13	62
95th Queue (ft)	38	109
Link Distance (ft)		
Upstream Blk Time (%)		
Queuing Penalty (veh)		
Storage Bay Dist (ft)		
Storage Blk Time (%)		
Queuing Penalty (veh)		



Intersection: 1: Sneffels St & Mesa Ridge Pkwy, All Intervals

Movement	EB	EB	EB	EB	WB	WB	WB	WB	SE	SE	SE	NW	
Directions Served	L	T	T	R	L	T	T	R	L	T	R	L	
Maximum Queue (ft)	140	152	103	22	63	225	188	22	107	49	70	102	
Average Queue (ft)	72	64	39	5	17	116	78	1	39	12	35	42	
95th Queue (ft)	122	126	85	15	47	198	158	11	79	38	62	80	
Link Distance (ft)											363		
Upstream Blk Time (%)													
Queuing Penalty (veh)													
Storage Bay Dist (ft)	325			315		510		225		160		160 315	
Storage Blk Time (%)	0												
Queuing Penalty (veh)	0												

Intersection: 1: Sneffels St & Mesa Ridge Pkwy, All Intervals

Movement	NW	NW
Directions Served	T	R
Maximum Queue (ft)	40	142
Average Queue (ft)	13	68
95th Queue (ft)	37	116
Link Distance (ft)		
Upstream Blk Time (%)		
Queuing Penalty (veh)		
Storage Bay Dist (ft)		
Storage Blk Time (%)		
Queuing Penalty (veh)		

Intersection: 2: Landover Ln & Sneffels St, Interval #1

Movement	NW	NE	SW
Directions Served	L	LTR	LTR
Maximum Queue (ft)	19	26	78
Average Queue (ft)	2	7	40
95th Queue (ft)	15	29	79
Link Distance (ft)		430	647
Upstream Blk Time (%)			
Queuing Penalty (veh)			
Storage Bay Dist (ft)	85		
Storage Blk Time (%)			
Queuing Penalty (veh)			

Intersection: 2: Landover Ln & Sneffels St, Interval #2

Movement	SE	NW	NE	SW
Directions Served	L	L	LTR	LTR
Maximum Queue (ft)	15	14	31	68
Average Queue (ft)	2	2	10	37
95th Queue (ft)	15	14	33	65
Link Distance (ft)			430	647
Upstream Blk Time (%)				
Queuing Penalty (veh)				
Storage Bay Dist (ft)	50	85		
Storage Blk Time (%)				
Queuing Penalty (veh)				

Intersection: 2: Landover Ln & Sneffels St, Interval #3

Movement	NW	NE	SW
Directions Served	L	LTR	LTR
Maximum Queue (ft)	15	21	54
Average Queue (ft)	2	6	32
95th Queue (ft)	15	26	55
Link Distance (ft)		430	647
Upstream Blk Time (%)			
Queuing Penalty (veh)			
Storage Bay Dist (ft)	85		
Storage Blk Time (%)			
Queuing Penalty (veh)			

Intersection: 2: Landover Ln & Sneffels St, Interval #4

Movement	NW	NE	SW
Directions Served	L	LTR	LTR
Maximum Queue (ft)	14	21	54
Average Queue (ft)	2	6	38
95th Queue (ft)	14	25	64
Link Distance (ft)		430	647
Upstream Blk Time (%)			
Queuing Penalty (veh)			
Storage Bay Dist (ft)	85		
Storage Blk Time (%)			
Queuing Penalty (veh)			

Intersection: 2: Landover Ln & Sneffels St, All Intervals

Movement	SE	NW	NE	SW
Directions Served	L	L	LTR	LTR
Maximum Queue (ft)	15	29	31	90
Average Queue (ft)	1	2	7	37
95th Queue (ft)	7	14	28	67
Link Distance (ft)			430	647
Upstream Blk Time (%)				
Queuing Penalty (veh)				
Storage Bay Dist (ft)	50	85		
Storage Blk Time (%)				
Queuing Penalty (veh)				

Intersection: 1: Sneffels St & Mesa Ridge Pkwy, Interval #1

Movement	EB	EB	EB	EB	WB	WB	WB	WB	SE	SE	SE	NW
Directions Served	L	T	T	R	L	T	T	R	L	T	R	L
Maximum Queue (ft)	176	183	171	66	89	122	100	7	61	37	39	59
Average Queue (ft)	112	125	111	43	45	72	51	1	34	14	11	28
95th Queue (ft)	171	197	185	69	89	124	103	7	68	39	39	63
Link Distance (ft)		1898	1898			1888	1888	1888		363		
Upstream Blk Time (%)												
Queuing Penalty (veh)												
Storage Bay Dist (ft)	578			315	510				160		160	315
Storage Blk Time (%)												
Queuing Penalty (veh)												

Intersection: 1: Sneffels St & Mesa Ridge Pkwy, Interval #1

Movement	NW	NW
Directions Served	T	R
Maximum Queue (ft)	39	73
Average Queue (ft)	18	44
95th Queue (ft)	43	80
Link Distance (ft)		
Upstream Blk Time (%)		
Queuing Penalty (veh)		
Storage Bay Dist (ft)		
Storage Blk Time (%)		
Queuing Penalty (veh)		

Intersection: 1: Sneffels St & Mesa Ridge Pkwy, Interval #2

Movement	EB	EB	EB	EB	WB	WB	WB	WB	SE	SE	SE	NW
Directions Served	L	T	T	R	L	T	T	R	L	T	R	L
Maximum Queue (ft)	186	211	214	58	89	112	108	11	64	51	33	49
Average Queue (ft)	120	139	135	43	47	75	56	3	44	19	12	28
95th Queue (ft)	201	229	231	66	95	120	108	13	76	52	36	55
Link Distance (ft)		1898	1898			1888	1888	1888		363		
Upstream Blk Time (%)												
Queuing Penalty (veh)												
Storage Bay Dist (ft)	578			315	510				160		160	315
Storage Blk Time (%)												
Queuing Penalty (veh)												

Intersection: 1: Sneffels St & Mesa Ridge Pkwy, Interval #2

Movement	NW	NW
Directions Served	T	R
Maximum Queue (ft)	64	95
Average Queue (ft)	26	55
95th Queue (ft)	67	97
Link Distance (ft)		
Upstream Blk Time (%)		
Queuing Penalty (veh)		
Storage Bay Dist (ft)		
Storage Blk Time (%)		
Queuing Penalty (veh)		

Intersection: 1: Sneffels St & Mesa Ridge Pkwy, Interval #3

Movement	EB	EB	EB	EB	WB	WB	WB	WB	SE	SE	SE	NW
Directions Served	L	T	T	R	L	T	T	R	L	T	R	L
Maximum Queue (ft)	181	168	159	79	76	113	92	24	67	44	29	45
Average Queue (ft)	108	119	107	46	44	68	42	7	34	16	8	21
95th Queue (ft)	179	181	165	79	78	115	91	25	72	46	32	49
Link Distance (ft)		1898	1898			1888	1888	1888		363		
Upstream Blk Time (%)												
Queuing Penalty (veh)												
Storage Bay Dist (ft)	578			315	510				160		160	315
Storage Blk Time (%)												
Queuing Penalty (veh)												

Intersection: 1: Sneffels St & Mesa Ridge Pkwy, Interval #3

Movement	NW	NW
Directions Served	T	R
Maximum Queue (ft)	53	72
Average Queue (ft)	18	44
95th Queue (ft)	47	72
Link Distance (ft)		
Upstream Blk Time (%)		
Queuing Penalty (veh)		
Storage Bay Dist (ft)		
Storage Blk Time (%)		
Queuing Penalty (veh)		

Intersection: 1: Sneffels St & Mesa Ridge Pkwy, Interval #4

Movement	EB	EB	EB	EB	WB	WB	WB	WB	SE	SE	SE	NW
Directions Served	L	T	T	R	L	T	T	R	L	T	R	L
Maximum Queue (ft)	176	155	157	60	94	127	104	14	77	44	34	58
Average Queue (ft)	121	108	97	44	49	76	53	3	39	23	11	25
95th Queue (ft)	191	174	167	69	95	123	114	14	84	50	38	56
Link Distance (ft)		1898	1898			1888	1888	1888		363		
Upstream Blk Time (%)												
Queuing Penalty (veh)												
Storage Bay Dist (ft)	578			315	510				160		160	315
Storage Blk Time (%)												
Queuing Penalty (veh)												

Intersection: 1: Sneffels St & Mesa Ridge Pkwy, Interval #4

Movement	NW	NW
Directions Served	T	R
Maximum Queue (ft)	39	100
Average Queue (ft)	21	56
95th Queue (ft)	46	106
Link Distance (ft)		
Upstream Blk Time (%)		
Queuing Penalty (veh)		
Storage Bay Dist (ft)		
Storage Blk Time (%)		
Queuing Penalty (veh)		

Intersection: 1: Sneffels St & Mesa Ridge Pkwy, All Intervals

Movement	EB	EB	EB	EB	WB	WB	WB	WB	SE	SE	SE	NW
Directions Served	L	T	T	R	L	T	T	R	L	T	R	L
Maximum Queue (ft)	230	227	221	83	108	149	138	29	88	58	41	74
Average Queue (ft)	115	122	113	44	46	73	50	3	38	18	10	26
95th Queue (ft)	186	198	191	71	90	121	105	16	76	47	37	56
Link Distance (ft)		1898	1898			1888	1888	1888		363		
Upstream Blk Time (%)												
Queuing Penalty (veh)												
Storage Bay Dist (ft)	578			315	510				160		160	315
Storage Blk Time (%)												
Queuing Penalty (veh)												

Intersection: 1: Sneffels St & Mesa Ridge Pkwy, All Intervals

Movement	NW	NW
Directions Served	T	R
Maximum Queue (ft)	73	114
Average Queue (ft)	21	50
95th Queue (ft)	52	91
Link Distance (ft)		
Upstream Blk Time (%)		
Queuing Penalty (veh)		
Storage Bay Dist (ft)		
Storage Blk Time (%)		
Queuing Penalty (veh)		



Intersection: 2: Landover Ln & Sneffels St, Interval #1

Movement	SE	NW	NE	SW
Directions Served	L	L	LTR	LTR
Maximum Queue (ft)	5	10	26	54
Average Queue (ft)	1	2	6	28
95th Queue (ft)	8	15	25	55
Link Distance (ft)			430	647
Upstream Blk Time (%)				
Queuing Penalty (veh)				
Storage Bay Dist (ft)	50	85		
Storage Blk Time (%)				
Queuing Penalty (veh)				

Intersection: 2: Landover Ln & Sneffels St, Interval #2

Movement	SE	NW	NE	SW
Directions Served	L	L	LTR	LTR
Maximum Queue (ft)	20	10	35	75
Average Queue (ft)	4	1	11	37
95th Queue (ft)	20	12	37	73
Link Distance (ft)			430	647
Upstream Blk Time (%)				
Queuing Penalty (veh)				
Storage Bay Dist (ft)	50	85		
Storage Blk Time (%)				
Queuing Penalty (veh)				

Intersection: 2: Landover Ln & Sneffels St, Interval #3

Movement	NW	NE	SW
Directions Served	L	LTR	LTR
Maximum Queue (ft)	5	21	54
Average Queue (ft)	1	4	27
95th Queue (ft)	11	22	55
Link Distance (ft)		430	647
Upstream Blk Time (%)			
Queuing Penalty (veh)			
Storage Bay Dist (ft)	85		
Storage Blk Time (%)			
Queuing Penalty (veh)			

Intersection: 2: Landover Ln & Sneffels St, Interval #4

Movement	SE	NW	NE	SW
Directions Served	L	L	LTR	LTR
Maximum Queue (ft)	10	10	31	51
Average Queue (ft)	1	1	7	27
95th Queue (ft)	12	12	28	51
Link Distance (ft)			430	647
Upstream Blk Time (%)				
Queuing Penalty (veh)				
Storage Bay Dist (ft)	50	85		
Storage Blk Time (%)				
Queuing Penalty (veh)				

Intersection: 2: Landover Ln & Sneffels St, All Intervals

Movement	SE	NW	NE	SW
Directions Served	L	L	LTR	LTR
Maximum Queue (ft)	25	20	35	81
Average Queue (ft)	2	2	7	30
95th Queue (ft)	12	12	29	60
Link Distance (ft)			430	647
Upstream Blk Time (%)				
Queuing Penalty (veh)				
Storage Bay Dist (ft)	50	85		
Storage Blk Time (%)	0			
Queuing Penalty (veh)	0			

Intersection: 3: Pinfeather Dr/Pitcher Pt & Sneffels St, Interval #1

Movement	NW	NE	SW
Directions Served	L	LTR	LTR
Maximum Queue (ft)	27	31	30
Average Queue (ft)	4	12	16
95th Queue (ft)	24	37	39
Link Distance (ft)		433	157
Upstream Blk Time (%)			
Queuing Penalty (veh)			
Storage Bay Dist (ft)	50		
Storage Blk Time (%)	0		
Queuing Penalty (veh)	0		

Intersection: 3: Pinfeather Dr/Pitcher Pt & Sneffels St, Interval #2

Movement	SE	NW	NE	SW
Directions Served	L	L	LTR	LTR
Maximum Queue (ft)	5	20	31	29
Average Queue (ft)	1	3	14	19
95th Queue (ft)	12	18	40	35
Link Distance (ft)			433	157
Upstream Blk Time (%)				
Queuing Penalty (veh)				
Storage Bay Dist (ft)	50	50		
Storage Blk Time (%)		0		
Queuing Penalty (veh)		0		

Intersection: 3: Pinfeather Dr/Pitcher Pt & Sneffels St, Interval #3

Movement	SE	NW	NE	SW
Directions Served	L	L	LTR	LTR
Maximum Queue (ft)	9	10	31	44
Average Queue (ft)	1	1	9	16
95th Queue (ft)	11	12	31	37
Link Distance (ft)			433	157
Upstream Blk Time (%)				
Queuing Penalty (veh)				
Storage Bay Dist (ft)	50	50		
Storage Blk Time (%)		0		
Queuing Penalty (veh)		0		

Intersection: 3: Pinfeather Dr/Pitcher Pt & Sneffels St, Interval #4

Movement	SE	NW	NW	NE	SW
Directions Served	L	L	R	LTR	LTR
Maximum Queue (ft)	15	10	3	31	38
Average Queue (ft)	2	1	0	15	18
95th Queue (ft)	15	8	6	40	43
Link Distance (ft)			255	433	157
Upstream Blk Time (%)					
Queuing Penalty (veh)					
Storage Bay Dist (ft)	50	50			
Storage Blk Time (%)					
Queuing Penalty (veh)					

Intersection: 3: Pinfeather Dr/Pitcher Pt & Sneffels St, All Intervals

Movement	SE	NW	NW	NE	SW
Directions Served	L	L	R	LTR	LTR
Maximum Queue (ft)	25	32	3	31	62
Average Queue (ft)	1	2	0	13	17
95th Queue (ft)	11	16	3	37	39
Link Distance (ft)			255	433	157
Upstream Blk Time (%)					
Queuing Penalty (veh)					
Storage Bay Dist (ft)	50	50			
Storage Blk Time (%)		0			
Queuing Penalty (veh)		0			

Zone Summary

Zone wide Queuing Penalty, Interval #1: 0
Zone wide Queuing Penalty, Interval #2: 0
Zone wide Queuing Penalty, Interval #3: 0
Zone wide Queuing Penalty, Interval #4: 0
Zone wide Queuing Penalty, All Intervals: 0

Intersection: 1: Sneffels St & Mesa Ridge Pkwy, Interval #1

Movement	EB	EB	EB	EB	WB	WB	WB	WB	WB	SE	SE	SE	
Directions Served	L	T	T	R	L	L	T	T	R	L	T	R	
Maximum Queue (ft)	286	540	510	40	52	679	690	706	505	114	49	50	
Average Queue (ft)	192	403	370	17	13	305	682	684	86	39	19	15	
95th Queue (ft)	333	554	527	42	46	840	690	702	432	113	56	50	
Link Distance (ft)												357	
Upstream Blk Time (%)													
Queuing Penalty (veh)													
Storage Bay Dist (ft)	578				315	510	510				378	200	160
Storage Blk Time (%)			1	21				77	77				
Queuing Penalty (veh)			1	15				76	42				

Intersection: 1: Sneffels St & Mesa Ridge Pkwy, Interval #1

Movement	NW	NW	NW
Directions Served	L	T	R
Maximum Queue (ft)	148	49	135
Average Queue (ft)	69	13	68
95th Queue (ft)	164	45	151
Link Distance (ft)			
Upstream Blk Time (%)			
Queuing Penalty (veh)			
Storage Bay Dist (ft)	315		
Storage Blk Time (%)			
Queuing Penalty (veh)			

Intersection: 1: Sneffels St & Mesa Ridge Pkwy, Interval #2

Movement	EB	EB	EB	EB	WB	WB	WB	WB	WB	SE	SE	SE	
Directions Served	L	T	T	R	L	L	T	T	R	L	T	R	
Maximum Queue (ft)	287	565	535	112	34	679	692	687	600	107	58	52	
Average Queue (ft)	205	375	324	34	11	195	681	681	143	52	21	19	
95th Queue (ft)	355	627	587	162	48	672	694	687	564	112	58	51	
Link Distance (ft)												357	
Upstream Blk Time (%)													
Queuing Penalty (veh)													
Storage Bay Dist (ft)	578				315	510	510				378	200	160
Storage Blk Time (%)			1	21				78	76				
Queuing Penalty (veh)			2	17				81	45				

Intersection: 1: Sneffels St & Mesa Ridge Pkwy, Interval #2

Movement	NW	NW	NW
Directions Served	L	T	R
Maximum Queue (ft)	152	36	255
Average Queue (ft)	74	12	106
95th Queue (ft)	151	36	234
Link Distance (ft)			
Upstream Blk Time (%)			
Queuing Penalty (veh)			
Storage Bay Dist (ft)	315		
Storage Blk Time (%)			
Queuing Penalty (veh)			

Intersection: 1: Sneffels St & Mesa Ridge Pkwy, Interval #3

Movement	EB	EB	EB	EB	WB	WB	WB	WB	WB	SE	SE	SE	
Directions Served	L	T	T	R	L	L	T	T	R	L	T	R	
Maximum Queue (ft)	273	522	489	48	60	577	688	689	600	79	39	42	
Average Queue (ft)	197	401	373	21	11	217	682	682	185	30	15	13	
95th Queue (ft)	309	547	517	48	58	702	689	692	643	86	41	46	
Link Distance (ft)											357		
Upstream Blk Time (%)													
Queuing Penalty (veh)													
Storage Bay Dist (ft)	578			315		510		510		378		200	160
Storage Blk Time (%)	0		25				80		79				
Queuing Penalty (veh)	0		18				78		44				

Intersection: 1: Sneffels St & Mesa Ridge Pkwy, Interval #3

Movement	NW	NW	NW
Directions Served	L	T	R
Maximum Queue (ft)	162	24	186
Average Queue (ft)	84	6	83
95th Queue (ft)	173	25	196
Link Distance (ft)			
Upstream Blk Time (%)			
Queuing Penalty (veh)			
Storage Bay Dist (ft)	315		
Storage Blk Time (%)			
Queuing Penalty (veh)			

Intersection: 1: Sneffels St & Mesa Ridge Pkwy, Interval #4

Movement	EB	EB	EB	EB	WB	WB	WB	WB	WB	SE	SE	SE	
Directions Served	L	T	T	R	L	L	T	T	R	L	T	R	
Maximum Queue (ft)	245	569	512	123	53	677	698	688	600	113	51	40	
Average Queue (ft)	133	363	306	34	15	294	684	682	200	49	17	17	
95th Queue (ft)	244	618	557	163	55	818	697	690	666	108	54	46	
Link Distance (ft)												357	
Upstream Blk Time (%)													
Queuing Penalty (veh)													
Storage Bay Dist (ft)	578				315	510	510				378	200	160
Storage Blk Time (%)			1	20				75	74				0
Queuing Penalty (veh)			2	14				74	41				0

Intersection: 1: Sneffels St & Mesa Ridge Pkwy, Interval #4

Movement	NW	NW	NW
Directions Served	L	T	R
Maximum Queue (ft)	153	19	159
Average Queue (ft)	59	5	87
95th Queue (ft)	136	26	161
Link Distance (ft)			
Upstream Blk Time (%)			
Queuing Penalty (veh)			
Storage Bay Dist (ft)	315		
Storage Blk Time (%)			
Queuing Penalty (veh)			



Intersection: 1: Sneffels St & Mesa Ridge Pkwy, All Intervals

Movement	EB	EB	EB	EB	WB	WB	WB	WB	WB	SE	SE	SE	
Directions Served	L	T	T	R	L	L	T	T	R	L	T	R	
Maximum Queue (ft)	330	605	582	214	79	679	699	712	600	142	68	67	
Average Queue (ft)	182	385	343	27	12	253	682	682	154	43	18	16	
95th Queue (ft)	320	595	560	120	52	764	693	694	585	107	53	49	
Link Distance (ft)												357	
Upstream Blk Time (%)													
Queuing Penalty (veh)													
Storage Bay Dist (ft)	578				315	510	510				378	200	160
Storage Blk Time (%)			1	22				78	77				0
Queuing Penalty (veh)			1	16				77	43				0

Intersection: 1: Sneffels St & Mesa Ridge Pkwy, All Intervals

Movement	NW	NW	NW
Directions Served	L	T	R
Maximum Queue (ft)	199	53	264
Average Queue (ft)	72	9	86
95th Queue (ft)	158	34	190
Link Distance (ft)			
Upstream Blk Time (%)			
Queuing Penalty (veh)			
Storage Bay Dist (ft)	315		
Storage Blk Time (%)			
Queuing Penalty (veh)			

Intersection: 2: Landover Ln & Sneffels St, Interval #1

Movement	NE	SW
Directions Served	LTR	LTR
Maximum Queue (ft)	21	63
Average Queue (ft)	4	36
95th Queue (ft)	22	66
Link Distance (ft)	430	647
Upstream Blk Time (%)		
Queuing Penalty (veh)		
Storage Bay Dist (ft)		
Storage Blk Time (%)		
Queuing Penalty (veh)		

Intersection: 2: Landover Ln & Sneffels St, Interval #2

Movement	NW	NE	SW
Directions Served	L	LTR	LTR
Maximum Queue (ft)	15	31	66
Average Queue (ft)	2	12	42
95th Queue (ft)	15	37	72
Link Distance (ft)		430	647
Upstream Blk Time (%)			
Queuing Penalty (veh)			
Storage Bay Dist (ft)	50		
Storage Blk Time (%)			
Queuing Penalty (veh)			

Intersection: 2: Landover Ln & Sneffels St, Interval #3

Movement	NW	NE	SW
Directions Served	L	LTR	LTR
Maximum Queue (ft)	9	31	54
Average Queue (ft)	1	9	30
95th Queue (ft)	11	32	46
Link Distance (ft)		430	647
Upstream Blk Time (%)			
Queuing Penalty (veh)			
Storage Bay Dist (ft)	50		
Storage Blk Time (%)			
Queuing Penalty (veh)			

Intersection: 2: Landover Ln & Sneffels St, Interval #4

Movement	SE	NW	NE	SW
Directions Served	L	L	LTR	LTR
Maximum Queue (ft)	5	10	30	73
Average Queue (ft)	1	1	12	40
95th Queue (ft)	8	12	37	74
Link Distance (ft)			430	647
Upstream Blk Time (%)				
Queuing Penalty (veh)				
Storage Bay Dist (ft)	50	50		
Storage Blk Time (%)				
Queuing Penalty (veh)				

Intersection: 2: Landover Ln & Sneffels St, All Intervals

Movement	SE	NW	NE	SW
Directions Served	L	L	LTR	LTR
Maximum Queue (ft)	5	20	31	81
Average Queue (ft)	0	1	9	37
95th Queue (ft)	4	11	33	66
Link Distance (ft)			430	647
Upstream Blk Time (%)				
Queuing Penalty (veh)				
Storage Bay Dist (ft)	50	50		
Storage Blk Time (%)				
Queuing Penalty (veh)				

Intersection: 1: Sneffels St & Mesa Ridge Pkwy, Interval #1

Movement	EB	EB	EB	EB	WB	WB	WB	WB	WB	NB	NB	SB
Directions Served	L	T	T	R	L	L	T	T	R	L	T	L
Maximum Queue (ft)	194	1180	1199	525	145	173	260	257	9	117	97	74
Average Queue (ft)	123	1050	1070	487	95	136	186	183	1	68	49	46
95th Queue (ft)	205	1312	1327	710	161	179	278	276	15	124	105	86
Link Distance (ft)	1267	1267	1267				1765	1765			726	
Upstream Blk Time (%)		0	1									
Queuing Penalty (veh)		4	7									
Storage Bay Dist (ft)				315	510	510			378	315		200
Storage Blk Time (%)			44					0				
Queuing Penalty (veh)			150					0				

Intersection: 1: Sneffels St & Mesa Ridge Pkwy, Interval #1

Movement	SB	SB
Directions Served	T	R
Maximum Queue (ft)	74	46
Average Queue (ft)	37	15
95th Queue (ft)	78	44
Link Distance (ft)	352	
Upstream Blk Time (%)		
Queuing Penalty (veh)		
Storage Bay Dist (ft)		185
Storage Blk Time (%)		
Queuing Penalty (veh)		

Intersection: 1: Sneffels St & Mesa Ridge Pkwy, Interval #2

Movement	EB	EB	EB	EB	WB	WB	WB	WB	WB	NB	NB	SB
Directions Served	L	T	T	R	L	L	T	T	R	L	T	L
Maximum Queue (ft)	191	1267	1285	525	149	177	267	258	19	134	86	119
Average Queue (ft)	115	1234	1244	450	83	123	198	196	5	77	42	68
95th Queue (ft)	191	1321	1319	753	167	182	292	287	32	134	90	118
Link Distance (ft)	1267	1267	1267				1765	1765			726	
Upstream Blk Time (%)		1	3									
Queuing Penalty (veh)		12	27									
Storage Bay Dist (ft)				315	510	510			378	315		200
Storage Blk Time (%)				38								
Queuing Penalty (veh)			141									

Intersection: 1: Sneffels St & Mesa Ridge Pkwy, Interval #2

Movement	SB	SB
Directions Served	T	R
Maximum Queue (ft)	70	39
Average Queue (ft)	27	14
95th Queue (ft)	67	40
Link Distance (ft)	352	
Upstream Blk Time (%)		
Queuing Penalty (veh)		
Storage Bay Dist (ft)		185
Storage Blk Time (%)		
Queuing Penalty (veh)		

Intersection: 1: Sneffels St & Mesa Ridge Pkwy, Interval #3

Movement	EB	EB	EB	EB	WB	WB	WB	WB	NB	NB	SB	SB
Directions Served	L	T	T	R	L	L	T	T	L	T	L	T
Maximum Queue (ft)	193	1273	1288	525	141	170	290	302	156	69	122	65
Average Queue (ft)	132	1259	1266	487	78	129	202	201	84	37	55	34
95th Queue (ft)	217	1275	1291	710	148	178	310	317	161	83	122	80
Link Distance (ft)	1267	1267	1267				1765	1765		726		352
Upstream Blk Time (%)		2	4									
Queuing Penalty (veh)		16	36									
Storage Bay Dist (ft)				315	510	510			315		200	
Storage Blk Time (%)			43					0			0	
Queuing Penalty (veh)			149					0			0	

Intersection: 1: Sneffels St & Mesa Ridge Pkwy, Interval #3

Movement	SB
Directions Served	R
Maximum Queue (ft)	38
Average Queue (ft)	12
95th Queue (ft)	38
Link Distance (ft)	
Upstream Blk Time (%)	
Queuing Penalty (veh)	
Storage Bay Dist (ft)	185
Storage Blk Time (%)	
Queuing Penalty (veh)	

Intersection: 1: Sneffels St & Mesa Ridge Pkwy, Interval #4

Movement	EB	EB	EB	EB	WB	WB	WB	WB	WB	NB	NB	SB
Directions Served	L	T	T	R	L	L	T	T	R	L	T	L
Maximum Queue (ft)	167	1275	1284	525	155	182	252	261	37	127	65	81
Average Queue (ft)	102	1257	1260	449	92	130	181	185	8	71	35	49
95th Queue (ft)	173	1279	1283	752	169	190	267	274	40	127	72	85
Link Distance (ft)	1267	1267	1267				1765	1765			726	
Upstream Blk Time (%)		2	3									
Queuing Penalty (veh)		15	28									
Storage Bay Dist (ft)				315	510	510			378	315		200
Storage Blk Time (%)				38								
Queuing Penalty (veh)			130									

Intersection: 1: Sneffels St & Mesa Ridge Pkwy, Interval #4

Movement	SB	SB
Directions Served	T	R
Maximum Queue (ft)	90	38
Average Queue (ft)	33	14
95th Queue (ft)	86	40
Link Distance (ft)	352	
Upstream Blk Time (%)		
Queuing Penalty (veh)		
Storage Bay Dist (ft)		185
Storage Blk Time (%)		
Queuing Penalty (veh)		

Intersection: 1: Sneffels St & Mesa Ridge Pkwy, All Intervals

Movement	EB	EB	EB	EB	WB	WB	WB	WB	WB	NB	NB	SB
Directions Served	L	T	T	R	L	L	T	T	R	L	T	L
Maximum Queue (ft)	232	1284	1290	525	171	203	299	317	46	167	108	136
Average Queue (ft)	118	1200	1210	468	87	130	192	191	4	75	41	54
95th Queue (ft)	199	1400	1400	736	163	183	288	290	26	138	89	106
Link Distance (ft)	1267	1267	1267				1765	1765			726	
Upstream Blk Time (%)		1	3									
Queuing Penalty (veh)		12	24									
Storage Bay Dist (ft)				315	510	510			378	315		200
Storage Blk Time (%)			41					0				0
Queuing Penalty (veh)			142					0				0

Intersection: 1: Sneffels St & Mesa Ridge Pkwy, All Intervals

Movement	SB	SB
Directions Served	T	R
Maximum Queue (ft)	104	54
Average Queue (ft)	33	14
95th Queue (ft)	79	41
Link Distance (ft)	352	
Upstream Blk Time (%)		
Queuing Penalty (veh)		
Storage Bay Dist (ft)		185
Storage Blk Time (%)		
Queuing Penalty (veh)		



Intersection: 2: Landover Ln & Sneffels St, Interval #1

Movement	SE	SE	NE	SW
Directions Served	L	R>	LTR	LTR
Maximum Queue (ft)	3	5	28	81
Average Queue (ft)	0	1	7	39
95th Queue (ft)	5	9	27	74
Link Distance (ft)		255	313	656
Upstream Blk Time (%)				
Queuing Penalty (veh)				
Storage Bay Dist (ft)	50			
Storage Blk Time (%)				
Queuing Penalty (veh)				

Intersection: 2: Landover Ln & Sneffels St, Interval #2

Movement	NB	NB	SE	NE	SW
Directions Served	L	R	L	LTR	LTR
Maximum Queue (ft)	3	0	10	27	97
Average Queue (ft)	0	0	1	10	50
95th Queue (ft)	3	0	12	32	97
Link Distance (ft)	352			313	656
Upstream Blk Time (%)					
Queuing Penalty (veh)					
Storage Bay Dist (ft)		190	50		
Storage Blk Time (%)					
Queuing Penalty (veh)					

Intersection: 2: Landover Ln & Sneffels St, Interval #3

Movement	NB	SE	NE	SW
Directions Served	L	L	LTR	LTR
Maximum Queue (ft)	1	8	23	62
Average Queue (ft)	0	2	7	35
95th Queue (ft)	2	11	26	60
Link Distance (ft)	352		313	656
Upstream Blk Time (%)				
Queuing Penalty (veh)				
Storage Bay Dist (ft)		50		
Storage Blk Time (%)				
Queuing Penalty (veh)				

**Intersection: 2: Landover Ln & Sneffels St, Interval #4**

Movement	SE	SE	NE	SW
Directions Served	L	R>	LTR	LTR
Maximum Queue (ft)	19	8	23	63
Average Queue (ft)	3	1	10	35
95th Queue (ft)	16	10	32	65
Link Distance (ft)		255	313	656
Upstream Blk Time (%)				
Queuing Penalty (veh)				
Storage Bay Dist (ft)	50			
Storage Blk Time (%)				
Queuing Penalty (veh)				

**Intersection: 2: Landover Ln & Sneffels St, All Intervals**

Movement	NB	NB	SE	SE	NE	SW
Directions Served	L	R	L	R>	LTR	LTR
Maximum Queue (ft)	4	0	24	14	28	104
Average Queue (ft)	0	0	2	0	8	40
95th Queue (ft)	2	0	12	7	29	76
Link Distance (ft)	352			255	313	656
Upstream Blk Time (%)						
Queuing Penalty (veh)						
Storage Bay Dist (ft)		190	50			
Storage Blk Time (%)				0		
Queuing Penalty (veh)				0		

**Intersection: 3: Pinfeather Dr/Pitcher Pt & Sneffels St, Interval #1**

Movement	SE	NW	NE	SW
Directions Served	L	L	LTR	LTR
Maximum Queue (ft)	15	20	31	38
Average Queue (ft)	4	4	12	21
95th Queue (ft)	19	20	36	42
Link Distance (ft)			433	157
Upstream Blk Time (%)				
Queuing Penalty (veh)				
Storage Bay Dist (ft)	50	50		
Storage Blk Time (%)		0		
Queuing Penalty (veh)		0		

**Intersection: 3: Pinfeather Dr/Pitcher Pt & Sneffels St, Interval #2**

Movement	SE	NW	NE	SW
Directions Served	L	L	LTR	LTR
Maximum Queue (ft)	15	10	31	36
Average Queue (ft)	2	1	16	20
95th Queue (ft)	15	12	41	42
Link Distance (ft)			433	157
Upstream Blk Time (%)				
Queuing Penalty (veh)				
Storage Bay Dist (ft)	50	50		
Storage Blk Time (%)				
Queuing Penalty (veh)				

**Intersection: 3: Pinfeather Dr/Pitcher Pt & Sneffels St, Interval #3**

Movement	SE	NW	NE	SW
Directions Served	L	L	LTR	LTR
Maximum Queue (ft)	30	20	31	28
Average Queue (ft)	6	4	12	19
95th Queue (ft)	25	22	37	40
Link Distance (ft)			433	157
Upstream Blk Time (%)				
Queuing Penalty (veh)				
Storage Bay Dist (ft)	50	50		
Storage Blk Time (%)		0		
Queuing Penalty (veh)		0		

**Intersection: 3: Pinfeather Dr/Pitcher Pt & Sneffels St, Interval #4**

Movement	SE	NW	NE	SW
Directions Served	L	L	LTR	LTR
Maximum Queue (ft)	5	5	34	32
Average Queue (ft)	1	1	16	17
95th Queue (ft)	12	8	42	39
Link Distance (ft)			433	157
Upstream Blk Time (%)				
Queuing Penalty (veh)				
Storage Bay Dist (ft)	50	50		
Storage Blk Time (%)				
Queuing Penalty (veh)				

Intersection: 3: Pinfeather Dr/Pitcher Pt & Sneffels St, All Intervals

Movement	SE	NW	NE	SW
Directions Served	L	L	LTR	LTR
Maximum Queue (ft)	30	26	35	50
Average Queue (ft)	3	3	14	19
95th Queue (ft)	18	16	39	41
Link Distance (ft)			433	157
Upstream Blk Time (%)				
Queuing Penalty (veh)				
Storage Bay Dist (ft)	50	50		
Storage Blk Time (%)	0	0		
Queuing Penalty (veh)	0	0		

Zone Summary

Zone wide Queuing Penalty, Interval #1: 0
Zone wide Queuing Penalty, Interval #2: 0
Zone wide Queuing Penalty, Interval #3: 0
Zone wide Queuing Penalty, Interval #4: 0
Zone wide Queuing Penalty, All Intervals: 0

























# Levels of Service

---



Lanes, Volumes, Timings  
1: Sneffels St & Mesa Ridge Pkwy

Existing  
AM

												
Lane Group	EBL	EBT	EBR	WBL	WBT	WBR	SEL	SET	SER	NWL	NWT	NWR
Lane Configurations												
Traffic Volume (vph)	89	496	13	20	834	11	43	4	173	25	5	59
Future Volume (vph)	89	496	13	20	834	11	43	4	173	25	5	59
Ideal Flow (vphpl)	1900	1900	1900	1900	1900	1900	1900	1900	1900	1900	1900	1900
Storage Length (ft)	325		315	510		225	160		160	315		0
Storage Lanes	1		1	1		1	1		1	1		1
Taper Length (ft)	160			170			75			120		
Lane Util. Factor	1.00	0.95	1.00	1.00	0.95	1.00	1.00	1.00	1.00	1.00	1.00	1.00
Frt			0.850			0.850			0.850			0.850
Flt Protected	0.950			0.950			0.950			0.950		
Satd. Flow (prot)	1770	3539	1583	1770	3539	1583	1770	1863	1583	1770	1863	1583
Flt Permitted	0.950			0.950			0.754			0.754		
Satd. Flow (perm)	1770	3539	1583	1770	3539	1583	1405	1863	1583	1405	1863	1583
Right Turn on Red			Yes			Yes			Yes			Yes
Satd. Flow (RTOR)			118			118			208			155
Link Speed (mph)		55			55			25			25	
Link Distance (ft)		1962			1437			447			886	
Travel Time (s)		24.3			17.8			12.2			24.2	
Peak Hour Factor	0.93	0.93	0.93	0.93	0.93	0.93	0.83	0.83	0.83	0.87	0.87	0.87
Adj. Flow (vph)	96	533	14	22	897	12	52	5	208	29	6	68
Shared Lane Traffic (%)												
Lane Group Flow (vph)	96	533	14	22	897	12	52	5	208	29	6	68
Enter Blocked Intersection	No	No	No	No	No	No	No	No	No	No	No	No
Lane Alignment	Left	Left	Right	Left	Left	Right	Left	Left	Right	Left	Left	Right
Median Width(ft)		12			12			12			12	
Link Offset(ft)		0			0			0			0	
Crosswalk Width(ft)		16			16			16			16	
Two way Left Turn Lane												
Headway Factor	1.00	1.00	1.00	1.00	1.00	1.00	1.00	1.00	1.00	1.00	1.00	1.00
Turning Speed (mph)	15		9	15		9	15		9	15		9
Number of Detectors	1	2	1	1	2	1	1	2	1	1	2	1
Detector Template	Left	Thru	Right	Left	Thru	Right	Left	Thru	Right	Left	Thru	Right
Leading Detector (ft)	20	100	20	20	100	20	20	100	20	20	100	20
Trailing Detector (ft)	0	0	0	0	0	0	0	0	0	0	0	0
Detector 1 Position(ft)	0	0	0	0	0	0	0	0	0	0	0	0
Detector 1 Size(ft)	20	6	20	20	6	20	20	6	20	20	6	20
Detector 1 Type	Cl+Ex	Cl+Ex	Cl+Ex	Cl+Ex	Cl+Ex	Cl+Ex	Cl+Ex	Cl+Ex	Cl+Ex	Cl+Ex	Cl+Ex	Cl+Ex
Detector 1 Channel												
Detector 1 Extend (s)	0.0	0.0	0.0	0.0	0.0	0.0	0.0	0.0	0.0	0.0	0.0	0.0
Detector 1 Queue (s)	0.0	0.0	0.0	0.0	0.0	0.0	0.0	0.0	0.0	0.0	0.0	0.0
Detector 1 Delay (s)	0.0	0.0	0.0	0.0	0.0	0.0	0.0	0.0	0.0	0.0	0.0	0.0
Detector 2 Position(ft)		94			94			94			94	
Detector 2 Size(ft)		6			6			6			6	
Detector 2 Type		Cl+Ex			Cl+Ex			Cl+Ex			Cl+Ex	
Detector 2 Channel												
Detector 2 Extend (s)		0.0			0.0			0.0			0.0	
Turn Type	Prot	NA	Perm	Prot	NA	Perm	Perm	NA	Perm	Perm	NA	Perm
Protected Phases	7	4		3	8			6			2	
Permitted Phases			4			8	6		6	2		2



Lanes, Volumes, Timings  
 1: Sneffels St & Mesa Ridge Pkwy

Existing  
 AM

Splits and Phases: 1: Sneffels St & Mesa Ridge Pkwy

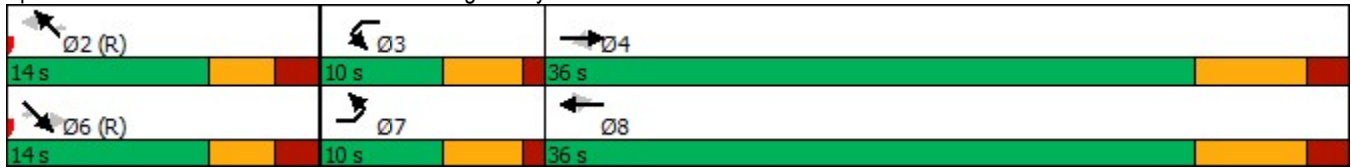



HCM 6th TWSC  
2: Landover Ln & Sneffels St

Existing  
AM

Intersection												
Int Delay, s/veh	1.5											
Movement	SEL	SET	SER	NWL	NWT	NWR	NEL	NET	NER	SWL	SWT	SWR
Lane Configurations	↔	↔		↔	↔	↔		↔			↔	↔
Traffic Vol, veh/h	0	186	1	5	70	30	3	0	1	33	0	0
Future Vol, veh/h	0	186	1	5	70	30	3	0	1	33	0	0
Conflicting Peds, #/hr	0	0	0	0	0	0	0	0	0	0	0	0
Sign Control	Free	Free	Free	Free	Free	Free	Stop	Stop	Stop	Stop	Stop	Stop
RT Channelized	-	-	None	-	-	None	-	-	None	-	-	Stop
Storage Length	50	-	-	85	-	190	-	-	-	-	-	-
Veh in Median Storage, #	-	0	-	-	0	-	-	0	-	-	0	-
Grade, %	-	0	-	-	0	-	-	0	-	-	0	-
Peak Hour Factor	87	87	87	83	83	83	78	78	78	78	78	78
Heavy Vehicles, %	2	2	2	2	2	2	2	2	2	2	2	2
Mvmt Flow	0	214	1	6	84	36	4	0	1	42	0	0

Major/Minor	Major1			Major2			Minor1			Minor2		
Conflicting Flow All	120	0	0	215	0	0	329	347	215	311	311	84
Stage 1	-	-	-	-	-	-	215	215	-	96	96	-
Stage 2	-	-	-	-	-	-	114	132	-	215	215	-
Critical Hdwy	4.12	-	-	4.12	-	-	7.12	6.52	6.22	7.12	6.52	6.22
Critical Hdwy Stg 1	-	-	-	-	-	-	6.12	5.52	-	6.12	5.52	-
Critical Hdwy Stg 2	-	-	-	-	-	-	6.12	5.52	-	6.12	5.52	-
Follow-up Hdwy	2.218	-	-	2.218	-	-	3.518	4.018	3.318	3.518	4.018	3.318
Pot Cap-1 Maneuver	1468	-	-	1355	-	-	624	576	825	642	604	975
Stage 1	-	-	-	-	-	-	787	725	-	911	815	-
Stage 2	-	-	-	-	-	-	891	787	-	787	725	-
Platoon blocked, %	-	-	-	-	-	-	-	-	-	-	-	-
Mov Cap-1 Maneuver	1468	-	-	1355	-	-	622	574	825	639	602	975
Mov Cap-2 Maneuver	-	-	-	-	-	-	622	574	-	639	602	-
Stage 1	-	-	-	-	-	-	787	725	-	911	812	-
Stage 2	-	-	-	-	-	-	887	784	-	786	725	-

Approach	SE			NW			NE			SW		
HCM Control Delay, s	0			0.4			10.5			11		
HCM LOS							B			B		

Minor Lane/Major Mvmt	NELn1	NWL	NWT	NWR	SEL	SET	SERSWLn1
Capacity (veh/h)	663	1355	-	-	1468	-	639
HCM Lane V/C Ratio	0.008	0.004	-	-	-	-	0.066
HCM Control Delay (s)	10.5	7.7	-	-	0	-	11
HCM Lane LOS	B	A	-	-	A	-	B
HCM 95th %tile Q(veh)	0	0	-	-	0	-	0.2

HCM 6th TWSC  
3: Pinfeather Dr/Pitcher Pt & Sneffels St

Existing  
AM

Intersection												
Int Delay, s/veh	2											
Movement	SEL	SET	SER	NWL	NWT	NWR	NEL	NET	NER	SWL	SWT	SWR
Lane Configurations	↖	↗		↖	↗	↖		↕			↕	
Traffic Vol, veh/h	0	153	1	9	46	18	7	0	0	34	0	2
Future Vol, veh/h	0	153	1	9	46	18	7	0	0	34	0	2
Conflicting Peds, #/hr	0	0	0	0	0	0	0	0	0	0	0	0
Sign Control	Free	Free	Free	Free	Free	Free	Stop	Stop	Stop	Stop	Stop	Stop
RT Channelized	-	-	None	-	-	None	-	-	None	-	-	None
Storage Length	50	-	-	50	-	0	-	-	-	-	-	-
Veh in Median Storage, #	-	0	-	-	0	-	-	0	-	-	0	-
Grade, %	-	0	-	-	0	-	-	0	-	-	0	-
Peak Hour Factor	87	87	87	83	83	83	78	78	78	78	78	78
Heavy Vehicles, %	2	2	2	2	2	2	2	2	2	2	2	2
Mvmt Flow	0	176	1	11	55	22	9	0	0	44	0	3



























Major/Minor	Major1			Major2			Minor1			Minor2		
Conflicting Flow All	77	0	0	177	0	0	267	276	177	254	254	55
Stage 1	-	-	-	-	-	-	177	177	-	77	77	-
Stage 2	-	-	-	-	-	-	90	99	-	177	177	-
Critical Hdwy	4.12	-	-	4.12	-	-	7.12	6.52	6.22	7.12	6.52	6.22
Critical Hdwy Stg 1	-	-	-	-	-	-	6.12	5.52	-	6.12	5.52	-
Critical Hdwy Stg 2	-	-	-	-	-	-	6.12	5.52	-	6.12	5.52	-
Follow-up Hdwy	2.218	-	-	2.218	-	-	3.518	4.018	3.318	3.518	4.018	3.318
Pot Cap-1 Maneuver	1522	-	-	1399	-	-	686	632	866	699	650	1012
Stage 1	-	-	-	-	-	-	825	753	-	932	831	-
Stage 2	-	-	-	-	-	-	917	813	-	825	753	-
Platoon blocked, %	-	-	-	-	-	-	-	-	-	-	-	-
Mov Cap-1 Maneuver	1522	-	-	1399	-	-	680	627	866	695	645	1012
Mov Cap-2 Maneuver	-	-	-	-	-	-	680	627	-	695	645	-
Stage 1	-	-	-	-	-	-	825	753	-	932	824	-
Stage 2	-	-	-	-	-	-	907	806	-	825	753	-

Approach	SE			NW			NE			SW		
HCM Control Delay, s	0			0.9			10.4			10.4		
HCM LOS							B			B		

Minor Lane/Major Mvmt	NELn1	NWL	NWT	NWR	SEL	SET	SERSWLn1
Capacity (veh/h)	680	1399	-	-	1522	-	707
HCM Lane V/C Ratio	0.013	0.008	-	-	-	-	0.065
HCM Control Delay (s)	10.4	7.6	-	-	0	-	10.4
HCM Lane LOS	B	A	-	-	A	-	B
HCM 95th %tile Q(veh)	0	0	-	-	0	-	0.2

Lanes, Volumes, Timings  
1: Sneffels St & Mesa Ridge Pkwy

Existing  
PM

													
Lane Group	EBL	EBT	EBR	WBL	WBT	WBR	SEL	SET	SER	NWL	NWT	NWR	
Lane Configurations													
Traffic Volume (vph)	220	1153	220	89	679	56	32	13	96	22	16	97	
Future Volume (vph)	220	1153	220	89	679	56	32	13	96	22	16	97	
Ideal Flow (vphpl)	1900	1900	1900	1900	1900	1900	1900	1900	1900	1900	1900	1900	
Storage Length (ft)	325		315	510		225	160		160	315		0	
Storage Lanes	1		1	1		1	1		1	1		1	
Taper Length (ft)	160			170			75			120			
Lane Util. Factor	1.00	0.95	1.00	1.00	0.95	1.00	1.00	1.00	1.00	1.00	1.00	1.00	
Frt			0.850			0.850			0.850			0.850	
Flt Protected	0.950			0.950			0.950			0.950			
Satd. Flow (prot)	1770	3539	1583	1770	3539	1583	1770	1863	1583	1770	1863	1583	
Flt Permitted	0.950			0.950			0.745			0.747			
Satd. Flow (perm)	1770	3539	1583	1770	3539	1583	1388	1863	1583	1391	1863	1583	
Right Turn on Red			Yes			Yes			Yes			Yes	
Satd. Flow (RTOR)			232			118			155			155	
Link Speed (mph)		55			55			25			25		
Link Distance (ft)		1962			1437			447			886		
Travel Time (s)		24.3			17.8			12.2			24.2		
Peak Hour Factor	0.95	0.95	0.95	0.93	0.93	0.93	0.83	0.83	0.83	0.83	0.83	0.83	
Adj. Flow (vph)	232	1214	232	96	730	60	39	16	116	27	19	117	
Shared Lane Traffic (%)													
Lane Group Flow (vph)	232	1214	232	96	730	60	39	16	116	27	19	117	
Enter Blocked Intersection	No	No	No	No	No	No	No	No	No	No	No	No	
Lane Alignment	Left	Left	Right	Left	Left	Right	Left	Left	Right	Left	Left	Right	
Median Width(ft)		12			12			12			12		
Link Offset(ft)		0			0			0			0		
Crosswalk Width(ft)		16			16			16			16		
Two way Left Turn Lane													
Headway Factor	1.00	1.00	1.00	1.00	1.00	1.00	1.00	1.00	1.00	1.00	1.00	1.00	
Turning Speed (mph)	15		9	15		9	15		9	15		9	
Number of Detectors	1	2	1	1	2	1	1	2	1	1	2	1	
Detector Template	Left	Thru	Right	Left	Thru	Right	Left	Thru	Right	Left	Thru	Right	
Leading Detector (ft)	20	100	20	20	100	20	20	100	20	20	100	20	
Trailing Detector (ft)	0	0	0	0	0	0	0	0	0	0	0	0	
Detector 1 Position(ft)	0	0	0	0	0	0	0	0	0	0	0	0	
Detector 1 Size(ft)	20	6	20	20	6	20	20	6	20	20	6	20	
Detector 1 Type	Cl+Ex	Cl+Ex	Cl+Ex	Cl+Ex	Cl+Ex	Cl+Ex	Cl+Ex	Cl+Ex	Cl+Ex	Cl+Ex	Cl+Ex	Cl+Ex	
Detector 1 Channel													
Detector 1 Extend (s)	0.0	0.0	0.0	0.0	0.0	0.0	0.0	0.0	0.0	0.0	0.0	0.0	
Detector 1 Queue (s)	0.0	0.0	0.0	0.0	0.0	0.0	0.0	0.0	0.0	0.0	0.0	0.0	
Detector 1 Delay (s)	0.0	0.0	0.0	0.0	0.0	0.0	0.0	0.0	0.0	0.0	0.0	0.0	
Detector 2 Position(ft)		94			94			94			94		
Detector 2 Size(ft)		6			6			6			6		
Detector 2 Type		Cl+Ex			Cl+Ex			Cl+Ex			Cl+Ex		
Detector 2 Channel													
Detector 2 Extend (s)		0.0			0.0			0.0			0.0		
Turn Type	Prot	NA	Perm	Prot	NA	Perm	Perm	NA	Perm	Perm	NA	Perm	
Protected Phases	7	4		3	8			6			2		
Permitted Phases			4			8	6		6	2		2	



Lanes, Volumes, Timings  
 1: Sneffels St & Mesa Ridge Pkwy

Existing  
 PM

Splits and Phases: 1: Sneffels St & Mesa Ridge Pkwy

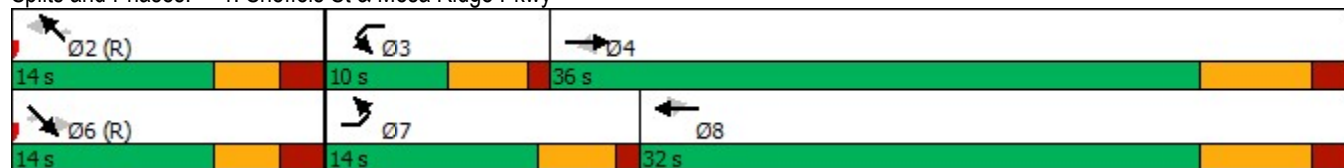

HCM 6th TWSC  
2: Landover Ln & Sneffels St

Existing  
PM

Intersection												
Int Delay, s/veh	1.1											
Movement	SEL	SET	SER	NWL	NWT	NWR	NEL	NET	NER	SWL	SWT	SWR
Lane Configurations	↖	↗		↖	↗	↖		↕			↕	
Traffic Vol, veh/h	0	110	3	8	228	56	0	0	5	26	0	2
Future Vol, veh/h	0	110	3	8	228	56	0	0	5	26	0	2
Conflicting Peds, #/hr	0	0	0	0	0	0	0	0	0	0	0	0
Sign Control	Free	Free	Free	Free	Free	Free	Stop	Stop	Stop	Stop	Stop	Stop
RT Channelized	-	-	None	-	-	None	-	-	None	-	-	Stop
Storage Length	50	-	-	85	-	190	-	-	-	-	-	-
Veh in Median Storage, #	-	0	-	-	0	-	-	0	-	-	0	-
Grade, %	-	0	-	-	0	-	-	0	-	-	0	-
Peak Hour Factor	83	83	83	83	83	83	78	78	78	78	78	78
Heavy Vehicles, %	2	2	2	2	2	2	2	2	2	2	2	2
Mvmt Flow	0	133	4	10	275	67	0	0	6	33	0	3

Major/Minor	Major1		Major2			Minor1			Minor2			
Conflicting Flow All	342	0	0	137	0	0	464	497	135	433	432	275
Stage 1	-	-	-	-	-	-	135	135	-	295	295	-
Stage 2	-	-	-	-	-	-	329	362	-	138	137	-
Critical Hdwy	4.12	-	-	4.12	-	-	7.12	6.52	6.22	7.12	6.52	6.22
Critical Hdwy Stg 1	-	-	-	-	-	-	6.12	5.52	-	6.12	5.52	-
Critical Hdwy Stg 2	-	-	-	-	-	-	6.12	5.52	-	6.12	5.52	-
Follow-up Hdwy	2.218	-	-	2.218	-	-	3.518	4.018	3.318	3.518	4.018	3.318
Pot Cap-1 Maneuver	1217	-	-	1447	-	-	508	475	914	533	516	764
Stage 1	-	-	-	-	-	-	868	785	-	713	669	-
Stage 2	-	-	-	-	-	-	684	625	-	865	783	-
Platoon blocked, %		-	-	-	-	-						
Mov Cap-1 Maneuver	1217	-	-	1447	-	-	503	472	914	527	512	764
Mov Cap-2 Maneuver	-	-	-	-	-	-	503	472	-	527	512	-
Stage 1	-	-	-	-	-	-	868	785	-	713	664	-
Stage 2	-	-	-	-	-	-	677	621	-	859	783	-

Approach	SE		NW			NE			SW		
HCM Control Delay, s	0		0.2			9			12.2		
HCM LOS						A			B		

Minor Lane/Major Mvmt	NELn1	NWL	NWT	NWR	SEL	SET	SERSWLn1
Capacity (veh/h)	914	1447	-	-	1217	-	539
HCM Lane V/C Ratio	0.007	0.007	-	-	-	-	0.067
HCM Control Delay (s)	9	7.5	-	-	0	-	12.2
HCM Lane LOS	A	A	-	-	A	-	B
HCM 95th %tile Q(veh)	0	0	-	-	0	-	0.2

HCM 6th TWSC  
3: Pinfeather Dr/Pitcher Pt & Sneffels St

Existing  
PM

Intersection												
Int Delay, s/veh	1.9											
Movement	SEL	SET	SER	NWL	NWT	NWR	NEL	NET	NER	SWL	SWT	SWR
Lane Configurations	↖	↗		↖	↗	↖		↕			↕	
Traffic Vol, veh/h	6	72	3	11	171	48	1	0	10	31	0	3
Future Vol, veh/h	6	72	3	11	171	48	1	0	10	31	0	3
Conflicting Peds, #/hr	0	0	0	0	0	0	0	0	0	0	0	0
Sign Control	Free	Free	Free	Free	Free	Free	Stop	Stop	Stop	Stop	Stop	Stop
RT Channelized	-	-	None	-	-	None	-	-	None	-	-	None
Storage Length	50	-	-	50	-	0	-	-	-	-	-	-
Veh in Median Storage, #	-	0	-	-	0	-	-	0	-	-	0	-
Grade, %	-	0	-	-	0	-	-	0	-	-	0	-
Peak Hour Factor	87	87	87	87	87	87	78	78	78	78	78	78
Heavy Vehicles, %	2	2	2	2	2	2	2	2	2	2	2	2
Mvmt Flow	7	83	3	13	197	55	1	0	13	40	0	4



























Major/Minor	Major1			Major2			Minor1			Minor2		
Conflicting Flow All	252	0	0	86	0	0	352	377	85	328	323	197
Stage 1	-	-	-	-	-	-	99	99	-	223	223	-
Stage 2	-	-	-	-	-	-	253	278	-	105	100	-
Critical Hdwy	4.12	-	-	4.12	-	-	7.12	6.52	6.22	7.12	6.52	6.22
Critical Hdwy Stg 1	-	-	-	-	-	-	6.12	5.52	-	6.12	5.52	-
Critical Hdwy Stg 2	-	-	-	-	-	-	6.12	5.52	-	6.12	5.52	-
Follow-up Hdwy	2.218	-	-	2.218	-	-	3.518	4.018	3.318	3.518	4.018	3.318
Pot Cap-1 Maneuver	1313	-	-	1510	-	-	603	555	974	625	595	844
Stage 1	-	-	-	-	-	-	907	813	-	780	719	-
Stage 2	-	-	-	-	-	-	751	680	-	901	812	-
Platoon blocked, %	-	-	-	-	-	-	-	-	-	-	-	-
Mov Cap-1 Maneuver	1313	-	-	1510	-	-	594	547	974	610	587	844
Mov Cap-2 Maneuver	-	-	-	-	-	-	594	547	-	610	587	-
Stage 1	-	-	-	-	-	-	902	809	-	776	713	-
Stage 2	-	-	-	-	-	-	741	674	-	884	808	-

Approach	SE			NW			NE			SW		
HCM Control Delay, s	0.6			0.4			9			11.2		
HCM LOS							A			B		

Minor Lane/Major Mvmt	NELn1	NWL	NWT	NWR	SEL	SET	SERSWLn1
Capacity (veh/h)	920	1510	-	-	1313	-	625
HCM Lane V/C Ratio	0.015	0.008	-	-	0.005	-	0.07
HCM Control Delay (s)	9	7.4	-	-	7.8	-	11.2
HCM Lane LOS	A	A	-	-	A	-	B
HCM 95th %tile Q(veh)	0	0	-	-	0	-	0.2

Lanes, Volumes, Timings  
1: Sneffels St & Mesa Ridge Pkwy

Short-Term Baseline  
AM

													
Lane Group	EBL	EBT	EBR	WBL	WBT	WBR	SEL	SET	SER	NWL	NWT	NWR	
Lane Configurations													
Traffic Volume (vph)	135	500	40	55	850	40	70	15	260	65	15	85	
Future Volume (vph)	135	500	40	55	850	40	70	15	260	65	15	85	
Ideal Flow (vphpl)	1900	1900	1900	1900	1900	1900	1900	1900	1900	1900	1900	1900	
Storage Length (ft)	325		315	510		225	160		160	315		0	
Storage Lanes	1		1	1		1	1		1	1		1	
Taper Length (ft)	160			170			75			120			
Lane Util. Factor	1.00	0.95	1.00	1.00	0.95	1.00	1.00	1.00	1.00	1.00	1.00	1.00	
Frt			0.850			0.850			0.850			0.850	
Flt Protected	0.950			0.950			0.950			0.950			
Satd. Flow (prot)	1770	3539	1583	1770	3539	1583	1770	1863	1583	1770	1863	1583	
Flt Permitted	0.950			0.950			0.746			0.747			
Satd. Flow (perm)	1770	3539	1583	1770	3539	1583	1390	1863	1583	1391	1863	1583	
Right Turn on Red			Yes			Yes			Yes			Yes	
Satd. Flow (RTOR)			118			118			283			155	
Link Speed (mph)		55			55			25				25	
Link Distance (ft)		1962			1437			447				886	
Travel Time (s)		24.3			17.8			12.2				24.2	
Peak Hour Factor	0.93	0.93	0.93	0.93	0.93	0.93	0.92	0.92	0.92	0.87	0.87	0.87	
Adj. Flow (vph)	145	538	43	59	914	43	76	16	283	75	17	98	
Shared Lane Traffic (%)													
Lane Group Flow (vph)	145	538	43	59	914	43	76	16	283	75	17	98	
Enter Blocked Intersection	No	No	No	No	No	No	No	No	No	No	No	No	
Lane Alignment	Left	Left	Right	Left	Left	Right	Left	Left	Right	Left	Left	Right	
Median Width(ft)		12			12			12				12	
Link Offset(ft)		0			0			0				0	
Crosswalk Width(ft)		16			16			16				16	
Two way Left Turn Lane													
Headway Factor	1.00	1.00	1.00	1.00	1.00	1.00	1.00	1.00	1.00	1.00	1.00	1.00	
Turning Speed (mph)	15		9	15		9	15		9	15		9	
Number of Detectors	1	2	1	1	2	1	1	2	1	1	2	1	
Detector Template	Left	Thru	Right	Left	Thru	Right	Left	Thru	Right	Left	Thru	Right	
Leading Detector (ft)	20	100	20	20	100	20	20	100	20	20	100	20	
Trailing Detector (ft)	0	0	0	0	0	0	0	0	0	0	0	0	
Detector 1 Position(ft)	0	0	0	0	0	0	0	0	0	0	0	0	
Detector 1 Size(ft)	20	6	20	20	6	20	20	6	20	20	6	20	
Detector 1 Type	Cl+Ex	Cl+Ex	Cl+Ex	Cl+Ex	Cl+Ex	Cl+Ex	Cl+Ex	Cl+Ex	Cl+Ex	Cl+Ex	Cl+Ex	Cl+Ex	
Detector 1 Channel													
Detector 1 Extend (s)	0.0	0.0	0.0	0.0	0.0	0.0	0.0	0.0	0.0	0.0	0.0	0.0	
Detector 1 Queue (s)	0.0	0.0	0.0	0.0	0.0	0.0	0.0	0.0	0.0	0.0	0.0	0.0	
Detector 1 Delay (s)	0.0	0.0	0.0	0.0	0.0	0.0	0.0	0.0	0.0	0.0	0.0	0.0	
Detector 2 Position(ft)		94			94			94				94	
Detector 2 Size(ft)		6			6			6				6	
Detector 2 Type		Cl+Ex			Cl+Ex			Cl+Ex				Cl+Ex	
Detector 2 Channel													
Detector 2 Extend (s)		0.0			0.0			0.0				0.0	
Turn Type	Prot	NA	Perm	Prot	NA	Perm	Perm	NA	Perm	Perm	NA	Perm	
Protected Phases	7	4		3	8			6				2	
Permitted Phases			4			8	6		6	2		2	



Lanes, Volumes, Timings  
1: Sneffels St & Mesa Ridge Pkwy

Short-Term Baseline  
AM

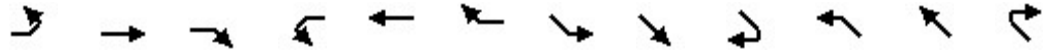

Lane Group	EBL	EBT	EBR	WBL	WBT	WBR	SEL	SET	SER	NWL	NWT	NWR
Detector Phase	7	4	4	3	8	8	6	6	6	2	2	2
Switch Phase												
Minimum Initial (s)	5.0	5.0	5.0	5.0	5.0	5.0	5.0	5.0	5.0	5.0	5.0	5.0
Minimum Split (s)	9.5	25.0	25.0	9.5	25.0	25.0	23.0	23.0	23.0	23.0	23.0	23.0
Total Split (s)	15.0	31.0	31.0	15.0	31.0	31.0	14.0	14.0	14.0	14.0	14.0	14.0
Total Split (%)	25.0%	51.7%	51.7%	25.0%	51.7%	51.7%	23.3%	23.3%	23.3%	23.3%	23.3%	23.3%
Maximum Green (s)	10.5	24.0	24.0	10.5	24.0	24.0	9.0	9.0	9.0	9.0	9.0	9.0
Yellow Time (s)	3.5	5.0	5.0	3.5	5.0	5.0	3.0	3.0	3.0	3.0	3.0	3.0
All-Red Time (s)	1.0	2.0	2.0	1.0	2.0	2.0	2.0	2.0	2.0	2.0	2.0	2.0
Lost Time Adjust (s)	0.0	0.0	0.0	0.0	0.0	0.0	0.0	0.0	0.0	0.0	0.0	0.0
Total Lost Time (s)	4.5	7.0	7.0	4.5	7.0	7.0	5.0	5.0	5.0	5.0	5.0	5.0
Lead/Lag	Lead	Lag	Lag	Lead	Lag	Lag						
Lead-Lag Optimize?	Yes	Yes	Yes	Yes	Yes	Yes						
Vehicle Extension (s)	3.0	3.0	3.0	3.0	3.0	3.0	3.0	3.0	3.0	3.0	3.0	3.0
Recall Mode	None	None	None	None	None	None	C-Max	C-Max	C-Max	C-Max	C-Max	C-Max
Act Effct Green (s)	9.2	24.9	24.9	7.5	21.2	21.2	15.3	15.3	15.3	15.3	15.3	15.3
Actuated g/C Ratio	0.15	0.42	0.42	0.12	0.35	0.35	0.26	0.26	0.26	0.26	0.26	0.26
v/c Ratio	0.54	0.37	0.06	0.27	0.73	0.07	0.21	0.03	0.46	0.21	0.04	0.19
Control Delay	30.8	12.8	0.1	26.2	20.5	0.2	24.1	21.9	6.5	24.0	22.0	2.7
Queue Delay	0.0	0.0	0.0	0.0	0.0	0.0	0.0	0.0	0.0	0.0	0.0	0.0
Total Delay	30.8	12.8	0.1	26.2	20.5	0.2	24.1	21.9	6.5	24.0	22.0	2.7
LOS	C	B	A	C	C	A	C	C	A	C	C	A
Approach Delay		15.7			20.0			10.7			12.8	
Approach LOS		B			C			B			B	
Queue Length 50th (ft)	48	67	0	20	144	0	24	5	0	23	5	0
Queue Length 95th (ft)	95	102	0	47	191	0	60	19	57	57	20	13
Internal Link Dist (ft)		1882			1357			367			806	
Turn Bay Length (ft)	325		315	510		225	160		160	315		
Base Capacity (vph)	309	1555	762	309	1415	704	354	475	614	354	475	519
Starvation Cap Reductn	0	0	0	0	0	0	0	0	0	0	0	0
Spillback Cap Reductn	0	0	0	0	0	0	0	0	0	0	0	0
Storage Cap Reductn	0	0	0	0	0	0	0	0	0	0	0	0
Reduced v/c Ratio	0.47	0.35	0.06	0.19	0.65	0.06	0.21	0.03	0.46	0.21	0.04	0.19

Intersection Summary

Area Type: Other  
 Cycle Length: 60  
 Actuated Cycle Length: 60  
 Offset: 0 (0%), Referenced to phase 2:NWTL and 6:SETL, Start of Green  
 Natural Cycle: 60  
 Control Type: Actuated-Coordinated  
 Maximum v/c Ratio: 0.73  
 Intersection Signal Delay: 16.5  
 Intersection LOS: B  
 Intersection Capacity Utilization 57.9%  
 ICU Level of Service B  
 Analysis Period (min) 15

Splits and Phases: 1: Sneffels St & Mesa Ridge Pkwy

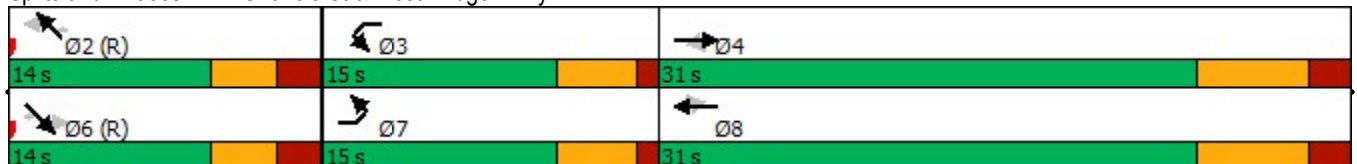

Intersection												
Int Delay, s/veh	1.4											
Movement	SEL	SET	SER	NWL	NWT	NWR	NEL	NET	NER	SWL	SWT	SWR
Lane Configurations	↖	↗		↖	↗	↖		↕			↕	
Traffic Vol, veh/h	1	303	5	7	148	35	2	0	5	40	0	1
Future Vol, veh/h	1	303	5	7	148	35	2	0	5	40	0	1
Conflicting Peds, #/hr	0	0	0	0	0	0	0	0	0	0	0	0
Sign Control	Free	Free	Free	Free	Free	Free	Stop	Stop	Stop	Stop	Stop	Stop
RT Channelized	-	-	None	-	-	None	-	-	None	-	-	Stop
Storage Length	50	-	-	85	-	190	-	-	-	-	-	-
Veh in Median Storage, #	-	0	-	-	0	-	-	0	-	-	0	-
Grade, %	-	0	-	-	0	-	-	0	-	-	0	-
Peak Hour Factor	92	92	92	87	87	87	78	78	78	78	78	78
Heavy Vehicles, %	2	2	2	2	2	2	2	2	2	2	2	2
Mvmt Flow	1	329	5	8	170	40	3	0	6	51	0	1

Major/Minor	Major1			Major2			Minor1			Minor2		
Conflicting Flow All	210	0	0	334	0	0	540	560	332	523	522	170
Stage 1	-	-	-	-	-	-	334	334	-	186	186	-
Stage 2	-	-	-	-	-	-	206	226	-	337	336	-
Critical Hdwy	4.12	-	-	4.12	-	-	7.12	6.52	6.22	7.12	6.52	6.22
Critical Hdwy Stg 1	-	-	-	-	-	-	6.12	5.52	-	6.12	5.52	-
Critical Hdwy Stg 2	-	-	-	-	-	-	6.12	5.52	-	6.12	5.52	-
Follow-up Hdwy	2.218	-	-	2.218	-	-	3.518	4.018	3.318	3.518	4.018	3.318
Pot Cap-1 Maneuver	1361	-	-	1225	-	-	453	437	710	465	459	874
Stage 1	-	-	-	-	-	-	680	643	-	816	746	-
Stage 2	-	-	-	-	-	-	796	717	-	677	642	-
Platoon blocked, %	-	-	-	-	-	-	-	-	-	-	-	-
Mov Cap-1 Maneuver	1361	-	-	1225	-	-	450	434	710	458	455	874
Mov Cap-2 Maneuver	-	-	-	-	-	-	450	434	-	458	455	-
Stage 1	-	-	-	-	-	-	679	642	-	815	741	-
Stage 2	-	-	-	-	-	-	790	712	-	670	641	-

Approach	SE			NW			NE			SW		
HCM Control Delay, s	0			0.3			11			13.8		
HCM LOS							B			B		

Minor Lane/Major Mvmt	NELn1	NWL	NWT	NWR	SEL	SET	SERSWLn1
Capacity (veh/h)	609	1225	-	-	1361	-	463
HCM Lane V/C Ratio	0.015	0.007	-	-	0.001	-	0.114
HCM Control Delay (s)	11	8	-	-	7.6	-	13.8
HCM Lane LOS	B	A	-	-	A	-	B
HCM 95th %tile Q(veh)	0	0	-	-	0	-	0.4

Intersection												
Int Delay, s/veh	1.9											
Movement	SEL	SET	SER	NWL	NWT	NWR	NEL	NET	NER	SWL	SWT	SWR
Lane Configurations												
Traffic Vol, veh/h	2	273	1	20	124	10	10	0	1	35	0	3
Future Vol, veh/h	2	273	1	20	124	10	10	0	1	35	0	3
Conflicting Peds, #/hr	0	0	0	0	0	0	0	0	0	0	0	0
Sign Control	Free	Free	Free	Free	Free	Free	Stop	Stop	Stop	Stop	Stop	Stop
RT Channelized	-	-	None	-	-	None	-	-	None	-	-	None
Storage Length	50	-	-	50	-	0	-	-	-	-	-	-
Veh in Median Storage, #	-	0	-	-	0	-	-	0	-	-	0	-
Grade, %	-	0	-	-	0	-	-	0	-	-	0	-
Peak Hour Factor	92	92	92	87	87	87	78	78	78	78	78	78
Heavy Vehicles, %	2	2	2	2	2	2	2	2	2	2	2	2
Mvmt Flow	2	297	1	23	143	11	13	0	1	45	0	4

Major/Minor	Major1			Major2			Minor1			Minor2		
Conflicting Flow All	154	0	0	298	0	0	499	502	298	491	491	143
Stage 1	-	-	-	-	-	-	302	302	-	189	189	-
Stage 2	-	-	-	-	-	-	197	200	-	302	302	-
Critical Hdwy	4.12	-	-	4.12	-	-	7.12	6.52	6.22	7.12	6.52	6.22
Critical Hdwy Stg 1	-	-	-	-	-	-	6.12	5.52	-	6.12	5.52	-
Critical Hdwy Stg 2	-	-	-	-	-	-	6.12	5.52	-	6.12	5.52	-
Follow-up Hdwy	2.218	-	-	2.218	-	-	3.518	4.018	3.318	3.518	4.018	3.318
Pot Cap-1 Maneuver	1426	-	-	1263	-	-	482	471	741	488	478	905
Stage 1	-	-	-	-	-	-	707	664	-	813	744	-
Stage 2	-	-	-	-	-	-	805	736	-	707	664	-
Platoon blocked, %	-	-	-	-	-	-	-	-	-	-	-	-
Mov Cap-1 Maneuver	1426	-	-	1263	-	-	473	462	741	480	469	905
Mov Cap-2 Maneuver	-	-	-	-	-	-	473	462	-	480	469	-
Stage 1	-	-	-	-	-	-	706	663	-	812	731	-
Stage 2	-	-	-	-	-	-	787	723	-	705	663	-

Approach	SE	NW	NE	SW
HCM Control Delay, s	0.1	1	12.6	13
HCM LOS			B	B

Minor Lane/Major Mvmt	NELn1	NWL	NWT	NWR	SEL	SET	SERSWLn1
Capacity (veh/h)	489	1263	-	-	1426	-	498
HCM Lane V/C Ratio	0.029	0.018	-	-	0.002	-	0.098
HCM Control Delay (s)	12.6	7.9	-	-	7.5	-	13
HCM Lane LOS	B	A	-	-	A	-	B
HCM 95th %tile Q(veh)	0.1	0.1	-	-	0	-	0.3

Lanes, Volumes, Timings  
1: Sneffels St & Mesa Ridge Pkwy

Short-Term Baseline  
PM

Lane Group	EBL	EBT	EBR	WBL	WBT	WBR	SEL	SET	SER	NWL	NWT	NWR
Lane Configurations												
Traffic Volume (vph)	225	1150	300	120	700	85	50	30	125	50	25	145
Future Volume (vph)	225	1150	300	120	700	85	50	30	125	50	25	145
Ideal Flow (vphpl)	1900	1900	1900	1900	1900	1900	1900	1900	1900	1900	1900	1900
Storage Length (ft)	325		315	510		225	160		160	315		0
Storage Lanes	1		1	1		1	1		1	1		1
Taper Length (ft)	160			170			75			120		
Lane Util. Factor	1.00	0.95	1.00	1.00	0.95	1.00	1.00	1.00	1.00	1.00	1.00	1.00
Frt			0.850			0.850			0.850			0.850
Flt Protected	0.950			0.950			0.950			0.950		
Satd. Flow (prot)	1770	3539	1583	1770	3539	1583	1770	1863	1583	1770	1863	1583
Flt Permitted	0.950			0.950			0.738			0.735		
Satd. Flow (perm)	1770	3539	1583	1770	3539	1583	1375	1863	1583	1369	1863	1583
Right Turn on Red			Yes			Yes			Yes			Yes
Satd. Flow (RTOR)			316			118			155			167
Link Speed (mph)		55			55			25			25	
Link Distance (ft)		1962			1437			447			886	
Travel Time (s)		24.3			17.8			12.2			24.2	
Peak Hour Factor	0.95	0.95	0.95	0.93	0.93	0.93	0.87	0.87	0.87	0.87	0.87	0.87
Adj. Flow (vph)	237	1211	316	129	753	91	57	34	144	57	29	167
Shared Lane Traffic (%)												
Lane Group Flow (vph)	237	1211	316	129	753	91	57	34	144	57	29	167
Enter Blocked Intersection	No	No	No	No	No	No	No	No	No	No	No	No
Lane Alignment	Left	Left	Right	Left	Left	Right	Left	Left	Right	Left	Left	Right
Median Width(ft)		12			12			12			12	
Link Offset(ft)		0			0			0			0	
Crosswalk Width(ft)		16			16			16			16	
Two way Left Turn Lane												
Headway Factor	1.00	1.00	1.00	1.00	1.00	1.00	1.00	1.00	1.00	1.00	1.00	1.00
Turning Speed (mph)	15		9	15		9	15		9	15		9
Number of Detectors	1	2	1	1	2	1	1	2	1	1	2	1
Detector Template	Left	Thru	Right	Left	Thru	Right	Left	Thru	Right	Left	Thru	Right
Leading Detector (ft)	20	100	20	20	100	20	20	100	20	20	100	20
Trailing Detector (ft)	0	0	0	0	0	0	0	0	0	0	0	0
Detector 1 Position(ft)	0	0	0	0	0	0	0	0	0	0	0	0
Detector 1 Size(ft)	20	6	20	20	6	20	20	6	20	20	6	20
Detector 1 Type	Cl+Ex	Cl+Ex	Cl+Ex	Cl+Ex	Cl+Ex	Cl+Ex	Cl+Ex	Cl+Ex	Cl+Ex	Cl+Ex	Cl+Ex	Cl+Ex
Detector 1 Channel												
Detector 1 Extend (s)	0.0	0.0	0.0	0.0	0.0	0.0	0.0	0.0	0.0	0.0	0.0	0.0
Detector 1 Queue (s)	0.0	0.0	0.0	0.0	0.0	0.0	0.0	0.0	0.0	0.0	0.0	0.0
Detector 1 Delay (s)	0.0	0.0	0.0	0.0	0.0	0.0	0.0	0.0	0.0	0.0	0.0	0.0
Detector 2 Position(ft)		94			94			94			94	
Detector 2 Size(ft)		6			6			6			6	
Detector 2 Type		Cl+Ex			Cl+Ex			Cl+Ex			Cl+Ex	
Detector 2 Channel												
Detector 2 Extend (s)		0.0			0.0			0.0			0.0	
Turn Type	Prot	NA	Perm	Prot	NA	Perm	Perm	NA	Perm	Perm	NA	Perm
Protected Phases	7	4		3	8			6			2	
Permitted Phases			4			8	6		6	2		2

Lanes, Volumes, Timings  
1: Sneffels St & Mesa Ridge Pkwy

Short-Term Baseline  
PM

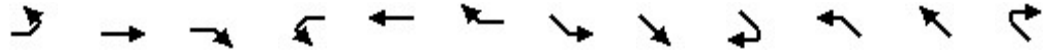







Lane Group	EBL	EBT	EBR	WBL	WBT	WBR	SEL	SET	SER	NWL	NWT	NWR
Detector Phase	7	4	4	3	8	8	6	6	6	2	2	2
Switch Phase												
Minimum Initial (s)	5.0	5.0	5.0	5.0	5.0	5.0	5.0	5.0	5.0	5.0	5.0	5.0
Minimum Split (s)	9.5	25.0	25.0	9.5	25.0	25.0	23.0	23.0	23.0	23.0	23.0	23.0
Total Split (s)	15.0	31.0	31.0	15.0	31.0	31.0	14.0	14.0	14.0	14.0	14.0	14.0
Total Split (%)	25.0%	51.7%	51.7%	25.0%	51.7%	51.7%	23.3%	23.3%	23.3%	23.3%	23.3%	23.3%
Maximum Green (s)	10.5	24.0	24.0	10.5	24.0	24.0	9.0	9.0	9.0	9.0	9.0	9.0
Yellow Time (s)	3.5	5.0	5.0	3.5	5.0	5.0	3.0	3.0	3.0	3.0	3.0	3.0
All-Red Time (s)	1.0	2.0	2.0	1.0	2.0	2.0	2.0	2.0	2.0	2.0	2.0	2.0
Lost Time Adjust (s)	0.0	0.0	0.0	0.0	0.0	0.0	0.0	0.0	0.0	0.0	0.0	0.0
Total Lost Time (s)	4.5	7.0	7.0	4.5	7.0	7.0	5.0	5.0	5.0	5.0	5.0	5.0
Lead/Lag	Lead	Lag	Lag	Lead	Lag	Lag						
Lead-Lag Optimize?	Yes	Yes	Yes	Yes	Yes	Yes						
Vehicle Extension (s)	3.0	3.0	3.0	3.0	3.0	3.0	3.0	3.0	3.0	3.0	3.0	3.0
Recall Mode	None	None	None	None	None	None	C-Max	C-Max	C-Max	C-Max	C-Max	C-Max
Act Effct Green (s)	10.2	25.3	25.3	8.9	21.9	21.9	11.4	11.4	11.4	11.4	11.4	11.4
Actuated g/C Ratio	0.17	0.42	0.42	0.15	0.36	0.36	0.19	0.19	0.19	0.19	0.19	0.19
v/c Ratio	0.79	0.81	0.37	0.49	0.58	0.14	0.22	0.10	0.34	0.22	0.08	0.38
Control Delay	45.2	21.7	3.2	29.6	17.0	2.4	25.2	23.0	6.8	25.3	22.8	7.6
Queue Delay	0.0	0.0	0.0	0.0	0.0	0.0	0.0	0.0	0.0	0.0	0.0	0.0
Total Delay	45.2	21.7	3.2	29.6	17.0	2.4	25.2	23.0	6.8	25.3	22.8	7.6
LOS	D	C	A	C	B	A	C	C	A	C	C	A
Approach Delay		21.5			17.3			13.6			13.3	
Approach LOS		C			B			B			B	
Queue Length 50th (ft)	83	195	0	43	105	0	19	11	0	19	9	0
Queue Length 95th (ft)	#183	#320	40	87	151	16	46	31	35	46	28	41
Internal Link Dist (ft)		1882			1357			367			806	
Turn Bay Length (ft)	325		315	510		225	160		160	315		
Base Capacity (vph)	309	1489	849	309	1415	704	261	354	426	260	354	436
Starvation Cap Reductn	0	0	0	0	0	0	0	0	0	0	0	0
Spillback Cap Reductn	0	0	0	0	0	0	0	0	0	0	0	0
Storage Cap Reductn	0	0	0	0	0	0	0	0	0	0	0	0
Reduced v/c Ratio	0.77	0.81	0.37	0.42	0.53	0.13	0.22	0.10	0.34	0.22	0.08	0.38

Intersection Summary

Area Type: Other  
 Cycle Length: 60  
 Actuated Cycle Length: 60  
 Offset: 0 (0%), Referenced to phase 2:NWTL and 6:SETL, Start of Green  
 Natural Cycle: 65  
 Control Type: Actuated-Coordinated  
 Maximum v/c Ratio: 0.81  
 Intersection Signal Delay: 19.0 Intersection LOS: B  
 Intersection Capacity Utilization 61.6% ICU Level of Service B  
 Analysis Period (min) 15  
 # 95th percentile volume exceeds capacity, queue may be longer.  
 Queue shown is maximum after two cycles.

Splits and Phases: 1: Sneffels St & Mesa Ridge Pkwy

 Ø2 (R) 14 s	 Ø3 15 s	 Ø4 31 s
 Ø6 (R) 14 s	 Ø7 15 s	 Ø8 31 s

Intersection												
Int Delay, s/veh	1.1											
Movement	SEL	SET	SER	NWL	NWT	NWR	NEL	NET	NER	SWL	SWT	SWR
Lane Configurations	↖	↗		↖	↗	↖		↕			↕	
Traffic Vol, veh/h	1	183	5	10	265	65	1	0	7	30	0	3
Future Vol, veh/h	1	183	5	10	265	65	1	0	7	30	0	3
Conflicting Peds, #/hr	0	0	0	0	0	0	0	0	0	0	0	0
Sign Control	Free	Free	Free	Free	Free	Free	Stop	Stop	Stop	Stop	Stop	Stop
RT Channelized	-	-	None	-	-	None	-	-	None	-	-	Stop
Storage Length	50	-	-	85	-	190	-	-	-	-	-	-
Veh in Median Storage, #	-	0	-	-	0	-	-	0	-	-	0	-
Grade, %	-	0	-	-	0	-	-	0	-	-	0	-
Peak Hour Factor	87	87	87	92	92	92	78	78	78	83	83	83
Heavy Vehicles, %	2	2	2	2	2	2	2	2	2	2	2	2
Mvmt Flow	1	210	6	11	288	71	1	0	9	36	0	4

Major/Minor	Major1			Major2			Minor1			Minor2		
Conflicting Flow All	359	0	0	216	0	0	561	596	213	530	528	288
Stage 1	-	-	-	-	-	-	215	215	-	310	310	-
Stage 2	-	-	-	-	-	-	346	381	-	220	218	-
Critical Hdwy	4.12	-	-	4.12	-	-	7.12	6.52	6.22	7.12	6.52	6.22
Critical Hdwy Stg 1	-	-	-	-	-	-	6.12	5.52	-	6.12	5.52	-
Critical Hdwy Stg 2	-	-	-	-	-	-	6.12	5.52	-	6.12	5.52	-
Follow-up Hdwy	2.218	-	-	2.218	-	-	3.518	4.018	3.318	3.518	4.018	3.318
Pot Cap-1 Maneuver	1200	-	-	1354	-	-	438	417	827	460	456	751
Stage 1	-	-	-	-	-	-	787	725	-	700	659	-
Stage 2	-	-	-	-	-	-	670	613	-	782	723	-
Platoon blocked, %	-	-	-	-	-	-	-	-	-	-	-	-
Mov Cap-1 Maneuver	1200	-	-	1354	-	-	433	413	827	452	452	751
Mov Cap-2 Maneuver	-	-	-	-	-	-	433	413	-	452	452	-
Stage 1	-	-	-	-	-	-	786	724	-	699	654	-
Stage 2	-	-	-	-	-	-	661	608	-	773	722	-

Approach	SE			NW			NE			SW		
HCM Control Delay, s	0			0.2			9.9			13.4		
HCM LOS							A			B		

Minor Lane/Major Mvmt	NELn1	NWL	NWT	NWR	SEL	SET	SERSWLn1
Capacity (veh/h)	743	1354	-	-	1200	-	469
HCM Lane V/C Ratio	0.014	0.008	-	-	0.001	-	0.085
HCM Control Delay (s)	9.9	7.7	-	-	8	-	13.4
HCM Lane LOS	A	A	-	-	A	-	B
HCM 95th %tile Q(veh)	0	0	-	-	0	-	0.3

Intersection												
Int Delay, s/veh	1.8											
Movement	SEL	SET	SER	NWL	NWT	NWR	NEL	NET	NER	SWL	SWT	SWR
Lane Configurations	↖	↗		↖	↗	↖		↕			↕	
Traffic Vol, veh/h	7	142	4	15	204	50	2	0	12	35	0	3
Future Vol, veh/h	7	142	4	15	204	50	2	0	12	35	0	3
Conflicting Peds, #/hr	0	0	0	0	0	0	0	0	0	0	0	0
Sign Control	Free	Free	Free	Free	Free	Free	Stop	Stop	Stop	Stop	Stop	Stop
RT Channelized	-	-	None	-	-	None	-	-	None	-	-	None
Storage Length	50	-	-	50	-	0	-	-	-	-	-	-
Veh in Median Storage, #	-	0	-	-	0	-	-	0	-	-	0	-
Grade, %	-	0	-	-	0	-	-	0	-	-	0	-
Peak Hour Factor	87	87	87	87	87	87	78	78	78	78	78	78
Heavy Vehicles, %	2	2	2	2	2	2	2	2	2	2	2	2
Mvmt Flow	8	163	5	17	234	57	3	0	15	45	0	4

Major/Minor	Major1			Major2			Minor1			Minor2		
Conflicting Flow All	291	0	0	168	0	0	481	507	166	457	452	234
Stage 1	-	-	-	-	-	-	182	182	-	268	268	-
Stage 2	-	-	-	-	-	-	299	325	-	189	184	-
Critical Hdwy	4.12	-	-	4.12	-	-	7.12	6.52	6.22	7.12	6.52	6.22
Critical Hdwy Stg 1	-	-	-	-	-	-	6.12	5.52	-	6.12	5.52	-
Critical Hdwy Stg 2	-	-	-	-	-	-	6.12	5.52	-	6.12	5.52	-
Follow-up Hdwy	2.218	-	-	2.218	-	-	3.518	4.018	3.318	3.518	4.018	3.318
Pot Cap-1 Maneuver	1271	-	-	1410	-	-	495	468	878	514	503	805
Stage 1	-	-	-	-	-	-	820	749	-	738	687	-
Stage 2	-	-	-	-	-	-	710	649	-	813	747	-
Platoon blocked, %	-	-	-	-	-	-	-	-	-	-	-	-
Mov Cap-1 Maneuver	1271	-	-	1410	-	-	486	460	878	498	494	805
Mov Cap-2 Maneuver	-	-	-	-	-	-	486	460	-	498	494	-
Stage 1	-	-	-	-	-	-	815	745	-	734	679	-
Stage 2	-	-	-	-	-	-	698	641	-	794	743	-

























Approach	SE			NW			NE			SW		
HCM Control Delay, s	0.4			0.4			9.7			12.8		
HCM LOS							A			B		

Minor Lane/Major Mvmt	NELn1	NWL	NWT	NWR	SEL	SET	SERSWLn1
Capacity (veh/h)	787	1410	-	-	1271	-	513
HCM Lane V/C Ratio	0.023	0.012	-	-	0.006	-	0.095
HCM Control Delay (s)	9.7	7.6	-	-	7.8	-	12.8
HCM Lane LOS	A	A	-	-	A	-	B
HCM 95th %tile Q(veh)	0.1	0	-	-	0	-	0.3



Lanes, Volumes, Timings  
1: Sneffels St & Mesa Ridge Pkwy

Short-Term Baseline + Site  
AM

												
Lane Group	EBL	EBT	EBR	WBL	WBT	WBR	SEL	SET	SER	NWL	NWT	NWR
Lane Configurations												
Traffic Volume (vph)	150	500	40	55	850	46	89	19	309	65	16	85
Future Volume (vph)	150	500	40	55	850	46	89	19	309	65	16	85
Ideal Flow (vphpl)	1900	1900	1900	1900	1900	1900	1900	1900	1900	1900	1900	1900
Storage Length (ft)	578		315	510		378	160		160	315		0
Storage Lanes	1		1	1		1	1		1	1		1
Taper Length (ft)	222			170			75			120		
Lane Util. Factor	1.00	0.95	1.00	1.00	0.95	1.00	1.00	1.00	1.00	1.00	1.00	1.00
Frt			0.850			0.850			0.850			0.850
Flt Protected	0.950			0.950			0.950			0.950		
Satd. Flow (prot)	1770	3539	1583	1770	3539	1583	1770	1863	1583	1770	1863	1583
Flt Permitted	0.950			0.950			0.746			0.744		
Satd. Flow (perm)	1770	3539	1583	1770	3539	1583	1390	1863	1583	1386	1863	1583
Right Turn on Red			Yes			Yes			Yes			Yes
Satd. Flow (RTOR)			118			118			336			155
Link Speed (mph)		55			55			25			25	
Link Distance (ft)		1962			1437			447			886	
Travel Time (s)		24.3			17.8			12.2			24.2	
Peak Hour Factor	0.93	0.93	0.93	0.93	0.93	0.93	0.92	0.92	0.92	0.87	0.87	0.87
Adj. Flow (vph)	161	538	43	59	914	49	97	21	336	75	18	98
Shared Lane Traffic (%)												
Lane Group Flow (vph)	161	538	43	59	914	49	97	21	336	75	18	98
Enter Blocked Intersection	No	No	No	No	No	No	No	No	No	No	No	No
Lane Alignment	Left	Left	Right	Left	Left	Right	Left	Left	Right	Left	Left	Right
Median Width(ft)		12			12			12			12	
Link Offset(ft)		0			0			0			0	
Crosswalk Width(ft)		16			16			16			16	
Two way Left Turn Lane												
Headway Factor	1.00	1.00	1.00	1.00	1.00	1.00	1.00	1.00	1.00	1.00	1.00	1.00
Turning Speed (mph)	15		9	15		9	15		9	15		9
Number of Detectors	1	2	1	1	2	1	1	2	1	1	2	1
Detector Template	Left	Thru	Right	Left	Thru	Right	Left	Thru	Right	Left	Thru	Right
Leading Detector (ft)	20	100	20	20	100	20	20	100	20	20	100	20
Trailing Detector (ft)	0	0	0	0	0	0	0	0	0	0	0	0
Detector 1 Position(ft)	0	0	0	0	0	0	0	0	0	0	0	0
Detector 1 Size(ft)	20	6	20	20	6	20	20	6	20	20	6	20
Detector 1 Type	Cl+Ex	Cl+Ex	Cl+Ex	Cl+Ex	Cl+Ex	Cl+Ex	Cl+Ex	Cl+Ex	Cl+Ex	Cl+Ex	Cl+Ex	Cl+Ex
Detector 1 Channel												
Detector 1 Extend (s)	0.0	0.0	0.0	0.0	0.0	0.0	0.0	0.0	0.0	0.0	0.0	0.0
Detector 1 Queue (s)	0.0	0.0	0.0	0.0	0.0	0.0	0.0	0.0	0.0	0.0	0.0	0.0
Detector 1 Delay (s)	0.0	0.0	0.0	0.0	0.0	0.0	0.0	0.0	0.0	0.0	0.0	0.0
Detector 2 Position(ft)		94			94			94			94	
Detector 2 Size(ft)		6			6			6			6	
Detector 2 Type		Cl+Ex			Cl+Ex			Cl+Ex			Cl+Ex	
Detector 2 Channel												
Detector 2 Extend (s)		0.0			0.0			0.0			0.0	
Turn Type	Prot	NA	Perm	Prot	NA	Perm	Perm	NA	Perm	Perm	NA	Perm
Protected Phases	7	4		3	8			6			2	
Permitted Phases			4			8	6		6	2		2

Lanes, Volumes, Timings  
1: Sneffels St & Mesa Ridge Pkwy

Short-Term Baseline + Site  
AM

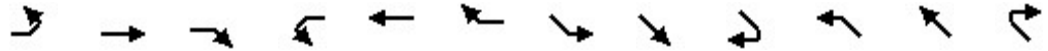

Lane Group	EBL	EBT	EBR	WBL	WBT	WBR	SEL	SET	SER	NWL	NWT	NWR
Detector Phase	7	4	4	3	8	8	6	6	6	2	2	2
Switch Phase												
Minimum Initial (s)	5.0	5.0	5.0	5.0	5.0	5.0	5.0	5.0	5.0	5.0	5.0	5.0
Minimum Split (s)	9.5	25.0	25.0	9.5	25.0	25.0	23.0	23.0	23.0	23.0	23.0	23.0
Total Split (s)	15.0	31.0	31.0	15.0	31.0	31.0	14.0	14.0	14.0	14.0	14.0	14.0
Total Split (%)	25.0%	51.7%	51.7%	25.0%	51.7%	51.7%	23.3%	23.3%	23.3%	23.3%	23.3%	23.3%
Maximum Green (s)	10.5	24.0	24.0	10.5	24.0	24.0	9.0	9.0	9.0	9.0	9.0	9.0
Yellow Time (s)	3.5	5.0	5.0	3.5	5.0	5.0	3.0	3.0	3.0	3.0	3.0	3.0
All-Red Time (s)	1.0	2.0	2.0	1.0	2.0	2.0	2.0	2.0	2.0	2.0	2.0	2.0
Lost Time Adjust (s)	0.0	0.0	0.0	0.0	0.0	0.0	0.0	0.0	0.0	0.0	0.0	0.0
Total Lost Time (s)	4.5	7.0	7.0	4.5	7.0	7.0	5.0	5.0	5.0	5.0	5.0	5.0
Lead/Lag	Lead	Lag	Lag	Lead	Lag	Lag						
Lead-Lag Optimize?	Yes	Yes	Yes	Yes	Yes	Yes						
Vehicle Extension (s)	3.0	3.0	3.0	3.0	3.0	3.0	3.0	3.0	3.0	3.0	3.0	3.0
Recall Mode	None	None	None	None	None	None	C-Max	C-Max	C-Max	C-Max	C-Max	C-Max
Act Effct Green (s)	9.4	25.2	25.2	7.5	21.3	21.3	15.0	15.0	15.0	15.0	15.0	15.0
Actuated g/C Ratio	0.16	0.42	0.42	0.12	0.36	0.36	0.25	0.25	0.25	0.25	0.25	0.25
v/c Ratio	0.58	0.36	0.06	0.27	0.73	0.08	0.28	0.05	0.52	0.22	0.04	0.19
Control Delay	32.1	12.7	0.1	26.2	20.3	0.3	25.3	22.1	6.7	24.3	22.0	2.7
Queue Delay	0.0	0.0	0.0	0.0	0.0	0.0	0.0	0.0	0.0	0.0	0.0	0.0
Total Delay	32.1	12.7	0.1	26.2	20.3	0.3	25.3	22.1	6.7	24.3	22.0	2.7
LOS	C	B	A	C	C	A	C	C	A	C	C	A
Approach Delay		16.2			19.7			11.4			13.0	
Approach LOS		B			B			B			B	
Queue Length 50th (ft)	54	67	0	20	144	0	31	6	0	24	5	0
Queue Length 95th (ft)	105	102	0	47	191	1	73	23	62	57	20	13
Internal Link Dist (ft)		1882			1357			367			806	
Turn Bay Length (ft)	578		315	510		378	160		160	315		
Base Capacity (vph)	309	1573	769	309	1415	704	347	465	647	346	465	512
Starvation Cap Reductn	0	0	0	0	0	0	0	0	0	0	0	0
Spillback Cap Reductn	0	0	0	0	0	0	0	0	0	0	0	0
Storage Cap Reductn	0	0	0	0	0	0	0	0	0	0	0	0
Reduced v/c Ratio	0.52	0.34	0.06	0.19	0.65	0.07	0.28	0.05	0.52	0.22	0.04	0.19

Intersection Summary

Area Type: Other  
 Cycle Length: 60  
 Actuated Cycle Length: 60  
 Offset: 0 (0%), Referenced to phase 2:NWTL and 6:SETL, Start of Green  
 Natural Cycle: 60  
 Control Type: Actuated-Coordinated  
 Maximum v/c Ratio: 0.73  
 Intersection Signal Delay: 16.5  
 Intersection LOS: B  
 Intersection Capacity Utilization 61.0%  
 ICU Level of Service B  
 Analysis Period (min) 15

Splits and Phases: 1: Sneffels St & Mesa Ridge Pkwy

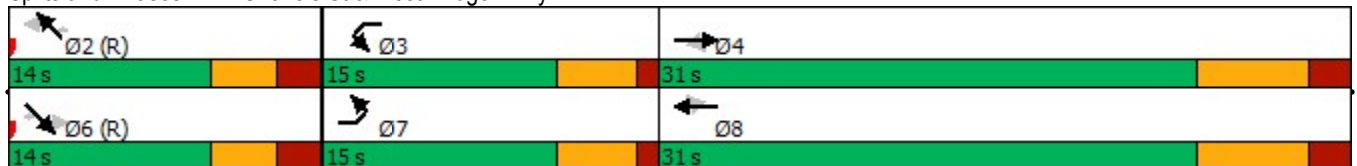

Intersection												
Int Delay, s/veh	3.3											
Movement	SEL	SET	SER	NWL	NWT	NWR	NEL	NET	NER	SWL	SWT	SWR
Lane Configurations												
Traffic Vol, veh/h	2	303	5	7	148	56	5	0	2	112	0	5
Future Vol, veh/h	2	303	5	7	148	56	5	0	2	112	0	5
Conflicting Peds, #/hr	0	0	0	0	0	0	0	0	0	0	0	0
Sign Control	Free	Free	Free	Free	Free	Free	Stop	Stop	Stop	Stop	Stop	Stop
RT Channelized	-	-	None	-	-	None	-	-	None	-	-	Stop
Storage Length	50	-	-	85	-	190	-	-	-	-	-	-
Veh in Median Storage, #	-	0	-	-	0	-	-	0	-	-	0	-
Grade, %	-	0	-	-	0	-	-	0	-	-	0	-
Peak Hour Factor	92	92	92	87	87	87	78	78	78	83	83	83
Heavy Vehicles, %	2	2	2	2	2	2	2	2	2	2	2	2
Mvmt Flow	2	329	5	8	170	64	6	0	3	135	0	6

Major/Minor	Major1			Major2			Minor1			Minor2		
Conflicting Flow All	234	0	0	334	0	0	554	586	332	523	524	170
Stage 1	-	-	-	-	-	-	336	336	-	186	186	-
Stage 2	-	-	-	-	-	-	218	250	-	337	338	-
Critical Hdwy	4.12	-	-	4.12	-	-	7.12	6.52	6.22	7.12	6.52	6.22
Critical Hdwy Stg 1	-	-	-	-	-	-	6.12	5.52	-	6.12	5.52	-
Critical Hdwy Stg 2	-	-	-	-	-	-	6.12	5.52	-	6.12	5.52	-
Follow-up Hdwy	2.218	-	-	2.218	-	-	3.518	4.018	3.318	3.518	4.018	3.318
Pot Cap-1 Maneuver	1333	-	-	1225	-	-	443	422	710	465	458	874
Stage 1	-	-	-	-	-	-	678	642	-	816	746	-
Stage 2	-	-	-	-	-	-	784	700	-	677	641	-
Platoon blocked, %	-	-	-	-	-	-	-	-	-	-	-	-
Mov Cap-1 Maneuver	1333	-	-	1225	-	-	437	418	710	460	454	874
Mov Cap-2 Maneuver	-	-	-	-	-	-	437	418	-	460	454	-
Stage 1	-	-	-	-	-	-	677	641	-	814	741	-
Stage 2	-	-	-	-	-	-	774	695	-	674	640	-

Approach	SE			NW			NE			SW		
HCM Control Delay, s	0			0.3			12.5			15.9		
HCM LOS							B			C		

Minor Lane/Major Mvmt	NELn1	NWL	NWT	NWR	SEL	SET	SERSWLn1
Capacity (veh/h)	491	1225	-	-	1333	-	470
HCM Lane V/C Ratio	0.018	0.007	-	-	0.002	-	0.3
HCM Control Delay (s)	12.5	8	-	-	7.7	-	15.9
HCM Lane LOS	B	A	-	-	A	-	C
HCM 95th %tile Q(veh)	0.1	0	-	-	0	-	1.2

Intersection												
Int Delay, s/veh	1.8											
Movement	SEL	SET	SER	NWL	NWT	NWR	NEL	NET	NER	SWL	SWT	SWR
Lane Configurations	↖	↗		↖	↗	↖		↕			↕	
Traffic Vol, veh/h	2	306	1	20	128	10	10	0	1	35	0	3
Future Vol, veh/h	2	306	1	20	128	10	10	0	1	35	0	3
Conflicting Peds, #/hr	0	0	0	0	0	0	0	0	0	0	0	0
Sign Control	Free	Free	Free	Free	Free	Free	Stop	Stop	Stop	Stop	Stop	Stop
RT Channelized	-	-	None	-	-	None	-	-	None	-	-	None
Storage Length	50	-	-	50	-	0	-	-	-	-	-	-
Veh in Median Storage, #	-	0	-	-	0	-	-	0	-	-	0	-
Grade, %	-	0	-	-	0	-	-	0	-	-	0	-
Peak Hour Factor	92	92	92	87	87	87	78	78	78	78	78	78
Heavy Vehicles, %	2	2	2	2	2	2	2	2	2	2	2	2
Mvmt Flow	2	333	1	23	147	11	13	0	1	45	0	4

























Major/Minor	Major1			Major2			Minor1			Minor2		
Conflicting Flow All	158	0	0	334	0	0	539	542	334	531	531	147
Stage 1	-	-	-	-	-	-	338	338	-	193	193	-
Stage 2	-	-	-	-	-	-	201	204	-	338	338	-
Critical Hdwy	4.12	-	-	4.12	-	-	7.12	6.52	6.22	7.12	6.52	6.22
Critical Hdwy Stg 1	-	-	-	-	-	-	6.12	5.52	-	6.12	5.52	-
Critical Hdwy Stg 2	-	-	-	-	-	-	6.12	5.52	-	6.12	5.52	-
Follow-up Hdwy	2.218	-	-	2.218	-	-	3.518	4.018	3.318	3.518	4.018	3.318
Pot Cap-1 Maneuver	1422	-	-	1225	-	-	453	447	708	459	454	900
Stage 1	-	-	-	-	-	-	676	641	-	809	741	-
Stage 2	-	-	-	-	-	-	801	733	-	676	641	-
Platoon blocked, %	-	-	-	-	-	-	-	-	-	-	-	-
Mov Cap-1 Maneuver	1422	-	-	1225	-	-	444	438	708	451	445	900
Mov Cap-2 Maneuver	-	-	-	-	-	-	444	438	-	451	445	-
Stage 1	-	-	-	-	-	-	675	640	-	808	727	-
Stage 2	-	-	-	-	-	-	783	719	-	674	640	-

Approach	SE	NW	NE	SW
HCM Control Delay, s	0	1	13.1	13.6
HCM LOS			B	B

Minor Lane/Major Mvmt	NELn1	NWL	NWT	NWR	SEL	SET	SERSWLn1
Capacity (veh/h)	460	1225	-	-	1422	-	469
HCM Lane V/C Ratio	0.031	0.019	-	-	0.002	-	0.104
HCM Control Delay (s)	13.1	8	-	-	7.5	-	13.6
HCM Lane LOS	B	A	-	-	A	-	B
HCM 95th %tile Q(veh)	0.1	0.1	-	-	0	-	0.3

Lanes, Volumes, Timings  
1: Sneffels St & Mesa Ridge Pkwy

Short-Term Baseline + Site  
PM

												
Lane Group	EBL	EBT	EBR	WBL	WBT	WBR	SEL	SET	SER	NWL	NWT	NWR
Lane Configurations												
Traffic Volume (vph)	269	1150	300	120	700	102	61	27	174	50	33	125
Future Volume (vph)	269	1150	300	120	700	102	61	27	174	50	33	125
Ideal Flow (vphpl)	1900	1900	1900	1900	1900	1900	1900	1900	1900	1900	1900	1900
Storage Length (ft)	578		315	510		378	160		160	315		0
Storage Lanes	1		1	1		1	1		1	1		1
Taper Length (ft)	222			170			75			120		
Lane Util. Factor	1.00	0.95	1.00	1.00	0.95	1.00	1.00	1.00	1.00	1.00	1.00	1.00
Frt			0.850			0.850			0.850			0.850
Flt Protected	0.950			0.950			0.950			0.950		
Satd. Flow (prot)	1770	3539	1583	1770	3539	1583	1770	1863	1583	1770	1863	1583
Flt Permitted	0.950			0.950			0.732			0.738		
Satd. Flow (perm)	1770	3539	1583	1770	3539	1583	1364	1863	1583	1375	1863	1583
Right Turn on Red			Yes			Yes			Yes			Yes
Satd. Flow (RTOR)			316			118			189			155
Link Speed (mph)		55			55			25			25	
Link Distance (ft)		1962			1437			447			886	
Travel Time (s)		24.3			17.8			12.2			24.2	
Peak Hour Factor	0.95	0.95	0.95	0.93	0.93	0.93	0.92	0.92	0.92	0.87	0.87	0.87
Adj. Flow (vph)	283	1211	316	129	753	110	66	29	189	57	38	144
Shared Lane Traffic (%)												
Lane Group Flow (vph)	283	1211	316	129	753	110	66	29	189	57	38	144
Enter Blocked Intersection	No	No	No	No	No	No	No	No	No	No	No	No
Lane Alignment	Left	Left	Right	Left	Left	Right	Left	Left	Right	Left	Left	Right
Median Width(ft)		12			12			12			12	
Link Offset(ft)		0			0			0			0	
Crosswalk Width(ft)		16			16			16			16	
Two way Left Turn Lane												
Headway Factor	1.00	1.00	1.00	1.00	1.00	1.00	1.00	1.00	1.00	1.00	1.00	1.00
Turning Speed (mph)	15		9	15		9	15		9	15		9
Number of Detectors	1	2	1	1	2	1	1	2	1	1	2	1
Detector Template	Left	Thru	Right	Left	Thru	Right	Left	Thru	Right	Left	Thru	Right
Leading Detector (ft)	20	100	20	20	100	20	20	100	20	20	100	20
Trailing Detector (ft)	0	0	0	0	0	0	0	0	0	0	0	0
Detector 1 Position(ft)	0	0	0	0	0	0	0	0	0	0	0	0
Detector 1 Size(ft)	20	6	20	20	6	20	20	6	20	20	6	20
Detector 1 Type	Cl+Ex	Cl+Ex	Cl+Ex	Cl+Ex	Cl+Ex	Cl+Ex	Cl+Ex	Cl+Ex	Cl+Ex	Cl+Ex	Cl+Ex	Cl+Ex
Detector 1 Channel												
Detector 1 Extend (s)	0.0	0.0	0.0	0.0	0.0	0.0	0.0	0.0	0.0	0.0	0.0	0.0
Detector 1 Queue (s)	0.0	0.0	0.0	0.0	0.0	0.0	0.0	0.0	0.0	0.0	0.0	0.0
Detector 1 Delay (s)	0.0	0.0	0.0	0.0	0.0	0.0	0.0	0.0	0.0	0.0	0.0	0.0
Detector 2 Position(ft)		94			94			94			94	
Detector 2 Size(ft)		6			6			6			6	
Detector 2 Type		Cl+Ex			Cl+Ex			Cl+Ex			Cl+Ex	
Detector 2 Channel												
Detector 2 Extend (s)		0.0			0.0			0.0			0.0	
Turn Type	Prot	NA	Perm	Prot	NA	Perm	Perm	NA	Perm	Perm	NA	Perm
Protected Phases	7	4		3	8			6			2	
Permitted Phases			4			8	6		6	2		2



Splits and Phases: 1: Sneffels St & Mesa Ridge Pkwy

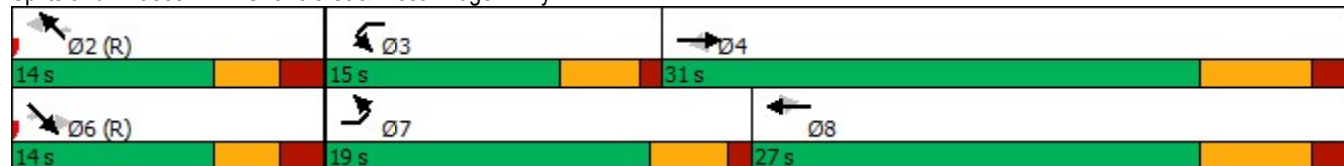

Intersection												
Int Delay, s/veh	2.1											
Movement	SEL	SET	SER	NWL	NWT	NWR	NEL	NET	NER	SWL	SWT	SWR
Lane Configurations	↖	↗		↖	↗	↖		↕			↕	
Traffic Vol, veh/h	4	183	5	10	265	129	1	0	7	72	0	5
Future Vol, veh/h	4	183	5	10	265	129	1	0	7	72	0	5
Conflicting Peds, #/hr	0	0	0	0	0	0	0	0	0	0	0	0
Sign Control	Free	Free	Free	Free	Free	Free	Stop	Stop	Stop	Stop	Stop	Stop
RT Channelized	-	-	None	-	-	None	-	-	None	-	-	Stop
Storage Length	50	-	-	85	-	190	-	-	-	-	-	-
Veh in Median Storage, #	-	0	-	-	0	-	-	0	-	-	0	-
Grade, %	-	0	-	-	0	-	-	0	-	-	0	-
Peak Hour Factor	87	87	87	92	92	92	78	78	78	83	83	83
Heavy Vehicles, %	2	2	2	2	2	2	2	2	2	2	2	2
Mvmt Flow	5	210	6	11	288	140	1	0	9	87	0	6

Major/Minor	Major1			Major2			Minor1			Minor2		
Conflicting Flow All	428	0	0	216	0	0	603	673	213	538	536	288
Stage 1	-	-	-	-	-	-	223	223	-	310	310	-
Stage 2	-	-	-	-	-	-	380	450	-	228	226	-
Critical Hdwy	4.12	-	-	4.12	-	-	7.12	6.52	6.22	7.12	6.52	6.22
Critical Hdwy Stg 1	-	-	-	-	-	-	6.12	5.52	-	6.12	5.52	-
Critical Hdwy Stg 2	-	-	-	-	-	-	6.12	5.52	-	6.12	5.52	-
Follow-up Hdwy	2.218	-	-	2.218	-	-	3.518	4.018	3.318	3.518	4.018	3.318
Pot Cap-1 Maneuver	1131	-	-	1354	-	-	411	377	827	454	451	751
Stage 1	-	-	-	-	-	-	780	719	-	700	659	-
Stage 2	-	-	-	-	-	-	642	572	-	775	717	-
Platoon blocked, %		-	-	-	-	-						
Mov Cap-1 Maneuver	1131	-	-	1354	-	-	404	372	827	445	446	751
Mov Cap-2 Maneuver	-	-	-	-	-	-	404	372	-	445	446	-
Stage 1	-	-	-	-	-	-	777	716	-	697	654	-
Stage 2	-	-	-	-	-	-	632	567	-	763	714	-

Approach	SE			NW			NE			SW		
HCM Control Delay, s	0.2			0.2			10			14.9		
HCM LOS							B			B		

Minor Lane/Major Mvmt	NELn1	NWL	NWT	NWR	SEL	SET	SERSWLn1
Capacity (veh/h)	731	1354	-	-	1131	-	457
HCM Lane V/C Ratio	0.014	0.008	-	-	0.004	-	0.203
HCM Control Delay (s)	10	7.7	-	-	8.2	-	14.9
HCM Lane LOS	B	A	-	-	A	-	B
HCM 95th %tile Q(veh)	0	0	-	-	0	-	0.8



Intersection												
Int Delay, s/veh	1.8											
Movement	SEL	SET	SER	NWL	NWT	NWR	NEL	NET	NER	SWL	SWT	SWR
Lane Configurations	↖	↗		↖	↗	↖		↕			↕	
Traffic Vol, veh/h	7	145	4	15	206	50	2	0	12	35	0	3
Future Vol, veh/h	7	145	4	15	206	50	2	0	12	35	0	3
Conflicting Peds, #/hr	0	0	0	0	0	0	0	0	0	0	0	0
Sign Control	Free	Free	Free	Free	Free	Free	Stop	Stop	Stop	Stop	Stop	Stop
RT Channelized	-	-	None	-	-	None	-	-	None	-	-	None
Storage Length	50	-	-	50	-	0	-	-	-	-	-	-
Veh in Median Storage, #	-	0	-	-	0	-	-	0	-	-	0	-
Grade, %	-	0	-	-	0	-	-	0	-	-	0	-
Peak Hour Factor	87	87	87	87	87	87	78	78	78	78	78	78
Heavy Vehicles, %	2	2	2	2	2	2	2	2	2	2	2	2
Mvmt Flow	8	167	5	17	237	57	3	0	15	45	0	4

























Major/Minor	Major1			Major2			Minor1			Minor2		
Conflicting Flow All	294	0	0	172	0	0	488	514	170	464	459	237
Stage 1	-	-	-	-	-	-	186	186	-	271	271	-
Stage 2	-	-	-	-	-	-	302	328	-	193	188	-
Critical Hdwy	4.12	-	-	4.12	-	-	7.12	6.52	6.22	7.12	6.52	6.22
Critical Hdwy Stg 1	-	-	-	-	-	-	6.12	5.52	-	6.12	5.52	-
Critical Hdwy Stg 2	-	-	-	-	-	-	6.12	5.52	-	6.12	5.52	-
Follow-up Hdwy	2.218	-	-	2.218	-	-	3.518	4.018	3.318	3.518	4.018	3.318
Pot Cap-1 Maneuver	1268	-	-	1405	-	-	490	464	874	508	499	802
Stage 1	-	-	-	-	-	-	816	746	-	735	685	-
Stage 2	-	-	-	-	-	-	707	647	-	809	745	-
Platoon blocked, %	-	-	-	-	-	-	-	-	-	-	-	-
Mov Cap-1 Maneuver	1268	-	-	1405	-	-	481	456	874	492	490	802
Mov Cap-2 Maneuver	-	-	-	-	-	-	481	456	-	492	490	-
Stage 1	-	-	-	-	-	-	811	742	-	731	677	-
Stage 2	-	-	-	-	-	-	695	639	-	790	741	-

Approach	SE			NW			NE			SW		
HCM Control Delay, s	0.4			0.4			9.7			12.9		
HCM LOS							A			B		

Minor Lane/Major Mvmt	NELn1	NWL	NWT	NWR	SEL	SET	SERSWLn1
Capacity (veh/h)	783	1405	-	-	1268	-	507
HCM Lane V/C Ratio	0.023	0.012	-	-	0.006	-	0.096
HCM Control Delay (s)	9.7	7.6	-	-	7.9	-	12.9
HCM Lane LOS	A	A	-	-	A	-	B
HCM 95th %tile Q(veh)	0.1	0	-	-	0	-	0.3

Lanes, Volumes, Timings  
1: Sneffels St & Mesa Ridge Pkwy

2041 Background  
AM

												
Lane Group	EBL	EBT	EBR	WBL	WBT	WBR	SEL	SET	SER	NWL	NWT	NWR
Lane Configurations												
Traffic Volume (vph)	140	800	75	100	1850	50	85	25	285	165	20	250
Future Volume (vph)	140	800	75	100	1850	50	85	25	285	165	20	250
Ideal Flow (vphpl)	1900	1900	1900	1900	1900	1900	1900	1900	1900	1900	1900	1900
Storage Length (ft)	325		315	510		225	200		160	315		0
Storage Lanes	1		1	2		1	1		1	1		1
Taper Length (ft)	160			170			75			120		
Lane Util. Factor	1.00	0.95	1.00	0.97	0.95	1.00	1.00	1.00	1.00	1.00	1.00	1.00
Frt			0.850			0.850			0.850			0.850
Flt Protected	0.950			0.950			0.950			0.950		
Satd. Flow (prot)	1770	3539	1583	3433	3539	1583	1770	1863	1583	1770	1863	1583
Flt Permitted	0.058			0.950			0.612			0.740		
Satd. Flow (perm)	108	3539	1583	3433	3539	1583	1140	1863	1583	1378	1863	1583
Right Turn on Red			Yes			Yes			Yes			Yes
Satd. Flow (RTOR)			100			100			200			272
Link Speed (mph)		55			55			25				25
Link Distance (ft)		1962			1437			447				886
Travel Time (s)		24.3			17.8			12.2				24.2
Peak Hour Factor	0.93	0.93	0.93	0.95	0.95	0.95	0.92	0.92	0.92	0.92	0.92	0.92
Adj. Flow (vph)	151	860	81	105	1947	53	92	27	310	179	22	272
Shared Lane Traffic (%)												
Lane Group Flow (vph)	151	860	81	105	1947	53	92	27	310	179	22	272
Enter Blocked Intersection	No	No	No	No	No	No	No	No	No	No	No	No
Lane Alignment	Left	Left	Right	Left	Left	Right	Left	Left	Right	Left	Left	Right
Median Width(ft)		24			24			12				12
Link Offset(ft)		0			0			0				0
Crosswalk Width(ft)		16			16			16				16
Two way Left Turn Lane												
Headway Factor	1.00	1.00	1.00	1.00	1.00	1.00	1.00	1.00	1.00	1.00	1.00	1.00
Turning Speed (mph)	15		9	15		9	15		9	15		9
Number of Detectors	1	2	1	1	2	1	1	2	1	1	2	1
Detector Template	Left	Thru	Right	Left	Thru	Right	Left	Thru	Right	Left	Thru	Right
Leading Detector (ft)	20	100	20	20	100	20	20	100	20	20	100	20
Trailing Detector (ft)	0	0	0	0	0	0	0	0	0	0	0	0
Detector 1 Position(ft)	0	0	0	0	0	0	0	0	0	0	0	0
Detector 1 Size(ft)	20	6	20	20	6	20	20	6	20	20	6	20
Detector 1 Type	Cl+Ex	Cl+Ex	Cl+Ex	Cl+Ex	Cl+Ex	Cl+Ex	Cl+Ex	Cl+Ex	Cl+Ex	Cl+Ex	Cl+Ex	Cl+Ex
Detector 1 Channel												
Detector 1 Extend (s)	0.0	0.0	0.0	0.0	0.0	0.0	0.0	0.0	0.0	0.0	0.0	0.0
Detector 1 Queue (s)	0.0	0.0	0.0	0.0	0.0	0.0	0.0	0.0	0.0	0.0	0.0	0.0
Detector 1 Delay (s)	0.0	0.0	0.0	0.0	0.0	0.0	0.0	0.0	0.0	0.0	0.0	0.0
Detector 2 Position(ft)		94			94			94				94
Detector 2 Size(ft)		6			6			6				6
Detector 2 Type		Cl+Ex			Cl+Ex			Cl+Ex				Cl+Ex
Detector 2 Channel												
Detector 2 Extend (s)		0.0			0.0			0.0				0.0
Turn Type	pm+pt	NA	Perm	Prot	NA	Perm	pm+pt	NA	Perm	pm+pt	NA	Perm
Protected Phases	7	4		3	8		1	6		5	2	
Permitted Phases	4		4			8	6		6	2		2

Lanes, Volumes, Timings  
1: Sneffels St & Mesa Ridge Pkwy

2041 Background  
AM

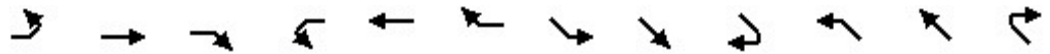

Lane Group	EBL	EBT	EBR	WBL	WBT	WBR	SEL	SET	SER	NWL	NWT	NWR
Detector Phase	7	4	4	3	8	8	1	6	6	5	2	2
Switch Phase												
Minimum Initial (s)	5.0	5.0	5.0	5.0	5.0	5.0	4.5	4.0	4.0	4.5	4.0	4.0
Minimum Split (s)	10.0	25.0	25.0	10.0	25.0	25.0	9.0	9.0	9.0	9.0	9.0	9.0
Total Split (s)	22.0	72.0	72.0	18.0	68.0	68.0	11.0	22.0	22.0	8.0	19.0	19.0
Total Split (%)	18.3%	60.0%	60.0%	15.0%	56.7%	56.7%	9.2%	18.3%	18.3%	6.7%	15.8%	15.8%
Maximum Green (s)	17.5	65.0	65.0	13.5	61.0	61.0	6.5	17.0	17.0	3.5	14.0	14.0
Yellow Time (s)	3.5	5.0	5.0	3.5	5.0	5.0	3.5	3.0	3.0	3.5	3.0	3.0
All-Red Time (s)	1.0	2.0	2.0	1.0	2.0	2.0	1.0	2.0	2.0	1.0	2.0	2.0
Lost Time Adjust (s)	0.0	0.0	0.0	0.0	0.0	0.0	0.0	0.0	0.0	0.0	0.0	0.0
Total Lost Time (s)	4.5	7.0	7.0	4.5	7.0	7.0	4.5	5.0	5.0	4.5	5.0	5.0
Lead/Lag	Lead	Lag	Lag	Lead	Lag	Lag	Lead	Lag	Lag	Lead	Lag	Lag
Lead-Lag Optimize?	Yes	Yes	Yes	Yes	Yes	Yes	Yes	Yes	Yes	Yes	Yes	Yes
Vehicle Extension (s)	3.0	3.0	3.0	3.0	3.0	3.0	3.0	3.0	3.0	3.0	3.0	3.0
Recall Mode	None	None	None	None	None	None	None	C-Max	C-Max	None	C-Max	C-Max
Act Effct Green (s)	84.9	69.5	69.5	9.0	64.9	64.9	24.0	17.0	17.0	18.0	14.0	14.0
Actuated g/C Ratio	0.71	0.58	0.58	0.08	0.54	0.54	0.20	0.14	0.14	0.15	0.12	0.12
v/c Ratio	0.57	0.42	0.08	0.41	1.02	0.06	0.35	0.10	0.78	0.82	0.10	0.64
Control Delay	29.2	15.1	1.7	57.3	53.4	0.3	43.7	46.1	32.8	75.8	48.8	13.3
Queue Delay	0.0	0.0	0.0	0.0	0.0	0.0	0.0	0.0	0.0	0.0	0.0	0.0
Total Delay	29.2	15.1	1.7	57.3	53.4	0.3	43.7	46.1	32.8	75.8	48.8	13.3
LOS	C	B	A	E	D	A	D	D	C	E	D	B
Approach Delay		16.0			52.3			36.0			38.6	
Approach LOS		B			D			D			D	
Queue Length 50th (ft)	56	184	0	40	~844	0	60	18	82	122	15	0
Queue Length 95th (ft)	124	243	15	68	#1027	3	108	47	#219	#244	42	83
Internal Link Dist (ft)		1882			1357			367			806	
Turn Bay Length (ft)	325		315	510		225	200		160	315		
Base Capacity (vph)	319	2049	958	386	1912	901	262	263	395	218	217	424
Starvation Cap Reductn	0	0	0	0	0	0	0	0	0	0	0	0
Spillback Cap Reductn	0	0	0	0	0	0	0	0	0	0	0	0
Storage Cap Reductn	0	0	0	0	0	0	0	0	0	0	0	0
Reduced v/c Ratio	0.47	0.42	0.08	0.27	1.02	0.06	0.35	0.10	0.78	0.82	0.10	0.64

Intersection Summary

Area Type: Other  
 Cycle Length: 120  
 Actuated Cycle Length: 120  
 Offset: 0 (0%), Referenced to phase 2:NWTL and 6:SETL, Start of Green  
 Natural Cycle: 90  
 Control Type: Actuated-Coordinated  
 Maximum v/c Ratio: 1.02  
 Intersection Signal Delay: 39.3  
 Intersection LOS: D  
 Intersection Capacity Utilization 91.7%  
 ICU Level of Service F  
 Analysis Period (min) 15  
 ~ Volume exceeds capacity, queue is theoretically infinite.  
 Queue shown is maximum after two cycles.  
 # 95th percentile volume exceeds capacity, queue may be longer.  
 Queue shown is maximum after two cycles.

Splits and Phases: 1: Sneffels St & Mesa Ridge Pkwy

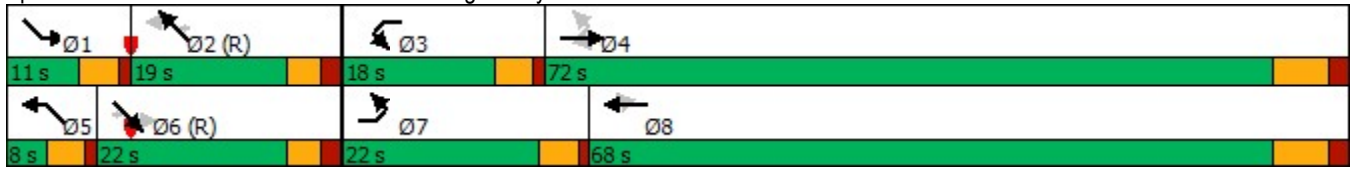

Intersection												
Int Delay, s/veh	1.9											
Movement	SEL	SET	SER	NWL	NWT	NWR	NEL	NET	NER	SWL	SWT	SWR
Lane Configurations	↖	↗		↖	↗	↖		↕			↕	
Traffic Vol, veh/h	2	333	6	10	155	45	4	0	7	55	0	2
Future Vol, veh/h	2	333	6	10	155	45	4	0	7	55	0	2
Conflicting Peds, #/hr	0	0	0	0	0	0	0	0	0	0	0	0
Sign Control	Free	Free	Free	Free	Free	Free	Stop	Stop	Stop	Stop	Stop	Stop
RT Channelized	-	-	None	-	-	None	-	-	None	-	-	Stop
Storage Length	50	-	-	50	-	190	-	-	-	-	-	-
Veh in Median Storage, #	-	0	-	-	0	-	-	0	-	-	0	-
Grade, %	-	0	-	-	0	-	-	0	-	-	0	-
Peak Hour Factor	92	92	92	87	87	87	78	78	78	83	83	83
Heavy Vehicles, %	2	2	2	2	2	2	2	2	2	2	2	2
Mvmt Flow	2	362	7	11	178	52	5	0	9	66	0	2

Major/Minor	Major1			Major2			Minor1			Minor2		
Conflicting Flow All	230	0	0	369	0	0	596	622	366	574	573	178
Stage 1	-	-	-	-	-	-	370	370	-	200	200	-
Stage 2	-	-	-	-	-	-	226	252	-	374	373	-
Critical Hdwy	4.12	-	-	4.12	-	-	7.12	6.52	6.22	7.12	6.52	6.22
Critical Hdwy Stg 1	-	-	-	-	-	-	6.12	5.52	-	6.12	5.52	-
Critical Hdwy Stg 2	-	-	-	-	-	-	6.12	5.52	-	6.12	5.52	-
Follow-up Hdwy	2.218	-	-	2.218	-	-	3.518	4.018	3.318	3.518	4.018	3.318
Pot Cap-1 Maneuver	1338	-	-	1190	-	-	415	403	679	430	430	865
Stage 1	-	-	-	-	-	-	650	620	-	802	736	-
Stage 2	-	-	-	-	-	-	777	698	-	647	618	-
Platoon blocked, %	-	-	-	-	-	-	-	-	-	-	-	-
Mov Cap-1 Maneuver	1338	-	-	1190	-	-	410	399	679	421	426	865
Mov Cap-2 Maneuver	-	-	-	-	-	-	410	399	-	421	426	-
Stage 1	-	-	-	-	-	-	649	619	-	801	729	-
Stage 2	-	-	-	-	-	-	768	692	-	637	617	-

Approach	SE			NW			NE			SW		
HCM Control Delay, s	0			0.4			11.7			15		
HCM LOS							B			C		

Minor Lane/Major Mvmt	NELn1	NWL	NWT	NWR	SEL	SET	SERSWLn1
Capacity (veh/h)	548	1190	-	-	1338	-	429
HCM Lane V/C Ratio	0.026	0.01	-	-	0.002	-	0.16
HCM Control Delay (s)	11.7	8.1	-	-	7.7	-	15
HCM Lane LOS	B	A	-	-	A	-	C
HCM 95th %tile Q(veh)	0.1	0	-	-	0	-	0.6

Intersection												
Int Delay, s/veh	2.1											
Movement	SEL	SET	SER	NWL	NWT	NWR	NEL	NET	NER	SWL	SWT	SWR
Lane Configurations	↖	↗		↖	↗	↖		↕			↕	
Traffic Vol, veh/h	3	294	2	25	121	15	3	0	11	36	0	8
Future Vol, veh/h	3	294	2	25	121	15	3	0	11	36	0	8
Conflicting Peds, #/hr	0	0	0	0	0	0	0	0	0	0	0	0
Sign Control	Free	Free	Free	Free	Free	Free	Stop	Stop	Stop	Stop	Stop	Stop
RT Channelized	-	-	None	-	-	None	-	-	None	-	-	None
Storage Length	50	-	-	50	-	0	-	-	-	-	-	-
Veh in Median Storage, #	-	0	-	-	0	-	-	0	-	-	0	-
Grade, %	-	0	-	-	0	-	-	0	-	-	0	-
Peak Hour Factor	92	92	92	87	87	87	78	78	78	78	78	78
Heavy Vehicles, %	2	2	2	2	2	2	2	2	2	2	2	2
Mvmt Flow	3	320	2	29	139	17	4	0	14	46	0	10

























Major/Minor	Major1			Major2			Minor1			Minor2		
Conflicting Flow All	156	0	0	322	0	0	538	541	321	531	525	139
Stage 1	-	-	-	-	-	-	327	327	-	197	197	-
Stage 2	-	-	-	-	-	-	211	214	-	334	328	-
Critical Hdwy	4.12	-	-	4.12	-	-	7.12	6.52	6.22	7.12	6.52	6.22
Critical Hdwy Stg 1	-	-	-	-	-	-	6.12	5.52	-	6.12	5.52	-
Critical Hdwy Stg 2	-	-	-	-	-	-	6.12	5.52	-	6.12	5.52	-
Follow-up Hdwy	2.218	-	-	2.218	-	-	3.518	4.018	3.318	3.518	4.018	3.318
Pot Cap-1 Maneuver	1424	-	-	1238	-	-	454	448	720	459	458	909
Stage 1	-	-	-	-	-	-	686	648	-	805	738	-
Stage 2	-	-	-	-	-	-	791	725	-	680	647	-
Platoon blocked, %	-	-	-	-	-	-	-	-	-	-	-	-
Mov Cap-1 Maneuver	1424	-	-	1238	-	-	440	437	720	441	447	909
Mov Cap-2 Maneuver	-	-	-	-	-	-	440	437	-	441	447	-
Stage 1	-	-	-	-	-	-	685	647	-	803	721	-
Stage 2	-	-	-	-	-	-	764	708	-	665	646	-

Approach	SE			NW			NE			SW		
HCM Control Delay, s	0.1			1.2			10.8			13.4		
HCM LOS							B			B		

Minor Lane/Major Mvmt	NELn1	NWL	NWT	NWR	SEL	SET	SERSWLn1
Capacity (veh/h)	634	1238	-	-	1424	-	487
HCM Lane V/C Ratio	0.028	0.023	-	-	0.002	-	0.116
HCM Control Delay (s)	10.8	8	-	-	7.5	-	13.4
HCM Lane LOS	B	A	-	-	A	-	B
HCM 95th %tile Q(veh)	0.1	0.1	-	-	0	-	0.4

Lanes, Volumes, Timings  
1: Sneffels St & Mesa Ridge Pkwy

2041 Background  
PM

													
Lane Group	EBL	EBT	EBR	WBL	WBT	WBR	SEL	SET	SER	NWL	NWT	NWR	
Lane Configurations													
Traffic Volume (vph)	230	2150	350	250	1200	105	65	35	160	100	40	275	
Future Volume (vph)	230	2150	350	250	1200	105	65	35	160	100	40	275	
Ideal Flow (vphpl)	1900	1900	1900	1900	1900	1900	1900	1900	1900	1900	1900	1900	
Storage Length (ft)	325		315	510		225	200		160	315		0	
Storage Lanes	1		1	2		1	1		1	1		1	
Taper Length (ft)	160			170			75			120			
Lane Util. Factor	1.00	0.95	1.00	0.97	0.95	1.00	1.00	1.00	1.00	1.00	1.00	1.00	
Frt			0.850			0.850			0.850			0.850	
Flt Protected	0.950			0.950			0.950			0.950			
Satd. Flow (prot)	1770	3539	1583	3433	3539	1583	1770	1863	1583	1770	1863	1583	
Flt Permitted	0.144			0.950			0.729			0.510			
Satd. Flow (perm)	268	3539	1583	3433	3539	1583	1358	1863	1583	950	1863	1583	
Right Turn on Red			Yes			Yes			Yes			Yes	
Satd. Flow (RTOR)			303			141			174			205	
Link Speed (mph)		55			55			25			25		
Link Distance (ft)		1962			1437			447			886		
Travel Time (s)		24.3			17.8			12.2			24.2		
Peak Hour Factor	0.95	0.95	0.95	0.95	0.95	0.95	0.92	0.92	0.92	0.92	0.92	0.92	
Adj. Flow (vph)	242	2263	368	263	1263	111	71	38	174	109	43	299	
Shared Lane Traffic (%)													
Lane Group Flow (vph)	242	2263	368	263	1263	111	71	38	174	109	43	299	
Enter Blocked Intersection	No	No	No	No	No	No	No	No	No	No	No	No	
Lane Alignment	Left	Left	Right	Left	Left	Right	Left	Left	Right	Left	Left	Right	
Median Width(ft)		24			24			12			12		
Link Offset(ft)		0			0			0			0		
Crosswalk Width(ft)		16			16			16			16		
Two way Left Turn Lane													
Headway Factor	1.00	1.00	1.00	1.00	1.00	1.00	1.00	1.00	1.00	1.00	1.00	1.00	
Turning Speed (mph)	15		9	15		9	15		9	15		9	
Number of Detectors	1	2	1	1	2	1	1	2	1	1	2	1	
Detector Template	Left	Thru	Right	Left	Thru	Right	Left	Thru	Right	Left	Thru	Right	
Leading Detector (ft)	20	100	20	20	100	20	20	100	20	20	100	20	
Trailing Detector (ft)	0	0	0	0	0	0	0	0	0	0	0	0	
Detector 1 Position(ft)	0	0	0	0	0	0	0	0	0	0	0	0	
Detector 1 Size(ft)	20	6	20	20	6	20	20	6	20	20	6	20	
Detector 1 Type	Cl+Ex	Cl+Ex	Cl+Ex	Cl+Ex	Cl+Ex	Cl+Ex	Cl+Ex	Cl+Ex	Cl+Ex	Cl+Ex	Cl+Ex	Cl+Ex	
Detector 1 Channel													
Detector 1 Extend (s)	0.0	0.0	0.0	0.0	0.0	0.0	0.0	0.0	0.0	0.0	0.0	0.0	
Detector 1 Queue (s)	0.0	0.0	0.0	0.0	0.0	0.0	0.0	0.0	0.0	0.0	0.0	0.0	
Detector 1 Delay (s)	0.0	0.0	0.0	0.0	0.0	0.0	0.0	0.0	0.0	0.0	0.0	0.0	
Detector 2 Position(ft)		94			94			94			94		
Detector 2 Size(ft)		6			6			6			6		
Detector 2 Type		Cl+Ex			Cl+Ex			Cl+Ex			Cl+Ex		
Detector 2 Channel													
Detector 2 Extend (s)		0.0			0.0			0.0			0.0		
Turn Type	pm+pt	NA	Perm	Prot	NA	Perm	pm+pt	NA	Perm	pm+pt	NA	Perm	
Protected Phases	7	4		3	8		1	6		5	2		
Permitted Phases	4		4			8	6		6	2		2	

Lanes, Volumes, Timings  
1: Sneffels St & Mesa Ridge Pkwy

2041 Background  
PM

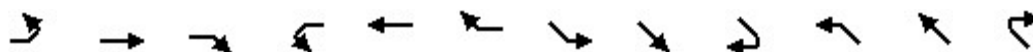

Lane Group	EBL	EBT	EBR	WBL	WBT	WBR	SEL	SET	SER	NWL	NWT	NWR
Detector Phase	7	4	4	3	8	8	1	6	6	5	2	2
Switch Phase												
Minimum Initial (s)	5.0	5.0	5.0	5.0	5.0	5.0	5.0	5.0	5.0	5.0	5.0	5.0
Minimum Split (s)	9.5	25.0	25.0	9.5	25.0	25.0	9.5	23.0	23.0	9.5	23.0	23.0
Total Split (s)	23.0	77.0	77.0	16.0	70.0	70.0	14.0	11.0	11.0	16.0	13.0	13.0
Total Split (%)	19.2%	64.2%	64.2%	13.3%	58.3%	58.3%	11.7%	9.2%	9.2%	13.3%	10.8%	10.8%
Maximum Green (s)	18.5	70.0	70.0	11.5	63.0	63.0	9.5	6.0	6.0	11.5	8.0	8.0
Yellow Time (s)	3.5	5.0	5.0	3.5	5.0	5.0	3.5	3.0	3.0	3.5	3.0	3.0
All-Red Time (s)	1.0	2.0	2.0	1.0	2.0	2.0	1.0	2.0	2.0	1.0	2.0	2.0
Lost Time Adjust (s)	0.0	0.0	0.0	0.0	0.0	0.0	0.0	0.0	0.0	0.0	0.0	0.0
Total Lost Time (s)	4.5	7.0	7.0	4.5	7.0	7.0	4.5	5.0	5.0	4.5	5.0	5.0
Lead/Lag	Lead	Lag	Lag	Lead	Lag	Lag	Lead	Lag	Lag	Lead	Lag	Lag
Lead-Lag Optimize?	Yes	Yes	Yes	Yes	Yes	Yes	Yes	Yes	Yes	Yes	Yes	Yes
Vehicle Extension (s)	3.0	3.0	3.0	3.0	3.0	3.0	3.0	3.0	3.0	3.0	3.0	3.0
Recall Mode	None	None	None	None	None	None	None	C-Max	C-Max	None	C-Max	C-Max
Act Effct Green (s)	84.8	70.1	70.1	11.4	68.8	68.8	16.1	7.1	7.1	20.5	11.1	11.1
Actuated g/C Ratio	0.71	0.58	0.58	0.10	0.57	0.57	0.13	0.06	0.06	0.17	0.09	0.09
v/c Ratio	0.69	1.09	0.35	0.81	0.62	0.11	0.34	0.35	0.68	0.47	0.25	0.90
Control Delay	19.9	76.7	3.5	72.7	19.4	1.3	46.3	64.1	22.0	49.5	57.5	48.9
Queue Delay	0.0	0.0	0.0	0.0	0.0	0.0	0.0	0.0	0.0	0.0	0.0	0.0
Total Delay	19.9	76.7	3.5	72.7	19.4	1.3	46.3	64.1	22.0	49.5	57.5	48.9
LOS	B	E	A	E	B	A	D	E	C	D	E	D
Approach Delay		62.5			26.7			33.8			49.8	
Approach LOS		E			C			C			D	
Queue Length 50th (ft)	50	~1044	21	104	322	0	47	29	0	74	32	~77
Queue Length 95th (ft)	122	#1180	64	#169	445	16	91	67	#91	130	71	#265
Internal Link Dist (ft)		1882			1357			367			806	
Turn Bay Length (ft)	325		315	510		225	200		160	315		
Base Capacity (vph)	429	2067	1050	328	2027	967	225	110	257	242	172	331
Starvation Cap Reductn	0	0	0	0	0	0	0	0	0	0	0	0
Spillback Cap Reductn	0	0	0	0	0	0	0	0	0	0	0	0
Storage Cap Reductn	0	0	0	0	0	0	0	0	0	0	0	0
Reduced v/c Ratio	0.56	1.09	0.35	0.80	0.62	0.11	0.32	0.35	0.68	0.45	0.25	0.90

Intersection Summary

Area Type:	Other
Cycle Length:	120
Actuated Cycle Length:	120
Offset:	0 (0%), Referenced to phase 2:NWTL and 6:SETL, Start of Green
Natural Cycle:	150
Control Type:	Actuated-Coordinated
Maximum v/c Ratio:	1.09
Intersection Signal Delay:	48.7
Intersection LOS:	D
Intersection Capacity Utilization:	94.4%
ICU Level of Service:	F
Analysis Period (min):	15
~	Volume exceeds capacity, queue is theoretically infinite. Queue shown is maximum after two cycles.
#	95th percentile volume exceeds capacity, queue may be longer. Queue shown is maximum after two cycles.



Splits and Phases: 1: Sneffels St & Mesa Ridge Pkwy

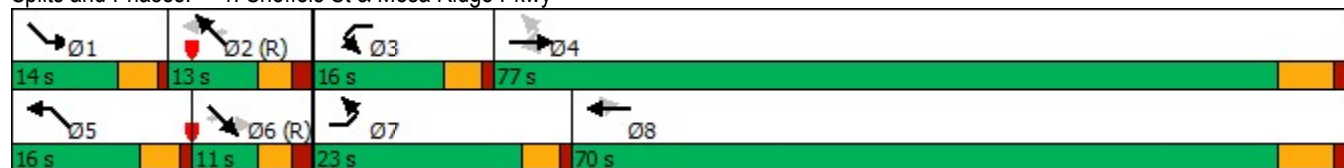

Intersection												
Int Delay, s/veh	1.6											
Movement	SEL	SET	SER	NWL	NWT	NWR	NEL	NET	NER	SWL	SWT	SWR
Lane Configurations	↖	↗		↖	↗	↖		↕			↕	
Traffic Vol, veh/h	2	210	6	15	280	80	2	0	10	40	0	4
Future Vol, veh/h	2	210	6	15	280	80	2	0	10	40	0	4
Conflicting Peds, #/hr	0	0	0	0	0	0	0	0	0	0	0	0
Sign Control	Free	Free	Free	Free	Free	Free	Stop	Stop	Stop	Stop	Stop	Stop
RT Channelized	-	-	None	-	-	None	-	-	None	-	-	Stop
Storage Length	50	-	-	50	-	190	-	-	-	-	-	-
Veh in Median Storage, #	-	0	-	-	0	-	-	0	-	-	0	-
Grade, %	-	0	-	-	0	-	-	0	-	-	0	-
Peak Hour Factor	87	87	87	92	92	92	78	78	78	78	78	78
Heavy Vehicles, %	2	2	2	2	2	2	2	2	2	2	2	2
Mvmt Flow	2	241	7	16	304	87	3	0	13	51	0	5

Major/Minor	Major1			Major2			Minor1			Minor2		
Conflicting Flow All	391	0	0	248	0	0	629	672	245	591	588	304
Stage 1	-	-	-	-	-	-	249	249	-	336	336	-
Stage 2	-	-	-	-	-	-	380	423	-	255	252	-
Critical Hdwy	4.12	-	-	4.12	-	-	7.12	6.52	6.22	7.12	6.52	6.22
Critical Hdwy Stg 1	-	-	-	-	-	-	6.12	5.52	-	6.12	5.52	-
Critical Hdwy Stg 2	-	-	-	-	-	-	6.12	5.52	-	6.12	5.52	-
Follow-up Hdwy	2.218	-	-	2.218	-	-	3.518	4.018	3.318	3.518	4.018	3.318
Pot Cap-1 Maneuver	1168	-	-	1318	-	-	395	377	794	419	421	736
Stage 1	-	-	-	-	-	-	755	701	-	678	642	-
Stage 2	-	-	-	-	-	-	642	588	-	749	698	-
Platoon blocked, %	-	-	-	-	-	-	-	-	-	-	-	-
Mov Cap-1 Maneuver	1168	-	-	1318	-	-	388	372	794	408	415	736
Mov Cap-2 Maneuver	-	-	-	-	-	-	388	372	-	408	415	-
Stage 1	-	-	-	-	-	-	753	700	-	677	634	-
Stage 2	-	-	-	-	-	-	630	581	-	736	697	-

Approach	SE			NW			NE			SW		
HCM Control Delay, s	0.1			0.3			10.4			14.8		
HCM LOS							B			B		

Minor Lane/Major Mvmt	NELn1	NWL	NWT	NWR	SEL	SET	SERSWLn1
Capacity (veh/h)	676	1318	-	-	1168	-	425
HCM Lane V/C Ratio	0.023	0.012	-	-	0.002	-	0.133
HCM Control Delay (s)	10.4	7.8	-	-	8.1	-	14.8
HCM Lane LOS	B	A	-	-	A	-	B
HCM 95th %tile Q(veh)	0.1	0	-	-	0	-	0.5

Intersection												
Int Delay, s/veh	2											
Movement	SEL	SET	SER	NWL	NWT	NWR	NEL	NET	NER	SWL	SWT	SWR
Lane Configurations												
Traffic Vol, veh/h	8	167	5	20	206	60	3	0	15	36	0	8
Future Vol, veh/h	8	167	5	20	206	60	3	0	15	36	0	8
Conflicting Peds, #/hr	0	0	0	0	0	0	0	0	0	0	0	0
Sign Control	Free	Free	Free	Free	Free	Free	Stop	Stop	Stop	Stop	Stop	Stop
RT Channelized	-	-	None	-	-	None	-	-	None	-	-	None
Storage Length	50	-	-	50	-	0	-	-	-	-	-	-
Veh in Median Storage, #	-	0	-	-	0	-	-	0	-	-	0	-
Grade, %	-	0	-	-	0	-	-	0	-	-	0	-
Peak Hour Factor	87	87	87	92	92	92	78	78	78	78	78	78
Heavy Vehicles, %	2	2	2	2	2	2	2	2	2	2	2	2
Mvmt Flow	9	192	6	22	224	65	4	0	19	46	0	10

























Major/Minor	Major1			Major2			Minor1			Minor2		
Conflicting Flow All	289	0	0	198	0	0	519	546	195	491	484	224
Stage 1	-	-	-	-	-	-	213	213	-	268	268	-
Stage 2	-	-	-	-	-	-	306	333	-	223	216	-
Critical Hdwy	4.12	-	-	4.12	-	-	7.12	6.52	6.22	7.12	6.52	6.22
Critical Hdwy Stg 1	-	-	-	-	-	-	6.12	5.52	-	6.12	5.52	-
Critical Hdwy Stg 2	-	-	-	-	-	-	6.12	5.52	-	6.12	5.52	-
Follow-up Hdwy	2.218	-	-	2.218	-	-	3.518	4.018	3.318	3.518	4.018	3.318
Pot Cap-1 Maneuver	1273	-	-	1375	-	-	467	445	846	488	483	815
Stage 1	-	-	-	-	-	-	789	726	-	738	687	-
Stage 2	-	-	-	-	-	-	704	644	-	780	724	-
Platoon blocked, %	-	-	-	-	-	-	-	-	-	-	-	-
Mov Cap-1 Maneuver	1273	-	-	1375	-	-	453	435	846	468	472	815
Mov Cap-2 Maneuver	-	-	-	-	-	-	453	435	-	468	472	-
Stage 1	-	-	-	-	-	-	783	721	-	733	676	-
Stage 2	-	-	-	-	-	-	684	634	-	757	719	-

Approach	SE	NW	NE	SW
HCM Control Delay, s	0.3	0.5	10	13
HCM LOS			B	B

Minor Lane/Major Mvmt	NELn1	NWL	NWT	NWR	SEL	SET	SERSWLn1
Capacity (veh/h)	739	1375	-	-	1273	-	507
HCM Lane V/C Ratio	0.031	0.016	-	-	0.007	-	0.111
HCM Control Delay (s)	10	7.7	-	-	7.8	-	13
HCM Lane LOS	B	A	-	-	A	-	B
HCM 95th %tile Q(veh)	0.1	0	-	-	0	-	0.4

Lanes, Volumes, Timings  
1: Sneffels St & Mesa Ridge Pkwy

2041 Background + Site  
AM

												
Lane Group	EBL	EBT	EBR	WBL	WBT	WBR	SEL	SET	SER	NWL	NWT	NWR
Lane Configurations												
Traffic Volume (vph)	155	800	75	100	1850	56	104	29	334	165	21	250
Future Volume (vph)	155	800	75	100	1850	56	104	29	334	165	21	250
Ideal Flow (vphpl)	1900	1900	1900	1900	1900	1900	1900	1900	1900	1900	1900	1900
Storage Length (ft)	578		315	510		378	200		160	315		0
Storage Lanes	1		1	2		1	1		1	1		1
Taper Length (ft)	222			170			75			120		
Lane Util. Factor	1.00	0.95	1.00	0.97	0.95	1.00	1.00	1.00	1.00	1.00	1.00	1.00
Frt			0.850			0.850			0.850			0.850
Flt Protected	0.950			0.950			0.950			0.950		
Satd. Flow (prot)	1770	3539	1583	3433	3539	1583	1770	1863	1583	1770	1863	1583
Flt Permitted	0.058			0.950			0.611			0.736		
Satd. Flow (perm)	108	3539	1583	3433	3539	1583	1138	1863	1583	1371	1863	1583
Right Turn on Red			Yes			Yes			Yes			Yes
Satd. Flow (RTOR)			100			100			200			272
Link Speed (mph)		55			55			25				25
Link Distance (ft)		1962			1437			447				886
Travel Time (s)		24.3			17.8			12.2				24.2
Peak Hour Factor	0.93	0.93	0.93	0.95	0.95	0.95	0.92	0.92	0.92	0.92	0.92	0.92
Adj. Flow (vph)	167	860	81	105	1947	59	113	32	363	179	23	272
Shared Lane Traffic (%)												
Lane Group Flow (vph)	167	860	81	105	1947	59	113	32	363	179	23	272
Enter Blocked Intersection	No	No	No	No	No	No	No	No	No	No	No	No
Lane Alignment	Left	Left	Right	Left	Left	Right	Left	Left	Right	Left	Left	Right
Median Width(ft)		24			24			12				12
Link Offset(ft)		0			0			0				0
Crosswalk Width(ft)		16			16			16				16
Two way Left Turn Lane												
Headway Factor	1.00	1.00	1.00	1.00	1.00	1.00	1.00	1.00	1.00	1.00	1.00	1.00
Turning Speed (mph)	15		9	15		9	15		9	15		9
Number of Detectors	1	2	1	1	2	1	1	2	1	1	2	1
Detector Template	Left	Thru	Right	Left	Thru	Right	Left	Thru	Right	Left	Thru	Right
Leading Detector (ft)	20	100	20	20	100	20	20	100	20	20	100	20
Trailing Detector (ft)	0	0	0	0	0	0	0	0	0	0	0	0
Detector 1 Position(ft)	0	0	0	0	0	0	0	0	0	0	0	0
Detector 1 Size(ft)	20	6	20	20	6	20	20	6	20	20	6	20
Detector 1 Type	Cl+Ex	Cl+Ex	Cl+Ex	Cl+Ex	Cl+Ex	Cl+Ex	Cl+Ex	Cl+Ex	Cl+Ex	Cl+Ex	Cl+Ex	Cl+Ex
Detector 1 Channel												
Detector 1 Extend (s)	0.0	0.0	0.0	0.0	0.0	0.0	0.0	0.0	0.0	0.0	0.0	0.0
Detector 1 Queue (s)	0.0	0.0	0.0	0.0	0.0	0.0	0.0	0.0	0.0	0.0	0.0	0.0
Detector 1 Delay (s)	0.0	0.0	0.0	0.0	0.0	0.0	0.0	0.0	0.0	0.0	0.0	0.0
Detector 2 Position(ft)		94			94			94				94
Detector 2 Size(ft)		6			6			6				6
Detector 2 Type		Cl+Ex			Cl+Ex			Cl+Ex				Cl+Ex
Detector 2 Channel												
Detector 2 Extend (s)		0.0			0.0			0.0				0.0
Turn Type	pm+pt	NA	Perm	Prot	NA	Perm	pm+pt	NA	Perm	pm+pt	NA	Perm
Protected Phases	7	4		3	8		1	6		5	2	
Permitted Phases	4		4			8	6		6	2		2

Lanes, Volumes, Timings  
1: Sneffels St & Mesa Ridge Pkwy

2041 Background + Site  
AM

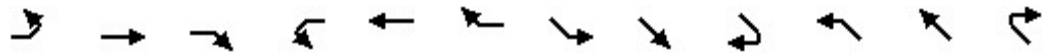

Lane Group	EBL	EBT	EBR	WBL	WBT	WBR	SEL	SET	SER	NWL	NWT	NWR
Detector Phase	7	4	4	3	8	8	1	6	6	5	2	2
Switch Phase												
Minimum Initial (s)	5.0	5.0	5.0	5.0	5.0	5.0	4.5	4.0	4.0	4.5	4.0	4.0
Minimum Split (s)	10.0	25.0	25.0	10.0	25.0	25.0	9.0	9.0	9.0	9.0	9.0	9.0
Total Split (s)	22.0	72.0	72.0	18.0	68.0	68.0	11.0	22.0	22.0	8.0	19.0	19.0
Total Split (%)	18.3%	60.0%	60.0%	15.0%	56.7%	56.7%	9.2%	18.3%	18.3%	6.7%	15.8%	15.8%
Maximum Green (s)	17.5	65.0	65.0	13.5	61.0	61.0	6.5	17.0	17.0	3.5	14.0	14.0
Yellow Time (s)	3.5	5.0	5.0	3.5	5.0	5.0	3.5	3.0	3.0	3.5	3.0	3.0
All-Red Time (s)	1.0	2.0	2.0	1.0	2.0	2.0	1.0	2.0	2.0	1.0	2.0	2.0
Lost Time Adjust (s)	0.0	0.0	0.0	0.0	0.0	0.0	0.0	0.0	0.0	0.0	0.0	0.0
Total Lost Time (s)	4.5	7.0	7.0	4.5	7.0	7.0	4.5	5.0	5.0	4.5	5.0	5.0
Lead/Lag	Lead	Lag	Lag	Lead	Lag	Lag	Lead	Lag	Lag	Lead	Lag	Lag
Lead-Lag Optimize?	Yes	Yes	Yes	Yes	Yes	Yes	Yes	Yes	Yes	Yes	Yes	Yes
Vehicle Extension (s)	3.0	3.0	3.0	3.0	3.0	3.0	3.0	3.0	3.0	3.0	3.0	3.0
Recall Mode	None	None	None	None	None	None	None	C-Max	C-Max	None	C-Max	C-Max
Act Effect Green (s)	85.2	69.5	69.5	9.0	64.1	64.1	24.0	17.0	17.0	18.0	14.0	14.0
Actuated g/C Ratio	0.71	0.58	0.58	0.08	0.53	0.53	0.20	0.14	0.14	0.15	0.12	0.12
v/c Ratio	0.61	0.42	0.08	0.41	1.03	0.07	0.43	0.12	0.92	0.82	0.11	0.64
Control Delay	32.2	15.1	1.7	57.3	57.4	0.8	46.0	46.4	52.1	76.4	48.9	13.3
Queue Delay	0.0	0.0	0.0	0.0	0.0	0.0	0.0	0.0	0.0	0.0	0.0	0.0
Total Delay	32.2	15.1	1.7	57.3	57.4	0.8	46.0	46.4	52.1	76.4	48.9	13.3
LOS	C	B	A	E	E	A	D	D	D	E	D	B
Approach Delay		16.7			55.9			50.4			38.9	
Approach LOS		B			E			D			D	
Queue Length 50th (ft)	68	184	0	40	~858	0	74	22	132	122	16	0
Queue Length 95th (ft)	140	243	15	68	#1027	6	129	53	#317	#245	42	83
Internal Link Dist (ft)		1882			1357			367			806	
Turn Bay Length (ft)	578		315	510		378	200		160	315		
Base Capacity (vph)	319	2049	958	386	1890	892	261	263	395	217	217	424
Starvation Cap Reductn	0	0	0	0	0	0	0	0	0	0	0	0
Spillback Cap Reductn	0	0	0	0	0	0	0	0	0	0	0	0
Storage Cap Reductn	0	0	0	0	0	0	0	0	0	0	0	0
Reduced v/c Ratio	0.52	0.42	0.08	0.27	1.03	0.07	0.43	0.12	0.92	0.82	0.11	0.64

Intersection Summary

Area Type: Other  
 Cycle Length: 120  
 Actuated Cycle Length: 120  
 Offset: 0 (0%), Referenced to phase 2:NWTL and 6:SETL, Start of Green  
 Natural Cycle: 90  
 Control Type: Actuated-Coordinated  
 Maximum v/c Ratio: 1.03  
 Intersection Signal Delay: 42.9  
 Intersection LOS: D  
 Intersection Capacity Utilization 94.7%  
 ICU Level of Service F  
 Analysis Period (min) 15  
 ~ Volume exceeds capacity, queue is theoretically infinite.  
 Queue shown is maximum after two cycles.  
 # 95th percentile volume exceeds capacity, queue may be longer.  
 Queue shown is maximum after two cycles.

Splits and Phases: 1: Sneffels St & Mesa Ridge Pkwy

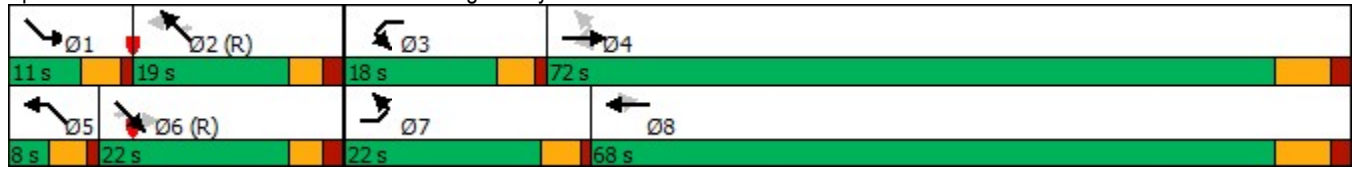

Intersection												
Int Delay, s/veh	3.8											
Movement	SEL	SET	SER	NWL	NWT	NWR	NEL	NET	NER	SWL	SWT	SWR
Lane Configurations												
Traffic Vol, veh/h	3	333	6	10	155	66	4	0	7	127	0	6
Future Vol, veh/h	3	333	6	10	155	66	4	0	7	127	0	6
Conflicting Peds, #/hr	0	0	0	0	0	0	0	0	0	0	0	0
Sign Control	Free	Free	Free	Free	Free	Free	Stop	Stop	Stop	Stop	Stop	Stop
RT Channelized	-	-	None	-	-	None	-	-	None	-	-	Stop
Storage Length	50	-	-	50	-	190	-	-	-	-	-	-
Veh in Median Storage, #	-	0	-	-	0	-	-	0	-	-	0	-
Grade, %	-	0	-	-	0	-	-	0	-	-	0	-
Peak Hour Factor	92	92	92	87	87	87	78	78	78	87	87	87
Heavy Vehicles, %	2	2	2	2	2	2	2	2	2	2	2	2
Mvmt Flow	3	362	7	11	178	76	5	0	9	146	0	7

Major/Minor	Major1			Major2			Minor1			Minor2		
Conflicting Flow All	254	0	0	369	0	0	610	648	366	576	575	178
Stage 1	-	-	-	-	-	-	372	372	-	200	200	-
Stage 2	-	-	-	-	-	-	238	276	-	376	375	-
Critical Hdwy	4.12	-	-	4.12	-	-	7.12	6.52	6.22	7.12	6.52	6.22
Critical Hdwy Stg 1	-	-	-	-	-	-	6.12	5.52	-	6.12	5.52	-
Critical Hdwy Stg 2	-	-	-	-	-	-	6.12	5.52	-	6.12	5.52	-
Follow-up Hdwy	2.218	-	-	2.218	-	-	3.518	4.018	3.318	3.518	4.018	3.318
Pot Cap-1 Maneuver	1311	-	-	1190	-	-	407	389	679	428	429	865
Stage 1	-	-	-	-	-	-	648	619	-	802	736	-
Stage 2	-	-	-	-	-	-	765	682	-	645	617	-
Platoon blocked, %		-	-	-	-	-						
Mov Cap-1 Maneuver	1311	-	-	1190	-	-	400	385	679	419	424	865
Mov Cap-2 Maneuver	-	-	-	-	-	-	400	385	-	419	424	-
Stage 1	-	-	-	-	-	-	647	618	-	800	729	-
Stage 2	-	-	-	-	-	-	752	676	-	635	616	-

Approach	SE			NW			NE			SW		
HCM Control Delay, s	0.1			0.3			11.8			18		
HCM LOS							B			C		

Minor Lane/Major Mvmt	NELn1	NWL	NWT	NWR	SEL	SET	SERSWLn1
Capacity (veh/h)	542	1190	-	-	1311	-	429
HCM Lane V/C Ratio	0.026	0.01	-	-	0.002	-	0.356
HCM Control Delay (s)	11.8	8.1	-	-	7.8	-	18
HCM Lane LOS	B	A	-	-	A	-	C
HCM 95th %tile Q(veh)	0.1	0	-	-	0	-	1.6

Intersection												
Int Delay, s/veh	2.1											
Movement	SEL	SET	SER	NWL	NWT	NWR	NEL	NET	NER	SWL	SWT	SWR
Lane Configurations												
Traffic Vol, veh/h	3	295	2	25	125	15	3	0	11	36	0	8
Future Vol, veh/h	3	295	2	25	125	15	3	0	11	36	0	8
Conflicting Peds, #/hr	0	0	0	0	0	0	0	0	0	0	0	0
Sign Control	Free	Free	Free	Free	Free	Free	Stop	Stop	Stop	Stop	Stop	Stop
RT Channelized	-	-	None	-	-	None	-	-	None	-	-	None
Storage Length	50	-	-	50	-	0	-	-	-	-	-	-
Veh in Median Storage, #	-	0	-	-	0	-	-	0	-	-	0	-
Grade, %	-	0	-	-	0	-	-	0	-	-	0	-
Peak Hour Factor	92	92	92	87	87	87	78	78	78	78	78	78
Heavy Vehicles, %	2	2	2	2	2	2	2	2	2	2	2	2
Mvmt Flow	3	321	2	29	144	17	4	0	14	46	0	10

Major/Minor	Major1			Major2			Minor1			Minor2		
Conflicting Flow All	161	0	0	323	0	0	544	547	322	537	531	144
Stage 1	-	-	-	-	-	-	328	328	-	202	202	-
Stage 2	-	-	-	-	-	-	216	219	-	335	329	-
Critical Hdwy	4.12	-	-	4.12	-	-	7.12	6.52	6.22	7.12	6.52	6.22
Critical Hdwy Stg 1	-	-	-	-	-	-	6.12	5.52	-	6.12	5.52	-
Critical Hdwy Stg 2	-	-	-	-	-	-	6.12	5.52	-	6.12	5.52	-
Follow-up Hdwy	2.218	-	-	2.218	-	-	3.518	4.018	3.318	3.518	4.018	3.318
Pot Cap-1 Maneuver	1418	-	-	1237	-	-	450	445	719	455	454	903
Stage 1	-	-	-	-	-	-	685	647	-	800	734	-
Stage 2	-	-	-	-	-	-	786	722	-	679	646	-
Platoon blocked, %	-	-	-	-	-	-	-	-	-	-	-	-
Mov Cap-1 Maneuver	1418	-	-	1237	-	-	436	434	719	437	443	903
Mov Cap-2 Maneuver	-	-	-	-	-	-	436	434	-	437	443	-
Stage 1	-	-	-	-	-	-	684	646	-	798	717	-
Stage 2	-	-	-	-	-	-	759	705	-	664	645	-

























Approach	SE			NW			NE			SW		
HCM Control Delay, s	0.1			1.2			10.9			13.5		
HCM LOS							B			B		

Minor Lane/Major Mvmt	NELn1	NWL	NWT	NWR	SEL	SET	SERSWLn1
Capacity (veh/h)	631	1237	-	-	1418	-	482
HCM Lane V/C Ratio	0.028	0.023	-	-	0.002	-	0.117
HCM Control Delay (s)	10.9	8	-	-	7.5	-	13.5
HCM Lane LOS	B	A	-	-	A	-	B
HCM 95th %tile Q(veh)	0.1	0.1	-	-	0	-	0.4



Lanes, Volumes, Timings  
1: Sneffels St & Mesa Ridge Pkwy

2041 Background + Site  
PM

												
Lane Group	EBL	EBT	EBR	WBL	WBT	WBR	SEL	SET	SER	NWL	NWT	NWR
Lane Configurations												
Traffic Volume (vph)	274	2150	350	250	1200	122	76	37	189	100	43	275
Future Volume (vph)	274	2150	350	250	1200	122	76	37	189	100	43	275
Ideal Flow (vphpl)	1900	1900	1900	1900	1900	1900	1900	1900	1900	1900	1900	1900
Storage Length (ft)	578		315	510		378	200		160	315		0
Storage Lanes	1		1	2		1	1		1	1		1
Taper Length (ft)	222			170			75			120		
Lane Util. Factor	1.00	0.95	1.00	0.97	0.95	1.00	1.00	1.00	1.00	1.00	1.00	1.00
Frt			0.850			0.850			0.850			0.850
Flt Protected	0.950			0.950			0.950			0.950		
Satd. Flow (prot)	1770	3539	1583	3433	3539	1583	1770	1863	1583	1770	1863	1583
Flt Permitted	0.128			0.950			0.726			0.608		
Satd. Flow (perm)	238	3539	1583	3433	3539	1583	1352	1863	1583	1133	1863	1583
Right Turn on Red			Yes			Yes			Yes			Yes
Satd. Flow (RTOR)			303			141			205			202
Link Speed (mph)		55			55			25			25	
Link Distance (ft)		1962			1436			447			886	
Travel Time (s)		24.3			17.8			12.2			24.2	
Peak Hour Factor	0.95	0.95	0.95	0.95	0.95	0.95	0.92	0.92	0.92	0.92	0.92	0.92
Adj. Flow (vph)	288	2263	368	263	1263	128	83	40	205	109	47	299
Shared Lane Traffic (%)												
Lane Group Flow (vph)	288	2263	368	263	1263	128	83	40	205	109	47	299
Enter Blocked Intersection	No	No	No	No	No	No	No	No	No	No	No	No
Lane Alignment	Left	Left	Right	Left	Left	Right	Left	Left	Right	Left	Left	Right
Median Width(ft)		24			24			12			12	
Link Offset(ft)		0			0			0			0	
Crosswalk Width(ft)		16			16			16			16	
Two way Left Turn Lane												
Headway Factor	1.00	1.00	1.00	1.00	1.00	1.00	1.00	1.00	1.00	1.00	1.00	1.00
Turning Speed (mph)	15		9	15		9	15		9	15		9
Number of Detectors	1	2	1	1	2	1	1	2	1	1	2	1
Detector Template	Left	Thru	Right	Left	Thru	Right	Left	Thru	Right	Left	Thru	Right
Leading Detector (ft)	20	100	20	20	100	20	20	100	20	20	100	20
Trailing Detector (ft)	0	0	0	0	0	0	0	0	0	0	0	0
Detector 1 Position(ft)	0	0	0	0	0	0	0	0	0	0	0	0
Detector 1 Size(ft)	20	6	20	20	6	20	20	6	20	20	6	20
Detector 1 Type	Cl+Ex	Cl+Ex	Cl+Ex	Cl+Ex	Cl+Ex	Cl+Ex	Cl+Ex	Cl+Ex	Cl+Ex	Cl+Ex	Cl+Ex	Cl+Ex
Detector 1 Channel												
Detector 1 Extend (s)	0.0	0.0	0.0	0.0	0.0	0.0	0.0	0.0	0.0	0.0	0.0	0.0
Detector 1 Queue (s)	0.0	0.0	0.0	0.0	0.0	0.0	0.0	0.0	0.0	0.0	0.0	0.0
Detector 1 Delay (s)	0.0	0.0	0.0	0.0	0.0	0.0	0.0	0.0	0.0	0.0	0.0	0.0
Detector 2 Position(ft)		94			94			94			94	
Detector 2 Size(ft)		6			6			6			6	
Detector 2 Type		Cl+Ex			Cl+Ex			Cl+Ex			Cl+Ex	
Detector 2 Channel												
Detector 2 Extend (s)		0.0			0.0			0.0			0.0	
Turn Type	pm+pt	NA	Perm	Prot	NA	Perm	pm+pt	NA	Perm	pm+pt	NA	Perm
Protected Phases	7	4		3	8		1	6		5	2	
Permitted Phases	4		4			8	6		6	2		2



Splits and Phases: 1: Sneffels St & Mesa Ridge Pkwy

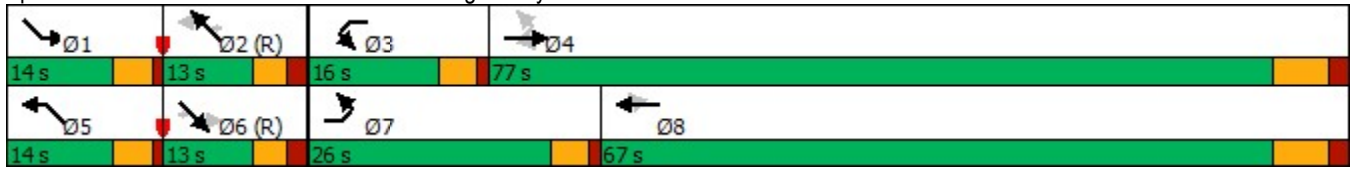

Intersection												
Int Delay, s/veh	2.4											
Movement	SEL	SET	SER	NWL	NWT	NWR	NEL	NET	NER	SWL	SWT	SWR
Lane Configurations	↖	↗		↖	↗	↖		↕			↕	
Traffic Vol, veh/h	5	210	6	15	280	144	2	0	10	82	0	6
Future Vol, veh/h	5	210	6	15	280	144	2	0	10	82	0	6
Conflicting Peds, #/hr	0	0	0	0	0	0	0	0	0	0	0	0
Sign Control	Free	Free	Free	Free	Free	Free	Stop	Stop	Stop	Stop	Stop	Stop
RT Channelized	-	-	None	-	-	None	-	-	None	-	-	Stop
Storage Length	50	-	-	50	-	190	-	-	-	-	-	-
Veh in Median Storage, #	-	0	-	-	0	-	-	0	-	-	0	-
Grade, %	-	0	-	-	0	-	-	0	-	-	0	-
Peak Hour Factor	92	92	92	87	87	87	78	78	78	87	87	87
Heavy Vehicles, %	2	2	2	2	2	2	2	2	2	2	2	2
Mvmt Flow	5	228	7	17	322	166	3	0	13	94	0	7

Major/Minor	Major1			Major2			Minor1			Minor2		
Conflicting Flow All	488	0	0	235	0	0	681	764	232	604	601	322
Stage 1	-	-	-	-	-	-	242	242	-	356	356	-
Stage 2	-	-	-	-	-	-	439	522	-	248	245	-
Critical Hdwy	4.12	-	-	4.12	-	-	7.12	6.52	6.22	7.12	6.52	6.22
Critical Hdwy Stg 1	-	-	-	-	-	-	6.12	5.52	-	6.12	5.52	-
Critical Hdwy Stg 2	-	-	-	-	-	-	6.12	5.52	-	6.12	5.52	-
Follow-up Hdwy	2.218	-	-	2.218	-	-	3.518	4.018	3.318	3.518	4.018	3.318
Pot Cap-1 Maneuver	1075	-	-	1332	-	-	364	334	807	410	414	719
Stage 1	-	-	-	-	-	-	762	705	-	661	629	-
Stage 2	-	-	-	-	-	-	597	531	-	756	703	-
Platoon blocked, %	-	-	-	-	-	-	-	-	-	-	-	-
Mov Cap-1 Maneuver	1075	-	-	1332	-	-	356	328	807	398	407	719
Mov Cap-2 Maneuver	-	-	-	-	-	-	356	328	-	398	407	-
Stage 1	-	-	-	-	-	-	758	701	-	658	621	-
Stage 2	-	-	-	-	-	-	584	524	-	741	699	-

Approach	SE			NW			NE			SW		
HCM Control Delay, s	0.2			0.3			10.5			16.6		
HCM LOS							B			C		

Minor Lane/Major Mvmt	NELn1	NWL	NWT	NWR	SEL	SET	SERSWLn1
Capacity (veh/h)	666	1332	-	-	1075	-	410
HCM Lane V/C Ratio	0.023	0.013	-	-	0.005	-	0.247
HCM Control Delay (s)	10.5	7.7	-	-	8.4	-	16.6
HCM Lane LOS	B	A	-	-	A	-	C
HCM 95th %tile Q(veh)	0.1	0	-	-	0	-	1

Intersection												
Int Delay, s/veh	2											
Movement	SEL	SET	SER	NWL	NWT	NWR	NEL	NET	NER	SWL	SWT	SWR
Lane Configurations	↖	↗		↖	↗	↖		↕			↕	
Traffic Vol, veh/h	8	170	5	20	208	60	3	0	15	36	0	8
Future Vol, veh/h	8	170	5	20	208	60	3	0	15	36	0	8
Conflicting Peds, #/hr	0	0	0	0	0	0	0	0	0	0	0	0
Sign Control	Free	Free	Free	Free	Free	Free	Stop	Stop	Stop	Stop	Stop	Stop
RT Channelized	-	-	None	-	-	None	-	-	None	-	-	None
Storage Length	50	-	-	50	-	0	-	-	-	-	-	-
Veh in Median Storage, #	-	0	-	-	0	-	-	0	-	-	0	-
Grade, %	-	0	-	-	0	-	-	0	-	-	0	-
Peak Hour Factor	92	92	92	87	87	87	78	78	78	78	78	78
Heavy Vehicles, %	2	2	2	2	2	2	2	2	2	2	2	2
Mvmt Flow	9	185	5	23	239	69	4	0	19	46	0	10

Major/Minor	Major1			Major2			Minor1			Minor2		
Conflicting Flow All	308	0	0	190	0	0	531	560	188	500	493	239
Stage 1	-	-	-	-	-	-	206	206	-	285	285	-
Stage 2	-	-	-	-	-	-	325	354	-	215	208	-
Critical Hdwy	4.12	-	-	4.12	-	-	7.12	6.52	6.22	7.12	6.52	6.22
Critical Hdwy Stg 1	-	-	-	-	-	-	6.12	5.52	-	6.12	5.52	-
Critical Hdwy Stg 2	-	-	-	-	-	-	6.12	5.52	-	6.12	5.52	-
Follow-up Hdwy	2.218	-	-	2.218	-	-	3.518	4.018	3.318	3.518	4.018	3.318
Pot Cap-1 Maneuver	1253	-	-	1384	-	-	459	437	854	481	477	800
Stage 1	-	-	-	-	-	-	796	731	-	722	676	-
Stage 2	-	-	-	-	-	-	687	630	-	787	730	-
Platoon blocked, %	-	-	-	-	-	-	-	-	-	-	-	-
Mov Cap-1 Maneuver	1253	-	-	1384	-	-	445	427	854	462	466	800
Mov Cap-2 Maneuver	-	-	-	-	-	-	445	427	-	462	466	-
Stage 1	-	-	-	-	-	-	790	726	-	717	665	-
Stage 2	-	-	-	-	-	-	667	619	-	764	725	-

Approach	SE	NW	NE	SW
HCM Control Delay, s	0.3	0.5	10	13.1
HCM LOS			B	B

Minor Lane/Major Mvmt	NELn1	NWL	NWT	NWR	SEL	SET	SERSWLn1
Capacity (veh/h)	741	1384	-	-	1253	-	500
HCM Lane V/C Ratio	0.031	0.017	-	-	0.007	-	0.113
HCM Control Delay (s)	10	7.6	-	-	7.9	-	13.1
HCM Lane LOS	B	A	-	-	A	-	B
HCM 95th %tile Q(veh)	0.1	0.1	-	-	0	-	0.4