

**STORM WATER MANAGEMENT PLAN
FOR
O'REILLY AUTO PARTS (C11)
2417 Marksheffel Road
Colorado Springs, CO**

Owner/Designated Operator:



**O'Reilly Auto Parts Stores, Inc.
233 South Patterson
Springfield, Missouri 65802
Phone: (417) 862-3333**

SWMP Preparer:



**Tait & Associates, Inc.
6163 East County Road 16
Loveland, Colorado 80537
Phone: (970) 613-1447
Fax: (970) 613-1897**

Qualified Stormwater Manager:

Contractor:

February 2020

Table of Contents

I.	SITE DESCRIPTION.....	2
A.	DESCRIPTION OF CONSTRUCTION ACTIVITY _____	2
B.	PROPOSED CONSTRUCTION SCHEDULE _____	3
C.	SITE CHARACTERISTICS _____	3
D.	SOIL EROSION POTENTIAL _____	3
E.	ESTIMATED RUNOFF COEFFICIENTS, EXISTING SOILS, AND EROSION POTENTIAL _____	3
F.	EXISTING VEGETATION _____	4
G.	LOCATION OF OTHER POTENTIAL POLLUTION SOURCES (i.e., VEHICLE FUELING, STORAGE OF CHEMICALS, ETC.) _____	4
H.	DESCRIPTION OF OTHER POTENTIAL POLLUTION SOURCES (i.e., CONCRETE WASHOUT, PORT-O-LETS, DUMPSTER, ETC.) _____	4
I.	RECEIVING WATERS OR DISCHARGE TO MUNICIPAL SEPARATE STORM SEWER (MS4) _____	6
J.	STREAM CROSSINGS _____	6
II.	LOCATION AND DESCRIPTION OF BMPs	6
A.	PHASE 1 – GRADING PHASE–BMPs FOR INITIAL INSTALLATION OF PERIMETER CONTROLS ____	7
B.	PHASE 2 – INFRASTRUCTURE PHASE–BMPs FOR UTILITY; PAVING; CURB AND GUTTER INSTALLATIONS _____	8
C.	PHASE 3 – PERMANENT BMPs AND FINAL STABILIZATION _____	9
III.	INSPECTION AND MAINTENANCE PROCEDURES.....	9
A.	INSPECTIONS _____	9
B.	MAINTENANCE _____	11
IV.	IDENTIFICATION OF NON-STORMWATER DISCHARGES	11
	APPENDIX.....	12
	VICINITY MAP	
	BEST MANAGEMENT PRACTICES	
	SITE EROSION AND SEDIMENT CONTROL PLAN	
	SITE GRADING PLAN	
	SPILL PREVENTION AND CONTROL PLAN	
	STORMWATER CONSTRUCTION FIELD INSPECTION REPORT	
	EL PASO COUNTY STORMWATER MANAGEMENT PLAN CHECKLIST	
	EL PASO COUNTY EROSION AND STORMWATER QUALITY CONTROL PERMIT (ESQCP)	

SWMP ADMINISTRATOR:

A. SWMP ADMINISTRATOR FOR DESIGN:

Name/Title	Contact Information
Alex Hoime, PE	970-613-1447 – ahoime@tait.com



B. SWMP ADMINISTRATOR FOR CONSTRUCTION: (As defined in Subsection 208)

The Contractor shall designate a SWMP Administrator for Construction upon ownership of the SWMP. The SWMP Administrator shall become the owner/operator and assume responsibility for all design changes to the SWMP implementation and maintenance in accordance to 208.03. The SWMP Administrator shall be responsible for implementing, maintaining and revising SWMP, including the title and contact information. The activities and responsibilities of the SWMP Administrator shall address all aspects of the projects SWMP. (Update the information below for each new SWMP Administrator) (Copy of TECS Certification must also be included in the SWMP Notebook.) The SWMP Administration for construction is not a separate pay item but is included in the cost of the work.

Name/Title	Contact Information	Certification #	Start Date	Engineer Approval

I. SITE DESCRIPTION

This report is intended to summarize the Storm Water Management Plan (SWMP) for the construction activities that will occur with the O'Reilly Auto Parts (C11) site located at 2417 Marksheffel Road, Colorado Springs, Colorado. The proposed site is part of an overall subdivision, thus requiring this plan. This plan is required by El Paso County and has been prepared according to regulations of the Colorado Department of Health and Water Quality Control Division.

The O'Reilly Auto Parts (C11) site is located in Lot 4 of Claremont Ranch filing number 9B, in the City of Colorado Springs, County of El Paso, and State of Colorado. The site is bound to the north by undeveloped land similar in appearance to the subject site, to the east by a King Soopers Supermarket, to the south by an asphalt access road, and to the west by North Marksheffel Road. See Appendix for Vicinity Map.

A. DESCRIPTION OF CONSTRUCTION ACTIVITY

Proposed development for this site includes a 7,453 sf commercial building, paved parking and drive aisles, curb, gutter and sidewalk, utility services, landscaping, and drainage facilities. The overall site will be comprised of landscaping, building, and paved areas. The proposed development will be 64% impervious.

1. The first phase of construction will involve over lot grading, temporary and permanent erosion controls, as necessary.
2. The second phase of construction will involve building, utility services, parking and drive aisles, curb, gutter and sidewalk, landscaping, and drainage facilities.
3. The construction will occur approximately in the following order, but it is possible that some of these activities will occur simultaneously.
 - Temporary erosion controls.
 - Over lot grading.
 - Construction of drainage improvements.
 - Other utility and site improvements.
 - Permanent landscaping and erosion controls, as needed.

B. PROPOSED CONSTRUCTION SCHEDULE

Expected Start Date: May 2020

Expected Completion Date: January 2021

C. SITE CHARACTERISTICS

- Total Area: 0.97 acres
- Total Disturbed Area: 0.97 acres

D. SOIL EROSION POTENTIAL

Construction BMPs will be implemented to ensure erosion and sediment control problems do not occur. Post-construction erosion and sediment control problems are also not anticipated. The likelihood is very minimal due to the proposed landscaping and improvements that will permanently stabilize the disturbed area of the site.

E. ESTIMATED RUNOFF COEFFICIENTS, EXISTING SOILS, AND EROSION POTENTIAL

The estimated onsite runoff coefficient before construction activities is 0.35. The estimated onsite runoff coefficient after construction activities are completed is 0.75.

Existing onsite soils are classified according to the Geotechnical Engineering Report by Terracon dated September 20, 2019. The fill soils consist of sand with varying amounts of silt and clay encountered to depths of approximately 3½ to 10 feet. Native sand soils with varying amounts of silt and clay were encountered below fill soils to the total depths explored (15 feet below existing site grades). Groundwater was not encountered.

All land disturbing activities shall be conducted in such a manner so as to effectively reduce accelerated soil erosion and resulting sedimentation. All land disturbing activities shall be designed, constructed and completed in such a manner that the exposure of disturbed land shall be limited to the shortest possible period of time. If conditions warrant, the contractor will install the appropriate erosion and sediment control facilities shown on this Storm Water Management Plan.

- Sediment caused by accelerated soil erosion shall be removed from runoff water before leaving the site. Temporary swales shall be designed and constructed as needed to limit the water to a slow non-erosive velocity.

- Any stock pile for excess cut shall be maintained with a silt fence around its base which is sufficient in size to control runoff until it percolates into the native soil to preclude the escape of sediment laden runoff.
- Permanent or temporary soil surface stabilization shall be applied to disturbed areas and soil stockpiles as soon as possible. Soil surface stabilization may also be applied to disturbed areas that may not be at final grade but will remain dormant (undisturbed) for longer than 30 days.
- Any settlement or soil accumulations beyond property limits due to grading or erosion shall be repaired immediately by the contractor. Any construction debris or mud tracking in the public right-of-way or shared access roads resulting from this development shall be removed immediately or as soon as practical by the contractor.
- To the extent practicable, erosion and sediment control measures shall be installed prior to grading activities at all times during project construction. All temporary and permanent erosion and sediment control measures shall be maintained and repaired as needed to prevent accelerated erosion on the site and any adjacent properties.

F. EXISTING VEGETATION

The existing site is relatively undeveloped. There is light vegetation and weed growth onsite. The ground cover is about 50%. This is an estimation from the site photos provided with the Survey. The area around the site has undergone relatively recent development and mass grading operations are known to have occurred in the area. Review of historical aerial imagery appears to show mass grading operations occurring between 2015 and 2017.

G. LOCATION OF OTHER POTENTIAL POLLUTION SOURCES (i.e., VEHICLE FUELING, STORAGE OF CHEMICALS, ETC.)

Environmental concerns are identified in the Phase I Environmental Site Assessment prepared by ATC and dated April 30, 2019. To date, based on distance, environmental setting, facility characteristics, and/or inquiry results from the local agencies, the identified facilities do not constitute Recognized Environmental Conditions (RECs) in connection with the site at this time.

H. DESCRIPTION OF OTHER POTENTIAL POLLUTION SOURCES (i.e., CONCRETE WASHOUT, PORT-O-LETS, DUMPSTER, ETC.)

- a) All disturbed and stored soils present potential pollutant sources due to increased sediment laden runoff. Appropriate BMP's including inlet protection, curb socks, silt fence, and seeding and mulching shall be used to mitigate the effects of sediment laden runoff. Any stock pile for excess

cut shall be maintained with a silt fence around its base which is sufficient in size to control runoff until it percolates into the native soil to preclude the escape of sediment laden runoff.

- b) Off-site soil tracking shall be controlled by the installation of paving, gravel or vehicle tracking control over all traffic areas of the site. The vehicle tracking pad, rock socks and inlet protection locations are shown on the site specific erosion control plans. The vehicle tracking pad is at the entrance to the site, and the rock socks and inlet protections are placed to intercept any sediments from entering downstream inlets.
- c) There are no additional known current contaminated soils for this site, nor are they anticipated to be a pollutant source during the development process.
- d) Loading and unloading operations are to be conducted in/near the stabilized staging area whenever possible. This combined with vehicle tracking control will mitigate the pollution sources possible during construction.
- e) All outdoor storage activities (building materials, fertilizers, chemicals, etc.) are to be located in the stabilized staging area and use the good housekeeping practices provided by MHFD. Any associated waste stockpile will be located in the stabilizing staging area shown on the site specific erosion control plan.
- f) Minor vehicle equipment maintenance and fueling activities are anticipated on site. Should there be any spills steps laid out in the Spill Prevention Control Plan are to be taken.
- g) Fugitive dust emissions resulting from significant dust or particulate generating processes such as grading and/or wind, and shall be controlled using available control technology and best management practices as defined by the Colorado Department of Health at the time of construction.
- h) Routine maintenance activities involving fertilizers, pesticides, detergents, fuels, solvents, oils, etc. are not anticipated to be an issue with this site. Any fertilizers used to provide regular maintenance of the associated landscape should be run through a buffer and landscape swale prior to discharge.
- i) On-site waste management practices including but not limited to (waste piles, liquid wastes, dumpsters, etc.) are to be regularly monitored and maintained. Any piles during construction are to be located in the stabilized staging area.

- j) A concrete truck washout area will be provided as designated on the Erosion control plans provided with this submittal. This is a potential allowable non-stormwater discharge. No dewatering per the CDPHE is anticipated to be required at this point in time.
- k) Non-industrial waste sources that may be significant such as worker trash and portable toilets are anticipated for this site. Trash and debris shall be collected and trucked from the site. The location of the sanitary facilities are shown on the site specific erosion control plan.
- l) There are no dedicated asphalt and concrete batch plant anticipated during the development of this lot. Therefore, spill prevention and pollution controls for dedicated batch plants are not provided.
- m) There is one bulk storage area (e.g., fuel tanks, chemical storage over 55-gallon capacity) onsite. It shall be provided in a stabilized staging area.
- n) There is only one known anticipated non-storm water discharge (concrete washout with appropriate controls) anticipated during construction. The concrete washout area has been shown with the designated BMP's on the plan.
- o) There are no anticipated other areas or procedures where potential spills can occur.
- p) Trash and debris shall be collected and trucked from the site.

I. RECEIVING WATERS OR DISCHARGE TO MUNICIPAL SEPARATE STORM SEWER (MS4)

Onsite drainage will initially be routed east via storm drain pipe and discharge into the existing storm drain manhole along the access road. The stormwater will then be discharged into the existing water quality and detention pond east of the site. Stormwater is ultimately discharged to the East Fork Sub Tributary of Sand Creek.

J. STREAM CROSSINGS

There are no streams that cross the project area.

II. LOCATION AND DESCRIPTION OF BMPs

See the attached plans for information related to projected placement of mitigation measures included with this report.

A. PHASE 1 – GRADING PHASE–BMPs FOR INITIAL INSTALLATION OF PERIMETER CONTROLS

1. Vehicle Tracking Control

Prior to beginning earthwork activities, vehicle tracking control pads will be installed at every entrance/exit to the site as designated on the plan. The vehicle tracking control pad provides stabilized construction site access where vehicles exit the site onto paved public roads. The vehicle tracking control shall remain in place until there is longer potential for vehicle tracking to occur, typically after the site is stabilized.

2. Silt Fence

Prior to beginning earthwork activities, silt fences will be installed around the construction site as designated on the plan on the downstream side of the disturbed areas. The silt fence will protect downstream property from receiving excessive sediment loads from the up gradient disturbed ground surface. The silt fence along the boundaries shall remain in place until permanent landscaping and lawns have been established.

3. Seeding/Mulching

All disturbed areas may be mulched or seeded and mulched, after final grade is reached on any portion of the site not otherwise permanently stabilized. Mulch consisting of long-stemmed hay shall be applied evenly at the rate of two tons per acre, and anchored on slopes of 3:1 or less by mechanical crimping on the contour to a depth of 4”.

4. Permanent or Temporary Soil Stabilization

Soil stabilization measures shall be applied to disturbed areas and soil stockpiles within 7 days after final grade is reached on any portion of the site. Soil stabilization measures shall be applied within 7 days to disturbed areas, which may not be at final grade, but will be left dormant for longer than 14 days.

5. Soil Stockpiles

Soil stockpiles expected to be in place longer than 60 days shall be seeded with a temporary grass cover and mulched within 7 days after completion of stockpile construction if conditions warrant according to the details depicted in this storm water management plans.

6. Rock Socks/Gravel Bags

All storm sewer inlets/ curb and gutter downstream and offsite will have sediment entrapment facilities installed as needed to prevent sediment –laden runoff from entering the inlet. Contractor shall install inlet protection in accordance with the UDFCD standard details.

7. Inlet/Outlet Protection

For existing storm sewer inlets, all storm sewer inlets made operable during construction will have sediment entrapment facilities installed as needed to prevent sediment –laden runoff from entering the inlet. Contractor shall install inlet protection in accordance with the UDFCD standard details. Gravel bags for proposed flowline.

8. Sanitary Facilities

All Sanitary Facilities shall be placed in or near the designated Stabilized Staging Area on site.

B. PHASE 2 – INFRASTRUCTURE PHASE–BMPs FOR UTILITY; PAVING; CURB AND GUTTER INSTALLATIONS

1. Inlet Protection

All storm sewer inlets made operable during construction will have sediment entrapment facilities installed as needed to prevent sediment–laden runoff from entering the inlet. Contractor shall install inlet protection in accordance with the UDFCD standard details included within this report.

2. Sediment Control

All runoff leaving a disturbed area shall pass through at least one sediment entrapment facility before it exits the site.

3. Disposition of Temporary Measures

All temporary erosion and sediment control measures shall be removed within 30 days after final stabilization is achieved, or after the temporary measures are no longer needed, whichever occurs earliest.

4. Materials Handling and Spill Prevention

A concrete truck washout area will be provided as designated on the erosion control plans provided with this submittal. Refer to the Appendix for the Spill Prevention and Control Plan.

5. Concrete Washout

Concrete waste management involves designating and properly managing a specific area of the construction site as a concrete washout area. A concrete washout area can be created using one of several approaches designed to receive wash water from washing of tools and concrete mixer chutes, liquid concrete waste from dump trucks, mobile batch mixers, or pump trucks. Three basic approaches are available: excavation of a pit in the ground, use of an above ground storage area, or use of prefabricated haul away concrete washout containers. Surface discharges of concrete washout water from construction sites are prohibited.

C. PHASE 3 – PERMANENT BMPs AND FINAL STABILIZATION

Permanent vegetative cover consisting as designated by the Landscape Architect shall be drill seeded. Mulch shall be used to stabilize the exposed surface.

1. Landscaping:

- On-site landscaping areas shall be left in rough surface condition until covered with plantings and stone or wood mulch.
- Final vegetative cover density is to be 70% of pre-disturbed levels.

2. Final stabilization and long-term storm water management

- Grass buffers and swales shall be provided in the locations shown on the plans and in accordance the requirements stated in UDFCD's Urban Storm Drainage Criteria Manual: Volume 3.
- All erosion and pollution control measures shall be installed as shown, unless amended by El Paso County, the Colorado Department of Health, or the Owner.
- All construction debris shall be removed and all drainage facilities cleaned by the contractor either prior to or at the completion of the project.

III. INSPECTION AND MAINTENANCE PROCEDURES

A. INSPECTIONS

1. Perform every 14 days, or within 24 hours following each precipitation or snowmelt event that results in runoff. Inspections should include but are not limited to observation of:

- a. the construction site perimeter and discharge points (including discharges into a storm sewer system);
 - b. all disturbed areas;
 - c. areas used for material/waste storage that are exposed to precipitation;
 - d. other areas determined to have a significant potential for stormwater pollution, such as demolition areas or concrete washout locations, or locations where vehicles enter or leave the site;
 - e. erosion and sediment control measures identified in the SWMP;
 - f. any other structural BMPs that may require maintenance, such the condition of spill response kits.
2. Complete an inspection report for each inspection performed. At a minimum the following items must be documented as part of the site inspections:
- a. The inspection date;
 - b. Name(s) and title(s) of personnel making the inspection;
 - c. Location(s) of discharges of sediment or other pollutants from the site;
 - d. Location(s) of BMPs that need to be maintained;
 - e. Location(s) of BMPs that failed to operate as designed or proved inadequate for a particular location;
 - f. Location(s) where additional BMPs are needed that were not in place at the time of inspection;
 - g. Deviations from the minimum inspection frequency as discussed above;
 - h. Description of corrective action for items c, d, e, and f, above, dates corrective action(s) taken, and measures taken to prevent future violations, including requisite changes to the SWMP, as necessary; and
 - i. After adequate corrective action(s) has been taken, or where a report does not identify any incidents requiring corrective action, the report shall contain a signed statement indicating the site is in compliance with the permit to the best of the signer's knowledge and belief.
3. Keep inspection reports on site and include signatures on all reports. Additionally, it is recommended that a logbook be maintained for inspection reports, maintenance records, spill response, weather conditions, training, correspondence, etc.
4. Refer to the Appendix for a template of the Colorado Standard Management Plan Field Inspection Report.

B. MAINTENANCE

1. The contractor shall perform maintenance and repairs as soon as possible on all temporary and permanent erosion and sediment control practices identified in the inspection report to assure continued performance of their intended function.
2. Perform maintenance as indicated in the El Paso County Stormwater Management Manual, per manufacturer’s specifications, or other sources determined to be acceptable.

It is understood that additional erosion control measures may be required of the owner and his or her agents due to unforeseen erosion problems or if the submitted plan does not function as intended. The requirements of this plan shall run with the land and be the obligation of the landowner until such time as the plan is properly completed, modified or voided. The erosion and sediment control plan may be modified by El Paso County or Colorado Department of Public Health & Environment (CDPHE) or authorized representative as field conditions warrant.

IV. IDENTIFICATION OF NON-STORMWATER DISCHARGES

Authorized Non-Storm Water Discharges*	Comments
Discharges from fire-fighting activities.	In emergency situations.
Non-detergent based vehicle washing.	Concrete truck wash out. Wash water is retained onsite.
Water used for dust control.	Water is used during construction to control dust.
Potable water sources including waterline flushing.	Domestic drinking water supply lines are flushed to ensure lines are clean and have no residual chlorine.
Occasional external building wash down that does not use detergents.	Pressure washing of building. Do not use detergents.
Pavement wash waters where spill or leaks of toxic or hazardous materials have not occurred (unless all spilled material has been removed) and where detergents are not used.	Pavement is pressure washed on an occasional basis. No chemicals are used and after all leaks or spills have been cleaned up.
Uncontaminated air conditions or compressor condensate.	Air conditioning condensate from the construction trailer during construction.
Landscape irrigation.	Temporary and permanent vegetation may be irrigated to establish and enhance growth.
Discharge covered by CDPHE Low Risk Guidance	Uncontaminated Groundwater

*The Stormwater Construction Permit only covers discharges composed entirely of stormwater. Emergency firefighting water is the only authorized exception. Concrete Washout water can NOT be discharged to surface waters or to storm sewer systems without separate permit coverage. The discharge of Concrete Washout water to the ground, under specific conditions, may be allowed by the Stormwater Construction Permit when appropriate BMPs are implemented.

APPENDIX

VICINITY MAP

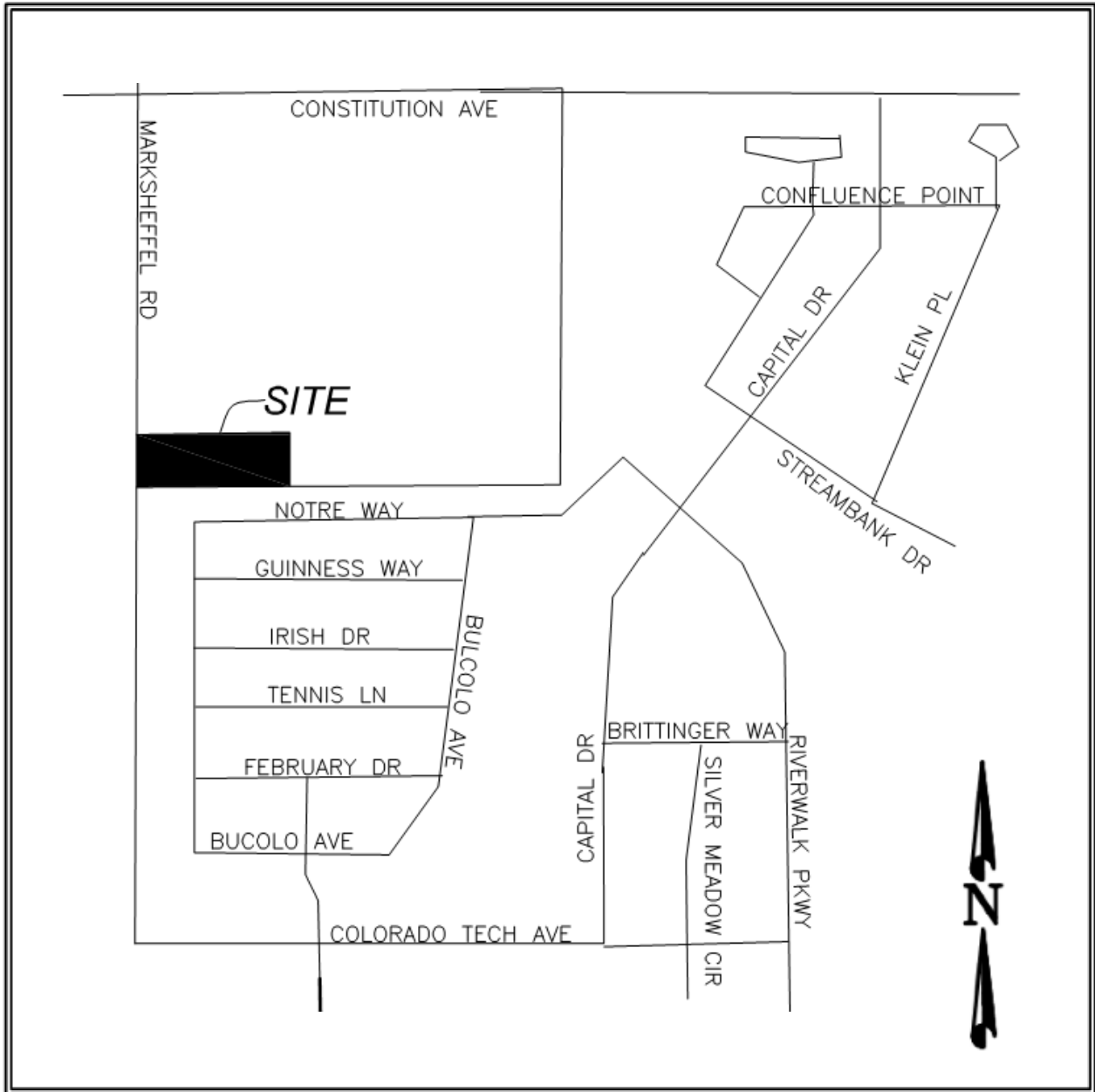

VICINITY MAP
Not to Scale

BEST MANAGEMENT PRACTICES

Description

Temporary seeding can be used to stabilize disturbed areas that will be inactive for an extended period. Permanent seeding should be used to stabilize areas at final grade that will not be otherwise stabilized. Effective seeding includes preparation of a seedbed, selection of an appropriate seed mixture, proper planting techniques, and protection of the seeded area with mulch, geotextiles, or other appropriate measures.



Photograph TS/PS -1. Equipment used to drill seed. Photo courtesy of Douglas County.

Appropriate Uses

When the soil surface is disturbed and will remain inactive for an extended period (typically 30 days or longer), proactive stabilization measures should be implemented. If the inactive period is short-lived (on the order of two weeks), techniques such as surface roughening may be appropriate. For longer periods of inactivity, temporary seeding and mulching can provide effective erosion control. Permanent seeding should be used on finished areas that have not been otherwise stabilized.

Typically, local governments have their own seed mixes and timelines for seeding. Check jurisdictional requirements for seeding and temporary stabilization.

Design and Installation

Effective seeding requires proper seedbed preparation, selection of an appropriate seed mixture, use of appropriate seeding equipment to ensure proper coverage and density, and protection with mulch or fabric until plants are established.

The USDCM Volume 2 *Revegetation* Chapter contains detailed seed mix, soil preparations, and seeding and mulching recommendations that may be referenced to supplement this Fact Sheet.

Drill seeding is the preferred seeding method. Hydroseeding is not recommended except in areas where steep slopes prevent use of drill seeding equipment, and even in these instances it is preferable to hand seed and mulch. Some jurisdictions do not allow hydroseeding or hydromulching.

Seedbed Preparation

Prior to seeding, ensure that areas to be revegetated have soil conditions capable of supporting vegetation. Overlot grading can result in loss of topsoil, resulting in poor quality subsoils at the ground surface that have low nutrient value, little organic matter content, few soil microorganisms, rooting restrictions, and conditions less conducive to infiltration of precipitation. As a result, it is typically necessary to provide stockpiled topsoil, compost, or other

Temporary and Permanent Seeding	
Functions	
Erosion Control	Yes
Sediment Control	No
Site/Material Management	No

EC-2 Temporary and Permanent Seeding (TS/PS)

soil amendments and rototill them into the soil to a depth of 6 inches or more.

Topsoil should be salvaged during grading operations for use and spread on areas to be revegetated later. Topsoil should be viewed as an important resource to be utilized for vegetation establishment, due to its water-holding capacity, structure, texture, organic matter content, biological activity, and nutrient content. The rooting depth of most native grasses in the semi-arid Denver metropolitan area is 6 to 18 inches. At a minimum, the upper 6 inches of topsoil should be stripped, stockpiled, and ultimately respread across areas that will be revegetated.

Where topsoil is not available, subsoils should be amended to provide an appropriate plant-growth medium. Organic matter, such as well digested compost, can be added to improve soil characteristics conducive to plant growth. Other treatments can be used to adjust soil pH conditions when needed. Soil testing, which is typically inexpensive, should be completed to determine and optimize the types and amounts of amendments that are required.

If the disturbed ground surface is compacted, rip or rototill the surface prior to placing topsoil. If adding compost to the existing soil surface, rototilling is necessary. Surface roughening will assist in placement of a stable topsoil layer on steeper slopes, and allow infiltration and root penetration to greater depth.

Prior to seeding, the soil surface should be rough and the seedbed should be firm, but neither too loose nor compacted. The upper layer of soil should be in a condition suitable for seeding at the proper depth and conducive to plant growth. Seed-to-soil contact is the key to good germination.

Seed Mix for Temporary Vegetation

To provide temporary vegetative cover on disturbed areas which will not be paved, built upon, or fully landscaped or worked for an extended period (typically 30 days or more), plant an annual grass appropriate for the time of planting and mulch the planted areas. Annual grasses suitable for the Denver metropolitan area are listed in Table TS/PS-1. These are to be considered only as general recommendations when specific design guidance for a particular site is not available. Local governments typically specify seed mixes appropriate for their jurisdiction.

Seed Mix for Permanent Revegetation

To provide vegetative cover on disturbed areas that have reached final grade, a perennial grass mix should be established. Permanent seeding should be performed promptly (typically within 14 days) after reaching final grade. Each site will have different characteristics and a landscape professional or the local jurisdiction should be contacted to determine the most suitable seed mix for a specific site. In lieu of a specific recommendation, one of the perennial grass mixes appropriate for site conditions and growth season listed in Table TS/PS-2 can be used. The pure live seed (PLS) rates of application recommended in these tables are considered to be absolute minimum rates for seed applied using proper drill-seeding equipment.

If desired for wildlife habitat or landscape diversity, shrubs such as rubber rabbitbrush (*Chrysothamnus nauseosus*), fourwing saltbush (*Atriplex canescens*) and skunkbrush sumac (*Rhus trilobata*) could be added to the upland seedmixes at 0.25, 0.5 and 1 pound PLS/acre, respectively. In riparian zones, planting root stock of such species as American plum (*Prunus americana*), woods rose (*Rosa woodsii*), plains cottonwood (*Populus sargentii*), and willow (*Populus spp.*) may be considered. On non-topsoiled upland sites, a legume such as Ladak alfalfa at 1 pound PLS/acre can be included as a source of nitrogen for perennial grasses.

Seeding dates for the highest success probability of perennial species along the Front Range are generally in the spring from April through early May and in the fall after the first of September until the ground freezes. If the area is irrigated, seeding may occur in summer months, as well. See Table TS/PS-3 for appropriate seeding dates.

Table TS/PS-1. Minimum Drill Seeding Rates for Various Temporary Annual Grasses

Species ^a (Common name)	Growth Season ^b	Pounds of Pure Live Seed (PLS)/acre ^c	Planting Depth (inches)
1. Oats	Cool	35 - 50	1 - 2
2. Spring wheat	Cool	25 - 35	1 - 2
3. Spring barley	Cool	25 - 35	1 - 2
4. Annual ryegrass	Cool	10 - 15	½
5. Millet	Warm	3 - 15	½ - ¾
6. Sudangrass	Warm	5-10	½ - ¾
7. Sorghum	Warm	5-10	½ - ¾
8. Winter wheat	Cool	20-35	1 - 2
9. Winter barley	Cool	20-35	1 - 2
10. Winter rye	Cool	20-35	1 - 2
11. Triticale	Cool	25-40	1 - 2

^a Successful seeding of annual grass resulting in adequate plant growth will usually produce enough dead-plant residue to provide protection from wind and water erosion for an additional year. This assumes that the cover is not disturbed or mowed closer than 8 inches.

Hydraulic seeding may be substituted for drilling only where slopes are steeper than 3:1 or where access limitations exist. When hydraulic seeding is used, hydraulic mulching should be applied as a separate operation, when practical, to prevent the seeds from being encapsulated in the mulch.

^b See Table TS/PS-3 for seeding dates. Irrigation, if consistently applied, may extend the use of cool season species during the summer months.

^c Seeding rates should be doubled if seed is broadcast, or increased by 50 percent if done using a Brillion Drill or by hydraulic seeding.

EC-2 Temporary and Permanent Seeding (TS/PS)

Table TS/PS-2. Minimum Drill Seeding Rates for Perennial Grasses

Common ^a Name	Botanical Name	Growth Season ^b	Growth Form	Seeds/ Pound	Pounds of PLS/acre
Alakali Soil Seed Mix					
Alkali sacaton	<i>Sporobolus airoides</i>	Cool	Bunch	1,750,000	0.25
Basin wildrye	<i>Elymus cinereus</i>	Cool	Bunch	165,000	2.5
Sodar streambank wheatgrass	<i>Agropyron riparium 'Sodar'</i>	Cool	Sod	170,000	2.5
Jose tall wheatgrass	<i>Agropyron elongatum 'Jose'</i>	Cool	Bunch	79,000	7.0
Arriba western wheatgrass	<i>Agropyron smithii 'Arriba'</i>	Cool	Sod	110,000	5.5
Total					17.75
Fertile Loamy Soil Seed Mix					
Ephriam crested wheatgrass	<i>Agropyron cristatum 'Ephriam'</i>	Cool	Sod	175,000	2.0
Dural hard fescue	<i>Festuca ovina 'duriuscula'</i>	Cool	Bunch	565,000	1.0
Lincoln smooth brome	<i>Bromus inermis leys 'Lincoln'</i>	Cool	Sod	130,000	3.0
Sodar streambank wheatgrass	<i>Agropyron riparium 'Sodar'</i>	Cool	Sod	170,000	2.5
Arriba western wheatgrass	<i>Agropyron smithii 'Arriba'</i>	Cool	Sod	110,000	7.0
Total					15.5
High Water Table Soil Seed Mix					
Meadow foxtail	<i>Alopecurus pratensis</i>	Cool	Sod	900,000	0.5
Redtop	<i>Agrostis alba</i>	Warm	Open sod	5,000,000	0.25
Reed canarygrass	<i>Phalaris arundinacea</i>	Cool	Sod	68,000	0.5
Lincoln smooth brome	<i>Bromus inermis leys 'Lincoln'</i>	Cool	Sod	130,000	3.0
Pathfinder switchgrass	<i>Panicum virgatum 'Pathfinder'</i>	Warm	Sod	389,000	1.0
Alkar tall wheatgrass	<i>Agropyron elongatum 'Alkar'</i>	Cool	Bunch	79,000	5.5
Total					10.75
Transition Turf Seed Mix^c					
Ruebens Canadian bluegrass	<i>Poa compressa 'Ruebens'</i>	Cool	Sod	2,500,000	0.5
Dural hard fescue	<i>Festuca ovina 'duriuscula'</i>	Cool	Bunch	565,000	1.0
Citation perennial ryegrass	<i>Lolium perenne 'Citation'</i>	Cool	Sod	247,000	3.0
Lincoln smooth brome	<i>Bromus inermis leys 'Lincoln'</i>	Cool	Sod	130,000	3.0
Total					7.5

Table TS/PS-2. Minimum Drill Seeding Rates for Perennial Grasses (cont.)

Common Name	Botanical Name	Growth Season ^b	Growth Form	Seeds/Pound	Pounds of PLS/acre
Sandy Soil Seed Mix					
Blue grama	<i>Bouteloua gracilis</i>	Warm	Sod-forming bunchgrass	825,000	0.5
Camper little bluestem	<i>Schizachyrium scoparium</i> 'Camper'	Warm	Bunch	240,000	1.0
Prairie sandreed	<i>Calamovilfa longifolia</i>	Warm	Open sod	274,000	1.0
Sand dropseed	<i>Sporobolus cryptandrus</i>	Cool	Bunch	5,298,000	0.25
Vaughn sideoats grama	<i>Bouteloua curtipendula</i> 'Vaughn'	Warm	Sod	191,000	2.0
Arriba western wheatgrass	<i>Agropyron smithii</i> 'Arriba'	Cool	Sod	110,000	5.5
Total					10.25
Heavy Clay, Rocky Foothill Seed Mix					
Ephriam crested wheatgrass ^d	<i>Agropyron cristatum</i> 'Ephriam'	Cool	Sod	175,000	1.5
Oahe Intermediate wheatgrass	<i>Agropyron intermedium</i> 'Oahe'	Cool	Sod	115,000	5.5
Vaughn sideoats grama ^e	<i>Bouteloua curtipendula</i> 'Vaughn'	Warm	Sod	191,000	2.0
Lincoln smooth brome	<i>Bromus inermis</i> leys 'Lincoln'	Cool	Sod	130,000	3.0
Arriba western wheatgrass	<i>Agropyron smithii</i> 'Arriba'	Cool	Sod	110,000	5.5
Total					17.5
<p>^a All of the above seeding mixes and rates are based on drill seeding followed by crimped straw mulch. These rates should be doubled if seed is broadcast and should be increased by 50 percent if the seeding is done using a Brillion Drill or is applied through hydraulic seeding. Hydraulic seeding may be substituted for drilling only where slopes are steeper than 3:1. If hydraulic seeding is used, hydraulic mulching should be done as a separate operation.</p> <p>^b See Table TS/PS-3 for seeding dates.</p> <p>^c If site is to be irrigated, the transition turf seed rates should be doubled.</p> <p>^d Crested wheatgrass should not be used on slopes steeper than 6H to 1V.</p> <p>^e Can substitute 0.5 lbs PLS of blue grama for the 2.0 lbs PLS of Vaughn sideoats grama.</p>					

EC-2 Temporary and Permanent Seeding (TS/PS)

Table TS/PS-3. Seeding Dates for Annual and Perennial Grasses

Seeding Dates	Annual Grasses (Numbers in table reference species in Table TS/PS-1)		Perennial Grasses	
	Warm	Cool	Warm	Cool
January 1–March 15			✓	✓
March 16–April 30	4	1,2,3	✓	✓
May 1–May 15	4		✓	
May 16–June 30	4,5,6,7			
July 1–July 15	5,6,7			
July 16–August 31				
September 1–September 30		8,9,10,11		
October 1–December 31			✓	✓

Mulch

Cover seeded areas with mulch or an appropriate rolled erosion control product to promote establishment of vegetation. Anchor mulch by crimping, netting or use of a non-toxic tackifier. See the Mulching BMP Fact Sheet for additional guidance.

Maintenance and Removal

Monitor and observe seeded areas to identify areas of poor growth or areas that fail to germinate. Reseed and mulch these areas, as needed.

An area that has been permanently seeded should have a good stand of vegetation within one growing season if irrigated and within three growing seasons without irrigation in Colorado. Reseed portions of the site that fail to germinate or remain bare after the first growing season.

Seeded areas may require irrigation, particularly during extended dry periods. Targeted weed control may also be necessary.

Protect seeded areas from construction equipment and vehicle access.

Description

Mulching consists of evenly applying straw, hay, shredded wood mulch, rock, bark or compost to disturbed soils and securing the mulch by crimping, tackifiers, netting or other measures. Mulching helps reduce erosion by protecting bare soil from rainfall impact, increasing infiltration, and reducing runoff. Although often applied in conjunction with temporary or permanent seeding, it can also be used for temporary stabilization of areas that cannot be reseeded due to seasonal constraints.

Mulch can be applied either using standard mechanical dry application methods or using hydromulching equipment that hydraulically applies a slurry of water, wood fiber mulch, and often a tackifier.



Photograph MU-1. An area that was recently seeded, mulched, and crimped.

Appropriate Uses

Use mulch in conjunction with seeding to help protect the seedbed and stabilize the soil. Mulch can also be used as a temporary cover on low to mild slopes to help temporarily stabilize disturbed areas where growing season constraints prevent effective reseeded. Disturbed areas should be properly mulched and tacked, or seeded, mulched and tacked promptly after final grade is reached (typically within no longer than 14 days) on portions of the site not otherwise permanently stabilized.

Standard dry mulching is encouraged in most jurisdictions; however, hydromulching may not be allowed in certain jurisdictions or may not be allowed near waterways.

Do not apply mulch during windy conditions.

Design and Installation

Prior to mulching, surface-roughen areas by rolling with a crimping or punching type roller or by track walking. Track walking should only be used where other methods are impractical because track walking with heavy equipment typically compacts the soil.

A variety of mulches can be used effectively at construction sites. Consider the following:

Mulch	
Functions	
Erosion Control	Yes
Sediment Control	Moderate
Site/Material Management	No

- Clean, weed-free and seed-free cereal grain straw should be applied evenly at a rate of 2 tons per acre and must be tacked or fastened by a method suitable for the condition of the site. Straw mulch must be anchored (and not merely placed) on the surface. This can be accomplished mechanically by crimping or with the aid of tackifiers or nets. Anchoring with a crimping implement is preferred, and is the recommended method for areas flatter than 3:1. Mechanical crimpers must be capable of tucking the long mulch fibers into the soil to a depth of 3 inches without cutting them. An agricultural disk, while not an ideal substitute, may work if the disk blades are dull or blunted and set vertically; however, the frame may have to be weighted to afford proper soil penetration.
- Grass hay may be used in place of straw; however, because hay is comprised of the entire plant including seed, mulching with hay may seed the site with non-native grass species which might in turn out-compete the native seed. Alternatively, native species of grass hay may be purchased, but can be difficult to find and are more expensive than straw. Purchasing and utilizing a certified weed-free straw is an easier and less costly mulching method. When using grass hay, follow the same guidelines as for straw (provided above).
- On small areas sheltered from the wind and heavy runoff, spraying a tackifier on the mulch is satisfactory for holding it in place. For steep slopes and special situations where greater control is needed, erosion control blankets anchored with stakes should be used instead of mulch.
- Hydraulic mulching consists of wood cellulose fibers mixed with water and a tackifying agent and should be applied at a rate of no less than 1,500 pounds per acre (1,425 lbs of fibers mixed with at least 75 lbs of tackifier) with a hydraulic mulcher. For steeper slopes, up to 2000 pounds per acre may be required for effective hydroseeding. Hydromulch typically requires up to 24 hours to dry; therefore, it should not be applied immediately prior to inclement weather. Application to roads, waterways and existing vegetation should be avoided.
- Erosion control mats, blankets, or nets are recommended to help stabilize steep slopes (generally 3:1 and steeper) and waterways. Depending on the product, these may be used alone or in conjunction with grass or straw mulch. Normally, use of these products will be restricted to relatively small areas. Biodegradable mats made of straw and jute, straw-coconut, coconut fiber, or excelsior can be used instead of mulch. (See the ECM/TRM BMP for more information.)
- Some tackifiers or binders may be used to anchor mulch. Check with the local jurisdiction for allowed tackifiers. Manufacturer's recommendations should be followed at all times. (See the Soil Binder BMP for more information on general types of tackifiers.)
- Rock can also be used as mulch. It provides protection of exposed soils to wind and water erosion and allows infiltration of precipitation. An aggregate base course can be spread on disturbed areas for temporary or permanent stabilization. The rock mulch layer should be thick enough to provide full coverage of exposed soil on the area it is applied.

Maintenance and Removal

After mulching, the bare ground surface should not be more than 10 percent exposed. Reapply mulch, as needed, to cover bare areas.

Description

Wind erosion and dust control BMPs help to keep soil particles from entering the air as a result of land disturbing construction activities. These BMPs include a variety of practices generally focused on either graded disturbed areas or construction roadways. For graded areas, practices such as seeding and mulching, use of soil binders, site watering, or other practices that provide prompt surface cover should be used. For construction roadways, road watering and stabilized surfaces should be considered.



Photograph DC-1. Water truck used for dust suppression. Photo courtesy of Douglas County.

Appropriate Uses

Dust control measures should be used on any site where dust poses a problem to air quality. Dust control is important to control for the health of construction workers and surrounding waterbodies.

Design and Installation

The following construction BMPs can be used for dust control:

- An irrigation/sprinkler system can be used to wet the top layer of disturbed soil to help keep dry soil particles from becoming airborne.
- Seeding and mulching can be used to stabilize disturbed surfaces and reduce dust emissions.
- Protecting existing vegetation can help to slow wind velocities across the ground surface, thereby limiting the likelihood of soil particles to become airborne.
- Spray-on soil binders form a bond between soil particles keeping them grounded. Chemical treatments may require additional permitting requirements. Potential impacts to surrounding waterways and habitat must be considered prior to use.
- Placing rock on construction roadways and entrances will help keep dust to a minimum across the construction site.
- Wind fences can be installed on site to reduce wind speeds. Install fences perpendicular to the prevailing wind direction for maximum effectiveness.

Maintenance and Removal

When using an irrigation/sprinkler control system to aid in dust control, be careful not to overwater. Overwatering will cause construction vehicles to track mud off-site.

Wind Erosion Control/ Dust Control	
Functions	
Erosion Control	Yes
Sediment Control	No
Site/Material Management	Moderate

Description

Concrete waste management involves designating and properly managing a specific area of the construction site as a concrete washout area. A concrete washout area can be created using one of several approaches designed to receive wash water from washing of tools and concrete mixer chutes, liquid concrete waste from dump trucks, mobile batch mixers, or pump trucks. Three basic approaches are available: excavation of a pit in the ground, use of an above ground storage area, or use of prefabricated haul-away concrete washout containers. Surface discharges of concrete washout water from construction sites are prohibited.



Photograph CWA-1. Example of concrete washout area. Note gravel tracking pad for access and sign.

Appropriate Uses

Concrete washout areas must be designated on all sites that will generate concrete wash water or liquid concrete waste from onsite concrete mixing or concrete delivery.

Because pH is a pollutant of concern for washout activities, when unlined pits are used for concrete washout, the soil must have adequate buffering capacity to result in protection of state groundwater standards; otherwise, a liner/containment must be used. The following management practices are recommended to prevent an impact from unlined pits to groundwater:

- The use of the washout site should be temporary (less than 1 year), and
- The washout site should be not be located in an area where shallow groundwater may be present, such as near natural drainages, springs, or wetlands.

Design and Installation

Concrete washout activities must be conducted in a manner that does not contribute pollutants to surface waters or stormwater runoff. Concrete washout areas may be lined or unlined excavated pits in the ground, commercially manufactured prefabricated washout containers, or aboveground holding areas constructed of berms, sandbags or straw bales with a plastic liner.

Although unlined washout areas may be used, lined pits may be required to protect groundwater under certain conditions.

Do not locate an unlined washout area within 400 feet of any natural drainage pathway or waterbody or within 1,000 feet of any wells or drinking water sources. Even for lined concrete washouts, it is advisable to locate the facility away from waterbodies and drainage paths. If site constraints make these

Concrete Washout Area	
Functions	
Erosion Control	No
Sediment Control	No
Site/Material Management	Yes

setbacks infeasible or if highly permeable soils exist in the area, then the pit must be installed with an impermeable liner (16 mil minimum thickness) or surface storage alternatives using prefabricated concrete washout devices or a lined aboveground storage area should be used.

Design details with notes are provided in Detail CWA-1 for pits and CWA-2 for aboveground storage areas. Pre-fabricated concrete washout container information can be obtained from vendors.

Maintenance and Removal

A key consideration for concrete washout areas is to ensure that adequate signage is in place identifying the location of the washout area. Part of inspecting and maintaining washout areas is ensuring that adequate signage is provided and in good repair and that the washout area is being used, as opposed to washout in non-designated areas of the site.

Remove concrete waste in the washout area, as needed to maintain BMP function (typically when filled to about two-thirds of its capacity). Collect concrete waste and deliver offsite to a designated disposal location.

Upon termination of use of the washout site, accumulated solid waste, including concrete waste and any contaminated soils, must be removed from the site to prevent on-site disposal of solid waste. If the wash water is allowed to evaporate and the concrete hardens, it may be recycled.



Photograph CWA-2. Prefabricated concrete washout. Photo courtesy of CDOT.



Photograph CWA-3. Earthen concrete washout. Photo courtesy of CDOT.

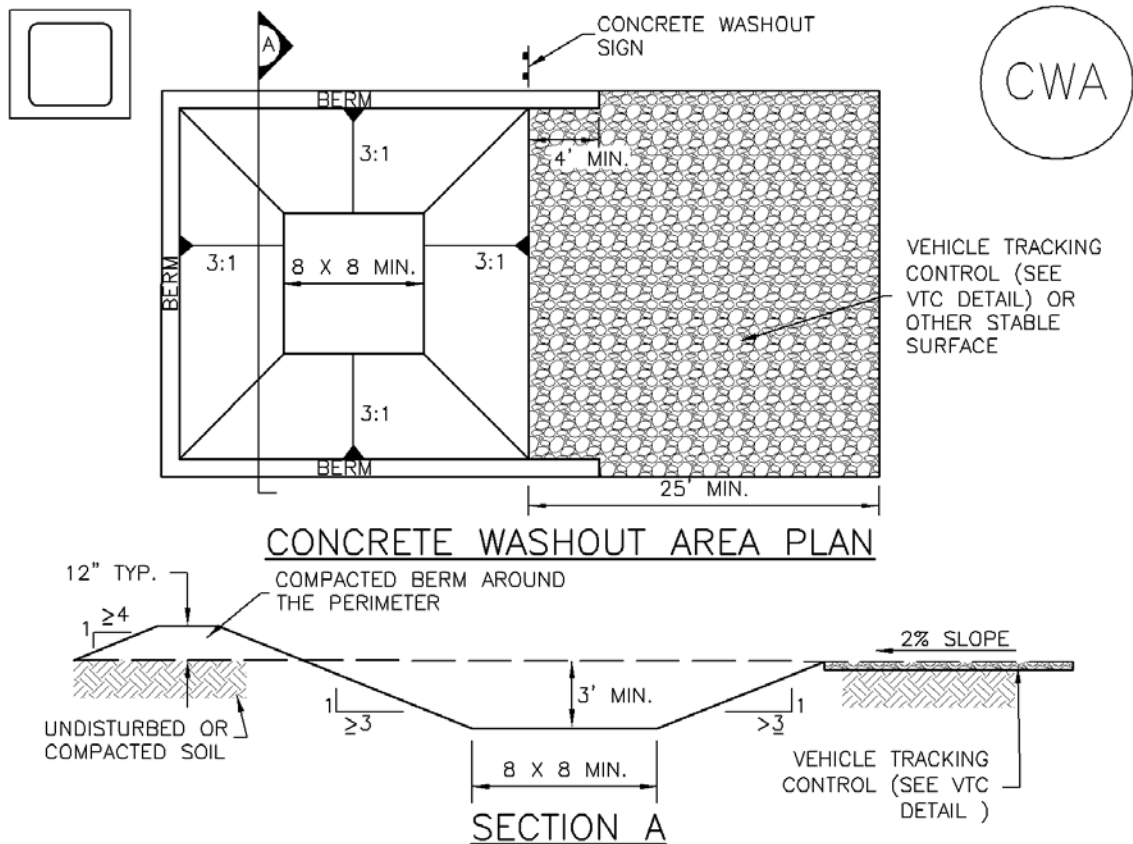

CWA-1. CONCRETE WASHOUT AREA

CWA INSTALLATION NOTES

1. SEE PLAN VIEW FOR:
-CWA INSTALLATION LOCATION.
2. DO NOT LOCATE AN UNLINED CWA WITHIN 400' OF ANY NATURAL DRAINAGE PATHWAY OR WATERBODY. DO NOT LOCATE WITHIN 1,000' OF ANY WELLS OR DRINKING WATER SOURCES. IF SITE CONSTRAINTS MAKE THIS INFEASIBLE, OR IF HIGHLY PERMEABLE SOILS EXIST ON SITE, THE CWA MUST BE INSTALLED WITH AN IMPERMEABLE LINER (16 MIL MIN. THICKNESS) OR SURFACE STORAGE ALTERNATIVES USING PREFABRICATED CONCRETE WASHOUT DEVICES OR A LINED ABOVE GROUND STORAGE ARE SHOULD BE USED.
3. THE CWA SHALL BE INSTALLED PRIOR TO CONCRETE PLACEMENT ON SITE.
4. CWA SHALL INCLUDE A FLAT SUBSURFACE PIT THAT IS AT LEAST 8' BY 8' SLOPES LEADING OUT OF THE SUBSURFACE PIT SHALL BE 3:1 OR FLATTER. THE PIT SHALL BE AT LEAST 3' DEEP.
5. BERM SURROUNDING SIDES AND BACK OF THE CWA SHALL HAVE MINIMUM HEIGHT OF 1'.
6. VEHICLE TRACKING PAD SHALL BE SLOPED 2% TOWARDS THE CWA.
7. SIGNS SHALL BE PLACED AT THE CONSTRUCTION ENTRANCE, AT THE CWA, AND ELSEWHERE AS NECESSARY TO CLEARLY INDICATE THE LOCATION OF THE CWA TO OPERATORS OF CONCRETE TRUCKS AND PUMP RIGS.
8. USE EXCAVATED MATERIAL FOR PERIMETER BERM CONSTRUCTION.

CWA MAINTENANCE NOTES

1. INSPECT BMPs EACH WORKDAY, AND MAINTAIN THEM IN EFFECTIVE OPERATING CONDITION. MAINTENANCE OF BMPs SHOULD BE PROACTIVE, NOT REACTIVE. INSPECT BMPs AS SOON AS POSSIBLE (AND ALWAYS WITHIN 24 HOURS) FOLLOWING A STORM THAT CAUSES SURFACE EROSION, AND PERFORM NECESSARY MAINTENANCE.

2. FREQUENT OBSERVATIONS AND MAINTENANCE ARE NECESSARY TO MAINTAIN BMPs IN EFFECTIVE OPERATING CONDITION. INSPECTIONS AND CORRECTIVE MEASURES SHOULD BE DOCUMENTED THOROUGHLY.

3. WHERE BMPs HAVE FAILED, REPAIR OR REPLACEMENT SHOULD BE INITIATED UPON DISCOVERY OF THE FAILURE.

4. THE CWA SHALL BE REPAIRED, CLEANED, OR ENLARGED AS NECESSARY TO MAINTAIN CAPACITY FOR CONCRETE WASTE. CONCRETE MATERIALS, ACCUMULATED IN PIT, SHALL BE REMOVED ONCE THE MATERIALS HAVE REACHED A DEPTH OF 2'.

5. CONCRETE WASHOUT WATER, WASTED PIECES OF CONCRETE AND ALL OTHER DEBRIS IN THE SUBSURFACE PIT SHALL BE TRANSPORTED FROM THE JOB SITE IN A WATER-TIGHT CONTAINER AND DISPOSED OF PROPERLY.

6. THE CWA SHALL REMAIN IN PLACE UNTIL ALL CONCRETE FOR THE PROJECT IS PLACED.

7. WHEN THE CWA IS REMOVED, COVER THE DISTURBED AREA WITH TOP SOIL, SEED AND MULCH OR OTHERWISE STABILIZED IN A MANNER APPROVED BY THE LOCAL JURISDICTION.

(DETAIL ADAPTED FROM DOUGLAS COUNTY, COLORADO AND THE CITY OF PARKER, COLORADO, NOT AVAILABLE IN AUTOCAD).

NOTE: MANY JURISDICTIONS HAVE BMP DETAILS THAT VARY FROM UDFCD STANDARD DETAILS. CONSULT WITH LOCAL JURISDICTIONS AS TO WHICH DETAIL SHOULD BE USED WHEN DIFFERENCES ARE NOTED.

Description

Implement construction site good housekeeping practices to prevent pollution associated with solid, liquid and hazardous construction-related materials and wastes. Stormwater Management Plans (SWMPs) should clearly specify BMPs including these good housekeeping practices:

- Provide for waste management.
- Establish proper building material staging areas.
- Designate paint and concrete washout areas.
- Establish proper equipment/vehicle fueling and maintenance practices.
- Control equipment/vehicle washing and allowable non-stormwater discharges.
- Develop a spill prevention and response plan.

Acknowledgement: This Fact Sheet is based directly on EPA guidance provided in *Developing Your Stormwater Pollution Prevent Plan (EPA 2007)*.



Photographs GH-1 and GH-2. Proper materials storage and secondary containment for fuel tanks are important good housekeeping practices. Photos courtesy of CDOT and City of Aurora.

Appropriate Uses

Good housekeeping practices are necessary at all construction sites.

Design and Installation

The following principles and actions should be addressed in SWMPs:

- **Provide for Waste Management.** Implement management procedures and practices to prevent or reduce the exposure and transport of pollutants in stormwater from solid, liquid and sanitary wastes that will be generated at the site. Practices such as trash disposal, recycling, proper material handling, and cleanup measures can reduce the potential for stormwater runoff to pick up construction site wastes and discharge them to surface waters. Implement a comprehensive set of waste-management practices for hazardous or toxic materials, such as paints, solvents, petroleum products, pesticides, wood preservatives, acids, roofing tar, and other materials. Practices should include storage, handling, inventory, and cleanup procedures, in case of spills. Specific practices that should be considered include:

Solid or Construction Waste

- Designate trash and bulk waste-collection areas on-site.

Good Housekeeping	
Functions	
Erosion Control	No
Sediment Control	No
Site/Material Management	Yes

- Recycle materials whenever possible (e.g., paper, wood, concrete, oil).
- Segregate and provide proper disposal options for hazardous material wastes.
- Clean up litter and debris from the construction site daily.
- Locate waste-collection areas away from streets, gutters, watercourses, and storm drains. Waste-collection areas (dumpsters, and such) are often best located near construction site entrances to minimize traffic on disturbed soils. Consider secondary containment around waste collection areas to minimize the likelihood of contaminated discharges.
- Empty waste containers before they are full and overflowing.

Sanitary and Septic Waste

- Provide convenient, well-maintained, and properly located toilet facilities on-site.
- Locate toilet facilities away from storm drain inlets and waterways to prevent accidental spills and contamination of stormwater.
- Maintain clean restroom facilities and empty portable toilets regularly.
- Where possible, provide secondary containment pans under portable toilets.
- Provide tie-downs or stake-downs for portable toilets.
- Educate employees, subcontractors, and suppliers on locations of facilities.
- Treat or dispose of sanitary and septic waste in accordance with state or local regulations. Do not discharge or bury wastewater at the construction site.
- Inspect facilities for leaks. If found, repair or replace immediately.
- Special care is necessary during maintenance (pump out) to ensure that waste and/or biocide are not spilled on the ground.

Hazardous Materials and Wastes

- Develop and implement employee and subcontractor education, as needed, on hazardous and toxic waste handling, storage, disposal, and cleanup.
- Designate hazardous waste-collection areas on-site.
- Place all hazardous and toxic material wastes in secondary containment.



Photograph GH-3. Locate portable toilet facilities on level surfaces away from waterways and storm drains. Photo courtesy of WWE.

- Hazardous waste containers should be inspected to ensure that all containers are labeled properly and that no leaks are present.
- **Establish Proper Building Material Handling and Staging Areas.** The SWMP should include comprehensive handling and management procedures for building materials, especially those that are hazardous or toxic. Paints, solvents, pesticides, fuels and oils, other hazardous materials or building materials that have the potential to contaminate stormwater should be stored indoors or under cover whenever possible or in areas with secondary containment. Secondary containment measures prevent a spill from spreading across the site and may include dikes, berms, curbing, or other containment methods. Secondary containment techniques should also ensure the protection of groundwater. Designate staging areas for activities such as fueling vehicles, mixing paints, plaster, mortar, and other potential pollutants. Designated staging areas enable easier monitoring of the use of materials and clean up of spills. Training employees and subcontractors is essential to the success of this pollution prevention principle. Consider the following specific materials handling and staging practices:
 - Train employees and subcontractors in proper handling and storage practices.
 - Clearly designate site areas for staging and storage with signs and on construction drawings. Staging areas should be located in areas central to the construction site. Segment the staging area into sub-areas designated for vehicles, equipment, or stockpiles. Construction entrances and exits should be clearly marked so that delivery vehicles enter/exit through stabilized areas with vehicle tracking controls (See Vehicle Tracking Control Fact Sheet).
 - Provide storage in accordance with Spill Protection, Control and Countermeasures (SPCC) requirements and plans and provide cover and impermeable perimeter control, as necessary, for hazardous materials and contaminated soils that must be stored on site.
 - Ensure that storage containers are regularly inspected for leaks, corrosion, support or foundation failure, or other signs of deterioration and tested for soundness.
 - Reuse and recycle construction materials when possible.
- **Designate Concrete Washout Areas.** Concrete contractors should be encouraged to use the washout facilities at their own plants or dispatch facilities when feasible; however, concrete washout commonly occurs on construction sites. If it is necessary to provide for concrete washout areas on-site, designate specific washout areas and design facilities to handle anticipated washout water. Washout areas should also be provided for paint and stucco operations. Because washout areas can be a source of pollutants from leaks or spills, care must be taken with regard to their placement and proper use. See the Concrete Washout Area Fact Sheet for detailed guidance.

Both self-constructed and prefabricated washout containers can fill up quickly when concrete, paint, and stucco work are occurring on large portions of the site. Be sure to check for evidence that contractors are using the washout areas and not dumping materials onto the ground or into drainage facilities. If the washout areas are not being used regularly, consider posting additional signage, relocating the facilities to more convenient locations, or providing training to workers and contractors.

When concrete, paint, or stucco is part of the construction process, consider these practices which will help prevent contamination of stormwater. Include the locations of these areas and the maintenance and inspection procedures in the SWMP.

- Do not washout concrete trucks or equipment into storm drains, streets, gutters, uncontained areas, or streams. Only use designated washout areas.
- Establish washout areas and advertise their locations with signs. Ensure that signage remains in good repair.
- Provide adequate containment for the amount of wash water that will be used.
- Inspect washout structures daily to detect leaks or tears and to identify when materials need to be removed.
- Dispose of materials properly. The preferred method is to allow the water to evaporate and to recycle the hardened concrete. Full service companies may provide dewatering services and should dispose of wastewater properly. Concrete wash water can be highly polluted. It should not be discharged to any surface water, storm sewer system, or allowed to infiltrate into the ground in the vicinity of waterbodies. Washwater should not be discharged to a sanitary sewer system without first receiving written permission from the system operator.
- **Establish Proper Equipment/Vehicle Fueling and Maintenance Practices.** Create a clearly designated on-site fueling and maintenance area that is clean and dry. The on-site fueling area should have a spill kit, and staff should know how to use it. If possible, conduct vehicle fueling and maintenance activities in a covered area. Consider the following practices to help prevent the discharge of pollutants to stormwater from equipment/vehicle fueling and maintenance. Include the locations of designated fueling and maintenance areas and inspection and maintenance procedures in the SWMP.
 - Train employees and subcontractors in proper fueling procedures (stay with vehicles during fueling, proper use of pumps, emergency shutoff valves, etc.).
 - Inspect on-site vehicles and equipment regularly for leaks, equipment damage, and other service problems.
 - Clearly designate vehicle/equipment service areas away from drainage facilities and watercourses to prevent stormwater run-on and runoff.
 - Use drip pans, drip cloths, or absorbent pads when replacing spent fluids.
 - Collect all spent fluids, store in appropriate labeled containers in the proper storage areas, and recycle fluids whenever possible.
- **Control Equipment/Vehicle Washing and Allowable Non-Stormwater Discharges.** Implement practices to prevent contamination of surface and groundwater from equipment and vehicle wash water. Representative practices include:
 - Educate employees and subcontractors on proper washing procedures.
 - Use off-site washing facilities, when available.
 - Clearly mark the washing areas and inform workers that all washing must occur in this area.
 - Contain wash water and treat it using BMPs. Infiltrate washwater when possible, but maintain separation from drainage paths and waterbodies.

- Use high-pressure water spray at vehicle washing facilities without detergents. Water alone can remove most dirt adequately.
- Do not conduct other activities, such as vehicle repairs, in the wash area.
- Include the location of the washing facilities and the inspection and maintenance procedures in the SWMP.
- **Develop a Spill Prevention and Response Plan.** Spill prevention and response procedures must be identified in the SWMP. Representative procedures include identifying ways to reduce the chance of spills, stop the source of spills, contain and clean up spills, dispose of materials contaminated by spills, and train personnel responsible for spill prevention and response. The plan should also specify material handling procedures and storage requirements and ensure that clear and concise spill cleanup procedures are provided and posted for areas in which spills may potentially occur. When developing a spill prevention plan, include the following:
 - Note the locations of chemical storage areas, storm drains, tributary drainage areas, surface waterbodies on or near the site, and measures to stop spills from leaving the site.
 - Provide proper handling and safety procedures for each type of waste. Keep Material Safety Data Sheets (MSDSs) for chemical used on site with the SWMP.
 - Establish an education program for employees and subcontractors on the potential hazards to humans and the environment from spills and leaks.
 - Specify how to notify appropriate authorities, such as police and fire departments, hospitals, or municipal sewage treatment facilities to request assistance. Emergency procedures and contact numbers should be provided in the SWMP and posted at storage locations.
 - Describe the procedures, equipment and materials for immediate cleanup of spills and proper disposal.
 - Identify personnel responsible for implementing the plan in the event of a spill. Update the spill prevention plan and clean up materials as changes occur to the types of chemicals stored and used at the facility.

Spill Prevention, Control, and Countermeasure (SPCC) Plan

Construction sites may be subject to 40 CFR Part 112 regulations that require the preparation and implementation of a SPCC Plan to prevent oil spills from aboveground and underground storage tanks. The facility is subject to this rule if it is a non-transportation-related facility that:

- Has a total storage capacity greater than 1,320 gallons or a completely buried storage capacity greater than 42,000 gallons.
- Could reasonably be expected to discharge oil in quantities that may be harmful to navigable waters of the United States and adjoining shorelines.

Furthermore, if the facility is subject to 40 CFR Part 112, the SWMP should reference the SPCC Plan. To find out more about SPCC Plans, see EPA's website on SPPC at www.epa.gov/oilspill/spcc.htm.

Reporting Oil Spills

In the event of an oil spill, contact the National Response Center toll free at 1-800-424- 8802 for assistance, or for more details, visit their website: www.nrc.uscg.mil.

Maintenance and Removal

Effective implementation of good housekeeping practices is dependent on clear designation of personnel responsible for supervising and implementing good housekeeping programs, such as site cleanup and disposal of trash and debris, hazardous material management and disposal, vehicle and equipment maintenance, and other practices. Emergency response "drills" may aid in emergency preparedness.

Checklists may be helpful in good housekeeping efforts.

Staging and storage areas require permanent stabilization when the areas are no longer being used for construction-related activities.

Construction-related materials, debris and waste must be removed from the construction site once construction is complete.

Design Details

See the following Fact Sheets for related Design Details:

MM-1 Concrete Washout Area

MM-2 Stockpile Management

SM-4 Vehicle Tracking Control

Design details are not necessary for other good housekeeping practices; however, be sure to designate where specific practices will occur on the appropriate construction drawings.

Description

A silt fence is a woven geotextile fabric attached to wooden posts and trenched into the ground. It is designed as a sediment barrier to intercept sheet flow runoff from disturbed areas.

Appropriate Uses

A silt fence can be used where runoff is conveyed from a disturbed area as sheet flow. Silt fence is not designed to receive concentrated flow or to be used as a filter fabric. Typical uses include:

- Down slope of a disturbed area to accept sheet flow.
- Along the perimeter of a receiving water such as a stream, pond or wetland.
- At the perimeter of a construction site.



Photograph SF-1. Silt fence creates a sediment barrier, forcing sheet flow runoff to evaporate or infiltrate.

Design and Installation

Silt fence should be installed along the contour of slopes so that it intercepts sheet flow. The maximum recommended tributary drainage area per 100 lineal feet of silt fence, installed along the contour, is approximately 0.25 acres with a disturbed slope length of up to 150 feet and a tributary slope gradient no steeper than 3:1. Longer and steeper slopes require additional measures. This recommendation only applies to silt fence installed along the contour. Silt fence installed for other uses, such as perimeter control, should be installed in a way that will not produce concentrated flows. For example, a "J-hook" installation may be appropriate to force runoff to pond and evaporate or infiltrate in multiple areas rather than concentrate and cause erosive conditions parallel to the silt fence.

See Detail SF-1 for proper silt fence installation, which involves proper trenching, staking, securing the fabric to the stakes, and backfilling the silt fence. Properly installed silt fence should not be easily pulled out by hand and there should be no gaps between the ground and the fabric.

Silt fence must meet the minimum allowable strength requirements, depth of installation requirement, and other specifications in the design details. Improper installation of silt fence is a common reason for silt fence failure; however, when properly installed and used for the appropriate purposes, it can be highly effective.

Silt Fence	
Functions	
Erosion Control	No
Sediment Control	Yes
Site/Material Management	No

Maintenance and Removal

Inspection of silt fence includes observing the material for tears or holes and checking for slumping fence and undercut areas bypassing flows. Repair of silt fence typically involves replacing the damaged section with a new section. Sediment accumulated behind silt fence should be removed, as needed to maintain BMP effectiveness, typically before it reaches a depth of 6 inches.

Silt fence may be removed when the upstream area has reached final stabilization.



Photograph SF-2. When silt fence is not installed along the contour, a "J-hook" installation may be appropriate to ensure that the BMP does not create concentrated flow parallel to the silt fence. Photo courtesy of Tom Gore.

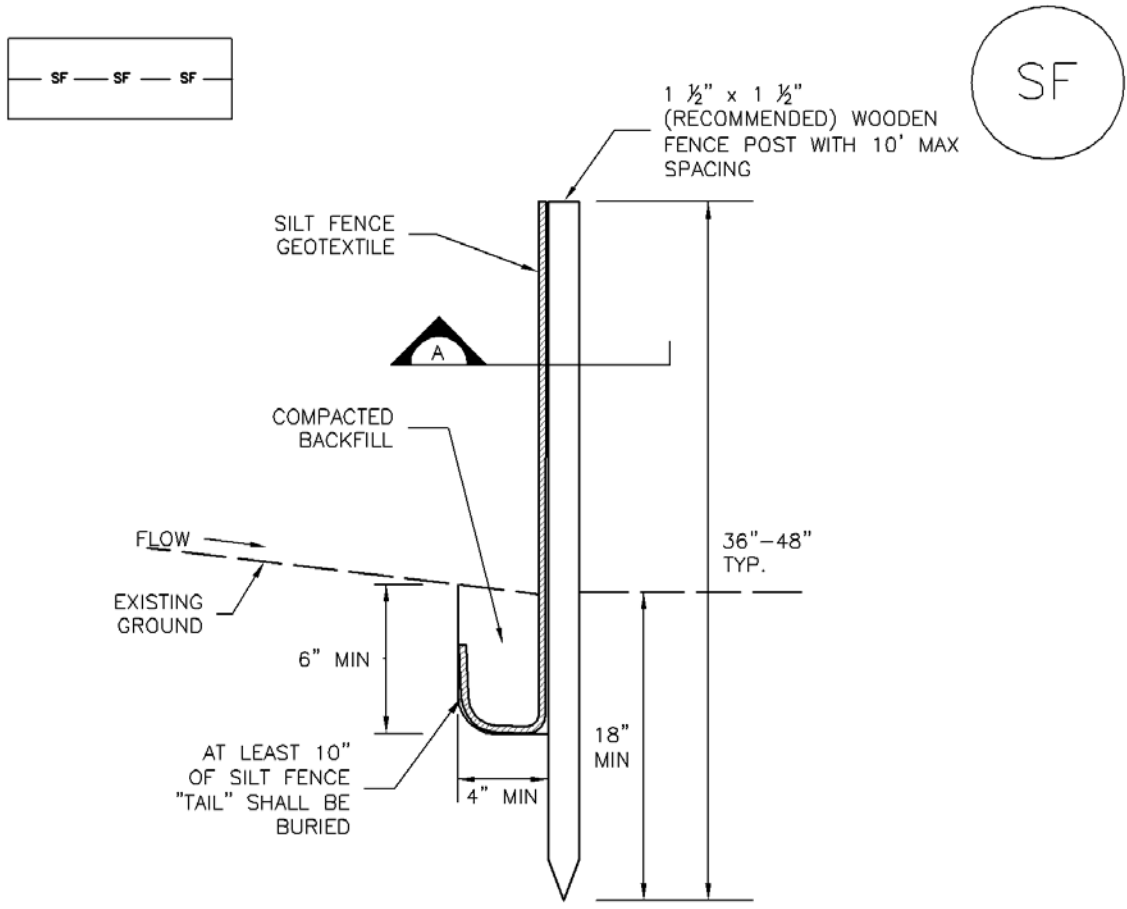

SILT FENCE

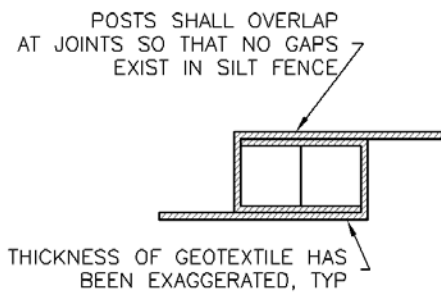
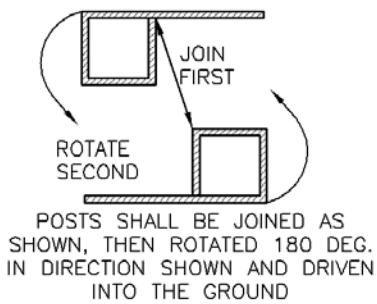

SECTION A

SF-1. SILT FENCE

SILT FENCE INSTALLATION NOTES

1. SILT FENCE MUST BE PLACED AWAY FROM THE TOE OF THE SLOPE TO ALLOW FOR WATER PONDING. SILT FENCE AT THE TOE OF A SLOPE SHOULD BE INSTALLED IN A FLAT LOCATION AT LEAST SEVERAL FEET (2-5 FT) FROM THE TOE OF THE SLOPE TO ALLOW ROOM FOR PONDING AND DEPOSITION.
2. A UNIFORM 6" X 4" ANCHOR TRENCH SHALL BE EXCAVATED USING TRENCHER OR SILT FENCE INSTALLATION DEVICE. NO ROAD GRADERS, BACKHOES, OR SIMILAR EQUIPMENT SHALL BE USED.
3. COMPACT ANCHOR TRENCH BY HAND WITH A "JUMPING JACK" OR BY WHEEL ROLLING. COMPACTION SHALL BE SUCH THAT SILT FENCE RESISTS BEING PULLED OUT OF ANCHOR TRENCH BY HAND.
4. SILT FENCE SHALL BE PULLED TIGHT AS IT IS ANCHORED TO THE STAKES. THERE SHOULD BE NO NOTICEABLE SAG BETWEEN STAKES AFTER IT HAS BEEN ANCHORED TO THE STAKES.
5. SILT FENCE FABRIC SHALL BE ANCHORED TO THE STAKES USING 1" HEAVY DUTY STAPLES OR NAILS WITH 1" HEADS. STAPLES AND NAILS SHOULD BE PLACED 3" ALONG THE FABRIC DOWN THE STAKE.
6. AT THE END OF A RUN OF SILT FENCE ALONG A CONTOUR, THE SILT FENCE SHOULD BE TURNED PERPENDICULAR TO THE CONTOUR TO CREATE A "J-HOOK." THE "J-HOOK" EXTENDING PERPENDICULAR TO THE CONTOUR SHOULD BE OF SUFFICIENT LENGTH TO KEEP RUNOFF FROM FLOWING AROUND THE END OF THE SILT FENCE (TYPICALLY 10' - 20').
7. SILT FENCE SHALL BE INSTALLED PRIOR TO ANY LAND DISTURBING ACTIVITIES.

SILT FENCE MAINTENANCE NOTES

1. INSPECT BMPs EACH WORKDAY, AND MAINTAIN THEM IN EFFECTIVE OPERATING CONDITION. MAINTENANCE OF BMPs SHOULD BE PROACTIVE, NOT REACTIVE. INSPECT BMPs AS SOON AS POSSIBLE (AND ALWAYS WITHIN 24 HOURS) FOLLOWING A STORM THAT CAUSES SURFACE EROSION, AND PERFORM NECESSARY MAINTENANCE.
2. FREQUENT OBSERVATIONS AND MAINTENANCE ARE NECESSARY TO MAINTAIN BMPs IN EFFECTIVE OPERATING CONDITION. INSPECTIONS AND CORRECTIVE MEASURES SHOULD BE DOCUMENTED THOROUGHLY.
3. WHERE BMPs HAVE FAILED, REPAIR OR REPLACEMENT SHOULD BE INITIATED UPON DISCOVERY OF THE FAILURE.
4. SEDIMENT ACCUMULATED UPSTREAM OF THE SILT FENCE SHALL BE REMOVED AS NEEDED TO MAINTAIN THE FUNCTIONALITY OF THE BMP, TYPICALLY WHEN DEPTH OF ACCUMULATED SEDIMENTS IS APPROXIMATELY 6".
5. REPAIR OR REPLACE SILT FENCE WHEN THERE ARE SIGNS OF WEAR, SUCH AS SAGGING, TEARING, OR COLLAPSE.
6. SILT FENCE IS TO REMAIN IN PLACE UNTIL THE UPSTREAM DISTURBED AREA IS STABILIZED AND APPROVED BY THE LOCAL JURISDICTION, OR IS REPLACED BY AN EQUIVALENT PERIMETER SEDIMENT CONTROL BMP.
7. WHEN SILT FENCE IS REMOVED, ALL DISTURBED AREAS SHALL BE COVERED WITH TOPSOIL, SEEDED AND MULCHED OR OTHERWISE STABILIZED AS APPROVED BY LOCAL JURISDICTION.

(DETAIL ADAPTED FROM TOWN OF PARKER, COLORADO AND CITY OF AURORA, NOT AVAILABLE IN AUTOCAD)

NOTE: MANY JURISDICTIONS HAVE BMP DETAILS THAT VARY FROM UDFCD STANDARD DETAILS. CONSULT WITH LOCAL JURISDICTIONS AS TO WHICH DETAIL SHOULD BE USED WHEN DIFFERENCES ARE NOTED.

Description

A rock sock is constructed of gravel that has been wrapped by wire mesh or a geotextile to form an elongated cylindrical filter. Rock socks are typically used either as a perimeter control or as part of inlet protection. When placed at angles in the curb line, rock socks are typically referred to as curb socks. Rock socks are intended to trap sediment from stormwater runoff that flows onto roadways as a result of construction activities.



Photograph RS-1. Rock socks placed at regular intervals in a curb line can help reduce sediment loading to storm sewer inlets. Rock socks can also be used as perimeter controls.

Appropriate Uses

Rock socks can be used at the perimeter of a disturbed area to control localized sediment loading. A benefit of rock socks as opposed to other perimeter controls is that they do not have to be trenched or staked into the ground; therefore, they are often used on roadway construction projects where paved surfaces are present.

Use rock socks in inlet protection applications when the construction of a roadway is substantially complete and the roadway has been directly connected to a receiving storm system.

Design and Installation

When rock socks are used as perimeter controls, the maximum recommended tributary drainage area per 100 linear feet of rock socks is approximately 0.25 acres with disturbed slope length of up to 150 feet and a tributary slope gradient no steeper than 3:1. A rock sock design detail and notes are provided in Detail RS-1. Also see the Inlet Protection Fact Sheet for design and installation guidance when rock socks are used for inlet protection and in the curb line.

When placed in the gutter adjacent to a curb, rock socks should protrude no more than two feet from the curb in order for traffic to pass safely. If located in a high traffic area, place construction markers to alert drivers and street maintenance workers of their presence.

Maintenance and Removal

Rock socks are susceptible to displacement and breaking due to vehicle traffic. Inspect rock socks for damage and repair or replace as necessary. Remove sediment by sweeping or vacuuming as needed to maintain the functionality of the BMP, typically when sediment has accumulated behind the rock sock to one-half of the sock's height.

Once upstream stabilization is complete, rock socks and accumulated sediment should be removed and properly disposed.

Rock Sock	
Functions	
Erosion Control	No
Sediment Control	Yes
Site/Material Management	No

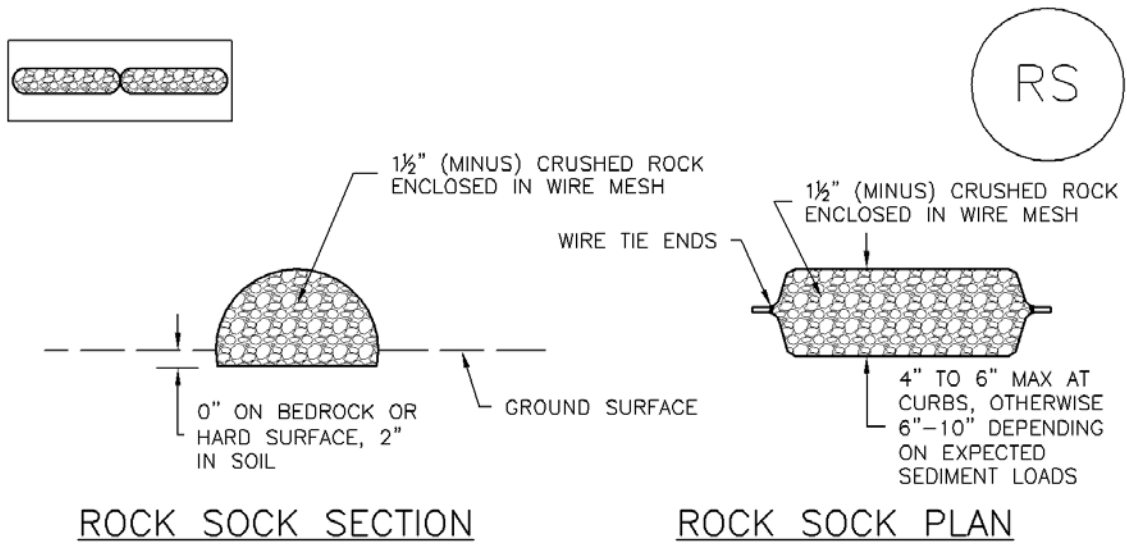

ROCK SOCK SECTION

ROCK SOCK PLAN

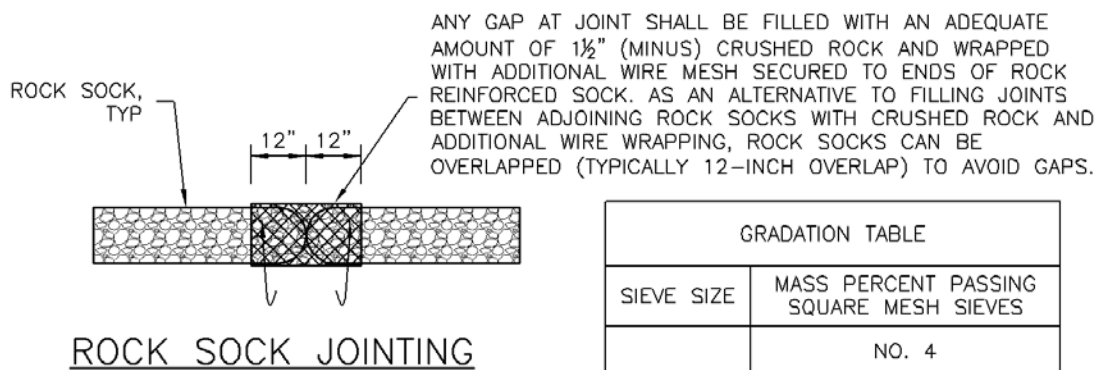

ROCK SOCK JOINTING

ANY GAP AT JOINT SHALL BE FILLED WITH AN ADEQUATE AMOUNT OF 1½" (MINUS) CRUSHED ROCK AND WRAPPED WITH ADDITIONAL WIRE MESH SECURED TO ENDS OF ROCK REINFORCED SOCK. AS AN ALTERNATIVE TO FILLING JOINTS BETWEEN ADJOINING ROCK SOCKS WITH CRUSHED ROCK AND ADDITIONAL WIRE WRAPPING, ROCK SOCKS CAN BE OVERLAPPED (TYPICALLY 12-INCH OVERLAP) TO AVOID GAPS.

GRADATION TABLE	
SIEVE SIZE	MASS PERCENT PASSING SQUARE MESH SIEVES
	NO. 4
2"	100
1½"	90 - 100
1"	20 - 55
¾"	0 - 15
⅜"	0 - 5

MATCHES SPECIFICATIONS FOR NO. 4 COARSE AGGREGATE FOR CONCRETE PER AASHTO M43. ALL ROCK SHALL BE FRACTURED FACE, ALL SIDES.

ROCK SOCK INSTALLATION NOTES

1. SEE PLAN VIEW FOR:
-LOCATION(S) OF ROCK SOCKS.
2. CRUSHED ROCK SHALL BE 1½" (MINUS) IN SIZE WITH A FRACTURED FACE (ALL SIDES) AND SHALL COMPLY WITH GRADATION SHOWN ON THIS SHEET (1½" MINUS).
3. WIRE MESH SHALL BE FABRICATED OF 10 GAGE POULTRY MESH, OR EQUIVALENT, WITH A MAXIMUM OPENING OF ½", RECOMMENDED MINIMUM ROLL WIDTH OF 48"
4. WIRE MESH SHALL BE SECURED USING "HOG RINGS" OR WIRE TIES AT 6" CENTERS ALONG ALL JOINTS AND AT 2" CENTERS ON ENDS OF SOCKS.
5. SOME MUNICIPALITIES MAY ALLOW THE USE OF FILTER FABRIC AS AN ALTERNATIVE TO WIRE MESH FOR THE ROCK ENCLOSURE.

RS-1. ROCK SOCK PERIMETER CONTROL

ROCK SOCK MAINTENANCE NOTES

1. INSPECT BMPs EACH WORKDAY, AND MAINTAIN THEM IN EFFECTIVE OPERATING CONDITION. MAINTENANCE OF BMPs SHOULD BE PROACTIVE, NOT REACTIVE. INSPECT BMPs AS SOON AS POSSIBLE (AND ALWAYS WITHIN 24 HOURS) FOLLOWING A STORM THAT CAUSES SURFACE EROSION, AND PERFORM NECESSARY MAINTENANCE.
2. FREQUENT OBSERVATIONS AND MAINTENANCE ARE NECESSARY TO MAINTAIN BMPs IN EFFECTIVE OPERATING CONDITION. INSPECTIONS AND CORRECTIVE MEASURES SHOULD BE DOCUMENTED THOROUGHLY.
3. WHERE BMPs HAVE FAILED, REPAIR OR REPLACEMENT SHOULD BE INITIATED UPON DISCOVERY OF THE FAILURE.
4. ROCK SOCKS SHALL BE REPLACED IF THEY BECOME HEAVILY SOILED, OR DAMAGED BEYOND REPAIR.
5. SEDIMENT ACCUMULATED UPSTREAM OF ROCK SOCKS SHALL BE REMOVED AS NEEDED TO MAINTAIN FUNCTIONALITY OF THE BMP, TYPICALLY WHEN DEPTH OF ACCUMULATED SEDIMENTS IS APPROXIMATELY $\frac{1}{2}$ OF THE HEIGHT OF THE ROCK SOCK.
6. ROCK SOCKS ARE TO REMAIN IN PLACE UNTIL THE UPSTREAM DISTURBED AREA IS STABILIZED AND APPROVED BY THE LOCAL JURISDICTION.
7. WHEN ROCK SOCKS ARE REMOVED, ALL DISTURBED AREAS SHALL BE COVERED WITH TOPSOIL, SEEDED AND MULCHED OR OTHERWISE STABILIZED AS APPROVED BY LOCAL JURISDICTION.

(DETAIL ADAPTED FROM TOWN OF PARKER, COLORADO AND CITY OF AURORA, COLORADO, NOT AVAILABLE IN AUTOCAD)

NOTE: MANY JURISDICTIONS HAVE BMP DETAILS THAT VARY FROM UDFCD STANDARD DETAILS. CONSULT WITH LOCAL JURISDICTIONS AS TO WHICH DETAIL SHOULD BE USED WHEN DIFFERENCES ARE NOTED.

NOTE: THE DETAILS INCLUDED WITH THIS FACT SHEET SHOW COMMONLY USED, CONVENTIONAL METHODS OF ROCK SOCK INSTALLATION IN THE DENVER METROPOLITAN AREA. THERE ARE MANY OTHER SIMILAR PROPRIETARY PRODUCTS ON THE MARKET. UDFCD NEITHER NDORSES NOR DISCOURAGES USE OF PROPRIETARY PROTECTION PRODUCTS; HOWEVER, IN THE EVENT PROPRIETARY METHODS ARE USED, THE APPROPRIATE DETAIL FROM THE MANUFACTURER MUST BE INCLUDED IN THE SWMP AND THE BMP MUST BE INSTALLED AND MAINTAINED AS SHOWN IN THE MANUFACTURER'S DETAILS.

Description

Inlet protection consists of permeable barriers installed around an inlet to filter runoff and remove sediment prior to entering a storm drain inlet. Inlet protection can be constructed from rock socks, sediment control logs, silt fence, block and rock socks, or other materials approved by the local jurisdiction. Area inlets can also be protected by over-excavating around the inlet to form a sediment trap.



Photograph IP-1. Inlet protection for a curb opening inlet.

Appropriate Uses

Install protection at storm sewer inlets that are operable during construction. Consider the potential for tracked-out sediment or temporary stockpile areas to contribute sediment to inlets when determining which inlets must be protected. This may include inlets in the general proximity of the construction area, not limited to downgradient inlets. Inlet protection is not a stand-alone BMP and should be used in conjunction with other upgradient BMPs.

Design and Installation

To function effectively, inlet protection measures must be installed to ensure that flows do not bypass the inlet protection and enter the storm drain without treatment. However, designs must also enable the inlet to function without completely blocking flows into the inlet in a manner that causes localized flooding. When selecting the type of inlet protection, consider factors such as type of inlet (e.g., curb or area, sump or on-grade conditions), traffic, anticipated flows, ability to secure the BMP properly, safety and other site-specific conditions. For example, block and rock socks will be better suited to a curb and gutter along a roadway, as opposed to silt fence or sediment control logs, which cannot be properly secured in a curb and gutter setting, but are effective area inlet protection measures.

Several inlet protection designs are provided in the Design Details. Additionally, a variety of proprietary products are available for inlet protection that may be approved for use by local governments. If proprietary products are used, design details and installation procedures from the manufacturer must be followed. Regardless of the type of inlet protection selected, inlet protection is most effective when combined with other BMPs such as curb socks and check dams. Inlet protection is often the last barrier before runoff enters the storm sewer or receiving water.

Design details with notes are provided for these forms of inlet protection:

- IP-1. Block and Rock Sock Inlet Protection for Sump or On-grade Inlets
- IP-2. Curb (Rock) Socks Upstream of Inlet Protection, On-grade Inlets

Inlet Protection (various forms)	
Functions	
Erosion Control	No
Sediment Control	Yes
Site/Material Management	No

IP-3. Rock Sock Inlet Protection for Sump/Area Inlet

IP-4. Silt Fence Inlet Protection for Sump/Area Inlet

IP-5. Over-excavation Inlet Protection

IP-6. Straw Bale Inlet Protection for Sump/Area Inlet

CIP-1. Culvert Inlet Protection

Proprietary inlet protection devices should be installed in accordance with manufacturer specifications.

More information is provided below on selecting inlet protection for sump and on-grade locations.

Inlets Located in a Sump

When applying inlet protection in sump conditions, it is important that the inlet continue to function during larger runoff events. For curb inlets, the maximum height of the protective barrier should be lower than the top of the curb opening to allow overflow into the inlet during larger storms without excessive localized flooding. If the inlet protection height is greater than the curb elevation, particularly if the filter becomes clogged with sediment, runoff will not enter the inlet and may bypass it, possibly causing localized flooding, public safety issues, and downstream erosion and damage from bypassed flows.

Area inlets located in a sump setting can be protected through the use of silt fence, concrete block and rock socks (on paved surfaces), sediment control logs/straw wattles embedded in the adjacent soil and stacked around the area inlet (on pervious surfaces), over-excavation around the inlet, and proprietary products providing equivalent functions.

Inlets Located on a Slope

For curb and gutter inlets on paved sloping streets, block and rock sock inlet protection is recommended in conjunction with curb socks in the gutter leading to the inlet. For inlets located along unpaved roads, also see the Check Dam Fact Sheet.

Maintenance and Removal

Inspect inlet protection frequently. Inspection and maintenance guidance includes:

- Inspect for tears that can result in sediment directly entering the inlet, as well as result in the contents of the BMP (e.g., gravel) washing into the inlet.
- Check for improper installation resulting in untreated flows bypassing the BMP and directly entering the inlet or bypassing to an unprotected downstream inlet. For example, silt fence that has not been properly trenched around the inlet can result in flows under the silt fence and directly into the inlet.
- Look for displaced BMPs that are no longer protecting the inlet. Displacement may occur following larger storm events that wash away or reposition the inlet protection. Traffic or equipment may also crush or displace the BMP.
- Monitor sediment accumulation upgradient of the inlet protection.

- Remove sediment accumulation from the area upstream of the inlet protection, as needed to maintain BMP effectiveness, typically when it reaches no more than half the storage capacity of the inlet protection. For silt fence, remove sediment when it accumulates to a depth of no more than 6 inches. Remove sediment accumulation from the area upstream of the inlet protection as needed to maintain the functionality of the BMP.
- Proprietary inlet protection devices should be inspected and maintained in accordance with manufacturer specifications. If proprietary inlet insert devices are used, sediment should be removed in a timely manner to prevent devices from breaking and spilling sediment into the storm drain.

Inlet protection must be removed and properly disposed of when the drainage area for the inlet has reached final stabilization.

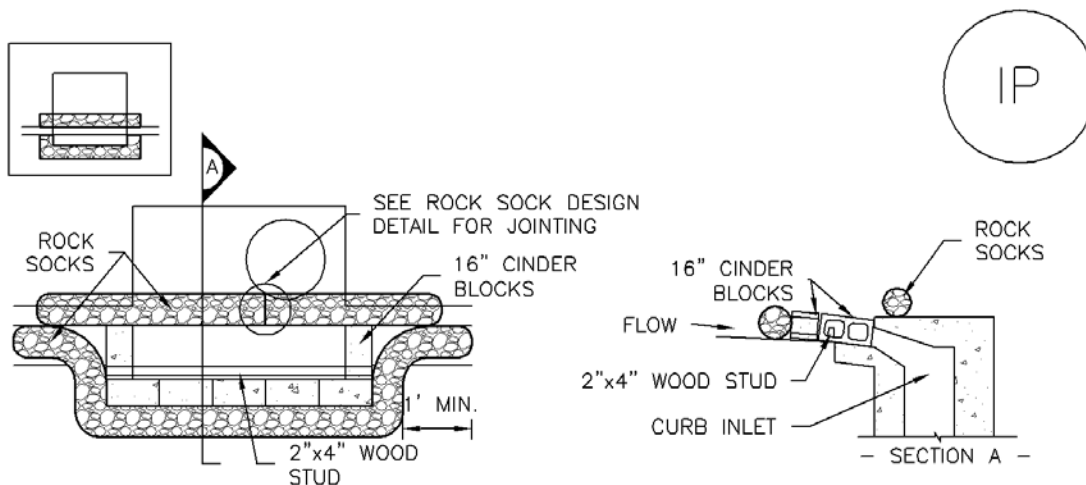

IP-1. BLOCK AND ROCK SOCK SUMP OR ON GRADE INLET PROTECTION

BLOCK AND CURB SOCK INLET PROTECTION INSTALLATION NOTES

1. SEE ROCK SOCK DESIGN DETAIL FOR INSTALLATION REQUIREMENTS.
2. CONCRETE "CINDER" BLOCKS SHALL BE LAID ON THEIR SIDES AROUND THE INLET IN A SINGLE ROW, ABUTTING ONE ANOTHER WITH THE OPEN END FACING AWAY FROM THE CURB.
3. GRAVEL BAGS SHALL BE PLACED AROUND CONCRETE BLOCKS, CLOSELY ABUTTING ONE ANOTHER AND JOINTED TOGETHER IN ACCORDANCE WITH ROCK SOCK DESIGN DETAIL.

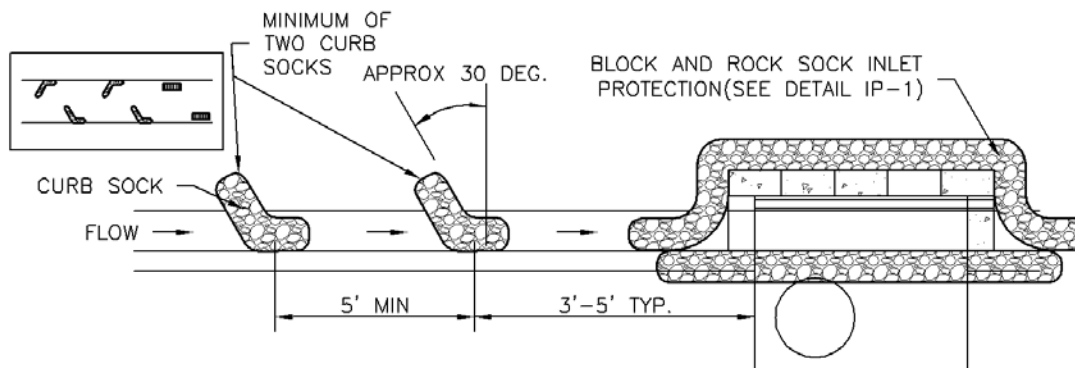

IP-2. CURB ROCK SOCKS UPSTREAM OF INLET PROTECTION

CURB ROCK SOCK INLET PROTECTION INSTALLATION NOTES

1. SEE ROCK SOCK DESIGN DETAIL INSTALLATION REQUIREMENTS.
2. PLACEMENT OF THE SOCK SHALL BE APPROXIMATELY 30 DEGREES FROM PERPENDICULAR IN THE OPPOSITE DIRECTION OF FLOW.
3. SOCKS ARE TO BE FLUSH WITH THE CURB AND SPACED A MINIMUM OF 5 FEET APART.
4. AT LEAST TWO CURB SOCKS IN SERIES ARE REQUIRED UPSTREAM OF ON-GRADE INLETS.

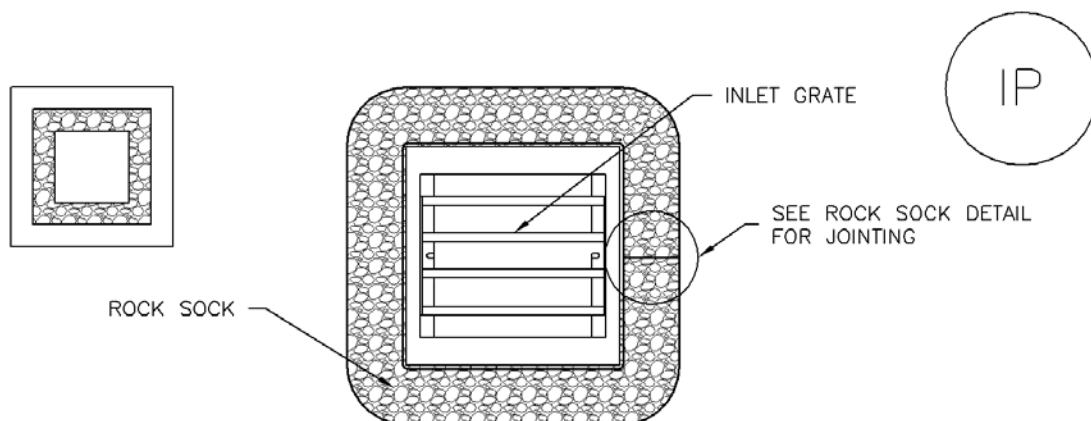

IP-3. ROCK SOCK SUMP/AREA INLET PROTECTION

ROCK SOCK SUMP/AREA INLET PROTECTION INSTALLATION NOTES

1. SEE ROCK SOCK DESIGN DETAIL FOR INSTALLATION REQUIREMENTS.
2. STRAW WATTLES/SEDIMENT CONTROL LOGS MAY BE USED IN PLACE OF ROCK SOCKS FOR INLETS IN PERVIOUS AREAS. INSTALL PER SEDIMENT CONTROL LOG DETAIL.

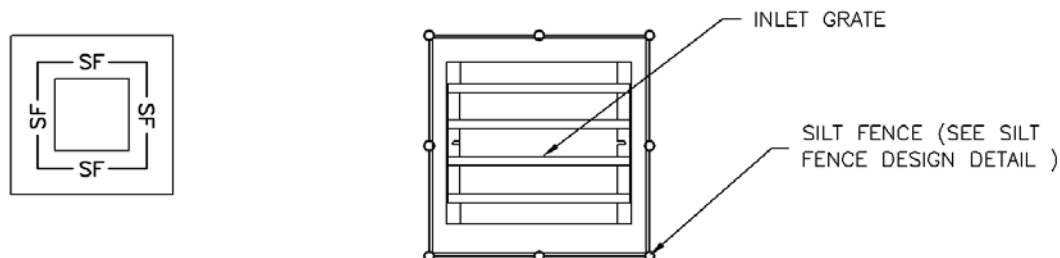

IP-4. SILT FENCE FOR SUMP INLET PROTECTION

SILT FENCE INLET PROTECTION INSTALLATION NOTES

1. SEE SILT FENCE DESIGN DETAIL FOR INSTALLATION REQUIREMENTS.
2. POSTS SHALL BE PLACED AT EACH CORNER OF THE INLET AND AROUND THE EDGES AT A MAXIMUM SPACING OF 3 FEET.
3. STRAW WATTLES/SEDIMENT CONTROL LOGS MAY BE USED IN PLACE OF SILT FENCE FOR INLETS IN PERVIOUS AREAS. INSTALL PER SEDIMENT CONTROL LOG DETAIL.

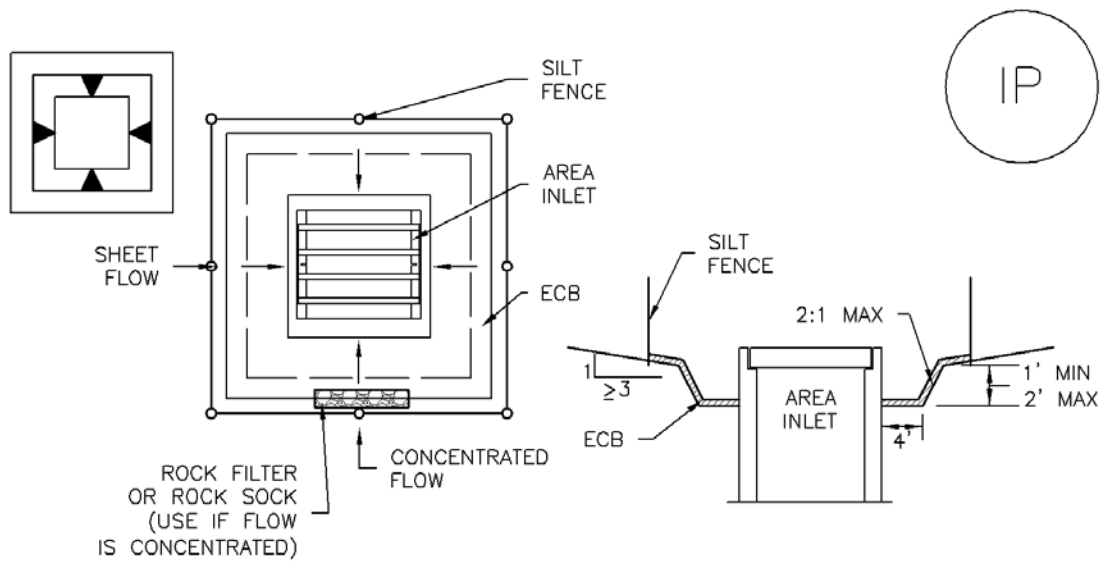

IP-5. OVEREXCAVATION INLET PROTECTION

OVEREXCAVATION INLET PROTECTION INSTALLATION NOTES

1. THIS FORM OF INLET PROTECTION IS PRIMARILY APPLICABLE FOR SITES THAT HAVE NOT YET REACHED FINAL GRADE AND SHOULD BE USED ONLY FOR INLETS WITH A RELATIVELY SMALL CONTRIBUTING DRAINAGE AREA.
2. WHEN USING FOR CONCENTRATED FLOWS, SHAPE BASIN IN 2:1 RATIO WITH LENGTH ORIENTED TOWARDS DIRECTION OF FLOW.
3. SEDIMENT MUST BE PERIODICALLY REMOVED FROM THE OVEREXCAVATED AREA.

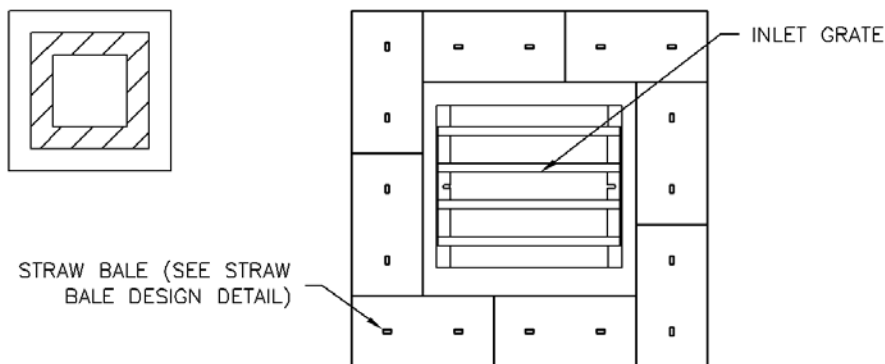

IP-6. STRAW BALE FOR SUMP INLET PROTECTION

STRAW BALE BARRIER INLET PROTECTION INSTALLATION NOTES

1. SEE STRAW BALE DESIGN DETAIL FOR INSTALLATION REQUIREMENTS.
2. BALES SHALL BE PLACED IN A SINGLE ROW AROUND THE INLET WITH ENDS OF BALES TIGHTLY ABUTTING ONE ANOTHER.

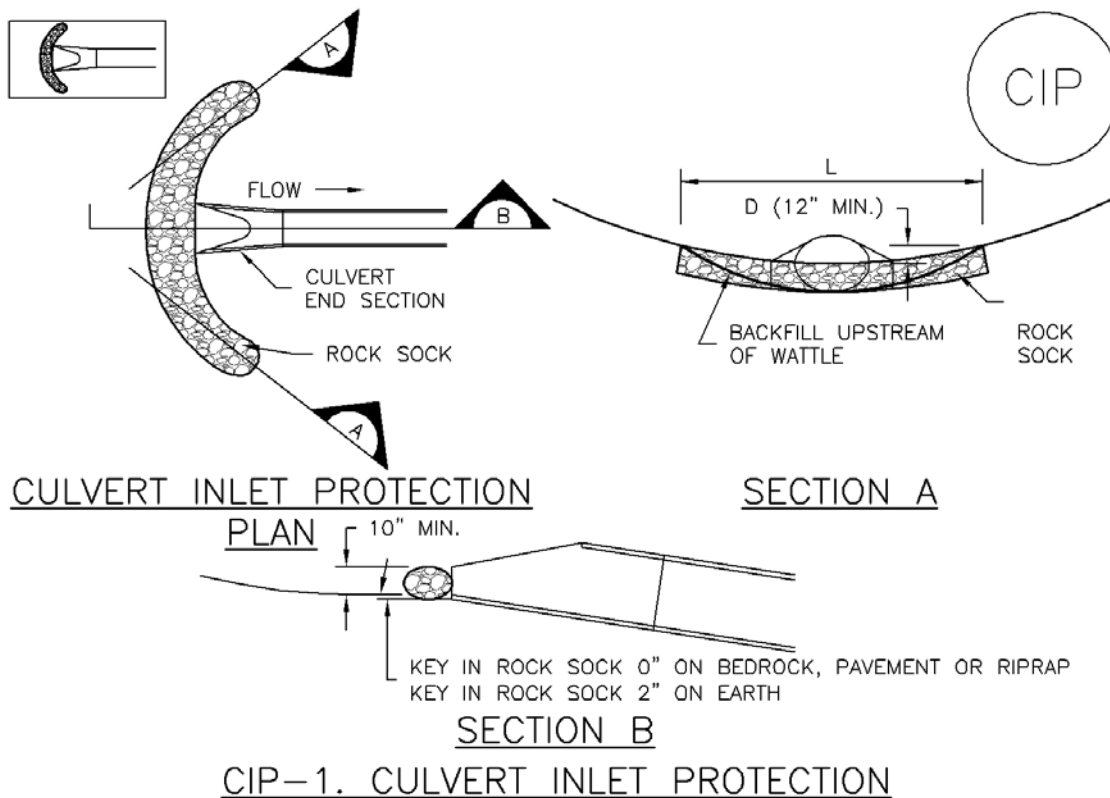

CULVERT INLET PROTECTION INSTALLATION NOTES

1. SEE PLAN VIEW FOR
-LOCATION OF CULVERT INLET PROTECTION.
2. SEE ROCK SOCK DESIGN DETAIL FOR ROCK GRADATION REQUIREMENTS AND JOINTING DETAIL.

CULVERT INLET PROTECTION MAINTENANCE NOTES

1. INSPECT BMPs EACH WORKDAY, AND MAINTAIN THEM IN EFFECTIVE OPERATING CONDITION. MAINTENANCE OF BMPs SHOULD BE PROACTIVE, NOT REACTIVE. INSPECT BMPs AS SOON AS POSSIBLE (AND ALWAYS WITHIN 24 HOURS) FOLLOWING A STORM THAT CAUSES SURFACE EROSION, AND PERFORM NECESSARY MAINTENANCE.
2. FREQUENT OBSERVATIONS AND MAINTENANCE ARE NECESSARY TO MAINTAIN BMPs IN EFFECTIVE OPERATING CONDITION. INSPECTIONS AND CORRECTIVE MEASURES SHOULD BE DOCUMENTED THOROUGHLY.
3. WHERE BMPs HAVE FAILED, REPAIR OR REPLACEMENT SHOULD BE INITIATED UPON DISCOVERY OF THE FAILURE.
4. SEDIMENT ACCUMULATED UPSTREAM OF THE CULVERT SHALL BE REMOVED WHEN THE SEDIMENT DEPTH IS 1/2 THE HEIGHT OF THE ROCK SOCK.
5. CULVERT INLET PROTECTION SHALL REMAIN IN PLACE UNTIL THE UPSTREAM DISTURBED AREA IS PERMANENTLY STABILIZED AND APPROVED BY THE LOCAL JURISDICTION.

(DETAILS ADAPTED FROM AURORA, COLORADO, NOT AVAILABLE IN AUTOCAD)

NOTE: MANY JURISDICTIONS HAVE BMP DETAILS THAT VARY FROM UDFCD STANDARD DETAILS. CONSULT WITH LOCAL JURISDICTIONS AS TO WHICH DETAIL SHOULD BE USED WHEN DIFFERENCES ARE NOTED.

GENERAL INLET PROTECTION INSTALLATION NOTES

1. SEE PLAN VIEW FOR:
 - LOCATION OF INLET PROTECTION.
 - TYPE OF INLET PROTECTION (IP.1, IP.2, IP.3, IP.4, IP.5, IP.6)
2. INLET PROTECTION SHALL BE INSTALLED PROMPTLY AFTER INLET CONSTRUCTION OR PAVING IS COMPLETE (TYPICALLY WITHIN 48 HOURS). IF A RAINFALL/RUNOFF EVENT IS FORECAST, INSTALL INLET PROTECTION PRIOR TO ONSET OF EVENT.
3. MANY JURISDICTIONS HAVE BMP DETAILS THAT VARY FROM UDFCD STANDARD DETAILS. CONSULT WITH LOCAL JURISDICTIONS AS TO WHICH DETAIL SHOULD BE USED WHEN DIFFERENCES ARE NOTED.

INLET PROTECTION MAINTENANCE NOTES

1. INSPECT BMPs EACH WORKDAY, AND MAINTAIN THEM IN EFFECTIVE OPERATING CONDITION. MAINTENANCE OF BMPs SHOULD BE PROACTIVE, NOT REACTIVE. INSPECT BMPs AS SOON AS POSSIBLE (AND ALWAYS WITHIN 24 HOURS) FOLLOWING A STORM THAT CAUSES SURFACE EROSION, AND PERFORM NECESSARY MAINTENANCE.
2. FREQUENT OBSERVATIONS AND MAINTENANCE ARE NECESSARY TO MAINTAIN BMPs IN EFFECTIVE OPERATING CONDITION. INSPECTIONS AND CORRECTIVE MEASURES SHOULD BE DOCUMENTED THOROUGHLY.
3. WHERE BMPs HAVE FAILED, REPAIR OR REPLACEMENT SHOULD BE INITIATED UPON DISCOVERY OF THE FAILURE.
4. SEDIMENT ACCUMULATED UPSTREAM OF INLET PROTECTION SHALL BE REMOVED AS NECESSARY TO MAINTAIN BMP EFFECTIVENESS, TYPICALLY WHEN STORAGE VOLUME REACHES 50% OF CAPACITY, A DEPTH OF 6" WHEN SILT FENCE IS USED, OR ¼ OF THE HEIGHT FOR STRAW BALES.
5. INLET PROTECTION IS TO REMAIN IN PLACE UNTIL THE UPSTREAM DISTURBED AREA IS PERMANENTLY STABILIZED, UNLESS THE LOCAL JURISDICTION APPROVES EARLIER REMOVAL OF INLET PROTECTION IN STREETS.
6. WHEN INLET PROTECTION AT AREA INLETS IS REMOVED, THE DISTURBED AREA SHALL BE COVERED WITH TOP SOIL, SEEDED AND MULCHED, OR OTHERWISE STABILIZED IN A MANNER APPROVED BY THE LOCAL JURISDICTION.

(DETAIL ADAPTED FROM TOWN OF PARKER, COLORADO AND CITY OF AURORA, COLORADO, NOT AVAILABLE IN AUTOCAD)

NOTE: MANY JURISDICTIONS HAVE BMP DETAILS THAT VARY FROM UDFCD STANDARD DETAILS. CONSULT WITH LOCAL JURISDICTIONS AS TO WHICH DETAIL SHOULD BE USED WHEN DIFFERENCES ARE NOTED.

NOTE: THE DETAILS INCLUDED WITH THIS FACT SHEET SHOW COMMONLY USED, CONVENTIONAL METHODS OF INLET PROTECTION IN THE DENVER METROPOLITAN AREA. THERE ARE MANY PROPRIETARY INLET PROTECTION METHODS ON THE MARKET. UDFCD NEITHER ENDORSES NOR DISCOURAGES USE OF PROPRIETARY INLET PROTECTION; HOWEVER, IN THE EVENT PROPRIETARY METHODS ARE USED, THE APPROPRIATE DETAIL FROM THE MANUFACTURER MUST BE INCLUDED IN THE SWMP AND THE BMP MUST BE INSTALLED AND MAINTAINED AS SHOWN IN THE MANUFACTURER'S DETAILS.

NOTE: SOME MUNICIPALITIES DISCOURAGE OR PROHIBIT THE USE OF STRAW BALES FOR INLET PROTECTION. CHECK WITH LOCAL JURISDICTION TO DETERMINE IF STRAW BALE INLET PROTECTION IS ACCEPTABLE.

Description

Effective construction site management to minimize erosion and sediment transport includes attention to construction phasing, scheduling, and sequencing of land disturbing activities. On most construction projects, erosion and sediment controls will need to be adjusted as the project progresses and should be documented in the SWMP.

Construction phasing refers to disturbing only part of a site at a time to limit the potential for erosion from dormant parts of a site. Grading activities and construction are completed and soils are effectively stabilized on one part of a site before grading and construction begins on another portion of the site.



Photograph CP-1. Construction phasing to avoid disturbing the entire area at one time. Photo courtesy of WWE.

Construction sequencing or scheduling refers to a specified work schedule that coordinates the timing of land disturbing activities and the installation of erosion and sediment control practices.

Appropriate Uses

All construction projects can benefit from upfront planning to phase and sequence construction activities to minimize the extent and duration of disturbance. Larger projects and linear construction projects may benefit most from construction sequencing or phasing, but even small projects can benefit from construction sequencing that minimizes the duration of disturbance.

Typically, erosion and sediment controls needed at a site will change as a site progresses through the major phases of construction. Erosion and sediment control practices corresponding to each phase of construction must be documented in the SWMP.

Design and Installation

BMPs appropriate to the major phases of development should be identified on construction drawings. In some cases, it will be necessary to provide several drawings showing construction-phase BMPs placed according to stages of development (e.g., clearing and grading, utility installation, active construction, final stabilization). Some municipalities in the Denver area set maximum sizes for disturbed area associated with phases of a construction project. Additionally, requirements for phased construction drawings vary among local governments within the UDFCD boundary. Some local governments require separate erosion and sediment control drawings for initial BMPs, interim conditions (in active construction), and final stabilization.

Construction Scheduling	
Functions	
Erosion Control	Moderate
Sediment Control	Moderate
Site/Material Management	Yes

Typical construction phasing BMPs include:

- Limit the amount of disturbed area at any given time on a site to the extent practical. For example, a 100-acre subdivision might be constructed in five phases of 20 acres each.
- If there is carryover of stockpiled material from one phase to the next, position carryover material in a location easily accessible for the pending phase that will not require disturbance of stabilized areas to access the stockpile. Particularly with regard to efforts to balance cut and fill at a site, careful planning for location of stockpiles is important.

Typical construction sequencing BMPs include:

- Sequence construction activities to minimize duration of soil disturbance and exposure. For example, when multiple utilities will occupy the same trench, schedule installation so that the trench does not have to be closed and opened multiple times.
- Schedule site stabilization activities (e.g., landscaping, seeding and mulching, installation of erosion control blankets) as soon as feasible following grading.
- Install initial erosion and sediment control practices before construction begins. Promptly install additional BMPs for inlet protection, stabilization, etc., as construction activities are completed.

Table CP-1 provides typical sequencing of construction activities and associated BMPs.

Maintenance and Removal

When the construction schedule is altered, erosion and sediment control measures in the SWMP and construction drawings should be appropriately adjusted to reflect actual "on the ground" conditions at the construction site. Be aware that changes in construction schedules can have significant implications for site stabilization, particularly with regard to establishment of vegetative cover.

Table CP-1. Typical Phased BMP Installation for Construction Projects

Project Phase	BMPs
Pre-disturbance, Site Access	<ul style="list-style-type: none"> ▪ Install sediment controls downgradient of access point (on paved streets this may consist of inlet protection). ▪ Establish vehicle tracking control at entrances to paved streets. Fence as needed. ▪ Use construction fencing to define the boundaries of the project and limit access to areas of the site that are not to be disturbed. <p>Note: it may be necessary to protect inlets in the general vicinity of the site, even if not downgradient, if there is a possibility that sediment tracked from the site could contribute to the inlets.</p>
Site Clearing and Grubbing	<ul style="list-style-type: none"> ▪ Install perimeter controls as needed on downgradient perimeter of site (silt fence, wattles, etc). ▪ Limit disturbance to those areas planned for disturbance and protect undisturbed areas within the site (construction fence, flagging, etc). ▪ Preserve vegetative buffer at site perimeter. ▪ Create stabilized staging area. ▪ Locate portable toilets on flat surfaces away from drainage paths. Stake in areas susceptible to high winds. ▪ Construct concrete washout area and provide signage. ▪ Establish waste disposal areas. ▪ Install sediment basins. ▪ Create dirt perimeter berms and/or brush barriers during grubbing and clearing. ▪ Separate and stockpile topsoil, leave roughened and/or cover. ▪ Protect stockpiles with perimeter control BMPs. Stockpiles should be located away from drainage paths and should be accessed from the upgradient side so that perimeter controls can remain in place on the downgradient side. Use erosion control blankets, temporary seeding, and/or mulch for stockpiles that will be inactive for an extended period. ▪ Leave disturbed area of site in a roughened condition to limit erosion. Consider temporary revegetation for areas of the site that have been disturbed but that will be inactive for an extended period. ▪ Water to minimize dust but not to the point that watering creates runoff.

Project Phase	BMPs
Utility And Infrastructure Installation	<p>In Addition to the Above BMPs:</p> <ul style="list-style-type: none"> ▪ Close trench as soon as possible (generally at the end of the day). ▪ Use rough-cut street control or apply road base for streets that will not be promptly paved. ▪ Provide inlet protection as streets are paved and inlets are constructed. ▪ Protect and repair BMPs, as necessary. ▪ Perform street sweeping as needed.
Building Construction	<p>In Addition to the Above BMPs:</p> <ul style="list-style-type: none"> ▪ Implement materials management and good housekeeping practices for home building activities. ▪ Use perimeter controls for temporary stockpiles from foundation excavations. ▪ For lots adjacent to streets, lot-line perimeter controls may be necessary at the back of curb.
Final Grading	<p>In Addition to the Above BMPs:</p> <ul style="list-style-type: none"> ▪ Remove excess or waste materials. ▪ Remove stored materials.
Final Stabilization	<p>In Addition to the Above BMPs:</p> <ul style="list-style-type: none"> ▪ Seed and mulch/tackify. ▪ Seed and install blankets on steep slopes. ▪ Remove all temporary BMPs when site has reached final stabilization.

Description

Vehicle tracking controls provide stabilized construction site access where vehicles exit the site onto paved public roads. An effective vehicle tracking control helps remove sediment (mud or dirt) from vehicles, reducing tracking onto the paved surface.



Photograph VTC-1. A vehicle tracking control pad constructed with properly sized rock reduces off-site sediment tracking.

Appropriate Uses

Implement a stabilized construction entrance or vehicle tracking control where frequent heavy vehicle traffic exits the construction site onto a paved roadway. An effective vehicle tracking control is particularly important during the following conditions:

- Wet weather periods when mud is easily tracked off site.
- During dry weather periods where dust is a concern.
- When poorly drained, clayey soils are present on site.

Although wheel washes are not required in designs of vehicle tracking controls, they may be needed at particularly muddy sites.

Design and Installation

Construct the vehicle tracking control on a level surface. Where feasible, grade the tracking control towards the construction site to reduce off-site runoff. Place signage, as needed, to direct construction vehicles to the designated exit through the vehicle tracking control. There are several different types of stabilized construction entrances including:

VTC-1. Aggregate Vehicle Tracking Control. This is a coarse-aggregate surfaced pad underlain by a geotextile. This is the most common vehicle tracking control, and when properly maintained can be effective at removing sediment from vehicle tires.

VTC-2. Vehicle Tracking Control with Construction Mat or Turf Reinforcement Mat. This type of control may be appropriate for site access at very small construction sites with low traffic volume over vegetated areas. Although this application does not typically remove sediment from vehicles, it helps protect existing vegetation and provides a stabilized entrance.

Vehicle Tracking Control	
Functions	
Erosion Control	Moderate
Sediment Control	Yes
Site/Material Management	Yes

VTC-3. Stabilized Construction Entrance/Exit with Wheel Wash. This is an aggregate pad, similar to VTC-1, but includes equipment for tire washing. The wheel wash equipment may be as simple as hand-held power washing equipment to more advanced proprietary systems. When a wheel wash is provided, it is important to direct wash water to a sediment trap prior to discharge from the site.

Vehicle tracking controls are sometimes installed in combination with a sediment trap to treat runoff.

Maintenance and Removal

Inspect the area for degradation and replace aggregate or material used for a stabilized entrance/exit as needed. If the area becomes clogged and ponds water, remove and dispose of excess sediment or replace material with a fresh layer of aggregate as necessary.

With aggregate vehicle tracking controls, ensure rock and debris from this area do not enter the public right-of-way.

Remove sediment that is tracked onto the public right of way daily or more frequently as needed. Excess sediment in the roadway indicates that the stabilized construction entrance needs maintenance.

Ensure that drainage ditches at the entrance/exit area remain clear.

A stabilized entrance should be removed only when there is no longer the potential for vehicle tracking to occur. This is typically after the site has been stabilized.

When wheel wash equipment is used, be sure that the wash water is discharged to a sediment trap prior to discharge. Also inspect channels conveying the water from the wash area to the sediment trap and stabilize areas that may be eroding.

When a construction entrance/exit is removed, excess sediment from the aggregate should be removed and disposed of appropriately. The entrance should be promptly stabilized with a permanent surface following removal, typically by paving.



Photograph VTC-2. A vehicle tracking control pad with wheel wash facility. Photo courtesy of Tom Gore.

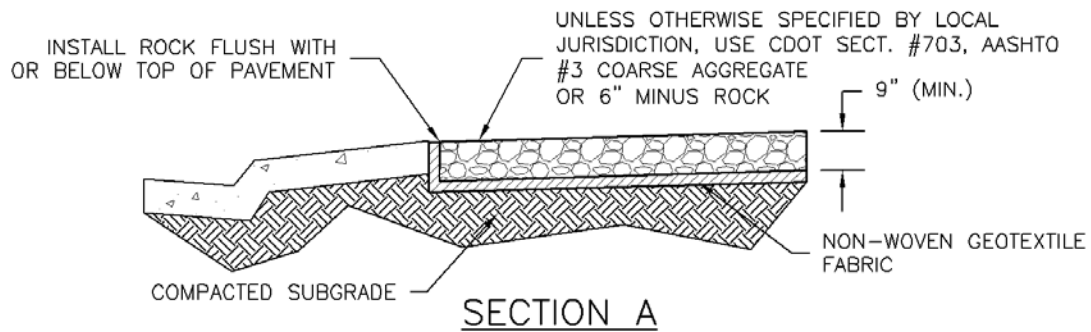
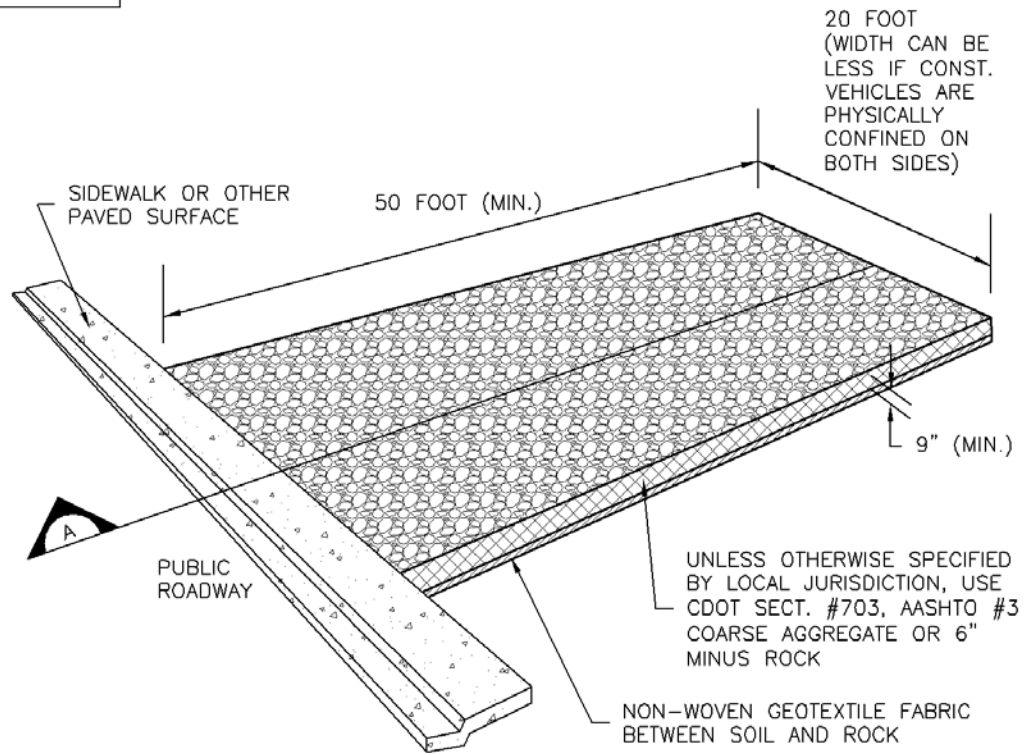
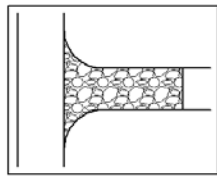

VTC-1. AGGREGATE VEHICLE TRACKING CONTROL

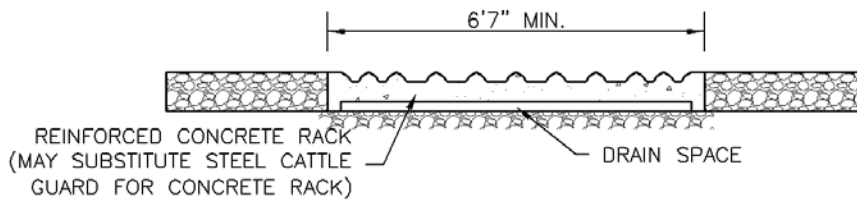
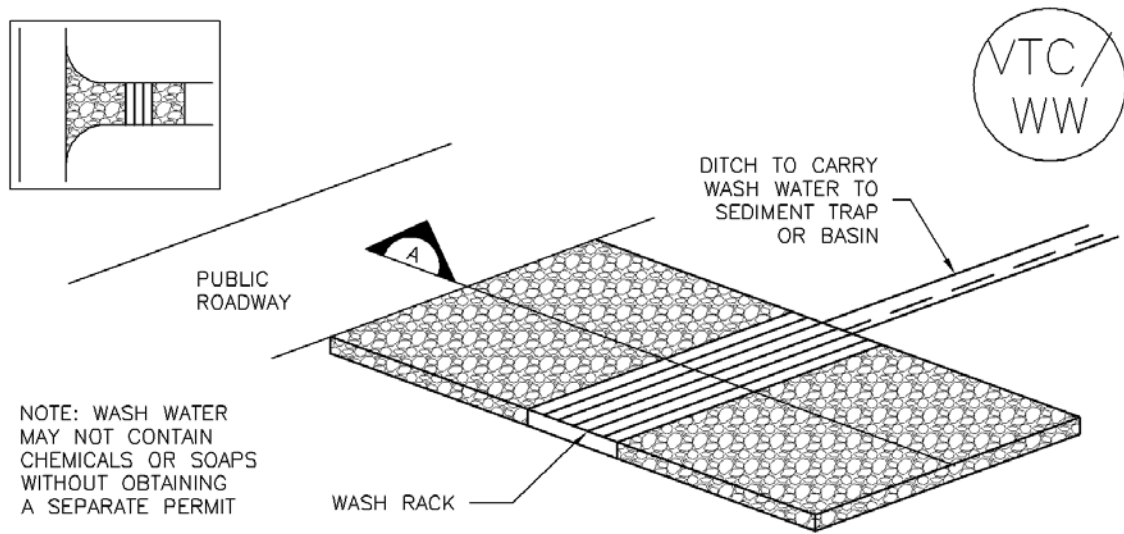

SECTION A

VTC-2. AGGREGATE VEHICLE TRACKING CONTROL WITH WASH RACK

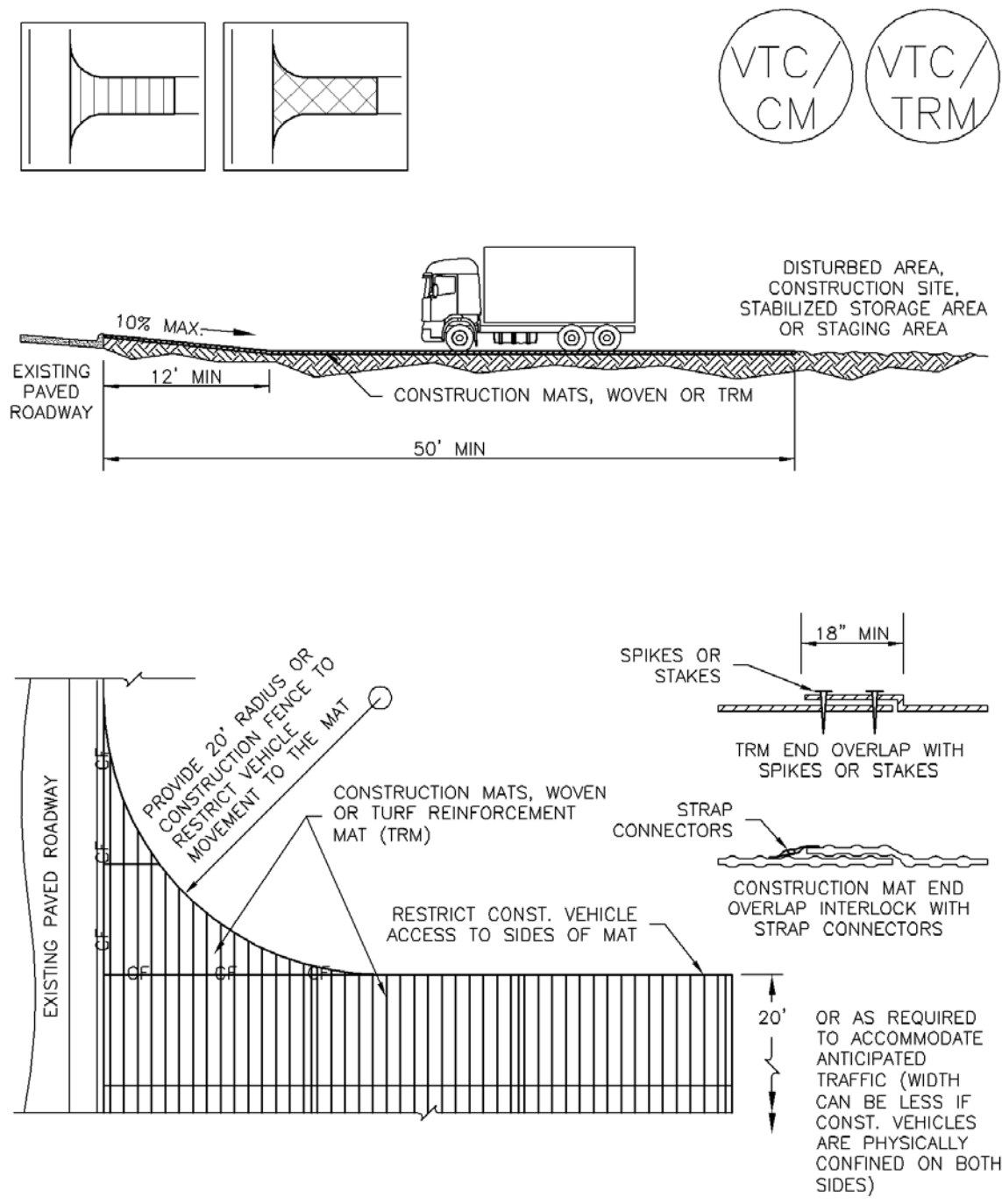

VTC-3. VEHICLE TRACKING CONTROL W/ CONSTRUCTION MAT OR TURF REINFORCEMENT MAT (TRM)

STABILIZED CONSTRUCTION ENTRANCE/EXIT INSTALLATION NOTES

1. SEE PLAN VIEW FOR
 - LOCATION OF CONSTRUCTION ENTRANCE(S)/EXIT(S).
 - TYPE OF CONSTRUCTION ENTRANCE(S)/EXITS(S) (WITH/WITHOUT WHEEL WASH, CONSTRUCTION MAT OR TRM).
2. CONSTRUCTION MAT OR TRM STABILIZED CONSTRUCTION ENTRANCES ARE ONLY TO BE USED ON SHORT DURATION PROJECTS (TYPICALLY RANGING FROM A WEEK TO A MONTH) WHERE THERE WILL BE LIMITED VEHICULAR ACCESS.
3. A STABILIZED CONSTRUCTION ENTRANCE/EXIT SHALL BE LOCATED AT ALL ACCESS POINTS WHERE VEHICLES ACCESS THE CONSTRUCTION SITE FROM PAVED RIGHT-OF-WAYS.
4. STABILIZED CONSTRUCTION ENTRANCE/EXIT SHALL BE INSTALLED PRIOR TO ANY LAND DISTURBING ACTIVITIES.
5. A NON-WOVEN GEOTEXTILE FABRIC SHALL BE PLACED UNDER THE STABILIZED CONSTRUCTION ENTRANCE/EXIT PRIOR TO THE PLACEMENT OF ROCK.
6. UNLESS OTHERWISE SPECIFIED BY LOCAL JURISDICTION, ROCK SHALL CONSIST OF DOT SECT. #703, AASHTO #3 COARSE AGGREGATE OR 6" (MINUS) ROCK.

STABILIZED CONSTRUCTION ENTRANCE/EXIT MAINTENANCE NOTES

1. INSPECT BMPs EACH WORKDAY, AND MAINTAIN THEM IN EFFECTIVE OPERATING CONDITION. MAINTENANCE OF BMPs SHOULD BE PROACTIVE, NOT REACTIVE. INSPECT BMPs AS SOON AS POSSIBLE (AND ALWAYS WITHIN 24 HOURS) FOLLOWING A STORM THAT CAUSES SURFACE EROSION, AND PERFORM NECESSARY MAINTENANCE.
2. FREQUENT OBSERVATIONS AND MAINTENANCE ARE NECESSARY TO MAINTAIN BMPs IN EFFECTIVE OPERATING CONDITION. INSPECTIONS AND CORRECTIVE MEASURES SHOULD BE DOCUMENTED THOROUGHLY.
3. WHERE BMPs HAVE FAILED, REPAIR OR REPLACEMENT SHOULD BE INITIATED UPON DISCOVERY OF THE FAILURE.
4. ROCK SHALL BE REAPPLIED OR REGRADED AS NECESSARY TO THE STABILIZED ENTRANCE/EXIT TO MAINTAIN A CONSISTENT DEPTH.
5. SEDIMENT TRACKED ONTO PAVED ROADS IS TO BE REMOVED THROUGHOUT THE DAY AND AT THE END OF THE DAY BY SHOVELING OR SWEEPING. SEDIMENT MAY NOT BE WASHED DOWN STORM SEWER DRAINS.

NOTE: MANY JURISDICTIONS HAVE BMP DETAILS THAT VARY FROM UDFCD STANDARD DETAILS. CONSULT WITH LOCAL JURISDICTIONS AS TO WHICH DETAIL SHOULD BE USED WHEN DIFFERENCES ARE NOTED.

(DETAILS ADAPTED FROM CITY OF BROOMFIELD, COLORADO, NOT AVAILABLE IN AUTOCAD)

Description

A stabilized staging area is a clearly designated area where construction equipment and vehicles, stockpiles, waste bins, and other construction-related materials are stored. The contractor office trailer may also be located in this area. Depending on the size of the construction site, more than one staging area may be necessary.



Photograph SSA-1. Example of a staging area with a gravel surface to prevent mud tracking and reduce runoff. Photo courtesy of Douglas County.

Appropriate Uses

Most construction sites will require a staging area, which should be clearly designated in SWMP drawings. The layout of the staging area may vary depending on the type of construction activity. Staging areas located in roadways due to space constraints require special measures to avoid materials being washed into storm inlets.

Design and Installation

Stabilized staging areas should be completed prior to other construction activities beginning on the site. Major components of a stabilized staging area include:

- Appropriate space to contain storage and provide for loading/unloading operations, as well as parking if necessary.
- A stabilized surface, either paved or covered, with 3-inch diameter aggregate or larger.
- Perimeter controls such as silt fence, sediment control logs, or other measures.
- Construction fencing to prevent unauthorized access to construction materials.
- Provisions for Good Housekeeping practices related to materials storage and disposal, as described in the Good Housekeeping BMP Fact Sheet.
- A stabilized construction entrance/exit, as described in the Vehicle Tracking Control BMP Fact Sheet, to accommodate traffic associated with material delivery and waste disposal vehicles.

Over-sizing the stabilized staging area may result in disturbance of existing vegetation in excess of that required for the project. This increases costs, as well as requirements for long-term stabilization following the construction period. When designing the stabilized staging area, minimize the area of disturbance to the extent practical.

Stabilized Staging Area	
Functions	
Erosion Control	Yes
Sediment Control	Moderate
Site/Material	Yes

Minimizing Long-Term Stabilization Requirements

- Utilize off-site parking and restrict vehicle access to the site.
- Use construction mats in lieu of rock when staging is provided in an area that will not be disturbed otherwise.
- Consider use of a bermed contained area for materials and equipment that do not require a stabilized surface.
- Consider phasing of staging areas to avoid disturbance in an area that will not be otherwise disturbed.

See Detail SSA-1 for a typical stabilized staging area and SSA-2 for a stabilized staging area when materials staging in roadways is required.

Maintenance and Removal

Maintenance of stabilized staging areas includes maintaining a stable surface cover of gravel, repairing perimeter controls, and following good housekeeping practices.

When construction is complete, debris, unused stockpiles and materials should be recycled or properly disposed. In some cases, this will require disposal of contaminated soil from equipment leaks in an appropriate landfill. Staging areas should then be permanently stabilized with vegetation or other surface cover planned for the development.

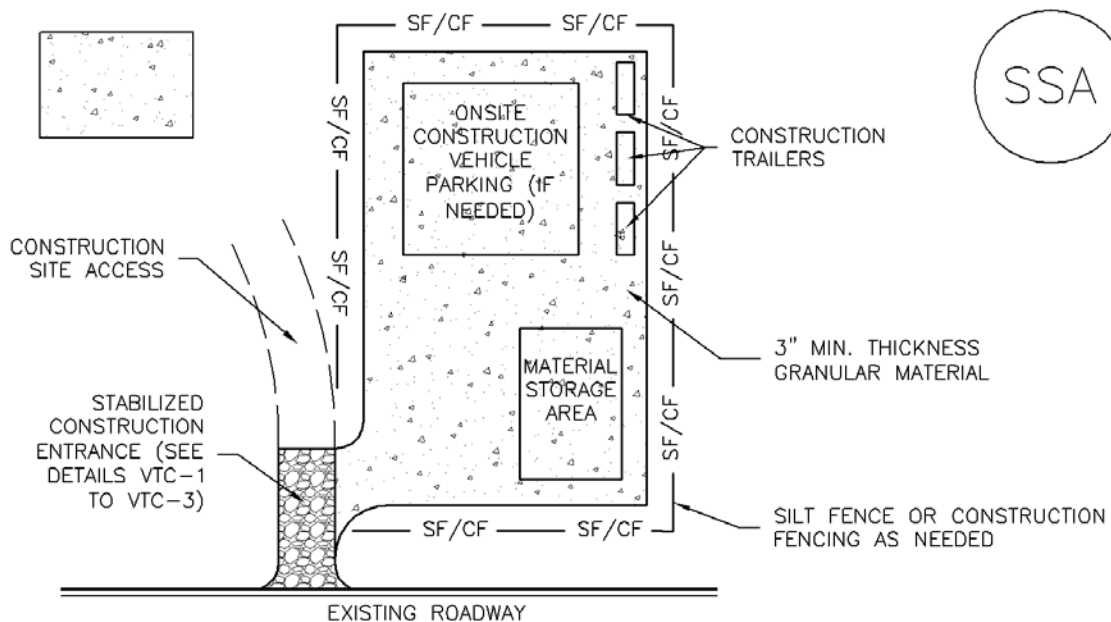

SSA-1. STABILIZED STAGING AREA

STABILIZED STAGING AREA INSTALLATION NOTES

1. SEE PLAN VIEW FOR
 - LOCATION OF STAGING AREA(S).
 - CONTRACTOR MAY ADJUST LOCATION AND SIZE OF STAGING AREA WITH APPROVAL FROM THE LOCAL JURISDICTION.
2. STABILIZED STAGING AREA SHOULD BE APPROPRIATE FOR THE NEEDS OF THE SITE. OVERSIZING RESULTS IN A LARGER AREA TO STABILIZE FOLLOWING CONSTRUCTION.
3. STAGING AREA SHALL BE STABILIZED PRIOR TO OTHER OPERATIONS ON THE SITE.
4. THE STABILIZED STAGING AREA SHALL CONSIST OF A MINIMUM 3" THICK GRANULAR MATERIAL.
5. UNLESS OTHERWISE SPECIFIED BY LOCAL JURISDICTION, ROCK SHALL CONSIST OF DOT SECT. #703, AASHTO #3 COARSE AGGREGATE OR 6" (MINUS) ROCK.
6. ADDITIONAL PERIMETER BMPs MAY BE REQUIRED INCLUDING BUT NOT LIMITED TO SILT FENCE AND CONSTRUCTION FENCING.

STABILIZED STAGING AREA MAINTENANCE NOTES

1. INSPECT BMPs EACH WORKDAY, AND MAINTAIN THEM IN EFFECTIVE OPERATING CONDITION. MAINTENANCE OF BMPs SHOULD BE PROACTIVE, NOT REACTIVE. INSPECT BMPs AS SOON AS POSSIBLE (AND ALWAYS WITHIN 24 HOURS) FOLLOWING A STORM THAT CAUSES SURFACE EROSION, AND PERFORM NECESSARY MAINTENANCE.
2. FREQUENT OBSERVATIONS AND MAINTENANCE ARE NECESSARY TO MAINTAIN BMPs IN EFFECTIVE OPERATING CONDITION. INSPECTIONS AND CORRECTIVE MEASURES SHOULD BE DOCUMENTED THOROUGHLY.
3. WHERE BMPs HAVE FAILED, REPAIR OR REPLACEMENT SHOULD BE INITIATED UPON DISCOVERY OF THE FAILURE.
4. ROCK SHALL BE REAPPLIED OR REGRADED AS NECESSARY IF RUTTING OCCURS OR UNDERLYING SUBGRADE BECOMES EXPOSED.

STABILIZED STAGING AREA MAINTENANCE NOTES

5. STABILIZED STAGING AREA SHALL BE ENLARGED IF NECESSARY TO CONTAIN PARKING, STORAGE, AND UNLOADING/LOADING OPERATIONS.

6. THE STABILIZED STAGING AREA SHALL BE REMOVED AT THE END OF CONSTRUCTION. THE GRANULAR MATERIAL SHALL BE REMOVED OR, IF APPROVED BY THE LOCAL JURISDICTION, USED ON SITE, AND THE AREA COVERED WITH TOPSOIL, SEEDED AND MULCHED OR OTHERWISE STABILIZED IN A MANNER APPROVED BY LOCAL JURISDICTION.

NOTE: MANY MUNICIPALITIES PROHIBIT THE USE OF RECYCLED CONCRETE AS GRANULAR MATERIAL FOR STABILIZED STAGING AREAS DUE TO DIFFICULTIES WITH RE-ESTABLISHMENT OF VEGETATION IN AREAS WHERE RECYCLED CONCRETE WAS PLACED.

NOTE: MANY JURISDICTIONS HAVE BMP DETAILS THAT VARY FROM UDFCD STANDARD DETAILS. CONSULT WITH LOCAL JURISDICTIONS AS TO WHICH DETAIL SHOULD BE USED WHEN DIFFERENCES ARE NOTED.

(DETAILS ADAPTED FROM DOUGLAS COUNTY, COLORADO, NOT AVAILABLE IN AUTOCAD)

Description

Street sweeping and vacuuming remove sediment that has been tracked onto roadways to reduce sediment transport into storm drain systems or a surface waterway.

Appropriate Uses

Use this practice at construction sites where vehicles may track sediment offsite onto paved roadways.

Design and Installation

Street sweeping or vacuuming should be conducted when there is noticeable sediment accumulation on roadways adjacent to the construction site. Typically, this will be concentrated at the entrance/exit to the construction site. Well-maintained stabilized construction entrances, vehicle tracking controls and tire wash facilities can help reduce the necessary frequency of street sweeping and vacuuming.

On smaller construction sites, street sweeping can be conducted manually using a shovel and broom. Never wash accumulated sediment on roadways into storm drains.

Maintenance and Removal

- Inspect paved roads around the perimeter of the construction site on a daily basis and more frequently, as needed. Remove accumulated sediment, as needed.
- Following street sweeping, check inlet protection that may have been displaced during street sweeping.
- Inspect area to be swept for materials that may be hazardous prior to beginning sweeping operations.



Photograph SS-1. A street sweeper removes sediment and potential pollutants along the curb line at a construction site. Photo courtesy of Tom Gore.

Street Sweeping/ Vacuuming	
Functions	
Erosion Control	No
Sediment Control	Yes
Site/Material Management	Yes

Description

Spills and leaks of solid and liquid materials processed, handled or stored outdoors can be a significant source of stormwater pollutants. Spilled substances can reach receiving waters when runoff washes these materials from impervious surfaces or when spills directly enter the storm sewer system during dry weather conditions.

Effective spill control includes both spill prevention and spill response measures and depends on proper employee training for spill response measures and may also include structural spill containment, particularly at industrial locations. Structural spill containment measures typically include temporary or permanent curbs or berms that surround a potential spill site. Berms may be constructed of concrete, earthen material, metal, synthetic liners, or other material that will safely contain the spill. Spill control devices may also include valves, slide gates, or other devices that can control and contain spilled material before it reaches the storm sewer system or receiving waters.



Photograph SPCC-1. Use of secondary containment around supplies stored outside helps to reduce the likelihood of spill and leaks reaching the storm sewer system in runoff. Photo courtesy of Tom Gore.

Appropriate Uses

Implement spill prevention, containment and control measures at municipal, commercial and industrial facilities in areas where materials may be spilled in quantities that may adversely impact receiving waters when discharged directly or through the storm sewer system. Check local, state, and/or federal regulations to determine when spill containment and control measures are required by law. Spill Prevention, Control and Countermeasures Plans may be required for certain facilities handling oil and hazardous substances under Section 311(j)(1)(C) of the federal Clean Water Act.

Practice Guidelines

Spill Prevention Measures

- Train employees on potential sources of pollution on-site and provide clear, common-sense spill prevention practices. Require that these practices be strictly followed.
- Identify equipment that may be exposed to stormwater, pollutants that may be generated and possible sources of leaks or discharges.
- Perform regular inspection and preventative maintenance of equipment to ensure proper operation and to check for leaks or evidence of discharge (stains). Provide clear procedures to ensure that needed repairs are completed and provide temporary leak containment until such repairs can be implemented.

Also See These BMP Fact Sheets

- Covering Storage/Handling Areas
- Good Housekeeping
- Vehicle Fueling, Maintenance, Washing & Storage
- Preventative Maintenance

S-2 Spill Prevention, Containment and Control

- Drain or replace motor oil and other automotive fluids in a designated area away from storm sewer inlets. Collect spent fluids and recycle or dispose of properly. Never dispose of these fluids in the storm sewer or sanitary sewer.
- In fueling areas, clean up spills with dry methods (absorbents) and use damp cloths on gas pumps and damp mops on paved surfaces. Never use a hose to “wash down” a fuel spill.
- Where practical, reduce stormwater contact with equipment and materials by implementing indoor or covered storage, implementing stormwater run-on control measures and following good housekeeping practices.

Identification of Spill Areas

Identify potential spill areas, potential spill volumes, material types, frequency of material use, and drainage paths from spill areas with relation to storm sewer inlets, adjacent waterbodies, structural BMPs, and containment structures. Use this information to determine the types of spill prevention and control measures needed specific to the site conditions. Examples of potential spill locations include:

- Loading and unloading areas
- Outdoor storage areas
- Outdoor manufacturing or processing activities
- Waste disposal/storage areas
- Areas that generate significant dust or particulates (that may be subsequently deposited on the ground)
- Salt piles
- Areas prone to spills based on past experience at the site
- Locations where other routine maintenance activities occur such as equipment maintenance and cleaning, pesticide/fertilizer application, etc.

Additionally, areas where smaller leaks may occur such as parking should also have basic spill cleanup procedures.

Material Handling Procedures

From a water quality perspective, the primary principle behind effective material handling practices is to minimize exposure to stormwater. This can be accomplished by storing the material indoors under weather-resistant covering, elevating the material off the ground by using pallets, and diverting stormwater around materials storage areas. Representative outdoor materials handling procedures include:

- Keep bulk solid materials such as raw materials, sand, gravel, topsoil, compost, concrete, packing materials, metal products and other materials covered and protected from stormwater.
- When practical, store materials on impermeable surfaces.
- Store hazardous materials according to federal, state, and local hazardous materials requirements.

- Adopt procedures that reduce the chance of spills or leaks during filling or transfer of materials.
- Substitute less toxic or non-toxic materials for toxic materials.
- Store containers that are easily punctured or damaged away from high traffic areas (i.e., adopt a materials flow/plant layout plan).
- Add waste-capture containers such as collection pans for lubricating fluids.
- Store drums and containers with liquid materials on impermeable surfaces and provide secondary containment where appropriate. Drums stored outdoors should be located on pallets to minimize contact with runoff.

Spill Response Procedures and Equipment

Spill response procedures should be tailored to site-specific conditions and industry-specific regulatory requirements. General spill response procedures include:

- Containment and cleanup of spills should begin promptly after the spill is observed.
- Sweep up small quantities of dry chemical or solids to reduce exposure to runoff. Shoveling may be used for larger quantities of materials.
- Absorbents should be readily accessible in fueling areas or other areas susceptible to spills.
- Wipe up small spills with a shop rag, store shop rags in appropriate containers, dispose of rags properly or use a professional industrial cleaning service.
- Contain medium-sized spills with absorbents (e.g., kitty litter, sawdust) and use inflatable berms or absorbent “snakes” as temporary booms for the spill. Store and dispose of absorbents properly. Wet/dry vacuums may also be used, but not for volatile fluids.
- Develop procedures and locations for containing and storing leaking containers.
- Install drip pans below minor equipment leaks and properly dispose of collected material until a repair can be made.
- For large spills, first contain the spill and plug storm drain inlets where the liquid may migrate off-site, then clean up the spill.
- Excavation of spill areas to removed contaminated material may be required where large liquid spills occur on unpaved surfaces.
- An inventory of cleanup materials should be maintained onsite and strategically located based on the types and quantities of chemicals present.

Structural Spill Containment Measures

Two general approaches are often used when implementing spill containment measures. The first approach is designed to contain the entire spill. The second approach uses curbing to route spilled material to a collection basin. Both containment berming and curbing should be sized to safely contain or convey to a collection basin a spill from the largest storage tank, rail car, tank truck, or other containment device in the possible spill area. The spill containment area must have an impermeable surface (e.g.,

S-2 Spill Prevention, Containment and Control

impermeable liner, asphalt or concrete) to prevent groundwater contamination. The containment system must be designed to enable collection and removal of spilled material through a pump or vacuum trucks, use of sorbent or gelling material, or other measures. Material removed from the spill area must be disposed of or recycled according to local, state, and federal standards.

If the capacity of the containment berming or the collection basin is exceeded, supplemental spill control measures should be available such as a portable containment device, sorbent materials, or gelling agents that eventually solidify the material. Water that collects within containment areas due to rainfall or snowmelt must be appropriately treated before release from the spill area.

Spill Plan Development

Many industries are required by federal law to have a Spill Prevention, Control and Countermeasures Plan (SPCC) that meets specific regulatory criteria when certain types and quantities of materials are used or processed at a site. These plans can be instrumental in developing a spill control plan for stormwater management purposes. Even if an SPCC plan is not legally required at a site, a spill control plan for stormwater management purposes may be necessary. Representative information appropriate for a spill control plan, building on concepts previously introduced in this Fact Sheet, includes:

- Site plan showing where materials are stored and handled, and where associated activities occur.
- Notification procedures to be used in the event of an accident
- Instructions for clean-up procedures.
- A designated person with spill response and clean-up authority.
- Training of key personnel in plan and clean-up procedures.
- Signs posted at critical locations providing a summary of SPCC plan information, phone numbers, contacts, equipment locations, etc.
- Provisions requiring spills to be cleaned up, corrective actions taken, or countermeasures implemented immediately.
- Provisions for absorbents to be made available for use in fuel areas, and for containers to be available for used absorbents.
- Prohibition on washing absorbents into the storm drainage system or into the sanitary sewer system via floor drains.
- Provision for emergency spill containment and clean-up kits in accessible and convenient locations. Kits should contain the appropriate clean-up materials applicable to the materials stored at the site.

Key Spill Notification Contacts in Colorado

- Colorado Department of Public Health and Environment Toll-Free 24-hour Environmental Emergency Spill Reporting Line: 1-877-518-5608
- National Response Center: 1-800-424-8802 (24-hour)
- Local Emergency Planning Committee (OEM): 303-273-162
- Division of Oil & Public Safety-Storage Tanks: 303-318-8547
- Oil and Gas Conservation Commission: 303-894-2100 or 1-888-235-1101 (toll-free spill/complaint line)

Description

Improperly disposed household wastes are a source of stormwater pollution. These wastes can include household chemicals, pet waste, yard waste, litter, automotive maintenance waste, and others. These materials can be transported in stormwater when the materials are dumped directly into the storm drains or when they are spilled on impervious surfaces and washed into the storm sewer system. Household wastes can contribute solids, nutrients, oxygen demanding substances, toxic substances, and bacteria to receiving waters. Improper disposal of household wastes on the ground surface can also lead to groundwater contamination.

Proper disposal of household waste is dependent on behavioral change, which can be encouraged through public education programs and local ordinances that prohibit improper disposal of household waste. Additionally, local governments can provide appropriate facilities for proper disposal of waste.

This Fact Sheet focuses primarily on household waste. See the Good Housekeeping Fact Sheet for additional information on waste management at commercial and industrial sites.

Appropriate Uses

Educational efforts related to proper disposal of household waste can be targeted to homeowners and businesses through municipal programs, civic groups, and others. Local governments should consider measures needed in the following general categories:

- **Household/Commercial Waste:** Household waste includes materials discarded on the land surface or into the stormwater system from residential and commercial areas. Wastes from commercial businesses are generated by stores, restaurants, hotels, offices, and other non-manufacturing activities. Household waste disposal objectives include containing and properly disposing of refuse (garbage), reducing litter, and encouraging proper household toxic waste disposal through public education and access to appropriate disposal facilities.
- **Litter:** Most litter is biodegradable and can create an oxygen demand in water as it decomposes. Examples of litter are paper products, used diapers, etc. Research by Keep America Beautiful, Inc. (1990) has shown that people litter where litter has already accumulated. Also according to Keep America Beautiful, Inc. (1987), pedestrians and motorists account for less than 25 percent of litter, with the other sources being household waste, commercial and industrial waste, haulage vehicles, loading docks, and construction sites. Reduction of litter through proper disposal can reduce its accumulation on the urban landscape and its eventual entry into the stormwater system.
- **Pet Waste:** Pet waste deposited on the ground can be transported by the storm drainage system to receiving waters or by overland flow into waterways. Fecal matter potentially contains pathogenic viruses and bacteria; it also creates an oxygen demand in water. The majority of improperly disposed pet waste occurs in public areas, such as streets and parks. Pet waste ordinances are common in municipalities; however, these are difficult to enforce, especially with limited municipal resources. Education can help bring this problem to the public's attention, and can thereby reduce deposition of pet waste on urban surfaces.

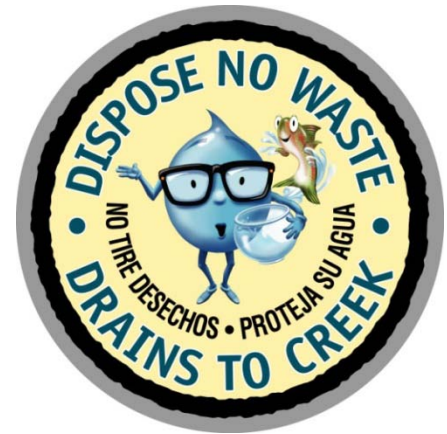

Photograph DHW-1. Placing storm drain markers (or stenciling) at storm sewer inlets is a public education tool that can be used to educate citizens and discourage improper disposal of household waste in storm drains. Photo courtesy of Nonpoint Source Colorado.

- **Yard Waste:** Yard waste includes limbs, leaves and grass clippings that can contribute nutrients, lawn chemicals, and oxygen demand to receiving waters when washed into storm sewers and waterways. Public education efforts on the benefits of composting and on proper disposal of yard waste can help to reduce the volume of yard waste entering the stormwater system and receiving waters. Most yard waste can be reused following composting, with the exception of weeds and diseased plant materials.
- **Used Oil and Automotive Fluids:** Used oil and automotive fluids including antifreeze, brake fluid, transmission fluid, grease, other lubricants, and petroleum-based cleaning solvents are wastes generated during automobile maintenance by residential households and commercial businesses. These can enter the storm drainage system if poured directly into storm inlets or from residual on concrete or asphalt exposed to precipitation. Improper disposal of used oil and automotive fluids causes receiving waters to become contaminated with hydrocarbons and residual metals that can be toxic to stream organisms. Used oil and other petroleum products can be recycled and are accepted by many auto parts stores and repair shops. Public education on the location of these centers, the benefits of recycling, prevention of fluid leaks, and the importance of proper disposal for improving stormwater quality can reduce the amounts of oil and used automotive fluids reaching receiving waters.
- **Toxic Wastes:** Toxic wastes are generated in small quantities by residential households and commercial businesses. Examples include paint, solvents, putties, cleaners, waxes, polishes, oil products, aerosols, acids, caustics, pesticides, herbicides, and certain medicines or cosmetics. These products and their containers should always be disposed of in accordance with the product label or recycled, if appropriate. When such toxic substances are improperly disposed of by dumping on impervious surfaces or into street gutters or storm inlets, stormwater can transport these materials to receiving waters.

Composting

Composting is a natural method for recycling organics such as yard trimmings and food scraps, which comprise nearly a quarter of municipal solids waste generated (Keep America Beautiful 2010). Nearly half of all U.S. states now ban yard waste from landfills because it represents such a large volume that can be productively composted. Composted yard waste used as mulch or soil amendment can provide landscape water conservation benefits, reduce the burden on landfills and is protective of water quality.

Municipal Recycling Programs

Many communities throughout the country have implemented municipal recycling programs, rather than relying on citizens to research and seek out recycling opportunities on their own. Curbside recycling programs and municipal education campaigns can improve the success of recycling programs. For more information on implementing a municipal recycling program, visit a variety of U.S. Environmental Protection Agency websites such as: <http://www.epa.gov/epawaste/conserv/rrr/index.htm> and <http://www.epa.gov/region4/waste/rcra/mgtoolkit/index.html> or review well developed local programs such as Denver Recycles.

Practice Guidelines

To reduce improper disposal of household waste, implement public education efforts regarding how improper disposal of wastes can degrade the quality of streams, rivers, lakes, and wetlands. Local governments have many public education options that can be tailored to fit local needs and budget constraints the best. Within local governments, opportunities for coordinated efforts among multiple departments may be beneficial. For example, properly composting of yard waste can provide a stormwater benefit when these materials are kept out of the gutter, as well as a water conservation benefit when the materials are reused as mulch and a solid waste management benefit when these materials are kept out of landfills. Similarly, public works and parks and recreation departments both benefit from efforts related to pet waste disposal signage as well as disposal facilities in parks.

Representative public education strategies may include:

- Development, publication, and distribution of brochures.
- Utility bill inserts, flyers, and handbills.
- Newspaper articles and/or advertisements.
- Development and distribution of educational videos.
- Public workshops, field demonstrations, or presentations to targeted civic organizations, youth organizations, etc.
- Developing and offering school curricula or assembly programs.
- Creating posters, signs, and graphics for installation at parks, school hallways, trails, etc.
- Storm drain stenciling to discourage dumping of materials into storm drains.
- Signs, including graphics, on dumpsters and other locations encouraging proper waste disposal.
- Signs in parks and along streets on pet waste control and ordinances.
- Brochures and utility bill inserts on separation of wastes and recycling.
- Advertising the locations of existing toxic disposal sites and waste recycling centers.
- Advertising the locations of existing automobile fluids and used oil disposal sites.

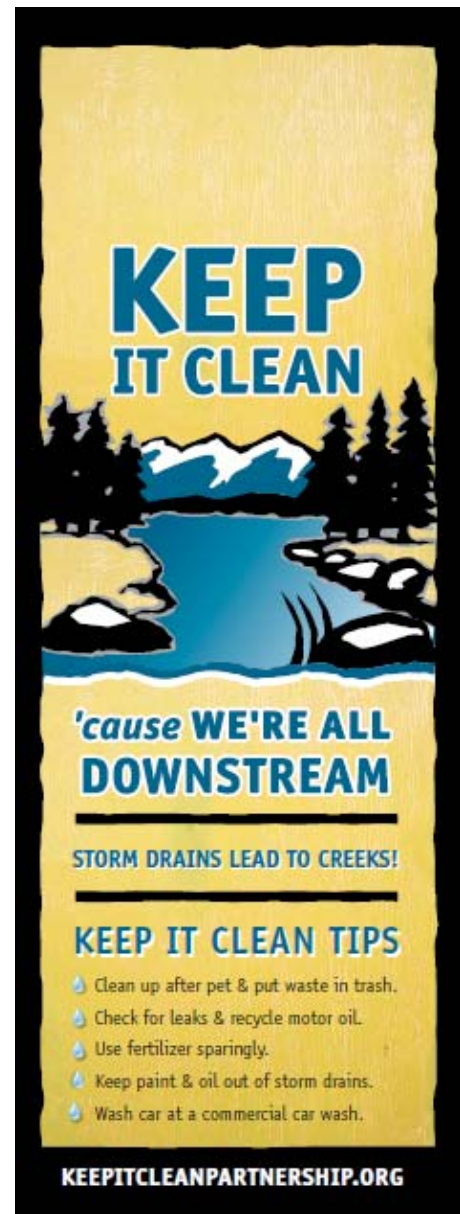

Photograph DHW-2. Check with state and local water quality agencies for public education materials such as this door hanger developed by the Keep It Clean Partnership that can be adopted for use in your community. Photo courtesy of Nonpoint Source Colorado.

- Developing campaigns promoting voluntary neighborhood clean-up efforts.
- Advertisements or notices of private locations accepting yard waste for composting.
- Information on backyard or neighborhood composting and proper disposal of yard waste.

In addition to public education efforts, local governments can provide facilities that provide readily available proper disposal opportunities. These practices include:

- Establishing and maintaining household toxics disposal sites.
- Annual or curbside collection of household toxics.
- Pet waste disposal bags in public parks.
- Providing waste containers in problem litter areas.
- Requiring waste-haulage truck covers.
- Seasonal or on-going collection programs for grass clippings, tree branches, and leaves with disposal at composting or chipping facilities, paired with distribution programs for reuse of composted or chipped materials.

With regard to household toxics, local governments should be aware that collection and disposal of household wastes is expensive. Such programs require adequate training of operators, analysis of unknown materials, safe transport and containers, extensive recordkeeping and awareness of regulatory requirements (e.g., the federal Resource Conservation and Recovery Act) regarding disposal of such materials.

Description

Good housekeeping practices are designed to maintain a clean and orderly work environment. The most effective first steps towards preventing pollution in stormwater from work sites simply involve using common sense to improve the facility's basic housekeeping methods. Poor housekeeping practices result in increased waste and potential for stormwater contamination.

A clean and orderly work site reduces the possibility of accidental spills caused by mishandling of chemicals and equipment and should reduce safety hazards to personnel. A well-maintained material and chemical storage area will reduce the possibility of stormwater mixing with pollutants.



Photograph GH-1. Use dry clean-up methods to remove spilled materials. Photo courtesy of Colorado Nonpoint Source Program.

Some simple procedures a facility can use to promote good housekeeping include improved operation and maintenance of machinery and processes, material storage practices, material inventory controls, routine and regular clean-up schedules, maintaining well organized work areas, signage, and educational programs for employees and the general public about all of these practices.

Appropriate Uses

Good housekeeping practices require education and training, typically targeted to industries and businesses, municipal employees, as well as the general public.

Practice Guidelines

Good housekeeping practices include these general areas:

- Operation and Maintenance
- Material Storage
- Material Inventory
- Training and Participation.

Operation and Maintenance

Consider implementing the following practices:

- Maintain dry and clean floors and ground surfaces by using brooms, shovels, vacuums or cleaning machines, rather than wet clean-up methods.
- Regularly collect and dispose of garbage and waste material.

- Routinely inspect equipment to ensure that it is functioning properly without leaking and conduct preventative maintenance and needed repairs.
- Train employees on proper clean up and spill response procedures.
- Designate separate areas of the site for auto parking, vehicle refueling and routine maintenance.
- Promptly clean up leaks, drips and other spills.
- Cover and maintain dumpsters and waste receptacles. Add additional dumpsters or increase frequency of waste collection if overflowing conditions reoccur.
- Where outdoor painting and sanding occur, implement these practices:
 - Conduct these activities in designated areas that provide adequate protection to prevent overspray and uncontrolled emissions. All operations should be conducted on paved surfaces to facilitate cleanup.
 - Use portable containment as necessary for outside operations.
 - Clean up and properly dispose of excess paint, paint chips, protective coatings, grit waste, etc.
- Maintain vegetation on facility grounds in a manner that minimizes erosion. Follow the Landscape Maintenance and Pesticide, Herbicide and Fertilizer Usage BMPs to ensure that minimum amounts of chemicals needed for healthy vegetation are applied in a manner that minimizes transport of these materials in runoff.

Material Storage Practices

Proper storage techniques include the following:

- Provide adequate aisle space to facilitate material transfer and ease of access for inspection.
- Store containers, drums, and bags away from direct traffic routes to reduce container damage resulting in accidental spills.
- Stack containers according to manufacturer's instructions to avoid damaging the containers from improper weight distribution. Also store materials in accordance with directions in Material Safety Data Sheets (MSDSs).
- Store containers on pallets or similar devices to prevent corrosion of containers that results from containers coming in contact with moisture on the ground.
- Store toxic or hazardous liquids within curbed areas or secondary containers.

Material Inventory Practices

An up-to-date materials inventory can keep material costs down by preventing overstocking, track how materials are stored and handled onsite, and identify which materials and activities pose the most risk to the environment. Assign responsibility of hazardous material inventory to individuals trained to handle such materials. A material inventory should include these steps:

- Identify all chemical substances present at work site. Perform a walk-through of the site, review

purchase orders, list all chemical substances used and obtain Material Safety Data Sheets (MSDS) for all chemicals.

- Label all containers. Labels should provide name and type of substance, stock number, expiration date, health hazards, handling suggestions, and first aid information. Much of this information can be found on an MSDS.
- Clearly identify special handling, storage, use and disposal considerations for hazardous materials on the material inventory.
- Institute a shelf-life program to improve material tracking and inventory that can reduce the amount of materials that are overstocked and ensure proper disposal of expired materials. Careful tracking of materials ordered can result in more efficient materials use. Decisions on the amounts of hazardous materials that are stored on site should include an evaluation of any emergency control systems that are in place. All storage areas for hazardous materials should be designed to contain spills.

Training and Participation

Frequent and proper training in good housekeeping techniques reduces the likelihood that chemicals or equipment will be mishandled. To promote good housekeeping, consider implementing these practices:

- Discuss good housekeeping practices in training programs and meetings.
- Publicize pollution prevention concepts through posters or signs.
- Post bulletin boards with updated good housekeeping procedures, tips and reminders.

Description

Preventative maintenance involves proactive routine inspection and testing of plant equipment and operational systems to prevent leaks and spills. A preventative maintenance program should also include inspections of conveyance channels, storm sewers, inlets, catch basins, stormwater detention areas, and other water quality treatment systems associated with the site.



Photograph PM-1. Preventative maintenance can reduce the frequency and occurrence of leaked or spilled material that can be transported in stormwater runoff.

Appropriate Uses

This BMP is applicable to municipal, industrial and commercial sites.

Preventative maintenance programs typically incorporate practices identified in the Good Housekeeping, Materials Storage and Handling, Vehicle Fueling, Maintenance and Storage, and other source control BMPs. See the Structural BMP Maintenance chapter for preventative maintenance for stormwater BMPs.

Practice Guidelines

Elements of a good preventative maintenance program should include:

- Identification of equipment or systems, which may malfunction and cause spills, leaks, or other situations that could lead to contamination of stormwater runoff. Typical equipment to inspect includes pipes, pumps, storage tanks and bins, pressure vessels, pressure release valves, process and material handling equipment.
- Once equipment and areas to be inspected have been identified at the facility, establish schedules and procedures for routine inspections and scheduling repairs.
- Periodic testing of plant equipment for structural soundness is a key element in a preventative maintenance program.
- Promptly repair or replace defective equipment found during inspection and testing.
- Keep spare parts for equipment that needs frequent repair.
- Replace worn parts prior to failure.
- Implement, maintain and regularly review a record keeping system for scheduling tests and documenting inspections in the preventative maintenance program. Be sure to follow inspections promptly with completion of needed repairs. Clearly record the problem and the specific actions taken to correct the problem. Photos can be helpful components of such records. An annual review of these records should be conducted to evaluate the overall effectiveness of the preventative maintenance program. Refinements to the preventative maintenance procedures and tasking should be implemented as necessary.

Description

Pesticides, herbicides, fertilizers, fuel and other landscape maintenance chemicals must be properly applied, stored, handled and disposed of to prevent contamination of surface water and groundwater. Misuse of pesticides and herbicides can result in adverse impacts to aquatic life, even at low concentrations. Misuse of fertilizer can result in increased algae growth in waterbodies due to excessive phosphorus and nitrogen loading.



Photograph PHF-1. Pesticide, fertilizer, and herbicide applications should be applied in the minimum quantities necessary to achieve specific landscaping objectives, while keeping chemicals out of storm drain systems. Photo courtesy of WWE.

Appropriate Uses

This BMP applies to both commercial and municipal landscaping operations, as well as to homeowners and homeowner associations. For commercial operations, the scale of chemical usage and handling is greater; therefore, additional measures are often required under federal and state law.

Practice Guidelines¹

Public education regarding appropriate landscape chemical application and handling is an important action that local governments can take to reduce the likelihood that landscape chemicals are washed into storm drains and receiving waters through runoff. Local governments can make landscape care information available on websites, in utility mailers, lawn care centers, and other locations. A variety of professional organizations for lawn care professionals already exist and can be contacted for additional information or partnered with for both public education and landscape professional educational efforts and certification programs (See www.ext.colostate.edu and www.greenco.org).

General Guidelines for Pesticide, Herbicide, and Fertilizer Application

- Apply fertilizers, pesticides, and other chemicals according to manufacturer's directions. The label is the law for pesticide usage. Apply pesticides and herbicides only when needed and use in a manner to minimize off-target effects. See the Landscape Management Fact Sheet for fertilizer application guidelines.
- Accurately diagnose the pest. Disease and insect symptoms can mimic each other in many plants. A fungicide will not control an insect, and an insecticide will not control a disease.
- Be aware that commercial chemical applicators must receive thorough training, licensure and proper certification prior to chemical use. Consult Colorado Department of Agriculture (CDA) Regulations for specific requirements.

¹ These practice guidelines have been adapted from the *GreenCO Best Management Practices for the Conservation and Protection of Water Quality in Colorado: Moving Toward Sustainability* (GreenCO and WWE 2008). See that manual for additional detail and references.

S-8 Use of Pesticides, Herbicides and Fertilizers

- Know characteristics of the application site, including soil type and depth to groundwater to avoid migration of chemicals into groundwater.
- Select pesticides and herbicides best suited to the characteristics of the target site and the particular pest or weed. Half-life, solubility, and adsorption should be compared to site characteristics to determine the safest chemical. Choose least toxic and less persistent sprays whenever possible based on comparison of labels and associated material safety data sheets.
- Employ application techniques that increase efficiency and allow the lowest effective application rate. Carefully calibrate application equipment and follow all label instructions.
- Recognize that it is not realistic for a landscape to be completely pest-free or weed-free. Consider using Integrated Pest Management (IPM) strategies to minimize chemical usage.
- Keep pesticide and fertilizer equipment properly calibrated according to the manufacturer's instructions and in good repair. Recalibrate equipment periodically to compensate for wear in pumps, nozzles and metering systems. Calibrate sprayers when new nozzles are installed.
- All mixing and loading operations must occur on an impervious surface.

Integrated Pest Management (IPM)

Integrated pest management (IPM) (also known as Plant Health Care) is the practice of using targeted biological, chemical, cultural, and physical measures to manage pests while minimizing or eliminating the use of chemical pesticides. IPM measures benefit the landscape and help reduce the likelihood that lawn chemicals will be washed into storm drainage systems in stormwater runoff. The pros and cons of various tools should be weighed and used in an integrated manner to achieve pest control objectives in a safe, effective, and cost-effective manner. Basic IPM practices that can be adopted include:

- Consider spot treatments of pests rather than treating the entire area.
- Consider pest occurrence and history when developing pest management strategies.
- Time pesticide application to minimize host plant damage and maximize pest control.
- Rotate annual garden plants to reduce the buildup of soil-borne pests. Clean up plant litter and remove weeds before they go to seed. Remove infested plant residue from the garden in the fall so that pests do not over-winter there.
- Implement cultural controls such as proper plant selection, planting time, and planting method to reduce susceptibility to insects, pests, and diseases, thereby reducing pesticide usage.
- Implement mechanical and physical controls where practical as an alternative to chemical application. Examples include a wide variety of practices such as "collars" around seedlings, mulching, solar heating, syringing, handpicking, mowing, hoeing, and traps.
- Use biological controls where appropriate to reduce pesticide usage. For example, introduce natural enemies of pests such as lady beetles and green lacewings. (Note: pesticides may kill these natural enemies.)
- Consider applying environmentally friendly chemical alternatives such as insecticidal soaps, horticultural oils, and other such measures when practical and effective and when mechanical approaches are impractical.

Application Practices

- Keep records of pesticide application and provide signage as required by law.
- Do not apply pesticides or herbicides during high temperatures, windy conditions or immediately prior to heavy rainfall or irrigation.
- Treat for and control noxious weeds prior to installing the landscape using an herbicide targeted to the weeds that are present and applied in accordance with the product label.
- Be aware that some pesticide formulations are not compatible with other pesticides and combining them may result in increased potency and phytotoxicity.

Managing Mosquitoes in Stormwater Facilities

(Adapted from: Peairs and Cranshaw 2007)

The key to mosquito control is larval management. Larvae occur in specific areas and can be controlled by modifying the habitat through drainage or insecticides applied to larval breeding sites. Weekly mosquito inspections at stormwater facilities with targeted treatments are frequently less costly and more effective than regular widespread application of insecticides. These inspections can be performed by a mosquito control source and typically start in mid-May and extend to mid-September. Mosquito control measures must be cost effective and environmentally sound. Consider alternatives before application of conventional chemical insecticides.

- **Habitat Modification:** Eliminating breeding sites, or habitat modification, is an effective and long-term solution. Proper maintenance of stormwater BMPs to avoid shallow standing water is important.
- **Natural Predators:** Fish, dragonfly nymphs, and diving beetles are natural predators of mosquito larvae; dragonflies, birds, and bats feed on adults. Consult the Colorado Division of Wildlife for recommendations, restrictions and regulations regarding mosquito-eating fish.
- **Insecticides:** Microbial insecticides such as the bacteria "Bti" (*Bacillus thuringiensis israeliensis*) can be as effective as chemical insecticides. Bti is toxic only to mosquito and midge larvae. It is not hazardous to non-target organisms but can reduce midge populations that serve as fish food.

"Soft" chemical insecticides, such as the insect growth regulator methoprene, are toxic only to insects and other arthropods. They are similar to certain insect hormones and create imbalances in the levels of hormones needed for proper mosquito growth and development. They do not directly harm fish or other wildlife but can reduce the amount of available food.

Mosquito larvae also can be controlled by the application of larvicidal oils or chemical insecticides to the water where they occur or are suspected to occur. Remember, several alternatives to conventional chemical larvicides have been developed because of concerns about applying chemicals to water that might be used for drinking or that contains fish and other aquatic life.

If larval control fails, adult mosquito control may be necessary. Adult control generally is done with insecticide applications using ground equipment or aircraft. For more information visit:

www.ext.colostate.edu/westnile/mosquito_mgt.html or www.ext.colostate.edu/westnile/faq.html.

S-8 Use of Pesticides, Herbicides and Fertilizers

- Maintain a buffer zone around wells or surface water where pesticides are not applied. Consult local regulations and landscape ordinances, as well as the product label, for distances, which may vary depending on the type of chemical and the sensitivity of the waterbody. The purpose of this practice is to keep pesticides and herbicides out of surface waterbodies.

Storage Practices

- Storage areas should be secure and covered, preventing exposure to rain and unauthorized access. Commercial and municipal facilities should provide basic safety equipment such as fire extinguishers, warning signs (e.g., "no smoking"), adequate light and ventilation, and spill clean-up materials should be present. Floors and shelves should be non-porous (e.g., metal, concrete) to prevent sorption of chemicals. If possible, temperature control should be provided to avoid excessive heat or cold. Storage areas should be kept clear of combustible material and debris.
- Commercial operations handling large quantities of pesticides and fertilizers should consult the Colorado Department of Agriculture for storage and handling requirements. Commercial greenhouses and nurseries that are storing recycled water laden with fertilizer may need to provide secondary containment to contain the water in the event of a tank rupture or leak.
- Store chemicals in their original containers, tightly closed, with labels intact. Also inspect them regularly for leaks. Store nitrate-based and other oxidizing fertilizers separately from solvents, fuels, and pesticides to reduce fire risk. Follow the general principle of storing like chemicals together. Dry chemicals should be stored above liquids and on pallets to ensure that they do not get wet.
- Locate chemical storage and maintenance areas, as well as vehicle refueling and maintenance areas, away from wells and surface waterbodies in accordance with local regulations, typically at least 50 to 100 feet away.

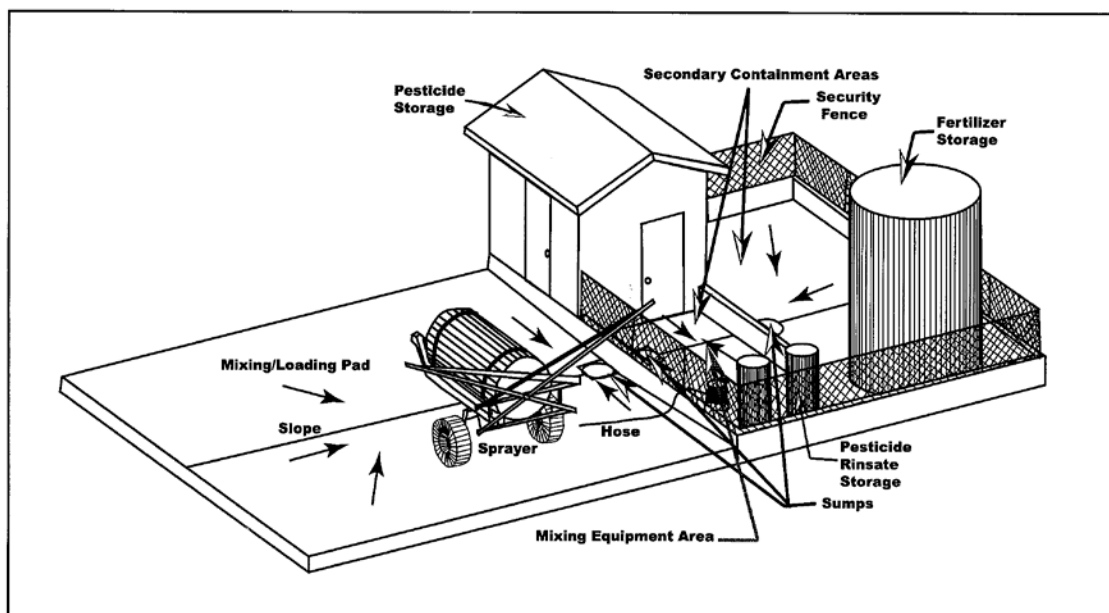

Figure PHF-1. Example Combined Pesticide and Fertilizer Storage and Mixing Area. Figure courtesy of *Designing Facilities for Pesticides and Fertilizer Containment*, Midwest Planning Service, Agricultural Engineering, Iowa State University 1991.

- Make available all Material Safety Data Sheets (MSDSs) in a readily accessible area. A list of all hazardous chemicals in the work place must be completed to ensure that all MSDSs are readily available.
- Do not store large quantities of pesticides for long periods of time. Adopt the "first in, first out" principle, using the oldest products first to ensure that the shelf life does not expire. Buy smaller quantities of pesticides and fertilizers, thereby reducing storage issues.

Spills and Disposal

- Never pour lawn and garden chemicals or rinse water down storm drains (or sanitary drains) and keep chemicals off impervious surfaces (e.g., streets, gutters) during application.
- Follow label directions for disposal. This typically involves triple-rinsing empty containers, puncturing and crushing. All visible chemicals should be cleaned from the container prior to disposal. Use local recycling or hazardous waste collection centers to dispose of unused chemicals.
- Properly manage chemical spills by cleaning them up as soon as possible, controlling actively spilling or leaking materials, containing the spilled material (e.g., with absorbents, sand), collecting the spilled material, storing or disposing of the spilled material, and following relevant spill reporting requirements. "Washing down" a spill with water is not an appropriate cleanup approach.
- Commercial operations should be aware of and comply with basic spill reporting requirements required by law, and keep chemical spill cleanup equipment, personal protective equipment and emergency phone numbers available when handling chemicals and their containers.

For More Information on Legal Requirements

Many federal and state regulations address pesticide, herbicide, and other chemical usage. These sources should be consulted for the most current legal requirements related to chemical handling, storage, application, disposal, and reporting of chemical spills. Examples include the federal Insecticide, Fungicide and Rodenticide Act (FIFRA), the Superfund Amendments and Reauthorization Act (SARA), the Emergency Planning and Community-Right-to-Know Act (EPCRA), and Occupational Safety and Health Administration (OSHA) requirements, particularly the Hazard Communication Standard. Colorado-related regulations include the Colorado Pesticide Applicator's Act, and the Colorado Water Quality Control Act (25-8-601 and 25-8-606), Senate Bill 90-126, and The Agricultural Chemicals and Groundwater Protection Act, which identifies special requirements for facilities handling more than 3,000 pounds (or 500 gallons) of bulk-formulated pesticides.

Description

Proper landscape maintenance, including maintenance of vegetated stormwater BMPs, is important to reduce nutrient and chemical loading to the storm drain system, reduce nuisance flows and standing water in stormwater BMPs, and maintain healthy vegetation that helps minimize erosion. Additionally, when landscapes and vegetated BMPs are over-irrigated, the ground remains saturated and capacity to infiltrate runoff is reduced.



Photograph LM-1. Over-irrigation and overspray can wash fertilizers and lawn chemicals into the storm drain system. These flows can combine with storm runoff and cause nuisance flow conditions in stormwater BMPs. Photo courtesy of the City of Westminster.

Appropriate Uses

Appropriate lawn care practices are applicable to residential, commercial, municipal, and some industrial operations.

Practice Guidelines¹

Practice guidelines for a healthy lawn that reduces pollution during both wet and dry weather conditions include a combination of practices such as mowing, aeration, fertilization, and irrigation. Also, see the Pesticide, Herbicide, and Fertilizer Usage BMP for information on proper use of these chemicals and Integrated Pest Management (IPM) strategies.

Lawn Mowing and Grass Clipping Waste Disposal

- Keep lawn clippings and debris out of gutters. When blowing walkways or mowing lawns, direct equipment so that the clippings blow back onto the lawn rather than into the street, or collect clippings blown onto the street and properly dispose of them.
- Mulch-mowing turfgrass at a height of 2.5 to 3 inches helps turfgrass develop deeper root systems. No more than one-third of the grass blade should be removed in a single mowing. Mulched grass clippings can return roughly 25 to 30% of the needed nitrogen that grass requires to be healthy, thereby reducing fertilizer requirements. Avoid throwing grass clippings onto streets and sidewalks to reduce nutrient pollution to surface waterbodies.
- Minimize thatch development by mowing at appropriate frequencies and heights for the grass type, avoiding overwatering, preventing over fertilization, and aerating the turf.

¹ These practice guidelines have been adapted from the *GreenCO Best Management Practices for the Conservation and Protection of Water Quality in Colorado: Moving Toward Sustainability* (GreenCO and WWE 2008). See this manual for additional detail and references.

Lawn Aeration

- Aerate turf once or twice per year, as needed, in the early spring and/or late fall to aid in capturing the natural precipitation during non-weed germination periods and prior to adding organic materials and fertilizers. Aeration reduces soil compaction and helps control thatch in lawns while helping water and fertilizer move into the root zone.
- A lawn can be aerated at any time the ground is not frozen, but should not be done when it is extremely hot and dry. Heavy traffic areas will require aeration more frequently.
- Do not use spike-type aerators, which compact the soil. Holes should be two to three inches deep and no more than two to four inches apart. Lawns should be thoroughly watered the day before aerating so plugs can be pulled more deeply and easily. Mark all sprinkler heads, shallow irrigation lines, and buried cable TV lines before aerating so those lines will not be damaged.

Fertilizer Application

- Apply fertilizer when needed to achieve a clearly defined objective such as increasing shoot growth, root growth, flowering or fruiting; enhancing foliage color, and plant appearance; or correcting or preventing nutrient deficiencies.
- Because manufactured fertilizers can be relatively high in nutrient content, it is critical to follow the manufacturer's directions, using the minimum amount recommended. Over-application "burns" leaves and may lead to water pollution, thatch buildup, excessive mowing, and weed growth.
- Only apply nutrients the plants can use. Fertilizer labels identify product contents in terms of ratios that indicate percentage of ingredients by product weight.

Phosphorus

Phosphorus is commonly overused and application should be based on soil tests. Phosphorus washing into surface waterbodies leads to excessive algae growth.

Phosphorous does not move out of the soil like nitrogen, so constant additions are unnecessary.

Soil Testing

There are several qualified laboratories in Colorado that provide soils tests to determine recommendations for fertilizer type and application rates. There are also commercially available quick test kits that are less accurate but could be used by a homeowner. Without an analysis, a homeowner may be buying unnecessary fertilizer or applying too much. A \$20 to \$40 soil analysis has potential to save an owner much more.

The CSU Extension program offers a soil testing service. Contact the CSU Extension for your county or visit <http://www.ext.colostate.edu> for more information including a list of laboratories.

- When practical and appropriate, base fertilizer application on soil analysis. Be aware that at many new development sites, soil conditions following grading often no longer consist of topsoil. "Basement" soils with poor texture and low nutrient content may be present. As a result, soil amendment is often needed to improve the physical properties (tilth) of the soil to provide a better environment for plant roots to improve nutrient uptake. Soil analysis can help to identify soil amendments that improve both the physical and nutrient characteristics of the soil, as well as identify fertilization requirements.
- Utilize split applications of slow-release (controlled-release) fertilizer forms such as IBDU, sulfur-coated urea and natural organic-based fertilizers (not to be confused with raw manure) to minimize the risk of nutrients leaching into groundwater or running off in surface water. When properly applied, other forms of fertilizer can also be safely used, provided that over-watering and over-fertilization do not occur.
- When applying fertilizer, broadcast it uniformly over the targeted area of the landscape. Keep fertilizer off streets, sidewalks, and driveways to prevent water pollution. Fertilizer that inadvertently falls on impervious surfaces should be swept back onto the lawn.
- Recommendations for fertilizer application vary among industry professionals. CSU Extension's fertilizer recommendations for established Colorado lawns are provided in the table below. Site-specific conditions should also be considered when determining the need for fertilizer.

Table LM-1. CSU Extension Recommendations for Nitrogen Application Rate

Turfgrass Species	Nitrogen Application Rate in Pounds/1,000 sq. ft.				
	Mid-March to April ^{A,B}	May to Mid-June ^B	July to Early August ^B	Mid-August to Mid-September ^{B,C}	Early October to Early November ^{B,D}
High Maintenance Bluegrass Ryegrass	0.5-1	1	Not Required	1	1-2 (optional)
Low Maintenance Bluegrass	0.5	0.5-1	Not Required	1	1 (optional)
Tall Fescue	0.5	0.5-1	Not Required	1	1 (optional)
Fine Fescue	0.5	0.5-1	Not Required	0.5-1	None
Buffalo grass, Blue Grama, Bermuda grass	None	0.5-1	0.5-1	None	None

Notes:

^A The March-April nitrogen application may not be needed if prior fall fertilization was completed. If spring green-up and growth is satisfactory, delay fertilizing to May or June.

^B Application rates may be reduced by 1/4 to 1/3 when grass clippings are left on the lawn.

^C On very sandy soils do not fertilize turf after late September to prevent nitrogen from leaching into groundwater during the winter months.

^D Apply when the grass is still green and at least 2-3 weeks prior to the ground freezing. Optional nitrogen applications are indicated for use where higher quality or heavily-used turf is present.

Source: T. Koski and V. Skinner, CSU Extension, 2003.

- If possible, properly irrigate turf following fertilization to help grass utilize applied nutrients and to minimize the potential for fertilizer burn. Care should be taken to avoid excessive irrigation that would result in fertilizer being washed away. Similarly, avoid application of fertilizer immediately prior to heavy rainfall.
- Fall is the best time of year to fertilize bluegrass lawns. Over-application of nitrogen fertilizer in April may cause grass to grow too fast before roots can support the growth, resulting in less heat tolerance.
- Generally, the Colorado Nursery and Greenhouse Association recommends waiting until the second growing season to fertilize ornamental (woody) plants. Commercial fertilizer should not be used in the backfill where it comes in direct contact with the roots.
- Maintain a buffer zone around wells or surface waterbodies where fertilizers are not applied to minimize pollution. Consult the fertilizer product label and local regulations and landscape ordinances for appropriate distances. Research in this area is limited; however, CSU Extension recommends a buffer of 6 to 10 feet for mowed turf areas.
- In areas with sandy soils, it is particularly important to avoid over-application of fertilizer that could leach into groundwater. These areas may be particularly well suited to slow-release fertilizer forms and conservative application rates.

Lawn Irrigation

- The approximate amount of water that needs to be applied **each week** for an average, traditional lawn to supplement normal rainfall is listed in Table 2. (Water utilities may provide additional guidance in terms of suggested run-times for various sprinkler types; <http://www.denverwater.org/Conservation/>.)

Table LM-2. General Guideline for Approximate Supplemental Water for an Average Traditional Lawn (inches per week)

Condition ³	April ¹	May	June	July	Aug	Sept	Oct ²
Non-Drought Conditions	1/4"	1"	1½"	1½"	1¼"	1"	1/2"
During Drought Restrictions (approx. 20% reduction)	1/4"	3/4"	1¼"	1¼"	1"	3/4"	1/2"

¹ For established lawns, water may not be required during April. Base decision on weather conditions.

² For established lawns, water is typically not required after Oct 15.

³ Under less-than-average rainfall conditions, the amounts shown in the chart should be increased. If there is greater-than-normal rainfall, then the amount of supplemental water should be reduced.

- Consult with the CSU Extension Turfgrass program for recommendations for irrigating turfgrasses with lower water requirements (e.g. blue grama, buffalo grass). For native grasses, irrigation may be unnecessary or limited to certain conditions.
- Irrigate the lawn uniformly until the soil is moist to a depth of 4 to 6 inches to encourage deep roots. Frequent, light sprinklings moisten only the surface and may cause shallow-rooted turf and increase weed seed germination. Properly maintain the irrigation system to ensure that the irrigation is being applied at appropriate rates and to the turfgrass, not the sidewalk.

- Maintain irrigation systems in good operating condition with uniform distribution of water. "Smart" irrigation controllers and weather sensors can reduce water waste by shutting off irrigation during storm events and helping owners water according to the needs of the plants to replace water lost to evapotranspiration (ET).
- Proper irrigation can minimize the amount of fertilizer and other chemicals that are leached below the root zone of the grass or washed away by runoff.

Description

For obvious safety reasons, snow removal in Colorado is important; however, snow removal and management practices can adversely impact vegetation, soils, water quality, and air quality. Snow removal contractors and operators should be knowledgeable of these potential impacts and choose management measures with the fewest adverse impacts, while still protecting the public safety, health and welfare.



Photograph SIM-1. Snow storage locations should be clearly communicated to snow removal contractors and located where they can drain to stormwater BMPs or landscaped areas. Photo courtesy of WWE.

Appropriate Uses

Snow and ice management procedures are relevant for homeowners, contractors, business owners, and transportation departments.

Practice Guidelines¹

- Physical removal of snow and ice by shovels, snowplows, or snow blowers usually has the least water quality and landscape impacts, provided that storage areas are not piled directly on landscape plants or drained directly to receiving waters. Plan for snow storage locations that minimize water quality and landscape impacts prior to winter.
- Ensure that equipment is calibrated to optimum levels according to manufacturer's instructions.
- Consider placing barriers in targeted site-specific locations (i.e., along streams or direct drainages) to route deicing material away from waterbodies.
- Reduce plowing speed in sensitive areas to prevent exposure to deicing material.
- Designate snow storage areas in locations that enable runoff to be directed to stormwater BMPs for treatment, when practicable.
- The use of deicing chemicals can have a severe impact on plants growing near roads and sidewalks. This can become a water quality issue when plants die and erosion results. Many deicing chemicals are salts and can adversely affect plants through either direct contact with foliage or through buildup in the soil over time. Representative impacts include:

¹These practice guidelines have been adapted from the *GreenCO Best Management Practices for the Conservation and Protection of Water Quality in Colorado: Moving Toward Sustainability* (GreenCO and WWE 2008). See this manual for additional detail and references.

- Direct contact often occurs when the deicing chemicals accumulate on the plants due to drift during application, or when snow or ice containing the chemical is shoveled or blown onto nearby plants. Because these chemicals are salts, direct contact with the foliage may result in burning due to a rapid dehydration effect.
- Buildup of de-icing chemicals in the soil may have even more detrimental effects. Repeated application over time (either during a particular winter season or over many seasons) may damage plants by making their roots unable to take up water. Symptoms will include wilting even when the soil is moist, leaf burn or needle tip burn, stunting or lack of vigor, and/or deficiency symptoms for one or more plant nutrients. The structure of clay soils can be changed to the point that they are unable to support plant life.
- Deicing chemicals that are considered safer to use around plants include calcium magnesium acetate (CMA) or calcium chloride. As with all chemicals used in the landscape, be sure to read and follow label instructions and do not over apply.
- The Colorado Department of Transportation (CDOT) has conducted multiple studies on deicing chemicals. The SeaCrest Group (2001) studied three groups of deicers for CDOT that were chloride-based, acetate-based, and sanding materials. The chloride-based deicers included magnesium chloride (FreezGard Zero® with Shield LS®, Ice-Stop™ CI, Caliber™ M1000, Ice Ban™ M50), calcium chloride (Liquidow®, Armor®), and sodium chloride (road salt and Ice Slicer®). The acetate-based deicers include Calcium Magnesium Acetate (CMA®), Potassium Acetate (CF7®), Sodium Acetate (NAAC®), and CMAK™ (a mixture of CMA and Potassium Acetate). Table 1 contains a partial summary of the study findings.
- Highlights of the SeaCrest (2001) study regarding impacts associated with the three categories include:
 - The chloride-based deicers have been shown to have adverse effects on terrestrial vegetation. Damage to vegetation from deicing salts has been reported to a distance of 100-650 feet. However, there is a wide range of tolerance of different species of plants to the effects of chlorides. The chloride ions in deicers increase the salinity of the soil near the roadways where they are applied. The magnesium and calcium ions increase the stability and permeability of the soil, whereas sodium ions decrease soil stability and permeability.
 - The acetate-based deicers are organic and have different kinds of effects on the environment than the chloride-based deicers. The acetate ions are broken down by soil microorganisms and may result in oxygen depletion of the soil, which can impact vegetation; however, the acetate deicers CMA and Potassium Acetate (CMAK) are not harmful to terrestrial vegetation at the concentrations typically used on roadways. However, NAAC may potentially have an adverse effect on vegetation because of the presence of the sodium ion, which decreases the stability and permeability of the soil. The depletion of oxygen in the soil from the breakdown of the acetate ion can have a negative effect on plant growth, but field evidence of this effect is limited.
 - Sand is not a deicer, but is used for snow and ice control because it improves traction. Sand has a negative effect on water quality as a result of the increased turbidity caused by the presence of sand particles in water. Excessive quantities of sand can smother vegetation.

Table SIM-1. Potential Environmental Impacts of Various Deicers
(Source: The SeaCrest Group 2001)²

Deicer/ Parameter	Inhibited Magnesium Chloride (Liquid)	Caliber + Magnesium Chloride (Liquid)	Ice Ban + Magnesium Chloride (Liquid)	Sodium Chloride/ Ice Slider (Solid)	Inhibited Calcium Chloride (Liquid)	CMA (Solid/ Liquid)	CMAK (Liquid)	Potassium Acetate (Liquid)	NAAC (Solid)	Sand
Chemicals	Trace metals	Trace metals, phosphorus, ammonia	Trace metals, phosphorus, ammonia, nitrates	Trace metals	Trace metals, ammonia, nitrates.	Trace metals	Trace metals, ammonia, nitrates.	Trace metals	Trace metals, phosphorus	Trace metals
Soil	Improves structure, increases salinity	Improves structure, increases salinity, oxygen depletion	Improves structure, increases salinity, oxygen depletion	Increases salinity; decreases stability	Improves structure, increases salinity	Improves structure; oxygen depletion	Improves structure; oxygen depletion	Improves structure; oxygen depletion	Decreases stability; oxygen depletion	Minimal effects
Water Quality	Increases salinity	Increases salinity; oxygen depletion	Increases salinity; oxygen depletion	Increases salinity	Increases salinity		Oxygen depletion	Oxygen depletion	Oxygen depletion	Increases turbidity
Air Quality	Minimal air pollution	Minimal air pollution	Minimal air pollution	Some air pollution	Minimal air pollution	Minimal air pollution	Minimal air pollution	Minimal air pollution	Some air pollution	High air pollution potential
Aquatic Organisms	Relatively low toxicity	Relatively low toxicity	Moderate toxicity	Relatively low toxicity	Relatively low toxicity	Relatively low toxicity	Moderate toxicity	Moderate toxicity	Relatively low toxicity	Can cover benthic organisms and cause mortality
Terrestrial Vegetation	Chlorides damage vegetation	Chlorides damage vegetation	Chlorides damage vegetation	Chlorides damage vegetation	Chlorides damage vegetation	Minimal damage to vegetation	Minimal damage to vegetation	Minimal damage to vegetation	Effects to vegetation not determined	Can cover vegetation and cause mortality
Terrestrial Animals	Does not attract wildlife	Does not attract wildlife	Does not attract wildlife	Attracts wildlife contributing to road kills	Does not attract wildlife	Not expected to attract wildlife	Not expected to attract wildlife	Not expected to attract wildlife	May attract wildlife contributing to roadkills	May cover burrows of small animals and cause mortality

Note: Trace metals that may be present include arsenic, barium, cadmium, chromium, copper, lead, mercury, selenium, and zinc. Soil comments related to structure refer to the affect on soil stability, which relates to erosion. See <http://www.coloradodot.info/programs/research/pdfs/2001/deicers.pdf/view> for more information.

- Where practicable, do not use deicers to melt snow or ice completely, but to make their removal easier. Deicers melt down through the ice or snow to the hard surface, then spread out underneath. This undercuts and loosens the snow so shoveling and plowing can be done. For this reason, it is helpful to apply deicers prior to snow events in some cases.
- Research has shown that the shape of deicing particles affects the speed of their penetration through ice. Uniformly shaped spherical pellets of about 1/16 inch to 3/16 inch penetrate ice faster and more efficiently than other shapes.
- Try to avoid the use of rock salt since it is generally most damaging to plants, soils and concrete and metal surfaces. In areas where deicing salts are unavoidable, select plants with higher salt tolerances.

² The SeaCrest Group, 2001. *Evaluation of Selected Deicers Based on a Review of the Literature*, Report No. CDOT-DTD-2001-15. Prepared for Colorado Department of Transportation Research Branch.

- Do not plow snow directly into streams or wetlands. Snow storage and disposal areas should be located in an area where snowmelt can infiltrate into the ground, filter through a vegetated buffer or be otherwise treated prior to reaching streams and wetlands. Provide adequate storage volume to trap sediment left behind by melting snow and plan regular maintenance to remove accumulated sediment.
- In areas subject to heavy chemical deicing use, flushing the soil with water after the last freeze may alleviate burn potential. Year-round proper plant care will also make plants more tolerant to salt exposure. However, for the overall health of the landscape, the goal should be to reduce or minimize the use of deicing chemicals where they are not necessary for safety reasons.
- If an electric/mechanical snow melting device is used to dispose of removed snow (e.g., The Can snow melter, Snow Dragon, etc.), the owner or operator must obtain the appropriate permit prior to discharge. Snowmelt from melting machines is typically considered process wastewater.

Description

Street sweeping uses mechanical pavement cleaning practices to reduce sediment, litter and other debris washed into storm sewers by runoff. This can reduce pollutant loading to receiving waters and in some cases reduce clogging of storm sewers and prolong the life of infiltration oriented BMPs and reduce clogging of outlet structures in detention BMPs.

Different designs are available with typical sweepers categorized as a broom and conveyor belt sweeper, wet or dry vacuum-assisted sweepers, and regenerative-air sweepers. The effectiveness of street sweeping is dependent upon particle loadings in the area being swept, street texture, moisture conditions, parked car management, equipment operating conditions and frequency of cleaning (Pitt et al. 2004).



Photograph SSC-1. Monthly street sweeping from April through November removed nearly 40,690 cubic yards of sediment/debris from Denver streets in 2009. Photo courtesy of Denver Public Works.

Appropriate Uses

Street sweeping is an appropriate technique in urban areas where sediment and litter accumulation on streets is of concern for aesthetic, sanitary, water quality, and air quality reasons. From a pollutant loading perspective, street cleaning equipment can be most effective in areas where the surface to be cleaned is the major source of contaminants. These areas include freeways, large commercial parking lots, and paved storage areas (Pitt et al. 2004). Where significant sediment accumulation occurs on pervious surfaces tributary to infiltration BMPs, street sweeping may help to reduce clogging of infiltration media. In areas where construction activity is occurring, street sweeping should occur as part of construction site stormwater management plans. Vacuuming of permeable pavement systems is also considered a basic routine maintenance practice to maintain the BMP in effective operating condition. See the maintenance chapter for more information on permeable pavement systems. Not all sweepers are appropriate for this application.

Practice Guidelines¹

1. Post street sweeping schedules with signs and on local government websites so that cars are not parked on the street during designated sweeping days.
2. Sweeping frequency is dependent on local government budget, staffing, and equipment availability, but monthly sweeping during non-winter months is a common approach in the metro Denver urban

¹ Practice guidelines adapted from CASQA (2003) *California Stormwater BMP Handbook*, Practice SC-70 Road and Street Maintenance.

area. Consider increasing sweeping frequency based on factors such as traffic volume, land use, field observations of sediment and trash accumulation, proximity to watercourses, etc. For example:

- Increase the sweeping frequency for streets with high pollutant loadings, especially in high traffic and industrial areas.
 - Conduct street sweeping prior to wetter seasons to remove accumulated sediments.
 - Increase the sweeping frequency for streets in special problem areas such as special events, high litter or erosion zones.
3. Perform street cleaning during dry weather if possible.
 4. Avoid wet cleaning the street; instead, utilize dry methods where possible.
 5. Maintain cleaning equipment in good working condition and purchase replacement equipment as needed. Old sweepers should be replaced with more technologically advanced sweepers (preferably regenerative air sweepers) that maximize pollutant removal.
 6. Operate sweepers at manufacturer recommended optimal speed levels to increase effectiveness.
 7. Regularly inspect vehicles and equipment for leaks and repair promptly.
 8. Keep accurate logs of the number of curb-miles swept and the amount of waste collected.
 9. Dispose of street sweeping debris and dirt at a landfill.
 10. Do not store swept material along the side of the street or near a storm drain inlet.

Changes in Street Sweeper Technology (Source: Center for Watershed Protection 2002)

At one time, street sweepers were thought to have great potential to remove stormwater pollutants from urban street surfaces and were widely touted as a stormwater treatment practice in many communities. Street sweeping gradually fell out of favor, largely as a result of performance monitoring conducted as part of the National Urban Runoff Program (NURP). These studies generally concluded that street sweepers were not very effective in reducing pollutant loads (USEPA, 1983). The primary reason for the mediocre performance was that mechanical sweepers of that era were unable to pick up fine-grained sediment particles that carry a substantial portion of the stormwater pollutant load. In addition, the performance of sweepers is constrained by that portion of a street's stormwater pollutant load delivered from outside street pavements (e.g., pollutants that wash onto the street from adjacent areas or are directly deposited on the street by rainfall). Street sweeping technology, however, has evolved considerably since the days of the NURP testing. Today, communities have a choice in three basic sweeping technologies to clean their urban streets: traditional mechanical sweepers that utilize a broom and conveyor belt, vacuum-assisted sweepers, and regenerative-air sweepers (those that blast air onto the pavement to loosen sediment particles and vacuum them into a hopper).

For more information, see

http://www.cwp.org/Resource_Library/Center_Docs/PWP/ELC_PWP121.pdf

Description¹

Periodic storm sewer system cleaning can help to remove accumulated sediment, trash, and other substances from various components of the storm sewer system including inlets, pipes and stormwater BMPs. Some common pollutants found in storm drains include: trash and debris, sediments, oil and grease, antifreeze, paints, cleaners and solvents, pesticides, fertilizers, animal waste, and detergents. Routine cleaning reduces the amount of pollutants, trash, and debris both in the storm drain system and in receiving waters. Clogged drains and storm drain inlets can cause the drains to overflow, leading to increased erosion (Livingston et al. 1997).

Cleaning increases dissolved oxygen, reduces levels of bacteria, and supports in-stream habitat. Areas with relatively flat grades or low flows should be given special attention because they rarely achieve high enough flows to flush themselves (Ferguson et al. 1997).



Photograph SSC-1. Storm drain cleaning may help to remove pollutant sources and helps to maintain the capacity of the storm pipes.

Appropriate Uses

Storm sewer system cleaning is typically conducted by local governments or state agencies; however, homeowners associations, businesses and industries are usually responsible for maintaining system components on their sites.

Due to the cost and time involved with storm sewer system cleaning, communities may target recurrent problem areas or use another type of prioritization system for maintenance. Also see the BMP Maintenance chapter for BMP-specific maintenance requirements.

Practice Guidelines

A variety of jet/vacuum vehicles can be used to remove debris from stormwater catch basins and pipes. This equipment breaks up clogged/accumulated material with high-pressure water jets and vacuums the material from the sewer. Water used in storm drain cleaning must be collected and properly disposed of, typically at a sanitary wastewater treatment facility.

Simpler methods in localized areas can also include manual trash collection and shoveling from inlets and outlets.

¹ Guidelines adapted from Center for Watershed Protection (2009) *Urban Stormwater Restoration Manual Series 8: Municipal Practices and Programs*.

Frequency and prioritization of storm sewer cleaning is affected by multiple factors such as the activity and intensity of use in the tributary area (e.g., parking lot, stadium), storm sewer system design, municipal budgets (staff and equipment), and other factors.

To be most effective, storm sewer cleaning needs an effective recordkeeping system and clearly defined procedures. CWP (2009) recommends the following practices:

- **Tracking:** The location and maintenance of storm drains should be tracked using a database and spatial referencing system (e.g., Global Positioning System or Geographic Information System). Additionally, knowing the type and era of the storm drain system may be of use since some inlets/catch basins are designed to be self-cleaning while others have some trapping capacity.
- **Frequency:** Should be defined such that blockage of storm sewer outlet is prevented and it is recommended that the sump should not exceed 40- 50 percent of its capacity. Semi-annual cleanouts in residential streets and monthly cleanouts for industrial streets are suggested by Pitt and Bissonnett (1984) and Mineart and Singh (1994). More frequent cleanouts should be scheduled in the fall as leaves can contribute 25% of nutrient loadings in catch basins.
- **Technology:** A variety of methods of cleaning catch basins are available, including manual cleaning, eductor vehicles, vacuum cleaning and vacuum combination jet cleaning. Choose the approach that is most effective for site conditions, taking into consideration budget, equipment, and staffing constraints.
- **Staff training:** Operators need to be properly trained in catch basin maintenance including waste collection and disposal methods. Staff should also be trained to report water quality problems and illicit discharges.
- **Material disposal:** Most catch basin waste is of acceptable quality for landfills. If it is suspected that catch basin waste contains hazardous material, it should be tested and disposed of accordingly. Maintenance personnel should keep a log of the amount of sediment collected and the removal date at the catch basin.

SITE EROSION AND SEDIMENT CONTROL PLAN

STANDARD NOTES FOR EL PASO COUNTY GRADING AND EROSION CONTROL PLANS

1. STORMWATER DISCHARGES FROM CONSTRUCTION SITES SHALL NOT CAUSE OR THREATEN TO CAUSE POLLUTION, CONTAMINATION, OR DEGRADATION OF STATE WATERS. ALL WORK AND EARTH DISTURBANCE SHALL BE DONE IN A MANNER THAT MINIMIZES POLLUTION OF ANY ON-SITE OR OFF-SITE WATERS, INCLUDING WETLANDS.
2. NOTWITHSTANDING ANYTHING DEPICTED IN THESE PLANS IN WORDS OR GRAPHIC REPRESENTATION, ALL DESIGN AND CONSTRUCTION RELATED TO ROADS, STORM DRAINAGE AND EROSION CONTROL SHALL CONFORM TO THE STANDARDS AND REQUIREMENTS OF THE MOST RECENT VERSION OF THE RELEVANT ADOPTED EL PASO COUNTY STANDARDS, INCLUDING THE LAND DEVELOPMENT CODE, THE ENGINEERING CRITERIA MANUAL, THE DRAINAGE CRITERIA MANUAL, AND THE DRAINAGE CRITERIA MANUAL VOLUME 2. ANY DEVIATIONS FROM REGULATIONS AND STANDARDS MUST BE REQUESTED, AND APPROVED, IN WRITING.
3. A SEPARATE STORMWATER MANAGEMENT PLAN (SMMP) FOR THIS PROJECT SHALL BE COMPLETED AND AN EROSION AND STORMWATER QUALITY CONTROL PERMIT (ESQCP) ISSUED PRIOR TO COMMENCING CONSTRUCTION. MANAGEMENT OF THE SWMP DURING CONSTRUCTION IS THE RESPONSIBILITY OF THE DESIGNATED QUALIFIED STORMWATER MANAGER OR CERTIFIED EROSION CONTROL INSPECTOR. THE SWMP SHALL BE LOCATED ON SITE AT ALL TIMES DURING CONSTRUCTION AND SHALL BE KEPT UP TO DATE WITH WORK PROGRESS AND CHANGES IN THE FIELD.
4. ONCE THE ESQCP IS APPROVED AND A "NOTICE TO PROCEED" HAS BEEN ISSUED, THE CONTRACTOR MAY INSTALL THE INITIAL STAGE EROSION AND SEDIMENT CONTROL MEASURES AS INDICATED ON THE APPROVED GEC. A PRECONSTRUCTION MEETING BETWEEN THE CONTRACTOR, ENGINEER, AND EL PASO COUNTY WILL BE HELD PRIOR TO ANY CONSTRUCTION. IT IS THE RESPONSIBILITY OF THE APPLICANT TO COORDINATE THE MEETING TIME AND PLACE WITH COUNTY STAFF.
5. CONTROL MEASURES MUST BE INSTALLED PRIOR TO COMMENCEMENT OF ACTIVITIES THAT COULD CONTRIBUTE POLLUTANTS TO STORMWATER. CONTROL MEASURES FOR ALL SLOPES, CHANNELS, DITCHES, AND DISTURBED LAND AREAS SHALL BE INSTALLED IMMEDIATELY UPON COMPLETION OF THE DISTURBANCE.
6. ALL TEMPORARY SEDIMENT AND EROSION CONTROL MEASURES SHALL BE MAINTAINED AND REMAIN IN EFFECTIVE OPERATING CONDITION UNTIL PERMANENT SOIL EROSION CONTROL MEASURES ARE IMPLEMENTED AND FINAL STABILIZATION IS ESTABLISHED. ALL PERSONS ENGAGED IN LAND DISTURBANCE ACTIVITIES SHALL ASSESS THE ADEQUACY OF CONTROL MEASURES AT THE SITE AND IDENTIFY IF CHANGES TO THOSE CONTROL MEASURES ARE NEEDED TO ENSURE THE CONTINUED EFFECTIVE PERFORMANCE OF THE CONTROL MEASURES. ALL CHANGES TO TEMPORARY SEDIMENT AND EROSION CONTROL MEASURES MUST BE INCORPORATED INTO THE STORMWATER MANAGEMENT PLAN.
7. TEMPORARY STABILIZATION SHALL BE IMPLEMENTED ON DISTURBED AREAS AND STOCKPILES WHERE GROUND DISTURBING CONSTRUCTION ACTIVITY HAS PERMANENTLY CEASED OR TEMPORARILY CEASED FOR LONGER THAN 14 DAYS.
8. FINAL STABILIZATION MUST BE IMPLEMENTED AT ALL APPLICABLE CONSTRUCTION SITES. FINAL STABILIZATION IS ACHIEVED WHEN ALL GROUND DISTURBING ACTIVITIES ARE COMPLETE AND ALL DISTURBED AREAS EITHER HAVE A UNIFORM VEGETATIVE COVER WITH INDIVIDUAL PLANT DENSITY OF 70 PERCENT OF PRE-DISTURBANCE LEVELS ESTABLISHED OR EQUIVALENT PERMANENT ALTERNATIVE STABILIZATION METHOD IS IMPLEMENTED. ALL TEMPORARY SEDIMENT AND EROSION CONTROL MEASURES SHALL BE REMOVED UPON FINAL STABILIZATION AND BEFORE PERMIT CLOSURE.
9. ALL PERMANENT STORMWATER MANAGEMENT FACILITIES SHALL BE INSTALLED AS DESIGNED IN THE APPROVED PLANS. ANY PROPOSED CHANGES THAT EFFECT THE DESIGN OR FUNCTION OF PERMANENT STORMWATER MANAGEMENT STRUCTURES MUST BE APPROVED BY THE ECM ADMINISTRATOR PRIOR TO IMPLEMENTATION.
10. EARTH DISTURBANCES SHALL BE CONDUCTED IN SUCH A MANNER SO AS TO EFFECTIVELY MINIMIZE ACCELERATED SOIL EROSION AND RESULTING SEDIMENTATION. ALL DISTURBANCES SHALL BE DESIGNED, CONSTRUCTED, AND COMPLETED SO THAT THE EXPOSED AREA OF ANY DISTURBED LAND SHALL BE LIMITED TO THE SHORTEST PRACTICAL PERIOD OF TIME. PRE-EXISTING VEGETATION SHALL BE PROTECTED AND MAINTAINED WITHIN 50 HORIZONTAL FEET OF A WATERS OF THE STATE UNLESS SHOWN TO BE INFEASIBLE AND SPECIFICALLY REQUESTED AND APPROVED.
11. COMPACTION OF SOIL MUST BE PREVENTED IN AREAS DESIGNATED FOR INFILTRATION CONTROL MEASURES OR WHERE FINAL STABILIZATION WILL BE ACHIEVED BY VEGETATIVE COVER. AREAS DESIGNATED FOR INFILTRATION CONTROL MEASURES SHALL ALSO BE PROTECTED FROM SEDIMENTATION DURING CONSTRUCTION UNTIL FINAL STABILIZATION IS ACHIEVED. IF COMPACTION PREVENTION IS NOT FEASIBLE DUE TO SITE CONSTRAINTS, ALL AREAS DESIGNATED FOR INFILTRATION AND VEGETATION CONTROL MEASURES MUST BE LOOSENED PRIOR TO INSTALLATION OF THE CONTROL MEASURE(S).
12. ANY TEMPORARY OR PERMANENT FACILITY DESIGNED AND CONSTRUCTED FOR THE CONVEYANCE OF STORMWATER AROUND, THROUGH, OR FROM THE EARTH DISTURBANCE AREA SHALL BE A STABILIZED CONVEYANCE DESIGNED TO MINIMIZE EROSION AND THE DISCHARGE OF SEDIMENT OFF SITE.
13. CONCRETE WASH WATER SHALL BE CONTAINED AND DISPOSED OF IN ACCORDANCE WITH THE SWMP. NO WASH WATER SHALL BE DISCHARGED TO OR ALLOWED TO ENTER STATE WATERS, INCLUDING ANY SURFACE OR SUBSURFACE STORM DRAINAGE SYSTEM OR FACILITIES. CONCRETE WASHOUTS SHALL NOT BE LOCATED IN AN AREA WHERE SHALLOW GROUNDWATER MAY BE PRESENT, OR WITHIN 50 FEET OF A SURFACE WATER BODY, CREEK OR STREAM.
14. DURING DEWATERING OPERATIONS OF UNCONTAMINATED GROUND WATER MAY BE DISCHARGED ON SITE, BUT SHALL NOT LEAVE THE SITE IN THE FORM OF SURFACE RUNOFF UNLESS AN APPROVED STATE DEWATERING PERMIT IS IN PLACE.

15. EROSION CONTROL BLANKETING OR OTHER PROTECTIVE COVERING SHALL BE USED ON SLOPES STEEPER THAN 3:1.
16. CONTRACTOR SHALL BE RESPONSIBLE FOR THE REMOVAL OF ALL WASTES FROM THE CONSTRUCTION SITE FOR DISPOSAL IN ACCORDANCE WITH LOCAL AND STATE REGULATORY REQUIREMENTS. NO CONSTRUCTION DEBRIS, TREE SLASH, BUILDING MATERIAL WASTES OR UNUSED BUILDING MATERIALS SHALL BE BURIED, DUMPED, OR DISCHARGED AT THE SITE.
17. WASTE MATERIALS SHALL NOT BE TEMPORARILY PLACED OR STORED IN THE STREET, ALLEY, OR OTHER PUBLIC WAY, UNLESS IN ACCORDANCE WITH AN APPROVED TRAFFIC CONTROL PLAN. CONTROL MEASURES MAY BE REQUIRED BY EL PASO COUNTY ENGINEERING IF DEEMED NECESSARY, BASED ON SPECIFIC CONDITIONS AND CIRCUMSTANCES.
18. TRACKING OF SOILS AND CONSTRUCTION DEBRIS OFF-SITE SHALL BE MINIMIZED. MATERIALS TRACKED OFF-SITE SHALL BE CLEANED UP AND PROPERLY DISPOSED OF IMMEDIATELY.
19. THE OWNER/DEVELOPER SHALL BE RESPONSIBLE FOR THE REMOVAL OF ALL CONSTRUCTION DEBRIS, DIRT, TRASH, ROCK, SEDIMENT, SOIL, AND SAND THAT MAY ACCUMULATE IN ROADS, STORM DRAINS AND OTHER DRAINAGE CONVEYANCE SYSTEMS AND STORMWATER APPURTENANCES AS A RESULT OF SITE DEVELOPMENT.
20. THE QUANTITY OF MATERIALS STORED ON THE PROJECT SITE SHALL BE LIMITED, AS MUCH AS PRACTICAL, TO THAT QUANTITY REQUIRED TO PERFORM THE WORK IN AN ORDERLY SEQUENCE. ALL MATERIALS STORED ON-SITE SHALL BE STORED IN A NEAT, ORDERLY MANNER, IN THEIR ORIGINAL CONTAINERS, WITH ORIGINAL MANUFACTURER'S LABELS.
21. NO CHEMICAL(S) HAVING THE POTENTIAL TO BE RELEASED IN STORMWATER ARE TO BE STORED OR USED ONSITE UNLESS PERMISSION FOR THE USE OF SUCH CHEMICAL(S) IS GRANTED IN WRITING BY THE ECM ADMINISTRATOR. IN GRANTING APPROVAL FOR THE USE OF SUCH CHEMICAL(S), SPECIAL CONDITIONS AND MONITORING MAY BE REQUIRED.
22. BULK STORAGE OF ALLOWED PETROLEUM PRODUCTS OR OTHER ALLOWED LIQUID CHEMICALS IN EXCESS OF 55 GALLONS SHALL REQUIRE ADEQUATE SECONDARY CONTAINMENT PROTECTION TO CONTAIN ALL SPILLS ONSITE AND TO PREVENT ANY SPILLED MATERIALS FROM ENTERING STATE WATERS, ANY SURFACE OR SUBSURFACE STORM DRAINAGE SYSTEM OR OTHER FACILITIES.
23. NO PERSON SHALL CAUSE THE IMPEDIMENT OF STORMWATER FLOW IN THE CURB AND GUTTER OR DITCH EXCEPT WITH APPROVED SEDIMENT CONTROL MEASURES.
24. OWNER/DEVELOPER AND THEIR AGENTS SHALL COMPLY WITH THE "COLORADO WATER QUALITY CONTROL ACT" (TITLE 25, ARTICLE 8, CRS), AND THE "CLEAN WATER ACT" (33 USC 1344), IN ADDITION TO THE REQUIREMENTS OF THE LAND DEVELOPMENT CODE, DCM VOLUME II AND THE ECM APPENDIX I. ALL APPROPRIATE PERMITS MUST BE OBTAINED BY THE CONTRACTOR PRIOR TO CONSTRUCTION (1041, NPDES, FLOODPLAIN, 404, FUGITIVE DUST, ETC.). IN THE EVENT OF CONFLICTS BETWEEN THESE REQUIREMENTS AND OTHER LAWS, RULES, OR REGULATIONS OF OTHER FEDERAL, STATE, LOCAL, OR COUNTY AGENCIES, THE MOST RESTRICTIVE LAWS, RULES, OR REGULATIONS SHALL APPLY.
25. ALL CONSTRUCTION TRAFFIC MUST ENTER/EXIT THE SITE ONLY AT APPROVED CONSTRUCTION ACCESS POINTS.
26. PRIOR TO CONSTRUCTION THE PERMITTEE SHALL VERIFY THE LOCATION OF EXISTING UTILITIES.
27. A WATER SOURCE SHALL BE AVAILABLE ON SITE DURING EARTHWORK OPERATIONS AND SHALL BE UTILIZED AS REQUIRED TO MINIMIZE DUST FROM EARTHWORK EQUIPMENT AND WIND.
28. THE SOILS REPORT FOR THIS SITE HAS BEEN PREPARED BY TERRACON AND SHALL BE CONSIDERED A PART OF THESE PLANS.
29. AT LEAST TEN (10) DAYS PRIOR TO THE ANTICIPATED START OF CONSTRUCTION, FOR PROJECTS THAT WILL DISTURB ONE (1) ACRE OR MORE, THE OWNER OR OPERATOR OF CONSTRUCTION ACTIVITY SHALL SUBMIT A PERMIT APPLICATION FOR STORMWATER DISCHARGE TO THE COLORADO DEPARTMENT OF PUBLIC HEALTH AND ENVIRONMENT, WATER QUALITY DIVISION. THE APPLICATION CONTAINS CERTIFICATION OF COMPLETION OF A STORMWATER MANAGEMENT PLAN (SWMP), OF WHICH THIS GRADING AND EROSION CONTROL PLAN MAY BE A PART. FOR INFORMATION OR APPLICATION MATERIALS CONTACT:

COLORADO DEPARTMENT OF PUBLIC HEALTH AND ENVIRONMENT
 WATER QUALITY CONTROL DIVISION
 WOOD - PERMITS
 4300 CHERRY CREEK DRIVE SOUTH
 DENVER, CO 80246-1530
 ATTN: PERMITS UNIT

PREPARED UNDER THE SUPERVISION OF TAIT & ASSOCIATES, INC.

TAIT
Since 1984

6163 East County Road 16
Loveland, CO 80537
p: 970.613.1447 f: 970.613.1897
www.tait.com

Los Angeles Boise Sacramento
Denver Dallas Rancho Cucamonga

ALEX.HOME, PE 41703

CRAIG A. SCHNEIDER, AIA
ARCHITECT

1736 East Sunshine, Suite 417
Springfield, Missouri 65804

417.862.0558
Fax: 417.862.3265
e-mail: architect@esterfyschneider.com

PROJECT:
NEW O'REILLY AUTO PARTS STORE
N. MARKSHEFFEL ROAD
COLORADO SPRINGS, CO #11

GENERAL NOTES

CORPORATE OFFICES
233 SOUTH PATTERSON
SPRINGFIELD, MISSOURI 65802
(417) 862-2674 TELEPHONE

COMM # 4369
 DATE: 10-11-19
 REVISION
 DATE: 02-26-2020

CAUTION:
 INFORMATION ON THIS DRAWING CONCERNING TYPE AND LOCATION OF UNDERGROUND AND OTHER UTILITIES IS NOT GUARANTEED TO BE ACCURATE OR ALL INCLUSIVE. THE CONTRACTOR IS RESPONSIBLE FOR MAKING HIS OWN DETERMINATION AS TO THE TYPE AND LOCATION OF UNDERGROUND AND OTHER UTILITIES AS MAY BE NECESSARY TO AVOID DAMAGE THERETO.



**Know what's below
 Call before you dig.**

C1.3

Silt Fence (SF)

SC-1

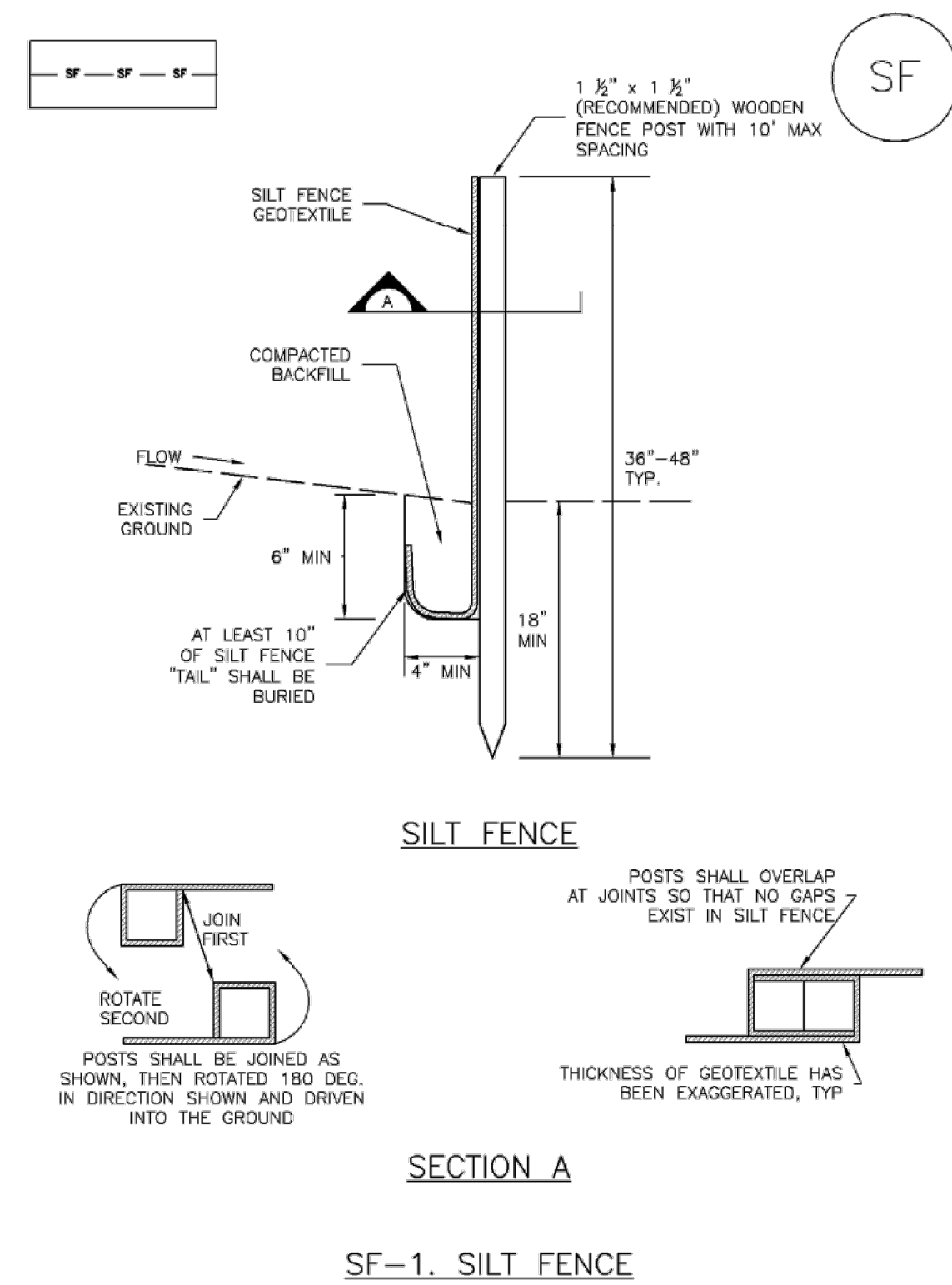

SF-1. SILT FENCE

November 2010 Urban Drainage and Flood Control District Urban Storm Drainage Criteria Manual Volume 3 SF-3

SC-6

Inlet Protection (IP)

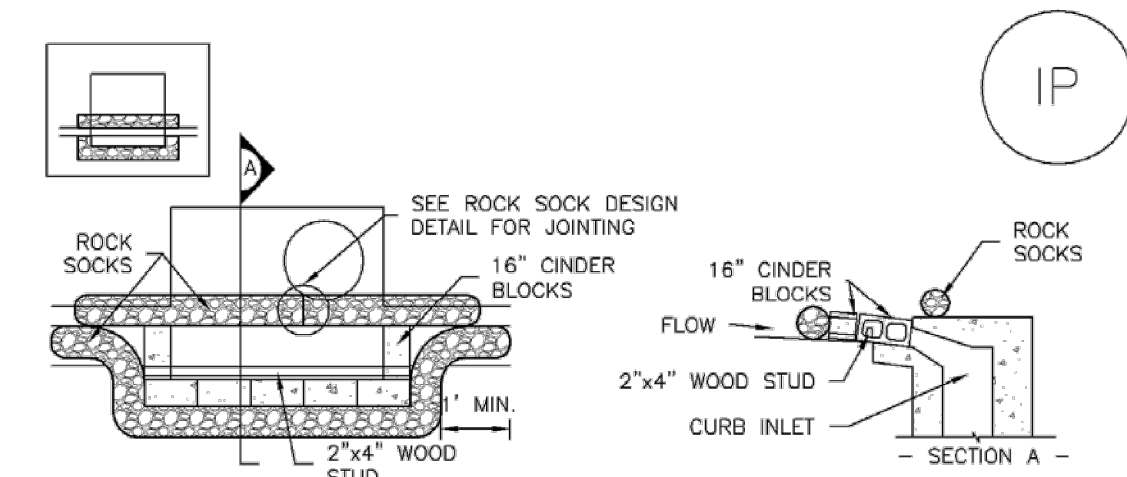

IP-1. BLOCK AND ROCK SOCK SUMP OR ON GRADE INLET PROTECTION

- BLOCK AND CURB SOCK INLET PROTECTION INSTALLATION NOTES**
1. SEE ROCK SOCK DESIGN DETAIL FOR INSTALLATION REQUIREMENTS.
 2. CONCRETE "CINDER" BLOCKS SHALL BE LAID ON THEIR SIDES AROUND THE INLET IN A SINGLE ROW, ABUTTING ONE ANOTHER WITH THE OPEN END FACING AWAY FROM THE CURB.
 3. GRAVEL BAGS SHALL BE PLACED AROUND CONCRETE BLOCKS, CLOSELY ABUTTING ONE ANOTHER AND JOINED TOGETHER IN ACCORDANCE WITH ROCK SOCK DESIGN DETAIL.

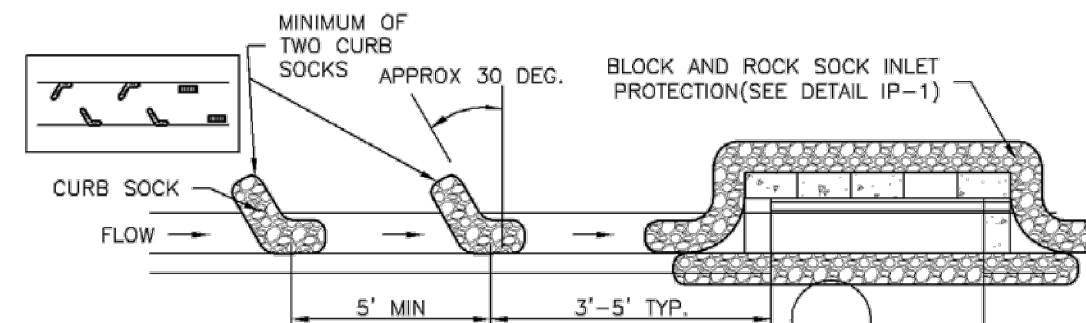

IP-2. CURB ROCK SOCKS UPSTREAM OF INLET PROTECTION

- CURB ROCK SOCK INLET PROTECTION INSTALLATION NOTES**
1. SEE ROCK SOCK DESIGN DETAIL INSTALLATION REQUIREMENTS.
 2. PLACEMENT OF THE SOCK SHALL BE APPROXIMATELY 30 DEGREES FROM PERPENDICULAR IN THE OPPOSITE DIRECTION OF FLOW.
 3. SOCKS ARE TO BE FLUSH WITH THE CURB AND SPACED A MINIMUM OF 5 FEET APART.
 4. AT LEAST TWO CURB SOCKS IN SERIES ARE REQUIRED UPSTREAM OF ON-GRADE INLETS.

IP-4 Urban Drainage and Flood Control District Urban Storm Drainage Criteria Manual Volume 3 August 2013

Inlet Protection (IP)

SC-6

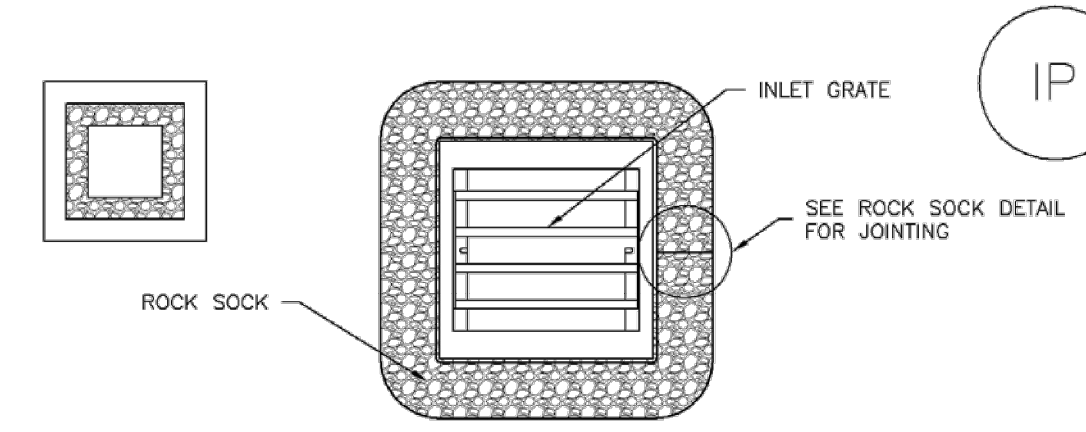

IP-3. ROCK SOCK SUMP/AREA INLET PROTECTION

- ROCK SOCK SUMP/AREA INLET PROTECTION INSTALLATION NOTES**
1. SEE ROCK SOCK DESIGN DETAIL FOR INSTALLATION REQUIREMENTS.
 2. STRAW WATTLES/SEDIMENT CONTROL LOGS MAY BE USED IN PLACE OF ROCK SOCKS FOR INLETS IN PERVIOUS AREAS. INSTALL PER SEDIMENT CONTROL LOG DETAIL.

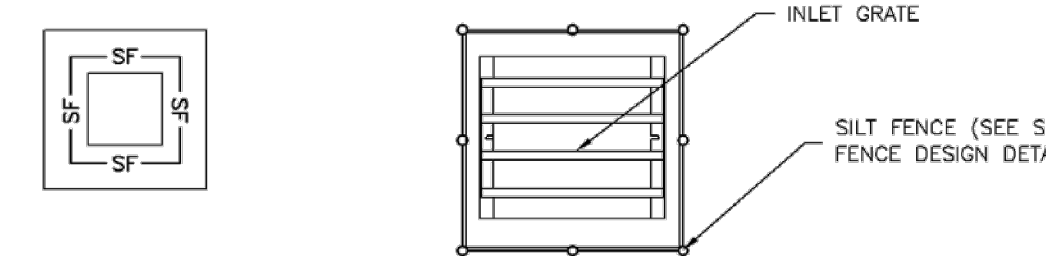

IP-4. SILT FENCE FOR SUMP INLET PROTECTION

- SILT FENCE INLET PROTECTION INSTALLATION NOTES**
1. SEE SILT FENCE DESIGN DETAIL FOR INSTALLATION REQUIREMENTS.
 2. POSTS SHALL BE PLACED AT EACH CORNER OF THE INLET AND AROUND THE EDGES AT A MAXIMUM SPACING OF 3 FEET.
 3. STRAW WATTLES/SEDIMENT CONTROL LOGS MAY BE USED IN PLACE OF SILT FENCE FOR INLETS IN PERVIOUS AREAS. INSTALL PER SEDIMENT CONTROL LOG DETAIL.

August 2013 Urban Drainage and Flood Control District Urban Storm Drainage Criteria Manual Volume 3 IP-5

Concrete Washout Area (CWA)

MM-1

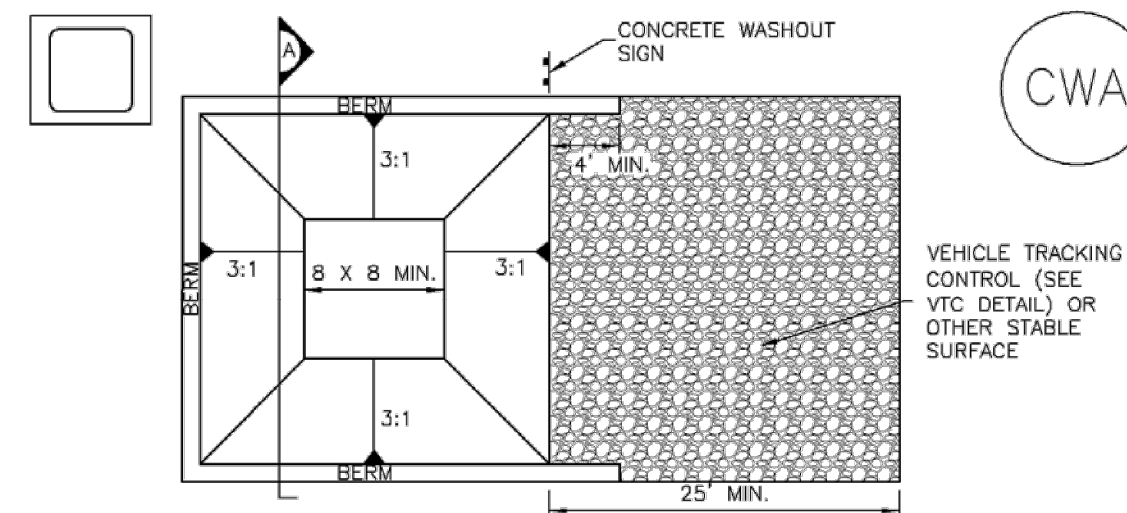

CWA-1. CONCRETE WASHOUT AREA

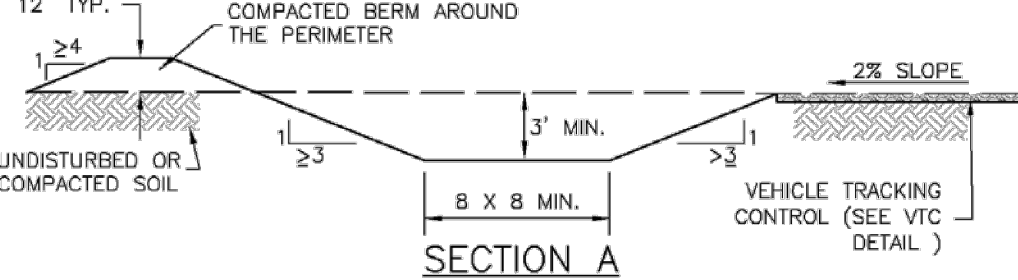

CWA-1. CONCRETE WASHOUT AREA

- CWA INSTALLATION NOTES**
1. SEE PLAN VIEW FOR: -LOCATION(S) OF CWA.
 2. DO NOT LOCATE AN UNLINED CWA WITHIN 400' OF ANY NATURAL DRAINAGE PATHWAY OR WATERBODY. DO NOT LOCATE WITHIN 1,000' OF ANY WELLS OR DRINKING WATER SOURCES. IF SITE CONSTRAINTS MAKE THIS INFEASIBLE, OR IF HIGHLY PERMEABLE SOILS EXIST ON SITE, THE CWA MUST BE INSTALLED WITH AN IMPERMEABLE LINER (16 MIL MIN. THICKNESS) OR SURFACE STORAGE ALTERNATIVES USING PREFABRICATED CONCRETE WASHOUT DEVICES OR A LINED ABOVE GROUND STORAGE ARE SHOULD BE USED.
 3. THE CWA SHALL BE INSTALLED PRIOR TO CONCRETE PLACEMENT ON SITE.
 4. CWA SHALL INCLUDE A FLAT SUBSURFACE PIT THAT IS AT LEAST 8' BY 8' SLOPES LEADING OUT OF THE SUBSURFACE PIT SHALL BE 3:1 OR FLATTER. THE PIT SHALL BE AT LEAST 3' DEEP.
 5. BERM SURROUNDING SIDES AND BACK OF THE CWA SHALL HAVE MINIMUM HEIGHT OF 1'.
 6. VEHICLE TRACKING PAD SHALL BE SLOPED 2% TOWARDS THE CWA.
 7. SIGNS SHALL BE PLACED AT THE CONSTRUCTION ENTRANCE, AT THE CWA, AND ELSEWHERE AS NECESSARY TO CLEARLY INDICATE THE LOCATION OF THE CWA TO OPERATORS OF CONCRETE TRUCKS AND PUMP TRUCKS.
 8. USE EXCAVATED MATERIAL FOR PERIMETER BERM CONSTRUCTION.

November 2010 Urban Drainage and Flood Control District Urban Storm Drainage Criteria Manual Volume 3 CWA-3

SC-5

Rock Sock (RS)

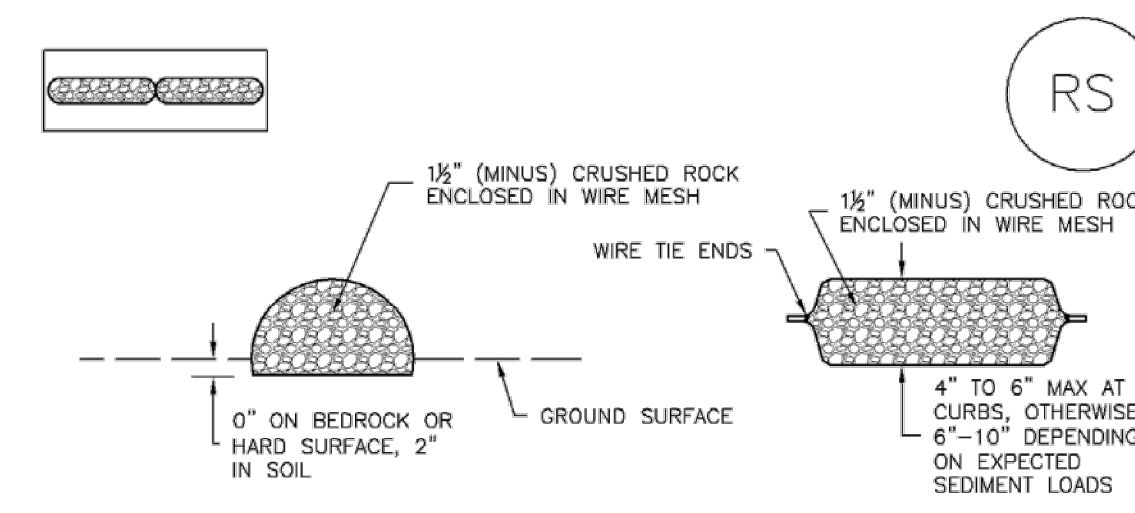

ROCK SOCK SECTION

ROCK SOCK PLAN

ANY GAP AT JOINT SHALL BE FILLED WITH AN ADEQUATE AMOUNT OF 1/2" (MINUS) CRUSHED ROCK AND WRAPPED WITH ADDITIONAL WIRE MESH SECURED TO ENDS OF ROCK REINFORCED SOCK. AS AN ALTERNATIVE TO FILING JOINTS BETWEEN ADJOINING ROCK SOCKS WITH CRUSHED ROCK AND ADDITIONAL WIRE WRAPPING, ROCK SOCKS CAN BE OVERLAPPED (TYPICALLY 12-INCH OVERLAP) TO AVOID GAPS.

GRADATION TABLE	
SIEVE SIZE	MASS PERCENT PASSING SQUARE MESH SIEVES
NO. 4	
2"	100
1 1/2"	90 - 100
1"	20 - 55
3/4"	0 - 15
3/8"	0 - 5

- ROCK SOCK INSTALLATION NOTES**
1. SEE PLAN VIEW FOR: -LOCATION(S) OF ROCK SOCKS.
 2. CRUSHED ROCK SHALL BE 1/2" (MINUS) IN SIZE WITH A FRACTURED FACE (ALL SIDES) AND SHALL COMPLY WITH GRADATION SHOWN ON THIS SHEET (1/2" MINUS).
 3. WIRE MESH SHALL BE FABRICATED OF 10 GAGE POULTRY MESH, OR EQUIVALENT, WITH A MAXIMUM OPENING OF 1/2", RECOMMENDED MINIMUM ROLL WIDTH OF 48"
 4. WIRE MESH SHALL BE SECURED USING "HOG RINGS" OR WIRE TIES AT 6" CENTERS ALONG ALL JOINTS AND AT 2" CENTERS ON ENDS OF SOCKS.
 5. SOME MUNICIPALITIES MAY ALLOW THE USE OF FILTER FABRIC AS AN ALTERNATIVE TO WIRE MESH FOR THE ROCK ENCLOSURE.

RS-1. ROCK SOCK PERIMETER CONTROL

RS-2 Urban Drainage and Flood Control District Urban Storm Drainage Criteria Manual Volume 3 November 2010

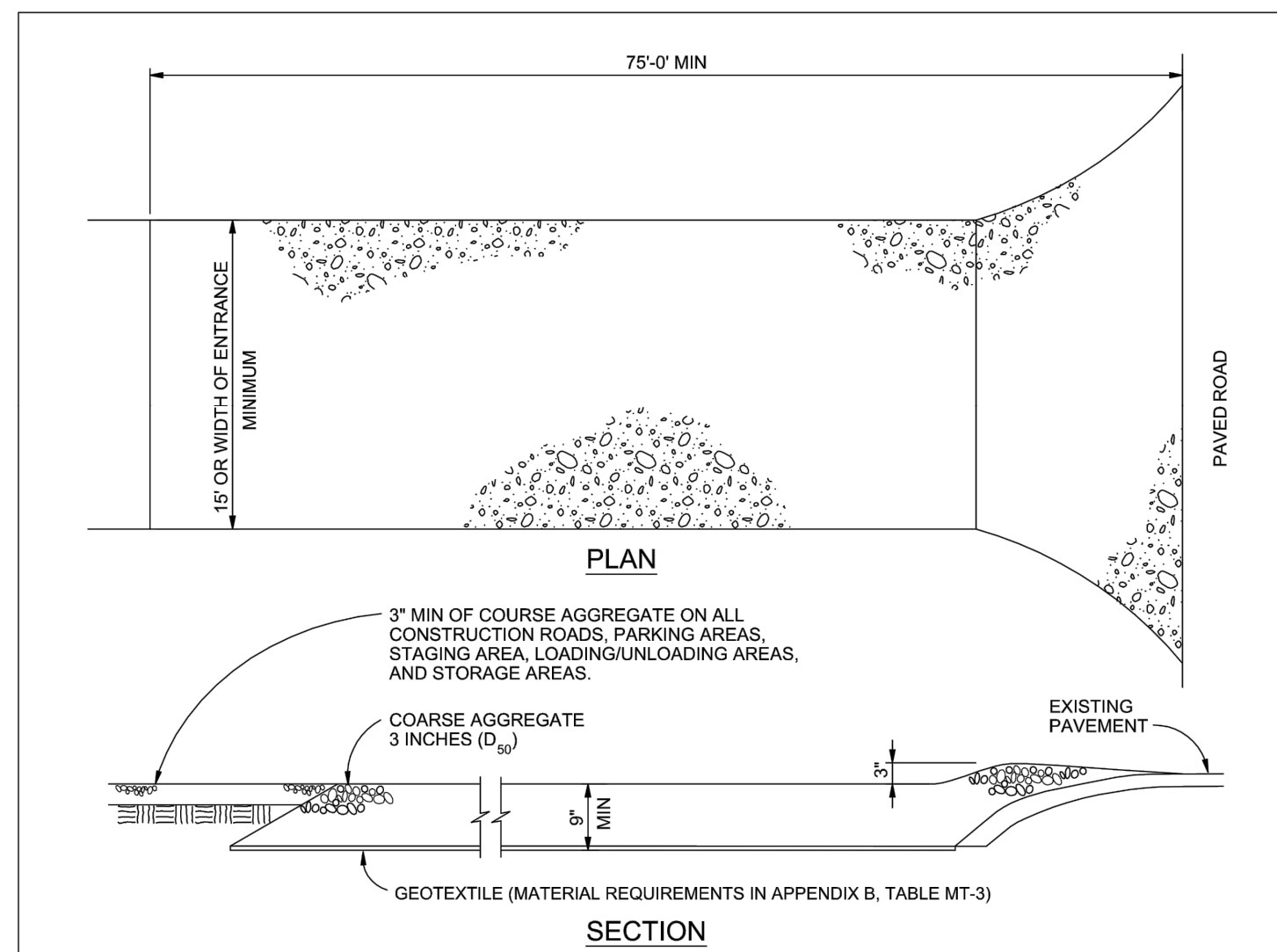

VEHICLE TRACKING NOTES

VEHICLE TRACKING NOTES

- INSTALLATION REQUIREMENTS**
1. ALL ENTRANCES TO THE CONSTRUCTION SITE ARE TO BE STABILIZED PRIOR TO CONSTRUCTION BEGINNING.
 2. CONSTRUCTION ENTRANCES ARE TO BE BUILT WITH AN APRON TO ALLOW FOR TURNING TRAFFIC, BUT SHOULD NOT BE BUILT OVER EXISTING PAVEMENT EXCEPT FOR A SLIGHT OVERLAP.
 3. AREAS TO BE STABILIZED ARE TO BE PROPERLY GRADED AND COMPACTED PRIOR TO LAYING DOWN GEOTEXTILE AND STONE.
 4. CONSTRUCTION ROADS, PARKING AREAS, LOADING/UNLOADING ZONES, STORAGE AREAS, AND STAGING AREAS ARE TO BE STABILIZED.
 5. CONSTRUCTION ROADS ARE TO BE BUILT TO CONFORM TO SITE GRADES, BUT SHOULD NOT HAVE SIDE SLOPES OR ROAD GRADES THAT ARE EXCESSIVELY STEEP.

MAINTENANCE REQUIREMENTS

1. REGULAR INSPECTIONS ARE TO BE MADE OF ALL STABILIZED AREAS, ESPECIALLY AFTER STORM EVENTS.
2. STONES ARE TO BE REAPPLIED PERIODICALLY AND WHEN REPAIR IS NECESSARY.
3. SEDIMENT TRACKED ONTO PAVED ROADS IS TO BE REMOVED DAILY BY SHOVELING OR SWEEPING. SEDIMENT IS NOT TO BE WASHED DOWN STORM SEWER DRAINS.
4. STORM SEWER INLET PROTECTION IS TO BE IN PLACE, INSPECTED, AND CLEANED IF NECESSARY.
5. OTHER ASSOCIATED SEDIMENT CONTROL MEASURES ARE TO BE INSPECTED TO ENSURE GOOD WORKING CONDITION.

City of Colorado Springs Stormwater Quality Figure VT-2 Vehicle Tracking Application Examples

PREPARED UNDER THE SUPERVISION OF TAIT & ASSOCIATES, INC.

6163 East County Road 16
Loveland, CO 80537
p: 970/613/1447 f: 970/613/1897
www.tait.com



Los Angeles, Boise, Sacramento, Denver, Dallas, Rancho Cucamonga

ALEX.HOME, PE 41703

CRAIG A. SCNEIDER, AIA
ARCHITECT

1736 East Sunshine, Suite 417
Springfield, Missouri 65804
417.862.0558
Fax: 417.862.3265
e-mail: architect@esteryschneider.com

PROJECT:
NEW O'REILLY AUTO PARTS STORE
N. MARKSHEFFEL ROAD
COLORADO SPRINGS, CO #11



COMM # 4369
DATE: 02-26-2020
REVISION
DATE: 05-28-2020

CAUTION:
INFORMATION ON THIS DRAWING CONCERNING TYPE AND LOCATION OF UNDERGROUND AND OTHER UTILITIES IS NOT GUARANTEED TO BE ACCURATE OR ALL INCLUSIVE. THE CONTRACTOR IS RESPONSIBLE FOR MAKING HIS OWN DETERMINATION AS TO THE TYPE AND LOCATION OF UNDERGROUND AND OTHER UTILITIES AS MAY BE NECESSARY TO AVOID DAMAGE THERETO.



Know what's below
Call before you dig.

SITE GRADING PLAN

O'REILLY AUTO PARTS STORE GRADING AND EROSION CONTROL PLAN EL PASO COUNTY, COLORADO

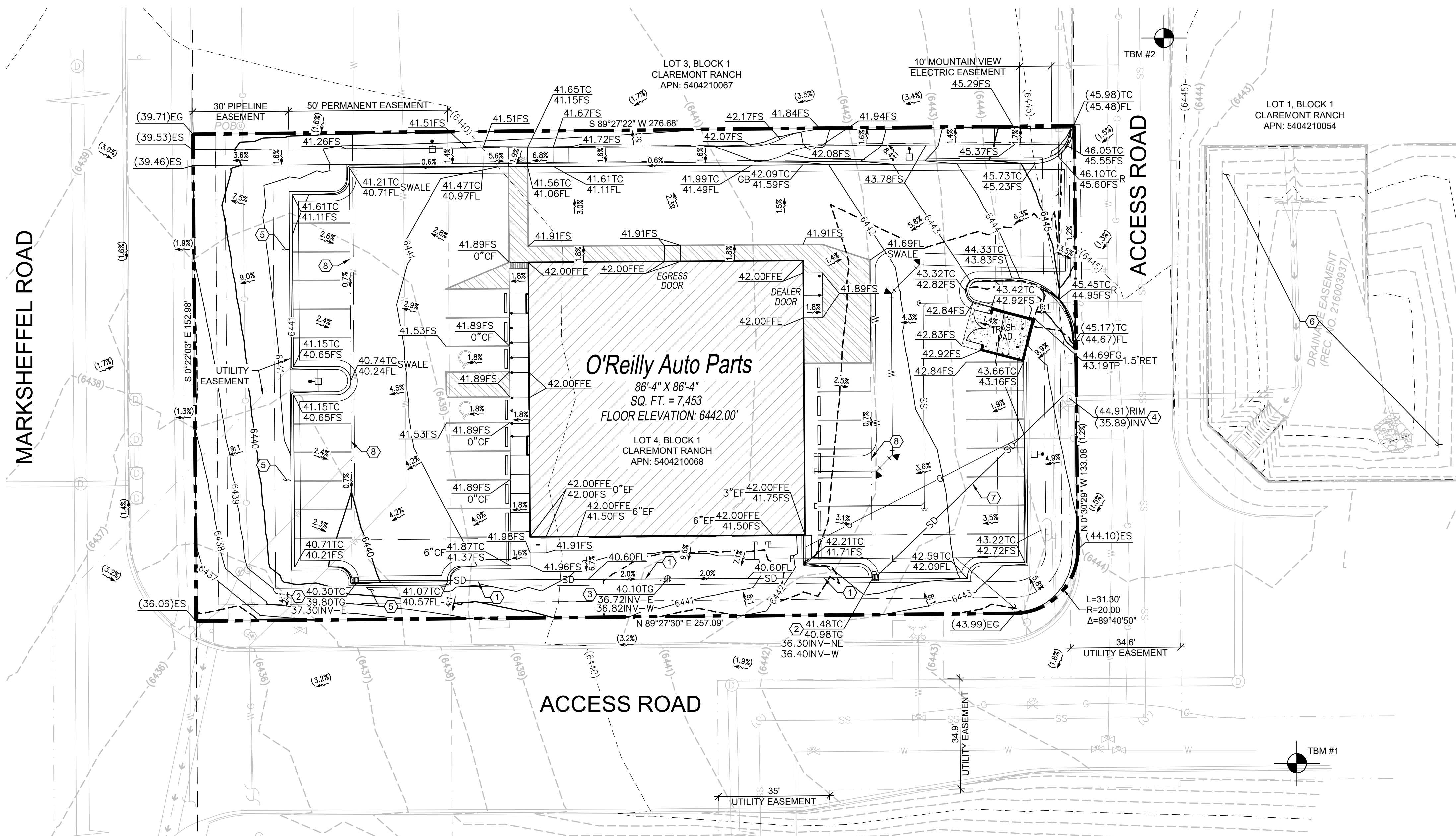

1 SITE GRADING PLAN
C1.1 SCALE: 1" = 20'-0"

OWNER'S STATEMENT:
I, THE OWNER/DEVELOPER HAVE READ AND WILL COMPLY WITH THE REQUIREMENTS OF THE GRADING AND EROSION CONTROL PLAN.

OWNER SIGNATURE _____ DATE _____

ENGINEER'S STATEMENT:
THIS GRADING AND EROSION CONTROL PLAN WAS PREPARED UNDER MY DIRECTION AND SUPERVISION AND IS CORRECT TO THE BEST OF MY KNOWLEDGE AND BELIEF. SAID PLAN HAS BEEN PREPARED ACCORDING TO THE CRITERIA ESTABLISHED BY THE COUNTY FOR GRADING AND EROSION CONTROL PLANS. I ACCEPT RESPONSIBILITY FOR ANY LIABILITY CAUSED BY ANY NEGLIGENT ACTS, ERRORS OR OMISSIONS ON MY PART IN PREPARING THIS REPORT.

ENGINEER OF RECORD SIGNATURE _____ DATE _____

EL PASO COUNTY:
COUNTY PLAN REVIEW IS PROVIDED ONLY FOR GENERAL CONFORMANCE WITH COUNTY DESIGN CRITERIA. THE COUNTY IS NOT RESPONSIBLE FOR THE ACCURACY AND ADEQUACY OF THE DESIGN, DIMENSIONS, AND/OR ELEVATIONS WHICH SHALL BE CONFIRMED AT THE JOB SITE. THE COUNTY THROUGH THE APPROVAL OF THIS DOCUMENT ASSUMES NO RESPONSIBILITY FOR COMPLETENESS AND/OR ACCURACY OF THIS DOCUMENT. FILED IN ACCORDANCE WITH THE REQUIREMENTS OF THE EL PASO COUNTY LAND DEVELOPMENT CODE, DRAINAGE CRITERIA, AND ENGINEERING CRITERIA MANUAL AS AMENDED.

IN ACCORDANCE WITH ECM SECTION 1.12, THESE CONSTRUCTION DOCUMENTS WILL BE VALID FOR CONSTRUCTION FOR A PERIOD OF 2 YEARS FROM THE DATE SIGNED BY THE EL PASO COUNTY ENGINEER. IF CONSTRUCTION HAS NOT STARTED WITHIN THOSE 2 YEARS, THE PLANS WILL NEED TO BE RESUBMITTED FOR APPROVAL, INCLUDING PAYMENT OF REVIEW FEES AT THE PLANNING AND COMMUNITY DEVELOPMENT DIRECTOR'S DISCRETION.

COUNTY PROJECT ENGINEER SIGNATURE _____ DATE _____

GENERAL NOTES

- REFER TO PROJECT MANUAL FOR ADDITIONAL REQUIREMENTS.
- SITE CONDITIONS BASED UPON SURVEY PROVIDED BY OWNER FIELD VERIFY EXISTING CONDITIONS BY DETAILED INSPECTION PRIOR TO SUBMITTING BID AND BEGINNING CONSTRUCTION. NOTIFY ENGINEER IF EXISTING CONDITIONS DEVIATE SUBSTANTIALLY FROM THOSE INDICATED HEREIN.
- FIELD VERIFY SANITARY SEWER SERVICE CONNECTION INVERT PRIOR TO ESTABLISHING FINAL FINISH FLOOR ELEVATION. NOTIFY ENGINEER IF EXISTING CONDITIONS REQUIRE REVISED FINISH FLOOR ELEVATION TO PROVIDE PROPER DRAINAGE.
- ACCESSIBLE PARKING AREAS TO SLOPE 2% MAXIMUM IN ALL DIRECTIONS. DESIGNATED ACCESSIBLE ROUTE TO SLOPE 5% MAXIMUM IN DIRECTION OF TRAVEL WITH 2% MAXIMUM CROSS SLOPE.
- THE PROPOSED DEVELOPMENT DISTURBS LESS THAN ONE ACRE.

SITE EXCAVATION REQUIREMENTS

- A A GEOTECHNICAL ANALYSIS HAS BEEN PERFORMED ON THIS SITE. REFER TO PROJECT MANUAL.
- B FOLLOW GEOTECHNICAL ANALYSIS RECOMMENDATIONS FOR SITE EXCAVATION REQUIREMENTS.
- C REFER TO STRUCTURAL DRAWINGS FOR BUILDING EXCAVATION REQUIREMENTS.

ADA NOTE

- ALL ACCESSIBLE PATHS OF TRAVEL ARE TO ABIDE BY THE FOLLOWING PARAMETERS:
- CROSS-SLOPE NOT TO EXCEED 2%
 - LONGITUDINAL SLOPE NOT TO EXCEED 5%
 - LONGITUDINAL RAMP SLOPE NOT TO EXCEED 8.33%
 - RAMP LANDINGS NOT TO EXCEED 2% (LANDING PLACEMENT PER RAMP DETAILS)
 - PATHWAYS EXCEEDING THESE STANDARDS WILL BE REPLACED AT THE CONTRACTORS EXPENSE
- THE PARTIES RESPONSIBLE FOR THIS PLAN HAVE FAMILIARIZED THEMSELVES WITH ALL CURRENT ACCESSIBILITY CRITERIA AND SPECIFICATIONS AND THE PROPOSED PLAN REFLECTS ALL SITE ELEMENTS REQUIRED BY THE APPLICABLE ADA DESIGN STANDARDS AND GUIDELINES AS PUBLISHED BY THE UNITED STATES DEPARTMENT OF JUSTICE. APPROVAL OF THIS PLAN BY EL PASO COUNTY DOES NOT ASSURE COMPLIANCE WITH THE ADA OR ANY REGULATIONS OR GUIDELINES ENACTED OR PROMULGATED UNDER OR WITH RESPECT TO SUCH LAWS

BASIS OF BEARING

BEARINGS ARE BASED ON GRID CENTRAL FOR COLORADO COORDINATE SYSTEM, CENTRAL ZONE, NAD83. LATITUDE = 38°51'57.09193", LONGITUDE = 10°40'53.61704", CONVERGENCE ANGLE = 0°11'59".

KEY NOTES

- 12" HDPE STORM DRAIN PIPE AT 0.5% SLOPE.
- 2' X 2' NYLOPLAST CURB INLET WITH STANDARD GRATE AND 24" BASIN.
- 24" AREA INLET WITH 24" NYLOPLAST DOME GRATE.
- CONNECT TO EXISTING STORM DRAIN MANHOLE.
- 2' BENCH AT 2%.
- EXISTING WATER QUALITY AND DETENTION POND.
- 15" HDPE STORM DRAIN PIPE AT 0.5% SLOPE.
- PROPOSED SWALE IN CONCRETE.

BENCHMARK

TEMPORARY BENCHMARK #1: ELEVATION = 6443.54', SET MAG NAIL, N:1377025.58, E:3233108.44.
TEMPORARY BENCHMARK #2: ELEVATION = 6445.80', SET MAG NAIL, N:1377253.45, E:3233066.72.

VERTICAL DATUM: BASED ON OPUS SOLUTION DATED 4/30/2019, NAVD88.

GRADE FLAG ELEVATIONS SHOWN HEREON ARE TRUNCATED BY 6400 FEET.

VICINITY MAP

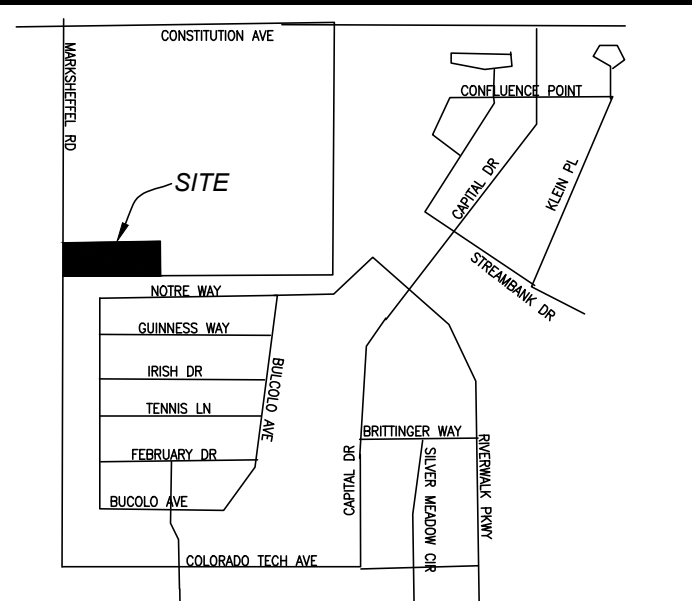

SYMBOLS LEGEND

NOTE: REFER TO SURVEY FOR EXISTING CONDITIONS SYMBOLS LEGEND.

(300.00)	EXISTING ELEV.
300.00	PROPOSED ELEV.
(4300)	EXISTING CONTOURS
4300	PROPOSED CONTOURS
1.5%	PROPOSED FLOW ARROW
(1.5%)	EXISTING FLOW ARROW
	ADJACENT PROPERTY LINE/ RIGHT OF WAY
	EASEMENT LINE
	BUILDING/LANDSCAPE SETBACK LINE
	PROPOSED SAWCUT
	PROPERTY LINE/ RIGHT OF WAY
	NEW BUILDING CONSTRUCTION
	CUT/FILL LINE
	NEW CONCRETE PARKING BLOCK
	PROPOSED LIGHT POST
	PROPOSED SWALE

GRADING & EROSION CONTROL SHEET INDEX

- C1.1 - SITE GRADING PLAN
- C1.2 - SITE EROSION CONTROL PLAN
- C1.3 - GENERAL NOTES
- C1.4 - BMP DETAILS

2 ADA PARKING DETAIL

C1.1 SCALE: 1" = 10'-0"

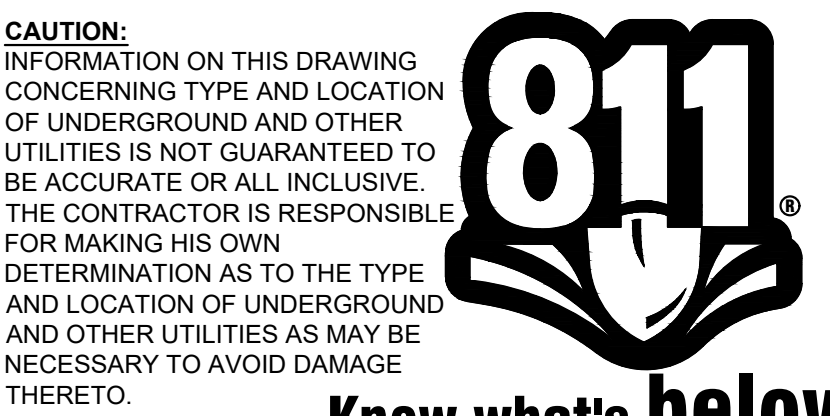
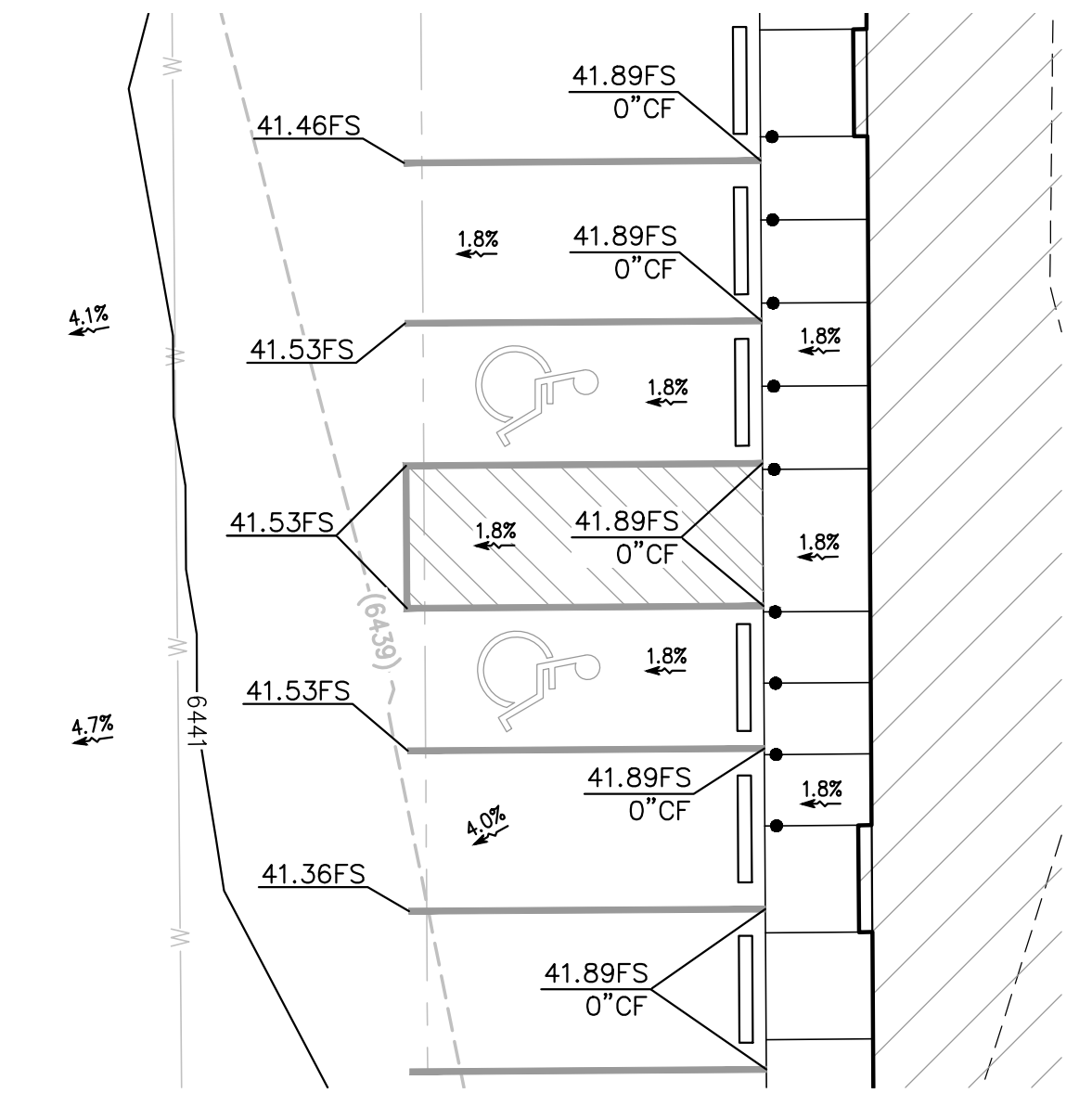

PREPARED UNDER THE SUPERVISION OF TAIT & ASSOCIATES, INC.

6143 East County Road 16
Loveland, CO 80537
p: 970.613.1447 f: 970.613.1897
www.tait.com

TAIT
Since 1984

Los Angeles, Boise, Sacramento, Denver, Dallas, Rancho Cucamonga

ALEX.HOME, PE 41703

CRAIG A. SCHNEIDER, AIA
ARCHITECT

1736 East Sunshine, Suite 417
Springfield, Missouri 65804
417.862.0558
Fax: 417.862.3265
e-mail: architec@esterfyschneider.com

PROJECT:
NEW O'REILLY AUTO PARTS STORE
N. MARKSHEFFEL ROAD
COLORADO SPRINGS, CO #11
SITE GRADING PLAN

O'Reilly AUTO PARTS
CORPORATE OFFICES
233 SOUTH PATTERSON
SPRINGFIELD, MISSOURI 65802
(417) 862-2674 TELEPHONE

COMM #	4369
DATE:	10-11-19
REVISION	DATE: 02-26-2020
	05-28-2020

C1.1

SPILL PREVENTION AND CONTROL PLAN

SPILL PREVENTION and CONTROL PLAN: COLORADO SPRINGS O'REILLY

Whenever significant quantities of fuels, materials, vehicle fluids, or other pollutants are to be used on site, specific procedures for material containment and spill prevention shall be developed and implemented.

Introduction

The following Spill Prevention and Response Plan shall be implemented during the construction of Colorado Springs O'Reilly, Colorado Springs, CO.

Materials On-Site

Spill control procedures will be implemented when materials are stockpiled or when chemicals and/or fluids are used in the construction area.

Stockpiles of Dry Materials

The following spill prevention procedures shall be implemented:

All materials shall be stockpiled in designated areas, with BMPs used to reduce and minimize the runoff of contaminants. BMPs such as silt fence and sediment control logs, and rock socks will be installed according to Town criteria using the details shown in the Erosion Control plans. Loading and unloading operations shall be performed in a manner to limit materials from being spilled. Any spilled materials shall be swept up immediately after the operations are performed.

Vehicle Fueling

The following spill prevention procedures shall be implemented:

All vehicle fueling will be done off-site as much as possible. All on-site fueling operations will be performed in designated areas. Measures will be taken where necessary to reduce and minimize spills during vehicle fueling operations. These measures may include the placement of a temporary berm around the fueling area, covering the fueling area under a temporary portable structure, and/or the placement of drip pans under valves and tank openings. Berms will be constructed around all fueling areas. An adequate supply of absorbents will also be stockpiled at each fueling area.

Routine Vehicle and Equipment Maintenance

The following spill prevention procedures shall be implemented:

All vehicle maintenance will be performed off-site when possible. However, there may be occasions where construction equipment and vehicles may break down at the site and on-site repairs are more feasible. On-site vehicle and equipment maintenance, if needed, will be performed in designated areas, where practical, and enclosed by earthen berms. All maintenance areas will maintain an adequate supply of drip pans.

These pans will be placed underneath vehicles as needed and absorbents will be used in the event of a minor spill or leak.

SPILL RESPONSE

Cleanup and Removal Procedures

- Upon detection of any spill, the first action to be taken is to ensure personal safety. All possible ignition sources, including running engines, electrical equipment (including cellular telephones, etc.), or other hazards will be immediately turned off or removed from the area. The extent of the spill and the nature of the spilled material will be evaluated to determine if remedial actions could result in any health hazards, escalation of the spill, or further damage that would intensify the problem. If such conditions exist, a designated employee will oversee the area of the spill and the construction supervisor will be notified immediately.
- The source of the spill will be identified and if possible the flow of pollutants stopped if it can be done safely. However, no employee will attend to the source or begin cleanup of the spill until **ALL** emergency priorities (fire, injuries, etc.) have been addressed.

NOTE: IN CASE OF FIRE, EVACUATE ALL PERSONNEL FROM THE IMMEDIATE AREA, RENDER FIRST AID TO ANYONE WHO IS INJURED, AND DIAL 911 IMMEDIATELY. TAKE APPROPRIATE STEPS TO PROTECT HUMAN LIFE AND TO CONTROL FIRES FIRST. SPILL CONTROL IS A SECONDARY CONCERN.

Small Spills

Small spills (usually <5 gallons) consist of minor quantities of gasoline, oil, anti-freeze, or other materials that can be cleaned up by a single employee using readily available materials.

The following procedures shall be used for clean up of small spills:

1. Ensure personal safety, evaluate the spill, and if possible, stop the flow of pollutants.
2. Contain the spread of the spill using absorbents, portable berms, sandbags, or other available measures.
3. Spread absorbent materials on the area to soak up as much of the liquid as possible and to prevent or minimize infiltration into the soil.

4. Once the liquids have been absorbed, remove all absorbents from the spill and place the materials in a suitable storage container. On paved areas, wipe any remaining liquids from the surface and place the materials in a storage container. Do not spray or wash down the area using water. For open soil areas, excavate any contaminated soil as soon as possible and place the soil in a suitable storage container. All materials will then be transported off-site for disposal.
5. If immediate transfer and storage of the contaminated soil is not practical, excavate and place the contaminated soil on a double thickness sheet of 3-mil or higher polyethylene film. In addition, a small berm should be formed around the outer edges of the soil stockpile, underneath the polyethylene film, to ensure that contaminants are not washed from the site during precipitation events and that materials do not seep through the berm.
6. Record all significant facts and information about the spill, including the following:
 - Type of pollutant
 - Location
 - Apparent source
 - Estimated volume
 - Time of discovery
 - Actions taken to clean up spill
7. Notify the supervisor of the spill and provide the information from Item #6. The supervisor will then contact El Paso County.

Medium to Large Spills

Medium to large spills consist of larger quantities of materials (usually >5 – 25 gallons) that are used on site that cannot be controlled by a single employee. Generally, a number of facility personnel will be needed to control the spill and a response may require the suspension of other facility activities.

The following procedure shall be used for the cleanup of medium to large spills:

1. Ensure personal safety, evaluate the spill, and if possible, stop the flow of pollutants.
2. Immediately dispatch a front-end loader or similar equipment to the spill and construct a berm or berms down gradient of the spill to minimize the spread of potential pollutants. On paved surfaces, portable berms, sandbags, booms, or other measures will be used to control the lateral spread of the pollutants.
3. When the spread of the spill has been laterally contained, contact the supervisor or designated facility employee and provide them information on the location, type, and amount of spilled material, and a briefing on the extent of the spread and measures undertaken to contain the contaminants.

4. Depending on the nature of the spill, mobilize additional resources as needed to contain the contaminants.
5. Cleanup will commence when the lateral spread has been contained and the notification to the supervisor has been made.
6. Freestanding liquid will be bailed or pumped into 55-gallon storage drums, steel tanks, or other suitable storage containers. When all the liquid has been removed from the pavement or soil layer, absorbents will be applied to the surface and transferred to the storage containers when they have soaked up as much of the spill as possible.
7. On paved surfaces, the remaining contaminants will be removed to the extent possible, with rags, sweeping, or similar measures. The area of the spill will not be sprayed or washed down using water. Any contaminant soaked materials will be placed into the storage containers with the other absorbents.
8. The remaining contaminated soils will be excavated and loaded into a dump truck(s) for disposal off-site at a designated facility. If transport off-site is not immediately available, the remaining soils will be stockpiled on a double thickness sheet of 3-mil or higher polyethylene film. In addition, a small berm will be formed around the outer edges of the soil stockpile, underneath the polyethylene film, to ensure that contaminants are not washed from the site during precipitation and do not seep through the berm.
9. Record all significant facts and information about the spill, including the following:
 - Type of pollutant
 - Location
 - Apparent source
 - Estimated volume
 - Time of discovery
 - Actions taken to clean up spill
10. Provide the supervisor (or designated employee) with the information from Item #9. The supervisor will then contact El Paso County.

NOTIFICATION

Notification to the Colorado Department of Public Health & Environment (CDPHE) is required if there is any release or suspected release of any substance, including oil or other substances that spill into or threaten State waters. Unless otherwise noted, notifications are to be made by the supervisor and only after emergency responses related to the release have been implemented. This will prevent misinformation and assures that notifications are properly conducted.

The notification requirements are as follows:

1. **Spills into/or Threatens State Waters:** Immediate notification is required for releases that occur beneath the surface of the land or impact or threaten waters of the State that threaten the public health and welfare. Notifications that will be made are:
 - a. For any substance, regardless of quantity, contact CDPHE at 1-877-518- 5608. State as follows:
 - a) Give your name.
 - b) Give location of spill (name of city).
 - c) Describe the nature of the spill, type of products, and estimate size of spill.
 - d) Describe type of action taken thus far, type of assistance or equipment needed.
 - b. For any quantity of oil or other fluids, call the National Response Center at 1-800-424-8802. State as follows:
 - a) Give your name.
 - b) Give location of spill (name of city and state).
 - c) Describe the nature of the spill, type of product, and estimate size of spill.
 - d) Describe type of action taken thus far, type of assistance or equipment needed.
2. **Reportable Quantity Spill on Land Surface:** Immediate notification is required of a release upon the land surface of an oil in quantity that exceeds 25 gallons, or of a hazardous substance that equals or exceeds 10 pounds or its reportable quantity under Section 101(14) of the Comprehensive Environmental Response, Compensation Liability Act (CERCLA) of 1980 as amended (40 CFR Part 302) and Section 329 (3) of the Emergency Planning and Community Right to Know Act of 1986 (40 CFR Part 355) whichever is less. This requirement does apply at a minimum to the substances listed in Table A below.

TABLE A: *Substances Requiring Notification*

SUBSTANCE	REPORTABLE QUANTITY
Motor Oil	25 Gallons
Hydraulic Oil	25 Gallons
Gasoline/Diesel Fuel	25 Gallons

The notification procedures to be followed are:

- a) Give your name.
- b) Give location of spill (name of city and state).
- c) Describe nature of the spill, type of product, and estimate size of spill.
- d) Describe type of action taken thus far, type of assistance or equipment needed.
- e) Give name of land owner.
- f) Specify department responsible for any facilities that may be impacted.

3. Notification is not required for release of oil upon the land surface of 25 gallons or less that will not constitute a threat to public health and welfare, the environmental or a threat of entering the waters of the State.

4. Notification, as required in paragraphs 1 and 2 above, will be made to the CDPHE using the 24-hour telephone number to report environmental spills. All information known about the release at the time of discovery is to be included, such as the time of occurrence, quantity and type of material, location and any corrective or clean-up actions presently being taken. Table B lists these phone numbers.

SPILL RESPONSE CONTACTS

TABLE B: *Emergency Notification Contacts*

NAME / AGENCY	NUMBER
Colorado Springs Fire Department	911 (719) 385-5950
Colorado Springs Police Department	911 (719) 444-7000
Ambulance	911
Hospital	911
National Response Center	1-800-424-8802
CDPHE – Report Environmental Spills (24 hrs/day)	1-877-518-5608
Colorado Emergency Planning Committee	303-273-1622

It is the responsibility of the supervisor to contact El Paso County, CDPHE, and/or the National Response Center.

- **The National Response Center** is to be contacted when a release containing a hazardous substance or oil in an amount equal to or in excess of a reportable

quantity established under either 40 CFR 110, 4- DFR 117, or 40 CFR 302 occurs during a 24-hour period.

- Notification to the **CDPHE** is required if there is any release or suspected release of any material, including oil or hazardous substances that spill into or threaten state waters.

REPORTS

The CDPHE requires written notification of a spill or discharge of oil or other substance that may cause pollution of the waters of the State of Colorado. A written report must be submitted to the Water Quality Control District (WQCD) within five days after becoming aware of the spill or discharge.

The CDPHE requires a written final report within 15 days for all releases of an oil or hazardous substance that require implementation of a contingency plan. The CDPHE may also require additional reports on the status of the clean up until any required remedial action has been complete.

Written notification of reports must contain at a minimum:

1. Date, time, and duration of the release.
2. Location of the release.
3. Person or persons causing and responsible for the release.
4. Type and amount of oil or substance released.
5. Cause of the release.
6. Environmental damage caused by the release.
7. Actions taken to respond, contain, and clean up the release.
8. Location and method of ultimate disposal of the oil or other fluids.
9. Actions taken to prevent a reoccurrence of the release.
10. Any known or anticipated acute or chronic health risks associated with the release.
11. When appropriate advice regarding medical attention necessary for exposed individuals.

STORMWATER CONSTRUCTION FIELD INSPECTION REPORT

CONSTRUCTION STORMWATER SITE INSPECTION REPORT

Facility Name		Permittee					
Date of Inspection		Weather Conditions					
Permit Certification #		Disturbed Acreage					
Phase of Construction		Inspector Title					
Inspector Name							
Is the above inspector a qualified stormwater manager? (permittee is responsible for ensuring that the inspector is a qualified stormwater manager)			<table border="1" style="width: 100%; border-collapse: collapse;"> <tr> <td style="width: 50%; text-align: center;">YES</td> <td style="width: 50%; text-align: center;">NO</td> </tr> <tr> <td style="text-align: center;"><input type="checkbox"/></td> <td style="text-align: center;"><input type="checkbox"/></td> </tr> </table>	YES	NO	<input type="checkbox"/>	<input type="checkbox"/>
YES	NO						
<input type="checkbox"/>	<input type="checkbox"/>						

INSPECTION FREQUENCY					
Check the box that describes the minimum inspection frequency utilized when conducting each inspection					
At least one inspection every 7 calendar days	<input type="checkbox"/>				
At least one inspection every 14 calendar days, with post-storm event inspections conducted within 24 hours after the end of any precipitation or snowmelt event that causes surface erosions	<input type="checkbox"/>				
<ul style="list-style-type: none"> • This is this a post-storm event inspection. Event Date: _____ 	<input type="checkbox"/>				
Reduced inspection frequency - Include site conditions that warrant reduced inspection frequency	<input type="checkbox"/>				
<ul style="list-style-type: none"> • Post-storm inspections at temporarily idle sites • Inspections at completed sites/area • Winter conditions exclusion 	<input type="checkbox"/>				
Have there been any deviations from the minimum inspection schedule? If yes, describe below.	<table border="1" style="width: 100%; border-collapse: collapse;"> <tr> <td style="width: 50%; text-align: center;">YES</td> <td style="width: 50%; text-align: center;">NO</td> </tr> <tr> <td style="text-align: center;"><input type="checkbox"/></td> <td style="text-align: center;"><input type="checkbox"/></td> </tr> </table>	YES	NO	<input type="checkbox"/>	<input type="checkbox"/>
YES	NO				
<input type="checkbox"/>	<input type="checkbox"/>				

INSPECTION REQUIREMENTS*
i. Visually verify all implemented control measures are in effective operational condition and are working as designed in the specifications
ii. Determine if there are new potential sources of pollutants
iii. Assess the adequacy of control measures at the site to identify areas requiring new or modified control measures to minimize pollutant discharges
iv. Identify all areas of non-compliance with the permit requirements, and if necessary, implement corrective action
*Use the attached Control Measures Requiring Routine Maintenance and Inadequate Control Measures Requiring Corrective Action forms to document results of this assessment that trigger either maintenance or corrective actions

AREAS TO BE INSPECTED			
Is there evidence of, or the potential for, pollutants leaving the construction site boundaries, entering the stormwater drainage system or discharging to state waters at the following locations?			
	NO	YES	If "YES" describe discharge or potential for discharge below. Document related maintenance, inadequate control measures and corrective actions Inadequate Control Measures Requiring Corrective Action form
Construction site perimeter	<input type="checkbox"/>	<input type="checkbox"/>	
All disturbed areas	<input type="checkbox"/>	<input type="checkbox"/>	
Designated haul routes	<input type="checkbox"/>	<input type="checkbox"/>	
Material and waste storage areas exposed to precipitation	<input type="checkbox"/>	<input type="checkbox"/>	
Locations where stormwater has the potential to discharge offsite	<input type="checkbox"/>	<input type="checkbox"/>	
Locations where vehicles exit the site	<input type="checkbox"/>	<input type="checkbox"/>	
Other: _____	<input type="checkbox"/>	<input type="checkbox"/>	

REPORTING REQUIREMENTS

The permittee shall report the following circumstances orally within twenty-four (24) hours from the time the permittee becomes aware of the circumstances, and shall mail to the division a written report containing the information requested within five (5) working days after becoming aware of the following circumstances. The division may waive the written report required if the oral report has been received within 24 hours.

All Noncompliance Requiring 24-Hour Notification per Part II.L.6 of the Permit		
a. Endangerment to Health or the Environment Circumstances leading to any noncompliance which may endanger health or the environment regardless of the cause of the incident (See Part II.L.6.a of the Permit) <i>This category would primarily result from the discharge of pollutants in violation of the permit</i>		
b. Numeric Effluent Limit Violations <ul style="list-style-type: none"> o Circumstances leading to any unanticipated bypass which exceeds any effluent limitations (See Part II.L.6.b of the Permit) o Circumstances leading to any upset which causes an exceedance of any effluent limitation (See Part II.L.6.c of the Permit) o Daily maximum violations (See Part II.L.6.d of the Permit) <i>Numeric effluent limits are very uncommon in certifications under the COR400000 general permit. This category of noncompliance only applies if numeric effluent limits are included in a permit certification.</i>		

Has there been an incident of noncompliance requiring 24-hour notification?	NO	YES	
	<input type="checkbox"/>	<input type="checkbox"/>	If "YES" document below

Date and Time of Incident	Location	Description of Noncompliance	Description of Corrective Action	Date and Time of 24 Hour Oral Notification	Date of 5 Day Written Notification *

*Attach copy of 5 day written notification to report. Indicate if written notification was waived, including the name of the division personnel who granted waiver.

After adequate corrective action(s) and maintenance have been taken, or where a report does not identify any incidents requiring corrective action or maintenance, the individual(s) designated as the Qualified Stormwater Manager, shall sign and certify the below statement:

"I verify that, to the best of my knowledge and belief, all corrective action and maintenance items identified during the inspection are complete, and the site is currently in compliance with the permit."

Name of Qualified Stormwater Manager

Title of Qualified Stormwater Manager

Signature of Qualified Stormwater Manager

Date

Notes/Comments

**EL PASO COUNTY STORMWATER MANAGEMENT PLAN
CHECKLIST**



2880 International Circle, Suite 110
 Colorado Springs, CO 80910
 Phone 719-520-6300
 Fax 719-520-6695
 www.elpasoco.com

**EL PASO COUNTY PLANNING AND
 COMMUNITY DEVELOPMENT
 DEPARTMENT**

STORMWATER MANAGEMENT PLAN CHECKLIST

Revised: July 2019

		Applicant	PCD
1. STORMWATER MANAGEMENT PLAN (SWMP)			
1	Applicant (owner/designated operator), SWMP Preparer, Qualified Stormwater Manager, and Contractor Information. (On cover/title sheet)	X	
2	Table of Contents	X	
3	Site description and location to include: vicinity map with nearest street/crossroads description.	X	
4	Narrative description of construction activities proposed (e.g., may include clearing and grubbing, temporary stabilization, road grading, utility / storm installation, final grading, final stabilization, and removal of temporary control measures)	X	
5	Phasing plan – may require separate drawings indicating initial, interim, and final site phases for larger projects. Provide “living maps” that can be revised in the field as conditions dictate.	X	
6	Proposed sequence for major activities: Provide a construction schedule of anticipated starting and completion dates for each stage of land-disturbing activity depicting conservation measures anticipated, including the expected date on which the final stabilization will be completed.	X	
7	Estimates of the total site area and area to undergo disturbance; current area of disturbance must be updated on the SWMP as changes occur.	X	
8	Soil erosion potential and impacts on discharge that includes a summary of the data used to determine soil erosion potential	X	
9	A description of existing vegetation at the site and percent ground cover and method used to determine ground cover	X	
10	Location and description of all potential pollution sources including but not limited to: disturbed and stored soils; vehicle tracking; management of contaminated soils; loading and unloading operations; outdoor storage of materials; vehicle and equipment maintenance and fueling; significant dust generating process; routine maintenance activities involving fertilizers, pesticides, herbicides, detergents, fuels, solvents, oils, etc.; on-site waste management; concrete truck/equipment washing; dedicated asphalt, concrete batch plants and masonry mixing stations; non-industrial waste such as trash and portable toilets	X	
11	Material handling to include spill prevention and response plan and procedures.	X	
12	Spill prevention and pollution controls for dedicated batch plants	X	
13	Other SW pollutant control measures to include waste disposal and off site soil tracking	X	
14	Location and description of any anticipated allowable non-stormwater discharge (ground water, springs, irrigation, discharge covered by CDPHE Low Risk Guidance, etc.)	X	
15	Name(s) of ultimate receiving waters; size, type and location of stormwater outfall or storm sewer system discharge	X	
16	Description of all stream crossings located within the project area or statement that no streams cross the project area	X	



2880 International Circle, Suite 110
 Colorado Springs, CO 80910
 Phone 719-520-6300
 Fax 719-520-6695
 www.elpasoco.com

**EL PASO COUNTY PLANNING AND
 COMMUNITY DEVELOPMENT
 DEPARTMENT**

STORMWATER MANAGEMENT PLAN CHECKLIST

Revised: July 2019

		Applicant	PCD
17	SWMP Map to include:	X	
17a	construction site boundaries	X	
17b	flow arrows to depict stormwater flow directions	X	
17c	all areas of disturbance	X	
17d	areas of cut and fill	X	
17e	areas used for storage of building materials, soils (stockpiles) or wastes	X	
17f	location of any dedicated asphalt / concrete batch plants	X	
17g	location of all structural control measures	X	
17h	location of all non-structural control measures	X	
17i	springs, streams, wetlands and other surface waters, including areas that require maintenance of pre-existing vegetation within 50 feet of a receiving water	X	
18	Narrative description of all structural control measures to be used. Modifications to EPC standard control measures must meet or exceed County-approved details.	X	
19	Description of all non-structural control measures to be used including seeding, mulching, protection of existing vegetation, site watering, sod placement, etc.	X	
20	Technical drawing details for all control measure installation and maintenance; custom or other jurisdiction's details used must meet or exceed EPC standards	X	
21	Procedure describing how the SWMP is to be revised	X	
22	Description of Final Stabilization and Long-term Stormwater Quality (describe nonstructural and structural measures to control SW pollutants after construction operations have been completed, including detention, water quality control measure etc.)	X	
23	Specification that final vegetative cover density is to be 70% of pre-disturbed levels	X	
24	Outline of permit holder inspection procedures to install, maintain, and effectively operate control measures to manage erosion and sediment	X	
25	Record keeping procedures identified to include signature on inspection logs and location of SWMP records on-site	X	
26	If this project relies on control measures owned or operated by another entity, a documented agreement must be included in the SWMP that identifies location, installation and design specifications, and maintenance requirements and responsibility of the control measure(s).	X	
	Please note: all items above must be addressed. If not applicable, explain why, simply identifying "not applicable" will not satisfy CDPHE requirement of explanation.		
2. ADDITIONAL REPORTS/PERMITS/DOCUMENTS			
a	Grading and Erosion Control Plan (signed)	X	
b	Erosion and Stormwater Quality Control Permit (ESQCP) (signed)	X	
3. Applicant Comments:			
a			
b			
c			



2880 International Circle, Suite 110
 Colorado Springs, CO 80910
 Phone 719-520-6300
 Fax 719-520-6695
 www.elpasoco.com

**EL PASO COUNTY PLANNING AND
 COMMUNITY DEVELOPMENT
 DEPARTMENT**

STORMWATER MANAGEMENT PLAN CHECKLIST

Revised: July 2019

		Applicant	PCD
4. Checklist Review Certifications:			
a	<p>Engineer of Record: The Stormwater Management Plan was prepared under my direction and supervision and is correct to the best of my knowledge and belief. Said Plan has been prepared according to the criteria established by the County and State for Stormwater Management Plans.</p> <p><i>[Signature]</i> _____ <u>5-27-2020</u> Engineer of Record Signature Date</p>	X	
b	<p>Review Engineer: The Stormwater Management Plan was reviewed and found to meet the checklist requirements except where otherwise noted or allowed by an approved deviation request.</p> <p>_____ Review Engineer Date</p>		

**EL PASO COUNTY EROSION AND STORMWATER QUALITY
CONTROL PERMIT (ESQCP)**

EROSION AND STORMWATER QUALITY CONTROL PERMIT (ESQCP) EL PASO COUNTY APPLICATION AND PERMIT

APPLICANT INFORMATION

PERMIT NUMBER

Owner Information	
Owner	O'Reilly Auto Enterprises, LLC
Name (person of responsibility)	Jared Minor
Company/Agency	O'Reilly Auto Parts
Position of Applicant	Project Administrator
Address (physical address, not PO Box)	233 South Patterson
City	Springfield
State	MO
Zip Code	65802
Mailing address, if different from above	
Telephone	407-862-2674
FAX number	
Email Address	jminor10@oreillyauto.com
Cellular Phone number	
Contractor/Operator Information	
Name (person of responsibility)	
Company	
Address (physical address, not PO Box)	
City	
State	
Zip Code	
Mailing address, if different from above	
Telephone	
FAX number	
Email Address	
Cellular Phone number	
Erosion Control Supervisor (ECS)*	
ECS Phone number*	
ECS Cellular Phone number*	

*Required for all applicants. May be provided at later date pending securing a contract when applicable.

PROJECT INFORMATION

Project Information	
Project Name	O'Reilly Auto Parts
Legal Description	Lot 4, Block 1 Claremont Ranch Filing No. 9B, County of El Paso, State Of Colorado
Address (or nearest major cross streets)	2417 Marksheffel Road Colorado Springs, Colorado
Acreage (total and disturbed)	Total: 0.97 acres Disturbed: 0.97 acres
Schedule	Start of Construction: Completion of Construction: Final Stabilization:
Project Purpose	Development of a new O'Reilly Auto Parts Store.
Description of Project	Construction of a New 7,453 square foot O'Reilly Auto Parts Store for the purpose of the retail sale of auto parts including site improvements, landscaping, parking, and utilities.
Tax Schedule Number	

FOR OFFICE USE ONLY

The following signature from the ECM Administrator signifies the approval of this ESQCP. All work shall be performed in accordance with the permit, the El Paso County Engineering Criteria Manual (ECM) Standards, City of Colorado Springs Drainage Criteria Manual, Volume 2 (DCM2) as adopted by El Paso County Addendum, approved plans, and any attached conditions. The approved plans are an enforceable part of the ESQCP. Construction activity, except for the installation of initial construction BMPs is not permitted until issuance of a Construction permit and Notice to Proceed.

Signature of ECM Administrator: _____

Date _____

1.1 REQUIRED SUBMISSIONS

In addition to this completed and signed application, the following items must be submitted to obtain an ESQCP:

- Permit fees
- Stormwater Management Plan (SWMP) meeting the requirements of DCM2 and ECM either as part of the plan set or as a separate document;
- Cost estimates of construction and maintenance of construction and permanent stormwater control measures (Cost estimates shall be provided on a unit cost basis for all stormwater BMPs);
- Financial surety in an amount agreeable to the ECM Administrator based on the cost estimates of the stormwater quality protection measures provided. The financial surety shall be provided in the form of a Letter of Credit, Surety with a Bonding Company, or other forms acceptable to El Paso County;
- Operation and Maintenance Plan for any proposed permanent stormwater control measures; and
- Signed Private Detention Basin/Stormwater Quality Best Management Practice Maintenance Agreement and Easement, if any permanent stormwater control measures are to be located on site.

1.2 RESPONSIBILITY FOR DAMAGE

The County and its officers and employees, including but not limited to the ECM Administrator, shall not be answerable or accountable in any manner, for injury to or death of any person, including but not limited to a permit holder, persons employed by the permit holder, persons acting in behalf of the permit holder, or for damage to property resulting from any activities undertaken by a permit holder or under the direction of a permit holder. The permit holder shall be responsible for any liability imposed by law and for injuries to or death of any person, including but not limited to the permit holder, persons employed by the permit holder, persons acting in behalf of the permit holder, or damage to property arising out of work or other activity permitted and done by the permit holder under a permit, or arising out of the failure on the permit holder's part to perform the obligations under any permit in respect to maintenance or any other obligations, or resulting from defects or obstructions, or from any cause whatsoever during the progress of the work, or other activity, or at any subsequent time work or other activity is being performed under the obligations provided by and contemplated by the permit.

To the extent allowed by law, the permit holder shall indemnify, save, and hold harmless the County and its officers and employees, including but not limited to the BOCC and ECM Administrator, from all claims, suits or actions of every name, kind and description brought for or on account of injuries to or death of any person, including but not limited to the permit holder, persons employed by the permit holder, persons acting in behalf of the permit holder and the public, or damage to property resulting from the performance of work or other activity under the permit, or arising out of the failure on the permit holder's part to perform his obligations under any permit in respect to maintenance or any other obligations, or resulting from defects or obstructions, or from any cause whatsoever during the progress of the work, or other activity or at any subsequent time work or other activity is being performed under the obligations provided by and contemplated by the permit, except as otherwise provided by state law. The permit holder waives any and all rights to any type of expressed or implied indemnity against the County, its officers or employees.

1.3 APPLICATION CERTIFICATION

We, as the Applicants or the representative of the Applicants, hereby certify that this application is correct and complete as per the requirements presented in this application and the El Paso County Engineering Criteria Manual and Drainage Criteria Manual, Volume 2 and El Paso County Addendum.

We, as the Applicants or the representatives of the Applicants, have read and will comply with all of the requirements of the specified Stormwater Management Plan and any other documents specifying stormwater best management practices to be used on the site including permit conditions that may be required by the ECM Administrator. We understand that the stormwater control measures are to be maintained on the site and revised as necessary to protect stormwater quality as the project progresses. We further understand that a Construction Permit must be obtained and all necessary stormwater quality control measures are to be installed in accordance with the SWMP, the El Paso County Engineering Criteria Manual, Drainage Criteria Manual, Volume 2 and El Paso County Addendum before land disturbance begins and that failure to comply will result in a Stop Work Order and may result in other penalties as allowed by law. We further understand and agree to indemnify, save, and hold harmless the County and its officers and employees, including but not limited to the BOCC and ECM Administrator, from all claims, suits or actions of every name, kind and description as outlined in Section 1.2 Responsibility for Damage.



Signature of Owner or Representative

Date: 4-13-20

Scott Kraus, SVP Red Estate Expansion

Print Name of Owner or Representative

Signature of Operator or Representative

Date: _____

Print Name of Operator or Representative

Permit Fee \$ _____

Surcharge \$ _____

Financial Surety \$ _____

Type of Surety _____

Total \$ _____