

Finite Element Analysis Report by CANDE (Culvert Analysis and Design)

Sterling Ranch Colorado Springs

Merlin# 635632

Colorado Springs, Colorado

March 2, 2022

The purpose of this report is to present the study of how a BridgeCor structure is expected to behave with the site conditions including soils information. A CANDE analysis was performed assuming the soil conditions based on provided information and some assumptions, which are summarized on the following pages. This report will examine: combined thrust and moment, seam strength, wall area, global buckling, and deflection, and unfactored footing reactions. The analysis was in accordance with the AASHTO LRFD Bridge Design Specification.

Structure:

Maximum Span: 43'-0"
Bottom Span: 41'-11"
Rise: 26'-4"
Design cover: 7'-0"
Gage: 5

Summary:

- a. Load Factors: 1.75 for Live Load and 1.50 for Dead Load
- b. Modified Load Factors: 1.05 for Live Load (Multiple Presence Factor)
- c. For this structure, HL-93 design truck (32,000 pound axles spaced at 14 feet) and HL-93 tandem (25,000 pound axles spaced at 4 feet) loading were used as live load. The HL-93 design truck governed. As required by AASHTO, the combination of loads was the factored Dead Load plus the factored Live Load, which is determined as the controlling load case.
- d. Resistance Factors: Plastic Hinge Resistance Factor (ϕ_h) = 0.90, Wall Area and Buckling Resistance Factor (ϕ_w) = 0.70, Seam Strength Resistance Factor (ϕ_{SS}) = 0.67.
- e. Properties: Area of the Wall Cross-Section = 0.3003 in.²/in., Moment of Inertia = 1.1436 in.⁴/in., Section Modulus = 0.3741 in.³/in., Plastic Section Modulus = 0.5224 in.³/in.
- f. Profile of the BridgeCor deep corrugated plate (See next page for profile and data table). Profile is 15" Pitch and 5.5" Depth.
- g. Density of the backfill soil on top of the structure = 120 pcf (pounds per cubic foot)
- h. Density of the soil outside of the excavation of the arches = 120 pcf (pounds per cubic foot)
- i. Calculations of the Live loads, dead loads, etc.: See the following summary report.



Product Details and Fabrication

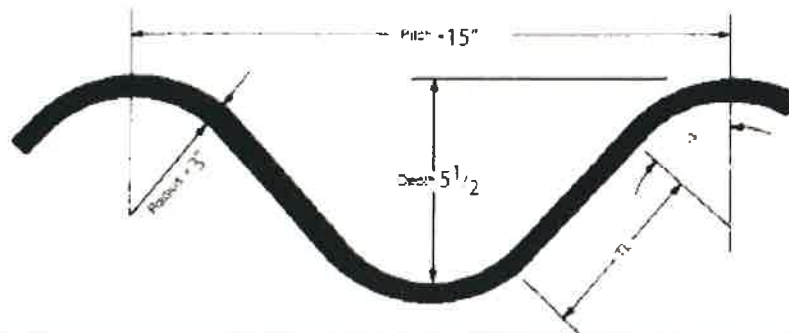

Table 2.14

Sectional properties of 15 x 5 1/2 in. (Annular)

Specified Thickness	Uncoated Thickness T	Area of Section A	Tangent Length T_L	Tangent Angle Δ	Moment of Inertia I	Section Modulus S	Radius of Gyration r	Developed Width Factor
(in.)	(in.)	(in. ² /ft)	(in.)	(Degrees)	(in. ⁴ /in)	(in. ³ /ft)	(in.)	
0.140	0.1345	2.260	4.361	49.75	0.7146	2.8406	1.9481	1.400
0.170	0.1644	2.762	4.323	49.89	0.8746	3.4602	1.9494	1.400
0.188	0.1838	3.088	4.299	49.99	0.9786	3.8599	1.9502	1.400
0.218	0.2145	3.604	4.259	50.13	1.1436	4.4888	1.9515	1.400
0.249	0.2451	4.118	4.220	50.28	1.3084	5.1114	1.9527	1.400
0.280	0.2758	4.633	4.179	50.43	1.4722	5.7317	1.9540	1.400
0.193	0.1875	3.150	4.293	50.00	0.9985	3.9359	1.9503	1.400
0.255	0.2500	4.200	4.213	50.31	1.3349	5.2107	1.9529	1.400
0.318	0.3125	5.250	4.131	50.62	1.6730	6.4678	1.9555	1.400
0.380	0.3750	6.300	4.047	50.94	2.0128	7.7076	1.9580	1.400

- Notes: 1. Per foot of projection about the neutral axis.
To obtain A or S per *inch* of width, divide the above values by 12.
2. Developed width factor measures the increase in profile length due to corrugating.
Dimensions are subject to manufacturing tolerances.

CANDE Generated Cross Section

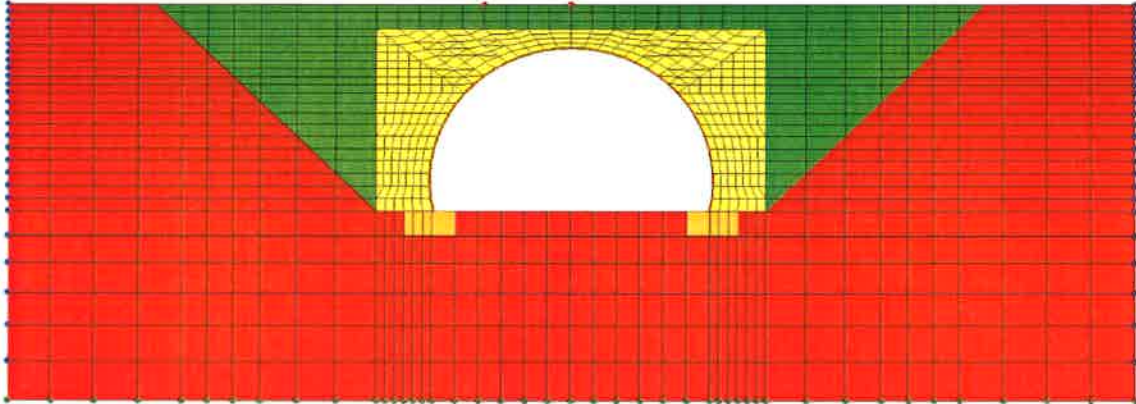

Single Radius Arch Bridge Cor: 58S 41'-11" Bottom Span x 26'-4" Rise (Inside Dimensions) Gage: 5

Height of cover above crown: 7'-0"

- Red mesh: Assumed: Isotropic-linear elastic, Young's modulus = 3,000 psi, Poisson's ratio = 0.30, density = 1 pcf (Density assumed to be 1 pcf to represent existing, consolidated soil – modeled to approximate no displacement)
- Green mesh: Embankment fill (assumed): Duncan/Selig SM90 , Density = 120 pcf
- Yellow mesh: Select backfill (assumed): Backfill width = 8'-0" , Duncan/Selig SW95, Density = 120 pcf
- Orange mesh: Reinforced concrete footing (assumed): Isotropic-linear elastic, Young's modulus = 3,500,000 psi, Poisson's ratio = 0.18, Density = 150 pcf
- Green boundary point: Displacement restricted in the vertical direction
- Blue boundary point: Displacement restricted in the horizontal direction
- Red boundary point: Force above crown of arch representing 32,000 pound, HL-93 Design Truck live load

*Design Criterion Summary:

- Wall Thrust Resistance Ratio = $32.77 / 111.0 = 0.295 < 1.00$ OK
- Global Buckling Resistance Ratio = $2.73103 / 10.96 = 0.249 < 1.00$ OK
- Seam Thrust Resistance Ratio = $32.77 / 85.09 = 0.385 < 1.00$ OK
- Combined Thrust & Moment Ratio = $0.732 < 1.00$ OK

*See sections below for more on calculations

CANDE Unfactored Thrust Reactions

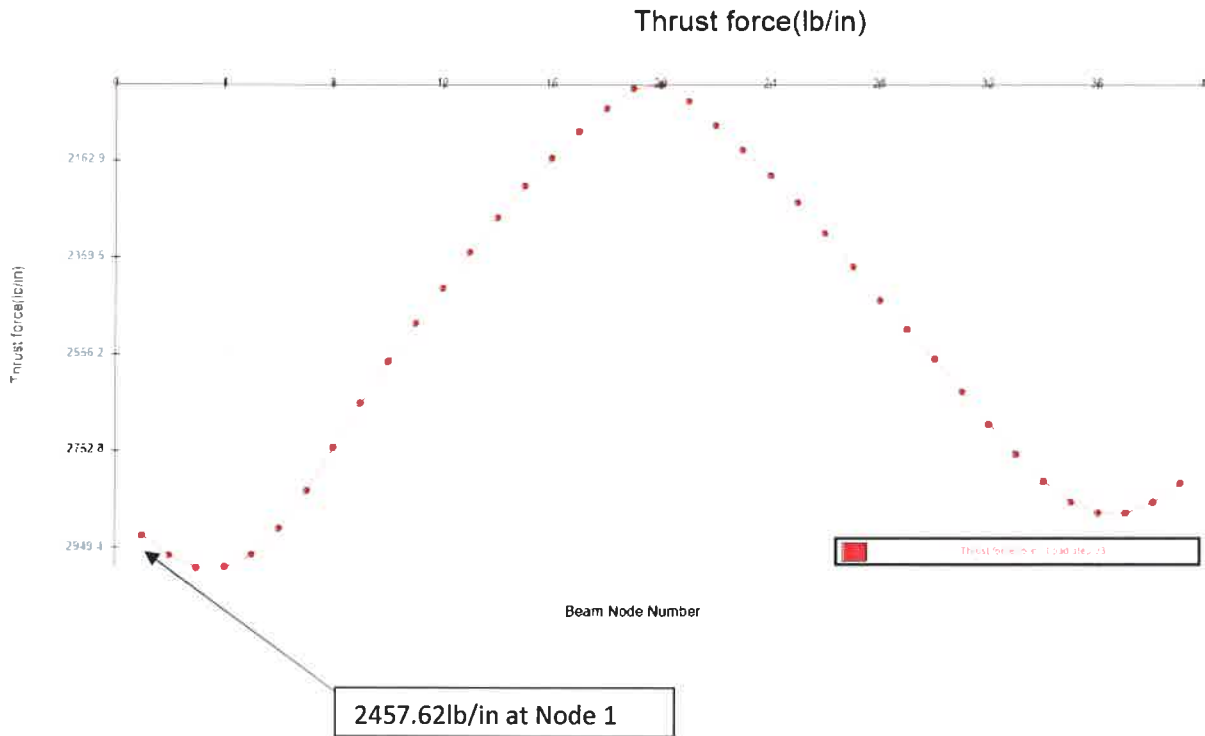

Base Angle: -12.95 degrees

Unfactored Vertical Footing Reaction: $R_V = \cos (-12.95) \times 2925.56 \times 12 = 34,214 \text{ lbs/ft}$

Unfactored Horizontal Footing Reaction: $R_H = \sin (-12.95) \times 2925.56 \times 12 = -7,867 \text{ lbs/ft}$

Notes:

- Each node represents a location along perimeter of cross-section
- Unfactored reactions are for each leg

AASHTO 12.8.9.5 (Combined Thrust & Moment Resistance) requires deep-corrugated metal plate structures to be analyzed using a finite element analysis. The results from the analysis are then used to compute a combined thrust and moment ratio (Combined T&M Ratio):

$$\text{Combined T\&M Ratio} = (T_f/R_t)^2 + M_u/M_n \leq 1.00$$

$$(\text{Factored thrust} / \text{Factored Thrust Resistance})^2 + (\text{Factored moment} / \text{Factored Moment Resistance}) \leq 1.00$$

The factored thrust resistance is the minimum yield point ($F_y = 44,000$ psi) multiplied by the area of wall cross-section (0.3003 in²/in for 5 gage) multiplied by the plastic hinge resistance factor (0.90). The factored moment resistance is the plastic moment capacity (23070 lbs-in/in for 5 gage) multiplied by the plastic hinge resistance factor. Refer to the NCSA Design manual (Table 2.14, pg. 37) for cross-section properties of BridgeCor.

The following graphs show the bending moments and thrust forces along the cross-section of the BridgeCor structure. The x-axis correlates to the distance along the perimeter of the cross-section of the Single Radius Arch BridgeCor structure in inches.

$$\text{Combined Thrust \& Moment Ratio} = (1763.55/(44,000 \times 0.3003 \times 0.90))^2 + (14744.5/(23070 \times 0.90)) = 0.732 < 1.00 \text{ OK}$$

Bending moment(lb-in/in): Load steps 1,2,3,4,5,6,7,8,9,10,11,12,13,14,15,16,17,18,19,20,21,22,23,

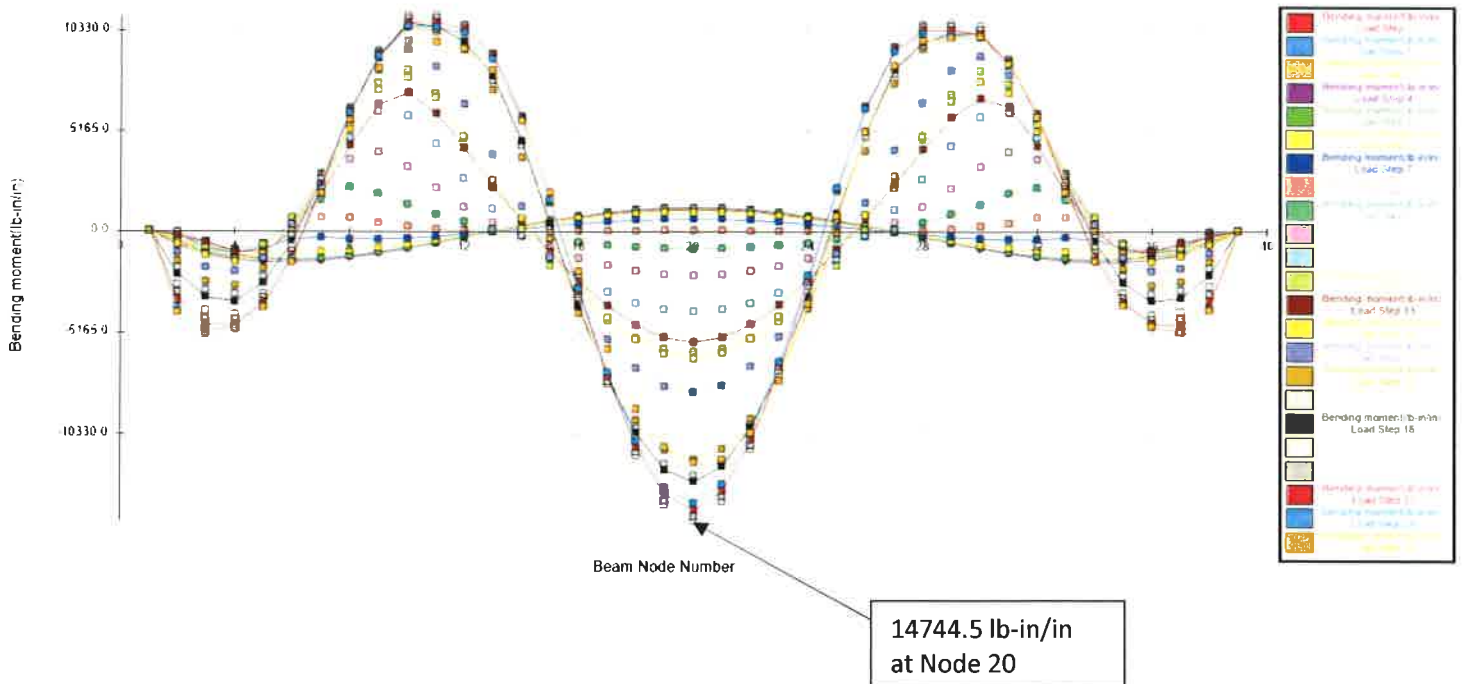

Thrust force(lb/in): Load steps 1,2,3,4,5,6,7,8,9,10,11,12,13,14,15,16,17,18,19,20,21,22,23,

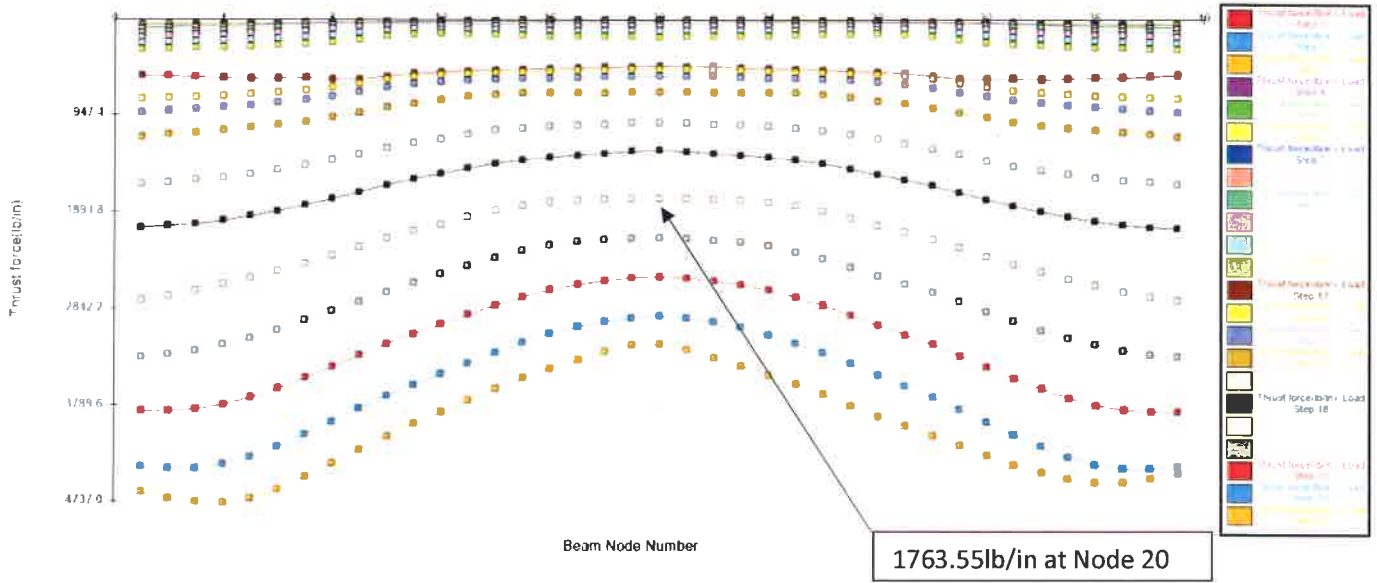

CANDE Controlling Node Output

NODE	X-COORD Y-COORD	X-DISP. Y-DISP.	N-PRES. S-PRES.	MOMENT THRUST	MAX-STRESS HOOP-STRESS	SHEAR S-STRESS
20	0.00 319.17	-0.141E-01 0.805E+00	-0.375E+01 -0.498E-01	-0.147E+05 -0.176E+04	-0.440E+05 -0.587E+04	-0.338E+01 -0.113E+02
39	254.12 0.00	0.326E+00 -0.246E+01	-0.777E+01 -0.130E+01	-0.161E-10 -0.277E+04	-0.923E+04 -0.923E+04	-0.143E+03 -0.476E+03

AASHTO Section 12.8.9.6 (Global Buckling) requires that the factored thrust in the culvert wall under the final installed condition shall not exceed the nominal resistance to general buckling capacity of the culvert, computed as:

$$R_b, \text{ nominal axial force in culvert wall to cause general buckling} = 1.2\Phi_b C_n (E_m I_p)^{1/3} (\Phi_s M_s K_b)^{2/3} R_h$$

Φ_b , resistance factor for general buckling = 0.70

C_n , scalar calibration factor to account for some nonlinear effects = 0.55

E_m , modulus of elasticity of pipe wall material = 29000 ksi

I_p , moment of inertia of stiffened culvert wall per unit length = 1.144 in⁴/in

Φ_s , resistance factor for soil = 0.9

γ , soil density = 120 pcf

R_{sp} , rise above springline = 258 inches

$P_{sp} = 0.5\gamma R_{sp} = 8.96$ psi

M_s , constrained modulus of embedment computed = 2.92 ksi based on the free field vertical stress at a depth halfway between the top and springline of the structure (Table 12.12.3.5-1)

ν , Poisson's ratio of soil = 0.30

$K_b = (1-2\nu)/(1-\nu^2) = 0.44$

R_h , correction factor for backfill geometry = 11.4/(11+S/H) = 0.67

S, culvert span = 503 inches

H, depth of fill over top of culvert = 84 inches

$$R_b = 1.2 \times 0.70 \times 0.55 \times (29000 \times 1.144)^{1/3} (0.9 \times 2.92 \times 0.44)^{2/3} (0.67) = 10.96 \text{ kips/in}$$

$$R_b = 10.96 \text{ kips/in} > \text{Max Factored Buckling Thrust} = 2.73103 \text{ kips/in}$$

$$\text{Global Buckling Resistance Ratio} = 2.73103 / 10.96 = 0.249 < 1.00 \text{ OK}$$

Table 12.12.3.5-1—M. Based on Soil Type and Compaction Condition

P_{sp} Stress Level (psi)	Sn-100 (ksi)	Sn-95 (ksi)	Sn-90 (ksi)	Sn-85 (ksi)
1.0	2.350	2.000	1.275	0.470
5.0	3.450	2.600	1.500	0.520
10.0	4.200	3.000	1.625	0.570
20.0	5.500	3.450	1.800	0.650
40.0	7.500	4.250	2.100	0.825
60.0	9.300	5.000	2.500	1.000
P_{sp} Stress Level (psi)		Si-95 (ksi)	Si-90 (ksi)	Si-85 (ksi)

AASHTO Section 12.7.2.3 (Wall Resistance) requires the wall resistance to be greater than the factored thrust.

The wall resistance is defined as:

$$R_w = \Phi_w F_y A_w$$

$$A_w = \text{wall area (in}^2\text{/ft)} = 3.604 \text{ in}^2\text{/ft}$$

$$F_y = \text{yield strength of metal} = 44 \text{ ksi}$$

$$R_w = \Phi_w F_y A_w = 0.70 \times 44 \times 3.604 = 111.0 \text{ kips/ft} > \text{Max Factored Material Thrust} = 32.77 \text{ kips/ft}$$

$$\text{Wall Thrust Resistance Ratio} = 32.77 / 111.0 = 0.295 < 1.00 \text{ OK}$$

AASHTO Section 12.7.2.5 (Seam Strength) requires the factored seam strength to be greater than the factored thrust.

The factored seam strength is defined as:

$$R_s = \Phi_{ss} SS$$

$$\Phi_{ss}, \text{ Seam Strength} = 0.67 \text{ (AASHTO Table 12.5.5-1)}$$

$$SS = \text{Seam Strength} = 127 \text{ kips/ft (from Table 7.4B on page 376 of the NCSA Design Manual).}$$

$$R_s = 0.67 \times 127 = 85.09 \text{ kips/ft} > \text{Max Factored Seam Thrust} = 32.77 \text{ kips/ft}$$

$$\text{Seam Thrust Resistance Ratio} = 32.77 / 85.09 = 0.385 < 1.00 \text{ OK}$$

CANDE Output Summary for controlling load step

ASSESSMENT SUMMARY STEEL-GROUP 1, LOAD-STEP 19

LRFD STRENGTH-LIMIT RATIOS AT STEP 19, FOR STEEL GROUP # 1

DESIGN-CRITERION	CONTROL NODE	FACTORED DEMAND	FACTORED CAPACITY	RATIO VALUE
MATERIAL THRUST (psi)	39	9233.	30800.	0.300
BUCKLING THRUST (psi)	39	9233.	46744.	0.198
SEAM THRUST (psi)	39	9233.	23052.	0.401
PLASTIC-PENETRATE (%)	20	1.68	90.00	0.019
COMBINED T&M Ratio	20	0.735	1.000	0.735

Displacement Y-Direction(in): Load steps 1,2,3,4,5,6,7,8,9,10,11,12,13,14,15,16,17,18,19,20,21,22,23,

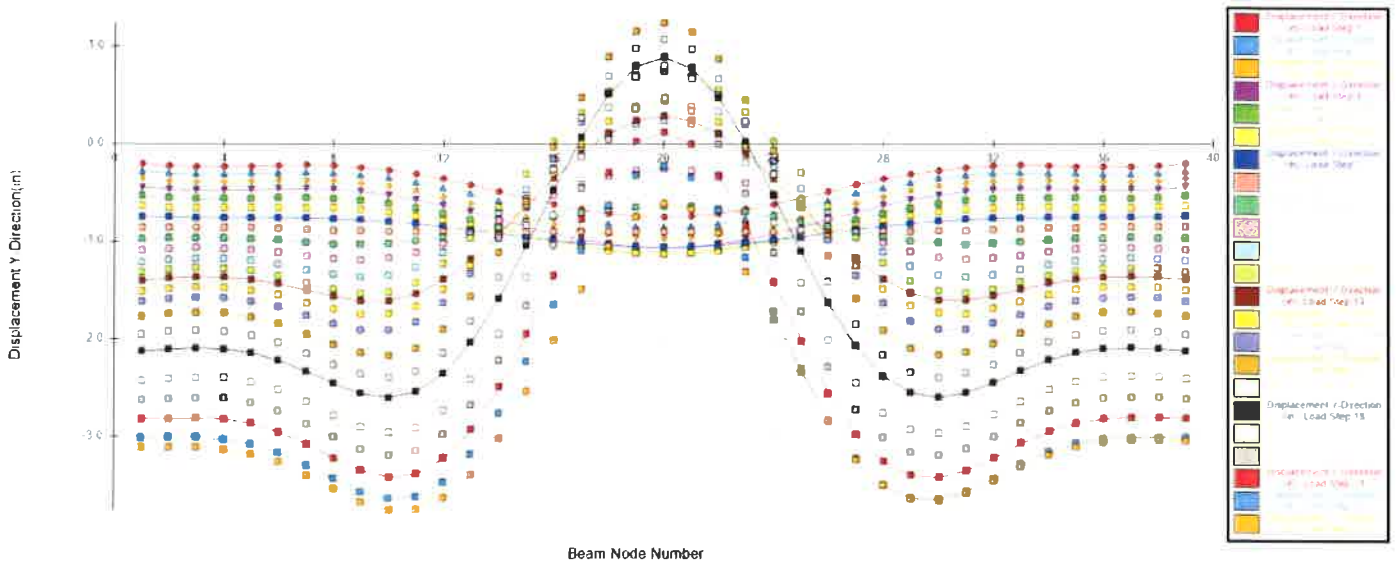

CANDE OUTPUT FOR CONTROLLING LOAD STEP 19

STRUCTURAL RESPONSES OF STEEL-GROUP 1, LOAD STEP 19

UNITS INCH-LB SYSTEM: (FORCE = LB/IN, MOMENT = IN-LB/IN, STRESS = PSI)

NODE	X-COORD Y-COORD	X-DISP. Y-DISP.	N-PRES. S-PRES.	MOMENT THRUST	MAX-STRESS HOOP-STRESS	SHEAR S-STRESS
1	-254.12 0.00	-0.320E+00 -0.246E+01	-0.799E+01 0.146E+01	0.371E-10 -0.277E+04	-0.922E+04 -0.922E+04	0.139E+03 0.462E+03
2	-258.50 24.26	-0.165E+00 -0.244E+01	-0.818E+01 0.200E+01	-0.276E+04 -0.272E+04	-0.165E+05 -0.907E+04	0.824E+02 0.274E+03
3	-260.57 48.82	0.329E-01 -0.243E+01	-0.837E+01 0.254E+01	-0.412E+04 -0.267E+04	-0.199E+05 -0.890E+04	0.311E+02 0.104E+03
4	-260.31 73.47	0.296E+00 -0.245E+01	-0.796E+01 0.240E+01	-0.430E+04 -0.261E+04	-0.202E+05 -0.869E+04	-0.172E+02 -0.572E+02
5	-257.73 97.98	0.625E+00 -0.249E+01	-0.765E+01 0.228E+01	-0.321E+04 -0.255E+04	-0.171E+05 -0.848E+04	-0.681E+02 -0.227E+03
6	-252.84 122.14	0.998E+00 -0.257E+01	-0.780E+01 0.227E+01	-0.831E+03 -0.248E+04	-0.105E+05 -0.825E+04	-0.115E+03 -0.382E+03
7	-245.70 145.73	0.137E+01 -0.270E+01	-0.865E+01 0.245E+01	0.259E+04 -0.241E+04	-0.149E+05 -0.801E+04	-0.142E+03 -0.474E+03
8	-236.35 168.54	0.169E+01 -0.284E+01	-0.102E+02 0.281E+01	0.634E+04 -0.233E+04	-0.247E+05 -0.775E+04	-0.133E+03 -0.443E+03
9	-224.90 190.36	0.190E+01 -0.296E+01	-0.105E+02 0.292E+01	0.929E+04 -0.224E+04	-0.323E+05 -0.747E+04	-0.935E+02 -0.311E+03
10	-211.44 211.01	0.198E+01 -0.301E+01	-0.111E+02 0.320E+01	0.111E+05 -0.216E+04	-0.368E+05 -0.719E+04	-0.344E+02 -0.115E+03
11	-196.08 230.29	0.191E+01 -0.296E+01	-0.874E+01 0.254E+01	0.111E+05 -0.209E+04	-0.366E+05 -0.695E+04	0.107E+02 0.357E+02
12	-178.98 248.04	0.171E+01 -0.278E+01	-0.925E+01 0.279E+01	0.106E+05 -0.202E+04	-0.350E+05 -0.673E+04	0.398E+02 0.133E+03
13	-160.27 264.09	0.142E+01 -0.245E+01	-0.103E+02 0.324E+01	0.912E+04 -0.195E+04	-0.309E+05 -0.650E+04	0.950E+02 0.316E+03

14	-140.14 278.31	0.106E+01 -0.198E+01	-0.904E+01 0.291E+01	0.585E+04 -0.189E+04	-0.219E+05 -0.628E+04	0.154E+03 0.513E+03
15	-118.75 290.56	0.712E+00 -0.139E+01	-0.746E+01 0.246E+01	0.140E+04 -0.184E+04	-0.984E+04 -0.611E+04	0.183E+03 0.610E+03
16	-96.30 300.73	0.407E+00 -0.752E+00	-0.628E+01 0.159E+01	-0.338E+04 -0.180E+04	-0.150E+05 -0.600E+04	0.182E+03 0.607E+03
17	-72.98 308.74	0.183E+00 -0.140E+00	-0.542E+01 0.892E+00	-0.783E+04 -0.179E+04	-0.269E+05 -0.595E+04	0.159E+03 0.530E+03
18	-49.02 314.51	0.501E-01 0.366E+00	-0.489E+01 0.785E+00	-0.115E+05 -0.178E+04	-0.365E+05 -0.592E+04	0.120E+03 0.398E+03
19	-24.62 318.00	-0.419E-02 0.697E+00	-0.410E+01 0.688E+00	-0.139E+05 -0.177E+04	-0.431E+05 -0.589E+04	0.648E+02 0.216E+03
20	0.00 319.17	-0.141E-01 0.805E+00	-0.375E+01 -0.498E-01	-0.147E+05 -0.176E+04	-0.440E+05 -0.587E+04	-0.338E+01 -0.113E+02
21	24.62 318.00	-0.253E-01 0.673E+00	-0.413E+01 -0.696E+00	-0.137E+05 -0.177E+04	-0.426E+05 -0.589E+04	-0.713E+02 -0.237E+03
22	49.02 314.51	-0.830E-01 0.320E+00	-0.490E+01 -0.782E+00	-0.111E+05 -0.178E+04	-0.357E+05 -0.592E+04	-0.126E+03 -0.418E+03
23	72.98 308.74	-0.220E+00 -0.203E+00	-0.548E+01 -0.921E+00	-0.735E+04 -0.179E+04	-0.256E+05 -0.595E+04	-0.164E+03 -0.547E+03
24	96.30 300.73	-0.447E+00 -0.823E+00	-0.642E+01 -0.170E+01	-0.279E+04 -0.180E+04	-0.135E+05 -0.600E+04	-0.185E+03 -0.617E+03
25	118.75 290.56	-0.752E+00 -0.146E+01	-0.765E+01 -0.252E+01	0.201E+04 -0.184E+04	-0.115E+05 -0.612E+04	-0.182E+03 -0.606E+03
26	140.14 278.31	-0.110E+01 -0.204E+01	-0.919E+01 -0.295E+01	0.637E+04 -0.189E+04	-0.233E+05 -0.630E+04	-0.149E+03 -0.496E+03
27	160.27 264.09	-0.144E+01 -0.250E+01	-0.107E+02 -0.334E+01	0.947E+04 -0.196E+04	-0.318E+05 -0.652E+04	-0.841E+02 -0.280E+03
28	178.98 248.04	-0.172E+01 -0.281E+01	-0.928E+01 -0.278E+01	0.106E+05 -0.203E+04	-0.350E+05 -0.676E+04	-0.250E+02 -0.831E+02
29	196.08 230.29	-0.190E+01 -0.297E+01	-0.844E+01 -0.244E+01	0.107E+05 -0.210E+04	-0.356E+05 -0.698E+04	-0.104E+00 -0.347E+00

30	211.44 211.01	-0.195E+01 -0.301E+01	-0.107E+02 -0.308E+01	0.105E+05 -0.217E+04	-0.353E+05 -0.722E+04	0.356E+02 0.119E+03
31	224.90 190.36	-0.187E+01 -0.295E+01	-0.104E+02 -0.290E+01	0.884E+04 -0.225E+04	-0.311E+05 -0.749E+04	0.880E+02 0.293E+03
32	236.35 168.54	-0.165E+01 -0.283E+01	-0.102E+02 -0.283E+01	0.606E+04 -0.233E+04	-0.240E+05 -0.776E+04	0.126E+03 0.421E+03
33	245.70 145.73	-0.134E+01 -0.269E+01	-0.876E+01 -0.249E+01	0.246E+04 -0.241E+04	-0.146E+05 -0.803E+04	0.137E+03 0.457E+03
34	252.84 122.14	-0.967E+00 -0.257E+01	-0.790E+01 -0.230E+01	-0.861E+03 -0.248E+04	-0.106E+05 -0.827E+04	0.112E+03 0.372E+03
35	257.73 97.98	-0.599E+00 -0.248E+01	-0.777E+01 -0.231E+01	-0.319E+04 -0.255E+04	-0.170E+05 -0.850E+04	0.673E+02 0.224E+03
36	260.31 73.47	-0.275E+00 -0.244E+01	-0.806E+01 -0.243E+01	-0.429E+04 -0.262E+04	-0.202E+05 -0.871E+04	0.183E+02 0.611E+02
37	260.57 48.82	-0.157E-01 -0.243E+01	-0.836E+01 -0.254E+01	-0.415E+04 -0.268E+04	-0.200E+05 -0.892E+04	-0.296E+02 -0.987E+02
38	258.50 24.26	0.177E+00 -0.244E+01	-0.807E+01 -0.192E+01	-0.282E+04 -0.273E+04	-0.166E+05 -0.909E+04	-0.831E+02 -0.277E+03
39	254.12 0.00	0.326E+00 -0.246E+01	-0.777E+01 -0.130E+01	-0.161E-10 -0.277E+04	-0.923E+04 -0.923E+04	-0.143E+03 -0.476E+03

Finite Element Analysis Report by CANDE (Culvert Analysis and Design)

Sterling Ranch Colorado Springs

Merlin# 635632

Colorado Springs, Colorado

March 2, 2022

The purpose of this report is to present the study of how a BridgeCor structure is expected to behave with the site conditions including soils information. A CANDE analysis was performed assuming the soil conditions based on provided information and some assumptions, which are summarized on the following pages. This report will examine: combined thrust and moment, seam strength, wall area, global buckling, and deflection, and unfactored footing reactions. The analysis was in accordance with the AASHTO LRFD Bridge Design Specification.

Structure:

Maximum Span: 43'-0"

Bottom Span: 41'-11"

Rise: 26'-4"

Design cover: 5'-0"

Gage: 5

Summary:

- a. Load Factors: 1.75 for Live Load and 1.50 for Dead Load
- b. Modified Load Factors: 1.05 for Live Load (Multiple Presence Factor)
- c. For this structure, HL-93 design truck (32,000 pound axles spaced at 14 feet) and HL-93 tandem (25,000 pound axles spaced at 4 feet) loading were used as live load. The HL-93 design truck governed. As required by AASHTO, the combination of loads was the factored Dead Load plus the factored Live Load, which is determined as the controlling load case.
- d. Resistance Factors: Plastic Hinge Resistance Factor (ϕ_h) = 0.90, Wall Area and Buckling Resistance Factor (ϕ_w) = 0.70, Seam Strength Resistance Factor (ϕ_{SS}) = 0.67.
- e. Properties: Area of the Wall Cross-Section = 0.3003 in.²/in., Moment of Inertia = 1.1436 in.⁴/in., Section Modulus = 0.3741 in.³/in., Plastic Section Modulus = 0.5224 in.³/in.
- f. Profile of the BridgeCor deep corrugated plate (See next page for profile and data table). Profile is 15" Pitch and 5.5" Depth.
- g. Density of the backfill soil on top of the structure = 120 pcf (pounds per cubic foot)
- h. Density of the soil outside of the excavation of the arches = 120 pcf (pounds per cubic foot)
- i. Calculations of the Live loads, dead loads, etc.: See the following summary report.

Product Details and Fabrication

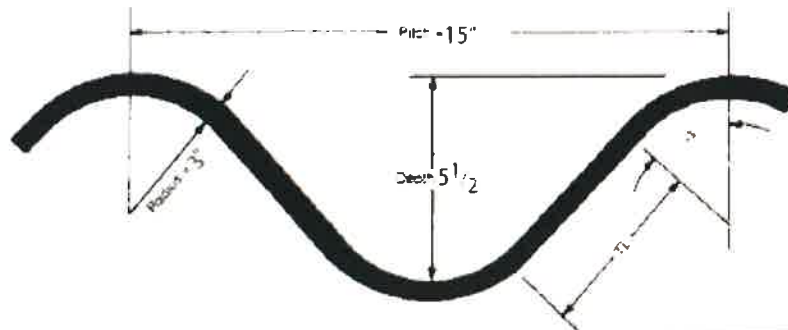

Table 2.14

Sectional properties of 15 x 5 1/2 in. (Annular)

Specified Thickness	Uncoated Thickness T	Area of Section A	Tangent Length T_L	Tangent Angle Δ	Moment of Inertia I	Section Modulus S	Radius of Gyration r	Developed Width Factor
(in.)	(in.)	(in. ² /ft)	(in.)	(Degrees)	(in. ⁴ /in)	(in. ³ /ft)	(in.)	
0.140	0.1345	2.260	4.361	49.75	0.7146	2.8406	1.9481	1.400
0.170	0.1644	2.762	4.323	49.89	0.8746	3.4602	1.9494	1.400
0.188	0.1838	3.088	4.299	49.99	0.9786	3.8599	1.9502	1.400
0.218	0.2145	3.604	4.259	50.13	1.1436	4.4888	1.9515	1.400
0.249	0.2451	4.118	4.220	50.28	1.3084	5.1114	1.9527	1.400
0.280	0.2758	4.633	4.179	50.43	1.4722	5.7317	1.9540	1.400
0.193	0.1875	3.150	4.293	50.00	0.9985	3.9359	1.9503	1.400
0.255	0.2500	4.200	4.213	50.31	1.3349	5.2107	1.9529	1.400
0.318	0.3125	5.250	4.131	50.62	1.6730	6.4678	1.9555	1.400
0.380	0.3750	6.300	4.047	50.94	2.0128	7.7076	1.9580	1.400

- Notes: 1. Per foot of projection about the neutral axis.
To obtain A or S per *inch* of width, divide the above values by 12.
2. Developed width factor measures the increase in profile length due to corrugating.
Dimensions are subject to manufacturing tolerances.

CANDE Generated Cross Section

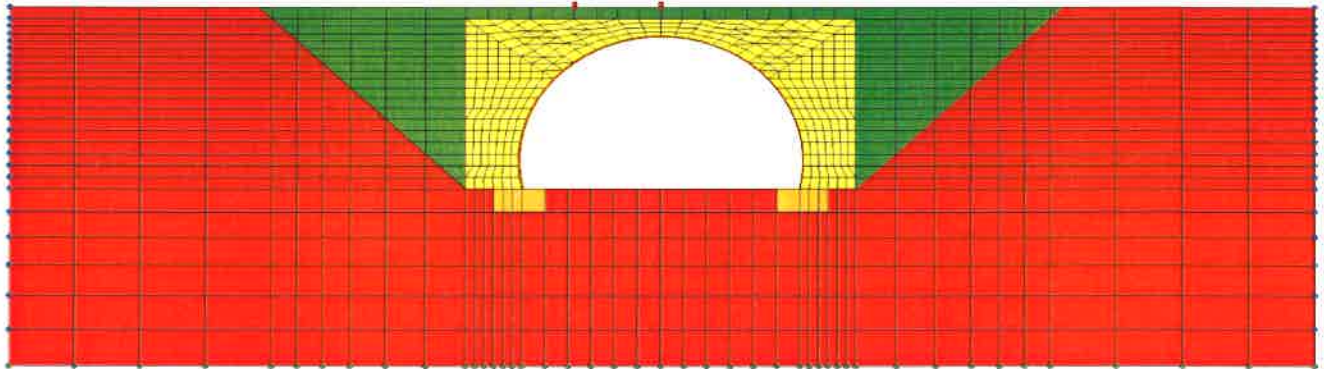

Single Radius Arch Bridge Cor: 58S 41'-11" Bottom Span x 26'-4" Rise (Inside Dimensions) Gage: 5

Height of cover above crown: 5'-0"

- Red mesh: Assumed: Isotropic-linear elastic, Young's modulus = 3,000 psi, Poisson's ratio = 0.30, density = 1 pcf (Density assumed to be 1 pcf to represent existing, consolidated soil – modeled to approximate no displacement)
- Green mesh: Embankment fill (assumed): Duncan/Selig SM90 , Density = 120 pcf
- Yellow mesh: Select backfill (assumed): Backfill width = 8'-0", Duncan/Selig SW95, Density = 120 pcf
- Orange mesh: Reinforced concrete footing (assumed): Isotropic-linear elastic, Young's modulus = 3,500,000 psi, Poisson's ratio = 0.18, Density = 150 pcf
- Green boundary point: Displacement restricted in the vertical direction
- Blue boundary point: Displacement restricted in the horizontal direction
- Red boundary point: Force above crown of arch representing 32,000 pound, HL-93 Design Truck live load

***Design Criterion Summary:**

- Wall Thrust Resistance Ratio = $32.79 / 111.0 = 0.295 < 1.00$ OK
- Global Buckling Resistance Ratio = $2.73216 / 9.60 = 0.284 < 1.00$ OK
- Seam Thrust Resistance Ratio = $32.79 / 85.09 = 0.385 < 1.00$ OK
- Combined Thrust & Moment Ratio = $0.727 < 1.00$ OK

*See sections below for more on calculations

CANDE Unfactored Thrust Reactions

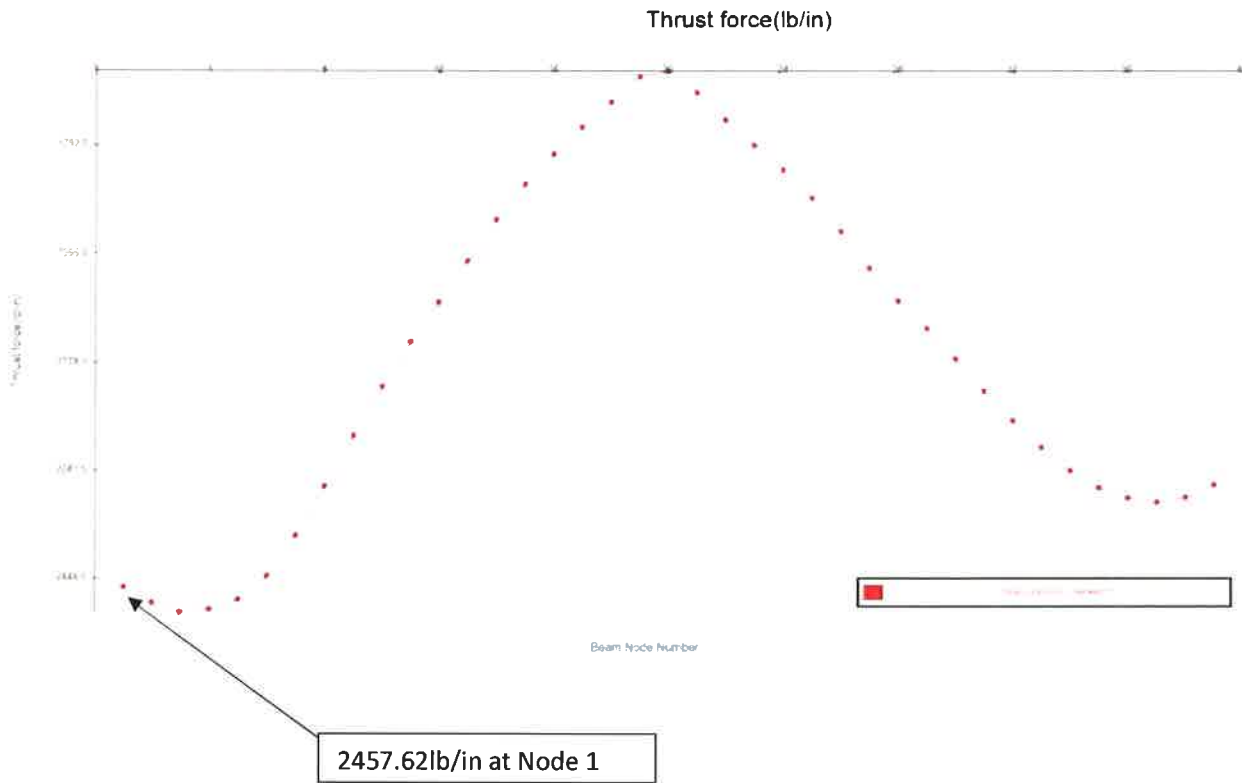

Base Angle: -12.95 degrees

Unfactored Vertical Footing Reaction: $R_v = \cos (-12.95) \times 2457.62 \times 12 = 28,741 \text{ lbs/ft}$

Unfactored Horizontal Footing Reaction: $R_H = \sin (-12.95) \times 2457.62 \times 12 = -6,609 \text{ lbs/ft}$

Notes:

- Each node represents a location along perimeter of cross-section
- Unfactored reactions are for each leg

AASHTO 12.8.9.5 (Combined Thrust & Moment Resistance) requires deep-corrugated metal plate structures to be analyzed using a finite element analysis. The results from the analysis are then used to compute a combined thrust and moment ratio (Combined T&M Ratio):

$$\text{Combined T\&M Ratio} = (T_f/R_t)^2 + M_u/M_n \leq 1.00$$

$$(\text{Factored thrust} / \text{Factored Thrust Resistance})^2 + (\text{Factored moment} / \text{Factored Moment Resistance}) \leq 1.00$$

The factored thrust resistance is the minimum yield point ($F_y = 44,000$ psi) multiplied by the area of wall cross-section (0.3003 in²/in for 5 gage) multiplied by the plastic hinge resistance factor (0.90). The factored moment resistance is the plastic moment capacity (23070 lbs-in/in for 5 gage) multiplied by the plastic hinge resistance factor. Refer to the NCSA Design manual (Table 2.14, pg. 37) for cross-section properties of BridgeCor.

The following graphs show the bending moments and thrust forces along the cross-section of the BridgeCor structure. The x-axis correlates to the distance along the perimeter of the cross-section of the Two Radius Arch BridgeCor structure in inches.

$$\text{Combined Thrust \& Moment Ratio} = (1759.78/(44,000 \times 0.3003 \times 0.90))^2 + (14634.7/(23070 \times 0.90)) = 0.727 < 1.00 \text{ OK}$$

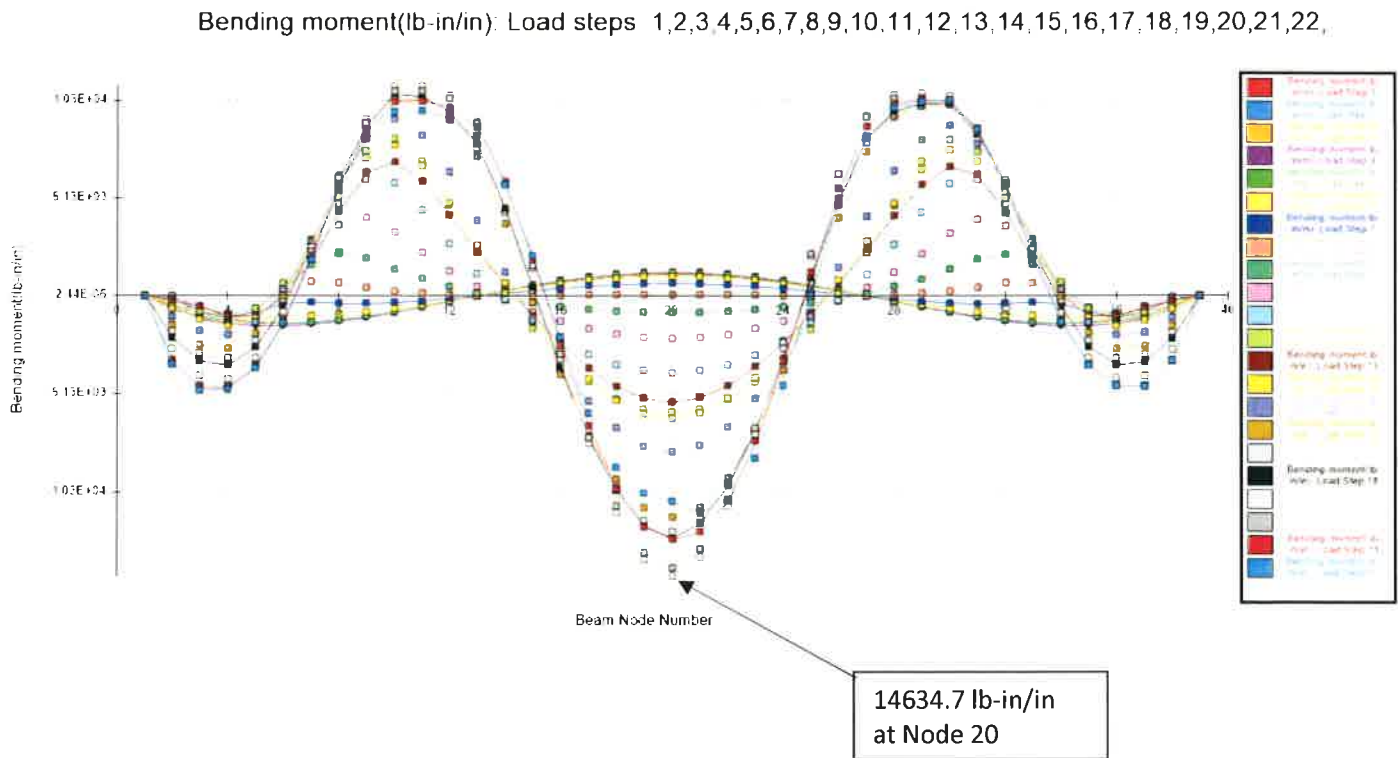

Thrust force(lb/in): Load steps 1,2,3,4,5,6,7,8,9,10,11,12,13,14,15,16,17,18,19,20,21,22,

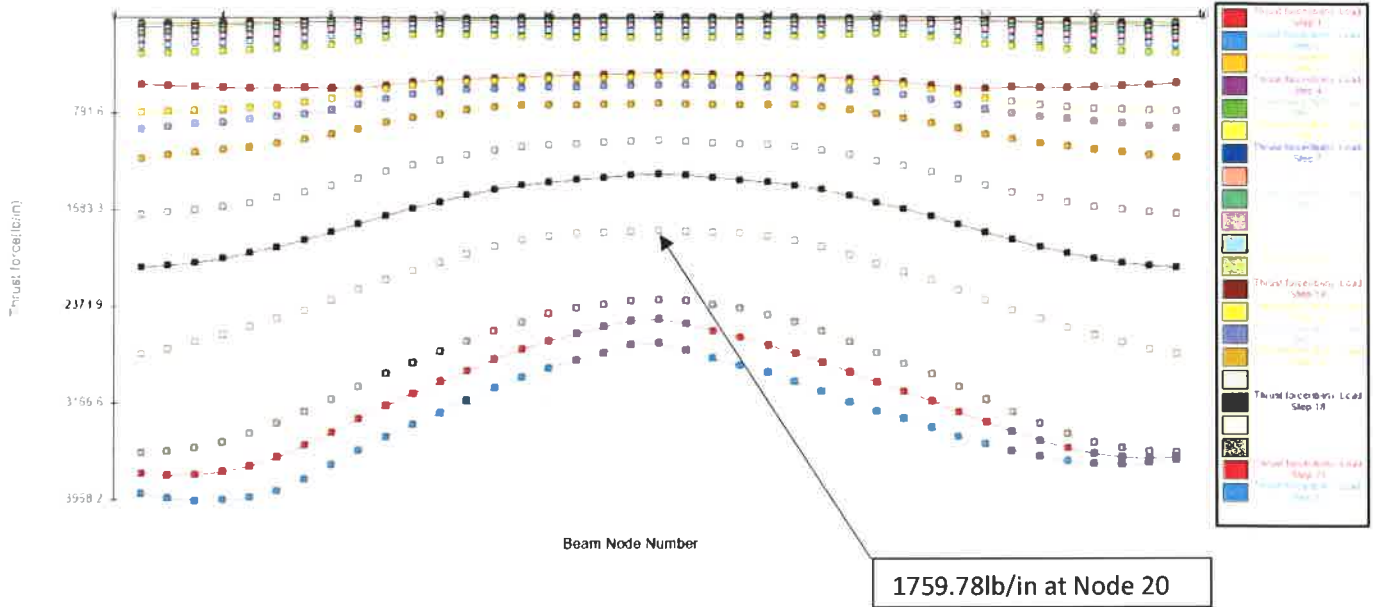

CANDE Controlling Node Output

NODE	X-COORD Y-COORD	X-DISP. Y-DISP.	N-PRES. S-PRES.	MOMENT THRUST	MAX-STRESS HOOP-STRESS	SHEAR S-STRESS
20	0.00 319.17	-0.140E-01 0.742E+00	-0.374E+01 -0.477E-01	-0.146E+05 -0.176E+04	-0.440E+05 -0.586E+04	-0.338E+01 -0.113E+02
39	254.12 0.00	0.355E+00 -0.247E+01	-0.781E+01 -0.127E+01	-0.290E-10 -0.277E+04	-0.923E+04 -0.923E+04	-0.144E+03 -0.479E+03

AASHTO Section 12.8.9.6 (Global Buckling) requires that the factored thrust in the culvert wall under the final installed condition shall not exceed the nominal resistance to general buckling capacity of the culvert, computed as:

$$R_b, \text{ nominal axial force in culvert wall to cause general buckling} = 1.2\Phi_b C_n (E_m I_p)^{1/3} (\Phi_s M_s K_b)^{2/3} R_h$$

Φ_b , resistance factor for general buckling = 0.70

C_n , scalar calibration factor to account for some nonlinear effects = 0.55

E_m , modulus of elasticity of pipe wall material = 29000 ksi

I_p , moment of inertia of stiffened culvert wall per unit length = 1.144 in⁴/in

Φ_s , resistance factor for soil = 0.9

γ , soil density = 120 pcf

R_{sp} , rise above springline = 258 inches

$P_{sp} = 0.5\gamma R_{sp} = 8.96$ psi

M_s , constrained modulus of embedment computed = 2.92 ksi

based on the free field vertical stress at a depth

halfway between the top and springline of the

structure (Table 12.12.3.5-1)

ν , Poisson's ratio of soil = 0.30

$K_b = (1-2\nu)/(1-\nu^2) = 0.44$

R_h , correction factor for backfill geometry = 11.4/(11+S/H) = 0.59

S, culvert span = 503 inches

H, depth of fill over top of culvert = 60 inches

$$R_b = 1.2 \times 0.70 \times 0.55 \times (29000 \times 1.144)^{1/3} (0.9 \times 2.92 \times 0.44)^{2/3} (0.59) = 9.60 \text{ kips/in}$$

$$R_b = 9.60 \text{ kips/in} > \text{Max Factored Buckling Thrust} = 2.73216 \text{ kips/in}$$

$$\text{Global Buckling Resistance Ratio} = 2.73216 / 9.60 = 0.284 < 1.00 \text{ OK}$$

Table 12.12.3.5-1—M. Based on Soil Type and Compaction Condition

P_{sp} Stress Level (psi)	Sn-100 (ksi)	Sn-95 (ksi)	Sn-90 (ksi)	Sn-85 (ksi)
1.0	2.350	2.000	1.275	0.470
5.0	3.450	2.600	1.500	0.520
10.0	4.200	3.000	1.625	0.570
20.0	5.500	3.450	1.800	0.650
40.0	7.500	4.250	2.100	0.825
60.0	9.300	5.000	2.500	1.000
P_{sp} Stress Level (psi)		Si-95 (ksi)	Si-90 (ksi)	Si-85 (ksi)

AASHTO Section 12.7.2.3 (Wall Resistance) requires the wall resistance to be greater than the factored thrust.

The wall resistance is defined as:

$$R_w = \Phi_w F_y A_w$$

$$A_w = \text{wall area (in}^2\text{/ft)} = 3.604 \text{ in}^2\text{/ft}$$

$$F_y = \text{yield strength of metal} = 44 \text{ ksi}$$

$$R_w = \Phi_w F_y A_w = 0.70 \times 44 \times 3.604 = 111.0 \text{ kips/ft} > \text{Max Factored Material Thrust} = 32.79 \text{ kips/ft}$$

$$\text{Wall Thrust Resistance Ratio} = 32.79 / 111.0 = 0.295 < 1.00 \text{ OK}$$

AASHTO Section 12.7.2.5 (Seam Strength) requires the factored seam strength to be greater than the factored thrust.

The factored seam strength is defined as:

$$R_s = \Phi_{ss} SS$$

$$\Phi_{ss}, \text{ Seam Strength} = 0.67 \text{ (AASHTO Table 12.5.5-1)}$$

$$SS = \text{Seam Strength} = 127 \text{ kips/ft (from Table 7.4B on page 376 of the NCSA Design Manual).}$$

$$R_s = 0.67 \times 127 = 85.09 \text{ kips/ft} > \text{Max Factored Seam Thrust} = 32.79 \text{ kips/ft}$$

$$\text{Seam Thrust Resistance Ratio} = 32.79 / 85.09 = 0.385 < 1.00 \text{ OK}$$

CANDE Output Summary for controlling load step

ASSESSMENT SUMMARY STEEL-GROUP 1, LOAD-STEP 19

LRFD STRENGTH-LIMIT RATIOS AT STEP 19, FOR STEEL GROUP # 1

DESIGN-CRITERION	CONTROL NODE	FACTORED DEMAND	FACTORED CAPACITY	RATIO VALUE
MATERIAL THRUST (psi)	39	9235.	30800.	0.300
BUCKLING THRUST (psi)	39	9235.	40838.	0.226
SEAM THRUST (psi)	39	9235.	23052.	0.401
PLASTIC-PENETRATE (%)	20	1.28	90.00	0.014
COMBINED T&M Ratio	20	0.729	1.000	0.729

Displacement Y-Direction(in): Load steps 1,2,3,4,5,6,7,8,9,10,11,12,13,14,15,16,17,18,19,20,21,22,

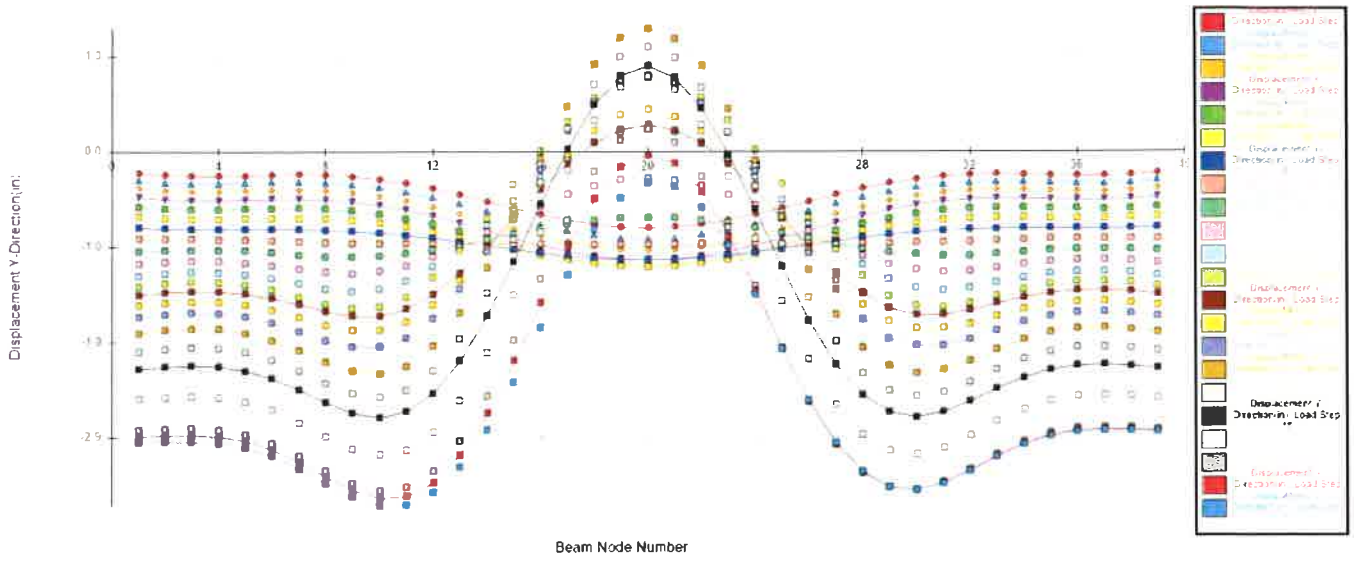

CANDE OUTPUT FOR CONTROLLING LOAD STEP 19

STRUCTURAL RESPONSES OF STEEL-GROUP 1, LOAD STEP 19

UNITS INCH-LB SYSTEM: (FORCE = LB/IN, MOMENT = IN-LB/IN, STRESS = PSI)

NODE	X-COORD Y-COORD	X-DISP. Y-DISP.	N-PRES. S-PRES.	MOMENT THRUST	MAX-STRESS HOOP-STRESS	SHEAR S-STRESS
1	-254.12 0.00	-0.350E+00 -0.248E+01	-0.803E+01 0.142E+01	0.986E-10 -0.277E+04	-0.922E+04 -0.922E+04	0.140E+03 0.466E+03
2	-258.50 24.26	-0.198E+00 -0.246E+01	-0.819E+01 0.198E+01	-0.279E+04 -0.273E+04	-0.165E+05 -0.908E+04	0.835E+02 0.278E+03
3	-260.57 48.82	-0.263E-02 -0.245E+01	-0.834E+01 0.254E+01	-0.418E+04 -0.267E+04	-0.201E+05 -0.890E+04	0.319E+02 0.106E+03
4	-260.31 73.47	0.259E+00 -0.246E+01	-0.797E+01 0.240E+01	-0.437E+04 -0.261E+04	-0.204E+05 -0.869E+04	-0.169E+02 -0.563E+02
5	-257.73 97.98	0.588E+00 -0.250E+01	-0.764E+01 0.228E+01	-0.329E+04 -0.255E+04	-0.173E+05 -0.848E+04	-0.681E+02 -0.227E+03
6	-252.84 122.14	0.961E+00 -0.259E+01	-0.780E+01 0.227E+01	-0.899E+03 -0.248E+04	-0.107E+05 -0.826E+04	-0.115E+03 -0.383E+03
7	-245.70 145.73	0.134E+01 -0.271E+01	-0.866E+01 0.245E+01	0.253E+04 -0.241E+04	-0.148E+05 -0.802E+04	-0.143E+03 -0.475E+03
8	-236.35 168.54	0.166E+01 -0.285E+01	-0.102E+02 0.282E+01	0.629E+04 -0.233E+04	-0.246E+05 -0.775E+04	-0.133E+03 -0.444E+03
9	-224.90 190.36	0.187E+01 -0.298E+01	-0.105E+02 0.293E+01	0.925E+04 -0.224E+04	-0.322E+05 -0.747E+04	-0.935E+02 -0.311E+03
10	-211.44 211.01	0.195E+01 -0.303E+01	-0.111E+02 0.320E+01	0.110E+05 -0.216E+04	-0.367E+05 -0.720E+04	-0.345E+02 -0.115E+03
11	-196.08 230.29	0.189E+01 -0.299E+01	-0.875E+01 0.254E+01	0.110E+05 -0.209E+04	-0.365E+05 -0.695E+04	0.106E+02 0.354E+02
12	-178.98 248.04	0.169E+01 -0.281E+01	-0.925E+01 0.278E+01	0.106E+05 -0.202E+04	-0.349E+05 -0.674E+04	0.396E+02 0.132E+03
13	-160.27 264.09	0.140E+01 -0.249E+01	-0.103E+02 0.323E+01	0.909E+04 -0.195E+04	-0.308E+05 -0.650E+04	0.944E+02 0.314E+03
14	-140.14 278.31	0.105E+01 -0.202E+01	-0.903E+01 0.291E+01	0.584E+04 -0.189E+04	-0.219E+05 -0.629E+04	0.153E+03 0.510E+03

15	-118.75 290.56	0.706E+00 -0.143E+01	-0.746E+01 0.247E+01	0.142E+04 -0.184E+04	-0.991E+04 -0.612E+04	0.182E+03 0.606E+03
16	-96.30 300.73	0.403E+00 -0.802E+00	-0.628E+01 0.167E+01	-0.333E+04 -0.180E+04	-0.149E+05 -0.600E+04	0.181E+03 0.604E+03
17	-72.98 308.74	0.181E+00 -0.195E+00	-0.543E+01 0.937E+00	-0.775E+04 -0.179E+04	-0.267E+05 -0.594E+04	0.158E+03 0.527E+03
18	-49.02 314.51	0.496E-01 0.307E+00	-0.489E+01 0.816E+00	-0.114E+05 -0.178E+04	-0.363E+05 -0.591E+04	0.119E+03 0.396E+03
19	-24.62 318.00	-0.420E-02 0.635E+00	-0.410E+01 0.729E+00	-0.138E+05 -0.177E+04	-0.428E+05 -0.588E+04	0.646E+02 0.215E+03
20	0.00 319.17	-0.140E-01 0.742E+00	-0.374E+01 -0.477E-01	-0.146E+05 -0.176E+04	-0.440E+05 -0.586E+04	-0.338E+01 -0.113E+02
21	24.62 318.00	-0.252E-01 0.610E+00	-0.413E+01 -0.736E+00	-0.136E+05 -0.177E+04	-0.423E+05 -0.588E+04	-0.710E+02 -0.237E+03
22	49.02 314.51	-0.824E-01 0.260E+00	-0.490E+01 -0.813E+00	-0.110E+05 -0.178E+04	-0.354E+05 -0.591E+04	-0.125E+03 -0.417E+03
23	72.98 308.74	-0.218E+00 -0.258E+00	-0.549E+01 -0.967E+00	-0.727E+04 -0.178E+04	-0.254E+05 -0.594E+04	-0.163E+03 -0.544E+03
24	96.30 300.73	-0.443E+00 -0.873E+00	-0.643E+01 -0.177E+01	-0.274E+04 -0.180E+04	-0.133E+05 -0.600E+04	-0.184E+03 -0.613E+03
25	118.75 290.56	-0.745E+00 -0.150E+01	-0.765E+01 -0.252E+01	0.203E+04 -0.184E+04	-0.116E+05 -0.613E+04	-0.181E+03 -0.602E+03
26	140.14 278.31	-0.109E+01 -0.208E+01	-0.919E+01 -0.295E+01	0.637E+04 -0.189E+04	-0.233E+05 -0.630E+04	-0.148E+03 -0.493E+03
27	160.27 264.09	-0.142E+01 -0.253E+01	-0.107E+02 -0.333E+01	0.945E+04 -0.196E+04	-0.318E+05 -0.653E+04	-0.835E+02 -0.278E+03
28	178.98 248.04	-0.170E+01 -0.284E+01	-0.928E+01 -0.278E+01	0.105E+05 -0.203E+04	-0.349E+05 -0.677E+04	-0.248E+02 -0.825E+02
29	196.08 230.29	-0.187E+01 -0.300E+01	-0.845E+01 -0.244E+01	0.107E+05 -0.210E+04	-0.355E+05 -0.698E+04	0.106E-01 0.352E-01

30	211.44 211.01	-0.193E+01 -0.303E+01	-0.107E+02 -0.308E+01	0.105E+05 -0.217E+04	-0.352E+05 -0.722E+04	0.356E+02 0.119E+03
31	224.90 190.36	-0.184E+01 -0.297E+01	-0.104E+02 -0.290E+01	0.879E+04 -0.225E+04	-0.310E+05 -0.749E+04	0.879E+02 0.293E+03
32	236.35 168.54	-0.162E+01 -0.285E+01	-0.102E+02 -0.284E+01	0.601E+04 -0.233E+04	-0.238E+05 -0.777E+04	0.127E+03 0.422E+03
33	245.70 145.73	-0.130E+01 -0.271E+01	-0.877E+01 -0.249E+01	0.240E+04 -0.241E+04	-0.145E+05 -0.803E+04	0.137E+03 0.458E+03
34	252.84 122.14	-0.929E+00 -0.258E+01	-0.790E+01 -0.231E+01	-0.929E+03 -0.249E+04	-0.108E+05 -0.828E+04	0.112E+03 0.373E+03
35	257.73 97.98	-0.561E+00 -0.250E+01	-0.777E+01 -0.231E+01	-0.327E+04 -0.255E+04	-0.172E+05 -0.850E+04	0.674E+02 0.224E+03
36	260.31 73.47	-0.237E+00 -0.246E+01	-0.805E+01 -0.243E+01	-0.436E+04 -0.262E+04	-0.204E+05 -0.872E+04	0.181E+02 0.601E+02
37	260.57 48.82	0.196E-01 -0.245E+01	-0.834E+01 -0.253E+01	-0.421E+04 -0.268E+04	-0.202E+05 -0.893E+04	-0.305E+02 -0.101E+03
38	258.50 24.26	0.210E+00 -0.245E+01	-0.807E+01 -0.190E+01	-0.285E+04 -0.273E+04	-0.167E+05 -0.910E+04	-0.842E+02 -0.280E+03
39	254.12 0.00	0.355E+00 -0.247E+01	-0.781E+01 -0.127E+01	-0.290E-10 -0.277E+04	-0.923E+04 -0.923E+04	-0.144E+03 -0.479E+03