

**REVISED
DRAINAGE PLAN AND REPORT**

PROPOSED AIRPORT HANGER

**8140 and 8150
CESSNA DRIVE
LOT 7 BLOCK 1
MEADOW LAKE AIRPORT
FILING NO. 2**

County Fil No.: PPR2138

February 28, 2024

Prepared for

RYAN SCHNEIDER

Oliver E. Watts, Consulting Engineer, Inc.
Colorado Springs, Colorado

OLIVER E. WATTS, PE-LS
OLIVER E. WATTS, CONSULTING ENGINEER, INC.
CIVIL ENGINEERING AND SURVEYING
614 ELKTON DRIVE
COLORADO SPRINGS, COLORADO 80907
(719) 593-0173
fax (719) 265-9660
olliewatts@aol.com
Celebrating over 43 years in business

February 28, 2024

El Paso County Planning and Community Development
2880 International Circle
Colorado Springs, CO 80910

ATTN: *Joshua Palmer*

SUBJECT: Final Drainage Plan and Report
Building at 8140 and 8150 Cessna Drive

Transmitted herewith for your review and approval is the revised drainage plan and report for the proposed 8140 and 8150 Cessna Drive in El Paso County. . It is now revised as requested by the FAA representative to avoid obstructions within the aviation easements.

Please contact me if I may provide any further information.

Oliver E. Watts, Consulting Engineer, Inc.

BY: _____
Oliver E. Watts, President

Encl:

Table of Contents

1. Cover
2. Transmittal Letter
3. Table of Contents
4. Signatures / approvals page
5. Drainage Report 9 pages
6. Vicinity Map
7. Computations 8 pages
8. FEMA Panels No. 08041C0554 G
9. SCS Soils Map and Interpretation Sheet, 2 pages
10. Backup Information, 5 pages
11. Drainage Plan, Existing Conditions Dwg 20-5498-04
12. Drainage Plan, Proposed Conditions Dwg 20-5498-07
13. Pond Outlet plan, Dwg 20-5498-08

1. ENGINEER'S STATEMENT:

The attached drainage plan and report were prepared under my direction and supervision and are correct to the best of my knowledge and belief. Said drainage report has been prepared according to the criteria established by the County for drainage reports and said report is in conformity with the applicable master plan of the drainage basin. I accept responsibility for any liability caused by any negligent acts, errors or omissions on my part in preparing this report.

Oliver E. Watts, Consulting Engineer, Inc.

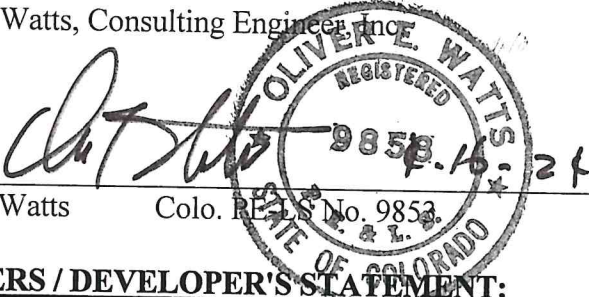

Oliver E. Watts

Colo. Reg. No. 9853

date

2. OWNERS / DEVELOPER'S STATEMENT:

I the owner / developer have read and will comply with all of the requirements specified in this drainage report and plan.

Ryan Schneider

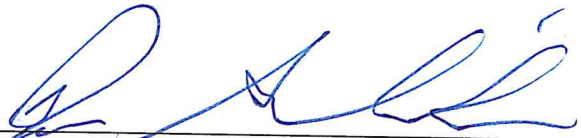
By:  4-16-2024
2610 Fairmont Street
Colorado Springs, CO 80909

EL PASO COUNTY:

Filed in accordance with the requirements of the El Paso Land Development Code, Drainage Criteria Manual Volumes 1 and 2, and the Engineering Criteria Manual, as amended.

Joshua Palmer, P.E.,
County Engineer / ECM Administrator

date

Conditions:

4. LOCATION AND DESCRIPTION:

The proposed building is located at 8140 and 8150 Cessna Drive. The legal description is Lot 7, Block 1, Meadow Lake Airport Filing No. 2; being in Section 4, Township 13 South, Range 64 West of the 6th P.M., in El Paso County. The site is 3.262 acres total. It is proposed that an airport hanger, along with parking lot and sidewalks be constructed on the east portion of the property. Approximately 2.292 acres of the site will undergo construction, excavation and grading. The details of the proposal are shown on the enclosed drainage plan. Parking area, driveway and sidewalks will be asphalt, and the remaining area outside the building will be landscaped. The property is in the Sand Creek drainage basin. The lot is currently undeveloped in a range land condition; approximately 85% of the lot is covered with native grasses. The purpose of this revision is to redesign the detention pond to avoid obstructions within the aviation easements on and adjacent to the property.

5. FLOOD PLAIN STATEMENT:

This subdivision is not within the limits of a flood plain or flood hazard area, according to FEMA map panel number 08041C0554 G, dated December 7, 2018, a copy of which is enclosed for reference.

6. METHOD AND CRITERIA:

The method used for all computations is that specified in the City-County Drainage Criteria Manual, using the rational method for areas of the size of the development. All computations are enclosed for reference and review.

The soils in the subdivision have been mapped by the local USDA/SCS office, and a soils map and interpretation sheet are enclosed for reference. All soils in this area are of the Perrypark complex, being in hydrologic group "B".

7. DESCRIPTION OF RUNOFF:

EXISTING DRAINAGE CONDITIONS

The site is located as shown on the enclosed drainage plans in the Meadow Lake Airport of El Paso County. The natural basin consists of basins A through C on the enclosed existing drainage conditions map that discharges 0.57 cfs (5-year runoff) / 4.12 cfs (100-year runoff) historically, as shown on the existing conditions drainage plan. No offsite basins runoff into this development.

PROPOSED DRAINAGE CONDITIONS

The area will be graded to conform to the existing topography shown on the drainage plan, routing all runoff into a lot area at the southeast portion of the construction site. No clearing will be necessary within the construction site.

Runoff will be routed southeasterly along airport taxiways to a northerly taxiway where storm sewers will pick up the runoff from respective basins and direct it to the proposed full spectrum detention pond located in the southeast corner of the lot, in accordance with County criteria, since the total disturbed area is over 1 acre. The total runoff into the pond will be 2.2 cfs / 5.9 cfs. As shown on the enclosed computation sheet the 100 year storage required is 0.198 acre feet, which occurs at a depth of 4.37'. Details of the design are shown on the drainage and outlet plans in the appendix.

Runoff is directed (sheet flow) by grading down the traffic runways to the storm sewer shown on the drainage plan and routed to the detention pond.

The outfall storm sewer will be routed to the existing drainage channel along side of the main entry taxiway as shown on the enclosed drainage plan, considered the suitable outfall for the site. 229.16 LF of 18" CMP is proposed for an outfall storm sewer, discharging into the existing channel along Cessna Drive. The design runoff for the 18" CMP and the spillway is 5.9 cfs, the total inflow, as required by county criteria, so the minimum slope on the outfall pipe is 0.46%. The hydrographs show the pond outflow to be approximately 3 cfs.

FOUR STEP PROCESS

The following process has been followed to minimize adverse impacts of urbanization

Step1 Employ Runoff Reduction Practices – The extent of impervious materials is minimized consistent with the objectives of the facility. No curb and gutter or other items that might concentrate runoff are proposed. Standard BMP's are provided as shown on the grading and erosion control plan; Vehicle tracking control, stockpile and staging area protection, and a concrete washout basin. Silt fence is not used as requested by the Airport, as it is considered a hazard to taxiing aircraft – instead drainage berms and swales are used as indicated by the finish topography and identified on the erosion control plan.

Step 1: Employ Runoff Reduction Practices

To reduce runoff peaks and volumes from urbanizing areas, employ a practice generally termed "minimizing directly connected impervious areas" (MDCIA). The principal behind MDCIA is twofold -- to reduce impervious areas and to route runoff from impervious surfaces over grassy areas to slow down runoff and promote infiltration. The benefits are less runoff, less stormwater pollution, and less cost for drainage infrastructure. There are several approaches to reduce the effective imperviousness of a development site:

Reduced Pavement Area

Sometimes, creative site layout can reduce the extent of paved areas including parking, thereby saving on initial capital cost of pavement and then saving on pavement maintenance, repair, and replacement over time.

Grass Swales

The use of grass swales instead of storm sewers slows down runoff, promotes infiltration, and also reducing effective imperviousness. It also may reduce the size and cost of downstream storm sewers and detention.

Implementing these approaches on a new development site is discussed further in the DCM2 section titled Employing Runoff Reduction Techniques. This section provides a procedure for estimating a reduced imperviousness based on the use of grass buffers and swales. The latter three of the approaches for reducing imperviousness are structural BMPs and are described in detail in Section 4.2 of DCM2 (New Development BMP Fact sheets):

Grass Buffer.

Grass Swale.

Modular Block Porous Pavement (or Stabilized-Grass Porous Pavement;

Step 2 Stabilize Drainageways –The development of this project does not create Drainageways and is not anticipated to have any negative effects on downstream Drainageways. Grass swales along the north and south sides of the building are minimized and slopes are minimized, and they will outfall onto the proposed parking lot which will direct the flows to inlets and eventually the detention pond. Runoff across the asphalt pavement will not be concentrated along the said swales.

Step 2: Stabilize Drainageways

Drainageway, natural and manmade, erosion can be a major source of sediment and associated constituents, such as phosphorus. Natural Drainageways are often subject to bed and bank erosion when urbanizing areas increase the frequency, rate, and volume of runoff. Therefore, Drainageways are required to be stabilized. One of three basic methods of stabilization may be selected.

Constructed Grass, Riprap, or Concrete-Lined Channel

These methods of channel stabilization have been in practice for some time. The water quality benefit associated with these channels is the reduction of severe bed and bank erosion that can occur in the absence of a stabilized channel. On the other hand, the hard-lined low flow channels that are often used do not offer much in the way of water quality enhancement or wetland habitat. The use of riprap or concrete lined flood conveyance channels is not recommended, unless hydraulic or physical conditions require such an alternative. A grass lined channel is recommended along the north line of Basin A.

Step 3 Provide Water Quality Capture Volume – The limit of disturbance for the proposed construction is 2.292 acres, therefore water quality / water detention provisions are required and necessary. Therefore the full spectrum detention pond is proposed.

Step 3: Provide Water Quality Capture Volume (WQCV)

All sites defined as "New Development and Significant Redevelopment" and all sites requiring stormwater quantity detention, as listed above in the Section I.7.1B, shall address stormwater quality by providing the WQCV. One or more of six types of water quality basins, each draining slowly to provide for long-term settling of sediment particles, may be selected. Information on selecting and configuring one or more of these WQCV facilities at a site is provided in the section providing Water Quality Capture Volume (WQCV). An Extended Detention Basin is recommended for this installation.

Step 4 Consider Need for Industrial and Commercial BMP's – This submittal provides a final grading and erosion control plans with BMP's in place. The proposed project will use (dirt) berms, a vehicle tracking control pad, and concrete washout area, reseeded and landscaping to mitigate the potential for erosion across the site. The proposed BMP's are considered fully adequate.

8. COST ESTIMATE:

All facilities are private.

Item No.	Description	Quantity	Unit Cost	Cost
1	Firebaugh Grated Inlet	2 ea	\$ 1500.00	\$ 3,000.00
2	18" CMP storm sewer	229.16 lf	35.00	8,020.60
3	Detention Pond	900 CY	6.00	5,400.00
4	Outlet Structure	1 Ea	3000.00	3000.00
Subtotal Construction Cost				\$ 19,420.60
Engineering			10%	1,942.06
Total Estimated Cost				\$21,362.66

9. FEES:

No subdivision is required, therefore fees are not due.

10. SUMMARY

The proposed building at this address provides a minimum encroachment in an attractive natural setting in order to aid in the operation of the Meadow Lake Airport. There will be no adverse effects on downstream or surrounding properties.

The drainage analysis has been prepared in accordance with the current El Paso County Drainage Criteria Manual. Supporting information and calculations are included in this report.

References

1. El Paso County Engineering Criteria Manual, December 13, 2016
2. City of Colorado Springs Drainage Criteria Manual, Volumes 1 and 2, May, 2014
3. El Paso County Drainage Criteria Manuals, Volumes 1 and 2 (and updates), October 31, 2018
4. Urban Drainage Criteria Manuals, Volumes 1, 2 and 3, 2016 and 2019

MAJOR BASIN	SUB BASIN	AREA		BASIN		T _c MIN	I in./hr.		SOIL GRP	DEV. TYPE	C		FLOW		RETURN PERIOD -years-	
		PLANIM READ	ACRES	LENGTH -FT.-	HEIGHT -FT.-								5-ry	100-yr		
													qp -CFS-	qp -CFS-		
DEVELOPED	A	COGO	0.196	300	5	12			A	ROOF	0.73	0.81			5	100
ULTIMATE		V=1.1	0.062	+150	2.5	+2				A.C.	0.90	0.96				
			0.434							R/L	0.08	0.36				
			0.692			14	3.4	2.8		MIX	0.338	0.535	0.8	1.8		
	B	COGO	0.124	300	6	6.0			A	ROOF	0.73	0.81				
		V=2.0	0.198	+1580	1.8	+1.5				A.C.	0.90	0.96				
			0.568							R/L	0.08	0.35				
			0.890			7.5	4.6	7.8		MIX	0.352	0.550	1.4	3.8		
	C	COGO	0.150	300	5	20.7			A	ROOF	0.73	0.81				
		V=2.0	0.279	+165	+1.65	+0.1				A.C.	0.90	0.96				
			0.932			20.8				R/L	0.08	0.365				
			1.361				3.0	4.9		MIX	0.320	0.523	1.3	3.4		
	.+B		0.890	+136.37	V=4.05	+0.5										
	TOTAL		2.251			21.3	2.9	4.9		MIX	0.333	0.536	2.2	5.9		
	.+A		0.692	+31.24	V=7.64	+0.1					0.338	0.535				
	TOTAL		2.943			24.4	2.9	4.9		MIX	0.334	0.536	2.9	7.7		
											46%	IMP				
HYDROLOGICAL COMPUTATION - BASIC DATA															PAGE 2	
PROJ: 8140 CESSNA BY: O.E. WATTS										OLIVER E. WATTS, CONSULTING ENGINEER, INC.					OF	
RATIONAL METHOD DATE: 7/9/21 3-16-22															8	
										614 ELKTON DRIVE COLORADO SPRINGS, CO 80907						

STREET AND STORM SEWER CALCULATIONS

STREET	LOCATION	DISTANCE -ft.-	ELEVATION & SLOPE	TOTAL RUNOFF -cfs- 5-yr./100-yr	STREET FLOW / CAPACITY -cfs- 5-yr./100-yr	PIPE FLOW -cfs-	TYPE PIPE, CATCH BASIN & SLOPE %
PRIVATE	C		31.61/30.11	1.3/3.5		3.5	FIREBAUGH GRATE
		130.37	0.67%			3.5	12" PVC S=0.67% V=4.45
	B		30.70/29.20				FIREBAUGH GRATE
		31.24		2.2/5.9		5.9	12" PVC V=7.5
	C		28 OUT				OUTLET STRUCTURE
		228.16	2.63%			5.9	12" PVC, 1.62% MIN.
	OF DITCH		22				
	SPILLWAY		d=dc			5.9	B=10' D=1' Z=4:1 d=0.33'

STREET AND STORM SEWER CALCULATIONS
PROJECT: 8140 CESSNA **BY: O.E. WATTS**
DATE: 7/9/21

OLIVER E. WATTS, CONSULTING ENGINEER, INC.
 614 ELKTON DRIVE COLORADO SPRINGS, CO 80907

Page:3
 Of
 Pages: 8

518

DETENTION BASIN STAGE-STORAGE TABLE BUILDER

UD-Detention, Version 3.07 (February 2017)

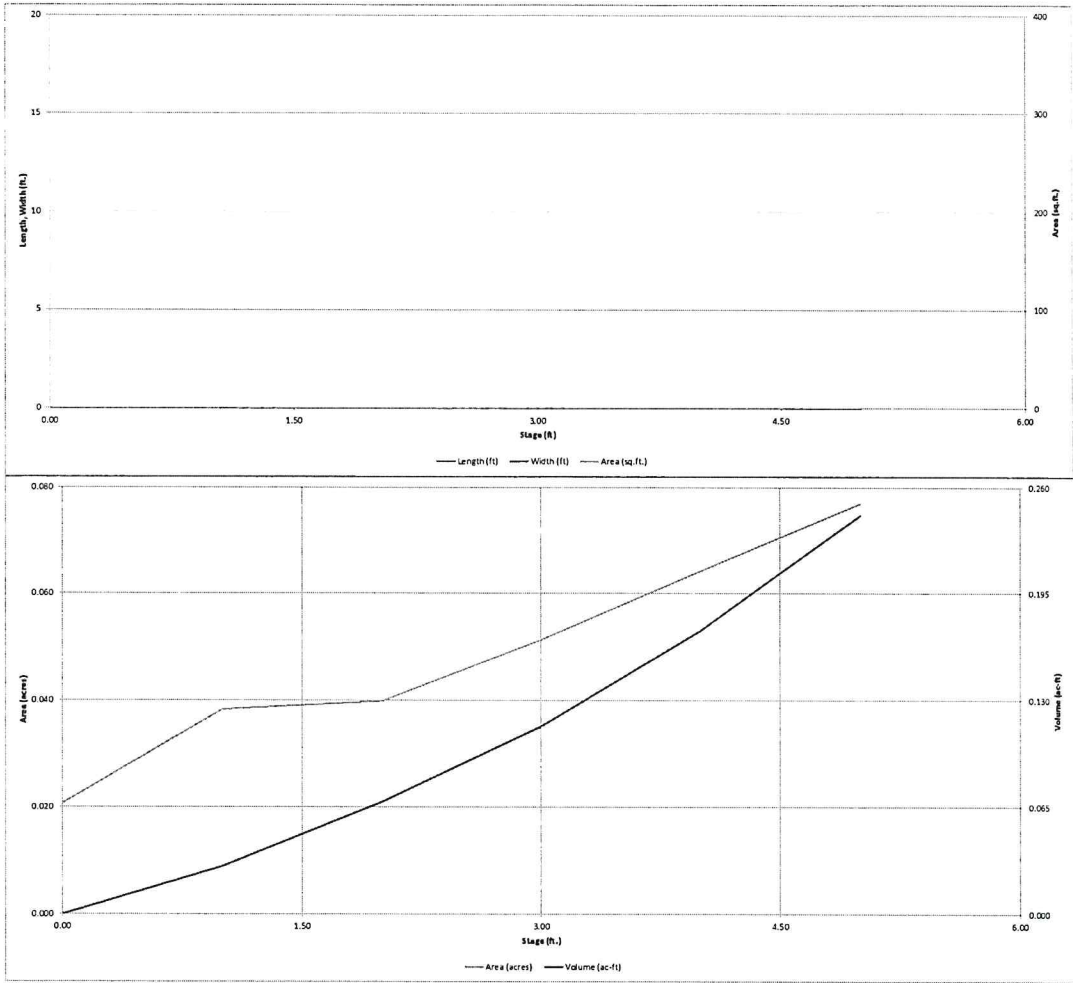

Detention Basin Outlet Structure Design

UD-Detention, Version 3.07 (February 2017)

Project: **8140 CESSNA DRIVE**

Basin ID: **2-28-24 PRIVATE EDB**

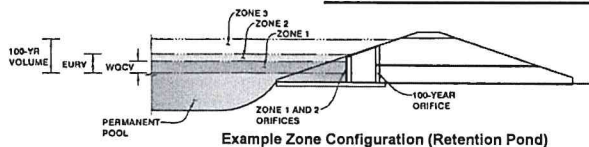

	Stage (ft)	Zone Volume (ac-ft)	Outlet Type
Zone 1 (WQCV)	1.48	0.048	Orifice Plate
Zone 2 (EURV)	3.69	0.104	Orifice Plate
Zone 3 (100-year)		0.095	Not Utilized
		0.248	Total

User Input: Orifice at Underdrain Outlet (typically used to drain WQCV in a Filtration BMP)

Underdrain Orifice Invert Depth =	N/A	ft (distance below the filtration media surface)
Underdrain Orifice Diameter =	N/A	inches

Calculated Parameters for Underdrain

Underdrain Orifice Area =	N/A	ft ²
Underdrain Orifice Centroid =	N/A	feet

User Input: Orifice Plate with one or more orifices or Elliptical Slot Weir (typically used to drain WQCV and/or EURV in a sedimentation BMP)

Invert of Lowest Orifice =	0.00	ft (relative to basin bottom at Stage = 0 ft)
Depth at top of Zone using Orifice Plate =	3.13	ft (relative to basin bottom at Stage = 0 ft)
Orifice Plate: Orifice Vertical Spacing =	12.50	inches
Orifice Plate: Orifice Area per Row =	N/A	inches

Calculated Parameters for Plate

WQ Orifice Area per Row =	N/A	ft ²
Elliptical Half-Width =	N/A	feet
Elliptical Slot Centroid =	N/A	feet
Elliptical Slot Area =	N/A	ft ²

User Input: Stage and Total Area of Each Orifice Row (numbered from lowest to highest)

	Row 1 (required)	Row 2 (optional)	Row 3 (optional)	Row 4 (optional)	Row 5 (optional)	Row 6 (optional)	Row 7 (optional)	Row 8 (optional)
Stage of Orifice Centroid (ft)	0.00	1.04	2.09					
Orifice Area (sq. inches)	2.00	2.00						

	Row 9 (optional)	Row 10 (optional)	Row 11 (optional)	Row 12 (optional)	Row 13 (optional)	Row 14 (optional)	Row 15 (optional)	Row 16 (optional)
Stage of Orifice Centroid (ft)								
Orifice Area (sq. inches)								

User Input: Vertical Orifice (Circular or Rectangular)

	Not Selected	Not Selected	
Invert of Vertical Orifice =	0.00	n/a	ft (relative to basin bottom at Stage = 0 ft)
Depth at top of Zone using Vertical Orifice =	N/A	N/A	ft (relative to basin bottom at Stage = 0 ft)
Vertical Orifice Diameter =	N/A	N/A	inches

Calculated Parameters for Vertical Orifice

	Not Selected	Not Selected	
Vertical Orifice Area =	N/A	N/A	ft ²
Vertical Orifice Centroid =	N/A	N/A	feet

User Input: Overflow Weir (Dropbox) and Grate (Flat or Sloped)

	Not Selected	Not Selected	
Overflow Weir Front Edge Height, H _o =	N/A	N/A	ft (relative to basin bottom at Stage = 0 ft)
Overflow Weir Front Edge Length =	N/A	N/A	feet
Overflow Weir Slope =	N/A	N/A	H:V (enter zero for flat grate)
Horiz. Length of Weir Sides =	N/A	N/A	feet
Overflow Grate Open Area % =	N/A	N/A	% grate open area/total area
Debris Clogging % =	N/A	N/A	%

Calculated Parameters for Overflow Weir

	Not Selected	Not Selected	
Height of Grate Upper Edge, H _g =	N/A	N/A	feet
Over Flow Weir Slope Length =	N/A	N/A	feet
Grate Open Area / 100-yr Orifice Area =	N/A	N/A	should be ≥ 4
Overflow Grate Open Area w/o Debris =	N/A	N/A	ft ²
Overflow Grate Open Area w/ Debris =	N/A	N/A	ft ²

User Input: Outlet Pipe w/ Flow Restriction Plate (Circular Orifice, Restrictor Plate, or Rectangular Orifice)

	Not Selected	Not Selected	
Depth to Invert of Outlet Pipe =	0.00	N/A	ft (distance below basin bottom at Stage = 0 ft)
Circular Orifice Diameter =	18.00	N/A	inches

Calculated Parameters for Outlet Pipe w/ Flow Restriction Plate

	Not Selected	Not Selected	
Outlet Orifice Area =	1.77	N/A	ft ²
Outlet Orifice Centroid =	0.75	N/A	feet
Half-Central Angle of Restrictor Plate on Pipe =	N/A	N/A	radians

User Input: Emergency Spillway (Rectangular or Trapezoidal)

Spillway Invert Stage =	4.21	ft (relative to basin bottom at Stage = 0 ft)
Spillway Crest Length =	10.00	feet
Spillway End Slopes =	4.00	H:V
Freeboard above Max Water Surface =	0.50	feet

Calculated Parameters for Spillway

Spillway Design Flow Depth =	0.28	feet
Stage at Top of Freeboard =	4.99	feet
Basin Area at Top of Freeboard =	0.08	acres

Routed Hydrograph Results

	WQCV	EURV	2 Year	5 Year	10 Year	25 Year	50 Year	100 Year	500 Year
Design Storm Return Period =									
One-Hour Rainfall Depth (in) =	0.53	1.07	1.19	1.50	1.75	2.00	2.25	2.52	3.41
Calculated Runoff Volume (acre-ft) =	0.048	0.152	0.104	0.137	0.169	0.212	0.269	0.337	0.536
OPTIONAL Override Runoff Volume (acre-ft) =									
Inflow Hydrograph Volume (acre-ft) =	0.048	0.152	0.103	0.136	0.168	0.212	0.268	0.336	0.535
Predevelopment Unit Peak Flow, q (cfs/acre) =	0.00	0.00	0.00	0.00	0.01	0.02	0.16	0.39	0.98
Predevelopment Peak Q (cfs) =	0.0	0.0	0.0	0.0	0.0	0.1	0.5	1.1	2.9
Peak Inflow Q (cfs) =	0.7	2.2	1.5	2.0	2.5	3.1	3.9	4.9	7.7
Peak Outflow Q (cfs) =	0.1	0.3	0.2	0.3	0.3	0.3	1.5	3.0	6.8
Ratio Peak Outflow to Predevelopment Q =	N/A	N/A	N/A	21.3	10.5	5.4	3.1	2.6	2.4
Structure Controlling Flow =	Plate	Plate	Plate	Plate	Plate	Plate	Spillway	Spillway	Spillway
Max Velocity through Gate 1 (fps) =	N/A	N/A	N/A	N/A	N/A	N/A	N/A	N/A	N/A
Max Velocity through Gate 2 (fps) =	N/A	N/A	N/A	N/A	N/A	N/A	N/A	N/A	N/A
Time to Drain 97% of Inflow Volume (hours) =	11	15	14	15	15	16	17	16	15
Time to Drain 99% of Inflow Volume (hours) =	12	17	15	16	17	18	19	18	18
Maximum Ponding Depth (ft) =	1.19	3.10	2.29	2.84	3.34	3.96	4.32	4.40	4.54
Area at Maximum Ponding Depth (acres) =	0.04	0.05	0.04	0.05	0.06	0.06	0.07	0.07	0.07
Maximum Volume Stored (acre-ft) =	0.037	0.119	0.081	0.106	0.133	0.170	0.193	0.198	0.209

Detention Basin Outlet Structure Design

UD-Detention, Version 3.07 (February 2017)

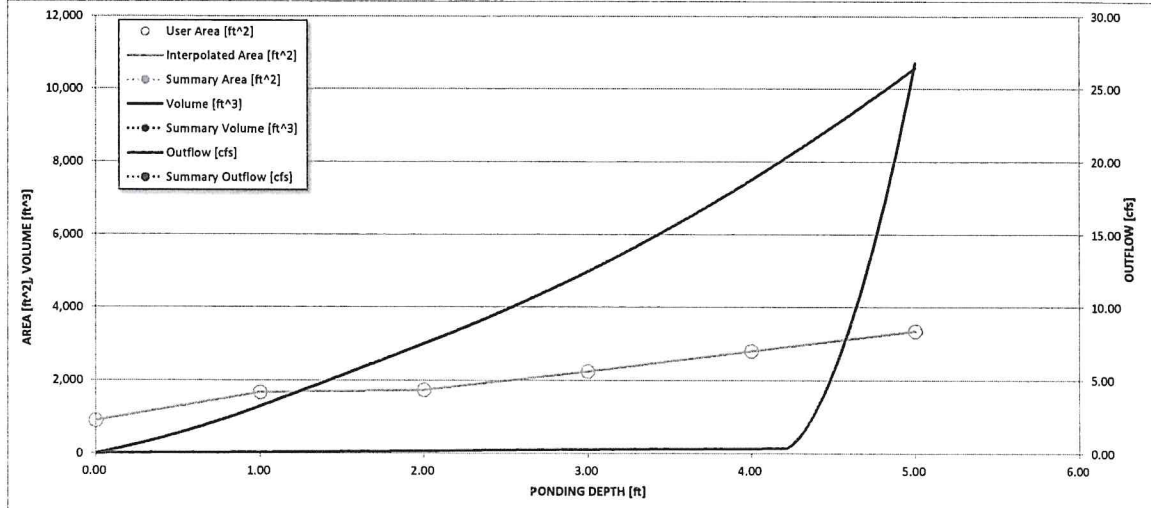
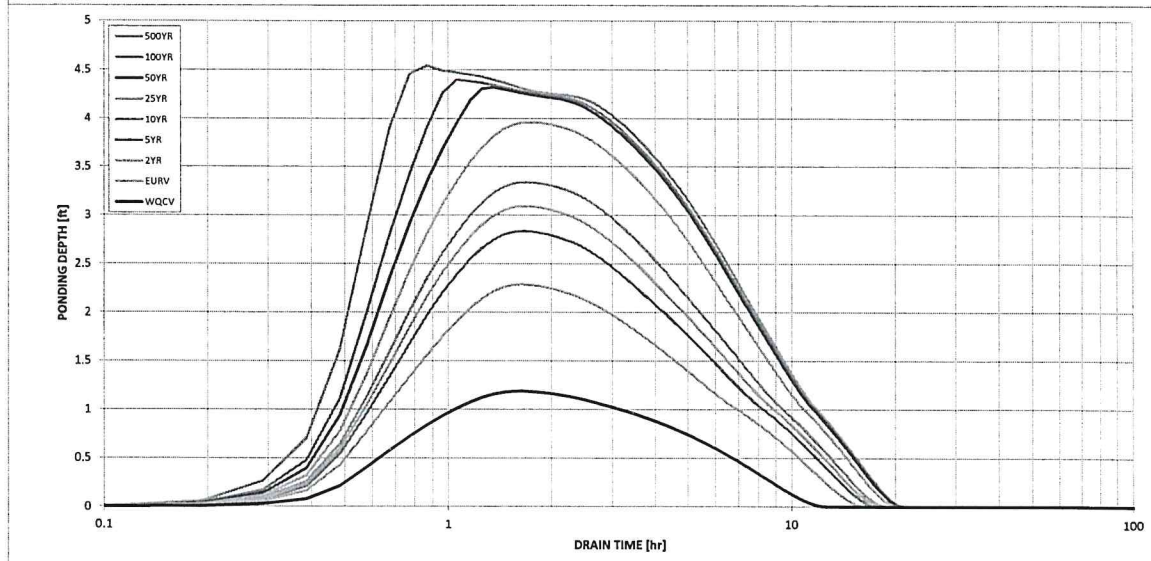
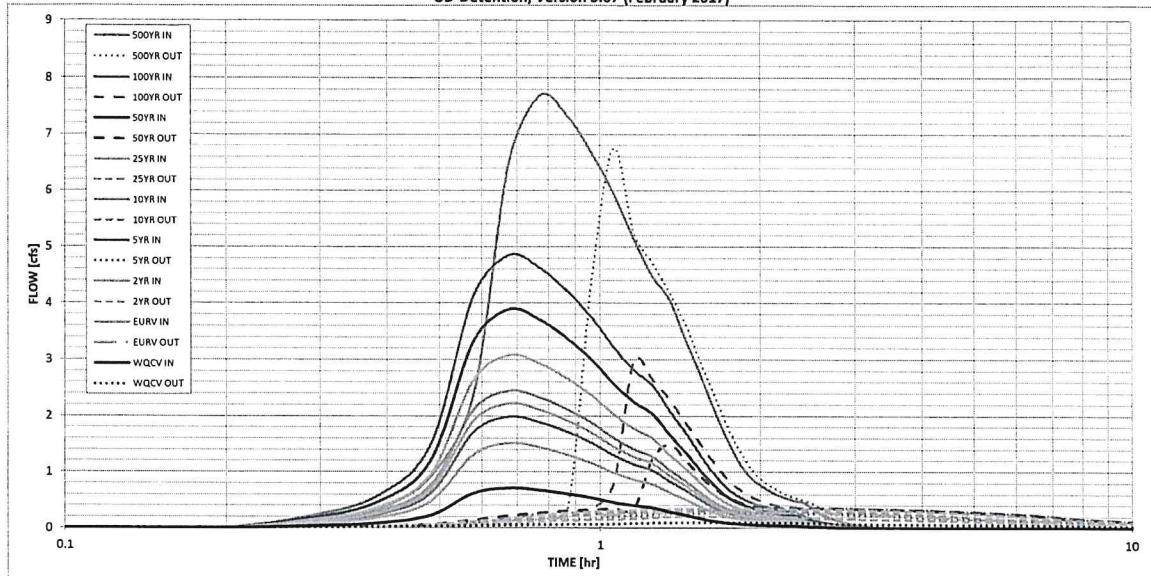

S-A-V-D Chart Axis Override

	X-axis	Left Y-Axis	Right Y-Axis
minimum bound			
maximum bound			

National Flood Hazard Layer FIRMette



104°34'29"W 38°57'16"N

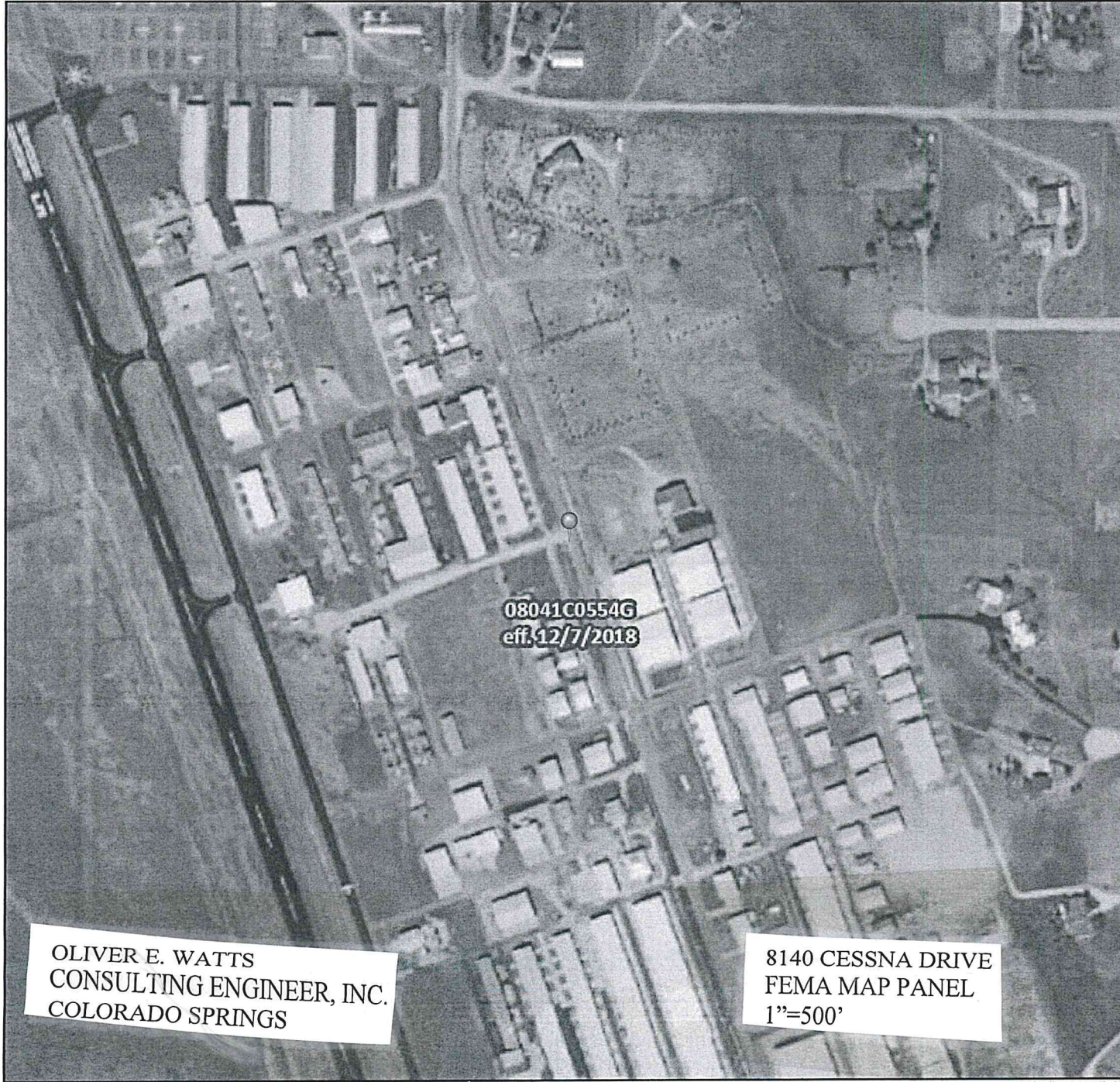

Legend

SEE FIS REPORT FOR DETAILED LEGEND AND INDEX MAP FOR FIRM PANEL LAYOUT

SPECIAL FLOOD HAZARD AREAS	<ul style="list-style-type: none"> Without Base Flood Elevation (BFE) Zone A, V, A99 With BFE or Depth Zone AE, AO, AH, VE, AR Regulatory Floodway
OTHER AREAS OF FLOOD HAZARD	<ul style="list-style-type: none"> 0.2% Annual Chance Flood Hazard, Area of 1% annual chance flood with average depth less than one foot or with drainage areas of less than one square mile Zone J Future Conditions 1% Annual Chance Flood Hazard Zone X Area with Reduced Flood Risk due to Levee. See Notes. Zone X Area with Flood Risk due to Levee Zone D
OTHER AREAS	<ul style="list-style-type: none"> NO SCREEN Area of Minimal Flood Hazard Zone X Effective LOMRs Area of Undetermined Flood Hazard Zone
GENERAL STRUCTURES	<ul style="list-style-type: none"> Channel, Culvert, or Storm Sewer Levee, Dike, or Floodwall
OTHER FEATURES	<ul style="list-style-type: none"> Cross Sections with 1% Annual Chance Water Surface Elevation Coastal Transect Base Flood Elevation Line (BFE) Limit of Study Jurisdiction Boundary Coastal Transect Baseline Profile Baseline Hydrographic Feature
MAP PANELS	<ul style="list-style-type: none"> <input type="checkbox"/> Digital Data Available <input type="checkbox"/> No Digital Data Available <input checked="" type="checkbox"/> Unmapped <p> The pin displayed on the map is an approximate point selected by the user and does not represent an authoritative property location.</p>

08041C0554G
eff. 12/7/2018

OLIVER E. WATTS
CONSULTING ENGINEER, INC.
COLORADO SPRINGS

8140 CESSNA DRIVE
FEMA MAP PANEL
1"=500'



This map complies with FEMA's standards for the use of digital flood maps if it is not void as described below. The basemap shown complies with FEMA's basemap accuracy standards

The flood hazard information is derived directly from the authoritative NFHL web services provided by FEMA. This map was exported on 7/9/2021 at 12:31 PM and does not reflect changes or amendments subsequent to this date and time. The NFHL and effective information may change or become superseded by new data over time.

This map image is void if the one or more of the following map elements do not appear: basemap imagery, flood zone labels, legend, scale bar, map creation date, community identifiers, FIRM panel number, and FIRM effective date. Map images for unmapped and unmodernized areas cannot be used for regulatory purposes.



OLIVER E. WATTS
CONSULTING ENGINEER, INC.
COLORADO SPRINGS

8140 CESSNA DRIVE
SCS SOILS MAP
1"=2000'

EL PASO COUNTY AREA, COLORADO

TABLE 16.--SOIL AND WATER FEATURES

[Absence of an entry indicates the feature is not a concern. See "flooding" in Glossary for definition of terms as "rare," "brief," and "very brief." The symbol > means greater than]

Soil name and map symbol	Hydro-logic group	Flooding			Bedrock		Potential frost action
		Frequency	Duration	Months	Depth	Hardness	
Alamosa: 1-----	C	Frequent-----	Brief-----	May-Jun	In >60	---	High.
Ascalon: 2, 3-----	B	None-----	---	---	>60	---	Moderate.
Badland: 4-----	D	---	---	---	---	---	---
Bijou: 5, 6, 7-----	B	None-----	---	---	>60	---	Low.
Blakeland: 8-----	A	None-----	---	---	>60	---	Low.
19: Blakeland part-	A	None-----	---	---	>60	---	Low.
Fluvaquentic Haplaquolls part-----	D	Common-----	Very brief----	Mar-Aug	>60	---	High.
Blendon: 10-----	B	None-----	---	---	>60	---	Moderate.
Bresser: 11, 12, 13-----	B	None-----	---	---	>60	---	Low.
Brussett: 14, 15-----	B	None-----	---	---	>60	---	Moderate.
Chaseville: 16, 17-----	A	None-----	---	---	>60	---	Low.
118: Chaseville part	A	None-----	---	---	>60	---	Low.
Midway part---	D	None-----	---	---	10-20	Rippable	Moderate.
Columbine: 19-----	A	None to rare	---	---	>60	---	Low.
Connerton: 120: Connerton part-	B	None-----	---	---	>60	---	High.
Rock outcrop part-----	D	---	---	---	---	---	---
Cruckton: 21-----	B	None-----	---	---	>60	---	Moderate.
Cushman: 22, 23-----	C	None-----	---	---	20-40	Rippable	Moderate.
124: Cushman part---	C	None-----	---	---	20-40	Rippable	Moderate.
Kutch part-----	C	None-----	---	---	20-40	Rippable	Moderate.
Elbeth: 25, 26-----	B	None-----	---	---	>60	---	Moderate.
127: Elbeth part---	B	None-----	---	---	>60	---	Moderate.

See footnote at end of table.

Table 6-6. Runoff Coefficients for Rational Method
(Source: UDFCD 2001)

Land Use or Surface Characteristics	Percent Impervious	Runoff Coefficients											
		2-year		5-year		10-year		25-year		50-year		100-year	
		HSG A&B	HSG C&D	HSG A&B	HSG C&D	HSG A&B	HSG C&D	HSG A&B	HSG C&D	HSG A&B	HSG C&D	HSG A&B	HSG C&D
Business													
Commercial Areas	95	0.79	0.80	0.81	0.82	0.83	0.84	0.85	0.87	0.87	0.88	0.88	0.89
Neighborhood Areas	70	0.45	0.49	0.49	0.53	0.53	0.57	0.58	0.62	0.60	0.65	0.62	0.68
Residential													
1/8 Acre or less	65	0.41	0.45	0.45	0.49	0.49	0.54	0.54	0.59	0.57	0.62	0.59	0.65
1/4 Acre	40	0.23	0.28	0.30	0.35	0.36	0.42	0.42	0.50	0.46	0.54	0.50	0.58
1/3 Acre	30	0.18	0.22	0.25	0.30	0.32	0.38	0.39	0.47	0.43	0.52	0.47	0.57
1/2 Acre	25	0.15	0.20	0.22	0.28	0.30	0.36	0.37	0.46	0.41	0.51	0.46	0.56
1 Acre	20	0.12	0.17	0.20	0.26	0.27	0.34	0.35	0.44	0.40	0.50	0.44	0.55
Industrial													
Light Areas	80	0.57	0.60	0.59	0.63	0.63	0.66	0.66	0.70	0.68	0.72	0.70	0.74
Heavy Areas	90	0.71	0.73	0.73	0.75	0.75	0.77	0.78	0.80	0.80	0.82	0.81	0.83
Parks and Cemeteries													
Parks	7	0.05	0.09	0.12	0.19	0.20	0.29	0.30	0.40	0.34	0.46	0.39	0.52
Playgrounds	13	0.07	0.13	0.16	0.23	0.24	0.31	0.32	0.42	0.37	0.48	0.41	0.54
Railroad Yard Areas	40	0.23	0.28	0.30	0.35	0.36	0.42	0.42	0.50	0.46	0.54	0.50	0.58
Undeveloped Areas													
Historic Flow Analysis-- Greenbelts, Agriculture	2	0.03	0.05	0.09	0.16	0.17	0.26	0.26	0.38	0.31	0.45	0.36	0.51
Pasture/Meadow	0	0.02	0.04	0.08	0.15	0.15	0.25	0.25	0.37	0.30	0.44	0.35	0.50
Forest	0	0.02	0.04	0.08	0.15	0.15	0.25	0.25	0.37	0.30	0.44	0.35	0.50
Exposed Rock	100	0.89	0.89	0.90	0.90	0.92	0.92	0.94	0.94	0.95	0.95	0.96	0.96
Offsite Flow Analysis (when landuse is undefined)	45	0.26	0.31	0.32	0.37	0.38	0.44	0.44	0.51	0.48	0.55	0.51	0.59
Streets													
Paved	100	0.89	0.89	0.90	0.90	0.92	0.92	0.94	0.94	0.95	0.95	0.96	0.96
Gravel	80	0.57	0.60	0.59	0.63	0.63	0.66	0.66	0.70	0.68	0.72	0.70	0.74
Drive and Walks													
Drive and Walks	100	0.89	0.89	0.90	0.90	0.92	0.92	0.94	0.94	0.95	0.95	0.96	0.96
Roofs	90	0.71	0.73	0.73	0.75	0.75	0.77	0.78	0.80	0.80	0.82	0.81	0.83
Lawns	0	0.02	0.04	0.08	0.15	0.15	0.25	0.25	0.37	0.30	0.44	0.35	0.50

3.2 Time of Concentration

One of the basic assumptions underlying the Rational Method is that runoff is a function of the average rainfall rate during the time required for water to flow from the hydraulically most remote part of the drainage area under consideration to the design point. However, in practice, the time of concentration can be an empirical value that results in reasonable and acceptable peak flow calculations.

For urban areas, the time of concentration (t_c) consists of an initial time or overland flow time (t_i) plus the travel time (t_t) in the storm sewer, paved gutter, roadside drainage ditch, or drainage channel. For non-urban areas, the time of concentration consists of an overland flow time (t_i) plus the time of travel in a concentrated form, such as a swale or drainageway. The travel portion (t_t) of the time of concentration can be estimated from the hydraulic properties of the storm sewer, gutter, swale, ditch, or drainageway. Initial time, on the other hand, will vary with surface slope, depression storage, surface cover, antecedent rainfall, and infiltration capacity of the soil, as well as distance of surface flow. The time of concentration is represented by Equation 6-7 for both urban and non-urban areas.

$$t_c = t_i + t_l \quad (\text{Eq. 6-7})$$

Where:

t_c = time of concentration (min)

t_i = overland (initial) flow time (min)

t_l = travel time in the ditch, channel, gutter, storm sewer, etc. (min)

3.2.1 Overland (Initial) Flow Time

The overland flow time, t_i , may be calculated using Equation 6-8.

$$t_i = \frac{0.395(1.1 - C_s)\sqrt{L}}{S^{0.33}} \quad (\text{Eq. 6-8})$$

Where:

t_i = overland (initial) flow time (min)

C_s = runoff coefficient for 5-year frequency (see Table 6-6)

L = length of overland flow (300 ft maximum for non-urban land uses, 100 ft maximum for urban land uses)

S = average basin slope (ft/ft)

Note that in some urban watersheds, the overland flow time may be very small because flows quickly concentrate and channelize.

3.2.2 Travel Time

For catchments with overland and channelized flow, the time of concentration needs to be considered in combination with the travel time, t_l , which is calculated using the hydraulic properties of the swale, ditch, or channel. For preliminary work, the overland travel time, t_l , can be estimated with the help of Figure 6-25 or Equation 6-9 (Guo 1999).

$$V = C_v S_w^{0.5} \quad (\text{Eq. 6-9})$$

Where:

V = velocity (ft/s)

C_v = conveyance coefficient (from Table 6-7)

S_w = watercourse slope (ft/ft)

Table 6-7. Conveyance Coefficient, C_v

Type of Land Surface	C_v
Heavy meadow	2.5
Tillage/field	5
Riprap (not buried)*	6.5
Short pasture and lawns	7
Nearly bare ground	10
Grassed waterway	15
Paved areas and shallow paved swales	20

* For buried riprap, select C_v value based on type of vegetative cover.

The travel time is calculated by dividing the flow distance (in feet) by the velocity calculated using Equation 6-9 and converting units to minutes.

The time of concentration (t_c) is then the sum of the overland flow time (t_t) and the travel time (t_l) per Equation 6-7.

3.2.3 First Design Point Time of Concentration in Urban Catchments

Using this procedure, the time of concentration at the first design point (typically the first inlet in the system) in an urbanized catchment should not exceed the time of concentration calculated using Equation 6-10. The first design point is defined as the point where runoff first enters the storm sewer system.

$$t_c = \frac{L}{180} + 10 \quad (\text{Eq. 6-10})$$

Where:

t_c = maximum time of concentration at the first design point in an urban watershed (min)

L = waterway length (ft)

Equation 6-10 was developed using the rainfall-runoff data collected in the Denver region and, in essence, represents regional "calibration" of the Rational Method. Normally, Equation 6-10 will result in a lesser time of concentration at the first design point and will govern in an urbanized watershed. For subsequent design points, the time of concentration is calculated by accumulating the travel times in downstream drainageway reaches.

3.2.4 Minimum Time of Concentration

If the calculations result in a t_c of less than 10 minutes for undeveloped conditions, it is recommended that a minimum value of 10 minutes be used. The minimum t_c for urbanized areas is 5 minutes.

3.2.5 Post-Development Time of Concentration

As Equation 6-8 indicates, the time of concentration is a function of the 5-year runoff coefficient for a drainage basin. Typically, higher levels of imperviousness (higher 5-year runoff coefficients) correspond to shorter times of concentration, and lower levels of imperviousness correspond to longer times of

Figure 6-5. Colorado Springs Rainfall Intensity Duration Frequency

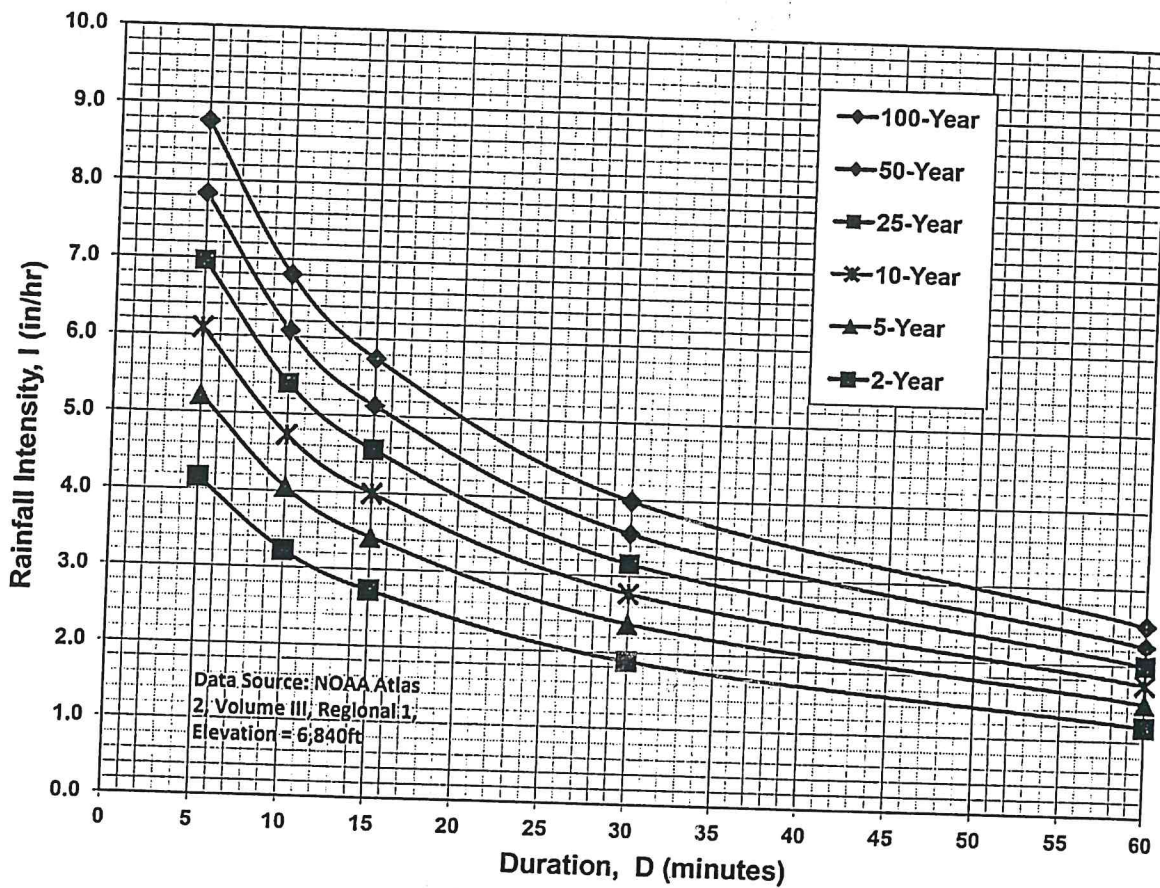

IDF Equations

$$I_{100} = -2.52 \ln(D) + 12.735$$

$$I_{50} = -2.25 \ln(D) + 11.375$$

$$I_{25} = -2.00 \ln(D) + 10.111$$

$$I_{10} = -1.75 \ln(D) + 8.847$$

$$I_5 = -1.50 \ln(D) + 7.583$$

$$I_2 = -1.19 \ln(D) + 6.035$$

Note: Values calculated by equations may not precisely duplicate values read from figure.

$$Q = \frac{0.463}{n} D^{8/3} S^{1/2}$$

$$Q = KS^{1/2}$$

DIAMETER - IN. -	AREA - FT ² -	D 8/3 - FT -	K			
			N=0.010	N=0.013	N=0.024	N=0.024
2	0.02182	0.008413	0.3895	---	---	---
4	0.08727	0.053420	2.4733	---	---	---
6	0.19630	0.157500	7.2922	5.609	---	---
8	0.34910	0.339200	15.7050	12.081	---	---
10	0.54540	0.615000	28.4745	21.903	---	---
12	0.78540	1.000000	46.3000	35.615	---	---
15	1.22720	1.813100	83.9465	64.574	---	---
18	1.76710	2.948300	136.5100	105.000	56.88	52.5
21	2.40530	4.447400	205.9100	158.400	85.80	79.2
24	3.14160	6.349600	293.9900	226.140	122.49	113.0
27	3.97610	8.692700	402.4700	309.590	167.70	154.7
30	4.90870	11.512600	533.0300	410.030	222.10	205.0
33	5.93960	14.844100	---	528.680	---	---
36	7.06860	18.720800	866.7700	666.700	361.20	333.3
39	8.29580	23.175100	---	825.400	---	---
42	9.62110	28.238900	---	1005.000	544.80	502.5
48	12.56640	40.317500	---	1436.000	777.80	718.0
54	15.90430	55.195000	---	1966.000	1065.00	983.0
60	19.63500	73.100400	---	2604.000	1410.00	1302.0
66	23.75830	94.254200	---	3357.000	1818.00	1678.0
72	28.27430	118.869400	---	4234.000	2293.00	2117.0
78	33.18310	147.152900	---	5241.000	2839.00	2620.0
84	38.48450	179.306000	---	6386.000	3459.00	3193.0
90	44.17860	215.524500	---	7676.000	4158.00	3838.0
96	50.26550	256.000000	---	9118.000	4939.00	4559.0
108	63.61730	350.466600	---	12480.000	6761.00	6140.0
120	78.53980	464.158900	---	16530.000	8954.00	8265.0

Oliver E. Watts
 Consulting Engi
 Colorado Spring

INTERCEPTED FLOW - CUBIC FEET PER SECOND

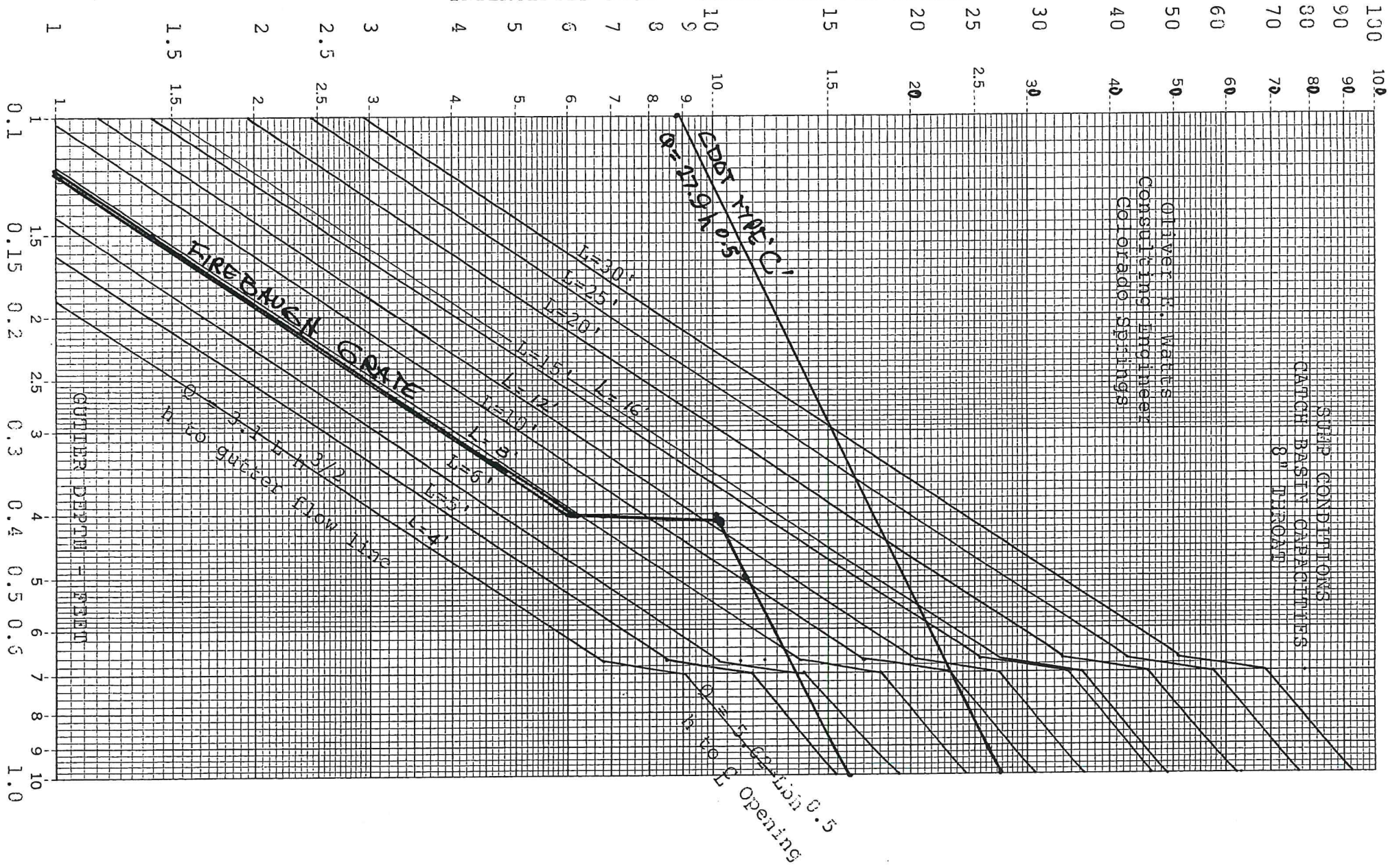

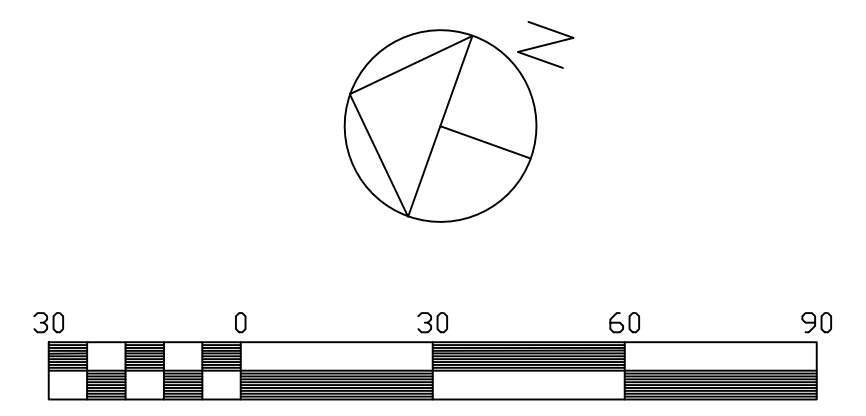
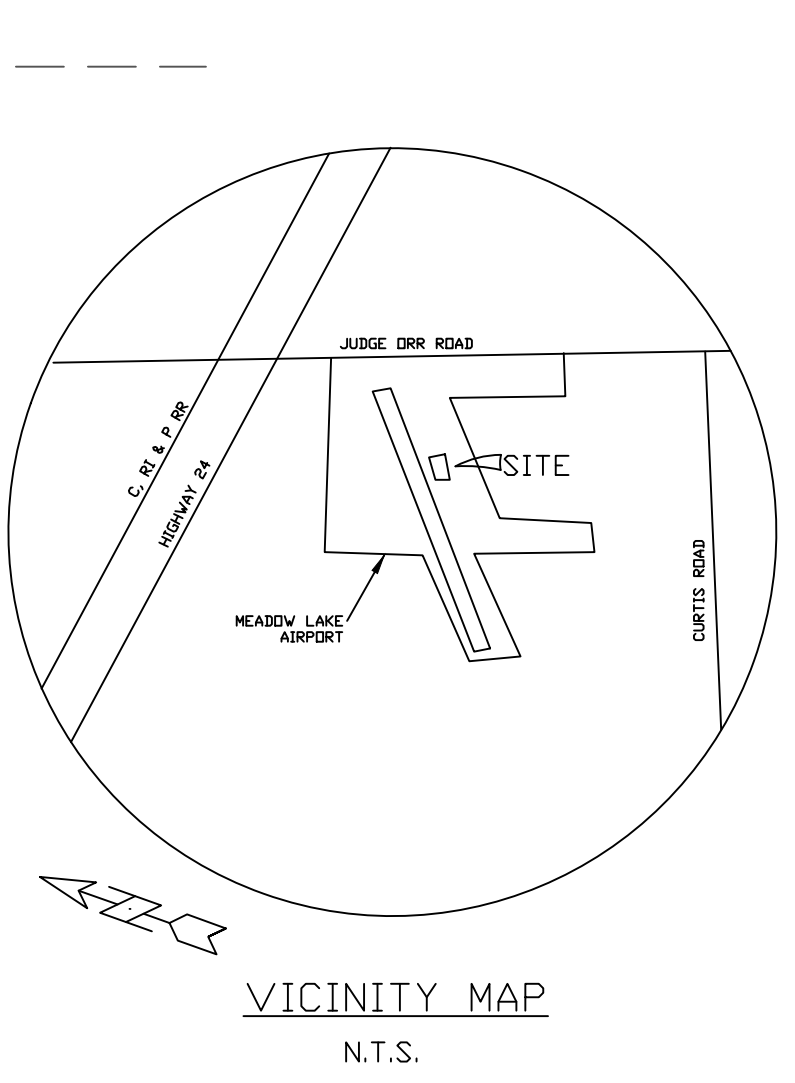
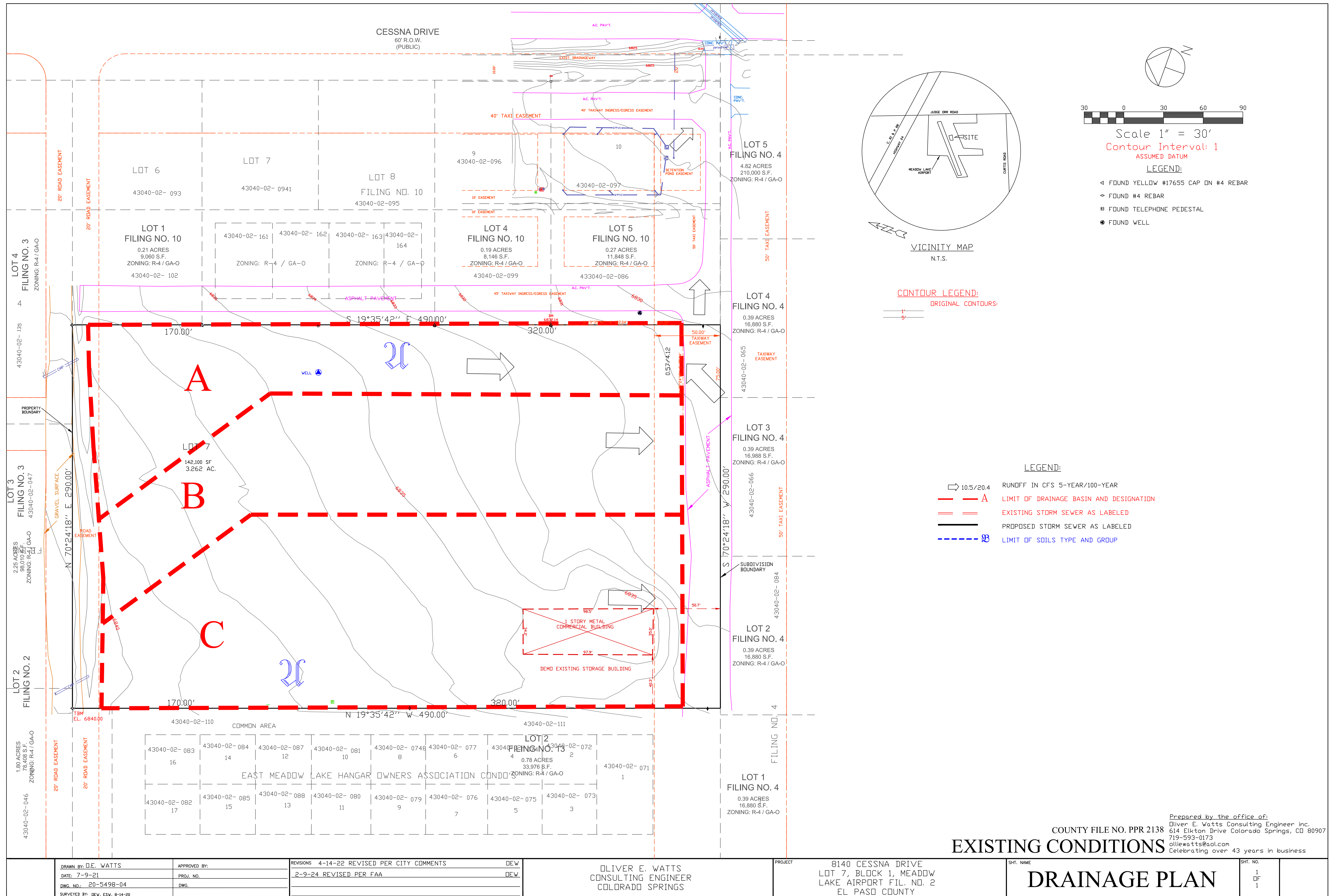

Scale 1" = 30'
 Contour Interval: 1'
 ASSUMED DATUM

- LEGEND:**
- ◁ FOUND YELLOW #17655 CAP ON #4 REBAR
 - ◇ FOUND #4 REBAR
 - FOUND TELEPHONE PEDESTAL
 - FOUND WELL

- CONTOUR LEGEND:**
- ORIGINAL CONTOURS:
 - 1" = 1'
 - 5" = 5'

- LEGEND:**
- ◁ 10.5/20.4 RUNOFF IN CFS 5-YEAR/100-YEAR
 - - - A LIMIT OF DRAINAGE BASIN AND DESIGNATION
 - — — EXISTING STORM SEWER AS LABELED
 - — — PROPOSED STORM SEWER AS LABELED
 - - - B LIMIT OF SOILS TYPE AND GROUP

Prepared by the office of:
 COUNTY FILE NO. PPR 2138
EXISTING CONDITIONS
 Oliver E. Watts Consulting Engineers Inc.
 614 Elkton Drive Colorado Springs, CO 80907
 719-593-0173
 olliewatts@aol.com
 Celebrating over 43 years in business

DRAWN BY: D.E. WATTS DATE: 7-9-21 DWG. NO.: 20-5498-04 SURVEYED BY: DEV, ESV, 8-14-20	APPROVED BY: PROJ. NO. DWG.	REVISIONS 4-14-22 REVISED PER CITY COMMENTS	DEW	PROJECT 8140 CESSNA DRIVE LOT 7, BLOCK 1, MEADOW LAKE AIRPORT FIL. NO. 2 EL PASO COUNTY	SHT. NO. 1 OF 1
		2-9-24 REVISED PER FAA	DEW		
OLIVER E. WATTS CONSULTING ENGINEER COLORADO SPRINGS					

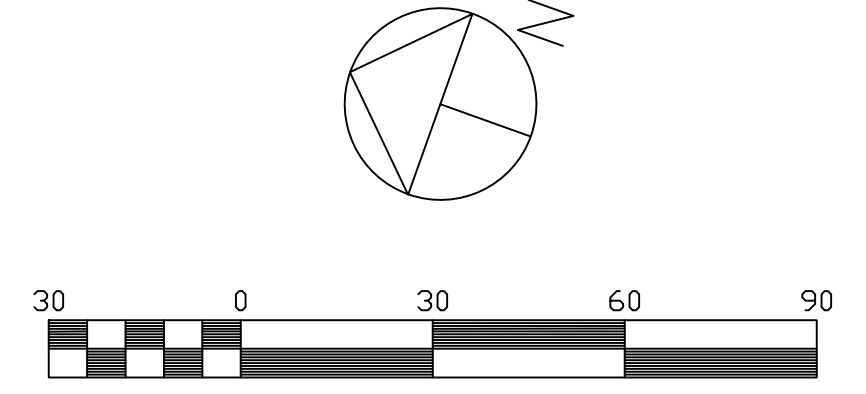
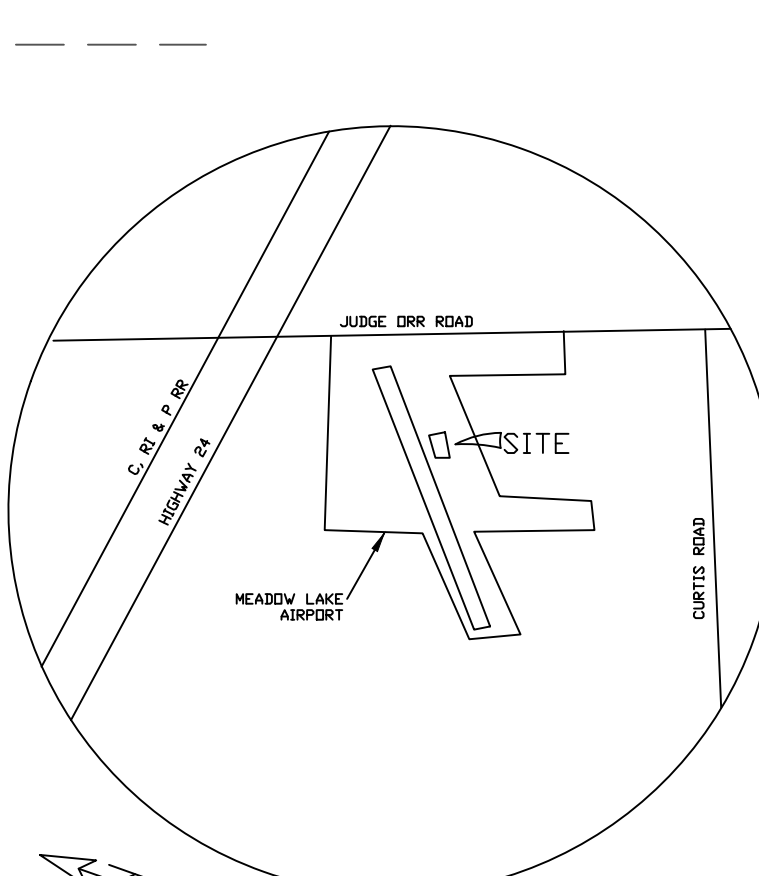
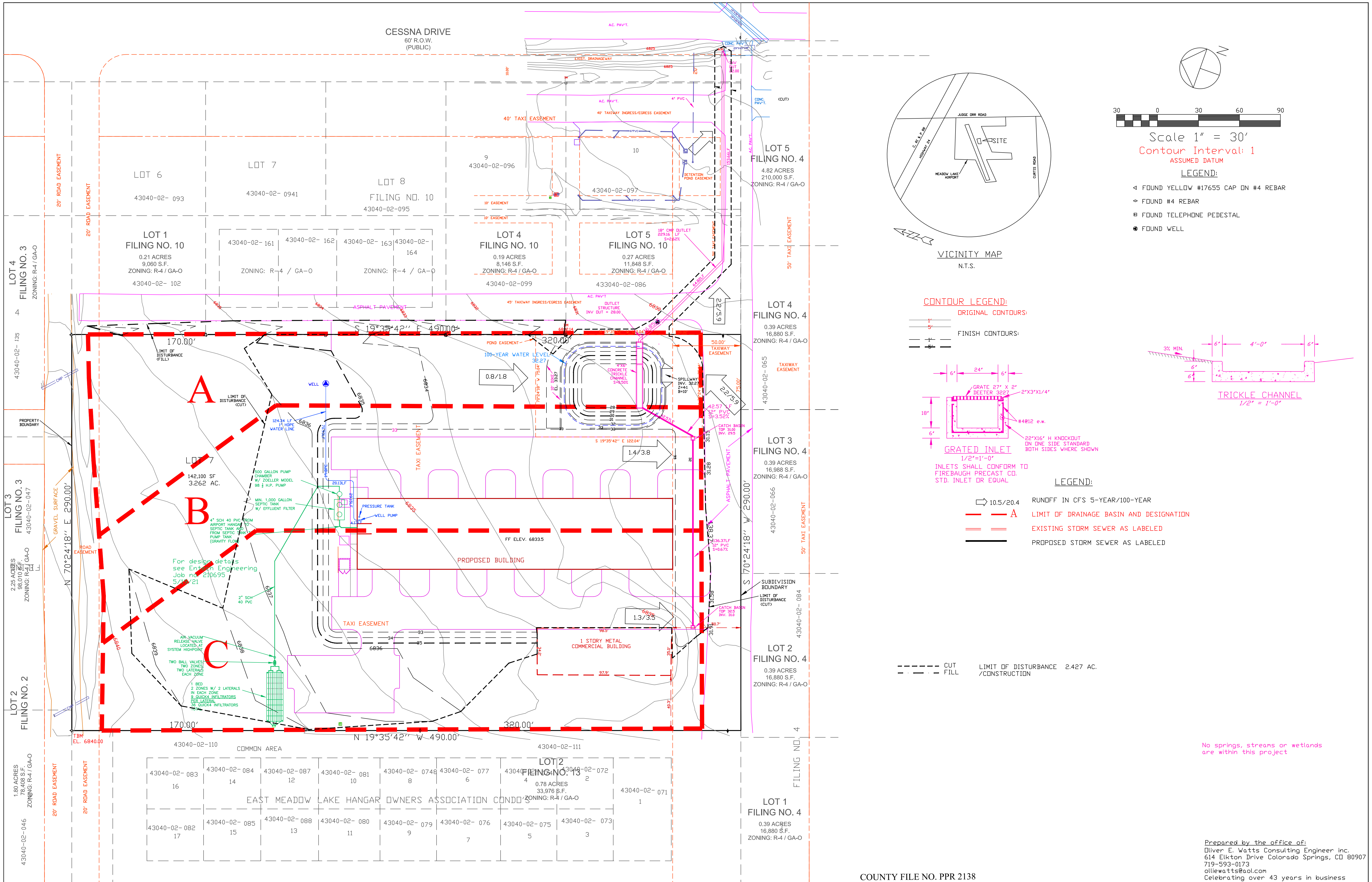

Scale 1" = 30'
Contour Interval: 1'
ASSUMED DATUM

- LEGEND:**
- ◁ FOUND YELLOW #17655 CAP ON #4 REBAR
 - ◊ FOUND #4 REBAR
 - FOUND TELEPHONE PEDESTAL
 - FOUND WELL

CONTOUR LEGEND:

- ORIGINAL CONTOURS:**
- 1" = 1'
 - 5" = 5'
- FINISH CONTOURS:**
- 1" = 1'
 - 5" = 5'

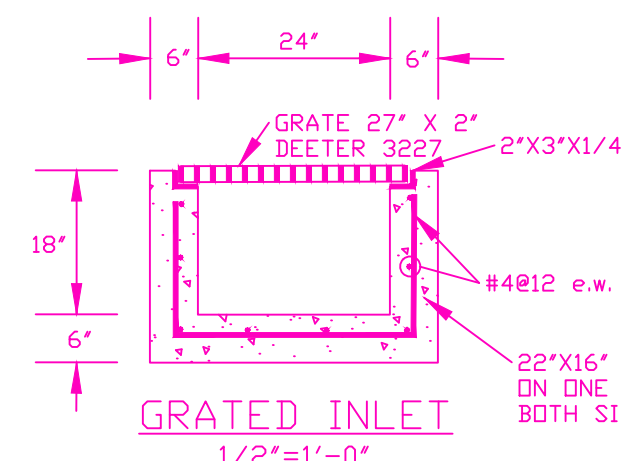

GRATED INLET
1/2" x 1'-0"
INLETS SHALL CONFORM TO FIREBAUGH PRECAST CO. STD. INLET OR EQUAL

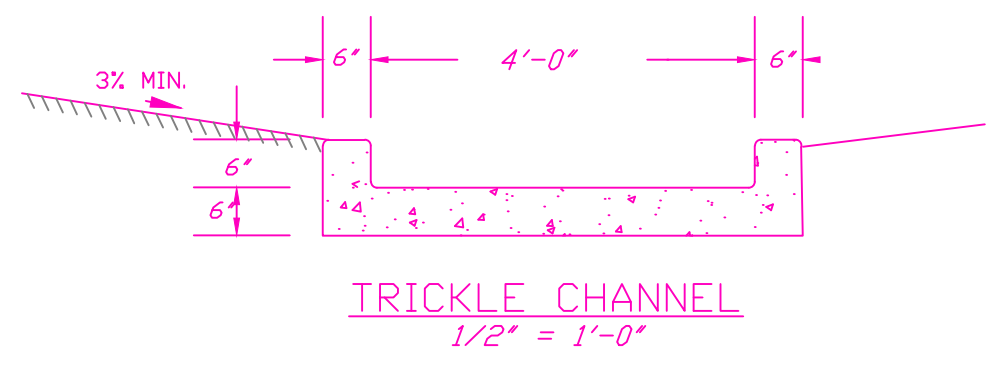

TRICKLE CHANNEL
1/2" x 1'-0"

LEGEND:

- ◻ 10.5/20.4 RUNOFF IN CFS 5-YEAR/100-YEAR
- A — LIMIT OF DRAINAGE BASIN AND DESIGNATION
- — — EXISTING STORM SEWER AS LABELED
- — — PROPOSED STORM SEWER AS LABELED

--- CUT
--- FILL
LIMIT OF DISTURBANCE 2.427 AC. /CONSTRUCTION

No springs, streams or wetlands are within this project

Prepared by the office of:
Oliver E. Watts Consulting Engineers Inc.
614 Elkton Drive Colorado Springs, CO 80907
719-593-0173
oliewatts@aol.com
Celebrating over 43 years in business

COUNTY FILE NO. PPR 2138

DRAWN BY: D.E. WATTS DATE: 7-9-21 DWG. NO.: 20-5498-05 SURVEYED BY: DEV, ESV, 8-14-20	APPROVED BY: PROJ. NO. DWG.	REVISIONS 4-14-22 REVISED PER CITY COMMENTS DEW 2-9-24 REVISED PER FAA DEW	OLIVER E. WATTS CONSULTING ENGINEER COLORADO SPRINGS	PROJECT 8140 CESSNA DRIVE LOT 7, BLOCK 1, MEADOW LAKE AIRPORT FIL. NO. 2 EL PASO COUNTY	SHEET NAME DRAINAGE PLAN	SHEET NO. 1 OF 1
--	-----------------------------------	---	--	---	------------------------------------	---------------------------

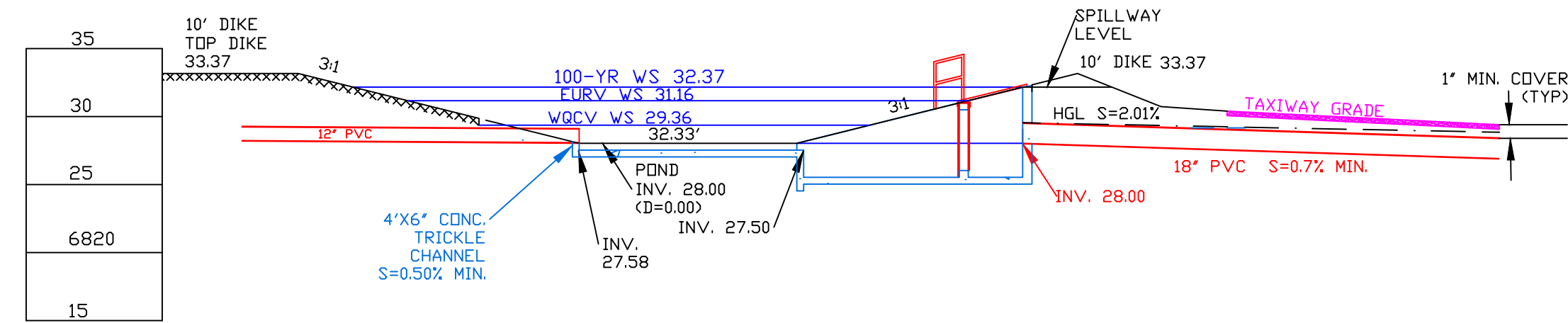

OUTLET WORKS SECTION

1"=10'

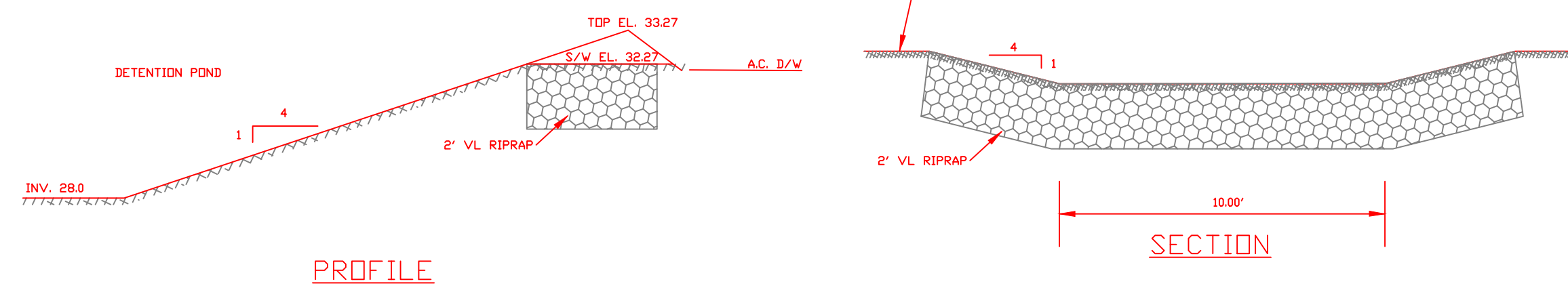

PROFILE

SPILLWAY DETAILS

1/4"=1'-0"

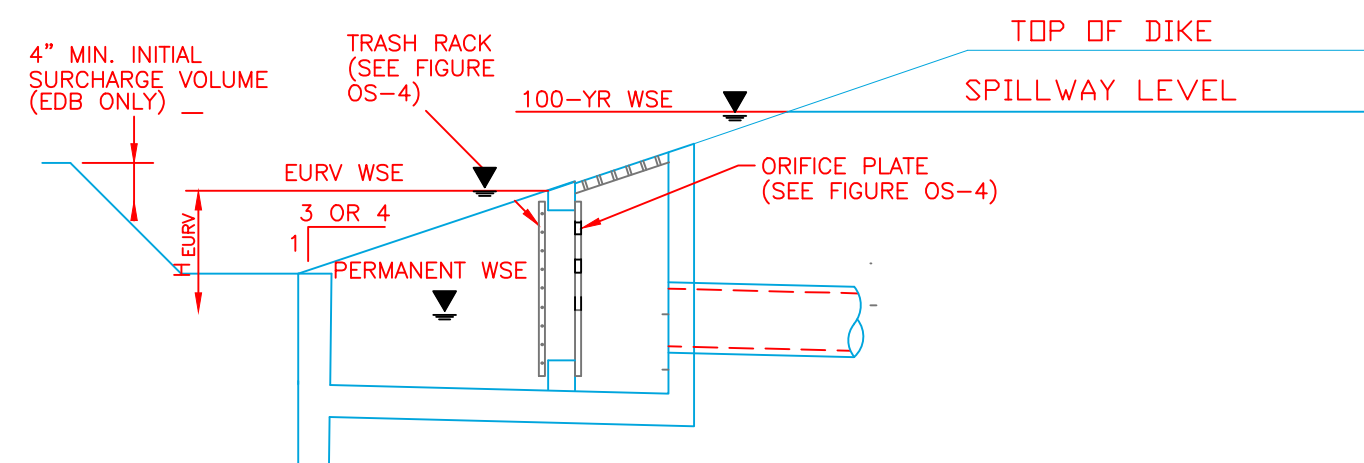
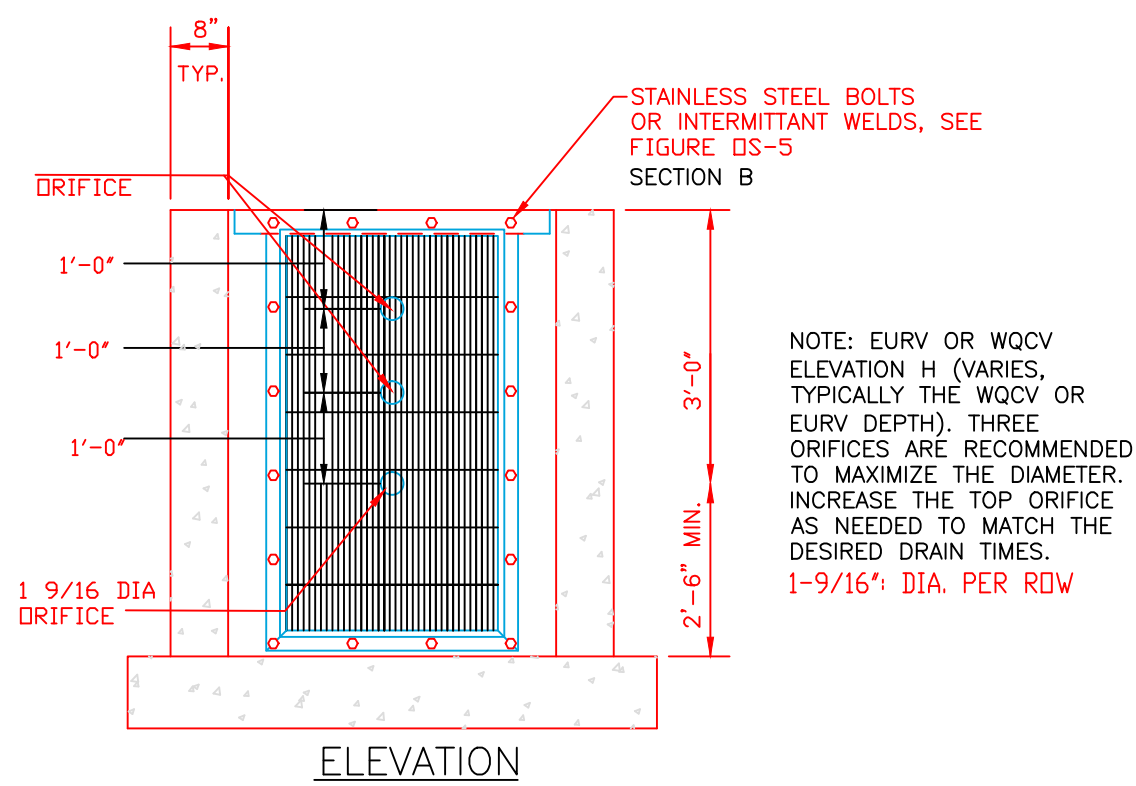

FIGURE OS-2 TYPICAL OUTLET STRUCTURE FOR FULL SPECTRUM DETENTION



ORIFICE PLATE NOTES:

1. PROVIDE CONTINUOUS NEOPRENE GASKET MATERIAL BETWEEN THE ORIFICE PLATE AND CONCRETE.
 2. BOLT PLATE TO CONCRETE 12" ON CENTER MAX.
- EURV AND WQCV TRASH RACKS:
1. WELL-SCREEN TRASH RACKS SHALL BE STAINLESS STEEL AND SHALL BE ATTACHED BY INTERMITTENT WELDS ALONG THE EDGE OF THE MOUNTING FRAME.
 2. BAR GATE TRASH RACKS SHALL BE ALUMINUM AND SHALL BE BOLTED USING STAINLESS STEEL HARDWARE.
 3. TRASH RACK OPEN AREAS ARE FOR SPECIFIED TRASH RACK MATERIALS. TOTAL TRASH RACK SIZE MAY NEED TO BE ADJUSTED FOR MATERIALS HAVING DIFFERENT OPEN AREA/GROSS AREA RATIO (R VALUE).
 4. STRUCTURAL DESIGN OF TRASH RACKS SHALL BE BASED ON FULL HYDROSTATIC HEAD WITH ZERO HEAD DOWNSTREAM OF THE RACK.
- OVERFLOW SAFETY GRATES:
1. ALL SAFETY GRATES SHALL BE MOUNTED USING STAINLESS STEEL HARDWARE AND PROVIDED WITH HINGED AND LOCKABLE OR BOLTABLE ACCESS PANELS.
 2. SAFETY GRATES SHALL BE STAINLESS STEEL, ALUMINUM, OR STEEL. STEEL GRATES SHALL BE HOT DIP GALVANIZED AND MAY BE HOT POWDER COATED AFTER GALVANIZING.
 3. SAFETY GRATES SHALL BE DESIGNED SUCH THAT THE DIAGONAL DIMENSION OF EACH OPENING IS SMALLER THAN THE DIAMETER OF THE OUTLET PIPE.
 4. STRUCTURAL DESIGN OF SAFETY GRATES SHALL BE BASED ON FULL HYDROSTATIC HEAD WITH ZERO HEAD DOWNSTREAM OF THE RACK.

FIGURE OS-4 ORIFICE PLATE AND TRASH RACK DETAILS AND NOTES

NTS

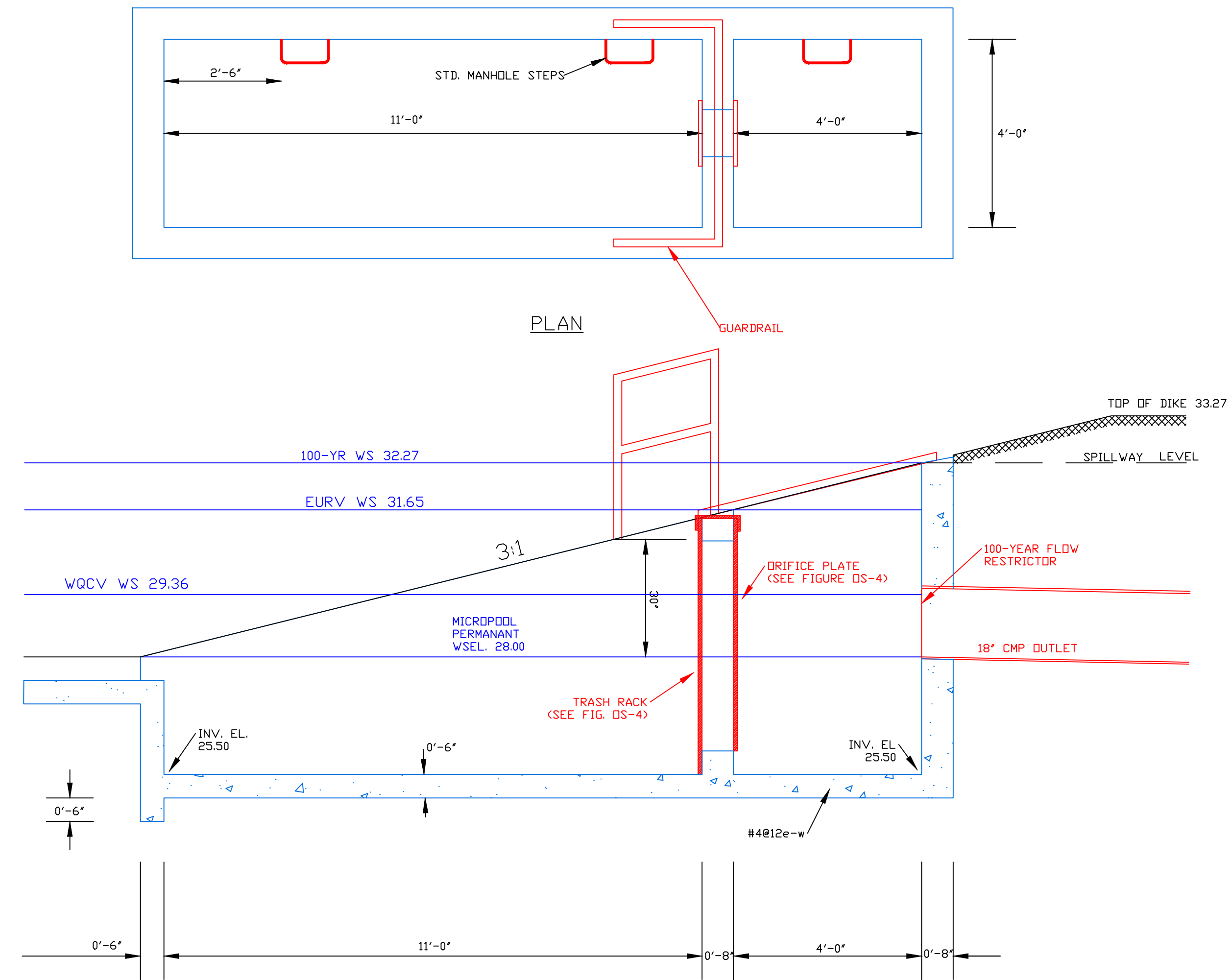

PLAN

PROFILE

OUTLET WORKS

1/2"=1'-0"

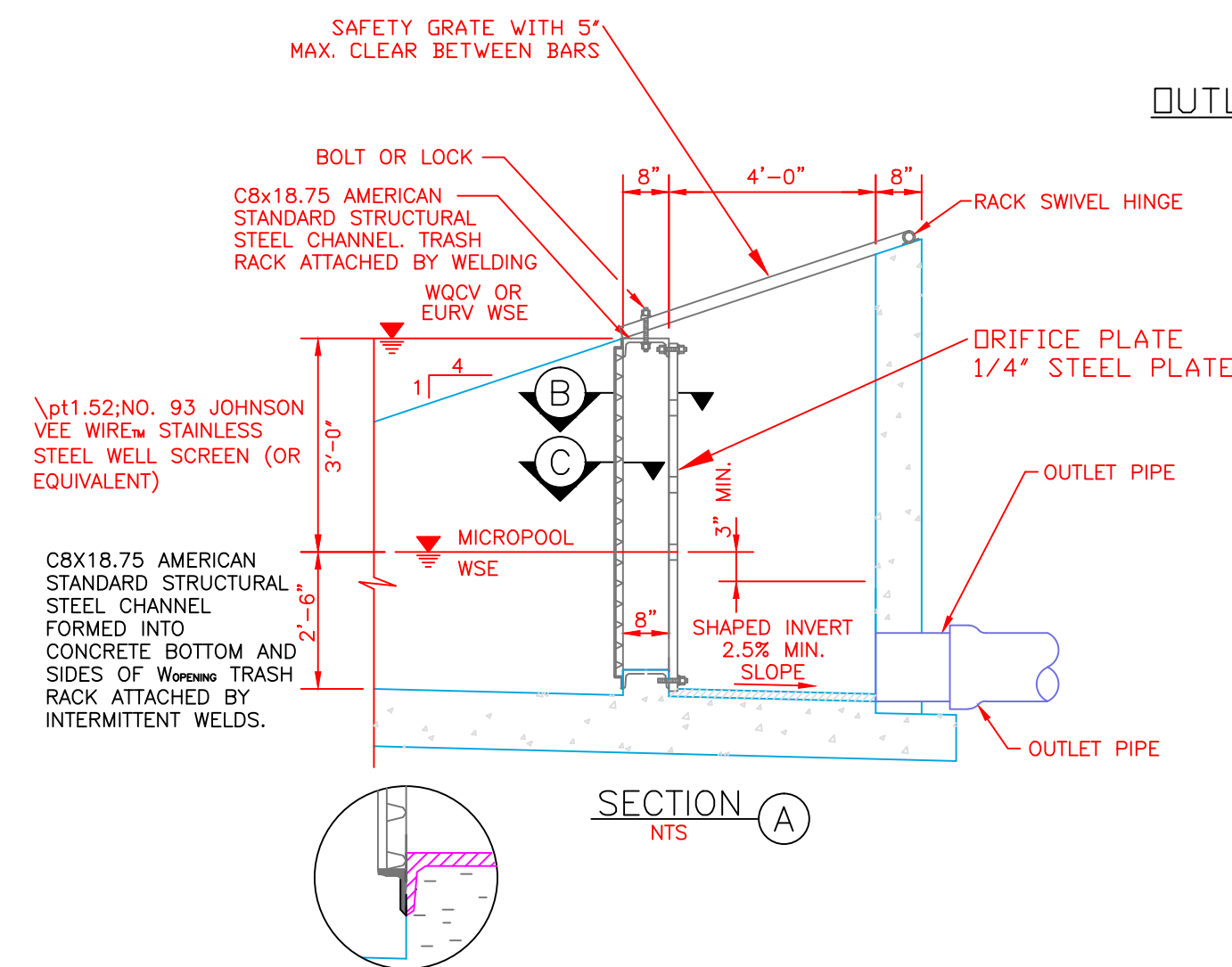

SECTION A

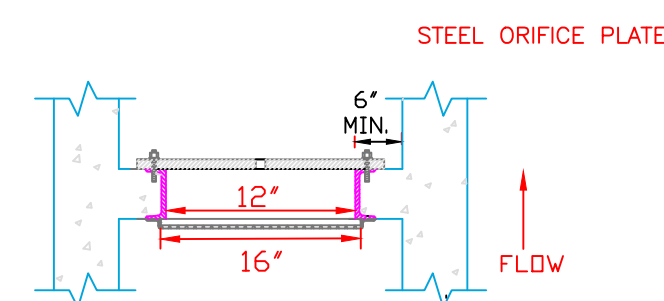

SECTION B

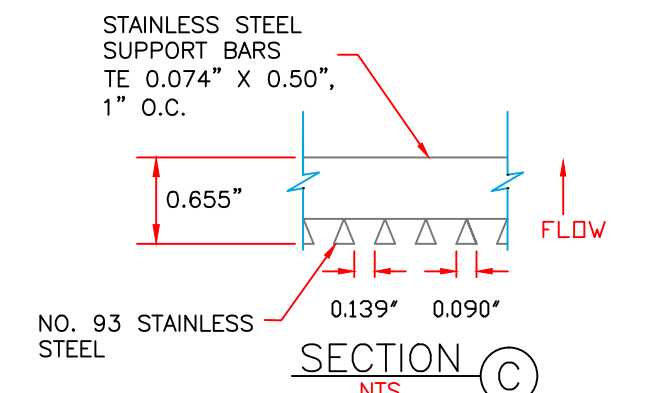

SECTION C

FIGURE OS-5 TYPICAL OUTLET STRUCTURE WITH WELL SCREEN TRASH RACK

DRAWN BY: O.E. WATTS
DATE: 11-8-21
DWG. NO.: 20-5498-08

APPROVED BY:
PROJ. NO.:
DWG.:

REVISIONS 4-14-22 REVISED PER CITY REVIEW COMMENTS DEW
2-28-24 REVISED POND DEW

OLIVER E. WATTS
CONSULTING ENGINEER
COLORADO SPRINGS

PROJECT 8140 CESSNA DRIVE
LOT 7, BLOCK 1, MEADOW LAKE
AIRPORT FILING NO. 2
EL PASO COUNTY

SHT. NO. 2
OF 5
EDB OUTLET DETAILS