

Reattach the "Design Procedure Form: Rain Garden" UD-BMP worksheet which was a part of the previous submittal. This worksheet provided the supporting calculations for the rain garden.

Drainage Letter

for:

CRACKERJACK

or Claremont Business Park, Filing 2, Lot 21
El Paso County, Colorado Springs, Colorado

Prepared for:

Hammers Construction, LLC.
1411 Woolsey Heights
Colorado Springs, CO 809151
Phone (719) 571-1599
Attn: Yury Dyachenko

Prepared by:

Galloway & Company, Inc.
1755 Telstar Drive, Suite 107
Colorado Springs, CO 80918
Phone (719) 900-7220
Attn: Todd Cartwright PE, LEED AP

Dated:

June 29, 2017
Revised 09/15/17

El Paso County Project# PPR-17-031

[Add the table of contents.](#)

The attached drainage plan and report were prepared under my direction and supervision and are correct to the best of my knowledge and belief. Said drainage report has been prepared according to the criteria established by the County for drainage reports and said report is in conformity with the applicable master plan of the drainage basin. I accept responsibility for any liability caused by any negligent acts, errors or omissions on my part in preparing this report.



 Todd Cartwright
 Registered Professional Engineer
 State of Colorado No. 33365

 Date

09/18/2017

Developer's Statement:

I, the developer have read and will comply with all of the requirements specified in this drainage report and plan.

[Handwritten Signature]

 Hammers Construction

By: *Jerry D. Djarhekas*

Title: *Project Manager*

Address: 1411 Woolsey Heights
 Colorado Springs, CO 80915

EL PAASO COUNTY:

Filed in accordance with the requirements of the Drainage Criteria Manual, Volumes 1 & 2, El Paso County Engineering Criteria Manual and Land Development Code as amended.

 Jennifer Irvine, P.E.
 County Engineer/ECM Administrator

 Date

Conditions:

Hammers Construction
CBP 2, Lot 21 – Crackerjack
6/27/17

I. GENERAL LOCATION AND DRAINAGE DESIGN DESCRIPTION

A. Purpose

The purpose of this letter is to show that there shall be no negative drainage effects associated with the proposed development of Lot 21 within the Claremont Business Park Filing 2A, recorded 4/14/2010 under Reception No. 210713035 of the El Paso County Records. This final drainage letter is being submitted concurrently with the improvement construction plans proposing a light industrial building and the associated drivelines.

B. Property Description

The proposed project site is within the Northeast Quarter of Section 8, Township 14 South, Range 65 West of the 6th Principal Meridian. The site can be further described as bounded by Cole View on the north and McClain Point on the east. See Figure 1. Lot 21 consists of approximately 0.3 acres and is currently vacant. The proposed project consists of all infrastructure typically associated with light industrial development. Most the site will consist of crushed asphalt, curb, lighting, and landscaping.

C. Existing Drainage Characteristics

The site is currently vacant with a relatively new roadway infrastructure and associated utilities with slopes ranging from 0-4% from northeast to southwest. Flows from the site run in a sheet-flow manner and drain to the northwest portion of the site, and then eventually outfalls to an existing storm sewer collection system at the northwest corner of Lot 21 and ultimately discharges to the East Fork Sand Creek.

Lots 18-20 are developed to the east of the CrackerJack Site. Lot 20 has a sand filter basin that is designed to discharge 6.8 CFS in the 100 year event (1.1 CFS in 5 year event). This flow is routed to the drainage easement and the drain pan located in the easement. The drain pan has been sized to contain the 100 year flow.

D. Floodplain Statement

According to LOMR 06-08-B137P adjusted the FEMA FIRM map 08041C0752F, effective March 17, 1997, the site lies within Unshaded Zone X. Unshaded Zone X is identified as areas of 500-year flood; areas of 100-year flood with average depths of less than 1 foot.

E. Proposed Drainage Characteristics

Most the site will consist of asphalt, crushed asphalt, a building and, a Storm Water Quality Facility and landscaping. The subject site was previously analyzed within the Final Drainage Report (FDR) for Claremont Business Park Filing 2 prepared by Matrix Design Group approved 04/23/2007. Onsite Water Quality Control Volume (WQCV) is required but on-site storm water detention is not required per the FDR for Claremont Business Park Filing 2A.

The post-developed flows from Lot 21 shall be directed to a Storm Water Quality Facility (rain garden type), which is located along the western property line along Cole View. Flows also enter the Rain Garden near the northwestern portion of the site via curb opening (1.2 cfs for the 5-yr

and 2.2 cfs for the 100-yr). The Rational calculations were made knowing an existing hydraulic soil group (HSC) of type A (See Appendix B).

Flows that penetrate the Rain Garden will discharge into an existing storm drain catch basin within Cole view. Overflows from the Rain Garden will overtop a berm near the southwestern portion of the site and flow into Cole view as it does currently.

F. Water Quality Provisions – Rain Garden

The proposed Rain Garden will be built per Urban Drainage and Flood Control recommendations (see Appendix B for additional information on the Rain Garden). The volume provided by the Rain Garden is approximately 279 cu-ft which exceeds the required Water Quality Control Volume of 208 cu-ft. The size of the Rain Garden is based on an impervious area of 68%, a drainage area of approximately 0.27 acres, and a runoff of 0.6-inches of precipitation per *City of Colorado Springs – Drainage Criteria Manual Volume 2*. See Appendix B for Design Procedure Form for Sand Filter.

G. The Four-Step Process

Per the Engineering Criteria Manual - Appendix 1, the four-step process was implemented for stormwater management:

Step 1: Employ Runoff Reduction Practices. Due to the small site, employing runoff reduction practices is not possible.

Step 2: Stabilize Drainageways. There are no stream channels onsite to stabilize.

Step 3: Provide Water Quality Capture Volume (WQCV). The WQCV is being provided by a Rain Garden located on the western edge of the property.

Step 4: Consider Need for Industrial and Commercial BMPs. The business use will not be producing any industrial or commercial hazards. In addition, due to the small-scale development of the site, no additional source controls are necessary.

H. Private Water Quality Facility – Cost Estimate

Private Water Quality Facility (rain garden): \$6,000

I. Drainage Fees

Since the property has already been platted, no drainage fees are required to be paid.

II. CONCLUSIONS

The proposed runoff patterns for the site have no negative drainage effects within Claremont Business Park Filing 2A or the surrounding area. The methodologies and drainage criteria used in the overall drainage design meet the current County DCM requirements. This drainage letter is in conformance

with the Final Drainage Report for Claremont Business Park Filing 2.

III. REFERENCES

1. *El Paso County Drainage Criteria Manual*, El Paso County, most recent version.
2. *Urban Storm Drainage and Criteria Manual*, *Urban Drainage and Flood Control District*, most recent version.
3. *Final Drainage Report for Claremont Business Park Filing No. 2, November 2006*, by the Matrix Design Group.
4. *Final Drainage Report for , Lots 18-20 Claremont Business Park Filing No. 2, April 2017*, by the Westworks Engineering, *EPC PCD Project File No. PPR172*.

APPENDIX A

VICINITY MAP

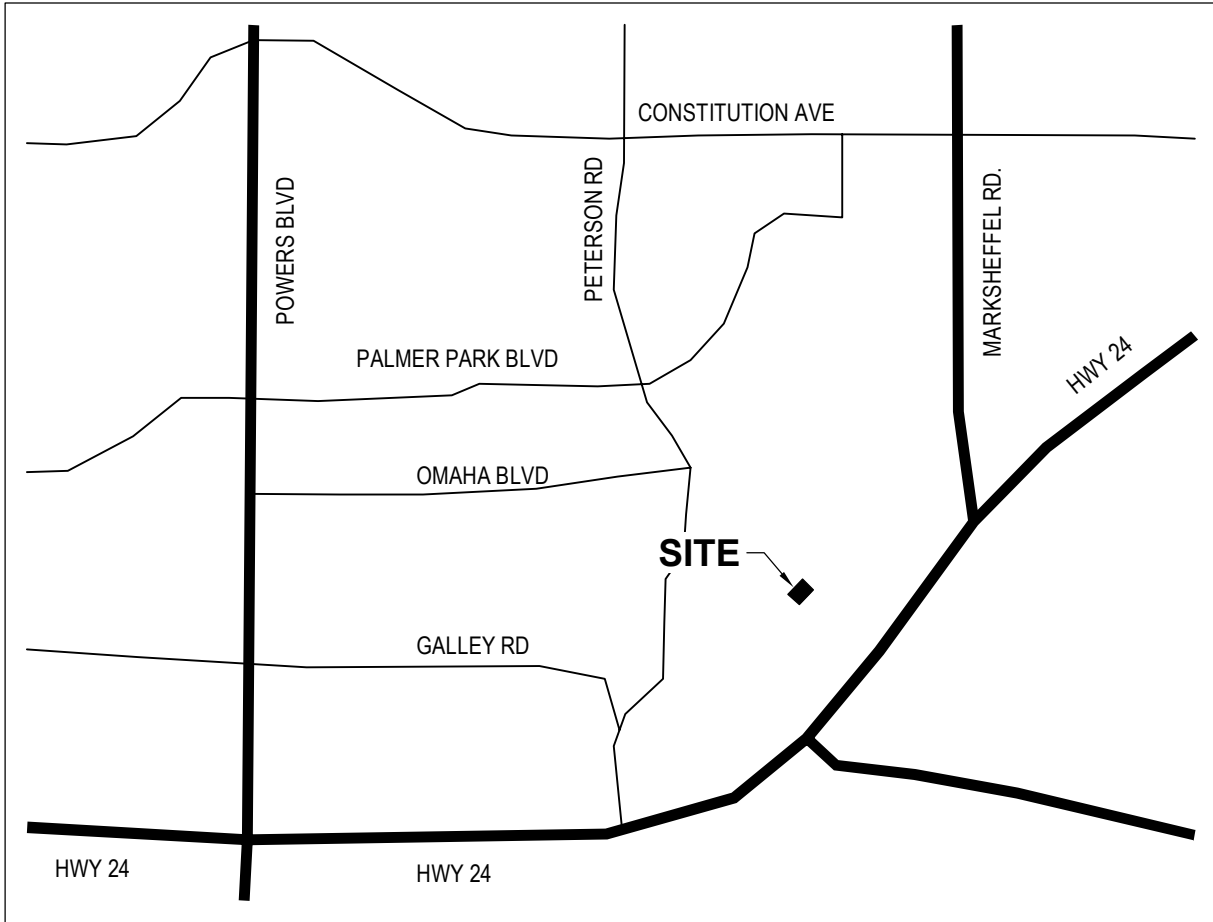

VICINITY MAP
NTS



CBP F2, LOT 21
HAMMERS CONSTRUCTION

7315 McClain Point
COLORADO SPRINGS, CO

FIGURE 1 - VICINITY MAP

Project No:	HCI 003.01
Drawn By:	TAC
Checked By:	TAC
Date:	06/27/17

Galloway
Planning. Architecture. Engineering.

Trolley Corners Building
515 South 700 East, Suite 3F
Salt Lake City, UT 84102
303.770.8884
www.gallowayUS.com

©2016, Galloway & Company, Inc. All Rights Reserved

APPENDIX B

RAIN GARDEN DESIGN INFORMATION

Description

A BMP that utilizes bioretention is an engineered, depressed landscape area designed to capture and filter or infiltrate the water quality capture volume (WQCV). BMPs that utilize bioretention are frequently referred to as rain gardens or porous landscape detention areas (PLDs). The term PLD is common in the UDFCD region as this manual first published the BMP by this name in 1999. In an effort to be consistent with terms most prevalent in the stormwater industry, this document generally refers to the treatment process as *bioretention* and to the BMP as a *rain garden*.



Photograph B-1. This recently constructed rain garden provides bioretention of pollutants, as well as an attractive amenity for a residential building. Treatment should improve as vegetation matures.

The design of a rain garden may provide detention for events exceeding that of the WQCV. There are generally two ways to achieve this. The design can provide the flood control volume above the WQCV or the design can provide and slowly release the flood control volume in an area downstream of one or more rain gardens. See the *Storage* chapter in Volume 2 of the USDCM for more information.

This infiltrating BMP requires consultation with a geotechnical engineer when proposed adjacent to a structure. A geotechnical engineer can assist with evaluating the suitability of soils, identifying potential impacts, and establishing minimum distances between the BMP and structures.

Terminology

The term *bioretention* refers to the treatment process although it is also frequently used to describe a BMP that provides biological uptake and retention of the pollutants found in stormwater runoff. This BMP is sometimes referred to as a *porous landscape detention (PLD) area* or *rain garden*.

Bioretention (Rain Garden)	
Functions	
LID/Volume Red.	Yes
WQCV Capture	Yes
WQCV+Flood Control	Yes
Fact Sheet Includes EURV Guidance	No
Typical Effectiveness for Targeted Pollutants³	
Sediment/Solids	Very Good ¹
Nutrients	Moderate
Total Metals	Good
Bacteria	Moderate
Other Considerations	
Life-cycle Costs ⁴	Moderate
¹ Not recommended for watersheds with high sediment yields (unless pretreatment is provided). ³ Based primarily on data from the International Stormwater BMP Database (www.bmpdatabase.org). ⁴ Based primarily on BMP-REALCOST available at www.udfcd.org . Analysis based on a single installation (not based on the maximum recommended watershed tributary to each BMP).	

Site Selection

This BMP allows WQCV treatment within one or more areas designated for landscape (see design step 7 for suggested vegetation). In this way, it is an excellent alternative to extended detention basins for small sites. A typical rain garden serves a tributary area of one impervious acre or less, although they can be designed for larger tributary areas. Multiple installations can be used within larger sites. Rain gardens should not be used when a baseflow is anticipated. They are typically small and installed in locations such as:

- Parking lot islands
- Street medians
- Landscape areas between the road and a detached walk
- Planter boxes that collect roof drains

Bioretention requires a stable watershed. Retrofit applications are typically successful for this reason. When the watershed includes phased construction, sparsely vegetated areas, or steep slopes in sandy soils, consider another BMP or provide pretreatment before runoff from these areas reaches the rain garden.

The surface of the rain garden should be flat. For this reason, rain gardens can be more difficult to incorporate into steeply sloping terrain; however, terraced applications of these facilities have been successful in other parts of the country.

When bioretention (and other BMPs used for infiltration) are located adjacent to buildings or pavement areas, protective measures should be implemented to avoid adverse impacts to these structures. Oversaturated subgrade soil underlying a structure can cause the structure to settle or result in moisture-related problems. Wetting of expansive soils or bedrock can cause swelling, resulting in structural movements. A geotechnical engineer should evaluate the potential impact of the BMP on adjacent structures based on an evaluation of the subgrade soil, groundwater, and bedrock conditions at the site. Additional minimum requirements include:

- In locations where subgrade soils do not allow infiltration and/or where infiltration could adversely impact adjacent structures, include a drainage layer (with underdrain) under the growing medium.
- In locations where potentially expansive soils or bedrock exist, placement of a rain garden adjacent to structures and pavement should only be considered if the BMP includes a drainage layer (with underdrain) and an impermeable geomembrane liner designed to restrict seepage.

Benefits

- Bioretention uses multiple treatment processes to remove pollutants, including sedimentation, filtering, adsorption, evapotranspiration, and biological uptake of constituents.
- Stormwater treatment occurs within attractive landscaped areas.
- There is a potential reduction of irrigation requirements by taking advantage of site runoff.

Limitations

- Additional design and construction steps are required for placement of any ponding or infiltration area near or upgradient from a building foundation and/or when expansive (low to high swell) soils exist. This is discussed in the design procedure section.
- In developing or otherwise erosive watersheds, high sediment loads can clog the facility.

Designing for Maintenance

Recommended maintenance practices for all BMPs are in Chapter 6 of this manual. During design, consider the following to ensure ease of maintenance over the long-term:

- Do not put a filter sock on the underdrain. This is not necessary and can cause the underdrain to clog.
- The best surface cover for a rain garden is full vegetation. Use rock mulch sparingly within the rain garden because rock mulch limits infiltration and is more difficult to maintain. Wood mulch handles sediment build-up better than rock mulch; however, wood mulch floats and may clog the overflow depending on the configuration of the outlet or settle unevenly. Some municipalities may not allow wood mulch for this reason.
- Consider all potential maintenance requirements such as mowing (if applicable) and replacement of the growing medium. Consider the method and equipment for each task required. For example, in a large rain garden where the use of hand tools is not feasible, does the shape and configuration of the rain garden allow for removal of the growing medium using a backhoe?
- Provide pre-treatment when it will reduce the extent and frequency of maintenance necessary to maintain function over the life of the BMP. For example, if the tributary is larger than one acre, prone to debris or the use of sand for ice control, consider a small forebay.
- Make the rain garden as shallow as possible. Increasing the depth unnecessarily can create erosive side slopes and complicate maintenance. Shallow rain gardens are also more attractive.
- Design and adjust the irrigation system (temporary or permanent) to provide appropriate water for the establishment and maintenance of selected vegetation.

Is Pretreatment Needed?

Designing the inflow gutter to the rain garden at a minimal slope of 0.5% can facilitate sediment and debris deposition prior to flows entering the BMP. Be aware, this will reduce maintenance of the BMP, but may require more frequent sweeping of the gutter to ensure that the sediment does not impede flow into the rain garden.

Design Procedure and Criteria

1. **Subsurface Exploration and Determination of a No-Infiltration, Partial Infiltration, or Full Infiltration Section:** Infiltration BMPs can have three basic types of sections. The appropriate section will depend on land use and activities, proximity to adjacent structures and soil characteristics. Sections of each installation type are shown in Figure B-1.
 - **No-Infiltration Section:** This section includes an underdrain and an impermeable liner that prevents infiltration of stormwater into the subgrade soils. Consider using this section when any of the following conditions exist:
 - The site is a stormwater hotspot and infiltration could result in contamination of groundwater.
 - The site is located over contaminated soils and infiltration could mobilize these contaminants.
 - The facility is located over potentially expansive soils or bedrock that could swell due to infiltration and potentially damage adjacent structures (e.g., building foundation or pavement).
 - **Partial Infiltration Section:** This section does not include an impermeable liner, and allows some infiltration. Stormwater that does not infiltrate is collected and removed by an underdrain

system.

- **Full Infiltration Section:** This section is designed to infiltrate the water stored in the basin into the subgrade below. UDFCD recommends a minimum infiltration rate of 2 times the rate needed to drain the WQCV over 12 hours. A conservative design could utilize the partial infiltration section with the addition of a valve at the underdrain outlet. In the event that infiltration does not remain adequate following construction, the valve could be opened and allow this section to operate as a partial infiltration section.

A geotechnical engineer should scope and perform a subsurface study. Typical geotechnical investigation needed to select and design the section includes:

- Prior to exploration review geologic and geotechnical information to assess near-surface soil, bedrock and groundwater conditions that may be encountered and anticipated ranges of infiltration rate for those materials. For example, if the facility is located adjacent to a structure and the site is located in a general area of known shallow, potentially expansive bedrock, a no-infiltration section will likely be required. It is also possible that this BMP may be infeasible, even with a liner, if there is a significant potential for damage to the adjacent structures (e.g., areas of dipping bedrock).
- Drill exploratory borings or exploratory pits to characterize subsurface conditions beneath the subgrade and develop requirements for subgrade preparation. Drill at least one boring or pit for every 40,000 ft², and at least two borings or pits for sites between 10,000 ft² and 40,000 ft². The boring or pit should extend at least 5 feet below the bottom of the base, and at least 20 feet in areas where there is a potential of encountering potentially expansive soils or bedrock. More borings or pits at various depths may be required by the geotechnical engineer in areas where soil types may change, in low-lying areas where subsurface drainage may collect, or where the water table is likely within 8 feet below the planned bottom of the base or top of subgrade. Installation of temporary monitoring wells in selected borings or pits for monitoring groundwater levels over time should be considered where shallow groundwater is encountered.
- Perform laboratory tests on samples obtained from the borings or pits to initially characterize the subgrade, evaluate the possible section type, and to assess subgrade conditions for supporting traffic loads. Consider the following tests: moisture content (ASTM D 2216); dry density (ASTM D 2936); Atterberg limits (ASTM D 4318); gradation (ASTM D 6913); swell-consolidation (ASTM D 4546); subgrade support testing (R-value, CBR or unconfined compressive strength); and hydraulic conductivity. A geotechnical engineer should determine the appropriate test method based on the soil type.
- For sites where a full infiltration section may be feasible, perform on-site infiltration tests using a double-ring infiltrometer (ASTM D 3385). Perform at least one test for every 160,000 ft² and at least two tests for sites between 40,000 ft² and 160,000 ft². The tests should be located near completed borings or pits so the test results and subsurface conditions encountered in the borings can be compared, and at least one test should be located near the boring or pit showing the most unfavorable infiltration condition. The test should be performed at the planned top of subgrade underlying the growing media.
- Be aware that actual infiltration rates are highly variable dependent on soil type, density and moisture content and degree of compaction as well as other environmental and construction influences. Actual rates can differ an order of magnitude or more from those indicated by infiltration or permeability testing. Select the type of section based on careful assessment of the subsurface exploration and testing data.

The following steps outline the design procedure and criteria, with Figure B-1 providing a corresponding cross-section.

2. **Basin Storage Volume:** Provide a storage volume based on a 12-hour drain time.

Find the required WQCV (watershed inches of runoff). Using the imperviousness of the tributary area (or effective imperviousness where LID elements are used upstream), use Figure 3-2 located in Chapter 3 of this manual to determine the WQCV based on a 12-hour drain time.

Calculate the design volume as follows:

$$V = \left[\frac{\text{WQCV}}{12} \right] A \quad \text{Equation B-1}$$

Where:

V = design volume (ft³)

A = area of watershed tributary to the rain garden (ft²)

3. **Basin Geometry:** UDFCD recommends a maximum WQCV ponding depth of 12 inches to maintain vegetation properly. Provide an inlet or other means of overflow at this elevation. Depending on the type of vegetation planted, a greater depth may be utilized to detain larger (more infrequent) events. The bottom surface of the rain garden, also referred to here as the filter area, should be flat. Sediment will reside on the filter area of the rain garden; therefore, if the filter area is too small, it may clog prematurely. If the filter area is not flat, the lowest area of the filter is more likely to clog as it will have a higher sediment loading. Increasing the filter area will reduce clogging and decrease the frequency of maintenance. Equation B-2 provides a minimum filter area allowing for some of the volume to be stored beyond the area of the filter (i.e., above the sideslopes of the rain garden).

Note that the total surcharge volume provided by the design must also equal or exceed the design volume. Where needed to meet the the required volume, also consider the porosity of the media at 14 percent. Use vertical walls or slope the sides of the basin to achieve the required volume. Sideslopes should be no steeper than 4:1 (horizontal:vertical).

$$A_F = 0.02 AI \quad \text{Equation B-2}$$

Where:

A_F = minimum (flat) filter area (ft²)

A = area tributary to the rain garden (ft²)

I = imperviousness of area tributary to the rain garden (percent expressed as a decimal)

4. **Growing Medium:** Provide a minimum of 18 inches of growing medium to enable establishment of the roots of the vegetation (see Figure B-1). A previous version of this manual specified a mixture consisting of 85% coarse sand and a 15% compost/shredded paper mixture (by volume). Based on field monitoring of this medium, compost was removed to reduce export of nutrients and fines and silts were added to both benefit the vegetation and increase capture of metals in stormwater.

Table B-1 specifies the growing media as well as other materials discussed in this Fact Sheet. Growing media is engineered media that requires a high level of quality control and must almost always be imported. Obtaining a particle size distribution and nutrient analysis is the only way to ensure that the media is acceptable. UDFCD has identified placement of media not meeting the specification as the most frequent cause of failure. Sample the media after delivery and prior to placement or obtain a sample from the supplier in advance of delivery and placement and have this analyzed prior to delivery.

Other Rain Garden Growing Medium Amendments

The specified growing medium was designed for filtration ability, clogging characteristics, and vegetative health. It is important to preserve the function provided by the rain garden growing medium when considering additional materials for incorporation into the growing medium or into the standard section shown in Figure B-1. When desired, amendments may be included to improve water quality or to benefit vegetative health as long as they do not add nutrients, pollutants, or modify the infiltration rate. For example, a number of products, including steel wool, capture and retain dissolved phosphorus (Erickson 2009). When phosphorus is a target pollutant, proprietary materials with similar characteristics may be considered. Do not include amendments such as top soil, sandy loam, and compost.

Table B-1. Material specification for bioretention/rain garden facilities

Material	Specification	Submittals	Testing	Notes																				
Bioretention Growing Media (soil + organics)	Particle size distribution: 80-90% sand (0.05 - 2.0 mm diameter) 3-17% silt (0.002-0.5 mm diameter) 3-17% clay (<0.002 diameter) Chemical attributes and nutrient analysis: pH 6.8 - 7.5 organic matter < 15% nitrogen < 15 ppm phosphorus < 15 ppm salinity < 6 mmhos/cm	Particle size distribution and nutrient analysis required.		Percentages are in weight.																				
	3 to 5% shredded mulch (by weight of growing media)			bioretention soil required. Aged 6 months (minimum). Aged 6 months (minimum). No weed fabric allowed.																				
Landscape mulch	Shredded hardwood																							
Underdrain aggregate	COOT filler material (Class B or C as specified)	Particle size distribution required.	Required	Pipe must conform to requirements of ASTM designation F949. There shall be no evidence of splitting, cracking, or breaking when the pipe is tested per ASTM test method D2412 in accordance with F949 section 7.5 and ASTM F794 section 8.5.																				
					<table border="1"> <thead> <tr> <th>Sieve Size</th> <th>Mass Percent Passing Square Mesh Sieve Class B</th> <th>Class C</th> </tr> </thead> <tbody> <tr> <td>37.5 mm (1.5")</td> <td>100</td> <td></td> </tr> <tr> <td>19.0 mm (0.75")</td> <td></td> <td>100</td> </tr> <tr> <td>4.75 mm (No. 4)</td> <td>20-60</td> <td>60-100</td> </tr> <tr> <td>1.18 um (No. 16)</td> <td>10-30</td> <td></td> </tr> <tr> <td>300 um (No. 50)</td> <td>0-10</td> <td>10-30</td> </tr> <tr> <td>150 um (No. 100)</td> <td>0-10</td> <td></td> </tr> <tr> <td>75 um (No. 200)</td> <td>0-3</td> <td>0-3</td> </tr> </tbody> </table>	Sieve Size	Mass Percent Passing Square Mesh Sieve Class B	Class C	37.5 mm (1.5")	100		19.0 mm (0.75")		100	4.75 mm (No. 4)	20-60	60-100	1.18 um (No. 16)	10-30		300 um (No. 50)	0-10	10-30	150 um (No. 100)
Sieve Size	Mass Percent Passing Square Mesh Sieve Class B	Class C																						
37.5 mm (1.5")	100																							
19.0 mm (0.75")		100																						
4.75 mm (No. 4)	20-60	60-100																						
1.18 um (No. 16)	10-30																							
300 um (No. 50)	0-10	10-30																						
150 um (No. 100)	0-10																							
75 um (No. 200)	0-3	0-3																						
Underdrain Pipes	Pipe diameter and type	Minimum open area (per foot)		Contech A-2000 slotted pipe (or equal)																				
Impermeable liner	4-inch slotted PVC	Maximum slot width (inches)																						
	6-inch slotted PVC		1.90 in. ²																					
		Thickness	1.86 in. ²																					
		0.76 mm (30 mil)																						
		+/-5	Test method																					
		ASTM D 1693																						
		Tensile strength, kN/m (lb/in)	ASTM D6.82, method B																					
		12.25 (70)	ASTM D6.82, method B																					
		Modulus at 100% elongation, kN/m	ASTM D6.82, method B																					
		5.25 (30)	ASTM D6.82, method A																					
	Ultimate elongation, %	ASTM D6.82, method A																						
	360	ASTM D 1004																						
	Tear resistance, N(lbs)	ASTM D 1790																						
	38 (8.5)	ASTM D 1790																						
	Low temperature impact, °C (°F)	ASTM D 6.82, method A																						
	-29 (-20)	ASTM D 6.82, method A																						
	Volatiles loss, % maximum	1(max)	NA																					
	Pinholes, no. per 8 m ² (no. per 10 yd. ²)	80	NA																					
	Bonded seam strength, % of tensile																							

5. **Underdrain System:** When using an underdrain system, provide a control orifice sized to drain the design volume in 12 hours or more (see Equation B-3). Use a minimum orifice size of 3/8 inch to avoid clogging. This will provide detention and slow release of the WQCV, providing water quality benefits and reducing impacts to downstream channels. Space underdrain pipes a maximum of 20 feet on center. Provide cleanouts to enable maintenance of the underdrain. Cleanouts can also be used to conduct an inspection (by camera) of the underdrain system to ensure that the pipe was not crushed or disconnected during construction.

Calculate the diameter of the orifice for a 12-hour drain time using Equation B-3 (Use a minimum orifice size of 3/8 inch to avoid clogging.):

$$D_{12 \text{ hour drain time}} = \sqrt{\frac{V}{1414 y^{0.41}}} \quad \text{Equation B-3}$$

Where:

- D = orifice diameter (in)
- y = distance from the lowest elevation of the storage volume (i.e., surface of the filter) to the center of the orifice (ft)
- V = volume (WQCV or the portion of the WQCV in the rain garden) to drain in 12 hours (ft³)

In previous versions of this manual, UDFCD recommended that the underdrain be placed in an aggregate layer and that a geotextile (separator fabric) be placed between this aggregate and the growing medium. This version of the manual replaces that section with materials that, when used together, eliminate the need for a separator fabric.

The underdrain system should be placed within an 6-inch-thick section of CDOT Class B or Class C filter material meeting the gradation in Table B-1. Use slotted pipe that meets the slot dimensions provided in Table B-3.

6. Impermeable Geomembrane Liner and Geotextile Separator Fabric

Separator Fabric: For no-infiltration sections, install a 30 mil (minimum) PVC geomembrane liner, per Table B-1, on the bottom and sides of the basin, extending up at least to the top of the underdrain layer. Provide at least 9 inches (12 inches if possible) of cover over the membrane where it is attached to the wall to protect the membrane from UV deterioration. The geomembrane should be field-seamed using a dual track welder, which allows for non-destructive testing of almost all field seams. A small amount of single track is allowed in limited areas to seam around pipe perforations, to patch seams removed for destructive seam testing, and for limited repairs. The liner should be installed with slack to prevent tearing due to backfill, compaction, and settling. Place CDOT Class B geotextile separator fabric above the geomembrane to protect it from being punctured during the placement of the filter material above the liner. If the subgrade contains angular rocks or other material that could puncture the geomembrane, smooth-roll the surface to create a suitable surface. If smooth-rolling the surface does not provide a suitable surface, also place the separator fabric between the geomembrane and the underlying subgrade. This should only be done when necessary because fabric placed under the geomembrane can increase seepage losses through pinholes or other geomembrane defects. Connect the geomembrane to perimeter concrete walls around the basin perimeter, creating a watertight seal between the geomembrane and the walls using a continuous batten bar and anchor connection (see Figure B-3). Where the need for the impermeable membrane is not as critical, the membrane can be attached with a nitrile-based vinyl adhesive. Use watertight PVC boots for underdrain pipe penetrations through the liner (see Figure B-2) or the technique shown in photo B-3.



Photograph B-2. The impermeable membrane in this photo has ripped from the bolts due to placement of the media without enough slack in the membrane.



Photograph B-3. Ensure a water-tight connection where the underdrain penetrated the liner. The heat-welded “boot” shown here is an alternative to the clamped detail shown in Figure B-2.

Table B-2. Physical requirements for separator fabric¹

Property	Class B		Test Method
	Elongation < 50% ²	Elongation > 50% ²	
Grab Strength, N (lbs.)	800 (180)	510 (115)	ASTM D 4632
Puncture Resistance, N (lbs.)	310 (70)	180 (40)	ASTM D 4833
Trapezoidal Tear Strength, N (lbs.)	310 (70)	180 (40)	ASTM D 4533
Apparent Opening Size, mm (US Sieve Size)	AOS < 0.3mm (US Sieve Size No. 50)		ASTM D 4751
Permittivity, sec ⁻¹	0.02 default value, must also be greater than that of soil		ASTM D 4491
Permeability, cm/sec	k fabric > k soil for all classes		ASTM D 4491
Ultraviolet Degradation at 500 hours	50% strength retained for all classes		ASTM D 4355

¹ Strength values are in the weaker principle direction

² As measured in accordance with ASTM D 4632

- Inlet and Outlet Control:** In order to provide the proper drain time, the bioretention area can be restricted at the underdrain outlet with an orifice plate or can be designed without an underdrain (provided the subgrade meets the requirements above). Equation B-3 is a simplified equation for sizing an orifice plate for a 12-hour drain time. UD-BMP or UD-Detention, available at www.udfcd.org, also perform this calculation.

How flow enters and exits the BMP is a function of the overall drainage concept for the site. Curb cuts can be designed to both allow stormwater into the rain garden as well as to provide release of stormwater in excess of the WQCV. Roadside rain gardens located on a steep site might pool and overflow into downstream cells with a single curb cut, level spreader, or outlet structure located at the most downstream cell. When selecting the



Photograph B-4. The curb cut shown allows flows to enter this rain garden while excess flows bypass the facility.

type and location of the outlet structure, ensure runoff will not short-circuit the rain garden. This is a frequent problem when using a curb inlet located outside the rain garden for overflow.

For rain gardens with concentrated points of inflow, provide a forebay and energy dissipation. A depressed concrete slab works best for a forebay. It helps maintain a vertical drop at the inlet and allows for easily removal of sediment using a square shovel. Where rock is used for energy dissipation, provide separator fabric between the rock and growing medium to minimize subsidence.

8. **Vegetation:** UDFCD recommends that the filter area be vegetated with drought tolerant species that thrive in sandy soils. Table B-3 provides a suggested seed mix for sites that will not need to be irrigated after the grass has been established.

Mix seed well and broadcast, followed by hand raking to cover seed and then mulched. Hydromulching can be effective for large areas. Do not place seed when standing water or snow is present or if the ground is frozen. Weed control is critical in the first two to three years, especially when starting with seed.

When using sod, specify sand-grown sod. Do not use conventional sod. Conventional sod is grown in clay soil that will seal the filter area, greatly reducing overall function of the BMP.

When using an impermeable liner, select plants with diffuse (or fibrous) root systems, not taproots. Taproots can damage the liner and/or underdrain pipe. Avoid trees and large shrubs that may interfere with restorative maintenance. Plant these outside of the area of growing medium. Use a cutoff wall to ensure that roots do not grow into the underdrain or place trees and shrubs a conservative distance from the underdrain.

9. **Irrigation:** Provide spray irrigation at or above the WQCV elevation or place temporary irrigation on top of the rain garden surface. Do not place sprinkler heads on the flat surface. Remove temporary irrigation when vegetation is established. If left in place this will become buried over time and will be damaged during maintenance operations.

Adjust irrigation schedules during the growing season to provide the minimum water necessary to maintain plant health and to maintain the available pore space for infiltration.

Designing for Flood Protection

Provide the WQCV in rain gardens that direct excess flow into to a landscaped basin designed for flood control or design a single basin to provide water quality and flood control. See the *Storage* chapter in Volume 2 of the USDCM for more information. UD-Detention, available at www.udfcd.org, will facilitate design either alternative.

Table B-3. Native seed mix for rain gardens

Common Name	Scientific Name	Variety	PLS ² lbs per Acre	Ounces per Acre
Sand bluestem	Andropogon hallii	Garden	3.5	
Sideoats grama	Bouteloua curtipendula	Butte	3	
Prairie sandreed	Calamovilfa longifolia	Goshen	3	
Indian ricegrass	Oryzopsis hymenoides	Paloma	3	
Switchgrass	Panicum virgatum	Blackwell	4	
Western wheatgrass	Pascopyrum smithii	Ariba	3	
Little bluestem	Schizachyrium scoparium	Patura	3	
Alkali sacaton	Sporobolus airoides		3	
Sand dropseed	Sporobolus cryptandrus		3	
Pasture sage ¹	Artemisia frigida			2
Blue aster ¹	Aster laevis			4
Blanket flower ¹	Gaillardia aristata			8
Prairie coneflower ¹	Ratibida columnifera			4
Purple prairieclover ¹	Dalea (Petalostemum) purpurea			4
Sub-Totals:			27.5	22
Total lbs per acre:			28.9	

¹ Wildflower seed (optional) for a more diverse and natural look.

² PLS = Pure Live Seed.

Aesthetic Design

In addition to effective stormwater quality treatment, rain gardens can be attractively incorporated into a site within one or several landscape areas. Aesthetically designed rain gardens will typically either reflect the character of their surroundings or become distinct features within their surroundings. Guidelines for each approach are provided below.

Reflecting the Surrounding

- Determine design characteristics of the surrounding. This becomes the context for the drainage improvement. Use these characteristics in the structure.
- Create a shape or shapes that "fix" the forms surrounding the improvement. Make the improvement part of the existing surrounding.
- The use of material is essential in making any new improvement an integral part of the whole. Select materials that are as similar as possible to the surrounding architectural/engineering materials. Select materials from the same source if possible. Apply materials in the same quantity, manner, and method as original material.
- Size is an important feature in seamlessly blending the addition into its context. If possible, the overall size of the improvement should look very similar to the overall sizes of other similar objects in the improvement area.
- The use of the word texture in terms of the structure applies predominantly to the selection of plant material. The materials used should as closely as possible, blend with the size and texture of other plant material used in the surrounding. The plants may or may not be the same, but should create a similar feel, either individually or as a mass.

Reflective Design

A reflective design borrows the characteristics, shapes, colors, materials, sizes and textures of the built surroundings. The result is a design that fits seamlessly and unobtrusively in its environment.

Creating a Distinct Feature

Designing the rain garden as a distinct feature is limited only by budget, functionality, and client preference. There is far more latitude in designing a rain garden that serves as a distinct feature. If this is the intent, the main consideration beyond functionality is that the improvement create an attractive addition to its surroundings. The use of form, materials, color, and so forth focuses on the improvement itself and does not necessarily reflect the surroundings, depending on the choice of the client or designer.

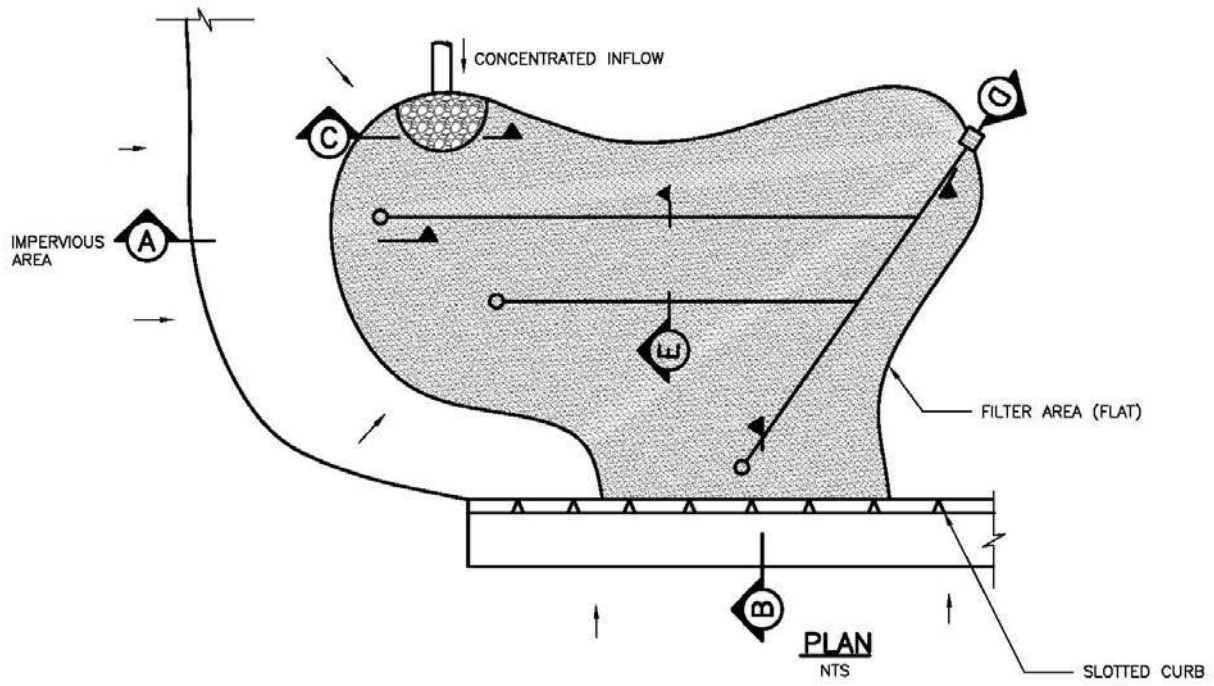
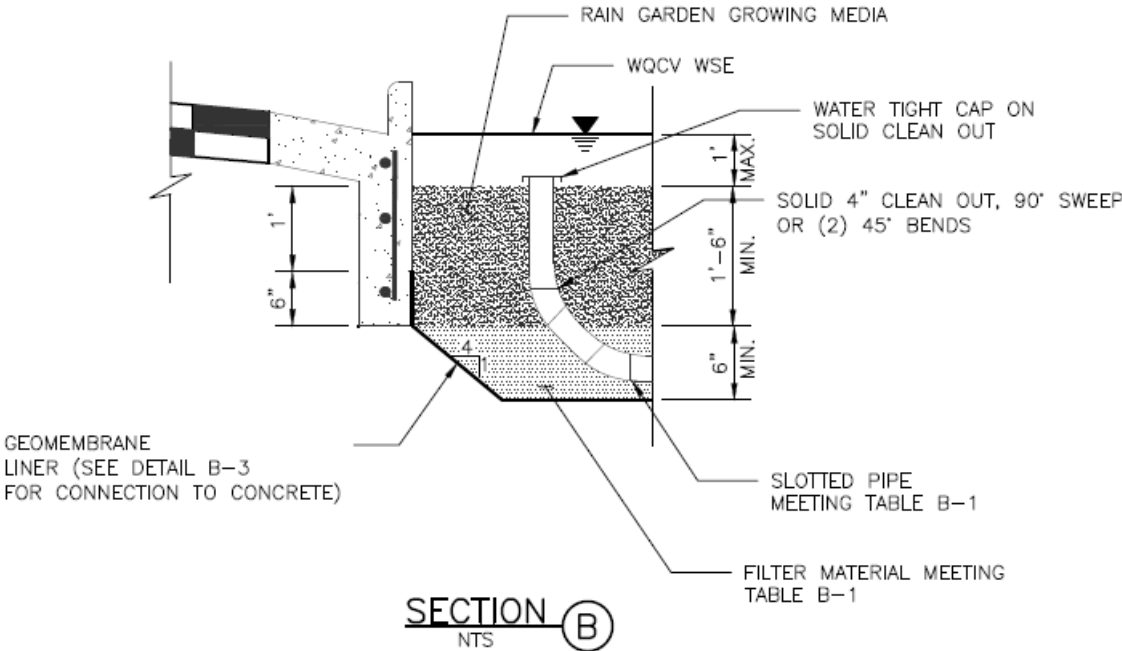
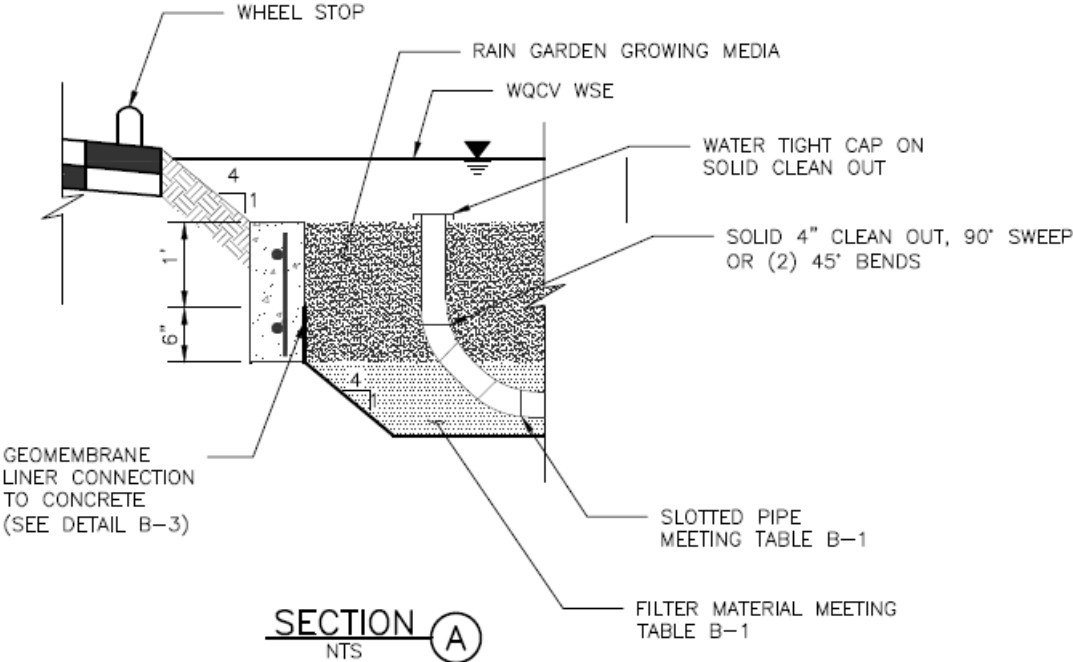
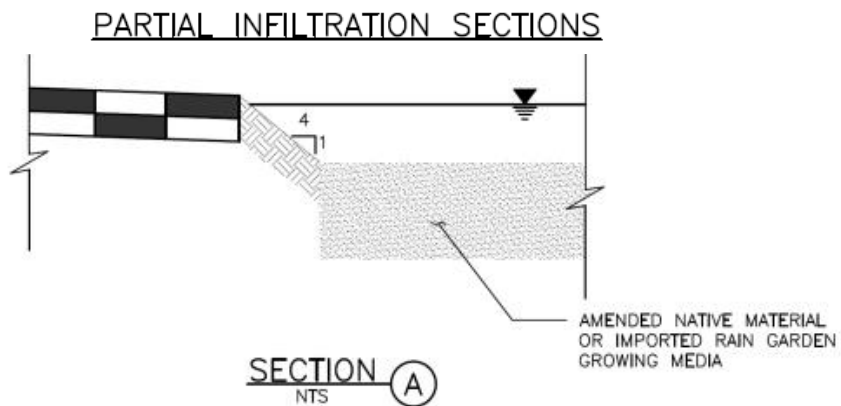
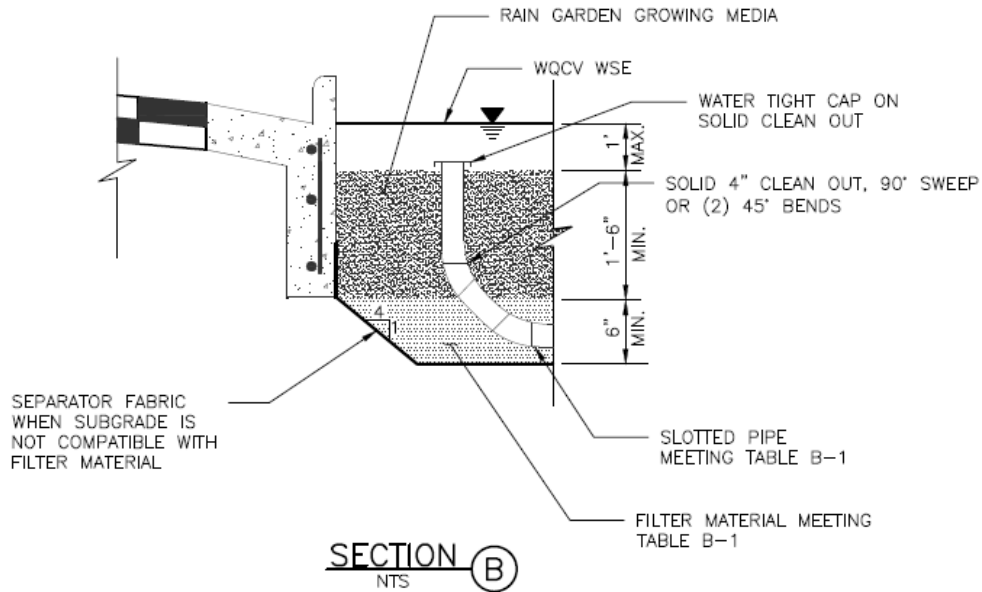
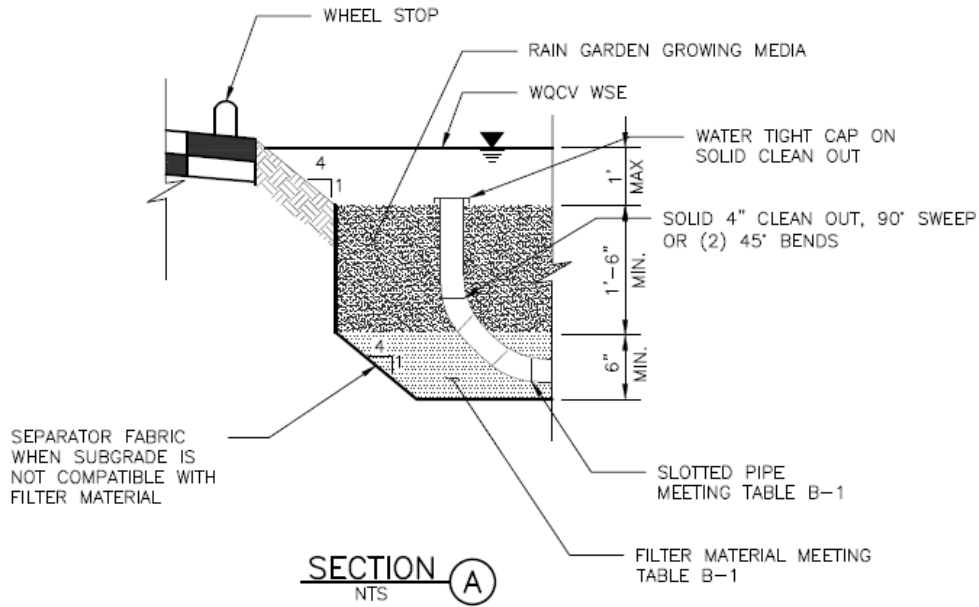

Figure B-1 – Typical rain garden plan and sections



NO-INFILTRATION SECTIONS



FULL INFILTRATION SECTION

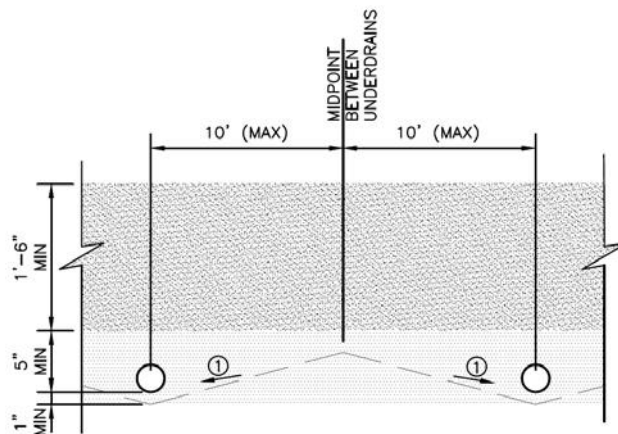
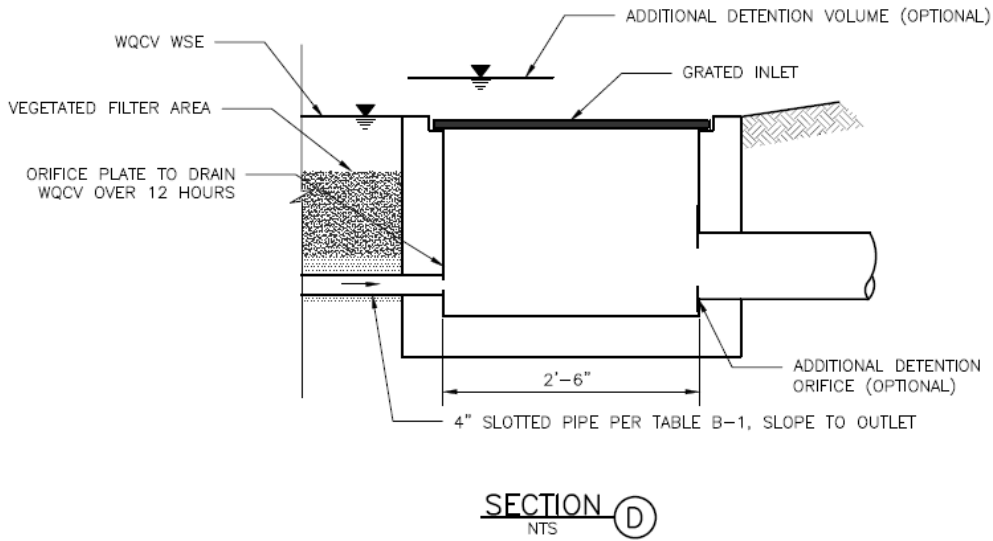
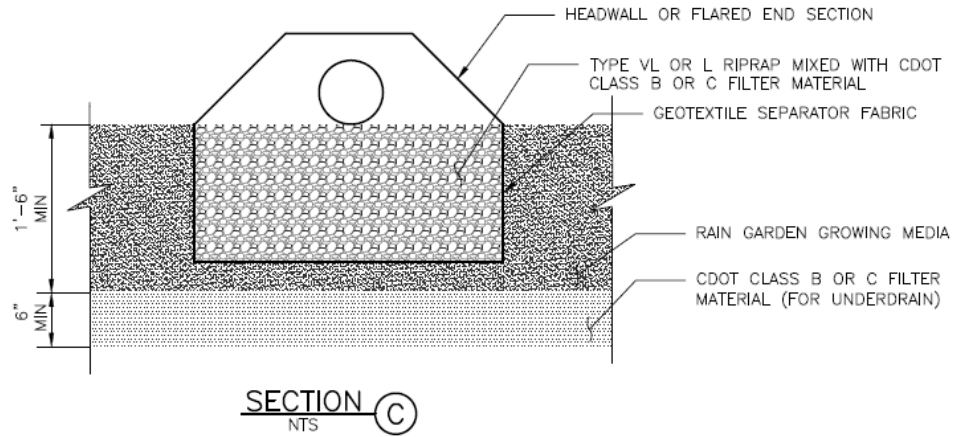

① SLOPE (STRAIGHT GRADE) SUBGRADE (2-10%) TO UNDERDRAIN TO REDUCE SATURATED SOIL CONDITIONS BETWEEN STORM EVENTS (OPTIONAL)

SECTION E
NTS

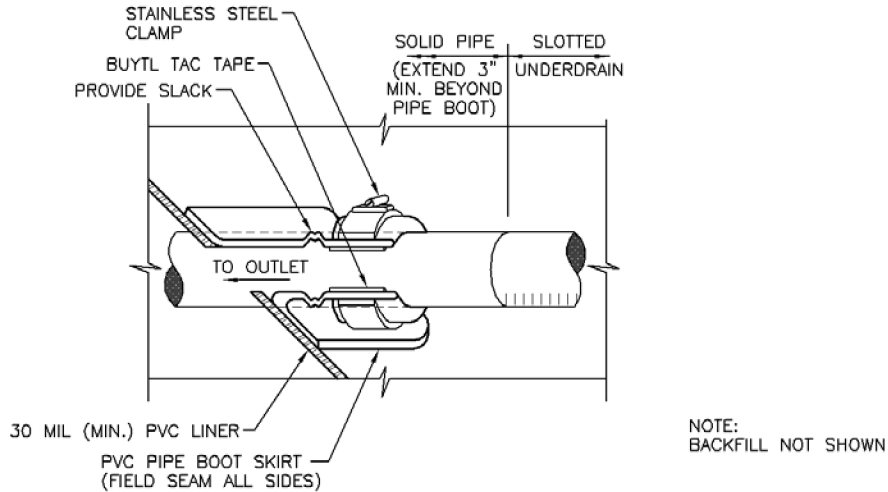

Figure B-2. Geomembrane Liner/Underdrain Penetration Detail

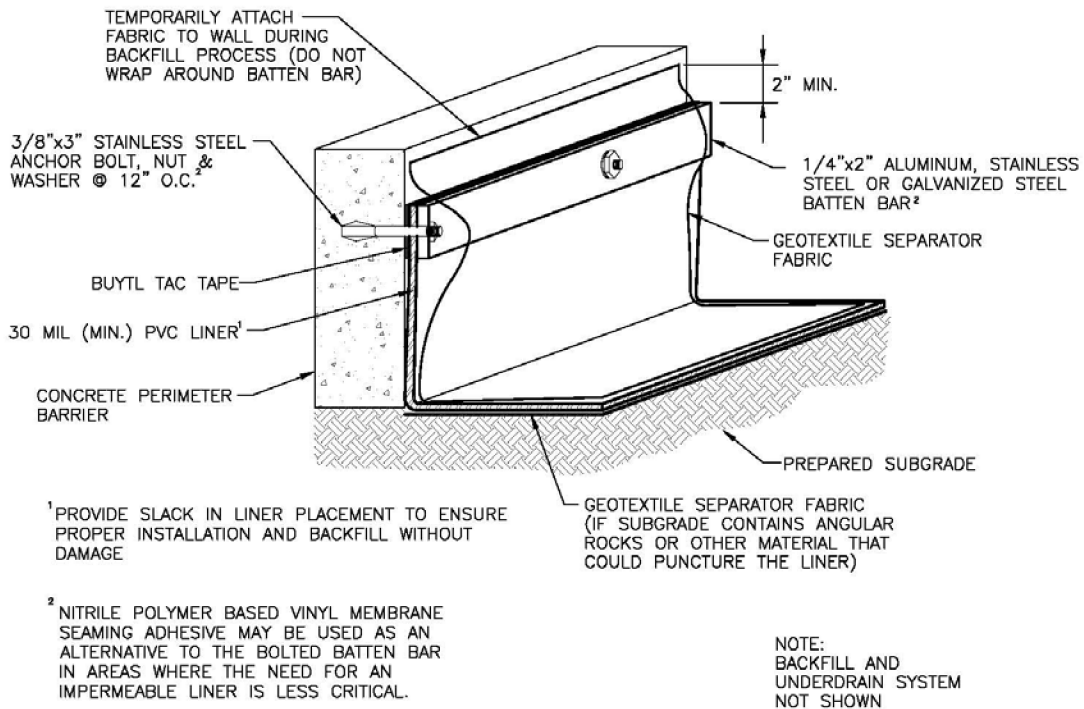

Figure B-3. Geomembrane Liner/Concrete Connection Detail

Construction Considerations

Proper construction of rain gardens involves careful attention to material specifications, final grades, and construction details. For a successful project, implement the following practices:

- Protect area from excessive sediment loading during construction. This is the most common cause of clogging of rain gardens. The portion of the site draining to the rain garden must be stabilized before allowing flow into the rain garden. This includes completion of paving operations.
- Avoid over compaction of the area to preserve infiltration rates (for partial and full infiltration sections).
- Provide construction observation to ensure compliance with design specifications. Improper installation, particularly related to facility dimensions and elevations and underdrain elevations, is a common problem with rain gardens.
- When using an impermeable liner, ensure enough slack in the liner to allow for backfill, compaction, and settling without tearing the liner.
- Provide necessary quality assurance and quality control (QA/QC) when constructing an impermeable geomembrane liner system, including but not limited to fabrication testing, destructive and non-destructive testing of field seams, observation of geomembrane material for tears or other defects, and air lace testing for leaks in all field seams and penetrations. QA/QC should be overseen by a professional engineer. Consider requiring field reports or other documentation from the engineer.
- Provide adequate construction staking to ensure that the site properly drains into the facility, particularly with respect to surface drainage away from adjacent buildings. Photo B-3 and Photo B-4 illustrate a construction error for an otherwise correctly designed series of rain gardens.



Photograph B-3. Inadequate construction staking may have contributed to flows bypassing this rain garden.



Photograph B-4. Runoff passed the upgradient rain garden, shown in Photo B-3, and flooded this downstream rain garden.

References

- Erickson, Andy. 2009. Field Applications of Enhanced Sand Filtration. University of Minnesota *Stormwater Management Practice Assessment Project Update*. <http://wrc.umn.edu>.
- Hunt, William F., Davis, Allen P., Traver, Robert. G. 2012. "Meeting Hydrologic and Water Quality Goals through Targeted Bioretention Design" *Journal of Environmental Engineering*. (2012) 138:698-707. Print.

APPENDIX C

HYDRAULIC CALCULATIONS:

- 1) RATIONAL CALCULATIONS – PROPOSED CONDITION**
- 2) DESIGN PROCEDURE FOR RAIN GARDEN**

Hammers Construction - CrackerJack
Project# HCI003
Area Runoff Coefficient Summary - PROPOSED

BASIN	TOTAL AREA		DEVELOPED			UNDEVELOPED			WEIGHTED		
	(SF)	(Acres)	AREA (Acres)	C ₅	C ₁₀₀	AREA (Acres)	C ₅	C ₁₀₀	C ₅	C ₁₀₀	C ₁₀₀
P-1	11,736	0.27	0.25	0.90	0.95	0.02	0.25	0.35	0.85	0.91	
P-2	4,339	0.10	0.02	0.90	0.95	0.08	0.25	0.35	0.39	0.48	
% Impervious											
P-1			0.25	100%		0.02	0%			68%	
P-2			0.02	100%		0.08	0%			6%	
Total Area =		0.37	0.27	100%		0.10	0%			74%	

Calculated by: _____
 Date: _____
 Checked by: _____

The % impervious for the individual subbasin (P-1, & P-2) is incorrect. Double check the excel formula.

Hammers Construction - Cracker-Jack
Project# HCI003
Area Drainage Summary - PROPOSED

BASIN	WEIGHTED		OVERLAND			STREET / CHANNEL FLOW				CA		INTENSITY		TOTAL FLOW			
	AREA TOTAL (Acres)	C ₅	C ₁₀₀	Length (ft)	Height (ft)	T _C (min)	Grass/Paved	Length (ft)	Slope (%)	Velocity (fps)	T _r (min)	CA ₅	CA ₁₀₀	I ₅ (in/hr)	I ₁₀₀ (in/hr)	Q ₅ (c.f.s.)	Q ₁₀₀ (c.f.s.)
P-1	0.27	0.85	0.91	25	1	1.2	Paved	120	0.5%	1.4	1.5	0.23	0.24	5.0	9.1	1.2	2.2
						0.0					0.0						
						0.0					0.0						
P-2	0.10	0.39	0.48	20	1	1.0	Paved	100	2.0%	1.4	1.2	0.04	0.05	5.0	9.1	0.2	0.4
						0.0					0.0						
						0.0					0.0						

Calculated by: _____
Date: _____
Checked by: _____

STAGE-DISCHARGE SIZING OF THE WEIRS AND ORIFICES (INLET CONTROL)

Project: Crackerjack

Basin ID: _____

STAGE-DISCHARGE CURVE FOR THE OUTLET STRUCTURE

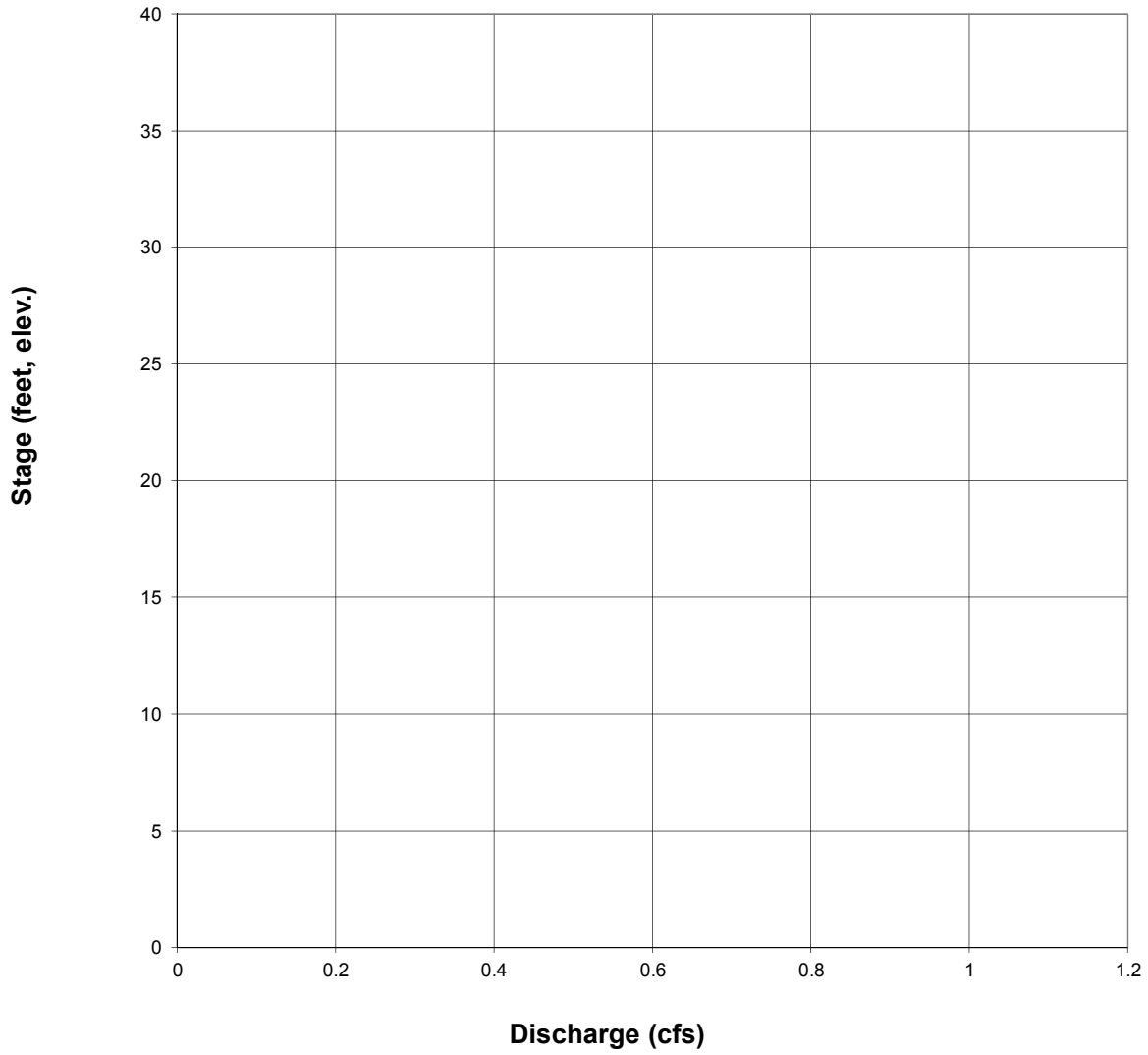

APPENDIX D

- 1) NRCS Soil Study**
- 2) FEMA FIRMETTE**

Custom Soil Resource Report for El Paso County Area, Colorado









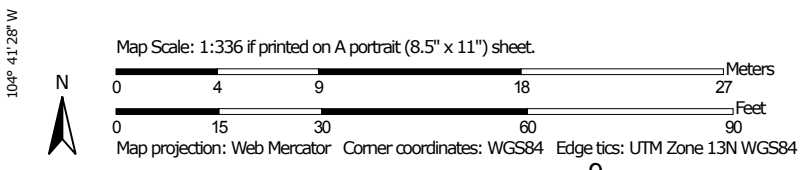























Soil Map

The soil map section includes the soil map for the defined area of interest, a list of soil map units on the map and extent of each map unit, and cartographic symbols displayed on the map. Also presented are various metadata about data used to produce the map, and a description of each soil map unit.

Custom Soil Resource Report Soil Map



MAP LEGEND

- Area of Interest (AOI)**
 -  Area of Interest (AOI)
- Soils**
 -  Soil Map Unit Polygons
 -  Soil Map Unit Lines
 -  Soil Map Unit Points
- Special Point Features**
 -  Blowout
 -  Borrow Pit
 -  Clay Spot
 -  Closed Depression
 -  Gravel Pit
 -  Gravelly Spot
 -  Landfill
 -  Lava Flow
 -  Marsh or swamp
 -  Mine or Quarry
 -  Miscellaneous Water
 -  Perennial Water
 -  Rock Outcrop
 -  Saline Spot
 -  Sandy Spot
 -  Severely Eroded Spot
 -  Sinkhole
 -  Slide or Slip
 -  Sodic Spot
- Water Features**
 -  Streams and Canals
- Transportation**
 -  Rails
 -  Interstate Highways
 -  US Routes
 -  Major Roads
 -  Local Roads
- Background**
 -  Aerial Photography

MAP INFORMATION

The soil surveys that comprise your AOI were mapped at 1:24,000.

Warning: Soil Map may not be valid at this scale.

Enlargement of maps beyond the scale of mapping can cause misunderstanding of the detail of mapping and accuracy of soil line placement. The maps do not show the small areas of contrasting soils that could have been shown at a more detailed scale.

Please rely on the bar scale on each map sheet for map measurements.

Source of Map: Natural Resources Conservation Service
 Web Soil Survey URL:
 Coordinate System: Web Mercator (EPSG:3857)

Maps from the Web Soil Survey are based on the Web Mercator projection, which preserves direction and shape but distorts distance and area. A projection that preserves area, such as the Albers equal-area conic projection, should be used if more accurate calculations of distance or area are required.

This product is generated from the USDA-NRCS certified data as of the version date(s) listed below.

Soil Survey Area: El Paso County Area, Colorado
 Survey Area Data: Version 14, Sep 23, 2016

Soil map units are labeled (as space allows) for map scales 1:50,000 or larger.

Date(s) aerial images were photographed: Jun 3, 2014—Jun 17, 2014

The orthophoto or other base map on which the soil lines were compiled and digitized probably differs from the background imagery displayed on these maps. As a result, some minor shifting of map unit boundaries may be evident.

Map Unit Legend

El Paso County Area, Colorado (CO625)			
Map Unit Symbol	Map Unit Name	Acres in AOI	Percent of AOI
28	Ellicott loamy coarse sand, 0 to 5 percent slopes	0.3	100.0%
Totals for Area of Interest		0.3	100.0%

Map Unit Descriptions

The map units delineated on the detailed soil maps in a soil survey represent the soils or miscellaneous areas in the survey area. The map unit descriptions, along with the maps, can be used to determine the composition and properties of a unit.

A map unit delineation on a soil map represents an area dominated by one or more major kinds of soil or miscellaneous areas. A map unit is identified and named according to the taxonomic classification of the dominant soils. Within a taxonomic class there are precisely defined limits for the properties of the soils. On the landscape, however, the soils are natural phenomena, and they have the characteristic variability of all natural phenomena. Thus, the range of some observed properties may extend beyond the limits defined for a taxonomic class. Areas of soils of a single taxonomic class rarely, if ever, can be mapped without including areas of other taxonomic classes. Consequently, every map unit is made up of the soils or miscellaneous areas for which it is named and some minor components that belong to taxonomic classes other than those of the major soils.

Most minor soils have properties similar to those of the dominant soil or soils in the map unit, and thus they do not affect use and management. These are called noncontrasting, or similar, components. They may or may not be mentioned in a particular map unit description. Other minor components, however, have properties and behavioral characteristics divergent enough to affect use or to require different management. These are called contrasting, or dissimilar, components. They generally are in small areas and could not be mapped separately because of the scale used. Some small areas of strongly contrasting soils or miscellaneous areas are identified by a special symbol on the maps. If included in the database for a given area, the contrasting minor components are identified in the map unit descriptions along with some characteristics of each. A few areas of minor components may not have been observed, and consequently they are not mentioned in the descriptions, especially where the pattern was so complex that it was impractical to make enough observations to identify all the soils and miscellaneous areas on the landscape.

The presence of minor components in a map unit in no way diminishes the usefulness or accuracy of the data. The objective of mapping is not to delineate pure taxonomic classes but rather to separate the landscape into landforms or landform segments that have similar use and management requirements. The delineation of such segments on the map provides sufficient information for the development of resource plans. If intensive use of small areas is planned, however,

Custom Soil Resource Report

onsite investigation is needed to define and locate the soils and miscellaneous areas.

An identifying symbol precedes the map unit name in the map unit descriptions. Each description includes general facts about the unit and gives important soil properties and qualities.

Soils that have profiles that are almost alike make up a *soil series*. Except for differences in texture of the surface layer, all the soils of a series have major horizons that are similar in composition, thickness, and arrangement.

Soils of one series can differ in texture of the surface layer, slope, stoniness, salinity, degree of erosion, and other characteristics that affect their use. On the basis of such differences, a soil series is divided into *soil phases*. Most of the areas shown on the detailed soil maps are phases of soil series. The name of a soil phase commonly indicates a feature that affects use or management. For example, Alpha silt loam, 0 to 2 percent slopes, is a phase of the Alpha series.

Some map units are made up of two or more major soils or miscellaneous areas. These map units are complexes, associations, or undifferentiated groups.

A *complex* consists of two or more soils or miscellaneous areas in such an intricate pattern or in such small areas that they cannot be shown separately on the maps. The pattern and proportion of the soils or miscellaneous areas are somewhat similar in all areas. Alpha-Beta complex, 0 to 6 percent slopes, is an example.

An *association* is made up of two or more geographically associated soils or miscellaneous areas that are shown as one unit on the maps. Because of present or anticipated uses of the map units in the survey area, it was not considered practical or necessary to map the soils or miscellaneous areas separately. The pattern and relative proportion of the soils or miscellaneous areas are somewhat similar. Alpha-Beta association, 0 to 2 percent slopes, is an example.

An *undifferentiated group* is made up of two or more soils or miscellaneous areas that could be mapped individually but are mapped as one unit because similar interpretations can be made for use and management. The pattern and proportion of the soils or miscellaneous areas in a mapped area are not uniform. An area can be made up of only one of the major soils or miscellaneous areas, or it can be made up of all of them. Alpha and Beta soils, 0 to 2 percent slopes, is an example.

Some surveys include *miscellaneous areas*. Such areas have little or no soil material and support little or no vegetation. Rock outcrop is an example.

El Paso County Area, Colorado

28—Ellicott loamy coarse sand, 0 to 5 percent slopes

Map Unit Setting

National map unit symbol: 3680
Elevation: 5,500 to 6,500 feet
Mean annual precipitation: 13 to 15 inches
Mean annual air temperature: 47 to 50 degrees F
Frost-free period: 125 to 145 days
Farmland classification: Not prime farmland

Map Unit Composition

Ellicott and similar soils: 85 percent
Estimates are based on observations, descriptions, and transects of the mapunit.

Description of Ellicott

Setting

Landform: Flood plains, stream terraces
Landform position (three-dimensional): Tread
Down-slope shape: Linear
Across-slope shape: Linear
Parent material: Sandy alluvium

Typical profile

A - 0 to 4 inches: loamy coarse sand
C - 4 to 60 inches: stratified coarse sand to sandy loam

Properties and qualities

Slope: 0 to 5 percent
Depth to restrictive feature: More than 80 inches
Natural drainage class: Somewhat excessively drained
Runoff class: Very low
Capacity of the most limiting layer to transmit water (Ksat): High to very high (5.95 to 19.98 in/hr)
Depth to water table: More than 80 inches
Frequency of flooding: Frequent
Frequency of ponding: None
Available water storage in profile: Low (about 4.1 inches)

Interpretive groups

Land capability classification (irrigated): None specified
Land capability classification (nonirrigated): 7w
Hydrologic Soil Group: A
Ecological site: Sandy Bottomland LRU's A & B (R069XY031CO)
Other vegetative classification: SANDY BOTTOMLAND (069AY031CO)
Hydric soil rating: No

Minor Components

Fluvaquentic haplaquoll

Percent of map unit:
Landform: Swales
Hydric soil rating: Yes

Custom Soil Resource Report

Other soils

Percent of map unit:
Hydric soil rating: No

Pleasant

Percent of map unit:
Landform: Depressions
Hydric soil rating: Yes

References

- American Association of State Highway and Transportation Officials (AASHTO). 2004. Standard specifications for transportation materials and methods of sampling and testing. 24th edition.
- American Society for Testing and Materials (ASTM). 2005. Standard classification of soils for engineering purposes. ASTM Standard D2487-00.
- Cowardin, L.M., V. Carter, F.C. Golet, and E.T. LaRoe. 1979. Classification of wetlands and deep-water habitats of the United States. U.S. Fish and Wildlife Service FWS/OBS-79/31.
- Federal Register. July 13, 1994. Changes in hydric soils of the United States.
- Federal Register. September 18, 2002. Hydric soils of the United States.
- Hurt, G.W., and L.M. Vasilas, editors. Version 6.0, 2006. Field indicators of hydric soils in the United States.
- National Research Council. 1995. Wetlands: Characteristics and boundaries.
- Soil Survey Division Staff. 1993. Soil survey manual. Soil Conservation Service. U.S. Department of Agriculture Handbook 18. http://www.nrcs.usda.gov/wps/portal/nrcs/detail/national/soils/?cid=nrcs142p2_054262
- Soil Survey Staff. 1999. Soil taxonomy: A basic system of soil classification for making and interpreting soil surveys. 2nd edition. Natural Resources Conservation Service, U.S. Department of Agriculture Handbook 436. http://www.nrcs.usda.gov/wps/portal/nrcs/detail/national/soils/?cid=nrcs142p2_053577
- Soil Survey Staff. 2010. Keys to soil taxonomy. 11th edition. U.S. Department of Agriculture, Natural Resources Conservation Service. http://www.nrcs.usda.gov/wps/portal/nrcs/detail/national/soils/?cid=nrcs142p2_053580
- Tiner, R.W., Jr. 1985. Wetlands of Delaware. U.S. Fish and Wildlife Service and Delaware Department of Natural Resources and Environmental Control, Wetlands Section.
- United States Army Corps of Engineers, Environmental Laboratory. 1987. Corps of Engineers wetlands delineation manual. Waterways Experiment Station Technical Report Y-87-1.
- United States Department of Agriculture, Natural Resources Conservation Service. National forestry manual. http://www.nrcs.usda.gov/wps/portal/nrcs/detail/soils/home/?cid=nrcs142p2_053374
- United States Department of Agriculture, Natural Resources Conservation Service. National range and pasture handbook. <http://www.nrcs.usda.gov/wps/portal/nrcs/detail/national/landuse/rangepasture/?cid=stelprdb1043084>

Custom Soil Resource Report

United States Department of Agriculture, Natural Resources Conservation Service. National soil survey handbook, title 430-VI. http://www.nrcs.usda.gov/wps/portal/nrcs/detail/soils/scientists/?cid=nrcs142p2_054242

United States Department of Agriculture, Natural Resources Conservation Service. 2006. Land resource regions and major land resource areas of the United States, the Caribbean, and the Pacific Basin. U.S. Department of Agriculture Handbook 296. http://www.nrcs.usda.gov/wps/portal/nrcs/detail/national/soils/?cid=nrcs142p2_053624

United States Department of Agriculture, Soil Conservation Service. 1961. Land capability classification. U.S. Department of Agriculture Handbook 210. http://www.nrcs.usda.gov/Internet/FSE_DOCUMENTS/nrcs142p2_052290.pdf



APPROXIMATE SCALE IN FEET

500 0 500

NATIONAL FLOOD INSURANCE PROGRAM

FIRM FLOOD INSURANCE RATE MAP
 EL PASO COUNTY,
 COLORADO AND
 INCORPORATED AREAS

PANEL 752 OF 1300
 (SEE MAP INDEX FOR PANELS NOT PRINTED)

CONTAINS COMMUNITY	NUMBER	PANEL	SUFFIX
COLORADO SPRINGS, CITY OF	080086	0752	F
EL PASO COUNTY, UNINCORPORATED AREAS	080059	0752	F

MAP NUMBER
 08041C0752 F

EFFECTIVE DATE:
 MARCH 17, 1997



Federal Emergency Management Agency

This is an official copy of a portion of the above referenced flood map. It was extracted using F-MIT On-Line. This map does not reflect changes or amendments which may have been made subsequent to the date on the title block. For the latest product information about National Flood Insurance Program flood maps, check the FEMA Flood Map Store at www.msc.fema.gov

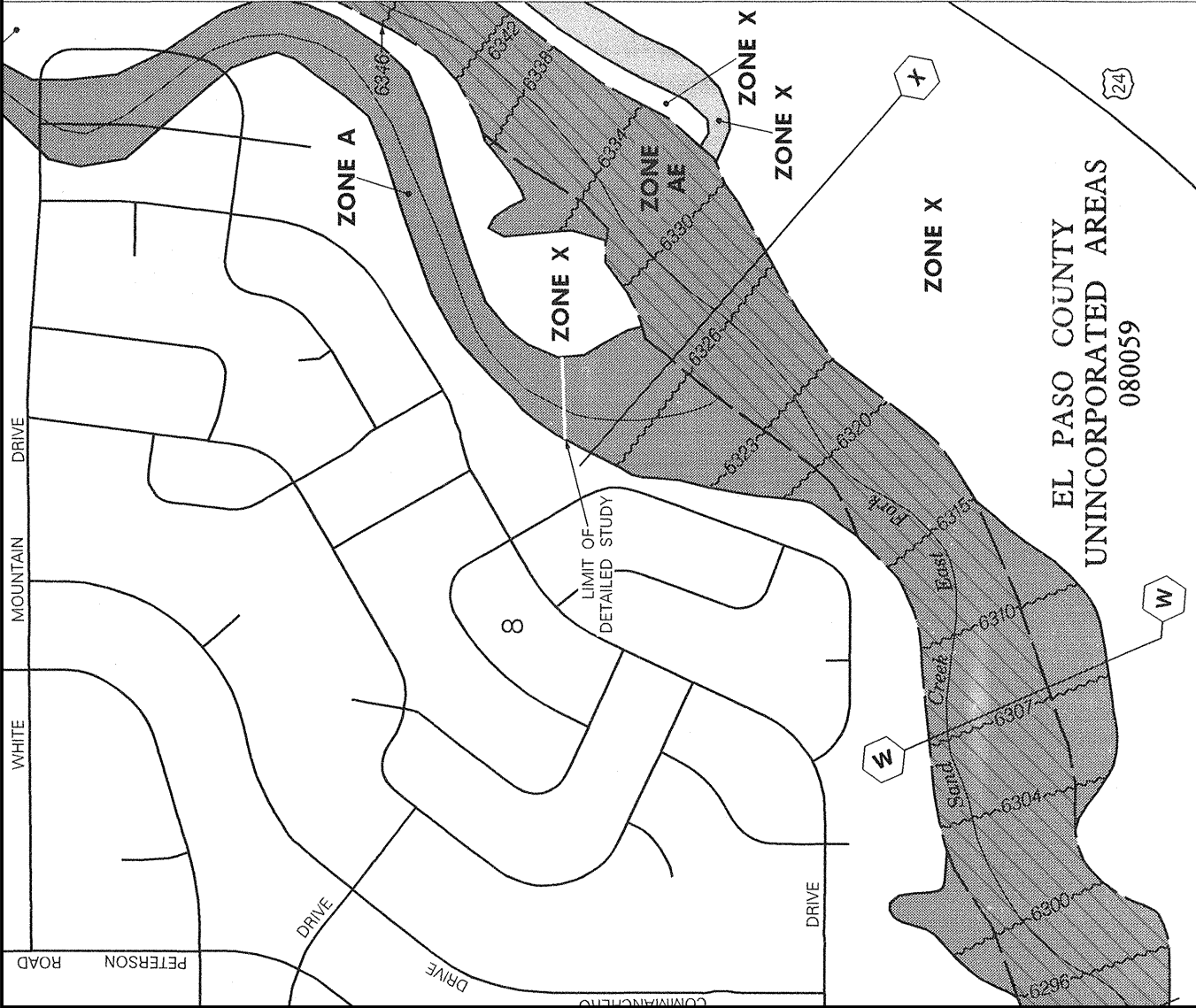

**EL PASO COUNTY
 UNINCORPORATED AREAS
 080059**

38°50'37"
 104°41'15"

APPENDIX E

Drainage Map

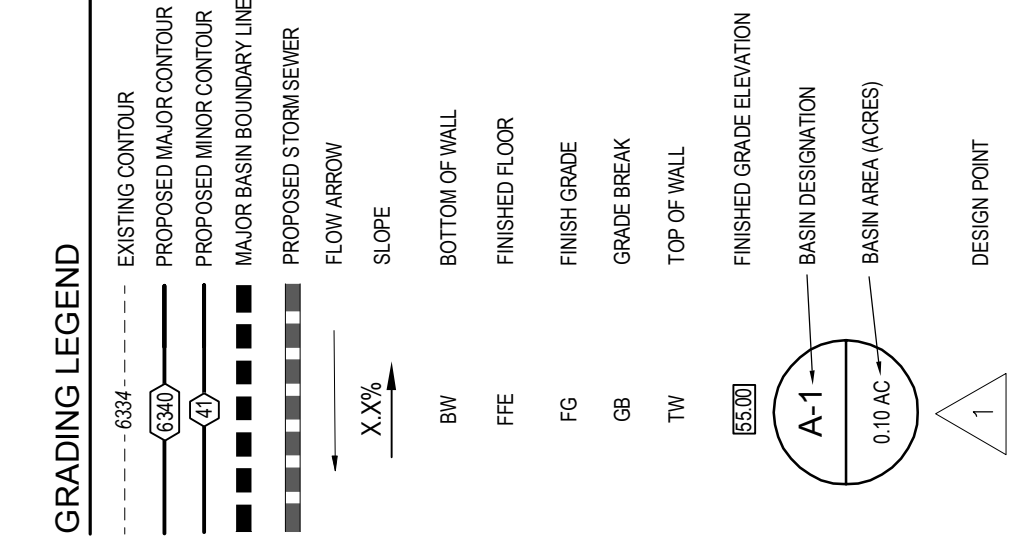

RUNOFF SUMMARY

SP	GR (CF/S)	OR (CF/S)
0	1.1	6.3
1	1.2	2.2
2	0.2	0.4

RAIN GARDEN BMP SUMMARY

WQCV REQUIRED = 208 CF
 WQCV PROVIDED = 279 CF (PROVIDED) = 140 SF
 MIN FLAT SURFACE PROVIDED = 198 SF
 WQCV DEPTH = 0.21 ft

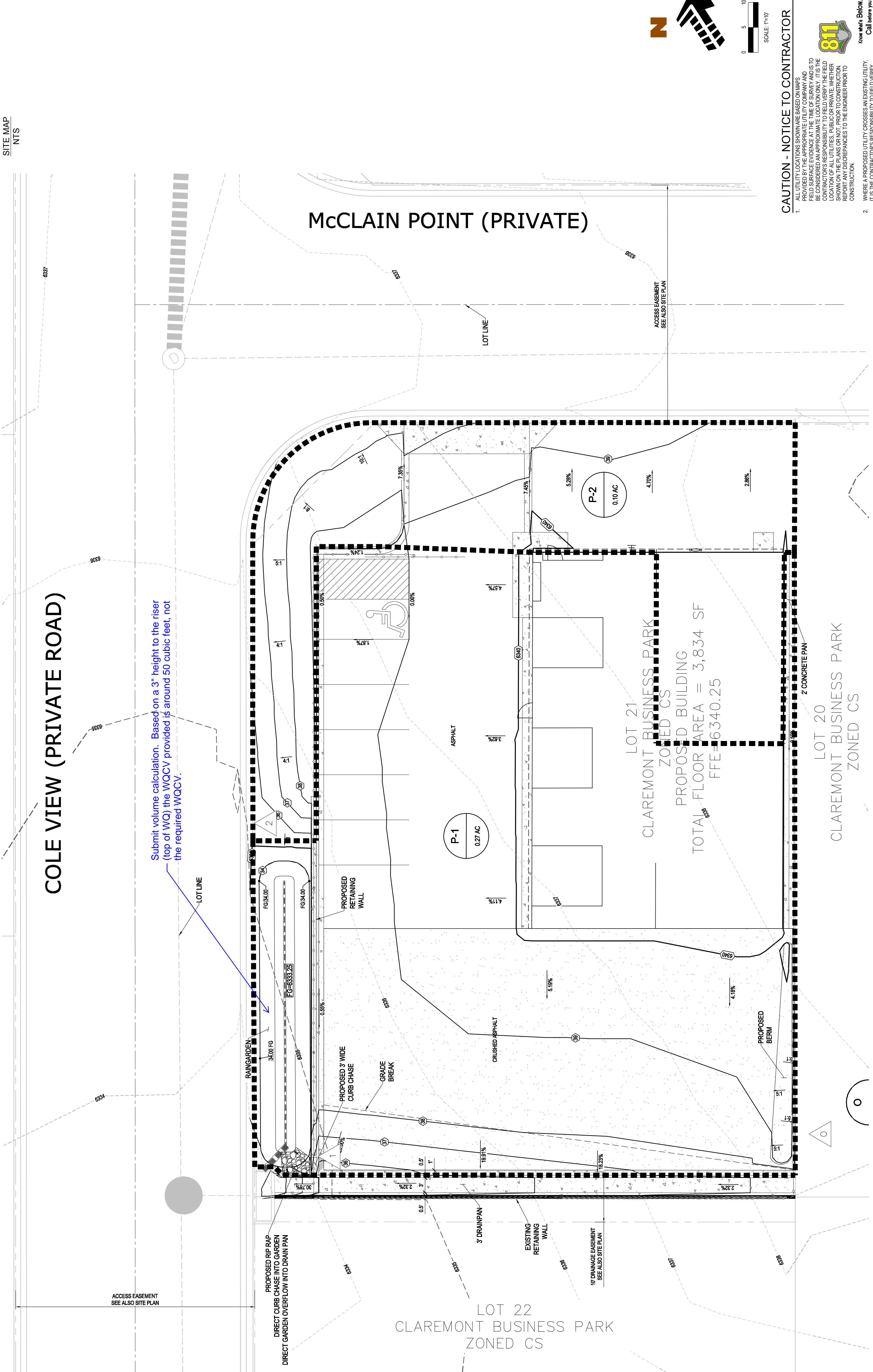
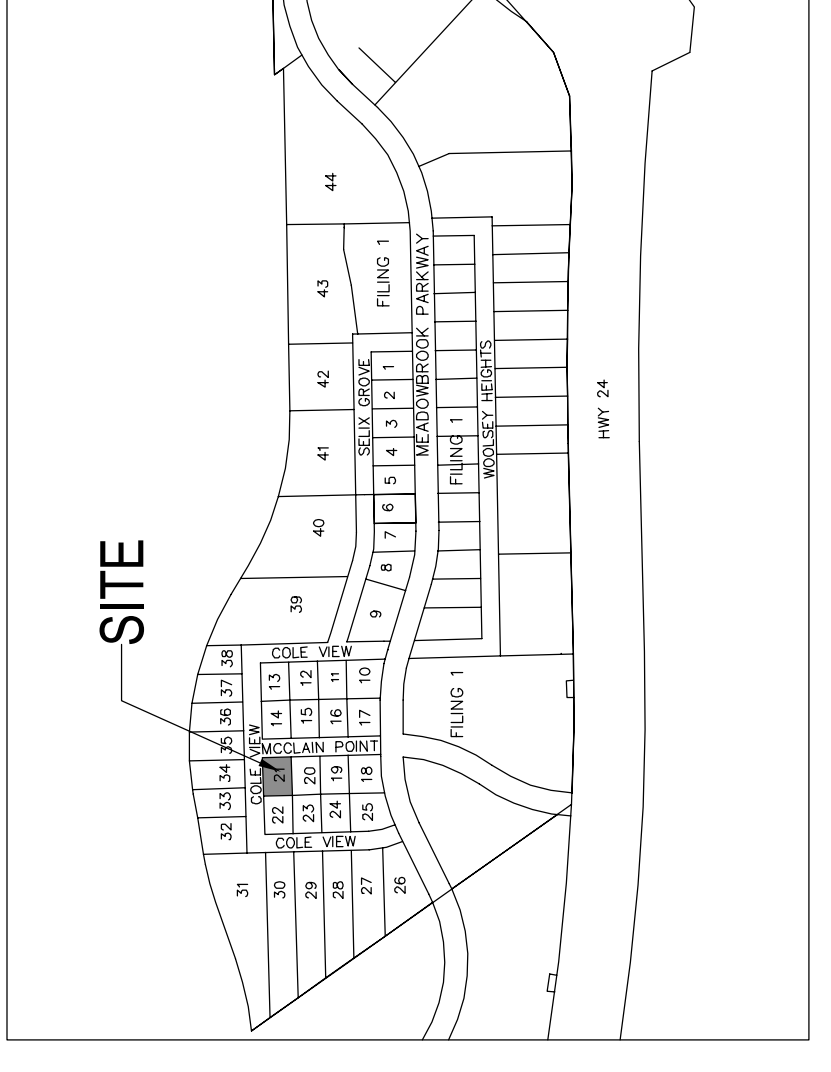

Submit volume calculation. Based on a 3" height to the riser (top of WQ) the WQCV provided is around 50 cubic feet, not the required WQCV.

COLE VIEW (PRIVATE ROAD)

McCLAIN POINT (PRIVATE)

LOT 21
 CLAREMONT BUSINESS PARK
 ZONED CS
 PROPOSED BUILDING
 TOTAL FLOOR AREA = 3,834 SF
 FFE = 6340.25

LOT 20
 CLAREMONT BUSINESS PARK
 ZONED CS

COPYRIGHT
 THESE PLANS ARE AN INSTRUMENT OF SERVICE AND ARE THE PROPERTY OF GALLOWAY. ANY REPRODUCTION, DISCLOSED, OR REPRODUCED WITHOUT THE WRITTEN CONSENT OF GALLOWAY. ALL RIGHTS AND ARRANGEMENTS WILL BE ENFORCED AND PROSECUTED.

DRAINAGE MAP
 CRACKERJACK MUD JACKING INC.
 CBP, F2 - LOT #21
 7315 McCLAIN POINT,
 COLORADO SPRINGS, CO

#	Date	Issue / Description	Init.
00	08/18/17	AGENCY SUBMITTAL	TAC
01	08/20/17	OWNER REVISIONS	TAC

Project No: HC0003.1
 Drawn By: RCG
 Checked By: TAC
 Date: AUGUST 2017

PROPOSED DRAINAGE MAP

PR

CAUTION - NOTICE TO CONTRACTOR

- ALL UTILITY LOCATIONS SHOWN ARE BASED ON MAPS AND FIELD SURFACE EVIDENCE AT THE TIME OF SURVEY AND SHOULD BE CONSIDERED APPROXIMATE LOCATION ONLY. IT IS THE RESPONSIBILITY OF THE CONTRACTOR TO VERIFY THE LOCATION OF ALL UTILITIES, PUBLIC OR PRIVATE, WHETHER SHOWN ON THE PLANS OR NOT, PRIOR TO CONSTRUCTION. REPORT ANY DISCREPANCIES TO THE ENGINEER PRIOR TO CONSTRUCTION.
- WHERE A PROPOSED UTILITY CROSSES AN EXISTING UTILITY, IT IS THE CONTRACTOR'S RESPONSIBILITY TO VERIFY THE EXISTING UTILITY, EITHER THROUGH POT-HOLING OR ALTERNATIVE METHOD. REPORT INFORMATION TO THE ENGINEER PRIOR TO CONSTRUCTION.

Know what's Below
 Call before you dig

Markup Summary

dsdlaforce (4)

Reattach the "Design Procedure Form: Rain Garden" UD-BMP worksheet which was a part of the previous submittal. This worksheet provided the supporting calculations for the rain garden.

Subject: Text Box
Page Label: 1
Lock: Unlocked
Author: dsdlaforce
Date: 9/26/2017 8:00:22 AM

Reattach the "Design Procedure Form: Rain Garden" UD-BMP worksheet which was a part of the previous submittal. This worksheet provided the supporting calculations for the rain garden.

Add the table of contents.

Subject: Text Box
Page Label: 2
Lock: Unlocked
Author: dsdlaforce
Date: 9/26/2017 10:56:00 AM

Add the table of contents.

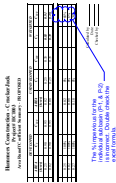

Subject: Cloud+
Page Label: 37
Lock: Unlocked
Author: dsdlaforce
Date: 9/26/2017 8:09:13 AM

The % impervious for the individual subbasin (P-1, & P-2) is incorrect. Double check the excel formula.

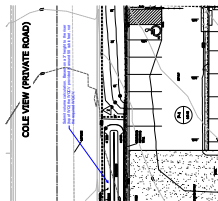

Subject: Callout
Page Label: 56
Lock: Unlocked
Author: dsdlaforce
Date: 9/26/2017 10:38:57 AM

Submit volume calculation. Based on a 3" height to the riser (top of WQ) the WQCV provided is around 50 cubic feet, not the required WQCV.