

Accepted for File

By: Daniel Torres, P.E.
Senior Engineer

Date: 10/23/2023 10:28:28 AM
El Paso County Department of Public Works



TRAFFIC ANALYSIS REPORT

Lewis Palmer Middle School
Monument, CO

Prepared for:

Lewis Palmer District Transportation
99 Santa Fe Ave
Monument, CO 80132



7-19-23

Prepared by:

Felsburg Holt & Ullevig
6400 South Fiddlers Green Circle, Suite 1500
Greenwood Village, CO 80111
303.721.1440

Project Manager: Lyle DeVries, PE, PTOE
Project Engineer: Faith Kelley, EI

FHU Reference No. 122227-01
May 2023
PCD File No. CDR-23-005

Traffic Engineer's Statement

The attached traffic report and supporting information were prepared under my responsible charge and they comport with the standard of care. So far as is consistent with the standard of care, said report was prepared in general conformance with the criteria established by the County for traffic reports.

Lyle E. DeVries PE #: 37203

Date

Developer's Statement

I, the Developer, have read and will comply with all commitments made on my behalf within this report.

Chris Coulter

8.04.2023

Chris Coulter
Lewis Palmer Middle School
P.O Box 40
Monument, CO 80132-0040

Date

TABLE OF CONTENTS

	<u>Page</u>
I. INTRODUCTION.....	1
II. EXISTING CONDITIONS.....	4
II.A. Surrounding Land Use.....	4
II.B. School Traffic Circulation	4
II.C. Roadway Network.....	4
II.D. Traffic Volumes.....	6
II.E. Traffic Operations.....	6
III. FUTURE CONDITIONS.....	8
III.A. Redistributed Traffic.....	8
III.B. Future Traffic Conditions.....	8
III.C. Recommended New Circulation Pattern.....	13
III.D. Traffic Control Needs.....	14
III.E. Access Design Considerations.....	15
III.F. Parking Lot C Queueing.....	16
III.G. Pedestrian and Bicyclist Safety	16
IV. SUMMARY AND RECOMMENDATIONS.....	18

Appendices

- Appendix A. Existing Traffic Counts
- Appendix B. Existing Level of Service Worksheets
- Appendix C. Short-term Future Level of Service Worksheets
- Appendix D. Long-term Future Level of Service Worksheets

List of Figures

	<u>Page</u>
Figure 1. Vicinity Map.....	2
Figure 2. Site Plan.....	3
Figure 3. LPMS Parking Lots and Lot Access Locations	5
Figure 4. Existing (2022) Traffic Conditions	7
Figure 5. Existing (2022) Redistributed Traffic Conditions.....	9
Figure 6. 2023 Future Traffic Conditions.....	11
Figure 7. Long-term Future Traffic Conditions	12
Figure 8. Recommended Passenger Vehicle Circulation	13
Figure 9. AutoTurn Bus Results	17

List of Tables

	<u>Page</u>
Table 1. Proposed Reconfigurations to Parking and Access	8
Table 2. Current Traffic Control.....	14
Table 3. Slowing Distance – Woodmoor Drive/New Bus Access	15

I. INTRODUCTION

The Lewis-Palmer School District #38 is proposing to reconfigure an existing parking lot at the Lewis Palmer Middle School (LPMS) in unincorporated El Paso County, Colorado to only serve buses during school peak hours and implement a one-way inbound access to this lot for buses. The new access would be located north of the existing parking lot access on Woodmoor Drive. Woodmoor Drive is an important transportation connector located in Monument, Colorado. The collector roadway serves multiple residential developments and provides access to highway (HWY) 105 and Interstate (I-) 25. The roadway network adjacent to the site can be seen on **Figure 1**.

The proposed parking lot/access reconfiguration is intended to improve school traffic circulation and provide exclusive bus access and parking. **Figure 2** shows the layout of the proposed bus access. This access will serve as an inbound only bus access during school peak hours and provide parking for buses. During off peak hours, parents and visitors will be allowed to use this lot for parking purposes and may use the inbound access outside of normal school hours.

FHU has completed an assessment of current and future (with reconfiguration) transportation conditions along Woodmoor Drive and surrounding the Lewis Palmer Middle School. This assessment provides considerations for future improvements and determines safety and efficiency needs for the proposed new access while serving the needs of multiple user types. The parameters of this analysis have been coordinated with El Paso County Staff. Based on staff input, this report includes information on existing traffic conditions, redistributed traffic with implementation of the bus only parking lot, total traffic volume projections, sight distance needs, multimodal circulation needs, and any recommended roadway improvements.

The following two future scenarios have been analyzed for this report:

- **Short-term Future** – Time period for the completion of the bus only access, currently anticipated as the Year 2023.
- **Long-term Future** – The Long-term Future scenario reflects projected Year 2045 traffic conditions.

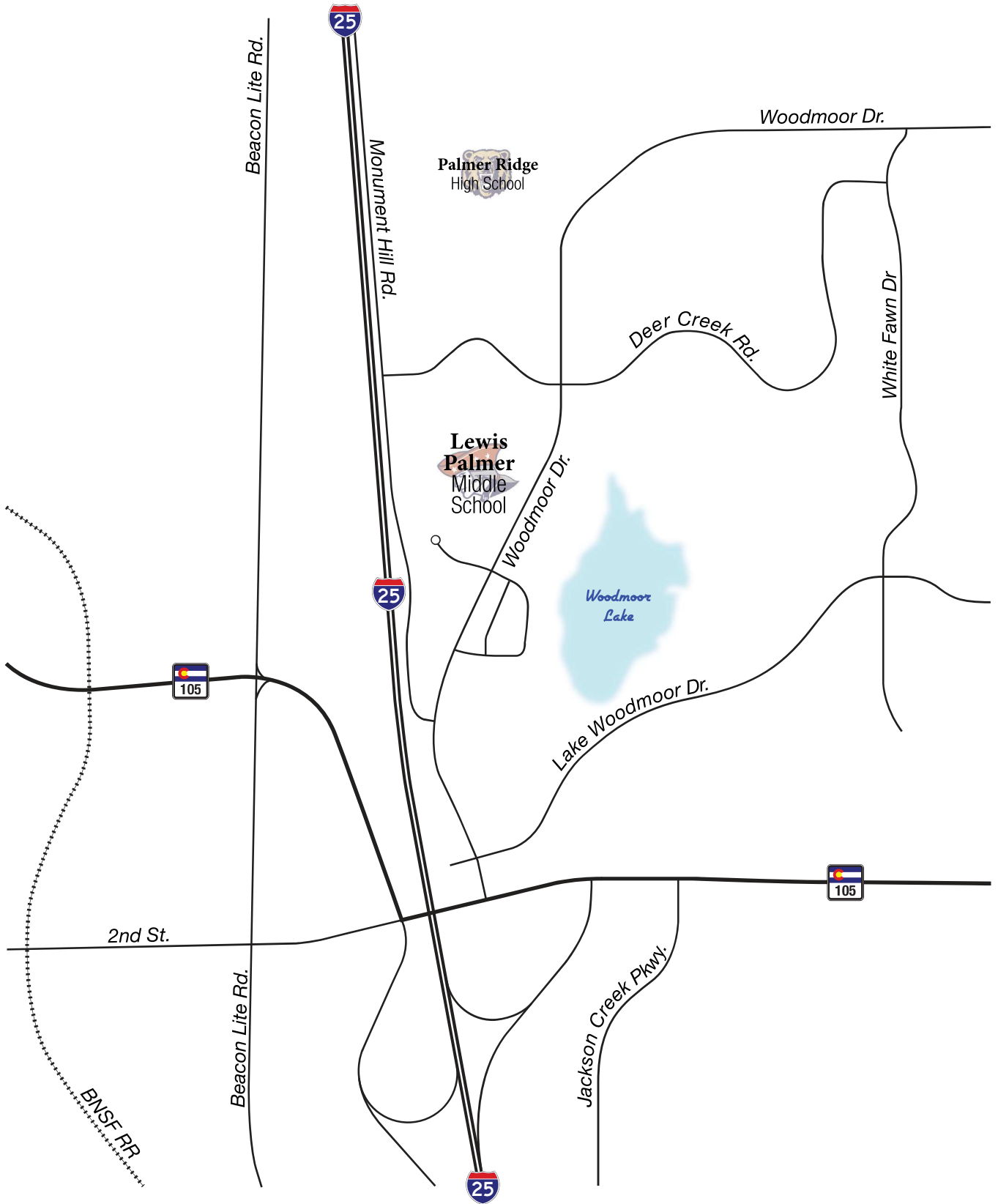

PARKING LOT A

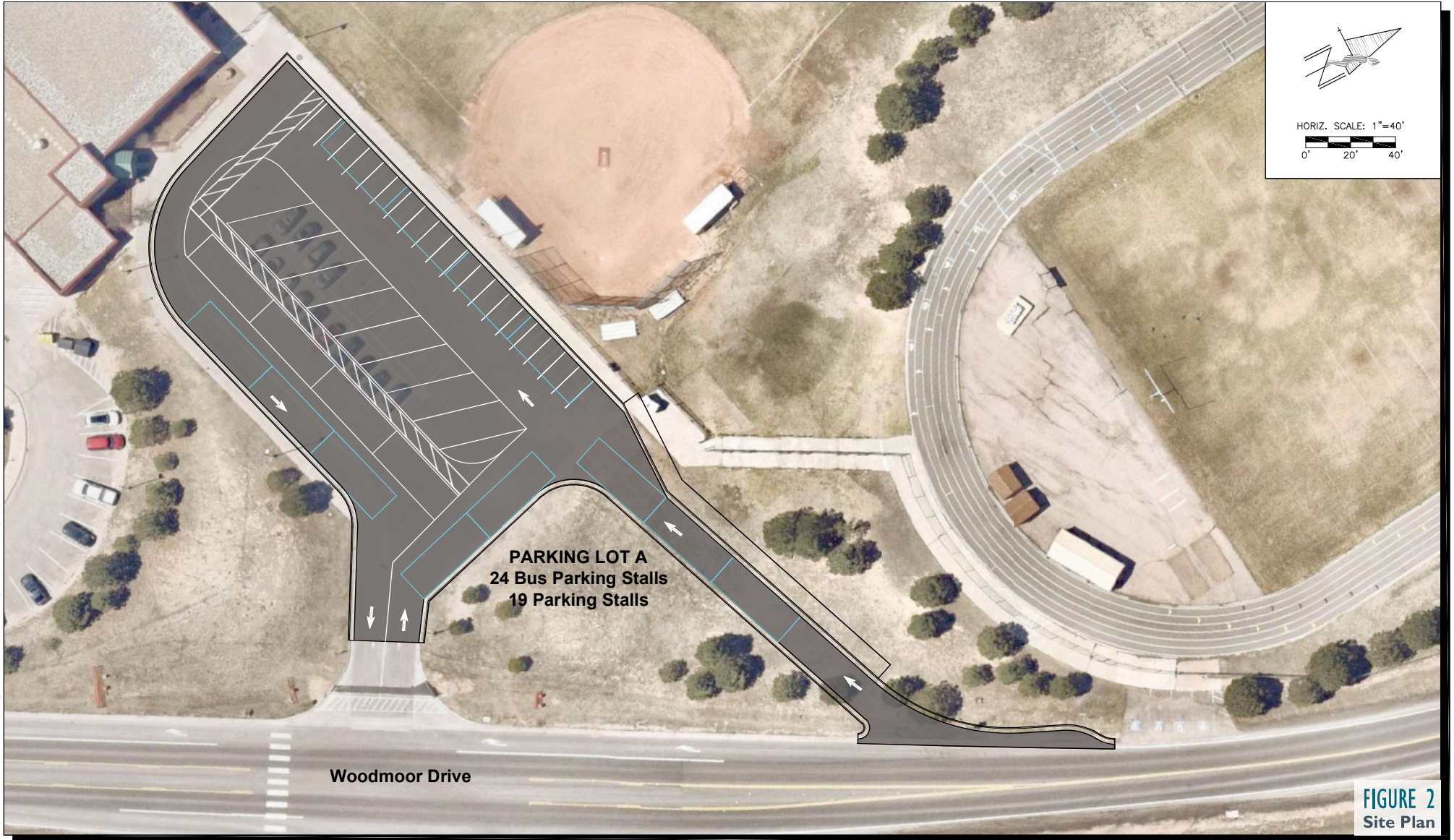

13/2022/2023 LEVIT, ET AL. 4850 WOODMOOR DRIVE, WOODMOOR, MISSOURI 64094. 13/2022/2023 LEVIT, ET AL. 4850 WOODMOOR DRIVE, WOODMOOR, MISSOURI 64094. 13/2022/2023 LEVIT, ET AL. 4850 WOODMOOR DRIVE, WOODMOOR, MISSOURI 64094.

II. EXISTING CONDITIONS

II.A. Surrounding Land Use

Much of the area adjacent to the project site has been developed. The land uses surrounding the site are primarily residential with some commercial development north of the Middle School.

II.B. School Traffic Circulation

Currently, there are four parking lots which serve the school, one parking lot north of the school near the track field, two rows of parking along the one-way drive adjacent to the school, and one parking lot south of the school. The school traffic plan is provided to parents to help govern circulation. Each of these lots and their accesses serve multiple users and vehicle types. **Figure 3** shows the current and proposed lots and access locations. Current usage/guidance is described as follows:

- Lot A: provides 39 spaces, including accessible parking. Provides student drop-off and pickup from the north along Woodmoor Drive. It is accessed via full movement Access 3.
- Lot B: provides 15 spaces. Accessed via full movement Access 1 to Woodmoor Drive.
- Lot C: provides 38 parking spaces, including accessible parking. Parking aisle is one-way southbound during peak periods. During AM school peak, aisle serves bus only traffic. During PM school peak, aisle sequentially serves bus traffic then student pickup. Lot provides general parking during off peak hours.
- Lot D: provides approximately 35 unmarked spaces for faculty and staff. Student drop-off is provided from the south via Woodmoor Drive adjacent to the Willow Park Way north curb line.

A field visit was conducted to observe school traffic operations during the 2022/2023 school year. These observations confirmed that the above described usage is typical with the below exceptions:

- Lot A is accommodating drop-off and pick-up activity from both directions along Woodmoor Drive.
- Some student drop-off activity from the south is occurring on both the north and south sides of Willow Park Way, contradicting instructions (shown right with blue lines).



II.C. Roadway Network

The existing roadway network adjacent to the vicinity of the site includes Woodmoor Drive and Willow Park Way. The roadway network is as follows:

Woodmoor Drive: Woodmoor Drive is a three-lane collector in the project area serving mainly residential developments and provides connectivity to HWY 105 and I-25. The posted speed limit is 30 miles per hour (mph); however, during school peaks the speed limit is reduced to 20 mph 620 feet



north of the parking lot access to 250 feet south of Willow Park Way. Given this study is primarily focused on school hours, this roadway was analyzed with a posted speed of 20 mph.

Willow Park Way: Willow Park Way is a two-lane minor local street which provides access to the Lewis Palmer Middle School as well as a few other commercial developments. There is no posted speed limit, but, for the purpose of this study, the speed limit was assumed to be 20 mph.

II.D. Traffic Volumes

Weekday AM and PM school peak hour turning movement counts (TMCs) were collected on Wednesday, December 14, 2022, at the following intersections:

- Woodmoor Drive & Existing Parking Lot Access
- Woodmoor Drive & Main School Access
- Woodmoor Drive & Willow Park Way
- Willow Park Way & Secondary School Access

The peak hour traffic counts were collected in 15-minute intervals between 6:30 and 8:30 AM and 2:00 to 4:00 PM. The AM peak hour was found to be 7:00 to 8:00 AM, and the PM peak was 2:15 to 3:15 PM. **Appendix A** contains the TMCs. Peak hour traffic volumes are shown on **Figure 4**. Daily traffic volumes are also depicted on **Figure 4** as multiples of the counted peak hour traffic levels.

Based on the counts collected, Peak Hour Factors (PHFs) were found to range from 0.33 to 0.92. The majority of heavy vehicle percentages were found to be under 8 percent; however, the southbound volume at the secondary school access as well as the eastbound movements at the intersection of Woodmoor Drive with Willow Park Way were found to be a bit higher, likely reflecting buses leaving the school. In order to reflect school peaking conditions, existing PHFs and heavy vehicle percentages were applied for both existing and future conditions by approach at each study intersection.

II.E. Traffic Operations

Existing operational conditions were analyzed at each study intersection. The analysis is based on procedures documented in the *Highway Capacity Manual (6th Edition)*. This analysis procedure provides a Level of Service (LOS), a qualitative measure of traffic operational conditions, based on intersection capacity and vehicle delay. LOS is described by a letter designation ranging from A to F, LOS A represents almost free-flow conditions, while LOS F represents congested conditions. LOS is calculated for movements which must yield right-of-way for unsignalized intersections.

Figure 4 shows the results of the existing conditions analysis. **Appendix B** contains LOS worksheets. As shown, all stop-controlled movements operate at LOS D or better with the exception of the following:

Willow Park Way/Woodmoor Drive

- Eastbound movement operates at LOS F during the AM peak hour
- Westbound movement operates at LOS F during the AM peak hour

Woodmoor Drive/Parking Lot A Access

- Westbound left/through movement operates at LOS E during the AM peak hour

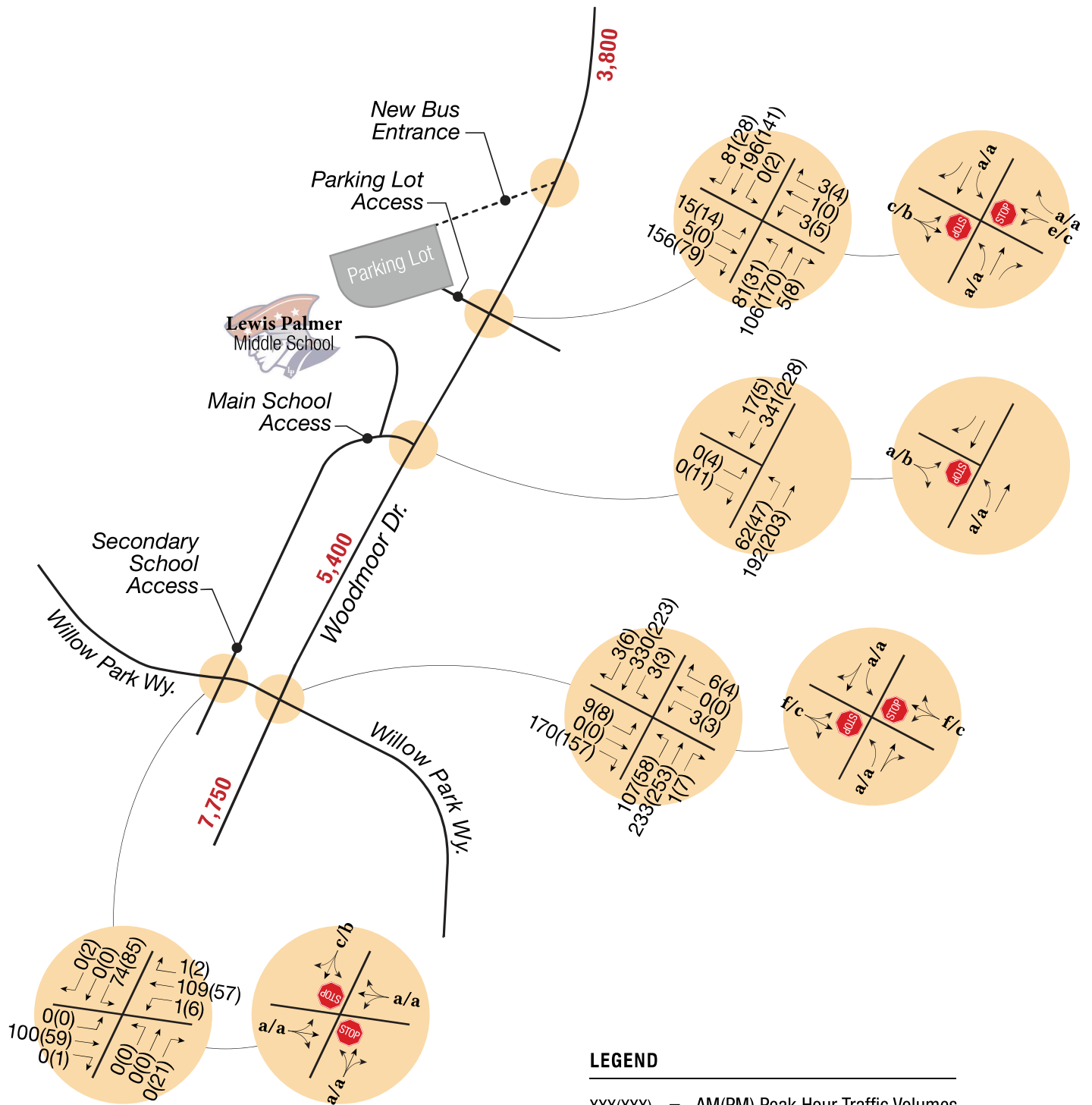

LEGEND

XXX(XXX) = AM(PM) Peak Hour Traffic Volumes

XXXX = Daily Traffic Volumes

x/x = AM/PM Peak Hour Unsignalized Intersection Level of Service

= Stop Sign

III. FUTURE CONDITIONS

III.A. Redistributed Traffic

The new bus access would restrict the north parking lot to bus only during school peak hours, and all buses are anticipated to use the reconfigured lot to the north, which would have one inbound only access (proposed) and the second access would be outbound only for buses. Further, new circulation patterns for buses will cause all buses to arrive and depart from the school traveling southbound, meaning no school buses are anticipated to make a northbound left turn into this lot. **Table I** outlines the current and proposed users and accesses for each lot.

Table I. Proposed Reconfigurations to Parking and Access

Parking Lot	Current			Future w/ Reconfiguration		
	Uses	Entrance Access	Exit Access	Use	Entrance Access	Exit Access
A	Student pickup/drop-off	3	3	Bus only during school peaks	3a	3
	Visitors	3	3	Visitors at other times	3	3
B	Faculty and Staff	1	1	Faculty and Staff	1	1
C	Bus Only During School Peaks	1	2	Student pickup/drop-off	1	2
	Student Pickup/Drop-off	1	2	Visitors	1	2
	Visitors	1	2			
D	Faculty and Staff	4, 2	4, 2	Faculty and Staff	4, 2	4, 2

III.B. Future Traffic Conditions

Because the implementation of the new parking lot access will restrict parking lot A to allow only buses during the peak hours, peak hour volumes will be redistributed so all buses use the parking lot and all passenger cars only use the main and secondary school accesses. **Figure 5** shows the redistributed existing volumes and subsequent traffic operations. Of note, it is recommended and assumed that all passenger vehicle pick up and drop off traffic will utilize intersection 1 as inbound access to the aisle through parking lot C and access 2 as outbound only, creating a drop off/pick up loop. As shown, congested (LOS F) conditions are expected to occur at Willow Park Way intersections for passenger vehicle movements exiting the site during school pick up and drop off activities. Recommended mitigation measures are highlighted in **Section III.C**.

Future traffic was estimated for the short-term (2023) and long-term (2045) timeframes and accounts for existing traffic already using the transportation system, plus a general upward factoring of current traffic levels to capture the effects of anticipated future growth in the area. Because the Middle School is not anticipated to increase attendance in the future and the surrounding area is mostly developed, only the northbound and southbound through traffic along Woodmoor Drive was increased to account for growth. The Pikes Peak Area Council of Governments (PPACG) regional model was used to determine an annual growth rate of 0.6% per year along Woodmoor Drive.

Year 2023 traffic projections were developed assuming 0.6 percent growth per year for one year, this results in minimal growth along Woodmoor Drive. It is important to note that the growth factor was applied to only the northbound and southbound through movements on Woodmoor Drive.

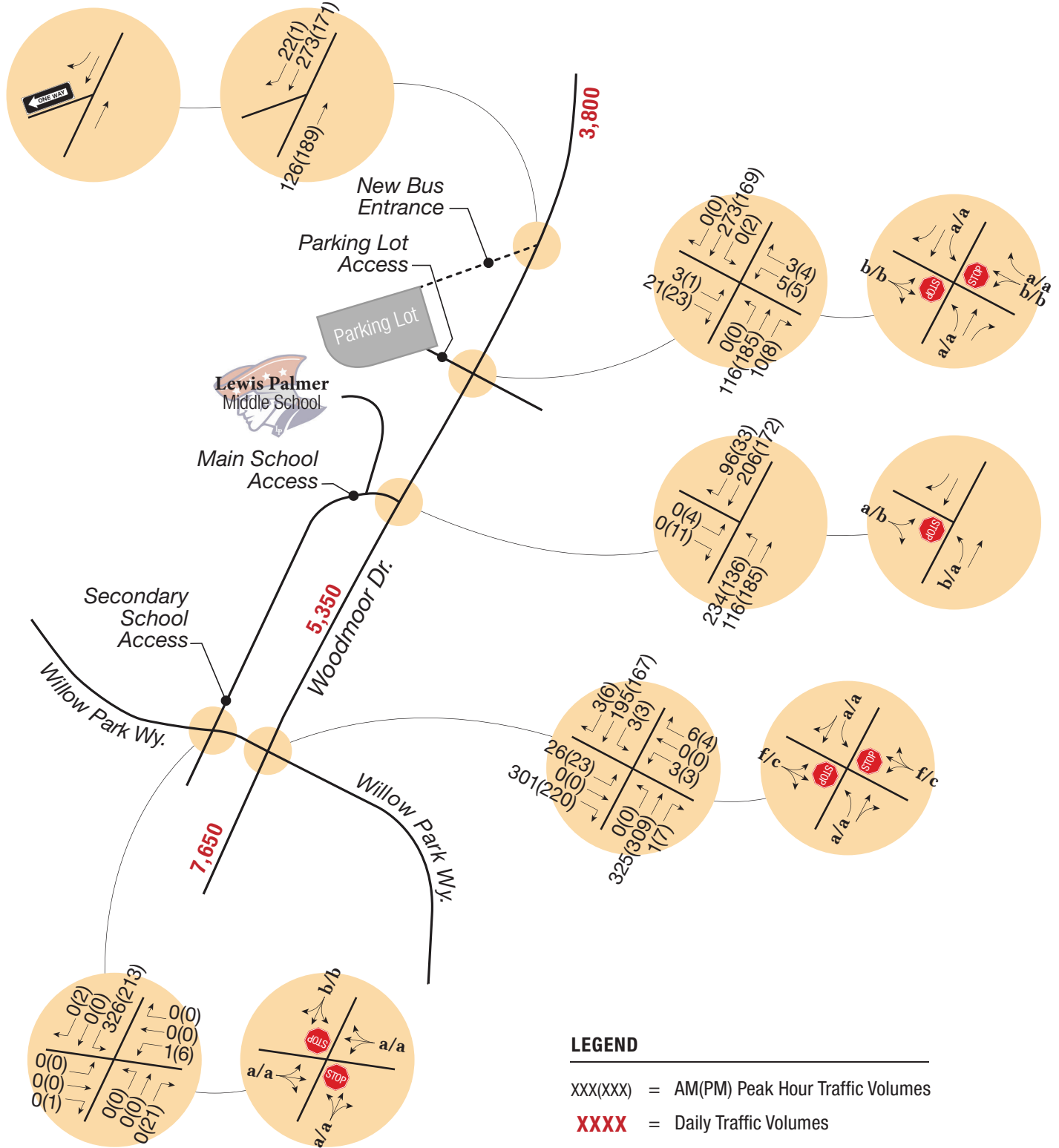

LEGEND

XXX(XXX) = AM(PM) Peak Hour Traffic Volumes

XXXX = Daily Traffic Volumes

x/x = AM/PM Peak Hour Unsignalized Intersection Level of Service

= Stop Sign

Short-term Future Traffic Operations

Figure 6 depicts short-term future AM and PM peak hour turning movement projections for the study area intersections and **Appendix C** contains the LOS worksheets. Using the existing PHFs and heavy vehicle percentages outlined in **Section 0**, all unsignalized movements are anticipated to remain at acceptable operations with the exception of the following:

Woodmoor Drive/Willow Park Way

- Eastbound movement anticipated to operate at LOS F in the AM peak hour
- Westbound movement anticipated to operate at LOS F in the AM peak hour

Willow Park Way/Secondary School Access

- Southbound movement anticipated to operate at LOS F during the AM peak hour

Long-term Future Traffic Operations

Figure 7 shows the long-term peak hour turning movement projections for the study area intersections and **Appendix D** contains the LOS worksheets. It is important to note that the growth factor was only applied to northbound and southbound through movements on Woodmoor Drive.

Using the existing PHFs and heavy vehicle percentages outlined in **Section 0**, all unsignalized movements are projected to remain acceptable with the exception of the following:

Woodmoor Drive/Willow Park Way

- Eastbound movements are anticipated to operate at LOS F during the AM peak hour
- Westbound movements are anticipated to operate at LOS F during the AM peak hour

Willow Park Way/Secondary School Access

- Southbound movement anticipated to operate at LOS F during the AM peak hour

As noted in the short-term conditions above, the intersection of Willow Park Way with Secondary School Access will not meet signal warrant thresholds and does not warrant any improvements. The eastbound movement at Woodmoor Drive with Willow Park way is anticipated to experience very high delays and queueing. Recommended mitigation measures are described in **Section III.C**.

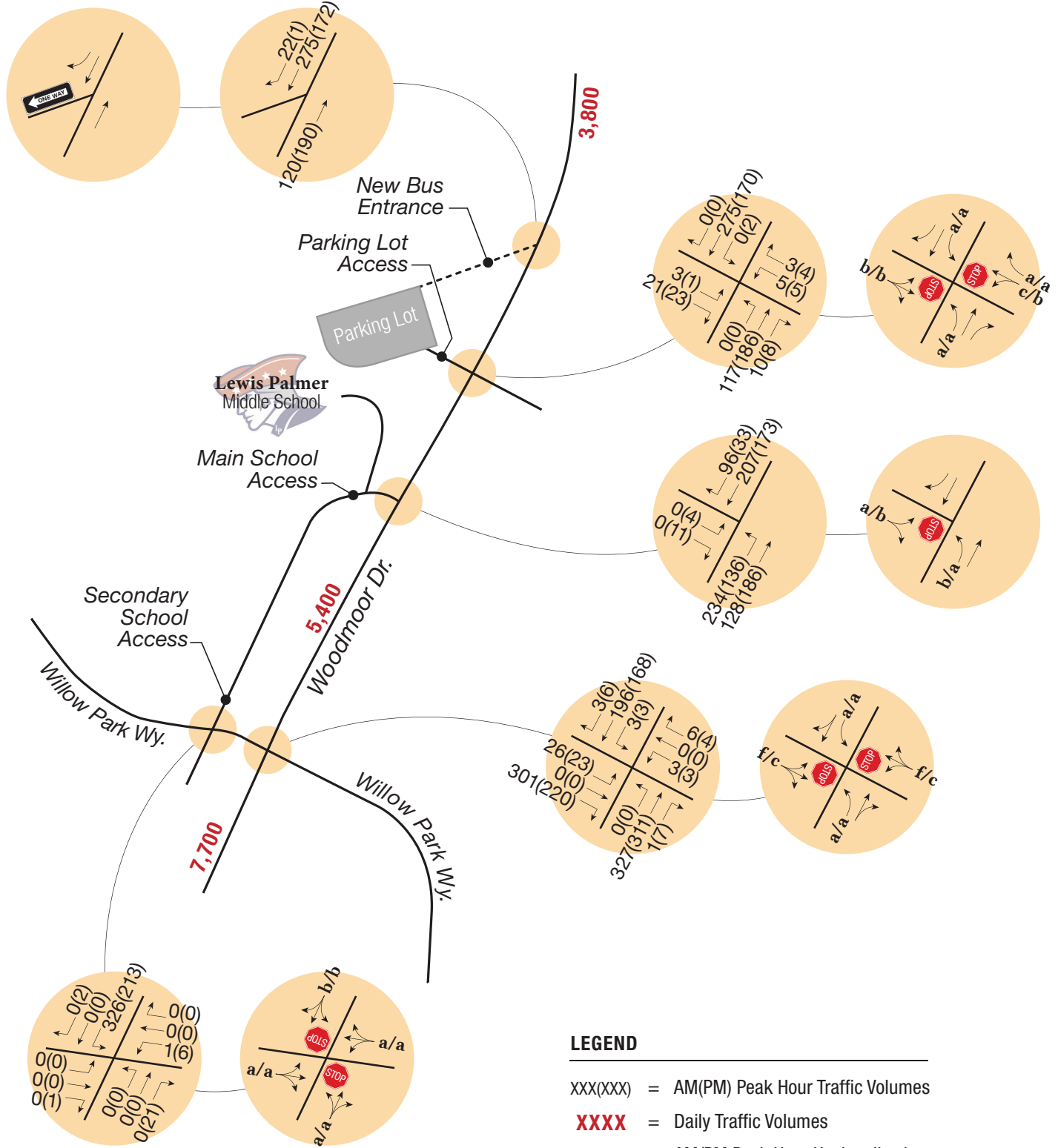

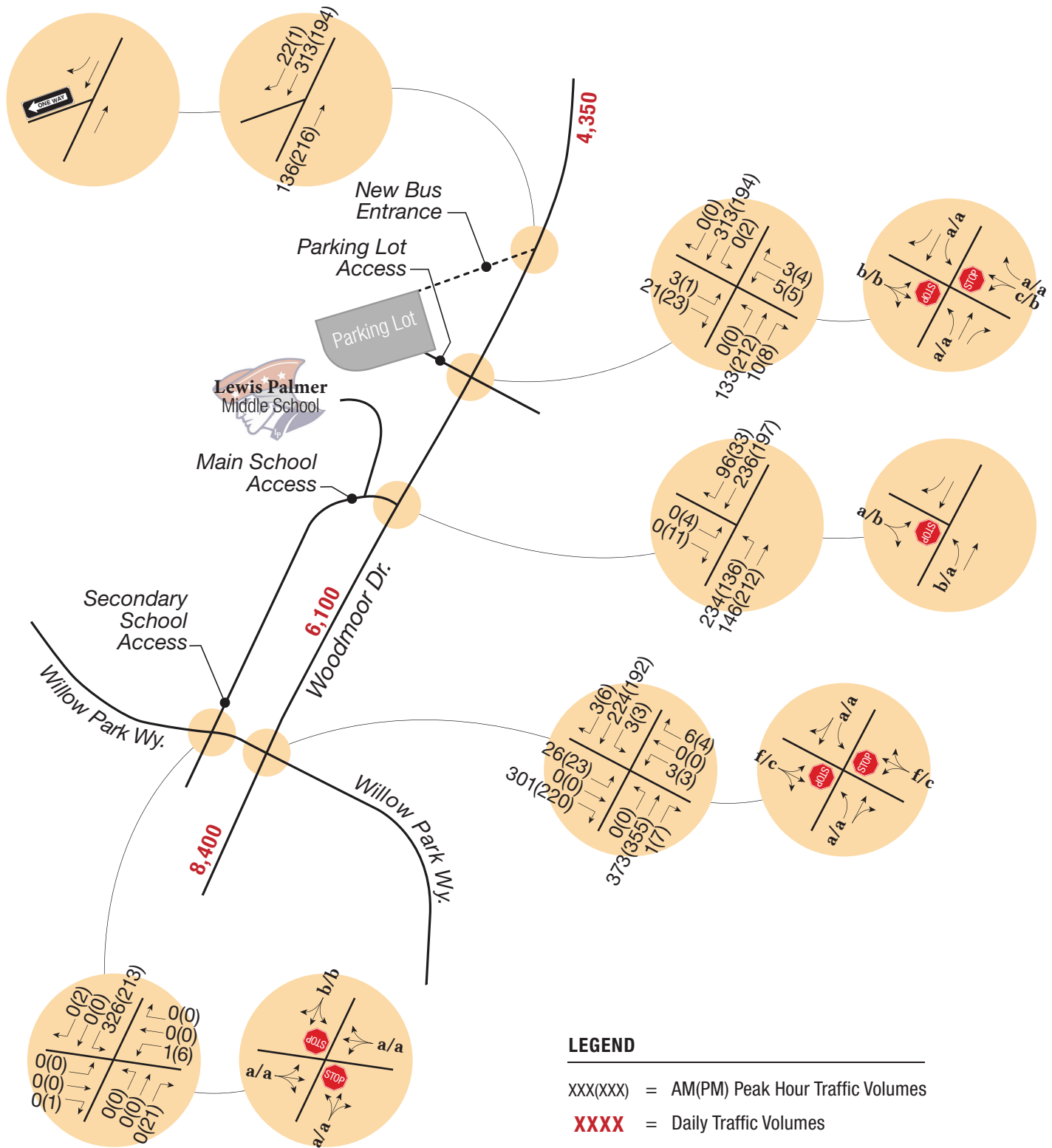

III.C. Recommended New Circulation Pattern

Upon exiting the pick up and drop off aisle in parking lot C, operational analyses of future conditions indicate that vehicles will encounter congested conditions while attempting to exit the school approaching Willow Park Way and Woodmoor Drive. The southbound movement at intersection 2 may reach queue lengths up to of 100 feet in length, and eastbound movements at the Woodmoor Drive/Willow Park Way would operate at poor LOS with lengthy queues blocking intersection 2. This condition would result in congestion along the parking lot C aisle and impede efficient student pick up and drop off.

In view of the anticipated congestion, it is recommended that adjustments be made in passenger vehicle patterns with the proposed change to parking lot usage, access and configuration. **Figure 8** depicts a recommended option for acceptably accommodating outbound traffic to maintain efficiency.

Figure 8. Recommended Passenger Vehicle Circulation

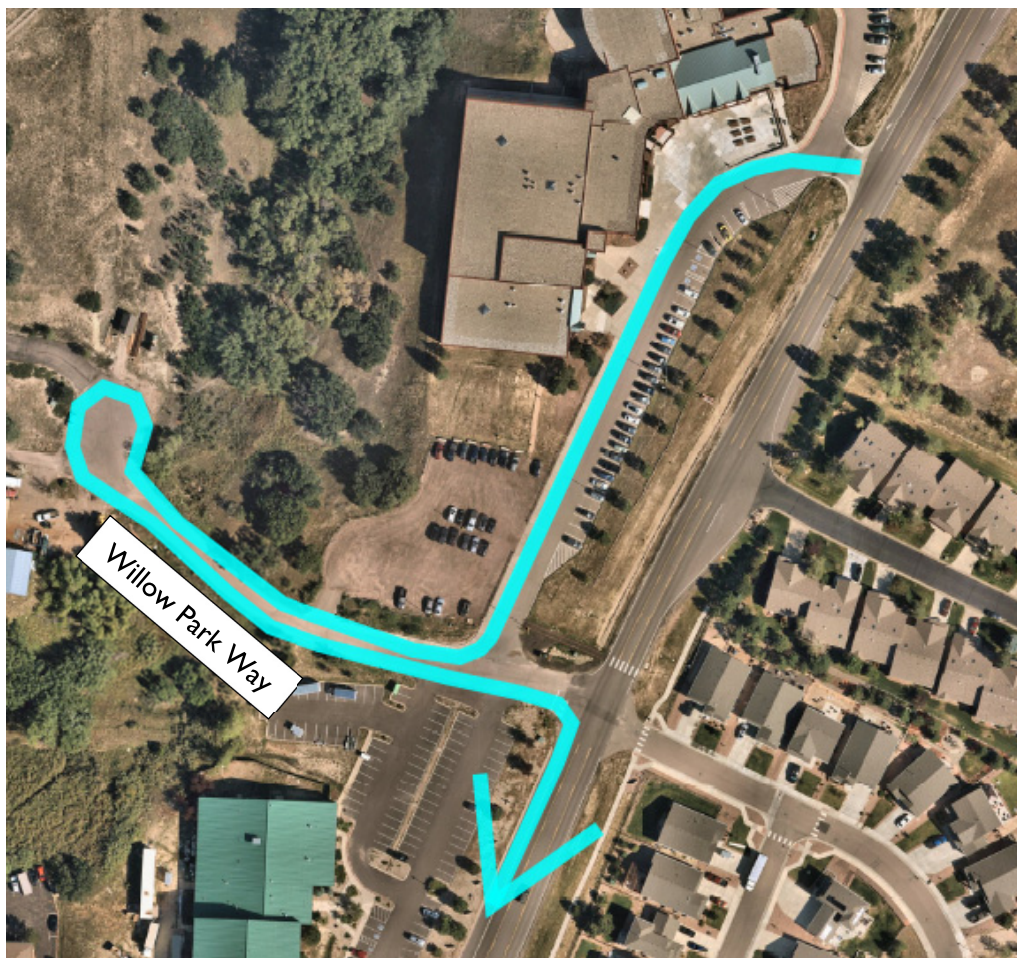

As shown all southbound traffic would turn right on Willow Park Way to make use of additional curb space, travel west to the end of the cul-de-sac, U-turn, then approach Woodmoor Drive. At Woodmoor Drive, all traffic would be required to make a right turn to efficiently exit the site. The objective of this pattern is to minimize left turn movements, which experience greater delay and congestion than right turns, and prevent crossing vehicle paths. At the intersection of Woodmoor Drive with Willow Park Way, it is recommended that a channelizing island be painted to facilitate free flow eastbound to southbound right turns into the existing southbound auxiliary lane.

It is recommended that this configuration should be monitored upon implementation with respect to the following items:

- **U-turn activity:** The limitation to outbound right turns only onto Woodmoor Drive will likely result in some traffic seeking to make a U-turn from southbound Woodmoor Drive to northbound Woodmoor Drive. It is likely that this pattern will cause some school traffic to utilize neighborhood streets east of the school to complete this maneuver. It is recommended that guidance be provided to school traffic to ensure U-turns are completed in an appropriate manner, and monitoring occur to limit neighborhood impact.
- **Ease of entry/exit:** The ease of entry into and exit from Lot C to pick up or drop off students should be monitored to ensure that traffic backups onto Woodmoor Drive are kept to a minimum.

The recommended traffic pattern may require alterations in the field upon implementation. Such alterations may include need for uniformed traffic control or adjustments to routing.

III.D. Traffic Control Needs

Current traffic control at the study intersections is shown in **Table 2**.

Table 2. Current Traffic Control

Intersection	Traffic Control Type
Woodmoor Drive & Parking Lot Access	Two-Way Stop Control (TWSC) (EB & WB)
Woodmoor Drive & Main School Access	TWSC (EB)
Woodmoor Drive & Willow Park Way	TWSC (EB & WB)
Willow Park Way & Secondary School Access	TWSC (NB & SB)

As shown, all of the study intersections are currently unsignalized. The *Manual on Uniform Traffic Control Devices* (MUTCD, 2009 Edition) outlines 9 warrants that may be used to justify installing a traffic signal at an intersection. The warrants are listed as follows:

1. Eight-Hour Vehicular Volume
2. Four-Hour Vehicular Volume
3. Peak Hour
4. Pedestrian Volume
5. School Crossing
6. Coordinated Signal System
7. Crash Experience
8. Roadway Network
9. Intersection Near a Grade Crossing

Of these nine, warrants 1, 2, and 5 are applicable to conditions at the study intersections. Given the failing LOS on the eastbound and westbound approaches, the intersection of Woodmoor Drive with Willow Park Way is the only intersection that may need a signal in order to facilitate acceptable operations. Projected vehicular traffic volumes and pedestrian volumes were compared with warrant criteria to assess this potential. Because the intersection traffic counts only covered peak periods, a scaling factor of 0.0571 was used to estimate the fourth and eighth highest hour volumes using information from the Missouri Department of Transportation (MoDOT). Based on this information, it is estimated that the eighth highest hour comprises approximately 75 percent of the peak recorded hour. Each of the eight highest hours are estimated by scaling in linear fashion.

Utilizing the scaling assumptions, the evaluation of traffic-volume based Warrant 1 (eight-hour volume) and 2 (Four-Hour Volume) indicates that traffic volumes do not meet any of the specified conditions. A review of pedestrian volumes at the study intersections revealed a maximum of only 4 pedestrians crossing the intersection of Woodmoor Drive with Willow Park Way during the peak hour. Warrant 5 of the MUTCD specifies a need for at least 20 pedestrians during the peak hour to satisfy this warrant. Therefore, none of the study intersections are anticipated to meet signal warrant criteria.

III.E. Access Design Considerations

The proposed bus access would be inbound only, meaning sight distance for outbound movements will not be of concern. The proposed access location will be approximately 200 feet north of the current Parking Lot A access. This spacing does not meet El Paso County *Engineering Criteria Manual*, (ECM) standards, which identify a minimum access spacing of 260 feet along roadways posted at 20 mph for single unit trucks (it is assumed that buses operate at single unit trucks).

Although traffic volumes for entering turning movements are not anticipated to meet auxiliary lane thresholds, it is recommended that a right turn deceleration lane be provided to provide refuge for slower moving buses. The El Paso County Engineering Criteria Manual, (ECM) requires a right turn deceleration right turn lane width of 12 feet and a total length of 235 feet (25 mph design speed). Proximity of the existing handicap spaces along Woodmoor Drive would limit the recommended right turn deceleration lane length to 75 feet including taper, and existing topography along the west side of Woodmoor Drive would limit the available turn lane width to approximately 9 feet at its most narrow location. The turn lane dimensions have been maximized given these constraints, as shown on **Figure 9**.

Upon El Paso County review and approval of this traffic study, necessary deviation requests will be submitted to support access spacing and design deviations from the ECM.

The minimal storage length introduces a potential concern for vehicles coming around the Woodmoor Drive horizontal curve lacking adequate sight distance to see buses slowing at the proposed access. Calculations were completed to determine the distance needed for buses to slow to a reasonable turning speed in order to enter the parking lot. **Table 3** outlines the calculation parameters and results.

Table 3. Slowing Distance – Woodmoor Drive/New Bus Access

Movement	Planned Lane Length	Slowing Distance for School Buses				
		Posted Speed	Turning Speed	Assumed Deceleration	Slowing Time	Slowing Distance
Southbound Right	75 ft	20 mph	9 mph	-4.49 ft/sec ²	3.59 sec	52.5 ft

As shown above, the planned 75 feet of lane length (including taper) is anticipated to be sufficient room for buses to slow from the posted speed of 20 mph during school hours to a safe right turning speed of 9 mph. Buses will need just over 50 feet of space to make this adjustment. Therefore, buses will be able to decelerate within the lane and should not create sight distance safety issues. Also, in order to minimize outbound movements at this access, “DO NOT ENTER” signage should be considered within the parking lot.

Figure 9 shows the turning template for a typical bus. The new bus access configuration is anticipated to acceptably accommodate the turning movements of a typical bus. It should be noted that due to size constraints, bus drivers will likely need to coordinate to ensure all parking lots are filled and emptied during arrival and departure. Buses must leave the parking lot in a first in/first out sequence. If not used properly, buses will block entrances and exits which could lead to blockages and queueing onto Woodmoor Drive.

The intersection of Woodmoor Drive with Access 1 currently includes a southbound right turn deceleration lane and northbound center two way left turn lane. The southbound right turn lane is approximately 240 feet long and the northbound two way left turn lane provides approximately 250 feet of storage length to the next adjacent intersection. Operational analyses indicate these lengths will be adequate to accommodate anticipated queue lengths, and these lengths also satisfy ECM criteria for a 25 mph design speed. Of note, these lanes are likely to experience some queueing during peak school times, particularly during the PM peak hour as waiting drivers stage in the center northbound left turn lane. This condition should be monitored upon implementation.

III.F. Parking Lot C Queueing

As previously discussed, all private vehicle pick up and drop off activity will occur in Lot C upon completion of the proposed reconfiguration. This activity will place demand on the sidewalk space along the west edge of Parking Lot C. This sidewalk length currently totals approximately 560 feet, plus the additional 140 feet of curb length provided along Willow Park Way west of Access 2 for a total of 700 feet of curb space. It is anticipated that the recommended circulation pattern shown in **Figure 8** would make use of this full 700 feet of curb space for pick up and drop off activity.

Based on calculations from school calculator worksheets provided by the North Carolina Department of Transportation (NDOT), the LPMS school size can translate to a need for roughly 1500 feet of queueing space needed for pick up and drop off. It is likely that this length is conservative, given that some similar schools to LPMS reviewed provide roughly 500 feet of curbside space for pick up and drop off. In light of the range of potential curb space needs, it is possible that the existing curb space available in Parking Lot C will not be sufficient to accommodate all demand. In the event that offsite queueing space is needed along Woodmoor Drive, such space would be provided within the existing right and left turn auxiliary lanes approaching Access 1. This condition should be monitored upon implementation.

III.G. Pedestrian and Bicyclist Safety

Pedestrian and bicyclist counts were taken at each intersection within the study area. Pedestrian and bicyclist volumes were generally low with no more than 4 crossings at any location during the peak hours. Currently, there are sidewalks within the school property; however, there are no sidewalks along Woodmoor Drive or controlled crossings. Due to the low volume of pedestrians and cyclists in this area, the lack of sidewalks, crosswalks, and bicycle lanes may not be an issue. However, adequate sidewalks are desirable to maximize student safety walking to and from the school. Provision of a sidewalk along the west side of Woodmoor Drive from Willow Park Way would be appropriate for future consideration; with or without the proposed reconfiguration of school traffic and parking currently under consideration.

PARKING LOT A - AUTOTURN

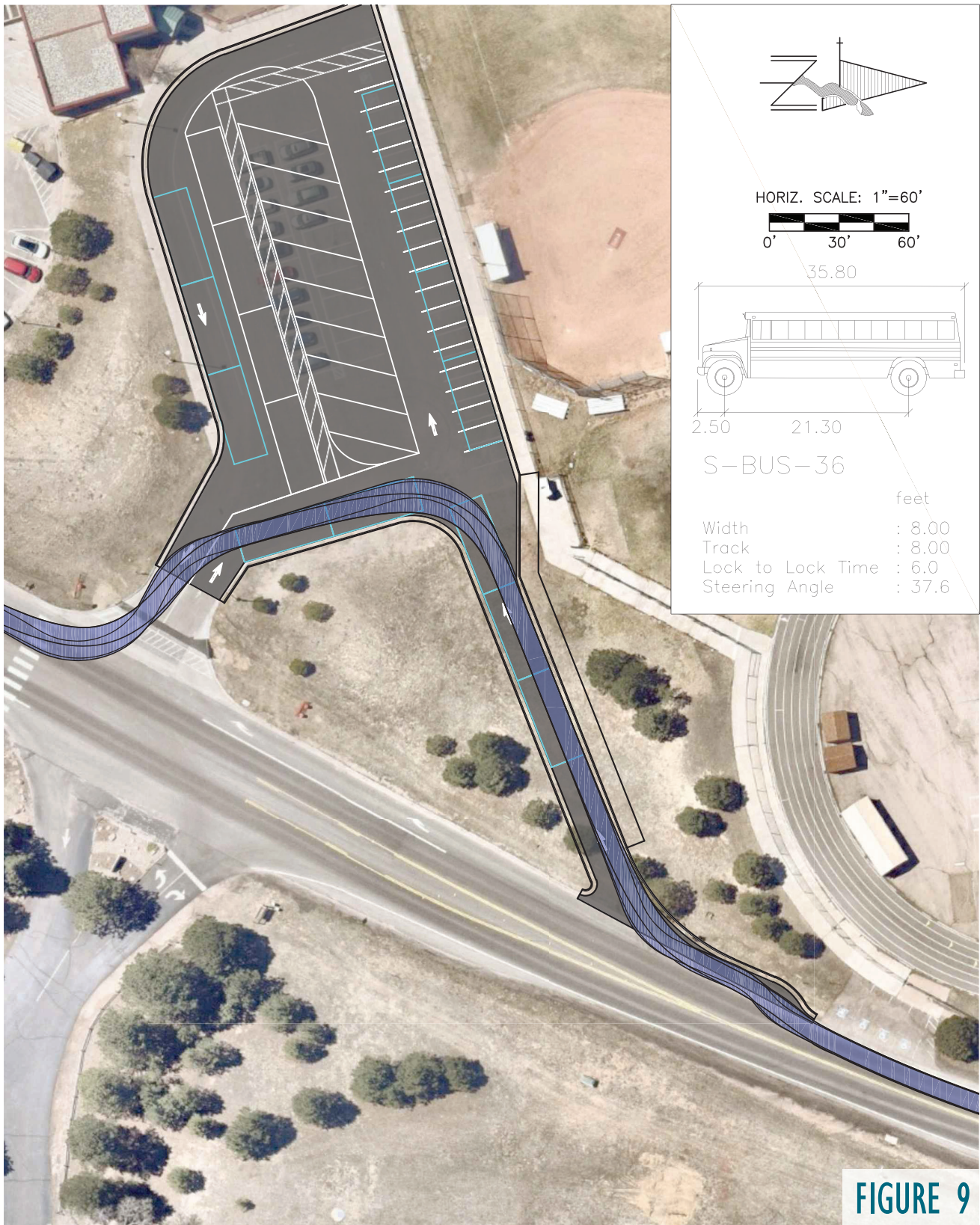

IV. SUMMARY AND RECOMMENDATIONS

A new inbound only bus access is proposed for the Lewis Palmer Middle School parking lot to convert to bus only during school peaks. The proposed bus access would be constructed north of the existing parking lot access along Woodmoor Drive in Monument, Colorado. Surrounding areas are primarily residential with some commercial space north of the school.

Two future scenarios were analyzed for this report:

- **Short-term Future** – Time period for the completion of the new access, estimated as the Year 2023.
- **Long-term Future** – The year 2045 was used to assess traffic impacts of the development in the long-term future.

The following is a summary of the findings and recommendations related to the analysis for the development:

- The planned 75 feet of turn lane length (including taper) for the southbound right turn deceleration lane at the new bus access is anticipated to provide enough space for buses to slow from the posted speed of 20 mph to a safe turning speed of 9 mph without causing sight distance issues for vehicles traveling around the Woodmoor Drive horizontal curve.
- The eastbound approach to the intersection of Woodmoor Drive with Willow Park Way is anticipated to experience delays and queuing during school pick up and drop off activities. In view of this, it is recommended that the configuration shown in **Figure 8** be implemented to provide enhanced exit efficiency and safety. This configuration would restrict left turns and route exiting traffic west along Willow Park Way in order to reach Woodmoor Drive.
- Monitoring of both bus and parent traffic within the study area should occur upon implementation of these changes to determine if adjustments should be made if problems emerge.
 - Access 3 should be monitored to ensure parents and visitors are aware of the new access restriction and do not use this lot during peak hours.
 - Access 3A should be monitored to ensure efficiency entering the parking lot. Woodmoor Drive should not experience blockages due to the new access.
 - Access 2 should be monitored to ensure drivers unfamiliar with this access treat it as outbound only.
 - Access 1 and parking area C should be monitored to ensure that additional student drop-off and pickup activities do not cause concern or backups onto Woodmoor Drive.
 - U-turn activity along Woodmoor Drive should be monitored.
- Provision of a sidewalk along the west side of Woodmoor Drive from Willow Park Way would be appropriate for future consideration; with or without the proposed reconfiguration of school traffic and parking currently under consideration.
- Upon El Paso County review and approval of this traffic study, necessary deviation requests will be submitted to support access spacing and design deviations from the ECM.

APPENDIX A. EXISTING TRAFFIC COUNTS

Location: 1 WOODMOOR DR & PARKING LOT ACCESS AM

Date: Wednesday, December 14, 2022

Peak Hour: 07:00 AM - 08:00 AM

Peak 15-Minutes: 07:15 AM - 07:30 AM

Peak Hour - Motorized Vehicles

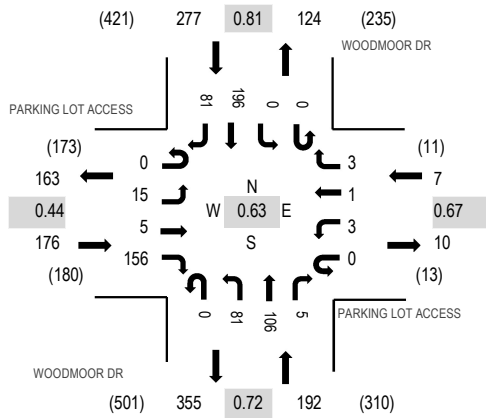

Peak Hour - Bicycles

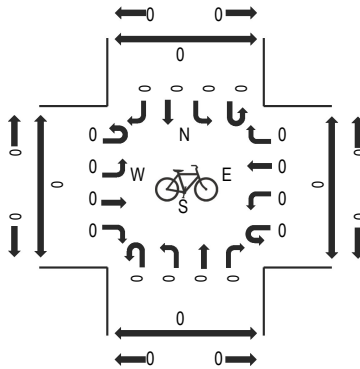

Peak Hour - Pedestrians

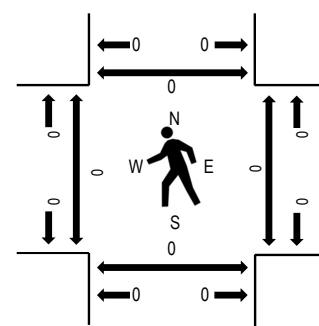

Note: Total study counts contained in parentheses.

Traffic Counts - Motorized Vehicles

Interval Start Time	PARKING LOT ACCESS Eastbound				PARKING LOT ACCESS Westbound				WOODMOOR DR Northbound				WOODMOOR DR Southbound				Total	Rolling Hour	Pedestrian Crossings			
	U-Turn	Left	Thru	Right	U-Turn	Left	Thru	Right	U-Turn	Left	Thru	Right	U-Turn	Left	Thru	Right			West	East	South	North
6:30 AM	0	0	0	0	0	2	0	0	0	0	4	1	0	0	21	0	28	559	0	0	0	0
6:45 AM	0	1	0	1	0	1	0	0	0	7	14	0	0	0	34	3	61	612	0	0	0	0
7:00 AM	0	9	2	63	0	2	0	0	0	45	16	0	0	0	34	41	212	652	0	0	0	0
7:15 AM	0	6	3	93	0	0	1	2	0	36	30	1	0	0	46	40	258	540	0	0	0	0
7:30 AM	0	0	0	0	0	1	0	0	0	0	24	0	0	0	56	0	81	363	0	0	0	0
7:45 AM	0	0	0	0	0	0	0	1	0	0	36	4	0	0	60	0	101		0	0	0	0
8:00 AM	0	0	2	0	0	0	0	0	0	0	58	0	0	0	40	0	100		0	0	0	0
8:15 AM	0	0	0	0	0	1	0	0	0	0	34	0	0	0	46	0	81		0	0	0	0
Count Total	0	16	7	157	0	7	1	3	0	88	216	6	0	0	337	84	922		0	0	0	0
Peak Hour	0	15	5	156	0	3	1	3	0	81	106	5	0	0	196	81	652		0	0	0	0

Peak Hour - Motorized Vehicles

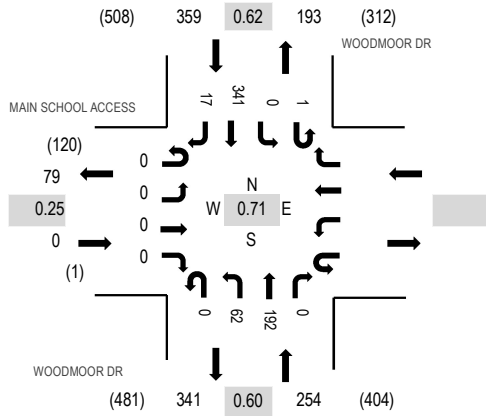

Peak Hour - Bicycles

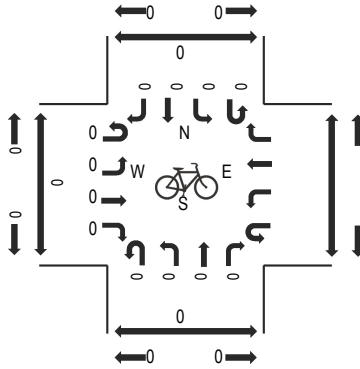

Peak Hour - Pedestrians

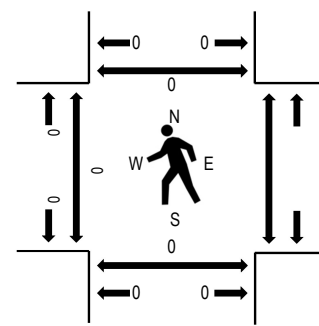

Note: Total study counts contained in parentheses.

Traffic Counts - Motorized Vehicles

Interval Start Time	MAIN SCHOOL ACCESS				WOODMOOR DR						Total	Rolling Hour	Pedestrian Crossings								
	Eastbound				Westbound			Northbound					Southbound				West	East	South	North	
	U-Turn	Left	Thru	Right	U-Turn	Left	Thru	Right	U-Turn	Left			Thru	Right	U-Turn	Left					Thru
6:30 AM	0	1	0	0					0	5	5	0	0	0	22	1	34	525	0	0	0
6:45 AM	0	0	0	0					0	17	21	0	0	0	28	8	74	579	0	0	0
7:00 AM	0	0	0	0					0	38	67	0	1	0	88	8	202	613	0	0	0
7:15 AM	0	0	0	0					0	11	60	0	0	0	141	3	215	515	0	0	0
7:30 AM	0	0	0	0					0	8	25	0	0	0	52	3	88	388	0	0	0
7:45 AM	0	0	0	0					0	5	40	0	0	0	60	3	108		0	0	0
8:00 AM	0	0	0	0					0	4	59	0	0	0	41	0	104		0	0	0
8:15 AM	0	0	0	0					0	6	33	0	0	0	49	0	88		0	0	0
Count Total	0	1	0	0					0	94	310	0	1	0	481	26	913		0	0	0
Peak Hour	0	0	0	0					0	62	192	0	1	0	341	17	613		0	0	0

Location: 3 WOODMOOR DR & WILLOW PARK WAY AM

Date: Wednesday, December 14, 2022

Peak Hour: 07:00 AM - 08:00 AM

Peak 15-Minutes: 07:00 AM - 07:15 AM

Peak Hour - Motorized Vehicles

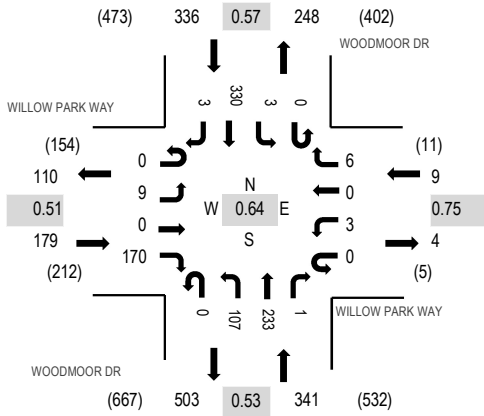

Peak Hour - Bicycles

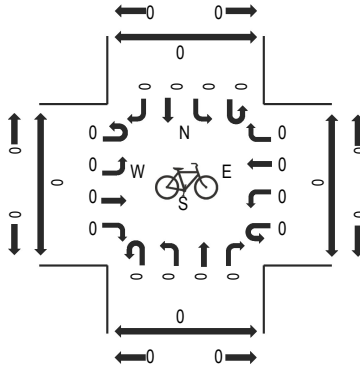

Peak Hour - Pedestrians

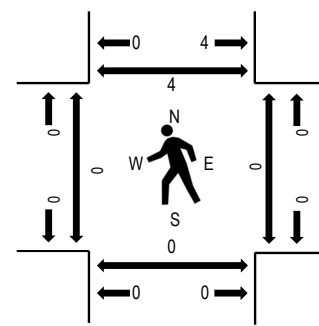

Note: Total study counts contained in parentheses.

Traffic Counts - Motorized Vehicles

Interval Start Time	WILLOW PARK WAY Eastbound				WILLOW PARK WAY Westbound				WOODMOOR DR Northbound				WOODMOOR DR Southbound				Total	Rolling Hour	Pedestrian Crossings			
	U-Turn	Left	Thru	Right	U-Turn	Left	Thru	Right	U-Turn	Left	Thru	Right	U-Turn	Left	Thru	Right			West	East	South	North
6:30 AM	0	0	0	2	0	0	0	1	0	10	9	0	0	0	23	0	45	794	0	0	0	0
6:45 AM	0	2	0	10	0	0	0	0	0	26	37	1	0	0	27	0	103	853	0	0	0	0
7:00 AM	0	0	0	90	0	1	0	1	0	62	108	0	0	0	75	1	338	865	0	0	0	4
7:15 AM	0	2	0	60	0	1	0	1	0	36	61	0	0	1	145	1	308	642	0	0	0	0
7:30 AM	0	5	0	15	0	1	0	2	0	3	26	0	0	1	50	1	104	434	0	0	0	0
7:45 AM	0	2	0	5	0	0	0	2	0	6	38	1	0	1	60	0	115		0	0	0	0
8:00 AM	0	0	0	7	0	0	0	1	0	3	64	0	0	0	39	1	115		0	0	0	0
8:15 AM	0	4	0	8	0	0	0	0	1	4	36	0	0	0	47	0	100		0	0	0	0
Count Total	0	15	0	197	0	3	0	8	1	150	379	2	0	3	466	4	1,228		0	0	0	4
Peak Hour	0	9	0	170	0	3	0	6	0	107	233	1	0	3	330	3	865		0	0	0	4

Location: 4 SECONDARY SCHOOL ACCESS & WILLOW PARK WAY AM

Date: Wednesday, December 14, 2022

Peak Hour: 06:45 AM - 07:45 AM

Peak 15-Minutes: 07:00 AM - 07:15 AM

Peak Hour - Motorized Vehicles

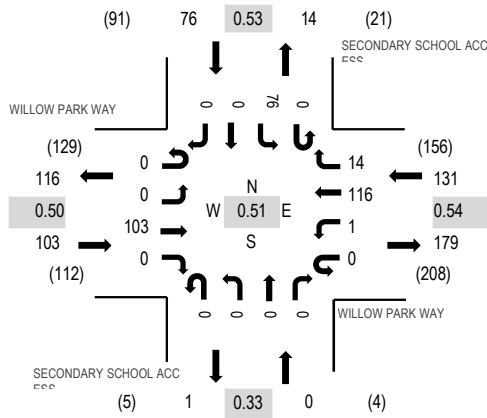

Peak Hour - Bicycles

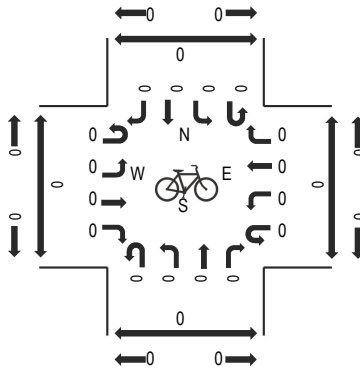

Peak Hour - Pedestrians

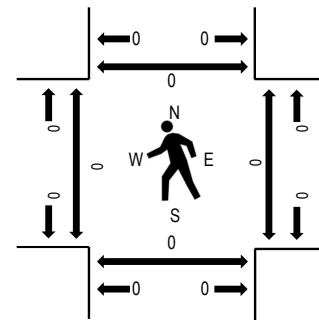

Note: Total study counts contained in parentheses.

Traffic Counts - Motorized Vehicles

Interval Start Time	WILLOW PARK WAY Eastbound				WILLOW PARK WAY Westbound				SECONDARY SCHOOL ACCESS Northbound				SECONDARY SCHOOL ACCESS Southbound				Total	Rolling Hour	Pedestrian Crossings			
	U-Turn	Left	Thru	Right	U-Turn	Left	Thru	Right	U-Turn	Left	Thru	Right	U-Turn	Left	Thru	Right			West	East	South	North
	6:30 AM	0	0	2	0	0	0	3	7	0	0	0	0	0	0	0			0	12	300	0
6:45 AM	0	0	5	0	0	1	12	13	0	0	0	0	0	7	0	0	38	310	0	0	0	0
7:00 AM	0	0	52	0	0	0	62	1	0	0	0	0	0	36	0	0	151	285	0	0	0	0
7:15 AM	0	0	42	0	0	0	38	0	0	0	0	0	0	19	0	0	99	145	0	0	0	0
7:30 AM	0	0	4	0	0	0	4	0	0	0	0	0	0	14	0	0	22	63	0	0	0	0
7:45 AM	0	0	2	0	0	1	5	0	0	0	0	0	0	5	0	0	13		0	0	0	0
8:00 AM	0	0	1	0	0	1	3	0	0	0	0	1	0	5	0	0	11		0	0	0	0
8:15 AM	0	0	4	0	1	2	2	0	0	0	0	3	0	5	0	0	17		0	0	0	0
Count Total	0	0	112	0	1	5	129	21	0	0	0	4	0	91	0	0	363		0	0	0	0
Peak Hour	0	0	103	0	0	1	116	14	0	0	0	0	0	76	0	0	310		0	0	0	0

Location: 1 WOODMOOR DR & PARKING LOT ACCESS PM

Date: Wednesday, December 14, 2022

Peak Hour: 02:30 PM - 03:30 PM

Peak 15-Minutes: 02:30 PM - 02:45 PM

Peak Hour - Motorized Vehicles

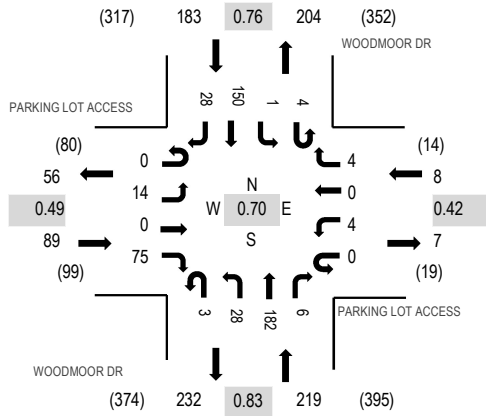

Peak Hour - Bicycles

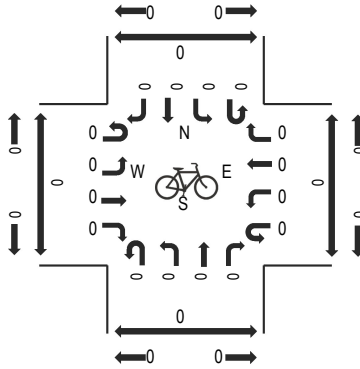

Peak Hour - Pedestrians

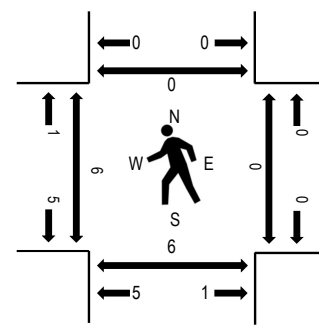

Note: Total study counts contained in parentheses.

Traffic Counts - Motorized Vehicles

Interval Start Time	PARKING LOT ACCESS Eastbound				PARKING LOT ACCESS Westbound				WOODMOOR DR Northbound				WOODMOOR DR Southbound				Total	Rolling Hour	Pedestrian Crossings			
	U-Turn	Left	Thru	Right	U-Turn	Left	Thru	Right	U-Turn	Left	Thru	Right	U-Turn	Left	Thru	Right			West	East	South	North
2:00 PM	0	0	1	0	0	1	0	1	0	14	29	2	0	0	29	3	80	485	0	0	0	0
2:15 PM	0	0	0	4	0	1	0	0	2	3	39	3	0	1	28	0	81	491	0	0	0	0
2:30 PM	0	2	0	45	0	2	0	4	2	19	42	3	4	1	32	23	179	499	4	0	4	0
2:45 PM	0	9	0	25	0	1	0	0	1	7	48	1	0	0	49	4	145	400	2	0	2	0
3:00 PM	0	3	0	5	0	1	0	0	0	2	41	1	0	0	32	1	86	340	0	0	0	0
3:15 PM	0	0	0	0	0	0	0	0	0	0	51	1	0	0	37	0	89		0	0	0	0
3:30 PM	0	1	1	0	0	2	0	0	0	1	37	2	0	0	36	0	80		0	0	0	0
3:45 PM	0	0	2	1	0	1	0	0	0	3	41	0	0	0	37	0	85		0	0	1	0
Count Total	0	15	4	80	0	9	0	5	5	49	328	13	4	2	280	31	825		6	0	7	0
Peak Hour	0	14	0	75	0	4	0	4	3	28	182	6	4	1	150	28	499		6	0	6	0

Peak Hour - Motorized Vehicles

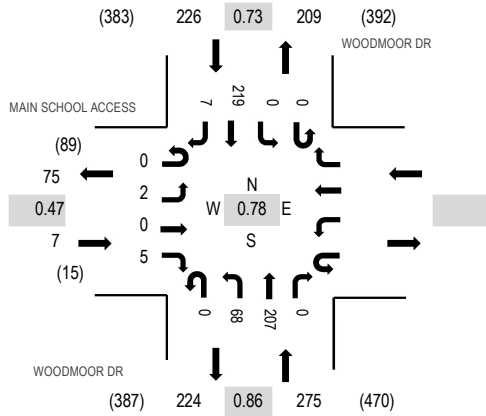

Peak Hour - Bicycles

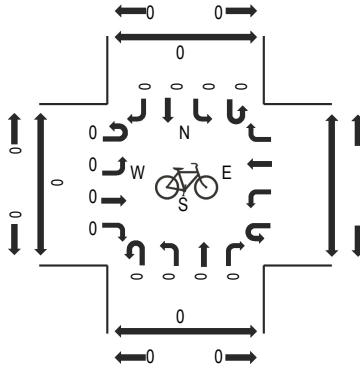

Peak Hour - Pedestrians

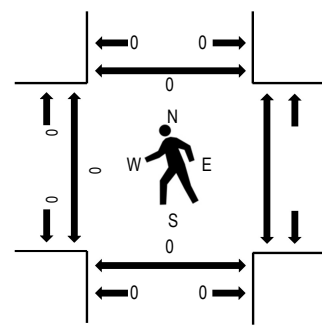

Note: Total study counts contained in parentheses.

Traffic Counts - Motorized Vehicles

Interval Start Time	MAIN SCHOOL ACCESS				Westbound			WOODMOOR DR Northbound				WOODMOOR DR Southbound				Total	Rolling Hour	Pedestrian Crossings				
	Eastbound				U-Turn	Left	Thru	Right	U-Turn	Left	Thru	Right	U-Turn	Left	Thru			Right	West	East	South	North
2:00 PM	0	0	0	0				0	25	45	0	0	0	0	30	2	102	508	0	0	0	0
2:15 PM	0	1	0	2				0	5	50	0	0	0	0	31	0	89	498	0	0	0	0
2:30 PM	0	1	0	1				0	14	56	0	0	0	0	82	0	154	502	0	0	0	0
2:45 PM	0	0	0	2				0	24	56	0	0	0	0	76	5	163	431	0	0	0	0
3:00 PM	0	2	0	6				0	4	41	0	0	0	0	39	0	92	360	0	0	0	0
3:15 PM	0	0	0	0				0	5	51	0	0	0	0	37	0	93		0	0	0	0
3:30 PM	0	0	0	0				0	1	42	0	0	0	0	40	0	83		0	0	0	0
3:45 PM	0	0	0	0				0	4	47	0	0	0	0	41	0	92		0	0	0	0
Count Total	0	4	0	11				0	82	388	0	0	0	0	376	7	868		0	0	0	0
Peak Hour	0	2	0	5				0	68	207	0	0	0	0	219	7	508		0	0	0	0

Location: 3 WOODMOOR DR & WILLOW PARK WAY PM

Date: Wednesday, December 14, 2022

Peak Hour: 02:15 PM - 03:15 PM

Peak 15-Minutes: 02:45 PM - 03:00 PM

Peak Hour - Motorized Vehicles

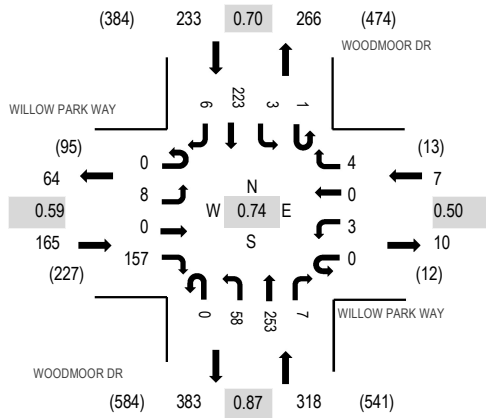

Peak Hour - Bicycles

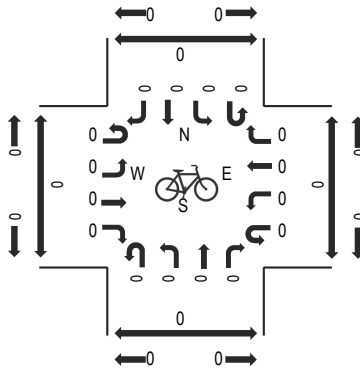

Peak Hour - Pedestrians

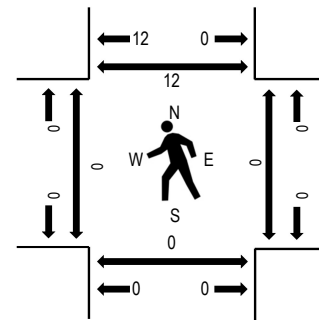

Note: Total study counts contained in parentheses.

Traffic Counts - Motorized Vehicles

Interval Start Time	WILLOW PARK WAY Eastbound				WILLOW PARK WAY Westbound				WOODMOOR DR Northbound				WOODMOOR DR Southbound				Total	Rolling Hour	Pedestrian Crossings			
	U-Turn	Left	Thru	Right	U-Turn	Left	Thru	Right	U-Turn	Left	Thru	Right	U-Turn	Left	Thru	Right			West	East	South	North
2:00 PM	0	1	0	11	0	1	0	0	0	10	53	0	0	0	30	1	107	716	0	0	0	0
2:15 PM	0	2	0	6	0	0	0	0	0	19	76	0	1	0	30	0	134	723	0	0	0	0
2:30 PM	0	0	0	64	0	2	0	1	0	23	64	5	0	1	70	1	231	701	0	0	0	12
2:45 PM	0	5	0	70	0	1	0	3	0	7	72	1	0	1	80	4	244	591	0	0	0	0
3:00 PM	0	1	0	17	0	0	0	0	0	9	41	1	0	1	43	1	114	449	0	0	0	0
3:15 PM	0	5	0	14	0	0	0	1	0	4	52	0	0	0	36	0	112		0	0	0	0
3:30 PM	0	1	0	23	0	1	0	2	0	11	41	0	0	1	39	2	121		0	0	0	0
3:45 PM	0	3	0	4	0	1	0	0	0	3	49	0	0	1	41	0	102		0	0	0	0
Count Total	0	18	0	209	0	6	0	7	0	86	448	7	1	5	369	9	1,165		0	0	0	12
Peak Hour	0	8	0	157	0	3	0	4	0	58	253	7	1	3	223	6	723		0	0	0	12

Peak Hour - Motorized Vehicles

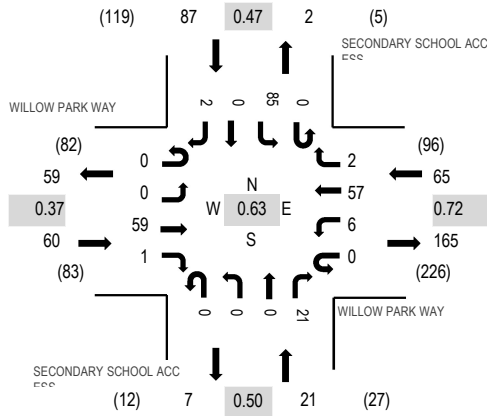

Peak Hour - Bicycles

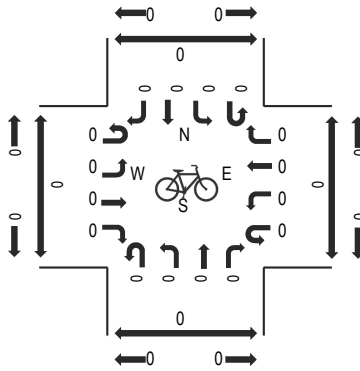

Peak Hour - Pedestrians

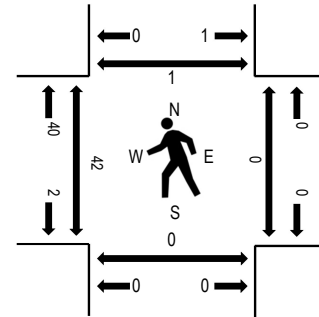

Note: Total study counts contained in parentheses.

Traffic Counts - Motorized Vehicles

Interval Start Time	WILLOW PARK WAY Eastbound				WILLOW PARK WAY Westbound				SECONDARY SCHOOL ACCESS Northbound				SECONDARY SCHOOL ACCESS Southbound				Total	Rolling Hour	Pedestrian Crossings				
	U-Turn	Left	Thru	Right	U-Turn	Left	Thru	Right	U-Turn	Left	Thru	Right	U-Turn	Left	Thru	Right			West	East	South	North	
2:00 PM	0	0	6	0	0	0	10	1	0	0	0	0	0	0	6	0	0	23	228	0	0	0	0
2:15 PM	0	0	0	0	0	1	20	0	0	0	0	3	0	4	0	0	28	233	1	0	0	0	
2:30 PM	0	0	44	1	0	2	21	0	0	0	0	3	0	21	0	0	92	228	38	0	0	1	
2:45 PM	0	0	14	0	0	0	11	0	0	0	0	11	0	47	0	2	85	173	1	0	0	0	
3:00 PM	0	0	1	0	0	3	5	2	0	0	0	4	0	13	0	0	28	97	2	0	0	0	
3:15 PM	0	0	6	0	0	0	4	0	0	0	0	4	0	9	0	0	23		0	0	0	0	
3:30 PM	0	0	7	0	0	5	6	2	0	0	0	2	0	15	0	0	37		0	0	0	0	
3:45 PM	0	0	4	0	0	0	3	0	0	0	0	0	0	2	0	0	9		0	0	0	0	
Count Total	0	0	82	1	0	11	80	5	0	0	0	27	0	117	0	2	325		42	0	0	1	
Peak Hour	0	0	59	1	0	6	57	2	0	0	0	21	0	85	0	2	233		42	0	0	1	

APPENDIX B. EXISTING LEVEL OF SERVICE WORKSHEETS

HCM 6th TWSC
1: Woodmoor Drive & Parking Lot Access

Existing Conditions
AM Peak

Intersection												
Int Delay, s/veh	8.7											
Movement	EBL	EBT	EBR	WBL	WBT	WBR	NBL	NBT	NBR	SBL	SBT	SBR
Lane Configurations		↔			↔	↔	↔	↔	↔	↔	↔	↔
Traffic Vol, veh/h	15	5	156	3	1	3	81	106	5	0	196	81
Future Vol, veh/h	15	5	156	3	1	3	81	106	5	0	196	81
Conflicting Peds, #/hr	0	0	0	0	0	0	0	0	0	0	0	0
Sign Control	Stop	Stop	Stop	Stop	Stop	Stop	Free	Free	Free	Free	Free	Free
RT Channelized	-	-	None	-	-	None	-	-	None	-	-	None
Storage Length	-	-	-	-	-	0	100	-	100	100	-	125
Veh in Median Storage, #	-	0	-	-	0	-	-	0	-	-	0	-
Grade, %	-	0	-	-	0	-	-	0	-	-	0	-
Peak Hour Factor	42	42	42	36	36	36	60	60	60	72	72	72
Heavy Vehicles, %	2	2	2	0	0	0	0	0	0	0	0	0
Mvmt Flow	36	12	371	8	3	8	135	177	8	0	272	113

Major/Minor	Minor2		Minor1		Major1			Major2				
Conflicting Flow All	729	727	272	967	832	177	385	0	0	185	0	0
Stage 1	272	272	-	447	447	-	-	-	-	-	-	-
Stage 2	457	455	-	520	385	-	-	-	-	-	-	-
Critical Hdwy	7.12	6.52	6.22	7.1	6.5	6.2	4.1	-	-	4.1	-	-
Critical Hdwy Stg 1	6.12	5.52	-	6.1	5.5	-	-	-	-	-	-	-
Critical Hdwy Stg 2	6.12	5.52	-	6.1	5.5	-	-	-	-	-	-	-
Follow-up Hdwy	3.518	4.018	3.318	3.5	4	3.3	2.2	-	-	2.2	-	-
Pot Cap-1 Maneuver	338	351	767	236	307	871	1185	-	-	1402	-	-
Stage 1	734	685	-	595	577	-	-	-	-	-	-	-
Stage 2	583	569	-	543	614	-	-	-	-	-	-	-
Platoon blocked, %								-	-	-	-	-
Mov Cap-1 Maneuver	303	311	767	108	272	871	1185	-	-	1402	-	-
Mov Cap-2 Maneuver	303	311	-	108	272	-	-	-	-	-	-	-
Stage 1	650	685	-	527	511	-	-	-	-	-	-	-
Stage 2	509	504	-	275	614	-	-	-	-	-	-	-

Approach	EB		WB		NB			SB		
HCM Control Delay, s	19.8		24.5		3.6			0		
HCM LOS	C		C							

Minor Lane/Major Mvmt	NBL	NBT	NBR	EBLn1	WBLn1	WBLn2	SBL	SBT	SBR
Capacity (veh/h)	1185	-	-	654	127	871	1402	-	-
HCM Lane V/C Ratio	0.114	-	-	0.641	0.087	0.01	-	-	-
HCM Control Delay (s)	8.4	-	-	19.8	36	9.2	0	-	-
HCM Lane LOS	A	-	-	C	E	A	A	-	-
HCM 95th %tile Q(veh)	0.4	-	-	4.6	0.3	0	0	-	-

Intersection							
Int Delay, s/veh	0.9						
Movement	EBL	EBR	NBL	NBT	SBU	SBT	SBR
Lane Configurations	↘↗		↘	↗		↗	↘
Traffic Vol, veh/h	0	0	62	192	1	341	17
Future Vol, veh/h	0	0	62	192	1	341	17
Conflicting Peds, #/hr	0	0	0	0	0	0	0
Sign Control	Stop	Stop	Free	Free	Free	Free	Free
RT Channelized	-	None	-	None	-	-	None
Storage Length	0	-	100	-	-	-	200
Veh in Median Storage, #	0	-	-	0	-	0	-
Grade, %	0	-	-	0	-	0	-
Peak Hour Factor	92	92	64	64	60	60	60
Heavy Vehicles, %	2	2	8	8	1	1	1
Mvmt Flow	0	0	97	300	2	568	28

Major/Minor	Minor2	Major1	Major2				
Conflicting Flow All	1062	568	596	0	-	-	0
Stage 1	568	-	-	-	-	-	-
Stage 2	494	-	-	-	-	-	-
Critical Hdwy	6.42	6.22	4.18	-	-	-	-
Critical Hdwy Stg 1	5.42	-	-	-	-	-	-
Critical Hdwy Stg 2	5.42	-	-	-	-	-	-
Follow-up Hdwy	3.518	3.318	2.272	-	-	-	-
Pot Cap-1 Maneuver	247	522	952	-	-	-	-
Stage 1	567	-	-	-	-	-	-
Stage 2	613	-	-	-	-	-	-
Platoon blocked, %				-	-	-	-
Mov Cap-1 Maneuver	222	522	952	-	-	-	-
Mov Cap-2 Maneuver	222	-	-	-	-	-	-
Stage 1	509	-	-	-	-	-	-
Stage 2	613	-	-	-	-	-	-

Approach	EB	NB	SB
HCM Control Delay, s	0	2.2	
HCM LOS	A		

Minor Lane/Major Mvmt	NBL	NBT	EBLn1	SBT	SBR
Capacity (veh/h)	952	-	-	-	-
HCM Lane V/C Ratio	0.102	-	-	-	-
HCM Control Delay (s)	9.2	-	0	-	-
HCM Lane LOS	A	-	A	-	-
HCM 95th %tile Q(veh)	0.3	-	-	-	-

HCM 6th TWSC
3: Woodmoor Drive & Willow Park Way

Existing Conditions
AM Peak

Intersection												
Int Delay, s/veh	18.9											
Movement	EBL	EBT	EBR	WBL	WBT	WBR	NBL	NBT	NBR	SBL	SBT	SBR
Lane Configurations		↕			↕		↗	↘		↗	↘	
Traffic Vol, veh/h	9	0	170	3	0	6	107	233	1	3	330	3
Future Vol, veh/h	9	0	170	3	0	6	107	233	1	3	330	3
Conflicting Peds, #/hr	0	0	0	0	0	0	0	0	0	0	0	0
Sign Control	Stop	Stop	Stop	Stop	Stop	Stop	Free	Free	Free	Free	Free	Free
RT Channelized	-	-	None	-	-	None	-	-	None	-	-	None
Storage Length	-	-	-	-	-	-	100	-	-	100	-	-
Veh in Median Storage, #	-	0	-	-	0	-	-	0	-	-	0	-
Grade, %	-	0	-	-	0	-	-	0	-	-	0	-
Peak Hour Factor	47	47	47	75	75	75	50	50	50	57	57	57
Heavy Vehicles, %	13	13	13	0	0	0	6	6	6	0	0	0
Mvmt Flow	19	0	362	4	0	8	214	466	2	5	579	5

Major/Minor	Minor2		Minor1		Major1		Major2					
Conflicting Flow All	1491	1488	582	1668	1489	467	584	0	0	468	0	0
Stage 1	592	592	-	895	895	-	-	-	-	-	-	-
Stage 2	899	896	-	773	594	-	-	-	-	-	-	-
Critical Hdwy	7.23	6.63	6.33	7.1	6.5	6.2	4.16	-	-	4.1	-	-
Critical Hdwy Stg 1	6.23	5.63	-	6.1	5.5	-	-	-	-	-	-	-
Critical Hdwy Stg 2	6.23	5.63	-	6.1	5.5	-	-	-	-	-	-	-
Follow-up Hdwy	3.617	4.117	3.417	3.5	4	3.3	2.254	-	-	2.2	-	-
Pot Cap-1 Maneuver	96	117	493	77	125	600	971	-	-	1104	-	-
Stage 1	474	477	-	338	362	-	-	-	-	-	-	-
Stage 2	319	344	-	395	496	-	-	-	-	-	-	-
Platoon blocked, %								-	-	-	-	-
Mov Cap-1 Maneuver	78	91	493	17	97	600	971	-	-	1104	-	-
Mov Cap-2 Maneuver	78	91	-	17	97	-	-	-	-	-	-	-
Stage 1	370	475	-	264	282	-	-	-	-	-	-	-
Stage 2	245	268	-	105	494	-	-	-	-	-	-	-

Approach	EB		WB		NB		SB	
HCM Control Delay, s	73.6		103.4		3.1		0.1	
HCM LOS	F		F					

Minor Lane/Major Mvmt	NBL	NBT	NBR	EBLn1	WBLn1	SBL	SBT	SBR
Capacity (veh/h)	971	-	-	389	48	1104	-	-
HCM Lane V/C Ratio	0.22	-	-	0.979	0.25	0.005	-	-
HCM Control Delay (s)	9.8	-	-	73.6	103.4	8.3	-	-
HCM Lane LOS	A	-	-	F	F	A	-	-
HCM 95th %tile Q(veh)	0.8	-	-	11.5	0.8	0	-	-

HCM 6th TWSC
4: Willow Park Way & Secondary School Access

Existing Conditions
AM Peak

Intersection												
Int Delay, s/veh	3.9											
Movement	EBL	EBT	EBR	WBL	WBT	WBR	NBL	NBT	NBR	SBL	SBT	SBR
Lane Configurations		↕			↕			↕			↕	
Traffic Vol, veh/h	0	100	0	1	109	1	0	0	0	74	0	0
Future Vol, veh/h	0	100	0	1	109	1	0	0	0	74	0	0
Conflicting Peds, #/hr	0	0	0	0	0	0	0	0	0	0	0	0
Sign Control	Free	Free	Free	Free	Free	Free	Stop	Stop	Stop	Stop	Stop	Stop
RT Channelized	-	-	None	-	-	None	-	-	None	-	-	None
Storage Length	-	-	-	-	-	-	-	-	-	-	-	-
Veh in Median Storage, #	-	0	-	-	0	-	-	0	-	-	0	-
Grade, %	-	0	-	-	0	-	-	0	-	-	0	-
Peak Hour Factor	48	48	48	44	44	44	92	92	92	51	51	51
Heavy Vehicles, %	1	1	1	1	1	1	2	2	2	28	28	28
Mvmt Flow	0	208	0	2	248	2	0	0	0	145	0	0

Major/Minor	Major1			Major2			Minor1			Minor2		
Conflicting Flow All	250	0	0	208	0	0	461	462	208	461	461	249
Stage 1	-	-	-	-	-	-	208	208	-	253	253	-
Stage 2	-	-	-	-	-	-	253	254	-	208	208	-
Critical Hdwy	4.11	-	-	4.11	-	-	7.12	6.52	6.22	7.38	6.78	6.48
Critical Hdwy Stg 1	-	-	-	-	-	-	6.12	5.52	-	6.38	5.78	-
Critical Hdwy Stg 2	-	-	-	-	-	-	6.12	5.52	-	6.38	5.78	-
Follow-up Hdwy	2.209	-	-	2.209	-	-	3.518	4.018	3.318	3.752	4.252	3.552
Pot Cap-1 Maneuver	1321	-	-	1369	-	-	511	497	832	470	461	730
Stage 1	-	-	-	-	-	-	794	730	-	697	652	-
Stage 2	-	-	-	-	-	-	751	697	-	738	684	-
Platoon blocked, %		-	-		-	-						
Mov Cap-1 Maneuver	1321	-	-	1369	-	-	510	496	832	469	460	730
Mov Cap-2 Maneuver	-	-	-	-	-	-	510	496	-	469	460	-
Stage 1	-	-	-	-	-	-	794	730	-	697	651	-
Stage 2	-	-	-	-	-	-	749	696	-	738	684	-

Approach	EB			WB			NB			SB		
HCM Control Delay, s	0			0.1			0			16.1		
HCM LOS							A			C		

Minor Lane/Major Mvmt	NBLn1	EBL	EBT	EBR	WBL	WBT	WBR	SBLn1
Capacity (veh/h)	-	1321	-	-	1369	-	-	469
HCM Lane V/C Ratio	-	-	-	-	0.002	-	-	0.309
HCM Control Delay (s)	0	0	-	-	7.6	0	-	16.1
HCM Lane LOS		A	A	-	-	A	A	C
HCM 95th %tile Q(veh)	-	0	-	-	0	-	-	1.3

HCM 6th TWSC
1: Woodmoor Drive & Parking Lot Access

Existing Conditions
PM Peak

Intersection														
Int Delay, s/veh	3.7													
Movement	EBL	EBT	EBR	WBL	WBT	WBR	NBU	NBL	NBT	NBR	SBU	SBL	SBT	SBR
Lane Configurations		↕			↕	↕		↕	↕	↕		↕	↕	↕
Traffic Vol, veh/h	14	0	79	5	0	4	5	31	170	8	4	2	141	28
Future Vol, veh/h	14	0	79	5	0	4	5	31	170	8	4	2	141	28
Conflicting Peds, #/hr	0	0	0	0	0	0	0	0	0	0	0	0	0	0
Sign Control	Stop	Stop	Stop	Stop	Stop	Stop	Free	Free	Free	Free	Free	Free	Free	Free
RT Channelized	-	-	None	-	-	None	-	-	-	None	-	-	-	None
Storage Length	-	-	-	-	-	0	-	100	-	100	-	100	-	125
Veh in Median Storage, #	-	0	-	-	0	-	-	-	0	-	-	-	0	-
Grade, %	-	0	-	-	0	-	-	-	0	-	-	-	0	-
Peak Hour Factor	43	43	43	46	46	46	92	81	81	81	92	65	65	65
Heavy Vehicles, %	0	0	0	0	0	0	2	3	3	3	2	0	0	0
Mvmt Flow	33	0	184	11	0	9	5	38	210	10	4	3	217	43

Major/Minor	Minor2		Minor1			Major1			Major2					
Conflicting Flow All	519	537	217	623	570	210	-	260	0	0	-	220	0	0
Stage 1	223	231	-	286	296	-	-	-	-	-	-	-	-	-
Stage 2	296	306	-	337	274	-	-	-	-	-	-	-	-	-
Critical Hdwy	7.1	6.5	6.2	7.1	6.5	6.2	-	4.13	-	-	-	4.1	-	-
Critical Hdwy Stg 1	6.1	5.5	-	6.1	5.5	-	-	-	-	-	-	-	-	-
Critical Hdwy Stg 2	6.1	5.5	-	6.1	5.5	-	-	-	-	-	-	-	-	-
Follow-up Hdwy	3.5	4	3.3	3.5	4	3.3	-	2.227	-	-	-	2.2	-	-
Pot Cap-1 Maneuver	471	453	828	401	434	835	-	1299	-	-	-	1361	-	-
Stage 1	784	717	-	726	672	-	-	-	-	-	-	-	-	-
Stage 2	717	665	-	681	687	-	-	-	-	-	-	-	-	-
Platoon blocked, %									-	-			-	-
Mov Cap-1 Maneuver	466	453	828	312	434	835	~ -8	~ -8	-	-	~	~	-	-
Mov Cap-2 Maneuver	466	453	-	312	434	-	-	-	-	-	-	-	-	-
Stage 1	784	717	-	726	672	-	-	-	-	-	-	-	-	-
Stage 2	710	665	-	530	687	-	-	-	-	-	-	-	-	-

Approach	EB		WB			NB			SB			
HCM Control Delay, s	11.8		13.6									
HCM LOS	B		B									

Minor Lane/Major Mvmt	NBL	NBT	NBR	EBLn1	WBLn1	WBLn2	SBL	SBT	SBR
Capacity (veh/h)	+	-	-	741	312	835	~	-	-
HCM Lane V/C Ratio	-	-	-	0.292	0.035	0.01	~	-	-
HCM Control Delay (s)	-	-	-	11.8	17	9.4	-	-	-
HCM Lane LOS	-	-	-	B	C	A	-	-	-
HCM 95th %tile Q(veh)	-	-	-	1.2	0.1	0	~	-	-

Notes
~: Volume exceeds capacity \$: Delay exceeds 300s +: Computation Not Defined *: All major volume in platoon

Intersection						
Int Delay, s/veh	1.2					
Movement	EBL	EBR	NBL	NBT	SBT	SBR
Lane Configurations	↔		↔	↑	↑	↔
Traffic Vol, veh/h	4	11	47	203	228	5
Future Vol, veh/h	4	11	47	203	228	5
Conflicting Peds, #/hr	0	0	0	0	0	0
Sign Control	Stop	Stop	Free	Free	Free	Free
RT Channelized	-	None	-	None	-	None
Storage Length	0	-	100	-	-	200
Veh in Median Storage, #	0	-	-	0	0	-
Grade, %	0	-	-	0	0	-
Peak Hour Factor	47	47	83	83	69	69
Heavy Vehicles, %	13	13	2	2	0	0
Mvmt Flow	9	23	57	245	330	7

Major/Minor	Minor2	Major1	Major2			
Conflicting Flow All	689	330	337	0	-	0
Stage 1	330	-	-	-	-	-
Stage 2	359	-	-	-	-	-
Critical Hdwy	6.53	6.33	4.12	-	-	-
Critical Hdwy Stg 1	5.53	-	-	-	-	-
Critical Hdwy Stg 2	5.53	-	-	-	-	-
Follow-up Hdwy	3.617	3.417	2.218	-	-	-
Pot Cap-1 Maneuver	395	687	1222	-	-	-
Stage 1	704	-	-	-	-	-
Stage 2	683	-	-	-	-	-
Platoon blocked, %				-	-	-
Mov Cap-1 Maneuver	376	687	1222	-	-	-
Mov Cap-2 Maneuver	481	-	-	-	-	-
Stage 1	671	-	-	-	-	-
Stage 2	683	-	-	-	-	-

Approach	EB	NB	SB
HCM Control Delay, s	11.2	1.5	0
HCM LOS	B		

Minor Lane/Major Mvmt	NBL	NBT	EBLn1	SBT	SBR
Capacity (veh/h)	1222	-	617	-	-
HCM Lane V/C Ratio	0.046	-	0.052	-	-
HCM Control Delay (s)	8.1	-	11.2	-	-
HCM Lane LOS	A	-	B	-	-
HCM 95th %tile Q(veh)	0.1	-	0.2	-	-

HCM 6th TWSC
3: Woodmoor Drive & Willow Park Way

Existing Conditions
PM Peak

Intersection													
Int Delay, s/veh	5.3												
Movement	EBL	EBT	EBR	WBL	WBT	WBR	NBL	NBT	NBR	SBU	SBL	SBT	SBR
Lane Configurations		↕			↕		↗	↘			↗	↘	
Traffic Vol, veh/h	8	0	157	3	0	4	58	253	7	1	3	223	6
Future Vol, veh/h	8	0	157	3	0	4	58	253	7	1	3	223	6
Conflicting Peds, #/hr	0	0	0	0	0	0	0	0	0	0	0	0	0
Sign Control	Stop	Stop	Stop	Stop	Stop	Stop	Free	Free	Free	Free	Free	Free	Free
RT Channelized	-	-	None	-	-	None	-	-	None	-	-	-	None
Storage Length	-	-	-	-	-	-	100	-	-	-	100	-	-
Veh in Median Storage, #	-	0	-	-	0	-	-	0	-	-	-	0	-
Grade, %	-	0	-	-	0	-	-	0	-	-	-	0	-
Peak Hour Factor	55	55	55	35	35	35	78	78	78	92	69	69	69
Heavy Vehicles, %	13	13	13	0	0	0	9	9	9	2	0	0	0
Mvmt Flow	15	0	285	9	0	11	74	324	9	1	4	323	9

Major/Minor	Minor2		Minor1		Major1			Major2					
Conflicting Flow All	818	819	328	955	819	329	332	0	0	-	333	0	0
Stage 1	336	338	-	477	477	-	-	-	-	-	-	-	-
Stage 2	482	481	-	478	342	-	-	-	-	-	-	-	-
Critical Hdwy	7.23	6.63	6.33	7.1	6.5	6.2	4.19	-	-	-	4.1	-	-
Critical Hdwy Stg 1	6.23	5.63	-	6.1	5.5	-	-	-	-	-	-	-	-
Critical Hdwy Stg 2	6.23	5.63	-	6.1	5.5	-	-	-	-	-	-	-	-
Follow-up Hdwy	3.617	4.117	3.417	3.5	4	3.3	2.281	-	-	-	2.2	-	-
Pot Cap-1 Maneuver	282	298	689	240	312	717	1189	-	-	-	1238	-	-
Stage 1	656	621	-	573	559	-	-	-	-	-	-	-	-
Stage 2	545	536	-	572	642	-	-	-	-	-	-	-	-
Platoon blocked, %								-	-	-	-	-	-
Mov Cap-1 Maneuver	264	280	689	134	293	717	1189	-	-	~-5	~-5	-	-
Mov Cap-2 Maneuver	264	280	-	134	293	-	-	-	-	-	-	-	-
Stage 1	615	621	-	537	524	-	-	-	-	-	-	-	-
Stage 2	503	503	-	335	642	-	-	-	-	-	-	-	-

Approach	EB		WB		NB		SB			
HCM Control Delay, s	15.5		20.6		1.5					
HCM LOS	C		C							

Minor Lane/Major Mvmt	NBL	NBT	NBR	EBLn1	WBLn1	SBL	SBT	SBR
Capacity (veh/h)	1189	-	-	639	250	+	-	-
HCM Lane V/C Ratio	0.063	-	-	0.469	0.08	-	-	-
HCM Control Delay (s)	8.2	-	-	15.5	20.6	-	-	-
HCM Lane LOS	A	-	-	C	C	-	-	-
HCM 95th %tile Q(veh)	0.2	-	-	2.5	0.3	-	-	-

Notes
~: Volume exceeds capacity \$: Delay exceeds 300s +: Computation Not Defined *: All major volume in platoon

HCM 6th TWSC
4: Willow Park Way & Secondary School Access

Existing Conditions
PM Peak

Intersection												
Int Delay, s/veh	6.3											
Movement	EBL	EBT	EBR	WBL	WBT	WBR	NBL	NBT	NBR	SBL	SBT	SBR
Lane Configurations		↕			↕			↕			↕	
Traffic Vol, veh/h	0	59	1	6	57	2	0	0	21	85	0	2
Future Vol, veh/h	0	59	1	6	57	2	0	0	21	85	0	2
Conflicting Peds, #/hr	0	0	0	0	0	0	0	0	0	0	0	0
Sign Control	Free	Free	Free	Free	Free	Free	Stop	Stop	Stop	Stop	Stop	Stop
RT Channelized	-	-	None	-	-	None	-	-	None	-	-	None
Storage Length	-	-	-	-	-	-	-	-	-	-	-	-
Veh in Median Storage, #	-	0	-	-	0	-	-	0	-	-	0	-
Grade, %	-	0	-	-	0	-	-	0	-	-	0	-
Peak Hour Factor	33	33	33	65	65	65	48	48	48	45	45	45
Heavy Vehicles, %	0	0	0	3	3	3	0	0	0	25	25	25
Mvmt Flow	0	179	3	9	88	3	0	0	44	189	0	4

Major/Minor	Major1		Major2		Minor1			Minor2				
Conflicting Flow All	91	0	0	182	0	0	291	290	181	311	290	90
Stage 1	-	-	-	-	-	-	181	181	-	108	108	-
Stage 2	-	-	-	-	-	-	110	109	-	203	182	-
Critical Hdwy	4.1	-	-	4.13	-	-	7.1	6.5	6.2	7.35	6.75	6.45
Critical Hdwy Stg 1	-	-	-	-	-	-	6.1	5.5	-	6.35	5.75	-
Critical Hdwy Stg 2	-	-	-	-	-	-	6.1	5.5	-	6.35	5.75	-
Follow-up Hdwy	2.2	-	-	2.227	-	-	3.5	4	3.3	3.725	4.225	3.525
Pot Cap-1 Maneuver	1517	-	-	1387	-	-	665	624	867	599	584	908
Stage 1	-	-	-	-	-	-	825	754	-	844	763	-
Stage 2	-	-	-	-	-	-	900	809	-	749	708	-
Platoon blocked, %		-	-	-	-	-						
Mov Cap-1 Maneuver	1517	-	-	1387	-	-	658	620	867	565	580	908
Mov Cap-2 Maneuver	-	-	-	-	-	-	658	620	-	565	580	-
Stage 1	-	-	-	-	-	-	825	754	-	844	758	-
Stage 2	-	-	-	-	-	-	889	803	-	711	708	-

Approach	EB		WB		NB		SB	
HCM Control Delay, s	0		0.7		9.4		14.5	
HCM LOS					A		B	

Minor Lane/Major Mvmt	NBLn1	EBL	EBT	EBR	WBL	WBT	WBR	SBLn1
Capacity (veh/h)	867	1517	-	-	1387	-	-	570
HCM Lane V/C Ratio	0.05	-	-	-	0.007	-	-	0.339
HCM Control Delay (s)	9.4	0	-	-	7.6	0	-	14.5
HCM Lane LOS	A	A	-	-	A	A	-	B
HCM 95th %tile Q(veh)	0.2	0	-	-	0	-	-	1.5

APPENDIX C. SHORT-TERM FUTURE LEVEL OF SERVICE WORKSHEETS

Intersection												
Int Delay, s/veh	1.6											
Movement	EBL	EBT	EBR	WBL	WBT	WBR	NBL	NBT	NBR	SBL	SBT	SBR
Lane Configurations		↔			↔	↔	↔	↔	↔	↔	↔	↔
Traffic Vol, veh/h	3	0	21	5	0	3	0	117	10	0	275	0
Future Vol, veh/h	3	0	21	5	0	3	0	117	10	0	275	0
Conflicting Peds, #/hr	0	0	0	0	0	0	0	0	0	0	0	0
Sign Control	Stop	Stop	Stop	Stop	Stop	Stop	Free	Free	Free	Free	Free	Free
RT Channelized	-	-	None	-	-	None	-	-	None	-	-	None
Storage Length	-	-	-	-	-	0	100	-	-	100	-	125
Veh in Median Storage, #	-	0	-	-	0	-	-	0	-	-	0	-
Grade, %	-	0	-	-	0	-	-	0	-	-	0	-
Peak Hour Factor	42	42	42	36	36	36	60	60	60	72	72	72
Heavy Vehicles, %	100	100	100	0	100	0	100	0	0	0	0	100
Mvmt Flow	7	0	50	14	0	8	0	195	17	0	382	0

Major/Minor	Minor2		Minor1		Major1			Major2				
Conflicting Flow All	590	594	382	602	577	195	382	0	0	212	0	0
Stage 1	382	382	-	195	195	-	-	-	-	-	-	-
Stage 2	208	212	-	407	382	-	-	-	-	-	-	-
Critical Hdwy	8.1	7.5	7.2	7.1	7.5	6.2	5.1	-	-	4.1	-	-
Critical Hdwy Stg 1	7.1	6.5	-	6.1	6.5	-	-	-	-	-	-	-
Critical Hdwy Stg 2	7.1	6.5	-	6.1	6.5	-	-	-	-	-	-	-
Follow-up Hdwy	4.4	4.9	4.2	3.5	4.9	3.3	3.1	-	-	2.2	-	-
Pot Cap-1 Maneuver	304	311	495	414	319	851	793	-	-	1370	-	-
Stage 1	482	473	-	811	588	-	-	-	-	-	-	-
Stage 2	615	577	-	625	473	-	-	-	-	-	-	-
Platoon blocked, %								-	-	-	-	-
Mov Cap-1 Maneuver	301	311	495	372	319	851	793	-	-	1370	-	-
Mov Cap-2 Maneuver	301	311	-	372	319	-	-	-	-	-	-	-
Stage 1	482	473	-	811	588	-	-	-	-	-	-	-
Stage 2	609	577	-	562	473	-	-	-	-	-	-	-

Approach	EB	WB	NB	SB
HCM Control Delay, s	14	12.9	0	0
HCM LOS	B	B		

Minor Lane/Major Mvmt	NBL	NBT	NBR	EBLn1	WBLn1	WBLn2	SBL	SBT	SBR
Capacity (veh/h)	793	-	-	458	372	851	1370	-	-
HCM Lane V/C Ratio	-	-	-	0.125	0.037	0.01	-	-	-
HCM Control Delay (s)	0	-	-	14	15.1	9.3	0	-	-
HCM Lane LOS	A	-	-	B	C	A	A	-	-
HCM 95th %tile Q(veh)	0	-	-	0.4	0.1	0	0	-	-

Intersection						
Int Delay, s/veh	3.4					
Movement	EBL	EBR	NBL	NBT	SBT	SBR
Lane Configurations	↘↗		↘	↑	↑	↘
Traffic Vol, veh/h	0	0	234	128	207	96
Future Vol, veh/h	0	0	234	128	207	96
Conflicting Peds, #/hr	0	0	0	0	0	0
Sign Control	Stop	Stop	Free	Free	Free	Free
RT Channelized	-	None	-	None	-	None
Storage Length	0	-	100	-	-	-
Veh in Median Storage, #	0	-	-	0	0	-
Grade, %	0	-	-	0	0	-
Peak Hour Factor	92	92	64	64	60	60
Heavy Vehicles, %	0	0	0	8	1	0
Mvmt Flow	0	0	366	200	345	160

Major/Minor	Minor2	Major1	Major2			
Conflicting Flow All	1277	345	505	0	-	0
Stage 1	345	-	-	-	-	-
Stage 2	932	-	-	-	-	-
Critical Hdwy	6.4	6.2	4.1	-	-	-
Critical Hdwy Stg 1	5.4	-	-	-	-	-
Critical Hdwy Stg 2	5.4	-	-	-	-	-
Follow-up Hdwy	3.5	3.3	2.2	-	-	-
Pot Cap-1 Maneuver	185	702	1070	-	-	-
Stage 1	722	-	-	-	-	-
Stage 2	386	-	-	-	-	-
Platoon blocked, %				-	-	-
Mov Cap-1 Maneuver	122	702	1070	-	-	-
Mov Cap-2 Maneuver	249	-	-	-	-	-
Stage 1	475	-	-	-	-	-
Stage 2	386	-	-	-	-	-

Approach	EB	NB	SB
HCM Control Delay, s	0	6.5	0
HCM LOS	A		

Minor Lane/Major Mvmt	NBL	NBT	EBLn1	SBT	SBR
Capacity (veh/h)	1070	-	-	-	-
HCM Lane V/C Ratio	0.342	-	-	-	-
HCM Control Delay (s)	10.1	-	0	-	-
HCM Lane LOS	B	-	A	-	-
HCM 95th %tile Q(veh)	1.5	-	-	-	-

Intersection												
Int Delay, s/veh	51											
Movement	EBL	EBT	EBR	WBL	WBT	WBR	NBL	NBT	NBR	SBL	SBT	SBR
Lane Configurations		↕			↕		↕	↕		↕	↕	
Traffic Vol, veh/h	26	0	301	3	0	6	0	327	1	3	196	3
Future Vol, veh/h	26	0	301	3	0	6	0	327	1	3	196	3
Conflicting Peds, #/hr	0	0	0	0	0	0	0	0	0	0	0	0
Sign Control	Stop	Stop	Stop	Stop	Stop	Stop	Free	Free	Free	Free	Free	Free
RT Channelized	-	-	None	-	-	None	-	-	None	-	-	None
Storage Length	-	-	-	-	-	-	100	-	-	100	-	-
Veh in Median Storage, #	-	0	-	-	0	-	-	0	-	-	0	-
Grade, %	-	0	-	-	0	-	-	0	-	-	0	-
Peak Hour Factor	47	47	47	75	75	75	50	50	50	57	57	57
Heavy Vehicles, %	2	2	2	0	0	0	6	6	6	0	0	0
Mvmt Flow	55	0	640	4	0	8	0	654	2	5	344	5

Major/Minor	Minor2		Minor1			Major1			Major2			
Conflicting Flow All	1016	1013	347	1332	1014	655	349	0	0	656	0	0
Stage 1	357	357	-	655	655	-	-	-	-	-	-	-
Stage 2	659	656	-	677	359	-	-	-	-	-	-	-
Critical Hdwy	7.12	6.52	6.22	7.1	6.5	6.2	4.16	-	-	4.1	-	-
Critical Hdwy Stg 1	6.12	5.52	-	6.1	5.5	-	-	-	-	-	-	-
Critical Hdwy Stg 2	6.12	5.52	-	6.1	5.5	-	-	-	-	-	-	-
Follow-up Hdwy	3.518	4.018	3.318	3.5	4	3.3	2.254	-	-	2.2	-	-
Pot Cap-1 Maneuver	216	239	696	133	240	470	1188	-	-	941	-	-
Stage 1	661	628	-	458	466	-	-	-	-	-	-	-
Stage 2	453	462	-	446	631	-	-	-	-	-	-	-
Platoon blocked, %								-	-	-	-	-
Mov Cap-1 Maneuver	211	238	696	11	239	470	1188	-	-	941	-	-
Mov Cap-2 Maneuver	211	238	-	11	239	-	-	-	-	-	-	-
Stage 1	661	625	-	458	466	-	-	-	-	-	-	-
Stage 2	445	462	-	35	628	-	-	-	-	-	-	-

Approach	EB		WB			NB			SB		
HCM Control Delay, s	122.8		173.8			0			0.1		
HCM LOS	F		F								

Minor Lane/Major Mvmt	NBL	NBT	NBR	EBLn1	WBLn1	SBL	SBT	SBR
Capacity (veh/h)	1188	-	-	588	32	941	-	-
HCM Lane V/C Ratio	-	-	-	1.183	0.375	0.006	-	-
HCM Control Delay (s)	0	-	-	122.8	173.8	8.8	-	-
HCM Lane LOS	A	-	-	F	F	A	-	-
HCM 95th %tile Q(veh)	0	-	-	24.2	1.2	0	-	-

Intersection												
Int Delay, s/veh	14.4											
Movement	EBL	EBT	EBR	WBL	WBT	WBR	NBL	NBT	NBR	SBL	SBT	SBR
Lane Configurations		↕			↕			↕			↕	
Traffic Vol, veh/h	0	0	0	1	1	0	0	0	0	326	0	0
Future Vol, veh/h	0	0	0	1	1	0	0	0	0	326	0	0
Conflicting Peds, #/hr	0	0	0	0	0	0	0	0	0	0	0	0
Sign Control	Free	Free	Free	Free	Free	Free	Stop	Stop	Stop	Stop	Stop	Stop
RT Channelized	-	-	None	-	-	None	-	-	None	-	-	None
Storage Length	-	-	-	-	-	-	-	-	-	-	-	-
Veh in Median Storage, #	-	0	-	-	0	-	-	0	-	-	0	-
Grade, %	-	0	-	-	0	-	-	0	-	-	0	-
Peak Hour Factor	48	48	48	44	44	44	92	92	92	51	51	51
Heavy Vehicles, %	1	1	1	1	1	1	2	2	2	2	2	2
Mvmt Flow	0	0	0	2	2	0	0	0	0	639	0	0

Major/Minor	Major1			Major2			Minor1			Minor2		
Conflicting Flow All	2	0	0	2	0	0	8	8	2	8	8	2
Stage 1	-	-	-	-	-	-	2	2	-	6	6	-
Stage 2	-	-	-	-	-	-	6	6	-	2	2	-
Critical Hdwy	4.11	-	-	4.11	-	-	7.12	6.52	6.22	7.12	6.52	6.22
Critical Hdwy Stg 1	-	-	-	-	-	-	6.12	5.52	-	6.12	5.52	-
Critical Hdwy Stg 2	-	-	-	-	-	-	6.12	5.52	-	6.12	5.52	-
Follow-up Hdwy	2.209	-	-	2.209	-	-	3.518	4.018	3.318	3.518	4.018	3.318
Pot Cap-1 Maneuver	1627	-	-	1627	-	-	1011	887	1082	1011	887	1082
Stage 1	-	-	-	-	-	-	1021	894	-	1016	891	-
Stage 2	-	-	-	-	-	-	1016	891	-	1021	894	-
Platoon blocked, %		-	-		-	-						
Mov Cap-1 Maneuver	1627	-	-	1627	-	-	1010	886	1082	1010	886	1082
Mov Cap-2 Maneuver	-	-	-	-	-	-	1010	886	-	1010	886	-
Stage 1	-	-	-	-	-	-	1021	894	-	1016	890	-
Stage 2	-	-	-	-	-	-	1015	890	-	1021	894	-

Approach	EB			WB			NB			SB		
HCM Control Delay, s	0			3.6			0			14.5		
HCM LOS							A			B		

Minor Lane/Major Mvmt	NBLn1	EBL	EBT	EBR	WBL	WBT	WBR	SBLn1
Capacity (veh/h)	-	1627	-	-	1627	-	-	1010
HCM Lane V/C Ratio	-	-	-	-	0.001	-	-	0.633
HCM Control Delay (s)	0	0	-	-	7.2	0	-	14.5
HCM Lane LOS		A	A	-	-	A	A	B
HCM 95th %tile Q(veh)	-	0	-	-	0	-	-	4.7

Intersection												
Int Delay, s/veh	1.6											
Movement	EBL	EBT	EBR	WBL	WBT	WBR	NBL	NBT	NBR	SBL	SBT	SBR
Lane Configurations		↔			↔	↔	↔	↔	↔	↔	↔	↔
Traffic Vol, veh/h	1	0	23	5	0	4	0	186	8	2	170	0
Future Vol, veh/h	1	0	23	5	0	4	0	186	8	2	170	0
Conflicting Peds, #/hr	0	0	0	0	0	0	0	0	0	0	0	0
Sign Control	Stop	Stop	Stop	Stop	Stop	Stop	Free	Free	Free	Free	Free	Free
RT Channelized	-	-	None	-	-	None	-	-	None	-	-	None
Storage Length	-	-	-	-	-	0	100	-	-	100	-	125
Veh in Median Storage, #	-	0	-	-	0	-	-	0	-	-	0	-
Grade, %	-	0	-	-	0	-	-	0	-	-	0	-
Peak Hour Factor	43	43	43	46	46	46	81	81	81	65	65	65
Heavy Vehicles, %	100	100	100	0	100	0	100	3	3	0	0	100
Mvmt Flow	2	0	53	11	0	9	0	230	10	3	262	0

Major/Minor	Minor2		Minor1		Major1			Major2				
Conflicting Flow All	508	508	262	525	498	230	262	0	0	240	0	0
Stage 1	268	268	-	230	230	-	-	-	-	-	-	-
Stage 2	240	240	-	295	268	-	-	-	-	-	-	-
Critical Hdwy	8.1	7.5	7.2	7.1	7.5	6.2	5.1	-	-	4.1	-	-
Critical Hdwy Stg 1	7.1	6.5	-	6.1	6.5	-	-	-	-	-	-	-
Critical Hdwy Stg 2	7.1	6.5	-	6.1	6.5	-	-	-	-	-	-	-
Follow-up Hdwy	4.4	4.9	4.2	3.5	4.9	3.3	3.1	-	-	2.2	-	-
Pot Cap-1 Maneuver	350	353	589	466	358	814	895	-	-	1339	-	-
Stage 1	566	540	-	777	565	-	-	-	-	-	-	-
Stage 2	588	558	-	718	540	-	-	-	-	-	-	-
Platoon blocked, %	-	-	-	-	-	-	-	-	-	-	-	-
Mov Cap-1 Maneuver	346	352	589	423	357	814	895	-	-	1339	-	-
Mov Cap-2 Maneuver	346	352	-	423	357	-	-	-	-	-	-	-
Stage 1	566	539	-	777	565	-	-	-	-	-	-	-
Stage 2	582	558	-	651	539	-	-	-	-	-	-	-

Approach	EB		WB		NB		SB	
HCM Control Delay, s	12		11.8		0		0.1	
HCM LOS	B		B					

Minor Lane/Major Mvmt	NBL	NBT	NBR	EBLn1	WBLn1	WBLn2	SBL	SBT	SBR
Capacity (veh/h)	895	-	-	572	423	814	1339	-	-
HCM Lane V/C Ratio	-	-	-	0.098	0.026	0.011	0.002	-	-
HCM Control Delay (s)	0	-	-	12	13.7	9.5	7.7	-	-
HCM Lane LOS	A	-	-	B	B	A	A	-	-
HCM 95th %tile Q(veh)	0	-	-	0.3	0.1	0	0	-	-

Intersection						
Int Delay, s/veh	2.4					
Movement	EBL	EBR	NBL	NBT	SBT	SBR
Lane Configurations	↘		↘	↑	↑	↘
Traffic Vol, veh/h	4	11	136	186	173	33
Future Vol, veh/h	4	11	136	186	173	33
Conflicting Peds, #/hr	0	0	0	0	0	0
Sign Control	Stop	Stop	Free	Free	Free	Free
RT Channelized	-	None	-	None	-	None
Storage Length	0	-	100	-	-	-
Veh in Median Storage, #	0	-	-	0	0	-
Grade, %	0	-	-	0	0	-
Peak Hour Factor	47	47	83	83	69	69
Heavy Vehicles, %	0	0	0	2	0	0
Mvmt Flow	9	23	164	224	251	48

Major/Minor	Minor2	Major1	Major2			
Conflicting Flow All	803	251	299	0	-	0
Stage 1	251	-	-	-	-	-
Stage 2	552	-	-	-	-	-
Critical Hdwy	6.4	6.2	4.1	-	-	-
Critical Hdwy Stg 1	5.4	-	-	-	-	-
Critical Hdwy Stg 2	5.4	-	-	-	-	-
Follow-up Hdwy	3.5	3.3	2.2	-	-	-
Pot Cap-1 Maneuver	355	793	1274	-	-	-
Stage 1	795	-	-	-	-	-
Stage 2	581	-	-	-	-	-
Platoon blocked, %				-	-	-
Mov Cap-1 Maneuver	309	793	1274	-	-	-
Mov Cap-2 Maneuver	427	-	-	-	-	-
Stage 1	692	-	-	-	-	-
Stage 2	581	-	-	-	-	-

Approach	EB	NB	SB
HCM Control Delay, s	10.9	3.5	0
HCM LOS	B		

Minor Lane/Major Mvmt	NBL	NBT	EBLn1	SBT	SBR
Capacity (veh/h)	1274	-	645	-	-
HCM Lane V/C Ratio	0.129	-	0.049	-	-
HCM Control Delay (s)	8.2	-	10.9	-	-
HCM Lane LOS	A	-	B	-	-
HCM 95th %tile Q(veh)	0.4	-	0.2	-	-

Intersection												
Int Delay, s/veh	7.4											
Movement	EBL	EBT	EBR	WBL	WBT	WBR	NBL	NBT	NBR	SBL	SBT	SBR
Lane Configurations		↕			↕		↕	↕		↕	↕	
Traffic Vol, veh/h	23	0	220	3	0	4	0	311	7	3	168	6
Future Vol, veh/h	23	0	220	3	0	4	0	311	7	3	168	6
Conflicting Peds, #/hr	0	0	0	0	0	0	0	0	0	0	0	0
Sign Control	Stop	Stop	Stop	Stop	Stop	Stop	Free	Free	Free	Free	Free	Free
RT Channelized	-	-	None	-	-	None	-	-	None	-	-	None
Storage Length	-	-	-	-	-	-	100	-	-	100	-	-
Veh in Median Storage, #	-	0	-	-	0	-	-	0	-	-	0	-
Grade, %	-	0	-	-	0	-	-	0	-	-	0	-
Peak Hour Factor	55	55	55	35	35	35	78	78	78	69	69	69
Heavy Vehicles, %	2	2	2	0	0	0	9	9	9	0	0	0
Mvmt Flow	42	0	400	9	0	11	0	399	9	4	243	9

Major/Minor	Minor2		Minor1		Major1			Major2				
Conflicting Flow All	665	664	248	860	664	404	252	0	0	408	0	0
Stage 1	256	256	-	404	404	-	-	-	-	-	-	-
Stage 2	409	408	-	456	260	-	-	-	-	-	-	-
Critical Hdwy	7.12	6.52	6.22	7.1	6.5	6.2	4.19	-	-	4.1	-	-
Critical Hdwy Stg 1	6.12	5.52	-	6.1	5.5	-	-	-	-	-	-	-
Critical Hdwy Stg 2	6.12	5.52	-	6.1	5.5	-	-	-	-	-	-	-
Follow-up Hdwy	3.518	4.018	3.318	3.5	4	3.3	2.281	-	-	2.2	-	-
Pot Cap-1 Maneuver	374	381	791	278	384	651	1274	-	-	1162	-	-
Stage 1	749	696	-	627	603	-	-	-	-	-	-	-
Stage 2	619	597	-	588	697	-	-	-	-	-	-	-
Platoon blocked, %								-	-	-	-	-
Mov Cap-1 Maneuver	367	380	791	137	383	651	1274	-	-	1162	-	-
Mov Cap-2 Maneuver	367	380	-	137	383	-	-	-	-	-	-	-
Stage 1	749	694	-	627	603	-	-	-	-	-	-	-
Stage 2	608	597	-	290	695	-	-	-	-	-	-	-

Approach	EB		WB		NB		SB	
HCM Control Delay, s	17.9		20.6		0		0.1	
HCM LOS	C		C					

Minor Lane/Major Mvmt	NBL	NBT	NBR	EBLn1	WBLn1	SBL	SBT	SBR
Capacity (veh/h)	1274	-	-	713	250	1162	-	-
HCM Lane V/C Ratio	-	-	-	0.62	0.08	0.004	-	-
HCM Control Delay (s)	0	-	-	17.9	20.6	8.1	-	-
HCM Lane LOS	A	-	-	C	C	A	-	-
HCM 95th %tile Q(veh)	0	-	-	4.3	0.3	0	-	-

Intersection												
Int Delay, s/veh	12.5											
Movement	EBL	EBT	EBR	WBL	WBT	WBR	NBL	NBT	NBR	SBL	SBT	SBR
Lane Configurations		↕			↕			↕			↕	
Traffic Vol, veh/h	0	0	1	6	1	0	0	0	21	213	0	2
Future Vol, veh/h	0	0	1	6	1	0	0	0	21	213	0	2
Conflicting Peds, #/hr	0	0	0	0	0	0	0	0	0	0	0	0
Sign Control	Free	Free	Free	Free	Free	Free	Stop	Stop	Stop	Stop	Stop	Stop
RT Channelized	-	-	None	-	-	None	-	-	None	-	-	None
Storage Length	-	-	-	-	-	-	-	-	-	-	-	-
Veh in Median Storage, #	-	0	-	-	0	-	-	0	-	-	0	-
Grade, %	-	0	-	-	0	-	-	0	-	-	0	-
Peak Hour Factor	33	33	33	65	65	65	48	48	48	45	45	45
Heavy Vehicles, %	0	0	0	3	3	3	0	0	0	2	2	2
Mvmt Flow	0	0	3	9	2	0	0	0	44	473	0	4

Major/Minor	Major1			Major2			Minor1			Minor2		
Conflicting Flow All	2	0	0	3	0	0	24	22	2	44	23	2
Stage 1	-	-	-	-	-	-	2	2	-	20	20	-
Stage 2	-	-	-	-	-	-	22	20	-	24	3	-
Critical Hdwy	4.1	-	-	4.13	-	-	7.1	6.5	6.2	7.12	6.52	6.22
Critical Hdwy Stg 1	-	-	-	-	-	-	6.1	5.5	-	6.12	5.52	-
Critical Hdwy Stg 2	-	-	-	-	-	-	6.1	5.5	-	6.12	5.52	-
Follow-up Hdwy	2.2	-	-	2.227	-	-	3.5	4	3.3	3.518	4.018	3.318
Pot Cap-1 Maneuver	1634	-	-	1612	-	-	993	876	1088	958	870	1082
Stage 1	-	-	-	-	-	-	1026	898	-	999	879	-
Stage 2	-	-	-	-	-	-	1002	883	-	994	893	-
Platoon blocked, %		-	-	-	-	-						
Mov Cap-1 Maneuver	1634	-	-	1612	-	-	984	871	1088	915	865	1082
Mov Cap-2 Maneuver	-	-	-	-	-	-	984	871	-	915	865	-
Stage 1	-	-	-	-	-	-	1026	898	-	999	874	-
Stage 2	-	-	-	-	-	-	992	878	-	954	893	-

Approach	EB	WB	NB	SB
HCM Control Delay, s	0	6.2	8.4	13.1
HCM LOS			A	B

Minor Lane/Major Mvmt	NBLn1	EBL	EBT	EBR	WBL	WBT	WBR	SBLn1
Capacity (veh/h)	1088	1634	-	-	1612	-	-	916
HCM Lane V/C Ratio	0.04	-	-	-	0.006	-	-	0.522
HCM Control Delay (s)	8.4	0	-	-	7.2	0	-	13.1
HCM Lane LOS	A	A	-	-	A	A	-	B
HCM 95th %tile Q(veh)	0.1	0	-	-	0	-	-	3.1

APPENDIX D. LONG-TERM FUTURE LEVEL OF SERVICE WORKSHEETS

Intersection												
Int Delay, s/veh	1.5											
Movement	EBL	EBT	EBR	WBL	WBT	WBR	NBL	NBT	NBR	SBL	SBT	SBR
Lane Configurations		↔			↔	↔	↔	↔	↔	↔	↔	↔
Traffic Vol, veh/h	3	0	21	5	0	3	0	133	10	0	313	0
Future Vol, veh/h	3	0	21	5	0	3	0	133	10	0	313	0
Conflicting Peds, #/hr	0	0	0	0	0	0	0	0	0	0	0	0
Sign Control	Stop	Stop	Stop	Stop	Stop	Stop	Free	Free	Free	Free	Free	Free
RT Channelized	-	-	None	-	-	None	-	-	None	-	-	None
Storage Length	-	-	-	-	-	0	100	-	-	100	-	125
Veh in Median Storage, #	-	0	-	-	0	-	-	0	-	-	0	-
Grade, %	-	0	-	-	0	-	-	0	-	-	0	-
Peak Hour Factor	42	42	42	36	36	36	60	60	60	72	72	72
Heavy Vehicles, %	100	100	100	0	100	0	100	0	0	0	0	100
Mvmt Flow	7	0	50	14	0	8	0	222	17	0	435	0

Major/Minor	Minor2		Minor1			Major1		Major2				
Conflicting Flow All	670	674	435	682	657	222	435	0	0	239	0	0
Stage 1	435	435	-	222	222	-	-	-	-	-	-	-
Stage 2	235	239	-	460	435	-	-	-	-	-	-	-
Critical Hdwy	8.1	7.5	7.2	7.1	7.5	6.2	5.1	-	-	4.1	-	-
Critical Hdwy Stg 1	7.1	6.5	-	6.1	6.5	-	-	-	-	-	-	-
Critical Hdwy Stg 2	7.1	6.5	-	6.1	6.5	-	-	-	-	-	-	-
Follow-up Hdwy	4.4	4.9	4.2	3.5	4.9	3.3	3.1	-	-	2.2	-	-
Pot Cap-1 Maneuver	265	276	458	367	283	823	752	-	-	1340	-	-
Stage 1	447	444	-	785	570	-	-	-	-	-	-	-
Stage 2	592	559	-	585	444	-	-	-	-	-	-	-
Platoon blocked, %								-	-	-	-	-
Mov Cap-1 Maneuver	262	276	458	327	283	823	752	-	-	1340	-	-
Mov Cap-2 Maneuver	262	276	-	327	283	-	-	-	-	-	-	-
Stage 1	447	444	-	785	570	-	-	-	-	-	-	-
Stage 2	586	559	-	521	444	-	-	-	-	-	-	-

Approach	EB		WB			NB		SB		
HCM Control Delay, s	14.9		13.8			0		0		
HCM LOS	B		B							

Minor Lane/Major Mvmt	NBL	NBT	NBR	EBLn1	WBLn1	WBLn2	SBL	SBT	SBR
Capacity (veh/h)	752	-	-	419	327	823	1340	-	-
HCM Lane V/C Ratio	-	-	-	0.136	0.042	0.01	-	-	-
HCM Control Delay (s)	0	-	-	14.9	16.5	9.4	0	-	-
HCM Lane LOS	A	-	-	B	C	A	A	-	-
HCM 95th %tile Q(veh)	0	-	-	0.5	0.1	0	0	-	-

Intersection						
Int Delay, s/veh	3.3					
Movement	EBL	EBR	NBL	NBT	SBT	SBR
Lane Configurations	↘↗		↘	↑	↑	↘
Traffic Vol, veh/h	0	0	234	146	236	96
Future Vol, veh/h	0	0	234	146	236	96
Conflicting Peds, #/hr	0	0	0	0	0	0
Sign Control	Stop	Stop	Free	Free	Free	Free
RT Channelized	-	None	-	None	-	None
Storage Length	0	-	100	-	-	-
Veh in Median Storage, #	0	-	-	0	0	-
Grade, %	0	-	-	0	0	-
Peak Hour Factor	92	92	64	64	60	60
Heavy Vehicles, %	0	0	0	8	1	0
Mvmt Flow	0	0	366	228	393	160

Major/Minor	Minor2	Major1	Major2			
Conflicting Flow All	1353	393	553	0	-	0
Stage 1	393	-	-	-	-	-
Stage 2	960	-	-	-	-	-
Critical Hdwy	6.4	6.2	4.1	-	-	-
Critical Hdwy Stg 1	5.4	-	-	-	-	-
Critical Hdwy Stg 2	5.4	-	-	-	-	-
Follow-up Hdwy	3.5	3.3	2.2	-	-	-
Pot Cap-1 Maneuver	167	660	1027	-	-	-
Stage 1	686	-	-	-	-	-
Stage 2	375	-	-	-	-	-
Platoon blocked, %				-	-	-
Mov Cap-1 Maneuver	108	660	1027	-	-	-
Mov Cap-2 Maneuver	234	-	-	-	-	-
Stage 1	442	-	-	-	-	-
Stage 2	375	-	-	-	-	-

Approach	EB	NB	SB
HCM Control Delay, s	0	6.4	0
HCM LOS	A		

Minor Lane/Major Mvmt	NBL	NBT	EBLn1	SBT	SBR
Capacity (veh/h)	1027	-	-	-	-
HCM Lane V/C Ratio	0.356	-	-	-	-
HCM Control Delay (s)	10.4	-	0	-	-
HCM Lane LOS	B	-	A	-	-
HCM 95th %tile Q(veh)	1.6	-	-	-	-

HCM 6th TWSC
3: Woodmoor Drive & Willow Park Way

2045 Conditions
AM Peak

Intersection												
Int Delay, s/veh	75.7											
Movement	EBL	EBT	EBR	WBL	WBT	WBR	NBL	NBT	NBR	SBL	SBT	SBR
Lane Configurations		↕			↕		↕	↕		↕	↕	
Traffic Vol, veh/h	26	0	301	3	0	6	0	373	1	3	224	3
Future Vol, veh/h	26	0	301	3	0	6	0	373	1	3	224	3
Conflicting Peds, #/hr	0	0	0	0	0	0	0	0	0	0	0	0
Sign Control	Stop	Stop	Stop	Stop	Stop	Stop	Free	Free	Free	Free	Free	Free
RT Channelized	-	-	None	-	-	None	-	-	None	-	-	None
Storage Length	-	-	-	-	-	-	100	-	-	100	-	-
Veh in Median Storage, #	-	0	-	-	0	-	-	0	-	-	0	-
Grade, %	-	0	-	-	0	-	-	0	-	-	0	-
Peak Hour Factor	47	47	47	75	75	75	50	50	50	57	57	57
Heavy Vehicles, %	2	2	2	0	0	0	6	6	6	0	0	0
Mvmt Flow	55	0	640	4	0	8	0	746	2	5	393	5

Major/Minor	Minor2		Minor1		Major1			Major2				
Conflicting Flow All	1157	1154	396	1473	1155	747	398	0	0	748	0	0
Stage 1	406	406	-	747	747	-	-	-	-	-	-	-
Stage 2	751	748	-	726	408	-	-	-	-	-	-	-
Critical Hdwy	7.12	6.52	6.22	7.1	6.5	6.2	4.16	-	-	4.1	-	-
Critical Hdwy Stg 1	6.12	5.52	-	6.1	5.5	-	-	-	-	-	-	-
Critical Hdwy Stg 2	6.12	5.52	-	6.1	5.5	-	-	-	-	-	-	-
Follow-up Hdwy	3.518	4.018	3.318	3.5	4	3.3	2.254	-	-	2.2	-	-
Pot Cap-1 Maneuver	173	197	653	106	199	416	1139	-	-	870	-	-
Stage 1	622	598	-	408	423	-	-	-	-	-	-	-
Stage 2	403	420	-	419	600	-	-	-	-	-	-	-
Platoon blocked, %								-	-	-	-	-
Mov Cap-1 Maneuver	169	196	653	~2	198	416	1139	-	-	870	-	-
Mov Cap-2 Maneuver	169	196	-	~2	198	-	-	-	-	-	-	-
Stage 1	622	594	-	408	423	-	-	-	-	-	-	-
Stage 2	395	420	-	8	596	-	-	-	-	-	-	-

Approach	EB	WB	NB	SB
HCM Control Delay, s	174.7	\$ 1598.5	0	0.1
HCM LOS	F	F		

Minor Lane/Major Mvmt	NBL	NBT	NBR	EBLn1	WBLn1	SBL	SBT	SBR
Capacity (veh/h)	1139	-	-	532	6	870	-	-
HCM Lane V/C Ratio	-	-	-	1.308	2	0.006	-	-
HCM Control Delay (s)	0	-	-	174.	\$ 1598.5	9.2	-	-
HCM Lane LOS	A	-	-	F	F	A	-	-
HCM 95th %tile Q(veh)	0	-	-	29.4	2.5	0	-	-

Notes
~: Volume exceeds capacity \$: Delay exceeds 300s +: Computation Not Defined *: All major volume in platoon

Intersection												
Int Delay, s/veh	14.4											
Movement	EBL	EBT	EBR	WBL	WBT	WBR	NBL	NBT	NBR	SBL	SBT	SBR
Lane Configurations		↕			↕			↕			↕	
Traffic Vol, veh/h	0	0	0	1	1	0	0	0	0	326	0	0
Future Vol, veh/h	0	0	0	1	1	0	0	0	0	326	0	0
Conflicting Peds, #/hr	0	0	0	0	0	0	0	0	0	0	0	0
Sign Control	Free	Free	Free	Free	Free	Free	Stop	Stop	Stop	Stop	Stop	Stop
RT Channelized	-	-	None	-	-	None	-	-	None	-	-	None
Storage Length	-	-	-	-	-	-	-	-	-	-	-	-
Veh in Median Storage, #	-	0	-	-	0	-	-	0	-	-	0	-
Grade, %	-	0	-	-	0	-	-	0	-	-	0	-
Peak Hour Factor	48	48	48	44	44	44	92	92	92	51	51	51
Heavy Vehicles, %	1	1	1	1	1	1	2	2	2	2	2	2
Mvmt Flow	0	0	0	2	2	0	0	0	0	639	0	0

Major/Minor	Major1		Major2		Minor1		Minor2					
Conflicting Flow All	2	0	0	2	0	0	8	8	2	8	8	2
Stage 1	-	-	-	-	-	-	2	2	-	6	6	-
Stage 2	-	-	-	-	-	-	6	6	-	2	2	-
Critical Hdwy	4.11	-	-	4.11	-	-	7.12	6.52	6.22	7.12	6.52	6.22
Critical Hdwy Stg 1	-	-	-	-	-	-	6.12	5.52	-	6.12	5.52	-
Critical Hdwy Stg 2	-	-	-	-	-	-	6.12	5.52	-	6.12	5.52	-
Follow-up Hdwy	2.209	-	-	2.209	-	-	3.518	4.018	3.318	3.518	4.018	3.318
Pot Cap-1 Maneuver	1627	-	-	1627	-	-	1011	887	1082	1011	887	1082
Stage 1	-	-	-	-	-	-	1021	894	-	1016	891	-
Stage 2	-	-	-	-	-	-	1016	891	-	1021	894	-
Platoon blocked, %		-	-		-	-						
Mov Cap-1 Maneuver	1627	-	-	1627	-	-	1010	886	1082	1010	886	1082
Mov Cap-2 Maneuver	-	-	-	-	-	-	1010	886	-	1010	886	-
Stage 1	-	-	-	-	-	-	1021	894	-	1016	890	-
Stage 2	-	-	-	-	-	-	1015	890	-	1021	894	-

Approach	EB	WB	NB	SB
HCM Control Delay, s	0	3.6	0	14.5
HCM LOS			A	B

Minor Lane/Major Mvmt	NBLn1	EBL	EBT	EBR	WBL	WBT	WBR	SBLn1
Capacity (veh/h)	-	1627	-	-	1627	-	-	1010
HCM Lane V/C Ratio	-	-	-	-	0.001	-	-	0.633
HCM Control Delay (s)	0	0	-	-	7.2	0	-	14.5
HCM Lane LOS	A	A	-	-	A	A	-	B
HCM 95th %tile Q(veh)	-	0	-	-	0	-	-	4.7

Intersection												
Int Delay, s/veh	1.5											
Movement	EBL	EBT	EBR	WBL	WBT	WBR	NBL	NBT	NBR	SBL	SBT	SBR
Lane Configurations		↕↔			↕↔	↕↔	↕↔	↕	↕	↕	↕	↕
Traffic Vol, veh/h	1	0	23	5	0	4	0	212	8	2	194	0
Future Vol, veh/h	1	0	23	5	0	4	0	212	8	2	194	0
Conflicting Peds, #/hr	0	0	0	0	0	0	0	0	0	0	0	0
Sign Control	Stop	Stop	Stop	Stop	Stop	Stop	Free	Free	Free	Free	Free	Free
RT Channelized	-	-	None	-	-	None	-	-	None	-	-	None
Storage Length	-	-	-	-	-	0	100	-	-	100	-	125
Veh in Median Storage, #	-	0	-	-	0	-	-	0	-	-	0	-
Grade, %	-	0	-	-	0	-	-	0	-	-	0	-
Peak Hour Factor	43	43	43	46	46	46	81	81	81	65	65	65
Heavy Vehicles, %	100	100	100	0	100	0	100	3	3	0	0	100
Mvmt Flow	2	0	53	11	0	9	0	262	10	3	298	0

Major/Minor	Minor2		Minor1		Major1			Major2				
Conflicting Flow All	576	576	298	593	566	262	298	0	0	272	0	0
Stage 1	304	304	-	262	262	-	-	-	-	-	-	-
Stage 2	272	272	-	331	304	-	-	-	-	-	-	-
Critical Hdwy	8.1	7.5	7.2	7.1	7.5	6.2	5.1	-	-	4.1	-	-
Critical Hdwy Stg 1	7.1	6.5	-	6.1	6.5	-	-	-	-	-	-	-
Critical Hdwy Stg 2	7.1	6.5	-	6.1	6.5	-	-	-	-	-	-	-
Follow-up Hdwy	4.4	4.9	4.2	3.5	4.9	3.3	3.1	-	-	2.2	-	-
Pot Cap-1 Maneuver	312	319	559	420	324	782	863	-	-	1303	-	-
Stage 1	538	518	-	747	544	-	-	-	-	-	-	-
Stage 2	562	538	-	687	518	-	-	-	-	-	-	-
Platoon blocked, %								-	-	-	-	-
Mov Cap-1 Maneuver	308	318	559	379	323	782	863	-	-	1303	-	-
Mov Cap-2 Maneuver	308	318	-	379	323	-	-	-	-	-	-	-
Stage 1	538	517	-	747	544	-	-	-	-	-	-	-
Stage 2	556	538	-	620	517	-	-	-	-	-	-	-

Approach	EB	WB	NB	SB
HCM Control Delay, s	12.4	12.5	0	0.1
HCM LOS	B	B		

Minor Lane/Major Mvmt	NBL	NBT	NBR	EBLn1	WBLn1	WBLn2	SBL	SBT	SBR
Capacity (veh/h)	863	-	-	541	379	782	1303	-	-
HCM Lane V/C Ratio	-	-	-	0.103	0.029	0.011	0.002	-	-
HCM Control Delay (s)	0	-	-	12.4	14.8	9.7	7.8	-	-
HCM Lane LOS	A	-	-	B	B	A	A	-	-
HCM 95th %tile Q(veh)	0	-	-	0.3	0.1	0	0	-	-

Intersection						
Int Delay, s/veh	2.2					
Movement	EBL	EBR	NBL	NBT	SBT	SBR
Lane Configurations	↘↗		↘	↑	↑	↘
Traffic Vol, veh/h	4	11	136	212	197	33
Future Vol, veh/h	4	11	136	212	197	33
Conflicting Peds, #/hr	0	0	0	0	0	0
Sign Control	Stop	Stop	Free	Free	Free	Free
RT Channelized	-	None	-	None	-	None
Storage Length	0	-	100	-	-	-
Veh in Median Storage, #	0	-	-	0	0	-
Grade, %	0	-	-	0	0	-
Peak Hour Factor	47	47	83	83	69	69
Heavy Vehicles, %	0	0	0	2	0	0
Mvmt Flow	9	23	164	255	286	48

Major/Minor	Minor2	Major1	Major2			
Conflicting Flow All	869	286	334	0	-	0
Stage 1	286	-	-	-	-	-
Stage 2	583	-	-	-	-	-
Critical Hdwy	6.4	6.2	4.1	-	-	-
Critical Hdwy Stg 1	5.4	-	-	-	-	-
Critical Hdwy Stg 2	5.4	-	-	-	-	-
Follow-up Hdwy	3.5	3.3	2.2	-	-	-
Pot Cap-1 Maneuver	325	758	1237	-	-	-
Stage 1	767	-	-	-	-	-
Stage 2	562	-	-	-	-	-
Platoon blocked, %				-	-	-
Mov Cap-1 Maneuver	282	758	1237	-	-	-
Mov Cap-2 Maneuver	405	-	-	-	-	-
Stage 1	665	-	-	-	-	-
Stage 2	562	-	-	-	-	-

Approach	EB	NB	SB
HCM Control Delay, s	11.2	3.3	0
HCM LOS	B		

Minor Lane/Major Mvmt	NBL	NBT	EBLn1	SBT	SBR
Capacity (veh/h)	1237	-	615	-	-
HCM Lane V/C Ratio	0.132	-	0.052	-	-
HCM Control Delay (s)	8.4	-	11.2	-	-
HCM Lane LOS	A	-	B	-	-
HCM 95th %tile Q(veh)	0.5	-	0.2	-	-

HCM 6th TWSC
3: Woodmoor Drive & Willow Park Way

2045 Conditions
PM Peak

Intersection												
Int Delay, s/veh	7.7											
Movement	EBL	EBT	EBR	WBL	WBT	WBR	NBL	NBT	NBR	SBL	SBT	SBR
Lane Configurations		↕			↕		↕	↕		↕	↕	
Traffic Vol, veh/h	23	0	220	3	0	4	0	355	7	3	192	6
Future Vol, veh/h	23	0	220	3	0	4	0	355	7	3	192	6
Conflicting Peds, #/hr	0	0	0	0	0	0	0	0	0	0	0	0
Sign Control	Stop	Stop	Stop	Stop	Stop	Stop	Free	Free	Free	Free	Free	Free
RT Channelized	-	-	None	-	-	None	-	-	None	-	-	None
Storage Length	-	-	-	-	-	-	100	-	-	100	-	-
Veh in Median Storage, #	-	0	-	-	0	-	-	0	-	-	0	-
Grade, %	-	0	-	-	0	-	-	0	-	-	0	-
Peak Hour Factor	55	55	55	35	35	35	78	78	78	69	69	69
Heavy Vehicles, %	2	2	2	0	0	0	9	9	9	0	0	0
Mvmt Flow	42	0	400	9	0	11	0	455	9	4	278	9

Major/Minor	Minor2		Minor1		Major1			Major2				
Conflicting Flow All	756	755	283	951	755	460	287	0	0	464	0	0
Stage 1	291	291	-	460	460	-	-	-	-	-	-	-
Stage 2	465	464	-	491	295	-	-	-	-	-	-	-
Critical Hdwy	7.12	6.52	6.22	7.1	6.5	6.2	4.19	-	-	4.1	-	-
Critical Hdwy Stg 1	6.12	5.52	-	6.1	5.5	-	-	-	-	-	-	-
Critical Hdwy Stg 2	6.12	5.52	-	6.1	5.5	-	-	-	-	-	-	-
Follow-up Hdwy	3.518	4.018	3.318	3.5	4	3.3	2.281	-	-	2.2	-	-
Pot Cap-1 Maneuver	325	338	756	242	340	605	1236	-	-	1108	-	-
Stage 1	717	672	-	585	569	-	-	-	-	-	-	-
Stage 2	578	564	-	563	673	-	-	-	-	-	-	-
Platoon blocked, %								-	-	-	-	-
Mov Cap-1 Maneuver	318	337	756	114	339	605	1236	-	-	1108	-	-
Mov Cap-2 Maneuver	318	337	-	114	339	-	-	-	-	-	-	-
Stage 1	717	669	-	585	569	-	-	-	-	-	-	-
Stage 2	567	564	-	264	670	-	-	-	-	-	-	-

Approach	EB		WB		NB		SB	
HCM Control Delay, s	20.2		23.6		0		0.1	
HCM LOS	C		C					

Minor Lane/Major Mvmt	NBL	NBT	NBR	EBLn1	WBLn1	SBL	SBT	SBR
Capacity (veh/h)	1236	-	-	669	213	1108	-	-
HCM Lane V/C Ratio	-	-	-	0.66	0.094	0.004	-	-
HCM Control Delay (s)	0	-	-	20.2	23.6	8.3	-	-
HCM Lane LOS	A	-	-	C	C	A	-	-
HCM 95th %tile Q(veh)	0	-	-	5	0.3	0	-	-

Intersection												
Int Delay, s/veh	12.5											
Movement	EBL	EBT	EBR	WBL	WBT	WBR	NBL	NBT	NBR	SBL	SBT	SBR
Lane Configurations		↕			↕			↕			↕	
Traffic Vol, veh/h	0	0	1	6	1	0	0	0	21	213	0	2
Future Vol, veh/h	0	0	1	6	1	0	0	0	21	213	0	2
Conflicting Peds, #/hr	0	0	0	0	0	0	0	0	0	0	0	0
Sign Control	Free	Free	Free	Free	Free	Free	Stop	Stop	Stop	Stop	Stop	Stop
RT Channelized	-	-	None	-	-	None	-	-	None	-	-	None
Storage Length	-	-	-	-	-	-	-	-	-	-	-	-
Veh in Median Storage, #	-	0	-	-	0	-	-	0	-	-	0	-
Grade, %	-	0	-	-	0	-	-	0	-	-	0	-
Peak Hour Factor	33	33	33	65	65	65	48	48	48	45	45	45
Heavy Vehicles, %	0	0	0	3	3	3	0	0	0	2	2	2
Mvmt Flow	0	0	3	9	2	0	0	0	44	473	0	4

Major/Minor	Major1			Major2			Minor1			Minor2		
Conflicting Flow All	2	0	0	3	0	0	24	22	2	44	23	2
Stage 1	-	-	-	-	-	-	2	2	-	20	20	-
Stage 2	-	-	-	-	-	-	22	20	-	24	3	-
Critical Hdwy	4.1	-	-	4.13	-	-	7.1	6.5	6.2	7.12	6.52	6.22
Critical Hdwy Stg 1	-	-	-	-	-	-	6.1	5.5	-	6.12	5.52	-
Critical Hdwy Stg 2	-	-	-	-	-	-	6.1	5.5	-	6.12	5.52	-
Follow-up Hdwy	2.2	-	-	2.227	-	-	3.5	4	3.3	3.518	4.018	3.318
Pot Cap-1 Maneuver	1634	-	-	1612	-	-	993	876	1088	958	870	1082
Stage 1	-	-	-	-	-	-	1026	898	-	999	879	-
Stage 2	-	-	-	-	-	-	1002	883	-	994	893	-
Platoon blocked, %		-	-		-	-						
Mov Cap-1 Maneuver	1634	-	-	1612	-	-	984	871	1088	915	865	1082
Mov Cap-2 Maneuver	-	-	-	-	-	-	984	871	-	915	865	-
Stage 1	-	-	-	-	-	-	1026	898	-	999	874	-
Stage 2	-	-	-	-	-	-	992	878	-	954	893	-

Approach	EB	WB	NB	SB
HCM Control Delay, s	0	6.2	8.4	13.1
HCM LOS			A	B

Minor Lane/Major Mvmt	NBLn1	EBL	EBT	EBR	WBL	WBT	WBR	SBLn1
Capacity (veh/h)	1088	1634	-	-	1612	-	-	916
HCM Lane V/C Ratio	0.04	-	-	-	0.006	-	-	0.522
HCM Control Delay (s)	8.4	0	-	-	7.2	0	-	13.1
HCM Lane LOS	A	A	-	-	A	A	-	B
HCM 95th %tile Q(veh)	0.1	0	-	-	0	-	-	3.1