

---

# GLENEAGLE GOLF COURSE RESIDENTIAL INFILL DEVELOPMENT FILING NO. 2

## GRADING, EROSION CONTROL AND STORMWATER QUALITY REPORT

---

PREPARED BY

Mike Bartusek

RESPEC

3520 Austin Bluffs Parkway, Suite 102  
Colorado Springs, CO 80918

PREPARED FOR

G & S Development, Inc.  
9800 Pyramid Court  
Suite340  
Englewood, CO 80112

FEBRUARY 2019

Project Number 03524



# Table of Contents

TABLE OF CONTENTS	i
VICINITY MAP	ii
PROJECT DESCRIPTION	1
General Location	1
SITE DESCRIPTION	1
Soils	1
EROSION AND SEDIMENT CONTROL CRITERIA	1
Areas and Volumes	1
Erosion and Sediment Control Measures	2
Initial Stage	2
Temporary Stabilization	2
Vehicle Tracking Control	2
Silt Fence	2
Outlet Protection	2
Non-Structural Practices	2
Construction Timing	3
Permanent Stabilization	3
Stormwater Management	4
Maintenance	4
Cost	4
STORMWATER MANAGEMENT	5
Stormwater Management	5
Potential Pollution Sources	5
CONCLUSION	6
Compliance with Standards	7
REFERENCES	7
APPENDIX A	
Grading and Erosion Control Plans	
APPENDIX C	
Inspection Checklist	

# PROJECT DESCRIPTION

## General Location

The Gleneagle Golf Course Residential Infill Development Fil No 2 consists of a total of 7.62 acres, which previously comprised the Gleneagle Golf Club. The area will be developed with 12 lots located on 7.62 acres of the subdivision with 0.83 acres of ROW. The project is located in northwestern El Paso County. It is situated in Sections 6, Townships 11 South, Range 67 West of the 6<sup>th</sup> Principal Meridian, El Paso County, Colorado.

The proposed development was part of the Black Forest Drainage Basin Planning Study, prepared by Wilson and Company in May 1989. The study used storm intervals of ten and 100 years. Our study follows the current City/County Drainage Criteria Manual and uses the five- and 100-year storms. The existing outfalls from the site consisting of swales to ditches which transport flows to Struthers Road and eventually into Monument Creek.

# SITE DESCRIPTION

## Existing Site Conditions

The existing site is undeveloped and is located on the original golf course and is totally covered with rangeland grasses.

## Soils

The Soil Conservation Service (NRCS) soil survey for El Paso County has identified three soil types in this study area. They are as follows:

Map Symbol No.	Soil Name	Hydrologic Soil Group
68	Peyton-Pring Complex	B
71	Pring Coarse Sandy Loam	B

# EROSION AND SEDIMENT CONTROL CRITERIA

## Areas and Volumes

The proposed site development shall require the construction of approximately 1,100 lineal feet of roadway and associated utilities. The development shall occur west of Huntington Beach Drive and north of Gleneagle Drive.

Improvements shall include the construction of a detention/water quality basin on the property to account for the areas of the disturbances. The total area of disturbance shall be about 7.6 acres. Construction activities shall consist of clearing, grubbing and grading for the new lot developments. Approximately 2,000 cubic yards of cut and fill shall be moved. Disturbed and exposed areas of the site shall be seeded and mulched if construction activities cease for more than 30 consecutive days. The site shall also require the sedimentation basins listed below to handle the potential erosion.

## Erosion and Sediment Control Measures

Erosion control and sediment prevention measures describe a wide range of management procedures, schedules of activities, prohibitions on practices, and other best management practices (BMP). BMPs also include operating procedures, treatment requirements and practices to control site runoff, drainage from materials storage, spills or leaks. Structural practices for this

site include silt fences, straw bales, inlet protection, and vehicular tracking control. Erosion matting may be required on unstable slopes, if directed by the engineer. General descriptions of the BMPs to be used during the construction of this project are listed below. See the Erosion Control Plans for the specific type and location of each erosion and sediment control device required for this project.

### **Initial Stage**

These BMPs shall be installed at the outset of construction, prior to the initial pre-construction meeting and any other land-disturbing activities. Initial controls are to be placed on existing grades but shall be based in part on proposed grading operations. The initial stage includes clearing, grubbing, overlot grading, and utility and other construction prior to paving operations.

### **Temporary Stabilization**

Disturbed areas will be temporarily stabilized as soon as construction activities are completed. Seeding will be applied to completed areas within 14 days of completion.

### **Vehicle Tracking Control**

A vehicle tracking control device will be installed at the construction entrance where the construction entrance intersects an existing paved private roadway.

### **Silt Fence**

Prior to the start of construction, silt fence will be installed along the perimeter of all disturbed areas that are within the project site. Silt fence shall be placed as indicated on the plan drawing. Sediment shall be removed when depth exceeds one-fourth the height of the silt fence. The engineer may require additional silt fence as necessary to retard sediment transport on or off the project site.

### **Outlet Protection**

Outlet protection at the water quality basin on the site will be provided to prevent erosion and scour of the water quality basin area by the concentrated flows gathered by the storm sewer system both during and after construction.

### **Non-Structural Practices**

Upon completion of the grading, temporary seeding and mulching will be applied to all disturbed areas on and adjacent to the site. All seeding, fertilizers, and mulching shall conform to *El Paso County Engineering Criteria Manual*.

### **Construction Timing**

The site will be graded to accommodate the proposed redevelopment items delineated previously. This project will be constructed in a single phase. Once construction begins, it will continue until the project is complete; therefore, construction phasing will not be necessary. The construction process will consist of grading (excavation and fill) activities, installation of utilities, paving, concrete placement, landscaping, and building construction. The general sequence for major construction activities will be as follows:

- Establish limits of disturbance
- Install vehicle tracking control (VTC)
- Install silt fence
- Clear and grub the site
- Excavation and fill placement

- Install underground utilities
- Install inlet and outlet protection BMPs
- Building construction
- Paving and curb placement
- Install permanent landscaping and irrigation
- Remove temporary sediment pond and reshape for water quality basin
- Remove BMPs

To be fully effective, erosion and sediment control measures must be installed and phased with the construction activities. The vehicular tracking control device shall be installed at the entrance prior to the mobilization of construction equipment on-site. Prior to the clearing and grubbing of the entire construction area, localized clearing shall be performed for the placement of perimeter erosion control measures. Site clearing shall commence only after the perimeter erosion control measures are in place. Erosion control devices must be in place to reduce the potential of eroded excavated material entering the storm drainage system. Protection devices shall be placed during grading activities, in the appropriate areas, as indicated on the plan drawing that is located in the Appendix.

Anticipated starting and completion date: May 1, 2019 to October 1, 2019

Expected date on which the final stabilization will be completed: October 1, 2019

### **Permanent Stabilization**

Disturbed areas shall be permanently stabilized as soon as construction activities are completed. Viable vegetative cover shall be established no later than one year from disturbance. Areas to be revegetated shall be treated with soil amendments to provide an adequate grown medium to sustain vegetation and shall match the existing 70 percent pre-disturbed vegetation cover.

The seedbed shall be well settled and firm, but friable enough that seed can be placed at the seeding depth specified. The seedbed shall be reasonably free of weeds. Soils that have been over-compacted by traffic or equipment, especially when wet, shall be tilled to break up rooting restrictive layers and then harrowed, rolled, or packed to prepare the required firm seedbed. Mulch shall be applied at a rate of two and one-half (2 ½) tons per acre and shall be spread uniformly, in a continuous blanket, after seeding is complete. Mulch shall be clean, weed and seed free, long-stemmed grass or hay, or long-stemmed straw of oats, wheat, or rye. At least 50 percent of mulch, by weight, shall be ten inches or longer. Mulch shall be spread by hand or blower-type mulch spreader. Mulching shall be started on the windward side of relatively flat areas or on the upper part of steep slope and continued uniformly until the area is covered. The mulch shall not be bunched. Immediately following spreading, the mulch shall be anchored to the soil by a v-type wheel land packer or scalloped-disk land packer designed to force mulch into the soil surface a minimum of three inches. All seeded areas shall be mulched after seeding on the same day as the seeding. The type of seed mix used for permanent vegetation shall utilize perennial grasses as delineated on the plans.

### **Stormwater Management**

All developed stormwater will be routed through the EDB facilities to provide stormwater quality as delineated on the drawings.

## Maintenance

All temporary and permanent erosion and sediment control practices shall be maintained and repaired as needed by the contractor throughout the duration of construction to assure that each BMP will function as intended. As required by the stormwater discharge permit, a weekly inspection of these items will be performed. In addition, all facilities must be inspected by the owner or the owner's representative following each heavy precipitation or snowmelt event that results in runoff, with maintenance occurring immediately after discovering a need.

Silt fence may require periodic replacement. All sediment accumulated behind the silt fence must be removed and disposed of properly when depth exceeds one-fourth the height of the silt fence. On-site construction traffic will be monitored to minimize the transport of sediment onto the proposed on-site streets, as well as onto adjacent city streets. The Owner, Site Developer, Contractor, and/or their authorized agents shall prevent loss of cut and fill material being transported to and from the site by taking appropriate measures. All mud and sediment tracked onto public streets shall be cleaned immediately. Road cleaning includes shoveling and sweeping activities.

Diversion ditches shall be kept clean and functional during construction. They shall be routinely checked on a weekly basis and cleaned if the height of sedimentation exceeds one-half its depth.

Inlet/outlet protection shall be inspected to ensure proper operation. Excess debris or sediment must be removed prior to final acceptance of the project.

The temporary sedimentation pond shall remain in place until such time as the major grading operations in the area are completed and the ground stabilized by either temporary or permanent measures. The ponds will be cleaned out periodically with depth of sediment at no time allowed to accumulate more than one-half the depth of the facility.

## Cost

An engineer's cost estimate for the anticipated erosion and sediment control items for the entire site are listed below:

Section 1 – Grading & Erosion Control BMPs	Quantity	Units	Price	Total
Earthwork*	2,000.00	CY	\$5	\$10,000.00
Permanent Seeding*	6.79	AC	\$582	\$3,951.78
Mulching*	6.79	AC	\$507	\$3,442.52
Erosion Bales	28	EA	\$21	\$588.00
Inlet Protection	1	EA	\$153	\$153.00
Vehicle Tracking Control	1	EA	\$1,625	\$1,625.00
Sedimentation Basin	1	EA	\$1,625	\$1,625.00
Temporary Seeding	5.00	AC	\$485	\$2,425.00
Temporary Much	5.00	AC	\$507	\$2,535.00
Silt Fence	4,050.00	LF	\$4	\$16,200.00
Concrete Washout Basin	1	EA	\$776	\$776.00
<b>TOTAL EROSION &amp; SEDIMENT CONTROL COST</b>				<b>\$43,321.30</b>

# STORMWATER MANAGEMENT

## Stormwater Management

Stormwater quality shall be protected and preserved throughout the life of this development. During mass grading and construction, measures such as sediment fences, straw bales, and vehicle tracking control shall be used to minimize erosion and sedimentation on site. During construction, the proposed extended detention basin shall function as a temporary sediment basin to reduce the potential for sediment leaving this development. Temporary diversion dikes shall be constructed to transport runoff that may contain sediment to the temporary sediment basin located on site until a stormwater system is installed. After various stages of the construction, when applicable, temporary or permanent erosion control stabilization shall be installed and maintained (landscaping, seeding, mulching, etc.).

## Potential Pollution Sources

Materials are sometimes used at the construction site that present a potential for contamination of stormwater runoff. These include sediment, equipment/vehicle washing, vehicle maintenance and fueling, petroleum products, paint, solvents, treated wood products, asphalt (bituminous) paving, concrete, concrete-curing compounds, metal, waste storage and disposal and other liquid chemicals such as fertilizers, herbicides, and pesticides. Practices that can be used to prevent or minimize toxic materials in runoff from a construction site are described in this section.

Areas at the construction site that are used for storage of toxic materials and petroleum products shall be designed with an enclosure, container, or dike located around the perimeter of the storage area to prevent discharge of these materials in runoff from the construction site. These barriers shall also function to contain spilled materials from contact with surface runoff. Proposed locations for storage of toxic materials have not been determined at the time of this report. Locations shall depend upon construction phasing.

Measures to prevent spills or leaks of fuel, gear oil, lubricants, antifreeze, and other fluids from construction vehicles and heavy equipment shall be considered to protect groundwater and runoff quality. All equipment maintenance shall be performed in designated areas and shall use spill control measures, such as drip pans, to contain petroleum products. Spills of construction-related materials, such as paints, solvents, or other fluids and chemicals, shall be cleaned up immediately and disposed of properly.

Trash receptacles shall be provided and kept clean as required to keep the site clean of trash. In addition, portable toilets shall be provided for all workers on the site during construction. All portable toilet facilities shall be located at least three feet from curb flow lines and paved surfaces. The facilities shall be stationed on ground and secured down to prevent tipping.

Potable water is anticipated as a non-stormwater discharge. Potable water shall be used for grading, dust control, and irrigation of erosion control and permanent landscaping. An effort shall be made to use only the amount of potable water required for these operations.

## Owner Inspection and Maintenance of Constructed BMPs

All inspection logs will include signatures on the logs and be kept on site along with other SWWP records.

1. **Minimum Inspection Schedule.** The permittee shall, at a minimum, make a thorough inspection at least once every 14 calendar days. Also, post-storm event inspections shall be conducted

within 24 hours after the end of any precipitation or snowmelt event that causes surface erosion. Provided the timing is appropriate, the post-storm inspections shall be used to fulfill the 14-day routine inspection requirement. A more frequent inspection schedule than the minimum inspections described may be necessary to ensure that BMPs continue to operate as needed to comply with the permit.

- 1.1. **Post-Storm Event Inspections at Temporarily Idle Sites.** If no construction activities will occur following a storm event, post-storm event inspections shall be conducted prior to recommencing construction activities, but no later than 72 hours following the storm event. The occurrence of any such delayed inspection must be documented in the inspection record. Routine inspections still must be conducted at least every 14 calendar days.
- 1.2. **Inspections at Completed Sites/Areas.** For sites, or portions of sites, that meet the following criteria; but final stabilization has not been achieved due to a vegetative cover that has not become established, the permittee shall make a thorough inspection of their stormwater management system at least once every month. Post-storm event inspections are not required. This reduced inspection schedule is only allowed if:
  - 1.2.1.all construction activities that will result in surface ground disturbance are completed;
  - 1.2.2.all activities required for final stabilization in accordance with the Grading and Erosion Control/Stormwater Quality Plan have been completed, with the exception of the application of seed that has not occurred due to seasonal conditions or the necessity for additional seed application to augment previous efforts; and
  - 1.2.3.the Grading and Erosion Control/Stormwater Quality Plan has been amended to indicate those areas that will be inspected in accordance with the reduced schedule allowed for in this section.
- 1.3. **Winter Conditions Inspections Exclusion.** No changes are expected for winter work.

## CONCLUSION

This SWMP Report and the Best Management Practices (BMPs) specified on the Erosion Control Plans have been designed to reduce any adverse impacts the construction of this project might have on the surrounding properties. If properly installed and maintained, the design shall protect the quality of the stormwater runoff that is released from this development.

All temporary erosion and sediment control measures shall be removed and disposed of within thirty (30) days after final site stabilization is achieved, or after temporary measures are no longer needed, whichever occurs earliest, or as authorized by the local governing jurisdiction.

Temporary erosion control measures may be removed only after streets and drives are paved, and all disturbed areas have been stabilized. Trapped sediment and disturbed soil areas resulting from the disposal of temporary measures must be returned to final plan grades and permanently stabilized to prevent additional soil erosion.

Final stabilization is reached when all soil disturbing activities at the site have been completed, and uniform vegetative cover has been established with a density of at least 70 percent of pre-



disturbance levels; or equivalent permanent, physical erosion reduction methods have been employed.

### **Compliance with Standards**

This report was prepared in accordance with the procedures and concepts outlined in the *El Paso County Engineering Criteria Manual*.

## **REFERENCES**

- *City of Colorado Springs Drainage Criteria Manual*, Volume 2, including Addendums I and II.
- *El Paso County Engineering Criteria Manual*.

## **APPENDIX A**

### Grading and Erosion Control Plans

NAME: Z:\COLORADO SPRINGS OFFICE\0342\_GLENEAGLE\CAD\SHR0342-LS-GRAD.DWG  
 PLOT DATE: MAY 22, 2019 11:20 AM, BY: CHRIS MEENS



- LEGEND:**
- PROPOSED MAJOR CONTOUR
  - PROPOSED MINOR CONTOUR
  - - - EXISTING MAJOR CONTOUR
  - - - EXISTING MINOR CONTOUR
  - - - PROPOSED SANITARY
  - - - EXISTING SANITARY
  - SF — PROPOSED SILT FENCE
  - LIMITS OF DISTURBANCE
  - CONSTRUCTION SITE BOUNDARIES
  - EXISTING WATER VALVES
  - EXISTING FIRE HYDRANT
  - EXISTING FIRE HYDRANT TO BE REMOVED
  - PROPOSED FIRE HYDRANT
  - PROPOSED WATER VALVES & REDUCERS
  - EXISTING SANITARY MANHOLE
  - EXISTING SANITARY MANHOLE TO BE REMOVED
  - PROPOSED SANITARY MANHOLE
  - CONCRETE WASHOUT
  - VEHICLE TRACKING CONTROL
  - STRAW BALE BARRIER
  - INLET PROTECTION
  - ROCK SOCKS

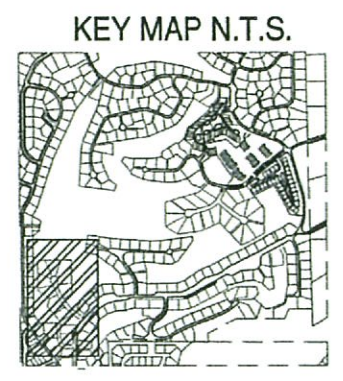

- SHEET INDEX**
- 1 - OVER ALL
  - 2 - STONE EAGLE PLACE & LOTS 1 & 12
  - 3 - GRADING & EROSION CONTROL DETAILS
  - 4 - GRADING & EROSION CONTROL DETAILS
  - 5 - GRADING & EROSION CONTROL DETAILS

**OWNER'S STATEMENT:**  
 THE OWNER WILL COMPLY WITH THE REQUIREMENTS OF THE GRADING AND EROSION CONTROL PLAN.  
*Scott Gratrix* 5/22/19  
 G & S DEVELOPMENT, INC DATE  
 MR. SCOTT GRATRUX  
 303-858-0599

**ENGINEER'S STATEMENT:**  
 These detailed plans were prepared under my direction and supervision. Said plans and specifications have been prepared in accordance to the criteria established by the County for detailed roadway, drainage, grading and erosion control plans and specifications, and said plan and specifications are in conformity with applicable master drainage plans and master transportation plans. Said plans and specifications meet the purposes for which the particular roadway and drainage facilities are designed and are correct to the best of my knowledge and belief. I accept responsibility for any liability caused by any negligent acts, errors or omissions on my part in preparing these detailed plans and specifications.  
*Michael A. Bartusek*  
 Michael A. Bartusek, P.E. #23329

**DEVELOPER'S STATEMENT:**  
 I, the Developer, have read and will comply with all of the requirements specified on this plan.  
 By: Scott Gratrix  
 Title: President  
 Address: G & S Development, Inc  
 9800 Pyramid Court, Suite 340  
 Englewood, CO 80112  
*Scott Gratrix* 5/22/19  
 Scott Gratrix Date

**ENGINEER'S STATEMENT:**  
 THIS GRADING AND EROSION CONTROL PLAN WAS PREPARED UNDER MY DIRECTION AND SUPERVISION AND IS CORRECT TO THE BEST OF MY KNOWLEDGE AND BELIEF. SAID PLAN HAS BEEN PREPARED ACCORDING TO THE CRITERIA ESTABLISHED BY THE COUNTY FOR GRADING AND EROSION CONTROL PLANS. I ACCEPT RESPONSIBILITY FOR ANY LIABILITY CAUSED BY ANY NEGLIGENT ACTS, ERRORS OR OMISSIONS ON MY PART IN PREPARING THIS PLAN.  
*Michael A. Bartusek*  
 MICHAEL BARTUSEK, COLORADO P.E. # 23329  
 RESPEC

**EL PASO COUNTY:**  
 COUNTY PLAN REVIEW IS PROVIDED ONLY FOR GENERAL CONFORMANCE WITH COUNTY DESIGN CRITERIA. THE COUNTY IS NOT RESPONSIBLE FOR THE ACCURACY AND ADEQUACY OF THE DESIGN, DIMENSIONS, AND/OR ELEVATIONS WHICH SHALL BE CONFIRMED AT THE JOB SITE. THE COUNTY THROUGH THE APPROVAL OF THIS DOCUMENT ASSUMES NO RESPONSIBILITY FOR COMPLETENESS AND/OR ACCURACY OF THIS DOCUMENT.

FILED IN ACCORDANCE WITH THE REQUIREMENTS OF THE EL PASO COUNTY LAND DEVELOPMENT CODE, DRAINAGE CRITERIA MANUAL, VOLUMES 1 AND 2, AND ENGINEERING CRITERIA MANUAL AS AMENDED.

JENIFER IRVINE P.E. DATE  
 COUNTY ENGINEER/ECM ADMINISTRATOR

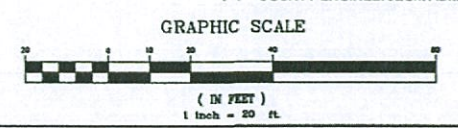

**NOTE:**  
 IF CONSTRUCTION HAS NOT STARTED WITHIN 2 YEARS OF PLANS BEING SIGNED BY THE EL PASO COUNTY ENGINEER, THE PLANS WILL NEED TO BE RESUBMITTED FOR APPROVAL UNDER CURRENT CRITERIA.  
 A MIN OF 18" DRIVEWAY CULVERTS SHALL BE DESIGNED AND PLACED BY THE CONTRACTOR FOR ALL LOTS ADJACENT TO DITCH SECTIONS AT TIME OF DEVELOPMENT

**BENCHMARK:**  
 TMS MONUMENT 100 IS N.G.S. TRIANGULATION STATION "MONUMENT" - A STANDARD TRIANGULATION STATION DISK. THE MARK IS APPROXIMATELY 0.7 MILES SOUTH ALONG INTERSTATE HIGHWAY 25 FROM THE BAPTIST ROAD OVERPASS. THE MARK IS 75.1 FEET SOUTHWEST OF A FENCE LINE AND 34.5 FEET WEST OF REFERENCE MONUMENT #1.  
 ELEVATION - 8788.48 FEET NGVD 29

THE BASIS OF BEARINGS FOR THIS PROJECT IS THE WEST LINE OF THE NORTHWEST QUARTER OF THE NORTHWEST QUARTER OF SECTION 9, T12S, R66W N00°15'58"W - 1324.20 FEET. THE BEARING IS A GRID BEARING OF THE COLORADO STATE PLANE CENTRAL ZONE NAD 83. THE LINE IS MONUMENTED BY 1934 GLO BRASS CAP ON THE NORTH END AND A 2" DIAMETER ALUMINUM CAP PLS 4842 ON THE SOUTH END.

DESIGNED: MAB	REVISION
DRAWN: JUG	
CHECKED: MAB	
DATE: 2/19/2019	
RESPEC 720 S COLORADO BLVD SUITE 410S DENVER, CO 80246 PHONE (303) 757-3655	
STAMP	
Know what's below. Call before you dig. PROJ NO. 03524 DWG NO. 03524-Dev-FR2	
GUMAN & ASSOCIATES, LLC 731 N. WEBER ST., SUITE 10 COLORADO SPRINGS, CO 80903	
GLENEAGLE SUBDIVISION FILE #2	
DRAINAGE, GRADING & EROSION CONTROL PLAN	
DRAWING NUMBER: C	
VR-18-018	SHEET 1

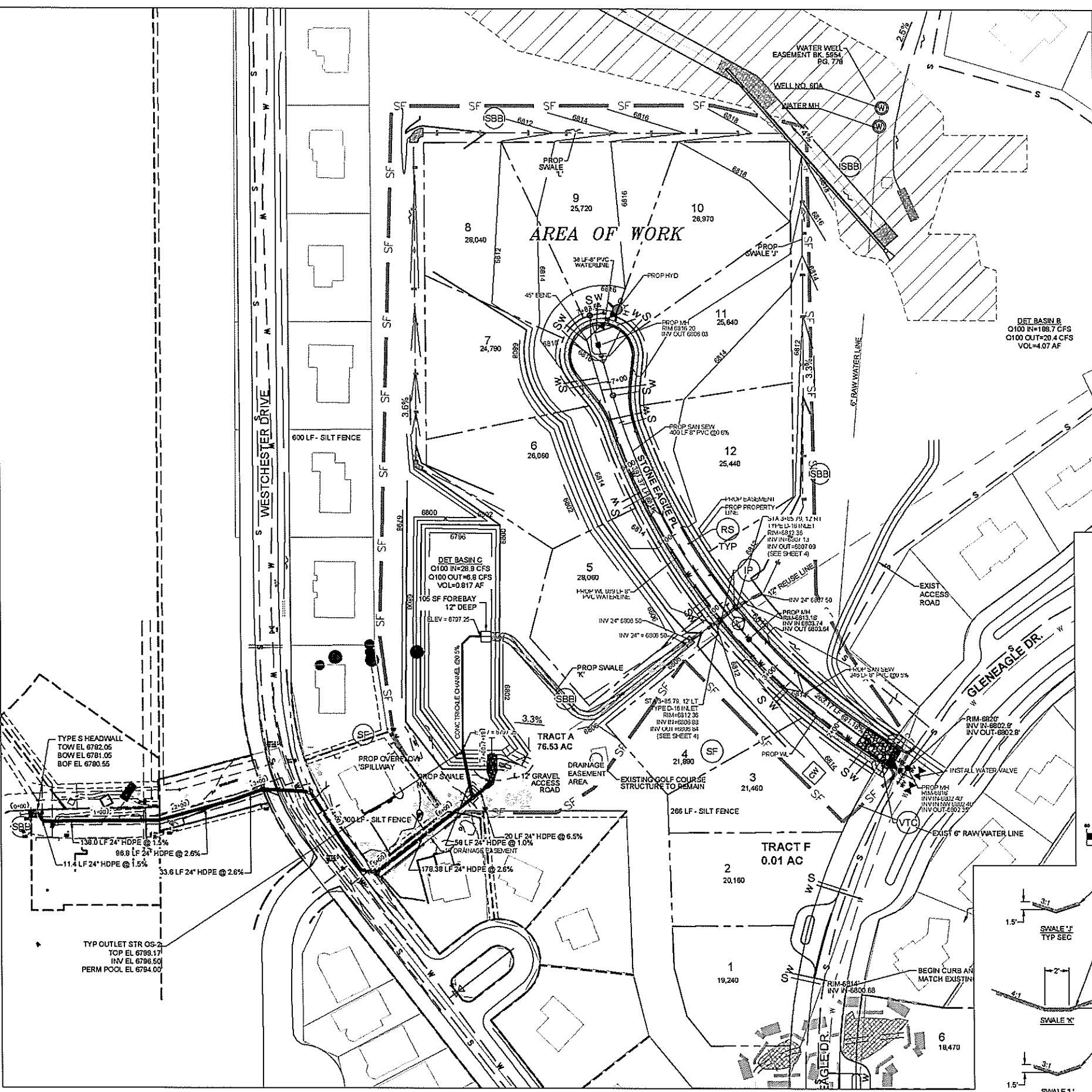

**KEY MAP N.T.S.**

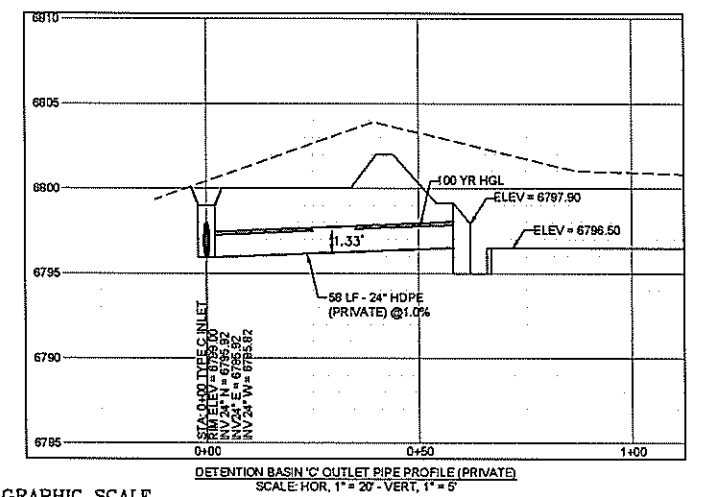
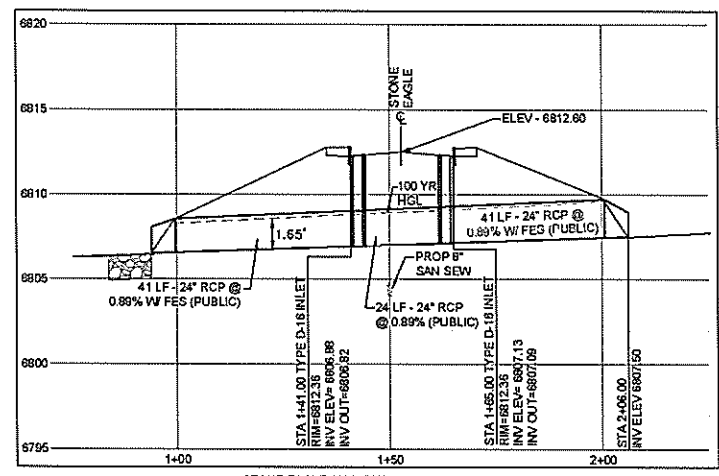
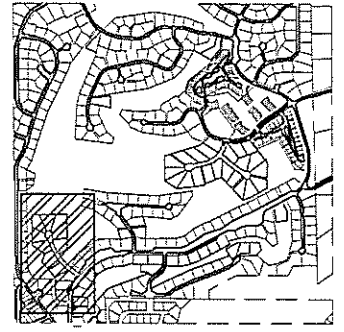

**GRAPHIC SCALE**

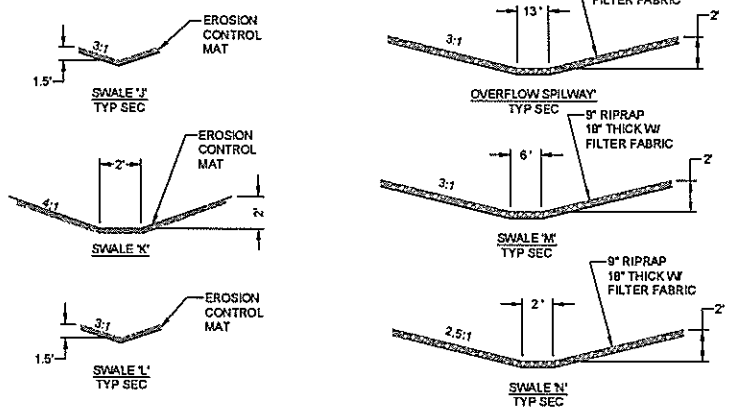
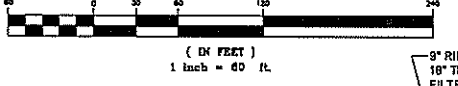

DESIGNED	MAR	HIG	REVISION
DRAWN			
CHECKED			
DATE			

RESPEC	730 S. COLORADO BLVD	
DRAWN	SUITE 4105	
CHECKED	DENVER, CO 80246	
DATE	PHONE (303) 757-3655	

**811**  
Know what's below. Call before you dig.  
PROJ. NO. 03524  
DWG. NM. 03524-Dev-Flt2

**GUMAN & ASSOCIATES, LLC**  
731 N. WEBER ST., SUITE 10  
COLORADO SPRINGS, CO 80903

**GLENEAGLE SUBDIVISION FIL #2**

**DRAINAGE, GRADING & EROSION CONTROL PLAN**

DRAWING NUMBER:  
**C**

VR-18-018 **SHEET 2**

NAME: 210 COLORADO SPRINGS OFFICE 6/23/24 GLENEAGLE CULVERT SHEET 2 OF 2 - S-CRAB D143  
PLOT DATE: MAY 22, 2019 10:54 AM BY: CHRIS MEEKS

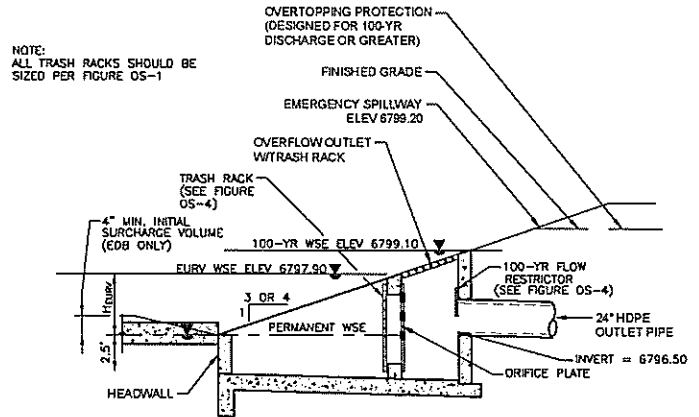
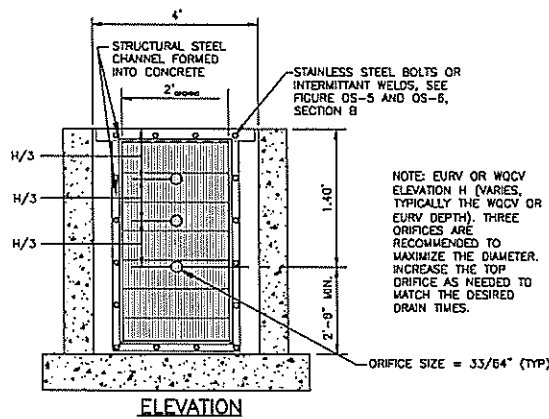
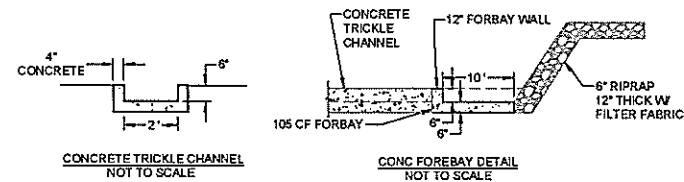

FIGURE OS-2 TYPICAL OUTLET STRUCTURE FOR FULL SPECTRUM DETENTION

OUTLET STRUCTURES DETAILS  
NOT TO SCALE



ORIFICE PLATE NOTES:

1. PROVIDE CONTINUOUS NEOPRENE GASKET MATERIAL BETWEEN THE ORIFICE PLATE AND CONCRETE.
2. BOLT PLATE TO CONCRETE 12" MAX. ON CENTER. SEE TABLE OS-2 FOR PLATE THICKNESS.

EURY AND WQCV TRASH RACKS:

1. WELL-SCREEN TRASH RACKS SHALL BE STAINLESS STEEL AND SHALL BE ATTACHED BY INTERMITTENT WELDS ALONG THE EDGE OF THE MOUNTING FRAME.
2. BAR GATE TRASH RACKS SHALL BE ALUMINUM AND SHALL BE BOLTED USING STAINLESS STEEL HARDWARE.
3. TRASH RACK OPEN AREAS ARE FOR SPECIFIED TRASH RACK MATERIALS. TOTAL TRASH RACK SIZE MAY NEED TO BE ADJUSTED FOR MATERIALS HAVING DIFFERENT OPEN AREA/GROSS AREA RATIO (R VALUE).
4. STRUCTURAL DESIGN OF TRASH RACKS SHALL BE BASED ON FULL HYDROSTATIC HEAD WITH ZERO HEAD DOWNSTREAM OF THE RACK.

OVERFLOW SAFETY GRATES:

1. ALL SAFETY GRATES SHALL BE MOUNTED USING STAINLESS STEEL HARDWARE AND PROVIDED WITH HINGED AND LOCKABLE OR BOLTABLE ACCESS PANELS.
2. SAFETY GRATES SHALL BE STAINLESS STEEL, ALUMINUM, OR STEEL. STEEL GRATES SHALL BE HOT DIP GALVANIZED AND MAY BE HOT POWDER COATED AFTER GALVANIZING.
3. SAFETY GRATES SHALL BE DESIGNED SUCH THAT THE DIAGONAL DIMENSION OF EACH OPENING IS SMALLER THAN THE DIAMETER OF THE OUTLET PIPE.
4. STRUCTURAL DESIGN OF SAFETY GRATES SHALL BE BASED ON FULL HYDROSTATIC HEAD WITH ZERO HEAD DOWNSTREAM OF THE RACK.

FIGURE OS-4 ORIFICE PLATE AND TRASH RACK DETAILS AND NOTES

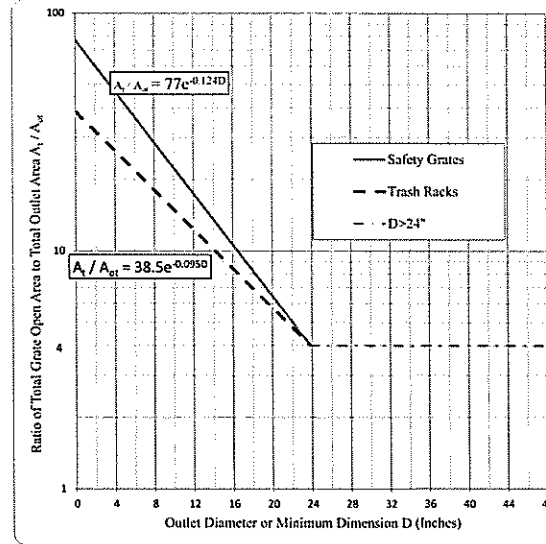
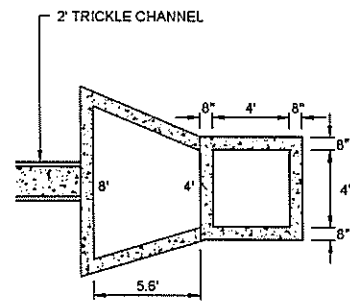

Figure OS-1. Trash Rack Sizing

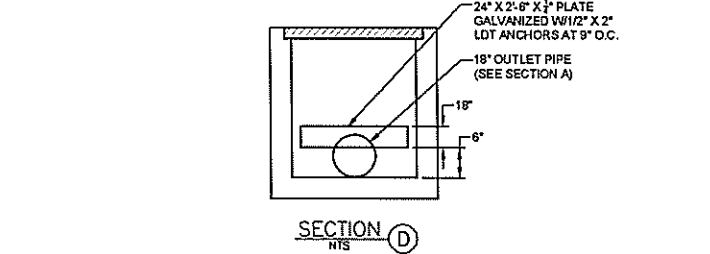
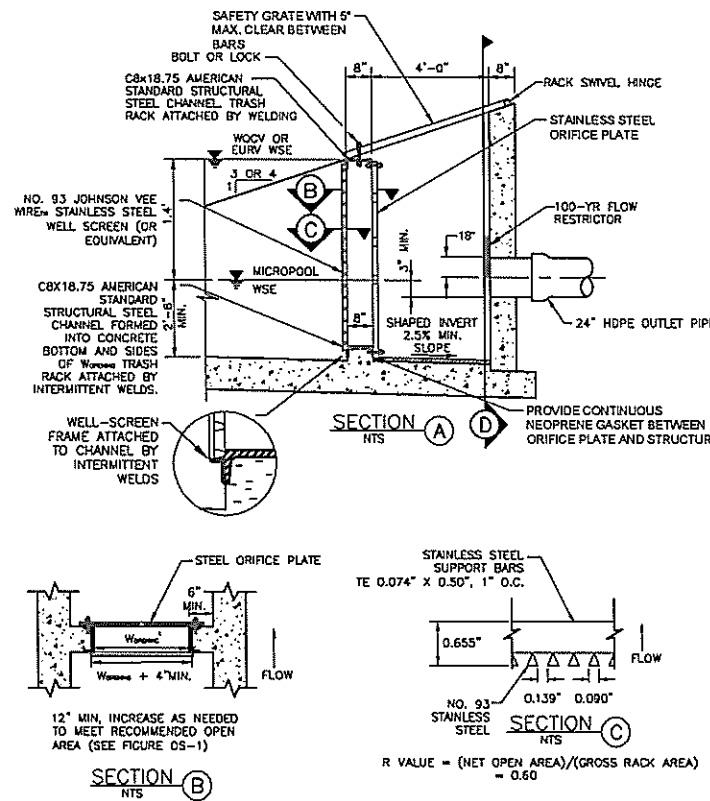

FIGURE OS-5 TYPICAL OUTLET STRUCTURE WITH WELL SCREEN TRASH RACK

1. ALL CONSTRUCTION AND MATERIALS SHALL BE IN ACCORDANCE WITH THE EL PASO COUNTY ENGINEERING SPECIFICATIONS.
  2. THE CONTRACTOR SHALL NOTIFY COLORADO STATE UTILITIES CENTRAL LOCATING (1-800-922-1987) AT LEAST 48 HOURS PRIOR TO ANY EXCAVATION SO THAT THEY MAY LOCATE THEIR FACILITIES. THE LOCATION OF FACILITIES SHOWN ON THE DRAWINGS IS FROM AVAILABLE RECORDS AND IS APPROXIMATE.
  3. ALL EXISTING UTILITY LOCATIONS SHOWN ON THE DRAWINGS REFLECT THE AVAILABLE INFORMATION AND DO NOT NECESSARILY INDICATE THE ACTUAL LOCATIONS. PRIOR TO ANY CONSTRUCTION THE CONTRACTOR SHALL VERIFY THE HORIZONTAL AND VERTICAL LOCATIONS OF ALL UTILITIES THAT MAY CONFLICT WITH OR OBSTRUCT THE NEW CONSTRUCTION. ANY REQUIRED RELOCATIONS THAT ARE NOT SPECIFICALLY SHOWN ON THE DRAWINGS SHALL BE COORDINATED WITH AND HAVE PRIOR APPROVAL OF EL PASO COUNTY UTILITIES.
  4. ALL DIMENSIONS ARE TO FACE OF CURB, EDGE OF ASPHALT & FLOWLINE OF PAV.
  5. ALL ELEVATIONS ARE TO TOP/ASPHALT & FLOWLINE/CURB UNLESS OTHERWISE NOTED.
- ALL STORM SEWER PIPE AND SANITARY SEWER PIPE LENGTHS AND SLOPES ARE SHOWN FROM CENTER OF STRUCTURE TO CENTER OF STRUCTURE

STANDARD NOTES FOR EL PASO COUNTY GRADING AND EROSION CONTROL PLANS

1. CONSTRUCTION MAY NOT COMMENCE UNTIL A CONSTRUCTION PERMIT IS OBTAINED FROM DEVELOPMENT SERVICES AND A PRE-CONSTRUCTION CONFERENCE IS HELD WITH PLANNING AND COMMUNITY DEVELOPMENT.
2. STORM-WATER DISCHARGES FROM CONSTRUCTION SITES SHALL NOT CAUSE OR THREATEN TO CAUSE POLLUTION, CONTAMINATION, OR DEGRADATION OF STATE WATERS. ALL WORK AND EARTH DISTURBANCE SHALL BE DONE IN A MANNER THAT MINIMIZES POLLUTION OF ANY ON-SITE OR OFF-SITE WATERS, INCLUDING WETLANDS.
3. NOTWITHSTANDING ANYTHING DEPICTED IN THESE PLANS IN WORDS OR GRAPHIC REPRESENTATION, ALL DESIGN AND CONSTRUCTION RELATED TO ROADS, STORM DRAINAGE AND EROSION CONTROL SHALL CONFORM TO THE STANDARDS AND REQUIREMENTS OF THE MOST RECENT VERSION OF THE RELEVANT ADOPTED EL PASO COUNTY STANDARDS, INCLUDING THE LAND DEVELOPMENT CODE, THE ENGINEERING CRITERIA MANUAL, THE DRAINAGE CRITERIA MANUAL, AND THE DRAINAGE CRITERIA MANUAL VOLUME 2. ANY DEVIATIONS TO REGULATIONS AND STANDARDS MUST BE REQUESTED, AND APPROVED, IN WRITING.
4. A SEPARATE STORM-WATER MANAGEMENT PLAN (SWMP) FOR THIS PROJECT SHALL BE COMPLETED AND AN EROSION AND STORM-WATER QUALITY CONTROL PERMIT (ESQCP) ISSUED PRIOR TO COMMENCING CONSTRUCTION. DURING CONSTRUCTION THE SWMP IS THE RESPONSIBILITY OF THE DESIGNATED STORM-WATER MANAGER. SHALL BE LOCATED ON SITE AT ALL TIMES AND SHALL BE KEPT UP TO DATE WITH WORK PROGRESS AND CHANGES IN THE FIELD. ONCE THE ESQCP HAS BEEN ISSUED, THE CONTRACTOR MAY INSTALL THE INITIAL STAGE EROSION AND SEDIMENT CONTROL BARRIERS AS INDICATED ON THE GEC. A PRE-CONSTRUCTION MEETING BETWEEN THE CONTRACTOR, ENGINEER, AND EL PASO COUNTY WILL BE HELD PRIOR TO ANY CONSTRUCTION. IT IS THE RESPONSIBILITY OF THE APPLICANT TO COORDINATE THE MEETING TIME AND PLACE WITH COUNTY PCD INSPECTIONS STAFF.
5. SOIL EROSION CONTROL MEASURES FOR ALL SLOPES, CHANNELS, DITCHES, OR ANY DISTURBED LAND ARE REQUIRED. 30 DAYS AFTER FINAL GRADING, OR FINAL EARTH DISTURBANCE, HAS BEEN COMPLETED, DISTURBED AREAS AND STOCKPILES WHICH ARE NOT AT FINAL GRADE BUT WILL REMAIN DORMANT FOR LONGER THAN 30 DAYS SHALL ALSO BE MULCHED WITHIN 21 DAYS AFTER INTERIM GRADING. AN AREA THAT IS GOING TO REMAIN IN AN INTERIM STATE FOR MORE THAN 60 DAYS SHALL ALSO BE SEEDED. ALL TEMPORARY SOIL EROSION CONTROL MEASURES SHALL BE MAINTAINED UNTIL PERMANENT SOIL EROSION CONTROL MEASURES ARE IMPLEMENTED AND ESTABLISHED.
6. TEMPORARY SOIL EROSION CONTROL FACILITIES SHALL BE REMOVED AND EARTH DISTURBANCE AREAS GRADED AND STABILIZED WITH PERMANENT SOIL EROSION CONTROL MEASURES PURSUANT TO STANDARDS AND SPECIFICATION PRESCRIBED IN THE DCM VOLUME II AND THE ENGINEERING CRITERIA MANUAL (ECM) APPENDIX I.
7. ALL PERSONS ENGAGED IN EARTH DISTURBANCE SHALL IMPLEMENT AND MAINTAIN ACCEPTABLE SOIL EROSION AND SEDIMENT CONTROL MEASURES INCLUDING BMPs IN CONFORMANCE WITH THE EROSION CONTROL TECHNICAL STANDARDS OF THE DRAINAGE CRITERIA MANUAL (DCM) VOLUME II AND IN ACCORDANCE WITH THE STORM-WATER MANAGEMENT PLAN (SWMP).
8. ALL TEMPORARY EROSION CONTROL FACILITIES INCLUDING BMPs AND ALL PERMANENT FACILITIES INTENDED TO CONTROL EROSION OF ANY EARTH DISTURBANCE OPERATIONS, SHALL BE INSTALLED AS DEFINED IN THE APPROVED PLANS, THE SWMP AND THE DCM VOLUME II AND MAINTAINED THROUGHOUT THE DURATION OF THE EARTH DISTURBANCE OPERATION.
9. ANY EARTH DISTURBANCE SHALL BE CONDUCTED IN SUCH A MANNER SO AS TO EFFECTIVELY REDUCE ACCELERATED SOIL EROSION AND RESULTING SEDIMENTATION. ALL DISTURBANCES SHALL BE DESIGNED, CONSTRUCTED, AND COMPLETED SO THAT THE EXPOSED AREA OF ANY DISTURBED LAND SHALL BE LIMITED TO THE SHORTEST PRACTICAL PERIOD OF TIME.
10. ANY TEMPORARY OR PERMANENT FACILITY DESIGNED AND CONSTRUCTED FOR THE CONVEYANCE OF STORM-WATER AROUND, THROUGH, OR FROM THE EARTH DISTURBANCE AREA SHALL BE DESIGNED TO LIMIT THE DISCHARGE TO A NON-EROSIVE VELOCITY.
11. CONCRETE WASH WATER SHALL BE CONTAINED AND DISPOSED OF IN ACCORDANCE WITH THE SWMP. NO WASH WATER SHALL BE DISCHARGED TO OR ALLOWED TO RUNOFF TO STATE WATERS, INCLUDING ANY SURFACE OR SUBSURFACE STORM DRAINAGE SYSTEM OR FACILITIES.
12. EROSION CONTROL BLANKETING IS TO BE USED ON SLOPES STEEPER THAN 3:1.
13. BUILDING, CONSTRUCTION, EXCAVATION, OR OTHER WASTE MATERIALS SHALL NOT BE TEMPORARILY PLACED OR STORED IN THE STREET, ALLEY, OR OTHER PUBLIC WAY, UNLESS IN ACCORDANCE WITH AN APPROVED TRAFFIC CONTROL PLAN. BMPs MAY BE REQUIRED BY EL PASO COUNTY ENGINEERING IF DEEMED NECESSARY, BASED ON SPECIFIC CONDITIONS AND CIRCUMSTANCES.
14. VEHICLE TRACKING OF SOILS AND CONSTRUCTION DEBRIS OFF-SITE SHALL BE MINIMIZED. MATERIALS TRACKED OFF-SITE SHALL BE CLEANED UP AND PROPERLY DISPOSED OF IMMEDIATELY.
15. CONTRACTOR SHALL BE RESPONSIBLE FOR THE REMOVAL OF ALL WASTES FROM THE CONSTRUCTION SITE FOR DISPOSAL IN ACCORDANCE WITH LOCAL AND STATE REGULATORY REQUIREMENTS. NO CONSTRUCTION DEBRIS, TREE SLASH, BUILDING MATERIAL WASTES OR UNUSED BUILDING MATERIALS SHALL BE BURIED, DUMPED, OR DISCHARGED AT THE SITE.
16. THE OWNER, SITE DEVELOPER, CONTRACTOR, AND/OR THEIR AUTHORIZED AGENTS SHALL BE RESPONSIBLE FOR THE REMOVAL OF ALL CONSTRUCTION DEBRIS, DIRT, TRASH, ROCK, SEDIMENT, AND SAND THAT MAY ACCUMULATE IN THE STORM SEWER OR OTHER DRAINAGE CONVEYANCE SYSTEM AND STORM-WATER APPURTENANCES AS A RESULT OF SITE DEVELOPMENT.
17. THE QUANTITY OF MATERIALS STORED ON THE PROJECT SITE SHALL BE LIMITED, AS MUCH AS PRACTICAL, TO THAT QUANTITY REQUIRED TO PERFORM THE WORK IN AN ORDERLY SEQUENCE. ALL MATERIALS STORED ON-SITE SHALL BE STORED IN A NEAT, ORDERLY MANNER, IN THEIR ORIGINAL CONTAINERS, WITH ORIGINAL MANUFACTURER'S LABELS.
18. NO CHEMICALS ARE TO BE USED BY THE CONTRACTOR, WHICH HAVE THE POTENTIAL TO BE RELEASED IN STORM-WATER UNLESS PERMISSION FOR THE USE OF A SPECIFIC CHEMICAL IS GRANTED IN WRITING BY THE ECM ADMINISTRATOR. IN GRANTING THE USE OF SUCH CHEMICALS, SPECIAL CONDITIONS AND MONITORING MAY BE REQUIRED.
19. BULK STORAGE STRUCTURES FOR PETROLEUM PRODUCTS AND OTHER CHEMICALS SHALL HAVE ADEQUATE PROTECTION SO AS TO CONTAIN ALL SPILLS AND PREVENT ANY SPILLED MATERIAL FROM ENTERING STATE WATERS, INCLUDING ANY SURFACE OR SUBSURFACE STORM DRAINAGE SYSTEM OR FACILITIES.
20. NO PERSON SHALL CAUSE THE IMPEDIMENT OF STORM-WATER FLOW IN THE FLOW LINE OF THE CURB AND GUTTER OR IN THE DITCH-LINE.
21. INDIVIDUALS SHALL COMPLY WITH THE "COLORADO WATER QUALITY CONTROL ACT" (TITLE 25, ARTICLE 6, CRS), AND THE "CLEAN WATER ACT" (33 USC 1344), IN ADDITION TO THE REQUIREMENTS INCLUDED IN THE DCM VOLUME II AND THE ECM APPENDIX I. ALL APPROPRIATE PERMITS MUST BE OBTAINED BY THE CONTRACTOR PRIOR TO CONSTRUCTION (NPDES, FLOODPLAIN, 404, FUGITIVE DUST, ETC.). IN THE EVENT OF CONFLICTS BETWEEN THESE REQUIREMENTS AND LAWS, RULES, OR REGULATIONS OF OTHER FEDERAL, STATE, OR COUNTY AGENCIES, THE MORE RESTRICTIVE LAWS, RULES, OR REGULATIONS SHALL APPLY.
22. ALL CONSTRUCTION TRAFFIC MUST ENTER/EXIT THE SITE AT APPROVED CONSTRUCTION ACCESS POINTS.
23. PRIOR TO ACTUAL CONSTRUCTION THE PERMITEE SHALL VERIFY THE LOCATION OF EXISTING UTILITIES.
24. A WATER SOURCE SHALL BE AVAILABLE ON SITE DURING EARTHWORK OPERATIONS AND UTILIZED AS REQUIRED TO MINIMIZE DUST FROM EARTHWORK EQUIPMENT AND WIND.
25. THE SOILS REPORT FOR THIS SITE HAS BEEN PREPARED BY RMG INC AND SHALL BE CONSIDERED A PART OF THESE PLANS.
26. AT LEAST TEN DAYS PRIOR TO THE ANTICIPATED START OF CONSTRUCTION, FOR PROJECTS THAT WILL DISTURB 1 ACRE OR MORE, THE OWNER OR OPERATOR OF CONSTRUCTION ACTIVITY SHALL SUBMIT A PERMIT APPLICATION FOR STORM-WATER DISCHARGE TO THE COLORADO DEPARTMENT OF PUBLIC HEALTH AND ENVIRONMENT, WATER QUALITY DIVISION. THE APPLICATION CONTAINS CERTIFICATION OF COMPLETION OF A STORM-WATER MANAGEMENT PLAN (SWMP), OF WHICH THIS GRADING AND EROSION CONTROL PLAN MAY BE A PART. FOR INFORMATION OR APPLICATION MATERIALS CONTACT: COPHE, 4300 CHERRY CREEK DR. S., DENVER, CO 80246-1530, PH: 303-692-3500

DESIGNED		DRAWN		CHECKED		DATE	
MAB	HUG	MAB	HUG	MAB	HUG	2/19/2019	
RESPEC	730 S COLORADO BLVD	SUITE 4105	DENVER, CO 80246	PHONE (303) 757-3655			

STAMP

Know what's below. Call before you dig.

PROJ NO. 03524  
DWG NAME. 03524-Dev-FI2

GUMAN & ASSOCIATES, LLC  
731 N. WEBER ST., SUITE 10  
COLORADO SPRINGS, CO 80903

GLENLEAGLE  
SUBDIVISION FILE #2

DRAINAGE, GRADING & EROSION DETAILS

DRAWING NUMBER:  
C  
SHEET 3

NAME: 210 COLORADO SPRINGS OFFICE: GLENLEAGLE, CAD: CHEET/DIG/SCH-C GRAD DWG PLOT DATE: May 22, 2019 10:54 AM BY: CHRIS RIEBES

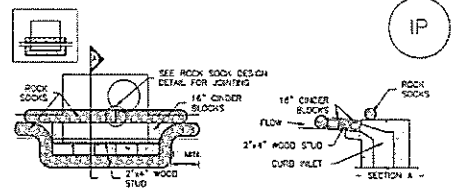

IP-1. BLOCK AND ROCK SOCK SUMP OR ON-GRADE INLET PROTECTION

**ROCK AND CURB SOCK SUMP/INLET PROTECTION INSTALLATION NOTES**

- SEE ROCK SOCK DESIGN DETAIL FOR INSTALLATION REQUIREMENTS.
- CONCRETE "TOE" BLOCKS SHALL BE LAD ON THEIR SIDES AROUND THE INLET IN A SINGLE ROW, ADJOINING ONE ANOTHER WITH THE OPEN END FACING AWAY FROM THE CURB.
- GRAVEL BARS SHALL BE PLACED AROUND CONCRETE BLOCKS, CLOSELY ADJOINING ONE ANOTHER AND JOINED TOGETHER IN ACCORDANCE WITH ROCK SOCK DESIGN DETAIL.

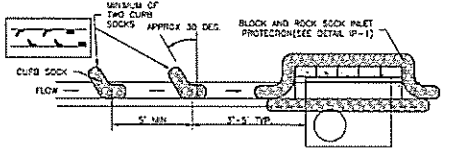

IP-2. CURB ROCK SOCKS UPSTREAM OF INLET PROTECTION

**CURB ROCK SOCK SUMP/INLET PROTECTION INSTALLATION NOTES**

- SEE ROCK SOCK DESIGN DETAIL INSTALLATION REQUIREMENTS.
- PLACEMENT OF THE SOCK SHALL BE APPROXIMATELY 30 DEGREES FROM PERPENDICULAR IN THE OPPOSITE DIRECTION OF FLOW.
- SOCKS ARE TO BE FLUSH WITH THE CURB AND SPACED A MINIMUM OF 3 FEET APART.
- AT LEAST TWO CURB SOCKS IN SERIES ARE REQUIRED UPSTREAM OF ON-GRADE INLETS.

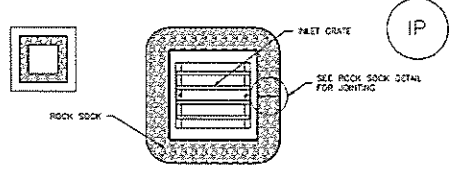

IP-3. ROCK SOCK SUMP/AREA INLET PROTECTION

**ROCK SOCK SUMP/AREA INLET PROTECTION INSTALLATION NOTES**

- SEE ROCK SOCK DESIGN DETAIL FOR INSTALLATION REQUIREMENTS.
- STRAW MATS/SEDIMENT CONTROL LOSS MAY BE USED IN PLACE OF ROCK SOCKS FOR INLETS IN PREVIOUS AREAS. INSTALL FOR SEDIMENT CONTROL LOSS DETAIL.

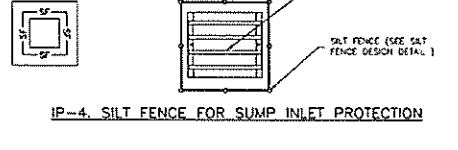

IP-4. SILT FENCE FOR SUMP INLET PROTECTION

**SILT FENCE INLET PROTECTION INSTALLATION NOTES**

- SEE SILT FENCE DESIGN DETAIL FOR INSTALLATION REQUIREMENTS.
- POSTS SHALL BE PLACED AT EACH CORNER OF THE INLET AND AROUND THE EDGES AT A MAXIMUM SPACING OF 3 FEET.
- STRAW MATS/SEDIMENT CONTROL LOSS MAY BE USED IN PLACE OF SILT FENCE FOR INLETS IN PREVIOUS AREAS. INSTALL FOR SEDIMENT CONTROL LOSS DETAIL.

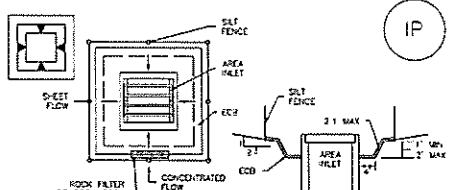

IP-5. OVEREXCAVATION INLET PROTECTION

**OVEREXCAVATION INLET PROTECTION INSTALLATION NOTES**

- THIS FORM OF INLET PROTECTION IS PRIMARILY APPLICABLE FOR SITES THAT HAVE NOT YET REACHED FINAL GRADE AND SHOULD BE USED ONLY FOR INLETS WITH A RELATIVELY SMALL CONTRIBUTING DRAINAGE AREA.
- WHEN USING FOR CONCENTRATED FLOW, SHAPE BASH IN 2:1 RATIO WITH LENGTH ORIENTED TOWARDS DIRECTION OF FLOW.
- SEDIMENT MUST BE PERIODICALLY REMOVED FROM THE OVEREXCAVATED AREA.

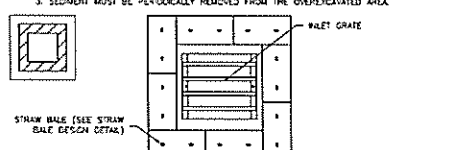

IP-6. STRAW BALE FOR SUMP INLET PROTECTION

**STRAW BALE SUMP/INLET PROTECTION INSTALLATION NOTES**

- SEE STRAW BALE DESIGN DETAIL FOR INSTALLATION REQUIREMENTS.
- BALES SHALL BE PLACED IN A SINGLE ROW AROUND THE INLET WITH ENDS OF BALES TOILEY ADJOINING ONE ANOTHER.

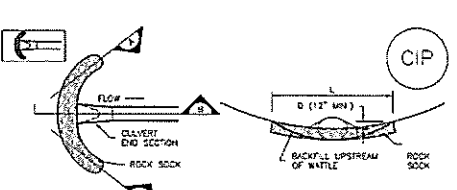

CIP-1. CULVERT INLET PROTECTION

**CULVERT INLET PROTECTION INSTALLATION NOTES**

- SEE PLAN VIEW FOR -LOCATION OF CULVERT INLET PROTECTION.
- SEE ROCK SOCK DESIGN DETAIL FOR ROCK SOCK REQUIREMENTS AND JOINTING DETAIL.

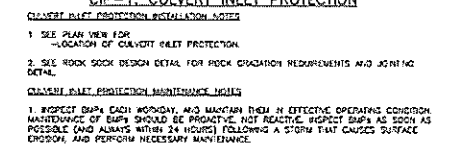

CIP-1. CULVERT INLET PROTECTION

**CULVERT INLET PROTECTION INSTALLATION NOTES**

- SEE PLAN VIEW FOR -LOCATION OF CULVERT INLET PROTECTION.
- SEE ROCK SOCK DESIGN DETAIL FOR ROCK SOCK REQUIREMENTS AND JOINTING DETAIL.
- STRAW MATS/SEDIMENT CONTROL LOSS MAY BE USED IN PLACE OF ROCK SOCKS FOR INLETS IN PREVIOUS AREAS. INSTALL FOR SEDIMENT CONTROL LOSS DETAIL.

**GENERAL SILT PROTECTION INSTALLATION NOTES**

- SEE PLAN VIEW FOR -LOCATION OF INLET PROTECTION -TYPE OF INLET PROTECTION (P.1, P.2, P.3, P.4, P.5, P.6)
- INLET PROTECTION SHALL BE INSTALLED PROMPTLY AFTER PALET CONSTRUCTION OR PAVING IS COMPLETE (TYPICALLY WITHIN 48 HOURS) IF A RAINFALL/SPRINKLE EVENT IS FORECAST. INSTALL INLET PROTECTION PRIOR TO START OF EVENT.
- MANY JURISDICTIONS HAVE BMP DETAILS THAT VARY FROM LEICD STANDARD DETAILS. CONSULT WITH LOCAL JURISDICTIONS AS TO WHICH DETAIL SHOULD BE USED WHEN DIFFERENCES ARE NOTED.

**INLET PROTECTION MAINTENANCE NOTES**

- INSPECT BMPs EACH WORKDAY, AND MAINTAIN THEM IN EFFECTIVE OPERATING CONDITION. MAINTENANCE OF BMPs SHOULD BE PROACTIVE, NOT REACTIVE. INSPECT BMPs AS SOON AS POSSIBLE (AND ALWAYS WITHIN 24 HOURS) FOLLOWING A STORM THAT CAUSES SURFACE EROSION, AND PERFORM NECESSARY MAINTENANCE.
- FREQUENT OBSERVATIONS AND MAINTENANCE ARE NECESSARY TO MAINTAIN BMPs IN EFFECTIVE OPERATING CONDITION. INSPECTIONS AND CORRECTIVE MEASURES SHOULD BE DOCUMENTED THOROUGHLY.
- WHERE BMPs HAVE FAILED, REPAIR OR REPLACEMENT SHOULD BE INITIATED UPON DISCOVERY OF THE FAILURE.
- SEDIMENT ACCUMULATED UPSTREAM OF INLET PROTECTION SHALL BE REMOVED AS NEEDED TO MAINTAIN FUNCTIONALITY OF THE BMP, TYPICALLY WHEN DEPTH OF ACCUMULATED SEDIMENTS IS APPROXIMATELY 1/3 OF THE HEIGHT OF THE STRAW BALES.
- INLET PROTECTION IS TO REMAIN IN PLACE UNTIL THE UPSTREAM DISTURBED AREA IS PERMANENTLY STABILIZED, UNLESS THE LOCAL JURISDICTION APPROVES EARLIER REMOVAL OF INLET PROTECTION IN STREETS.
- WHEN INLET PROTECTION AT AREA INLETS IS REMOVED, THE DISTURBED AREA SHALL BE COVERED WITH TOPSOIL, SEEDS AND MULCH, OR OTHERWISE STABILIZED IN A MANNER APPROVED BY THE LOCAL JURISDICTION.

(DETAIL ADAPTED FROM FORM OF PAPER, COLORADO AND CITY OF ALBUQUERQUE, NOT AVAILABLE IN ALBUQUERQUE)

**NOTE: MANY JURISDICTIONS HAVE BMP DETAILS THAT VARY FROM LEICD STANDARD DETAILS. CONSULT WITH LOCAL JURISDICTIONS AS TO WHICH DETAIL SHOULD BE USED WHEN DIFFERENCES ARE NOTED.**

**NOTE: THE DETAILS INCLUDED WITH THIS FACT SHEET SHOW COMMONLY USED, CONVENTIONAL METHODS OF INLET PROTECTION IN THE DENVER METROPOLITAN AREA. THERE ARE MANY PROPRIETARY METHODS OF INLET PROTECTION. HOWEVER, IN THE EVENT PROPRIETARY METHODS ARE USED, THE APPROPRIATE DETAIL FROM THE MANUFACTURER'S MANUAL SHOULD BE INCLUDED IN THE SWMP AND THE BMP MUST BE INSTALLED AND MAINTAINED AS SHOWN IN THE MANUFACTURER'S DETAILS.**

**NOTE: SOME MUNICIPALITIES DISCOURAGE OR PROHIBIT THE USE OF STRAW BALES FOR INLET PROTECTION. CHECK WITH LOCAL JURISDICTION TO DETERMINE IF STRAW BALE PROTECTION IS ACCEPTABLE.**

(DETAILS ADAPTED FROM FORM OF PAPER, COLORADO, NOT AVAILABLE IN ALBUQUERQUE)

**NOTE: MANY JURISDICTIONS HAVE BMP DETAILS THAT VARY FROM LEICD STANDARD DETAILS. CONSULT WITH LOCAL JURISDICTIONS AS TO WHICH DETAIL SHOULD BE USED WHEN DIFFERENCES ARE NOTED.**

**DESIGNED** MAE  
**DRAWN** HUG  
**CHECKED** MAR  
**DATE** 2/19/2019

RESPEC  
750 S. COLORADO BLVD  
SUITE 400  
DENVER, CO 80246  
PHONE (303) 757-9665

STAMP

811  
Know what's below.  
Call before you dig.

PROJ NO. 03524  
DWG NO. 03524-Dev-F12

GUMAN & ASSOCIATES, LLC  
731 N. WEBER ST., SUITE 10  
COLORADO SPRINGS, CO 80903

GLENEAGLE  
SUBDIVISION #2

DRAINAGE, GRADING &  
EROSION DETAILS

DRAWING NUMBER:  
C  
SHEET 4

INLET PROTECTION - NOT TO SCALE

SC-5 Rock Sock (RS)

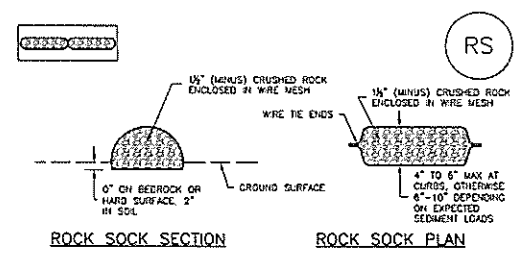

RS-1. ROCK SOCK PERIMETER CONTROL

**ROCK SOCK MAINTENANCE NOTES**

- INSPECT BMPs EACH WORKDAY, AND MAINTAIN THEM IN EFFECTIVE OPERATING CONDITION. MAINTENANCE OF BMPs SHOULD BE PROACTIVE, NOT REACTIVE. INSPECT BMPs AS SOON AS POSSIBLE (AND ALWAYS WITHIN 24 HOURS) FOLLOWING A STORM THAT CAUSES SURFACE EROSION, AND PERFORM NECESSARY MAINTENANCE.
- FREQUENT OBSERVATIONS AND MAINTENANCE ARE NECESSARY TO MAINTAIN BMPs IN EFFECTIVE OPERATING CONDITION. INSPECTIONS AND CORRECTIVE MEASURES SHOULD BE DOCUMENTED THOROUGHLY.
- WHERE BMPs HAVE FAILED, REPAIR OR REPLACEMENT SHOULD BE INITIATED UPON DISCOVERY OF THE FAILURE.
- ROCK SOCKS SHALL BE REPLACED IF THEY BECOME HEAVILY SOILED, OR DAMAGED BEYOND REPAIR.
- SEDIMENT ACCUMULATED UPSTREAM OF ROCK SOCKS SHALL BE REMOVED AS NEEDED TO MAINTAIN FUNCTIONALITY OF THE BMP, TYPICALLY WHEN DEPTH OF ACCUMULATED SEDIMENTS IS APPROXIMATELY 1/3 OF THE HEIGHT OF THE ROCK SOCK.
- ROCK SOCKS ARE TO REMAIN IN PLACE UNTIL THE UPSTREAM DISTURBED AREA IS STABILIZED AND APPROVED BY THE LOCAL JURISDICTION.
- WHEN ROCK SOCKS ARE REMOVED, ALL DISTURBED AREAS SHALL BE COVERED WITH TOPSOIL, SEEDS AND MULCH, OR OTHERWISE STABILIZED AS APPROVED BY LOCAL JURISDICTION.

(DETAIL ADAPTED FROM FORM OF PAPER, COLORADO AND CITY OF ALBUQUERQUE, NOT AVAILABLE IN ALBUQUERQUE)

**NOTE: MANY JURISDICTIONS HAVE BMP DETAILS THAT VARY FROM LEICD STANDARD DETAILS. CONSULT WITH LOCAL JURISDICTIONS AS TO WHICH DETAIL SHOULD BE USED WHEN DIFFERENCES ARE NOTED.**

**NOTE: THE DETAILS INCLUDED WITH THIS FACT SHEET SHOW COMMONLY USED, CONVENTIONAL METHODS OF ROCK SOCK INSTALLATION IN THE DENVER METROPOLITAN AREA. THERE ARE MANY OTHER SIMILAR PROPRIETARY PRODUCTS ON THE MARKET. UNLESS OTHERWISE NOTED, DISCOURAGES USE OF PROPRIETARY PROTECTION PRODUCTS. HOWEVER, IN THE EVENT PROPRIETARY METHODS ARE USED, THE APPROPRIATE DETAIL FROM THE MANUFACTURER'S MANUAL SHOULD BE INCLUDED IN THE SWMP AND THE BMP MUST BE INSTALLED AND MAINTAINED AS SHOWN IN THE MANUFACTURER'S DETAILS.**

**GRADATION TABLE**

NO. 4	NO. 10
2" - 100	100
1 1/2" - 90 - 100	90 - 100
1" - 70 - 100	70 - 100
3/4" - 50 - 100	50 - 100
1/2" - 30 - 100	30 - 100
3/8" - 10 - 100	10 - 100
1/4" - 5 - 100	5 - 100

**MATCHES SPECIFICATIONS FOR NO. 4 CRUSHED ROCK APPROPRIATE FOR CONCRETE PER AASHTO M43. ALL ROCK SHALL BE FRACTURED FACE, ALL SIDES.**

**ROCK SOCK INSTALLATION NOTES**

- SEE PLAN VIEW FOR -LOCATION(S) OF ROCK SOCKS
- CRUSHED ROCK SHALL BE 1/2" (MINUS) IN SIZE WITH A FRACTURED FACE (ALL SIDES) AND SHALL COMPLY WITH GRADATION SHOWN ON THIS SHEET (1/2" MINUS).
- WIRE MESH SHALL BE FABRICATED OF 10 GAUGE POLYESTER WIRE, OR EQUIVALENT WITH A MAXIMUM OPENING OF 1/2". RECOMMENDED WIRE MESH ROLL WIDTH OF 48".
- WIRE MESH SHALL BE SECURED USING "NOC RINGS" OR WIRE TIES AT 6" CENTERS ALONG ALL JOINTS AND AT 2" CENTERS ON ENDS OF SOCKS.
- SOME MUNICIPALITIES MAY ALLOW THE USE OF FILTER FABRICS AS AN ALTERNATIVE TO WIRE MESH FOR THE ROCK ENCLOSURE.

SC-5 Rock Sock (RS)

**ROCK SOCK SECTION**

1/2" (MINUS) CRUSHED ROCK ENCLOSED IN WIRE MESH

WIRE TIE ENDS

4" TO 6" MAX AT CURBS, OTHERWISE 6"-10" DEPENDING ON EXPECTED SEDIMENT LOADS

0" ON BEDROCK OR HARD SURFACE, 2" IN SOIL

GROUND SURFACE

**ROCK SOCK PLAN**

12" x 12"

ROCK SOCK JOINTING

ROCK SOCK TIP

RS-2 Urban Drainage and Flood Control District November 2010 Urban Storm Drainage Criteria Manual Volume 3

RS-3 Urban Drainage and Flood Control District November 2010 Urban Storm Drainage Criteria Manual Volume 3

SC-3 Straw Bale Barrier (SBB)

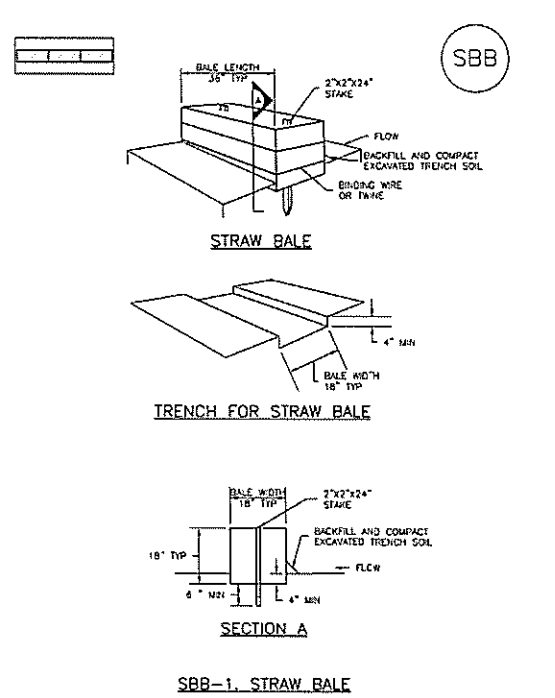

SBB-1. STRAW BALE

**STRAW BALE INSTALLATION NOTES**

- SEE PLAN VIEW FOR -LOCATION(S) OF STRAW BALES.
- STRAW BALES SHALL CONSIST OF CERTIFIED WEED FREE STRAW OR HAY. LOCAL JURISDICTIONS MAY REQUIRE PROOF THAT BALES ARE WEED FREE.
- STRAW BALES SHALL CONSIST OF APPROXIMATELY 5 CUBIC FEET OF STRAW OR HAY AND WEIGH NOT LESS THAN 25 POUNDS.
- WHEN STRAW BALES ARE USED IN SERIES AS A BARRIER, THE END OF EACH BALE SHALL BE TIGHTLY ADJOINING ONE ANOTHER.
- STRAW BALE DIMENSIONS SHALL BE APPROXIMATELY 16"x18"x18".
- A UNIFORM ANCHOR TRENCH SHALL BE EXCAVATED TO A DEPTH OF 4". STRAW BALES SHALL BE PLACED SO THAT BEHAVIOR TRAP IS ENCLOSING THE VERTICAL SIDES OF THE BALES(S). ALL EXCAVATED SOIL SHALL BE PLACED ON THE UPHILL SIDE OF THE STRAW BALE(S) AND COMPACTED.
- TWO (2) WOODEN STAKES SHALL BE USED TO HOLD EACH BALE IN PLACE. WOODEN STAKES SHALL BE 2"x2"x24" WOODEN STAKES SHALL BE DRIVEN 6" INTO THE GROUND.

**STRAW BALE MAINTENANCE NOTES**

- INSPECT BMPs EACH WORKDAY, AND MAINTAIN THEM IN EFFECTIVE OPERATING CONDITION. MAINTENANCE OF BMPs SHOULD BE PROACTIVE, NOT REACTIVE. INSPECT BMPs AS SOON AS POSSIBLE (AND ALWAYS WITHIN 24 HOURS) FOLLOWING A STORM THAT CAUSES SURFACE EROSION, AND PERFORM NECESSARY MAINTENANCE.
- FREQUENT OBSERVATIONS AND MAINTENANCE ARE NECESSARY TO MAINTAIN BMPs IN EFFECTIVE OPERATING CONDITION. INSPECTIONS AND CORRECTIVE MEASURES SHOULD BE DOCUMENTED THOROUGHLY.
- WHERE BMPs HAVE FAILED, REPAIR OR REPLACEMENT SHOULD BE INITIATED UPON DISCOVERY OF THE FAILURE.
- STRAW BALES SHALL BE REPLACED IF THEY BECOME HEAVILY SOILED, ROTTEN, OR DAMAGED BEYOND REPAIR.
- SEDIMENT ACCUMULATED UPSTREAM OF STRAW BALE BARRIER SHALL BE REMOVED AS NEEDED TO MAINTAIN FUNCTIONALITY OF THE BMP, TYPICALLY WHEN DEPTH OF ACCUMULATED SEDIMENTS IS APPROXIMATELY 1/3 OF THE HEIGHT OF THE STRAW BALE BARRIER.
- STRAW BALES ARE TO REMAIN IN PLACE UNTIL THE UPSTREAM DISTURBED AREA IS STABILIZED AND APPROVED BY THE LOCAL JURISDICTION.
- WHEN STRAW BALES ARE REMOVED, ALL DISTURBED AREAS SHALL BE COVERED WITH TOPSOIL, SEEDS AND MULCH, OR OTHERWISE STABILIZED AS APPROVED BY LOCAL JURISDICTION.

(DETAILS ADAPTED FROM FORM OF PAPER, COLORADO, NOT AVAILABLE IN ALBUQUERQUE)

**NOTE: MANY JURISDICTIONS HAVE BMP DETAILS THAT VARY FROM LEICD STANDARD DETAILS. CONSULT WITH LOCAL JURISDICTIONS AS TO WHICH DETAIL SHOULD BE USED WHEN DIFFERENCES ARE NOTED.**

SBB-2 Urban Drainage and Flood Control District November 2010 Urban Storm Drainage Criteria Manual Volume 3

SBB-3 Urban Drainage and Flood Control District November 2010 Urban Storm Drainage Criteria Manual Volume 3

SC-3 Straw Bale Barrier (SBB)

**STRAW BALE**

BALE LENGTH 36" TIP

2"x2"x24" STAKE

FLOW

BACKFILL AND COMPACT EXCAVATED TRENCH SOIL

BINDING WIRE OR TWINE

**TRENCH FOR STRAW BALE**

4" MIN

BALE WIDTH 18" TIP

**SECTION A**

18" TIP

6" MIN

2"x2"x24" STAKE

BACKFILL AND COMPACT EXCAVATED TRENCH SOIL

FLOW

SBB-2 Urban Drainage and Flood Control District November 2010 Urban Storm Drainage Criteria Manual Volume 3

SBB-3 Urban Drainage and Flood Control District November 2010 Urban Storm Drainage Criteria Manual Volume 3

NAME: 2 COLORADO SPRINGS OFFICE: GLENEAGLE/CAD/SHEET: 03524-5-GRAD DWG PLOT DATE: MAY 22 2019 10:51 AM BY: CHRS/ME/MS

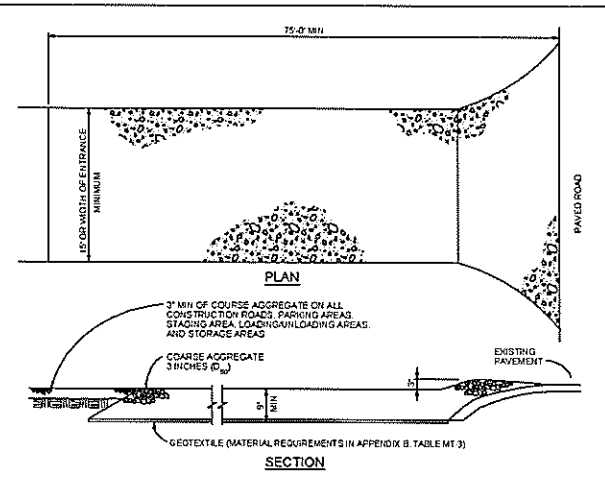

**VEHICLE TRACKING**  
TTS

**VEHICLE TRACKING NOTES**

**INSTALLATION REQUIREMENTS**

1. ALL ENTRANCES TO THE CONSTRUCTION SITE ARE TO BE STABILIZED PRIOR TO CONSTRUCTION BEGINNING.
2. CONSTRUCTION ENTRANCES ARE TO BE BUILT WITH AN APRON TO ALLOW FOR TURNING TRAFFIC, BUT SHOULD NOT BE BUILT OVER EXISTING PAVEMENT EXCEPT FOR A SLIGHT OVERLAP.
3. AREAS TO BE STABILIZED ARE TO BE PROPERLY GRADED AND COMPACTED PRIOR TO LAYING DOWN GEOTEXTILE AND STONE.
4. CONSTRUCTION ROADS, PARKING AREAS, LOADING/UNLOADING ZONES, STORAGE AREAS, AND STAGING AREAS ARE TO BE STABILIZED.
5. CONSTRUCTION ROADS ARE TO BE BUILT TO CONFORM TO SITE GRADES, BUT SHOULD NOT HAVE SIDE SLOPES OR ROAD GRADES THAT ARE EXCESSIVELY STEEP.

**MAINTENANCE REQUIREMENTS**

1. REGULAR INSPECTIONS ARE TO BE MADE OF ALL STABILIZED AREAS, ESPECIALLY AFTER STORM EVENTS.
2. STONES ARE TO BE REAPPLIED PERIODICALLY AND WHEN REPAIR IS NECESSARY.
3. SEDIMENT TRASHED ONTO PAVED ROADS IS TO BE REMOVED DAILY BY SHOVELING OR SWEEPING. SEDIMENT IS NOT TO BE WASHED DOWN STORM SEWER DRAINS.
4. STORM SEWER INLET PROTECTION IS TO BE IN PLACE, INSPECTED, AND CLEANED IF NECESSARY.
5. OTHER ASSOCIATED SEDIMENT CONTROL MEASURES ARE TO BE INSPECTED TO ENSURE GOOD WORKING CONDITION.

City of Colorado Springs  
Stormwater Quality

Figure VT-2  
Vehicle Tracking  
Application Examples

**GENERAL NOTES**

1. Do not prepare or seed frozen soils.
2. Do not seed when wind exceeds 5 mph.
3. Perform seeding only after preceding work affecting ground surface is completed.
4. Do not mulch over seeded areas when wind exceeds 15 mph.
5. Seed all disturbed areas.
6. Seed to be a blend of native prairie grasses.
7. Watering shall be provided in the form of watering trucks and spray bars.

**MULCH MATERIALS**

1. HAY OR STRAW MULCH
  - A) Chopped of oats, wheat or rye grass hay.
  - B) Free from noxious weed seeds.
  - C) Rotted, brittle or matted hay is not acceptable.
  - D) 50% by weight greater than 10" inch length.
2. FIBER
  - A) Short wood fiber.
  - B) "Conwed", "Silver Fiber" or equivalent.

**BED PREPARATION**

1. Prepare to a minimum depth of 4" with disc harrow or chiseling tools.
2. Uproot all competitive vegetation.
3. Work soil uniformly to a smooth surface free of clods, stones over 2" in any dimension or any material which will interfere seeding equipment.
4. Till across slopes.
5. Do not till when soil moisture is unsuitable.
  - A) Soil texture after tillage shall be uniform, free of wet compressed or dry lumps.
6. Do not prepare seed bed more than twenty four hours in advance of seeding.
7. Fertilize at a rate of fifty (2) lbs. nitrogen per 1,000 sq. ft.
  - A) Till fertilizer into soil a minimum of two (2) inches.

Species		lbs/acre drilled
Western Wheat Grass	Paspalum smithii	3.0
Sideoats Grama	Bouteloua curtipendula	2.0
Slender Wheat Grass	Schizachyrium scoparium	2.0
Little Bluestem	Bouteloua gracilis	0.5
Switch Grass	Panicum virgatum	2.0
Sand Dropseed	Sporobolus cryptandrus	

**EROSION CONTROL PLAN NOTES**

1. All disturbed areas are to be reseeded.
2. Schedule of Grading - approximate time frame of one month to complete grading and installation of erosion control measures.
3. Temporary Sediment Barriers shall be kept in place and maintained until the vegetation has been reestablished. Removal of sediment is required once it reaches half the height of the sediment control log.

DESIGNED	DRAWN	CHECKED	DATE
MAB	HJG	MAB	2/19/2019

RESPEC  
730 S. COLORADO BLVD  
SUITE 4105  
DENVER, CO 80246  
PHONE (303) 757-3655

STAMP



GUMAN & ASSOCIATES, LLC  
731 N. WEBER ST., SUITE 10  
COLORADO SPRINGS, CO 80903

GLENEAGLE  
SUBDIVISION FIL #2

DRAINAGE, GRADING &  
EROSION DETAILS

DRAWING NUMBER:  
C  
SHEET 5

NAME: 7: COLORADO SPRINGS OFFICE 03524, GLENEAGLE/CAD/SHEET/03524-5-GRAD.DWG  
PLOT DATE: May 22, 2019 10:54 AM BY: CHRIS.MEEKS

**APPENDIX C**  
Inspection Checklist



# Appendix C

## EXTENDED DETENTION BASIN (EDB) INSPECTION FORM

Date: \_\_\_\_\_

Subdivision/Business Name: \_\_\_\_\_ Inspector: \_\_\_\_\_

Subdivision/Business Address: \_\_\_\_\_

Weather: \_\_\_\_\_

Date of Last Rainfall: \_\_\_\_\_ Amount: \_\_\_\_\_ Inches

Property Classification: Residential Multi Family Commercial Other: \_\_\_\_\_  
(Circle One)

Reason for Inspection: Routine Complaint After Significant Rainfall Event  
(Circle One)

**INSPECTION SCORING** - For each facility inspection item, insert one of the following scores:  
0 = No deficiencies identified                      2 = Routine maintenance required  
1 = Monitor (potential for future problem)      3 = Immediate repair necessary  
N/A = Not applicable

### FEATURES

#### 1.) Inflow Points

- Riprap Displaced
- Erosion Present/Outfall Undercut
- Sediment Accumulation
- Structural Damage (pipe, end-section, etc.)
- Woody Growth/Weeds Present

#### 2.) Forebay

- Sediment/Debris Accumulation
- Concrete Cracking/Falling
- Drain Pipe/Wier Clogged (not draining)
- Wier/Drain Pipe Damage

#### 3.) Trickle Channel (Low-flow)

- Sediment/Debris Accumulation
- Concrete/Riprap Damage
- Woody Growth/Weeds Present
- Erosion Outside Channel

#### 4.) Bottom Stage (Micro-Pool)

- Sediment/Debris Accumulation
- Woody Growth/Weeds Present
- Bank Erosion
- Mosquitoes/Algae Treatment
- Petroleum/Chemical Sheen

#### 5.) Outlet Works

- Trash Rack/Well Screen Clogged
- Structural Damage (concrete, steel, subgrade)
- Orifice Plate(s) Missing/Not Secure
- Manhole Access (cover, steps, etc.)
- Woody Growth/Weeds Present

#### 6.) Emergency Spillway

- Riprap Displaced
- Erosion Present
- Woody Growth/Weeds Present
- Obstruction/Debris

#### 7.) Upper Stage (Dry Storage)

- Vegetation Sparse
- Woody Growth/Undesirable Vegetation
- Standing Water/Boggy Areas
- Sediment Accumulation
- Erosion (banks and bottom)
- Trash/Debris
- Maintenance Access

#### 8.) Miscellaneous

- Encroachment in Easement Area
- Graffiti/Vandalism
- Public Hazards
- Burrowing Animals/Pests
- Other

Inspection Summary / Additional Comments: \_\_\_\_\_

### OVERALL FACILITY RATING (Circle One)

- 0 = No Deficiencies Identified                      2 = Routine Maintenance Required  
1 = Monitor (potential for future problem exists)      3 = Immediate Repair Necessary

This inspection form shall be kept a minimum of 5 years and made available to El Paso County upon request.