

# **DRAINAGE LETTER FOR WIDEFIELD COMMUNITY BIBLE CHURCH ADDITION**

**PCD File No. PPR2438**

October 2024

Prepared for:  
Casco Construction Corp.  
6380 Corporate Centre Cir, Ste 210  
Colorado Springs, CO 80919

Prepared By:

The logo for Catamount Engineering features a stylized mountain range with three peaks. The word "CATAMOUNT" is written in a bold, sans-serif font across the middle of the mountain, and the word "ENGINEERING" is written in a similar font below it.

**CATAMOUNT  
ENGINEERING**

321 W. Henrietta Ave, Suite A  
Woodland Park, CO 80863  
719-426-2124

**DRAINAGE LETTER**  
**WIDEFIELD COMMUNITY BIBLE CHURCH ADDITION**

**Engineer's Statement:**

The attached drainage plan and report were prepared under my direction and supervision and are correct to the best of my knowledge and belief. Said drainage report has been prepared according the criteria established for drainage reports and said report is in conformity with the master plan of the drainage basin. I accept responsibility for any liability caused by any negligent acts, errors, or omissions on my part in preparing this report.

**Certification Statement:**

This report and plan for the final drainage design for Widefield Community Bible Church Addition was prepared by me (or under my direct supervision) in accordance with the provisions of El Paso County/City of Colorado Springs Drainage Criteria Manual Drainage Design and Technical Criteria for the owners thereof. I understand that El Paso County does not and will not assume liability for drainage facilities designed by others.

\_\_\_\_\_  
David L. Mijares, Colorado PE #40510  
For and on behalf of Catamount Engineering

\_\_\_\_\_  
Date

**Developer's Statement:**

I, the developer have read and will comply with all of the requirements specified in this drainage report and plan.

Widefield Community Bible Church hereby certifies that the drainage facilities for Widefield Community Bible Church Addition shall be constructed according to the design presented in this report. I understand that El Paso County does not and will not assume liability for the drainage facilities designed and or certified by my engineer and that El Paso County reviews drainage plans pursuant to Colorado Revised Statutes, Title 30, Article 28; but cannot, on behalf of Widefield Community Bible Church, guarantee that final drainage design review will absolve Widefield Community Bible Church, and/or their successors and/or assigns of future liability for improper design. I further understand that approval of the final plat does not imply approval of my engineer's drainage design.

\_\_\_\_\_  
Widefield Community Bible Church

By: \_\_\_\_\_

Title: \_\_\_\_\_

Address: \_\_\_\_\_

\_\_\_\_\_

**El Paso County:**

Filed in accordance with the requirements of the El Paso County land Development Code and the Drainage Criteria manual Volumes 1 and 2, and the El Paso County Engineering Criteria Manual, latest revision.

\_\_\_\_\_  
Josh Palmer, PE  
County Engineer/ECM Administrator

\_\_\_\_\_  
Date

Conditions:

AGE LETTER  
Y BIBLE CHURCH ADDITION

Please include a statement that the existing facility was designed to accept flows from this property and add a statement on the condition of the pond, ie the pond is functioning as intended and does not require maintenance to accept additional flow.

**PURPOSE**

The purpose of this drainage report is to identify and analyze revisions to existing drainage patterns with development of additional structure on the Widefield Community Church property. Redevelopment of the parcel will include an additional structure and expansion of the existing parking lot. The parcel will outfall directly to the adjacent sub-regional detention facility constructed with Mesa Ridge Self Storage. The sub-regional facility outfalls directly to the Detention Area A developed in the “Powers Boulevard/Peaceful Valley Road Storm Drainage Detention Study,” prepared by Wilson & Company and “Plan and Details of proposed peaceful Valley Road Detention Basin,” prepared by El Paso County Department of Transportation.

This addendum solely addresses conveyance of on-site runoff and conveyance to the sub-regional facility. The proposed disturbance for building addition and parking improvements is 0.66 acres and water quality is not required.

**GENERAL LOCATION AND DESCRIPTION**

The parcel is located within the southwest 1/4 of Section 19, Township 15 South, Range 65 West of the 6<sup>th</sup> principal within unincorporated El Paso County. The parcel is bounded to the north by existing Webster Elementary School, to the east by Quebec Street, to the South by the sub-regional detention pond, and to the west by Blue Sky Self Storage.

The site has been platted as a portion of Tract B Wilsons Widefield Addition No. 6. Existing soils on the site consist of Fort Collins loam, hydrologic soil group B (30) and Nunn Clay loam, hydrologic soils group C (59) as determined by the Natural Resources Conservation Service Web Soil Survey. Hydrologic Group ‘C’ soils were utilized in calculations. The site is located within the East Big Johnson Basin and ultimately drains to Fountain Creek.

**FLOODPLAIN STATEMENT**

No portion of the site lies within an F.E.M.A. designated floodplain per FIRM 08041C0952 G, effective December 07, 2018. The F.E.M.A. Flood Insurance Rate Map has been provided.

**EXISTING DRAINAGE CONDITIONS**

The parcel does not accept offsite flows from offsite parcels. Existing curblines within Quebec Street convey flows Southeast to the unimproved portion of Quebec ROW. The southerly portion of Webster Elementary School is graded to convey flows west away from the northerly property line of Widefield Community Bible Church.

I believe this is the Q2 flow, not Q5

**Basin EX-A: 0.92 Acres , $Q_5=1.6$  cfs,  $Q_{100}=5.0$  cfs**

On-site Basin EX-A consists of existing parking, building, and landscaped area predominantly captured in the existing parking lot and conveyed southeast through an existing curb cut to the existing sub-regional detention pond. The southeasterly portion of Basin EX-A is conveyed to the detention pond as sheet flow.

**Basin EX-B: 0.96 Acres , $Q_5=0.8$  cfs,  $Q_{100}=3.2$  cfs**

On-site Basin EX-B consists of the southeasterly portion of the parcel parallel to the southwest property line containing existing buildings, and landscaped area which sheet flows to the southwest and is conveyed in storage site improvements directly to the detention basin.

Combined runoff from the existing site at DP EX-1 (detention pond) is  $Q_5=2.6$  cfs,  $Q_{100}=7.3$  cfs

### **PROPOSED DRAINAGE IMPROVEMENTS**

Proposed drainage improvements are separated into ‘A’ designated basins captured predominantly within proposed parking lot improvements and conveyed southeasterly to extended detention basin; and ‘B’ designated basins conveying flows southwesterly as sheet flow to existing storage site improvements conveying flows to the detention basin.

**Basin A1: 0.17 Acres , $Q_5=0.7$  cfs,  $Q_{100}=1.3$  cfs**

On-site Basin A1 consists of the northwesterly portion of parking and tributary landscape areas conveyed within the parking to the 1.0’ wide curb chase located at DP-1 ( $Q_5=0.7$  cfs,  $Q_{100}=1.3$ ). Runoff conveyed within the 1.0’ curb cut are conveyed through the southeasterly parking to southeast to a proposed 2.0’ curb cut at DP-2

I believe this is the Q2 flow, not Q5

**Basin A2: 0.77 Acres , $Q_5=2.1$  cfs,  $Q_{100}=5.5$  cfs**

Basin A2 consists of the southeasterly parking area and tributary landscape areas, proposed walkways, and tributary portions of existing and proposed buildings conveyed within the parking to the 2.0’ wide curb chase located at DP-2 ( $Q_5=3.5$  cfs,  $Q_{100}=6.9$ ). Runoff conveyed within the 2.0’ curb cut are conveyed through a 5’ wide 1.5’ deep riprap swale to the bottom of the existing detention pond. An 8’ wide by 10’ long rip rap energy dissipation pad is proposed at the bottom of the pond embankment.

**Basin A3: 0.15 Acres , $Q_5=0.1$  cfs,  $Q_{100}=0.6$  cfs**

Basin A3 consists of the southeast portion of landscaped area not captured within the proposed parking lot and sheet flows southeast directly to the existing detention basin.

**Basin B: 0.79 Acres , $Q_5=0.9$  cfs,  $Q_{100}=3.1$  cfs**

Basin B consists of the southeasterly portion of the parcel parallel to the southwest property line containing existing and proposed buildings, and landscaped area which sheet flows to the southwest and is conveyed in storage site improvements directly to the detention basin.

Anticipated runoff from basin B of  $Q_5=0.9$  cfs,  $Q_{100}=3.1$  cfs matches existing condition basin EX-B contribution to adjacent ministorage site of  $Q_5=0.8$  cfs,  $Q_{100}=3.2$  cfs.

Combined developed runoff from the proposed site at DP-3 (detention pond) is  $Q_5=3.8$  cfs,  $Q_{100}=9.1$  cfs exceeds historic runoff at existing design point EX-1 of  $Q_5=2.6$  cfs,  $Q_{100}=7.3$  cfs. The subregional pond constructed with adjacent Mesa Ridge Self Storage Site was designed with excess capacity and excerpts of the report are included in the appendix.

## **DRAINAGE FEE CALCULATION**

Please include a statement of who owns and maintains the pond

There are no Drainage, Bridge, or Pond Fees associated with the East Big Johnson Drainage Basin.

## **DRAINAGE METHODOLOGY**

### **DRAINAGE METHODOLOGY**

This drainage report was prepared in accordance to the criteria established in the El Paso County CDM Vol 1 and 2 with Vol 1 updates.

The rational method for drainage basin study areas of less than 100 acres was utilized in the analysis. For the Rational Method, flows were calculated for the 2, 5, 10, 25, 50, and 100-year recurrence intervals. The average runoff coefficients, 'C' values, are taken from Table 6-6 and the Intensity-Duration-Frequency curves are taken from Figure 6-5 of the City Drainage Criteria Manual. Time of concentration for overland flow and storm drain or gutter flow are calculated per Chapter 6 Section 3.2 of the City Drainage Criteria Manual. Calculations for the Rational Method are shown in the Appendix of this report.

Mile High Flood District methodology was utilized for determination of street capacity and inlet sizing. Calculations are shown in the appendix of this report. Hydraulic Grade Line Calculations have been provided within this report.

The analysis, presented in the appendix, provides more detailed calculations for the system in accordance with the requirements of the El Paso County DCM criteria. The storm sewer plan and profile drawings have been submitted concurrently with this analysis.

## **WATER QUALITY/4-STEP PROCESS**

### **4-STEP PROCESS**

#### **STEP 1: EMPLOY RUNOFF REDUCTION PRACTICES**

The development addresses Low Impact Development strategies primarily through routing runoff developed within impervious areas through landscape area buffers prior to direction off-site where feasible.

### STEP 2: STABILIZE DRAINAGEWAYS

The ultimate recipient of runoff from the site is Fountain Creek. Detention of developed runoff from the site will be provided in both the Sub-regional detention pond (Mesa Ridge Self Storage) and downstream in the regional detention pond (Detention Area A) prior to release in the downstream conveyance.

### STEP 3: PROVIDE WATER QUALITY CAPTURE VOLUME

No water quality capture volume is proposed as anticipated disturbance is less than 1 acre.

### STEP 4: CONSIDER NEED FOR INDUSTRIAL AND COMMERCIAL BMP'S

A Grading, Erosion Control, and Stormwater Quality Plan and narrative will be prepared for the development and will be subject to county approval prior to any soil disturbance. The erosion control plan included specific source control BMPs as well-defined overall site management practices for the construction period. No industrial or commercial uses are proposed with the Church Building Addition and parking improvements. No temporary batch plant operations are proposed with development.

### SUMMARY

Improvements proposed in the drainage letter for Widefield Community Bible Church addition are consistent with drainage patterns anticipated in the Final Drainage Report for Mesa Ridge Self Storage preliminary/Final Drainage Report prepared by M&S Engineering. Development of the parcel is in conformance with current El Paso County criteria and will not adversely affect downstream properties or drainage facilities.

## **REFERENCES:**

City of Colorado Springs Engineering Division Drainage Criteria Manual Volumes 1 and 2, revised May 2014

Amendment to the Mesa Ridge Self Storage Preliminary/Final Drainage Report,” prepared by Catamount Engineering, dated February 2017.

Mesa Ridge Self Storage Preliminary/Final Drainage Report,” prepared by M&S Engineering, dated September 20, 2014.

“Plan and Details of Proposed Peaceful Valley Road Detention Basin” prepared by El Paso County Department of Transportation.

Flood Insurance Rate Map Number 08041C0952 F, effective date march 17, 1997

Soil Map-El Paso County Area, Colorado, generated from Natural Resources Conservation Service Web Soil Survey, generated 9/01/2016

## **APPENDIX**



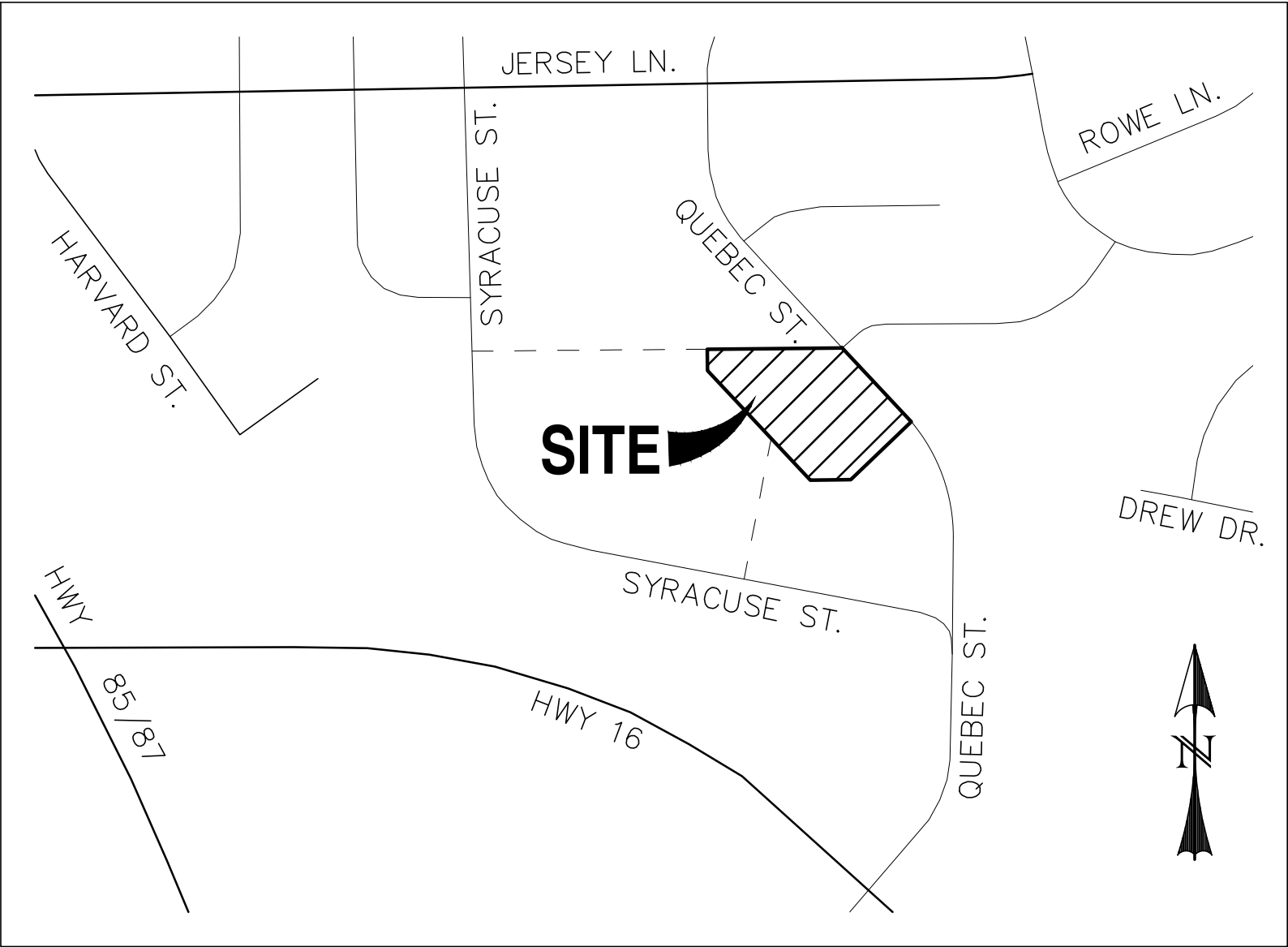

# VICINITY MAP

SCALE: N.T.S.

# National Flood Hazard Layer FIRMette



104°43'2"W 38°43'40"N

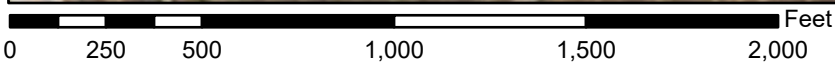

1:6,000

104°42'24"W 38°43'12"N

Basemap Imagery Source: USGS National Map 2023

## Legend

SEE FIS REPORT FOR DETAILED LEGEND AND INDEX MAP FOR FIRM PANEL LAYOUT

SPECIAL FLOOD HAZARD AREAS		Without Base Flood Elevation (BFE) <i>Zone A, V, A99</i>
		With BFE or Depth <i>Zone AE, AO, AH, VE, AR</i>
		Regulatory Floodway
OTHER AREAS OF FLOOD HAZARD		0.2% Annual Chance Flood Hazard, Areas of 1% annual chance flood with average depth less than one foot or with drainage areas of less than one square mile <i>Zone X</i>
		Future Conditions 1% Annual Chance Flood Hazard <i>Zone X</i>
		Area with Reduced Flood Risk due to Levee. See Notes. <i>Zone X</i>
		Area with Flood Risk due to Levee <i>Zone D</i>
OTHER AREAS		NO SCREEN Area of Minimal Flood Hazard <i>Zone X</i>
		Effective LOMRs
GENERAL STRUCTURES		Area of Undetermined Flood Hazard <i>Zone D</i>
		Channel, Culvert, or Storm Sewer
		Levee, Dike, or Floodwall
OTHER FEATURES		20.2 Cross Sections with 1% Annual Chance
		17.5 Water Surface Elevation
		Coastal Transect
		Base Flood Elevation Line (BFE)
		Limit of Study
		Jurisdiction Boundary
MAP PANELS		Coastal Transect Baseline
		Profile Baseline
		Hydrographic Feature
		Digital Data Available
		No Digital Data Available
		Unmapped



The pin displayed on the map is an approximate point selected by the user and does not represent an authoritative property location.

This map complies with FEMA's standards for the use of digital flood maps if it is not void as described below. The basemap shown complies with FEMA's basemap accuracy standards

The flood hazard information is derived directly from the authoritative NFHL web services provided by FEMA. This map was exported on 8/2/2024 at 2:44 PM and does not reflect changes or amendments subsequent to this date and time. The NFHL and effective information may change or become superseded by new data over time.







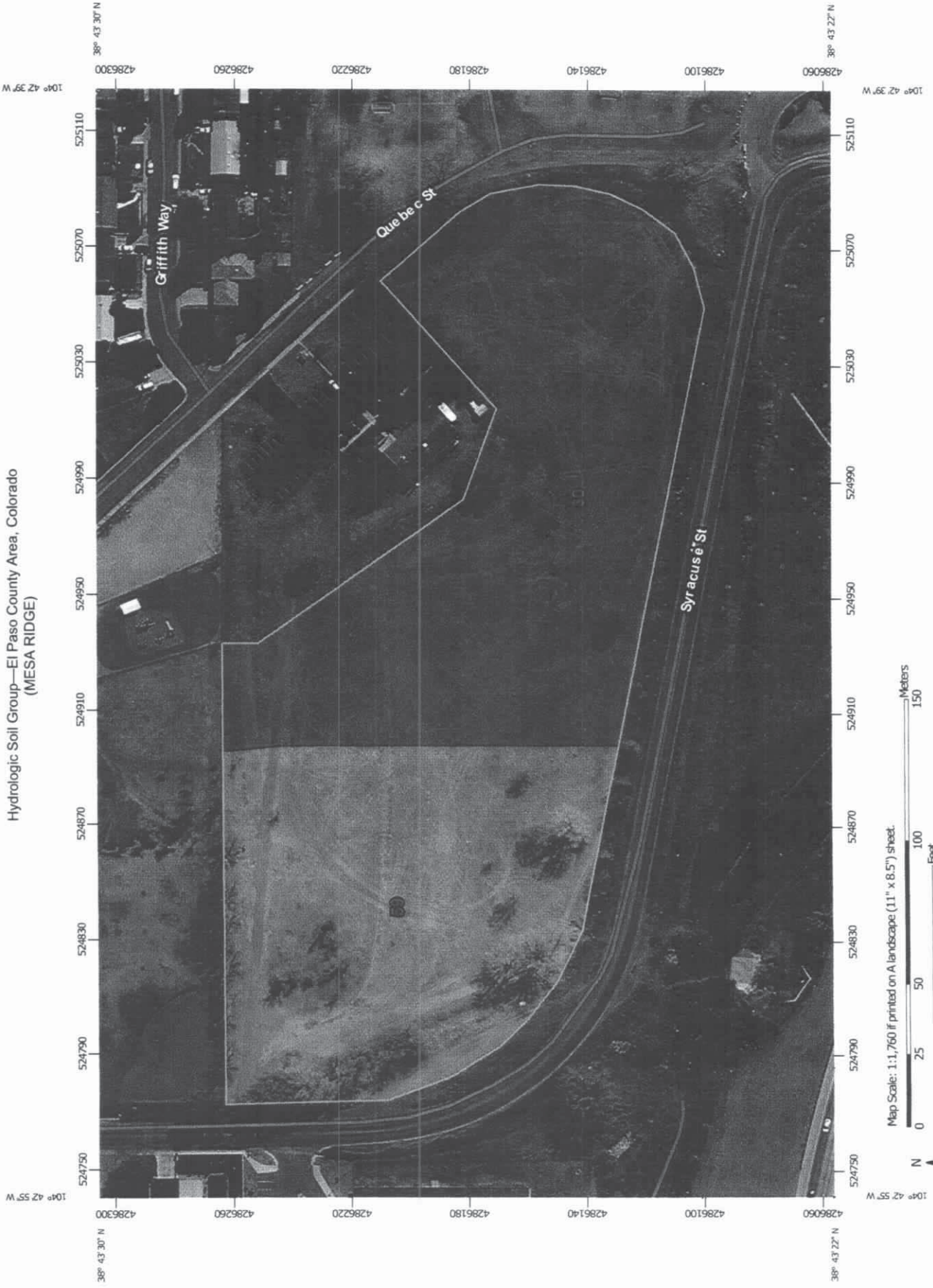































This map image is void if the one or more of the following map elements do not appear: basemap imagery, flood zone labels, legend, scale bar, map creation date, community identifiers, FIRM panel number, and FIRM effective date. Map images for unmapped and unmodernized areas cannot be used for regulatory purposes.



Hydrologic Soil Group—El Paso County Area, Colorado  
(MESA RIDGE)



## MAP LEGEND

 Area of Interest (AOI)	 C
 Soil Rating Polygons	 C/D
 A	 D
 A/D	 Not rated or not available
 B	 Water Features
 B/D	 Streams and Canals
 C	 Transportation
 C/D	 Rails
 D	 Interstate Highways
 Not rated or not available	 US Routes
 Soil Rating Lines	 Major Roads
 A	 Local Roads
 A/D	 Background
 B	 Aerial Photography
 B/D	
 C	
 C/D	
 D	
 Not rated or not available	
 Soil Rating Points	
 A	
 A/D	
 B	
 B/D	

## MAP INFORMATION

The soil surveys that comprise your AOI were mapped at 1:24,000.

Warning: Soil Map may not be valid at this scale.

Enlargement of maps beyond the scale of mapping can cause misunderstanding of the detail of mapping and accuracy of soil line placement. The maps do not show the small areas of contrasting soils that could have been shown at a more detailed scale.

Please rely on the bar scale on each map sheet for map measurements.

Source of Map: Natural Resources Conservation Service  
Web Soil Survey URL: <http://websoilsurvey.nrcs.usda.gov>  
Coordinate System: Web Mercator (EPSG:3857)

Maps from the Web Soil Survey are based on the Web Mercator projection, which preserves direction and shape but distorts distance and area. A projection that preserves area, such as the Albers equal-area conic projection, should be used if more accurate calculations of distance or area are required.

This product is generated from the USDA-NRCS certified data as of the version date(s) listed below.

Soil Survey Area: El Paso County Area, Colorado  
Survey Area Data: Version 10, Dec 23, 2013

Soil map units are labeled (as space allows) for map scales 1:50,000 or larger.

Date(s) aerial images were photographed: Apr 15, 2011—Sep 22, 2011

The orthophoto or other base map on which the soil lines were compiled and digitized probably differs from the background imagery displayed on these maps. As a result, some minor shifting of map unit boundaries may be evident.



## Hydrologic Soil Group

Hydrologic Soil Group— Summary by Map Unit — El Paso County Area, Colorado (CO625)				
Map unit symbol	Map unit name	Rating	Acres in AOI	Percent of AOI
30	Fort Collins loam, 0 to 3 percent slopes	B	4.5	56.3%
59	Nunn clay loam, 0 to 3 percent slopes	C	3.5	43.7%
<b>Totals for Area of Interest</b>			<b>8.1</b>	<b>100.0%</b>

### Description

Hydrologic soil groups are based on estimates of runoff potential. Soils are assigned to one of four groups according to the rate of water infiltration when the soils are not protected by vegetation, are thoroughly wet, and receive precipitation from long-duration storms.

The soils in the United States are assigned to four groups (A, B, C, and D) and three dual classes (A/D, B/D, and C/D). The groups are defined as follows:

Group A. Soils having a high infiltration rate (low runoff potential) when thoroughly wet. These consist mainly of deep, well drained to excessively drained sands or gravelly sands. These soils have a high rate of water transmission.

Group B. Soils having a moderate infiltration rate when thoroughly wet. These consist chiefly of moderately deep or deep, moderately well drained or well drained soils that have moderately fine texture to moderately coarse texture. These soils have a moderate rate of water transmission.

Group C. Soils having a slow infiltration rate when thoroughly wet. These consist chiefly of soils having a layer that impedes the downward movement of water or soils of moderately fine texture or fine texture. These soils have a slow rate of water transmission.

Group D. Soils having a very slow infiltration rate (high runoff potential) when thoroughly wet. These consist chiefly of clays that have a high shrink-swell potential, soils that have a high water table, soils that have a claypan or clay layer at or near the surface, and soils that are shallow over nearly impervious material. These soils have a very slow rate of water transmission.

If a soil is assigned to a dual hydrologic group (A/D, B/D, or C/D), the first letter is for drained areas and the second is for undrained areas. Only the soils that in their natural condition are in group D are assigned to dual classes.

### Rating Options

*Aggregation Method:* Dominant Condition

# **HYDROLOGIC CALCULATIONS**



BASIN	AREA TOTAL (Acres)	C						CONVEYANCE TC							TT	INTENSITY						TOTAL FLOWS							
		C <sub>2</sub>	C <sub>5</sub>	C <sub>10</sub>	C <sub>25</sub>	C <sub>50</sub>	C <sub>100</sub>	Length (ft)	Height (ft)	TI (min)	Length (ft)	Height (ft)	C <sub>v</sub>	Slope (%)	Velocity (fps)	TC (min)	TOTAL (min)	I <sub>2</sub> (in/hr)	I <sub>5</sub> (in/hr)	I <sub>10</sub> (in/hr)	I <sub>25</sub> (in/hr)	I <sub>50</sub> (in/hr)	I <sub>100</sub> (in/hr)	Q <sub>2</sub> (c.f.s.)	Q <sub>5</sub> (c.f.s.)	Q <sub>10</sub> (c.f.s.)	Q <sub>25</sub> (c.f.s.)	Q <sub>50</sub> (c.f.s.)	Q <sub>100</sub> (c.f.s.)
<b>A1</b>	0.17	<b>0.80</b>	<b>0.82</b>	<b>0.85</b>	<b>0.88</b>	<b>0.89</b>	<b>0.91</b>	87	2	3.6 DP-2	27	0.4	20	1.5%	2.4	0.2	5.0	4.1	5.2	6.0	6.9	7.8	8.7	<b>0.6</b>	<b>0.7</b>	<b>0.9</b>	<b>1.0</b>	<b>1.2</b>	<b>1.3</b>
ROOF	0.00	0.73	0.75	0.77	0.80	0.82	0.83																						
PAVEMENT	0.15	0.89	0.90	0.92	0.94	0.95	0.96																						
LANDSCAPE	0.02	0.09	0.19	0.29	0.40	0.46	0.52																						
<b>A2</b>	0.77	<b>0.65</b>	<b>0.69</b>	<b>0.73</b>	<b>0.78</b>	<b>0.80</b>	<b>0.82</b>	37	1	3.3	206	3.2	20	1.6%	2.5	1.4	5.0	4.1	5.2	6.0	6.9	7.8	8.7	<b>2.1</b>	<b>2.7</b>	<b>3.4</b>	<b>4.1</b>	<b>4.8</b>	<b>5.5</b>
ROOF	0.09	0.73	0.75	0.77	0.80	0.82	0.83																						
PAVEMENT	0.47	0.89	0.90	0.92	0.94	0.95	0.96																						
LANDSCAPE	0.21	0.09	0.19	0.29	0.40	0.46	0.52																						
<b>A3</b>	0.15	<b>0.09</b>	<b>0.19</b>	<b>0.29</b>	<b>0.40</b>	<b>0.46</b>	<b>0.52</b>	55	2.5	7.4	20	1	7	5.0%	1.6	0.2	7.6	3.6	4.5	5.3	6.1	6.8	7.6	<b>0.0</b>	<b>0.1</b>	<b>0.2</b>	<b>0.4</b>	<b>0.5</b>	<b>0.6</b>
ROOF	0.00	0.73	0.75	0.77	0.80	0.82	0.83																						
PAVEMENT	0.00	0.89	0.90	0.92	0.94	0.95	0.96																						
LANDSCAPE	0.15	0.09	0.19	0.29	0.40	0.46	0.52																						
<b>B</b>	0.79	<b>0.17</b>	<b>0.26</b>	<b>0.35</b>	<b>0.45</b>	<b>0.51</b>	<b>0.56</b>	64	2	8.3	95	2	7	2.1%	1.0	1.6	9.9	3.3	4.2	4.8	5.5	6.2	7.0	<b>0.5</b>	<b>0.9</b>	<b>1.3</b>	<b>2.0</b>	<b>2.5</b>	<b>3.1</b>
ROOF	0.09	0.73	0.75	0.77	0.80	0.82	0.83																						
PAVEMENT	0.01	0.89	0.90	0.92	0.94	0.95	0.96																						
LANDSCAPE	0.69	0.09	0.19	0.29	0.40	0.46	0.52																						

Calculated by: DLM  
Date: 10/1/2024



DESIGN POINT	AREA TOTAL (Acres)	WEIGHTED						TT	INTENSITY						TOTAL FLOWS					
		C <sub>2</sub>	C <sub>5</sub>	C <sub>10</sub>	C <sub>25</sub>	C <sub>50</sub>	C <sub>100</sub>	TOTAL (min)	I <sub>2</sub> (in/hr)	I <sub>5</sub> (in/hr)	I <sub>10</sub> (in/hr)	I <sub>25</sub> (in/hr)	I <sub>50</sub> (in/hr)	I <sub>100</sub> (in/hr)	Q <sub>2</sub> (c.f.s.)	Q <sub>5</sub> (c.f.s.)	Q <sub>10</sub> (c.f.s.)	Q <sub>25</sub> (c.f.s.)	Q <sub>50</sub> (c.f.s.)	Q <sub>100</sub> (c.f.s.)
EX-1	1.88	0.30	0.38	0.46	0.54	0.59	0.64	13.7	2.9	3.7	4.3	4.9	5.5	6.1	1.7	2.6	3.7	5.0	6.1	7.3
BASIN EX A	0.92	0.49	0.55	0.61	0.67	0.70	0.74	8.5												
BASIN EX B	0.96	0.13	0.22	0.32	0.42	0.48	0.54	13.7												

Calculated by: DLM  
Date: 10/1/2024

DESIGN POINT	AREA TOTAL (Acres)	WEIGHTED						TT	INTENSITY						TOTAL FLOWS					
		C <sub>2</sub>	C <sub>5</sub>	C <sub>10</sub>	C <sub>25</sub>	C <sub>50</sub>	C <sub>100</sub>	TOTAL (min)	I <sub>2</sub> (in/hr)	I <sub>5</sub> (in/hr)	I <sub>10</sub> (in/hr)	I <sub>25</sub> (in/hr)	I <sub>50</sub> (in/hr)	I <sub>100</sub> (in/hr)	Q <sub>2</sub> (c.f.s.)	Q <sub>5</sub> (c.f.s.)	Q <sub>10</sub> (c.f.s.)	Q <sub>25</sub> (c.f.s.)	Q <sub>50</sub> (c.f.s.)	Q <sub>100</sub> (c.f.s.)
<b>DP-1</b> BASIN A1	<b>0.17</b> 0.17	<b>0.80</b> 0.80	<b>0.82</b> 0.82	<b>0.85</b> 0.85	<b>0.88</b> 0.88	<b>0.89</b> 0.89	<b>0.91</b> 0.91	5.0 5.0	4.1	5.2	6.0	6.9	7.8	8.7	<b>0.6</b>	<b>0.7</b>	<b>0.9</b>	<b>1.0</b>	<b>1.2</b>	<b>1.3</b>
<b>DP-2</b> DP-1 BASIN A2	<b>0.94</b> 0.17 0.77	<b>0.68</b> 0.80 0.65	<b>0.71</b> 0.82 0.69	<b>0.75</b> 0.85 0.73	<b>0.79</b> 0.88 0.78	<b>0.82</b> 0.89 0.80	<b>0.84</b> 0.91 0.82	5.0 5.0 5.0	4.1	5.2	6.0	6.9	7.8	8.7	<b>2.6</b>	<b>3.5</b>	<b>4.3</b>	<b>5.1</b>	<b>6.0</b>	<b>6.9</b>
<b>DP-3</b> DP-2 BASIN A3 BASIN B	<b>1.88</b> 0.94 0.15 0.79	<b>0.42</b> 0.68 0.09 0.17	<b>0.48</b> 0.71 0.19 0.26	<b>0.55</b> 0.75 0.29 0.35	<b>0.62</b> 0.79 0.40 0.45	<b>0.66</b> 0.82 0.46 0.51	<b>0.70</b> 0.84 0.52 0.56	9.9 5.0 7.6 9.9	3.3	4.2	4.8	5.5	6.2	7.0	<b>2.6</b>	<b>3.8</b>	<b>5.0</b>	<b>6.4</b>	<b>7.7</b>	<b>9.1</b>

Calculated by: DLM  
Date: 10/1/2024

# **HYDRAULIC CALCULATIONS**

# **DRAINAGE LETTER ADDENDUM TO MESA RIDGE SELF STORAGE PRELIMINARY/FINAL DRAINAGE REPORT**

April 2017

Prepared for:  
Mesa Ridge Self Storage LLC  
791 Copper Center Parkway  
Colorado Springs, CO 80921

Prepared By:



321 W. Henrietta Ave, Suite A  
Woodland Park, CO 80863  
719-426-2124

# DRAINAGE LETTER ADDENDUM TO MESA RIDGE SELF STORAGE PRELIMINARY/FINAL DRAINAGE REPORT

## **PURPOSE**

The purpose of this drainage report is to identify and analyze interim condition revisions to proposed drainage patterns for the Mesa Ridge development. El Paso County Board of County Commissioner's action allows development of Lot 1 Mesa Ridge Self Storage Filing 1 without pursuing infrastructure associated with Quebec Street and Syracuse frontage of Tract A. Future development action within Tract A will require replatting of the tract and development of Quebec Street, Syracuse Frontage, and drainage conveyance of tributary offsite flows to the existing regional detention facility located south of Syracuse Street.

The interim condition is proposed to replace the dual 54" culverts exhibited in the M&S engineering FDR. The proposed improvements will convey flows historically carried by the existing 48" culvert crossing of Syracuse Street and releasing to the regional detention facility. The interim condition will remain until ultimate improvements are constructed with development of Tract A.

This report will accept hydrology for offsite basins developed in the approved "Mesa Ridge Self Storage Preliminary/Final Drainage Report," by M&S Engineering and size drainage facilities for conveyance of offsite basin runoff to regional Detention Area A developed in the "Powers Boulevard/Peaceful Valley Road Storm Drainage Detention Study," prepared by Wilson & Company and "Plan and Details of proposed peaceful Valley Road Detention Basin," prepared by El Paso County Department of Transportation.. This addendum solely addresses development of replacement conveyance for offsite flows crossing Syracuse within Tract 'A'.

## **GENERAL LOCATION AND DESCRIPTION**

The parcel is located within the southwest 1/4 of Section 19, Township 15 South, Range 65 West of the 6<sup>th</sup> principal within unincorporated El Paso County. The parcel is bounded to the north by existing Webster Elementary School and Widefield Community Bible Church, to the east by undeveloped Quebec Street, to the south and west by existing Syracuse Street.

The site has been platted as Mesa Ridge Self Storage Filing 1 and remains undeveloped. Undetained runoff from upstream development is conveyed in a roadside ditch along the northern limits of Syracuse Street to an existing culvert crossing which outfalls into the existing regional detention pond. Lot 1 and Tract A drain to the culvert crossing at the southwest corner of the development.

Existing soils on the site consist of Fort Collins loam, hydrologic soil group B (30) and Nunn Clay loam, hydrologic soils group C (59) as determined by the Natural Resources Conservation Service Web Soil Survey. The site is located within the East Big Johnson Basin and ultimately drains to Fountain Creek.

## **EXISTING DRAINAGE CONDITIONS**

From “Mesa Ridge Self Storage Preliminary/Final Drainage Report” by M&S Engineering-

*The overall site consists of 7.95 acres, and is currently undeveloped. Runoff from the site sheet flows into drainage swales located along the perimeter of the site on the; west, east, and south to an existing 48” concrete pipe which conveys flows under Syracuse Street. Existing developed flows northwest of the site are routed via Syracuse Street into an existing drainage swale that runs the perimeter of the site along the west and south to the existing 48” concrete pipe. Existing developed flows from the northeast and east of the site are routed via a drainage swale that runs the perimeter of our site along the east and south to the existing 48” concrete pipe. The existing 48” concrete pipe conveys flows underneath Syracuse Street to Detention Area A (PPVDDS).*

*The site is tributary to Detention Area A (PPVDDS) and the 5-year and 100-year storm water infrastructure from this site has already been incorporated and constructed. However, WQCV will be provided onsite for the proposed run off.*

*The site was originally studied in the “Powers Boulevard/Peaceful Valley Road Storm Drainage Detention Study” (PPVDDS), prepared by Wilson & Company dated September 1996.*

## **PROPOSED DRAINAGE AMENDMENT**

Development of the mini storage site on Lot 1 will remove historic basins OS-3, OS-A2, and B from historic outfall at the 48” RCP at Design Point 13. The approved drainage report proposed to convey undetained off-site flows from Basins OS-3 and OS-A2 in a dual 54” RCP crossing of Syracuse to existing El Paso County Detention Area A (Design Point 12 M&S report). A portion of the 100-Year design flows was proposed to overtop existing Syracuse at the crossing.

From “Mesa Ridge Self Storage Preliminary/Final Drainage Report” by M&S Engineering-

*Flows from both Basins OS-3 and OS-A2 are intended to end up in Pond A. The dual 54” culverts will convey 355 CFS of the  $Q_{100}=397$  CFS. Overtopping of Syracuse to Pond A at a depth of approximately 0.4’ is less than the maximum allowable.*

The existing design exhibits 42 CFS not contained within the proposed culvert crossing and being conveyed to Syracuse Right-of-Way in the major storm event.

The proposed redesign proposes a detention facility within tract ‘A’ to attenuate the major storm event. The proposed detention facility within tract ‘A’ will capture runoff from Basins OS-3, OS-A2, and B and release flows through a 48” RCP across Syracuse Road to existing regional Pond A.

The pond contains approximately 7.67 acre-feet of storage below the emergency overflow. Total 100-YR peak volume while the overflow is in operation is 9.05 acre-ft. The emergency overflow consists of a soil riprap weir 50’ long with a minimum depth of 1.55’ and is sized to convey the

100 year storm in the event of fully plugged primary outlet. The pond was designed with a minimum berm width of 10' and minimum elevation of 5658.75

The 100-YR maximum release from the pond will convey 145 CFS in the 48" RCP and 38 CFS in the overflow spillway. Release from the overflow spillway will overtop Syracuse to Pond A.

**Drainage Concept Comparison-**

	M&S report	Letter Addendum
Concept	Dual 54" RCP	Pond with Single 48" RCP
100-YR Inflow	397 CFS	399 CFS
100-YR peak outflow	397 CFS	183 CFS
100-YR peak pipe flow	355 CFS	146 CFS
100-YR overtopping	42 CFS	38 CFS

**SUMMARY**

The pond is private and will be owned and maintained by the property owner.

Revisions proposed in the addendum will not adversely affect the surrounding development and improve conveyance of existing drainage to existing Detention Area A. This report is in conformance with previous drainage studies, and the construction drawings for Peaceful Valley Road Detention Basin.

**FLOODPLAIN STATEMENT**

No portion of the site lies within an F.E.M.A. designated floodplain per FIRM 08041C0952 F, effective March 17, 1997. The F.E.M.A. Flood Insurance Rate Map has been provided.

**COST ESTIMATE**

**Public Improvements-Non reimbursable**

Item	Quantity	Unit Cost	Cost
48" RCP Outfall	127 LF	\$ 178/LF	\$22,606
48" FES	2 EA	\$2,000/EA	\$ 4,000
Outlet Cutoff Wall	1.74CY	\$ 550/CY	\$ 957
Soil Riprap	54/CY	\$ 98/CY	\$ 5,292
	<b>Total Public Improvements</b>		<b>\$32,855</b>

**Private Improvements-Non reimbursable**

Item	Quantity	Unit Cost	Cost
Emergency Spillway	1 EA	\$ 2,500/EA	\$ 2,500
Soil Riprap	100 CY	\$ 98/CY	\$ 9,800
	<b>Total Private Improvements</b>		<b>\$12,300</b>

## **DRAINAGE FEE CALCULATION**

There are no Drainage, Bridge, or Pond Fees associated with the East Big Johnson Drainage Basin.

## **DRAINAGE METHODOLOGY**

This drainage report was prepared in accordance to the criteria established in the El Paso County/City of Colorado Springs Drainage Criteria Manual Volumes 1 and 2, as revised May 2014.

Hydrology used in the analysis was taken directly from the “Mesa Ridge Self Storage Preliminary/Final Drainage Report”, prepared by M&S Engineering, dated September 20, 2014.

## **REFERENCES:**

City of Colorado Springs Engineering Division Drainage Criteria Manual Volumes 1 and 2, revised May 2014

Mesa Ridge Self Storage Preliminary/Final Drainage Report”, prepared by M&S Engineering, dated September 20, 2014.

“Plan and Details of Proposed Peaceful Valley Road Detention Basin” prepared by El Paso County Department of Transportation.

Flood Insurance Rate Map Number 08041C0952 F, effective date march 17, 1997

Soil Map-El Paso County Area, Colorado, generated from Natural Resources Conservation Service Web Soil Survey, generated 9/01/2016



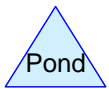
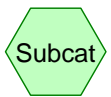
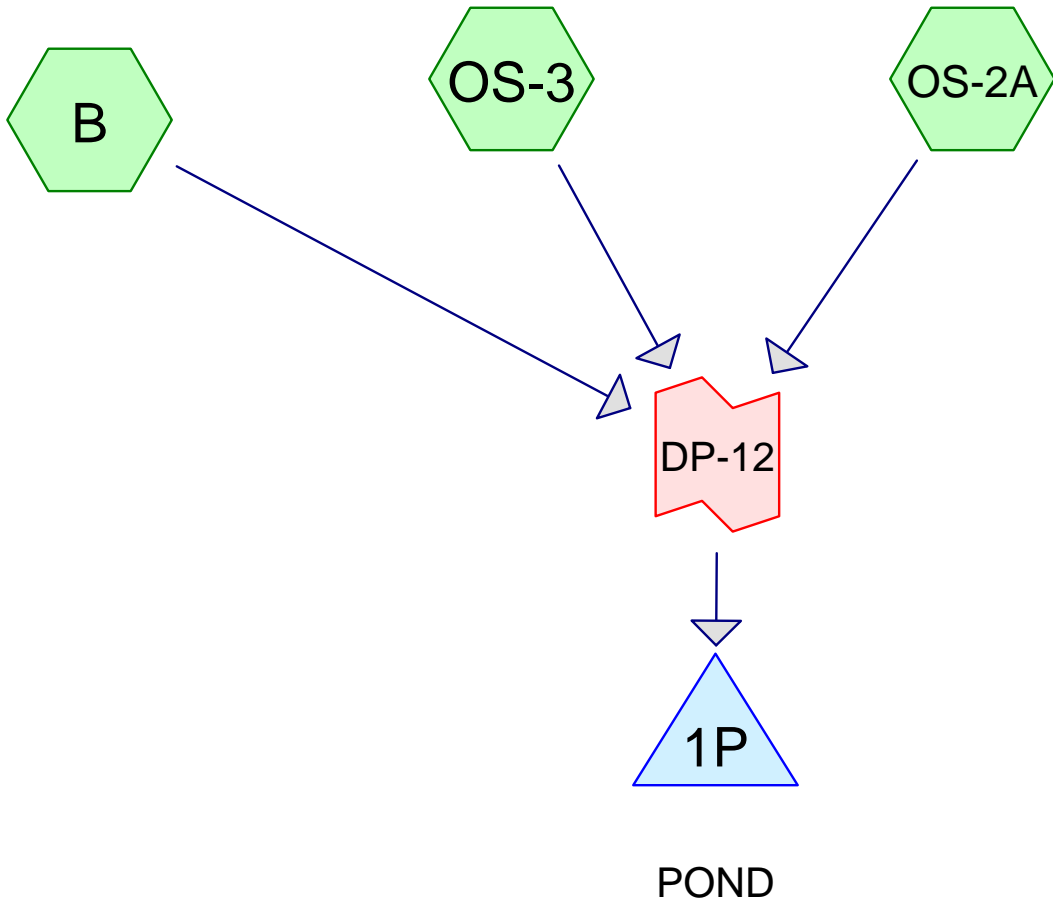

```
// HydroCAD Rainfall table  
// Copyright (c) 1990-2001 Applied Microcomputer Systems  
// For details see Rainfall.txt
```

```
name=Type IIA 24-hr
```

```
timeunits=hours
```

```
duration=24
```

```
comment=SCS Type IIA Colorado Springs Modified
```

```
smoothing=false
```

```
depth= 0.000 0.001 0.002 0.003 0.005 0.006 0.008 0.010 0.012 0.014  
depth= 0.017 0.019 0.021 0.023 0.026 0.028 0.032 0.039 0.046 0.053  
depth= 0.060 0.075 0.100 0.400 0.700 0.725 0.750 0.765 0.780 0.790  
depth= 0.800 0.810 0.820 0.825 0.830 0.835 0.840 0.845 0.850 0.855  
depth= 0.860 0.864 0.868 0.871 0.875 0.879 0.883 0.886 0.890 0.894  
depth= 0.898 0.901 0.905 0.908 0.912 0.915 0.918 0.921 0.924 0.927  
depth= 0.930 0.933 0.935 0.938 0.940 0.943 0.945 0.948 0.950 0.953  
depth= 0.955 0.958 0.960 0.963 0.965 0.968 0.970 0.973 0.975 0.978  
depth= 0.980 0.981 0.983 0.984 0.985 0.986 0.988 0.989 0.990 0.991  
depth= 0.993 0.994 0.995 0.996 0.998 0.999 1.000
```

**POND.100**

Type IIA 24-hr Rainfall=4.50"

Prepared by {enter your company name here}

Page 2

HydroCAD® 7.00 s/n 002053 © 1986-2003 Applied Microcomputer Systems

4/18/2017

Time span=5.00-20.00 hrs, dt=0.05 hrs, 301 points

Runoff by SCS TR-20 method, UH=SCS

Reach routing by Stor-Ind+Trans method - Pond routing by Stor-Ind method

**Subcatchment B:**

Runoff Area=3.100 ac Runoff Depth=1.83"  
Tc=8.1 min CN=73 Runoff=9.31 cfs 0.472 af

**Subcatchment OS-2A:**

Runoff Area=79.500 ac Runoff Depth=2.05"  
Tc=25.0 min CN=76 Runoff=186.29 cfs 13.557 af

**Subcatchment OS-3:**

Runoff Area=82.700 ac Runoff Depth=2.21"  
Tc=24.7 min CN=78 Runoff=210.47 cfs 15.207 af

**Pond 1P: POND**

Peak Elev=5,657.71' Storage=394,192 cf Inflow=399.15 cfs 29.236 af  
Primary=144.58 cfs 28.503 af Secondary=38.48 cfs 0.712 af Outflow=183.06 cfs 29.215 af

**Link DP-12:**

Inflow=399.15 cfs 29.236 af  
Primary=399.15 cfs 29.236 af

**POND.100**

Type IIA 24-hr Rainfall=4.50"

Prepared by {enter your company name here}

Page 3

HydroCAD® 7.00 s/n 002053 © 1986-2003 Applied Microcomputer Systems

4/18/2017

**Subcatchment B:**

Runoff = 9.31 cfs @ 6.03 hrs, Volume= 0.472 af, Depth= 1.83"

Runoff by SCS TR-20 method, UH=SCS, Time Span= 5.00-20.00 hrs, dt= 0.05 hrs  
Type IIA 24-hr Rainfall=4.50"

Area (ac)	CN	Description
3.100	73	Pasture/grassland/range, Poor, HSG B

Tc (min)	Length (feet)	Slope (ft/ft)	Velocity (ft/sec)	Capacity (cfs)	Description
8.1					<b>Direct Entry,</b>

**Subcatchment OS-2A:**

Runoff = 186.29 cfs @ 6.18 hrs, Volume= 13.557 af, Depth= 2.05"

Runoff by SCS TR-20 method, UH=SCS, Time Span= 5.00-20.00 hrs, dt= 0.05 hrs  
Type IIA 24-hr Rainfall=4.50"

Area (ac)	CN	Description
79.500	76	M&S REPORT

Tc (min)	Length (feet)	Slope (ft/ft)	Velocity (ft/sec)	Capacity (cfs)	Description
25.0					<b>Direct Entry, M&amp;S REPORT</b>

**Subcatchment OS-3:**

Runoff = 210.47 cfs @ 6.17 hrs, Volume= 15.207 af, Depth= 2.21"

Runoff by SCS TR-20 method, UH=SCS, Time Span= 5.00-20.00 hrs, dt= 0.05 hrs  
Type IIA 24-hr Rainfall=4.50"

Area (ac)	CN	Description
82.700	78	MS Final Report

Tc (min)	Length (feet)	Slope (ft/ft)	Velocity (ft/sec)	Capacity (cfs)	Description
24.7					<b>Direct Entry, M&amp;S REPORT</b>

**Pond 1P: POND**

Inflow Area = 165.300 ac, Inflow Depth = 2.12"  
 Inflow = 399.15 cfs @ 6.18 hrs, Volume= 29.236 af  
 Outflow = 183.06 cfs @ 6.45 hrs, Volume= 29.215 af, Atten= 54%, Lag= 16.4 min  
 Primary = 144.58 cfs @ 6.45 hrs, Volume= 28.503 af  
 Secondary = 38.48 cfs @ 6.45 hrs, Volume= 0.712 af

**POND.100**

Type IIA 24-hr Rainfall=4.50"

Prepared by {enter your company name here}

Page 4

HydroCAD® 7.00 s/n 002053 © 1986-2003 Applied Microcomputer Systems

4/18/2017

Routing by Stor-Ind method, Time Span= 5.00-20.00 hrs, dt= 0.05 hrs  
 Peak Elev= 5,657.71' @ 6.45 hrs Surf.Area= 88,794 sf Storage= 394,192 cf  
 Plug-Flow detention time= 23.1 min calculated for 29.215 af (100% of inflow)  
 Center-of-Mass det. time= 22.6 min ( 518.3 - 495.7 )

#	Invert	Avail.Storage	Storage Description
1	5,650.00'	419,360 cf	<b>Custom Stage Data (Prismatic)</b> Listed below

Elevation (feet)	Surf.Area (sq-ft)	Inc.Store (cubic-feet)	Cum.Store (cubic-feet)
5,650.00	10	0	0
5,651.00	2,144	1,077	1,077
5,652.00	18,582	10,363	11,440
5,653.00	54,705	36,644	48,084
5,654.00	67,609	61,157	109,241
5,655.00	72,146	69,878	179,118
5,656.00	76,777	74,462	253,580
5,657.00	81,502	79,140	332,719
5,658.00	91,780	86,641	419,360

#	Routing	Invert	Outlet Devices
1	Primary	5,650.00'	<b>48.0" x 126.0' long Culvert</b> RCP, end-section conforming to fill, Ke= 0.500 Outlet Invert= 5,641.29' S= 0.0691 '/' n= 0.013 Cc= 0.900
2	Secondary	5,657.20'	<b>40.0' long x 10.0' breadth Broad-Crested Rectangular Weir</b> Head (feet) 0.20 0.40 0.60 0.80 1.00 1.20 1.40 1.60 Coef. (English) 2.49 2.56 2.70 2.69 2.68 2.69 2.67 2.64

**Primary OutFlow** Max=144.57 cfs @ 6.45 hrs HW=5,657.71' (Free Discharge)↑**1=Culvert** (Inlet Controls 144.57 cfs @ 11.5 fps)**Secondary OutFlow** Max=38.27 cfs @ 6.45 hrs HW=5,657.71' (Free Discharge)↑**2=Broad-Crested Rectangular Weir** (Weir Controls 38.27 cfs @ 1.9 fps)**Link DP-12:**

Inflow Area = 165.300 ac, Inflow Depth = 2.12"  
 Inflow = 399.15 cfs @ 6.18 hrs, Volume= 29.236 af  
 Primary = 399.15 cfs @ 6.18 hrs, Volume= 29.236 af, Atten= 0%, Lag= 0.0 min

Primary outflow = Inflow, Time Span= 5.00-20.00 hrs, dt= 0.05 hrs

**POND.100**

Type IIA 24-hr Rainfall=4.50"

Prepared by {enter your company name here}

HydroCAD® 7.00 s/n 002053 © 1986-2003 Applied Microcomputer Systems

4/18/2017

**Pond 1P: POND**

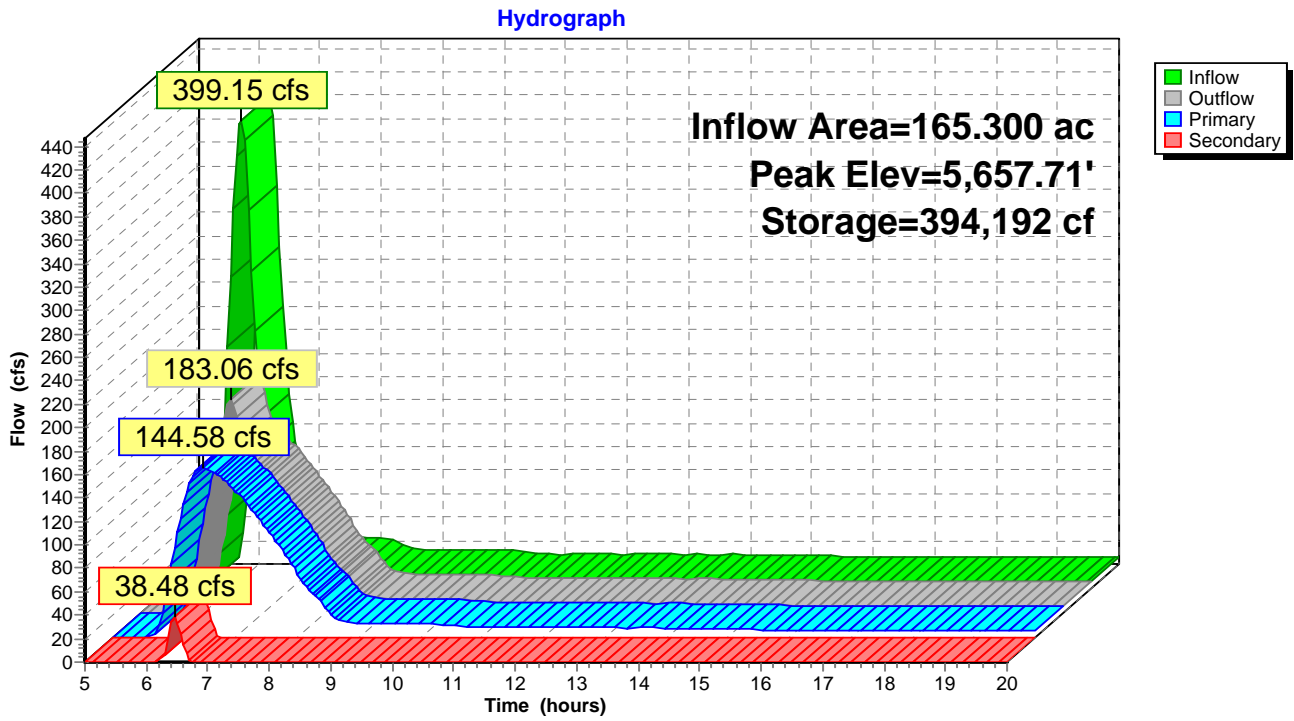

# CULVERT STAGE-DISCHARGE SIZING (INLET vs. OUTLET CONTROL WITH TAILWATER EFFECTS)

Project: **Mesa Ridge Self Storage**  
 Basin ID: **Existing 48" RCP CROSSING OF SYRACUSE**  
 Status: \_\_\_\_\_

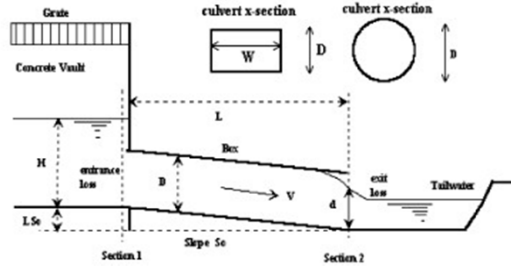

**Design Information (Input):**

**Circular Culvert:** Barrel Diameter in Inches D =  inches  
 Inlet Edge Type (choose from pull-down list)

**OR:**

**Box Culvert:** Barrel Height (Rise) in Feet Height (Rise) =  ft.  
 Barrel Width (Span) in Feet Width (Span) =  ft.  
 Inlet Edge Type (choose from pull-down list)

Number of Barrels No =   
 Inlet Elevation at Culvert Invert Inlet Elev =  ft. elev.  
 Outlet Elevation at Culvert Invert OR Slope of Culvert (ft v./ft h.) Outlet Elev =  ft. elev.  
 Culvert Length in Feet L =  ft.  
 Manning's Roughness n =   
 Bend Loss Coefficient K<sub>b</sub> =   
 Exit Loss Coefficient K<sub>x</sub> =

**Design Information (calculated):**

Entrance Loss Coefficient K<sub>e</sub> =   
 Friction Loss Coefficient K<sub>f</sub> =   
 Sum of All Loss Coefficients K<sub>s</sub> =   
 Orifice Inlet Condition Coefficient C<sub>d</sub> =   
 Minimum Energy Condition Coefficient KE<sub>low</sub> =

**Calculations of Culvert Capacity (output):**

Water Surface Elevation (ft., linked)	Tailwater Surface Elevation ft	Culvert Inlet-Control Flowrate cfs	Culvert Outlet-Control Flowrate cfs	Controlling Culvert Flowrate cfs (output)	Inlet Equation Used:	Flow Control Used
5656.00	95.00	115.90	224.64	115.90	Regression Eqn.	INLET
5656.10		117.60	225.68	117.60	Regression Eqn.	INLET
5656.20		119.30	226.72	119.30	Regression Eqn.	INLET
5656.30		121.00	227.76	121.00	Regression Eqn.	INLET
5656.40		122.70	228.79	122.70	Regression Eqn.	INLET
5656.50		124.30	229.81	124.30	Regression Eqn.	INLET
5656.60		125.90	230.83	125.90	Regression Eqn.	INLET
5656.70		127.50	231.86	127.50	Regression Eqn.	INLET
5656.80		129.00	232.86	129.00	Regression Eqn.	INLET
5656.90		130.60	233.89	130.60	Regression Eqn.	INLET
5657.00		132.10	234.89	132.10	Regression Eqn.	INLET
5657.10		133.60	235.88	133.60	Regression Eqn.	INLET
5657.20		135.10	236.88	135.10	Regression Eqn.	INLET
5657.30		136.50	237.87	136.50	Regression Eqn.	INLET
5657.40		138.00	238.86	138.00	Regression Eqn.	INLET
5657.50		139.40	239.85	139.40	Regression Eqn.	INLET
5657.60		140.80	240.83	140.80	Regression Eqn.	INLET
5657.70		142.20	241.80	142.20	Regression Eqn.	INLET
5657.80		143.60	242.77	143.60	Regression Eqn.	INLET
5657.90		145.00	243.74	145.00	Regression Eqn.	INLET
5658.00		146.30	244.71	146.30	Regression Eqn.	INLET
5658.10		147.70	245.68	147.70	Regression Eqn.	INLET
5658.20		149.00	246.63	149.00	Regression Eqn.	INLET
5658.30		150.30	247.58	150.30	Regression Eqn.	INLET
5658.40		151.60	248.53	151.60	Regression Eqn.	INLET
5658.50		152.90	249.48	152.90	Regression Eqn.	INLET
5658.60		154.20	250.41	154.20	Regression Eqn.	INLET
5658.70		155.50	251.36	155.50	Regression Eqn.	INLET
5658.80		156.70	252.30	156.70	Regression Eqn.	INLET
5658.90		158.00	253.23	158.00	Regression Eqn.	INLET

Processing Time: 00.21 Seconds

**CULVERT STAGE-DISCHARGE SIZING (INLET vs. OUTLET CONTROL WITH TAILWATER EFFECTS)**

Project: Mesa Ridge Self Storage  
Basin ID: Existing 48" RCP CROSSING OF SYRACUSE

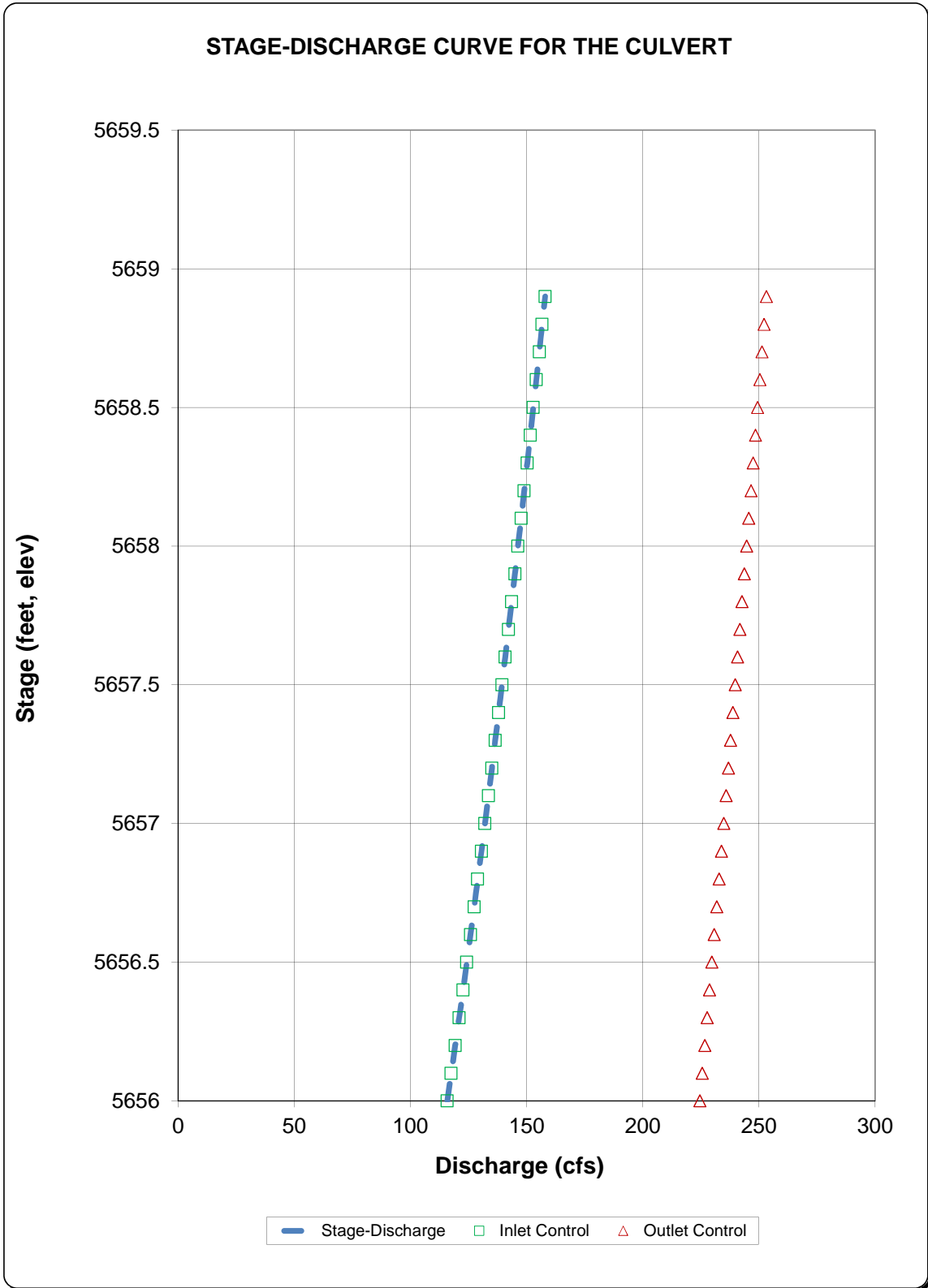



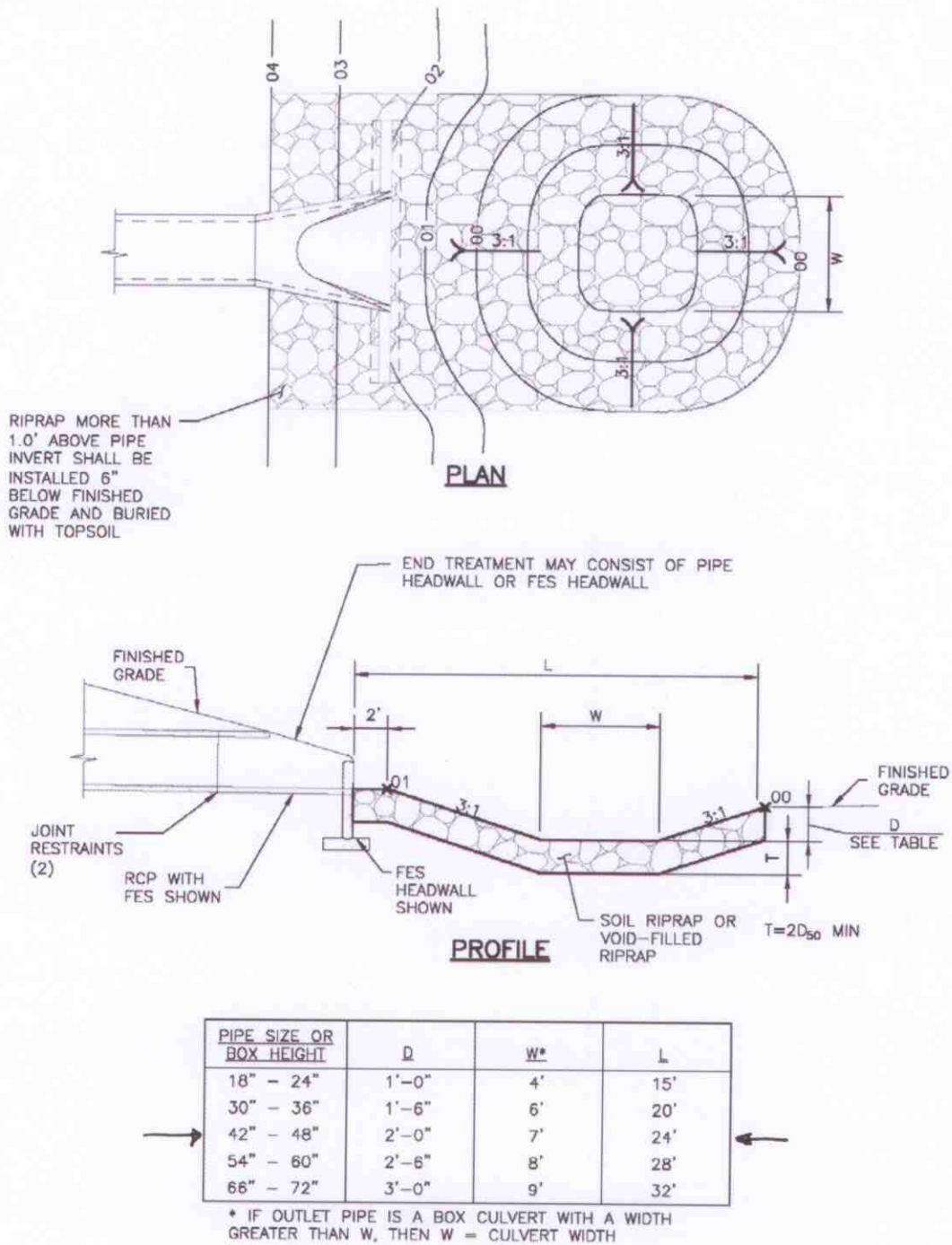
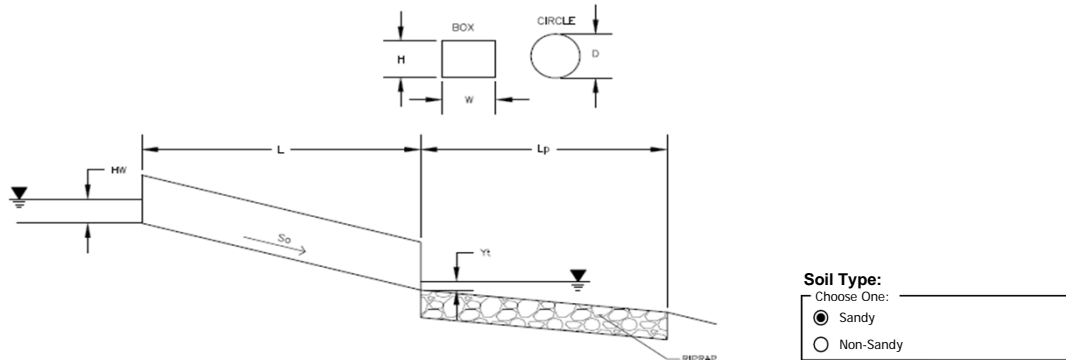

Figure 9-37. Low tailwater riprap basin

## Determination of Culvert Headwater and Outlet Protection

Project: **Mesa Ridge Self Storage Filing No. 1**

Basin ID: **Proposed 48" Pond Outfall**



**Soil Type:**  
 Choose One: \_\_\_\_\_  
 Sandy  
 Non-Sandy

**Supercritical Flow! Using Da to calculate protection type.**

<b>Design Information (Input):</b>	
Design Discharge	Q = <input style="width: 80px;" type="text" value="136"/> cfs
<b>Circular Culvert:</b>	
Barrel Diameter in Inches	D = <input style="width: 80px;" type="text" value="48"/> inches
Inlet Edge Type (Choose from pull-down list)	Square End Projection <input type="text" value="v"/>
<b>OR</b>	
<b>Box Culvert:</b>	
Barrel Height (Rise) in Feet	Height (Rise) = <input style="width: 80px;" type="text"/>
Barrel Width (Span) in Feet	Width (Span) = <input style="width: 80px;" type="text"/>
Inlet Edge Type (Choose from pull-down list)	<input type="text" value="v"/>
Number of Barrels	No = <input style="width: 80px;" type="text" value="1"/>
Inlet Elevation	Elev IN = <input style="width: 80px;" type="text" value="5650"/> ft
Outlet Elevation <b>OR</b> Slope	Elev OUT = <input style="width: 80px;" type="text" value="5641.29"/> ft
Culvert Length	L = <input style="width: 80px;" type="text" value="134.42"/> ft
Manning's Roughness	n = <input style="width: 80px;" type="text" value="0.012"/>
Bend Loss Coefficient	k <sub>b</sub> = <input style="width: 80px;" type="text" value="0"/>
Exit Loss Coefficient	k <sub>x</sub> = <input style="width: 80px;" type="text" value="1"/>
Tailwater Surface Elevation	Elev Y <sub>t</sub> = <input style="width: 80px;" type="text"/>
Max Allowable Channel Velocity	V = <input style="width: 80px;" type="text" value="5"/> ft/s

<b>Required Protection (Output):</b>	
Tailwater Surface Height	Y <sub>t</sub> = <input style="width: 80px;" type="text" value="1.60"/> ft
Flow Area at Max Channel Velocity	A <sub>t</sub> = <input style="width: 80px;" type="text" value="27.20"/> ft <sup>2</sup>
Culvert Cross Sectional Area Available	A = <input style="width: 80px;" type="text" value="12.57"/> ft <sup>2</sup>
Entrance Loss Coefficient	k <sub>e</sub> = <input style="width: 80px;" type="text" value="0.50"/>
Friction Loss Coefficient	k <sub>f</sub> = <input style="width: 80px;" type="text" value="0.56"/>
Sum of All Losses Coefficients	k <sub>s</sub> = <input style="width: 80px;" type="text" value="2.06"/> ft
Culvert Normal Depth	Y <sub>n</sub> = <input style="width: 80px;" type="text" value="1.61"/> ft
Culvert Critical Depth	Y <sub>c</sub> = <input style="width: 80px;" type="text" value="3.47"/> ft
Tailwater Depth for Design	d = <input style="width: 80px;" type="text" value="3.74"/> ft
Adjusted Diameter <b>OR</b> Adjusted Rise	D <sub>a</sub> = <input style="width: 80px;" type="text" value="2.81"/> ft
Expansion Factor	1/(2*tan(θ)) = <input style="width: 80px;" type="text" value="5.32"/>
Flow/Diameter <sup>2.5</sup> <b>OR</b> Flow/(Span * Rise <sup>1.5</sup> )	Q/D <sup>2.5</sup> = <input style="width: 80px;" type="text" value="4.25"/> ft <sup>0.5</sup> /s
Froude Number	Fr = <input style="width: 80px;" type="text" value="4.59"/> <span style="color: red; font-weight: bold;">Supercritical!</span>
Tailwater/Adjusted Diameter <b>OR</b> Tailwater/Adjusted Rise	Y <sub>t</sub> /D = <input style="width: 80px;" type="text" value="0.57"/>
Inlet Control Headwater	HW <sub>i</sub> = <input style="width: 80px;" type="text" value="7.27"/> ft
Outlet Control Headwater	HW <sub>o</sub> = <input style="width: 80px;" type="text" value="-1.22"/>
<b>Design Headwater Elevation</b>	<b>HW = <input style="width: 80px;" type="text" value="5,657.27"/> ft</b>
<b>Headwater/Diameter <b>OR</b> Headwater/Rise Ratio</b>	<b>HW/D = <input style="width: 80px;" type="text" value="1.82"/> <span style="color: red; font-weight: bold;">HW/D &gt; 1.5!</span></b>
Minimum Theoretical Riprap Size	d <sub>50</sub> = <input style="width: 80px;" type="text" value="16"/> in
Nominal Riprap Size	d <sub>50</sub> = <input style="width: 80px;" type="text" value="18"/> in
<b>UDFCD Riprap Type</b>	<b>Type = <input style="width: 80px;" type="text" value="H"/></b>
<b>Length of Protection</b>	<b>L<sub>p</sub> = <input style="width: 80px;" type="text" value="40"/> ft</b>
<b>Width of Protection</b>	<b>T = <input style="width: 80px;" type="text" value="12"/> ft</b>

## **DRAINAGE MAPS**







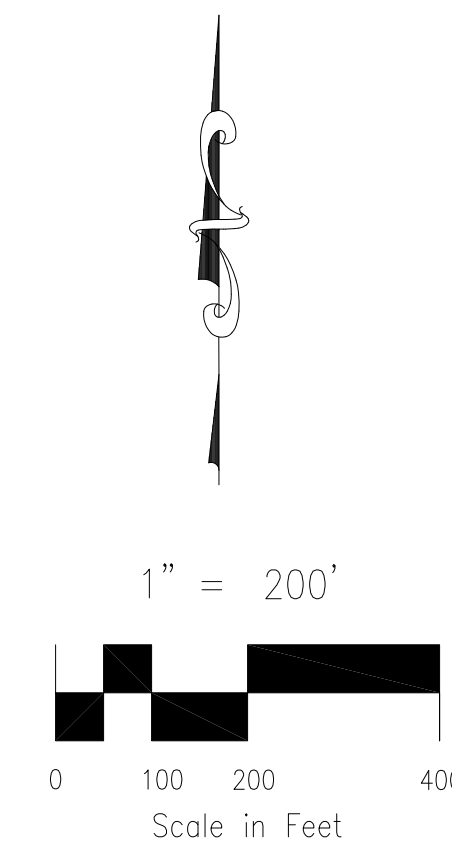
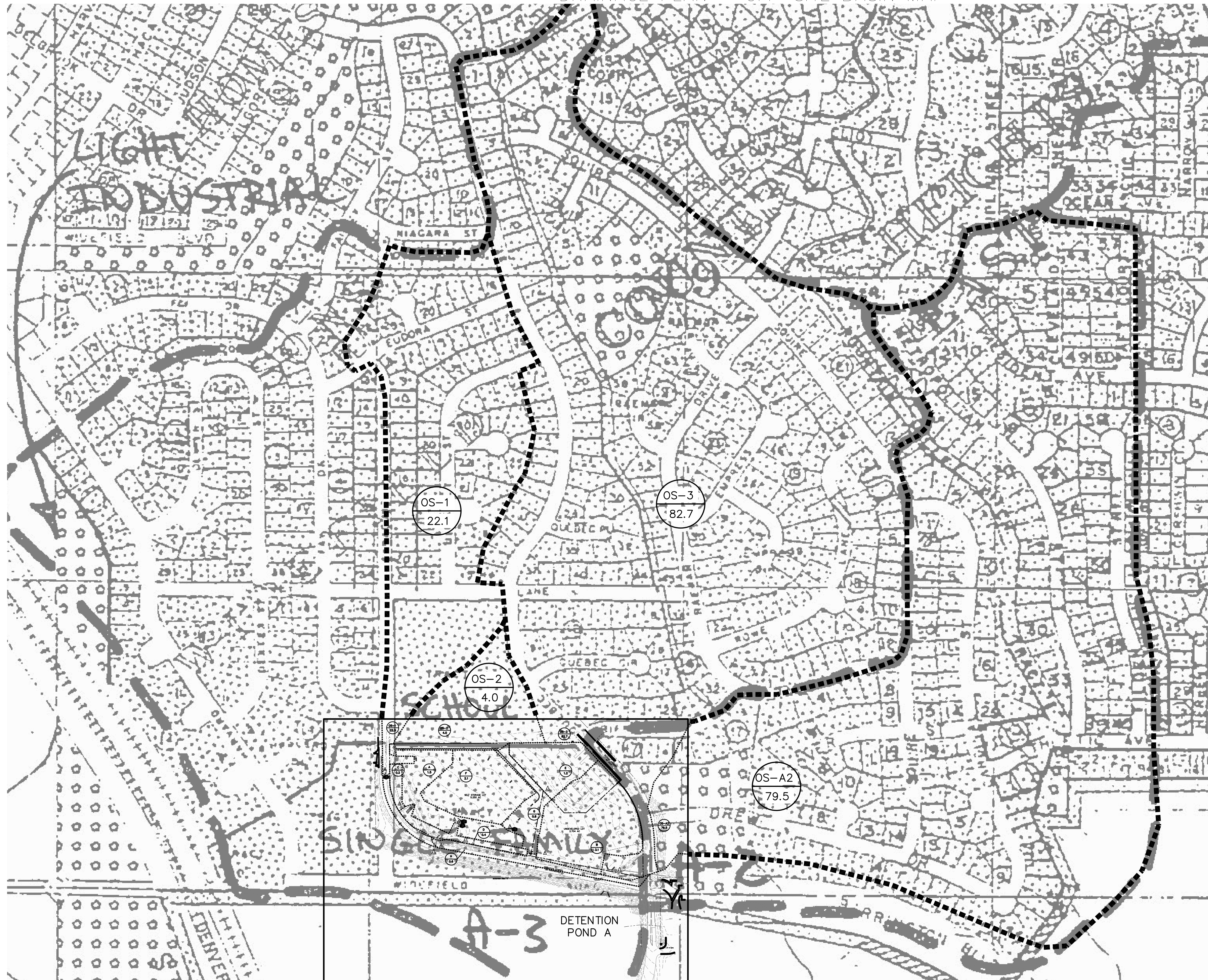

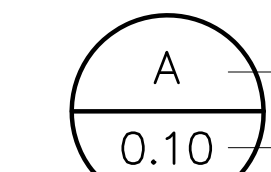
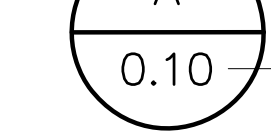

# MESA RIDGE SELF STORAGE

EL PASO COUNTY, STATE OF COLORADO  
DRAINAGE PLAN - OFF-SITE BASIN MAP

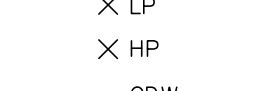
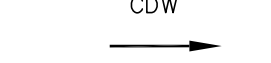

### LEGEND

-  BASIN DESCRIPTION
-  BASIN AREA, ACRES
-  SURFACE ROUTING DESIGN POINT
-  EX MAJ CONT
-  EX MIN CONT
-  PROP MAJ CONT
-  PROP MIN CONT
-  LP
-  HP
-  CDW
-  DRAINAGE FLOW ARROW

FOR BURIED UTILITY INFORMATION  
**48 HRS BEFORE YOU DIG CALL 811**  
FOR LOCATING & MARKING GAS, ELECTRIC, WATER & TELEPHONE LINES  
WATER EMERGENCIES 520-0300

MESA RIDGE SELF STORAGE

JOB NO. 10-004  
DATE PREPARED: MARCH 2014  
DATE REVISED: JULY 2014



102 E. PIKES PEAK AVE. STE 304  
COLORADO SPRINGS,  
COLORADO 80903

v 719.955.5485  
f 719.444.8427

W:\projects\01407 - Mesa Ridge.dwg, DR10004\_Drainage.dwg, off-site, 2/10/2016, 3:31:13 PM, CDK



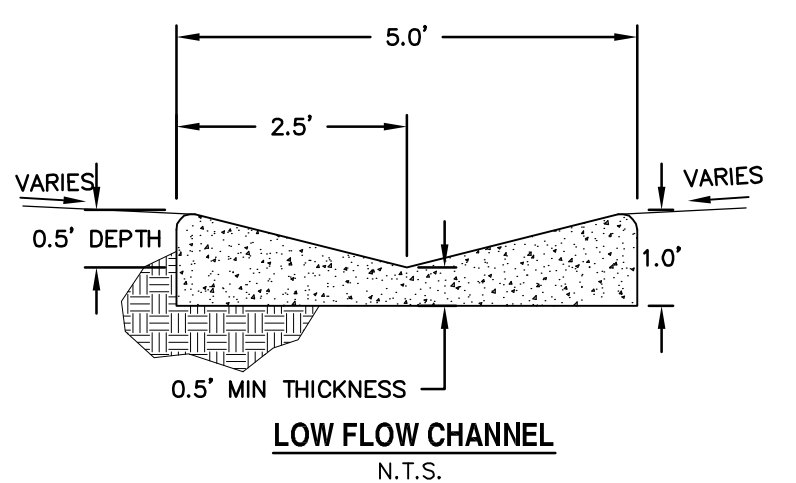
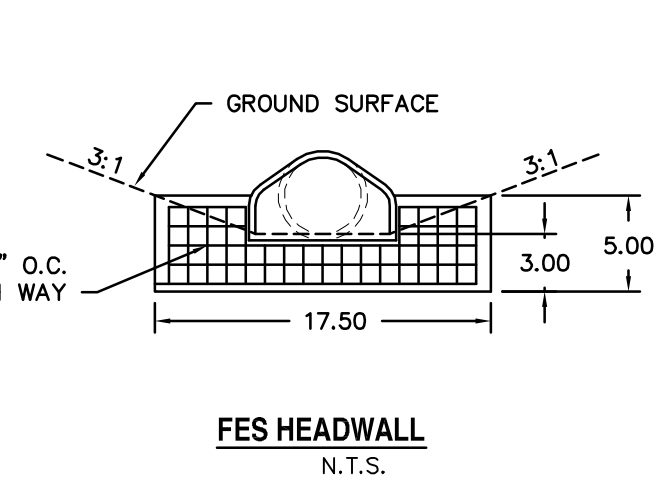
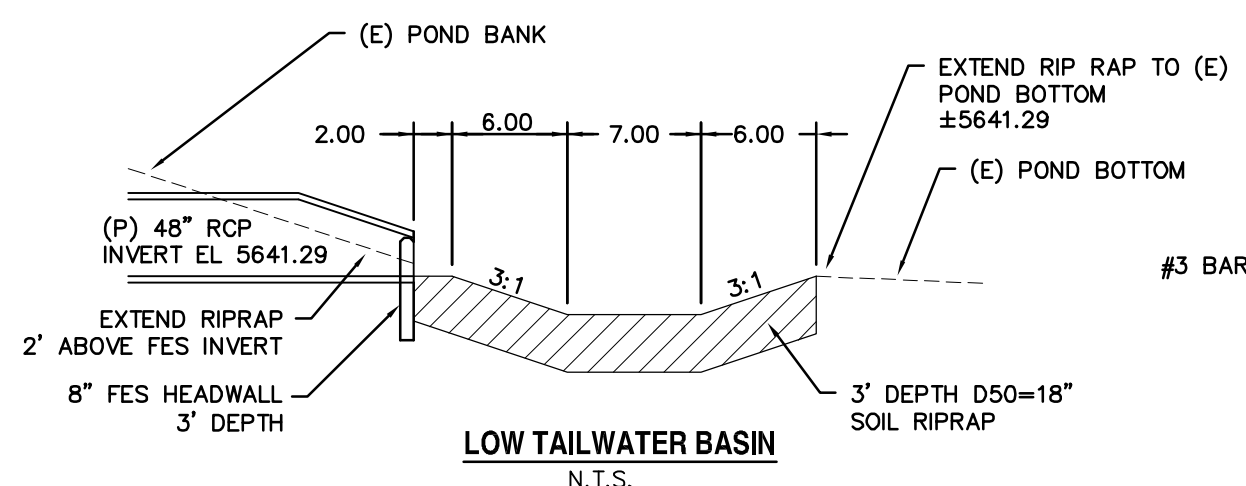
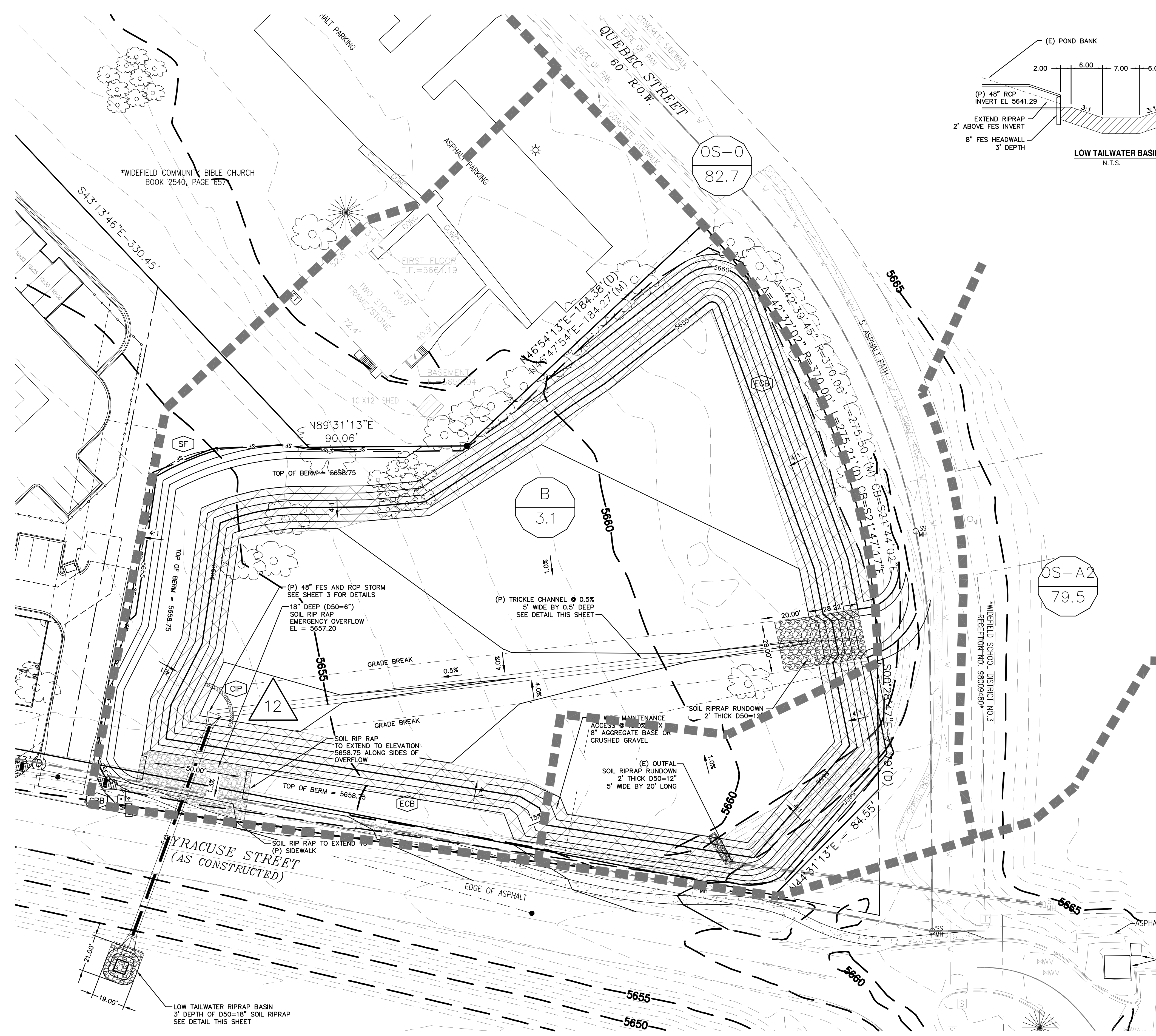

**SEEDING GUIDELINES:**

- SEEDING PREPARATION:** THE SEEDBED SHOULD BE WELL-SETTLED AND FIRM, BUT FRIABLE ENOUGH THAT THE SEED CAN BE PLACED AT THE SPECIFIED DEPTHS. COMPETITIVE STANDS OF WEEDS THAT ARE PRESENT BEFORE SEEDING MUST BE CONTROLLED BY SHALLOW TILLAGE OR BY APPLICATION OF HERBICIDES. SOILS THAT HAVE BEEN OVER-COMPACTED BY TRAFFIC OR EQUIPMENT, ESPECIALLY WHEN WET, SHOULD BE TILLED TO BREAK UP ROOTING-RESTRICTIVE LAYERS, THEN HARROWED, ROLLED, OR PACKED TO PREPARE THE REQUIRED FIRM SEEDBED.
- FERTILIZER:** FERTILIZER SHOULD BE APPLIED AT A RATE OF 50 POUNDS OF AVAILABLE NITROGEN PER ACRE AND 40 POUNDS OF AVAILABLE PHOSPHATE PER ACRE. THE TIME OF APPLICATION SHOULD BE IMMEDIATELY PRIOR TO SEEDING, AT THE TIME OF SEEDING, OR IMMEDIATELY FOLLOWING SEEDING, DEPENDING ON THE KIND OF FERTILIZER AND TYPE OF EQUIPMENT USED.
- SEEDING:** SEED SHOULD BE PLANTED WITH A GRASS DRILL ON ALL SLOPES OF 33% (3:1) OR FLATTER. SEED MAY BE BROADCAST BY HAND, BY MECHANICAL SPREADER, OR BY HYDRAULIC EQUIPMENT ON AREAS THAT ARE SMALL, TOO STEEP, OR NOT ACCESSIBLE FOR SEED DRILL OPERATIONS. PLS RATES SHOULD BE DOUBLED IF BROADCAST BY HAND. SEED PLANTED WITH A DRILL SHOULD BE COVERED WITH SOIL TO A DEPTH OF 1/4 TO 3/4 INCH. SEED PLANTED BY THE BROADCAST METHOD SHALL BE INCORPORATED INTO THE SOIL SURFACE, NOT TO EXCEED A DEPTH OF 3/4 INCH, BY RAKING, HARROWING, OR OTHER PROVEN METHOD.  
THE TIME OF SEEDING IS FROM OCTOBER 15TH - MAY 31ST. SEED PLANTED IN THE LATE FALL WILL REMAIN DORMANT UNTIL SPRING, WHEN IT WILL GERMINATE.
- MULCHING:** SEEDING AREAS SHOULD BE MULCHED TO CONSERVE MOISTURE; PREVENT SURFACE COMPACTION OR CRUSTING; REDUCE RUNOFF AND EROSION; CONTROL INSECTS; AND HELP ESTABLISH PLANT COVER. NATIVE HAY OR STRAW SHOULD BE APPLIED AT A RATE OF 4,000 POUNDS PER ACRE AND CRIMPED INTO THE GROUND. ON SLOPES GREATER THAN 3:1, AN AGRONOMY BLANKET SHOULD BE USED.
- SUPPLEMENTAL WATER:** IN LOW RAINFALL AREAS, WHERE WATER IS AVAILABLE AND WHERE RAPID ESTABLISHMENT IS NEEDED, IRRIGATION OF NEW SEEDING SHOULD BE PERFORMED DURING THE FIRST GROWING SEASON. WATER SHOULD BE APPLIED AT APPROXIMATELY ONE WEEK INTERVALS, AT A RATE OF 3/4 TO 1 INCH PER APPLICATION, WHEN RAINFALL IS DEFICIENT FOR PLANT DEVELOPMENT.

**EROSION PROTECTION & RE-VEGETATION REQUIREMENTS**  
\*PER U.S.D.A. SOIL CONSERVATION SERVICE GUIDELINES\*

1 PRACTICE NO & NAME	342 - CRITICAL AREA TREATMENT
RANGE SITE	SANDY FOOTHILLS
2 PLANNED SEEDING PREP:	
A METHOD	SEEDING OPERATION:
B DATES OCT 15 - MAY 31	A METHOD: _____
C CLEAN TILLED: XX	DRILL: XX
FIRM SEEDBED: XX	INTERSEED: _____
STUBBLE COVER: _____	BROADCAST: _____
INTERSEED: _____	B DRILL SPACING: 6-12"
OTHER: _____	TYPE GRASS: W/AGITATOR
	C DATE OCT 15 - MAY 31
	D PLANTING DEPTH: 1/4-1/2"
FERTILIZER:	WEED CONTROL: N/A
POUNDS ACTUAL PER ACRE N2	40
(AVAILABLE)	40
P205	40
K	N/A
	SEE S.C.S. FOR SPECIFIC RECOMMENDATIONS AT HERBICIDE APPLICATION TIME

MULCH:	LONG - STEM NATIVE HAY
KIND:	4,000 POUNDS/ACRE
AMOUNT:	N/A
HOW-APPLIED:	CRIMPED
HOW-ANCHORED:	4"
ANCHORAGE DEPTH:	

SEED:	VARIETY	SPECIES	REQUIRED PLS RATES PER ACRES (100%):
	EL REND	SIBEDATS GRAMA	3.0
	BARTON	WESTERN WHEATGRASS	2.5
	NATIVE	SLENDER WHEAT GRASS	2.0
	PASTURA	LITTLE BLUESTEM	2.0
	NATIVE	SAND DROPSSEED	0.5
	NEBRASKA 28	SWITCH GRASS	3.0
	MORPHA	WEEPING LOVE GRASS	1.0

(2) % OF SPECIES IN MIXTURE	(3) PLS SEEDING RATE PER SPECIES/ACRE (1) x (2)	(4) PLANNED ACRE	(5) TOTAL PLS LBS/ SPECIES PLANNED (3) x (4)
20	0.60	2.4	1.4
20	0.50	2.4	1.2
15	0.30	2.4	0.7
15	0.30	2.4	0.7
5	0.03	2.4	0.1
20	0.60	2.4	1.4
5	0.05	2.4	0.1

REV.	DESCRIPTION	DATE
1	ADDRESSED COUNTY COMMENTS	4/17/17



PREPARED FOR:  
**GY5 LLC**  
791 COPPER CENTER PARKWAY  
COLORADO SPRINGS, CO 80921  
(936) 671-1422

PREPARED UNDER MY DIRECT SUPERVISION FOR AND BEHALF OF CATAMOUNT ENGINEERING.

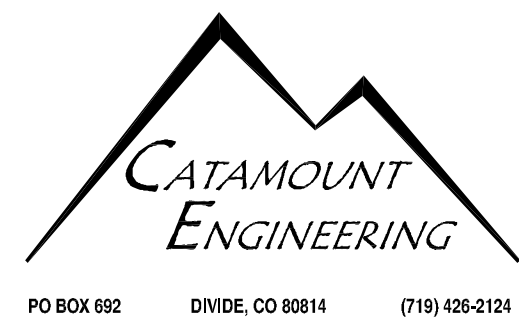

**MESA RIDGE SELF STORAGE**

**DETENTION POND GRADING & EROSION CONTROL PLAN**

SCALE:	1" = 30'	DATE:	4/10/17
JOB NUMBER:	16-086	SHEET:	2 OF 4

DAVID L. MIJARES, COLORADO PE #40510 DATE



PROPOSED DRAINAGE BASINS							
BASIN	AREA (ACRES)	Q2 (CFS)	Q5 (CFS)	Q10 (CFS)	Q25 (CFS)	Q50 (CFS)	Q100 (CFS)
A1	0.17	0.6	0.7	0.9	1.0	1.0	1.3
A2	0.77	2.1	2.7	3.4	4.1	4.8	5.5
A3	0.15	0.0	0.1	0.2	0.4	0.5	0.6
B	0.79	0.5	0.9	1.3	2.0	2.5	3.1

PROPOSED DESIGN POINTS							
DESIGN POINT	Q2 (CFS)	Q5 (CFS)	Q10 (CFS)	Q25 (CFS)	Q50 (CFS)	Q100 (CFS)	
DP-1	0.6	0.7	0.9	1.0	1.2	1.3	
DP-2	2.6	3.5	4.3	5.1	6.0	6.9	
DP-3	2.6	3.8	5.0	6.4	7.7	9.1	

**DRAINAGE LEGEND**

- BASIN IDENTIFIER X
- BASIN AREA [AC] X.XX
- DESIGN POINT IDENTIFIERS X
- DRAINAGE BASIN BOUNDARY

Please change the weighting on the basin line work

Include riprap design calculations in the report

Ensure that all line work is included in the legend



- LEGEND**
- EXISTING (E)
  - PROPOSED (P)
  - CURB AND GUTTER C&G
  - EASEMENT ESMT
  - PUBLIC PUB
  - PRIVATE PVT
  - PROPERTY BOUNDARY
  - RIGHT-OF-WAY
  - LOT LINE
  - (E) CONTOUR, INDEX
  - (E) CONTOUR
  - (E) SANITARY MAIN, MH
  - (E) STORM SEWER, INLET, MH
  - (E) WATER MAIN, VALVE, FH
  - (P) CONTOUR, INDEX
  - (P) CONTOUR
  - (P) RETAINING WALL
  - DIRECTION OF FLOW
  - (E) DIRECTION OF OVERLAND FLOW
  - LIMITS OF DISTURBANCE & CONSTRUCTION LIMITS

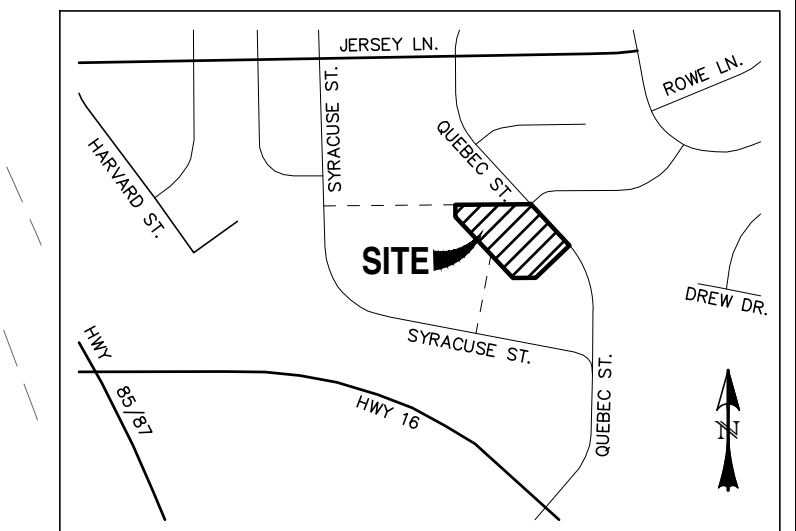
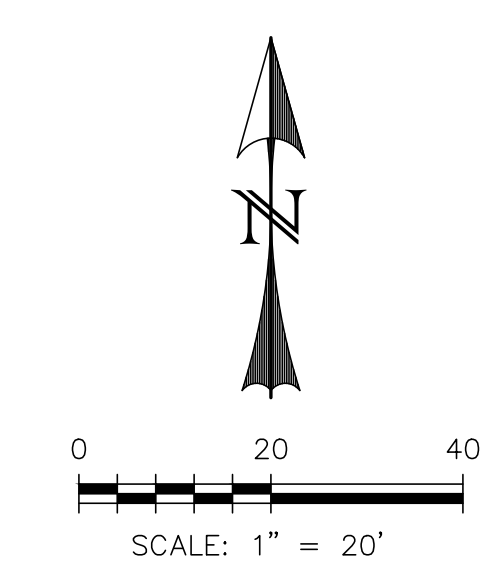

REV.	DESCRIPTION	DATE

**811** Know what's below.  
Call 72 hours before you dig.  
For more details visit:  
www.call811.com

PREPARED FOR:  
BUCHER DESIGN STUDIO  
12325 ORACLE BOULEVARD SUITE 101  
COLORADO SPRINGS, CO 80921  
(719) 484-0480

**CATAMOUNT ENGINEERING**  
321 W. HENRIETTA AVE WOODLAND PARK CO 80866  
PO BOX 221 (719) 428-2124

WIDEFIELD COMMUNITY BIBLE CHURCH  
**PROPOSED DRAINAGE MAP**

DESIGNED BY: DLM	DRAWN BY: MGP
SCALE: 1" = 20'	DATE: 10/02/24
JOB NUMBER: 24-416	SHEET: 1 OF 1



EXISTING DRAINAGE BASINS							
BASIN	AREA (ACRES)	Q2 (CFS)	Q5 (CFS)	Q10 (CFS)	Q25 (CFS)	Q50 (CFS)	Q100 (CFS)
EX-A	0.92	1.6	2.2	2.8	3.6	4.3	5.0
EX-B	0.96	0.4	0.8	1.3	2.0	2.5	3.2

EXISTING DESIGN POINTS							
DESIGN POINT	Q2 (CFS)	Q5 (CFS)	Q10 (CFS)	Q25 (CFS)	Q50 (CFS)	Q100 (CFS)	
EX1	1.7	2.6	3.7	5.0	6.1	7.3	

**DRAINAGE LEGEND**

- BASIN IDENTIFIER
- BASIN AREA [AC]
- DESIGN POINT IDENTIFIERS
- DRAINAGE BASIN BOUNDARY

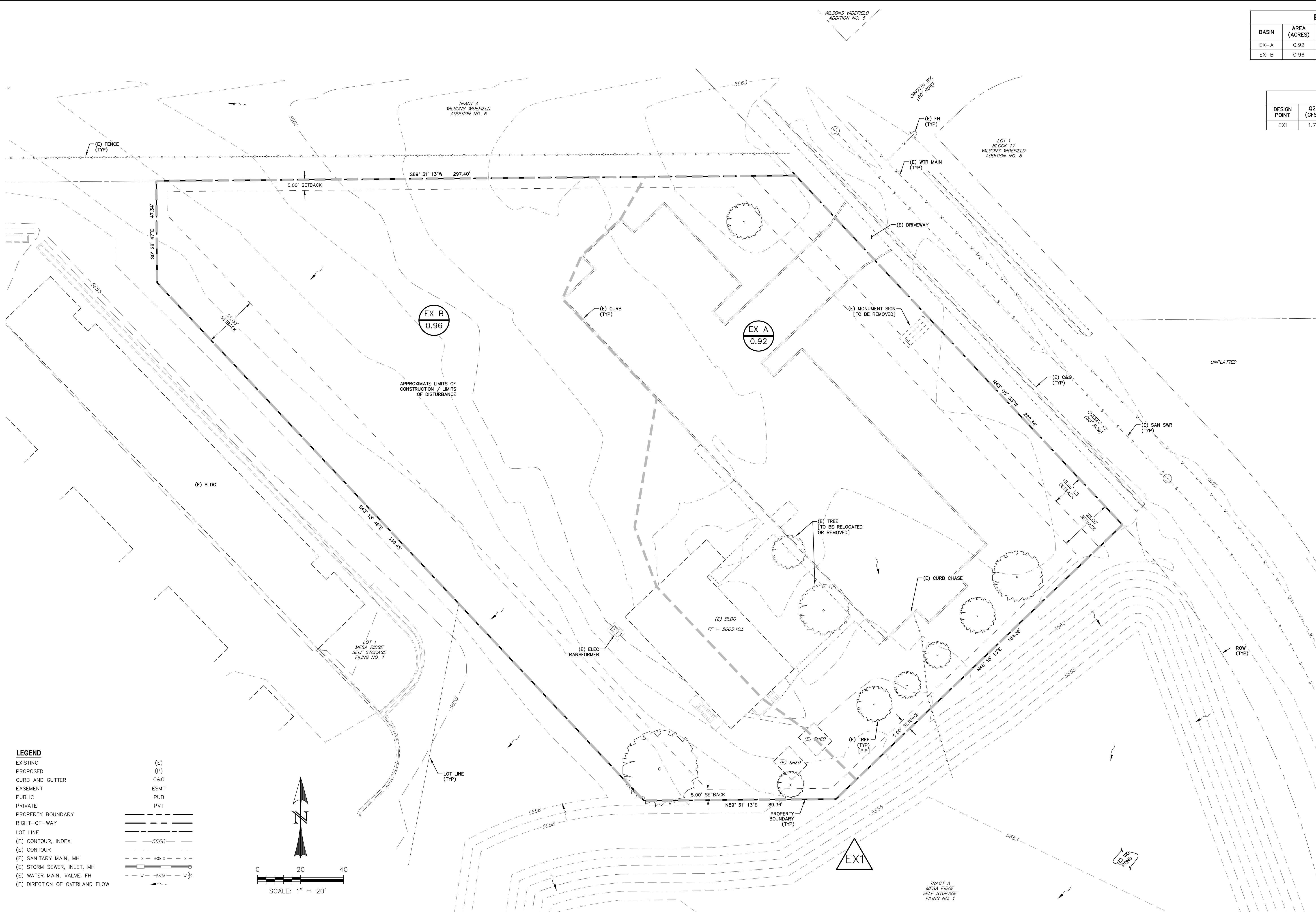

- LEGEND**
- (E) EXISTING
  - (P) PROPOSED
  - C&G CURB AND GUTTER
  - ESMT EASEMENT
  - PUB PUBLIC
  - PVT PRIVATE
  - PROPERTY BOUNDARY
  - RIGHT-OF-WAY
  - LOT LINE
  - (E) CONTOUR, INDEX
  - (E) CONTOUR
  - (E) SANITARY MAIN, MH
  - (E) STORM SEWER, INLET, MH
  - (E) WATER MAIN, VALVE, FH
  - (E) DIRECTION OF OVERLAND FLOW

- (E) EXISTING
- (P) PROPOSED
- C&G CURB AND GUTTER
- ESMT EASEMENT
- PUB PUBLIC
- PVT PRIVATE

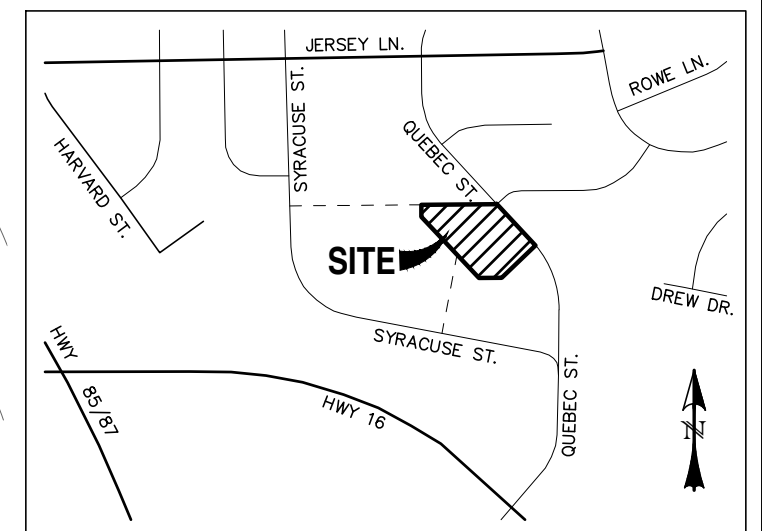
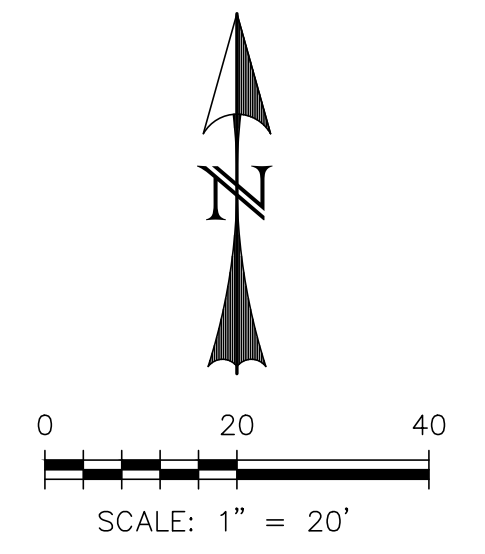

REV.	DESCRIPTION	DATE

**811** Know what's below.  
Call 72 hours before you dig.  
For more details visit:  
[www.call811.com](http://www.call811.com)

PREPARED FOR:  
**BUCHER DESIGN STUDIO**  
12325 ORACLE BOULEVARD SUITE 101  
COLORADO SPRINGS, CO 80921  
(719) 484-0480

**CATAMOUNT ENGINEERING**  
321 W. HENRIETTA AVE WOODLAND PARK, CO 80866  
PO BOX 221 (719) 428-2124

**WIDEFIELD COMMUNITY BIBLE CHURCH**  
**EXISTING DRAINAGE MAP**

DESIGNED BY: DLM	DRAWN BY: MGP
SCALE: 1" = 20'	DATE: 10/02/24
JOB NUMBER: 24-416	SHEET: 1 OF 1